

PLYMOUTH



1936



1937



1938



1939



1940



1941



1942

SERVICE MANUAL

Plymouth recognizes the role played by the automobile service man who, since Pearl Harbor, has shouldered the entire responsibility of keeping the transportation system of this country rolling.

This manual is dedicated to the men who service Plymouth cars—to help them continue to do the good service work which has resulted in keeping the millions of Plymouth cars rendering satisfactory service.

PLYMOUTH SERVICE MANUAL

for

PLYMOUTH PASSENGER CARS

<u>YEAR</u>	<u>MODELS</u>
1942	P14S, P14C
1941	P11, P12
1940	P9, P10
1939	P7, P8
1938	P5, P6
1937	P3, P4
1936	P1, P2

This manual contains combined service information
taken from the following Plymouth Shop Manuals:

D-10062—1942 Models—P14S, P14C	D-8096 —1939 Models—P7, P8
D-9298 —1941 Models—P11, P12	D-4291 —1938 Models—P5, P6
D-8634 —1940 Models—P9, P10	D-3906 —1937 Models—P3, P4
D-3496 —1936 Models—P1, P2	

Price—\$1.50 Net Postage Prepaid in United States
Order by part number D-10974

CHRYSLER CORPORATION

PLYMOUTH DIVISION
DETROIT 31, MICHIGAN

SPECIFICATION CHARTS AND DIAGRAMS

	Page
General data and specifications	11
Car serial numbers and engine numbers	12
Table of capacities, frequencies and lubricants	16-17
Lubrication charts	18-19
Front axle	32
Rear axle	51
Brakes	76
Clutch	88
Clutch fixture spacers and feeler gauges	93
Cooling system	96
Engine	101
Engine tune-up	104
Frame alignment diagrams	120-123
Fuel System	126
Generator	132
Generator regulator	140
Ignition system	144
Lighting system	148
Wiring diagrams	154-164
Starting motor	165
Shock absorbers	171
Springs	178
Transmission	192
Wheels and tires	212

TABLE OF CONTENTS

	Page
FOREWORD	7
General data and specifications	11
Car serial numbers and engine numbers	12

SECTION I—LUBRICATION AND MAINTENANCE

Table of capacities, frequencies and lubricants	16-17
Lubrication charts	18-19
1. Importance of lubrication and maintenance	13
2. Engine oil recommendations	13
3. Checking the engine oil level	14
4. When to change engine oil	14
5. Cleaning of carburetor air cleaner	14
6. Lubrication of transmission	14
7. Lubrication of rear axle	15
8. Lubrication of front wheel bearings	15
9. Lubrication of rear wheel bearings	20
10. Lubrication of steering gear	20
11. Lubrication of water pump	20
12. Lubrication of universal joints	20
13. Chassis lubricant fittings	20
14. Lubrication of starter	20
15. Lubrication of generator	21
16. Lubrication of distributor	21
17. Lubrication of hand brake linkage	21
18. Lubrication of pedals and linkage (brake and clutch)	21
19. Lubrication of springs with metal covers	21
20. Lubrication of Powermatic shift	22
21. Cleaning and lubricating power cylinder in air cleaner	22
22. Cleaning and oiling crankcase oil filler pipe air cleaner	23
23. Replacement of oil filter	23
24. Maintenance of rubber parts	23
25. Maintenance of Oilite bearings	23
26. Servicing batteries	24
27. Recommended tire pressures	24

SECTION II—TROUBLE SHOOTING

1. Engine will not turn	25
2. Engine turns but will not start	25
3. Engine does not develop normal power	26
4. Engine runs unevenly	27
5. Engine noises	27
6. Low or no oil pressure	28
7. Excessive oil consumption	28
8. Excessive fuel consumption	28
9. Engine overheats	28
10. Improper generator charging rate	29
11. Lights	29
12. Improper clutch operation	29
13. Difficult gear shifting	30
14. Noise or play in drive line	30
15. Noisy rear axle	30
16. Brakes	30
17. Steering	31

SECTION III—FRONT AXLE

	Page
Data and specifications	32
1. Front wheel alignment	33
2. Checking king pin inclination	33
3. Checking camber	34
4. Checking caster angle	35
5. Adjusting camber and caster	36
6. Measuring toe-in	37
7. Adjusting toe-in	37
8. Measuring toe-out on turns	38
9. Location of pitman arm for proper toe-out on turns	38
10. Removal of steering knuckles and bushings	39
11. Installation of steering knuckles and bushings	40
12. Removal of upper control arm	40
13. Installation of upper control arm	40
14. Installation of upper control arm bushings	40
15. Removal of lower control arm and front spring	40
16. Installation of lower control arm and front spring	41
17. Removal of tie rods	41
18. Installation of tie rods	41

SECTION IV—REAR AXLE

Data and specifications	51
1. Description	53
2. Adjustment of axle shaft end play	53
3. Removal of axle drive shaft and oil seal	53
4. Installation of axle drive shaft and oil seal	54
5. Removal of broken end of axle drive shaft	54
6. Replacement of drive pinion bearing oil seal	54
7. Replacement of differential carrier assembly	54
8. Disassembly of differential carrier	54
9. Assembly of differential carrier	54
10. Removal of rear axle housing	56
11. Installation of rear axle housing	56
12. Removal of rear axle assembly	56
13. Installation of rear axle assembly	56

SECTION V—BODY

1. Adjustment of door striker plate	57
2. Removal of door remote control handle and window regulator handle	57
3. Removal of door outside handle	57
4. Installation of door outside handle	58
5. Replacement of door lock cylinder	58
6. Replacement of luggage compartment lock cylinder	58
7. Removal of door garnish molding and ventilator	59

	Page		Page
8. Replacement of door trim panel	59	17. Adjusting hand brake.....	85
9. Removal of front door vertical sliding glass	59	18. Replacement of hand brake.....	85
10. Replacement of window lift regulator	61	19. Replacement of hand brake lining	85
11. Removal of front door latch and remote control	64		
12. Replacement of front door ventilator assembly	65	SECTION VII—CLUTCH	
13. Removal of rear door glass.....	65	Data and specifications.....	88
14. Removal of rear door window regulator	66	Clutch fixture spacers and feeler gauges	93
15. Removal of rear door latch and remote control	66	1. Description	87
16. Replacement of rear quarter window	66	2. Adjustment of clutch pedal free play	87
17. Replacement of ventilator window (rear side quarter) ..	67	3. Adjustment of over-center spring	87
18. Removal of rear quarter window glass and regulator assembly (2-door sedan)	67	4. Replacement of over-center spring	87
19. Replacement of rear window glass	67	5. Removal of clutch	91
20. Replacement of rear arm rest and trim assembly.....	68	6. Installation of clutch.....	91
21. Removal of seat back cushion (front or rear)	68	7. Disassembly of clutch.....	91
22. Adjustment of front seat guide..	68	8. Assembly of clutch	92
23. Removal of windshield glass....	68	9. Adjustment of clutch release levers with fixture C-585.....	92
24. Installation of windshield glass..	70	10. Adjustment of clutch levers with fixture C-411	94
25. Adjustment of hood striker plate and lock	72		
26. Adjustment of hood lock control cable	73	SECTION VIII—COOLING SYSTEM	
27. Adjusting Convertible Coupe top to fit body	73	Data and specifications.....	96
28. Replacement of Convertible Coupe top vacuum cylinder..	74	1. Adjustment of fan belt.....	95
29. Replacement of Convertible Coupe top vacuum valve	74	2. Replacement of fan belt.....	95
30. Removal of Convertible Coupe body window and frame.....	75	3. Replacement of engine water thermostat	95
31. Removal of Convertible Coupe body door latch	75	4. Replacement of water distributor tube	95
32. Removal of Convertible Coupe body window regulator.....	75	5. Replacement of water pump....	95
		6. Disassembly of water pump....	98
SECTION VI—BRAKES		7. Assembly of water pump.....	98
Data and specifications	76	8. Water temperature indicator...	99
1. Brake pedal free play.....	77	9. Removal of radiator core.....	99
2. Foot brake minor adjustment...	77	10. Removal and installation of radiator and fender unit.....	100
3. Foot brake major adjustment...	78		
4. Bleeding brake system.....	79	SECTION IX—ENGINE	
5. Removal of brake shoes.....	80	Data and specifications.....	101
6. Installation of brake shoes.....	80	Engine tune-up chart.....	104
7. Replacement of brake lining....	80	1. Description	103
8. Removal of wheel cylinder.....	80	2. Engine tests and adjustments...	103
9. Installation of wheel cylinder...	81	3. Removal and installation of engine	105
10. Disassembly of wheel cylinder..	83	4. Cylinder head installation.....	107
11. Assembly of wheel cylinder....	83	5. Replacement of valves and springs	107
12. Removal of master cylinder....	83	6. Adjustment of valve tappet clearance	109
13. Installation of master cylinder..	83	7. Reconditioning of exhaust valve seat inserts	110
14. Disassembly of master cylinder.	83	8. Replacement of exhaust valve seat inserts	110
15. Assembly of master cylinder....	83	9. Replacement of valve stem guides (valves and springs removed)	110
16. Reconditioning brake cylinders.	83	10. Replacement of valve tappets...	110
		11. Checking valve timing.....	110
		12. Replacement of timing gear case cover and oil seal.....	110
		13. Replacement of timing chain and sprockets	111
		14. Replacement of camshaft.....	111

	Page		Page
15. Replacement of camshaft bearings	112	SECTION XIV—GENERATOR REGULATOR	
16. Replacement of connecting rod and piston assembly	112	Data and specifications	140
17. Reconditioning of cylinder walls	112	1. Testing and adjusting generator regulator (1940-42)	139
18. Fitting pistons	112	2. Testing and adjusting cut-out relay (1936-39)	142
19. Replacement of piston rings	113	3. Testing and adjusting circuit breaker and voltage regulator (1936-39)	142
20. Replacement of piston pins (pistons removed)	114	SECTION XV—IGNITION SYSTEM	
21. Replacement of connecting rod bearings	114	Data and specifications	144
22. Replacement of crankshaft (main) bearings	115	1. Description	143
23. Checking crankshaft end play ..	115	2. Disassembly of distributor	143
24. Installation of crankshaft bearing oil seals	116	3. Assembly of distributor	145
25. Replacement of flywheel	116	4. Spark plugs	147
26. Engine Oiling System	116	SECTION XVI—LIGHTING AND WIRING SYSTEMS	
27. Removal and installation of oil pan and strainer	116	Data and specifications	148
28. Removal and installation of oil pump	117	1. Description of lights	149
SECTION X—EXHAUST SYSTEM		2. Aiming of headlights	149
1. Disassembly and assembly of manifold heat control	118	3. Replacement of light bulbs	151
2. Replacement of exhaust pipe and muffler	118	4. Description of wiring	153
3. Replacement of intake and exhaust manifold gaskets	118	Wiring diagrams	154-164
SECTION XI—FRAME		SECTION XVII—STARTING MOTOR	
1. Frame alignment	119	Data and specifications	165
Frame alignment diagrams ..	120-123	1. Description	165
SECTION XII—FUEL SYSTEM		2. Replacement of starting motor brushes	165
Data and specifications	126	3. Disassembly of starting motor ..	165
1. Description of carburetor	125	4. Replacement of starting motor field coils	167
2. Disassembly of carburetor	125	5. Assembly of starting motor	168
3. Assembly of carburetor	125	6. Testing starting motor	169
4. Adjusting idle speed of carburetor ..	125	SECTION XVIII—SHOCK ABSORBERS	
5. Accelerating pump setting	125	Data and specifications	171
6. Replacement of main metering jet ..	125	1. Description	171
7. Adjustment of carburetor float level	125	2. Testing shock absorber operation ..	171
8. Cleaning carburetor air cleaner ..	127	3. Refilling shock absorbers	172
9. Description of fuel pump	127	4. Disassembly of shock absorbers ..	172
10. Disassembly of fuel pump	127	5. Assembly of shock absorbers	173
11. Assembly of fuel pump	127	6. Installation of shock absorbers ..	175
12. Testing fuel gauge	130	SECTION XIX—SPRINGS	
13. Calibrating fuel gauge (dash unit)	130	Data and specifications	178
SECTION XIII—GENERATOR		1. Front spring height	177
Data and specifications	132	2. Installation of front spring	177
1. Description	133	3. Adjustment of front spring shackles	177
2. Disassembly of generator	133	4. Installation of steering shock eliminator	177
3. Removal of field coils	136	5. Installation of rear spring	177
4. Installation of field coils	136	6. Adjustment of rear spring shackles	178
5. Assembly of generator	136	7. Adjustment of rear spring bolts ..	179
6. Testing generator on test stand ..	137	8. Spring clip maintenance	179
7. Testing generator on engine	138		

	Page		Page
SECTION XX—STEERING GEAR			
1. Description	180	8. Replacement of rear oil seal	204
2. Adjustment of worm bearings	180	9. Disassembly of gearshift lever housing	204
3. Adjustment of roller tooth and worm	180	10. Adjustment of gearshift control rod (manual shift)	204
4. Removal of horn button (with blowing ring)	181	11. Adjustment of gear selector rod (manual shift)	205
5. Removal of horn button (without blowing ring)	181	12. Adjustment of Powermatic shift	205
6. Removal of steering wheel	183	13. Lubricating Powermatic shift	205
7. Disassembly of gearshift control	183	14. Cleaning power cylinder air cleaner	207
8. Removal of steering gear	184		
9. Installation of steering gear	189	SECTION XXII—UNIVERSAL JOINTS AND PROPELLER SHAFT	
10. Alignment of steering gear in frame	190	1. Description	208
11. Alignment of steering and front wheels	190	2. Replacement of universal joint (ball and trunnion)	208
12. Disassembly of steering gear	191	3. Replacement of universal joint boot (ball and trunnion)	208
13. Assembly of steering gear	191	4. Replacement of universal joint (cross and roller type)	211
SECTION XXI—TRANSMISSION		SECTION XXIII—WHEELS AND TIRES	
Data and specifications	192	Data and specifications	212
1. Description	193	1. Adjustment of front wheel bearings	213
2. Replacement of transmission	193	2. Adjustment of rear wheel bearings	213
3. Disassembly of transmission (1940-42 models)	196	3. Installation of front wheel bearings	213
4. Assembly of transmission (1940-42 models)	196	4. Removal of tires	213
5. Disassembly of transmission (1936-39 models)	198	5. Installation of tires	214
6. Assembly of transmission (1936-39 models)	203	6. Rotation of tires	214
7. Measuring clutch housing alignment (transmission removed)	204		

FOREWORD

This manual contains maintenance and service information for all Plymouth cars built from 1936 through 1942.

The mechanical information and repair instructions are intended for the use of service men already familiar with the construction of Plymouth cars. No attempt has been made in this manual to give detailed information covering the function or construction of units.

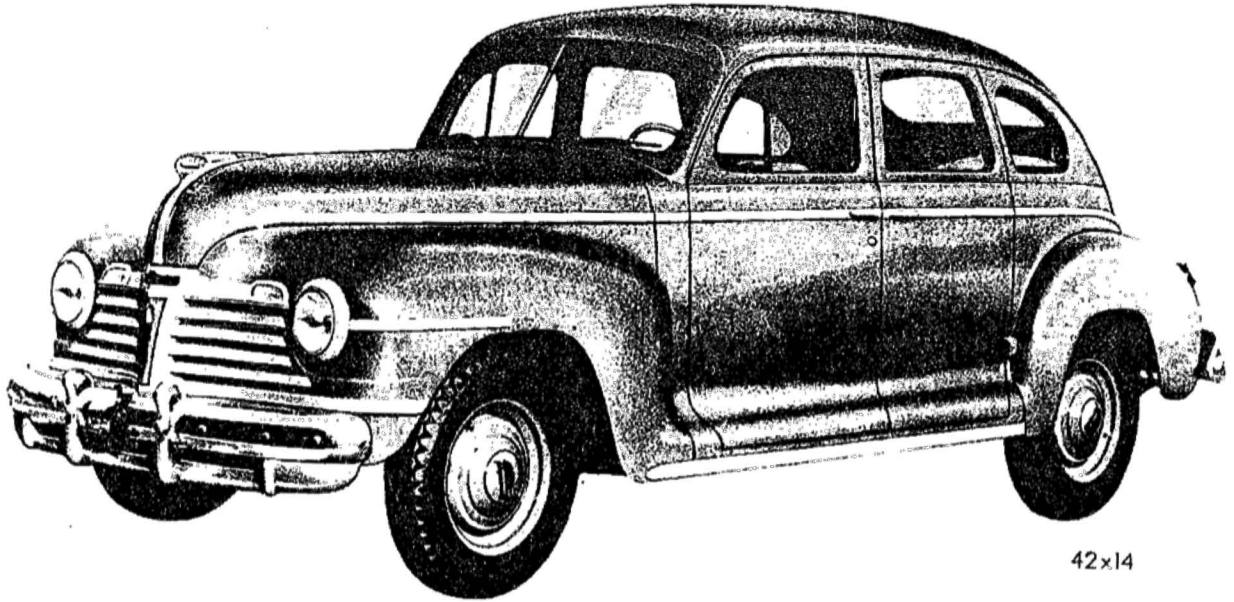
Data and specifications are arranged in chart form for service men who already know how to perform the work, but wish to quickly obtain the necessary repair specifications.

The clearances given for fitting parts when rebuilding units of the car are based on the type of equipment usually available for service work. Manufacturing tolerances are usually held to much closer limits by the use of special machinery and tools designed specifically for manufacturing purposes.

Servicing instructions covering units originally installed on cars as "special equipment," such as Powermatic shift, springs with metal covers, directional signals and horn blowing rings, are included in the manual. No attempt has been made to designate such units as "special equipment" in this manual.

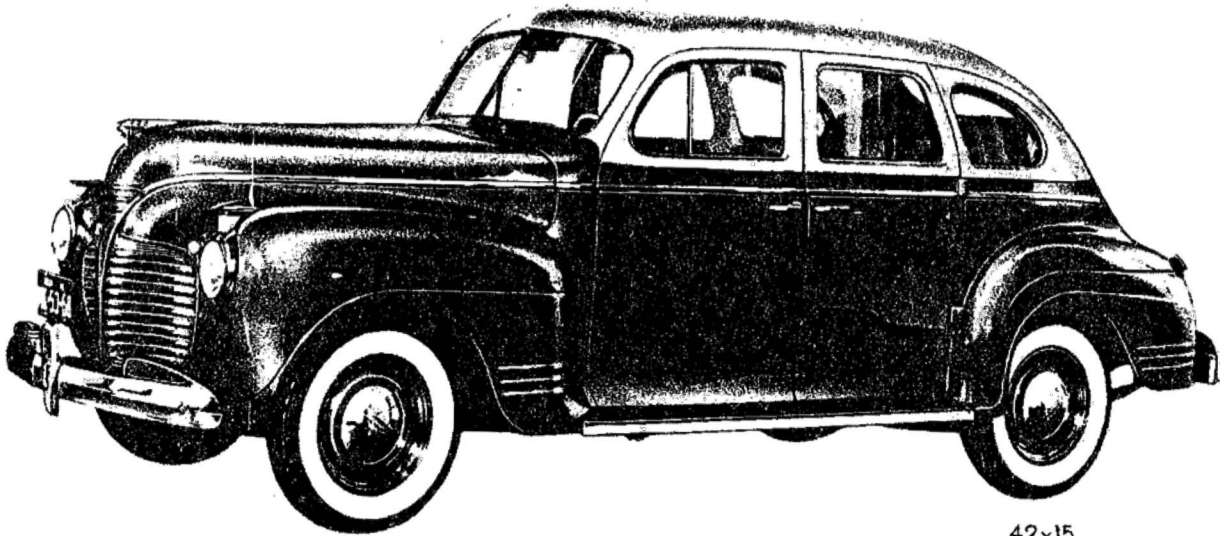
Special tool equipment required for the proper servicing of Plymouth cars is referred to throughout the manual. The special tool number is given in each instance, and the use of the tool is illustrated when its application is of a special nature. A catalog of all Plymouth special tool equipment may be obtained from the Miller Manufacturing Company, 1725 16th Street, Detroit 16, Michigan.

PLYMOUTH SERVICE MANUAL



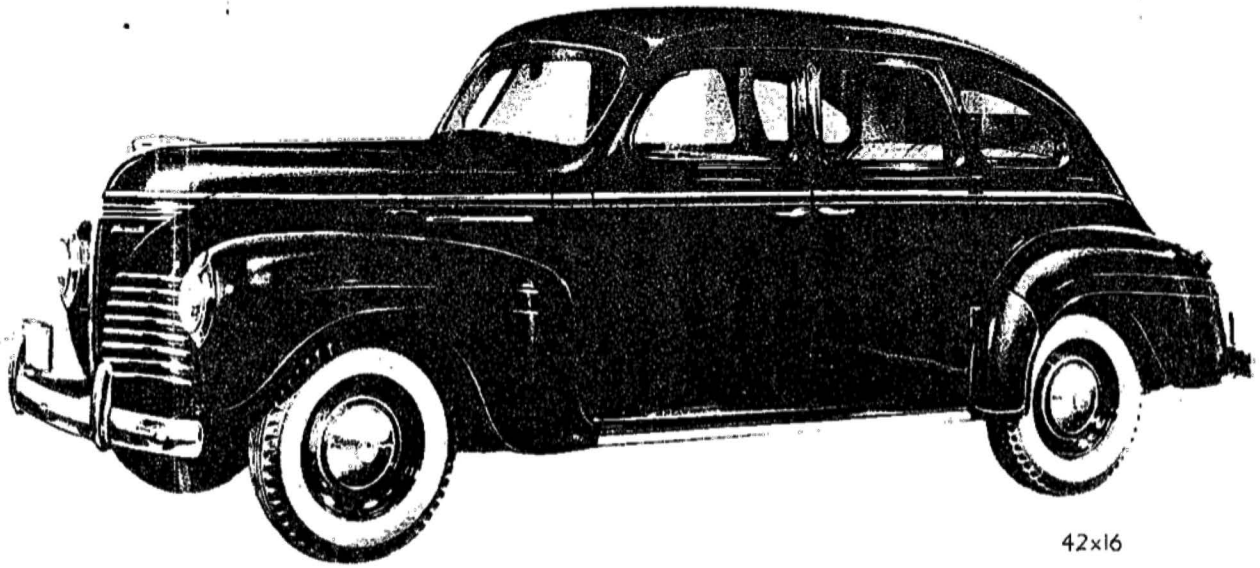
42x14

1942 Plymouth Four Door Sedan



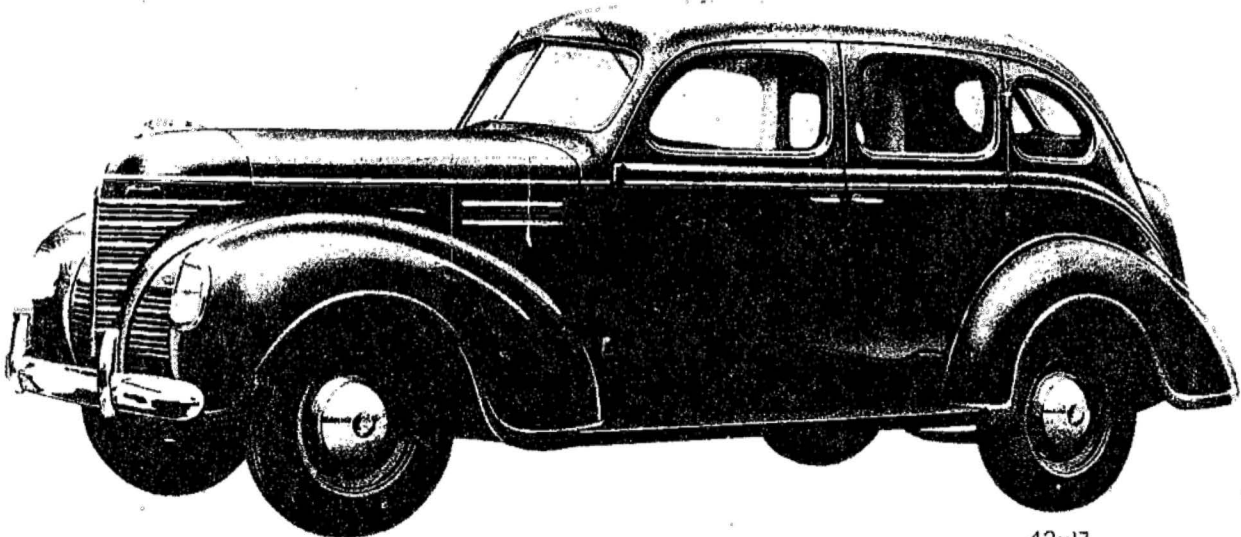
42x15

1941 Plymouth Four Door Sedan



42x16

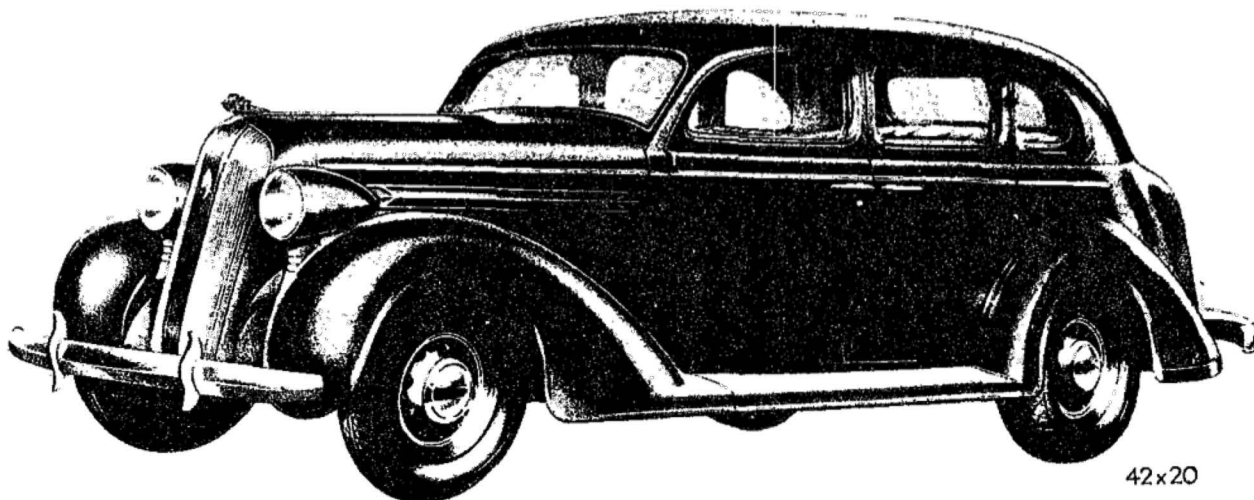
1940 Plymouth Four Door Sedan



42x17

1939 Plymouth Four Door Sedan

**PAGE 10
MISSING**



42x20

1936 Plymouth Four Door Sedan

GENERAL DATA AND SPECIFICATIONS							
Year	1942	1941	1940	1939	1938	1937	1936
Bore and stroke, inches	$3\frac{1}{4} \times 4\frac{3}{8}$	$3\frac{1}{8} \times 4\frac{3}{8}$	$3\frac{1}{8} \times 4\frac{3}{8}$	$3\frac{1}{8} \times 4\frac{3}{8}$	$3\frac{1}{8} \times 4\frac{3}{8}$	$3\frac{1}{8} \times 4\frac{3}{8}$	$3\frac{1}{8} \times 4\frac{3}{8}$
Piston displacement, inches	217.8	201.3	201.3	201.3	201.3	201.3	201.3
Compression ratio (standard)	6.8	6.7	6.7	6.7	6.7	6.7	6.7
Taxable horse power	25.35	23.44	23.44	23.44	23.44	23.44	23.44
Brake horse power	95 @ 3400 rpm	87 @ 3800 rpm	84 @ 3600 rpm	82 @ 3600 rpm	82 @ 3600 rpm	82 @ 3600 rpm	82 @ 3600 rpm
Wheelbase, inches	117	117	117	114	112	112	113
Overall length (with bumpers), inches	$195\frac{5}{16}$	$194\frac{3}{4}$	$194\frac{1}{2}$	$194\frac{1}{4}$	$194\frac{3}{16}$	$193\frac{3}{8}$	$189\frac{5}{8}$ *

*De Luxe, Model P2— $190\frac{1}{8}$ inches.

CAR SERIAL NUMBERS AND ENGINE NUMBERS

Year and Model	SERIAL NUMBERS*			ENGINE NUMBERS**
	Detroit Plant	Los Angeles Plant	Evansville Plant	
1942 De Luxe Six P14S	15135501 to 15153935	3134501 to 3136266	22037001 to 22041356	P14-1001 to P14-149161
Special DeLuxe Six P14C	11399501 to 11494048	3297001 to 3306756	20148001 to 20164436	P14-1001 to P14-149161
1941 Six and DeLuxe Six P11	15000101 to 15135030	3121501 to 3133962	22001001 to 22036667	P11-1001 to P11-535085
Special DeLuxe Six P12	11123001 to 11399250	3269301 to 3296572	20105101 to 20147921	P12-1001 to P12-535085
1940 Road King Six P9	1378001 to 1454303	3114801 to 3121385	9062201 to 9081375	P9-1001 to P9-415461
DeLuxe Six P10	10883001 to 11122538	3242501 to 3269066	20063001 to 20104165	P10-1001 to P10-415461
1939 Road King Six P7	1298001 to 1377475	3110001 to 3114680	9150401 to 9164593	P8-1001 to P8-411923
DeLuxe Six P8	10630001 to 10879874	3222001 to 3242203	20027001 to 20062199	P8-1001 to P8-411923
1938 Road King Six P5	1240001 to 1296615	3105301 to 3109407	9097601 to 9107725	P6-1001 to P6-286619
DeLuxe Six P6	10470001 to 10625650	3206001 to 3220997	20001001 to 20025900	P6-1001 to P6-286619
1937 Six P3	1184001 to 1237460	3101401 to 3105159	9085551 to 9097493	P4-1001 to P4-571569
DeLuxe Six P4	10101001 to 10468044	3162501 to 3205879	9950001 to 9999021 9190000 to 9199074	P4-1001 to P4-571569
1936 Six P1	1111701 to 1183569	3157151 to 3162365	9000101 to 9012724	P2-1001 to P2-532087
DeLuxe Six P2	2641401 to 2987635	3040601 to 3077397	9025101 to 9062168	P2-1001 to P2-532087

*Located on right front body hinge post. **Located on left front side of cylinder block between numbers 1 and 2 cylinders.

Section I

LUBRICATION AND MAINTENANCE

1. IMPORTANCE OF LUBRICATION AND MAINTENANCE.

Under extreme conditions of heat, cold and dust, the Plymouth car has proven itself to be dependable and worthy of the slogan "Plymouth Builds Great Cars."

Much of the credit for Plymouth's dependability goes to the men who do the lubrication and maintenance work necessary to keep Plymouth cars in good operating condition. Periodical lubrication and maintenance combat the effects of heat, water and abrasive dirt which destroy the smooth bearing surfaces of moving parts. The use of the right type and quantity of lubricant is an important factor in extending the useful life of a car.

All Plymouth cars are equipped with adequate lubrication facilities designed to protect vital parts. To keep the car in condition to render uninterrupted service, each point of lubrication requires attention at the frequencies recommended in this manual. Neglect and the use of improper lubricants result in wear, noisy operation and ultimate failure of parts. Good care and periodical lubrication result in quiet, trouble-free service and thousands of extra miles of good service.

2. ENGINE OIL RECOMMENDATIONS.

1936-42

(1) The recommendations shown on the "Table of Capacities, Frequencies and Lubricants" are based upon the principle that the lower viscosity oils circulate more rapidly and lubricate parts with closer clearances more readily than heavier oils. Complete satisfaction, however, depends upon the use of only well refined, high quality products.

IMPORTANT

The frequencies recommended on the following pages for lubrication services are intended for normal service. If the car is operated under extreme conditions of heat, water, dust, sand, mud or snow or over rough gravel or dirt roads, lubricate at more frequent intervals than recommended. Such conditions may warrant lubrication attention as often as once a day, and the frequency should be governed by conditions encountered.

(2) For cars of comparatively low mileage, SAE 20 or No. 20-W Engine Oil is recommended as a general summer oil. Either grade may be used in tropical climates during the winter months or No. 20-W Engine Oil may be used in localities where only very mild winter conditions prevail, such as territories where temperatures never go below 10°F above zero. If, however, as a result of continued high speed driving or other causes, oil consumption becomes a factor, SAE 30 Engine Oil may be used for temperatures above 32°F above zero.

(3) No. 10-W Engine Oil is recommended as a general winter oil for temperatures as low as 10°F below zero, but not lower. However, should atmospheric temperatures rise above +32°F during winter, No. 10-W Engine Oil is satisfactory, and a change is not necessary until the next mileage period. No. 10-W Engine Oil may also be used during summer, if desired, provided driving habits are moderate.

(4) For sub-zero winter conditions, such as in temperatures below -10°F , No. 10-W Engine Oil should be diluted with about 10% colorless, refined kerosene, which should be thoroughly mixed with the oil before it is added to the engine.

3. CHECKING THE ENGINE OIL LEVEL.

1936-42—The engine oil level should be checked each time a car is refueled. The oil level indicator is marked at “full” and “ $\frac{1}{2}$.” A third marking between these two marks indicates the proper running level (fig. 1).

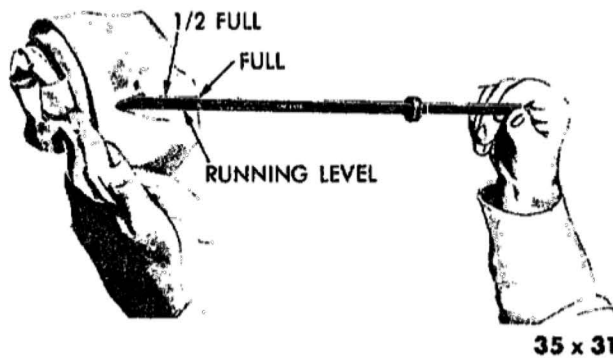


Figure 1—Engine Oil Level Indicator
(1936-42 Models)

The “full” mark shows the proper level for the oil after the engine has *not* been run for a few hours. When the engine is started, the oil level will drop due to the filling of the oil passages and filter. Oil should *not* be added until the level is *below* the mark indicating the running level, but the oil level should never be allowed to drop below the “ $\frac{1}{2}$ ” mark.

4. WHEN TO CHANGE ENGINE OIL.

1936-42—Oil changes should be made, under normal conditions, every 1500 to 2000 miles during winter and every 2500 to 3000 miles during summer. It is always advisable to drain the oil while the engine is at normal operating temperature, because the oil will drain more completely when hot,

carrying more of the foreign material and dirt with it.

(2) During winter, the engine oil should have a pour point or cold test below the lowest temperature that will be encountered during its use. If the car is driven for short distances of only a few miles at a time, moisture in the crankcase will condense and form a sludge which may freeze and clog the oil inlet screen. This condition is greatly aggravated by extremely low temperatures extending for a long period of time. Under driving conditions of this type, the engine does not become sufficiently warm to expel the moisture through the crankcase ventilator. Therefore, under these conditions, the oil should be changed every 500 miles to eliminate sludge.

(3) An alternative to this frequent change period during winter is an occasional drive of 30 miles or more which will help to eliminate water accumulation through the crankcase ventilation system. If the car is driven in this manner frequently, the oil may be changed at the normally recommended winter change period of 1500 to 2000 miles.

5. CLEANING OF CARBURETOR AIR CLEANER.

1936-42—The carburetor air cleaner (figs. 2 and 3) should be cleaned at least every 2000 miles (or more often if extremely dusty conditions are encountered) or whenever the oil sump, on oil bath type, becomes half filled with a semi-solid mixture of oil and dirt.

6. LUBRICATION OF TRANSMISSION.

1936-42—Every 1000 miles, check the transmission lubricant level to see that it is up to the filler hole in the side of the transmission case. The transmission should be drained and refilled yearly or every 15,000 miles. The capacity is $2\frac{3}{4}$ pints.

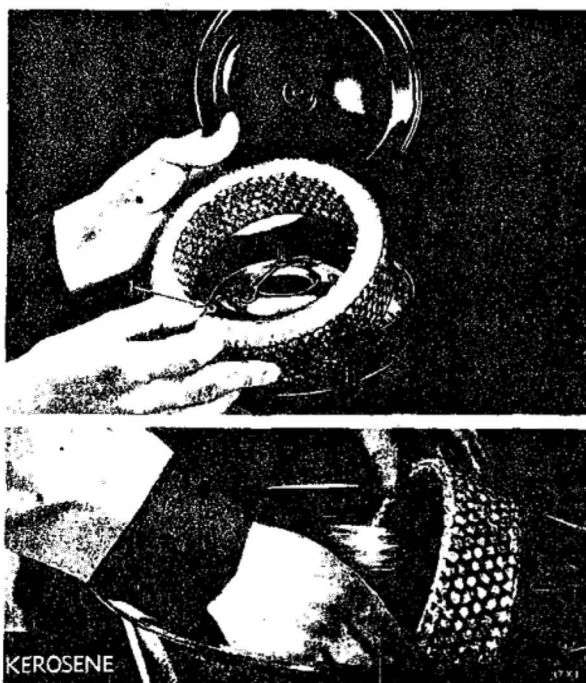
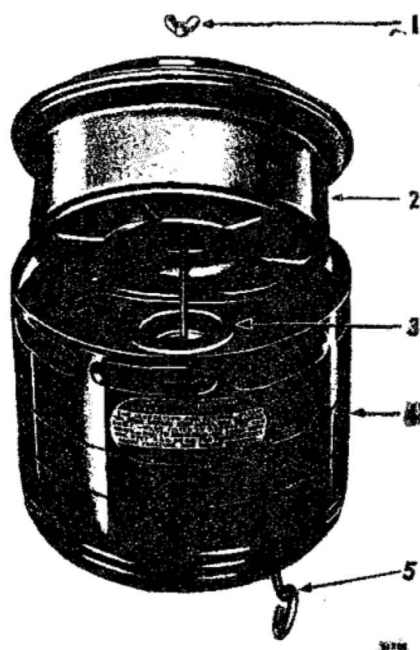


Figure 2—Cleaning Carburetor Air Cleaner (Oiled Mesh Type)—Wash Filter Element in Kerosene, Let Dry and Reoil with SAE 50 Engine Oil



- | | |
|------------------|---|
| 1—Wing nut | 4—Oil reservoir |
| 2—Filter element | 5—Air cleaner to carburetor clamp screw |
| 3—Gasket | |

Figure 3—Cleaning Carburetor Air Cleaner (Oil Bath Type)—Rinse Filter Element in Kerosene. Wash Reservoir and Refill to Indicated Level with SAE 50 Engine Oil for Temperatures Above +32°F; Use No. 20-W for Temperatures Below +32°F

7. LUBRICATION OF REAR AXLE.

1936-42

(1) The hypoid type rear axle gear requires Extreme Pressure Hypoid Gear Lubricant especially designed for hypoid gear lubrication. The gear lubricant should always be fluid at the temperature in which the vehicle is to be operated. Lubricants containing solid materials are undesirable for roller bearing lubrication. Every 1000 miles, inspect the differential lubricant level to see that it is up to the filler hole.

NOTE

Never mix one brand of Extreme Pressure Hypoid Gear Lubricant with another brand.

(2) Drain and refill the rear axle every 15,000 miles with the proper viscosity of Extreme Pressure Hypoid Gear Lubricant. The rear axle may be drained with a suction gun through the filler hole, or by removing two of the lower cap screws which hold the differential carrier in the housing and allowing it to drain. The capacity is 3¼ pints.

8. LUBRICATION OF FRONT WHEEL BEARINGS.

1936-42

(1) Lubricate the front wheel bearings every 6000 miles with Short Fibre Wheel Bearing Grease, Medium.

(2) Remove the front wheels, remove the old grease from the hubs and bearings and pack new grease into them.

(3) Do not put too much grease in the hub because it may be forced out past the grease seals and get on the brake lining.

(4) The lubricant capacity of each wheel is 2½ ounces.

TABLE OF CAPACITIES

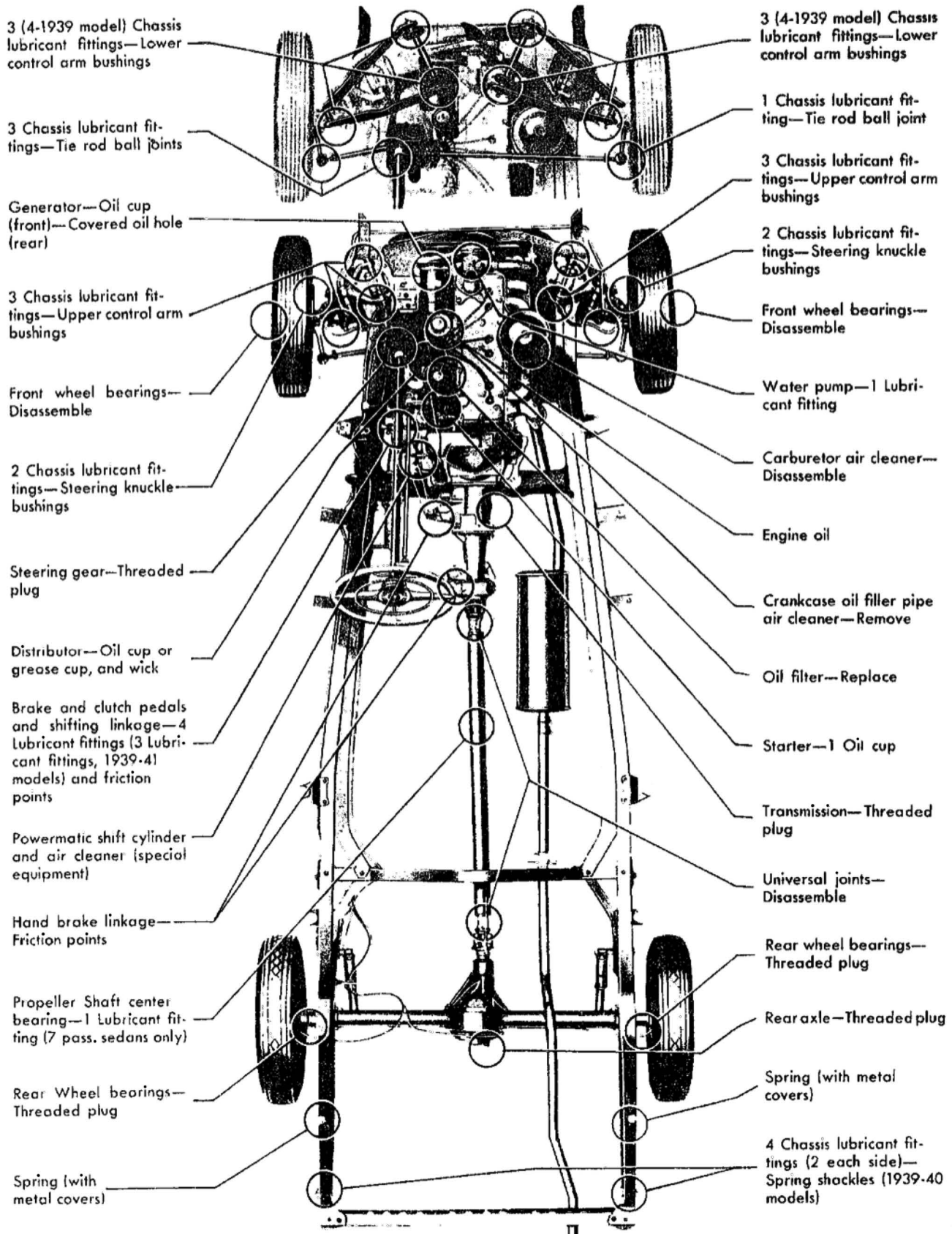
Unit**	Models	Capacity	Normal Frequency of Lubrication**	Paragraphs Containing Additional Information
Engine	1936-42	5 qt.	2500-3000 miles—Summer 1500-2000 miles—Winter Inspect level when refueling	2, 3 and 4
Carburetor air cleaner	1936-42	To oil level	2000 miles	5
Transmission	1936-42	2¾ pts.	1000 miles—Inspect level 15,000 miles—Drain and refill	6
Rear axle	1936-42	3¼ pts.	1000 miles—Inspect level 15,000 miles—Drain and refill	7
Front wheel bearings	1936-42		6000 miles	8
Rear wheel bearings	1936-42		15,000 miles	9
Steering gear	1936-42	8 oz.	1000 miles—Inspect level	10
Water pump	1936-42		2000 miles	11
Universal joints	1936-42	1¼ oz.	15,000 miles	12
Chassis lubricant fittings	1936-42		1000 miles	13
Starter	1936-42		6000 miles	14
Generator	1936-42		6000 miles	15
Distributor	1936-40		1000 miles—Grease cup 6000 miles—Wick	16
	1941-42		2000 miles—Oil cup 6000 miles—Wick	16
Hand brake linkage	1936-42		1000 miles	17
Brake and clutch pedals and shifting linkage	1936-42		1000 miles	18
Springs (with metal covers)	1936-42		15,000 miles	19
Powermatic shift cylinder	1941-42		15,000 miles	20
Powermatic shift cylinder air cleaner	1941-42		10,000 miles	21
Oil filler pipe air cleaner	1936-42		2000 miles	22
Engine oil filter	1936-42		8000 miles	23

*See Lubrication Charts (Figures 4 and 5).

**Under extremely sandy or dusty conditions, lubricate more frequently. See page 13.

FREQUENCIES AND LUBRICANTS

Lowest Expected Temperature			
Above +32° F.	Above +10° F.	Above -10° F.	Below -10° F.
SAE 20 or 20-W ENGINE OIL	No. 20-W ENGINE OIL	No. 10-W ENGINE OIL	No. 10-W ENGINE OIL+10% colorless refined kerosene
SAE 50 ENGINE OIL	No. 20-W ENGINE OIL		No. 20-W ENGINE OIL
SAE 90 FLUID GEAR LUBRICANT (LOW COLD TEST)			SAE 80 FLUID GEAR LUBRICANT
SAE 90 EXTREME PRESSURE HYPOID GEAR LUBRICANT (LOW COLD TEST)			SAE 80 EXTREME PRESSURE HYPOID GEAR LUBRICANT
SHORT FIBRE WHEEL BEARING GREASE—MEDIUM			
SHORT FIBRE WHEEL BEARING GREASE—MEDIUM			
SAE 90 FLUID GEAR LUBRICANT, LOW COLD TEST			
WATER PUMP GREASE			
HEAVY SHORT FIBRE GREASE—MEDIUM			
SEMI-FLUID CHASSIS LUBRICANT			
SAE 10 ENGINE OIL			
SAE 10 ENGINE OIL			
SHORT FIBRE GREASE—MEDIUM—IN GREASE CUP SAE 10 ENGINE OIL ON WICK			
SAE 10 ENGINE OIL IN OIL CUP AND ON WICK			
SAE 10 ENGINE OIL			
SEMI-FLUID CHASSIS LUBRICANT SAE 10 ENGINE OIL			
SPECIAL SPRING LUBRICANT			
ICE MACHINE OR TRANSFORMER OIL			
SAE 50 ENGINE OIL			
SAE 50 ENGINE OIL			
INSTALL NEW FILTER OR REPLACE CARTRIDGE			



42 X 24

Figure 4—Lubrication Chart (1942 Model, Typical of 1939-41 Models)

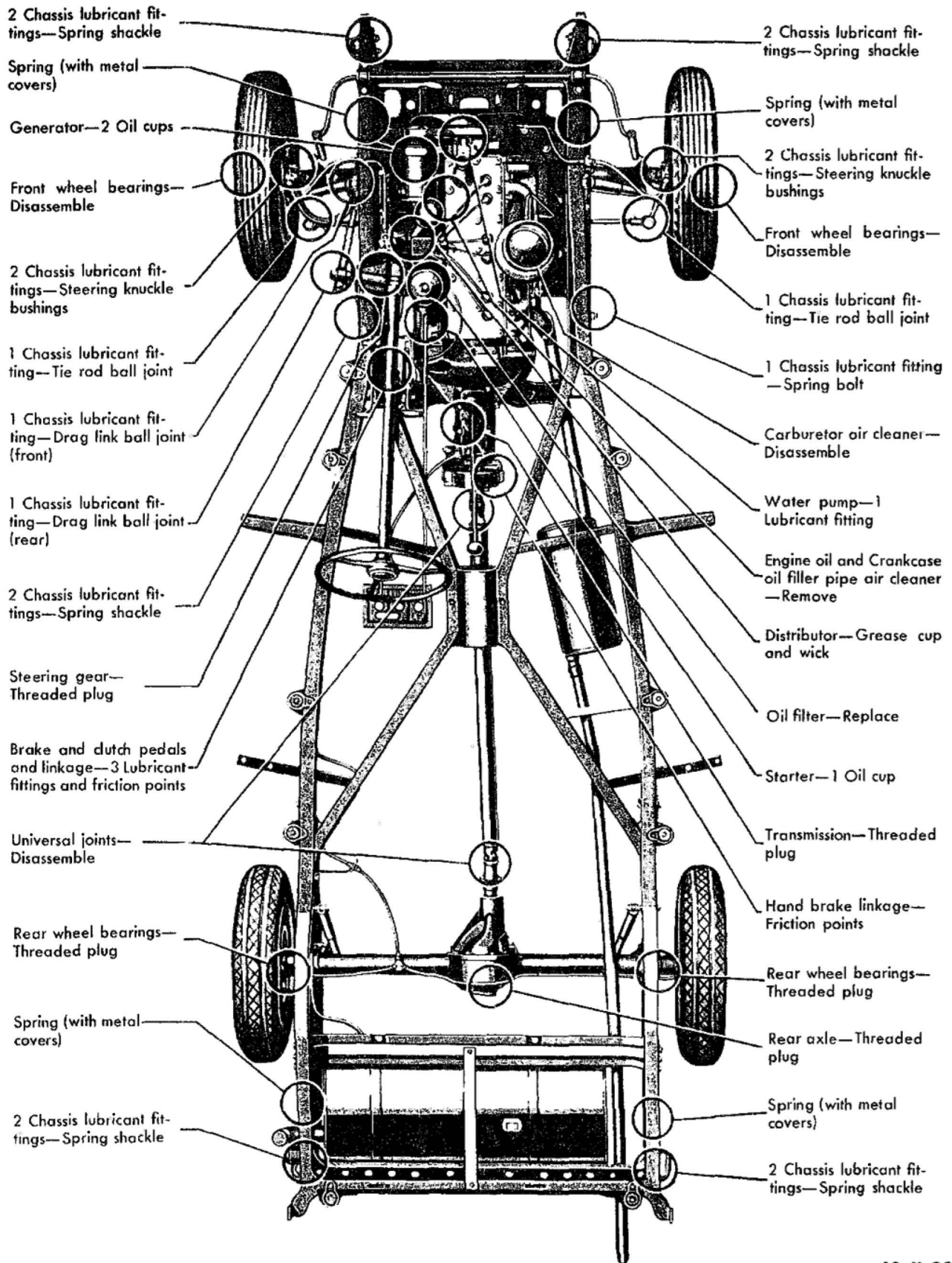


Figure 5—Lubrication Chart (1938 Model, Typical of 1936-37 Models)

9. LUBRICATION OF REAR WHEEL BEARINGS.

1936-42—Lubricate the rear wheel bearings every 15,000 miles. Remove the plug at each end of the axle housing, near the brake supports, and temporarily install lubricant fittings. Lubricate each bearing with *no more* than ½ ounce of Short Fibre Wheel Bearing Grease, Medium; *then remove the lubricant fittings and reinstall the plugs.* Excessive lubrication at these points might result in forcing the lubricant through the oil seals and onto the brake lining.

10. LUBRICATION OF STEERING GEAR.

1936-42—Check the steering gear lubricant level every 1000 miles; if necessary, replenish with Fluid Gear Lubricant (SAE 90, low cold test). Avoid overfilling the steering gear body. The use of too much lubricant may fill the steering column jacket to overflowing, causing damage to clothing and upholstery. The lubricant capacity is 8 ounces.

11. LUBRICATION OF WATER PUMP.

1936-42—Lubricate the water pump with Water Pump Grease every 2000 miles. *Do not use Chassis Lubricant.* Because of its hard and almost butter-like consistency, it is usually difficult to confuse Water Pump Grease with other types of lubricants.

12. LUBRICATION OF UNIVERSAL JOINTS.

a. *Ball and Trunnion Type.*

1936-42—The universal joints are lubricated when assembled and due to the design and protection given them, should not require additional lubrication for 15,000 miles of ordinary driving. Cars operated on unimproved roads should be inspected regularly for damage to the universal joint boots caused by flying stones. The boots, if damaged, should be replaced before the loss or contamination of lubricant occurs resulting in damage to working parts of the joints. To

properly lubricate the universal joints, they should be disassembled and all the old grease cleaned out thoroughly. Then the body of the joint should be packed with 1¼ ounces of Heavy Short Fibre Grease made from high viscosity mineral stock. Soft grease such as Chassis Lubricant or calcium base greases must *not* be used.

b. *Cross and Roller Type.*

1940-41

(1) The universal joints on 7-Passenger Sedans are lubricated when assembled. If for any reason it is necessary to disassemble the universal joints, it is recommended that they be inspected and lubricated at that time. All parts should be thoroughly cleaned and then lubricated with a Heavy Short Fibre Grease made from a high viscosity mineral stock. Graphite greases are not considered desirable for the lubrication of this unit; soft lubricants such as Chassis Lubricant or calcium base lubricants must *not* be used.

(2) The splined joint at the front end of the rear propeller shaft on 7-Passenger Sedans should be lubricated with Chassis Lubricant every 1000 miles.

(3) The propeller shaft center bearing on 7-passenger sedans should be lubricated every 6000 miles with Short Fibre Wheel Bearing Grease—Medium.

13. CHASSIS LUBRICANT FITTINGS.

1936-42—Lubricate every 1000 miles at points shown on Lubrication Charts (figs 4 and 5). Clean all lubricant fittings before applying new lubricant and lubricate with Semi-Fluid Chassis Lubricant until all old lubricant, water and dirt are forced from the bearing.

14. LUBRICATION OF STARTER.

1936-42—The starter has an oil cup at the front bearing. Lubricate with a few drops of SAE 10 Engine Oil every 6000 miles.

15. LUBRICATION OF GENERATOR.

1936-42—The generator has an oil cup at the front bearing and an oil hole at the rear bearing. Lubricate each with a few drops of SAE 10 Engine Oil every 6000 miles. Be sure to return the slide cover to cover the oil hole after oiling the rear bearing (fig. 6).

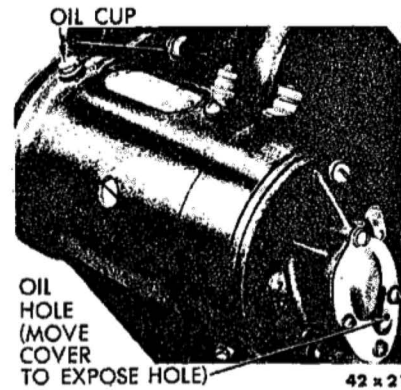


Figure 6—Lubricating Generator (1942 Models, Typical of 1936-41 Models)

16. LUBRICATION OF DISTRIBUTOR.

1936-40—The distributor has two lubrication points—a grease cup on the side of the distributor and a wick in the center of the cam. Fill the grease cup with Short Fibre Grease, Medium every 6000 miles and turn the cup one complete turn every 1000 miles of operation. Add two or three drops of SAE 10 Engine Oil to the wick every 6000 miles of operation.

1941-42—The distributor has two lubrication points—an oil cup on the side of the distributor and a wick in the center of the cam. Add two or three drops of SAE 10 Engine Oil to the oil cup every 2000 miles of operation. Add two or three drops of SAE 10 Engine Oil to the wick every 6000 miles of operation.

IMPORTANT

Do not allow oil or grease to get on the distributor points, as this will cause burning of the points.

17. LUBRICATION OF HAND BRAKE LINKAGE.

1936-42—Oil the various connections with SAE 10 Engine Oil every 1000 miles of operation.

18. LUBRICATION OF PEDALS AND LINKAGE (BRAKE AND CLUTCH).

1936-42—Use a Semi-fluid Chassis Lubricant in the lubricant fittings of the cross shaft and SAE 10 Engine Oil on the connections every 1000 miles of operation.

19. LUBRICATION OF SPRINGS WITH METAL COVERS.

1936-42

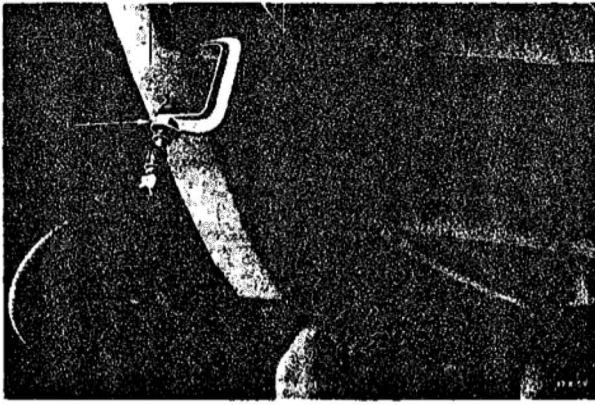
a. General. The frequency of lubrication depends upon driving conditions. Necessity of re-lubrication will be evidenced by stiff riding or squeaks. Lubrication will usually be required more frequently in hot climates than in cold climates. Lubricants containing inert materials such as asbestos fibre, graphite, silica, etc., are undesirable for spring lubrication. A lubricant containing a rust preventive (inhibitor) is recommended in order to avoid rust formation which leads to hard riding and spring squeaks.

b. Lubrication of Springs with Metal covers.

(1) Raise the frame until the wheel is entirely free from the floor, removing all load from the spring. The spring leaves will then be separated sufficiently to force the lubricant between the leaves.

(2) If the cover does not have a 3/16 inch hole, drill one in the center of the bottom about 1/3 of the distance from the end of the spring to the axle, but not less than 1 inch from the edge of any lap. If the cover has a lubricant hole with a plug in it, the plug may be easily pried out with a screwdriver. When lubrication has been completed, all holes should be closed with plugs.

(3) Set the adjustment screw of Tool C-408 so that the distance between it and the sleeve is a little more than the thickness



1—Tool C-408

Figure 7—Lubricating Spring with Metal Cover
(1936-42 Models)

of the spring, at the point where the hole has been drilled. (See figure 7.)

(4) Push the threaded end of the plunger out of the sleeve and into the 3/16 inch hole in the cover, forcing the canvas against the spring. Screw the plunger to the right several times thereby threading the end through the canvas, and allowing the lubricant to come in direct contact with the spring leaves. *This is very important.*

(5) Screw the sleeve against the bottom of the spring cover so that the tool is held firmly in position.

(6) Attach the lubricant gun, using a flexible connection to preclude possible damage to the lubricant plunger.

(7) Operate the gun slowly until traces of lubricant appear at both ends of the cover. Then install a new plug in the lubricant hole.

20. LUBRICATION OF POWERMATIC SHIFT.

a. Lubrication of Powermatic Shift Cylinder.

1941-42—In the event sluggish operation of the power shift is apparent, it may be due to the necessity of lubrication inside the power unit. Lubricate as follows:

- (1) Remove leather boot.
- (2) Remove vacuum line at cylinder and also air cleaner line at cylinder.
- (3) Remove power pin from cylinder

yoke and castellated nut from cylinder anchor stud.

(4) Remove cylinder as assembly, being careful not to turn internal valve yoke or damage it. Reinsert power pin immediately to prevent turning valve yoke in relation to cylinder yoke. Adjustment of valve yoke will upset the balance of the cylinder.

(5) Mount cylinder horizontally in vise, clamping at mounting stud and locate piston rod in mid position.

(6) While holding valve rod in "full-in" position, pour in ½ ounce of Shock Absorber, Ice Machine or Transformer Oil in vacuum stack. Allow sufficient time for oil to run through valve port into cylinder.

(7) Repeat the above operation, holding valve rod in "full-out" position. This will introduce lubricant into *both* sides of the piston.

(8) Work piston through full travel several times, also rotate cylinder to get lubricant on all sides of inner cylinder wall and piston packings.

(9) Replace wires on boot if necessary after installing unit.

21. CLEANING AND LUBRICATING POWER CYLINDER AIR CLEANER.

1941-42—Every 10,000 miles clean and oil as follows:

- (1) Remove the two screws which hold the cleaner to the frame.
- (2) Remove cleaner element and clean in kerosene.
- (3) Dip in SAE 50 Engine Oil and re-install.

IMPORTANT

Cars operated principally on gravel, dusty or dirt roads, may require cleaning of the air cleaner more frequently. A sluggish operation of the power unit may be caused by a dirty cleaner, reducing the amount of air volume to the unit.

22. CLEANING AND OILING CRANK-CASE OIL FILLER PIPE AIR CLEANER.

1936-42—Every 2000 miles, wash filter element in kerosene and dry thoroughly, then oil with SAE 50 Engine Oil.

23. REPLACEMENT OF OIL FILTER.

1936-42—Install a new oil filter, or a new oil filter cartridge (if equipped with the replaceable cartridge type) every 8000 miles. In dusty areas, it may be advisable to change filter, or cartridge, at any time when the oil appears to be excessively dirty.

24. MAINTENANCE OF RUBBER PARTS.

1936-42

(1) Most of the rubber parts used on Plymouth cars with the exception of oil seals are made from non oil-resistant rubber. Because mineral oil will cause rapid deterioration of rubber, these parts should not be allowed to come in contact with any form of mineral oil. Rubber parts such as the bushings used in spring shackles, sway bar, and shock absorbers are designed to operate without any lubrication; in fact lubrication of these bushings is detrimental because it permits slippage on the shafts causing rapid wear. These bushings deflect in torsion, and there should be no relative movement between the rubber and the metal under ordinary conditions of operation.

(2) The only rubber parts which, under unusual operating conditions, may require lubrication are the Silent-bloc rubber thrust washers located at the rear spring front pivot points. Should these parts require lubrication, use MoPar Rubber Lubricant or MoPar Brake Fluid. If it is necessary to lubricate parts near other rubber parts to eliminate squeaks, MoPar Rubber Lubricant or MoPar Brake Fluid may be used.

25. MAINTENANCE OF OILITE BEARINGS.

1936-42

(1) "Oilite" bearings are, to a great extent, self-lubricating and are for this reason ideal for locations where lubrication is difficult to maintain. They contain copper, tin, solid lubricants and lubricating oil of different proportions and characteristics depending upon the requirements of the bearings.

(2) "Oilite" bronze appears to be the same as ordinary bronze, but when subjected to heat or pressure, oil comes to the surface in a quantity sufficient to supply a constant thin coating which is often sufficient for the lifetime lubrication requirements of a bearing. In other instances where the loads are greater and more constant, a gradual replenishment of the lubricating oil is necessary. Such bearings are supplied with oil through an oil cup or suitable fitting. The added oil is absorbed by the "Oilite" material so that adequate lubrication is constantly maintained.

(3) Replacement, if ever necessary, should be made with another "Oilite" bearing of the same size as the bearing being replaced. "Oilite" bearings should not be reamed, filed or otherwise cut to size, although they may be burnished to a final running fit. Cutting an "Oilite" bearing tends to seal up the pores of the metal which prevents seepage of the oil necessary for lubrication.

(4) If machining is necessary, machine like cast bronze. Apply no coolant. After machining, soak for 20 minutes in a good grade of crankcase lubricating oil. For finishing surfaces where lubrication is necessary, use a sharp tungsten carbide tool bit (any shape except "dead sharp"). Take a very light cut, .002 to .004 inch on the diameter, with fine feed and high speed.

26. SERVICING BATTERIES.**1936-42**

(1) Maintain the proper electrolyte level by adding pure distilled water or any water which is odorless, tasteless, colorless and suitable for drinking, to each cell until the solution is $\frac{3}{8}$ inch above the plates.

(2) On batteries with "star" level indicators, fill until the solution reaches the star level.

(3) On batteries with special vent plugs, fill after removing the filler plugs and attaching them to the vents. Fill each cell to the top of the filler plug opening, then remove the plugs from the vents, and the electrolyte will drop to the proper level which is $\frac{3}{8}$ inch above the top of the plates.

(4) Inspect battery level at *least* once a month or every 1000 miles and fill as directed on battery cover or until the solution is $\frac{3}{8}$ inch above the plates.

(5) Do not overfill or fill too frequently.

(6) Check the state of charge of the battery periodically with a hydrometer. The following hydrometer readings show the charge condition:

Fully charged 1.275 to 1.300

Half charged 1.225

Dangerously low . . 1.150

(7) A fully charged battery will not freeze in temperatures ordinarily encountered, but a battery with 1.150 specific gravity will freeze at 5°F above zero, while

a battery with 1.100 specific gravity will freeze at 18°F above zero. For this reason, the battery should be kept fully charged.

(8) Keep the battery securely fastened in its carrier and clean and dry the battery at frequent intervals.

(9) Remove the terminals at regular intervals and clean and inspect them thoroughly. When installing connections, tighten the terminals securely at both engine and battery ends.

(10) A loose battery connection will cause excessively high generator voltage, which is likely to burn out light bulbs, pit and burn distributor breaker points and cause damage to the generator and other electrical equipment.

27. RECOMMENDED TIRE PRESSURES.

1936-42—Tires should be checked weekly and kept inflated to the following pressures:

<i>Tire Size</i>	<i>Front</i>	<i>Rear</i>
5.25 x 17 inch	32 lbs	32 lbs
5.25 x 20 inch	30 lbs	30 lbs
5.50 x 16 inch	32 lbs	32 lbs
6.00 x 16 inch	28 lbs	28 lbs
6.00 x 18 inch (except 7-passenger)	28 lbs	28 lbs.
6.00 x 18 inch (7 passenger)	32 lbs	32 lbs
6.50 x 16 inch (except 7-passenger)	28 lbs	28 lbs
6.50 x 16 inch (7-passenger)	30 lbs	30 lbs

Section II

TROUBLE SHOOTING

1. ENGINE WILL NOT TURN.

1936-42

(1) If the engine does not turn when the starter pedal is depressed, test the battery and recharge or replace if the battery is discharged.

(2) If the battery is not discharged, clean and tighten the battery cable terminals; make certain the ground stud is clean and tight.

(3) If the starter will not crank the engine when the battery and cables are known to be satisfactory, disconnect the negative cable from the battery and the starter switch. Remove the upper portion of the starter switch and hold the cable tightly against the starter terminal. Then touch the other end of the cable to the battery post. If the starter operates, repair or replace the starter switch. If the starter does not operate, repair or replace the starter.

(4) If the engine cannot be started with the recommended grade and viscosity oil in the engine, remove the spark plugs and check for water as the engine is cranked. If no water is present in the cylinders, remove the cylinder head and oil pan and inspect for internal damage to the engine.

2. ENGINE TURNS BUT WILL NOT START.

1936-42

a. Inspect Operation of Choke. Inspect the choke valve to be sure it is fully closed when the choke button is all the way "out" and fully open when the choke button is all the way "in." If the engine has been cranked excessively with the choke closed, push the button all the way in and crank the engine with the throttle wide open.

b. Inspect Ignition System. Remove the cable from a spark plug and turn on the ignition switch. Hold the cable terminal $\frac{1}{4}$ inch from the cylinder head and crank the engine with the starter. If a spark jumps the $\frac{1}{4}$ inch gap, the ignition current is adequate. Check the ignition timing and clean and adjust the spark plugs. If the spark does not jump the $\frac{1}{4}$ inch gap, check the ignition system as follows:

(1) Wipe the distributor cap terminals, cables, spark plugs and coil thoroughly dry.

(2) Remove distributor cap and rotor; inspect for cracks or carbon runners.

(3) Clean and adjust the breaker points or replace the points if excessively burned.

(4) Examine condenser lead wire for breakage or loose connection.

(5) Crank engine and note whether distributor shaft turns; if not, shaft may be broken; repair or replace distributor.

(6) Turn on the headlights. If they burn fairly bright, there will be ample current in the ignition circuit at least as far as the ammeter.

(7) If the headlights do not burn, but the starter will crank the engine, test for current through the wire from starter to ammeter.

(8) Test primary circuit from ammeter to coil and distributor.

(9) Turn engine until the distributor points are closed.

(10) Turn on ignition switch and push the distributor points apart with finger. If there is a slight arc of current as the points are opened, the primary circuit is complete and will function if the points make and break properly when the engine is cranked.

3. ENGINE TURNS BUT WILL NOT START.

1936-42—cont'd

(11) If there is no arc of current when the distributor points are pushed apart with the finger, with the ignition switch turned on, turn the engine until the distributor points are open and connect the *positive* lead from a voltmeter to any part of the chassis that will provide a definite ground and test the circuit.

(12) Hold the *negative* lead from the voltmeter against the input post of the ignition switch. If approximate battery voltage is shown on voltmeter, the circuit is complete to the ignition switch.

(13) Hold the *negative* lead against the output post of the ignition switch. If about the same voltage is shown, current is passing through the switch.

(14) Hold the *negative* lead against the post of the coil where the ignition switch wire is connected. If battery voltage is shown, current is reaching that post.

(15) Hold the *negative* lead against the post on the coil where the primary wire to the distributor is connected and then to the distributor breaker arm. If battery voltage is shown at one of these points of test and not at the other, the difficulty will be located between the two points. If very little or no voltage is shown at the coil and breaker arm, disconnect the condenser lead wire from the distributor body and connect the voltmeter lead to the breaker arm; if normal battery voltage is shown, the condenser is shorted. No voltage reading between the coil and breaker arm (with the distributor points open and the condenser lead disconnected) would indicate a broken primary circuit in the ignition coil.

(16) If all tests and inspections in steps (1) through (15) are satisfactory and the engine will not start, pull the ignition coil to distributor secondary wire out of the distributor cap and turn on the ignition switch.

Hold the end of the wire $\frac{1}{4}$ inch from the cylinder head and crank the engine. If spark does not jump the $\frac{1}{4}$ inch gap, replace the ignition coil.

c. *Inspect Fuel System.*

(1) Disconnect the fuel tube at the carburetor and crank the engine.

(2) If fuel is discharged from the disconnected tube it will reach the combustion chambers unless the carburetor float valve is stuck or the carburetor jets are clogged.

(3) If no fuel is discharged from the disconnected tube, inspect the fuel filter, fuel tubes, fuel tank cap for restriction, and fuel pump inlet and outlet valves for dirt, warpage and broken springs.

3. ENGINE DOES NOT DEVELOP NORMAL POWER.

1936-42

(1) Check ignition timing and reset if necessary.

(2) Check automatic advance of distributor against advance curve in "Data and Specifications" chart on page 144.

(3) Service the carburetor air cleaner. See paragraph 5 on page 14.

(4) Connect a low pressure gauge between the fuel pump and carburetor and crank the engine with the starter. If the fuel pressure shown on the gauge is less than 3 pounds, repair or replace the fuel pump. If fuel is delivered under normal pressure to the carburetor, disassemble and inspect the carburetor.

(5) Inspect the exhaust pipe, muffler or tail pipe for being clogged or damaged and repair or replace any damaged parts.

(6) Make vacuum and compression tests; if the compression is low on one or more cylinders, check valve tappet clearance, grind valves or replace the piston rings as indicated by tests.

(7) Check valve timing. See paragraph 11 on page 110.

4. ENGINE RUNS UNEVENLY.**1936-42**

- (1) Clean, test and adjust spark plugs.
- (2) Tighten carburetor to manifold nuts.
- (3) Adjust carburetor throttle stop screw and idle fuel mixture.
- (4) Check ignition timing and adjust if necessary.
- (5) Inspect distributor breaker sub-plate and bearing; replace if worn.
- (6) Clean and adjust distributor points, replace points if badly burned.
- (7) Inspect distributor shaft bushings for wear; repair or replace distributor if wear exceeds .008 inch.
- (8) Inspect and test ignition system, as outlined in paragraph 2 on page 25.
- (9) Test for low compression, as outlined in paragraph 3 on page 26.

5. ENGINE NOISES.**1936-42**

a. Spark knock (a sharp metallic knock occurring on acceleration or when operating under heavy load). Ignition timing may be too early for the grade of fuel used; inspect ignition timing and reset if early. Check the engine operating temperatures, and if excessive, inspect the engine cooling system. If spark knock occurs with normal engine temperature and ignition properly timed, test the distributor automatic advance.

b. Valve Noise.

- (1) Inspect valve tappet clearance and adjust if necessary. (See "Data and Specifications" chart on page 103.)
- (2) Inspect for cocked or broken valve spring.
- (3) Inspect valve stems and tappets for wear in the guides.
- (4) If noise is not located by above inspections, remove oil pan and inspect tappets and cams.

c. Piston Noise. Piston slap is a clear metallic knock, most noticeable when the engine is under load at low speed but may not be heard at higher speed or when engine is idling. If noise is noticeable when engine is cold and diminishes or disappears as the engine temperature increases, it will cause no trouble and piston replacement is not necessary. Scored or excessively worn pistons which slap badly after the engine is thoroughly warm should be replaced.

d. Piston Pin Noise. Loose piston pins cause a metallic knock, usually occurring when idling with the engine hot. The noise will come and go as the piston pin turns or shifts in the piston, and the piston pin should be replaced.

e. Bearing Noise

(1) A loose bearing is usually heard when accelerating at about 2/3 maximum engine speed. The noise is usually heard momentarily in a series of rapid, distinct knocks. Replace loose bearings. *Do not file bearing caps to reduce bearing clearance.*

(2) A burned-out connecting rod bearing will be heard as a sharp, distinct knock at most engine speeds. The bearing responsible for the knock can usually be determined by shorting the ignition at the spark plugs.

(3) A burned-out main bearing will cause a knock at moderate speeds, especially under acceleration. If the front or intermediate bearing is responsible, the noise usually can be shorted out; if in the rear main bearing, the knock will have a duller sound, due to the additional area of that bearing.

f. Other Engine Noises.

(1) A partially broken fan belt will cause a rhythmic metallic noise. A glazed belt will cause an intermittent squeal.

(2) A loose spark plug will cause a sharp metallic knock at piston speed frequently confused with other internal engine noises.

5. ENGINE NOISES.*1936-42—Cont'd.*

(3) If the clutch housing pan is damaged or bent, the flywheel may rub against the pan, causing a scraping sound. The sound may be intermittent when driving over rough roads.

6. LOW OR NO OIL PRESSURE.*1936-42*

(1) Inspect for leakage at oil tubes and connections at filter, gauge and cylinder block. If external leak is not apparent, remove oil pan and tighten oil pump suction and outlet pipe connections.

(2) Remove, clean and inspect the relief valve.

(3) Inspect engine bearings and replace if clearance is excessive. (Refer to "Data and Specifications" chart on page 101 for clearances.)

(4) If causes listed in steps (1), (2) and (3) are not evident, repair or replace oil pump.

7. EXCESSIVE OIL CONSUMPTION.*1936-42*

(1) Inspect oil level. Do not add oil above the recommended oil level. See paragraph 3 on page 14.

(2) Inspect all external oil tubes for leakage. Inspect for leakage at oil pan and timing gear case gaskets and at rear main bearing.

(3) Inspect bearing clearances and crankshaft journals.

(4) Inspect cylinder walls. Recondition if damaged and install new pistons and rings.

8. EXCESSIVE FUEL CONSUMPTION.*1936-42*

(1) Clean and inspect choke valve to be sure it is fully open when the choke button is pushed "in."

(2) Adjust carburetor.

(3) Inspector carburetor float level (adjust to 5/64 inch; 17/32 inch on Chandler Groves carburetor only).

(4) Remove distributor vacuum advance unit and inspect diaphragm for damage. Blow into vacuum tube end of unit; if air passes through unit, replace the unit.

(5) Inspect and reset ignition timing if necessary.

(6) Inspect for dragging brakes or misalignment of wheels.

(7) Inspect transmission and rear axle for use of proper grade of lubricant. See paragraphs 6 and 7 on pages 14 and 15.

(8) Inflate tires to recommended pressures.

9. ENGINE OVERHEATS.*1936-42*

(1) Inspect hose connections and drain cocks for leakage.

(2) If coolant overflows from radiator, causing overheating, test the radiator for restricted flow or replace cylinder head gasket.

(3) Inspect fan belt tension and adjust if necessary.

(4) Clean all foreign matter from between the radiator fins or from the inside of the cells. Blow out with compressed air or flush *from the engine side* with water from a hose.

(5) Inspect the thermostat for proper operation.

(6) Inspect the hose for restrictions and watch for collapsing of the lower hose when the engine is speeded up. Tighten hose connections.

(7) Inspect the water pump to make sure the impeller turns with the shaft.

(8) Reverse flush the cylinder block and radiator core.

10. IMPROPER GENERATOR CHARGING RATE.

1936-42

a. Generator Does Not Charge or Rate is Too Low.

(1) Inspect wiring to see that it is properly connected to the generator, regulator and ammeter.

(2) If generator has third brush control, inspect the fuse (if so equipped) and the brush setting.

(3) If charging rate is still unsatisfactory, remove the generator drive belt and the relay or regulator cover.

(4) Ground the generator field terminal. Close the circuit breaker contact points.

(5) If the generator revolves slowly as a motor and the ammeter shows a steady discharge of approximately 5 amperes, test and repair or replace regulator.

(6) If the generator does not revolve slowly, or the ammeter reading is unsteady or not approximately 5 amperes discharge, replace or repair the generator.

b. Charging Rate Excessive.

(1) On generators with third brush control, check third brush setting. If the condition cannot be corrected by retarding the third brush, repair generator.

(2) Make certain generator regulator is properly grounded (where regulator is used). Remove wire from generator field terminal. If excessive charging rate continues with field wire removed, the field circuit is grounded in the generator and generator repairs are necessary. If there is no charging rate with the field wire removed, test and repair or replace the regulator.

11. LIGHTS.

1936-42

a. Lights Inoperative.

(1) If the engine cranks and starts, there will be current in the lighting circuit at least as far as the ammeter, and light failure will be caused by switches, wiring harness, lights or bulbs.

(2) If all lights are inoperative, inspect the fuse (see "Data and Specifications" chart on page 148 for location), and the wire from ammeter to lighting switch.

(3) If current is delivered to the switch but not to the wiring harness, replace the lighting switch.

(4) If only one light is inoperative, inspect the bulb and wire at the light.

(5) If the bulb is good and there is no current to the lights, be sure the light is properly grounded.

(6) If there is no current at the end of the wire connected to the light, inspect the connectors and connections at the terminal blocks.

(7) If both headlights fail, inspect the dimmer switch.

(8) If stop light only fails, inspect connections and test stop light switch.

(9) Replace or repair the wiring harness if trouble is not located by the above procedure.

b. Light Bulbs Burn Out Frequently.

(1) Inspect connections at generator, ammeter and battery and clean and tighten.

(2) Inspect battery terminals and clean and tighten.

(3) Inspect and clean ground connection for bulb.

(4) Inspect generator regulator and adjust if necessary.

12. IMPROPER CLUTCH OPERATION.

1936-42

(1) If the clutch slips when the pedal is fully released, check the pedal free play and adjust if necessary.

(2) If the clutch slips with the correct free play, or if it grabs or chatters, remove the clutch assembly for inspection and repairs.

13. DIFFICULT GEAR SHIFTING.**1936-42**

(1) Inspect the clutch pedal for excessive free play which would not allow full disengagement of clutch. See paragraph 2 on page 87.

(2) Inspect and lubricate gearshift linkage (on models with remote control).

(3) Remove the transmission cover and inspect the gearshift rails and forks.

(4) Inspect the splines on the transmission main shaft for damage.

14. NOISE OR PLAY IN DRIVE LINE.

1936-42—Inspect propeller shaft companion flanges for looseness. If loose, disconnect propeller shaft and tighten companion flange nuts or replace flange. Examine universal joints for play between bearings and crosses; replace worn parts.

15. NOISY REAR AXLE.**1936-42**

(1) Certain road surfaces cause tire noise that may seem to come from the axle. Before attempting to correct axle noise, be sure the noise is not coming from the tires.

(2) Do not attempt to locate axle noise by operating the vehicle with the wheels off the ground.

(3) Inspect level and quality of lubricant in the axle. See paragraph 7 on page 15.

(4) If excessive noise is evident when gears are properly lubricated, remove the differential carrier assembly for inspection and repair.

16. BRAKES.**1936-42****a. Brakes Fail Completely.**

(1) Inspect the mechanical linkage between the pedal and master cylinder. See paragraph 1 on page 77.

(2) Inspect the tubes from the master cylinder to all wheel cylinders for leakage of fluid.

(3) If the source of trouble is not located by visual inspection, fill the master cylinder with "MoPar Brake Fluid" and depress the pedal. Watch the tubes and wheel cylinders for leakage.

(4) If no leakage is shown, remove the master cylinder for inspection and repair.

b. Brakes Fail on First Operation but Function After Several Quick Operations.

(1) Adjust the brake shoes to recommended clearance, as shown in "Data and Specifications" chart on page 76.

(2) Inspect fluid level in master cylinder. If brake fluid level in master cylinder is too low, it may be necessary to bleed all brake lines to remove air from the brake system. See paragraph 4 on page 79.

c. Excessive Pressure Required to Operate Brake Pedal.

(1) Make major brake adjustment. Refer to paragraph 3 on page 78.

(2) Inspect the linings and replace if badly worn or glazed.

(3) Repair or replace the brake drums if badly scored.

d. "Spongy" Brake Pedal. Bleed the brake system thoroughly. See paragraph 4 on page 79. Make major brake adjustment. See paragraph 3 on page 78.

e. Brake Pedal Goes to Floor Board Under Pressure.

(1) Inspect brake tubes and wheel cylinders for leakage and repair if necessary. If level of brake fluid is low, it may be necessary to bleed the brake system after replenishing the brake fluid. See paragraph 4 on page 79.

(2) Remove master cylinder and inspect piston cups.

f. Brakes Drag.

(1) Adjust brake shoes to recommended clearances. See "Data and Specifications" chart on page 76.

(2) Inspect brake shoe linings and return springs and replace if necessary.

(3) Be sure the brake shoes are free on the anchor bolts.

(4) Adjust wheel bearings.

(5) Inspect wheel cylinder pistons for sticking.

(6) Inspect brake pedal free travel. If the pedal has no free travel when brakes are warm, the master cylinder piston cup is covering the relief port. Adjust the master cylinder piston push rod or replace piston cup. See paragraph 1 on page 77.

g. Brakes Grab, Chatter or Brake Unevenly.

(1) Inspect brake drums for excessive scores or cracks.

(2) Inspect linings for grease or being loose on the shoes. *Be sure both front wheels are equipped with the same kind of lining. Be sure both rear wheels are equipped with the same kind of lining.*

(3) Inspect wheel cylinder pistons for sticking.

(4) Be sure brake supports are tight on axles and tighten spring clip nuts.

(5) Make major brake adjustment. See paragraph 3 on page 78.

17. STEERING.

1936-42

a. Hard Steering.

(1) Inflate tires to recommended pressure. See paragraph 27 on page 24.

(2) Lubricate steering gear, linkage and steering knuckles.

(3) Check alignment of steering post bracket. See paragraph 10 on page 190.

(4) Adjust steering gear or repair if hard steering is due to damaged steering gear.

b. Shimmy and Tramp.

(1) Inflate tires to recommended pressures. See paragraph 27 on page 24.

(2) Inspect tire and wheel assemblies and balance both statically and dynamically.

(3) Inspect steering gear, steering connections, king pins and bushings for excessive wear causing looseness and backlash.

(4) Inspect front axle component parts for damage which would change caster and camber angles. See paragraph 1 on page 33.

FRONT AXLE DATA AND SPECIFICATIONS				
YEAR	1940-42	1939	1937-38	1936
Type	**	**	*	*
Tread, front, inches	57	56 $\frac{5}{16}$	55 $\frac{29}{32}$	55 $\frac{7}{8}$
Tread, rear, inches	59 $\frac{15}{16}$	59 $\frac{15}{16}$	59 $\frac{15}{16}$	58
Camber, degrees	0 to + $\frac{3}{4}$, $\frac{1}{4}$ preferred	0 to + $\frac{3}{4}$, $\frac{1}{4}$ preferred	0 to + $\frac{3}{4}$, $\frac{1}{4}$ preferred	0 to + $\frac{3}{4}$, $\frac{1}{4}$ preferred
Caster, degrees	-1 to +1, 0 preferred	-1 to +1, 0 preferred	1 to 3 2 preferred	1 to 3 2 preferred
Toe-in, inches	$\frac{1}{32}$	$\frac{1}{32}$	$\frac{1}{32}$	$\frac{1}{32}$
King pin angle, degrees	4 $\frac{3}{4}$ to 6	5 $\frac{1}{4}$ to 6 $\frac{1}{2}$	4 $\frac{1}{2}$ to 5 $\frac{1}{2}$	9 to 10
King pin bushing—ream after installing, inches	.7960-.7975	.7960-.7975	.7960-.7975	.7960-.7975
**Independent Front Wheel Suspension		*Rigid, Reverse Elliott		

Section III FRONT AXLE

I. FRONT WHEEL ALIGNMENT.

1936-42—The factors involved in front wheel alignment are inclination of the steering knuckle pins, camber, caster, toe-in and toe-out on turns, all of which are related and dependent upon each other. In addition, there are several other conditions that affect the alignment of the wheels, such as tire inflation, wheel wobble, wheel and tire balance, straightness of wheel suspension parts and frame, alignment of the wheels with the frame, adjustment of the front wheel bearings, the steering gear and connections and proper operation of the shock absorbers. The car should be carefully checked and adjusted so that all factors related to front wheel alignment are known to be satisfactory before checking the alignment of the wheels.

2. CHECKING KING PIN INCLINATION.

1936-42

(1) Inflate all tires to recommended pressure.

(2) Place front wheels on locking turntables, with the front wheels in the straight-ahead position (fig. 1) and lock the turntables. Be certain that the wheels are in the center of the turntables. *Set the foot brakes so that the front wheels cannot turn.*

(3) Assemble the gauge to the right front wheel, as shown in figure 2 with the quadrant parallel with the wheel. Pull out turntable lock pins.

(4) *With the gauge on the right wheel,* turn the front wheels to the left until the right wheel has turned 20 degrees, as indicated on the turntable scale.

(5) Adjust the secondary screw which controls the short pointer (fig. 3), until the bubble is centered between the two lines on the spirit level. *Do not disturb the gauge setting or release the brakes.*

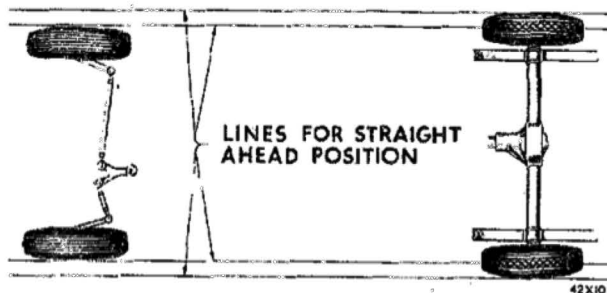
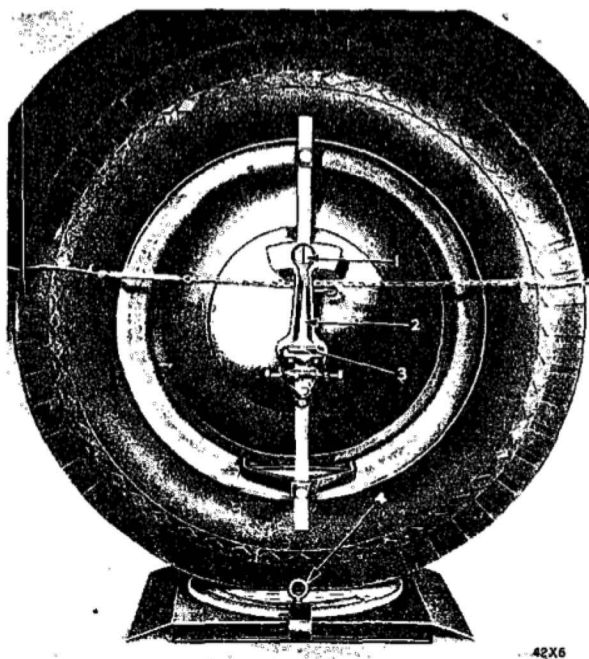


Figure 1—Wheels In Straight-ahead Position
(1936-42 Models)

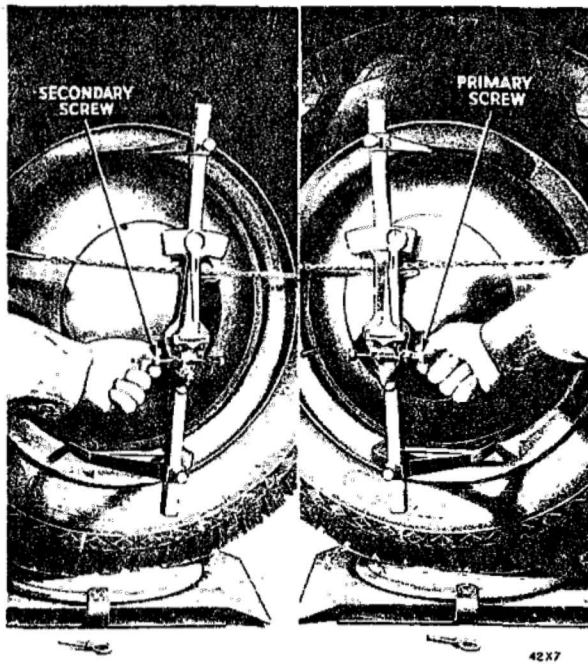


Gauge—Tool DD-428, Turntable—Tool DD-435
1—Hair line on zero 3—Bubble level
2—Pointer on scratch mark 4—Turntable lock pin

Figure 2—Checking King Pin Angle—Gauge on
Right Wheel (1936-42 Models)

IMPORTANT

To relieve bind or friction in steering mechanism, it is advisable to turn the wheels slightly beyond 20 degrees, then back to exactly 20 degrees. The brakes must be applied constantly during this operation.



Gauge—Tool DD-428, Turntable—Tool DD-435
 Figure 3—Checking King Pin Angle—Gauge on Right Wheel (1936-42 Models)

(6) With the foot brakes still applied, turn the front wheels to the right until the right wheel has been turned back to an angle of 20 degrees past the straight-ahead position. Turn the wheels slightly past the 20 degree mark on turntable, then return to exactly 20 degrees, to relieve any possible bind in steering mechanism.

(7) Adjust the primary screw (fig. 3) which controls the hair line, until the bubble centers in the spirit level. The reading on the 40 degree scale on the gauge will be the king pin angle for the right wheel.

(8) To check the king pin angle of the left wheel, place wheels in straight-ahead position, and attach gauge to left wheel as explained in step (3). Then turn the wheels to the right until the left wheel has turned slightly past 20 degrees, then return to exactly 20 degrees, to relieve any possible bind in steering mechanism. Keep foot brakes constantly applied.

(9) Adjust secondary screw (fig. 3) as explained in step (5).

(10) Keeping the foot brakes applied, turn the front wheels to the left until the

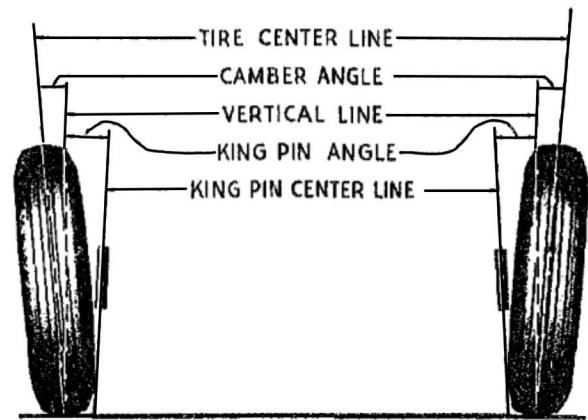


Figure 4—Camber Angle and King Pin Angle (1936-42 Models)

left wheel has been turned back to an angle of 20 degrees past the straight-ahead position. Turn the wheels slightly past the 20 degree mark on turntable, then return to exactly 20 degrees, to relieve any possible bind in steering mechanism.

(11) Adjust primary screw (fig. 3) as explained in step (7). The reading on the 40 degree scale on the gauge will be the king pin angle for the left wheel.

3. CHECKING CAMBER.

1936-42

(1) Be sure the king pin inclination is correct. Place the front wheels in the straight-ahead position (fig. 1) with the weight of the car on the wheels and the front end of car level.

(2) With the gauge assembled on the wheel as shown in figure 5, adjust the secondary screw on the quadrant assembly so that the pointer which is just above the spirit level is on the scratch mark.

(3) Adjust the primary screw so the spirit level bubble is centered.

(4) Take the camber reading in degrees on the scale. Use the 60 degree section of the scale on the quadrant assembly of the gauge for checking camber. If the wheel is not true, turn it 180 degrees; take another reading and average the two readings to obtain the camber angle.

(5) Readings from zero toward the wheel indicate camber. Readings from zero

away from the wheel indicate reverse camber.

(6) Check the camber of the opposite wheel in the same manner.

4. CHECKING CASTER ANGLE.
1936-42

(1) Be sure the king pin angle and the camber angle are correct.

IMPORTANT

Keep the foot brakes applied while all of the following operations are being performed.

(2) Locate the front wheels centrally on the turntables and place them in the straight-ahead position (fig. 1). Pull out the turntable lock pins.

(3) *With the gauge on the right wheel, turn the front wheels to the left until the right wheel has turned 20 degrees, as indicated on the turntable scale. Turn wheels slightly past 20 degrees, then back to exactly 20 degrees in order to relieve any possible bind in steering mechanism.*

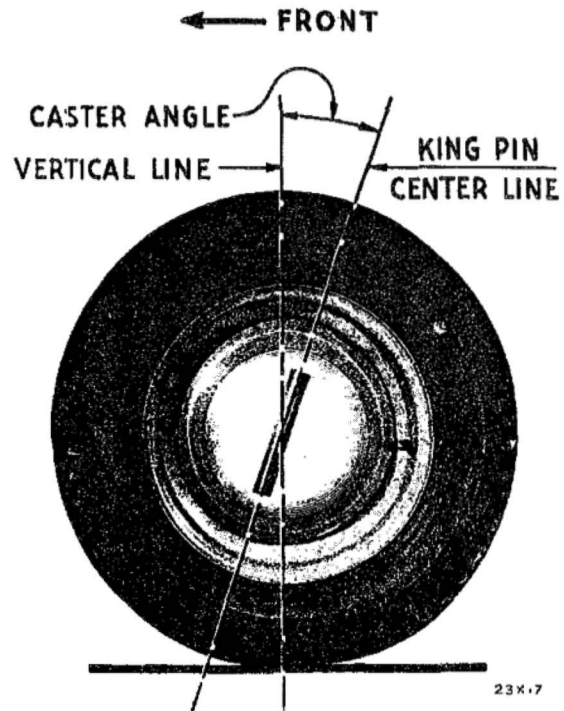
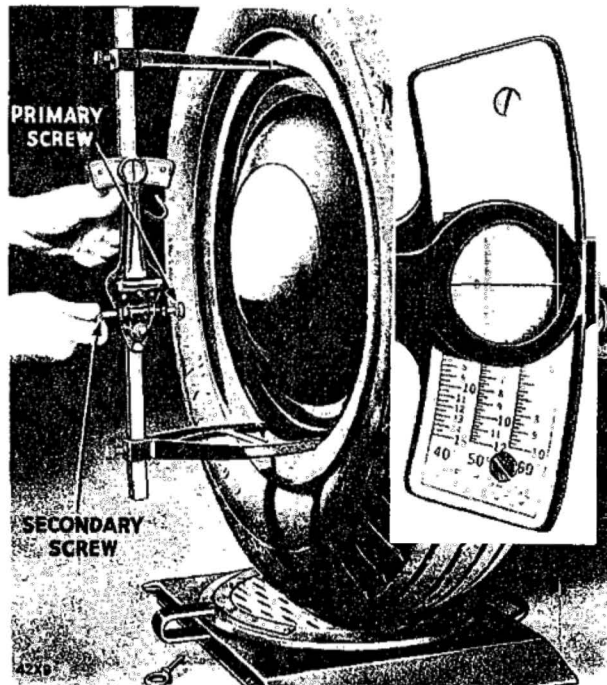
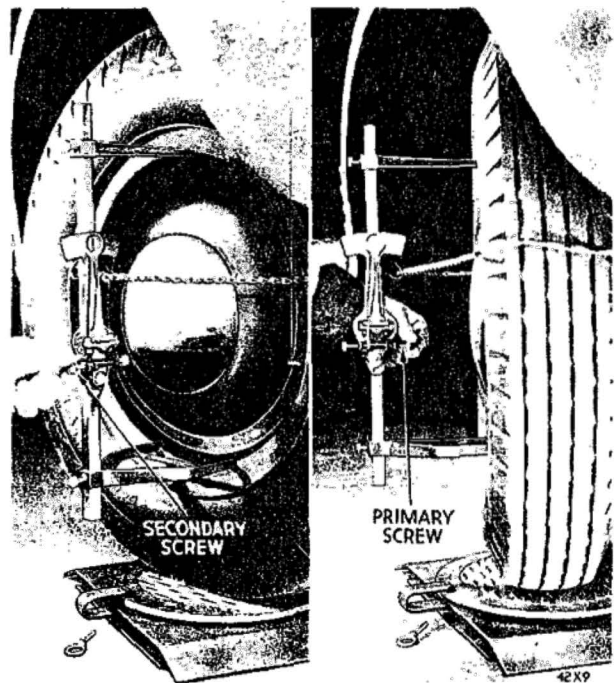


Figure 6—Positive Caster Angle (1936-42 Models)



Gauge—Tool DD-428, Turntable—Tool DD-435
Figure 5—Checking Camber (1936-42 Models)



Gauge—Tool DD-428, Turntable—Tool DD-435
Figure 7—Checking Caster—Gauge on Right Wheel (1936-42 Models)

4. CHECKING CASTER ANGLE.

1936-42—Cont'd

(4) Adjust the secondary screw until the bubble is centered between the two lines on the spirit level. *Do not disturb this gauge setting.*

(5) Turn the front wheels to the right, until the right wheel has turned to an angle of 20 degrees past the straight-ahead position. *Turn wheels slightly past 20 degrees, then back to exactly 20 degrees in order to relieve any possible bind in steering mechanism.*

(6) Adjust the primary screw until the bubble centers in the spirit level. The reading on the 40 degree scale will be the caster angle. Readings from zero toward the wheel indicates positive caster. Readings from zero away from the wheel indicates reverse caster.

(7) *To check the amount of caster in left wheel*, place wheels in straight-ahead position and attach gauge to left wheel. Then turn the wheels to the right until the left wheel has turned 20 degrees as indicated on turntable scale. *Turn wheels slightly past 20 degrees, then back to exactly 20 degrees to relieve any possible bind in steering mechanism.*

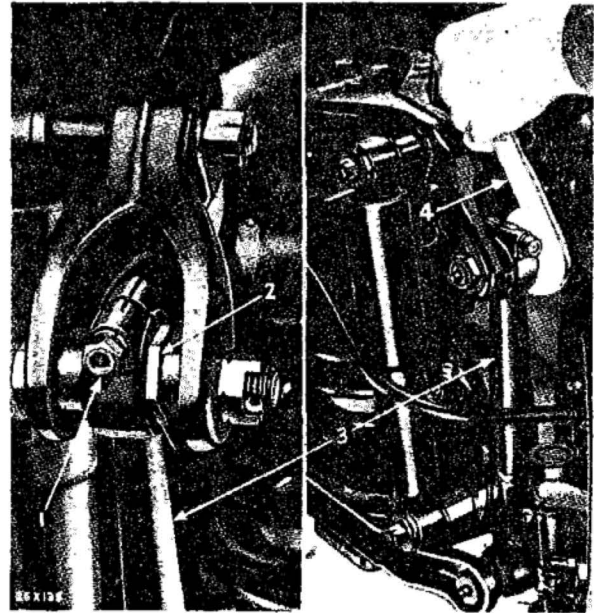
(8) Adjust secondary screw until the bubble is centered between the two lines on the spirit level. *Do not disturb this gauge setting.*

(9) Turn the front wheels to the left until the left wheel has turned to an angle of 20 degrees past the straight-ahead position. *Turn wheels slightly past 20 degrees, then back to exactly 20 degrees in order to relieve any possible bind in steering mechanism.*

(10) Adjust the primary screw until the bubble centers in the spirit level. The reading on the 50 degree scale on the gauge will be the caster angle. Readings from zero toward the wheel indicate positive caster. Readings from zero away from the wheel indicate reverse caster.

5. ADJUSTING CAMBER AND CASTER.

1941-42—Caster angle is not adjustable, but proper setting is obtained when assembling the camber eccentric bushing. To adjust camber, loosen the lock screw (fig. 8) and turn the bushing to obtain the correct setting within $\frac{1}{2}$ revolution from the point where correct caster setting is obtained. Do not turn the eccentric bushing until it binds against either side of the upper control arm.



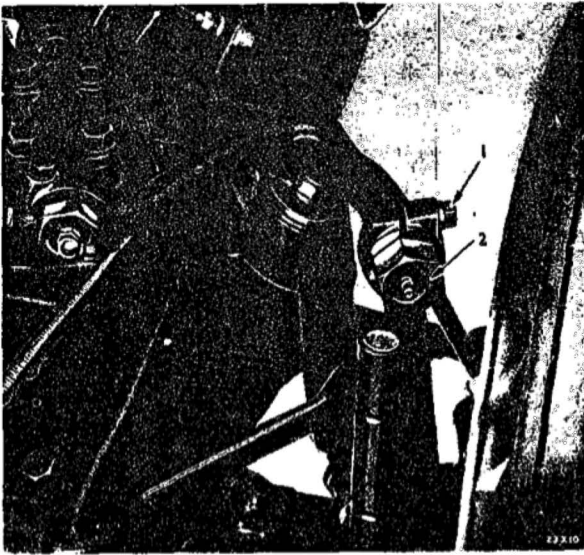
1—Lock screw
2—Upper control arm pin
(eccentric) bushing

3—Steering knuckle
support
4—Tool C-611 (Tool C-619
for 7-Pass. Sedans)

Figure 8—Camber Angle Adjustment
(1941-42 Models)

Keep the steering knuckle support as nearly central between the upper control arm as possible. Adjust to specifications and tighten lock screw.

1939-40—Caster angle is not adjustable but proper setting is obtained when assembling the camber eccentric bushing. To adjust camber, loosen the lock screw (fig. (9)) and turn the eccentric bushing to obtain the correct setting within $\frac{1}{2}$ revolution from the point where correct setting is obtained.



1—Clamp screw 2—Front wheel upper control arm (eccentric) bushing

Figure 9—Camber Angle Adjustment (1939-40 Models)

NOTE

On 1939 model cars, at least a thread or two should be exposed beyond the face of the bushing after the setting is completed. On 1940 model cars, the distance between the rear face of the steering knuckle support and the shoulder on the upper control arm should be $\frac{5}{8}$ inch, after the camber setting is correct. Tighten the lock screw.

1936-38—Axles used on these models are rigid, reverse Elliott type. Caster can be adjusted by inserting wedge plates between the springs and the axle center. To increase the caster, place the thick ends of the plates toward the rear of the car. To decrease the caster, place the thick ends of the plates toward the front of the car. If the caster is out more than 2 degrees, replace the axle center as this type axle cannot be straightened successfully. Camber angle is not adjustable and if it is not within the limits shown (0 to $+\frac{3}{4}$ deg., $+\frac{1}{4}$ deg. preferred), the axle center or steering knuckle has been bent and should be replaced.

6. MEASURING TOE-IN.

1936-42—Spin the front wheels and scribe a line in the center of each tire tread. Turn front wheels to the straight-ahead position (fig. 1) and place them on turntables, to allow the wheels to float freely and eliminate any bind in steering connections. Measure the distance, at hub height, between points (A) and between points (B), (fig. 10). The distance between points (B) should be $\frac{1}{32}$ inch less than between points (A), indicating $\frac{1}{32}$ inch toe-in.

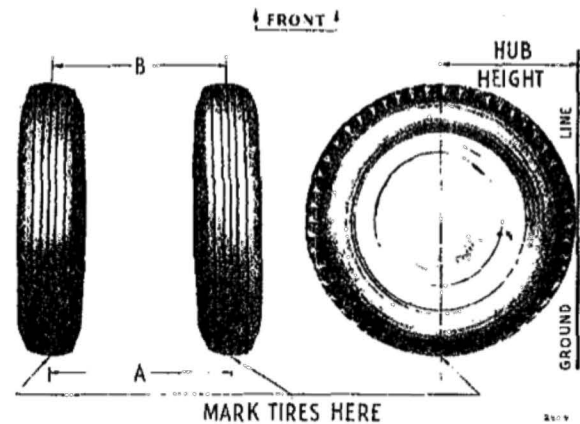


Figure 10—Checking Toe-in (1936-42 Models)

7. ADJUSTING TOE-IN.

1940-42—With the steering wheel in its mid-position and with the center spoke of the wheel pointing straight down, loosen the clamping bolts on the ends of both tie-rods and turn both tie-rods an equal amount until the toe-in is $\frac{1}{32}$ inch (fig. 10). When the adjustment is correct, pivot the ends of the tie-rods on the ball studs so they are both against the front or back sides of the studs and tighten the clamp bolts. This will provide sufficient angular rotation of the tie-rod on the ball studs when making extreme turns. The clamping bolt on the left end of the long tie-rod should be beneath the tie-rod to prevent interference on extreme turns.

1939—To adjust the toe-in, first adjust the long tie-rod to measure $31 \frac{11}{16}$ inches between centers of the tie-rod balls, and

7. ADJUSTING TOE-IN.

1939—Cont'd

with the front wheels in the straight-ahead position (fig. 1), with the steering wheel in its mid-position. When this part of the adjustment is correct, loosen the clamping bolts at the ends of the short tie-rod and turn the tie-rod in the direction required to obtain 1/32 inch toe-in (fig. 10). While making these adjustments, be careful not to disturb the position of the steering wheel.

1936-38—Adjust the toe-in by loosening the clamp bolts on the tie-rod ends and turning the tie-rod. Turn the tie-rod as required to obtain 1/32 inch toe-in (fig. 10).

8. MEASURING TOE-OUT ON TURNS.

1936-42—Before checking toe-out (wheel alignment on turns) (fig. 11) all other factors of front wheel alignment should be checked in their proper sequence, namely: king pin inclination, caster, camber, and toe-in. Check the amount of toe-out on turns as follows:

- (1) Place turntable under the front wheels.
- (2) Turn the front wheels to the left until the turntable under the right wheel registers 20 degrees.
- (3) Take the reading of the turntable under the *left* wheel. With the right wheel set at 20 degree angle, the angle of the left wheel should be 22½ degrees.
- (4) Repeat the foregoing operations but turn the wheels to the *right* until the

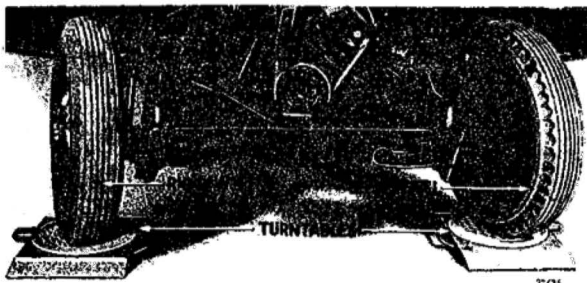


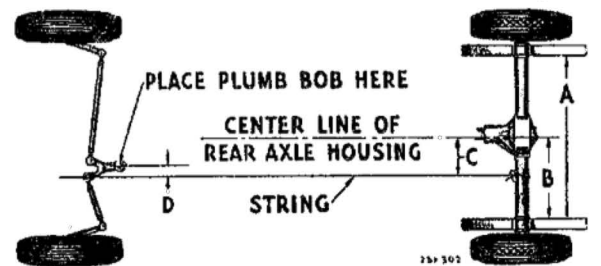
Figure 11—Checking Toe-out on Turns (1936-42 Models)

turntable under the left wheel registers 20 degrees. Under this condition the angle of the right wheel should be 22½ degrees.

9. LOCATION OF PITMAN ARM FOR PROPER TOE-OUT ON TURNS.

1941-42—The proper location of the pitman arm in the straight-ahead driving position is necessary in order to obtain the proper toe-out when turning to left or right. If the pitman arm angle is not correct on a turn, it changes the relationship of both front wheels to the extent that it will cause an excessive scuffing action between the tires and the road. However, the relationship between the steering wheel, the steering tube, the steering gear sector shaft, and the pitman arm is controlled by master serrations on the component parts and, with the steering wheel in proper straight-ahead driving position, the steering gear arm, unless bent, is also in proper position. To determine whether the pitman arm or steering gear assembly has been damaged, proceed as follows:

- (1) Place the front wheels in the straight-ahead driving position (fig. 1).
- (2) Determine the center point of the rear axle housing by measuring the distance between the rear springs (A, fig. 12). Measure one-half of this distance (B) and mark this point on the axle housing. Then measure 10¼ inches, (C) to the left of the center position and attach a string or cord by tying it around the housing. Extend the string forward to the center point of the left tie



A—Distance between rear springs
B—One-half of distance "A"

C—10¼"
D—1⅜"

Figure 12—Location of Pitman Arm for Proper Toe-out on Turns (1941-42 Models)

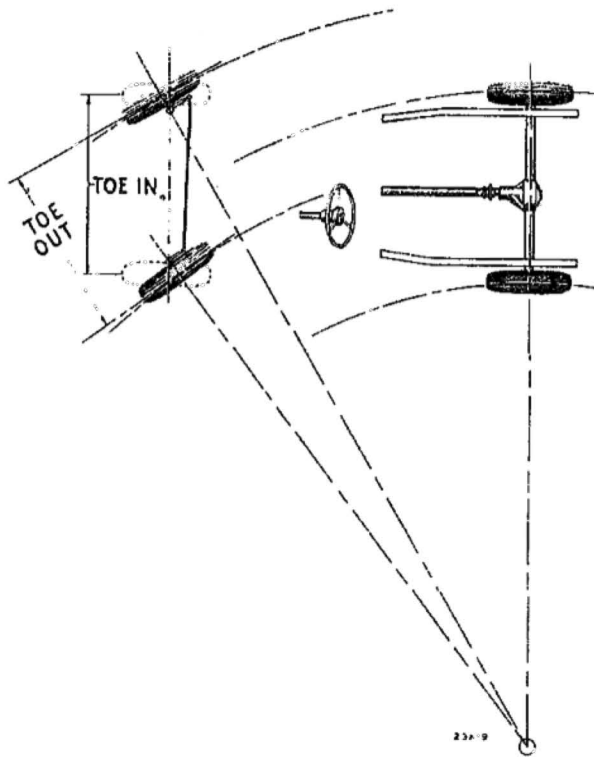


Figure 13—Steering Geometry on Turns (1936-42 Models)

rod ball at the pitman arm and fasten fairly tight.

(3) Place a plumb bob on center point of pitman arm at serrated hole. *Do not remove pitman arm.*

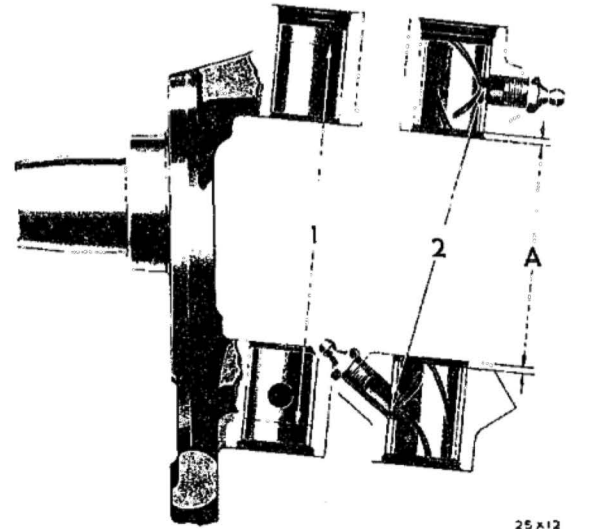
(4) Measure distance from plumb bob string to long stretched string (D). This dimension should be $1\frac{3}{8}$ inches with the pitman arm in its proper location. If not, all component parts should be examined for damage and replaced if necessary.

10. REMOVAL OF STEERING KNUCKLES AND BUSHINGS.

1936-42

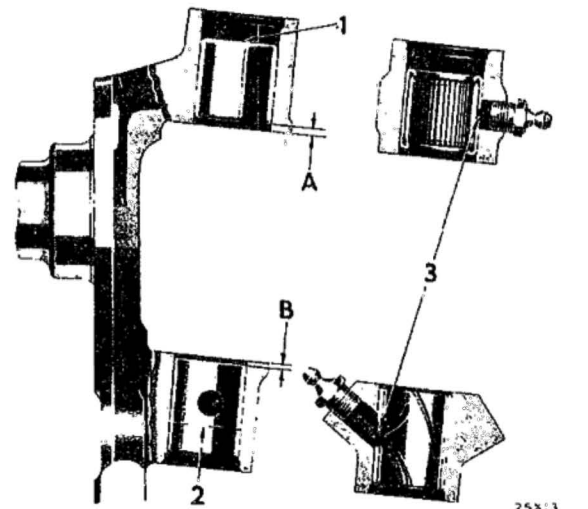
(1) Block the brake pedal so it cannot be depressed. Remove the wheel and hub assembly. Disconnect the brake support from the steering knuckle and remove the knuckle arm from the steering knuckle. Lift the complete brake support and brake shoe assembly off the steering knuckle without disconnecting the brake tube.

(2) Remove the steering knuckle pivot lock pin or set screw, drive a punch into the upper steering knuckle oil seal disc and pry the seal out of the steering knuckle. Using a brass drift, drive the steering knuckle pivot pin downward, forcing out the lower oil seal. Using special tool C-328, remove the steering knuckle bushings or bearings.



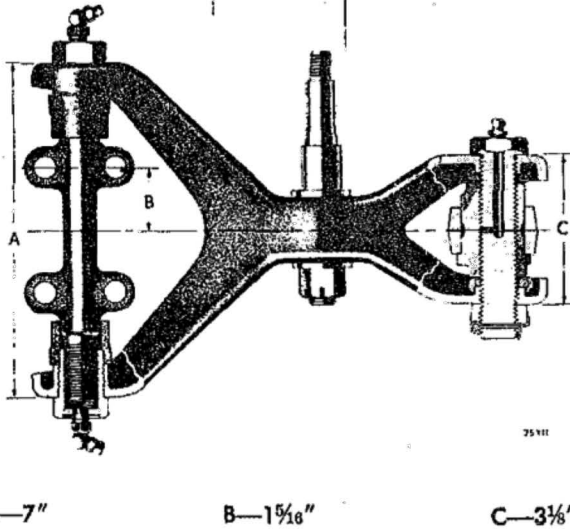
1—Identification lines 2—Oil holes A— $\frac{1}{16}$ "

Figure 14—King Pin Bushings Installed (1936-42 Models Equipped with Upper and Lower Bushings)



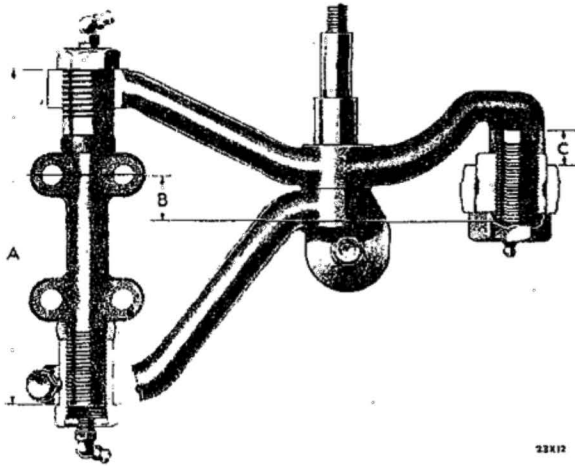
1—Bearing identification mark 2—Bushing identification line 3—Oil holes A— $\frac{3}{32}$ " B— $\frac{1}{16}$ "

Figure 15—King Pin Bearing and Bushing Installed (1936-42 Models Equipped with Bearing and Bushing)



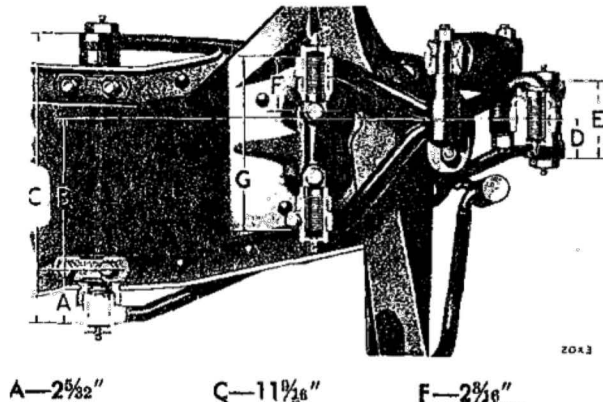
A—7" B—1 $\frac{5}{16}$ " C—3 $\frac{3}{8}$ "

Figure 16—Front Wheel Upper Control Arm Alignment (1941-42 Models)



A—7" B—1" (1 $\frac{3}{32}$ " on 7-pass. sedans only)
C— $\frac{5}{8}$ "

Figure 17—Front Wheel Upper Control Arm Alignment (1940 Model)



A—2 $\frac{5}{32}$ " B—11 $\frac{1}{16}$ " F—2 $\frac{3}{8}$ "

11. INSTALLATION OF STEERING KNUCKLES AND BUSHINGS.

1936-42—Install the upper bushing or bearing from top of the steering knuckle as shown in figures 14 and 15, with the trade mark on the bearing at the top. Install the lower bushing and rear bushings to .7960 to .7975 inch. After assembling the steering knuckle to axle center or support, install the oil seals with the convex side toward the pivot pin. Peening over or staking of the oil seal is unnecessary. On 1939-42 models, select shim (46, figs. 23, 24 and 26) to give .003 to .005 inch clearance between steering knuckle support and steering knuckle.

12. REMOVAL OF UPPER CONTROL ARM.

1939-42—With a jack under the lower control arm spring seat, raise the car and remove the wheel and shock absorber. Remove the pin from the outer end of the arm on the 1941-42 models; remove the upper control arm eccentric bushing on the 1939-40 models. Unfasten the pivot bar from the frame and remove the arm.

13. INSTALLATION OF UPPER CONTROL ARM.

1941-42—When installing the upper control arm, keep the support as nearly central between the web of the arm as possible to prevent binding (fig. 16).

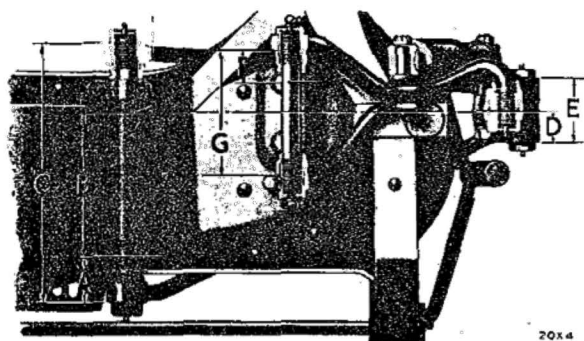
1940—Assemble the bushings to the dimensions shown in figure 17.

1939—Assemble the bushings to the dimensions shown in figures 18 or 19.

14. INSTALLATION OF UPPER CONTROL ARM BUSHINGS.

1941-42—Spread the control arms 1/16 inch from "at rest" position (fig. 20) to assure free movement of the pivot bar, and install the bushings to the dimensions shown in figure 16.

15. REMOVAL OF LOWER CONTROL ARM AND FRONT SPRING.



A— $2\frac{1}{4}$ " C— $12\frac{1}{2}$ " F— $1\frac{9}{16}$ "
 B— $6\frac{1}{8}$ " D— $1\frac{1}{16}$ " G—6"

Figure 19—Front Wheel Upper and Lower Control Arm Alignment (1939 Model) (7-Pass. Sedan)

unit. Remove wheel and disconnect sway eliminator and shock absorber. Relieve the pressure on the pivot bar fastening bolts and remove the bolts. Lower the control arm and remove the spring. Disconnect the control arm from the steering knuckle support and remove the arm.

16. INSTALLATION OF LOWER CONTROL ARM AND FRONT SPRING.

1939-42—Use tool C-594 (fig. 21) to assemble the lower control arm, pivot bar and bushings on 1940-42 models, as shown in figure 22 and tighten with a minimum torque of 165 foot pounds. When making installation on the car, position the flat end of the spring at the top and the lower end of the spring in the recessed part of the spring seat, with the spacer (on driver's side only) and silencers positioned as shown in figure 2, on page 176.

17. REMOVAL OF TIE-RODS.

1936-42—Disconnect the tie-rod end from steering knuckle arm and unscrew the end from tie-rod. The tie-rod balls are not removable from the tie-rod ends.

18. INSTALLATION OF TIE-RODS.

1936-42—When installing tie-rods on 1940-42 models, be sure the clamping bolt on the left end of the long tie-rod is beneath the tie-rod to prevent interference on extreme turns. Adjust toe-in as described in paragraph 7.

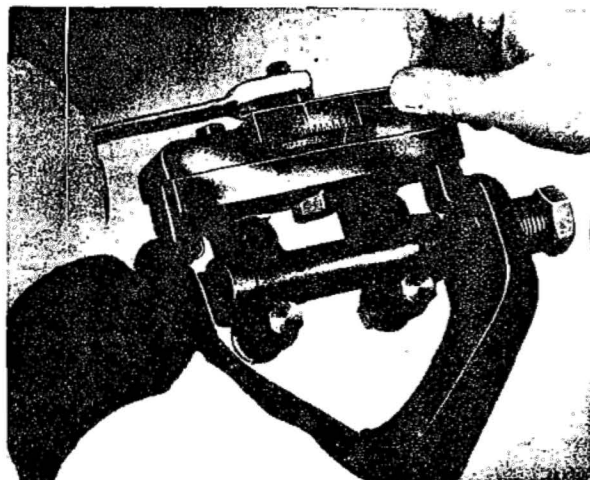


Figure 20—Spreading Upper Control Arm With Tool C-608 (1941-42 Models)

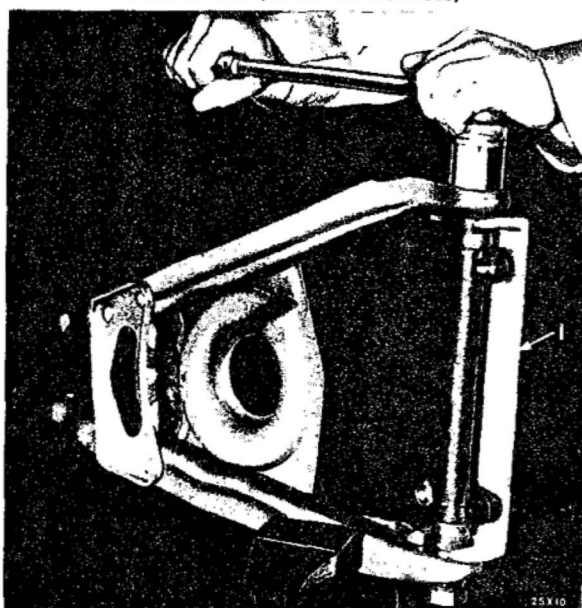
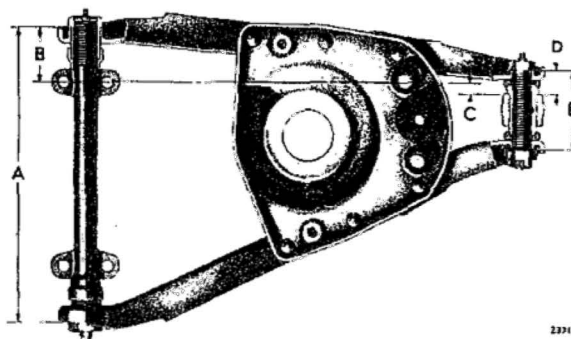
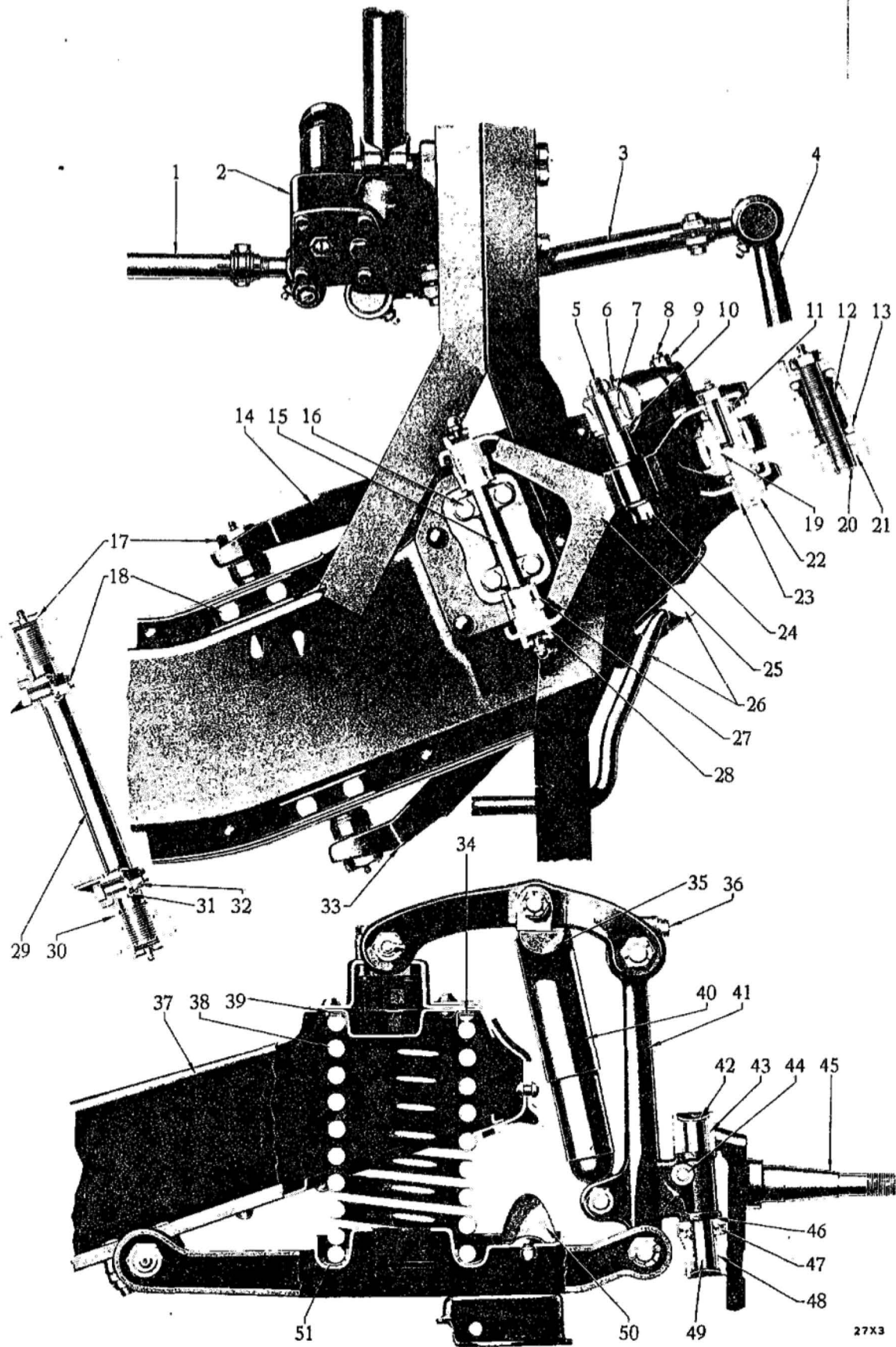


Figure 21—Installing Lower Control Arm Bar Bushings with Tool (1) C-594 (1940-42 Models)



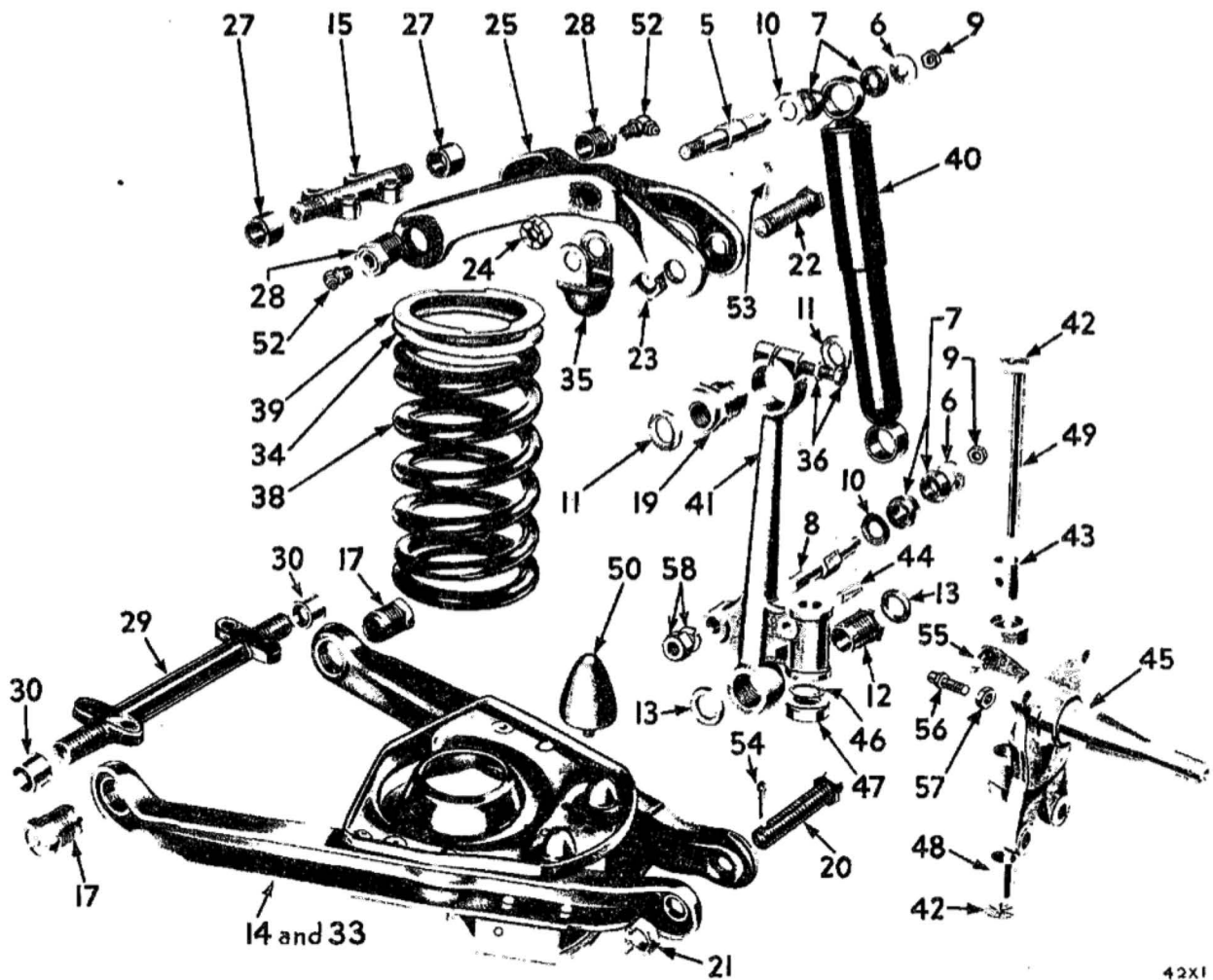
A— $11\frac{1}{16}$ " ($11\frac{13}{16}$ " 7-pass. sedans only) D— $1\frac{1}{16}$ " ($1\frac{1}{32}$ " 7-pass. sedans only)
 B— $2\frac{5}{32}$ " ($2\frac{7}{32}$ " 7-pass. sedans only) E— $3\frac{1}{8}$ " ($3\frac{5}{16}$ " 7-pass. sedans only)
 C— $\frac{7}{16}$ "

Figure 22—Front Wheel Lower Control Arm Alignment (1940-42 Models)



27X3

Figure 23—Front Wheel Suspension (Assembled View) (1942 Model, Typical of 1941 Model)



42X1

Figure 24—Front Wheel Suspension (Disassembled View) (1942 Model, Typical of 1941 Model)

- | | | |
|--|---|--|
| 1—Steering knuckle tie rod assembly—long | 20—Lower control arm pin | 40—Front shock absorber assembly |
| 2—Steering gear assembly | 21—Lower control arm pin nut | 41—Steering knuckle support |
| 3—Steering knuckle tie rod assembly—short | 22—Upper control arm pin | 42—Steering knuckle oil seal plug |
| 4—Steering knuckle arm | 23—Upper control arm pin nut | 43—Steering knuckle bushing (bearing on 1941-7 Pass. Model) |
| 5—Upper control arm shock absorber stud | 24—Upper control arm shock absorber stud nut | 44—Steering knuckle king pin lock pin |
| 6—Front shock absorber bushing retainer—outer | 25—Upper control arm | 45—Steering knuckle |
| 7—Front shock absorber bushings | 26—Sway eliminator shaft and link assembly | 46—Steering knuckle thrust bearing shim |
| 8—Front shock absorber lower stud | 27—Upper control arm pivot bar dust seal | 47—Steering knuckle thrust bearing |
| 9—Front shock absorber mounting nut | 28—Upper control arm pivot bar bushing | 48—Steering knuckle bushing |
| 10—Front shock absorber bushing retainer—inner | 29—Lower control arm bar | 49—Steering knuckle king pin (pivot pin) |
| 11—Upper control arm pin dust seal | 30—Lower control arm bar bushing dust seal | 50—Lower control arm bumper |
| 12—Lower control arm pin bushing | 31—Lower control arm bar bolt lock | 51—Front spring silencer—lower (not used on all 1942 Models) |
| 13—Lower control arm pin dust seal | 32—Lower control arm bar bolt nut and lock washer | 52—Lubricant nipple |
| 14—Lower control arm assembly | 33—Lower control arm assembly | 53—Cotter pin |
| 15—Upper control arm pivot bar | 34—Front spring spacer | 54—Cotter pin |
| 16—Upper control arm pivot bar bolt and lockwasher | 35—Upper control arm bumper | 55—Lubricant nipple |
| 17—Lower control arm bar bushing | 36—Steering knuckle support clamp screw and lock washer | 56—Stop screw |
| 18—Lower control arm bar bolt | 37—Frame front crossmember | 57—Stop screw lock nut |
| 19—Upper control arm pin bushing | 38—Front spring | 58—Front shock absorber lower stud nut and lock washer |
| | 39—Front spring silencer—upper | |

PLYMOUTH SERVICE MANUAL

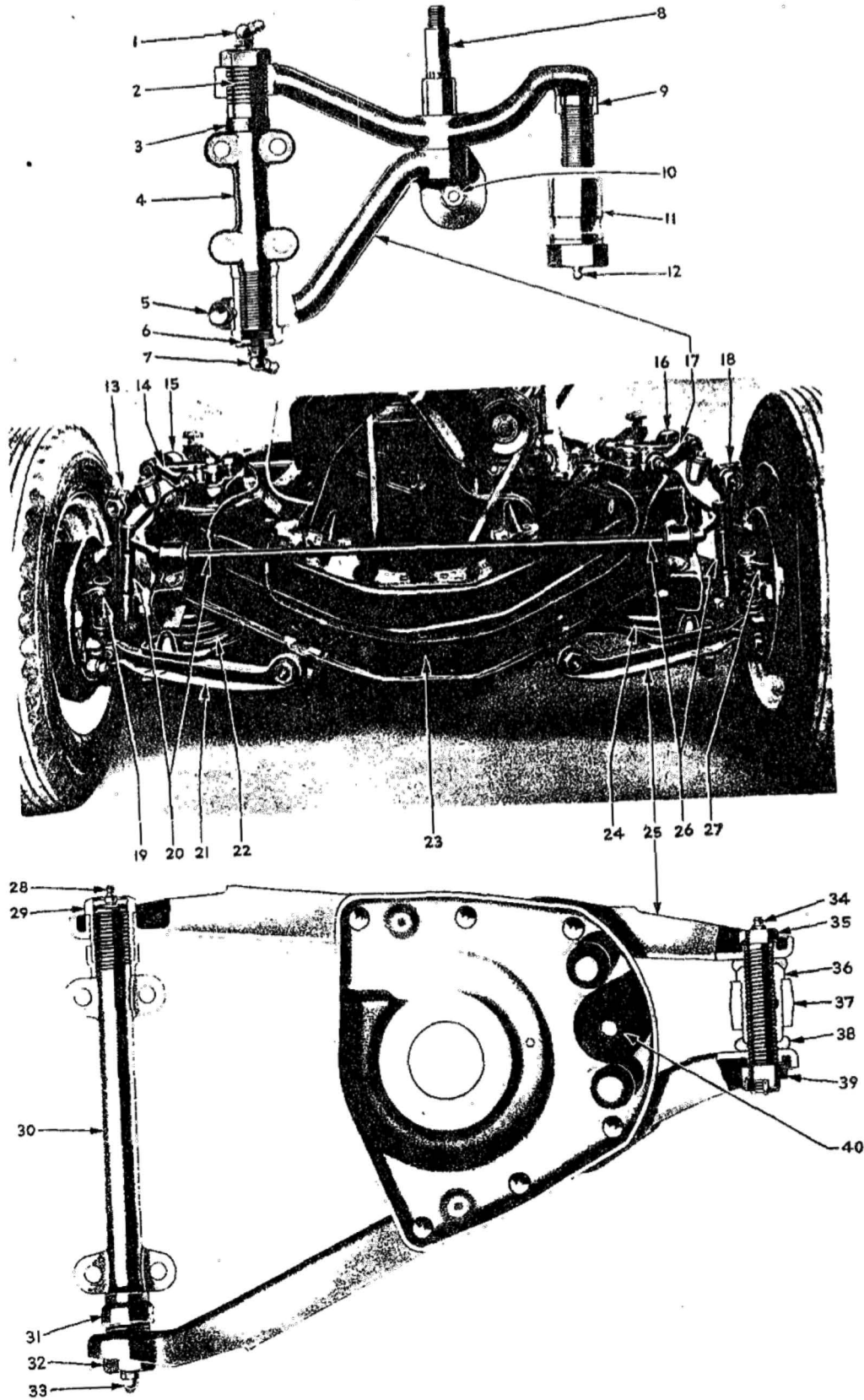
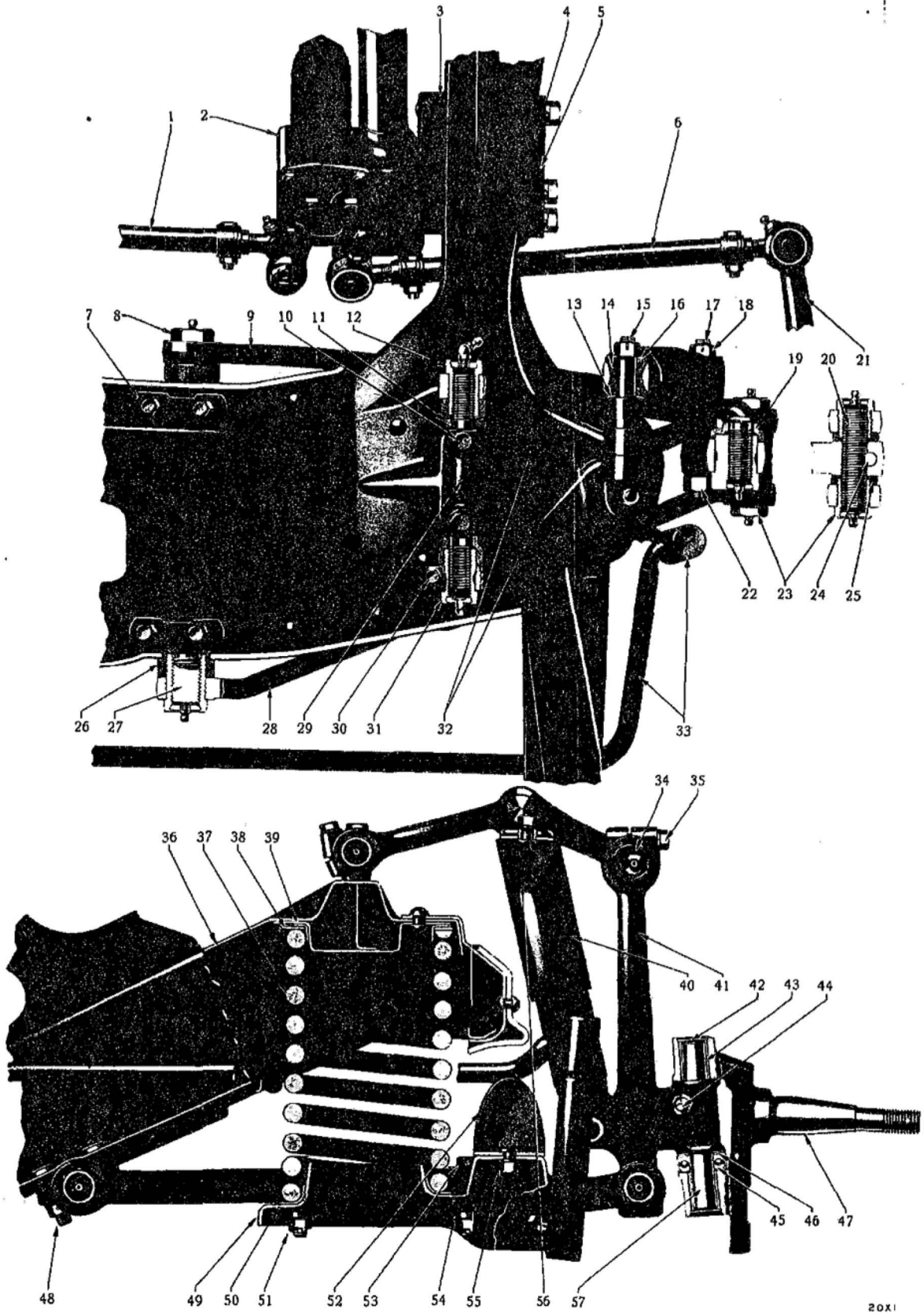


Figure 25—Front Wheel Suspension (1940 Model)

Legend for Figure 25—Front Wheel Suspension (1940 Model)

- | | | |
|--|--|--|
| 1—Front wheel upper control arm pivot bar bushing lubricant fitting. | 12—Front wheel upper control arm eccentric bushing lubricant fitting | 29—Front wheel lower control arm bar bushing—rear |
| 2—Front wheel upper control arm pivot bar bushing | 13—Steering knuckle support | 30—Front wheel lower control arm bar |
| 3—Front wheel upper control arm pivot bar bushing dust seal | 14—Front wheel upper control arm and brace assembly—right | 31—Front wheel lower control arm bar bushing dust seal |
| 4—Front wheel upper control arm pivot bar | 15—Front shock absorber assembly | 32—Front wheel lower control arm bar bushing—front |
| 5—Front wheel upper control arm brace clamp screw | 16—Front shock absorber assembly | 33—Front wheel lower control arm bar bushing lubricant fitting—front |
| 6—Front wheel upper control arm pivot bar bushing plug | 17—Front wheel upper control arm and brace assembly—left | 34—Front wheel lower control arm pin lubricant fitting |
| 7—Front wheel upper control arm pivot bar bushing lubricant fitting | 18—Steering knuckle support | 35—Front wheel lower control arm pin |
| 8—Front shock absorber upper stud | 19—Steering knuckle—right | 36—Front wheel lower control arm pin bushing |
| 9—Front wheel upper control arm eccentric bushing dust seal | 20—Sway eliminator shaft and link | 37—Steering knuckle support |
| 10—Front wheel upper control arm bumper and stud | 21—Front wheel lower control arm and spring seat assembly—right | 38—Front wheel lower control arm pin dust seal |
| 11—Front wheel upper control arm eccentric bushing | 22—Front spring | 39—Front wheel lower control arm pin nut |
| | 23—Frame front crossmember | 40—Front wheel lower control arm bumper |
| | 24—Front spring | |
| | 25—Front wheel lower control arm and spring seat assembly—left | |
| | 26—Sway eliminator shaft and link | |
| | 27—Steering knuckle—left | |
| | 28—Front wheel lower control arm bar bushing lubricant fitting—rear | |

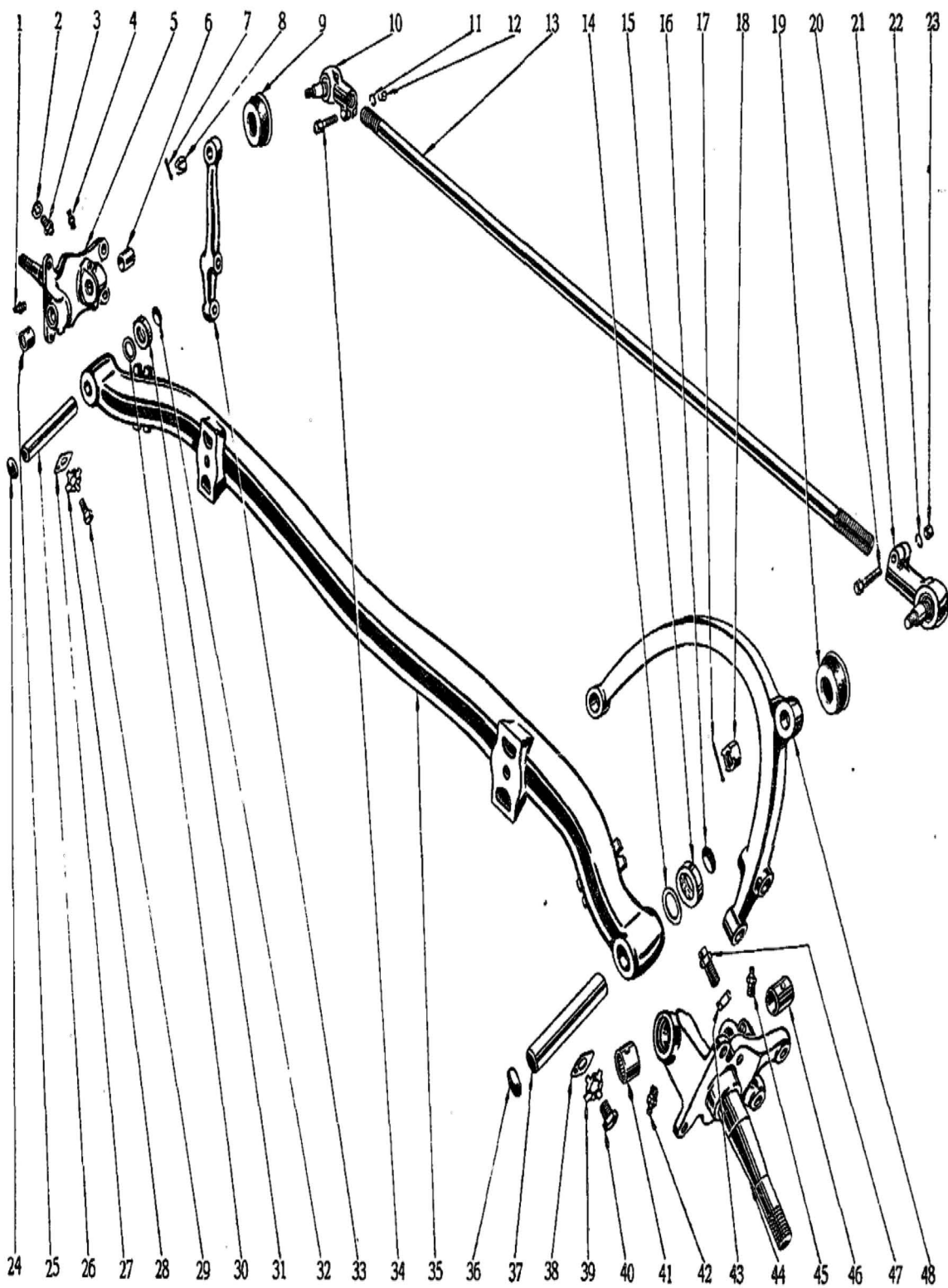


20X1

Figure 26—Front Wheel Suspension (1939 Model)

Legend for Figure 26—Front Wheel Suspension (1939 Model)

- | | | |
|---|---|--|
| 1—Steering knuckle tie rod—long | 18—Front shock absorber mounting nut | 40—Front shock absorber assembly |
| 2—Steering gear assembly | 19—Upper control arm dust seal | 41—Steering knuckle support |
| 3—Steering gear to frame insulator—inner | 20—Lower control arm pin | 42—Steering knuckle lubricant seal plug |
| 4—Steering gear to frame insulator—outer | 21—Steering knuckle arm—left | 43—Steering knuckle bushing |
| 5—Steering gear to frame reinforcement plate | 22—Front shock absorber lower stud nut and lock washer | 44—Steering knuckle pivot lock pin |
| 6—Steering knuckle tie rod—short | 23—Lower control arm pin bushing, plug and lubricant nipple | 45—Steering knuckle thrust bearing |
| 7—Lower control arm front cross-member flange reinforcement | 24—Lower control arm pin lock pin | 46—Steering knuckle thrust bearing shims |
| 8—Lower control arm bar bushing, plug and lubricant nipple | 25—Lower control arm pin dust seal | 47—Steering knuckle and bushings—left |
| 9—Lower control arm—left rear | 26—Lower control arm bar dust seal | 48—Lower control arm bolt, nut and lock washer |
| 10—Upper control arm pivot bar screw and lock washer | 27—Lower control arm bar | 49—Lower control arm spring seat |
| 11—Upper control arm pivot bar dust seal | 28—Lower control arm—left front | 50—Front spring silencer—lower |
| 12—Upper control arm pivot bar bushing, plug and lubricant nipple | 29—Upper control arm pivot bar | 51—Lower control arm spring seat bolt nut |
| 13—Front shock absorber pivot bushing retainer—upper inner | 30—Upper control arm brace clamp screw and lock washer | 52—Lower control arm bumper and bolt |
| 14—Front shock absorber pivot bushing | 31—Upper control arm brace pivot bar bushing, plug and lubricant nipple | 53—Lower control arm spring seat bolt |
| 15—Upper control arm shock absorber stud and mounting nut | 32—Upper control arm and brace | 54—Lower control arm spring seat bolt washer |
| 16—Front shock absorber pivot bushing retainer—upper outer | 33—Sway eliminator shaft and link | 55—Lower control arm bumper bolt nut and lock washer |
| 17—Front shock absorber lower stud | 34—Upper control arm bushing, plug and lubricant nipple | 56—Upper control arm bumper and bolt |
| | 35—Steering knuckle support clamp screw and lock washer | 57—Steering knuckle pivot or king pin |
| | 36—Frame front crossmember | |
| | 37—Front spring | |
| | 38—Front spring spacer | |
| | 39—Front spring silencer—upper | |



5x54A

Figure 27—Front Axle (Disassembled View) (1938 Model, Typical of 1936-37 Models)

Legend for Figure 27—Front Axle (Disassembled View) (1938 Model, Typical of 1936-37 Models)

- | | | |
|--|---|--|
| 1—Steering knuckle king pin lubricant nipple | 17—Steering knuckle tie rod end ball stud nut cotter pin | 31—Steering knuckle thrust bearing |
| 2—Steering knuckle stop screw lock nut | 18—Steering knuckle tie rod end ball stud nut | 32—Steering knuckle oil seal plug |
| 3—Steering knuckle stop screw | 19—Steering knuckle tie rod end dust seal (three piece dust seal on 1936-37 Models) | 33—Steering knuckle arm—right |
| 4—Steering knuckle king pin lubricant nipple | 20—Steering knuckle tie rod end clamp bolt | 34—Steering knuckle tie rod end clamp bolt |
| 5—Steering knuckle—right | 21—Steering knuckle tie rod end assembly—left | 35—Tube |
| 6—Steering knuckle bushing | 22—Steering knuckle tie rod end clamp bolt nut lock washer | 36—Steering knuckle oil seal plug |
| 7—Steering knuckle tie rod and ball stud nut cotter pin | 23—Steering knuckle tie rod end clamp bolt nut | 37—Steering knuckle pivot or king pin |
| 8—Steering knuckle tie rod and ball stud nut | 24—Steering knuckle oil seal plug | 38—Steering knuckle king pin set screw spring washer |
| 9—Steering knuckle tie rod end dust seal (three piece dust seal on 1936-37 Models) | 25—Steering knuckle bearing | 39—Steering knuckle king pin set screw lock |
| 10—Steering knuckle tie rod end assembly—right | 26—Steering knuckle pivot or king pin | 40—Steering knuckle king pin set screw |
| 11—Steering knuckle tie rod end clamp bolt nut lock washer | 27—Steering knuckle king pin set screw spring washer | 41—Steering knuckle bearing |
| 12—Steering knuckle tie rod end clamp bolt nut | 28—Steering knuckle king pin set screw lock | 42—Steering knuckle king pin lubricant nipple |
| 13—Steering knuckle tie rod | 29—Steering knuckle king pin set screw | 43—Steering knuckle stop screw lock nut |
| 14—Steering knuckle thrust bearing shim | 30—Steering knuckle thrust bearing shim | 44—Steering knuckle—left |
| 15—Steering knuckle thrust bearing | | 45—Steering knuckle king pin lubricant nipple |
| 16—Steering knuckle oil seal plug | | 46—Steering knuckle bushing |
| | | 47—Steering knuckle stop screw |
| | | 48—Steering knuckle arm—left |

Legend for Figure 1—Rear Axle (Disassembled View) (1942 Model, Typical of 1936-41 Models)

- | | | |
|--|---|--|
| 1—Axle drive shaft nut cotter pin | 21—Axle drive pinion flange nut cotter pin | 40—Axle drive gear bolt nut |
| 2—Axle drive shaft nut washer | 22—Axle drive pinion flange nut | 41—Differential case |
| 3—Axle drive shaft key | 23—Axle drive pinion flange nut washer | 42—Differential bearing adjuster lock screw |
| 4—Axle drive shaft bearing oil seal | 24—Axle drive pinion bearing oil seal | 43—Differential bearing adjuster lock screw lock washer |
| 5—Axle drive shaft bearing oil seal retainer gasket | 25—Axle drive pinion front bearing adjusting shims | 44—Differential bearing cone and rollers |
| 6—Axle drive shaft bearing cup | 26—Axle drive pinion rear bearing cone and rollers | 45—Differential bearing adjuster lock |
| 7—Axle drive bearing cone and rollers | 27—Axle drive pinion rear bearing cup | 46—Axle drive shaft |
| 8—Axle drive shaft oil washer | 28—Axle drive pinion rear bearing washer (shims on some models) | 47—Axle drive bearing oil hole plug |
| 9—Axle drive shaft carrier gasket | 29—Differential gear thrust washer | 48—Rear wheel brake support to axle housing bolt |
| 10—Differential bearing adjuster | 30—Axle drive shaft thrust block | 49—Axle drive shaft bearing shim |
| 11—Differential bearing cup | 31—Axle drive pinion carrier and cap | 50—Rear wheel brake support to axle housing bolt nut lock washer |
| 12—Differential pinion | 32—Housing | 51—Rear wheel brake support to axle housing bolt nut |
| 13—Axle drive shaft thrust block spacer | 33—Axle drive shaft | 52—Axle drive shaft nut |
| 14—Differential pinion shaft lock pin (screw on some models) | 34—Differential pinion thrust washer | 53—Axle drive pinion carrier screw |
| 15—Differential gear | 35—Housing cover plug | 54—Axle drive pinion carrier screw lock washer |
| 16—Axle drive pinion | 36—Differential pinion shaft | 55—Differential bearing cap screw lock washer |
| 17—Axle drive pinion bearing spacer | 37—Axle drive gear | 56—Differential bearing cap screw |
| 18—Axle drive pinion front bearing cup | 38—Axle drive gear bolt | |
| 19—Axle drive pinion front bearing cone and rollers | 39—Axle drive gear bolt nut lock | |
| 20—Axle drive pinion flange | | |

Section IV

REAR AXLE

DATA AND SPECIFICATIONS		
Year	1937-42	1936
Type	Semi-floating	Semi-floating
Drive gear type	Hypoid	Spiral bevel
Drive gear and pinion backlash, inches	.006 to .010	.006 to .008
Differential side gear and pinion clearance, inches	.004 to .012	.004 to .012
Axle shaft end play, inches	.003 to .008	.003 to .008
Drive pinion bearing draw tension, inches	.0015 to .0025	.004 to .008
Pinion bearing adjustment	Shims	Shims
Axle shaft bearing adjustment	Shims	Shims
Lubricant capacity	3¼ pints	3¼ pints

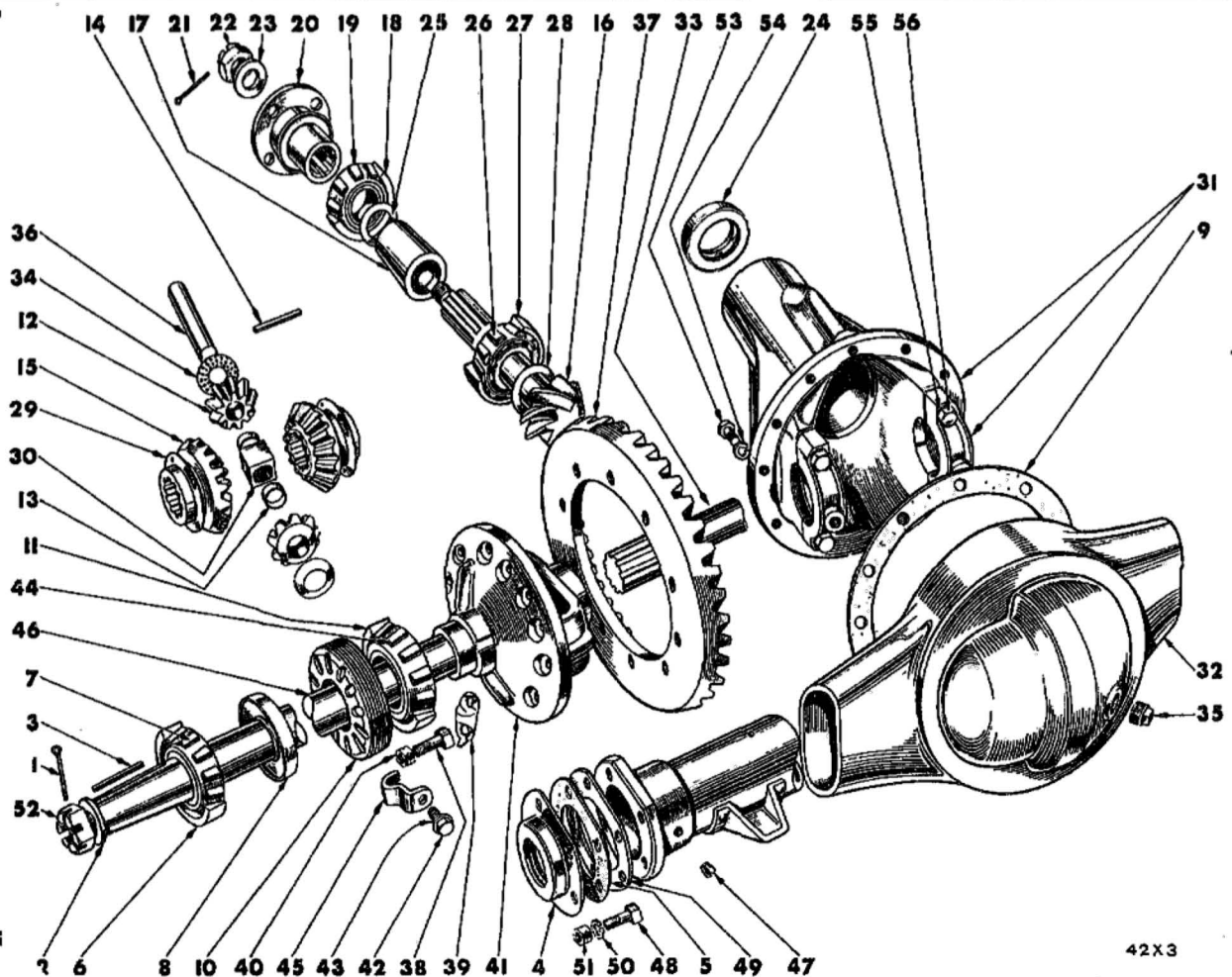


Figure 1—Rear Axle (Disassembled View) (1942 Model. Typical of 1936-41 Models)

42X3

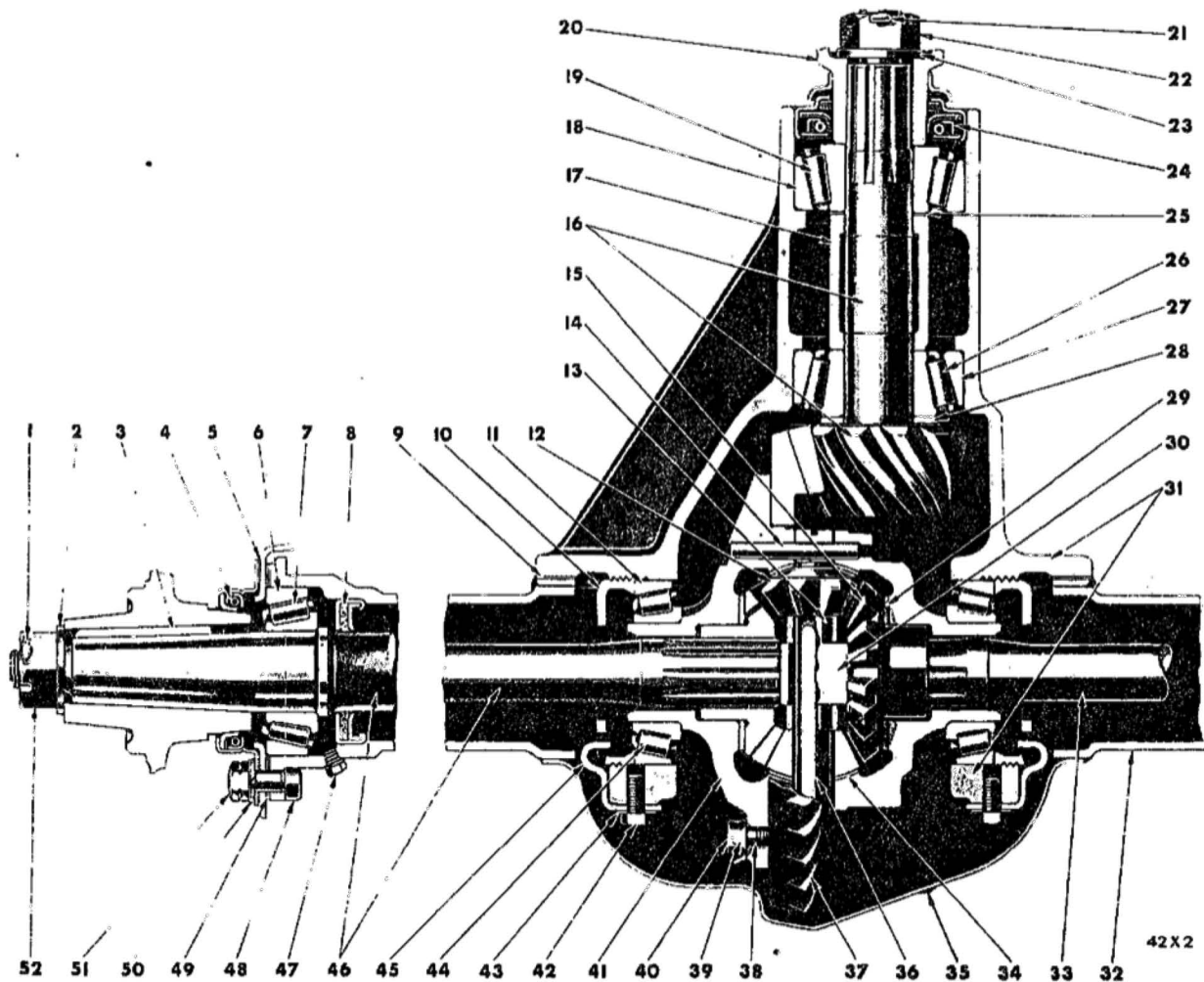


Figure 2—Rear Axle (Assembled View) (1942 Model, Typical of 1936-41 Models)

- | | | |
|--|---|---|
| 1—Axle drive shaft nut cotter pin | 20—Axle drive pinion flange | 36—Differential pinion shaft |
| 2—Axle drive shaft nut washer | 21—Axle drive pinion flange nut cotter pin | 37—Axle drive gear |
| 3—Axle drive shaft key | 22—Axle drive pinion flange nut | 38—Axle drive gear bolt |
| 4—Axle drive shaft bearing oil seal | 23—Axle drive pinion flange nut washer | 39—Axle drive gear bolt nut lock |
| 5—Axle drive shaft bearing oil seal retainer gasket | 24—Axle drive pinion bearing oil seal | 40—Axle drive gear bolt nut |
| 6—Axle drive shaft bearing cup | 25—Axle drive pinion front bearing adjusting shims | 41—Differential case |
| 7—Axle drive shaft bearing cone and rollers | 26—Axle drive pinion rear bearing cone and rollers | 42—Differential bearing adjuster lock screw |
| 8—Axle drive shaft oil washer | 27—Axle drive pinion rear bearing cup | 43—Differential bearing adjuster lock screw lockwasher |
| 9—Axle drive pinion carrier gasket | 28—Axle drive pinion rear bearing washer (shims on some models) | 44—Differential bearing cone and rollers |
| 10—Differential bearing adjuster | 29—Differential gear thrust washer | 45—Differential bearing adjuster lock |
| 11—Differential bearing cup | 30—Axle drive shaft thrust block | 46—Axle drive shaft |
| 12—Differential pinion | 31—Axle drive pinion carrier and cap | 47—Axle drive bearing oil hole plug |
| 13—Axle drive shaft thrust block spacer | 32—Housing | 48—Rear wheel brake support to axle housing bolt |
| 14—Differential pinion shaft lock pin (screw on some models) | 33—Axle drive shaft | 49—Axle drive shaft bearing shim |
| 15—Differential gear | 34—Differential pinion thrust washer | 50—Rear wheel brake support to axle housing bolt nut lockwasher |
| 16—Axle drive pinion | 35—Housing cover plug | 51—Rear wheel brake support to axle housing bolt nut |
| 17—Axle drive pinion bearing spacer | | 52—Axle drive shaft nut |
| 18—Axle drive pinion front bearing cup | | |
| 19—Axle drive pinion front bearing cone and rollers | | |

1. DESCRIPTION.

1936-42—The rear axle is of the semi-floating type (figs. 1 and 2) with hypoid drive gear and drive pinion, on 1937-42 models, and spiral bevel drive gear and drive pinion on 1936 model. The differential, drive pinion and axle shafts are carried on adjustable tapered roller bearings. The rear cover is welded to the axle housing, necessitating removal of the differential carrier assembly in order to adjust the differential and drive pinion bearings.

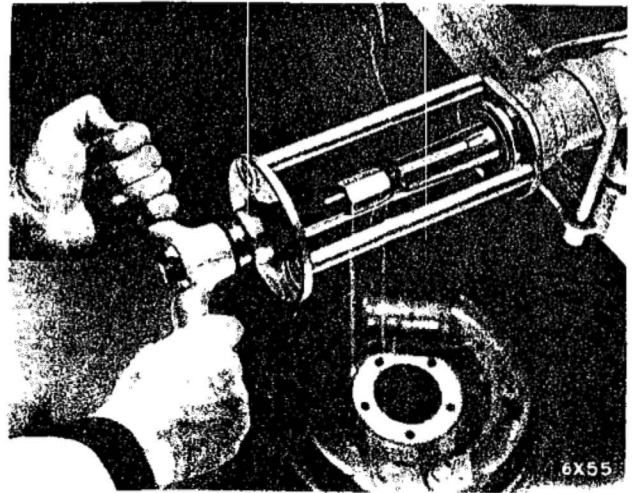
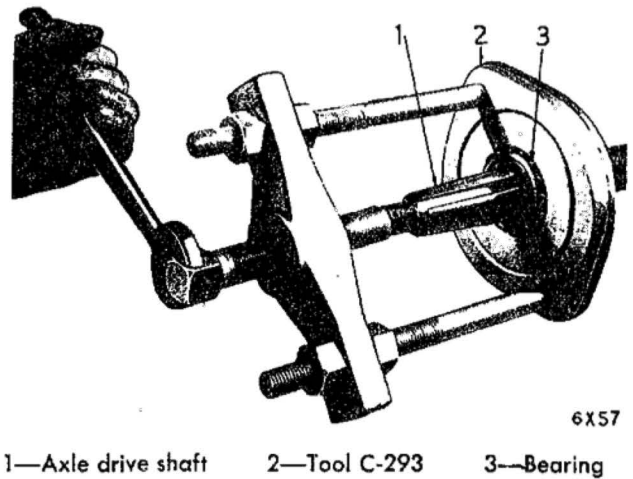


Figure 3—Removing Axle Shaft and Bearing With Tool C-158 (1936-42 Models)

2. ADJUSTMENT OF AXLE SHAFT END PLAY.

1936-42—Remove the wheel, hub and drum. Disconnect the brake tube and remove the axle drive shaft oil seal and brake support. Add or remove shims to obtain the required end play, .003 to .008 inch. When adjusting these bearings, remove or install an equal thickness of shims on the right and left sides of the axle housing, so as to retain central position of the axle shafts. After installing the brake support and wheel, be sure to connect the brake tube and bleed the brakes.

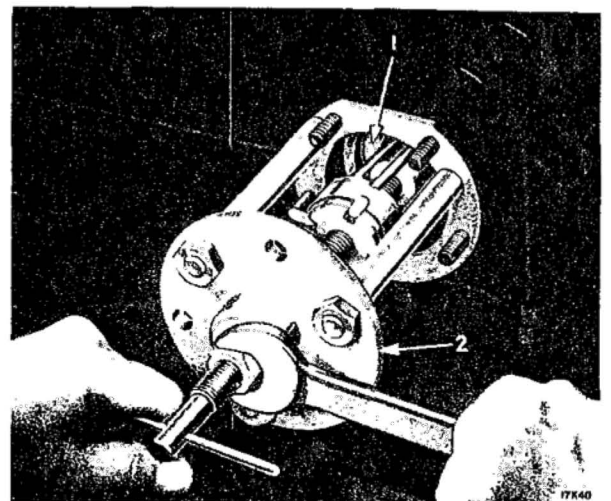


1—Axle drive shaft 2—Tool C-293 3—Bearing

Figure 4—Removing Axle Drive Shaft Bearing (1936-42 Models)

3. REMOVAL OF AXLE DRIVE SHAFT AND OIL SEAL.

1936-42—Remove wheel, hub and brake drum. Disconnect the brake tube and remove the oil seal and brake support. If both axle shafts are being removed, be sure to keep the shims separate and assembled to their respective ends of the axle housing so as to maintain the bearing adjustment and locate the axle shafts centrally in the axle housing. Using puller C-158 (fig. 3), remove the axle shaft and bearing from the housing and remove bearing from axle shaft (fig. 4). Use oil seal puller C-358 to remove the inner oil seal from housing (fig. 5).



1—Oil washer 2—Tool C-358

Figure 5—Removing Axle Drive Shaft Oil Washer (1936-42 Models)

4. INSTALLATION OF AXLE DRIVE SHAFT AND OIL SEAL.

1936-42—Drive the inner oil seal into the axle housing. Install the axle shaft and bearing and brake support. Check axle shaft end play and if within limits (.003 inch to .008 inch), connect brake tube and install brake drum and hub. Bleed brakes and install wheel.

5. REMOVAL OF BROKEN END OF AXLE DRIVE SHAFT.

1936-42—Remove the wheel, drum and axle shaft. If the break is less than about 8 inches from the inner end of the shaft, it will be necessary to remove the differential carrier assembly. If the break is more than 8 inches from the inner end of the shaft, it will be necessary to remove the inner oil seal and snare the inner end out through the housing with a wire loop.

6. REPLACEMENT OF DRIVE PINION BEARING OIL SEAL.

1936-42—Disconnect the propeller shaft from the pinion shaft and remove the drive pinion flange. Use puller C-358 to remove the oil seal from carrier (fig. 6). To install, drive oil seal into housing so that it is tight against its seat. Use flange installing tool C-496 to prevent damaging gear teeth when installing flange on drive pinion.

7. REPLACEMENT OF DIFFERENTIAL CARRIER ASSEMBLY.

1936-42—Remove wheels, hub and drums, and axle shafts. Disconnect the propeller shaft from the drive pinion shaft. Disconnect the carrier from housing and pull it out of the housing. When installing, be sure contacting surfaces are clean and use new gasket.

8. DISASSEMBLY OF DIFFERENTIAL CARRIER.

1936-42

(1) Mount assembly in stand and mark both differential bearing adjusters and caps, to facilitate assembly.

(2) Loosen the differential bearing cap retaining screws and loosen the bearing

adjusters to relieve the load on the bearings, then remove caps and bearings.

(3) Lift out the differential and ring gear assembly.

(4) Remove the differential bearings.

(5) Remove the bolts which attach the ring gear to the differential case and press the ring gear off the case.

(6) Remove the differential pinion shaft lock pin or screw, push out the pinion shaft and remove differential parts.

(7) Remove the drive pinion flange and pull the drive pinion out through the gear end of the differential case, being careful not to lose the shims between the spacer on the shaft and the bearing next to the flange.

(8) Use tool C-293 to remove bearing from pinion shaft (fig. 7).

(9) Use tool C-358 to remove the drive pinion oil seal from the carrier (fig. 6).

(10) Remove both drive pinion bearing cups from carrier.

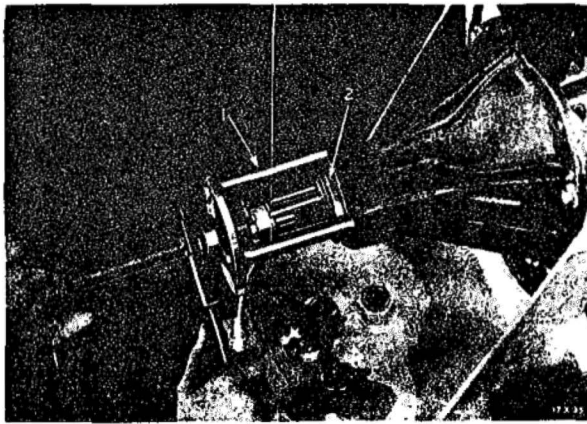
9. ASSEMBLY OF DIFFERENTIAL CARRIER.

1936-42—If the differential assembly was satisfactory from a standpoint of noise, before the unit was disassembled, the drive pinion may be assembled with the original shims (or washer if used) behind the rear bearing. If new parts were installed or if an adjustment was necessary, change these shims until the correct thickness is obtained to locate the pinion properly with the ring gear. See figures 8 through 13. After the differential pinion shaft is in position, install the lock pin and peen over the outside edge of the hole to retain the pin in place.

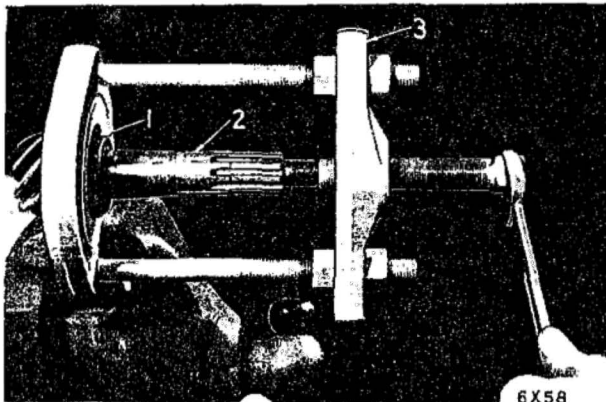
NOTE

Play in the pinion shaft bearings should be pre-loaded from .0015 to .0025 inch on all models except 1936 (.004 to .008 inch on 1936 models.)

To obtain this play or pre-load, insert sufficient shims between the bearing spacer and the front bearing.



1—Tool C-358 2—Oil seal
Figure 6—Removing Rear Axle Drive Pinion Oil Seal (1936-42 Models)



1—Bearing 2—Pinion 3—Tool C-293
Figure 7—Removing Axle Drive Pinion Rear Bearing (1936-42 Models)

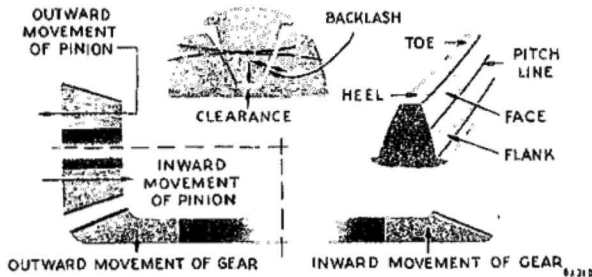


Figure 8—Gear Tooth Nomenclature

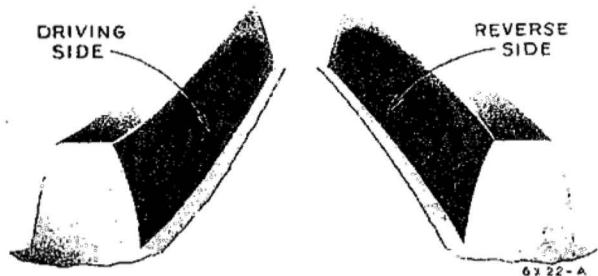


Figure 9—Correct Tooth Contact—Gears Making contact as shown give best results for quiet operation and long life.

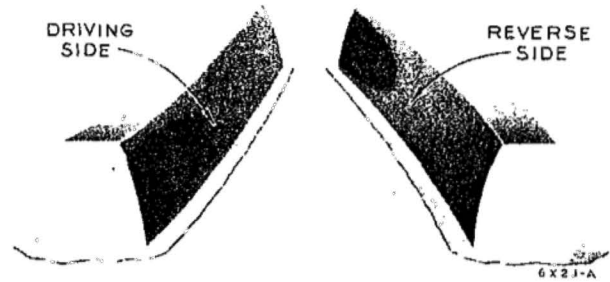


Figure 10—Drive bearing at heel will cause gear to break. Move ring gear in toward pinion. Move pinion in if necessary to retain proper backlash.

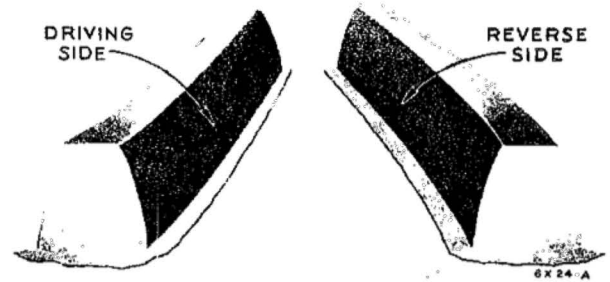


Figure 11—Drive bearing at toe will also cause gear to break. Move ring gear out away from pinion. Move pinion out if necessary to retain proper backlash.

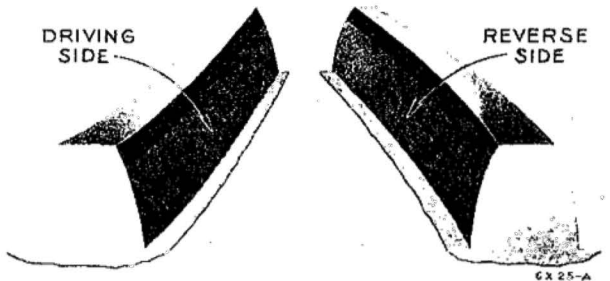


Figure 12—Heavy face contact will cause noisy gears. Move pinion in toward ring gear. Move gear out, away from pinion if necessary to retain proper backlash.

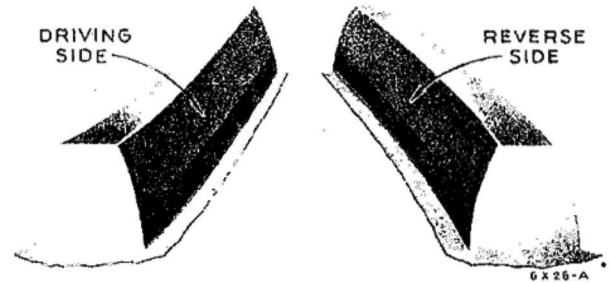


Figure 13—Heavy flank contact will result in noisy gears. Move pinion away from ring gear. Move gear in toward pinion if necessary to retain proper backlash.

10. REMOVAL OF REAR AXLE HOUSING.

1936-42—Remove the rear axle assembly from car. Remove both axle shafts. Disconnect the brake tubes at the brake supports and remove the tube and hose from axle housing. Remove the brake support and shoe assemblies. Remove the retaining screws and lift the differential assembly out of the axle housing.

11. INSTALLATION OF REAR AXLE HOUSING.

1936-42—Install new axle shaft inner seals in axle housing. Using a new gasket, install the differential assembly and tighten the retaining screws securely. Be sure there are no kinks in the brake tube and hose after it is installed on the axle housing. Use new axle shaft outer oil seals and gaskets when installing the axle shafts and brake supports.

12. REMOVAL OF REAR AXLE ASSEMBLY.

1936-42—Raise the rear end of the car and place a support under either side of the frame, just forward of the rear axle assembly. Remove both rear wheels. Disconnect the brake hose at the frame bracket. Disconnect both shock absorbers at the lower ends. Disconnect the propeller shaft from the axle drive pinion flange. Remove the rear axle clips and lift the axle housing off the rear springs.

13. INSTALLATION OF REAR AXLE ASSEMBLY.

1936-42—Make sure the head of each spring center bolt enters the center hole in its respective spring saddle and tighten the spring clips securely. Lubricate the differential and bleed the brake lines after the rear axle assembly is installed in the car.

Section V

BODY

1. ADJUSTMENT OF DOOR STRIKER PLATE.

1940-42—The door striker plate may be moved up or down, or in or out for adjustment (fig. 1). Adjust the striker plate (1) so that the block (3) just rubs lightly against the top of the plate (1) when closing the door. Tighten screws securely after the adjustment is complete.

CAUTION

Never hit or try to bend the rotor wheel, striker plate or dovetail block to bring them into proper alignment.

1936-39—Adjust the male dovetail so that it will fit into the female dovetail, with equal pressure up and down when the door is closed (fig. 2). Tighten the screws securely after the adjustment is complete.

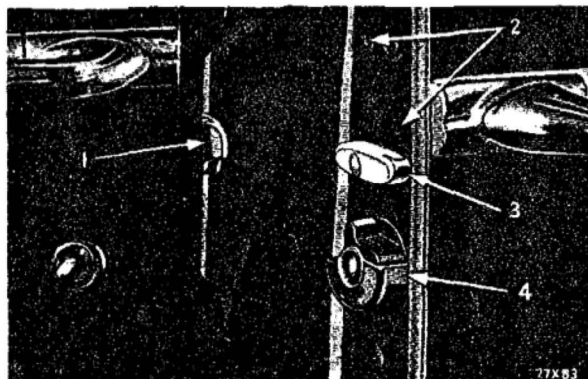
2. REMOVAL OF DOOR REMOTE CONTROL HANDLE AND WINDOW REGULATOR HANDLE.

1936-42—Press the escutcheon plate against the trim panel, exposing the retainer pin (2, fig. 3). Push the pin out of the shaft and remove the handle.

3. REMOVAL OF DOOR OUTSIDE HANDLE.

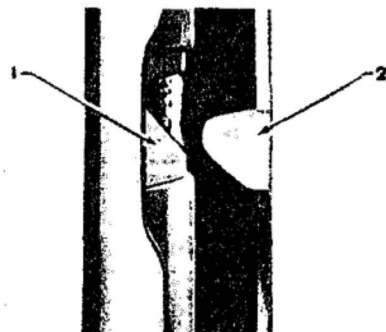
1938-42—Remove the screws which attach the escutcheon to the door. Pry the trim panel away from the door, remove the outside door handle shaft retaining screw (4, fig. 31) and withdraw the handle from the door.

1936-37—The handle is held in place by a keeper, inside the door lock, to prevent loss of the door handle in the event the escutch-



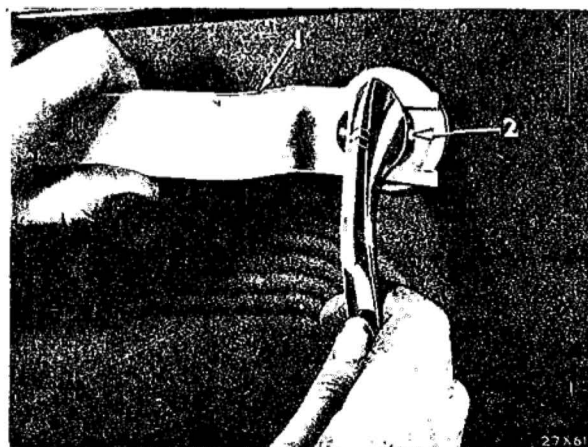
1—Striker plate and dovetail 3—Dovetail block
2—Oil holes 4—Rotor wheel

Figure 1—Door Dovetail and Latch (1942 Model, Typical of 1940-41 Models)



1—Female dovetail 2—Male dovetail

Figure 2—Door Dovetail (1939 Model, Typical of 1936-38 Models)



1—Tool C-533 2—Retainer pin

Figure 3—Removing Door Remote Control Handle (1942 Model, Typical of 1936-41 Models)

Page 58
MISSING

**PAGE 59
MISSING**

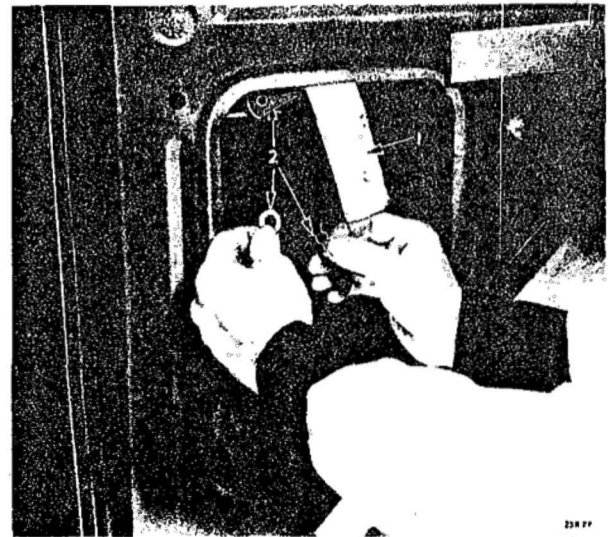


1—Top center of panel 2—Control handle shaft
Figure 8—Removing Door Trim Panel—First Position (1939 Model, Typical of 1936-38 Models)



1—Clip 3—Screws removed
 2—Clips 4—Clips at bottom edge of panel
 A—Direction of panel movement
Figure 9—Removing Door Trim Panel—Second Position (1939 Model, Typical of 1936-38 Models)

regulator arms from the glass lower channel and raise the glass up about 4 inches. Remove the glass by tipping it toward the front of the car (fig. 11), until the glass run roller at the front of the glass assembly can be pulled through the large opening at the rear of the window opening.



1—Wood block wedge
 2—Retainer washer and lock wire

Figure 10—Removing Regulator Arm Retainer Washers and Lock Wire (1940-42 Models)

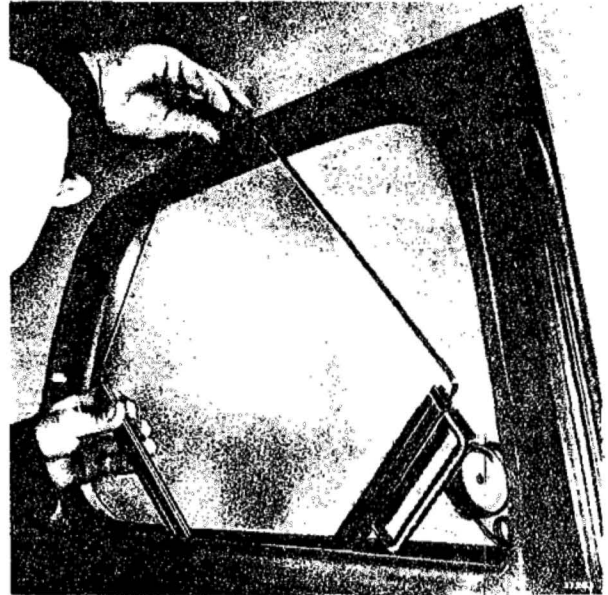


Figure 11—Removing Front Door Vertical Sliding Glass (1940-42 Models)

NOTE

If the run roller will not come out, lower the glass below normal open level by removing the window stop screw and the bracket and remove the felt anti-rattler at the top.

1936-39 — Run the glass all the way down. Remove the door trim panel and the glass run vertical channel (if front door).

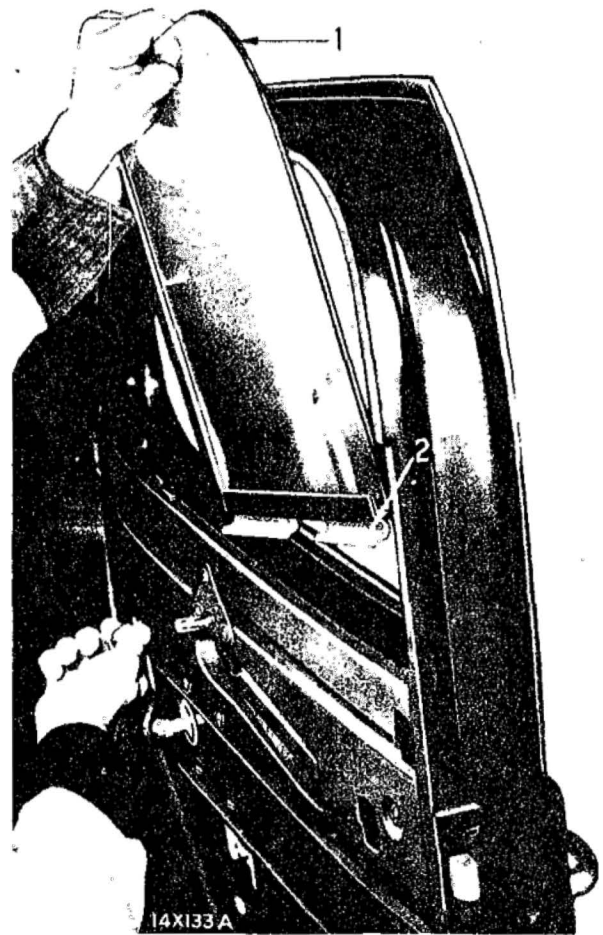
Pull the glass channel, top and side, down from the top of the door. Grasp the side channel near the top of the glass at the corner near the door frame. Run the glass up and at the same time pull up on the side channel in the door frame. Run the glass down, but hold the channel so it will not go down. Pull the side channel up and out, raising and lowering the glass, as necessary. Raise the glass slowly and pull top edge of glass away from the door frame while the glass is going up and as far as the lift mechanism will run it. Tip the corner of the glass (nearest the latch side of the door) up to unhook it from the first roller of lifter arm (2, fig. 12). Tip the glass still further (toward door hinges) and unhook glass frame from the second roller. Before assembling, rub a little soft grease into the grooves of glass frame and on the rollers.

10. REPLACEMENT OF WINDOW LIFT REGULATOR.

1940-42—Remove the vertical sliding glass. Remove the adjustment bolt and washers (fig. 13). Wind the window regulator to the "up" position and unhook the regulator arm from the regulator body. (On 1940 model, turn the window regulator in direction for lowering and unhook the regulator arm from the body.) Remove the screws (fig. 14) which hold the regulator body to the door panel and remove the regulator. When installing regulator, place it in position inside the door, turn the regulator handle so the arm is in the raised position and hook the regulator arm into the channel in back of panel. Turn the regulator handle so the regulator arm can be hooked on the regulator body. Install the adjusting screw and washers.

1939

(1) Remove the inside door handles, garnish molding, trim panel (and glass if front door). Remove the regulator stops from the window run channel (fig. 15). Run the regulator arm down until regulator arm unhooks from the lower glass channel. Push



1—Door window glass 2—Door window glass channel

Figure 12—Removing Door Window Glass (1936-39 Models)

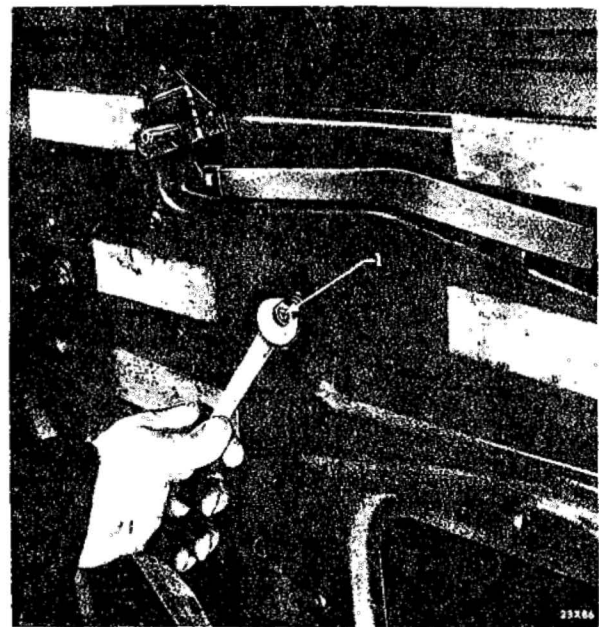


Figure 13—Removing Front Window Regulator Adjusting Bolt Nut (1) (1940-42 Models)

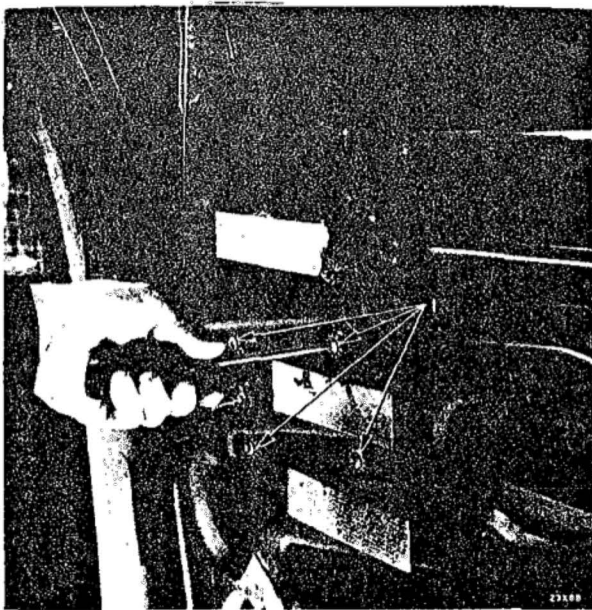


Figure 14—Removing Front Window Regulator Body Fastening Screws (1) (1940-42 Models)

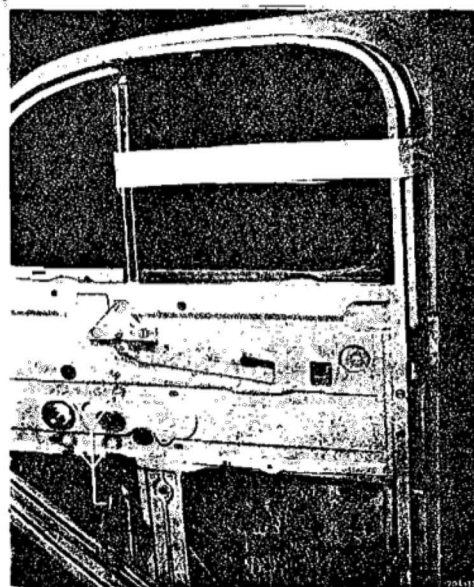
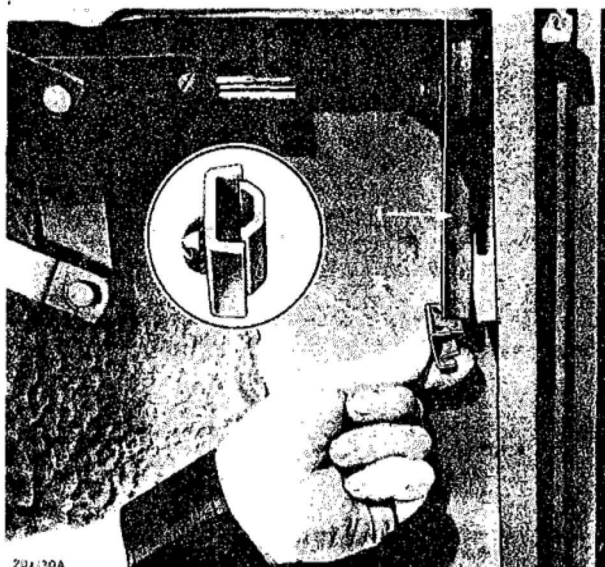


Figure 16—Front Door Window Glass Fastened in Place with Tape (1939 Model)



204130A

1—Run channel 2—Stop (1st type)
3—Stop (2nd type)

Figure 15—Front Door Window Lift Regulator Stop Removed from Window Run Channel (1939 Model)

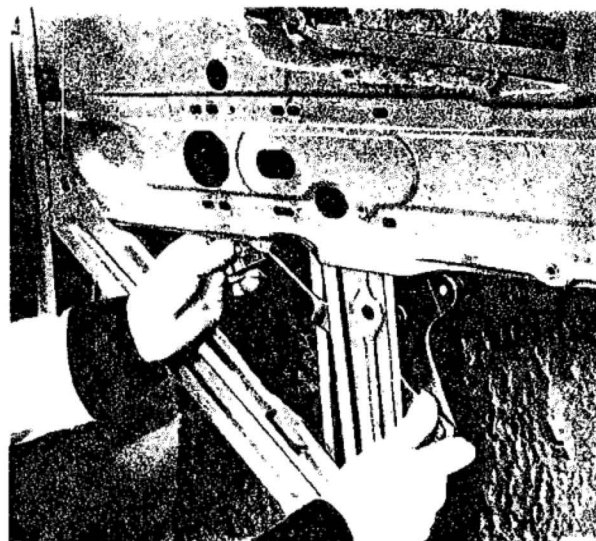


Figure 17—Removing Front Door Window Lift Regulator—First Position (1939 Model)

10. REPLACEMENT OF WINDOW LIFT REGULATOR.

1939—Cont'd.

the glass up to its high position and fasten in place (fig. 16). Remove the screws from the regulator base (fig. 16). Pull the regulator down and out through the forward triangular opening in door panel (fig. 17 and 18).

(2) To install, place the regulator in position in the door, lower the glass and hook both rollers of regulator arm to the lower glass channel. Raise the window and slide the regulator stops up on glass run channels to the first notch of serrations (fig. 19). Lower the glass until top edge of glass is flush with the top of window reveal. Then with the glass in proper position, push the stops up until they touch the glass lower channel ends. Bend the lips of the first type

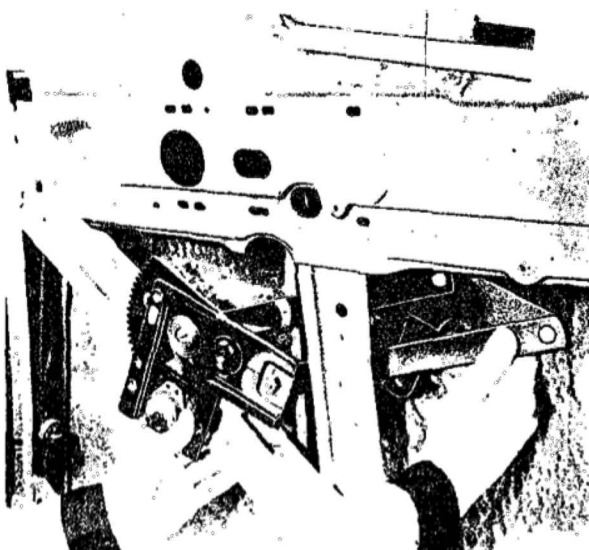
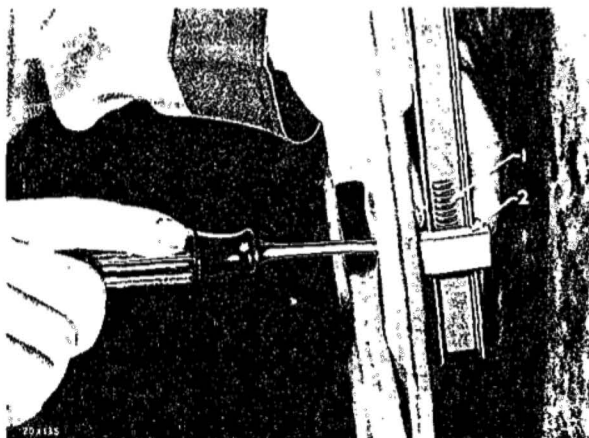


Figure 18—Removing Front Door Window Lift Regulator—Second Position (1939 Model)

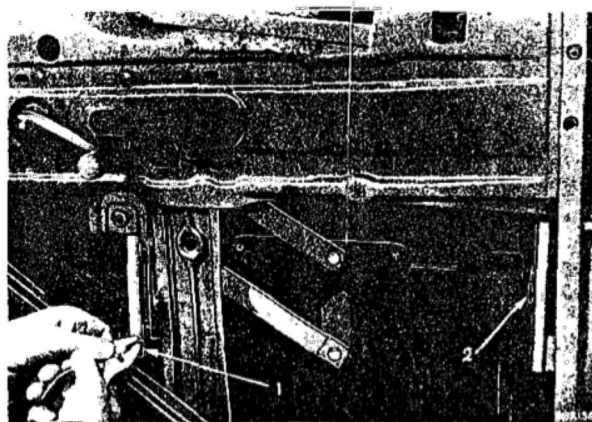


1—Glass run channel serrations 2—Stop

Figure 19—Installing Front Door Window Lift Regulator Stops on Glass Run Channel (1939 Model)

stops to prevent rattles (fig. 20). Raise the glass to within about 1 inch from the top of the window opening and pull the glass tightly into the rear run channel. If the glass will not slide into proper position, loosen nut (2, fig. 21) on the adjusting bolt at bottom of the regulator base while pulling the glass toward the edge of door. With the glass in position, tighten nut.

1936-38 — Remove the inside door handles, garnish molding, trim panel, glass run (if front door) and glass. Remove the



1—Bending lips of stop 2—Stop locked

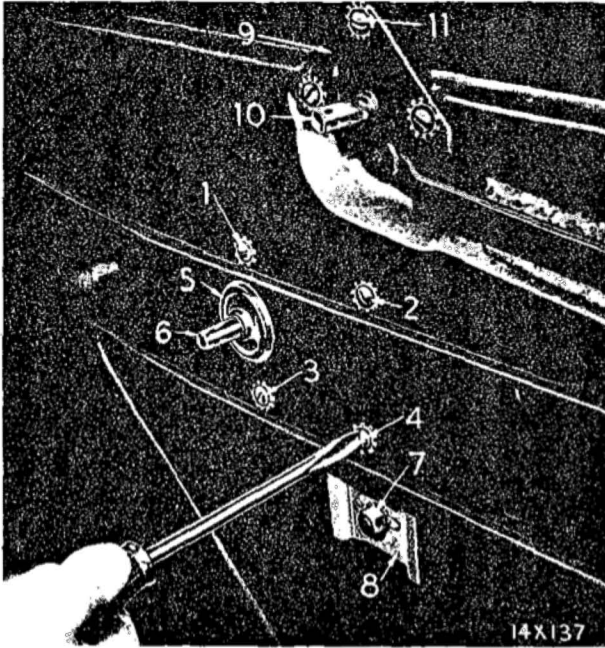
Figure 20—Locking Front Door Window Lift Regulator Stops—First Type (1939 Model)



1—Regulator base fastening screws
2—Adjusting bolt nut

Figure 21—Positioning Front Door Window in Rear Run Channel (1939 Model)

regulator stop and regulator mounting screws (fig. 22). Pull the regulator down and out through the opening in door panel (fig. 23). To install, loosen nut (7, fig. 22) and while the glass is up, press the glass tightly against glass channel in the lock side of the door. Pound the glass into place with hand, if necessary, *but glass must be tight against the latch side of door*. While holding the glass in place and straight up and down, tighten the nut (7, fig. 22). Tighten the regulator mounting screws (1-4, fig. 22).



- 1-4—Regulator mounting screws
- 5—Regulator escutcheon plate
- 6—Regulator control handle shank
- 7—Regulator adjusting screw nut
- 8—Regulator assembly
- 9—Remote control plate
- 10—Remote control handle shank
- 11—Remote control plate screw

Figure 22—Removing Window Lift Regulator or Base (1936-38 Models)

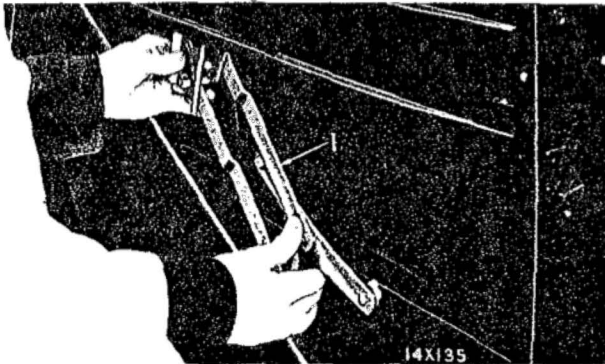


Figure 23—Removing Door Window Regulator Mechanism (1) (1936-38 Models)

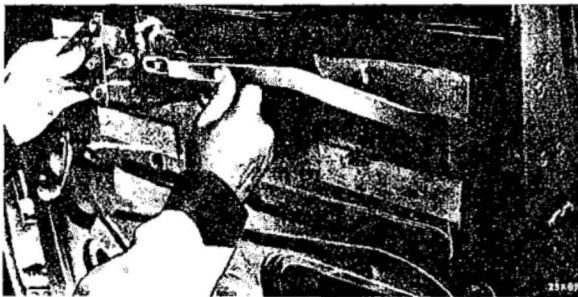


Figure 24—Removing Front Door Latch Remote Control Base (1940-42 Models)

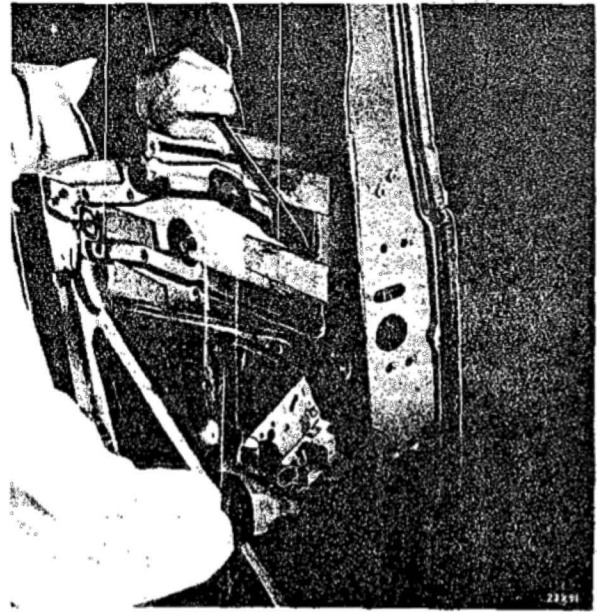
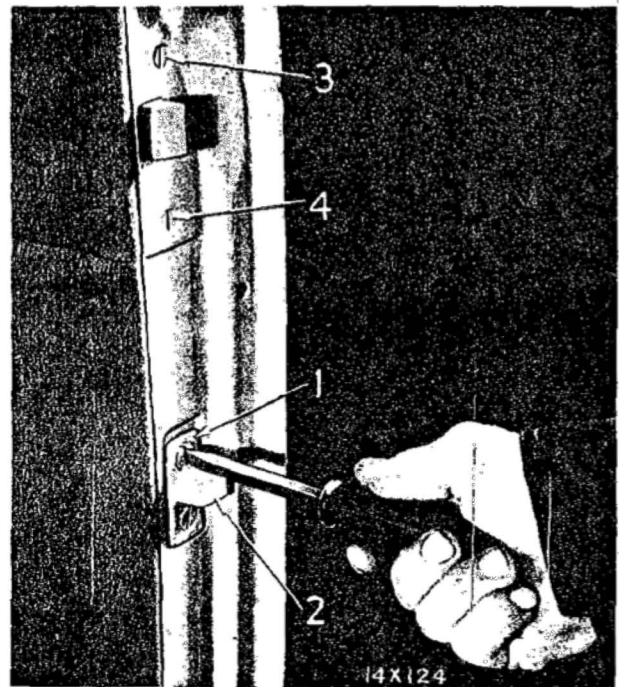


Figure 25—Removing Front Door Latch Assembly (1940-42 Models)



- 1—Dovetail screw
- 2—Door dovetail
- 3—Door lock screw
- 4—Door lock screw

Figure 26—Door Lock and Dovetail Screws (1936-39 Models)

11. REMOVAL OF FRONT DOOR LATCH AND REMOTE CONTROL.

1940-42—Remove door vertical sliding glass. Remove door outside handle and lock cylinder. Remove screws which hold remote control base to panel of door and unhook the

base from the remote control bar (fig. 24). Remove lower glass run channel. Remove the screws (3, fig. 31). Lower the latch assembly and pull it out through the opening in door panel (fig. 25). (Bend the control bar outward from door as necessary to guide it out of the opening in the inside panel.)

1939—Remove the window lift regulator, door outside handle and lock cylinder. Remove the screws (3 and 4, fig. 26). Remove the screws which hold the remote control plate (9, fig. 22) to door panel and unhook the plate from the remote control link (2, fig. 27). Push the lock assembly toward the door hinges and lower it out of the door.

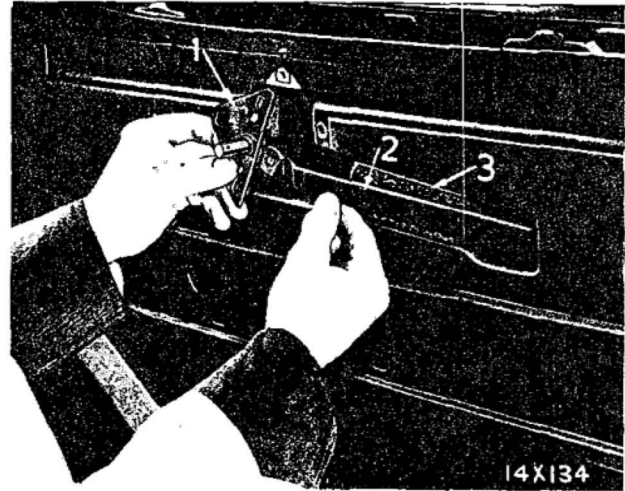
1936-38—Remove the trim panel, glass run, glass lift regulator and lock cylinder. Remove the outside door handle. Remove the lock plate screws and remote control plate screws (11, fig. 22). Push the lock assembly toward the door hinges and lower it out of the door.

12. REPLACEMENT OF FRONT DOOR VENTILATOR ASSEMBLY.

1936-42—Remove the garnish molding and ventilator assembly. Remove the spring and spacer or bolts from lower pivot pin. Remove the upper pivot bracket screws (fig. 28). Open the ventilator and pull the rubber weatherstrip up and off the upper pivot pin. Using a wooden block, drive the lower pivot pin out of stop plate. To remove the ventilator lock lever assembly, drive out the pin which goes through the hub of lever and pull the lever off the shaft. When installing the ventilator assembly, make sure the stop plate is installed in the correct position. To install the glass in channel, run a strip of tape on the edge and sides of glass and slide glass into channel. Force the glass into place in the channel with a screw clamp or with a rubber mallet.

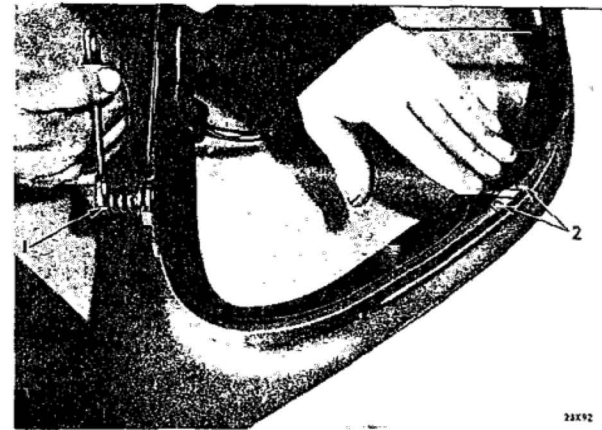
13. REMOVAL OF REAR DOOR GLASS.

1940-42—Remove the inside door handles, door lock buttons, garnish molding and trim panel. With the window all the way



1—Remote control plate 2—Remote control latch lever
3—Remote control lever silencer

Figure 27—Removing Remote Control Plate (1936-39 Models)



1—Lower pivot nut 2—Upper pivot bracket screws

Figure 28—Removing Front Door Ventilator Assembly (1940-42 Models)

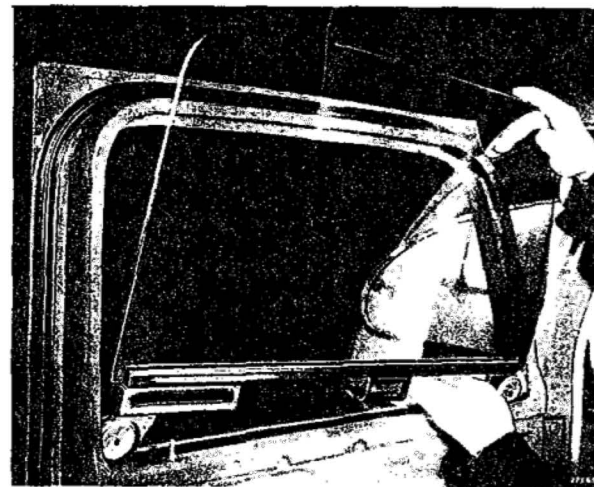


Figure 29—Removing Rear Door Window (1942 Model, Typical of 1936-41 Models)

13. REMOVAL OF REAR DOOR GLASS.*1940-42—cont'd.*

down, unlock the lower ends of the glass run channel and remove the channel. Remove the window regulator attaching studs and lift the glass up and out of the door (fig. 29).

*1936-39—*Remove the trim panel. Run the window all the way to the bottom. Pull the glass run channel down and out of the "U" clips at the top of the door. Run the glass up while pulling outward at the top of the glass, at the same time guiding the glass out of run channel. Turn the regulator handle until the lift arm is straight up, then lift the glass and frame assembly out of the door.

14. REMOVAL OF REAR DOOR WINDOW REGULATOR.

*1936-42—*Remove the inside door handles, garnish molding, trim panel and door glass. Remove the screws which hold the regulator base to the door panel and remove the regulator (fig. 30).

15. REMOVAL OF REAR DOOR LATCH AND REMOTE CONTROL.

*1940-42—*Remove the door glass and outside door handle. Remove the lower glass run channel. Remove the screws (3, fig. 31) and remove the assembly (fig. 32).

*1939—*Remove the garnish moldings and trim panel. Remove the lock plate screws in the edge of door. Remove the screws which hold the bracket to door panel.

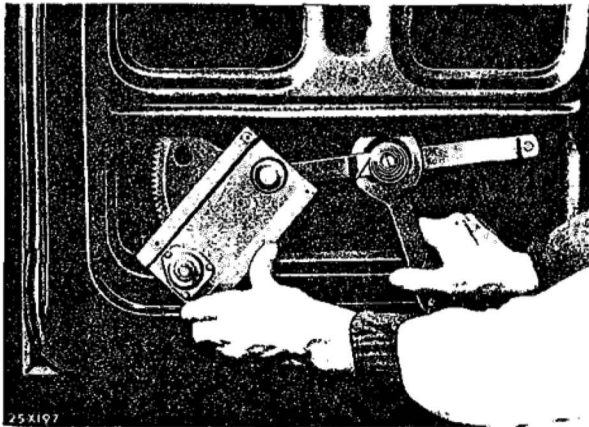


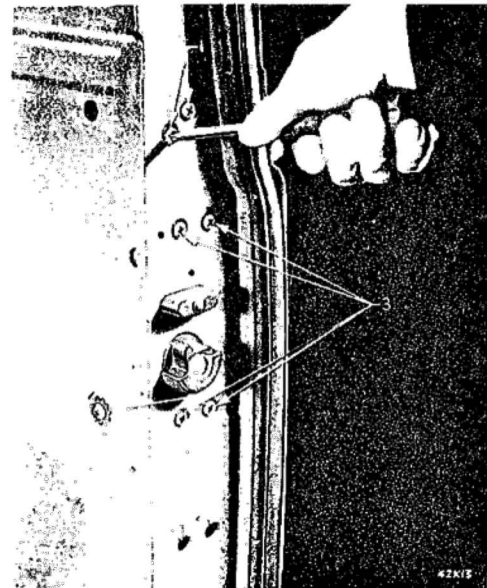
Figure 30—Removing Rear Door Window Regulator (1942 Model)

Push the assembly downward and out through opening in door panel.

*1936-38—*Remove the trim panel, glass lift regulator and outside door handle. Remove the lock plate screws and remote control plate screws (11, fig. 22). Push the lock assembly toward the door hinges and lower it out of the door.

16. REPLACEMENT OF REAR QUARTER WINDOW.

*1936-42—*Remove the garnish molding. Push the glass and rubber weatherstrip toward the inside of body. Using a wooden wedge, force the rubber lip molding off the metal edge of body opening. To install, seal the rubber weatherstrip with "MoPar Windshield Sealer," forcing the compound between the glass and rubber, making a watertight joint when the rubber springs back into place. Insert a strong cord under the lip of rubber seal and leave the ends hang out. Force the glass and rubber assembly tightly in place in body opening and pull the cord, forcing the rubber molding in place. Install the garnish molding.



- | | |
|---|---|
| 1—Glass run channel fastening screws (upper) | 3—Latch assembly fastening screws |
| 2—Glass run channel fastening screw holes (lower) | 4—Outside door handle shaft retaining screw |

Figure 31—Removing Door Latch Assembly (1940-42 Models)

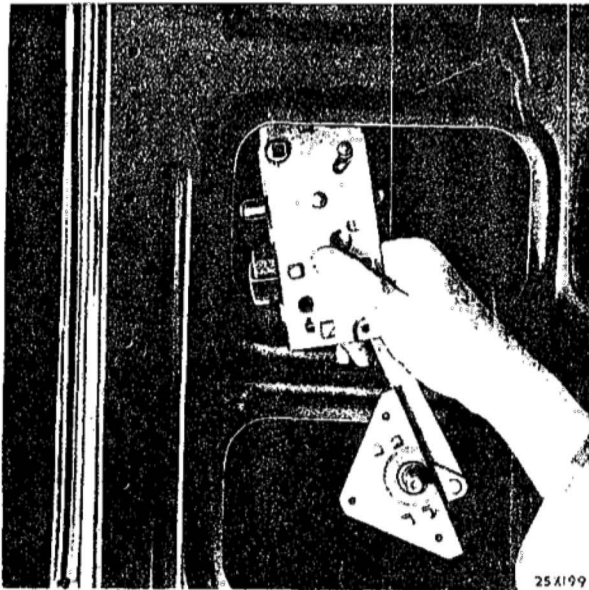


Figure 32—Removing Rear Door Latch and Remote Control Assembly (1942 Model, Typical of 1939-41 Models)

17. REPLACEMENT OF VENTILATOR WINDOW (REAR SIDE QUARTER).

1936-42—Remove the garnish molding. Lift the window assembly up and away from the body. Raise the rear end slightly higher than front end and pull the assembly out of body. When installing, use care to keep the edge of rubber weatherstrip from going inside the window reveal. It must be outside all around. Put a strong cord under the lip of rubber weatherstrip, with the ends of cord at one corner of the weatherstrip. Allow the ends of the cord to hang outside the body as the assembly is being pushed into the window opening of the body. When the assembly is pushed almost into position, pull the cord straight out from and around the weatherstrip, pulling the edges of weatherstrip in place in the same manner as illustrated for the rear window glass (fig. 33). Push the assembly against the body and install the garnish molding.

18. REMOVAL OF REAR QUARTER WINDOW GLASS AND REGULATOR ASSEMBLY (2-DOOR SEDAN).

1940-42—Remove the garnish molding, regulator handle and ash tray. Remove the

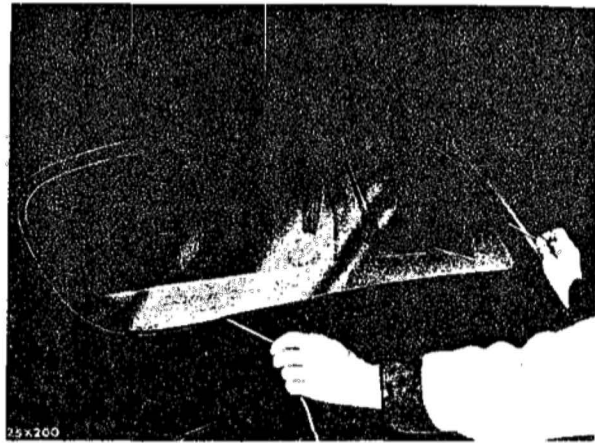
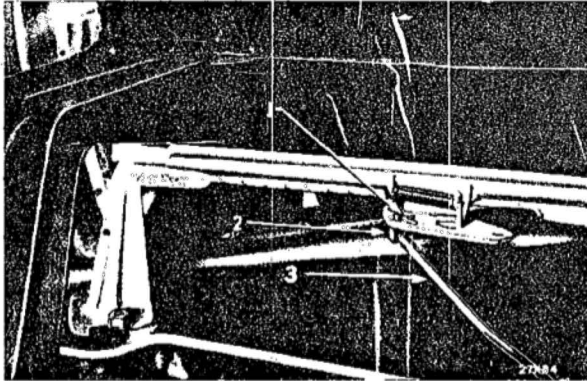


Figure 33—Installing Rear Window Glass (1936-42 Models)

rear seat cushion and arm rest. Loosen the trim panel and pull it out. Remove the cardboard splash panel. Remove the glass run. Pull out the hair pin lock wires and washers which hold the regulator arm to the glass channel. Remove the regulator arms from the glass channel and lift out the glass. Remove the screws which hold the regulator base and remove the assembly (base and arms).

19. REPLACEMENT OF REAR WINDOW GLASS.

1936-42—Remove the garnish molding. Push the glass and weatherstrip toward the inside of body and remove the assembly (on 1937-39 models only). Using a wooden wedge, force the rubber lip molding off the metal edge of the body opening (on 1940-42 models only). Roll the rubber weatherstrip off the edges of glass. To install, seal the rubber weatherstrip with "MoPar Windshield Sealer," forcing the sealing compound between the glass and rubber, making a water tight joint when the rubber springs back against the glass. Insert a strong cord under the lip of rubber and leave the long ends hang out. Force the glass and rubber tightly into place in the body opening. Pull the cord to force the rubber molding in place. (See figure 33.) Work a coating of "MoPar Windshield Sealer" between the outside of the body and rubber weatherstrip to make a water tight joint at that point.



- 1—Cotter pin
- 2—Front seat guide lock connector rod nut
- 3—Front seat guide lock connector rod

Figure 34—Front Seat Guide Lock Adjustment
(1942 Model)



Figure 35—Removing Windshield Glass—
Loosening Rubber Molding Around
Body Frame (1940-42 Models)



Figure 36—Removing Windshield Glass—Pressing
Windshield Glass in After Rubber Molding has
been Lifted off Body Edge (1940-42 Models)

20. REPLACEMENT OF REAR ARM REST AND TRIM ASSEMBLY.

1937-42—Remove the screw in lower front corner of trim. Lift up front end of the arm rest to unhook it, then pull assembly forward to unhook the rear end. When installing, be sure the assembly is properly fastened at the rear end before installing the screw at the front end.

21. REMOVAL OF SEAT BACK CUSHION (FRONT OR REAR).

1936-42—Remove the screws at bottom of seat back. Pull the bottom of the cushion upward to unhook the cushion from the back frame.

22. ADJUSTMENT OF FRONT SEAT GUIDE.

1942—Remove the cotter pin (fig. 34). With the adjuster handle in the locked position, turn the lock connector on end of rod until it just enters the hole in latch.

23. REMOVAL OF WINDSHIELD GLASS.

1940-42

(1) Install masking tape on top of instrument panel to prevent damaging finish.

(2) Remove the garnish molding.

(3) Remove the center strip molding and strip.

(4) Lift off clips at top and bottom of windshield in front.

(5) Pull the ends of metal molding away from rubber molding, separating with a flat tool if necessary.

(6) Loosen the rubber molding all the way around body edge and glass (inside and outside) also at the center bar (fig. 35).

(7) Work the rubber molding off the upper outside corner of the body edge with a hard wedge. Push the glass in at upper outside corner, rolling the rubber lip molding off body edge (fig. 36).

(8) Roll the rubber molding off the glass, starting at the upper outside corner, working across the top and down outside to the bottom of the glass, pulling the glass toward inside of car (fig. 37).

(9) Using a hard wood wedge, free the glass from center strip and bottom of rubber molding and pull the glass away from the center bar. While pulling the glass away from center bar molding, free the upper inside corner (fig. 38).

(10) Remove the glass as soon as it is free at the upper inside corner.

1938-39

(1) Remove the wiper arm and rear view mirror.

(2) Remove the garnish molding.

(3) Remove the center strip molding (1939 model only).

(4) Loosen the windlace at sides of windshield (fig. 39).

(5) Lift off clips at top and bottom of the windshield in front center.

(6) Pull the ends of metal molding (1939 model only) away from the rubber

molding, separating the steel and rubber with a thin flat tool.

(7) Push the rubber away with fingers and pull the molding off (fig. 40) (1939 model only).

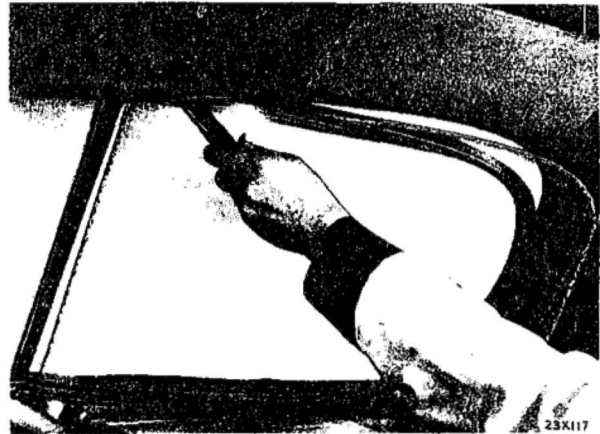


Figure 38—Removing Windshield Glass—Pulling Glass from Center Bar (1940-42 Models)

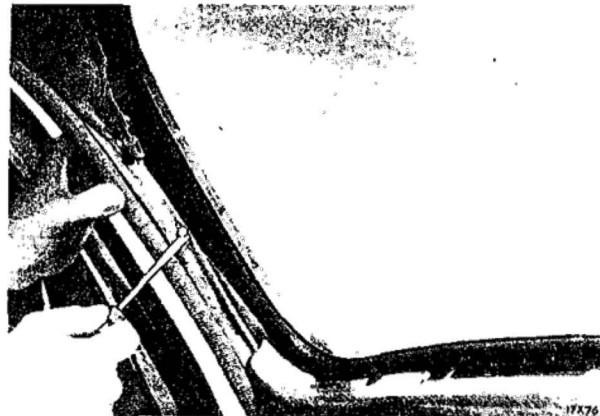


Figure 39—Removing Windshield Glass—Loosening Windlace at Sides of Windshield After Garnish Moldings have been Removed (1938-39 Models)



Figure 37—Removing Windshield Glass—Rolling Rubber Molding off Glass (1940-42 Models)

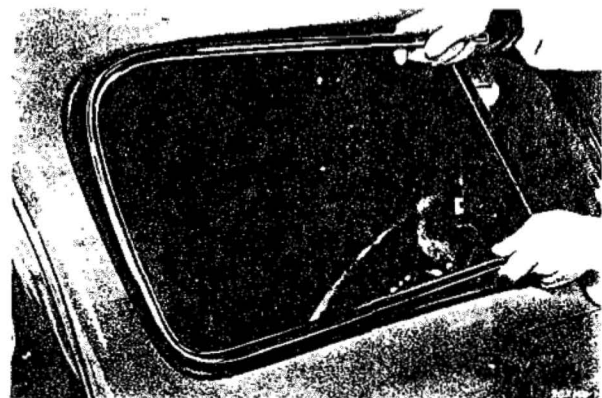
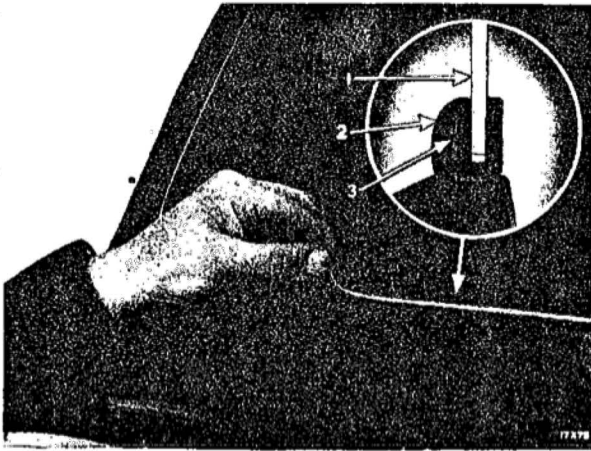


Figure 40—Removing Windshield Glass—Removing Windshield Metal Molding (1939 Model)



1—Windshield glass 2—Rubber seal
3—Body edge around windshield

Figure 41—Removing Windshield Glass—Lifting Rubber Seal Around Windshield (1938-39 Models)



Figure 42—Removing Windshield Glass—Pressing Windshield in after Seal has been Lifted (1938-39 Models)



Figure 43—Installing Windshield Glass—Inserting Glass in Rubber Molding (1940-42 Models)

23. REMOVAL OF WINDSHIELD GLASS.

1938-39—cont'd.

(8) Lift the rubber molding away from body all the way around windshield opening (fig. 41).

(9) Press against the glass to push it and the rubber molding through the opening in body (fig. 42) and remove the assembly.

(10) Roll the rubber off glass.

*1936-37—*Open the windshield as far as it will go with the panel crank and remove the screws which hold the hinge to windshield and crank mechanism. Remove the screws at joints of windshield glass frame and pull the channel apart at these telescoped joints. Pull the channel frame off glass.

24. INSTALLATION OF WINDSHIELD GLASS.

1940-42

(1) Coat the edges of glass with a good grade of soft soap, such as linseed oil soap or its equivalent, containing no free alkali. *Do not use oil or grease.*

(2) Insert the glass in the bottom of the rubber molding and slide it to within about 4 inches of the center bar (fig. 43).

(3) Hook the rubber molding over glass at top inside corner and slide the glass toward the center strip, at the same time keeping the rubber molding on the bottom of the glass.

(4) Continue working the rubber molding over the top of the glass and at the same time slide the glass toward the center bar (fig. 44).

(5) Using a wood wedge, work the rubber molding over the glass at upper outside corner (fig. 45).

(6) Work the glass into the groove of the rubber molding at the center strip.

(7) Hold the glass close to the windshield opening and work the lip of the rubber molding up and over the body edge (fig. 46).

(8) Seal the rubber channel and glass with "MoPar Windshield Sealer." Be sure the compound goes along the edge of glass between the glass and rubber, making a water tight joint when the rubber springs back against the glass. Work a thin coating of "MoPar Windshield Sealer" between the outside of the body edge and rubber molding to make a water tight joint at that point (fig. 47). Also work the sealing compound under the chrome strip.

(9) Install the metal molding and clips on front of windshield.

(10) Using liquid soap around the rubber molding, to prevent distortion of metal molding, use a rubber mallet to install the molding.

1938-39

(1) Coat the edges of glass with a good grade of soft soap, such as linseed oil soap or its equivalent, containing no free alkali. *Do not use oil or grease.*

(2) Insert the glass in rubber molding and roll the molding on glass. With both glasses in place in molding, wind a strong



Figure 44—Installing Windshield Glass—Working Rubber Molding Over Glass (1940-42 Models)



Figure 45—Installing Windshield Glass—Working Upper Outside Corner of Molding Over Glass (1940-42 Models)

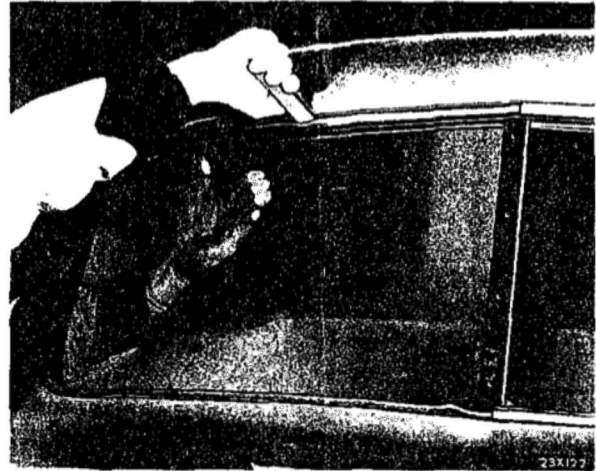


Figure 46—Installing Windshield Glass—Working Lip of Rubber Molding over Body Edge (1940-42 Models)

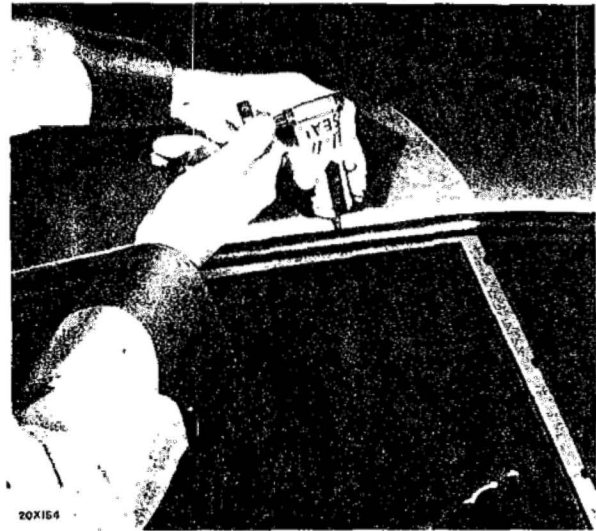


Figure 47—Installing Windshield Glass—Sealing Rubber Molding to Body Edge After Windshield Glass has been Installed (1940-42 Models)

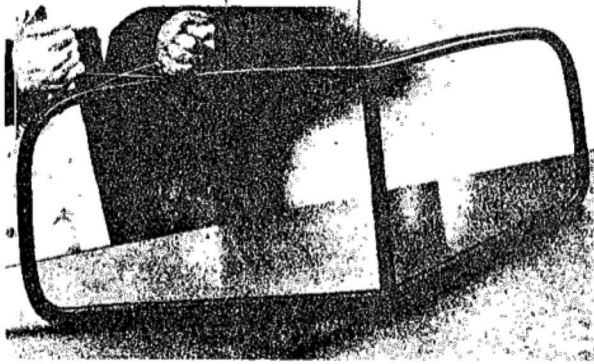


Figure 48—Installing Windshield Glass—Placing Draw-string Around Windshield (1938-39 Models)

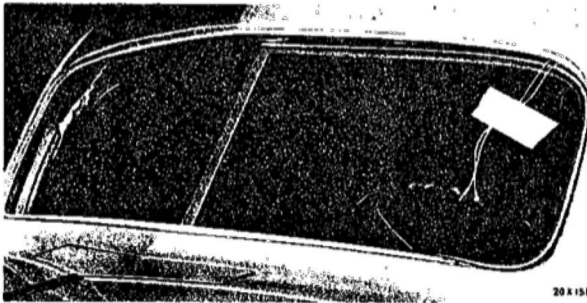


Figure 49—Installing Windshield Glass—Ends of Draw-string Taped in Place (1938-39 Models)



Figure 50—Installing Windshield Glass—Using a Strip of Celluloid and Sheet Metal to Aid in Pushing Glass into Position (1938-39 Models)



Figure 51—Installing Windshield Glass—Drawing Rubber Seal Over Body Edge with Draw-string (1938-39 Models)

24. INSTALLATION OF WINDSHIELD GLASS.

1938-39—Cont'd.

cord around the entire molding and into bottom of the groove (fig. 48). Tie cord and, with long ends hanging over, tape them to the front side of the assembly (fig. 49).

(3) Hold the assembly in the body opening and push one end of the assembly into end of body opening (fig. 49).

(4) Roll the rubber molding flange over the edge of body for a short distance, just so the assembly will hold itself in place. Then push the assembly against the edge of opening in the body all the way around. A strip of celluloid and sheet metal will aid in pushing the assembly into place (fig. 50).

(5) While pressing the glass forward, pull the ends of string, one at a time, directly away from the glass (fig. 51). This will pull the flange of rubber molding to the outside.

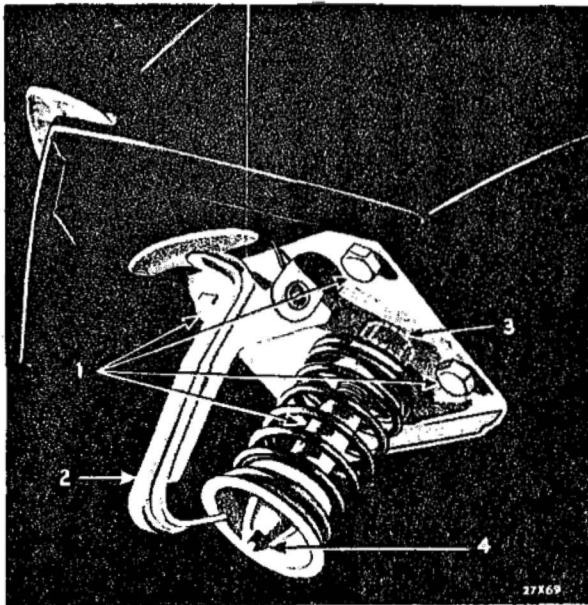
(6) Seal the rubber channel and glass with "MoPar Windshield Sealer." Be sure the sealing compound goes along the edge of glass between the glass and rubber, making a water tight joint when the rubber springs back against the glass. Work a thin coating of "MoPar Windshield Sealer" between the outside of fence and rubber molding to make a water tight joint at that point (fig. 47).

(7) Install the metal moldings on front of windshield. Install the clips on ends of moldings.

1936-37—Install the channel frame on the glass and install the screws at the frame joints. Attach hinges to the windshield, open glass and attach panel crank mechanism.

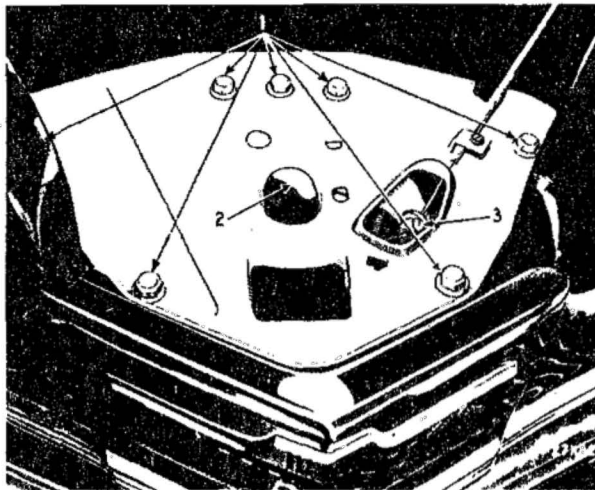
25. ADJUSTMENT OF HOOD STRIKER PLATE AND LOCK.

1942—Loosen the nuts and cap screws (1, fig. 52 and 1, fig. 53). Loosen the lock nut (3, fig. 52) and adjust the striker so that the spring is slightly compressed when the



1—Fastening bolts
2—Safety catch
3—Lock nut
4—Striker

Figure 52—Hood Lock Upper Half and Safety Catch (1942 Model)



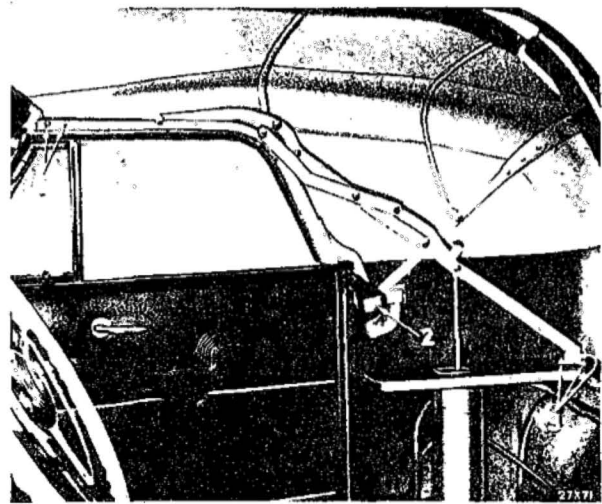
1—Fastening screws
2—Lock
3—Cable clip screw

Figure 53—Hood Lock Lower Half (1942 Model)

hood is closed and the hood will close without undue effort; but not loose enough to rattle. Be sure the lock nut (3, fig. 52) is tightened securely. After completing the adjustment, adjust the lock cable if necessary.

26. ADJUSTMENT OF HOOD LOCK CONTROL CABLE.

1941-42—Adjust the clamp on cable so there is $\frac{1}{8}$ inch free play between the clamp and latch arm, in the locked position.



1—Header corner bracket bolts
2—Pillar hinge bolts
3—Lower joint to body bracket bolts

Figure 54—Convertible Coupe Folding Top Adjustments (1940-42 Models)

27. ADJUSTING CONVERTIBLE COUPE TOP TO FIT BODY.

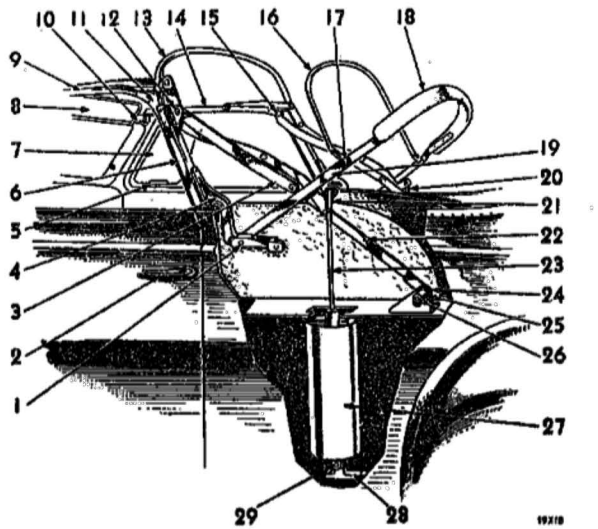
1940-42

- (1) Place the top in halfway position between "up" and "down."
- (2) Loosen the bolts (1, fig. 54).
- (3) Place the top in "up" position and leave the header bar unlocked.
- (4) Remove the bolts (3, fig. 54).
- (5) Loosen the bolts (2, fig. 54).
- (6) Raise both front windows. With the pillar parallel to window glass, move the hinge in slotted bracket until the proper clearance is obtained between the glass frame and pillar weatherstrip. Tighten bolt (2, fig. 54).

(7) Lock the header bar on windshield header and attach the side rails to the header corner brackets.

(8) Fasten the lower joint bracket to the shelf panel. Add or remove shims between the bracket and shelf panel, as necessary, to hold the bracket in proper position so as not to affect the adjustment of side rails in respect to the window frames.

(9) Unlock the header bar and try lowering and raising the top. If the header is



- | | |
|---|---|
| 1—Folding top rear bow arm to hinge bolt | 17—Folding top No. 2 auxiliary bow to rear bow arm bolt |
| 2—Outside door handle | 18—Folding top rear bow |
| 3—Folding top No. 2 link | 19—Folding top rear bow arm |
| 4—Folding top pillar hinge—lower | 20—Vacuum cylinder to folding top arm link No. 3 ball joint |
| 5—Door side wing pivot bracket—lower | 21—Vacuum cylinder to folding top arm link No. 3 ball joint |
| 6—Folding top pillar assembly | 22—Folding top No. 3 link |
| 7—Door side wing glass | 23—Vacuum cylinder piston rod |
| 8—Sun visor panel assembly | 24—Folding top No. 3 link to shelf panel bracket |
| 9—Folding top side rail assembly | 25—Folding top No. 3 link to shelf panel bracket spacer |
| 10—Sun visor arm and bracket assembly | 26—Folding top No. 3 link to shelf panel bracket bolt |
| 11—Folding top pillar filler bracket | 27—Folding top vacuum cylinder assembly |
| 12—Folding top No. 2 link to point bracket bolt | 28—Folding top vacuum cylinder pivot bracket |
| 13—Folding top bow No. 1 | 29—Folding top vacuum cylinder pivot pin |
| 14—Folding top side rail assembly | |
| 15—Folding top slat iron rivets | |
| 16—Folding top No. 2 auxiliary bow | |

Figure 55—Convertible Coupe Folding Top Mechanism (1940-42 Models)

27. ADJUSTING CONVERTIBLE COUPE TOP TO FIT BODY.

1940-42—Cont'd.

shifted to one side and doesn't fall over the locating studs without manual assistance, make the necessary correction at header corner brackets.

(10) With the top partly lowered, remove the corner bracket to side rail bolts. Place the top in "up" position and lock the header bar. If either bracket extension does not align with the side rail, carefully bend the extension into alignment with the rail.

(11) Partially lower the top and assemble the header to side rails.

(12) Place the top in "up" position, lock header and tighten the bracket extension to side rail bolts.

28. REPLACEMENT OF CONVERTIBLE COUPE TOP VACUUM CYLINDER.

1940-42—Remove the trim panel in rear seat compartment. Remove the hose connections from cylinder. Remove the bolts which hold the cylinder to body and top and lift out the cylinder. (See figure 55.) When installing a new cylinder, do not bend or kink the cylinder. Be careful to place the piston rod end into the top bracket in such a way that the cylinder and piston rod are in a straight line between the bolt which holds the cylinder to top and bolt which holds the cylinder to body. Be sure the upper hose line is fastened to the top of cylinder and the lower hose line is fastened to the bottom of cylinder.

29. REPLACEMENT OF CONVERTIBLE COUPE TOP VACUUM VALVE.

1940-42—Release the retainer spring and remove the control valve knob. Remove the glove box. Disconnect the hose connection from valves. Tag each hose to facilitate correct installation. Remove the control valve lock nut on back of instrument panel

and outer ferrule. Pull the valve out toward dash. To disassemble the valve, remove the check nut at the stem end and pull out the valve plunger.

30. REMOVAL OF CONVERTIBLE COUPE BODY WINDOW AND FRAME.

1940-42—Remove the garnish molding and arm rest. Remove the regulator and door lock handles and trim panel. Remove the stops on front and rear window frame support. Remove the clip pins from the sliding arms, spring the arms out of slots in frame and lift out the window.

31. REMOVAL OF CONVERTIBLE COUPE BODY DOOR LATCH.

1940-42—Remove the window glass. Remove the door handle and lock cylinder. Remove the window glass rear channel. Disconnect the remote control and remove the latch attaching screws. Remove the latch and remote control arm (fig. 56).



Figure 56—Removing Convertible Coupe Door Latch Assembly (1940-42 Models)

32. REMOVAL OF CONVERTIBLE COUPE BODY WINDOW REGULATOR.

1940-42—Remove the window glass. Turn the regulator to the "up" position and remove the screws that hold the plate to door. Hold the arms together and slide the regulator to the rear to remove the roller from guide rail, then remove the regulator from door.

FOOT BRAKES DATA AND SPECIFICATIONS				
YEAR		1942	1938-41	1936-37
Type		†	†	†
Clearance—toe, inches		.012	.012	.012
Clearance—heel, inches		.006	.006	.006
Pedal free play, inches		$\frac{1}{4}$ to $\frac{3}{8}$	$\frac{1}{4}$ to $\frac{3}{8}$	$\frac{1}{4}$ to $\frac{3}{8}$
Drum diameter, inches		10	*10	*10
Lining width, inches		2	2	2
Lining thickness, inches		$\frac{13}{64}$	$\frac{13}{64}$	$\frac{13}{64}$
Lining Length— inches	Front wheel, front shoe	$10\frac{5}{16}$	$10\frac{9}{32}$	$9\frac{29}{32}$
	Front wheel, rear shoe	$7\frac{11}{16}$	$7\frac{11}{16}$	$9\frac{29}{32}$
	Rear wheel, front shoe	$10\frac{5}{16}$	$10\frac{9}{32}$	$9\frac{29}{32}$
	Rear wheel, rear shoe	$7\frac{11}{16}$	$7\frac{11}{16}$	$7\frac{25}{64}$
Wheel Cylinder Bore Diameter—inches	Front wheel, front shoe	$1\frac{1}{4}$	$1\frac{1}{4}$	$1\frac{1}{4}$
	Front wheel, rear shoe	$1\frac{3}{8}$	$1\frac{3}{8}$	$1\frac{3}{8}$
	Rear wheel, front shoe	1	$1\frac{1}{8}$	$1\frac{1}{8}$
	Rear wheel, rear shoe	$1\frac{1}{8}$	** $1\frac{1}{4}$	$1\frac{1}{4}$
Master cylinder bore, inches		$1\frac{1}{8}$	** $1\frac{1}{4}$	$1\frac{1}{4}$
Cylinder piston clearance (wheel and master), inches		.001 to .003	.001 to .003	.001 to .003

*7 Pass. Model, 11 inches

**7 Pass. Model, $1\frac{1}{8}$ inches

†Hydraulic, Internal Expanding

HAND BRAKE DATA AND SPECIFICATIONS				
YEAR	1942	1938-41	1937	1936
Type	*	*	*	*
Location	**	**	**	**
Band Clearance at Drum, inches	.015 to .020	.020	.020	.020
Drum Diameter, inches	6	6	6	6
Lining Width, inches	2	2	2	2
Lining Thickness, inches	$\frac{5}{32}$	$\frac{5}{32}$	$\frac{5}{32}$	$\frac{5}{32}$
Lining Length, inches	$16\frac{11}{16}$	$17\frac{1}{16}$	$16\frac{15}{16}$	$18\frac{13}{32}$

*External Contracting

**Rear of Transmission

Section VI

BRAKES

1. BRAKE PEDAL FREE PLAY

1936-42

(1) Free play ("A," fig. 1) in the brake pedal should be from $\frac{1}{4}$ to $\frac{3}{8}$ inch. This free play may be readily felt by hand and is the movement of the pedal before the push rod touches the master cylinder piston. If necessary, this free play may be altered by changing the length of the piston push rod.

CAUTION

Piston cup (16, fig. 13) must clear port ("B," fig. 13) when pedal is in released position.

(2) After the free play is taken up, and the pedal is pushed slowly for an additional $\frac{5}{8}$ to $\frac{3}{4}$ inch ("B," fig. 1) fluid should be forced up through the relief port in the master cylinder. If it does not, and the free play is correct, the master cylinder should be disassembled and checked for swollen cups or improper assembly of parts. The additional pedal travel ("C," fig. 1) of approximately 1 inch is required to move the brake shoes outward against the brake drums.

2. FOOT BRAKE MINOR ADJUSTMENT.

1936-42—Inspect the level of the fluid in the master cylinder reservoir. The level of the fluid should not be allowed to go lower than $\frac{1}{2}$ inch below the bottom of the reservoir filler plug opening. Use only Iso-Brake fluid when replenishing. Turn the brake shoe adjusting cam (1, fig. 2) until the front shoe lining is solid against the brake drum and the wheel is locked, then

back off the cam until the wheel may be spun without interference. Turn the cam on the rear shoe at the top "out" until the wheel is locked, then back off until free. Follow the same procedure at all four wheels. After completing the foregoing operations, apply and release the brakes. Then check each wheel to make sure the brakes are not too tight. Check and refill the master cylinder reservoir.

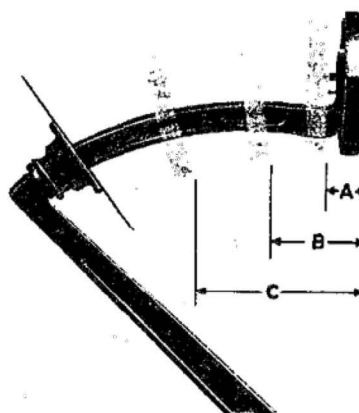


Figure 1—Brake Pedal Free Play (1936-42 Models)

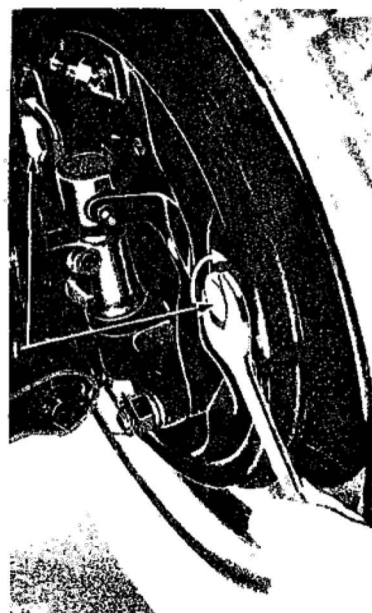


Figure 2—Turning Brake Shoe Adjusting Cams (1) (1936-42 Models)

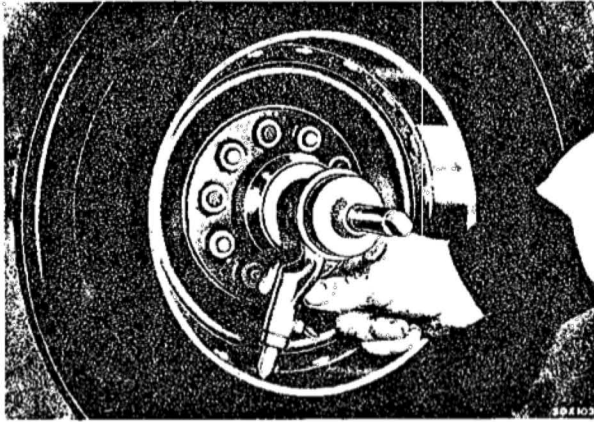


Figure 3—Checking Brake Drum Diameter With Tool MT-19-C (1936-42 Models)

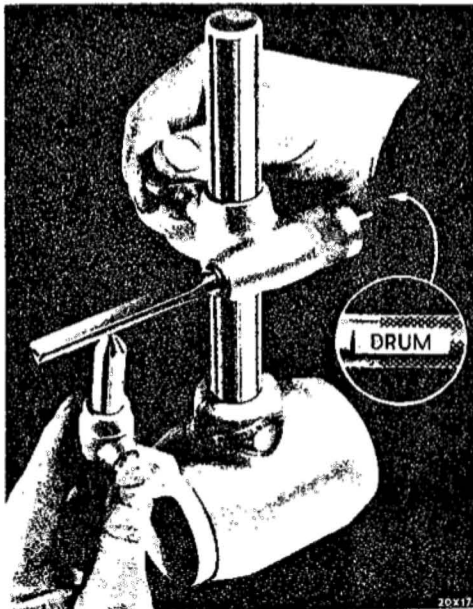


Figure 4—Setting Brake Gauge With Tool MT-19-C (1936-42 Models)

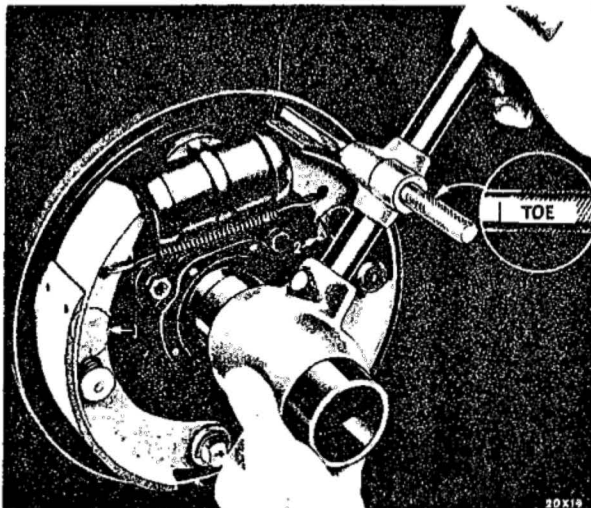


Figure 5—Checking Brake Shoe Toe Adjustment With Tool MT-19-C (1936-42 Models)

3. FOOT BRAKE MAJOR ADJUSTMENT.

1936-42

(1) Inspect the level of the brake fluid in the master cylinder reservoir. This level should not be allowed to go lower than $\frac{1}{2}$ inch below the bottom of the reservoir filler plug opened. Use only MoPar Brake fluid when replenishing.

(2) Remove the brake shoe return springs and test the spring tension by comparing with a new spring. Discard weak springs.

(3) Inspect the linings for exposed rivet heads, abnormal wear and glazed braking surface, also for uniform material on the opposite wheel. Clean the brake drums; if they are scored or out-of-round, resurface them.

(4) Install the brake shoe return springs and set the shoe adjusting cams in the released position.

(5) Mount tool MT-19-C in brake drum and set gauge so the pin just contacts the drum (fig. 3).

(6) Set the brake shoe gauge arbor so that the finger marked "DRUM" is just in contact with the point of the brake drum gauge pin (fig. 4).

(7) Place the proper adapter bushing on the steering knuckle or rear axle shaft and slide the brake shoe gauge over the adapter bushing (fig. 5).

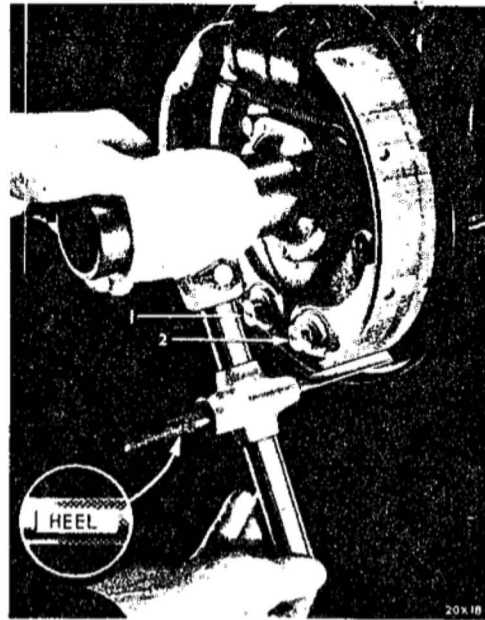
(8) Place the gauge on the point marked "toe" and check the clearance between the lining and drum at the "toe" of the brake shoe (fig. 5). Turn the toe adjusting cam until the lining at the "toe" of the brake shoe just contacts the gauge arbor. The "toe" of the shoe is then properly adjusted and will have .012 inch clearance between the lining and the drum. The pointed edges of the brake gauge (three pointed arbor) are the gauging edges. The "toe" edge of the gauge is machined for .012 inch clearance.

(9) On the head of each anchor bolt, on 1939 to 1942 models, an arrow is stamped to indicate the position of the brake shoe anchor bolt cam (fig. 6). *These arrows must point towards each other before starting to adjust the brake shoes.* Turn the right hand anchor bolt *counterclockwise* and the left hand anchor bolt *clockwise* to *tighten* the brakes. When turning the anchor bolts as directed, the "heels" of the brake shoes will move downward and outward. Turn the anchor bolts until the "heels" of the brake shoes just contact the "heel" adjusting finger of the brake shoe gauge arbor. (The correct .006 inch "heel" clearance is machined into the brake shoe gauge arbor.)

(10) As the anchor bolts are being adjusted for correct "heel" clearance, the "toe" adjustment will also change. Change the "heel" adjustment gradually and at the same time keep the "toe" clearance at .012 inch as the anchor bolt adjustment progresses.

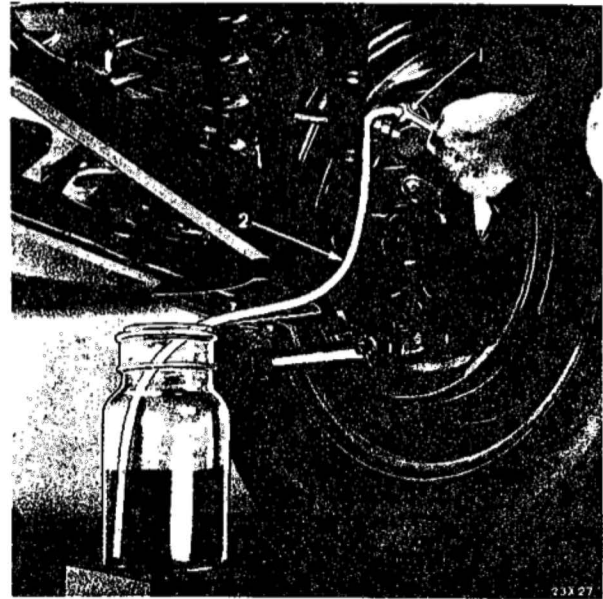
4. BLEEDING BRAKE SYSTEM.

1936-42—When any part of the brake system is disconnected for any reason, or the fluid level is allowed to get too low, it is necessary to bleed the brake lines at all four wheel cylinders. Keep the master cylinder filled with MoPar Brake fluid during the bleeding operation. Attach a short length of rubber hose to bleeder screw (fig. 7). (Remove cylinder bleeder screw cap screw on 1939 model to install hose.) Submerge the free end of the hose in a clean glass container of brake fluid and unscrew the bleeder screw. Depress the brake pedal slowly through half the limit of its travel. Allow the pedal to return to its released position and depress it again or until fluid runs out of the bleeder hose in a continuous stream, *without air bubbles*. When all air bubbles



1 and 2—Wheel brake shoe anchor bolts

Figure 6—Checking Brake Shoe Heel Adjustment With Tool MT-19-C (1936-42 Models)



1—Bleeder Screw

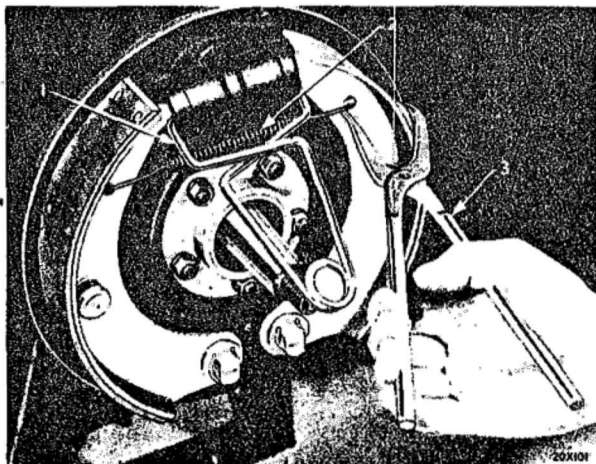
2—Bleeder Hose

Figure 7—Bleeding Brake Lines (1936-42 Models)

have been forced out of the line, *close the bleeder screw tightly before taking the bleeder hose out of the fluid.*

IMPORTANT

Discard any fluid drained from the system.



1—Tool C-416 2—Wheel brake shoe return spring
3—Tool C-312

Figure 8—Removing Brake Shoe Return Spring
(1936-42 Models)

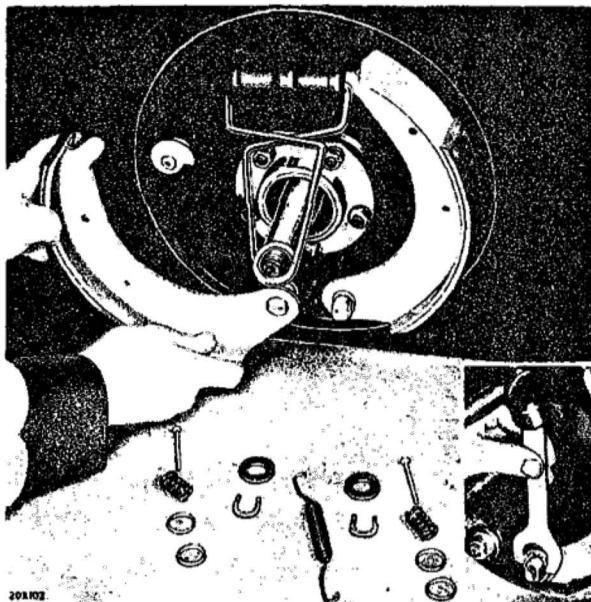


Figure 9—Removing Brake Shoe (1936-42 Models)

5. REMOVAL OF BRAKE SHOES.

1936-42—Block the brake pedal in the released position to prevent its downward movement. Remove wheel. Install a wheel cylinder clamp on the wheel cylinder and remove the brake shoe return spring using a suitable tool (fig. 8). Remove the brake shoe anchor bolt "C" washers, oil washer retainers, oil washers, guide spring retainers, guide springs and the brake shoe (fig. 9). Inspect the brake shoe return springs for tension and discard any weak springs. Both front and

rear wheel springs should be uniform in tension.

6. INSTALLATION OF BRAKE SHOES.

1936-42—When installing the brake shoes, exercise care to prevent leakage of brake fluid on the brake lining. If one of the wheel cylinder pistons should be accidentally forced out of the cylinders, bleed the brake lines. Make sure the brake support is not sprung.

7. REPLACEMENT OF BRAKE LINING.

1936-42—Always reline the brake shoes for BOTH front wheels with lining of the same material. Always reline the brake shoes for BOTH rear wheels with lining of the same material. Remove the old lining by punching out the rivets. Countersink the rivet heads in the lining approximately two-thirds the thickness of the lining. Rivet the lining to the brake shoe with the proper type of rivets. *Never use aluminum rivets.* Chamfer the end of the lining back about $\frac{1}{2}$ inch to $\frac{5}{8}$ inch from the top and bottom and remove high spots or burrs around rivet holes with grinding tool MT-29 (fig. 10). Adjust brake shoes as outlined in paragraph 3.

IMPORTANT

Examine the brake drums for scoring and deep cuts. If necessary to resurface the brake drums, do not remove more than .030 inch of stock which will increase the original diameter of the drum .060 inch. Replace the drums if the damaged surface requires the removal of more than .030 inch of material from them.

8. REMOVAL OF WHEEL CYLINDER.

1936-42—Block the brake pedal in the released position to prevent its downward movement. Remove the wheel, hub and drum assembly. Disconnect the brake hose at the frame bracket, then disconnect it from the wheel cylinder. Remove the brake shoe return spring. Rock the brake shoes so the upper ends pull out of the wheel cylinder boots. Remove the cap screws which hold the

wheel cylinder body to the brake support and remove the cylinder.

IMPORTANT

Do not allow any brake fluid to come in contact with the brake lining, either from dripping or from soiled hands.

9. INSTALLATION OF WHEEL CYLINDER.

1936-42—Install the wheel cylinder on the brake support. Be sure the contacting surfaces of the brake hose are clean, then connect hose to cylinder and to frame bracket. Connect brake shoes to cylinder, install hub and drum, bleed brakes, and adjust shoes for proper clearance.

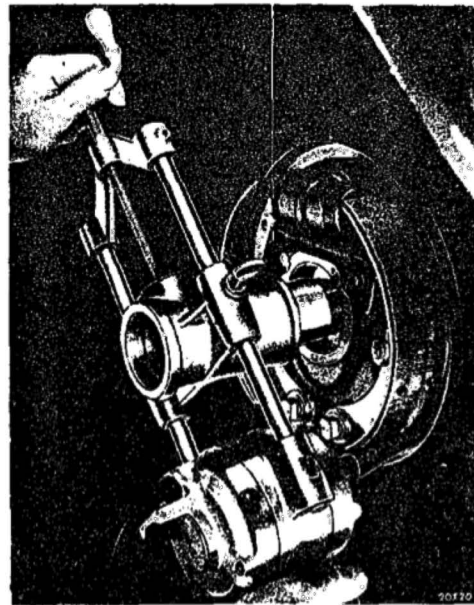


Figure 10—Grinding Brake Shoe Facing With Tool MT-29 (1936-42 Models)

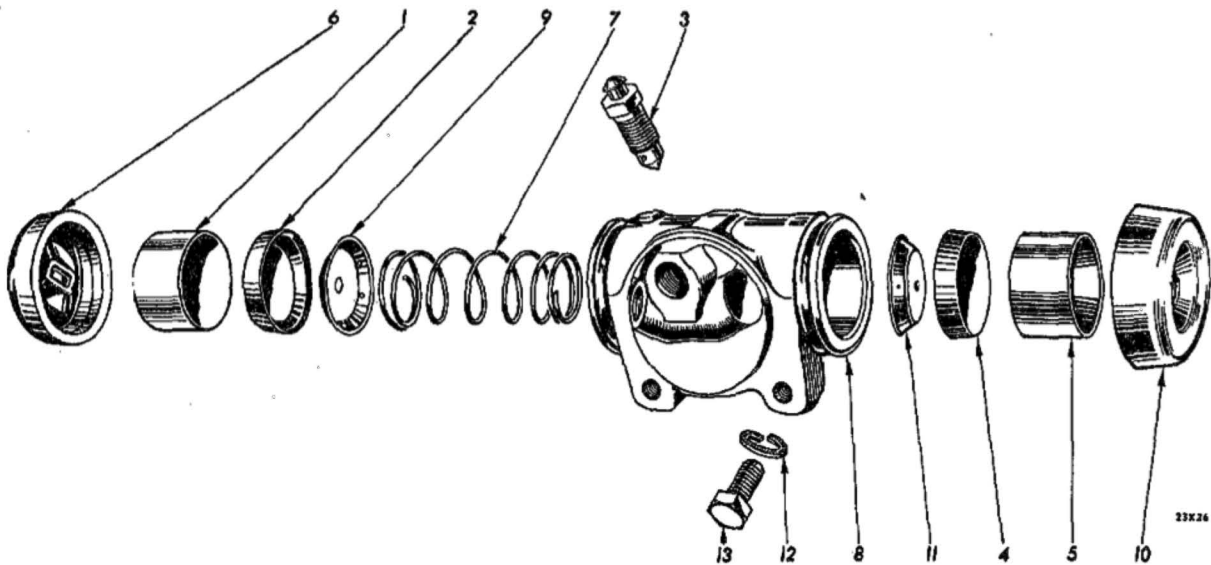


Figure 11—Brake Wheel Cylinder (Disassembled View) (1942 Model, Typical of 1936-41 Models)

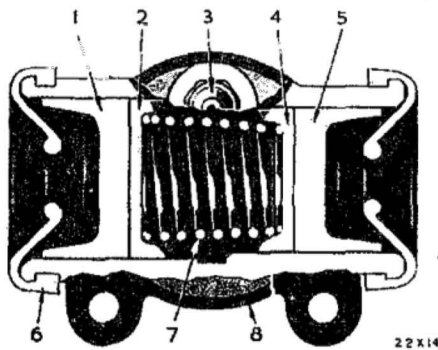


Figure 12—Brake Wheel Cylinder (Assembled View) (1942 Model, Typical of 1936-41 Models)

- | | |
|--|--|
| 1—Piston (large)—rear | 9—Piston cup expander (service assemblies only) |
| 2—Piston cup (large)—rear | 10—Boot |
| 3—Bleeder screw (2 piece bleeder screw used on 1936-39 Models) | 11—Piston cup expander (service assemblies only) |
| 4—Piston cup (small)—front | 12—Cylinder to brake support screw lock washer |
| 5—Piston (small)—front | 13—Cylinder to brake support screw |
| 6—Boot | |
| 7—Piston cup spring | |
| 8—Cylinder (body) | |

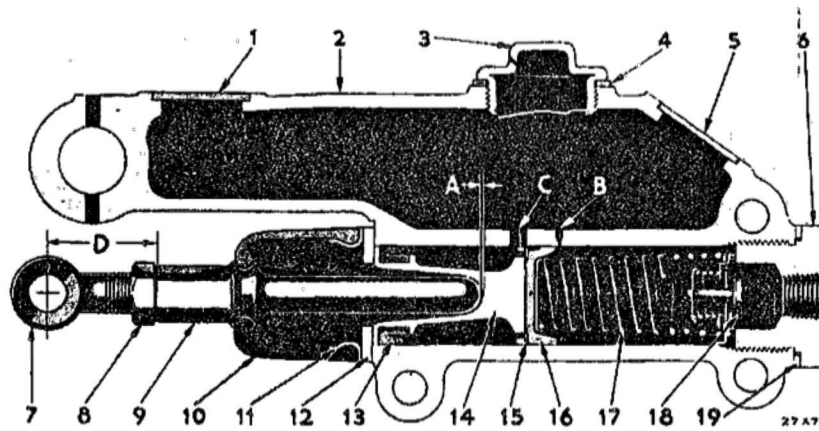


Figure 13—Brake Master Cylinder (Assembled View) (1942 Model)

- | | | | |
|--|--------------------------------|---------------------------------|-------------------------------|
| 1—Expansion plug | 8—Piston push rod end lock nut | 14—Piston | 21—Outlet connection or tee |
| 2—Pedal bracket and master cylinder body | 9—Piston push rod | 15—Piston cup washer | A—Free pedal movement |
| 3—Filler plug | 10—Boot | 16—Piston cup | B—Relief port |
| 4—Filler plug gasket | 11—Boot collar | 17—Piston return spring | C—Port |
| 5—Expansion plug | 12—Piston stop | 18—Valve | D—Piston push rod end setting |
| 6—End plug | 13—Secondary cup | 19—End plug gasket | |
| 7—Piston push rod end | | 20—Piston stop fastening screws | |

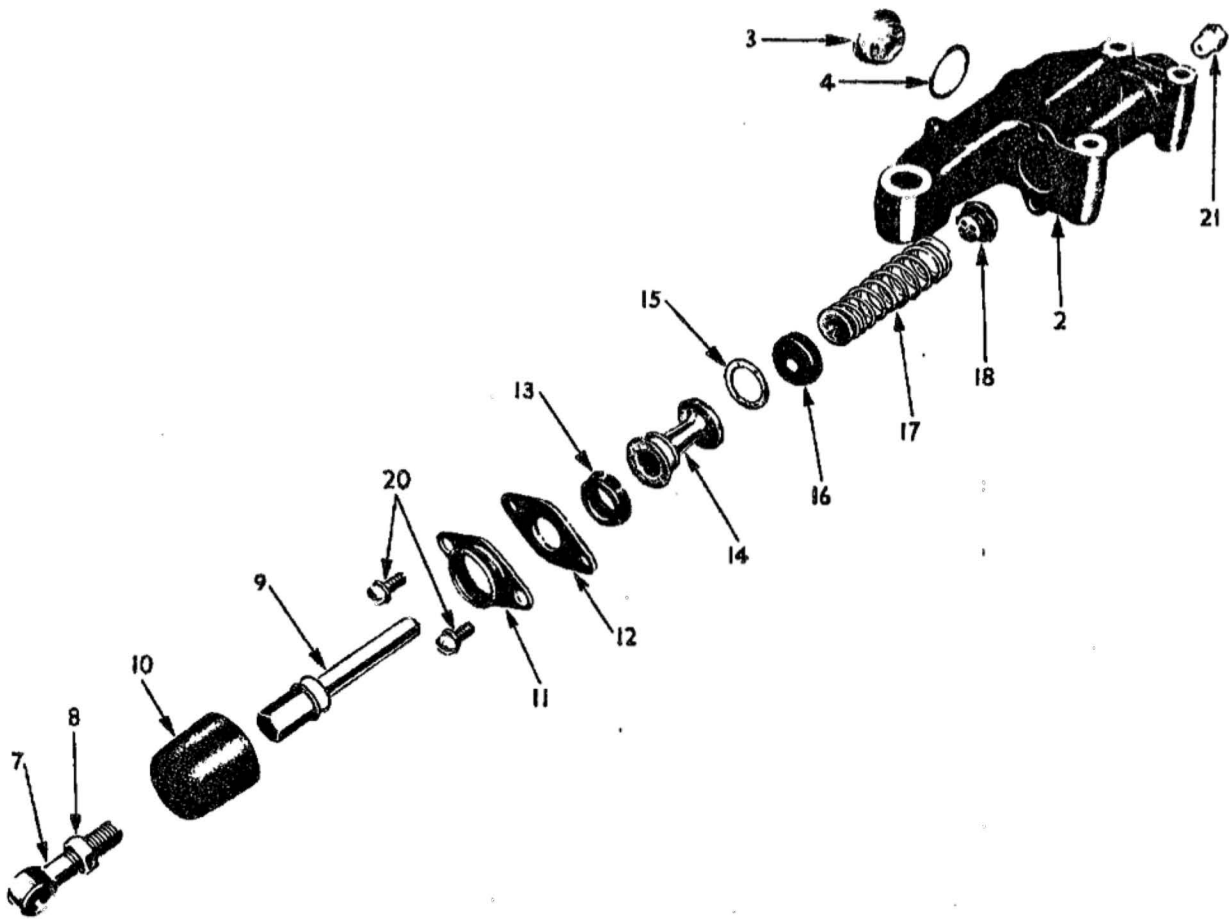


Figure 14—Brake Master Cylinder (Disassembled View) (1942 Model)

10. DISASSEMBLY OF WHEEL CYLINDER.

1936-42 — Roll the rubber boot off each end of cylinder and remove the pistons, cups and internal parts of the cylinder. (See figure 11.)

11. ASSEMBLY OF WHEEL CYLINDER.

1936-42—Clean the cylinder body inside and outside thoroughly and wash all parts in alcohol. Work on a clean bench where no dirt or grit can be picked up. Coat the walls of the cylinder and internal parts with *brake fluid* while assembling the wheel cylinder. (See figure 12.) *Never use mineral oil or any type of mineral lubricant for this purpose.*

12. REMOVAL OF MASTER CYLINDER.

1936-42 — Disconnect the brake line tubes at the master cylinder. Disconnect brake pedal from master cylinder. Remove the bolts which attach master cylinder to chassis and lift out the master cylinder assembly.

13. INSTALLATION OF MASTER CYLINDER.

1936-42—After the master cylinder is installed on the chassis, fill with brake fluid and bleed brake lines at all four wheel brake cylinders. Check master cylinder push rod "free play" and adjust if necessary. (See paragraph 1.)

14. DISASSEMBLY OF MASTER CYLINDER.

1936-42

IMPORTANT

Do not disturb the original factory setting of master cylinder push rod as it is not subject to wear or variation in setting, unless final check of "free play" requires adjustment. (See paragraph 1.) Do not remove the sealing plug at the end of the master cylinder.

Clean the outside of cylinder assembly thoroughly. Roll the boot off the master cylinder body and remove boot and piston push rod end. Remove reservoir filler plug and drain out all brake fluid. Remove piston stop lock wire (1936-41 models), boot collar (1942 model), and remove piston stop. Remove piston, cup, spring and valve assembly. (See figures 14 and 16.)

15. ASSEMBLY OF MASTER CYLINDER.

1936-1942

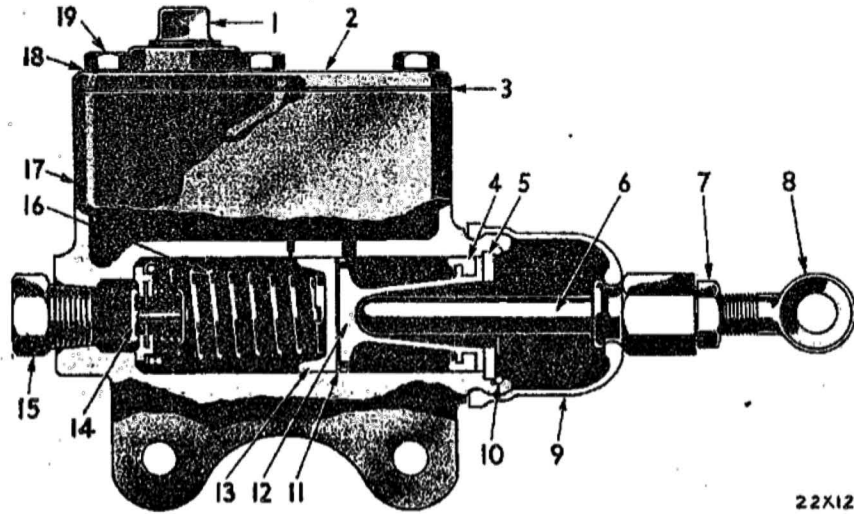
IMPORTANT

When cleaning brake cylinder parts, never allow them to come in contact with mineral oil or lubricating stock. Use only alcohol (not antifreeze) or clean brake fluid.

Wash all parts in alcohol before starting to assemble them and work on a clean bench where no grit or dirt will be picked up. First install valve assembly and spring, then piston cup, piston cup washer and piston. Install piston stop and secure it in body. Insert the piston push rod end in piston and install boot over end of body. (See figures 13 and 15.)

16. RECONDITIONING BRAKE CYLINDERS.

1936-42 — When wheel cylinders or master cylinders are corroded, they may be reconditioned by removing cylinder from car and lapping with a felt lap and fine lapping compound. *Always wash cylinder thoroughly after reconditioning. Replace cylinder if scored.* Clearance between piston and cylinder wall (in both wheel cylinder and master cylinder) should not be more than .003 inch. Clearance greater than .003 inch may result in the edge of the rubber cup extruding between cylinder wall and piston when brakes are applied with heavy pressure.



22X12

Figure 15—Brake Master Cylinder (Assembled View) (1941 Model, Typical of 1936-40 Models)

- | | | |
|--------------------------------|--------------------------|---|
| 1—Filler plug | 9—Boot | 17—Master cylinder and supply tank body |
| 2—Cover | 10—Piston stop lock wire | 18—Cover screw gasket |
| 3—Cover gasket | 11—Piston washer | 19—Cover screw |
| 4—Piston secondary cup | 12—Piston | 20—Fastening screw nut |
| 5—Piston stop | 13—Piston cup | 21—Fastening screw nut lock washer |
| 6—Piston push rod | 14—Valve assembly | 22—Fastening screw |
| 7—Piston push rod end lock nut | 15—Outlet connection | |
| 8—Piston push rod end | 16—Piston return spring | |

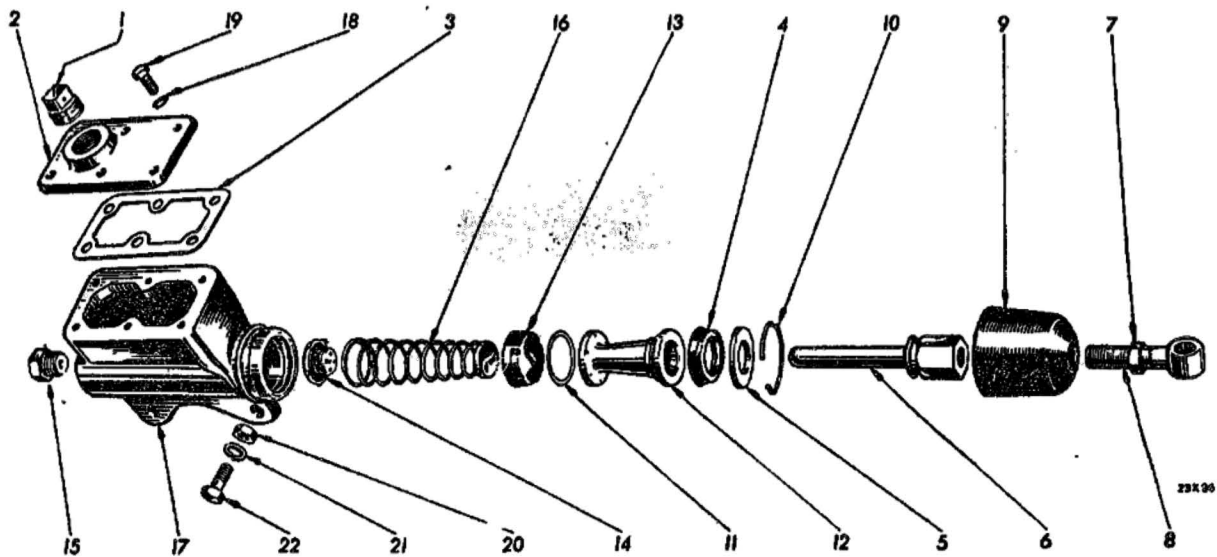
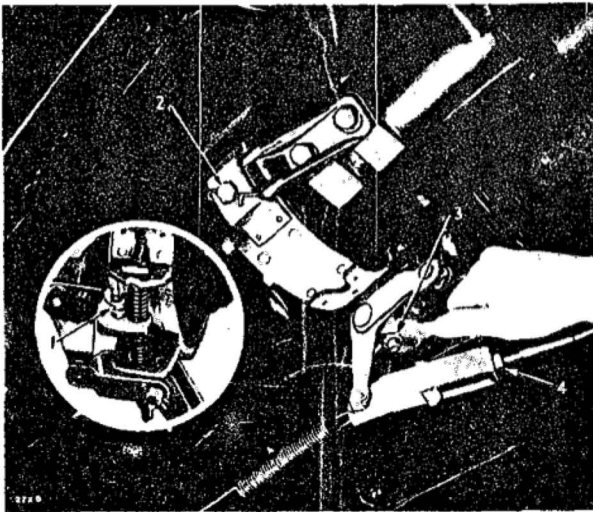
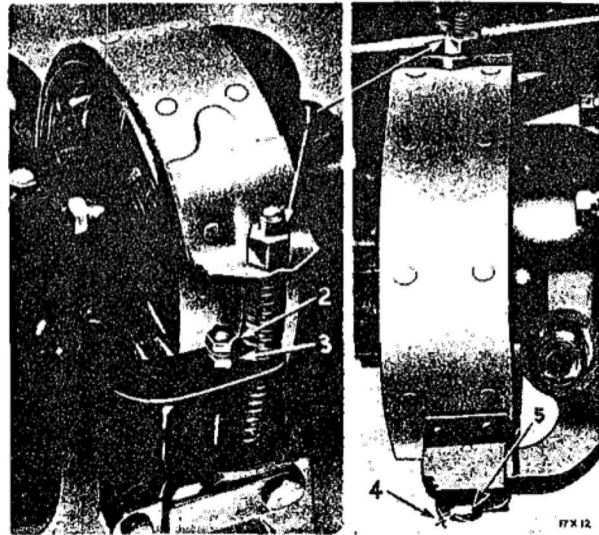


Figure 16—Brake Master Cylinder (Disassembled View) (1941 Model, Typical of 1936-40 Models)



- | | |
|---|-----------------------------|
| 1—Guide bolt adjusting nut and lock nut | 3—Adjusting bolt nut |
| 2—Anchor screw | 4—Hand brake cable lock nut |

Figure 17—Hand Brake Band Adjustments (1940-42 Models)



- | | |
|----------------------------|--------------------------|
| 1—Adjusting bolt nut | 4—Anchor screw lock wire |
| 2—Guide bolt lock nut | 5—Anchor screw |
| 3—Guide bolt adjusting nut | |

Figure 18—Hand Brake Band Adjustments (1936-39 Models)

17. ADJUSTING HAND BRAKE.

1940-42—Set the hand brake lever in the fully released position. Be sure the free play between the side of the anchor bracket on the center of the band and the anchor does not exceed .005 inch. Adjust the anchor screw (2, fig. 17) so the clearance between band and drum is .020 inch. Lock anchor screw securely. Turn guide bolt adjusting nut (1) until the clearance between band and drum is .020 inch, then lock guide bolt securely. Turn the adjusting bolt nut (3) until the clearance between the upper half of band and drum is .020 inch. To adjust cable length, loosen lock nut (4) and turn yoke to secure proper adjustment of cable. Be sure to tighten lock nut.

1936-39—Set hand brake lever in the fully released position. Be sure the free play between side of the anchor bracket on the center of the band and the anchor does not exceed .005 inch. Adjust anchor screw (5, fig. 18) so the clearance between band and drum is .020 inch, then lock anchor screw securely. Loosen the adjusting bolt nut (1) until free. Loosen lock nut (2) and turn

guide bolt adjusting nut (3) until the clearance between drum and band is .020 inch, then tighten lock nut. Tighten adjusting bolt nut (1) until tension on guide bolt is just relieved.

18. REPLACEMENT OF HAND BRAKE.

1936-42—Remove adjusting bolt, nut and guide bolt adjusting bolt nuts. Remove anchor adjusting screw and pull band assembly away from transmission and off propeller shaft. When installing band, be sure clearance between anchor and bracket does not exceed .005 inch, then adjust band as explained in paragraph 17.

19. REPLACEMENT OF HAND BRAKE LINING.

1936-42 — When relining hand brake band, use lining of dimensions specified in "Data and Specifications" chart, on page 76. Rivet lining securely to band, then cut out the portion of the lining next to the anchor. Be sure the contour of the band conforms to the shape of the drum. Excessive squeal or chatter may be eliminated by bending the toe end of the band slightly away from the drum.

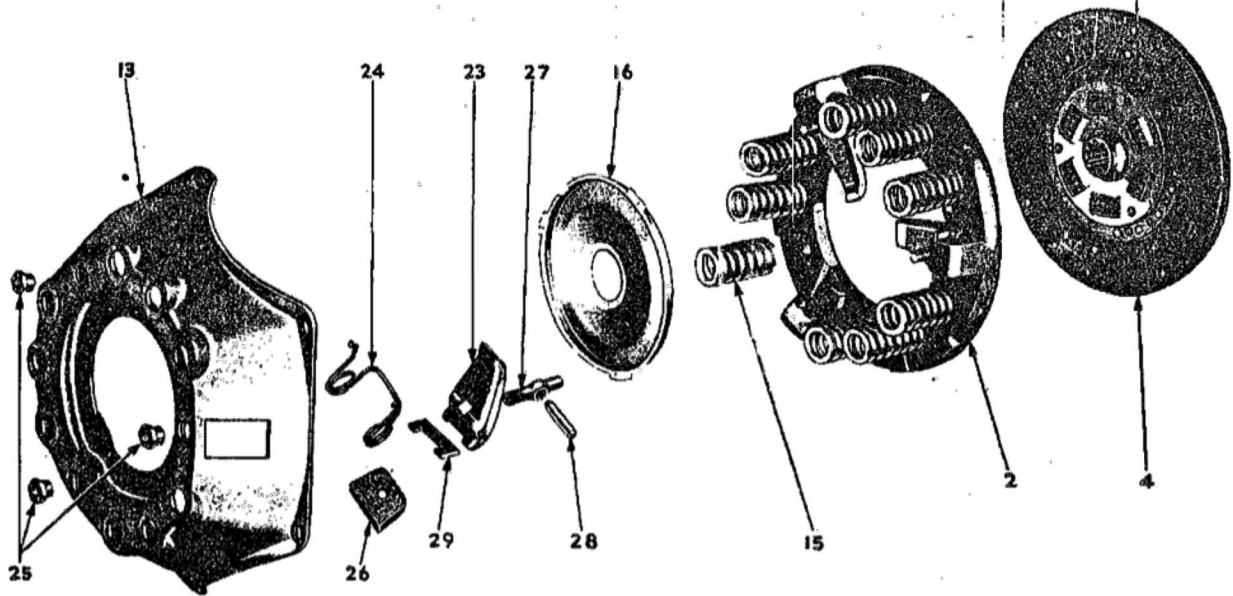


Figure 1—Clutch (Disassembled View) (1942 Model, Typical of 1936-41 Models)

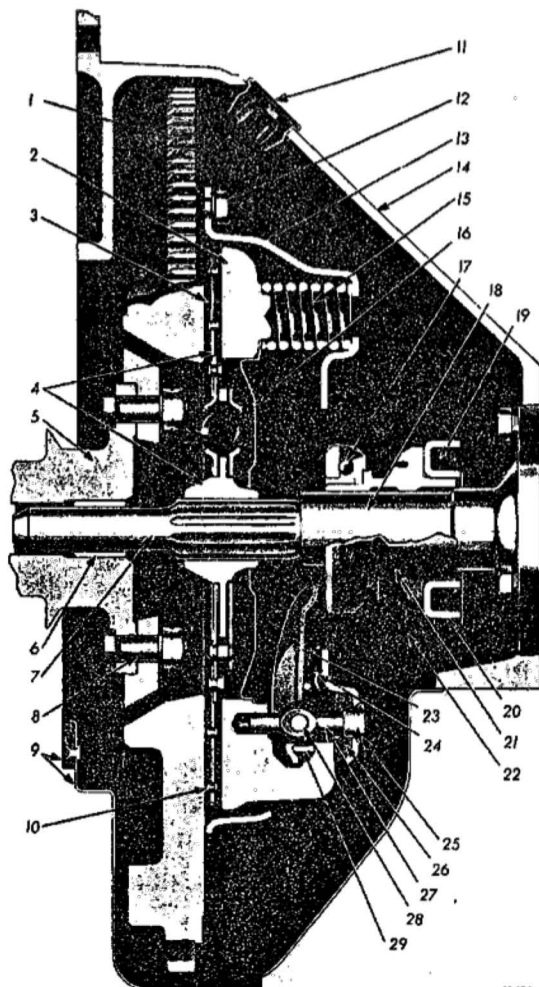


Figure 2—Clutch (Assembled View) (1942 Model, Typical of 1936-41 Models)

- | | |
|--|---|
| 1—Flywheel and ring gear | 17—Release bearing |
| 2—Pressure plate | 18—Transmission drive pinion bearing retainer |
| 3—Disc facing | 19—Release bearing pull-back spring |
| 4—Disc assembly | 20—Release fork |
| 5—Engine crankshaft | 21—Release bearing sleeve |
| 6—Crankshaft bushing (transmission drive pinion pilot bushing) | 22—Clutch housing ventilator (1941-42 Models) |
| 7—Transmission drive pinion | 23—Release lever |
| 8—Flywheel bolt | 24—Release lever spring |
| 9—Housing pan and seal | 25—Release lever eye bolt nut |
| 10—Disc facing rivet | 26—Pressure plate driving lug grease pad (1941-42 Models) |
| 11—Housing ventilator screen—small (1940-42 Models) | 27—Release lever eye bolt |
| 12—Cover to flywheel screw and lock washer | 28—Release lever pin |
| 13—Cover | 29—Release lever strut |
| 14—Housing | |
| 15—Pressure spring | |
| 16—Pressure plate baffle (1938-42 Models) | |

Section VII

CLUTCH

1. DESCRIPTION.

1936-42—The clutch (figs. 1 and 2) is a single plate, dry disc type. The release levers are adjusted individually in production to the correct height and no attempt should be made to adjust them in the vehicle.

2. ADJUSTMENT OF CLUTCH PEDAL FREE PLAY.

1942—Wear of the clutch facings can be compensated for by adjusting the clutch pedal free play to maintain proper clearance between the release bearing and the clutch release lever. To make this adjustment, turn the clutch release fork rod adjusting nut (40, fig. 4) until the clutch pedal has 1 inch free play (A, fig. 3).

CAUTION

When adjusting clutch pedal free play, do not disturb the turnbuckle (18, fig. 4) which controls the adjustment of the over-center spring.

1939-41—Turn the clutch release fork adjusting nut (2, fig. 5) until the clutch pedal has 1 inch free play (A, fig. 3).

1937-38—Turn the clutch release fork rod adjusting nut (2, fig. 6) until the clutch pedal has 1 inch free play (A, fig. 3).

1936—Adjust the nut on the clutch release fork rod (23, fig. 7) until the clutch pedal has 1 inch free play (A, fig. 3).

3. ADJUSTMENT OF OVER-CENTER SPRING.

1942—If the clutch pedal will not return completely to the pedal stop screw, turn the turnbuckle (18, fig. 4) to lengthen the clutch

pedal rod. If the initial pedal movement is excessively heavy, shorten the rod with the turnbuckle adjustment. If turnbuckle is adjusted, readjust the clutch pedal location and free play.

1939-41—The over-center spring is attached to the frame by a bracket and is not adjustable.

4. REPLACEMENT OF OVER-CENTER SPRING.

1942—Remove the bottom bolt which holds the spring bracket to the frame, so that the pressure of the spring will be relieved, then remove the spring. To install, first install the hook end on the clevis pin on the torque shaft, making sure there is a spacing washer between the hook and the lever; then attach the other end of the spring to the bracket on the frame. With the upper bolt of frame bracket in place, pivot the bracket into position and insert bottom bolt.

1939-41—To remove or install, use Tool C-529.

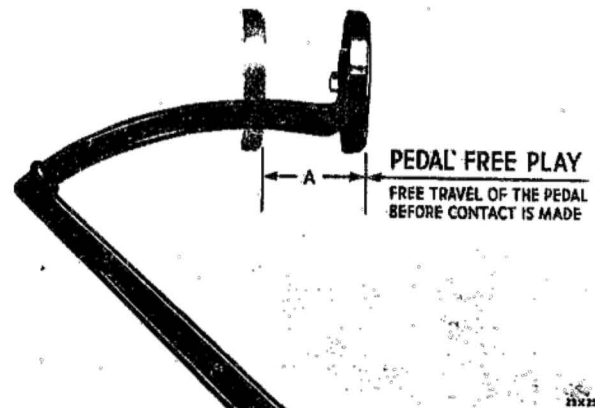


Figure 3—Clutch Pedal Free Play (1936-42 Models)

DATA AND SPECIFICATIONS				
YEAR	1940-42	1939	1938	1936-37
Release bearing, type	Ball, prelubricated	Ball, prelubricated	Ball, prelubricated	Ball, prelubricated
Free pedal travel, inches	1	1	1	1
Lever height	Adjust with fixture	Adjust with fixture	Adjust with fixture	Adjust with fixture
Cover screws, tightening torque, pounds	15-20	15-20	15-20	15-20
Clutch assembly model number 9 $\frac{1}{4}$ inch clutch	955	918	918	869 or 918
Clutch assembly model number— 10 inch clutch	928 or 957	928 or 957	913	899 or 913
Clutch assembly model number— 11 inch clutch	931 or 941	931 or 941	917	P3-P4 908
Facing dimensions, inches— 9 $\frac{1}{4}$ inch clutch	6 x 9 $\frac{1}{4}$ x $\frac{1}{8}$	5 $\frac{5}{8}$ x 9 $\frac{1}{4}$ x .133	5 $\frac{5}{8}$ x 9 $\frac{1}{4}$ x .133	5 $\frac{5}{8}$ x 9 $\frac{1}{4}$ x .133
Facing dimensions, inches— 10 inch clutch	7 x 10 x $\frac{1}{8}$	6 x 10 x $\frac{1}{8}$	6 x 10 x $\frac{1}{8}$	6 x 10 x $\frac{1}{8}$
Facing dimensions, inches— 11 inch clutch	6 $\frac{1}{2}$ x 11 x $\frac{1}{8}$	6 $\frac{1}{2}$ x 11 x $\frac{1}{8}$	6 $\frac{1}{2}$ x 11 x $\frac{1}{8}$	6 $\frac{1}{2}$ x 11 x $\frac{1}{8}$
Clutch Pressure Spring Arrangement		Spring Pressure and Length		
Clutch Assembly Model Number	Arrangement	Purple-130-140 lbs @ 1 $\frac{1}{16}$ inch Green-105-115 lbs. @ 1 $\frac{1}{16}$ inch Lavender-145-155 lbs. @ 1 $\frac{1}{2}$ inch Plain-150-160 lbs. @ 1 $\frac{1}{16}$ inch		
869	9 Purple springs			
899	9 Purple springs			
908	12 Springs, grouped in threes, center purple, two outer green			
913	9 Purple springs			
917	12 Springs, grouped in threes, center purple, two outer green			
918	9 Springs, grouped in threes, center purple, two outer plain			
928	9 Springs, grouped in threes, center purple, two outer plain			
931	12 Springs, grouped in threes, center green, two outer purple			
941	12 Springs, located alternately 1 purple, 1 plain			
955	9 Lavender springs			
957	9 Plain springs			

- 1—Clutch torque shaft crank pin, washers and cotter pin
- 2—Clutch torque shaft frame pivot bracket
- 3—Overcenter spring crank pin, washers and cotter pin
- 4—Clutch pedal rod—front
- 5—Clutch pedal rod turnbuckle lock nuts—front and rear
- 6—Clutch pedal
- 7—Pedal shaft lock pin
- 8—Pedal shaft lock
- 9—Clutch pedal stop screw
- 10—Clutch pedal stop screw lock nut
- 11—Clutch pedal lubricant fitting
- 12—Clutch pedal bushing
- 13—Clutch release over-center spring bracket
- 14—Clutch release over-center spring
- 15—Clutch torque shaft
- 16—Clutch release fork pull-back spring
- 17—Clutch torque shaft pivot bracket spring
- 18—Clutch pedal rod turnbuckle
- 19—Brake pedal pull-back spring
- 20—Clutch pedal rod—rear
- 21—Clutch pedal rod bolt, nut, washer and cotter pin
- 22—Brake pedal pull-back spring clip
- 23—Frame brake master cylinder support bracket
- 24—Brake pedal
- 25—Pedal shaft lock
- 26—Clutch and brake pedal shaft
- 27—Brake pedal stop screw
- 28—Brake pedal stop screw lock nut
- 29—Master cylinder fastening screw and lock washer
- 30—Master cylinder assembly
- 31—Clutch torque shaft crank pin, washers and cotter pin
- 32—Clutch torque shaft clutch housing pivot bracket
- 33—Clutch torque shaft pivot bracket bearing lock ring
- 34—Clutch torque shaft pivot bracket bearings

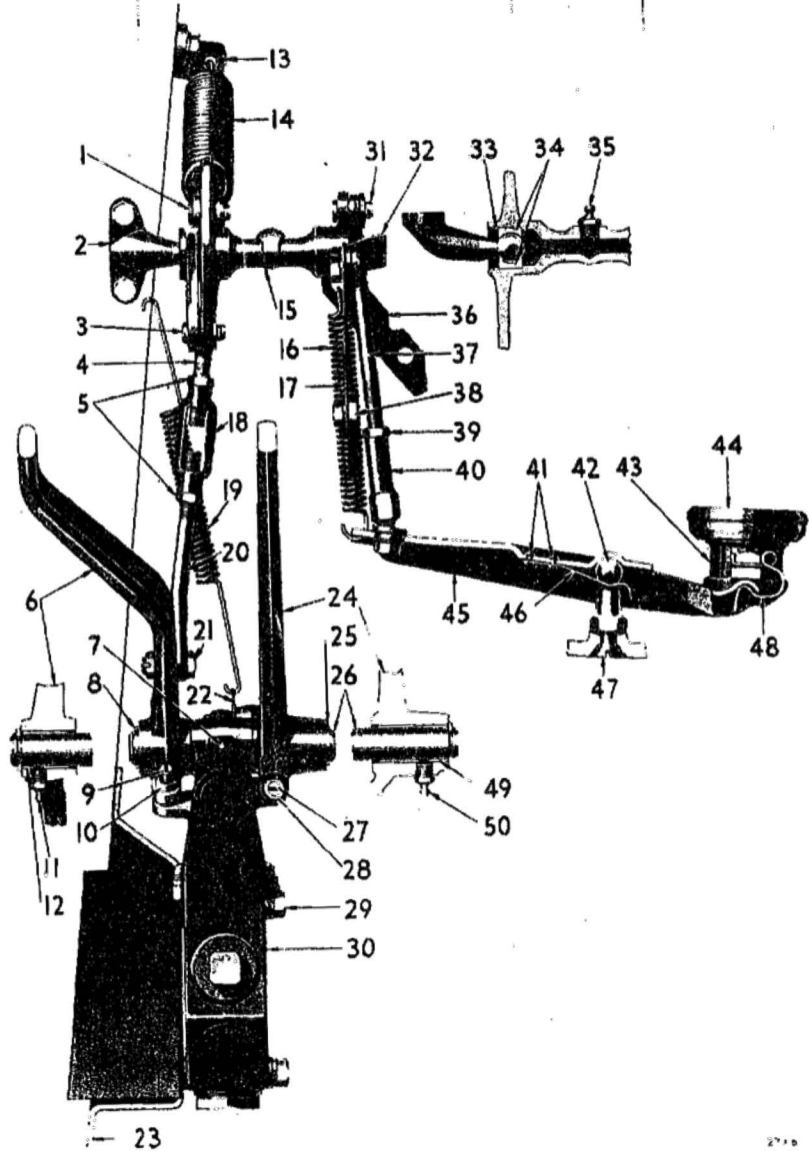
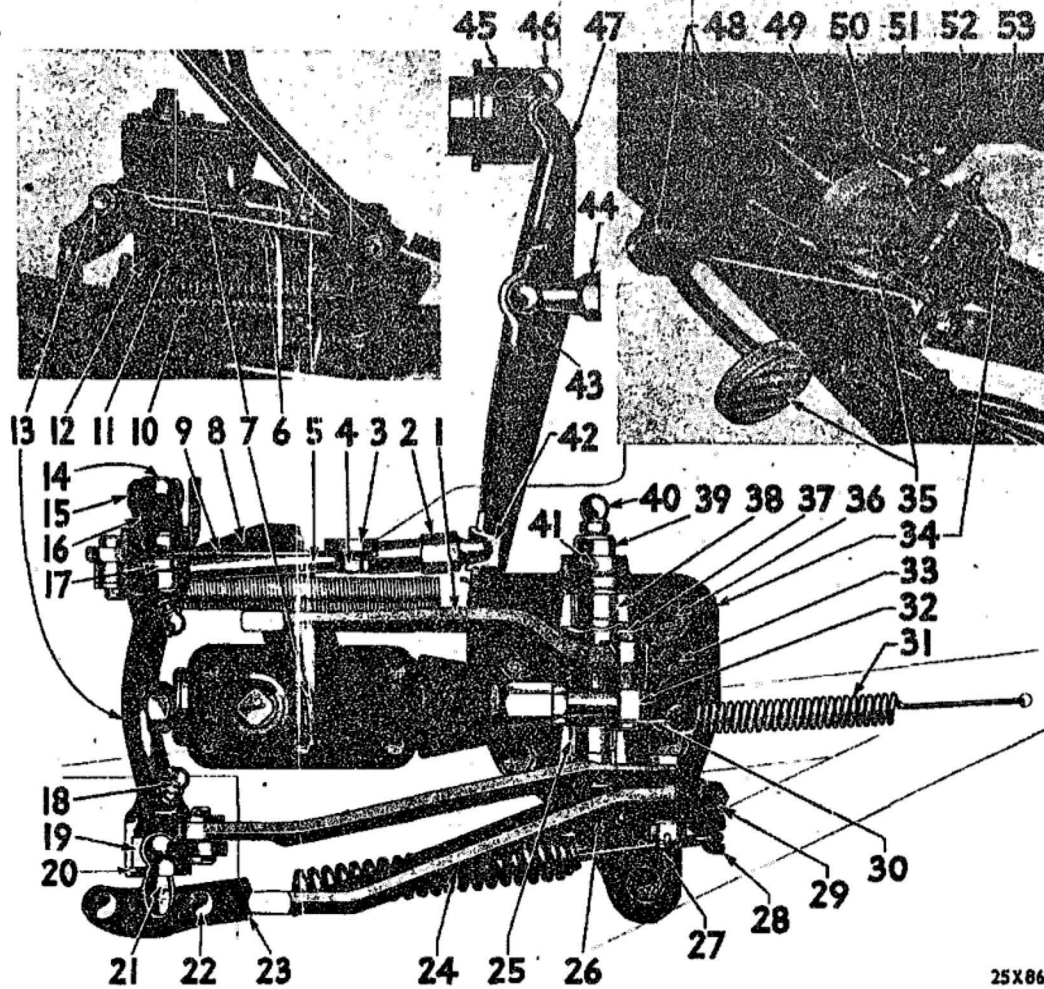


Figure 4—Clutch and Brake Pedal Linkage (1942 Model)

- 35—Clutch torque shaft lubricant fitting
- 36—Clutch release fork pull-back spring bracket
- 37—Clutch release fork rod
- 38—Gearshift control rod bellcrank bracket
- 39—Clutch release fork rod adjusting nut lock nut
- 40—Clutch release fork rod adjusting nut
- 41—Clutch release fork pivot spring rivets
- 42—Clutch release fork pivot
- 43—Clutch release bearing sleeve
- 44—Clutch release bearing
- 45—Clutch release fork
- 46—Clutch release fork pivot spring
- 47—Clutch release fork pivot screw and lock washer
- 48—Clutch release bearing pull-back spring
- 49—Brake pedal bushing
- 50—Brake pedal lubricant fitting



25X86

Figure 5—Clutch and Brake Pedal Linkage (1939-41 Models)

- | | | |
|---|--|--|
| 1—Brake pedal | 17—Clutch torque shaft pivot bracket to spring screw | 33—Brake pedal stop screw |
| 2—Clutch release fork rod adjusting nut | 18—Clutch torque shaft lubricant nipple | 34—Brake bracket |
| 3—Clutch torque shaft pivot bracket spring spacer | 19—Clutch torque shaft pivot bracket bearing | 35—Pedal pad |
| 4—Clutch torque shaft spring to housing screw | 20—Clutch torque shaft pivot bracket bearing lock ring | 36—Pedal bracket to frame screw |
| 5—Clutch release fork rod | 21—Clutch torque shaft frame pivot bracket | 37—Brake master cylinder piston push rod end pin |
| 6—Clutch pedal rod | 22—Clutch torque shaft frame pivot bracket screw | 38—Brake pedal bushing |
| 7—Master cylinder assembly | 23—Clutch release overcenter spring bracket | 39—Pedal shaft |
| 8—Clutch pedal pull-back spring bracket | 24—Clutch pedal | 40—Pedal shaft lubricant fitting |
| 9—Clutch torque shaft pivot bracket spring or plate | 25—Clutch pedal bushing | 41—Pedal shaft pin |
| 10—Clutch release overcenter spring | 26—Pedal shaft lock | 42—Clutch release fork rod socket |
| 11—Pedal to master cylinder bracket | 27—Clutch pedal rod screw | 43—Clutch release fork pivot spring |
| 12—Pedal to master cylinder bracket frame screw | 28—Clutch release overcenter spring clip | 44—Clutch release fork pivot |
| 13—Clutch torque shaft | 29—Clutch pedal stop screw | 45—Clutch release bearing sleeve |
| 14—Clutch torque shaft pivot (on clutch housing) | 30—Brake pedal pull-back spring clip | 46—Clutch release bearing pull-back spring |
| 15—Clutch torque shaft pivot bracket pin | 31—Brake pedal pull-back spring | 47—Clutch release fork |
| 16—Clutch torque shaft pivot bracket | 32—Brake master cylinder piston push rod end | 48—Pedal draft pads |
| | | 49—Clutch torque shaft pivot bracket spring or plate |
| | | 50—Clutch pedal pull-back spring |
| | | 51—Clutch release fork rod adjusting nut lock nut |
| | | 52—Clutch release fork |
| | | 53—Clutch release fork seal |

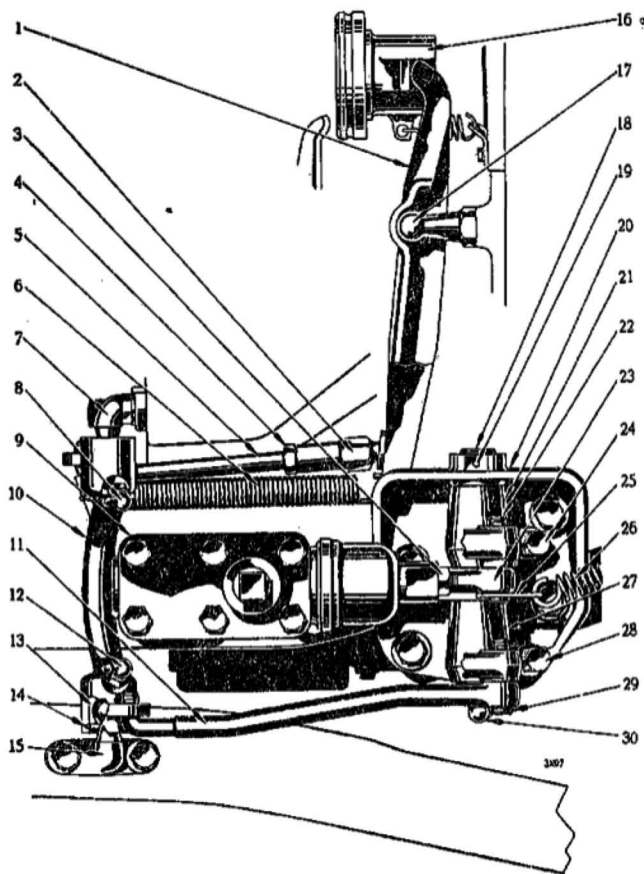


Figure 6—Clutch and Brake Pedal Linkage (1937-38 Models)

- | | |
|---|--|
| 1—Clutch release fork assembly | 15—Clutch torque shaft pivot bearing bracket |
| 2—Clutch release fork rod adjusting rod | 16—Clutch release bearing sleeve |
| 3—Master cylinder piston push rod end check nut | 17—Clutch release fork pivot |
| 4—Clutch release fork rod adjusting nut check nut | 18—Clutch and brake pedal shaft |
| 5—Clutch release fork rod | 19—Clutch and brake pedal shaft pin |
| 6—Clutch release fork pull-back spring | 20—Pedal bracket |
| 7—Clutch torque shaft pivot bracket | 21—Brake pedal assembly |
| 8—Clutch torque shaft oiler | 22—Master cylinder piston push rod end pin |
| 9—Master cylinder assembly | 23—Master cylinder piston push rod end |
| 10—Clutch torque shaft | 24—Brake pedal stop screw |
| 11—Clutch pedal rod | 25—Brake pedal pull-back spring clip |
| 12—Clutch torque shaft oiler | 26—Brake pedal pull-back spring |
| 13—Clutch torque shaft pivot bearing | 27—Clutch pedal assembly |
| 14—Clutch torque shaft pivot bearing snap ring | 28—Clutch pedal stop screw |
| | 29—Clutch pedal rod clevis pin |
| | 30—Clutch and brake pedal shaft oiler |

5. REMOVAL OF CLUTCH.

1936-42—Disconnect the release fork pull-back spring and remove the pivot screw or clevis pin from the release fork rod. Remove the transmission and the clutch housing pan. Mark the clutch cover and flywheel, so that the clutch may be installed in the same relative position, and remove the clutch assembly from underneath the car.

6. INSTALLATION OF CLUTCH.

1936-42—Coat the transmission main drive pinion pilot bushing with short fibre grease. Hold the clutch cover plate and disc in place and insert clutch disc aligning arbor C-360 through the hub of the driving disc and into the drive pinion bushing. Line up the marks on the cover and flywheel and bolt the cover plate loosely to the flywheel.

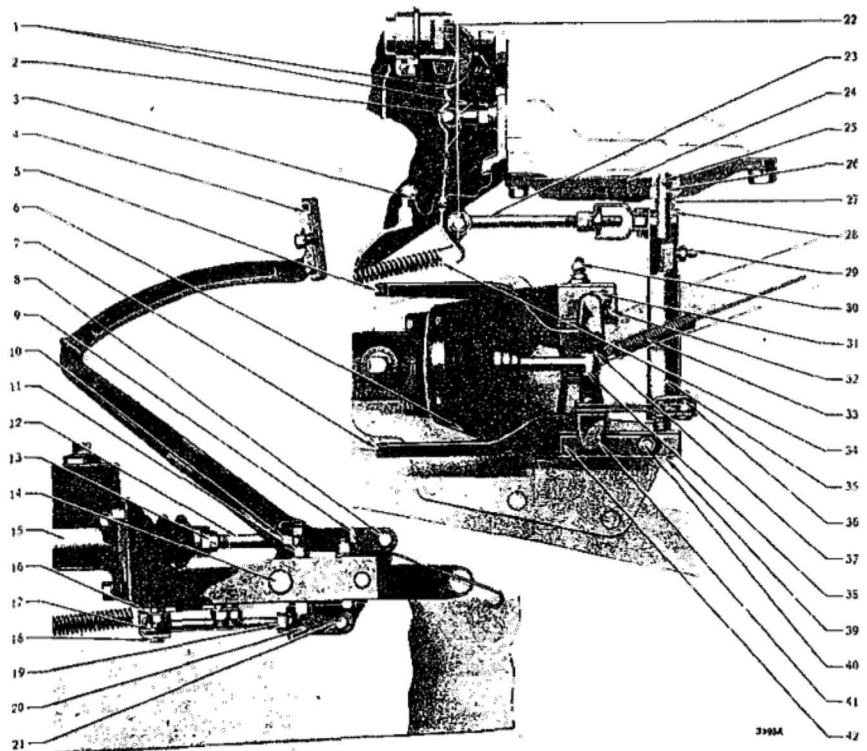
Tighten the cover cap screws a few turns each in progression until they are tight.

7. DISASSEMBLY OF CLUTCH.

1936-42—Mount the clutch assembly on the clutch compressing fixture and compress the springs. Remove the clutch release lever eye bolt nuts and slowly relieve the spring pressure. To remove the release levers, grasp the lever and eye bolt between the thumb and fingers (fig. 8), so that the flat side of the lever and upper end of the eye bolt are as close together as possible, keeping the eye bolt pin seated in its socket in the lever. The strut can then be lifted over the ridge on the end of the lever, making it possible to lift the lever and eye bolt off the pressure plate.

Figure 7—Clutch and Brake Pedal Linkage (1936 Model)

- 1—Clutch release fork and pivot spring assembly
- 2—Clutch release fork pivot
- 3—Clutch release fork seal
- 4—Pedal pad
- 5—Brake pedal and bushing assembly
- 6—Pedal and master cylinder bracket
- 7—Clutch pedal and bushing assembly
- 8—Clutch release torque tube clevis pin
- 9—Clutch pedal link
- 10—Clutch pedal to link clevis pin
- 11—Pedal adjusting clamp screw check nut
- 12—Master cylinder piston push rod end
- 13—Master cylinder piston push rod end check nut
- 14—Clutch and brake pedal shaft
- 15—Master cylinder assembly
- 16—Frame pedal bracket plate
- 17—Clutch release fork clevis pin spring washer
- 18—Clutch release fork clevis pin
- 19—Clutch release fork rod adjusting nut
- 20—Clutch release fork rod yoke
- 21—Clutch release torque tube clevis pin
- 22—Clutch release bearing sleeve
- 23—Clutch release fork rod
- 24—Clutch release torque tube support bracket
- 25—Clutch release torque tube to transmission bracket support pin



- 26—Clutch release torque tube to transmission bracket support
- 27—Clutch release torque tube spring
- 28—Clutch release torque tube washer
- 29—Clutch release torque tube lubricant nipple
- 30—Pedal shaft lubricant nipple
- 31—Pedal adjusting clamp screw—long
- 32—Pedal shaft clamp—short
- 33—Brake pedal pull-back spring
- 34—Clutch release fork pull-back spring

- 35—Clutch release torque tube
- 36—Clutch release torque tube clevis pin spring washer
- 37—Brake pedal pull-back spring clip
- 38—Master cylinder piston push rod end pin
- 39—Clutch release torque tube to pedal bracket support
- 40—Pedal shaft clamp screw—short
- 41—Pedal adjusting clamp screw—long
- 42—Pedal shaft clamp—long

8. ASSEMBLY OF CLUTCH.

1936-42—Place the pressure plate on the base of the clutch fixture. Install the baffle plate (on clutches so equipped). Hold the threaded end of the eye bolt between the thumb and index finger, with the lever end resting on the second finger (fig. 8), holding the lever and eye bolt close together. With the other hand, insert the strut in the slot of the pressure plate lug. By lifting the strut upward and tilting it at the same time, it will pass the ridge on the lower end of the lever and drop into its groove in the lever. Make sure the release lever springs are in position

and place the cover over the pressure springs. The tops of the pressure springs should index with the embossed seats in the cover. Compress the springs with the fixture and install the release lever eye bolt nuts, with the nuts about flush with the end of the eye bolt. Adjust release levers.

9. ADJUSTMENT OF CLUTCH RELEASE LEVERS WITH FIXTURE C-585.

1936-42—Using the clutch assembly model number (stamped on the clutch cover) as a guide, select the proper spacer

CHART OF CLUTCH FIXTURE SPACERS AND FEELER GAUGES

Clutch Assembly Model Number and Size		Fixture C-411		Fixture C-585
		Thickness Gauge	Feeler Blade	Spacer Number
869	9 $\frac{1}{4}$ "	None	"A"	18
899	10"	None	"A"	18
908	11"	$\frac{3}{16}$ inch	"B"	15
913	10"	$\frac{1}{16}$ inch	"B"	17
917	11"	$\frac{3}{16}$ inch	"B"	15
918	9 $\frac{1}{4}$ "	$\frac{1}{16}$ inch	"B"	17
928	10"	None	"E"	21
931	11"	None	"E" *	19
941	11"	None	"C"	19
955	9 $\frac{1}{4}$ "	None	"D"	20
957	10"	None	"E"	21

from the above chart. Then adjust the release levers as follows:

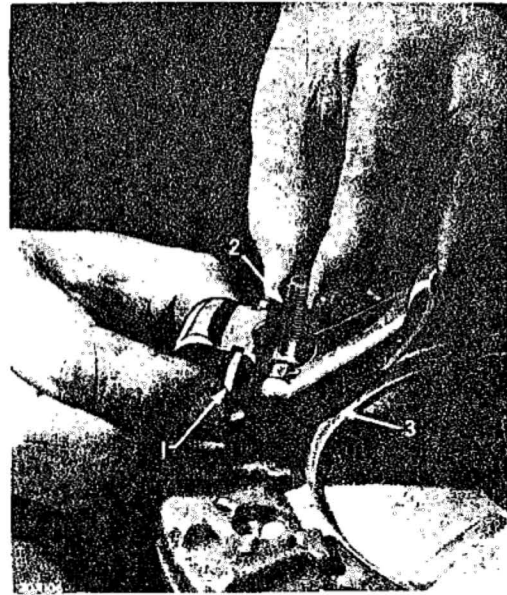
(1) Mount the clutch cover and pressure plate assembly on the fixture, with the release levers over the feeler blades in the base of the fixture (fig. 9).

(2) Place the proper spacer on the center screw of the fixture.

(3) Install the compression plate on the center screw. Make sure that it rests against the fingers of the clutch release levers. This plate can be reversed for proper clearance, depending on the size of the clutch.

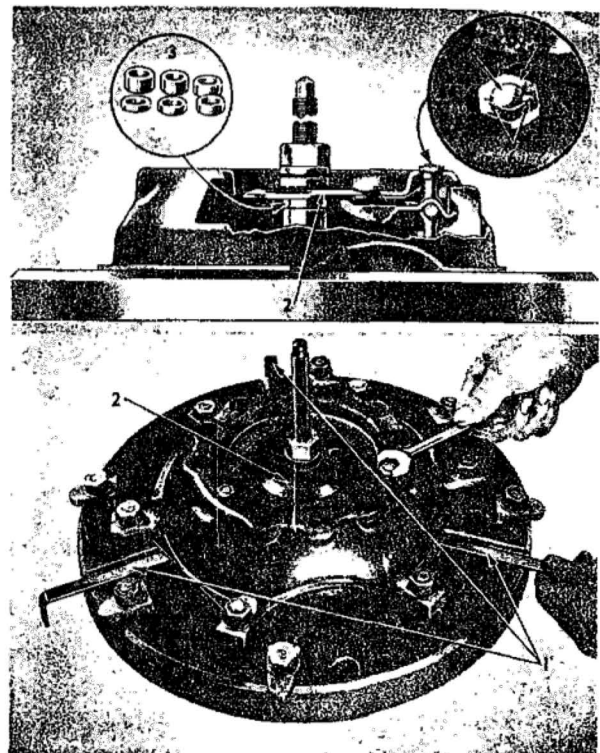
(4) Install the self-aligning washer, the plain thrust washer and the compression nut and tighten the nut until the clutch is fully compressed.

(5) Install the clutch housing clamps over the bolt holes and tighten them securely.



1—Release lever strut 2—Eye bolt
3—Release lever

Figure 8—Removing or Installing Release Lever (1936-42 Models)



1—Feeler blades (part of
Fixture C-585) 4—Clutch release lever
eye bolt
2—Compression plate
(part of Fixture C-585) 5—Clutch release lever
eye bolt nut
3—Spacers (part of
Fixture C-585) 6—Stake here to lock

**Figure 9—Adjusting Clutch Release Levers on
Fixture C-585 (1936-42 Models)**

9. ADJUSTMENT OF CLUTCH RELEASE LEVERS.

1936-42—Cont'd

(6) Adjust the clutch release levers until each of the three feeler blades have the same slight "drag" or "feel" while being pushed in and out. Tighten the release lever nuts to decrease "drag" and loosen to increase "drag."

(7) Stake the release lever nuts.

IMPORTANT

When removing the clutch cover assembly from the fixture, loosen the housing clamps first, then remove the compression nut. This will avoid throwing unequal strain on the release levers.

10. ADJUSTMENT OF CLUTCH RELEASE LEVERS WITH FIXTURE C-411.

1936-42—Determine the clutch assembly model number which is stamped on the clutch cover. Then, by using this number as a guide, select the proper thickness gauge and feeler blade from the chart shown on page 93. Adjust the release levers as follows:

(1) Insert the proper thickness gauge under the "Y" extension gauge and place them in that sequence on the main screw of the fixture. Then, with the extending end of the "Y" extension gauge directly over a clutch release lever, tighten the extension gauge lock nut (6, fig. 10).

(2) Insert the end of the feeler blade between the release lever and the extended end of the "Y" gauge and turn the clutch release lever adjusting nut until the feeler blade can just be moved, with a slight drag, between the "Y" gauge and the clutch release finger.

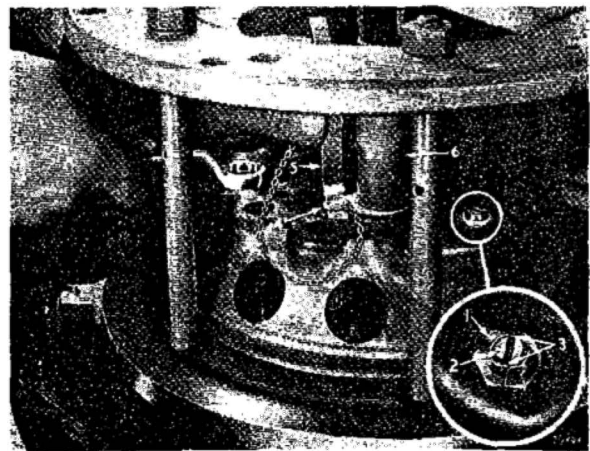
(3) Loosen the extension gauge lock nut and repeat the procedure of measuring for all of the clutch release levers.

(4) When adjustments have been made on all release levers, recheck the measurements with the feeler gauge. They must all have equal clearance adjustment.

CAUTION

Proper operation of the clutch is dependent upon accurate adjustments of the release levers. They must all be adjusted to exactly the same height above the machined surface of the pressure plate so as to maintain parallelism of the pressure plate and the flywheel. This adjustment cannot be accomplished by setting the levers parallel to the face of the release bearings after the clutch has been assembled to the flywheel because of variations in thickness of the driven plate. The most accurate method is to adjust the levers by using the special clutch compressing and adjusting fixture and following the settings as given in the foregoing.

(5) Pressure may then be relieved on the cover plate and the assembly installed on the flywheel making certain that the center punch marks on the flywheel and clutch cover register as they were marked before the assembly was removed from the flywheel.



- | | |
|----------------------|---|
| 1—Eye bolt nut | 5—Tool C-411-37-A |
| 2—Eye bolt | 6—Extension gauge lock nut—part of fixture. |
| 3—Stake here to lock | Tool C-411 |
| 4—Tool C-411-37-A | |

Figure 10—Adjusting Clutch Release Levers on Fixture C-411 (1936-42 Models)

Section VIII

COOLING SYSTEM

1. ADJUSTMENT OF FAN BELT.

1936-42—Loosen the generator mounting bracket pivot bolts and the adjusting strap lock screw. Pull out on the generator until the belt is just snug. Hold the generator in this position and tighten the adjusting strap lock screw and bracket pivot bolts.

CAUTION

Never adjust the fan belt by moving the generator with a pry bar and do not over-tighten the belt.

2. REPLACEMENT OF FAN BELT.

1936-42—Loosen the generator mounting bracket pivot bolts and the adjusting strap lock screw. Push the generator toward the engine and remove the belt from both pulleys. After installing belt, adjust it to the proper tension.

3. REPLACEMENT OF ENGINE WATER THERMOSTAT.

1936-42—Remove the by-pass elbow and cylinder head water outlet elbow and remove the thermostat. The thermostat has no adjustment and if it fails to operate, it should be replaced. *When installing the unit, be sure to install the cylinder water outlet elbow gasket and on the 1940-42 models the thermostat gasket.* Also on the 1940-42 models the thermostat has four by-pass ports and the alignment of the thin bridge that divides the ports should be from front to rear of the car (fig. 1). This will place two ports toward the radiator and the other two toward the rear, leaving the two wide faces toward right and left.

4. REPLACEMENT OF WATER DISTRIBUTOR TUBE.

1936-42—The water distributor tube is located between the cylinders and the valve ports near the top of the cylinder block. It

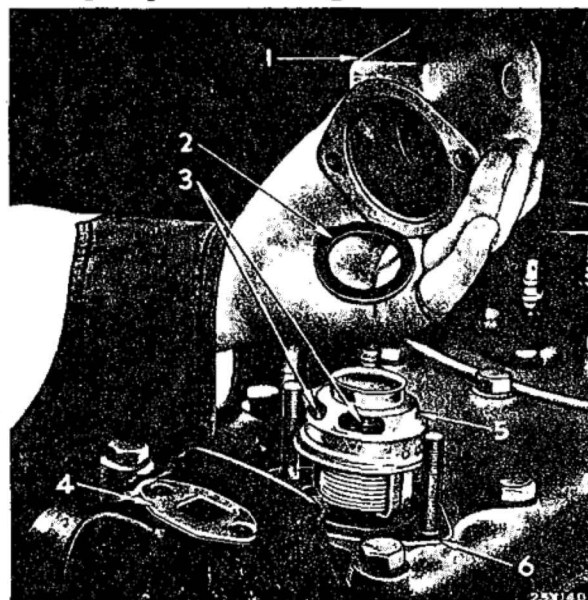
directs the flow of water from the water pump against the valve ports, which are the hottest spots in the engine. To remove tube, remove radiator and water pump, then use a stiff, hooked rod to pull the tube out of the cylinder block.

NOTE

It is recommended that the water distributor tube be replaced whenever the engine is completely overhauled. If the tube becomes rusted or corroded, overheating of the engine will occur due to failure of the water to circulate properly through the cylinder block.

5. REPLACEMENT OF WATER PUMP.

1941-42—Remove the fan belt and disconnect the water pump hose. Unfasten the water pump from the engine and lift out the



- | | |
|--|--------------------------------------|
| 1—Cylinder water outlet elbow, water pump by-pass elbow and hose | 4—Water pump by-pass elbow gasket |
| 2—Thermostat gasket | 5—Thermostat |
| 3—Thermostat openings | 6—Cylinder water outlet elbow gasket |

Figure 1—Removing Thermostat (1940-42 Models, Typical of 1936-39 Models)

DATA AND SPECIFICATIONS						
YEAR	1942	1941	1939-40	1938	1936-37	
Capacity, quarts	15	14	14	14	15	
Thermostat starts to open, degrees Fahrenheit	157-162	157-162	157-162	150-155	150-155	
Thermostat fully open, degrees Fahrenheit	187	187	187	180	185	
Hose Inside Diameter, inches	Inlet	1 $\frac{3}{4}$	1 $\frac{3}{4}$	1 $\frac{3}{4}$	1 $\frac{3}{4}$	
	Outlet-upper	1 $\frac{1}{2}$	1 $\frac{1}{2}$	1 $\frac{1}{2}$	1 $\frac{1}{2}$	
	Outlet-lower	1 $\frac{1}{2}$	1 $\frac{1}{2}$	1 $\frac{1}{2}$	1 $\frac{1}{2}$	
	By-pass	1 (P14C only)	1 (P12 only)	1 (P8, P10 only)	1 (P6 only)	1 (P2, P4 only)
Hose Length, inches	Inlet	P14C, 6 $\frac{1}{4}$ P14S, 7 $\frac{3}{4}$	P11, 9 $\frac{1}{2}$ P12, 8	P9, 9 P10, 7 $\frac{1}{2}$ P7, 10 $\frac{1}{2}$ P8, 6	P5, 8 P6, 6 $\frac{1}{2}$	P3, P4, 6 $\frac{1}{2}$ P1, 8 $\frac{3}{4}$ P2, 7 $\frac{1}{2}$
	Outlet-upper	3 $\frac{1}{2}$	3 $\frac{1}{2}$	P9, P10, 3 $\frac{1}{2}$ P7, P8, 3 $\frac{3}{4}$	3 $\frac{1}{2}$	3 $\frac{1}{2}$
	Outlet-lower	5 $\frac{1}{4}$	5 $\frac{1}{4}$	P9, P10, 5 $\frac{3}{4}$ P7, P8, 6 $\frac{3}{4}$	5 $\frac{1}{4}$	5 $\frac{1}{4}$
	By-pass	1 $\frac{5}{8}$ (P14C only)	1 $\frac{5}{8}$ (P12 only)	1 $\frac{3}{4}$ (P8, P10 only)	1 $\frac{3}{4}$ (P6 only)	1 $\frac{3}{4}$ (P2, P4 only)
Water pump shaft end play, inch	.003	.003	.003	.003	.003	

5. REPLACEMENT OF WATER PUMP.

1941-42—Cont'd

pump and fan blade assembly. When installing the pump, make sure all mating surfaces are clean, use new gaskets and attach pump securely to cylinder block.

1940—Remove the fan belt and disconnect the water pump hose. Unfasten the pump from the engine and push the pump against the radiator core. With stud pliers or a pipe wrench used on the studs between the pump and the block, remove the studs and lift off the pump and fan blade assembly.

NOTE

To facilitate installation, clean and oil the threads of the studs so they may be installed without difficulty. Make sure all mating surfaces are clean, use new gaskets and attach pump securely to cylinder block.

1939—Remove the hood lower side panels. Disconnect the fan blades and push the pulley and belt from the pump shaft.

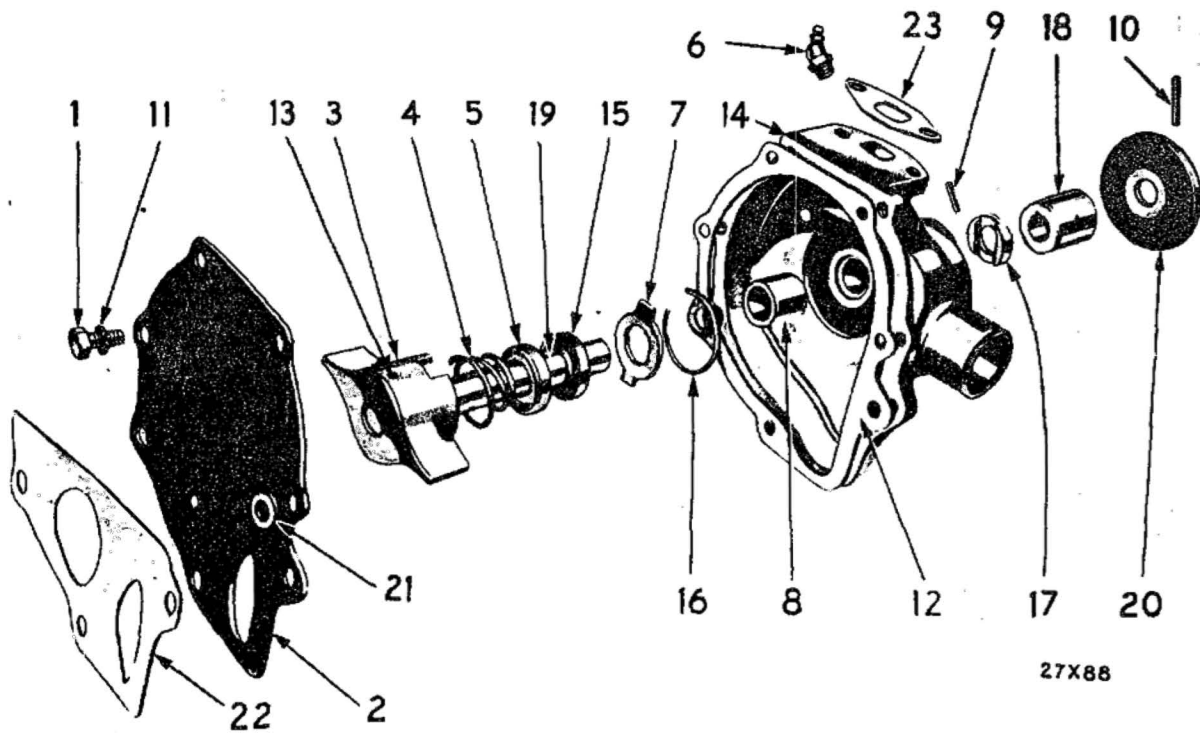


Figure 2—Water Pump (Disassembled View) (1942 Model, Typical of 1936-41 Models)

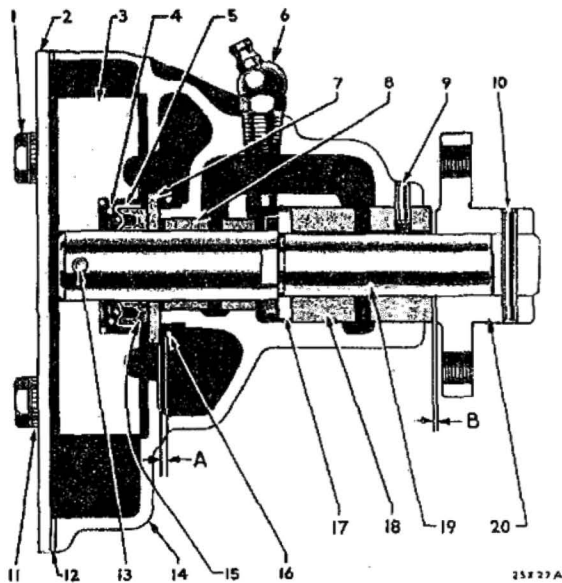


Figure 3—Water Pump (Assembled View) (1942 Model, Typical of 1936-41 Models)

- | | |
|--------------------------------------|---|
| 1—Body cover plate screw | 14—Body |
| 2—Body cover plate | 15—Seal |
| 3—Impeller | 16—Seal retainer washer lock ring |
| 4—Seal thrust spring | 17—Shaft thrust washer |
| 5—Seal retainer | 18—Shaft front bushing |
| 6—Lubricant nipple | 19—Shaft |
| 7—Seal retainer washer | 20—Fan pulley hub |
| 8—Shaft rear bushing | 21—Body cover plate screw washer |
| 9—Shaft front bushing pin | 22—Cover plate to cylinder block gasket |
| 10—Fan pulley hub pin | 23—By-pass elbow gasket |
| 11—Body cover plate screw lockwasher | A—Minimum dimension (3/32") |
| 12—Body cover plate gasket | B—End play (.003) |
| 13—Impeller pin | |

Remove the radiator outlet hose and the by-pass elbow from the pump body. Take off the cylinder head water outlet elbow and hose. Disconnect the pump from the engine and lift off the assembly. When installing the pump, make sure all mating surfaces are clean, use new gaskets and attach pump se-

curely to cylinder block.

1936-38—Remove the fan belt and disconnect the fan blades and pulley from the pump. Remove the by-pass elbow from the pump body and disconnect the pump from the engine.

5. REPLACEMENT OF WATER PUMP.

1936-38—Cont'd

NOTE

On 1938 models, it is necessary to remove the radiator core. For this procedure, see paragraph 9.

When installing pump, be sure all mating surfaces are clean, use new gaskets and attach pump securely to cylinder block.

6. DISASSEMBLY OF WATER PUMP.

1936-42—Drive the pin out of the fan pulley hub and use a puller to pull the hub off the shaft. Remove the cover and pull the impeller and shaft out of the body. Drive out the pin that holds the impeller to the shaft (if either the impeller or shaft is to be replaced). Drive the front bushing pin into the shaft hole of the bushing to permit removal of the bushings. Pull the front and rear bushings from the body, pulling them out toward the front (fig. 4). Remove the seal, spring and retainer washers from shaft.

7. ASSEMBLY OF WATER PUMP.

1936-42—Before assembling the pump inspect the seal surface of the body; if rough, reface it with refacer C-384. (Omit this

operation if the bushings are to be replaced.) If new bushings are to be installed, insert the pump shaft thrust washer in pump body, with the flat side facing out. Press the bushings into the body, from opposite sides (fig. 5) to the dimensions shown on figure 6. Drill and pin the front bushing. Remove any burrs inside the bushings and line burnish both bushings and reface the seal seat as shown in figure 7. Then continue to assemble the pump as follows:

(1) Install the impeller on the shaft and drill for the impeller pin with a $\frac{1}{8}$ inch drill. Peen both ends of pin after installing.

(2) Assemble the seal thrust spring, seal retainer, seal (fig. 8), seat retainer washer with glazed surface against seal, and seal retainer lock ring.

(3) Insert the shaft assembly through

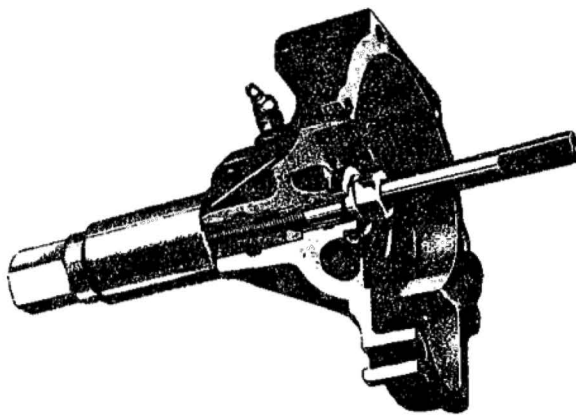


Figure 4—Removing Water Pump Shaft Bushings with Tool C-373 (1936-42 Models)

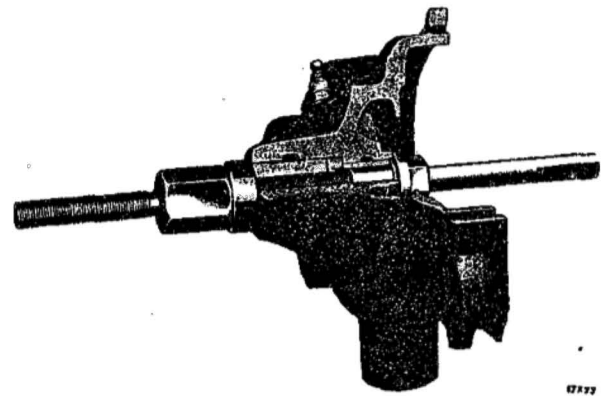


Figure 5—Installing Water Pump Shaft Bushings with Tool C-373 (1936-42 Models)

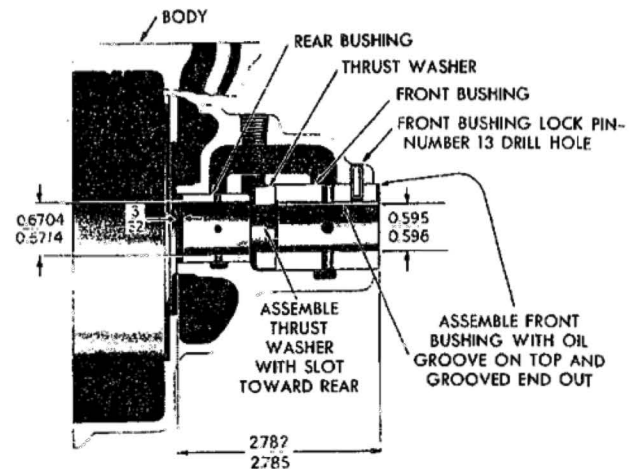


Figure 6—Water Pump Bushings Installed (1936-42 Models)

the rear bushing, thrust washer and front bushing.

(4) Press the fan pulley hub on the pump shaft, leaving a clearance between the bushing and hub to provide a shaft end play of .003 inch. Drill the shaft (if a new one is being used), and install the retaining pin. When installing the hub, position it on the shaft (if the old one is being used) so the shaft can be drilled 90 degrees from the old hole.

(5) Remove all traces of gaskets, install the cover and lubricate the pump.

8. WATER TEMPERATURE INDICATOR.

1936-42—The thermometer on the instrument panel is operated by a gas-filled metal bulb connected to the gauge assembly by a capillary tube. This tube is screwed into the water jacket of the cylinder head. If the gauge fails to indicate or operate properly, the complete assembly (tube, gauge and bulb) should be replaced.

NOTE

The gauge will not stand a temperature in excess of 250° F. If the gauge is found to have a permanent set so that it does not return to 100° F when cold, it is an indication that extreme high temperatures have been produced by conditions such as low water level or frozen radiator.

If the inaccuracy of the gauge is not over 30° F, it is frequently possible to correct the instrument reading by bending the link which connects the operating tube to the gauge pointer. The metal bulb should be immersed in water and tested at approximately 140° and 212° F after this adjustment.

CAUTION

Care should be used when working on the engine or when removing the cylinder head, not to damage the tube or bulb. Sharp kinks in the tube must be avoided.

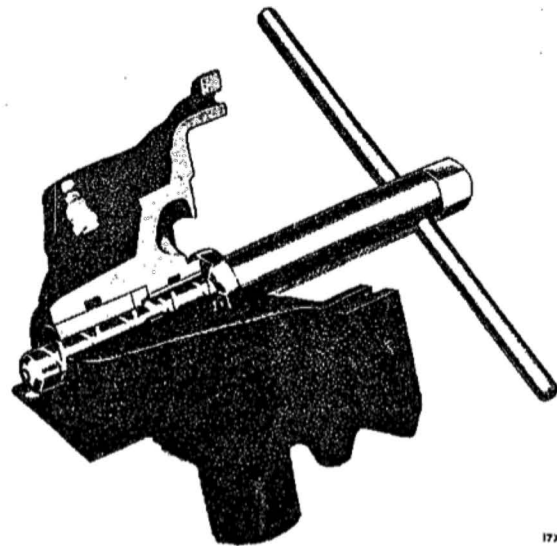
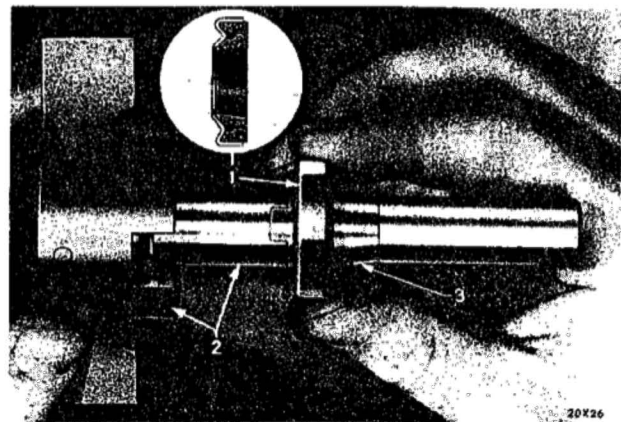


Figure 7—Line Burnishing Bushings and Facing Water Pump Housing with Tool C-384 (1936-42 Models)



1—Seal 2—Water pump shaft and impeller
3—Tool C-528

Figure 8—Installing Water Pump Seal (1936-42 Models)

9. REMOVAL OF RADIATOR CORE.

1942—Remove radiator inlet and outlet hose. Remove the screws which hold the core to the support and lift out the core assembly.

1941—Disconnect the upper and lower radiator hose. Unclip headlight wires and move them out of way. Remove the brackets at the upper corners of the radiator support, disconnect the support from the core and lift out the core.

1940—Remove the hood and water pump assembly. Disconnect the engine water outlet hose. Bend back the clips which hold

9. REMOVAL OF RADIATOR CORE.

1940—Cont'd

the headlight wires to the radiator core. Disconnect the core from the radiator support and lift out the radiator core.

1939—Remove the hood and lower side panels. Remove the radiator inlet and outlet hose connections. Remove the fan and pulley assembly. Disconnect the headlight wires at the junction block on the lower left front fender shield and push the wires, toward the front, through the side flange of the radiator core. When assembling, these wires may be easily entered and passed through the hole in the flange by first tying a long strong piece of twine around the terminals of the wires and passing the string through the hole (from the front toward the rear). When the core is in place, pull the wires through with the string. Remove the cap screws which hold the radiator core to the radiator support (3 on each side) and lift out the core. In some instances it may be necessary to loosen the lower front screws which hold the upper sections of the right and left fender shields. The ends of these screws may interfere with the radiator core flanges.

1936-38—Remove fan blades. Remove hood and radiator brace rods. Remove radiator inlet and outlet hose connections. Remove radiator core mounting bolts and lift out the core.

10. REMOVAL AND INSTALLATION OF RADIATOR AND FENDER UNIT.

1942—Disconnect the battery cables, the horn wires at the relay, hood lock plate cable,

and the headlight wires at the junction block at the left fender. Remove the hood side panel, disconnect the inlet and outlet water hoses, and remove the front bumper. Unfasten the fenders from the body, the radiator core from the support, and the lower bolt and nut on each inspection shield at the fenders. Bend back the skirt of the shield to eliminate interference and lift off the assembly. After installing the assembly, aim the headlights.

1941—Remove the hood, battery and front bumpers. Disconnect the horn wires at the relay and remove the horn and mounting plate assembly. Disconnect the headlight wires at the junction block on the left fender. Remove the hood lock and plate assembly, being sure to mark the plate and radiator shield so that the lock assembly can be installed in approximately the same position. Disconnect the inlet and outlet water hoses. Disconnect the fenders from the body, then remove the nuts from the fender braces and running boards. After removing the radiator support bolts, lift off the fenders, radiator core, hood side panels and radiator shell as one complete unit. After installing the assembly, aim the headlights.

1939-40—Remove the engine inlet and outlet hoses. Remove the hood and front bumper. Disconnect the headlight wires at the junction block on the left fender upper inspection shield. Disconnect the fenders from the cowl and lift off the complete unit. After installing the assembly, aim the headlights.

Section IX

ENGINE

DATA AND SPECIFICATIONS					
Year	1942	1941	1937-40	1936	
Type	"L" head	"L" head	"L" head	"L" head	
No. of cylinders	6	6	6	6	
Taxable horsepower	25.35	23.44	23.44	23.44	
Piston displacement	217.8 cu. in.	201.3 cu. in.	201.3 cu. in.	201.3 cu. in.	
Bore	3 $\frac{1}{4}$ in.	3 $\frac{1}{8}$ in.	3 $\frac{1}{8}$ in.	3 $\frac{1}{8}$ in.	
Stroke	4 $\frac{3}{8}$ in.	4 $\frac{3}{8}$ in.	4 $\frac{3}{8}$ in.	4 $\frac{3}{8}$ in.	
Compression ratio	6.8 to 1	6.7 to 1	6.7 to 1	6.7 to 1	
Compression pressure at cranking speed	See paragraph 2	See paragraph 2	See paragraph 2	See paragraph 2	
Oiling System	Engine lubrication, type	Pressure	Pressure	Pressure	
	Oil pump, type	Gear	Gear	Gear	
	Oil pump driven by	Camshaft	Camshaft	Camshaft	
	Oil pressure, normal, above 30 M.P.H.	30 to 45 lb.	30 to 45 lb.	30 to 45 lb.	30 to 40 lb.
	Engine oil refill capacity	5 qt.	5 qt.	5 qt.	5 qt.
Connecting Rod & Bearings	Bearings, type	Replaceable precision	Replaceable precision	Replaceable precision	Replaceable precision
	Bearing clearance desired, inches	.001-.002	.001-.002	.001-.002	.001-.002
	Bearing end play, inches	.005-.011	.005-.011	.005-.011	.005-.011
	Piston pin bushing inside diameter, inches	$\frac{55}{64}$	$\frac{55}{64}$	$\frac{55}{64}$	$\frac{55}{64}$
Crankshaft and Bearings	Bearings, type	Replaceable precision	Replaceable precision	Replaceable precision	Replaceable precision
	Number of main bearings	4	4	4	4
	Bearing clearance desired, inches	.001-.002	.001-.002	.001-.002	.001-.002
	Bearing end play, inches	.003-.007	.003-.007	.003-.007	.003-.007
	End thrust taken by	Rear bearing	Rear bearing	Rear bearing	Rear bearing

DATA AND SPECIFICATIONS—Cont'd					
Year	1942	1941	1937-40	1936	
Pistons	Piston type	Light weight cast iron	Aluminum alloy, U-slot, cam ground	Aluminum alloy, U-slot, cam ground	Aluminum alloy, T-slot, cam ground
	Head clearance, inches	.021	.028	.021	.022
	Skirt clearance	.001-.0015 in. or 10 to 15 lb. pull on .0015 in. feeler (see paragraph 17)	.0005-.001 in. or 6 to 9 lb. pull on .002 in. feeler (see paragraph 17)	.0005-.001 in. or 6 to 9 lb. pull on .002 in. feeler (see paragraph 17)	.0005-.001 in. or 10 to 15 lb. pull on .0015 in. feeler (see paragraph 17)
Piston Pins	Type	Floating	Floating	Floating	Floating
	Piston pin clearance in piston	Double thumb press fit at 70°	Thumb press fit at 130° F.	Thumb press fit at 130° F.	Thumb press fit at 130° F.
	Piston pin clearance in rod bushing	Tight thumb press fit at 70°	Tight thumb press fit at 70° F.	Tight thumb press fit at 70° F.	Tight thumb press fit at 70° F.
Piston Rings	Number per piston	4	4	4	4
	End gap, inches	.007-.015	.007-.015	.007-.015	.007-.015
	Compression rings, width, inches	2 rings— $\frac{3}{32}$	Upper— $\frac{3}{32}$ Lower— $\frac{1}{8}$	2 rings— $\frac{1}{8}$	2 rings— $\frac{1}{8}$
	Oil rings, width, inches	2 rings— $\frac{5}{32}$	2 rings— $\frac{5}{32}$	2 rings— $\frac{5}{32}$	2 rings— $\frac{5}{32}$
	Compression ring side clearance in groove, inches	.0025-.004	.0025-.004	.002-.004	.002-.004
	Oil ring side clearance in groove, inches	.001-.0025	.001-.0025	.001-.0025	.002-.003
Cams, Valves, Springs and Guides	Valve seat angle, degrees	45	45	45	45
	Intake valve stem clearance in guide, inches	.001-.003	.001-.003	.001-.003	.001-.003
	Exhaust valve stem clearance in guide, inches	.003-.005	.003-.005	.003-.005	.003-.005
	Intake valve stem guide, ream to, inches	.342-.343	.342-.343	.342-.343	.342-.343
	Exhaust valve stem guide, ream to, inches	.344-.345	.344-.345	.344-.345	.344-.345

DATA AND SPECIFICATIONS—Cont'd					
Year	1942	1941	1937-40	1936	
Camshaft, Valves, Springs and Guides—Cont'd	Distance from top of cylinder block to valve guide, inches	$\frac{7}{8}$	$\frac{7}{8}$	$\frac{7}{8}$	$\frac{7}{8}$
	Intake valve tappet clearance (hot), inches	.008	.008	.006	.006
	Exhaust valve tappet clearance (hot), inches	.010	.010	.008	.008
	Intake valve tappet clearance (cold), inches	.009	.009	.007	.007
	Exhaust valve tappet clearance (cold), inches	.014	.014	.012	.012
	Valve spring pressure, valve closed, pounds and inches	40-45 @ $1\frac{3}{4}$	40-45 @ $1\frac{3}{4}$	34-38 @ $1\frac{3}{4}$	34-38 @ $1\frac{3}{4}$
	Valve spring pressure, valve open, pounds and inches	107-115 @ $1\frac{3}{8}$	107-115 @ $1\frac{3}{8}$	77-83 @ $1\frac{1}{16}$	77-83 @ $1\frac{1}{16}$
	Camshaft end play, inches	.002-.006	.002-.006	.002-.006	.002-.006
	Camshaft bearing clearance, inches	.001-.003	.001-.003	.001-.003	.001-.003

1. DESCRIPTION.

1936-42—The Plymouth engine is a 6-cylinder, L-head type, equipped with hardened seat inserts for the exhaust valves and replaceable camshaft, crankshaft and connecting rod bearings. All bearings are lubricated under pressure through a system of drilled passages. The pistons, piston pins, cylinder walls and valve tappets are lubricated by oil spray from the lower connecting rod bearings. Full length water jackets and a water distributor tube provides uniform cooling of the cylinder block.

2. ENGINE TESTS AND ADJUSTMENTS.

1936-42—To maintain engine operating efficiency, keep the units of the ignition and fuel systems in proper adjustment. Vacuum and compression tests will reveal the oper-

ating condition of the engine and indicate the need for engine tune-up or replacement of internal parts.

a. Test Compression. With the engine at normal operating temperature, remove all spark plugs and install compression gauge in one cylinder. Hold throttle wide open and crank engine with starter until maximum reading is obtained. Note reading and test the other 5 cylinders. If reading indicated by the compression gauge is reasonably high, 90 pounds or higher at sea level (with a reduction of approximately 3 lb. for each 1000 feet altitude), compression pressures can be considered normal. If pressure in any cylinder is weak, make the following inspections:

(1) Inject oil in the spark plug hole on top of the piston with the piston down.

ENGINE TUNE-UP CHART				
Year	1942	1941	1939-40	1936-38
Distributor point gap, inches	.020	.020	.020	.020
Cam angle (point dwell), degrees	38	38	38	38
Breaker point spring tension, ounces	16 to 19	18 to 20	18 to 20	18 to 20
Timing marks on	Crankshaft vibration damper	Fan drive pulley	Fan drive pulley	Fan drive pulley
Ignition timing (spark occurs)	T.D.C.	T.D.C.	T.D.C.	.007 in. A.T.D.C.
Spark plug size	14 mm	14 mm	14 mm	14 mm
Spark plug gap, inches	.025	.025	.025	.025
Carburetor idle adjustment—No. turns open	½ to 1¼	½ to 1¼	½ to 1¼	½ to 1¼
Carburetor float level, inches below top of float chamber	¾	¾	¾	¾ P5—17/32*
Intake tappet clearance, running, inches	.008	.008	.006	.006
Exhaust tappet clearance, running, inches	.010	.010	.008	.008
*Dimension for Chandler Groves carburetor. Dimension for Carter carburetor ¾ inch.				

a. Test Compression.

1936-42—Cont'd

(2) Wait a few minutes for oil to run down over the rings, to prevent oil getting on the valves, and repeat the compression test.

(3) The oil seals the rings so that a low reading on the first test, which remains low on the second test, indicates leaky valves.

(4) A low reading on the first test, which becomes a high reading on the second test, indicates leaky piston rings.

(5) If either condition exists, grind the valves or replace the piston rings.

(6) An extremely low compression reading on two adjacent cylinders indicates a leaking cylinder head gasket. A gasket which has blown out between cylinders will cause erratic explosions between the two cylinders.

b. *Test Vacuum.* A steady reading of 18 to 21 inches of vacuum at sea level (with a reduction of approximately ¾ inch for each 1000 feet altitude) indicates normal engine performance at idling speed. Vacuum readings are affected by the following conditions:

- (1) Improper carburetor adjustment.
- (2) Improper ignition timing.
- (3) Burned, riding or sticking valves.
- (4) Loose valve guides; weak valve springs.
- (5) Leaky intake manifold or carburetor gaskets.

- (6) Poor piston ring seal

c. Adjust Ignition System.

(1) Use a round feeler gauge to adjust spark plug points, to insure accurate read-

ings, and adjust the points to .025 inch. Too wide a gap reduces speed and power. Too narrow a gap causes uneven engine idling.

(2) Adjust the distributor points to .020 inch.

(3) Test the condenser with an accurate condenser tester. A defective condenser may cause burning of the distributor points.

(4) Inspect the distributor cap and rotor for cracks and damage.

(5) Inspect the small flexible lead wires for breakage or damaged insulation.

(6) Test the ignition coil with an accurate coil tester.

(7) Inspect both primary and high tension wires for poor insulation or connections and tighten as required.

(8) Check ignition timing and adjust to specifications in "Engine Tune-up Chart."

d. Service Fuel System.

(1) Clean and oil the carburetor air cleaner.

(2) Disconnect the main fuel line at the fuel pump and tank, then blow through the line with compressed air.

(3) Use a gauge and measure from the top edge of the float chamber, with gasket removed, to top of float and adjust to 5/64 inch on all Carter carburetors and to 17/32 inch on the Chandler Groves carburetor (used on 1938 P5 model). On the Carter carburetors, bend vertical lip of float only; bend the lip away from needle to raise the float level and toward the needle to lower float level. On Chandler Groves carburetors, bend both float arms equally; bend the float arms away from the needle to raise the float and toward needle to lower the float. While the carburetor cover is off, clean out dirt and foreign material from the bowl.

(4) Clean the fuel pump filter bowl. Inspect the bowl gasket and replace if necessary.

(5) Use a vacuum gauge and set the carburetor idle mixture adjustment to the highest vacuum reading.

(6) Adjust the carburetor throttle stop screw so the engine idles at not less than 6 miles per hour.

(7) Set the accelerator pump linkage according to the season of the year: Hot weather—short stroke hole, Normal summer driving—center hole, Cold weather—long stroke hole.

e. Tighten Cylinder Head and Manifold.

(1) Tighten manifold stud nuts.

(2) Tighten cylinder head cap screws to 65 to 70 foot pounds; tighten nuts to 55 to 60 foot pounds in the sequence shown in figure 3.

f. Adjust Valve Tappets. Adjust the valve tappets to specifications shown on "Engine Tune-up Chart."

g. Service Cooling System.

(1) Tighten the hose connections and inspect the entire cooling system for water leaks.

(2) Inspect the fan belt for condition and tension and replace or adjust as necessary.

3. REMOVAL AND INSTALLATION OF ENGINE.

1942

NOTE

It is not necessary to remove the radiator and front fender unit to take out the engine.

(1) Remove the hood, and the storage battery.

(2) Remove the radiator core, as explained in paragraph 9 on page 99, and take off the fan blades.

(3) Remove the floor boards and remove the transmission. See paragraph 2 on page 193.

(4) Disconnect fuel pump flexible line at fuel pump and exhaust pipe at the manifold.

(5) Disconnect throttle and choke controls.

3. REMOVAL AND INSTALLATION OF ENGINE.

1942—Cont'd

(6) Disconnect heat indicator tube and bulb at cylinder head and oil gauge line at oil line flexible tube.

(7) Disconnect high and low tension ignition wires at ignition coil and wires at generator.

(8) Disconnect clutch pedal linkage and windshield wiper vacuum hose.

(9) Remove the crankcase ventilator breather pipe, and the engine front and rear support bolts.

(10) After raising the engine sufficiently, remove the front engine support and lift out the engine.

(11) When installing the engine, use new cotter pins, gaskets, etc. Before tightening the engine support bolts (figs. 1 and 2), loosen the exhaust pipe support brackets and allow the engine to run a few seconds, then tighten engine support bolts and exhaust pipe support brackets. *This is important for correct engine alignment.* Align hood and aim headlights.

1939-41

(1) Remove the hood and front bumper.

(2) Remove the upper and lower water hose.

(3) Remove floor boards, propeller shaft and, if equipped with power shift, remove the vacuum control from transmission and disconnect speedometer cable from transmission.

(4) Remove radiator shell, core, fenders and sheet metal as a unit.

(5) Disconnect fuel pump flexible line and exhaust pipe from manifold.

(6) Disconnect oil gauge line at oil gauge flexible tube and throttle and choke controls.

(7) Disconnect headlight wires at left front fender apron, starter cable at starter, coil wires at coil, battery ground cable and wires at generator.

(8) Disconnect hand brake cable at brake band, gearshift and selector rods or cable at transmission and the clutch pedal linkage.

(9) On model P7, remove transmission cover and shift lever.

(10) Disconnect heat indicator tube and bulb at cylinder head.

(11) Remove crankcase ventilator breather pipe.

(12) Remove engine front and rear support bolts and after loosening the engine splash pans at both sides, lift out the power plant assembly.

(13) When installing the engine, use new cotter pins, gaskets, etc. Before tightening the engine support bolts (figs. 1 and 2), loosen the exhaust pipe support brackets and allow the engine to run a few seconds, then tighten the engine support bolts and exhaust pipe support brackets. *This is important for correct engine alignment.* Align hood and aim headlights.

1936-38

(1) Remove the hood and radiator brace rods on 1936-37 models, and the hood side panels on 1938 model cars.

(2) Remove the fan blades and radiator core.

(3) Remove floor boards.

(4) Disconnect hand brake cable, propeller shaft, clutch release fork and remove transmission.

(5) Disconnect starter cable, generator wire and distributor wires.

(6) Disconnect oil line from gauge to cylinder block.

(7) Disconnect heat indicator tube and bulb at cylinder head and throttle and choke control rods.

(8) Disconnect fuel line at fuel pump.

(9) Disconnect exhaust pipe.

(10) Remove engine front and rear support bolts and lift engine out of chassis.

(11) When installing the engine, use new cotter pins, gaskets, etc. Before tightening engine support bolts (figs. 1 and 2), loosen the exhaust pipe support brackets and allow the engine to run a few seconds, then tighten engine support bolts and exhaust pipe support brackets. *This is important for correct engine alignment.* Align hood and aim headlights.

4. CYLINDER HEAD INSTALLATION.

1936-42—When installing cylinder head, always use a new gasket and make sure cylinder head and cylinder block are free from carbon and dirt. Tighten cap screws, or nuts, in the sequence shown in figure 3, drawing all screws or nuts down evenly, repeating the operation until they are tight. A final tightening should be made on engines with cast iron heads when the engine has been run sufficiently long to bring all parts to operating temperature. For engines with aluminum heads, check the tension after the engine has been run and cooled and while it is still cool. Using a torque wrench, tighten cap screws to 65 to 70 foot pounds; nuts to 55 to 60 foot pounds.

5. REPLACEMENT OF VALVES AND SPRINGS.

1936-42

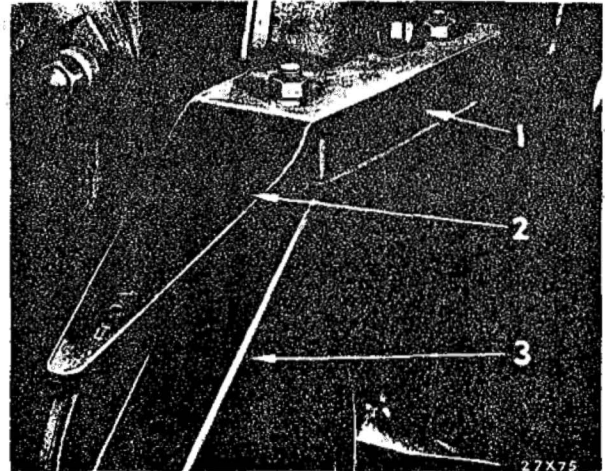
(1) Remove cylinder head and gasket.

(2) Remove right front wheel and lower wheel housing panel.

(3) Remove the valve compartment covers and plug the holes in the cylinder block around the valve tappets so that the valve locks will not fall into the oil pan when the locks are removed.

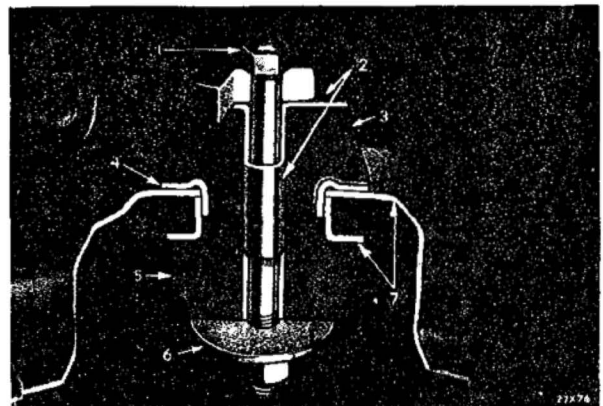
(4) Compress the valve springs, remove the valve locks and lift out the valves.

(Continued on page 109)



1—Insulator assembly 2—Chain case cover plate
3—Engine front support plate

Figure 1—Engine Front Support (1936-42 Models)



1—Bolt 5—Insulator—lower
2—Spacer 6—Insulator washer—
3—Insulator—upper lower
4—Insulator retainer— 7—Frame
upper

Figure 2—Engine Rear Support (1936-42 Models)

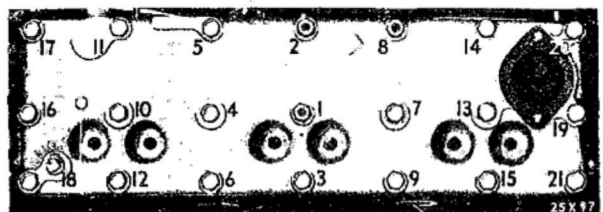


Figure 3—Sequence for Tightening Cylinder Head
(1936-42 Models)

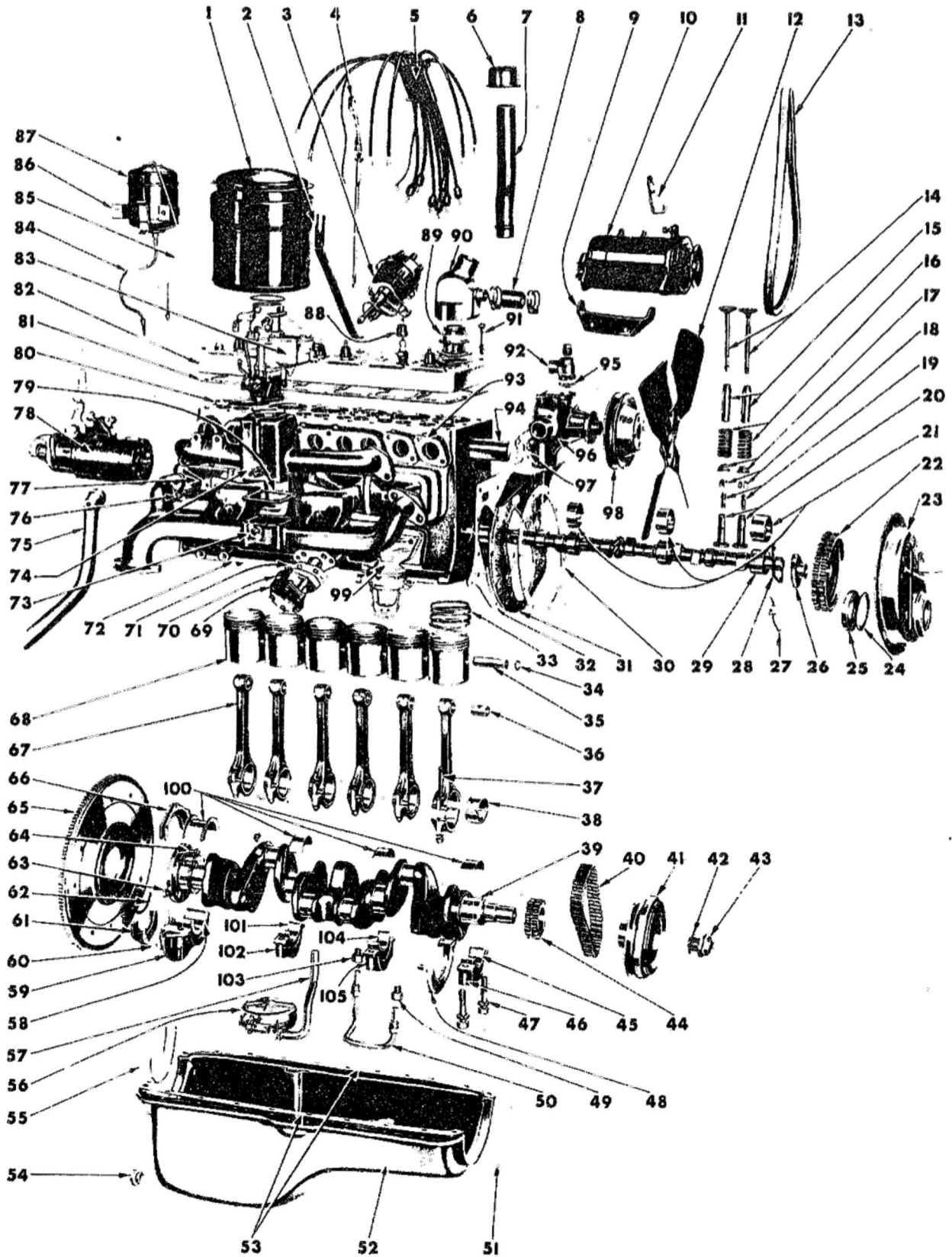


Figure 4—Engine (Disassembled View) (1942 Model, Typical of 1936-41 Models)

Legend for Figure 4—Engine (Disassembled View) (1942 Model, Typical of 1936-41 Models)

- | | | |
|---|---|--|
| 1—Carburetor air cleaner assembly | 40—Timing chain | 74—Intake manifold |
| 2—Carburetor air cleaner steady bracket | 41—Hub and fan pulley—lower | 75—Crankcase ventilator outlet pipe |
| 3—Ignition distributor assembly | 42—Crankshaft starting jaw lockwasher | 76—Valve spring cover screw and gasket |
| 4—Oil level indicator | 43—Crankshaft starting jaw | 77—Valve spring cover |
| 5—Ignition cable tube and bracket | 44—Crankshaft sprocket | 78—Starter assembly |
| 6—Crankcase ventilator air cleaner | 45—Crankshaft bearing—No. 1 lower | 79—Intake to exhaust manifold gasket |
| 7—Oil filler or breather pipe | 46—Crankshaft bearing cap—No. 1 | 80—Exhaust valve seat |
| 8—Water pump by-pass hose | 47—Crankshaft bearing cap bolt and lockwasher | 81—Cylinder head gasket |
| 9—Generator mounting bracket | 48—Oil pan front end oil seal plate | 82—Cylinder head |
| 10—Generator assembly | 49—Oil pump outlet pipe nipple | 83—Carburetor assembly |
| 11—Generator adjusting strap | 50—Oil pump outlet pipe | 84—Oil filter to engine tube |
| 12—Fan | 51—Oil pan gasket—front | 85—Engine to oil filter tube |
| 13—Fan and generator belt | 52—Oil pan | 86—Oil filter clamp |
| 14—Inlet and exhaust valves | 53—Oil pan gaskets—right and left | 87—Oil filter assembly |
| 15—Valve stem guides | 54—Oil pan drain plug and gasket | 88—Spark plug cover |
| 16—Valve springs | 55—Oil pan gasket—rear | 89—Thermostat |
| 17—Valve spring retainers | 56—Oil pump strainer | 90—Cylinder head water outlet elbow |
| 18—Valve spring retainer locks | 57—Oil suction pipe | 91—Cylinder head screw |
| 19—Valve tappet adjusting screws | 58—Crankshaft bearing—No. 4 lower | 92—Water pump by-pass elbow |
| 20—Valve tappets | 59—Crankshaft bearing cap—No. 4 | 93—Manifold gasket |
| 21—Camshaft bearings | 60—Crankshaft rear bearing oil seal retainer gasket | 94—Cylinder block water distributor tube |
| 22—Camshaft sprocket | 61—Crankshaft rear bearing oil seal retainer | 95—By-pass elbow gasket |
| 23—Chain case cover | 62—Crankshaft rear bearing oil seal | 96—Water pump assembly |
| 24—Chain case cover oil seal gasket | 63—Flywheel bolt nut and lockwasher | 97—Water pump to cylinder block gasket |
| 25—Chain case cover oil seal | 64—Flywheel bolt | 98—Fan pulley—upper |
| 26—Camshaft sprocket hub | 65—Flywheel and ring gear | 99—Fuel pump assembly |
| 27—Camshaft sprocket oil tube | 66—Crankshaft rear bearing oil seal retainer and gasket | 100—Crankshaft bearings—upper |
| 28—Camshaft sprocket hub thrust plate | 67—Connecting rod | 101—Crankshaft bearing—No. 3—lower |
| 29—Camshaft | 68—Piston | 102—Crankshaft bearing cap—No. 3 |
| 30—Chain case cover gasket | 69—Oil pump cover and gasket | 103—Oil pump outlet pipe nipple |
| 31—Chain case cover plate | 70—Oil pump body | 104—Crankshaft bearing—No. 2 lower |
| 32—Chain case cover plate gasket | 71—Oil pump body gasket | 105—Crankshaft bearing cap—No. 2 |
| 33—Piston rings | 72—Cylinder block | |
| 34—Piston pin lock ring | 73—Manifold heat control valve thermostat | |
| 35—Piston pin | | |
| 36—Piston pin bushing | | |
| 37—Connecting rod cap bolt | | |
| 38—Connecting rod bearing | | |
| 39—Crankshaft | | |

5. REPLACEMENT OF VALVES AND SPRINGS.*1936-42—Cont'd***NOTE**

Whenever valve springs are removed, they should be checked for proper tension according to the specifications given in the "Data and Specifications" Chart on page 103. If not within the limits specified, they should be replaced. When installing springs, the closely coiled ends must be at the top and against the cylinder block.

6. ADJUSTMENT OF VALVE TAPPET CLEARANCE.*1936-42*

(1) The clearances shown in the "Data and Specifications" Chart on page 103 should be maintained at all times.

(2) If the tappets are still noisy after they have been adjusted to the proper clearances, check for tappets being loose in guides, weak valve springs and sticky valves.

(3) To adjust the clearance, remove the right front wheel, take off the sheet metal panel, remove the valve compartment covers and adjust the valve clearance.

6. ADJUSTMENT OF VALVE TAPPET CLEARANCE.

1936-42—Cont'd

(4) Be sure the valve compartment covers fit tight, to prevent an oil leak at this point.

7. RECONDITIONING OF EXHAUST VALVE SEAT INSERTS.

1936-42—The exhaust valve inserts are too hard to reface by the ordinary hand grinding method, therefore they should be reground with a stone. Special valve seat insert reconditioning equipment (C-372) is available for this purpose. When using this equipment, be sure the valve guides are clean and that the valve guide pilot is a snug fit, in order to assure a concentric finish. Finished seats should be checked with a dial indicator and run-out should not exceed .001 inch.

8. REPLACEMENT OF EXHAUST VALVE SEAT INSERTS.

1936-42

(1) Remove the old seat with puller C-378 and remove all burrs and rough edges.

(2) Chill the new seat with dry ice, to obtain maximum contraction, and install seat in cylinder block.

(3) If a standard seat insert is too loose (less than .002 in. press fit), a .010 inch oversize seat is available. To install an oversize seat, the cylinder block must be recut to fit the seat.

9. REPLACEMENT OF VALVE STEM GUIDES (VALVES AND SPRINGS REMOVED).

1936-42—When installing new guides, drift into position so that the distance from the top of the cylinder block to the top of the valve guide is $\frac{7}{8}$ inch. Then ream intake guides to .342 to .343 inch and exhaust guides to .344 to .345 inch.

10. REPLACEMENT OF VALVE TAPPETS.

1936-42—If the valve tappet guides are worn excessively, remove the tappets, ream the guides and install oversize tappets. To

remove tappets, remove valves and springs, oil pan, and camshaft, and take the tappets out through the bottom of the engine. When reaming the valve tappet guides, insert the reamer pilot through the valve stem guide hole, to insure perfect alignment.

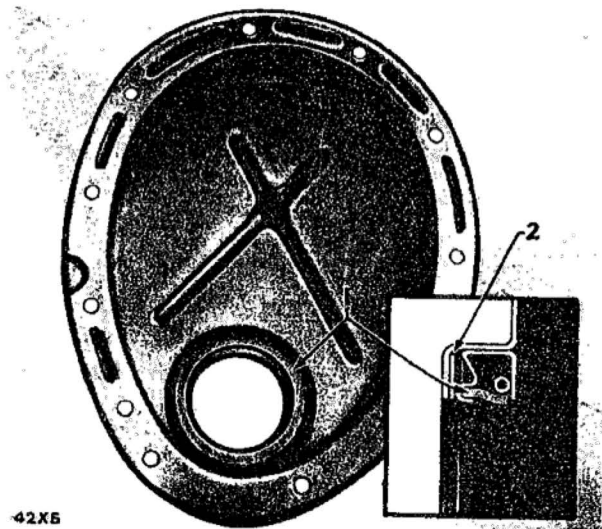
11. CHECKING VALVE TIMING.

1936-42—The intake valve should start to open just before the piston reaches top dead center on the exhaust stroke and the exhaust valve should be fully closed shortly after center. If the intake valve does not start to open before center or if exhaust valve is fully closed before center, remove chain case cover and inspect timing chain and sprockets for proper assembly as shown in figure 7.

12. REPLACEMENT OF TIMING GEAR CASE COVER AND OIL SEAL.

1936-42

(1) On all except the 1942 model, it is necessary to remove the radiator and front fenders in order to remove the timing gear case cover. On 1942 models, it is necessary to remove radiator core only. When installing timing gear case cover, place a new composition gasket in chain case cover, then drive the seal into position, using a drift or a piece of flat metal slightly larger than the



42X5

1—Chain case cover oil seal

2—Oil seal gasket

Figure 5—Chain Case Cover and Oil Seal
(1936-42 Models)

seal to assure a tight, even contact between the seal and its seat (fig. 5).

(2) When installing the cover, tighten screws only enough to hold it in place. Install special tool C-522 (fig. 6), holding it in place with crankshaft starting jaw and tighten starting jaw with fingers only. As the cover screws are being tightened and the gasket is being compressed, tighten the starting jaw nut, maintaining a slight tension between the seal and the centering tool. Then remove tool, install starting jaw and tighten it to a minimum of 108 foot pounds torque.

13. REPLACEMENT OF TIMING CHAIN AND SPROCKETS.

1936-42—The timing chain is not adjustable. To remove the chain or sprockets, remove the timing gear case cover, timing chain and sprockets. To assemble, place the chain over the sprockets so that when the camshaft sprocket is bolted to its hub, the timing marks on both sprockets are opposite each other, and in line with the centers of both the camshaft and crankshaft (fig. 7). Be sure the oil tube is located so as to direct oil onto the crankshaft sprocket.

14. REPLACEMENT OF CAMSHAFT.

1936-42

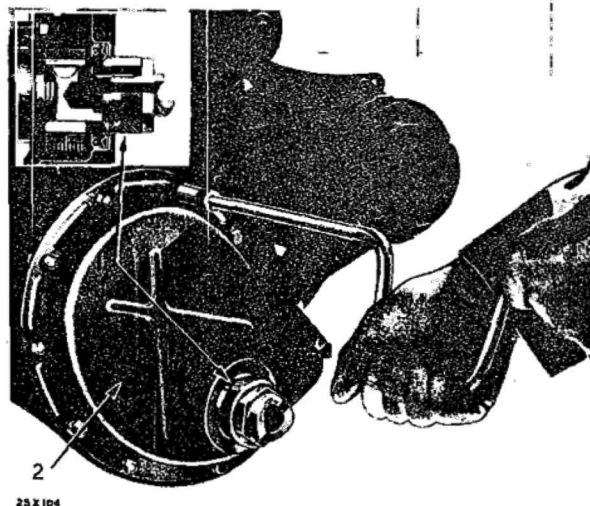
(1) To remove camshaft or thrust plate without removing engine, remove the radiator core and two radiator grilles on 1942 models; remove radiator and front fenders as a unit on 1939-41 models; remove radiator assembly on 1936-38 models. See paragraphs 9 and 10 on page 100.

(2) Remove fuel pump, oil pump and valve compartment covers.

(3) Remove timing gear case cover and timing chain. Lift valves and tappets clear of camshaft.

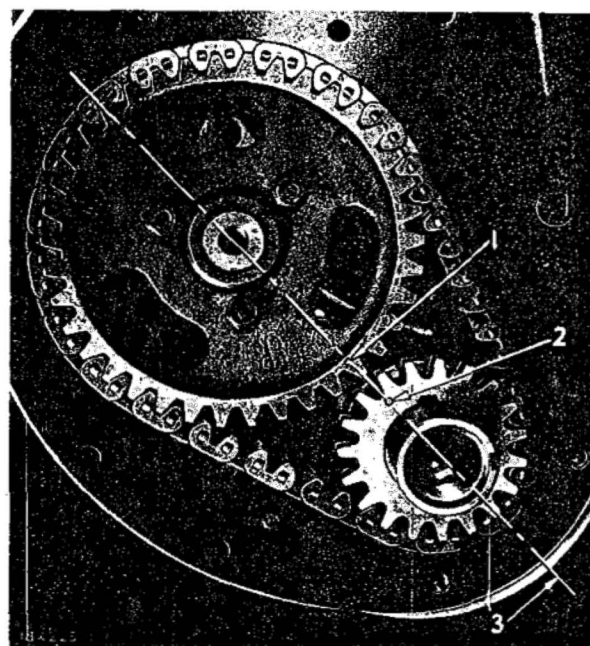
(4) Rotate camshaft to clear any obstruction, and withdraw it from cylinder block.

(5) Before installing camshaft, check end play between the sprocket hub and



1—Centering tool C-522
2—Engine chain case cover and oil seal

Figure 6—Centering Chain Case Cover Oil Seal (1936-42 Models)



1—Mark on camshaft sprocket
2—Mark on crankshaft sprocket
3—Center line

Figure 7—Marks on Timing Sprockets (1936-42 Models)

thrust plate; if end play exceeds .006 inch, press off the thrust plate and install a new one.

(6) When installing camshaft, use new gaskets, reset the ignition timing and check the valve clearance with the engine hot. Align hood and aim headlights, if necessary.

15. REPLACEMENT OF CAMSHAFT BEARINGS.

1936-42

(1) All camshaft bearings, except the rear, are replaceable.

(2) If bearing clearance is excessive, use tool C-536 to remove old bearings and install new ones.

(3) Replacement bearings are finished to such close limits when manufactured that they do not require reaming, scraping or burnishing.

NOTE

Before installing new bearings, be sure that oil feeder holes are clean and free from sludge or other foreign particles; and when installing bearings, be sure to line up the holes in the bearings with those in the cylinder block and locate the camshaft sprocket oil tube so as to direct oil onto the sprockets.

16. REPLACEMENT OF CONNECTING ROD AND PISTON ASSEMBLY

1936-42

(1) Remove cylinder head and oil pan.

(2) Use a ridge reamer and remove any ridge that may have formed on the cylinder wall at the top of the piston ring travel. Do not cut more than 1/64 inch below the bottom edge of the ridge. (See figure 11.)

(3) Remove the assembly from top of engine. Identify the connecting rods when removing them, so they may be installed in their original position.

(4) When assembling piston to connecting rod, assemble aluminum alloy pistons so that the slotted side of piston is opposite the metered oil hole in the connecting rod.

(5) When installing piston and connecting rod assembly in the engine, be sure the metered oil hole in the connecting rod is *toward the camshaft side of engine.*

17. RECONDITIONING OF CYLINDER WALLS.

1936-42

(1) Cylinders which are not badly scored but need "cleaning up" to bring them within satisfactory working limits may be reconditioned with a hone.

(2) If cylinders are scored badly or excessively out-of-round, they should be re-bored first with a reliable boring tool and then polished with a hone. When measured, a good job should show measurements of not more than .0005 inch out-of-round or taper.

CAUTION

When reconditioning cylinders, cover the crankshaft and main bearings to prevent cuttings and abrasives from getting into the bearings and oil passages. After completing the reconditioning operations, clean the engine thoroughly, being sure to remove all traces of chips, dirt or other foreign matter from cylinder walls.

18. FITTING PISTONS.

1942—Cast Iron

(1) For checking sizes of pistons, measurements should be made with micrometer calipers across the maximum diameter at the center of the piston skirt.

(2) When replacing a piston or partial set of pistons, be sure to use the same type as those already in the engine.

(3) Place feeler stock, .0015 inch thick, 1/2 inch wide and long enough to extend down into the bore for the full length of the piston, in cylinder bore.

(4) Insert the piston (upside down) into the cylinder bore, with the feeler stock between the piston and cylinder wall on the high spot of the piston contour.

(5) The amount of pull required to withdraw the feeler stock should be 10 to 15 pounds.

1936-42—Aluminum

(1) For checking sizes of pistons, measurements should be made with micrometer calipers across the maximum diameter at the bottom of the piston skirt.

(2) When replacing a piston or partial set of pistons be sure to use the same type as those already in the engine.

(3) Place feeler stock, .002 inch thick (.0015 inch thick, 1936 model only), ½ inch wide and long enough to extend down into the bore for the full length of the piston, in cylinder bore.

(4) Insert the piston (upside down) into the cylinder bore, with the feeler stock between the piston and cylinder wall on the high spot of the piston contour.

(5) The amount of pull required to withdraw the feeler stock should be 6 to 9 pounds on 1937-40 models and 10 to 15 pounds on 1936 model.

NOTE

If adequate means of determining the size of the piston and cylinder bores is not available, the piston is properly fitted when it has a slight drag in the bore but still free enough to fall slowly through of its own weight.

19. REPLACEMENT OF PISTON RINGS.**1936-42**

(1) Replacement piston rings are available as follows:

For cylinder bores with less than .005 inch taper. See figure 8 for location of rings on piston.

For cylinder bores with more than .005 inch taper, but less than .030 inch taper. See figure 9 for location of rings on piston.

Original equipment type rings for use when bores are reconditioned. See figure 10 for location of rings on piston.

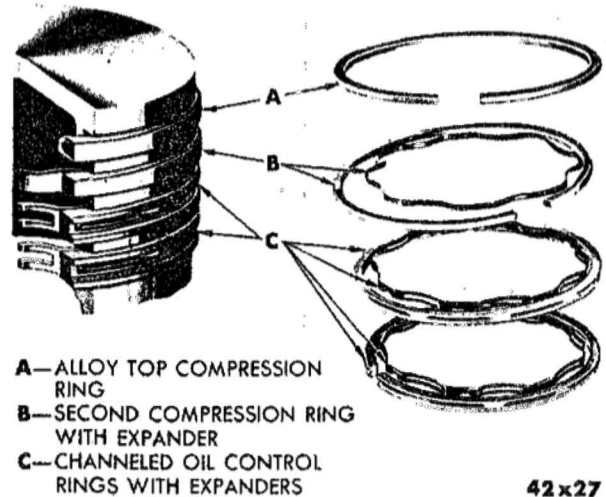


Figure 8—Oil Saver Piston Ring Set (1936-42 Models)

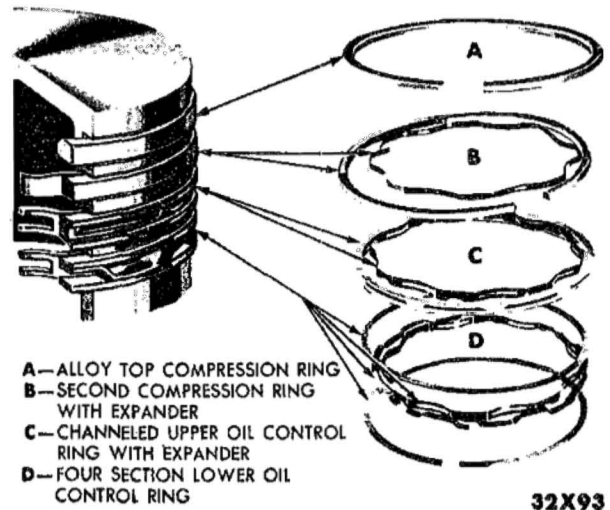
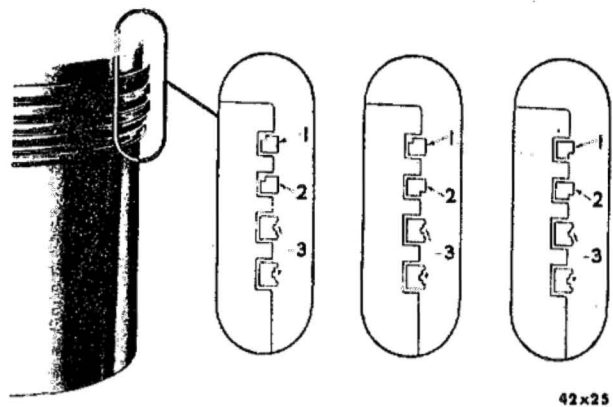


Figure 9—Oil Master Piston Ring Set (1936-42 Models)



- 1—Compression ring—upper
- 2—Compression ring—lower
- 3—Oil rings

Figure 10—Original Equipment Type Piston Ring Set (1936-42 Models)

19. REPLACEMENT OF PISTON RINGS.

1936-42—Cont'd

(2) When installing original equipment type piston rings, insert the rings in the cylinder bore, at lower end of piston travel and with ring square in the bore, measure the end clearance.

(3) When installing piston rings without reconditioning the cylinder bores, always remove the top ridge of the bore with a ridge reamer (fig. 11). *Do not cut more than 1/64 inch below the bottom edge of the ridge.* Always remove the ridge before removing the piston assemblies, keeping the tops of the pistons covered to prevent cuttings from reaching bearings, crankshaft, or other closely fitted parts in the engine. Be sure the ring grooves in piston are clean before installing rings.

20. REPLACEMENT OF PISTON PINS (PISTONS REMOVED).

1942—Cast Iron

(1) Fit piston pin in piston with a double thumb press fit when both pin and holes are clean and dry and with both at 70° F.

(2) Fit piston pin in connecting rod so the pin will carry its own weight through the bushing when both the pin and bushing are clean and dry and with both at 70° F.

1936-42—Aluminum

(1) Fit piston pin in piston with a thumb press fit with the piston at 130° F.

(2) Fit the piston pin in the connecting rod bushing with a tight thumb press fit at 70° F.

21. REPLACEMENT OF CONNECTING ROD BEARINGS.

1936-42—Connecting rod bearings are removable from the connecting rods and can be replaced after removing the oil pan. Both standard and undersize bearings are avail-

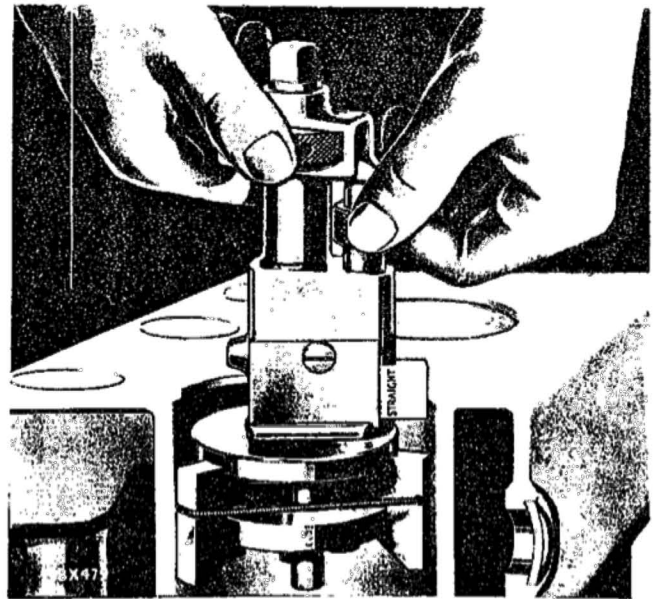


Figure 11—Removing Cylinder Bore Ridge (1936-42 Models)

able. These bearings are machined to such close limits that they do not require reaming, scraping or burnishing.

CAUTION

Never use a new bearing half with an old bearing half. Never file a rod or cap, or otherwise mutilate a connecting rod, in an attempt to fit bearings.

(1) Before installing bearings, be sure the crankshaft is not nicked or scored.

(2) Measure the clearance between bearing and crankshaft when installing either old or new bearings.

(3) Coat a piece of .0015 inch brass shim stock (1/2 inch wide and 1 inch long) with oil and place it between the bearing and crankshaft journal (fig. 12).

(4) Install bearing cap and draw it up tight.

(5) If clearance is not excessive, there will be a slight drag when the crankshaft is turned. The clearance desired is .001 to .002 inch and the end play .005 to .011 inch. If the clearance is excessive, install standard or undersize bearings.

(6) Tighten the cap bolts to 45 to 50 foot pounds.

22. REPLACEMENT OF CRANKSHAFT (MAIN) BEARINGS.

1936-42—Crankshaft bearings can be replaced after removal of the oil pan. Both standard and undersize crankshaft bearings are available. These bearings are machined to such close limits that they do not require reaming, scraping or burnishing.

CAUTION

Never use a new bearing half with an old bearing half. Never file or shim original bearing caps in an attempt to fit bearings.

(1) Remove oil pan, clutch housing pan and oil suction pipe.

(2) Disconnect timing case cover from oil pan seal and remove oil pan gasket seal plate on 1940-42 models.

(3) Remove timing gear case cover and screw which fastens timing gear case cover plate to front gasket oil seal plate on 1936-39 models.

(4) Loosen bearing caps slightly.

(5) Remove one cap at a time and replace both upper and lower bearing shells.

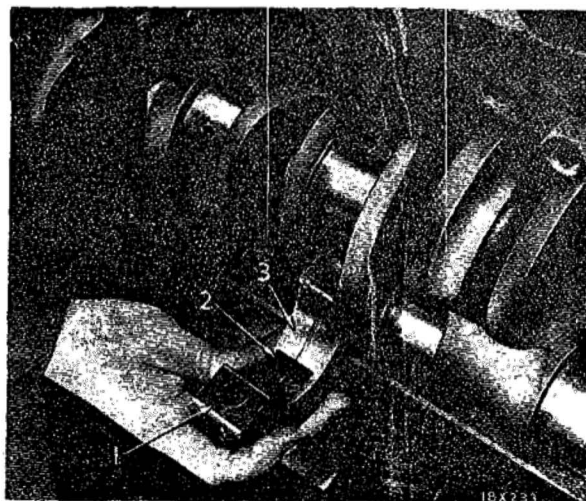
(6) Before installing bearings, be sure the crankshaft is not nicked or scored.

(7) Measure the clearance between the bearing and crankshaft when installing either old or new bearings.

(8) Coat a piece of .0015 inch brass shim stock ($\frac{1}{2}$ inch wide and 1 inch long) with oil and place it between the bearing and crankshaft (fig. 12).

(9) Install the bearing cap and draw it up tight.

(10) If the clearance is not excessive, there will be a slight drag when the crankshaft is turned. The clearance desired is .001 to .002 inch and the end play is .003 to .007 inch.



1—Crankshaft bearing cap 2—Feeler stock 3—Bearing
Figure 12—Checking Crankshaft Bearing Clearance with Feeler Stock (Use Same Procedure for Connecting Rod Bearings) (1936-42 Models)

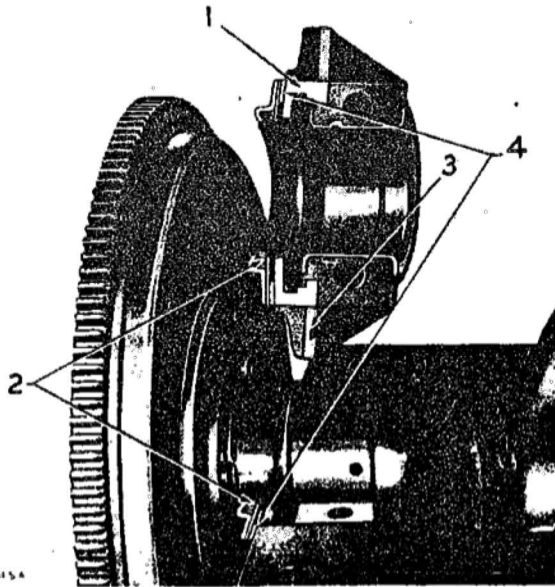
(11) Tighten caps to 80 to 85 foot pounds.

NOTE

Replacement main bearing caps have stud holes $\frac{1}{64}$ inch larger than original caps and are $\frac{1}{64}$ inch shorter. This permits shimming or filing as required to adjust for variations between original and replacement caps.

23. CHECKING CRANKSHAFT END PLAY.

1936-42—The crankshaft should have .003 to .007 inch end play (minimum desired). To check this end play, measure the movement of the crankshaft lengthwise in the cylinder block with a dial indicator. To be sure of having end play when installing the bearing caps, partially tighten the rear main bearing cap and turn the crankshaft to seat the bearing. Then tighten the bearing cap and check the end play of the crankshaft. If the crankshaft has more than .007 inch end play, replace the rear main bearing inserts and recheck the end play. If there is still too much end play, replace the crankshaft.



1—Cap gasket—left 3—Cap gasket—right
2—Bearing oil seal 4—Bearing oil seal gasket

**Figure 13—Crankshaft Rear Bearing Oil Seals
(1936-42 Models)**

24. INSTALLATION OF CRANKSHAFT BEARING OIL SEALS.

1936-42—Locate the seals and gaskets carefully before the cap is installed, as shown in figure 13. To replace the upper seal, it is necessary to remove the flywheel.

25. REPLACEMENT OF FLYWHEEL.

1936-42

(1) Remove clutch assembly. See Section VII.

(2) Remove oil pan and crankshaft rear bearing cap.

(3) Turn flywheel to make the bolts accessible and remove the flywheel to crankshaft bolts.

(4) When installing flywheel, be sure the run-out does not exceed .003 inch.

(5) Tighten nuts to 55 to 60 foot pounds.

26. ENGINE OILING SYSTEM.

1936-42

(1) Oil is drawn through a strainer from the oil pan and forced under pressure to the crankshaft bearings, connecting rod bearings and camshaft bearings. It is forced in a limited quantity from the front camshaft bearing to the timing chain and sprockets. The cylinder walls, pistons, piston pins and valve tappets are lubricated by oil spray from metered holes in the connecting rod lower bearings.

(2) Oil is by-passed through an absorption type filter. Due to the manner of connecting the oil filter to the oiling system, clogging of the oil filter will not stop the circulation of the oil to the bearings.

(3) The crankcase is ventilated through the use of a pipe at the rear, right side of the engine which draws off fumes or vapors. Fresh air enters through the breather pipe, which carries an air cleaner to remove dirt and dust from the air before it enters the crankcase.

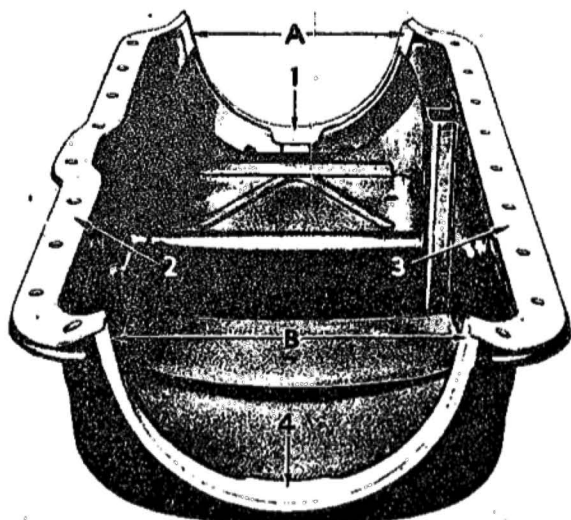
(4) Oil pressure is controlled by a relief valve on the left side of the engine. When checking the oil pressure, be sure oil is of the proper viscosity and with engine at normal operating temperature. Different colored springs are used in the oil pressure relief valve to denote spring pressure. If for any reason the spring has to be replaced, use the same color spring.

27. REMOVAL AND INSTALLATION OF OIL PAN AND STRAINER.

1936-42

(1) Remove the clutch housing dust pan to prevent damaging oil pan gaskets on housing.

(2) Lower the oil pan part way, lift up oil strainer (1941-42 models) and remove pan.



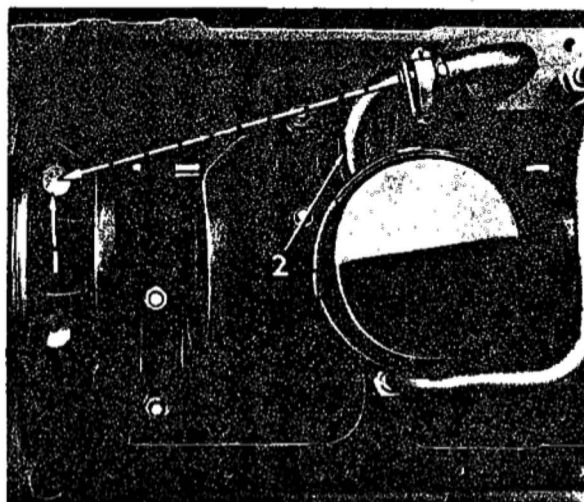
- | | |
|----------------|---------------------|
| 1—Gasket—rear | 4—Gasket—front |
| 2—Gasket—right | A—Rear gasket lips |
| 3—Gasket—left | B—Front gasket lips |

Figure 14—Oil Pan Gaskets

(3) When installing the pan, install the end gaskets so they protrude $\frac{1}{8}$ to $\frac{1}{4}$ inch above the oil pan (fig. 14). Do not cut the gasket ends off as they will compress into place when the oil pan is installed.

NOTE

When installing the oil strainer on 1941-42 models, position the elbow so that the strainer will be located as shown in figure 15. Proper installation is important to prevent interference between strainer and oil pan baffles.



- 1—Crankshaft rear bearing cap screw 2—Oil strainer

Figure 15—Oil Strainer Installed (1941-42 Models)

28. REMOVAL AND INSTALLATION OF OIL PUMP.

1936-42

(1) Before removing the pump, remove the distributor cap and rotate crankshaft until the rotor is in the firing position for No. 1 cylinder and keep the engine in this position while the pump is off.

(2) Remove the oil pump.

(3) When installing the oil pump, be sure No. 1 cylinder is in firing position, install the pump and check the ignition timing.

Section X

EXHAUST SYSTEM

1. DISASSEMBLY AND ASSEMBLY OF MANIFOLD HEAT CONTROL.

1940-42—Check occasionally to insure valve is free and not restricted in its operation. To disassemble (fig. 1) remove shield (3) and thermostat (6). When assembling, place center end of the thermostat in manifold heat control shaft groove and turn the thermostat one complete turn counterclockwise before hooking other end of the thermostat on stop. *Never turn thermostat more than one turn when installing.*

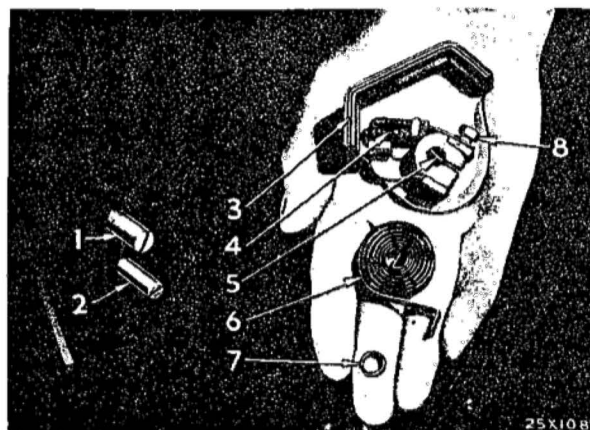
1936-39—Check occasionally to insure valve is free and not restricted in its operation. To disassemble (fig. 2) remove counterweight (3) and thermostat (2). When assembling, place center of thermostat in manifold heat control shaft groove and turn the thermostat 1/3 turn counterclockwise before hooking the other end of the thermostat on the stop. *Never turn thermostat more than 1/3 turn when installing.*

2. REPLACEMENT OF EXHAUST PIPE AND MUFFLER.

1936-42—Whenever any part of the exhaust system has been replaced, leave the attaching bolts and clamps loose, run the engine to allow all the parts of the system to align themselves, then tighten all bolts and clamps securely.

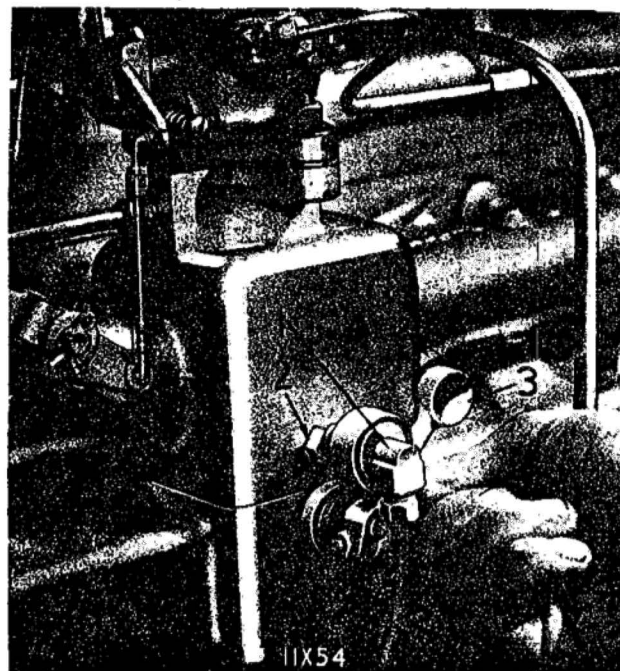
3. REPLACEMENT OF INTAKE AND EXHAUST MANIFOLD GASKETS.

1936-42—Before assembling the intake and exhaust manifolds, remove all residue from inside manifolds. When assembling, tighten the intake and exhaust manifold connecting bolts until they are snug but not tight. Install assembly on engine and tighten manifolds to cylinder block evenly to 15 to 20 foot pounds, so that both intake and exhaust manifold flanges seat themselves evenly on the cylinder block. Then tighten



- | | |
|--------------------------------|--|
| 1—Valve stop stud | 6—Valve thermostat |
| 2—Valve shaft | 7—Valve thermostat spacer |
| 3—Thermostat shield or cover | 8—Thermostat shield clamp bolt, nut, plain washer and lockwasher |
| 4—Valve stop | |
| 5—Thermostat shield clamp lock | |

Figure 1—Manifold Heat Control (1940-42 Models)



- | | |
|---|--------------|
| 1—Manifold drain tube elbow | 2—Thermostat |
| 3—Manifold heat control valve counterweight | |

Figure 2—Manifold Heat Control (1936-39 Models)

intake and exhaust manifold connecting bolts securely.

Section XI

FRAME

1. FRAME ALIGNMENT.

1936-42—The various dimensions which can be used as a guide in checking frame alignment are shown in figures 2 through 8. The dimensions given are the true length in inches between the two points as measured with a steel tape. Figure 1 shows a few of the various diagonal measurements that may be taken to check the "squareness" of the frame. Diagonal measuring will quickly determine which section of the frame is bent and where force should be applied to restore correct alignment. To check a frame for alignment, diagonal measuring should be performed with the greatest of accuracy and care. When the body is removed, the frame may be easily checked by measuring diagonals shown in figure 1, with trammels or with a steel tape and checking dimensions given in figures 2 through 8. Measurements may be taken without removing the body from the chassis, by using a plumb-bob and chalk line as follows:

- (1) Place the car on a level floor.
- (2) Attach the line of a plumb-bob to the center of one of the rear body bolts. The plumb-bob should be suspended slightly above the floor. When the plumb-bob comes to rest, mark the floor directly underneath it.
- (3) Then, using the plumb-bob, mark

the floor directly underneath the center of the other body bolts. The marks made on the floor will represent various points of the frame to be checked diagonally:

(4) Move the car away so that the distance between the marks on the floor can be measured.

(5) Measure the distance between the points connected by line "A," figure 1. This distance should agree within $\frac{1}{4}$ " with the distance between the points connected by line "B."

(6) Likewise, the distance between points connected by line "C" should agree within $\frac{1}{4}$ " with the distance between points connected by line "D", and "E" should agree with "F."

The diagonals shown in figure 1 represent only a few that may be checked. Many other diagonals may be measured in the same way. For example, if some of the frame body brackets are bent, diagonals may be checked from corresponding points on the frame side rails or cross members.

NOTE

Care should be taken to see that any two diagonals compared represent exactly corresponding points on each side of the frame.

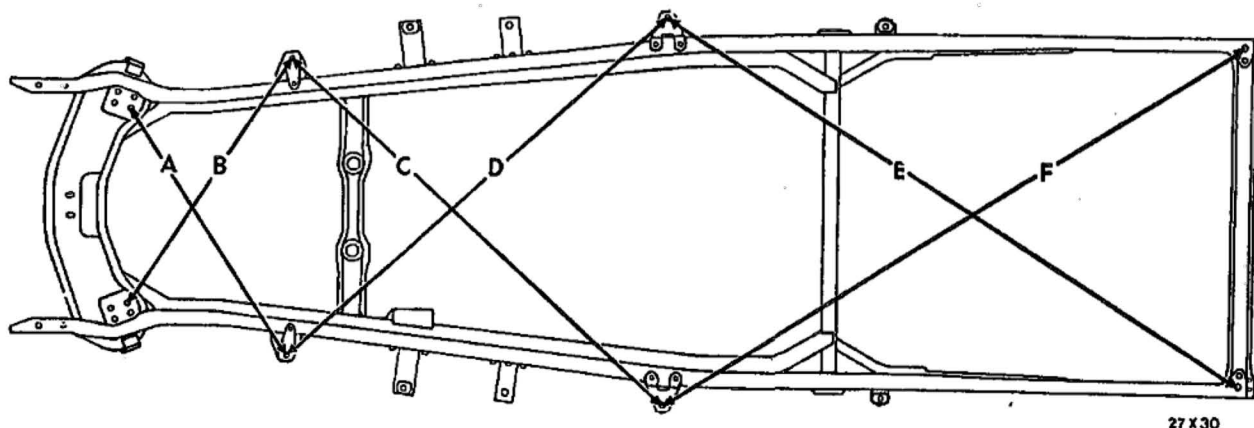


Figure 1—Frame Diagonal Measurements (1942 Model, Typical of 1936-41 Models)

Correct frame alignment can usually be restored by straightening the frame parts which have been bent, although badly distorted frame parts, due to a serious accident, can in most cases be replaced more economi-

cally than by attempting repairs. When assembling the body to the frame, the body should be properly aligned so that it and the frame will fit together without the necessity of forcing the body bolts in place.

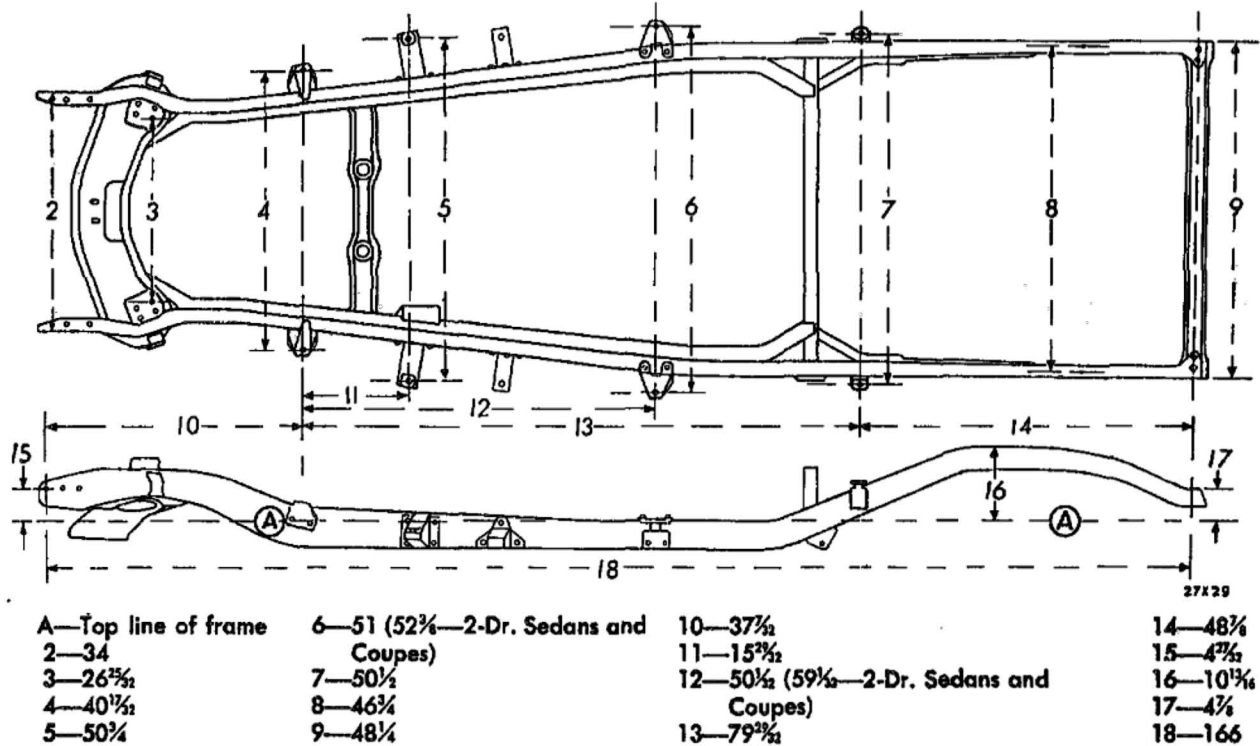


Figure 2—Frame Alignment (Dimensions Given in Inches) (1942 Model)

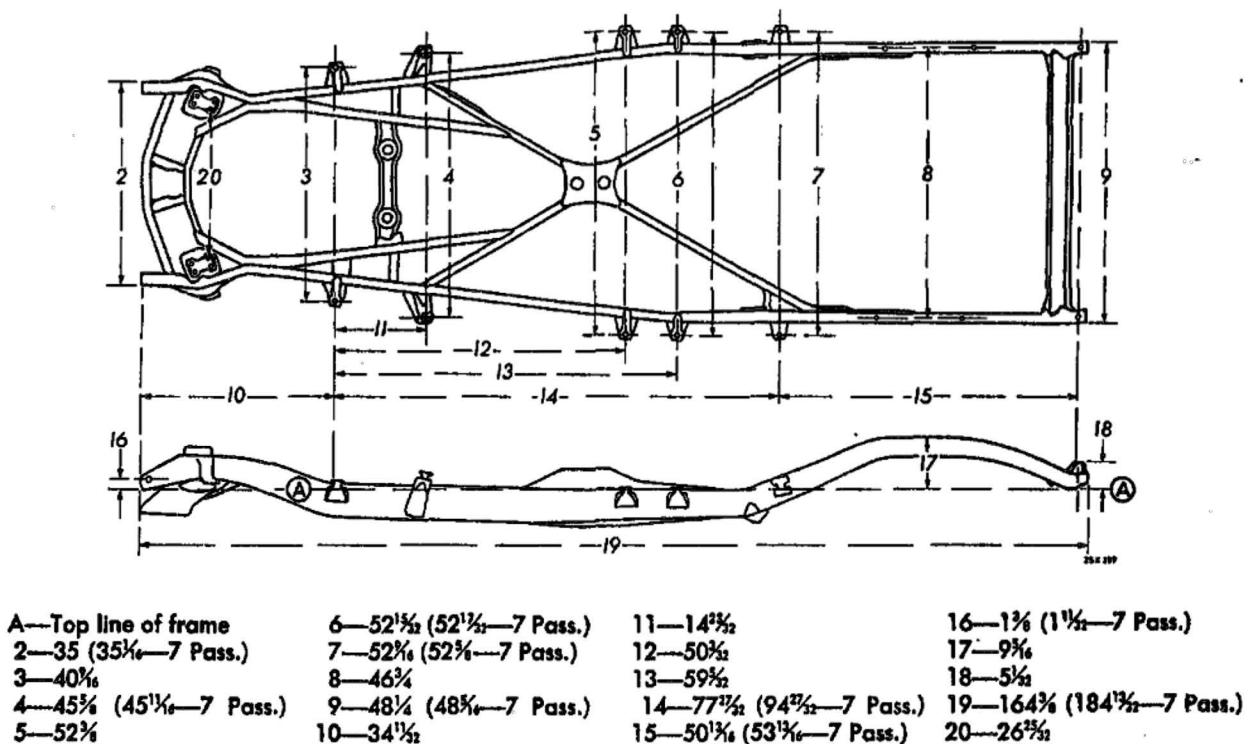
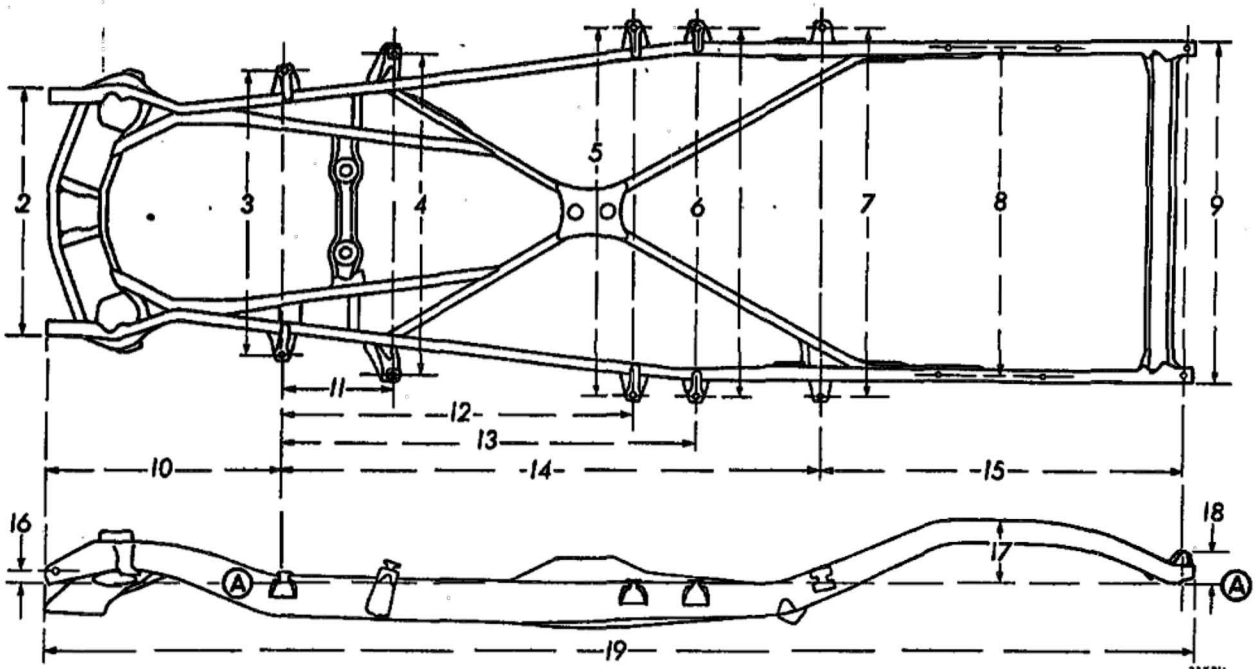
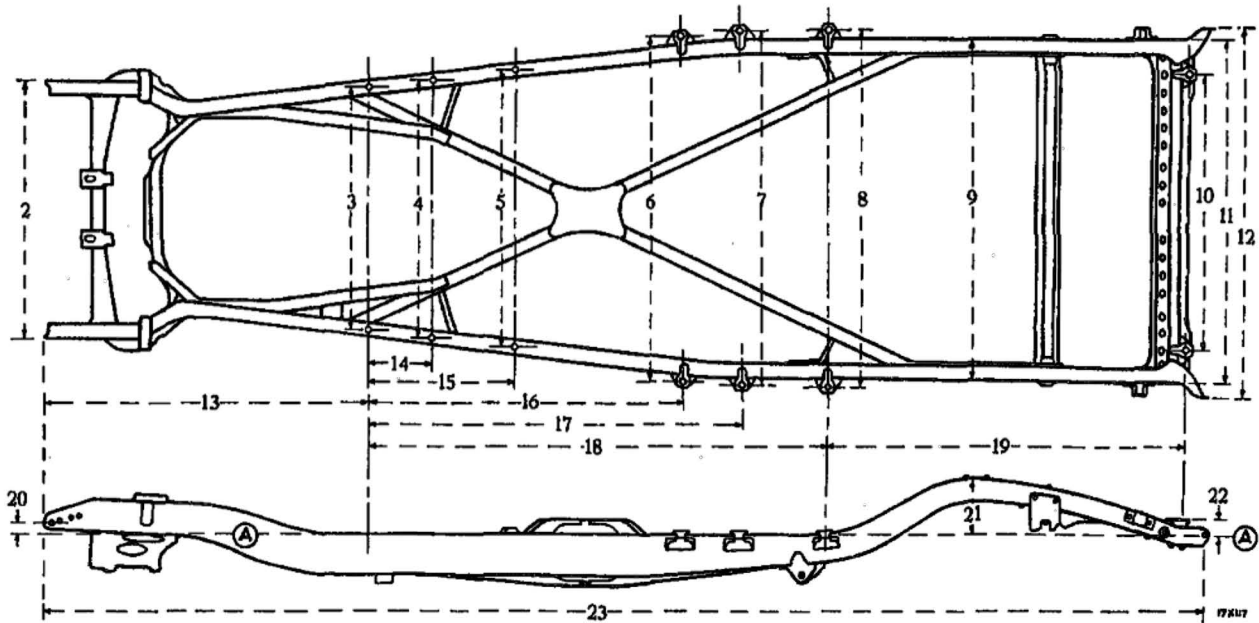


Figure 3—Frame Alignment (Dimensions Given in Inches) (1941 Model)



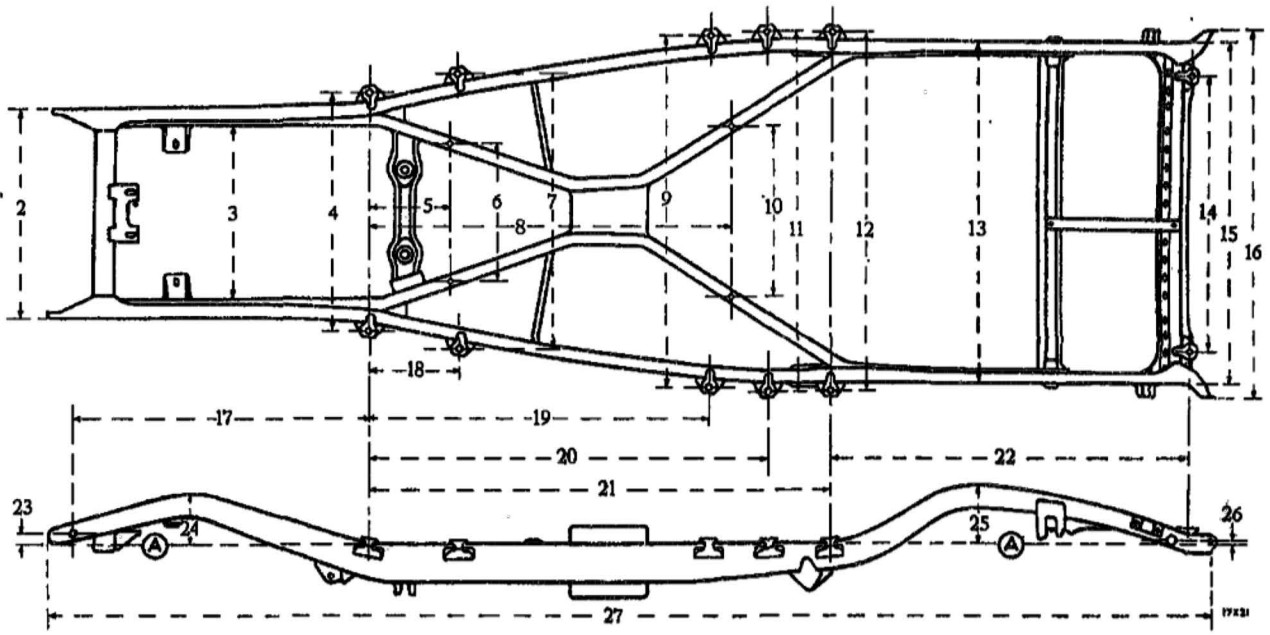
A—Top line of frame	6— $52\frac{1}{2}$ ($52\frac{1}{2}$ —7 Pass.)	11— $14\frac{1}{2}$	16— $1\frac{1}{8}$ ($1\frac{1}{2}$ —7 Pass.)
2— 35 ($35\frac{1}{8}$ —7 Pass.)	7— $52\frac{3}{8}$ ($52\frac{3}{8}$ —7 Pass.)	12— $50\frac{1}{2}$	17— $9\frac{1}{8}$
3— $40\frac{1}{2}$ ($40\frac{1}{8}$ —7 Pass.)	8— $46\frac{3}{4}$	13— $59\frac{1}{2}$	18— $5\frac{1}{2}$
4— $45\frac{1}{8}$ ($45\frac{1}{8}$ —7 Pass.)	9— $48\frac{1}{4}$ ($48\frac{1}{8}$ —7 Pass.)	14— $77\frac{1}{2}$ ($94\frac{1}{2}$ —7 Pass.)	19— $164\frac{1}{8}$ ($184\frac{1}{2}$ —7 Pass.)
5— $52\frac{1}{8}$	10— $34\frac{1}{2}$	15— $50\frac{1}{8}$ ($53\frac{1}{8}$ —7 Pass.)	

Figure 4—Frame Alignment (Dimensions Given in Inches) (1940 Model)



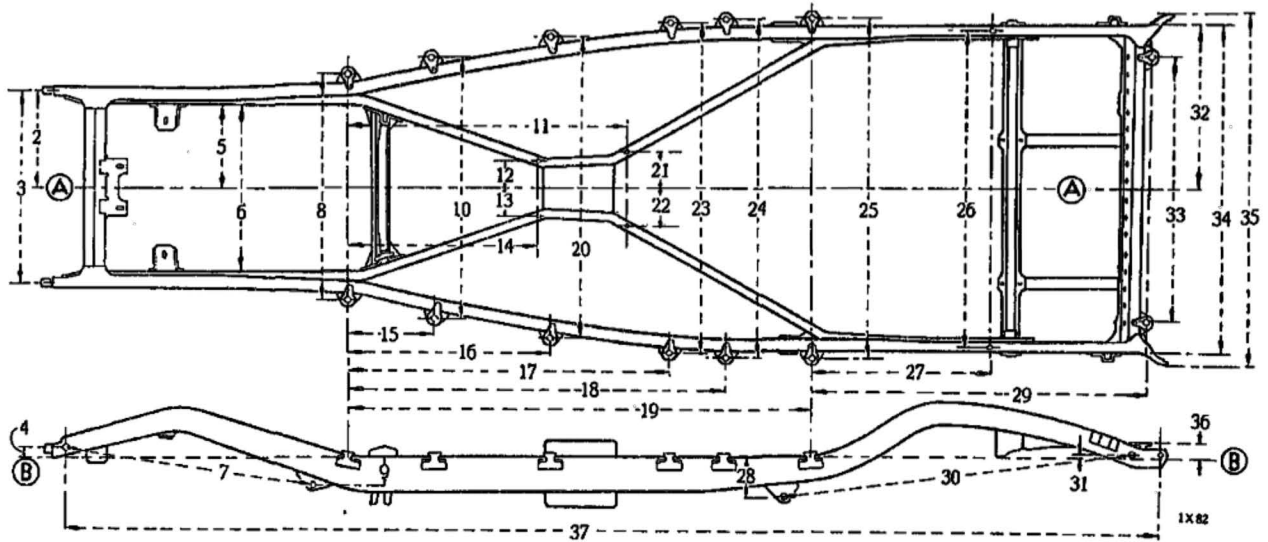
A—Top line of frame	7— $50\frac{1}{8}$ ($50\frac{1}{2}$ —7 Pass.)	13— $42\frac{1}{8}$ ($41\frac{1}{4}$ —7 Pass.)	19— $51\frac{1}{2}$
2— $36\frac{1}{8}$ ($36\frac{1}{8}$ —7 Pass.)	8— $50\frac{1}{8}$ ($50\frac{1}{2}$ —7 Pass.)	14— $12\frac{1}{8}$	20— $1\frac{1}{8}$ ($1\frac{1}{2}$ —7 Pass.)
3— $33\frac{1}{8}$	9— $48\frac{1}{4}$ ($48\frac{1}{8}$ —7 Pass.)	15— $24\frac{1}{2}$	21—8
4— $36\frac{3}{8}$	10— $38\frac{1}{8}$	16— $47\frac{1}{8}$	22— $2\frac{1}{2}$ ($2\frac{1}{8}$ —7 Pass.)
5— $39\frac{1}{8}$	11— $48\frac{1}{4}$ ($48\frac{1}{8}$ —7 Pass.)	17— $56\frac{1}{2}$	23— $162\frac{1}{4}$ ($181\frac{1}{8}$ —7 Pass.)
6—49	12— $51\frac{1}{8}$ ($51\frac{1}{8}$ —7 Pass.)	18— $65\frac{1}{8}$ ($85\frac{1}{8}$ —7 Pass.)	

Figure 5—Frame Alignment (Dimensions Given in Inches) (1939 Model)



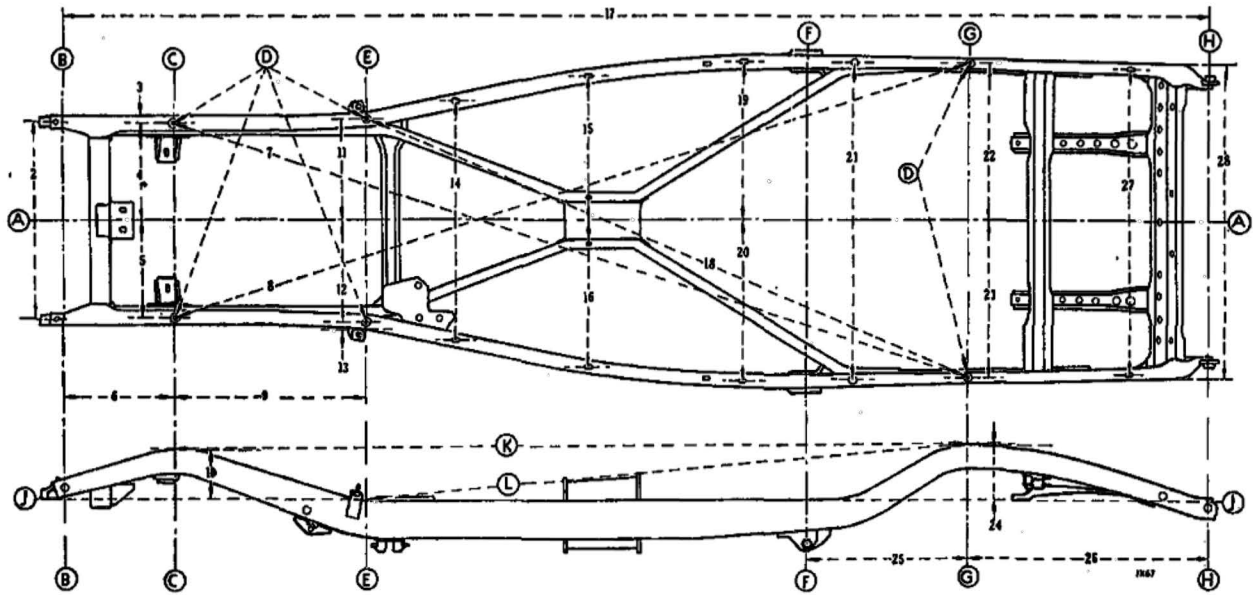
- | | | |
|--|---|---|
| A—Top line of frame | 10—22 $\frac{1}{4}$ (26 $\frac{3}{4}$ —7 Pass. Sedan) | 19—47 $\frac{1}{4}$ |
| 2—29 $\frac{1}{2}$ (29 $\frac{1}{2}$ —7 Pass. Sedan) | 11—50 $\frac{1}{4}$ (50 $\frac{1}{4}$ —7 Pass. Sedan) | 20—56 $\frac{3}{4}$ |
| 3—24 $\frac{1}{4}$ | 12—50 $\frac{1}{4}$ (50 $\frac{1}{2}$ —7 Pass. Sedan) | 21—65 $\frac{1}{2}$ (85 $\frac{1}{2}$ —7 Pass. Sedan) |
| 4—33 $\frac{3}{4}$ | 13—48 $\frac{1}{4}$ (48 $\frac{1}{4}$ —7 Pass. Sedan) | 22—51 $\frac{1}{2}$ |
| 5—12 $\frac{1}{2}$ | 14—38 $\frac{1}{4}$ | 23—1 $\frac{1}{2}$ (1 $\frac{1}{4}$ —7 Pass. Sedan) |
| 6—18 $\frac{1}{4}$ | 15—48 $\frac{1}{4}$ (48 $\frac{1}{4}$ —7 Pass. Sedan) | 24—7 $\frac{1}{2}$ |
| 7—38 $\frac{3}{4}$ | 16—51 $\frac{1}{4}$ (51 $\frac{1}{4}$ —7 Pass. Sedan) | 25—8 |
| 8—50 $\frac{1}{4}$ (63 $\frac{3}{4}$ —7 Pass. Sedan) | 17—41 $\frac{1}{4}$ | 26— $\frac{1}{2}$ ($\frac{1}{2}$ —7 Pass. Sedan) |
| 9—49 | 18—12 $\frac{1}{4}$ | 27—164 $\frac{3}{4}$ (184 $\frac{1}{4}$ —7 Pass. Sedan) |

Figure 6—Frame Alignment (Dimensions Given in Inches) (1938 Model)



- | | | | | |
|------------------------|---------------------|---------------------|---------------------|----------------------|
| A—Center line of frame | 8—33 $\frac{3}{4}$ | 16—30 $\frac{1}{2}$ | 24—50 $\frac{1}{4}$ | 31— $\frac{1}{2}$ |
| B—Top line of frame | 9—4 $\frac{1}{2}$ | 17—47 $\frac{1}{4}$ | 25—50 $\frac{1}{4}$ | 32—24 $\frac{1}{4}$ |
| 1— $\frac{1}{4}$ | 10—38 $\frac{3}{4}$ | 18—56 $\frac{3}{4}$ | 26—46 $\frac{3}{4}$ | 33—38 $\frac{3}{4}$ |
| 2—27 $\frac{3}{4}$ | 11—41 $\frac{1}{2}$ | 19—65 $\frac{1}{2}$ | 27—26 $\frac{3}{4}$ | 34—48 $\frac{1}{4}$ |
| 3—1 $\frac{3}{4}$ | 12—4 $\frac{1}{4}$ | 20—44 $\frac{1}{4}$ | 28—6 $\frac{1}{4}$ | 35—51 $\frac{1}{4}$ |
| 4—12 $\frac{1}{4}$ | 13—4 $\frac{1}{4}$ | 21—5 $\frac{1}{2}$ | 29—50 $\frac{1}{2}$ | 36—2 $\frac{1}{2}$ |
| 5—24 $\frac{1}{4}$ | 14—28 $\frac{1}{4}$ | 22—5 $\frac{1}{2}$ | 30—52 | 37—161 $\frac{1}{4}$ |
| 6—36 $\frac{3}{4}$ | 15—12 $\frac{1}{4}$ | 23—49 | | |

Figure 7—Frame Alignment (Dimensions Given in Inches) (1937 Model)



A—Centerline of frame	2— $28\frac{1}{2}$	16— $20\frac{3}{4}$
B—Centerline of front spring shackle bolt	3—1	17— $162\frac{1}{2}$
C—Centerline of front wheels	4— $13\frac{3}{4}$	18— $96\frac{3}{4}$
D—Locate and prick punch	5— $13\frac{3}{4}$	19— $22\frac{1}{4}$
E—Dash line	6— $16\frac{1}{4}$	20— $22\frac{1}{4}$
F—Centerline of rear spring front bolt	7— $118\frac{3}{4}$	21— $45\frac{1}{4}$
G—Centerline of rear axle	8— $118\frac{3}{4}$	22— $22\frac{1}{2}$
H—Centerline of rear spring rear shackle bolt	9— $24\frac{1}{2}$	23— $22\frac{1}{2}$
J—Top of frame	10— $7\frac{1}{4}$	24—8
K—Diagonal dimensions 7 and 8 taken straight along this line	11— $14\frac{1}{2}$	25— $24\frac{1}{6}$
L—Diagonal dimension 18 taken straight along this line	12— $14\frac{1}{2}$	26— $32\frac{3}{4}$
	13—1	27— $43\frac{1}{4}$
	14— $33\frac{1}{6}$	28— $44\frac{3}{2}$
	15— $20\frac{3}{4}$	

Figure 8—Frame Alignment (Dimensions Given in Inches) (1936 Model)

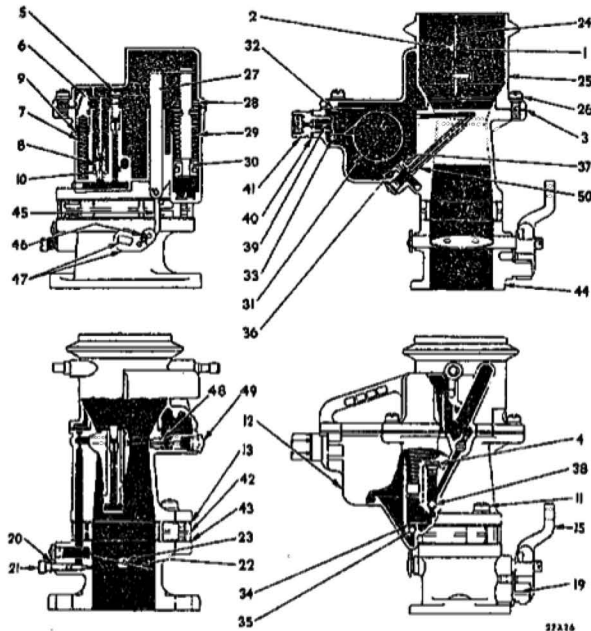


Figure 1—Carburetor (Assembled View) (1942 Model, Typical of 1936-41 Models)

- | | |
|--|---------------------------------|
| 1—Valve attaching screws | 24—Choke valve |
| 2—Choke shaft | 25—Air horn |
| 3—Body gasket | 26—Air horn attaching screw |
| 4—Pump check plug | 27—Pump connector link |
| 5—Idle orifice tube and plug | 28—Pump spring retainer |
| 6—Step-up piston, plate and rod | 29—Pump spring |
| 7—Step-up piston spring | 30—Plunger, spring and rod |
| 8—Step-up jet | 31—Float and lever |
| 9—Step-up piston gasket | 32—Float lever pin retainer |
| 10—Step-up jet gasket | 33—Float lever pin |
| 11—Flange attaching screw | 34—Pump retainer ring |
| 12—Body | 35—Pump cylinder ball |
| 13—Flange gasket | 36—Main metering jet |
| 14—Choke connector rod | 37—Main metering jet gasket |
| 15—Throttle shaft lever | 38—Pump check ball |
| 16—Throttle lever clamp screw | 39—Float needle |
| 17—Throttle lever adjusting screw spring | 40—Float needle seat gasket |
| 18—Throttle lever adjusting screw | 41—Float needle seat |
| 19—Throttle shaft dog | 42—Insulator |
| 20—Idle adjustment screw spring | 43—Flange gasket |
| 21—Idle adjustment screw | 44—Body flange |
| 22—Throttle valve | 45—Pump operating link |
| 23—Valve attaching screw | 46—Pin lock spring |
| | 47—Throttle valve shaft and arm |
| | 48—Pump jet |
| | 49—Pump jet rivet |
| | 50—Main vent tube |

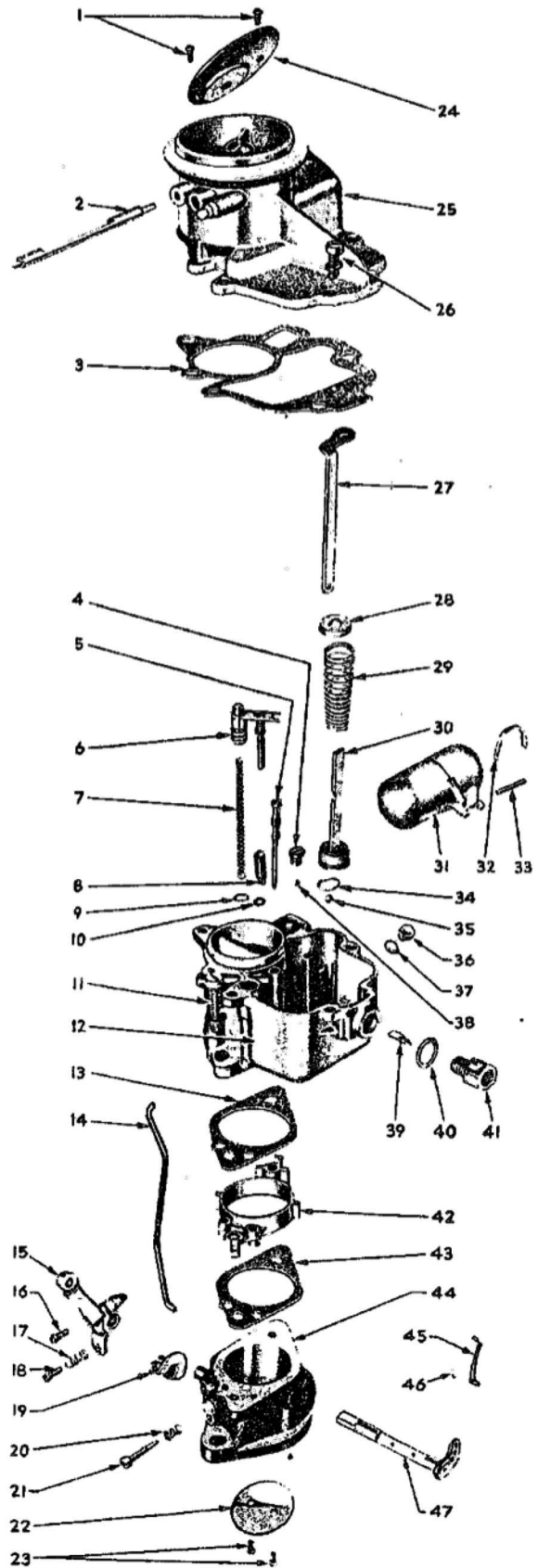


Figure 2—Carburetor (Disassembled View) (1942 Model, Typical of 1936-41 Models)

Section XII

FUEL SYSTEM

1. DESCRIPTION OF CARBURETOR.

1936-42—The carburetor (figs. 1 and 2) is the down-draft, fixed jet type, with manually controlled choke.

2. DISASSEMBLY OF CARBURETOR.

1936-42—Refer to figures 1 and 2:

(1) Raise air horn (25) and disconnect choke connector rod (14).

(2) Remove float pin retainer (32), float (31) and float needle (39).

(3) Remove accelerator pump link (45).

(4) Push out accelerator pump plunger assembly (30).

(5) Remove idle orifice plug and tube (5), step-up assembly (6) and step-up jet (8).

(6) Remove main metering jet (36).

(7) Remove pump check plug (4) and ball (38).

(8) Remove idle adjustment screw (21) and spring (20).

3. ASSEMBLY OF CARBURETOR.

1936-42—Refer to figures 1 and 2. Before assembling, wash all parts in clean gasoline or other solvent. Soak needle valve, valve seat and jets in denatured alcohol, or other suitable commercial solvent, for a period of time depending on the deposit, and then scrub with a stiff bristled brush. When assembling, use new gaskets, check float level, adjust accelerating pump and idle needle valve.

CAUTION

Never clean jets with a wire or other mechanical means because jets will become enlarged which will make mixture too rich for proper performance. Do not gauge main metering jet for size. If in doubt, replace with a new jet.

4. ADJUSTING IDLE SPEED OF CARBURETOR.

1936-42—Turn the adjusting screw (21, figs. 1 and 2) clockwise to reduce amount of fuel and counterclockwise to increase amount of fuel. Use a vacuum gauge and adjust screw to obtain maximum vacuum.

5. ACCELERATING PUMP SETTING.

1936-42—Move pump link (45, figs. 1 and 2) to different positions provided in pump lever for best seasonal performance. Summer setting—inner hole, short stroke. Intermediate setting—center hole. Winter setting—outer hole, long stroke.

6. REPLACEMENT OF MAIN METERING JET.

1936-42—Remove air horn (25, figs. 1 and 2) and float (31, figs. 1 and 2). Unscrew jet (36, figs. 1 and 2) to remove. When installing, use new gasket and tighten jet securely.

7. ADJUSTMENT OF CARBURETOR FLOAT LEVEL.

1936-42—*Carter Carburetor*—Remove air horn (25, figs. 1 and 2) and gasket. Measure distance from top of float chamber (gasket removed) to top of float (fig. 3); if other than 5/64 inch, adjust by bending lip of float. Bend lip away from needle to raise float and toward needle to lower float. *Bend vertical lip of float only.*

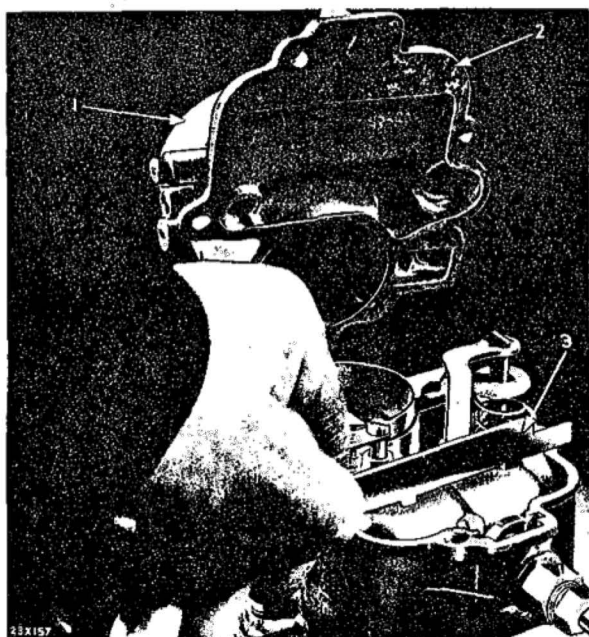
1938—*Chandler Groves Carburetor*—Remove air horn and gasket. Measure distance from top of float chamber (gasket removed) to top of float; if other than 17/32 inch, adjust by bending both float arms equally; bend the float arms away from needle to raise float and toward needle to lower float.

DATA AND SPECIFICATIONS								
YEAR	1942	1939-41		1938		1937	1936	
Carburetor model (Carter)	DTC1	D6A1 D6C1	D6A2 D6C2	C6J1	C6K1	C6F1 C6F3 C6F5	C6F2 C6F4 C6H1	C6E1 C6E2
Throttle bore, inches	1 $\frac{1}{16}$	1 $\frac{1}{16}$		1 $\frac{1}{16}$		1 $\frac{1}{16}$		1 $\frac{1}{16}$
Main venturi, inches	1 $\frac{1}{4}$	1 $\frac{1}{4}$		1 $\frac{1}{4}$		1 $\frac{1}{4}$		1 $\frac{1}{4}$
Flange size, inches	1 $\frac{1}{2}$	1 $\frac{1}{2}$		1 $\frac{1}{4}$		1 $\frac{1}{4}$		1 $\frac{1}{4}$
Float setting, inch	$\frac{5}{64}$	$\frac{5}{64}$		$\frac{5}{64}$ ***		$\frac{5}{64}$		$\frac{5}{64}$
Outside vent, inch				$\frac{3}{16}$		$\frac{3}{16}$		$\frac{3}{16}$
Inside vent, inch	.218	.218						
Gas intake needle seat No.	44	44		44		42		42
Idle Tube	Idle jet, inch	.0295	.0276	.0276		0.276		.0276
	Idle air bleed, inch	.067	.067	.067		.067		.063
	Economizer, inch	.054-.055	.053-.054	.051-.052		.049		.049
Idle Ports	Length, inch	.160	.160	.160		.160		.132
	Width, inch	.030	.030	.030		.030		.030
	Diameter top of hole, inch	.045	.045	.045		No		.063
	Port opening with valve closed, inch	.118-.122	.118-.122	.118-.122		.118-.122		.085-.089
	Lower port (idle screw) inch	.053-.057	.053-.057	.053-.057		.053-.057		.053-.057
	Idle screw setting, turns open	$\frac{1}{2}$ to 1 $\frac{1}{4}$	$\frac{1}{2}$ to 1 $\frac{1}{4}$		$\frac{1}{2}$ to 1 $\frac{1}{4}$		$\frac{1}{2}$ to 1 $\frac{1}{4}$	
Main vent through diffuser, inch	.0315	.0315		.0315		.0315		.0315
Step-up jet, No.	63	63		63		63		65
Accelerating Pump	Intake passage check seat, inch	.115 .120	.115 .120	.115 .120		.115 .120		.115 .120
	Pump discharge passage, inch	.062-.065	.062-.065	.062-.065		.062-.065		.062-.065
	Pump discharge jet, inch	.0276	.0315	.0315		.0335		.0315
	Pump plunger travel, inch	$\frac{3}{8}$	$\frac{3}{8}$		$\frac{25}{64}$		*	
Main Metering Jet, Carter No.	Standard	159-61S	159-61S	159-58S		159-58S		159-68S
	1 size lean	159-66S	159-66S	159-60S		159-60S		159-69S
	2 sizes lean	159-82S	159-82S	159-64S		159-64S		None
Fuel tank capacity, gals.	17	17**		16		16		15

*No specified setting.

**1939 model, 18 gallons.

*** $\frac{1}{32}$ in. for Chandler Groves Carburetor.



1—Carburetor air horn 2—Carburetor body gasket
3—Checking gauge (Tool C-449)

Figure 3—Measuring Float Level (1936-42 Models)

8. CLEANING CARBURETOR AIR CLEANER.

1936-42—The air cleaner should be cleaned at least every 2000 miles (or more often if extremely dusty conditions are encountered) or whenever oil sump, on oil bath type, becomes half filled with a semi-solid mixture of oil and dirt. For servicing instructions, refer to paragraph 5 on page 14.

9. DESCRIPTION OF FUEL PUMP.

1936-42—The fuel pump (figs. 4 through 7) is the diaphragm non-adjustable type and is driven off the engine camshaft. It has a working pressure of 3 to 4½ pounds on 1936-40 models and 4 to 5½ pounds on 1941-42 models.

10. DISASSEMBLY OF FUEL PUMP.

1939-42—Refer to figures 4 and 5. Remove strainer bowl (9) and strainer screen (26). Remove body (4) from cover (8). Remove valve retainer (22) and lift out valves (18) and (23). Compress diaphragm and unhook it from inner rocker arm. Remove rocker arm spring (11). Drive out pivot pin (2) and remove rocker arm.

NOTE

If an excessive amount of oil leaks out of vent hole in body above diaphragm, chip off pieces of pump body which clinch oil seal (6) in place and install new seal.

1936-38—Refer to figures 6 and 7. Mark the cover and pump body so that they may be assembled in the same relative position. Remove filter bowl, screen and gasket. Remove inlet valve plug (8), spring and valve (7). Remove body bottom cover, gasket, rocker arm springs and spring seats. Remove top cover and valve seat (6) and diaphragm (2). Remove rocker arm links (14) and push rod (5). Remove rocker arm pin (28), rocker arm and linkage.

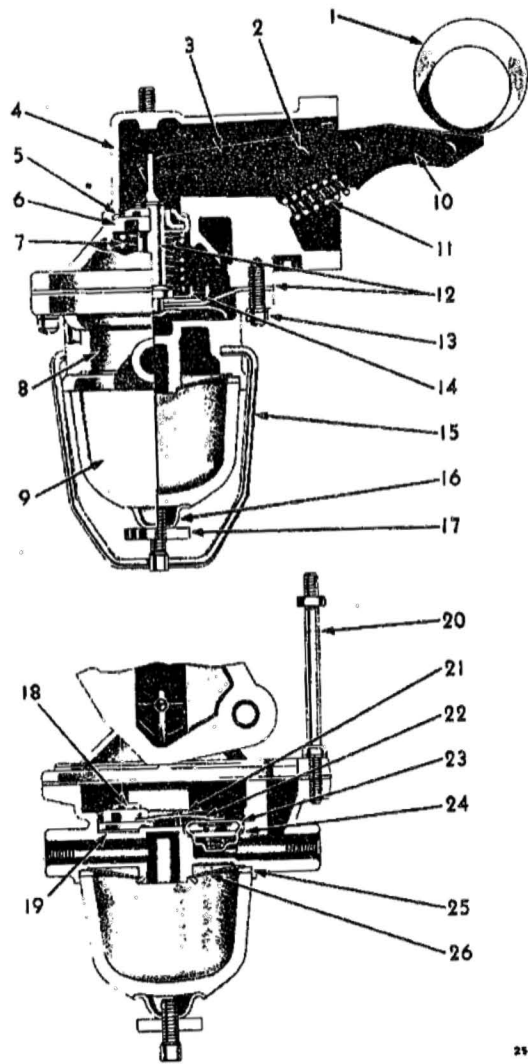
11. ASSEMBLY OF FUEL PUMP.

1939-42—Refer to figures 4 and 5. Before assembling, wash all parts thoroughly in gasoline or kerosene. When assembling inlet and outlet valves (18 and 23), make certain they are assembled as shown in figure 5. Both of these valves are identical, but one should be assembled with the spring side "up" and the other with spring side "down." Install a new diaphragm, soaking it in clean kerosene to make it flexible and to facilitate seating.

CAUTION

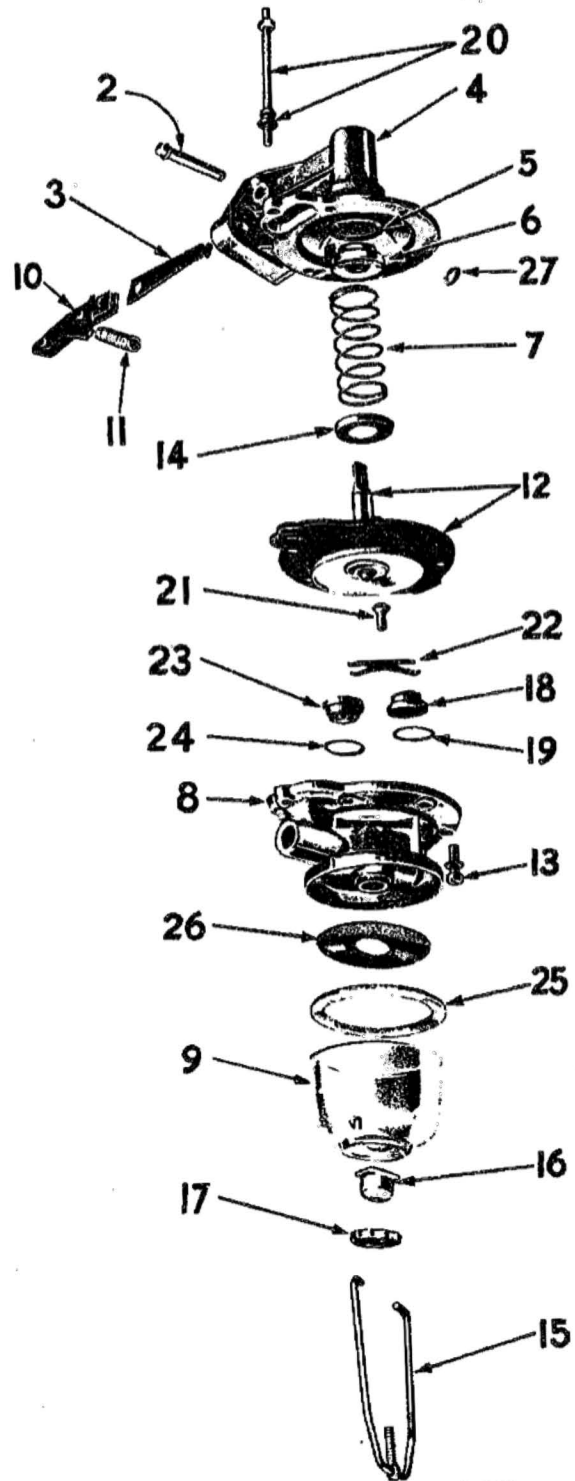
Do not use shellac or other sealing compounds on diaphragm.

If rocker arm spring is collapsed, install a new one. Use care to hold rocker arm to end of its stroke tight against spring pressure when tightening screws which hold cover to body. When installing cover, partially tighten screws in order to properly locate diaphragm, then tighten screws evenly to prevent creasing diaphragm.



**Figure 4—Fuel Pump (Assembled View)
(1939-42 Models)**

- | | |
|--------------------------------|------------------------------------|
| 1—Engine camshaft | 13—Cover screw and lock-washer |
| 2—Rocker arm pin | 14—Diaphragm spring retainer |
| 3—Rocker arm—inner | 15—Strainer bowl bail |
| 4—Body | 16—Strainer bowl seat |
| 5—Body oil seal gasket | 17—Strainer bowl bail screw nut |
| 6—Body oil seal | 18—Valve |
| 7—Diaphragm spring | 19—Valve gasket |
| 8—Cover | 20—Heat shield stud and lockwasher |
| 9—Strainer bowl | |
| 10—Rocker arm—outer | |
| 11—Rocker arm spring | |
| 12—Diaphragm and stem assembly | |



**Figure 5—Fuel Pump (Disassembled View)
(1939-42 Models)**

- | | |
|-------------------------|--------------------------|
| 21—Valve retainer screw | 25—Strainer bowl gasket |
| 22—Valve retainer | 26—Strainer screen |
| 23—Valve | 27—Rocker arm pin washer |
| 24—Valve gasket | |

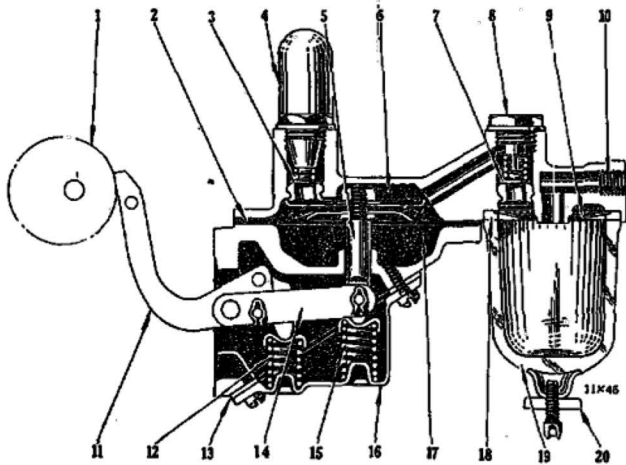


Figure 6—Fuel Pump (Assembled View)
(1936-38 Models)

- | | |
|---|---|
| 1—Fuel pump eccentric (integral with engine camshaft) | 24—Top cover valve chamber valve spring |
| 2—Diaphragm | 25—Heat shield stud lockwasher |
| 3—Top cover valve—pressure | 26—Bowl bail and screw |
| 4—Top cover air dome | 27—Strainer screen bowl seat |
| 5—Diaphragm push rod | 28—Rocker arm pin |
| 6—Top cover and valve seat | 29—Rocker arm link pin clips |
| 7—Top cover valve chamber valve—inlet | 30—Rocker arm link pins |
| 8—Top cover valve chamber valve plug | 31—Diaphragm push rod spring cap |
| 9—Strainer screen | 32—Body bottom cover screws and lockwashers |
| 10—Fuel inlet | 33—Top cover air dome gasket |
| 11—Rocker arm | 34—Top cover valve spring |
| 12—Rocker arm spring | 35—Top cover screw and lockwasher |
| 13—Body bottom cover gasket | 36—Diaphragm protector nut |
| 14—Rocker arm links | 37—Diaphragm protector nut lockwasher |
| 15—Diaphragm push rod spring | 38—Diaphragm protector nut washer |
| 16—Body bottom cover | 39—Diaphragm protector—upper |
| 17—Body | 40—Diaphragm protector—lower |
| 18—Strainer screen bowl gasket | 41—Diaphragm push rod washer |
| 19—Strainer screen bowl | |
| 20—Bowl bail screw nut | |
| 21—Heat shield stud nut | |
| 22—Heat shield stud | |
| 23—Top cover valve chamber valve plug gasket | |

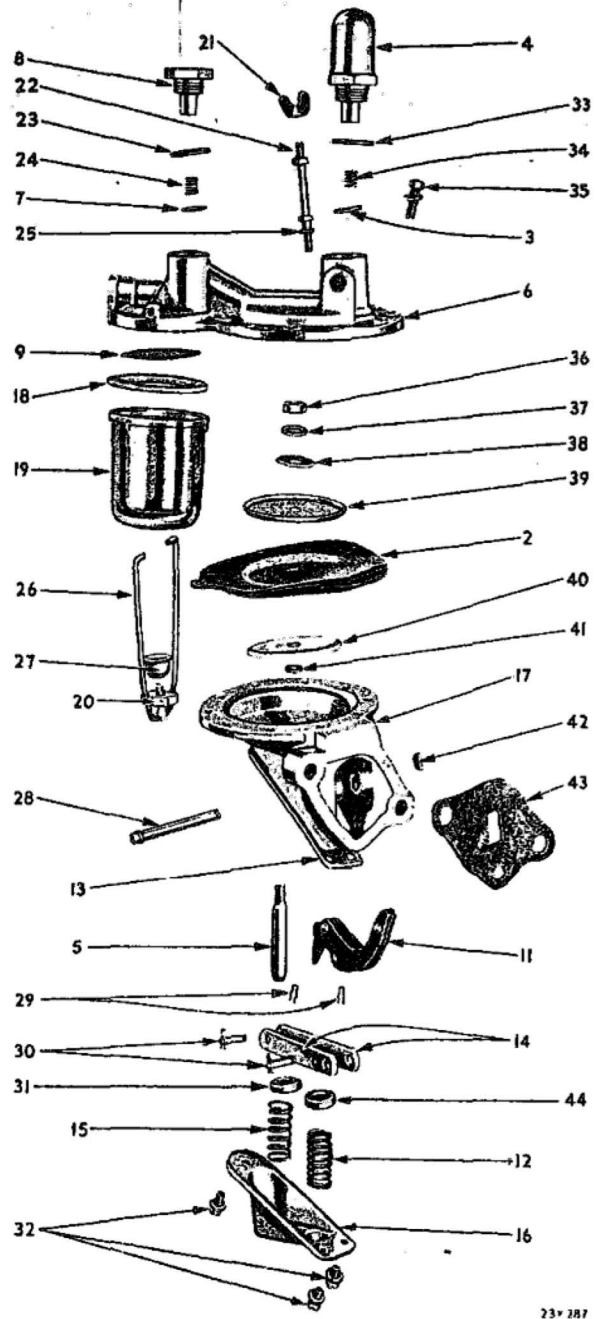


Figure 7—Fuel Pump (Disassembled View)
(1936-38 Models)

- | | |
|--------------------------|--------------------------|
| 42—Rocker arm pin washer | 43—Pump gasket |
| | 44—Rocker arm spring cap |

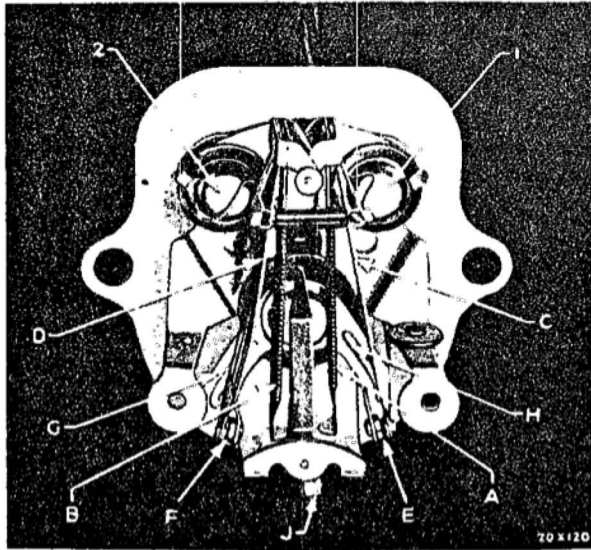
11. ASSEMBLY OF FUEL PUMP—
Cont'd

1936-38—Refer to figures 6 and 7. Before assembling, wash all parts thoroughly in gasoline or kerosene. Soak a new diaphragm in clean kerosene to make it flexible

and to facilitate seating. When assembling, take care to prevent turning of diaphragm when tightening the push rod nut.

CAUTION

Do not use shellac or other sealing compounds on diaphragm.



- | | |
|--|---|
| 1—Terminal post—(connected to No. 1 terminal on tank unit) | D—Bi-metal blade (not heated) |
| 2—Terminal post—(connected to No. 2 terminal on tank unit) | E—Voltage compensation contact points (circuit breaker) |
| A—Bi-metal blade (heated) | F—Insulated contact points (do not carry current) |
| B—Bi-metal blade (heated) | G—Calibrating arm |
| C—Bi-metal blade (not heated) | H—Calibrating arm |
| | J—Pointer counterweight |

Figure 8—Fuel Gauge (Dial Removed)
(1936-42 Models)

12. TESTING FUEL GAUGE.

1936-42—Refer to figure 8.

(1) Select a spare tank unit known to be in good condition.

(2) Disconnect the wires at the terminals "1" and "2" on the back of the dash unit and connect those terminal posts with the corresponding terminals of the spare tank unit.

(3) Connect a third wire from the frame of the spare tank unit to any good grounding point on the car and turn on the ignition switch.

(4) Operate the float arm of the spare tank unit and then allow about one minute for the dash unit to heat.

(5) If the dash unit does not indicate correctly, it shows that the fault is in the dash unit.

(6) If the dash unit works properly, it shows the fault is either in the wiring or in the tank unit.

(7) If the wires at terminals "1" and "2" at the tank unit are reversed, the indication will be reversed. The gauge will show empty when it should show "full."

(8) If the wires at terminals "1" or "2" are open-circuited or grounded, the effect will be varied and can be checked, providing the quantity of fuel in the tank is known and also that the dash unit is in proper operating condition.

(9) To check for an open-circuited or grounded condition, scrape the paint off the tank unit cap, to locate the terminal numbers.

(10) The following table gives the gauge readings under varying grounded or open-circuited conditions:

Position of Float Arm	Wire at No. 1 Grounded	Wire at No. 2 Grounded	Wire at No. 1 Terminal Open	Wire at No. 2 Terminal Open
Empty	Empty	1/2 Full	1/2 Full	Empty
1/2 Full	1/4 Full	3/4 Full	3/4 Full	Empty
Full	1/2 Full	Full	Full	Empty

(11) A fluctuating pointer is caused by dirty contacts at the circuit breaker (E, fig. 8) and may be remedied by drawing a piece of bond paper between the points.

(12) If the pointer has a tendency to stick or bind, it can usually be freed by aligning the bearings or adjusting the end play. This is accomplished by bending the bearing supports slightly.

13. CALIBRATING FUEL GAUGE (DASH UNIT).

1936-42—Refer to figure 8.

(1) Remove the dash unit and clip a wire from the negative post of a battery to the center terminal (IGN. SW.) of the dash unit.

(2) Use a tank unit known to be operating properly and connect the terminal marked "1" on the tank unit to the terminal marked "1" on the dash unit.

(3) Then connect terminals marked "2" on each unit.

(4) Clip a wire from the positive terminal of the battery to the metal base of the tank unit.

(5) Move the float arm, of the tank unit, to the empty position, and allow the dash unit to heat for one minute. It is best to calibrate a dash unit in a small room not exposed to air currents, but if this is not available, protect the unit with a cardboard cylinder.

(6) Loosen both nuts on the center terminal at the back of the dash unit.

(7) Move the left hand calibrating arm "G" to the right to raise the indication or to the left to lower it

(8) Move the float arm, of the tank unit, to the "full" position.

(9) Move the right hand calibrating arm "H" to the right to raise the indication or to the left to lower it.

(10) Recheck the dash unit with the float arm of the tank unit at the empty position because setting the "Full" indication slightly changes the "Empty" indication. Intermediate indications will be correct if both ends are adjusted properly.

(11) Tighten the nuts on the center terminal post (IGN. SW.) These nuts should not be jammed excessively tight because of the possibility of moving the calibrating arms.

GENERATOR DATA AND SPECIFICATIONS					
Year and Model	1940—P9, P10 1941—P11, P12 1942—P14	1938—P6 1939—P8	1937—P4	1937—P3 1938—P5 1939—P7	1936—P1, P2
Generator model (stamped on plate attached to generator)	GDZ-4801	GDF-4801	G CJ-4802	GBM-4606-1	P2, GAR-4608-H P1, GBM-4603-H
Rated capacity (cold) (hot)	6 volts—35 amps. 6 volts—35 amps.	6 volts—30 amps. 6 volts—28 amps.	6 volts—25 amps. 6 volts—21.5 amps.	6 volts—18 amps. 6 volts—15.2 amps.	{ P2, 6 volts—21 amps. P1, 6 volts—18 amps. P2, 6 volts—18.5 amps. P1, 6 volts—15.2 amps.
Charging rate control (Model number—see Generator Regulator "Data and Specifications" Chart on Page 140.)	VRP-4001-A	VRR-4003-A	VRR-4003-A	CB-4014-C	P2-TC-4301-A P1-CB-4014-C
Maximum allowable output	8 volts—37 amps.	8 volts—30 amps.	8 volts—25 amps.	8 volts—18 amps.	8 volts—21 amps.
Field draw, both coils	1.6 to 1.8 amps. at 6 volts	1.9 to 2.1 amps. at 6 volts	1.9 to 2.1 amps. at 6 volts	3.8 to 4.2 amps. at 6 volts	3.5 to 3.9 amps. at 6 volts
Motorizing draw	4.1 to 4.6 amps. at 6 volts	5.3 to 5.9 amps. at 6 volts	4.0 to 4.4 amps. at 6 volts	5.7 to 6.3 amps. at 6 volts	5.0 to 5.6 amps. at 6 volts
Brush spring tension	45 to 53 oz.	35 to 53 oz.	35 to 53 oz.	50 to 60 oz.	50 to 60 oz.
Armature end play	.003 to .010 in.	.003 to .010 in.	.003 to .010 in.	.003 to .010 in.	.003 to .010 in.
Maximum commutator run-out	.002 in.	.002 in.	.002 in.	.002 in.	.002 in.

Section XIII

GENERATOR

1. DESCRIPTION.

1940-42—The generator is of the two brush type. The charging rate is controlled by voltage and current regulation.

1936-39—The generator is of the third brush type. The charging rate is controlled by the position of the third brush. On models P2, P4, P6 and P8, a voltage regulator controls the voltage output of the generator in accordance with the requirements of the battery.

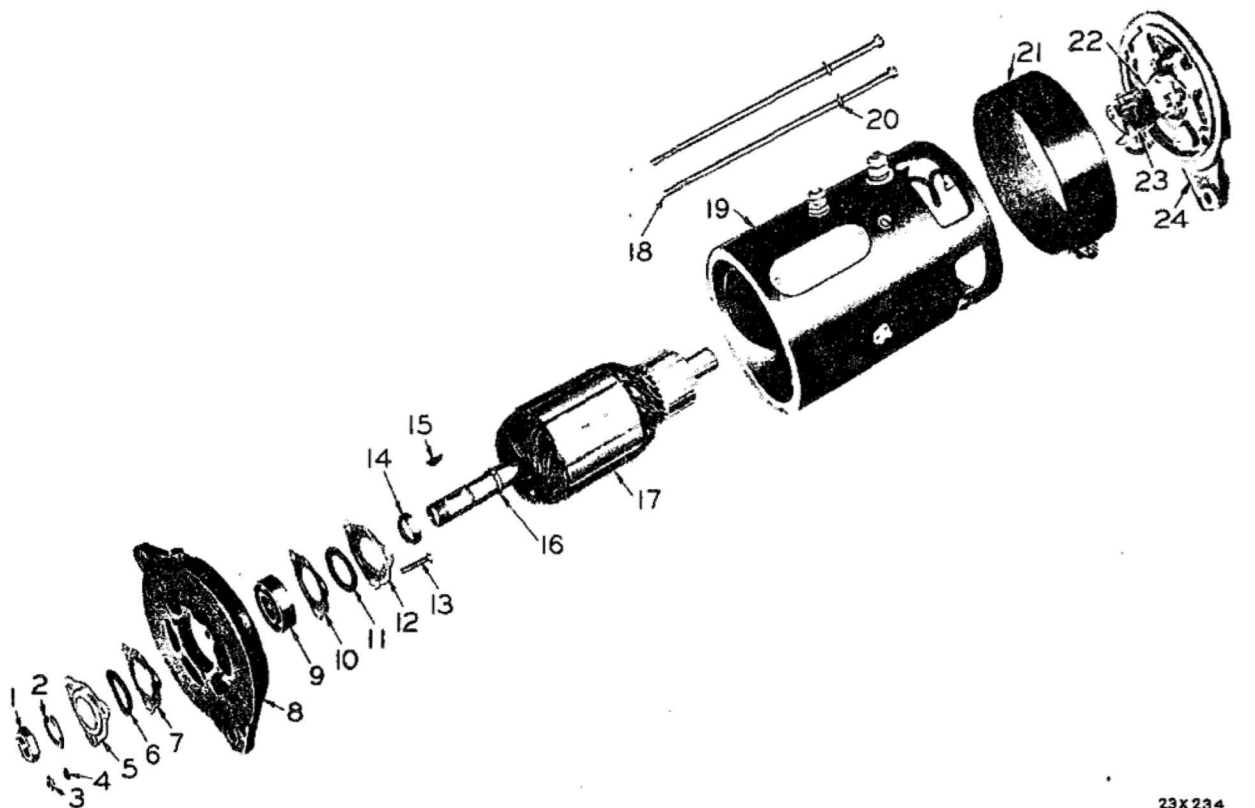
2. DISASSEMBLY OF GENERATOR.

1936-42—(See figures 1, 2 and 3.)

(1) Clean the outside of the generator thoroughly while the inspection band is in place. Dry the generator, remove the inspection band and blow out all dust and dirt with compressed air.

(2) Remove the brushes, commutator end plate and pull the armature and drive end head out of the frame.

(3) Remove the drive pulley end head.



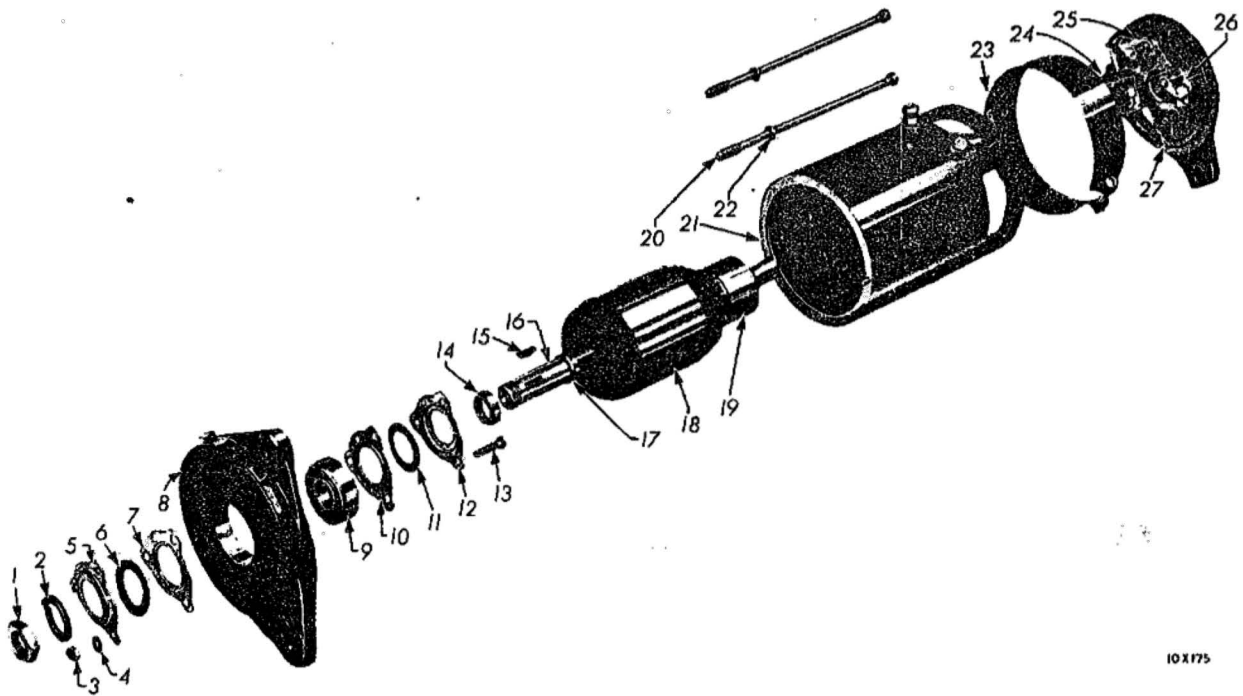
23X 234

1—Armature shaft nut
2—Armature shaft nut lockwasher
3—Bearing retainer screw nut
4—Bearing retainer screw nut lockwasher
5—Bearing retainer
6—Felt washer
7—Felt guard
8—Drive end head

9—Front bearing
10—Felt guard
11—Felt washer
12—Bearing retainer
13—Bearing retainer screw
14—Felt washer retainer
15—Pulley key
16—Snap ring

17—Armature assembly
18—Frame screw
19—Frame and field assembly
20—Frame screw lockwasher
21—Head or inspection band
22—Main brush set
23—Main brush set
24—Commutator end plate assembly

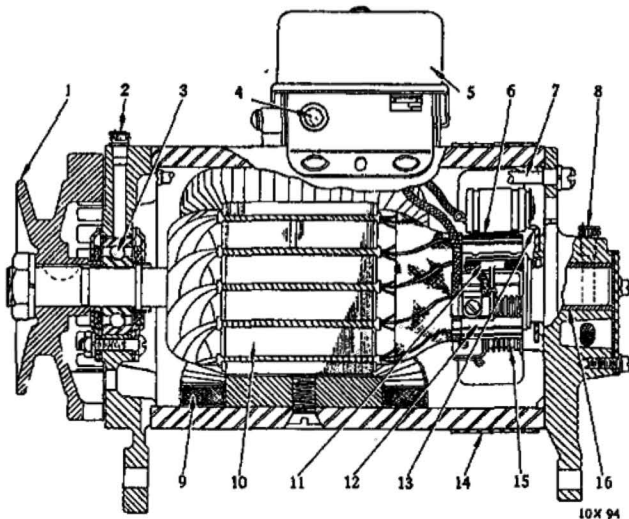
Figure 1—Generator (1940-42 Models)



10X175

- | | | |
|---|---|----------------------------------|
| 1—Armature shaft nut | 10—Felt guard | 19—Armature (commutator end) |
| 2—Armature shaft nut lockwasher | 11—Felt washer | 20—Frame screw or tie bolt |
| 3—Bearing retainer screw nut | 12—Bearing retainer | 21—Body |
| 4—Bearing retainer screw nut lockwasher | 13—Bearing retainer screw | 22—Lock washer |
| 5—Bearing retainer | 14—Felt washer retainer | 23—Head or inspection band |
| 6—Felt washer | 15—Pulley key | 24—Ground brush |
| 7—Felt guard | 16—Armature shaft and armature assembly | 25—Third brush |
| 8—Drive end head | 17—Armature snap ring | 26—Main brush |
| 9—Front bearing | 18—Armature | 27—Commutator end plate assembly |

Figure 2—Generator (1937-39 Models)



10X 94

- | |
|------------------------------------|
| 1—Generator pulley |
| 2—Front bearing oil cup |
| 3—Front bearing |
| 4—Fuse cup |
| 5—Cutout and voltage control relay |
| 6—Third brush |
| 7—Assembly bolt |
| 8—Rear bushing oil cup |
| 9—Field coil |
| 10—Armature |
| 11—Main brush |
| 12—Commutator |
| 13—Third brush rocker ring |
| 14—Inspection cover band |
| 15—Ground brush |
| 16—Rear bushing |

Figure 3—Generator (1936 Model)

2. DISASSEMBLY OF GENERATOR.

1936-42—Cont'd

(4) Blow out dust and dirt from field coils and armature windings and wipe these parts with a clean cloth damp with cleaning solvent.

CAUTION

Do not dip or soak the field coils and armature in cleaning solvent.

(5) Clean all other parts thoroughly.

(6) Inspect parts. If the end head or end plate are broken or brush holders are bent or damaged, install new parts. If the bearing fits loosely in the drive end head, replace the head. If the bushing in the commutator end plate is worn, replace the bushing. Replace the bearing retainers and felts if bent or damaged.

(7) If the armature core and shaft bearing surfaces are scored, damaged or excessively worn, replace the armature.

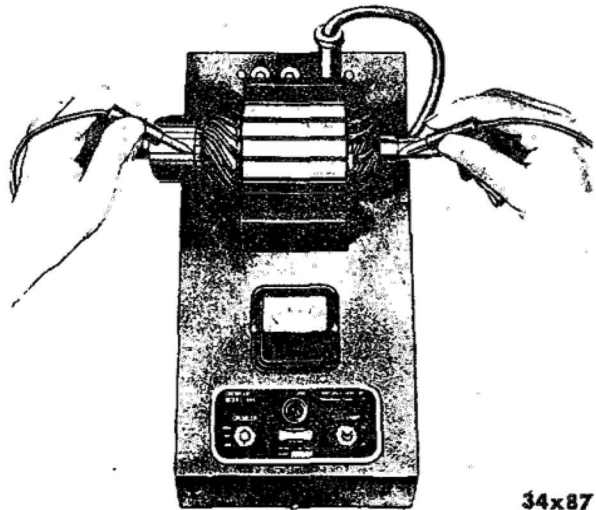
(8) Place the armature in a growler as shown in figure 4 and connect one test light lead to the armature shaft and the other to the commutator segments. If the test light burns, indicating a grounded condition, replace the armature.

(9) Turn on the growler and hold a strip of metal on the armature core, parallel with the commutator bars (fig. 5). Turn the armature slowly in the growler. If the metal strip becomes magnetized and vibrates, indicating a short circuit, replace the armature.

(10) Polish the commutator with "00" sand paper or turn the commutator down and undercut the mica strips if badly burned or more than .002 inch out-of-round.

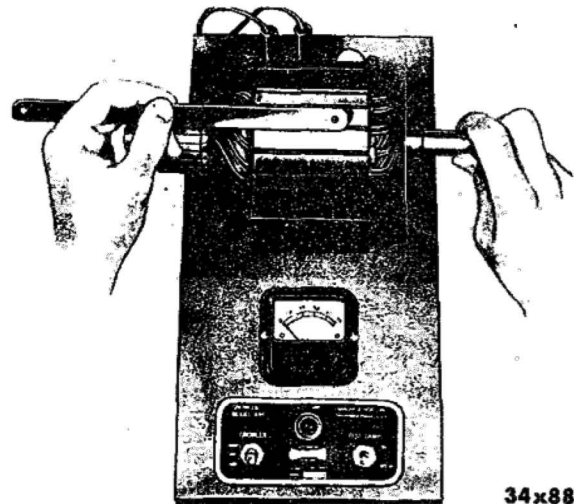
(11) Examine the brush holders for misalignment or damage and test the insulated brush for ground (fig. 6). Replace the commutator end plate assembly if damaged or grounded.

(12) Connect one test light lead to the field terminal on the generator and the other lead to the field coil wire (fig. 7). If the light



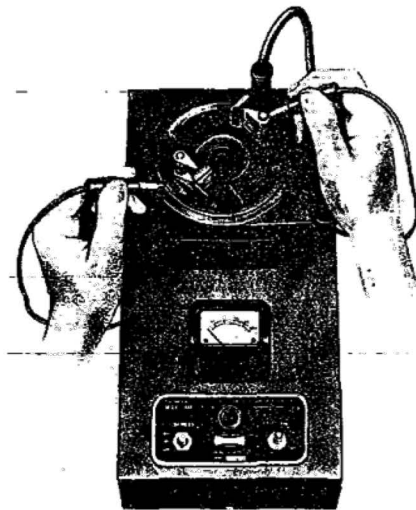
34x87

Figure 4—Testing Armature for Ground (1936-42 Models)



34x88

Figure 5—Testing Generator Armature for Short Circuit (1936-42 Models)



34x89

Figure 6—Testing Generator Insulated Brush Holder (1936-42 Models)

2. DISASSEMBLY OF GENERATOR.

1936-42—Cont'd

does not burn, the fields are open. Remove the insulation, if any, from the lead where the two coils are joined together and test each coil separately. Replace the faulty coil or coils.

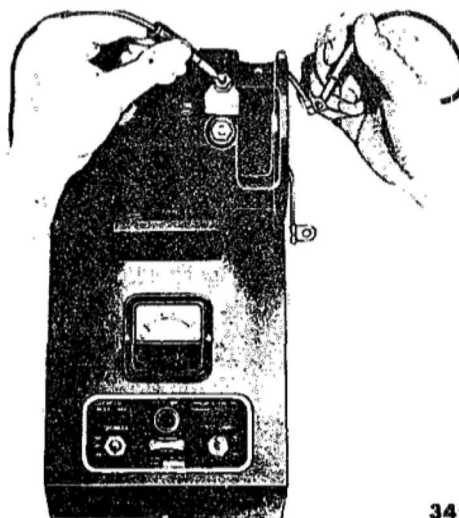
(13) Connect one test light lead to the generator field terminal or field coil brush wire and the other lead to the generator frame (fig. 8). If the light burns, the coils are grounded. Remove the field coils, inspect for grounds and replace if necessary. If the field coils are not grounded or shorted, test for amperage draw. Connect the fields to the test leads of the generator test bench and adjust the variable resistance to obtain 6 volts. Replace the field coils if the ammeter shows more amperage draw than specified in "Data and Specifications" chart. If a test bench is not available, use a separate ammeter in series with a battery and the generator field coils, and a voltmeter in parallel with a carbon pile or lamp bank resistor across the battery terminals.

3. REMOVAL OF FIELD COILS.

1936-42—Remove the nut and insulating washer from the generator field terminal and remove the terminal from the generator frame. Mark the field coil pole shoes so they can be assembled in the same location. Remove the screws which hold the pole shoes to the frame and remove the field coils and pole shoes together. Preserve the field coil connection insulator. Note the sequence in which the insulators are removed from the terminal screw.

4. INSTALLATION OF FIELD COILS.

1936-42—Place the pole shoes into the field coils so that they will be in the same position as when removed. Slide the coils into the generator frame with the lead wires toward the commutator end. Start the pole shoe screws to hold the coils in position and install the field connection insulator under the wire that connects the coils to-



34x90

Figure 7—Testing Generator Field Coils for Open Circuit (1936-42 Models)



34x91

Figure 8—Testing Generator Field Coils for Ground (1936-42 Models)

gether. Place the loop in the insulating paper in a position so that the frame screw will go under the paper. Tighten the pole shoe screws and install the field terminal screw in the frame with the insulating washers and spacers in the same sequence as removed.

5. ASSEMBLY OF GENERATOR.

1936-42—(See figures 1, 2 and 3.)

(1) Clamp the armature between the padded jaws of a vise and place the commutator end plate on the armature shaft.

(2) Install the brushes in the holders and position the brush springs. Hook a spring scale on the brush arm, hold the end plate steady on the shaft and pull straight

with the brush. The scale should read the number of ounces specified in "Data and Specifications" chart on page 132, just as the arm leaves the brush. Remove and bend the brush spring to obtain proper tension.

(3) If new brushes are used or the commutator is turned down, seat the brushes to the commutator by placing a narrow strip of "00" sand paper under the brush on the commutator with the sand side toward the brush. Form the sand paper around the commutator and pull the paper under the brush so that the brush is forced toward the holder. Usually two strokes of the paper is sufficient. Remove the brushes from the holders and the commutator end plate from the armature.

(4) Pack the ball bearing half full with high temperature grease and soak the felt retainers with engine oil. Place the inner retainer and felt washer on the armature shaft and press the bearing on the shaft with the sealed side toward the armature core. Assemble the drive end head over the bearing and align the oil relief with the oil cup hole.

(5) Install the outer felt and retainer on the shaft and install the retainer bolts.

(6) Install the drive pulley.

(7) Place the armature in the frame with the commutator toward the inspection holes and align the drive end head with the dowel in the frame.

(8) Install the commutator end plate on the armature and align with dowel. Install the frame screws. *Make sure that one screw passes under the field connection insulator.*

(9) Tighten the screws while striking the end head and end plate with a soft hammer to align the bearings and seat the parts.

(10) Raise the brush arm springs, install the brushes so that they fit the contour of the commutator and connect the brush leads.

(11) Connect the armature terminal wire to the insulated brush holder.

6. TESTING GENERATOR ON TEST STAND.

1940-42

(1) Mount generator on test stand but do not connect drive motor. Open test stand switch and connect negative (—) lead to armature terminal of generator and positive (+) lead to field terminal.

(2) Ground the field terminal to the frame of the generator and close the switch. The generator should motorize.

(3) Adjust the variable resistance so that the voltmeter reads 6 volts. The ammeter should indicate 4.1 to 4.6 amperes.

(4) Open the switch and connect the generator for output test.

(5) When testing for output, the test stand should be equipped with a calibrated regulator and a fully charged battery to duplicate car operation.

(6) Connect the field and armature lead from the regulator to the corresponding terminals on the generator.

(7) Connect the drive motor and run the generator for approximately 20 minutes to seat the brushes.

(8) Operate generator at 2700 revolutions per minute and adjust variable resistance to obtain maximum charging rate which should be 34 to 36 amperes. Disconnect generator and install cover band.

1936-39

(1) Mount generator on test stand but do not connect drive motor. Open test stand switch and connect negative (—) lead to armature terminal of generator and positive (+) lead to field terminal.

(2) Ground the field terminal to the frame of the generator and close the switch. The generator should motorize.

(3) Adjust the variable resistance so that the voltmeter reads 6 volts. The ammeter should indicate the amount of amperage draw specified for motorizing draw in "Data and Specifications" chart.

6. TESTING GENERATOR ON TEST STAND.

1936-39—Cont'd

(4) Open the switch and connect the generator for output test.

(5) When testing for output, the test stand should be equipped with the proper type regulator and a fully charged battery to duplicate car operation.

(6) Connect the field and armature lead from the regulator to the corresponding terminals on the generator.

(7) Connect the drive motor and run the generator for approximately 20 minutes to seat the brushes.

(8) Operate generator at 2700 revolutions per minute and adjust variable resistance to 6 volts and adjust the third brush to obtain maximum charging rate as shown in "Data and Specifications" chart. Disconnect generator and install cover band.

7. TESTING GENERATOR ON ENGINE.

1940-42

(1) Install the generator on the engine and connect all wires.

(2) Run the engine at a speed equivalent to 30 miles per hour car speed for about 20 minutes to seat the brushes.

(3) If the charging rate is not satisfactory, remove the drive belt and the regulator cover.

(4) Close the circuit breaker contact points by holding the armature down. If the generator revolves slowly as a motor and the ammeter shows a discharge not greater than the motorizing draw given in "Data and Specifications" chart on page 132, the generator will charge.

(5) To test the maximum output of the generator, install the drive belt and accelerate the engine to about 35 miles per hour while watching the ammeter.

CAUTION

Do not operate the generator with output in excess of maximum recommended.

(6) If the output is not within the maxi-

mum output figures given in "Data and Specifications" chart, ground the field terminal to eliminate the regulator while testing for maximum output.

(7) If the output does not build up with the field grounded, the generator is at fault.

(8) If the output is satisfactory with the field grounded but is not satisfactory with the regulator in the circuit, clean and test the regulator.

1936-39

(1) Install the generator on the engine and connect all wires.

(2) Run the engine at a speed equivalent to 30 miles per hour car speed for about 20 minutes to seat the brushes.

(3) If the charging rate is not satisfactory, remove the drive belt and the relay cover.

(4) Close the circuit breaker contact points by holding the armature down. If the generator revolves slowly as a motor and the ammeter shows a discharge not greater than the motorizing draw given in "Data and Specifications" chart, the generator will charge.

(5) To test the maximum output of the generator, install the drive belt and accelerate the engine to about 35 miles per hour while watching the ammeter.

CAUTION

Do not operate generator with output in excess of maximum recommended.

(6) If the output is not within the maximum output figures given in "Data and Specifications" chart, adjust the third brush.

(7) If a voltage regulator is used, ground the field terminal to eliminate the regulator while testing for maximum generator output.

(8) If the output does not build up with the field grounded, the generator is at fault.

(9) If the output is satisfactory with the regulator field terminal grounded, but is not satisfactory with the regulator in the circuit, clean and test the regulator.

Section XIV

GENERATOR REGULATOR

1. TESTING AND ADJUSTING GENERATOR REGULATOR.

1940-42 (Models P9-P10-P11-P12-P14)

NOTE

The following tests and adjustments can be made without removing regulator from the car. If the generator regulator is being tested or adjusted on a test bench, mount it firmly and in a place where there is no excessive vibration. The test bench should be equipped with a motor driven generator and fully charged battery duplicating the operation of the regulator when in service. Mount it on the test bench in the same position as when installed on the car.

a. Circuit Breaker.

(1) Run the engine with the hood raised until the regulator is warm.

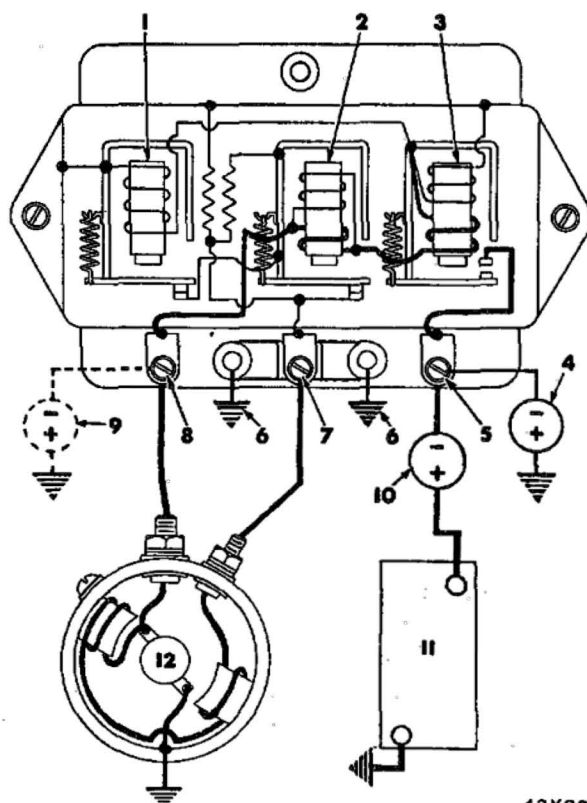
(2) Make certain the battery is fully charged; if not, install a fully charged battery.

(3) Disconnect the wire from the regulator "B" terminal, connect the positive (+) lead of a test ammeter to the wire removed and the negative (—) lead to the regulator "B" terminal (10, fig. 1).

(4) Connect the negative (—) lead of a test voltmeter to the "A" terminal of the regulator and positive (+) lead to the regulator housing (ground) (9, fig. 1).

(5) Start the engine and make certain it idles smoothly.

(6) Increase engine speed slowly to determine when the circuit breaker points close. Watch the voltmeter and observe when the hand kicks back slightly, indicat-



42X22

- | | |
|--|---|
| 1—Voltage regulator coil | 7—Regulator field terminal |
| 2—Current regulator coil | 8—Regulator armature terminal |
| 3—Circuit breaker coil | 9—Voltmeter connection for circuit breaker test |
| 4—Voltmeter connection for current and voltage regulator tests | 10—Test ammeter |
| 5—Regulator battery terminal | 11—Battery |
| 6—Regulator ground screws | 12—Generator |

Figure 1—Generator Circuit Diagram and Test Connections (1937-42 Models)

ing that the points have closed; this should occur at 6.4 to 6.6 volts. This will also be indicated on the ammeter as the hand will just have left the "0" mark.

(7) If an adjustment is necessary, remove the regulator cover and inspect the contacts of all three units. In normal use, the

(Continued on page 141)

DATA AND SPECIFICATIONS					
Year	1940—P9, P10 1941—P11, P12 1942—P14	1937—P4 1938—P6 1939—P8	1936—P2	1936—P1 1937—P3 1938—P5 1939—P7	
Regulator model (stamped on plate attached to reg- ulator)	VRP-4001-A	VRR-4003-A	TC-4301-A	CB-4014-C	
Rated capacity	6 volts—35 amps	6 volts—30 amps	6 volts—21 amps	6 volts—18 amps	
Ground polarity	Positive	Positive	Positive	Positive	
Value of carbon re- sistors	Marked 38— 36-40 ohms Marked 7— 6.5-7.5 ohms	Marked 20— 19-21 ohms	Marked 1.4— 1.3-1.5 ohms	None	
Circuit Breaker	Resistance of winding	29.8 to 33.0 ohms	35 to 39 ohms	15.9 to 17.8 ohms	35 to 39 ohms
	Armature air gap	.031 to .034 in.	.034 to .038 in.	.034 to .038 in.	.034 to .038 in.
	No. of coils in armature spring	12 $\frac{3}{4}$	10 $\frac{3}{4}$	10 $\frac{3}{4}$	10 $\frac{3}{4}$
	Minimum con- tact point gap	.015 in.	.015 in.	.015 in.	.015 in.
	Contact points close at	6.4—6.6 volts	6.4—7.0 volts	6.5—7.25 volts	6.5—7.25 volts
	Contact points open at	4 to 6 amps discharge	.5 to 3 amps discharge	.5 to 2.5 amps discharge	.5 to 2.5 amps discharge
Voltage Regulator	Resistance of winding	10.8 to 12.0 ohms	10.4 to 11.2 ohms	29 to 33 ohms	
	Armature air gap	.048 to .052 in.	.060 to .063 in.	.044 to .046 in.	
	No. of coils in armature spring	14 $\frac{1}{2}$	10 $\frac{3}{4}$	10	
	Minimum con- tact point gap	.012	.010	.005	
	Operating volt- age	7.1—7.3 volts	7.3—7.6 volts	Open at 8.2—8.7 volts; close at 1.2 —1.4 volts lower	
Current Regulator	Armature air gap	.048 to .052 in.			
	No. of coils in armature spring	12 $\frac{3}{4}$			
	Minimum con- tact point gap	.012 in.			
	Operating amperage	34-36 amps			

1. TESTING AND ADJUSTING GENERATOR REGULATOR

1940-42 (Models P9-P10-P11-P12-P14)—Cont'd

contacts will become grayed. If the contacts are burned or dirty or if they are not smooth, file them with a No. 6 American Swiss cut equalling file. Move the file parallel and lengthwise to the armature. File just enough so that the contacts present a smooth flat surface toward each other. It is not necessary to remove every trace of burning. After filing, dampen a piece of linen tape in refined carbon tetrachloride and draw the tape between the contacts. Repeat with a dry piece of tape. Use clean tape for each set of contacts.

(8) Bend the lower armature spring holder to secure proper closing voltage (fig. 2). Vary the contact point spacing to secure opening voltage adjustment. Keep the contacts aligned and not less than .015 inch gap.

(9) If necessary, bend the lower spring hanger so that the points will close at 6.4 to 6.6 volts.

(10) Adjust the point gap (fig. 3) so that the points will open at 4 to 6 amps discharge as the engine speed is reduced.

b. Voltage Regulator.

(1) Change voltmeter connection from armature to battery terminal of regulator (4, fig. 1).

(2) Maintain engine speed equivalent to about 30 miles per hour car speed for 15 minutes.

(3) The voltage regulator must control the voltage to 7.1 to 7.3 volts, with the cover on the regulator.

(4) If an adjustment is necessary, bend the lower spring hanger of the voltage regulator as shown in figure 2 to increase or decrease the spring tension. *This adjustment must be made carefully so that the voltage will be within specifications with the regu-*

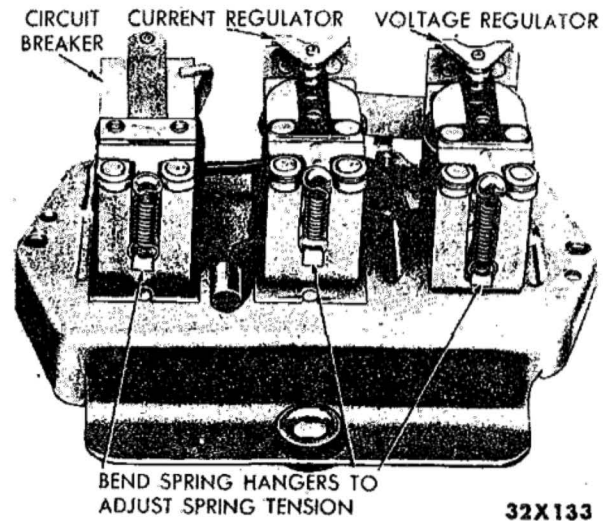


Figure 2—Generator Regulator Spring Hangers (1937-42 Models)

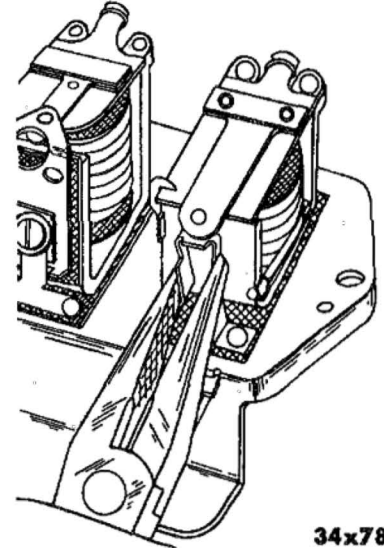


Figure 3—Adjusting and Aligning Circuit Breaker Contact Points (1937-42 Models)

lator at normal operating temperature and with the cover installed.

CAUTION

When removing and installing the cover, exercise care to prevent touching the cover on the circuit breaker which would cause a short circuit and damage the regulator assembly.

c. Current Regulator.

(1) Connect a variable resistance across the battery posts and leave the voltmeter and ammeter connected as when testing the voltage regulator (paragraph b).

(2) Set the engine speed equivalent to 35 miles per hour and the voltmeter should show 7.1 to 7.3 volts. Maintain the engine speed and adjust the resistance across the battery to lower the voltage to 6.6 volts. At this voltage, the generator output should be controlled to 34 to 36 amperes with the cover on the regulator.

(3) If an adjustment is necessary, bend the lower spring hanger of the current regulator (fig. 2).

2. TESTING AND ADJUSTING CUT-OUT RELAY.

1936-39 (Models P1-P3-P5-P7)

(1) Remove the relay cover and connect a voltmeter between the generator armature terminal and ground.

(2) Connect a test ammeter in series with the vehicle ammeter, accelerate the engine slowly and note the reading on the voltmeter when the relay contacts close. This will be indicated by the ammeter which should just start to show a charge.

(3) Decelerate the engine slowly and note the discharge shown by the ammeter at the time the contact points open. Refer to "Data and Specifications" chart for circuit breaker opening and closing specifications.

(4) Adjust the relay point gap and relay opening amperage by bending the armature stop.

(5) Adjust the relay closing voltage by bending the lower armature spring hanger.

3. TESTING AND ADJUSTING CIRCUIT BREAKER AND VOLTAGE REGULATOR.

1936-39 (Models P2-P4-P6-P8)

a. Circuit Breaker.

(1) Remove the relay cover and connect a voltmeter between the generator armature terminal and ground.

(2) Connect a test ammeter in series with the vehicle ammeter, accelerate the engine slowly and note the reading on the voltmeter when the relay contacts close. This will be indicated by the ammeter just starting to show a charge.

(3) Decelerate the engine slowly and note the discharge shown by the ammeter at the same time the contact points open. Refer to "Data and Specifications" chart for circuit breaker opening and closing specifications.

(4) Adjust the relay point gap and relay opening amperage by bending the armature stop.

(5) Adjust the relay closing voltage by bending the lower armature spring hanger.

b. Voltage Regulator.

(1) Be sure the battery is fully charged; if not, install a fully charged battery.

(2) Remove the wire from the regulator "B" terminal and connect an ammeter between the wire and the terminal.

(3) Connect a voltmeter across the regulator "B" terminal and ground.

(4) Run the engine at a speed equivalent to 35 miles per hour road speed until the voltage remains constant.

(5) If voltage and amperage is not within specifications given in "Data and Specifications" chart, make the necessary adjustment by bending the lower spring hanger of the voltage regulator.

(6) Maintain engine speed at approximately 35 miles per hour and ground the field terminal, to eliminate the regulator.

(7) Adjust the generator third brush for maximum allowable generator output.

(8) Eliminate the field ground and if the charging voltage is then not within specifications, clean and adjust the regulator.

Section XV

IGNITION SYSTEM

1. DESCRIPTION.

1936-42—The ignition distributor (figs. 2 and 3) contains a single set of breaker points, a built-in centrifugal type governor and a vacuum operated unit attached to the side of the distributor.

2. DISASSEMBLY OF DISTRIBUTOR.

1936-42—Refer to figures 2 and 3.

- (1) Remove the vacuum control unit.
- (2) Remove the breaker plate assembly.
- (3) Remove felt wick from top of cam and stop plate, remove snap ring which holds the cam and stop plate to the drive shaft and lift the cam and stop plate and washer off the drive shaft.

- (4) Hold the distributor in a vise.

CAUTION

Clamp distributor in the vise so that the drive shaft bushing will not be distorted.

- (5) Check the bushing wear with a dial indicator; replace bushings if worn more than .008 inch (fig. 1).

- (6) Remove the rivet from the drive shaft coupling and slide the coupling and thrust washer off the shaft.

- (7) Remove the drive shaft, unhook the governor weight springs and remove the governor weights.

CAUTION

Do not distort governor weight springs when removing them.

- (8) Press the bearings out of the distributor base.

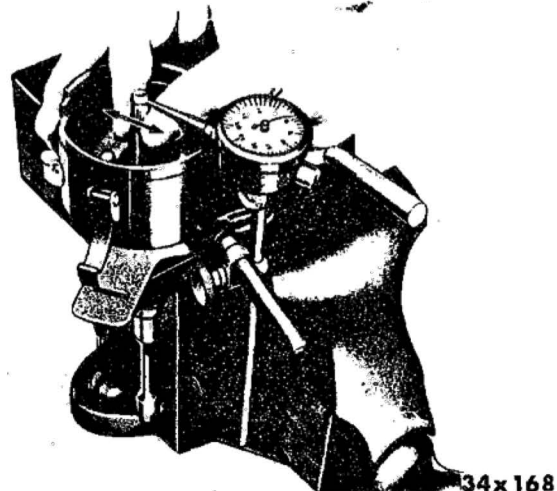
- (9) If the breaker points have a grayish color and are only slightly pitted they will be satisfactory for further use. However, if they are excessively pitted or burned, replace the points.

- (10) Test the condenser with a tester or load the condenser by connecting it across a battery and then touch the leads of a voltmeter in reverse polarity across the condenser. The voltmeter should show a momentary reading.

- (11) Lift the sub-plate and bearing assembly from the breaker plate and inspect the ball bearing. If the bearing is not smooth and free, or if it is worn, replace the plate and bearing assembly.

- (12) Test the diaphragm by sucking and placing the tongue over opening for vacuum tube. If vacuum is formed in the unit, the diaphragm is not leaking. Press on the end of the control arm and if the counteraction of the spring is smooth and firm, the vacuum unit should operate satisfactorily.

- (13) Clean the distributor cap and examine for cracks, carbon runners or corroded terminals. If any of these conditions are present or if the vertical faces of the inserts are excessively burned, install a new cap. If the horizontal faces of the inserts are burned, replace the rotor, as this condition indicates



34x168

**Figure 1—Measuring Drive Shaft Bearing Wear
(1936-42 Models)**

DATA AND SPECIFICATIONS					
Year	1942	1941	1940	1939	1936-38
Distributor model (stamped on plate attached to distributor)	IGS-4203-C-1	IGS-4204-1	IGS-4109-1	IGS-4103-A-1	IGS-4003-B-1
Ignition timing	T.D.C.	T.D.C.	T.D.C.	T.D.C.	4 degrees A.T.D.C.
Breaker point gap	.020 in.	.020 in.	.020 in.	.020 in.	.020 in.
Breaker point dwell (cam angle)	38°	38°	38°	38°	38°
Breaker point spring tension	17 to 20 oz.	17 to 20 oz.	17 to 20 oz.	17 to 20 oz.	17 to 20 oz.
Maximum allowable drive shaft bushing wear	.008 in.	.008 in.	.008 in.	.008 in.	.008 in.
Condenser capacity	.25 to .28 mfd.	.25 to .28 mfd.	.25 to .28 mfd.	.25 to .28 mfd.	.25 to .28 mfd.
Automatic mechanical advance curve in degrees of distributor advance at distributor R.P.M.	0° @ 350 R.P.M.	0° @ 350 R.P.M.	0° @ 350 R.P.M.	0° @ 350 R.P.M.	0° @ 350 R.P.M.
	3° @ 400 R.P.M.	3° @ 400 R.P.M.	3° @ 400 R.P.M.	3° @ 400 R.P.M.	3° @ 400 R.P.M.
	5° @ 620 R.P.M.	6° @ 950 R.P.M.	6° @ 950 R.P.M.	6° @ 950 R.P.M.	6° @ 950 R.P.M.
	8° @ 940 R.P.M.	9° @ 1500 R.P.M.	9° @ 1500 R.P.M.	9° @ 1500 R.P.M.	9° @ 1500 R.P.M.
	10° @ 1150 R.P.M.	11° @ 1850 R.P.M.	11° @ 1850 R.P.M.	11° @ 1850 R.P.M.	11° @ 1850 R.P.M.
Vacuum advance curve in degrees of distributor advance with inches of manifold vacuum	2° with 6¾ in. of vacuum	2° with 6¾ in. of vacuum	2° with 6¾ in. of vacuum	2° with 6¾ in. of vacuum	2° with 6¾ in. of vacuum
	8½° with 15 in. of vacuum	11° with 17 in. of vacuum	11° with 17 in. of vacuum	11° with 17 in. of vacuum	11° with 14 in. of vacuum
Spark plug size	14 mm	14 mm	14 mm	14 mm	14 mm
Spark plug gap, inches	.025	.025	.025	.025	.025

2. DISASSEMBLY OF DISTRIBUTOR.

1936-42—Cont'd

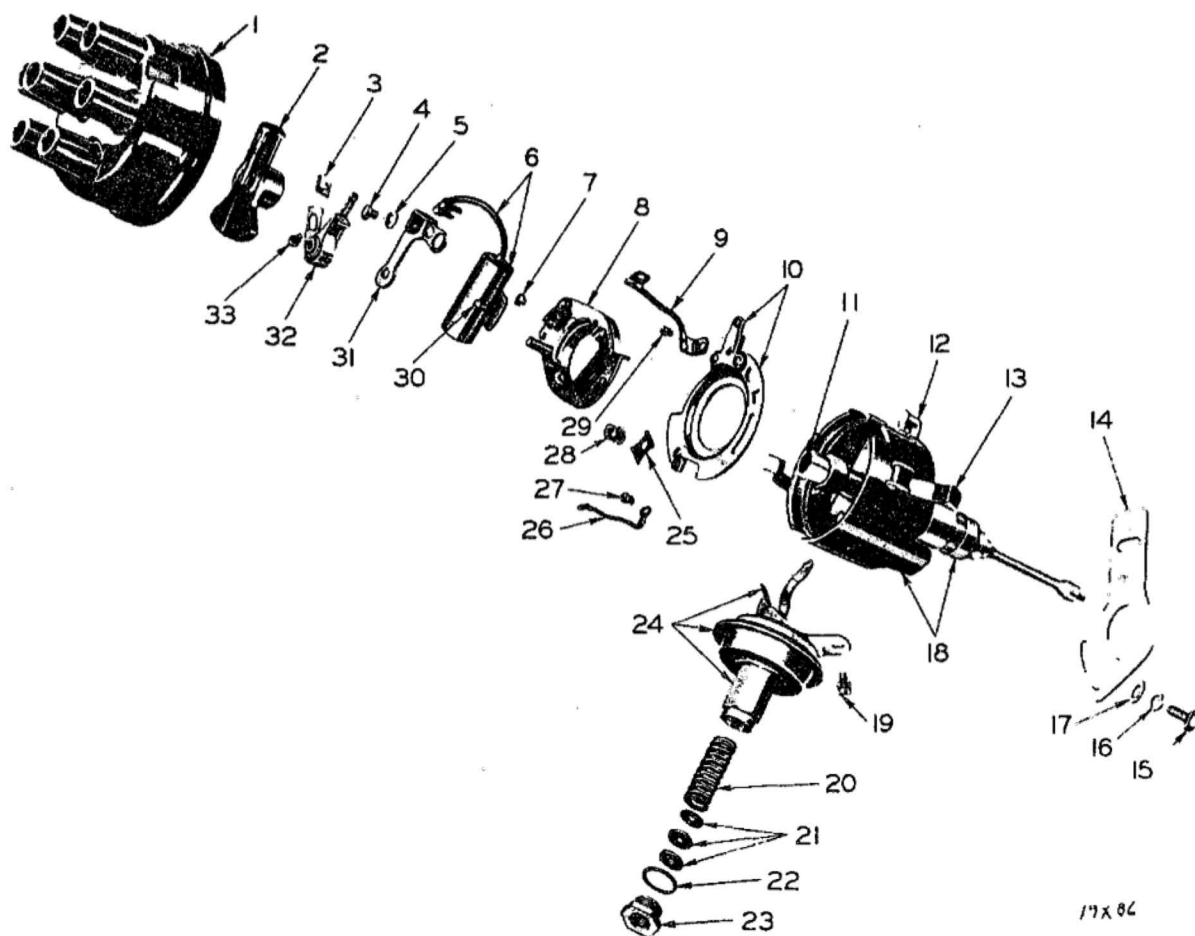
that the rotor is too short. If the center contact plunger is excessively worn or stuck, or if the spring is damaged, replace the spring and plunger. A slight burning at the end of the rotor metal strip is a normal condition and will not affect the operation of the dis-

tributor. If the top of the rotor metal strip is burned or the rotor is cracked or damaged, replace the rotor.

3. ASSEMBLY OF DISTRIBUTOR.

1936-42—Refer to figures 2 and 3.

(1) Soak new bearings in engine oil for about fifteen minutes. Press the upper bearing into the distributor base from the top,



- | | | |
|--|--|---|
| 1—Cap assembly | 12—Oiler—press-in elbow | 23—Vacuum chamber plug |
| 2—Rotor | 13—Cap spring | 24—Vacuum chamber assembly |
| 3—Breaker arm spring clip | 14—Advance control arm | 25—Bearing clamp |
| 4—Adjustable breaker point lock screw | 15—Advance control arm lock screw | 26—Ground lead and terminals |
| 5—Adjustable breaker point lock screw washer | 16—Advance control arm lock screw lockwasher | 27—Terminal screw |
| 6—Condenser | 17—Advance control arm lock screw washer | 28—Bearing clamp screw and lockwasher |
| 7—Terminal screw | 18—Base assembly | 29—Terminal screw |
| 8—Breaker sub-plate and bearing assembly | 19—Vacuum chamber fastening screw and lockwasher | 30—Condenser fastening screw |
| 9—Primary lead and terminals | 20—Vacuum chamber spring | 31—Breaker point |
| 10—Breaker plate assembly | 21—Vacuum chamber washers | 32—Breaker arm assembly |
| 11—Cam sleeve felt wick | 22—Vacuum chamber plug basket | 33—Breaker arm spring clip terminal screw |

Figure 2—Distributor (1942 Model, Typical of 1939-41 Models)

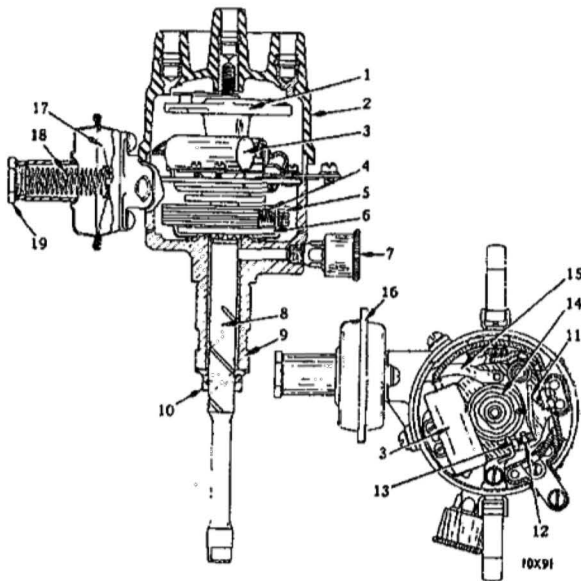
3. ASSEMBLY OF DISTRIBUTOR.

1936-42—Cont'd

making sure the oil hole in the bearing lines up with the oiler in the base. Press the lower bearing into the base from the bottom.

(2) Be sure the lubrication grooves are filled with short fibre grease before the weights are assembled. (See figure 4.) Press the pivot holes full of grease.

(3) Install the governor weights over the pivot pins and wipe away the surplus grease. Connect the governor weight springs to the weights and to the spring brackets.



- | | |
|---|---|
| 1—Ignition distributor rotor | 11—Ignition distributor breaker arm |
| 2—Ignition distributor cap | 12—Ignition distributor adjustable breaker point |
| 3—Ignition distributor condenser | 13—Ignition distributor breaker point lock nut |
| 4—Ignition distributor governor spring | 14—Ignition distributor breaker cam |
| 5—Ignition distributor governor weight | 15—Vacuum control arm |
| 6—Ignition distributor governor weight base | 16—Vacuum advance unit |
| 7—Ignition distributor grease cup | 17—Vacuum unit diaphragm |
| 8—Ignition distributor shaft | 18—Vacuum unit return spring |
| 9—Ignition distributor body | 19—Vacuum unit return spring retaining nut and gasket |
| 10—Ignition distributor shaft collar | |

Figure 3—Distributor (1936-38 Models)

CAUTION

Do not distort the governor weight springs when installing them.

(4) Lubricate the bearings thoroughly and slide the cup-shaped thrust washer on the drive shaft, concave side first.

(5) Install the shaft through the distributor base, slide the drive shaft thrust washer and drive coupling on the shaft, and install a new rivet.

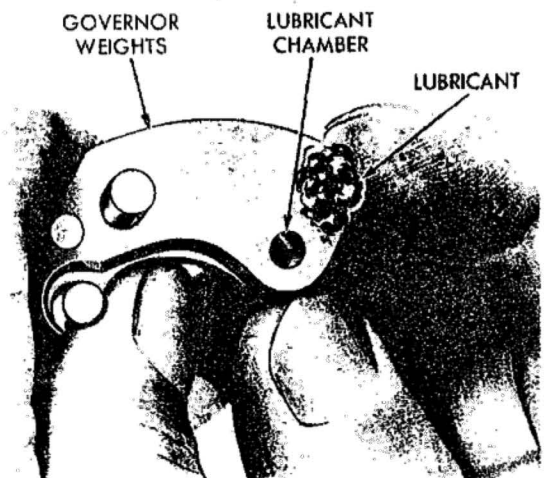
(6) If a new shaft is installed, use a new drive coupling, and drill the rivet hole. Hold the shaft down and the coupling up against the base while drilling so there will be no end play in the shaft after the rivet has been installed.

(7) Place the thrust washer over the top end of the drive shaft.

(8) Place the cam and stop plate over the end of the drive shaft, and the lugs on the governor weights. Put a drop of engine oil on each lug.

(9) Install the spring snap ring and felt wick in the top of the drive shaft. Put three to five drops of SAE 10 engine oil on the felt wick.

(10) Place the sub-plate and bearing assembly into the breaker plate with the stop lug in the shorter slot.



32X38

Figure 4—Packing Governor Weight with Lubricant (1936-42 Models)

(11) Place the breaker plate in the distributor body and install the bearing clamps (with the small depression up) and mounting screws.

(12) Install the vacuum control unit.

(13) Adjust the breaker point gap to .020 inch.

(14) Hook a spring scale on the breaker point arm at the point end and pull at right angles to the point surfaces. Take a reading as the breaker points separate. The spring tension should be 17 to 20 ounces. Loosen the screw which holds the end of the breaker point spring and slide the end of the spring in or out as necessary. Tighten the screw and check the tension.

(15) If a testing fixture is available, test automatic advance, vacuum control and point dwell against specifications shown in "Data and Specifications" chart.

4. SPARK PLUGS.

1936-42—Spark plugs should be tested occasionally with a reliable tester and replaced if faulty. To insure maximum efficiency, replace the plugs every 10,000 miles. Adjust spark plug gap to .025 inch using a round feeler gauge. Make all adjustments on the side wire of the plug. If the center electrode is bent, the porcelain may crack, resulting in plug failure.

LIGHTING SYSTEM DATA AND SPECIFICATIONS					
Year	1941-42	1940	1939	1937-38	1936
Headlight type	Sealed beam	Sealed beam	Door	Doorless	Doorless
Headlight, candle power—Mazda number	Sealed beam unit	Sealed beam unit	32-32-2331	32-32-2331	32-32-2331
Beam indicator, candle power—Mazda number	1-51	1-51	1-51	(1938) 1½-55 (1937) 1-51	
Tail light, candle power—Mazda number	3-63				
Tail and stop light, candle power—Mazda number		21-3-1158	21-3-1158	21-3-1158	21-3-1158
Stop light, candle power—Mazda number	21-1129				
Instrument lights, candle power—Mazda number	(1942) 6-81 (1941) 1½-55	1½-55	1½-55	(1938) 1½-55 (1937) 1-51	1½-55
Dome light, candle power—Mazda number	15-87	15-87	15-87	15-87	15-87
Rear license light, candle power—Mazda number	3-63	3-63	3-63	3-63	
Ignition switch light, candle power—Mazda number	1-51	1-51		1½-55	1½-55
Front parking lights, candle power—Mazda number	(1942) 3-63 (1941) 1½-55	1½-55	1½-55	1½-55	1½-55
Front direction signal candle power—Mazda number	21-1129				
Rear direction signal candle power—Mazda number	21-3-1158				
Direction signal indicator candle power—Mazda number	1½-51				
Light Fuse	Location	①	①	①	②
	Amperes	30	30	20	20
	Diameter, inches	⅜	⅜	¼	¼
	Length, inches	1⅞	1⅞	1¼	1¼
Horn Fuse	Location	None used	None used	③	④
	Amperes			30	30
	Diameter, inches			⅜	⅜
	Length, inches			1⅞	1⅞
Radio Fuse	Location	⑤	⑤		
	Amperes	14	14		
	Diameter, inches	¼	¼		
	Length, inches	1⅞	1⅞		

① In back of headlight switch. ② Back of ammeter. ③ In horn relay. ④ In horn feed cable. ⑤ In radio feed cable.

Section XVI

LIGHTING AND WIRING

1. DESCRIPTION OF LIGHTS.

1940-42—The headlight consists of a reflector, bulb and lens sealed into a pre-focused Sealed Beam Unit. The unit is replaced as an assembly, after removing the headlight rim. Both horizontal and vertical adjustments of the light beam are provided. The parking light bulb is independent of the headlight unit. On the 1941-42 models, the stop light is combined with the license plate light, two separate bulbs being used. On the 1940 model, the stop light and taillight are combined and only one bulb is used.

1939—The headlight consists of a removable door, lens, bulb and reflector. The bulb is of the prefocused type, therefore it is only necessary to aim the light beam. Both horizontal and vertical adjustments of the light beam are provided. The parking light bulb is independent of the headlight bulb. The stop light and taillight are combined and only one bulb is used.

1936-38—The headlight consists of a lens, bulb and reflector. It is only necessary to remove the lens in order to remove the bulb. The lens is held in position by a retainer and screw at the bottom of the headlight body. Both horizontal and vertical adjustments of the light beam are provided. The parking light bulb is independent of the headlight bulb. The stop light and taillight are combined and only one bulb is used.

2. AIMING OF HEADLIGHTS.

1936-42

(1) It is necessary to use a screen as shown in figure 1 to aim the headlights properly. Adjustment should be made with the country beam (high beam) turned "on." The traffic beam (low beam) will then also be properly aimed. *Do not use the traffic beam for aiming the lights.* Adjust one headlight at a time, with the other one covered.

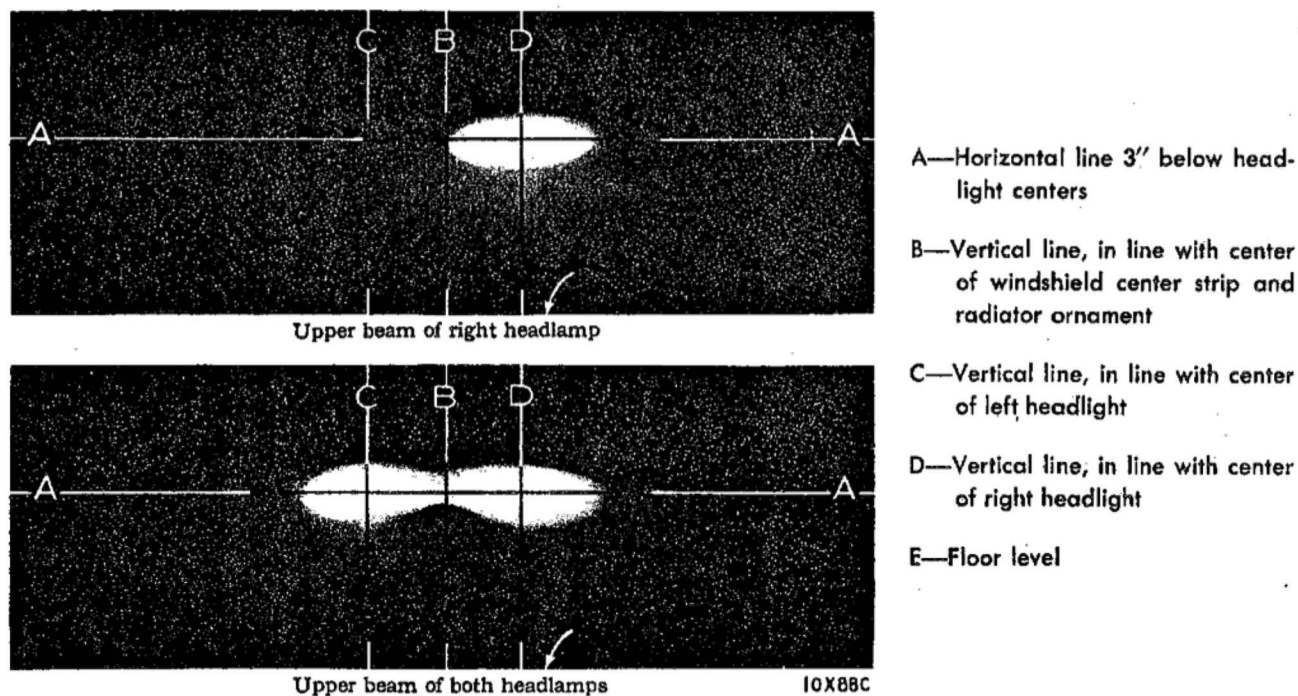


Figure 1—Light Reflections from Properly Aimed Headlights (1936-42 Models)

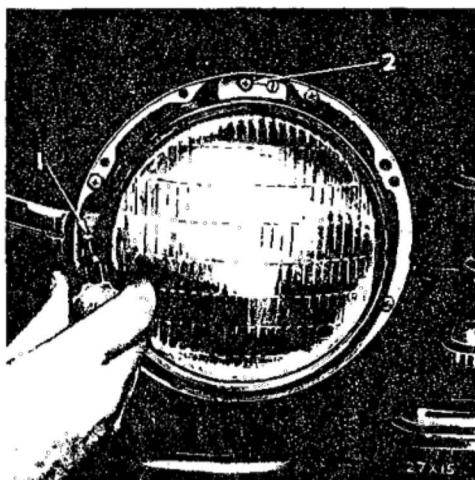
2. AIMING OF HEADLIGHTS.

1936-42—Cont'd

NOTE

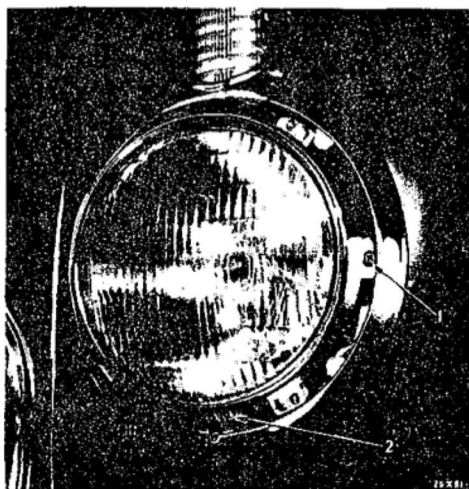
In most cases, headlights should be aimed as shown in figure 1. When state or local laws differ from these specifications, however, lights should be aimed to conform with such laws.

(2) Locate the car on a level floor (with no passengers in the car), with the headlights 25 feet from the aiming screen



1—Horizontal adjustment screw
2—Vertical adjustment screw

Figure 2—Headlight Adjustments (1942 Model)



1—Horizontal adjustment screw
2—Vertical adjustment screw

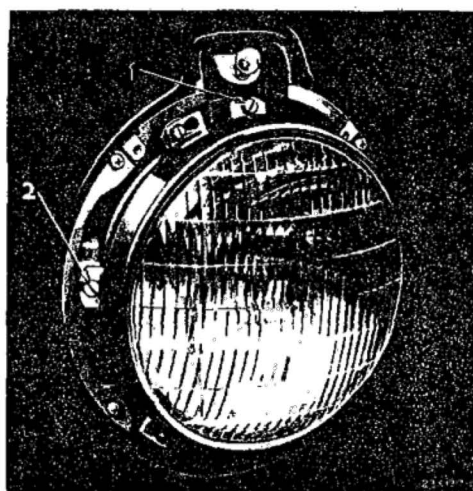
Figure 3—Headlight Adjustments (1941 Model)

and aim the high beam as shown in figure 1, as follows:

1940-42—Remove the headlight rim. Adjust the headlights by means of screws shown in figure 2, 3 or 4.

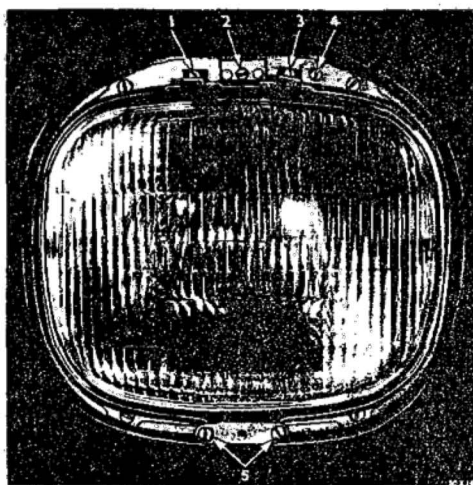
1939—Remove the chrome ring. Adjust the headlights by means of screws shown in figure 5.

1936-38—Loosen the headlight mounting bolts (1, fig. 6) and move the lights as required.



1—Vertical adjustment screw
2—Horizontal adjustment screw

Figure 4—Headlight Adjustments (1940 Model)



1—Lens clip screw
2—Vertical adjustment screw
3—Lens clip screw
4—Horizontal adjustment screw
5—Lens clip screws

Figure 5—Headlight Adjustments (1939 Model)

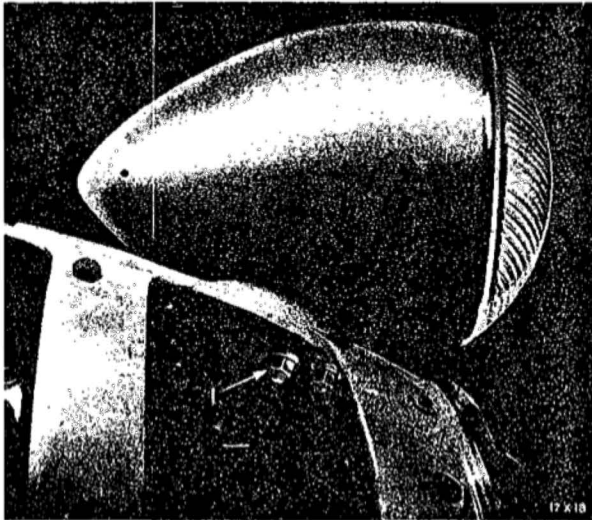


Figure 6—Headlight Mounting Bolt (1)
(1938 Model, Typical of 1936-37 Models)

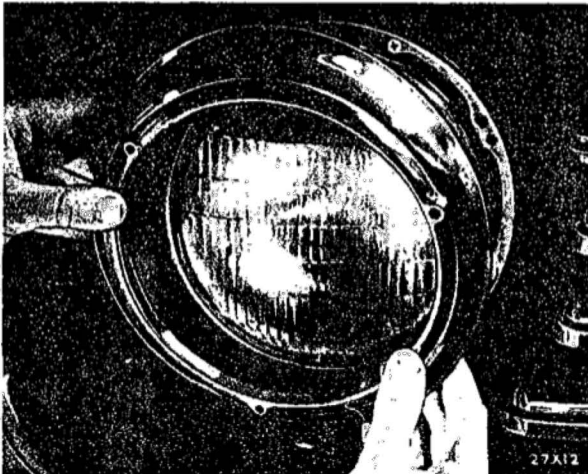


Figure 7—Removing Headlight Door (1942 Model)

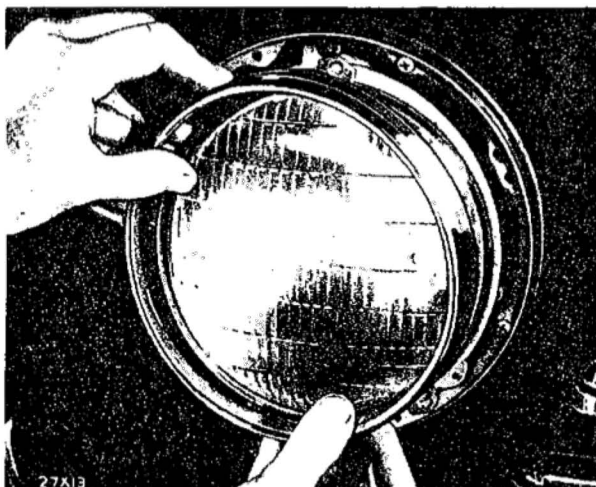


Figure 8—Removing Headlight Unit Retaining Ring (1942 Model)

3. REPLACEMENT OF LIGHT BULBS.

1942

(1) *Headlight.* Remove the headlight door (fig. 7). Remove the retaining ring screws and withdraw the ring from the light (fig. 8). Pull the sealed beam unit from the retaining seats and pull the wire connector straight off (fig. 9). After the new unit is installed, aim the headlights.

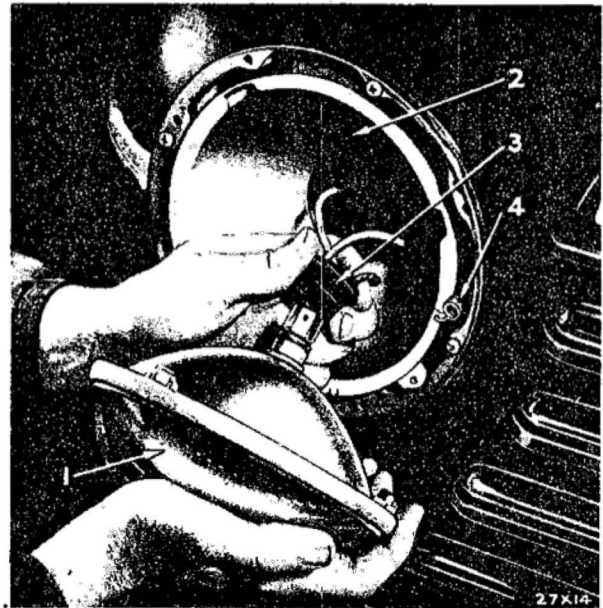
(2) *Parking Light.* Remove the lens retainer, lens and bulb.

(3) *Taillight.* Reach inside the luggage compartment, squeeze the socket retainer and pull it out of its holder.

(4) *Stop Light.* Remove the socket and bulb from the underside of the deck lid to replace the bulb.

1941

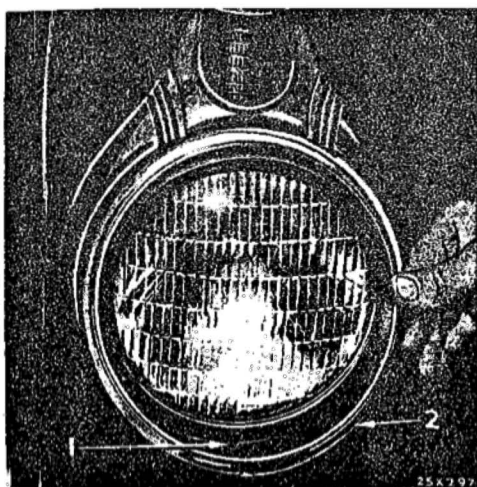
(1) *Headlight.* Remove the screw at the bottom of the headlight rim, pull outward at bottom and unhook the rim at the top (fig. 10). Loosen the retaining ring screws (fig. 11) and turn the ring to the left to unhook it from the screws. Pull the sealed



1—Sealed beam unit
2—Sealed beam unit mounting seat

3—Three-way cable connector socket
4—Sealed beam unit mounting seat spring

Figure 9—Removing Headlight Sealed Beam Unit (1942 Model, Typical of 1940-41 Models)



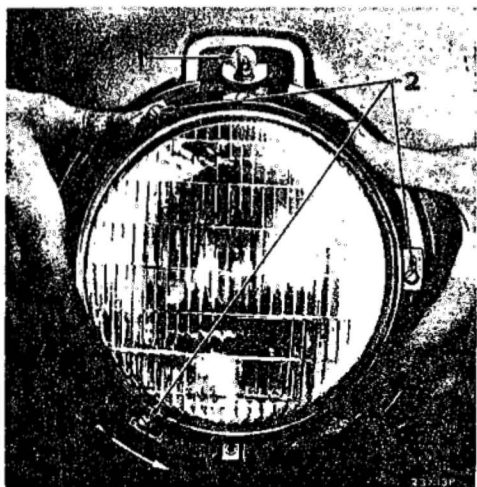
1—Access ring fastening screw hole 2—Access ring

Figure 10—Removing Headlight Ring (1941 Model)



1—Retaining ring mounting screws 2—Sealed beam unit

Figure 11—Removing Headlight Unit Retaining Ring (1941 Model)



1—Parking light 2—Retaining ring mounting screws

Figure 12—Removing Headlight Sealed Beam Unit (1940 Model)

3. REPLACEMENT OF LIGHT BULBS.

1941—Cont'd

beam unit from the retaining clips, then pull the wire connector straight off (fig. 9). After the new unit is installed, aim the headlights.

(2) *Parking Light.* Remove the lens retainer, lens and bulb.

(3) *Taillight.* Reach inside the luggage compartment, squeeze the socket retainer and pull it out of its holder.

(4) *Stop Light.* Remove the socket and bulb from the underside of the deck lid to replace the bulb.

1940

(1) *Headlight.* Remove the screws which hold the headlight rim in place and lift off the rim. Loosen the retaining ring screws (2, fig. 12). Turn the retaining ring to unhook it from the screws. Pull the sealed beam unit loose from the spring retaining clips, then pull the wire connector straight off (fig. 9). After the new unit is installed, aim the headlights.

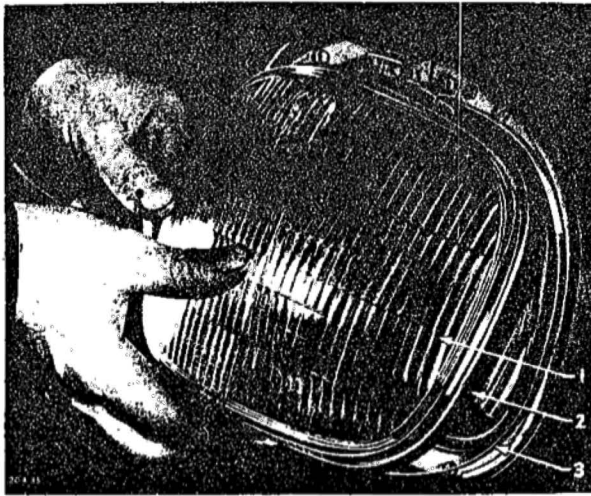
(2) *Parking Light.* Remove the headlight rim and withdraw bulb from socket (1, fig. 12).

(3) *Taillight and Stop Light.* Reach inside luggage compartment, squeeze the socket retainer and pull it out of its holder.

1939

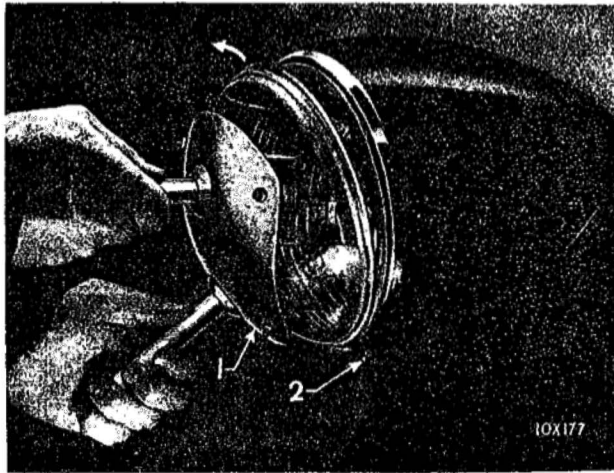
(1) *Headlight and Parking Light.* Remove the screw at the bottom of the light and lift off the chrome ring. Remove the screws which hold the lens retaining clips (fig. 5) and lift off the lens (fig. 13). Replace the bulb. When installing the lens, be sure it is properly sealed with the gasket. Aim the headlights before installing the chrome ring.

(2) *Taillight and Stop Light.* Remove the retaining screw from the light body at the base of the door, lift up and out on the assembly and remove the bulb.



1—Lens 2—Lens gasket 3—Lens gasket retainer band

Figure 13—Removing Headlight Lens (1939 Models)



1—Tool C-439 2—Lens retaining screw

Figure 14—Removing Headlight Lens (1938 Model, Typical of 1936-37 Models)

1936-38

(1) *Headlight.* Loosen the screw at the bottom of the headlight body (fig. 14). Using the lens removing tool C-439, press inward at the bottom of lens, causing it to come out at the top of the body and withdraw it upward and out of the body.

NOTE

If the lens tends to stick in the body, hold the tool with one hand, and give the upper portion of the body a sharp rap with the palm of the other hand. This will loosen the lens and permit its removal. Replace the bulb, then enter the lens at the bottom, lining up the locator with the locating notch in the body. Slide the lens toward the bottom of the body until the top of the lens clears the body opening. Press inward at the top of the lens, hold the lens in place and tighten the lens retainer screw. Aim the headlight beam.

4. DESCRIPTION OF WIRING.

1936-42—A one-wire, grounded type circuit is used on all models. See Wiring Diagrams (figs. 15-25). The positive terminal of the battery is grounded. Fuses are used to protect various circuits. See "Data and Specifications" chart.

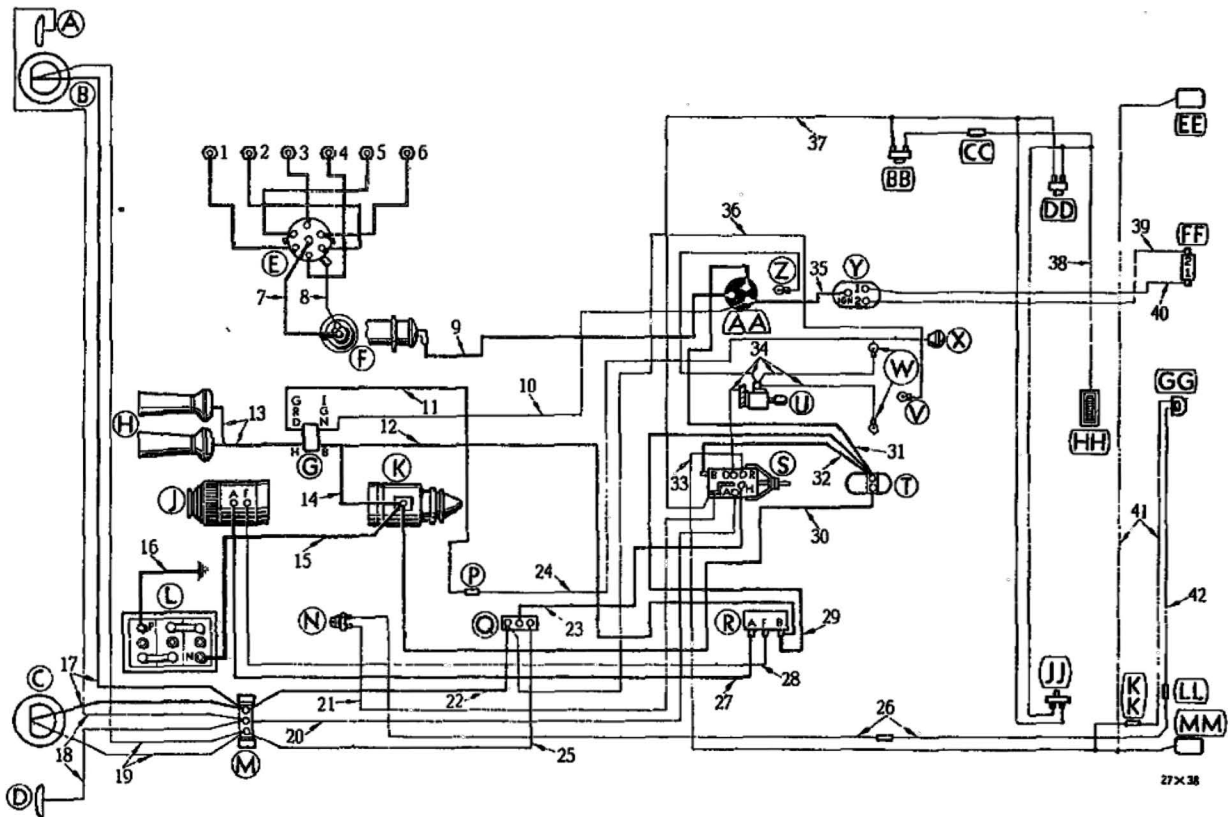


Figure 15—Wiring Diagram (1942 Model)

- | | | |
|---|--|--|
| A—Parking light—right | BB—Automatic door switch | 16—Battery ground cable and terminals (+) positive |
| B—Headlight—right | (P14-C only) | 17—Red |
| C—Headlight—left | CC—Cable connector | 18—Yellow |
| D—Parking light—left | DD—Dome light pillar switch | 19—Black |
| E—Ignition distributor | (P14-S) | 20—Yellow |
| F—Ignition coil | EE—Tail light—right | 21—Red |
| G—Horn relay | FF—Fuel gauge (tank unit) | 22—Red |
| H—Horns | GG—License and signal light | 23—Yellow |
| J—Generator | HH—Dome light | 24—Black |
| K—Starter motor | JJ—Dome light pillar switch | 25—Black |
| L—Battery | (P14-C) | 26—Red |
| M—Terminal block | KK—Cable connector | 27—Red |
| N—Signal light switch | LL—Cable connector | 28—Green |
| P—Cable connector | MM—Tail light—left | 29—Black |
| Q—Headlight dimmer foot switch | 1-6—Spark plug cables (high tension cable) | 30—Red |
| R—Voltage regulator | 7—Secondary cable (high tension cable) | 31—Brown |
| S—Main lighting switch and fuse | 8—Primary cable (black) | 32—Brown |
| T—Ammeter | 9—Ignition switch cable | 33—Black |
| U—Instrument light switch | 10—Green | 34—Black |
| V—Headlight bright beam indicator light | 11—Green | 35—Blue |
| W—Instrument lights | 12—Red | 36—Brown |
| X—Horn blowing ring or push button | 13—Green | 37—Red |
| Y—Fuel gauge (panel unit) | 14—Red | 38—Yellow |
| Z—Ignition switch light | 15—Starter cable and terminals | 39—Black and yellow |
| AA—Ignition switch and lock | (-) negative | 40—Blue |
| | | 41—Black |
| | | 42—Red |

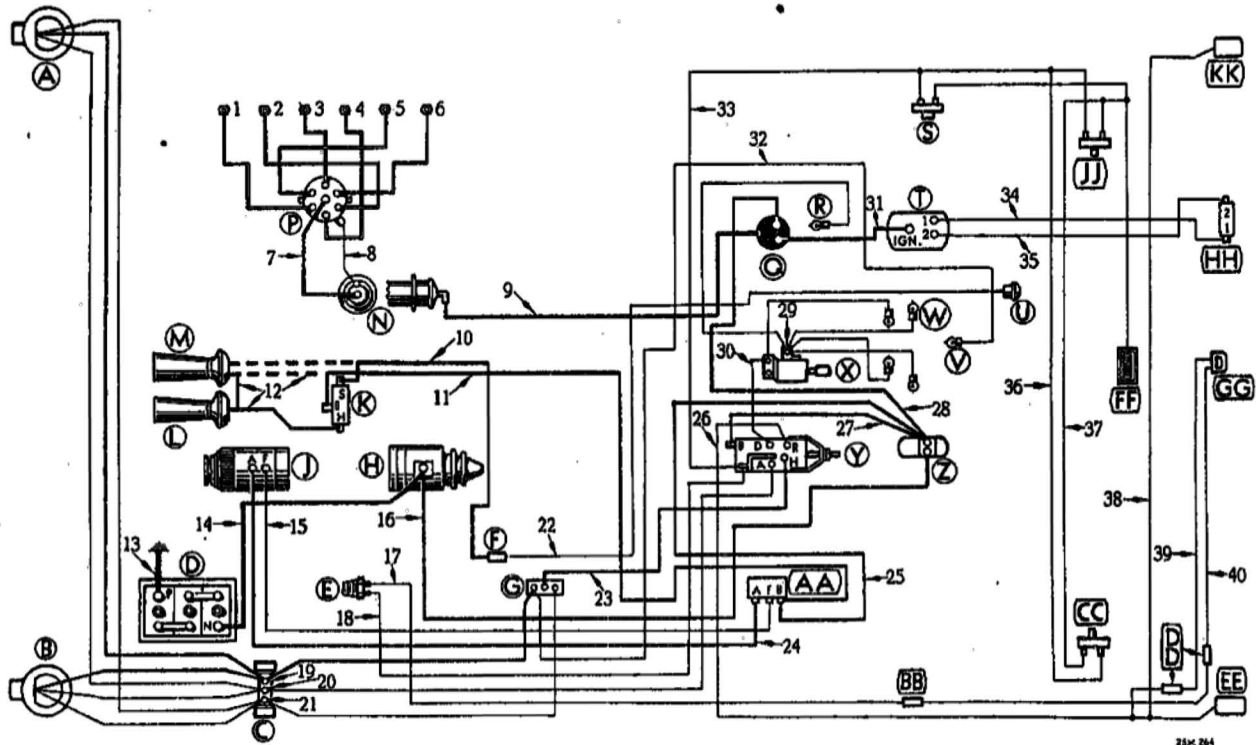


Figure 16—Wiring Diagram (1941 Model)

- | | | |
|--|--|---------------------|
| A—Headlight—right | AA—Voltage regulator | 15—Green |
| B—Headlight—left | BB—Cable connector | 16—Red |
| C—Headlight cable terminal block | CC—Automatic door switch—left
(7-Pass. Sedans and Limousine) | 17—Red |
| D—Battery | DD—Cable connectors | 18—Red |
| E—Signal light switch | EE—Tail light—left | 19—Red |
| F—Horn button cable connector | FF—Dome light | 20—Yellow |
| G—Headlight dimmer foot switch | GG—License and signal light | 21—Black |
| H—Starter motor | HH—Fuel gauge (tank unit) | 22—Black |
| J—Generator | JJ—Automatic door switch—right
(7-Pass. Sedans and Limousine) | 23—Yellow |
| K—Horn relay (dual horns) | KK—Tail light—right | 24—Red |
| L—Dual horn | 1-6—Spark plug cables
(high tension cable) | 25—Black |
| M—Single horn | 7—Secondary cable
(high tension cable) | 26—White |
| N—Ignition coil | 8—Primary cable (black) | 27—Brown |
| P—Ignition distributor | 9—Ignition switch cable | 28—Brown |
| Q—Ignition switch and lock | 10—Green | 29—Black |
| R—Ignition switch light | 11—Red | 30—Black |
| S—Dome light pillar switch | 12—Green | 31—Blue |
| T—Fuel gauge (panel unit) | 13—Battery ground cable and
terminals (+) positive | 32—Brown |
| U—Horn push button | 14—Starter motor cable and
terminal (—) negative | 33—Red |
| V—Headlight bright beam
indicator light | | 34—Blue |
| W—Instrument lights | | 35—Black and yellow |
| X—Instrument light switch | | 36—Red |
| Y—Main lighting switch and fuse | | 37—Yellow |
| Z—Ammeter | | 38—White |
| | | 39—White |
| | | 40—Red |

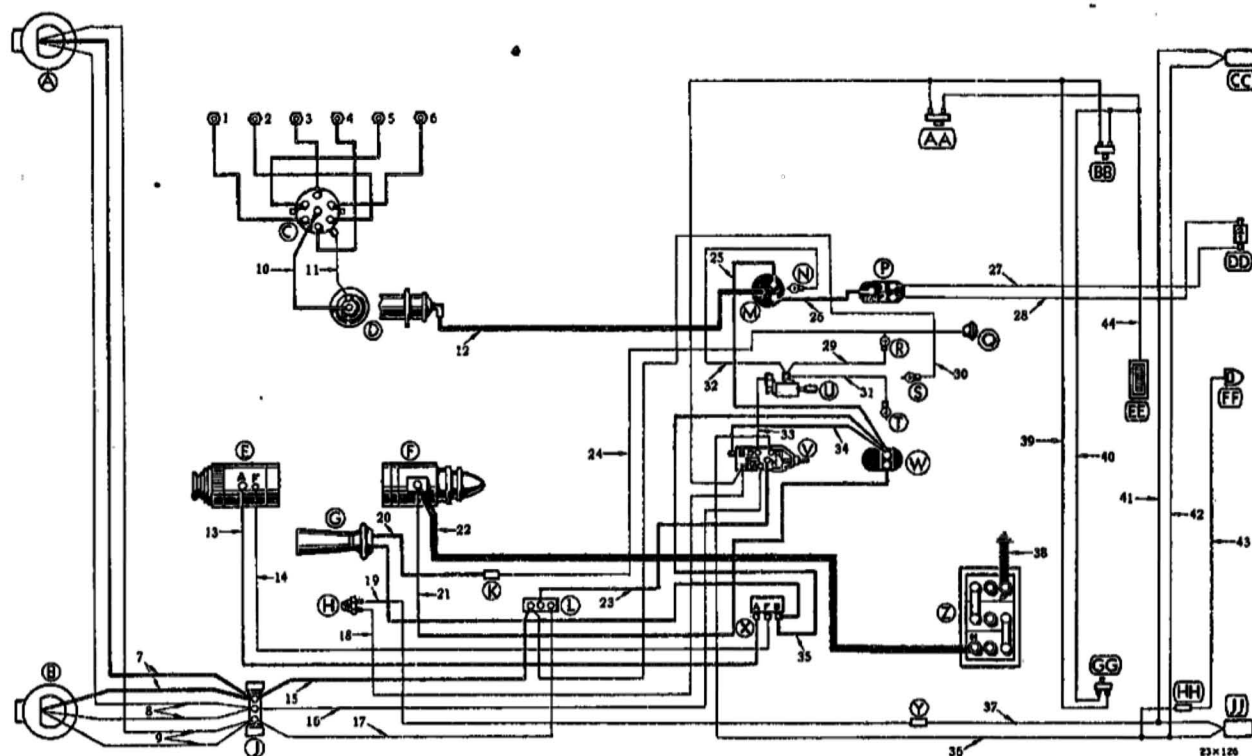


Figure 17—Wiring Diagram (1940 Model)

- | | | |
|---|---|---|
| A—Headlight—right | BB—Reading lamp automatic door switch—right (7-Pass. Sedan and Limousine) | 20—Green |
| B—Headlight—left | CC—Tail and signal light—right | 21—Red |
| C—Ignition distributor | DD—Fuel gauge (tank unit) | 22—Starter cable and terminal (—) negative |
| D—Ignition coil | EE—Reading light | 23—Yellow |
| E—Generator | FF—Rear license plate light | 24—Black |
| F—Starter motor and switch | GG—Reading lamp automatic door switch—left (7-Pass. Sedan and Limousine) | 25—Brown |
| G—Horn | HH—Cable connector | 26—Blue |
| H—Signal lamp switch | JJ—Tail and signal light—left | 27—Blue |
| J—Headlight cables terminal block | 1-6—Spark plug cables (high tension cable) | 28—Black and yellow |
| K—Cable connector | 7—Red | 29—Black |
| L—Headlight dimmer foot switch | 8—Yellow | 30—Brown |
| M—Ignition switch and lock | 9—Black | 31—Black |
| N—Ignition switch light | 10—Secondary cable (high tension cable) | 32—Black |
| P—Fuel gauge (panel unit) | 11—Primary cable (black) | 33—Black |
| Q—Horn button | 12—Ignition switch cable | 34—Brown |
| R—Instrument light—right | 13—Red | 35—Black |
| S—Headlight bright beam indicator light | 14—Green | 36—White |
| T—Instrument light—left | 15—Red | 37—Red |
| U—Instrument light switch | 16—Yellow | 38—Battery ground cable and terminal (+) positive |
| V—Head and tail light switch and fuse | 17—Black | 39—Red |
| W—Ammeter | 18—Red | 40—Yellow |
| X—Voltage regulator | 19—Red | 41—Red |
| Y—Cable connector | | 42—White |
| Z—Battery | | 43—White |
| AA—Reading lamp pillar switch | | 44—Yellow |

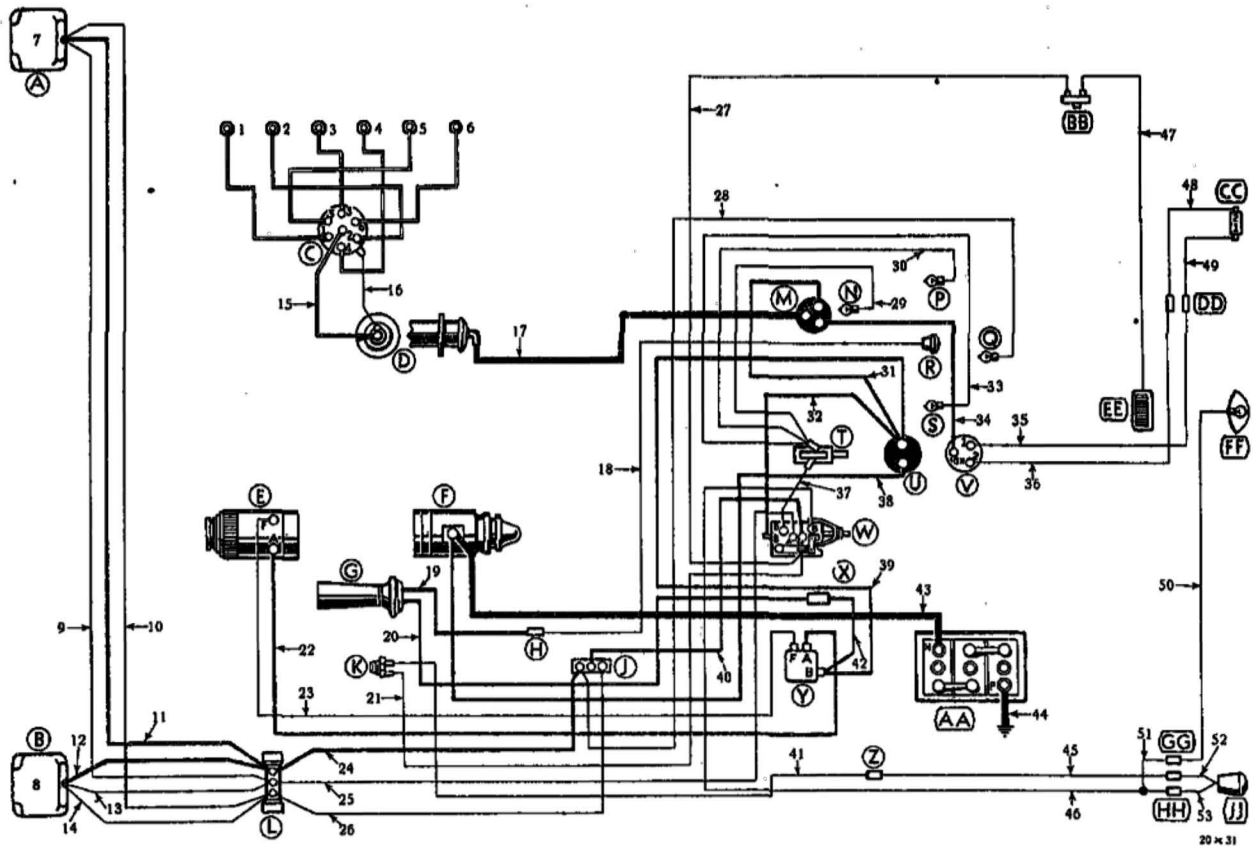


Figure 18—Wiring Diagram (1939, P8 Model)

- | | | |
|--|--|--|
| A—Headlamp—right | DD—Cable connectors | 26—Black (upper filament) |
| B—Headlamp—left | EE—Reading lamp | 27—Red |
| C—Ignition distributor | FF—License plate lamp | 28—Black |
| D—Coil | GG—Cable connector | 29—Black |
| E—Generator | HH—Cable connectors | 30—Black |
| F—Starter motor and switch | JJ—Tail and signal lamp | 31—Brown |
| G—Horn (single) | 1-6—Spark plug cables
(high tension cable) | 32—Brown |
| H—Cable connector | 7—Headlamp internal cables
and sockets assembly—right | 33—Black |
| J—Headlamp dimmer foot switch | 8—Headlamp internal cables and
sockets assembly—left | 34—Blue |
| K—Signal lamp switch | 9—Yellow | 35—Blue |
| L—Headlamp cables terminal
block | 10—Black | 36—Brown |
| M—Ignition switch and lock | 11—Red | 37—Black |
| N—Ignition switch lamp | 12—Red | 38—Red |
| P—Instrument lamp—right | 13—Yellow | 39—Black |
| Q—Headlamp bright beam
indicator lamp | 14—Black | 40—Yellow |
| R—Horn button | 15—Coil secondary cable
(high tension cable) | 41—Red |
| S—Instrument lamp—left | 16—Coil primary cable (black) | 42—Green |
| T—Instrument lamp—switch | 17—Ignition switch cable | 43—Starter cable and terminal
(—) negative |
| U—Ammeter | 18—Black | 44—Battery ground cable and
terminal (+) positive |
| V—Fuel gauge (panel unit) | 19—Green | 45—Red |
| W—Head and tail lamp lighting
switch and fuse | 20—Green | 46—White |
| X—Cable connector and fuse | 21—Red | 47—Yellow |
| Y—Voltage regulator | 22—Red | 48—Brown |
| Z—Cable connector | 23—Green | 49—Blue |
| AA—Battery | 24—Red (lower filament) | 50—White |
| BB—Reading lamp pillar switch | 25—Yellow (auxiliary bulb) | 51—White |
| CC—Fuel gauge (tank unit) | | 52—Red (signal lamp) |
| | | 53—White (tail lamp) |

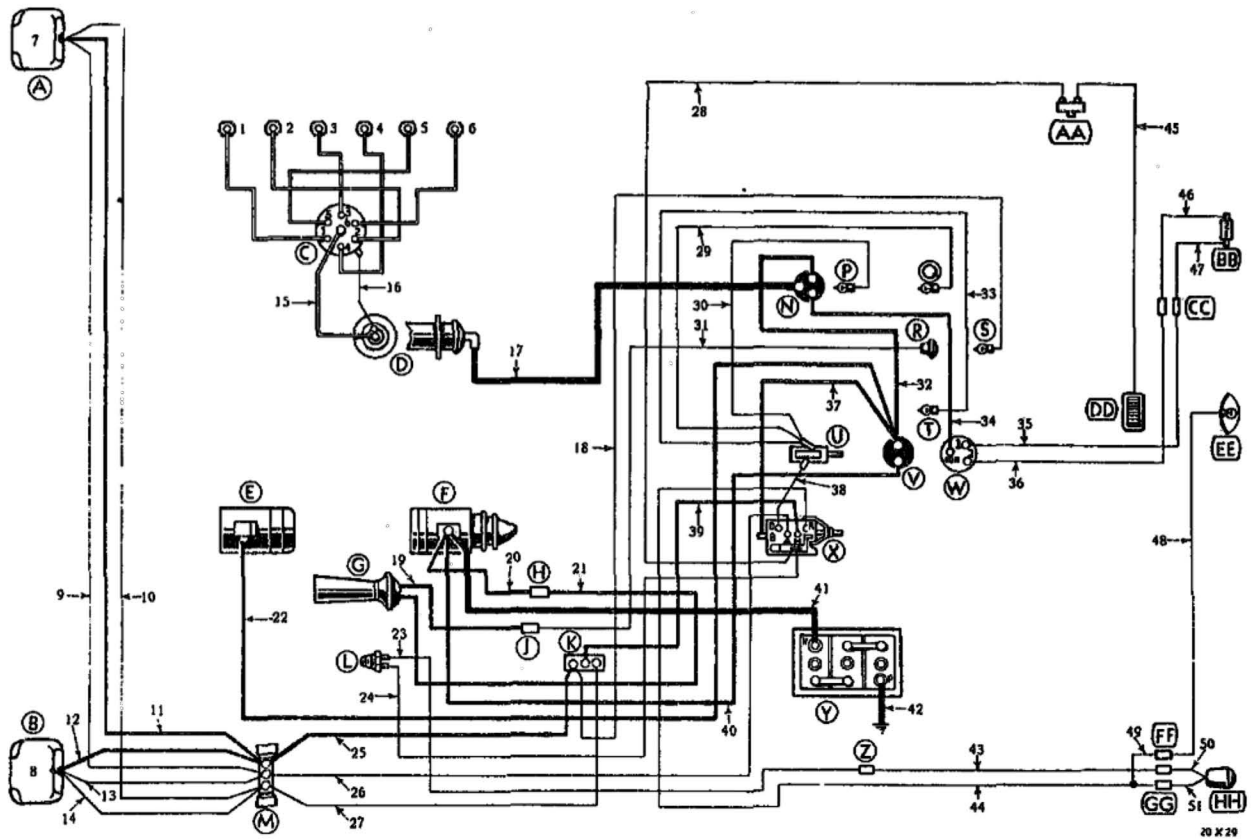


Figure 19—Wiring Diagram (1939, P7 Model)

- | | | |
|-------------------------------|-------------------------------|-------------------------------|
| A—Headlamp—right | CC—Cable connector | 25—Red (lower filament) |
| B—Headlamp—left | DD—Reading lamp | 26—Yellow (auxiliary bulb) |
| C—Ignition distributor | EE—License plate lamp | 27—Black (upper filament) |
| D—Coil | FF—Cable connectors | 28—Red |
| E—Generator and relay | GG—Cable connectors | 29—Black |
| F—Starter motor and switch | HH—Tail and signal lamp | 30—Black |
| G—Horn (single) | 1-6—Spark plug cables | 31—Black |
| H—Cable connector and fuse | (high tension cable) | 32—Brown |
| J—Cable connector | 7—Headlamp internal cables | 33—Black |
| K—Headlamp dimmer foot switch | and sockets—right | 34—Blue |
| L—Signal lamp switch | 8—Headlamp internal cables | 35—Blue |
| M—Headlamp cables terminal | and sockets—left | 36—Brown |
| N—Ignition switch and lock | 9—Yellow | 37—Brown |
| P—Ignition switch lamp | 10—Black | 38—Black |
| Q—Instrument lamp—right | 11—Red | 39—Yellow |
| R—Horn button | 12—Red | 40—Red |
| S—Headlamp bright beam | 13—Yellow | 41—Starter cable and terminal |
| indicator lamp | 14—Black | (—) negative |
| T—Instrument lamp—left | 15—Coil secondary cable | 42—Battery ground cable and |
| U—Instrument lamp switch | (high tension cable) | terminal (+) positive |
| V—Ammeter | 16—Coil primary cable (black) | 43—Red |
| W—Fuel gauge (panel unit) | 17—Ignition lock switch cable | 44—White |
| X—Head and tail lamp lighting | 18—Red | 45—Yellow |
| switch and fuse | 19—Green | 46—Brown |
| Y—Battery | 20—Green | 47—Blue |
| Z—Cable connector | 21—Green | 48—White |
| AA—Reading lamp pillar switch | 22—Black | 49—White |
| BB—Fuel gauge (tank unit) | 23—Red | 50—Red (signal lamp) |
| | 24—Red | 51—White (tail lamp) |

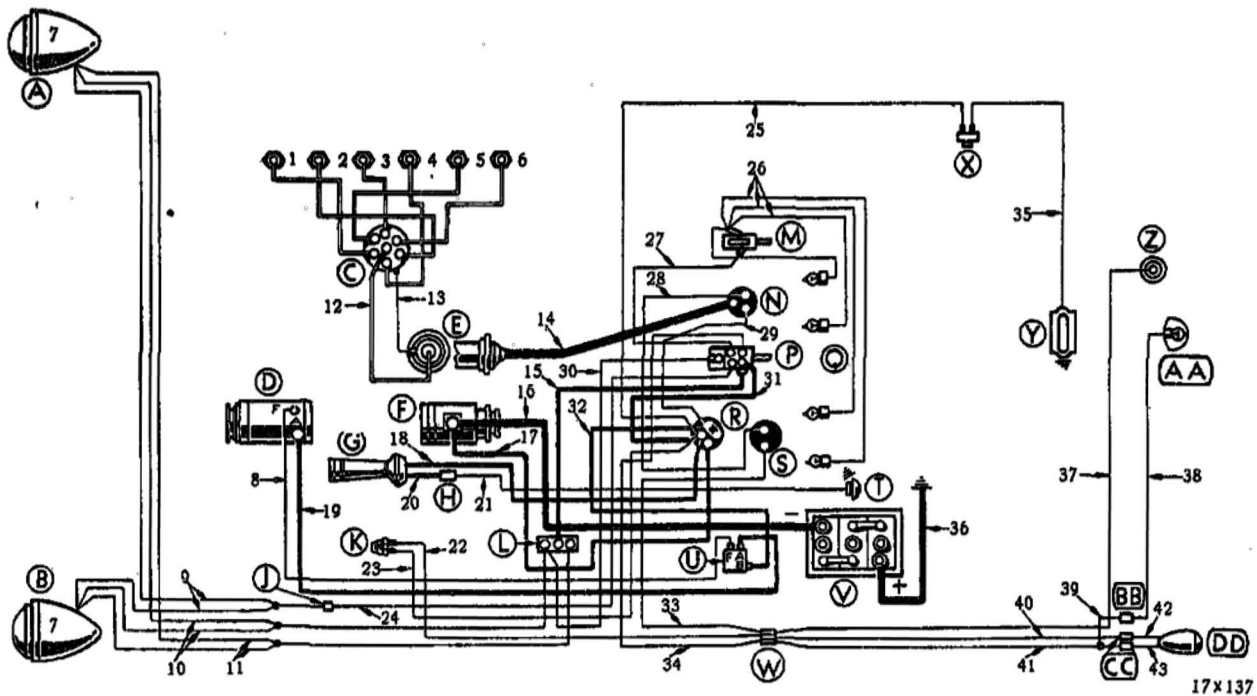


Figure 20—Wiring Diagram (1938, P6 Model)

- | | | |
|---|--|---|
| A—Headlamp—right | AA—License plate lamp | 21—Black |
| B—Headlamp—left | BB—Cable connector | 22—Red |
| C—Distributor | CC—Cable connector | 23—Red |
| D—Generator | DD—Tail and signal lamp | 24—Yellow |
| E—Coil | 1-6—Spark plug cables
(high tension cable) | 25—Red |
| F—Starter motor | 7—Headlamp internal cables
and sockets assembly | 26—Black |
| G—Horn | 8—Green | 27—Black |
| H—Cable connector | 9—Yellow | 28—Blue |
| J—Cable connector | 10—Red | 29—Brown |
| K—Signal lamp switch | 11—Black | 30—Red |
| L—Headlamp dimmer foot switch | 12—Coil secondary cable
(high tension cable) | 31—Brown |
| M—Instrument lamp switch | 13—Coil primary cable (black) | 32—Ammeter to regulator cable |
| N—Ignition switch and lock | 14—Ignition lock switch and
cable assembly | 33—Blue |
| P—Head and tail lamp
lighting switch | 15—Yellow | 34—White |
| Q—Instrument lamps | 16—Starter cable and terminal
assembly (—) negative | 35—Yellow |
| R—Ammeter and fuse | 17—Red | 36—Battery ground cable and
terminal assembly (+) positive |
| S—Fuel gauge (panel unit) | 18—Green | 37—Blue |
| T—Horn button | 19—Red | 38—White |
| U—Voltage regulator | 20—Green | 39—White |
| V—Battery | | 40—Red |
| W—Chassis wiring triple connector | | 41—White |
| X—Reading lamp pillar switch | | 42—Red |
| Y—Reading lamp | | 43—White |
| Z—Fuel gauge (tank unit) | | |

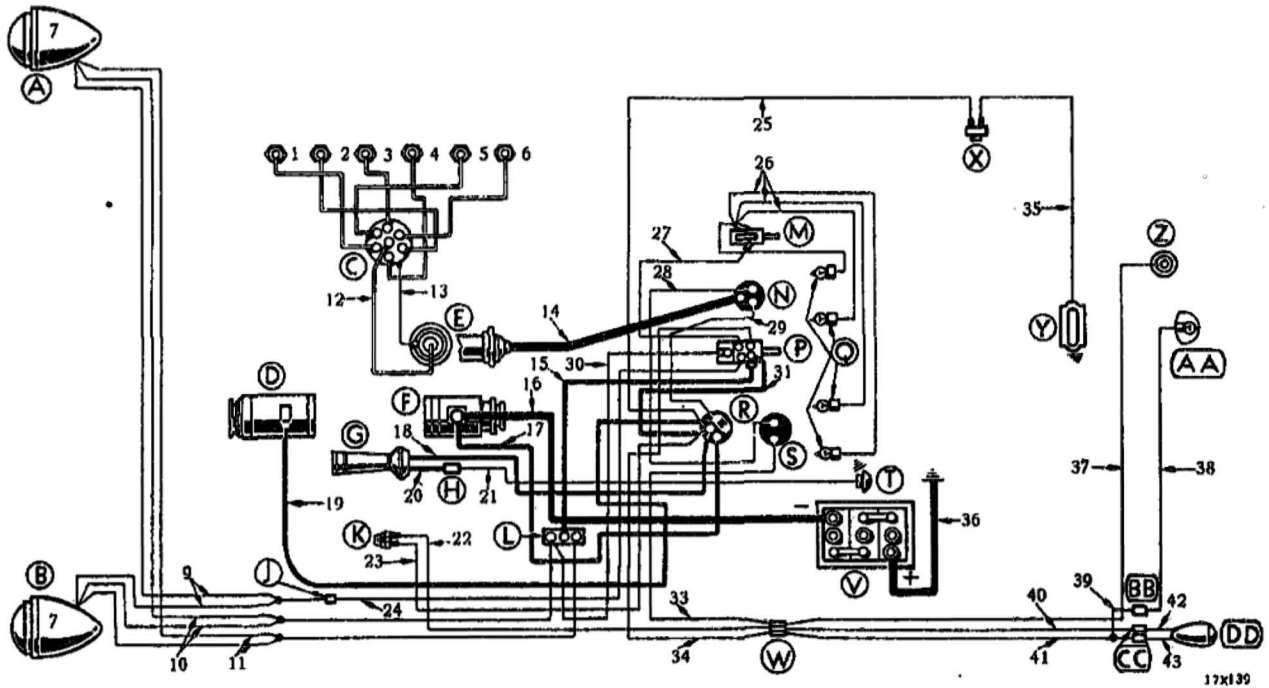


Figure 21—Wiring Diagram (1938, P5 Model)

A—Headlamp—right	AA—License plate lamp	21—Black
B—Headlamp—left	BB—Cable connector	22—Red
C—Distributor	CC—Cable connectors	23—Red
D—Generator and relay	DD—Tail and signal lamp	24—Yellow
E—Coil	1-6—Spark plug cables (high tension cable)	25—Red
F—Starter motor	7—Headlamp internal cables and sockets assembly	26—Black
G—Horn	9—Yellow	27—Black
H—Cable connector	10—Red	28—Blue
J—Cable connector	11—Black	29—Brown
K—Signal lamp switch	12—Coil secondary cable (high tension cable)	30—Red
L—Headlamp dimmer foot switch	13—Black	31—Brown
M—Instrument lamp switch	14—Ignition lock switch and cable assembly	33—Blue
N—Ignition switch and lock	15—Yellow	34—White
P—Head and tail lamp lighting switch	16—Starter cable and terminal assembly (—) negative	35—Yellow
Q—Instrument lamps	17—Red	36—Battery ground cable and terminal assembly (+) positive
R—Ammeter and fuse	18—Green	37—Blue
S—Fuel gauge (panel unit)	19—Black	38—White
T—Horn button	20—Green	39—White
V—Battery		40—Red
W—Chassis wiring triple connector		41—White
X—Reading lamp pillar switch		42—Red
Y—Reading lamp		43—White
Z—Fuel gauge (tank unit)		

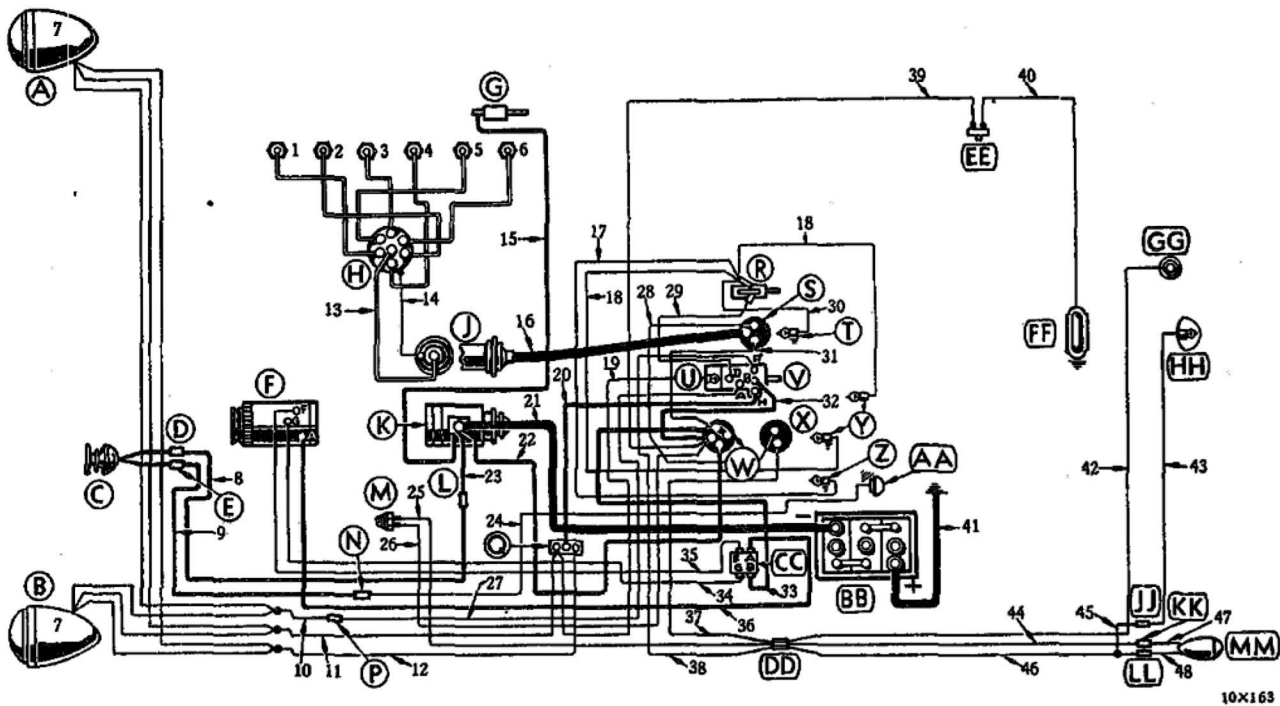


Figure 22—Wiring Diagram (1937, P4 Model)

- | | | |
|---|---|--|
| A—Headlamp—right | AA—Horn push button | 21—Starter cable and terminal assembly (—) negative |
| B—Headlamp—left | BB—Battery | 22—Red |
| C—Horn | CC—Generator voltage regulator | 23—Red |
| D—Cable connector (if so equipped) | DD—Chassis wiring triple connector | 24—Black |
| E—Cable connector (if so equipped) | EE—Dome lamp pillar switch | 25—Red |
| F—Generator | FF—Dome lamp | 26—Red |
| G—Automatic choke (special equipment) | GG—Fuel gauge (tank unit) | 27—Yellow |
| H—Distributor | HH—License plate lamp | 28—Blue |
| J—Coil (ignition coil and lock switch assembly) | JJ—Cable connector | 29—Black |
| K—Starter motor | KK—Cable connector | 30—Black |
| L—Horn feed cable fuse and connector | LL—Cable connector | 31—Brown |
| M—Signal lamp switch | MM—Tail and signal lamp | 32—Brown |
| N—Cable connector | 1-6—Spark plug cables (high tension cable) | 33—Black |
| P—Cable connector | 7—Headlamp internal cables and sockets assembly | 34—Black |
| Q—Headlamp dimmer foot switch | 8—Green | 35—Green |
| R—Instrument lamp switch | 9—Green | 36—Red |
| S—Ignition switch and lock | 10—Yellow | 37—Blue |
| T—Ignition switch lamp | 11—Red | 38—White |
| U—Headlamp upper beam indicator lamp | 12—Black | 39—Red |
| V—Head and tail lamp lighting switch | 13—Coil secondary cable (high tension cable) | 40—Yellow |
| W—Ammeter and fuse | 14—Black | 41—Battery ground cable and terminal assembly (+) positive |
| X—Fuel gauge (panel unit) | 15—White | 42—Blue |
| Y—Instrument panel lights | 16—Ignition lock switch and cable assembly | 43—White |
| Z—Speedometer and instrument lamp | 17—Black | 44—Red |
| | 18—Black | 45—White |
| | 19—Red | 46—White |
| | 20—Yellow | 47—Red |
| | | 48—White |

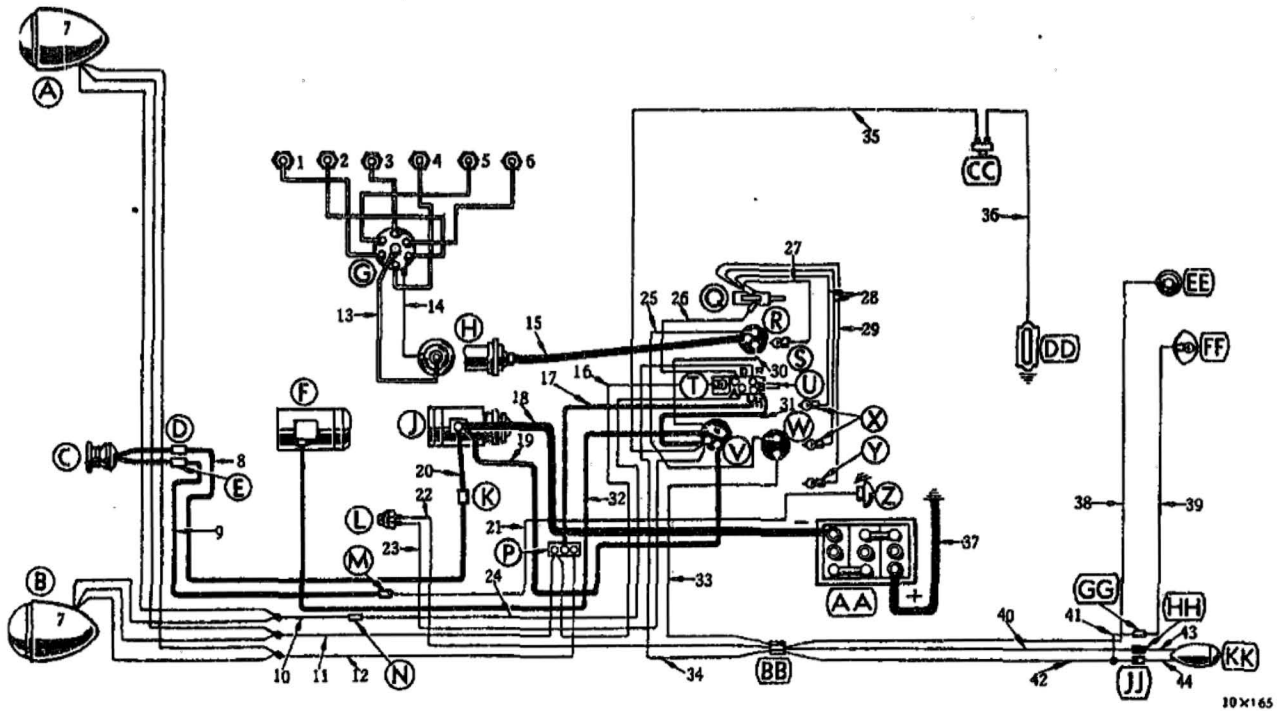


Figure 23—Wiring Diagram (1937, P3 Model)

A—Headlamp—right	AA—Battery	19—Red
B—Headlamp—left	BB—Chassis wiring triple connector	20—Red
C—Horn	CC—Dome lamp pillar switch	21—Black
D—Cable connector (if so equipped)	DD—Dome lamp	22—Red
E—Cable connector (if so equipped)	EE—Fuel gauge (tank unit)	23—Red
F—Generator and relay	FF—License plate lamp	24—Yellow
G—Distributor	GG—Cable connector	25—Blue
H—Coil (ignition coil and lock switch assembly)	HH—Cable connector	26—Black
J—Starter motor	JJ—Cable connector	27—Black
K—Horn feed cable fuse and connector	KK—Tail and signal lamp	28—Black
L—Signal lamp switch	1-6—Spark plug cables (high tension cable)	29—Black
M—Cable connector	7—Headlamp internal cables and sockets assembly	30—Brown
N—Cable connector	8—Green	31—Brown
P—Headlamp dimmer foot switch	9—Green	32—Black
Q—Instrument lamp switch	10—Yellow	33—Blue
R—Ignition switch and lock	11—Red	34—White
S—Ignition switch lamp	12—Black	35—Red
T—Headlamp upper beam indicator lamp	13—Coil secondary cable (high tension cable)	36—Yellow
U—Head and tail lamp lighting switch	14—Black	37—Battery ground cable and terminal assembly (+) positive
V—Ammeter and fuse	15—Ignition lock switch and cable assembly	38—Blue
W—Fuel gauge (panel unit)	16—Red	39—White
X—Instrument panel lights	17—Yellow	40—Red
Y—Speedometer and instrument lamp	18—Starter cable and terminal assembly (—) negative	41—White
Z—Horn push button		42—White
		43—Red
		44—White

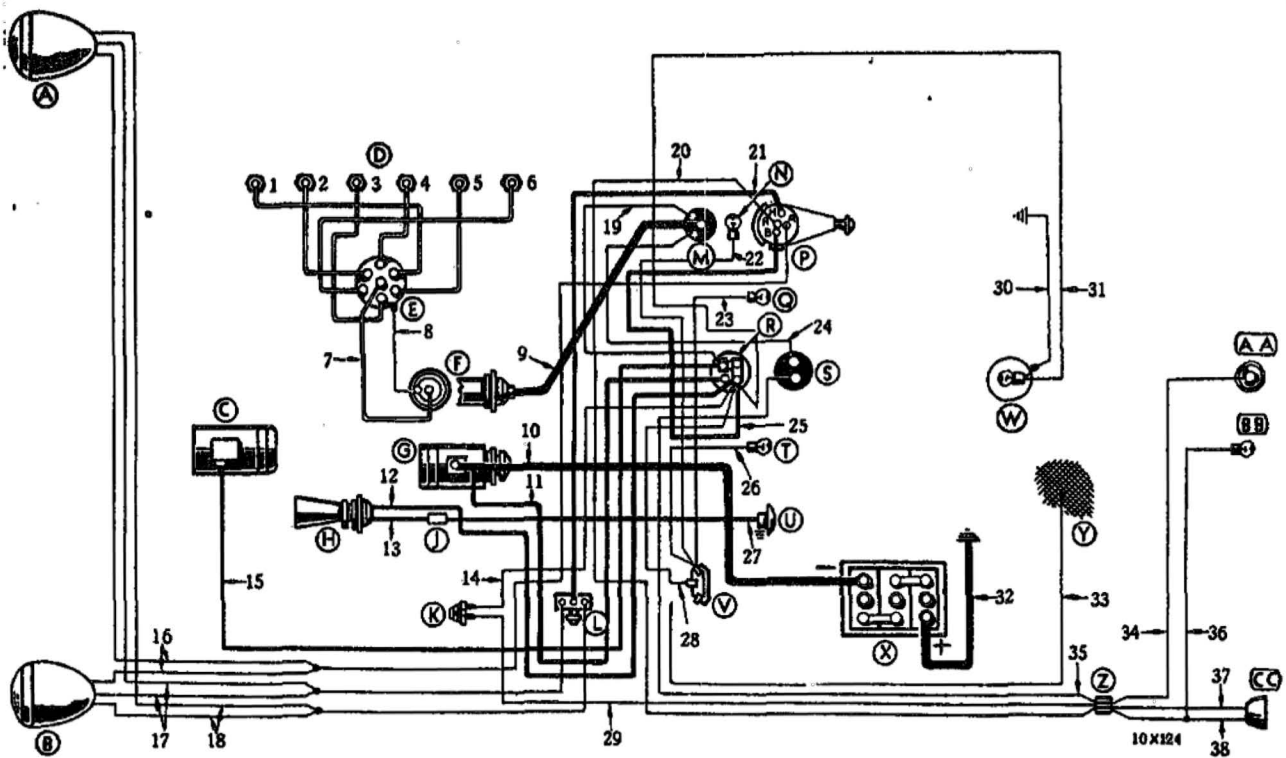


Figure 24—Wiring Diagram (1936, P2 Model)

- | | | |
|---|---|---|
| A—Headlamp—right | W—Dome lamp and switch
(closed bodies only) | 16—Yellow |
| B—Headlamp—left | X—Battery | 17—Red |
| C—Generator, relay and voltage control | Y—Radio antenna (closed body top deck) | 18—Black |
| D—Spark plugs | Z—Triple connector | 19—Brown |
| E—Ignition distributor | AA—Fuel gauge (tank unit) | 20—White |
| F—Coil (ignition coil and lock switch assembly) | BB—License lamp (if so equipped) | 21—Yellow |
| G—Starter motor | CC—Tail and signal lamp | 22—Black |
| H—Horn | 1-6—Spark plug cables
(high tension cable) | 23—Black |
| J—Horn cable connector | 7—Ignition coil secondary cable
(high tension cable) | 24—Blue |
| K—Signal lamp switch | 8—Black | 25—Brown |
| L—Headlamp beam foot control or dimmer switch | 9—Coil to switch connecting cable
(ignition coil and lock switch assembly) | 26—Black |
| M—Ignition switch and lock
(coil and lock switch assembly) | 10—Starter cable and terminal
assembly (—) negative | 27—Green |
| N—Ignition switch lamp | 11—Red | 28—Black |
| P—Head and tail lamp lighting switch | 12—Green | 29—Red |
| Q—Instrument lamp—right | 13—Green | 30—Black |
| R—Ammeter and fuse | 14—Red | 31—Red |
| S—Fuel gauge (panel unit) | 15—Black | 32—Battery ground cable and
terminal assembly (+) positive |
| T—Instrument lamp—left | | 33—White |
| U—Horn push button | | 34—Blue |
| V—Instrument lamp switch | | 35—Blue |
| | | 36—White |
| | | 37—Red |
| | | 38—White |

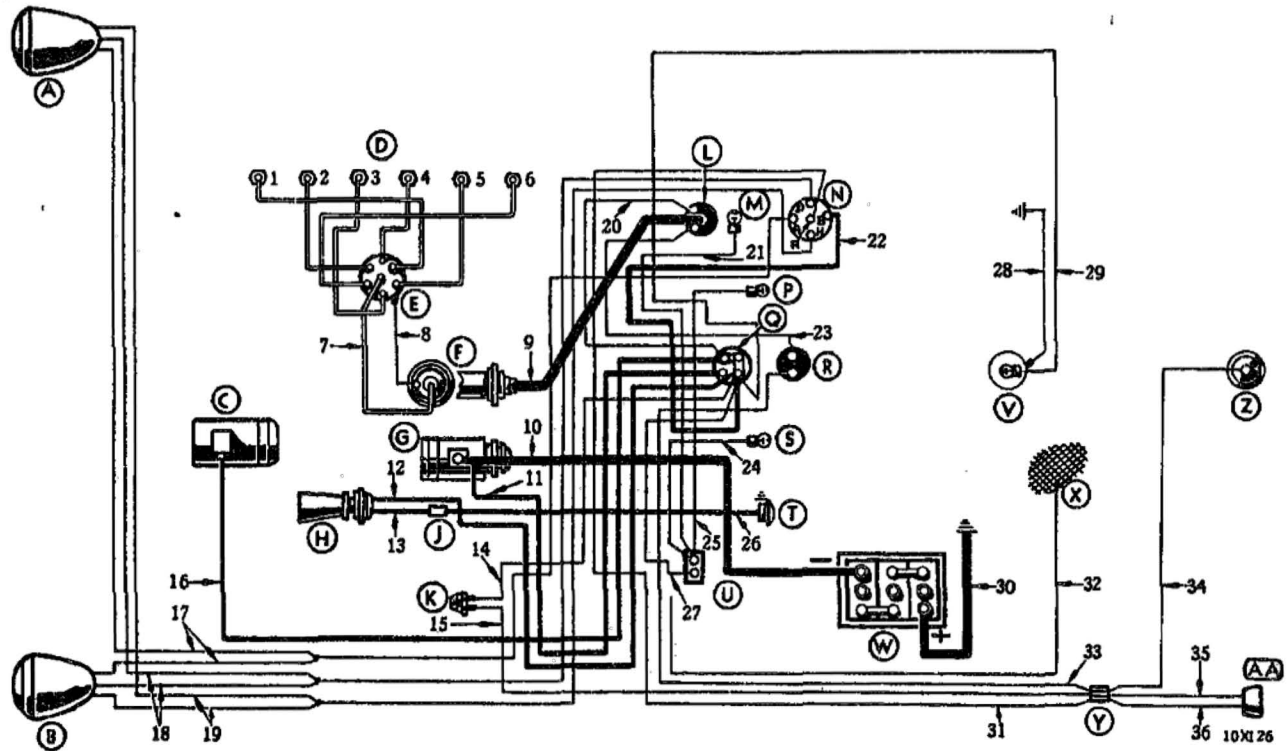


Figure 25—Wiring Diagram (1936, P1 Model)

- | | | |
|--|--|--|
| A—Headlamp—right | V—Dome lamp and switch | 17—Yellow |
| B—Headlamp—left | W—Battery | 18—Red |
| C—Generator and relay | X—Radio antenna | 19—Black |
| D—Spark plugs | Y—Triple connector | 20—Brown |
| E—Ignition distributor | Z—Fuel gauge (tank unit) | 21—Black |
| F—Coil (ignition coil and lock switch assembly) | AA—Tail and signal lamp | 22—Brown |
| G—Starter motor | 1-6—Spark plug cables (high tension cable) | 23—Blue |
| H—Horn | 7—Ignition coil secondary cable (high tension cable) | 24—Black |
| J—Horn cable connector | 8—Black | 25—Black |
| K—Signal lamp switch | 9—Coil to switch connecting cable (ignition coil and lock switch assembly) | 26—Green |
| L—Ignition switch and lock (coil and lock switch assembly) | 10—Starter cable and terminal assembly (—) negative | 27—Black |
| M—Ignition switch lamp | 11—Red | 28—Black |
| N—Head and tail lamp lighting switch | 12—Green | 29—Red |
| P—Instrument lamp—right | 13—Green | 30—Battery ground cable and terminal assembly (+) positive |
| Q—Ammeter and fuse | 14—Red | 31—White |
| R—Fuel gauge (panel unit) | 15—Red | 32—White |
| S—Instrument lamp—left | 16—Black | 33—Blue |
| T—Horn push button | | 34—Blue |
| U—Instrument lamp switch | | 35—Red |
| | | 36—White |

Section XVII

STARTING MOTOR

1. DESCRIPTION.

1936-42—The starting motor (fig. 2) is of the same general design on all models with slight differences in test specifications.

2. REPLACEMENT OF STARTING MOTOR BRUSHES.

1936-42—Replace brushes when worn more than half their original length. To remove, unsolder and unclinch the brush leads from the field coil connector loops and remove the brushes. To install, install the new brush leads into the loops of the field coil

connector to their fullest depth and clinch tightly. Solder the connections with rosin core solder.

3. DISASSEMBLY OF STARTING MOTOR.

1936-42

(1) Remove the starting motor switch and clean the outside of the starting motor thoroughly.

(2) Measure the end play of the armature shaft with a dial indicator to determine the proper thrust washers to be installed

DATA AND SPECIFICATIONS						
Year and Model		1942—P14	1941— P11-P12	1939—P7-P8 1940— P9-P10	1938—P5	1936—P1-P2 1937—P3-P4 1938—P6
Starting motor model (stamped on plate attached to starter)		MZ-4105	MZ-4089A	MZ-4062	MZ-4056	MAW-4009
Type of drive		Over-running clutch	Over-running clutch	Over-running clutch	Over-running clutch	Over-running clutch
Rated voltage		6 volts	6 volts	6 volts	6 volts	6 volts
Armature end play, inches		.005 to .030	.005 to .030	.005 to .030	.005 to .030	.005 to .030
Maximum allowable armature run-out, inches		.003	.003	.003	.003	.003
Brush spring tension, ounces		42 to 53	42 to 53	42 to 53	42 to 53	42 to 53
Free Running Specifications	Voltage	5.5	5.5	5.5	5.5	5.5
	Amperage draw	70	70	70	70	65
	Minimum speed, rpm	4300	4300	4300	4300	4900
Stall Torque Specifications	Voltage	3.8 volts	3.8 volts	3.8 volts	3.8 volts	3.4 volts
	Amperage draw	450	450	450	450	525
	Torque (ft. lb.)	9-10	9-10	9-10	9-10	12.0

3. DISASSEMBLY OF STARTING MOTOR.

1936-42—Cont'd

when assembling. The end play should be from .005 to .030 inch (fig.1).

(3) Remove the inspection cover band. Raise the brush springs and lift the brushes out of the holders.

(4) Remove the two long frame screws which hold the commutator end plate, frame and pinion housing together. Remove the commutator end plate from the armature shaft and remove the pinion housing and armature assembly from the frame.

(5) Slide the pinion housing with the clutch assembly off the armature.

(6) Remove the shift yoke pivot screw, raise the shift yoke and remove the clutch assembly from the pinion housing.

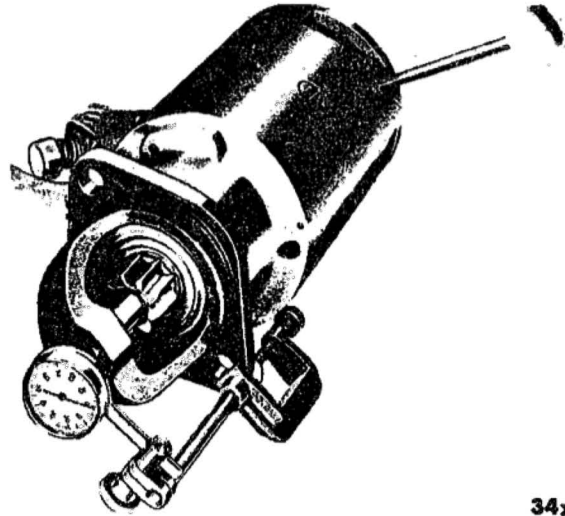
CAUTION

Do not lose the thrust washer.

(7) Blow dirt off all parts with compressed air; blow out dust around field coils in the starting motor frame.

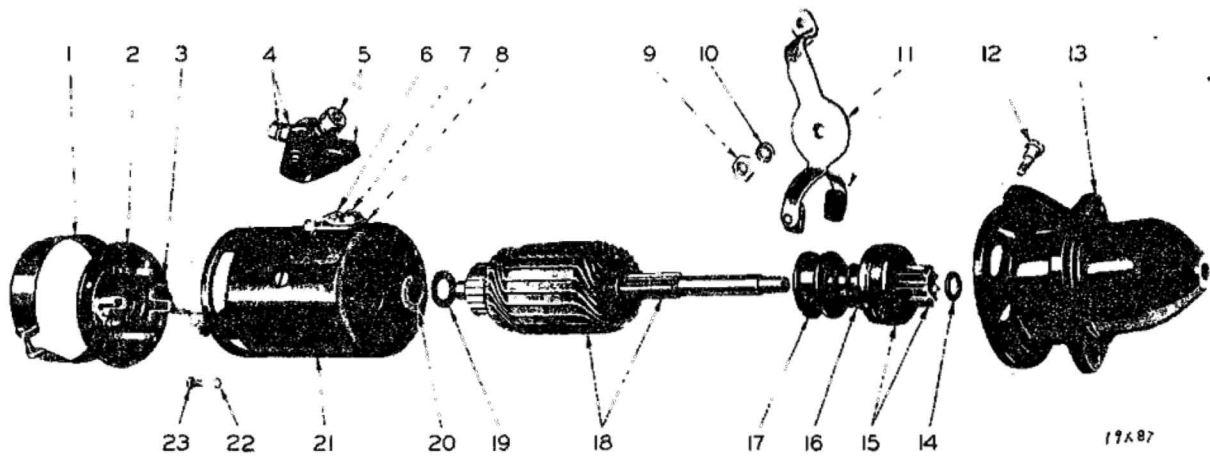
(8) Wipe parts with a clean cloth dampened with cleaning solvent. *Do not soak the field coils, armature or starting motor switch in cleaning solvent.*

(9) Clean the clutch and inspect for damaged pinion teeth and wear. *To avoid washing the lubricant out of the unit, do not soak the assembly when cleaning, as this assembly is sealed and cannot be lubricated. If the clutch assembly is damaged or worn, re-*



34x92

Figure 1—Measuring Starting Motor End Play (1936-42 Models)



19x87

- 1—Inspection cover or head band
- 2—Commutator end plate and bearing assembly
- 3—Brush spring
- 4—Switch terminal post nut and lockwasher
- 5—Starting switch assembly
- 6—Switch contact—lower
- 7—Terminal post

- 8—Insulating block
- 9—Yoke pivot screw nut
- 10—Yoke pivot screw nut lockwasher
- 11—Yoke assembly
- 12—Yoke pivot screw
- 13—Pinion housing assembly
- 14—Thrust washer
- 15—Starter clutch assembly

- 16—Shift spring
- 17—Shift collar
- 18—Armature assembly
- 19—Thrust washer
- 20—Thrust washer
- 21—Frame and field assembly
- 22—End plate to frame screw lockwasher
- 23—End plate to frame screw

Figure 2—Starting Motor (1942 Model, Typical of 1936-41 Models)

place the assembly. If armature windings are damaged, replace the clutch as well as the armature.

(10) Replace the armature if the core is scored or the windings are damaged, or if the bearing surfaces on the armature shaft are worn. Make sure the armature windings are down in the core slots and staked slightly.

(11) Inspect the soldered connections on the commutator bars. Solder with rosin core solder if necessary.

(12) Clean the commutator with "00" sandpaper and turn down the commutator if burned, rough or over .003 inch out-of-round. Replace the armature if the shaft is bent.

(13) Place the armature in a growler and connect one test lead to the armature shaft and touch the other test lead to the commutator bars. See figure 4 on page 135. *Do not touch the brush surface of the commutator bars, to avoid damage from arcing.* Replace the armature if the light burns, indicating the armature is grounded.

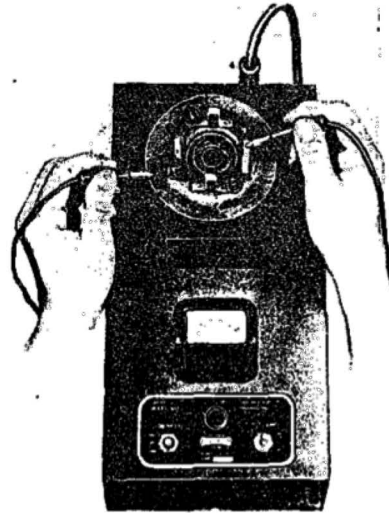
(14) Place the housing on the splined end of the armature shaft and note whether the bushing is worn. If the housing is broken or cracked, replace it; if the bushing is worn, replace the bushing.

(15) Connect one lead of the test light to the end plate casting and touch the other lead to the insulated brush holders (fig. 3); if the light burns, the brushes are grounded.

(16) Place the end plate, with the thrust washer, on the armature shaft and note whether the bushing is worn.

(17) Try a spare brush in the holders to see whether the brush fits properly in the holder and contacts the commutator parallel with the bars. Straighten the brush holders if necessary.

(18) If the end plate is broken, insulated brush holders are loose or grounded or the bushing is worn, replace the end plate assembly.



34x93

Figure 3—Testing Brush Holder for Ground (1936-42 Models)

(19) If the ground brush holders are loose, rivet them down tight or replace them if necessary.

(20) Fasten the armature, with the end plate on the shaft, between the padded jaws of a vise. Install a spare brush in one of the holders and position the brush spring on the brush. Hook a spring scale into the curve of the brush spring and pull straight with the brush. Observe the reading of the scale just as the spring leaves the brush. If the tension is other than 42 to 53 ounces, install new brush springs. Replace the brushes when worn more than half their original length.

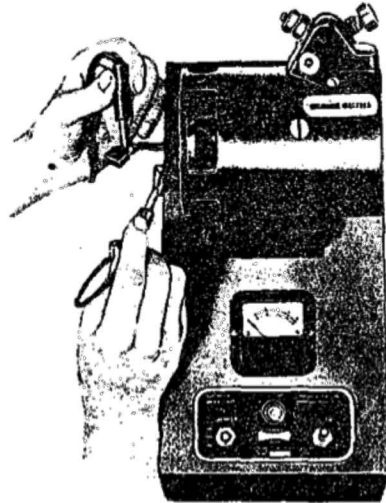
(21) Place the frame and field coil assembly on the test stand and test for grounds between the insulated brushes and the frame; if the test light burns, the coils are grounded (fig. 5).

(22) Test between the insulated brushes (fig. 4) and from each insulated brush to the starting motor terminal; if the light does not burn, the coils are open. If the coils are open or grounded, replace them.

4. REPLACEMENT OF STARTING MOTOR FIELD COILS.

1936-42

(1) Mark the field coil pole shoes so they can be installed in exactly the same position when assembled. Remove the ter-



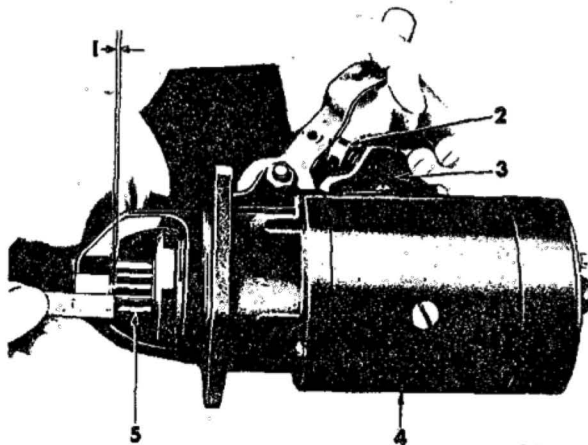
34x94

Figure 4—Testing Starting Motor Field Coils for Open Circuit (1936-42 Models)



34x95

Figure 5—Testing Starting Motor Field Coils for Ground (1936-42 Models)



34x96

1—Pinion clearance
2—Switch button
3—Starting motor switch
4—Starting motor
5—Starting motor pinion

Figure 6—Measuring Starting Motor Pinion Clearance (1936-42 Models)

4. REPLACEMENT OF STARTING MOTOR FIELD COILS.

1936-42—Cont'd

minal nut and washers. Push terminal out of frame. Remove the pole shoe screws from the frame and pull the coils and shoes out of the frame.

(2) To install, position the pole shoes in the new coils so that the assembly will fit into the frame with the shoes in the same place as before removal. Make sure that the field coil connection insulators are in place. Dip the pole shoe screws in oil and screw them into the pole shoes through the frame. Strike the frame with a soft hammer while tightening the screws to assist in seating the pole shoes. Install insulating washers and bushing on the terminal stud, position in frame and install nut.

5. ASSEMBLY OF STARTING MOTOR.

1936-42

(1) Stand the pinion housing on the bench with the open end up and place thrust washer over the bushing. Thrust washers are supplied in various thicknesses for adjustment of end play to .005 to .030 inch. Measure the thickness of the washer that was removed and select the proper washer needed by comparing with the end play measurement made before the starting motor was disassembled.

(2) Install the shift yoke in the housing with the round face of the shoes toward the bushing end of the housing and install the clutch assembly with the pinion against the thrust washer. Install the shift yoke pivot screw and nut. Lubricate the bushing freely with SAE 30 engine oil.

(3) Hold the pinion housing and pinion up so that the armature shaft will go through the thrust washer and into the bushing. Lubricate the splined end of the armature shaft and install into the pinion.

(4) Position the frame assembly over the armature and align the attaching bolt holes.

(5) Place the commutator end plate on the armature shaft and align the attaching bolt holes with the frame. Install the two long frame screws through the end plate and frame and screw them down into the pinion housing. Tap the end plate and pinion housing while tightening the screws, to align the bushings.

(6) Raise the brush springs and place the brushes into the proper holders. Make sure that the ground brushes are in the grounded holders and see that brush leads are not rubbing against the armature.

(7) Install the starting motor switch over the terminal with the switch button toward the pinion end. Press the shift yoke lever down so that the switch button is depressed. Screw the button in or out of the switch to adjust the pinion clearance to 1/16 to 1/32 inch (fig. 6).

CAUTION

Do not attempt to change the starting motor pinion clearance without removing starting motor to verify proper setting.

6. TESTING STARTING MOTOR.

1936-42

(1) If test equipment is available, connect the starting motor to a test bench equipped with a fully charged 6-volt battery with one lead grounded to the starting motor frame.

(2) Press the switch button and adjust the resistor to 5.5 volts.

(3) Run the starting motor about two minutes to seat the brushes, if necessary. The ammeter should read current draw as specified in "Data and Specifications" Chart while the starting motor is running free.

(4) If a test bench is not available, connect the starter to a battery and press starter switch. If the armature revolves smoothly at a satisfactory speed the unit will crank the engine.

(5) Connect the starting motor to the test bench as explained in step (1) above. Mount torque arm and spring scale on the starting motor. Close the test stand switch, press the switch button and adjust the resistor so that 3.0 volts are shown on the voltmeter. The current reading on the ammeter and the torque developed should be within limits given in the "Data and Specifications" Chart on page 165.

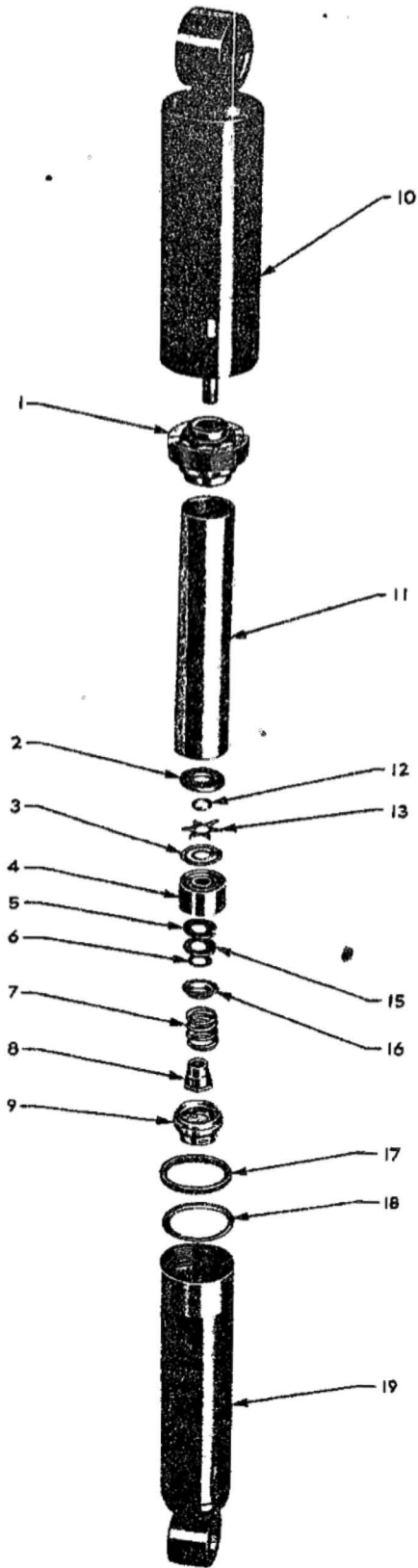


Figure 1—Shock Absorber (Disassembled View)
(1942 Model, Typical of 1937-41 Models)

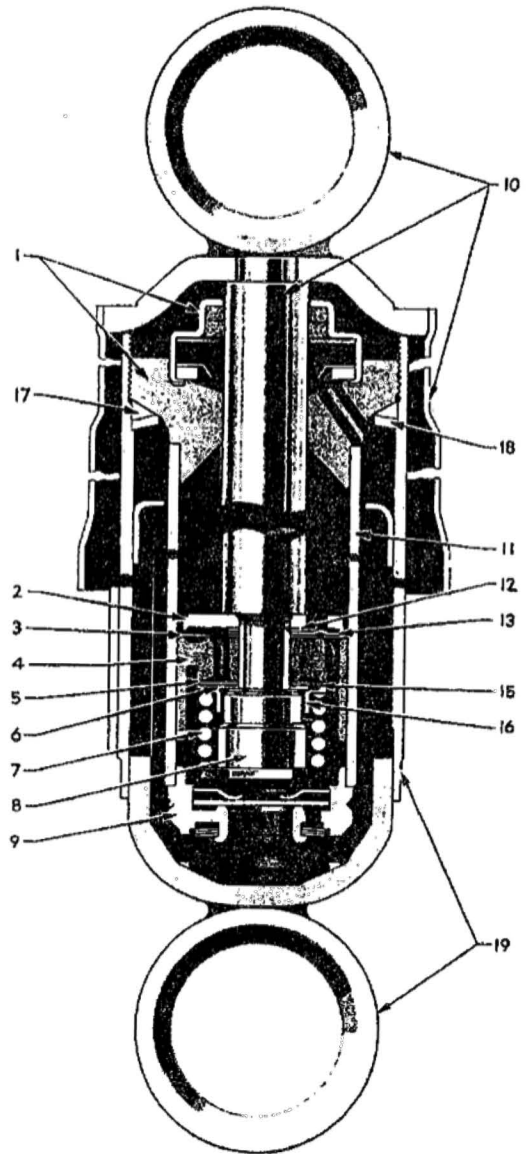


Figure 2—Shock Absorber (Assembled View)
(1942 Model, Typical of 1937-41 Models)

- | | |
|-------------------------------|--|
| 1—Piston rod guide and seal | 10—Dust shield tube and piston rod |
| 2—Piston washer | 11—Cylinder tube |
| 3—Piston intake valve plate | 12—Piston washer spacer |
| 4—Piston | 13—Piston intake valve plate spider spring |
| 5—Rebound valve orifice plate | 15—Rebound valve spring disc |
| 6—Rebound valve back plate | 16—Rebound valve spring seat |
| 7—Rebound valve spring | 17—Gasket—upper |
| 8—Piston rod nut | 18—Gasket retainer |
| 9—Compression valve | 19—Reservoir tube |

28X790

23X32A

Section XVIII

SHOCK ABSORBERS

1. DESCRIPTION.

1937-42—The front and rear shock absorbers are of the telescopic (direct-acting) type and rubber insulated at both ends. See figures 1 and 2.

1936—The front and rear shock absorbers are of the hydraulic, cam and lever type.

2. TESTING SHOCK ABSORBER OPERATION.

1937-42

(1) To check a shock absorber after it has been removed from the car, clamp the flat side of the lower eye in a vise with the shock absorber in an upright position. Operate shock absorber a few full strokes to remove air from pressure cylinder. The valves should seat instantly and resistance

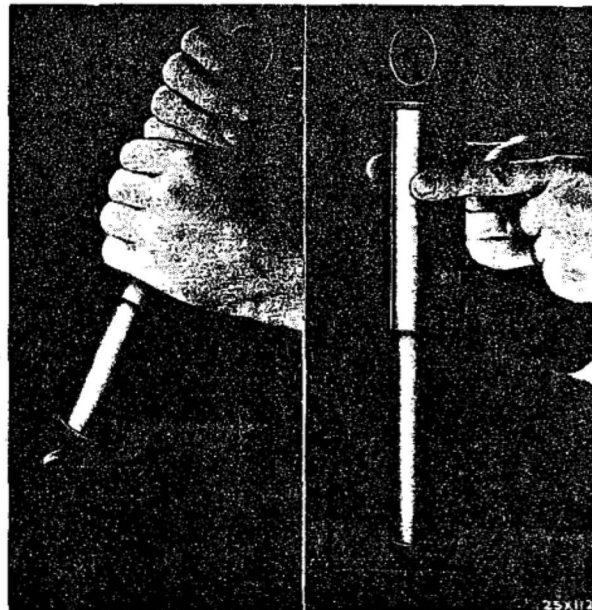


Figure 3—Checking Shock Absorber Action
(1937-42 Models)

DATA AND SPECIFICATIONS						
YEAR		1940-42	1939	1938	1937	1936
Type		*	*	*	*	**
Size, diameter, inches		1	1	1	1	1½
Fluid capacity, ounces	Front	3¾	3⅞	6⅝	6⅝	Fill to filler hole
	Rear	6⅝	6½	6⅝	6⅝	***
	Front (with 18 inch or 20 inch wheels)	3¾	3⅞	7	7	Fill to filler hole
	Rear (with 18 inch or 20 inch wheels)	7	7	7	7	***
Length, collapsed, c to c, inches	Front	8¾	8¾	12½	12½	
	Rear	12½	12½	12½	12½	
	Front (with 18 inch or 20 inch wheels)	8¾	8¾	13¼	13¼	
	Rear (with 18 inch or 20 inch wheels)	13¼	13¼	13¼	13¼	
*Hydraulic, double acting, telescopic. **Hydraulic, cam and lever. ***Remove unit, remove cover, fill to top of casting.						

2. TESTING SHOCK ABSORBER OPERATION.

1937-42—Cont'd

to any movement of the shock absorber should be felt without any lost motion in either direction. If there is any lost motion, a valve is not seating because of bent or improperly assembled parts, foreign material in the shock absorber or lack of fluid.

(2) Fasten the shock absorber in an upright position (dust shield up), and with the index finger of each hand (fig. 3) press against the dust shield and rotate it between the fingers. If the dust shield does not turn freely, a binding condition may exist between internal parts of the shock absorber.

(3) When investigating for noise, first make certain that the noise is coming from the shock absorber and not from other parts of the chassis or body. If noise exists in the shock absorber it will be necessary to disassemble it to check individual parts to determine what is causing the noise. See paragraph 4.

3. REFILLING SHOCK ABSORBERS.

1937-42—The necessity for refilling a shock absorber is an indication that disassembling and inspection are required to determine the reason for loss of fluid so that worn or damaged parts can be replaced. See paragraph 4.

4. DISASSEMBLY OF SHOCK ABSORBER.

1937-42—Refer to figures 1 and 2.

NOTE

Shock absorbers do not require periodic servicing and should not be disassembled for inspection or filling, unless there is a known failure.

(1) Wash off all external dirt.

IMPORTANT

Utmost care in cleanliness of parts, tools and hands is essential when servicing shock absorbers.

(2) Grip the lower eye of the shock absorber in a vise. Insert the prongs of the spanner wrench through the opening in the outer dust shield tube and engage with the notches in the piston rod seal housing (fig. 4). Make sure the spanner wrench fits into the notches of the piston rod seal. To help hold the wrench in place, use two small screwdrivers over the top of the wrench in the openings of the dust shield. This will keep the wrench from working up. Unscrew the seal and cylinder assembly from the reservoir tube and separate the two halves of the shock absorber.

(3) Pour the liquid out of the reservoir (half held in the vise) and discard the liquid.

(4) Remove and discard the rubber composition gasket (17, fig. 2).

(5) Remove the compression valve (2, fig. 5) from the cylinder. This may be done by lightly tapping a screwdriver or blunt chisel against the groove in the edge of the valve body. (The valve body is held in the cylinder by a light press fit.)



Figure 4—Disassembling Shock Absorber Tubes With Tool MT-101 (1937-42 Models)

CAUTION

Do not hold the shock absorber cylinder in a vise when removing the valve because of danger of squeezing the thin wall of cylinder out-of-round.

The valve assembly cannot be disassembled for replacement of parts. If the shock absorber is being inspected because of a chuckle at low speeds on smooth pavement, replace this valve with a new one.

(6) Discard the liquid from the cylinder. Then grip the sides of the eye, on the end, in a vise with the open end of the shell up.

(7) Push the cylinder down in the dust shield and remove the nut and spring from the piston rod. Pull the cylinder and seal assembly up off the piston rod and shake the loose washers and piston out of the cylinder. Do not force the cylinder up and off the piston rod if the washers catch in the threads on the piston rod. If they should catch and prevent the cylinder leaving the piston rod easily, shake the cylinder a little up and down and rotate it a few times to move the washers into alignment so the cylinder can be lifted off easily. Individual parts of the piston rod oil seal and bushing assembly are not available for replacement; therefore the entire assembly should be replaced, if necessary. It is a light press fit in the cylinder tube and may be removed with a wooden or hollow drift.

(8) Wash all parts in naphtha or similar cleaner and dry them with compressed air. Do not wipe dry with a cloth because lint clinging to the parts may cause poor valve seating which in turn will cause improper performance.

IMPORTANT

Rigid precautions must be taken for cleanliness all during the servicing of shock absorbers.



1—Dust shield tube and piston rod 2—Compression valve
3—Wedge shaped tool
4—Cylinder tube

Figure 5—Removing Compression Valve from Cylinder (1937-42 Models)

(9) Place all parts on a clean paper and inspect each piece. Check the piston to see that it is free from nicks. Measure the outside diameter of the piston. If it is worn more than .003 inch out-of-round, it should be replaced.

(10) Check the rebound valve spring seat (16, fig. 2). It should be flat and not distorted. All washers should be flat and free of burrs.

5. ASSEMBLY OF SHOCK ABSORBER.

1937-42—After all internal parts have been cleaned and inspected, wipe or blow out the inside of the dust shield. Then proceed as follows:

(1) Press the rod guide and seal assembly into the cylinder.

CAUTION

Do not press against the steel retainer of the rod guide and seal assembly. Press only on the large threaded housing.

5. ASSEMBLY OF SHOCK ABSORBER.

1937-42—Cont'd

(2) Place the thimble MT-178 over the threads of the piston rod to prevent damage to the seal (fig. 6).

(3) Slide the cylinder and seal assembly onto the piston rod. Install the piston and washers in exactly the same sequence as shown in figures 1 and 2. The prongs of the piston intake valve plate spider spring (13, figs. 1 and 2) should face the piston intake valve plate (3). Make certain that the proper sides of all parts face in the correct direction and tighten the nut on the end of the piston rod.

(4) Move the tube up and down and rotate it at the same time to determine whether or not the piston binds in the cylinder. If it binds, loosen the piston rod nut and work the cylinder up and down a few times and rotate the piston to another position. Then tighten the nut. It may be necessary to repeat this operation in order to make certain of correct alignment of the parts and free movement of the cylinder. The piston

is ground concentric with the rod. If a binding condition exists between the piston and cylinder which cannot be eliminated, install a new piston.

(5) When free movement of the piston in the cylinder is obtained, tighten the nut on the end of the piston rod with a force equivalent to a 25-pound pull on the end of a 5 inch wrench.

(6) Measure the exact amount of shock absorber fluid required. Filler cup MT-105 or a graduated beaker may be used for measuring the fluid. Always filter new fluid. Use a paint filter to remove any dirt or sediment present in the fluid.

(7) While holding the eye of the cylinder and dust shield assembly in a vise, pull up the inner cylinder until it stops against the piston. Remove the half of the shock absorber from the vise and fasten the reservoir in the vise.

(8) Pour enough of the previously measured shock absorber liquid into the inner cylinder to fill it. (See figure 7.) Then pour the balance of the fluid in the reservoir.



1—Piston rod guide and seal 2—Thimble MT-178

Figure 6—Assembling Cylinder on Piston Rod
(1937-42 Models)

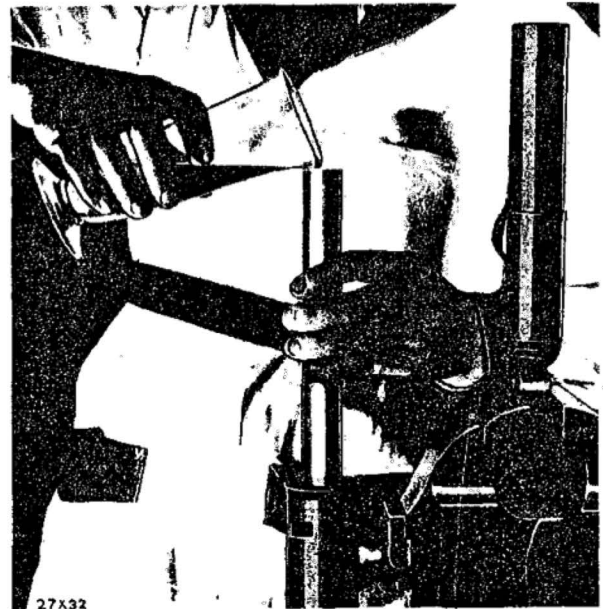


Figure 7—Filling Shock Absorber (1937-42 Models)

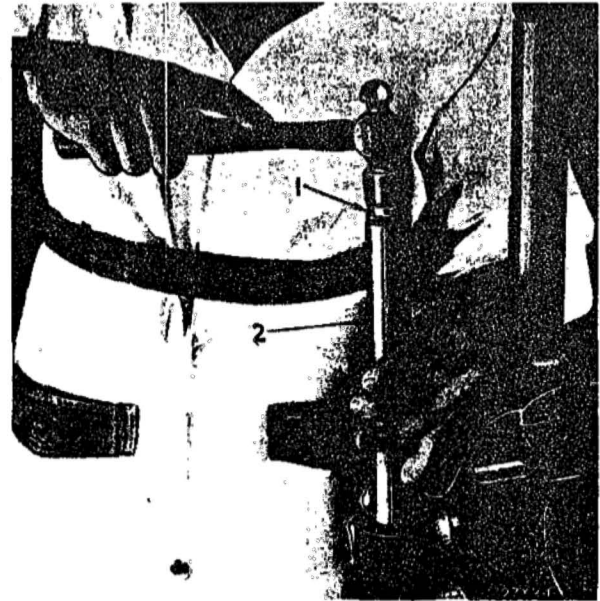
(9) Install the compression valve in the open end of the cylinder tube and tap it snugly into place with a clean, small steel hammer as shown in figure 8.

(10) While holding the reservoir vertically in a vise, to prevent spilling the fluid, insert the convex gasket retainer washer (with the convex side toward the open end of the tube) and then install a new rubber composition gasket on top of the convex retainer washer.

(11) Turn the half of the shock absorber containing the cylinder and piston, eye end up, and slide it down into the reservoir until it reaches bottom. Then turn it clockwise to catch the threads of the piston rod seal in the threads of the reservoir. When the threads catch, pull the two halves of the shock absorber in opposite directions until the notches in the piston rod seal line up with the slots in the outer shell.

(12) Tighten the piston rod seal in the reservoir with the special wrench used for separating the two halves of the shock absorber and bring it up tight.

(13) Hold the completed assembly right end up (as when in the vehicle) and grip the bottom eye in a vise. Move the upper chamber slowly up and down several times to the limit of travel so as to pump any air out of the cylinder into the reservoir. This pumping must be done with the assembly in the position described or the air will not leave the cylinder.



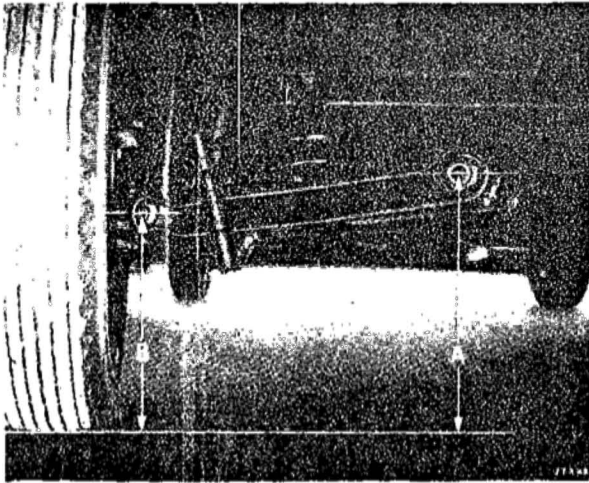
1—Compression valve 2—Cylinder tube

Figure 8—Installing Compression Valve
(1937-42 Models)

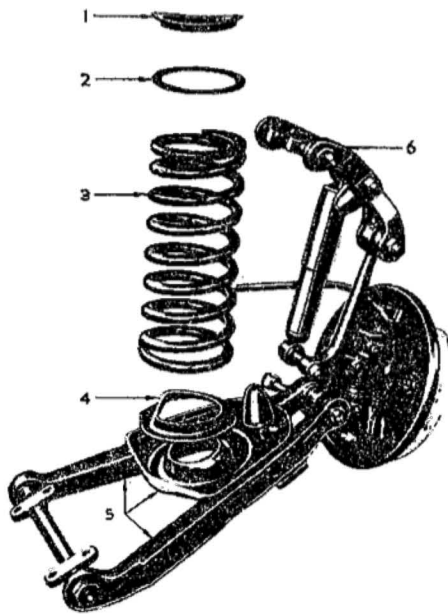
(14) A predetermined volume of air is required in the reservoir for proper action of the shock absorber. Therefore, it is imperative that the exact amount of liquid specified be used so as to obtain the required volume of air.

6. INSTALLATION OF SHOCK ABSORBERS.

1937-42—“Front” or “Rear” is stamped on unit for identification. Be sure to install front or rear as indicated. When installing, be sure that the tapered rubber bushings are placed between the pins and eyes of the shock absorbers with the flat washers at the outer ends of the bushings. Never use oil or grease on the rubber bushings.

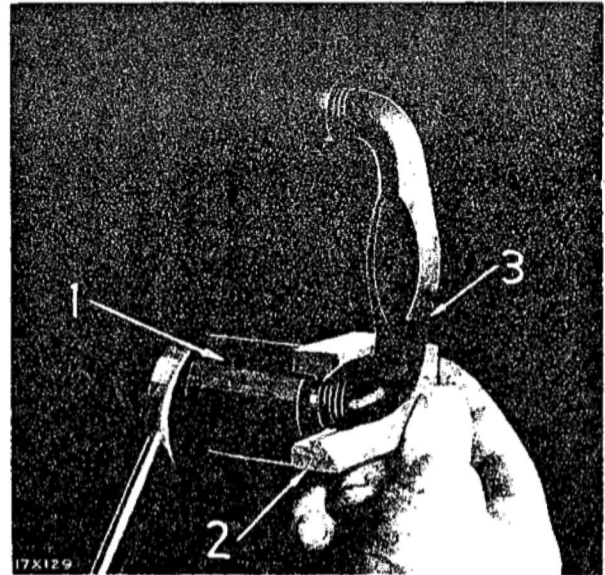


**Figure 1—Checking Front Spring Height
(1939-42 Models)**



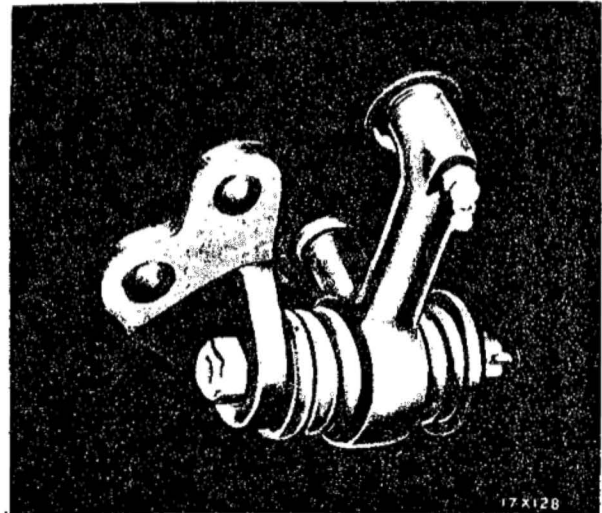
- 1—Silencer—upper
- 2—Spacer
- 3—Spring
- 4—Silencer—lower
- 5—Front wheel suspension lower control arm assembly

Figure 2—Front Spring Mounting (1942 Model, Typical of 1939-41 Models)



- 1—Spring
- 2—Gauge C-329
- 3—Shackle

**Figure 3—Adjusting Spring Shackle
(1936-38 Models)**



**Figure 4—Steering Shock Eliminator
(1937-38 Models)**

Section XIX

SPRINGS

1. FRONT SPRING HEIGHT

1939-42—With equal pressure in each tire and the car on a level floor, with only the weight of the car on the springs (no passengers in the car), measure distances "A" and "B," figure 1. Measurement "A" should be approximately $\frac{1}{2}$ inch longer than measurement "B". Check these measurements on both the right and left sides of car and compare the difference between "A" and "B" measurements on both sides. If the difference varies more than $\frac{1}{4}$ inch between the two sides of the car, the car should be leveled by the use of spacers which should be placed between the spring and the silencer at the top of the spring. One spacer will raise the car $\frac{5}{16}$ inch.

2. INSTALLATION OF FRONT SPRING.

1939-42—Position flat end of spring at top. Fit lower end of spring into recessed part of spring seat, with spacer (on driver's side only) and silencers positioned as shown in figure 2. Be sure to level right and left sides when installing spring.

1937-38—Be sure spring center bolt is properly located in recess in axle center. Adjust shackles as specified in paragraph 3.

3. ADJUSTMENT OF FRONT SPRING SHACKLES.

1937-38—Place a $\frac{3}{4}$ inch gauge between the front end of the front spring and the spring shackle, and a $\frac{11}{16}$ inch gauge between the front end of the front spring front hanger and the spring shackle. Screw the shackle bushings in until the gauges are against the shackle and remove the gauges (fig. 3). Center the rear end of right spring in the hanger and screw the bolt up tight. Place a $\frac{9}{32}$ inch gauge between the spring shock eliminator shackle and the bushing retainer and a $1\frac{1}{4}$ inch gauge between the

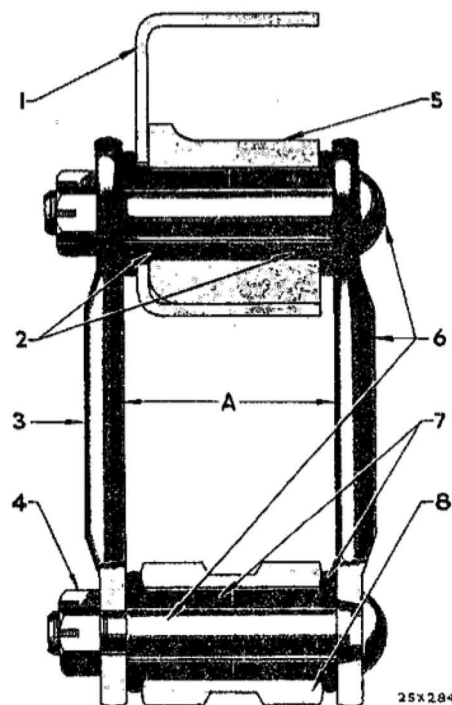
shock eliminator and the spring. Tighten bushings and remove gauges.

4. INSTALLATION OF STEERING SHOCK ELIMINATOR.

1937-38—No adjustment is required on the bolt running through the coil springs of the shock eliminator, but the nut on the bolt must be turned tight and locked with the cotter pin (fig. 4).

5. INSTALLATION OF REAR SPRING.

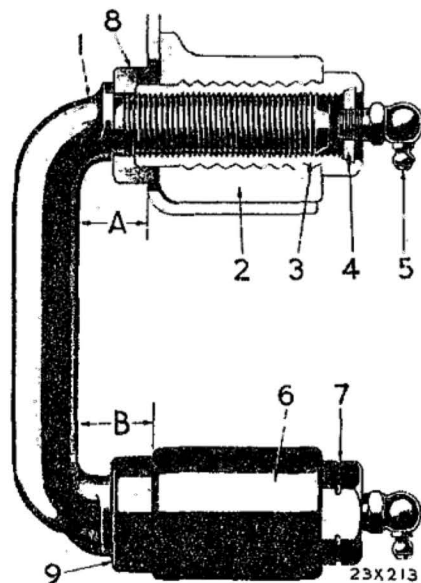
1936-42—When installing rear spring, be sure the spring center bolt is properly seated in spring seat and that both sides of the rear axle assembly are properly located, front to rear.



- | | |
|--------------------|---------------------------------|
| 1—Frame | 5—Frame rear spring rear hanger |
| 2—Rubber bushings | 6—Shackle and bolts |
| 3—Shackle—outer | 7—Rubber bushings |
| 4—Shackle bolt nut | 8—Rear spring |
| | A—1.980 in. to 2.000 in. |

Figure 5—Rear Spring Shackle (Rear Mounting)
(1941-42 Models)

DATA AND SPECIFICATIONS					
YEAR		1942	1939-41	1937-38	1936
Front (Leaf Type)	Length, inches			37	P2-37 P1-38
	Width, inches			1 $\frac{3}{4}$	1 $\frac{3}{4}$
	Number of leaves			P3, P5-8 P4, P6-10 P4, P6 7 pass.-12	P1-8 P2-10 P2 7 pass.-11
Front (Coil Type)	Inside diameter of coil, inches	4	4		
	Static height of coil, inches	8 $\frac{3}{4}$	8 $\frac{3}{4}$ 9 $\frac{3}{4}$ (7 pass. 1940-41)		
Rear	Length, inches	53 $\frac{5}{8}$	53 $\frac{5}{8}$	53 $\frac{5}{8}$	53 $\frac{5}{8}$
	Width, inches	1 $\frac{3}{4}$	1 $\frac{3}{4}$	1 $\frac{3}{4}$	1 $\frac{3}{4}$
	Number of leaves	P14-C-8 P14-S-7	P7, P9, P11-7 P8, P10, P12-9 P12 7 pass.-10 P8, P10 7 pass.-11	P3, P5-7 P4, P6-9 P4, P6 7 pass.-11	P1-7 P2-9 P2 7 pass.-11
Sway eliminator		Yes	P7, P9 No P8, P10, P11, P12 Yes	P3, P5 No P4, P6 Yes	P1 No P2 Yes



- | | |
|-------------------------------------|-------------------------------------|
| 1—Shackle | 5—Shackle bushing lubricant fitting |
| 2—Frame rear spring rear hanger | 6—Rear spring |
| 3—Rear spring shackle bushing—upper | 7—Rear spring shackle bushing—lower |
| 4—Shackle bushing plug | 8—Dust seal |
| | 9—Dust seal |
- A—Clearance between shackle and frame
B—Clearance between shackle and spring

Figure 6—Rear Spring Shackle (Rear Mounting)
(1940 Model, Typical of 1936-39 Models)

6. ADJUSTMENT OF REAR SPRING SHACKLES.

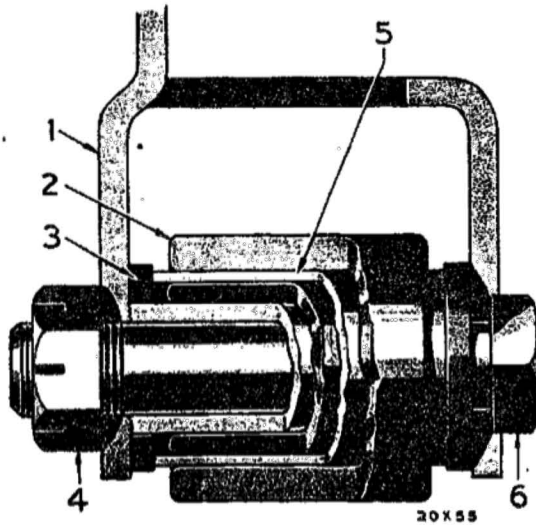
1941-42—Assemble shackle and adjust to dimension shown on figure 5.

1940—Place a $\frac{7}{8}$ inch gauge between the spring shackle and the frame side rail and between the end of the spring and the spring shackle. Install the shackle bushing and remove the gauge (fig. 6).

CAUTION

The lower leg of the left rear spring shackle has left hand threads. This is indicated by the notches in the lower shackle bushing (7, fig. 6).

1936-39—Place a $\frac{13}{16}$ inch gauge between the spring shackle and the frame side rail and a $\frac{7}{8}$ inch gauge between the end of the spring and the spring shackle. Then tighten the shackle bushings and remove gauges (fig. 6).



- 1—Frame rear spring front hanger
- 2—Rear spring
- 3—Thrust washer
- 4—Bolt nut
- 5—Silent-bloc
- 6—Bolt

Figure 7—Rear Spring Front Bolt (1939-42 Models, Typical of 1936-38 Models)

7. ADJUSTMENT OF REAR SPRING BOLTS.

1936-42—The only adjustment required on the rear spring front bolts (fig. 7) is to draw bolts up tight so the inner sleeve is held in place and cannot rotate.

8. SPRING CLIP MAINTENANCE.

It is important that the spring clips be inspected at regular intervals and kept tight to prevent spring breakage.

Section XX

STEERING GEAR

1. DESCRIPTION.

1936-42—The steering gear is of the worm and roller type. Two adjustments are provided for proper mesh of the worm and roller. The worm bearings may be adjusted without removing the steering gear assembly from the car.

2. ADJUSTMENT OF WORM BEARINGS.

1936-42

(1) To eliminate any stiffness resulting from friction in the steering connections, and to permit a true test of the operation of the steering gear, remove the steering gear arm from the steering gear shaft with puller C-143.

(2) Rotate the steering wheel to the extreme right or left and then back $\frac{1}{4}$ turn.

(3) Remove shims (5, fig. 1 or 3, fig. 2) between the grease retainer cover and steering gear body of sufficient thickness to

eliminate end-play in the worm but not enough to cause binding when the cover is bolted tightly in place.

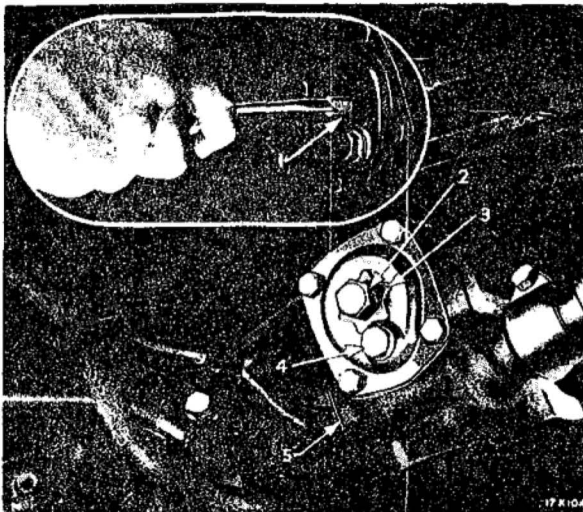
(4) Test adjustment by rotating the steering wheel from extreme right to extreme left. When properly adjusted, a pull of approximately 1 to 2 $\frac{1}{4}$ pounds (at rim of steering wheel) will be required to rotate the wheel through the mid-position.

3. ADJUSTMENT OF ROLLER TOOTH AND WORM.

1941-42

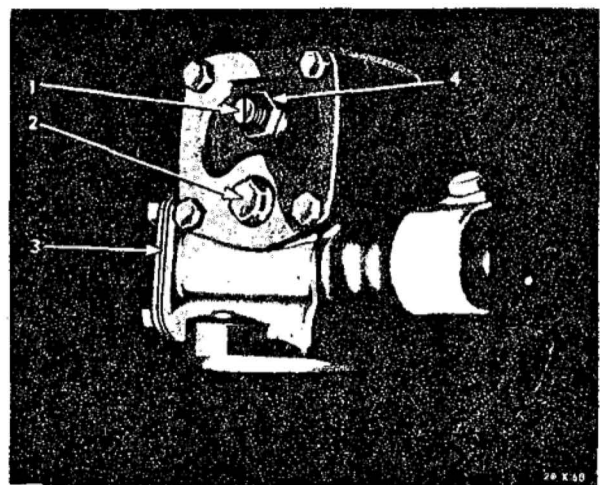
(1) Using puller C-143, remove the steering gear arm from the steering gear shaft and install another arm.

(2) Turn the steering wheel to the mid-position. To do this, turn the wheel from extreme right or left to the opposite extreme, counting the number of turns required. Then turn the wheel back $\frac{1}{2}$ the number of turns required to turn the wheel from one extreme to the other extreme.



- | | |
|-------------------------------------|------------------------------|
| 1—Adjusting screw and thrust washer | 3—Adjusting screw lock plate |
| 2—Adjusting screw lock nut | 4—Lubricant filler plug |
| | 5—Bearing adjusting shims |

**Figure 1—Steering Gear Adjustments
(1941-42 Models)**



- | | |
|--|---|
| 1—Shaft and roller tooth adjusting screw | 4—Shaft and roller tooth adjusting screw lock nut |
| 2—Lubricant filler plug | |
| 3—Worm adjusting shims | |

**Figure 2—Steering Gear Adjustments
(1936-40 Models)**

(3) With the steering wheel in the mid-position, move the steering gear arm back and forth to determine whether or not there is any backlash. If there is more than 1/32 inch free movement, the gear should be adjusted.

(4) To adjust, refer to figure 1. Remove the lock nut (2) and slide off the lock plate (3).

(5) Tighten the roller tooth shaft adjustment screw (1) just enough to eliminate the free play between the roller tooth shaft and the worm.

(6) Slide the lock plate (3) in position against the roller tooth shaft cover and lock it.

(7) Install and tighten the lock nut (2).

(8) Test adjustment by rotating the steering wheel from one extreme to the opposite extreme. When properly adjusted, a pull of approximately 1 to 2¼ pounds (at rim of steering wheel) will be required to rotate the wheel through the mid-position.

1936-40

(1) Using a puller, remove the steering arm, with the two tie rods assembled, from the steering gear shaft and install another arm.

(2) Turn the steering wheel to the mid-position. To do this, turn the wheel from extreme right or left to the opposite extreme, counting the number of turns required. Then turn the wheel back ½ the number of turns required to turn the wheel from one extreme to the other extreme.

(3) With the steering wheel in the mid-position, move the steering gear arm back and forth to determine whether or not there is any backlash. If there is more than 1/32 inch free movement, the gear should be adjusted.

(4) To adjust, refer to figure 2. Remove the steering arm and the shaft cover.

(5) Remove the roller tooth shaft (steering arm shaft) from the housing and remove a shim from the shaft. (Shims are used to prevent the roller tooth pressing too hard against the worm, causing unnecessary friction and rapid wear.)

(6) Install the roller tooth shaft and install the cover. Before tightening the cover, loosen the adjusting screw (1) in the cover about two full turns, then tighten the cover.

(7) Tighten the adjusting screw (1) and then back it off just enough to eliminate drag when rotating the steering wheel. Lock the adjusting screw with lock nut.

(8) Install the steering gear arm.

(9) Test adjustment by rotating the steering wheel from extreme right to extreme left. When properly adjusted, a pull of approximately 1 to 2¼ pounds (at rim of steering wheel) will be required to rotate the wheel through the mid-position.

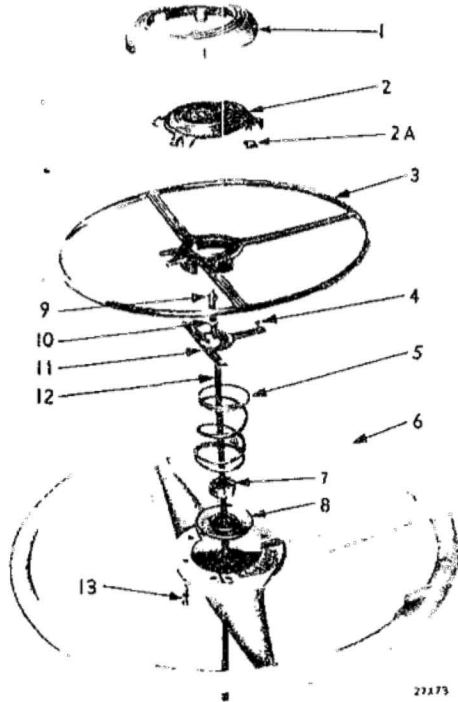
4. REMOVAL OF HORN BUTTON (WITH BLOWING RING).

1939-42—Disconnect wire at connector at bottom of steering gear. Remove screws from underside of steering wheel hub and lift off blowing ring and retainer (fig. 3). Remove screws which hold contact plate to wheel hub. Pull wire out of steering tube. To remove wire terminal, push it out of contact plate.

5. REMOVAL OF HORN BUTTON (WITHOUT BLOWING RING).

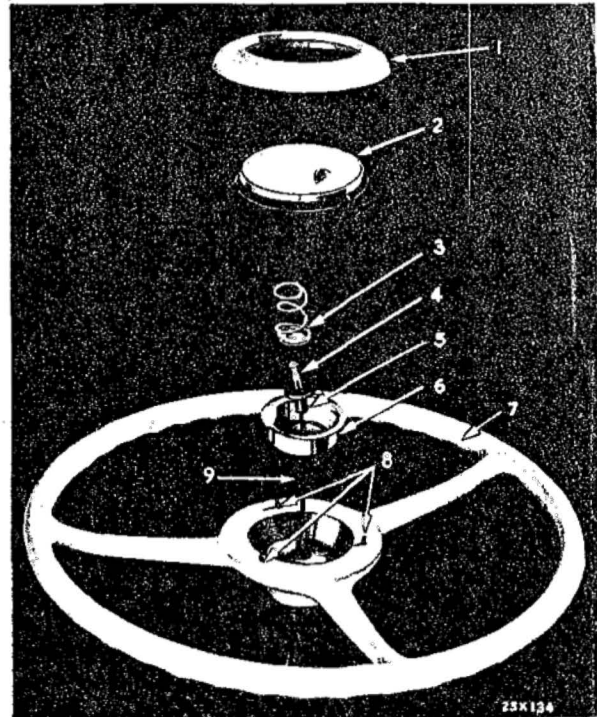
1939-42—Disconnect horn wire at connector at bottom of steering gear. Remove screws from underside of steering wheel hub and lift off horn button retainer and button (fig. 5). Pull wire out of steering tube.

1936-38—Disconnect horn wire at connector at bottom of steering gear. Press firmly on horn button and rotate it to the right as far as it will go. Relieve pressure and button will pop out.



- 1—Blowing ring retainer
- 2—Blowing ring retainer ornament
- 2A—Blowing ring retainer ornament mounting nut
- 3—Blowing ring
- 4—Blowing ring contact plate retaining screw
- 5—Blowing ring spring
- 6—Steering wheel
- 7—Steering wheel nut
- 8—Blowing ring ground cup
- 9—Cable contact
- 10—Cable contact retainer
- 11—Blowing ring contact plate
- 12—Cable
- 13—Blowing ring retainer screw and lockwasher

Figure 3—Horn Blowing Ring Disassembled (1942 Model, Typical of 1939-41 Models)



- 1—Retainer
- 2—Button
- 3—Spring and base
- 4—Cable contact
- 5—Steering wheel nut insulator
- 6—Contact cup
- 7—Steering wheel
- 8—Retainer screws
- 9—Cable

Figure 5—Horn Button Disassembled (1941 Model, Typical of 1939-42 Models)

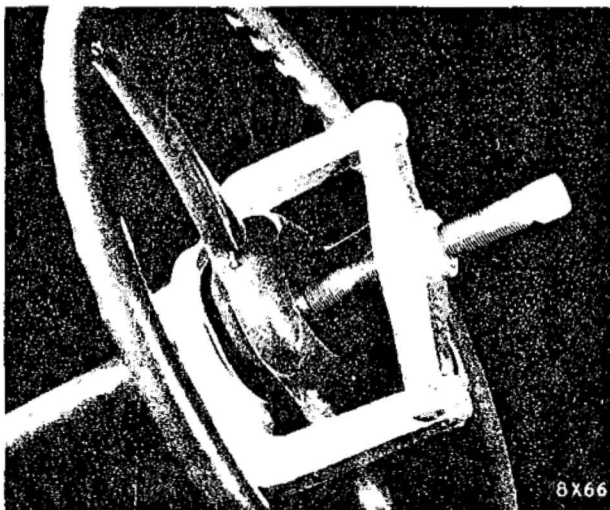


Figure 4—Removing Steering Wheel with Puller C-232 (1936-38 Models)

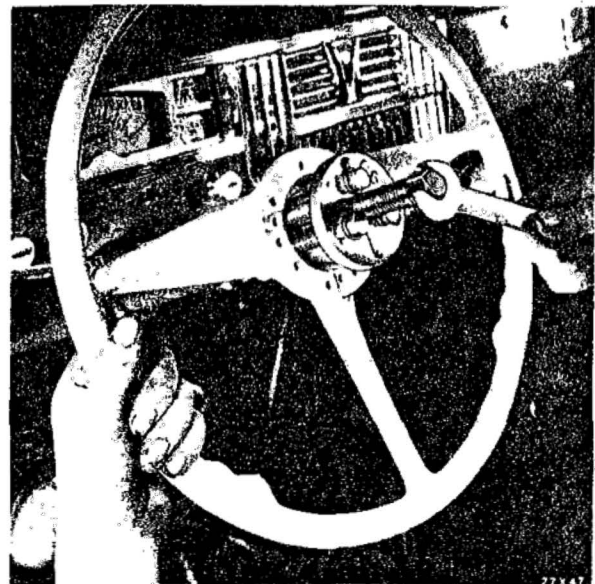


Figure 6—Removing Steering Wheel with Puller C-612 (1942 Model, Typical of 1939-41 Models)

6. REMOVAL OF STEERING WHEEL.

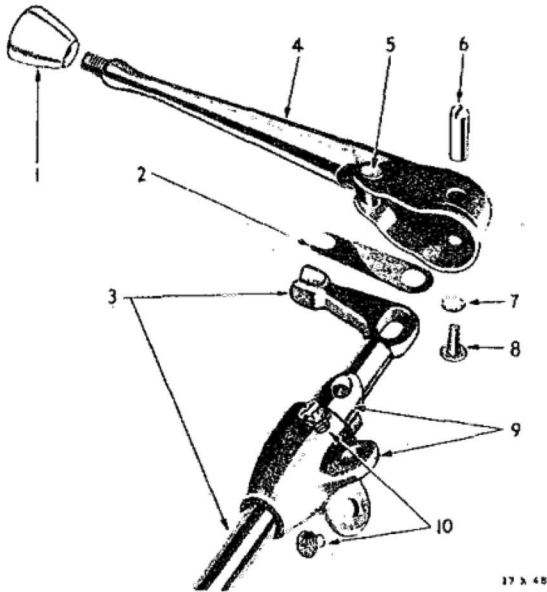
1939-42—Remove the horn button or horn blowing ring, retainer and wire. Remove steering wheel nut. Attach puller C-612 to wheel by means of the threaded holes in the steering wheel hub and pull off wheel (fig. 6).

1936-38—Remove the horn button and wire. Remove steering wheel nut and pull off wheel with puller C-232 (fig. 4).

7. DISASSEMBLY OF GEARSHIFT CONTROL.

1941-42—Remove the gearshift lever (fig. 7). Disconnect the selector rod and the gearshift rod from steering column tube. Disconnect the shifter rod end and remove the lever from the lower end. Remove the column bracket clamp at the instrument panel and withdraw the control rod.

1940—Remove the horn button, horn wire and steering wheel. Disconnect the gear selector cable and gearshift control rod (between steering gear and transmission) at the



- 1—Knob
- 2—Spring washer (anti-rattle)
- 3—Rod
- 4—Lever
- 5—Pin
- 6—Bearing
- 7—Bearing screw lockwasher
- 8—Bearing screw
- 9—Pivot and bracket
- 10—Pivot bracket attaching screws and lockwashers

Figure 7—Remote Control Gearshift Lever Removed from Rod (1942 Model, Typical of 1941 Model)

bottom of the control rod. Pull off the slotted control rod adjusting lever and spring. Remove the screws which attach upper end of the control rod to steering column (fig. 8).

CAUTION

The control rod attaching screws are held by nuts inside column. Hold the nuts so they will not drop down when screws are removed.

Pull out the control rod and handle. To disassemble, unscrew the control lever pivot support from the pivot, compress the gearshift lever bearings and spring (fig. 9) and withdraw pivot. Drive out the clevis pin in handle and remove the handle from the control rod.

1939—Remove the screws which hold the remote control housing to upper end of jacket. (See figure 12.) Hold the housing in place with hand when removing screws so as not to lose the ball and spring from the shifter hand lever. Lift off the housing and pick out spring and ball (22 and 23, fig. 12). Remove the nut (52) which holds the gearshift hand lever to shifter tube. Pull gearshifter tube assembly out of jacket.

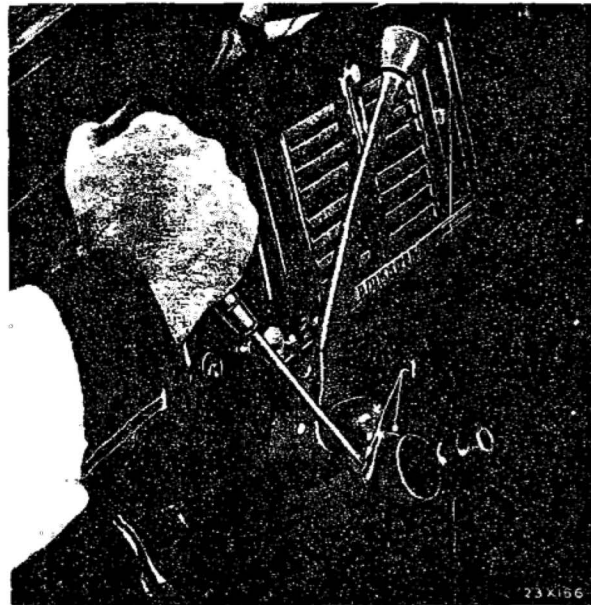


Figure 8—Removing Steering Gear Remote Control Gearshift Lever Pivot Bracket Screws (1) (1940 Model)

7. DISASSEMBLY OF GEARSHIFT CONTROL.

1939—Cont'd

If necessary to remove the rubber draft pad, rub a film of soft soap over lower end of column jacket and pull draft pad off over that end.

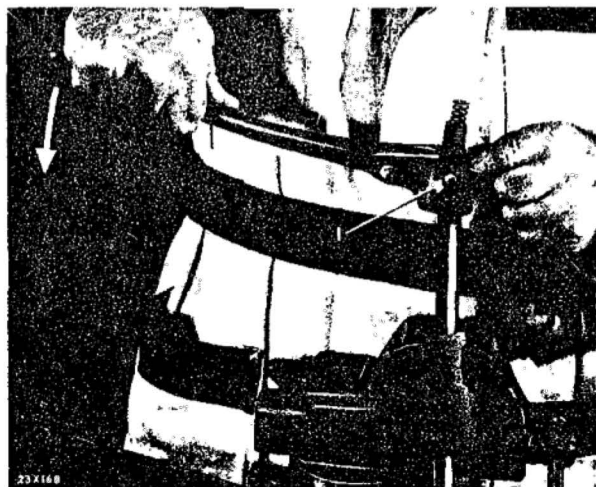


Figure 9—Removing Remote Control Gearshift Lever from Rod—(1) Compressing Gearshift Lever Bearings and Spring (1940 Model)

8. REMOVAL OF STEERING GEAR.

1941-42

(1) Using puller C-143, remove the steering gear arm.

(2) Remove the steering wheel.

(3) Disconnect the selector rod and the gearshift rod and disconnect the shifter rod end and remove from lower end.

(4) Disconnect the steering gear housing from the frame.

(5) Remove the engine splash pan on the left side and disconnect the brake cable clamp from the steering tube.

(6) Remove the draft pad screws, disconnect the column jacket from the instrument panel and lift the assembly out of the car.

1940

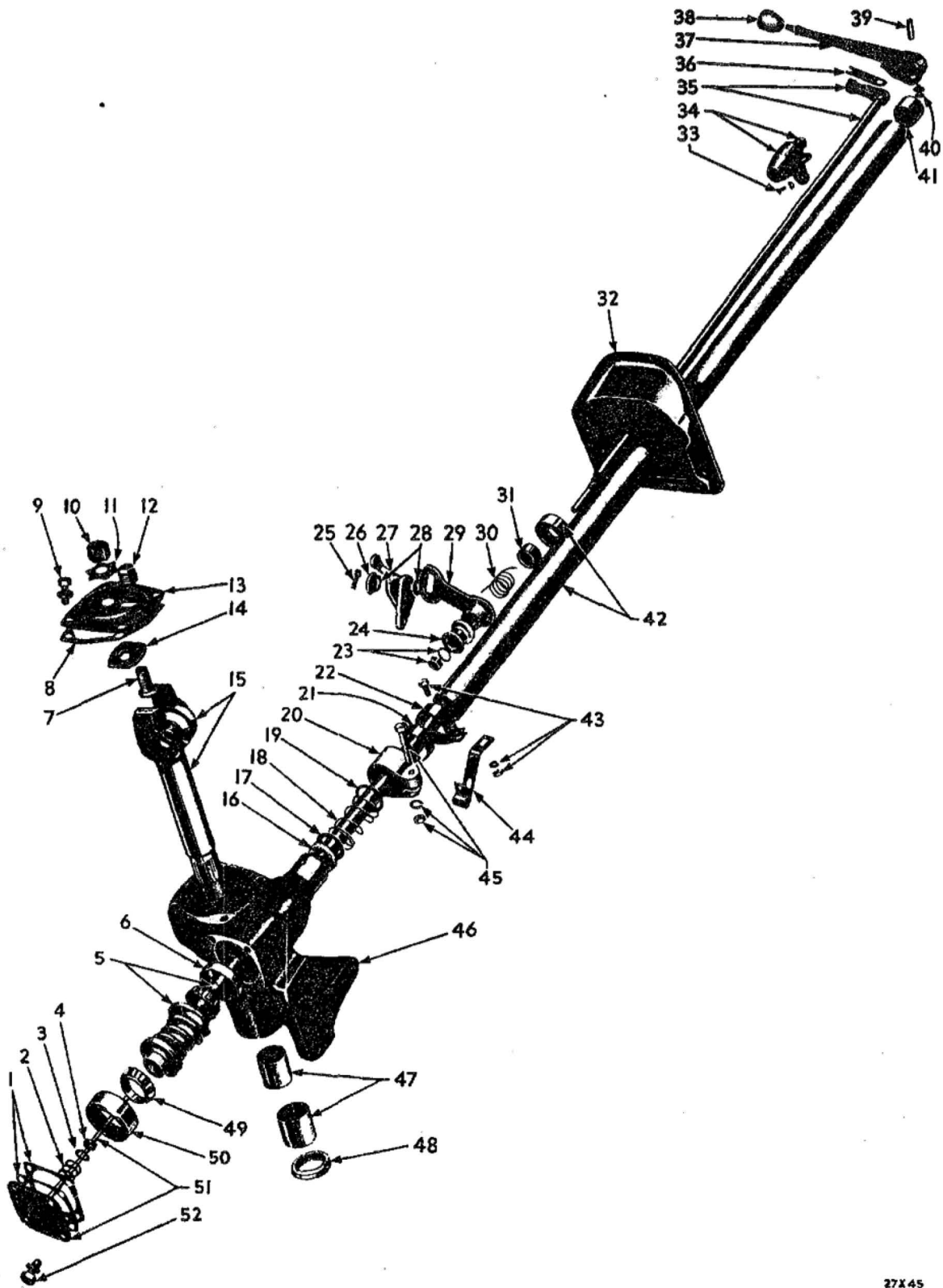
(1) Disconnect the battery ground cable.

(2) Using puller C-143, remove the steering gear arm.

(Continued on page 187)

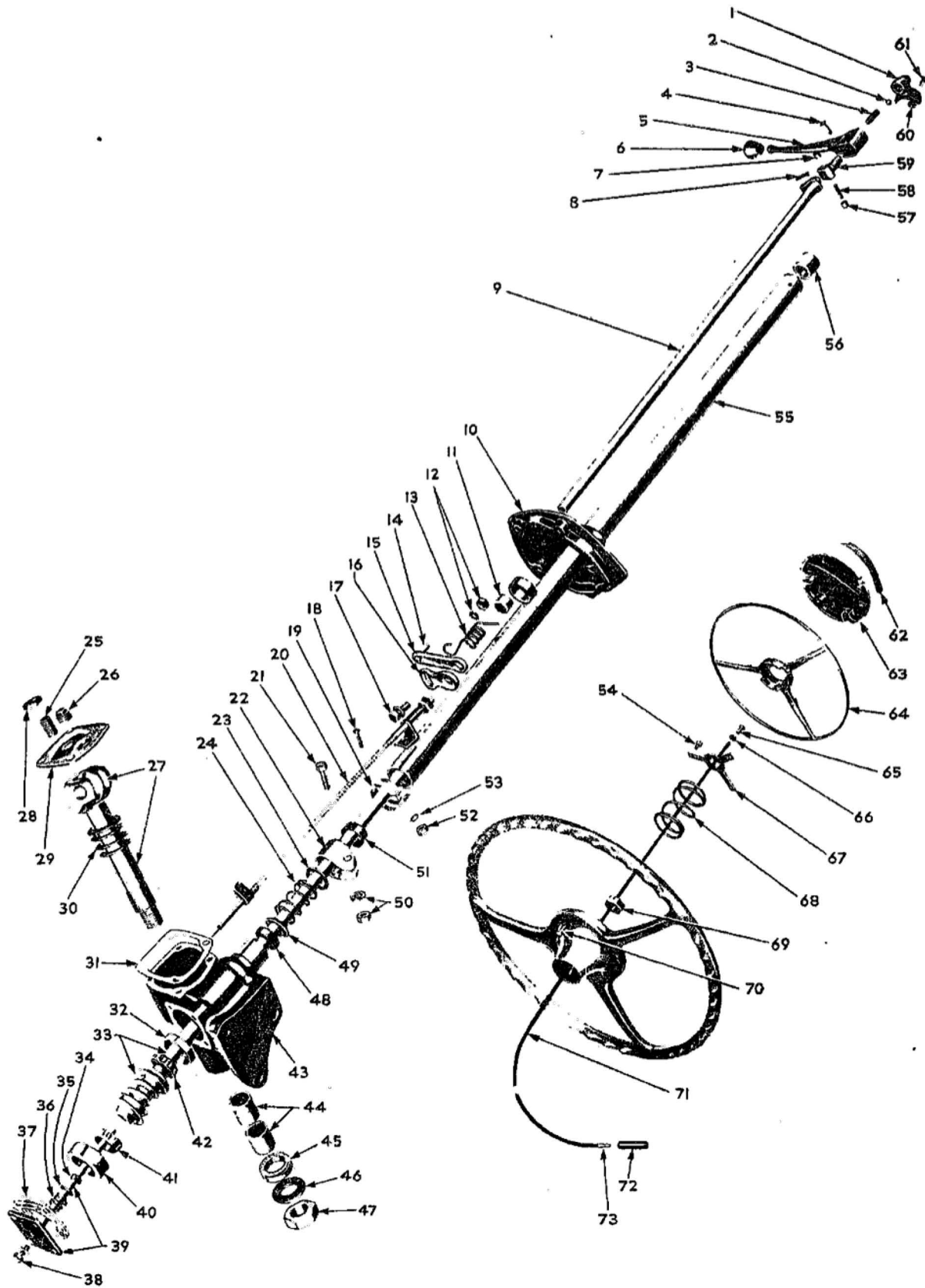
Legend for Figure 10—Steering Gear (Disassembled View) (1942 Model, Typical of 1941 Model)

- | | | |
|--|--|--|
| 1—Housing cover shims (worm adjusting shims) | 22—Hand brake cable to steering post clip | 37—Remote control gearshift lever |
| 2—Steering tube oil seal spring | 23—Remote control gearshift rod end nut and lockwasher | 38—Remote control gearshift lever knob |
| 3—Steering tube oil seal washer | 24—Remote control gearshift rod end | 39—Remote control gearshift lever bearing |
| 4—Steering tube oil seal | 25—Column jacket selector lever stud cotterpin | 40—Remote control gearshift lever bearing screw and lockwasher |
| 5—Steering tube and worm assembly | 26—Column jacket selector lever stud plain washer | 41—Column jacket bushing |
| 6—Worm thrust bearing cup—upper | 27—Column jacket selector lever stud spring washers | 42—Column jacket assembly |
| 7—Shaft adjusting screw | 28—Column jacket selector lever stud spring washers | 43—Hand brake cable to steering post clip bolt, nut and lockwasher |
| 8—Shaft cover gasket | 29—Remote control gearshift rod lever | 44—Hand brake cable to steering post cable clip |
| 9—Shaft cover screw and lockwasher | 30—Remote control gearshift rod return spring | 45—Column jacket clamp bolt, nut and lockwasher |
| 10—Shaft adjusting screw lock nut | 31—Remote control gearshift rod bearing | 46—Housing |
| 11—Shaft adjusting screw lock plate | 32—Steering post hole cover pad | 47—Shaft bushings |
| 12—Housing lubricant filler plug | 33—Remote control gearshift lever pivot bracket screw and lockwasher | 48—Shaft oil seal |
| 13—Shaft cover | 34—Remote control gearshift lever pivot bracket assembly | 49—Worm thrust bearing |
| 14—Shaft thrust washer | 35—Remote control gearshift rod | 50—Worm thrust bearing cup—lower |
| 15—Shaft and roller tooth assembly | 36—Remote control gearshift lever spring washer (anti-rattle) | 51—Housing cover and grease retaining tube assembly |
| 16—Column jacket oil seal | | 52—Housing cover screw and lockwasher |
| 17—Column jacket oil seal washer | | |
| 18—Column jacket oil seal spring washer | | |
| 19—Column jacket oil seal spring washer | | |
| 20—Column jacket clamp | | |
| 21—Column jacket relief hole cover | | |



27X45

Figure 10—Steering Gear (Disassembled View) (1942 Model, Typical of 1941 Model)



33x209

Figure 11—Steering Gear (Disassembled View) (1940 Model)

8. REMOVAL OF STEERING GEAR.**1940—Cont'd**

- (3) Remove the steering wheel.
- (4) Disconnect the selector cable bracket and the hand brake cable bracket from the steering column.
- (5) Disconnect the gear selector cable at the bottom of the gearshifter rod and pull off the slotted adjusting lever and spring.
- (6) Remove the shifter rod and handle.
- (7) Disconnect the steering gear housing from the frame and disconnect the steering column from the instrument panel.
- (8) Pull the rubber draft pad from the steering column and lift the steering gear assembly out of car.

1939 (P8 Model).

- (1) Remove the steering wheel and floor boards.
- (2) Disconnect the draft pad from the dash and pull it upward on the steering column jacket about 6 inches.
- (3) Disconnect the steering column from the instrument panel.
- (4) Remove the hood lower left side panel, then raise the front end of the car about 6 inches.
- (5) Using puller C-143, remove the steering gear arm.
- (6) Disconnect the hand brake cable from the steering column.

Legend for Figure 11—Steering Gear (Disassembled View) (1940 Model)

- | | | |
|---|---|---|
| 1—Remote control gearshift lever pivot bracket | 21—Column jacket clamp bolt | 50—Column jacket clamp bolt nut and lockwasher |
| 2—Remote control gearshift lever pivot spring ball | 22—Column jacket clamp | 51—Column jacket oil hole cover |
| 3—Remote control gearshift lever pivot spring | 23—Column jacket oil seal spring washer | 52—Column jacket remote control cable clip screw nut |
| 4—Remote control gearshift lever pin | 24—Column jacket oil seal spring | 53—Column jacket remote control cable clip screw nut lockwasher |
| 5—Remote control gearshift lever | 25—Shaft adjusting screw | 54—Horn blowing ring contact plate retaining screw |
| 6—Remote control gearshift lever knob | 26—Housing lubricant filler plug | 55—Column jacket |
| 7—Remote control gearshift lever bearing | 27—Shaft and roller tooth assembly | 56—Column jacket bushing |
| 8—Remote control gearshift lever anti-rattle | 28—Shaft adjusting screw locknut | 57—Remote control gearshift lever bearing |
| 9—Remote control gearshift rod | 29—Shaft cover | 58—Remote control gearshift lever bearing spring |
| 10—Steering post hole cover pad | 30—Shaft thrust washer and shims | 59—Remote control gearshift lever pivot |
| 11—Remote control gearshift rod bushing | 31—Shaft cover gasket | 60—Remote control gearshift lever pivot bracket screw nut |
| 12—Remote control gearshift rod adjusting lever bolt nut and lockwasher | 32—Worm thrust bearing cup—upper | 61—Remote control gearshift lever pivot bracket screw |
| 13—Remote control gearshift rod return spring | 33—Steering tube and worm assembly | 62—Horn blowing ring retainer ornament |
| 14—Remote control gearshift rod lever and pin | 34—Steering tube oil seal | 63—Horn blowing ring retainer |
| 15—Remote control gearshift lever pin | 35—Steering tube oil seal washer | 64—Horn blowing ring |
| 16—Remote control gearshift rod adjusting lever | 36—Steering tube oil seal spring | 65—Horn button cable contact |
| 17—Remote control gearshift rod adjusting lever bolt and plain washer | 37—Housing cover shims (worm adjusting shims) | 66—Horn button cable contact retainer |
| 18—Column jacket remote control cable clip screw | 38—Housing cover screw and lockwasher | 67—Horn blowing ring contact plate |
| 19—Column jacket remote control cable clip | 39—Housing cover and grease retaining tube assembly | 68—Horn blowing ring spring |
| 20—Remote control gearshift cable assembly | 40—Worm thrust bearing cup—lower | 69—Steering wheel nut |
| | 41—Worm thrust bearing cage and rollers | 70—Horn blowing ring retainer screw and lockwasher |
| | 42—Worm thrust bearing cage and rollers | 71—Horn button cable |
| | 43—Housing and bushing assembly | 72—Horn button cable connector plug |
| | 44—Housing or shaft bushings | 73—Horn button cable terminal |
| | 45—Shaft oil seal | |
| | 46—Arm nut lockwasher | |
| | 47—Arm nut | |
| | 48—Column jacket oil seal | |
| | 49—Column jacket oil seal washer | |

8. REMOVAL OF STEERING GEAR.**1939 (P8 Model)—Cont'd**

(7) Loosen the clamping bolt (3, fig. 13 on page 202) and remove the gear selector cable adjusting screw from the bracket on the steering column (above the gear housing).

(8) Remove the gearshifter control rod at the lever on the steering gear and at

the transmission. Use care not to lose the spring washers at the clevis pins.

(9) Disconnect the upper and lower sections of the steering column jacket and pull the upper section off the steering tube.

(10) Disconnect the steering gear housing from the frame and lift the assembly out of the engine compartment.

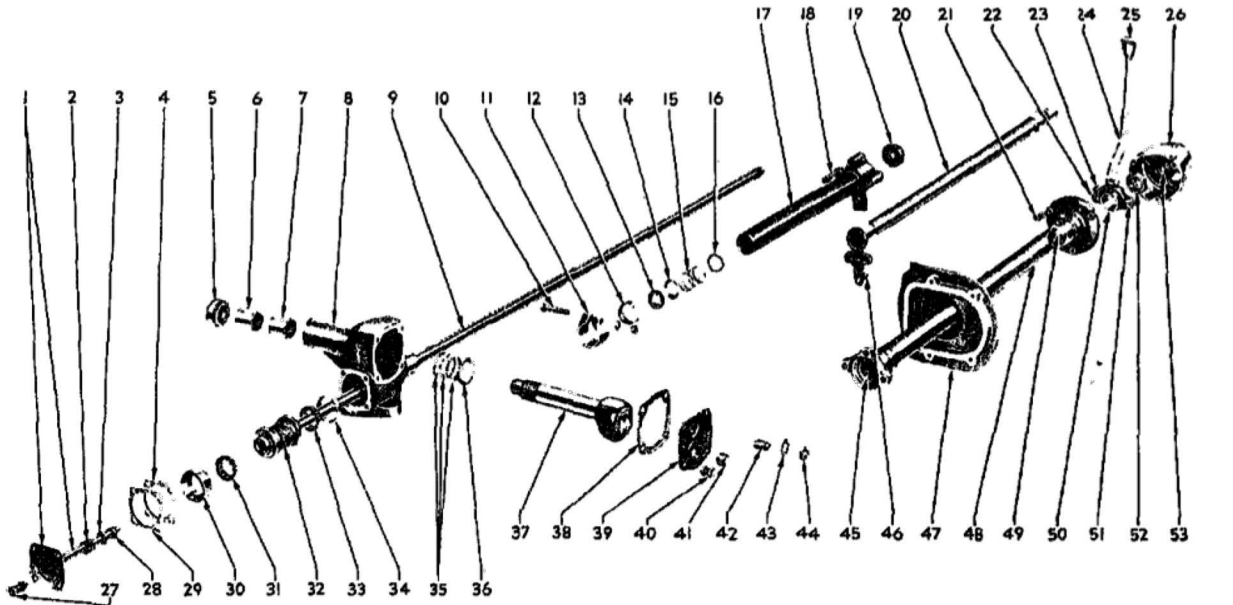


Figure 12—Steering Gear (Disassembled View) (1939 Model P8)

- | | | |
|---|--|---|
| 1—Cover and grease tube | 22—Remote control gearshift lever detent spring ball | 38—Shaft cover gasket |
| 2—Steering tube oil seal spring | 23—Remote control gearshift lever detent spring | 39—Shaft cover |
| 3—Steering tube oil seal washer | 24—Remote control gearshift lever | 40—Shaft cover screw and lockwasher |
| 4—Cover and grease tube shim | 25—Remote control gearshift lever knob | 41—Housing lubricant filler plug |
| 5—Shaft oil seal | 26—Remote control gearshift lever housing—upper | 42—Shaft adjusting screw |
| 6—Housing bushing—outer | 27—Cover and grease tube screw and lockwasher | 43—Shaft adjusting screw nut lockwasher |
| 7—Housing bushing—inner | 28—Steering tube oil seal | 44—Shaft adjusting screw nut |
| 8—Housing | 29—Cover and grease tube shim | 45—Upper column jacket bushing—lower |
| 9—Steering tube | 30—Worm thrust bearing cup—lower | 46—Remote control gearshift tube lower lever pin |
| 10—Column jacket clamp bolt, nut and lockwasher | 31—Worm thrust bearing cage and rollers—lower | 47—Steering gear toe board opening draft pad |
| 11—Column jacket clamp | 32—Steering tube and worm | 48—Column jacket—upper |
| 12—Column jacket oil hole cover | 33—Worm thrust bearing cage and rollers—upper | 49—Upper column jacket bushing—upper |
| 13—Column jacket oil seal | 34—Worm thrust bearing cup—upper | 50—Remote control gearshift tube collar |
| 14—Column jacket oil seal washer | 35—Shaft thrust shims | 51—Remote control gearshift tube collar pin |
| 15—Column jacket oil seal spring | 36—Shaft thrust washer | 52—Remote control gearshift tube end nut |
| 16—Column jacket oil seal spring washer | 37—Shaft and roller tooth | 53—Remote control gearshift lever housing bushing |

1936-38 and 1939, P7 Model.

- (1) Remove the steering wheel.
- (2) Disconnect the draft pad from the dash and move it upward on the steering column about 6 inches (model P7 only).
- (3) Disconnect the steering column from the instrument panel.

- (4) Remove the hood lower left side panel (model P7 only).
- (5) Using a puller, remove the steering arm from the steering shaft.
- (6) Disconnect the steering gear housing from the frame and lift assembly out of engine compartment.

9. INSTALLATION OF STEERING GEAR.

1936-42—With steering gear in position on frame, install the mounting bolts but do not draw them up tight. Line up the column jacket at the instrument panel, tighten clamp securely and tighten the mounting bolts. Be sure the front wheels are in the straight ahead position (fig. 1 on page 33) and that the steering wheel is in mid-position before installing the steering gear arm on the steering shaft.

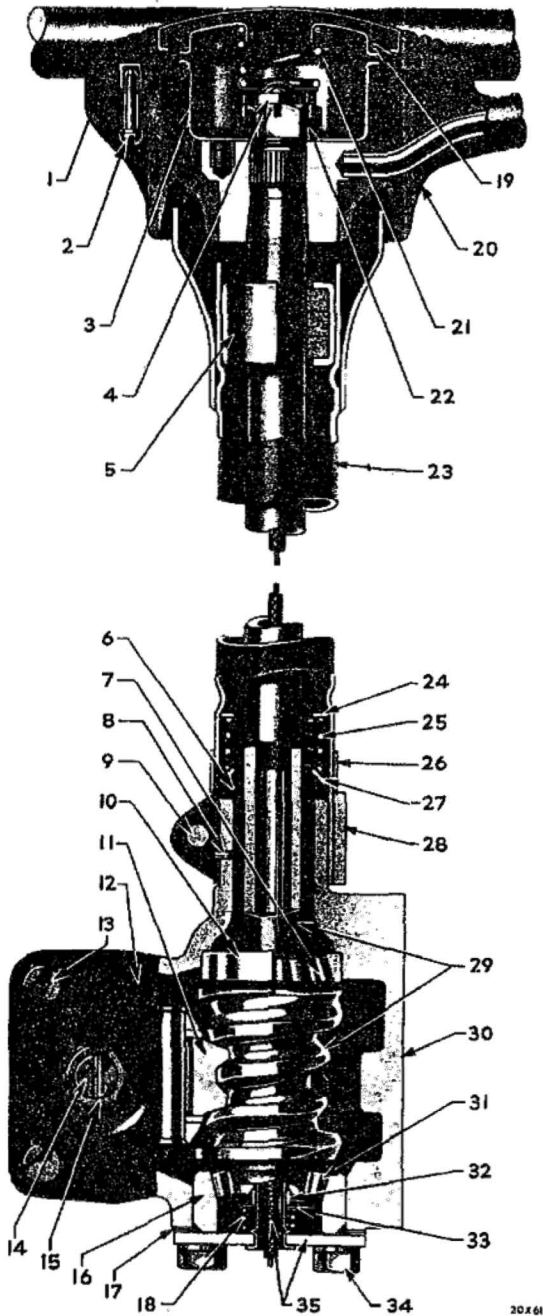


Figure 13—Steering Gear (Assembled View) (1939 Model P7)

Legend for Figure 13—Steering Gear (Assembled View) (1939 Model P7)

- | | |
|--|---|
| 1—Horn button retainer | 18—Steering tube oil seal spring |
| 2—Horn button retainer screw and lockwasher | 19—Horn button |
| 3—Horn button contact cup | 20—Steering wheel |
| 4—Steering wheel nut insulator | 21—Horn button spring |
| 5—Column jacket bushing | 22—Steering wheel nut |
| 6—Column jacket oil seal | 23—Column jacket |
| 7—Worm thrust bearing cage and rollers—upper | 24—Column jacket oil seal spring washer |
| 8—Housing pin | 25—Column jacket oil seal spring |
| 9—Column jacket clamp bolt, nut and lockwasher | 26—Column jacket oil hole cover |
| 10—Worm thrust bearing cup—upper | 27—Column jacket oil seal washer |
| 11—Shaft and roller tooth | 28—Column jacket clamp |
| 12—Shaft cover | 29—Steering tube and worm |
| 13—Shaft cover screw and lockwasher | 30—Housing |
| 14—Shaft and roller tooth adjusting screw | 31—Worm thrust bearing cage and rollers—lower |
| 15—Shaft and roller tooth adjusting screw nut | 32—Steering tube oil seal |
| 16—Worm thrust bearing cup—lower | 33—Steering tube oil seal washer |
| 17—Worm thrust bearing shims (cover and grease tube shims) | 34—Cover and grease tube screw and lockwasher |
| | 35—Cover and grease tube |

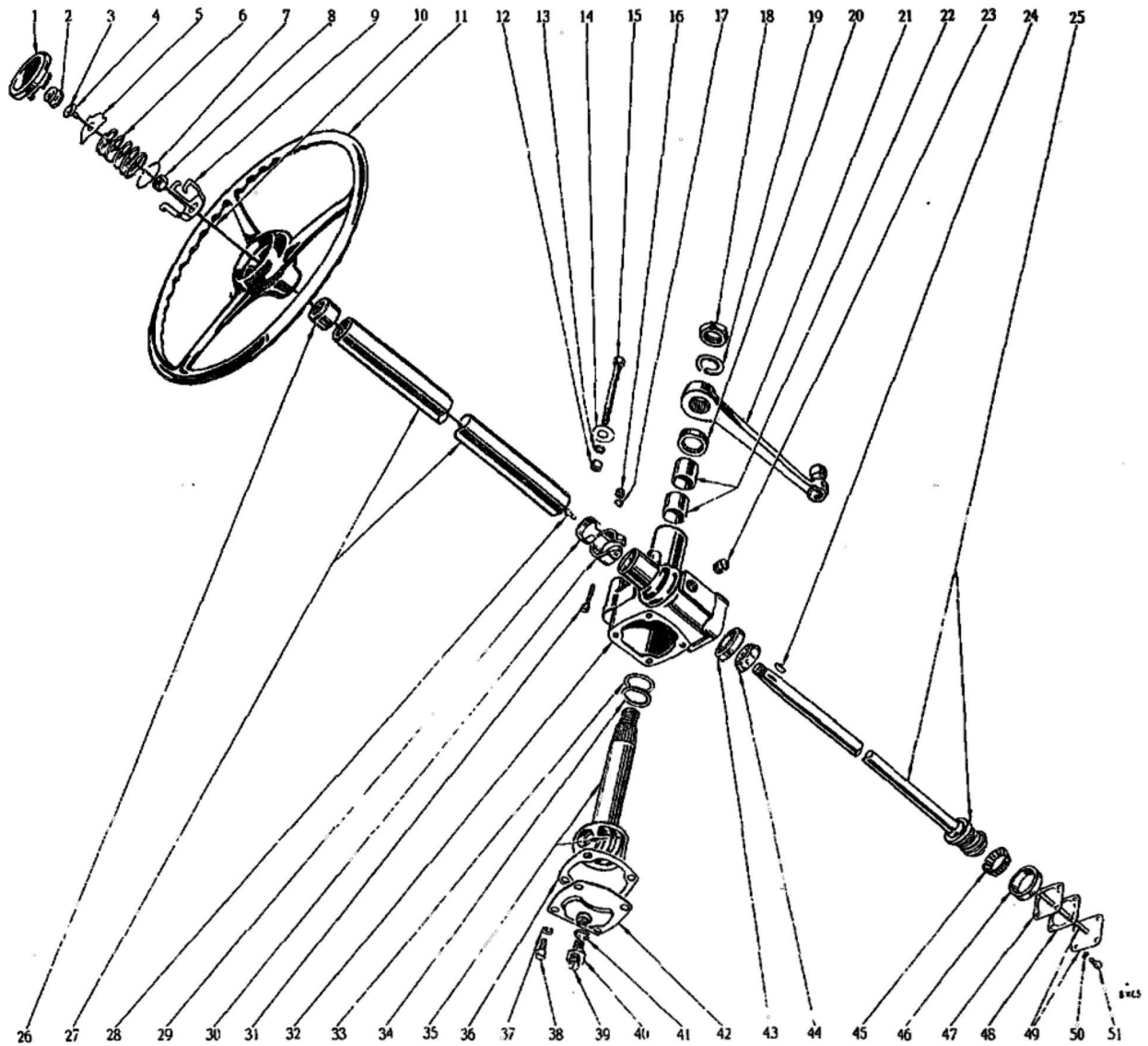


Figure 14—Steering Gear (Disassembled View) (1938 Model, Typical of 1936-37 Models)

10. ALIGNMENT OF STEERING GEAR IN FRAME.

1936-42—A slight bind of the steering gear is sometimes caused by shifting of the body, due to loosened bolts. If this condition occurs, the body bolts should first be tightened, then the steering gear should be loosened at the frame and dash bracket and allowed to seek its natural position. Then tighten the steering gear to frame and next tighten the dash bracket.

11. ALIGNMENT OF STEERING AND FRONT WHEELS.

1941-42—The relationship between the steering wheel, the steering tube, the steering gear sector shaft and the steering arm is controlled by master serrations on the component parts and with the steering wheel in the proper straight-ahead driving position (with the lower spoke pointing straight down) the steering gear arm, unless bent, is also in proper position. To properly align

Legend for Figure 14—Steering Gear (Disassembled View)
(1938 Model, Typical of 1936-37 Models)

1—Horn button	17—Column jacket clamp bolt nut lockwasher	38—Housing cover screw
2—Horn button spring	18—Steering arm nut	39—Shaft adjusting screw
3—Horn button cable contact	19—Steering arm nut lockwasher	40—Shaft adjusting screw lock nut
4—Steering wheel nut insulator	20—Shaft oil seal	41—Shaft adjusting screw lock nut lockwasher
5—Horn button retainer upper plate	21—Steering arm (pitman arm)	42—Housing cover
6—Horn button retainer plate spring	22—Shaft bushings	43—Worm thrust bearing cup— upper
7—Horn button retainer plate spring lock wire	23—Lubricant filler plug	44—Worm thrust bearing cage and rollers
8—Steering wheel nut	24—Steering wheel key	45—Worm thrust bearing cage and rollers
9—Horn button retainer lower plate	25—Worm and steering tube assembly	46—Worm thrust bearing cup— lower
10—Horn button cable	26—Column jacket bushing	47—Worm thrust bearing adjusting shim—thin
11—Steering wheel	27—Column jacket	48—Worm thrust bearing adjusting shim—thick
12—Housing to frame bolt nut	28—Horn button cable connector plug	49—Grease retainer tube and plate assembly
13—Housing to frame bolt nut lockwasher	29—Column jacket oil hole cover	50—Grease retainer tube plate screw lockwasher
14—Housing to frame bolt nut plain washer	30—Column jacket clamp	51—Grease retainer tube plate screw
15—Housing to frame bolt	31—Column jacket clamp bolt	
16—Column jacket clamp bolt nut	32—Housing	
	33—Shaft thrust washer shim	
	34—Shaft thrust washer	
	35—Shaft and roller tooth assembly	
	36—Housing cover gasket	
	37—Housing cover screw lockwasher	

the steering from wheel to road wheels proceed as follows:

(1) Set the road wheels in the straight-ahead driving position (fig. 1 on page 33).

(2) The steering wheel can only be installed in one position.

(3) Rotate the steering wheel so that the wheel is in mid-position (midway between extreme right and extreme left turns) and the lower spoke points straight down.

(4) Install the steering gear on the steering gear cross shaft, using the nearest master serration.

(5) If the road wheels and steering wheel do not line up perfectly in driving position, it will be necessary to adjust the tie rods to correct. Refer to paragraph 7, on page 37.

12. DISASSEMBLY OF STEERING GEAR.

1936-42

(1) Remove the shaft adjusting screw lock nut and cover.

(2) Cover the serrations on the shaft and roller tooth assembly with paper, to prevent damage to the oil seal (unless the seal is to be discarded).

(3) Remove the shaft oil seal (if necessary to replace).

(4) Remove the housing cover and grease retaining tube assembly.

(5) Pull the tube and worm assembly out of the bottom end of housing.

(6) Remove the shaft bushings (if necessary to replace).

13. ASSEMBLY OF STEERING GEAR.

1936-42—Press new bushings into place and burnish to size. Coat parts with oil while assembling. Be sure not to damage the shaft oil seal when installing the shaft and roller tooth assembly. Adjust the worm bearings and the roller tooth and worm, as outlined in paragraphs 2 and 3 and lubricate the assembly.

TRANSMISSION DATA AND SPECIFICATIONS						
Year	1941-42	1940	1939	1937-38	1936	
Gearshift, type	Remote control	Remote control	P8—Remote control P7—Standard—lever	Standard—lever	Standard—lever	
Gears, type	Helical	Helical	Helical	Helical	Helical	
Clutch housing face run-out, inches	.003	.003	.003	.003	.003	
Clutch housing bore run-out, inches	.005	.005	.005	.005	.005	
Countershaft end play, inches	.002 to .008	.002 to .008	.002 to .008	.002 to .008	.002 to .008	
Second speed gear end play, inches	.003 to .008	.003 to .008	.003 to .008	.003 to .008	.003 to .008	
Transmission companion flange nuts, tightening torque, pounds	95 to 105	95 to 105	95 to 105	95 to 105	95 to 105	
Transmission to clutch housing studs, tightening torque, pounds	45 to 50	45 to 50	45 to 50	45 to 50	45 to 50	
Ratios	Third	1.00 to 1	1.00 to 1	1.00 to 1	1.00 to 1	
	Second	1.83 to 1	1.55 to 1	1.55 to 1	1.55 to 1	
	First	2.57 to 1	2.57 to 1	2.57 to 1	2.57 to 1	
	Reverse	3.48 to 1	3.48 to 1	3.48 to 1	3.48 to 1	
Bearing Type	Drive pinion	Ball	Ball	Ball	Ball	
	Mainshaft pilot	Roller	Roller	Roller	Roller	
	Mainshaft rear	Ball	Ball	Ball	Ball	
	Countershaft	Roller	Roller	Roller	Roller	
	Idler shaft	Roller	Roller	Roller	Roller	Bronze bushing
	Transmission extension	Ball	Ball	None	None	None
Lubricant capacity, pints	2¾	2¾	2¼	2¼	2¼	

Section XXI

TRANSMISSION

L. DESCRIPTION.

1936-42—The transmission is of the silent shifting type with three forward speeds and one reverse speed. The rear end of the main drive pinion (clutch shaft) is mounted on a ball bearing. The transmission mainshaft is mounted in a pilot bearing at the front end and a ball bearing at the rear end. The countershaft gear set runs on straight roller bearings over the countershaft. The countershaft is locked rigidly in the transmission case so it cannot rotate.

2. REPLACEMENT OF TRANSMISSION.

1940-42

(1) Remove the propeller shaft. If the transmission is to be disassembled, loosen mainshaft flange nut. Disconnect speedometer cable. Disconnect hand brake cable at brake band. Disconnect battery ground cable from transmission on 1940 model. Disconnect gearshift control rod and gearshift selector rod at transmission. Remove cap screws or nuts which hold transmission to clutch housing. Handle transmission carefully to avoid springing clutch disc as unit is withdrawn from clutch housing.

(2) Before installing transmission, check clutch housing for run-out of both bore and face. (See paragraph 7.) Face run-out not to exceed .003 inch; bore run-out should not exceed .005 inch. Use clutch plate aligning arbor C-360 or transmission drive pinion to align clutch plate before installing transmission. When installing unit, handle transmission carefully to avoid springing clutch disc. Check clutch pedal adjustment after the transmission is installed.

1939

(1) Remove floor boards and disconnect battery ground cable from transmission. Disconnect speedometer cable from transmission. Remove propeller shaft. If

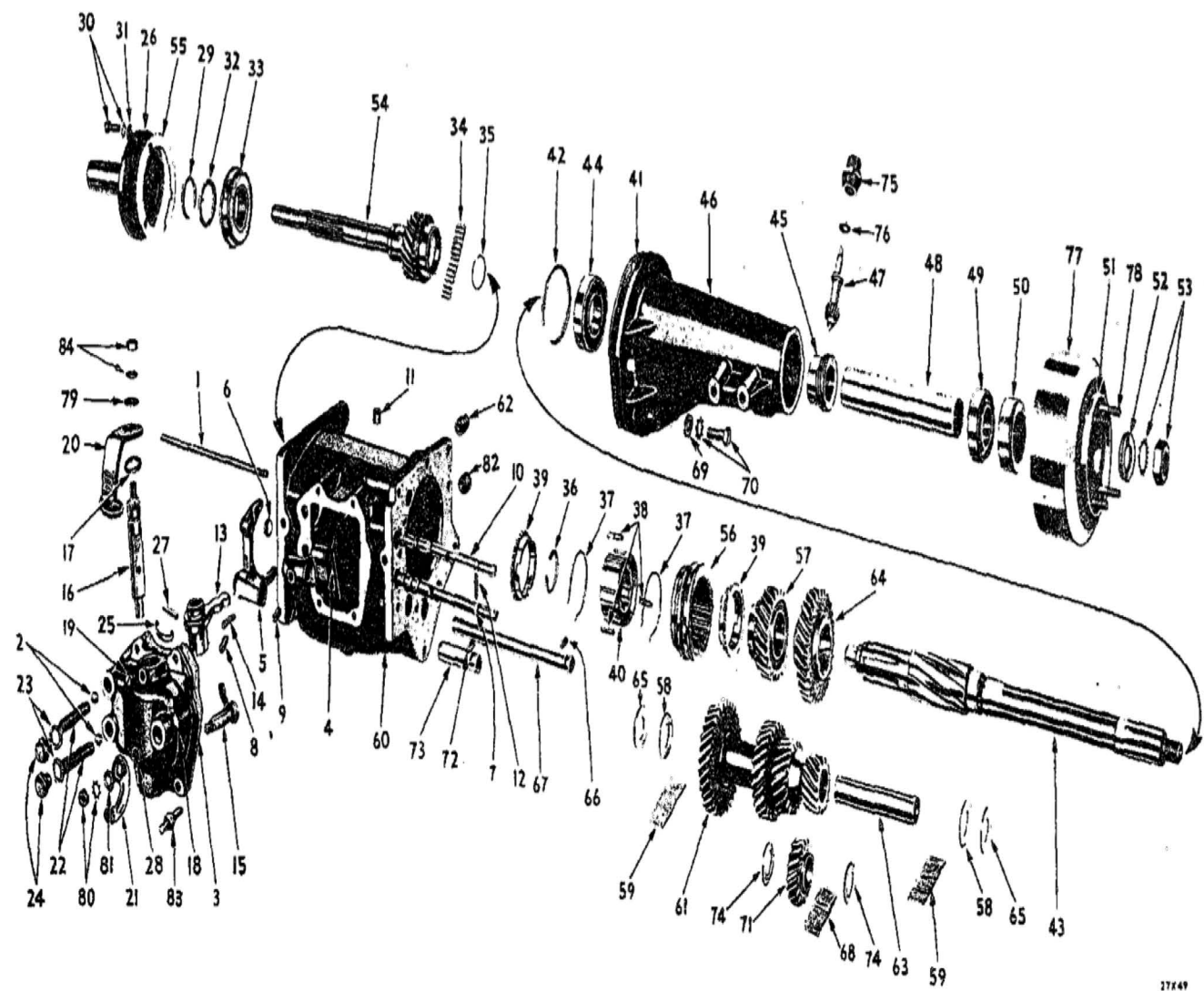
transmission is to be disassembled, loosen mainshaft flange nut. Disconnect hand brake cable at lower end. Disconnect gearshifter rod and cable at transmission case (model P8 only). Remove gearshift lever and cover assembly (model P7 only). Remove cover only on P8 model. Remove cap screws or nuts which attach transmission to clutch housing. Handle transmission carefully to avoid springing clutch disc as unit is withdrawn from clutch housing.

(2) Before installing transmission, check clutch housing for run-out of both bore and face. Bore run-out should not exceed .005 inch; face run-out should not exceed .003 inch. (See paragraph 7.) Handle transmission carefully to avoid springing clutch disc. Check clutch pedal adjustment after transmission is installed.

1936-38

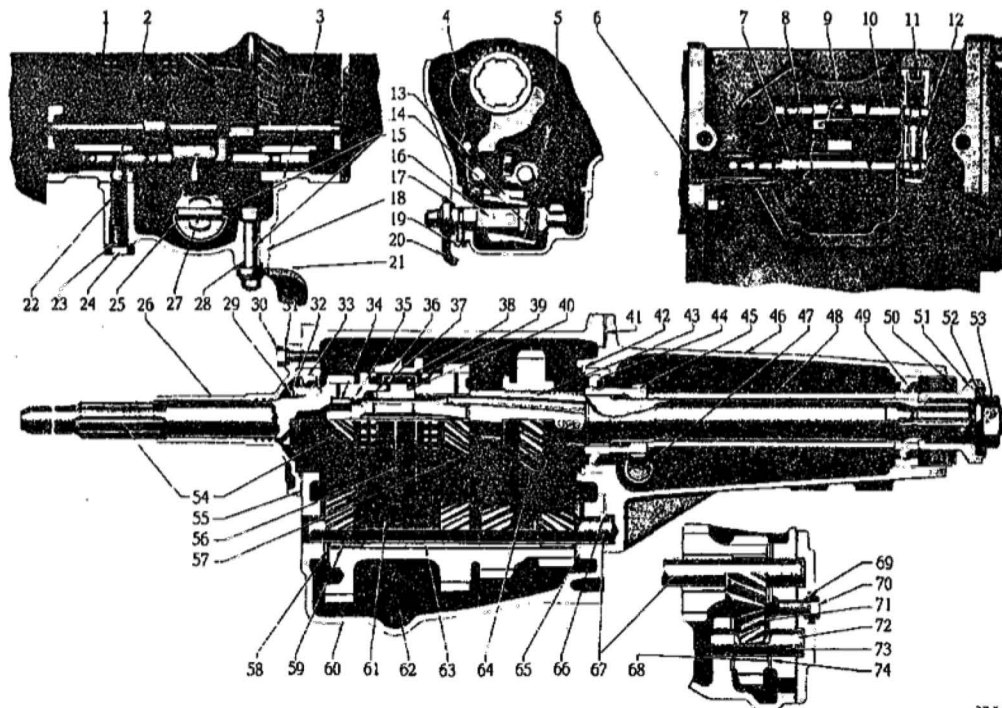
(1) Remove floor boards and disconnect battery ground cable at transmission. Remove propeller shaft and disconnect speedometer cable from transmission. If transmission is to be disassembled, loosen mainshaft flange nut. Disconnect hand brake cable at hand brake. Remove nuts from studs which attach transmission to clutch housing. Disconnect clutch release fork pull-back spring from release fork and remove clevis pin from clutch release fork rod. Remove gearshift lever and cover assembly. Handle transmission carefully to avoid springing clutch disc as unit is withdrawn from clutch housing.

(2) Before installing transmission, check clutch housing for run-out of both bore and face. Face run-out should not exceed .003 inch; bore run-out should not exceed .005 inch. When installing, handle transmission carefully to avoid springing clutch disc. Check clutch pedal adjustment after the transmission is installed.



27x49

Figure 1—Transmission (Disassembled View) (1942 Model, Typical of 1940-41 Models)



27 A 10

Figure 2—Transmission (Assembled View) (1942 Model, Typical of 1940-41 Models)

- | | | |
|--|---|---|
| 1—Gearshift fork guide rail | 30—Drive pinion bearing retainer screw and lockwasher | 59—Countershaft bearing rollers |
| 2—Gearshift selector ball | 31—Drive pinion bearing retainer screw grommet | 60—Case |
| 3—Gearshift housing gasket | 32—Drive pinion bearing washer | 61—Countershaft gears |
| 4—Gearshift fork—first and reverse | 33—Drive pinion bearing | 62—Drain plug |
| 5—Gearshift fork—second and direct | 34—Main shaft pilot bearing rollers | 63—Countershaft bearing spacer |
| 6—Gearshift rail plug | 35—Main shaft pilot bearing snap ring | 64—Sliding gear—first and reverse |
| 7—Gearshift rail—second and direct | 36—Clutch gear snap ring | 65—Countershaft thrust washer |
| 8—Gearshift fork lock screw | 37—Synchronizer spring | 66—Countershaft key |
| 9—Gearshift fork lock screw | 38—Synchronizer shifting plate | 67—Countershaft |
| 10—Gearshift rail—first and reverse | 39—Synchronizer stop ring | 68—Reverse idler gear bearing rollers |
| 11—Gearshift rail interlock plug | 40—Clutch gear | 69—Extension screw grommet |
| 12—Gearshift rail interlock | 41—Extension gasket | 70—Extension screw and lockwasher |
| 13—Gearshift lever | 42—Main shaft rear bearing snap ring | 71—Reverse idler gear |
| 14—Gearshift lever return spring | 43—Main shaft | 72—Reverse idler shaft key |
| 15—Gearshift selector cam and shaft | 44—Main shaft rear bearing | 73—Reverse idler shaft |
| 16—Gearshift lever shaft | 45—Speedometer drive gear | 74—Reverse idler gear washer |
| 17—Gearshift housing seal | 46—Extension | 75—Speedometer drive pinion sleeve |
| 18—Gearshift housing | 47—Speedometer drive pinion | 76—Speedometer drive pinion oil seal |
| 19—Gearshift lever shaft screw and lockwasher | 48—Main shaft bearing spacer | 77—Transmission or hand brake drum |
| 20—Gearshift operating lever | 49—Extension bearing | 78—Universal joint attaching bolt |
| 21—Gearshift selector lever | 50—Main shaft rear bearing oil seal | 79—Gearshift operating lever nut plain washer |
| 22—Gearshift selector ball spring | 51—Main shaft flange | 80—Gearshift selector lever nut and lockwasher |
| 23—Gearshift selector ball spring screw washer | 52—Main shaft flange washer | 81—Gearshift selector lever nut plain washer |
| 24—Gearshift selector ball spring screw | 53—Main shaft flange nut and lockwasher | 82—Transmission case filler plug |
| 25—Gearshift lever pin lock spring | 54—Drive pinion | 83—Gearshift housing screw and lockwasher |
| 26—Drive pinion bearing retainer | 55—Drive pinion bearing retainer gasket | 84—Gearshift operating lever nut and lockwasher |
| 27—Gearshift lever pin | 56—Clutch gear sleeve | |
| 28—Camshaft selector cam shaft seal | 57—Second speed gear | |
| 29—Drive pinion bearing snap ring | 58—Countershaft thrust washer plate | |

3. DISASSEMBLY OF TRANSMISSION.

1940-42—Refer to figures 1 and 2.

- (1) Remove speedometer drive pinion.
- (2) Remove screws (24), remove cover and gear selector assembly, roll transmission over and remove balls (2).
- (3) Using puller C-452, remove mainshaft flange and brake drum assembly.
- (4) Remove shifter fork guide rail (1).
- (5) With transmission gears in neutral position, remove lock screws (8 and 9) in shift forks.
- (6) Remove plug (6) for lower shifter rail.
- (7) Remove upper and lower shifter rails by sliding them out through the front of the case.
- (8) Lift out shifter forks (4) and (5).
- (9) Remove extension (46) and mainshaft assembly.

CAUTION

Handle extension carefully to prevent disassembling synchronizer clutch assembly.

- (10) Remove synchronizer retaining snap ring (36) synchronizer unit, second speed gear (57) and low speed gear (64).
- (11) Remove rear bearing snap ring (42) and pull mainshaft out of extension.
- (12) Remove mainshaft bearing, spacer and speedometer drive gear.
- (13) Remove mainshaft bearing and oil seal from extension with puller C-497 (fig. 3).
- (14) Using arbor C-578, drive countershaft (67) toward rear and out of transmission case. Pick key (66) out of shaft as soon as shaft has moved far enough to uncover key. Leave arbor in countershaft gear set to keep bearing rollers in place.

(15) Remove main drive pinion and bearing assembly.

(16) Remove snap ring (35) from rear end of drive pinion shaft and pick out bearing rollers. Remove drive pinion bearing snap ring (29) and bearing.

(17) Lift countershaft gear set out of case.

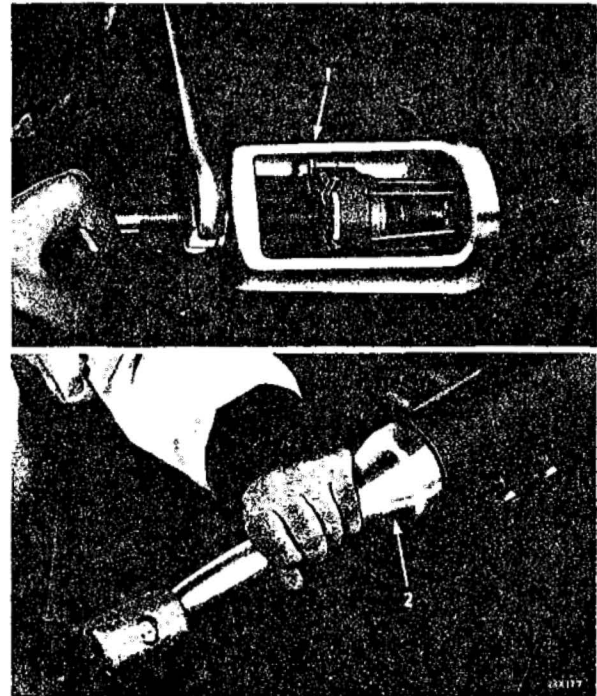
(18) Using arbor C-464, drive reverse idler gear shaft (73) toward rear of case. Pick key (72) out of keyway in shaft, as soon as it can be reached, finish driving out shaft and lift out reverse idler gear and bearing assembly.

4. ASSEMBLY OF TRANSMISSION.

1940-42

(1) When assembling, use new gaskets, oil seals and snap rings and be sure snap rings are fitted carefully into their grooves.

(2) Place countershaft gear thrust washer plates (steel) next to bearing rollers and thrust washers (bronze) next to transmission case, selecting proper washers to give countershaft gear end play of .002 to .008 inch.



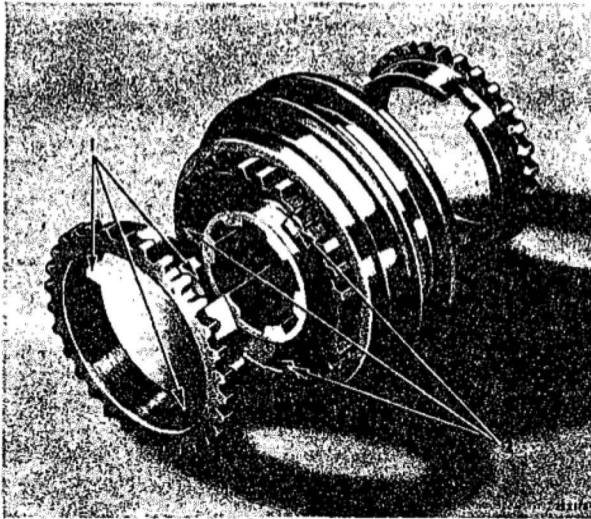
1—Puller C-497

2—Installing drift C-579

Figure 3—Removing or Installing Mainshaft Rear Bearing Oil Seal (1940-42 Models)

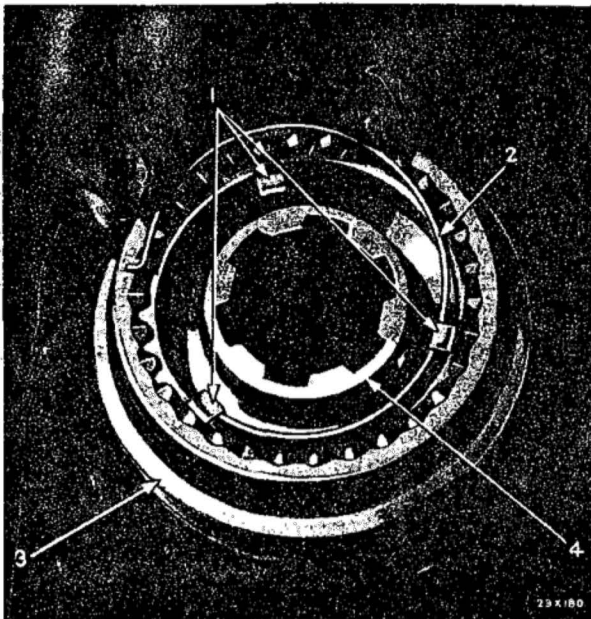
(3) Use drift C-579 to install oil seal properly in rear end of extension (fig. 3). If drift is not available be sure oil seal protrudes 7/32 inch out of extension.

(4) Refer to figures 4 and 5 for assembly of synchronizer unit. Place one bent up end of synchronizer spring into pocket of



1—Slots in synchronizer stop rings 2—Synchronizer shifting plates

Figure 4—Clutch Gear Synchronizer Shifting Plates and Stop Rings (1940-42 Models)



1—Synchronizer shifting plates 3—Clutch gear sleeve
2—Synchronizer spreader spring 4—Clutch gear

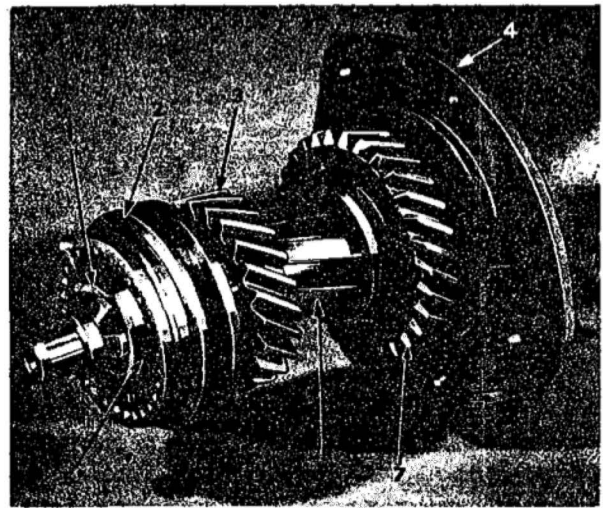
Figure 5—Installing Synchronizer Shifting Plates (1940-42 Models)

shifting plate. Then install bent up end of other spring into pocket of same plate on opposite side of synchronizer. Spring on one side should leave plate in opposite direction from spring on other side.

(5) Assemble synchronizing unit on mainshaft as shown in figure 6.

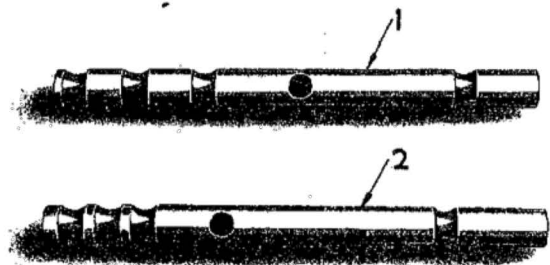
(6) If second speed gear end play is not between .003 and .008 inch use a snap ring of different thickness.

(7) Install first and reverse shifter rail (1, fig. 7) on top, other rail on bottom.



1—Clutch gear snap ring 5—Clutch gear
2—Clutch gear sleeve 6—Mainshaft
3—Second speed gear 7—Sliding gear—first and reverse
4—Extension

Figure 6—Transmission Mainshaft and Extension Assembly (1940-42 Models)



1—Manual remote gearshift rail—first and reverse 2—Manual remote gearshift rail—second and direct

Figure 7—Manual Remote Gearshift Rails (1940-42 Models)

23X182

**Legend for Figure 9—Transmission (Disassembled View)
(1939 Model, P7, Typical of 1936-38 Models)**

- | | | |
|---|---|--|
| 1—Gearshift lever friction plate spring | 28—Speedometer drive pinion sleeve | 56—Case to clutch housing gasket |
| 2—Gearshift lever locating pin | 29—Speedometer drive pinion oil seal | 57—Case |
| 3—Gearshift lever knob | 30—Mainshaft | 58—Filler plug |
| 4—Gearshift lever | 31—Speedometer drive pinion | 59—Drain plug |
| 5—Gearshift lever friction plate | 32—Mainshaft rear bearing snap ring | 60—Clutch gear |
| 6—Gearshift lever friction plate support | 33—Mainshaft rear bearing | 61—Clutch gear sleeve |
| 7—Gearshift housing | 34—Transmission brake support gasket | 62—Countershaft gear thrust washer |
| 8—Gearshift lever thrust spring housing pin | 35—Speedometer drive gear spacer | 63—Countershaft gear thrust washer plate |
| 9—Gearshift lever thrust spring cup | 36—Speedometer drive gear | 64—Countershaft gear |
| 10—Gearshift lever thrust spring | 37—Mainshaft rear bearing oil seal | 65—Reverse idler gear washer |
| 11—Gearshift lever thrust spring ball | 38—Mainshaft flange nut cotter pin | 66—Reverse idler gear bearing roller |
| 12—Gearshift housing screw | 39—Mainshaft flange | 67—Reverse idler gear |
| 13—Gearshift housing screw lock-washer | 40—Mainshaft flange nut washer | 68—Reverse idler gear washer |
| 14—Gearshift rail interlock ball | 41—Mainshaft flange nut | 69—Reverse idler gear shaft |
| 15—Gearshift housing gasket | 42—Drive pinion bearing retainer screw | 70—Countershaft gear thrust washer plate |
| 16—Gearshift rail selector balls | 43—Drive pinion bearing retainer screw lockwasher | 71—Countershaft gear thrust washer |
| 17—Gearshift rail and fork—low and reverse | 44—Drive pinion bearing retainer | 72—Countershaft bearing rollers |
| 18—Gearshift rail and fork—second and direct | 45—Drive pinion bearing retainer screw grommet | 73—Countershaft |
| 19—Gearshift rail retainer screw | 46—Drive pinion bearing retainer gasket | 74—Countershaft and reverse idler gear shaft lock plate |
| 20—Gearshift rail retainer screw lockwasher | 47—Drive pinion bearing snap ring | 75—Countershaft and reverse idler gear shaft lock plate screw lockwasher |
| 21—Gearshift rail retainer | 48—Drive pinion bearing washer | 76—Countershaft and reverse idler gear shaft lock plate screw |
| 22—Clutch gear spring ball | 49—Drive pinion bearing | 77—Countershaft bearing spacer |
| 23—Clutch gear spring | 50—Gearshift rail retainer oil seal | 78—Countershaft bearing rollers |
| 24—Mainshaft second speed gear thrust washer lock | 51—Drive pinion | 79—Transmission brake support |
| 25—Mainshaft second speed gear thrust washer | 52—Gearshift rail retainer | 80—Transmission brake support screw lockwasher |
| 26—Mainshaft second speed gear | 53—Mainshaft pilot bearing rollers | 81—Transmission brake support screw |
| 27—Sliding gear—first and reverse | 54—Mainshaft pilot bearing snap ring | |
| | 55—Gearshift rail selector ball springs | |

4. ASSEMBLY OF TRANSMISSION.

1940-42—Cont'd

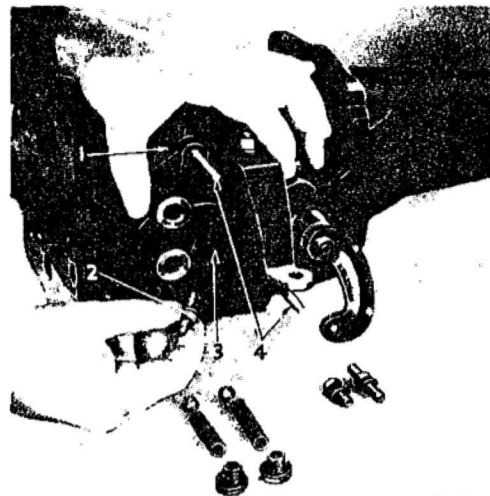
(8) Install gearshift housing as shown in figure 8.

5. DISASSEMBLY OF TRANSMISSION.

1936-39—Refer to figures 9 and 10 for 1936-39 models except model P8 transmission which is illustrated in figures 11 and 12.

(1) Remove gearshifter fork and rail assemblies. *Be careful not to lose the interlock ball.*

(Continued on page 203)



- | | |
|----------------------------|------------------------------|
| 1—Gearshift housing gasket | 3—Gearshift housing assembly |
| 2—Gearshift housing screw | 4—Pilot studs C-590 |

**Figure 8—Installing Gearshift Housing Assembly
(1940-42 Models)**

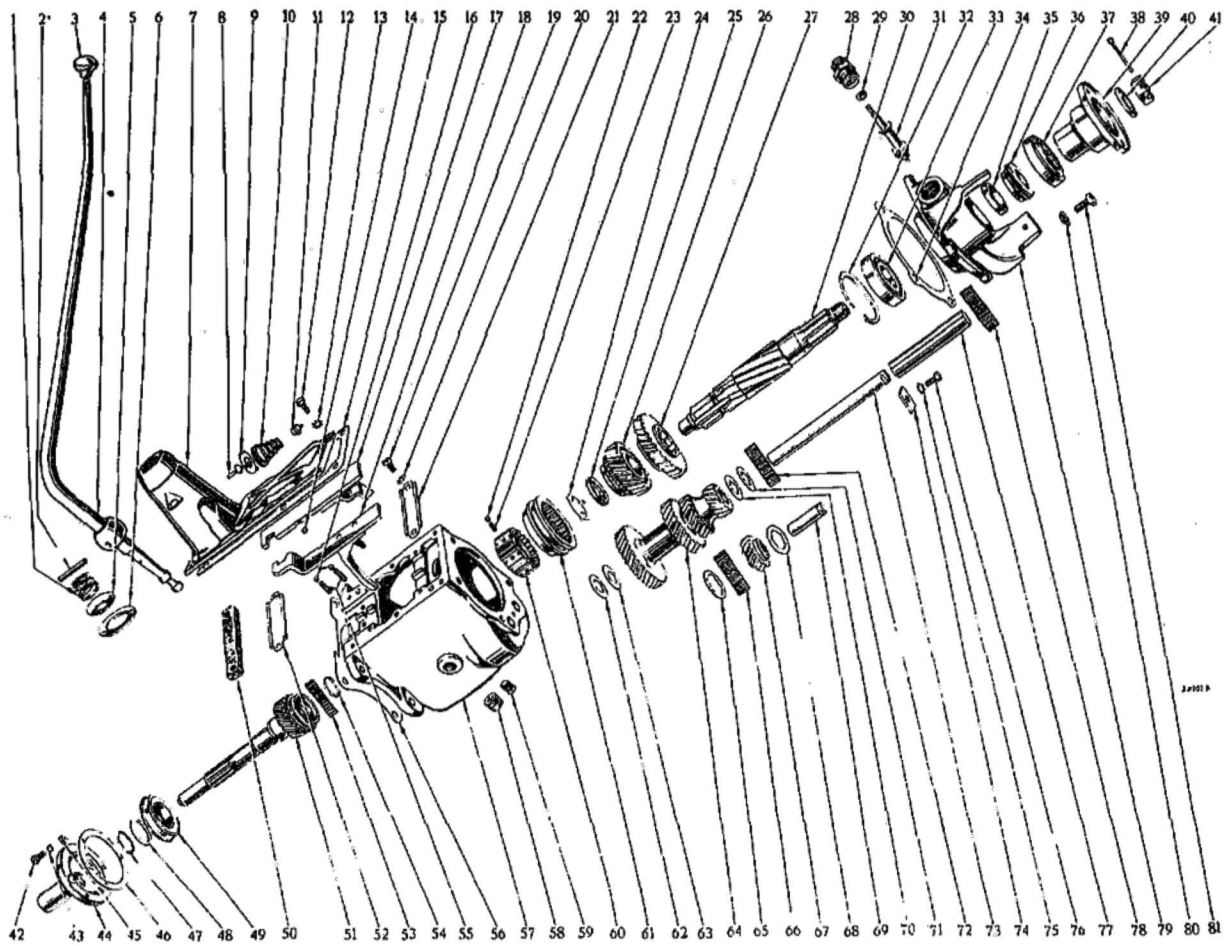


Figure 9—Transmission (Disassembled View) (1939 Model P7, Typical of 1936-38 Models)

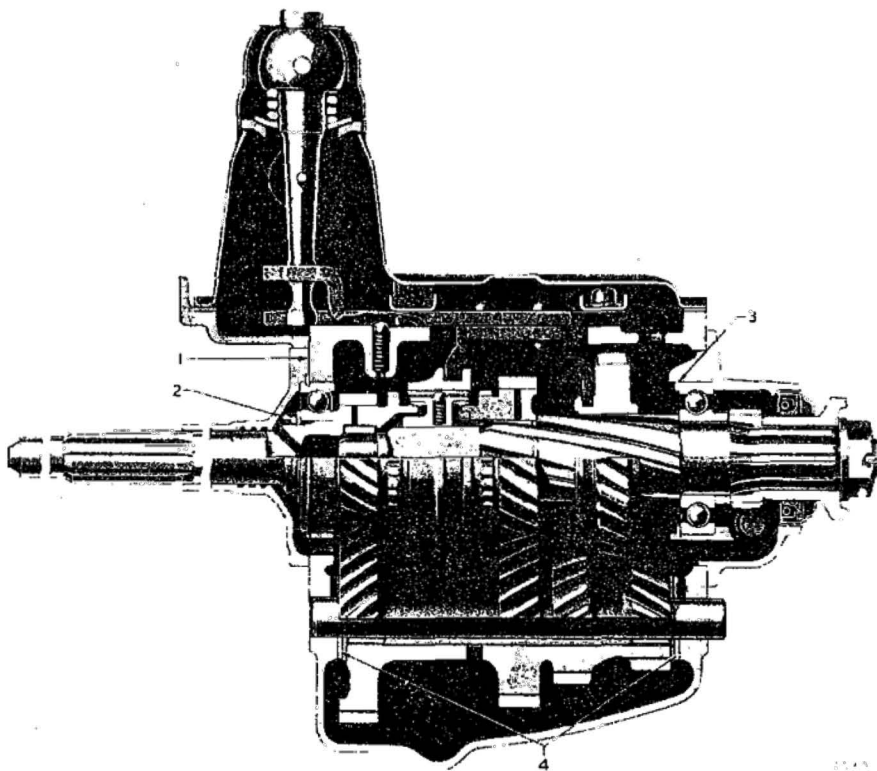


Figure 10—Transmission (Assembled View) (1939 Model P7, Typical of 1936-38 Models)

- 1—Main drive pinion bearing retainer gasket
- 2—Main drive pinion bearing snap ring
- 3—Mainshaft rear bearing snap ring
- 4—Countershaft gear thrust washer

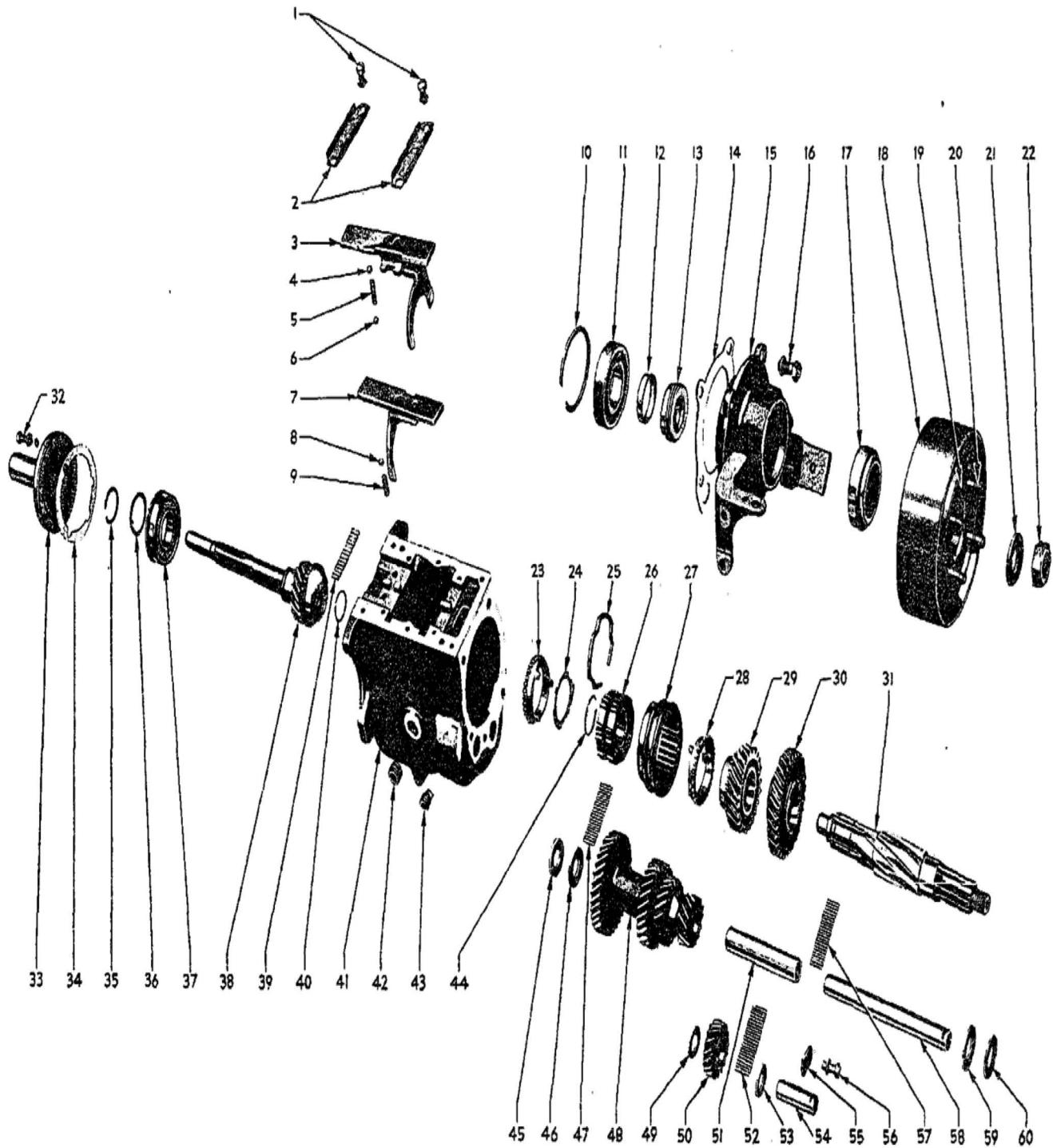
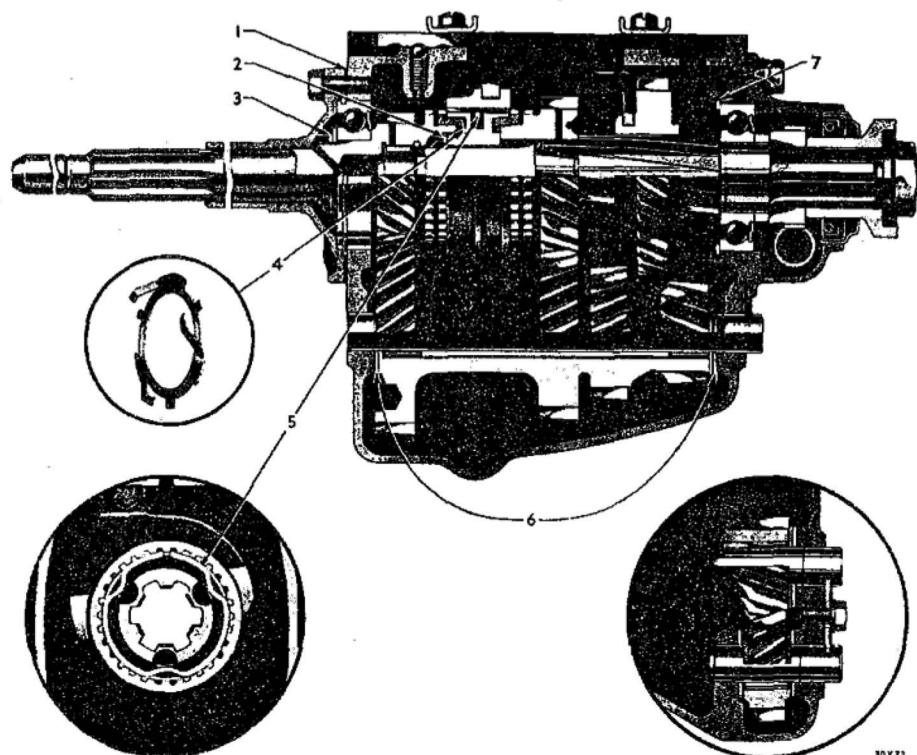


Figure 11—Transmission (Disassembled View) (1939 Model P8)

Legend for Figure 11—Transmission (Disassembled View) (1939 Model P8)

- | | | |
|--|---|---|
| 1—Gearshift rail retainer screw and lockwasher | 22—Mainshaft flange nut | 41—Case |
| 2—Gearshift rail retainer | 23—Synchronizer stop ring | 42—Filler plug |
| 3—Gearshift rail and fork—low and reverse | 24—Synchronizer stop ring spreader spring | 43—Drain plug |
| 4—Gearshift rail selector ball | 25—Clutch gear friction ring | 44—Clutch gear snap ring |
| 5—Gearshift rail selector ball spring | 26—Clutch gear | 45—Countershaft gear thrust washer |
| 6—Gearshift rail interlock ball | 27—Clutch gear sleeve | 46—Countershaft gear thrust washer plate |
| 7—Gearshift rail and fork—direct and second | 28—Synchronizer stop ring | 47—Countershaft bearing |
| 8—Gearshift rail selector ball | 29—Second speed gear | 48—Countershaft gear |
| 9—Gearshift rail selector ball spring | 30—Sliding gear—low and reverse | 49—Reverse idler gear washer |
| 10—Mainshaft rear bearing snap ring | 31—Mainshaft | 50—Reverse idler gear |
| 11—Mainshaft rear bearing | 32—Main drive pinion bearing retainer screw, lockwasher and grommet | 51—Countershaft bearing spacer |
| 12—Speedometer drive gear spacer | 33—Main drive pinion bearing retainer | 52—Reverse idler gear bearing rollers |
| 13—Speedometer drive gear | 34—Main drive pinion bearing retainer gasket | 53—Reverse idler gear washer |
| 14—Hand brake support gasket | 35—Main drive pinion bearing snap ring | 54—Reverse idler gear shaft |
| 15—Hand brake support | 36—Main drive pinion bearing washer | 55—Reverse idler gear shaft and countershaft lock plate |
| 16—Hand brake support screw and lockwasher | 37—Main drive pinion bearing | 56—Reverse idler gear shaft lock plate screw and lockwasher |
| 17—Mainshaft rear bearing oil seal | 38—Main drive pinion | 57—Countershaft bearing |
| 18—Hand brake drum and mainshaft flange | 39—Mainshaft front or pilot bearing | 58—Countershaft |
| 19—Mainshaft flange | 40—Mainshaft front or pilot bearing snap ring | 59—Countershaft gear thrust washer plate |
| 20—Front universal joint bolt | | 60—Countershaft gear thrust washer |



Legend for Figure 12—Transmission (Assembled View) (1939 Model P8)

- | |
|---|
| 1—Main drive pinion bearing retainer gasket |
| 2—Clutch gear snap ring |
| 3—Main drive pinion bearing snap ring |
| 4—Synchronizer stop ring spreader spring |
| 5—Clutch gear friction ring |
| 6—Countershaft gear thrust washers |
| 7—Mainshaft rear bearing snap ring |

Figure 12—Transmission (Assembled View) (1939 Model P8)

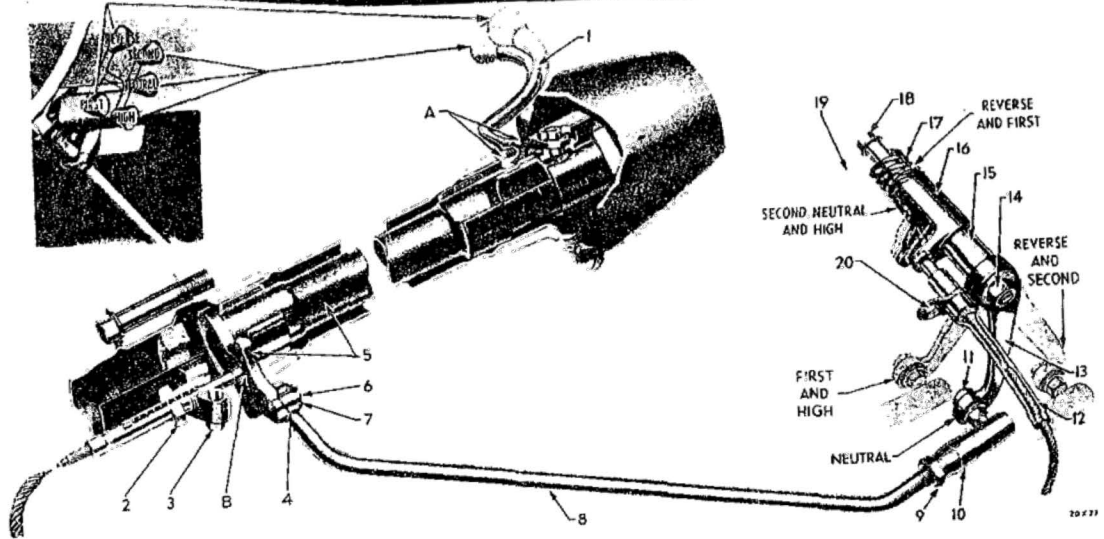
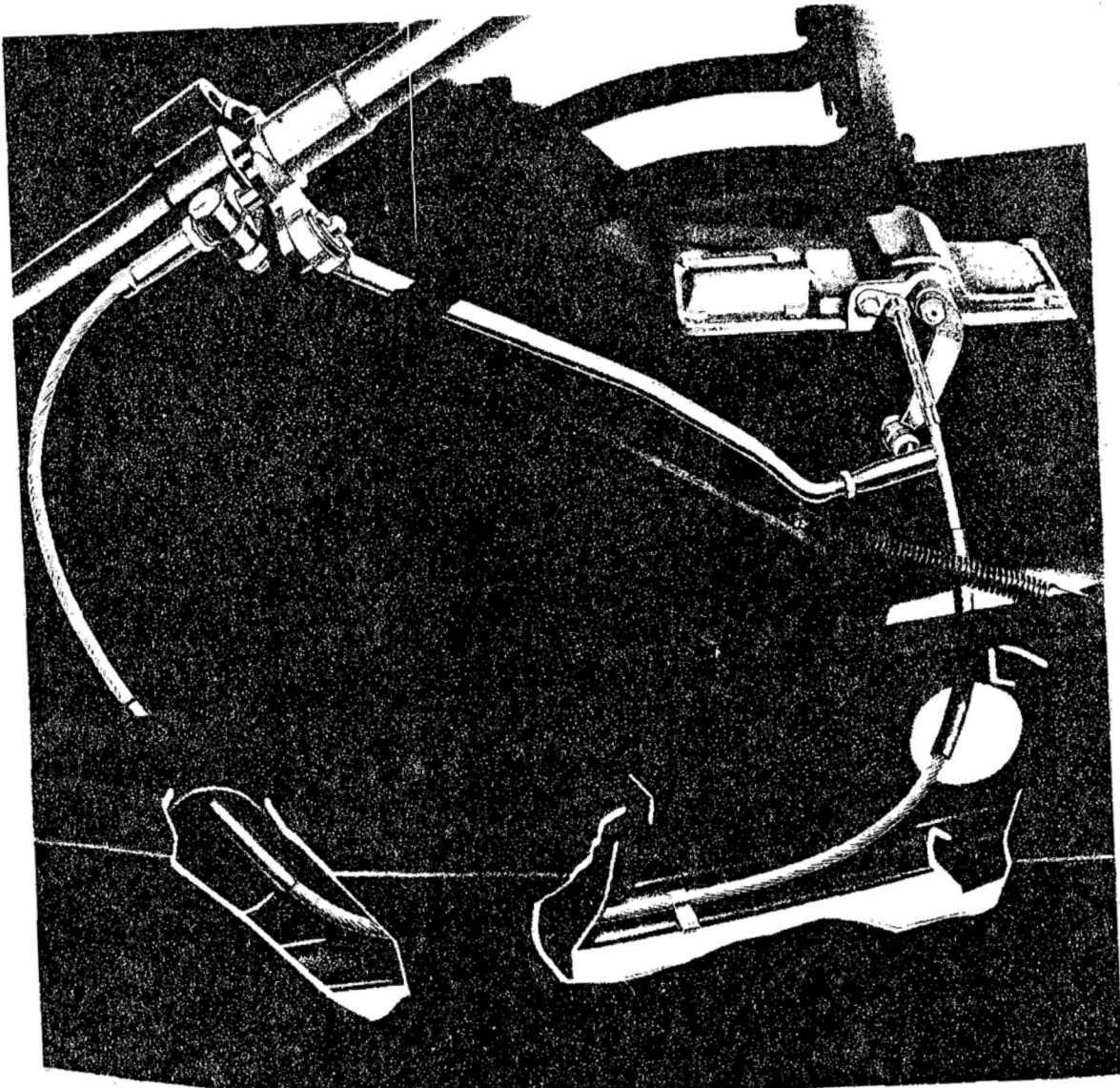


Figure 13—Remote Control Gearshift (1939 Model P8)

5. DISASSEMBLY OF TRANSMISSION.

1936-39—Cont'd

(2) Using a puller, remove universal joint flange. *Do not drive flange off with a hammer.*

(3) Remove brake support assembly.

(4) Pull mainshaft assembly out of rear end of transmission case, using care not to touch sliding clutch assembly as shaft is being pulled out.

(5) Remove countershaft and reverse idler gear shaft lock plate (at rear of case).

(6) Using arbor C-403, drive out countershaft, allowing gear set to drop to bottom of case.

(7) Remove drive pinion and bearing assembly.

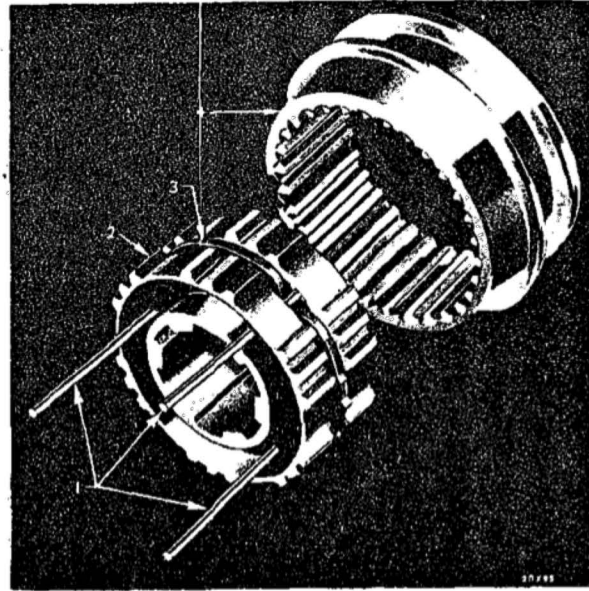
(8) Lift out countershaft gear set, thrust plates, thrust washers and rollers.

(9) Push idler gear shaft out through rear of case and remove idler gear.

(10) Remove snap ring from front end of mainshaft (*1939 model P8 only*).

(11) Pull hub out of sliding clutch sleeve, using care not to lose balls and springs which hold the two units in neutral position.

(12) On all models except 1939 model P8, push a wire through hole in outer edge of second speed gear thrust washer, press down the plunger which holds thrust washer from rotating, until washer can be rotated so that its internal slots line up with flange on mainshaft. Then slide washer and second speed gear off shaft.



1—Friction ring pins
2—Clutch gear
3—Clutch gear friction ring
4—Clutch gear sleeve

Figure 14—Installing Transmission Clutch Gear Friction Ring (1939 Model P8)

6. ASSEMBLY OF TRANSMISSION.

1936-39

(1) When assembling, use new gaskets and new snap rings; make sure snap rings fit snugly in grooves.

(2) Place countershaft gear thrust washer plates (steel) next to bearing rollers and thrust washers (bronze) next to transmission case, selecting proper washers to give countershaft gear end play of .002 to .008 inch.

(3) Be sure second speed gear end play is between .003 and .008 inch.

(4) Assemble synchronizing unit on model P8 as shown in figure 14, so that the ends of friction ring (3) straddle a tooth of sliding clutch sleeve and that reverse bends

Legend for Figure 13—Remote Control Gearshift (1939 Model P8)

- | | | | |
|----------------------------------|--|--|--|
| 1—Hand lever | 8—Control rod and rubber bushing | 13—Lever and shaft (lever) | washer and lock-washer |
| 2—Control cable | 9—Control rod ball joint check nut | 14—Lever to shaft nut, plain washer and lockwasher | 19—Housing |
| 3—Lower column jacket clamp bolt | 10—Control rod ball joint | 15—Lever and shaft (shaft) | 20—Cable to housing screw and lockwasher |
| 4—Lower lever washer (rubber) | 11—Control rod ball joint nut and lockwasher | 16—Rail shifter lever | A—Lubrication point at hand lever |
| 5—Tube and lower lever | 12—Control cable radius clamp | 17—Rail shifter lever kick over spring | B—Lubrication point at lower lever |
| 6—Lower lever pin | | 18—Lever shaft nut, plain | |
| 7—Lower lever plain washer | | | |

6. ASSEMBLY OF TRANSMISSION.

1936-39—*Cont'd*

in friction ring are directly over the three holes of clutch gear, as shown at 5, figure 12.

(5) When installing mainshaft assembly on model P8, be careful not to tilt bronze synchronizing rings in clutch hub.

(6) Install flat bronze spring between high speed synchronizer ring and clutch hub, with the three raised fingers toward synchronizer ring.

7. MEASURING CLUTCH HOUSING ALIGNMENT (TRANSMISSION REMOVED).

1936-42—Install arbor C-360, in fly-wheel and mount dial indicator on arbor. Measure run-out of both face and bore of housing (figs. 15 and 16). Face run-out should not exceed .003 inch; bore run-out should not exceed .005 inch.

8. REPLACEMENT OF REAR OIL SEAL.

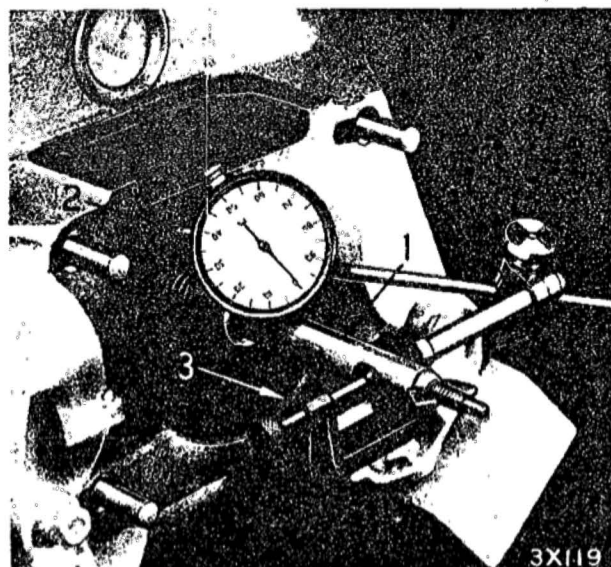
1936-42

(1) Remove propeller shaft. Using puller C-452, remove mainshaft flange and brake drum assembly. *Do not drive flange off with a hammer.* Using puller C-497, remove oil seal (fig. 3).

(2) When installing seal on 1940-42 models, use drift C-579 to drive the seal into proper position. If drift is not available, be sure oil seal protrudes 7/32 inch beyond case (fig. 3). When installing seal on 1936-39 models, use drift C-475 to drive the seal into position.

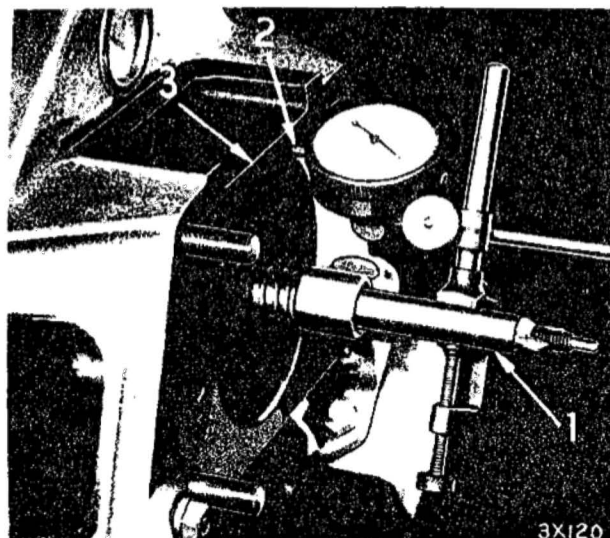
9. DISASSEMBLY OF GEARSHIFT LEVER HOUSING.

1940-42 — Remove gearshift selector lever (21, fig. 2). Remove selector cam and shaft assembly. Remove gearshift lever lock spring (6, fig. 17) by prying it out of pin holes, then remove pin. Remove set screw (19, fig. 2) from housing, compress lever return spring (1, fig. 17) and slide shaft out.



1—Universal clutch plate aligning arbor 2—Indicator plunger
3—Clutch housing bore

Figure 15—Measuring Bore of Clutch Housing (1936-42 Models)



1—Universal clutch plate aligning arbor 2—Indicator plunger
3—Clutch housing face

Figure 16—Measuring Face of Clutch Housing (1936-42 Models)

10. ADJUSTMENT OF GEARSHIFT CONTROL ROD (MANUAL SHIFT).

1941-42—Loosen lock bolt on upper lever at lower end of steering column. Make certain transmission gears are in neutral position and, with gearshift lever set at a horizontal position, tighten lock bolt.

1940—Place transmission gears in neutral position. Loosen lock nut on cable at transmission selector lever, then tighten acorn nut until all end play is removed from cable and back off nut 1/2 turn. Tighten lock nut.

11. ADJUSTMENT OF GEAR SELECTOR ROD (MANUAL SHIFT).

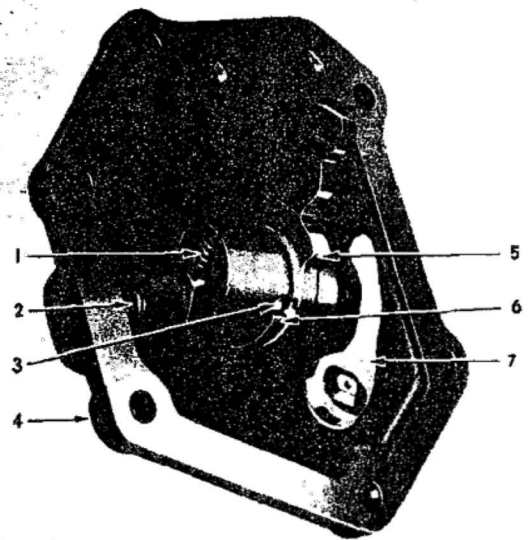
1941-42—Place transmission gears in neutral position. Loosen lock nut on front end of selector rod (9, fig. 18, or 2, fig. 20) and tighten adjusting nut until all play is removed from rod. Back adjusting nut off 1/2 turn for clearance and tighten lock nut.

12. ADJUSTMENT OF POWERMATIC SHIFT.

1941-42—Be sure linkage has free movement, is not stiff and does not bind. Make certain the boot is intact and linkage lubricated. To adjust, remove boot and valve clevis pin (30, fig. 19 on 1942 model or 22, fig. 20 on 1941 model). With pin removed, adjust clevis in or out as required. If gear shifting into second or reverse is sluggish, screw clevis out on valve rod. If gear shifting is sluggish into third or first, screw clevis in on valve rod.

13. LUBRICATING POWERMATIC SHIFT.

1941-42—Remove leather boot and disconnect vacuum line at cylinder and air cleaner line at cylinder. Remove cylinder assembly, being careful not to turn internal valve yoke or damage it. Reinsert power pin

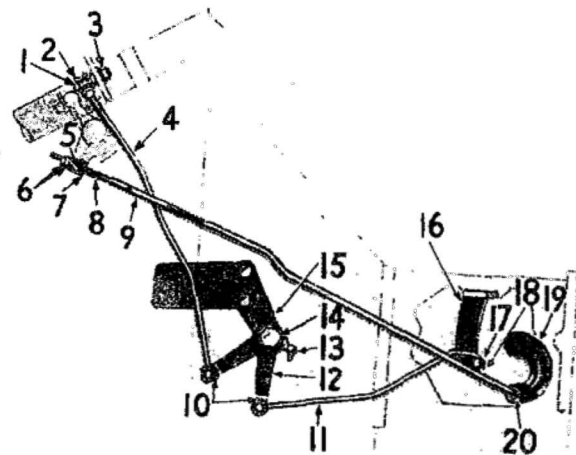


27X53

- | | |
|---------------------------------|------------------------------------|
| 1—Gearshift lever return spring | 5—Gearshift lever pin lock spring |
| 2—Gearshift lever shaft | 6—Gearshift lever pin lock spring |
| 3—Gearshift lever pin | 7—Gearshift selector cam and shaft |
| 4—Gearshift housing | |

Figure 17—Gearshift Housing Assembly (1941-42 Models)

- | | |
|---|--|
| 1—Front control rod stud | 12—Gearshift control bellcrank and bushing |
| 2—Front control rod bushing (or rubber grommet) | 13—Gearshift control bell crank lubricant nipple |
| 3—Front control rod stud nut, plain washer and lockwasher | 14—Gearshift control bell crank bolt, nut and lockwasher |
| 4—Control rod—front | 15—Gearshift control bellcrank bracket |
| 5—Selector rod swivel, spring washer and clip | 16—Gearshift operating lever |
| 6—Selector rod lock nuts | 17—Rear control rod flat washer |
| 7—Selector rod swivel flat washer | 18—Rear control rod cotter clip |
| 8—Selector rod swivel spring | 19—Gearshift selector lever |
| 9—Selector rod | 20—Selector rod flat washer and cotter clip |
| 10—Control rod cotter clips | |
| 11—Control rod—rear. | |



27X74

Figure 18—Gearshift Control Rods (1942 Model, Typical of 1941 Model)

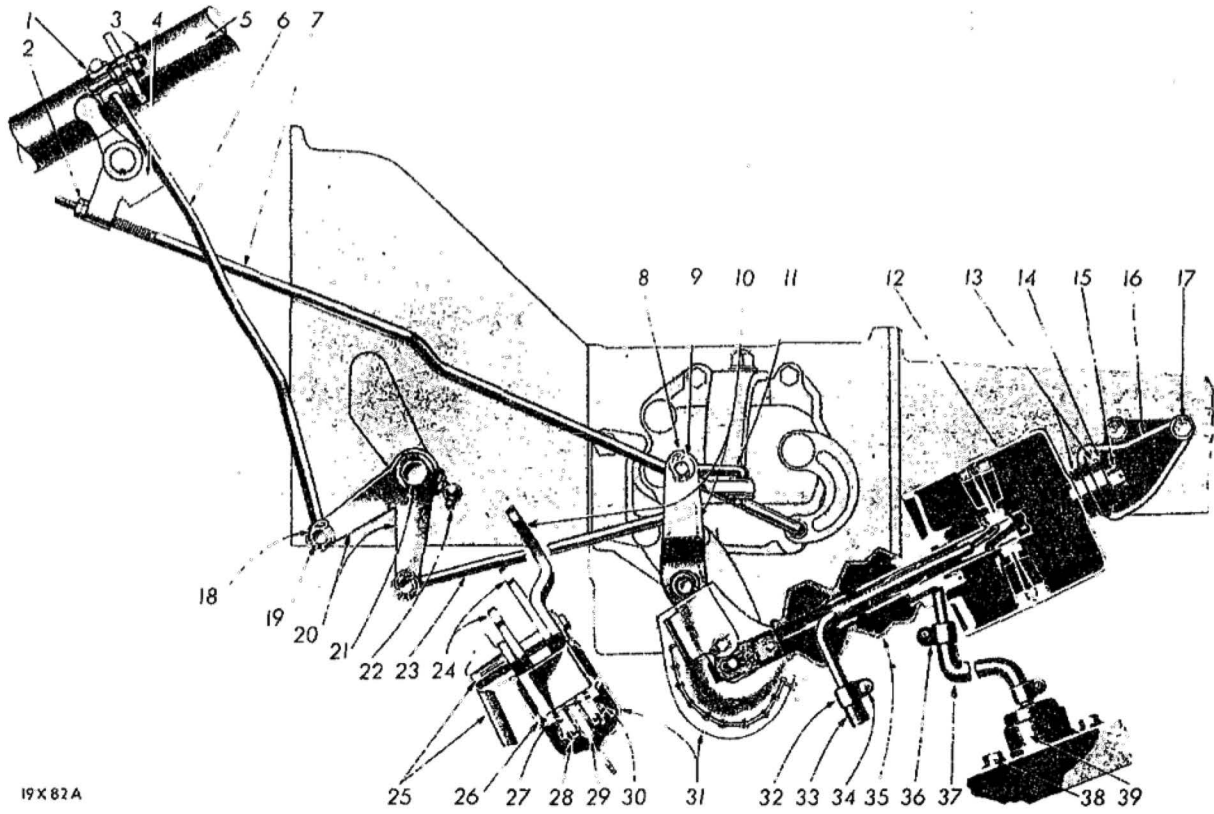


Figure 19—Transmission Power Shift (1942 Model)

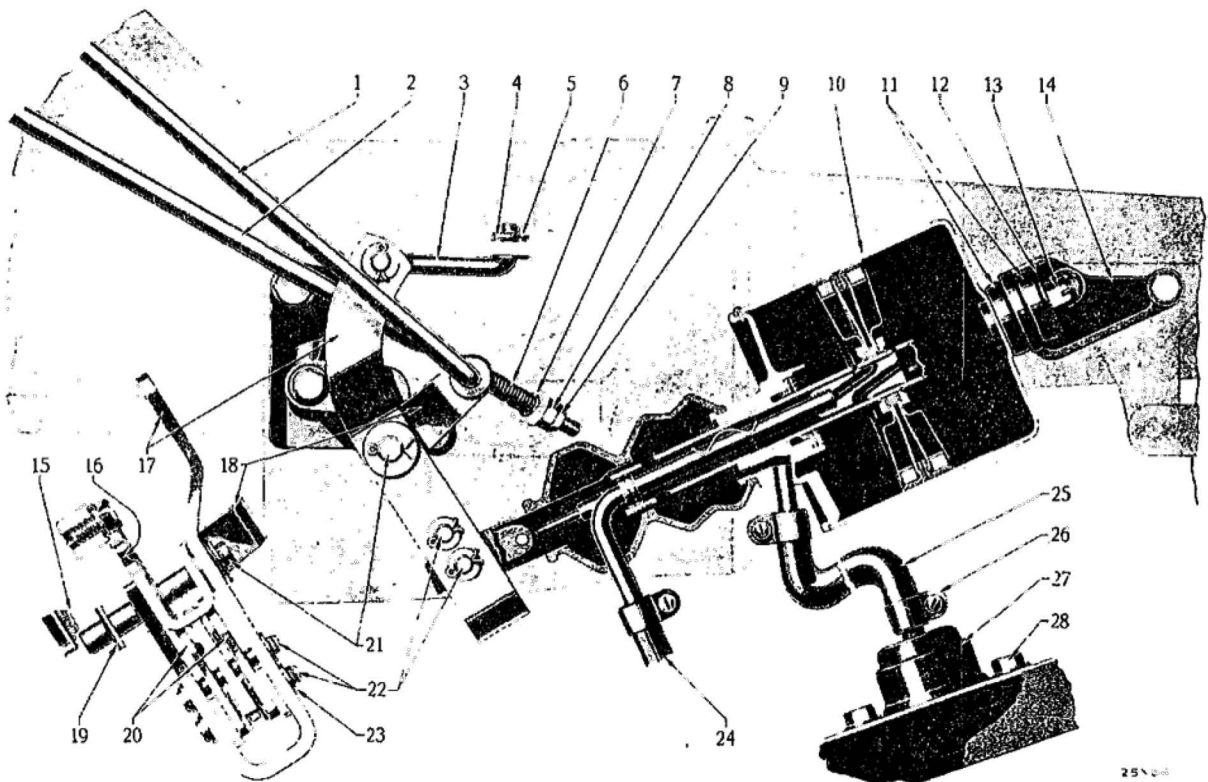


Figure 20—Transmission Power Shift (1941 Model)

Legend for Figure 19—Transmission Power Shift (1942 Model)

1—Gearshift front control rod bushing (rubber grommet)	15—Power shift cylinder mounting nut	25—Power shift lever and hand brake cable bracket
2—Gearshift selector rod lock nuts	16—Power shift cylinder mounting bracket	26—Power shift reaction lever pin
3—Gearshift front control rod stud	17—Power shift cylinder mounting bracket bolt	27—Power shift reaction levers
4—Steering gear column jacket selector lever	18—Gearshift front control rod flat washer	28—Power shift cylinder pin retainer
5—Steering gear column jacket	19—Gearshift front control rod cotter clip	29—Power shift valve lever
6—Gearshift control rod—front	20—Gearshift control bellcrank and bushing	30—Power shift cylinder to linkage pin
7—Gearshift selector rod	21—Gearshift control bellcrank bolt, nut and lockwasher	31—Power shift lever boot
8—Gearshift selector rod cotter clip	22—Gearshift control bellcrank lubricant nipple	32—Power shift vacuum hose clamp
9—Gearshift selector rod flat washer	23—Gearshift control rod—rear	33—Power shift vacuum hose
10—Power shift relay lever	24—Power shift valve lever	34—Power shift vacuum hose clamp screw
11—Power shift link		35—Power shift cylinder boot
12—Power shift cylinder assembly		36—Power shift air hose clamp
13—Power shift cylinder mounting bushings		37—Power shift air hose
14—Power shift cylinder mounting washer		38—Power shift air cleaner mounting bolt
		39—Power shift air cleaner assembly

Legend for Figure 20—Transmission Power Shift (1941 Model)

1—Gearshift control rod	9—Gearshift selector rod adjusting nut lock nut	19—Lever bracket shaft groove pin
2—Gearshift selector rod	10—Power cylinder assembly	20—Reaction levers
3—Link	11—Cylinder mounting bushing	21—Lever bracket shaft
4—Link spring washer	12—Cylinder mounting washer	22—Shift lever clevis pins
5—Link plain washer	13—Cylinder mounting nut	23—Shift lever clevis pin washer
6—Gearshift selector rod spring	14—Cylinder bracket	24—Vacuum hose
7—Gearshift selector rod spring plain washer	15—Lever bracket assembly	25—Air hose
8—Gearshift selector rod adjusting nut	16—Neutral spring	26—Hose clamp
	17—Relay lever	27—Air cleaner
	18—Valve lever	28—Air cleaner mounting screw

13. LUBRICATING POWERMATIC SHIFT.*1941-42—Cont'd*

immediately to prevent turning valve yoke in relation to cylinder yoke. While holding valve rod in "full in" position, pour in ½ ounce of shock absorber, ice machine or transformer oil in vacuum stack. Allow sufficient time for oil to run through valve port into cylinder, then repeat above operation (while holding valve rod in "full out" position) to lubricate all sides of inner cylinder wall and piston packings.

14. CLEANING POWER CYLINDER AIR CLEANER.

1941-42—The air cleaner should be removed, cleaned and re-oiled every 10,000 miles, or more frequently if operating principally on gravel, dusty or dirty roads. Sluggish operation of power unit may be caused by a dirty cleaner, reducing amount of air volume to unit. To clean, remove cleaner from frame. Remove cleaner element and clean in kerosene. Dip in SAE 50 engine oil and reinstall.

Section XXII

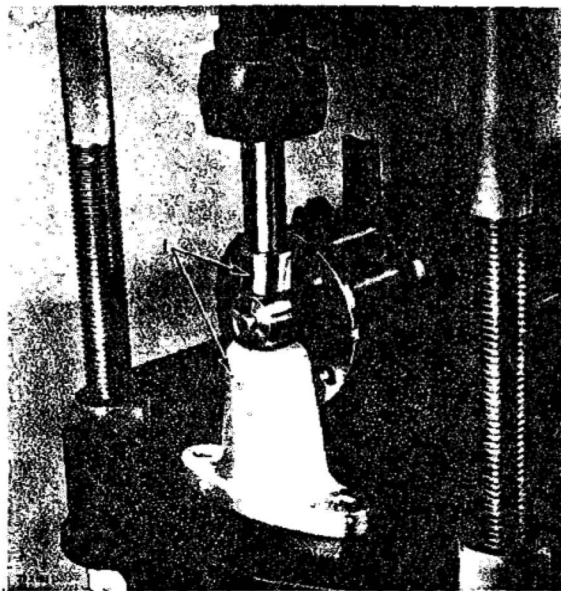
UNIVERSAL JOINTS AND PROPELLER SHAFT

1. DESCRIPTION.

1936-42—The ball and trunnion type universal joint is used on all models, except the 7-passenger sedan, which is equipped with the cross and roller type.

2. REPLACEMENT OF UNIVERSAL JOINT (BALL AND TRUNNION).

1936-42—With the propeller shaft removed from the car, bend clip ends of the grease cover straight and slip cover off body. Remove centering buttons and springs, ball rollers and thrust washers (figs. 4 and 5). Press the trunnion pin through and out of shaft end. When assembling, be sure the trunnion pin is a tight press fit in shaft. *Each end of trunnion pin must protrude the same distance with a variation of not more than .006 inch (fig. 1).* Pack body with 1¼ ounces of Heavy Short Fibre Grease.



1—Jig and locating bushing (Tool C-522)

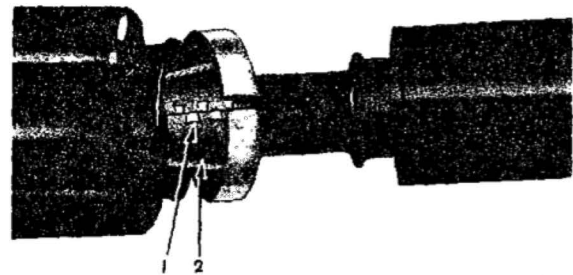
Figure 1—Installing Universal Joint Trunnion Pin (Ball and Trunnion Type) (1936-42 Models)

3. REPLACEMENT OF UNIVERSAL JOINT BOOT (BALL AND TRUNNION)

1936-42—Three types of boots are used as described below:

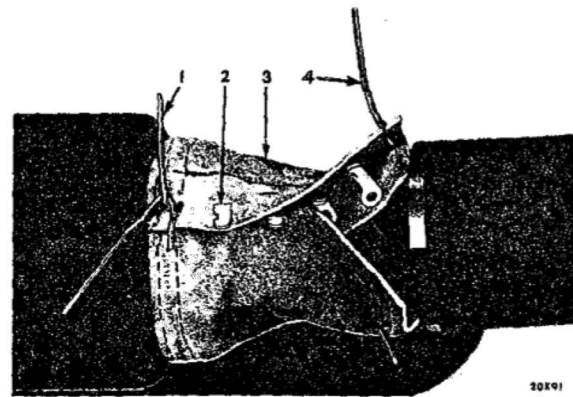
(1) *Rubber Boot.* The outer boot and inner seal are integral and are held in place by flat clamps. This boot can only be replaced after pressing the trunnion pin out of the end of the propeller shaft.

(Continued on page 211)



1—Clip 2—Boot—inner

Figure 2—Installing Universal Joint Service Boot—Inner—(Ball and Trunnion Type) (1936-42 Models)



1—Clamp wire—long 3—Boot—outer
2—Clip 4—Clamp wire—short

Figure 3—Installing Universal Joint Service Boot—Outer (Ball and Trunnion Type) (1936-42 Models)

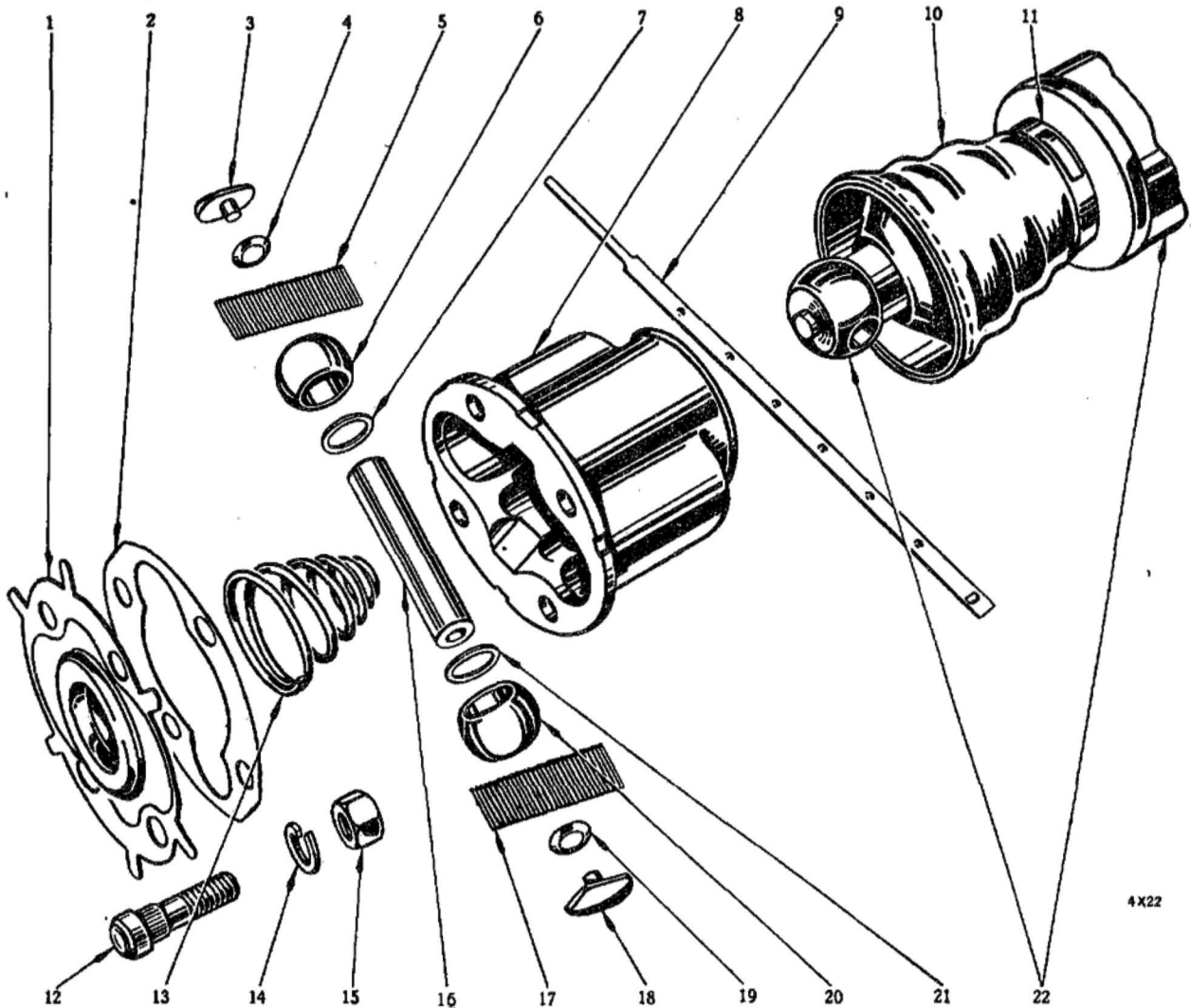


Figure 4—Propeller Shaft and Universal Joints (Disassembled) (Ball and Trunnion Type) (1936-42 Models)

- | | | | |
|---------------------------|---------------------------|--------------------------------------|----------------------------|
| 1—Grease cover | 7—Thrust washer | 12—Propeller shaft bolt (front only) | 18—Centering button |
| 2—Gasket | 8—Body | 13—Spring | 19—Centering button spring |
| 3—Centering button | 9—Dust cover clamp—long | 14—Bolt nut lockwasher | 20—Ball |
| 4—Centering button spring | 10—Dust cover or boot | 15—Bolt nut | 21—Thrust washer |
| 5—Rollers | 11—Dust cover clamp—short | 16—Pin | 22—Propeller shaft |
| 6—Ball | | 17—Rollers | |

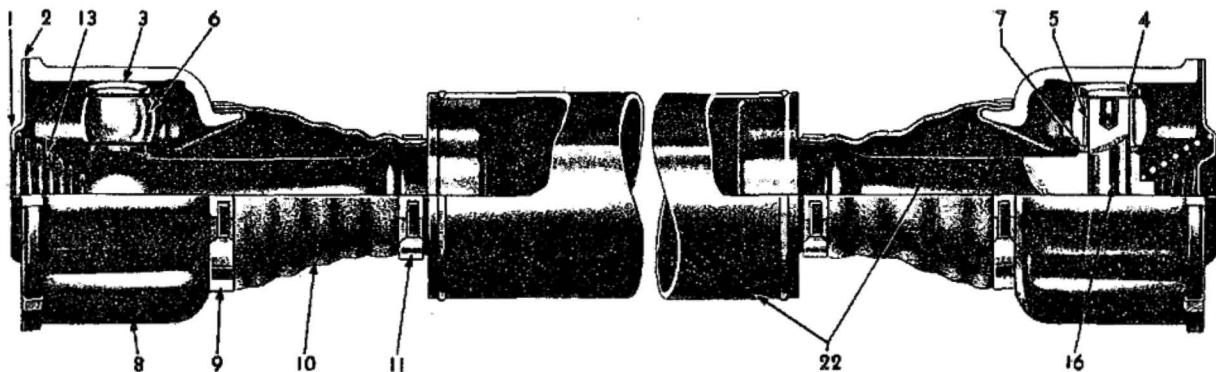
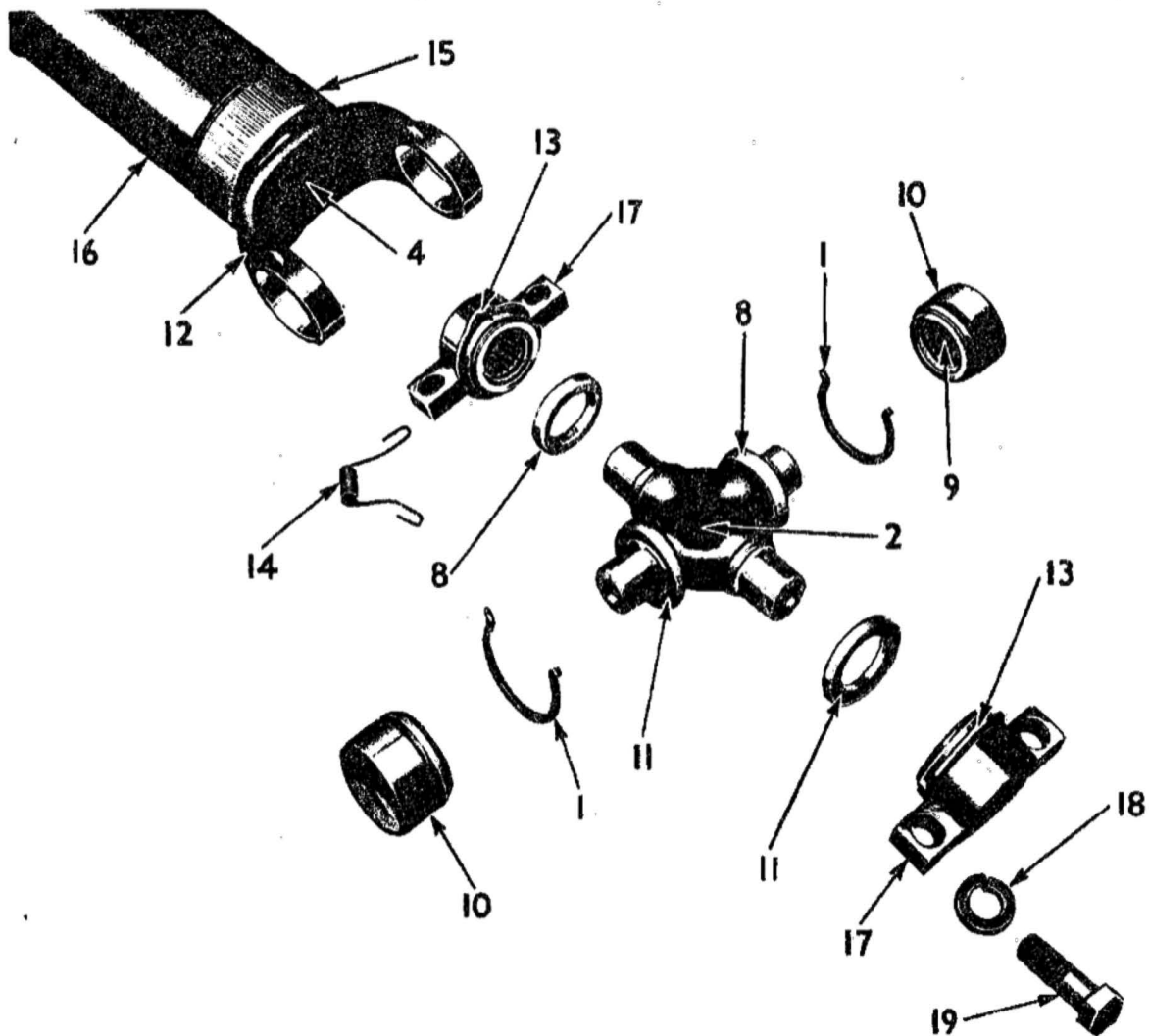
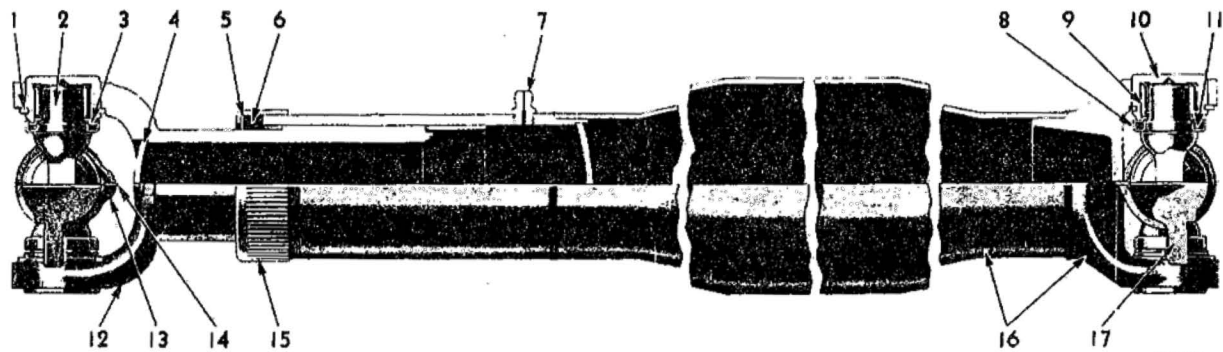


Figure 5—Propeller Shaft and Universal Joints (Assembled) (Ball and Trunnion Type) (1936-42 Models)



23X202

**Figure 6—Propeller Shaft and Universal Joints (Disassembled View)
(Cross and Roller Type) (1940-41 Seven Passenger Models)**



23X200

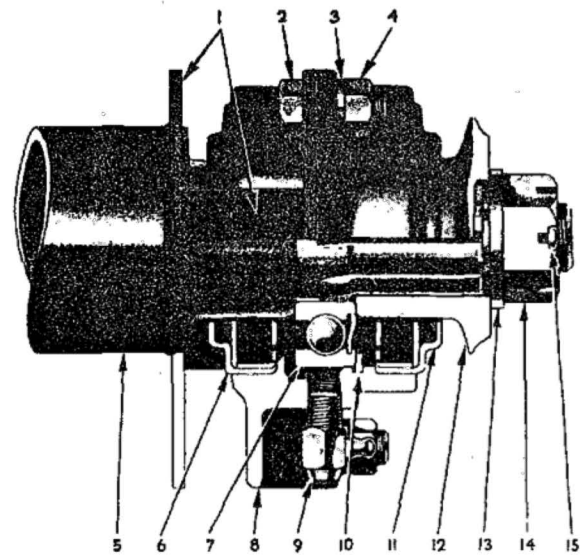
**Figure 7—Propeller Shaft and Universal Joints (Assembled View)
(Cross and Roller Type) (1940-41 Seven Passenger Models)**

3. REPLACEMENT OF UNIVERSAL JOINT BOOT (BALL AND TRUNNION).

1936-42—Cont'd

(2) *Leather Boot with Inner Seal Attached.* The seams of seal and boot are permanently joined together when assembled at the factory and this type can only be replaced after pressing the trunnion pin out of the end of the propeller shaft.

(3) *Service Boot with Inner Boot Separate.* This type boot can be replaced without disassembling the universal joint. When replacing the boot, be sure to remove all traces of old boot, to insure a water-tight joint. Place the inner boot in position (fig. 2) and secure with clips. Install the outer boot and secure with clips (fig. 3). Twist wire very tightly on boot to prevent the inner boot sliding over the rib on end of the universal joint body. As the ends of the wire are being twisted, tap wire with a rubber or wooden mallet so that the wire sinks into leather.



- | | |
|-------------------------------|--------------------------|
| 1—Housing insulator | 8—Housing |
| 2—Housing bolt | 9—Lubricant fitting |
| 3—Housing bolt nut lockwasher | 10—Bearing snap ring |
| 4—Housing bolt nut | 11—Oil seal |
| 5—Propeller shaft—front | 12—Flange |
| 6—Oil seal | 13—Flange washer |
| 7—Bearing | 14—Flange nut |
| | 15—Flange nut cotter pin |

Figure 8—Propeller Shaft Center Bearing (1940-41 Seven Passenger Models)

4. REPLACEMENT OF UNIVERSAL JOINT (CROSS AND ROLLER TYPE).

*1940-41—*No adjustments are provided to compensate for wear of any parts. Parts which show wear must be replaced. The cross roller bearing block and its component parts form an assembly. (See figures 6 and 7). The cross roller bearing with its component parts is also an assembly. When assembling, lubricate all parts. If the splined joint at the front of propeller shaft has been disassembled, assemble with the balance marking arrows mated as shown in figure 9.

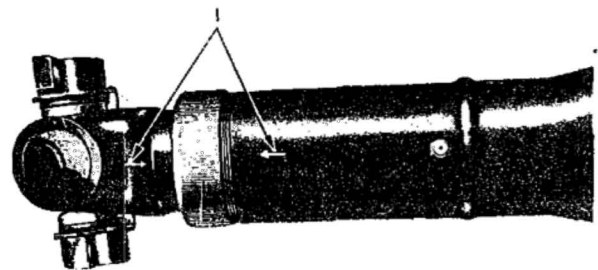


Figure 9—Balance Arrows (1) on Spline Joint (Cross and Roller Type) (1940-41 Seven Passenger Models)

Legend for Figures 6 and 7—Propeller Shaft and Universal Joints (Cross and Roller Type) (1940-41 Seven Passenger Models)

- | | | | |
|---------------------------------|--------------------------------------|--|--|
| 1—Cross roller bushing retainer | 6—Spline yoke oil seal | 11—Cross roller dust seal | 15—Spline yoke oil seal cap |
| 2—Cross assembly | 7—Spline yoke lubricant nipple | 12—Spline yoke and plug assembly | 16—Propeller shaft |
| 3—Cross roller retainer | 8—Cross roller dust seal retainer | 13—Cross roller bearing block retainer | 17—Cross roller and bearing block assembly |
| 4—Spline yoke plug | 9—Cross rollers | 14—Cross roller bearing block tie spring | 18—Lockwasher |
| 5—Spline yoke oil seal washer | 10—Cross roller and bushing assembly | | 19—Screw |

WHEEL AND TIRE DATA AND SPECIFICATIONS					
Year	1941-42		1937-40		1936
Type	Steel disc		Steel disc		Steel spoke
Rim type	Drop center— "E" flange safeguard wheel		Drop center— "E" flange		Drop center— "E" flange
TIRE PRESSURES					
Tire Size	Front	Rear	Tire Size	Front	Rear
5.25 x 17 inch	32 lbs.	32 lbs.	6.00 x 18 inch (7 passenger)	32 lbs.	32 lbs.
5.25 x 20 inch	30 lbs.	30 lbs.			
5.50 x 16 inch	32 lbs.	32 lbs.	6.50 x 16 inch (except 7-passenger)	28 lbs.	28 lbs.
6.00 x 16 inch	28 lbs.	28 lbs.			
6.00 x 18 inch (except 7-passenger)	28 lbs.	28 lbs.	6.50 x 16 inch (7-passenger)	30 lbs.	30 lbs.

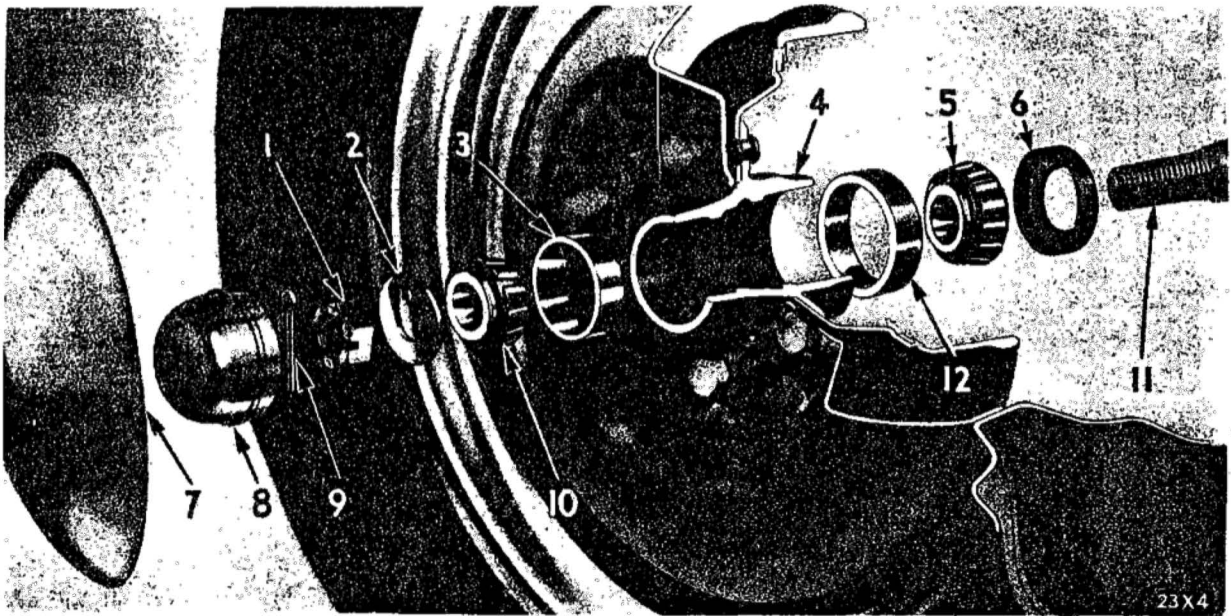


Figure 1—Front Wheel Bearings (Disassembled View) (1936-42 Models)

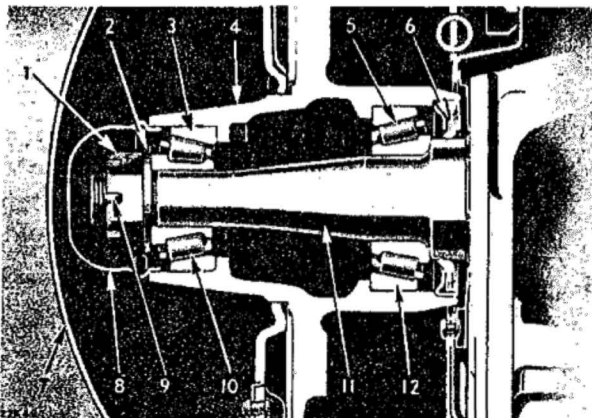


Figure 2—Front Wheel Bearings (Assembled View) (1936-42 Models)

- 1—Bearing nut
- 2—Bearing thrust washer
- 3—Outer bearing cup
- 4—Hub
- 5—Inner bearing cone and rollers
- 6—Hub dust seal
- 7—Hub cap
- 8—Grease cap
- 9—Bearing nut cotter pin
- 10—Outer bearing cone and rollers
- 11—Steering knuckle
- 12—Inner bearing cup

Section XXIII

WHEELS AND TIRES

1. ADJUSTMENT OF FRONT WHEEL BEARINGS.

1936-42—Turn bearing nut tight. Turn nut back two slots, then to nearest cotter pin slot. Insert a new cotter pin and bend ends of pin back to prevent interference with grease cap.

2. ADJUSTMENT OF REAR WHEEL BEARINGS.

1936-42—Refer to paragraph 2 on page 53.

3. INSTALLATION OF FRONT WHEEL BEARINGS.

1936-42—When installing bearings in hubs, be sure the hub dust seal (6, fig. 2) is in position.

4. REMOVAL OF TIRES.

1941-42

(1) Special removing tools are necessary to remove tires from safeguard wheels.

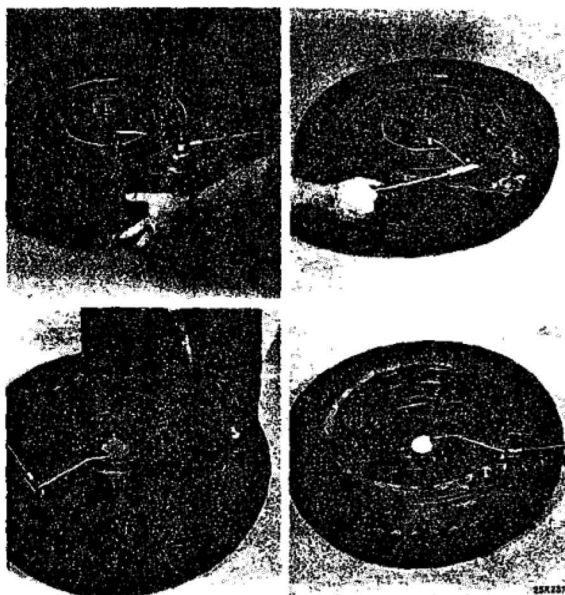


Figure 3—Removing Tire from Wheel with Tool Supplied with Car (1941-42 Models)

The tool provided with each car is not designed for heavy duty service. A special heavy duty service tool C-610 is available for service station use.

(2) *Removing Tire from Wheel with Tool Supplied with Car (fig. 3).* Place tire and wheel on ground, outside up, and completely deflate tire. Place hook of tool past outer notch, with inner notch hooking through center of wheel. Use wheel wrench for handle, hook tip of wedge between side of tire and wheel rim, and rotate handle clockwise one-half turn to force bead away from rim flange. Stand on tire and push rest of bead loose. To dislodge inside bead, turn the wheel over and repeat the same operation, using the outer notch of hook on inside of wheel. After both beads have been loosened, the tire can be removed with ordinary type tire tools.

(3) *Removing Tire from Wheel with Special Tool.* Deflate the tire completely. Insert the jaws of tool between the tire and rim, pushing the jaws in as far as possible, then apply roller to outside of rim flange (fig. 4). Hold lower portion of tool flat against the tire and push the lever back to force the wedge jaws between the rim and tire. The tool will lock in place. Install the extension handle over the end of the single jaw lever and push it toward the outside of the tire (fig. 5). Leverage is sufficient to force a portion of the bead over the hump. The rest of the bead can be pressed over the hump by stepping on the tire. Turn the tire over and repeat the operation on the inside of the tire. The tire will then be free from rim and may be removed from the wheel with use of ordinary type tire tools.



Figure 4—Removing Tire from Wheel with Special Tool C-610—Placing Tool in Position (1941-42 Models)

5. INSTALLATION OF TIRES.

1941-42—When installing tire, coat tire beads or raised portion of rim freely with liquid soap or soft soap to enable tire bead to slip easily over humps on rim. **Do not use oil or grease.** To avoid pinching tube, be sure the beads of the tire are started on the rim before inflating tire.

6. ROTATION OF TIRES.

1936-42—To equalize tire wear it is

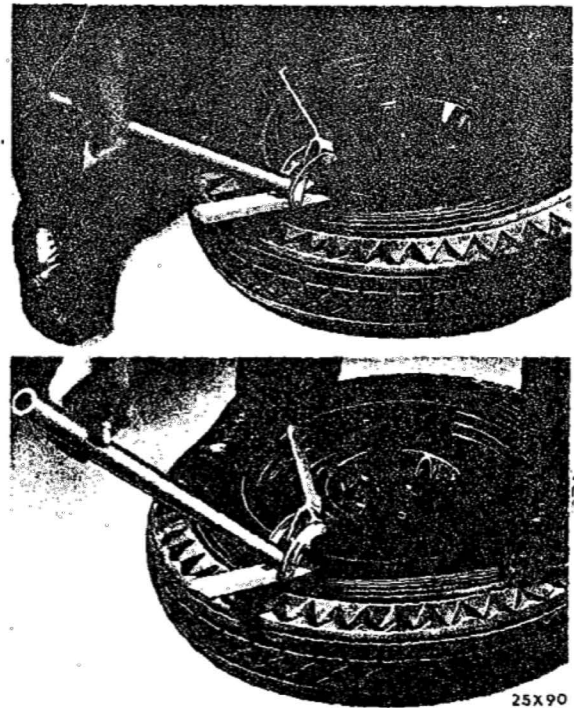


Figure 5—Removing Tire from Wheel with Special Tool C-610—Operating Tool (1941-42 Models)

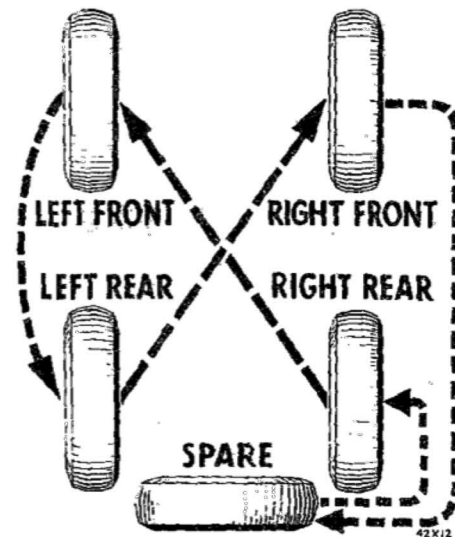


Figure 6—Tire Rotation (1936-42 Models)

recommended that tires be interchanged, as shown in figure 6, at regular intervals of approximately 2500 miles, or more frequently if the tires are subjected to extremely hard service.



USE MOPAR PARTS TO SPEED SERVICE AND ASSURE QUALITY SERVICE WORK

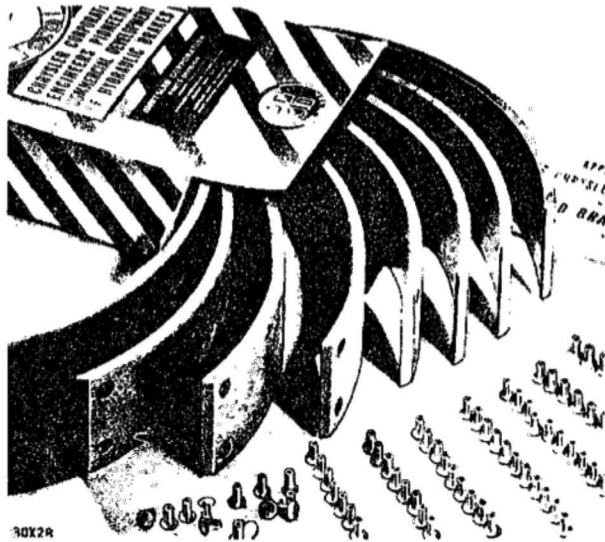
The word MOPAR has been established as a symbol or trade name for approved factory engineered parts and accessories for Plymouth vehicles.

MOPAR factory engineered parts are of standard production quality. They are engineered, manufactured and inspected under the same high standards of quality required in the building of Plymouth cars.

The use of MOPAR factory engineered and inspected parts in the maintenance of Plymouth vehicles assures dependable performance, long car life, and customer satisfaction.

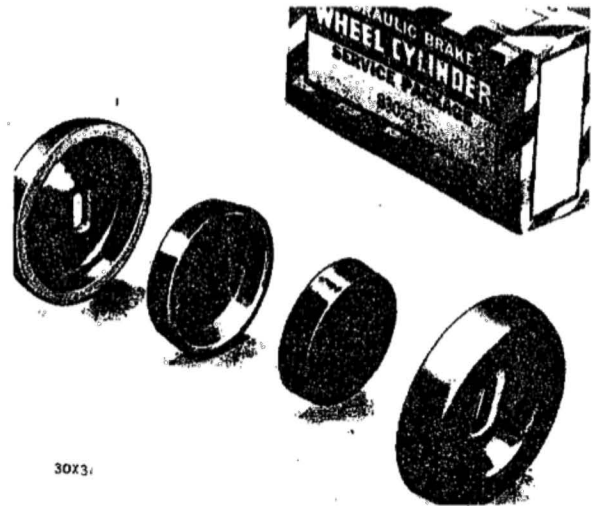
To simplify ordering and stocking of material—to insure the service man of having the correct material to do the job—and to save installation time, parts are available in Service Packages. Each package contains all of the parts which should usually be replaced at one time to do a good job. Illustrated installation instructions are included in the packages to help the service man perform the operation.

The accompanying illustrations are typical of the Service Packages available. Refer to the Plymouth Parts List for a complete list of Service Packages, individual replacement parts and assemblies.



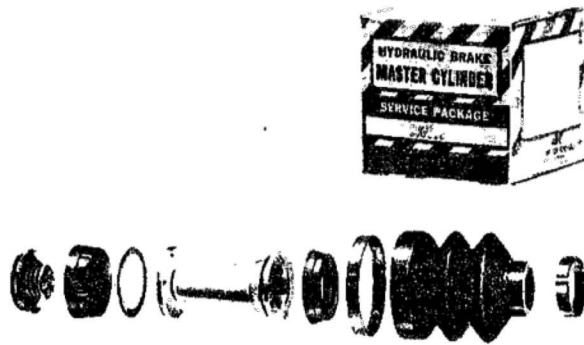
30X28

Brake Lining Set



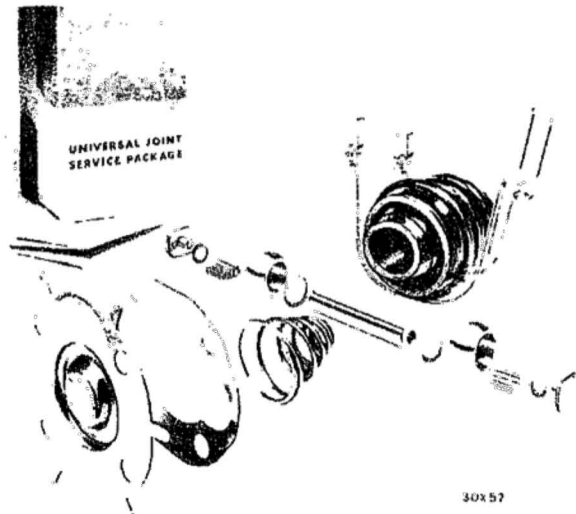
30X31

Wheel Cylinder Service Package



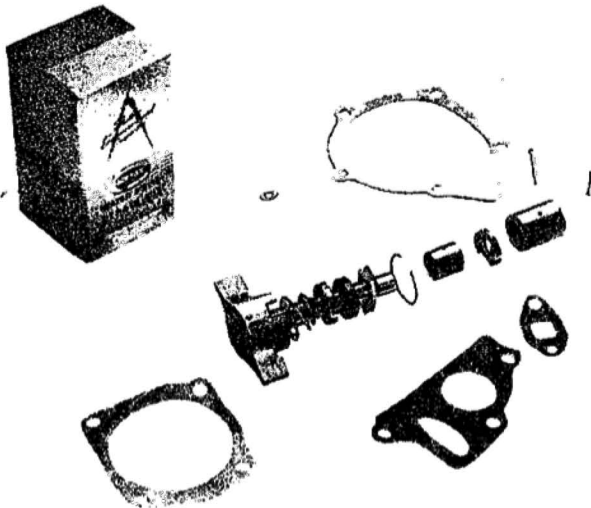
30X29

Master Cylinder Service Package



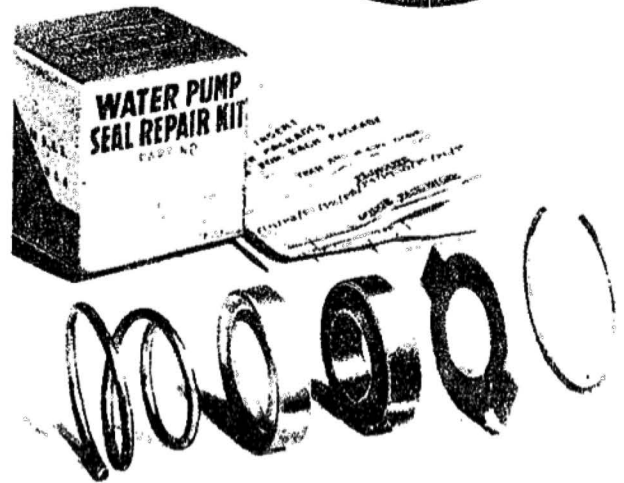
30X57

Universal Joint Service Package



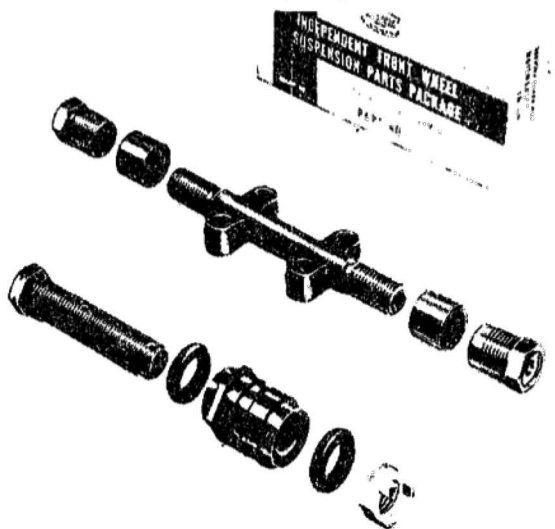
30X33

Water Pump Repair Kit



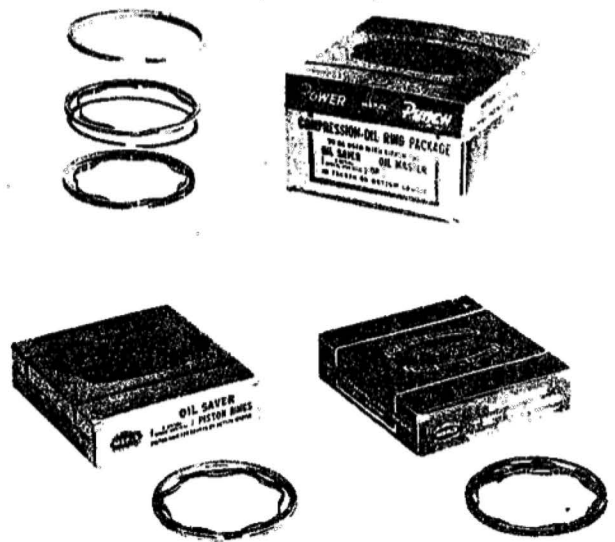
30X32

Water Pump Seal Repair Kit



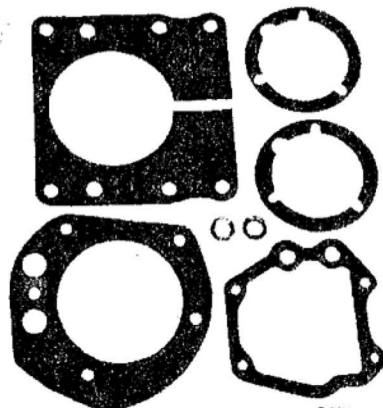
30X23

Independent Front Wheel Suspension—Upper Control Arm Package



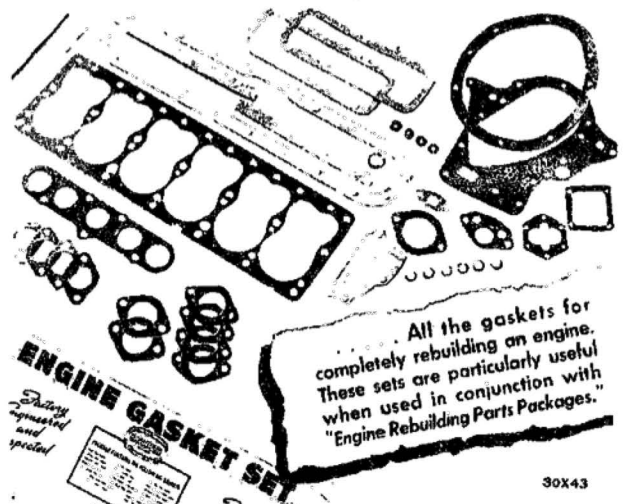
30X45

Power Punch Piston Ring Sets



30X100

Transmission Gasket Set

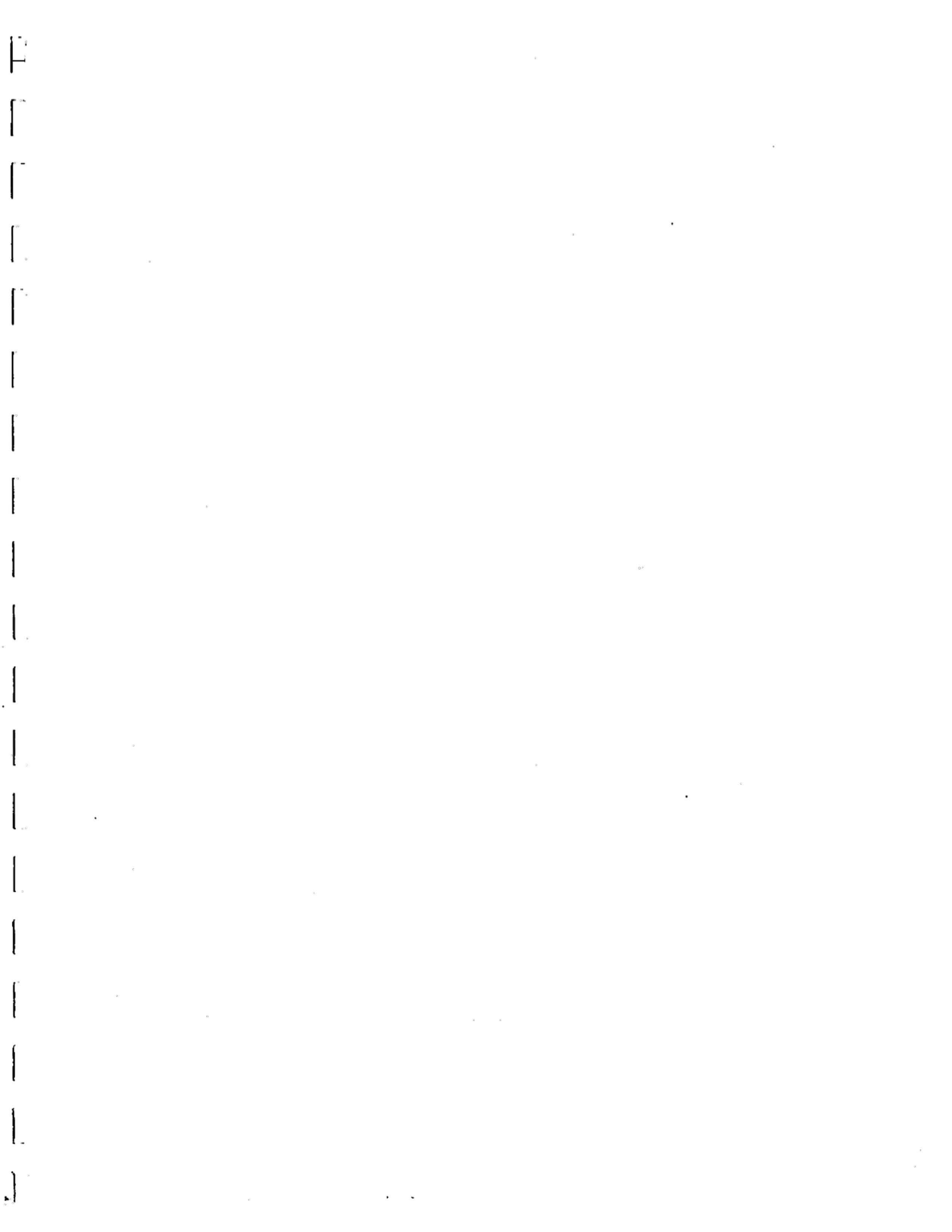


ENGINE GASKET SET
Factory Engineered and Inspected

All the gaskets for completely rebuilding an engine. These sets are particularly useful when used in conjunction with "Engine Rebuilding Parts Packages."

30X43

Engine Gasket Set





PLYMOUTH

BUILDS GREAT CARS



GOOD SERVICE KEEPS
THEM GREAT

CHRYSLER CORPORATION

PLYMOUTH DIVISION
DETROIT 31 MICHIGAN