



# CHASSIS and BODY PARTS CATALOG

Chevrolet  
1946 - 1976



# CHEVROLET ALL GROUPS



## ALPHABETICAL INDEX

### ALPHABETICAL INDEX

#### A

ABSORBER ASSY., Front and Rear Bumper Shock.....	7.840	ADAPTER UNIT, Speedometer.....	4.329
ABSORBER ASSY., Steering Relay and Tie Rod Shock.....	6.865	ADAPTER UNIT, Steering.....	6.508
ABSORBER, Clutch Fork.....	0.797	ADHESIVE.....	8.800
ACTUATOR ASSY., Direction Signal Lamp (See Group 9.748 Tell Tale Wind.).....	2.895	ADJUSTER ASSY., Steering Gear Housing End Cover Worm Bearing.....	6.830
ACTUATOR ASSY., Folding Top.....	14.475	ADJUSTER, Front Seat.....	11.561
ACTUATOR ASSY., Front Seat Adjuster.....	11.561	ADJUSTER, Pitman Shaft.....	6.822
ACTUATOR ASSY., Front Seat Back Lock.....	11.390	AIR CLEANER, Air Injection Reactor.....	3.672
ACTUATOR ASSY., Heater Vacuum Actuating.....	8.850	ALARM UNIT, Ignition Switch Warning.....	2.195
ACTUATOR ASSY., Transmission Parking Brake.....	4.290	AMMETER, Electrical Output (See Group 9.748 for Telltale Windows).....	2.515
ACTUATOR ASSY., Transmission Parking Lock.....	4.220	AMPLIFIER ASSY., Air Conditioning Electrical Temperature and Blower Motor Control.....	9.275
ACTUATOR ASSY., Vacuum Power Door Lock.....	10.485	AMPLIFIER, Ignition Pulse (Transistorized).....	2.383
ACTUATOR, Air Cleaner Intake Valve.....	3.415	AMPLIFIER, Lighting.....	2.485
ACTUATOR, Air Cleaner.....	3.417	ANTENNA UNIT, Radio.....	9.645
ACTUATOR, Air Conditioning Electrical Temperature and Blower Motor Control.....	9.275	ANTI, Front Fender and Skirt.....	8.154
ACTUATOR, Air Conditioning Vacuum Control.....	9.280	ANTI SQUEAK, Accelerator.....	3.451
ACTUATOR, Concealed Headlamp Control Drive.....	2.760	ANTI, Universal.....	8.205
ACTUATOR, Cowl.....	9.789	APPLIQUE, Gas Tank Filler Neck Compartment.....	12.945
ACTUATOR, Exhaust Manifold Heat Control Valve.....	3.640	APPLIQUE, Seat Separator.....	10.240
ACTUATOR, Ignition Switch Warning.....	2.195	APPLIQUE, Tail and Stop Lamp.....	2.681
ACTUATOR, Seat Back Reclining.....	11.377	APPLIQUE, Underbody Trim (floor mounted).....	4.017
ADAPTER, Air Cleaner to Carb.....	3.407	ARM, Air Conditioning Control.....	9.281
ADAPTER, Air Cleaner.....	3.417	ARM, Air Flow.....	9.786
ADAPTER, Air Conditioning Evaporator Air Distributor and Astro-Ventilation.....	9.262	ARM ASSY., Air Conditioning Electrical Temperature and Blower Motor Control.....	9.275
ADAPTER, Air Flow.....	9.786	ARM ASSY., Folding Seat (For Load Floor Parts See Group 12.977).....	11.620
ADAPTER, Air Injection Reactor.....	3.675	ARM ASSY., Rear Axle Control.....	5.382
ADAPTER, Air Suspension or Level Control Air Compressor.....	7.452	ARM ASSY., Steering Knuckle Upper and Lower Control Arm Assy.....	6.168
ADAPTER, Air Suspension Level Control.....	7.447	ARM ASSY., Windshield Wiper Motor Aux.....	10.151
ADAPTER, Antenna.....	9.647	ARM ASSY., Windshield Wiper.....	10.147
ADAPTER ASSY., Air Suspension Pressure, or Level Control.....	7.465	ARMATURE ASSY., Rear Door Window.....	10.791
ADAPTER ASSY., Oil Filter.....	1.840	ARMATURE ASSY., Windshield Wiper.....	10.150
ADAPTER ASSY., Speedometer.....	4.329	ARMATURE, Folding Top Motor and Pump.....	14.482
ADAPTER ASSY., Steering Gear Hydraulic.....	6.550	ARMATURE, Generator.....	2.279
ADAPTER, Crankcase.....	1.745	ARMATURE, Quarter Window.....	11.041
ADAPTER, Generator.....	2.313	ARMATURE, Starting Motor.....	2.043
ADAPTER, Horn Button and Blowing Ring.....	2.819	ARMATURE, Tailgate.....	12.195
ADAPTER, Manifold Vacuum Take-Off.....	3.278	ARMATURE UNIT, Front Door Window.....	10.783
ADAPTER, Mast Jacket.....	6.521	ARMATURE UNIT, Rear Door Window.....	10.791
ADAPTER, Oil (Also see Group 8.963).....	1.531	ARM, Carburetor Idle Vapor Vent.....	3.852
ADAPTER, Oil Pressure.....	1.803	ARM, Carburetor Pump.....	3.845
ADAPTER, Rear Window Defogger.....	9.778	ARM, Carburetor Throttle.....	3.762
ADAPTER, Speed and Cruise Control Power.....	3.885	ARM, Cowl.....	9.789
ADAPTER, Steering.....	6.508	ARM, Generator Brush.....	2.291
ADAPTER, Tire Traction.....	5.885	ARM, Heater.....	8.852
ADAPTER, Transmission Overdrive.....	4.455	ARM, Inside Rear View Mirror.....	10.187
ADAPTER UNIT, Carburetor and Fuel Meter Fuel Inlet.....	3.740	ARM, Pitman.....	6.859
ADAPTER UNIT, Headlamp.....	2.726	ARM, Rear Axle Control Arm.....	5.380
		ARM REST ASSY., Arm Rest Front Seat.....	14.900
		ARM, Seat Separator.....	10.242
		ARM, Steering Knuckle.....	6.103
		ARM, Transmission Rail End.....	4.302
		ARM UNIT, Air Suspension, Air Compressor.....	7.460
		ARM UNIT, Valve Rocker with Adjusting Screw and Nut.....	0.333
		ARM, Valve Rocker with Adjusting Screw and Nut.....	0.333
		ARRESTOR, Crankcase.....	1.745

## ALPHABETICAL INDEX

ASPIRATOR ASSY., Air Conditioning Electrical Temperature and Blower Motor Control.....	9.275
ATTACHMENT UNIT, Bumper Valance Panel	7.833

### B

BACK ASSY., Rear Seat Back with Frame, Springs, and Padding (less trim cover).....	11.628A
BACK PLATE, Air Conditioning Evaporator Core Housing.....	9.211
BACKPLATE, Electrical Output (See Group 9.748 for Telltale Windows).....	2.515
BACKPLATE, Instrument.....	9.743
BACK, Rear Window Defogger.....	9.778
BAFFLE, Air Conditioning Evaporator Air Inlet.....	9.218
BAFFLE, Air Conditioning Evaporator By- Pass.....	9.198
BAFFLE, Air Conditioning Refrigerant.....	9.190
BAFFLE, Air Flow.....	9.786
BAFFLE ASSY., Defroster.....	9.779
BAFFLE ASSY., Rear and Auxiliary Speakers.....	9.665
BAFFLE, Automatic Choke Control.....	3.750
BAFFLE, Carburetor and Fuel Meter Fuel Inlet.....	3.740
BAFFLE, Carburetor and Fuel Meter Intake (w/seat and gasket).....	3.814
BAFFLE, Carburetor to Manifold.....	3.726
BAFFLE, Carburetor Idle Vapor Vent.....	3.852
BAFFLE, Heater.....	8.854
BAFFLE, Oil Pan Upper.....	1.430
BAFFLE, Radiator Core Side and Lower.....	1.272
BAFFLE, Transmission Case.....	4.105
BAFFLE, Transmission Overdrive.....	4.455
BAG ASSY., Dust Boot Storage.....	13.450A
BAG ASSY., Fldg. Top Compt.....	15.027
BAIL.....	4.651
BAIL, Fuel Pump Mounting.....	3.901
BALANCER, Crankshaft.....	0.659
BALL, Air Conditioning Compressor (Internal).....	9.172
BALL, Carburetor Pump Inlet Valve.....	3.826
BALL, Carburetor Pump Outlet Valve.....	3.825
BALL, Folding Top Motor and Pump.....	14.482
BALL, Steering Gear.....	6.844
BALL, Trailer.....	7.068
BALL, Transmission Clutch.....	4.166
BALL, Transmission Countershaft Gear.....	4.429
BALL, Transmission Locking.....	4.429
BALL, Transmission Low and Drive Valve.....	4.265
BALL UNIT, Universal.....	5.548
BALL, Valve Push Rod Adjusting.....	0.429
BALL, Windshield Wiper.....	10.150
BAND ASSY., Transmission Brake.....	4.251
BAR.....	7.836A
BAR ASSY., Electric Seat Adjuster Switch.....	11.558
BAR ASSY., Front Door Outer.....	12.895
BAR ASSY., Radiator Support.....	1.271
BAR ASSY., Rear Compartment Floor.....	12.981
BAR ASSY., Rear Door Outer.....	12.913
BAR, Bumper Face.....	7.831
BAR, Frame to Bumper Attaching (Also See Group 7.869).....	7.836
BAR, Horn Blowing.....	2.830
BAR, Radiator Grille.....	1.267
BAR, Rear Compartment End.....	12.986
BASE, Air Cleaner Oil.....	3.406
BASE ASSY., Auto.....	8.820
BASE ASSY., Belt Unit and Shoulder Strap Unit Components.....	14.875A
BASE ASSY., Electric Seat Adjuster Switch ...	11.558
BASE, Front Door Arm Rest.....	14.686
BASE, Instrument Case.....	9.746
BASE, Instrument.....	9.743
BASE PLATE, Air Conditioning Control.....	9.279
BASE, Rear Door Arm-Less Tray.....	14.762
BASE, Rear Quarter Arm Trimmed.....	15.108
BASE, Roof Luggage and Ski.....	12.815
BEARING, Accelerator.....	3.454

BEARING, Air Conditioning Compressor (Internal).....	9.172
BEARING, Air Injection Reactor Pump.....	3.665
BEARING and CUP UNIT, Universal.....	5.548
BEARING ASSY., Air Conditioning Compressor Pulley.....	9.181
BEARING ASSY., Direction Signal Lamp (See Group 9.748 Tell Tale Wind.).....	2.895
BEARING ASSY., Distributor Mainshaft.....	2.375
BEARING ASSY., Drive Pinion Rear.....	5.484
BEARING ASSY., Drive Pinion-Front.....	5.447
BEARING ASSY., Front Wheel Inner.....	6.311
BEARING ASSY., Front Wheel Outer.....	6.313
BEARING ASSY., Generator Commutator or Rotor Slip Ring End Frame.....	2.298
BEARING ASSY., Low Sun Gear and Clutch... ..	4.162
BEARING ASSY., Mast Jacket.....	6.521
BEARING ASSY., Planet Carrier.....	4.176
BEARING ASSY., Rear Wheel.....	5.855
BEARING ASSY., Transmission.....	4.164
BEARING, Camshaft (Center and Rear Intermediate).....	0.546
BEARING, Camshaft (Front or No. 1).....	0.539
BEARING, Camshaft (Rear).....	0.549
BEARING, Camshaft No. 1 (Front).....	0.539
BEARING, Camshaft No. 2 (Front Intermediate).....	0.543
BEARING, Camshaft Rear.....	0.549
BEARING, Camshaft.....	0.539
BEARING, Carburetor Air Valve.....	3.757
BEARING, Clutch throwout with Collar.....	0.799
BEARING, Clutch Pilot.....	0.649
BEARING, Clutch Throwout w/Collar.....	0.799
BEARING, Crankshaft Clutch Pilot.....	0.649
BEARING, Differential Side.....	5.536
BEARING, Fan-Idler Arm.....	1.060
BEARING, Fifth Speed.....	4.416
BEARING, Folding Top.....	14.478
BEARING, Generator Drive End.....	2.306
BEARING, Pitman Shaft.....	6.786
BEARING PKG., Air Conditioning Electrical Temperature and Blower Motor Control..	9.275
BEARING, Rear Axle Shaft Bearing or Hub....	5.822
BEARING, Steering Gear Worm Lower.....	6.826
BEARING, Steering Shaft U-Joint.....	6.525
BEARING, Steering Worm Thrust.....	6.835
BEARING, Transmission Clutch Gear.....	4.352
BEARING, Transmission Countershaft Gear... ..	4.422
BEARING, Transmission Main Drive Gear (Ball).....	4.355
BEARING, Transmission Main Shaft Front Pilot to Main Drive Gear.....	4.352
BEARING, Transmission Main Shaft Rear.....	4.408
BEARING, Transmission Reverse Idler Gear Thrust.....	4.437
BEARING, Transmission Synchronizer.....	4.384
BEARING UNIT, Camshaft Thrust.....	0.533
BEARING UNIT, Connecting Rod (1 Upper and 1 Lower).....	0.616
BEARING UNIT, Crankshaft Center (1 upper and 1 lower). See chart following group 0.096 for model application.....	0.101
BEARING UNIT, Crankshaft Front (1 Upper and 1 Lower) See chart for model application.....	0.096
BEARING UNIT, Crankshaft Front Intermediate (1 upper and 1 lower). See chart following group 0.096 for model application.....	0.099
BEARING UNIT, Crankshaft No. 1-2-3.....	0.096
BEARING UNIT, Crankshaft No. 4.....	0.103
BEARING UNIT, Crankshaft No. 5.....	0.106
BEARING UNIT, Crankshaft Rear Intermediate (1 upper and 1 lower). See chart following group 0.096 for model application.....	0.103
BEARING UNIT, Transmission Rear Unit.....	4.187
BEARING UNIT, Transmission Sun Gear and Parts.....	4.159
BEARING, Universal Joint Yoke Trunnion.....	5.566
BEARING, Vacuum Power Brake Cylinder Piston.....	4.924
BELLOWS, Windshield Washer.....	10.153
BELT, Camshaft Timing Belt.....	0.724

## ALPHABETICAL INDEX

BELT, Fan, Gen. and Accessory Drive.....	1.066	BOLT ASSY., Folding Top Hydraulic Motor and Pump.....	14.486
BELT, Steering Gear Hydraulic Pump Drive....	6.660	BOLT ASSY., Heater and Defroster Motor.....	8.856
BELT, Timing Belt.....	0.724	BOLT ASSY., Rear Compartment Lid or Tailgate Hinge.....	12.187
BEZEL, Air Conditioning Evaporator Core Housing.....	9.211	BOLT, Auto.....	8.820
BEZEL, Air Conditioning Remote Evaporator Air Distributor Outlet.....	9.264	BOLT, Battery to Starter Switch, with Terminals (Insulated).....	2.342
BEZEL, Antenna.....	9.647	BOLT, Battery Cable.....	2.343
BEZEL, Back-Up.....	2.697	BOLT, Battery Hanger Clamp.....	2.334
BEZEL, Cigarette Lighter.....	9.709	BOLT, Belt Unit and Shoulder Strap Unit Components.....	14.875A
BEZEL, Cowl.....	9.789	BOLT, Body.....	9.008
BEZEL, Folding Top.....	14.483	BOLT, Brake Connector.....	4.671
BEZEL, Front Fender.....	8.147	BOLT, Brake Main Cylinder.....	4.653
BEZEL, Hazard Flasher.....	2.575	BOLT, Brake Shoe Anchor Pin.....	5.056
BEZEL, Headlamp (Rim or Door).....	2.728	BOLT, Camshaft Housing and Cover.....	0.413
BEZEL, Heater.....	8.852	BOLT, Carburetor Air.....	3.730
BEZEL, Hood (Also See Group 1.303).....	8.055	BOLT, Carburetor Body.....	3.741
BEZEL, Ignition Lock.....	2.198	BOLT, Catalytic Converter.....	3.685
BEZEL, Instrument Case Face.....	9.748	BOLT, Clutch Cover and Pressure Plate.....	0.862
BEZEL, Instrument Case.....	9.746	BOLT, Clutch Pressure Plate.....	0.864
BEZEL, Instrument Panel Compartment Door Lock.....	10.267	BOLT, Concealed Headlamp Control Opening Cover.....	2.765
BEZEL, Instrument Panel.....	14.655A	BOLT, Concealed Headlamp Opening Cover..	2.770
BEZEL, Instrument.....	9.743	BOLT, Connecting Rod Bearing Cap.....	0.623
BEZEL, Lever Hand (Floor Mounted).....	4.015	BOLT, Coolant Pump.....	1.073
BEZEL, Lighting Switch Rod.....	2.487	BOLT, Crankshaft Bearing Cap.....	0.056
BEZEL, Lighting.....	2.485	BOLT, Crankshaft Damper.....	0.662
BEZEL, Parking Lamp.....	2.593	BOLT, Crankshaft Main Bearing Cap.....	0.056
BEZEL, Radio Control.....	9.649	BOLT, Cylinder Head.....	0.293
BEZEL, Rear Quarter Outer.....	12.940A	BOLT, Differential Carrier Cap.....	5.506
BEZEL, Rear Window Defogger.....	9.778	BOLT, Dist. Spark Advance Trans. Electric Control (Also See Group 4.075).....	2.408
BEZEL, Safety Light.....	9.773	BOLT, Door Hinge to Hinge Pillar.....	10.463
BEZEL, Seat Belt, Check Doors and Low Fuel Warning Lights.....	9.765	BOLT, Door Window Lower Sash.....	10.747
BEZEL, Seat Separator.....	10.242	BOLT, Door Window Regulator Manual or Electric.....	10.792
BEZEL, Tail and Stop Lamp.....	2.681	BOLT, Engine Mounting (Small Attaching).....	0.002
BEZEL, Tailgate.....	12.195	BOLT, Flange Plate.....	5.002
BEZEL, Transmission Control Lever Boot.....	4.017	BOLT, Flywheel and Clutch.....	0.683
BEZEL, Windshield Wiper Control.....	10.166	BOLT, Flywheel to Crankshaft.....	0.669
BEZEL, Windshield Wiper.....	10.163	BOLT, Flywheel.....	0.679
BINDING, Floor Carpet.....	15.294	BOLT, Folding Seat (For Load Floor Parts See Group 12.977).....	11.620
BLADE ASSY., Fan.....	1.064	BOLT, Folding Top Frame.....	14.155
BLADE ASSY., Tail Gate.....	12.180B	BOLT, Folding Top Front Roof Rail.....	14.080A
BLADE, Windshield Wiper.....	10.146	BOLT, Folding Top No. 1-Center.....	14.215
BLEED RESET, Venturi Cluster.....	3.790	BOLT, Folding Top.....	14.310
BLOCK ASSEMBLY, Cylinder.....	0.033	BOLT, Frame to Bumper Attaching (Also See Group 7.869).....	7.836
BLOCK ASSY., Battery to Starter Switch, with Terminals (Insulated).....	2.342	BOLT, Front and Rear Bumper Shock.....	7.840
BLOCK ASSY., Cylinder.....	0.033	BOLT, Front or Rear Bumper Bar Mounting and Attaching.....	7.874
BLOCK, Fuse & Junction.....	2.483	BOLT, Front Door Window Glass Lower Sash.....	10.685
BLOCK UNIT, Speed and Cruise Control.....	3.887	BOLT, Front Fender and Skirt.....	8.143
BLOWER ASSY., Heater.....	8.857	BOLT, Front Seat Adjuster.....	11.561
BLOWER CASE, Rear Window Defogger.....	9.778	BOLT, Front Seat Back Lock.....	11.390
BOARD ASSY., Windshield Washer.....	10.153	BOLT, Front Spring.....	7.418
BOARD ASSY., Windshield Wiper.....	10.150	BOLT, Fuel Tank Evaporative Control.....	3.120
BOARD UNIT, Air Conditioning Electrical Temperature and Blower Motor Control..	9.275	BOLT, Fuel Tank Gauge.....	3.112
BOARD UNIT, Heater.....	8.852	BOLT, Fuel Tank Strap.....	3.023
BODY ASSY., Air Conditioning less Clutch....	9.170	BOLT, Gearshift Control Hand Lever.....	4.008
BODY ASSY., Carburetor Air Valve.....	3.757	BOLT, Gearshift Hand Lever Housing.....	4.012
BODY ASSY., Carburetor Float.....	3.734	BOLT, Generator (see 2.317 for brace).....	2.277
BODY ASSY., Transmission Low and Drive Valve.....	4.265	BOLT, Generator Through.....	2.316
BODY ASSY., Transmission Main Valve.....	4.216	BOLT, Generator.....	2.313
BODY ASSY., Transmission Oil.....	4.224	BOLT, Harmonic Balancer and Crankshaft Pulley.....	0.662
BODY ASSY., Transmission.....	4.256	BOLT, Hood Lock-Lower.....	8.080
BODY, Carburetor.....	3.729	BOLT, Hood Moulding and Hinge Attaching..	8.016
BODY, Oil Filter.....	1.837	BOLT, Hood Panel.....	8.015
BODY, Vacuum Power Brake Cylinder.....	4.922	BOLT, Hood Upper Lock Plate.....	8.085
BOLT.....	7.831A	BOLT, Hub or Drum (Front and Rear Wheel)..	5.812
BOLT.....	7.836A	BOLT, Intake & Exhaust Manifold.....	3.275
BOLT, Air Cleaner.....	3.417	BOLT, Intake Manifold to Carburetor.....	3.288
BOLT, Air Conditioning Compressor Mounting Attaching Parts.....	9.173	BOLT, License Plate.....	7.800
BOLT, Air Conditioning Compressor Mounting.....	9.171	BOLT, Low Sun Gear and Clutch.....	4.162
BOLT, Air Injection Reactor Pump Mounting..	3.655	BOLT, Luggage Compartment.....	12.977
BOLT, Air Injection Reactor.....	3.680	BOLT, Manifold.....	3.602
BOLT, Air Suspension or Level Control Air Compressor.....	7.452	BOLT, Oil.....	1.652
BOLT AND CLIP ASSY., Radio and Stereo Mounting.....	9.667	BOLT, Oil Filter.....	1.840
BOLT AND CLIP ASSY., Rear and Auxiliary Speakers.....	9.665	BOLT, Oil Pan Attaching, with Lockwasher...	1.428

## ALPHABETICAL INDEX

BOLT, Oil Pan Pump Suction.....	4.197	BOW, Roof.....	12.952
BOLT, Oil Supply Pump.....	4.203	BOX ASSY., Rear Compartment Lid.....	12.184
BOLT, Propeller Shaft Damper.....	5.544A	BOX, Floor (less Rear Compartment Floor Pan).....	12.980
BOLT, Quarter Window Lower Sash.....	11.007A	BOX, Front Door Trim Stowage.....	14.692
BOLT, Quarter Window Upper Sash.....	11.005	BOX, Front Door, Lower.....	10.454
BOLT, Radiator Core.....	1.270	BOX, Front Door, Upper.....	10.450
BOLT, Rear Axle U Joint.....	5.428	BOX, Instrument Panel Compartment.....	10.260
BOLT, Rear Axle Control Arm.....	5.383	BRACE, Air Conditioning Compressor Mounting.....	9.171
BOLT, Rear Axle Tie Rod.....	5.418	BRACE, Air Conditioning Evaporator Blower Motor.....	9.216
BOLT, Rear Compartment Front and Shelf.....	12.971	BRACE, Air Injection Reactor Pump Mounting.....	3.655
BOLT, Rear Compartment Lid.....	12.184	BRACE ASSY., Dash to Chassis Frame.....	12.650
BOLT, Rear Spring and Shock Absorber.....	7.516	BRACE ASSY., Front Fender Skirt.....	8.155
BOLT, Rear Spring.....	7.529	BRACE ASSY., Hood Panel.....	8.015
BOLT, Rear Window Defogger.....	9.778	BRACE, Battery.....	2.333
BOLT, Ring Gear.....	5.531	BRACE, Bumper Valance Panel.....	7.833
BOLT, Shock Absorber Frame.....	7.395	BRACE, Carburetor Throttle Return Check.....	3.444
BOLT, Shock Absorber.....	7.347	BRACE, Center Body.....	12.491
BOLT, Speed and Cruise Control.....	3.880	BRACE, Cross Member.....	7.039
BOLT, Speedometer and Odometer (Miles).....	9.761	BRACE, Engine Intake.....	3.265
BOLT, Spring Center (Front and Rear).....	7.506	BRACE, Folding Top Compartment (See Group 15.100 for TRIM ASSY.).....	12.989
BOLT, Stabilizer Shaft.....	7.242	BRACE, Frame to Bumper Attaching (Also See Group 7.869).....	7.836
BOLT, Stabilizer.....	7.240	BRACE, Front Fender.....	8.141
BOLT, Starting Motor (Internal).....	2.077	BRACE, Front Fender.....	8.153
BOLT, Starting Motor to Engine Attaching.....	2.042	BRACE, Gearshift Control Hand Lever.....	4.008
BOLT, Steering Column Lock Bolt.....	6.500	BRACE, Gearshift Hand Lever.....	4.010
BOLT, Steering Column.....	6.760	BRACE, Generator (Bracket listed in Group 2.277).....	2.317
BOLT, Steering Gear to Frame.....	6.509	BRACE, Hinge Pillar to Floor.....	12.659
BOLT, Steering Gear Ball Return Guide.....	6.843	BRACE, Instrument Panel to Dash.....	10.230
BOLT, Steering Gear Housing Side Cover.....	6.809	BRACE, Lock Pillar.....	12.684
BOLT, Steering Gear Hydraulic Pump Mounting.....	6.606	BRACE, Muffler.....	3.704
BOLT, Steering Gear Hydraulic Pump.....	6.635	BRACE, Radiator Grille.....	1.267
BOLT, Steering Idler.....	6.897	BRACE, Radio and Stereo Mounting.....	9.667
BOLT, Steering Knuckle Lower Control Arm Attaching.....	6.172	BRACE, Rear Quarter Side Inner.....	12.941A
BOLT, Steering Knuckle Lower Control Arm Pivot.....	6.174	BRACE, Rear Compartment End.....	12.986
BOLT, Steering Knuckle Upper and Lower Control Arm Assy.....	6.168	BRACE, Rear Compartment Floor.....	12.981
BOLT, Steering Knuckle Upper Control Arm..	6.164	BRACE, Rear Compartment Lid.....	12.996
BOLT, Steering Knuckle Upper Control Arm..	6.178	BRACE, Speed and Cruise Control.....	3.880
BOLT, Steering Knuckle.....	6.104	BRACE, Starting Motor (Internal).....	2.077
BOLT, Steering Shaft U-Joint.....	6.525	BRACE, Starting Motor to Engine Attaching..	2.042
BOLT, Stop Folding Top-Rear.....	14.340	BRACE, Steering Gear Hydraulic Pump Mounting.....	6.606
BOLT, Tail Gate.....	12.184A	BRACE, Steering Knuckle Lower Control Arm Shaft.....	6.170
BOLT, Tailgate.....	12.195	BRACE, Transmission Gearshift Control Shaft or Tube.....	4.027
BOLT, Timing Belt.....	0.724	BRACE, Vacuum Power Brake Cylinder Air....	4.913
BOLT, Trailer.....	7.068	BRACE, Vacuum Power Brake.....	4.898
BOLT, Transmission (Rebuilt for General Motors).....	4.115	BRACE, Wheelhouse.....	12.944
BOLT, Transmission Case.....	4.105	BRACKET.....	7.836A
BOLT, Transmission Gearshift Control Cable..	4.047	BRACKET, Accelerator Pedal.....	3.452
BOLT, Transmission Mounting Support.....	4.085	BRACKET, Accelerator Pull Back.....	3.459
BOLT, Transmission Overdrive.....	4.495	BRACKET, Accelerator.....	3.454
BOLT, Transmission.....	4.115	BRACKET, Air Cleaner Intake Valve.....	3.415
BOLT, Valve Rocker Cover and Support (Also See Group 0.366).....	0.413	BRACKET, Air Cleaner.....	3.405
BOLT, Valve, Push Rod Cover.....	0.446	BRACKET, Air Cleaner.....	3.417
BOLT, Wheel Brake (Also See Group 4.667) ..	4.665	BRACKET, Air Conditioning Compressor Mounting.....	9.171
BOLT, Wheel Carrier.....	7.632	BRACKET, Air Conditioning Control.....	9.281
BOLT, Windshield Wiper.....	10.150	BRACKET, Air Conditioning Electrical.....	9.277
BOLT, 'U' Joint Trunnion and Yoke.....	5.586	BRACKET, Air Conditioning Evaporator Air Distributor and Astro-Ventilation.....	9.262
BOOT, Air Cleaner.....	3.417	BRACKET, Air Conditioning Evaporator Blower Motor.....	9.216
BOOT, Belt Unit and Shoulder Strap Unit Components.....	14.875A	BRACKET, Air Conditioning Evaporator Core Housing.....	9.211
BOOT, Carburetor (with Leather and Shaft)....	3.838	BRACKET, Air Conditioning Evaporator Expansion Valve.....	9.214
BOOT, Clutch Fork.....	0.797	BRACKET, Air Conditioning Hose.....	9.242
BOOT, Distributor Vacuum Control Clamp.....	2.414	BRACKET, Air Conditioning Refrigerant.....	9.190
BOOT, Electrical.....	2.530	BRACKET, Air Conditioning Refrigerant.....	9.196
BOOT, Gearshift Linkage.....	4.067	BRACKET, Air Duct Intake (Outside Air).....	9.784
BOOT, Instrument Case.....	9.749	BRACKET, Air Flow Control with Tube.....	9.787
BOOT, Lever Hand (Floor Mounted).....	4.015	BRACKET, Air Flow.....	9.786
BOOT, Main Cylinder (Rubber).....	4.659	BRACKET, Air Injection Reactor Pump Mounting.....	3.655
BOOT, Parking Brake.....	4.592	BRACKET, Air Injection Reactor Pump.....	3.665
BOOT, Top Dust (with Fasteners).....	13.450	BRACKET, Air Injection Reactor Valve.....	3.670
BOOT, Transmission Control Lever.....	4.015		
BOOT, Wheel Cylinder.....	4.670		
BOW ASSY., Stop Folding Top-Rear.....	14.340		
BOW, Folding Top No. 1-Center.....	14.215		
BOW, Folding Top.....	14.130		
BOWL, Carburetor Float.....	3.734		
BOWL, Carburetor.....	3.890		
BOWL, Gearshift Hand Lever.....	4.010		
BOWL, Mast (Also see Group 6.803).....	6.518		

## ALPHABETICAL INDEX

BRACKET, Antenna.....	9.647	BRACKET, Hand Control Wires and Tubes.....	3.483
BRACKET ASSY., Air Suspension or Level Control Air Compressor.....	7.452	BRACKET, Headlamp (Rim or Door).....	2.728
BRACKET ASSY., Brake Pedal.....	4.634	BRACKET, Headlamp Lens and Sealed Beam Retaining.....	2.736
BRACKET ASSY., Carburetor.....	3.755	BRACKET, Headlamp Moulding.....	2.729
BRACKET ASSY., Clutch Cable.....	0.855	BRACKET, Heater.....	8.852
BRACKET ASSY., Engine Mounting.....	0.029	BRACKET, Hot Water.....	8.845
BRACKET ASSY., Gearshift Hand Lever.....	4.010	BRACKET, Hydraulic Brake.....	4.686
BRACKET ASSY., Mast (Also see Group 6.803).....	6.518	BRACKET, Hydraulic Steering Pump Hose.....	6.672
BRACKET ASSY., Steering Column.....	6.760	BRACKET, Ignition Coil Mounting.....	2.183
BRACKET ASSY., Tilt or Tel. Steering Column.....	6.514	BRACKET, Ignition Pulse (Transistorized).....	2.383
BRACKET ASSY., Transmission Control Safety.....	4.054	BRACKET, Instrument Panel to Dash.....	10.230
BRACKET ASSY., Transmission Gearshift.....	4.004	BRACKET, Instrument Panel Assist Handle ...	14.660
BRACKET ASSY., Transmission Throttle Valve Control (T.V.).....	4.050	BRACKET, Instrument Panel Compartment, Seat Separator Compartment and Courtesy.....	10.275
BRACKET ASSY., Wheel Cover Panel.....	8.176	BRACKET, Instrument Panel Compartment.....	10.260
BRACKET, Auto.....	8.820	BRACKET, Instrument Panel Harness.....	2.482
BRACKET, Automatic Choke Control.....	3.750	BRACKET, Instrument Panel.....	10.252
BRACKET, Auxiliary Spring.....	7.526	BRACKET, License Plate.....	7.800
BRACKET, Back Door Reveal.....	12.180C	BRACKET, Lighting.....	2.485
BRACKET, Back-Up.....	2.698	BRACKET, Manifold Heat Control Valve.....	3.641
BRACKET, Battery.....	2.333	BRACKET, Manifold.....	3.602
BRACKET, Body.....	7.330	BRACKET, Muffler Tail Pipe.....	3.706
BRACKET, Brake Flange Front.....	5.001	BRACKET, Muffler.....	3.704
BRACKET, Brake Hose or Pipe.....	4.681	BRACKET, Oil Pressure.....	1.803
BRACKET, Brake Press Ind.....	4.874	BRACKET, Parking Brake Cable.....	4.785
BRACKET, Bumper Guard Mounting.....	7.829	BRACKET, Parking Lamp Attaching.....	2.587
BRACKET, Bumper Valance Panel.....	7.833	BRACKET, Quarter Window.....	11.041
BRACKET, Bumper.....	7.865	BRACKET, Radiator (Mouldings in group 1.268).....	1.266
BRACKET, By-Pass Mounting.....	9.199	BRACKET, Radiator and Grille Filler.....	1.287
BRACKET, Carburetor and Fuel Meter Intake (w/seat and gasket).....	3.814	BRACKET, Radiator Core.....	1.270
BRACKET, Carburetor Air.....	3.730	BRACKET, Radiator Fan.....	1.277
BRACKET, Carburetor Throttle Return Check.....	3.440	BRACKET, Radiator Grille.....	1.267
BRACKET, Carburetor Throttle Return Check.....	3.444	BRACKET, Radiator Support.....	1.271
BRACKET, Carburetor Vacuum.....	3.765	BRACKET, Radio and Stereo Mounting.....	9.667
BRACKET, Carburetor.....	3.890	BRACKET, Radio Instrument Panel.....	10.256
BRACKET, Catalytic Converter.....	3.685	BRACKET, Rear Axle Control Arm.....	5.380
BRACKET, Catalytic Converter.....	3.690	BRACKET, Rear Axle Tie Rod.....	5.418
BRACKET, Clock Mounting and Attaching.....	9.772	BRACKET, Rear Axle.....	5.395
BRACKET, Clutch Fork.....	0.796	BRACKET, Rear Brake Pressure Regulator.....	4.690
BRACKET, Clutch Pedal Intermediate.....	0.852	BRACKET, Rear Bumper Upper Face Bar.....	7.832
BRACKET, Clutch.....	0.829	BRACKET, Rear Door Window.....	10.791
BRACKET, Concealed Headlamp Control Drive.....	2.760	BRACKET, Rear Spring.....	7.535
BRACKET, Concealed Headlamp Control Opening Cover.....	2.765	BRACKET, Rear View Mirror.....	10.186
BRACKET, Concealed Headlamp Motor.....	2.755	BRACKET, Rear Window Defogger.....	9.778
BRACKET, Coolant Recovery Unit.....	1.240	BRACKET, Roof Luggage and Ski.....	12.815
BRACKET, Cowl.....	12.803	BRACKET, Safety Light.....	9.773
BRACKET, Cowl.....	9.789	BRACKET, Seat Separator.....	10.240
BRACKET, Defroster.....	9.779	BRACKET, Shock Absorber Frame.....	7.395
BRACKET, Dist. Spark Advance Trans. Electric Control (Also See Group 4.075).....	2.408	BRACKET, Shock Absorber, Air Lift.....	7.346
BRACKET, Distributor Vacuum Control.....	2.420	BRACKET, Shock Absorber.....	7.380
BRACKET, Distributor, with Bracket and Lead.....	2.393	BRACKET, Spark Plug Wire.....	2.251
BRACKET, Engine Mounting.....	0.029	BRACKET, Speed and Cruise Control Power..	3.885
BRACKET, Fan-Idler Arm.....	1.060	BRACKET, Speed and Cruise Control.....	3.880
BRACKET, Folding Top.....	14.483	BRACKET, Speed Indicator.....	9.762
BRACKET, Frame to Bumper Attaching (Also See Group 7.869).....	7.836	BRACKET, Stabilizer Shaft.....	7.242
BRACKET, Front and Rear Bumper Shock.....	7.840	BRACKET, Steering Gear Hydraulic Pump Mounting.....	6.606
BRACKET, Front and Rear Bumper.....	7.869	BRACKET, Steering Knuckle Upper and Lower Control Arm.....	6.177
BRACKET, Front Center Speaker Mounting....	9.655	BRACKET, Stop Lamp.....	2.447
BRACKET, Front Door Window.....	10.783	BRACKET, Tail Gate.....	12.180B
BRACKET, Front End and Close.....	1.263	BRACKET, Tailgate.....	12.195
BRACKET, Front Fender.....	8.141	BRACKET, Transmission Control Idler.....	4.040
BRACKET, Front Fender.....	8.153	BRACKET, Transmission Control Safety.....	4.054
BRACKET, Fuel Feed Pipe.....	3.162	BRACKET, Transmission Control Switch.....	4.060
BRACKET, Fuel Injection.....	3.302	BRACKET, Transmission Gearshift Control Cable.....	4.047
BRACKET, Fuel Injector.....	3.330	BRACKET, Transmission Gearshift Shaft or Tube (Lower).....	4.030
BRACKET, Fuel Pump Mounting.....	3.901	BRACKET, Transmission Mounting.....	4.083
BRACKET, Fuel Tank Evaporative Control.....	3.120	BRACKET, Transmission Oil.....	4.128
BRACKET, Fuel Tank Evaporative Control.....	3.130	BRACKET, Transmission Overdrive.....	4.480
BRACKET, Gearshift Control (Hand).....	4.006	BRACKET, Transmission Overdrive.....	4.495
BRACKET, Gearshift Control Hand Lever.....	4.008	BRACKET, Transmission Parking Brake.....	4.290
BRACKET, Gearshift Hand Lever.....	4.010	BRACKET, Transmission Parking Lock.....	4.220
BRACKET, Generator (see 2.317 for brace)....	2.277	BRACKET, Transmission Throttle valve Operating Parts.....	4.275
BRACKET, Generator (Current Regulator Listed in Group 2.500).....	2.319	BRACKET, Transmission Throttle Valve Control (T.V.).....	4.050
		BRACKET, Underbody Trim (floor mounted)...	4.017
		BRACKET, Vacuum Power Brake.....	4.898

## ALPHABETICAL INDEX

BRACKET, Wheel Brake (Also See Group 4.667).....	4.665	BUMPER, Vacuum Power Brake Cyl. Reaction.....	4.934
BRACKET, Wheel Opening Cover.....	8.179	BUMPER, Wheel Cover Panel.....	8.176
BRACKET, Windshield Wiper Motor Mounting Parts.....	10.152	BUMPER, Windshield Pillar Weatherstrip.....	10.093A
BRACKET, Windshield Wiper Parts.....	10.154	BUSHING, Air Conditioning Compressor (Internal).....	9.172
BRACKET, Windshield Wiper.....	10.150	BUSHING, Air Conditioning Compressor Mounting.....	9.171
BRAKE ASSY., Carburetor.....	3.755	BUSHING ASSY., Radiator Core.....	1.270
BRAKE UNIT, Vacuum Power Brake.....	4.901	BUSHING ASSY., Rear Axle Control Arm.....	5.381
BREAKER ASSY., Concealed Headlamp Motor.....	2.755	BUSHING ASSY., Rear Axle.....	5.417
BREAKER ASSY., Lighting.....	2.485	BUSHING ASSY., Steering Idler.....	6.897
BREAKER ASSY., Tailgate.....	12.195	BUSHING, Brake Pedal.....	4.626
BREAKER, Electric Seat Adjuster Switch.....	11.558	BUSHING, Carburetor and Fuel Injection Choke.....	3.752
BREATHER, Air Cleaner.....	3.410	BUSHING, Carburetor Fast Idle Cam.....	3.767
BRIDGE, Generator (Current Regulator Listed in Group 2.500).....	2.319	BUSHING, Carburetor Throttle.....	3.762
BRUSH.....	2.051	BUSHING, Center Bearing.....	2.082
BRUSH ASSY., Windshield Wiper.....	10.150	BUSHING, Clutch Pedal (see group 4.626 for brake pedal bushing).....	0.831
BRUSH, Distributor.....	2.368	BUSHING, Clutch Pedal.....	0.854
BRUSH, Folding Top Motor and Pump.....	14.482	BUSHING, Concealed Headlamp Control Opening Cover.....	2.765
BRUSH, Generator.....	2.285	BUSHING, Door Hinge.....	10.464
BRUSH UNIT, Windshield Wiper.....	10.150	BUSHING, Door Window Lower Sash.....	10.747
BUMPER, Air Cleaner.....	3.417	BUSHING, Door Window Regulator Manual or Electric.....	10.792
BUMPER, Air Conditioning Compressor Suction and Discharge.....	9.226	BUSHING, Exhaust Manifold.....	3.647
BUMPER, Air Conditioning Refrigerant.....	9.190	BUSHING, Folding Seat (For Load Floor Parts See Group 12.977).....	11.620
BUMPER, Ash Receiver.....	12.009	BUSHING, Folding Top Back Window.....	13.395
BUMPER ASSY., Front Door Ventilator.....	10.670	BUSHING, Folding Top Motor and Pump.....	14.482
BUMPER ASSY.....	7.831A	BUSHING, Folding Top Side Roof Rail.....	14.160
BUMPER, Auto.....	8.820	BUSHING, Forward Cone Freewheel.....	4.168
BUMPER, Back-Up.....	2.697	BUSHING, Front Door Glass Lower Sash Channel.....	10.687
BUMPER, Battery.....	2.333	BUSHING, Front Door Window Glass Lower Sash.....	10.685
BUMPER, Body Back Lower (Rear End).....	12.966	BUSHING, Gearshift Control (Hand).....	4.006
BUMPER, Bumper Valance Panel.....	7.833	BUSHING, Gearshift Control Hand Lever.....	4.008
BUMPER, Clutch.....	0.829	BUSHING, Gearshift Shaft Lever.....	4.032
BUMPER, Concealed Headlamp Motor.....	2.755	BUSHING, Generator (see 2.317 for brace)....	2.277
BUMPER, Direction Signal Lamp (See Group 9.748 Tell Tale Wind.).....	2.895	BUSHING, Generator (Current Regulator Listed in Group 2.500).....	2.319
BUMPER, Door Lock Remote Control Connecting.....	10.506A	BUSHING, Generator Commutator or Rotor Slip Ring End Frame.....	2.298
BUMPER, Door Lock Inside.....	10.512	BUSHING, Heater.....	8.852
BUMPER, Door Window Regulator Manual or Electric.....	10.792	BUSHING, Horn Button and Blowing Ring.....	2.819
BUMPER, Door Window.....	10.716	BUSHING, Load Floor.....	12.975
BUMPER, End Gate Lock.....	12.237A	BUSHING, Low Sun Gear and Clutch.....	4.162
BUMPER, End Gate Rear Door.....	12.242A	BUSHING, Mast (Also see Group 6.803).....	6.518
BUMPER, Engine Air Cooling Control.....	1.035	BUSHING, Oil Supply Pump.....	4.203
BUMPER, Folding Seat (For Load Floor Parts See Group 12.977).....	11.620	BUSHING, Pitman Shaft.....	6.786
BUMPER, Folding Top Side Roof Rail.....	14.180	BUSHING, Planet Carrier.....	4.176
BUMPER, Front Door Outer Panel.....	12.112	BUSHING, Quarter Window Glass.....	11.010
BUMPER, Fuel Pump.....	3.903	BUSHING, Quarter Window Lower Sash.....	11.007A
BUMPER, Gas Tank Filler Neck Compartment.....	12.945	BUSHING, Rear Door Window.....	10.768
BUMPER, Hazard Flasher.....	2.575	BUSHING, Rear Spring Eye.....	7.504
BUMPER, Headlamp Control.....	2.775	BUSHING, Rear Spring Shackle.....	7.524
BUMPER, Hood.....	8.024	BUSHING, Rear View Mirror.....	10.186
BUMPER, Instrument Case.....	9.749	BUSHING, Shock Absorber Link.....	7.388
BUMPER, Instrument Panel Compartment Door.....	10.263	BUSHING, Speedometer and Odometer (Miles).....	9.761
BUMPER, License Plate.....	7.800	BUSHING, Stabilizer Shaft.....	7.243
BUMPER, Load Floor (for Folding Seat Parts see Group 11.620).....	12.977	BUSHING, Starting Motor End.....	2.083
BUMPER, Load Floor.....	12.975	BUSHING, Steering Knuckle Lower Control Arm Shaft.....	6.170
BUMPER, Parking Lamp Attaching.....	2.587	BUSHING, Steering Knuckle Upper Control Arm.....	6.164
BUMPER, Quarter Window Garnish and Quarter Belt Finishing.....	11.119	BUSHING, Tail Gate.....	12.184A
BUMPER, Rear Axle.....	5.395	BUSHING, Throttle Control Rod.....	3.425
BUMPER, Rear Compartment.....	12.212	BUSHING, Transmission Case.....	4.104
BUMPER, Rear Spring.....	7.535	BUSHING, Transmission Clutch.....	4.169
BUMPER, Rear Spring.....	7.535	BUSHING, Transmission Control Idler Attaching.....	4.042
BUMPER, Seat Back.....	11.381	BUSHING, Transmission Control Safety.....	4.054
BUMPER, Seat Separator.....	10.242	BUSHING, Transmission Extension.....	4.319
BUMPER, Side Door.....	10.587	BUSHING, Transmission Front Servo.....	4.226
BUMPER, Spare Tire Cover.....	12.579	BUSHING, Transmission Gearshift Rod to Lever.....	4.037
BUMPER, Speedometer and Odometer (Miles).....	9.761	BUSHING, Transmission Low and Drive Valve.....	4.265
BUMPER, Steering Knuckle Upper and Lower Control Arm.....	6.176	BUSHING, Transmission Overdrive.....	4.455
BUMPER, Tail Gate.....	12.180B	BUSHING, Transmission Planet.....	4.161
BUMPER, Tail Gate.....	12.180		
BUMPER, Tail Gate.....	12.184A		
BUMPER, Tailgate.....	12.195		
BUMPER, Tilt or Tel. Steering Column.....	6.514		

## ALPHABETICAL INDEX

BUSHING, Transmission Rear Main Bearing.....	4.319	CAM ASSY., Folding Top Side Roof-Front.....	14.100
BUSHING, Transmission Reverse.....	4.431	CAM ASSY., Front Seat Adjuster.....	11.561
BUSHING, Transmission.....	4.256	CAM ASSY., Tail Gate.....	12.180
BUSHING UNIT, Rear Axle Control Arm.....	5.380	CAM ASSY., Transmission Overdrive.....	4.465
BUSHING UNIT, Transmission Main Valve.....	4.216	CAM, Carburetor and Fuel Injection Fast Idle.....	3.766
BUSHING, Wheel Brake (Also See Group 4.667).....	4.665	CAM, Carburetor Pump.....	3.842
BUTTON ASSY., Front Seat Back Lock.....	11.390	CAM, Direction Signal Lamp (Cancelling).....	2.896
BUTTON ASSY., Horn Blowing.....	2.820	CAM, Distributor.....	2.381
BUTTON ASSY., Seat Back and Trim Pad.....	14.804	CAM, Front Door Glass Lower Sash Channel.....	10.687
BUTTON, Door Handle Push Button.....	10.529	CAM, Fuel Tank Gauge.....	3.107
BUTTON, Electric Seat Adjuster Switch.....	11.558	CAM, Gearshift Detent.....	4.311
BUTTON, Gearshift Control (Hand).....	4.006	CAM, Rear Compartment Lock Handle.....	12.252
BUTTON, Speed and Cruise Selector.....	3.883	CAM, Rear Door Lower Window Sash Channel.....	10.748
BUZZER ASSY., Automatic Headlamp Control.....	2.461	CAMSHAFT.....	0.519
BUZZER ASSY., Lighting.....	2.485	CAMSHAFT, Engine.....	0.519
BUZZER ASSY., Speed Indicator.....	9.762	CAM, Steering Knuckle Lower Control Arm Attaching.....	6.172
BUZZER, Belt Unit and Shoulder Strap Unit Components.....	14.875A	CAM, Transmission Forward Cone Freewheel.....	4.167
BUZZER, Ignition Switch Warning.....	2.195	CAM, Transmission Internal Shift.....	4.302
<b>C</b>			
CABLE ASSEMBLY, Folding Top Trim Hold Down.....	14.102	CAM, Windshield Washer.....	10.153
CABLE ASSY., Air Conditioning Control.....	9.281	CANISTER, Fuel Tank Evaporative Control.....	3.130
CABLE ASSY., Air Flow Control with Tube.....	9.787	CAP.....	4.651
CABLE ASSY., Antenna.....	9.647	CAPACITOR ASSY., Rear Window Defogger..	9.778
CABLE ASSY., Carburetor to Accelerator Lever.....	3.430	CAPACITOR, Distributor, with Bracket and Lead.....	2.393
CABLE ASSY., Clutch Cable.....	0.854	CAPACITOR, Generator (Current Regulator Listed in Group 2.500).....	2.319
CABLE ASSY., Direction Signal Lamp (See Group 9.748 Tell Tale Wind.).....	2.895	CAPACITOR, Ignition Pulse (Transistorized)...	2.383
CABLE ASSY., Ducted Hood.....	8.036	CAPACITOR, Radio Noise Suppression.....	9.663
CABLE ASSY., Folding Seat (For Load Floor Parts See Group 12.977).....	11.620	CAPACITOR, Radio.....	9.654
CABLE ASSY., Folding Top.....	14.475	CAP, Air Conditioning Compressor Oil Test ..	9.177
CABLE ASSY., Front Seat Adjuster.....	11.561	CAP, Air Conditioning Evaporator By-Pass ....	9.198
CABLE ASSY., Hood Lock Release.....	8.075	CAP, Air Injection Reactor Valve.....	3.670
CABLE ASSY., Load Floor (for Folding Seat Parts see Group 11.620).....	12.977	CAP, Antenna.....	9.647
CABLE ASSY., Rear Axle Lateral Movement-(Stop).....	5.410	CAP ASSY., Horn Blowing.....	2.820
CABLE ASSY., Safety Light.....	9.773	CAP ASSY., Inside Rear View Mirror.....	10.187
CABLE ASSY., Seat Back Reclining.....	11.377	CAP ASSY., Steering Gear Hydraulic Pump....	6.635
CABLE ASSY., Sliding Sunroof.....	14.550	CAP ASSY., Windshield Wiper.....	10.150
CABLE ASSY., Speed and Cruise Control.....	3.880	CAP, Body Center Pillar (With Metal Inner Panel).....	14.730
CABLE ASSY., Speed Indicator.....	9.762	CAP, Carburetor and Fuel Meter Float Lever..	3.747
CABLE ASSY., Tail Gate.....	12.180B	CAP, Carburetor Float.....	3.734
CABLE ASSY., Tail Gate.....	12.180	CAP, Carburetor Idle Vapor Vent.....	3.852
CABLE ASSY., Tailgate.....	12.195	CAP, Clutch Fork Ball.....	0.796
CABLE ASSY., Transmission Gearshift Control Cable.....	4.047	CAP, Coolant Pump.....	1.070
CABLE ASSY., Transmission Throttle Valve Control (T.V.).....	4.050	CAP, Coolant Recovery Unit.....	1.240
CABLE, Battery to Starter Switch, with Terminals (Insulated).....	2.342	CAP, Crankshaft Front Bearing.....	0.095
CABLE, Battery Ground, with Terminal.....	2.341	CAP, Crankshaft Main Bearing.....	0.095
CABLE, Clutch.....	0.854	CAP, Crankshaft Main Bearing.....	0.102
CABLE, Electrical.....	2.530	CAP, Crankshaft Main Bearing.....	0.105
CABLE, Gearshift Control (Hand).....	4.006	CAP, Crankshaft Rear Bearing.....	0.105
CABLE, Parking Brake.....	4.779	CAP, Crankshaft Rear Intermediate Bearing...	0.102
CABLE, Seat Back.....	11.381	CAP, Distributor.....	2.367
CABLE, Transmission Gearshift Control.....	4.020	CAP, Door Outside Handle Push Button and Lock Cylinder.....	10.552
CABLE UNIT, Engine (Also See Group 4.081).....	0.027	CAP, Door Window Regulator Manual or Electric.....	10.792
CAGE ASSY., Transmission Overdrive.....	4.470	CAP, Door Window.....	10.716
CAGE, Differential Clutch (Positraction).....	5.511	CAP, Electric Seat Adjuster Switch.....	11.558
CAGE, Transmission Overdrive.....	4.467	CAP, Folding Top Side Roof Rail-Rear.....	14.260
CALIPER ASSY., Wheel Brake (Also See Group 4.667).....	4.665	CAP, Front Door Window Glass Lower Sash..	10.685
CAM, Air Conditioning Electrical Temperature and Blower Motor Control..	9.275	CAP, Front Seat Back Lock.....	11.390
CAM, Air Flow.....	9.786	CAP, Front Seat Side Trim (See Group 12.976 for 2nd and 3rd Seat Moulding and Escutcheon).....	14.818
CAM AND RING UNIT, Windshield Washer...	10.153	CAP, Fuel Tank Evaporative Control.....	3.130
CAM ASSY., Air Conditioning Control.....	9.281	CAP, Fuel Tank Filler Cap.....	3.028
CAM ASSY., Air Conditioning Vacuum Control.....	9.280	CAP, Gearshift Level Selector and Indicator...	4.022
CAM ASSY., Door Window Regulator Manual or Electric.....	10.792	CAP, Heater.....	8.852
		CAP, Heater.....	8.866
		CAP, Load Floor (for Folding Seat Parts see Group 11.620).....	12.977
		CAP, Lock Pillar Finishing.....	14.731
		CAP, Luggage Deck Lid.....	12.815B
		CAP, Oil Filler.....	1.758
		CAP, Radiator and Recovery Tank.....	1.203
		CAP, Rear Seat Back.....	15.011
		CAP, Roof Drip.....	12.075
		CAP, Roof Luggage and Ski.....	12.815
		CAP, Seat Back.....	11.381
		CAP, Shock Absorber, Air Lift.....	7.346



## ALPHABETICAL INDEX

CAP, Steering Knuckle Lower Control Arm Shaft.....	6.170	CLAMP, Air Conditioning Control .....	9.281
CAP, Tire Valve.....	5.875	CLAMP, Air Conditioning Evaporator Core Housing .....	9.211
CAP, Transmission Case .....	4.104	CLAMP, Air Conditioning Evaporator Expansion Valve .....	9.214
CAP, Transmission Gearshift Control.....	4.020	CLAMP, Air Conditioning Hose.....	9.242
CAP, Transmission .....	4.256	CLAMP, Air Conditioning Refrigerant Line (Fitting Pkgs. Include 'O' Rings and Hose Clamps) .....	9.222
CAP UNIT, Body Sill.....	8.304	CLAMP, Air Conditioning Refrigerant.....	9.190
CAP UNIT, Front Fender (See Group 8.147 for Front Fender Mouldings which include Series Designations) .....	8.132	CLAMP, Air Conditioning Refrigerant.....	9.196
CAP UNIT, Rear Quarter Outer.....	12.940A	CLAMP, Air Flow Control with Tube.....	9.787
CAP UNIT, Tail and Stop Lamp .....	12.943	CLAMP, Air Flow.....	9.786
CAP, Valve Spring.....	0.309	CLAMP, Air Injection Reactor.....	3.680
CAP, Windshield Washer.....	10.153	CLAMP, Auto.....	8.820
CAP, Windshield Wiper Motor Aux.....	10.151	CLAMP, Battery Top.....	2.335
CAP, Windshield Wiper Parts .....	10.154	CLAMP, Bumper Guard Mounting.....	7.829
CARBURETORS.....	3.725	CLAMP, By-Pass Mounting.....	9.199
CARPET.....	15.286A	CLAMP, Carburetor Air Valve.....	3.757
CARPET ASSY., Front Floor.....	15.286	CLAMP, Carburetor Throttle Return Check.....	3.444
CARPET ASSY., Load Floor.....	15.320	CLAMP, Carburetor.....	3.890
CARPET ASSY., Rear Floor.....	15.306	CLAMP, Catalytic Converter.....	3.685
CARPET, Doors, Seats, Cowl and Load Floor.....	15.512	CLAMP, Crankcase Ventilator Tube .....	1.750
CARPET, Front Floor.....	15.286	CLAMP, Dist. Spark Advance Trans. Electric Control (Also See Group 4.075).....	2.408
CARPET MATERIAL, Load Floor.....	15.320	CLAMP, Distributor Housing.....	2.363
CARRIER ASSY., Transmission Planet.....	4.175	CLAMP, Exhaust Pipe Support.....	3.616
CARRIER, Instrument.....	9.743	CLAMP, Frame to Bumper Attaching (Also See Group 7.869) .....	7.836
CARRIER UNIT, Child Safety.....	14.870	CLAMP, Fuel Feed Pipe.....	3.162
CARRIER UNIT, Roof Luggage and Ski.....	12.815	CLAMP, Fuel Tank Filler .....	3.003
CASE, Air Conditioning Evaporator Core Housing .....	9.211	CLAMP, Generator Commutator or Rotor Slip Ring End Frame .....	2.298
CASE, Air Flow.....	9.786	CLAMP, Hand Control Wires and Tubes.....	3.483
CASE ASSEMBLY, Instrument Panel Compartment Door .....	10.266	CLAMP, Heater.....	8.854
CASE ASSY., Heater.....	8.857	CLAMP, Hood Lock Release .....	8.075
CASE ASSY., Instrument Panel Compartment Door.....	10.266	CLAMP, Hood Upper Lock Plate .....	8.085
CASE ASSY., Instrument.....	9.743	CLAMP, Hose, with Nut and Bolt.....	1.166
CASE ASSY., Transmission.....	4.103	CLAMP, Hydraulic Steering Pump Hose .....	6.672
CASE ASSY., Wheel Carrier.....	7.675	CLAMP, Manifold.....	3.273
CASE, Differential and Planet.....	5.510	CLAMP, Mast Jacket.....	6.521
CASE, Heater.....	8.854	CLAMP, Muffler Exhaust Pipe and Tail Pipe... ..	3.708
CASE, Rear Window Defogger.....	9.778	CLAMP, Muffler Tail Pipe .....	3.706
CASE, Transmission Overdrive.....	4.455	CLAMP, Rear Axle Control Arm.....	5.383
CASE, Transmission.....	4.103	CLAMP, Rear Axle.....	5.638
CASE, Wheel Carrier Lock .....	7.679	CLAMP, Rear Spring 'U' Bolt (See Group 5.403) .....	7.518
CASE, Windshield Wiper.....	10.150	CLAMP, Roof Luggage and Ski .....	12.815
CATALYST PKG., Catalytic Converter.....	3.685	CLAMP, Sliding Sun Roof.....	12.809
CATCH ASSY., Folding Top.....	14.310	CLAMP, Stabilizer Shaft.....	7.242
CATCH ASSY., Spare Tire Cover.....	12.579	CLAMP, Stabilizer Shaft.....	7.243
CATCH, Folding Seat (For Load Floor Parts See Group 12.977) .....	11.620	CLAMP, Steering Column .....	6.760
CATCH, Hood Lock-Lower.....	8.080	CLAMP, Steering Gear Ball Return Guide .....	6.843
CATCH, Hood Lock-Upper.....	8.083	CLAMP, Steering Shaft U-Joint.....	6.525
CATCH, Luggage Compartment.....	12.977	CLAMP, Tie Rod End.....	6.234
CHAIN ASSY., Speed and Cruise Control Power .....	3.885	CLAMP, Transmission Gearshift Rod to Lever.....	4.037
CHAIN, Camshaft Timing.....	0.724	CLAMP, Transmission Oil .....	4.128
CHANNEL ASSY., Back Door Reveal.....	12.180C	CLAMP UNIT, Muffler Exhaust Pipe and Tail Pipe .....	3.708
CHANNEL ASSY., Division Rear Door Ventilator Glass .....	10.826	CLAMP UNIT, Muffler.....	3.704
CHANNEL ASSY., Rear Door Stationary Ventilator Glass Division.....	10.829	CLAMP, Vacuum Power Brake Cylinder .....	4.930
CHANNEL ASSY., Windshield Glass .....	10.092	CLEANER, Air Suspension Level Control .....	7.447
CHANNEL, Door Glass Sash .....	10.689	CLEANER, Carburetor Air .....	3.402
CHANNEL, Door Window Lower Sash .....	10.747	CLEANER, Engine Concentrate .....	1.850
CHANNEL, Front Door Glass Run.....	10.701	CLEVIS, Main Cylinder Adjusting .....	4.662
CHANNEL, Front Door Vent Division .....	10.688	CLEVIS, Transmission Gearshift Rod to Lever.....	4.037
CHANNEL, Front Door Ventilator Glass (with tee shaft) .....	10.655	CLIP.....	12.971
CHANNEL, Front Door Window Glass Lower Sash .....	10.685	CLIP, Air Conditioning Compressor Suction and Discharge .....	9.226
CHANNEL, Quarter Window Glass Run .....	11.021	CLIP, Air Conditioning Control.....	9.281
CHANNEL, Quarter Window Lower Sash .....	11.007	CLIP, Air Conditioning Electrical Temperature and Blower Motor Control.. ..	9.275
CHANNEL, Rear Door Window Glass .....	10.759	CLIP, Air Conditioning Evaporator Air Distributor and Astro-Ventilation .....	9.262
CHANNEL, Tail Gate.....	12.180	CLIP, Air Conditioning Evaporator Expansion Valve .....	9.214
CIRCUIT BOARD ASSY., Air Conditioning Electrical Temperature and Blower Motor Control.....	9.275	CLIP, Air Conditioning Hose .....	9.242
CIRCUIT BREAKER, Body Wiring.....	13.095	CLIP, Air Conditioning Refrigerant .....	9.190
CIRCUIT, Instrument Case.....	9.744	CLIP, Air Conditioning Refrigerant .....	9.196
CLAMP.....	7.836A	CLIP, Air Flow Control with Tube .....	9.787
CLAMP, Air Cleaner.....	3.405	CLIP, Air Flow .....	9.786
CLAMP, Air Cleaner.....	3.417	CLIP, Air Injection Reactor.....	3.675
CLAMP, Air Conditioning Control .....	9.279		

## ALPHABETICAL INDEX

CLIP, Air Injection Reactor.....	3.680	CLIP, Fuel Tank Filler.....	3.003
CLIP, Ash Tray.....	12.012	CLIP, Fuel Tank.....	3.015
CLIP ASSY., Body Rear Panel.....	12.121	CLIP, Garnish Moulding (sheet metal type)....	11.128
CLIP ASSY., Front or Rear Bumper Bar Mounting and Attaching.....	7.874	CLIP, Gearshift Control (Hand).....	4.006
CLIP ASSY., Rear Compartment Lid.....	12.183	CLIP, Hazard Flasher.....	2.575
CLIP ASSY., Rear Quarter Upper-Above Belt.....	14.645	CLIP, Headlamp Dimmer.....	2.459
CLIP ASSY., Tail Gate.....	12.180B	CLIP, Headlining Finish and Back Window....	14.650
CLIP, Auto.....	8.820	CLIP, Headlining Trim.....	14.651A
CLIP, Back Body Opening.....	12.968	CLIP, Headlining Trim.....	14.651
CLIP, Back Window Garnish.....	11.120	CLIP, Headlining Wire.....	12.954
CLIP, Back Window Glass Reveal Moulding..	11.209	CLIP, Heater (See Group 1.166 for Clamps)...	8.846
CLIP, Belt Moulding, Door and Quarter Mldg. Attaching Parts.....	12.118	CLIP, Heater.....	8.852
CLIP, Belt Unit and Shoulder Strap Unit Components.....	14.875A	CLIP, Hood Lock Release.....	8.075
CLIP, Body Back Lower (Rear End).....	12.966	CLIP, Hood Lock-Lower.....	8.080
CLIP, Body Mounting.....	9.023	CLIP, Hood Panel.....	8.010
CLIP, Body Sill Moulding.....	8.309	CLIP, Hood Panel.....	8.021
CLIP, Body Wiring (Also See Group 2.480 for additional Body Harnesses).....	13.090	CLIP, Hood Upper Lock Plate.....	8.085
CLIP, Brake Hose or Pipe.....	4.681	CLIP, Hydraulic Brake.....	4.685
CLIP, Brake Shoe Anchor Pin.....	5.056	CLIP, Hydraulic Brake.....	4.686
CLIP, Bumper Valance Panel.....	7.833	CLIP, Hydraulic Steering Pump Hose.....	6.672
CLIP, Carburetor (with Leather and Shaft).....	3.838	CLIP, Ignition Switch Warning.....	2.195
CLIP, Carburetor and Fuel Injection Choke....	3.752	CLIP, Instrument Case Face.....	9.748
CLIP, Carburetor and Fuel Meter Intake (w/ seat and gasket).....	3.814	CLIP, Instrument Case.....	9.744
CLIP, Carburetor Pump.....	3.842	CLIP, Instrument Face Glass.....	9.747
CLIP, Carburetor Throttle.....	3.762	CLIP, Instrument Panel to Dash.....	10.230
CLIP, Chassis Wiring (segmented).....	2.480	CLIP, Instrument Panel.....	10.252
CLIP, Chassis Wiring Harness.....	2.559	CLIP, Instrument Panel.....	14.655A
CLIP, Clock Mounting and Attaching.....	9.772	CLIP, Instrument.....	9.743
CLIP, Cluster Gauge.....	9.735	CLIP, Lighting Monitor.....	2.584
CLIP, Clutch Fork Release.....	0.787	CLIP, Load Floor (for Folding Seat Parts see Group 11.620).....	12.977
CLIP, Clutch Pedal.....	0.854	CLIP, Parking Brake Cable Pulley.....	4.790
CLIP, Clutch.....	0.829	CLIP, Parking Brake Cable.....	4.785
CLIP, Concealed Headlamp Control Opening Cover.....	2.765	CLIP, Parking Brake Lever Release.....	4.595
CLIP, Concealed Headlamp Motor.....	2.755	CLIP, Parking Brake.....	4.765
CLIP, Coolant Recovery Unit.....	1.240	CLIP, Quarter Window Glass Run.....	11.024
CLIP, Cowl Side.....	12.804	CLIP, Quarter Window Lower Sash.....	11.007A
CLIP, Crankcase Ventilator-Outer.....	1.762	CLIP, Quarter Window Reveal Mldg., Tailgate Moulding Clips.....	11.032
CLIP, Crankcase.....	1.745	CLIP, Quarter Window Reveal.....	11.031
CLIP, Defroster.....	9.779	CLIP, Quarter Window.....	11.041
CLIP, Direction Signal Lamp.....	2.892	CLIP, Radiator Grille and Engine Baffle Attaching.....	1.276
CLIP, Dist. Spark Advance Trans. Electric Control (Also See Group 4.075).....	2.408	CLIP, Radiator Grille Moulding.....	1.269
CLIP, Door Edge.....	10.352A	CLIP, Radio Noise Suppression.....	9.663
CLIP, Door Handle Push Button.....	10.529	CLIP, Rear Compartment Lid or Tailgate Hinge.....	12.187
CLIP, Door Inside Locking Rod.....	10.565	CLIP, Rear Compartment Lid.....	12.183
CLIP, Door Window Reveal Moulding.....	10.708	CLIP, Rear Door Outer Panel.....	12.114
CLIP, Ducted Hood.....	8.036	CLIP, Rear Quarter.....	15.100A
CLIP, Electric Seat Adjuster Switch.....	11.558	CLIP, Rear Quarter Ventilator and Back Window Drain.....	10.997
CLIP, Electric Window Lift.....	10.777	CLIP, Rear Seat Back Compartment Shelf Foundation.....	15.024
CLIP, End Gate Lock Handle.....	12.247A	CLIP, Rear View Mirror.....	10.186
CLIP, End Gate Rear Door.....	12.242A	CLIP, Rear Window Defogger.....	9.778
CLIP, End Gate.....	12.203	CLIP, Roof Drip.....	12.075
CLIP, Fldg. Top and Dust Boot.....	13.384	CLIP, Roof Ski.....	12.815A
CLIP, Folding Seat (For Load Floor Parts See Group 12.977).....	11.620	CLIP, Roof Trim.....	14.640A
CLIP, Folding Top Back Window.....	13.395	CLIP, Shock Absorber, Air Lift.....	7.346
CLIP, Folding Top Bow Binding End.....	13.342	CLIP, Shock Absorber.....	7.380
CLIP, Folding Top Side Roof Rail-Front.....	14.120	CLIP, Side Roof Rail.....	10.721
CLIP, Folding Top.....	14.483	CLIP, Sliding Sun Roof.....	12.809
CLIP, Front and Rear Door Lock.....	10.474	CLIP, Spare Tire Cover.....	12.579
CLIP, Front Door Outer Panel.....	12.112	CLIP, Spark Plug Wire.....	2.251
CLIP, Front Door Ventilator.....	10.661	CLIP, Speed and Cruise Control Power.....	3.885
CLIP, Front Door Window Glass Lower Sash..	10.685	CLIP, Speed and Cruise Control.....	3.887
CLIP, Front Door Window Reveal.....	10.707	CLIP, Speedometer without Casing.....	4.342
CLIP, Front Fender and Skirt.....	8.143	CLIP, Speedometer Drive Gear.....	4.345
CLIP, Front Fender and Skirt.....	8.154	CLIP, Speedometer.....	4.342C
CLIP, Front Fender Moulding.....	8.133	CLIP, Steering Shaft U-Joint.....	6.525
CLIP, Front Fender.....	8.147	CLIP, Stop Lamp.....	2.447
CLIP, Front Seat Adjuster.....	11.561	CLIP, Tail Gate.....	12.180
CLIP, Front Seat Back Lock.....	11.390	CLIP, Tailgate.....	12.195
CLIP, Front Seat Bottom with Frame, Springs and Padding (less trim cover).....	11.419	CLIP, Tail Lamp.....	2.688
CLIP, Front Seat Side Trim (See Group 12.976 for 2nd and 3rd Seat Moulding and Escutcheon).....	14.818	CLIP, Throttle Control Rod.....	3.425
CLIP, Fuel Feed Pipe.....	3.162	CLIP, Top Roof Outer.....	12.810
CLIP, Fuel Tank Evaporative Control.....	3.120	CLIP, Transmission Control Safety.....	4.054
CLIP, Fuel Tank Evaporative Control.....	3.130	CLIP, Transmission Control Switch.....	4.060
		CLIP, Transmission Gearshift Control.....	4.020
		CLIP, Transmission Gearshift Control Cable... CLIP, Transmission Gearshift Control.....	4.047 4.020
		CLIP, Transmission Gearshift Rod to Lever....	4.037
		CLIP, Transmission Oil.....	4.128

## ALPHABETICAL INDEX

CLIP, Transmission Overdrive.....	4.495	CONNECTOR, Coolant Pump By-Pass.....	1.097
CLIP, Transmission Throttle valve Operating Parts.....	4.275	CONNECTOR, Cowl.....	9.789
CLIP, Transmission Throttle Valve Control.....	4.052	CONNECTOR, Crankcase.....	1.745
CLIP, Transmission, Smog Control.....	4.075	CONNECTOR, Direction Signal Lamp (See Group 9.748 Tell Tale Wind.).....	2.895
CLIP, Vacuum Power Brake Cylinder.....	4.930	CONNECTOR, Dist. Spark Advance Trans. Electric Control (Also See Group 4.075).....	2.408
CLIP, Vacuum Power Door Lock.....	10.485	CONNECTOR, Distributor Terminal.....	2.400
CLIP, Vacuum.....	4.205	CONNECTOR, Electrical.....	2.530
CLIP, Vinyl Roof Panel Cover.....	13.260	CONNECTOR, Fuel Lines.....	3.163
CLIP, Wheel Cover Appearance.....	5.871	CONNECTOR, Fuel Pump Mounting.....	3.901
CLIP, Wheel Cover Panel Rubber.....	8.177	CONNECTOR, Fuel Tank Evaporative Control	3.130
CLIP, Windshield Garnish Moulding.....	10.056	CONNECTOR, Horn Button and Blowing Ring.....	2.819
CLIP, Windshield Pillar Weatherstrip.....	10.093A	CONNECTOR, Hydraulic Brake.....	4.686
CLIP, Windshield Reveal Moulding.....	10.096	CONNECTOR, Lighting Monitor.....	2.584
CLIP, Windshield Wiper Parts.....	10.156	CONNECTOR, Oil (Also see Group 8.963).....	1.531
CLIP, Windshield Wiper.....	10.147	CONNECTOR, Oil Filter Fitting.....	1.855
CLIP, Windshield Wiper.....	10.159	CONNECTOR, Parking Brake Cable.....	4.785
CLOCK, Clock Mounting and Attaching.....	9.772	CONNECTOR, Parking Brake.....	4.765
CLUTCH ASSY., Engine Air Fan.....	1.050	CONNECTOR, Shock Absorber, Air Lift.....	7.346
CLUTCH ASSY., Transmission Forward Cone Freewheel.....	4.167	CONNECTOR, Transmission Low and Drive Valve.....	4.265
CLUTCH ASSY., Transmission RearRing Gear.....	4.180	CONNECTOR, Transmission Oil.....	4.128
CLUTCH ASSY., Transmission 1st & Rev. ....	4.380	CONNECTOR, Vacuum Power Brake Cyl.....	4.931
CLUTCH ASSY., Transmission.....	4.164	CONNECTOR, Windshield Wiper Pipe.....	10.155
CLUTCH DRIVE ASSY., Air Conditioning Compressor Clutch Actuating.....	9.186	CONSOLE, Instrument.....	9.743
CLUTCH PLATE, Concealed Headlamp Control Drive.....	2.760	CONTACT ASSY., Distributor (Consists of Breaker Arm and Support).....	2.384
CLUTCH, Tailgate.....	12.195	CONTACT, Horn Button and Blowing Ring....	2.819
CLUTCH UNIT, Differential Clutch (Positraction).....	5.511	CONTACT, Starting Motor Solenoid.....	2.102
COATED FABRIC.....	15.506	CONTROL UNIT, Direction Signal Lamp (See Group 9.748 Tell Tale Wind.).....	2.895
COIL, Air Conditioning Compressor Clutch Actuating.....	9.186	CONTAINER ASSY., Tire Traction.....	5.885
COIL ASSY., Headlamp Washer.....	2.780	CONTAINER, Belt Unit and Shoulder Strap Unit Components.....	14.875A
COIL ASSY., Starting Motor Field.....	2.049	CONTAINER, Litter, Tissue.....	8.891
COIL, Automatic Choke Control.....	3.750	CONTROL ASSY., Air Conditioning Evaporator Air Distributor and Astro- Ventilation.....	9.262
COIL, Ignition.....	2.170	CONTROL ASSY., Air Conditioning Instrument Panel.....	9.273
COIL UNIT, Generator Field.....	2.310	CONTROL ASSY., Air Flow Control with Tube.....	9.787
COLLAR, Generator Drive End.....	2.307	CONTROL ASSY., Carburetor Vacuum.....	3.765
COLLAR, Starting Motor Thrust.....	2.063	CONTROL ASSY., Carburetor.....	3.755
COLLAR, Steering Column.....	6.758	CONTROL ASSY., Direction Signal Lamp (See Group 9.748 Tell Tale Wind.).....	2.895
COLUMN ASSY., Mast (Also see Group 6.803).....	6.518	CONTROL ASSY., Front Seat Back Lock.....	11.390
COMPARTMENT ASSY., Seat Separator.....	10.240	CONTROL ASSY., Heater.....	8.849
COMPARTMENT, Instrument Panel.....	10.260	CONTROL ASSY., Hood Lock Release.....	8.075
COMPASS UNIT, Auto.....	8.873	CONTROL ASSY., Radio Control.....	9.649
COMPENSATOR KIT, Carburetor Idle Air Compensator.....	3.820	CONTROL ASSY., Rear Compartment Lid Opener.....	12.243
COMPOUND UNIT, Crankshaft Rear Bearing and Cap Oil.....	0.137	CONTROL ASSY., Speed and Cruise Control.....	3.880
COMPRESSOR ASSY., Air Suspension Air Compressor.....	7.455	CONTROL ASSY., Transmission Gearshift.....	4.004
CONDENSER REPAIR UNIT, Air Conditioning Refrigerant.....	9.190	CONTROL, Distributor Vacuum.....	2.410
CONDENSER, Air Conditioning Refrigerant....	9.190	CONTROL, Door Lock Remote.....	10.500
CONDENSER, Distributor, with Bracket and Lead.....	2.393	CONTROL, End Gate Rear Door.....	12.242A
CONDUCTOR ASSY., Ash Tray.....	12.016	CONTROL, Fuel Injection.....	3.300
CONDUCTOR, Fluid Level.....	10.154A	CONTROL UNIT, Dist. Spark Advance Trans. Electric Control (Also See Group 4.075).....	2.408
CONDUCTOR, Lighting Monitor.....	2.580	CONVECTOR AND LEAD ASSY., Stereo Tape Player.....	9.670
CONDUCTOR, Windshield Wiper.....	10.163	CONVERSION UNIT, Direction Signal Lamp (Cancelling).....	2.896
CONDUIT ASSY, Tail Gate.....	12.180B	CONVERTER, Catalytic Converter.....	3.685
CONDUIT, Electric Window Lift.....	10.777	COOLER ASSY., Oil.....	1.540
CONDUIT, Front and Rear Door.....	10.778	CORD ASSY., Engine Heater.....	1.152
CONDUIT, Sliding Sun Roof.....	12.809	CORE, Air Conditioning Compressor Oil Test.....	9.177
CONDUIT, Tailgate.....	12.195	CORE, Air Conditioning Evaporator By-Pass....	9.198
CONNECTION BODY, Electrical.....	2.530	CORE ASSY., Air Conditioning Evaporator.....	9.210
CONNECTOR, Air Conditioning Control.....	9.281	CORE, Heater.....	8.854
CONNECTOR, Air Conditioning Electrical Temperature and Blower Motor Control.....	9.275	CORE, Radiator.....	1.219
CONNECTOR, Air Conditioning Evaporator Air Distributor and Astro-Ventilation.....	9.262	COUNTERGEAR UNIT, Transmission.....	4.421
CONNECTOR, Air Conditioning Evaporator By-Pass.....	9.198	COUPLING ASSY., Rear Compartment Lid Opener.....	12.243
CONNECTOR, Air Conditioning Evaporator ....	9.220	COUPLING ASSY., Steering Shaft U-Joint.....	6.525
CONNECTOR, Air Flow.....	9.786	COUPLING, Front Seat Adjuster.....	11.561
CONNECTOR, Air Injection Reactor.....	3.675	COVER.....	12.971
CONNECTOR, Body Wiring.....	13.100	COVER.....	4.651
CONNECTOR, Carburetor and Fuel Meter Fuel Inlet.....	3.740	COVER, Air Cleaner.....	3.410
CONNECTOR, Carburetor.....	3.755	COVER, Air Cleaner.....	3.417

## ALPHABETICAL INDEX

COVER, Air Conditioning Compressor (Internal).....	9.172	COVER, Heater.....	8.852
COVER, Air Conditioning Electrical Temperature and Blower Motor Control..	9.275	COVER, Hood Lock-Lower.....	8.080
COVER, Air Conditioning Evaporator Air Distributor and Astro-Ventilation.....	9.262	COVER, Hot Water.....	8.845
COVER, Air Conditioning Evaporator By-Pass	9.198	COVER, Ignition Coil Mounting.....	2.183
COVER, Air Conditioning Evaporator Core Housing.....	9.211	COVER, Instrument Case.....	9.746
COVER, Air Flow.....	9.786	COVER, Instrument Panel Assist Handle.....	14.660
COVER, Antenna.....	9.647	COVER KIT, Hydraulic Steering Valve.....	6.554
COVER, Arm Rest Front Seat.....	14.900	COVER, Lever Hand (Floor Mounted).....	4.015
COVER ASSEMBLY, Steering Gear Housing (also see group 6.518).....	6.807	COVER, License Plate.....	7.800
COVER ASSY., Camshaft.....	0.386	COVER, Load Floor (for Folding Seat Parts see Group 11.620).....	12.977
COVER ASSY., Carburetor Idle Air Compensator.....	3.820	COVER, Low Servo.....	4.228
COVER ASSY., Carburetor Pump.....	3.844	COVER, Main Cylinder (Rubber).....	4.659
COVER ASSY., Clutch Pressure Plate.....	0.859	COVER, Main Cylinder Push.....	4.658
COVER ASSY., Clutch.....	0.861	COVER, Mast (Also see Group 6.803).....	6.518
COVER ASSY., Crankcase Front End.....	0.206	COVER, Oil Pump.....	1.723
COVER ASSY., Engine Timing.....	0.219	COVER, Parking Brake Lever.....	4.615
COVER ASSY., Front Door Arm Rest.....	14.686	COVER, Radio Instrument Panel.....	10.256
COVER ASSY., Front Seat Back Head Restraint.....	14.924	COVER, Rear Bumper Upper Face Bar.....	7.832
COVER ASSY., Lock Pillar Finishing.....	14.731	COVER, Rear Compartment (Less Hardware).....	12.181
COVER ASSY., Oil Supply Pump.....	4.203	COVER, Rear Compartment End.....	12.986
COVER ASSY., Rear Door Arm-Less Tray.....	14.762	COVER, Rear Compartment Floor.....	12.981
COVER ASSY., Rear Quarter.....	15.100A	COVER, Rear Compartment Lid and Rear End Panel.....	12.182
COVER ASSY., Spare Tire Cover.....	12.579	COVER, Rear Compartment Lid or Tailgate Hinge.....	12.187
COVER ASSY., Spare Tire Cover.....	15.100C	COVER, Rear Door Trim Finish.....	14.764
COVER ASSY., Transmission Oil.....	4.224	COVER, Rear License Lamp.....	2.705
COVER ASSY., Valve Rocker Arm.....	0.386	COVER, Rear License Lamp.....	2.706
COVER, Auto.....	8.820	COVER, Rear Quarter Arm Trimmed.....	15.108
COVER, Automatic Choke Control.....	3.750	COVER, Rear Quarter Side Inner.....	12.941A
COVER, Axle Housing with Filler Plug.....	5.398	COVER, Rear Window Defogger.....	9.778
COVER, Back Body Opening.....	12.968	COVER, Reverse Servo.....	4.241
COVER, Belt Unit and Shoulder Strap Unit Components.....	14.875A	COVER, Roof Panel.....	12.812
COVER, Body Center Pillar (With Metal Inner Panel).....	14.730	COVER, Seat Adjuster Track.....	11.573
COVER, Body Wiring.....	13.100	COVER, Seat Back.....	14.810
COVER, Brake and Clutch Pedal.....	4.630	COVER, Seat Separator.....	10.240
COVER, Brake Adjusting Hole.....	5.117	COVER, Seat Separator.....	10.242
COVER, Camshaft Timing Belt.....	0.724	COVER, Servo.....	4.212
COVER, Carburetor (with Leather and Shaft).....	3.838	COVER, Side Door.....	10.587
COVER, Carburetor Power.....	3.858	COVER, Sliding Sunroof.....	14.550
COVER, Carburetor.....	3.755	COVER, Speed and Cruise Control.....	3.880
COVER, Clock Mounting and Attaching.....	9.772	COVER, Speed and Cruise Control.....	3.887
COVER, Clutch Housing and Transmission Under Pan.....	0.679	COVER, Starting Motor.....	2.104
COVER, Clutch.....	0.829	COVER, Steering Column Lock Bolt.....	6.500
COVER, Clutch.....	0.861	COVER, Steering Column.....	6.758
COVER, Concealed Headlamp Opening Cover.....	2.770	COVER, Tail Gate.....	12.180
COVER, Cowl Side.....	12.804	COVER, Tailgate.....	12.195
COVER, Cowl.....	9.789	COVER, Timing Belt.....	0.206
COVER, Crankcase Front End.....	0.206	COVER, Timing Belt.....	0.724
COVER, Direction Control Switch.....	2.906	COVER, Top Roof Outer.....	12.810
COVER, Distributor Vacuum Control Clamp...	2.414	COVER, Transmission Case.....	4.105
COVER, Distributor.....	2.362	COVER, Transmission.....	4.256
COVER, Distributor.....	2.368	COVER UNIT, Rear Wheel (Wheel Shield).....	8.175
COVER, Door Rocker.....	12.934	COVER UNIT, Roof Luggage and Ski.....	12.815
COVER, Electric Seat Adjuster.....	11.556	COVER UNIT, Roof Ski.....	12.815A
COVER, End Gate Rear Door.....	12.242A	COVER, Valve Push Rod.....	0.439
COVER, End Gate.....	12.203	COVER, Valve Rocker Arm.....	0.386
COVER, Engine Timing Belt.....	0.206	COVER, Wheel Cylinder.....	4.666
COVER, Floor (less Rear Compartment Floor Pan).....	12.980	COVER, Wheelhouse.....	12.944
COVER, Flywheel.....	0.679	COVER, Wheel.....	5.858
COVER, Folding Seat (For Load Floor Parts See Group 12.977).....	11.620	COVER, Windshield Washer.....	10.153
COVER, Folding Top Compartment (See Group 15.100 for TRIM ASSY.).....	12.989	COVER, Windshield Wiper Motor Aux.....	10.151
COVER, Folding Top Motor and Pump.....	14.482	CRANK ASSY., Windshield Wiper Motor Aux.....	10.151
COVER, Front Door Trim Finish.....	14.691	CRANK, Cowl.....	9.789
COVER, Front Floor.....	15.300	CRANKSHAFT ASSY., Engine.....	0.646
COVER, Front Seat Back Lock.....	11.390	CRANKSHAFT, Engine.....	0.646
COVER, Front Seat Hinge Arm.....	11.375	CROSSMEMBER, Front and Rear Bumper Shock.....	7.840
COVER, Fuel Tank Evaporative Control.....	3.120	CROSSMEMBER, Roof Luggage and Ski.....	12.815
COVER, Fuel Tank Filler Neck.....	3.008	CUP, Air Conditioning Evaporator By-Pass.....	9.198
COVER, Gas Tank Filler Neck Compartment..	12.945	CUP, Differential Clutch (Positraction).....	5.511
COVER, Gearshift Control (Hand).....	4.006	CUP, Direction Control Switch.....	2.906
COVER, Gearshift Hand Lever.....	4.010	CUP, Distributor Mainshaft.....	2.375
		CUP, Door Arm Rest and Trim Pad.....	14.688
		CUP, Gearshift Control Hand Lever.....	4.008
		CUP, Generator Oil.....	2.301
		CUP, Horn Button and Blowing Ring.....	2.819
		CUP, Main Cylinder Piston.....	4.654
		CUP, Speedometer Adapter.....	4.330
		CUP, Steering Worm Thrust.....	6.835
		CUP, Vacuum Power Brake.....	4.910

## ALPHABETICAL INDEX

CUP, Wheel Cylinder Piston (Also See Group 4.665).....	4.667
CURTAIN, Arm Rest Front Seat.....	14.900
CURTAIN, Back (with glass).....	13.389
CUSHION.....	7.831A
CUSHION, Air Cleaner.....	3.417
CUSHION ASSY., Bumper and Grille.....	7.828
CUSHION ASSY., Folding Seat (For Load Floor Parts See Group 12.977).....	11.620
CUSHION, Body Mounting.....	9.023
CUSHION, Bumper.....	7.865
CUSHION, Electrical Output (See 2.319 for Breaker).....	2.500
CUSHION, Front Seat Bottom with Frame, Springs and Padding (less trim cover).....	11.419
CUSHION, Radiator Core.....	1.270
CUSHION, Rear Seat Back with Frame, Springs, and Padding (less trim cover).....	11.628A
CUSHION, Rear Axle.....	5.395
CUSHION, Rear Seat Bottom (Less Trim Cover).....	11.610
CUSHION, Spring.....	7.545
CYLINDER ASSEMBLY, Vacuum Power Brake.....	4.901
CYLINDER ASSY., Air Conditioning less Clutch.....	9.170
CYLINDER ASSY., Door Lock Outside Locking Handle.....	10.550
CYLINDER ASSY., Ignition Switch.....	2.188
CYLINDER ASSY., Load Floor (For Folding Seat Parts See Group 11.620).....	12.977
CYLINDER ASSY., Luggage Compartment.....	12.977
CYLINDER ASSY., Rear Compartment Lid Opener.....	12.243
CYLINDER ASSY., Steering Gear Hydraulic.....	6.576
CYLINDER ASSY., Tailgate.....	12.195
CYLINDER ASSY., Wheel Brake (Also See Group 4.667).....	4.665
CYLINDER ASSY., Wheel Carrier Lock.....	7.680
CYLINDER ASSY.....	4.650
CYLINDER, Instrument Panel Compartment Door.....	10.266
CYLINDER, Rear Compartment or Tail Gate Lock.....	12.248
CYLINDER UNIT, Door Lock Outside Locking Handle.....	10.550

### D

DAMPENER, Exhaust Pipe Support.....	3.616
DAMPENER UNIT, Spring.....	7.545
DAMPER ASSY., Propeller Shaft Damper.....	5.544A
DAMPER ASSY., Air Conditioning less Clutch.....	9.170
DAMPER ASSY., Crankshaft.....	0.659
DAMPER ASSY., Transmission Main Valve.....	4.216
DAMPER, Steering Knuckle Upper Control Arm.....	6.178
DAMPER, Transmission Output Shaft.....	4.404
DAMPER UNIT, Rear Axle Control Arm.....	5.383
DAMPER UNIT, Universal Joint.....	5.555
DAM UNIT, Bumper Valance Panel.....	7.833
DASH POT ASSY., Carburetor Throttle Return Check.....	3.440
DEADENER, Floor Pan.....	15.492
DEADENER, Seat Back.....	14.810
DECAL, Also See Group 8.800 for Stencil Units.....	10.354
DECAL, Back Door Reveal.....	12.180C
DECAL, Front Fender (See Group 8.147 for Front Fender Mouldings which include Series Designations).....	8.132
DECAL, Front Fender.....	8.147
DECAL, Headlamp (Rim or Door).....	2.728
DECAL, Hood (Also See Group 1.303).....	8.055
DECAL, Rear Compartment Lid and Rear End Panel.....	12.182
DECLINE, Hydraulic Brake.....	4.683
DEFECTOR ASSY., Tail Gate.....	12.180B
DEFECTOR UNIT, Tail Gate.....	12.180B
DEFLECTOR UNIT, Front Door (less glass).....	10.650

DEFLECTOR UNIT, Rain.....	9.694
DEFLECTOR, Air Conditioning Evaporator Air Distributor and Astro-Ventilation.....	9.262
DEFLECTOR, Air Conditioning Evaporator Core Housing.....	9.211
DEFLECTOR, Air Conditioning Remote Evaporator Air Distributor Outlet.....	9.264
DEFLECTOR, Air Flow.....	9.786
DEFLECTOR, Back Door Reveal.....	12.180C
DEFLECTOR, Bumper Valance Panel.....	7.833
DEFLECTOR, Cowl Side.....	12.804
DEFLECTOR, Cowl.....	9.789
DEFLECTOR, Flywheel.....	0.679
DEFLECTOR, Front Panel Access Hole.....	10.355
DEFLECTOR, Propeller Shaft Pinion.....	5.545
DEFLECTOR, Radiator Core Side and Lower.....	1.272
DEFLECTOR, Rain.....	9.694
DEFLECTOR, Rear Quarter Outer.....	12.940A
DEFLECTOR, Rear Quarter Side Inner.....	12.941A
DEFLECTOR, Sliding Sun Roof.....	12.809
DEFLECTOR, Top Roof Outer.....	12.810
DEFOGGER UNIT, Rear Window Defogger.....	9.778
DEHYDRATOR ASSY., Air Conditioning Refrigerant (with Dehydrator).....	9.195
DELAYER ASSY., Carburetor and Fuel Injection Choke.....	3.752
DESICCANT, Air Conditioning Refrigerant (with Dehydrator).....	9.195
DETENT, Gearshift Hand Lever Housing.....	4.012
DIAL, Air Conditioning Control.....	9.279
DIAL AND POINTER UNIT, Drive and Engine.....	9.750
DIAL, Coolant Temperature (Dash Unit).....	1.148
DIAL, Electrical Output (See Group 9.748 for Telltale Windows).....	2.515
DIAL, Heater.....	8.852
DIAL, Instrument Case Face.....	9.748
DIAL, Oil Pressure.....	1.803
DIAL, Transmission Gearshift Control.....	4.020
DIAPHRAGM ASSY., Carburetor (with Leather and Shaft).....	3.838
DIAPHRAGM ASSY., Carburetor.....	3.755
DIAPHRAGM ASSY., Screw Carburetor Throttle.....	3.758
DIAPHRAGM UNIT, Air Suspension, Air Compressor.....	7.460
DIAPHRAGM UNIT, Fuel and Vacuum Pump Repair.....	3.925
DIAPHRAGM, Air Conditioning Evaporator By-Pass.....	9.198
DIAPHRAGM, Fuel Pump Pulsator.....	3.910
DIAPHRAGM, Vacuum Power Brake Cylinder.....	4.922
DIODE, Generator (Current Regulator Listed in Group 2.500).....	2.319
DIODE, Ignition Pulse (Transistorized).....	2.383
DISC, Front and Rear Wheel Brake.....	5.809
DISC, Vacuum Power Brake Cyl. Reaction.....	4.934
DISC, Windshield Wiper.....	10.150
DISC, with Facing, Clutch.....	0.886
DISPENSER ASSY., Tire Traction.....	5.885
DISPENSER UNIT, Litter, Tissue.....	8.891
DISTRIBUTOR ASSY., Defroster.....	9.779
DISTRIBUTOR, Air Conditioning Evaporator Air Distributor and Astro-Ventilation.....	9.262
DISTRIBUTOR, Ignition.....	2.361
DIVIDER, Vacuum Power Brake Cylinder.....	4.904
DOG, Electric Seat Adjuster.....	11.556
DOME, Fuel and Vacuum Pump Repair.....	3.925
DOOR, Air Cleaner.....	3.417
DOOR ASM., Gas Tank Filler Neck Compartment.....	12.945
DOOR ASSY., Instrument Panel Compartment.....	10.261
DOOR ASSY., Lower End (Less Hardware).....	12.179
DOOR ASSY., Seat Separator.....	10.242
DOOR, Belt Unit and Shoulder Strap Unit Components.....	14.875A
DOOR, Cowl.....	9.789
DOOR, Front (less paint, trim and hardware).....	10.351
DOOR, Rear (less paint, trim and hardware).....	10.373
DOWEL, Crankshaft Bearing Cap.....	0.107
DOWEL, Flywheel and Clutch Housing to Cylinder Block.....	0.685
DOWEL, Flywheel to Crankshaft.....	0.669
DRIVE ASSY., Starting Motor.....	2.086

# ALPHABETICAL INDEX

DRIVE LINK, Concealed Headlamp Control Drive.....	2.760
DRIVER, Tailgate.....	12.195
DRIVE SHAFT ASSY., Windshield Wiper.....	10.159
DRUM ASSY., Front and Rear Wheel Brake.....	5.809
DRUM ASSY., Transmission Clutch.....	4.169
DRUM, Transmission Clutch.....	4.169
DUCT, Air Cleaner.....	3.417
DUCT, Air Conditioning Evaporator Air Distributor and Astro-Ventilation.....	9.262
DUCT, Air Flow.....	9.786
DUCT, Cowl.....	9.789
DUCT, Rear Window Defogger.....	9.778

## E

ELBOW, Air Cleaner.....	3.417
ELBOW, Air Conditioning Evaporator Air Inlet.....	9.218
ELBOW, Air Injection Reactor.....	3.680
ELBOW, Coolant Pump By-Pass.....	1.097
ELBOW, Crankcase.....	1.745
ELBOW, Distributor Lubricating.....	2.364
ELBOW, Fuel Lines.....	3.163
ELBOW, Fuel Pump Mounting.....	3.901
ELBOW, Oil Pressure.....	1.803
ELBOW, Thermostat.....	1.251
ELEMENT, Air Cleaner.....	3.410
ELEMENT, Air Conditioning Control.....	9.281
ELEMENT, Air Conditioning Vacuum Control.....	9.280
ELEMENT, Air Injection Reactor.....	3.672
ELEMENT, Carburetor.....	3.890
ELEMENT, Cigarette Lighter.....	9.709
ELEMENT, Cowl.....	9.789
ELEMENT, Hydraulic Steering Pump Inlet.....	6.630
ELEMENT, Oil Filter.....	1.836
ELEMENT, Speed and Cruise Control.....	3.887
EMBLEM ASSY., Roof Panel.....	12.812
EMBLEM, Front Door Trim Finish.....	14.691
EMBLEM, Front Fender.....	8.147
EMBLEM, Hood (Also See Group 1.303).....	8.055
EMBLEM, Horn Blowing.....	2.820
EMBLEM, Instrument Panel.....	10.254
EMBLEM, Radiator Grille & Frt. End (Also See Group 8.055).....	1.303
EMBLEM, Rear Compartment Lid and Rear End Panel.....	12.182
EMBLEM, Rear Door Trim Finish.....	14.764
EMBLEM, Seat Separator.....	10.242
EMBLEM, Tail Gate.....	12.180
EMBLEM UNIT.....	12.116A
EMBLEM UNIT, Rear Bumper Upper Face Bar.....	7.832
EMBLEM UNIT, Rear Compartment Lid and Rear End Panel.....	12.182
EMBLEM UNIT, Roof Panel.....	12.812
EMBLEM, Valve Rocker Arm.....	0.386
EMBLEM, Wheel Cover Appearance.....	5.871
END ASSY., Tie Rod.....	6.233
ENGINE ASSEMBLY.....	0.000
EQUALIZER, Parking Brake.....	4.765
ESCUTCHEON ASSY., End Gate Lock Handle.....	12.247A
ESCUTCHEON ASSY., Headlining Finish and Back Window.....	14.650
ESCUTCHEON ASSY., Rear Compartment Lid Lock Cylinder.....	12.249
ESCUTCHEON ASSY.....	12.116A
ESCUTCHEON UNIT, Body Rear Panel.....	12.121
ESCUTCHEON, Air Conditioning Control.....	9.279
ESCUTCHEON, Ash Tray.....	12.048
ESCUTCHEON, Back Door Reveal.....	12.180C
ESCUTCHEON, Back Window Glass Reveal Moulding.....	11.209
ESCUTCHEON, Belt Unit and Shoulder Strap Unit Components.....	14.875A
ESCUTCHEON, Coat.....	15.388
ESCUTCHEON, Dome Lamp Switch.....	11.938
ESCUTCHEON, Door Lock Inside Handle Escutcheon (Trim Protector).....	10.515
ESCUTCHEON, Door Outside Handle Ferrule.....	10.537

ESCUTCHEON, Electric Seat Adjuster Switch.....	11.558
ESCUTCHEON, End Gate Rear Door.....	12.242A
ESCUTCHEON, Folding Seat (For Load Floor Parts See Group 12.977).....	11.620
ESCUTCHEON, Folding Top.....	14.483
ESCUTCHEON, Front Door Trim Finish.....	14.691
ESCUTCHEON, Front Seat Back Lock.....	11.390
ESCUTCHEON, Front Seat Headrest.....	11.376
ESCUTCHEON, Garnish Moulding.....	11.133
ESCUTCHEON, Headlining Trim.....	14.651A
ESCUTCHEON, Headlining Trim.....	14.651
ESCUTCHEON, Heater.....	8.852
ESCUTCHEON, Ignition Lock.....	2.198
ESCUTCHEON, Instrument Panel Compartment Door Lock.....	10.267
ESCUTCHEON, Lighting Switch Rod.....	2.487
ESCUTCHEON, Load Floor.....	12.976
ESCUTCHEON, Luggage Compartment.....	12.977
ESCUTCHEON, Quarter Window Garnish and Quarter Belt Finishing.....	11.119
ESCUTCHEON, Quarter Window Reveal.....	11.031
ESCUTCHEON, Rear Quarter Upper-Above Belt.....	14.645
ESCUTCHEON, Rear View Mirror.....	10.186
ESCUTCHEON, Roof Drip.....	12.075
ESCUTCHEON, Tail Gate.....	12.180
ESCUTCHEON, Tail Gate.....	12.184A
ESCUTCHEON, Tailgate.....	12.195
ESCUTCHEON, Windshield Garnish.....	10.051A
ESCUTCHEON, Windshield Pillar Weatherstrip.....	10.093A
ESCUTCHEON, Windshield Wiper.....	10.147
EXPANSION PLUG, Cylinder Block (Also See Group 8.970).....	0.034
EXPANSION PLUGS, Cylinder Block (Also see Group 8.970 of the Standard Parts Catalog).....	0.034
EXTENSION ASSY., Door Window.....	10.716
EXTENSION ASSY., Front and Rear Bumper.....	7.869
EXTENSION ASSY., Radiator Grille.....	1.267
EXTENSION ASSY., Transmission Rear Main Bearing.....	4.317
EXTENSION ASSY.....	7.831A
EXTENSION UNIT, Frame.....	7.009
EXTENSION UNIT.....	12.116A
EXTENSION, Air Cleaner.....	3.417
EXTENSION, Air Conditioning Evaporator Air Distributor and Astro-Ventilation.....	9.262
EXTENSION, Air Injection Reactor.....	3.675
EXTENSION, Back Body Opening.....	12.968
EXTENSION, Belt Unit and Shoulder Strap Unit Components.....	14.875A
EXTENSION, Body Back Lower (Rear End).....	12.966
EXTENSION, Brake Pull Back.....	4.760
EXTENSION, Bumper Valance Panel.....	7.833
EXTENSION, Center Body.....	12.491
EXTENSION, Clutch Fork Release.....	0.787
EXTENSION, Clutch Pedal Pull Back Spring.....	0.846
EXTENSION, Cowl Side.....	12.804
EXTENSION, Dash to Chassis Frame.....	12.650
EXTENSION, Door Rocker.....	12.934
EXTENSION, Engine to Muffler Exhaust.....	3.609
EXTENSION, Folding Top Back Window.....	13.395
EXTENSION, Folding Top.....	14.310
EXTENSION, Frame to Bumper Attaching (Also See Group 7.869).....	7.836
EXTENSION, Frame Cross, Front.....	7.010
EXTENSION, Front Door Sill.....	11.175
EXTENSION, Front Fender.....	8.131
EXTENSION, Front Fender.....	8.153
EXTENSION, Front.....	8.130
EXTENSION, Fuel Injector.....	3.330
EXTENSION, Gearshift Hand Lever.....	4.010
EXTENSION, Headlamp (Rim or Door).....	2.728
EXTENSION, Hood Lock Release.....	8.075
EXTENSION, Ignition Pulse (Transistorized).....	2.383
EXTENSION, Instrument Panel to Dash.....	10.230
EXTENSION, Lock Pillar.....	12.684
EXTENSION, Mast (Also see Group 6.803).....	6.518
EXTENSION, Muffler Tail.....	3.705
EXTENSION, Radiator (Mouldings in group 1.268).....	1.266
EXTENSION, Radiator and Grille Filler.....	1.287

## ALPHABETICAL INDEX

EXTENSION, Radiator Fan .....	1.277
EXTENSION, Rear Body Lock Pillar .....	12.942
EXTENSION, Rear Compartment (Less Hardware) .....	12.181
EXTENSION, Rear Compartment End .....	12.986
EXTENSION, Rear Compartment Floor .....	12.981
EXTENSION, Rear Compartment Front and Shelf .....	12.971
EXTENSION, Rear Compartment Lid .....	12.996
EXTENSION, Rear Fender and Door .....	8.203
EXTENSION, Rear Quarter Outer .....	12.940A
EXTENSION, Rear Quarter Side Inner .....	12.941A
EXTENSION, Roof Drip .....	12.075
EXTENSION, Roof Luggage and Ski .....	12.815
EXTENSION, Spare Tire Cover .....	12.579
EXTENSION, Spare Tire Cover .....	15.100C
EXTENSION, Tire Valve .....	5.875
EXTENSION, Underbody Trim (floor mounted) .....	4.017
EXTENSION, Wheelhouse .....	12.944
EXTENSION .....	7.836A
EXTINGUISHER .....	9.990
EXTRACTOR, Wheel Carrier .....	7.632

### F

FABRIC, Top and Well .....	15.530
FAN, Air Injection Reactor Pump .....	3.665
FAN ASSY., Air Conditioning Evaporator Blower Motor .....	9.216
FAN ASSY., Heater .....	8.857
FAN ASSY., Rear Window Defogger .....	9.778
FAN, Generator .....	2.274
FASTENER, Back-Up .....	2.698
FASTENER, Belt Unit and Shoulder Strap Unit Components .....	14.875A
FASTENER, Body Center Pillar (With Metal Inner Panel) .....	14.730
FASTENER, Cowl .....	9.789
FASTENER, Door Weatherstrip .....	10.695
FASTENER, End Gate .....	12.269A
FASTENER, Fldg. Top and Dust Boot .....	13.384
FASTENER, Folding Seat (For Load Floor Parts See Group 12.977) .....	11.620
FASTENER, Folding Top Front Roof Rail .....	14.060
FASTENER, Folding Top Motor and Pump .....	14.482
FASTENER, Folding Top Side Roof Rail-Rear .....	14.260
FASTENER, Front Door Trim Binding Strip Replacement .....	14.683
FASTENER, Front Door Trim Finish .....	14.691
FASTENER, Front Door Window Glass Lower Sash .....	10.685
FASTENER, Front Fender and Skirt .....	8.154
FASTENER, Front Seat Hinge Arm .....	11.375
FASTENER, Garnish Moulding (sheet metal type) .....	11.128
FASTENER, Gearshift Control Hand Lever .....	4.008
FASTENER, Gearshift Level Selector and Indicator .....	4.022
FASTENER, Instrument Panel .....	14.655A
FASTENER, Radiator Grille and Engine Baffle Attaching .....	1.276
FASTENER, Rear and Center Seat Back Cover .....	15.000
FASTENER, Rear Compartment .....	15.222
FASTENER, Rear Door Window Glass .....	10.759
FASTENER, Rear Door .....	14.760
FASTENER, Rear Quarter Upper-Above Belt .....	14.645
FASTENER, Rear Quarter .....	15.100A
FASTENER, Rear View Mirror .....	10.186
FASTENER, Seat Adjuster Track .....	11.573
FASTENER, Seat Back and Trim Pad .....	14.804
FASTENER, Steering Column .....	6.758
FASTENER, Throttle Control Rod .....	3.425
FASTENER, Top Roof Outer .....	12.810
FASTENER, Transmission Control Switch .....	4.060
FASTENER, Wheel Opening Cover .....	8.179
FELT, Air Flow .....	9.786
FENDER, Front .....	8.130
FERRULE, Air Conditioning Evaporator Air Distributor and Astro-Ventilation .....	9.262

FERRULE, Door Inside Locking Rod .....	10.560
FERRULE, Lighting Switch Rod .....	2.487
FIELD ASSY., Folding Top Motor and Pump .....	14.482
FILLER, Air Conditioning Evaporator Air Distributor and Astro-Ventilation .....	9.262
FILLER ASSY., Tailgate .....	12.195
FILLER, Back Body Opening .....	12.968
FILLER, Body Back Lower (Rear End) .....	12.966
FILLER, Bumper Valance Panel .....	7.833
FILLER, Cowl Ventilator .....	12.800
FILLER, Door Window Lower Sash .....	10.747
FILLER, Front Door Ventilator Glass (with tee shaft) .....	10.655
FILLER, Front Door Window Glass Lower Sash .....	10.685
FILLER, Front End and Close .....	1.263
FILLER, Front Fender .....	8.131
FILLER, Front Fender .....	8.153
FILLER, Gas Tank Filler Neck Compartment .....	12.945
FILLER, Headlamp .....	2.726
FILLER, Instrument .....	9.743
FILLER, Load Floor .....	12.975
FILLER, Quarter Window Lower Sash .....	11.007
FILLER, Radiator (Mouldings in group 1.268) .....	1.266
FILLER, Rear Body Lock Pillar .....	12.942
FILLER, Rear Compartment End .....	12.986
FILLER, Rear Compartment Floor .....	12.981
FILLER, Rear Quarter Outer .....	12.940A
FILLER, Rear Quarter Side Inner .....	12.941A
FILLER, Rear Seat Back .....	11.629
FILLER, Spare Tire Cover .....	12.579
FILLER, Tail Gate .....	12.180B
FILLER, Wheelhouse .....	12.944
FILTER, Air Conditioning Control .....	9.279
FILTER ASSY., Carburetor Idle Air Compensator .....	3.820
FILTER ASSY., Concealed Headlamp Control Drive .....	2.760
FILTER ASSY., Drive and Engine .....	9.750
FILTER ASSY., Oil Pan Pump Suction .....	4.197
FILTER, Carburetor and Fuel Meter Fuel Inlet .....	3.740
FILTER, Carburetor Air .....	3.402
FILTER, Fuel Tank Evaporative Control .....	3.130
FILTER, Gearshift Level Selector and Indicator .....	4.022
FILTER, Heater .....	8.852
FILTER, Hydraulic Steering Pump Inlet .....	6.630
FILTER, Instrument Case Face .....	9.748
FILTER NUT, Carburetor and Fuel Meter Fuel Inlet .....	3.740
FILTER NUT, Windshield Washer .....	10.153
FILTER, Radio .....	9.654
FILTER, Rear Compartment (Less Hardware) .....	12.181
FILTER, Seat Belt, Check Doors and Low Fuel Warning Lights .....	9.765
FILTER UNIT, Oil (see group 3.163 for flexible pipes) .....	1.835
FILTER UNIT, Oil Pan Pump Suction .....	4.197
FILTER, Vacuum Power Brake Cylinder Air .....	4.913
FILTER, Windshield Wiper Parts .....	10.154
FITTING, Air Conditioning Refrigerant .....	9.190
FITTING, Air Injection Reactor .....	3.680
FITTING ASSY., Air Conditioning Compressor Suction and Discharge .....	9.226
FITTING ASSY., Air Suspension Level Control .....	7.447
FITTING ASSY., Heater .....	8.866
FITTING ASSY., Shock Absorber, Air Lift .....	7.346
FITTING ASSY., Speed and Cruise Control .....	3.880
FITTING ASSY., Steering Gear Hydraulic Valve Hose .....	6.673
FITTING ASSY., Vacuum Power Brake Cyl. .....	4.931
FITTING, Carburetor and Fuel Meter Fuel Inlet .....	3.740
FITTING, Carburetor Pump .....	3.842
FITTING, Manifold Vacuum Take-Off .....	3.278
FITTING, Oil Pressure (See group 9.748 for tell tale windows) .....	1.800
FITTING, Oil Pressure Gauge .....	3.374
FITTING, Oil Pressure .....	1.803
FITTING PKG., Air Conditioning Refrigerant Line (Fitting Pkgs. Include 'O' Rings and Hose Clamps) .....	9.222

## ALPHABETICAL INDEX

FITTING, Radiator and Recovery Tank .....	1.203	GASKET, Air Conditioning Evaporator	
FITTING, Speedometer Driven Gear .....	4.338	Expansion Valve .....	9.214
FITTING, Steering Knuckle, Upper and		GASKET, Air Flow .....	9.786
Lower Control Arm .....	6.166	GASKET, Air Injection Reactor Valve.....	3.670
FLAG, Hazard Flasher .....	2.575	GASKET, Air Injection Reactor.....	3.680
FLAG, Wheel and Tire .....	8.821	GASKET, Air Suspension Air Compressor	
FLANGE, Air Cleaner .....	3.417	Level Control .....	7.457
FLANGE ASSY., Low Sun Gear and Clutch....	4.162	GASKET, Antenna .....	9.647
FLANGE, Exhaust Pipe Packing .....	3.610	GASKET, Automatic Choke Control.....	3.750
FLANGE, Gearshift Control Hand Lever .....	4.008	GASKET, Axle Filler and Drain.....	5.400
FLANGE, Oil Pan Drain.....	1.453	GASKET, Axle Housing to Differential Carrier	
FLANGE, Propeller Shaft Pinion .....	5.545	(paper) .....	5.508
FLANGE, Steering Shaft U-Joint.....	6.525	GASKET, Axle Housing Cover (Cork).....	5.399
FLANGE, Transmission Oil .....	4.195	GASKET, Axle Housing Flange.....	5.819
FLARE ASSY., Hazard Flasher .....	2.575	GASKET, Back Door Reveal .....	12.180C
FLARE ASSY., Wheel and Tire .....	8.821	GASKET, Back-Up .....	2.697
FLASHER ASSY., Hazard Flasher .....	2.575	GASKET, Brake Cyl. and Pedal Shaft (Also	
FLASHER, Direction Signal Lamp .....	2.892	See Group 0.847 for pedal shaft	
FLOAT, Carburetor and Fuel Meter .....	3.745	bracket) .....	4.648
FLUID, Hydraulic Brake .....	4.683	GASKET, Camshaft Cover.....	0.529
FLYWHEEL ASSY., Engine .....	0.666	GASKET, Camshaft Housing .....	0.529
FLYWHEEL, w/Ring Gear .....	0.666	GASKET, Camshaft .....	0.738
FLYWHEEL, with Ring Gear.....	0.666	GASKET, Carburetor and Fuel Meter Fuel	
FLYWHEEL, With Ring Gear .....	0.666	Inlet .....	3.740
FOLLOWER UNIT, Windshield Washer.....	10.153	GASKET, Carburetor to Manifold .....	3.726
FORK ASSY., Clutch Release.....	0.795	GASKET, Carburetor Float Bowl to Cover (or	
FORK, Gearshift .....	4.303	Air Horn) .....	3.738
FORK, Transmission Overdrive Shifting .....	4.490	GASKET, Carburetor Idle Air Compensator ...	3.820
FOUNDATION ASSY., Rear Seat Back with		GASKET, Carburetor.....	3.890
Frame, Springs, and Padding (less trim		GASKET, Clock Mounting and Attaching .....	9.772
cover) .....	11.628A	GASKET, Clutch Release Bearing Support	
FOUNDATION, Rear Compartment .....	15.222	Guide.....	0.805
FOUNDATION, Rear Seat Back		GASKET, Coolant Outlet .....	1.154
Compartment Shelf Foundation.....	15.024	GASKET, Coolant Pump Assembly (to Block)..	1.079
FOUNDATION, Spare Tire Cover.....	12.579	GASKET, Cowl.....	9.789
FRAME, Air Cleaner Intake Valve.....	3.415	GASKET, Crankcase Front End Cover.....	0.207
FRAME ASSEMBLY, Rear Seat Back, with		GASKET, Crankcase .....	1.745
Springs.....	11.628	GASKET, Cylinder Head .....	0.289
FRAME ASSEMBLY .....	7.003	GASKET, Distributor Housing.....	2.363
FRAME ASSY., Front Seat Back, with		GASKET, Door Handle Push Button .....	10.529
Springs (less Cushion) .....	11.373	GASKET, Door Lock Inside Handle.....	10.517
FRAME ASSY., Front Seat Bottom with		GASKET, Door Outside Handle Ferrule .....	10.537
Frame, Springs and Padding (less trim		GASKET, Door Outside Lock Handle.....	10.551
cover) .....	11.419	GASKET, Door Ventilator Regulator.....	10.664
FRAME ASSY., License Plate.....	7.800	GASKET, Ducted Hood .....	8.036
FRAME ASSY., Quarter Window Glass .....	11.010	GASKET, End Gate Lock Handle .....	12.247A
FRAME ASSY., Rear Seat Bottom (Less Trim		GASKET, Exhaust Pipe.....	3.611
Cover).....	11.610	GASKET, Flange Plate .....	5.002
FRAME ASSY., Tail and Stop Lamp .....	2.680	GASKET, Folding Seat (For Load Floor Parts	
FRAME ASSY., Windshield Upper & Lower....	12.807	See Group 12.977).....	11.620
FRAME, Front Door Ventilator.....	10.656	GASKET, Fuel Pump Bowl and Mounting.....	3.904
FRAME, Generator Commutator End, with		GASKET, Fuel Pump .....	3.903
Bushing .....	2.297	GASKET, Fuel Tank Evaporative Control .....	3.120
FRAME, Generator Drive End.....	2.305	GASKET, Fuel Tank Evaporative Control .....	3.130
FRAME, Rear Compartment Floor.....	12.981	GASKET, Fuel Tank Filler Neck .....	3.008
FRAME, Seat Separator.....	10.240	GASKET, Fuel Tank Gauge.....	3.112
FRAME, Starting Motor Commutator End,		GASKET, Gearshift Detent.....	4.311
with Pins .....	2.067	GASKET, Generator Drive End .....	2.307
FRAME, Windshield Side.....	12.808	GASKET, Hazard Flasher.....	2.575
FUEL FILTER ASSY., Carburetor .....	3.890	GASKET, Heater.....	8.854
FUEL RAIL, Fuel Injector.....	3.330	GASKET, Horn Button and Blowing Ring .....	2.819
FUSE ASSY., Air Conditioning Compressor		GASKET, Hot Water .....	8.845
(Internal).....	9.172	GASKET, Hydraulic Steering Valve.....	6.554
		GASKET, Ignition Pulse (Transistorized) .....	2.383
		GASKET, Instrument Case .....	9.749
		GASKET, Intake to Exhaust Manifold.....	3.272
		GASKET, Intake Manifold .....	3.270
		GASKET KIT, Carburetor.....	3.724
		GASKET, Luggage Compartment .....	12.977
		GASKET, Oil Filler.....	1.758
		GASKET, Oil Filter .....	1.844
		GASKET, Oil Pan Drain Screw .....	1.456
		GASKET, Oil Pan Pump Suction.....	4.197
		GASKET, Oil Pump Cover .....	1.724
		GASKET, Oil Pump.....	1.609
		GASKET, Oil Supply Pump.....	4.203
		GASKET, Parking Brake Apply.....	4.591
		GASKET, Parking Lamp Lens .....	2.590
		GASKET PKG., Intake Manifold .....	3.270
		GASKET, Quarter Window .....	11.041
		GASKET, Rear and Auxiliary Speakers.....	9.665
		GASKET, Rear Body Lock Pillar.....	12.942
		GASKET, Rear Compartment Lid Lock	
		Cylinder.....	12.249

### G

GASKET .....	4.651
GASKET, Accelerator Rod Linkage.....	3.469
GASKET, Air Cleaner Oil.....	3.406
GASKET, Air Cleaner.....	3.403
GASKET, Air Cleaner.....	3.417
GASKET, Air Conditioning Compressor Oil	
Test.....	9.177
GASKET, Air Conditioning Compressor	
Pressure Relief.....	9.178
GASKET, Air Conditioning Electrical	
Temperature and Blower Motor Control..	9.275
GASKET, Air Conditioning Evaporator Air	
Distributor and Astro-Ventilation .....	9.262
GASKET, Air Conditioning Evaporator Core	
Housing .....	9.211



## ALPHABETICAL INDEX

GASKET, Rear Compartment Lid Lock.....	12.247	GEAR, Front Door Window.....	10.783
GASKET, Rear Compartment Lid Opener.....	12.243	GEAR, Front Seat Adjuster.....	11.561
GASKET, Rear License Lamp Lens.....	2.707	GEARNUT, Front Seat Adjuster.....	11.561
GASKET, Rear Quarter Side Inner.....	12.941A	GEAR & PINION ASSY., Folding Top.....	14.478
GASKET, Rear View Mirror.....	10.186	GEAR, Quarter Window.....	11.041
GASKET, Rear Window Defogger.....	9.778	GEAR, Rear Door Window.....	10.791
GASKET, Reverse Servo.....	4.241	GEAR, Safety Light.....	9.773
GASKET, Roof Luggage and Ski.....	12.815	GEAR, Speedometer Drive.....	4.343
GASKET, Servo.....	4.212	GEAR, Steering Gear Pitman.....	6.850
GASKET, Spark Plug Seat.....	2.271	GEAR, Transmission (1st and Reverse Sliding).....	4.417
GASKET, Speed and Cruise Control.....	3.887	GEAR, Transmission Countershaft.....	4.422
GASKET, Steering Gear Housing Side Cover.....	6.809	GEAR, Transmission First Speed.....	4.417
GASKET, Steering Gear Hydraulic Pump.....	6.609	GEAR, Transmission Main Drive (Clutch).....	4.351
GASKET, Tail and Stop Lamp.....	12.943	GEAR, Transmission Overdrive.....	4.470
GASKET, Tail Gate or Rear Door Lock Cylinder.....	12.249A	GEAR, Transmission Overdrive.....	4.485
GASKET, Tail Gate.....	12.180B	GEAR, Transmission Planet.....	4.175
GASKET, Tail Lamp.....	2.660	GEAR, Transmission Rear Unit.....	4.187
GASKET, Tail, Stop and Direction Signal Lamp Lens.....	2.684	GEAR, Transmission Reverse Idler (with bushings).....	4.430
GASKET, Tailgate.....	12.195	GEAR, Transmission Second Speed.....	4.395
GASKET, Thermostat Housing.....	1.252	GEAR, Transmission Speedometer Driven Gears (only).....	4.337
GASKET, Transmission to Clutch Housing.....	0.686	GEAR, Transmission Sun Gear and Parts.....	4.159
GASKET, Transmission Case Cover.....	4.109	GEAR, Transmission Third & Fifth Speed.....	4.415
GASKET, Transmission Front Servo.....	4.226	GEAR, Transmission 1st and Reverse Sliding.....	4.417
GASKET, Transmission Low and Drive Valve.....	4.265	GEAR, Transmission 2nd Speed.....	4.395
GASKET, Transmission Main Drive Gear Bearing Retainer.....	4.358	GEAR, Transmission 3rd Speed.....	4.415
GASKET, Transmission Main Valve Body Accumulator.....	4.217	GEAR, Transmission.....	4.421
GASKET, Transmission Oil Pan.....	4.196	GEAR UNIT, Differential Side with Pinion.....	5.527
GASKET, Transmission Oil.....	4.128	GEAR UNIT, Distributor.....	2.374
GASKET, Transmission Overdrive.....	4.460	GEAR UNIT, Steering.....	6.508
GASKET, Transmission Rear Bearing Retainer.....	4.318	GEAR UNIT, Transmission.....	4.256
GASKET, Transmission Throttle Valve.....	4.278	GEAR, Windshield Wiper Motor Aux.....	10.151
GASKET, Transmission, Smog Control.....	4.075	GENERATOR (less pulley).....	2.275
GASKET, Transmission.....	4.256	GENUINE LEATHER.....	15.504
GASKET UNIT, Camshaft Housing.....	0.529	GLASS, Back Window (Safety).....	11.204
GASKET UNIT, Cylinder Head.....	0.289	GLASS, Front Door Ventilator (safety).....	10.658
GASKET UNIT, Engine or Tune Up.....	0.010	GLASS, Front Door Window (Safety).....	10.681
GASKET UNIT, Oil Pan.....	1.429	GLASS, Quarter Window (safety).....	11.011
GASKET UNIT, Transmission.....	4.005	GLASS, Rear Door (safety).....	10.741
GASKET, Vacuum Power Brake Cylinder.....	4.922	GLASS, Rear Door Ventilator.....	10.827
GASKET, Vacuum Power Brake.....	4.898	GLASS, Rear View Mirror.....	10.186
GASKET, Vacuum Power Brake.....	4.901	GLASS, Tail Gate.....	12.180
GASKET, Vacuum Power Brake.....	4.910	GLASS, Windshield (safety).....	10.027
GASKET, Vacuum.....	4.205	GOVERNOR ASSY., Transmission Overdrive.....	4.485
GASKET, Valve Push Rod Cover.....	0.443	GOVERNOR ASSY., Transmission.....	4.256
GASKET, Valve Rocker Cover.....	0.423	GREASE, Air Injection Reactor Pump.....	3.665
GASKET, Venturi Cluster.....	3.790	GREASE CAP, wheel bearing.....	6.330
GASKET, Windshield Washer.....	10.153	GREASE CAP, Wheel.....	5.858
GASKET, Windshield Wiper Motor Mounting Parts.....	10.152	GRILLE, Air Conditioning Control.....	9.279
GASKET, Windshield Wiper.....	10.163	GRILLE, Air Conditioning Remote Evaporator Air Distributor Outlet.....	9.264
GATE ASSY., Lower End (Less Hardware).....	12.179	GRILLE, Bumper Valance Panel.....	7.833
GATE, Tilt or Tel. Steering Column.....	6.514	GRILLE, Cowl Ventilator.....	12.800
GATE, Transmission Gearshift Control Shaft or Tube.....	4.027	GRILLE, Cowl.....	9.789
GAUGE ASSY., Coolant Temperature (Dash Unit).....	1.148	GRILLE, Hood (Also See Group 1.303).....	8.055
GAUGE ASSY., Electrical Output (See Group 9.748 for Telltale Windows).....	2.515	GRILLE, Radiator (Mouldings in group 1.268).....	1.266
GAUGE, Fuel Tank Gauge.....	3.107	GRILLE, Rear and Auxiliary Speakers.....	9.665
GAUGE, Instrument Panel Fuel.....	3.108	GRILLE, Rear Quarter Side Inner.....	12.941A
GAUGE, Oil Level.....	1.516	GRILLE, Rear Window Defogger.....	9.778
GAUGE, Oil Pressure.....	1.803	GROMMET.....	9.775
GAUGE, Transmission Oil Filler.....	4.133	GROMMET, Air Cleaner Intake Valve.....	3.415
GAUGE UNIT, Coolant Temperature (Engine Unit).....	1.150	GROMMET, Air Conditioning Control.....	9.281
GEAR.....	14.555	GROMMET, Air Conditioning Electrical Temperature and Blower Motor Control.....	9.275
GEAR ASSEMBLY, Ring and Pinion (not sold separately).....	5.529	GROMMET, Air Conditioning Evaporator Core Housing.....	9.211
GEAR ASSY., Folding Top.....	14.478	GROMMET, Air Conditioning Refrigerant.....	9.196
GEAR ASSY., Steering.....	6.508	GROMMET, Air Injection Reactor Valve.....	3.670
GEAR ASSY., Transmission Front Drive.....	4.158	GROMMET, Automatic Choke Control.....	3.750
GEAR, Camshaft Timing.....	0.736	GROMMET, Back-Up.....	2.697
GEAR, Crankshaft Timing (Steel).....	0.728	GROMMET, Body Wiring (Also See Group 2.480 for additional Body Harnesses).....	13.090
GEAR, Differential Pinion.....	5.526	GROMMET, Channel Quarter Vent. window hinge.....	11.008
GEAR, Differential Side.....	5.528	GROMMET, Chassis Wiring (segmented).....	2.480
GEAR, Electric Seat Adjuster.....	11.556	GROMMET, Clutch Fork.....	0.797
GEAR, Fifth Speed.....	4.416	GROMMET, Crankcase.....	1.745
GEAR, Flywheel Ring.....	0.673	GROMMET, Distributor Terminal.....	2.401
GEAR, Folding Top Motor and Pump.....	14.482	GROMMET, Distributor, with Weight Plate.....	2.372
		GROMMET, Dome Lamp Door Jamb.....	11.950
		GROMMET, End Gate.....	12.203

## ALPHABETICAL INDEX

GROMMET, Folding Top Motor and Pump.....	14.482	GUIDE, Sliding Sunroof.....	14.550
GROMMET, Front Floor.....	15.300	GUIDE, Speed and Cruise Control Power.....	3.885
GROMMET, Front Seat Back Lock.....	11.390	GUIDE, Steering Gear Ball Return.....	6.842
GROMMET, Fuel Injection.....	3.300	GUIDE, Tilt or Tel. Steering Column.....	6.514
GROMMET, Fuel Injector.....	3.330	GUIDE, Transmission Gearshift Control.....	4.020
GROMMET, Fuel Tank Filler Neck.....	3.008	GUIDE, Transmission.....	4.164
GROMMET, Gearshift Control Hand Lever.....	4.008	GUIDE, Valve Push Rod.....	0.439
GROMMET, Hood Lock Release.....	8.075	GUIDE, Valve Push ROD.....	0.439
GROMMET, Hydraulic Brake.....	4.685	GUSSET, Front and Rear Bumper.....	7.869
GROMMET, Hydraulic Steering Cylinder Piston Rod.....	6.581	GUSSET, Radiator Core.....	1.270
GROMMET, Inside Rear View Mirror.....	10.187	GUTTER, Rear Compartment Lid.....	12.996
GROMMET, Lever Hand (Floor Mounted).....	4.015	GUTTER, Rear Quarter Ventilator and Back Window Drain.....	10.997
GROMMET, Lighting Monitor.....	2.580		
GROMMET, Oil (Also see Group 8.963).....	1.531	<b>H</b>	
GROMMET, Oil Pan Pump Suction.....	4.197		
GROMMET, Parking Brake Lever Release.....	4.594		
GROMMET, Quarter Window Glass.....	11.010		
GROMMET, Rear Compartment Lid or Tailgate Hinge.....	12.187	HANDLE, Ash Receiver.....	12.009
GROMMET, Rear License Lamp w/Wire.....	2.714	HANDLE ASSY., Folding Seat (For Load Floor Parts See Group 12.977).....	11.620
GROMMET, Shock Absorber Link.....	7.388	HANDLE ASSY., Front Door Trim Finish.....	14.691
GROMMET, Shock Absorber, Air Lift.....	7.346	HANDLE ASSY., Instrument Panel Assist Handle.....	14.660
GROMMET, Sliding Sun Roof.....	12.809	HANDLE ASSY., Instrument Panel.....	14.655A
GROMMET, Spark Plug Wire.....	2.251	HANDLE ASSY., Load Floor (For Folding Seat Parts See Group 11.620).....	12.977
GROMMET, Speed and Cruise Control.....	3.880	HANDLE ASSY., Parking Brake Lever Release.....	4.594
GROMMET, Speedometer without Casing.....	4.342	HANDLE ASSY., Safety Light.....	9.773
GROMMET, Speedometer Driven Gear.....	4.338	HANDLE, Door Lock Inside.....	10.512
GROMMET, Stabilizer Link.....	7.244	HANDLE, Door Outside Locking (less cylinder).....	10.527
GROMMET, Starting Motor Solenoid.....	2.102	HANDLE, Door Ventilator Regulator.....	10.664
GROMMET, Sunshade.....	10.219	HANDLE, Door Window Regulator.....	10.797
GROMMET, Transmission Control Lever.....	4.015	HANDLE, End Gate Rear Door.....	12.242A
GROMMET, Transmission Gearshift Control Cable.....	4.047	HANDLE, Front Seat Back Lock.....	11.390
GROMMET, Transmission Gearshift Rod to Lever.....	4.037	HANDLE, Fuel Tank Filler Cap.....	3.028
GROMMET, Transmission Gearshift Shaft Tube Lever.....	4.032	HANDLE, Gearshift Control (Hand).....	4.006
GROMMET, Transmission Overdrive.....	4.495	HANDLE, Parking Brake.....	4.592
GROMMET, Vacuum Power Brake Check.....	4.955	HANDLE, Quarter Window Regulator.....	11.044
GROMMET, Vacuum Power Brake Cyl.....	4.931	HANDLE, Rear Door Trim Finish.....	14.764
GROMMET, Valve Rocker Arm.....	0.386	HANDLE, Seat Back Reclining.....	11.377
GROMMET, Windshield Wiper Motor Aux.....	10.151	HANDLE, Tailgate.....	12.195
GROMMET, Windshield Wiper Motor Mounting Parts.....	10.152	HANDLE UNIT, Locking Sun Roof Panel Front Guide.....	14.570
GROMMET, Windshield Wiper.....	10.150	HAND RAIL ASSY., Child Safety.....	14.870
GUARD, Air Conditioning Evaporator Expansion.....	9.213	HANGER ASSY., Exhaust Pipe Support.....	3.616
GUARD, Bumper and Grille.....	7.828	HANGER ASSY., Muffler Tail Pipe.....	3.706
GUARD, Clutch Cable.....	0.854	HANGER ASSY., Muffler.....	3.704
GUARD, Door Edge.....	10.352	HANGER, Catalytic Converter.....	3.685
GUARD, Engine Intake.....	3.265	HANGER, Catalytic Converter.....	3.690
GUARD, Main Cylinder (Rubber).....	4.659	HANGER, Parking Brake Cable Pulley.....	4.790
GUARD, Radiator Fan.....	1.277	HANGER, Rear Spring Front and Rear.....	7.112
GUARD, Rear Compartment Lid Lock Cylinder.....	12.249	HARNES, Air Conditioning Compressor (Internal).....	9.172
GUARD, Steering Gear Hydraulic Pump.....	6.655	HARNES ASSY., Air Conditioning Electrical Temperature and Blower Motor Control..	9.275
GUARD UNIT, Door Edge.....	10.352A	HARNES ASSY., Air Conditioning, Electrical.....	9.276
GUARD UNIT, Door Inside Locking Rod.....	10.559	HARNES ASSY., Body Wiring (Also See Group 2.480 for additional Body Harnesses).....	13.090
GUARD, Vacuum Power Brake Cylinder.....	4.922	HARNES ASSY., Chassis Wiring (segmented).....	2.480
GUIDE, Air Flow Control with Tube.....	9.787	HARNES ASSY., Dist. Spark Advance Trans. Electric Control (Also See Group 4.075).....	2.408
GUIDE ASSY., Front and Rear Bumper Shock.....	7.840	HARNES ASSY., Electric Fuel Injection.....	2.225
GUIDE ASSY., Front Seat Headrest.....	11.376	HARNES ASSY., Heater.....	8.852
GUIDE ASSY., Tail Gate.....	12.180B	HARNES ASSY., Instrument Panel Compartment, Seat Separator Compartment and Courtesy.....	10.275
GUIDE, Belt Unit and Shoulder Strap Unit Components.....	14.875A	HARNES ASSY., Radio and Speaker Wiring.....	9.656
GUIDE, Carburetor Pump Outlet Valve.....	3.825	HARNES ASSY., Rear Compartment Lid Opener.....	12.243
GUIDE, Crankcase and Push Rod.....	0.439	HARNES ASSY., Rear Window Defogger.....	9.778
GUIDE, Differential Clutch (Positraction).....	5.511	HARNES ASSY., Speed and Cruise Control.....	3.887
GUIDE, Direction Control Switch.....	2.906	HARNES ASSY., Tire Traction.....	5.885
GUIDE, End Gate Lock.....	12.237A	HARNES ASSY., Trailer.....	7.068
GUIDE, Folding Seat (For Load Floor Parts See Group 12.977).....	11.620	HARNES ASSY., Transmission Control Safety.....	4.054
GUIDE, Folding Top Hydraulic Motor and Pump.....	14.486	HARNES, Ignition Pulse (Transistorized).....	2.383
GUIDE, Folding Top Roof Rail.....	14.090		
GUIDE, Front Door Window Glass Lower Sash.....	10.685		
GUIDE, Gearshift Control Hand Lever.....	4.008		
GUIDE, Heater.....	8.852		
GUIDE, Manual Valve.....	4.218		
GUIDE, Parking Brake Cable.....	4.785		
GUIDE, Rear Quarter Window.....	11.040		

## ALPHABETICAL INDEX

HARNESSES, Seat Belt, Check Doors and Low Fuel Warning Lights.....	9.765	HOSE, Coolant Recovery Unit.....	1.240
HARNESSES, Starting, Ignition.....	2.525	HOSE, Crankcase Ventilator-Outer.....	1.762
HARNESSES UNIT, Spark Plug.....	2.239	HOSE, Defroster.....	9.779
HARNESSES UNIT, Trailer.....	7.068	HOSE, Distributor Vacuum Control.....	2.420
HEAD, Air Conditioning Compressor (External).....	9.174	HOSE, Folding Top Motor to Operating Valve.....	14.472
HEAD ASSY., Cylinder.....	0.269	HOSE, Fuel Injector.....	3.330
HEAD ASSY., Speedometer and Odometer (Miles).....	9.761	HOSE, Fuel Lines.....	3.163
HEAD, Cylinder.....	0.269	HOSE, Fuel Pump Mounting.....	3.901
HEAD, Gearshift.....	4.303	HOSE, Fuel Tank Filler.....	3.003
HEADLAMP ASSEMBLY, Complete with Sealed Beam.....	2.725	HOSE, Gas Tank Filler Neck Compartment.....	12.945
HEADLINING ASSY.....	14.640	HOSE, Heater (See Group 1.166 for Clamps).....	8.846
HEADLINING UNIT (Exc. Sun Roof).....	14.640	HOSE, Oil Pressure.....	1.803
HEAD RESTRAINT ASSY., Front Seat Back Head Restraint.....	14.924	HOSE, Radiator Inlet.....	1.159
HEATER ASSY., Hot Water.....	8.845	HOSE, Radiator Outlet.....	1.173
HEATER UNIT, Engine Heater.....	1.152	HOSE, Rear Window Defogger.....	9.778
HEAT SINK ASSY., Generator (Current Regulator Listed in Group 2.500).....	2.319	HOSE, Sliding Sun Roof.....	12.809
HINGE ASSY., Front Door, Upper.....	10.450	HOSE, Speed and Cruise Control Power.....	3.885
HINGE ASSY., Load Floor (For Folding Seat Parts See Group 11.620).....	12.977	HOSE, Steering Gear Pressure.....	6.670
HINGE ASSY., Quarter Window Glass.....	11.010	HOSE, Steering Gear Return.....	6.671
HINGE ASSY., Rear Compartment Lid.....	12.184	HOSE, Tire Traction.....	5.885
HINGE ASSY., Tail Gate.....	12.184A	HOSE, Vacuum Power Brake Cyl.....	4.931
HINGE, Concealed Headlamp Control Opening Cover.....	2.765	HOSE, Vacuum.....	4.205
HINGE, Folding Top.....	14.310	HOSE, Windshield Wiper Pipe.....	10.155
HINGE, Front Door, Lower.....	10.454	HOUSING, Air Conditioning Evaporator Air Distributor and Astro-Ventilation.....	9.262
HINGE, Hood Panel.....	8.015	HOUSING, Air Conditioning Refrigerant (with Dehydrator).....	9.195
HINGE, Instrument Panel Compartment Door.....	10.262	HOUSING, Air Flow Control with Tube.....	9.787
HINGE, Rear Door, Lower.....	10.460	HOUSING, Air Flow.....	9.786
HINGE, Rear Door, Upper.....	10.456	HOUSING, Air Suspension Air Compressor.....	7.455
HINGE, Seat Separator.....	10.242	HOUSING ASSY., Back-Up.....	2.697
HINGE, Sunshade.....	10.219	HOUSING ASSY., Camshaft.....	0.386
HINGE, Tail Gate.....	12.184A	HOUSING ASSY., Dome Lamp.....	11.927
HITCH UNIT, Trailer.....	7.068	HOUSING ASSY., Flywheel and Clutch.....	0.683
HOLDER, Folding Top Motor and Pump.....	14.482	HOUSING ASSY., Instrument Panel Compartment, Seat Separator Compartment and Courtesy.....	10.275
HOLDER, Front Door Window.....	10.783	HOUSING ASSY., Rear Compartment Floor.....	12.981
HOLDER, Generator Brush.....	2.291	HOUSING ASSY., Rear License Lamp.....	2.705
HOLDER PKG., Electrical.....	2.530	HOUSING ASSY., Sliding Sun Roof.....	12.809
HOLDER, Quarter Window.....	11.041	HOUSING ASSY., Steering Gear Hydraulic Pump.....	6.608
HOLDER, Rear Door Window.....	10.791	HOUSING ASSY., Tail and Stop Lamp.....	2.680
HOLDER, Starting Motor Brush.....	2.052	HOUSING ASSY., Tilt or Tel. Steering Column.....	6.514
HOLDER, Tailgate.....	12.195	HOUSING, Automatic Choke Control.....	3.750
HOLDER UNIT, Carburetor Metering.....	3.806	HOUSING, Carburetor and Fuel Injection Choke.....	3.752
HOLDER UNIT, Generator.....	2.313	HOUSING, Carburetor Power.....	3.858
HOLDER, Windshield Wiper.....	10.150	HOUSING, Cigarette Lighter.....	9.709
HOOK ASSY., Coat.....	15.388	HOUSING, Clutch.....	0.683
HOOK, Coat.....	15.388	HOUSING, Cowl.....	9.789
HOOK, Folding Top Front Roof Rail.....	14.080A	HOUSING, Direction Control Switch.....	2.906
HORN ASSEMBLY, Horn.....	2.810	HOUSING, Distributor.....	2.362
HORN ASSY., Carburetor Air.....	3.730	HOUSING, Door Outside Handle Push Button and Lock Cylinder.....	10.552
HORN UNIT, Horn.....	2.810	HOUSING, Fiber Optic Conductor.....	2.583
HOSE, Air Cleaner to Carb.....	3.407	HOUSING, Fluid Level.....	10.154A
HOSE, Air Cleaner.....	3.417	HOUSING, Flywheel and Clutch.....	0.683
HOSE, Air Conditioning Control.....	9.281	HOUSING, Folding Top.....	14.483
HOSE, Air Conditioning Electrical Temperature and Blower Motor Control.....	9.275	HOUSING, Gas Tank Filler Neck Compartment.....	12.945
HOSE, Air Conditioning Evaporator Air Distributor and Astro-Ventilation.....	9.262	HOUSING, Gearshift Hand Lever.....	4.010
HOSE, Air Conditioning Evaporator Air.....	9.260	HOUSING, Headlamp.....	2.726
HOSE, Air Conditioning Evaporator Core Housing.....	9.211	HOUSING, Instrument Case Face.....	9.748
HOSE, Air Conditioning Refrigerant Line (Fitting Pkgs. Include 'O' Rings and Hose Clamps).....	9.222	HOUSING, Instrument Case.....	9.746
HOSE, Air Conditioning.....	9.225	HOUSING, Lever Hand (Floor Mounted).....	4.015
HOSE, Air Flow.....	9.786	HOUSING, Mast (Also see Group 6.803).....	6.518
HOSE, Air Injection Reactor.....	3.675	HOUSING, Parking Brake Apply.....	4.591
HOSE ASSY., Air Suspension Pressure, or Level Control.....	7.465	HOUSING, Parking Lamp.....	2.586
HOSE ASSY., Hydraulic Brake.....	4.680	HOUSING, Rear Axle.....	5.387
HOSE ASSY., Shock Absorber, Air Lift.....	7.346	HOUSING, Rear Compartment End.....	12.986
HOSE, Carburetor and Fuel Injection Choke.....	3.752	HOUSING, Rear Compartment Lid Lock Cylinder.....	12.249
HOSE, Carburetor Idle Air Compensator.....	3.820	HOUSING, Rear Compartment Lock Handle.....	12.252
HOSE, Carburetor Throttle Return Check.....	3.444	HOUSING, Rear Window Defogger.....	9.778
HOSE, Carburetor.....	3.755	HOUSING, Starting Motor Drive, with Bushing.....	2.085
HOSE, Concealed Headlamp Control Opening Cover.....	2.765	HOUSING, Steering Gear.....	6.803
HOSE, Coolant Pump By-Pass.....	1.097	HOUSING, Tailgate.....	12.195
		HOUSING, Transmission Clutch.....	4.169
		HOUSING, Transmission Gearshift Control.....	4.020

## ALPHABETICAL INDEX

HOUSING, Transmission Gearshift Shaft or Tube (Lower).....	4.030
HOUSING UNIT, Thermostat.....	1.251
HOUSING, Wheel Brake (Also See Group 4.667).....	4.665
HOUSING, Windshield Wiper Control.....	10.166
HOUSING, Windshield Wiper.....	10.159
HUB ASSY., Steering Wheel Hub.....	6.512
HUB CAP, Wheel.....	5.858
HUB, Crankshaft.....	0.659
HUB, Front Wheel.....	6.307
HUB, Transmission.....	4.164
HUB, Wheel Cover Appearance.....	5.871
HYDRAMATIC (250, 350, 375, 400).....	4.003
Hydraulic Brake Main.....	4.650

### I

INDICATOR, Transmission Gearshift Control.....	4.020
INFLATER ASSY.....	5.880
INLET ASSY., Air Conditioning Refrigerant (with Dehydrator).....	9.195
INLET ASSY., Air Flow.....	9.786
INLET, Cowl.....	9.789
INSERT, Air Conditioning Control.....	9.279
INSERT ASSY., Windshield Wiper.....	10.146
INSERT, Brake Connector.....	4.671
INSERT, Carburetor Float.....	3.734
INSERT, Door Ventilator Regulator.....	10.664
INSERT, Front Door Window Glass Lower Sash.....	10.685
INSERT, Front Fender.....	8.147
INSERT, Heater.....	8.852
INSERT, Hydraulic Brake.....	4.686
INSERT, Lighting Monitor.....	2.584
INSERT, Main Cylinder Outlet Fitting.....	4.661
INSERT, Parking Lamp.....	2.593
INSERT, Seat Separator.....	10.242
INSERT, Shock Absorber, Air Lift.....	7.346
INSERT, Spring Leaf.....	7.495
INSERT UNIT, Hood (Also See Group 1.303).....	8.055
INSERT, Wheel Cover Appearance.....	5.871
INSULATION, Air Conditioning Evaporator Expansion Valve.....	9.214
INSULATION, Air Conditioning Evaporator Expansion.....	9.213
INSULATION, Starting Motor Field.....	2.049
INSULATOR ASSY., Air Conditioning Refrigerant.....	9.190
INSULATOR ASSY., Transmission Control Lever.....	4.004
INSULATOR UNIT, Brake Shoe.....	5.018
INSULATOR, Air Conditioning Electrical Temperature and Blower Motor Control..	9.275
INSULATOR, Air Conditioning Evaporator Air Distributor and Astro-Ventilation.....	9.262
INSULATOR, Air Conditioning.....	9.225
INSULATOR, Back Window Garnish.....	11.120
INSULATOR, Brake Caliper.....	4.668
INSULATOR, Brake Pedal.....	4.634
INSULATOR, Bumper Valance Panel.....	7.833
INSULATOR, Carburetor and Fuel Injection Choke.....	3.752
INSULATOR, Carburetor to Manifold.....	3.726
INSULATOR, Dash Panel.....	15.280
INSULATOR, Electrical Output (See Group 9.748 for Telltale Windows).....	2.515
INSULATOR, Engine Rear Cross Member.....	7.011
INSULATOR, Floor (less Rear Compartment Floor Pan).....	12.980
INSULATOR, Floor Pan.....	15.492
INSULATOR, Fuel Tank.....	3.022
INSULATOR, Generator.....	2.313
INSULATOR, Hood Panel.....	8.021
INSULATOR, Horn Button and Blowing Ring.....	2.819
INSULATOR, Ignition Pulse (Transistorized).....	2.383
INSULATOR, Instrument Case.....	9.749
INSULATOR, Lever Hand (Floor Mounted).....	4.015
INSULATOR, Muffler Tail Pipe.....	3.706
INSULATOR, Muffler.....	3.704
INSULATOR, Rear Window Defogger.....	9.778

INSULATOR, Roof Luggage and Ski.....	12.815
INSULATOR, Spring.....	7.545
INSULATOR, Steering Wheel Hub.....	6.512
INSULATOR, Wheel Cover Appearance.....	5.871
INTERLOCK, Gearshift.....	4.307
INTERLOCK, Transmission Gearshift Control Shaft or Tube.....	4.027
ISOLATOR, Gearshift Control Hand Lever.....	4.008
ISOLATOR, Transmission Gearshift.....	4.004

### J

JACK, Auto.....	8.820
JACKET ASSY., Mast (Also see Group 6.803).....	6.518
JACKSCREW, Front Seat Adjuster.....	11.561
JAR, Windshield Wiper Parts.....	10.154
JET, Carburetor Idle.....	3.798
JET, Carburetor Metering Rod, with Gasket...	3.792

### K

KEY, Air Conditioning Compressor Clutch Actuating.....	9.188
KEY, Camshaft Sprocket.....	0.738
KEY, Crankshaft.....	0.659
KEY, Door Lock Outside Locking Handle.....	10.550
KEY, Harmonic Balancer and Crankshaft Pulley.....	0.662
KEY, Hydraulic Steering Adapter.....	6.560
KEY, Ignition-Door-Compartment-Trunk-Gas Tank Cap-Tire Locks.....	2.187
KEY, Instrument Panel Compartment Door.....	10.266
KEY, Speedometer Adapter.....	4.330
KEY, Transmission Synchronizer.....	4.384
KEY, Vacuum Power Brake Cylinder Air Valve (See Group 4.658 for Valve and Push Rod Assy.).....	4.918
KEY, Valve Stem.....	0.310
KIT, Back Window (Safety).....	11.204
KIT, Crankcase.....	1.745
KIT, Folding Seat (For Load Floor Parts See Group 12.977).....	11.620
KIT, Fuel and Vacuum Pump Repair.....	3.925
KIT, Hydraulic Steering (Small Parts) (see Groups 6.551 for adapter kits and 6.609, 6.610, 6.612, 6.614, 6.615 for pump kits).....	6.507
KIT, Quarter Window (safety).....	11.011
KIT, Steering Gear Hydraulic Valve.....	6.551
KIT, Transmission Gearshift.....	4.004
KIT, Windshield (Safety).....	10.027A
KNOB, Air Conditioning Control.....	9.278
KNOB, Air Conditioning Evaporator Air Distributor and Astro-Ventilation.....	9.262
KNOB, Air Flow Control with Tube.....	9.787
KNOB ASSY., Air Conditioning Electrical Temperature and Blower Motor Control..	9.275
KNOB ASSY., Rear Window Defogger.....	9.778
KNOB ASSY., Windshield Wiper.....	10.163
KNOB, Cigarette Lighter.....	9.709
KNOB, Clock Mounting and Attaching.....	9.772
KNOB, Direction Signal Lamp.....	2.897
KNOB, Door Inside Locking Rod.....	10.559
KNOB, Front Seat Adjuster.....	11.588
KNOB, Front Seat Back Lock.....	11.390
KNOB, Gearshift Control (Hand).....	4.006
KNOB, Hazard Flasher.....	2.575
KNOB, Heater.....	8.852
KNOB, Radio Control.....	9.649
KNOB, Rear View Mirror.....	10.186
KNOB, Seat Back Reclining.....	11.377
KNOB, Tailgate.....	12.195
KNOB, Tilt or Tel. Steering Column.....	6.514
KNOB, Windshield Wiper Control.....	10.164
KNUCKLE ASSY., Steering.....	6.020

# ALPHABETICAL INDEX

## L

LACE ASSY., Body Lock Pillar .....	14.735
LACE ASSY., Wheelhouse Cover.....	15.099
LACE, Body Center Pillar (With Metal Inner Panel).....	14.730
LACE, Door (with filler).....	15.520
LACE, Front Floor.....	15.286
LACE, Headlining Finish and Back Window.....	14.650
LACE, Hood Ledge (Cowl).....	12.801
LACE, Roof Drip.....	12.075
LAMP ASSY., Back-Up.....	2.697
LAMP ASSY., Hazard Flasher.....	2.575
LAMP ASSY., Instrument Lamp.....	2.776
LAMP ASSY., Parking.....	2.585
LAMP ASSY., Rear License, Complete with Bulb.....	2.700
LAMP ASSY., Tail and Stop.....	2.679
LAMP, Cigarette Lighter.....	9.709
LAMP PKG., Domé Lamp.....	11.927
LAMP, Rear Luggage Compartment.....	9.988
LAMP, Underhood.....	8.890
LAMP UNIT, Instrument Panel Compartment, Seat Separator Compartment and Courtesy.....	10.275
LAMP UNIT, Safety Light.....	9.773
LATCH.....	12.971
LATCH ASSY., End Gate Rear Door.....	12.242A
LATCH ASSY., Hood Lock-Lower.....	8.080
LATCH ASSY., Hood Lock-Upper.....	8.083
LATCH ASSY., Quarter Window Glass.....	11.010
LATCH, Folding Seat (For Load Floor Parts See Group 12.977).....	11.620
LATCH, Windshield Washer.....	10.153
LEAD ASSY., Antenna.....	9.647
LEAD ASSY., Dist. Spark Advance Trans. Electric Control (Also See Group 4.075).....	2.408
LEAD ASSY., Engine Air Auxiliary Cooling.....	1.055
LEAD ASSY., Horn.....	2.859
LEAD, Distributor Terminal.....	2.400
LEAD, Generator.....	2.313
LEAD, Starting Motor Brush.....	2.055
LENS and ORNAMENT ASSY., Tail Lamp.....	2.682
LENS ASSY., Hazard Flasher.....	2.575
LENS ASSY., Transmission Control Pedal Rod.....	4.260
LENS, Back-Up.....	2.697
LENS, Clock Mounting and Attaching.....	9.772
LENS, Dome Lamp.....	11.928
LENS, Fiber Optic Conductor.....	2.583
LENS, Heater.....	8.852
LENS, Inside Rear View Mirror.....	10.187
LENS, Instrument Case Face.....	9.748
LENS, Instrument Panel Compartment, Seat Separator Compartment and Courtesy.....	10.275
LENS, Parking Brake Alarm.....	4.589
LENS, Parking Lamp.....	2.589
LENS PLATE, Air Conditioning Control.....	9.279
LENS, Rear License Lamp.....	2.709
LENS, Tail Lamp.....	2.682
LENS, Transmission Gearshift Control.....	4.020
LETTER UNIT, Front Fender.....	8.147
LETTER UNIT, Hood (Also See Group 1.303).....	8.055
LEVEL INDICATOR, Fluid Level.....	10.154A
LEVER, Accelerator.....	3.454
LEVER, Air Conditioning Control.....	9.278
LEVER, Air Conditioning Evaporator Air Distributor and Astro-Ventilation.....	9.262
LEVER AND SEAL ASSY., Cowl.....	9.789
LEVER ASSY., Air Flow.....	9.786
LEVER ASSY., Carburetor Throttle Valve and Throttle Lever Adjusting.....	3.761
LEVER ASSY., Manual Valve.....	4.218
LEVER ASSY., Parking Brake Apply.....	4.591
LEVER ASSY., Parking Brake.....	4.792
LEVER ASSY., Speed and Cruise Control.....	3.887
LEVER ASSY., Steering Idler.....	6.895
LEVER ASSY., Transmission Control.....	4.006
LEVER ASSY., Transmission Detent.....	4.279
LEVER ASSY., Transmission Gearshift.....	4.004
LEVER ASSY., Transmission Inter. Shift.....	4.302
LEVER ASSY., Transmission Mounted Gearshift (External).....	4.045

LEVER ASSY., Transmission Throttle Valve.....	4.278
LEVER, Brake Shoe Automatic Adjusting.....	5.103
LEVER, Carburetor and Fuel Injection Choke.....	3.752
LEVER, Carburetor and Fuel Injection Fast Idle.....	3.766
LEVER, Carburetor Air Valve.....	3.757
LEVER, Carburetor Power.....	3.858
LEVER, Carburetor Pump Connector.....	3.843
LEVER, Carburetor Pump.....	3.842
LEVER, Carburetor Throttle.....	3.762
LEVER, Clutch Pedal Intermediate.....	0.852
LEVER, Clutch Pedal, Intermediate (See Group 4.648 for brake).....	0.852
LEVER, Direction Signal Lamp.....	2.897
LEVER, Gearshift Control (Hand).....	4.006
LEVER, Heater.....	8.852
LEVER, Parking Brake Shoe.....	5.149
LEVER, Parking Brake.....	4.592
LEVER, Starting Motor Drive Shaft.....	2.108
LEVER, Steering Idler.....	6.895
LEVER, Tilt or Tel. Steering Column.....	6.514
LEVER, Transmission Control Idler.....	4.040
LEVER, Transmission Control Safety.....	4.054
LEVER, Transmission Control Switch.....	4.060
LEVER, Transmission Gearshift Anti-Theft.....	4.070
LEVER, Transmission Gearshift Shaft or Tube (Lower).....	4.030
LEVER, Transmission Internal Shift.....	4.302
LEVER, Transmission Mounted Gearshift (External).....	4.045
LEVER, Transmission Overdrive.....	4.495
LEVER, Transmission Rail End.....	4.302
LEVER, Transmission Throttle Valve Control (T.V.).....	4.050
LEVER, Vacuum Power Brake Cyl. Reaction.....	4.934
LEVER, Wheel Opening Cover.....	8.179
LID ASSY., Rear Compartment (Less Hardware).....	12.181
LID, Rear Compartment (Less Hardware).....	12.181
LIFT ASSY., Folding Top.....	14.475
LIGHT ASSY., Seat Belt, Check Doors and Low Fuel Warning Lights.....	9.765
LIGHTER UNIT, Cigarette Lighter.....	9.709
LIMITER, Carburetor and Fuel Injection Idle Adjusting Screw.....	3.823
LINER, Rear Spring and Shock Absorber.....	7.516
LINING ASSY., Top Side Pad.....	13.349
LINING, Top and Well.....	15.530
LINING UNIT, Brake Shoe.....	5.018
LINK, Air Flow.....	9.786
LINK ASSY., Air Conditioning, Electrical.....	9.276
LINK ASSY., Folding Seat (For Load Floor Parts See Group 12.977).....	11.620
LINK ASSY., Folding Top Back Window.....	13.395
LINK ASSY., Rear Compartment Lid or Tailgate Hinge.....	12.187
LINK, Brake Shoe Automatic Adjusting Lever.....	5.105
LINK, Carburetor and Fuel Injection Choke.....	3.752
LINK, Carburetor Power.....	3.858
LINK, Carburetor Pump Connector.....	3.843
LINK, Carburetor.....	3.755
LINK, Concealed Headlamp Control Opening Cover.....	2.765
LINK, Cowl.....	9.789
LINK, Folding Top Side Roof Rail Control.....	14.140
LINK, Front Door Hinge Hold Open.....	10.455
LINK, Gearshift.....	4.303
LINK, Hood Lock-Lower.....	8.080
LINK, Rear Compartment Lid or Tailgate Hinge.....	12.187
LINK, Rear Door, Lower.....	10.460
LINK, Stabilizer.....	7.240
LINK, Transmission Throttle valve Operating Parts.....	4.275
LINK, Windshield Wiper.....	10.159
LOCK, Air Injection Reactor Valve.....	3.670
LOCK ASSY., Folding Seat (For Load Floor Parts See Group 12.977).....	11.620
LOCK ASSY., Folding Top Front Roof Rail.....	14.080
LOCK ASSY., Front Seat Back Lock.....	11.390
LOCK ASSY., Ignition Switch.....	2.188
LOCK ASSY., Rear Compartment or Tail Gate Lock.....	12.248
LOCK ASSY., Rear Compartment Lid Opener.....	12.243

## ALPHABETICAL INDEX

LOCK ASSY., Rear Compartment Lid.....	12.242	MOTOR ASSY., Air Conditioning Evaporator Blower.....	9.215
LOCK, Axle Shaft.....	5.422	MOTOR ASSY., Air Conditioning Vacuum Control.....	9.280
LOCK, Brake Shoe Anchor Pin.....	5.056	MOTOR ASSY., Concealed Headlamp Control Drive.....	2.760
LOCK, Camshaft Sprocket.....	0.738	MOTOR ASSY., Folding Top.....	14.481
LOCK, Distributor Housing.....	2.363	MOTOR ASSY., Front Door Window.....	10.783
LOCK, End Gate Rear Door.....	12.242A	MOTOR ASSY., Rear Door Window.....	10.791
LOCK, Exhaust Manifold Bolt.....	3.604	MOTOR ASSY., Speed and Cruise Control.....	3.887
LOCK, Exhaust Pipe.....	3.613	MOTOR ASSY., Starter.....	2.041
LOCK, Front Door.....	10.470	MOTOR ASSY., Tailgate.....	12.195
LOCK, Gearshift.....	4.307	MOTOR, Electric Seat Adjuster.....	11.556
LOCK LEVER, Ignition Switch Warning.....	2.195	MOTOR, Engine Air Auxiliary Cooling.....	1.055
LOCK LEVER, Steering Column Lock Bolt.....	6.500	MOTOR, Heater and Evaporator.....	8.855
LOCK NUT, Steering Gear Housing End Cover Worm Bearing.....	6.830	MOTOR, Quarter Window.....	11.041
LOCKOUT ASSY., Gearshift Control Hand Lever.....	4.008	MOTOR, Rear Window Defogger.....	9.778
LOCK OUT UNIT, Gearshift Control Hand Lever.....	4.008	MOTOR, Sliding Sunroof.....	14.550
LOCK, Rear Door.....	10.473	MOTOR, Windshield Wiper.....	10.150
LOCK RING, 'U' Joint Trunnion and Yoke.....	5.586	MOULDING.....	12.971
LOCK, Tilt or Tel. Steering Column.....	6.514	MOULDING ASSY., Front Door Belt Trim Finish.....	11.075
LOCK, Transmission Control Idler Attaching.. Lock, Transmission Main Drive Gear Bearing.....	4.042 4.356	MOULDING ASSY., Front Door Window Reveal.....	10.707
LOGIC ASSY., Body Wiring.....	13.095	MOULDING ASSY., Rear Bumper Upper Face Bar.....	7.832
LOOM, Electrical.....	2.530	MOULDING ASSY., Rear Compartment Lid and Rear End Panel.....	12.182
LOOM, Fuel Lines.....	3.163	MOULDING ASSY., Rear Door Belt Trim Finish.....	11.089
LOUVER, Front Door Window Reveal.....	10.707	MOULDING ASSY., Rear Quarter Trim.....	15.101
LOUVER, Quarter Stationary Window.....	12.811	MOULDING ASSY., Rear Seat Back.....	15.011
LOUVER, Rear Body Lock Pillar.....	12.942	MOULDING ASSY., Tailgate.....	12.195
LOUVER, Roof Panel.....	12.812	MOULDING, Back Body Opening.....	12.180A
LUBRICANT, Hypoid Gear.....	5.535	MOULDING, Back Door Reveal.....	12.180C
LUBRICATING OIL, Maintenance Items, Air Conditioning.....	9.282	MOULDING, Back Window Garnish.....	11.120
LUBRICATOR, Distributor Lubricating.....	2.364	MOULDING, Back Window Glass Reveal.....	11.208
LUG, Headlamp Lens and Sealed Beam Retaining.....	2.736	MOULDING, Belt Unit and Shoulder Strap Unit Components.....	14.875A
<b>M</b>			
MAGNET ASSY., Speed and Cruise Control... MAGNET ASSY., Windshield Washer.....	3.887 10.153	MOULDING, Body Center Pillar (With Metal Inner Panel).....	14.730
MAGNET UNIT, Transmission Case.....	4.105	MOULDING, Center Pillar Scalp.....	12.113
MAGNET, Windshield Wiper.....	10.150	MOULDING, Concealed Headlamp Opening Cover.....	2.770
MANIFOLD, Engine Exhaust.....	3.601	MOULDING, Console.....	12.240
MANIFOLD, Engine Intake.....	3.265	MOULDING, Door Arm Rest and Trim Pad.....	14.688
MANIFOLD, Fuel Injector.....	3.330	MOULDING, Front Door Outer Panel.....	12.112
MAT ASSY., Rear Floor.....	15.306A	MOULDING, Front Door Trim Finish.....	14.691
MAT ASSY., Rear Floor.....	15.306	MOULDING, Front Door Window Reveal.....	10.707
MAT, Dash Panel.....	15.280	MOULDING, Front Fender (See Group 8.147 for Front Fender Mouldings which include Series Designations).....	8.132
MATERIAL, Top Covering.....	15.490	MOULDING, Front Seat Side Trim (See Group 12.976 for 2nd and 3rd Seat Moulding and Escutcheon).....	14.818
MAT, Front Floor.....	15.286B	MOULDING, Headlamp (Rim or Door).....	2.728
MAT, Front Floor.....	15.286	MOULDING, Headlining Trim.....	14.651A
MAT, Rear Compartment.....	15.222	MOULDING, Instrument Panel.....	14.655A
MAT, Rear Floor.....	15.306A	MOULDING, Instrument Panel.....	10.252
MAT, Rear Floor.....	15.306	MOULDING, Lock Pillar Finishing.....	14.731
MAT UNIT.....	15.306B	MOULDING, Quarter Window Garnish and Quarter Belt Finishing.....	11.119
MAT UNIT, Front Floor.....	15.286B	MOULDING, Quarter Window Lower Sash.....	11.007A
MAT UNIT (Rear Floor Contour Twin Type Rubber).....	15.268	MOULDING, Quarter Window Reveal.....	11.031
MAT UNIT, Rear Floor.....	15.306	MOULDING, Radiator Grille.....	1.268
MAT, Well Lining and Load Floor.....	15.311	MOULDING, Rear Body Lock Pillar.....	12.942
MEMBER ASSY., Frame Cross, Front.....	7.010	MOULDING, Rear Door Outer Panel.....	12.114
MEMBER ASSY., Transmission Mounting.....	4.081	MOULDING, Rear Door Trim Finish.....	14.764
MEMBER, Frame Cross, Intermediate.....	7.012	MOULDING, Rear Door Window Reveal.....	10.772
MEMBER, Frame Cross, Rear.....	7.014	MOULDING, Rear Quarter Trim.....	15.101
MEMBER, Frame Side.....	7.006	MOULDING, Rear Seat Back.....	15.011
MEMBER, Rear Axle Control Arm.....	5.380	MOULDING, Roof Drip.....	12.075
MEMBER, Shock Absorber Frame.....	7.395	MOULDING, Roof Panel.....	12.812
METER, Fuel Tank Gauge.....	3.107	MOULDING, Seat Separator.....	10.240
MIRROR ASSEMBLY, Rear View.....	10.185	MOULDING, Seat Separator.....	10.242
MIRROR UNIT, Vanity Visor.....	10.195	MOULDING, Side Roof Rail.....	10.721
MODULATOR, Vacuum.....	4.205	MOULDING, Tail Gate.....	12.180
MODULE ASSY., Radiator and Recovery Tank.....	1.203	MOULDING UNIT, Back Door Reveal.....	12.180C
MODULE, Ignition Pulse (Transistorized).....	2.383	MOULDING UNIT, Body Rear Panel.....	12.121
MOLDING, Back Body Opening.....	12.968	MOULDING UNIT, Body Sill.....	8.304
MOLDING, Gas Tank Filler Neck Compartment.....	12.945	MOULDING UNIT, Bumper Valance Panel.....	7.833
MOLDING, Load Floor.....	12.976	MOULDING UNIT, Front Door Outer Panel.....	12.112
MOLDING, Parking Lamp.....	2.586	MOULDING UNIT, Radiator Grille & Frt. End (Also See Group 8.055).....	1.303

## ALPHABETICAL INDEX

MOULDING UNIT, Rear Compartment Lid and Rear End Panel.....	12.182	NUT, Body Sill Moulding.....	8.309
MOULDING UNIT, Rear Fender Outer Panel ..	12.116	NUT, Brake Band Adjusting.....	4.253
MOULDING UNIT, Wheel Cover Panel.....	8.176	NUT, Brake Shoe Anchor Pin.....	5.056
MOULDING, Vinyl Roof Panel Cover.....	13.260	NUT, Brake Shoe Hold Down.....	5.043A
MOULDING, Windshield Garnish.....	10.051	NUT, Bumper Guard Mounting.....	7.829
MOULDING, Windshield Reveal.....	10.093	NUT, Bumper Valance Panel.....	7.833
MOUNT, Air Suspension or Level Control Air Compressor.....	7.452	NUT, Bumper.....	7.865
MOUNT, Fuel Injection.....	3.300	NUT, Camshaft Timing Belt.....	0.724
MOUNTING ASSY., Engine (also see group 4.081).....	0.027	NUT, Carburetor and Fuel Injection Choke.....	3.752
MOUNTING ASSY., Engine Mounting.....	0.029	NUT, Carburetor and Fuel Meter Fuel Inlet....	3.740
MOUNTING ASSY., Engine.....	0.027	NUT, Carburetor and Fuel Meter Intake (w/ seat and gasket).....	3.814
MOUNTING ASSY., Fuel Pump Mounting.....	3.901	NUT, Carburetor Idle Vapor Vent.....	3.852
MOUNTING ASSY., Transmission Mounting ..	4.081	NUT, Carburetor Throttle.....	3.762
MOUNTING UNIT, Engine (also see group 4.081).....	0.027	NUT, Cargo Tie Down Hook.....	9.025
MOUNTING UNIT, Radiator Core.....	1.270	NUT, Catalytic Converter.....	3.685
MUFFLER, Air Conditioning Compressor Suction and Discharge.....	9.226	NUT, Clock Mounting and Attaching.....	9.772
MUFFLER ASSY., Engine to Muffler Exhaust..	3.609	NUT, Concealed Headlamp Control Drive.....	2.760
MUFFLER, Engine Exhaust.....	3.701	NUT, Connecting Rod Bearing Cap olt.....	0.626
MUFFLER PKG., Air Conditioning Refrigerant Line (Fitting Pkgs. Include 'O' Rings and Hose Clamps).....	9.222	NUT, Cylinder Head.....	0.293
<b>N</b>		NUT, Dome Lamp Door Jamb.....	11.950
NAIL, Vinyl Roof Panel Cover.....	13.260	NUT, Door Lock Inside.....	10.512
NECK, Fuel Tank Filler.....	3.003	NUT, Door Outside Handle Ferrule.....	10.537
NEEDLE, Carburetor Pump Outlet Valve.....	3.825	NUT, Door Window Lower Sash.....	10.747
NEEDLE UNIT, Carburetor and Fuel Injection Idle Adjusting.....	3.822	NUT, Door Window Regulator Manual or Electric.....	10.792
NEEDLE UNIT, Carburetor and Fuel Meter Intake (w/seat and gasket).....	3.814	NUT, Door Window.....	10.716
NIPPLE, Carburetor.....	3.755	NUT, Door Window.....	10.728
NIPPLE, Crankcase.....	1.745	NUT, Electrical Output (See 2.319 for Breaker).....	2.500
NIPPLE, Distributor Vacuum Control.....	2.420	NUT, End Gate Lock.....	12.237A
NIPPLE, Heater.....	8.866	NUT, End Gate.....	12.203
NIPPLE, Shock Absorber, Air Lift.....	7.346	NUT, Engine Timing Belt.....	0.206
NIPPLE, Spark Plug Wire.....	2.258	NUT, Exhaust Pipe.....	3.613
NOZZLE ASSY., Headlamp Washer.....	2.780	NUT, Flange Plate.....	5.002
NOZZLE ASSY., Rear Window Defogger.....	9.778	NUT, Front Door Arm Rest.....	14.686
NOZZLE ASSY., Windshield Wiper Parts.....	10.156	NUT, Front Door Trim Binding Strip Replacement.....	14.683
NOZZLE, Carburetor.....	3.774	NUT, Front Door Trim Finish.....	14.691
NOZZLE, Timing Gear Oil.....	0.748	NUT, Front Door Ventilator.....	10.670
NUT.....	12.971	NUT, Front Door Window Glass Lower Sash..	10.685
NUT, Air Cleaner.....	3.403	NUT, Front Fender and Skirt.....	8.143
NUT, Air Conditioning Compressor Pulley.....	9.181	NUT, Front Fender Moulding.....	8.133
NUT, Air Conditioning Electrical Temperature and Blower Motor Control..	9.275	NUT, Front Fender.....	8.147
NUT, Air Conditioning Evaporator Air Distributor and Astro-Ventilation.....	9.262	NUT, Front or Rear Bumper Bar Mounting and Attaching.....	7.874
NUT, Air Conditioning Evaporator Blower Motor.....	9.216	NUT, Front Seat Adjuster.....	11.561
NUT, Air Conditioning Evaporator By-Pass....	9.198	NUT, Fuel Lines.....	3.163
NUT, Air Conditioning Evaporator Core Housing.....	9.211	NUT, Fuel Tank Strap.....	3.023
NUT, Air Conditioning Refrigerant.....	9.190	NUT, Gas Tank Filler Neck Compartment.....	12.945
NUT, Air Duct.....	9.782	NUT, Gearshift Control Hand Lever.....	4.008
NUT, Air Flow Control with Tube.....	9.787	NUT, Generator (Current Regulator Listed in Group 2.500).....	2.319
NUT, Air Flow.....	9.786	NUT, Generator Armature.....	2.280
NUT, Air Injection Reactor Pump Mounting ..	3.655	NUT, Generator Through.....	2.316
NUT AND GUIDE ASSY., Antenna.....	9.647	NUT, Hazard Flasher.....	2.575
NUT ASSY., Back Door Reveal.....	12.180C	NUT, Headlamp (Rim or Door).....	2.728
NUT ASSY., Hood Lock-Upper.....	8.083	NUT, Headlamp to Fender.....	2.722
NUT ASSY., Lighting Switch Rod.....	2.487	NUT, Headlamp Beam Adjusting.....	2.737
NUT ASSY., Lighting Switch, with Knob.....	2.486	NUT, Headlamp Lens and Sealed Beam Retaining.....	2.736
NUT ASSY., Parking Brake.....	4.765	NUT, Headlamp Moulding.....	2.729
NUT ASSY., Rear Compartment Lid and Rear End Panel.....	12.182	NUT, Heater.....	8.852
NUT ASSY., Tail Gate.....	12.180B	NUT, Heater.....	8.857
NUT ASSY., Wheel Cover Appearance.....	5.871	NUT, Hood.....	8.024
NUT, Auto.....	8.820	NUT, Hood Moulding and Hinge Attaching ...	8.016
NUT, Back-Up.....	2.697	NUT, Hood Panel.....	8.015
NUT, Back Window Glass Reveal Moulding...	11.209	NUT, Hood (Top) Moulding and Ornament....	8.056
NUT, Belt Moulding, Door and Quarter Mldg. Attaching Parts.....	12.118	NUT, Horn.....	2.812
NUT, Belt Unit and Shoulder Strap Unit Components.....	14.875A	NUT, Hot Water.....	8.845
		NUT, Hub-Front and Rear.....	5.813
		NUT, Hydraulic Brake.....	4.686
		NUT, Hydraulic Steering Cylinder.....	6.575
		NUT, Ignition Coil Mounting.....	2.183
		NUT, Ignition Lock.....	2.198
		NUT, Instrument Case Face.....	9.748
		NUT, Instrument Case.....	9.744
		NUT, Instrument Panel.....	14.655A
		NUT, Instrument.....	9.743
		NUT KIT, Air Conditioning less Clutch.....	9.170
		NUT, License Plate.....	7.800
		NUT, Main Cylinder Push.....	4.658
		NUT, Mast Jacket.....	6.521
		NUT, Muffler Tail Pipe.....	3.706

## ALPHABETICAL INDEX

NUT, Muffler.....	3.704	NUT, Windshield Wiper.....	10.159
NUT, Oil (Also see Group 8.963).....	1.531	NUT, Windshield Wiper.....	10.163
NUT, Parking Brake Lever Release.....	4.594	NUT, 'U' Joint Trunnion and Yoke.....	5.586
NUT, Parking Lamp Attaching.....	2.587		
NUT, Parking Lamp Door or Lens.....	2.594	<b>O</b>	
NUT, Pitman Arm.....	6.861		
NUT, Pitman Shaft.....	6.822	OCTANE ADJ. UNIT, Dist. Spark Advance	
NUT, Propeller Shaft Damper.....	5.544A	Trans. Electric Control (Also See Group	
NUT, Propeller Shaft Pinion Flange.....	5.595	4.075).....	2.408
NUT, Quarter Window Garnish and Quarter		OIL, Engine Concentrate.....	1.850
Belt Finishing.....	11.119	OIL, Steering Gear Hydraulic.....	6.605
NUT, Quarter Window Glass.....	11.010	ORIFICE ASSY., Air Conditioning Evaporator	
NUT, Quarter Window Lower Sash.....	11.007A	Expansion.....	9.213
NUT, Quarter Window Upper Sash.....	11.005	O RING, Air Suspension Air Compressor	
NUT, Radiator Core.....	1.270	Level Control.....	7.457
NUT, Radiator Grille & Frt. End (Also See		O RING, Air Suspension Leveling Valve.....	7.476
Group 8.055).....	1.303	ORNAMENT.....	12.116A
NUT, Radiator Grille and Engine Baffle		ORNAMENT ASSY., Radiator Grille & Frt.	
Attaching.....	1.276	End (Also See Group 8.055).....	1.303
NUT, Radiator Grille Moulding.....	1.269	ORNAMENT, Back-Up.....	2.697
NUT, Radiator Grille.....	1.267	ORNAMENT, Front Door Outer Panel.....	12.112
NUT, Radio and Stereo Mounting.....	9.667	ORNAMENT, Front Fender.....	8.147
NUT, Rear Axle Control Arm.....	5.383	ORNAMENT, Hood (Also See Group 1.303)...	8.055
NUT, Rear Axle Tie Rod.....	5.418	ORNAMENT, Parking Lamp.....	2.586
NUT, Rear Compartment Emblem.....	12.246	ORNAMENT, Rear Door Outer Panel.....	12.114
NUT, Rear Compartment Lid.....	12.183	ORNAMENT, Tail and Stop Lamp.....	2.680
NUT, Rear Door Arm-Less Tray.....	14.762	ORNAMENT, Tail Gate.....	12.180
NUT, Rear Door Lower Window Sash		ORNAMENT, Wheel Cover Appearance.....	5.871
Channel.....	10.748	OUTLET, Air Conditioning Evaporator Air	
NUT, Rear Door Trim Finish.....	14.764	Distributor and Astro-Ventilation.....	9.262
NUT, Rear Door Window.....	10.768	OUTLET, Air Flow.....	9.786
NUT, Rear Door Window.....	10.791	OUTLET ASSY., Defroster.....	9.779
NUT, Rear License Lamp.....	2.708	OUTLET, Coolant.....	1.153
NUT, Rear Quarter Trim.....	15.101A	OUTLET, Cowl.....	9.789
NUT, Rear Quarter Arm Trimmed.....	15.108	OUTLET, Rear Window Defogger.....	9.778
NUT, Rear Spring and Shock Absorber.....	7.516		
NUT, Rear Spring Eye.....	7.530	<b>P</b>	
NUT, Rear View Mirror.....	10.186		
NUT, Rear Window Defogger.....	9.778	PACKAGE ASSY., Front Door Window.....	10.783
NUT, Roof Luggage and Ski.....	12.815	PACKAGE ASSY., Locking Sun Roof Panel	
NUT, Roof Rail.....	14.157	Front Guide.....	14.570
NUT, Shock Absorber Frame.....	7.395	PACKAGE ASSY., Quarter Window.....	11.041
NUT, Shock Absorber, Air Lift.....	7.346	PACKAGE ASSY., Rear Door Window.....	10.791
NUT, Shock Absorber.....	7.347	PACKAGE ASSY., Tailgate.....	12.195
NUT, Sliding Sunroof.....	14.550	PACKAGE, Door Edge.....	10.352A
NUT, Stabilizer Link.....	7.238	PACKING, Automatic Choke Control.....	3.750
NUT, Stabilizer Link.....	7.245	PACKING, Exhaust Pipe.....	3.611
NUT, Starting Motor.....	2.104	PAD.....	7.836A
NUT, Steering Column.....	6.760	PAD ASSY.....	7.831A
NUT, Steering Connecting (With Internal		PAD ASSY., Bumper.....	7.865
Parts).....	6.870	PAD ASSY., Front Door Arm Rest.....	14.686
NUT, Steering Gear Ball.....	6.841	PAD ASSY., Front Seat Back.....	14.802
NUT, Steering Gear Hydraulic Pump.....	6.655	PAD ASSY., Front Seat Bottom with Frame,	
NUT, Steering Gear Worm Bearing.....	6.832	Springs and Padding (less trim cover).....	11.419
NUT, Steering Idler.....	6.896	PAD ASSY., Front Seat Cushion.....	14.890
NUT, Steering Idler.....	6.897	PAD ASSY., Front Seat Headrest.....	11.376
NUT, Steering Knuckle Lower Control Arm		PAD ASSY., Instrument Panel.....	14.655
Attaching.....	6.172	PAD ASSY., Rear Bumper.....	7.875
NUT, Steering Knuckle Spindle.....	6.022	PAD ASSY., Rear Seat Back.....	15.002
NUT, Steering Knuckle Upper Control Arm....	6.164	PAD ASSY., Rear Seat Cushion.....	15.036
NUT, Steering Knuckle Upper Control Arm....	6.178	PAD ASSY., Roof Trim.....	14.640A
NUT, Steering Knuckle.....	6.104	PAD, Auto.....	8.820
NUT, Steering Wheel.....	6.515	PAD, Back-Up.....	2.697
NUT, Stop Lamp.....	2.447	PAD, Child Safety.....	14.870
NUT, Tail Gate.....	12.180	PAD, Door Lock Inside Handle Escutcheon	
NUT, Tail Gate.....	12.184A	(Trim Protector).....	10.515
NUT, Tailgate.....	12.195	PAD, Electric Seat Adjuster.....	11.556
NUT, Tail Lamp.....	2.688	PAD, Folding Top Cover (less Back Curtain)..	13.347
NUT, Transmission Control Idler Attaching....	4.042	PAD, Frame to Bumper Attaching (Also See	
NUT, Transmission Gearshift External		Group 7.869).....	7.836
Control Lever.....	4.046	PAD, Front Floor.....	15.286
NUT, Transmission Gearshift Rod to Lever....	4.037	PAD, Front Seat Back Head Restraint.....	14.924
NUT, Transmission Main Drive Gear Bearing.	4.356	PAD, Gearshift.....	4.303
NUT, Transmission Main Valve Body		PAD, Radiator Core.....	1.270
Accumulator.....	4.217	PAD, Rear Door Arm-Less Tray.....	14.762
NUT, Transmission Overdrive.....	4.480	PAD, Rear Quarter Arm Trimmed.....	15.108
NUT, Transmission Throttle Valve Control		PAD, Rear View Mirror.....	10.186
(T.V.).....	4.050	PAD, Roof Panel (Exterior).....	13.250
NUT, Transmission Throttle Valve Control....	4.052		
NUT, Underbody Trim (floor mounted).....	4.017		
NUT, Valve Push Rod Adjusting.....	0.429		
NUT, Vanity Visor.....	10.195		
NUT, Wheel Carrier.....	7.633		
NUT, Windshield Wiper Motor Aux.....	10.151		



## ALPHABETICAL INDEX

PAD, Seat Back.....	14.810	PAWL, Transmission Parking Lock.....	4.220
PAD, Steering Wheel Hub.....	6.512	PAWL, Windshield Washer.....	10.153
PAD UNIT, Instrument Panel.....	14.655	PAWL, Windshield Wiper Motor Aux.....	10.151
PAN ASSY., Oil.....	1.426	PEDAL, Accelerator.....	3.451
PAN ASSY., Rear Compartment Floor.....	12.981	PEDAL ASSY., Brake.....	4.625
PANEL ASSY., Door Rocker.....	12.934	PEDAL ASSY., Clutch.....	0.830
PANEL ASSY., Front Door Outer.....	12.895	PEDAL ASSY., Parking Brake Apply.....	4.591
PANEL ASSY., Front Door Trim Finish.....	14.691	PEDAL, Clutch.....	0.830
PANEL ASSY., Front Seat Back, with Springs (less Cushion).....	11.373	PILLAR ASSY., Center Body.....	12.491
PANEL ASSY., Front Seat Side Lower.....	11.362	PIN, Accelerator Intermediate.....	3.463
PANEL ASSY., Front.....	8.130	PIN, Accelerator Pedal.....	3.452
PANEL ASSY., Rear Quarter Side Inner.....	12.941	PIN, Air Conditioning Compressor Pressure Relief.....	9.178
PANEL ASSY., Rear Quarter Trim.....	15.101	PIN, Air Flow.....	9.786
PANEL ASSY., Rear Quarter Upper-Above Belt.....	14.645	PIN ASSY., Front Door Window Glass Lower Sash.....	10.685
PANEL ASSY., Rear Seat Back, with Springs.....	11.628	PIN, Brake Shoe Anchor.....	5.055
PANEL ASSY., Sliding Sun Roof.....	12.809	PIN, Brake Shoe.....	5.043
PANEL, Back Body Opening.....	12.968	PIN, Camshaft Housing and Cover.....	0.413
PANEL, Back Window Inner.....	12.964	PIN, Camshaft Rear Bearing Hole.....	0.553
PANEL, Body Back Lower (Rear End).....	12.966	PIN, Camshaft Sprocket.....	0.738
PANEL, Bumper Valance Panel.....	7.833	PIN, Carburetor and Fuel Injection Choke.....	3.752
PANEL, Cowl Side.....	12.804	PIN, Carburetor and Fuel Meter Float Lever.....	3.747
PANEL, Cowl Trim.....	14.630	PIN, Carburetor Throttle Return Check.....	3.440
PANEL, Folding Top Compartment (See Group 15.100 for TRIM ASSY.).....	12.989	PIN, Child Safety.....	14.870
PANEL, Front Body Hinge.....	12.840	PIN, Clutch Cable.....	0.854
PANEL, Front Door Outer.....	12.895	PIN, Clutch Housing.....	0.685
PANEL, Front Door.....	14.685A	PIN, Clutch Pedal.....	0.833
PANEL, Front End and Close.....	1.263	PIN, Clutch Pedal.....	0.854
PANEL, Front Fender (See Group 8.147 for Front Fender Mouldings which include Series Designations).....	8.132	PIN, Concealed Headlamp Control Drive.....	2.760
PANEL, Front Fender.....	8.131	PIN, Concealed Headlamp Control Opening Cover.....	2.765
PANEL, Front Fender.....	8.153	PIN, Cowl.....	9.789
PANEL, Front Seat Back.....	11.358	PIN, Crankcase Front End.....	0.206
PANEL, Front Seat Center Arm Rest.....	11.374	PIN, Crankshaft Bearing Cap.....	0.107
PANEL, Front Seat Headrest.....	11.376	PIN, Crankshaft Rear Bearing.....	0.105
PANEL, Front Seat Side Lower.....	11.362	PIN, Cylinder Head.....	0.293
PANEL, Gas Tank Filler Neck Compartment.....	12.945	PIN, Distributor Housing.....	2.363
PANEL, Hood Top.....	8.000	PIN, Door Handle Push Button.....	10.529
PANEL, Instrument Panel to Dash.....	10.230	PIN, Door Hinge.....	10.466
PANEL, Load Floor.....	12.975	PIN, Door Ventilator Regulator.....	10.664
PANEL, Lock Pillar Finishing.....	14.731	PIN, Ducted Hood.....	8.036
PANEL, Lower End (Less Hardware).....	12.179	PIN, Electric Seat Adjuster Switch.....	11.558
PANEL, Radiator (Mouldings in group 1.268).....	1.266	PIN, Flywheel and Clutch Housing to Cylinder Block.....	0.685
PANEL, Radiator and Grille Filler.....	1.287	PIN, Folding Top Front Roof Rail.....	14.080A
PANEL, Radiator Core.....	1.270	PIN, Front and Rear Door Lock.....	10.474
PANEL, Radiator Fan.....	1.277	PIN, Front Seat Adjuster.....	11.561
PANEL, Rear Body Lock Pillar.....	12.942	PIN, Gear Shifter Shaft & Fork (Yoke).....	4.312
PANEL, Rear Compartment Floor.....	12.981	PIN, Gearshift Control (Hand).....	4.006
PANEL, Rear Compartment Front and Shelf.....	12.971	PIN, Gearshift Control Hand Lever.....	4.008
PANEL, Rear Compartment.....	15.222	PIN, Gearshift Detent.....	4.311
PANEL, Rear Door.....	12.913	PIN, Gearshift Hand Lever Housing.....	4.012
PANEL, Rear Door Trim Finish.....	14.764	PIN, Gearshift.....	4.307
PANEL, Rear Door.....	14.760	PIN, Heater.....	8.852
PANEL, Rear Quarter Arm Trimmed.....	15.108	PIN, Hood Lock-Lower.....	8.080
PANEL, Rear Quarter Outer.....	12.940A	PIN, Hood Moulding and Hinge Attaching.....	8.016
PANEL, Rear Quarter Side Inner.....	12.941	PINION, Folding Top Motor and Pump.....	14.482
PANEL, Rear Quarter Side Outer (Outer Panel Only).....	12.940	PINION, Transmission Planet.....	4.175
PANEL, Rear Quarter Trim.....	15.101	PINION UNIT, Transmission Planet.....	4.175
PANEL, Rear Quarter.....	15.100A	PIN, Luggage Deck Lid.....	12.815B
PANEL, Roof Trim.....	14.640A	PIN, Main Cylinder Adjusting.....	4.662
PANEL, Seat Separator.....	10.240	PIN, Manifold Heat Control Valve.....	3.641
PANEL, Seat Separator.....	10.242	PIN, Manual Valve.....	4.218
PANEL, Spare Tire Cover.....	12.579	PIN, Oil Level.....	1.516
PANEL, Spare Tire Cover.....	15.100C	PIN, Oil Pump Shaft.....	1.639
PANEL, Tailgate.....	12.195	PIN, Oil Pump.....	1.609
PANEL, Top Roof Outer.....	12.810	PIN, Oil Supply Pump.....	4.203
PANEL, Wheelhouse Cover.....	15.099	PIN, Quarter Window Glass.....	11.010
PANEL, Wheelhouse.....	12.944	PIN, Quarter Window Lower Sash.....	11.007A
PAN, Transmission Oil.....	4.195	PIN, Rear Compartment Hinge, Tail Gate.....	12.186
PAWL ASSY., Tailgate.....	12.195	PIN, Rear Compartment Lid or Tailgate Hinge.....	12.187
PAWL, Direction Signal Lamp (See Group 9.748 Tell Tale Wind.).....	2.895	PIN, Rear Compartment Lid.....	12.184
PAWL, Door Outside Lock Handle.....	10.551	PIN, Reverse Servo.....	4.241
PAWL, Luggage Compartment.....	12.977	PIN, Safety Light.....	9.773
PAWL, Rear Compartment Lid Lock Cylinder.....	12.249	PIN, Starting Motor Brush.....	2.052
PAWL, Transmission Gearshift Control Shaft or Tube.....	4.027	PIN, Starting Motor Commutator End, with Pins.....	2.067
PAWL, Transmission Interlock.....	4.307	PIN, Steering Gear Hydraulic Pump.....	6.608
PAWL, Transmission Overdrive Shifting.....	4.490	PIN, Tailgate.....	12.195
PAWL, Transmission Parking Brake.....	4.294	PIN, Throttle Control Rod.....	3.425
		PIN, Tilt or Tel. Steering Column.....	6.514
		PIN, Transmission Control Idler Attaching.....	4.042

# ALPHABETICAL INDEX

PIN, Transmission Control Safety .....	4.054	PLATE ASSY., Back Door Reveal .....	12.180C
PIN, Transmission Front Servo .....	4.226	PLATE ASSY., Clutch Driven .....	0.886
PIN, Transmission Gearshift Control Cable .....	4.047	PLATE ASSY., Clutch Pressure with Cover .....	0.859
PIN, Transmission Gearshift Control Shaft or Tube .....	4.027	PLATE ASSY., Concealed Headlamp Control Opening Cover .....	2.765
PIN, Transmission Gearshift External Control Lever .....	4.046	PLATE ASSY., Cowl Side .....	12.804
PIN, Transmission Gearshift Rod to Lever .....	4.037	PLATE ASSY., Cowl .....	12.803
PIN, Transmission Low and Drive Valve .....	4.265	PLATE ASSY., Folding Top Motor and Pump .....	14.482
PIN, Transmission Overdrive Shifting .....	4.490	PLATE ASSY., Frame to Bumper Attaching (Also See Group 7.869) .....	7.836
PIN, Transmission Overdrive .....	4.495	PLATE ASSY., Hood Lock-Upper .....	8.083
PIN, Transmission Parking Lock .....	4.220	PLATE ASSY., Quarter Window Lower Sash .....	11.007A
PIN, Transmission Reverse Idler Shaft .....	4.435	PLATE ASSY., Radio Instrument Panel .....	10.256
PIN, Transmission Selector .....	4.046	PLATE ASSY., Roof Panel .....	12.812
PIN, Transmission Throttle valve Operating Parts .....	4.275	PLATE ASSY., Tail and Stop Lamp .....	2.681
PIN, Transmission Throttle Valve Control (T.V.) .....	4.050	PLATE ASSY., Wheelhouse .....	12.944
PIN, Transmission .....	4.256	PLATE ASSY., Windshield Wiper Motor Mounting Parts .....	10.152
PIN UNIT, Brake Shoe Hold Down .....	5.043A	PLATE ASSY., With Facing, Clutch .....	0.886
PIN, Wheel Brake (Also See Group 4.667) .....	4.665	PLATE ASSY. .....	12.116A
PIPE, Air Injection Reactor .....	3.675	PLATE ASSY. .....	7.836A
PIPE ASSY., Automatic Choke Control .....	3.750	PLATE, Automatic Choke Control .....	3.750
PIPE ASSY., Heater (See Group 1.166 for Clamps) .....	8.846	PLATE, Belt Unit and Shoulder Strap Unit Components .....	14.875A
PIPE ASSY., Hydraulic Steering .....	6.677	PLATE, Brake and Clutch Pedal .....	4.630
PIPE ASSY., Oil Pan Pump Suction .....	4.197	PLATE, Brake Shoe Guide .....	5.045
PIPE ASSY., Oil Pan Upper .....	1.430	PLATE, Bumper Valance Panel .....	7.833
PIPE ASSY., Oil Pressure .....	1.803	PLATE, Carburetor Float .....	3.734
PIPE ASSY., Transmission Case .....	4.104	PLATE, Carburetor Power .....	3.858
PIPE ASSY., Vacuum Power Brake Cylinder .....	4.930	PLATE, Center Bearing .....	2.082
PIPE ASSY., Vacuum .....	4.205	PLATE, Clock Mounting and Attaching .....	9.772
PIPE, Carburetor and Fuel Meter Fuel Inlet .....	3.740	PLATE, Clutch Pressure .....	0.863
PIPE, Catalytic Converter .....	3.685	PLATE, Differential Clutch (Positraction) .....	5.511
PIPE, Crankcase Ventilator-Outer .....	1.762	PLATE, Direction Signal Lamp (See Group 9.748 Tell Tale Wind.) .....	2.895
PIPE, Distributor Housing .....	2.363	PLATE, Distributor Breaker .....	2.385
PIPE, Distributor Vacuum Control .....	2.420	PLATE, Distributor Weight and Cam, with Stop .....	2.390
PIPE, Engine to Muffler Exhaust .....	3.609	PLATE, Door Arm Rest and Trim Pad .....	14.688
PIPE, Exhaust Manifold .....	3.647	PLATE, Door Arm Rest Trim .....	14.690
PIPE, Fuel Injector .....	3.330	PLATE, Door Dovetail Bumper Wedge .....	10.584
PIPE, Fuel Lines .....	3.163	PLATE, Door Lock Inside Handle Escutcheon (Trim Protector) .....	10.515
PIPE, Fuel Tank Evaporative Control .....	3.120	PLATE, Door Lock Striker .....	10.571
PIPE, Hydraulic Brake .....	4.685	PLATE, Door Rocker .....	12.934
PIPE, Intake & Exhaust Manifold .....	3.275	PLATE, Door Window Lower Sash .....	10.747
PIPE, Muffler Tail .....	3.705	PLATE, Door Window Regulator Handle .....	10.805
PIPE, Transmission Case .....	4.104	PLATE, Door Window Regulator Manual or Electric .....	10.792
PIPE, Transmission Oil .....	4.248	PLATE, Door Window .....	10.728
PISTON, Air Conditioning Compressor (Internal) .....	9.172	PLATE, Ducted Hood .....	8.036
PISTON, Air Conditioning Evaporator By-Pass .....	9.198	PLATE, Electric Window Lift .....	10.777
PISTON ASSEMBLY, with Pin (Refer to Piston Chart for Model Application) .....	0.629	PLATE, End Gate Lock .....	12.237A
PISTON ASSEMBLY, With Pin .....	0.629	PLATE, Floor (less Rear Compartment Floor Pan) .....	12.980
PISTON ASSY., w/Pin .....	0.629	PLATE, Folding Seat (For Load Floor Parts See Group 12.977) .....	11.620
PISTON ASSY., with Pin .....	0.629	PLATE, Folding Top Back Window .....	13.395
PISTON ASSY., Air Suspension Air Compressor .....	7.455	PLATE, Folding Top Side Roof .....	14.170
PISTON ASSY., Brake Caliper .....	4.668	PLATE, Folding Top .....	14.310
PISTON ASSY., Engine .....	0.629	PLATE, Front and Rear Bumper Shock .....	7.840
PISTON ASSY., Windshield Washer .....	10.153	PLATE, Front or Rear Bumper Bar Mounting and Attaching .....	7.874
PISTON, Brake Main Cylinder .....	4.653	PLATE, Front Door Sill .....	11.175
PISTON, Carburetor and Fuel Injection Choke .....	3.752	PLATE, Front Door Trim Finish .....	14.691
PISTON, Carburetor Power .....	3.858	PLATE, Front Door Window Glass Lower Sash .....	10.685
PISTON, Low Servo .....	4.228	PLATE, Front Door, Lower .....	10.454
PISTON, Reverse Servo .....	4.241	PLATE, Front Door, Upper .....	10.450
PISTON, Transmission Clutch .....	4.166	PLATE, Front Door .....	14.685A
PISTON, Vacuum Power Brake Cylinder .....	4.922	PLATE, Front Fender (See Group 8.147 for Front Fender Mouldings which include Series Designations) .....	8.132
PIVOT, Brake Shoe Automatic Adjusting .....	5.103	PLATE, Front Fender .....	8.147
PIVOT, Horn Button and Blowing Ring .....	2.819	PLATE, Front Fender .....	8.153
PIVOT, Transmission Rail End .....	4.302	PLATE, Front Seat Adjuster .....	11.561
PLASTIGAGE, Crankshaft Bearing .....	0.093	PLATE, Front Seat Hinge Arm .....	11.375
PLATE, Accelerator .....	3.451	PLATE, Fuel Meter Enrichment .....	3.320
PLATE, Air Cleaner .....	3.417	PLATE, Fuel Pump Mounting .....	3.901
PLATE, Air Conditioning Compressor Clutch Actuating .....	9.188	PLATE, Gearshift Hand Lever Housing .....	4.012
PLATE, Air Conditioning Evaporator Core Housing .....	9.211	PLATE, Gearshift Hand Lever .....	4.010
PLATE, Air Conditioning Refrigerant .....	9.190	PLATE, Generator Drive End .....	2.307
PLATE, Air Flow .....	9.786	PLATE, Headlamp .....	2.726
PLATE, Ash Receiver .....	12.009	PLATE, Heater .....	8.849
PLATE ASSEMBLY, Brake Flange Front .....	5.001		
PLATE ASSY., with Facing, Clutch .....	0.886		

## ALPHABETICAL INDEX

PLATE, Heater.....	8.852	PLUG, Battery.....	2.345
PLATE, Hood (Also See Group 1.303).....	8.055	PLUG, Belt Unit and Shoulder Strap Unit Components.....	14.875A
PLATE, Hood Lock-Lower.....	8.080	PLUG, Camshaft Bearing Hole (In Cylinder Block).....	0.553
PLATE, Hood Panel.....	8.015	PLUG, Camshaft Rear Bearing Hole.....	0.553
PLATE, Horn Button and Blowing Ring.....	2.819	PLUG, Carburetor and Fuel Meter Float Lever.....	3.747
PLATE, Ignition Coil Mounting.....	2.183	PLUG, Carburetor Idle Vapor Vent.....	3.852
PLATE, Ignition Switch Warning.....	2.195	PLUG, Carburetor Nozzle Passage.....	3.775
PLATE, Instrument Case Face.....	9.748	PLUG, Carburetor Pump Outlet Valve.....	3.825
PLATE, Instrument Case.....	9.744	PLUG, Center Body.....	12.491
PLATE, Instrument Panel.....	10.252	PLUG, Clutch.....	0.829
PLATE, Instrument Panel.....	10.254	PLUG, Cowl Side.....	12.804
PLATE, Instrument.....	9.743	PLUG, Cylinder Block.....	0.034
PLATE, Lighting Switch Rod.....	2.487	PLUG, End Gate Rear Door.....	12.242A
PLATE, Locking Sun Roof Panel Front Guide.....	14.570	PLUG, Engine Intake.....	3.265
PLATE, Luggage Compartment.....	12.977	PLUG, Floor (less Rear Compartment Floor Pan).....	12.980
PLATE, Luggage Deck Lid.....	12.815B	PLUG, Folding Top Hydraulic Motor and Pump.....	14.486
PLATE, Oil Supply Pump.....	4.203	PLUG, Folding Top.....	14.478
PLATE, Parking Brake Cable Pulley.....	4.790	PLUG, Front Body Hinge.....	12.840
PLATE, Planet Carrier.....	4.176	PLUG, Front Door Trim Binding Strip Replacement.....	14.683
PLATE, Quarter Window Regulator Handle.....	11.047	PLUG, Front Door Window.....	10.783
PLATE, Radiator and Grille Filler.....	1.287	PLUG, Front Door.....	14.685A
PLATE, Radiator Grille & Frt. End (Also See Group 8.055).....	1.303	PLUG, Front Floor.....	15.300
PLATE, Rear Body Lock Pillar.....	12.942	PLUG, Gearshift Control Hand Lever.....	4.008
PLATE, Rear Compartment End.....	12.986	PLUG, Gearshift Detent.....	4.311
PLATE, Rear Compartment Floor.....	12.981	PLUG, Gearshift Hand Lever.....	4.010
PLATE, Rear Compartment Lid and Rear End Panel.....	12.182	PLUG, Generator Commutator or Rotor Slip Ring End Frame.....	2.298
PLATE, Rear Compartment Lid or Tailgate Hinge.....	12.187	PLUG, Generator Oil.....	2.301
PLATE, Rear Compartment Lid Lock Cylinder.....	12.249	PLUG, Hydraulic Steering Adapter.....	6.560
PLATE, Rear Compartment Lid Lock.....	12.237	PLUG, Hydraulic Steering Cylinder Piston Rod.....	6.581
PLATE, Rear Door Sill.....	11.179	PLUG, Instrument Panel.....	10.252
PLATE, Rear Door Trim Finish.....	14.764	PLUG, Oil (Also see Group 8.963).....	1.531
PLATE, Rear Quarter Side Inner.....	12.941A	PLUG, Oil Level.....	1.516
PLATE, Rear Spring 'U' Bolt (See Group 5.403).....	7.518	PLUG, Oil Pan Drain.....	1.453
PLATE, Rear View Mirror.....	10.186	PLUG, Oil Pump.....	1.609
PLATE, Rear Window Defogger.....	9.778	PLUG, Rad. Core and Support.....	1.274
PLATE, Roof Panel.....	12.812	PLUG, Rear Body Lock Pillar.....	12.942
PLATE, Safety Light.....	9.773	PLUG, Rear Compartment (Less Hardware).....	12.181
PLATE, Seat Separator.....	10.240	PLUG, Rear Compartment End.....	12.986
PLATE, Sliding Sunroof.....	14.550	PLUG, Rear Compartment Floor.....	12.981
PLATE, Spare Tire Cover.....	12.579	PLUG, Rear Compartment.....	12.212
PLATE, Speed and Cruise Control.....	3.880	PLUG, Rear Door Arm-Less Tray.....	14.762
PLATE, Steering Column Lock Bolt.....	6.500	PLUG, Rear Quarter Side Inner.....	12.941A
PLATE, Steering Column.....	6.760	PLUG, Rear Quarter.....	15.100A
PLATE, Steering Gear Hydraulic Pump.....	6.609	PLUG, Roof Trim.....	14.640A
PLATE, Steering Gear Hydraulic Pump.....	6.612	PLUG, Shock Absorber.....	7.347
PLATE, Steering Knuckle Upper Control Arm.....	6.178	PLUG, Side Door.....	10.587
PLATE, Steering Wheel Hub.....	6.512	PLUG, Spark.....	2.270
PLATE, Tail and Stop Lamp.....	12.943	PLUG, Steering Connecting Rod End.....	6.881
PLATE, Tail Gate.....	12.180	PLUG, Steering Gear Housing End.....	6.824
PLATE, Tailgate.....	12.195	PLUG, Steering Gear.....	6.586
PLATE, Tilt or Tel. Steering Column.....	6.514	PLUG, Tail Gate.....	12.180B
PLATE, Transmission Clutch Drive and Driven.....	4.163	PLUG, Tail Lamp.....	2.688
PLATE, Transmission Gearshift Control.....	4.020	PLUG, Transmission Case.....	4.105
PLATE, Transmission Gearshift Control Shaft or Tube.....	4.027	PLUG, Transmission Low and Drive Valve.....	4.265
PLATE, Transmission Gearshift Control.....	4.020	PLUG, Transmission Main with Gear.....	4.172
PLATE, Transmission Gearshift Shaft or Tube (Lower).....	4.030	PLUG, Transmission Overdrive.....	4.455
PLATE, Transmission Low and Drive Valve.....	4.265	PLUG, Transmission Parking Brake.....	4.294
PLATE, Transmission Overdrive Sun Gear.....	4.472	PLUG, Weatherstrip, Door Opening.....	10.694A
PLATE, Transmission Overdrive.....	4.495	PLUG, Wheel Cylinder.....	4.666
PLATE, Transmission Rail End.....	4.302	PLUG, Wheelhouse.....	12.944
PLATE, Transmission Synchronizing.....	4.384	PLUG, Windshield Wiper.....	10.150
PLATE, Transmission.....	4.215	PLUG, Windshield Wiper.....	10.159
PLATE, Underbody Trim (floor mounted).....	4.017	PLUNGER ASSY., Door Inside Locking Rod.....	10.559
PLATE UNIT, Clutch Pressure with Cover.....	0.859	PLUNGER ASSY., Vacuum Power Brake Cylinder Air Valve (See Group 4.658 for Valve and Push Rod Assy.).....	4.918
PLATE UNIT, Roof Panel.....	12.812	PLUNGER ASSY., Windshield Washer.....	10.153
PLATE UNIT.....	12.116A	PLUNGER, Carburetor (with Leather and Shaft).....	3.838
PLATE, Vacuum Power Brake Cyl. Reaction.....	4.934	PLUNGER, Electric Seat Adjuster.....	11.556
PLATE, Vacuum Power Brake Cylinder.....	4.922	PLUNGER, Gearshift Detent.....	4.311
PLATE, Vacuum Power Door Lock.....	10.485	PLUNGER, Seat Separator.....	10.242
PLIERS, Air Flow Control with Tube.....	9.787	PLUNGER, Starting Motor Drive Shift.....	2.113
PLUG, Air Conditioning Control.....	9.281	PLUNGER, Transmission Gearshift Control Shaft or Tube.....	4.027
PLUG, Air Injection Reactor Valve.....	3.670	PLUNGER, Transmission Overdrive Shifting.....	4.490
PLUG, Air Injection Reactor.....	3.680		
PLUG ASSY., Steering Gear Housing End Cover Worm Bearing.....	6.830		
PLUG, Automatic Choke Control.....	3.750		
PLUG, Axle Filler and Drain.....	5.400		

# ALPHABETICAL INDEX

<p>PLUNGER, Vacuum..... 4.205</p> <p>POCKET ASSY., Belt Unit and Shoulder Strap Unit Components..... 14.875A</p> <p>POCKET ASSY., Gas Tank Filler Neck Compartment..... 12.945</p> <p>POCKET, License Plate..... 7.800</p> <p>POCKET, Rear Compartment Floor..... 12.981</p> <p>POCKET, Tail and Stop Lamp..... 12.943</p> <p>POINTER, Eng. Timing..... 0.219</p> <p>POINTER, Engine Timing..... 0.219</p> <p>POINTER, Speedometer and Odometer (Miles)..... 9.761</p> <p>POINTER, Timing..... 0.219</p> <p>POINTER, Transmission Gearshift Control..... 4.020</p> <p>POINT UNIT, Distributor (Consists of Breaker Arm and Support)..... 2.384</p> <p>POLE PIECE, Distributor, with Weight Plate... 2.372</p> <p>POLE PIECE, Starting Motor (Internal)..... 2.077</p> <p>POPPET ASM., Vac. Pwr. Brake Cyl..... 4.940</p> <p>POWERGLIDE TRANSMISSION..... 4.003</p> <p>PROBE ASSY., Radiator and Recovery Tank.. 1.203</p> <p>PROGRAMMER ASSY., Air Conditioning Electrical Temperature and Blower Motor Control..... 9.275</p> <p>PROTECTOR, Belt Unit and Shoulder Strap Unit Components..... 14.875A</p> <p>PROTECTOR, Main Cylinder Piston..... 4.654</p> <p>PROTECTOR, Spark Plug Wire..... 2.258</p> <p>PROTECTOR, Speed and Cruise Control..... 3.887</p> <p>PULLEY, Air Conditioning Compressor Drive. 9.180</p> <p>PULLEY, Air Injection Reactor..... 3.650</p> <p>PULLEY ASSY., Crankshaft..... 0.659</p> <p>PULLEY, Clutch Cable..... 0.855</p> <p>PULLEY, Crankshaft..... 0.659</p> <p>PULLEY, Electric Seat Adjuster..... 11.556</p> <p>PULLEY, Fan and Water Pump..... 1.062</p> <p>PULLEY, Generator..... 2.274</p> <p>PULLEY, Steering Gear Hydraulic Pump..... 6.655</p> <p>PUMP ASM., Carburetor (with Leather and Shaft)..... 3.838</p> <p>PUMP ASSEMBLY, Oil..... 1.652</p> <p>PUMP ASSY., Air Injection Reactor Pump..... 3.660</p> <p>PUMP ASSY., Fuel with Gasket..... 3.900</p> <p>PUMP ASSY., Steering Gear Hydraulic..... 6.605</p> <p>PUMP ASSY., Transmission Oil Supply..... 4.200</p> <p>PUMP ASSY., Windshield Washer..... 10.153</p> <p>PUMP, Fuel Tank Gauge..... 3.107</p> <p>PUMP UNIT, Air Conditioning Compressor (Internal)..... 9.172</p> <p>PUMP UNIT, Engine Coolant..... 1.069</p>	<p>RAIL, Roof Luggage and Ski..... 12.815</p> <p>RAIL, Side Roof-Inner..... 12.957</p> <p>RAIL, Sliding Sunroof..... 14.550</p> <p>RAIL UNIT, Top Roof Outer..... 12.810</p> <p>RATCHET, Windshield Washer..... 10.153</p> <p>REBUILT CONVERTER ASSY., Transmission (Rebuilt for General Motors)..... 4.115</p> <p>RECEIVER ASSY., Air Conditioning Refrigerant (with Dehydrator)..... 9.195</p> <p>RECOVERY UNIT, Coolant Recovery Unit..... 1.240</p> <p>REFLECTOR ASSY., Bumper Valance Panel... 7.833</p> <p>REFLECTOR, Dome Lamp..... 11.927</p> <p>REFLECTOR, Seat Separator..... 10.242</p> <p>REFLEX ASSY., Back-Up..... 2.697</p> <p>REFRIGERANT, Maintenance Items, Air Conditioning..... 9.282</p> <p>REGULATOR ASSY., Fuel Pump Pulsator..... 3.910</p> <p>REGULATOR ASSY., Speed and Cruise Control Power..... 3.885</p> <p>REGULATOR ASSY., Tail Gate..... 12.184A</p> <p>REGULATOR ASSY., Tailgate..... 12.195</p> <p>REGULATOR UNIT, Air Suspension, Air Compressor..... 7.460</p> <p>REGULATOR, Electrical Output (See 2.319 for Breaker)..... 2.500</p> <p>REGULATOR, Front Door Ventilator..... 10.661</p> <p>REGULATOR, Front Door Window..... 10.783</p> <p>REGULATOR, Quarter Window..... 11.041</p> <p>REGULATOR, Rear Door Window..... 10.791</p> <p>REINFORCEMENT..... 7.836A</p> <p>REINFORCEMENT ASSY., Instrument Panel Compartment..... 10.260</p> <p>REINFORCEMENT, Accelerator Pedal..... 3.452</p> <p>REINFORCEMENT, Accelerator..... 3.454</p> <p>REINFORCEMENT, Back Body Opening..... 12.968</p> <p>REINFORCEMENT, Body Back Lower (Rear End)..... 12.966</p> <p>REINFORCEMENT, Bumper Guard Mounting. 7.829</p> <p>REINFORCEMENT, Bumper Valance Panel.... 7.833</p> <p>REINFORCEMENT, Center Body..... 12.491</p> <p>REINFORCEMENT, Cowl Side..... 12.804</p> <p>REINFORCEMENT, Cowl..... 9.789</p> <p>REINFORCEMENT, Cross Member..... 7.039</p> <p>REINFORCEMENT, Dash to Chassis Frame.... 12.650</p> <p>REINFORCEMENT, Door Rocker..... 12.934</p> <p>REINFORCEMENT, Electric Window Lift..... 10.777</p> <p>REINFORCEMENT, Exhaust Pipe Support..... 3.616</p> <p>REINFORCEMENT, Fan and Water Pump..... 1.062</p> <p>REINFORCEMENT, Floor (less Rear Compartment Floor Pan)..... 12.980</p> <p>REINFORCEMENT, Frame to Bumper Attaching (Also See Group 7.869)..... 7.836</p> <p>REINFORCEMENT, Frame Cross, Front..... 7.010</p> <p>REINFORCEMENT, Front and Rear Bumper Shock..... 7.840</p> <p>REINFORCEMENT, Front Door Ventilator Tee 10.657</p> <p>REINFORCEMENT, Front End and Close..... 1.263</p> <p>REINFORCEMENT, Front Fender Skirt..... 8.155</p> <p>REINFORCEMENT, Front Fender..... 8.141</p> <p>REINFORCEMENT, Front Fender..... 8.153</p> <p>REINFORCEMENT, Harmonic Balancer and Crankshaft Pulley..... 0.662</p> <p>REINFORCEMENT, Hinge Pillar to Floor..... 12.659</p> <p>REINFORCEMENT, Hood Lock-Lower..... 8.080</p> <p>REINFORCEMENT, Hood Panel..... 8.015</p> <p>REINFORCEMENT, Instrument Panel to Dash 10.230</p> <p>REINFORCEMENT, Instrument..... 9.743</p> <p>REINFORCEMENT, Mast (Also see Group 6.803)..... 6.518</p> <p>REINFORCEMENT, Mast Jacket..... 6.521</p> <p>REINFORCEMENT, Radiator (Mouldings in group 1.268)..... 1.266</p> <p>REINFORCEMENT, Radiator and Grille Filler. 1.287</p> <p>REINFORCEMENT, Radiator Core..... 1.270</p> <p>REINFORCEMENT, Radiator Grille..... 1.267</p> <p>REINFORCEMENT, Radiator Outlet..... 1.173</p> <p>REINFORCEMENT, Rear and Auxiliary Speakers..... 9.665</p> <p>REINFORCEMENT, Rear Axle Control Arm..... 5.380</p> <p>REINFORCEMENT, Rear Axle Control..... 5.382</p> <p>REINFORCEMENT, Rear Body Lock Pillar..... 12.942</p> <p>REINFORCEMENT, Rear Compartment End... 12.986</p> <p>REINFORCEMENT, Rear Compartment Floor.. 12.981</p>
<h2 style="margin: 0;">R</h2>	
<p>RACE, Air Conditioning Compressor (Internal)..... 9.172</p> <p>RACE ASSY., Low Sun Gear and Clutch..... 4.162</p> <p>RACE, Forward Cone Freewheel..... 4.168</p> <p>RACE, Mast Jacket..... 6.521</p> <p>RACE, Steering Worm Thrust..... 6.835</p> <p>RACE, Transmission Clutch Gear..... 4.352</p> <p>RACE, Transmission Rear Ring Gear..... 4.180</p> <p>RACK ASSY., Luggage Deck Lid..... 12.815B</p> <p>RACK ASSY., Roof Ski..... 12.815A</p> <p>RACK, Ignition Switch Warning..... 2.195</p> <p>RACK, Mast (Also see Group 6.803)..... 6.518</p> <p>RACK, Steering Column Lock Bolt..... 6.500</p> <p>RACK, Steering Gear..... 6.586</p> <p>RACK UNIT, Roof Ski..... 12.815A</p> <p>RACK UNIT, Roof Luggage and Ski..... 12.815</p> <p>RADIO UNIT, Radio Primary..... 9.650</p> <p>RAIL ASSY., Folding Top Side Roof..... 14.170</p> <p>RAIL ASSY., Folding Top Side Roof-Front..... 14.100</p> <p>RAIL ASSY., Side Roof-Outer..... 12.956</p> <p>RAIL ASSY., Transmission Overdrive Shifting 4.490</p> <p>RAIL, Door Window Lower Sash..... 10.747</p> <p>RAIL, Folding Top Front Roof..... 14.050</p> <p>RAIL, Frame Side..... 7.006</p> <p>RAIL, Front Fender..... 8.153</p> <p>RAIL, Gearshift..... 4.303</p> <p>RAIL, Rear Compartment End..... 12.986</p> <p>RAIL, Rear Quarter Belt-Outer..... 12.428</p>	

## ALPHABETICAL INDEX

REINFORCEMENT, Rear Compartment Front and Shelf .....	12.971	RETAINER ASM., Folding Top.....	14.478
REINFORCEMENT, Rear Quarter Outer.....	12.940A	RETAINER ASSY., Bumper .....	7.865
REINFORCEMENT, Rear Quarter Side Inner.....	12.941A	RETAINER ASSY., Front Center Speaker Mounting.....	9.655
REINFORCEMENT, Rear Quarter .....	15.100A	RETAINER ASSY., Windshield Pillar Weatherstrip.....	10.093A
REINFORCEMENT, Rear View Mirror.....	10.186	RETAINER, Accelerator.....	3.454
REINFORCEMENT, Seat Adjuster Track .....	11.573	RETAINER, Air Cleaner Intake Valve.....	3.415
REINFORCEMENT, Stabilizer Shaft .....	7.242	RETAINER, Air Cleaner.....	3.410
REINFORCEMENT, Steering Shaft U-Joint.....	6.525	RETAINER, Air Conditioning less Clutch.....	9.170
REINFORCEMENT, Top Roof Outer .....	12.810	RETAINER, Air Conditioning Compressor (Internal).....	9.172
REINFORCEMENT, Vacuum Power Door Lock.....	10.485	RETAINER, Air Conditioning Compressor Shaft.....	9.175
REINFORCEMENT, Valve Rocker Cover and Support (Also See Group 0.366).....	0.413	RETAINER, Air Conditioning Electrical Temperature and Blower Motor Control..	9.275
REINFORCEMENT, Wheel Cover Appearance	5.871	RETAINER, Air Conditioning Evaporator Air Distributor and Astro-Ventilation .....	9.262
REINFORCEMENT, Wheelhouse .....	12.944	RETAINER, Air Conditioning Evaporator Expansion Valve .....	9.214
REINFORCEMENT .....	7.831A	RETAINER, Air Conditioning Hose .....	9.242
RELAY, Air Cleaner Intake Valve.....	3.415	RETAINER, Air Conditioning Refrigerant .....	9.190
RELAY ASSY., Air Conditioning Electrical.....	9.277	RETAINER, Air Conditioning Remote Evaporator Air Distributor Outlet .....	9.264
RELAY ASSY., Air Conditioning Evaporator Blower.....	9.215	RETAINER, Air Flow Control with Tube .....	9.787
RELAY ASSY., Carburetor Throttle Return Check .....	3.440	RETAINER, Air Flow .....	9.786
RELAY ASSY., Concealed Headlamp Motor...	2.755	RETAINER, Air Injection Reactor.....	3.675
RELAY ASSY., Dist. Spark Advance Trans. Electric Control (Also See Group 4.075) ..	2.408	RETAINER, Air Injection Reactor.....	3.680
RELAY ASSY., Rear Window Defogger.....	9.778	RETAINER, Ash Receiver.....	12.009
RELAY ASSY., Seat Belt, Check Doors and Low Fuel Warning Lights .....	9.765	RETAINER, Ash Tray Anti-Rattle.....	12.050
RELAY ASSY., Speed and Cruise Control.....	3.887	RETAINER, Ash Tray .....	12.012
RELAY ASSY., Transmission Overdrive .....	4.480	RETAINER, Auto. ....	8.820
RELAY ASSY., Transmission, Smog Control...	4.075	RETAINER, Automatic Choke Control.....	3.750
RELAY ASSY., Windshield Wiper.....	10.150	RETAINER, Back Body Opening .....	12.968
RELAY ASSY., Windshield Wiper.....	10.163	RETAINER, Back-Up .....	2.697
RELAY, Body Wiring .....	13.095	RETAINER, Battery Top .....	2.335
RELAY, Ignition Switch Warning.....	2.195	RETAINER, Belt Moulding, Door and Quarter Midg. Attaching Parts.....	12.118
RELAY, Matched Horn .....	2.815	RETAINER, Belt Unit and Shoulder Strap Unit Components.....	14.875A
RELEASE UNIT, Rear Compartment Lid Opener.....	12.243	RETAINER, Body Back Lower (Rear End) .....	12.966
REPAIR KIT, Drive and Engine .....	9.750	RETAINER, Body Sill Moulding.....	8.309
REPAIR KIT, Oil Filter .....	1.837	RETAINER, Body Wiring (Also See Group 2.480 for additional Body Harnesses).....	13.090
REPAIR KIT, Rear Axle U Joint.....	5.428	RETAINER, Brake Pedal .....	4.634
REPAIR KIT, Rear Spring Shackles.....	7.523	RETAINER, Brake Shoe .....	5.043
REPAIR KIT, Rear Spring .....	7.529	RETAINER, Bumper Guard Mounting.....	7.829
REPAIR KIT, Rear Window Defogger.....	9.778	RETAINER, Bumper Valance Panel.....	7.833
REPAIR KIT, Steering Gear, with Worm.....	6.524	RETAINER, Camshaft .....	0.738
REPAIR KIT, Universal .....	5.548	RETAINER, Carburetor and Fuel Injection Choke.....	3.752
REPAIR KITS .....	3.725	RETAINER, Carburetor and Fuel Injection Fast Idle .....	3.766
REPAIR PKG., Catalytic Converter.....	3.685	RETAINER, Carburetor and Fuel Meter Intake (w/seat and gasket) .....	3.814
REPAIR PKG., Fuel Tank Evaporative Control	3.130	RETAINER, Carburetor Idle Vapor Vent.....	3.852
REPAIR UNIT, Air Suspension Air Compressor Level Control .....	7.457	RETAINER, Carburetor Idle .....	3.798
REPAIR UNIT, Hydraulic Brake Main Cylinder.....	4.649	RETAINER, Carburetor Power.....	3.858
REPAIR UNIT, Stabilizer.....	7.240	RETAINER, Carburetor Pump Inlet Valve.....	3.826
REPAIR UNIT, Vacuum Power Brake .....	4.898	RETAINER, Carburetor Pump Outlet Valve.....	3.825
REPAIR UNIT, Wheel Brake (Also See Group 4.667).....	4.665	RETAINER, Carburetor Pump.....	3.841
REPAIR UNIT, Wheel Cylinder Piston (Also See Group 4.665) .....	4.667	RETAINER, Carburetor Throttle.....	3.762
REPAIR UNIT .....	8.800	RETAINER, Center Pillar Weatherstrip .....	10.730
RESERVOIR ASSY., Steering Gear Hydraulic Pump .....	6.635	RETAINER, Chassis Wiring Harness.....	2.559
RESERVOIR, Folding Top Hydraulic Motor and Pump .....	14.486	RETAINER, Cigarette Lighter.....	9.709
RESERVOIR, Fuel Lines .....	3.163	RETAINER, Clutch and Brake Pedal Shaft (Also see Groups 4.634 and 4.648).....	0.837
RESERVOIR, Windshield Wiper Parts.....	10.154	RETAINER, Clutch .....	0.829
RESISTOR ASSY., Heater and Evaporator.....	8.855	RETAINER, Concealed Headlamp Control Opening Cover .....	2.765
RESISTOR, Air Conditioning Electrical Temperature and Blower Motor Control..	9.275	RETAINER, Coolant Recovery Unit.....	1.240
RESISTOR, Electrical Output (See Group 9.748 for Telltale Windows).....	2.515	RETAINER, Cyl. Poppet.....	4.942
RESISTOR, Generator (Current Regulator Listed in Group 2.500) .....	2.319	RETAINER, Cyl. Push Rod.....	4.926
RESISTOR, Ignition Coil .....	2.173	RETAINER, Door Safety Lock .....	10.551A
RESISTOR, Ignition Pulse (Transistorized).....	2.383	RETAINER, Dash Panel.....	15.280
RESONATOR ASSY., Muffler Tail.....	3.702	RETAINER, Distributor Breaker.....	2.385
RESONATOR, Muffler Tail .....	3.705	RETAINER, Distributor Contact Point Support Clamp .....	2.387
REST ASSY., Front Door Arm Rest.....	14.686	RETAINER, Distributor Housing .....	2.363
REST ASSY., Rear Door Arm-Less Tray.....	14.762	RETAINER, Distributor Lubricating .....	2.364
REST ASSY., Rear Quarter Arm Trimmed.....	15.108	RETAINER, Door Lock Inside.....	10.512
RESTRICTOR, Fuel Tank Evaporative Control	3.130	RETAINER, Door Outside Lock Handle.....	10.551
RESTRICTOR, Fuel Tank Filler .....	3.003	RETAINER, Electric Window Lift .....	10.777
RETAINER .....	5.880	RETAINER, End Gate Rear Door.....	12.242A

## ALPHABETICAL INDEX

RETAINER, End Gate.....	12.269A	RETAINER, Quarter Window Garnish and Quarter Belt Finishing .....	11.119
RETAINER, Engine Rear Cross Member.....	7.011	RETAINER, Quarter Window Glass Run.....	11.024
RETAINER, Fiber Optic Conductor.....	2.583	RETAINER, Quarter Window Glass.....	11.010
RETAINER, Fldg. Top and Dust Boot.....	13.384	RETAINER, Quarter Window Lower Sash.....	11.007A
RETAINER, Floor (less Rear Compartment Floor Pan).....	12.980	RETAINER, Quarter Window Reveal Mldg., Tailgate Moulding Clips.....	11.032
RETAINER, Folding Seat (For Load Floor Parts See Group 12.977).....	11.620	RETAINER, Radiator and Grille Filler.....	1.287
RETAINER, Folding Top.....	14.130	RETAINER, Radiator Grille & Frt. End (Also See Group 8.055).....	1.303
RETAINER, Folding Top.....	14.475	RETAINER, Radiator Grille Moulding.....	1.269
RETAINER, Front Door Arm Rest.....	14.686	RETAINER, Rear and Auxiliary Speakers.....	9.665
RETAINER, Front Door Trim Binding Strip Replacement.....	14.683	RETAINER, Rear Axle Bumper.....	5.394
RETAINER, Front Door Trim Finish.....	14.691	RETAINER, Rear Axle Shaft Bearing.....	5.816
RETAINER, Front Door.....	14.685A	RETAINER, Rear Bumper Upper Face Bar.....	7.832
RETAINER, Front Fender and Skirt.....	8.154	RETAINER, Rear Compartment Floor.....	12.981
RETAINER, Front Fender Moulding.....	8.133	RETAINER, Rear Compartment Lid or Tailgate Hinge.....	12.187
RETAINER, Front Fender.....	8.153	RETAINER, Rear Compartment Lid Lock Cylinder.....	12.249
RETAINER, Front Floor.....	15.300	RETAINER, Rear Compartment Lid.....	12.183
RETAINER, Front Seat Adjuster.....	11.561	RETAINER, Rear Compartment Lid.....	12.269
RETAINER, Front Seat Adjusting Lock.....	11.589	RETAINER, Rear Door Glass Run Channel.....	10.703
RETAINER, Front Seat Back Lock.....	11.390	RETAINER, Rear Door Trim Finish.....	14.764
RETAINER, Front Seat Back, Side Panels.....	11.368	RETAINER, Rear Door Window Glass.....	10.759
RETAINER, Front Seat Center Arm Rest.....	11.374	RETAINER, Rear Door.....	14.760
RETAINER, Front Seat Headrest.....	11.376	RETAINER, Rear Quarter Side Inner.....	12.941A
RETAINER, Front Seat Hinge Arm.....	11.375	RETAINER, Rear Quarter.....	15.100A
RETAINER, Fuel Pump Bowl and Mounting....	3.904	RETAINER, Rear Seat Back Compartment Shelf Foundation.....	15.024
RETAINER, Fuel Pump Mounting.....	3.901	RETAINER, Rear Seat Bottom (Less Trim Cover).....	11.610
RETAINER, Gas Tank Filler Neck Compartment.....	12.945	RETAINER, Rear Spring Eye.....	7.530
RETAINER, Gearshift Control Hand Lever.....	4.008	RETAINER, Rear View Mirror.....	10.186
RETAINER, Gearshift Hand Lever.....	4.010	RETAINER, Rear Window Defogger.....	9.778
RETAINER, Gearshift Level Selector and Indicator.....	4.022	RETAINER, Roof Drip.....	12.075
RETAINER, Gearshift Shaft Lever.....	4.032	RETAINER, Roof Luggage and Ski.....	12.815
RETAINER, Gearshift.....	4.307	RETAINER, Roof Trim.....	14.640A
RETAINER, Generator Drive End.....	2.307	RETAINER, Seat Back and Trim Pad.....	14.804
RETAINER, Hazard Flasher.....	2.575	RETAINER, Seat Separator.....	10.240
RETAINER, Headlamp Moulding.....	2.729	RETAINER, Seat Separator.....	10.242
RETAINER, Headlining Trim.....	14.651	RETAINER, Shock Absorber Bushing (Double Acting).....	7.389
RETAINER, Heater (See Group 1.166 for Clamps).....	8.846	RETAINER, Side Roof Rail.....	10.721
RETAINER, Heater.....	8.852	RETAINER, Spare Tire Cover.....	12.579
RETAINER, Heater.....	8.857	RETAINER, Spark Plug Wire.....	2.251
RETAINER, Heater.....	8.866	RETAINER, Speed and Cruise Control.....	3.880
RETAINER, Hood (Also See Group 1.303).....	8.055	RETAINER, Speedometer without Casing.....	4.342
RETAINER, Hood Ledge (Cowl).....	12.801	RETAINER, Speedometer Driven Gear.....	4.338
RETAINER, Hood Lock-Lower.....	8.080	RETAINER, Spring.....	7.545
RETAINER, Hood Panel.....	8.021	RETAINER, Stabilizer Link.....	7.245
RETAINER, Hood Upper Lock Plate.....	8.085	RETAINER, Steering Gear Hydraulic Valve.....	6.552
RETAINER, Horn Blowing.....	2.820	RETAINER, Steering Knuckle Lower Control Arm Shaft.....	6.170
RETAINER, Hydraulic Brake.....	4.680	RETAINER, Steering Knuckle Upper Control Arm.....	6.163
RETAINER, Ignition Pulse (Transistorized).....	2.383	RETAINER, Steering Shaft U-Joint.....	6.525
RETAINER, Ignition Switch Warning.....	2.195	RETAINER, Steering Wheel Hub.....	6.512
RETAINER, Instrument Face Glass.....	9.747	RETAINER, Steering Wheel.....	6.515
RETAINER, Instrument Panel Compartment Door Lock.....	10.267	RETAINER, Steering Worm Thrust.....	6.835
RETAINER, Instrument Panel.....	10.252	RETAINER, Sun Roof Motor.....	14.560
RETAINER, Instrument Panel.....	14.655A	RETAINER, Sunshade.....	10.219
RETAINER, Lever Hand (Floor Mounted).....	4.015	RETAINER, Tail Gate or Rear Door Lock Cylinder.....	12.249A
RETAINER, Load Floor (For Folding Seat Parts See Group 11.620).....	12.977	RETAINER, Tail and Stop Lamp.....	2.681
RETAINER, Load Floor.....	12.975	RETAINER, Tail Gate.....	12.180B
RETAINER, Low Servo.....	4.228	RETAINER, Tail Gate.....	12.180
RETAINER, Luggage Compartment.....	12.977	RETAINER, Tail Lamp.....	2.688
RETAINER, Main Cylinder (Rubber).....	4.659	RETAINER, Tailgate.....	12.195
RETAINER, Main Cylinder Adjusting.....	4.662	RETAINER, Throttle Control Rod.....	3.425
RETAINER, Main Cylinder Piston.....	4.654	RETAINER, Tilt or Tel. Steering Column.....	6.514
RETAINER, Main Cylinder Push.....	4.658	RETAINER, Top Roof Outer.....	12.810
RETAINER, Main Cylinder Return.....	4.655	RETAINER, Transmission (Rebuilt for General Motors).....	4.115
RETAINER, Main Cylinder Stop.....	4.656	RETAINER, Transmission Control Idler Attaching.....	4.042
RETAINER, Manual Valve.....	4.218	RETAINER, Transmission Control Lever Boot.....	4.017
RETAINER, Mast Jacket.....	6.521	RETAINER, Transmission Forward Cone Freewheel.....	4.167
RETAINER, Muffler Tail Pipe.....	3.706	RETAINER, Transmission Front Servo.....	4.233
RETAINER, Muffler.....	3.704	RETAINER, Transmission Gearshift Control....	4.020
RETAINER, Oil Pressure.....	1.803	RETAINER, Transmission Gearshift Control Shaft or Tube.....	4.027
RETAINER, Oil Pump Shaft.....	1.639	RETAINER, Transmission Gearshift Control....	4.020
RETAINER, Oil Pump.....	1.609		
RETAINER, Parking Brake Cable.....	4.785		
RETAINER, Parking Brake Lever Release.....	4.594		
RETAINER, Parking Brake Lever Release.....	4.595		
RETAINER, Parking Lamp Door or Lens.....	2.594		
RETAINER, Piston Pin.....	0.639		

## ALPHABETICAL INDEX

RETAINER, Transmission Gearshift Rod to Lever.....	4.037	RING, Ignition Switch.....	2.188
RETAINER, Transmission Gearshift Shaft Tube Lever.....	4.032	RING, Low Servo.....	4.228
RETAINER, Transmission Main Drive Gear Bearing.....	4.356	RING, Low Sun Gear and Clutch.....	4.162
RETAINER, Transmission Overdrive Shifting..	4.490	RING, Main Cylinder (Rubber).....	4.659
RETAINER, Transmission Overdrive.....	4.467	RING, Main Cylinder Stop.....	4.656
RETAINER, Transmission Overdrive.....	4.485	RING, Manual Valve.....	4.218
RETAINER, Transmission Rear Main Bearing..	4.317	RING, Mast Jacket.....	6.521
RETAINER, Transmission Rear Servo.....	4.247	RING, Pitman Shaft Packing.....	6.856
RETAINER, Transmission Synchronizing.....	4.383	RING, Planet Carrier.....	4.176
RETAINER, Transmission Throttle Valve Control (T.V.).....	4.050	RING, Rear and Auxiliary Speakers.....	9.665
RETAINER, Transmission.....	4.164	RING, Rear View Mirror.....	10.186
RETAINER, Transmission.....	4.256	RING, Reverse Servo.....	4.241
RETAINER UNIT, Lock Tumbler.....	10.553A	RING, Safety Light.....	9.773
RETAINER, Vacuum Power Brake Cyl. Reaction.....	4.934	RING, Sealed Beam Retaining.....	2.731
RETAINER, Vacuum Power Brake Cyl. Relay Valve.....	4.935	RING, Speedometer Drive Gear.....	4.345
RETAINER, Vacuum Power Brake Cylinder Air Valve (See Group 4.658 for Valve and Push Rod Assy.).....	4.918	RING, Speedometer Driven Gear.....	4.338
RETAINER, Vacuum Power Brake Cylinder Air.....	4.913	RING, Starting Motor Thrust.....	2.063
RETAINER, Vacuum Power Brake Cylinder Piston.....	4.924	RING, Steering Gear Housing End.....	6.824
RETAINER, Vacuum Power Brake Cylinder.....	4.922	RING, Steering Gear Hydraulic Cylinder Piston.....	6.579
RETAINER, Vacuum Power Brake.....	4.910	RING, Steering Gear Hydraulic Pump.....	6.609
RETAINER, Vacuum Power Door Lock.....	10.485	RING, Steering Gear Hydraulic Pump.....	6.610
RETAINER, Vacuum.....	4.205	RING, Tail and Stop Lamp.....	2.680
RETAINER, Vinyl Roof Panel Cover.....	13.260	RING, Tailgate.....	12.195
RETAINER, Windshield Pillar Weatherstrip.....	10.093A	RING, Transmission Clutch.....	4.169
RETAINER, Wheel Brake (Also See Group 4.667).....	4.665	RING, Transmission Control Safety.....	4.054
RETAINER, Wheel Carrier.....	7.633	RING, Transmission Forward Cone Freewheel.....	4.167
RETAINER, Wheel Cover Appearance.....	5.871	RING, Transmission Front Drive.....	4.158
RETAINER, Wheel Cover Panel Rubber.....	8.177	RING, Transmission Front Servo Piston Parts.....	4.229
RETAINER, Wheel Cover Panel.....	8.176	RING, Transmission Front Servo.....	4.226
RETAINER, Windshield Washer.....	10.153	RING, Transmission Gearshift Control Shaft or Tube.....	4.027
RETAINER, Windshield Wiper Transmission..	10.160	RING, Transmission Input.....	4.123
RIM, Air Conditioning Compressor Drive.....	9.180	RING, Transmission Main with Gear.....	4.172
RIM, Dome Lamp.....	11.928	RING, Transmission Main Drive Gear Bearing.....	4.376
RING, Accelerator Pedal.....	3.452	RING, Transmission Main Shaft Front Pilot to Main Drive Gear.....	4.353
RING, Accelerator.....	3.454	RING, Transmission Main Valve.....	4.216
RING, Air Conditioning Compressor (Internal).....	9.172	RING, Transmission Overdrive Snap.....	4.477
RING, Air Conditioning Compressor Pulley....	9.181	RING, Transmission Overdrive Sun Gear.....	4.472
RING, Air Conditioning Compressor Shaft.....	9.175	RING, Transmission Parking Brake.....	4.290
RING, Air Conditioning Refrigerant (with Dehydrator).....	9.195	RING, Transmission Parking Lock.....	4.220
RING, Air Flow Control with Tube.....	9.787	RING, Transmission Rear Bearing and Mainshaft.....	4.412
RING, Antenna.....	9.647	RING, Transmission Rear Main Bearing.....	4.317
RING ASSY., Generator.....	2.279	RING, Transmission Rear Servo.....	4.242
RING ASSY., Wheel Cover Appearance.....	5.871	RING, Transmission Rear Unit.....	4.187
RING, Automatic Choke Control.....	3.750	RING, Transmission Rear Ring Gear.....	4.180
RING, Carburetor and Fuel Meter Fuel Inlet...	3.740	RING, Transmission Reverse Idler Shaft.....	4.435
RING, Carburetor Pump.....	3.842	RING, Transmission Synchronizer.....	4.383
RING, Clutch.....	0.829	RING, Transmission Synchronizer.....	4.384
RING, Differential Clutch (Positraction).....	5.511	RING, Transmission Synchronizing.....	4.383
RING, Direction Signal Lamp (See Group 9.748 Tell Tale Wind.).....	2.895	RING, Transmission Synchronizing.....	4.384
RING, Door Handle Push Button.....	10.529	RING, Transmission Throttle Valve Control (T.V.).....	4.050
RING, Door Hinge.....	10.466	RING, Transmission.....	4.164
RING, Electric Seat Adjuster.....	11.556	RING, Transmission.....	4.256
RING, Exhaust Pipe.....	3.611	RING, Transmission.....	4.421
RING, Fifth Speed.....	4.416	RING UNIT, Piston (Service Sets).....	0.643
RING, Folding Top.....	14.478	RING UNIT, Transmission.....	4.005
RING, Forward Cone Freewheel.....	4.168	RING, Vacuum Power Brake Cyl. Relay Valve	4.935
RING, Front Seat Back, with Springs (less Cushion).....	11.373	RING, Vacuum Power Brake Cylinder Air Valve (See Group 4.658 for Valve and Push Rod Assy.).....	4.918
RING, Fuel Tank Filler.....	3.003	RING, Vacuum Power Brake Cylinder Air.....	4.913
RING, Gearshift Control (Hand).....	4.006	RING, Vacuum Power Brake Cylinder Piston..	4.924
RING, Gearshift Control Hand Lever.....	4.008	RING, Vacuum Power Brake Cylinder.....	4.922
RING, Gearshift.....	4.309	RING, Wheel Cylinder.....	4.666
RING GEAR, Transmission Planet.....	4.175	RING, Windshield Washer.....	10.153
RING, Headlamp.....	2.726	RING, Windshield Wiper Motor Aux.....	10.151
RING, Horn Blowing.....	2.830	RING, Windshield Wiper Motor Mounting Parts.....	10.152
RING, Horn Button and Blowing Ring.....	2.819	RIVET, End Gate Rear Door.....	12.242A
RING, Hydraulic Pump Drive Shaft Outer Bearing Retaining.....	6.616	RIVET, Front Door Hinge Hold Open.....	10.455
RING, Hydraulic Steering Cylinder Piston Rod.....	6.581	RIVET, Front Door Vent Division.....	10.688
		RIVET, Front Door Ventilator Glass (with tee shaft).....	10.655
		RIVET, Front Door Ventilator.....	10.669
		RIVET, Front Door Ventilator.....	10.670
		RIVET, Front Seat Adjuster.....	11.561
		RIVET, Litter, Tissue.....	8.891
		RIVET, Radiator Grille Moulding.....	1.269





## ALPHABETICAL INDEX

SCREW ASSY., Battery.....	2.333	SCREW, Door Inside Locking Control.....	10.556
SCREW ASSY., Camshaft Timing Belt.....	0.724	SCREW, Door Lock Inside.....	10.512
SCREW ASSY., Carburetor Pump.....	3.845	SCREW, Door Lock Remote Control	
SCREW ASSY., Engine Mounting.....	0.002	Connecting.....	10.506A
SCREW ASSY., Flywheel.....	0.679	SCREW, Door Lock Striker to Pillar.....	10.570
SCREW ASSY., Front or Rear Bumper Bar		SCREW, Door Outside Locking (less	
Mounting and Attaching.....	7.874	cylinder).....	10.527
SCREW ASSY., Speed Indicator.....	9.762	SCREW, Door Ventilator Regulator.....	10.664
SCREW ASSY., Steering Gear Ball Return		SCREW, Door Weatherstrip.....	10.695
Guide.....	6.843	SCREW, Door Window Lower Sash.....	10.747
SCREW ASSY., Valve Rocker Cover.....	0.413	SCREW, Door Window Regulator Manual or	
SCREW ASSY., Wheel Brake (Also See		Electric.....	10.792
Group 4.667).....	4.665	SCREW, Door Window.....	10.716
SCREW, Automatic Choke Control.....	3.750	SCREW, Electric Seat Adjuster.....	11.556
SCREW, Automatic Headlamp Control.....	2.461	SCREW, Electrical Output (See 2.319 for	
SCREW, Axle Filler and Drain.....	5.400	Breaker).....	2.500
SCREW, Axle Housing with Filler Plug.....	5.398	SCREW, End Gate Lock.....	12.237A
SCREW, Back Door Reveal.....	12.180C	SCREW, End Gate Rear Door.....	12.242A
SCREW, Back Window Glass Reveal		SCREW, End Gate.....	12.203
Moulding.....	11.209	SCREW, Flywheel.....	0.679
SCREW, Back-Up.....	2.697	SCREW, Folding Seat (For Load Floor Parts	
SCREW, Back-Up.....	2.698	See Group 12.977).....	11.620
SCREW, Battery Cable.....	2.343	SCREW, Folding Top Frame.....	14.155
SCREW, Belt Moulding, Door and Quarter		SCREW, Folding Top Front Roof Rail.....	14.080A
Mldg. Attaching Parts.....	12.118	SCREW, Folding Top.....	14.310
SCREW, Belt Unit and Shoulder Strap Unit		SCREW, Front and Rear Door Lock.....	10.474
Components.....	14.875A	SCREW, Front Door Arm Rest.....	14.686
SCREW, Body Sill Moulding.....	8.309	SCREW, Front Door Glass Lower Sash	
SCREW, Brake Band Adjusting.....	4.253	Channel.....	10.687
SCREW, Brake Cyl. and Pedal Shaft (Also		SCREW, Front Door Glass Run.....	10.701
See Group 0.847 for pedal shaft		SCREW, Front Door Ventilator.....	10.661
bracket).....	4.648	SCREW, Front Door Ventilator.....	10.670
SCREW, Brake Press Ind.....	4.874	SCREW, Front Door Window Glass Lower	
SCREW, Brake Shoe Adjusting.....	5.110	Sash.....	10.685
SCREW, Bumper Guard Mounting.....	7.829	SCREW, Front Door Window Reveal.....	10.707
SCREW, Bumper Valance Panel.....	7.833	SCREW, Front Door Window.....	10.783
SCREW, Carburetor (with Leather and Shaft)		SCREW, Front Fender and Skirt.....	8.143
SCREW, Carburetor and Fuel Injection		SCREW, Front Seat Adjuster.....	11.561
Choke.....	3.752	SCREW, Front Seat Center Arm Rest.....	11.374
SCREW, Carburetor and Fuel Injection Fast		SCREW, Fuel Pump Mounting.....	3.901
Idle.....	3.766	SCREW, Fuel Tank Filler Cap.....	3.028
SCREW, Carburetor and Fuel Injection Idle		SCREW, Fuel Tank Strap.....	3.023
Adjusting.....	3.822	SCREW, Garnish Moulding (sheet metal	
SCREW, Carburetor and Fuel Meter Intake		type).....	11.128
(w/seat and gasket).....	3.814	SCREW, Gearshift Control Hand Lever.....	4.008
SCREW, Carburetor Air Valve.....	3.757	SCREW, Gearshift Hand Lever Housing.....	4.012
SCREW, Carburetor Air.....	3.730	SCREW, Generator (Current Regulator Listed	
SCREW, Carburetor Body.....	3.741	in Group 2.500).....	2.319
SCREW, Carburetor Choke.....	3.751	SCREW, Generator Brush.....	2.291
SCREW, Carburetor Fast Idle Cam.....	3.767	SCREW, Generator Drive End.....	2.307
SCREW, Carburetor Idle Air Compensator.....	3.820	SCREW, Generator.....	2.313
SCREW, Carburetor Idle Vapor Vent.....	3.852	SCREW, Harmonic Balancer and Crankshaft	
SCREW, Carburetor Power.....	3.858	Pulley.....	0.662
SCREW, Carburetor Pump Outlet Valve.....	3.825	SCREW, Hazard Flasher.....	2.575
SCREW, Carburetor Pump.....	3.841	SCREW, Headlamp Beam Adjusting.....	2.737
SCREW, Carburetor Pump.....	3.842	SCREW, Headlamp Lens and Sealed Beam	
SCREW, Carburetor Throttle Return Check ..	3.440	Retaining.....	2.736
SCREW, Carburetor Throttle Return Check ..	3.444	SCREW, Headlamp Moulding.....	2.729
SCREW, Carburetor Throttle Valve and		SCREW, Hood Lock-Lower.....	8.080
Throttle Lever Adjusting.....	3.761	SCREW, Hood Moulding and Hinge	
SCREW, Carburetor Throttle.....	3.762	Attaching.....	8.016
SCREW, Carburetor.....	3.755	SCREW, Hood.....	8.024
SCREW, Carburetor.....	3.786	SCREW, Ignition Coil Mounting.....	2.183
SCREW, Cargo Tie Down Hook.....	9.025	SCREW, Ignition Pulse (Transistorized).....	2.383
SCREW, Chassis Wiring Harness.....	2.559	SCREW, Ignition Switch.....	2.188
SCREW, Child Safety.....	14.870	SCREW, Inside Rear View Mirror.....	10.187
SCREW, Clutch Housing and Transmission		SCREW, Instrument Panel to Dash.....	10.230
Under Pan.....	0.679	SCREW, Instrument Panel Compartment	
SCREW, Concealed Headlamp Control		Door Lock.....	10.267
Opening Cover.....	2.765	SCREW, Instrument Panel Compartment	
SCREW, Concealed Headlamp Motor.....	2.755	Door.....	10.262
SCREW, Cowl Trim.....	14.630	SCREW, Instrument Panel Compartment,	
SCREW, Crankcase Ventilator Tube.....	1.750	Seat Separator Compartment and	
SCREW, Direction Control Switch.....	2.906	Courtesy.....	10.275
SCREW, Direction Signal Lamp (See Group		SCREW, Instrument Panel Compartment.....	10.260
9.748 Tell Tale Wind.).....	2.895	SCREW, Instrument Panel.....	10.252
SCREW, Distributor Contact Point Support		SCREW, Instrument Panel.....	14.655A
Clamp.....	2.387	SCREW, Lever Hand (Floor Mounted).....	4.015
SCREW, Distributor Vacuum Control Clamp..	2.414	SCREW, Low Sun Gear and Clutch.....	4.162
SCREW, Distributor, with Bracket and Lead..	2.393	SCREW, Luggage Deck Lid.....	12.815B
SCREW, Distributor.....	2.362	SCREW, Main Cylinder Stop.....	4.656
SCREW, Distributor.....	2.368	SCREW, Mast (Also see Group 6.803).....	6.518
SCREW, Distributor.....	2.382	SCREW, Muffler Exhaust Pipe and Tail Pipe..	3.708
SCREW, Door Hinge to Hinge Pillar.....	10.463	SCREW, Muffler Tail Pipe.....	3.706

## ALPHABETICAL INDEX

SCREW, Muffler.....	3.704	SCREW, Windshield Wiper.....	10.150
SCREW, Oil Pan Attaching, with Lockwasher.....	1.428	SEAL.....	9.775
SCREW, Oil Pan Drain.....	1.453	SEAL, Air Cleaner Intake Valve.....	3.415
SCREW, Oil Supply Pump.....	4.203	SEAL, Air Cleaner.....	3.417
SCREW, Parking Lamp Attaching.....	2.587	SEAL, Air Conditioning Compressor (Internal).....	9.172
SCREW, Parking Lamp Door or Lens.....	2.594	SEAL, Air Conditioning Compressor Shaft.....	9.175
SCREW, Parking Lamp.....	2.589	SEAL, Air Conditioning Compressor Suction and Discharge.....	9.226
SCREW, Pinion Shaft Lock.....	5.518	SEAL, Air Conditioning Electrical Temperature and Blower Motor Control..	9.275
SCREW, Planet Carrier.....	4.176	SEAL, Air Conditioning Evaporator Air Distributor and Astro-Ventilation.....	9.262
SCREW, Quarter Window Glass.....	11.012	SEAL, Air Conditioning Evaporator Blower Motor.....	9.216
SCREW, Quarter Window Lower Sash.....	11.007A	SEAL, Air Conditioning Evaporator By-Pass... Housing.....	9.198
SCREW, Quarter Window Regulator Handle..	11.047	SEAL, Air Conditioning Evaporator Core.....	9.211
SCREW, Quarter Window Reveal.....	11.031	SEAL, Air Conditioning Evaporator Expansion.....	9.213
SCREW, Quarter Window.....	11.041	SEAL, Air Conditioning Refrigerant.....	9.190
SCREW, Radiator Core.....	1.270	SEAL, Air Duct.....	9.782
SCREW, Radiator Grille and Engine Baffle Attaching.....	1.276	SEAL, Air Flow.....	9.786
SCREW, Radiator Grille Moulding.....	1.269	SEAL, Air Injection Reactor Pump.....	3.665
SCREW, Radiator Grille.....	1.267	SEAL, Air Suspension Leveling Valve Junction.....	7.482
SCREW, Rear and Auxiliary Speakers.....	9.665	SEAL ASSY., Crankcase Front End Cover.....	0.213
SCREW, Rear Bumper.....	7.875	SEAL ASSY., Crankshaft Oil.....	0.213
SCREW, Rear Compartment Lid or Tailgate Hinge.....	12.187	SEAL ASSY., Crankshaft Rear Bearing and Cap Oil.....	0.137
SCREW, Rear Compartment Lid Lock.....	12.237	SEAL ASSY., Drive Pinion.....	5.469
SCREW, Rear Compartment Lid.....	12.183	SEAL ASSY., Engine Timing Belt Cover.....	0.213
SCREW, Rear Compartment Lid.....	12.184	SEAL ASSY., Front Wheel Bearing.....	6.326
SCREW, Rear Compartment Lid.....	12.242	SEAL ASSY., Pitman Shaft.....	6.855
SCREW, Rear Door Arm-Less Tray.....	14.762	SEAL ASSY., Transmission Extension Oil.....	4.318
SCREW, Rear Door Lower Window Sash Channel.....	10.748	SEAL ASSY., Transmission Gearshift Control SEAL ASSY., Transmission Rear Bearing Retainer.....	4.020
SCREW, Rear Door Trim Finish.....	14.764	SEAL, Bumper Valance Panel.....	7.833
SCREW, Rear Door Window Frame.....	10.763	SEAL, Camshaft Housing.....	0.529
SCREW, Rear Door Window Glass.....	10.759	SEAL, Camshaft.....	0.738
SCREW, Rear Door Window.....	10.768	SEAL, Carburetor and Fuel Injection Choke... SEAL, Carburetor Float.....	3.752
SCREW, Rear Door Window.....	10.791	SEAL, Carburetor Idle Air Compensator.....	3.734
SCREW, Rear License Lamp.....	2.708	SEAL, Carburetor Intermediate Lever Shaft Ball.....	3.820
SCREW, Rear Quarter Arm Trimmed.....	15.108	SEAL, Clutch.....	0.851
SCREW, Rear Quarter Window.....	11.040	SEAL, Clutch.....	0.829
SCREW, Rear View Mirror.....	10.186	SEAL, Coolant Pump.....	1.123
SCREW, Roof Drip.....	12.075	SEAL, Cowl Ventilator.....	12.800
SCREW, Roof Luggage and Ski.....	12.815	SEAL, Crankcase Front End Cover.....	0.213
SCREW, Safety Light.....	9.773	SEAL, Crankcase.....	1.745
SCREW, Seat Separator.....	10.240	SEAL, Crankshaft Rear Bearing and Cap Oil.. SEAL, Dash Panel.....	0.137
SCREW, Shock Absorber Bushing (Double Acting).....	7.389	SEAL, Defroster.....	15.280
SCREW, Shock Absorber Frame.....	7.395	SEAL, Distributor Mainshaft.....	9.779
SCREW, Sliding Sunroof.....	14.550	SEAL, Distributor Mainshaft.....	2.375
SCREW, Stabilizer Shaft.....	7.243	SEALED BEAM, Headlamp.....	2.727
SCREW, Starting Motor (Internal).....	2.077	SEALED BEAM, Safety Light.....	9.773
SCREW, Starting Motor to Engine Attaching.	2.042	SEAL, Folding Top Hydraulic Motor and Pump.....	14.486
SCREW, Starting Motor Brush.....	2.052	SEAL, Folding Top Motor and Pump.....	14.482
SCREW, Steering Column Lock Bolt.....	6.500	SEAL, Front Fender and Skirt.....	8.154
SCREW, Steering Column.....	6.760	SEAL, Front Floor.....	15.300
SCREW, Steering Gear.....	6.586	SEAL, Front Spring.....	7.418
SCREW, Steering Shaft U-Joint.....	6.525	SEAL, Fuel Pump Bowl and Mounting.....	3.904
SCREW, Sun Roof Motor.....	14.560	SEAL, Fuel Tank Filler Neck.....	3.008
SCREW, Sunshade.....	10.219	SEAL & GASKET UNIT, Air Suspension, Air Compressor.....	7.460
SCREW, Tail and Stop Lamp.....	2.680	SEAL, Gear Shaft.....	6.519
SCREW, Tail Gate.....	12.180B	SEAL, Gearshift Control Hand Lever.....	4.008
SCREW, Tail Gate.....	12.180	SEAL, Generator Commutator or Rotor Slip Ring End Frame.....	2.298
SCREW, Tail Gate.....	12.184A	SEAL, Heater.....	8.854
SCREW, Tail Lamp.....	2.688	SEAL, Heater.....	8.857
SCREW, Tailgate.....	12.195	SEAL, Hood (Also See Group 1.303).....	8.055
SCREW, Tilt or Tel. Steering Column.....	6.514	SEAL, Hood Ledge (Cowl).....	12.801
SCREW, Transmission Control Safety.....	4.054	SEAL, Hood Panel.....	8.010
SCREW, Transmission Front Servo.....	4.226	SEAL, Hydraulic Steering Cylinder Piston Rod.....	6.581
SCREW, Transmission Gearshift Control Shaft or Tube.....	4.027	SEAL, Ignition Coil Mounting.....	2.183
SCREW, Transmission Gearshift Rod to Lever.....	4.037	SEALING, Load Floor (For Folding Seat Parts See Group 11.620).....	12.977
SCREW, Transmission Oil.....	4.195	SEALING, Quarter Window Glass Rubber.....	11.015
SCREW, Transmission.....	4.256	SEALING STRIP, Floor (less Rear Compartment Floor Pan).....	12.980
SCREW, Trim.....	12.946		
SCREW, Valve.....	4.059		
SCREW, Venturi Cluster.....	3.790		
SCREW, Wheel Cover Appearance.....	5.871		
SCREW, Wheel Cover Panel Rubber.....	8.177		
SCREW, Wheel Cover Panel.....	8.176		
SCREW, Windshield Garnish Moulding.....	10.056		
SCREW, Windshield Reveal Moulding.....	10.096		
SCREW, Windshield Washer.....	10.153		
SCREW, Windshield Wiper Motor Aux.....	10.151		
SCREW, Windshield Wiper Motor Mounting Parts.....	10.152		

## ALPHABETICAL INDEX

SEALING STRIP, Rear Compartment Floor.....	12.981	SEAL UNIT, Crankshaft Rear Bearing and Cap Oil .....	0.137
SEALING STRIP, Rear Compartment Front and Shelf .....	12.971	SEAL UNIT, Steering Gear .....	6.586
SEALING STRIP, Top Roof Outer .....	12.810	SEAL UNIT, Transmission Clutch.....	4.166
SEAL, Injection Valve to Intake Manifold.....	3.304	SEAL UNIT, Transmission.....	4.005
SEAL, Instrument Case .....	9.749	SEAL UNIT, Valve Stem Oil .....	0.308
SEAL KIT, Air Conditioning less Clutch .....	9.170	SEAL, Vacuum Power Brake Cylinder Air Valve (See Group 4.658 for Valve and Push Rod Assy.).....	4.918
SEAL KIT, Steering Gear Hydraulic Pump.....	6.609	SEAL, Vacuum Power Brake Cylinder .....	4.922
SEAL KIT, Steering Gear Thrust .....	6.840	SEAL, Vacuum Power Brake.....	4.910
SEAL, Lever Hand (Floor Mounted) .....	4.015	SEAL, Vacuum.....	4.205
SEAL, Lighting Monitor .....	2.584	SEAL, Valve Spring Cap.....	0.308
SEAL, Main Cylinder Piston .....	4.654	SEAL, Wheel Cover Panel Rubber .....	8.177
SEAL, Main Cylinder Stop .....	4.656	SEAL, Wheel Cylinder Piston (Also See Group 4.665).....	4.667
SEAL, Maintenance Items, Air Conditioning...	9.282	SEAL, Windshield Washer .....	10.153
SEAL, Oil Level.....	1.516	SEAL, Windshield Wiper Parts .....	10.154
SEAL, Oil Pan Pump Suction .....	4.197	SEAT, Air Conditioning Compressor (Internal).....	9.172
SEAL, Oil Pan .....	1.429	SEAT, Air Conditioning Evaporator Core Housing.....	9.211
SEAL, Oil Supply Pump.....	4.203	SEAT ASSY., Clutch .....	0.829
SEAL, Parking Brake Apply.....	4.591	SEAT ASSY, Front.....	14.896
SEAL, Parking Brake Lever Housing .....	4.612	SEAT ASSY., Hood Upper Lock Plate.....	8.085
SEAL, Parking Lamp.....	2.599	SEAT BELT UNIT.....	14.875
SEAL, Pitman Arm.....	6.861	SEAT, Clutch Pedal Intermediate Lever Shaft Ball .....	0.851
SEAL, Propeller Shaft Universal Joint Trunnion.....	5.560	SEAT, Front Spring.....	7.418
SEAL, Rad. Core and Support .....	1.274	SEAT, Hydraulic Steering Adapter.....	6.560
SEAL, Radiator and Grille Filler.....	1.287	SEAT, Hydraulic Steering Cylinder Piston Rod .....	6.581
SEAL, Rear Axle Shaft Bearing or Hub .....	5.822	SEAT, Main Cylinder Outlet Fitting .....	4.661
SEAL, Rear Window Defogger.....	9.778	SEAT, Mast Jacket.....	6.521
SEAL RING, Air Conditioning Evaporator Expansion Valve .....	9.214	SEAT, Spring .....	7.545
SEAL RING, Air Conditioning Evaporator .....	9.220	SEAT, Steering Connecting Rod .....	6.874
SEAL RING, Air Conditioning Freon Inspection.....	9.202	SEAT, Steering Gear Hydraulic Valve Hose...	6.673
SEAL RING, Air Conditioning Refrigerant.....	9.196	SEAT, Transmission Front Servo .....	4.233
SEAL, Seat Separator .....	10.240	SEAT, Transmission.....	4.164
SEAL, Servo .....	4.212	SEAT, Valve Spring .....	0.309
SEAL, Shock Absorber, Air Lift.....	7.346	SECTOR ASSY., Folding Top.....	14.478
SEAL, Speedometer Driven Gear .....	4.338	SECTOR, Ignition Switch Warning .....	2.195
SEAL, Steering Column .....	6.758	SELECTOR, Transmission Rail End.....	4.302
SEAL, Steering Column .....	6.760	SENDER ASSY., Coolant Temperature (Engine Unit).....	1.150
SEAL, Steering Connecting or Relay Rod .....	6.886	SENDER, Fuel Tank Gauge.....	3.107
SEAL, Steering Gear End Cover.....	6.825	SENSOR ASSY., Air Conditioning Electrical Temperature and Blower Motor Control..	9.275
SEAL, Steering Gear Housing Side Cover .....	6.809	SENSOR ASSY., Fuel Meter Enrichment.....	3.320
SEAL, Steering Gear Hydraulic Cylinder Piston.....	6.579	SENSOR, Body Wiring.....	13.095
SEAL, Steering Gear Hydraulic Pump Drive Shaft.....	6.617	SENSOR UNIT, Air Cleaner Intake Valve.....	3.415
SEAL, Steering Gear Hydraulic Pump.....	6.609	SENSOR UNIT, Radiator and Recovery Tank..	1.203
SEAL, Steering Gear Hydraulic Pump.....	6.635	SEPARATOR, Fuel Tank Evaporative Control.	3.120
SEAL, Steering Gear Hydraulic Valve Hose and Fitting 'O' Ring .....	6.674	SERVO ASSY., Air Conditioning Vacuum Control .....	9.280
SEAL, Steering Gear Hydraulic Valve .....	6.552	SERVO ASSY., Speed and Cruise Control Power.....	3.885
SEAL, Steering Gear Thrust.....	6.840	SHACKLE, Rear Spring Shackle .....	7.523
SEAL, Steering Gear .....	6.806	SHAFT, Air Conditioning Evaporator Air Distributor and Astro-Ventilation .....	9.262
SEAL, Steering Idler.....	6.898	SHAFT, Air Flow Control with Tube.....	9.787
SEAL, Steering Knuckle, Upper and Lower Control Arm .....	6.166	SHAFT, Air Flow.....	9.786
SEAL, Steering Shaft U-Joint.....	6.525	SHAFT AND LEVER ASSY., Heater.....	8.854
SEAL, Tail Lamp .....	2.660	SHAFT ASSEMBLY with Casing.....	4.342A
SEAL, Thermostat Housing.....	1.252	SHAFT ASSY., Speed and Cruise Control .....	4.342B
SEAL, Tie Rod Dust .....	6.242	SHAFT ASSY., Speedometer.....	4.342C
SEAL, Transmission Case .....	4.104	SHAFT ASSY., Air Conditioning less Clutch...	9.170
SEAL, Transmission Clutch Gear Oil.....	4.354	SHAFT ASSY., Air Conditioning Evaporator Core Housing.....	9.211
SEAL, Transmission Front Servo Piston Parts	4.229	SHAFT ASSY., Coolant Pump, with Bearing...	1.105
SEAL, Transmission Front Servo .....	4.226	SHAFT ASSY., Defroster .....	9.779
SEAL, Transmission Gearshift Control Cable.	4.047	SHAFT ASSY., Distributor Mainshaft .....	2.375
SEAL, Transmission Gearshift Control Shaft or Tube .....	4.027	SHAFT ASSY., Gear Shifter.....	4.309
SEAL, Transmission Internal Selector Shaft...	4.313	SHAFT ASSY., Speed and Cruise Control .....	3.880
SEAL, Transmission Main Drive Gear Bearing .....	4.354	SHAFT ASSY., Speedometer without Casing.	4.342
SEAL, Transmission Oil Filler .....	4.133	SHAFT ASSY., Steering Gear, with Worm.....	6.524
SEAL, Transmission Overdrive .....	4.460	SHAFT ASSY., Transmission Gearshift Rod to Lever .....	4.037
SEAL, Transmission Overdrive .....	4.485	SHAFT ASSY., Transmission Internal Shift....	4.302
SEAL, Transmission Parking Brake .....	4.294	SHAFT ASSY., Transmission Planet.....	4.161
SEAL, Transmission Parking Lock.....	4.220	SHAFT ASSY., Transmission Planet.....	4.175
SEAL, Transmission Rear Bearing Retainer ...	4.318	SHAFT, Axle.....	5.420
SEAL, Transmission Rear Servo.....	4.242	SHAFT, Brake Pedal.....	4.634
SEAL, Transmission Throttle valve Operating Parts .....	4.275	SHAFT, Carburetor and Fuel Injection Choke	3.752
SEAL, Transmission .....	4.256		
SEAL UNIT, Air Suspension Air Compressor Level Control .....	7.457		

## ALPHABETICAL INDEX

SHAFT, Carburetor and Fuel Meter.....	3.745	SHIELD, Fuel Meter Enrichment.....	3.320
SHAFT, Carburetor Air Valve.....	3.757	SHIELD, Fuel Tank.....	3.015
SHAFT, Clutch Pedal, Intermediate (See Group 4.648 for brake).....	0.852	SHIELD, Gearshift Level Selector and Indicator.....	4.022
SHAFT, Concealed Headlamp Control Opening Cover.....	2.765	SHIELD, Gearshift Linkage.....	4.067
SHAFT, Cowl.....	9.789	SHIELD, Hydraulic Brake.....	4.685
SHAFT, Differential Pinion.....	5.517	SHIELD, Hydraulic Steering Adapter.....	6.560
SHAFT, Distributor, with Weight Plate.....	2.372	SHIELD, Hydraulic Steering Pump Hose.....	6.672
SHAFT, Electric Seat Adjuster.....	11.556	SHIELD, Instrument Panel Compartment Door.....	10.262
SHAFT, Folding Top Motor and Pump.....	14.482	SHIELD, Manifold.....	3.602
SHAFT, Front Door Ventilator Tee.....	10.657	SHIELD, Muffler Tail.....	3.705
SHAFT, Gear Shifter.....	4.309	SHIELD, Parking Lamp.....	2.593
SHAFT, Gearshift Control Hand Lever.....	4.008	SHIELD, Pinion Flange.....	5.468
SHAFT, Gearshift Control.....	4.025	SHIELD, Shock Absorber.....	7.371
SHAFT, Gearshift Detent.....	4.311	SHIELD, Spark Plug Wire.....	2.251
SHAFT, Gearshift Hand Lever.....	4.010	SHIELD, Starting Motor.....	2.104
SHAFT, Gearshift.....	4.309	SHIELD, Steering Connecting Rod End.....	6.881
SHAFT, Heater Air Deflector.....	8.858	SHIELD, Tilt or Tel. Steering Column.....	6.514
SHAFT, Heater.....	8.852	SHIELD, Transmission Control Safety.....	4.054
SHAFT, Hot Water.....	8.845	SHIELD UNIT, Distributor, with Bracket and Lead.....	2.393
SHAFT, Ignition Switch Warning.....	2.195	SHIELD UNIT, Steering Shaft U-Joint.....	6.525
SHAFT, Oil Pump Shaft.....	1.639	SHIELD, Valve Spring Cap.....	0.308
SHAFT, Rear Compartment Lock Handle.....	12.252	SHIELD, Windshield Wiper Motor Aux.....	10.151
SHAFT, Rear Propeller (Shaft attaches to rear axle).....	5.441	SHIELD, Windshield Wiper.....	10.150
SHAFT, Rear Propeller (Shaft attaches to rear axle).....	5.544	SHIFT FINGER, Gearshift Control (Hand).....	4.006
SHAFT, Stabilizer.....	7.241	SHIM, Air Conditioning Compressor Mounting.....	9.171
SHAFT, Starting Motor Drive Shaft.....	2.108	SHIM, Bumper.....	7.865
SHAFT, Steering Gear Hydraulic Pump Drive.....	6.614	SHIM, Crankshaft Main Bearing Cap.....	0.153
SHAFT, Transmission Control Idler.....	4.040	SHIM, Differential Clutch (Positraction).....	5.511
SHAFT, Transmission Counter.....	4.428	SHIM, Distributor Gear.....	2.379
SHAFT, Transmission Gearshift Control Shaft or Tube.....	4.027	SHIM, Front and Rear Bumper Shock.....	7.840
SHAFT, Transmission Input.....	4.123	SHIM, Front Fender.....	8.153
SHAFT, Transmission Main with Gear.....	4.172	SHIM, Gearshift Control Hand Lever.....	4.008
SHAFT, Transmission Main.....	4.403	SHIM, Headlamp Control.....	2.775
SHAFT, Transmission Overdrive.....	4.465	SHIM, Hood Moulding and Hinge Attaching..	8.016
SHAFT, Transmission Overdrive.....	4.495	SHIM, Locking Sun Roof Panel Front Guide..	14.570
SHAFT, Transmission Parking Brake.....	4.294	SHIM, Pinion Shaft Bearing.....	5.460
SHAFT, Transmission Parking Lock.....	4.220	SHIM, Radiator Core.....	1.270
SHAFT, Transmission Planet.....	4.175	SHIM, Rear Axle Control Arm.....	5.380
SHAFT, Transmission Reverse Idler Gear.....	4.433	SHIM, Stabilizer Shaft.....	7.243
SHAFT, Transmission Throttle valve Operating Parts.....	4.275	SHIM, Steering Knuckle Upper Control Arm..	6.178
SHAFT, Transmission Throttle Valve Control (T.V.).....	4.050	SHIM, Transmission Mounting Support.....	4.085
SHAFT, Transmission.....	4.256	SHIM UNIT, Crankshaft Bearing Cap.....	0.153
SHAFT, Transmission.....	4.403	SHIM UNIT, Differential Bearing Adjusting ...	5.537
SHAFT UNIT, Carburetor Choke.....	3.751	SHIM UNIT, Rear Spring 'U' Bolt (See Group 5.403).....	7.518
SHAFT UNIT, Drive and Engine.....	9.750	SHIM UNIT, Steering Gear Lash Adjuster.....	6.828
SHAFT UNIT, Speedometer without Casing ...	4.342	SHIM UNIT, Transmission Case.....	4.104
SHAFT UNIT, Steering Gear, with Worm.....	6.524	SHIM, Valve.....	0.303
SHAFT UNIT, Steering Knuckle Upper Control Arm.....	6.164	SHIM, Valve.....	0.459
SHAFT, Windshield Wiper Motor Aux.....	10.151	SHOCK ABSORBERS.....	7.345
SHELL, Air Conditioning Refrigerant (with Dehydrator).....	9.195	SHOE, Air Injection Reactor Pump.....	3.665
SHELL ASSY., Air Conditioning less Clutch... Cylinder.....	9.170	SHOE, Door Inside Lock to Knob.....	10.563
SHELL ASSY., Vacuum Power Brake.....	4.906	SHOE, Front Seat Adjuster.....	11.561
SHELL, Transmission Planet.....	4.175	SHOE & LINING PACKAGE, Brakes.....	5.017
SHIELD, Air Conditioning Refrigerant.....	9.190	SHOE, Tilt or Tel. Steering Column.....	6.514
SHIELD ASSY., Chassis Wiring Harness.....	2.559	SHOE UNIT, Brake With Facing, Metallic.....	5.017
SHIELD ASSY., Clock Mounting and Attaching.....	9.772	SHOULDER STRAP UNIT.....	14.875
SHIELD ASSY., Engine Timing Belt.....	0.206	SHROUD AND BAFFLE ASSY., Heater.....	8.854
SHIELD, Automatic Choke Control.....	3.750	SHROUD ASSY., Steering Wheel Hub.....	6.512
SHIELD, Back-Up.....	2.698	SHROUD, Gearshift Hand Lever.....	4.010
SHIELD, Battery Cable.....	2.343	SHROUD, Generator Commutator or Rotor Slip Ring End Frame.....	2.298
SHIELD, Carburetor Idle Vapor Vent.....	3.852	SHROUD, Instrument Panel.....	10.252
SHIELD, Carburetor Throttle Return Check....	3.444	SHROUD, Mast (Also see Group 6.803).....	6.518
SHIELD, Clutch Housing and Transmission Under Pan.....	0.679	SHROUD, Radiator Fan.....	1.277
SHIELD, Concealed Headlamp Control Drive..	2.760	SHROUD, Steering Wheel Hub.....	6.512
SHIELD, Direction Control Switch.....	2.906	SIGHT GLASS KIT, Air Conditioning Freon Inspection.....	9.202
SHIELD, Distributor.....	2.362	SILENCER ASSY., Air Injection Reactor.....	3.672
SHIELD, Engine Mounting.....	0.029	SILENCER, Back Window Garnish.....	11.120
SHIELD, Flange Plate.....	5.002	SILENCER, Carburetor Air.....	3.402
SHIELD, Flywheel.....	0.679	SILENCER, Door Lock Remote.....	10.500
SHIELD, Front Fender and Skirt.....	8.154	SILENCER, Vacuum Power Brake Cylinder Air.....	4.913
SHIELD, Front Fender.....	8.153	SILENCER, Windshield Garnish.....	10.051A
SHIELD, Fuel Lines.....	3.163	SKIRT, Front Fender.....	8.153
		SLEEVE, Accelerator Intermediate.....	3.463
		SLEEVE, Air Conditioning Compressor (Internal).....	9.172
		SLEEVE, Air Conditioning Refrigerant.....	9.196

## ALPHABETICAL INDEX

SLEEVE, Air Conditioning.....	9.225	SOLENOID, Electric Seat Adjuster.....	11.556
SLEEVE, Air Duct.....	9.782	SOLENOID, Engine Fuel or Air Inlet Shut Down.....	3.485
SLEEVE, Auto.....	8.820	SOLENOID, Exhaust Manifold Heat Control Valve.....	3.640
SLEEVE, Clock Mounting and Attaching.....	9.772	SOLENOID, Heat Valve.....	3.140
SLEEVE, Clutch Cable.....	0.854	SOLENOID, Transmission Overdrive.....	4.480
SLEEVE, Clutch Pedal.....	0.854	SPACER, Air Cleaner.....	3.417
SLEEVE, Distributor Breaker.....	2.385	SPACER, Air Conditioning Compressor Mounting.....	9.171
SLEEVE, Door Window Regulator Manual or Electric.....	10.792	SPACER, Air Conditioning Compressor Pulley.....	9.181
SLEEVE, Folding Seat (For Load Floor Parts See Group 12.977).....	11.620	SPACER, Air Conditioning Evaporator Air Distributor and Astro-Ventilation.....	9.262
SLEEVE, Front and Rear Bumper Shock.....	7.840	SPACER, Air Conditioning Evaporator Air.....	9.260
SLEEVE, Front Axle Tie Rod.....	6.232	SPACER, Air Conditioning Evaporator Core Housing.....	9.211
SLEEVE, Front Seat Back Lock.....	11.390	SPACER, Air Conditioning Hose.....	9.242
SLEEVE, Fuel Lines.....	3.163	SPACER, Air Conditioning Remote Evaporator Air Distributor Outlet.....	9.264
SLEEVE, Gearshift Control Hand Lever.....	4.008	SPACER, Air Injection Reactor Pump Mounting.....	3.655
SLEEVE, Gearshift.....	4.307	SPACER, Back Window (Safety).....	11.204
SLEEVE, Hydraulic Steering Adapter.....	6.560	SPACER, Back Window Glass Reveal Moulding.....	11.209
SLEEVE, Hydraulic Steering Pump Hose.....	6.672	SPACER, Back Window Inner.....	12.964
SLEEVE, Ignition Switch.....	2.188	SPACER, Belt Unit and Shoulder Strap Unit Components.....	14.875A
SLEEVE, Instrument Case Face.....	9.748	SPACER, Body Back Lower (Rear End).....	12.966
SLEEVE, Luggage Deck Lid.....	12.815B	SPACER, Body Mounting.....	9.023
SLEEVE, Mast Jacket.....	6.521	SPACER, Body Rear Panel.....	12.121
SLEEVE, Oil Pump Shaft.....	1.639	SPACER, Brake Pedal.....	4.634
SLEEVE, Seat Belt Deluxe.....	14.875B	SPACER, Bumper and Grille.....	7.828
SLEEVE, Seat Back.....	11.381	SPACER, Bumper Guard Mounting.....	7.829
SLEEVE, Speed and Cruise Control.....	3.880	SPACER, Bumper Valance Panel.....	7.833
SLEEVE, Speedometer Driven Gear.....	4.338	SPACER, Bumper.....	7.865
SLEEVE, Stabilizer Shaft.....	7.243	SPACER, Carburetor and Fuel Injection Choke.....	3.752
SLEEVE, Steering Knuckle Lower Control Arm Shaft.....	6.170	SPACER, Carburetor and Fuel Meter Fuel Inlet.....	3.740
SLEEVE, Sunshade.....	10.219	SPACER, Catalytic Converter.....	3.685
SLEEVE, Throttle Control Rod.....	3.425	SPACER, Clutch and Brake Pedal Shaft (Also see Groups 4.634 and 4.648).....	0.837
SLEEVE, Transmission (1st and Reverse Gear).....	4.419	SPACER, Clutch Fork Release.....	0.787
SLEEVE, Transmission Gearshift Rod to Lever.....	4.037	SPACER, Concealed Headlamp Control Drive SPACER, Concealed Headlamp Control Opening Cover.....	2.765
SLEEVE, Transmission Rear Bearing Retainer.....	4.318	SPACER, Coolant Recovery Unit.....	1.240
SLEEVE, Transmission Throttle Valve Control.....	4.052	SPACER, Crankshaft Pulley.....	0.662
SLEEVE, Wheel Brake (Also See Group 4.667).....	4.665	SPACER, Differential Bearing Adjusting.....	5.537
SLEEVE, Wheel Cover Appearance.....	5.871	SPACER, Differential Clutch (Positraction).....	5.511
SLIDERS UNIT, Top Roof Outer.....	12.810	SPACER, Direction Signal Lamp (See Group 9.748 Tell Tale Wind.).....	2.895
SLINGER, Generator Drive End.....	2.307	SPACER, Door Dovetail Bumper Wedge.....	10.584
SLINGER, Propeller Shaft Pinion.....	5.545	SPACER, Door Inside Locking Rod.....	10.565
SLINGER, Transmission Main Drive Gear Bearing.....	4.374	SPACER, Door Lock Striker.....	10.571
SNUBBER ASSY., Timing Belt.....	0.219	SPACER, Door Ventilator Regulator.....	10.664
SOCKET, Ash Tray.....	12.012	SPACER, Door Window Lower Sash.....	10.747
SOCKET ASSY., Ash Tray.....	12.016	SPACER, End Gate Lock.....	12.237A
SOCKET ASSY., Dome Lamp.....	11.927	SPACER, Engine Mounting (Small Attaching) SPACER, Exhaust Manifold.....	0.002
SOCKET ASSY., Gearshift Level Selector and Indicator.....	4.022	SPACER, Fan.....	3.647
SOCKET ASSY., Hazard Flasher.....	2.575	SPACER, Fifth Speed.....	1.064
SOCKET ASSY., Lighting Monitor.....	2.584	SPACER, Flange Plate.....	4.416
SOCKET ASSY., Parking Brake Alarm.....	4.589	SPACER, Folding Top Roof Rail.....	5.002
SOCKET ASSY., Parking Lamp.....	2.596	SPACER, Folding Top Roof Rail.....	14.090
SOCKET ASSY., Rear License Lamp w/Wire..	2.714	SPACER, Folding Top.....	14.130
SOCKET ASSY., Tie Rod.....	6.233	SPACER, Folding Top.....	14.475
SOCKET, Back-Up.....	2.697	SPACER, Front and Rear Bumper Shock.....	7.840
SOCKET, Brake Shoe Adjusting Screw.....	5.111	SPACER, Front Door Window (Safety).....	10.681
SOCKET, Instrument Case.....	9.744	SPACER, Front Door Window Glass Lower Sash.....	10.685
SOCKET, Instrument Lamp.....	2.776	SPACER, Front Fender and Skirt.....	8.154
SOCKET, Tail and Stop Lamp.....	2.694	SPACER, Front Seat Adjuster.....	11.561
SOCKET UNIT, Windshield Wiper Transmission.....	10.160	SPACER, Front Seat Back, Side Panels.....	11.368
SOLENOID ASSY., Carburetor Idle Air Compensator.....	3.820	SPACER, Front Seat Center Arm Rest.....	11.374
SOLENOID ASSY., Carburetor.....	3.755	SPACER, Front Spring.....	7.425
SOLENOID ASSY., Dist. Spark Advance Trans. Electric Control (Also See Group 4.075).....	2.408	SPACER, Fuel Tank Strap.....	3.023
SOLENOID ASSY., Front Seat Back Lock.....	11.390	SPACER, Gearshift Control Hand Lever.....	4.008
SOLENOID ASSY., Rear Compartment Lid Opener.....	12.243	SPACER, Gearshift Hand Lever Housing.....	4.012
SOLENOID ASSY., Transmission Low and Drive Valve.....	4.265	SPACER, Generator (see 2.317 for brace).....	2.277
SOLENOID, Air Cleaner Intake Valve.....	3.415	SPACER, Generator (Bracket listed in Group 2.277).....	2.317
SOLENOID, Carburetor and Fuel Injection Choke.....	3.752	SPACER, Generator.....	2.274
SOLENOID, Carburetor Throttle Return Check.....	3.440		

## ALPHABETICAL INDEX

SPACER, Hydraulic Steering Cylinder Piston Rod.....	6.581	SPRING, Accelerator Pull Back.....	3.459
SPACER, Hydraulic Steering Valve.....	6.554	SPRING, Air Conditioning Electrical Temperature and Blower Motor Control..	9.275
SPACER, Instrument Panel to Dash.....	10.230	SPRING, Air Conditioning Evaporator Air Distributor and Astro-Ventilation.....	9.262
SPACER, Instrument Panel.....	14.655A	SPRING, Air Conditioning Evaporator By-Pass.....	9.198
SPACER, License Plate.....	7.800	SPRING, Air Conditioning Evaporator Core Housing.....	9.211
SPACER, Lighting Switch Rod.....	2.487	SPRING, Air Conditioning Vacuum Control....	9.280
SPACER, Locking Sun Roof Panel Front Guide.....	14.570	SPRING, Air Flow.....	9.786
SPACER, Low Sun Gear and Clutch.....	4.162	SPRING, Air Injection Reactor Pump.....	3.665
SPACER, Luggage Compartment.....	12.977	SPRING, Ash Receiver.....	12.009
SPACER, Mast Jacket.....	6.521	SPRING, Ash Tray Anti-Rattle.....	12.050
SPACER, Parking Brake Cable Pulley.....	4.790	SPRING ASSEMBLY, Rear.....	7.503
SPACER, Parking Lamp.....	2.586	SPRING ASSY., Front and Rear Bumper Shock.....	7.840
SPACER, Pinion Shaft Bearing.....	5.453	SPRING ASSY., Front and Rear.....	7.503
SPACER, Planet Carrier.....	4.176	SPRING ASSY., Transmission Throttle valve Operating Parts.....	4.275
SPACER, Quarter Window (safety).....	11.011	SPRING, Brake Drum.....	5.810
SPACER, Quarter Window Glass.....	11.010	SPRING, Brake Hose or Pipe.....	4.681
SPACER, Quarter Window Reveal Mldg., Tailgate Moulding Clips.....	11.032	SPRING, Brake Pedal Return.....	4.639
SPACER, Quarter Window Reveal.....	11.013	SPRING, Brake Pedal.....	4.634
SPACER, Radiator Core.....	1.270	SPRING, Brake Pull Back.....	4.760
SPACER, Radiator Grille & Frt. End (Also See Group 8.055).....	1.303	SPRING, Brake Shoe Automatic Adjusting Lever.....	5.107
SPACER, Radiator Grille.....	1.267	SPRING, Brake Shoe Hold Down.....	5.043A
SPACER, Radio Control.....	9.649	SPRING, Brake Shoe.....	5.026
SPACER, Rear Axle Bumper.....	5.394	SPRING, carburetor Metering Rod.....	3.810
SPACER, Rear Axle Control Arm.....	5.383	SPRING, Carburetor and Fuel Injection Choke.....	3.752
SPACER, Rear Axle Lateral Movement-(Stop).....	5.410	SPRING, Carburetor and Fuel Injection Fast Idle.....	3.766
SPACER, Rear Axle Tie Rod.....	5.418	SPRING, Carburetor and Fuel Injection Idle.....	3.766
SPACER, Rear Brake Pressure Regulator.....	4.690	SPRING, Carburetor and Fuel Injection Adjusting Screw.....	3.823
SPACER, Rear Compartment Lid Lock.....	12.237	SPRING, Carburetor and Fuel Meter Float Lever.....	3.747
SPACER, Rear Spring.....	7.535	SPRING, Carburetor and Fuel Meter Fuel Inlet.....	3.740
SPACER, Rear Window Defogger.....	9.778	SPRING, Carburetor Air Valve.....	3.757
SPACER RING, Transmission Main Shaft Front Pilot to Main Drive Gear.....	4.353	SPRING, Carburetor Choke.....	3.753
SPACER, Speedometer and Odometer (Miles).....	9.761	SPRING, Carburetor Idle Vapor Vent.....	3.852
SPACER, Stabilizer Shaft.....	7.242	SPRING, Carburetor Power Piston.....	3.859
SPACER, Stabilizer Shaft.....	7.243	SPRING, Carburetor Pump Outlet Valve.....	3.825
SPACER, Stabilizer.....	7.240	SPRING, Carburetor Pump.....	3.841
SPACER, Starting Motor to Engine Attaching Mounting.....	2.042	SPRING, Carburetor Throttle Return Check....	3.440
SPACER, Steering Gear Hydraulic Pump.....	6.606	SPRING, Carburetor Throttle Shaft.....	3.763
SPACER, Steering Gear Thrust.....	6.840	SPRING, Carburetor Throttle Valve and Throttle Lever Adjusting.....	3.761
SPACER, Steering Knuckle Upper and Lower Control Arm.....	6.176	SPRING, Carburetor.....	3.755
SPACER, Steering Shaft U-Joint.....	6.525	SPRING, Clutch and Brake Pedal Shaft-(Also see groups 4.634 and 4.648).....	0.837
SPACER, Tailgate.....	12.195	SPRING, Clutch Fork Pull Back.....	0.844
SPACER, Tilt or Tel. Steering Column.....	6.514	SPRING, Clutch Fork.....	0.796
SPACER, Transmission Control Idler Attaching.....	4.042	SPRING, Clutch Fork.....	0.844
SPACER, Transmission Counter Gear Bearing.....	4.423	SPRING, Clutch Pedal Intermediate Lever Shaft Ball.....	0.851
SPACER, Transmission Gearshift Shaft Tube Lever.....	4.032	SPRING, Clutch Pedal Pull Back.....	0.844
SPACER, Transmission Main Shaft Front Pilot to Main Drive Gear.....	4.353	SPRING, Clutch Pressure Plate.....	0.864
SPACER, Transmission Oil.....	4.128	SPRING, Concealed Headlamp Control Opening Cover.....	2.765
SPACER, Transmission Overdrive.....	4.495	SPRING, Cowl.....	9.789
SPACER UNIT, Transmission (Rebuilt for General Motors).....	4.115	SPRING, Differential Clutch (Positraction).....	5.511
SPACER UNIT, Transmission Low and Drive Valve.....	4.265	SPRING, Direction Control Switch.....	2.906
SPACER, Universal Joint Yoke Trunnion.....	5.566	SPRING, Direction Signal Lamp (Cancelling)..	2.896
SPACER, Wheel Cover Appearance.....	5.871	SPRING, Direction Signal Lamp (Detent).....	2.910
SPACER, Wheel Cover Panel.....	8.176	SPRING, Distributor Breaker.....	2.385
SPACER, Window Regulator Handle Escutcheon Plate.....	10.806	SPRING, Distributor Contact Point Support Clamp.....	2.387
SPACER, Windshield (Safety).....	10.027A	SPRING, Distributor Weight.....	2.389
SPACER, Windshield Garnish Moulding.....	10.056	SPRING, Door Handle Push Button.....	10.529
SPACER, Windshield Garnish.....	10.051A	SPRING, Door Lock Inside Handle Escutcheon.....	10.516
SPACER, Windshield Reveal Moulding.....	10.096	SPRING, Door Lock Remote.....	10.500
SPACER, Windshield Wiper Control.....	10.164	SPRING, Door Ventilator Regulator.....	10.664
SPEAKER, Radio Primary.....	9.650	SPRING, Electric Seat Adjuster.....	11.556
SPEAKER, Rear and Auxiliary Speakers.....	9.665	SPRING, End Gate Rear Door.....	12.242A
SPEAKER UNIT, Rear and Auxiliary Speakers.....	9.665	SPRING, End Gate.....	12.203
SPHERE, Tilt or Tel. Steering Column.....	6.514	SPRING, Folding Seat (For Load Floor Parts See Group 12.977).....	11.620
SPOILER, Bumper Valance Panel.....	7.833	SPRING, Folding Top Front Roof Rail.....	14.080A
SPOKE ASSY., Wheel Cover Appearance.....	5.871	SPRING, Folding Top.....	14.475
SPRAG ASSEMBLY, Transmission Forward Cone Freewheel.....	4.167		
SPRAG ASSY., Transmission Rear Ring Gear..	4.180		

## ALPHABETICAL INDEX

SPRING, Front (coil) (CHEVY, CHEVELLE, CAMARO).....	7.412	SPRING, Transmission Rear Ring Gear.....	4.180
SPRING, Front and Rear Door Lock.....	10.474	SPRING, Transmission Synchronizer.....	4.384
SPRING, Front Door Hinge Hold Open.....	10.455	SPRING, Transmission Synchronizing.....	4.413
SPRING, Front Door Vent Reg. Handle.....	10.666	SPRING, Transmission Throttle Valve Control.....	4.052
SPRING, Front Door Ventilation Channel.....	10.660	SPRING, Transmission.....	4.164
SPRING, Front Seat Adjuster.....	11.561	SPRING, Transmission.....	4.256
SPRING, Front Seat Adjuster.....	11.581	SPRING UNIT, Lock Tumbler.....	10.553A
SPRING, Front Seat Back Lock.....	11.390	SPRING UNIT, Valve.....	0.303
SPRING, Front Seat Headrest.....	11.376	SPRING, Vacuum Power Brake Cyl. Reaction Valve (See Group 4.658 for Valve and Push Rod Assy.).....	4.934
SPRING, Fuel Pump Rocker Arm.....	3.927	SPRING, Vacuum Power Brake Cylinder Piston.....	4.924
SPRING, Gas Tank Filler Neck Compartment.....	12.945	SPRING, Vacuum.....	4.205
SPRING, Gearshift Control Hand Lever.....	4.008	SPRING, Valve Rocker Shaft.....	0.376
SPRING, Gearshift Detent.....	4.311	SPRING, Valve.....	0.303
SPRING, Gearshift Hand Lever.....	4.010	SPRING, Wheel Cylinder Piston.....	4.669
SPRING, Generator (Current Regulator Listed in Group 2.500).....	2.319	SPRING, Window Regulator Handle Escutcheon Plate.....	10.806
SPRING, Headlamp Beam Adjusting.....	2.737	SPRING, Windshield Washer.....	10.153
SPRING, Headlamp Control.....	2.775	SPRING, Windshield Wiper Motor Aux.....	10.151
SPRING, Heater.....	8.852	SPRING, Windshield Wiper.....	10.150
SPRING, Hood (Also See Group 1.303).....	8.055	SPROCKET, Camshaft Timing.....	0.736
SPRING, Hood Hinge.....	8.013	SPROCKET, Crankshaft Timing (Steel).....	0.728
SPRING, Hood Lock-Upper.....	8.083	SPROCKET, Distributor.....	2.374
SPRING, Hood Upper Lock Plate.....	8.085	SQUEAK, Front Fender and Skirt.....	8.154
SPRING, Horn Button and Blowing Ring.....	2.819	SQUEAK, Universal.....	8.205
SPRING, Hydraulic Steering Adapter.....	6.560	STABILIZER, Floor (less Rear Compartment Floor Pan).....	12.980
SPRING, Hydraulic Steering Cylinder Piston Rod.....	6.581	Starting Motor.....	2.051
SPRING, Ignition Switch Warning.....	2.195	STATOR ASSY., Generator Field.....	2.310
SPRING KIT, Brake Shoe Hold Down.....	5.043A	STEM ASSY., Tire Valve.....	5.875
SPRING, Main Cylinder Return.....	4.655	STICK, Trim.....	12.946
SPRING, Manifold Heat Control Valve.....	3.641	STIFFENER, Rear Body Lock Pillar.....	12.942
SPRING, Manual Valve.....	4.218	STIFFENER, Rear Compartment Floor.....	12.981
SPRING, Mast Jacket.....	6.521	STIFFENER, Rear Quarter Side Inner.....	12.941A
SPRING, Oil Filter.....	1.837	STIFFENER, Wheelhouse.....	12.944
SPRING, Oil Pump.....	1.609	STOP ASSY., Auto.....	8.820
SPRING, Oil Supply Pump.....	4.203	STOP ASSY., Front Door Window Glass Lower Sash.....	10.685
SPRING, Parking Brake Cable Pulley.....	4.790	STOP ASSY., Tail Gate.....	12.180B
SPRING, Parking Brake Lever.....	4.606	STOP, Belt Unit and Shoulder Strap Unit Components.....	14.875A
SPRING, Parking Brake Release.....	4.597	STOP, Brake Main Cylinder.....	4.653
SPRING, Parking Brake Shoe Lever.....	5.151	STOP, Bumper Valance Panel.....	7.833
SPRING, Pressure Plate.....	0.864	STOP, Cowl Side.....	12.804
SPRING, Quarter Window Lower Sash.....	11.007A	STOP, Door Window.....	10.716
SPRING, Quarter Window Regulator Handle.....	11.047	STOP, Folding Seat (For Load Floor Parts See Group 12.977).....	11.620
SPRING, Quarter Window Upper Sash.....	11.005	STOP, Folding Top.....	14.310
SPRING, Radio Control.....	9.649	STOP, Front Door Ventilation Channel.....	10.660
SPRING, Rear Compartment Floor.....	12.981	STOP, Front Seat Adjuster.....	11.561
SPRING, Rear Compartment Lid Lock Cylinder.....	12.249	STOP, Instrument Panel and Seat Separator Compartment Lock.....	10.268
SPRING, Rear Door, Lower.....	10.460	STOP, Instrument Panel Compartment Door.....	10.262
SPRING, Reverse Brake Band.....	4.246	STOP, Load Floor (For Folding Seat Parts See Group 11.620).....	12.977
SPRING, Seat Separator.....	10.242	STOP, Quarter Window Glass.....	11.012
SPRING, Speed and Cruise Control Power.....	3.885	STOP, Rear Axle.....	5.395
SPRING, Speedometer without Casing.....	4.342	STOP, Rear Compartment Floor.....	12.981
SPRING, Speedometer.....	4.342C	STOP, Rear Compartment.....	12.212
SPRING, Starting Motor Brush.....	2.053	STOP, Rear Door Window.....	10.768
SPRING, Starting Motor Drive Shaft.....	2.108	STOP, Seat Separator.....	10.242
SPRING, Steering Column Lock Bolt.....	6.500	STOP, Tailgate.....	12.195
SPRING, Steering Connecting Rod.....	6.876	STOP, Tilt or Tel. Steering Column.....	6.514
SPRING, Steering Gear Hydraulic Pump.....	6.612	STOP, Top Roof Outer.....	12.810
SPRING, Steering Gear Hydraulic Valve.....	6.552	STOP, Windshield Side.....	12.808
SPRING, Steering Shaft U-Joint.....	6.525	STOVE, Air Cleaner.....	3.417
SPRING, Tail Gate or Rear Door Lock Cylinder.....	12.249A	STRAINER, Carburetor and Fuel Meter Fuel Inlet.....	3.740
SPRING, Tail Gate.....	12.180B	STRAINER, Fuel Tank Gauge.....	3.110
SPRING, Tailgate.....	12.195	STRAP, Air Cleaner.....	3.417
SPRING, Tilt or Tel. Steering Column.....	6.514	STRAP, Air Conditioning Evaporator Air.....	9.260
SPRING, Transmission (1st and Reverse Gear).....	4.419	STRAP, Air Conditioning Hose.....	9.242
SPRING, Transmission Clutch Drive and Driven.....	4.163	STRAP, Air Conditioning Remote Evaporator Air Distributor Outlet.....	9.264
SPRING, Transmission Control Idler Attaching.....	4.042	STRAP, Air Injection Reactor Valve.....	3.670
SPRING, Transmission Front Servo.....	4.226	STRAP ASSY., Assist.....	15.390
SPRING, Transmission Front Servo.....	4.233	STRAP ASSY., Front Door Trim Finish.....	14.691
SPRING, Transmission Gearshift Control.....	4.020	STRAP ASSY., Ignition Switch.....	2.188
SPRING, Transmission Gearshift Control Shaft or Tube.....	4.027	STRAP ASSY., Rear Compartment Lid.....	12.184
SPRING, Transmission Gearshift Control.....	4.020		
SPRING, Transmission Low and Drive Valve.....	4.265		
SPRING, Transmission Main Valve.....	4.216		
SPRING, Transmission Overdrive.....	4.467		
SPRING, Transmission Parking Brake.....	4.295		
SPRING, Transmission Parking Lock.....	4.220		

## ALPHABETICAL INDEX

STRAP, Belt Unit and Shoulder Strap Unit Components.....	14.875A	STUD, Air Conditioning Compressor Mounting.....	9.171
STRAP, Chassis Wiring Harness.....	2.559	STUD, Air Conditioning Electrical Temperature and Blower Motor Control..	9.275
STRAP, Cluster Gauge.....	9.735	STUD, Air Conditioning Evaporator Air Distributor and Astro-Ventilation.....	9.262
STRAP, Front Door, Lower.....	10.454	STUD, Air Conditioning Remote Evaporator Air Distributor Outlet.....	9.264
STRAP, Front Door, Upper.....	10.450	STUD, Air Injection Reactor.....	3.680
STRAP, Fuel Tank.....	3.022	STUD ASSY., Air Conditioning Evaporator Blower.....	9.215
STRAP, Instrument Panel Compartment Door.....	10.262	STUD, Clutch Fork Ball.....	0.796
STRAP, Lighting.....	2.485	STUD, Clutch Pedal Intermediate Lever Shaft Ball.....	0.851
STRAP, Muffler Tail Pipe.....	3.706	STUD, Coolant Pump.....	1.073
STRAP, Parking Brake Alarm.....	4.589	STUD, Crankshaft Bearing Cap.....	0.056
STRAP, Radiator Outlet.....	1.173	STUD, Cylinder Head.....	0.293
STRAP, Radio Noise Suppression.....	9.663	STUD, Distributor Housing.....	2.363
STRAP, Rear Compartment Lid or Tailgate Hinge.....	12.187	STUD, Division Rear Door Ventilator Glass....	10.826
STRAP, Rear Door Trim Finish.....	14.764	STUD, Door Ventilator Regulator.....	10.664
STRAP, Roof Luggage and Ski.....	12.815	STUD, Door Window Regulator Manual or Electric.....	10.792
STRAP, Steering Gear Pressure.....	6.670	STUD, Door Window.....	10.728
STRAP, Steering Shaft U-Joint.....	6.525	STUD, Ducted Hood.....	8.036
STRAP, Tail Gate.....	12.184A	STUD, End Gate.....	12.203
STRAP, Transmission Gearshift Control Shaft or Tube.....	4.027	STUD, Engine Air Fan.....	1.050
STRAP, Windshield Wiper.....	10.150	STUD, Engine Mounting.....	0.002
STRAP, 'U' Joint Trunnion and Yoke.....	5.586	STUD, Exhaust Pipe.....	3.613
STRIKER ASSY., Rear Quarter Side Inner.....	12.941A	STUD, Flywheel.....	0.679
STRIKER, Door Lock.....	10.569	STUD, Front Door Glass Run.....	10.701
STRIKER, End Gate Lock.....	12.237A	STUD, Front Door Ventilator.....	10.670
STRIKER, Folding Seat (For Load Floor Parts See Group 12.977).....	11.620	STUD, Front Door Window (Outer-Inner).....	10.710
STRIKER, Folding Top Front Roof Rail.....	14.080A	STUD, Front Door Window Glass Lower Sash.....	10.685
STRIKER, Front Seat Back Lock.....	11.390	STUD, Front Fender Moulding.....	8.133
STRIKER, Hood Lock-Lower.....	8.080	STUD, Gearshift Hand Lever Housing.....	4.012
STRIKER, Instrument Panel and Seat Separator Compartment Lock.....	10.268	STUD, Gearshift.....	4.307
STRIKER, Load Floor (For Folding Seat Parts See Group 11.620).....	12.977	STUD, Generator (see 2.317 for brace).....	2.277
STRIKER, Luggage Compartment.....	12.977	STUD, Generator.....	2.313
STRIKER, Parking Brake Alarm.....	4.589	STUD, Hub or Drum (Front and Rear Wheel).....	5.812
STRIKER, Rear Compartment Lid Lock.....	12.237	STUD, Hydraulic Steering Cylinder Piston Rod.....	6.581
STRIKER, Seat Separator.....	10.242	STUD, Intake & Exhaust Manifold.....	3.275
STRIKER, Spare Tire Cover.....	12.579	STUD, Intake Manifold to Carburetor.....	3.288
STRIKER, Speed and Cruise Control.....	3.880	STUD, Manifold.....	3.602
STRIKER, Stop Lamp.....	2.447	STUD, Oil.....	1.652
STRIP ASSY., Front Door Window (Outer-Inner).....	10.710	STUD, Parking Brake Apply.....	4.591
STRIP ASSY., Quarter Window Glass Rubber.....	11.015	STUD, Radiator Grille Moulding.....	1.269
STRIP ASSY., Rear Door Window.....	10.774	STUD, Rear Axle Tie Rod.....	5.418
STRIP ASSY., Roof Luggage and Ski.....	12.815	STUD, Rear Bumper Upper Face Bar.....	7.832
STRIP ASSY., Tail Gate.....	12.180	STUD, Rear Door Window Glass.....	10.759
STRIP ASSY.....	7.831A	STUD, Rear Door Window.....	10.768
STRIP, Back Window Glass Reveal Moulding.....	11.209	STUD, Rear Quarter Window.....	11.040
STRIP, Door Opening and Windshield Pillar.....	10.694	STUD, Seat Back.....	11.381
STRIPE, Also See Group 8.800 for Stencil Units.....	10.354	STUD, Seat Separator.....	10.242
STRIPE, Front Door Outer Panel.....	12.112	STUD, Sliding Sun Roof.....	12.809
STRIPE, Front Fender (See Group 8.147 for Front Fender Mouldings which include Series Designations).....	8.132	STUD, Speed and Cruise Control.....	3.880
STRIPE, Hood (Also See Group 1.303).....	8.055	STUD, Starting Motor Drive Shaft.....	2.108
STRIP, End Gate.....	12.269A	STUD, Starting Motor Solenoid.....	2.102
STRIPE, Radiator Grille & Frt. End (Also See Group 8.055).....	1.303	STUD, Steering Connecting Rod.....	6.874
STRIPE, Rear Compartment Lid and Rear End Panel.....	12.182	STUD, Steering Gear Housing Side Cover.....	6.809
STRIP, Folding Top No. 1-Center.....	14.215	STUD, Steering Gear Hydraulic Pump Mounting.....	6.606
STRIP, Front Door Window (Safety).....	10.681	STUD, Thermostat Housing.....	1.252
STRIP, Gas Tank Filler Neck Compartment.....	12.945	STUD, Throttle Control Rod.....	3.425
STRIP, Hood Ledge (Cowl).....	12.801	STUD, Transmission Main Valve.....	4.216
STRIP, Hood Panel.....	8.021	STUD, Transmission Throttle Valve Control.....	4.052
STRIP, Quarter Window Glass Run.....	11.021	STUD UNIT, Steering Knuckle Lower Control Arm Pivot.....	6.174
STRIP, Rear Quarter Side Inner.....	12.941A	STUD UNIT, Steering Knuckle Upper Control Arm.....	6.164
STRIP, Roof Drip.....	12.075	STUD, Valve Push Rod Adjusting.....	0.429
STRIP, Side Roof Rail.....	10.721	STUD, Valve Rocker Cover and Support.....	0.413
STRIP, Stop Folding Top-Rear.....	14.340	STUD, Valve, Push Rod Cover.....	0.446
STRIP, Tailgate.....	12.195	SUB BODY, Headlamp.....	2.726
STRUT, Frame Cross, Front.....	7.010	Sun Roof Motor.....	14.555
STRUT, Parking Brake Shoe Lever.....	5.150	SUNSHADE ASSEMBLY.....	10.203
STRUT, Steering Knuckle Upper and Lower Control Arm Assy.....	6.168	SUPPORT.....	7.831A
STRUT, Transmission Brake.....	4.251	SUPPORT.....	7.836A
STUD, Accelerator Intermediate.....	3.463	SUPPORT, Accelerator Pedal to Lever.....	3.431
STUD, Accelerator Pedal.....	3.452	SUPPORT, Accelerator Pedal.....	3.452
STUD, Air Cleaner.....	3.403	SUPPORT, Accelerator.....	3.454
STUD, Air Cleaner.....	3.417	SUPPORT, Air Cleaner.....	3.417



## ALPHABETICAL INDEX

SUPPORT, Air Conditioning Compressor Mounting.....	9.171	SUPPORT, Gearshift Hand Lever Housing.....	4.012
SUPPORT, Air Flow Control with Tube.....	9.787	SUPPORT, Gearshift Hand Lever.....	4.010
SUPPORT, Air Flow.....	9.786	SUPPORT, Generator (see 2.317 for brace)....	2.277
SUPPORT ASSEMBLY, End Gate.....	12.203	SUPPORT, Headlining Wire.....	12.954
SUPPORT ASSY., Bumper Valance Panel.....	7.833	SUPPORT, Heater.....	8.852
SUPPORT ASSY., Direction Control Switch.....	2.906	SUPPORT, Hood Lock-Lower.....	8.080
SUPPORT ASSY., End Gate Lock.....	12.237A	SUPPORT, Horn Blowing.....	2.820
SUPPORT ASSY., Engine Rear Cross Member.....	7.011	SUPPORT, Inside Rear View Mirror.....	10.187
SUPPORT ASSY., Gearshift Hand Lever.....	4.010	SUPPORT, Instrument Panel to Dash.....	10.230
SUPPORT ASSY., Low Sun Gear and Clutch..	4.162	SUPPORT, Instrument Panel Compartment, Seat Separator Compartment and Courtesy.....	10.275
SUPPORT ASSY., Oil Pump Intake.....	1.656	SUPPORT, License Plate.....	7.800
SUPPORT ASSY., Quarter Window Glass Rubber.....	11.015	SUPPORT, Load Floor (for Folding Seat Parts see Group 11.620).....	12.977
SUPPORT ASSY., Radiator Core.....	1.270	SUPPORT, Luggage Deck Lid.....	12.815B
SUPPORT ASSY., Radiator Support.....	1.271	SUPPORT MOUNTING, Rear Axle Control Arm.....	5.380
SUPPORT ASSY., Radio and Stereo Mounting.....	9.667	SUPPORT, Muffler.....	3.704
SUPPORT ASSY., Rear Spring Front and Rear.....	7.112	SUPPORT, Parking Brake Cable.....	4.785
SUPPORT ASSY., Tilt or Tel. Steering Column.....	6.514	SUPPORT, Parking Lamp Attaching.....	2.587
SUPPORT ASSY., Transmission Control Idler	4.040	SUPPORT, Quarter Window Glass.....	11.010
SUPPORT ASSY., Transmission Gearshift Anti-Theft.....	4.070	SUPPORT, Radiator Grille.....	1.267
SUPPORT ASSY., Transmission.....	4.081	SUPPORT, Rear Bumper.....	7.875
SUPPORT, Auto.....	8.820	SUPPORT, Rear Compartment End.....	12.986
SUPPORT, Back Body Opening.....	12.968	SUPPORT, Rear Compartment Floor.....	12.981
SUPPORT, Battery.....	2.333	SUPPORT, Rear Compartment Lid or Tailgate Hinge.....	12.187
SUPPORT, Belt Unit and Shoulder Strap Unit Components.....	14.875A	SUPPORT, Rear Compartment Lid.....	12.184
SUPPORT, Body Back Lower (Rear End).....	12.966	SUPPORT, Rear Door Lower Window Sash Channel.....	10.748
SUPPORT, Body Wiring (Also See Group 2.480 for additional Body Harnesses)....	13.090	SUPPORT, Rear License Lamp.....	2.705
SUPPORT, Carburetor Throttle Return Check	3.444	SUPPORT, Rear Quarter Outer.....	12.940A
SUPPORT, Carburetor.....	3.890	SUPPORT, Rear Quarter Side Inner.....	12.941A
SUPPORT, Catalytic Converter.....	3.685	SUPPORT, Rear Quarter Window.....	11.040
SUPPORT, Catalytic Converter.....	3.690	SUPPORT, Rear Quarter.....	15.100A
SUPPORT, Clutch Release Bearing Support Guide.....	0.805	SUPPORT, Rear Seat Back.....	11.629
SUPPORT, Coat.....	15.388	SUPPORT, Rear Window Defogger.....	9.778
SUPPORT, Concealed Headlamp Control Opening Cover.....	2.765	SUPPORT, Roof Luggage and Ski.....	12.815
SUPPORT, Cowl Side.....	12.804	SUPPORT, Seat Adjuster Track.....	11.573
SUPPORT, Dash to Chassis Frame.....	12.650	SUPPORT, Seat Separator.....	10.240
SUPPORT, Dome Lamp.....	12.953	SUPPORT, Sliding Sun Roof.....	14.565
SUPPORT, Door Opening Carpet.....	11.176	SUPPORT, Spark Plug Wire.....	2.251
SUPPORT, Door Rocker.....	12.934	SUPPORT, Speed and Cruise Control.....	3.880
SUPPORT, Door Ventilator Regulator.....	10.664	SUPPORT, Stabilizer Shaft.....	7.242
SUPPORT, Door Window.....	10.716	SUPPORT, Steering Column.....	6.760
SUPPORT, Door Window.....	10.728	SUPPORT, Steering Gear Hydraulic Pump Mounting.....	6.606
SUPPORT, Electric Seat Adjuster Switch.....	11.558	SUPPORT, Steering Idler.....	6.896
SUPPORT, Electric Seat Adjuster.....	11.556	SUPPORT, Stereo Tape Player.....	9.670
SUPPORT, Engine Mounting.....	0.029	SUPPORT, Sunshade.....	10.219
SUPPORT, Exhaust Pipe Support.....	3.616	SUPPORT, Tail and Stop Lamp.....	12.943
SUPPORT, Floor (less Rear Compartment Floor Pan).....	12.980	SUPPORT, Tail Gate.....	12.180
SUPPORT, Folding Seat (For Load Floor Parts See Group 12.977).....	11.620	SUPPORT, Top Roof Outer.....	12.810
SUPPORT, Folding Top Back Window.....	13.395	SUPPORT, Transmission Control Idler Attaching.....	4.042
SUPPORT, Folding Top Motor and Pump.....	14.482	SUPPORT, Transmission Low and Drive Valve.....	4.265
SUPPORT, Folding Top.....	14.130	SUPPORT, Transmission Mounting.....	4.081
SUPPORT, Frame to Bumper Attaching (Also See Group 7.869).....	7.836	SUPPORT, Transmission.....	4.403
SUPPORT, Frame Side.....	7.006	SUPPORT UNIT, Starting Motor Brush.....	2.052
SUPPORT, Front Body Hinge.....	12.840	SUPPORT, Vacuum Power Brake Cylinder.....	4.922
SUPPORT, Front Door Glass Lower Sash Channel.....	10.687	SUPPORT, Vacuum Power Brake Cylinder.....	4.930
SUPPORT, Front Door Trim Binding Strip Replacement.....	14.683	SUPPORT, Wheelhouse.....	12.944
SUPPORT, Front Door Ventilator.....	10.669	SUPPORT, Windshield (Safety).....	10.027A
SUPPORT, Front End and Close.....	1.263	SUPPORT, Windshield Wiper Parts.....	10.154
SUPPORT, Front Fender.....	8.141	SUPPRESSION PKG., Radio Noise Suppression.....	9.663
SUPPORT, Front Fender.....	8.153	SWITCH, Air Cleaner Intake Valve.....	3.415
SUPPORT, Front Seat Adjuster.....	11.561	SWITCH, Air Conditioning Electrical Temperature and Blower Motor Control..	9.275
SUPPORT, Front Seat Back Lock.....	11.390	SWITCH, Air Conditioning Vacuum Control...	9.280
SUPPORT, Front Seat Back, Side Panels.....	11.368	SWITCH, Air Injection Reactor Valve.....	3.670
SUPPORT, Front Seat Center Arm Rest.....	11.374	SWITCH ASSY., Air Conditioning Compressor (Internal).....	9.172
SUPPORT, Fuel Injection.....	3.302	SWITCH ASSY., Air Flow Control with Tube..	9.787
SUPPORT, Fuel Tank Evaporative Control.....	3.130	SWITCH ASSY., Antenna.....	9.647
SUPPORT, Fuel Tank.....	3.015	SWITCH ASSY., Body Wiring.....	13.095
SUPPORT, Gas Tank Filler Neck Compartment.....	12.945	SWITCH ASSY., Brake Press Ind.....	4.874
		SWITCH ASSY., Carburetor Throttle Return Check.....	3.440
		SWITCH ASSY., Carburetor.....	3.755
		SWITCH ASSY., Concealed Headlamp Motor	2.755

## ALPHABETICAL INDEX

SWITCH ASSY., Coolant Temperature (Engine Unit).....	1.150	TANK ASSY., Fuel Tank.....	3.001
SWITCH ASSY., Direction Signal Lamp (See Group 9.748 Tell Tale Wind.).....	2.895	TANK ASSY., Vacuum Power Door Lock.....	10.485
SWITCH ASSY., Dist. Spark Advance Trans. Electric Control (Also See Group 4.075).....	2.408	TANK, Coolant Recovery Unit.....	1.240
SWITCH ASSY., Distributor Vacuum.....	2.410	TAPE.....	12.116A
SWITCH ASSY., Electric Window Lift.....	10.777	TAPE ASSY., Roof Panel.....	12.812
SWITCH ASSY., End Gate Rear Door.....	12.242A	TAPE, Door Outside Locking (less cylinder)....	10.527
SWITCH ASSY., Engine Air Auxiliary Cooling.....	1.055	TAPE, Front Door Outer Panel.....	12.112
SWITCH ASSY., Folding Top.....	14.483	TAPE, Front Fender (See Group 8.147 for Front Fender Mouldings which include Series Designations).....	8.132
SWITCH ASSY., Hazard Flasher.....	2.575	TAPE, Hood (Also See Group 1.303).....	8.055
SWITCH ASSY., Heat Valve.....	3.140	TAPE, Rear Bumper Upper Face Bar.....	7.832
SWITCH ASSY., Heater Vacuum Actuating.....	8.850	TAPE, Rear Door Outer Panel.....	12.114
SWITCH ASSY., Heater.....	8.852	TAPPET ASSY., Valve.....	0.459
SWITCH ASSY., Horn Button and Blowing Ring.....	2.819	TAPPET, Valve (or Lifter).....	0.459
SWITCH ASSY., Hydraulic Brake.....	4.686	TAPPET, Valve (Or Lifter).....	0.459
SWITCH ASSY., Ignition Switch Warning.....	2.195	TEE, Air Conditioning Control.....	9.281
SWITCH ASSY., Ignition Switch.....	2.188	TEE, Air Conditioning Evaporator By-Pass.....	9.198
SWITCH ASSY., Instrument Case.....	9.746	TEE, Air Injection Reactor.....	3.680
SWITCH ASSY., Instrument Cluster.....	9.755	TEE AND TUBE ASSY., Air Suspension Level Control.....	7.447
SWITCH ASSY., Instrument Panel Compartment, Seat Separator Compartment and Courtesy.....	10.275	TEE ASSY., Air Suspension Level Control.....	7.447
SWITCH ASSY., Rear Brake Pressure Regulator.....	4.690	TEE ASSY., Speed and Cruise Control.....	3.880
SWITCH ASSY., Rear Compartment Lid Opener.....	12.243	TEE ASSY., Vacuum Power Brake Cyl.....	4.931
SWITCH ASSY., Rear Window Defogger.....	9.778	TEE ASSY., Vacuum.....	4.205
SWITCH ASSY., Seat Belt, Check Doors and Low Fuel Warning Lights.....	9.765	TEE, Carburetor Idle Air Compensator.....	3.820
SWITCH ASSY., Sliding Sun Roof.....	14.565	TEE, Carburetor.....	3.755
SWITCH ASSY., Starting Motor (on Motor)....	2.100	TEE, Concealed Headlamp Control Drive.....	2.760
SWITCH ASSY., Stop Lamp.....	2.447	TEE, Crankcase.....	1.745
SWITCH ASSY., Tailgate.....	12.195	TEE, Fuel Lines.....	3.163
SWITCH ASSY., Tire Traction.....	5.885	TEE, Hydraulic Brake.....	4.686
SWITCH ASSY., Transmission Control Safety.....	4.054	TEE, Instrument Cluster.....	9.755
SWITCH ASSY., Transmission Throttle Control (Electric).....	4.057	TEE, Manifold Vacuum Take-Off.....	3.278
SWITCH ASSY., Transmission, Smog Control.....	4.075	TEE, Oil Pressure (See group 9.748 for tell tale windows).....	1.800
SWITCH ASSY., Vacuum Power Door Lock.....	10.485	TEE, Speed and Cruise Control Power.....	3.885
SWITCH ASSY., Windshield Wiper.....	10.163	TEE, Vacuum Power Door Lock.....	10.485
SWITCH, Back-Up.....	2.698	TEE, Valve.....	0.303
SWITCH, Dome Lamp Door Jamb.....	11.950	TEE, Windshield Wiper Pipe.....	10.155
SWITCH, Dome Lamp.....	11.935	TERMINAL BOARD, Windshield Wiper.....	10.150
SWITCH, Fuel Injector Air.....	3.335	TERMINAL, Cluster Gauge.....	9.735
SWITCH, Headlamp Dimmer.....	2.459	TERMINAL, Electrical.....	2.530
SWITCH, Lighting.....	2.485	TERMINAL, Generator.....	2.313
SWITCH, Oil Pressure (See group 9.748 for tell tale windows).....	1.800	TERMINAL UNIT, Generator (Current Regulator Listed in Group 2.500).....	2.319
SWITCH, Parking Brake Alarm.....	4.589	THERMOSTAT ASSY., Automatic Choke Control.....	3.750
SWITCH, Safety Light.....	9.773	THERMOSTAT, Exhaust Manifold Heat Control Valve.....	3.640
SWITCH, Speed and Cruise Control.....	3.887	THERMOSTAT, Radiator and Hot Water Heater.....	1.246
SWITCH, Speed and Cruise Selector.....	3.883	THRUST WASHER KIT, Air Conditioning less Clutch.....	9.170
SWITCH, Transmission Overdrive.....	4.480	TIE ROD ASSY., Tie Rod.....	6.230
SWITCH UNIT, Horn.....	2.810	TIE ROD ASSY., Tie Rod.....	6.233
SWITCH, Windshield Washer.....	10.153	TIMER ASSY., Rear Window Defogger.....	9.778
SWIVEL, Clutch Fork Release.....	0.787	TIMER, Seat Belt, Check Doors and Low Fuel Warning Lights.....	9.765
SWIVEL, Front Seat Adjuster.....	11.561	TOP ASSY., Frame less trim.....	13.365
SWIVEL, Throttle Control Rod.....	3.425	TOWER ASSY., Shock Absorber Frame.....	7.395
SWIVEL, Transmission Control Safety.....	4.054	TRANS. ASSY., Electric Seat Adjuster.....	11.556
SWIVEL, Transmission Gearshift Rod to Lever.....	4.037	TRANS. ASSY., Windshield Wiper.....	10.159
SWIVEL, Transmission Throttle Valve Control.....	4.052	TRANSDUCER ASSY., Air Conditioning Electrical Temperature and Blower Motor Control.....	9.275
SYNCHRONIZER, Transmission 1st & Rev.....	4.380	TRANSDUCER, Heater.....	8.852
<b>T</b>		TRANSFER, Also See Group 8.800 for Stencil Units.....	10.354
TAB, Front Door Trim Binding Strip Replacement.....	14.683	TRANSFER, Front Door Outer Panel.....	12.112
TAB, Front Door.....	14.685A	TRANSFER, Front Fender (See Group 8.147 for Front Fender Mouldings which include Series Designations).....	8.132
TAB, Rear Door.....	14.760	TRANSFER, Hood (Also See Group 1.303)....	8.055
TACHOMETER, Drive and Engine.....	9.750	TRANSFER, Rear Compartment Lid and Rear End Panel.....	12.182
TAG, Axle Filler and Drain.....	5.400	TRANSISTOR, Ignition Pulse (Transistorized).....	2.383
TANK ASSY., Air Conditioning Control.....	9.281	TRANSISTOR, Voltage Regulator Output.....	2.505
TANK ASSY., Concealed Headlamp Control Drive.....	2.760	TRANSMISSION ASSY. (less hand brake).....	4.003
		TRANSER.....	12.116A
		TRAY ASSEMBLY, Ash.....	12.030
		TRAY ASSY., Ash (in arm rest).....	12.045
		TRAY ASSY., Ash Receiver.....	12.009
		TRAY ASSY., Battery.....	2.333
		TRAY, Seat Separator.....	10.240

## ALPHABETICAL INDEX

TRIM ASSY.....	15.306B
TRIM ASSY., Bucket Seat Back (Passenger or Driver).....	14.800A
TRIM ASSY., Bucket Seats Cushion.....	14.880A
TRIM ASSY., Folding Top Cover (less Back Curtain).....	13.347
TRIM ASSY., Front Door (less arm rest).....	14.685
TRIM ASSY., Front Seat Back and Back of Back.....	14.800
TRIM ASSY., Front Seat Back Head Restraint.....	14.924
TRIM ASSY., Front Seat Bench Cushion Cover.....	14.880
TRIM ASSY., Lock Pillar Finishing.....	14.731
TRIM ASSY., Rear and Center Seat Back Cover.....	15.000
TRIM ASSY., Rear and Center Seat Cushion Cover.....	15.035
TRIM ASSY., Rear Door.....	14.760
TRIM ASSY., Rear Floor.....	15.306
TRIM ASSY., Rear Quarter Arm Trimmed.....	15.108
TRIM ASSY., Rear Quarter Upper-Above Belt.....	14.645
TRIM ASSY., Rear Quarter.....	15.100
TRIM ASSY., Rear Seat Back Compartment Shelf Foundation.....	15.024
TRIM ASSY., Roof Panel (Exterior).....	13.250
TRIM ASSY., Spare Tire Cover.....	15.100C
TRIM ASSY., Top Compartment Side Trim Panel.....	15.100B
TRIM ASSY., Third Seat Back Cover.....	15.060
TRIM ASSY., Third Seat Cushion.....	15.070
TRIM ASSY., Wheelhouse Cover.....	15.099
TRIM, Rear Compartment.....	15.222
TRIM STICK ASSY., Trim.....	12.946
TRUNK LINING, Rear Compartment.....	15.222
TUBE, Air Cleaner.....	3.417
TUBE, Air Conditioning Compressor (Internal).....	9.172
TUBE, Air Conditioning Evaporator Air Inlet.....	9.208
TUBE, Air Conditioning Evaporator Air Inlet.....	9.218
TUBE, Air Conditioning Evaporator Core Housing.....	9.211
TUBE, Air Conditioning Refrigerant (with Dehydrator).....	9.195
TUBE, Air Conditioning Refrigerant.....	9.196
TUBE, Air Injection Reactor.....	3.675
TUBE, Air Injection Reactor.....	3.680
TUBE ASSY., Air Conditioning Evaporator.....	9.220
TUBE ASSY., Air Suspension Level Control.....	7.447
TUBE ASSY., Automatic Choke Control.....	3.750
TUBE ASSY., Crankcase.....	1.745
TUBE ASSY., Door Window Lower Sash.....	10.747
TUBE ASSY., Door Window.....	10.728
TUBE ASSY., Front and Rear Bumper Shock.....	7.840
TUBE ASSY., Front Seat Adjuster.....	11.561
TUBE ASSY., Gearshift Control.....	4.025
TUBE ASSY., Rear Compartment Lid or Tailgate Hinge.....	12.187
TUBE ASSY., Transmission Oil Filler.....	4.133
TUBE, Carburetor Idle.....	3.818
TUBE, Carburetor.....	3.786
TUBE, Crankcase Ventilator-Outer.....	1.762
TUBE, Exhaust Manifold Choke Heat.....	3.603
TUBE, Front Seat Headrest.....	11.376
TUBE, Gearshift Control Hand Lever.....	4.008
TUBE, Hood (Also See Group 1.303).....	8.055
TUBE, Mast (Also see Group 6.803).....	6.518
TUBE, Oil Level.....	1.516
TUBE, Shock Absorber, Air Lift.....	7.346
TUBE, Transmission Main Valve.....	4.216
TUBING, Electrical.....	2.530
TUMBLER UNIT, Door Lock Cylinder.....	10.553
TUMBLER UNIT, Rear Compartment Lid Lock Cylinder.....	12.249
TUNE.....	2.270
TURBO, 350, 375, 400).....	4.003

### U

U BOLT, Muffler Exhaust Pipe and Tail Pipe.....	3.708
UNDERPAN ASSY., Flywheel.....	0.679

UNDER PAN, Clutch Housing and Transmission Under Pan.....	0.679
UNDERPAN, Flywheel.....	0.679
UNIT, Brake Shoe Adjusting.....	5.110
UNIT, Front Axle Tie Rod.....	6.232
UNIT, Rear Propeller (Shaft attaches to rear axle).....	5.544
UNIT, Rear Wheel Spacer.....	5.811
UPHOLSTERY CLOTH, Seat Cushion and Sidewall (See Yardage Code preceding group 15.500).....	15.500
UP KITS.....	2.270
UP RING, Rear Window Defogger.....	9.778

### V

VACUUM ELEMENT, Defroster.....	9.779
VACUUM GAUGE, Instrument Cluster.....	9.755
VACUUM MOTOR PKG., Air Cleaner Intake Valve.....	3.415
VALVE, Air Cleaner Intake Valve.....	3.415
VALVE, Air Conditioning Compressor (Internal).....	9.172
VALVE, Air Conditioning Evaporator Air Distributor and Astro-Ventilation.....	9.262
VALVE, Air Conditioning Vacuum Control.....	9.280
VALVE, Air Flow.....	9.786
VALVE ASSEMBLY, Oil Filter.....	1.837
VALVE ASSY., Air Conditioning Compressor Pressure Relief.....	9.178
VALVE ASSY., Air Conditioning Control.....	9.281
VALVE ASSY., Air Conditioning Evaporator By-Pass.....	9.198
VALVE ASSY., Air Conditioning Evaporator Core Housing.....	9.211
VALVE ASSY., Air Conditioning Evaporator Expansion.....	9.213
VALVE ASSY., Air Injection Reactor Check.....	3.670
VALVE ASSY., Air Injection Reactor.....	3.650
VALVE ASSY., Air Suspension Leveling or Level Control.....	7.475
VALVE ASSY., Brake Press Ind.....	4.874
VALVE ASSY., Carburetor Idle Air Compensator.....	3.820
VALVE ASSY., Carburetor Pump Inlet Valve.....	3.826
VALVE ASSY., Carburetor Throttle Return Check.....	3.440
VALVE ASSY., Concealed Headlamp Control Drive.....	2.760
VALVE ASSY., Concealed Headlamp Motor.....	2.755
VALVE ASSY., Crankcase.....	1.745
VALVE ASSY., Defroster.....	9.779
VALVE ASSY., Exhaust Gas Recirculation.....	3.670
VALVE ASSY., Exhaust Manifold.....	3.647
VALVE ASSY., Fuel Mixture Control.....	3.670
VALVE ASSY., Heater Vacuum Actuating.....	8.850
VALVE ASSY., Heater Water Temp.....	9.795
VALVE ASSY., Heater.....	8.866
VALVE ASSY., Hot Water.....	8.845
VALVE ASSY., Main Cylinder Push.....	4.658
VALVE ASSY., Oil Filter By-Pass.....	1.637
VALVE ASSY., Rear Brake Pressure Regulator.....	4.690
VALVE ASSY., Rear Compartment (Less Hardware).....	12.181
VALVE ASSY., Roof Panel.....	12.812
VALVE ASSY., Speed and Cruise Control Power.....	3.885
VALVE ASSY., Steering Gear Hydraulic Pump Control.....	6.624
VALVE ASSY., Steering Gear Hydraulic.....	6.550
VALVE ASSY., Vacuum Power Brake Check.....	4.955
VALVE ASSY., Vacuum Power Door Lock.....	10.485
VALVE ASSY., Windshield Washer.....	10.153
VALVE, Carburetor Air Valve.....	3.757
VALVE, Carburetor Choke.....	3.751
VALVE, Carburetor Idle Vapor Vent.....	3.852
VALVE, Carburetor Throttle Return Check.....	3.440
VALVE, Cowl.....	9.789
VALVE, Engine Exhaust.....	0.297
VALVE, Engine Inlet.....	0.296

## ALPHABETICAL INDEX

VALVE (Exhaust).....	0.297	WASHER, Clutch Pedal Intermediate Lever	
VALVE, Exhaust.....	0.297	Shaft Ball.....	0.851
VALVE, Fuel Injection.....	3.302	WASHER, Concealed Headlamp Control	
VALVE, Headlamp Washer.....	2.780	Drive.....	2.760
VALVE, Heater Air Deflector.....	8.858	WASHER, Crankcase.....	1.745
VALVE (Inlet).....	0.296	WASHER, Crankshaft Damper.....	0.662
VALVE, Inlet.....	0.296	WASHER, Cross Member.....	7.039
VALVE KIT, Steering Gear Hydraulic Valve		WASHER, Cylinder Head.....	0.293
Hose.....	6.673	WASHER, Differential Pinion Thrust.....	5.542
VALVE, Main Cylinder.....	4.657	WASHER, Differential Side with Pinion.....	5.527
VALVE, Oil Pump.....	1.609	WASHER, Differential Side Gear Thrust.....	5.543
VALVE, Oil Supply Pump.....	4.203	WASHER, Distributor Breaker.....	2.385
VALVE, Rear Body Lock Pillar.....	12.942	WASHER, Distributor Gear.....	2.379
VALVE, Rear Quarter Side Inner.....	12.941A	WASHER, Distributor Lubricating.....	2.364
VALVE, Rear Quarter Ventilator and Back		WASHER, Door Handle Push Button.....	10.529
Window Drain.....	10.997	WASHER, Door Inside Locking Control.....	10.556
VALVE, Screw Carburetor Throttle.....	3.758	WASHER, Door Lock Inside Handle.....	10.517
VALVE, Shock Absorber, Air Lift.....	7.346	WASHER, Door Lock Remote.....	10.500
VALVE, Transmission Front Servo.....	4.226	WASHER, Door Lock Striker.....	10.571
VALVE, Transmission Low and Drive Valve.....	4.265	WASHER, Door Ventilator Regulator.....	10.664
VALVE, Transmission Main Valve.....	4.216	WASHER, Door Window Lower Sash.....	10.747
VALVE, Transmission Oil Supply.....	4.200	WASHER, Door Window Regulator Manual	
VALVE, Transmission.....	4.256	or Electric.....	10.792
VALVE UNIT, Air Suspension, Air		WASHER, Door Window Regulator.....	10.797
Compressor.....	7.460	WASHER, Door Window.....	10.728
VALVE UNIT, Carburetor Power.....	3.858	WASHER, Electric Seat Adjuster.....	11.556
VALVE UNIT, Oil Supply Pump.....	4.203	WASHER, End Gate Lock.....	12.237A
VALVE UNIT, Transmission Main Valve.....	4.216	WASHER, Engine Mounting (Small	
VALVE UNIT, Vacuum Power Brake Cyl.		Attaching).....	0.002
Relay Valve.....	4.935	WASHER, Exhaust Pipe.....	3.613
VALVE, Vacuum.....	4.205	WASHER, Fifth Speed.....	4.416
VALVE, Wheel Cylinder.....	4.666	WASHER, Folding Seat (For Load Floor	
VALVE, Windshield Wiper.....	10.150	Parts See Group 12.977).....	11.620
VANE, Air Injection Reactor Pump.....	3.665	WASHER, Folding Top Side Roof Rail.....	14.162
VANE KIT, Steering Gear Hydraulic Pump.....	6.610	WASHER, Folding Top.....	14.478
VEGA, MONZA.....	3.725	WASHER, Frame Cross, Front.....	7.010
VENT ASSY., Transmission Case.....	4.104	WASHER, Front or Rear Bumper Bar	
VENTILATOR ASSEMBLY, Front Door (less		Mounting and Attaching.....	7.874
glass).....	10.650	WASHER, Front Door Glass Run.....	10.701
VENTILATOR, Crankcase.....	1.745	WASHER, Front Door Vent.....	10.665
VENTILATOR, Rear Axle.....	5.387	WASHER, Front Door Ventilation Channel.....	10.660
VENT, Transmission Case.....	4.104	WASHER, Front Door Window Glass Lower	
VENTURI, Carburetor.....	3.786	Sash.....	10.685
		WASHER, Front Fender and Skirt.....	8.143
		WASHER, Front Fender and Skirt.....	8.154
		WASHER, Front Seat Adjuster.....	11.561
		WASHER, Front Seat Back Lock.....	11.390
		WASHER, Fuel Feed Pipe.....	3.162
		WASHER, Fuel Tank Strap.....	3.023
		WASHER, Gear Shifter Shaft and Fork	
		(Yoke).....	4.312
		WASHER, Gearshift Control Hand Lever.....	4.008
		WASHER, Gearshift Hand Lever Housing.....	4.012
		WASHER, Gearshift Level Selector and	
		Indicator.....	4.022
		WASHER, Gearshift Shaft Lever.....	4.032
		WASHER, Generator (see 2.317 for brace).....	2.277
		WASHER, Generator (Current Regulator	
		Listed in Group 2.500).....	2.319
		WASHER, Generator Armature.....	2.280
		WASHER, Generator Brush.....	2.291
		WASHER, Generator Drive End.....	2.307
		WASHER, Generator.....	2.313
		WASHER, Harmonic Balancer and	
		Crankshaft Pulley.....	0.662
		WASHER, Heater.....	8.852
		WASHER, Hold-Down Bolt.....	9.011
		WASHER, Hood Moulding and Hinge	
		Attaching.....	8.016
		WASHER, Horn Button and Blowing Ring.....	2.819
		WASHER, Horn.....	2.812
		WASHER, Hydraulic Steering Cylinder	
		Piston Rod.....	6.581
		WASHER, Hydraulic Steering Valve.....	6.554
		WASHER, Ignition Switch Warning.....	2.195
		WASHER, Ignition Switch.....	2.188
		WASHER, Instrument Case.....	9.744
		WASHER, Instrument Panel Compartment	
		Door.....	10.266
		WASHER, Intake Manifold to Carburetor.....	3.288
		WASHER, Load Floor (For Folding Seat	
		Parts See Group 11.620).....	12.977
		WASHER, Low Servo.....	4.228
		WASHER, Low Sun Gear and Clutch.....	4.162

### W

WARMER UNIT, Hot Water.....	8.845
WASHER.....	13.346
WASHER, Air Conditioning Compressor	
Drive.....	9.180
WASHER, Air Conditioning Compressor	
Mounting Attaching Parts.....	9.173
WASHER, Air Conditioning Evaporator Air	
Distributor and Astro-Ventilation.....	9.262
WASHER, Air Conditioning Evaporator	
Blower Motor.....	9.216
WASHER, Air Conditioning Evaporator Core	
Housing.....	9.211
WASHER, Air Flow.....	9.786
WASHER, Air Suspension Level Control.....	7.447
WASHER, Automatic Choke Control.....	3.750
WASHER, Back-Up.....	2.698
WASHER, Battery.....	2.345
WASHER, Belt Moulding, Door and Quarter	
Mldg. Attaching Parts.....	12.118
WASHER, Brake Connector.....	4.671
WASHER, Brake Pedal.....	4.634
WASHER, Brake Shoe Adjusting.....	5.110
WASHER, Brake Shoe Anchor Pin.....	5.056
WASHER, Bumper.....	7.865
WASHER, Camshaft.....	0.738
WASHER, Carburetor and Fuel Injection	
Choke.....	3.752
WASHER, Carburetor Air Valve.....	3.757
WASHER, Carburetor Fast Idle.....	3.768
WASHER, Carburetor Pump.....	3.842
WASHER, Carburetor Throttle Valve and	
Throttle Lever Adjusting.....	3.761
WASHER, Carburetor Throttle.....	3.762
WASHER, Child Safety.....	14.870
WASHER, Clutch Fork Push Rod.....	0.793

## ALPHABETICAL INDEX

WASHER, Main Cylinder (Rubber).....	4.659	WASHER, Transmission Gearshift Shaft Tube Lever.....	4.032
WASHER, Main Cylinder Adjusting.....	4.662	WASHER, Transmission Low and Drive Valve.....	4.265
WASHER, Mast (Also see Group 6.803).....	6.518	WASHER, Transmission Main Drive Gear Bearing.....	4.376
WASHER, Muffler.....	3.704	WASHER, Transmission Planet.....	4.175
WASHER, Parking Brake Lever Anchor.....	5.158	WASHER, Transmission Reverse Idler Gear Thrust.....	4.437
WASHER, Parking Brake.....	4.765	WASHER, Transmission Selector.....	4.046
WASHER, Pinion Shaft Bearing.....	5.453	WASHER, Transmission Shaft and 2nd Speed Gear Thrust.....	4.398
WASHER, Pinion Shaft Lock.....	5.518	WASHER, Transmission Throttle Valve Control.....	4.052
WASHER, Pitman Arm.....	6.861	WASHER, Transmission Throttle Valve.....	4.278
WASHER, Pitman Shaft.....	6.822	WASHER, Transmission 1st Reverse Gear.....	4.419
WASHER, Pitman Shaft.....	6.855	WASHER, Transmission.....	4.164
WASHER, Planet Carrier.....	4.176	WASHER, Transmission.....	4.256
WASHER, Propeller Shaft Damper.....	5.544A	WASHER, Windshield Garnish Moulding.....	10.056
WASHER, Propeller Shaft Pinion Flange.....	5.595	WASHER, Windshield Wiper Control.....	10.164
WASHER, Propeller Shaft Pinion.....	5.545	WASHER, Windshield Wiper Motor Aux.....	10.151
WASHER, Quarter Window Lower Sash.....	11.007A	WASHER, Windshield Wiper Transmission.....	10.160
WASHER, Quarter Window Regulator Handle.....	11.047	WASHER, Windshield Wiper.....	10.150
WASHER, Quarter Window Upper Sash.....	11.005	WEATHERSTRIP, End Gate.....	12.269A
WASHER, Radiator Core.....	1.270	WEATHERSTRIP ASSY., Front Door Ventilator.....	10.652
WASHER, Radio and Stereo Mounting.....	9.667	WEATHERSTRIP, Door Opening and Windshield Pillar.....	10.694
WASHER, Rear Axle Control Arm.....	5.381	WEATHERSTRIP, Folding Top Cover (on side belt rail).....	13.352
WASHER, Rear Axle Control Arm.....	5.383	WEATHERSTRIP, Folding Top Front Roof Rail.....	14.060
WASHER, Rear Axle Tie Rod.....	5.418	WEATHERSTRIP, Folding Top Side Roof Rail-Center.....	14.190
WASHER, Rear Compartment Floor.....	12.981	WEATHERSTRIP, Folding Top Side Roof Rail-Front.....	14.120
WASHER, Rear Compartment Lid and Rear End Panel.....	12.182	WEATHERSTRIP, Folding Top Side Roof Rail-Rear.....	14.260
WASHER, Rear Compartment Lid.....	12.183	WEATHERSTRIP, Hood Ledge (Cowl).....	12.801
WASHER, Rear Door Ventilator.....	10.824	WEATHERSTRIP, Quarter Window Glass Rubber.....	11.015
WASHER, Rear Door Window Glass.....	10.759	WEATHERSTRIP, Rear Compartment Lid.....	12.269
WASHER, Rear Door Window.....	10.791	WEATHERSTRIP, Rear Door Window Frame.....	10.764
WASHER, Rear Fender Attaching.....	8.206	WEATHERSTRIP, Side Roof Rail.....	10.721
WASHER, Rear Spring 'U' Bolt (See Group 5.403).....	7.518	WEATHERSTRIP, Top Roof Outer.....	12.810
WASHER, Reverse Servo.....	4.241	WEDGE, Door Dovetail Bumper Wedge.....	10.584
WASHER, Roof Luggage and Ski.....	12.815	WEDGE, Mast (Also see Group 6.803).....	6.518
WASHER, Seat Back.....	11.381	WEDGE, Tilt or Tel. Steering Column.....	6.514
WASHER, Shock Absorber Bushing (Double Acting).....	7.389	WEIGHT ASSY., Transmission.....	4.256
WASHER, Shock Absorber, Air Lift.....	7.346	WEIGHT, Distributor.....	2.388
WASHER, Shock Absorber.....	7.347	WEIGHT, Wheel Balance.....	5.805
WASHER, Shock Absorber.....	7.371	WHEEL ASSY., Steering.....	6.513
WASHER, Shock Absorber.....	7.397	WHEEL, Front or Rear.....	5.803
WASHER, Sliding Sunroof.....	14.550	WHEEL UNIT, Windshield Washer.....	10.153
WASHER, Speed and Cruise Selector.....	3.883	WICK, Starting Motor Commutator End, with Pins.....	2.067
WASHER, Starting Motor Solenoid.....	2.102	WINDLACE ASSY., Body Center Pillar (With Metal Inner Panel).....	14.730
WASHER, Starting Motor Thrust.....	2.063	WINDLACE, Door (with filler).....	15.520
WASHER, Steering Column Lock Bolt.....	6.500	WIRE, Air Flow Control with Tube.....	9.787
WASHER, Steering Column.....	6.760	WIRE ASM., Horn.....	2.859
WASHER, Steering Gear to Frame.....	6.509	WIRE ASSY., Air Cleaner Intake Valve.....	3.415
WASHER, Steering Gear Hydraulic Pump Mounting.....	6.606	WIRE ASSY., Air Conditioning, Electrical.....	9.276
WASHER, Steering Gear Hydraulic Pump.....	6.655	WIRE ASSY., Arm Rest Front Seat.....	14.900
WASHER, Steering Gear Hydraulic Valve.....	6.552	WIRE ASSY., Back-Up.....	2.697
WASHER, Steering Idler.....	6.897	WIRE ASSY., Body Wiring (Also See Group 2.480 for additional Body Harnesses).....	13.090
WASHER, Steering Knuckle Spindle.....	6.321	WIRE ASSY., Carburetor Throttle Return Check.....	3.440
WASHER, Steering Knuckle Upper Control Arm.....	6.164	WIRE ASSY., Clock Mounting and Attaching.....	9.772
WASHER, Steering Shaft U-Joint.....	6.525	WIRE ASSY., Engine Fuel or Air Inlet Shut Down.....	3.485
WASHER, Steering Wheel.....	6.515	WIRE ASSY., Front Seat Adjusting Lock.....	11.589
WASHER, Sun Roof Motor.....	14.560	WIRE ASSY., Fuel Tank Extension.....	3.115
WASHER, Tail and Stop Lamp.....	12.943	WIRE ASSY., Fuel Tank Gauge.....	3.107
WASHER, Tail Gate.....	12.180	WIRE ASSY., Hazard Flasher.....	2.575
WASHER, Tailgate.....	12.195	WIRE ASSY., Ignition Coil.....	2.171
WASHER, Tilt or Tel. Steering Column.....	6.514	WIRE ASSY., Instrument Panel Compartment, Seat Separator Compartment and Courtesy.....	10.275
WASHER, Top Side Pad.....	13.349	WIRE ASSY., Parking Lamp.....	2.596
WASHER, Trailer.....	7.068	WIRE ASSY., Radio and Speaker Wiring.....	9.656
WASHER, Transmission (1st and Reverse Gear).....	4.419	WIRE ASSY., Rear Compartment Lid Opener.....	12.243
WASHER, Transmission Clutch Gear.....	4.352	WIRE ASSY., Rear License Lamp w/Wire.....	2.714
WASHER, Transmission Clutch.....	4.169		
WASHER, Transmission Control Idler Attaching.....	4.042		
WASHER, Transmission Control Idler.....	4.040		
WASHER, Transmission Counter Gear Bearing.....	4.423		
WASHER, Transmission Front Drive.....	4.158		
WASHER, Transmission Gearshift Control Cable.....	4.047		
WASHER, Transmission Gearshift Control Shaft or Tube.....	4.027		
WASHER, Transmission Gearshift Rod to Lever.....	4.037		

## ALPHABETICAL INDEX

WIRE ASSY., Rear Luggage Compartment.....	9.988
WIRE ASSY., Rear Window Defogger .....	9.778
WIRE ASSY., Spark Plug, with Terminals (Single Wire Replacement).....	2.240
WIRE ASSY., Starting, Ignition .....	2.525
WIRE ASSY., Transmission Control Safety .....	4.054
WIRE ASSY., Transmission Throttle Control (Electric) .....	4.057
WIRE ASSY., Transmission, Smog Control .....	4.075
WIRE ASSY., Windshield Wiper.....	10.150
WIRE, Chassis Wiring (segmented) .....	2.480
WIRE, Electrical .....	2.530
WIRE, Front Seat Center Arm Rest.....	11.374
WIRE, Headlining Listing Support .....	12.955
WIRE, Hot Water .....	8.845
WIRE, Transmission Throttle valve Operating Parts .....	4.275
WIRE UNIT, Spark Plug .....	2.239
WORM, Folding Top.....	14.478
WRENCH, Spark Plug .....	2.273
WRENCH, Wheel and Tire.....	8.821

### Y

YARDAGE, Doors, Seats, Cowl and Load Floor .....	15.512
YOKE ASSY., Direction Signal Lamp (Detent)	2.910
YOKE ASSY., Steering Shaft U-Joint.....	6.525
YOKE, Heater .....	8.854
YOKE, Universal Joint.....	5.555

### Z

ZIPPER, Folding Top Cover (less Back Curtain).....	13.347
ZIPPER, F/Top Back Window.....	13.392



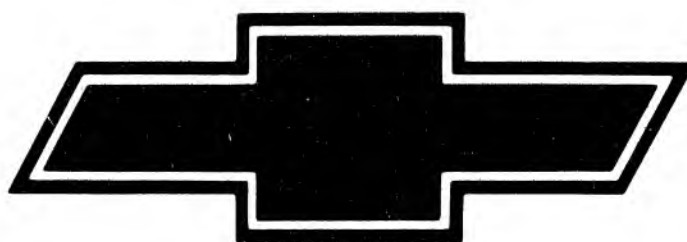

# **CHEVROLET**

## **MODELS THRU 1975 PARTS CATALOG**

APRIL, 1976

**GENERAL MOTORS PARTS DIVISION**

GENERAL MOTORS CORPORATION  
FLINT, MICHIGAN 48554



# CHEVROLET PARTS PUBLICATIONS

The Chevrolet Parts Catalog System is divided into the following publications.

<b>NO.</b>	<b>TITLE</b>
10	1976 Chevrolet Parts Catalog except Corvette
10A	1976 Chevrolet Parts Illustration Catalog except Corvette
11	Chevrolet Parts Catalog Models thru 1975 includes:  1965-1975 Passenger Car 1962-1975 Chevy II and Nova 1964-1975 Chevelle 1967-1975 Camaro 1971-1975 Vega and Monza
11A	Chevrolet Models thru 1975 Parts Illustration Catalog
14	1953-1976 Chevrolet Corvette Parts Catalog
14A	1953-1976 Chevrolet Corvette Parts Illustration Catalog
16	Chevrolet Dealer Parts and Accessories Price Schedule
LUV	Chevrolet LUV Truck (Series 1, 2, 3 & 4)
72 TL	1946-1972 Chevrolet Series 10 thru 30 Truck Parts & Accessories Catalog
72 TM	1946-1972 Chevrolet Series 40 thru 60 Truck Parts & Accessories Catalog
76 TL	1973-1975 Chevrolet Series 10 thru 30 Truck Parts & Accessories Catalog
76 TM	1973-1976 Chevrolet Series 40 thru 60 Truck Parts & Accessories Catalog
72 TH-70,80	Chevrolet Heavy Duty Truck Parts Catalog for:  1966-1972 2½ Ton Series 70000 Trucks 1966-1973 3 Ton Series 80000 Trucks
72 TH-90	1970-1972 3½ Ton Series 90000 Trucks
76 TH	1973-1976 2½ thru 3½ Ton Truck Parts & Accessories Catalog
87	GM Parts Division History Catalog
89	GM Standard Parts and Maintenance Products Catalog

# CONTENTS

	GROUP
INTRODUCTION .....	—
GENERAL INFORMATION .....	—
ALPHABETICAL INDEX .....	—
ENGINE — CLUTCH .....	0.000
COOLING — GRILLE — OIL SYSTEM .....	1.000
CHASSIS WIRING — LAMPS .....	2.000
FUEL — EXHAUST — CARBURETION .....	3.000
TRANSMISSION — BRAKES .....	4.000
BRAKES — REAR AXLE — PROPELLER SHAFT — WHEELS .....	5.000
FRONT SUSPENSION — STEERING .....	6.000
FRAME — SPRINGS — SHOCKS — BUMPERS .....	7.000
FRONT END SHEET METAL — HEATER .....	8.000
BODY MOLDING — AIR CONDITIONING — INSTRUMENT CLUSTER .....	9.000
DOORS — REGULATORS — WINDSHIELD — WIPER — WASHER .....	10.000
REAR GLASS — SEAT PARTS — ADJUSTER .....	11.000
BODY MOLDINGS — SHEET METAL .....	12.000
CONVERTIBLE TOP TRIM — BODY WIRING .....	13.000
CONVERTIBLE TOP HARDWARE — INTERIOR TRIM — SEAT BELTS .....	14.000
REAR SEAT TRIM — CARPETS — YARDAGE .....	15.000

# ABBREVIATIONS

Abs. .... Absorber	Def. .... Defroster	K/Pin .... King Pin	Ret. .... Retainer
A.C. .... Automatic Choke	Dev. .... Developed	Lea. .... Leather	R.H. .... Right Hand
Carburetor	Diaph. .... Diaphragm	L. .... Left	Rkr. .... Rocker
A.C. Gen. .... Alternating Current	Dia. .... Diameter	L.C.F. .... Low Cab Forward	Rnft. .... Reinforcement
Generator	Diff. .... Differential	L.C.I. .... Low Cut-in	Roch. .... Rochester
Acc. .... Accessory	Distr. .... Distributor	L.D. .... Light Duty	Rbr. .... Rubber
Accel. .... Accelerator	Div. .... Division	L.H. .... Left Hand	Run/Bd. .... Running Board
A/Cl. .... Air Cleaner	Dr. .... Door	Lg. .... Long	Rr. .... Rear
Adj. .... Adjustable	Drid. .... Drilled	L.P. Gas .... Liquid Petroleum	R.S. .... Rally Sport
Adjusting	D-D, ....	Gas	
A.I.R. .... Air Injection	Dubl-Duti .. Forward Control	Lower	SBC .... School Bus Chassis
Reactor	Chassis	Max. .... Maximum	Sch. Bus. ....
Air. Equip. .... Air Over Hydraulic	Econ. .... Economy	Mkd. .... Marked	Ch.
Brake and Air	Emerg. .... Emergency	Mas. .... Master	Sed. .... Sedan
Brake	Eng. .... Engine	Matl. .... Material	SDL .... Sedan Delivery
Air/S .... Air Suspension	Equip. .... Equipment	Mech. .... Mechanical	Serv. .... Service
A.M. .... Air Meter	Escn. .... Escutcheon	Med. .... Medium	Sgl. .... Single
Amp. .... Ampere	Exc. .... Except	Mbr. .... Member	Shk./Abs. .... Shock Absorber
A.O.H.B. .... Air Over Hydraulic	Exch. .... Exchange	Min. .... Minimum	Shldr. .... Shoulder
Brake	Exh. .... Exhaust	Mfld. .... Manifold	Slt. .... Slotted
A.R. .... As Required	Expan. .... Expansion	Mldg. .... Moulding	Spd. .... Speed
Assy. .... Assembly	Ext. .... External	Mtg. .... Mounting	Spec. .... Special
A.T. .... All Automatic	Extn. .... Extension	Mtr. Rod .. Metering Rod	Sp. H/Per. .... Special High
Transmissions	E.E.C. .... Evaporative	ND .... New Departure	Performance
Aux. .... Auxiliary	Emission Control	NL .... Not Listed	Speedo. .... Speedometer
B-A .... Bel Air	E.H.D. .... Extra Heavy Duty	No. .... Number	Spg. .... Spring
Batt. .... Battery	Fcg. .... Facing	NP .... New Process	Sq. .... Square
Bind. .... Binding	F.C. .... Forward Control	N.R.E. .... Noise Reduction	St. Steel .... Stainless Steel
Blk. .... Black	FFC .... Flat Face Cowl	Exhaust	Staty. .... Stationary
Brg. .... Bearing	F.I. .... Fuel Injection	NSS .... Not Serviced	STA. WAG. .... Station Wagon
Brk. .... Brake	Fill. .... Fillister	Separately	Std. .... Standard
Brkt. .... Bracket	Flwhl. .... Flywheel	O.B.A.C. .... Oil Bath Air Cleaner	Stmpd. .... Stamped
Bpr. .... Bumper	Fltn. .... Fleetline	O.C. .... Oil Cooler	Strg. .... Steering
B.S. .... Bucket Seats	Flex. .... Flexible	O.D. .... Outside Diameter	SUB .... Suburban Carryall
Bshg. .... Bushing	Flg. .... Flange	O/D .... Overdrive	Supt. .... Support
C.A.C. .... Car Air Conditioning	Fldg. .... Folding	OL .... Overall Length	Syncro. .... Synchronizing
(All Weather, 4	F.M. .... Fuel Meter	Oper. .... Operating	T. .... Teeth
Season, Deluxe)	Frgd. .... Forged	Opg. .... Opening	Tach. .... Tachometer
Cad. .... Cadmium	Frt. .... Front	Ornam. .... Ornament	TDM. .... Tandem
C/Shaft .... Camshaft	4 BC .... 4 Barrel Carburetor	OS .... Oversize	Tel. W. .... Telescopic Wheel
Carb. .... Carburetor	4WD .... Four Wheel Drive	O.S.R.V. .... Outside Rear View	Temp. .... Temperature
Carr. .... Carrier	Gal. .... Gallon	Pack. .... Packing	Ter. .... Terminal
C.C. .... Comfort and	Garn. .... Garnish	P.R.W. .... Panoramic Rear	T.G. .... Turboglide
Convenience	Gen. .... Generator	Window	T.H. .... Turbo Hydramatic
Equip.	Gov. .... Governor	Pnl. .... Panel	Thd. .... Thread
Ch. .... Chassis	Gskt. .... Gasket	Pass. .... Passenger	Therm. .... Thermostat
Chnl. .... Channel	H.D. .... Heavy Duty	Park. .... Parkerized	T. Ign. .... Transistor Ignition
Chr. .... Chrome	H/Perf. .... High Performance	P.B. .... Power Brake	T.W. .... Tilt Wheel
Ck/C .... Crankcase	Hex. .... Hexagon	PDL .... Pick-Up Delivery	Trans. .... Transmission
Ck/Shaft .... Crankshaft	Hdl. .... Handle	(EI Camino)	2/B.C. .... Two Barrel
Cl. .... Clutch	Hd. .... Head	P.G. .... Powerglide	Carburetor
C.T.C. .... Continental Tire	Hdng. .... Headlining	P/R .... Pressure Regulator	3/2 B.C. .... Treiple Two Barrel
Carrier	Hdlp. .... Headlamp	P/S .... Power Steering	Carburetor
C'bore .... Counterbore	H.D./A/CL. .... Heavy Duty Air	Pit. .... Pitman	Trf. .... Transfer
C/Deluxe .... Custom Deluxe Air	Cleaner	Pkg. .... Package	Turbo. .... Turbocharger
Conditioner	H.D. Susp. .... Heavy Duty	Pl. .... Plain	U-Joint .... Universal Joint
C.O.E. .... Cab Over Engine	Suspension	Pitfm. .... Platform	US .... Undersize
Comb. .... Combination	H.L. .... High Lift	Press. .... Pressure	Univ. .... Universal
Comm. .... Commercial	Hsg. .... Housing	Prop. .... Propeller	U/Pan .... Underpan
Comp. .... Compressor	H.T. .... Truck Hydramatic	Pt. .... Part	Upr. .... Upper
Compt. .... Compartment	Transmission	P.T. .... Powermatic	Util. .... Utility
Compr. .... Compression	Htr. .... Heater	Transmission or	Vac. .... Vacuum
Conn. .... Connecting	Hvy. .... Heavy	Allison Automatic	Vent. .... Ventilator
Conv. .... Convertible	Hy. .... Hyatt	P/Trac. .... Positraction	W.G.T. .... Warner Gear
CPE. .... Coupe	Hyd. .... Hydraulic	Qt. .... Quart	Transmission
Cplg. .... Coupling	ID .... Inside Diameter	Qtr. .... Quarter	W/ .... With
Ctr./S. .... Countershaft	Ident. .... Identification	R. .... Right	W/A.C. .... Automatic Choke
C'sunk .... Countersunk	Ign. .... Ignition	Rad. .... Radiator	W/O .... Without Carburetor
C.S. .... Custom Sport Truck	Imit. .... Imitation	Rd. .... Round	W/Pump .... Water Pump
Ctr. .... Center	Incl. .... Includes	Recir. .... Recirculating	WB. .... Wheelbase
Cush. .... Cushion	Ind. .... Indicator	Rect. .... Rectangular	W/Cord .... Weathercord
Custom .... Custom Air	Inl. .... Inlet	Reg. .... Regulator	WhlHse. .... Wheelhouse
Conditioner	Instr. .... Instrument	Reg. Prod. .... Regular Production	Wind. .... Window
Cyl. .... Cylinder	Ins. .... Insulator		W/S .... Windshield
2 cyc. .... 2 Cycle	Int. .... Internal Intake		W/Strip .... Weatherstrip
4 cyc. .... 4 Cycle	Inter. .... Intermediate		W/W .... Windshield Washer
Dbl. .... Double			
Defl. .... Deflector			

# INTRODUCTION

This Parts Catalog has been compiled for the purpose of locating, identifying, and ordering replacement parts. All data and specifications contained in this publication are based on the latest product information available at the time of printing. General Motors Parts Division reserves the right to make changes at any time without notice in data, price, specifications, materials, material, and model. The "List Prices" shown are suggested prices only for sales to consumers.

Replacement parts are listed in this catalog under 16 major groups, as shown on the content page. Individual parts are assigned a Prime Group number, the first numeral of the group identifies the main unit it is affiliated with, and following the decimal is the Sub-Group number under which all parts of the same name and function are listed. For example, Group 0.519 Camshaft. The "0" denotes that it is an Engine Part, "519" the sub-group where all Engine Camshafts are listed. Related parts may also be found in the same group. Within each group, parts are listed by model year, vehicle series, part number, number used per vehicle or R.H.-L.H. designation, suggested list price, part name and description.

Parts may be used in different locations on the car requiring the listing of the part number in more than one group. When this "Cross Referencing" occurs, the prime group is shown in brackets i.e. (1.850) in the description column.

To locate a listing for a part, determine the model vehicle and refer to the group number identifying it, which may be determined by using any of the following methods.

- A. When the name of the part is known, consult the ALPHABETICAL INDEX, which lists parts by noun name and Group Number where part is listed.
- B. Reference may be made to the ILLUSTRATION CATALOG, where Group Numbers, noun names or part numbers are shown.
- C. When a part number is known and model application or a similar part is required, consult the DEALER PRICE SCHEDULE for the Group Number to locate the part in the Parts Catalog.

Parts having application or used with optional equipment are identified by Option Number or abbreviation of option. Familiarity with Option Numbers will assist in determining correct part required.

Complete identification for models and options listed in this catalog will be found preceding the alphabetical index.

Service part numbers are assigned to individual parts that make up an assembly used in the production of models. Certain items may not be listed, such as short tubing parts or fuel lines that can be made up by dealers from bulk material or attaching parts may be included in packages with the major assembly and not listed separately.

Right Hand and Left Hand parts are so designated from the driver's position when seated in the car.

## 1966-75 REGULAR PRODUCTION OPTIONS (RPO)

The purpose of this listing is to assist in the identification  
of optional Equipment installed on Chevrolet Vehicles.

RPO	DESCRIPTION	RPO	DESCRIPTION
A01	Body Glass - Tinted	B84	Body Side Mouldings
A02	Windshield Glass	B85	Belt Reveal Moulding
A20	Swing Out Rear Quarter Window	B90	Door and Window Frame Moulding
A31	Window Electric Control	B93	Door Edge Guards
A33	Tail Gate Window Electric Control	B94	Emblem Body
A39	Front and Rear Seat Belts w/Retractors on Front Belts	B96	Moldings Wheel Opening
A41	Front Seat Electric Control (4-Way)	BS1	Body Accoustical Package
A42	Front Seat Electric Control (6-Way)	BW2	Exterior Ornamentation
A43	Six Way Manual Seat Adjuster	BX3	Woodgrain Exterior Ornamentation
A44	Seat Adjuster	BX4	Body Side Moulding - Upper
A46	Drivers Seat Electric Control (4-Way) Bucket Seat)	BX7	Door Edge Guards
A49	Front Seat Belt (With Retractors) (Use with RPO A63)	BX8	Mouldings used w/2 Tone Paint
A51	Front Bucket Seat - Astro Type	BY2	Police Car Equipment
A52	Front Bench Seat	C05	Folding Top
A53	Front Bench Seat - Astro Type	C06	Folding Top Power Lift
A57	Auxiliary Seat L.H.	C07	Auxiliary Top
A61	Auxiliary Seat	C08	Exterior Soft Trim Roof Cover
A62	Less Rear Seat Belt	C09	Vinyl Roof
A63	Less Rear Seat Belt	C14	2-Speed W/S Wiper and Washer
A65	Front Bench Seat - Split Seat Belt	C24	Special Windshield Wiper
A66	Split Second Seat	C26	Power Operated Tailgate
A67	Folding Rear Seat	C28	Dual Action Tailgate
A68	Rear Seat Center Belt - Std.	C49	Rear Window Electric Defogger
A75	H.D. Front Seat - Low Profile Type	C50	Rear Window Defroster and Defogging
A76	H.D. Rear Seat	C51	Rear Window Air Deflector
A81	Headrest - Astro Type Seat	C56	Upper Level Ventilation
A82	Headrest - Conventional Type Seat	C60	Air Conditioning - All Weather
A85	Shoulder Harness	C61	A/Cond. Automatic Temp. Control
A90	Rear Compartment Lid Release Electric Control	C64	Air Conditioning
A91	Rear Compartment Lid Release - Vacuum Control	C75	Air Conditioning Automatic Temperature Control
A93	Vacuum Operated Door Lock	C80	Door Jamb Switch
A96	Rear Compartment Lock	C88	Rear Comp. Courtesy Lamp
AB8	Landau Formal Roof Equipment	C95	Dome Reading Lamp
AD2	Prop. Hold Open rr. Comp. Floor	CA1	Sun Roof Electric
AG7	Power Front Seat L.H. 6-Way	CB1	Exterior Soft Trim Cover
AK1	Deluxe Seat Belts and Shoulder Harness	CB4	Landau Top
AL4	Front Bench Seat - Special Contour (Strato)	CB6	Vinyl Roof - Halo Type
AL5	Rear Seat Center Belt - Deluxe	CB7	Forward Vinyl Roof Cover
AN5	Lateral Restraint Seat	CD2	Windshield Washer Fluid Level
AN6	Electric Seat Back Lock RElease	CD3	Electro-Tip Windshield Wiper Control
AN7	Front Seat Swivel	CD4	Pulse Type W/S Wiper
AQ4	Station Wagon 3rd Seat	CE1	Headlamp Washer
AQ5	Shoulder Harness - Std.	D10	Arm Rest - Rear
AS1	Headrest - Special Contour Type Seat (Strato)	D24	Litter Container
AS2	Rear Seat Shoulder Harness Deluxe	D31	Inside Non-Glare Rear View Mirror
AS4	Rear Seat Shoulder Harness - Std.	D33	Outside Rear View Mirror L.H. Remote Control
AS5	Drivers Seat Adjustable Back	D34	Visor Vanity Mirror
AT8	Front Bench Seat 50-50	D35	Outside Rr. View Mirror - L.H. - Custom - Rem. Control
AU1	Electric Door Lock	D55	Front Compartment Floor Console
AU3	Power Door Lock	D68	Dual Sport Mirrors
AU6	Electric Liftgate Lock Release	D69	Remote Control Outside Rear View Mirror
BO1	Heavy Duty Body	D80	Auxiliary Panel and Valance
B02	Taxi Cab (Includes 3.07 Rear Axle)	D88	SS Hood & Deck Lid Strip
B07	Police Car	D91	Front End Paint Stripe
B34	H.D. Front Floor Mat	D92	Door Handle Decor Tape
B35	H.D. Rear Floor Mat	D96	Wide Paint Stripe - Side
B37	Floor Mats	D99	Special Two-Tone Paint
B39	Load Floor Carpet	DF3	R.H. Rear View Mirror - Remote Control
B41	Mat Load Floor (Rubber)	DX1	Front End and Hood Stripe
B44	Loose Load Floor Carpet	DX3	Striping Paint
B48	Deluxe Luggage Comp. Trim	F40	Heavy Duty Front and Rear Suspension
B49	High Pile Carpeting	F41	Special Performance - Front and Rear Suspension
B50	Foam Rubber Front Seat Cushion	F60	Heavy Front Spring
B55	Deluxe Front Seat Cushion	F62	Front Springs
B69	Insulator Roof	FE8	Radial Tuned Suspension
B70	Instrument Panel Pad	FR1	Front Spring L.H.
B80	Roof Drip Moulding	FR2	Front Spring R.H.
		G31	Special Rear Spring
		G32	Rear Springs
		G33	Rear Spring L.H.

## 1966-75 REGULAR PRODUCTION OPTIONS (RPO) (Cont'd.)

RPO	DESCRIPTION	RPO	DESCRIPTION
G34	Rear Spring R.H.	K24	Closed Engine Positive Ventilation
G66	Air Booster Rear Shock Absorber	K30	Speed and Cruise Control
G67	Rear Shock Absorber Level Control	K45	Air Cleaner - Oil Bath Type 1 Lb. Capacity
G75	Rear Axle - 3.70 Ratio	K46	Air Cleaner - Heavy Duty Pre-Cleaner
G76	Rear Axle - 3.36 Ratio	K47	Air Cleaner - Oil Bath Pre-Cleaner
G80	Rear Axle - Positraction	K66	Transistor Ignition
G81	Differential Carrier - Positraction	K76	61 Amp. Generator - Delcotron
G91	Differential Carrier - 3.08 Ratio	K77	55 Amp. Generator
G92	Rear Axle - 3.08 Ratio	K79	42 Amp. Generator - Delcotron
G93	Differential Carrier - 3.27 Ratio	K81	62 Amp. Generator - Delcotron
G94	Rear Axle - 3.31 Ratio	K84	Amp. Generator - Delcotron
G95	Differential Carrier - 3.55 Ratio	K85	63 Amp. Generator - Delcotron
G96	Rear Axle - 3.55 Ratio	K89	Reactor - Catalytic Converter
G97	Rear Axle - 2.37 Ratio	KD5	Heavy Duty Closed Position Ventilation
GH2	Rear Axle 2.29.1	KK6	Air Injection Reactor
GM8	Rear Axle 2.56 Ratio	L11	L4 Engine - 170 Cu. In. OHC Alum. (2 Bbl. Carb.)
GR3	Rear Axle and Multi-Leaf Suspension Conversion For Export CKD Canada	L13	L4 Engine - 140 Cu. In. OHC Alum. (Std. 1 Bbl. Carb.)
GS1	Rear Axle - 2.73 Ratio	L14	V8 Engine - 307 Cu. In. - Standard
GS2	Rear Axle - 3.08 Ratio	L22	L-6 Engine - 250 Cu. Inch.
GS3	Rear Axle - 3.73 Ratio	L26	L-6 Engine - 230 Cu. In.
GS4	Differential Carrier - 3.70 Ratio Positraction	L30	V-8 Engine - 327 Cu. In.
GS5	Differential Carrier - 4.11 Ratio	L34	V-8 Engine - 396 Cu. In. Hi-Perf.
GS6	Differential Carrier - 4.56 Ratio Positraction	L35	V-8 Engine - 396 Cu. In.
GS8	Rear Axle 3.42 Ratio	L36	V-8 Engine - 427 Cu. In. Hi-Perf.
GS9	Rear Axle 3.73 Ratio	L46	V-8 Engine - 350 Cu. In.
GT1	Rear Axle - 2.56 Ratio	L48	V-8 Engine - 350 Cu. In.
GT2	Rear Axle - 2.29 Ratio	L62	P-6 Engine - Hi-Perf.
GT4	Rear Axle - 2.73 Ratio	L63	P-6 Engine - Spec. Hi-Perf.
GT5	Rear Axle - 4.10 Ratio	L65	V-8 Engine - 350 Cu. In. (2 Bbl. Carb.)
GT6	Rear Axle - 3.42 Ratio	L66	V-8 Engine - 396 Cu. In. (2 Bbl. Carb.)
GU2	Rear Axle 2.73 Ratio	L68	V-8 Engine - 427 Cu. In. - Hi-Perf. - Tri Carb.
GU4	Rear Axle 3.08 Ratio	L71	V-8 Engine - 427 Cu. In. - Spec. Hi-Perf. Tri Carb.
GU6	Rear Axle 3.42 Ratio	L72	V-8 Engine - 427 Cu. In. - Spec. Hi-Perf.
GV1	Differential Carrier - 2.73 Ratio Positraction	L73	V-8 Engine - 396 Cu. In. - Spec. Hi-Perf.
GV2	Differential Carrier - 3.08 Ratio	L78	V-8 Engine - 396 Cu. In. - Spec. Hi-Perf.
GV3	Differential Carrier - 3.08 Ratio	L79	V-8 Engine - 327 Cu. In. - LD - Spec. Hi-Perf.
GV4	Differential Carrier - 3.36 Ratio	L82	V-8 Engine 350 Cu. In.
GV5	Differential Carrier - 3.55 Ratio	L85	L-6 Engine - 250 Cu. In. (4 Bbl. Carburetor)
GV7	Differential Carrier - 3.55 Ratio	L87	P-6 Turbo Charged Engine
GV8	Differential Carrier - 4.11 Ratio	L88	V-8 Engine - 427 Cu. In. Heavy Duty
GV9	Rear Axle - 2.53 Ratio	L89	Aluminum Cylinder Heads
GW2	Rear Axle - 2.56 Ratio	L90	Low Compression Engine 6 Cyl. (Export)
GW3	Rear Axle - 2.56 Ratio	L92	Low Compression Engine V8 (Export)
GW4	Rear Axle - 2.56 Ratio	LF6	V8 Engine 400 Cu. In. (2 Bbl. Carb. LD)
GW5	Rear Axle - 2.73 Ratio	LF7	V-8 Engine - 327 Cu. In. (2 Bbl. Carb.) (Reg. Fuel)
GW7	Rear Axle - 2.73 Ratio	LM1	V-8 Engine - 350 Cu. In. (4 Bbl. Carb.) (Reg. Fuel)
GW8	Rear Axle - 4.10 Ratio	LO8	Engine Emission Identification Chart
GW9	Rear Axle 2.93 Ratio	LS1	V-8 Engine - 427 Cu. In. (4 Bbl. Carb.) (Reg. Fuel)
GX1	Rear Axle - 3.07 Ratio	LS3	V-8 Engine 400 Cu. In. 4 Bbl. Carb.
GX2	Rear Axle - 3.07 Ratio	LS4	V-8 Engine 454 Cu. In. 4 Bbl. Carb.
GX5	Rear Axle - 3.08 Ratio	LS5	V-8 Engine 454 Cu. In. 4 Bbl. Carb. Hi-Perf.
GX9	Rear Axle - 2.92 Ratio	LS6	V-8 Engine 454 Cu. In. 4 Bbl. Carb. Spec. Hi-Perf.
GY2	Rear Axle - 3.31 Ratio	LS7	V-8 Engine 454 Cu. In. 4 Bbl. Heavy Duty
GY4	Rear Axle - 3.73 Ratio	LT1	V-8 Engine - 350 Cu. In. Special High Performance
GZ1	Rear Axle - 3.08 Ratio	LT4	V-8 Engine 400 Cu. In. 4 Bbl. Carb.
GZ3	Rear Axle - 3.08 Ratio	LV1	V-8 Engine 4.8 Litre
GZ5	Rear Axle - 3.42 Ratio	LY3	122 C.I.D. L-4 Engine
GZ6	Rear Axle - 3.42 Ratio	M01	Heavy Duty Clutch
H01	Rear Axle - 3.07 Ratio	M10	Transmission Overdrive
H05	Rear Axle - 3.73 Ratio	M11	Floor Shift Transmission Control
J50	Vacuum Power Brake	M13	Heavy Duty 3-Speed Transmission
J52	Disc Brakes - Front	M15	3-Speed Transmission
J55	Heavy Duty Brakes	M20	4-Speed Transmission
J56	Heavy Duty Brake	M21	4-Speed Transmission - Close Ratio
J61	Shoe and Drum Type Brake (Disc Brakes Deleted)	M22	Heavy Duty 4-Speed Transmission
J65	Metallic Brake Facing	M35	Powerglide Transmission
JL2	Disc Brake - Front	M38	3-Speed Automatic Transmission
JL8	Disc Brakes - Front and Rear	M40	3-Speed Automatic Transmission
K02	Fan Drive	M55	Transmission Oil Cooler
K05	Engine Blcok Heater	M75	5-Speed Transmission
K19	Air Injection Reactor	MB1	2-Speed Transmission - Manual Shift
K21	Engine Controlled Combustion System	MC1	H.D. 3-Speed Transmission

**1966-75 REGULAR PRODUCTION OPTIONS (RPO) (Cont'd.)**

<b>RPO</b>	<b>DESCRIPTION</b>	<b>RPO</b>	<b>DESCRIPTION</b>
MC3	3-Speed Transmission	UA1	Heavy Duty Battery
NO3	Gas Tank - 36-1/2 Gallon and Wheelhouse Filler Panel	UA6	Horn Alarm System
N10	Dual Exhaust	UF1	Map Lamp
N11	Off Road Service Exhaust	UF3	Map Light
N14	Side Mounted Dual Exhaust	UF4	Gauge Package - Econominder
N30	Deluxe Steering Wheel	UF7	Gauge Package
N31	Sport Styled Steering Wheel	UM1	MA Pushbutton Radio & Tape Player
N32	Steering Wheel - Wood	UM2	AM-FM Pushbutton Radio & Tape Player
N33	Steering Wheel - Tilt Type	V01	Heavy Duty Radiator
N34	Steering Wheel - Wood Grained Plastic	V30	Bumper Guards
N36	Telescopic Steering Shaft	V31	Front Bumper Guard
N37	Steering Wheel - Tilt - Telescopic	V32	Rear Bumper Guard
N40	Hydraulic Steering	V54	Deluxe Adjustable Roof Luggage Carrier
N41	Hydraulic Steering Variable Ratio	V55	Roof Luggage Carrier
N44	Special Steering	V74	Hazard Warning Switch
N58	Converter 260 Under	VE3	Special Front Bumper
N61	Dual Exhaust - Deep Tone Muffler	VE5	Bumper Impact Strip
N65	Space Saver Spare Wheel and Tire	VK3	Mount Front License Plate
N66	Super Sport Wheel, Hub Cap & Trim Ring	VQ1	Engine Coolant Recovery
N77	Forged Aluminum Wheels	Y10	Door and quarter Custom Buildup
N89	Aluminum Wheel - 15 x 66	Y19	Body Side Lower Mldg.
N95	Simulated Wire Wheel Trim Cover	YA2	"Estate" Model
N96	Simulated Magnesium Wheel Trim Cover	YC1	Differential Carrier - 3.08 Ratio Positraction
N98	Rally II Wheels	YC2	Differential Carrier - 3.36 Ratio Positraction
NA9	Evaporative Emission Control California	YC3	Differential Carrier - 3.55 Ratio Positraction
NB2	Exhaust Emission Control	YC4	Differential Carrier - 4.11 Ratio Positraction
NF2	Dual Exhaust - Deep Tone Muffler	YC6	SS 454 Conversion
NK2	Deluxe Vinyl Steering Wheel	YD1	Trailer Rear Axle Ratio
NK4	Sport Steering Wheel	YE1	Rear Axle - Special Ratio 3.70:1
P01	Wheel Trim Cover	YE2	Rear Axle - Special Ratio 4.11:1
P02	Simulated Wire Wheel Trim Cover	YE4	Deluxe Interior and Exterior
P06	Wheel Trim Ring	YF1	Nova Rally Package
P12	14 x 6 JK Wheel (8.25-14 Tires)	YF3	"Heavy Chevy" Exterior
P19	Spare Wheel Lock	YF3	Deluxe Front and Rear Bumper
P42	15 x 6 J Wheel	YF4	Bumper Guard and Bumper Strip
P48	15 x 6 L Wheel (Quick Take Off)	YF9	Special Deluxe Equipment
P49	Chrome Wheel	YG5	Acoustics, Appearance and Convenience Equip.
PA2	Simulated Magnesium Wheel Trim Cover	YJ8	Cast Aluminum Wheel
PA3	Special Wheel Trim Cover	YJ9	Exterior Decor
PE1	Special Styled Urethane/Steel Turbin Wheel 14 x 7	Y02	Front Custom Seat
PE2	15 x 7 Wheel "Custom"	Y03	Rear Custom Seat
T58	Rear Wheel Opening Skirt	Y05	Floor Deadner
T60	Heavy Duty Battery	Z01	Comfort and Convenience Equipment Includes:
T63	Headlamp Warning Buzzer		Inside Mirror
T78	Front Fender Running Lamp		Standard Outside Mirror - (Exc. Corvette)
T81	Headlamp Light Watch & Off Control		2-Speed Wiper and Washer - (Exc. Corvette)
T83	Retractable Headlamp Cover		Back-Up Lights
TJ2	Front Fender Louver		Glove Box Lamp - (Exc. Corvette)
U03	Low "D" Note Horn		Luggage Lamp - (Reg. Pass. only)
U05	Dual Horn		Bottle W/S Washer Fluid - (Exc. Corvette)
U14	Instrument Panel Gauges	Z03	Super Sport
U15	Speed Warning Indicator	Z04	Heavy Duty Chassis
U16	Tachometer	Z06	S.S. 396
U17	Front Compartment Console Instrument Cluster	Z08	Exterior Sports Decor
U18	Speedometer - Export	Z11	Luxury Nova "LN"
U23	Ignition Lock Light	Z12	Speedometer Driven Gear & Fitting
U25	Luggage Compartment Lamp	Z13	Comfort and Convenience Equipment
U26	Underhood Lamp	Z14	Air Conditioning (All Weather) Body Conversion
U27	Glove Compartment Lamp	Z15	SS 454
U28	Ash Trap Lamp	Z17	Special Suspension and Steering
U29	Instrument Panel Courtesy Lights	Z21	Exterior Moulding
U35	Electric Clock	Z22	Rally Sport Package
U37	Cigarette Lighter	Z23	Interior Decor Package
U46	Lamp Monitoring	Z24	SS 427
U57	Tape Player	Z25	SS 396
U58	AM-FM Stereophonic	Z26	Super Sport
U63	Radio - Push Button	Z27	Super Sport
U69	Radio - AM/FM - Push Button	Z28	Special Engine
U73	Manual Antenna - Rear	Z29	Vinyl Stripe
U75	Power Antenna - Rear	Z50	Interior Trim
U76	Windshield Antenna	Z52	Full Foam Seat
U79	Radio Stereo	Z53	Ammeter, Oil Pressure and Temperature Gauge
U80	Auxiliary Speaker	Z54	Interior Decor/Quite Sound Group
		Z55	Special Vehicle Identification Number Plate

## 1966-75 REGULAR PRODUCTION OPTIONS (RPO) (Cont'd.)

RPO	DESCRIPTION	RPO	DESCRIPTION
Z67	Speedometer Driven Gear Adapters & Keys	ZK3	Deluxe Seat Belts and Front Seat Shoulder Harness
Z76	Monte Carlo "S" Opt.	ZL2	Special Ducted Hood Air Systems
Z85	Rally Sport Equipment	ZL3	SS Conversion
Z86	Gymkhaqna Sport Equipment 77	Z04	Vega "LX"
Z87	Deluxe Interior	Z06	Luxury Interior Trim
ZJ1	Custom Interior	Z08	Exterior Sport Package
ZJ2	Custom Exterior	ZP5	Appearance Guard Group
ZJ3	Interior Convenience Package	ZP8	Special Trim
ZJ4	Trailer Axle Cooling Package	ZQ2	Operating Convenience Group
ZJ5	Exterior Decor	ZQ8	Rear Axle Economy Ratio
ZJ6	Special Sport Sedan	ZQ9	Rear Axle - Performance Ratio
ZJ7	Special Wheel, Hub Cap and Trim Ring	ZR1	Off Road Package (LT1)
ZJ9	Auxiliary Lighting Group	ZR2	Off Road Package (LS7)
ZK1	Body Insulation Package		



# MODEL SERIES IDENTIFICATION

## PASSENGER

### 1965

Biscayne (6 cyl.)	15300	Impala (6 cyl.)	16300
Biscayne (8 cyl.)	15400	Impala (8 cyl.)	16400
Bel Air (6 cyl.)	15500	Impala S.S. (6 cyl.)	16500
Bel Air (8 cyl.)	15600	Impala S.S. (8 cyl.)	16600

### 1966-67

Biscayne (6 cyl.)	15300	Impala (8 cyl.)	16400
Biscayne (8 cyl.)	15400	Caprice (8 cyl.)	16600
Bel Air (6 cyl.)	15500	Impala S.S. (6 cyl.)	16700
Bel Air (8 cyl.)	15600	Impala S.S. (8 cyl.)	16800
Impala (6 cyl.)	16300		

### 1968

Biscayne (6 cyl.)	15300	Impala (8 cyl.)	16400
Biscayne (8 cyl.)	15400	Impala Custom (6 cyl.)	16300
Bel Air (6 cyl.)	15500	Impala Custom (8 cyl.)	16400
Bel Air (8 cyl.)	15600	Caprice (8 cyl.)	16600
Impala (6 cyl.)	16300		

### 1969

Biscayne (6 cyl.)	15300	Townsmen (8 cyl.)	15600
Biscayne (8 cyl.)	15400	Impala (6 cyl.)	16300
Brookwood (6 cyl.)	15300	Impala (8 cyl.)	16400
Brookwood (8 cyl.)	15400	Kingswood (8 cyl.)	16400
Bel Air (6 cyl.)	15500	Caprice (8 cyl.)	16600
Bel Air (8 cyl.)	15600	Estate Wagon (8 cyl.)	16600
Townsmen (6 cyl.)	15500		

### 1970-71

Passenger	15000-16000	Impala (Custom)	16447
Biscayne	15300-15400	Impala (Conv.)	16467
Biscayne (4-Dr. Sed.)	15369-15469	Caprice	16600
Bel Air	15500-15600	Caprice (4-Dr. Spt. Sed.)	16639
Bel Air (4-Dr. Sed.)	15569-15669	Caprice (Spt. Cpe.)	16647
Impala	16300-16400	Brookwood	15336-15436
Impala (4-Dr. Sed.)	16369-16469	Townsmen	15336-15436
Impala (4-Dr. Spt. Sed.)	16339-16439	Kingswood	16436-16446
Impala (Spt. Cpe.)	16337-16437	Kingswood Estate	16636-16646

### 1972

Passenger	15000-16000	Impala (Custom)	16447
Biscayne	15300-15400	Impala (Conv.)	16467
Biscayne (4-Dr. Sed.)	15369-15469	Caprice	16600
Bel Air	15500-15600	Caprice (4-Dr. Spt. Sed.)	16639
Bel Air (4-Dr. Sed.)	15569-15669	Caprice (Spt. Cpe.)	16647
Impala	16300-16400	Brookwood	15336-15436
Impala (4-Dr. Sed.)	16369-16469	Townsmen	15536-15546-15636-15646
Impala (4-Dr. Spt. Sed.)	16339-16439	Kingswood	16436-16446
Impala (Spt. Cpe.)	16337-16437	Kingswood Estate	16636-16646

### 1973-75

Passenger (All Models)	1BA00	Impala Station Wagon (2-Seat)	1BL35
Bel Air 4-Door Sedan	1BK69	Impala Station Wagon (3-Seat)	1BL45
Bel Air Station Wagon (2-Seat)	1BK35	Caprice Classic 4-Door Sedan	1BN69
Bel Air Station Wagon (3-Seat)	1BK45	Caprice Classic 2-Door Sport Coupe	1BN47
Impala 4-Door Sedan	1BL69	Caprice Classic 2-Door Convertible	1BN67
Impala Sport Sedan	1BL39	Caprice Classic 4-Door Sport Sedan	1BN39
Impala Sport Coupe	1BL57	Caprice Estate Wagon (2-Seat)	1BN35
Impala Custom Coupe	1BL47	Caprice Estate Wagon (3-Seat)	1BN45

# MODEL SERIES IDENTIFICATION

## CHEVELLE

### 1965 CHEVELLE

Chevelle	13100-200-300-400-500-600-700-800	Malibu (2-Dr.)	13537-3567-3637-3667-3737-3767-3837-3867
Chevelle Std.	13111-3115-3169-3211-3215-3269	Malibu (Spt. Cpe.)	13537-3637-3737-3837
Chevelle Std. (2-Dr.)	13111-3115-3211-3215	Malibu (Conv.)	13567-3667-3767-3867
Chevelle Std. (2-Dr. Sed.)	13111-3211	Malibu (4-Dr.)	13535-3569-3635-3669
Chevelle Sta. Wag. (2-Dr.)	13115-3215	Malibu (4-Dr. Sed.)	13569-3669
Chevelle Std. (4-Dr. Sed.)	13169-3269	Malibu (Sta. Wag.)	13535-3635
Chevelle Deluxe	13311-3335-3369-3380-3411-3435-3469-3480	Malibu (exc. S.S.)	13535-3537-3567-3569-3635-3637-3667-3669
Chevelle Deluxe (2-Dr.)	13311-3380-3411-3480	Malibu (S.S.)	13737-3767-3837-3867
Chevelle Deluxe (2-Dr. Sed.)	13311-3411	Malibu (Spt. Cpe.) (exc. S.S.)	13537-3637
Chevelle Deluxe (4-Dr.)	13335-3369-3435-3469	Malibu (Conv.) (exc. S.S.)	13567-3667
Chevelle Deluxe (4-Dr. Sed.)	13369-3469	Malibu (S.S. Spt. Cpe.)	13737-3837
Chevelle Deluxe (Sta. Wag.)	13335-3435	Malibu (S.S. Conv.)	13767-3867
Malibu	13535-3537-3567-3569-3635-3637-3667-3669-3737-3767-3837-3867	El Camino	13380-3480-3580-3680
		El Camino (Deluxe)	13380-3480
		El Camino (Custom)	13580-3680

### 1966 CHEVELLE

Chevelle	13100-200-300-400-500-600-800	Malibu	13517-3567-3617-3667
Chevelle Std.	13111-3169-13211-3269	Malibu (Spt. Cpe.)	13517-3617
Chevelle Std. (2-Dr.)	13111-3211	Malibu (Conv.)	13567-3667
Chevelle Std. (4-Dr.)	13169-3269	Malibu (4-Dr. Sed.)	13539-3569-3639-3669-3635-3639-3669
Chevelle Deluxe	13311-3335-3369-3380-3411-3435-3469-3480	Malibu (4-Dr. Sed.)	13539-3569-3639-3669
Chevelle Deluxe (2-Dr.)	13311-3380-3411-3480	Malibu (Sta. Wag.)	13535-3635
Chevelle Deluxe (2-Dr. Sed.)	13311-3411	Malibu (Spt. Cpe.)	13517-3617
Chevelle Deluxe (4-Dr.)	13335-3369-3435-3469	Malibu (Conv.)	13517-3617
Chevelle Deluxe (4-Dr. Sed.)	13369-13469	Chevelle (S.S.)	13817-3867
Chevelle Deluxe (Sta. Wag.)	13335-13435	Chevelle (S.S. Spt. Cpe.)	13817
Malibu	13517-3535-3539-3567-3569-3617-3635-3639-3667-3669	Chevelle (S.S. Conv.)	13867
		El Camino	13380-3480-3580-3680
		El Camino (Deluxe)	13380-3480
		El Camino (Custom)	13580-3680

### 1967-68 CHEVELLE

Chevelle	13100-200-300-400-500-600-700-800	Chevelle (4-Dr. Sed.)	13169-13269-13369-13469-13539-13569-13639-13669
Chevelle Std.	13111-13127-13169-13211-13227-13269	Chevelle (Sta. Wag.)	13335-13435-13535-13635-13735-13835
Chevelle Std. (2-Dr.)	13111-13127-13211-13227	Malibu	13517-13535-13539-13567-13569-13617-13635-13639-13667-13669
Chevelle Std. (4-Dr.)	13169-13269	Malibu (2-Dr.)	13517-13567-13617-13667
Chevelle Deluxe	13311-13327-13335-13369-13380-13411-13427-13435-13469-13480	Malibu (Spt. Cpe.)	13517-13617
Chevelle Deluxe (2-Dr.)	13311-13327-13380-13411-13427-13480	Malibu (Conv.)	13667-13667
Chevelle Deluxe (2-Dr. Sed.)	13311-13411	Malibu (4-Dr.)	13535-13539-13569-13635-13639-13669
Chevelle Deluxe (2-Dr. Plr. Cpe.)	13327-13427	Malibu (4-Dr. Sed.)	13539-13569-13639-13669
Chevelle Deluxe (4-Dr.)	13335-13369-13435-13469	Malibu (Sta. Wag.)	13535-13635
Chevelle Deluxe (4-Dr. Sed.)	13369-13469	Malibu (Spt. Cpe.)	13517-13617
Chevelle Deluxe (Sta. Wag.)	13335-13435	Malibu (Conv.)	13567-13667
Chevelle (2-Dr.)	13111-13127-13211-13227-13311-13327-13380-13411-13427-13480-13517-13567-13580-13617-13667-13680-13817-13867	Chevelle (S.S. Spt. Cpe.)	13817
Chevelle (2-Dr. Sed.)	13111-13211-13311-13411	Chevelle (S.S. Conv.)	13867
Chevelle (2-Dr. Plr. Cpe.)	13127-13227-13817-13867	Chevelle (S.S.)	13817-13867
Chevelle (4-Dr.)	13169-13269-13335-13369-13435-13469-13535-13539-13569-13635-13639-13669-13735-13835	Concours	13735-13835
		El Camino	13380-13480-13580-13680
		El Camino (Deluxe)	13380-13480
		El Camino (Custom)	13580-13680
		El Camino (Malibu)	13580-13680
		El Camino (S.S.)	13880

# MODEL SERIES IDENTIFICATION

## CHEVELLE

### 1969 CHEVELLE

Chevelle . . . . .	13100-200-300-400-500-600	Chevelle (Conv.) . . . . .	13567-13667
Chevelle (2-Dr.) . . . . .	13327-13337-13380-13427-13437-13480- 13537-13567-13580-13637-13667-13680	Chevelle (4-Dr.) . . . . .	13135-13136-13235-13236-13335-13336- 13346-13369-13435-13436-13446-13469- 13535-13536-13539-13546-13569-13635- 13636-13639-13646-13669-13835-13836-13846
Chevelle (2-Dr. Spt. Cpe.) . . . . .	13327-13427	Chevelle Deluxe (Spt. Cpe.) . . . . .	13337-13437
Chevelle (Spt. Cpe.) . . . . .	13337-13437-13537-13637	Chevelle Deluxe (2-Dr. Plr. Cpe.) . . . . .	13327-13427
Chevelle (4-Dr. Spt. Sed.) . . . . .	13539-13639	Chevelle Deluxe (4-Dr.) . . . . .	13369-13469
Chevelle (4-Dr. Sed.) . . . . .	13369-13469-13569-13669	Malibu . . . . .	13537-13539-13567-13569-13580-13637- 13639-13667-13669-13680
Chevelle (Sta. Wag.) . . . . .	13135-13136-13235-13236-13335- 13336-13346-13435-13436-13446-13535-13536- 13546-13635-13636-13646-13835-13836-13846	Malibu (2-Dr.) . . . . .	13537-13567-13580-13637-13667- 13680
Nomad (Sta. Wag.) . . . . .	13135-13136-13235-13236	Malibu (Spt. Cpe.) . . . . .	13537-13637
Greenvriar (Sta. Wag.) . . . . .	13335-13336-13346-13435- 13436-13446	Malibu (Conv.) . . . . .	13567-13667
Concours (Sta. Wag.) . . . . .	13535-13536-13546-13635- 13636-13646	Malibu (4-Dr.) . . . . .	13539-13569-13639-13669
Concours (Estate Wag.) . . . . .	13835-13836-13846	Malibu (4-Dr. Spt. Sed.) . . . . .	13539-13639
Chevelle Deluxe . . . . .	13327-13337-13369-13380-13427-13437- 13469-13480	Malibu (4-Dr. Sed.) . . . . .	13569-13669
Chevelle Deluxe (2-Dr.) . . . . .	13327-13337-13380-13427- 13437-13480	El Camino . . . . .	13380-13480-13580-13680
		El Camino (Deluxe) . . . . .	13380-13480
		El Camino (Custom) . . . . .	13580-13680

### 1970-71 CHEVELLE

Chevelle . . . . .	13000	Monte Carlo . . . . .	13800
Chevelle (Standard) . . . . .	13300-13400	Monte Carlo (Spt. Cpe.) . . . . .	13857
Chevelle (Standard) (4-Dr. Sed.) . . . . .	13369-13469	Nomad (Sta. Wag.) . . . . .	13135-13136-13235-13236
Chevelle (Standard) (2-Dr. Sed.) . . . . .	13327-13427	Greenbrier (Sta. Wag.) . . . . .	13335-13336-13346-13435- 13436-13446
Chevelle (Standard) (Spt. Cpe.) . . . . .	13337-13437	Concours (Sta. Wag.) . . . . .	13536-13546-13636-13646
Malibu . . . . .	13500-13600	Concours (Estate Wag.) . . . . .	13836-13846
Malibu (4-Dr. Sed.) . . . . .	13569-13669	El Camino . . . . .	13380-13480
Malibu (4-Dr. Spt. Sed.) . . . . .	13539-13639	El Camino (Custom) . . . . .	13580-13680
Malibu (Spt. Cpe.) . . . . .	13537-13637		
Malibu (Conv.) . . . . .	13567-13667		

### 1972 CHEVELLE

Chevelle . . . . .	13000	Monte Carlo . . . . .	13800
Chevelle (Standard) . . . . .	13300-13400	Monte Carlo (Spt. Cpe.) . . . . .	13857
Chevelle (Standard) (4-Dr. Sed.) . . . . .	13369-13469	Nomad (Sta. Wag.) . . . . .	13135-13136-13235-13236
Chevelle (Standard) (Spt. Cpe.) . . . . .	13337-13437	Greenbrier (Sta. Wag.) . . . . .	13335-13336-13346-13435- 13436-13446
Malibu . . . . .	13500-13600	Concours (Sta. Wag.) . . . . .	13536-13546-13636-13646
Malibu (4-Dr. Sed.) . . . . .	13569-13669	Concours (Estate Wag.) . . . . .	13836-13846
Malibu (4-Dr. Spt. Sed.) . . . . .	13539-13639	El Camino . . . . .	13380-13480
Malibu (Spt. Cpe.) . . . . .	13537-13637	El Camino (Custom) . . . . .	13580-13680
Malibu (Conv.) . . . . .	13567-13667		

### 1973-75 CHEVELLE

Chevelle (All Models) . . . . .	1A A00	Laguna 4-Door Sport Sedan . . . . .	1A E29
Deluxe 4-Door Sport Sedan . . . . .	1A C29	Laguna 2-Door Sport Coupe . . . . .	1A E37
Deluxe 2-Door Sport Coupe . . . . .	1A C37	Laguna Station Wagon (2-Seat) . . . . .	1A E35
Deluxe Stations Wagon (2-Seat) . . . . .	1A C35	Laguna Estate Wagon (2-Seat) . . . . .	1A H35
Malibu 4-Door Sport Sedan . . . . .	1A D29	El Camino Pick-up Delivery . . . . .	1A C80
Malibu 2-Door Sport Coupe . . . . .	1A D37	El Camino Custom Pick-up Delivery . . . . .	1A D80
Malibu Station Wagon (2-Seat) . . . . .	1A D35	Monte Carlo 2-Door Sport Coupe . . . . .	1A H57
Malibu Estate Wagon (2-Seat) . . . . .	1A G35		

# MODEL SERIES IDENTIFICATION

## CHEVY AND NOVA

### 1965-67 CHEVY

Chevy .....	11100-11300-11400-11500- 11600-11700-11800	Chevy Std. (2-Dr.) .....	11111-11311-11411
Chevy (2-Dr.) .....	11111-11311-11411-11537- 11637-11737-11837	Chevy Std. (4-Dr. Sed.) .....	11169-11369-11469
Chevy (4-Dr.) .....	11169-11335-11369-11435- 11469-11535-11569-11635-11669	Chevy Std. (Sta. Wag.) .....	11335-11435
Chevy (4-Dr. Sed.) .....	11169-11369-11469- 11539-11569	Nova .....	11535-11537-11569-11635 11637-11669-11737-11837
Chevy (Sta. Wag.) .....	11335-11435-11535-11635	Nova (Spt. Cpe.) .....	11537-11637- 11737-11837
Chevy Std. .....	11111-11169-11311-11335- 11369-11411-11435-11469	Nova (S.S.) .....	11737-11837
		Nova (4-Dr.) .....	11535-11569-11635-11669
		Nova (4-Dr. Sed.) .....	11569-11669
		Nova (Sta. Wag.) .....	11535-11635

### 1968-69 CHEVY-NOVA

Chevy .....	11100-11300-11400	Chevy Std. (4-Dr. Sed.) .....	11169
Chevy (2-Dr.) .....	11127-11327-11427	Nova .....	11327-11427-11369-11469
Chevy (4-Dr. Sed.) .....	11169-11369-11469	Nova (Spt. Cpe.) .....	11327-11427
Chevy Std. .....	11127-11169	Nova (4-Dr. Sed.) .....	11369-11469
Chevy Std. (Spt. Cpe.) .....	11127		

### 1970-72 NOVA

Nova .....	11000
Nova (4-dr.) .....	11169-11369-11469
Nova (2-Dr.) .....	11127-11327-11427

### 1973-75 NOVA

Nova (All Models) .....	1XA00	Nova Custom 4-Dr. Sed. ....	1XY69
Nova 4-Dr. Sed. ....	1XX69	Nova Custom 2-Dr. Sed. ....	1XY27
Nova 2-Dr. Cpe. ....	1XX27	Nova Custom 2-Dr. Hatchback Coupe .....	1XY17
Nova 2-Dr. Hatchback .....	1XX17		

## CAMARO

### 1967-69 CAMARO

Camaro .....	12300-12400-12500-12600	Camaro (Conv.) .....	12367-12467-12567-12667
Camaro Std. ....	12300-12400	Camaro Std. (Spt. Cpe.) .....	12337-12437
Camaro Deluxe .....	12500-12600	Camaro Std. (Conv.) .....	12367-12467
Camaro (Spt. Cpe.) .....	12337-12437- 12537-12637	Camaro Deluxe (Spt. Cpe.) .....	12537-12637
		Camaro Deluxe (Conv.) .....	12567-12667

### 1970-72 CAMARO

Camaro .....	12387-12487
--------------	-------------

### 1973-75 CAMARO

Camaro (All Models) .....	
Camaro 2-Dr. Sport Coupe .....	1FA00
Camaro Type LT 2-Dr. Sport Coupe .....	1FQ87

# MODEL SERIES IDENTIFICATION

## VEGA

### 1971-72 VEGA

2-Door Sedan (4-Pass.) . . . . .	14111
2-Door Hatchback Coupe (4-Pass.) . . . . .	14177
2-Door Station Wagon (4-Pass.) . . . . .	14115
2-Door Panel Delivery (1-Pass.) . . . . .	14105

### 1973-75 VEGA

2-Door Sedan (4-Pass.) . . . . .	1HV11
2-Door Hatchback Coupe (4-Pass.) . . . . .	1HV77
2-Door Station Wagon (4-Pass.) . . . . .	1HV15
2-Door Hatchback Coupe (4-Pass.) Monza . . . . .	1HR07
2-Door Hatchback Coupe (4-Pass.) Monza 2 + 2 . . . . .	1HM27

# 1973-75 VEHICLE IDENTIFICATION NUMBER

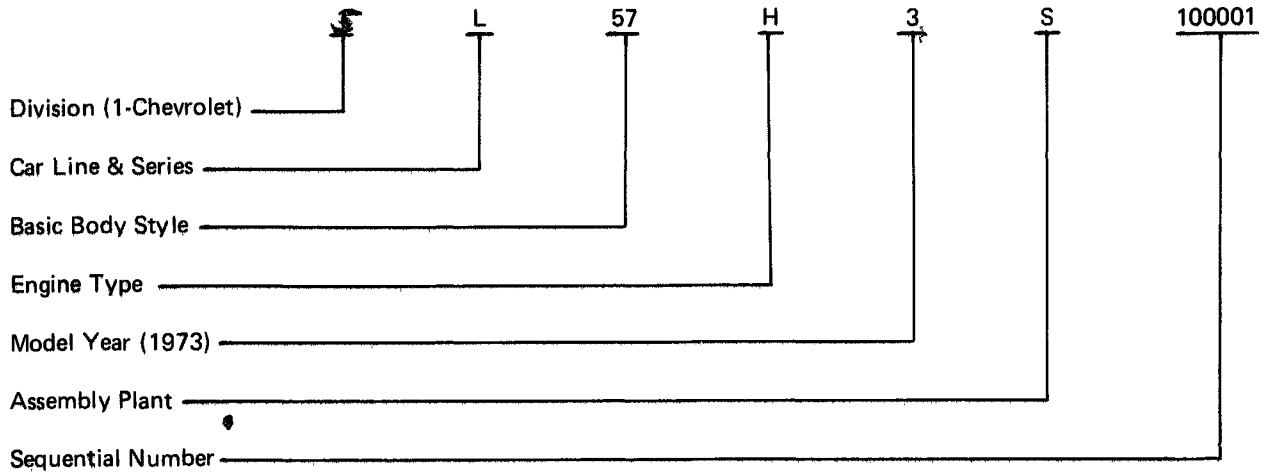

### CAR LINE AND SERIES

- C—Deluxe (Chevelle)/El Camino
- D—Malibu/El Camino Custom
- E—Laguna
- G—Malibu Estate
- H—Monte Carlo/Laguna Estate
- K—Bel Air
- L—Impala
- N—Caprice Classic/Caprice Estate
- Q—Camaro
- S—Camaro Type LT
- V—Vega
- X—Nova
- Y—Nova Custom
- Z—Corvette

### BASIC BODY STYLE

- 39—Sport Sedan (Chevrolet)
- 47—Coupe (Chevrolet)
- 57—Sport Coupe  
(Chevrolet/Monte Carlo)
- 57/Z03—Landau Coupe  
(Monte Carlo)
- 57/Z76—S Coupe (Monte Carlo)
- 67—Convertible  
(Chevrolet/Corvette)
- 69—4-Door Sedan  
(Chevrolet/Nova)
- 29—4-Door Sedan  
(Chevelle)
- 37—Sport Coupe  
(Chevelle/Corvette)
- 35—2-Seat Wagon  
(Chevrolet/Chevelle)
- 35/AQ4—3-Seat Wagon (Chevelle)
- 45—3-Seat Wagon  
(Chevrolet)
- 87—Sport Coupe (Camaro)
- 17—Hatchback Coupe  
(Nova)
- 27—Coupe (Nova)
- 05—Panel Express (Vega)
- 11—Panel Express (Vega)
- 15—Kammback Wagon  
(Vega)
- 77—Hatchback Coupe  
(Vega)
- 80—El Camino

### ENGINE TYPE

Ordering Code	Disp. (cu. in.)	Carb. (bbl.)
A—L13	140	1
B—L11	140	2
D—L22	250	1
F—L14	307	2
H—L65	350	2
K—L48	350	4
R—LF6	400	2
T—Z28*	350	4
Y—LS4	454	4
X—LS4	454	4

### ASSEMBLY PLANT

A—GMAD — Lakewood	R—GMAD — Arlington
B—GMAD — Baltimore	S—Chevrolet — St. Louis
C—GMAD — Southgate	T—GMAD — Tarrytown
D—GMAD — Doraville	U—Chevrolet — Lordstown
F—Chevrolet — Flint	W—Chevrolet — Willow Run
J—GMAD — Janesville	Y—GMAD — Wilmington
K—GMAD — Leeds	Z—GMAD — Fremont
L—GMAD — Van Nuys	1—GM of Canada — Oshawa
N—Chevrolet — Norwood	2—GM of Canada — St. Therese
V—G.M. TRUCK — Pontiac	

\*or L82

## SEQUENTIAL NUMBER

Models 11000 & 21000 (Nova & Ventura II) will be numbered in continuous sequence starting with 100001 at Willow Run. At Van Nuys, they will be numbered separately in continuous sequence starting at 100001. Norwood will number the Nova in continuous sequence starting with 300001.

Model 12000 ("F" Body) will be numbered continuous starting with 100001.

Models 13000 ("A" Body includes Monte Carlo) will be numbered continuous starting with 500001 at each Assembly Plant.

Models 15-16000 ("B" Body) will be numbered continuous starting with 100001 at each Assembly Plant. "B" Body built by G.M. of Canada will not be allocated a separate closed number sequence but will be numbered along with regular Canadian Production. Canadian numbers will start with 100001.

Model 19000 ("V" Body) at St. Louis will be numbered continuous starting with 500001.

Model 14000 ("H" Body) will be numbered continuous starting with 100001.

# 1965-67 CHEVROLET PROTECT-O-PLATE

The Chevrolet Protect-O-Plate furnished with all vehicles is imprinted at the plant with identifying information covering the majority of standard and RPO equipment. The exact type of engine, transmission, and rear axle with which a vehicle is equipped may be obtained from the plate, as well as exterior color, month of vehicle production and basic vehicle identification. All passenger cars have interior trim information and all passenger models except Corvette include information on major extra cost RPO equipment.

Information is stamped on the plate in two forms;

1. Production identification numbers, such as engine production code number.
2. RPO numbers which are coded with a single digit (passenger except Corvette).

The type of information available on the plate furnished with a given vehicle is shown in the following chart.

## 1965

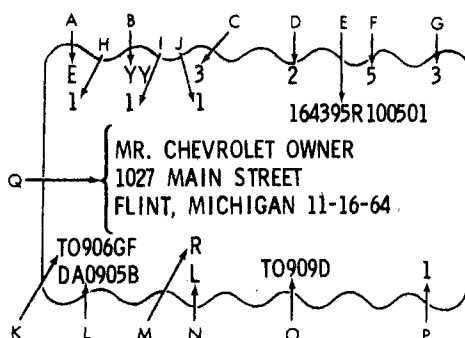

### INFORMATION AVAILABILITY CHART

Location	Description	Location	Description
A	Interior Trim	J	Seat Equipment
B	Body Exterior Paint	K	Engine Number
C	Power Steering and/or Power Brakes	L	Rear Axle Number
D	Generator	M	Carburetor Source Code
E	Vehicle Identification Number	N	Vehicle Build Month Code
F	Radio	O	Transmission Number
G	Windshield Wiper	P	Chevrolet Trade Mark
H	Air Conditioning	Q	Dealer Supplied Owner Information as Shown in Dealer Policy and Procedures Manual
I	Power Window		

### LOCATION A

#### Interior Trim

Passenger Except Corvette				Corvette			
Code	Color	Code	Color	Code	Color	Code	Color
A	Aqua	H	White-Aqua	B	Blue-Vinyl	N	Blue-Leather
B	Blue	L	Black-Vinyl	C	Saddle-Vinyl	P	Silver & Black-Leather
C	Saddle	S	White/Black	D	Red-Vinyl	Q	White/Red-Vinyl
D	Red	V	Fawn-Vinyl	E	Black-Vinyl	S	White & Black-Leather
E	Black	W	Slate	F	White/Black-Vinyl	T	White & Red-Leather
F	Fawn	X	Slate/Gun Metal	H	White/Black-Vinyl	U	White & Blue-Leather
G	Green			J	Saddle-Leather	V	Maroon-Leather
				K	Black-Leather	X	Green-Vinyl
				L	Green-Leather	Y	Silver & Black-Vinyl
				M	Red-Leather	Z	Maroon-Vinyl



**1965-67 CHEVROLET PROTECT-O-PLATE (Continued)**

**LOCATION B**

**Exterior Colors**

All Passenger Models will have RPO designation stamped in this location. See Paint Combination Chart in supplementary Section of Catalog.

**LOCATION C**

**Power Brakes and/or Steering**

<u>Option</u>	<u>Code</u>	<u>RPO</u>
Power Steering Only	1	N40
Power Brakes Only	2	J50
Both Power Steering and Brakes	3	N40 & J50

**LOCATION D**

**Generator Option**

<u>Vehicle</u>	<u>Code</u>	<u>RPO</u>
Chevrolet, Chevelle & Chevy II	1	K79
	2	K77
	3	K81
Corvair	1	K84

**LOCATION E**

**Vehicle Identification Number**

See Location C of the 1966 - 1967 Protect-O-Plate Identification.

**LOCATION F**

**Radio Option**

<u>Vehicle</u>	<u>Code</u>	<u>RPO</u>
Chevrolet, Chevelle, Chevy II & Corvair	2	U60
	3	U63
	4	U63 & U80
	5	U69
	6	U69 & U80

**LOCATION G**

**Windshield Wiper Option**

<u>Vehicle</u>	<u>Code</u>	<u>RPO</u>
Chevrolet	1	Z01
	2	Z13
	3	C14
Chevelle, Chevy II & Corvair	1	Z01
	2	Z13

**LOCATION H**

**Air Conditioning**

<u>Vehicle</u>	<u>Code</u>	<u>RPO</u>
Chevrolet, Chevelle & Chevy II	1	C60
	5	C60 & C50
	2	C64
Corvair	5	C64 & C48

**LOCATION I**

**Power Window Equipment**

<u>Vehicle</u>	<u>Code</u>	<u>RPO</u>
Chevrolet	1	A31
	2	A33
	3	A31 & A33
Chevelle	1	A31
	2	A33
	3	A31 & A33
	5	A31 & C06
Chevy II	2	A33

**LOCATION J**

**Seat Equipment**

<u>Vehicle</u>	<u>Code</u>	<u>RPO</u>
Chevrolet	1	A42
	2	A66
	3	A42 & A66
	4	B50
	6	A66 & B50
Chevelle	1	A41
	2	A66
	3	A41 & A66
Chevy II	2	A66
Corvair	7	A67

**LOCATION K & L**

**K Engine Production Code Number Explanation**

**L Rear Axle Number**

See location E & F of the 1966 - 1967 Protect-O-Plate Identification.

## 1965-67 CHEVROLET PROTECT-O-PLATE (Continued)

LOCATION M			LOCATION N			
Carburetor Source			Month of Vehicle Build			
<u>Code</u>	<u>Plant</u>		<u>Code</u>	<u>Month</u>	<u>Code</u>	<u>Month</u>
B	Bay City		Z	January	S	July
C	Carter		Y	February	R	August
H	Holley		X	March	P	September
R	Rochester		W	April	N	October
			V	May	L	November
			T	June	K	December

### LOCATION O

#### Transmission Production Code Number Explanation

Chevrolet - 3 Speed, 4-Speed and Powerglide transmissions built at Chevrolet Plants will carry a production code number consisting of a prefix letter, production date and a shift suffix letter where day and night shifts are in operation.

#### EXAMPLE: M701

(M)  
3-Speed  
Muncie

(7)  
Month - July

(01)  
Day - 1st

#### EXAMPLE: C1116N

(C)  
Powerglide  
Cleveland

(11)  
Month - November

(16)  
Day - 16th

(N)  
Night Shift

<u>Prefix</u>	<u>Plant</u>	<u>Description</u>	<u>Prefix</u>	<u>Plant</u>	<u>Description</u>
C	Cleveland	Powerglide - 230" L-6 and 283" V-8	T	Toledo	Powerglide (Incl. Corvair) 164" HO-6, 194" and 230" L-6, 283" - 327" - 409" V-8
P	Muncie	4-Speed Chevrolet, Chevelle, Chevy II and Corvette	S	Saginaw	3-Speed - All
			R		4-Speed - Corvair

#### Turbo Hydra-Matic

Production code number contains model year, model identification and production date. Below the production code is the source serial number.

#### EXAMPLE: 65A372

(65)  
Model Year

(A)  
Model Identification

(372)  
Date code unique  
for date represented.

# 1966-68 CHEVROLET PROTECT-O-PLATE

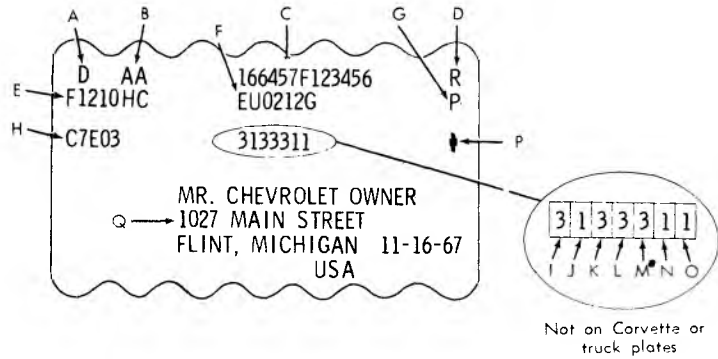

## INFORMATION AVAILABILITY CHART

Location	Description	Location	Description
A	Interior Trim	K	Radio Code
B	Body Exterior Paint	L	Windshield Wiper (1966)
C	Vehicle Identification Number	L	Disc Brake Code (1967-68)
D	Carburetor Source Code	M	Air Conditioning
E	Engine Number	N	Power Window Code
F	Rear Axle Number	O	Power Seat Code
G	Vehicle Build Month Code	P	Chevrolet Trade Mark
H	Transmission Number	Q	Dealer Supplied Owner Information as Shown in Dealer Policy and Procedures Manual
I	Power Steering and/or Power Brakes	R	Carburetor Usage on certain Engines (1966 Only)
J	Generator (1966)		
J	Radio - Clock Group (1967-68)		

The following charts explain codes used on Chevrolet plates instead of RPO numbers. Note that general option headings are also related to the location of that option on the Protect-O-Plate.

## 1966 LOCATION A

### Interior Trim

Passenger Except Corvette				Code		Corvette
Code	Color	Code	Color	Leather/Vinyl		Color
B	Blue	L	Black Vinyl	J	C	Saddle
C	Saddle	R	Bright Blue	K	E	Black
D	Red	S	White/Black	L	X	Dark Green
E	Black	T	Turquoise	M	D	Red
F	Fawn	V	Fawn Vinyl	N	B	Dark Blue
G	Green	Z	Bronze	P	Y	Silver
				T	R	Bright Blue
				V	Z	Maroon
					W	Blue/White

# 1966-68 CHEVROLET PROTECT-O-PLATE (Continued)

## 1967 LOCATION A

Passenger Except Corvette				Corvette			
Code	Color	Code	Color	Code	Color	Code	Color
A	Red Vinyl	M	Maroon	B	Dark Teal Blue-Vinyl	N	Dark Teal Blue-Leather
B	Blue	N	Black Cloth	C	Saddle-Vinyl	R	Bright Blue Vinyl
C	Black Vinyl	P	Plum	D	Red-Vinyl	S	White/Black Vinyl
D	Red	R	Bright Blue	E	Black-Vinyl	T	Bright Blue Leather
E	Black	S	Blue Cloth	J	Saddle-Leather	W	White/Blue Vinyl
F	Fawn	T	Turquoise	K	Black-Leather	X	Dark Green-Vinyl
G	Golf	U	Blue Vinyl (Opt.)	M	Red Leather		
H	Blue Vinyl	V	Fawn Vinyl				
K	Parchment Black	W	Gold Cloth				
L	Black Vinyl (Opt.)	Y	Yellow				

## 1968 LOCATION A

Passenger (Except Corvette)				Corvette			
Code	Color	Code	Color	Code	Color	Code	Color
B	Blue - Cloth & Vinyl	Q	Black & White Vinyl	B	Dark Blue Vinyl	R	Bright Blue Vinyl
D	Red - Cloth & Vinyl	R	Gray Green - Cloth & Vinyl	D	Red Vinyl	T	Bright Blue Leather
E	Black - Cloth & Vinyl	T	Turquoise - Cloth & Vinyl	E	Black Vinyl	W	Dark Orange Vinyl
G	Gold - Cloth & Vinyl	U	Blue Vinyl (Opt.)	G	Gun Metal Vinyl	X	Dark Orange Leather
J	Saddle Vinyl	X	Teal Vinyl	K	Black Leather	Y	Tobacco Vinyl
P	Gold Vinyl (Opt.)			M	Red Leather	Z	Tobacco Leather

## LOCATION B

### Exterior Colors

All Passenger models will have RPO letter designation stamped in this location. On two tone combinations, the first letter indicates the lower color, second letter the upper color. See Paint Combination Chart in supplementary section of catalog.

## LOCATION C

### Passenger Car Identification Number Explanation

A five digit numbering system will be used on all 1967-69 passenger cars. The basic number groups are:

10000 Series - Corvair	12000 Series - Camaro	15000 Series - Chevrolet	19000 Series - Corvette
11000 Series - Chevy II	13000 Series - Chevelle	16000 Series - Chevrolet	

The first two digits denote the vehicle series. The third indicates base engine equipment, and the two remaining numbers identify the body style. When the third digit is odd (1, 3, 5, 7), the base engine is an L-4 or L-6. When the third number is even (2, 4, 6, 8), the base engine is a V-8.

The complete serial number consists of the above model identification, year of manufacture, plant designation, and sequence number.

EXAMPLE: 164397F100500

(16439)	(7)	(F)	(100500)
Impala V-8 4-Dr. Sport Sedan	1967 Model	Flint Built	500th 1967 Chevrolet built at Flint

Each passenger vehicle will have a build sequence number.

### ASSEMBLY PLANT DESIGNATIONS:

A Atlanta - Chevelle	J Janesville - Chevrolet	T Tarrytown - Chevrolet
B Baltimore - Chevelle*	K Kansas City - Chevelle*	U Lordstown - Chevrolet
C Southgate - Chevrolet	L Los Angeles - Chevrolet, Camaro	W Willow Run - Corvair, Chevy II
D Doraville - Chevrolet	N Norwood - Camaro	Y Wilmington - Chevrolet
F Flint - Chevrolet	R Arlington - Chevrolet	Z Fremont - Chevelle*
G Framingham - Chevelle	S St. Louis - Chevrolet, Corvette	2 St. Therese - Chevrolet

\*Includes El Camino

# 1966-1968 CHEVROLET PROTECT-O-PLATE (Continued)

## LOCATION D

### Carburetor Source

Code	Plant	Code	Plant
B	Bay City	H	Holley
C	Carter	R	Rochester

## LOCATION E

### Engine Production Code Number Explanation

EXAMPLE: F1210FA

(F)	(12)	(10)	(FA)
Flint Motor	Month December	Day - 10th	153-155-163-16500 Series "230" 6-Cyl.

(F) Flint Motor (T) Tonawanda Engine Plant (K) McKinnon Industries (V) Flint Engine (S) Saginaw Service Engine plants, will stamp a source, production date and engine suffix on all engines.

Assembly plants will stamp assembly plant designation and continuous sequence number portion of the vehicle identification number on all 327, 350, 396, 409, and 427 cubic inch engines, except Corvette. Since all Corvettes are built at St. Louis, the assembly plant designation is not required. Here, only the continuous sequence number will be used.

### Engine Production Code Number Locations

PASSENGER 4 or 6-Cyl. - Stamped on pad right side of engine at rear of distributor.

CORVAIR - Stamped on top of engine block immediately forward of generator - oil filter adapter.

PASSENGER V-8 - Stamped on pad immediately forward of right hand cylinder head.

## LOCATION F

### Rear Axle Number

Number will contain prefix letters, production date numbers and suffix letter.

EXAMPLE: BH0212G

(BH)	(02)	(12)	(G)
Chevy II	Month February	Day - 12th	Axle Plant*

\*G - Chevrolet Gear & Axle

W - Warren

B - Buffalo

K - McKinnon Industries

## LOCATION G

### Month of Vehicle Build

#### 1966

Code	Month
H	January
B	February
M	March
E	April
J	May
G	June

Code	Month
A	July
D	August
U	September
F	October
Q	November
C	December

#### 1967

Code	Month
V	August, 1966
L	September, 1966
R	October, 1966
K	November, 1966
Z	December, 1966
S	January, 1967

Code	Month
P	February, 1967
W	March, 1967
N	April, 1967
Y	May, 1967
T	June, 1967
X	July, 1967

#### 1968

Code	Month	Code	Month
8	August, 1967	2	February, 1968
9	September, 1967	3	March, 1968
0	October, 1967	4	April, 1968
N	November, 1967	5	May, 1968
D	December, 1967	6	June, 1968
1	January, 1968	7	July, 1968

# 1966-68 CHEVROLET PROTECT-O-PLATE (Continued)

## LOCATION H

### Transmission Number

Code number identifies the source, model year, month and day produced.

EXAMPLE: P7E03

(P) 4-Speed Muncie	(7) Model Year	(E) Month - May	(03) Day - 3rd
<b>Source Designations</b>			
<u>3-Speed</u> S - Saginaw - Overdrive (1966) D - Saginaw (3 Speed w/Overdrive) O - Saginaw (3 Speed w/Overdrive (1968)) M - Muncie K - McKinnon Industries H - Muncie - Heavy Duty	<u>4-Speed</u> K - McKinnon Industries R - Saginaw P - Muncie (Exc Corvair)	<u>Powerglide</u> C - Cleveland (Exc. Corvair) T - Toledo E - McKinnon Industries  <u>Turbo Hydra-Matic 350</u> X - Cleveland* B - Cleveland Y - Toledo *Prior to 8/12/68	

### Calendar Month

Calendar month produced are as follows:

A - January	D - April	K - July	R - October
B - February	E - May	M - August	S - November
C - March	H - June	P - September	T - December

## 1966

Turbo Hydra-Matic - Production Code number contains model year, model identification, and production date. Below the production code is the source serial number.

EXAMPLE: 66 CA 372

(66) Model Year	(CA) Model Identification	(372) Date code unique for day represented
CA - 396 Cu. In. Engine.		CB - 427 Cu. In. Engine.

## 1967-68

Turbo Hydra-matic - code number contains model year, model identification, and production date. Below the production code is the source serial number.

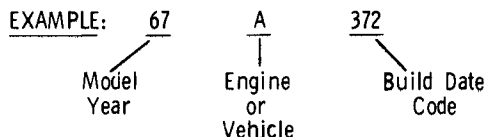

The engine or vehicle designations are as follows:

A - 396 cu. in. engine	E - 396 cu. in. (High Per.) (1958)
B - 427 cu. in. engine	H - 396 cu. in. (1968)
C - 396 cu. in. engine (Chevelle & Camaro)	K - 327 cu. in. (Corvette) (1968)
D - 327 cu. in. engine	L - 327 cu. in. (Corvette) (1968)

The build date code for the 1967 model year starts with the first day of the calendar year 1966 and continues through the 1967 calendar year.

The build date code for the 1968 model year starts with the first day of the calendar year 1967 and continues through the 1968 calendar year.

Example: Build date code 234 is for August 22, (August 22 is the 234th day of the year). Build date code 367 is January 2.

# 1966-68 CHEVROLET PROTECT-O-PLATE (Continued)

## LOCATION I

### Power Brakes and/or Steering

Option	Code	RPO
Power Steering Only	1	N40
Power Brakes Only	2	J50
Both Power Steering and Power Brakes	3	N40 & J50

## 1966 LOCATION J

### Generator Option

Vehicle	Code	RPO
Chevrolet Chevelle and Chevy II	1	K79
	4	K76
	3	K81
Corvaire	1	K84

## 1967 LOCATION J

### Radio-Clock Group

Vehicle	Code
Chevrolet, Chevelle, Chevy II, Corvaire & Camaro	1

## 1966-67 LOCATION K

### Radio Option

Vehicle	Code	RPO
Chevrolet, Chevelle, Chevy II, Corvaire & Camaro	3	U63
	4	U63/U80
	5	U69
	6	U69/U80
	7	U69/U79
Chevrolet Only	2	U79

## 1968 LOCATION K

### Radio Option

Vehicle	Code	RPO
Chevrolet, Chevelle, Chevy II, Corvaire & Camaro	1	U80
	3	U63
	4	U63/U80
Chevrolet, Chevelle, & Camaro	2	U79
	7	U69/U79
All (Except Chevy II)	5	U69
All (Except Chevy II)	6	U69/U80

## 1966 LOCATION L

### Windshield Wiper Option

None

## 1967 LOCATION L

### Disc Brake Option

Vehicle	Code	RPO
Chevrolet, Chevelle, Chevy II & Camaro	3	J52
Chevrolet, Chevelle & Chevy II	4	F40/J52
Corvette	5	F41/K56
Chevrolet, Camaro	5	F41/J52

## 1968 LOCATION L

### Disc Brake Option

Vehicle	Code	RPO
Chevrolet, Chevelle, Chevy II & Camaro	3	J52
Chevrolet, Chevelle, & Chevy II	4	F40/J52
Chevrolet, Camaro	5	F41/J52
Corvette, Camaro	6	J56
Corvette, Camaro	8	F41/J56
Camaro	9	J52/J56

## 1966-67 LOCATION M

### Air Conditioning

Vehicle	Code	RPO
Chevrolet	1	C60
	3	C60/C75
	4	C48
Chevelle, Chevy II & Camaro	1	C60
	1	C60
	4	C48
Corvaire	1	C64
	4	C48

(C48 is heater delete)

## 1968 LOCATION M

### Air Conditioning

Vehicle	Code	RPO
Chevrolet, Chevelle, Chevy II, Corvaire, & Camaro	1	C60
Chevrolet	3	C60/C75
All (Except Corvette)	4	C48

(C48 is Heater Delete)

## 1966-67 LOCATION N

### Power Window Equipment

Vehicle	Code	RPO
Chevrolet, Chevelle	1	A31
	2	A33
	3	A31/A33
	5	A31/B93
	6	A33/B93
	7	A31/A33
		B93
Chevy II	2	A33
	6	A33/B93
Corvette	1	A31
Camaro	1	A31
	5	A31/B93

## 1968 LOCATION N

### Power Window Equipment

Vehicle	Code	RPO
Chevrolet, Chevelle, Corvette & Camaro	1	A31
Chevrolet & Chevelle	2	A33
Camaro	5	A31/N65

## LOCATION O

### Power Seat Equipment

Vehicle	Code	RPO
Chevrolet	1	A42
	2	A46
Chevelle	2	A41

## LOCATION R

### Carburetor Usage (1966)

Code	Plant
R	Rochester
H	Holley or Carter

# 1969-72 CHEVROLET PROTECT-O-PLATE

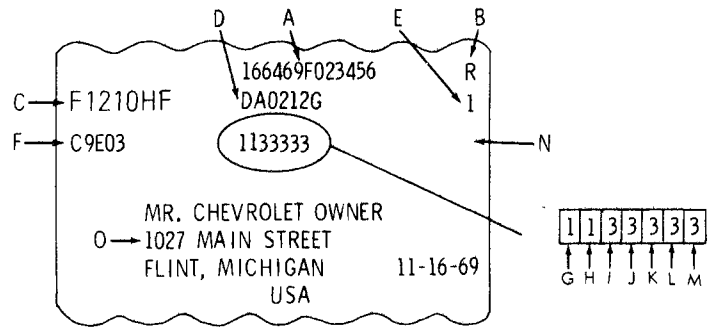

## INFORMATION AVAILABILITY CHART

<u>Location</u>	<u>Description</u>	<u>Location</u>	<u>Description</u>
A	Vehicle Identification Number	I	Radio Code
B	Carburetor Source Code	J	Disc Brake Code
C	Engine Number	K	Air Conditioning
D	Rear Axle Number	L	Power Window Code
E	Vehicle Build Month Code	M	Power Seat Code
F	Transmission Number	N	Chevrolet Trade Mark
G	Power Steering	O	Dealer Supplied Owner Information as Shown in Dealer Policy and Procedures Manual
H	Power Brakes		

The following charts explain codes used on Chevrolet plates instead of RPO numbers. Note that general option headings are also related to the location of that option on the Protect-O-Plate.



# 1969-72 CHEVROLET PROTECT-O-PLATE (Continued)

## LOCATION A

### Passenger Car Identification Number Explanation

A five digit numbering system will be used on all 1967-68 passenger cars. The basic number groups are:

10000 Series - Corvair	12000 Series - Camaro	15000 Series - Chevrolet	19000 Series - Corvette
11000 Series - Chevy II	13000 Series - Chevelle	16000 Series - Chevrolet	

The first two digits denote the vehicle series. The third indicates base engine equipment, and the two remaining numbers identify the body style. When the third digit is odd (1, 3, 5, 7), the base engine is an L-4 or L-6. When the third number is even (2, 4, 6, 8), the base engine is a V-8.

The complete serial number consists of the above model identification, year of manufacture, plant designation, and sequence number.

Example: 164399F000500

(16439)	(9)	(F)	(000500)
Impala V-8 4-Door Sport Sedan	1969 Model	Flint Built	500th 1969 Chevrolet Built at Flint

Passenger vehicle build sequence numbers start as follows at each assembly plant location.

Corvair	700001	Camaro	500001	Chevrolet	000001
Chevy Nova	300001	Chevelle	300001	Corvette	700001

### ASSEMBLY PLANT DESIGNATIONS:

A Atlanta - Chevelle, Truck	P GM Truck - Heavy Duty Truck, Chevy Van
B Baltimore - Chevelle*, Truck	R Arlington - Chevrolet
C Southgate - Chevrolet	S St. Louis - Chevrolet, Corvette, Truck
D Doraville - Chevrolet	T Tarrytown - Chevrolet, Truck
F Flint - Chevrolet, Truck	U Lordstown - Chevrolet
G Framingham - Chevelle	W Willow Run - Corvair, Chevy Nova
J Janesville - Chevrolet, Truck	Y Wilmington - Chevrolet
K Kansas City - Chevelle*	Z Fremont - Chevelle*, Truck
L Los Angeles - Chevrolet, Camaro	1 Oshawa - Truck
N Norwood - Camaro	2 St. Therese - Chevrolet

\* Includes El Camino

# 1969-72 CHEVROLET PROTECT-O-PLATE (Continued)

## LOCATION B

### Carburetor Source

<u>Code</u>	<u>Plant</u>	<u>Code</u>	<u>Plant</u>
B	Bay City	H	Holley
C	Carter	R	Rochester

## LOCATION C

### Engine Production Code Number Explanation

EXAMPLE: F1210BA

(F) Flint Motor	(12) Month December	(10) Day - 10th	(BA) 153-155-163-16500 Series '250" 6-Cyl.
--------------------	---------------------------	--------------------	--

(F) Flint Motor    (T) Tonawanda Engine Plant    (K) McKinnon Industries    (V) Flint Engine    (S) Saginaw Service

Engine plants, will stamp a source, production date and engine suffix on all engines.

Assembly plants will stamp assembly plant designation and continuous sequence number portion of the vehicle identification number on all 307, 327, 350, 396, and 427 cubic inch engines, except Corvette. Since all Corvettes are built at St. Louis, the assembly plant designation is not required. Here, only the continuous sequence number will be used.

### Engine Production Code Number Locations

PASSENGER 4 or 6-Cyl. - Stamped on pad right side of engine at rear of distributor.

CORVAIR - Stamped on top of engine block immediately forward of generator - oil filter adapter.

PASSENGER V-8 - Stamped on pad immediately forward of right hand cylinder head.

## LOCATION D

### Rear Axle Number

Number will contain prefix letters, production date numbers and suffix letter.

EXAMPLE: BA0212G

(BA) Chevy II	(02) Month February	(12) Day - 12th	(G) Axle Plant*
------------------	---------------------------	--------------------	--------------------

\*G - Chevrolet Gear & Axle

W - Warren

B - Buffalo

K - McKinnon Industries

# 1969-72 CHEVROLET PROTECT-O-PLATE (Continued)

## LOCATION E

### Month of Vehicle Build

<u>MONTH</u>	<u>CODE</u>	<u>MONTH</u>	<u>CODE</u>
August, 1968	8	February, 1969	2
September, 1968	9	March, 1969	3
October, 1968	0	April, 1969	4
November, 1968	N	May, 1969	5
December, 1968	D	June, 1969	6
January, 1969	1	July, 1969	7

## LOCATION F

### Transmission Number

Code number identifies the source, model year, month and day produced.

EXAMPLE: C9E03

(C)	(9)	(E)	(03)
Powerglide	Model Year	Month - May	Day - 3

### Source Designations

<u>3-Speed</u>	<u>4-Speed</u>	<u>Powerglide</u>
S - Saginaw M - Muncie H - Muncie H.D. K - McKinnon Industries	R - Saginaw P - Muncie	C - Cleveland T - Toledo E - McKinnon Industries

Torque Drive  
A - Cleveland

Turbo Hydra-Matic 350  
B - Cleveland  
Y - Toledo

## 1969-72 CHEVROLET PROTECT-O-PLATE (Continued)

Turbo Hydra-Matic 400 - Production code number contains model year, model identification, and production date. Below the production code is the source serial number.

EXAMPLE: 69A372

(69)	(A)	(372)
Model Year	Engine or Vehicle	Build Date Code

The engine or vehicle designations are as follows:

<p>A - 350 Cu. In. 255 H.P. (Chevrolet)              396 Cu. In. 265 H.P. (Chevrolet)          B - 427 Cu. In. 390 H.P. (Chevrolet)          C - 396 Cu. In. 325 H.P. (Chevelle, Camaro)          D - 350 Cu. In. 250 H.P. (Chevrolet)              327 Cu. In. 235 H.P. (Chevrolet)          E - 396 Cu. In. 350 H.P. (Chevelle, Nova, Camaro)          F - 427 Cu. In. 335 H.P. (Chevrolet, 2.29:1 Axle)          G - 396 Cu. In. 265 H.P. (Chevrolet, 2.29:1 Axle)          H - 427 Cu. In. 390 H.P. (Chevrolet 2.29:1 Axle)          J - 396 Cu. In. (Truck 10 &amp; 20 Series)</p>	<p>K - 350 Cu. In. 300 H.P. (Corvette)          L - 427 Cu. In. 400 H.P. (Corvette)          P - Truck (30 Series)          Q - 427 Cu. In. 335 H.P. (Chevrolet)          Y - 427 Cu. In. 425 H.P. (Chevrolet)              427 Cu. In. 430 H.P. (Corvette)              427 Cu. In. 435 H.P. (Corvette)              396 Cu. In. 375 H.P. (Chevelle, Nova, Camaro)</p> <p style="text-align: center;">High Shift Point</p>
---	---

The build date code for the 1969 model year starts with the first day of the calendar year 1968 and continues through the 1969 calendar year.

Example: Build date code 234 is for August 21, 1968 (August 21 is the 234th day of the year). Build date code 367 is January 1, 1969.

### LOCATION G THRU M

<u>Location</u>	<u>Code</u>	<u>Option</u>	<u>R.P.O.</u>	<u>Location</u>	<u>Code</u>	<u>Option</u>	<u>R.P.O.</u>
G	1	Power Steering	N-40	J	3	Disc Brake	J-52
H	1	Power Brakes	J-50	K	1	Air Conditioning	C-60
I	3	Radio	U-63		3	Comfortron	C-75
	3	Radio - AM/FM	U-69	L	3	Power Windows	A-31
	3	Radio - Stereo	U-79	M	3	Power Seat	A-42

# ENGINE SERIES NUMBER AND SUFFIX CHART

## 1965 CHEVROLET "230"—6 CYLINDER

Description	Type Designation	Description	Type Designation
Manual Trans. . . . .	FA	Manual Trans. and C.A.C. . . . .	FL
H.D. Clutch . . . . .	FE	Powerglide . . . . .	FM
H.D. Clutch and Air Cond. . . . .	FF	Powerglide (Taxi) . . . . .	FP
(Taxi) . . . . .	FK	Powerglide and C.A.C. . . . .	FR

## "283"—8 CYLINDER

Manual Trans. . . . .	GA	4BC . . . . .	GK
(Police) . . . . .	GC	Powerglide and 4BC . . . . .	GL
Powerglide . . . . .	GF		

## "327"—8 CYLINDER

Manual Trans. . . . .	HA	Powerglide . . . . .	HC
Manual Trans. and High Performance . . . . .	HB	Powerglide and High Performance . . . . .	HD

## "396"—8 CYLINDER

Manual Trans. . . . .	IA,LF	Powerglide and Transistor Ignition . . . . .	II
Manual Trans. and Spec. High Performance . . . . .	IE	Turbo. Hydramatic . . . . .	IV,LC
Manual Trans. and Transistor Ignition . . . . .	IC	Turbo. Hydramatic and Transistor Ignition . . . . .	IW
Powerglide . . . . .	IG,LB		

## "409"—8 CYLINDER

Manual Trans. and High Performance . . . . .	JA	Transistor Ignition and High Performance . . . . .	JD
Manual Trans. . . . .	JB	Powerglide . . . . .	JE
Transistor Ignition . . . . .	JC	Powerglide and Transistor Ignition . . . . .	JF

## CHEVELLE

### "194"—6 CYLINDER

Manual Trans. . . . .	AA	(Taxi) . . . . .	AK
H.D. Clutch . . . . .	AC	Powerglide . . . . .	AL
C.A.C. . . . .	AG	Powerglide (Taxi) . . . . .	AN
H.D. Clutch and Air Cond. . . . .	AH	Powerglide and C.A.C. . . . .	AR

### "230"—6 CYLINDER

Manual Trans. . . . .	CA	Powerglide . . . . .	CC
Manual Trans. and C.A.C. . . . .	CB	Powerglide and C.A.C. . . . .	CD

### "283"—8 CYLINDER

3-Speed Trans. . . . .	DA	Powerglide . . . . .	DE
3-Speed Trans. and 4BC . . . . .	DG	Powerglide and 4BC . . . . .	DH
4-Speed Trans. . . . .	DB		

## ENGINE SERIES NUMBER AND SUFFIX CHART (Cont.)

### "327"—8 CYLINDER

Description	Type Designation	Description	Type Designation
Manual Trans. . . . .	EA	Transistor Ignition. . . . .	ED
High Performance . . . . .	EB	Powerglide . . . . .	EE
Spec. High Performance . . . . .	EC	Powerglide and High Performance . . . . .	EF

### CHEVY II

#### "153"—4 CYLINDER

Manual Trans. . . . .	OA	Powerglide . . . . .	OH
H.D. Clutch . . . . .	OC	Powerglide (Taxi) . . . . .	OJ
(Taxi) . . . . .	OG		

#### "194"—6 CYLINDER

Manual Trans. . . . .	OK	Powerglide . . . . .	OR
H.D. Clutch . . . . .	OM	Powerglide (Taxi) . . . . .	OT
(Taxi) . . . . .	OQ		

#### "230"—6 CYLINDER

Manual Trans. . . . .	PV	Powerglide . . . . .	PX
-----------------------	----	----------------------	----

#### "283"—8 CYLINDER

Manual Trans. . . . .	PD	4-Speed Trans. and C.A.C. . . . .	PM
4BC . . . . .	PE	Powerglide . . . . .	PN
C.A.C. . . . .	PF	Powerglide and 4BC . . . . .	PK
4BC and C.A.C. . . . .	PG	Powerglide and C.A.C. . . . .	PP
4-Speed Trans. . . . .	PL	Powerglide, 4BC and C.A.C. . . . .	PB

#### "327"—8 CYLINDER

Manual Trans. . . . .	ZA	Powerglide . . . . .	ZK
Manual Trans. and High Performance . . . . .	ZB	Powerglide and High Performance . . . . .	ZL
Manual Trans. and Air Cond. . . . .	ZE	Powerglide and C.A.C. . . . .	ZM
Manual Trans., High Performance and Air Cond. . . . .	ZF	Powerglide, High Performance and C.A.C. . . . .	ZN

## 1966

### CHEVROLET

#### "250"—6 CYLINDER

Manual Trans. . . . .	FA	Powerglide and C.A.C. . . . .	FR
H.D. Clutch . . . . .	FE	A.I.R. and C.A.C. . . . .	FY
H.D. Clutch and C.A.C. . . . .	FF	(Taxi) with A.I.R. . . . .	FZ
A.I.R. . . . .	FV	A.I.R. and Powerglide . . . . .	GP
(Taxi) . . . . .	FK	A.I.R., C.A.C. and Powerglide . . . . .	GQ
C.A.C. . . . .	FL	(Taxi) with A.I.R. and Powerglide . . . . .	GR
(Taxi) with Powerglide . . . . .	FP		

#### "283"—8 CYLINDER

Manual Trans. . . . .	GA	A.I.R. and Powerglide . . . . .	GT
4-Speed Trans. . . . .	GC	4BC . . . . .	GW
A.I.R. . . . .	GK	4BC and A.I.R. . . . .	GX
A.I.R. and 4-Speed Trans. . . . .	GS	4BC and Powerglide . . . . .	GL
Powerglide . . . . .	GF	4BC, Powerglide and A.I.R. . . . .	GZ

## ENGINE SERIES NUMBER AND SUFFIX CHART (Cont.)

### "327"—8 CYLINDER

Description	Type Designation	Description	Type Designation
Manual Trans. . . . .	HA	Powerglide . . . . .	HC
A.I.R. . . . .	HB	A.I.R. with Powerglide . . . . .	HF

### "396"—8 CYLINDER

Manual Trans. . . . .	IA	3-Speed Automatic Trans. . . . .	IV
A.I.R. . . . .	IB	A.I.R. with Powerglide . . . . .	IC
Powerglide . . . . .	IG	A.I.R. and 3-Speed Automatic Trans. . . . .	IN

### "427"—8 CYLINDER

Manual Trans. . . . .	IH	A.I.R. . . . .	II
Special High Performance . . . . .	ID	High Performance with A.I.R. and 3-Speed Automatic Trans. . . . .	IO
3-Speed Automatic Trans. . . . .	IJ		

## CHEVELLE

### "194"—6 CYLINDER

Manual Trans. . . . .	AA	Air Cond. and A.I.R. . . . .	AT
H.D. Clutch . . . . .	AC	Powerglide . . . . .	AL
H.D. Clutch and Air Cond. . . . .	AH	Powerglide and Air Cond. . . . .	AR
Air Cond. . . . .	AG	Powerglide and A.I.R. . . . .	AX
A.I.R. . . . .	AS	Powerglide, Air Cond. and A.I.R. . . . .	AY

### "230"—6 CYLINDER

Manual Trans. . . . .	CA	Powerglide . . . . .	CC
Air Cond. . . . .	CB	Powerglide and Air Cond. . . . .	CD
A.I.R. . . . .	BN	Powerglide and A.I.R. . . . .	BL
Air Cond. and A.I.R. . . . .	BO	Powerglide, Air Cond. and A.I.R. . . . .	BM

### "283"—8 CYLINDER

Manual Trans. . . . .	DA	Powerglide and A.I.R. . . . .	DJ
4-Speed Trans. . . . .	DB	4-Speed Trans. and A.I.R. . . . .	DK
4BC . . . . .	DG	4BC and A.I.R. . . . .	DL
4BC and Powerglide . . . . .	DH	4BC, Powerglide and A.I.R. . . . .	DM
A.I.R. . . . .	DI	Powerglide . . . . .	DF

### "327"—8 CYLINDER

Manual Trans. . . . .	EA	Powerglide . . . . .	EE
A.I.R. . . . .	EB	Powerglide and A.I.R. . . . .	EC

### "396"—8 CYLINDER

Manual Trans. . . . .	ED	Powerglide . . . . .	EK
High Performance . . . . .	EF	High Performance and Powerglide . . . . .	EL
Special High Performance . . . . .	EG	Powerglide and A.I.R. . . . .	EM
A.I.R. . . . .	EH	High Performance, Powerglide and A.I.R. . . . .	EN
High Performance and A.I.R. . . . .	EJ		

## ENGINE SERIES NUMBER AND SUFFIX CHART (Cont.)

Description	Type Designation	Description	Type Designation
-------------	---------------------	-------------	---------------------

### CHEVY II

#### "153"—4 CYLINDER

Manual Trans. . . . .	OA	Powerglide . . . . .	OH
H.D. Clutch . . . . .	OC		

#### "194"—6 CYLINDER

Manual Trans. . . . .	OK	Powerglide . . . . .	OR
H.D. Clutch . . . . .	OM	Powerglide and A.I.R. . . . .	ZX
A.I.R. . . . .	ZY	(Taxi) with Powerglide and A.I.R. . . . .	OS

#### "230"—6 CYLINDER

Manual Trans. . . . .	PV	Powerglide . . . . .	PX
A.I.R. . . . .	PC	Powerglide and A.I.R. . . . .	PI

#### "283"—8 CYLINDER

Manual Trans. . . . .	PD	Powerglide and A.I.R. . . . .	PU
Air Cond. . . . .	PF	Powerglide, Air Cond. and A.I.R. . . . .	PO
4-Speed Trans. . . . .	PL	4BC . . . . .	QA
4-Speed Trans. and Air Cond. . . . .	PM	4BC and Air Cond. . . . .	QB
A.I.R. . . . .	PE	4BC and A.I.R. . . . .	QC
A.I.R. and Air Cond. . . . .	PG	4BC, Air Cond. and A.I.R. . . . .	QF
4-Speed Trans. and A.I.R. . . . .	PQ	4BC, and Powerglide . . . . .	PK
4-Speed Trans., Air Cond. and A.I.R. . . . .	PS	4BC, Powerglide and Air Cond. . . . .	PP
Powerglide . . . . .	PN	4BC, Powerglide and A.I.R. . . . .	QD
Powerglide and Air Cond. . . . .	PP	4BC, Powerglide, Air Cond. and A.I.R. . . . .	QE

#### "327"—8 CYLINDER

Manual Trans. . . . .	ZA	Spec. High Performance and A.I.R. . . . .	ZG
Spec. High Performance . . . . .	ZI	Spec. High Performance, Air Cond. and A.I.R. . . . .	ZH
Air Cond. . . . .	ZE	Powerglide . . . . .	ZK
Spec. High Performance and Air Cond. . . . .	ZJ	Powerglide and Air Cond. . . . .	ZM
A.I.R. . . . .	ZB	Powerglide and A.I.R. . . . .	ZD
Air Cond. and A.I.R. . . . .	ZC	Powerglide, Air Cond. and Air. . . . .	ZF

## 1967

### CHEVROLET

#### "250"—6 CYLINDER

Manual Trans. . . . .	FA	(Taxi) with Powerglide . . . . .	FP
H.D. Clutch . . . . .	FE	Powerglide and C.A.C. . . . .	FR
H.D. Clutch and C.A.C. . . . .	FF	A.I.R. and C.A.C. . . . .	FY
A.I.R. . . . .	FV	(Taxi) with A.I.R. . . . .	FZ
(Taxi) . . . . .	FK	A.I.R. and Powerglide . . . . .	GP
C.A.C. . . . .	FL	A.I.R., C.A.C. and Powerglide . . . . .	GQ
Powerglide . . . . .	FM	(Taxi) with A.I.R. and Powerglide . . . . .	GR

#### "283"—8 CYLINDER

Manual Trans. . . . .	GA	H.D. Clutch . . . . .	GU
4-Speed Trans. and H.D. Chassis . . . . .	GC	Powerglide . . . . .	GF
A.I.R. . . . .	GK	A.I.R. and Powerglide . . . . .	GO-GT
A.I.R. and 4-Speed Trans. . . . .	GS		



## ENGINE SERIES NUMBER AND SUFFIX CHART (Cont.)

Description	Type Designation	Description	Type Designation
<b>"327"—8 CYLINDER</b>			
Manual Trans. . . . .	HA	4-Speed Trans. . . . .	KE
A.I.R. . . . .	HB	3-Speed Automatic Trans. . . . .	KL
Powerglide . . . . .	HC	3-Speed Automatic Trans. and A.I.R. . . . .	KM
A.I.R. and Powerglide . . . . .	HF		

<b>"396"—8 CYLINDER</b>			
Manual Trans. . . . .	IA	3-Speed Automatic Trans. . . . .	IV
A.I.R. . . . .	IB	A.I.R. and Powerglide . . . . .	IC
Powerglide . . . . .	IG	A.I.R. and 3-Speed Automatic Trans. . . . .	IN

<b>"427"—8 CYLINDER</b>			
Manual Trans. . . . .	IE-IH	A.I.R. . . . .	II-IX
Special High Performance . . . . .	ID	Special High Performance and A.I.R. . . . .	IK
3-Speed Automatic Trans. . . . .	IJ-IS	A.I.R. and 3-Speed Automatic Trans. . . . .	IF-IO

### CHEVELLE

<b>"230"—6 CYLINDER</b>			
Manual Trans. . . . .	CA	A.I.R. and Air Cond . . . . .	BO
H.D. Clutch . . . . .	BC	Powerglide . . . . .	CC
H.D. Clutch and Air Cond. . . . .	BB	Powerglide and Air Cond. . . . .	CD
Air Cond. . . . .	CB	Powerglide and A.I.R. . . . .	BL
A.I.R. . . . .	BN	Powerglide, A.I.R. and Air Cond. . . . .	BM

<b>"250"—6 CYLINDER</b>			
Manual Trans. . . . .	CM	Powerglide . . . . .	CQ
Air Cond. . . . .	CN	Powerglide and Air Cond. . . . .	CR
A.I.R. . . . .	CO	Powerglide and A.I.R. . . . .	CS
A.I.R. and Air Cond. . . . .	CP	Powerglide, A.I.R. and Air Cond. . . . .	CT

<b>"283"—8 CYLINDER</b>			
Manual Trans. . . . .	DA	4-Speed Trans. and A.I.R. . . . .	DK
4-Speed Trans. . . . .	DB	H.D. Clutch . . . . .	DN
A.I.R. . . . .	DI	Powerglide . . . . .	DE
Powerglide and A.I.R. . . . .	DJ		

<b>"327"—8 CYLINDER</b>			
4BC . . . . .	EA	Special High Performance and H.D. Clutch . . . . .	ES
Special High Performance . . . . .	EP	H.D. Clutch . . . . .	EQ
A.I.R. . . . .	EB	Powerglide . . . . .	EE
Special High Performance and A.I.R. . . . .	ER	Powerglide and A.I.R. . . . .	EC

<b>"396"—8 CYLINDER</b>			
Manual and Powerglide Trans. . . . .	ED	Powerglide and A.I.R. . . . .	EM
High Performance . . . . .	EF	High Performance, Powerglide and A.I.R. . . . .	EN
Special High Performance . . . . .	EG	3-Speed Automatic Trans. . . . .	ET
A.I.R. . . . .	EH	High Performance and 3-Speed Automatic Trans. . . . .	EU
High Performance and A.I.R. . . . .	EJ	3-Speed Automatic Trans. and A.I.R. . . . .	EV
Powerglide . . . . .	EK	High Performance, 3-Speed Automatic Trans. and A.I.R. . . . .	EW
High Performance and Powerglide . . . . .	EL	Special High Performance and A.I.R. . . . .	EX

# ENGINE SERIES NUMBER AND SUFFIX CHART (Cont.)

## CHEVY II

### "153"—4 CYLINDER

Description	Type Designation	Description	Type Designation
Manual Trans. . . . .	OA	Powerglide . . . . .	OH
H.D. Clutch . . . . .	OC		

### "194"—6 CYLINDER

Manual Trans. . . . .	OK	Powerglide. . . . .	OR
H.D. Clutch . . . . .	OM	Powerglide and A.I.R. . . . .	ZX
A.I.R. . . . .	ZY		

### "250"—6 CYLINDER

Manual Trans. . . . .	PV	Powerglide . . . . .	PX
A.I.R. . . . .	PC	Powerglide and A.I.R. . . . .	PI

### "283"—8 CYLINDER

Manual Trans. . . . .	PD	4-Speed Trans. . . . .	PL
Air Cond. . . . .	PF	Powerglide . . . . .	PN
4-Speed Trans. and Air Cond. . . . .	PM	Powerglide and Air Cond. . . . .	PP
A.I.R. . . . .	PE	Powerglide and A.I.R. . . . .	PU
4-Speed Trans. and A.I.R. . . . .	PQ		

### "327"—8 CYLINDER

4BC . . . . .	ZA	Special High Performance . . . . .	ZI
A.I.R. . . . .	ZB	Special High Performance and C.A.C. . . . .	ZJ
Powerglide and A.I.R. . . . .	ZD	Powerglide . . . . .	ZK
Air Cond. . . . .	ZE	Powerglide and Air Cond. . . . .	ZM
Special High Performance, A.I.R. and C.A.C. . . . .	ZG		

## CAMARO

### "230"—6 CYLINDER

Manual Trans. . . . .	LA	Powerglide . . . . .	LE
Manual Trans. and C.A.C. . . . .	LB	Powerglide and C.A.C. . . . .	LF
A.I.R. . . . .	LC	Powerglide and A.I.R. . . . .	LG
A.I.R. and C.A.C. . . . .	LD	Powerglide, A.I.R. and C.A.C. . . . .	LH

### "250"—6 CYLINDER

Manual Trans. . . . .	LN	Powerglide . . . . .	FM
Manual Trans. and C.A.C. . . . .	LO	Powerglide and C.A.C. . . . .	FR
A.I.R. . . . .	LP	Powerglide and A.I.R. . . . .	GP
A.I.R. and C.A.C. . . . .	LQ	Powerglide, A.I.R. and C.A.C. . . . .	GQ

### "283"—8 CYLINDER—2 BARREL

4-Speed Trans. . . . .	MD	Powerglide . . . . .	MJ
------------------------	----	----------------------	----

### "283"—8 CYLINDER—4 BARREL

Special Engine Z28 . . . . .	MO	A.I.R. . . . .	MP
------------------------------	----	----------------	----

### "327"—8 CYLINDER—2 BARREL

Manual Trans. . . . .	MA	Powerglide . . . . .	ME
A.I.R. . . . .	MB	Powerglide and A.I.R. . . . .	MF

# ENGINE SERIES NUMBER AND SUFFIX CHART (Cont.)

Description	Type Designation	Description	Type Designation
<b>"327"—8 CYLINDER—4 BARREL</b>			
Manual Trans. . . . .	MK	Powerglide . . . . .	MM
A.I.R. . . . .	ML	Powerglide and A.I.R. . . . .	MN
<b>"350"—8 CYLINDER</b>			
Manual Trans. . . . .	MS	Powerglide . . . . .	MU
A.I.R. . . . .	MT	Powerglide and A.I.R. . . . .	MV
<b>"396"—8 CYLINDER</b>			
High Performance . . . . .	EI	Manual and A.T. Trans. . . . .	MW
High Performance and 3-Speed Automatic Trans. . . . .	EQ	A.I.R. . . . .	MX
High Performance and A.I.R. . . . .	EY	3-Speed Automatic Trans. . . . .	MY
Special High Performance . . . . .	MQ	3-Speed Automatic Trans. and A.I.R. . . . .	MZ
A.I.R. Special High Performance . . . . .	MR		

## 1968

### CHEVROLET

<b>"250"—6 CYLINDER</b>			
Manual Trans . . . . .	CA	Manual Trans . . . . .	CM
(Taxi) . . . . .	CB	Air Cond . . . . .	CN
C.A.C. . . . .	CC	Powerglide . . . . .	CQ
H.D. Clutch . . . . .	CJ	Powerglide and C.A.C. . . . .	CR
H.D. Clutch and C.A.C. . . . .	CK	(Police) C.A.C. . . . .	CS
(Taxi-Police) Powerglide . . . . .	CL	(Police) Powerglide and C.A.C. . . . .	CT
<b>"307"—8 CYLINDER</b>			
Powerglide . . . . .	DH	3-Speed Automatic Trans . . . . .	DS
3-Speed Automatic T.H. 400 . . . . .	DK	H.D. Clutch . . . . .	DQ
Manual Trans . . . . .	DO	Powerglide . . . . .	DR
S.S. 4-Speed Trans . . . . .	DP		
<b>"327"—8 CYLINDER</b>			
Manual Trans . . . . .	HA	Manual Trans . . . . .	HI
H.D. Clutch . . . . .	HB	4-Bbl. Carb. Reg. Fuel Powerglide . . . . .	HK
4-Bbl. Carb. . . . .	HI	H.D. Clutch . . . . .	HL
Powerglide . . . . .	HC	4-Bbl Carb Powerglide . . . . .	HJ
3-Speed Automatic Trans . . . . .	HF	4-Bbl Carb H-D Clutch . . . . .	HL
Powerglide . . . . .	HG	4-Bbl Carb 3-Speed Automatic Trans . . . . .	HM
Powerglide . . . . .	HH	4-Bbl Reg. Fuel Powerglide . . . . .	HN
<b>"396"—8 CYLINDER</b>			
Manual Trans . . . . .	IA	(Police) Manual Trans. . . . .	IK
Powerglide . . . . .	IG	(Police) Powerglide . . . . .	IN
3-Speed Automatic Trans . . . . .	IV	(Police) H.D. Clutch . . . . .	IF
<b>"427"—8 CYLINDER</b>			
Police 3-Speed Automatic T.H. 400 . . . . .	IB	3-Speed Automatic Trans . . . . .	IJ-IS
Manual Trans . . . . .	IE-IH	(Police) Manual Trans . . . . .	IC
Special High Performance . . . . .	ID		
<b>CHEVELLE</b>			
<b>"230"—6 CYLINDER</b>			
Manual Trans . . . . .	BA	C.A.C. . . . .	BD
H.D. Clutch and C.A.C. . . . .	BB	Powerglide . . . . .	BF
H.D. Clutch . . . . .	BC	Powerglide and C.A.C. . . . .	BH
<b>"250"—6 CYLINDER</b>			
Manual Trans . . . . .	CM	Powerglide . . . . .	CQ
C.A.C. . . . .	CN	Powerglide and C.A.C. . . . .	CR
<b>"307"—8 CYLINDER</b>			
Manual Trans . . . . .	DA	Powerglide . . . . .	DE
4-Speed Trans . . . . .	DB	Powerglide . . . . .	DF
		H.D. Clutch . . . . .	DN

## ENGINE SERIES NUMBER AND SUFFIX CHART (Cont.)

### "327"—8 CYLINDER

Description	Type Designation	Description	Type Designation
Manual Trans . . . . .	EA	H.D. Clutch - Special High Performance . . . . .	ES
Powerglide . . . . .	EC	4-Bbl Carb . . . . .	EH
Powerglide . . . . .	EE	4-Bbl Carb Powerglide . . . . .	EI
H.D. Clutch . . . . .	EO	4-Bbl Carb H.D. Clutch . . . . .	EJ
Special High Performance . . . . .	EP		

### "396"—8 CYLINDER

Manual Trans . . . . .	ED	High Performance and Powerglide . . . . .	EL
High Performance . . . . .	EF	3-Speed Automatic Trans . . . . .	ET
Special High Performance . . . . .	EG	High Performance and 3-Speed	
Powerglide . . . . .	EK	Automatic Trans . . . . .	EU

## CHEVY II

### "153"—4 CYLINDER

Manual Trans . . . . .	OA	Powerglide . . . . .	OH
H.D. Clutch . . . . .	OC		

### "230"—6 CYLINDER

Manual Trans . . . . .	BA	C.A.C. . . . .	BD
H.D. Clutch and C.A.C. . . . .	BB	Powerglide . . . . .	BF
H.D. Clutch . . . . .	BC	Powerglide and C.A.C. . . . .	BH

### "250"—6 CYLINDER

Manual Trans . . . . .	CM	Powerglide . . . . .	CQ
C.A.C. . . . .	CN	Powerglide and C.A.C. . . . .	CR

### "307"—8 CYLINDER

Manual Trans . . . . .	DA	Powerglide . . . . .	DE
4 - Speed Trans . . . . .	DB		

### "327"—8 CYLINDER

Manual Trans . . . . .	EA	Special High Performance . . . . .	EP
Manual Trans . . . . .	MK	Powerglide . . . . .	EE
Special High Performance . . . . .	ML	Powerglide . . . . .	MM

### "350"—8 CYLINDER

Manual Trans . . . . .	MS	Powerglide . . . . .	MU
------------------------	----	----------------------	----

### "396"—8 CYLINDER

Manual Trans . . . . .	MX	3-Speed Automatic T.H. 400 . . . . .	MR
Manual Trans . . . . .	MQ		

## CAMARO

### "230"—6 CYLINDER

Manual Trans . . . . .	BA	C.A.C. . . . .	BD
H.D. Clutch and C.A.C. . . . .	BB	Powerglide . . . . .	BF
H.D. Clutch . . . . .	BC	Powerglide and C.A.C. . . . .	BH

### "250"—6 CYLINDER

Manual Trans . . . . .	CM	Powerglide . . . . .	CQ
C.A.C. . . . .	CN	Powerglide and C.A.C. . . . .	CR

### "302"—8 CYLINDER

Manual Trans . . . . .	MO		
------------------------	----	--	--

### "327"—8 CYLINDER—2 BARREL

Manual Trans . . . . .	MA	Powerglide . . . . .	ME
------------------------	----	----------------------	----

### "350"—8 CYLINDER

Manual Trans . . . . .	MS	Powerglide . . . . .	MU
------------------------	----	----------------------	----

### "396"—8 CYLINDER

Special High Performance . . . . .	MQ	Manual and AT Trans . . . . .	MW
High Performance and 3-Speed Automatic Trans . . . . .	MR	High Performance . . . . .	MX
Special High Performance and Aluminum Heads . . . . .	MT	3-Speed Automatic Trans . . . . .	MY

# ENGINE SERIES NUMBER AND SUFFIX CHART (Cont.)

## 1969

### CHEVROLET

#### "250"—6 CYLINDER

Description	Type Designation	Description	Type Designation
Manual Trans. . . . .	BA	(Police) Powerglide and C.A.C. . . . .	BO
Manual Trans. and C.A.C. . . . .	BG	(Taxi-Police) Manual Trans. . . . .	BP
(Taxi-Police) Powerglide . . . . .	BJ	(Police) C.A.C. . . . .	BQ
(Taxi-Police) Powerglide . . . . .	BL		

#### "327"—8 CYLINDER

Manual Trans. . . . .	FA	Powerglide . . . . .	FK
Powerglide . . . . .	FB	3-Speed Automatic T.H. 350 . . . . .	FL
3-Speed Automatic Trans. T.H. 350 . . . . .	FC	(Taxi) Manual Trans. . . . .	FY
3-Speed Automatic Trans. T.H. 400 . . . . .	FH	(Taxi) Powerglide . . . . .	FZ
(Police) . . . . .	FG	(Taxi) 3-Speed Automatic T.H. 350 . . . . .	GA
Manual Trans. . . . .	FJ	(Taxi) 3-Speed Automatic T.H. 400 . . . . .	GB

#### "350"—8 CYLINDER

Powerglide . . . . .	GE	3-Speed Automatic T.H. 350 . . . . .	HY
2 Bbl. Carb. 3-Speed Automatic T.H. 350 . . . . .	HD	3-Speed Automatic T.H. 400 . . . . .	IA
2 Bbl. Carb. Powerglide . . . . .	HF	2-Bbl. Carb. (Taxi) Manual Trans. . . . .	IL
Manual Trans. . . . .	HG	2-Bbl. Carb. (Taxi) Powerglide . . . . .	IM
3-Speed Automatic Trans. T.H. 400 . . . . .	HH	2-Bbl. Carb. (Taxi) 3-Speed Automatic T.H. 350 . . . . .	IN
2-Bbl. Carb. . . . .	HI	2-Bbl. Carb. (Taxi) 3-Speed Automatic T.H. 400 . . . . .	IP
2-Bbl. Carb. 3-Speed Automatic Trans. T.H. 400 . . . . .	HJ	(Taxi) Manual Trans. . . . .	IQ
Powerglide . . . . .	HK	(Taxi) Manual Trans. . . . .	IR
2-Bbl. Carb. Powerglide . . . . .	HL	(Taxi) Powerglide . . . . .	IS
2-Bbl. Carb. 3-Speed Automatic Trans. T.H. 350 . . . . .	HM	(Taxi) 3-Speed Automatic T.H. 350 . . . . .	IT
3-Speed Automatic Trans. T.H. 350 . . . . .	HN	(Taxi) 3-Speed Automatic T.H. 400 . . . . .	IV
Manual Trans. . . . .	HD	(Taxi) Manual . . . . .	IW
Manual Trans. . . . .	HP	(Taxi) Powerglide . . . . .	IX
Manual Trans. . . . .	HT	(Taxi) 3-Speed Automatic T.H. 350 . . . . .	IY
Powerglide . . . . .	HU	(Taxi) 3-Speed Automatic T.H. 400 . . . . .	IZ

#### "396"—8 CYLINDER

2-Bbl. Carb. Manual Trans. . . . .	JN	2-Bbl. Carb. 3-Speed Automatic Trans. T.H. 400 . . . . .	JQ
(Police) 2-Bbl. Carb. 3-Speed Automatic Trans. T.H. 400 . . . . .	JO	Manual Trans. . . . .	JT
(Police) 2-Bbl. Carb. . . . .	JP	(Police) Manual Trans. . . . .	JR

#### "427"—8 CYLINDER

High Performance . . . . .	LA	(Police) 4-Bbl. Carb. 3-Speed Automatic Trans. T.H. 400 . . . . .	LJ
4-Bbl. Carb. . . . .	LB	(Police) 4-Bbl. Carb. Manual Trans. . . . .	LK
High Performance 3-Speed Automatic Trans. T.H. 400 . . . . .	LC	Special High Performance 3-Speed Automatic Trans. T.H. 400 . . . . .	LS
Special High Performance Manual Trans. . . . .	LD	(Police) Manual Trans. . . . .	LY
4-Bbl. Carb. 3-Speed Automatic Trans. T.H. 400 . . . . .	LE	(Police) High Performance Manual Trans. . . . .	LZ
(Police) High Performance 3-Speed Automatic Trans. . . . .	LF	Manual Trans. . . . .	MA
(Police) High Performance Manual Trans. . . . .	LG	(Police) High Performance Manual Trans. . . . .	MB
High Performance Manual Trans. . . . .	LH	High Performance Manual Trans. . . . .	MC
3-Speed Automatic Trans. T.H. 400 . . . . .	LI	Special High Performance Manual Trans. . . . .	MD

# ENGINE SERIES NUMBER AND SUFFIX CHART (Cont.)

## CHEVELLE

### "230"—6 CYLINDER

Description	Type Designation	Description	Type Designation
Manual Trans. . . . .	AM	C.A.C. . . . .	AP
Powerglide, Torque Drive . . . . .	AN	Powerglide, Torque Drive and C.A.C. . . . .	AQ
3-Speed Automatic Trans. T.H. 350 . . . . .	AD	3-Speed Automatic Trans. T.H. 350 with C.A.C. . . . .	AR

### "250"—6 CYLINDER

Powerglide, Torque Drive . . . . .	BB	Manual Trans. . . . .	BE
Powerglide, Torque with C.A.C. . . . .	BC	C.A.C. . . . .	BF
3-Speed Automatic Trans. T.H. 350 . . . . .	BD	3-Speed Automatic Trans. T.H. 350 with C.A.C. . . . .	BH

### "307"—8 CYLINDER

Manual Trans. . . . .	DA	3-Speed Automatic Trans. T.H. 350 . . . . .	DD
Powerglide. . . . .	DC	4-Speed Trans. . . . .	DE

### "350"—8 CYLINDER

Manual Trans. . . . .	HA	2-Bbl. Carb. Powerglide . . . . .	HF
3-Speed Automatic Trans. T.H. . . . .	HB	Manual Trans. . . . .	HP
2-Bbl. Carb. . . . .	HC	Manual Trans. . . . .	HR
2-Bbl. Carb. 3-Speed Automatic Trans. T.H. 350 . . . . .	HD	Powerglide . . . . .	HR
Powerglide . . . . .	HE	3-Speed Automatic T.H. 350 . . . . .	HS

### "396"—8 CYLINDER

Manual Trans. . . . .	JA	Manual Trans. . . . .	KG
High Performance . . . . .	JC	3-Speed Automatic T.H. 400 . . . . .	KH
Special High Performance . . . . .	JD	High Performance Manual Trans. . . . .	KB
High Performance 3-Speed Automatic Trans. T.H. 400 . . . . .	JE	Manual Trans. . . . .	JV
3-Speed Automatic Trans. T.H. 400 . . . . .	JK	Spec. High Performance Manual Trans. . . . .	KD
Spec. High Performance 3-Speed Automatic T.H. 400 . . . . .	KF	Manual Trans. . . . .	KI

## CHEVY II

### "153"—4 CYLINDER

Manual Trans. . . . .	AA	Powerglide, Torque Drive . . . . .	AB
-----------------------	----	------------------------------------	----

### "230"—6 CYLINDER

Manual Trans. . . . .	AM	C.A.C. . . . .	AP
Powerglide, Torque Drive . . . . .	AN	Powerglide, Torque Drive and C.A.C. . . . .	AQ
3-Speed Automatic Trans. T.H. 350 . . . . .	AO	3-Speed Automatic Trans. T.H. 350 with C.A.C. . . . .	AR

### "250"—6 CYLINDER

Powerglide, Torque Drive . . . . .	BB	Manual Trans. . . . .	BE
Powerglide, Torque with C.A.C. . . . .	BC	C.A.C. . . . .	BF
3-Speed Automatic Trans. T.H. 350 . . . . .	BD	3-Speed Automatic Trans. T.H. 350 with C.A.C. . . . .	BH

# ENGINE SERIES NUMBER AND SUFFIX CHART (Cont.)

## "307"—8 CYLINDER

Description	Type Designation	Description	Type Designation
Manual Trans. . . . .	DA	3-Speed Automatic Trans. T.H. 350 . . . . .	DD
Powerglide . . . . .	DC	4-Speed Trans. . . . .	DE

## "350"—8 CYLINDER

Manual Trans. . . . .	HA	2-Bbl. Carb. Powerglide . . . . .	HF
3-Speed Automatic Trans. T.H. . . . .	HB	Manual Trans. . . . .	HQ
2-Bbl. Carb. . . . .	HC	Powerglide . . . . .	HR
2-Bbl. Carb. 3-Speed Automatic Trans. T.H. 350 . . . . .	HD	3-Speed Automatic . . . . .	HS
Powerglide. . . . .	HE		

## "396"—8 CYLINDER

High Performance . . . . .	JF	3-Speed Automatic T.H. 400 . . . . .	JM
Special High Performance . . . . .	JH	Powerglide . . . . .	JU
High Performance 3-Speed Automatic Trans. T.H. 400 . . . . .	JI	Spec. High Performance . . . . .	KA
Special High Performance 3-Speed Automatic Trans. T.H. 400 . . . . .	JL	Spec. High Performance . . . . .	KC
		Manual Trans. . . . .	KE

## CAMARO

### "230"—6 CYLINDER

Manual Trans. . . . .	AM	C.A.C. . . . .	AP
Powerglide, Torque Drive . . . . .	AN	Powerglide, Torque Drive and C.A.C. . . . .	AQ
3-Speed Automatic Trans. T.H. 350 . . . . .	AO	3-Speed Automatic Trans. T.H. 350 with C.A.C. . . . .	AR

### "250"—6 CYLINDER

Powerglide, Torque Drive . . . . .	BB	Manual Trans. . . . .	BE
Powerglide, Torque Drive with C.A.C. . . . .	BC	C.A.C. . . . .	BF
3-Speed Automatic Trans. T.H. 350 . . . . .	BD	3-Speed Automatic Trans. T.H. 350 with C.A.C. . . . .	BH

### "302"—8 CYLINDER

Special Engine . . . . .	DZ
--------------------------	----

### "307"—8 CYLINDER

Manual Trans. . . . .	DA	3-Speed Automatic Trans. T.H. 350 . . . . .	DD
Powerglide. . . . .	DC	4-Speed Trans. . . . .	DE

### "350"—8 CYLINDER

Manual Trans. . . . .	HA	2-Bbl. Carb. Powerglide . . . . .	HF
3-Speed Automatic Trans. T.H. . . . .	HB	Manual Trans. . . . .	HQ
2-Bbl. Carb. . . . .	HC	Powerglide . . . . .	HR
2-Bbl. Carb. 3-Speed Automatic Trans. T.H. 350 . . . . .	HD	3-Speed Automatic . . . . .	HS
Powerglide . . . . .	HE		

### "396"—8 CYLINDER

Powerglide. . . . .	JB	Special High Performance 3-Speed Automatic Trans. T.H. 400 . . . . .	JL
High Performance . . . . .	JF	Aluminum Heads 3-Speed Automatic Trans. T.H. 400 . . . . .	JM
3-Speed Automatic Trans. T.H. 400 . . . . .	JG	Manual Trans. . . . .	JU
Special High Performance . . . . .	JH	Spec. High Performance Manual Trans. . . . .	KA
High Performance 3-Speed Automatic Trans. T.H. 400 . . . . .	JI	Spec. High Performance Manual Trans. . . . .	KC
Aluminum Heads Manual Trans. . . . .	JJ	Aluminum Heads Manual Trans. . . . .	KE

# ENGINE SERIES NUMBER AND SUFFIX CHART (Cont.)

1970

## PASSENGER

Description	H.P.	Type Description
<b>"250"—6 CYLINDER</b>		
Powerglide, Taxi and Police	155 H.P.	CCM
Manual Transmission	155 H.P.	CCG
Manual Transmission	155 H.P.	CCH
T.H. 350, Taxi and Police	155 H.P.	CCK
Manual Transmission	155 H.P.	CCZ
Manual Transmission, Taxi and Police	155 H.P.	CCL
Manual Transmission	155 H.P.	CRF
Manual Transmission	155 H.P.	CRG

## "350"—8 CYLINDER

Manual Transmission	250 H.P.	CND
Manual Transmission Taxi and Police	250 H.P.	CNP
Manual Transmission	300 H.P.	CNQ
T.H. 350	300 H.P.	CNR
Powerglide and Police	300 H.P.	CNS
T.H. 350 and Police	300 H.P.	CNT
Powerglide	250 H.P.	CNU
T.H. 350	250 H.P.	CNV
Powerglide, Taxi and Police	250 H.P.	CNW
T.H. 350, Taxi and Police	250 H.P.	CNX

## "400"—8 CYLINDER

Manual Transmission	265 H.P.	CGR
---------------------	----------	-----

## "454"—8 CYLINDER

Manual Transmission	345 H.P.	CGV
Manual Trans. and Police	345 H.P.	CGS
Manual Transmission and Police	390 H.P.	CGT
Manual Transmission	390 H.P.	CGU

## CHEVELLE

### "250"—6 CYLINDER

Powerglide, Taxi and Police	155 H.P.	CCM
T.H. 350, Taxi and Police	155 H.P.	CCK
Manual Transmission, Taxi and Police	155 H.P.	CCL

### "307"—8 CYLINDER

Manual Transmission	200 H.P.	CNC
4-Speed	200 H.P.	CND
Powerglide	200 H.P.	CNE
T.H. 350	200 H.P.	CNF



# ENGINE SERIES NUMBER AND SUFFIX CHART (Cont.)

1970

## CHEVELLE (Cont.)

Description	H.P.	Type Description
<b>"350"—8 CYLINDER</b>		
Manual Transmission	250 H.P.	CNI
Manual Transmission	300 H.P.	CNJ
Powerglide	300 H.P.	CNK
T.H. 350	300 H.P.	CRE
Powerglide	250 H.P.	CNM

## "396"—8 CYLINDER

T.H. 400	350 H.P.	CTW
Manual Transmission	350 H.P.	CTX
T.H. 400	375 H.P.	CTY
Manual Transmission, H.D. Clutch	350 H.P.	CTZ
Manual Transmission	375 H.P.	CKO
T.H. 400, Aluminum Heads	375 H.P.	CKP
Manual Transmission, H.D. Clutch	375 H.P.	CKQ
Manual Transmission	375 H.P.	CKT
Manual Transmission, H.D. Clutch	375 H.P.	CKU

## "400"—8 CYLINDER

Manual Transmission - 2 Bbl.	265 H.P.	CZX
T.H. 350-2 Bbl.	265 H.P.	CRH
Manual Transmission-4Bbl.	330 H.P.	CKR
Manual Transmission, H.D. Clutch - 4 Bbl.	330 H.P.	CKS

## "454"—8 CYLINDER

Manual Transmission	390 H.P.	CRN
T.H. 400	390 H.P.	CRQ
T.H. 400	450 H.P.	CRR
T.H. 400 and Aluminum Heads	450 H.P.	CRS
Manual Transmission	390 H.P.	CRT
Manual Transmission	450 H.P.	CRV

## NOVA

### "153"—4 CYLINDER

Manual Transmission	90 H.P.	CCA
Torque Drive	90 H.P.	CCB

### "230"—6. CYLINDER

Torque Drive	140 H.P.	CCD
--------------	----------	-----

# ENGINE SERIES NUMBER AND SUFFIX CHART (Cont.)

1970

## NOVA (Cont.)

Description	H.P.	Type Description
<b>"250"—6 CYLINDER</b>		
Powerglide, Taxi and Police . . . . .	155 H.P. . . . .	CCM
Manual Transmission . . . . .	155 H.P. . . . .	CCG
T.H. 350, Taxi and Police . . . . .	155 H.P. . . . .	CCK
Manual Transmission . . . . .	155 H.P. . . . .	CCZ
Manual Transmission, Taxi and Police . . . . .	155 H.P. . . . .	CCL
Manual Transmission . . . . .	155 H.P. . . . .	CRF
Manual Transmission . . . . .	155 H.P. . . . .	CRG
<b>"307"—8 CYLINDER</b>		
Manual Transmission . . . . .	200 H.P. . . . .	CNC
4-Speed Transmission . . . . .	200 H.P. . . . .	CND
Powerglide . . . . .	200 H.P. . . . .	CNE
T.H. 350 . . . . .	200 H.P. . . . .	CNF
<b>"350"—8 CYLINDER</b>		
Manual Transmission . . . . .	250 H.P. . . . .	CNI
Manual Transmission . . . . .	300 H.P. . . . .	CNJ
Powerglide . . . . .	300 H.P. . . . .	CNK
T.H. 350 . . . . .	300 H.P. . . . .	CRE
Powerglide . . . . .	250 H.P. . . . .	CNM
T.H. 350 . . . . .	250 H.P. . . . .	CNN
Manual Transmission . . . . .	320 H.P. . . . .	CTB
T.H. 400 . . . . .	320 H.P. . . . .	CTC
<b>"396"—8 CYLINDER</b>		
T.H. 400 . . . . .	350 H.P. . . . .	CTW
Manual Transmission . . . . .	350 H.P. . . . .	CTX
T.H. 400 . . . . .	375 H.P. . . . .	CTY
Manual Transmission, H.D. Clutch . . . . .	350 H.P. . . . .	CTZ
Manual Transmission . . . . .	375 H.P. . . . .	CKO
T.H. 400 and Aluminum Heads . . . . .	375 H.P. . . . .	CKP
Manual Trans., H.D. Clutch . . . . .	375 H.P. . . . .	CKQ
Manual Transmission, Aluminum Heads . . . . .	375 H.P. . . . .	CKT
Manual Transmission Aluminum Heads and H.D. Clutch . . . . .	375 H.P. . . . .	CKU
<b>"400"—8 CYLINDER</b>		

# ENGINE SERIES NUMBER AND SUFFIX CHART (Cont.)

1970

## CAMARO

Description	H.P.	Type Description
<b>"250"—6 CYLINDER</b>		
Powerglide, Taxi and Police	155 H.P.	CCM
Manual Transmission	155 H.T.	CCG
T.H. 350, Taxi and Police	155 H.P.	CCK
Manual Transmission	155 H.P.	CCZ
Manual Transmission, Taxi and Police	155 H.P.	CCL
Manual Transmission	155 H.P.	CRF
Manual Transmission	155 H.P.	CRG

## "307"—8 CYLINDER

Manual Transmission	200 H.P.	CNC
4-Speed Transmission	200 H.P.	CND
Powerglide Transmission	200 H.P.	CNE
T.H. 350	200 H.P.	CNF

## "350"—8 CYLINDER

Manual Transmission	250 H.P.	CNI
Manual Transmission	300 H.P.	CNJ
Powerglide Transmission	300 H.P.	CNK
T.H. 350	300 H.P.	CRE
Powerglide Transmission	250 H.P.	CNM
T.H. 350	250 H.P.	CNN
Manual Transmission	250 H.P.	CNI
Manual Transmission	300 H.P.	CNJ
Powerglide	300 H.P.	CNK
T.H. 350	300 H.P.	CRE
Powerglide	250 H.P.	CNM
T.H. 350	250 H.P.	CNN
Manual	320 H.P.	CTB
T.H. 400	320 H.P.	CTC

## "396"—8 CYLINDER

T.H. 400	375 H.P.	CJL
Manual Transmission	350 H.P.	CJF
Manual Transmission	375 H.P.	CJH
T.H. 400	350 H.P.	CJI

## "400"—8 CYLINDER

T.H. 400	350 H.P.	CTW
Manual Transmission	350 H.P.	CTX
T.H. 400	375 H.P.	CTY
Manual Transmission	375 H.P.	CKO

# ENGINE SERIES NUMBER AND SUFFIX CHART (Cont.)

1971

## PASSENGER

Description	H.P.	Type Designation
<b>"250"—6 CYLINDER</b>		
Manual Transmission . . . . .	145	CAA
Powerglide, Torque Drive . . . . .	145	CAB
Manual Transmission, Police and Taxi . . . . .	145	CAC
Powerglide Police and Taxi . . . . .	145	CAD
<b>"350"—8 CYLINDER</b>		
Manual Transmission . . . . .	245	CGA
Powerglide . . . . .	245	CGB
Manual Transmission . . . . .	245	CGC
T.H. 350 Police and Taxi . . . . .	245	CGJ
Manual Transmission Police . . . . .	270	CJB
Manual Transmission Police . . . . .	270	CJH
<b>"400"—8 CYLINDER</b>		
T.H. 350 . . . . .	300	CLP
T.H. 350 . . . . .	255	CLK
Manual Transmission, Police . . . . .	300	CLR
<b>"454"—8 CYLINDER</b>		
Manual Transmission, Police . . . . .	365	CPG
Manual Transmission . . . . .	365	CPD

## CHEVELLE

<b>"250"—6 CYLINDER</b>		
Manual Transmission . . . . .	145	CAA
<b>"307"—8 CYLINDER</b>		
Manual Transmission . . . . .	200	CCA
<b>"350"—8 CYLINDER</b>		
Manual Transmission . . . . .	245	CGA
Powerglide . . . . .	245	CGB
Manual Transmission . . . . .	270	CGK
T.H. 350 . . . . .	270	CGL
T.H. 350 . . . . .	270	CJD
Manual Transmission . . . . .	270	CJJ
<b>"400"—8 CYLINDER</b>		
T.H. 350 . . . . .	300	CLP
T.H. 400 . . . . .	300	CLB
Manual Transmission . . . . .	330	CLA
T.H. 350 . . . . .	255	CLK
Manual Transmission . . . . .	255	CAJ
4-Speed . . . . .	300	CLL
Manual Transmission Police . . . . .	300	CLR
Manual Transmission . . . . .	300	CLS
<b>"454"—8 CYLINDER</b>		
Manual Transmission . . . . .	365	CPA
Manual Transmission . . . . .	365	CPG
Manual Transmission . . . . .	365	CPD
Manual Transmission . . . . .	460	CPP
T.H. 400 . . . . .	460	CPR

# ENGINE SERIES NUMBER AND SUFFIX CHART (Cont.)

1971

## NOVA

Description	H.P.	Type Designation
<b>"250"—6 CYLINDER</b>		
Manual Transmission . . . . .	145	CAA
Powerglide, Torque Drive . . . . .	145	CAB
<b>"307"—8 CYLINDER</b>		
Manual Transmission . . . . .	200	CCA
Powerglide . . . . .	200	CCC
<b>"350"—8 CYLINDER</b>		
Powerglide . . . . .	245	CGB
Manual Transmission . . . . .	270	CGK
T.H. 350 . . . . .	270	CGL
T.H. 350 . . . . .	270	CJD
Manual Transmission . . . . .	270	CJG
<b>"454"—8 CYLINDER</b>		
T.H. 400 . . . . .	450	CPT
Manual Transmission . . . . .	450	CPS

## CAMARO

<b>"250"—6 CYLINDER</b>		
Manual Transmission . . . . .	145	CAA
Powerglide . . . . .	145	CAB
<b>"307"—8 CYLINDER</b>		
Manual Transmission . . . . .	200	CCA
Powerglide . . . . .	200	CCA
<b>"350"—8 CYLINDER</b>		
Powerglide . . . . .	245	CGB
T.H. 400 . . . . .	330	CGR
Manual Transmission . . . . .	270	CGK
T.H. 350 . . . . .	270	CGL
Manual Transmission . . . . .	330	CGP
T.H. 350 . . . . .	270	CJD
Manual Transmission . . . . .	270	CJG
<b>"400"—8 CYLINDER</b>		
T.H. 400 . . . . .	350	CLD
Manual Transmission . . . . .	350	CLC

# ENGINE SERIES NUMBER AND SUFFIX CHART (Cont.)

1972

## CHEVROLET

### "250"—6 CYLINDER

Manual Transmission	CNJ
Powerglide	CBJ
Manual Transmission, Police and Taxi	CBH
Powerglide, Police and Taxi	CBK
Powerglide, w/A.I.R.	CDL

### "350"—8 CYLINDER

Manual Transmission	CSJ
T.H.	CKB
T.H. Police and Taxi, w/NB2	CAR
T.H. Police and Taxi	CSH
T.H. w/NB2	CDB

### "400"—8 CYLINDER

Manual Transmission (L-S3)	CLB
T.H. (L-F6)	CKP
Manual Transmission, Police (L-S3)	CLR
T.H., w/NB2 (L-F6)	CAT
Manual Transmission, w/A.I.R. (L-S3)	CTB
Manual Transmission, Police, w/A.I.R. (L-S3)	CTJ
T.H., Police (L-F6)	CDL
T.H., Police, w/NB2 (L-F6)	CDM

### "454"—8 CYLINDER

T.H.	CPD
T.H. Police	CPG
T.H. w/A.I.R.	CRW
T.H. Police, w/A.I.R.	CRY

## CHEVELLE

### "250"—6 CYLINDER

Powerglide	CBJ
Manual Transmission	CBG
Powerglide, w/NB2	CSD
Manual Transmission w/NB2	CBA
Powerglide, Taxi	CBK
Manual Transmission, Taxi, w/NB2	CBD

### "307"—8 CYLINDER

Manual Transmission	CKG
Powerglide	CKH
Manual Transmission w/NB2	CAY
Powerglide, w/NB2	CAZ
T.H.	CTK
T.H., w/NB2	CMA

### "350"—8 CYLINDER

Manual Transmission (L-48)	CKK
*Manual Transmission (L-65)	CKA
*T.H. (L-65)	CTL
*T.H. (L-48)	CKD
T.H., Police	CSH
*Manual Transmission, w/NB2 (L-65)	CDA
Manual Transmission, w/NB2 (L-48)	CDG
*T.H., w/NB2, (L-65)	CMD
*T.H., w/NB2 (L-48)	CDD
T.H., Police, w/NB2	CAR
Powerglide (L-65) (Monte Carlo only)	CKB
Powerglide (L-65) w/NB2 (Monte Carlo only)	CDB

\*Includes Monte Carlo

# ENGINE SERIES NUMBER AND SUFFIX CHART (Cont.)

## "400"—8 CYLINDER

Manual Transmission	CLA-CLS
*T.H.	CLB
Manual Transmission, w/A.I.R., Police and Taxi	CTA
T.H., w/A.I.R.	CTB
*T.H., w/A.I.R., Police and Taxi	CTJ
H.D. 3-Speed, w/A.I.R.	CTH
*Includes Monte Carlo	

## "454"—8 CYLINDER

Manual Transmission	CPA
*T.H.	CPD
Manual Transmission, w/A.I.R.	CRX
*T.H., w/A.I.R.	CRW
*Includes Monte Carlo	

## NOVA

### "250"—6 CYLINDER

Manual Transmission	CBG
Powerglide	CBJ
Manual Transmission, Taxi	CAL
Powerglide, Taxi	CBK
Manual Transmission, w/A.I.R.	CDM
Powerglide, w/A.I.R.	CDL
Manual Transmission, w/NB2	CBA
Powerglide, w/NB2	CSD

### "307"—8 CYLINDER

Manual Transmission	CKG
Powerglide	CKH
T.H.	CTK
Manual Transmission, w/NB2	CAY
Powerglide, w/NB2	CAZ
T.H., w/NB2	CMA

### "350"—8 CYLINDER

Manual Transmission (L-65)	CKA
T.H. (L-65)	CTL
Manual Transmission (L-48)	CKK
T.H. (L-48)	CKD
Manual Transmission (L-48) w/A.I.R.	CRL
T.H. (L-48) w/A.I.R.	CRK
Manual Transmission (L-65) w/NB2	CDA
T.H. (L-65) w/NB2	CMD
Manual Transmission (L-48) w/NB2	CDG
T.H. (L-48) w/NB2	CDD

## CAMARO

### "250"—6 CYLINDER

Manual Transmission	CBG
Powerglide	CBJ
Manual Transmission, w/A.I.R.	CDM
Powerglide, w/A.I.R.	CDL
Manual Transmission, w/NB2	CBA
Powerglide, w/NB2	CSD

### "307"—8 CYLINDER

Manual Transmission	CKG
Powerglide	CKH
T.H.	CTK
Manual Transmission, w/NB2	CAY
Powerglide, w/NB2	CAZ
T.H., w/NB2	CAZ-CMA

# ENGINE SERIES NUMBER AND SUFFIX CHART (Cont.)

## "350"—8 CYLINDER

Manual Transmission (L65) .....	CKA
T.H. (L65) .....	CTL
Manual Transmission (L65), w/A.I.R. ....	CRG
T.H. (L65), w/A.I.R. ....	CRD
Manual Transmission (L48) .....	CKK
T.H. (L48) .....	CKD
Manual Transmission (L65), w/NB2 .....	CMH
T.H. (L65), w/NB2 .....	CMB
Manual Transmission (L48), w/NB2 .....	CDG
T.H. (L48), w/NB2 .....	CDD
Manual Transmission (Z28) .....	CKS
T.H. (Z28) .....	CKT

## "400"—8 CYLINDER

Manual Transmission .....	CLA
T.H. ....	CLB
Manual Transmission, w/A.I.R. ....	CTA
T.H., w/A.I.R. ....	CTB



# ENGINE SERIES NUMBER AND SUFFIX CHART (Cont.)

1973

## PASSENGER

## CHEVELLE

### 250 C.I.D.

Manual Trans. . . . . CCL  
Manual Trans. w/NB2 . . . . . CCM

### 350 C.I.D. (L65)

T.H. . . . . CKL  
T.H. . . . . CKS  
T.H. w/NB2 . . . . . CKK  
T.H. w/NB2 . . . . . CLT  
T.H. . . . . CLU  
T.H. w/NB2 . . . . . CLW  
. . . . . CLX

### 350 C.I.D. (L48)

T.H. w/NB2 . . . . . CKR  
T.H. w/NB2 . . . . . CKD  
T.H. . . . . CKJ

### 400 C.I.D.

T.H. . . . . CSA  
T.H. . . . . CSB  
T.H. w/NB2 . . . . . CSC

T.H. w/NB2 . . . . . CSD  
T.H. . . . . CSK  
T.H. w/NB2 . . . . . CSL  
. . . . . CSM  
T.H. w/NB2 . . . . .

### 454 C.I.D.

T.H. w/NB2 . . . . . CWD  
T.H. w/NB2 . . . . . CWJ  
T.H. . . . . CWL  
T.H. . . . . CWK

### 250 C.I.D.

T.H. . . . . CCA  
T.H. w/NB2 . . . . . CCB  
Manual Trans. . . . . CCC  
Manual Trans. w/NB2 . . . . . CCD

### 307 C.I.D.

T.H. . . . . CHA  
Manual Trans. . . . . CHB  
T.H. w/NB2 . . . . . CHC  
Manual Trans. w/NB2 . . . . .

### 350 C.I.D.

Manual Trans. . . . . CKA  
T.H. . . . . CKL  
Manual Trans (4 Speed) . . . . . CKB  
Manual Trans. w/NB2 . . . . . CKC  
T.H. w/NB2 . . . . . CKK  
Manual Trans. (4 Speed w/NB2) . . . . . CKH

T.H. w/NB2 . . . . . CKD  
T.H. . . . . CKJ

### 454 C.I.D.

Manual Trans. (4 Speed) w/NB2 . . . . . CWC  
T.H. w/NB2 . . . . . CWD  
Manual Trans. (4 Speed) . . . . . CWA  
T.H. . . . . CWB

# ENGINE SERIES NUMBER AND SUFFIX CHART (Cont.)

1973

## NOVA

## CAMARO

### 250 C.I.D.

### 250 C.I.D.

Powerglide . . . . . CCA  
 Powerglide w/NB2 . . . . . CCB  
 Manual Trans. . . . . CCC  
 Manual Trans. w/NB2 . . . . . CCD

T.H. . . . . CCA  
 T.H. w/NB2 . . . . . CCB  
 Manual Trans. . . . . CCC  
 Manual Trans. w/NB2 . . . . . CCD

### 307 C.I.D.

### 307 C.I.D.

Manual Trans. . . . . CHB  
 T.H. . . . . CHH  
 T.H. w/NB2 . . . . . CHC  
 Manual Trans. w/NB2 . . . . . CHD

Manual Trans. . . . . CHB  
 T.H. . . . . CHH  
 Manual Trans. w/NB2 . . . . . CHJ  
 T.H. w/NB2 . . . . . CHK

### 350 C.I.D.

### 350 C.I.D.

Manual Trans. . . . . CKA  
 T.H. . . . . CKU  
 Manual Trans. . . . . CKB  
 T.H. . . . . CKW  
 Manual Trans. w/NB2 . . . . . CKC  
 T.H. w/NB2 . . . . . CKK  
 T.H. w/NB2 . . . . . CKD  
 Manual Trans. w/NB2 . . . . . CKH

Manual Trnas. (4 Speed) . . . . . CLJ  
 T.H. 400 . . . . . CLK  
 Manual Trans. (4 Speed) (L65) . . . . . CKA  
 T.H. (L08) . . . . . CKU  
 Manual Trans. (L-48) . . . . . CKB  
 T.H. (L65) . . . . . CKW  
 T.H. 400 w/NB2 . . . . . CLL  
 Manual Trans. (4 Speed) w/NB2 . . . . . CLM  
 T.H. (L65) w/NB2 . . . . . CKX  
 Manual Trans. (L65) (4 Speed) w/NB2 . . . . . CKY  
 T.H. (L48) w/NB2 . . . . . CKD  
 Manual Trans. 4 Speed (L48) w/NB2 . . . . . CKH

# ENGINE SERIES NUMBER AND SUFFIX CHART (Cont.)

1974

## PASSENGER

### 350 C.I.D.

T.H. (M-40) w/4BC, NB2 Police, Taxi . . . . . CMK  
 T.H. (M-38) w/2BC . . . . . CMA  
 T.H. (M-38) w/2BC Police, Taxi . . . . . CMD  
 T.H. (M-40) w/4BC . . . . . CMH  
 T.H. (M-40) w/4BC . . . . . CMH  
 T.H. (M-40) w/4BC, Police . . . . . CMJ  
 T.H. (M-40) w/4BC, NB2 . . . . . CKD

### 400 C.I.D.

T.H. (M-40) w/4BC, NB2 . . . . . CTC  
 T.H. (M-40) w/4BC . . . . . CTD  
 T.H. (M-40) w/4BC, NB-2, Police . . . . . CTK  
 T.H. (M-40) w/4BC . . . . . CTJ  
 T.H. (M-40) w/2BC . . . . . CTA  
 T.H. (M-40) w/2BC, Police . . . . . CTB  
 T.H. (M-40) w/2BC, NB2 . . . . . CSU  
 T.M. (M-40) w/2BC . . . . . CSW

### 454 C.I.D.

T.H. (M-40) w/4BC, Police . . . . . CWU  
 T.H. (M-40) w/4BC, NB-2, Police . . . . . CWW  
 T.H. (M-40) w/4BC, NB-2 . . . . . CWY  
 T.H. (M-40) w/4BC, NB2 . . . . . CXA  
 T.H. (M-40) w/4BC, NB2 . . . . . CXB  
 T.H. (M-40) w/4BC, NB2 . . . . . CXC  
 T.H. (M-40) w/4BC . . . . . CXT  
 T.H. (M-40) w/4BC . . . . . CXU

### CHEVELLE

#### 250 C.I.D.

3-Speed (M-15) . . . . . CCR  
 T.H. (M-38) w/NB2 . . . . . CCW  
 T.H. (M-38) . . . . . CCX

#### 350 C.I.D.

3-Speed (M-15) w/2BC . . . . . CMC  
 T.H. (M-38) w/2BC . . . . . CMR  
 3-Speed (M-15) w/4BC . . . . . CKH  
 T.H. (M-38) w/4BC, NB2 . . . . . CKD

#### 400 C.I.D.

T.H. (M-38) w/4BC, NB2 . . . . . CTC  
 T.H. (M-38) w/4BC . . . . . CTA  
 T.H. (M-38) w/4BC . . . . . CSU  
 T.H. (M-38) w/4BC . . . . . CSX

### 454 C.I.D.

4-Speed w/4BC . . . . . CWA  
 T.H. (M-40) w/4BC . . . . . CWX  
 T.H. (M-40) w/4BC, NB2 . . . . . CWD  
 4-Speed w/4BC . . . . . CXM  
 T.H. (M-40) w/4BC . . . . . CXR  
 T.H. (M-40) w/4BC . . . . . CXS

## NOVA

### 250 C.I.D.

3-Speed . . . . . CCR  
 T.H. (M-38) w/NB2 . . . . . CCW  
 T.H. (M-38) . . . . . CCK

### 350 C.I.D.

3-Speed w/2BC . . . . . CMC  
 T.H. (M-38) w/2BC . . . . . CMA  
 4-Speed w/4BC . . . . . CKB  
 3-Speed, 4-Speed w/4BC, NB2 . . . . . CKH  
 T.H. (M-38) w/4BC . . . . . CKU  
 T.H. (M-38) w/4BC, NB2 . . . . . CKD

## CAMARO

### 250 C.I.D.

3-Speed . . . . . CCR  
 T.H. (M-38) w/4BC, NB2 . . . . . CCW  
 T.H. (M-38) . . . . . CCX

### 350 C.I.D.

T.H. (M-38) w/2BC . . . . . CMA  
 3-Speed, 4-Speed w/2BC . . . . . CMC  
 T.H. (M-40) w/4BC, Z28 . . . . . CMT  
 4-Speed w/4BC . . . . . CMS  
 3-Speed, 4-Speed w/4BC . . . . . CKB  
 3-Speed, 4-Speed w/4BC, NB2 . . . . . CKH  
 4-Speed w/4BC, Z28 . . . . . CLJ  
 T.H. (M-38) w/4BC . . . . . CKU  
 T.H. (M-38) w/4BC, NB2 . . . . . CKD  
 T.H. (M-40) w/4BC . . . . . CLK

# ENGINE SERIES NUMBER AND SUFFIX CHART (Cont.)

1975

PASSENGER		NOVA	
<b>350 C.I.D.</b>		<b>250 C.I.D.</b>	
CMX	CRY	CJL	.CJS
CMY	CRZ	CJM	CJT
CRU	CRF	KJR	CJU
CRW	CRS		
CRX			
<b>400 C.I.D.</b>		<b>262.5 C.I.D.</b>	
CSH	CTL	CZF	CZK
CSR	CTM	CZH	CZL
CSS	CTR	CZJ	CZM
CST	CTS		
<b>454 C.I.D.</b>		<b>350 C.I.D.</b>	
CXK	CXX	CMU	CRX
CXL	CXY	CMY	CUH
		CRC	CUJ
		CRD	CRZ
		CRT	CUM
		CRU	CUS
<b>CHEVELLE</b>		<b>CAMARO</b>	
<b>250 C.I.D.</b>		<b>250 C.I.D.</b>	
CJL	CJT		
CJR	CJU		
	CJS	CJL	CJT
			CJU
<b>350 C.I.D.</b>		<b>350 C.I.D.</b>	
CMY	CRX	CMU	CRX
CRU	CR2	CMB	CHW
CMJ	CUS		CML
CMH	CMM		
<b>400 C.I.D.</b>			
CTU	CTB		
CTX			
<b>454 C.I.D.</b>			
	CXW		

# ENGINE SERIES NUMBER AND SUFFIX CHART (Cont.)

## VEGA

STAMPING LOCATION — 4 cylinder-stamped opposite the number three cyl. on the right side of the case on the pad on the left side as close to the rear of pad as possible.

8 cylinder-stamped on top front of right hand bank of cylinder and case, as close as possible to upper end of pad.

### 1971

#### BASE ENGINE

Powerglide or Torque Drive . . . . . CHA  
Manual Transmission . . . . . CHC

#### OPTIONAL ENGINE

Powerglide or Torque Drive . . . . . CHB  
Manual Transmission . . . . . CHD

### 1972

#### BASE ENGINE

Torque Drive, Powerglide, T.H. 350 . . . . . CND  
Manual Transmission . . . . . CNA  
Manual Transmission . . . . . CGB  
Torque Drive, Powerglide . . . . . CGD

#### OPTIONAL ENGINE

Powerglide, T.H. 350 . . . . . CSK  
Manual Transmission . . . . . CNB  
Powerglide, T.H. 350 . . . . . CBM

# ENGINE SERIES NUMBER AND SUFFIX CHART (Cont.)

## VEGA

1973-74

### BASE ENGINE

Manual Transmission (exc. NB-2)	CAA
Powerglide, T.H. 350 (exc. NB-2)	CAB
Powerglide, T.H. 350, NB-2	CAH
Manual Transmission, NB-2	CAJ
4-Speed (1974)	ZCR

### OPTIONAL ENGINE

Powerglide, T.H. 350 (exc. NB-2)	CAC
Manual Transmission (exc. NB-2)	CAD
Powerglide, T.H. 350, NB-2	CAK
Manual Transmission, NB-2	CAL

### 140 C.I.D.

Manual (exc. NB-2)	CAM	Manual	CAW
TH 350 (exc. NB-2)	CAR	Manual	CBB
Manual w/NB-2	CAS	TH 350	CBC
TH 350 w/NB-2	CAT	Manual	CBD
TH 350	CAU	TH 350	CBF

### 262.5 C.I.D.

4-Spd. w/NB-2	CZA	4-Spd. w/A.I.R. (exc. NB-2)	CZT
TH 350 w/NB-2	CZB	TH 350 w/A.I.R. (exc. NB-2)	CZU
4-Spd. (exc. A.I.R. NB-2)	CZC	4-Spd. w/NB-2, N56	CZW
TH 350 (exc. A.I.R. NB-2)	CZD		

## 1975

### 122 C.I.D.

ZCA

### 140 C.I.D.

CAF	CAC
CAH	CAB
CAA	CAJ
CAK	CAD

### 262.5 C.I.D.

CZT CZU

### 350 C.I.D.

CHY

## PASSENGER REAR AXLE IDENTIFICATION

Series	Type	Plant Identification G & A Buffalo	Series	Type	Plant Identification G & A Buffalo Warren
<b>1965</b>					
PASS. . . . .	(3.08 ratio) . . . . .	DA	CHEVELLE . . . . .	Positraction w/Metallic Brakes (3.70 ratio) . . . . .	CS
PASS. . . . .	(3.36 ratio) . . . . .	DB	CHEVELLE . . . . .	w/Metallic Brakes (3.73 ratio) . . . . .	CT
PASS. . . . .	(3.55 ratio) . . . . .	DC	CHEVELLE . . . . .	Positraction w/Metallic Brakes (3.73 ratio) . . . . .	CU
PASS. . . . .	(3.31 ratio) . . . . .	DD	CHEVELLE . . . . .	Overdrive (3.70 ratio) . . . . .	CV
PASS. . . . .	(3.31 ratio) (Taxi, Police) . . . . .	DE	CHEVELLE . . . . .	(3.31 ratio) "327" w/Air Cond. . . . .	CW
PASS. . . . .	Positraction (3.07 ratio) . . . . .	DF	CHEVELLE . . . . .	(3.07 ratio) "327" . . . . .	CX
PASS. . . . .	Positraction (3.08 ratio) . . . . .	DG	CHEVY . . . . .	(3.08 ratio) . . . . .	BA
PASS. . . . .	Positraction (3.31 ratio) . . . . .	DH	CHEVY . . . . .	(3.36 ratio) . . . . .	BC
PASS. . . . .	Positraction (3.36 ratio) . . . . .	DI	CHEVY . . . . .	Positraction (3.08 ratio) . . . . .	BE
PASS. . . . .	Positraction (3.55 ratio) (small ring gear) . . . . .	DJ	CHEVY . . . . .	Positraction (3.36 ratio) . . . . .	BF
PASS. . . . .	Positraction (3.55 ratio) (large ring gear) . . . . .	DK	CHEVY . . . . .	Positraction (3.55 ratio) . . . . .	BG
PASS. . . . .	Positraction (3.70 ratio) . . . . .	DL	CHEVY . . . . .	w/Metallic Brakes (2.73 ratio) . . . . .	BZ
PASS. . . . .	Positraction (3.73 ratio) . . . . .	DM	CHEVY . . . . .	Positraction w/Metallic Brakes (2.73 ratio) . . . . .	FD
PASS. . . . .	Positraction (4.10 ratio) . . . . .	DN	CHEVY . . . . .	327 w/Powerglide (2.73 ratio) . . . . .	BX
PASS. . . . .	Positraction (4.56 ratio) . . . . .	DO	CHEVY . . . . .	Positraction (2.75 ratio) . . . . .	BY
PASS. . . . .	Positraction (4.88 ratio) . . . . .	DP	CHEVY . . . . .	w/Metallic Brakes (3.08 ratio) . . . . .	BJ
PASS. . . . .	(3.55 ratio) . . . . .	DQ	CHEVY . . . . .	Positraction w/Metallic Brakes (3.08 ratio) . . . . .	BK
PASS. . . . .	w/Metallic Brakes (307) . . . . .	DR	CHEVY . . . . .	w/Metallic Brakes (3.36 ratio) . . . . .	BL
PASS. . . . .	Positraction w/Metallic Brakes (3.07 ratio) . . . . .	DS	CHEVY . . . . .	Positraction w/Metallic Brakes (3.36 ratio) . . . . .	BM
PASS. . . . .	w/Metallic Brakes (3.08 ratio) . . . . .	DT	CHEVY . . . . .	w/Metallic Brakes (3.55 ratio) . . . . .	BN
PASS. . . . .	Positraction w/Metallic Brakes (3.08 ratio) . . . . .	DU	<b>1966</b>		
PASS. . . . .	w/Metallic Brakes (3.31 ratio) . . . . .	DV	PASS. . . . .	(3.08 ratio) . . . . .	DA
PASS. . . . .	Positraction w/Metallic Brakes . . . . .	DW	PASS. . . . .	(3.36 ratio) . . . . .	DB
PASS. . . . .	w/Metallic Brakes (3.36 ratio) . . . . .	DX	PASS. . . . .	(3.55 ratio) (H.D. and C.R. 4 Spd.) . . . . .	DC
PASS. . . . .	Positraction w/Metallic Brakes (3.36 ratio) . . . . .	DY	PASS. . . . .	(3.31 ratio) . . . . .	DD
PASS. . . . .	w/Metallic Brakes (3.55 ratio) . . . . .	DZ	PASS. . . . .	(3.31 ratio) (Taxi, Police) . . . . .	DE
PASS. . . . .	Positraction w/Metallic Brakes (3.55 ratio) . . . . .	EA	PASS. . . . .	Positraction (3.07 ratio) . . . . .	DF
PASS. . . . .	w/Metallic Brakes (3.55 ratio) . . . . .	EB	PASS. . . . .	Positraction (3.08 ratio) . . . . .	DG
PASS. . . . .	Positraction w/Metallic Brakes (3.55 ratio) . . . . .	EC	PASS. . . . .	Positraction (3.31 ratio) . . . . .	DH
PASS. . . . .	w/Metallic Brakes (3.70 ratio) . . . . .	ED	PASS. . . . .	Positraction (3.36 ratio) . . . . .	DI
PASS. . . . .	Positraction w/Metallic Brakes (3.70 ratio) . . . . .	EE	PASS. . . . .	Positraction (3.55 ratio) (small ring gear) . . . . .	DJ
PASS. . . . .	w/Metallic Brakes (3.73 ratio) . . . . .	EF	PASS. . . . .	Positraction (3.55 ratio) (large ring gear) . . . . .	DK
PASS. . . . .	Positraction w/Metallic Brakes (3.73 ratio) . . . . .	EG	PASS. . . . .	Positraction (3.70 ratio) . . . . .	DL
PASS. . . . .	w/Metallic Brakes (4.10 ratio) . . . . .	EH	PASS. . . . .	Positraction (3.73 ratio) . . . . .	DM
PASS. . . . .	w/Metallic Brakes (4.56 ratio) . . . . .	EI	PASS. . . . .	Positraction (4.10 ratio) . . . . .	DN
PASS. . . . .	w/Metallic Brakes (4.88 ratio) . . . . .	EJ	PASS. . . . .	Positraction (4.56 ratio) . . . . .	DO
PASS. . . . .	w/Overdrive (3.70 ratio) . . . . .	EK	PASS. . . . .	Positraction (4.88 ratio) . . . . .	DP
PASS. . . . .	Overdrive (3.73 ratio) . . . . .	EL	PASS. . . . .	(3.55 ratio) . . . . .	DQ
PASS. . . . .	(3.07 ratio) . . . . .	EM	PASS. . . . .	w/Metallic Brakes (307) . . . . .	DR
PASS. . . . .	Powerglide "327" (3.07 ratio) . . . . .	EN	PASS. . . . .	Positraction w/Metallic Brakes (3.07 ratio) . . . . .	DS
PASS. . . . .	(3.55 ratio) . . . . .	EO	PASS. . . . .	w/Metallic Brakes (3.08 ratio) . . . . .	DT
CHEVELLE . . . . .	327 w/Powerglide (2.73 ratio) . . . . .	GB	PASS. . . . .	Positraction w/Metallic Brakes (3.08 ratio) . . . . .	DU
CHEVELLE . . . . .	Positraction (2.73 ratio) . . . . .	GC	PASS. . . . .	w/Metallic Brakes (3.31 ratio) . . . . .	DV
CHEVELLE . . . . .	Metallic Brakes (2.73 ratio) . . . . .	GD	PASS. . . . .	Positraction w/Metallic Brakes . . . . .	DW
CHEVELLE . . . . .	Positraction w/Metallic Brakes (2.73 ratio) . . . . .	GE	PASS. . . . .	w/Metallic Brakes (3.36 ratio) . . . . .	DX
CHEVELLE . . . . .	(3.08 ratio) . . . . .	CA	PASS. . . . .	Positraction w/Metallic Brakes (3.36 ratio) . . . . .	DY
CHEVELLE . . . . .	(3.36 ratio) . . . . .	CB	PASS. . . . .	w/Metallic Brakes (3.55 ratio) (small ring gear) . . . . .	DZ
CHEVELLE . . . . .	(3.73 ratio) . . . . .	CC	PASS. . . . .	Positraction w/Metallic Brakes (3.55 ratio) . . . . .	
CHEVELLE . . . . .	Positraction (3.07 ratio) . . . . .	CD		(small ring gear) . . . . .	EA
CHEVELLE . . . . .	Positraction (3.08 ratio) . . . . .	CE	PASS. . . . .	w/Metallic Brakes (3.55 ratio) (large ring gear) . . . . .	EB
CHEVELLE . . . . .	Positraction (3.31 ratio) . . . . .	CF	PASS. . . . .	Positraction w/Metallic Brakes (3.55 ratio) . . . . .	
CHEVELLE . . . . .	Positraction (3.36 ratio) . . . . .	CG		(large ring gear) . . . . .	EC
CHEVELLE . . . . .	Positraction (3.70 ratio) . . . . .	CR	PASS. . . . .	w/Metallic Brakes (3.70 ratio) . . . . .	ED
CHEVELLE . . . . .	Positraction (3.73 ratio) . . . . .	CI	PASS. . . . .	Positraction w/Metallic Brakes (3.70 ratio) . . . . .	EE
CHEVELLE . . . . .	w/Metallic Brakes (3.07 ratio) . . . . .	CJ	PASS. . . . .	w/Metallic Brakes (3.73 ratio) . . . . .	EF
CHEVELLE . . . . .	Positraction w/Metallic Brakes (3.07 ratio) . . . . .	CK	PASS. . . . .	Positraction w/Metallic Brakes (3.73 ratio) . . . . .	EG
CHEVELLE . . . . .	w/Metallic Brakes (3.08 ratio) . . . . .	CL	PASS. . . . .	w/Metallic Brakes (4.10 ratio) . . . . .	EH
CHEVELLE . . . . .	Positraction w/Metallic Brakes (3.08 ratio) . . . . .	CM	PASS. . . . .	w/Metallic Brakes (4.56 ratio) . . . . .	EI
CHEVELLE . . . . .	w/Metallic Brakes (3.31 ratio) . . . . .	CN	PASS. . . . .	w/Metallic Brakes (4.88 ratio) . . . . .	EJ
CHEVELLE . . . . .	Positraction w/Metallic Brakes (3.31 ratio) . . . . .	CO	PASS. . . . .	w/Overdrive (3.70 ratio) . . . . .	EK
CHEVELLE . . . . .	w/Metallic Brakes (3.36 ratio) . . . . .	CP	PASS. . . . .	Overdrive (3.73 ratio) . . . . .	EL
CHEVELLE . . . . .	Positraction w/Metallic Brakes (3.36 ratio) . . . . .	CQ	PASS. . . . .	(3.07 ratio) . . . . .	EM
CHEVELLE . . . . .	w/Metallic Brakes (3.70 ratio) . . . . .	CH	PASS. . . . .	Powerglide "327" (3.07 ratio) . . . . .	EN
			PASS. . . . .	(3.55 ratio) (H.D. Chassis) . . . . .	EO
			PASS. . . . .	(2.73 ratio) . . . . .	EP

NOTE: Plant designation is to be stamped immediately following the production date. "B" Buffalo Plant, "G" Gear and Axle Plant, and "W" Warren Plant.

## PASSENGER REAR AXLE IDENTIFICATION (Cont.)

Series	Type	Plant Identification G & A Buffalo Warren	Series	Type	Plant Identification G & A Buffalo Warren
PASS....	Positraction (2.73 ratio)	EQ	CHEVELLE.	(3.55 ratio)	KJ
PASS....	Positraction w/3-Spd. Auto. Trans. (2.73 ratio)	ER	CHEVELLE.	w/Metallic Brakes (4.10 ratio)	KL
PASS....	Positraction w/Metallic Brakes (2.73 ratio)	ES	CHEVELLE.	w/Metallic Brakes (4.56 ratio)	KN
PASS....	(3.27") (3.31 ratio)	EU	CHEVELLE.	w/Metallic Brakes (4.88 ratio)	KP
PASS....	(Sta. Wag.) Positraction w/Metallic Brakes (3.70 ratio)	EW	CHEVELLE.	Positraction (4.10 ratio)	KK
PASS....	(Sta. Wag.) w/Overdrive (3.70 ratio)	EX	CHEVELLE.	Positraction (4.56 ratio)	KM
PASS....	(Sta. Wag.) Positraction (3.70 ratio)	EY	CHEVELLE.	Positraction (4.88 ratio)	KO
PASS....	(Sta. Wag.) w/Metallic Brakes (3.70 ratio)	EZ	CHEVY...	(3.08 ratio)	BA
PASS....	3-Speed Auto. Trans. with C.A.C. (3.07 ratio)	GA	CHEVY...	(3.36 ratio)	BC
PASS....	Positraction w/3-Spd. Auto. Trans. (3.07 ratio)	GF	CHEVY...	Positraction (3.08 ratio)	BE
PASS....	Metallic Brakes w/3-Spd. Auto. Trans. (3.07 ratio)	GG	CHEVY...	Positraction (3.36 ratio)	BF
PASS....	Positraction (3.31 ratio)	GJ	CHEVY...	Positraction (3.55 ratio) (small ring gear)	BG
PASS....	3-Spd. Auto. Trans. with C.A.C. (3.31 ratio)	GI	CHEVY...	(3.55)	BH
PASS....	Metallic Brakes (3.07 ratio)	GL	CHEVY...	w/Metallic Brakes (3.08 ratio)	BJ
PASS....	Metallic Brakes (3.31 ratio)	GN	CHEVY...	Positraction w/Metallic Brakes (3.08 ratio)	BK
PASS....	Positraction w/Metallic Brakes (3.31 ratio)	GO	CHEVY...	w/Metallic Brakes (3.36 ratio)	BL
PASS....	(3.55 ratio)	GP	CHEVY...	Positraction w/Metallic Brakes (3.36 ratio)	BM
PASS....	Powerglide "327" (3.08 ratio)	GQ	CHEVY...	w/Metallic Brakes (3.55 ratio) (small ring gear)	BN
PASS....	Positraction (3.08 ratio)	GR	CHEVY...	Positraction w/Metallic Brakes (3.55 ratio)	BO
PASS....	w/Metallic Brakes (3.08 ratio)	GS	CHEVY...	Air Cond. w/Sp. Hi Per. (3.31 ratio)	BQ
PASS....	Positraction w/Metallic Brakes (3.08 ratio)	GT	CHEVY...	Positraction (3.07 ratio)	BR
PASS....	Positraction (3.36 ratio)	GU	CHEVY...	Positraction (3.31 ratio)	BS
PASS....	w/Metallic Brakes (3.36 ratio)	GV	CHEVY...	w/Metallic Brakes (3.07 ratio)	BT
PASS....	Positraction w/Metallic Brakes (3.36 ratio)	GW	CHEVY...	Positraction w/Metallic Brakes (3.07 ratio)	BU
PASS....	(Sta. Wag.) Positraction (3.55 ratio) (small ring gear)	GX	CHEVY...	w/Metallic Brakes (3.31 ratio)	BV
PASS....	(Sta. Wag.) w/Metallic Brakes (3.55 ratio) (small ring gear)	GY	CHEVY...	Positraction w/Metallic Brakes (3.31 ratio)	BW
PASS....	(Sta. Wag.) Positraction w/Metallic Brakes (3.55 ratio) (small ring gear)	GZ	CHEVY...	w/4-Spd. Close Ratio (3.55 ratio)	FI
CHEVELLE.	(3.08 ratio)	CA	CHEVY...	w/Metallic Brakes (3.55 ratio) (large ring gear)	FJ
CHEVELLE.	(3.36 ratio)	CB	CHEVY...	Positraction w/Metallic Brakes (3.55 ratio) (large ring gear)	FK
CHEVELLE.	(3.73 ratio)	CC	CHEVY...	Positraction (3.55 ratio) (large ring gear)	FL
CHEVELLE.	Positraction (3.07 ratio)	CD	CHEVY...	(3.73 ratio)	FM
CHEVELLE.	Positraction (3.08 ratio)	CE	CHEVY...	w/Metallic Brakes (3.73 ratio)	FN
CHEVELLE.	Positraction (3.31 ratio)	CF	CHEVY...	Positraction w/Metallic Brakes (3.73 ratio)	FO
CHEVELLE.	Positraction (3.36 ratio)	CG	CHEVY...	Positraction (3.73 ratio)	FP
CHEVELLE.	w/Metallic Brakes (3.70 ratio)	CH	CHEVY...	w/"327" Sp. Hi. Per. (3.07 ratio)	FP
CHEVELLE.	Positraction (3.73 ratio)	CI			FQ
CHEVELLE.	w/Metallic Brakes (3.07 ratio)	CJ			
CHEVELLE.	Positraction w/Metallic Brakes (3.07 ratio)	CK			
CHEVELLE.	w/Metallic Brakes (3.08 ratio)	CL			
CHEVELLE.	Positraction w/Metallic Brakes (3.08 ratio)	CM	PASS....	(3.08 ratio)	DA
CHEVELLE.	w/Metallic Brakes (3.31 ratio)	CN	PASS....	(3.36 ratio)	DB
CHEVELLE.	Positraction w/Metallic Brakes (3.31 ratio)	CO	PASS....	(3.55 ratio) (H.D. and C.R. 4-Spd.)	DC
CHEVELLE.	w/Metallic Brakes (3.36 ratio)	CP	PASS....	(3.31 ratio)	DD
CHEVELLE.	Positraction w/Metallic Brakes (3.36 ratio)	CQ	PASS....	Heavy Duty (3.31 ratio)	DE
CHEVELLE.	Positraction (3.70 ratio)	CR	PASS....	Positraction (3.07 ratio)	DF
CHEVELLE.	Positraction w/Metallic Brakes (3.70 ratio)	CS	PASS....	Positraction (3.08 ratio)	DG
CHEVELLE.	w/Metallic Brakes (3.73 ratio)	CT	PASS....	Positraction (3.31 ratio)	DH
CHEVELLE.	Positraction w/Metallic Brakes (3.73 ratio)	CU	PASS....	Positraction (3.36 ratio)	DI
CHEVELLE.	Overdrive (3.70 ratio)	CV	PASS....	Positraction (3.55 ratio) (small ring gear)	DJ
CHEVELLE.	(3.31 ratio) "396" w/Air Cond.	CW	PASS....	Positraction (3.55 ratio) (large ring gear)	DK
CHEVELLE.	(3.07 ratio) "396" w/Air Cond. and PG	CX	PASS....	Positraction (3.70 ratio)	DL
CHEVELLE.	w/Metallic Brakes (3.55 ratio)	KF	PASS....	Positraction (3.73 ratio)	DM
CHEVELLE.	Positraction w/Metallic Brakes (3.55 ratio)	KG	PASS....	Positraction (4.10 ratio)	DN
CHEVELLE.	Positraction (3.55 ratio)	KH	PASS....	Positraction (4.56 ratio)	DO
CHEVELLE.	"396" w/PG (2.73 ratio)	KI	PASS....	Positraction (4.88 ratio)	DP
			PASS....	(3.55 ratio)	DQ
			PASS....	w/Metallic Brakes (3.07 ratio)	DR
			PASS....	Positraction (3.07 ratio)	DS
			PASS....	w/Metallic Brakes (3.31 ratio)	DV
			PASS....	Positraction w/Metallic Brakes (3.31 ratio)	DW
			PASS....	w/Metallic Brakes (3.55 ratio) (large ring gear)	EB
			PASS....	Positraction w/Metallic Brakes (3.55 ratio) (large ring gear)	EC
			PASS....	w/Metallic Brakes (3.73 ratio)	EF

**1967**

NOTE: The four digit number following the type designation will designate the calendar month and data produced.

NOTE: Plant designation is to be stamped immediately following the production date. "B" Buffalo Plant, "G" Gear and Axle Plant, and "W" Warren Plant.



## PASSENGER REAR AXLE IDENTIFICATION (Cont.)

Series	Type	Plant Identification	Series	Type	Plant Identification
PASS. . . .	Positraction w/Metallic Brakes (3.73 ratio) . . . .	EG	CHEVELLE.	Positraction (4.56 ratio) . . . . .	KM
PASS. . . .	w/Metallic Brakes (4.10 ratio). . . . .	EH	CHEVELLE.	w/Metallic Brakes (4.56 ratio) . . . . .	KN
PASS. . . .	w/Metallic Brakes (4.56 ratio). . . . .	EI	CHEVELLE.	Positraction (4.88 ratio) . . . . .	KO
PASS. . . .	w/Metallic Brakes (4.88 ratio). . . . .	EJ	CHEVELLE.	w/Metallic Brakes (4.88 ratio) . . . . .	KP
PASS. . . .	(3.70 ratio) . . . . .	EK			
PASS. . . .	(3.73 ratio) (large ring gear) . . . . .	EL			
PASS. . . .	(3.07 ratio) . . . . .	EM			
PASS. . . .	Powerglide "327" (3.07 ratio) . . . . .	EN			
PASS. . . .	(3.55 ratio) (H.D. Chassis) . . . . .	EO			
PASS. . . .	3-Spd. Auto. Trans. (2.73 ratio) . . . . .	EP			
PASS. . . .	Positraction (2.73 ratio) . . . . .	EQ			
PASS. . . .	w/Metallic Brakes (2.73 ratio). . . . .	ER	CHEVY . . .	(3.08 ratio) . . . . .	BA
PASS. . . .	Positraction w/Metallic Brakes (2.73 ratio) . . . .	ES	CHEVY . . .	(3.36 ratio) . . . . .	BC
PASS. . . .	"327" (3.36 ratio) . . . . .	EU	CHEVY . . .	Positraction (3.08 ratio) . . . . .	BE
PASS. . . .	w/Overdrive (3.70 ratio) . . . . .	EX	CHEVY . . .	Positraction (3.36 ratio) . . . . .	BF
PASS. . . .	Positraction (3.70 ratio) . . . . .	EY	CHEVY . . .	Positraction (3.55 ratio) (small ring gear) . . . .	BG
PASS. . . .	(3.07 ratio) (large ring gear) . . . . .	GA	CHEVY . . .	(3.55 ratio) . . . . .	BH
PASS. . . .	w/Metallic Brakes (2.73 ratio) . . . . .	GB	CHEVY . . .	Air Cond. w/Sp. Hi. Per. (3.31 ratio) . . . . .	BQ
PASS. . . .	Positraction w/Metallic Brakes (2.73 ratio) . . . .	GC	CHEVY . . .	Positraction (3.07 ratio) . . . . .	BR
PASS. . . .	(3.07 ratio) (Taxi) . . . . .	GD	CHEVY . . .	Positraction (3.31 ratio) . . . . .	BS
PASS. . . .	(3.31 ratio) (Taxi) . . . . .	GE	CHEVY . . .	w/Metallic Brakes (3.07 ratio) . . . . .	BT
PASS. . . .	Positraction (3.07 ratio) . . . . .	GF	CHEVY . . .	Positraction w/Metallic Brakes (3.07 ratio) . . . .	BU
PASS. . . .	Positraction w/Metallic Brakes (3.07 ratio) . . . .	GG	CHEVY . . .	w/Metallic Brakes (3.31 ratio) . . . . .	BV
PASS. . . .	(3.31 ratio) (large ring gear) . . . . .	GI	CHEVY . . .	Positraction w/Metallic Brakes (3.31 ratio) . . . .	BW
PASS. . . .	Positraction (3.31 ratio) . . . . .	GJ	CHEVY . . .	w/4-Spd. Close Ratio (3.55 ratio) . . . . .	FI
PASS. . . .	(2.73 ratio) . . . . .	GK	CHEVY . . .	w/Metallic Brakes (3.55 ratio) (large ring gear) . . . .	FJ
PASS. . . .	w/Metallic Brakes (3.07 ratio) . . . . .	GL	CHEVY . . .	Positraction w/Metallic Brakes (3.55 ratio) . . . . .	
PASS. . . .	Positraction (2.73 ratio) . . . . .	GM		(large ring gear) . . . . .	FK
PASS. . . .	w/Metallic Brakes (3.31 ratio) . . . . .	GN	CHEVY . . .	Positraction (3.55 ratio) (large ring gear) . . . .	FL
PASS. . . .	Positraction w/Metallic Brakes (3.31 ratio) . . . .	GO	CHEVY . . .	(3.73 ratio) . . . . .	FM
PASS. . . .	(3.55 ratio) . . . . .	GP	CHEVY . . .	w/Metallic Brakes (3.73 ratio) . . . . .	FN
PASS. . . .	(3.08 ratio) (small ring gear) . . . . .	GQ	CHEVY . . .	Positraction w/Metallic Brakes (3.73 ratio) . . . .	FO
PASS. . . .	Positraction (3.08 ratio) . . . . .	GR	CHEVY . . .	Positraction (3.73 ratio) . . . . .	FP
PASS. . . .	Positraction (3.36 ratio) . . . . .	GU	CHEVY . . .	w/"327" Sp. Hi. Per. (3.07 ratio) . . . . .	FQ
PASS. . . .	Positraction (3.55 ratio) (small ring gear) . . . .	GX			

### CHEVY II

### CHEVELLE

CHEVELLE.	(3.08 ratio) . . . . .	CA
CHEVELLE.	(3.36 ratio) . . . . .	CB
CHEVELLE.	(3.73 ratio) . . . . .	CC
CHEVELLE.	Positraction (3.07 ratio) . . . . .	CD
CHEVELLE.	Positraction (3.08 ratio) . . . . .	CE
CHEVELLE.	Positraction (3.31 ratio) . . . . .	CF
CHEVELLE.	Positraction (3.36 ratio) . . . . .	CG
CHEVELLE.	Positraction (2.73 ratio) . . . . .	CH
CHEVELLE.	Positraction (3.73 ratio) . . . . .	CI
CHEVELLE.	w/Metallic Brakes (3.07 ratio) . . . . .	CJ
CHEVELLE.	Positraction w/Metallic Brakes (3.07 ratio) . . . .	CK
CHEVELLE.	w/Metallic Brakes (3.31 ratio) . . . . .	CN
CHEVELLE.	Positraction w/Metallic Brakes (3.31 ratio) . . . .	CO
CHEVELLE.	Positraction (3.70 ratio) . . . . .	CR
CHEVELLE.	w/Metallic Brakes (3.73 ratio) . . . . .	CT
CHEVELLE.	Positraction w/Metallic Brakes (3.73 ratio) . . . .	CU
CHEVELLE.	(3.70 ratio) . . . . .	CV
CHEVELLE.	(3.31 ratio) . . . . .	CW
CHEVELLE.	(3.07 ratio) . . . . .	CX
CHEVELLE.	(2.73 ratio) . . . . .	CZ
CHEVELLE.	Positraction (3.55 ratio) . . . . .	KF
CHEVELLE.	Positraction w/Metallic Brakes (3.55 ratio) . . . .	KG
CHEVELLE.	w/Metallic Brakes (3.55 ratio) . . . . .	KH
CHEVELLE.	(3.55 ratio) . . . . .	KJ
CHEVELLE.	Positraction (4.10 ratio) . . . . .	KK
CHEVELLE.	w/Metallic Brakes (4.10 ratio) . . . . .	KL

### CAMARO

CAMARO .	(3.08 ratio) . . . . .	PA
CAMARO .	(3.36 ratio) . . . . .	PB
CAMARO .	4-Speed "350" (3.31 ratio) . . . . .	PC
CAMARO .	Positraction (3.07 ratio) . . . . .	PD
CAMARO .	Positraction (3.08 ratio) . . . . .	PE
CAMARO .	Positraction (3.31 ratio) . . . . .	PF
CAMARO .	Positraction (3.36 ratio) . . . . .	PG
CAMARO .	Positraction (3.55 ratio) (small ring gear) . . . .	PH
CAMARO .	Positraction (3.55 ratio) large ring gear) . . . .	PI
CAMARO .	Positraction (3.73 ratio) . . . . .	PJ
CAMARO .	4-Speed Trans. (3.55 ratio) . . . . .	PK
CAMARO .	4-Speed Close Ratio (3.55 ratio) . . . . .	PL
CAMARO .	(3.73 ratio) . . . . .	PM
CAMARO .	w/Metallic Brakes (3.07 ratio) . . . . .	PN
CAMARO .	Positraction w/Metallic Brakes (3.07 ratio) . . . .	PO
CAMARO .	w/Metallic Brakes (3.31 ratio) . . . . .	PP
CAMARO .	w/Metallic Brakes (3.55 ratio) (large ring gear) . . . .	PQ
CAMARO .	Positraction w/Metallic Brakes (3.31 ratio) . . . .	PR
CAMARO .	Positraction w/Metallic Brakes (3.55 ratio) . . . . .	
	(large ring gear) . . . . .	PS
CAMARO .	w/Metallic Brakes (3.73 ratio) . . . . .	PT
CAMARO .	Positraction w/Metallic Brakes (3.73 ratio) . . . .	PU
CAMARO .	(3.07 ratio) . . . . .	PV

## PASSENGER REAR AXLE IDENTIFICATION (Cont.)

Series	Type	Plant Identification	Series	Type	Plant Identification
<b>1968</b>					
PASS. . . . .	(3.08 ratio) . . . . .	DA	CHEVELLE . . . . .	(3.73 ratio) . . . . .	CC
PASS. . . . .	(3.36 ratio) . . . . .	DB	CHEVELLE . . . . .	Positraction (3.07 ratio) . . . . .	CD
PASS. . . . .	(3.55 ratio) (Special Susp.) . . . . .	DC	CHEVELLE . . . . .	Positraction (3.08 ratio) . . . . .	CE
PASS. . . . .	(3.31 ratio) . . . . .	DD	CHEVELLE . . . . .	Positraction (3.31 ratio) . . . . .	CF
PASS. . . . .	(3.31 ratio) (heavy duty chassis) . . . . .	DE	CHEVELLE . . . . .	Positraction (3.36 ratio) . . . . .	CG
PASS. . . . .	Positraction (3.07 ratio) . . . . .	DF	CHEVELLE . . . . .	Positraction (2.73 ratio) . . . . .	CH
PASS. . . . .	Positraction (3.08 ratio) . . . . .	DG	CHEVELLE . . . . .	Positraction (3.73 ratio) . . . . .	C1
PASS. . . . .	Positraction (3.31 ratio) . . . . .	DH	CHEVELLE . . . . .	(2.73 ratio) (2.73 ratio) . . . . .	CP
PASS. . . . .	Positraction (3.36 ratio) . . . . .	DI	CHEVELLE . . . . .	Positraction (3.70 ratio) . . . . .	CR
PASS. . . . .	Positraction (3.55 ratio) (small ring gear) . . . . .	DJ	CHEVELLE . . . . .	Positraction w/Metallic Brakes (3.73 ratio) . . . . .	CU
PASS. . . . .	Positraction (3.55 ratio) (large ring gear) . . . . .	DK	CHEVELLE . . . . .	(3.70 ratio) . . . . .	CV
PASS. . . . .	Positraction (3.70 ratio) . . . . .	DL	CHEVELLE . . . . .	(3.31 ratio) . . . . .	CW
PASS. . . . .	Positraction (3.73 ratio) . . . . .	DM	CHEVELLE . . . . .	(3.07 ratio) . . . . .	CX
PASS. . . . .	Positraction (4.10 ratio) . . . . .	DN	CHEVELLE . . . . .	(3.07 ratio) . . . . .	CY
PASS. . . . .	Positraction (4.56 ratio) . . . . .	DO	CHEVELLE . . . . .	(2.73 ratio) . . . . .	CZ
PASS. . . . .	Positraction (4.88 ratio) . . . . .	DP	CHEVELLE . . . . .	(2.73 ratio) (small ring gear) . . . . .	FH
PASS. . . . .	(3.55 ratio) . . . . .	DQ	CHEVELLE . . . . .	Positraction (2.73 ratio) (small ring gear) . . . . .	FI
PASS. . . . .	Positraction (2.73 ratio) (small ring gear) . . . . .	DX	CHEVELLE . . . . .	(3.08 ratio) . . . . .	FJ
PASS. . . . .	Positraction (2.73 ratio) (small ring gear) . . . . .	DY	CHEVELLE . . . . .	Positraction (3.08 ratio) . . . . .	FK
PASS. . . . .	(2.73 ratio) (small ring gear) . . . . .	DZ	CHEVELLE . . . . .	(3.36 ratio) . . . . .	FL
PASS. . . . .	(2.56 ratio) (large ring gear) . . . . .	EA	CHEVELLE . . . . .	Positraction (3.36 ratio) . . . . .	FM
PASS. . . . .	Positraction (2.56 ratio) (small ring gear) . . . . .	ED	CHEVELLE . . . . .	(3.55 ratio) (small ring gear) . . . . .	FN
PASS. . . . .	w/Overdrive (3.70 ratio) . . . . .	EK	CHEVELLE . . . . .	Positraction (3.55 ratio) (small ring gear) . . . . .	FO
PASS. . . . .	(3.73 ratio) (large ring gear) . . . . .	EL	CHEVELLE . . . . .	(3.70 ratio) . . . . .	FP
PASS. . . . .	(3.07 ratio) (large ring gear) . . . . .	EM	CHEVELLE . . . . .	Positraction (3.70 ratio) . . . . .	FQ
PASS. . . . .	(3.07 ratio) . . . . .	EN	CHEVELLE . . . . .	(3.55 ratio) (small ring gear) . . . . .	KA
PASS. . . . .	(3.55 ratio) . . . . .	EO	CHEVELLE . . . . .	Positraction (3.55 ratio) (small ring gear) . . . . .	KB
PASS. . . . .	(2.73 ratio) (large ring gear) . . . . .	EP	CHEVELLE . . . . .	Positraction (2.73 ratio) (small ring gear) . . . . .	KC
PASS. . . . .	Positraction (2.73 ratio) . . . . .	EQ	CHEVELLE . . . . .	(2.73 ratio) (large ring gear) . . . . .	KD
PASS. . . . .	"327" (3.36 ratio) . . . . .	EU	CHEVELLE . . . . .	Positraction (3.55 ratio) (large ring gear) . . . . .	KF
PASS. . . . .	(3.70 ratio) . . . . .	EX	CHEVELLE . . . . .	(3.55 ratio) (large ring gear) . . . . .	KJ
PASS. . . . .	Positraction (3.70 ratio) . . . . .	EY	CHEVELLE . . . . .	Positraction (4.10 ratio) . . . . .	KK
PASS. . . . .	(2.73 ratio) (small ring gear) . . . . .	EZ	CHEVELLE . . . . .	Positraction (4.56 ratio) . . . . .	KM
PASS. . . . .	(2.29 ratio) (large ring gear) . . . . .	FD	CHEVELLE . . . . .	Positraction (4.88 ratio) . . . . .	KO
PASS. . . . .	Positraction (2.29 ratio) (large ring gear) . . . . .	FE	CHEVELLE . . . . .	w/Metallic Brakes (2.73 ratio) . . . . .	KW
PASS. . . . .	(2.56 ratio) (small ring gear) . . . . .	FT	CHEVELLE . . . . .	Positraction (3.07 ratio) . . . . .	KX
PASS. . . . .	Positraction (2.56 ratio) (large ring gear) . . . . .	FV	CHEVELLE . . . . .	Positraction (3.31 ratio) . . . . .	KY
PASS. . . . .	Positraction (2.56 ratio) (large ring gear) . . . . .	FW	CHEVELLE . . . . .	(3.31 ratio) . . . . .	KZ
PASS. . . . .	Positraction (2.56 ratio) (large ring gear) . . . . .	FX	CHEVELLE . . . . .	(3.55 ratio) (large ring gear) . . . . .	K2
PASS. . . . .	(3.07 ratio) (large ring gear) . . . . .	GA	CHEVELLE . . . . .	Positraction (3.55 ratio) (large ring gear) . . . . .	K3
PASS. . . . .	Positraction (3.07 ratio) . . . . .	GF	CHEVELLE . . . . .	(3.73 ratio) . . . . .	K4
PASS. . . . .	Positraction w/H.D. Brake (3.31 ratio) . . . . .	GH	CHEVELLE . . . . .	Positraction (3.73 ratio) . . . . .	K5
PASS. . . . .	(3.31 ratio) (large ring gear) . . . . .	GI	CHEVELLE . . . . .	Positraction (4.10 ratio) . . . . .	K6
PASS. . . . .	Positraction (3.31 ratio) . . . . .	GJ	CHEVELLE . . . . .	Positraction (4.56 ratio) . . . . .	K7
PASS. . . . .	(2.73 ratio) (large ring gear) . . . . .	GK	CHEVELLE . . . . .	Positraction (4.88 ratio) . . . . .	K8
PASS. . . . .	Positraction (2.73 ratio) . . . . .	GM	<b>CHEVY II</b>		
PASS. . . . .	(3.55 ratio) . . . . .	GP	CHEVY . . . . .	(2.56 ratio) (small ring gear) . . . . .	BA
PASS. . . . .	(3.08 ratio) . . . . .	GQ	CHEVY . . . . .	Positraction (2.56 ratio) (small ring gear) . . . . .	BB
PASS. . . . .	Positraction (3.08 ratio) . . . . .	GR	CHEVY . . . . .	(3.36 ratio) . . . . .	BC
PASS. . . . .	(3.07 ratio) (large ring gear) . . . . .	GS	CHEVY . . . . .	Positraction (3.36 ratio) . . . . .	BD
PASS. . . . .	Positraction w/H.D. Brake (3.07 ratio) . . . . .	GT	CHEVY . . . . .	(2.73 ratio) . . . . .	B1
PASS. . . . .	Positraction (3.36 ratio) . . . . .	GU	CHEVY . . . . .	(3.07 ratio) . . . . .	BL
PASS. . . . .	Positraction w/H.D. Brake (3.55 ratio) . . . . .	GV	CHEVY . . . . .	(3.31 ratio) . . . . .	BM
PASS. . . . .	Positraction w/H.D. Brake (3.07 ratio) . . . . .	GW	CHEVY . . . . .	(3.55 ratio) . . . . .	BN
PASS. . . . .	Positraction (3.55 ratio) (small ring gear) . . . . .	GX	CHEVY . . . . .	(3.73 ratio) . . . . .	BO
<b>CHEVELLE</b>					
CHEVELLE . . . . .	(3.08 ratio) . . . . .	CA	CHEVY . . . . .	(2.73 ratio) . . . . .	BP
CHEVELLE . . . . .	(3.36 ratio) . . . . .	CB	CHEVY . . . . .	Positraction (2.73 ratio) (large ring gear) . . . . .	BQ
			CHEVY . . . . .	Positraction (3.07 ratio) . . . . .	BR
			CHEVY . . . . .	Positraction (3.31 ratio) . . . . .	BS
			CHEVY . . . . .	Positraction (3.55 ratio) . . . . .	BT
			CHEVY . . . . .	Positraction (3.37 ratio) . . . . .	BU
			CHEVY . . . . .	Positraction (4.10 ratio) . . . . .	BV
			CHEVY . . . . .	Positraction (4.56 ratio) . . . . .	BW
			CHEVY . . . . .	Positraction (4.88 ratio) . . . . .	BX
			CHEVY . . . . .	(3.08 ratio) . . . . .	PA

# PASSENGER REAR AXLE IDENTIFICATION (Cont.)

Series	Type	Plant Identification	Series	Type	Plant Identification
CHEVY . . .	Positraction (3.08 ratio) . . . . .	PE	PASS. . . . .	(3.31 ratio) . . . . .	DD
CHEVY . . .	Positraction (3.55 ratio) (small ring gear) . . . . .	PH	PASS. . . . .	(3.31 ratio) (heavy duty chassis) . . . . .	DE
CHEVY . . .	(3.55 ratio) . . . . .	PK-PL	PASS. . . . .	Positraction (3.07 ratio) . . . . .	DF
CHEVY . . .	Positraction (2.73 ratio) (small ring gear) . . . . .	PX	PASS. . . . .	Positraction (3.08 ratio) . . . . .	DG
CHEVY . . .	Positraction (2.73 ratio) (large ring gear) . . . . .	BQ	PASS. . . . .	Positraction (3.31 ratio) . . . . .	DH
CHEVY . . .	(3.55 ratio) . . . . .	QE	PASS. . . . .	Positraction (3.36 ratio) . . . . .	DI

## CAMARO

CAMARO . . .	(2.56 ratio) (small ring gear) . . . . .	BA
CAMARO . . .	Positraction (2.56 ratio) (small ring gear) . . . . .	BB
CAMARO . . .	(3.36 ratio) . . . . .	BC
CAMARO . . .	Positraction (3.36 ratio) . . . . .	BD
CAMARO . . .	(2.73 ratio) . . . . .	BI
CAMARO . . .	(3.07 ratio) . . . . .	BL
CAMARO . . .	(3.55 ratio) . . . . .	BN
CAMARO . . .	(3.31 ratio) . . . . .	BM
CAMARO . . .	Positraction (2.73 ratio) (large ring gear) . . . . .	BQ
CAMARO . . .	(3.73 ratio) . . . . .	BO
CAMARO . . .	(2.73 ratio) . . . . .	BP
CAMARO . . .	Positraction (3.07 ratio) . . . . .	BR
CAMARO . . .	Positraction (3.31 ratio) . . . . .	BS
CAMARO . . .	Positraction (3.35 ratio) . . . . .	BT
CAMARO . . .	Positraction (3.37 ratio) . . . . .	BU
CAMARO . . .	Positraction (4.10 ratio) . . . . .	BV
CAMARO . . .	Positraction (4.56 ratio) . . . . .	BW
CAMARO . . .	Positraction (4.88 ratio) . . . . .	BX
CAMARO . . .	Positraction (2.73 ratio) (large ring gear) . . . . .	BY
CAMARO . . .	(2.73 ratio) . . . . .	BZ
CAMARO . . .	(3.08 ratio) . . . . .	PA
CAMARO . . .	(3.31 ratio) . . . . .	PB
CAMARO . . .	Positraction (3.08 ratio) . . . . .	PE
CAMARO . . .	Positraction (3.07 ratio) . . . . .	PG
CAMARO . . .	Positraction (3.55 ratio) (small ring gear) . . . . .	PH
CAMARO . . .	(3.55 ratio) . . . . .	PK
CAMARO . . .	(2.56 ratio) (large ring gear) . . . . .	PN
CAMARO . . .	w/Metallic Brakes Positraction (2.56 ratio) (large ring gear) . . . . .	PO
CAMARO . . .	(3.07 ratio) . . . . .	PP
CAMARO . . .	Positraction (3.31 ratio) . . . . .	PR
CAMARO . . .	(2.56 ratio) (large ring gear) . . . . .	PY
CAMARO . . .	Positraction (2.73 ratio) (small ring gear) . . . . .	PX
CAMARO . . .	Positraction (2.56 ratio) (large ring gear) . . . . .	PZ
CAMARO . . .	Camaro (3.55 ratio) . . . . .	QE
CAMARO . . .	(3.55 ratio) (large ring gear) . . . . .	Q2
CAMARO . . .	Positraction (3.55 ratio) (large ring gear) . . . . .	Q3
CAMARO . . .	(3.55 ratio) (small ring gear) . . . . .	Q9
CAMARO . . .	(3.55 ratio) . . . . .	QE
CAMARO . . .	w/Disc Brakes-Front and Rear (4.88 ratio) . . . . .	QN
CAMARO . . .	w/Disc Brakes-Front and Rear (2.56 ratio) . . . . .	QS
CAMARO . . .	w/Disc Brakes-Front and Rear (2.73 ratio) . . . . .	QT
CAMARO . . .	w/Disc Brakes-Front and Rear (3.07 ratio) . . . . .	QU
CAMARO . . .	w/Disc Brakes-Front and Rear (3.31 ratio) . . . . .	QV
CAMARO . . .	w/Disc Brakes-Front and Rear (3.55 ratio) . . . . .	QW
CAMARO . . .	w/Disc Brakes-Front and Rear (3.73 ratio) . . . . .	QX
CAMARO . . .	w/Disc Brakes-Front and Rear (4.10 ratio) . . . . .	QY
CAMARO . . .	w/Disc Brakes-Front and Rear (4.56 ratio) . . . . .	QZ

## 1969

PASS. . . . .	(3.08 ratio) . . . . .	DA
PASS. . . . .	(3.36 ratio) . . . . .	DB
PASS. . . . .	(3.55 ratio) . . . . .	DC

PASS. . . . .	(3.31 ratio) . . . . .	DD
PASS. . . . .	(3.31 ratio) (heavy duty chassis) . . . . .	DE
PASS. . . . .	Positraction (3.07 ratio) . . . . .	DF
PASS. . . . .	Positraction (3.08 ratio) . . . . .	DG
PASS. . . . .	Positraction (3.31 ratio) . . . . .	DH
PASS. . . . .	Positraction (3.36 ratio) . . . . .	DI
PASS. . . . .	Positraction (3.55 ratio) (small ring gear) . . . . .	DJ
PASS. . . . .	Positraction (3.55 ratio) (large ring gear) . . . . .	DK
PASS. . . . .	Positraction (3.70 ratio) . . . . .	DL
PASS. . . . .	Positraction (3.73 ratio) . . . . .	DM
PASS. . . . .	Positraction (4.10 ratio) . . . . .	DN
PASS. . . . .	Positraction (4.56 ratio) . . . . .	DO
PASS. . . . .	Positraction (4.88 ratio) . . . . .	DP
PASS. . . . .	(3.55 ratio) . . . . .	DQ
PASS. . . . .	Positraction (2.73 ratio) (small ring gear) . . . . .	DX
PASS. . . . .	Positraction (2.73 ratio) (small ring gear) . . . . .	DY
PASS. . . . .	(2.73 ratio) (small ring gear) . . . . .	DZ
PASS. . . . .	(2.29 ratio) . . . . .	EB
PASS. . . . .	Positraction (2.29 ratio) . . . . .	EC
PASS. . . . .	(2.56 ratio) . . . . .	EF
PASS. . . . .	Positraction (2.56 ratio) . . . . .	EG
PASS. . . . .	(3.73 ratio) . . . . .	EL
PASS. . . . .	(3.07 ratio) H. D. Susp. . . . .	EM
PASS. . . . .	(3.07 ratio) . . . . .	EN
PASS. . . . .	(3.55 ratio) . . . . .	EO
PASS. . . . .	(3.36 ratio) . . . . .	EU
PASS. . . . .	(2.73 ratio) . . . . .	EZ
PASS. . . . .	(2.56 ratio) . . . . .	FT
PASS. . . . .	Positraction (2.56 ratio) . . . . .	FU
PASS. . . . .	Positraction (2.56 ratio) . . . . .	FV
PASS. . . . .	(2.56 ratio) . . . . .	FW
PASS. . . . .	Positraction (2.56 ratio) . . . . .	FX
PASS. . . . .	Positraction (3.31 ratio) . . . . .	GH
PASS. . . . .	(2.73 ratio) H. D. Susp. . . . .	GK
PASS. . . . .	Positraction (2.73 ratio) . . . . .	GM
PASS. . . . .	Positraction (3.55 ratio) . . . . .	GP
PASS. . . . .	(3.08 ratio) . . . . .	GQ
PASS. . . . .	Positraction (3.08 ratio) . . . . .	GR
PASS. . . . .	(3.07 ratio) . . . . .	GS
PASS. . . . .	Positraction (3.07 ratio) . . . . .	GT
PASS. . . . .	Positraction (3.36 ratio) . . . . .	GU
PASS. . . . .	Positraction (3.55 ratio) . . . . .	GV
PASS. . . . .	Positraction (3.07 ratio) . . . . .	GW
PASS. . . . .	Positraction (3.55 ratio) . . . . .	GX

## CHEVELLE

CHEVELLE . . .	(3.08 ratio) . . . . .	CA
CHEVELLE . . .	(3.36 ratio) . . . . .	CB
CHEVELLE . . .	(3.73 ratio) . . . . .	CC
CHEVELLE . . .	Positraction (3.07 ratio) . . . . .	CD
CHEVELLE . . .	Positraction (3.08 ratio) . . . . .	CE
CHEVELLE . . .	Positraction (3.31 ratio) . . . . .	CF
CHEVELLE . . .	Positraction (3.36 ratio) . . . . .	CG
CHEVELLE . . .	Positraction (2.73 ratio) . . . . .	CH
CHEVELLE . . .	Positraction (3.73 ratio) . . . . .	CI
CHEVELLE . . .	(2.56 ratio) . . . . .	CJ
CHEVELLE . . .	Positraction (2.56 ratio) . . . . .	CK
CHEVELLE . . .	(2.56 ratio) . . . . .	CL
CHEVELLE . . .	Positraction (2.56 ratio) . . . . .	CM
CHEVELLE . . .	(2.56 ratio) . . . . .	CN
CHEVELLE . . .	Positraction (2.56 ratio) . . . . .	CO
CHEVELLE . . .	(2.73 ratio) . . . . .	CP
CHEVELLE . . .	(2.56 ratio) . . . . .	CQ
CHEVELLE . . .	Positraction (2.56 ratio) . . . . .	CS
CHEVELLE . . .	(2.73 ratio) . . . . .	CT

# PASSENGER REAR AXLE IDENTIFICATION (Cont.)

Series	Type	Plant Identification
CHEVELLE.. (3,31 ratio)		CW
CHEVELLE.. (3,07 ratio)		CX
CHEVELLE.. (3,55 ratio) (small ring gear)		KA
CHEVELLE.. Positraction (2,55 ratio) (small ring gear)		KB
CHEVELLE.. Positraction (2,73 ratio) (small ring gear)		KC
CHEVELLE.. (2,73 ratio) (large ring gear)		KD
CHEVELLE.. Positraction (2,73 ratio) (small ring gear)		KE
CHEVELLE.. Positraction (3,55 ratio) (large ring gear)		KF
CHEVELLE.. (3,08 ratio) (small ring gear)		KG
CHEVELLE.. Positraction (3,08 ratio) (small ring gear)		KH
CHEVELLE.. (3,36 ratio)		KI
CHEVELLE.. (3,55 ratio) (large ring gear)		KJ
CHEVELLE.. Positraction (4,10 ratio)		KK
CHEVELLE.. Positraction (3,36 ratio) (small ring gear)		KL
CHEVELLE.. Positraction (4,56 ratio)		KM
CHEVELLE.. (3,55 ratio) (small ring gear)		KN
CHEVELLE.. Positraction (4,88 ratio)		KO
CHEVELLE.. Positraction (3,55 ratio) (small ring gear)		KP
CHEVELLE.. Positraction (3,07 ratio)		KX
CHEVELLE.. (2,73 ratio)		FH
CHEVELLE.. Positraction (2,73 ratio)		FI
CHEVELLE.. (3,08 ratio)		FJ
CHEVELLE.. Positraction (3,08 ratio)		FK
CHEVELLE.. (3,36 ratio)		FL
CHEVELLE.. Positraction (3,36 ratio)		FM
CHEVELLE.. (3,55 ratio)		FN
CHEVELLE.. Positraction (3,55 ratio)		FO

## CHEVY II

CHEVY.... (2,56 ratio)	BA
CHEVY.... Positraction (2,56 ratio)	BB
CHEVY.... (3,36 ratio)	BC
CHEVY.... Positraction (3,36 ratio)	BD
CHEVY.... (2,73 ratio)	BI
CHEVY.... (3,07 ratio)	BL
CHEVY.... (3,31 ratio)	BM
CHEVY.... (3,55 ratio)	BN
CHEVY.... (3,73 ratio)	BO
CHEVY.... (2,73 ratio)	BP
CHEVY.... Positraction (2,73 ratio)	BQ
CHEVY.... Positraction (3,07 ratio)	BR
CHEVY.... Positraction (3,31 ratio)	BS
CHEVY.... Positraction (3,55 ratio)	BT
CHEVY.... Positraction (3,73 ratio)	BU
CHEVY.... Positraction (4,10 ratio)	BV
CHEVY.... Positraction (4,56 ratio)	BW

Series	Type	Plant Identification
CHEVY.... Positraction (4,88 ratio)		BX
CHEVY.... (3,08 ratio)		PA
CHEVY.... (2,56 ratio)		PB
CHEVY.... Positraction (2,56 ratio)		PC
CHEVY.... Positraction (3,08 ratio)		PE
CHEVY.... Positraction (2,73 ratio)		PX

## CAMARO

CAMARO .. (2,56 ratio)	BA
CAMARO .. Positraction (2,56 ratio)	BB
CAMARO .. (3,36 ratio)	BC
CAMARO .. Positraction (3,36 ratio)	BD
CAMARO .. (2,73 ratio)	BI
CAMARO .. (3,07 ratio)	BL
CAMARO .. (3,31 ratio)	BM
CAMARO .. (3,55 ratio)	BN
CAMARO .. (3,73 ratio)	BO
CAMARO .. (2,73 ratio)	BP
CAMARO .. Positraction (2,73 ratio)	BQ
CAMARO .. Positraction (3,07 ratio)	BR
CAMARO .. Positraction (3,31 ratio)	BS
CAMARO .. Positraction (3,55 ratio)	BT
CAMARO .. Positraction (3,73 ratio)	BU
CAMARO .. Positraction (4,10 ratio)	BV
CAMARO .. Positraction (4,56 ratio)	BW
CAMARO .. Positraction (4,88 ratio)	BX
CAMARO .. (3,08 ratio)	PA
CAMARO .. (2,56 ratio)	PB
CAMARO .. Positraction (2,56 ratio)	PC
CAMARO .. Positraction (3,08 ratio)	PE
CAMARO .. Positraction (2,73 ratio)	PX
CAMARO .. (2,56 ratio)	PY
CAMARO .. Positraction (2,56 ratio)	PZ
CAMARO .. Positraction (2,56 ratio)	QS
CAMARO .. Positraction (2,73 ratio)	QT
CAMARO .. Positraction (3,07 ratio)	QU
CAMARO .. Positraction (3,31 ratio)	QV
CAMARO .. Positraction (3,55 ratio)	QW
CAMARO .. Positraction (3,73 ratio)	QX
CAMARO .. Positraction (4,10 ratio)	QY
CAMARO .. Positraction (4,56 ratio)	QZ
CAMARO .. Positraction (4,88 ratio)	QN

# PASSENGER REAR AXLE IDENTIFICATION CHART

Description	Type Description	Description	Type Description
<b>1970</b>		<b>CHEVELLE (Cont.)</b>	
<b>PASSENGER</b>		Positraction (2.56 Ratio) . . . . .	CCO
Positraction (3.08 Ratio) . . . . .	CET	Positraction (3.31 Ratio) . . . . .	CCF
Positraction (2.73 Ratio) . . . . .	CGM	Positraction (3.55 Ratio) . . . . .	CKF
Positraction (3.07 Ratio) . . . . .	CDF	(4.10 Ratio) . . . . .	CKK
(2.73 Ratio) . . . . .	CDZ	Positraction (2.73 Ratio) . . . . .	CKC
Positraction (2.73 Ratio) . . . . .	CDY	Positraction (3.08 Ratio) . . . . .	CCE
(3.08 Ratio) . . . . .	CDA	(2.56 Ratio) . . . . .	CRJ
Positraction (3.08 Ratio) . . . . .	CDG	Positraction (2.56 Ratio) . . . . .	CRK
(2.73 Ratio) . . . . .	CEZ	(3.31 Ratio) . . . . .	CRU
(3.36 Ratio) . . . . .	CEU	Positraction (3.31 Ratio) . . . . .	CRV
(2.56 Ratio) . . . . .	CEA	(4.10 Ratio) . . . . .	CRW
Positraction (2.56 Ratio) . . . . .	CED		
(3.08 Ratio) . . . . .	CES	<b>NOVA</b>	
(2.56 Ratio) . . . . .	CFW	Positraction (2.73 Ratio) . . . . .	CPX
(2.56 Ratio) . . . . .	CMY	Positraction (3.08 Ratio) . . . . .	CPE
(2.73 Ratio) . . . . .	CGK	Positraction (3.08 Ratio) . . . . .	CPR
(2.73 Ratio) . . . . .	CNA	Positraction (3.07 Ratio) . . . . .	CBR
(3.07 Ratio) . . . . .	CEM	(2.56 Ratio) . . . . .	CBA
(3.07 Ratio) . . . . .	CWK	Positraction (2.56 Ratio) . . . . .	CBB
(3.31 Ratio) . . . . .	CDD	(2.73 Ratio) . . . . .	CBP
Positraction (2.56 Ratio) . . . . .	CFX	(3.08 Ratio) . . . . .	CPA
Positraction (2.56 Ratio) . . . . .	CLJ	(3.36 Ratio) . . . . .	CBC
Positraction (2.73 Ratio) . . . . .	CLK	(2.56 Ratio) . . . . .	CBD
Positraction (3.07 Ratio) . . . . .	CWP	Positraction (2.56 Ratio) . . . . .	CPI
Positraction (3.31 Ratio) . . . . .	CDH	(3.08 Ratio) . . . . .	CPJ
(2.73 Ratio) . . . . .	CE3	(3.07 Ratio) . . . . .	CPO
(3.07 Ratio) . . . . .	CEN	(3.31 Ratio) . . . . .	CBL
(3.07 Ratio) . . . . .	CND	Positraction (3.31 Ratio) . . . . .	CBM
(3.31 Ratio) . . . . .	CDE	(3.55 Ratio) . . . . .	CBS
Positraction (3.07 Ratio) . . . . .	CGW	Positraction (3.55 Ratio) . . . . .	CBN
Positraction (3.07 Ratio) . . . . .	CLN		CBT
Positraction (3.31 Ratio) . . . . .	CGH		
Positraction (2.73 Ratio) . . . . .	CDX		
Positraction (3.36 Ratio) . . . . .	CGU		
(3.31 Ratio) . . . . .	CWY		
Positraction (3.31 Ratio) . . . . .	CWZ		
<b>CHEVELLE</b>		<b>CAMARO</b>	
Positraction (2.73 Ratio) . . . . .	CGD	(2.73 Ratio) . . . . .	COC
Positraction (2.73 Ratio) . . . . .	CCH	Positraction (2.73 Ratio) . . . . .	COD
Positraction (3.07 Ratio) . . . . .	CCD	(3.08 Ratio) . . . . .	COE
(2.73 Ratio) . . . . .	CCP	Positraction (3.08 Ratio) . . . . .	COF
(3.08 Ratio) . . . . .	CCA	(3.07 Ratio) . . . . .	COS
(2.56 Ratio) . . . . .	CGA	Positraction (3.07 Ratio) . . . . .	COT
(2.73 Ratio) . . . . .	CGC	(3.31 Ratio) . . . . .	COU
(3.36 Ratio) . . . . .	CGG	Positraction (3.31 Ratio) . . . . .	COV
Positraction (2.56 Ratio) . . . . .	CGB	Positraction (3.55 Ratio) . . . . .	COX
Positraction (3.36 Ratio) . . . . .	CGI	Positraction (3.73 Ratio) . . . . .	COZ
(2.56 Ratio) . . . . .	CCN	(4.10 Ratio) . . . . .	COO
(2.73 Ratio) . . . . .	CKD	(2.73 Ratio) . . . . .	CRX
(3.07 Ratio) . . . . .	CCX	Positraction (2.73 Ratio) . . . . .	CRY
(3.31 Ratio) . . . . .	CCW	Positraction (3.08 Ratio) . . . . .	CRI
(3.55 Ratio) . . . . .	CKJ		

1971  
PASSENGER REAR AXLE IDENTIFICATION CHART

Description	Type Designation	Description	Type Designation
<b>PASSENGER</b>		(3.31) . . . . .	RU
		Positraction (3.31) . . . . .	RV
(2.73) . . . . .	UD	(4.10) . . . . .	RW
(3.08) . . . . .	UF	(2.73) . . . . .	GH
(3.42) . . . . .	UH	(3.08) . . . . .	GN
(2.73) . . . . .	YD		
(3.08) . . . . .	YF	<b>NOVA</b>	
Positraction (3.42) . . . . .	YH	Positraction (3.08) . . . . .	PR
Positraction (2.73) . . . . .	VD	Positraction (3.07) . . . . .	BR
Positraction (3.08) . . . . .	VF	(2.56) . . . . .	PI
Positraction (3.42) . . . . .	VH	Positraction (2.56) . . . . .	PJ
Positraction (2.73) . . . . .	ZD	(3.08) . . . . .	PO
Positraction (3.08) . . . . .	ZF	(3.07) . . . . .	BL
(3.42) . . . . .	ZH	(3.31) . . . . .	BM
(3.08) . . . . .	WP	Positraction (3.31) . . . . .	BS
(3.42) . . . . .	WJ	(2.56) . . . . .	GJ
Positraction (3.08) . . . . .	XJ	(3.08) . . . . .	GR
Positraction (3.42) . . . . .	X3	(3.36) . . . . .	GT
(2.73) . . . . .	NK	Positraction (2.56) . . . . .	GK
Positraction (2.73) . . . . .	NT	Positraction (3.08) . . . . .	GS
(3.08) . . . . .	NA	Positraction (3.36) . . . . .	GW
Positraction . . . . .	NP		
<b>CHEVELLE</b>			
Positraction (2.73) . . . . .	GD	<b>CAMARO</b>	
(3.08) . . . . .	GF	(3.08) . . . . .	GX
Positraction (2.73) . . . . .	CH	Positraction (3.08) . . . . .	GY
(2.56) . . . . .	GA	(2.73) . . . . .	GZ
(2.73) . . . . .	GC	Positraction (2.73) . . . . .	CA
(3.36) . . . . .	GG	(4.10) . . . . .	CB
Positraction (2.56) . . . . .	GB	(3.73) . . . . .	CG
Positraction (3.36) . . . . .	GI	(3.42) . . . . .	CK
(2.73) . . . . .	KD	Positraction (3.42) . . . . .	CJ
(3.31) . . . . .	CW		
Positraction (3.31) . . . . .	CF		

PASSENGER REAR AXLE IDENTIFICATION CHART

Description	Type Designation	Description	Type Designation
<b>PASSENGER</b>		(3.31) .....	RU
		Positraction (3.31) .....	RV
		(4.10) .....	RW
		(2.73) .....	GH
		(3.08) .....	GN
(2.73) (GW5) .....	UD	<b>NOVA</b>	
(3.08) .....	UF	Positraction (3.08) (G92) .....	JQ
(3.42) .....	UH	(273) .....	PW
(2.73) (GW7) .....	YD	Positraction (2.73) .....	PX
(3.08) (GX5) .....	YF	(3.08) (G-92) .....	JC
Positraction (2.73) (GW7) .....	ZD	(3.42) (G-58) .....	JE
Positraction (3.08) (GZ1) .....	VF	(3.42) (GT6) .....	JK
Positraction (3.42) (GZ5) .....	VH	Positraction (3.42) (G58) .....	JS
Positraction (2.73) (GW5) .....	YD	(2.73) (G-97) .....	JB
Positraction (3.08) (GX5) .....	ZF	(3.08) (G-52) .....	JI
Positraction (3.42) (GZ6) .....	ZH	(3.36) .....	GT
(3.42) (GZ6) .....	YH	Positraction (2.73) (G-97) .....	JN
(3.08) (GZ3) .....	WP	Positraction (3.08) (G-52) .....	JW
(3.42) (GZ8) .....	X3	Positraction (3.42) (GT6) .....	JY
<b>CHEVELLE</b>		<b>CAMARO</b>	
Positraction (2.73) (G-97, GS1) .....	GD	(3.08) .....	GX
(3.08) (G92) .....	GF	Positraction (3.08) .....	GY
Positraction (2.73) .....	GH	(2.73) .....	GZ
(2.73) .....	GC	Positraction (2.73) .....	CA
(3.36) .....	GG	(4.10) .....	CB
Positraction (3.36) .....	GI	(3.73) .....	CG
(2.73) .....	GI	(3.42) .....	CK
(3.31) .....	CW	Positraction (3.42) .....	CJ
Positraction .....	CF		

1973-74

REAR AXLE IDENTIFICATION

Description	Type Designation	Description	Type Designation
<b>PASSENGER</b>			
2.73	UB	3.08	XC
3.08	UC	3.42 Positraction	XE
3.42	UE	2.73	AC
2.73 Positraction	VA	3.08	AD
2.73 Positraction	VB	3.42	AJ
3.08 Positraction	VC	2.73 Positraction	CC
3.42 Positraction	VE	3.08 Positraction	CD
3.08	UL	3.42 Positraction	CJ
3.08 Positraction	VL	<b>NOVA</b>	
2.73 Positraction	YA	2.73	JA
2.73	YB	2.73 Positraction	JM
3.08	YC	3.08	JB
3.42	YE	3.08 Positraction	JN
2.73 Positraction	ZA	3.42	JC
2.73 Positraction	ZB	3.42 Positraction	JP
3.08 Positraction	ZC	<b>CAMARO</b>	
3.42 Positraction	ZE	3.42	CL
2.73	KA	3.42 Positraction	CM
3.08 Positraction	LC	3.08	GX
3.08	KC	3.08 Positraction	GY
2.73 Positraction	LA	2.73	GZ
3.42	KE	2.73 Positraction	CA
3.42 Positraction	LE	4.10	CB
<b>CHEVELLE</b>			
2.73	WB	3.73	CG
3.08	WC		
3.42	WE		
2.73 Positraction	XA		
2.73 Positraction	XB		



1975

REAR AXLE IDENTIFICATION

PASSENGER		NOVA	
<b>2:56 RATIO</b>		<b>2:56 RATIO</b>	
	KF KL	GA	JU
<b>2:73 RATIO</b>		<b>2:73 RATIO</b>	
UA YA VA UJ	ZA KA LA VJ	GB	JV
<b>3:08 RATIO</b>		<b>3:08 RATIO</b>	
		GD	JX
UC UL YC VC	VL ZC KC LC	<b>3:42 RATIO</b>	
		GF	JZ
<b>3:42 RATIO</b>		<b>CAMARO</b>	
UE YE	VE ZE	<b>2:56 RATIO</b>	
		PH	PT
<b>CHEVELLE</b>			
<b>2:56 RATIO</b>		<b>2:73 RATIO</b>	
CH	AH	PA	PU
<b>2:73 RATIO</b>		<b>3:08 RATIO</b>	
WA XA	CC AC	PC	PW
<b>3:08 RATIO</b>		<b>3:42 RATIO</b>	
WC XC	CD AD	PZ	PY
<b>3:42 RATIO</b>			
WE XE	CJ AJ		

# REAR AXLE IDENTIFICATION CHART

## VEGA—MONZA

STAMPING LOCATION — Stamped on front of right hand axle tube inboard of upper control arm bracket approximately 30 to 45 degrees above horizontal.

1971-74

### TYPE DESIGNATION

Description	Type Designation	Description	Type Designation
(2.92 Ratio) . . . . .	HA	Positraction (3.36 Ratio) . . . . .	HH
(2.53 Ratio) . . . . .	HB	Positraction (2.92 Ratio) . . . . .	HJ
(3.36 Ratio) . . . . .	HC	Positraction (3.73 Ratio) 1974 . . . . .	HMD
Positraction (2.92 Ratio) . . . . .	HD	3.73 - 1974 . . . . .	HED
Positraction (2.53 Ratio) . . . . .	HG	(2.56 Ratio) . . . . .	HT
Positraction (3.36 Ratio) . . . . .	HH	Positraction (2.56 Ratio) . . . . .	HU
Positraction (2.92 Ratio) . . . . .	HJ	(2.93 Ratio) . . . . .	HP
Positraction (3:73 Ratio) 1974. . . . .	HMD	Positraction (2.93 Ratio) . . . . .	HW
3:73 - 1974 . . . . .	HED	(3:42 Ratio) . . . . .	HF
(2.92 Ratio) . . . . .	HA	Positraction (3:42 Ratio) . . . . .	HR
(2.53 Ratio) . . . . .	HB	(3:42 Ratio) . . . . .	HX
(3.36 Ratio) . . . . .	HC	Positraction (3:42 Ratio) . . . . .	HY
Positraction (2.92 Ratio) . . . . .	HD	(3:73 Ratio) - 1975 . . . . .	HN
Positraction (2.53 Ratio) . . . . .	HG	Positraction (3:73 Ratio) - 1975 . . . . .	HS

1975

<p><b>2.92 Ratio</b></p> <p>DA EA</p>	<p><b>2.56 Ratio</b></p> <p>DB EB</p>	<p><b>2.92 Ratio</b></p> <p>HA HD</p>
<p><b>2.93 Ratio</b></p> <p>DX EX</p>	<p><b>3.42 Ratio</b></p> <p>DE EF</p>	<p><b>3.73 Ratio</b></p> <p>DF EF</p>

# PASSENGER TRANSMISSION IDENTIFICATION

## LOCATION

- 1953-64 ALL 3 SPEED AND OVERDRIVE:,  
 1965 PASSENGER 3 SPEED AND OVERDRIVE:  
 Stamped on rear face of upper right corner.  
 1953-57 POWERGLIDE: Stamped on rear face of case on lower right corner.  
 56-63 WARNER 4-SPD.: Stamped on cover side rear flange.  
 1958-62 CAST IRON POWERGLIDE: Stamped on rear flange governor cover.  
 1957 TURBOGLIDE: Stamped on rear face of case on lower right corner.  
 1958-61 TURBOGLIDE: Stamped on boss on lower right rear of case.  
 1962 ALUMINUM POWERGLIDE: Stamped on machined surface on lower right of case.  
 1963-65 POWERGLIDE: Stamped on bottom of oil pan.  
 1963 MUNCIE 4-SPD.: Stamped on cover side of case with "P" designation.  
 65 PASSENGER(exc. CORVAIR) 4-SPD.: On the top right flat of the Case Assy.  
 65 CORVAIR, 3 and 4 SPD.: On the flat on the top of the Transmission Assy.  
 65-69 CORVAIR, POWERGLIDE: On top of the case in the rear at 11 o'clock.  
 65-69 PASSENGER (exc. CORVAIR) POWERGLIDE: Immediately behind right hand machining lug with the bottom of the sticker parallel to mold flash.  
 65-69 TURBO HYDRA-MATIC: Right hand vertical surface of transmission case.  
 65-69 POWERGLIDE: All models stamped on right side of transmission oil pan.  
 66-68 3-SPD: Corvair and fully synchronized Passenger (exc. Warner Gear) transmissions stamped on square boss on left side below and rear of cover.  
 66-68 4-SPD.: Passenger models except Corvair, stamped on right side of case ahead of the extension. Corvair stamped on boss on Lower left side of case just below side cover.  
 70-72 3-SPD.: Passenger and truck 3-speed stamped on the machined surface on the left side of the case just below the side cover.  
 70-72 4-SPD.: Muncie light duty (cast iron case) passenger transmission is stamped on the machined surface on the left side of the case just below the side cover. Muncie heavy duty (aluminum case) passenger is stamped vertically on the right side of the case just ahead of the extension.  
 70-72 POWERGLIDE: All models stamped on the right side of transmission oil pan.  
 70-72 TURBO HYDRA-MATIC 350: All models stamped on the right side of transmission oil pan.  
 70-72 TURBO HYDRA-MATIC 400: Identification plate is located on the right hand vertical surface of the transmission case.

## IDENTIFICATION FOR 1953 MODEL YEAR TO JUNE 30, 1953

STARTING UNIT NUMBER 1953: 1001 and up at each assembly plant regardless of series.

Series	1953 Model Year Designation	Type Designation and Plant	Type Transmission
15-21-2400	L	A-Saginaw	3-Speed
15-21-2400	L	B-Muncie	3-Speed
15-21-2400	L	C-Toledo	3-Speed
15-21-2400	L	G-Saginaw	3-Speed (Hvy. Duty)
15-21-2400	L	H-Muncie	3-Speed (Hvy. Duty)
15-21-2400	L	J-Toledo	3-Speed (Hvy. Duty)
21-2400	L	T-Cleveland	Powerglide
21-2400	L	U-Cleveland	Powerglide
CORVETTE	L	V-Cleveland	Powerglide

EXAMPLE:

Model Year Designation	Type and Plant	Number Unit
L	A	001030
L	T	001030

## TRANSMISSION IDENTIFICATION JULY 1, 1953 TO 1962

Plant and Type Designation Prefix	Plant	Type Transmission
W	Warner Gear	4-Speed
S	Saginaw	3-Speed, Overdrive*
C†	Cleveland	Powerglide
B†	Toledo	Turboglide Powerglide (Corvair)

\*To identify heavy duty 3-speed transmission the letter "H" will be used as a suffix to production date in 1953. Overdrive distinguished from 3-speed by physical appearance only.

NOTE: To identify Day (D) or Night (N) shift.

EXAMPLE:

Plant and Type	Month	Day
S	3	04

The above designation (S304) indicates the transmission was built at the Saginaw plant on March 4.

# PASSENGER TRANSMISSION IDENTIFICATION (CONT'D.)

## TRANSMISSION IDENTIFICATION 1963-75

Plant and Type Designation <u>Prefix</u>	<u>Plant</u>	<u>Type Transmission</u>
N	Muncie	4-Speed
W	Warner Gear	3 and 4-Speed
P	Muncie	4-Speed
R	Saginaw	4-Speed
S	Saginaw	3-Speed
M	Muncie	3-Speed, Overdrive*
C	Cleveland	Powerglide
T	Toledo	Powerglide
CA	Hydra-matic	3-Speed, Automatic Turbo Hydramatic
D	Saginaw	Overdrive
K	McKinnon	3-Speed
E	McKinnon	Powerglide
O	Saginaw	Overdrive
X	Cleveland	Turbo Hydramatic 350
B	Cleveland	Turbo Hydramatic 350
Y	Toledo	Turbo Hydramatic 350
A	Cleveland	2-Speed, Manual Powerglide

\*Overdrive distinguished from 3-SPD. by physical appearance only. The above transmissions (except Warner Gear) will carry a production code number such as:

<u>Plant and Type</u>	<u>Month</u>	<u>Day</u>	<u>Shift</u>
C	11	16	N

The above designation indicates this Powerglide transmission was built at the Cleveland plant on the November 16 night shift.

The Warner Gear transmissions will carry a production code number such as:

<u>Plant and Type</u>	<u>Month</u>	<u>Day</u>	<u>Year</u>	<u>Shift</u>
W	G	10	3	1

The above designation indicates this 4-speed transmission was built at Warner on July 10, 1963--first shift.

## TRANSMISSION IDENTIFICATION 1971-75

### 3-Speed

H - Muncie (Chevelle H.D. only)

M - Muncie (Truck H.D.)

S - Muncie (Pass. & Truck L.D.)

### Powerglide

C - Cleveland

### 4-Speed

N - Muncie (Truck)

P - Muncie (Pass. H.D. Aluminum Case)

R - Muncie Light Duty

### Turbo Hydra-Matic 350

B - Cleveland

Y - Toledo

J - G.M. of Canada

## VEGA

### TRANSMISSION IDENTIFICATION

STAMPING LOCATIONS: Three and four speed Adam Opel on bottom of Transmission cover Torque drive and Powerglide on right side of oil Pan. Turbo-Hydramatic on boss below side cover L.H. side of Transmission case.

Plant and Type Designation Prefix	Plant	Type Transmission
C	Cleveland	Powerglide
B	Cleveland	Turbo-Hydramatic
Y	Toledo	Turbo-Hydramatic
A	Cleveland	Torque Drive

### 1964 PAINT COMBINATION CHART

Color	R.P.O. No.	Lucite Stock No.	Rinshed-Mason Stock No.	Ditzler Stock No.	Color
Tuxedo Black	900	88-L	A-946	DDL-9300	Tuxedo Black
Meadow Green	905	4532-L	A-1613	DDL-43264	Meadow Green
Bahama Green	908	4534-L	A-1614	DDL-43263	Bahama Green
Silver Blue	912	4250-L	A-1481	DDL-12546	Silver Blue
Daytona Blue	916	4395-L	A-1539	DDL-12696	Daytona Blue
Azure Aqua	918	4253-L	A-1476	DDL-12525	Azure Aqua
Lagoon Aqua	919	4529-L	A-1611	DDL-12848	Lagoon Aqua
Almond Fawn	920	4527-L	A-1610	DDL-22392	Almond Fawn
Ember Red	922	4387-LH	A-1538R	DDL-71336	Ember Red
Saddle Tan	932	4392-L	A-1537	DDL-22269	Saddle Tan
Ermine White	936	4024-L	A-1199	DDL-8259	Ermine White
Desert Beige	938	4526-L	A-1609	DDL-22391	Desert Beige
Satin Silver	940	4247-L	A-1477	DDL-32173	Satin Silver
Goldwood Yellow	943	4530-LH	A-1612	DDL-81450	Goldwood Yellow
Palomar Red	948	4389-LM	A-1536R	DDL-50684	Palomar Red

### 1965 PAINT COMBINATION CHART

Color	Chev. Code	Lucite Stock No.	Rinshed-Mason Stock No.	Ditzler Stock No.
Tuxedo Black	A	88-L	A-946	DDL-9300
Ermine White	C	4024-L	A-1199	DDL-8259
Mist Blue	D	4630-L	A-1720	DDL-3301
Danube Blue	E	4631-L	A-1721	DDL-3302
Willow Green	H	4633-L	A-1716	DDL-3303
Cypress Green	J	4634-L	A-1717	DDL-3304
Artesian Turquoise	K	4628-L	A-1718	DDL-3305
Tahitian Turquoise	L	4629-L	A-1719	DDL-3306
Madeira Maroon	N	4624-LH	A-1711M	DDL-3307
Evening Orchid	P	4632-L	A-1722	DDL-3308
Regal Red	R	4625-LH	A-1712M	DDL-3309
Sierra Tan	S	4626-L	A-1713	DDL-3310
Cameo Beige	V	4401-L	A-1530	DDL-3136
Glacier Gray	W	4623-L	A-1710	DDL-3312
Crocus Yellow	Y	4620-L	A-1715	DDL-3313

### 1966 PAINT COMBINATION CHART

Color	Chev. Code	Lucite Stock No.	Rinshed-Mason Stock No.	Ditzler Stock No.
Tuxedo Black	A	88-L	A-946	DDL-9300
Ermine White	C	4024-L	A-1199	DDL-8259
Mist Blue	D	4630-L	A-1720	DDL-13042
Danube Blue	E	4631-L	A-1721	DDL-13002
Marina Blue	F	4704-L	A-1823	DDL-13148
Willow Green	H	4633-L	A-1716	DDL-43391
Artesian Turquoise	K	4628-L	A-1718	DDL-43364
Tropic Turquoise	L	4703-L	A-1816	DDL-43496
Aztec Bronze	M	4707-L	A-1817R	DDL-71525
Madeira Maroon	N	4624-LH	A-1711M	DDL-50700
Regal Red	R	4625-LH	A-1712M	DDL-71472
Sandalwood Tan	T	4706-L	A-1821	DDL-22660
Cameo Beige	V	4401-L	A-1530	DDL-22270
Chateau Slate	W	4708-L	A-1819	DDL-32525
Lemonwood Yellow	Y	4709-L	F-1824	DDL-81528

In two tone combinations on Passenger Models, first letter indicates the lower color, second letter the upper code.

\*Note: Two Tone Color Code. Basic color is color indicated. 2nd color is code 526 Ivory.

### 1967 PAINT COMBINATION CHART

Color	Chev. Code	Lucite Stock No.	Rinshed-Mason Stock No.	Ditzler Stock No.
Tuxedo Black	A	88	A-946	9300
Ermine White	C	4024L	A-1199	8259
Nantucket Blue	D	4815L	A-1899	13349
Deepwater Blue	E	4817L	A-1900	13346
Marina Blue	F	4850L	A-1920	13364
Granada Gold	G	4825L	A-1919	22818
Mountain Green	H	4816L	A-1901	43651
Emerald Turquoise	K	4818L	A-1903	43661
Tahoe Turquoise	L	4824L	A-1904G	43659
Royal Plum	M	4832L	A-1905	50717
Madeira Maroon	N	4624LH	A-1711M	50700
Bolero Red	R	4822LH	A-1907R	71583
Sierra Fawn	S	4826L	A-1908	22813
Capri Cream	T	4819L	A-1909	81578
Butternut Yellow	Y	4620L	A-1715	81500

In two tone combinations on Passenger Models, first letter indicates the lower color, second letter the upper code.

### 1968 PAINT COMBINATION CHART

Color	Chev. Code	Lucite Stock No.	Rinshed-Mason Stock No.	Ditzler Stock No.
Tuxedo Black	A	88	A-946	9300
Ermine White	C	4024-L	A-1199	8259
Grotto Blue	D	4892-L	A-1985	13512
Fathom Blue	E	4899-L	A-1992	13513
Island Teal	F	4901-L	A-1994	13514
Ash Gold	G	4896-L	A-1988	22942
Grecian Green	H	4902-L	A-1995	43775
Tripoli Turquoise	K	4900-L	A-1993	13516
Teal Blue	L	4893-L	A-1986	13516
Cordovan Maroon	N	4915-LH	A-1999M	50775
Seafrost Green	P	4897-L	A-1989	43774
Metador Red	R	4948-LH	A-1997R	71634
Palomino Ivory	T	4895-L	A-1987	81617
Sequoia Green	V	4898-L	A-1990	43773
Butternut Yellow	Y	4620-L	A-1715	81500

In two tone combinations on Passenger Models, first letter indicates the lower color, second letter the upper code.

**1969 PAINT COMBINATION CHART**

Color	Chev. Code	Lucite Stock No.	Rinshed-Mason Stock No.	Ditzler Stock No.
Tuxedo Black	10	88L	A-946	9300
Butternut Yellow	40	5036L	A-1715	81500
Dover White	50	5033L	A-2080	2058
Dusk Blue	51	5016L	A-2098	2075
Garnet Red	52	5099LH	A-2099R	2076
Glacier Blue	53	5015L	A-2100	2077
Azure Turquoise	55	5014L	A-2101	2078
Fathom Green	57	5013L	A-2102	2079
Frost Green	59	5012L	A-2103	2080
Burnished Brown	61	5011L	A-2104	2081
Champagne	63	5064L	A-2105	22813
Olympic Gold	65	5010L	A-2106D	2082
Burgundy	67	5063LH	A-2107M	50700
Cortez Silver	69	5032L	A-2108	2059
LeMans Blue	71	5030L	A-2109	2083
Hugger Orange	72	5021LM	A-2111R	2084
Daytona Yellow	76	5026LH	A-2119	2094
Rallye Green	79	5070L	A-2005D	43898

**1970 PASSENGER CAR PAINT COMBINATION CHART**

COLOR	CHEV. CODE	LUCITE STOCK NO.	RINSHED-MASON STOCK NO.	DITZLER STOCK NO.
Shadow Gray	17	5113L	A-1910	32604
Tuxedo Black	19	99L	A-946	9300
Classic White	10	5040L	A-1802	8631
Cortez Silver	14	5032L	A-2108	2059
Cranberry Red	75	5118LH	A-2278F	2189
Black Cherry	78	5063LH	A-2107M	50700
Champagne Gold	55	5120L	A-2271D	2178
Autumn Gold	58	5117L	A-2272	2179
Gobi Beige	50	5121L	A-2270D	2175
Desert Sand	63	5125L	A-2275	2183
Green Mist	45	5122L	A-2268	2171
Forest Green	48	5116L	A-2269	2173
Misty Turq.	34	5119L	A-2265	2168
Astro. Blue	25	5123L	A-2261	2165
Fatom Blue	28	5124L	A-2264	2166

**1971 PASSENGER CAR PAINT COMBINATION CHART**

COLOR	CHEV. CODE	DuPont Lucite Stock No.	RINSHED- MASON STOCK NO.	DITZLER STOCK NO.
Antique White	11	5338L	A-2080	2058
Nevada Silver	13	5276L	A-2438	2327
Silver Steel	16	5324L	A-2472	2161
Tuxedo Black	19	99L	A-946	9300
Ascot Blue	24	5270L	A-2439	2328
Mediterranean Blue	25	5295L	A-2440	2329
Mulsanne Blue	26	5327L	A-2482	2213
Command Blue	29	5272L	A-2441	2330
Sea Aqua	39	5277L	A-2442	2331
Cottonwood Green	42	5274L	A-2444G	2333
Lime Green	43	5322L	A-2445D	2334
Antique Green	49	5273L	A-2448	2337
Sunflower	52	5283LH	A-2422	2338
Placer Gold	53	5280LH	A-2449F	2339
Champagne Gold	55	5326L	A-2479D	2178
Sandlewood	61	5325L	A-2273	2181
Burnt Orange	62	5281L	A-2451G	2340
Mesa Sand	63	5296L	A 2452	2341
Classic Copper	67	5323L	A-2276G	23215
Cranberry Red	75	5339LH	A-2278F	2189
Rosewood	78	5275L	A-2461	2350

**1972 PASSENGER CAR PAINT COMBINATION CHART**

COLOR	CHEV. CODE	DuPont Lucite Stock No.	RINSHED- MASON STOCK NO.	DITZLER STOCK NO.
Antique White	11	5338L	A-2080	2058
Pewter Silver	14	5426L	A-2541	2429
Dusk Grey	18	5427L	A-2542	2430
Tuxedo Black	19	99L	A-946	9300
Ascot Blue	24	5270L	A-2439	2328
Muisanne Blue	26	5327L	A-2482	2213
Fathom Blue	28	5124L	A-2264	2166
Spring Green	36	5436L	A-2546D	2433
Gulf Green	43	5428L	A-2548	2435
Oasis Green	46	5441L	A-2552	2437
Sequoia Green	48	5429L	A-2552	2439
Covert Tan	50	5431L	A-2554	2441
Placer Gold	53	5280L	A-2449F	2339
Desert Gold	54	5432L	A-2556D	2442
Cream Yellow	56	5443L	A-2558G	2444
Golden Brown	57	5439L	A-2559	2445
Turan Tan	58	5442L	A-2555	2463
Driftwood	62	5437L	A-2561	2447
Mohave Gold	63	5434L	A-2562D	2448
Orange Flame	65	5435L	A-2564D	2450
Midnight Bronze	68	5430L	A-2565	2451
Aegean Brown	69	5438L	A-2566	2452
Cranberry Red	75	5339L	A-2278F	2189



### 1973 PASSENGER CAR EXTERIOR COLORS

Car Paint Code	Color Name	Fisher WA Number	Ditzler Code	Ditzler Uticolor Vinyl Roof Colors	Rinshed Mason	DuPont
11	Antique White	3967	2058	White 2-130	A2080	5338L
19	Tuxedo Black	848	9300	Black 182	A 946	99L
23	Medium Blue	4396	2522	Med. Blue 2-168	A2622	5486L
24	Light Blue Metallic	4313	2523		A2623	5473L
26	Dark Blue Metallic	4323	2524		A2624	5478L
29	Midnight Blue Metallic	4447	2526		A2626	5474L
41	Oasis Green	4268	2437	Med. Green 2-169	A2550G	5441L
42	Dark Green Metallic	4412	2528		A2628	5489L
44	Light Green Metallic	4316	2529		A2629	5475L
46	Green-Gold Metallic	4324	2530		A2631D	5479L
48	Midnight Green	4325	2531		A2632	5480L
51	Light Yellow	4239	2533		A2634G	5484L
56	Chamois	4326	2537	Med. Chamois 2-167	A2638	5481L
60	Light Copper Metallic	4413	2538		A2639D	5490L
61	Light Orange	4397	2539		A2640G	5487L
62	Med. Bronze Metallic	4398	2540		A2641G	5488L
64	Silver Metallic	4319	2541		A2643	5476L
66	Taupe Metallic	4327	2542		A2645	5482L
68	Dark Brown Metallic	4328	2543		A2647D	5483L
74	Dark Red Metallic	4321	2545	Maroon 2-170	A2649F	5477L
75	Medium Red	4330	2546		A2650F	5485L
81	Beige	4441	2549	Light Neutral 2-166	A2653	5491L
97	Med. Orange Metallic	4448	2555		A2659	5552L

### 1974 PASSENGER CAR EXTERIOR COLORS

Car Paint Code	Color Name	Fisher WA Number	DDL Ditzler Code	Uticolor Vinyl Roof Colors	Rinshed Mason	Dupont
11	Antique White	3967	2058	White 2-130	A-2080	5338L
13	Cosworth Silver Metallic	4322	2518		A-2618	5499L
19	Tuxedo Black	848	9300	Black 182	A-946	99L
24	Light Blue Metallic	4313	2523		A-2623	5473L
25	Medium Blue	4536	2639	Med. Blue 2-168	A-2701	42811L
26	Bright Blue Metallic	4323	2524		A-2624	5478LH
29	Midnight Blue Metallic	4447	2526		A-2626	5474L
36	Aqua Blue Metallic	4525	2640		A-2702	42805L
40	Lime-Yellow	4500	2641		A-2703	42800LH
44	Medium Green	4516	2642		A-2704	42802L
46	Bright Green Metallic	4526	2643		A-2705	42806L
47	Medium Green Metallic	4284	2438	Med. Green 2-207	A-2551	5462LH
49	Medium Dark Green Metallic	4517	2645		A-2707	42803L
50	Cream-Beige	4527	2646	Cream-Beige 2-208	A-2708	42807L
51	Bright Yellow	4642	2677		A-2709G	42809LM
53	Light Gold Metallic	4570	2649		A-2710G	42876LM
55	Sandstone	4528	2650		A-2711	42808L
59	Golden Brown Metallic	4223	2367	Brown 2-203	A-2480G	42875L
64	Silver Metallic	4319	2541		A-2643	5476L
66	Bronze Metallic	4618	2653	Russet 2-220	A-2714G	42801LH
67	Bright Orange	4538	2654		A-2715G	42813LM
69	Dark Taupe Metallic	4518	2656	Silver Taupe 2-230	A-2716	42804L
74	Medium Red Metallic	4533	2658	Maroon 2-170	A-2718F	42810LM
75	Medium Red	4330	2546		A-2650F	5485LM

### 1975 PASSENGER CAR EXTERIOR COLORS

Color	Car Paint Code	Fisher WA Number	DDL Ditzler Code	Uticoior Vinyl Roof Colors	Rinshed Mason	Dupont
Antique White	11	3967	2058	White 2-130	A-2080	5338L
Silver Metallic	13	4322	2518	Silver Metallic 2-271	A-2618	43537L
Light Gray	15	4630	2742		A-2793	43450L
Medium Gray Metallic	16	4640	2743		A-2794	43459L
Tuxedo Black	19	848	9300	Gloss-182, Flat-120	A-946	99L
Silver Blue Metallic	21	4267	2431		A-2543	5440L
Medium Blue	24	4631	2745		A-2798	43451L
Bright Blue Metallic	26	4632	2746		A-2799	43452L
Midnight Blue Metallic	29	4633	2748	Dark Blue 2-273	A-2802	43453L
Medium Green	44	4516	2642	Medium Green 2-207	A-2704	42802L
Light Green Metallic	45	4641	2750		A-2804G	43460LH
Dark Green Metallic	49	4634	2752		A-2805	43454LH
Cream-Beige	50	4527	2646		A-2708	42807L
Bright Yellow	51	4642	2677		A-2709G	42809L
Sandstone	55	4635	2755	Sandstone 2-258	A-2808	43455L
Dark Sandstone Metallic	58	4648	2757		A-2810	43461LH
Dark Brown Metallic	59	4636	2758	Cordovan 2-257	A-2811D	43456L
Light Saddle Metallic	63	4637	2759		A-2812D	43457LH
Medium Orange Metallic	64	4638	2760		A-2813F	43458LM
Bronze Metallic	66	4618	2653		A-2714G	42801LH
Medium Red	72	4460	2544		A-2648F	5498LM
Dark Red Metallic	74	4533	2658	Maroon 2-170	A-2718F	42810LM
Light Red	75	4330	2546	Red 2-243	A-2650F	5485LM
Burgundy Metallic	79	4540	2659		A-2719M	42814LM
Orange Metallic	80	4464	2548		A-2652F	5568LM

1970 TRIM COMBINATION CHART

Comb. No.	Material	Models	Comb. No.	Material	Models
<b>1970 REGULAR BENCH SEAT</b>					
731	Black Pattern Ctd. Fabric Black Coated Fabric	11427-69	774	Med. Gold Riano Cloth	13857
732	Black Coated Fabric	11427-69	775	Med. Gold Roma Cloth Met. Med. Gold Ctd. Fabric	13427-37-69
735	Med. Blue Roma Cloth Met. Blue Ctd. Fabric	11427-69	776	Med. Gold Rivar Cloth Met. Med. Gold Ctd. Fabric	13637-39-69
736	Med. Blue Remington Cloth Met. Med. Blue Ctd. Fab.	11427-69	778	Ant. Med. Saddle Pattern Ctd. Fabric	13867
737	Black Coded Fabric	11427-69		Ant. Med. Saddle Ctd. Fabric	
740	Med. Gold Roma Cloth Met. Med. Gold Ctd. Fabric	11427-69	779	Med. Turq. Rivar Cloth Met. Med. Turq. Ctd. Fabric	13639-69
741	Med. Gold Remington Cloth Met. Med. Gold Ctd. Fabric	11427-69	780	Dark Green Prima Cloth	13857
744	Dark Green Remington Cloth Met. Dark Green Ctd. Fabric	11427-69	782	Dark Green Rivar Cloth Met. Dark Green Ctd. Fabric	13637-39-69
745	Dark Green Roma Cloth Met. Dark Green Ctd. Fabric	11427-69	785	Met. Dark Green Pattern Ctd. Fabric	13867
747	Ant. Med. Sandalwood Ctd. Fabric	11427-69		Met. Dark Green Ctd. Fabric	
748	Black Prima Cloth	13857	786	Dark Green Roma Cloth Met. Dark Green Ctd. Fabric	13437-69
750	Black Pattern Ctd. Fabric Black Coated Fabric	13236	787	Med. Red Fabric	13637-67
751	Black Roma Cloth Black Coated Fabric	13427-37-69	790	Aff. Ivory Coated Fabric (With Black Carpet, etc.)	13637-67
752	Black Pattern Ctd. Fabric Black Coated Fabric	13427-36-37-46- 69-80	792	Med. Sandalwood Riano Cloth	13857
753	Black Rivar Cloth Black Coated Fabric	13637-39-69	795	Met. Dark Green Ctd. Fabric	13637-39-67
754	Black Pattern Ctd. Fabric w/Black Ctd. Fabric	13867	797	Black Fabric (Special Order)	13427-69
755	Black Coated Fabric	13636-37-39-46- 67-69-80 13836-46	802	Black Pattern Ctd. Fabric Black Ctd. Fabric	15436-69
758	Med. Blue Riano Cloth	13857	803	Black Rene Cloth Black Ctd. Fabric	15669
759	Met. Blue Pattern Ctd. Fabric Met. Med. Blue Ctd. Fabric	13236	804	Black Pattern Ctd. Fabric Black Ctd. Fabric	15636-46-69
760	Med. Blue Roma Cloth Met. Med. Blue Ctd. Fabric	13427-37-69	805	Black Rondo Cloth Black Ctd. Fabric	16437-39-47-69
761	Met. Med. Blue Pattern Ctd. Fabric	13436-36-80	806	Black Pattern Ctd. Fabric Black Ctd. Fabric	16436-37-39-46- 47-69- 16636-46
762	Med. Blue Rivar Cloth Met. Med. Blue Ctd. Fabric	13637-39-69	810	Black Ctd. Fabric (Special Order)	15469
764	Met. Med. Blue Ctd. Fabric	13636-46-67-80	813	Black Parma Cloth	16639-46
765	Met. Med. Blue Ctd. Fabric	13667-80	815	Met. Med. Blue Pattern Ctd. Fabric	15436-69
767	Dark Blue Prima	13857		Met. Med. Blue Ctd. Fabric	
768	Met. Med. Blue Pattern Ctd. Fabric	13867	818	Med. Blue Rene Cloth Met. Med. Blue Fabric	15669
770	Ant. Med. Saddle Ctd. Fabric	13636-37-46 67-80	819	Met. Med. Blue Pattern Ctd. Fabric	15636-46-69
772	Ant. Med. Saddle Pattern Ctd. Fabric	13236		Met. Med. Blue Ctd. Fabric	
773	Med. Saddle Pattern Ctd. Fabric	13436-46-80	820	Med. Blue Rondo Cloth Met. Med. Blue Ctd. Fabric	16437-39-47-69
	Ant. Med. Saddle Ctd. Fabric		821	Met. Med. Blue Pattern Ctd. Fabric	16436-37-39-46- 47-67-69- 16636-46
				Met. Med. Blue Ctd. Fabric	
			822	Med. Blue Randa Cloth	16639-47
			826	Dark Blue Prima Cloth	16639-47
			828	Ant. Med. Sandalwood Pattern Ctd. Fabric	16436-37-39- 46-47-67-69
				Ant. Med. Sandalwood Ctd. Fabric	16636-46

TRIM COMBINATION CHART—Continued

Comb. No.	Material	Models
830	Ant. Med. Saddle Pattern Ctd. Fabric	16436-37-39-46-37-67-69-
	Ant. Med. Saddle Ctd. Fabric	16636-46
831	Med. Saddle Pattern Ctd. Fabric	15436-69
	Ant. Med. Saddle Ctd. Fabric	
836	Med. Gold Rene Cloth	15669
	Met. Med. Gold Ctd. Fabric	
837	Med. Gold Rondo Cloth	16437-39-47-69
	Met. Med. Gold Ctd. Fabric	
838	Med. Saddle Pattern Ctd. Fabric	15636-46-69
	Ant. Med. Saddle Ctd. Fabric	
839	Met. Med. Gold Pattern Ctd. Fabric	15636-46-69
	Met. Med. Gold Ctd. Fabric	
840	Med. Gold Ranada Cloth	16639-47
841	Met. Med. Gold Pattern Ctd. Fabric	16436-37-39-46-47-67-
	Met. Med. Gold Ctd. Fabric	16636-46
843	Met. Med. Gold Pattern Ctd. Fabric	15436-69
	Met. Med. Gold Ctd. Fabric	
844	Med. Turq. Rondo Cloth	16437-39-47-69
	Met. Med. Turq. Ctd. Fabric	
845	Med. Turq. Ranada Cloth	16639-47
855	Dark Green Prima Cloth	16639-47
860	Dark Green Rondo Cloth	16437-39-47-69
	Met. Dark Green Ctd. Fabric	

Comb. No.	Material	Models
861	Met. Dark Green Pattern Ctd. Fabric	16436-37-39-46-47-67-
	Met. Dark Green Ctd. Fabric	16636-46
866	Med. Red Pattern Ctd. Fabric	16436-37-39-46-47-67-
	Med. Red Ctd. Fabric	16636-46
870	Med. Sandalwood Ronda Cloth	16639-47

1970 BUCKET SEATS

733	Black Coated Fabric	11427
742	Met. Med. Gold Ctd. Fabric	11427
746	Ant. Med. Sandalwood Ctd. Fabric	11427
749	Black Prima Cloth	13857
756	Black Coated Fabric	13637-67-80
757	Black Coated Fabric	13857-67
769	Ant. Med. Saddle Coated Fabric	13857-67
771	Ant. Med. Saddle Ctd. Fabric	13637-67-80
777	Met. Med. Gold Ctd. Fabric	13637-67
784	Met. Dark Green Ctd. Fabric	13857
788	Med. Red Ctd. Fabric	13637-67
791	Aff. Ivory Coated Fabric With Black Carpet, etc.	13637-67
796	Met. Dark Green Ctd. Fabric	13637-67

1971 TRIM COMBINATION CHART

Comb. No.	Materials	Models	Comb. No.	Materials	Models
701	Black Roma Cloth Black Coated Fabric	13437-69	726	Dk. Blue Elk Coated Fabric	13636-37-39-46- 67-69-80- 13836-46
702	Black Coated Fabric Black Coated Fabric	13236	729	Dk. Jade Coated Fabric Ant. Dk. Jade Coated Fabric	13857
703	Black Coated Fabric Black Coated Fabric	13436-46-80	730	Dk. Jade Rondel Cloth Ant. Dk. Jade Coated Fabric	13637-39-69
704	Black Randel Cloth Black Coated Fabric	13637-39-69	731	Ant. Dk. Jade Elk Coated Fabric	13636-37-39-46- 67-80
705	Black Elk Coated Fabric Black Coated Fabric	13637-39-46- 67-69-80- 13836-46	732	Ant. Dk. Jade Elk Coated Fabric	13637-67-80
706	Black Elk Coated Fabric Black Coated Fabric	13637-67-80	733	Dk. Jade Rapallo Cloth	13857
707	Black Rapallo Cloth	13857	734	Dk. Jade Rapallo Cloth	13857
708	Black Rapallo Cloth	13857	735	Ant. Dark Jade Elk Coated Fabric	13857
709	Black Elk Coated Fabric Black Coated Fabric	13857	736	Dk. Jade Roma Cloth Ant. Dk. Jade Coated Fabric	13437-39
710	Black Elk Coated Fabric Black Coated Fabric	13857	750	Black Roma Cloth Black Coated Fabric	11427-69
712	Lt. Sandalwood Coated Fabric Ant. Lt. Sandalwood Coated Fabric	13236	751	Black Coated Fabric Black Coated Fabric	11427-69
713	Lt. Sandalwood Coated Fabric Ant. Lt. Sandalwood Coated Fabric	13436-46-80	752	Black Rondel Cloth Black Coated Fabric	11427-69
714	Ant. Lt. Sandalwood Elk Coated Fabric	13636-37-39-46- 47-67-69-80	753	Black Coated Fabric	11427-69
715	Ant. Lt. Sandalwood Elk Coated Fabric	13637-67-80	754	Black Coated Fabric	11427
716	Lt. Sandalwood Rapallo Cloth	13857	756	Dk. Blue Roma Cloth Black Coated Fabric	11427-69
718	Lt. Sandalwood Rondel Cloth Ant. Lt. Sandalwood Coated Fabric	13637-39-69	757	Dk. Blue Coated Fabric Dk. Blue Coated Fabric	11427-69
719	Med. Saddle Coated Fabric Ant. Med. Saddle Coated Fabric	13236	759	Dk. Jade Roma Cloth Ant. Jade Coated Cloth	11427-69
720	Med. Saddle Coated Fabric Ant. Med. Saddle Coated Fabric	13436	760	Dk. Jade Coated Fabric Ant. Dk. Jade Coated Fabric	11427-69
721	Ant. Dk. Saddle Elk Coated Fabric	13636-37-46-67- 69-80	761	Dk. Jade Rondel Cloth Ant. Dk. Jade Coated Fabric	11427-69
722	Ant. Dk. Saddle Elk Coated Fabric	13637-67-80	763	Lt. Sandalwood Coated Fabric Ant. Lt. Sandalwood Coated Fabric	11427-69
724	Dk. Blue Roma Cloth Dk. Blue Coated Fabric	13437-69	764	Ant. Lt. Sandalwood Coated Fabric	11427-69
725	Dk. Blue Rondel Cloth Dk. Blue Coated Fabric	13637-39-69	767	Ant. Dk. Saddle Coated Fabric	11427
			775	Black Derma Coated Fabric Black Coated Fabric	12487
			776	Dk. Blue Derma Coated Fabric Dk. Blue Coated Fabric	12487
			777	Ant. Lt. Sandalwood Derma Coated Fabric	12487
				Ant. Lt. Sandalwood Coated Fabric	

1971 TRIM COMBINATION CHART (Cont.)

Comb. No.	Material	Models	Comb. No.	Material	Models
778	Dk. Jade Derma Coated Fabric Ant. Dk. Jade Coated Fabric	12487	821	Lt. Sandalwood Rahara Cloth Lt. Sandalwood Prima Cloth	16639-47
779	Ant. Dk. Saddle Derma Coated Fabric Ant. Dk. Saddle Coated Fabric	12487	823	Ant. Med. Saddle Pebble Coated Fabric Ant. Med. Saddle Coated Fabric	15435-69
785	Black Raydo Cloth Black Coated Fabric	12487	824	Ant. Med. Saddle Pebble Coated Fabric Ant. Med. Saddle Coated Fabric	15635-45-69
786	Blue & Black Raydo Cloth Dk. Blue Coated Fabric	12487	825	Ant. Dk. Saddle Roulet Coated Fabric Ant. Dk. Saddle Coated Fabric	16435-39-45-47- 57-67-69- 16635-45
787	Jade & Black Raydo Cloth Ant. Dr. Jade Coated Fabric	12487	827	Med. Maize Roulet Coated Fabric Med. Maize Coated Fabric	16435-39-45-47- 57-67- 16635-45
789	Ivory & Black Raydo Cloth Black Coated Fabric	12487	828	Med. Maize Rahara Cloth Med. Maize Prima Cloth	16639-47
792	Saddle & Black Raydo Cloth Ant. Dr. Saddle Coated Fabric	12487	829	Med. Maize Rancaro Cloth Med. Maize Coated Fabric	15669
802	Black Pebble Coated Fabric Black Coated Fabric	15435-69	830	Med. Maize Rimini Cloth Med. Maize Coated Fabric	16439-47-57-69
803	Black Rancaro Cloth Black Coated Fabric	15669	832	Dk. Jade Rancaro Cloth Ant. Dk. Jade Coated Fabric	15669
804	Black Pebble Coated Fabric Black Coated Fabric	15635-45-69	834	Dk. Jade Rimini Cloth Ant. Dk. Jade Coated Fabric	16439-47-57-69
805	Black Rimini Cloth Black Coated Fabric	16439-47-57-69	835	Ant. Dk. Jade Roulet Coated Fabric Ant. Dk. Jade Coated Fabric	16435-39-45-47- 57-67-69- 16635-45
806	Black Roulet Coated Fabric Black Coated Fabric	15669	836	Dk. Jade Rahara Cloth Dk. Jade Prima Cloth	16639-47
807	Black Rahara Cloth Black Prime Cloth	16639-47	873	<b>Black Coated Fabric with Black Coated Fabric</b>	<b>14105-11-15-77</b>
810	Dk. Blue Pebble Coated Fabric Dk. Blue Coated Fabric	15435-69	874	<b>Black Roulet Coated Fabric with Black Coated Fabric</b>	<b>14111-15-77</b>
811	Dk. Blue Rancaro Cloth Dk. Blue Coated Fabric	15669	878	<b>Dk. Green Coated Fabric with Dk. Green Coated Fabric</b>	<b>14105-11-15-77</b>
812	Dk. Blue Pebble Coated Fabric Dk. Blue Coated Fabric	15635-45-69	879	<b>Dk. Green Roulet Coated Fabric with Dk. Green Coated Fabric</b>	<b>14111-15-77</b>
813	Dk. Blue Rimini Cloth Dk. Blue Coated Fabric	16439-47-57-69	883	<b>Med. Saddle Coated Fabric with Med. Saddle Coated Fabric</b>	<b>14111-15-77</b>
814	Dk. Blue Roulet Coated Fabric Dk. Blue Coated Fabric	16435-39-45-47- 57-69	884	<b>Antique Med. Saddle Roulet Coated Fabric with Antique Med. Saddle Coated Fabric</b>	<b>14111-15-77</b>
815	Dk. Blue Rahara Cloth Dk. Blue Prima Cloth	16639-47	888	<b>Sandalwood Coated Fabric with Antique Lt. Sandalwood Coated Fabric</b>	<b>14105-11-15-77</b>
818	Ant. Lt. Sandalwood Pebble Coated Fabric Ant. Lt. Sandalwood Coated Fabric	15435-69	892	<b>Dk. Blue Roulet Coated Fabric with Dk. Blue Coated Fabric</b>	<b>14111-17</b>
819	Ant. Lt. Sandalwood Pebble Coated Fabric Ant. Lt. Sandalwood Coated Fabric	15635-45-69			
820	Ant. Lt. Sandalwood Roulet Coated Fabric Ant. Lt. Sandalwood Coated Fabric	16439-47-57- 16639-47-57			

1972 TRIM COMBINATION CHART

Comb No.	Materials	Models	Comb No.	Materials	Models
701	Black Pinta CTO Fabric Black Coated Fabric	13437-69-36-46-80	734	Ant. Lt. Covert Elk Coated Fabric Ant. Lt. Covert Ctd. Fabric	13857
702	Black Royal Cloth Black Coated Fabric	13437-69	735	Ant. Dark Saddle Elk Coated Fabric Ant. Dark Saddle Coated Fabric	13857
703	Black Rianon Cloth Black Coated Fabric	13637-39-69	740	Med. Pewter Rapallo Cloth (Ant. Med. Pewter Coated Fabric)	13857
704	Black Elk CTO Fabric Black Coated Fabric	13637-39-69-36-46-67-80 13836-46	743	White Elk Coated Fabric White Coated Fabric	13637-39-67
705	Black Pinta Coated Fabric Black Coated Fabric	13236	750	Black Royal Cloth Black Coated Fabric	11427-69
706	Black Rapallo Cloth Black Coated Fabric	13857	751	Black Pinta Coated Fabric Black Coated Fabric	11427-69
708	Black Elk Coated Fabric Black Coated Fabric	13857	752	Black Rhine Cloth Black Coated Fabric	11427-69
710	Ant. Dk Green Pinta Coated Fabric Ant. Dk. Green Coated Fabric	13436-37-46	753	Black Derma Coated Fabric Black Coated Fabric	11427-69
711	Dk. Green Royal Cloth Ant. Dk. Green Ctd. Fabric	13437-69	754	Black Coated Fabric	11427
713	Ant. Dk. Green Elk Coated Fabric Ant. Dk. Green Ctd. Fabric	13636-37-39-46-67-69- 13836-46	756	Dark Blue Royal Cloth Ant. Dk. Blue Coated Fabric	11427-69
715	Dk. Green Rapallo Cloth Ant. Dk. Green Coated Fabric	13857	757	Dark Blue Coated Fabric Dark Blue Coated Fabric	11427-60
717	Ant. Dk. Green Elk Coated Fabric Ant. Dk. Green CTO Fabric	13857	759	Dark Green Royal Cloth Ant. Dk. Green Coated Fabric	11427-69
719	Ant. Med. Tan Pinta Coated Fabric Ant. Med. Tan Ctd. Fabric	13436-37-46-69 & 80	760	Dk. Green Pinta Coated Fabric Ant. Dk. Green Coated Fabric	11427-69
720	Ant. Med. Tan Coated Fabric Ant. Med. Tan Coated Fabric	13636-37-46-13736-80-69-80- 13836-46	761	Dk. Green Rhine Cloth Ant. Dk. Green Coated Fabric	11427-69
721	Med. Tan Pinta Coated Fabric Ant. Med. Tan Ctd. Fabric	13226	763	Lt. Covert Pinta Coated Fabric Ant. Lt. Covert Coated Fabric	11427-69
723	Dk. Blue Royal Cloth Ant. Dk. Blue Ctd. Fabric	13437-69	764	Ant. Lt. Covert Derma Coated Fabric Ant. Lt. Covert Coated Fabric	11427-69
724	Dk. Blue Rianon Cloth Dk. Blue Coated Fabric	13637-39-69	765	Lt. Covert Royal Cloth Ant. Lt. Covert Ctd. Fabric	11427
725	Dk. Blue Rapallo Cloth Ant. Dk. Blue Coated Fabric	13857	766	Ant. Med. Tan Derma Coated Fabric Ant. Med. Tan Ctd. Fabric	11427
730	Lt. Covert Rianon Cloth Ant. Lt. Covert Ctd. Fabric	13637-39-69	767	White Pinta Coated Fabric White CF	11427
731	Lt. Covert Rapallo Cloth (Ant. Lt. Covert Ctd. Fab.)	13857	775	Black Elk Coated Fabric Black Coated Fabric	12487
732	Ant. Lt. Covert Elk Coated Fabric Ant. Lt. Covert Ctd. Fabric	13637-39-69-80	776	Dk. Blue Elk Ctd. Fabric Ant. Dk. Blue Ctd. Fabric	12487
			777	Ant. Dk. Green Elk Coated Fabric Ant. Dk. Green Ctd. Fabric	12487

1972 TRIM COMBINATION CHART (Cont.)

omb. No.	Material	Models	Comb. No.	Material	Models
778	Med. Tan Elk Ctd. Fabric Ant. Med. Tan Coated Fabric	12487	818	Ant. Lt. Covert Roulet Coated Fabric Ant. Lt. Covert Ctd. Fabric	16435-39-45-47- 57-67-69 16635-45
779	Lt. Covert Elk Ant. Coated Fabric Lt. Covert Ant. Ctd. Fabric	12487	819	Lt. Covert Rochelle Cloth Lt. Covert Prima Cloth	16639-47-69
785	Black Raydo Cloth Black Coated Fabric	12487	824	Dk. Saddle Pinta Coated Fabric Ant. Dk. Saddle Coated Fabric	15435
786	Blue & Black Raydo Cloth Ant. Dk. Blue Ctd. Fabric	12487	825	Ant. Dk. Saddle Derma Coated Fabric Ant. Dk. Saddle Coated Fabric	15635-45
787	Green & Black Raydo Cloth Ant. Dk. Green Coated Fabric	12487	826	Ant. Dk. Saddle Roulet Coated Fabric AntkDk. Saddle Ctd. Fabric	16435-39-45-47- 57-67-69=16635-45
788	Covert & Black Raydo Cloth Ant. Lt. Covert Coated Fabric	12487	828	Dk. Green Rhine Cloth Ant. Dk. Green Ctd. Fabric	15669
792	Saddle & Black Raydo Cloth Ant. Dr. Saddle Ctd. Fabric	12487	829	Dk. Green Ravara Cloth Ant. Dk. Green Ctd. Fabric	16439-47-57-69
801	Black Coated Fabric (U/on only N.Y. Taxi-B04)	15469	830	Ant. Dk. Green Roulet Ctd. Fab. Ant. Dk. Green Ctd. Fabric	16435-39-45-47- 57-6916635-45
802	Black Pinta Coated Fabric Black Coated Fabric	15435-69	831	Dk. Green Rochele Cloth Dk. Green Prima Cloth	16639-47
803	Black Rhine Cloth Black Coated Fabric	15669	833	Dk. Green Prima Cloth	16639-47-67
	Black Derma Coated Fabric Black Coated Fabric		834	Med. Pewter Ravara Cloth Ant. Med. Pewter Ctd. Fabric	16439-47-57
804	Black Derma Coated Fabric Black Coated Fabric	15635-45-69	835	Ant. Med. Pewter Roulet Ctd. Fabric Ant. Med. Pewter Ctd. Fabric	16439-47-57
805	Black Ravara Cloth Black Coated Fabric	16439-47-57-69	836	Med. Pewter Rochelle Cloth Med. Pewter Prima Cloth	16639-47-69
806	Black Roulet Coated Fabric Black Coated Fabric	16435-39-45-47- 57-67-69	838	Black Prima Cloth	16639-47-69
807	Black Rochelle Cloth Black Prime Cloth	16639-47	860	Black Pinta Coated Fabric with Black Coated Fabric	14111-15-77
808	Black Rochelle Cloth Black Ctd. Fabric	16635-45	860	Black Coated Fabric	14105
809	Dk. Blue Pinta Ctd. Fabric Ant. Dk. Blue Ctd. Fabric	15469	863	Dark Green Pinta Coated Fabric with Ant. Dark Green Coated Fabric	14111-15-77
810	Dk. Blue Rhine Cloth Ant. Dk. Blue Coated Fabric	15669	863	Ant. Dark Green Fabric	14105
811	Ant. Dk. Blue Perma Coated Fabric Ant. Dk. Blue Ctd. Fabric	15669	866	Med. Tan Pinta Coated Fabric with Ant. Medium Tan Coated Fabric	14111-15-77
812	Dk. Blue Ravara Ctd. Fabric Ant. Dk. Blue Ctd. Fabric	16439-47- 57-69	868	Light Covert Pinta Coated Fabric with Ant. Light Covert Coated Fabric	14111-15-77
813	Ant. Dk. Blue Roulet Cloth Ant. Dk. Blue Coated Fabric	16435-39-45-47 16635-45	861	Black Roulet Coated Fabric with Black Coated Fabric	14115-77
814	Dk. Blue Rochelle Coated Fabric Dk. Blue Prima Cloth	16639-47-69	867	Ant. Medium Tan Roulet Fabric with Ant. Medium Tan Coated Fabric	14115-77
815	Lt. Covert Ravara Cloth Ant. Lt. Covert Ctd. Fabric	16439-47-57-69	874	Ant. Light Covert Roulet CF with Ant. Light Covert Coated Fabric	
816	Lt. Covert Pinta Ctd. Fabric Ant. Lt. Covert Coated Fabric	15469	862	Black Raydo Cloth with Black Coated Fabric	14111-15-77
817	Ant. Lt. Covert Derma Coated Fabric Ant. Lt. Covert Coated Fabric	15669	869	Covert and Black Raydo Cloth with Ant. Light Covert CF	14111-15-77



## 1973 TRIM COMBINATION CHARTS

Comb. No.	Materials	Models	Comb. No.	Materials	Models
701	Black Nuevo Knit CTD. Fabric Black CTD. Fabric	IAC29-35-37-80	734	Ant. Lt. Neutral Tetra CTD. Fabric Ant. Lt. Neutral CTD. Fabric	IAE29-37
702	Black Revere Cloth Black CTD. Fabric	IAC29-37	735	Lt. Neutral Oxen CTD. Fabric Ant. Lt. Neutral CTD. Fabric	IAH57
703	Black & White Rally Cloth Black CTD. Fabric	IAC29-37	740	Dk. Oxblood Regatta Cloth Ant. Dk. Oxblood CTD. Fabric	IAH57
704	Black Oxen CTD. Fabric Black CTD. Fabric	IAH35 IAD37-80	802	Black & White Ranier Cloth Black CTD. Fabric	IBL39-57 IBM39-47
705	Ant. Med. Blue Oxen CTD. Fabric Ant. Med. Blue CTD. Fabric	IAD37	803	Black Pingree Cloth Black CTD. Fabric	IBK69
706	Black Regatta Cloth Black CTD. Fabric	IAH57	804	Black Navajo Knit CTD. Fabric Black CTD. Fabric	IBK69
707	Black Tetra CTD. Fabric Black CTD. Fabric	IAE29-37	805	Black Ridgecrest Cloth Black CTD. Fabric	IBM39-47-69
708	Black Oxen CTD. Fabric Black CTD. Fabric	IAH57	806	Black Tetra CTD. Fabric Black CTD. Fabric	IBN35-45
709	Ant. Dk. Oxblood Tetra CTD. Fabric Ant. Dk. Oxblood CTD. Fabric	IAE37	810	Medium Blue Pingree Cloth	IBK69
710	Dk. Green Nuevo Knit CTD. Fabric Ant. Dk. Green Ctd. Fabric	IAC29-37	812	Midnight Blue Ridgecrest Cloth Ant. Midnight Blue CTD. Fabric	IBM39-47-69
711	Dk. Green Revere Cloth Ant. Dk. Green CTD. Fabric	IAC29-37	813	Ant. Midnight Blue Tetra CTD. Fabric Ant. Midnight Blue CTD. Fabric	IBL39, IBM39
712	Black Minuet Cloth Black CTD. Fabric	IAE29-37	815	Lt. Neutral Ridgecrest Cloth Ant. Lt. Neutral CTD. Fabric	IBM39-69-47
713	Ant. Dk. Green Oxen CTD. Fabric Ant. Dk. Green CTD. Fabric	IAD29-35-37 IAH35	816	White Tetra CTD. Fabric White CTD. Fabric (Black Carpet, etc.)	IBM67
714	Dk. Oxblood Minuet Cloth Ant. Dk. Oxblood CTD. Fabric	IAE37	817	Lt. Neutral Navajo Knit CTD. Fabric Ant. Lt. Neutral CTD. Fabric	IBK35-45
715	Dk. Green Regatta Cloth Ant. Dk. Green CTD. Fabric	IAH57	818	Ant. Lt. Neutral Tetra CTD. Fabric Ant. Lt. Neutral CTD. Fabric	IBM39-47-67-69
716	Chamois & Black Rally Cloth Med. Chamois CTD. Fabric	IAD37	825	Dk. Saddle Navajo Knit CTD. Fabric Ant. Dk. Saddle CTD. Fabric	IBK35-45
717	Ant. Dk. Saddle Tetra CTD. Ant. Dk. Saddle CTD. Fabric	IAE37	826	Ant. Dk. Saddle Tetra CTD. Fabric Ant. Dk. Saddle CTD. Fabric	IBL35-45 IBN35-45
719	Ant. Med. Blue Tetra CTD. Fabric Ant. Med. Blue CTD. Fabric	IAE37	827	Dk. Green Navajo Knit CTD. Fabric Ant. Dk. Green CTD. Fabric	IBK69
720	Ant. Dk. Saddle Oxen CTD. Fabric Ant. Dk. Saddle CTD. Fabric	IAD35-37 IAH35	828	Dk. Green Pingree Cloth Ant. Dk. Green CTD. Fabric	IBK69
721	Med. Chamois Oxen CTD. Fabric Med. Chamois CTD. Fabric	IAD29-37	829	Dk. Green Ridgecrest Cloth Ant. Dk. Green CTD. Fabric	IBM39-47-69
722	Dk. Saddle Nuevo Knit CTD. Fabric Ant. Dk. Saddle CTD. Fabric	IAC35	830	Ant. Dk. Green Tetra CTD. Ant. Dk. Green CTD. Fabric	IBM39-47-67-69 IBN35-45
723	Med. Blue Minuet Cloth Ant. Med. Blue CTD. Fabric	IAE29-37	836	Dk. Oxblood Regatta Cloth Ant. Dk. Oxblood CTD. Fabric	IBN39-47-69
724	Blue & Black Rally Cloth Ant. Med. Blue CTD. Fabric	IAD29-37	840	Black Regatta Cloth Black CTD. Fabric	IBN39-47-69
725	Midnight Blue Regatta Cloth Ant. Midnight Blue CTD. Fabric	IAH57	841	Lt. Neutral Minuet Cloth Ant. Lt. Neutral CTD. Fabric	IBN39-47-69
726	Dk. Green Minuet Cloth Ant. Dk. Green CTD. Fabric	IAE29-37	842	Dk. Green Regatta Cloth Ant. Dk. Green CTD. Fabric	IBN39-47-69
727	Ant. Dk. Green Tetra CTD. Fabric Ant. Dk. Green CTD. Fabric	IAE29-37	843	Midnight Blue Regatta Cloth Ant. Midnight Blue CTD. Fabric	IBN39-47-69
728	Dk. Green Oxen CTD. Fabric Ant. Dk. Green CTD. Fabric	IAH57	773	Black Newport Knit CTD. Fabric Black CTD. Fabric	IFS87
730	Green & Black Rally Cloth Ant. Dk. Green CTD. Fabric	IAD29-37	774	Blue & Black Randolph Cloth Black CTD. Fabric	IFQ87
731	Lt. Neutral Minuet Cloth Ant. Lt. Neutral CTD. Fabric	IAH57	775	Black Caribou CTD. Fabric Black CTD. Fabric	IFQ87
732	Ant. Lt. Neutral Oxen CTD. Fabric Ant. Lt. Neutral CTD. Fabric	IAH35 IAD37-80			
733	Lt. Neutral Nuevo Knit CTD. Fabric Ant. Lt. Neutral CTD. Fabric	IAC37			

1973 TRIM COMBINATION CHARTS (Cont'd.)

Comb. No.	Material	Models
776	Black & White Randolph Black CTD, Fabric	IFQ87
777	Ant. Dk. Green Caribou CTD, Fabric	IFQ87
778	Ant. Dk. Green CTD, Fabric	IFQ87
779	Ant. Dk. Saddle Caribou CTD, Fabric	IFQ87
780	Ant. Lt. Neutral Caribou CTD, Fabric	IFQ87
781	Med. Chamois Caribou CTD, Fabric	IFQ87
782	Med. Chamois CTD, Fabric	IFQ87
783	Green & Black Rally Cloth Ant. Dk. Green CTD, Fabric	IFS87
784	Black & White Rally Cloth Black CTD, Fabric	IFS87
785	Blue & Black Rally Cloth Black CTD, Fabric	IFS87
786	Lt. Neutral Newport Knit CTD, Fabric	IFS87
787	Ant. Lt. Neutral CTD, Fabric	IFS87
788	Black & White Ranier Cloth Black CTD, Fabric	IXY69
789	Black Navajo Knit CTD, Fabric	IXX17-27
790	Black CTD, Fabric	IXX17-27
791	Black & White Ranier Cloth Black CTD, Fabric	IXY17-27
792	Black Navajo Knit CTD, Fabric	IXX69
793	Black CTD, Fabric	IXX69
794	Black Tetra CTD, Fabric	IXY17-27
795	Black CTD, Fabric	IXY17-27
796	Black Revere Cloth Black CTD, Fabric	IXX17-27
797	Med. Blue Revere Cloth Ant. Med. Blue CTD, Fabric	IXX69
798	Dk. Green Navajo Knit CTD, Fabric	IXX69
799	Ant. Dk. Green CTD, Fabric	IXX69
800	Dk. Green Revere Cloth Ant. Dk. Green CTD, Fabric	IXX17-27
801	Dk. Green Revere Cloth Ant. Dk. Green CTD, Fabric	IXX17-27
802	Dk. Green Navajo CTD, Fabric	IXX17-27
803	Ant. Dk. Green CTD, Fab	IXX17-27
804	Dk. Green Pingree Cloth Ant. Dk. Green CTD, Fabric	IXX17-27
805	Lt. Neutral Navajo Knit CTD, Fabric	IXX17-27
806	Ant. Lt. Neutral CTD, Fabric	IXX17-27
807	Lt. Neutral Pingree Cloth Ant. Lt. Neutral CTD, Fabric	IXY17-27
808	Black CTD, Fabric (Taxi Cab Only)	IXX69
809	Med. Chamois CTD, Fabric (Taxi Cab Only)	IXX69

Comb. No.	Material	Models
767	Med. Chamois Navajo Knit CTD, Fabric	IXX17-27
768	Med. Chamois CTD, Fabric	IXX17-27
769	Lt. Neutral Pingree Cloth Ant. Lt. Neutral CTD, Fabric	IXY69
770	Dk. Green Pingree Cloth Ant. Dk. Green CTD, Fabric	IXY69
771	Ant. Lt. Neutral Tetra CTD, Fabric	IXY17-27
772	Ant. Lt. Neutral CTD, Fabric	IXY17-27
773	Med. Blue Revere Cloth Ant. Med. Blue CTD, Fabric	IXX69
774	Ant. Lt. Neutral Tetra CF/Ant. Lt. Neutral CF	1HV11-15-77
775	Ant. Dk. Green Tetra CF/Ant. Dk. Green CF	1HV11-77-15
776	Ant. Dk. Saddle Tetra CF/Ant. Dk. Saddle CF	1HV15
777	Ant. Dk. Oxblood Tetra CF/Ant. Dk. Oxblood CF	1HV77
778	Med. Chamois Tetra CF/Med. Chamois CF	1HV77
779	Blue & Black Rally Cloth/Ant. Med. Blue CF	1HV11-15-77
780	Black & White Rally Cloth/Black CF	1HV11-15-77
781	Black Madera CF/Black CF	1HV11-15-77
782	Black CF	1HV05
783	Lt. Neutral Madera CF/Ant. Lt. Neutral CF	1HV11-15-77
784	Dk. Green Madera CF/Ant. Dk. Green CF	1HV11-77-15
785	Ant. Dk. Green CF (Uses Truck Seat in Pearl)	1HV05
786	Dk. Saddle Madera CF/Ant. Dk. Saddle CF	1HV15
787	Dk. Oxblood Madera CF/Ant. Dk. Oxblood CF	1HV77
788	Med. Chamois Madera CF/Med. Chamois CF	1HV77
789	Black Tetra CF/Black CF	1HV11-15-77

## 1974 TRIM COMBINATION CHARTS

Comb. No.	Materials	Models	Comb. No.	Materials	Models
701	Black		802	Black & White Ranier Cloth Black CF	IBL39-57-69 IBM39-47-69
701	Black Rosetta Cloth Black CF	IAC29-37-80	803	Black Rosetta Cloth Black CF	IBK69
702	Black Bravado Cloth Black CF	IAD29-37-80	805	Black Radiant Cloth Black CF	IBL39-57-69
703	Black Rhone Cloth Black CF	IAE29-37	806	Black Tetra CF Black CF	IBL39-45-57-69 IBM39-47-69 IBN35-45-67
704	Black & White Ranier Cloth Black CF	IAD-37	807	Black Rhone Cloth Black CF	IBM39-47-69
705	Black Repose Cloth Black CF	IAH57	808	Black Oxen CF Black CF	IBN39-47-69
706	Black Nakota Knit Vinyl Black CF	IAC29-35-37-80	813	Ant. Midnight Blue Tetra CF Ant. Midnight Blue CF	IBL35-39-45-57-69
707	Black Oxen CF Black CF	IAD29-35-37-80 IAG35	815	Lt. Neutral Rosetta Cloth Ant. Lt. Neutral CF	IBK69
708	Black Tetra CF Black CF	IAE29-35-37-IAH35	817	Lt. Neutral Nakota Knit Vinyl Ant. Lt. Neutral CF	IBK35-45-69
709	Black Oxen CF Black CF	IAH57	819	Ant. Lt. Neutral Tetra CF Ant. Lt. Neutral CF	IBM39-47-69 IBN35-45-67
711	Lt. Neutral Rhone Cloth Ant. Lt. Neutral CF	IAE29-37	821	Lt. Neutral Radiant Cloth Ant. Lt. Neutral CF	IBL39-57-69
713	Lt. Neutral Nakata Knit Vinyl Ant. Lt. Neutral CF	IAC29-37-80-35	822	Lt. Neutral Rhone Cloth Ant. Lt. Neutral CF	IBM39-47-69
714	Ant. Lt. Neutral Oxen CF Ant. Lt. Neutral CF	IAD29-35-37-80 IAG35	840	Black Repose Cloth Black CF	IBN39-47-69
715	Ant. Lt. Neutral Tetra CF Ant. Lt. Neutral CF	IAE29-35-37-IAH35	841	Ant. Lt. Neutral Oxen CF Ant. Lt. Neutral CF	IBN39-47-68
716	Ant. Lt. Neutral Oxen CF Ant. Lt. Neutral CF	IAH57	843	Midnight Blue Repose Cloth Ant. Midnight Blue CF	IBN39-47-69
722	Lt. Neutral Bravado Cloth Ant. Lt. Neutral CF	IAD29-37-80	847	Midnight Blue Radiant Cloth Ant. Midnight Blue CF	IBL39-57-69
723	Med. Green Rosetta Cloth Ant. Med. Green CF	IAC29-37-80	848	Midnight Blue Rhone Cloth Ant. Midnight Blue CF	IBM39-47-69
724	Med. Green Bravado Cloth Ant. Med. Green CF	IAD29-37-80	849	Ant. Med. Saddle Tetra CF Ant. Med. Saddle CF	IBL35-45 IBN35-45
725	Med. Green Rhone Cloth Ant. Med. Green CF	IAE29-37	850	Med. Green Repose Cloth Ant. Med. Green CF	IBN39-47-69
726	Med. Green Repose Cloth Ant. Med. Green CF	IAH57	851	Med. Green Nakota Knit Vinyl Ant. Med. Green CF	IBK35-45-69
727	Med. Green Nakata Knit Vinyl Ant. Med. Green CF	IAC29-37-80	852	Med. Green Rosetta Cloth Ant. Med. Green CF	IBK69
728	Ant. Med. Green Oxen CF Ant. Med. Green CF	IAD29-35-37-80 IAG35	853	Med. Green Radiant Cloth Ant. Med. Green CF	IBL39-57-69
729	Ant. Med. Green Tetra Ant. Med. Green CF	IAE29-35-37-IAH35	854	Med. Green Rhone Cloth Ant. Med. Green CF	IBM39-47-69
730	Ant. Med. Green Oxen CF Ant. Med. Green CF	IAH57	855	Ant. Med. Green Tetra CF Ant. Med. Green CF	IBM39-47-69 IBL35-39-45-57-69 IBL35-45-67
732	Midnight Blue Bravado Cloth Ant. Midnight Blue CF	IAD29-37-80	856	Dk. Oxblood Rhone Cloth Ant. Dk. Oxblood CF	IBM39-47-69
733	Midnight Blue Rhone Cloth Ant. Midnight Blue CF	IAE29-37	857	Dk. Oxblood Repose Cloth Ant. Dk. Oxblood CF	IBN39-47-69
734	Midnight Blue Repose Cloth Ant. Midnight Blue CF	IAH57	896	Med. Taupe Repose Cloth Ant. Med. Taupe CF	IBN39-47-69
735	Ant. Midnight Blue Oxen CF Ant. Midnight Blue CF	IAD35-IAG35	775	Black & White Randolph Cloth Black CF	IFQ87
736	Ant. Midnight Blue Tetra CF Ant. Midnight Blue CF	IAE35-IAH35	776	Black Rhone Cloth Black Haircell CF	IFS87
737	Ant. Midnight Blue Oxen CF Ant. Midnight Blue CF	IAH57	777	Black Oxen CF Black CF	IFQ87
740	Ant. Med. Saddle Oxen CF Ant. Med. Saddle CF	IAD29-35-37-80 IAG35	778	Black Tetra CF Black Haircell CF	IFS87
741	Ant. Med. Saddle Tetra CF Ant. Med. Saddle CF	IAE35-IAH35	779	Black Oxen CF Black CF Red Welts & Carpet)	IFQ87
742	Ant. Med. Saddle Oxen CF Ant. Med. Saddle CF	IAH57	780	Lt. Neutral Rhone Cloth Ant. Lt. Neutral Haircell CF	IFS87
743	Dk. Oxblood Rhone Cloth Ant. Dk. Oxblood CF	IAE29-37	781	Ant. Lt. Neutral Oxen CF Ant. Lt. Neutral CF	IFQ87
744	Dk. Oxblood Repose Cloth Ant. Dk. Oxblood CF	IAH57	783	Med. Taupe Rhone Cloth Ant. Med. Taupe Haircell CF	IFS87
			784	Ant. Med. Taupe Tetra CF Ant. Med. Taupe Haircell CF	IFS87
			786	Green & Black Randolph Cloth Ant. Med. Green CF	IFQ87

1974 TRIM COMBINATION CHARTS (Cont'd.)

Comb. No.	Materials	Models	Comb. No.	Material	Models
787	Ant. Med. Green Oxen CF Ant. Med. Green CF	IFQ87	861	Black Tetra Coated Fabric Black Coated Fabric	1HV11-15-77
792	Med. Red Oxen CF Med. Red CF	IFQ87	862	Black-White & Red Napachi Vinyl Black Coated Fabric	1HV05-11-15-77
796	Saddle & Black Randolph Cloth Ant. Med. Saddle CF	IFQ87	863	Ant. Lt. Neutral Tetra Coated Fabric Ant. Lt. Neutral Coated Fabric	1HV11-15-77
797	Med. Saddle Rhone Cloth Ant. Med. Saddle Haircell	IFS87	869	Black Tetra Coated Fabric Black Coated Fabric (Red Welts & Carpet)	1HV15-77
798	Ant. Med. Saddle Oxen CF Ant. Med. Saddle CF	IFQ87	870	Lt. Neutral Napachi Knit Vinyl Ant. Lt. Neutral Coated Fabric	1HV11-15-77
799	Ant. Med. Saddle Tetra CF Ant. Med. Saddle Haircell	IFS87	871	Black & White Ranier Cloth Black Coated Fabric	1HV11-15-77
750	Black & White Randolph Cloth Black CF	IXX17-27-69	873	Black & White Randolph Cloth Black Coated Fabric	1HV11-15-77
751	Black Bravado Cloth Black CF	IXY17-27-69	879	Med. Green Napachi Knit Vinyl Ant. Med. Green Coated Fabric	1HV05-11-15-77
752	Black & White Ranier Cloth Black CF	IXY17-27	880	Ant. Med. Green Tetra Coated Fabric Ant. Med. Green Coated Fabric	1HV11-15-77
753	Black Nakota Knit Vinyl Black CF	IXX17-27	801	Lt. Neutral Napachi Knit Vinyl Ant. Lt. Neutral Coated Fabric	1HV11-15-77
754	Black Tetra CF Black CF	IXX17-27	883	Green & Black Randolph Cloth Ant. Med. Green Coated Fabric	1HV11-15-77
756	Green & Black Randolph Cloth Ant. Med. Green CF	IXX17-27-69	884	Black-White & Red Napachi Knit Vinyl Med. Red Coated Fabric	1HV15-77
757	Med. Green Bravado Cloth Ant. Med. Green CF	IXY17-27-69	887	Green & Black Ranier Cloth Ant. Med. Green Coated Fabric	1HV11-15-77
758	Med. Green Nakota Knit Vinyl Ant. Med. Green CF	IXX17-27-69	888	Med. Saddle Napachi Knit Vinyl Ant. Med. Saddle Coated Fabric	1HV11-15-77
759	Ant. Med. Green Tetra CF Ant. Med. Green CF	IXY17-27	890	Ant. Med. Saddle Tetra Coated Fabric Ant. Med. Saddle Coated Fabric	1HV11-15-77
764	Neutral & Black Randolph Clark Ant. Lt. Neutral CF	IXX17-27-69			
765	Lt. Neutral Nakota Knit Vinyl Ant. Lt. Neutral CF	IXX17-27-69			
766	Ant. Lt. Neutral Tetra CF Ant. Lt. Neutral CF	IXY17-27-69			
771	Midnight Bravado Cloth Ant. Midnight Blue CF	IXY17-27			
772	Midnight Blue Nakota Knit Vinyl Ant. Midnight Blue CF	IXX17-27-69			
773	Med. Saddle Nakota Knit Vinyl Ant. Med. Saddle CF	IXX-17			

## 1975 TRIM COMBINATION CHARTS

Comb. No.	Materials	Models	Comb. No.	Materials	Models
<b>PASSENGER</b>			<b>CHEVELLE</b>		
02W	White Tetra CF/White CF (Blue Carpet)	1BL47-57-1BN67	02H	White Oxen CF White CF	1AH57
04W	White Tetra CF/White CF (Green Carpet)	1BL47-57-1BN67	04H	White Oxen CF White CF	1AH57
07W	White Tetra CF/White CF (Oxblood Carpet)	1BL47-57-1BN67	07E	Black Cavalier CL White CF	1AE37
11W	White Tetra CF/White CF (Black Carpet)	1BL47-57-1BN67	07H	White Oxen CF White	1AH57
19B	Black Chelsea Cloth Black CF	1BN39-47-69	07Z	White, Tetra CF White CF	1AE37
19C	Black Radiant Cloth Black CF	1BK69	11E	Black Cavalier CL White CF	1AE37
19D	Black Regatta Cloth Black CF	1BL39-47-57-69	11H	White Oxen CF White CF	1AH57
19H	Black Oxen CF Black CF	1BN39-47-69	11Z	White Tetra CF White CF	1AE37
19W	Black Tetra CF Black CF	1BL35-39-45-47-57-69 1BN35-45	16D	Med. Graystn Rhone Cloth Ant. Med. Graystn CF	1AD29-37-80
26B	Dk Blue Chelsea Cloth Ant. Dk Blue CF	1BN39-47-69	19B	Black Chelsea Cloth Black CF	1AH57
26C	Dk Blue Radiant Cloth Ant. Blue CF	1BK69	19C	Black Charade Cloth Black CF	1AC29-37-80
26D	Dk Blue Regatta Cloth Ant. Blue CF	1BL39-47-57-69	19D	Black Rhone Cloth Black CF	1AD29-37-80
26V	Dk Blue Nike Knit Vinyl Ant. Dk Blue CF	1BK35-45	19E	Black Cavalier CL Black CF	1AE37
26W	Ant. Dk Blue Tetra CF Ant. Dk Blue CF	1BL35-39-45-47-57-69 1BN-35-45	19H	Black Oxen CF Black CF	1AH57
44B	Med. Green Chelsea Cloth Ant. Med. Green CF	1BN39-47-69	19N	Black Carousel Cloth Black Repose Cloth	1AH57
44D	Med. Green Regatta Cloth Ant. Med. Green CF	1BL39-47-57-69	19V	Black Nike Knit Vinyl Black CF	1AC-29-35-37-80
44W	Ant. Med. Green Tetra CF Ant. Med. Green CF	1BL35-39-45-47-57-69 BN35-45	19W	Black Oxen CF Black CF	1AD29-35-37-80-1, AG35
55B	Med. Sandstn Chelsea Cloth Ant. Med. Sandstn CF	1BN39-47-69	19Z	Black Tetra CF Black CF	1AE37
55C	Med. Sandstn Radiant Cloth Ant. Med. Sandstn CF	1BK69	26B	Dk Blue Chelsea Cloth Ant. Dk Blue CF	1AH57
55D	Med. Sandstn Regatta Cloth Ant. Med. Sandstn CF	1BL39-47-57-69	26C	Dk Blue Charada Cloth Ant. Dk Blue CF	1AC29-37-80
55H	Ant. Med. Sandstn Oxen CF Ant. Med. Sandstn CF	1BN39-47-69	26D	Dk Blue Rhone Cloth Ant. Dk Blue CF	1AD29-37-80
55V	Med. Sandstn Nike Knit Vinyl Ant. Med. Sandstn CF	1BK35-45-69	26H	Dk Blue Oxen CF Ant. Dk Blue CF	1AH57
55W	Ant. Med. Sandstn Tetra CF Ant. Med. Sandstn CF	1BL35-39-45-47-57-69 1BN35-45-67	26N	Dk Blue Carousel Cloth Dk Blue Repose Cloth	1AH57
63E	Dk Saddle Cavalier Cloth Ant. Saddle CF	1BL35-39-45-47-57-69 1BN35-45-67	26V	Dk Blue Nike Knit Vinyl Ant. Dk Blue CF	1AC29-37-80
63W	Ant. Dk. Saddle Tetra CF Ant. Dk. Saddle CF	1BL35-39-45-47-57-69 1BN35-45-67	26W	Dk Blue Oxen CF Ant. Dk Blue CF	1AD29-35-37-80
73B	Dk Oxblood Chelsea Cloth Ant. Dk. Oxblood CF	1BN39-47-69	44D	Med. Green Rhone Cloth Ant. Med Green CF	1AD29-37-80
			44N	Med. Green Carousel Cloth Med. Green Repose Cloth	1AH57
			44V	Med. Green Nike Knit Vinyl Ant. Med. Green CF	1AC29-37-80
			55B	Med. Sandstn Chelsea Cloth Ant. Med. Green CF	1AH57

**1975 TRIM COMBINATION CHARTS (Cont'd.)**

Comb. No.	Materials	Models	Comb. No.	Materials	Models
55H	Med. Sandstone Oxen CF Ant. Med. Sandstn CF	1AH57	55W	Med. Sandstn Tetra CF Ant. Med. Sandstn CF	1XY17-27-69
55N	Med. Sandstn Carousel Cloth Med. Sandstn Repose CL	1AH57	55V	Med. Sandstn Plisse CF Ant. Med. Sandstn CF	1XX17-27-69
55V	Med. Sandstn Nike Knit Vinyl Ant. Med. Sandstn CF	1AC29-35-37-80	63E	Dk Saddle Cavalier Cloth Ant. Dk Saddle Espana CF	1XY17-27
55W	Ant. Med. Sandstn Oxen CF Ant. Med. Sandstn CF	1AD29-35-37-80-1,AG35-80	63V	Dk Saddle Plisse CF Ant. Dk Saddle CF	1XX17-27-69
63E	Dk Saddle Cavalier CL Ant. Saddle CF	1AE37	63W	Dk Saddle Tetra CF Ant. Dk Saddle CF	1XY17-27
63W	Ant. Dk Saddle Oxen CF Ant. Dk Saddle CF	1AD-35-37-80 1AG35	73G	Oxblood Cambridge Cloth Dk Oxblood Repose	1XY27-69
77B	Dk. Oxblood Chelsea Cloth Ant. Dk Oxblood CF	1AH57	73W	Dk Oxblood Tetra CF Ant. Dk Oxblood CF	1XY17-27
63Z	Ant. Dk Saddle Tetra CF Ant. Dk Saddle CF	1AE37		<b>CAMARO</b>	
73D	Dk Oxblood Rhone Cloth Ant. Dk Oxblood CF	1AD-29-37-80	16D	Med. Graystn Carousel Cloth Ant. Med. Graystn CF	1FS87
73E	Dk Oxblood Cavalier CL Ant. Dk Oxblood CF	1AE37	19C	Black Caballero Cloth Black CF	1FQ87
73N	Dk Oxblood Carousel Cloth Dk Oxblood Repose Cloth	1AH57	19V	Black Oxen CF Black CF	1FQ87
73Z	Ant. Dk Oxblood Tetra CF Ant. Dk Oxblood CF	1AE37	55C	Med. Sandstn Caballero Cloth Ant. Med. Sandstn CF	1FQ87
	<b>NOVA</b>		55D	Med. Sandstn Carousel Cloth Ant. Med. Sandstn CF	1FS87
02W	White Tetra CF White CF (Blue Carpet)	1XY17-27	55V	Ant. Med. Sandstn Oxen CF Ant. Med. Sandstn CF	1FQ87
04W	White Tetra CF White CF (Green Carpet)	1XY17-27	55W	Med. Sandstn Nyvin Knit Vinyl Ant. Med. Sandstn CF	1FS87
07W	White Tetra CF White CF (Oxblood Carpet)	1XY17-27	63D	Dk Saddle Carousel Cloth Ant. Dk Saddle CF	1FS87
11W	White Tetra CF White CF (Black Carpet)	1XY17-27	63V	Ant. Dk Saddle Oxen CF Ant. Dk. Saddle CF	1FQ87
16G	Med. Graystn Cambridge Cloth Med. Graystn Repose	1XY27-69	63W	Dk Saddle Nyvin Knit Vinyl Ant. Dk Saddle CF	1FS87
19G	Black Caballero Cloth Black CF	1XY17-27-69	73D	Dk Oxblood Carousel Cloth Ant. Dk Oxblood CF	1FS87
19E	Black Cavalier Cloth Black Espana CF	1XY17-27	91V	White Oxen CF White CF (Black Carpet)	1FQ87
19V	Black Plisse CF Black CF	1XX17-27-69	632	Ant. Dk Saddle Leather	1FS87
19W	Black Tetra CF Black CF	1XX17-27-69	732	Ant. Dk Oxblood Leather	1FS87
26C	Dk Blue Caballero Cloth Ant. Dk Blue CF	1XX17-27-69			
26D	Dk Blue Regatta Cloth Ant. Blue Espana CF	1XY17-27-69	02Y	White Tetra CF/White CF (Blue Carpet)	1HV77-15
26G	Dk Blue Cambridge Cloth Dk Blue Repose Cloth	1XY27-69	11Y	White Tetra CF/White CF (Black Carpet)	1HV77-15
26V	Dk Blue Plisse CF Ant. Dk Blue CF	1XX17-27-69	16G	Med. Chelsea Cloth/Black CF	1HR07
44D	Med. Green Regatta Cloth Ant. Med. Green Espana CF	1XY17-27-69	16Z	Ant. Med. Graystn CF	1HR07
55C	Med. Sandstn Caballero Cloth Ant. Med. Sandstn CF	1XX17-27-69	19D	Black Caballero Cloth/Black CF	1HV11-15-77
55D	Med. Sandstn Regatta Cloth Ant. Med. Sandstn Espana	1XY17-27-69	19E	Black Calypso Cloth/Black CF	1HV11-15-77
55G	Med. Sandstn Cambridge Cloth Med. Sandstn Repose	1XY27-69	19G	Black Chelsea Cloth/Black CF	1HR07
			19V	Black/Med. Graystn	1HV05
			19W	Black Nike Knit Vinyl/Black CF	1HV11-15-77
			19Y	Black Tetra CF/Black CF	1HV11-15-77

## 1975 TRIM COMBINATION CHARTS (Cont'd.)

Comb. No.	Material	Model	Comb. No.	Material	Models
19Z	Black CF	1HR07	55Z	Ant. Med. Sandstn CF	1HR07
26B	Dk. Blue Carousel Cloth/Dk. Blue Repose Cloth	1HV15-77	63G	Dk. Saddle Cloth/Ant. Dk. Saddle CF	1HR07
26G	Dk. Blue Chelsea Cloth/Ant. Dk. Blue CF	1HR07	63V	Dk. Saddle/Dk. Saddle	1HV05
26V	Dk. Blue/Dk Blue	1HV05	63W	Dk. Saddle Nike Knit Vinyl/ Ant. Dk. Saddle CF	1HV11-15-77
26W	Dk. Blue Nike Knit Vinyl/Ant. Dk. Blue CF	1HV11-15-77	63Y	Ant. Dk. Saddle Tetra/Ant. Dk. Saddle CF	1HV11-15-77
26Z	Ant. Dk. Blue CF	1HR07	63Z	Ant. Dk. Saddle CF	1RH07
55B	Med. Sandstn Carousel Cloth/ Med. Sandstn Repose Cloth	1HV15-77	73B	Oxblood Carousel Cloth/Dk. Oxblood Repose Cloth	1HV15-77
55D	Med. Sandstn Caballero Cloth/ Ant. Med. Sandstn CF	1HV11-15-77	73G	Dk. Oxblood Chelsea CL/ Ant. Dk. Oxblood	1HR07
55E	Med. Sandstn Calypso Cloth/Ant. Med. Sandstn CF	1HV11-15-77	73Y	Ant. Dk. Oxblood Tetra CF/ Ant. Dk. Oxblood CF	1HV15-77
55G	Med. Sandstn Chelsea CL/ Ant. Med. Sandstn CF	1HR07	73Z	Ant. Dk. Oxblood CF	1HR07
55W	Med. Sandstn Nike Knit Vinyl/ Ant. Med. Sandstn CF	1HV11-15-77	192	Black Leather	1HR07
55Y	Ant. Med. Sandstn Tetra CF/ Ant. Med. Sandstn CF	1HV11-15-77	632	Ant. Dk. Saddle Leather	1HR07
			732	Ant. Dk. Oxblood Leather	1HR07



# CHEVROLET CHASSIS GROUP 0.000



## ENGINE — CLUTCH

### ALPHABETICAL INDEX

<b>A</b>			
ABSORBER, Clutch Fork.....	0.797	BOLT, Flywheel.....	0.679
ARM UNIT, Valve Rocker with Adjusting Screw and Nut.....	0.333	BOLT, Harmonic Balancer and Crankshaft Pulley.....	0.662
ARM, Valve Rocker with Adjusting Screw and Nut.....	0.333	BOLT, Timing Belt.....	0.724
		BOLT, Valve Rocker Cover and Support (Also See Group 0.366).....	0.413
		BOLT, Valve, Push Rod Cover.....	0.446
		BOOT, Clutch Fork.....	0.797
		BRACKET ASSY., Clutch Cable.....	0.855
		BRACKET ASSY., Engine Mounting.....	0.029
		BRACKET, Clutch Fork.....	0.796
		BRACKET, Clutch Pedal Intermediate.....	0.852
		BRACKET, Clutch.....	0.829
		BRACKET, Engine Mounting.....	0.029
		BUMPER, Clutch.....	0.829
		BUSHING, Clutch Pedal (see group 4.626 for brake pedal bushing).....	0.831
		BUSHING, Clutch Pedal.....	0.854
		<b>B</b>	
BALANCER, Crankshaft.....	0.659		
BALL, Valve Push Rod Adjusting.....	0.429		
BEARING, Camshaft (Center and Rear Intermediate).....	0.546		
BEARING, Camshaft (Front or No. 1).....	0.539		
BEARING, Camshaft (Rear).....	0.549		
BEARING, Camshaft No. 1 (Front).....	0.539		
BEARING, Camshaft No. 2 (Front Intermediate).....	0.543		
BEARING, Camshaft Rear.....	0.549		
BEARING, Camshaft.....	0.539		
BEARING, Clutch throwout with Collar.....	0.799		
BEARING, Clutch Pilot.....	0.649		
BEARING, Clutch Throwout w/Collar.....	0.799		
BEARING, Crankshaft Clutch Pilot.....	0.649		
BEARING UNIT, Camshaft Thrust.....	0.533		
BEARING UNIT, Connecting Rod (1 Upper and 1 Lower).....	0.616		
BEARING UNIT, Crankshaft Center (1 upper and 1 lower). See chart following group 0.096 for model application.....	0.101		
BEARING UNIT, Crankshaft Front (1 Upper and 1 Lower) See chart for model application.....	0.096		
BEARING UNIT, Crankshaft Front Intermediate (1 upper and 1 lower). See chart following group 0.096 for model application.....	0.099		
BEARING UNIT, Crankshaft No. 1-2-3.....	0.096		
BEARING UNIT, Crankshaft No. 4.....	0.103		
BEARING UNIT, Crankshaft No. 5.....	0.106		
BEARING UNIT, Crankshaft Rear Intermediate (1 upper and 1 lower). See chart following group 0.096 for model application.....	0.103		
BELT, Camshaft Timing Belt.....	0.724		
BELT, Timing Belt.....	0.724		
BLOCK ASSEMBLY, Cylinder.....	0.033		
BLOCK ASSY., Cylinder.....	0.033		
BOLT, Camshaft Housing and Cover.....	0.413		
BOLT, Clutch Cover and Pressure Plate.....	0.862		
BOLT, Clutch Pressure Plate.....	0.864		
BOLT, Connecting Rod Bearing Cap.....	0.623		
BOLT, Crankshaft Bearing Cap.....	0.056		
BOLT, Crankshaft Damper.....	0.662		
BOLT, Crankshaft Main Bearing Cap.....	0.056		
BOLT, Cylinder Head.....	0.293		
BOLT, Engine Mounting (Small Attaching).....	0.002		
BOLT, Flywheel and Clutch.....	0.683		
BOLT, Flywheel to Crankshaft.....	0.669		
		<b>C</b>	
		CABLE ASSY., Clutch Cable.....	0.854
		CABLE, Clutch.....	0.854
		CABLE UNIT, Engine (Also See Group 4.081).....	0.027
		CAMSHAFT.....	0.519
		CAMSHAFT, Engine.....	0.519
		CAP, Clutch Fork Ball.....	0.796
		CAP, Crankshaft Front Bearing.....	0.095
		CAP, Crankshaft Main Bearing.....	0.095
		CAP, Crankshaft Main Bearing.....	0.102
		CAP, Crankshaft Main Bearing.....	0.105
		CAP, Crankshaft Rear Bearing.....	0.105
		CAP, Crankshaft Rear Intermediate Bearing... .....	0.102
		CAP, Valve Spring.....	0.309
		CHAIN, Camshaft Timing.....	0.724
		CLIP, Clutch Fork Release.....	0.787
		CLIP, Clutch Pedal.....	0.854
		CLIP, Clutch.....	0.829
		COMPOUND UNIT, Crankshaft Rear Bearing and Cap Oil.....	0.137
		COVER ASSY., Camshaft.....	0.386
		COVER ASSY., Clutch Pressure Plate.....	0.859
		COVER ASSY., Clutch.....	0.861
		COVER ASSY., Crankcase Front End.....	0.206
		COVER ASSY., Engine Timing.....	0.219
		COVER ASSY., Valve Rocker Arm.....	0.386
		COVER, Camshaft Timing Belt.....	0.724
		COVER, Clutch Housing and Transmission Under Pan.....	0.679
		COVER, Clutch.....	0.829
		COVER, Clutch.....	0.861
		COVER, Crankcase Front End.....	0.206
		COVER, Engine Timing Belt.....	0.206
		COVER, Flywheel.....	0.679
		COVER, Timing Belt.....	0.206
		COVER, Timing Belt.....	0.724
		COVER, Valve Push Rod.....	0.439
		COVER, Valve Rocker Arm.....	0.386
		CRANKSHAFT ASSY., Engine.....	0.646
		CRANKSHAFT, Engine.....	0.646



## ALPHABETICAL INDEX

<b>D</b>	
DAMPER ASSY., Crankshaft.....	0.659
DEFLECTOR, Flywheel.....	0.679
DISC, with Facing, Clutch.....	0.886
DOWEL, Crankshaft Bearing Cap.....	0.107
DOWEL, Flywheel and Clutch Housing to Cylinder Block.....	0.685
DOWEL, Flywheel to Crankshaft.....	0.669

<b>E</b>	
EMBLEM, Valve Rocker Arm.....	0.386
ENGINE ASSEMBLY.....	0.000
EXPANSION PLUG, Cylinder Block (Also See Group 8.970).....	0.034
EXPANSION PLUGS, Cylinder Block (Also see Group 8.970 of the Standard Parts Catalog).....	0.034
EXTENSION, Clutch Fork Release.....	0.787
EXTENSION, Clutch Pedal Pull Back Spring..	0.846

<b>F</b>	
FLYWHEEL ASSY., Engine.....	0.666
FLYWHEEL, w/Ring Gear.....	0.666
FLYWHEEL, with Ring Gear.....	0.666
FLYWHEEL, With Ring Gear.....	0.666
FORK ASSY., Clutch Release.....	0.795

<b>G</b>	
GASKET, Camshaft Cover.....	0.529
GASKET, Camshaft Housing.....	0.529
GASKET, Camshaft.....	0.738
GASKET, Clutch Release Bearing Support Guide.....	0.805
GASKET, Crankcase Front End Cover.....	0.207
GASKET, Cylinder Head.....	0.289
GASKET, Transmission to Clutch Housing.....	0.686
GASKET UNIT, Camshaft Housing.....	0.529
GASKET UNIT, Cylinder Head.....	0.289
GASKET UNIT, Engine or Tune Up.....	0.010
GASKET, Valve Push Rod Cover.....	0.443
GASKET, Valve Rocker Cover.....	0.423
GEAR, Camshaft Timing.....	0.736
GEAR, Crankshaft Timing (Steel).....	0.728
GEAR, Flywheel Ring.....	0.673
GROMMET, Clutch Fork.....	0.797
GROMMET, Valve Rocker Arm.....	0.386
GUARD, Clutch Cable.....	0.854
GUIDE, Crankcase and Push Rod.....	0.439
GUIDE, Valve Push Rod.....	0.439
GUIDE, Valve Push ROD.....	0.439

<b>H</b>	
HEAD ASSY., Cylinder.....	0.269
HEAD, Cylinder.....	0.269
HOUSING ASSY., Camshaft.....	0.386
HOUSING ASSY., Flywheel and Clutch.....	0.683
HOUSING, Clutch.....	0.683
HOUSING, Flywheel and Clutch.....	0.683
HUB, Crankshaft.....	0.659

<b>K</b>	
KEY, Camshaft Sprocket.....	0.738

KEY, Crankshaft.....	0.659
KEY, Harmonic Balancer and Crankshaft Pulley.....	0.662
KEY, Valve Stem.....	0.310

<b>L</b>	
LEVER, Clutch Pedal Intermediate.....	0.852
LEVER, Clutch Pedal, Intermediate (See Group 4.648 for brake).....	0.852
LOCK, Camshaft Sprocket.....	0.738

<b>M</b>	
MOUNTING ASSY., Engine (also see group 4.081).....	0.027
MOUNTING ASSY., Engine Mounting.....	0.029
MOUNTING ASSY., Engine.....	0.027
MOUNTING UNIT, Engine (also see group 4.081).....	0.027

<b>N</b>	
NOZZLE, Timing Gear Oil.....	0.748
NUT, Camshaft Timing Belt.....	0.724
NUT, Connecting Rod Bearing Cap olt.....	0.626
NUT, Cylinder Head.....	0.293
NUT, Engine Timing Belt.....	0.206
NUT, Valve Push Rod Adjusting.....	0.429

<b>P</b>	
PEDAL ASSY., Clutch.....	0.830
PEDAL, Clutch.....	0.830
PIN, Camshaft Housing and Cover.....	0.413
PIN, Camshaft Rear Bearing Hole.....	0.553
PIN, Camshaft Sprocket.....	0.738
PIN, Clutch Cable.....	0.854
PIN, Clutch Housing.....	0.685
PIN, Clutch Pedal.....	0.833
PIN, Clutch Pedal.....	0.854
PIN, Crankcase Front End.....	0.206
PIN, Crankshaft Bearing Cap.....	0.107
PIN, Crankshaft Rear Bearing.....	0.105
PIN, Cylinder Head.....	0.293
PIN, Flywheel and Clutch Housing to Cylinder Block.....	0.685
PISTON ASSEMBLY, with Pin (Refer to Piston Chart for Model Application).....	0.629
PISTON ASSEMBLY, With Pin.....	0.629
PISTON ASSY., w/Pin.....	0.629
PISTON ASSY., with Pin.....	0.629
PISTON ASSY., Engine.....	0.629
PLASTIGAGE, Crankshaft Bearing.....	0.093
PLATE ASSY., with Facing, Clutch.....	0.886
PLATE ASSY., Clutch Driven.....	0.886
PLATE ASSY., Clutch Pressure with Cover....	0.859
PLATE ASSY., With Facing, Clutch.....	0.886
PLATE, Clutch Pressure.....	0.863
PLATE UNIT, Clutch Pressure with Cover....	0.859
PLUG, Camshaft Bearing Hole (In Cylinder Block).....	0.553
PLUG, Camshaft Rear Bearing Hole.....	0.553
PLUG, Clutch.....	0.829
PLUG, Cylinder Block.....	0.034
POINTER, Eng. Timing.....	0.219
POINTER, Engine Timing.....	0.219
POINTER, Timing.....	0.219
PULLEY ASSY., Crankshaft.....	0.659
PULLEY, Clutch Cable.....	0.855
PULLEY, Crankshaft.....	0.659

# ALPHABETICAL INDEX

## R

REINFORCEMENT, Harmonic Balancer and Crankshaft Pulley.....	0.662
REINFORCEMENT, Valve Rocker Cover and Support (Also See Group 0.366).....	0.413
RETAINER, Camshaft.....	0.738
RETAINER, Clutch and Brake Pedal Shaft (Also see Groups 4.634 and 4.648).....	0.837
RETAINER, Clutch.....	0.829
RETAINER, Piston Pin.....	0.639
RING, Clutch.....	0.829
RING UNIT, Piston (Service Sets).....	0.643
ROD ASSEMBLY, Connecting.....	0.603
ROD ASSY., Connecting, Less Dipper.....	0.603
ROD, Clutch Fork Release.....	0.787
ROD, Clutch Pedal.....	0.854
ROD, Connecting.....	0.603
ROD, Valve Push.....	0.426
ROTATOR ASSY., Valve Spring.....	0.309
ROTATOR, Valve Spring.....	0.309

## S

SCREW ASSY., Camshaft Timing Belt.....	0.724
SCREW ASSY., Engine Mounting.....	0.002
SCREW ASSY., Flywheel.....	0.679
SCREW ASSY., Valve Rocker Cover.....	0.413
SCREW, Clutch Housing and Transmission Under Pan.....	0.679
SCREW, Flywheel.....	0.679
SCREW, Harmonic Balancer and Crankshaft Pulley.....	0.662
SCREW, Valve.....	0.459
SEAL ASSY., Crankcase Front End Cover.....	0.213
SEAL ASSY., Crankshaft Oil.....	0.213
SEAL ASSY., Crankshaft Rear Bearing and Cap Oil.....	0.137
SEAL ASSY., Engine Timing Belt Cover.....	0.213
SEAL, Camshaft Housing.....	0.529
SEAL, Camshaft.....	0.738
SEAL, Clutch Pedal Intermediate Lever Shaft Ball.....	0.851
SEAL, Clutch.....	0.829
SEAL, Crankcase Front End Cover.....	0.213
SEAL, Crankshaft Rear Bearing and Cap Oil.....	0.137
SEAL UNIT, Crankshaft Rear Bearing and Cap Oil.....	0.137
SEAL UNIT, Valve Stem Oil.....	0.308
SEAL, Valve Spring Cap.....	0.308
SEAT ASSY., Clutch.....	0.829
SEAT, Clutch Pedal Intermediate Lever Shaft Ball.....	0.851
SEAT, Valve Spring.....	0.309
SHAFT, Clutch Pedal, Intermediate (See Group 4.648 for brake).....	0.852
SHIELD ASSY., Engine Timing Belt.....	0.206
SHIELD, Clutch Housing and Transmission Under Pan.....	0.679
SHIELD, Engine Mounting.....	0.029
SHIELD, Flywheel.....	0.679
SHIELD, Valve Spring Cap.....	0.308
SHIM, Crankshaft Main Bearing Cap.....	0.153
SHIM UNIT, Crankshaft Bearing Cap.....	0.153
SHIM, Valve.....	0.303
SHIM, Valve.....	0.459
SLEEVE, Clutch Cable.....	0.854
SLEEVE, Clutch Pedal.....	0.854
SNUBBER ASSY., Timing Belt.....	0.219
SPACER, Clutch and Brake Pedal Shaft (Also see Groups 4.634 and 4.648).....	0.837
SPACER, Clutch Fork Release.....	0.787
SPACER, Crankshaft Pulley.....	0.662
SPACER, Engine Mounting (Small Attaching).....	0.002
SPRING, Clutch and Brake Pedal Shaft-(Also see groups 4.634 and 4.648).....	0.837
SPRING, Clutch Fork Pull Back.....	0.844
SPRING, Clutch Fork.....	0.796
SPRING, Clutch Fork.....	0.844

SPRING, Clutch Pedal Intermediate Lever Shaft Ball.....	0.851
SPRING, Clutch Pedal Pull Back.....	0.844
SPRING, Clutch Pressure Plate.....	0.864
SPRING, Pressure Plate.....	0.864
SPRING UNIT, Valve.....	0.303
SPRING, Valve Rocker Shaft.....	0.376
SPRING, Valve.....	0.303
SPROCKET, Camshaft Timing.....	0.736
SPROCKET, Crankshaft Timing (Steel).....	0.728
STUD, Clutch Fork Ball.....	0.796
STUD, Clutch Pedal Intermediate Lever Shaft Ball.....	0.851
STUD, Crankshaft Bearing Cap.....	0.056
STUD, Cylinder Head.....	0.293
STUD, Engine Mounting.....	0.002
STUD, Flywheel.....	0.679
STUD, Valve Push Rod Adjusting.....	0.429
STUD, Valve Rocker Cover and Support.....	0.413
STUD, Valve, Push Rod Cover.....	0.446
SUPPORT, Clutch Release Bearing Support Guide.....	0.805
SUPPORT, Engine Mounting.....	0.029
SWIVEL, Clutch Fork Release.....	0.787

## T

TAPPET ASSY., Valve.....	0.459
TAPPET, Valve (or Lifter).....	0.459
TAPPET, Valve (Or Lifter).....	0.459
TEE, Valve.....	0.303

## U

UNDERPAN ASSY., Flywheel.....	0.679
UNDER PAN, Clutch Housing and Transmission Under Pan.....	0.679
UNDERPAN, Flywheel.....	0.679

## V

VALVE, Engine Exhaust.....	0.297
VALVE, Engine Inlet.....	0.296
VALVE (Exhaust).....	0.297
VALVE, Exhaust.....	0.297
VALVE (Inlet).....	0.296
VALVE, Inlet.....	0.296

## W

WASHER, Camshaft.....	0.738
WASHER, Clutch Fork Push Rod.....	0.793
WASHER, Clutch Pedal Intermediate Lever Shaft Ball.....	0.851
WASHER, Crankshaft Damper.....	0.662
WASHER, Cylinder Head.....	0.293
WASHER, Engine Mounting (Small Attaching).....	0.002
WASHER, Harmonic Balancer and Crankshaft Pulley.....	0.662



**122 ENGINE ASSEMBLY**

<b>0.002 SCREW ASSY.—STUD—SPACER—WASHER, Engine Mounting</b>					
75	All (122)	336501	6	.18	( <sup>3</sup> / <sub>8</sub> "— 16 x 1 <sup>1</sup> / <sub>2</sub> ")
75	All (122)	3977160	6	.18	STUD
75	All (122)	9840757	L.H.	.81	SPACER, motor mount on shock absorber rear
75	All (122)	3876340	2	.24	WASHER, frame bracket rod ( <sup>15</sup> / <sub>32</sub> " I.D. x 1 <sup>1</sup> / <sub>2</sub> " O.D.)
<b>0.027 MOUNTING ASSY., Engine</b>					
75	All (122)	3978119	L.H.	5.50	left
75	All (122)	3978120	R.H.	5.50	right
<b>0.029 BRACKET ASSY., Engine Mounting</b>					
75	All (122)	3997293	L.H.	6.95	left
75	All (122)	3997294	R.H.	6.95	right
<b>0.033 BLOCK ASSY., Cylinder</b>					
75	All (122)	345009	1	901.00	fitted block (Note 1)
<i>NOTE 1: Includes block, pistons, pins, rings and bearings.</i>					
75	All (122)	345010	1	1210.00	partial engine (Note 2)
<i>NOTE 2: Includes block, crankshaft, pistons and connecting rods.</i>					
<b>0.034 PLUG, Cylinder Block</b>					
75	All (122)	3835577	1	.12	cyl. and case oil gallery rear hole
75	All (122)	141357	2	.31	inlet cam oil gallery— (8.939)
75	All (122)	3826504	1	.96	water jacket
75	All (122)	141380	1	.36	camshaft oil gallery
<b>0.056 BOLT, Crankshaft Main Bearing Cap</b>					
75	All (122)	3977137	10	.24	
<b>0.095 CAP, Crankshaft Main Bearing</b>					
75	All (122)	3983483	3	9.60	1-2-3
<b>0.096 BEARING UNIT, Crankshaft No. 1-2-3-</b>					
<hr/>					
		STD.	.001 U.S.	.002 U.S.	.010 U.S.
75	All (122)	6260595	6260596	6260597	6260598
<hr/>					
<b>0.102 CAP, Crankshaft Main Bearing</b>					
75	All (122)	3983484	1	9.60	#4
<b>0.103 BEARING UNIT, Crankshaft No. 4</b>					
<hr/>					
		STD.	.001 U.S.	.002 U.S.	.010 U.S.
75	All (122)	6260600	6260801	6260802	6260803
<hr/>					
<b>0.105 CAP, Crankshaft Main Bearing</b>					
75	All (122)	3983485	1	9.60	#5
<b>0.106 BEARING UNIT, Crankshaft No. 5</b>					
<hr/>					
		STD.	.001 U.S.	.002 U.S.	.010 U.S.
75	All (122)	6260981	6260982	6260983	6260984
<hr/>					
<b>0.137 COMPOUND UNIT— SEAL ASSY., Crankshaft Rear Bearing Cap and Oil</b>					
75	All (122)	3997597	A.R.	6.45	rear main bearing cap (Note 1)
<i>NOTE 1: Consists of 1 each, hardener, sealing compound, applicator, disc, rod, instruction sheet.</i>					
75	All (122)	3983488	2	.62	SEAL ASSY., rear oil
<b>0.153 SHIM UNIT, Crankshaft Bearing Cap</b>					
75	All (122)	3983486	A.R.	2.25	# 1-2-3-4 cap
75	All (122)	3983487	A.R.	2.25	#cap
<b>0.206 COVER, Timing Belt</b>					
75	All (122)	334029	1	4.15	lower rear
75	All (122)	352135	1	6.50	lower front
75	All (122)	352122	1	17.90	upper front

## 122 ENGINE ASSEMBLY

	<b>0.213</b>	<b>SEAL ASSY., Crankshaft Oil</b>			
75	All (122)	3973135	1	2.30	crankshaft
	<b>0.219</b>	<b>SNUBBER ASSY., Timing Belt</b>			
75	All (122)	352123	1	3.55	
	<b>0.269</b>	<b>HEAD ASSY., Cylinder</b>			
75	All (122)	6260845	1	353.00	less valve train
	<b>0.289</b>	<b>GASKET— GASKET UNIT, Cylinder Head</b>			
75	All (122)	352150	1	14.05	
75	All (122)	347090	1	29.75	GASKET UNIT, head
	<b>0.293</b>	<b>BOLT— WASHER, Cylinder Head</b>			
75	All (122)	334011	10	.56	
75	All (122)	3899696	10	.33	WASHER, bolt
	<b>0.296</b>	<b>VALVE, Engine Inlet</b>			
75	All (122)	348637	8	9.75	(standard)
75	All (122)	355703	8	14.10	(.003 OVSI)
	<b>0.297</b>	<b>VALVE, Engine Exhaust</b>			
75	All (122)	348639	8	12.50	(standard)
75	All (122)	355705	8	13.85	(.003 OVSI)
	<b>0.303</b>	<b>SPRING UNIT, Valve</b>			
75	All (122)	6260555	1	2.70	SPRING UNIT, valve
	<b>0.308</b>	<b>SEAL UNIT, Valve Stem</b>			
75	All (122)	6260848	1	6.20	oil inlet valve
	<b>0.309</b>	<b>CAP— SEAT, Valve Spring</b>			
75	All (122)	334067	16	1.20	
75	All (122)	334065	16	.41	SEAT, valve spring
	<b>0.310</b>	<b>KEY, Valve Stem</b>			
75	All (122)	334068	32	.42	
	<b>0.386</b>	<b>COVER ASSY.— HOUSING ASSY., Camshaft</b>			
75	All (122)	348615	1	44.50	camshaft
75	All (122)	348613	1	125.00	HOUSING ASSY., camshaft
	<b>0.413</b>	<b>BOLT— PIN, Camshaft Housing and Cover</b>			
75	All (122)	334044	12	.18	camshaft cover
75	All (122)	334081	17	1.00	camshaft housing to cyl. head
75	All (122)	334006	2	.40	PIN, cylinder head to camshaft housing
	<b>0.459</b>	<b>SHIM— TAPPET, Valve</b>			
75	All (122)	5233266 A.R.		3.00	(.110-.112) marked 111
75	All (122)	5233267 A.R.		3.00	(.112-.114) marked 113
75	All (122)	5233268 A.R.		3.00	(.114-.116) marked 115
75	All (122)	5233269 A.R.		3.00	(.116-.118) marked 117
75	All (122)	5233270 A.R.		3.00	(.118-.120) marked 119
75	All (122)	5233271 A.R.		3.00	(.120-.122) marked 121
75	All (122)	5233272 A.R.		3.00	(.122-.124) marked 123
75	All (122)	5233273 A.R.		3.00	(.124-.126) marked 125
75	All (122)	5233274 A.R.		3.00	(.126-.128) marked 127
75	All (122)	5233275 A.R.		3.00	(.128-.130) marked 129
75	All (122)	5233276 A.R.		3.00	(.130-.132) marked 131
75	All (122)	334071	16	3.55	TAPPET
	<b>0.519</b>	<b>CAMSHAFT, Engine</b>			
75	All (122)	348652	1	52.25	inlet
75	All (122)	348654	1	52.25	exhaust
	<b>0.529</b>	<b>GASKET— GASKET UNIT— SEAL, Camshaft Housing</b>			
75	All (122)	345129	1	2.80	GASKET UNIT
75	All (122)	347089	1	3.20	GASKET UNIT, camshaft cover
75	All (122)	334001		.45	SEAL, camshaft intake and exhaust, front
	<b>0.553</b>	<b>PIN— PLUG, Camshaft Rear Bearing Hole</b>			
75	All (122)	141344	1	.36	camshaft housing— (8.939)
75	All (122)	9427703	2	.46	PLUG, camshaft housing— (8.970)
	<b>0.603</b>	<b>ROD, Connecting</b>			
75	All (122)	334020	4	27.00	

## 122 ENGINE ASSEMBLY

	<b>0.616</b>	<b>BEARING UNIT, Connecting Rod</b>				
75	All (122)	3711828	4	4.65	std.	
	<b>0.623</b>	<b>BOLT, Connecting Rod</b>				
75	All (122)	334021	8	.63		
	<b>0.629</b>	<b>PISTON ASSY., w/Pin</b>				
75	All (122)	360171 A.R.		23.40	standard (S-4) (3.4975-3.4980)	
75	All (122)	360172 A.R.		23.40	standard (S-5) (3.4980-3.4985)	
75	All (122)	360173 A.R.		23.40	standard (S-6) (3.4985-3.4990)	
75	All (122)	360174 A.R.		23.40	standard (S-7) (3.4990-3.4995)	
75	All (122)	360175 A.R.		23.40	.020 oversize	
	<b>0.643</b>	<b>RING UNIT, Piston</b>				
75	All (122)	6263197 A.R.		6.70	standard	
75	All (122)	6263199 A.R.		6.70	.020 oversize	
	<b>0.646</b>	<b>CRANKSHAFT ASSY., Engine</b>				
75	All (122)	326315	1	244.00		
	<b>0.659</b>	<b>DAMPER ASSY., Crankshaft</b>				
75	All (122)	352121	1	28.25	torsional	
	<b>0.662</b>	<b>BOLT— WASHER, Crankshaft Damper</b>				
75	All (122)	334047	1	.31	damper ( <sup>5</sup> / <sub>16</sub> "— 18 x <sup>7</sup> / <sub>8</sub> ")	
75	All (122)	3954735	1	.13	WASHER, damper bolt— (14.875)	
	<b>0.666</b>	<b>FLYWHEEL ASSY., Engine</b>				
75	All (122)	334015	1	32.00		
	<b>0.669</b>	<b>BOLT, Flywheel</b>				
75	All (122) (exc. A.C.)	839756	6	.12		
	<b>0.673</b>	<b>GEAR, Flywheel Ring</b>				
75	All (122)	3991407	1	7.95		
	<b>0.679</b>	<b>COVER— SHIELD, Clutch Housing</b>				
75	All (122)	3973182	1	.42		
75	All (122)	3973181	1	1.10	SHIELD, housing side	
	<b>0.683</b>	<b>HOUSING, Clutch</b>				
75	All (122)	6270026	1	39.25		
	<b>0.685</b>	<b>PIN, Clutch Housing</b>				
75	All (122)	3992198	2	.42	housing	
	<b>0.724</b>	<b>BELT— BOLT— COVER, Timing Belt</b>				
75	All (122)	352133	1	11.90	timing	
75	All (122)	334051	1	5.70	distributor drive— (1.066)	
75	All (122)	334096	2	.31	BOLT, timing belt upper cover	
75	All (122)	333901	1	8.95	COVER, timing belt front	
75	All (122)	334027	1	12.65	COVER ASSY., timing belt upper	
	<b>0.728</b>	<b>SPROCKET, Crankshaft</b>				
75	All (122)	352132	1	13.00	crankshaft	
	<b>0.736</b>	<b>SPROCKET, Camshaft</b>				
75	All (122)	352130	1	26.50	inlet	
75	All (122)	352131	1	24.70	exhaust	
75	All (122)	352126	1	17.40	inlet com. distr. drive	
	<b>0.738</b>	<b>KEY— LOCK, Camshaft Sprocket</b>				
75	All (122)	334078	2	2.30	shaft retaining	
75	All (122)	334085	2	.83	LOCK, shaft sprocket bolt	
	<b>0.795</b>	<b>FORK ASSY., Clutch</b>				
75	All (122)	3994270	1	8.80		
	<b>0.796</b>	<b>CAP— STUD, Clutch Fork</b>				
75	All (122)	3973139	1	.21	fork ball stud	
75	All (122)	3973138	1	1.05	STUD, fork ball	
	<b>0.797</b>	<b>ABSORBER— GROMMET, Clutch Fork</b>				
75	All (122)	3994273	1	.47	fork	
75	All (122)	3978183	1	.22	GROMMET, fork pull back spring	

**122 ENGINE ASSEMBLY**

<b>0.799 BEARING, Clutch Throwout</b>					
75	All (122)	908093	1	13.56	
<b>0.829 BUMPER— PLUG— RING, Clutch</b>					
75	All (122)	340688	1	.21	pedal
75	All w/A.T. (122)	3984471	1	.16	PLUG, dash panel, clutch cable hole
75	All (122)	3978184	1	.15	RING, "O", clutch cable
<b>0.830 PEDAL ASSY., Clutch</b>					
75	All (122)	3978027	1	5.25	clutch
<b>0.833 PIN, Clutch Pedal</b>					
75	All (122)	3978029	1	.16	
<b>0.844 SPRING, Clutch Fork</b>					
75	All (122)	3978182	1	.31	pull back
<b>0.854 CABLE— GUARD— PIN— SLEEVE, Clutch</b>					
75	All (122)	361688	1	13.85	clutch
75	All (122)	3992900	1	.22	GUARD, cable
75	All (122)	3978090	1	.58	PIN, clutch fork cable retainer
75	All (122)	3997241	1	.32	SLEEVE, cable pulley
<b>0.855 BRACKET ASSY.— PULLEY, Clutch Cable</b>					
75	All (122)	3978181	1	1.55	cable
75	All (122)	3978088	1	.66	PULLEY, cable
<b>0.859 COVER ASSY., Clutch Pressure Plate</b>					
75	All (122)	3973142	1	45.25	w/pressure plate
<b>0.861 COVER ASSY., Clutch</b>					
75	All (122)	3973143	1	19.60	
<b>0.863 PLATE, Clutch Pressure</b>					
75	All (122)	3988716	1	13.75	
<b>0.864 SPRING, Pressure Plate</b>					
75	All (122)	3788059	3	.40	retractor
<b>0.886 PLATE ASSY., Clutch Driven</b>					
75	All (122)	338124	1	40.50	driven

**140 ENGINE ASSEMBLY**

<b>0.002</b>		<b>SCREW ASSY.—SPACER—STUD—WASHER, Engine Mounting</b>			
71-75	All (140)	336501	6	.18	engine mounting to frame ( <sup>3</sup> / <sub>8</sub> "— 15 x 1 <sup>1</sup> / <sub>2</sub> "
71-74	Vega (140)	9840757	L.H.	.81	SPACER, engine mounting assy. to shock housing— (11.390)
71-74	All (140)	9840756	R.H.	.81	SPACER, engine mounting assy. to shock housing— (11.390)
75	All (140)	1676843	A.R.	.77	SPACER, motor mount on shock absorber rear
71-75	All (140)	3977160	6	.18	STUD, engine mounting bracket to block ( <sup>7</sup> / <sub>16</sub> "— 14— <sup>7</sup> / <sub>16</sub> "— 20 x 1 <sup>7</sup> / <sub>8</sub> " O.L.)
74-75	All (140)	3876340	2	.24	WASHER, frame bracket rod ( <sup>15</sup> / <sub>32</sub> " I.D. x 1 <sup>1</sup> / <sub>2</sub> " O.D.)
<b>0.010</b>		<b>GASKET UNIT, Engine</b>			
71-75	All (140)	3998331	1	7.50	(Note 1, 2)
<i>NOTE 1: When using this Gasket Unit, it will be necessary to use compound unit, Part No. 3997597.</i>					
<i>NOTE 2: Consists of the following: One each gasket, oil pan, oil pan baffle, oil pump also one seal assy., crankshaft oil and two seal assy. crankshaft rear oil.</i>					
<b>0.027</b>		<b>MOUNTING ASSY., Engine (Also See Group 4.081)</b>			
71-75	All (140)	3978119	L.H.	5.50	
71-75	All (140)	3978120	R.H.	5.50	
<b>0.029</b>		<b>BRACKET, Engine Mounting</b>			
71-75	All (140)	3997293	L.H.	6.95	engine mtg. front
71-75	All (140)	3997294	R.H.	6.95	engine mtg. front
<b>0.033</b>		<b>BLOCK ASSY., Cylinder</b>			
71-75	All (140)	6259394	1	433.00	PARTIAL ENGINE (Note 1)
<i>NOTE 1: Includes block, crankshaft, pistons and connecting rods.</i>					
<b>0.034</b>		<b>EXPANSION PLUG, Cylinder Block (Also See Group 8.970)</b>			
71-74	All (140)	3835577	A.R.	.12	cyl. and case oil gallery rear hole plug, cyl. head oil gallery plug
72-75	All (140)	3994250	A.R.	.24	cyl. head oil gallery plug
75	All (140)	3826504	1	.96	water jacket
<b>0.056</b>		<b>BOLT, Crankshaft Main Bearing Cap</b>			
71-75	All (140)	3977137	10	.24	
<b>0.093</b>		<b>PLASTIGAGE, Crankshaft Bearing</b>			
71-75	All (140)	1390274	A.R.	6.15	crankshaft bearing (type PG-1) (12 pieces)
<b>0.095</b>		<b>CAP, Crankshaft Front Bearing</b>			
71-75	All (140)	3983483	3	9.60	(No. 1, 2, 3)
<b>0.096</b>		<b>BEARING UNIT, Crankshaft Front (1 Upper and 1 Lower)</b>			

**See Chart for Model Application**

*NOTE: See Dealer Price Schedule (P&A 26) for applicable prices.*

**CRANKSHAFT MAIN BEARING CHART**

	POSITION	STD.	.001 U.S.	.002 U.S.	.010 U.S.	.020 U.S.
71-75	All (140)	1-2-3	3988305	3988306	3988962	3988307
71-75	All (140)	4	3988309	3988310	3988963	3988311
71-73	All (140)	5	6258003	6258004	3988964	3988315
74-75	All (140)	5	6260981	6260982	6260983	6260984

**0.099 BEARING UNIT, Crankshaft Front Intermediate (1 Upper and 1 Lower)**

*See chart at end of section, Group 0.096 for Model Application.*

*NOTE: See Dealer Price Schedule for applicable prices.*

**0.101 BEARING UNIT, Crankshaft Center (1 Upper and 1 Lower)**

*See chart at end of section, Group 0.096 for Model Application.*

*NOTE: See Dealer Price Schedule for applicable prices.*

**0.102 CAP, Crankshaft Rear Intermediate Bearing**

71-75	All (140)	3983484	1	9.60	(No. 4)
-------	-----------	---------	---	------	---------

**0.103 BEARING UNIT, Crankshaft Rear Intermediate (1 Upper and 1 Lower)**

*See chart following Group 0.096 for Model Application.*

*NOTE: See Dealer Price Schedule for applicable prices.*



**140 ENGINE ASSEMBLY**

<b>0.105 CAP, Crankshaft Rear Bearing</b>				
71-75	All (140)	3983485	1	9.60 (No. 5)
<b>0.137 COMPOUND UNIT— SEAL ASSY., Crankshaft Rear Bearing and Cap Oil</b>				
71-75	All (140)	3997597	1	6.45 sealing rear main bearing and cap oil (Note 1)
<i>NOTE 1: Consists of 1 each, tube of hardener, jar of compound, applicator, disc-jar, stirring rod, and instruction sheet.</i>				
71-75	All (140)	3983488	1	.62 SEAL ASSY., crankshaft rear bearing and cap oil
<b>0.153 SHIM, Crankshaft Main Bearing Cap</b>				
71-75	All (140)	3983486	A.R.	2.25 crankshaft bearing cap (No. 1, 2, 3, 4)
71-75	All (140)	3983487	A.R.	2.25 crankshaft bearing cap (No. 5)
<b>0.206 COVER— NUT— SHIELD ASSY., Engine Timing Belt</b>				
71-74	All (140)	369106	1	4.65 timing belt lower (repl. 347105)
75	All (140) w/2BC) w/A.I.R.	357617	1	6.75 timing belt front
75	All (140)	3939394	2	.12 NUT, front cover (1/4" — 14) — (1.276)
72-75	All (140)	6273401	1	2.35 SHIELD ASSY., upper
72-75	All (140)	6273402	1	4.45 SHIELD ASSY., lower
<b>0.213 SEAL ASSY., Engine Timing Belt Cover</b>				
71-75	All (140)	3973135	1	2.30 crankshaft oil (part of 3998331 Gasket Unit)
<b>0.219 COVER ASSY., Engine Timing</b>				
75	All (140)	331139	1	2.40 timing belt upper
<b>0.269 HEAD ASSY., Cylinder</b>				
71-72	All (140)	338249	1	124.00
73-74	All (140)	6258453	1	124.00
75	All (140)	374591	1	145.00 less valve train
75	All (140) w/NB2	374529	1	212.00 partial
75	All (140) exc. NB2	374647	1	206.00 partial
<b>0.289 GASKET, Cylinder Head</b>				
71-75	All (140)	334000	1	5.10
71-74	All (140)	345035	1	15.10 GASKET UNIT, head
75	All (140)	372356	1	18.80 GASKET UNIT, head (repl. 361047)
<b>0.293 BOLT, Cylinder Head</b>				
71-75	All (140)	3977170	5	.36 (short) (6")
71-75	All (140)	3977169	5	.42 (long) (6 <sup>13</sup> / <sub>16</sub> " )
<b>0.296 VALVE, Inlet</b>				
71-72	All (140)	3992278	4	10.65 (.003 O.S.)
71-72	All (140)	3992279	4	10.65 (.015 O.S.)
71-72	All (140)	3992280	4	10.65 (.030 O.S.)
71-74	All (140)	5232774	4	7.65 (std.)
73-75	All (140)	338174	4	8.15 (.0035 O.S.) (repl. 5232775)
73-74	All (140)	5232776	4	11.55 (.0155 O.S.) (ident. by No. 15 stamped on valve stem)
73-74	All (140)	5232777	4	11.55 (.0305 O.S.) (ident. by No. 30 stamped on valve stem)
75	All (140)	331140	4	7.65 std.
75	All (140)	338176	4	13.60 (.0155 O.S.)
75	All (140)	338178	4	13.60 (.0305 O.S.)
<b>0.297 VALVE, Exhaust</b>				
71-74	All (140)	3992276	4	11.95 (std.)
71-75	All (140)	3992281	4	11.95 (.003 O.S.)
71-75	All (140)	370789	4	12.10 (.0035 O.S.) (repl. 362739)
71-75	All (140)	370790	4	12.10 (.0155 O.S.) (repl. 3992282 & 362740)
71-75	All (140)	370791	4	12.10 (.0305 O.S.) (repl. 3992283 & 362741)
75	All (140)	370788	4	12.10 (std.) (repl. 362725)
<b>0.303 SPRING— TEE, Valve</b>				
71-75	All (140)	3980278	8	1.45 w/damper
74-75	All (140)	3847085	1	TEE, exh. valve seat
<b>0.308 SEAL UNIT, Valve Stem Oil</b>				
71-74	All (140)	3998326	1	3.10
71-75	All (140)	372237	1	22.60 intake valve (.015 O.S.)
71-75	All (140)	372238	1	22.60 intake valve (.030 O.S.)
71-75	All (140)	372241	1	5.10 exhaust valve (.015 O.S.)

**140 ENGINE ASSEMBLY**

	<b>0.308</b>	<b>SEAL UNIT, Valve Stem Oil</b>			<b>(Con't)</b>	
71-75	All (140)	.....	372242	1	5.10	exhaust valve (.030 O.S.) .....
75	All (140)	.....	372333	1	8.15	int. & exh. valve stem (std.) (repl. 361046) .....
	<b>0.309</b>	<b>CAP, Valve Spring</b>				
71-75	All (140)	.....	3980281	8	.26	
	<b>0.310</b>	<b>KEY, Valve Stem</b>				
71-75	All (140)	.....	838029	16	.06	
	<b>0.386</b>	<b>COVER ASSY., Camshaft</b>				
71-75	All (140)	.....	3994274	1	15.15	
	<b>0.413</b>	<b>SCREW ASSY., Valve Rocker Cover</b>				
71-75	All (140)	.....	6262890	10	.11	machine w/rubber washer (1/4"—20 x 9/16") .....
	<b>0.459</b>	<b>TAPPET ASSY.— SCREW, Valve</b>				
71-75	All (140)	.....	5232770	8	3.60	valve adj. screw tip color (plain) (.430/.451-.375/.397) (Note 1) .....
						<i>NOTE 1: Used selectively as required for a total of 8 per veh. with 5232771-72 to obtain acceptable valve lash.</i>
71-75	All (140)	.....	5232771	8	3.60	valve adj. screw tip color (blue) (.438/.459-.383/.405) (Note 2) .....
						<i>NOTE 2: Used selectively as required for a total of 8 per veh. with 5232770-72 to obtain acceptable valve lash.</i>
71-75	All (140)	.....	5232772	8	3.60	valve adj. screw tip color (copper) (.422/.443-.383/.405) (Note 3) .....
						<i>NOTE 3: Used selectively as required for a total of 8 per veh. with 5232770-71 to obtain acceptable valve lash.</i>
71-74	All (140)	.....	5232760	1	.80	<b>SCREW, valve tappet assy. adjusting</b> .....
	<b>0.519</b>	<b>CAMSHAFT, Engine</b>				
71-72	All w/1BC (140) (exc. NB-2),					
73-75	All w/1BC (140)	.....	3973131	1	36.75	
71	All w/2BC (140)	.....	3988714	1	42.50	
72	All w/2BC, NB-2 (140),					
73-75	All w/2BC (140)	.....	6262888	1	36.75	
	<b>0.529</b>	<b>GASKET, Camshaft Cover</b>				
71-75	All (140)	.....	3988304	1	2.05	
	<b>0.539</b>	<b>BEARING, Camshaft</b>				
71-75	All (140)	.....	3996776	1	2.10	(No. 1) .....
71-75	All (140)	.....	3983489	4	2.25	(No. 2, 3, 4, 5) .....
	<b>0.553</b>	<b>PLUG, Camshaft Rear Bearing Hole</b>				
71-75	All (140)	.....	3973130	1	.18	
	<b>0.603</b>	<b>ROD ASSY., Connecting</b>				
71-75	All (140)	.....	370799	4	15.45	(repl. 3977110) .....
	<b>0.616</b>	<b>BEARING UNIT, Connecting Rod</b>				
71-75	All (140)	.....	347118	4	3.60	(std.) .....
71-75	All (140)	.....	347119	4	3.60	(.001 U.S.) .....
71-75	All (140)	.....	3715046	4	4.65	(.002 U.S.) .....
71-75	All (140)	.....	3715048	4	4.65	(.010 U.S.) .....
71-75	All (140)	.....	3715047	4	4.65	(.020 U.S.) .....
	<b>0.623</b>	<b>BOLT, Connecting Rod Bearing Cap</b>				
71-75	All (140)	.....	370739	8	.82	(11/32"—24 x 17/8") (repl. 3892670) .....
	<b>0.626</b>	<b>NUT, Connecting Rod Bearing Cap Bolt</b>				
71-75	All (140)	.....	3815280	8	.24	(11/32"—24) .....
	<b>0.629</b>	<b>PISTON ASSY., Engine</b>				
71-75	All (140)	.....	3992229	4	23.80	w/pin (S-5) (std.) (3.4977 to 3.4982) .....
71-75	All (140)	.....	3997405	4	23.80	w/pin (S-6) (std.) (3.4982 to 3.4987) .....
71-75	All (140)	.....	3992230	4	23.80	w/pin (S-7) (.001 O.S.) (3.4987 to 3.4992) .....
71-75	All (140)	.....	3997406	4	23.80	w/pin (S-8) (.001 O.S.) (3.4992 to 3.4997) .....
71-75	All (140)	.....	3992232	4	23.80	w/pin (.020 O.S.) .....
	<b>0.643</b>	<b>RING UNIT, Piston</b>				
71-75	All (140)	.....	6263199	4	6.70	piston (service sets) (.020 O.S.) .....
71-75	All (140)	.....	6263197	4	6.70	piston (service sets) (std.) .....

## 140 ENGINE ASSEMBLY

<b>0.646 CRANKSHAFT, Engine</b>					
71-75	All (140)	6270024	1	104.00	(Note 1)
<i>NOTE 1: On models with auto. trans. remove clutch pilot brg.</i>					
<b>0.649 BEARING, Clutch Pilot</b>					
71-75	All (140) (exc. A.T.)	3752487	1	1.20	
<b>0.659 PULLEY ASSY., Crankshaft</b>					
71-74	All (140),				
75	All (140) w/C.A.C. (exc. A.I.R.)	3977141	1	9.20	2 groove (Note 1, 2)
<i>NOTE 1: In some cases double groove pulleys may be used in place of single groove pulleys.</i>					
<i>NOTE 2: Used w/spacer in Group 0.662 to replace 2 groove cast iron damper.</i>					
75	All w/2BC (140) w/A.I.R. exc.				
	P/S	354606	1	9.80	crankshaft
<b>0.662 SPACER, Crankshaft Pulley</b>					
71-75	All	3977143	1	2.90	center (Note 1)
<i>NOTE 1: Used w/2 groove pulley, to replace 2 groove cast iron damper.</i>					
<b>0.666 FLYWHEEL ASSY.</b>					
71-75	All (140) (exc. A.T.)	3967048	1	43.00	
71-72	All w/A.T. (140)	3991402	1	26.75	
73-75	All w/A.T. (140)	333955	1	28.75	
<b>0.669 BOLT, Flywheel to Crankshaft</b>					
71-75	All (140) (exc. A.T.)	839756	6	.12	(7/16" — 20 x 1")
71-75	All w/A.T. (140)	3727207	6	.21	(7/16" — 20 x 23/32")
<b>0.673 GEAR, Flywheel Ring</b>					
75	All (140)	3991407	1	7.95	
<b>0.679 COVER— SCREW— SHIELD— UNDER PAN, Clutch Housing and Transmission Under Pan</b>					
71-75	All (140) (exc. A.T.)	3973182	1	.42	clutch housing
71-75	All (140) (exc. A.T.)	3817006	4	.12	SCREW, under pan clutch housing side shield (1/4" — 20 x 7/16")
71-73	All w/A.T. (140)	9420825	4		SCREW, trans. converter under pan (1/4" — 20 x 7/8")
71-75	All (140) (exc. A.T.)	3973181	1	1.10	SHIELD, clutch housing side
71-73	All w/P.G. (140)	3978775	1	4.70	UNDER PAN, trans. converter
72-74	All w/A.T. (140)	6271535	1	5.25	UNDER PAN, trans. converter
75	All (140)	355551	1	4.90	UNDER PAN, trans. converter
<b>0.683 HOUSING ASSY., Flywheel and Clutch</b>					
71-72	All (140)	3983415	1	50.25	
73-75	All (140)	6270026	1	39.25	
<b>0.685 DOWEL— PIN, Flywheel and Clutch Housing to Cylinder Block</b>					
71-73	All (140)	3712745	2	.50	(2 1/32" x 1 1/4" O.L.)
71-75	All (140)	3992198	2	.42	PIN, auto. trans. or clutch housing lineup (3/8" x 1" O.L.)
<b>0.686 GASKET, Transmission to Clutch Housing</b>					
71-73	All (140) (exc. A.T.)	6261801	1	.25	
<b>0.724 BELT— COVER— NUT— SCREW ASSY., Camshaft Timing Belt</b>					
71-75	All (140)	3980252	1	10.85	camshaft timing
71	All (140)	3977146	1	.74	COVER, belt upper
72	All (2BC w/NB2) (140)	6270080	1	7.80	COVER, belt front (Note 1)
<i>NOTE 1: When used on models with NB-2 cover 6270022 must also be used.</i>					
72	All w/2BC, NB2 (140),				
75	All (140) w/A.I.R.	331139	1	2.40	COVER ASSY., timing belt upper
71-75	All (140)	369106	1	4.65	COVER ASSY., timing belt lower (repl. 347105)—(0.206)
72	All w/1BC (140) (exc. NB2),				
73-74	All (140),				
75	All (140) (exc. A.I.R.)	331138	1	1.20	COVER ASSY., timing belt upper
71-72	All w/1BC (140) (exc. NB2),				
73-74	All (140),				
75	All (140) (exc. A.I.R.)	6258641	1	7.80	COVER UNIT, belt front timing
71-73	All (140)	3939394	4	.12	NUT, timing belt cover
<b>0.728 SPROCKET, Crankshaft Timing</b>					
71-75	All (140)	3980283	1	4.75	

**140 ENGINE ASSEMBLY**

<b>0.736 SPROCKET, Camshaft Timing</b>				
71-75	All (140)	6270006	1	8.35
<b>0.738 RETAINER— GASKET— SEAL— WASHER, Camshaft</b>				
71-75	All (140)	3992228	1	8.20 camshaft w/seal (blue) (.228/.230) (Note 1)
				<i>NOTE 1: To be used selectively for service in place of 3998100 or 3998101 to obtain camshaft end play of .004/.012 cam locater depth .228/.230.</i>
71-75	All (140)	3998100	1	8.20 camshaft w/seal (purple) (.230/.232) (Note 2)
				<i>NOTE 2: To be used selectively for service in place of 3992228 or 3998101 to obtain camshaft end play of .004/.012 cam locater depth .230/.232.</i>
71-75	All (140)	3998101	1	8.20 camshaft w/seal (orange) (.232/.234) (Note 3)
				<i>NOTE 3: To be used selectively for service in place of 3992228 or 3998100 to obtain camshaft end play of .004/.012.</i>
71-75	All (140)	3988771	1	.19 GASKET, camshaft retainer and seal
71-75	All (140)	3980267	1	3.35 SEAL, camshaft (also part of retainer and seal assy.)— (0.213)
71-75	All (140)	331122	1	1.60 WASHER, camshaft sprocket
<b>0.795 FORK ASSY., Clutch Release</b>				
71-75	All (140)	3994270	1	8.80
<b>0.796 CAP— STUD, Clutch Fork Ball</b>				
71-75	All (140)	3973139	1	.21 ball stud
71-75	All (140)	3973138	1	1.05 STUD, clutch fork ball
<b>0.797 ABSORBER— GROMMET, Clutch Fork</b>				
71-75	All (140)	3994273	1	.47 (included in fork assy.)
71-75	All (140)	3978183	1	.22 GROMMET, clutch fork pull back spring
<b>0.799 BEARING, Clutch Throwout</b>				
71-75	All (140)	908093	1	13.56
<b>0.805 GASKET— SUPPORT, Clutch Release Bearing Support Guide</b>				
71-73	All (140)	3983433	1	.15
71-73	All (140)	2888020	1	2.95 SUPPORT
<b>0.829 BUMPER— PLUG— RING, Clutch</b>				
71-75	All (140)	340688	1	.21 clutch pedal
73-75	All w/A.T. (140)	3984471	1	.16 PLUG, clutch cable hole
71-75	All (140)	3978184	1	.15 RING, clutch cable ("O")
<b>0.830 PEDAL ASSY., Clutch</b>				
71-75	Vega (140)	3978027	1	5.25
<b>0.833 PIN, Clutch Pedal</b>				
71-75	All (140)	3978029	1	.16
<b>0.844 SPRING, Clutch Fork Pull Back</b>				
71-75	All (140)	3978182	1	.31
<b>0.854 CABLE ASSY.— GUARD— PIN— SLEEVE, Clutch Cable</b>				
71-75	All (140)	355592	1	9.75 clutch
71-74	All (140)	3992900	1	.22 GUARD, clutch cable
71-75	All (140)	3978090	1	.58 PIN, clutch fork cable retainer
71-75	All (140)	3997241	1	.32 SLEEVE, cable pulley
<b>0.855 BRACKET ASSY.— PULLEY, Clutch Cable</b>				
71-75	All (140)	3978181	1	1.55
71-75	All (140)	3978088	1	.66 PULLEY, clutch cable
<b>0.859 PLATE ASSY., Clutch Pressure</b>				
71-75	All (140) (exc. A.T.)	3973142	1	45.25 w/cover
<b>0.861 COVER ASSY., Clutch</b>				
71-75	All (140)	3973143	1	19.60
<b>0.862 BOLT, Clutch Cover and Pressure Plate</b>				
71-75	All (140)	3829810	6	.18 ( <sup>5</sup> / <sub>16</sub> "— 18 x <sup>3</sup> / <sub>4</sub> ")
<b>0.863 PLATE, Clutch Pressure</b>				
71-75	All (140)	3988716	1	13.75

**140 ENGINE ASSEMBLY**

**0.864 BOLT— SPRING, Clutch Pressure Plate**

71-75	All (140)	3962058	3	.22	clutch pressure plate retracting spring ( <sup>5</sup> / <sub>16</sub> "— 18 x <sup>7</sup> / <sub>8</sub> ")
71-75	All (140)	3788059	3	.40	<b>SPRING</b> , clutch pressure plate retracting

**0.886 PLATE ASSY., Clutch Driven**

71-72	All (140) (exc. A.T.)	6262866	1	32.75	(hub has 14 tooth spline) (9" dia.)
73-75	All (140) (exc. A.T.)	328561	1	32.75	(hub has 10 tooth spline-9.12 dia.-blue)

**153 ENGINE ASSEMBLY**

**4-CYLINDER ENGINE ASSEMBLY**

**4 Cyl.**

YEAR	CU. IN. DISPL.	GROSS H.P.	CARBURETOR
65-70	153	90	Single Barrel

**0.002 BOLT— WASHER, Engine Mounting (Small Attaching)**

69-70	All (153)	3958448	2	.98	bracket to engine (7/16" — 20 x 4 <sup>29</sup> / <sub>32</sub> ")
62-69	All (153)	3954735	2	.13	WASHER, brkt. to engine (left side) (repl. 3693853)— (14.875)
64	All (153)	3818180	A.R.	.11	WASHER, mtg. (1 <sup>5</sup> / <sub>32</sub> " x 1 <sup>1</sup> / <sub>4</sub> " x 3 <sup>3</sup> / <sub>16</sub> " thk.)

**0.010 GASKET UNIT, Engine or Tune Up**

62-67	All (153)	3834936	1	4.70	engine (Note 1)
<i>NOTE 1 The above Engine Small Parts Gasket Units together with Oil Pan Gasket Unit (Group 1.429) and Cylinder Head Gasket Unit (Group 0.289) provide all necessary Gaskets for complete engine overhaul.</i>					
68-70	All (153)	6259390	1	5.35	engine

**0.027 MOUNTING ASSY.— MOUNTING UNIT, Engine (also see group 4.081)**

**4 CYLINDER**

62-67	All (153)	3793552	2	5.50	(rubber— thickness 2")
68-69	All (153) (1st design)	3930068	2	13.95	(Note 1)
<i>NOTE 1 Mounted with a vertical bolt which attaches to a welded nut inside the rubber mount.</i>					
69-70	All (153) (2nd design)	3958446	2	13.95	(Note 2)
<i>NOTE 2 Mounted with horizontal bolt with no nut required.</i>					
<i>NOTE 3 Unit consists of 2 - 3793552 Engine Mounting Assys. and 1 each - 3793623 and 3793624 Engine Mounting Body Bracket Assys. (Group 0.029).</i>					

**0.029 BRACKET, Engine Mounting**

62-67	All (153)	3791907	L.H.	3.60	engine
62-67	All (153)	3791908	R.H.	1.50	engine
62-67	All (153) (2nd design)	3793623	L.H.	3.30	BRACKET ASSY., body (Note 1)
62-67	All (153) (2nd design)	3793624	R.H.	3.45	BRACKET ASSY., body (Note 1)
<i>NOTE 1 For 1st design use 3793677 Mounting Unit Group 0.027.</i>					
68-69	All (153) (1st design)	3930093	L.H.	6.55	BRACKET ASSY., engine
68-69	All (153) (1st design)	3930094	R.H.	6.55	BRACKET ASSY., engine
69-70	All (153) (2nd design)	3958449	L.H.	11.70	BRACKET ASSY., engine (long bolt type)

**0.033 BLOCK ASSY., Cylinder**

*NOTE CAUTION. Combination not appearing below should be checked in the Engine Series Number and Suffix Chart in front of catalog to determine if the combination was available in production. If not available, no attempt should be made to make the installation.*

**PARTIAL ENGINE**

*NOTE Includes block, crankshaft, camshaft, timing gears, pistons and connecting rods.*

62-70	All (153)	3929279	1	408.00	(Note 1, 2)
-------	-----------	---------	---	--------	-------------

**FITTED CYLINDER BLOCK (Includes, Pistons, Pins, Rings and Bearings)**

62-70	All (153)	347061	1	294.00	
<i>NOTE 1 The Valve Spring and Damper Assy. unitized in this assy. must be used in conjunction with the camshaft of this Asm.</i>					
<i>NOTE 2 May contain Nodular Iron Type Crankshaft. It is necessary to install a harmonic balancer on vehicles which do not have an existing balancer.</i>					

**0.034 EXPANSION PLUGS, Cylinder Block (Also see 8.970)**

62-63	All (153)	444782	A.R.	.10	cylinder oil gallery rr. hole plug (3/4" — 18 thd.— 5/16" sq. socket)— (8.971)
62-69	All (153)	838538	A.R.	.18	water jacket balance shaft hole (cup type) (1 <sup>5</sup> / <sub>8</sub> ")
62-70	All (153)	3788418	A.R.	.24	cyl. head water jacket (cup type— 1 <sup>5</sup> / <sub>16</sub> " dia.)
62-70	All (153)	3789860	1	.24	water jacket rear (2" O.D.—cup type)
70	All (153)	3835577	8	.12	cyl. and case main oil gallery front hole (1 <sup>9</sup> / <sub>32</sub> " O.D.—cup type)

**0.056 BOLT— STUD, Crankshaft Bearing Cap**

62-70	All (153)	3872781	A.R.	.28	(1/16" — 14 x 3 <sup>9</sup> / <sub>32</sub> ")
65-70	All (153)	3852870	1	.34	STUD, No. 6 and No. 4 brg. cap right (3 <sup>3</sup> / <sub>4</sub> " — 16 x 7/16" — 14 x 3 <sup>3</sup> / <sub>4</sub> ")

## 153 ENGINE ASSEMBLY

### 0.093 PLASTIGAGE, Crankshaft Bearing

62-70 All (153) ..... 1390274 A.R. 6.15 (green package-type PG-1) (12 pieces) .....

### 0.095 CAP, Crankshaft Front Bearing

62-70 All (153) ..... 3970194 1 5.85 (No. 1, 2, 3, 4, 5, 6) (light blue stripe) .....

### 0.096 BEARING UNIT, Crankshaft Front (1 Upper and 1 Lower)

See chart for Model Application

*NOTE: See Dealer Price Schedule for applicable prices.*

### CRANKSHAFT MAIN BEARING CHART

	Position	STD.	.001 U.S.	.002 U.S.	.009 U.S.	.010 U.S.	.020 U.S.
62-70 All (153) .....	All (exc. Rear)	3792553	3792554	3792555	3876072	3792556	3792557
62-70 All (153) .....	Rear	3792558	3792559	3792560	3876073	3792561	3792562

### 0.105 CAP, Crankshaft Rear Bearing

62-67 All (153) ..... 3791428 1 5.05 (cast 3788407) (Note 1) .....

*NOTE 1 Use 3928975 on 1967 engines with date stamp FO619 thru end of production.*

68-70 All (153) ..... 3928975 1 5.75 .....

### 0.137 SEAL ASSY.— SEAL UNIT, Crankshaft Rear Bearing and Cap Oil

68-70 All (153) ..... 3958001 2 2.60 rear oil .....

62-67 All (153) ..... 3792463 1 2.85 SEAL UNIT, upper and lower (Note 1) .....

*NOTE 1 Use 3921972 on 1967 engines with date stamp FO619 thru end of production.*

### 0.153 SHIM UNIT, Crankshaft Bearing Cap

62-67 All (153) ..... 3791429 A.R. 1.90 rear (1<sup>23</sup>/<sub>32</sub>" O.L.) .....

62-70 All (153) ..... 3911010 A.R. 1.90 front and intermediate .....

68-70 All (153) ..... 3928985 A.R. 2.30 rear .....

### 0.206 COVER, Crankcase Front End

63-67 All (153) ..... 3998160 1 5.80 w/oil seal .....

68-70 All (153) ..... 3996616 1 8.95 COVER ASSY. ....

### 0.207 GASKET, Crankcase Front End Cover

62-70 All (153) ..... 3923472 1 .41 .....

### 0.213 SEAL, Crankcase Front End Cover

62-70 All (153) ..... 3980267 1 3.35 (2<sup>7</sup>/<sub>16</sub>" O.D.— stamped 3980267) .....

### 0.269 HEAD, Cylinder

62-70 All (153) ..... 361058 1 85.00 w/studs (repl. 347055) .....

### 0.289 GASKET, Cylinder Head

62-70 All (153) ..... 3868830 1 3.60 .....

62-70 All (153) ..... 3930963 1 10.30 GASKET UNIT .....

### 0.293 BOLT, Cylinder Head

62-70 All (153) ..... 3788417 A.R. .40 (1/2" — 13 x 3<sup>37</sup>/<sub>64</sub>") .....

### 0.296 VALVE (Inlet)

	STD.	.003 O.S.	.015 O.S.	.030 O.S.
62-68 All (153) .....	3989083	3995684	3995685	3995686
69-70 All (153) .....	3989088	3997749	3997750	3997751

### 0.297 VALVE (Exhaust)

	STD.	.003 O.S.	.015 O.S.	.030 O.S.
62-70 All (153) .....	3989084	3995602	3995603	3995604

**153 ENGINE ASSEMBLY**

<b>0.303 SPRING, Valve</b>			
62-63	All (153) .....	3836331 A.R.	1.10 outer (2 <sup>1</sup> / <sub>16</sub> " O.L. x 3 <sup>3</sup> / <sub>4</sub> " I.D.) (lt. pink, gray, lt. green, lavender, brown, med. blue) (Note 1, 2) .....
<i>NOTE 1 Used with valves having full dia. stems only.</i>			
<i>NOTE 2 Used only with Camshaft Assy. 3790022.</i>			
64-70	All (153) .....	3735381 A.R.	1.35 inlet and exhaust, w/damper (2 yellow stripes plus maroon, aluminum, dk. green, black, blue and white, or tan stripe) (Note 3) .....
<i>NOTE 3 Used only with Camshaft Assy. 3831607. Also part of Camshaft Unit 3837796.</i>			
<b>0.308 SEAL— SHIELD, Valve Spring Cap</b>			
62-70	All (153) .....	3835333 A.R.	.17 "O" ring, inlet and exhaust .....
62-69	All (153) .....	3836755 A.R.	.18 SHIELD (cup shape-7 <sup>7</sup> / <sub>8</sub> " I.D. x 1 <sup>3</sup> / <sub>8</sub> " O.D.) .....
<b>0.309 CAP, Valve Spring</b>			
62-70	All (153) .....	3729363 A.R.	.40 inlet and exhaust .....
<b>0.310 KEY, Valve Stem</b>			
62-70	All (153) .....	838029 A.R.	.06 ("U" shape) .....
<b>0.333 ARM UNIT, Valve Rocker with Adjusting Screw and Nut</b>			
62-70	All (153) .....	5723551 A.R.	2.45 inlet and exhaust .....
<b>0.386 COVER— GROMMET, Valve Rocker Arm</b>			
63-70	All (153) .....	2770090	1 9.40 w/grommet .....
63-70	All (153) .....	3894337	1 .11 GROMMET, cover to a/cl. (1 <sup>5</sup> / <sub>16</sub> " I.D. x 1 <sup>7</sup> / <sub>32</sub> " O.D.)— (1.745) (Note 1, 2) .....
<i>NOTE 1 May be used with or without closed vent.</i>			
<i>NOTE 2 When using on closed vent. equipped vehicles, it will be necessary to remove center from grommet to permit assembling of fresh air connector into side of cover.</i>			
<b>0.413 BOLT— REINFORCEMENT, Valve Rocker Cover and Support</b>			
62-70	All (153) .....	180016	1 (1 <sup>1</sup> / <sub>4</sub> "— 20 x 1 <sup>1</sup> / <sub>2</sub> ")— (8.900) .....
62-70	All (153) .....	3877670 A.R.	.12 REINFORCEMENT (1 <sup>1</sup> / <sub>2</sub> " O.L.) (Note 1) .....
<i>NOTE 1 Use with Bolt 180016.</i>			
<b>0.423 GASKET, Valve Rocker Cover</b>			
62-70	All (153) .....	3923468	1 1.80 (17 <sup>27</sup> / <sub>32</sub> " O.L., 6 holes) .....
<b>0.426 ROD, Valve Push</b>			
62-70	All (153) .....	3788495 A.R.	1.25 (9 <sup>5</sup> / <sub>8</sub> " O.L.) .....
<b>0.429 BALL— NUT— STUD, Valve Push Rod Adjusting</b>			
62-70	All (153) .....	3992294 A.R.	.28 (1 <sup>5</sup> / <sub>16</sub> " dia.) valve rocker arm .....
70	All (153) .....	3959142 A.R.	.38 (1 <sup>3</sup> / <sub>16</sub> " dia.) .....
62-70	All (153) .....	3744341	16 .22 NUT, valve rocker arm (3 <sup>3</sup> / <sub>8</sub> "— 24) (5 <sup>5</sup> / <sub>8</sub> " across the flats x 1 <sup>1</sup> / <sub>2</sub> ") .....
62-70	All (153) .....	3814692	16 .53 STUD, valve rocker arm ball (.003" O.S.- light blue paint) .....
62-69	All (153) .....	3815892	16 .53 STUD, valve rocker arm ball (.013 O.S.— 3 <sup>3</sup> / <sub>8</sub> "— 24 2 1 <sup>1</sup> / <sub>2</sub> ") (1 groove on shank-light blue paint) .....
<b>0.439 COVER, Valve Push Rod</b>			
62-70	All (153) .....	3788548	1 2.10 push rod (4 holes on top) .....
<b>0.443 GASKET, Valve Push Rod Cover</b>			
62-70	All (153) .....	3923469	1 1.20 push rod cover .....
<b>0.446 BOLT, Valve, Push Rod Cover</b>			
62-70	All (153) .....	3814350 A.R.	.27 w/lockwasher and seal (5 <sup>5</sup> / <sub>16</sub> "— 18 x 7 <sup>1</sup> / <sub>16</sub> ") ..
<b>0.459 TAPPET, Valve (or Lifter)</b>			
62-70	All (153) .....	5232450 A.R.	4.54 hydraulic type .....
<b>0.519 CAMSHAFT</b>			
<i>NOTE Engine Camshaft Break-in Oil 1050800, Group 1.850, should be used when installing new camshafts.</i>			
62-70	All (153) .....	3831607	1 33.50 (Ident. No. 3830998) .....
<b>0.533 BEARING UNIT, Camshaft Thrust</b>			
65-70	All (153) .....	3790531	1 1.80 w/spacing ring (1 <sup>1</sup> / <sub>2</sub> " O.D. x 1 <sup>9</sup> / <sub>32</sub> " I.D.) .....
<b>0.539 BEARING, Camshaft (Front or No. 1)</b>			
62-70	All (153) .....	3750882	1 2.40 precision type (stamped 2)— (0.543) .....



**153 ENGINE ASSEMBLY**

<b>0.543</b>	<b>BEARING, Camshaft No. 2 (Front Intermediate)</b>				
62-70	All (153)	3750882	1	2.40	precision type (stamped 2)
<b>0.546</b>	<b>BEARING, Camshaft (Center and Rear Intermediate)</b>				
62-70	All (153)	3750884	A.R.	2.40	(stamped 3-4)
<b>0.553</b>	<b>PLUG, Camshaft Bearing Hole, cup type (in cylinder block)</b>				
62-70	All (153)	3704158	1	.22	(2 1/8" dia.)
<b>0.603</b>	<b>ROD ASSY., Connecting, Less Dipper</b>				
62-70	All (153)	3977110	A.R.	15.00	(repl. 3788435)
<b>0.616</b>	<b>BEARING UNIT, Connecting Rod (1 Upper and 1 Lower)</b>				

**Refer to chart for Model Application**

*NOTE: See Dealer Price Schedule for applicable prices.*

**CONNECTING ROD BEARING UNIT CHART**

MODEL USAGE	STD.	.001 U.S.	.002 U.S.	.010 U.S.	.020 U.S.
62-70 All (153)	347118	347119	3715046	3715048	3715047

<b>0.623</b>	<b>BOLT, Connecting Rod Bearing Cap</b>				
62-70	All (153)	3892670	A.R.	.70	(1 1/32" — 24 x 1 7/8")
<b>0.626</b>	<b>NUT, Connecting Rod Bearing Cap Bolt</b>				
62-69	All (153)	9422298	A.R.	.11	(3/8" — 24 x 5/16" thick) (one end chamfered) — (8.917)
62-70	All (153)	3815280	16	.24	(1 1/16" — 24) (type EA) (phosphate coated and soaped)
70	All (153)	3866766	A.R.	.12	(3/8" — 24 x 3/8" thick) (hex. nut) (both ends flat) (Note 1)

*NOTE 1 Also used with bolts not requiring cotter pins.*

**0.629 PISTON ASSY., with Pin**

*NOTE Individual piston assemblies are available for warranty purposes and for replacement of pistons damaged when making repairs to engine assemblies. When ordering such parts it is necessary that you specify on your order the reason the parts are required and also that the following note appears on your order. Do not ship unit package quantity.*

ENGINE DISPLACEMENT	BASIC SIZE	SERVICE PISTON DIAMETER RANGE LIMITS ALUMINUM
153 cu. in.	3.8750— STD.	S-4— 3.8750 to 3.8755, S-5— 3.8755 to 3.8760
153 cu. in.	3.8760— .001	S-6— 3.8760 to 3.8765, S-7— 3.8765 to 3.8770

*NOTE The above chart is for information purposes only.*

**(Refer to chart for model application)**

*NOTE: See Dealer Price Schedule for applicable prices.*

**PISTON CHART**

	STD.	.001 O.S.	.020 O.S.	.030 O.S.	.040 O.S.
62-70 All (153)	3860407	3860413		3860426	3860432

**153 ENGINE ASSEMBLY**

**0.643 RING UNIT, Piston (Service Sets)**

*NOTE: See Dealer Price Schedule for applicable prices.*

**Original Equipment Type**

		STD.		.030 O.S.	
<b>69-70</b>	All (153) .....	326400 <sup>(1, 2)</sup>		328503 <sup>(1)</sup>	1
<b>62-68</b>	All (153) .....	326400 <sup>(1, 2, 3)</sup>		328503 <sup>(1)</sup>	1

**Special Replacement Type**

		STD.		.030 O.S.	
<b>62-70</b>	All (153) .....	326400		328503 <sup>(4, 5, 6)</sup>	

<sup>(1)</sup> These are Molybdenum premium rings.

<sup>(2)</sup> This part is eligible for wholesale compensation.

<sup>(3)</sup> 2/3 of this unit is required on 4 cyl. engines.

<sup>(4)</sup> Cromflex Ring Set having chrome plated oil rings, top compression ring, and chrome-plated rail for middle compression ring.

<sup>(5)</sup> These Ring Units contain 3/32 compression rings.

<sup>(6)</sup> Only half of the components in this unit are required for 4 cyl. models.

**0.646 CRANKSHAFT**

<b>62-70</b>	All (153) .....	5743124	1	110.00	
--------------	-----------------	---------	---	--------	--

**0.649 BEARING, Crankshaft Clutch Pilot**

<b>62-70</b>	All (153) .....	3752487	1	1.20	(bush type— 19/32" I.D. x 1 1/32" O.D. x 3/4") ..
--------------	-----------------	---------	---	------	---

**0.659 PULLEY— HUB, Crankshaft**

*NOTE In some cases double groove pulleys may be used in place of single groove pulleys.*

*NOTE Crankshaft harmonic balancer is also referred to as "torsional damper".*

<b>62-70</b>	All (153) .....	3793717	1	9.20	(stamped 3793717) .....
<b>62-63</b>	All (153) w/C.A.C., P/S,				
<b>63-66</b>	All (153) w/62 amp. A.C. Gen.,				
<b>64-65</b>	All (153) w/C/Deluxe Air Cond.,				
<b>68-70</b>	All (153) .....	3790327	1	9.20	front (stamped 3790327) .....
<b>65-70</b>	Chevy (153) .....	5743323	1	26.50	HUB, crankshaft pulley .....

**0.662 KEY— SCREW— WASHER, Harmonic Balancer and Crankshaft Pulley**

<b>65-66</b>	All w/key 3/4" long x 3/16" wide x 1/4" high .....	3883206 A.R.		.16	crankshaft pulley hub (Note 1) .....
<b>65-66</b>	All w/key 1 3/8" long x 3/16" wide x 1 1/32" high .....	3885092	1	.16	crankshaft pulley hub (Note 1) .....

*NOTE 1: Used with pulleys and hubs having a shallow (1/16" deep) keyway only. All full depth (1/8") slots take standard Woodruff key (106751 two short or 144542 one long) in Group 8.960.*

<b>62-70</b>	All (153) .....	3793101	1	.12	SCREW, w/lockwasher (5/16"— 24 x 9/16") ..
<b>62-70</b>	All (153) .....	3793100	2	.11	SCREW, w/lockwasher (3/8"— 24 x 1 7/32") ..
<b>66-69</b>	All (153) .....	3739422	1	.46	WASHER, balancer .....

**0.666 FLYWHEEL, with Ring Gear**

<b>62-70</b>	All (153) (exc. H.D. Clutch, A.T.) .	6270045	1	59.25	solid type .....
<b>62-69</b>	All (w/H.D. Clutch) (153) .....	3973452	1	59.25	solid type (cast 3791021) .....
<b>62-70</b>	All w/A.T. (153) .....	3789821	1	26.75	

**0.669 BOLT, Flywheel to Crankshaft**

<b>62-70</b>	All (153) (exc. A.T.) .....	839756	6	.12	(7/16"— 20 x 1) .....
<b>62-70</b>	All w/A.T., (153) .....	3727207	6	.21	(7/16"— 20 x 45/64"— 290M steel) .....

**0.673 GEAR, Flywheel Ring**

<b>62-70</b>	All (153) .....	3991408	1	6.40	
--------------	-----------------	---------	---	------	--

**0.679 UNDERPAN— BOLT— COVER— SCREW ASSY., Flywheel**

<b>69</b>	All w/P.G. (153) .....	3789149	1	4.15	transmission converter .....
<b>69-70</b>	All w/Torque Drive (153) .....	3950436	1	4.35	converter .....
<b>All</b>	All (153) .....	3817006 A.R.		.12	BOLT, w/washer (1/4"— 20 x 7/16") .....
<b>62-70</b>	All (153) (exc. A.T.) .....	354497	1	2.65	COVER, clutch housing (repl. 3788422) ..
<b>62-70</b>	All w/P.G., Torque Drive (153) ..	3924780 A.R.		.16	SCREW ASSY., w/washer (5/16"— 18 x 7/8")

**0.683 HOUSING, Flywheel and Clutch**

<b>62-63</b>	All (153) .....	3788381	1	34.25	clutch (Ident. No. 3788383) .....
<b>64-67</b>	All (153) .....	3849307	1	31.25	clutch (Ident. No. 3849309) .....

**153 ENGINE ASSEMBLY**

<b>0.683 HOUSING, Flywheel and Clutch (Con't)</b>				
68-70	All (153)	3858403	1	30.50 HOUSING ASSY., clutch (Ident. No. 3840383) (Note 1)
<i>NOTE 1 Less ball stud.</i>				
<b>0.685 DOWEL, Flywheel and Clutch Housing to Cylinder Block</b>				
62-70	All (153)	3712745	2	.50 clutch and flywheel ( $2\frac{1}{32}$ " x $1\frac{1}{4}$ " long)
<b>0.728 GEAR, Crankshaft Timing (Steel)</b>				
62-70	All (153)	3836605	1	5.60 (27 teeth— $\frac{1}{8}$ " O.D., stamped "71")
<b>0.736 GEAR, Camshaft Timing</b>				
62-70	All (153)	3788508	1	16.35 fiber (54 teeth—cast 3788508)
<b>0.748 NOZZLE, Timing Gear Oil</b>				
62-70	All (153)	3875950	1	.28 ( $1\frac{1}{32}$ " O.L.)
<b>0.787 ROD— CLIP— EXTENSION— SWIVEL, Clutch Fork Release</b>				
62-67	All (153)	3791159	1	1.20 fork push ( $12\frac{13}{64}$ " O.L.) ( $\frac{3}{8}$ "— 16 thd. on end)
68-69	All (153)	340690	1	1.10 fork push adjusting ( $4\frac{3}{4}$ " long)
68-70	All (153)	3939116	1	1.20 fork push adjusting ( $7\frac{3}{4}$ " long)
62-69	All (153)	3749084 A.R.		.27 CLIP, push rod and swivel— (4.037)
62-69	All (153)	1455017	1	.13 CLIP, push rod— (3.425)
62-67	All (153)	3834287	1	.36 EXTENSION, fork pull back spring
62-67	All (153)	3791200	1	.54 SWIVEL, fork push rod ( $1\frac{15}{64}$ " O.L.) (large hole w/ $\frac{3}{8}$ "— 16 thd.)
68-70	All (153)	3840845	1	1.40 SWIVEL, fork push rod ( $1\frac{1}{2}$ " O.L.) ( $\frac{3}{8}$ "— 16 thds.)
<b>0.793 WASHER, Clutch Fork Push Rod</b>				
62-70	All (153)	3756694	1	.11 push rod lever thrust ( $2\frac{3}{4}$ " dia. pedal shaft) pull rod lever
<b>0.795 FORK ASSY., Clutch Release</b>				
62-67	All (153)	3788401	1	7.85 (less ball stud)
68-70	All (153)	3892632	1	7.15
<b>0.796 SPRING— STUD, Clutch Fork</b>				
62-67	All (153)	3737456	1	.28 retaining ( $4\frac{1}{16}$ " dev. length)
62-67	All (153)	3790556	1	.84 STUD, ball ( $\frac{3}{16}$ "— 16 thds.)
68-70	All (153)	3729000	1	1.05 STUD, ball ( $1\frac{13}{16}$ "— 16 w/ $2\frac{1}{32}$ " diameter ball)
<b>0.797 BOOT, Clutch Fork</b>				
62-67	All (153)	3788402	1	.76 (3" O.L. at clutch hsg. face) (black rubber)
62-70	All (153)	3993851	1	.76 black rubber
<b>0.799 BEARING, Clutch Throwout with Collar</b>				
62-70	All (153)	908092	1	15.94 ball bearing type ( $1\frac{7}{8}$ " long)
<b>0.829 BUMPER— COVER— RETAINER— SEAL, Clutch</b>				
(For COVERS see group 4.630)				
68-70	All (153)	340688	1	.21 pedal
68-70	All w/A.T. (153)	3886689	1	.21 COVER, clutch pedal push rod hole
62-65	All (153)	3792551	1	.21 RETAINER, push rod dash seal
67	All (153)	3903518	1	.14 RETAINER, clutch pedal push rod dash seal
62-67	All (153)	3792550	1	.36 SEAL, clutch push rod dash
68-70	All (153)	3903466	1	.15 SEAL, clutch pedal push rod hole cover
68-70	All (153)	3909071	1	1.20 SEAL ASSY., clutch pedal push rod
<b>0.830 PEDAL, Clutch</b>				
62-65	All (153)	3830774	1	5.50
68-70	All (153)	6258554	1	6.55
<b>0.831 BUSHING, Clutch Pedal (see group 4.626 for brake pedal bushing)</b>				
62-68	All (153)	1247439	2	.11 ( $\frac{6}{8}$ " dia. pedal shaft)— (4.626)
<b>0.837 RETAINER— SPRING, Clutch and Brake Pedal Shaft—(Also see groups 4.634 and 4.648)</b>				
63-68	All (153)	3828428	1	.22 shaft— (4.634)
62	All (153)	148152	2	.06 SPRING, clutch pedal retainer ( $\frac{1}{2}$ " dia.)— (8.934)

**153 ENGINE ASSEMBLY**

<b>0.844</b>		<b>SPRING, Clutch Pedal Pull Back</b>			
62-67	All (153)	3653114	1	.63	clutch fork push rod pull back
68-70	All (153)	3899021	1	.28	clutch fork push rod pull back
<b>0.846</b>		<b>EXTENSION, Clutch Pedal Pull Back Spring</b>			
68-70	All (153)	3899022		.32	clutch fork push rod pull back spring
<b>0.851</b>		<b>SEAT— SEAL— SPRING— STUD— WASHER, Clutch Pedal Intermediate Lever Shaft Ball</b>			
62-70	All (153)	3743349	A.R.	.18	stud (7/8" dia.)
65-70	All (153)	382658	1	.19	SEAL, ball stud dust lever shaft ball stud
62-70	All (153)	3750696	1	.13	SPRING, frame stud seat, retaining (1" O.D.)
62-70	All (153)	3866568	1	1.15	STUD, lever shaft ball to engine
62-69	All (153)	3898610	1	.81	STUD, to body, to frame (2/8"— 24 x 1 <sup>13</sup> / <sub>16</sub> " O.L.)
70	All (153)	3935289	1	1.20	STUD, clutch lvr. & shaft ball to frame
62-64	All (153)	3743355	1	.13	WASHER, lever shaft ball stud dust seal
62-66	All (153)	3717880	1	.16	WASHER, ball to engine dust washer (rubber) (2 <sup>9</sup> / <sub>32</sub> " O.D. x 1 <sup>5</sup> / <sub>32</sub> " I.D. x 1/4" thk.)— (7.443)
62-70	All (153)	3743360	1	.18	WASHER, stud dust seal, L.H. to frame (felt— 2/16" I.D. x 1 <sup>3</sup> / <sub>8</sub> " O.D.) lever assy. seal
<b>0.852</b>		<b>LEVER— BRACKET, Clutch Pedal, Intermediate (See Group 4.648 for brake)</b>			
62-67	All (153)	3792909	1	6.90	w/shaft
68-70	All (153)	3998652	1	10.50	w/shaft
62-67	All (153)	3792365	1	.63	BRACKET, shaft body (3 <sup>3</sup> / <sub>4</sub> " O.L. w/2 weld nuts)
68-70	All (153)	3932760	1	.83	BRACKET, lever and shaft
<b>0.854</b>		<b>ROD— CLIP, Clutch Pedal</b>			
62-67	All (153)	3790008	1	1.95	pedal push (1 <sup>13</sup> / <sub>32</sub> " dev. length— 1/2" O.D.)
68-70	All (153)	3920262	1	1.95	pedal push
62	All (153)				CLIP, pedal push rod,
66-67	All (153)	3758162	1	.06	pedal push rod lower end (2/32" dia.)
<b>0.859</b>		<b>PLATE ASSY., Clutch Pressure with Cover</b>			
62-70	All (153)	3973142	1	45.25	diaphragm spring type (9") (Note 1)
62-68	All w/H.D. Clutch (153)	3999255	1	48.25	(10")
<i>NOTE 1: When using 3973142 in place of 3788655 discard old clutch rel. brg. 1<sup>1</sup>/<sub>8</sub> overall lgth. purchase and install 907963 clutch rel. brg. 1<sup>1</sup>/<sub>32</sub> overall lgth.</i>					
<b>0.861</b>		<b>COVER, Clutch</b>			
62-69	All (153) (exc. H.D. Clutch),				
70	All (153)	3973143	1	19.60	diaphragm spring type
62	All w/H.D. Clutch (153),				
64-68	All w/H.D. Clutch (153)	3821765	1	19.30	diaphragm spring type (12 <sup>31</sup> / <sub>64</sub> " O.D.)
<b>0.862</b>		<b>BOLT, Clutch Cover and Pressure Plate</b>			
62-69	All (153)	838653	A.R.	.12	(2/8"— 16 x 1")
62-69	All (153) (exc. H.D. Clutch),				
70	All (153)	3829810	6	.18	cover and pressure plate assy.
62-70	All (153)	3962058	A.R.	.22	retrac. spring (5/16"— 18 x 2 <sup>9</sup> / <sub>32</sub> " hex.)— (0.864)
<b>0.863</b>		<b>PLATE, Clutch Pressure</b>			
62-69	All (153) (exc. H.D. Clutch),				
70	All (153)	3988716	1	13.75	(9 <sup>9</sup> / <sub>32</sub> " O.D.) (cast 3788659)
<b>0.864</b>		<b>BOLT— SPRING, Clutch Pressure Plate</b>			
62-70	All (153)	3962058	A.R.	.22	retrac. spring (5/16"— 18 x 2 <sup>9</sup> / <sub>32</sub> " hex.)
62-69	All (153) (exc. H.D. Clutch),				
70	All (153)	3788059	2	.40	SPRING, retracting (9/32" thk.)
62-68	All w/H.D. Clutch (153)	3788605	3	.13	SPRING, retracting (1 <sup>9</sup> / <sub>32</sub> " dia. at wide end w/2/16" ctr. hole) (Note 1)
<i>NOTE 1 Replace only in sets of three.</i>					
<b>0.886</b>		<b>DISC, with Facing, Clutch</b>			
62-69	All (153) (exc. H.D. Clutch),				
70	All (153)	3791266	1	29.25	(9" woven) (Note 1)
<i>NOTE 1 A quantity of these clutch discs has been assembled with the stamping "Flywheel Side" and the paint circle on the rear end of the hub on the same side. The stamping "Flywheel Side" should be disregarded and the clutch discs installed in the vehicle with painted hub to the rear, or away from the flywheel.</i>					

**153 ENGINE ASSEMBLY**

---

**0.886 DISC, with Facing, Clutch (Con't)**

62-68 All (153) ..... **6259178** 1 37.75 (10" woven) .....

## 194-230-250 ENGINE ASSEMBLY

### 0.000 ENGINE ASSEMBLY

*NOTE When installing the following engines on applicable past models, non-interchangeable parts must be discarded and replaced with parts that fit the replacing engine. See Engine Installation Instruction Charts in the General Information Section for parts and instructions necessary with service engines on past model information.*

66-67	Pass. (250) (exc. A.I.R., C.A.C., Taxi),				
67	Camaro w/P.G. (250) (exc. C.A.C., A.I.R.),				
68-69	All (250) (exc. Taxi) . . . . .	3930948	1	725.00	(less dist., water pump, flywheel, clutch housing, and all clutch components) . . . . .
64-70	All (230) . . . . .	6263006	1	825.00	(less dist., water pump, flywheel, clutch housing and all clutch components) . . . . .
70-71	All (250) (exc. Taxi, Police) . . . . .	6263017	1	725.00	(less dist., water pump, flywheel, clutch housing and all clutch components) . . . . .

*The above engine assemblies do not include the following sub assemblies.*

Carburetor Fuel Pump Oil Filter Assy.	Fan Blade and Pulley Generator Ignition Coil	Ignition Wiring Starting Motor Ventilator Assy.
---	--	---

*NOTE Special equipment production assemblies are available while in production, through Central Office, on direct order Form PC 785.*

### 0.002 BOLT— SPACER— WASHER, Engine Mounting (Small Attaching)

70	All (6 cyl.) (exc. Taxi, Police),				
71	All (6 cyl.),				
72	All (6 cyl.) (exc. Taxi) . . . . .	3980715	2	.34	( <sup>7</sup> / <sub>16</sub> "— 14 x 4 <sup>3</sup> / <sub>16</sub> ") . . . . .
70	Taxi, Police (6 cyl.) . . . . .	3980716	2	.34	( <sup>7</sup> / <sub>16</sub> "— 14 x 3 <sup>7</sup> / <sub>8</sub> ") . . . . .
72	Taxi (6 cyl.),				
73-75	All . . . . .	334972	2	.34	( <sup>7</sup> / <sub>16</sub> "— 14 x 5) . . . . .
64-69	Pass., Chevelle, Camaro (6 cyl.),				
68-70	Chevy (6 cyl.),				
70	Chevelle, Camaro, Pass. (6 cyl.) (exc. Taxi, Police),				
71-72	All (6 cyl.) . . . . .	3826168	2	.18	SPACER, frt. mtg. eng. brkt. ("U" shape) (2 <sup>1</sup> / <sub>2</sub> " O.L.) (Note 1) . . . . .
<i>NOTE 1 It may be necessary to reduce length to 2<sup>3</sup>/<sub>8</sub>".</i>					
62-69	Chevy, Chevelle, Camaro (6 cyl.)	3693853	2		WASHER, brkt. to engine (left side) ( <sup>7</sup> / <sub>16</sub> "— (2.277) . . . . .
64	Chevy (6 cyl.) . . . . .	3818180	A.R.	.11	WASHER, mtg. ( <sup>15</sup> / <sub>32</sub> " x 1 <sup>1</sup> / <sub>4</sub> " x <sup>3</sup> / <sub>16</sub> " thk.) . . . . .

### 0.010 GASKET UNIT, Engine or Tune Up

62-67	All (6 cyl.) . . . . .	3834936	1	4.70	engine (Note 1) . . . . .
68-75	All (6 cyl.) . . . . .	6259390	1	5.35	engine . . . . .

*NOTE 1 The above Engine Small Parts Gasket Units together with Oil Pan Gasket Unit (Group 1.429) and Cylinder Head Gasket Unit (Group 0.289) provide all necessary Gaskets for complete engine overhaul.*

### 0.027 MOUNTING ASSY., Engine (also see group 4.081)

#### 6 CYLINDER

62-67	Chevy (6 cyl.) . . . . .	3792404	2	5.15	(Ident. No. 3792404) . . . . .
64	Chevelle (6 cyl.) . . . . .	3839620	2	5.15	
65-69	Pass., Chevelle (6 cyl.),				
67-68	Camaro (6 cyl.) (1st design),				
68-69	Chevy (6 cyl.),				
70	Pass., Nova, Chevelle (6 cyl.) (exc. Taxi, Police),				
71	Pass., Nova, Chevelle (6 cyl.),				
72	All (exc. Camaro, Taxi) . . . . .	3997595	2	9.60	w/stop bracket . . . . .
68-70	Camaro (6 cyl.) (2nd design),				
70	Taxi, Police (6 cyl.) . . . . .	3990914	2	9.95	
71-72	Camaro (6 cyl.) . . . . .	3998269	2	10.50	
72	Taxi (6 cyl.) . . . . .	6262208	2	8.80	
73-74	All (6 cyl.) . . . . .	6262215	2	8.80	
75	All (6 cyl.) . . . . .	6262232	2	8.80	

### 0.029 BRACKET, Engine Mounting

62-67	Chevy (6 cyl.) . . . . .	3791891	L.H.	3.65	engine . . . . .
62-67	Chevy (6 cyl.) . . . . .	3791892	R.H.	3.65	engine . . . . .
64-72	Chevelle (6 cyl.) . . . . .	3866249	L.H.	2.75	engine . . . . .
64-72	Chevelle (6 cyl.) . . . . .	3866250	R.H.	2.75	eng. frt. mtg. . . . .
64-72	Chevelle (6 cyl.) . . . . .	3839621	L.H.	1.05	body . . . . .
64-72	Chevelle (6 cyl.) . . . . .	3839622	R.H.	1.05	body . . . . .
65-69	Pass. (6 cyl.),				

**194-230-250 ENGINE ASSEMBLY**

**0.029 BRACKET, Engine Mounting (Con't)**

70	Pass. (6 cyl.) (exc. Taxi, Police)	3931887	L.H.	1.15	frt. mtg. to frame
65-69	Pass. (6 cyl.),				
70	Pass. (6 cyl.) (exc. Taxi, Police)	3931888	R.H.	1.15	frt. mtg. to frame
65-70	Pass., Chevelle, Camaro (6 cyl.),				
68-70	Chevy (6 cyl.)	3972745	2	.44	stop
67-69	Camaro (6 cyl.),				
68-72	Chevy (6 cyl.)	3892731	L.H.	2.00	engine mtg. to side member
67-69	Camaro (6 cyl.),				
68-72	Chevy (6 cyl.)	3892732	R.H.	2.00	engine mtg. to side member
70-72	Camaro (6 cyl.)	3964894	2	5.95	engine mtg. to side member
68-70	Camaro (6 cyl.),				
71	All (6 cyl.),				
72	All (6 cyl.) (exc. Taxi)	3991276	1	.81	eng. mtg. stop
71-72	Pass. (6 cyl.) (exc. Taxi)	3993785	L.H.	1.90	
71-72	Pass. (6 cyl.) (exc. Taxi)	3993786	R.H.	1.90	
72	Taxi (6 cyl.)	3993723	L.H.	2.75	
72	Taxi (6 cyl.)	3993724	R.H.	2.75	
73-75	Camaro (6 cyl.)	3998647	L.H.	5.00	left
73-75	Camaro (6 cyl.)	3998648	R.H.	5.00	right
73	Pass. (6 cyl.)	3993723	L.H.	2.75	left
73	Pass. (6 cyl.)	3993724	R.H.	2.75	right
73-74	Nova (6 cyl.)	3998655	L.H.	4.50	left
73-74	Nova (6 cyl.)	3998656	R.H.	4.50	right
73-74	Chevelle (6 cyl.),				
75	Nova, Chevelle (6 cyl.)	6262209	L.H.	4.50	left
73-74	Chevelle (6 cyl.),				
75	Nova, Chevelle (6 cyl.)	6262210	R.H.	4.50	right
62-67	Chevy (6 cyl.)	3791877	L.H.	4.95	BRACKET ASSY., body
62-67	Chevy (6 cyl.)	3791878	R.H.	4.95	BRACKET ASSY., body
65-71	Pass. (6 cyl.),				
67-72	Camaro (6 cyl.),				
68-72	Chevy (6 cyl.),				
72	Pass. (6 cyl.) (exc. Taxi)	3866235	L.H.	2.40	BRACKET ASSY., frt. mtg. engine
65-71	Pass. (6 cyl.),				
67-72	Camaro (6 cyl.),				
68-72	Chevy (6 cyl.),				
72	Pass. (6 cyl.) (exc. Taxi)	3866236	R.H.	2.40	BRACKET ASSY., frt. mtg. engine
67-69	Pass. (6 cyl.)	3790292	1	3.60	BRACKET ASSY., engine, right
70	Taxi, Police (6 cyl.)	3954637	L.H.	2.00	BRACKET ASSY., frame
70	Taxi, Police (6 cyl.)	3977234	R.H.	3.25	BRACKET ASSY., frame

**0.033 BLOCK ASSY., Cylinder**

*NOTE CAUTION. Combination not appearing below should be checked in the Engine Series Number and Suffix Chart in front of catalog to determine if the combination was available in production. If not available, no attempt should be made to make the installation.*

**PARTIAL ENGINE**

*NOTE Includes block, crankshaft, camshaft, timing gears, pistons and connecting rods. Bolts on front end plate may have to be cut off flush when installing on 6 cyl. pass.*

62-66	Chevy, Chevelle (194),				
67	Chevy (194)	3931603	1	461.00	(Note 1)
65-70	All (230)	3930966	1	516.00	(Note 2, 3, 4)
66-70	All (250) (exc. Police, Taxi)	3930974	1	516.00	(Note 3, 4)
72-74	All (6 cyl.) w/NB2	6272130	1	549.00	
67-69	Taxi, Police (250),				
70-71	All (6 cyl.),				
72	All (6 cyl.) (exc. NB2),				
74-75	Nova (exc. integrated cylinder head)	358824	1	549.00	
75	All w/integrated cylinder head	374212	1	549.00	(repl. 358825)

**FITTED CYLINDER BLOCK (Includes, Pistons, Pins, Rings and Bearings)**

64-70	All (230)	3930967	1	337.00	(Note 4)
66-69	Pass. (250),				
67-70	Chevy, Chevelle, Camaro (250) (exc. Police, Taxi),				
71-75	All (6 cyl.)	374210	1	358.00	

*NOTE 1 May contain Nodular iron type Crankshaft. It is necessary to install a harmonic balancer on vehicles which do not have an existing balancer.*

*NOTE 2 It may be desirable to replace camshaft gear with 3788508 to eliminate possible objectionable noise level.*

*NOTE 3 When using on models prior to 1968 it will be necessary to use 1968 Oil Pan Gasket Unit.*

*NOTE 4 1967 engines with date stamp FO619 thru end of production incorporate 1968 parts as follows: Crankshaft Rear Bearing Oil Seal, Rear Bearing Cap, Oil Pan Gasket. Refer to parts in their groups.*

## 194-230-250 ENGINE ASSEMBLY

### 0.034 EXPANSION PLUGS, Cylinder Block (Also see 8.970)

62-63	Chevy (6 cyl.)	444782 A.R.	.10	cylinder oil gallery rr. hole plug ( $\frac{3}{4}$ "— 18 thd.— $\frac{5}{16}$ " sq. socket)— (8.971)
62-69	Chevy, Chevelle, Camaro (6 cyl.)	838538 A.R.	.18	water jacket balance shaft hole (cup type) ( $\frac{15}{8}$ ")
62-69	Chevy, Chevelle, Camaro (6 cyl.),			
70-75	All (6 cyl.)	3788418 A.R.	.24	cyl. head water jacket (cup type— $\frac{15}{16}$ " dia.)
62-75	All (6 cyl.)	3789860 1	.24	water jacket rear (2" O.D.-cup type)
70-75	All (6 cyl.)	3835577 8	.12	cyl. and case main oil gallery front hole ( $\frac{19}{32}$ " O.D.-cup type)
75	All (6 cyl.)	3826504 1	.96	water jacket

### 0.056 BOLT— STUD, Crankshaft Bearing Cap

62-68	Chevy, Chevelle (6 cyl.),			
65-68	Pass. (6 cyl.),			
69-75	All (6 cyl.)	3872781 A.R.	.28	( $\frac{1}{16}$ "— 14 x $\frac{39}{32}$ ")
64	Chevelle (6 cyl.)	3872718 A.R.	1.25	STUD, No. 6 brg. cap, right ( $\frac{7}{16}$ "— 14— $\frac{3}{8}$ "— 16 x $\frac{51}{4}$ ")
65-75	All (6 cyl.)	3852870 1	.34	STUD, No. 6 and No. 4 brg. cap right ( $\frac{3}{4}$ "— 16 x $\frac{7}{16}$ "— 14 x $\frac{39}{32}$ ")

### 0.093 PLASTIGAGE, Crankshaft Bearing

62-75	All (6 cyl.)	1390274 A.R.	6.15	(green package-type PG-1) (12 pieces)
-------	--------------	--------------	------	---------------------------------------

### 0.095 CAP, Crankshaft Front Bearing

62-75	All (6 cyl.)	3970194 A.R.	5.85	(No. 1, 2, 3, 4, 5, 6) (ident. by blue stripe)
-------	--------------	--------------	------	--

### 0.096 BEARING UNIT, Crankshaft Front (1 Upper and 1 Lower)

See chart for Model Application

NOTE: See Dealer Price Schedule for applicable prices.

### CRANKSHAFT MAIN BEARING CHART

	Position	STD.	.001 U.S.	.002 U.S.	.009 U.S.	.010 U.S.	.020 U.S.
62-75	All (6 cyl.)	All (exc. Rear)	3792553	3792554	3792555	3876072	3792556 3792557
62-71	Chevy, Chevelle, Camaro (6 cyl.)						
65	Pass. (6 cyl.)						
66-72	Pass. (250) (exc. Taxi, Police w/A.T.)						
73-75	All (6 cyl.) (exc. A.T.)	Rear	3792558	3792559	3792560	3876073	3792561 3792562
66-72	Taxi w/A.T. (250)						
68-72	Police w/A.T. (250)	Rear	3829067(!)	3829068(!)	3829069(!)	3890979	3829070(!) 3829071(!)
73-75	All w/A.T. (6 cyl.)	(Rear)	3829067	3829068	3829069	3890979	3829070 3829071
<b>POSITION</b>		<b>.030 U.S.</b>					
66-72	Taxi w/A.T. (250)						
68-72	Police w/A.T. (250)						
73-75	All w/A.T. (6 cyl.)	Rear					3829072(!)

NOTE Bearings having no supplementary notes are Durex 100.  
(!) Aluminum M-400.

### 0.105 CAP, Crankshaft Rear Bearing

62-67	All (6 cyl.)	3791428 1	5.05	(cast 3788407) (Note 1)
NOTE 1 Use 3928975 on 1967 engines with date stamp FO619 thru end of production.				
68-75	All (6 cyl.)	3928975 1	5.75	(Note 2)
NOTE 2 3791428 will fit some 1968 6 cyl. engines which have a date stamp of FO623 and also have an R stamped under the date.				

### 0.137 SEAL ASSY., Crankshaft Rear Bearing and Cap Oil

68-75	All (6 cyl.)	3958001 2	2.60	rear oil
62-67	All (6 cyl.)	3792463 1	2.85	SEAL UNIT, upper and lower (Note 1, 2)
NOTE 1 Use 3921972 on 1967 engines with date stamp FO619 thru end of production.				
NOTE 2 3792463 will fit some 1968 6 cyl. engines which have a date stamp of "FO623" and also have an "R" stamped under the date.				

### 0.153 SHIM UNIT, Crankshaft Bearing Cap

62-67	All (6 cyl.)	3791429 A.R.	1.90	rear ( $\frac{123}{32}$ " O.L.)
62-75	All (6 cyl.)	3911010 A.R.	1.90	front and intermediate



**194-230-250 ENGINE ASSEMBLY**

**0.153 SHIM UNIT, Crankshaft Bearing Cap (Con't)**

68-75 All (6 cyl.) ..... **3928985** A.R. 2.30 rear .....

**0.206 COVER, Crankcase Front End**

63-67 All (6 cyl.) ..... **3998160** 1 5.80 w/oil seal .....  
 68-74 All (6 cyl.) ..... **3996616** 1 8.95 **COVER ASSY.** .....  
 75 All (6 cyl.) ..... **352179** 1 5.95 **COVER ASSY.** .....

**0.207 GASKET, Crankcase Front End Cover**

62-75 All (6 cyl.) ..... **3923472** 1 .41

**0.213 SEAL, Crankcase Front End Cover**

62-75 All (6 cyl.) ..... **3980267** 1 3.35 (27/16" O.D.— stamped 3980267) .....

**0.269 HEAD, Cylinder**

62-65 Chevy, Chevelle (194),  
 66 Chevy, Chevelle (194),  
 67 Chevy, Chevelle (194) ..... **329607** 1 101.00  
 64-69 All (230, 250),  
 70-75 All (6 cyl.) (exc. integrated cyl.  
 hd.) ..... **6259693** 1 101.00 w/studs .....  
 75 All w/integrated cyl. hd. (6 cyl.) . **359965** 1 191.00 w/studs .....

**0.289 GASKET, Cylinder Head**

62-67 Chevy, Chevelle (194) ..... **3886129** 1 4.40 (28" O.L.) .....  
 63-70 All (230, 250) (2nd design),  
 71-74 All (250) ..... **3901016** 1 4.65  
 75 All (6 cyl.) ..... **355754** 1 4.65  
 62-67 Chevy, Chevelle (194) ..... **6258181** 1 13.65 **GASKET UNIT** (Note 1) .....  
 62-74 All (6 cyl.),  
 75 Nova (6 cyl.) (exc. integrated  
 cylinder head) ..... **345030** 1 14.15 **GASKET UNIT** (Note 2, 3) .....  
 75 All w/integrated cylinder head  
 (6 cyl.) ..... **358827** 1 18.55 **GASKET UNIT** .....

*NOTE 1 Unit consists of cylinder head, water outlet, valve rocker cover, push rod cover, inlet and exhaust manifold, and thermostat housing gaskets, valve stem oil seals and exhaust pipe packing.*

*NOTE 2 It may be necessary to cut out the center ribs front exhaust port opening of inlet and exhaust manifold gasket.*

*NOTE 3 It may be necessary to cut off the six (6) locating tabs of the valve rocker cover gasket.*

**0.293 BOLT— NUT— PIN— STUD, Cylinder Head**

62-75 All (6 cyl.) (exc. integrated cyl.  
 hd.) ..... **3788417** A.R. .40 (1/2"— 13 x 3<sup>27</sup>/<sub>64</sub>") .....  
 75 All w/integrated cyl. hd. .... **352154** A.R. .41 (1/2"— 13 x 4<sup>11</sup>/<sub>32</sub>") .....  
 65-69 Chevelle, Camaro (6 cyl.) ..... **3866766** 12 .12 **NUT**, attaching (hex. 3/8"— 24)— (0.626) ...  
 65-75 Pass. (6 cyl.) ..... **585927** A.R. .16 **PIN** (5/16" x 9/16") .....  
 71-73 All (6 cyl.) ..... **3834490** 1 .40 **STUD** (1/2"— 13 x 3/8"— 16 x 4<sup>3</sup>/<sub>4</sub>") .....

**0.296 VALVE, Inlet**

**Refer to following Chart for Model Application**

*NOTE: See Dealer Price Schedule for applicable prices.*

**VALVE CHART (Inlet)**

	STD.	.003 O.S.	.015 O.S.	.030 O.S.
62-67 All (6 cyl.) .....				
68 All (230, 250) (exc. Taxi, Police) .....	3989083	3995684	3995685	3995686
68 Police, Taxi (250), 69-75 All (6 cyl.) (exc. integrated cylinder head) .....	3989088	3997749	3997750	3997751
75 All (6 cyl.) w/integrated cylinder head .....	3989083	3995684	3995685	3995686

**194-230-250 ENGINE ASSEMBLY**

**0.297 VALVE, Exhaust**

**Refer to following Chart for Model Application**

*NOTE: See Dealer Price Schedule for applicable prices.*

**VALVE CHART (Exhaust)**

	STD.	.003 O.S.	.015 O.S.	.030 O.S.
62-75 All (6 cyl.)	6263778	3995602	3995603	3995604

**0.303 SPRING, Valve**

62-72 All (194, 230, 250) (exc. H/Per. w/230),				
73-75 All (6 cyl.) (exc. integrated cylinder head)	3864895	12	1.10	inlet and exhaust (2 daubs of orange plus, stripe of aluminum, dark green, purple or tan)
64 Chevy, Chevelle w/H/Per. (230),				
64-68 Chevy, Chevelle (250),				
65-66 Pass. (250),				
75 All (6 cyl.) w/integrated cylinder head	3735381	A.R.	1.35	inlet and exhaust, w/damper (2 yellow stripes plus maroon, aluminum, dk. green, black, blue and white, or tan stripe) (Note 1, 2)

*NOTE 1 Used only with Camshaft Assy. 3831607. Also part of Camshaft Unit 3837796.*

*NOTE 2 When using in place of 3862395 (250 eng.) it will be necessary to discard old valve spring cap and replace with 3729333 identified by letter H on top face.*

**0.308 SEAL— SHIELD, Valve Spring Cap**

62-75 All (6 cyl.)	3835333	A.R.	.17	"O" ring, inlet and exhaust
62-75 All (6 cyl.)	3836755	A.R.	.18	SHIELD (cup shape-7/8" I.D. x 1 3/8" O.D.)

**0.309 CAP— ROTATOR ASSY., Valve Spring**

62-75 All (6 cyl.)	3729363	A.R.	.40	inlet and exhaust (1 3/16" O.D.-stamped H)
70-72 Taxi, Police (250),				
73 Taxi w/P.G. (6 cyl.)	6263794	6	2.95	ROTATOR ASSY., exhaust valve (1 5/16" O.D. x 35/64" thk.)

**0.310 KEY, Valve Stem**

62-75 All (6 cyl.)	838029	A.R.	.06	("U" shape)
73-75 All (6 cyl.)	3947770	A.R.	.12	(carbonized) (ident. by purple dye)

**0.333 ARM UNIT, Valve Rocker with Adjusting Screw and Nut**

62-75 All (6 cyl.)	5723551	A.R.	2.45	inlet and exhaust
--------------------	---------	------	------	-------------------

**0.376 SPRING, Valve Rocker Shaft**

65-69 Pass. (6 cyl.)	3835508	4	.11	(2 5/16" free length)
----------------------	---------	---	-----	-----------------------

**0.386 COVER ASSY.— GROMMET, Valve Rocker Arm**

63-70 All (6 cyl.)	3980229	1	7.90	
71-72 All (6 cyl.)	3994204	1	8.05	w/oil filler cap
73 All (6 cyl.)	6259798	1	8.65	w/grommet
74-75 All (6 cyl.) (exc. integrated cylinder head)	345007	1	8.65	w/grommet
75 All (6 cyl.) w/integrated cylinder head	352170	1	13.60	
64-70 All (6 cyl.)	3894337	1	.11	GROMMET, cover to a/cl. (1 5/16" I.D. x 1 7/32" O.D.)— (1.745) (Note 1, 2)

*NOTE 1 May be used with or without closed vent.*

*NOTE 2 When using on closed vent. equipped vehicles, it will be necessary to remove center from grommet to permit assembling of fresh air connector into side of cover.*

**0.413 BOLT— STUD— REINFORCEMENT, Valve Rocker Cover and Support**

62-75 All (6 cyl.)	180016	1		(1/4"— 20 x 1/2")— (8.900)
75 All (6 cyl.) w/integrated cylinder head	352173	A.R.	.47	STUD
62-75 All (6 cyl.) (exc. integrated cylinder head)	3877670	A.R.	.12	REINFORCEMENT (1 1/2" O.L.) (Note 1)
<i>NOTE 1 Use with Bolt 180016.</i>				
75 All (6 cyl.) w/integrated cylinder head	352172	1	.12	REINFORCEMENT

**194-230-250 ENGINE ASSEMBLY**

**0.423 GASKET, Valve Rocker Cover**

62-75	All (6 cyl.) (exc. integrated cylinder head) . . . . .	3930912	1	1.80	
75	All (6 cyl.) w/integrated cylinder head . . . . .	356846	1	3.10	

**0.426 ROD, Valve Push**

62-75	All (6 cyl.) (exc. Taxi, Police) . . .	3788495 A.R.		1.25	(9 <sup>5</sup> / <sub>8</sub> " O.L.) . . . . .
63-65	Chevy, Chevelle (6 cyl.),				
65-72	Taxi (6 cyl.),				
68-71	Police (250) . . . . .	3845266	12	2.25	(9 <sup>5</sup> / <sub>8</sub> " O.L.— white stripe) (Note 1) . . . . .

*NOTE 1 Color marked end to be at valve rocker arm.*

**0.429 BALL— NUT— STUD, Valve Push Rod Adjusting**

62-75	All (6 cyl.) . . . . .	3992294	12	.28	(1 <sup>5</sup> / <sub>16</sub> " dia.) . . . . .
70-71	All (6 cyl.) . . . . .	3959142 A.R.		.38	(1 <sup>3</sup> / <sub>16</sub> " dia.) . . . . .
62-75	All (6 cyl.) . . . . .	3744341	16	.22	NUT, valve rocker arm (3 <sup>3</sup> / <sub>8</sub> "— 24) (5 <sup>5</sup> / <sub>8</sub> " across the flats x 1 <sup>1</sup> / <sub>2</sub> ") . . . . .
62-75	All (230, 250) . . . . .	3814692	16	.53	STUD, valve rocker arm ball (.003 O.S.-light blue paint) . . . . .
62-75	All (6 cyl.) . . . . .	3815892	16	.53	STUD, valve rocker arm ball (.013 O.S.— 3 <sup>3</sup> / <sub>8</sub> "— 24 2 <sup>1</sup> / <sub>2</sub> ") (1 groove on shank-light blue paint) . . . . .

**0.439 COVER, Valve Push Rod**

62-75	All (6 cyl.) . . . . .	3788496	2	1.60	(4 <sup>5</sup> / <sub>32</sub> " x 12 <sup>3</sup> / <sub>4</sub> ") . . . . .
-------	------------------------	---------	---	------	---

**0.443 GASKET, Valve Push Rod Cover**

62-75	All (6 cyl.) . . . . .	3920938	2	1.35	
-------	------------------------	---------	---	------	--

**0.446 BOLT— STUD, Valve, Push Rod Cover**

62-75	All (6 cyl.) . . . . .	3814350 A.R.		.27	w/lockwasher and seal (5 <sup>5</sup> / <sub>16</sub> "— 18 x 7 <sup>7</sup> / <sub>16</sub> ") . . . . .
75	All (6 cyl.) . . . . .	352169	2	.33	STUD, w/seal . . . . .

**0.459 TAPPET, Valve (or Lifter)**

62-75	All (6 cyl.) . . . . .	5232450 A.R.		4.54	hydraulic type . . . . .
-------	------------------------	--------------	--	------	--------------------------

**0.519 CAMSHAFT, Engine**

*NOTE Engine Camshaft Break-in Oil 1050800, Group 1.850, should be used when installing new camshafts.*

62-70	All (194, 230) (exc. H/Per.) . . . . .	3864918	1	43.50	(Ident. No. 3864897) . . . . .
64	Chevy, Chevelle w/H/Per. (230),				
65-71	All (250),				
72	Pass. (6 cyl.),				
72	All (6 cyl.) (exc. NB2, Pass.),				
73-74	All (6 cyl.),				
75	All (6 cyl.) (exc. integrated cylinder head) . . . . .	3864497	1	43.50	(Ident. No. 3864896 or 3850958 "A") . . . . .
72	Chevelle, Nova, Camaro w/NB-2,				
75	All (6 cyl.) w/integrated cylinder head . . . . .	6262809	1	43.50	

**0.533 BEARING UNIT, Camshaft Thrust**

65-75	All (6 cyl.) . . . . .	3790531	1	1.80	w/spacing ring (1 <sup>1</sup> / <sub>2</sub> " O.D. x 1 <sup>9</sup> / <sub>32</sub> " I.D.) . . . . .
-------	------------------------	---------	---	------	---

**0.539 BEARING, Camshaft (Front or No. 1)**

62-70	All (6 cyl.) . . . . .	3750882	1	2.40	precision type (stamped 2)— (0.543) . . . . .
73-75	All (6 cyl.) . . . . .	3750884	1	2.40	(0.543) . . . . .

**0.543 BEARING, Camshaft No. 2 (Front Intermediate)**

62-70	All (6 cyl.) . . . . .	3750882	1	2.40	precision type (stamped 2) . . . . .
73-75	All (6 cyl.) . . . . .	3750884 A.R.		2.40	(0.546) . . . . .

**0.546 BEARING, Camshaft (Center and Rear Intermediate)**

62-75	All (6 cyl.) . . . . .	3750884 A.R.		2.40	(stamped 3-4) . . . . .
-------	------------------------	--------------	--	------	-------------------------

**0.549 BEARING, Camshaft Rear**

62-70	All (6 cyl.) . . . . .	3750882	1	2.40	precision type (stamped 2)— (0.543) . . . . .
73-75	All (6 cyl.) . . . . .	3750884 A.R.		2.40	(0.546) . . . . .

**0.553 PLUG, Camshaft Bearing Hole, Cup Type (In Cylinder Block)**

62-71	All (6 cyl.) . . . . .	3704158	1	.22	(2 <sup>1</sup> / <sub>8</sub> " dia.) . . . . .
72-75	All (6 cyl.) . . . . .	3994255	1	.25	rear bearing . . . . .

**0.603 ROD ASSY., Connecting, Less Dipper**

62-75	All (6 cyl.) . . . . .	3977110 A.R.		15.00	(cap forged 3788437) . . . . .
-------	------------------------	--------------	--	-------	--------------------------------

**194-230-250 ENGINE ASSEMBLY**

**0.616 BEARING UNIT, Connecting Rod (1 Upper and 1 Lower)**

Refer to chart for Model Application

*NOTE: See Dealer Price Schedule for applicable prices.*

**CONNECTING ROD BEARING UNIT CHART**

MODEL USAGE	STD.	.001 U.S.	.002 U.S.	.010 U.S.	.020 U.S.
62-75 All (6 cyl.)	347118	347119	3715046	3715048	3715047

**0.623 BOLT, Connecting Rod Bearing Cap**

62-75 All (6 cyl.)	3892670 A.R.	.70	( <sup>11</sup> / <sub>32</sub> "— 24 x <sup>17</sup> / <sub>8</sub> " )
--------------------	--------------	-----	--

**0.626 NUT, Connecting Rod Bearing Cap Bolt**

62-69 Chevy, Chevelle, Camaro (6 cyl.)	9422298 A.R.	.11	( <sup>3</sup> / <sub>8</sub> "— 24 x <sup>5</sup> / <sub>16</sub> " thick) (one end chamfered)— (8.917)
62-75 All (6 cyl.)	3815280 16	.24	( <sup>11</sup> / <sub>32</sub> "— 24) (type EA) (phosphate coated and soaped)
64-72 All (6 cyl.)	3866766 A.R.	.12	( <sup>3</sup> / <sub>8</sub> "— 24 x <sup>3</sup> / <sub>8</sub> " thick) (hex. nut) (both ends flat) (Note 1)

*NOTE 1 Also used with bolts not requiring cotter pins.*

**0.629 PISTON ASSY., with Pin**

*NOTE Individual piston assemblies are available for warranty purposes and for replacement of pistons damaged when making repairs to engine assemblies. When ordering such parts it is necessary that you specify on your order the reason the parts are required and also that the following note appears on your order. Do not ship unit package quantity.*

ENGINE DISPLACEMENT	BASIC SIZE	SERVICE PISTON DIAMETER RANGE LIMITS ALUMINUM
194 cu. in.	3.5625— STD.	S-4— 3.5625 to 3.5630, S-5— 3.5630 to 3.5635
194 cu. in.	3.5635— .001	S-6— 3.5635 to 3.5640, S-7— 3.5640 to 3.5645
230 cu. in.	3.8750— STD.	S-4— 3.8750 to 3.8755, S-5— 3.8755 to 3.8760
230 cu. in.	3.8760— .001	S-6— 3.8760 to 3.8765, S-7— 3.8765 to 3.8770
250 cu. in.	3.8750— STD.	S-4— 3.8750 to 3.8755, S-5— 3.8755 to 3.8760
250 cu. in.	3.8760— .001	S-6— 3.8760 to 3.8765, S-7— 3.8765 to 3.8770

*NOTE The above chart is for information purposes only.*

(Refer to chart for model application)

*NOTE: See Dealer Price Schedule for applicable prices.*

**PISTON CHART**

	STD.	.001 O.S.	.020 O.S.	.030 O.S.	.040 O.S.
62-70 All (230)	3860407	3860413	—	3860426	3860432
62-67 All (194)	3860409	3860414	3860419	3860428	—
66-69 All (250) (exc. Taxi, Police)					
70 All (250) (1st design) (exc. Taxi, Police)	3886040 <sup>(2)</sup>	3886041 <sup>(2)</sup>	—	3886043 <sup>(2)</sup>	—
66-70 Taxi (250)					
68-70 Police (250)					
70 All (250) (2nd design) (exc. Taxi, Police)					
71 All (6 cyl.)	3886048 <sup>(1)</sup>	3886049 <sup>(1)</sup>	—	3886051 <sup>(1)</sup>	—
72-75 All (6 cyl.)	6270033 <sup>(3)</sup>	6270034 <sup>(3)</sup>	—	6270036 <sup>(3)</sup>	—
75 Nova (6 cyl.)	6273463 <sup>(4)</sup>	—	—	6273467 <sup>(4)</sup>	—

*NOTE 1 Used on all Taxi, Police (250) and all 250 Eng. built after Feb. 16, 1970 (<sup>5</sup>/<sub>64</sub> inch ring grooves).*

*NOTE 2 Used on 250 Eng. built before Feb. 16, 1970 (<sup>1</sup>/<sub>16</sub> inch ring grooves).*

*NOTE 3: Use w/standard engine.*

*NOTE 4: Use w/low compression engine.*

**194-230-250 ENGINE ASSEMBLY**

**0.643 RING UNIT, Piston (Service Sets)**

*NOTE: Individual cylinder piston ring units (std. size only) for warranty replacement in a single engine cylinder may be ordered thru the local G.M.P.D. warehouse (refer to ACNC6775). Identify by eng. model and year. Specify on your order the reason the parts are required and also that the following note appears on your order. Do not ship unit package quantity. Each of these std. size piston ring units include the necessary components (ring, spacers, segments, expanders) required for replacement in a SINGLE engine cyl.*

*NOTE: See Dealer Price Schedule for applicable prices.*

**Original Equipment Type (complete set for one engine per container unless otherwise noted)**

	STD.	.020 O.S.	.030 O.S.	
62-67 Chevy, Chevelle (194) . . .	326355 <sup>(6)</sup>	—	3892357 <sup>(1)</sup>	1
66-70 Taxi (250),				
68-70 Police (250),				
69-70 All (230),				
70 All (250) (2nd design) (exc. Taxi, Police),				
71-72 All (6 cyl.) . . . . .	326400 <sup>(1, 2, 3, 5)</sup>	3892388 <sup>(1, 3)</sup>	328503 <sup>(1, 3, 5)</sup>	1
62-68 All (230) (exc. Taxi),				
65 Taxi (230) . . . . .	326400 <sup>(1, 2)</sup>	—	328503 <sup>(1)</sup>	1
66-69 All (250) (exc. Taxi, Police),				
70 All (250) (1st design) (exc. Taxi, Police) . . . . .	3892343 <sup>(1, 2, 4)</sup>	3892344 <sup>(1, 4)</sup>	—	1
70 All (250) . . . . .	—	—	326389	6
73-75 All (6 cyl.) . . . . .	326400		328503	6

**Special Replacement Type (complete set for one engine per container unless otherwise noted)**

	STD.	.020 O.S.	.030 O.S.	
62-67 Chevy, Chevelle (194) (exc. Taxi) . . . . .	326355 <sup>(6)</sup>	3791610	3838345	1
62-70 All (230),				
66-69 Police, Taxi (250),				
70-72 All (250) . . . . .	326400 <sup>(6)</sup>		328503 <sup>(6)</sup>	1

*(1) These are Molybdenum premium rings.*

*(2) This part is eligible for wholesale compensation.*

*(3) Used on all Taxi, Police (250) and all 250 Eng. built after Feb. 16, 1970 (5/64 inch thk. ring)*

*(4) Used on 250 Eng. built before Feb. 16, 1970 (1/16 inch thk. ring).*

*(5) Single cylinder replacement unit.*

**0.646 CRANKSHAFT, Engine**

62-70 All (194, 230) . . . . .	3864465	1	161.00	(Note 1)
66-75 All (250) . . . . .	3876840	1	161.00	(Note 1)

*NOTE 1 When used on A.T. it will be necessary to remove the pilot bearing.*

**0.649 BEARING, Crankshaft Clutch Pilot**

62-75 All (6 cyl.) . . . . .	3752487	1	1.20	(bush type— 19/32" I.D. x 1 3/32" O.D. x 3/4") . . .
------------------------------	---------	---	------	--

**0.659 BALANCER— PULLEY, Crankshaft**

*NOTE In some cases double groove pulleys may be used in place of single groove pulleys.*

*NOTE Crankshaft harmonic balancer is also referred to as "torsional damper".*

62-67 Chevy (6 cyl.),				
64-65 Chevelle (6 cyl.) (exc. Air Cond.),				
65 Pass. (230) (exc. Air Cond.),				
66-67 Chevelle, Camaro (230) (exc. Air Cond.),				
67 Pass. (230),				
68-69 Chevy, Chevelle, Camaro w/P/S (230) (exc. Air Cond.),				
70 All (230) . . . . .	3826280	1	24.45	w/pulley (timing mark on frt. face 30 degree left) . . . . .
65-66 Chevelle w/Air Cond. (6 cyl.),				
65 Pass. w/Air Cond. (6 cyl.),				
67 Chevelle, Camaro w/Air Cond. (250) . . . . .	3850666	1	28.75	w/o pulley (hub 6 1/2" O.D.) . . . . .
66-70 All (250) (exc. C.A.C.),				
71-72 All (6 cyl.) (exc. Taxi, Police),				
73-74 All (6 cyl.) . . . . .	3896590	1	24.45	w/2 groove pulley . . . . .

**194-230-250 ENGINE ASSEMBLY**

**0.659 BALANCER— PULLEY, Crankshaft (Con't)**

66-69	All w/Air Cond. (250),				
71-72	Taxi, Police (6 cyl.) . . . . .	3896591	1	31.00	w/2 groove pulley . . . . .
75	All (6 cyl.) . . . . .	352153	1	29.25	
62-66	Pass., Chevy w/Air Cond. (6 cyl.),				
63	Chevy w/62 amp. Gen. (6 cyl.) (exc. Air Cond., P/S),				
64-67	Chevy w/62 amp. Gen. (6 cyl.) (exc. P/S),				
64-66	Chevelle w/Access, Air Cond. (6 cyl.),				
64-66	Chevelle w/62 amp. Gen. (6 cyl.) (exc. Air Cond.),				
65-66	Pass. w/P/S (6 cyl.) (exc. Air Cond.),				
65-66	Pass. w/62 amp. A.C. Gen. (6 cyl.) (exc. Air Cond.),				
67	Pass. (6 cyl.),				
67	All w/A.I.R. (230) (exc. C.A.C.),				
67	All w/P/S (230) (exc. A.I.R., C.A.C.),				
68-69	All w/P/S, A.T. (230) (exc. C.A.C.),				
70	Nova w/P/S (230) . . . . .	3790337	1	9.20	PULLEY, front (stamped 3790337) . . . . .
64-66	Chevelle w/P/S, Air Cond. (6 cyl.),				
65	Pass. (Air Cond. w/P/S) (6 cyl.),				
67	Chevelle w/P/S (6 cyl.),				
68-69	All (Air Cond. w/P/S) (6 cyl.),				
70	Pass., Nova, Chevelle w/Acc. Air Cond. (6 cyl.),				
71	Chevelle w/Acc. Air Cond. (6 cyl.) . . . . .	3853104	1	8.50	PULLEY, front . . . . .
64-68	Chevelle, Camaro w/Air Cond. (exc. P/S, 250),				
65	Pass., w/Air Cond. (6 cyl.) (exc. P/S),				
68-69	Pass. (6 cyl.) . . . . .				PULLEY, front, . . . . .
64-69	Chevelle, Camaro (P/S w/Air Cond.) (6 cyl.),				
65	Pass. (P/S w/Air Cond.) (6 cyl.),				
70	Pass., Nova, Chevelle w/Acc. Air Cond. (6 cyl.),				
71	Chevelle w/Acc. Air Cond. (6 cyl.) . . . . .	3853400	1	8.50	center . . . . .
66-67	Pass. (A.I.R. w/C.A.C.) (6 cyl.),				
66-67	Pass. (P/S w/C.A.C.) (6 cyl.) (exc. A.I.R.),				
67	Chevelle, Camaro (C.A.C. w/A.I.R.) (250),				
67	Chevelle, Camaro (P/S w/C.A.C.) (250) (exc. A.I.R.),				
68-69	All w/P/S (A.T. w/C.A.C.) (6 cyl.),				
69	Chevy, Chevelle, Camaro w/C.A.C. (6 cyl.) (exc. A.T.),				
69	Pass. w/C.A.C. (6 cyl.) (exc. P.G.),				
74	Nova (6 cyl.) w/C.A.C. . . . . .	3876872	1	8.50	PULLEY (1 groove) . . . . .
66-67	Pass. w/accessory P/S (6 cyl.),				
68-69	Chevy, Chevelle, Camaro (Acc. Air Cond. w/3-Spd.) (230),				
72	All (NB-2 w/P/S) (6 cyl.) (exc. Pass.),				
73-74	All w/P/S (6 cyl.),				
75	All (6 cyl.) w/C.A.C. . . . . .	3883263	1	7.75	PULLEY (1 groove 6 <sup>3</sup> / <sub>4</sub> " dia.) . . . . .
<b>0.662 KEY— WASHER, Harmonic Balancer and Crankshaft Pulley</b>					
65-66	All w/key 3 <sup>3</sup> / <sub>4</sub> " long x 3 <sup>3</sup> / <sub>16</sub> " wide x 1 <sup>1</sup> / <sub>4</sub> " high . . . . .	3883206 A.R.		.16	crankshaft pulley hub (Note 1) . . . . .
65-66	All w/key 1 <sup>3</sup> / <sub>8</sub> " long x 3 <sup>3</sup> / <sub>16</sub> " wide x 1 <sup>11</sup> / <sub>32</sub> " high . . . . .	3885092	1	.16	crankshaft pulley hub (Note 1) full depth (1 <sup>1</sup> / <sub>8</sub> " slots take standard Woodruff key (106751 two short or 144542 one long) in Group 8.960 . . . . .

**194-230-250 ENGINE ASSEMBLY**

**0.662 KEY— WASHER, Harmonic Balancer and Crankshaft Pulley (Con't)**

*NOTE 1: Used with pulleys and hubs having a shallow (1/16" deep) keyway only. All full depth (1/8") slots take standard woodruff key (106751 two short or 144542 one long) in group 8.960.*

66-69 All (6 cyl.) ..... **3739422** 1 .46 **WASHER, balancer** .....

**0.666 FLYWHEEL, with Ring Gear**

62-69 Chevy, Chevelle (194) (exc. A.T., H.D. Clutch) ..... **6270045** 1 59.25 solid type .....

62-69 Chevy, Chevelle, Camaro w/P.G., reg. fuel (6 cyl.),

65-68 Pass. w/A.T. (6 cyl.),

69 Pass. w/A.T., reg. fuel (250),

70 All w/A.T. (250) ..... **3789821** 1 26.75 spoke type (6-2" dia. holes around ctr.) ....

62-69 Chevy, Chevelle w/H.D. Clutch (194),

64-69 All (230, 250) (exc. H.D. Clutch, Taxi, P.G.),

70-71 All (6 cyl.) (exc. A.T., Taxi, Police),

72 All (6 cyl.) (exc. A.T.),

73-74 All (6 cyl.) (exc. A.T.),

75 Nova, Camaro (6 cyl.) (exc. A.T.) ..... **3973452** 1 59.25 solid type (cast 3791021) .....

65 Pass. (230) (exc. A.T.),

66-68 Pass. w/H.D. Clutch (250),

70-71 Taxi, Police (250) (exc. A.T.) ..... **3998281** 1 68.25 w/11" coil sprg. clutch (12<sup>5</sup>/<sub>8</sub>" bolt circle) solid type .....

71-74 All w/A.T. (6 cyl.) ..... **3991402** 1 26.75

75 Chevelle,

75 Nova, Camaro (6 cyl.) w/A.T. .... **340296** 1 23.85 (repl. 3991403) .....

**0.669 BOLT, Flywheel to Crankshaft**

62-75 All (exc. A.T.) (6 cyl.) ..... **839756** 6 .12 (7/16" — 20 x 1") .....

62-75 All w/A.T. (6 cyl.) ..... **3727207** 6 .21 (7/16" — 20 x <sup>45</sup>/<sub>64</sub>" — 290M steel) .....

**0.673 GEAR, Flywheel Ring**

62-74 All (6 cyl.),

75 Chevelle,

75 Nova, Camaro (6 cyl.) ..... **3991408** 1 6.40 (13<sup>1</sup>/<sub>4</sub>" dia.) .....

75 Nova, Camaro (6 cyl.) ..... **3991407** 1 7.95 (12" dia.) .....

**0.679 UNDERPAN— BOLT— COVER— DEFLECTOR— SCREW ASSY.— STUD, Flywheel**

62-65 Police, Taxi w/P.G. (6 cyl.),

64-66 All w/Trans. oil cooler (6 cyl.),

64-69 Chevy, Chevelle w/P.G. (230),

65 Chevy, Chevelle (C.A.C. w/P.G.) (6 cyl.),

65-69 Pass. w/P.G. (6 cyl.) (2nd design),

66-68 Chevy (C.A.C. w/P.G.) (194),

69 All w/Torque Drive (6 cyl.) ..... **3789959** 1 3.95 transmission (17<sup>61</sup>/<sub>64</sub>" O.L.) .....

62-66 Chevy, Chevelle w/P.G. (exc. 230, C.A.C., Taxi, trans. oil cooler),

65 Pass. w/P.G. (6 cyl.) (1st design) (exc. Taxi, Police, Trans. oil cooler, C.A.C.),

67-68 Chevy w/P.G. (6 cyl.) (exc. C.A.C., 250) ..... **3789149** 1 4.15 transmission converter .....

70 Pass. w/P.G. (250),

70 Nova, Chevelle, Camaro w/Torque Drive, P.G. (230, 250),

71-72 All w/Torque Drive, P.G. (6 cyl.),

73 All w/Power Glide (6 cyl.) ..... **3933089** 1 4.35 trans. converter .....

73 All w/T.H. (6 cyl.),

74 All w/A.T. (6 cyl.) ..... **6261091** 1 4.20 trans. converter .....

75 All (6 cyl.) w/A.T. ..... **344249** 1 4.55 trans. converter .....

All (6 cyl.) ..... **3817006** A.R. .12 **BOLT, w/washer (1/4" — 20 x 7/16")** .....

62-69 Chevy, Chevelle, Camaro (6 cyl.) (exc. P.G.),

65-69 Pass. (6 cyl.) (exc. Taxi, A.T.),

70 All (230, 250) (exc. A.T.),

71-72 All (6 cyl.) (exc. A.T., Taxi, Police),

73-75 All (6 cyl.) ..... **354497** 1 2.65 **COVER, clutch housing (repl. 3788422)** ...

**194-230-250 ENGINE ASSEMBLY**

**0.679 UNDERPAN— BOLT— COVER— DEFLECTOR— SCREW ASSY.— STUD, Flywheel (Con't)**

65	Pass. (230),				
66-68	Pass. w/H.D. Clutch (250),				
66-69	Taxi (250) (exc. A.T.),				
71-72	Taxi, Police (6 cyl.) (exc. A.T.)	3843943	1	3.05	COVER, clutch housing
62-67	Chevy w/P.G. (6 cyl.) (exc. 250)	3792785	1	.84	DEFLECTOR, under pan outlet air ( <sup>3</sup> / <sub>8</sub> " dia.— 2 holes)
62-69	All w/P.G., Torque Drive (6 cyl.),				
70-72	Pass., Nova, Chevelle w/Torque Drive, P.G. (6 cyl.)	3924780 A.R.		.16	SCREW ASSY., w/washer ( <sup>5</sup> / <sub>16</sub> "— 18 x <sup>7</sup> / <sub>8</sub> ")
73-75	All w/T.H. (6 cyl.)	6261376	4	.16	SCREW ASSY., w/washer, converter under pan
73	All (6 cyl.) (exc. A.T.)	3817006	1	.12	SCREW ASSY., w/washer, clutch housing cover
72-73	All (6 cyl.)	6270052 A.R.		.11	STUD, w/washer ( <sup>1</sup> / <sub>4</sub> "— 20 x <sup>1</sup> / <sub>32</sub> ")

**0.683 HOUSING— BOLT, Flywheel and Clutch**

62-63	Chevy (6 cyl.)	3788381	1	34.25	clutch (Ident. No. 3788383)
64-67	Chevy (6 cyl.)	3849307	1	31.25	clutch (Ident. No. 3849309)
64-69	Pass. (230, 250) (exc. Taxi, Police, H.D. Clutch),				
64-68	Chevelle, Camaro (6 cyl.),				
68	Chevy (6 cyl.),				
69	Chevy, Chevelle, Camaro (230, 250),				
70-72	All (6 cyl.) (exc. Taxi, Police),				
73-75	All (6 cyl.)	3858403	1	30.50	HOUSING ASSY., clutch (Ident. No. 3840383) (Note 1)

*NOTE 1 Less ball stud.*

65-68	Pass. w/H.D. Clutch (230, 250),				
65-69	Pass. (Taxi) (230, 250) (exc. A.T.),				
69	Police (250),				
70-72	Taxi, Police (6 cyl.)	3899621	1	37.50	HOUSING ASSY., clutch (cast 3899621)
All	Pass. (6 cyl.)	3736035 A.R.		.22	BOLT, clutch housing attach. ( <sup>3</sup> / <sub>8</sub> "— 16 x <sup>1</sup> / <sub>16</sub> ") (300M steel-plain)— (3.275) (Note 2)

*NOTE 2 When using BOLT 3736035, it will be necessary to use washer 120394 (8.929).*

All	Pass. (6 cyl.)	3733130	2	.24	BOLT, clutch housing attach. ( <sup>3</sup> / <sub>8</sub> "— 16 x <sup>2</sup> / <sub>4</sub> "— washer hd.) (300M steel)— (3.275)
-----	----------------	---------	---	-----	---

**0.685 DOWEL, Flywheel and Clutch Housing to Cylinder Block**

62-75	All (6 cyl.)	3712745	2	.50	clutch and flywheel ( <sup>2</sup> / <sub>32</sub> " x <sup>1</sup> / <sub>4</sub> " long)
-------	--------------	---------	---	-----	--

**0.728 GEAR, Crankshaft Timing (Steel)**

62-74	All (6 cyl.)	3836605	1	5.60	
75	All (6 cyl.) (exc. integrated cylinder head)	3882892	1	6.65	(27 teeth— stamped "71")
75	All (6 cyl.) w/integrated cylinder head	352167	1	7.45	

**0.736 GEAR, Camshaft Timing**

62-75	All (6 cyl.)	3788508	1	16.35	fiber (54 teeth-cast 3788508)
-------	--------------	---------	---	-------	-------------------------------

**0.748 NOZZLE, Timing Gear Oil**

62-75	All (6 cyl.)	3875950	1	.28	( <sup>1</sup> / <sub>32</sub> " O.L.)
-------	--------------	---------	---	-----	--

**0.787 ROD— CLIP— EXTENSION— SWIVEL— SPACER, Clutch Fork Release**

62-67	Chevy (6 cyl.)	3791159	1	1.20	fork push (12 <sup>1</sup> / <sub>64</sub> " O.L.) ( <sup>3</sup> / <sub>8</sub> "— 16 thd. on end)
64-66	Chevelle (6 cyl.)	3973076	1	1.95	fork push
64-67	Chevelle (6 cyl.),				
68-69	Chevy, Camaro (6 cyl.),				
70	Camaro (6 cyl.)	340690	1	1.10	fork push adjusting (4 <sup>3</sup> / <sub>4</sub> " long)
65	Pass. (6 cyl.) (exc. Taxi),				
66-70	Pass. (6 cyl.)	3859863	1	1.25	fork push
67	Chevelle, Camaro (6 cyl.),				
68-75	Chevy, Camaro (6 cyl.)	3939116	1	1.20	fork push adjusting
68-75	Chevelle (6 cyl.),				
71-75	Pass. (6 cyl.) (exc. A.T.)	9779202	1	.88	fork push
62-69	All (6 cyl.)	3749084 A.R.		.27	CLIP, push rod and swivel— (4.037)
62-69	All (6 cyl.)	1455017	1	.13	CLIP, push rod— (3.425)
62-67	Chevy (6 cyl.)	3834287	1	.36	EXTENSION, fork pull back spring
62-67	Chevy (6 cyl.)	3791200	1	.54	SWIVEL, fork push rod (1 <sup>1</sup> / <sub>64</sub> " O.L.) (large hole w/ <sup>3</sup> / <sub>8</sub> "— 16 thd.)



**194-230-250 ENGINE ASSEMBLY**

**0.787 ROD— CLIP— EXTENSION— SWIVEL— SPACER, Clutch Fork Release  
(Con't)**

65	Taxi (230) .....	3813228	1	.59	SWIVEL, fork (1 <sup>21</sup> / <sub>64</sub> " x 3 <sup>3</sup> / <sub>8</sub> " from base of shoulder to end) .....
65-70	Pass. (6 cyl.) .....	3859839	1	.71	SWIVEL, pedal push .....
67-70	Chevy, Chevelle, Camaro (6 cyl.),				
71-72	All (6 cyl.) .....	3840845	1	1.40	SWIVEL, fork push rod, fork push rod (1 <sup>1</sup> / <sub>2</sub> " O.L.) (3 <sup>3</sup> / <sub>8</sub> "— 16 thds.) .....
73-75	All (6 cyl.) .....	335380	1	1.40	SWIVEL, adj. push rod .....
70-75	Camaro (6 cyl.),				
73-75	Nova (6 cyl.) .....	3975524	1	.25	SPACER, adj. push rod .....

**0.793 WASHER, Clutch Fork Push Rod**

62-73	All (6 cyl.) .....	3756694	1	.11	push rod lever thrust (2 <sup>3</sup> / <sub>4</sub> " dia. pedal shaft) pull rod lever .....
-------	--------------------	---------	---	-----	---

**0.795 FORK ASSY., Clutch Release**

62-67	Chevy (6 cyl.) .....	3788401	1	7.85	(less ball stud) .....
64-66	Chevelle (6 cyl.),				
68-69	All (6 cyl.),				
70-72	Nova, Chevelle, Camaro (6 cyl.),				
71-72	Pass. .....	3892632	1	7.15	
65-70	Pass. (6 cyl.) .....	3860005	1	7.15	
73-75	All (6 cyl.) .....	340278	1	11.70	

**0.796 SPRING— STUD— BRACKET, Clutch Fork**

62-67	Chevy (6 cyl.) .....	3737456	1	.28	retaining (4 <sup>1</sup> / <sub>16</sub> " dev. length) .....
75	Nova, Camaro (6 cyl.) .....	3849698	1	.63	fork retaining .....
62-67	Chevy (6 cyl.),				
65-70	Pass. (6 cyl.) .....	3790556	1	.84	STUD, ball (3 <sup>3</sup> / <sub>16</sub> "— 16 thds.) .....
64-67	Chevelle, Camaro (6 cyl.),				
68-72	Chevy, Chevelle, Camaro (6 cyl.),				
71-75	Pass. .....	3729000	1	1.05	STUD, ball (1 <sup>3</sup> / <sub>16</sub> "— 16 w/ <sup>21</sup> / <sub>32</sub> " diameter ball) .....
71-73	Chevelle (6 cyl.) .....	3992305	1	.40	BRACKET, pull back .....

**0.797 BOOT, Clutch Fork**

62-67	Chevy (6 cyl.) .....	3788402	1	.76	(3" O.L. at clutch hsg. face) (black rubber) ..
64-75	All (6 cyl.) .....	3993851	1	.76	
65-66	Taxi (6 cyl.) .....	3781385	1	1.65	black rubber .....

**0.799 BEARING, Clutch Throwout with Collar**

62-63	Chevy (6 cyl.),				
64-68	Chevy, Chevelle w/3-Spd. (6 cyl.),				
65-69	Pass. (6 cyl.) (exc. A.T.),				
67-69	Camaro (6 cyl.),				
69	Chevy (6 cyl.),				
69	Chevelle (6 cyl.) (exc. 4-Spd.),				
70	All (6 cyl.),				
71-72	All (6 cyl.) (exc. Taxi, Police),				
73-74	All (6 cyl.) (exc. Chevelle),				
74	Malibu (6 cyl.),				
75	All (6 cyl.) .....	908092	1	15.94	ball bearing type (1 <sup>7</sup> / <sub>8</sub> " long) .....
71-72	Taxi, Police (6 cyl.),				
73	Chevelle (6 cyl.),				
74	Laguna, El Camino .....	908093	1	13.56	

**0.829 BUMPER— BRACKET— CLIP— COVER— PLUG— RETAINER— SEAL, Clutch**

(For COVERS see Group 4.630)

64-68	Chevelle (exc. P.B.) (6 cyl.),				
68-69	Chevy, Chevelle, Camaro (6 cyl.),				
65-69	Pass. (6 cyl.),				
70-72	All (6 cyl.),				
73-75	Nova, Chevelle .....	340688	1	.21	pedal .....
73	Chevelle (6 cyl.) .....	6264981	1	1.30	BRACKET, pedal bumper .....
74-75	Chevelle (6 cyl.) .....	342435	1	1.30	BRACKET, pedal bumper .....
73-74	Chevelle (6 cyl.) .....	1243333	1	.16	CLIP, clutch armstop .....
67-75	Camaro w/A.T. (6 cyl.),				
68-75	Chevy w/A.T. (6 cyl.) .....	3886689	1	.21	COVER, clutch pedal push rod hole .....
65-68	Pass. w/A.T. (6 cyl.) .....	6256958	1		PLUG, pedal push rod hole (repl, 3872120)— (12.980) .....
62-65	Chevy (6 cyl.) .....	3792551	1	.21	RETAINER, push rod dash seal .....

**194-230-250 ENGINE ASSEMBLY**

**0.829 BUMPER— BRACKET— CLIP— COVER— PLUG— RETAINER— SEAL,  
Clutch (Con't)**

64-67	Chevelle (6 cyl.)	3903973	1	.42	RETAINER, clutch pedal push rod (bellows type)
67	Chevy (6 cyl.)	3903518	1	.14	RETAINER, clutch pedal push rod dash seal
62-67	Chevy (6 cyl.)	3792550	1	.36	SEAL, clutch push rod dash
64-67	Chevelle (6 cyl.)	9776826	1	1.15	SEAL, clutch push rod (bellows type)
65-68	Pass. (6 cyl.)	3857543	1	.65	SEAL, pedal push rod (Note 1)
<i>NOTE 1 When using in place of 3819156 seal up to 1965, it will be necessary to replace 3825188 anchor plate with 3877244 plate. For attachment use 3877244 plate as template and drill necessary mounting holes.</i>					
67-75	Camaro w/A.T. (6 cyl.),				
68-75	Chevy w/A.T. (6 cyl.)	3903466	1	.15	SEAL, clutch pedal push rod hole cover
69-71	Pass. (6 cyl.)	3950007	1	1.30	SEAL, pedal push rod
67	Camaro (6 cyl.),				
68-69	Camaro, Chevy (6 cyl.),				
70-74	Nova (6 cyl.)	3909071	1	1.20	SEAL ASSY., clutch pedal push rod
68-72	Chevelle (6 cyl.)	399904	1	3.20	SEAL ASSY., clutch pedal push rod
70-74	Camaro (6 cyl.),				
75	Nova, Camaro (6 cyl.)	3973089	1	2.65	SEAL ASSY., clutch pedal push rod
72-73	Pass. (6 cyl.)	3988202	1	3.40	SEAL ASSY., clutch pedal push rod
73-75	Chevelle (6 cyl.)	3994485	1	3.20	SEAL ASSY., clutch pedal push rod

**0.830 PEDAL, Clutch**

62-65	Chevy (6 cyl.)	3830774	1	5.50
64-66	Chevelle (6 cyl.)	3841214	1	5.65
65-66	Pass. (6 cyl.)	3854325	1	
67	Camaro (6 cyl.)	3890609	1	5.55
67	Chevelle (6 cyl.)	3900527	1	5.05
68-72	Chevelle (6 cyl.)	3967783	1	5.30
68-69	Chevy, Camaro (6 cyl.),			
70-75	Nova (6 cyl.)	6258554	1	6.55
69-70	Pass. (6 cyl.)	3968745	1	5.50
70-71	Camaro (6 cyl.)	3965693	1	5.30
71-73	Pass. (6 cyl.)	3988193	1	5.60
72	Camaro (6 cyl.)	3998671	1	5.30
73-75	Chevelle (6 cyl.)	3994483	1	8.85
73-75	Camaro (6 cyl.)	332519	1	5.60
75	Nova (6 cyl.)	355581	1	7.50

**0.831 BUSHING, Clutch Pedal (see Group 4.626 for brake pedal bushing)**

62-72	All (6 cyl.)	1247439	2	.11	(4.626)
-------	--------------	---------	---	-----	---------

**0.837 RETAINER— SPACER— SPRING, Clutch and Brake Pedal Shaft— (Also see Groups 4.634 and 4.648)**

63-68	All (6 cyl.)	3828428	1	.22	shaft— (4.634)
70	Camaro (6 cyl.)	9783098	1	.87	SPACER (4.634)
62	Chevy (6 cyl.)	148152	2	.06	SPRING, clutch pedal retainer (1/2" dia.)— (8.934)

**0.844 SPRING, Clutch Pedal Pull Back**

62-67	Chevy (6 cyl.)	3653114	1	.63	clutch fork push rod pull back
64-67	Chevelle (6 cyl.)	9776993	1	.40	push rod
64-67	Chevelle (6 cyl.)		1		push rod return,
65-70	Pass. (6 cyl.)	3849704	1	.34	fork pull back
65-70	Pass. (6 cyl.)	3879772	1	.22	clutch pull back
67-69	Camaro (6 cyl.),				
68-72	Chevy (6 cyl.)	3899021	1	.28	clutch fork push rod pull back
68-70	Chevelle (6 cyl.)	3920614	1	.34	
70	Camaro (6 cyl.),				
71-72	Pass., Camaro (6 cyl.)	3973088	1	.40	fork pull back
71-72	Chevelle (6 cyl.)	3992306	1	.52	fork pull back
73-75	Chevelle (6 cyl.)	3994494	1	1.75	fork pull back
73-74	Nova (6 cyl.)	332517	1	.46	fork pull back
73	Pass., Camaro (6 cyl.),				
74-75	Camaro	332521	1	.76	fork pull back
75	Nova (6 cyl.)	355585	1	1.25	fork pull back

**0.846 EXTENSION, Clutch Pedal Pull Back Spring**

70-72	Chevy (6 cyl.)	3899022	1	.32	clutch fork push rod pull back spring
73-74	Nova (6 cyl.)	332518	1	.63	clutch fork push rod pull back spring

**0.851 SEAT— SEAL— SPRING— STUD— WASHER, Clutch Pedal Intermediate Lever Shaft Ball**

62-75	All (6 cyl.)	3743349 A.R.		.18	stud (7/8" dia.)
65-75	All (6 cyl.)	382658	1	.19	SEAL, ball stud dust, lever shaft ball stud

**194-230-250 ENGINE ASSEMBLY**

**0.851 SEAT— SEAL— SPRING— STUD— WASHER, Clutch Pedal Intermediate  
Lever Shaft Ball (Con't)**

62-75	All (6 cyl.)	3750696	1	.13	SPRING, frame stud seat, retaining (1" O.D.)
62-70	Chevy, Chevelle, Camaro (6 cyl.),				
71-75	All (6 cyl.)	3866568	1	1.15	STUD, lever shaft ball to engine
62-69	Chevy (6 cyl.)				STUD, to body,
64-69	Pass., Chevelle, Camaro (6 cyl.)	3898610	1	.81	to frame ( $\frac{9}{8}$ "— 24 x $1\frac{13}{16}$ " O.L.)
65-70	Pass. (6 cyl.)	3859488	1	1.20	STUD, lever shaft ball to eng.
70	Camaro (6 cyl.)				STUD, clutch lvr. & shaft ball to brkt.,
70-72	Nova (6 cyl.)				clutch lvr. & shaft ball to eng.,
70	Pass., Chevelle (6 cyl.),				
71-75	All (6 cyl.)	3935289	1	1.20	clutch lvr. & shaft ball to frame
62-64	Chevy, Chevelle (6 cyl.)	3743355	1	.13	WASHER, lever shaft ball stud dust seal
62-66	Chevy, Chevelle (6 cyl.)	3717880	1	.16	WASHER, ball to engine dust washer (rubber) ( $\frac{29}{32}$ " O.D. x $\frac{15}{32}$ " I.D. x $\frac{1}{4}$ " thk.)— (7.443)
62-75	All (6 cyl.)	3743360	1	.18	WASHER, stud dust seal, L.H. to frame (felt— $\frac{9}{16}$ " I.D. x $1\frac{3}{8}$ " O.D.) lever assy. seal

**0.852 LEVER— BRACKET— SHAFT, Clutch Pedal, Intermediate (See Group 4.648  
for Brake)**

62-67	Chevy (6 cyl.)	3792909	1	6.90	w/shaft
64-66	Chevelle (6 cyl.),				
67	Chevelle (6 cyl.) (1st design)	3840836	1	6.60	w/shaft (used w/strg. col. w/lwr. brg. snap ring)
67	Chevelle (6 cyl.) (2nd design)	3921038	1	10.95	w/shaft (used w/strg. col. w/lwr. brg. clamp)
68-72	Chevelle (6 cyl.)	3920615	1	10.10	w/shaft
70-75	Camaro (6 cyl.)	3973082	1	12.25	w/shaft
71-72	Pass. (6 cyl.)	3988203	1	12.05	w/shaft
67-69	Camaro (6 cyl.),				
68-71	Chevy (6 cyl.),				
72-74	Nova (6 cyl.)	3998652	1	10.50	w/shaft
73	Pass. (6 cyl.)	332551	1	15.25	w/shaft
73-75	Chevelle (6 cyl.)	3994486	1	19.10	w/shaft
75	Nova (6 cyl.)	355574	1	15.35	w/shaft
62-67	Chevy (6 cyl.)	3792365	1	.63	BRACKET, shaft body ( $3\frac{3}{4}$ " O.L. w/2 weld nuts)
64-67	Chevelle (6 cyl.)	3840841	1	.84	BRACKET, lever and shaft
65-70	Pass. (6 cyl.) (exc. Police, Taxi)	3859861	1	.28	BRACKET, clutch shaft frame
65-70	Taxi (6 cyl.),				
68-70	Police (6 cyl.)	3869851	1	2.05	BRACKET, clutch shaft frame
67	Camaro (6 cyl.),				
68-69	Chevy, Camaro (6 cyl.),				
70-74	Nova (6 cyl.)	3932760	1	.83	BRACKET, lever and shaft
68-72	Chevelle (6 cyl.)	3918098	1	.81	BRACKET, lever and shaft frame
70-75	Camaro (6 cyl.)	3973086	1	.94	BRACKET, lever and shaft
72-73	Pass. (6 cyl.)	3988209	1	.83	BRACKET, clutch shaft frame
73-75	Chevelle (6 cyl.)	3994491	1	1.25	BRACKET, lever and shaft frame
75	Nova (6 cyl.)	355584	1	1.65	BRACKET, clutch shaft frame
65-70	Pass. (6 cyl.)	3954621	1	6.50	SHAFT, w/lever

**0.854 ROD— CLIP— BUSHING, Clutch Pedal**

62-67	Chevy (6 cyl.)	3790008	1	1.95	pedal push ( $15\frac{13}{32}$ " dev. length— $\frac{1}{2}$ " O.D.)
64-67	Chevelle (6 cyl.)	9774625	1	4.25	pedal push straight shaft ( $12\frac{51}{64}$ " O.L.)
65-70	Pass. (6 cyl.)	3859838	1	2.20	pedal push
67	Camaro (6 cyl.)	3899020	1	2.30	pedal push ( $12\frac{43}{64}$ " dev. length)
67	Camaro (6 cyl.)	6264907	1	4.85	clutch pull
68-72	Chevelle (6 cyl.)	3920618	1	2.10	pedal push
68-69	Chevy, Camaro (6 cyl.),				
70-72	Nova (6 cyl.)	3920262	1	1.95	pedal push
70-71	Camaro (6 cyl.)	3973087	1	3.50	push
71-73	Pass. (6 cyl.)	3988195	1	3.75	push
72-75	Camaro (6 cyl.)	3998670	1	3.00	push
73-75	Chevelle (6 cyl.)	3994490	1	5.20	push
73-74	Nova	332516	1	2.15	push
75	Nova (6 cyl.)	355583	1	3.15	push
62	Chevy (6 cyl.)				CLIP, pedal push rod,
66-67	Chevy (6 cyl.)	3758162	1	.06	pedal push rod lower end ( $\frac{9}{32}$ " dia.)
65-69	Pass. (6 cyl.)	1455017	2	.13	CLIP, pedal pull rod— (3.425)
71-75	Pass. (6 cyl.)	406172	1	.88	BUSHING, push rod

**0.859 PLATE ASSY., Clutch Pressure with Cover**

62-69	Chevy, Chevelle (194) (exc. H.D. Clutch)	3973142	1	45.25	diaphragm spring type (9") (Note 2)
-------	---	---------	---	-------	-------------------------------------

**194-230-250 ENGINE ASSEMBLY**

**0.859 PLATE ASSY., Clutch Pressure with Cover (Con't)**

*NOTE 2: When using 3973142 in place of 3788655 discard old clutch rel. brg. 1 7/8" overall lgth., purchase and install 907963 1 1/32" overall lgth.*

62-68	Chevy w/H.D. Clutch (194),				
64	Chevelle w/H.D. Clutch (194),				
65-68	Chevelle w/H.D. Clutch (194, 230) .....	3999255	1	48.25	(10") .....
66-68	Pass. (250) (exc. H.D. Clutch, Police, Taxi),				
66-70	Chevy, Chevelle, Camaro (230, 250),				
69-70	Pass. (250) (exc. Taxi, Police),				
71-75	All (6 cyl.) (exc. Pass.) .....	3992290	1	54.50	
71-73	Pass. (6 cyl.) (exc. Taxi, Police) .	3991496	1	65.00	
65-69	Pass. w/H.D. Clutch (6 cyl.),				
70-71	Taxi, Police (6 cyl.) .....	3962052	1	59.00	
65	Chevy (230),				
65	Pass. (6 cyl.) (exc. H.D. Clutch) ..	3819914	1	59.50	PLATE UNIT (std.— 10") (Note 1) .....
65-69	Taxi (230) (2nd design),				

*NOTE 1: Unit consists of cover & pressure plate assy. and return spring.*

**0.861 COVER, Clutch**

62-63	Chevy (6 cyl.) (exc. H.D. Clutch),				
64-69	Chevy, Chevelle (194) (exc. H.D. Clutch) .....	3973143	1	19.60	diaphragm spring type .....
62	Chevy w/H.D. Clutch (6 cyl.),				
64-68	Chevy, Chevelle w/H.D. Clutch, Taxi, H.D. Chassis (194),				
64	Chevy, Chevelle (230),				
65-68	Chevelle w/H.D. Clutch (230),				
71	All (6 cyl.) (exc. Pass.),				
71	Pass. (6 cyl.) (exc. A.T., Police, Taxi),				
73	Pass. (6 cyl.) .....	3821765	1	19.30	diaphragm spring type (12 <sup>31</sup> / <sub>64</sub> " O.D.) .....
65-70	Pass. (6 cyl.) (exc. H.D. Clutch, Taxi, Police),				
72-75	All (6 cyl.) (exc. Pass.) .....	3821764	1	19.70	diaphragm spring type (10 <sup>61</sup> / <sub>64</sub> " O.D.) .....
65-70	Taxi, Police (230, 250) (2nd design),				
65-68	Pass. w/H.D. Clutch (6 cyl.) .....	3821763	1	21.75	diaphragm spring type (13 <sup>3</sup> / <sub>4</sub> " O.D.) .....
71	Taxi, Police (6 cyl.) .....	3860361	1	21.30	

**0.862 BOLT, Clutch Cover and Pressure Plate**

62-69	All (6 cyl.),				
73-74	All (6 cyl.) .....	838653	A.R.	.12	( <sup>3</sup> / <sub>8</sub> "— 16 x 1) .....
62-69	Chevy, Chevelle (194) (exc. H.D. Chassis, H.D. Clutch) .....	3829810	6	.18	cover and pressure plate assy. .....
62-72	All (6 cyl.),				
75	All (6 cyl.) .....	3962058	A.R.	.22	retrac. spring ( <sup>5</sup> / <sub>16</sub> "— 18 x <sup>29</sup> / <sub>32</sub> " hex.)— (0.864) .....

**0.863 PLATE, Clutch Pressure**

62-63	Chevy (6 cyl.) (exc. H.D. Clutch),				
64-69	Chevy, Chevelle (194) (exc. H.D. Clutch) .....	3988716	1	13.75	(9 <sup>9</sup> / <sub>32</sub> " O.D.) (cast 3788659) .....
64-69	Chevy (230, 250),				
64-70	Chevelle, Camaro (230, 250) (exc. H.D. Clutch, Taxi),				
65-70	Pass. (6 cyl.) (exc. H.D. Clutch, Taxi),				
71-75	All (6 cyl.) (exc. Pass.) .....	3992287	1	15.55	(10 <sup>9</sup> / <sub>64</sub> " O.D.) .....
65-70	Taxi (230, 250) (2nd design),				
65-68	Pass. w/H.D. Clutch (230, 250),				
69-70	Police (250),				
71	Taxi, Police (6 cyl.) .....	3962057	1	16.90	(11" O.D.) .....
71	Pass. (6 cyl.) (exc. A.T., Police, Taxi),				
75	Pass. (6 cyl.) .....	3991497	1	15.70	(10 <sup>1</sup> / <sub>2</sub> " O.D.) .....

**0.864 BOLT— SPRING, Clutch Pressure Plate**

62-75	All (6 cyl.) .....	3962058	A.R.	.22	retrac. spring ( <sup>5</sup> / <sub>16</sub> "— 18 x <sup>29</sup> / <sub>32</sub> " hex.) .....
62-63	Chevy (6 cyl.) (exc. H.D. Clutch),				
64-69	Chevy, Chevelle (194) (exc. H.D. Clutch, Chassis) .....	3788059	2	.40	SPRING, retracting ( <sup>9</sup> / <sub>32</sub> " thk.) .....
62-68	Chevy, Chevelle w/H.D. Clutch (194),				

**194-230-250 ENGINE ASSEMBLY**

**0.864 BOLT— SPRING, Clutch Pressure Plate (Con't)**

<b>64-68</b>	Chevy, Chevelle, Camaro (exc. 194),				
<b>65-69</b>	Pass. (6 cyl.),				
<b>70-75</b>	All (6 cyl.)	<b>3788605</b>	<b>3</b>	<b>.13</b>	<b>SPRING, retracting (1<sup>9</sup>/<sub>32</sub>" dia. at wide end w/<sup>9</sup>/<sub>16</sub>" ctr. hole) (Note 1)</b>

*NOTE 1 Replace only in sets of three.*

**0.886 DISC, with Facing, Clutch**

<b>62-69</b>	Chevy, Chevelle (194) (exc. H.D. Clutch)	<b>3791266</b>	<b>1</b>	<b>29.25</b>	<b>(9" woven) (Note 1)</b>
<i>NOTE 1 A quantity of these clutch discs has been assembled with the stamping "Flywheel Side" and the paint circle on the rear end of the hub on the same side. The stamping "Flywheel Side" should be disregarded and the clutch discs installed in the vehicle with painted hub to the rear, or away from the flywheel.</i>					
<b>62-68</b>	Chevy, Chevelle w/H.D. Clutch (6 cyl.)	<b>6259178</b>	<b>1</b>	<b>37.75</b>	<b>(10" woven)</b>
<b>64-65</b>	All (6 cyl.) (exc. H.D. Clutch, Taxi),				
<b>66-70</b>	All (230, 250) (exc. H.D. Clutch, Taxi, Police),				
<b>71</b>	All (6 cyl.) (exc. Taxi, Police),				
<b>72-75</b>	All (6 cyl.) (exc. Pass.)	<b>3886126</b>	<b>1</b>	<b>31.50</b>	<b>woven (9") (Note 2)</b>
<i>NOTE 2 Words FLYWHEEL SIDE to appear on driven plate.</i>					
<b>65-72</b>	Taxi, Police (230, 250),				
<b>65-68</b>	Pass. w/H.D. Clutch (230, 250)	<b>3828848</b>	<b>1</b>	<b>41.75</b>	<b>woven (11")</b>
<b>67-68</b>	Chevy, Camaro (6 cyl.)	<b>3908960</b>	<b>1</b>	<b>40.00</b>	<b>woven (11")</b>
<b>72</b>	Pass. (6 cyl.) (exc. Taxi, Police),				
<b>73</b>	Pass. (6 cyl.)	<b>3927128</b>	<b>1</b>	<b>40.00</b>	<b>driven (10<sup>1</sup>/<sub>3</sub>" woven)</b>

**262 ENGINE ASSEMBLY**

<b>0.002 BOLT, Engine Mounting</b>					
75	Nova (262) .....	334972	2	.34	eng. mtg. to eng. bracket (7/16" — 14 x 5 1/8")
75	Monza (262) .....	331246	6	.11	(hex. 3/8" — 16 x 15/16") .....
<b>0.027 MOUNTING ASSY., Engine</b>					
75	Nova (262) .....	6262232	2	8.80	
75	Monza (262) .....	360309	L.H.	11.50	
75	Monza (262) .....	356334	R.H.	8.95	
<b>0.029 SUPPORT, Engine Mounting</b>					
75	Monza (262) .....	1688270	R.H.	9.20	engine mounting .....
75	Monza (262) .....	1705320	L.H.	11.45	engine mounting .....
<b>0.033 BLOCK ASSY., Cylinder</b>					

**PARTIAL ENGINE**

*Includes Block, Crankshaft, Timing Gears, Piston and Connecting Rods.*

75	All (262) .....	360852	1	597.00	
----	-----------------	--------	---	--------	--

**FITTED CYLINDER BLOCK**

*Includes Pistons, Pins, Rings and Bearings.*

75	All (262) .....	360851	1	370.00	
----	-----------------	--------	---	--------	--

<b>0.034 PLUG, Cylinder Block</b>					
75	All (262) .....	3826504	1	.96	water jacket .....
<b>0.056 BOLT, Crankshaft Bearing Cap</b>					
75	All (262) .....	3932480	10	.28	(7/16" — 14 x 3 11/32") .....
<b>0.095 CAP, Crankshaft Front Bearing</b>					
75	All (262) .....	3956688	A.R.	9.10	(No. 1, 2, 3, 4) .....
<b>0.096 BEARING UNIT, Crankshaft Front (1 Upper and 1 Lower) See Chart for Model Application</b>					

*NOTE: See Dealer Price Schedule for applicable prices.*

		POSITION	STD.	.001 U.S.	.002 U.S.	.009 U.S.	.010 U.S.	.020 U.S.
75	All (262) .....	All (exc. rear)	3912038	3912039	3912040	3912037	3912041	3912042
75	All (262) .....	Rear	3912030	3912032	3912033	3912034	3912035	3912036

<b>0.105 CAP— PIN, Crankshaft Rear Bearing</b>					
75	All (262) .....	3911007	1	5.35	
75	All (262) .....	3836903	A.R.	.11	PIN, bearing cap— (0.738) .....
<b>0.137 SEAL, Crankshaft Rear Bearing and Cap Oil</b>					
75	All (262) .....	3958001	2	2.60	
<b>0.153 SHIM UNIT, Crankshaft Bearing Cap</b>					
75	All (262) .....	3911010	A.R.	1.90	#1-2-3-4 cap .....
75	All (262) .....	3911011	A.R.	1.90	rear cap .....
<b>0.206 COVER ASSY.— PIN, Crankcase Front End</b>					
75	All (262) .....	3991433	1	6.30	
75	All (262) .....	3836903	2	.11	PIN, front end cover— (0.738) .....
<b>0.207 GASKET, Crankcase Front End Cover</b>					
75	All (262) .....	3799620	1	.26	
<b>0.213 SEAL ASSY., Crankcase Front End Cover</b>					
75	All (262) .....	3980267	1	3.35	(2 7/16" O.D.— stamped 3980267) .....
<b>0.219 POINTER, Engine Timing</b>					
75	All (262) .....	3997780	1	.53	
<b>0.269 HEAD, Cylinder</b>					
75	All (262) .....	358741	2	92.50	w/studs .....
<b>0.289 GASKET UNIT, Cylinder Head</b>					
75	All (262) .....	355958	2	2.85	GASKET .....
75	All (262) .....	358758	1	17.00	GASKET UNIT .....
<b>0.293 BOLT, Cylinder Head</b>					
75	All (262) .....	3704796	16	.22	short (7/16" — 14 x 1 3/4") .....

**262 ENGINE ASSEMBLY**

<b>0.293 BOLT, Cylinder Head (Con't)</b>					
75	All (262)	3734594	14	.22	long ( $\frac{7}{16}$ "— 14 x $\frac{3}{4}$ ")
75	All (262)	3767468	4	.22	medium ( $\frac{7}{16}$ "— 14 x 3")
<b>0.296 VALVE, Inlet</b>					
75	All (262)	3989083	8	5.05	(std.)
75	All (262)	3995684	8	5.05	(.003 O.S.)
75	All (262)	3995685	8	5.05	(.015 O.S.)
75	All (262)	3995686	8	5.05	(.030 O.S.)
<b>0.297 VALVE, Exhaust</b>					
75	All (262)	6263778	8	13.60	(std.) (repl. 3989084)
75	All (262)	3995602	8	5.80	(.003 O.S.)
75	All (262)	3995603	8	5.80	(.015 O.S.)
75	All (262)	3995604	8	5.80	(.030 O.S.)
<b>0.303 SPRING, Valve</b>					
75	All (262)	3911068	8	1.30	w/damper (inlet)
75	All (262)	6263796	8	1.40	w/damper (exh.)
<b>0.308 SEAL— SHIELD, Valve Spring Cap</b>					
75	All (262)	3835333	A.R.	.17	valve stem oil
75	All (262)	3836755	A.R.	.18	SHIELD, valve stem oil
<b>0.309 CAP— ROTATOR, Valve Spring</b>					
75	All (262)	3896934	8	.40	(stamped A on top surface)
75	All (262)	6263794	8	2.95	ROTATOR, exhaust valve
<b>0.310 KEY, Valve Stem</b>					
75	All (262)	838029	A.R.	.06	("U" shape)
75	All (262)	3947770	A.R.	.12	(carbonized) (ident. by purple dye)
<b>0.333 ARM, Valve Rocker</b>					
75	All (262)	3974290	A.R.	2.40	w/ball
<b>0.386 COVER, Valve Rocker Arm</b>					
75	All (262)	355965	L.H.	10.20	left
75	All (262)	340268	R.H.	9.10	right
<b>0.413 BOLT— REINFORCEMENT, Valve Rocker Cover</b>					
75	All (262)	180016	1		( $\frac{1}{4}$ "— 20 x $\frac{1}{2}$ ")— (8.900)
75	All (262)	3877670	A.R.	.12	REINFORCEMENT ( $1\frac{1}{2}$ " O.L.)
<b>0.423 GASKET, Valve Rocker Cover</b>					
75	All (262)	3933964	2	1.80	
<b>0.426 ROD, Valve Push</b>					
75	All (262)	3796243	16	2.15	
<b>0.429 BALL— NUT— STUD, Valve Push Rod Adjusting</b>					
75	All (262)	3959142	16	.38	( $\frac{13}{16}$ " dia.)
75	All (262)	3744341	16	.22	NUT ( $\frac{3}{8}$ "— 24)
75	All (262)	3814692	A.R.	.53	STUD ( $\frac{3}{8}$ "— 24 x $2\frac{1}{2}$ ") (.003 O.S.)
75	All (262)	3815892	A.R.	.53	STUD ( $\frac{3}{8}$ "— 24 x $2\frac{5}{8}$ ") (.013 O.S.)
<b>0.459 TAPPET, Valve (Or Lifter)</b>					
75	All (262)	5232670	16	4.54	
<b>0.519 CAMSHAFT</b>					
75	All (262)	357149	1	48.25	
<b>0.539 BEARING, Camshaft No. 1 (Front)</b>					
75	All (262)	3723584	1	2.40	precision type
<b>0.543 BEARING, Camshaft No. 2 (Front Intermediate)</b>					
75	All (262)	3723585	1	2.40	(0.539)
<b>0.546 BEARING, Camshaft (Center and Rear Intermediate)</b>					
75	All (262)	3723586	2	2.40	(0.539)
<b>0.549 BEARING, Camshaft (Rear)</b>					
75	All (262)	3723585	1	2.40	(0.539)
<b>0.553 PLUG, Camshaft Bearing Hole (In Cylinder Block)</b>					
75	All (262)	3997752	1	.12	

**262 ENGINE ASSEMBLY**

	<b>0.603</b>	<b>ROD ASSY., Connecting</b>			
75	All (262)	3916396	8	12.70	
	<b>0.616</b>	<b>BEARING UNIT, Connecting Rod</b>			
		<i>NOTE: See Dealer Price Schedule for applicable prices.</i>			

**CONNECTING ROD BEARING UNIT CHART**

	STD.	.001 U.S.	.002 U.S.	.010 U.S.	.020 U.S.
75 All (262)	3910555	3910556	3910557	3910558	3910559

	<b>0.623</b>	<b>BOLT, Connecting Rod Bearing Cap</b>			
75	All (262)	3916399	16	.60	( <sup>3</sup> / <sub>8</sub> "— 24 x 1 <sup>59</sup> / <sub>64</sub> ")

	<b>0.626</b>	<b>NUT, Connecting Rod Bearing Cap Bolt</b>			
75	All (262)	3866766	A.R.	.12	( <sup>3</sup> / <sub>8</sub> "— 24 x <sup>3</sup> / <sub>8</sub> " thick) (hex. head)

	<b>0.629</b>	<b>PISTON ASSEMBLY, With Pin</b>			
75	All (262)	359184	A.R.	19.00	(std.)
75	All (262)	359185	A.R.	19.00	(.001 O.S.)
75	All (262)	359186	A.R.	19.00	(.030 O.S.)

	<b>0.643</b>	<b>RING UNIT, Piston (Service Sets)</b>			
		<i>NOTE: Original Equipment Type (complete set for one cylinder per container).</i>			
75	All (262)	359081	A.R.	5.95	(std.)
75	All (262)	359086	A.R.	5.95	(.030)

	<b>0.646</b>	<b>CRANKSHAFT</b>			
75	All (262)	354490	1	147.00	(Note 1)
		<i>NOTE 1: When used on A.T. it will be necessary to remove the pilot bearing.</i>			

	<b>0.649</b>	<b>BEARING, Crankshaft Clutch Pilot</b>			
75	All (262)	3752487	1	1.20	(bush type) ( <sup>19</sup> / <sub>32</sub> " O.D. x <sup>3</sup> / <sub>4</sub> ")

	<b>0.659</b>	<b>PULLEY ASSY.— DAMPER ASSY., Crankshaft</b>			
75	Nova (262) w/P/S (exc. C.A.C.)	3956666	1	9.20	(2 groove)
75	Nova (262) w/C.A.C.	3972180	1	15.95	(3 groove)
75	Monza (262) w/C.A.C.	3911013	1	9.00	(2 groove)
75	Monza (262) (exc. C.A.C.)	3751232	1	7.75	frt.
75	Monza (262) w/C.A.C.	360453	1	8.50	frt. (1 groove)
75	All (262)	6272223	1	26.50	<b>DAMPER ASSY., torsional</b>

	<b>0.662</b>	<b>WASHER, Harmonic Balancer and Crankshaft Pulley</b>			
75	All (262)	3739422	1	.46	balancer

	<b>0.666</b>	<b>FLYWHEEL, With Ring Gear</b>			
75	All (262) w/A.T.	333955	1	28.75	
75	Nova (262) (exc. A.T.)	3973452	1	59.25	
75	Monza (262) (exc. A.T.)	361941	1	62.50	

	<b>0.669</b>	<b>BOLT, Flywheel to Crankshaft</b>			
75	All (262) (exc. A.T.)	839756	6	.12	( <sup>7</sup> / <sub>16</sub> "— 20 x 1")
75	All (262) w/A.T.	3727207	6	.21	( <sup>7</sup> / <sub>16</sub> "— 20 x <sup>45</sup> / <sub>64</sub> ")

	<b>0.673</b>	<b>GEAR, Flywheel Ring</b>			
75	All (262)	3991407	1	7.95	

	<b>0.679</b>	<b>UNDERPAN— COVER— SCREW— SHIELD— STUD, Flywheel</b>			
75	Monza (262) w/A.T.	355598	1	4.20	trans. converter
75	Nova (262) w/A.T.	6261091	1	4.20	converter
75	All (262)	354497	1	2.65	<b>COVER</b>
75	Nova (267) w/A.T.	6261376	4	.16	<b>SCREW, underpan assy. (<sup>1</sup>/<sub>4</sub>"— 20 x <sup>7</sup>/<sub>8</sub>")</b>
75	Monza (262) (edc. A.T.)	3817006	3	.12	<b>SCREW, clutch housing side shield (<sup>1</sup>/<sub>4</sub>"— 20 x <sup>7</sup>/<sub>16</sub>")</b>
75	Monza (262) (exc. A.T.)	355929	1	2.40	<b>SHIELD, clutch housing side</b>
75	Monza (262)	6270052	2	.11	<b>STUD, oil pan (2 and 4 R.H. holes)</b>

	<b>0.683</b>	<b>HOUSING, Flywheel and Clutch</b>			
75	Nova (262)	3858403	1	30.50	clutch
75	Monza (262)	354496	1	36.25	

	<b>0.685</b>	<b>PIN, Clutch Housing</b>			
75	All (262)	3712745	2	.50	( <sup>21</sup> / <sub>32</sub> " x 1 <sup>1</sup> / <sub>4</sub> ")



**262 ENGINE ASSEMBLY**

	<b>0.724</b>	<b>CHAIN, Camshaft Timing</b>			
75	All (262)	346261	1	11.20	
	<b>0.728</b>	<b>SPROCKET, Crankshaft Timing (Steel)</b>			
75	All (262)	3896959	1	4.65	(18 teeth)
	<b>0.736</b>	<b>SPROCKET, Camshaft</b>			
75	All (262)	340235	1	8.45	camshaft
	<b>0.738</b>	<b>PIN, Camshaft Sprocket</b>			
75	All (262)	3836903 A.R.		.11	(1/4" dia. x 5/8" O.L.)
	<b>0.787</b>	<b>ROD— SWIVEL, Clutch Fork Release</b>			
75	Nova (262) (exc. A.T.)	3973076	1	1.95	fork push
75	Nova (262) (exc. A.T.)	340690	1	1.10	fork push adjusting
75	Nova (262) (exc. A.T.)	3840845	1	1.40	<b>SWIVEL, fork push</b>
	<b>0.795</b>	<b>FORK ASSY., Clutch Release</b>			
75	Nova (262)	340278	1	11.70	
	<b>0.796</b>	<b>STUD— CAP— SPRING, Clutch Fork</b>			
75	Nova (262) (exc. A.T.)	3729000	1	1.05	(13/16"— 16 stud w/21/32" dia. ball)
75	Monza (262)	3973139	1	.21	<b>CAP, ball stud</b>
75	Nova (262)	3849698	1	.63	<b>SPRING, clutch fork ret.</b>
	<b>0.797</b>	<b>BOOT— GROMMET, Clutch Fork</b>			
75	Nova (262)	3993851	1	.76	
75	Monza (262)	3978183	1	.22	<b>GROMMET, clutch fork pull back spring</b>
	<b>0.799</b>	<b>BEARING, Clutch Throwout</b>			
75	All (262)	908093	1	13.56	
	<b>0.829</b>	<b>SEAL— BUMPER— COVER— PLUG— RING, Clutch</b>			
75	Nova w/A.T. (262)	3903466	1	.15	clutch pedal push rod hole cover
75	Nova (262) (exc. A.T.)	3973089	1	2.65	<b>SEAL ASSY., clutch pedal push rod</b>
75	All (262)	340688	1	.21	<b>BUMPER, clutch pedal (cut as reqd.)</b>
75	Nova w/A.T. (262)	3886689	1	.21	<b>COVER, pedal push rod hole</b>
75	Monza w/A.T. (262)	3984471	1	.16	<b>PLUG, clutch cable hole</b>
75	Monza (262) (exc. A.T.)	3978184	1	.15	<b>RING, clutch cable ("O")</b>
	<b>0.830</b>	<b>PEDAL ASSY., Clutch</b>			
75	Nova (262)	355581	1	7.50	
	<b>0.833</b>	<b>PIN, Clutch Pedal</b>			
75	Monza (262)	3978029	1	.16	
	<b>0.844</b>	<b>SPRING, Clutch Pedal Pull Back</b>			
75	Nova (262)	355585	1	1.25	fork pull back
75	Monza (exc. Town Cpe.) (262)	355594	1	.55	
75	Monza (Town Cpe.) (262)	3978182	1	.31	
	<b>0.851</b>	<b>SEAT— SEAL— SPRING— STUD— WASHER, Clutch Pedal Intermediate</b>			
75	Nova (262)	3743349	2	.18	lever shaft ball stud (7/8" dia.)
75	Nova (262)	382658	1	.19	<b>SEAL, lever shaft ball stud</b>
75	Nova (262)	3750696	1	.13	<b>SPRING, stud seat retaining (1" O.D.)</b>
75	Nova (262)	3935289	1	1.20	<b>STUD, clutch lever shaft ball to frame</b>
75	Nova (262)	3866568	1	1.15	<b>STUD, clutch lever shaft ball to engine</b>
75	Nova (262)	3743360	1	.18	<b>WASHER, stud dust seal (felt— 9/16" I.D. x 1 3/8" O.D.)</b>
	<b>0.852</b>	<b>LEVER— BRACKET, Clutch Pedal Intermediate</b>			
75	Nova (262)	355574	1	15.35	w/shaft
75	Nova (262)	355584	1	1.65	<b>BRACKET, clutch shaft frame</b>
	<b>0.854</b>	<b>ROD— CABLE ASSY.— PIN— SLEEVE, Clutch Pedal</b>			
75	Nova (262)	355583	1	3.15	pedal push
75	Monza (262)	355593	1	9.75	<b>CABLE ASSY., clutch</b>
75	Monza (262)	3978090	1	.58	<b>PIN, clutch fork cable retaining</b>
75	Monza (262)	3997241	1	.32	<b>SLEEVE, clutch cable pulley</b>
	<b>0.855</b>	<b>PULLEY, Clutch Cable</b>			
75	Monza (262)	3978088	1	.66	clutch cable
	<b>0.859</b>	<b>PLATE ASSY., Clutch Pressure with Cover</b>			
75	Nova (262)	3841673	1	61.50	diaphragm spring type (10 1/2")
75	Monza (262)	354500	1	59.50	w/cover

**262 ENGINE ASSEMBLY**

---

<b>0.861 COVER ASSY., Clutch</b>					
75	Nova (262) .....	3793478	1	23.90	diaphragm spring type (12 <sup>31</sup> / <sub>64</sub> " O.D.) .....
75	Monza (262) .....	355906	1	25.25	
<b>0.863 PLATE, Clutch Pressure</b>					
75	Nova (262) .....	3793480	1	34.00	(10 <sup>1</sup> / <sub>2</sub> ") .....
<b>0.864 SPRING, Clutch Pressure Plate</b>					
75	Nova (262) .....	3788605	3	.13	SPRING, retracting (1 <sup>9</sup> / <sub>32</sub> " dia. at wide end w/ <sup>9</sup> / <sub>16</sub> " ctr. hole) (Note 1) .....
<i>NOTE 1: Replace only in sets of three.</i>					
<b>0.886 PLATE ASSY., With Facing, Clutch</b>					
75	Nova (262) .....	3927128	1	40.00	driven (10 <sup>13</sup> / <sub>32</sub> " woven) .....
75	Monza (262) .....	354498	1	37.50	



## 283-ENGINE ASSEMBLY

### 0.000 ENGINE ASSEMBLY

*NOTE When installing the following engines on applicable past models, non-interchangeable parts must be discarded and replaced with parts that fit the replacing engine. See Engine Installation Instruction Charts in the General Information Section for parts and instructions necessary with service engines on past model information.*

<b>64-67</b> Chevelle (283), <b>65-67</b> Pass. (283) (exc. P.G.) .....	<b>3970186</b> 1    775.00	(less distributor, exhaust manifolds, flywheel, clutch housing and component parts) .....
--	----------------------------	---

*The above engine assemblies do not include the following sub assemblies.*

Carburetor Fuel Pump Oil Filter Assy.	Fan Blade and Pulley Generator Ignition Coil	Ignition Wiring Starting Motor Ventilator Assy.
---	--	---

*NOTE Special equipment production assemblies are available while in production, through Central Office, on direct order Form PC 785*

### 0.002 BOLT— WASHER, Engine Mounting (Small Attaching)

<b>64-67</b> Chevelle (283) .....	<b>3840748</b> 1    .28	right side ( $\frac{7}{16}$ "— 14 x 4) .....
<b>65</b> Malibu (S.S.) (283) .....	<b>3774468</b> 1    .36	rear mtg. (hex. $\frac{7}{16}$ "— 20 x 3) frt. bracket fdg. plate .....
<b>67</b> Pass., Chevelle w/A.I.R. (283), <b>67</b> Camaro w/A.I.R., C.A.C. (283) ..	<b>3785362</b> 1    .32	special hex. ( $\frac{3}{8}$ "— 16 x $2\frac{5}{8}$ " ) flat point (300M steel) w/pump and upper right side
<b>62-67</b> Chevy, Chevelle, Camaro (283) .	<b>3954735</b> 2    .13	<b>WASHER</b> , brkt. to engine (left side) ( $\frac{7}{16}$ " ) (repl. 3693853)— (14.875) .....
<b>64</b> Chevy (283) .....	<b>3818180</b> A.R.    .11	<b>WASHER</b> , mtg. ( $\frac{15}{32}$ " x $1\frac{1}{4}$ " x $\frac{3}{16}$ " thk.) ...

### 0.010 GASKET UNIT, Engine or Tune Up

<b>64-67</b> All (283) .....	<b>3970634</b> 1    5.50	engine .....
------------------------------	--------------------------	--------------

### 0.027 MOUNTING ASSY.— MOUNTING UNIT— CABLE UNIT, Engine

#### 8 CYLINDER

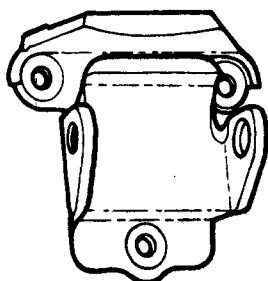

TYPE A

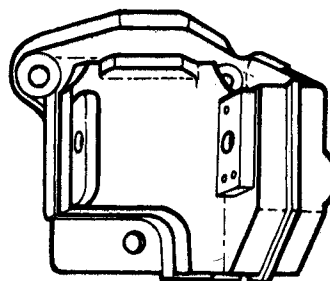

TYPE B

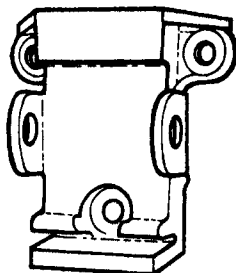

TYPE C

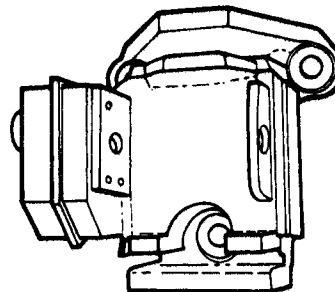

TYPE D

## 283-ENGINE ASSEMBLY

### 0.027 MOUNTING ASSY.— MOUNTING UNIT— CABLE UNIT, Engine (Con't)

*NOTE Mount unit 3988989 include a mount, mount to frame bracket bolt, washers and nut. Also a power steering pump brace and mount to cylinder case attaching bolts and lockwashers.*

64-67	Chevelle (283),				
64-67	Chevy, Chevelle (283),				
65-67	Pass. (283) (exc. P/S),				
65-67	Pass. w/P/S (283) (Right hand				
	side replacement only) . . . . .	3990914 A.R.	9.95	MOUNTING UNIT (Note 4, 5) . . . . .	

*NOTE 4 When using this unit on 1964-1967 Chevelle with 283 engine, it is necessary to procure Frame Bracket 3872815 for L.H. or 3872816 for R.H. mount replacement.*

*NOTE 5 Refer to illustration of mounting "Type A". This unit is to be used when replacing Type A mounting on.*

65-67	Pass. w/P/S (283) . . . . .	3988989 L.H.	13.55	MOUNTING UNIT (Note 6) . . . . .	
65-67	Pass. w/C.A.C. (283) . . . . .	325878 1	N.L.	CABLE UNIT, engine stop lift . . . . .	
65-67	Pass. (283) (exc. C.A.C.) . . . . .	325873 1	N.L.	CABLE UNIT, engine stop lift . . . . .	
65-67	Chevy (283) . . . . .	330267 1	N.L.	CABLE UNIT, engine stop lift . . . . .	

*NOTE 6 Refer to illustration of mounting "Type A". This unit is to be used when replacing Type A mounting.*

### 0.029 BRACKET— MOUNTING ASSY., Engine Mounting

67	Camaro (283) . . . . .	3955183 L.H.	2.95	engine mtg. to side member . . . . .	
67	Camaro (283) . . . . .	3980938 R.H.	2.95	engine mtg. to side member . . . . .	
62-67	Chevy (283) . . . . .	3790287 L.H.	3.80	BRACKET ASSY., body . . . . .	
62-67	Chevy (283) . . . . .	3790288 R.H.	3.80	BRACKET ASSY., body . . . . .	
65-67	Pass. (283) . . . . .	3977234 R.H.	3.25	BRACKET ASSY., frame . . . . .	
65-66	Pass. (283) . . . . .	3977235 L.H.	3.20	BRACKET ASSY., frame . . . . .	
66-67	Chevelle (283) . . . . .	3872815 L.H.	6.90	BRACKET ASSY., frame left . . . . .	
66-67	Chevelle (283) . . . . .	3872816 R.H.	6.90	BRACKET ASSY., frame right . . . . .	
67	Pass. (283) . . . . .	3954637 L.H.	2.00	BRACKET ASSY., frame . . . . .	
64-67	Chevelle (283) . . . . .	3840755 L.H.	2.45	MOUNTING ASSY., body . . . . .	
64-67	Chevelle (283) . . . . .	3840756 R.H.	2.45	MOUNTING ASSY., body . . . . .	

### 0.033 BLOCK ASSY., Cylinder

*NOTE CAUTION. Combination not appearing below should be checked in the Engine Series Number and Suffix Chart in front of catalog to determine if the combination was available in production. If not available, no attempt should be made to make the installation.*

#### PARTIAL ENGINE

*NOTE Includes block, crankshaft, camshaft, timing gears, pistons and connecting rods. Bolts on front end plate may have to be cut off flush when installing on 6 cyl. pass. jobs.*

64-67	Chevy (283) . . . . .	3991002 1	516.00	(Ident. No. 3862194) . . . . .	
64-67	Pass., Chevelle (283) . . . . .	3970164 1	571.00		

#### FITTED CYLINDER BLOCK (Includes Pistons, Pins, Rings and Bearings)

64-67	Pass., Chevelle (283) . . . . .	3970128 1	370.00		
-------	---------------------------------	-----------	--------	--	--

*NOTE 1 When using on models with A.T. it will be necessary to remove clutch pilot bearing from crankshaft.*

### 0.034 EXPANSION PLUGS, Cylinder Block (Also see 8.970)

62-63	Chevy (283) . . . . .	444782 A.R.	.10	cylinder oil gallery rr. hole plug (3/4"— 18	
				thd.— 5/16" sq. socket)— (8.971) . . . . .	
62-67	Chevy, Chevelle, Camaro (283) . . . . .	838538 A.R.	.18	water jacket balance shaft hole (cup type)	
				(1 5/8") . . . . .	
64-68	All (283) . . . . .	3738306 A.R.	.46	(square socket water jacket hole) (1 1/4") . . . . .	

### 0.056 BOLT, Crankshaft Bearing Cap

62-67	Chevy, Chevelle (283),				
65-67	Pass. (283) . . . . .	3872781 A.R.	.28	(1/16"— 14 x 3 9/32") . . . . .	

### 0.093 PLASTIGAGE, Crankshaft Bearing

62-67	All (283) . . . . .	1390274 A.R.	6.15	(green package-type PG-1) (12 pieces) . . . . .	
-------	---------------------	--------------	------	---	--

### 0.095 CAP, Crankshaft Front Bearing

62-67	All (283) . . . . .	3970194 1	5.85	(No. 1, 2, 3, 4, 5, 6) (blue stripe) . . . . .	
-------	---------------------	-----------	------	--	--

**283-ENGINE ASSEMBLY**

**0.096 BEARING UNIT, Crankshaft Front (1 Upper and 1 Lower)**

See chart for Model Application

NOTE: See Dealer Price Schedule for applicable prices.

**CRANKSHAFT MAIN BEARING CHART**

	Position	STD.	.001 U.S.	.002 U.S.	.009 U.S.	.010 U.S.	.020 U.S.
64-67 All (283)	Rear	3730189	3730190	3730191	—	3730192	3730193
64-67 All (283)	Front	3876116	3876117	3876118	3876069 <sup>(2)</sup>	3876119	3876120
64-67 All (283)	All (exc. Front and Rear)	3832930 <sup>(1)</sup>	3832931 <sup>(1)</sup>	3832932 <sup>(1)</sup>	3876070 <sup>(1)</sup>	3832933 <sup>(1)</sup>	3832934 <sup>(1)</sup>

NOTE Bearings having no supplementary notes are Durex 100.

<sup>(1)</sup> Aluminum M-420.

<sup>(2)</sup> Aluminum M-400.

**0.105 CAP, Crankshaft Rear Bearing**

64-67 All (283)	3911052	1	6.10	(Note 1)
-----------------	---------	---	------	----------

NOTE 1 When using in place of 3759260 it is necessary to discard oil pump atch. bolt 3754998 and use bolt 3892678.

**0.107 DOWEL, Crankshaft Bearing Cap**

64-67 All (283)	3836903 A.R.	.11	rear cap (14/32" O.D. x 5/8")— (0.738)
-----------------	--------------	-----	--

**0.137 SEAL ASSY., Crankshaft Rear Bearing and Cap Oil**

64-67 All (283)	3958001	2	2.60	rear oil
-----------------	---------	---	------	----------

**0.153 SHIM UNIT, Crankshaft Bearing Cap**

64-67 All (283)	3911011 A.R.	1.90	rear (29/16" O.L.)
-----------------	--------------	------	--------------------

**0.206 COVER— PIN, Crankcase Front End**

62-67 Chevy, Chevelle (283), 65-67 Pass., Camaro (283)	3928971	1	5.45	w/oil seal (double timing mark brkt.)
64-70 All (283)	3836903	2	.11	PIN, dowel (1/8" x 5/8")— (0.738)

**0.207 GASKET, Crankcase Front End Cover**

64-67 All (283)	3799620	1	.26	(attach. 2 dowel holes)
-----------------	---------	---	-----	-------------------------

**0.213 SEAL, Crankcase Front End Cover**

62-67 All (283)	3980267	1	3.35	(27/16" O.D.— stamped 3980267)
-----------------	---------	---	------	--------------------------------

**0.269 HEAD, Cylinder**

64-67 All (283)	3817680	2	97.00	right and left (Ident. No. 3795896)
-----------------	---------	---	-------	-------------------------------------

**0.289 GASKET, Cylinder Head**

64-67 All (283)	3830711	2	2.60	
64-67 All (283)	3931606	1	15.45	GASKET UNIT

**0.293 BOLT— NUT— PIN, Cylinder Head**

64-67 All (283)	3704796	16	.22	short (7/16"— 14 x 13/4")
64-67 All (283)	3734594 A.R.		.22	long (1/16"— 14 x 33/4") (circle on top of head)
64-67 All (283)	3767468	4	.22	medium (7/16"— 14 x 3) (circle on top of head) (Note 1)

NOTE 1 Use with cylinder head with cast-in oil trough on outer edge.

65-67 Chevelle, Camaro (283)	3866766	12	.12	NUT, attaching (hex. 3/8"— 24)— (0.626)
65-67 Pass. (283)	585927 A.R.		.16	PIN (5/16" x 9/16")

**0.296 VALVE, Inlet**

Refer to following Chart for Model Application

NOTE: See Dealer Price Schedule for applicable prices.

**VALVE CHART (Inlet)**

	STD.	.003 O.S.	.015 O.S.	.030 O.S.
62-67 All (283)	3989083	3995684	3995685	3995686

**283-ENGINE ASSEMBLY**

**0.297 VALVE, Exhaust**

Refer to following Chart for Model Application

*NOTE: See Dealer Price Schedule for applicable prices.*

**VALVE CHART (Exhaust)**

		STD.	.003 O.S.	.015 O.S.	.030 O.S.
62-67	All (283)	3989084	3995602	3995603	3995604

**0.303 SPRING— SHIM, Valve**

65-66	Pass. (283)	3735381 A.R.	1.35	inlet and exhaust, w/damper (2 yellow stripes plus maroon, aluminum, dk. green, black, blue and white, or tan stripe) (Note 1)
-------	-------------	--------------	------	--

*NOTE 1 Used only with Camshaft Assy. 3831607. Also part of Camshaft Unit 3837796.*

67	All (283)	3911068 16	1.30	w/damper
67	All (283)	3731058 A.R.	.12	SHIM (1/32" thk.) (Note 2)

*NOTE 2 To be used in place of Valve Stem Oil Shield when removed at customers request.*

**0.308 SEAL— SHIELD, Valve Spring Cap**

62-67	All (283)	3835333 A.R.	.17	"O" ring, inlet and exhaust
62-67	All (283)	3836755 A.R.	.18	SHIELD (cup shape—7/8" I.D. x 1 3/8" O.D.)

**0.309 CAP, Valve Spring**

64-66	All (283)	3729363 A.R.	.40	inlet and exhaust
67	All (283)	3896934 A.R.	.40	valve spring cap ("A" stamped on top of the surface, inlet) (1 3/16" O.D.)

**0.310 KEY, Valve Stem**

62-67	All (283)	838029 A.R.	.06	("U" shape)
-------	-----------	-------------	-----	-------------

**0.333 ARM, Valve Rocker with Adjusting Screw and Nut**

62-67	All (283)	3974290 16	2.40	inlet and exhaust ("V" stamped on inside of pad end)
-------	-----------	------------	------	--

**0.386 COVER— GROMMET, Valve Rocker Arm**

64-67	All (283)	3910298 2	7.25	right or left (8 13/16" outer hole spacing) (Note 2)
64-67	All (283)	3894337 1	.11	GROMMET, cover to a/cl. (15/16" I.D. x 1 7/32" O.D.)— (1.745) (Note 1, 3)

*NOTE 1 May be used with or without closed vent.*

*NOTE 2 Includes Cover Assy., Gasket and 2 Cylinder Head Bolts.*

*NOTE 3 When using on closed vent. equipped vehicles, it will be necessary to remove center from grommet to permit assembling of fresh air connector into side of cover.*

**0.413 BOLT— REINFORCEMENT, Valve Rocker Cover and Support**

62-67	All (283)	180016 1		(1/4"— 20 x 1/2")— (8.900)
62-67	All (283)	3877670 A.R.	.12	REINFORCEMENT (1 1/2" O.L.) (Note 1)

*NOTE 1 Use with Bolt 180016.*

**0.423 GASKET, Valve Rocker Cover**

64-67	All (283)	3933964 2	1.80	
-------	-----------	-----------	------	--

**0.426 ROD, Valve Push**

64-67	All (283)	3796243 A.R.	2.15	(7 25/32" O.L.) (blue stripe) (Note 1, 2, 3)
-------	-----------	--------------	------	--

*NOTE 1 May also be used on all past model 283 cu. in. high performance engines if improved durability is required.*

*NOTE 2 May have one black stripe at each end.*

*NOTE 3 Color marked end to be at valve rocker arm.*

**0.429 BALL— NUT— STUD, Valve Push Rod Adjusting**

64-69	All (283)	3959142 A.R.	.38	(13/16" dia.)
62-70	All (283)	3744341 16	.22	NUT, valve rocker arm (3/8"— 24) (5/8" across the flats x 1/2")
62-69	All (283)	3814692 16	.53	STUD, valve rocker arm ball (.003 O.S.—light blue paint)
62-69	All (283)	3815892 16	.53	STUD, valve rocker arm ball (.013 O.S.— 3/8"— 24 2 1/2") (1 groove on shank—light blue paint)

**0.459 TAPPET, Valve (or Lifter)**

62-67	All (283)	5232670 16	4.54	hydraulic type
-------	-----------	------------	------	----------------

**283-ENGINE ASSEMBLY**

**0.519 CAMSHAFT**

*NOTE Engine Camshaft Break-in Oil 1050800, Group 1.850, should be used when installing new camshafts.*

64-67 All (283) ..... **3896929** 1 48.25 standard (Ident. No. 3896930) .....

**0.539 BEARING, Camshaft (Front or No. 1)**

64-67 All (283) ..... **3723584** 1 2.40 precision type (stamped 1) .....

**0.543 BEARING, Camshaft No. 2 (Front Intermediate)**

64-67 All (283) ..... **3723585** 1 2.40 precision type (stamped 2) .....

**0.546 BEARING, Camshaft (Center and Rear Intermediate)**

64-67 All (283) ..... **3723586 A.R.** 2.40 (stamped 3 and 4) .....

**0.549 BEARING, Camshaft Rear**

64-67 All (283) ..... **3723585** 1 2.40 precision type (stamped 2)—(0.543) .....

**0.553 PLUG, Camshaft Bearing Hole, cup type (in cylinder block)**

62-67 All (283) ..... **3704158** 1 .22 (2 1/8" dia.) .....

**0.603 ROD ASSY., Connecting, Less Dipper**

64-67 All (283) ..... **3864881** 8 13.75

**0.616 BEARING UNIT, Connecting Rod (1 Upper and 1 Lower)**

**Refer to chart for Model Application**

*NOTE: See Dealer Price Schedule for applicable prices.*

**CONNECTING ROD BEARING UNIT CHART**

MODEL USAGE	STD.	.001 U.S.	.002 U.S.	.010 U.S.	.020 U.S.
62-67 All (283)	347118	3715041	3715046	3715048	3715047

**0.623 BOLT, Connecting Rod Bearing Cap**

64-67 All (283) ..... **3892670 A.R.** .70 (1 1/32"—24 x 1 7/8") .....

**0.626 NUT, Connecting Rod Bearing Cap Bolt**

62-67 Chevy, Chevelle, Camaro (283) . **9422298 A.R.** .11 (3/8"—24 x 5/16" thick) (one end chamfered)—(8.917) .....

65-67 Pass. (283) ..... **3815280** 16 .24 (1 1/32"—24) (type EA) (phosphate coated and soaped) .....

64-67 All (283) (exc. Chevy) ..... **3866766 A.R.** .12 (3/8"—24 x 3/8" thick) (hex. nut) (both ends flat) (Note 1) .....

*NOTE 1 Also used with bolts not requiring cotter pins.*

**0.629 PISTON ASSY., with Pin**

*NOTE Individual piston assemblies are available for warranty purposes and for replacement of pistons damaged when making repairs to engine assemblies. When ordering such parts it is necessary that you specify on your order the reason the parts are required and also that the following note appears on your order. Do not ship unit package quantity.*

ENGINE DISPLACEMENT	BASIC SIZE	SERVICE PISTON DIAMETER RANGE LIMITS ALUMINUM
283 cu. in.	3.8750—STD.	S-4—3.8750 to 3.8755, S-5—3.8755 to 3.8760
283 cu. in.	3.8760—.001	S-6—3.8760 to 3.8765, S-7—3.8765 to 3.8770

*NOTE The above chart is for information purposes only.*

**(Refer to chart for model application)**

*NOTE: See Dealer Price Schedule for applicable prices.*

**PISTON CHART**

	STD.	.001 O.S.	.030 O.S.	.040 O.S.
62-67 All (283)	3860407	3860413	3860426	3860432



## 283-ENGINE ASSEMBLY

### 0.643 RING UNIT, Piston (Service Sets)

NOTE: See Dealer Price Schedule for applicable prices.

#### Original Equipment Type (complete set for one engine per container unless otherwise noted)

	STD.	.030 O.S.	
62-67 All (283) . . . . .	326400 <sup>(1, 2, 5)</sup>	328503 <sup>(5)</sup>	1

#### Special Replacement Type (complete set for one engine per container unless otherwise noted)

	STD.	.030 O.S.	
62-67 All (283) . . . . .	326400 <sup>(5)</sup>	328503 <sup>(3, 4, 5)</sup>	

<sup>(1)</sup> These are Molybdenum premium rings.

<sup>(2)</sup> This part is eligible for wholesale compensation.

<sup>(3)</sup> These Ring Units contain 3/32" compression rings.

<sup>(4)</sup> Cromflex Ring Set having chrome plated oil rings, top compression ring, and chrome-plated rail for middle compression ring.

<sup>(5)</sup> Single cylinder replacement.

### 0.646 CRANKSHAFT, Engine

64-67 All (283) . . . . .	3889303	1	147.00	(Note 1) . . . . .
---------------------------	---------	---	--------	--------------------

NOTE 1 When used on A.T. it will be necessary to remove the pilot bearing.

### 0.649 BEARING, Crankshaft Clutch Pilot

62-67 All (283) . . . . .	3752487	1	1.20	(bush type— 19/32" I.D. x 13/32" O.D. x 3/4") . . . . .
---------------------------	---------	---	------	---

### 0.659 BALANCER— PULLEY— HUB, Crankshaft

NOTE In some cases double groove pulleys may be used in place of single groove pulleys.

NOTE Crankshaft harmonic balancer is also referred to as "torsional damper".

64-65 Chevelle w/4BC, forged crankshaft (283),				
65 Chevy w/4BC, forged crank (283),				
65 Pass. w/forged crankshaft (283),				
65-67 All w/nodular crankshaft (283) . . . . .	3896904	1	26.50	w/o pulley (hub 4 1/2" O.D.) . . . . .
66 All (4BC w/forged crankshaft) (283) . . . . .	3896903	1	26.50	w/o pulley . . . . .
64-67 Chevy, Chevelle, Camaro (283) (exc. C.A.C., C/Deluxe Air Cond., A.I.R.),				
65-67 Pass. (283) (exc. Air Cond., A.I.R.) . . . . .	3755820	1	7.75	PULLEY (stamped 3755820) . . . . .
64-66 Chevy w/Air Cond. (283),				
66-67 Chevelle w/A.I.R. (283) (exc. C.A.C.),				
66-67 Pass. w/A.I.R. (283) (exc. C.A.C.),				
67 Camaro (283) (exc. C.A.C.) . . . . .	3744043	1	8.20	PULLEY (double-6 5/8" O.D.— painted black) (stamped 3744043) . . . . .
64 Chevy, Chevelle w/P/S (283),				
65-68 All w/P/S (283) . . . . .	3751232	1	7.75	PULLEY, front (stamped 3751232) . . . . .
64-68 Chevy, Chevelle, Camaro w/Air Cond. (283),				
65-68 Pass. w/C.A.C., C/Deluxe Air Cond. (283) . . . . .	3850838	1	9.00	PULLEY (7 21/64" O.D.) . . . . .
66-67 Pass. w/62 amp. (C.A.C. w/T.H.) (283) . . . . .	3874414	1	9.00	PULLEY (2 grooves) (7 21/64" O.D.) . . . . .
66 El Camino w/A.I.R., 62 amp. (283),				
66 S.S. w/A.I.R., 62 amp. (283) (exc. Air Cond.) . . . . .	3874418	1	8.20	PULLEY, front (2 grooves) . . . . .
62 Pass. (283),				
64-67 All w/forged crankshaft (283) . . . . .	3795272	1	26.50	HUB, pulley or balance (4 3/4" dia.) . . . . .

### 0.662 KEY— WASHER, Harmonic Balancer and Crankshaft Pulley

65-66 All w/key 3/4" long x 3/16" wide x 1/4" high . . . . .	3883206	A.R.	.16	crankshaft pulley hub (Note 1) . . . . .
65-66 All w/key 1 3/8" long x 3/16" wide x 1 1/32" high . . . . .	3885092	1	.16	crankshaft pulley hub (Note 1) . . . . .

**283-ENGINE ASSEMBLY**

**0.662 KEY— WASHER, Harmonic Balancer and Crankshaft Pulley (Con't)**

*NOTE 1: Used with pulleys and hubs having a shallow (1/16" deep) keyway only. All full depth (1/8") slots take standard woodruff key (106751 two short or 144542 one long) in group 8.960.*

66-67 All (283) ..... 3739422 1 .46 WASHER, balancer .....

**0.666 FLYWHEEL, with Ring Gear**

62-67 Chevy, Chevelle, Camaro w/P.G.,  
reg. fuel (283),  
65-67 Pass. w/P.G. (283) ..... 3789821 1 26.75 spoke type (6-2" dia. holes around ctr.) ....  
64-67 All (283) (exc. A.T., H.D. Clutch) . 3973452 1 59.25 solid type .....

66-67 Pass. w/H.D. clutch (283),  
67 Chevelle w/H.D. clutch (283) ... 3998281 1 68.25 w/11" coil sprg. clutch (12<sup>5</sup>/<sub>8</sub>" bolt circle)  
solid type .....

65-67 All w/T.H. (283) ..... 336763 1 32.00

**0.669 BOLT, Flywheel to Crankshaft**

62-67 All (283) (exc. A.T.) ..... 839756 6 .12 (7/16"— 20 x 1) .....

62-67 All w/A.T. (283) ..... 3727207 6 .21 (7/16"— 20 x 4<sup>5</sup>/<sub>64</sub>"— 290M steel) .....

**0.673 GEAR, Flywheel Ring**

62-67 All (283) ..... 3991408 1 6.40

**0.679 UNDERPAN— BOLT— COVER— SCREW ASSY., Flywheel**

62-65 Police, Taxi w/P.G. (283),  
64-67 Chevy, Chevelle w/P.G. (283),  
65-67 Pass. w/P.G. (283) ..... 3789959 1 3.95 transmission (17<sup>41</sup>/<sub>64</sub>" O.L.) .....

65-67 All w/T.H. 400 (283) ..... 3868810 1 3.55 trans. converter .....

All All (283) ..... 3817006 A.R. .12 BOLT, w/washer (1/4"— 20 x 7/16") .....

62-67 Chevy, Chevelle, Camaro (283),  
65-66 Pass. (283),  
67 Pass. w/reg. fuel (283) ..... 354497 1 2.65 COVER, clutch housing (repl. 3788422) ...  
62-67 All w/P.G., Torque Drive (283) .. 3924780 A.R. .16 SCREW ASSY., w/washer (5/16"— 18 x 7/8")

**0.683 HOUSING— BOLT, Flywheel and Clutch**

64-67 Chevy (283) ..... 3849307 1 31.25 clutch (Ident. No. 3849309) .....

64-67 Pass. (283) (exc. Taxi, Police,  
H.D. Clutch),  
65-67 Chevelle (283) (exc. H.D. Clutch) 3858403 1 30.50 HOUSING ASSY., clutch (Ident. No.  
3840383) (Note 1) .....

*NOTE 1 Less ball stud.*

66-67 All w/H.D. clutch (283) ..... 3899621 1 37.50 HOUSING ASSY., clutch .....

All Pass. (283) ..... 3736035 A.R. .22 BOLT, clutch housing attach. (3/8"— 16 x  
1<sup>5</sup>/<sub>16</sub>" (300M steel-plain)— (3.275) (Note  
2) .....

*NOTE 2 When using Bolt 3736035, it will be necessary to use washer 120394 (8.929).*

All Pass. (283) ..... 3733130 2 .24 BOLT, clutch housing attach. (3/8"— 16 x  
2 1/4"— washer hd.) (300M steel)— (3.275)

**0.685 DOWEL, Flywheel and Clutch Housing to Cylinder Block**

62-67 All (283) ..... 3712745 2 .50 clutch and flywheel (2<sup>1</sup>/<sub>32</sub>" x 1 1/4" long) ....

**0.724 CHAIN, Camshaft Timing**

64-66 All (283) ..... 3704150 1 11.20 early link type .....

67 All (283) ..... 346261 1 11.20 early link type .....

**0.728 SPROCKET, Crankshaft Timing (Steel)**

64-66 All (283) ..... 3759980 1 4.65 (18 teeth— 2<sup>7</sup>/<sub>8</sub>" O.D.) (early link type) .....

67 All (283) ..... 3896959 1 4.65 (18 teeth— 2<sup>7</sup>/<sub>8</sub>" O.D.) (early link type) .....

**0.736 SPROCKET, Camshaft Timing**

64-66 All (283) ..... 3865964 1 7.55 (cast 3704214-36 teeth) (iron) (early link  
type) .....

67 All (283) ..... 340235 1 8.45 (36 teeth) (iron) (early link type) .....

**0.738 PIN, Camshaft Sprocket**

64-67 All (283) ..... 3836903 1 .11 dowel (1/4" x 5/8") (solid) .....

**0.787 ROD— CLIP— EXTENSION— SWIVEL, Clutch Fork Release**

64-67 Chevy (283) ..... 3790015 1 1.20 fork push .....

64-67 Chevy (283) ..... 3790902 1 1.15 fork adjusting .....

64-67 Chevelle (283),  
67 Camaro (283) ..... 3973076 1 1.95 fork push .....

64-67 Chevelle (283),  
67 Camaro (283) ..... 340690 1 1.10 fork push adjusting (4<sup>3</sup>/<sub>4</sub>" long) .....

65 Pass. (283) (exc. Taxi),  
66-67 Pass. (283) ..... 3859863 1 1.25 fork push .....

## 283-ENGINE ASSEMBLY

		<b>0.787</b>	<b>ROD— CLIP— EXTENSION— SWIVEL, Clutch Fork Release (Con't)</b>		
62-67	All (283)	3749084	A.R.	.27	CLIP, push rod and swivel— (4.037)
62-67	All (283)	1455017	1	.13	CLIP, push rod— (3.425)
62-67	Chevy (283)	3834287	1	.36	EXTENSION, fork pull back spring
65-67	Pass. (283)	3859839	1	.71	SWIVEL, pedal push
		<b>0.793</b>		<b>WASHER, Clutch Fork Push Rod</b>	
62-67	All (283)	3756694	1	.11	push rod lever thrust (2 <sup>3</sup> / <sub>4</sub> " dia. pedal shaft) pull rod lever
		<b>0.795</b>		<b>FORK ASSY., Clutch Release</b>	
62-67	Chevy (283)	3788401	1	7.85	(less ball stud)
64-67	Chevelle, Camaro (283)	3892632	1	7.15	
65	Pass. (283)	3739043	1	7.85	(stamped type)
65-67	Pass. (283)	3860005	1	7.15	
		<b>0.796</b>		<b>SPRING— STUD, Clutch Fork</b>	
62-67	Chevy (283)	3737456	1	.28	retaining (4 <sup>1</sup> / <sub>16</sub> " dev. length)
62-67	Chevy (283)				
65-67	Pass. (283)	3790556	1	.84	STUD, ball (3 <sup>3</sup> / <sub>16</sub> "— 16 thds.)
64-67	Chevelle, Camaro (283)	3729000	1	1.05	STUD, ball (1 <sup>3</sup> / <sub>16</sub> "— 16 w/ <sup>21</sup> / <sub>32</sub> " diameter ball)
		<b>0.797</b>		<b>BOOT, Clutch Fork</b>	
62-67	Chevy (283)	3788402	1	.76	(3" O.L. at clutch hsg. face) (black rubber)
64-67	All (283)	3993851	1	.76	black rubber
65-66	Taxi (283)	3781385	1	1.65	black rubber
		<b>0.799</b>		<b>BEARING, Clutch throwout with Collar</b>	
64-67	Chevy, Chevelle w/3-Spd. (283),				
65-67	Pass. (283) (exc. 4-Spd., A.T., H.D. 3-Spd.)	908092	1	15.94	ball bearing type (1 <sup>7</sup> / <sub>8</sub> " long)
64-67	Chevy, Chevelle, Camaro w/4BC (283),				
65-67	Police (283)	908093	1	13.56	(1 <sup>7</sup> / <sub>32</sub> " O.L.) (ND-HCT-24K)
		<b>0.829</b>		<b>BUMPER— COVER— PLUG— RETAINER— SEAL, Clutch</b>	
(For COVERS See Group 4.630)					
64-67	Chevelle (283) (exc. P.B.),				
65-67	Pass. (283)	340688	1	.21	pedal
67	Camaro w/A.T. (283)	3886689	1	.21	COVER, clutch pedal push rod hole
65-67	Pass. w/A.T. (283)	6256958	1		PLUG, pedal push rod hole (repl. 3872120)— (12.980)
62-65	Chevy (283)	3792551	1	.21	RETAINER, push rod dash seal
64-67	Chevelle (283)	3903973	1	.42	RETAINER, clutch pedal push rod bellows type
67	Chevy (283)	3903518	1	.14	RETAINER, clutch pedal push rod dash seal
62-67	Chevy (283)	3792550	1	.36	SEAL, clutch push rod dash
64-67	Chevelle (283)	9776826	1	1.15	SEAL, clutch push rod (bellows type)
65-67	Pass. (283)	3857543	1	.65	SEAL, pedal push rod (Note 1)
<i>NOTE 1 When using in place of 3819156 seal up to 1965, it will be necessary to replace 3825188 anchor plate with 3877244 plate. For attachment use 3877244 plate as template and drill necessary mounting holes.</i>					
67	Camaro w/A.T. (283)	3903466	1	.15	SEAL, clutch pedal push rod hole cover
67	Camaro (283)	3909071	1	1.20	SEAL ASSY., clutch pedal push rod
		<b>0.830</b>		<b>PEDAL, Clutch</b>	
62-65	Chevy (283)	3830774	1	5.50	
64-66	Chevelle (283)	3841214	1	5.65	
65-66	Pass. (283)	3854325	1		
67	Camaro (283)	3890609	1	5.55	
67	Chevelle (283)	3900527	1	5.05	
		<b>0.831</b>		<b>BUSHING, Clutch Pedal (see group 4.626 for brake pedal bushing)</b>	
62-67	All (283)	1247439	2	.11	(4.626)
		<b>0.837</b>		<b>RETAINER, Clutch and Brake Pedal Shaft— (Also see groups 4.634 and 4.648)</b>	
63-67	All (283)	3828428	1	.22	shaft— (4.634)
		<b>0.844</b>		<b>SPRING, Clutch Pedal Pull Back</b>	
62-67	Chevy (283)	3653114	1	.63	clutch fork push rod pull back
64-67	Chevelle (283)	9776993	1	.40	push rod
64-67	Chevelle (283)		1		push rod return,

**283-ENGINE ASSEMBLY**

**0.844 SPRING, Clutch Pedal Pull Back (Con't)**

65-67	Pass. (283)	3849704	1	.34	fork pull back
65-67	Pass. (283)	3879772	1	.22	clutch pull back
67	Camaro (283)	3899021	1	.28	clutch fork push rod pull back

**0.846 EXTENSION, Clutch Pedal Pull Back Spring**

67	Camaro (283)	3899022		.32	clutch fork push rod pull back spring
----	--------------	---------	--	-----	---------------------------------------

**0.851 SEAT— SEAL— SPRING— STUD— WASHER, Clutch Pedal Intermediate Lever Shaft Ball**

62-67	All (283)	3743349	A.R.	.18	stud (7/8" dia.)
65-67	All (283)	382658	1	.19	SEAL, ball stud dust, lever shaft ball stud
62-67	All (283)	3750696	1	.13	SPRING, frame stud seat, retaining (1" O.D.)
62-67	Chevy, Chevelle, Camaro (283)	3866568	1	1.15	STUD, lever shaft ball to engine
62-67	Chevy (283)				STUD, to body,
64-67	Pass., Chevelle, Camaro (283)	3898610	1	.81	to frame (9/8"— 24 x 1 <sup>13</sup> / <sub>16</sub> " O.L.)
65-67	Pass. (283)	3859488	1	1.20	STUD, lever shaft ball to eng.
62-64	Chevy, Chevelle (283)	3743355	1	.13	WASHER, lever shaft ball stud dust seal
62-66	Chevy, Chevelle (283)	3717880	1	.16	WASHER, ball to engine dust washer (rubber) (29/32" O.D. x 15/32" I.D. x 1/4" thk.)— (7.443)
62-67	All (283)	3743360	1	.18	WASHER, stud dust seal, L.H. to frame (felt— 9/16" I.D. x 1 9/8" O.D.) lever assy. seal

**0.852 LEVER— BRACKET— SHAFT, Clutch Pedal, Intermediate (See Group 4.648 for brake)**

62-67	Chevy (283)	3792909	1	6.90	w/shaft
64-66	Chevelle (283),				
67	Chevelle (283) (1st design)	3840836	1	6.60	w/shaft (used w/strg. col. w/lwr. brg. snap ring)
67	Camaro (283)	3998652	1	10.50	w/shaft
67	Chevelle (283) (2nd design)	3921038	1	10.95	w/shaft (used w/strg. col. w/lwr. brg. clamp)
62-67	Chevy (283)	3792365	1	.63	BRACKET, shaft body (3 3/4" O.L. w/2 weld nuts)
64-67	Chevelle (283)	3840841	1	.84	BRACKET, lever and shaft
65-67	Pass. (283) (exc. Taxi)	3859861	1	.28	BRACKET, clutch shaft frame
65-67	Taxi (283)	3869851	1	2.05	BRACKET, clutch shaft frame
67	Camaro (283)	3932760	1	.83	BRACKET, lever and shaft
65-67	Pass. (283)	3954621	1	6.50	SHAFT, w/lever

**0.854 ROD— CLIP, Clutch Pedal**

62-67	Chevy (283)	3790008	1	1.95	pedal push (15 <sup>13</sup> / <sub>32</sub> " dev. length— 1/2" O.D.)
64-67	Chevelle (283)	9774625	1	4.25	pedal push straight shaft (12 <sup>51</sup> / <sub>64</sub> " O.L.)
65-67	Pass. (283)	3859838	1	2.20	pedal push
67	Camaro (283)	3899020	1	2.30	pedal push (12 <sup>43</sup> / <sub>64</sub> " dev. length)
67	Camaro (283)	6264907	1	4.85	clutch pull
66-67	Chevy (283)	3758162	1	.06	CLIP, pedal push rod lower end
65-67	Pass. (283)	1455017	2	.13	CLIP, pedal pull rod— (3.425)

**0.859 PLATE ASSY.— PLATE UNIT, Clutch Pressure with Cover**

63-64	Police (283),				
64-67	Chevelle (2/BC w/4-Spd.) (283),				
64-67	Chevelle w/4BC (283) (2nd design) (exc. H.D. clutch),				
64-67	Chevy w/4-Spd. (283) (2nd design),				
65-66	Chevy w/4BC (283),				
65-67	Pass. w/H.D. chassis, 4-Spd. (283),				
66	Pass. w/4BC (283) (exc. H.D. Clutch)	3841673	1	61.50	(diaphragm spring type) (cast 3793480) (10 1/2")
66-67	Pass., Chevelle w/H.D. Clutch (283)	3962052	1	59.00	
64-67	Chevy, Chevelle w/2BC (283) (exc. 4-Spd.),				
64	Chevelle w/4BC (283) (1st design),				
64	Chevy w/4-Spd. (283) (1st design),				
65	Pass. (283) (exc. 4-Spd., H.D. Chassis),				
66-67	Pass. (283) (exc. 4-Spd., H.D. Chassis, 4BC)	3819914	1	59.50	PLATE UNIT (std.— 10") (Note 1)

**283-ENGINE ASSEMBLY**

**0.859 PLATE ASSY.— PLATE UNIT, Clutch Pressure with Cover (Con't)**

*NOTE 1: Unit consists of clutch cover and pressure plate assy., and return spring.*

**0.861 COVER, Clutch**

64	Chevy w/3-Spd. (283),				
64	Chevy w/4-Spd. (283) (1st design),				
64-67	Chevy, Chevelle (283) (exc. 4-Spd.),				
65	Pass. (283) (exc. H.D. Chassis, 4-Spd.),				
66-67	All (283) (exc. H.D. Chassis, 4-Spd., 4BC, H.D. Clutch) . . . . .	<b>3821765</b>	1	19.30	diaphragm spring type (12 <sup>31</sup> / <sub>64</sub> " O.D.) . . . . .
64-67	Chevy, Chevelle, Camaro w/4-Spd. (283) (2nd design),				
66	Chevy, Chevelle w/4BC (283),				
65	Pass. w/H.D. Chassis, 4-Spd. (283),				
66-67	Pass. w/H.D. Chassis, 4-Spd., 4BC (283) . . . . .	<b>3793478</b>	1	23.90	diaphragm spring type (12 <sup>31</sup> / <sub>64</sub> " O.D.) . . . . .
66-67	Pass., Chevelle w/H.D. Clutch (283) . . . . .	<b>3821763</b>	1	21.75	diaphragm spring type (13 <sup>3</sup> / <sub>4</sub> " O.D.) . . . . .

**0.862 BOLT, Clutch Cover and Pressure Plate**

62-67	All (283) . . . . .	<b>838653</b>	A.R.	.12	( <sup>3</sup> / <sub>8</sub> "— 16 x 1) . . . . .
62-67	All (283) . . . . .	<b>3962058</b>	A.R.	.22	retrac. spring ( <sup>5</sup> / <sub>16</sub> "— 18 x <sup>25</sup> / <sub>32</sub> " hex.)— (0.864) . . . . .

**0.863 PLATE, Clutch Pressure**

64-67	Chevy, Chevelle, Camaro (283) (exc. 4-Spd.),				
65	Pass. (283) (exc. H.D. Chassis, 4-Spd.),				
66-67	Chevy, Chevelle (283) (exc. 4BC, H.D. clutch),				
66-67	Pass. (283) (exc. H.D. Chassis, 4-Spd., 4BC, H.D. Clutch) . . . . .	<b>3992287</b>	1	15.55	(diaphragm spring type) (cast 3788213) (10") . . . . .
64-67	Pass., Chevy, Chevelle w/4-Spd. (283),				
65-67	Police (283),				
66	Chevy, Chevelle w/4BC (283) . . . . .	<b>3793480</b>	1	34.00	(cast 3793480) (10 <sup>1</sup> / <sub>2</sub> ") . . . . .
65-67	Pass. w/H.D. Clutch (283),				
66-67	Chevelle w/H.D. clutch (283) . . . . .	<b>3962057</b>	1	16.90	(11" O.D.) . . . . .

**0.864 BOLT— SPRING, Clutch Pressure Plate**

62-67	All (283) . . . . .	<b>3962058</b>	A.R.	.22	retrac. spring ( <sup>5</sup> / <sub>16</sub> "— 18 x <sup>25</sup> / <sub>32</sub> " hex.) . . . . .
64	Chevy, Chevelle (283),				
65-67	All (283) . . . . .	<b>3788605</b>	3	.13	<b>SPRING</b> , retracting (1 <sup>9</sup> / <sub>32</sub> " dia. at wide end w/ <sup>5</sup> / <sub>16</sub> " ctr. hole) (Note 1) . . . . .

*NOTE 1 Replace only in sets of three.*

**0.886 DISC, with Facing, Clutch**

64	Chevy w/4-Spd. (283) (1st design),				
64-65	Chevelle (4BC w/3-Spd.) (283) (1st design),				
64-65	Chevy, Chevelle (2BC w/3-Spd.) (283),				
65-67	Pass. (283) (exc. Police, H.D. Clutch, H.D. Chassis, 4-Spd., 4BC),				
66-67	Chevy, Chevelle (283) (exc. H.D. Clutch 4-Spd., 4BC) . . . . .	<b>3889346</b>	1	40.00	woven (10") (lavender paint on oil slinger) . . . . .
64	Chevy w/4-Spd. (283) (2nd design),				
64	Chevelle (4BC w/3-Spd.) (283) (2nd design),				
65	Chevy, Chevelle (283),				
65	Pass. w/H.D. Chassis (283),				
66	Pass. w/4BC (283),				
66-67	Chevy, Chevelle, Camaro (4BC w/4-Spd.) (283),				
67	Pass. w/4-Spd., H.D. Chassis (283) . . . . .	<b>3927128</b>	1	40.00	woven (10 <sup>13</sup> / <sub>32</sub> ") . . . . .

**283-ENGINE ASSEMBLY**

---

**0.886 DISC, with Facing, Clutch (Con't)**

<b>66-67</b>	Pass., Chevelle w/H.D. Clutch (283) .....	<b>3828848</b>	1	41.75	woven (11") .....
<b>67</b>	Chevy, Camaro (283) .....	<b>3908960</b>	1	40.00	woven (11") .....



## 302-ENGINE ASSEMBLY

### 0.002 BOLT—WASHER, Engine Mounting (Small Attaching)

67-68	All w/A.I.R., C.A.C. (302)	3785362	1	.32	special hex. ( $\frac{3}{8}$ "— $16 \times 2\frac{5}{8}$ ") flat point (300M steel) w/pump and upper right side
67-69	All (302)	3954735	2	.13	WASHER, brkt. to engine (left side) ( $\frac{7}{16}$ " (repl. 3693853)—(14.875)

### 0.010 GASKET UNIT, Engine or Tune-Up

67-69	All (302)	3970634	1	5.50	engine
-------	-----------	---------	---	------	--------

### 0.027 MOUNTING UNIT— CABLE UNIT, Engine

#### 8 CYLINDER

67-68	All (302)	3990916	2	16.10	
69	All (302)	3990918	A.R.	11.05	
67-68	All (302)				
69	All (302) (exc. C.A.C.)	330265	1	N.L.	CABLE UNIT, engine stop lift
69	All w/C.A.C. (302)	330280	1	N.L.	CABLE UNIT, engine stop lift

### 0.029 BRACKET, Engine Mounting

67-68	All (302)	3955183	L.H.	2.95	engine mtg. to side member
67-68	All (302)	3980938	R.H.	2.95	engine mtg. to side member
69	All (302)	3945507	L.H.	5.75	BRACKET ASSY., side member
69	All (302)	3945508	R.H.	5.00	BRACKET ASSY., side member

### 0.033 BLOCK ASSY., Cylinder

*CAUTION* Combination not appearing below should be checked in the Engine Series Number and Suffix Chart in front of catalog to determine if the combination was available in production. If not available, no attempt should be made to make the installation.

#### PARTIAL ENGINE

*NOTE* Includes block, crankshaft, camshaft, timing gears, pistons and connecting rods.

68-69	All (302)	3970657	1	793.00	(Note 10)
-------	-----------	---------	---	--------	-----------

#### FITTED CYLINDER BLOCK (Includes, Pistons, Pins, Rings and Bearings)

68	All (302)	3931639	1	408.00	
69	All (302)	3970647	1	408.00	

*NOTE 10* When using on 1968 models, it is mandatory to use 3957985 Inlet Manifold Gasket Unit.

### 0.034 EXPANSION PLUGS, Cylinder Block (Also see 8.970)

67-69	All (302)	838538	A.R.	.18	water jacket balance shaft hole (cup type) ( $\frac{1}{8}$ "
67-68	All (302)	3738306	A.R.	.46	(square socket water jacket hole) ( $1\frac{1}{4}$ "

### 0.056 BOLT— STUD, Crankshaft Bearing Cap

67-68	All (302)	3872718	A.R.	1.25	right ( $\frac{7}{16}$ "— $14$ — $\frac{3}{8}$ "— $16 \times 5\frac{1}{4}$ ")
69	All (302)	3932480	10	.28	( $\frac{7}{16}$ "— $14 \times 3\frac{11}{32}$ ")
69	All (302)	3960312	5	1.90	STUD ( $\frac{3}{8}$ "— $16 \times \frac{7}{16}$ "— $14 \times 5\frac{5}{8}$ ")

### 0.093 PLASTIGAGE, Crankshaft Bearing

67-69	All (302)	1390274	A.R.	6.15	(green package-type PG-1) (12 pieces)
-------	-----------	---------	------	------	---------------------------------------

### 0.095 CAP, Crankshaft Front Bearing

67-69	All (302)	3970194	1	5.85	(No. 1, 2, 3, 4, 5, 6) (light blue stripe)
-------	-----------	---------	---	------	--

### 0.096 BEARING UNIT, Crankshaft Front (1 Upper and 1 Lower)

See chart for Model Application

*NOTE:* See Dealer Price Schedule for applicable prices.

#### CRANKSHAFT MAIN BEARING CHART

		Position	STD.	.001 U.S.	.002 U.S.	.009 U.S.	.010 U.S.	.020 U.S.
67	All (302)	All (exc. Rear)	3832930 <sup>(?)</sup>	3832931 <sup>(?)</sup>	3832932 <sup>(?)</sup>	3876070 <sup>(?)</sup>	3832933 <sup>(?)</sup>	3832934 <sup>(?)</sup>
67	All (302)	Rear	3779460 <sup>(?)</sup>	3779461 <sup>(?)</sup>	3779462 <sup>(?)</sup>	3876071 <sup>(?)</sup>	3779463 <sup>(?)</sup>	3779464 <sup>(?)</sup>
68-69	All (302)	All (exc. Rear)	3912038	3912039	3912040	3912037	3912041	3912042
68-69	All (302)	Rear	3912030	3912032	3912033	3912034	3912035	3912036

*NOTE* Bearings having no supplementary notes are Durex 100.

<sup>(?)</sup> Aluminum M-400.

<sup>(?)</sup> Aluminum M-420.



## 302-ENGINE ASSEMBLY

### 0.105 CAP, Crankshaft Rear Bearing

68-69 All (302) ..... 3911007 1 5.35

**See Chart following Group 0.096 for Model Application**

*NOTE: See Dealer Price Schedule for applicable prices.*

### 0.107 DOWEL, Crankshaft Bearing Cap

67-69 All (302) ..... 3836903 A.R. .11 rear cap (1<sup>1</sup>/<sub>32</sub>" O.D. x 5<sup>5</sup>/<sub>8</sub>")— (0.738) .....

### 0.137 SEAL ASSY., Crankshaft Rear Bearing and Cap Oil

67-69 All (302) ..... 3958001 2 2.60 rear oil .....

### 0.153 SHIM UNIT, Crankshaft Bearing Cap

67-69 All (302) ..... 3911011 A.R. 1.90 rear (2<sup>9</sup>/<sub>16</sub>" O.L.) .....

69 All (302) ..... 3956690 A.R. 1.90 (Note 1) .....

*NOTE 1. Used only with, four bolt brg. cap.*

### 0.206 COVER ASSY.— PIN, Crankcase Front End

67-68 All (302) ..... 3923290 1 5.80

69 All (302) ..... 3991433 1 6.30

67-69 All (302) ..... 3836903 2 .11 PIN, dowel (1<sup>1</sup>/<sub>8</sub>" x 5<sup>5</sup>/<sub>8</sub>")— (0.738) .....

### 0.207 GASKET, Crankcase Front End Cover

67-69 All (302) ..... 3799620 1 .26 (attach. 2 dowel holes) .....

### 0.213 SEAL, Crankcase Front End Cover

67-69 All (302) ..... 3980267 1 3.35 (2<sup>7</sup>/<sub>16</sub>" O.D.— stamped 3980267) .....

### 0.269 HEAD, Cylinder

67-69 All (302) ..... 3987376 2 105.00

### 0.289 GASKET, Cylinder Head

67-69 All (302) ..... 3830711 2 2.60

67-68 All (302) ..... 3931606 1 15.45 GASKET UNIT .....

69 All (302) ..... 3957998 1 15.45 GASKET UNIT .....

### 0.293 BOLT— NUT, Cylinder Head

67-69 All (302) ..... 3704796 16 .22 short (7<sup>7</sup>/<sub>16</sub>"— 14 x 1<sup>3</sup>/<sub>4</sub>") .....

67-69 All (302) ..... 3734594 A.R. .22 long (1<sup>1</sup>/<sub>16</sub>"— 14 x 3<sup>3</sup>/<sub>4</sub>") (circle on top of head) .....

67-69 All (302) ..... 3767468 4 .22 medium (7<sup>7</sup>/<sub>16</sub>"— 14 x 3) (circle on top of head) (Note 1) .....

*NOTE 1 Use with cylinder head with cast-in oil trough on outer edge.*

69 All (302) ..... 3877669 A.R. .32 short (2<sup>1</sup>/<sub>16</sub>" O.L.) (raised cross) .....

67-69 All (302) ..... 3866766 12 .12 NUT, attaching (hex. 3<sup>3</sup>/<sub>8</sub>"— 24)— (0.626) ...

### 0.296 VALVE, Inlet

**Refer to following Chart for Model Application**

*NOTE: See Dealer Price Schedule for applicable prices.*

**VALVE CHART (Inlet)**

	STD.	.003 O.S.	.015 O.S.	.030 O.S.
67-69 All (302) .....	3849814	3849815	3849816	3849817

## 302-ENGINE ASSEMBLY

### 0.297 VALVE, Exhaust

Refer to following Chart for Model Application

NOTE: See Dealer Price Schedule for applicable prices.

#### VALVE CHART (Exhaust)

		STD.	.003 O.S.	.015 O.S.	.030 O.S.
67-69	All (302)	3849818	3850040	3850041	3850042
<b>0.303 SPRING— SHIM, Valve</b>					
67-69	All (302)	3911068	16	1.30	w/damper
67-69	All (302)	3731058	A.R.	.12	SHIM (1/32" thk.) (Note 1)
NOTE 1 To be used in place of Valve Stem Oil Shield when removed at customers request.					
<b>0.308 SEAL, Valve Spring Cap</b>					
67-69	All (302)	3835333	A.R.	.17	"O" ring, inlet and exhaust
<b>0.309 CAP, Valve Spring</b>					
67-69	All (302)	3896934	A.R.	.40	valve spring cap ("A" stamped on top of the surface, inlet) (13/16" O.D.)
<b>0.310 KEY, Valve Stem</b>					
67-69	All (302)	3947770	32	.12	(purple)
<b>0.333 ARM UNIT, Valve Rocker with Adjusting Screw and Nut</b>					
67-69	All (302)	3974290	16	2.40	inlet and exhaust ("V" stamped on inside of pad end)
<b>0.386 COVER ASSY.— GROMMET— EMBLEM, Valve Rocker Arm</b>					
67	All (302)	3910297	2	16.20	valve rocker
68	All (302)	3923226	2	16.40	(chrome)
69	All (302)	3965541	L.H.	19.00	(alum.)
69	All (302)	3965542	R.H.	19.00	(alum.)
68-69	All (302)	3894337	A.R.	.11	GROMMET, cover to a/c— (1.745)
69	All (302)	3946860	R.H.	.65	EMBLEM, cover
<b>0.413 BOLT— REINFORCEMENT, Valve Rocker Cover and Support</b>					
67-69	All (302)	180016	1		(1/4" — 20 x 1/2")— (8.900)
67-69	All (302)	3877670	A.R.	.12	REINFORCEMENT (1 1/2" O.L.) (Note 1)
NOTE 1 Use with Bolt 180016.					
<b>0.423 GASKET, Valve Rocker Cover</b>					
67-69	All (302)	3933964	2	1.80	
<b>0.426 ROD, Valve Push</b>					
67-69	All (302)	3796243	A.R.	2.15	(7 25/32" O.L.) (blue stripe) (Note 1, 2)
NOTE 1 May have one black stripe at each end.					
NOTE 2 Color marked end to be at valve rocker arm.					
<b>0.429 BALL— NUT— STUD, Valve Push Rod Adjusting</b>					
67-69	All (302)	3959142	A.R.	.38	(13/16" dia.)
67-69	All (302)	3744341	16	.22	NUT, valve rocker arm (3/8" — 24) (5/8" across the flats x 1/2")
67-69	All (302)	3814692	16	.53	STUD, valve rocker arm ball (.003 O.S.—light blue paint)
67-69	All (302)	3815892	16	.53	STUD, valve rocker arm ball (.013 O.S.— 3/8" — 24 2 1/2") (1 groove on shank—light blue paint)
<b>0.459 TAPPET, Valve (or Lifter)</b>					
67-69	All (302)	5232695	16	2.95	mechanical type (2" O.L. x 27/32" O.D.)
<b>0.519 CAMSHAFT</b>					
NOTE Engine Camshaft Break-in Oil 1050800, Group 1.850, should be used when installing new camshafts.					
67-69	All (302)	3972178	1	48.25	
<b>0.539 BEARING, Camshaft (Front or No. 1)</b>					
67-69	All (302)	3723584	1	2.40	precision type (stamped 1)
<b>0.543 BEARING, Camshaft No. 2 (Front Intermediate)</b>					
67-69	All (302)	3723585	1	2.40	precision type (stamped 2)

## 302-ENGINE ASSEMBLY

<b>0.546 BEARING, Camshaft (Center and Rear Intermediate)</b>					
67-69	All (302)	3723586 A.R.	2.40	(stamped 3 and 4)	.....
<b>0.549 BEARING, Camshaft Rear</b>					
67-69	All (302)	3723585	1	2.40	precision type (stamped 2)— (0.543) .....
<b>0.553 PLUG, Camshaft Bearing Hole, Cup Type (In Cylinder Block)</b>					
67-69	All (302)	3704158	1	.22	(2 <sup>1</sup> / <sub>8</sub> " dia.) .....
<b>0.603 ROD ASSY., Connecting, Less Dipper</b>					
67	All (302)	3864881	8	13.75	.....
68	All (302) (1st design)	3973386	8	39.25	(Note 1) .....
68-69	All (302) (2nd design)	3946841	8	39.25	.....

NOTE 1 Shot peen surface.

### 0.616 BEARING UNIT, Connecting Rod (1 Upper and 1 Lower)

Refer to Chart for Model Application

NOTE: See Dealer Price Schedule for applicable prices.

### CONNECTING ROD BEARING UNIT CHART

MODEL USAGE	STD.	.001 U.S.	.002 U.S.	.010 U.S.	.020 U.S.
67 All (302)	3711828 <sup>(1)</sup>	3715045 <sup>(1)</sup>	3715046 <sup>(1)</sup>	3715048 <sup>(1)</sup>	3715047 <sup>(2)</sup>
68-69 All (302)	3910555 <sup>(2)</sup>	3910556 <sup>(2)</sup>	3910557 <sup>(2)</sup>	3910558 <sup>(2)</sup>	3910559 <sup>(2)</sup>

<sup>(1)</sup> Aluminum M-420.

<sup>(2)</sup> Aluminum M-400.

<b>0.623 BOLT, Connecting Rod Bearing Cap</b>					
67	All (302)	3892670 A.R.	.70	( <sup>11</sup> / <sub>32</sub> " — 24 x <sup>17</sup> / <sub>8</sub> "	.....
68-69	All (302)	3916399	16	.60	( <sup>3</sup> / <sub>8</sub> " — 24 x <sup>159</sup> / <sub>64</sub> "
<b>0.626 NUT, Connecting Rod Bearing Cap Bolt</b>					
67-69	All (302)	9422298 A.R.	.11	( <sup>3</sup> / <sub>8</sub> " — 24 x <sup>5</sup> / <sub>16</sub> " thick) (one end	.....
				chamfered)— (8.917)	.....
67	All (302)	3815280	16	.24	( <sup>11</sup> / <sub>32</sub> " — 24) (type EA) (phosphate coated
				ans soaped)	.....
67-69	All (302)	3866766 A.R.	.12	( <sup>3</sup> / <sub>8</sub> " — 24 x <sup>3</sup> / <sub>8</sub> " thick) (hex. nut) (both ends	.....
				flat) (Note 1)	.....

NOTE 1 Also used with bolts not requiring cotter pins.

### 0.629 PISTON ASSY., with Pin

NOTE Individual piston assemblies are available for warranty purposes and for replacement of pistons damaged when making repairs to engine assemblies. When ordering such parts it is necessary that you specify on your order the reason the parts are required and also that the following note appears on your order. Do not ship unit package quantity.

ENGINE DISPLACEMENT	BASIC SIZE	SERVICE PISTON DIAMETER RANGE LIMITS ALUMINUM
302 cu. in.	3.9953— Std.	S-4— 3.9953 to 3.9958, S-5— 3.9958 to 3.9963

NOTE The above chart is for information purposes only.

**302-ENGINE ASSEMBLY**

(Refer to Chart for Model Application)

*NOTE: See Dealer Price Schedule for applicable prices.*

**PISTON CHART**

		STD.	.001 O.S.	.020 O.S.	.030 O.S.
67	All (302)	3927177	3927178	3927179	3927180
68	All (302)	3927177	3927178	3927179	3927180
69	All (302)	3946876	3946878	—	3946882

**0.639 RETAINER, Piston Pin**

68	All (302)	3946848	16	.22	
----	-----------	---------	----	-----	--

**0.643 RING UNIT, Piston (Service Sets)**

*NOTE: See Dealer Price Schedule for applicable prices.*

		STD.	.030 O.S.
67-69	All (302)	328506 <sup>(2)</sup>	328516 <sup>(1, 2)</sup>

*(1) These are Molybdenum premium rings.*

*(2) Single cylinder replacement.*

**0.646 CRANKSHAFT, Engine**

67	All (302)	3917265	1	161.00
68-69	All (302)	3941176	1	161.00

**0.649 BEARING, Crankshaft Clutch Pilot**

67-69	All (302)	3752487	1	1.20	(bush type— <sup>19</sup> / <sub>32</sub> " I.D. x <sup>13</sup> / <sub>32</sub> " O.D. x <sup>3</sup> / <sub>4</sub> " )
-------	-----------	---------	---	------	---

**0.659 BALANCER— PULLEY, Crankshaft**

*NOTE In some cases double groove pulleys may be used in place of single groove pulleys.*

*NOTE Crankshaft harmonic balancer is also referred to as "torsional damper".*

67-68	All (302)	3817173	1	44.75	
69	All (302)	3947708	1	26.50	
67-68	All w/Air Cond. (302)	3850838	1	9.00	PULLEY ( <sup>7</sup> / <sub>16</sub> " O.D.)
67	All (302) (exc. P/S),				
68	All (302)	3858533	1	8.20	PULLEY (double- <sup>6</sup> / <sub>16</sub> " O.D.) (stamped 3766987)
67-68	All w/P/S (302)	3765947	1	9.80	PULLEY, 1 groove pulley
69	All (302)	3956668	1	9.20	PULLEY, 2 groove pulley

**0.662 BOLT— WASHER— REINFORCEMENT, Harmonic Balancer and Crankshaft Pulley**

67-68	All (302)	3815933	1	.63	( <sup>7</sup> / <sub>16</sub> "— 20 x <sup>2</sup> / <sub>4</sub> ")
67-69	All (302)	3739422	1	.46	WASHER, balancer
69	All w/C.A.C. (302)	3965597	1	.59	REINFORCEMENT, crankshaft pulley

**0.666 FLYWHEEL, w/Ring Gear**

67-69	All (302)	3973452	1	59.25	solid type (cast 3791021)
-------	-----------	---------	---	-------	---------------------------

**0.669 BOLT, Flywheel to Crankshaft**

67-69	All (302) (exc. A.T.)	839756	6	.12	( <sup>7</sup> / <sub>16</sub> "— 20 x 1)
67-69	All w/A.T. (302)	3727207	6	.21	( <sup>7</sup> / <sub>16</sub> "— 20 x <sup>45</sup> / <sub>64</sub> "— 290M steel)

**0.673 GEAR, Flywheel Ring**

67-69	All (302)	3991408	1	6.40	
-------	-----------	---------	---	------	--

**0.679 UNDERPAN— BOLT— COVER— SCREW ASSY., Flywheel**

67-69	All (302)	3789959	1	3.95	transmission ( <sup>17</sup> / <sub>64</sub> " O.L.)
67-69	All (302)	3817006	A.R.	.12	BOLT, w/washer ( <sup>1</sup> / <sub>4</sub> "— 20 x <sup>7</sup> / <sub>16</sub> ")
67-69	All (302)	354497	1	2.65	COVER, clutch housing (repl. 3788422)
67-69	All w/P.G. (302)	3924780	A.R.	.16	SCREW ASSY., w/washer ( <sup>7</sup> / <sub>16</sub> "— 18 x <sup>7</sup> / <sub>8</sub> ")

**0.683 HOUSING ASSY., Flywheel and Clutch**

67-69	All (302)	3858403	1	30.50	clutch (Ident. No. 3840383)
-------	-----------	---------	---	-------	-----------------------------

**0.685 DOWEL, Flywheel and Clutch Housing to Cylinder Block**

67-69	All (302)	3712745	2	.50	clutch and flywheel ( <sup>21</sup> / <sub>32</sub> " x <sup>1</sup> / <sub>4</sub> " long)
-------	-----------	---------	---	-----	---

**0.724 CHAIN, Camshaft Timing**

67-69	All (302)	346261	1	11.20	early link type
-------	-----------	--------	---	-------	-----------------

## 302-ENGINE ASSEMBLY

<b>0.728 SPROCKET, Crankshaft Timing (Steel)</b>				
67-69	All (302)	3896959	1	4.65 (18 teeth— 2 <sup>7</sup> / <sub>8</sub> " O.D.) (early link type)
<b>0.736 SPROCKET, Camshaft Timing</b>				
67-69	All (302)	340235	1	8.45 (36 teeth) (iron) (early link type)
<b>0.738 PIN, Camshaft Sprocket</b>				
67-69	All (302)	3836903	1	.11 dowel (1 <sup>1</sup> / <sub>4</sub> " x 5 <sup>5</sup> / <sub>8</sub> ") (solid)
<b>0.787 ROD— CLIP, Clutch Fork Release</b>				
67-69	All (302)	3973076	1	1.95 fork push
67-69	All (302)	340690	1	1.10 fork push adjusting (4 <sup>3</sup> / <sub>4</sub> " long)
67-69	All (302)	3749084 A.R.		.27 CLIP, push rod and swivel— (4.037)
67-69	All (302)	1455017	1	.13 CLIP, push rod— (3.425)
<b>0.793 WASHER, Clutch Fork Push Rod</b>				
67-69	All (302)	3756694	1	.11 push rod lever thrust (2 <sup>3</sup> / <sub>4</sub> " dia. pedal shaft) pull rod lever
<b>0.795 FORK ASSY., Clutch Release</b>				
67-69	All (302)	3892632	1	7.15
<b>0.796 STUD, Clutch Fork</b>				
67-69	All (302)	3729000	1	1.05 ball (1 <sup>3</sup> / <sub>16</sub> "— 16 w/2 <sup>1</sup> / <sub>32</sub> " diameter ball)
<b>0.797 BOOT, Clutch Fork</b>				
67-69	All (302)	3993851	1	.76 black rubber
<b>0.799 BEARING, Clutch Throwout w/Collar</b>				
67-69	All (302)	908093	1	13.56 (1 <sup>7</sup> / <sub>32</sub> " O.L.)
<b>0.829 BUMPER— COVER— SEAL, Clutch</b>				

### (For COVERS See Group 4.630)

68-69	All (302)	340688	1	.21 clutch pedal
67-69	All w/A.T. (302)	3886689	1	.21 COVER, clutch pedal push rod hole
67-69	All w/A.T. (302)	3903466	1	.15 SEAL, clutch pedal push rod hole cover
67-69	All (302)	3909071	1	1.20 SEAL ASSY., clutch pedal push rod
<b>0.830 PEDAL, Clutch</b>				
67	All (302)	3890609	1	5.55
68-69	All (302)	6258554	1	6.55
<b>0.831 BUSHING, Clutch Pedal (See Group 4.626 for Brake Pedal Bushing)</b>				
67-68	All (302)	1247439	2	.11 (5 <sup>5</sup> / <sub>8</sub> " dia. pedal shaft)— (4.626)
<b>0.837 RETAINER, Clutch and Brake Pedal Shaft (Also See Groups 4.634 and 4.648)</b>				
67-69	All (302)	3828428	1	.22 shaft— (4.634)
<b>0.844 SPRING, Clutch Pedal Pull Back</b>				
67-69	All (302)	3899021	1	.28 clutch fork push rod pull back
<b>0.846 EXTENSION, Clutch Pedal Pull Back Spring</b>				
67-69	All (302)	3899022	1	.32 clutch fork push rod pull back spring
<b>0.851 SEAT— SEAL— SPRING— STUD— WASHER, Clutch Pedal Intermediate Lever Shaft Ball</b>				
67-69	All (302)	3743349 A.R.		.18 stud (7 <sup>7</sup> / <sub>8</sub> " dia.)
67-69	All (302)	382658	1	.19 SEAL, ball stud dust,
67-69	All (302)	3750696	1	.13 SPRING, frame stud seat, retaining (1" O.D.)
67-69	All (302)	3866568	1	1.15 STUD, lever shaft ball to engine
67-69	All (302)	3898610	1	.81 STUD, to frame (3 <sup>3</sup> / <sub>8</sub> "— 24 x 1 <sup>13</sup> / <sub>16</sub> " O.L.)
67-69	All (302)	3743360	1	.18 WASHER, stud dust seal, L.H. to frame (felt— 9 <sup>9</sup> / <sub>16</sub> " I.D. x 1 <sup>3</sup> / <sub>8</sub> " O.D.) lever assy. seal
<b>0.852 LEVER— BRACKET, Clutch Pedal, Intermediate (See Group 4.648 for Brake)</b>				
67-69	All (302)	3998652	1	10.50 w/shaft
67-69	All (302)	3932760	1	.83 BRACKET, lever and shaft
<b>0.854 ROD, Clutch Pedal</b>				
67	All (302)	3899020	1	2.30 pedal push (12 <sup>43</sup> / <sub>64</sub> " dev. length)
67	All (302)	6264907	1	4.85 clutch pull

## 302-ENGINE ASSEMBLY

<b>0.854 ROD, Clutch Pedal (Con't)</b>					
68-69	All (302)	.....	3920262	1	1.95 pedal push .....
<b>0.859 PLATE ASSY., Clutch Pressure with Cover</b>					
67-69	All (302)	.....	3841673	1	61.50 (diaphragm spring type) <sup>1</sup> (cast 3793480) (10 <sup>1</sup> / <sub>2</sub> " ) .....
<b>0.862 BOLT, Clutch Cover and Pressure Plate</b>					
67-69	All (302)	.....	838653	A.R.	.12 (3/ <sub>8</sub> "— 16 x 1) .....
67-69	All (302)	.....	3962058	A.R.	.22 retrac. spring (5/ <sub>16</sub> "— 18 x 29/ <sub>32</sub> " hex.)— (0.864) .....
<b>0.863 PLATE, Clutch Pressure</b>					
67-69	All (302)	.....	3793480	1	34.00 (cast 3793480) (10 <sup>1</sup> / <sub>2</sub> " ) .....
<b>0.864 BOLT— SPRING, Clutch Pressure Plate</b>					
67-69	All (302)	.....	3962058	A.R.	.22 retrac. spring (5/ <sub>16</sub> "— 18 x 29/ <sub>32</sub> " hex.) .....
67-68	All (302)	.....	3788605	3	.13 <b>SPRING</b> , retracting (1 <sup>9</sup> / <sub>32</sub> " dia. at wide end w/ <sup>9</sup> / <sub>16</sub> " ctr. hole) (Note 1) .....
<i>NOTE 1 Replace only in sets of three.</i>					
<b>0.886 DISC, with Facing, Clutch</b>					
67-69	All (302)	.....	3927128	1	40.00 woven (10 <sup>19</sup> / <sub>32</sub> " ) .....



## 307-ENGINE ASSEMBLY

### 0.002 BOLT—SPACER—WASHER, Engine Mounting (Small Attaching)

68-69	Chevelle (307)	3840748	1	.28	right side (7/16" — 14 x 4)
68	Pass., Chevelle w/A.I.R. (307),				
68	Chevy (307)	3785362	1	.32	special hex. (3/8" — 16 x 2 5/8") flat point (300M steel) w/pump and upper right side
72	All (307) (exc. Camaro)	3980716	2	.34	(7/16" — 14 x 3 7/8")
70-71	All (307),				
72	Camaro (307),				
73	All (307)	334972	2	.34	(7/16" — 14 x 5)
70	Chevelle, Camaro, Pass. (307) (exc. Taxi, Police)	3826168	2	.18	SPACER, frt. mtg. eng. brkt. ("U" shape) (2 1/2" O.L.) (Note 1)
<i>NOTE 1 It may be necessary to reduce length to 2 3/8".</i>					
68-69	Chevy, Chevelle, Camaro (307)	3954735	2	.13	WASHER, brkt. to engine (left side) (7/16") (repl. 3693853)— (14.875)

### 0.010 GASKET UNIT, Engine or Tune Up

68-73	All (307)	3970634	1	5.50	engine
-------	-----------	---------	---	------	--------

### 0.027 MOUNTING ASSY.— MOUNTING UNIT— CABLE UNIT, Engine

#### 8 CYLINDER

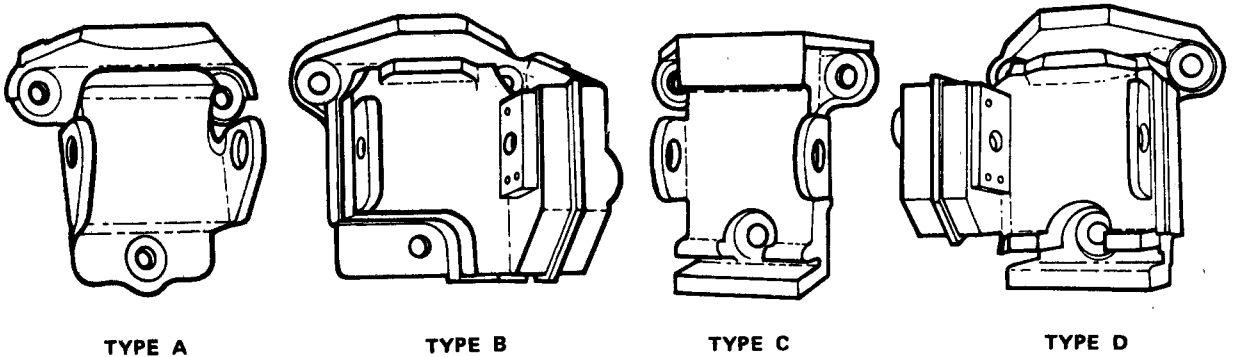

*NOTE Mount units 3990914, include a mount, mount to frame bracket bolt, washers and nut. Mount units 3988989 includes the above items and also a power steering pump brace and mount to cylinder case attaching bolts and lockwashers.*

72	Camaro (307),				
73	All (307)	6262215	1	8.80	
68	Pass. Chevy w/P/S (307)				R.H. only,
68	Chevy (307) (exc. P/S),				R.H. or L.H.,
68	Pass. (307) (exc. P/S)				
68-72	Chevelle (307),				
69-72	Camaro, Chevy (307)	3990914	A.R.	9.95	MOUNTING UNIT (R.H. or L.H.)
68	Pass. Chevy w/P/S (307)	3988989	L.H.	13.55	MOUNTING UNIT
68	Pass. w/C.A.C. (307)	325878	1	N.L.	CABLE UNIT, engine stop lift
68	Pass. (307) (exc. C.A.C.)	325873	1	N.L.	CABLE UNIT, engine stop lift
68	Chevy, Camaro (307),				
69	Chevy, Camaro (307) (exc. C.A.C.)	330265	1	N.L.	CABLE UNIT, engine stop lift
69	Chevy, Camaro w/C.A.C. (307)	330280	1	N.L.	CABLE UNIT, engine stop lift

### 0.029 BRACKET— SHIELD, Engine Mounting

69	Camaro (307),				
68-72	Chevy (307)	3955183	L.H.	2.95	engine mtg. to side member
69	Camaro (307),				
68-72	Chevy (307)	3980938	R.H.	2.95	engine mtg. to side member
68	Pass. (307)	3954637	L.H.	2.00	BRACKET ASSY., frame
68	Pass. (307)	3977234	R.H.	3.25	BRACKET ASSY., frame
68-72	Chevelle (307)	3980707	L.H.	2.40	BRACKET ASSY., eng. mtg. frame L.H.
68-72	Chevelle (307)	3980708	R.H.	2.10	BRACKET ASSY., eng. mtg. frame R.H.
70-71	Camaro (307)	3964890	L.H.	7.15	BRACKET ASSY., side member L.H.
70-71	Camaro (307)	3980930	R.H.	7.15	BRACKET ASSY., side member R.H.
72-73	Camaro (307)	332648	2	5.00	BRACKET ASSY.
73	Chevelle (307)	334970	2	5.15	BRACKET ASSY., frame R.H. or L.H.
73	Nova (307)	3998657	L.H.	2.50	BRACKET ASSY., left
73	Nova (307)	3998658	R.H.	2.50	BRACKET ASSY., right



## 307-ENGINE ASSEMBLY

### 0.029 BRACKET— SHIELD, Engine Mounting (Con't)

71-72 All (307) ..... 3989442 1 .84 SHIELD, heat (Note 1) .....  
 NOTE 1 Used on L.H. side for Nova.

### 0.033 BLOCK ASSY., Cylinder

NOTE CAUTION. Combination not appearing below should be checked in the Engine Series Number and Suffix Chart in front of catalog to determine if the combination was available in production. If not available, no attempt should be made to make the installation.

#### PARTIAL ENGINE

NOTE Includes block, crankshaft, camshaft, timing gears, pistons and connecting rods.

69-72 All (307) ..... 3970651 1 597.00  
 73 All (307) ..... 6259352 1 597.00

#### FITTED CYLINDER BLOCK (Includes Pistons, Pins, Rings and Bearings)

68-72 All (307) ..... 3970641 1 407.00  
 73 All (307) ..... 6259351 1 391.00

NOTE 1 When using on models with A.T. it will be necessary to remove clutch pilot bearing from crankshaft.  
 NOTE 2 When using on 1968 models, it is mandatory to use 3957985 Inlet Manifold Gasket Unit.

### 0.034 EXPANSION PLUGS, Cylinder Block (Also see 8.970)

68-69 Chevy, Chevelle, Camaro (307),  
 72-73 All (307) ..... 838538 A.R. .18 water jacket balance shaft hole (cup type)  
 (1<sup>5</sup>/<sub>8</sub>" ) .....  
 68 All (307) ..... 3738306 A.R. .46 (square socket water jacket hole) (1<sup>1</sup>/<sub>4</sub>" ) ...  
 70-71 All (307) ..... 3743389 A.R. .24 water jacket hole (1<sup>5</sup>/<sub>8</sub>" O.D.— CUP TYPE) ...

### 0.056 BOLT, Crankshaft Bearing Cap

68 All (307) ..... 3872781 A.R. .28 (1<sup>1</sup>/<sub>16</sub>" — 14 x 3<sup>9</sup>/<sub>32</sub>" ) .....  
 69-73 All (307) ..... 3932480 10 .28 (7<sup>1</sup>/<sub>16</sub>" — 14 x 3<sup>11</sup>/<sub>32</sub>" ) .....

### 0.093 PLASTIGAGE, Crankshaft Bearing

68-73 All (307) ..... 1390274 A.R. 6.15 (green package-type PG-1) (12 pieces) .....

### 0.095 CAP, Crankshaft Front Bearing

68-73 All (307) ..... 3956688 A.R. 9.10 (No. 1, 2, 3, 4) .....

### 0.096 BEARING UNIT, Crankshaft Front (1 Upper and 1 Lower)

#### See Chart for Model Application

NOTE See Dealer Price Schedule (P&A 26) for applicable prices.

#### CRANKSHAFT MAIN BEARING CHART

	POSITION	STD.	.001 U.S.	.002 U.S.	.009 U.S.	.010 U.S.	.020 U.S.
68-73 All (307) .....	All (exc. Rear)	3912038	3912039	3912040	3912037	3912041	3912042
68-73 All (307) .....	Rear	3912030	3912032	3912033	3912034	3912035	3912036

NOTE Bearings having no supplementary notes are Durex 100.

### 0.099 BEARING UNIT, Crankshaft Front Intermediate (1 Upper and 1 Lower) (See Chart Following Group 0.096 for Model Application)

NOTE: See Dealer Price Schedule for applicable prices.

### 0.101 BEARING UNIT, Crankshaft Center (1 Upper and 1 Lower) (See Chart Following Group 0.096 for Model Application)

NOTE: See Dealer Price Schedule for applicable prices.

### 0.103 BEARING UNIT, Crankshaft Rear Intermediate (1 Upper and 1 Lower) (See Chart Following Group 0.096 for Model Application)

NOTE: See Dealer Price Schedule for applicable prices.

### 0.105 CAP, Crankshaft Rear Bearing

68-73 All (307) ..... 3911007 1 5.35

### 0.106 BEARING UNIT, Crankshaft Rear (1 Upper and 1 Lower) (See Chart Following Group 0.096 for Model Application)

NOTE: See Dealer Price Schedule for applicable prices.

### 0.107 DOWEL, Crankshaft Bearing Cap

68-73 All (307) ..... 3836903 A.R. .11 rear cap (1<sup>4</sup>/<sub>32</sub>" O.D. x 5<sup>5</sup>/<sub>8</sub>" )— (0.738) .....

## 307-ENGINE ASSEMBLY

<b>0.137 SEAL ASSY., Crankshaft Rear Bearing and Cap Oil</b>					
68-73	All (307)	3958001	2	2.60	rear oil
<b>0.153 SHIM UNIT, Crankshaft Bearing Cap</b>					
68-71	All (307)	3911011 A.R.		1.90	rear (2 <sup>9</sup> / <sub>16</sub> " O.L.)
<b>0.206 COVER ASSY.— PIN, Crankcase Front End</b>					
68	All (307)	361927	1	7.05	(repl. 3917618)
69-73	All (307)	3991433	1	6.30	
68-73	All (307)	3836903	2	.11	PIN, dowel (1 <sup>1</sup> / <sub>8</sub> " x 5 <sup>5</sup> / <sub>8</sub> ")— (0.738)
<b>0.207 GASKET, Crankcase Front End Cover</b>					
68-73	All (307)	3799620	1	.26	(attach. 2 dowel holes)
<b>0.213 SEAL, Crankcase Front End Cover</b>					
68-73	All (307)	3980267	1	3.35	(2 <sup>7</sup> / <sub>16</sub> " O.D.— stamped 3980267)
<b>0.219 POINTER, Engine Timing</b>					
68-70	All (307),				
71	All (307) (1st design)	3991435	1	.53	2 <sup>1</sup> / <sub>2</sub> " high 1 <sup>1</sup> / <sub>4</sub> " dia. hole 2 <sup>3</sup> / <sub>32</sub> " from top of teeth
71-73	All (307) (2nd design)	3997780	1	.53	2 <sup>1</sup> / <sub>8</sub> " high, 1 <sup>1</sup> / <sub>4</sub> " dia. hole 2 <sup>1</sup> / <sub>64</sub> " from top of teeth
<b>0.269 HEAD, Cylinder</b>					
68-70	All (307)	3958602	2	92.25	w/studs
71-72	All (307) (1st design)	6272069	2	106.00	w/studs (repl. 3997417)
73	All (307)	6260856	2	112.00	w/studs
<b>0.289 GASKET, Cylinder Head</b>					
68-73	All (307)	3995633	2	2.60	
68	All (307)	3931595	1	15.45	GASKET UNIT
69-72	All (307)	3997563	1	15.45	GASKET UNIT
73	All (307)	6258832	1	15.45	GASKET UNIT
<b>0.293 BOLT— NUT— PIN, Cylinder Head</b>					
68-73	All (307)	3704796	16	.22	short (7 <sup>7</sup> / <sub>16</sub> "— 14 x 1 <sup>3</sup> / <sub>4</sub> ")
68-73	All (307)	3734594 A.R.		.22	long (1 <sup>1</sup> / <sub>16</sub> "— 14 x 3 <sup>3</sup> / <sub>4</sub> ") (circle on top of head)
68-73	All (307)	3767468	4	.22	medium (7 <sup>7</sup> / <sub>16</sub> "— 14 x 3) (circle on top of head) (Note 1)
<i>NOTE 1 Use with cylinder head with cast-in oil trough on outer edge.</i>					
68-69	Chevelle, Camaro (307)	3866766	12	.12	NUT, attaching (hex. 3 <sup>3</sup> / <sub>8</sub> "— 24)— (0.626)
68-69	Pass. (307)	585927 A.R.		.16	PIN (5 <sup>5</sup> / <sub>16</sub> " x 9 <sup>9</sup> / <sub>16</sub> ")

### 0.296 VALVE, Inlet

*NOTE: See Dealer Price Schedule for applicable prices.*

#### VALVE CHART (Inlet)

		STD.	.003 O.S.	.015 O.S.	.030 O.S.
68-72	All (307)	3989083	3995684	3995685	3995686
73	All (307)	3989085	3995681	3995682	3995683

### 0.297 VALVE, Exhaust

*NOTE: See Dealer Price Schedule for applicable prices.*

#### VALVE CHART (Exhaust)

		STD.	.003 O.S.	.015 O.S.	.030 O.S.
68-73	All (307)	6263778	3995602	3995603	3995604

### 0.303 SPRING— SHIM, Valve

68-71	All (307)				w/damper (inlet and exhaust),
72-73	All (307)	3911068 A.R.		1.30	w/damper (inlet)
72-73	All (307)	6263796	8	1.40	w/damper (exhaust)
68-73	All (307)	3731058 A.R.		.12	SHIM (1 <sup>1</sup> / <sub>32</sub> " thk.) (Note 1)

*NOTE 1 To be used in place of Valve Stem Oil Shield when removed at customers request.*

### 0.308 SEAL— SHIELD, Valve Spring Cap

68-73	All (307)	3835333 A.R.		.17	"O" ring, inlet and exhaust
-------	-----------	--------------	--	-----	-----------------------------

**307-ENGINE ASSEMBLY**

<b>0.308 SEAL— SHIELD, Valve Spring Cap (Con't)</b>				
68-73	All (307)	3836755 A.R.	.18	SHIELD (cup shape- $7/8$ " I.D. x $1\frac{3}{8}$ " O.D.)
<b>0.309 CAP— ROTATOR ASSY., Valve Spring</b>				
68-73	All (307)	3896934 A.R.	.40	valve spring cap ("A" stamped on top of the surface, inlet) ( $1\frac{3}{16}$ " O.D.)
72-73	All (307)	6263794 8	2.95	ROTATOR ASSY., exhaust valve
<b>0.310 KEY, Valve Stem</b>				
68-73	All (307)	838029 A.R.	.06	("U" shape)
73	All (307)	3947770 A.R.	.12	(carbonized) (ident. by purple dye)
<b>0.333 ARM UNIT, Valve Rocker with Adjusting Screw and Nut</b>				
68-73	All (307)	3974290 16	2.40	inlet and exhaust ("V" stamped on inside of pad end)
<b>0.386 COVER ASSY.— GROMMET, Valve Rocker Arm</b>				
68-72	All (307)	6272227 2	10.30	w/oil filler cap R.H., L.H.
73	All (307)	333866 L.H.	9.10	left
73	All (307)	333867 R.H.	9.10	right
68-70	All (307)	3894337 A.R.	.11	GROMMET, cover to a/cl.— (1.745)
<b>0.413 BOLT— REINFORCEMENT, Valve Rocker Cover and Support</b>				
68-73	All (307)	180016 1		( $1/4$ "— 20 x $1/2$ ")— (8.900)
68-73	All (307)	3877670 A.R.	.12	REINFORCEMENT ( $1\frac{1}{2}$ " O.L.) (Note 1)
<i>NOTE 1 Use with Bolt 180016.</i>				
<b>0.423 GASKET, Valve Rocker Cover</b>				
68-73	All (307)	3933964 2	1.80	
<b>0.426 ROD, Valve Push</b>				
68-73	All (307)	3796243 A.R.	2.15	( $7\frac{25}{32}$ " O.L.) (blue stripe) (Note 1, 2)
<i>NOTE 1 May have one black stripe at each end.</i>				
<i>NOTE 2 Color marked end to be at valve rocker arm.</i>				
<b>0.429 BALL— NUT— STUD, Valve Push Rod Adjusting</b>				
68-73	All (307)	3959142 A.R.	.38	( $13/16$ " dia.)
68-73	All (307)	3744341 16	.22	NUT, valve rocker arm ( $3/8$ "— 24) ( $5/8$ " across the flats x $1/2$ ")
68-73	All (307)	3814692 16	.53	STUD, valve rocker arm ball (.003 O.S.— light blue paint)
68-72	All (307)	3815892 16	.53	STUD, valve rocker arm ball (.013 O.S.— $3/8$ "— 24 $2\frac{1}{2}$ ") (1 groove on shank— light blue paint)
<b>0.459 TAPPET, Valve (or Lifter)</b>				
68-73	All (307)	5232670 16	4.54	hydraulic type
<b>0.519 CAMSHAFT, Engine</b>				
<i>NOTE Engine Camshaft Break-in Oil 1050800, Group 1.850, should be used when installing new camshafts.</i>				
68-73	All (307)	3896929 1	48.25	standard (ident. No. 3896930)
<b>0.539 BEARING, Camshaft (Front or No. 1)</b>				
68-73	All (307)	3723584 1	2.40	precision type (stamped 1)
<b>0.543 BEARING, Camshaft No. 2 (Front Intermediate)</b>				
68-72	All (307)	3723585 1	2.40	precision type (stamped 2)
73	All (307)	3723584 1	2.40	(0.539)
<b>0.546 BEARING, Camshaft (Center and Rear Intermediate)</b>				
68-72	All (307)	3723586 A.R.	2.40	(stamped 3 and 4)
73	All (307)	3723584 2	2.40	(0.539)
<b>0.549 BEARING, Camshaft Rear</b>				
68-72	All (307)	3723585 1	2.40	precision type (stamped 2)— (0.543)
73	All (307)	3723584 1	2.40	(0.539)
<b>0.553 PLUG, Camshaft Bearing Hole, cup type (in cylinder block)</b>				
68-71	All (307) (1st design)	3704158 1	.22	( $2\frac{1}{8}$ " dia.)
71-73	All (307) (2nd design)	3997752 1	.12	rear brg. (has mfg. ident. mark)
<b>0.603 ROD ASSY., Connecting, Less Dipper</b>				
68-73	All (307)	3916396 8	12.70	

### 307-ENGINE ASSEMBLY

#### 0.616 BEARING UNIT, Connecting Rod (1 Upper and 1 Lower)

Refer to chart for Model Application

*NOTE: See Dealer Price Schedule for applicable prices.*

#### CONNECTING ROD BEARING UNIT CHART

MODEL USAGE	STD.	.001 U.S.	.002 U.S.	.010 U.S.	.020 U.S.
68-73 All (307)	3910555 <sup>(1)</sup>	3910556 <sup>(1)</sup>	3910557 <sup>(1)</sup>	3910558 <sup>(1)</sup>	3910559 <sup>(1)</sup>

*(1) Aluminum M-400.*

#### 0.623 BOLT, Connecting Rod Bearing Cap

68-73 All (307)	3916399 16	.60	(3/8" — 24 x 1 <sup>59</sup> / <sub>64</sub> "
-----------------	------------	-----	--

#### 0.626 NUT, Connecting Rod Bearing Cap Bolt

68-69 Chevy, Chevelle, Camaro (307)	9422298 A.R.	.11	(3/8" — 24 x 5 <sup>5</sup> / <sub>16</sub> " thick) (one end chamfered) — (8.917)
68-69 All (exc. Chevy) (307), 70-73 All (307)	3866766 A.R.	.12	(3/8" — 24 x 3 <sup>3</sup> / <sub>8</sub> " thick) (hex. nut) (both ends flat) (Note 1)

*NOTE 1 Also used with bolts not requiring cotter pins.*

#### 0.629 PISTON ASSY., with Pin

*NOTE Individual piston assemblies are available for warranty purposes and for replacement of pistons damaged when making repairs to engine assemblies. When ordering such parts it is necessary that you specify on your order the reason the parts are required and also that the following note appears on your order. Do not ship unit package quantity.*

ENGINE DISPLACEMENT	BASIC SIZE	SERVICE PISTON DIAMETER RANGE LIMITS ALUMINUM
307 cu. in.	3.8750—STD.	S-4— 3.8750 to 3.8755, S-5— 3.8755 to 3.8760
307 cu. in.	3.8760—.001	S-6— 3.8760 to 3.8765, S-7— 3.8765 to 3.8770

*NOTE: The above chart is for information purposes only.*

*NOTE: See Dealer Price Schedule for applicable prices.*

#### PISTON CHART

MODEL USAGE	STD.	.001 O.S.	.030 O.S.
68-72 All (307)	3923294	3923295	3923297
73 All (307)	6271087	6271088	6271090

#### 0.643 RING UNIT, Piston (Service Sets)

*NOTE: See Dealer Price Schedule for applicable prices.*

**Original Equipment Type (complete set for one engine per container unless otherwise noted)**

MODEL USAGE	STD.	.030 O.S.
68-72 All (307)	326400 <sup>(1, 2, 5)</sup>	328503 <sup>(6)</sup>
73 All (307)	326400	328503

## 307-ENGINE ASSEMBLY

### Special Replacement Type

	STD.	.020 O.S.	.030 O.S.
68-72 All (307) .....	326400 <sup>(5)</sup>		328503 <sup>(3, 4, 5)</sup>

*(1) These are Molybdenum premium rings.*

*(2) This part is eligible for wholesale compensation.*

*(3) These Ring Units contain 3/32" compression rings.*

*(4) Cromflex Ring Set having chrome plated oil rings, top compression ring, and chrome-plated rail for middle compression ring.*

*(5) Single cylinder replacement.*

#### 0.646 CRANKSHAFT, Engine

68 All (307) .....	3930809	1	147.00	(Note 1) .....	
69-73 All (307) .....	3941172	1	170.00	(Note 1) .....	

*NOTE 1 When used on A.T. it will be necessary to remove the pilot bearing.*

#### 0.649 BEARING, Crankshaft Clutch Pilot

68-73 All (307) .....	3752487	1	1.20	(bush type— 19/32" I.D. x 1 3/32" O.D. x 3/4") ..	
-----------------------	---------	---	------	---	--

#### 0.659 BALANCER— PULLEY, Crankshaft

*NOTE In some cases double groove pulleys may be used in place of single groove pulleys.*

*NOTE Crankshaft harmonic balancer is also referred to as "torsional damper".*

68 All (307) .....	3896904	1	26.50	w/o pulley (hub 4 1/2" O.D.) .....	
69-73 All (307) .....	6272223	1	26.50		
68 Chevy, Chevelle (307) (exc. C.A.C., C/Deluxe Air Cond., A.I.R.) .....	3755820	1	7.75	PULLEY (stamped 3755820) .....	
68 Pass. w/A.I.R. (307) (exc. C.A.C.),					
68 Chevy (307) .....	3744043	1	8.20	PULLEY (double-6 5/8" O.D.— painted black) (stamped 3744043) .....	
68 Chevy, Chevelle, Pass. w/P/S (307) .....	3751232	1	7.75	PULLEY, front (stamped 3751232) .....	
68 Chevy, Chevelle w/Air Cond. (307),					
68 Pass. w/C.A.C., C/Deluxe Air Cond. (307) .....	3850838	1	9.00	PULLEY (7 21/64" O.D.) .....	
68 Pass. w/P/S, C.A.C. (307) (exc. T.H.) .....	3911013	1	9.00	PULLEY, crankshaft (7 47/64" O.D.) .....	
70 Nova w/Acc. Air Cond. (307) .....	3937787	1	12.90	PULLEY (3 groove) (Note 1) .....	
68 All (307) (exc. C.A.C., P/S),					
69-73 All (307) (exc. C.A.C.) .....	3956666	1	9.20	PULLEY ASSY. (2 groove) .....	
69 All w/Air Cond. (307),					
70 Nova, Chevelle w/Acc. Air Cond. (307),					
70-73 All w/C.A.C. (307) .....	3972180	1	15.95	PULLEY ASSY. (3 groove) (stamped 3972180) .....	

#### 0.662 WASHER— REINFORCEMENT, Harmonic Balancer and Crankshaft Pulley

68-73 All (307) .....	3739422	1	.46	balancer (29/64" I.D. x 1 3/4" O.D. x 5/16" thk.) ..	
69 All w/C.A.C. (307) .....	3965597	1	.59	REINFORCEMENT, crankshaft pulley .....	

#### 0.666 FLYWHEEL, with Ring Gear

68-70 All w/P.G. (307) .....	3789821	1	26.75	spoke type (6-2" dia. holes around ctr.) .....	
68 All (307) (exc. A.T., H.D. Clutch),					
69-73 All (307) (exc. A.T.) .....	3973452	1	59.25	solid type (cast 3791021) .....	
68-69 Chevelle w/H.D. clutch (307) .....	3998281	1	68.25	w/11" coil sprg. clutch (12 5/8" bolt circle) solid type .....	
68 Pass. w/T.H. 350 (307) .....	336763	1	32.00		
69-70 All w/T.H. 350 (307),					
71-73 All w/A.T. (307) .....	3991402	1	26.75		

#### 0.669 BOLT, Flywheel to Crankshaft

68-73 All (307) (exc. A.T.) .....	839756	6	.12	(7/16"— 20 x 1) .....	
68-73 All w/A.T. (307) .....	3727207	6	.21	(7/16"— 20 x 45/64"— 290M steel) .....	

#### 0.673 GEAR, Flywheel Ring

68-72 All (307) .....	3991408	1	6.40	
73 All (307) .....	3991407	1	7.95	

#### 0.679 UNDERPAN— BOLT— COVER— SCREW— STUD, Flywheel

68-69 All w/P.G. (307) .....	3789959	1	3.95	transmission (17 61/64" O.L.) .....	
68-69 All w/T.H. 400 (307) .....	3868810	1	3.55	trans. converter .....	
68-73 All w/T.H. 350 (307) .....	6261091	1	4.20	trans. converter .....	
70-73 All w/P.G. (307) .....	3933089	1	4.35	trans. converter .....	

**307-ENGINE ASSEMBLY**

**0.679 UNDERPAN— BOLT— COVER— SCREW— STUD, Flywheel (Con't)**

70	All w/T.H. 400 (307)	3952661	1	4.85	trans. converter
ALL	All (307)	3817006 A.R.		.12	BOLT, w/washer (1/4" — 20 x 7/16")
68-69	Chevy, Chevelle, Camaro (307) (exc. P.G.),				
68	Pass. w/reg. fuel (307),				
70-73	All (307) (exc. A.T.)	354497	1	2.65	COVER, clutch housing (repl. 3788422)
68	Pass. Chevelle w/H.D. Clutch (307)	3843943	1	3.05	COVER, clutch housing
69	All w/T.H. 350 (307)	9420825	4		SCREW (5/16" — 18 x 9/16") — (8.977) (Note 1)
68-73	Nova, Chevelle w/P.G. (307)	3924780 A.R.		.16	SCREW ASSY., w/washer (5/16" — 18 x 7/8")
72	All (307)	6270052 A.R.		.11	STUD (1/4" — 20 x 37/64")
	NOTE 1 Use with washer 120393 group (8.929).				

**0.683 HOUSING ASSY.— BOLT, Flywheel and Clutch**

68	Pass. (307) (exc. Taxi, Police, H.D. Clutch),				
68	Chevelle (307) (exc. H.D. Clutch),				
68	Chevy (307),				
70-73	All (307)	3858403	1	30.50	clutch (Ident. No. 3840383) (less ball stud)
68	All w/H.D. clutch (307)	3899621	1	37.50	clutch
ALL	Pass. (307)	3733130	2	.24	BOLT, clutch housing attach. (3/8" — 16 x 2 1/4" — washer hd.) (300M steel) — (3.275)

**0.685 DOWEL, Flywheel and Clutch Housing to Cylinder Block**

68-73	All (307)	3712745	2	.50	clutch and flywheel (2 1/32" x 1 1/4" long)
-------	-----------	---------	---	-----	---

**0.724 CHAIN, Camshaft Timing**

68-73	All (307)	346261	1	11.20	early link type
-------	-----------	--------	---	-------	-----------------

**0.728 SPROCKET, Crankshaft Timing (Steel)**

68-73	All (307)	3896959	1	4.65	(18 teeth — 2 7/8" O.D.) (early link type)
-------	-----------	---------	---	------	--

**0.736 SPROCKET, Camshaft Timing**

68-73	All (307)	340235	1	8.45	(36 teeth) (repl. 3896960)
-------	-----------	--------	---	------	----------------------------

**0.738 PIN, Camshaft Sprocket**

68-73	All (307)	3836903	1	.11	dowel (1/4" x 5/8") (solid)
-------	-----------	---------	---	-----	-----------------------------

**0.787 ROD— CLIP— SWIVEL, Clutch Fork Release**

68-73	Nova (307),				
69-73	Camaro (307)	3973076	1	1.95	fork push
68-72	Camaro, Nova (307)	340690	1	1.10	fork push adjusting (4 3/4" long)
68	Pass. (307)	3859863	1	1.25	fork push
68-73	Chevelle (307)	9779202	1	.88	fork push
73	Nova, Camaro (307)	335380	1	1.40	fork push adjusting (4 3/16" long)
68-69	All (307)	3749084 A.R.		.27	CLIP, push rod and swivel — (4.037)
68-69	All (307)	1455017	1	.13	CLIP, push rod — (3.425)
68	Pass. (307)	3859839	1	.71	SWIVEL, pedal push
68-72	Chevelle (307)	3840845	1	1.40	SWIVEL, fork push rod (1 1/2" O.L.) (3/8" — 16 thds.)

**0.793 WASHER, Clutch Fork Push Rod**

68-73	All (307)	3756694	1	.11	push rod lever thrust (2 3/4" dia. pedal shaft) pull rod lever
-------	-----------	---------	---	-----	---

**0.795 FORK ASSY., Clutch Release**

68-73	All (307)	3892632	1	7.15	
68	Pass. (307)	3860005	1	7.15	

**0.796 STUD— BRACKET, Clutch Fork**

68	Pass. (307)	3790556	1	.84	ball (3/16" — 16 thds.)
68-70	Chevy, Chevelle, Camaro (307),				
71-73	All (307)	3729000	1	1.05	ball (19/16" — 16 w/2 1/32" diameter ball)
71-72	Chevelle (307)	3992305	1	.40	BRACKET, pull back

**0.797 BOOT, Clutch Fork**

68-73	All (307)	3993851	1	.76	
-------	-----------	---------	---	-----	--

**0.799 BEARING, Clutch throwout with Collar**

68	Chevy, Chevelle w/3-Spd. (307),				
68	Pass. (307) (exc. 4-Spd., A.T., H.D. 3-Spd.),				
69	Chevy (307) (exc. 4-Spd.),				
69	Chevelle (307) (exc. 4-Spd.),				

## 307-ENGINE ASSEMBLY

### 0.799 BEARING, Clutch throwout with Collar (Con't)

69	Camaro (307),				
70	Nova, Chevelle w/3-Spd. (307),				
71-72	All w/3-Spd. (307),				
73	All (307) . . . . .	908092	1	15.94	ball bearing type (1 <sup>7</sup> / <sub>8</sub> " long) . . . . .
70	Nova, Chevelle w/4-Spd. (307) . . . . .	908093	1	13.56	(1 <sup>7</sup> / <sub>32</sub> " O.L.) . . . . .

### 0.829 BUMPER— BRACKET— COVER— PLUG— SEAL, Clutch

(For COVERS See Group 4.630)

68	Chevelle (307) (exc. P.B.),				
68-69	Chevy, Chevelle, Camaro (307),				
68	Pass. (307),				
70-72	All (307) . . . . .	340688	1	.21	pedal . . . . .
73	Chevelle (307) . . . . .	6264981	1	1.30	BRACKET, pedal bumper . . . . .
69-73	Camaro w/A.T. (307),				
68-73	Chevy w/A.T. (307) . . . . .	3886689	1	.21	COVER, clutch pedal push rod hole . . . . .
68	Pass. w/A.T. (307) . . . . .	6256958	1		PLUG, pedal push rod hole (repl. 3872120)— (12.980) . . . . .
68	Pass. (307) . . . . .	3857543	1	.65	SEAL, pedal push rod . . . . .
69-73	Camaro w/A.T. (307),				
68-73	Chevy w/A.T. (307) . . . . .	3903466	1	.15	SEAL, clutch pedal push rod hole cover . . . . .
68-69	Nova, Camaro (307),				
70-73	Nova (307) . . . . .	3909071	1	1.20	SEAL ASSY., clutch pedal push rod . . . . .
68-72	Chevelle (307) . . . . .	399904	1	3.20	SEAL ASSY., clutch pedal push rod . . . . .
70-73	Camaro (307) . . . . .	3973089	1	2.65	SEAL ASSY., clutch pedal push rod . . . . .
73	Chevelle (307) . . . . .	3994485	1	3.20	SEAL ASSY., clutch pedal push rod . . . . .

### 0.830 PEDAL, Clutch

68-72	Chevelle (307) . . . . .	3967783	1	5.30	
68-69	Nova, Camaro (307),				
70-71	Camaro (307) . . . . .	3965693	1	5.30	
72-73	Nova (307) . . . . .	6258554	1	6.55	
72	Camaro (307) . . . . .	3998671	1	5.30	
73	Chevelle (307) . . . . .	3994483	1	8.85	
73	Camaro (307) . . . . .	332519	1	5.60	

### 0.831 BUSHING, Clutch Pedal (see group 4.626 for brake pedal bushing)

68-71	All (307) . . . . .	1247439	2	.11	(4.626) . . . . .
-------	---------------------	---------	---	-----	-------------------

### 0.837 RETAINER— SPACER, Clutch and Brake Pedal Shaft-(Also see Groups 4.634 and 4.648)

68-71	All (307) . . . . .	3828428	1	.22	shaft— (4.634) . . . . .
70-71	Camaro (307) . . . . .	9783098	1	.87	SPACER (4.634) . . . . .

### 0.844 SPRING, Clutch Pedal Pull Back

68	Pass. (307) . . . . .	3849704	1	.34	fork pull back . . . . .
68	Pass. (307) . . . . .	3879772	1	.22	clutch pull back . . . . .
69	Camaro (307),				
68-72	Chevy (307) . . . . .	3899021	1	.28	clutch fork push rod pull back . . . . .
68-70	Chevelle (307) . . . . .	3920614	1	.34	
70-72	Camaro (307) . . . . .	3973088	1	.40	fork pull back . . . . .
71-72	Chevelle (307) . . . . .	3992306	1	.52	fork pull back . . . . .
73	Chevelle (307) . . . . .	3994494	1	1.75	fork pull back . . . . .
73	Nova (307) . . . . .	332517	1	.46	fork pull back . . . . .
73	Camaro . . . . .	332521	1	.76	fork pull back . . . . .

### 0.846 EXTENSION, Clutch Pedal Pull Back Spring

69	Camaro (307),				
68-72	Chevy (307) . . . . .	3899022	1	.32	clutch fork push rod pull back spring . . . . .
73	Nova (307) . . . . .	332518	1	.63	fork push rod pull back spring . . . . .

### 0.851 SEAT— SEAL— SPRING— STUD— WASHER, Clutch Pedal Intermediate Lever Shaft Ball

68-73	All (307) . . . . .	3743349	A.R.	.18	stud (7/8" dia.) . . . . .
68-73	All (307) . . . . .	382658	1	.19	SEAL, ball stud dust, lever shaft ball stud . . . . .
68-73	All (307) . . . . .	3750696	1	.13	SPRING, frame stud seat, retaining (1" O.D.) . . . . .
68-70	Chevy, Chevelle, Camaro (307),				
71-73	All (307) . . . . .	3866568	1	1.15	STUD, lever shaft ball to engine . . . . .
68-71	All (307) . . . . .	3898610	1	.81	STUD, to body, to frame (3/8"— 24 x 1 <sup>13</sup> / <sub>16</sub> " O.L.) . . . . .
68	Pass. (307) . . . . .	3859488	1	1.20	STUD, lever shaft ball to eng. . . . .
70	Camaro (307) . . . . .				STUD, clutch lvr. & shaft ball to brkt., . . . . .
70-72	Chevy (307) . . . . .				clutch lvr. & shaft ball, to eng., . . . . .
70	Chevelle (307) . . . . .				clutch lvr. & shaft ball to frame, . . . . .

### 307-ENGINE ASSEMBLY

		<b>0.851 SEAT— SEAL— SPRING— STUD— WASHER, Clutch Pedal Intermediate Lever Shaft Ball (Con't)</b>			
73	All (307)	3935289	1	1.20	lever shaft ball to frame ( $\frac{3}{8}$ "— 24 x $1\frac{13}{16}$ " O.L.)
68-73	All (307)	3743360	1	.18	WASHER, stud dust seal, L.H. to frame (felt— $\frac{9}{16}$ " I.D. x $1\frac{3}{8}$ " O.D.) lever assy. seal
		<b>0.852 LEVER— BRACKET— SHAFT, Clutch Pedal, Intermediate (See Group 4.648 for brake)</b>			
69	Camaro (307),				
68-73	Chevy (307)	3998652	1	10.50	w/shaft
68-72	Chevelle (307)	3920615	1	10.10	w/shaft
70-73	Camaro (307)	3973082	1	12.25	w/shaft
73	Chevelle (307)	3994486	1	19.10	w/shaft
68	Pass. (307) (exc. Police, Taxi)	3859861	1	.28	BRACKET, clutch shaft frame
68	Police, Taxi (307)	3869851	1	2.05	BRACKET, clutch shaft frame
68-69	Chevy, Camaro (307),				
70-73	Nova (307)	3932760	1	.83	BRACKET, lever and shaft
68-70	Chevelle (307) (exc. Monte Carlo),				
71-72	Chevelle (307)	3918098	1	.81	BRACKET, lever and shaft frame
70-73	Camaro (307)	3973086	1	.94	BRACKET, lever and shaft
73	Chevelle (307)	3994491	1	1.25	BRACKET, lever and shaft frame
68	Pass. (307)	3954621	1	6.50	SHAFT, w/lever
		<b>0.854 ROD— BUSHING— CLIP, Clutch Pedal</b>			
68	Pass. (307)	3859838	1	2.20	pedal push
68-72	Chevelle (307)	3920618	1	2.10	pedal push
68-69	Chevy, Camaro (307),				
70-72	Nova (307)	3920262	1	1.95	pedal push
70-71	Camaro (307)	3973087	1	3.50	push
72	Camaro (307)	3998670	1	3.00	push
73	Chevelle (307)	3994490	1	5.20	push
73	jova (307)	332516	1	2.15	push
72-73	Camaro (307)	406172	1	.88	BUSHING, push rod
68	Pass. (307)	1455017	2	.13	CLIP, pedal pull rod— (3.425)
		<b>0.859 PLATE ASSY., Clutch Pressure with Cover</b>			
68	Pass. w/H.D. Chassis, 4-Spd. (307),				
69-70	All w/4-Spd. (307)	3841673	1	61.50	(diaphragm spring type) (cast 3793480) ( $10\frac{1}{2}$ " )
68-70	All (307) (exc. 4-Spd., H.D. Clutch, H.D. Chassis),				
71-73	All (307)	3991496	1	65.00	
68	Pass., Chevelle w/H.D. Clutch (307)	3962052	1	59.00	
		<b>0.861 COVER, Clutch</b>			
68-69	Chevy, Chevelle (307) (exc. 4-Spd.),				
68	All (307) (exc. H.D. Chassis, 4-Spd., 4BC, H.D. Clutch),				
70	All (307),				
71-72	Nova, Camaro (307)	3821765	1	19.30	diaphragm spring type ( $12\frac{31}{64}$ " O.D.)
68-69	Chevy, Chevelle, Camaro w/4-Spd. (307) (2nd design),				
68	Pass. w/H.D. Chassis, 4-Spd., 4BC (307)	3793478	1	23.90	diaphragm spring type ( $12\frac{31}{64}$ " O.D.)
68	Pass., Chevelle w/H.D. Clutch (307)	3821763	1	21.75	diaphragm spring type ( $13\frac{3}{4}$ " O.D.)
		<b>0.862 BOLT, Clutch Cover and Pressure Plate</b>			
68-69	All (307)	838653 A.R.		.12	( $\frac{9}{8}$ "— 16 x 1)
68-71	All (307)	3962058 A.R.		.22	retrac. spring ( $\frac{5}{16}$ "— 18 x $\frac{29}{32}$ " hex.)— (0.864)
		<b>0.863 PLATE, Clutch Pressure</b>			
68	All w/4-Spd. (307),				
69-70	Nova, Chevelle w/4-Spd. (307)	3793480	1	34.00	(cast 3793480) ( $10\frac{1}{2}$ " )
68	Pass. w/H.D. Clutch (307),				
68	Chevelle w/4-Spd. (307)	3962057	1	16.90	(11" O.D.)
68-70	Chevy (307) (exc. 4-Spd.),				



### 307-ENGINE ASSEMBLY

#### 0.863 PLATE, Clutch Pressure (Con't)

68	Pass., Chevelle (307) (exc. 4-Spd., H.D. Clutch, H.D. Chassis),				
69-70	Chevelle (307) (exc. 4-Spd.),				
71-73	All (307) .....	3991497	1	15.70	(10½" O.D.) .....

#### 0.864 BOLT— SPRING, Clutch Pressure Plate

68-73	All (307) .....	3962058	A.R.	.22	retrac. spring (5/16" — 18 x 29/32" hex.) .....
68-73	All (307) .....	3788605	3	.13	<b>SPRING</b> , retracting (1 9/32" dia. at wide end w/5/16" ctr. hole) (Note 1) .....

*NOTE 1 Replace only in sets of three.*

#### 0.886 DISC, with Facing, Clutch

68	Chevelle w/H.D. Clutch (307),				
68	Chevy (307),				
68	All (307) (exc. H.D. Clutch),				
69-73	All (307) .....	3927128	1	40.00	woven (10 13/32") .....
68	Pass., Chevelle w/H.D. Clutch (307) .....	3828848	1	41.75	woven (11") .....

## 327-ENGINE ASSEMBLY

### 0.000 ENGINE ASSEMBLY

*NOTE When installing the following engines on applicable past models, non-interchangeable parts must be discarded and replaced with parts that fit the replacing engine. See Engine Installation Instruction Charts in the General Information Section for parts and instructions necessary with service engines on past model information.*

<b>64-67</b>	Chevelle, Camaro (327) (exc. Sp. H/Per.),				
<b>65-67</b>	Pass. (327) . . . . .	<b>3970188</b>	1	800.00	(less flywheel dist., exh. mfls. clutch housing, and all clutch components) . . . . .

*The above engine assemblies do not include the following sub assemblies.*

Carburetor Fuel Pump Oil Filter Assy.	Fan Blade and Pulley Generator Ignition Coil	Ignition Wiring Starting Motor Ventilator Assy.
---	--	---

*NOTE Special equipment production assemblies are available while in production, through Central Office, on direct order Form PC 785.*

### 0.002 BOLT— WASHER, Engine Mounting (Small Attaching)

<b>64-67</b>	Chevelle (327),				
<b>68</b>	Pass. (327) . . . . .	<b>3840748</b>	1	.28	right side ( $7/16$ "— 14 x 4) . . . . .
<b>65</b>	Malibu (S.S.) (327) . . . . .	<b>3774468</b>	1	.36	rear mtg. (hex. $7/16$ "— 20 x 3) frt. bracket fldg. plate . . . . .
<b>67-68</b>	Pass., Chevelle w/A.I.R. (327),				
<b>67-68</b>	Camaro w/A.I.R., C.A.C. (327),				
<b>68</b>	Chevy (327) . . . . .	<b>3785362</b>	1	.32	special hex. ( $3/8$ "— 16 x $2^{5/8}$ ") flat point (300M steel) w/pump and upper right side
<b>62-68</b>	All (327) (exc. Pass.) . . . . .	<b>3954735</b>	2	.13	<b>WASHER, brkt. to engine (left side) (<math>7/16</math>" (repl. 3693853)— (14.875) . . . . .</b>

### 0.010 GASKET UNIT, Engine or Tune Up

<b>64-69</b>	All (327) . . . . .	<b>3970634</b>	1	5.50	engine . . . . .
--------------	---------------------	----------------	---	------	------------------

### 0.027 MOUNTING UNIT— CABLE UNIT, Engine

## 8 CYLINDER

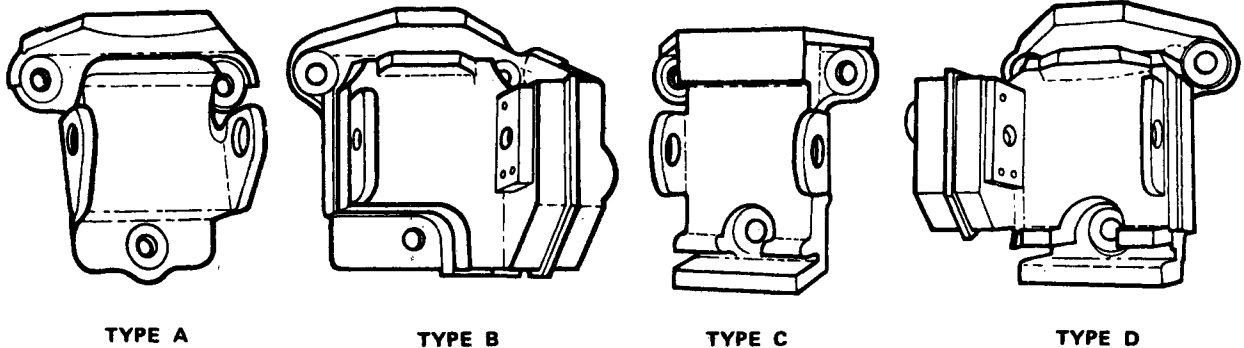

*NOTE Mount units 3990914 and 3990918 include a mount, mount to frame bracket bolt, washers and nut. Mount units 3988989 and 3990920 include the above items and also a power steering pump brace and mount to cylinder case attaching bolts and lockwashers.*

<b>64-67</b>	Chevelle (327) (See Note 4),				
<b>65-67</b>	Chevy (327),				
<b>65-68</b>	Pass. (327) (exc. P/S) (See Note 5),				
<b>65-68</b>	Pass. w/P/S (327) (Right hand side replacement only - See Note 5),				
<b>67-68</b>	Camaro (327) (exc. P/S),				
<b>67-68</b>	Camaro w/P/S (327) (Right hand side replacement only),				
<b>68</b>	Chevy (327) (exc. P/S),				
<b>68</b>	Chevy w/P/S (327) (Right hand side replacement only),				
<b>68</b>	Chevelle (327) (See Note 5),				
<b>69</b>	Pass., Camaro (327) . . . . .	<b>3990914 A.R.</b>		9.95	(Note 4, 5) . . . . .

## 327-ENGINE ASSEMBLY

### 0.027 MOUNTING UNIT— CABLE UNIT, Engine (Con't)

*NOTE 4* When using this unit on 1964-1967 Chevelle with 327 engine, it is necessary to procure Frame Bracket 3872815 for L.H. or 3872816 for R.H. mount replacement.

*NOTE 5* Refer to illustration of mounting "Type A". This unit is to be used when replacing Type A mounting on.

- (1) R.H. side 1968 Chevelle (327)
- (2) R.H. and/or L.H. side 1967-68 Pass. (327) (exc. P/S)
- (3) R.H. side only 1967-68 Pass. w/P/S (327)

65-68	Pass. w/P/S (327) (See Note 6),				
67-68	Camaro w/P/S (327),				
68	Chevy w/P/S (327) . . . . .	3988989	L.H.	13.55	(Note 6) . . . . .
	<i>NOTE 6</i> Refer to illustration of mounting "Type A". This unit is to be used when replacing Type A mounting on.				
	(1) L.H. side 1967-68 Pass. w/P/S (327)				
67-68	Pass. (327) (exc. P/S) (See Note 8),				
67-68	Pass. w/P/S (327) (Right hand side replacement only - See Note 8),				
68	Chevelle (327) (See Note 8) . . . . .	3990918	A.R.	11.05	(Note 8) . . . . .
	<i>NOTE 8</i> Refer to illustration of mounting "Type B". This unit is to be used when replacing Type B mounting on.				
	(1) L.H. side 1968 Chevelle (327)				
	(2) R.H. and/or L.H. side 1967-68 Pass. (327) (exc. P/S)				
	(3) R.H. side only 1967-68 Pass. w/P/S (327)				
67-68	Pass. w/P/S (327) . . . . .	3990920	L.H.	14.40	(Note 10) . . . . .
	<i>NOTE 10</i> Refer to illustration of mounting "Type B". This unit is to be used when replacing Type B mounting on.				
65-67	Chevy (327) . . . . .	330267	1	N.L.	CABLE UNIT, engine stop lift . . . . .
65-68	Pass. w/C.A.C. (327) . . . . .	325878	1	N.L.	CABLE UNIT, engine stop lift . . . . .
67-68	Camaro (327),				
68	Chevy (327),				
69	Chevy, Camaro (327) (exc. C.A.C.) . . . . .	330265	1	N.L.	CABLE UNIT, engine stop lift . . . . .
69	Camaro, Chevy w/C.A.C. (327) . . . . .	330280	1	N.L.	CABLE UNIT, engine stop lift . . . . .
69	Pass. w/P/S (327) . . . . .	325874	1	N.L.	CABLE UNIT, engine stop lift . . . . .
69	Pass. (327) (exc. P/S) . . . . .	325873	1	N.L.	CABLE UNIT, engine stop lift . . . . .
65-68	Pass. (327) (exc. C.A.C.),				
	(1) L.H. side 1967-68 Pass. w/P/S (327)				

### 0.029 BRACKET— MOUNTING ASSY., Engine Mounting

67-69	Camaro (327),				
68	Chevy (327) . . . . .	3955183	L.H.	2.95	engine mtg. to side member . . . . .
67-69	Camaro (327),				
68	Chevy (327) . . . . .	3980938	R.H.	2.95	engine mtg. to side member . . . . .
65-67	Chevy (327) . . . . .	3790287	L.H.	3.80	BRACKET ASSY., body . . . . .
65-67	Chevy (327) . . . . .	3790288	R.H.	3.80	BRACKET ASSY., body . . . . .
65-69	Pass. (327) . . . . .	3954637	L.H.	2.00	BRACKET ASSY., frame . . . . .
65-69	Pass. (327) . . . . .	3977234	R.H.	3.25	BRACKET ASSY., frame . . . . .
65-66	Pass. (327) . . . . .	3977235	L.H.	3.20	BRACKET ASSY., frame . . . . .
68	Chevelle (327) . . . . .	3980711	L.H.	5.00	BRACKET ASSY., frame . . . . .
68	Chevelle (327) . . . . .	3980712	R.H.	5.00	BRACKET ASSY., frame . . . . .
64-67	Chevelle (327) . . . . .	3840755	L.H.	2.45	MOUNTING ASSY., body . . . . .
64-67	Chevelle (327) . . . . .	3840756	R.H.	2.45	MOUNTING ASSY., body . . . . .

### 0.033 BLOCK ASSY., Cylinder

*NOTE CAUTION.* Combination not appearing below should be checked in the Engine Series Number and Suffix Chart in front of catalog to determine if the combination was available in production. If not available, no attempt should be made to make the installation.

#### PARTIAL ENGINE

*NOTE* Includes block, crankshaft, camshaft, timing gears, pistons and connecting rods.

65-67	Pass. (327),				
65-67	Chevelle, Camaro (327) (exc. H/Per., Sp. H/Per.) . . . . .	3970156	1	625.00	(Note 1) . . . . .
65	Chevelle w/H/Per., Sp. H/Per. (327),				
66-67	Chevelle w/Sp. H/Per. (327) . . . . .	3970158	1	647.00	(Note 3) . . . . .
62-67	Chevy (327) (exc. Sp. H/Per.) . . . . .	3991001	1	571.00	(Note 1) . . . . .
66-67	Chevy w/Sp. H/Per. (327) . . . . .	3991003	1	647.00	
68	Chevy, Chevelle (327) (exc. Sp. H/Per.),				
68-69	Pass., Camaro (327) . . . . .	3970654	1	625.00	(Note 5) . . . . .
68	Chevy, Chevelle w/Sp. H/Per. (327) . . . . .	3933044	1	647.00	

## 327-ENGINE ASSEMBLY

### 0.033 BLOCK ASSY., Cylinder (Con't)

#### FITTED CYLINDER BLOCK (Includes Pistons, Pins, Rings and Bearings)

64-67	Pass., Chevelle, Camaro (327) (exc. H/Per., Sp. H/Per.)	3970134	1	408.00	(Note 2)
64-67	Pass., Chevelle w/H/Per., Sp. H/Per. (327)	3970136	1	418.00	
68	Chevy, Chevelle w/Sp. H/Per. (327)	3931636	1	418.00	
68	All (327) (exc. Sp. H/Per.),				
69	Pass., Camaro (327)	3970644	1	408.00	(Note 5)

*NOTE 1 When using on models with A.T. it will be necessary to remove clutch pilot bearing from crankshaft.*  
*NOTE 2 Some early 1968 passenger models use 1967 engines. These will meet 1968 spec. except as follows: Cylinder and Case Assy., Conn. Rod Assy., Crankshaft Assy., Main and Conn. Rod Bearings. Replaceable element Oil Filters, by-pass valve and related parts. These can be identified by the oil filter. (1968 use the throw away type oil filter) Refer to the above 1967 components in their group.*  
*NOTE 3 Use with 1969 inlet manifold gasket.*  
*NOTE 4 It may be necessary to either transfer S. Bearing Cap Bolts or Bearing Cap Studs.*  
*NOTE 5 When using on 1968 models, it is mandatory to use 3957985 Inlet Manifold Gasket Unit.*

### 0.034 EXPANSION PLUGS, Cylinder Block (Also see 8.970)

62-69	All (327) (exc. Pass.)	838538 A.R.		.18	water jacket balance shaft hole (cup type) (1 <sup>5</sup> / <sub>8</sub> " )
64-68	All (327)	3738306 A.R.		.46	(square socket water jacket hole) (1 <sup>1</sup> / <sub>4</sub> " )

### 0.056 BOLT— STUD, Crankshaft Bearing Cap

62-68	Chevy, Chevelle (327),				
65-68	Pass. (327)	3872781 A.R.		.28	(1 <sup>1</sup> / <sub>16</sub> " — 14 x 3 <sup>9</sup> / <sub>32</sub> " )
69	All (327)	3932480	10	.28	(7 <sup>1</sup> / <sub>16</sub> " — 14 x 3 <sup>11</sup> / <sub>32</sub> " )
66	Chevy w/Sp. H/Per. (327)	3872718 A.R.		1.25	STUD, No. 6 brg. cap, right (7 <sup>1</sup> / <sub>16</sub> " — 14— 3 <sup>3</sup> / <sub>8</sub> " — 16 x 5 <sup>1</sup> / <sub>4</sub> " )

### 0.093 PLASTIGAGE, Crankshaft Bearing

62-69	All (327)	1390274 A.R.		6.15	(green package-type PG-1) (12 pieces)
-------	-----------	--------------	--	------	---------------------------------------

### 0.095 CAP, Crankshaft Front Bearing

62-67	All (327)	3970194	1	5.85	(No. 1, 2, 3, 4, 5, 6) (light blue stripe)
68-69	All (327)	3956688 A.R.		9.10	(No. 1, 2, 3, 4)

### 0.096 BEARING UNIT, Crankshaft Front (1 Upper and 1 Lower)

See chart for Model Application

*NOTE: See Dealer Price Schedule for applicable prices.*

#### CRANKSHAFT MAIN BEARING CHART

	Position	STD.	.001 U.S.	.002 U.S.	.009 U.S.	.010 U.S.	.020 U.S.
64-69	All (327) Front	3876116 <sup>(2,*)</sup>	3876117 <sup>(2,*)</sup>	3876118 <sup>(2,*)</sup>	3876069 <sup>(2,*)</sup>	3876119 <sup>(2,*)</sup>	3876120 <sup>(2,*)</sup>
64-69	All (327) All (exc. front and rear)	3832930 <sup>(2,*)</sup>	3832931 <sup>(2,*)</sup>	3832932 <sup>(2,*)</sup>	3876070 <sup>(2,*)</sup>	3832933 <sup>(2,*)</sup>	3832934 <sup>(2,*)</sup>
64-69	All (327) All (exc. rear)	3912038 <sup>(2)</sup>	3912039 <sup>(2)</sup>	3912040 <sup>(2)</sup>	3912037 <sup>(2)</sup>	3912041 <sup>(2)</sup>	3912042 <sup>(2)</sup>
64-69	All (327) Rear	3779460 <sup>(4)</sup>	3779461 <sup>(4)</sup>	3779462 <sup>(4)</sup>	3876071 <sup>(4)</sup>	3779463 <sup>(4)</sup>	3779464 <sup>(4)</sup>
64-69	All (327) Rear	3912030 <sup>(2)</sup>	3912032 <sup>(2)</sup>	3912033 <sup>(2)</sup>	3912034 <sup>(2)</sup>	3912035 <sup>(2)</sup>	3912036 <sup>(2)</sup>

*NOTE Bearings having no supplementary notes are Durex 100.*

<sup>(2)</sup> Aluminum M-400.

<sup>(2)</sup> Aluminum M-420.

<sup>(4)</sup> Use in engine with standard size crankshaft main bearing journal as follows - position #1-2-3-4 2.299 inch dia. and rear position #5 2.430 inch dia.

<sup>(2)</sup> Use in engine with standard size crankshaft main bearing journals as follows - position #1-2-3-4 2.449 inch dia. and rear position #5 2.448 inch dia.

### 0.105 CAP, Crankshaft Rear Bearing

64-67	All (327)	3911052	1	6.10	(Note 1)
68-69	All (327)	3911007	1	5.35	

*NOTE 1 When using in place of 3759260 it is necessary to discard oil pump atch. bolt 3754998 and use bolt 3892678.*

See chart following Group 0.096 for Model Application

*NOTE: See Dealer Price Schedule for applicable prices.*

## 327-ENGINE ASSEMBLY

<b>0.107 DOWEL, Crankshaft Bearing Cap</b>					
64-69	All (327) . . . . .	3836903 A.R.	.11	rear cap ( $1\frac{1}{32}$ " O.D. x $\frac{5}{8}$ " )— (0.738) . . . . .	
<b>0.137 SEAL ASSY., Crankshaft Rear Bearing and Cap Oil</b>					
64-69	All (327) . . . . .	3958001	2	2.60	rear oil . . . . .
<b>0.153 SHIM UNIT, Crankshaft Bearing Cap</b>					
64-69	All (327) . . . . .	3911011 A.R.	1.90	rear ( $2\frac{9}{16}$ " O.L.) . . . . .	
<b>0.206 COVER— PIN, Crankcase Front End</b>					
64-67	Chevy, Chevelle (327) (exc. Sp. H/Per.) . . . . .				
65-67	Pass., Camaro (327) . . . . .	3928971	1	5.45	w/oil seal (double timing mark brkt.) . . . . .
64-68	Chevy, Chevelle w/Sp. H/Per. (327) . . . . .	3923290	1	5.80	<b>COVER ASSY.</b> . . . . .
68	All (327) (exc. Sp. H/Per.) . . . . .	361927	1	7.05	<b>COVER ASSY.</b> (repl. 3917618) . . . . .
69	All w/2BC (327) . . . . .	3991433	1	6.30	<b>COVER ASSY.</b> . . . . .
64-69	All (327) . . . . .	3836903	2	.11	<b>PIN, dowel</b> ( $\frac{1}{8}$ " x $\frac{5}{8}$ " )— (0.738) . . . . .
<b>0.207 GASKET, Crankcase Front End Cover</b>					
64-69	All (327) . . . . .	3799620	1	.26	(attach. 2 dowel holes) . . . . .
<b>0.213 SEAL, Crankcase Front End Cover</b>					
62-69	All (327) . . . . .	3980267	1	3.35	( $2\frac{7}{16}$ " O.D.— stamped 3980267) . . . . .
<b>0.219 POINTER, Timing</b>					
62-69	All (327) . . . . .	3991436	1	.53	
<b>0.269 HEAD, Cylinder</b>					
64	Chevy, Chevelle (327) (exc. H/Per.) . . . . .	3817680	2	97.00	right and left (Ident. No. 3795896) . . . . .
64	Chevelle w/H/Per. (327), . . . . .				
65-68	All (327) (exc. Sp. H/Per., reg. fuel) . . . . .	3958603	2	92.50	w/studs . . . . .
65-67	Chevelle w/Sp. H/Per. (327), . . . . .				
66	Chevy w/Sp. H/Per. (327), . . . . .				
68	Chevy, Chevelle, Camaro w/Sp. H/Per. (327) . . . . .	3987376	1	105.00	w/studs . . . . .
67-68	All w/reg. fuel (327) . . . . .	3958607	1	92.50	w/studs . . . . .
69	All (327) . . . . .	3958602	2	92.25	w/studs . . . . .
<b>0.289 GASKET, Cylinder Head</b>					
64-69	All (327) . . . . .	3830711	2	2.60	
64-68	All (327) . . . . .	3931606	1	15.45	<b>GASKET UNIT</b> . . . . .
69	All (327) . . . . .	3957998	1	15.45	<b>GASKET UNIT</b> . . . . .
<b>0.293 BOLT— NUT— PIN, Cylinder Head</b>					
64-69	All (327) . . . . .	3704796	16	.22	short ( $\frac{7}{16}$ "— 14 x $1\frac{3}{4}$ " ) . . . . .
64-69	All (327) . . . . .	3734594 A.R.		.22	long ( $\frac{1}{16}$ "— 14 x $3\frac{3}{4}$ " ) (circle on top of head) . . . . .
64-69	All (327) . . . . .	3767468	4	.22	medium ( $\frac{7}{16}$ "— 14 x 3) (circle on top of head) (Note 1) . . . . .
65-69	Chevelle, Camaro (327) . . . . .	3866766	12	.12	<b>NUT, attaching</b> (hex. $\frac{3}{8}$ "— 24)— (0.626) . . . . .
65-69	Pass. (327) . . . . .	585927 A.R.		.16	<b>PIN</b> ( $\frac{5}{16}$ " x $\frac{9}{16}$ " ) . . . . .

*NOTE 1 Use with cylinder head with cast-in oil trough on outer edge.*

### 0.296 VALVE, Inlet

**Refer to following Chart for Model Application**

*NOTE: See Dealer Price Schedule for applicable prices.*

#### VALVE CHART (Inlet)

	STD.	.003 O.S.	.015 O.S.	.030 O.S.
64	Chevelle (327) (exc. H/Per.) . . . . .			
68-69	All w/reg. fuel (327) . . . . .	3989083	3995684	3995685
64	Chevelle w/H/Per. (327), . . . . .			
65-68	All (327) (exc. Sp. H/Per., reg. fuel) . . . . .	3989085	3995681	3995682
65-68	Chevy, Chevelle w/Sp. H/Per. (327) . . . . .	3849814	3849815	3849816

## 327-ENGINE ASSEMBLY

### 0.297 VALVE, Exhaust

Refer to following Chart for Model Application

*NOTE: See Dealer Price Schedule for applicable prices.*

#### VALVE CHART (Exhaust)

		STD.	.003 O.S.	.015 O.S.	.030 O.S.
62-69	All (327) (exc. Sp. H/Per.)	6263778	3995602	3995603	3995604
65-68	Chevy, Chevelle w/Sp. H/Per. (327)	3849818	3850040	3850041	3850042

### 0.303 SPRING— SHIM, Valve

65-66	Pass. (327)	3735381 A.R.	1.35	inlet and exhaust, w/damper (2 yellow stripes plus maroon, aluminum, dk. green, black, blue and white, or tan stripe) (Note 1)
67-69	All (327)	3911068	16	w/damper
67-69	All (327)	3731058 A.R.	.12	SHIM (1/2" thk.) (Note 2)

*NOTE 1 Used only with Camshaft 3831607. Also part of Camshaft Unit 3837796.*  
*NOTE 2 To be used in place of Valve Stem Oil Shield when removed at customers request.*

### 0.308 SEAL— SHIELD, Valve Spring Cap

62-69	All (327)	3835333 A.R.	.17	"O" ring, inlet and exhaust
62-69	All (327)	3836755 A.R.	.18	SHIELD (cup shape-7/8" I.D. x 1 3/8" O.D.)

### 0.309 CAP, Valve Spring

64-66	All (327)	3729363 A.R.	.40	inlet and exhaust
67-69	All (327)	3896934 A.R.	.40	valve spring cap ("A" stamped on top of the surface, inlet) (1 3/16" O.D.)

### 0.310 KEY, Valve Stem

62-69	All (327)	838029 A.R.	.06	("U" shape)
-------	-----------	-------------	-----	-------------

### 0.333 ARM UNIT, Valve Rocker with Adjusting Screw and Nut

62-69	All (327)	3974290	16	2.40 inlet and exhaust ("V" stamped on inside of pad end)
-------	-----------	---------	----	---

### 0.386 COVER ASSY.— GROMMET, Valve Rocker Arm

64-67	All (327) (exc. Sp. H/Per.),			
67	Camaro (327)	3910298	2	7.25 right or left
65-66	Chevelle w/Sp. H/Per. (327),			
66	Chevy w/Sp. H/Per. (327)	3858863	2	16.20 left and right (chrome)
67	Chevy, Chevelle w/Sp. H/Per. (327)			
		3910297	2	16.20 valve rocker
68	All w/Sp. H/Per. (327)	3923226	2	16.40 (chrome)
68-69	All (327) (exc. H/Per.)	6272227	2	10.30
64-69	All (327)	3894337	1	.11 GROMMET, cover to a/cl. (1 5/16" I.D. x 1 7/32" O.D.)— (1.745) (Note 1, 2)

*NOTE 1 May be used with or without closed vent.*

*NOTE 2 When using on closed vent. equipped vehicles, it will be necessary to remove center from grommet to permit assembling of fresh air connector into side of cover.*

### 0.413 BOLT— REINFORCEMENT, Valve Rocker Cover and Support

62-69	All (327)	180016	1	(1/4" — 20 x 1/2")— (8.900)
62-69	All (327)	3877670 A.R.		.12 REINFORCEMENT (1 1/2" O.L.) (Note 1)

*NOTE 1 Use with Bolt 180016.*

### 0.423 GASKET, Valve Rocker Cover

64-69	All (327)	3933964	2	1.80
-------	-----------	---------	---	------

### 0.426 ROD, Valve Push

64-69	All (327)	3796243 A.R.	2.15	(7 25/32" O.L.) (blue stripe) (Note 1, 2)
-------	-----------	--------------	------	---

*NOTE 1 May have one black stripe at each end.*  
*NOTE 2 Color marked end to be at valve rocker arm.*

### 0.429 BALL— NUT— STUD, Valve Push Rod Adjusting

64-69	All (327)	3959142 A.R.	.38	(1 3/16" dia.)
62-69	All (327)	3744341	16	.22 NUT, valve rocker arm (3/8" — 24) (5/8" across the flats x 1/2")
62-69	All (327)	3814692	16	.53 STUD, valve rocker arm ball (.003 O.S.-light blue paint)

## 327-ENGINE ASSEMBLY

### 0.429 BALL— NUT— STUD, Valve Push Rod Adjusting (Con't)

62-69	All (327)	3815892	16	.53	STUD, valve rocker arm ball (.013 O.S.— 3/8" — 242 1/2") (1 groove on shank-light blue paint)
-------	-----------	---------	----	-----	---

### 0.459 TAPPET, Valve (or Lifter)

62-69	All (327)	5232670	16	4.54	hydraulic type
-------	-----------	---------	----	------	----------------

### 0.519 CAMSHAFT, Engine

*NOTE Engine Camshaft Break-in Oil 1050800, Group 1.850, should be used when installing new camshafts.*

64-69	All (327) (exc. Sp. H/Per.)	3896929	1	48.25	standard (Ident. No. 3896930)
64	Chevelle w/Sp. H/Per. (327)	3972178	1	48.25	(Ident. No. 3849347)
65-68	All (Sp. H/Per. w/hyd. lifters) (327)	3863151	1	55.25	(Ident. No. 3849347, 3863152)

### 0.539 BEARING, Camshaft (Front or No. 1)

64-69	All (327)	3723584	1	2.40	precision type (stamped 1)
-------	-----------	---------	---	------	----------------------------

### 0.543 BEARING, Camshaft No. 2 (Front Intermediate)

64-69	All (327)	3723585	1	2.40	precision type (stamped 2)
-------	-----------	---------	---	------	----------------------------

### 0.546 BEARING, Camshaft (Center and Rear Intermediate)

64-69	All (327)	3723586 A.R.		2.40	(stamped 3 and 4)
-------	-----------	--------------	--	------	-------------------

### 0.549 BEARING, Camshaft Rear

64-69	All (327)	3723585	1	2.40	precision type (stamped 2)— (0.543)
-------	-----------	---------	---	------	-------------------------------------

### 0.553 PLUG, Camshaft Bearing Hole, cup type (in cylinder block)

62-69	All (327)	3704158	1	.22	(2 1/8" dia.)
-------	-----------	---------	---	-----	---------------

### 0.603 ROD ASSY., Connecting, Less Dipper

64-69	All (327)	3864881	8	13.75	(Note 2)
68-69	All (327)	3916396	8	12.70	(Note 1 & 3)

*NOTE 2: Use with 2.00 inch dia. standard crankshaft pins.*

*NOTE 3: Use with 2.01 inch dia. standard crankshaft pins.*

*NOTE 1 Some early 1968 (327) models used 1967 engines built to 1968 spec. Refer to Note 4 Group 0.033.*

### 0.616 BEARING UNIT, Connecting Rod (1 Upper and 1 Lower)

#### Refer to chart for Model Application

*NOTE: See Dealer Price Schedule for applicable prices.*

#### CONNECTING ROD BEARING UNIT CHART

MODEL USAGE	STD.	.001 U.S.	.002 U.S.	.010 U.S.	.020 U.S.
64-67 All (327)	3711828 <sup>(1)</sup>	3715045 <sup>(1)</sup>	3715046 <sup>(1)</sup>	3715048 <sup>(1)</sup>	3715047 <sup>(2)</sup>
64-69 All (327)	3910555 <sup>(2, 3, 4)</sup>	3910556 <sup>(2, 3, 4)</sup>	3910557 <sup>(2, 3, 4)</sup>	3910558 <sup>(2, 3, 4)</sup>	3910559 <sup>(2, 3, 4)</sup>

<sup>(1)</sup> Aluminum M-420.

<sup>(2)</sup> Aluminum M-400.

<sup>(3)</sup> Some early 1968 (327) models use 1967 engines, built to 1968 spec. Refer to Note 4 in Group 0.033.

<sup>(4)</sup> Use with 2.01 inch dia. standard crankshaft pins.

### 0.623 BOLT, Connecting Rod Bearing Cap

64-67	All (327)	3892670 A.R.		.70	(1 1/32" — 24 x 1 7/8")
68-69	All (327)	3916399	16	.60	(3/8" — 24 x 1 59/64")

### 0.626 NUT, Connecting Rod Bearing Cap Bolt

62-69	Chevy, Chevelle, Camaro (327)	9422298 A.R.		.11	(3/8" — 24 x 5/16" thick) (one end chamfered)— (8.917)
65-67	Pass. (327) (exc. Sp. H/Per., F.I.),				
65-67	Chevelle w/Sp. H/Per. (327),				
66	Chevy w/Sp. H/Per. (327)	3815280	16	.24	(1 1/32" — 24) (type EA) (phosphate coated and soaped)
64-69	All (327) (exc. Chevy)	3866766 A.R.		.12	(3/8" — 24 x 3/8" thick) (hex. nut) (both ends flat) (Note 1)

*NOTE 1 Also used with bolts not requiring cotter pins.*

**327-ENGINE ASSEMBLY**

**0.629 PISTON ASSY., with Pin**

*NOTE Individual piston assemblies are available for warranty purposes and for replacement of pistons damaged when making repairs to engine assemblies. When ordering such parts it is necessary that you specify on your order the reason the parts are required and also that the following note appears on your order. Do not ship unit package quantity.*

ENGINE DISPLACEMENT	BASIC SIZE	SERVICE PISTON DIAMETER RANGE LIMITS ALUMINUM
327 cu. in.	4.0000— STD.	S-4— 4.0000 to 4.0005, S-5— 4.0005 to 4.0010
327 cu. in.	4.0010— .001	S-6— 4.0010 to 4.0015, S-7— 4.0015 to 4.0020

*NOTE: The above chart is for information purposes only.*

**(Refer to chart for model application)**

*NOTE: See Dealer Price Schedule for applicable prices.*

**PISTON CHART**

	STD.	.001 O.S.	.030 O.S.
<b>64-69</b> All (327) (exc. Sp. H/Per.)	3799491	3799492	3799494
<b>64-68</b> Chevy, Chevelle w/Sp. H/Per. (327)	3871208	3871210	3850139

**0.643 RING UNIT, Piston (Service Sets)**

*NOTE: See Dealer Price Schedule for applicable prices.*

	STD.	.030 O.S.
<b>62-69</b> All (327)	328506(*)	328516(*)

**STD.**      **.030 O.S.**

<b>62-69</b> All (327) (exc. Sp. H/Per.)	328506(*)	328516(*)
--	-----------	-----------

(\*) Single cyl. replacement only.

**0.646 CRANKSHAFT, Engine**

<b>64-67</b> All (327) (exc. Sp. H/Per.)	<b>3889304</b>	1	147.00	(Ident. No. 3782680) (Note 1, 3)
<b>65-67</b> Chevelle w/Sp. H/Per. (327),				
<b>66-67</b> Chevy w/Sp. H/Per. (327)	<b>3838495</b>	1	179.00	(Ident. No. 2680) (Note 3)
<b>68</b> All (327) (exc. Sp. H/Per.)	<b>3930809</b>	1	147.00	(Note 1, 2)
<b>64-68</b> Chevy, Chevelle w/Sp. H/Per. (327)	<b>3914681</b>	1	179.00	(Note 4)
<b>64-69</b> All (327)	<b>3941172</b>	1	170.00	(Note 1, 4)

*NOTE 1 When used on A.T. it will be necessary to remove the pilot bearing.*

*NOTE 2 Some early 1968 (327) models use 1967 engines, built to 1968 spec. Refer to Note 4 in Group 0.033.*

*NOTE 3: With standard size crankshaft main bearing journals as follows - position #1-2-3-4 2.299 inch dia. and rear position #5 2.430 inch dia.*

*NOTE 4: With standard size crankshaft main bearing journals as follows - position #1-2-3-4 2.449 inch dia. and rear position #5 2.448 inch dia.*

**0.649 BEARING, Crankshaft Clutch Pilot**

<b>62-69</b> All (327)	<b>3752487</b>	1	1.20	(bush type— <sup>19</sup> / <sub>32</sub> " I.D. x <sup>13</sup> / <sub>32</sub> " O.D. x <sup>3</sup> / <sub>4</sub> " )
------------------------	----------------	---	------	---

**0.659 BALANCER— PULLEY, Crankshaft**

*NOTE In some cases double groove pulleys may be used in place of single groove pulleys.*

*NOTE Crankshaft harmonic balancer is also referred to as "torsional damper".*

<b>64-65</b> Chevelle w/4BC, forged crankshaft (327) (exc. Sp. H/Per.),				
<b>65</b> Chevy, Chevelle w/forged crank (327),				
<b>65</b> Pass. w/forged crankshaft (327) (exc. Sp. H/Per., F.I.)	<b>3896904</b>	1	26.50	w/o pulley (hub. 4 <sup>1</sup> / <sub>2</sub> " O.D.)
<b>66</b> All (4BC w/forged crankshaft) (327) (exc. Sp. H/Per.),				
<b>67</b> All w/forged crankshaft (327) (exc. Sp. H/Per.)	<b>3896903</b>	1	26.50	w/o pulley
<b>68</b> All (327) (exc. Sp. H/Per.)	<b>3914684</b>	1	26.50	
<b>69</b> All w/2BC (327)	<b>6272221</b>	1	26.50	
<b>65</b> Chevelle (327),				



**327-ENGINE ASSEMBLY**

**0.659 BALANCER— PULLEY, Crankshaft (Con't)**

66-68	Chevy, Chevelle w/Sp. H/Per. (327) . . . . .	3817173	1	44.75	BALANCER ASSY. . . . .
64-68	Chevy, Chevelle, Camaro (327) (exc. C.A.C., C/Deluxe Air Cond., A.I.R.),				
65-67	Pass. (327) (exc. Air Cond., A.I.R.),				
68	Pass. w/A.T. (327) (exc. C.A.C.) .	3755820	1	7.75	PULLEY (stamped 3755820) . . . . .
64-66	Chevy w/Air Cond. (327),				
66-67	Chevelle w/A.I.R. (327) (exc. El Camino, C.A.C.),				
66-67	El Camino w/A.I.R. (327) (exc. C.A.C.),				
66-68	Pass. w/A.I.R. (327) (exc. C.A.C.),				
67	Camaro (327) (exc. C.A.C.),				
68	Chevy (327) . . . . .	3744043	1	8.20	PULLEY (double-6 <sup>5</sup> / <sub>8</sub> " O.D.— painted black) (stamped 3744043) . . . . .
64	Chevy, Chevelle w/P/S (327) (exc. Air Cond.),				
64-68	Chevy, Chevelle, Camaro w/P/S (327),				
65-68	Pass. w/P/S (327) (exc. Sp. H/Per. . . . .	3751232	1	7.75	PULLEY, front (stamped 3751232) . . . . .
64-68	Chevy, Chevelle, Camaro w/Air Cond. (327),				
65-68	Pass. w/C.A.C., C/Deluxe Air Cond. (327) (exc. T.H.) . . . . .	3850838	1	9.00	PULLEY (7 <sup>21</sup> / <sub>64</sub> " O.D.) . . . . .
66-67	Pass. w/62 amp. (C.A.C. w/T.H.) (327) . . . . .	3874414	1	9.00	PULLEY (2 grooves) (7 <sup>21</sup> / <sub>64</sub> " O.D.) . . . . .
66	El Camino w/A.I.R., 62 amp. (327) (exc. Sp. H/Per.),				
66	S.S. w/A.I.R., 62 amp. (327) (exc. Sp. H/Per. Air Cond.) . . . . .	3874418	1	8.20	PULLEY, front (2 grooves) . . . . .
67	Chevelle w/C.A.C. (327) (exc. 62 amp.) . . . . .	3876844	1	5.70	PULLEY (2 grooves) (7 <sup>47</sup> / <sub>64</sub> " O.D.) . . . . .
67	Pass. (T.H. w/C.A.C.) (327),				
68	Pass. w/P/S. C.A.C. (327) (exc. T.H.) . . . . .	3911013	1	9.00	PULLEY, crankshaft (7 <sup>47</sup> / <sub>64</sub> " O.D.) . . . . .
69	Pass. w/Air Cond. (327) . . . . .	3972180	1	15.95	PULLEY (3 groove) . . . . .
69	All w/P/S (327) (exc. Chevy, C.A.C.),				
69	Pass., Chevelle (327) (exc. P/S, C, S, C) . . . . .	3956666	1	9.20	PULLEY ASSY. (2 groove) . . . . .

**0.662 BOLT— KEY— WASHER— REINFORCEMENT, Harmonic Balancer and Crankshaft Pulley**

66-68	Chevy, Chevelle w/Sp. H/Per. (327) . . . . .	3815933	1	.63	(7 <sup>1</sup> / <sub>16</sub> "— 20 x 2 <sup>1</sup> / <sub>4</sub> ") . . . . .
65-66	All w/key 3 <sup>3</sup> / <sub>4</sub> " long x 3 <sup>3</sup> / <sub>16</sub> " wide x 1 <sup>1</sup> / <sub>4</sub> " high . . . . .	3883206	A.R.	.16	KEY, crankshaft pulley hub (Note 1) . . . . .
65-66	All w/key 1 <sup>3</sup> / <sub>8</sub> " long x 3 <sup>3</sup> / <sub>16</sub> " wide 'x 1 <sup>1</sup> / <sub>32</sub> " high . . . . .	3885092	1	.16	KEY, crankshaft pulley hub (Note 1) . . . . .
<i>NOTE 1: Used with pulleys and hubs having a shallow (1<sup>1</sup>/<sub>16</sub>" deep) keyway only. All full depth (1<sup>1</sup>/<sub>8</sub>" slots take standard Woodruff Key (106751 two short or 144542 one long) in Group 8.960.</i>					
66-69	All (327) . . . . .	3739422	1	.46	WASHER, balancer . . . . .
69	All w/C.A.C. (327) . . . . .	3965597	1	.59	REINFORCEMENT, crankshaft pulley . . . . .

**0.666 FLYWHEEL, with Ring Gear**

62-69	Chevy, Chevelle, Camaro w/P.G., reg. fuel (327),				
65-68	Pass. w/P.G. (327),				
69	Pass. w/P.G., reg. fuel (327) . . . . .	3789821	1	26.75	spoke type (6-2" dia. holes around ctr.) . . . . .
64-68	All (327) (exc. A.T., H.D. Clutch),				
69	Pass. w/reg. fuel (327) (exc. A.T., Police) . . . . .	3973452	1	59.25	solid type . . . . .
66-68	Pass. w/H.D. clutch (327),				
67-69	Chevelle w/H.D. clutch (327) . . . . .	3998281	1	68.25	w/11" coil sprg. clutch (12 <sup>5</sup> / <sub>8</sub> " bolt circle) solid type . . . . .
65-67	All w/T.H. (327),				
68	All w/T.H. (327) (1st design) . . . . .	336763	1	32.00	(Note 1) . . . . .
68	All w/T.H. (327) (2nd design),				
69	All w/T.H. 400 (327) (exc. Sp. H/Per.) . . . . .	340296	1	23.85	(Note 1) (repl. 3991403) . . . . .

## 327-ENGINE ASSEMBLY

### 0.666 FLYWHEEL, with Ring Gear (Con't)

*NOTE 1 On some application 3991401 and 3937736 are used optionally in production. These parts can be identified by their bolt hole mounting patterns. 3991401 contains a single bolt hole mounting pattern 1 1/2" in dia. 3937736 contains two (staggered) bolt hole mounting patterns. The inner pattern 10 3/4" in dia., the outer 11 1/2" in dia.*

69 All w/T.H. 350 (327) ..... 3991402 1 26.75

### 0.669 BOLT, Flywheel to Crankshaft

62-69 All (327) (exc. A.T.) ..... 839756 6 .12 (7/16"— 20 x 1) .....  
 62-69 All w/A.T. (327) ..... 3727207 6 .21 (7/16"— 20 x 45/64"— 290M steel) .....

### 0.673 GEAR, Flywheel Ring

62-69 All (327) ..... 3991408 1 6.40

### 0.679 UNDERPAN— BOLT— COVER— SCREW, Flywheel

64-69 Chevy, Chevelle w/P.G. (327),  
 65-69 Pass. w/P.G. (327) ..... 3789959 1 3.95 transmission (17<sup>51</sup>/<sub>64</sub>" O.L.) .....  
 65-69 All w/T.H. 400 (327) ..... 3868810 1 3.55 trans. converter .....  
 68-69 All w/T.H. 350 (327) ..... 6261091 1 4.20 trans. converter .....  
 All All (327) ..... 3817006 A.R. .12 BOLT, w/washer (1/4"— 20 x 7/16") .....  
 62-69 Chevy, Chevelle, Camaro (327)  
 (exc. P.G.),  
 65-66 Pass. (327),  
 67-69 Pass. w/reg. fuel (327) ..... 354497 1 2.65 COVER, clutch housing (repl. 3788422) ...  
 66-68 Pass. w/H.D. clutch (327),  
 68 Chevelle w/H.D. Clutch (327) ... 3843943 1 3.05 COVER, clutch housing .....  
 69 All w/T.H. 350 (327) ..... 9420825 4 SCREW (5/16"— 18 x 9/16")— (8.977) (Note  
 1) .....  
 62-69 All w/P.G., Torque Drive (327) ... 3924780 A.R. .16 SCREW ASSY., w/washer (5/16"— 18 x 7/8")  
*NOTE 1 Use with washer 120393 Group 8.929.*

### 0.683 HOUSING— BOLT, Flywheel and Clutch

64-67 Chevy (327) ..... 3849307 1 31.25 clutch (ident. No. 3849309) .....  
 64-69 Pass. w/reg. fuel (327) (exc.  
 Taxi, Police, H.D. Clutch),  
 65-68 Chevelle (327) (exc. H.D. Clutch),  
 67-68 Camaro (327),  
 69 Chevy, Chevelle, Camaro w/reg.  
 fuel (327) ..... 3858403 1 30.50 HOUSING ASSY., clutch (Ident. No.  
 3840383) (Note 1) .....  
*NOTE 1 Less ball stud.*  
 66-68 All w/H.D. clutch (327),  
 69 Police (327) ..... 3899621 1 37.50 HOUSING ASSY., clutch .....  
 All Pass. (327) ..... 3736035 A.R. .22 BOLT, clutch housing attach. (3/8"— 16 x  
 1<sup>5</sup>/<sub>16</sub>" (300M steel-plain)— (3.275) (Note  
 2) .....  
*NOTE 2 When using BOLT 3736035, it will be necessary to use washer 120394 (8.929).*  
 All Pass. (327) ..... 3733130 2 .24 BOLT, clutch housing attach. (5/8"— 16 x  
 2 1/4"— washer hd.) (300M steel)— (3.275)

### 0.685 DOWEL, Flywheel and Clutch Housing to Cylinder Block

62-69 All (327) ..... 3712745 2 .50 clutch and flywheel (2<sup>1</sup>/<sub>32</sub>" x 1 1/4" long) ....

### 0.724 CHAIN, Camshaft Timing

64-66 All (327) ..... 3704150 1 11.20 early link type .....  
 67-69 All (327) ..... 346261 1 11.20 early link type .....

### 0.728 SPROCKET, Crankshaft Timing (Steel)

64-66 All (327) ..... 3759980 1 4.65 (18 teeth— 2 7/8" O.D.) (early link type) .....  
 67-69 All (327) ..... 3896959 1 4.65 (18 teeth— 2 7/8" O.D.) (early link type) .....

### 0.736 SPROCKET, Camshaft Timing

64-66 All (327) ..... 3865964 1 7.55 (cast 3704214-36 teeth) (iron) (early link  
 type) .....  
 67-69 All (327) ..... 340235 1 8.45 (36 teeth) (repl. 3896960) .....

### 0.738 PIN, Camshaft Sprocket

64-69 All (327) ..... 3836903 1 .11 dowel (1/4" x 5/8") (solid) .....

### 0.787 ROD— CLIP— EXTENSION— SWIVEL, Clutch Fork Release

64-67 Chevy (327) ..... 3790015 1 1.20 fork push .....  
 64-67 Chevy (327) ..... 3790902 1 1.15 fork adjusting .....  
 64-67 Chevelle (327),  
 67-69 Camaro (327),  
 68-69 Chevy (327) ..... 3973076 1 1.95 fork push .....  
 64-67 Chevelle (327),

**327-ENGINE ASSEMBLY**

**0.787 ROD— CLIP— EXTENSION— SWIVEL, Clutch Fork Release (Con't)**

67	Camaro (327),				
68-69	Chevy, Camaro (327) . . . . .	340690	1	1.10	fork push adjusting (4 <sup>3</sup> / <sub>4</sub> " long) . . . . .
65	Pass. (327) (exc. Taxi),				
66-69	Pass. (327) . . . . .	3859863	1	1.25	fork push . . . . .
68-69	Chevelle (327) . . . . .	9779202	1	.88	fork push . . . . .
62-69	All (327) . . . . .	3749084	A.R.	.27	CLIP, push rod and swivel— (4.037) . . . . .
62-69	All (327) . . . . .	1455017	1	.13	CLIP, push rod— (3.425) . . . . .
62-67	Chevy (327) . . . . .	3834287	1	.36	EXTENSION, fork pull back spring . . . . .
65-69	Pass. (327) . . . . .	3859839	1	.71	SWIVEL, pedal push . . . . .
68-69	Chevelle (327) . . . . .	3840845	1	1.40	SWIVEL, fork push rod (1 <sup>1</sup> / <sub>2</sub> " O.L.) ( <sup>3</sup> / <sub>8</sub> "— 16 thds.) . . . . .

**0.793 WASHER, Clutch Fork Push Rod**

62-69	All (327) . . . . .	3756694	1	.11	push rod lever thrust (2 <sup>3</sup> / <sub>4</sub> " dia. pedal shaft) pull rod lever . . . . .
-------	---------------------	---------	---	-----	--

**0.795 FORK ASSY., Clutch Release**

62-67	Chevy (327) . . . . .	3788401	1	7.85	(less ball stud) . . . . .
64-66	Chevelle (327),				
67	Chevelle, Camaro (327),				
68-69	All (exc. Pass.) (327) . . . . .	3892632	1	7.15	
65-69	Pass. (327) . . . . .	3860005	1	7.15	

**0.796 SPRING— STUD, Clutch Fork**

62-67	Chevy (327) . . . . .	3737456	1	.28	retaining (4 <sup>1</sup> / <sub>16</sub> " dev. length) . . . . .
62-67	Chevy (327),				
65-69	Pass. (327) . . . . .	3790556	1	.84	STUD, ball ( <sup>3</sup> / <sub>16</sub> "— 16 thds.) . . . . .
64-67	Chevelle, Camaro (327),				
68-69	Chevy, Chevelle, Camaro (327) . . . . .	3729000	1	1.05	STUD, ball ( <sup>13</sup> / <sub>16</sub> "— 16 w/ <sup>21</sup> / <sub>32</sub> " diameter ball) . . . . .

**0.797 BOOT, Clutch Fork**

62-67	Chevy (327) . . . . .	3788402	1	.76	(3" O.L. at clutch hsg. face) (black rubber) . . . . .
64-69	All (327) . . . . .	3993851	1	.76	
65-66	Taxi (327) . . . . .	3781385	1	1.65	black rubber . . . . .

**0.799 BEARING, Clutch throwout with Collar**

64-68	Chevy, Chevelle w/3-Spd. (327),				
69	Chevy (327) (exc. 4-Spd.),				
69	Chevelle (327) (exc. 4-Spd.),				
69	Camaro (327) . . . . .	908092	1	15.94	ball bearing type (1 <sup>7</sup> / <sub>8</sub> " long) . . . . .
64-67	Chevy, Chevelle, Camaro (327),				
65-67	Pass. (327),				
68-69	All (327) . . . . .	908093	1	13.56	(1 <sup>7</sup> / <sub>32</sub> " O.L.) . . . . .

**0.829 BUMPER— COVER— PLUG— RETAINER— SEAL, Clutch**

(For COVERS see group 4.630)

64-68	Chevelle (327) (exc. P.B.),				
68-69	Chevy, Chevelle, Camaro (327),				
65-69	Pass. (327) . . . . .	340688	1	.21	pedal . . . . .
67-69	Camaro w/A.T. (327),				
68-69	Chevy w/A.T. (327) . . . . .	3886689	1	.21	COVER, clutch pedal push rod hole . . . . .
65-68	Pass. w/A.T. (327) . . . . .	6256958	1		PLUG, pedal push rod hole (repl. 3872120)— (12.980) . . . . .
62-65	Chevy (327) . . . . .	3792551	1	.21	RETAINER, push rod dash seal . . . . .
64-67	Chevelle (327) . . . . .	3903973	1	.42	RETAINER, clutch pedal push rod bellows type . . . . .
67	Chevy (327) . . . . .	3903518	1	.14	RETAINER, clutch pedal push rod dash seal
62-67	Chevy (327) . . . . .	3792550	1	.36	SEAL, clutch push rod dash . . . . .
64-67	Chevelle (327) . . . . .	9776826	1	1.15	SEAL, clutch push rod (bellows type) . . . . .
65-68	Pass. (327) . . . . .	3857543	1	.65	SEAL, pedal push rod (Note 1) . . . . .

*NOTE 1 When using in place of 3819156 seal up to 1965, it will be necessary to replace 3825188 anchor plate with 3877244 plate. For attachment use 3877244 plate as template and drill necessary mounting holes.*

67-69	Camaro w/A.T. (327),				
68-69	Chevy w/A.T. (327) . . . . .	3903466	1	.15	SEAL, clutch pedal push rod hole cover . . . . .
69	Pass. (327) . . . . .	3950007	1	1.30	SEAL, pedal push rod . . . . .
67	Camaro (327),				
68-69	Camaro, Chevy (327) . . . . .	3909071	1	1.20	SEAL ASSY., clutch pedal push rod . . . . .
68-69	Chevelle (327) . . . . .	399904	1	3.20	SEAL ASSY., clutch pedal push rod . . . . .

**0.830 PEDAL, Clutch**

62-65	Chevy (327) . . . . .	3830774	1	5.50	
-------	-----------------------	---------	---	------	--

## 327-ENGINE ASSEMBLY

<b>0.830 PEDAL, Clutch (Con't)</b>				
64-66	Chevelle (327) .....	3841214	1	5.65
67	Camaro (327) .....	3890609	1	5.55
	Chevelle (327) .....	3900527	1	5.05
68-70	Chevelle (327) .....	3967783	1	5.30
68-69	Chevy, Camaro (327) .....	6258554	1	6.55
69	Pass. (327) .....	3968745	1	5.50
<b>0.831 BUSHING, Clutch Pedal (see group 4.626 for brake pedal bushing)</b>				
62-68	All (327) .....	1247439	2	.11 (5/8" dia. pedal shaft)— (4.626) .....
<b>0.837 RETAINER— SPACER, Clutch and Brake Pedal Shaft-(Also see Groups 4.634 and 4.648)</b>				
63-70	All (327) .....	3828428	1	.22 shaft— (4.634) .....
<b>0.844 SPRING, Clutch Pedal Pull Back</b>				
62-67	Chevy (327) .....	3653114	1	.63 clutch fork push rod pull back .....
64-67	Chevelle (327) .....	9776993	1	.40 push rod .....
64-67	Chevelle (327) .....			push rod return, .....
65-69	Pass. (327) .....	3849704	1	.34 fork pull back .....
65-69	Pass. (327) .....	3879772	1	.22 clutch pull back .....
67-69	Camaro (327),			
68-69	Chevy (327) .....	3899021	1	.28 clutch fork push rod pull back) .....
68-69	Chevelle (327) .....	3920614	1	.34
<b>0.846 EXTENSION, Clutch Pedal Pull Back Spring</b>				
67-69	Camaro (327),			
68-69	Chevy (327) .....	3899022		.32 clutch fork push rod pull back spring .....
<b>0.851 SEAL— SPRING— STUD— WASHER, Clutch Pedal Intermediate Lever Shaft Ball</b>				
62-69	All (327) .....	3743349	A.R.	.18 stud (7/8" dia.) .....
65-69	Chevy, Chevelle, Camaro (327) .			SEAL, ball stud dust. ....
65-69	Pass. (327) .....	382658	1	.19 lever shaft ball stud .....
62-69	All (327) .....	3750696	1	.13 SPRING, frame stud seat, retaining (1" O.D.)
62-69	Chevy, Chevelle, Camaro (327) .	3866568	1	1.15 STUD, lever shaft ball to engine .....
62-69	Chevy (327) .....			STUD, to body .....
64-69	Pass., Chevelle, Camaro (327) .	3898610	1	.81 to frame (5/8" — 24 x 1 <sup>13</sup> / <sub>16</sub> " O.L.) .....
65-69	Pass. (327) .....	3859488	1	1.20 STUD, lever shaft ball to eng. ....
62-64	Chevy, Chevelle (327) .....	3743355	1	.13 WASHER, lever shaft ball stud dust seal ...
62-66	Chevy, Chevelle (327) .....	3717880	1	.16 WASHER, ball to engine dust washer
				(rubber) (29/32" O.D. x 15/32" I.D. x 1/4" thk.) .
62-69	All (327) .....	3743360	1	.18 WASHER, stud dust seal, L.H. to frame
				(felt— 9/16" I.D. x 1 <sup>3</sup> / <sub>8</sub> " O.D.) lever assy.
				seal .....
<b>0.852 LEVER— BRACKET— SHAFT, Clutch Pedal, Intermediate (See Group 4.648 for brake)</b>				
62-67	Chevy (327) .....	3792909	1	6.90 w/shaft .....
64-66	Chevelle (327),			
67	Chevelle (327) (1st design) ....	3840836	1	6.60 w/shaft (used w/strg. col. w/lwr. brg. snap ring) .....
67-69	Camaro (327),			
68-69	Chevy (327) .....	3998652	1	10.50 w/shaft .....
67	Chevelle (327) (2nd design) ....	3921038	1	10.95 w/shaft (used w/strg. col. w/lwr. brg. clamp) .....
68-69	Chevelle (327) .....	3920615	1	10.10 w/shaft .....
62-67	Chevy (327) .....	3792365	1	.63 BRACKET, shaft body (3 <sup>3</sup> / <sub>4</sub> " O.L. w/2 weld nuts) .....
64-67	Chevelle (327) .....	3840841	1	.84 BRACKET, lever and shaft .....
65-69	Pass. (327) (exc. Police, Taxi) ...	3859861	1	.28 BRACKET, clutch shaft frame .....
65-69	Taxi (327),			
68-69	Police (327) .....	3869851	1	2.05 BRACKET, clutch shaft frame .....
67	Camaro (327),			
68-69	Chevy, Camaro (327) .....	3932760	1	.83 BRACKET, lever and shaft .....
68-69	Chevelle (327) (exc. Monte Carlo)			
		3918098	1	.81 BRACKET, lever and shaft frame .....
65-69	Pass. (327) .....	3954621	1	6.50 SHAFT, w/lever .....
<b>0.854 ROD— CLIP, Clutch Pedal</b>				
62-67	Chevy (327) .....	3790008	1	1.95 pedal push (15 <sup>13</sup> / <sub>32</sub> " dev. length— 1/2" O.D.) .
64-67	Chevelle (327) .....	9774625	1	4.25 pedal push straight shaft (12 <sup>51</sup> / <sub>64</sub> " O.L.) ....
65-69	Pass. (327) .....	3859838	1	2.20 pedal push .....
67	Camaro (327) .....	3899020	1	2.30 pedal push (12 <sup>43</sup> / <sub>64</sub> " dev. length) .....
67	Camaro (327) .....	6264907	1	4.85 clutch pull .....
68-69	Chevelle (327) .....	3920618	1	2.10 pedal push .....

**327-ENGINE ASSEMBLY**

**0.854 ROD— CLIP, Clutch Pedal (Con't)**

68-69	Chevy, Camaro (327) . . . . .	3920262	1	1.95	pedal push . . . . .
62	Chevy (327) . . . . .				CLIP, pedal push rod ( <sup>9</sup> / <sub>32</sub> " dia.), . . . . .
66-67	Chevy (327) . . . . .	3758162	1	.06	pedal push rod lower end . . . . .
65-69	Pass. (327) . . . . .	1455017	2	.13	CLIP, pedal pull rod— (3.425) . . . . .

**0.859 PLATE ASSY., Clutch Pressure with Cover**

64-68	Chevy, Chevelle, Camaro (327) (exc. H.D. clutch),				
65	Pass. (327),				
66	Pass. w/4BC (327) (exc. H.D. Clutch),				
69	All w/reg. fuel (327) (exc. Police) . . . . .	3841673	1	61.50	(diaphragm spring type) (cast 3793480) (10 <sup>1</sup> / <sub>2</sub> ") . . . . .
66-68	Pass., Chevelle w/H.D. Clutch (327) . . . . .	3884598	1	69.00	

**0.861 COVER, Clutch**

64-69	Chevy, Chevelle, Camaro (327),				
65-68	Pass. (327),				
69	All w/reg. fuel (327) (exc. Police) . . . . .	3793478	1	23.90	diaphragm spring type (12 <sup>21</sup> / <sub>64</sub> " O.D.) . . . . .
69	Police (327) . . . . .	3821763	1	21.75	diaphragm spring type (13 <sup>3</sup> / <sub>4</sub> " O.D.) . . . . .
67-68	Pass., Chevelle w/H.D. Clutch (327) . . . . .	3860361	1	21.30	diaphragm spring type (11" O.D.) . . . . .
66-67	Chevelle w/H.D. Clutch (327),				
66	Pass. w/H.D. Clutch (327) . . . . .	3884626	1	18.90	

**0.862 BOLT, Clutch Cover and Pressure Plate**

62-69	All (327) . . . . .	838653 A.R.		.12	( <sup>3</sup> / <sub>8</sub> "— 16 x 1) . . . . .
62-69	All (327) . . . . .	3962058 A.R.		.22	retrac. spring ( <sup>5</sup> / <sub>16</sub> "— 18 x <sup>29</sup> / <sub>32</sub> " hex.)— (0.864) . . . . .

**0.863 PLATE, Clutch Pressure**

64-69	Chevy, Chevelle, Camaro (327),				
65-69	Pass. w/reg. fuel (327) (exc. Police) . . . . .	3793480	1	34.00	(cast 3793480) (10 <sup>1</sup> / <sub>2</sub> ") . . . . .
69	Police (327) . . . . .	3962057	1	16.90	(11" O.D.) . . . . .
66-68	Pass., Chevelle w/H.D. Clutch (327) . . . . .	3884630	1	32.50	(cast 3860363) (11" O.D.) . . . . .

**0.864 BOLT— SPRING, Clutch Pressure Plate**

62-69	All (327) . . . . .	3962058 A.R.		.22	retrac. spring ( <sup>5</sup> / <sub>16</sub> "— 18 x <sup>29</sup> / <sub>32</sub> " hex.) . . . . .
64-68	Chev., Chevelle, Camaro (327),				
65-69	Pass. (327) . . . . .	3788605	3	.13	SPRING, retracting (1 <sup>9</sup> / <sub>32</sub> " dia. at wide end w/ <sup>5</sup> / <sub>16</sub> " ctr. hole) (Note 1) . . . . .

*NOTE 1 Replace only in sets of three.*

**0.886 DISC, with Facing, Clutch**

64-65	Chevy, Chevelle w/3-Spd. (327) . . . . .	3889346	1	40.00	woven (10") (lavender paint on oil slinger) . . . . .
64-65	All (327),				
66	Pass. w/4BC (327),				
67	Pass. (327),				
67-68	Camaro (327),				
67-68	Chevelle w/H.D. clutch (327),				
68	Chevy w/Sp. H/Per. (327),				
68	All (327) (exc. H.D. Clutch),				
69	Pass. w/reg. fuel (327) . . . . .	3927128	1	40.00	woven (10 <sup>13</sup> / <sub>32</sub> ") . . . . .
66-68	Pass., Chevelle w/H.D. Clutch (327),				
67-68	Chevy, Camaro (327),				
66-67	Pass., Chevelle w/H.D. Clutch (327),				
69	Pass. w/reg. fuel (327) . . . . .	3908960	1	40.00	woven (11") . . . . .

## 350-ENGINE ASSEMBLY

### 0.002 BOLT—SPACER—WASHER, Engine Mounting (Small Attaching)

67-68	Camaro w/A.I.R., C.A.C. (350) . . .	3785362	1	.32	special hex. ( $\frac{3}{8}$ "— 16 x $2\frac{5}{8}$ ") flat point (300M steel) w/pump and upper right side
69	All (350) . . . . .	3840748	1	.28	right side ( $\frac{7}{16}$ "— 14 x 4) . . . . .
70-71	All (350),				
72	All (350) (exc. Taxi, Police, Camaro) . . . . .	3980716	2	.34	( $\frac{7}{16}$ "— 14 x $3\frac{7}{8}$ ") . . . . .
72	Camaro, Taxi, Police (350),				
73-75	All (350) . . . . .	334972	2	.34	( $\frac{7}{16}$ "— 14 x 5) . . . . .
70	Chevelle, Camaro, Pass. (350) (exc. Taxi, Police) . . . . .	3826168	2	.18	<b>SPACER</b> , frt. mtg. eng. brkt. ("U" shape) (2 $\frac{1}{2}$ " O.L.) (Note 1) . . . . .
67-69	Chevy, Chevelle, Camaro (350) . . .	3954735	2	.13	<b>WASHER</b> , brkt. to engine (left side) ( $\frac{7}{16}$ " (repl. 3693853)— (14.875) . . . . .

*NOTE 1 It may be necessary to reduce length to  $2\frac{3}{8}$ ".*

### 0.010 GASKET UNIT, Engine or Tune Up

67-75	All (350) . . . . .	3970634	1	5.50	engine . . . . .
-------	---------------------	---------	---	------	------------------

### 0.027 MOUNTING ASSY.— MOUNTING UNIT— CABLE UNIT, Engine

#### 8 CYLINDER

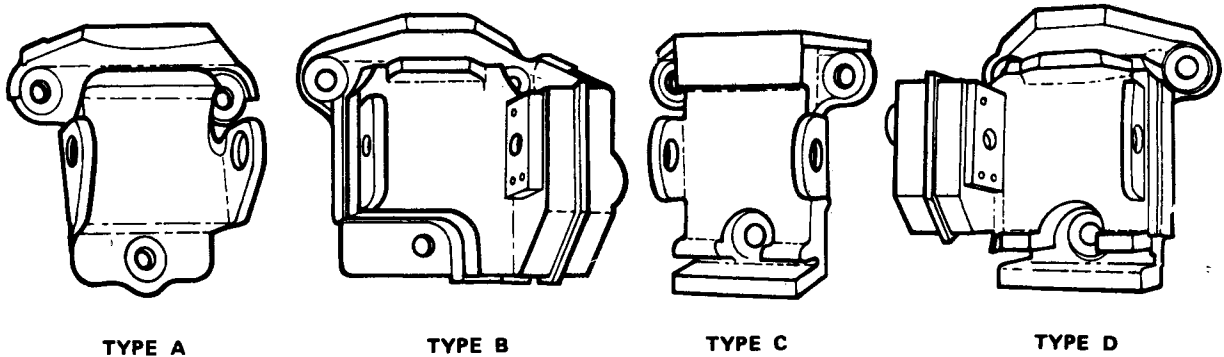

*NOTE Mount units 3990914, 3990916 and 3990918 include a mount, mount to frame bracket bolt, washers and nut.*

72	Camaro (350) (exc. Sp. H/Per.),				
73-75	All (350) . . . . .	6262215	2	8.80	
72	Taxi, Police (350) . . . . .	6262208	2	8.80	
72	Camaro w/Sp. H/Per. (350) . . . . .	3993721	2	12.70	
75	All (350) . . . . .	6262232	2	8.80	
70	Nova, Camaro (350) (exc. Sp. H/Per.),				
71	Nova, Camaro (350),				
70-72	Pass. w/2BC (350) (exc. Police, Sta. Wag.),				
70-71	Police (350) . . . . .	3990914 A.R.		9.95	<b>MOUNTING UNIT</b> . . . . .
67-68	Camaro, Chevy (350) . . . . .	3990916	2	16.10	<b>MOUNTING UNIT</b> . . . . .
69	All (350),				
70-71	Pass. w/4BC (350),				
70-72	Pass. (Sta. Wag.) w/2BC (350),				
70	Camaro w/Sp. H/Per. (350),				
70-72	Chevelle (350),				
72	Nova (350) . . . . .	3990918 A.R.		11.05	<b>MOUNTING UNIT</b> . . . . .
67-68	Camaro (350),				
68	Chevy (350),				
69	Chevy, Camaro (350) (exc. C.A.C.) . . . . .	330265	1	N.L.	<b>CABLE UNIT</b> , engine stop lift . . . . .
69	Chevy, Camaro w/C.A.C. (350) . . .	330280	1	N.L.	<b>CABLE UNIT</b> , engine stop lift . . . . .
69	Pass. w/P/S (350) . . . . .	325874	1	N.L.	<b>CABLE UNIT</b> , engine stop lift . . . . .
69	Pass. (350) (exc. P/S) . . . . .	325873	1	N.L.	<b>CABLE UNIT</b> , engine stop lift . . . . .

### 0.029 BRACKET— SHIELD, Engine Mounting

67-68	Camaro (350),				
70-71	Nova (350) . . . . .	3955183 L.H.		2.95	engine mtg. to side member . . . . .
67-68	Camaro (350),				
70-71	Nova (350) . . . . .	3980938 R.H.		2.95	engine mtg. to side member . . . . .

### 350-ENGINE ASSEMBLY

#### 0.029 BRACKET— SHIELD, Engine Mounting (Con't)

70	Pass. w/2BC (350) (exc. Sta. Wag., Taxi, Police) . . . . .	3954637 L.H.	2.00	BRACKET ASSY., frame . . . . .
70	Pass. w/2BC (350) (exc. Sta. Wag., Taxi, Police) . . . . .	3977234 R.H.	3.25	BRACKET ASSY., frame . . . . .
69	Pass. (350),			
70	Taxi, Police w/2BC (350),			
70	Pass. (Sta. Wag.) (350),			
70	Pass. w/4BC (350) . . . . .	3955186 R.H.	2.00	BRACKET ASSY., frame . . . . .
69-72	Chevelle (350) . . . . .	3980711 L.H.	5.00	BRACKET ASSY., frame . . . . .
69-72	Chevelle (350) . . . . .	3980712 R.H.	5.00	BRACKET ASSY., frame . . . . .
69	Chevy, Camaro (350),			
72	Nova (350) . . . . .	3945507 L.H.	5.75	BRACKET ASSY., side member . . . . .
69	Chevy, Camaro (350),			
72	Nova (350) . . . . .	3945508 R.H.	5.00	BRACKET ASSY., side member . . . . .
70-72	Camaro (350) (exc. Sp. H/Per.) . . . . .	3964890 L.H.	7.15	BRACKET ASSY., side member . . . . .
70-72	Camaro (350) (exc. Sp. H/Per.) . . . . .	3980930 R.H.	7.15	BRACKET ASSY., side member . . . . .
70-72	Camaro w/Sp. H/Per. (350) . . . . .	3982307 L.H.	4.25	BRACKET ASSY., side member . . . . .
70-72	Camaro w/Sp. H/Per. (350) . . . . .	3964886 R.H.	6.45	BRACKET ASSY., side member . . . . .
69	Pass. (350),			
70	Taxi, Police w/2BC (350),			
70	Pass. (Sta. Wag.) (350),			
70	Pass. w/4BC (350) . . . . .	3977235 L.H.	3.20	BRACKET ASSY., frame . . . . .
71	Taxi, Police w/2BC (350),			
71	Pass. w/4BC (350) (exc. Sta. Wag.),			
71-72	Pass. (Sta. Wag.) (350) . . . . .	3988229 L.H.	2.25	BRACKET ASSY., frame . . . . .
71	Taxi, Police w/2BC (350),			
71	Pass. w/4BC (350) (exc. Sta. Wag.),			
71-72	Pass. (Sta. Wag.) (350) . . . . .	3988230 R.H.	3.40	BRACKET ASSY., frame . . . . .
71	Pass. w/2BC (350) (exc. Sta. Wag., Taxi, Police),			
72	Pass. (350) (exc. Sta. Wag., Taxi, Police) . . . . .	3994459 L.H.	3.65	BRACKET ASSY., frame . . . . .
71	Pass. w/2BC (350) (exc. Sta. Wag., Taxi, Police),			
72	Pass. (350) (exc. Sta. Wag., Taxi, Police) . . . . .	3994460 R.H.	3.65	BRACKET ASSY., frame . . . . .
72	Taxi, Police (350),			
73-75	Chevelle (350) . . . . .	334970	2	5.15 BRACKET ASSY. . . . .
73	Pass. (350),			
75	Pass. (350) . . . . .	334602	2	7.25 BRACKET ASSY. . . . .
72-75	Camaro (350) . . . . .	332648	2	5.00 BRACKET ASSY., engine mtg. . . . .
71-72	All (350) . . . . .	3989442	1	.84 SHIELD, heat . . . . .

#### 0.033 BLOCK ASSY., Cylinder

*NOTE CAUTION. Combination not appearing below should be checked in the Engine Series Number and Suffix Chart in front of catalog to determine if the combination was available in production. If not available, no attempt should be made to make the installation.*

#### PARTIAL ENGINE

*NOTE Includes block, crankshaft, camshaft, timing gears, pistons and connecting rods.*

67	All (350) . . . . .	3912318	1	625.00	
68	All (350) . . . . .	3933043	1	625.00	(Note 1) . . . . .
69	All (350),				
70	All (350) (exc. Sp. H/Per.) . . . . .	3970655	1	623.00	(Note 2) . . . . .
70	All w/Sp. H/Per. (350) . . . . .	3966921	1	869.00	
71-72	All (350) (exc. Sp. H/Per., NB/2) . . . . .	3997466	1	623.00	
71-72	All w/Sp. H/Per. (350) . . . . .	3997472	1	922.00	
72	All w/NB/2 (350) (exc. Sp. H/Per.) . . . . .	325035	1	623.00	
73	All (350) (exc. Sp. H/Per.),				
74	All (350) (exc. Sp. H/Per., NB2),				
75	All (350) . . . . .	6259426	1	623.00	
74	All w/NB2 (350) (exc. Sp. H/Per.) . . . . .	344487	1	625.00	
73-74	All w/Sp. H/Per. (350) . . . . .	6259513	1	922.00	

#### FITTED CYLINDER BLOCK (Includes, Pistons, Pins, Rings and Bearings)

67	All (350) . . . . .	3912311	1	408.00	
69	All (350),				
70	All (350) (exc. Sp. H/Per.) . . . . .	3970645	1	407.00	(Note 2) . . . . .
70	All w/Sp. H/Per. (350) . . . . .	3966920	1	565.00	
71-72	All (350) (exc. Sp. H/Per.) . . . . .	3997426	1	407.00	
71-74	All w/Sp. H/Per. (350) . . . . .	3997428	1	567.00	

## 350-ENGINE ASSEMBLY

### 0.033 BLOCK ASSY., Cylinder (Con't)

73-75	All (350) (exc. Sp. H/Per.)	6259425	1	408.00	
-------	-----------------------------	---------	---	--------	--

*NOTE 1 When using on models with A.T. it will be necessary to remove clutch pilot bearing from crankshaft.*  
*NOTE 2 When using on 1968 models, it is mandatory to use 3957985 Inlet Manifold Gasket Unit.*

### 0.034 EXPANSION PLUGS, Cylinder Block (Also see 8.970)

67-75	All (350)	838538	A.R.	.18	water jacket balance shaft hole (cup type) (1 <sup>5</sup> / <sub>8</sub> " )
67-68	All (350)	3738306	A.R.	.46	(square socket water jacket hole) (1 <sup>1</sup> / <sub>4</sub> " )
75	All (350)	3826504	1	.96	water jacket

### 0.056 BOLT—STUD, Crankshaft Bearing Cap

69-75	All (350)	3932480	10	.28	( <sup>7</sup> / <sub>16</sub> "— 14 x 3 <sup>11</sup> / <sub>32</sub> " )
70-74	All w/4BC (350)	3877669	6	.32	(2 <sup>1</sup> / <sub>16</sub> " O.L.)— (0.293)
70-74	All w/Sp. H/Per. (350)	3960312	5	1.90	STUD ( <sup>9</sup> / <sub>8</sub> "— 16 x <sup>7</sup> / <sub>16</sub> "— 14 x 5 <sup>9</sup> / <sub>8</sub> " )

### 0.093 PLASTIGAGE, Crankshaft Bearing

67-75	All (350)	1390274	A.R.	6.15	(green package-type PG-1) (12 pieces)
-------	-----------	---------	------	------	---------------------------------------

### 0.095 CAP, Crankshaft Front Bearing

67	All (350)	3970194	1	5.85	(No. 1, 2, 3, 4, 5, 6) (light blue stripe)
69-70	All w/4BC (350),				
72-74	All w/Sp. H/Per. (350)	3956686	3	9.85	(4 bolt cap) (No. 2, 3, 4)
67-70	All (350),				
72-75	All (350) (exc. Sp. H/Per.)				(No. 1, 2, 3, 4),
69	All w/4BC (350) (exc. reg. fuel),				
70-71	All w/4BC (350) (exc. Sp. H/Per.),				
72-74	All w/Sp. H/Per. (350)	3956688	A.R.	9.10	(No. 1) (2 bolt cap)

### 0.096 BEARING UNIT, Crankshaft Front (1 Upper and 1 Lower)

See chart for Model Application

*NOTE: See Dealer Price Schedule for applicable prices.*

#### CRANKSHAFT MAIN BEARING CHART

	POSITION	STD.	.001 U.S.	.002 U.S.	.009 U.S.	.010 U.S.	.020 U.S.
67-75	All (350) All (exc. Rear)	3912038	3912039	3912040	3912037	3912041	3912042
67-75	All (350) Rear	3912030	3912032	3912033	3912034	3912035	3912036

*NOTE Bearings having no supplementary notes are Durex 100.*

### 0.099 BEARING UNIT, Crankshaft Front Intermediate (1 Upper and 1 Lower). See chart following Group 0.096 for Model Application.

*NOTE: See Dealer Price Schedule for applicable prices.*

### 0.101 BEARING UNIT, Crankshaft Center (1 Upper and 1 Lower). See chart following Group 0.096 for Model Application.

*NOTE: See Dealer Price Schedule for applicable prices.*

### 0.103 BEARING UNIT, Crankshaft Rear Intermediate (1 Upper and 1 Lower). See chart following Group 0.096 for Model Application.

*NOTE: See Dealer Price Schedule for applicable prices.*

### 0.105 CAP, Crankshaft Rear Bearing

67-70	All (350) (exc. Sp. H/Per.)				
71-75	All (350)	3911007	1	5.35	

### 0.106 BEARING UNIT, Crankshaft Rear (1 Upper and 1 Lower). See chart following Group 0.096 for Model Application.

*NOTE: See Dealer Price Schedule for applicable prices.*

### 0.107 DOWEL, Crankshaft Bearing Cap

67-75	All (350)	3836903	A.R.	.11	rear cap ( <sup>14</sup> / <sub>32</sub> " O.D. x <sup>5</sup> / <sub>8</sub> " )— (0.738)
-------	-----------	---------	------	-----	--

### 0.137 SEAL ASSY., Crankshaft Rear Bearing and Cap Oil

67-75	All (350)	3958001	2	2.60	rear oil
-------	-----------	---------	---	------	----------

### 0.153 SHIM UNIT, Crankshaft Bearing Cap

67-71	All (350),				
75	All (350)	3911011	A.R.	1.90	rear (2 <sup>9</sup> / <sub>16</sub> " O.L.)



## 350-ENGINE ASSEMBLY

### 0.153 SHIM UNIT, Crankshaft Bearing Cap (Con't)

69-71	All w/4BC (350) (exc. reg. fuel) . . . . .	3956690 A.R.	1.90	(Note 1) . . . . .
75	All (350) . . . . .	3911010 A.R.	1.90	# 1-2-3-4 cap . . . . .

*NOTE 1 Used only with four bolt brg. cap.*

### 0.206 COVER ASSY.— PIN, Crankcase Front End

67-68	Camaro (350) . . . . .	3923290	1	5.80	
69-75	All (350) . . . . .	3991433	1	6.30	
67-75	All (350) . . . . .	3836903	2	.11	PIN, dowel (1/8" x 5/8")— (0.738) . . . . .

### 0.207 GASKET, Crankcase Front End Cover

67-75	All (350) . . . . .	3799620	1	.26	(attach. 2 dowel holes) . . . . .
-------	---------------------	---------	---	-----	-----------------------------------

### 0.213 SEAL, Crankcase Front End Cover

67-75	All (350) . . . . .	3980267	1	3.35	(27/16" O.D.— stamped 3980267) . . . . .
-------	---------------------	---------	---	------	--

### 0.219 POINTER, Engine Timing

69-75	All (350) (exc. Sp. H/Per.) . . . . .	3991435	1	.53	
69-74	All w/Sp. H/Per. (350) . . . . .	3991436	1	.53	

### 0.269 HEAD, Cylinder

67-69	All (350) (exc. reg. fuel),				
70	All w/4BC (350) (exc. Sp. H/er.)	3958603	2	92.50	w/studs . . . . .
69	All w/reg. fuel (350),				
70	All w/2BC (350) . . . . .	3958606	2	92.50	w/studs . . . . .
70	All w/Sp. H/Per. (350) . . . . .	3987376	2	105.00	
71-72	All w/Sp. H/Per. (350) . . . . .	6272068	2		w/valve guide and studs (repl. 3990944) . . . . .
71-75	All (350) (exc. Sp. H/Per.) . . . . .	6260856	2	112.00	w/studs . . . . .
72*	All w/Sp. H/Per. (2nd design) (350),				
74	All w/Sp. H/Per. (350) . . . . .	369125	2	103.00	w/stud . . . . .
73	All w/Sp. H/Per. (350) . . . . .	6259515	2	92.50	w/studs . . . . .

### 0.289 GASKET, Cylinder Head

67-75	All (350) . . . . .	3830711	2	2.60	
67-68	All (350) . . . . .	3931606	1	15.45	GASKET UNIT . . . . .
69-72	All (350) . . . . .	3957998	1	15.45	GASKET UNIT . . . . .
73	All (350),				
74	All w/2BC (350) . . . . .	6258831	1	15.95	GASKET UNIT . . . . .
74	All w/4BC (350) . . . . .	345196	1	13.75	GASKET UNIT . . . . .
75	All (350) . . . . .	356804	1	15.70	GASKET UNIT . . . . .

### 0.293 BOLT— NUT— PIN, Cylinder Head

67-75	All (350) . . . . .	3704796	16	.22	short (7/16"— 14 x 1 3/4") . . . . .
67-75	All (350) . . . . .	3734594 A.R.		.22	long (1/16"— 14 x 3 3/4") (circle on top of head) . . . . .
67-75	All (350) . . . . .	3767468	4	.22	medium (7/16"— 14 x 3) (circle on top of head) (Note 1) . . . . .
69	All w/4BC (350) (exc. reg. fuel),				
70	All w/Sp. H/Per. (350) . . . . .	3877669 A.R.		.32	short (2 1/16" O.L.) (raised cross) . . . . .
67-69	Chevelle, Camaro (350) . . . . .	3866766	12	.12	NUT, attaching (hex. 3/8"— 24)— (0.626) . . . . .
67-69	Pass. (350),				
75	All (350) . . . . .	585927 A.R.		.16	PIN (5/16" x 9/16") . . . . .

*NOTE 1 Use with cylinder head with cast-in oil trough on outer edge.*

### 0.296 VALVE, Inlet

**Refer to following Chart for Model Application**

*NOTE: See Dealer Price Schedule for applicable prices.*

#### VALVE CHART (Inlet)

	STD.	.003 O.S.	.015 O.S.	.030 O.S.
67-68	All (350) (exc. Sp. H/Per., reg. fuel), . . . . .			
69	All (350) (exc. Police), . . . . .			
70-75	All (350) (exc. Taxi, Police, Sp. H/Per.) . . . . .	3989085	3995681	3995682
70-75	All w/Sp. H/Per. (350) . . . . .	3849814	3849815	3849816
69	Police (350), . . . . .			
70-72	Taxi, Police (350) . . . . .	3984180	—	—
73-75	Taxi, Police (350) . . . . .	3984180	—	3995946

## 350-ENGINE ASSEMBLY

### 0.297 VALVE, Exhaust

Refer to following Chart for Model Application

*NOTE: See Dealer Price Schedule for applicable prices.*

#### VALVE CHART (Exhaust)

	STD.	.003 O.S.	.015 O.S.	.030 O.S.
67-70 All (350) (exc. Sp. H/Per.)	6263778	3995602	3995603	3995604
70-72 All w/Sp. H/Per. (350) ..	3849818	3850040	3850041	3850042
71-75 All (350) (exc. Sp. H/Per.)	3989084	3995602	3995603	3995604
73-74 All w/Sp. H/Per. (350) ..	3937750	3940912	3940913	3940914

### 0.303 SPRING— SHIM, Valve

67-71 All (350),				
72-74 All w/Sp. H/Per. (350) .....				(exh. and inlet), .....
72-75 All (350) (exc. Sp. H/Per.) .....	3911068 A.R.	1.30		w/damper inlet .....
72-75 All (350) (exc. Sp. H/Per.) .....	6263796 8	1.40		w/damper (exhaust) .....
67-74 All (350) .....	3731058 A.R.	.12		SHIM (1/2" thk.) (Note 1) .....

*NOTE 1 To be used in place of Valve Stem Oil Shield when removed at customers request.*

### 0.308 SEAL— SHIELD, Valve Spring Cap

67-75 All (350) .....	3835333 A.R.	.17		"O" ring, inlet and exhaust .....
67-75 All (350) .....	3836755 A.R.	.18		SHIELD (cup shape-7/8" I.D. x 1 3/8" O.D.) ...

### 0.309 CAP— ROTATOR ASSY., Valve Spring

67-75 All (350) .....	3896934 A.R.	.40		valve spring cap ("A" stamped on top of the surface, inlet) (1 3/16" O.D.) .....
72-75 All (350) (exc. Sp. H/Per.) .....	6263794 8	2.95		ROTATOR ASSY., exhaust valve .....

### 0.310 KEY, Valve Stem

67-72 All (350) (exc. Sp. H/Per.),				
73-75 All (350) .....	838029 A.R.	.06		("U" shape) .....
70-71 All w/Sp. H/Per. (350),				
73-75 All (350) .....	3947770 32	.12		(carbonized) (Ident. by purple dye) .....

### 0.333 ARM UNIT, Valve Rocker with Adjusting Screw and Nut

67-75 All (350) .....	3974290 16	2.40		inlet and exhaust ("V" stamped on inside of pad end) .....
-----------------------	------------	------	--	--

### 0.386 COVER ASSY.— GROMMET— EMBLEM, Valve Rocker Arm

67 Camaro (350) .....	3910297 2	16.20		valve rocker .....
68 All w/Sp. H/Per. (350) .....	3923226 2	16.40		(chrome) .....
70-74 All w/Sp. H/Per. (350) .....	3965541 L.H.	19.00		(alum.) .....
70-74 All w/Sp. H/Per. (350) .....	3965542 R.H.	19.00		(alum.) .....
68-72 All (350) (exc. Sp. H/Per.) .....	6272227 2	10.30		w/oil filler cap, R.H., L.H. ....
73 All (350) (exc. Sp. H/Per.) .....	333867 R.H.	9.10		right .....
73 All (350) (exc. Sp. H/Per.) .....	333866 L.H.	9.10		left .....
74 All (350) (exc. Sp. H/Per.) .....	340267 L.H.	9.10		left .....
74-75 All (350) (exc. Sp. H/Per.) .....	340268 R.H.	9.10		right .....
75 All (350) (exc. Sp. H/er.) .....	355965 L.H.	10.20		left .....
67 Camaro (350) .....	3910298 2	7.25		COVER UNIT, right or left (8 13/16" outer hole spacing) (Note 1) .....
68-70 All (350) .....	3894337 A.R.	.11		GROMMET, cover to a/cl. (3 1/32" I.D. x 1 7/32" O.D.)— (1.745) .....
70-74 All w/Sp. H/Per. (350) .....	3946860 R.H.	.65		EMBLEM, cover .....

*NOTE 1 Includes Cover Assy., Gasket and 2 Cylinder Head Bolts.*

### 0.413 BOLT— REINFORCEMENT, Valve Rocker Cover and Support

67-75 All (350) .....	180016 1			(1/4" — 20 x 1/2")— (8.900) .....
67-75 All (350) .....	3877670 A.R.	.12		REINFORCEMENT (1 1/2" O.L.) (Note 1) .....

*NOTE 1 Use with Bolt 180016.*

### 0.423 GASKET, Valve Rocker Cover

67-75 All (350) .....	3933964 2	1.80		
-----------------------	-----------	------	--	--

### 0.426 ROD, Valve Push

67-75 All (350) .....	3796243 A.R.	2.15		(7 25/32" O.L.) (blue stripe) (Note 1, 2) .....
-----------------------	--------------	------	--	---

*NOTE 1 Color marked end to be at valve rocker arm.*

*NOTE 2 May have one black stripe at each end.*

### 0.429 BALL— NUT— STUD, Valve Push Rod Adjusting

67-75 All (350) .....	3959142 A.R.	.38		(13/16" dia.) .....
-----------------------	--------------	-----	--	---------------------

### 350-ENGINE ASSEMBLY

#### 0.429 BALL— NUT— STUD, Valve Push Rod Adjusting (Con't)

67-75	All (350)	3744341	16	.22	NUT, valve rocker arm ( $\frac{3}{8}$ "— 24) ( $\frac{5}{8}$ " across the flats x $\frac{1}{2}$ ")
67-72	All (350) (exc. Sp. H/Per.),				
73-75	All (350)	3814692	16	.53	STUD, valve rocker arm ball (.003 O.S.-light blue paint)
67-75	All (350)	3815892	16	.53	STUD, valve rocker arm ball (.013 O.S.— $\frac{3}{8}$ "— 24 $2\frac{1}{2}$ ") (1 groove on shank-light blue paint)
70-74	All w/Sp. H/Per. (350)	3973416	16	.53	STUD, ball

#### 0.439 GUIDE, Valve Push Rod

70-74	All w/Sp. H/Per. (350)	3973418	8	.63	push rod
-------	------------------------	---------	---	-----	----------

#### 0.459 TAPPET, Valve (or Lifter)

67-72	All (350) (exc. Sp. H/Per.),				
73-75	All (350) (exc. Sp. H/Per., Police, Taxi)	5232670	16	4.54	hydraulic type
70-72	All w/Sp. H/Per. (350)	5231585	16	2.77	
73-75	Police, Taxi,				
73-74	All w/Sp. H/Per. (350)	5232720	16	4.54	

#### 0.519 CAMSHAFT, Engine

*NOTE Engine Camshaft Break-in Oil 1050800, Group 1.850, should be used when installing new camshafts.*

67-72	All (350) (exc. Sp. H/Per., NB-2),				
73-75	All (350) (exc. Sp. H/Per.)	3896929	1	48.25	standard (Ident. No. 3896930)
70-72	All w/Sp. H/Per. (350)	3972178	1	48.25	(Note 1)
72	All w/NB/2 (350) (exc. Sp. H/Per.)	3998962	1	48.25	
73-74	All w/Sp. H/Per. (350)	3896962	1	48.25	

*NOTE 1 When using 3972178 Camshaft Assembly in place of 3849346 Camshaft Assembly, it is necessary to make valve lash adjustments of .024 intake and .030 exhaust for best performance.*

#### 0.539 BEARING, Camshaft (Front or No. 1)

67-75	All (350)	3723584	1	2.40	precision type (stamped 1)
-------	-----------	---------	---	------	----------------------------

#### 0.543 BEARING, Camshaft No. 2 (Front Intermediate)

67-75	All (350)	3723585	1	2.40	precision type (stamped 2)
-------	-----------	---------	---	------	----------------------------

#### 0.546 BEARING, Camshaft (Center and Rear Intermediate)

67-75	All (350)	3723586 A.R.		2.40	(stamped 3 and 4)
-------	-----------	--------------	--	------	-------------------

#### 0.549 BEARING, Camshaft Rear

67-75	All (350)	3723585	1	2.40	precision type (stamped 2)— (0.543)
-------	-----------	---------	---	------	-------------------------------------

#### 0.553 PLUG, Camshaft Bearing Hole, cup type (in cylinder block)

67-71	All (350) (1st design)	3704158	1	.22	( $2\frac{1}{8}$ " dia.)
71-75	All (350) (2nd design)	3997752	1	.12	rear brg. (has mfg. ident. mark)

#### 0.603 ROD ASSY., Connecting, Less Dipper

67-75	All (350) (exc. Sp. H/Per.)	3916396	8	12.70	
70-74	All w/Sp. H/Per. (350)	3973386	8	39.25	

#### 0.616 BEARING UNIT, Connecting Rod (1 Upper and 1 Lower)

#### Refer to chart for Model Application

*NOTE: See Dealer Price Schedule for applicable prices.*

#### CONNECTING ROD BEARING UNIT CHART

MODEL USAGE	STD.	.001 U.S.	.002 U.S.	.010 U.S.	.020 U.S.
67-75 All (350)	3910555(1)	3910556(1)	3910557(1)	3910558(1)	3910559(1)

(1) Aluminum M-400.

#### 0.623 BOLT, Connecting Rod Bearing Cap

67	All (350)	3892670 A.R.	.70	( $\frac{11}{32}$ "— 24 x $1\frac{7}{8}$ ")
68-75	All (350)	3916399	16	.60 ( $\frac{3}{8}$ "— 24 x $1\frac{59}{64}$ ")

#### 0.626 NUT, Connecting Rod Bearing Cap Bolt

67-69	Chevy, Chevelle, Camaro (350)	9422298 A.R.	.11	( $\frac{3}{8}$ "— 24 x $\frac{5}{16}$ " thick) (one end chamfered)— (8.917)
67-69	All (exc. Chevy) (350),			
70-75	All (350)	3866766 A.R.	.12	( $\frac{3}{8}$ "— 24 x $\frac{3}{8}$ " thick) (hex. nut) (both ends flat) (Note 1)

*NOTE 1 Also used with bolts not requiring cotter pins.*

## 350-ENGINE ASSEMBLY

### 0.629 PISTON ASSY., with Pin

*NOTE Individual piston assemblies are available for warranty purposes and for replacement of pistons damaged when making repairs to engine assemblies. When ordering such parts it is necessary that you specify on your order the reason the parts are required and also that the following note appears on your order. Do not ship unit package quantity.*

ENGINE DISPLACEMENT	BASIC SIZE	SERVICE PISTON DIAMETER RANGE LIMITS ALUMINUM
350 cu. in.	4.0000— STD.	S-4— 4.0000 to 4.0005, S-5— 4.0005 to 4.0010

*NOTE: The above chart is for information purposes only.*

**(Refer to chart for model application)**

*NOTE: See Dealer Price Schedule for applicable prices.*

### PISTON CHART

.....	STD.	.001 O.S.	.020 O.S.	.030 O.S.
67-70 All (350) (exc. Sp. H/Per.)	3911020	3911021	—	3911023
70 All w/Sp. H/Per. (350) ..	3989048	3989049	—	3989051
71-72 All (350) (exc. Sp. H/Per.)	3991488	3991489	—	3991491
71-72 All w/Sp. H/Per. (350) ..	336754	3991485	3991486	3991487
73-75 All (350) (exc. Sp. H/Per.)	6271097	6271098	—	329238
73 Ali w/Sp. H/Per. (350) ..	3991484	3991485	—	336757
74 Camaro w/Sp. H/Per. (350) .....	336754	336755	—	336757

### 0.643 RING UNIT, Piston (Service Sets)

*NOTE: See Dealer Price Schedule for applicable prices.*

.....	STD.	.030 O.S.
67-75 All (350) .....	328506(?)	328516(?)

*(?) Single cylinder replacement only.*

### 0.646 CRANKSHAFT, Engine

67-88 Chevy, Camaro (350) .....	3912335	1	147.00	
69-75 All (350) (exc. Sp. H/Per.) .....	3932444	1	147.00	(Note 1) .....
70-74 All w/Sp. H/Per. (350) .....	3941184	1	161.00	(Note 1) .....

*NOTE 1 When used on A.T. it will be necessary to remove the pilot bearing.*

### 0.649 BEARING, Crankshaft Clutch Pilot

67-75 All (350) .....	3752487	1	1.20	(bush type— <sup>19</sup> / <sub>32</sub> " I.D. x <sup>13</sup> / <sub>32</sub> " O.D. x <sup>3</sup> / <sub>4</sub> " ) ..
-----------------------	---------	---	------	--

### 0.659 BALANCER— PULLEY, Crankshaft

*NOTE In some cases double groove pulleys may be used in place of single groove pulleys.*

*NOTE Crankshaft harmonic balancer is also referred to as "torsional damper".*

69-75 All (350) (exc. Sp. H/Per.) .....	6272221	1	26.50	
69-70 All w/4BC (350) (exc. H/Per., Sp. H/Per.) .....	6272222	1	26.50	
70-74 All Sp. H/Per. (350) .....	6272224	1	44.75	
67-68 Camaro (350) .....	3896966	1	26.50	BALANCER ASSY., w/o pulley (8" O.D.) ...
67-68 Camaro (350) (exc. C.A.C., C/Deluxe Air Cond., A.I.R.) .....	3755820	1	7.75	PULLEY (stamped 3755820) .....
67 Camaro (350) (exc. C.A.C.) .....	3744043	1	8.20	PULLEY (double-6 <sup>5</sup> / <sub>8</sub> " O.D.— painted black) (stamped 3744043) .....
67-68 Camaro w/P/S (350) .....	3751232	1	7.75	PULLEY, front (stamped 3751232) .....
67-68 Camaro w/Air Cond. (350) .....	3850838	1	9.00	PULLEY (7 <sup>21</sup> / <sub>64</sub> " O.D.) .....
70 Pass., Nova w/Acc. Air Cond. (350) .....	3937787	1	12.90	PULLEY (3 groove) (Note 1) .....
67-68 All (350) (exc. C.A.C., P/S Sp. H/Per.) .....				
69-72 All (350) (exc. C.A.C., Sp/H/Per.) .....				
73-75 All (350) (exc. C.A.C., Sp. H/Per. 63 amp., Taxi, Police) .....	3956666	1	9.20	PULLEY (2 groove) .....
70-72 All w/Sp. H/Per. (350),				
73-74 Camaro w/Sp. H/Per. (350) (exc. C.A.C.) .....	3956668	1	9.20	PULLEY ASSY., cr. shaft (2 groove) .....
69 All w/Air Cond. (350),				

## 350-ENGINE ASSEMBLY

### 0.659 BALANCER— PULLEY, Crankshaft (Con't)

70	Pass., Nova, Chevelle w/Acc. Air Cond. (350),				
70-72	All w/C.A.C. (350),				
73-75	All w/63 amp. (350),				
73-75	Taxi, Police (350) (exc. C.A.C.),				
73-75	All w/C.A.C. (350) (exc. Sp. H/Per.)	3972180	1	15.95	PULLEY ASSY. (3 groove) (stamped 3972180)
73-74	All (Sp. H/Per. w/C.A.C.) (350)	329273	1	9.75	PULLEY ASSY. (2 groove)
75	Monza w/C.A.C. (350)	360453	1	8.50	PULLEY

### 0.662 BOLT— WASHER— REINFORCEMENT, Harmonic Balancer and Crankshaft Pulley

67-68	Camaro (350)	3815933	1	.63	(7/16" — 20 x 2 1/4")
67-75	All (350)	3739422	1	.46	WASHER, balancer (29/64" I.D. x 1 3/4" O.D. x 5/16" thk.)
69	All w/C.A.C. (350)	3965597	1	.59	REINFORCEMENT, crankshaft pulley

### 0.666 FLYWHEEL, with Ring Gear

67-69	All w/P.G., reg. fuel (350)	3789821	1	26.75	spoke type (6-2" dia. holes around ctr.)
69	Pass. w/reg. fuel (350) (exc. A.T., Police)	3973452	1	59.25	solid type (cast 3791021)
67-69	Camaro, Chevy (350) (exc. A.T.),				
69	Pass. (350) (exc. reg. fuel, Sp. H/Per., A.T.),				
70	All w/4BC (350) (exc. Sp. H/Per., A.T.),				
70-74	All w/Sp. H/Per. (350) (exc. A.T.)	3998281	1	68.25	w/11" coil sprg. clutch (12 5/8" bolt circle) solid type (repl. 3973453)
71	Nova, Monte Carlo, Camaro w/4BC (350) (exc. A.T.),				
68	All w/T.H. (350) (1st design),				
69	All w/T.H. (350),				
70	All w/T.H., Sp. H/Per. (350),				
71-72	All w/A.T., Sp. H/Per. (350)	336763	1	32.00	(Note 1)
68	All w/T.H. (350) (2nd design),				
69	All w/T.H. 400 (350) (exc. Sp. H/Per.),				
70-75	All w/A.T. (350) (exc. Sp. H/Per.)	340296	1	23.85	(repl. 3991403)
67-68	Camaro w/P.G. (350),				
69	All w/P.G. (350) (exc. reg. fuel),				
70	All w/P.G. (350)	3899668	1	31.00	(2 31/64" ctr. hole)
70-72	All w/2BC (350) (exc. A.T.),				
71	Chevelle w/4BC (350) (exc. A.T., Monte Carlo),				
73-74	All (350) (exc. A.T., Sp. H/Per.),				
73-74	Camaro (A.T. w/Sp. H/Per.) (350)	336763	1	32.00	
75	Nova, Camaro (350) (exc. A.T., Sp. H/Per.)	3986390	1	59.25	
75	Monza (350)	333955	1	28.75	FLYWHEEL

NOTE 1 On some application 3991401 and 3937736 are used optionally in production. These parts can be identified by their bolt hole mounting patterns. 3991401 contains a single bolt hole mounting pattern 1 1/2" in dia. 3937736 contains two (staggered) bolt hole mounting patterns. The inner pattern 10 3/4" in dia., the outer 11 1/2" in dia.

### 0.669 BOLT, Flywheel to Crankshaft

67-75	All (350) (exc. A.T.)	839756	6	.12	(7/16" — 20 x 1)
67-75	All w/A.T. (350)	3727207	6	.21	(7/16" — 20 x 45/64" — 290M steel)

### 0.673 GEAR, Flywheel Ring

67-75	All (350)	3991408	1	6.40	(13 1/4" dia.)
73-75	All (350)	3991407	1	7.95	(12" dia.)

### 0.679 UNDERPAN— BOLT— COVER— SCREW, Flywheel

67-69	All w/P.G. (350)	3831527	1	8.60	transmission converter (Note 1)
NOTE 1 This part is also used as a replacement part with Rebuilt trans. assy. 3832565 (P.G.) and (T.G.) conversion unit 3832566.					
67-69	All w/T.H. 400 (350)	3868810	1	3.55	trans. converter
68-69	All w/T.H. 350 (350)	6261091	1	4.20	trans. converter
70	Pass., Nova, Chevelle w/P.G. (350),				
71-72	All w/P.G. (350)	3952639	1	5.60	trans. converter
70-74	All w/T.H. 400 (350)	3952661	1	4.85	trans. converter

**350-ENGINE ASSEMBLY**

**0.679 UNDERPAN— BOLT— COVER— SCREW, Flywheel (Con't)**

70-74	All w/T.H. 350 (350),				
75	All w/A.T. (350) . . . . .	344249	1	4.55	converter . . . . .
All	All (350) . . . . .	3817006	A.R.	.12	BOLT, w/washer (1/4"— 20 x 7/16") . . . . .
69	Pass. w/reg. fuel (350),				
70	All w/Sp. H/Per. (350) . . . . .	354497	1	2.65	COVER, clutch housing (repl. 3788422) . . .
67	Camaro (350),				
68	Camaro (350) (exc. A.T.),				
69	Pass. (350) (exc. A.T., reg. fuel),				
70	All (350) (exc. Sp. H/Per.),				
71-74	All (350) . . . . .	3843943	1	3.05	COVER, clutch housing . . . . .
75	Nova, Camaro (350) (exc. A.T.) . . . . .	340252	1	2.65	COVER, clutch housing . . . . .
69	All w/T.H. 350 (350) . . . . .	9420825	4		SCREW (5/16"— 18 x 9/16") (Note 2)— (8.977) . . . . .
	<i>NOTE 2 Use with washer 120393 group (8.929).</i>				
75	All w/T.H. 350 (350) . . . . .	6261376	1	.16	SCREW, converter under pan (1/4"— 20 x 7/8") . . . . .
67-69	All w/P.G. (350),				
70	Pass., Nova, Chevelle w/P.G. (350) (exc. Sp. H/Per.),				
71	All w/P.G., 2BC (350) . . . . .	3924780	A.R.	.16	SCREW ASSY., w/washer (5/16"— 18 x 7/8")

**0.683 HOUSING— BOLT, Flywheel and Clutch**

69	Pass. (350 w/reg. fuel) (exc. Taxi, Police, H.D. Clutch),				
69	Chevy, Chevelle, Camaro w/reg. fuel (350) . . . . .	3858403	1	30.50	HOUSING ASSY., clutch (u/w 10.4 in. clutch) (Ident. No. 3840383) (Note 1) . . . .
67-70	All (350) (exc. Sp. H/Per.),				
70	All Sp. H/Per. (350)				
71-75	All (350) . . . . .	3899621	1	37.50	HOUSING ASSY., clutch (u/w 11 in. clutch)
All	Pass. (350) . . . . .	3736035	A.R.	.22	BOLT, clutch housing attach. (3/8"— 16 x 1 3/16") (300M steel-plain)— (3.275) (Note 2) . . . . .
All	Pass. (350) . . . . .	3733130	2	.24	BOLT, clutch housing attach. (3/8"— 16 x 2 1/4"— washer hd.) (300M steel)— (3.275)

*NOTE 1 Less ball stud.*

*NOTE 2 When using bolt 3736035, it will be necessary to use washer 120394 (8.929).*

**0.685 DOWEL, Flywheel and Clutch Housing to Cylinder Block**

67-75	All (350) . . . . .	3712745	2	.50	clutch and flywheel (2 1/32" x 1 1/4" long) . . . .
-------	---------------------	---------	---	-----	---

**0.724 CHAIN, Camshaft Timing**

67-75	All (350) . . . . .	346261	1	11.20	early link type . . . . .
-------	---------------------	--------	---	-------	---------------------------

**0.728 SPROCKET, Crankshaft Timing (Steel)**

67-75	All (350) . . . . .	3896959	1	4.65	(18 teeth— 2 7/8" O.D.) (early link type) . . . . .
-------	---------------------	---------	---	------	---

**0.736 SPROCKET, Camshaft Timing**

67-75	All (350) . . . . .	340235	1	8.45	(36 teeth) (repl. 3896960) . . . . .
-------	---------------------	--------	---	------	--------------------------------------

**0.738 PIN, Camshaft Sprocket**

67-75	All (350) . . . . .	3836903	1	.11	dowel (1/4" x 5/8") (solid) . . . . .
-------	---------------------	---------	---	-----	---------------------------------------

**0.787 ROD— CLIP— SWIVEL, Clutch Fork Release**

67-75	Camaro (350),				
69-75	Nova (350) . . . . .	3973076	1	1.95	fork push . . . . .
67-75	Camaro (350),				
69-75	Nova (350) . . . . .	340690	1	1.10	fork push adjusting (4 3/4" long) . . . . .
69-70	Pass. (350) . . . . .	3859863	1	1.25	fork push . . . . .
67-70	Chevelle (350),				
71-75	Pass., Chevelle (350) . . . . .	9779202	1	.88	fork push . . . . .
75	Nova (350) . . . . .	3939116	1	1.20	fork push adjusting . . . . .
67-69	All (350) . . . . .	3749084	A.R.	.27	CLIP, push rod and swivel— (4.037) . . . . .
67-69	All (350) . . . . .	1455017	1	.13	CLIP, push rod— (3.425) . . . . .
69-70	Pass. (350) . . . . .	3859839	1	.71	SWIVEL, pedal push . . . . .
69-71	Chevelle (350),				
71	Pass. (350) (exc. Sta. Wag.),				
75	Nova, Camaro (350) . . . . .	3840845	1	1.40	SWIVEL, fork push rod (1 1/2" O.L.) (3/8"— thds.) . . . . .
73-75	Pass., Chevelle (350) . . . . .	335380	1	1.40	SWIVEL, push rod adjusting . . . . .

**0.793 WASHER, Clutch Fork Push Rod**

67-72	All (350) . . . . .	3756694	1	.11	push rod lever thrust (2 3/4" dia. pedal shaft) pull rod lever . . . . .
-------	---------------------	---------	---	-----	---

**350-ENGINE ASSEMBLY**

**0.795 FORK ASSY., Clutch Release**

67-69	All (350),			
70	Nova, Chevelle, Camaro (350),			
71-72	All (350) .....	3892632	1	7.15
69-70	Pass. (350) .....	3860005	1	7.15
73-75	All (350) .....	340278	1	11.70

**0.796 STUD— BRACKET— SPRING, Clutch Fork**

69-70	Pass. (350) .....	3790556	1	.84	ball ( <sup>3</sup> / <sub>16</sub> "— 16 thds.) .....
67-70	Chevy, Chevelle, Camaro (350),				
71-75	All (350) .....	3729000	1	1.05	ball ( <sup>13</sup> / <sub>16</sub> "— 16 w/ <sup>21</sup> / <sub>32</sub> " diameter ball) .....
71-72	Chevelle (350) .....	3992305	1	.40	BRACKET, pull back .....
73-75	All (350) .....	3849698	1	.63	SPRING .....

**0.797 BOOT, Clutch Fork**

67-75	All (350) .....	3993851	1	.76	
-------	-----------------	---------	---	-----	--

**0.799 BEARING, Clutch throwout with Collar**

69	Pass. (350) (exc. 4-Spd., A.T., H.D. 3-Spd.),				
69	Chevelle (350) (exc. 4-Spd.),				
69	Camaro w/2BC (350),				
70	Police (350) .....	908092	1	15.94	ball bearing type (1 <sup>7</sup> / <sub>8</sub> " long) .....
67-70	All (350) (exc. Police),				
71-75	All (350) .....	908093	1	13.56	(1 <sup>7</sup> / <sub>32</sub> " O.L.) (ND-HCT-24K) .....

**0.829 BUMPER— BRACKET— CLIP— COVER— PLUG— SEAL, Clutch**

(For COVERS see group 4.630)

68-69	Chevy, Chevelle, Camaro (350),				
69	Pass. (350),				
70-75	All (350) .....	340688	1	.21	pedal .....
73	Chevelle (350) .....	6264981	1	1.30	BRACKET, pedal bumper .....
74-75	Chevelle .....	342435	1	1.30	BRACKET, pedal bumper .....
73-74	Chevelle .....	1243333	1	.16	CLIP, clutch arm stop .....
67-75	Camaro, Chevy w/A.T. (350) ...	3886689	1	.21	COVER, clutch pedal push rod hole .....
67-75	Camaro w/A.T. (350),				
69-75	Chevy w/A.T. (350) .....	3903466	1	.15	SEAL, clutch pedal push rod hole cover ...
69-70	Pass. (350) .....	3950007	1	1.30	SEAL, pedal push rod .....
67	Camaro (350),				
68-69	Camaro, Chevy (350),				
70-75	Nova (350) .....	3909071	1	1.20	SEAL ASSY., clutch pedal push rod .....
69-72	Chevelle (350) .....	399904	1	3.20	SEAL ASSY., clutch pedal push rod .....
70-75	Camaro (350),				
75	Nova (350) .....	3973089	1	2.65	SEAL ASSY., clutch pedal push rod .....
71	Pass. (350) .....	3988202	1	3.40	SEAL ASSY., clutch pedal push rod .....
73-75	Chevelle (350) .....	3994485	1	3.20	SEAL ASSY., clutch pedal push rod .....

**0.830 PEDAL, Clutch**

67	Camaro (350) .....	3890609	1	5.55	
68-72	Chevelle (350) .....	3967783	1	5.30	
68-69	Chevy, Camaro (350),				
70-75	Nova (350) .....	6258554	1	6.55	
69-70	Pass. (350) .....	3968745	1	5.50	
70-71	Camaro (350) .....	3965693	1	5.30	
71	Pass. (350) .....	3988193	1	5.60	
72	Camaro (350) .....	3998671	1	5.30	
73-75	Chevelle (350) .....	3994483	1	8.85	
73-75	Camaro (350) .....	332519	1	5.60	
75	Nova (350) .....	355581	1	7.50	

**0.831 BUSHING, Clutch Pedal (see group 4.626 for brake pedal bushing)**

67-70	All (350) .....	1247439	2	.11	(pedal shaft)— (4.626) .....
-------	-----------------	---------	---	-----	------------------------------

**0.837 RETAINER, Clutch and Brake Pedal Shaft— (Also see groups 4.634 and 4.648)**

67-70	All (350) .....	3828428	1	.22	shaft— (4.634) .....
70	Camaro (350) .....	9783098	1	.87	(4.634) .....

**0.844 SPRING, Clutch Pedal Pull Back**

69-70	Pass. (350) .....	3849704	1	.34	fork pull back .....
69-70	Pass. (350) .....	3879772	1	.22	clutch pull back .....
67-69	Camaro (350),				
68-72	Chevy (350) .....	3899021	1	.28	clutch fork push rod pull back .....
69-70	Chevelle (350) .....	3920614	1	.34	

**350-ENGINE ASSEMBLY**

**0.844 SPRING, Clutch Pedal Pull Back (Con't)**

70	Camaro (350),				
71-72	Pass., Camaro (350) .....	3973088	1	.40	fork pull back .....
71-72	Chevelle (350) .....	3992306	1	.52	fork pull back .....
73-75	Chevelle (350) .....	3994494	1	1.75	fork pull back .....
73-74	Nova (350) .....	332517	1	.46	fork pull back .....
73-75	Camaro (350) .....	332521	1	.76	clutch fork pull back .....
75	Nova (350) .....	355585	1	1.25	fork pull back .....

**0.846 EXTENSION, Clutch Pedal Pull Back Spring**

67-69	Camaro (350),				
69-72	Chevy (350) .....	3899022	1	.32	clutch fork push rod pull back spring .....
73-74	Nova (350) .....	332518	1	.63	fork push rod pull back spring .....

**0.851 SEAT— SEAL— SPRING— STUD— WASHER, Clutch Pedal Intermediate Lever Shaft Ball**

67-75	All (350) .....	3743349	A.R.	.18	stud (7/8" dia.) .....
67-75	All (350) .....	382658	1	.19	SEAL, ball stud dust, lever shaft ball stud ..
67-75	All (350) .....	3750696	1	.13	SPRING, frame stud seat, retaining (1" O.D.)
67-70	Chevy, Chevelle, Camaro (350),				
71-75	All (350) .....	3866568	1	1.15	STUD, lever shaft ball to engine .....
69	Chevy (350) .....				STUD, to body, .....
67-69	Pass., Chevelle, Camaro (350),				
71	All (350) .....	3898610	1	.81	to frame (3/8"— 24 x 1 <sup>13</sup> / <sub>16</sub> " O.L.) .....
69-70	Pass. (350) .....	3859488	1	1.20	STUD, lever shaft ball to eng. ....
70	Camaro (350) .....				STUD, clutch lvr. & shaft ball to brkt. ....
70-73	Chevy (350) .....				clutch lvr. & shaft ball to eng., .....
70	Pass., Chevelle (350),				
72-73	Pass.,				
74-75	All (350) .....	3935289	1	1.20	clutch lvr. & shaft ball to frame .....
67-75	All (350) .....	3743360	1	.18	WASHER, stud dust seal, L.H. to frame (felt— 9/16" I.D. x 1 <sup>3</sup> / <sub>8</sub> " O.D.) lever assy. seal .....

**0.852 LEVER— BRACKET— SHAFT, Clutch Pedal, Intermediate (See Group 4.648 for brake)**

67-69	Camaro (350),				
69-75	Chevy (350) .....	3998652	1	10.50	w/shaft .....
69-72	Chevelle (350) .....	3920615	1	10.10	w/shaft .....
70-75	Camaro (350) .....	3973082	1	12.25	w/shaft .....
71	Pass. (350) .....	3988203	1	12.05	w/shaft .....
73-75	Chevelle (350) .....	3994486	1	19.10	w/shaft .....
75	Nova (350) .....	355574	1	15.35	w/shaft .....
69-70	Pass. (350) (exc. Police, Taxi) ..	3859861	1	.28	BRACKET, clutch shaft frame .....
69-70	Taxi, Police (350) .....	3869851	1	2.05	BRACKET, clutch shaft frame .....
67	Camaro (350),				
68-69	Chevy, Camaro (350),				
70-74	Nova (350) .....	3932760	1	.83	BRACKET, lever and shaft .....
70-72	Chevelle (350) (exc. Monte Carlo) .....	3918098	1	.81	BRACKET, lever and shaft frame .....
68-72	Monte Carlo (350) .....	3972641	1	.92	BRACKET, lever and shaft .....
70-75	Camaro (350) .....	3973086	1	.94	BRACKET, lever and shaft .....
71	Pass. (350) .....	3988209	1	.83	BRACKET, clutch shaft frame .....
73-75	Chevelle (350) (exc. Monte Carlo) .....	3994491	1	1.25	BRACKET, lever and shaft frame .....
73-75	Monte Carlo .....	3994492	1	3.25	BRACKET, lever and shaft .....
75	Nova (350) .....	355584	1	1.65	BRACKET, shaft frame .....
70-71	Pass. (350) .....	3954621	1	6.50	SHAFT, w/lever .....

**0.854 ROD— CLIP— BUSHING, Clutch Pedal**

69-70	Pass. (350) .....	3859838	1	2.20	pedal push .....
67	Camaro (350) .....	3899020	1	2.30	pedal push (12 <sup>49</sup> / <sub>64</sub> " dev. length) .....
69-72	Chevelle (350) .....	3920618	1	2.10	pedal push .....
68-69	Chevy, Camaro (350),				
70-72	Nova (350) .....	3920262	1	1.95	pedal push .....
70-71	Camaro (350) .....	3973087	1	3.50	push .....
71-72	Pass. (350) .....	3988195	1	3.75	push .....
72-75	Camaro (350) .....	3998670	1	3.00	push .....
73-75	Chevelle (350) .....	3994490	1	5.20	push .....
74	Nova (350) .....	332516	1	2.15	push .....
75	Nova (350) .....	355583	1	3.15	push .....
69	Pass. (350) .....	1455017	2	.13	CLIP, pedal pull rod— (3.425) .....
71	Pass. (350),				
72-75	Camaro (350),				
73-75	Chevelle (350) .....	406172	1	.88	BUSHING, push rod .....



## 350-ENGINE ASSEMBLY

### 0.859 PLATE ASSY., Clutch Pressure with Cover

69	All w/reg. fuel (350) (exc. Police),				
70-71	All w/2BC (350),				
71	Chevelle w/4BC (350) (exc. Monte Carlo),				
72	All (350),				
73-75	All (350) (exc. Sp. H/Per.) . . . . .	3841673	1	61.50	diaphragm spring type (10 <sup>1</sup> / <sub>2</sub> " ) . . . . .
73-74	Camaro w/Sp. H/Per. (350) . . . . .	3884598	1	69.00	
67-69	All (350) (exc. reg. fuel),				
70	All w/4BC (350),				
71	Nova, Camaro, Monte Carlo w/4BC (350),				
72	Camaro w/Sp. H/Per. (350) . . . . .	3884598	1	69.00	

### 0.861 COVER, Clutch

69	All w/reg. fuel (350) (exc. Police),				
70-71	All w/2BC (350),				
72	All (350),				
73-75	All (350) (exc. Sp. H/Per.) . . . . .	3793478	1	23.90	diaphragm spring type (12 <sup>31</sup> / <sub>64</sub> " O.D.) . . . . .
67-68	Camaro (350),				
69	All (350) (exc. H.D. Clutch, reg. fuel),				
70-71	All w/4BC (350),				
73-74	Camaro w/Sp. H/Per. . . . .	3860361	1	21.30	diaphragm spring type (11" O.D.) . . . . .

### 0.862 BOLT, Clutch Cover and Pressure Plate

67-69	All (350) . . . . .	838653 A.R.		.12	( <sup>3</sup> / <sub>8</sub> "— 16 x 1) . . . . .
67-73	All (350) . . . . .	3962058 A.R.		.22	retrac. spring ( <sup>5</sup> / <sub>16</sub> "— 18 x <sup>29</sup> / <sub>32</sub> " hex.)— (0.864) . . . . .

### 0.863 PLATE, Clutch Pressure

69	All w/reg. fuel (350),				
70-71	All w/2BC (350),				
71	Chevelle w/4BC (350),				
72-75	All (350) (exc. Sp. H/Per.) . . . . .	3793480	1	34.00	(cast 3793480) (10 <sup>1</sup> / <sub>2</sub> " ) . . . . .
67-68	Camaro (350),				
69	All (350) (exc. H.D. Clutch, reg. fuel),				
70	All (350 w/4BC),				
72-75	All w/Sp. H/Per. (350) . . . . .	3884630	1	32.50	(cast 3860363) (11" O.D.) . . . . .

### 0.864 BOLT— SPRING, Clutch Pressure Plate

67-72	All (350) . . . . .	3962058 A.R.		.22	retrac. spring ( <sup>5</sup> / <sub>16</sub> "— 18 x <sup>29</sup> / <sub>32</sub> " hex.) . . . . .
69	Pass. (350),				
70-75	All (350) . . . . .	3788605	3	.13	<b>SPRING</b> , retracting (1 <sup>9</sup> / <sub>32</sub> " dia. at wide end w/ <sup>5</sup> / <sub>16</sub> " ctr. hole) (Note 1) . . . . .

NOTE 1 Replace only in sets of three.

### 0.886 DISC, with Facing, Clutch

68	All (350) (exc. H.D. Clutch),				
69	Pass. w/reg. fuel (350),				
70-72	All w/2BC (350),				
71	Chevelle w/4BC (350) (exc. Monte Carlo),				
73-75	All (350) (exc. Sp. H/Per.) . . . . .	3927128	1	40.00	driven (10 <sup>13</sup> / <sub>32</sub> " woven) . . . . .
67-68	Camaro (350),				
69	Pass. w/reg. fuel (350),				
69-70	All w/4BC (350),				
70	All w/Sp. H/Per. (350) . . . . .	3908960	1	40.00	woven (11") . . . . .
71	Nova, Camaro, Monte Carlo w/4BC (350) (exc. Sp. H/Per.) . . . . .	3989030	1	41.75	
71-72	All w/Sp. H/Per. (350),				
73-74	Camaro w/Sp. H/Per. (350) . . . . .	336720	1	41.75	driven (11" woven) . . . . .

## 396-ENGINE ASSEMBLY

### 0.000 ENGINE ASSEMBLY

*NOTE When installing the following engines on applicable past models, non-interchangeable parts must be discarded and replaced with parts that fit the replacing engine. See Engine Installation Instruction Charts in the General Information Section for parts and instructions necessary with service engines on past model information.*

<p>65 Pass. w/P.G. (396) (exc. Sp. H/Per., T. Ign.),                  66-67 Pass. (396),                  66-68 Chevelle, Camaro (396) (exc. H/Per., Sp. H/Per.),                  68 Pass. (396) (exc. Police),                  69 Camaro, Malibu, Concours (396) (exc. H/Per., Sp. H/Per., Estate Wagon)</p>	<p><b>3981903</b> 1 875.00</p>	<p>(less exh. manifolds, flywheel, water pump, clutch housing, and all related parts)</p>
---	--------------------------------	---

*The above engine assemblies do not include the following sub assemblies.*

Carburetor Fuel Pump Oil Filter Assy.	Fan Blade and Pulley Generator Ignition Coil	Ignition Wiring Starting Motor Ventilator Assy.
---	--	---

*NOTE Special equipment production assemblies are available while in production, through Central Office, on direct order Form PC 785.*

### 0.002 BOLT— SPACER— WASHER, Engine Mounting (Small Attaching)

<p>67 Chevelle (396) .....                  67-68 Camaro w/A.I.R., C.A.C. (396),                  68 Chevy (396) .....</p>	<p><b>3840748</b> 1 .28  <b>3785362</b> 1 .32  <b>3980716</b> 2 .34</p>	<p>right side (7/16" — 14 x 4) .....                  special hex. (3/8" — 16 x 25/8") flat point                  (300M steel) w/pump and upper right side                  (7/16" — 14 x 37/8") .....</p>
<p>70 All (396) .....                  70 Chevelle, Camaro, Pass. (396)                  (exc. Taxi, Police) .....</p>	<p><b>3826168</b> 2 .18</p>	<p><b>SPACER</b>, frt. mtg. eng. brkt. ("U" shape)                  (2 1/2" O.L.) (Note 1) .....</p>
<p>66-69 Chevy, Chevelle, Camaro (396) ..</p>	<p><b>3893853</b> 2 3.20</p>	<p><b>WASHER</b>, brkt. to engine (left side) (7/16" —                  (2.277) .....</p>

*NOTE 1 It may be necessary to reduce length to 2 3/8".*

### 0.010 GASKET UNIT, Engine or Tune-Up

<p>65-70 All (396) .....</p>	<p><b>328726</b> 1 5.55</p>	<p>w/seal, engine .....</p>
------------------------------	-----------------------------	-----------------------------

### 0.027 MOUNTING UNIT— CABLE UNIT, Engine (Also See Group 4.081)

### 8 CYLINDER

*NOTE Mount units 3990916 and 3990918 include a mount, mount to frame bracket bolt, washers and nut.*

<p>65-67 Pass., Chevelle (396) (See Note 1),                  67-68 Chevy, Camaro (396) .....</p>	<p><b>3990916</b> 2 16.10</p>	<p>(Note 1) .....</p>
<p><i>NOTE 1 Refer to illustration of mounting "Type C". This unit is to be used when replacing Type C mounting on (1) R.H. and/or L.H. side 1967 Pass. (396).</i></p>		
<p>67-69 Pass. (396) (See Note 2),                  68-69 Chevelle (396),                  69 Chevy, Camaro (396),                  70 All (396) .....</p>	<p><b>3990918</b> A.R. 11.05</p>	<p>(Note 2) .....</p>
<p>67-68 Camaro (396),                  67-69 Chevy (396),                  69 Camaro (396) (exc. C.A.C.) .....</p>	<p><b>330266</b> 1</p>	<p>N.L. <b>CABLE UNIT</b>, engine stop lift .....</p>
<p><i>NOTE 2 Refer to illustration of mounting "Type D". This unit is to be used when replacing Type D mounting on (1) R.H. and/or L.H. side 1967 Pass. (396).</i></p>		

### 0.029 BRACKET, Engine Mounting

<p>67-68 Chevy, Camaro (396) .....</p>	<p><b>3912597</b> L.H. 7.75</p>	<p>engine mtg. to side member .....</p>
<p>67-68 Chevy, Camaro (396) .....</p>	<p><b>3912598</b> R.H. 7.75</p>	<p>engine mtg. to side member .....</p>
<p>66-67 Chevelle (396) .....</p>	<p><b>3872815</b> L.H. 6.90</p>	<p><b>BRACKET ASSY.</b>, eng. mtg. frame .....</p>
<p>66-67 Chevelle (396) .....</p>	<p><b>3872816</b> R.H. 6.90</p>	<p><b>BRACKET ASSY.</b>, eng. mtg. frame .....</p>
<p>65-67 Pass. (396) .....</p>	<p><b>3954637</b> L.H. 2.00</p>	<p><b>BRACKET ASSY.</b>, frame .....</p>
<p>65-67 Pass. (396) .....</p>	<p><b>3977234</b> 1 3.25</p>	<p><b>BRACKET ASSY.</b>, right, frame .....</p>
<p>65-69 Pass. (396) .....</p>	<p><b>3955186</b> 1 2.00</p>	<p><b>BRACKET ASSY.</b>, right, frame .....</p>
<p>68-70 Chevelle (396) .....</p>	<p><b>3980711</b> L.H. 5.00</p>	<p><b>BRACKET ASSY.</b>, frame .....</p>
<p>68-70 Chevelle (396) .....</p>	<p><b>3980712</b> R.H. 5.00</p>	<p><b>BRACKET ASSY.</b>, frame .....</p>
<p>69 Chevy, Camaro (396),                  70 Nova (396) .....</p>	<p><b>3980941</b> L.H. 4.65</p>	<p><b>BRACKET ASSY.</b>, side member .....</p>
<p>69 Chevy, Camaro (396),                  70 Nova (396) .....</p>	<p><b>3980942</b> R.H. 4.65</p>	<p><b>BRACKET ASSY.</b>, side member .....</p>
<p>70 Camaro (396) .....</p>	<p><b>3982307</b> L.H. 4.25</p>	<p><b>BRACKET ASSY.</b>, side member .....</p>
<p>70 Camaro (396) .....</p>	<p><b>3964886</b> R.H. 6.45</p>	<p><b>BRACKET ASSY.</b>, side member .....</p>

**396-ENGINE ASSEMBLY**

**0.033 BLOCK ASSY., Cylinder**

*NOTE CAUTION Combination not appearing below should be checked in the Engine Series Number and Suffix Chart in front of catalog to determine if the combination was available in production. If not available, no attempt should be made to make the installation.*

**PARTIAL ENGINE**

*NOTE Includes block, crankshaft, camshaft, timing gears, pistons and connecting rods.*

65	Pass., w/Sp. H/Per. (396),			
66-68	Chevy, Chevelle, Camaro, w/Sp. H/Per. (396),			
69-70	All w/Sp. H/Per. (396) . . . . .	3981822	1	707.00
65-68	All (396) (exc. H/Per., Sp. H/Per.),			
69	All (396) (exc. H/Per., Sp. H/Per.) . . . . .	3981817	1	647.00
66-68	Chevy, Chevelle, Camaro w/H/Per. (396),			
69-70	Chevelle, Camaro w/H/Per. (396) . . . . .	3981821	1	679.00

**FITTED CYLINDER BLOCK (Includes, Pistons, Pins, Rings and Bearings)**

65-70	All w/Sp. H/Per. (396) . . . . .	3981811	1	489.00	(Note 1) . . . . .
65-70	All (396) (exc. Sp. H/Per.) . . . . .	3981807	1	440.00	(Note 1) . . . . .

*NOTE 1 When using on 1968 and past models, it is necessary to remove the two dowel pins from front of case when transferring front end cover from replaced engine.*

**0.034 EXPANSION PLUGS, Cylinder Block (Also See 8.970)**

66-69	Chevy, Chevelle, Camaro (396) . . . . .	838538	A.R.	.18	water jacket balance shaft hole (cup type) (1 <sup>5</sup> / <sub>8</sub> " ) . . . . .
65	Pass. (396) . . . . .	444776	9	.16	oil gallery (7 <sup>7</sup> / <sub>16</sub> " O.L. x 7 <sup>7</sup> / <sub>16</sub> " O.D.)— (8.971) . . . . .
65-70	All (396) . . . . .	3864810	4	.22	(1" square socket) (cast iron heads) . . . . .
65-70	All (396) . . . . .	3743389	A.R.	.24	(cup type) (1 <sup>3</sup> / <sub>4</sub> ) . . . . .

**0.056 BOLT— STUD, Crankshaft Bearing Cap**

66-70	Chevelle w/H/Per., Sp. H/Per. (396),				
65-69	Pass. w/Sp. H/Per. (396),				
68-70	Camaro w/Sp. H/Per. (396) . . . . .				inboard, . . . . .
65-69	Pass. (396) (exc. Sp. H/Per.),				
66	Chevelle (396),				
67-70	Chevelle, Camaro (396) (exc. Sp. H/Per.) . . . . .	3909834	A.R.	.34	cap (3 <sup>11</sup> / <sub>32</sub> " long x 1 <sup>3</sup> / <sub>16</sub> " thread length) . . . . .
65-70	All w/H/Per., Sp. H/Per. (396) . . . . .	3859927	10	.28	outboard (2 <sup>39</sup> / <sub>64</sub> " long x 5 <sup>3</sup> / <sub>64</sub> " thread) . . . . .
65-66	Pass. (396) . . . . .	3902885	4	2.20	STUD, inboard crankshaft bearing cap . . . . .

**0.093 PLASTIGAGE, Crankshaft Bearing**

65-70	All (396) . . . . .	1390274	A.R.	6.15	(green package-type PG-1) (12 pieces) . . . . .
-------	---------------------	---------	------	------	---

**0.095 CAP, Crankshaft Front Bearing**

65-70	All (396) (exc. Sp. H/Per.) . . . . .	3877462	4	5.60	(No. 1, 2, 3, 4) . . . . .
65-70	All w/Sp. H/Per. (396) . . . . .	3877470	4	7.65	(No. 1, 2, 3, 4) . . . . .

**0.096 BEARING UNIT, Crankshaft Front (1 Upper and 1 Lower)**

**See Chart for Model Application**

*NOTE: See Dealer Price Schedule for applicable prices.*

**CRANKSHAFT MAIN BEARING CHART**

		POSITION	STD.	.001 U.S.	.002 U.S.	.009 U.S.	.010 U.S.	.020 U.S.
65-70	All (396) . . . . .	All (exc. Rear)	347013	3885379	3885378	—	347016	—
65-70	All (396) . . . . .	Rear	347018	3876086	347020	—	347021	347022
		POSITION	.020 U.S.					
65-70	All (396) . . . . .	(All exc. Rear)	347017					

*NOTE Bearings having no supplementary notes are Durex 100.*

**0.105 CAP, Crankshaft Rear Bearing**

65-70	All (396) . . . . .	3877464	1	5.75
-------	---------------------	---------	---	------

## 396-ENGINE ASSEMBLY

<b>0.107 DOWEL, Crankshaft Bearing Cap</b>					
65-70	All (396)	3836903 A.R.	.11	rear cap (1 <sup>1</sup> / <sub>32</sub> " O.D. x 5 <sup>5</sup> / <sub>8</sub> ")— (0.738)	
<b>0.137 SEAL, Crankshaft Rear Bearing and Cap Oil</b>					
65-70	All (396)	3962863	2	2.60	rubber w/steel insert
<b>0.153 SHIM UNIT, Crankshaft Bearing Cap</b>					
65-69	All (396)	3877476 A.R.	1.90		rear
65-69	All (396)	3877468 A.R.	1.90		front and intermediate
<b>0.206 COVER— PIN, Crankcase Front End</b>					
65-70	All (396)	330850	1	7.15	
65-70	All (396)	3836903	2	.11	PIN, dowel (1 <sup>1</sup> / <sub>8</sub> " x 5 <sup>5</sup> / <sub>8</sub> ")— (0.738)
<b>0.207 GASKET, Crankcase Front End Cover</b>					
65-68	All (396)	3860096	1	.34	(10 holes)
69	All (396)	3935449	1	.41	
<b>0.213 SEAL, Crankcase Front End Cover</b>					
65-70	All (396)	3860095	1	2.30	(3" O.D.— stamped 3860095)
<b>0.269 HEAD, Cylinder</b>					
65-69	Chevy, Chevelle, Camaro (396) (exc. Sp. H/Per.),				
65-68	Pass. (396) (exc. Sp. H/Per.),				
69	Police (396)	3931062	2	110.00	w/valve guide (Note 1)
65-69	All w/Sp. H/Per. (396)	3919839	2	124.00	w/valve guide (cast iron head) (Note 1)
<i>NOTE 1 When using on models prior to 1968 use pipe plug 444667 or 444746 to plug water temp. switch hole.</i>					
69	Pass. (396) (exc. Police)	3933146	2	110.00	w/valve guide
70	All (396) (exc. Sp. H/Per.)	3964286	2	127.00	w/valve guide
70	All w/Sp. H/Per. (396)	3964287	2	124.00	w/valve guide
<b>0.289 GASKET, Cylinder Head</b>					
65-70	All (396) (exc. Sp. H/Per.)	3993890	2	2.60	
65-70	All w/Sp. H/Per. (396) (exc. Al. Head)	330860	2	2.60	(22 <sup>1</sup> / <sub>2</sub> " O.L.)
68-69	All w/Al. Head (396)	3921940	2	6.70	
65	Pass. w/Sp. H/Per. (396)	3878694	1	18.05	GASKET UNIT (Note 1)
<i>NOTE 1 Consists of 12 gaskets, 16 seals, 2 exhaust pipe packings.</i>					
65	Pass. (396) (exc. Sp. H/Per.)	3878693	1	16.50	GASKET UNIT (Note 2)
<i>NOTE 2 Consists of 13 gaskets, 16 seals, 2 exhaust pipe packings.</i>					
66-70	All (396) (exc. Sp. H/Per.)	3997459	1	18.55	GASKET UNIT (Note 3)
<i>NOTE 3 Unit consists of gaskets for cylinder heads, rocker covers, inlet manifold sides and end, water outlet, distributor, air cleaner, carburetor, heat valve, exhaust pipe packing and valve stem oil seal.</i>					
66-70	All w/Sp. H/Per. (396)	6259322	1	23.20	GASKET UNIT
69-70	All w/Al. Head (396)	6259319	1	25.75	GASKET UNIT
<b>0.293 BOLT— NUT— PIN— WASHER, Cylinder Head</b>					
65-70	All (396)	3877668	24	.40	long (4 <sup>1</sup> / <sub>2</sub> " O.L.) (raised cross on top of head)
65-70	All (396)	3877669 A.R.		.32	short (2 <sup>1</sup> / <sub>16</sub> " O.L.) (raised cross)
66-69	Chevelle, Camaro (396)	3866766	12	.12	NUT, attaching (hex. 3 <sup>3</sup> / <sub>8</sub> "— 24)— (0.626)
65-69	Pass. (396)	585927 A.R.		.16	PIN (5 <sup>9</sup> / <sub>16</sub> " x 9 <sup>9</sup> / <sub>16</sub> ")
65-69	All (396)	3894327	4	.16	PIN, special (1 <sup>1</sup> / <sub>2</sub> " I.D. x 5 <sup>5</sup> / <sub>8</sub> " diameter)
68	Camaro w/Sp. H/Per. (396)	3899696	32	.33	WASHER (aluminum cyl. head) (7 <sup>7</sup> / <sub>8</sub> " O.D. x 29 <sup>29</sup> / <sub>64</sub> " I.D. x 1 <sup>1</sup> / <sub>8</sub> " thick)

**396-ENGINE ASSEMBLY**

**0.296 VALVE, Inlet**

**Refer to Following Chart for Model Application**

*NOTE: See Dealer Price Schedule for applicable prices.*

**VALVE CHART (Inlet)**

		STD.	.003 O.S.	.015 O.S.	.030 O.S.
65-70	All w/Sp. H/Per. (396) . .	3864808	3876813	3876814	3876815
65-70	All (396) (exc. Sp. H/Per.)	6263754	6263767	6263768	3931096

**0.297 VALVE, Exhaust**

**Refer to Following Chart for Model Application**

*NOTE: See Dealer Price Schedule for applicable prices.*

**VALVE CHART (Exhaust)**

		STD.	.003 O.S.	.015 O.S.	.030 O.S.
65-70	All (396) (exc. Sp. H/Per.)	3931006	3931097	3931098	3931099
65-69	All w/Sp. H/Per. (396) (exc. Al. Head) . . . . .	3860002	3863185	3863186	—
68-69	Camaro w/Al. Head (396) . . . . .	3879619	3879903	—	3879905
70	All w/Sp. H/Per. (396) . .	3946077	3947872	3947873	3947874

**0.303 SPRING— SHIM, Valve**

65-67	Pass. (396) (exc. Sp. H/Per.),				
66	Chevelle (396) (exc. H/Per., Sp. H/Per.),				
68-69	Pass. (396) (exc. Police) . . . . .	3856860	16	1.85	w/damper (stripe of blue plus, aluminum, dk. green, purple or tan) . . . . .
65-66	All w/H/Per., Sp. H/Per. (396),				
67-69	Chevy, Chevelle, Camaro (396),				
68-69	Police (396),				
70	Nova, Chevelle, Camaro (396) . .	3970627	16	2.25	(Note 1) . . . . .
	<i>NOTE 1 When using 3970627 it is necessary to discard the valve spring cap and valve stem oil seal which were used with 1st design spring.</i>				
65	Pass. w/Sp. H/Per. (396) . . . . .	3864904	16	.12	SHIM ( <sup>45</sup> / <sub>64</sub> " I.D. x <sup>13</sup> / <sub>64</sub> " thick) . . . . .
65	Pass. (396) (exc. Sp. H/Per.),				
66-70	All (396) . . . . .	3875916	16	.13	SHIM, spring ( <sup>45</sup> / <sub>64</sub> " I.D. x <sup>131</sup> / <sub>64</sub> " O.D. x <sup>1</sup> / <sub>64</sub> " thick) . . . . .

**0.308 SEAL, Valve Spring Cap**

65	Pass. (396) (exc. Sp. H/Per.),				
66-68	Pass. (396),				
66-67	Chevelle (396) (exc. S.S., H/Per., Sp. H/Per.),				
67-69	Camaro (396) (exc. H/Per., Sp. H/Per.),				
69-70	Malibu (396) (exc. H/Per., Sp. H/Per.),				
70	Chevelle (396) (exc. Malibu) . . . . .	352698	1	5.35	valve stem oil seal inlet (Note 2) (repl. 347124) . . . . .
	<i>NOTE 2 When installing seals it is necessary to discard the valve stem oil defl. which is assembled to the valve spring cap.</i>				
65-69	All (396) (1st design) . . . . .	3866612	16	.22	valve stem oil, inlet and exhaust (Note 1) . . .
	<i>NOTE 1 For 2nd design application see 3964264 Cap Assy. Group 0.309.</i>				

**0.309 CAP, Valve Spring**

65-69	All (396) (1st design) . . . . .	3859909	16	.40	inlet and exhaust ( <sup>119</sup> / <sub>32</sub> " O.D.) (stamped "T") (Note 2) . . . . .
	<i>NOTE 2 For 2nd design application see 3964264 Cap Assy.</i>				
65	Pass. w/Sp. H/Per. (396) . . . . .	3864900	16	.40	(stamped "O") . . . . .
69	All (396) (2nd design),				
70	Nova, Chevelle, Camaro (396) . .	3964264	16	.47	CAP ASSY., w/deflector (Note 1) . . . . .
	<i>NOTE 1 1st design vehicles required a cap and seal while 2nd design vehicles require 3964264 Cap Assy.</i>				

## 396-ENGINE ASSEMBLY

### 0.310 KEY, Valve Stem

65-69 All (396) ..... 3947880 32 .12 (green) .....

### 0.333 ARM, Valve Rocker with Adjusting Screw and Nut

65-70 All (396) ..... 6258611 16 3.30 inside rocker arm at pilot end .....

### 0.386 COVER ASSY.— GROMMET, Valve Rocker Arm

65 Pass. (396),  
 66-69 Pass. (396) (exc. Sp. H/Per., S.S.) ..... 338261 L.H. 11.65 (painted) .....

65 Pass. w/Sp. H/Per. (396),  
 65-67 Pass. (396) (exc. Sp. H/Per.),  
 68-69 Pass. (396) (exc. S.S., Sp. H/Per.),  
 70 Pass., Chevelle (396) ..... 338262 R.H. 11.30 (painted) .....

66 Chevelle w/H/Per., Sp. H/Per. (396),  
 67 Chevelle, Camaro w/H/Per., Sp. H/Per. (396) (exc. A.I.R.),  
 68-69 Chevy, Chevelle, Camaro (396),  
 70 Nova, Camaro (396) ..... 325174 R.H. 19.70 (chrome) .....

66-67 Chevelle (396),  
 67 Camaro w/H/Per., Sp. H/Per. (396) (exc. A.I.R.),  
 67 Pass. w/Sp. H/Per. (396) ..... 3908923 L.H. 20.80 (chrome) (aluminum head) .....

66-68 Chevelle (396) (exc. H/Per., Sp. H/Per.) ..... 3889388 R.H. 19.85 (chrome) .....

67 Camaro (396) ..... 3916137 L.H. 19.30 valve rocker (chrome) .....

67 Chevelle w/A.I.R., H/Per., Sp. H/Per. (396),  
 67 Camaro w/A.I.R. (396) ..... 3902390 R.H. 20.80 (chrome plate) (w/aluminum head) .....

68 Chevelle, Camaro (396),  
 69 All (396),  
 70 Nova, Camaro (396) ..... 325169 L.H. 19.70 (chrome) .....

70 All (396) ..... 338261 L.H. 11.65 w/oil filler cap .....

65-70 All (396) ..... 3894337 1 .11 GROMMET, cover to a/c. (<sup>15</sup>/<sub>16</sub>" I.D. x <sup>17</sup>/<sub>32</sub>" O.D.)— (1.745) (Note 1, 2) .....

*NOTE 1 May be used with or without closed vent.*

*NOTE 2 When using on closed vent. equipped vehicles, it will be necessary to remove center from grommet to permit assembling of fresh air connector into side of cover.*

### 0.413 BOLT— REINFORCEMENT, Valve Rocker Cover and Support (Also See Group 0.366)

65-70 All (396) ..... 180016 1 (<sup>1</sup>/<sub>4</sub>"— 20 x <sup>1</sup>/<sub>2</sub>")— (8.900) .....

65-70 All (396) ..... 3877670 A.R. .12 REINFORCEMENT (<sup>1</sup>/<sub>2</sub>" O.L.) (Note 1) .....

*NOTE 1 Use with Bolt 180016.*

### 0.423 GASKET, Valve Rocker Cover

65-70 All (396) ..... 3860315 2 1.80 (2<sup>1</sup>/<sub>32</sub>" O.L. x 6<sup>11</sup>/<sub>16</sub>" wide) (6 tabs) .....

### 0.426 ROD, Valve Push

65-66 Pass., Chevelle (396),  
 67 All (396) (2nd design) (exc. Sp. H/Per.),  
 68 Chevy, Chevelle, Camaro (396),  
 68-70 Police (396),  
 69 All (396),  
 70 Nova, Chevelle, Camaro (396) .. 3946067 8 1.70 inlet (8<sup>7</sup>/<sub>32</sub>" O.L.) .....

65-66 Pass., Chevelle (396),  
 67 All (396) (2nd design) (exc. Sp. H/Per.),  
 68 Chevy, Chevelle, Camaro (396),  
 68-70 Police (396),  
 69 All (396),  
 70 Nova, Chevelle, Camaro (396) .. 3946069 8 1.70 exhaust (9<sup>3</sup>/<sub>16</sub>" O.L.) (Note 1) .....

67 All (396) (1st design) (exc. Sp. H/Per.),  
 68-69 Pass. (396) (exc. Police) ..... 346282 8 1.30 exhaust (9<sup>3</sup>/<sub>16</sub>" O.L.) (Note 1) .....

67 All (396) (1st design) (exc. Sp. H/Per.),  
 68-69 Pass. (396) (exc. Police) ..... 346280 8 1.30 inlet (8<sup>7</sup>/<sub>32</sub>" O.L.) (Note 1) .....

*NOTE 1 1st design engines will be built prior to 9-1-66 and will be identified on the engine stamp pad by TO8 plus the day built.*

### 0.429 BALL— NUT— STUD, Valve Push Rod Adjusting

65 Pass. (396) ..... 3860306 16 (<sup>31</sup>/<sub>32</sub>" ) .....

## 396-ENGINE ASSEMBLY

### 0.429 BALL— NUT— STUD, Valve Push Rod Adjusting (Con't)

70-75	All (396)	.....	3899622	16	.41	( <sup>81</sup> / <sub>64</sub> " dia.) valve rocker arm (repl. 3860306)
70	All (396)	.....	3959142	A.R.	.38	( <sup>13</sup> / <sub>16</sub> " dia.)
65-70	All (396)	.....	3896648	16	.22	NUT, valve rocker arm (hex. lk. <sup>7</sup> / <sub>8</sub> "— 20 cad.)
65-69	All (396)	.....	3921912	16	.58	STUD, valve rocker arm ball (Note 1)

*NOTE 1 When using 3921912 in place of 3904396 on aluminum head, it is mandatory to install 452716 helicoil.*

### 0.439 GUIDE, Valve Push Rod

65-66	Pass. (396),					
67	All (396) (2nd design) (exc. Sp. H/Per.),					
68-70	Chevy, Chevelle, Camaro (396),					
68-70	Police (396)	.....	3860038	8	.71	(2 holes and 2 "U" slots) (Note 1)
67	All (396) (1st design) (exc. Sp. H/Per.),					
68-69	Pass. (396) (exc. Police)	.....	3904378	8	.64	( <sup>3</sup> / <sub>16</sub> " push rod slot— <sup>3</sup> / <sub>32</sub> " thick) (Note 1)

*NOTE 1 1st design engines will be built prior to 9-1-66 and will be identified on the engine stamp pad by TO8 plus the day built.*

### 0.459 TAPPET, Valve (or Lifter)

65-69	Pass. w/Sp. H/Per. (396),					
70	All w/Sp. H/Per. (396)	.....	5232695	16	2.95	mechanical type (2" O.L. x <sup>27</sup> / <sub>32</sub> " O.D.)
65-69	All (396) (exc. Sp. H/Per.),					
70	All (396) (exc. Police, Sp. H/Per.)	.....	5232700	A.R.	4.68	

### 0.519 CAMSHAFT, Engine

*NOTE Engine Camshaft Break-in Oil 1050800, Group 1.850, should be used when installing new camshafts.*

65-70	All w/Sp. H/Per. (396)	.....	3863143	1	61.25	(Ident. No. 3863143)
65	Pass. (396) (exc. Sp. H/Per.),					
66-69	Pass. (396),					
66-69	Chevelle, Camaro (396) (exc. H/Per. Sp. H/Per.)	.....	3874872	1	53.50	(Ident. No. 3874874)
66-69	Chevy, Chevelle, Camaro w/H/Per. (396),					
70	All w/H/Per. (396)	.....	3883986	1	61.25	

### 0.539 BEARING, Camshaft (Front or No. 1)

65-70	All (396)	.....	3967808	1	2.50	precision type (stamped 1)
-------	-----------	-------	---------	---	------	----------------------------

### 0.543 BEARING, Camshaft No. 2 (Front Intermediate)

65-70	All (396)	.....	3967810	1	2.50	precision type (stamped 2)
-------	-----------	-------	---------	---	------	----------------------------

### 0.546 BEARING, Camshaft (Center and Rear Intermediate)

65-70	All (396)	.....	3967809	2	2.50	center and rear inter. (stamped 3-4)
-------	-----------	-------	---------	---	------	--------------------------------------

### 0.549 BEARING, Camshaft Rear

65-66	All (396)	.....	3876863	1	2.10	precision type (stamped 2)
67-70	All (396)	.....	3967810	2	2.50	precision type (stamped 2)— (0.543)

### 0.553 PLUG, Camshaft Bearing Hole, Cup Type (In Cylinder Block)

65-70	All (396)	.....	3859926	1	.22	steel ( <sup>27</sup> / <sub>32</sub> " dia. x <sup>1</sup> / <sub>4</sub> " thk.)
-------	-----------	-------	---------	---	-----	--

### 0.603 ROD ASSY., Connecting, Less Dipper

65-70	All (396) (exc. Sp. H/Per.)	.....	3933174	8	13.30	(orange)
65-70	All w/Sp. H/Per. (396)	.....	3856240	8	23.90	(Ident. rib on con. rod cap) (blue)

## 396-ENGINE ASSEMBLY

### 0.616 BEARING UNIT, Connecting Rod (1 Upper and 1 Lower)

Refer to Chart for Model Application

*NOTE: See Dealer Price Schedule for applicable prices.*

#### CONNECTING ROD BEARING UNIT CHART

MODEL USAGE	STD.	.001 U.S.	.002 U.S.	.010 U.S.	.020 U.S.
65-70 All (396)	347002	3876092	347004	347005	347006

### 0.623 BOLT, Connecting Rod Bearing Cap

65-70 All (396)	3862720	16	.60	(3/8"— 24 x 2 1/2") (knurled shank)
-----------------	---------	----	-----	-------------------------------------

### 0.626 NUT, Connecting Rod Bearing Cap Bolt

66-69 Chevy, Chevelle, Camaro (396)	9422298	A.R.	.11	(3/8"— 24 x 5/16" thick) (one end chamfered)— (8.917)
65-69 All (396) (exc. Chevy), 70 All (396)	3866766	A.R.	.12	(3/8"— 24 x 3/8" thick) (hex. nut) (both ends flat) (Note 1)

*NOTE 1 Also used with bolts not requiring cotter pins.*

### 0.629 PISTON ASSY., with Pin

*NOTE Individual piston assemblies are available for warranty purposes and for replacement of pistons damaged when making repairs to engine assemblies. When ordering such parts it is necessary that you specify on your order the reason the parts are required and also that the following note appears on your order. Do not ship unit package quantity.*

ENGINE DISPLACEMENT	BASIC SIZE	SERVICE PISTON DIAMETER RANGE LIMITS ALUMINUM
396 cu. in.	4.0920— STD.	S-4— 4.0920 to 4.0925, S-5— 4.0925 to 4.0930
396 cu. in.	4.0930— .001	S-6— 4.0930 to 4.0935, S-7— 4.0935 to 4.0940

*NOTE The above chart is for information purposes only.*

(Refer to Chart for Model Application)

*NOTE: See Dealer Price Schedule for applicable prices.*

#### PISTON CHART

MODEL USAGE	STD.	.010 U.S.	.020 U.S.	.030 U.S.	.060 U.S.
65-69 All (396) (1st design) (exc. Sp. H/Per.) (L.H.)	3878227	3874989	—	3874993	—
65-69 All (396) (1st design) (exc. Sp. H/Per.) (R.H.)	3878228	3874990	3874992	3874994	—
65-69 All w/Sp. H/Per. (396) (1st design)	3878231	3875905	—	3875906	3875907(†)
<i>(†) This is a .060 oversize Piston and Pin Assy.</i>					
69 Chevelle, Camaro (396) (2nd design) (exc. Sp. H/Per.)					
70 All (396) (exc. Sp. H/Per.) (L.H.)	3969981(†)	3969983(†)	—	3969987(†)	—
69 Chevelle, Camaro (396) (2nd design) (exc. Sp. H/Per.)					
70 All (396) (exc. Sp. H/Per.) (R.H.)	3969982(†)	3969984(†)	3969986(†)	3969988(†)	—
69 Chevelle, Camaro w/Sp. H/Per. (396) (2nd design)					
70 All w/Sp. H/Per. (396)	3969989(†)	3969990(†)	—	3969991(†)	—

*NOTE 4 These parts are used on models built with 2nd design 400 C.I.D. engine assys. These engines can be identified by the letter "C" preceding the existing suffix identification letters.*



## 396-ENGINE ASSEMBLY

### 0.643 RING UNIT, Piston (Service Sets)

NOTE: See Dealer Price Schedule for applicable prices.

		STD.	.030 O.S.		
65-69	All (396) (1st design) . . .	328521(*)	—	—	1
69	Chevelle, Camaro (396) (2nd design) . . . . .	328526(*)	328531(*)	—	1
70	All (396) . . . . .	328526(*)	328531(*)	—	1

(\*) One cylinder replacement only.

### 0.646 CRANKSHAFT, Engine

65-70	All (396) . . . . .	3882841	1	193.00	(Note 1) . . . . .
-------	---------------------	---------	---	--------	--------------------

NOTE 1 When used on A.T. it will be necessary to remove the pilot bearing.

### 0.649 BEARING, Crankshaft Clutch Pilot

65-70	All (396) . . . . .	3752487	1	1.20	(bush type— <sup>19</sup> / <sub>32</sub> " I.D. x <sup>13</sup> / <sub>32</sub> " O.D. x <sup>3</sup> / <sub>4</sub> ") . .
-------	---------------------	---------	---	------	--

### 0.659 BALANCER— PULLEY, Crankshaft

NOTE In some cases double groove pulleys may be used in place of single groove pulleys.

NOTE Crankshaft harmonic balancer is also referred to as "torsional damper".

65-70	All (396) (exc. Sp. H/Per.) . . . . .	3860008	1	44.75	w/o pulley ( <sup>7</sup> / <sub>16</sub> " O.D.) . . . . .
65-70	All w/Sp. H/Per. (396) . . . . .	3860010	1	44.75	w/o pulley (8" O.D.) . . . . .
66-67	Chevelle w/A.I.R. (396) (exc. El Camino, C.A.C.),				
68	Chevy (396) . . . . .	3744043	1	8.20	PULLEY (double-6 <sup>5</sup> / <sub>8</sub> " O.D.— painted black) (stamped 3744043) . . . . .
65-66	Pass., Chevelle w/Sp. H/Per. (396),				
66	Chevelle w/62 amp. (396) (exc. C.A.C., Sp. H/Per.),				
67	Camaro w/A.I.R. (396),				
67-69	Chevelle w/P/S, Sp. H/Per. (396),				
68	Chevy, Camaro w/P/S, Sp. H/Per. (396) . . . . .	3869978	1	25.25	PULLEY (3 grooves) . . . . .
65-66	Pass., El Camino, S.S. (396) (exc. Sp. H/Per., C.A.C., 62 amp., A.I.R.),				
67	El Camino, S.S. (396) (exc. H/Per., C.A.C., 62 amp.),				
67	Camaro (396) (exc. A.I.R.),				
67-68	Pass. w/A.T. (396) (exc. 62 amp., C.A.C.),				
68	Chevelle w/A.T. (396) (exc. H/Per., C.A.C.) . . . . .	3874412	1	8.55	PULLEY (1 groove) . . . . .
65-67	Pass., El Camino, S.S. w/P/S (396) (exc. Sp. H/Per.) . . . . .	3874416	1	9.80	PULLEY (1 groove) . . . . .
65-67	Pass. (396) (exc. Sp. H/Per., T.H.),				
66-67	Pass., El Camino, S.S., w/C.A.C. (396) (exc. Sp. H/Per., T.H.),				
66-67	Pass. w/62 amp. (C.A.C. w/T.H.) (396),				
68	Pass., Chevelle, Camaro w/C.A.C. (396) (1st design) (exc. T.H.) . . . . .	3874414	1	9.00	PULLEY (2 grooves) ( <sup>7</sup> / <sub>16</sub> " O.D.) . . . . .
65-66	Pass. w/62 amp. (396) (exc. Sp. H/Per., Air Cond.),				
66	El Camino w/A.I.R., 62 amp. (396) (exc. Sp. H/Per.),				
66	S.S. w/A.I.R., 62 amp. (396) (exc. Sp. H/Per. Air Cond.),				
66-67	Pass. w/A.I.R. (396) (exc. Sp. H/Per., Air Cond.),				
67	El Camino, S.S. w/A.I.R. (396) (exc. Air Cond., Sp. H/Per.),				
68	Chevy w/H/Per. (396),				
68	Chevelle (396) (exc. Sp. H/Per., C.A.C., A.T.),				
68	Camaro (396) (exc. H/Per., Sp. H/Per., C.A.C.),				
68	Pass. (396) (exc. C.A.C., A.T., Sp. H/Per.) . . . . .	3874418	1	8.20	PULLEY, front (2 grooves) . . . . .
67	El Camino, S.S. w/T.H. (396) . . .	3876872	1	8.50	PULLEY (1 groove) . . . . .

## 396-ENGINE ASSEMBLY

### 0.659 BALANCER— PULLEY, Crankshaft (Con't)

66	Pass. (Air Cond. w/T.H.) (396) (exc. 62 amp.),				
67	Chevelle w/C.A.C. (396) (exc. 62 amp.),				
67	Pass. (T.H. w/C.A.C.) (396) (exc. Sp. H/Per.),				
68	Pass., Chevelle, Camaro w/C.A.C. (396) (2nd design) (exc. T.H.)	3876844	1	5.70	PULLEY (2 grooves) (7 <sup>47</sup> / <sub>64</sub> " O.D.)
67	Chevelle w/Sp. H/Per. (396) (exc. P/S, A.I.R.)	3862772	1	22.15	PULLEY (1 groove)
67	Camaro w/A.I.R. (396) (exc. Sp. H/Per., P/S),				
67	Camaro w/Sp. H/Per. (396),				
67	Pass., Chevelle (A.I.R. w/Sp. H/Per.) (396) (exc. P/S)	3863108	1	29.25	PULLEY (2 grooves) (cast)
68	All w/P/S (396) (exc. Sp. H/Per.)	3925525	1	7.75	PULLEY, front (1 groove)
69-70	All w/Sp. H/Per. (396)	3955291	1	9.20	PULLEY (2 groove)
69-70	Chevelle, Camaro w/Air Cond. (396),				
69	Pass. w/Air Cond. (396) (exc. A.T.),				
70	Pass., Nova w/Acc. Air Cond. (396)	3937787	1	12.90	PULLEY (3 groove) (Note 1)
	<i>NOTE 1 Not used on models having Acc. Air Cond. and 2.56 or 2.73 axle ratio.</i>				
69	Camaro w/C.A.C., T.H. 400 (396) (exc. H/Per., Sp. H/Per.),				
69	Chevy, Chevelle, Camaro w/Acc. Air Cond. (396),				
69	Pass. (Air Cond. w/T.H.) (396)	3946014	1	12.90	PULLEY (3 groove) (Note 2)
	<i>NOTE 2 Used on models with Acc. Air Cond. and 2.56 or 2.73 axle ratio.</i>				
69	Chevelle (396) (exc. C.A.C.)	3956666	1	9.20	PULLEY ASSY. (2 groove)
69-70	Chevy w/H/Per. (396) (exc. P/S),				
69	Camaro (396) (exc. C.A.C., P/S, H/Per., Sp. H/Per.),				
69	Chevelle, Pass. (396) (exc. C.A.C., P/S, Sp. H/Per.),				
70	Pass., Chevelle, Camaro (396) (exc. C.A.C., P/S, Sp. H/Per.),				
69	Chevelle w/P/S (396) (exc. C.A.C., Sp. H/Per.),				
69	Chevy, Camaro w/P/S (396) (exc. Sp. H/Per.),				
69	Pass. w/P/S (396) (exc. C.A.C.),				
70	Nova w/P/S, H/Per. (396),				
70	Camaro, Chevelle w/P/S (396) (exc. Sp. H/Per., C.A.C.)	3955290	1	9.20	PULLEY ASSY. (2 groove)
69	Pass. w/Air Cond. (396),				
70	Pass., Nova, Chevelle w/Acc. Air Cond. (396)	3972180	1	15.95	PULLEY ASSY. (3 groove) (stamped 3972180)

### 0.662 KEY— WASHER, Harmonic Balancer and Crankshaft Pulley

65-66	All w/key <sup>3</sup> / <sub>4</sub> " long x <sup>3</sup> / <sub>16</sub> " wide x <sup>1</sup> / <sub>4</sub> " high	3883206	A.R.	.16	crankshaft pulley hub (Note 3)
65-66	All w/key <sup>13</sup> / <sub>8</sub> " long x <sup>3</sup> / <sub>16</sub> " wide x <sup>11</sup> / <sub>32</sub> " high	3885092	1	.16	crankshaft pulley hub (Note 3)
	<i>NOTE 3: Used with pulleys and hubs having a shallow (<sup>1</sup>/<sub>16</sub>" deep) keyway only. All full depth (<sup>1</sup>/<sub>8</sub>" slots take standard Woodruff Key (106751 two short or 144542 one long) in Group 8.960.</i>				
65-70	All (396)	3864814	1	.63	WASHER, balancer

### 0.666 FLYWHEEL, with Ring Gear

65-66	Pass., Chevelle w/P.G. (396)	3868806	1	31.00	(2 <sup>15</sup> / <sub>32</sub> " ctr. hole)
65	Pass. (396) (exc. A.T.),				
66-69	All (396) (exc. A.T.),				
70	All w/4BC (396) (exc. A.T.)	3998281	1	68.25	w/11" coil sprg. clutch (12 <sup>5</sup> / <sub>8</sub> " bolt circle) solid type
65-67	All w/T.H. (396),				
68	All w/T.H. (396) (1st design),				
69	All w/T.H. (396),				
70	All w/T.H., Sp. H/Per. (396)	336763	1	32.00	(Note 1)
68	All w/T.H. (396) (2nd design),				
69	All w/T.H. 400 (396) (exc. Sp. H/Per.),				
70	All w/T.H. (396) (exc. Sp. H/Per.)	340296	1	23.85	(Note 1) (repl. 3991403)

## 396-ENGINE ASSEMBLY

### 0.666 FLYWHEEL, with Ring Gear (Con't)

*NOTE 1 On some application 3991401 and 3937736 are used optionally in production. These parts can be identified by their bolt hole mounting patterns. 3991401 contains a single bolt hole mounting pattern 1 1/2" in dia. 3937736 contains two (staggered) bolt hole mounting patterns. The inner pattern 10 3/4" in dia., the outer 11 1/2" in dia.*

67-68	Pass., Chevelle w/P.G. (396) . . . . .	3899668	1	31.00	(2 31/64" ctr. hole) . . . . .
69	All w/T.H. 350 (396) . . . . .	3991402	1	26.75	
70	Nova, Chevelle w/Hvy. Duty Clutch (396) . . . . .	3955151	1	146.00	(Note 2) . . . . .

*NOTE 2 Used with dual plate clutch.*

### 0.669 BOLT, Flywheel to Crankshaft

65-70	All (396) (exc. A.T.) . . . . .	839756	6	.12	(7/16"— 20 x 1) . . . . .
65-70	All w/A.T. (396) . . . . .	3727207	6	.21	(7/16"— 20 x 45/64"— 290M steel) . . . . .

### 0.673 GEAR, Flywheel Ring

65-70	All (396) . . . . .	3991408	1	6.40	
-------	---------------------	---------	---	------	--

### 0.679 UNDERPAN— BOLT— COVER— SCREW, Flywheel

65-69	All w/P.G. (396) . . . . .	3831527	1	8.60	transmission converter (Note 1) . . . . .
-------	----------------------------	---------	---	------	---

*NOTE 1 This part is also used as a replacement part with Rebuilt trans. assy. 3832565 (P.G.) and (T.G.) conversion unit 3832566.*

65-69	All w/T.H. 400 (396) . . . . .	3868810	1	3.55	trans. converter . . . . .
68-69	All w/T.H. 350 (396) . . . . .	6261091	1	4.20	trans. converter . . . . .
70	All w/T.H. 400 (396) . . . . .	3952661	1	4.85	trans. converter . . . . .
All	All (396) . . . . .	3817006	A.R.	.12	BOLT, w/washer (1/4"— 20 x 7/16") . . . . .
66-69	Chevy, Chevelle, Camaro (396) (exc. A.T.),				
65-69	Pass. (396),				
70	All (396) . . . . .	3843943	1	3.05	COVER, clutch housing . . . . .
69	All w/T.H. 350 (396) . . . . .	9420825	4		SCREW (5/16"— 18 x 9/16")— (8.977) (Note 2) . . . . .

*NOTE 2 Use with washer 120393 group (8.929).*

65-70	All (396) . . . . .	3924780	A.R.	.16	SCREW ASSY., w/washer (5/16"— 18 x 7/8") . . . . .
-------	---------------------	---------	------	-----	--

### 0.683 HOUSING— BOLT, Flywheel and Clutch

65-68	Pass. (396) (exc. A.T.),				
66-69	Chevy, Chevelle, Camaro (396) (exc. reg. fuel),				
69	Pass. (396) (exc. reg. fuel),				
70	All (396) . . . . .	3899621	1	37.50	clutch . . . . .
All	Pass. (396) . . . . .	3736035	A.R.	.22	BOLT, clutch housing attach. (3/8"— 16 x 1 5/16") (300M steel-plain)— (3.275) (Note 1) . . . . .

*NOTE 1 When using Bolt 3736035, it will be necessary to use washer 120394 (8.929).*

All	Pass. (396) . . . . .	3733130	2	.24	BOLT, clutch housing attach. (3/8"— 16 x 2 1/4"— washer hd.) (300M steel)— (3.275)
-----	-----------------------	---------	---	-----	--

### 0.685 DOWEL, Flywheel and Clutch Housing to Cylinder Block

65-70	All (396) . . . . .	3712745	2	.50	clutch and flywheel (2 1/32" x 1 1/4" long) . . . . .
-------	---------------------	---------	---	-----	---

### 0.724 CHAIN, Camshaft Timing

65-66	Pass., Chevelle (396),				
67-70	All w/Sp. H/Per. (396) . . . . .	3860036	1	11.20	link type . . . . .
67-70	All (396) (exc. Sp. H/Per.) . . . . .	3902428	1	11.20	link type . . . . .

### 0.728 SPROCKET, Crankshaft Timing (Steel)

65-66	Pass., Chevelle (396),				
67-70	All w/Sp. H/Per. (396) . . . . .	3860035	1	5.90	(19 teeth— 3 1/2" O.D.) . . . . .
67-70	All (396) (exc. Sp. H/Per.) . . . . .	3902422	1	4.65	(19 teeth) (3 1/2" O.D.) . . . . .

### 0.736 SPROCKET, Camshaft Timing

65-66	Pass., Chevelle (396),				
67-70	All w/Sp. H/Per. (396) . . . . .	330815	1	8.20	(cast 3856356-38 teeth) (aluminum) . . . . .
67-70	All (396) (exc. Sp. H/Per.) . . . . .	330814	1	7.25	(38 teeth) . . . . .

### 0.738 PIN, Camshaft Sprocket

65-70	All (396) . . . . .	3836903	1	.11	dowel (1/4" x 5/8") (solid) . . . . .
-------	---------------------	---------	---	-----	---------------------------------------

### 0.787 ROD— CLIP— SWIVEL, Clutch Fork Release

66-67	Chevelle (396),				
70	Camaro (396) . . . . .	3973076	1	1.95	fork push . . . . .
66-67	Chevelle (396),				
70	Camaro (396) . . . . .	340690	1	1.10	fork push adjusting (4 3/4" long) . . . . .
65	Pass. (396) (exc. Taxi),				
66-69	Pass. (396) . . . . .	3859863	1	1.25	fork push . . . . .

**396-ENGINE ASSEMBLY**

**0.787 ROD— CLIP— SWIVEL, Clutch Fork Release (Con't)**

67-69	Chevy, Camaro (396),				
68-70	Chevelle (396),				
70	Nova (396) .....	9779202	1	.88	fork push .....
65-69	All (396) .....	3749084	A.R.	.27	CLIP, push rod and swivel— (4.037) .....
65-69	All (396) .....	1455017	1	.13	CLIP, push rod— (3.425) .....
65-69	Pass. (396) .....	3859839	1	.71	SWIVEL, pedal push .....
67-69	Camaro (396),				
68-70	Chevelle (396),				
68-69	Chevy (396),				
70	Nova w/Sp. H/Per. (396) .....				SWIVEL, fork push rod, .....
70	Nova w/H/Per. (396) .....	3840845	1	1.40	fork push rod (1 1/2" O.L.) (3/8"— 16 thds.) ..

**0.793 WASHER, Clutch Fork Push Rod**

65-70	All (396) .....	3756694	1	.11	push rod lever thrust (2 3/4" dia. pedal shaft) pull rod lever .....
-------	-----------------	---------	---	-----	---

**0.795 FORK ASSY., Clutch Release**

66-67	Chevelle, Camaro (396),				
68-69	All (396),				
70	Nova, Chevelle, Camaro (396) ..	3892632	1	7.15	
65-69	Pass. (396) .....	3860005	1	7.15	

**0.796 BRACKET— STUD, Clutch Fork**

67-69	Chevy, Camaro (396),				
70	Nova (396) .....	3912606	1	.16	pull, back spring .....
65-69	Pass. (396) .....	3790556	1	.84	STUD, ball (3/16"— 16 thds.) .....
66-67	Chevelle, Camaro (396),				
68-70	Chevy, Chevelle, Camaro (396) .	3729000	1	1.05	STUD, ball (13/16"— 16 w/21/32" diameter ball) .....

**0.797 BOOT, Clutch Fork**

65-69	All (396) .....	3993851	1	.76	black rubber .....
65-66	Taxi (396) .....	3781385	1	1.65	black rubber .....

**0.799 BEARING, Clutch throwout with Collar**

66-68	Chevy, Chevelle w/3-Spd. (396) (exc. 4BC),				
69	Chevelle (396) (exc. 4-Spd.),				
69	Camaro w/2BC (396) .....	908092	1	15.94	ball bearing type (1 7/8" long) .....
66-67	Chevelle, Camaro w/4BC (396),				
65-68	Pass. (396) (exc. w/3-Spd.),				
65-67	Police (396),				
68-70	All (396) .....	908093	1	13.56	(1 7/32" O.L.) .....

**0.829 BUMPER— COVER— PLUG— RETAINER— SEAL, Clutch**

(For COVERS See Group 4.630)

66-68	Chevelle (396) (exc. P.B.),				
68-69	Chevy, Chevelle, Camaro (396),				
70	Nova, Chevelle (396),				
65-69	Pass. (396),				
70	All (396) .....	340688	1	.21	pedal .....
67-70	Camaro w/A.T. (396),				
68-70	Chevy w/A.T. (396) .....	3886689	1	.21	COVER, clutch pedal push rod hole .....
65-68	Pass. w/A.T. (396) .....	6256958	1		PLUG, pedal push rod hole (repl. 3872120)— (12.980) .....
66-67	Chevelle (396) .....	3903973	1	.42	RETAINER, clutch pedal push rod bellows type .....
66-67	Chevelle (396) .....	9776826	1	1.15	SEAL, clutch push rod (bellows type) .....
65-68	Pass. (396) .....	3857543	1	.65	SEAL, pedal push rod (Note 1) .....

*NOTE 1 When using in place of 3819156 seal up to 1965, it will be necessary to replace 3825188 anchor plate with 3877244 plate. For attachment use 3877244 plate as template and drill necessary mounting holes.*

67-70	Camaro w/A.T. (396),				
68-70	Chevy w/A.T. (396) .....	3903466	1	.15	SEAL, clutch pedal push rod hole cover ...
69-70	Pass. (396) .....	3950007	1	1.30	SEAL, pedal push rod .....
67	Camaro (396),				
68-69	Camaro, Chevy (396),				
70	Nova (396) .....	3909071	1	1.20	SEAL ASSY., clutch pedal push rod .....
68-70	Chevelle (396) .....	399904	1	3.20	SEAL ASSY., clutch pedal push rod .....
70	Camaro (396) .....	3973089	1	2.65	SEAL ASSY., clutch pedal push rod .....

**0.830 PEDAL, Clutch**

66	Chevelle (396) .....	3841214	1	5.65	
----	----------------------	---------	---	------	--

**396-ENGINE ASSEMBLY**

**0.830 PEDAL, Clutch (Con't)**

67	Camaro (396)	3890609	1	5.55
67	Chevelle (396)	3900527	1	5.05
68-70	Chevelle (396)	3967783	1	5.30
68-69	Chevy, Camaro (396),			
70	Nova (396)	6258554	1	6.55
69-70	Pass. (396)	3968745	1	5.50
70	Camaro (396)	3965693	1	5.30

**0.831 BUSHING, Clutch Pedal (see group 4.626 for brake pedal bushing)**

65-70	All (396)	1247439	2	.11	(4.626)
-------	-----------	---------	---	-----	---------

**0.837 RETAINER— SPACER, Clutch and Brake Pedal Shaft— (Also see groups 4.634 and 4.648)**

65-70	All (396)	3828428	1	.22	shaft— (4.634)
70	Camaro (396)	9783098	1	.87	SPACER (4.634)

**0.844 SPRING, Clutch Pedal Pull Back**

65-69	Pass. (396)	3849704	1	.34	fork pull back
65-69	Pass. (396)	3879772	1	.22	clutch pull back
66-67	Chevelle (396)	9776993	1	.40	push rod
67	Chevelle (396)		1		push rod return,
67-69	Chevy, Camaro (396),				
70	Nova (396)	3914896	1	.34	push rod
68-70	Chevelle (396)	3920614	1	.34	
70	Camaro (396) (exc. A.T.)	3973088	1	.40	fork pull back

**0.851 SEAT— SEAL— SPRING— STUD— WASHER, Clutch Pedal Intermediate Lever Shaft Ball**

65-70	All (396)	3743349	A.R.	.18	stud (7/8" dia.)
66-70	Chevy, Chevelle, Camaro (396)				SEAL, ball stud dust,
65-69	Pass. (396)	382658	1	.19	lever shaft ball stud
65-70	All (396)	3750696	1	.13	SPRING, frame stud seat, retaining (1" O.D.)
66-70	Chevy, Chevelle, Camaro (396)	3866568	1	1.15	STUD, lever shaft ball to engine
68-69	Chevy (396)				STUD, to body
65-69	Pass., Chevelle, Camaro (396)	3898610	1	.81	to frame (3/8"— 24 x 1 <sup>13</sup> / <sub>16</sub> " O.L.)
65-70	Pass. (396)	3859488	1	1.20	STUD, lever shaft ball to eng.
70	Camaro (396)				STUD, clutch lvr. & shaft ball to brkt.,
70	Chevy (396)				clutch lvr. & shaft ball to eng.,
70	Chevelle (396)	3935289	1	1.20	clutch lvr. & shaft ball to frame
66	Chevelle (396)	3717880	1	.16	WASHER, ball to engine dust washer
					(rubber) (29/32" O.D. x 15/32" I.D. x 1/4" thk.)
65-70	All (396)	3743360	1	.18	WASHER, stud dust seal, L.H. to frame
					(felt— 9/16" I.D. x 1 <sup>3</sup> / <sub>8</sub> " O.D.) lever assy.
					seal

**0.852 LEVER— BRACKET— SHAFT, Clutch Pedal, Intermediate (See Group 4.648 for brake)**

66	Chevelle (396),				
67	Chevelle (396) (1st design)	3872895	1	10.95	w/shaft (used w/strg. col. w/lwr. brg. snap ring)
67-69	Chevy, Camaro (396),				
70	Nova (396)	3912602	1	11.95	w/shaft
67	Chevelle (396) (2nd design)	3921040	1	9.75	w/shaft (used w/strg. col. w/lwr. brg. clamp)
68-70	Chevelle (396)	3920615	1	10.10	w/shaft
70	Camaro (396)	3973082	1	12.25	w/shaft
66-67	Chevelle (396)	3840841	1	.84	BRACKET, lever and shaft
65-69	Pass. (396) (exc. Police, Taxi)	3859861	1	.28	BRACKET, clutch shaft frame
65-69	Taxi (396),				
68-69	Police (396)	3869851	1	2.05	BRACKET, clutch shaft frame
67	Camaro (396),				
68-69	Chevy, Camaro (396),				
70	Nova (396)	3932760	1	.83	BRACKET, lever and shaft
68-70	Chevelle (396) (exc. Monte Carlo)	3918098	1	.81	BRACKET, lever and shaft frame
70	Camaro (396)	3973086	1	.94	BRACKET, lever and shaft
65-69	Pass. (396)	3954621	1	6.50	SHAFT, w/lever

**0.854 ROD— CLIP, Clutch Pedal**

66-67	Chevelle (396)	9774625	1	4.25	pedal push straight shaft (12 <sup>51</sup> / <sub>64</sub> " O.L.)
65-69	Pass. (396)	3859838	1	2.20	pedal push
67	Camaro (396)	3899020	1	2.30	pedal push (12 <sup>43</sup> / <sub>64</sub> " dev. length)
68-70	Chevelle (396)	3920618	1	2.10	pedal push
68-69	Chevy, Camaro (396),				
70	Nova (396)	3920262	1	1.95	pedal push

## 396-ENGINE ASSEMBLY

<b>0.854 ROD— CLIP, Clutch Pedal (Con't)</b>					
70	Camaro (396) .....	3973087	1	3.50	push .....
65-69	Pass. (396) .....	1455017	2	.13	CLIP, pedal pull rod— (3.425) .....
<b>0.859 PLATE ASSY., Clutch Pressure with Cover</b>					
65-69	All (396) (exc. reg. fuel),				
70	All (396) .....	3884598	1	69.00	
<b>0.861 COVER, Clutch</b>					
65-68	Pass., Chevelle (396),				
67-68	Camaro (396),				
69	All (396) (exc. H.D. Clutch),				
70	All (396) .....	3860361	1	21.30	diaphragm spring type (11" O.D.) .....
<b>0.862 BOLT, Clutch Cover and Pressure Plate</b>					
65-69	All (396) .....	838653 A.R.		.12	( <sup>3</sup> / <sub>8</sub> "— 16 x 1) .....
65-70	All (396) .....	3962058 A.R.		.22	retrac. spring ( <sup>9</sup> / <sub>16</sub> "— 18 x <sup>29</sup> / <sub>32</sub> " hex.)— (0.864) .....
<b>0.863 PLATE, Clutch Pressure</b>					
65	Pass. (396),				
66-68	Chevelle, Camaro (396),				
66	Pass. (396) (exc. Sp. H/Per.),				
67-68	Pass. (396),				
69	All (396) (exc. H.D. Clutch),				
70	All (396) .....	3884630	1	32.50	(cast 3860363) (11" O.D.) .....
<b>0.864 BOLT— SPRING, Clutch Pressure Plate</b>					
65-70	All (396) .....	3962058 A.R.		.22	retrac. spring ( <sup>5</sup> / <sub>16</sub> "— 18 x <sup>29</sup> / <sub>32</sub> " hex.) .....
65-70	All (396) .....	3788605	3	.13	SPRING, retracting (1 <sup>9</sup> / <sub>32</sub> " dia. at wide end w/ <sup>5</sup> / <sub>16</sub> " ctr. hole) (Note 1) .....
<i>NOTE 1 Replace only in sets of three.</i>					
<b>0.886 DISC, with Facing, Clutch</b>					
65-70	All (396) .....	3908960	1	40.00	woven (11") .....
66	Police (396) .....	3927128	1	40.00	woven (10 <sup>13</sup> / <sub>32</sub> ") .....



## 400-ENGINE ASSEMBLY

### 0.002 BOLT, Engine Mounting (Small Attaching)

70-71	All (400),				
72	All (400) (exc. Police, Taxi) . . . . .	3980716	2	.34	(7/16" — 14 x 37/8") . . . . .
72	Taxi, Police (400),				
73-75	All (400) . . . . .	334972	2	.34	(7/16" — 14 x 5) . . . . .

### 0.010 GASKET UNIT, Engine or Tune-Up

70-72	All w/2BC (400),				
73-75	All (400) . . . . .	3970634	1	5.50	engine . . . . .
71	All w/4BC (400) . . . . .	328726	1	5.55	w/seal . . . . .

### 0.027 MOUNTING UNIT— MOUNTING ASSY., Engine

70	Pass. w/2BC (400),				
71-72	Pass. (400),				
70	Chevelle w/4BC (400),				
71	Chevelle, Camaro (400) . . . . .	3990918	2	11.05	
73	Pass. (400) . . . . .	3993721	2	12.70	MOUNTING ASSY. (black) . . . . .
74	All (400) . . . . .	6262215	2	8.80	MOUNTING ASSY. . . . .
75	All (400) . . . . .	6262232	2	8.80	MOUNTING ASSY. . . . .

### 0.029 BRACKET— SHIELD, Engine Mounting

70	Pass. (400) . . . . .	3955186	R.H.	2.00	frame . . . . .
70	Pass. (400) . . . . .	3977235	L.H.	3.20	frame . . . . .
70-71	Chevelle (400) . . . . .	3980711	L.H.	5.00	frame L.H. . . . .
70-71	Chevelle (400) . . . . .	3980712	R.H.	5.00	frame R.H. . . . .
71	Camaro (400) . . . . .	3982307	L.H.	4.25	side member L.H. . . . .
71	Camaro (400) . . . . .	3964886	R.H.	6.45	side member R.H. . . . .
71	Pass. (400),				
72	Pass. (400) (exc. Police) . . . . .	3988229	L.H.	2.25	frame L.H. . . . .
71	Pass. (400),				
72	Pass. (400) (exc. Police) . . . . .	3988230	R.H.	3.40	frame R.H. . . . .
72	Police (400),				
74-75	Pass. (400) . . . . .	334602	2	7.25	
73	Pass. (400) . . . . .	331287	1	2.40	
73-75	Chevelle (400) . . . . .	334970	2	5.15	right . . . . .
72	Pass. (400) . . . . .	3989442	1	.84	SHIELD, heat . . . . .

### 0.033 BLOCK ASSY., Cylinder

*NOTE CAUTION. Combination not appearing below should be checked in the Engine Series Number and Suffix Chart in front of catalog to determine if the combination was available in production. If not available, no attempt should be made to make the installation.*

#### PARTIAL ENGINE

*NOTE Includes block, crankshaft, camshaft, timing gears, pistons and connecting rods.*

70	All w/4BC (400) . . . . .	3981817	1	647.00	(Note 1) . . . . .
70	All w/2BC (400) . . . . .	3977677	1	674.00	
71-72	All w/2BC (400) (exc. NB2),				
73-74	All w/2BC (400),				
74	All w/4BC (400) (exc. NB-2),				
75	All (400) . . . . .	6259378	1	674.00	
72	All 2BC w/NB2 (400),				
74	All (NB-2 w/4BC) (400) . . . . .	6259514	1	675.00	
71	All w/4BC (400) . . . . .	3997536	1	674.00	

*NOTE 1 These 2nd design 400 C.I.D. assys. are identified by the letter "C" preceding the existing suffix identification letters.*

#### FITTED CYLINDER BLOCK (Includes, Pistons, Pins, Rings and Bearings)

70	All w/4BC (400) . . . . .	3981807	1	440.00	
70	All w/2BC (400) . . . . .	3977676	1	440.00	
71-72	All w/2BC (400),				
73-75	All (400) . . . . .	6259377	1	440.00	
71	All w/4BC (400) . . . . .	3997484	1	440.00	

### 0.034 EXPANSION PLUGS, Cylinder Block (Also see 8.970)

70-71	All w/4BC (400) . . . . .	3743389	11	.24	water jacket hole (cup type— 13/4" O.D.) . . .
70-71	All w/4BC (400) . . . . .	3864810	4	.22	(1" square socket) (cast iron heads) . . . . .
71-72	All w/2BC (400),				
73-75	All (400) . . . . .	838538	A.R.	.18	water jacket hole (15/8" O.D. cup type) . . . . .
75	All (400) . . . . .	3826504	1	.96	water jacket . . . . .

### 0.056 BOLT, Crankshaft Bearing Cap

70-71	All w/4BC (400) . . . . .	3909834	A.R.	.34	cap (31/32" long x 13/16" thread length) . . . . .
70-72	All w/2BC (400),				
73-75	All (400) . . . . .	3932480	10	.28	(7/16" — 14 x 31/32") . . . . .
70-72	All w/2BC (400) . . . . .	3877669	6	.32	(21/16" O.L.)— (0.293) . . . . .



**400-ENGINE ASSEMBLY**

**0.093 PLASTIGAGE, Crankshaft Bearing**

70-75 All (400) ..... **1390274** A.R. 6.15 (green package-type PG-1) (12 pieces) .....

**0.095 CAP, Crankshaft Front Bearing**

70-71 All w/4BC (400) ..... **3877462** 4 5.60 (No. 1, 2, 3, 4) .....

70-72 All w/2BC (400),

73-75 All (400) ..... **3973312** 1 5.75 (2 bolt cap) (No. 1) .....

70-72 All w/2BC (400),

73-75 All (400) ..... **6259412** 3 6.60 (4 bolt cap) (No. 2, 3, 4) .....

**0.096 BEARING UNIT, Crankshaft Front (1 Upper and 1 Lower)**

**See Chart for Model Application**

*NOTE: See Dealer Price Schedule for applicable prices.*

**CRANKSHAFT MAIN BEARING CHART**

	POSITION	STD.	.001 U.S.	.002 U.S.	.009 U.S.	.010 U.S.	.020 U.S.
70-71 All w/4BC (400) .....	All (exc. Rear)	347013	3885379	3885378	—	347016	347017
70-71 All w/4BC (400) .....	Rear	347018	347019	347020	—	347021	347022
70-72 All w/2BC (400), .....							
73-75 All (400) .....	All (exc. Rear)	3977522	3977523	3977524	3977525	3977526	3977527
70-72 All w/2BC (400), .....							
73-75 All (400) .....	Rear	3977528	3977529	3977530	3977531	3977532	3977533

*NOTE Bearings having no supplementary notes are Durex 100.*

**0.099 BEARING UNIT, Crankshaft Front Intermediate (1 upper and 1 lower). See chart following group 0.096 for model application.**

*NOTE: See Dealer Price Schedule for applicable prices.*

**0.101 BEARING UNIT, Crankshaft Center (1 upper and 1 lower). See chart following group 0.096 for model application.**

*NOTE: See Dealer Price Schedule for applicable prices.*

**0.103 BEARING UNIT, Crankshaft Rear Intermediate (1 upper and 1 lower). See chart following group 0.096 for model application.**

*NOTE: See Dealer Price Schedule for applicable prices.*

**0.105 CAP, Crankshaft Rear Bearing**

70-72 All w/2BC (400),

73-75 All (400) ..... **3973308** 1 6.20

70-71 All w/4BC (400) ..... **3877464** 1 5.75

**0.106 BEARING UNIT, Crankshaft Rear (1 Upper and 1 Lower). See chart following group 0.096 for model application.**

*NOTE: See Dealer Price Schedule for applicable prices.*

**0.107 PIN, Crankshaft Bearing Cap**

70-75 All (400) ..... **3836903** A.R. .11 rear cap (<sup>14</sup>/<sub>32</sub>" O.D. x <sup>5</sup>/<sub>8</sub>"—) (0.738) .....

**0.137 SEAL, Crankshaft Rear Bearing and Cap Oil**

71-72 All w/2BC (400),

73-75 All (400) ..... **3958001** 2 2.60

70-71 All w/4BC (400) ..... **3962863** 2 2.60 (Note 1) .....

*NOTE 1: Upper and lower seal must be replaced simultaneously.*

**0.153 SHIM UNIT, Crankshaft Bearing Cap**

70-71 All w/4BC (400) ..... **3877476** A.R. 1.90 rear .....

70-71 All w/4BC (400) ..... **3877468** A.R. 1.90 front and intermediate .....

70-71 All w/2BC (400) ..... **3956690** A.R. 1.90 (used only with, four bolt brg. cap) .....

70-71 All w/2BC (400),

75 All (400) ..... **3973316** A.R. 1.80 front (use only w/2 bolt cap) .....

75 All (400) ..... **3911011** A.R. 1.90 rear bearing cap .....

**0.206 COVER— PIN, Crankcase Front End**

70-71 All w/4BC (400) ..... **330850** 1 7.15

70-72 All w/2BC (400),

73-75 All (400) ..... **3991433** 1 6.30 **COVER ASSY.** .....

70-75 All (400) ..... **3836903** 2 .11 **PIN, dowel (<sup>1</sup>/<sub>8</sub>" x <sup>5</sup>/<sub>8</sub>"—) (0.738) .....**

## 400-ENGINE ASSEMBLY

### 0.207 GASKET, Crankcase Front End Cover

70-72	All w/2BC (400),				
73-75	All (400) .....	3799620	1	.26	(attach. 2 dowel holes) .....
70-71	All w/4BC (400) .....	3935449	1	.41	

### 0.213 SEAL, Crankcase Front End Cover

70-72	All w/2BC (400),				
73-75	All (400) .....	3980267	1	3.35	(2 <sup>7</sup> / <sub>16</sub> " O.D.— stamped 3980267) .....
70-71	All w/4BC (400) .....	3860095	1	2.30	(3" O.D.— stamped 3860095) .....

### 0.219 POINTER, Engine Timing

71-72	Pass., Monte Carlo w/2BC (400),				
73-75	All (400) .....	3991436	1	.53	
71	All w/4BC (400) .....	3992074	1	.46	

### 0.269 HEAD, Cylinder

70	All w/2BC (400) .....	3977544	2	110.00	w/studs .....
70	All w/4BC (400) .....	3964286	2	127.00	w/valve guide .....
71*	All w/4BC (400) .....	3999240	2	127.00	w/valve guide .....
71	All w/2BC (400),				
72-75	All (400) .....	6260857	2	110.00	w/studs .....

### 0.289 GASKET, Cylinder Head

70-72	All w/2BC (400),				
73	All (400),				
74	All (400) (exc. Police),				
75	All (400) .....	3997790	2	5.15	
70-71	All w/4BC (400) .....	3993890	2	2.60	
74	Police w/4BC (400) (exc. NB-2) .	3995633	2	2.60	
70-71	All w/4BC (400) .....	3997459	1	18.55	GASKET UNIT (Note 1) .....

*NOTE 1 Unit consists of gaskets for cylinder heads, rocker covers, inlet manifold sides and end, water outlet, distributor, air cleaner, carburetor, heat valve, exhaust pipe packing and valve stem oil seal.*

70-72	All w/2BC (400) .....	3977538	1	20.60	GASKET UNIT .....
73-74	All w/2BC (400) .....	6258830	1	21.65	GASKET UNIT .....
74	All w/4BC (400) .....	345197	1	21.65	GASKET UNIT, head .....
75	All (400) .....	356806	1	21.10	GASKET UNIT, head .....

### 0.293 BOLT— PIN, Cylinder Head

70-72	All w/2BC (400),				
73-75	All (400) .....	3704796	16	.22	short (7 <sup>7</sup> / <sub>16</sub> "— 14 x 1 <sup>3</sup> / <sub>4</sub> ") .....
70-72	All w/2BC (400),				
73-75	All (400) .....	3734594	A.R.	.22	long (1 <sup>1</sup> / <sub>16</sub> "— 14 x 3 <sup>3</sup> / <sub>4</sub> ") (circle on top of head) .....
70-72	All w/2BC (400),				
73-75	All (400) .....	3767468	4	.22	medium (7 <sup>7</sup> / <sub>16</sub> "— 14 x 3) (circle on top of head) (Note 1) .....
<i>NOTE 1 Use with cylinder head with cast-in oil trough on outer edge.</i>					
70-71	All w/4BC (400) .....	3877668	24	.40	long (4 <sup>1</sup> / <sub>2</sub> " O.L.) (raised cross on top of head) .....
70-71	All w/4BC (400) .....	3877669	A.R.	.32	short (2 <sup>1</sup> / <sub>16</sub> " O.L.) (raised cross) .....
70-71	All w/4BC (400) .....	3894327	4	.16	PIN, special (1 <sup>1</sup> / <sub>2</sub> " I.D. x 9 <sup>5</sup> / <sub>16</sub> " diameter) .....
75	All (400) .....	585927	4	.16	PIN, cyl. hd. (9 <sup>9</sup> / <sub>16</sub> " x 9 <sup>9</sup> / <sub>16</sub> ") .....

### 0.296 VALVE, Inlet

**Refer to following Chart for Model Application**

*NOTE: See Dealer Price Schedule for applicable prices.*

#### VALVE CHART (Inlet)

		STD.	.003 O.S.	.015 O.S.	.030 O.S.
70-71	All w/4BC (400) .....	6263754	6263767	6263768	3931096
70	All w/2BC (400) .....	3965583	3965584	3995658	3995659
71	All w/2BC (400),				
72-75	All (400) (exc. Police) ...	3995656	3995657	3995658	3995659
72	Police (400) .....	3984180			
73-75	Police (400) .....	3984180	3995945	3995946	3995947

**400-ENGINE ASSEMBLY**

**0.297 VALVE, Exhaust**

Refer to following Chart for Model Application

*NOTE: See Dealer Price Schedule for applicable prices.*

**VALVE CHART (Exhaust)**

	STD.	.003 O.S.	.015 O.S.	.030 O.S.
70-71 All w/4BC (400) . . . . .	3931006	3931097	3931098	3931099
70 All w/2BC (400) . . . . .	3951588	3951590	3951592	3951594
71-72 All w/2BC (400), . . . . .				
73-75 All (400) . . . . .	3989084	3995602	6263775	3995604

**0.303 SPRING— SHIM, Valve**

70-71 All w/4BC (400) . . . . .	<b>3970627</b>	16	2.25	(Note 1) . . . . .
<i>NOTE 1 When using 3970627 it is necessary to discard the valve spring cap and valve stem oil seal which were used with 1st design spring.</i>				
70-71 All w/2BC (400),				
72-75 All (400) . . . . .	<b>3911068</b>	A.R.	1.30	w/damper (inlet) . . . . .
71-72 All w/4BC (400) . . . . .	<b>3856860</b>	16	1.85	w/damper . . . . .
72-75 All (400) . . . . .	<b>6263796</b>	8	1.40	w/damper (exhaust) . . . . .
70-72 All w/2BC (400),				
73-75 All (400) . . . . .	<b>3731058</b>	A.R.	.12	<b>SHIM</b> (1/2" thk.) (Note 2) . . . . .
<i>NOTE 2 To be used in place of Valve Stem Oil Shield when removed at customers request.</i>				
70-71 All w/4BC (400) . . . . .	<b>3875916</b>	16	.13	<b>SHIM</b> , spring (48/64" I.D. x 1 31/64" O.D. x 1/64" thick) . . . . .

**0.308 SEAL— SHIELD, Valve Spring Cap**

70 Chevelle (400),				
71 All w/4BC (400) . . . . .	<b>352698</b>	1	5.35	valve stem oil seal inlet (Note 1) (repl. 347124) . . . . .
71-72 All w/2BC (400),				
73-75 All (400) . . . . .	<b>3835333</b>	A.R.	.17	valve stem oil (Note 1) . . . . .
71 All w/4BC (400) . . . . .	<b>3866612</b>	8	.22	exh. valve stem oil . . . . .
71-72 All w/2BC (400),				
73-75 All (400) . . . . .	<b>3836755</b>	A.R.	.18	<b>SHIELD</b> , valve stem oil . . . . .
<i>NOTE 1: When installing seals it is necessary to discard the valve stem oil defl. which is assembled to the valve spring cap.</i>				

**0.309 CAP— ROTATOR ASSY., Valve Spring**

70-72 All w/2BC (400),				
73-75 All (400) . . . . .	<b>3896934</b>	A.R.	.40	valve spring cap ("A" stamped on top of the surface, inlet) (1 13/32" O.D.) . . . . .
70-71 All w/4BC (400) . . . . .	<b>3964264</b>	16	.47	<b>CAP ASSY.</b> , w/deflector (Note 1) . . . . .
<i>NOTE 1: 1st design vehicles required a cap and seal, while 2nd design vehicles require 3964264 Cap Assy.</i>				
72-75 All (400) . . . . .	<b>6263794</b>	8	2.95	<b>ROTATOR ASSY.</b> , exhaust valve . . . . .

**0.310 KEY, Valve Stem**

70-72 All w/2BC (400),				
73-75 All (400) . . . . .	<b>838029</b>	A.R.	.06	("U" shape) . . . . .
70-71 All w/4BC (400) . . . . .	<b>3947880</b>	32	.12	(green) . . . . .
73-75 All (400) . . . . .	<b>3947770</b>	A.R.	.12	(carbonized) (ident. by purple dye) . . . . .

**0.333 ARM— ARM UNIT, Valve Rocker with Adjusting Screw and Nut**

70-71 All w/4BC (400) . . . . .	<b>6258611</b>	16	3.30	inlet and exhaust . . . . .
70-72 All w/2BC (400),				
73-75 All (400) . . . . .	<b>3974290</b>	16	2.40	<b>ARM UNIT</b> , inlet and exhaust ("V" stamped on inside of pad end) . . . . .

**0.386 COVER ASSY.— GROMMET, Valve Rocker Arm**

70-71 All w/4BC (400) . . . . .	<b>338262</b>	R.H.	11.30	w/oil filler cap . . . . .
70-71 All w/4BC (400) . . . . .	<b>338261</b>	L.H.	11.65	w/oil filler cap . . . . .
70-73 All (400) . . . . .	<b>6272227</b>	2	10.30	w/oil filler cap R.H., L.H. . . . .
74 All (400) . . . . .	<b>340267</b>	L.H.	9.10	left . . . . .
75 All (400) . . . . .	<b>355965</b>	L.H.	10.20	left . . . . .
74-75 All (400) . . . . .	<b>340268</b>	R.H.	9.10	right . . . . .
70 All (400) . . . . .	<b>3894337</b>	A.R.	.11	<b>GROMMET</b> , cover to a/cl. (31/32" I.D. x 1 7/32" O.D.)— (1.745) . . . . .

**0.413 BOLT— REINFORCEMENT, Valve Rocker Cover and Support**

70-75 All (400) . . . . .	<b>180016</b>	1		(1/4" — 20 x 1/2")— (8.900) . . . . .
70-75 All (400) . . . . .	<b>3877670</b>	A.R.	.12	<b>REINFORCEMENT</b> (1 1/2" O.L.) (Note 1) . . . . .
<i>NOTE 1 Use with Bolt 180016.</i>				

## 400-ENGINE ASSEMBLY

### 0.423 GASKET, Valve Rocker Cover

70-72	All w/2BC (400),				
73-75	All (400) . . . . .	3933964	2	1.80	
70-71	All w/4BC (400) . . . . .	3860315	2	1.80	(21 <sup>31</sup> / <sub>32</sub> " O.L. x 6 <sup>11</sup> / <sub>16</sub> " wide) (6 tabs) . . . . .

### 0.426 ROD, Valve Push

70-72	All w/2BC (400),				
73-75	All (400) . . . . .	3796243	A.R.	2.15	(7 <sup>25</sup> / <sub>32</sub> " O.L.) (blue stripe) (Note 1, 2) . . . . .
	<i>NOTE 1 Color marked end to be at valve rocker arm.</i>				
	<i>NOTE 2 May have one black stripe at each end.</i>				
70-71	All w/4BC (400) (1st design) . . . . .	3946067	8	1.70	inlet (8 <sup>7</sup> / <sub>32</sub> " O.L.) (5/8" dia.) . . . . .
70-71	All w/4BC (400) (1st design) . . . . .	3946069	8	1.70	exhaust (9 <sup>3</sup> / <sub>16</sub> " O.L.) (5/8" dia.) . . . . .
71	All w/4BC (400) (2nd design) . . . . .	346280	8	1.30	inlet (8 <sup>7</sup> / <sub>32</sub> " O.L.) (5/16" dia.) . . . . .
71	All w/4BC (400) (2nd design) . . . . .	346282	8	1.30	exhaust (9 <sup>3</sup> / <sub>16</sub> " O.L.) (5/16" dia.) (repl. 3904377) . . . . .

### 0.429 BALL— NUT— STUD, Valve Push Rod Adjusting

70-71	All w/4BC (400) . . . . .	3899622	16	.41	(6 <sup>1</sup> / <sub>64</sub> " dia.) valve rocker arm . . . . .
70-75	All (400) . . . . .	3959142	A.R.	.38	(1 <sup>3</sup> / <sub>16</sub> " dia.) . . . . .
70-71	All w/4BC (400) . . . . .	3896648	16	.22	NUT, valve rocker arm (hex. lk. 7/8"— 20 cad.) . . . . .
71-72	All w/2BC (400),				
73-75	All (400) . . . . .	3744341	A.R.	.22	NUT (5/8"— 24) . . . . .
70-72	All w/2BC (400),				
73-75	All (400) . . . . .	3814692	16	.53	STUD, valve rocker arm ball (.003 O.S.-light blue paint) . . . . .
70-71	All w/4BC (400) . . . . .	3921912	16	.58	STUD, valve rocker arm ball (Note 1) . . . . .
71-72	All w/2BC (400),				
73-75	All (400) . . . . .	3815892	A.R.	.53	STUD (5/8"— 24 x 2 <sup>5</sup> / <sub>8</sub> " (.013 O.S.) . . . . .
	<i>NOTE 1 When using 3921912 in place of 3904396 on aluminum head, it is mandatory to install 452716 helicoil.</i>				

### 0.439 GUIDE, Valve Push Rod

70-71	All w/4BC (400) (1st design) . . . . .	3860038	8	.71	(2 holes and 2 "U" slots) . . . . .
71	All w/4BC (400) (2nd design) . . . . .	3904378	8	.64	

### 0.459 TAPPET, Valve (or Lifter)

70-72	All w/4BC (400) . . . . .	5232700	16	4.68	
70-72	All w/2BC (400),				
73-75	All (400) (exc. Police) . . . . .	5232670	16	4.54	
73-75	Police (400) . . . . .	5232720	16	4.54	

### 0.519 CAMSHAFT, Engine

*NOTE Engine Camshaft Break-in Oil 1050800, Group 1.850, should be used when installing new camshafts.*

70-72	All w/2BC (400) (exc. NB-2),				
73	All (400),				
74	All (400) (exc. NB-2),				
75	All (400) . . . . .	3896929	1	48.25	standard (ident. No. 3896930) . . . . .
70	All w/4BC (400) . . . . .	3874872	1	53.50	(Ident. No. 3874874) . . . . .
71	All w/4BC (400) . . . . .	3963544	1	61.25	(ident. No. 3963545) . . . . .
72	All w/NB-2 (400),				
74	All w/NB-2 (400) . . . . .	3998962	1	48.25	

### 0.539 BEARING, Camshaft (Front or No. 1)

70-72	All w/2BC (400),				
73-75	All (400) . . . . .	3723584	1	2.40	precision type (stamped 1) . . . . .
70-71	All w/4BC (400) . . . . .	3967808	1	2.50	precision type (stamped 1) . . . . .

### 0.543 BEARING, Camshaft No. 2 (Front Intermediate)

70-72	All w/2BC (400),				
73-75	All (400) . . . . .	3723585	1	2.40	precision type (stamped 2) . . . . .
70-71	All w/4BC (400) . . . . .	3967810	1	2.50	precision type (stamped 2) . . . . .

### 0.546 BEARING, Camshaft (Center and Rear Intermediate)

70-72	All w/2BC (400),				
73-75	All (400) . . . . .	3723586	A.R.	2.40	(stamped 3 and 4) . . . . .
70-71	All w/4BC (400) . . . . .	3967809	2	2.50	center and rear inter. (stamped 3-4) . . . . .

### 0.549 BEARING, Camshaft Rear

70-72	All w/2BC (400),				
73-75	All (400) . . . . .	3723585	1	2.40	precision type (stamped 2)— (0.543) . . . . .
70-71	All w/4BC (400) . . . . .	3967810	2	2.50	precision type (stamped 2)— (0.543) . . . . .

### 0.553 PLUG, Camshaft Bearing Hole, cup type (in cylinder block)

70-71	All w/4BC (400) . . . . .	3859926	1	.22	steel (2 <sup>7</sup> / <sub>32</sub> " dia. x 1 <sup>1</sup> / <sub>4</sub> " thk.) . . . . .
71	All w/2BC (400) (1st design) . . . . .	3704158	1	.22	rear brg. . . . .

**400-ENGINE ASSEMBLY**

**0.553 PLUG, Camshaft Bearing Hole, cup type (in cylinder block) (Con't)**

71	Pass., Monte Carlo w/2BC (400) (2nd design),					
73-75	All (400) .....	3997752	1	.12	rear brg. has Mfg. Ident. Mark) .....	

**0.603 ROD ASSY., Connecting, Less Dipper**

70-71	All w/4BC (400) .....	3933174	8	13.30	(orange) .....	
70-72	All w/2BC (400),					
73-74	All (400) .....	3951629	8	13.80		
75	All (400) .....	361933	8	16.35	(repl. 346266) .....	

**0.616 BEARING UNIT, Connecting Rod (1 Upper and 1 Lower)**

**Refer to Chart for Model Application**

*NOTE: See Dealer Price Schedule for applicable prices.*

**CONNECTING ROD BEARING UNIT CHART**

	MODEL USAGE .....	STD.	.001 U.S.	.002 U.S.	.010 U.S.	.020 U.S.
70-71	All w/4BC (400) .....	347002	3876092	347004	347005	347006
70-72	All w/2BC (400),					
73-75	All (400) .....	3910555(!)	3910556(!)	3910557(!)	3910558(!)	3910559(!)

(!) Aluminum M-400.

**0.623 BOLT, Connecting Rod Bearing Cap**

70-71	All w/4BC (400) .....	3862720	16	.60	( <sup>3</sup> / <sub>8</sub> " — 24 x 2 <sup>1</sup> / <sub>2</sub> ") (knurled shank) .....
70-72	All w/2BC (400),				
73-75	All (400) .....	3951631	16	.60	( <sup>3</sup> / <sub>8</sub> " — 24 x 1 <sup>23</sup> / <sub>32</sub> ") (knurled shank) .....

**0.626 NUT, Connecting Rod Bearing Cap Bolt**

70-75	All (400) .....	3866766	A.R.	.12	( <sup>3</sup> / <sub>8</sub> " — 24 x <sup>3</sup> / <sub>8</sub> " thick) (hex. nut) (both ends flat) (Note 1) .....
-------	-----------------	---------	------	-----	--

*NOTE 1 Also used with bolts not requiring cotter pins.*

**0.629 PISTON ASSY., with Pin**

*NOTE Individual piston assemblies are available for warranty purposes and for replacement of pistons damaged when making repairs to engine assemblies. When ordering such parts it is necessary that you specify on your order the reason the parts are required and also that the following note appears on your order. Do not ship unit package quantity.*

**(Refer to Chart for model application)**

*NOTE: See Dealer Price Schedule for applicable prices.*

**PISTON CHART**

		STD.	.001 O.S.	.020 O.S.	.030 O.S.
70	All w/4BC (400) (L.H.) ..	3969981(!)	3969983(!)	—	3969987(!)
70	All w/4BC (400) (R.H.) ..	3969982(!)	3969984(!)	3969986(!)	3969988(!)
<i>NOTE 1 These parts are used on models built with 2nd design 400 C.I.D. engine assys. These engines can be identified by the letter "C" preceding the existing suffix identification letters.</i>					
70	All w/2BC (400) .....	3972160	3972162	3972164	3972166
71-72	All w/2BC (400) .....	3991457	3991458	3991459	3991460
71	All w/4BC (400) (L.H.) ..	3993861	3993863	3993865	3993867
71	All w/4BC (400) (R.H.) ..	3993862	3993864	3993866	3993868
73-75	All (400) .....	329245	329246		3991460

## 400-ENGINE ASSEMBLY

### 0.643 RING UNIT, Piston (Service Sets)

*NOTE: Individual cylinder piston ring units (std. size only) for warranty replacement in a single engine cylinder may be ordered thru the local G.M.P.D. warehouse (refer to ACNC6775). Identify by eng. model and year, specify on your order the reason the parts are required and also that the following note appears on your order. Do not ship unit package quantity. Each of these std. size piston ring units include the necessary components (ring, spacers, segments, expanders) required for replacement in a SINGLE engine cyl.*

*NOTE: See Dealer Price Schedule for applicable prices.*

		STD.	.020 O.S.	.030 O.S.	
70-75	All (400) .....	328526 <sup>(1, 2)</sup>		328531 <sup>(2)</sup>	1

<sup>(1)</sup> All engines with a 400 cubic inch designation contain a 4<sup>1</sup>/<sub>8</sub>" bore size.

<sup>(2)</sup> One cylinder replacement only.

### 0.646 CRANKSHAFT, Engine

70-71	All w/4BC (400) .....	3882841	1	193.00	(Note 1) .....
70-72	All w/2BC (400),				
73-75	All (400) .....	3951527	1	167.00	(Note 1) .....

*NOTE 1 When used on A.T. it will be necessary to remove the pilot bearing.*

### 0.649 BEARING, Crankshaft Clutch Pilot

70-74	All (400) .....	3752487	1	1.20	(bush type— <sup>19</sup> / <sub>32</sub> " I.D. x <sup>13</sup> / <sub>32</sub> " O.D. x <sup>3</sup> / <sub>4</sub> ") ..
-------	-----------------	---------	---	------	---

### 0.659 BALANCER— PULLEY, Crankshaft

*NOTE In some cases double groove pulleys may be used in place of single groove pulleys.*

*NOTE Crankshaft harmonic balancer is also referred to as "torsional damper".*

70-71	All w/4BC (400) .....	3860008	1	44.75	w/o pulley ( <sup>7</sup> / <sub>16</sub> " O.D.) .....
70-72	All w/2BC (400) .....	6272225	1	26.50	(stamped 9510) .....
70	All w/4BC (400),				
70	All w/Acc. Air Cond. (400),				
71	Pass., Chevelle w/Air Cond. 4BC (400) .....	3937787	1	12.90	PULLEY (3 groove) (Note 1) .....

*NOTE 1 Not used on models having Acc. Air Cond. and 2.56 or 2.73 axle ratio.*

71-72	All w/2BC (400) (exc. C.A.C.),				
73-75	All (400) (exc. C.A.C., 63 amp., Taxi, Police) .....	3956666	1	9.20	PULLEY (2 groove) .....
73-75	All (400) .....	6272225	1	26.50	PULLEY .....
70	All w/4BC (400),				
71	All 4BC (400) (exc. C.A.C.) .....	3955290	1	9.20	PULLEY ASSY. (2 groove) .....
70	All w/Acc. Air Cond. (400),				
71	Pass. (63 amp. w/2BC) (400) (exc. Taxi, Police),				
71-72	All w/C.A.C., 2BC (400),				
73-75	All w/63 amp. (400),				
73-75	Taxi, Police (400) (exc. C.A.C.),				
73-75	All w/C.A.C. (400) .....	3972180	1	15.95	PULLEY ASSY. (3 groove) (stamped 3972180) .....

### 0.662 WASHER, Harmonic Balancer and Crankshaft Pulley

70-71	All w/4BC (400) .....	3864814	1	.63	balancer .....
70-72	All w/2BC (400),				
73-75	All (400) .....	3739422	1	.46	balancer ( <sup>29</sup> / <sub>64</sub> " I.D. x <sup>13</sup> / <sub>4</sub> " O.D. x <sup>5</sup> / <sub>16</sub> " thk.) ..

### 0.666 FLYWHEEL, with Ring Gear

70-71	All w/4BC (400) (exc. A.T.) .....	3998281	1	68.25	w/11" coil sprg. clutch ( <sup>125</sup> / <sub>8</sub> " bolt circle) solid type .....
70	All T.H. w/4BC (400),				
71*	All w/A.T., 4BC (400) .....	340296	1	23.85	(repl. 3991403) .....
70	Monte Carlo w/2BC (400) (exc. A.T.) .....	3986394	1	68.25	
70-72	All A.T. w/2BC (400),				
73-75	All (400) .....	340298	1	24.10	(repl. 3991404) .....
70	Chevelle w/Hvy. Duty Clutch w/4BC (400) .....	3955151	1	146.00	(Note 1) .....

*NOTE 1 Used with dual plate clutch.*

71*	All w/2BC (400) (exc. A.T.) .....	3986394	1	68.25	
-----	-----------------------------------	---------	---	-------	--

### 0.669 BOLT— DOWEL, Flywheel to Crankshaft

70-71	All (400) (exc. A.T.) .....	839756	6	.12	( <sup>7</sup> / <sub>16</sub> "— 20 x 1) .....
70-72	All (400) w/A.T.,				
73-75	All (400) .....	3727207	6	.21	( <sup>7</sup> / <sub>16</sub> "— 20 x <sup>45</sup> / <sub>64</sub> "— 290M steel) .....
70-72	All w/2BC (400),				
73-75	All (400) .....	3701679	1	.16	DOWEL, flywheel ( <sup>7</sup> / <sub>16</sub> " dia. x <sup>7</sup> / <sub>8</sub> " long) .....

**400-ENGINE ASSEMBLY**

<b>0.673 GEAR, Flywheel Ring</b>					
70-75	All (400)	3991408	1	6.40	
<b>0.679 UNDERPAN— BOLT— COVER— SCREW, Flywheel</b>					
70-74	All w/T.H. 400 (400)	3952661	1	4.85	trans. converter
70-74	All w/T.H. 350,				
75	All w/A.T.	344249	1	4.55	converter
All	All (400)	3817006 A.R.		.12	BOLT, w/washer (1/4"— 20 x 7/16")
70-71	All (400)	3843943	1	3.05	COVER, clutch housing
75	All w/T.H. 350	6261376	4	.16	SCREW, underpan assy. (1/4"— 20 x 7/8")
<b>0.683 HOUSING— BOLT, Flywheel and Clutch</b>					
70-71	All (400)	3899621	1	37.50	clutch
All	Pass. (400)	3736035 A.R.		.22	BOLT, clutch housing attach. (3/8"— 16 x 1 5/16") (300-M steel-plain)— (3.275) (Note 1)
<i>NOTE 1 When using bolt 3736035, it will be necessary to use washer 120394 (8.929).</i>					
All	Pass. (400)	3733130	2	.24	BOLT, clutch housing attach. (3/8"— 16 x 2 1/4"— washer hd.) (300M steel)— (3.275)
<b>0.685 DOWEL, Flywheel and Clutch Housing to Cylinder Block</b>					
70-71	All (400)	3712745	2	.50	clutch and flywheel (2 1/32" x 1 1/4" long)
<b>0.724 CHAIN, Camshaft Timing</b>					
70-72	All w/2BC (400),				
73-75	All (400)	346261	1	11.20	(link type)
70-71	All w/4BC (400)	3902428	1	11.20	link type
<b>0.728 SPROCKET, Crankshaft Timing (Steel)</b>					
70-72	All w/2BC (400),				
73-75	All (400)	3896959	1	4.65	(18 teeth— 2 7/8" O.D.) (early link type)
70-71	All w/4BC (400)	3902422	1	4.65	(19 teeth) (3 1/2" O.D.)
<b>0.736 SPROCKET, Camshaft Timing</b>					
70-72	All w/2BC (400),				
73-75	All (400)	340235	1	8.45	(36 teeth) (iron) (repl. 3896960)
70-71	All w/4BC (400)	330814	1	7.25	(38 teeth)
<b>0.738 PIN, Camshaft Sprocket</b>					
70-75	All (400)	3836903	1	.11	dowel (1/4" x 5/8") (solid)
<b>0.787 ROD— SWIVEL, Clutch Fork Release</b>					
70	Pass. (400)	3859863	1	1.25	fork push
70	Chevelle (400),				
71	Pass., Chevelle (400)	9779202	1	.88	fork push
71	Camaro (400)	340690	1	1.10	fork push adjusting (4 3/16" long)
71	Camaro (400)	3973076	1	1.95	fork push
70	Pass. (400)	3859839	1	.71	SWIVEL, pedal push
70-71	Chevelle (400)	3840845	1	1.40	SWIVEL, fork push rod,
<b>0.793 WASHER, Clutch Fork Push Rod</b>					
70-71	All (400)	3756694	1	.11	push rod lever thrust (2 3/4" dia. pedal shaft) pull rod lever
<b>0.795 FORK ASSY., Clutch Release</b>					
70	Chevelle (400),				
71	All (400)	3892632	1	7.15	
70	Pass. (400)	3860005	1	7.15	
<b>0.796 STUD— BRACKET, Clutch Fork</b>					
70	Pass. (400)	3790556	1	.84	ball (3/16"— 16 thds.)
70	Chevelle (400),				
71	All (400)	3729000	1	1.05	ball (1 3/16"— 16 w/2 1/32" diameter ball)
71	Chevelle (400)	3992305	1	.40	BRACKET, pull back
<b>0.797 BOOT, Clutch Fork</b>					
70-71	All (400)	3993851	1	.76	
<b>0.799 BEARING, Clutch throwout with Collar</b>					
70	Police (400)	908092	1	15.94	ball bearing type (1 7/8" long)
70	All (400) (exc. Police),				
71	All (400)	908093	1	13.56	(1 7/32" O.L.) (ND-HCT-24K)

**400-ENGINE ASSEMBLY**

**0.829 BUMPER— COVER— SEAL, Clutch**

(For COVERS see Group 4.630)

70-71	All (400)	340688	1	.21	pedal
71	Camaro w/A.T. (400)	3886689	1	.21	COVER, pedal push rod hole
70	Pass. (400)	3950007	1	1.30	SEAL, pedal push rod
71	Camaro w/A.T. (400)	3903466	1	.15	SEAL, clutch pedal push rod hole cover
70-71	Chevelle (400)	399904	1	3.20	SEAL ASSY., clutch pedal push rod
71	Camaro (400)	3973089	1	2.65	SEAL ASSY., clutch pedal push rod
71*	Pass. (400)	3988202	1	3.40	SEAL ASSY., clutch pedal push rod

**0.830 PEDAL, Clutch**

70-71	Chevelle (400)	3967783	1	5.30
70	Pass. (400)	3968745	1	5.50
71	Camaro (400)	3965693	1	5.30

**0.844 SPRING, Clutch Pedal Pull Back**

70	Pass. (400)	3849704	1	.34	fork pull back
70	Pass. (400)	3879772	1	.22	clutch pull back
70	Chevelle (400)	3920614	1	.34	
71*	Chevelle (400)	3992306	1	.52	fork pull back
71	Camaro (400)	3973088	1	.40	fork pull back

**0.851 SEAT— SEAL— SPRING— STUD— WASHER, Clutch Pedal Intermediate Lever Shaft Ball**

70-71	All (400)	3743349	A.R.	.18	stud (7/8" dia.)
70	Chevelle (400)				SEAL, ball stud dust,
70	Pass. (400),				
71	All (400)	382658	1	.19	lever shaft ball stud
70-71	All (400)	3750696	1	.13	SPRING, frame stud seat, retaining (1" O.D.)
70	Chevelle (400),				
71	All (400)	3866568	1	1.15	STUD, lever shaft ball to engine
70	Pass. (400)	3859488	1	1.20	STUD, lever shaft ball to eng.
70	All (400)	3935289	1	1.20	STUD, clutch lvr. & shaft ball to frame
71	All (400)	3898610	1	.81	STUD, lever shaft ball to frame (3/8"— 24 x 1 13/16" O.L.)
70-71	All (400)	3743360	1	.18	WASHER, stud dust seal, L.H. to frame (felt— 9/16" I.D. x 1 3/8" O.D.) lever assy. seal

**0.852 LEVER— BRACKET— SHAFT, Clutch Pedal, Intermediate (See Group 4.648 for Brake)**

70-71	Chevelle (400)	3920615	1	10.10	w/shaft
71	Pass. (400)	3988203	1	12.05	w/shaft
71	Camaro (400)	3973082	1	12.25	w/shaft
70	Pass. (400) (exc. Police, Taxi)	3859861	1	.28	BRACKET, clutch shaft frame
70	Police, Taxi	3869851	1	2.05	BRACKET, clutch shaft frame
70	Police, Taxi (400)	3918098	1	.81	BRACKET, lever and shaft frame
70-71	Chevelle (400) (exc. Monte Carlo)	3972641	1	.92	BRACKET, lever and shaft
71	Camaro (400)	3973086	1	.94	BRACKET, lever and shaft
71	Pass. (400)	3988209	1	.83	BRACKET, clutch shaft frame
70-71	Monte Carlo (400)	3954621	1	6.50	SHAFT, w/lever

**0.854 ROD, Clutch Pedal**

70	Pass. (400)	3859838	1	2.20	pedal push
70-71	Chevelle (400)	3920618	1	2.10	pedal push
71	Camaro (400)	3973087	1	3.50	push
71	Pass. (400)	3988195	1	3.75	push

**0.859 PLATE ASSY., Clutch Pressure with Cover**

70-71	All (400)	3884598	1	69.00
-------	-----------	---------	---	-------

**0.861 COVER, Clutch**

70	All (400),				
71	Chevelle, Camaro (400)	3860361	1	21.30	diaphragm spring type (11" O.D.)

**0.862 BOLT, Clutch Cover and Pressure Plate**

70-71	All (400)	3962058	A.R.	.22	retrac. spring (9/16"— 18 x 29/32" hex.)— (0.864)
-------	-----------	---------	------	-----	---

**0.863 PLATE, Clutch Pressure**

70-71	All (400)	3884630	1	32.50	(cast 3860363) (11" O.D.)
-------	-----------	---------	---	-------	---------------------------



## 400-ENGINE ASSEMBLY

### 0.864 BOLT— SPRING, Clutch Pressure Plate

70-71	All (400) .....	3962058 A.R.	.22	retrac. spring ( $\frac{5}{16}$ "— 18 x $\frac{29}{32}$ " hex.) .....
70-71	All (400) .....	3788605 3	.13	SPRING, retracting ( $1\frac{9}{32}$ " dia. at wide end w/ $\frac{5}{16}$ " ctr. hole) (Note 1) .....

*NOTE 1 Replace only in sets of three.*

### 0.886 DISC, with Facing, Clutch

70	All (400),			
71	Pass. (400) .....	3908960 1	40.00	woven (11") .....
71	Monte Carlo w/2BC (400) .....	3989030 1	41.75	
71	All w/4BC (400) (exc. Pass.) ...	336720 1	41.75	driven (11" woven) .....

**402-ENGINE ASSEMBLY**

<b>0.002 BOLT, Engine Mounting</b>						
72	All (402) (exc. Camaro, Taxi, Police) .....	3980716	2	.34	(7/16" — 14 x 3 7/8") .....	
72	Camaro, Taxi, Police (402) .....	334972	2	.34	(7/16" — 14 x 5") .....	
<b>0.010 GASKET UNIT, Engine or Tune Up</b>						
72	All (402) .....	328726	1	5.55	w/seal .....	
<b>0.027 MOUNTING ASSY.— MOUNTING UNIT, Engine</b>						
72	Police (402) .....	3993721	2	12.70		
72	Pass., Chevelle, Camaro (exc. Police) (402) .....	3990918	2	11.05	<b>MOUNTING UNIT</b> .....	
<b>0.029 BRACKET ASSY.— SHIELD, Engine Mounting</b>						
72	Chevelle (402) .....	3980711	L.H.	5.00	frame L.H. ....	
72	Chevelle (402) .....	3980712	R.H.	5.00	frame R.H. ....	
72	Camaro (402) .....	332648	2	5.00		
72	Police (402) .....	334602	2	7.25		
72	Pass. (402) (exc. Police) .....	3988229	L.H.	2.25	frame L.H. ....	
72	Pass. (402) (exc. Police) .....	3988230	R.H.	3.40	frame R.H. ....	
72	All (402) (exc. Camaro) .....	3989442	1	.84	<b>SHIELD, heat</b> .....	

**0.033 BLOCK ASSEMBLY, Cylinder**  
*NOTE: Combination not appearing below should be checked in the Engine Series Number and Suffix Chart in front of catalog to determine if the combination was available in production. If not available, no attempt should be made to make the installation.*

**PARTIAL ENGINE**

**Includes Block, Crankshaft, Timing Gears, Piston and Connecting Rods.**

72	All (402) .....	6272184	1	680.00	
----	-----------------	---------	---	--------	--

**FITTED CYLINDER BLOCK**

**Includes Pistons, Pins, Rings and Bearings.**

72	All (402) .....	6272177	1	513.00	
----	-----------------	---------	---	--------	--

**0.034 EXPANSION PLUGS, Cylinder Block (Also see Group 8.970 of the Standard Parts Catalog)**

72	All (402) .....	3743389	8	.24	water jacket hole (1 3/4" O.D.— cup type) ...
72	All (402) .....	3864810	4	.22	cyl. head water jacket hole (1" square socket) .....

**0.056 BOLT, Crankshaft Bearing Cap**

72	All (402) .....	3909834	10	.34	(3 11/32" long x 1 3/16" thk. length) .....
----	-----------------	---------	----	-----	---

**0.093 PLASTIGAGE, Crankshaft Bearing**

72	All (402) .....	1390274	A.R.	6.15	(12 pieces type PG-1) .....
----	-----------------	---------	------	------	-----------------------------

**0.095 CAP, Crankshaft Front Bearing**

72	All (402) .....	3877462	4	5.60	(No. 1, 2, 3, 4) .....
----	-----------------	---------	---	------	------------------------

**0.096 BEARING UNIT, Crankshaft Front (1 Upper and 1 Lower) See chart for model application.**

*NOTE: See Dealer Price Schedule for applicable prices.*

**CRANKSHAFT MAIN BEARING CHART**

	POSITION	STD.	.001 U.S.	.002 U.S.	.009 U.S.	.010 U.S.	.020 U.S.
72	All (402) .....	All (exc. Rear)	347013	3885379	3885378	—	347016 347017
72	All (402) .....	Rear	347018	347019	347020	—	347021 347022

**0.099 BEARING UNIT, Crankshaft Front Intermediate (1 Upper and 1 Lower). See chart following Group 0.096 for model application.**

*NOTE: See Dealer Price Schedule for applicable prices.*

**0.101 BEARING UNIT, Crankshaft Center (1 Upper and 1 Lower). See chart following Group 0.096 for model application.**

*NOTE: See Dealer Price Schedule for applicable prices.*

**402-ENGINE ASSEMBLY**

**0.103 BEARING UNIT, Crankshaft Rear Intermediate (1 Upper and 1 Lower). See chart following Group 0.096 for model application.**

*NOTE: See Dealer Price Schedule for applicable prices.*

**0.105 CAP, Crankshaft Rear Bearing**

72 All (400) ..... 3877464 1 5.75

**0.106 BEARING UNIT, Crankshaft Rear (1 Upper and 1 Lower). See chart following Group 0.096 for model application.**

*NOTE: See Dealer Price Schedule for applicable prices.*

**0.107 PIN, Crankshaft Bearing Cap**

72 All (402) ..... 3836903 A.R. .11 (1/4" dia. x 5/8" O.L.)— (0.738) .....

**0.137 SEAL, Crankshaft Rear Bearing and Cap Oil**

72 All (402) ..... 3962863 2 2.60 (Note 1) .....

*NOTE 1: Upper and lower seal must be replaced simultaneously.*

**0.206 COVER ASSY.— PIN, Crankcase Front End**

72 All (402) ..... 330850 1 7.15  
 72 All (402) ..... 3836903 A.R. .11 PIN, cover— (0.738) .....

**0.207 GASKET, Crankcase Front End Cover**

72 All (402) ..... 3935449 1 .41

**0.213 SEAL ASSY., Crankcase Front End Cover**

72 All (402) ..... 3860095 1 2.30 (3" O.D.— stamped 3860095) .....

**0.219 POINTER, Eng. Timing**

72 All (402) ..... 3992074 1 .46

**0.269 HEAD, Cylinder**

72 All w/A.I.R. (402) ..... 6272290 2 127.00 w/valve guide .....

72 All (402) (exc. A.I.R.) ..... 3999240 2 127.00 w/valve guide .....

**0.289 GASKET, Cylinder Head**

72 All w/4BC (402) ..... 3993890 2 2.60  
 72 All (402) ..... 3997459 1 18.55 GASKET UNIT .....

**0.293 BOLT— PIN, Cylinder Head**

72 All (402) ..... 3877668 24 .40 long (4 1/2" O.L.) .....

72 All (402) ..... 3877669 8 .32 short (2 1/16" O.L.) .....

72 All (402) ..... 3894327 A.R. .16 PIN (1/2" x 7/8") .....

**0.296 VALVE, Inlet**

*NOTE: See Dealer Price Schedule for applicable prices.*

	STD.	.003 O.S.	.015 O.S.	.030 O.S.
72 All (402) .....	*6263754	*6263767	*6263768	*6263769

**0.297 VALVE, Exhaust**

*NOTE: See Dealer Price Schedule for applicable prices.*

	STD.	.003 O.S.	.015 O.S.	.030 O.S.
72 All (402) .....	3931006	3931097	3931098	3931099

**0.303 SPRING— SHIM, Valve**

72 All (402) ..... 3856860 16 1.85 w/damper .....

72 All (402) ..... 3970627 16 2.25 SPRING UNIT .....

72 All (402) ..... 3875916 16 .13 SHIM, valve spring .....

*NOTE 1: To be used in place of valve stem oil shield when removed at customers request.*

**0.308 SEAL, Valve Spring Cap**

72 All (402) ..... 3866612 A.R. .22 exh. valve stem oil .....

72 All (402) ..... 352698 1 5.35 SEAL UNIT, valve stem oil inlet (Note 1)  
 (repl. 347124) .....

*NOTE 1: When installing seals it is necessary to discard the valve stem oil defl. which is assembled to the valve spring cap.*

**0.309 CAP, Valve Spring**

72 All (402) ..... 3859909 16 .40

## 402-ENGINE ASSEMBLY

<b>0.310 KEY, Valve Stem</b>					
72	All w/4BC (402) .....	3947880 32	.12	(green) .....	
<b>0.333 ARM, Valve Rocker</b>					
72	All (402) .....	6258611 16	3.30		
<b>0.386 COVER ASSY., Valve Rocker Arm</b>					
72	All (402) .....	338262 R.H.	11.30	w/oil filler cap R.H. ....	
72	All (402) .....	338261 L.H.	11.65	w/oil filler cap L.H. ....	
<b>0.413 BOLT— REINFORCEMENT, Valve Rocker Cover</b>					
72	All (402) .....	180016 1		( <sup>1</sup> / <sub>4</sub> "— 20 x <sup>1</sup> / <sub>2</sub> ")— (8.900) .....	
72	All (402) .....	3877670 A.R.	.12	REINFORCEMENT ( <sup>1</sup> / <sub>2</sub> " O.L.) (Note 1) ....	
<i>NOTE 1: Use with bolt 180016.</i>					
<b>0.423 GASKET, Valve Rocker Cover</b>					
72	All (402) .....	3860315 2	1.80		
<b>0.426 ROD, Valve Push</b>					
<i>NOTE 1: Color marked end to be at valve rocker arm.</i>					
72	All (402) .....	346280 8	1.30	inlet (repl. 3904376) .....	
72	All (402) .....	346282 8	1.30	exhaust (repl. 3904377) .....	
<b>0.429 BALL— NUT— STUD, Valve Push Rod Adjusting</b>					
72	All (402) .....	3899622 16	.41	( <sup>8</sup> / <sub>64</sub> " dia.) .....	
72	All (402) .....	3896648 16	.22	NUT ( <sup>7</sup> / <sub>16</sub> "— 20) .....	
72	All (402) .....	3921912 16	.58	STUD, ball .....	
<b>0.439 GUIDE, Crankcase and Push Rod</b>					
72	All (402) .....	3904378 8	.64	push rod .....	
<b>0.459 TAPPET, Valve (or Lifter)</b>					
72	All (402) .....	5232700 16	4.68		
<b>0.519 CAMSHAFT, Engine</b>					
<i>NOTE: Engine Camshaft Break-in Oil 1050004, Group 1.850, should be used when installing new camshafts.</i>					
72	All (402) .....	3963544 1	61.25	(Ident. No. 3963545) .....	
<b>0.539 BEARING, Camshaft No. 1 (Front)</b>					
72	All (402) .....	3967808 1	2.50	(stamped 1) .....	
<b>0.543 BEARING, Camshaft No. 2 (Front Intermediate)</b>					
72	All (402) .....	3967810 1	2.50	(stamped 2) .....	
<b>0.546 BEARING, Camshaft (Center and Rear Intermediate)</b>					
72	All (402) .....	3967809 2	2.50	(stamped 3-4) .....	
<b>0.549 BEARING, Camshaft (Rear)</b>					
72	All (402) .....	3967810 1	2.50	(stamped 2)— (0.543) .....	
<b>0.603 ROD ASSEMBLY, Connecting</b>					
72	All (402) .....	3933174 8	13.30		
<b>0.616 BEARING UNIT, Connecting Rod</b>					
<i>NOTE: See Dealer Price Schedule for applicable prices.</i>					

		STD.	.001 U.S.	.002 U.S.	.010 U.S.	.020 U.S.
72	All (402) .....	347002	3876092	347004	347005	347006

<b>0.623 BOLT, Connecting Rod Bearing Cap</b>					
72	All (402) .....	3862720 16	.60	( <sup>3</sup> / <sub>8</sub> "— 24 x 2 <sup>1</sup> / <sub>8</sub> ") (knurled shank) .....	
<b>0.626 NUT, Connecting Rod Bearing Cap Bolt</b>					
72	All (400) .....	3866766 A.R.	.12	( <sup>3</sup> / <sub>8</sub> "— 24 x <sup>3</sup> / <sub>8</sub> " thick) (hex. head) .....	
<b>0.629 PISTON ASSEMBLY, with Pin (Refer to Piston Chart for Model Application)</b>					

*NOTE: Individual piston assemblies are available for warranty purposes and for replacement of pistons damaged when making repairs to engine assemblies. When ordering such parts it is necessary that you specify on your order the reason the parts are required and also that the following note appears on your order. Do not ship unit package quantity.*

*NOTE: See Dealer Price Schedule (P&A 26) for applicable prices.*

### PISTON CHART

**402-ENGINE ASSEMBLY**

**0.629 PISTON ASSEMBLY, with Pin (Refer to Piston Chart for Model Application) (Con't)**

		STD.	.001 O.S.	.010 O.S.	.020 O.S.	.030 O.S.
72	All (402) (L.H.)	3993861	3993863	—	3993865	3993867
72	All (402) (R.H.)	3993862	3993864	—	3993866	3993868

**0.643 RING UNIT, Piston (Service Sets)**

*NOTE: See Dealer Price Schedule for applicable prices.*

		STD.	.030 O.S.
72	All (402)	328526 <sup>(1)</sup>	328531 <sup>(1)</sup>

<sup>(1)</sup> One cylinder replacement only.

**0.646 CRANKSHAFT**

72	All (402)	3882841	1	193.00	(Note 1)
----	-----------	---------	---	--------	----------

*NOTE 1: When used on A.T. it will be necessary to remove the pilot bearing.*

**0.649 BEARING, Crankshaft Clutch Pilot**

72	All (402)	3752487	1	1.20	(bush type) (1 <sup>9</sup> / <sub>32</sub> " O.D. x 3/4")
----	-----------	---------	---	------	--

**0.659 BALANCER— PULLEY, Crankshaft**

*NOTE: In some cases double groove pulleys may be used in place of single groove pulleys.*

*NOTE: Crankshaft harmonic balancer is also referred to as "torsional damper".*

72	All (402)	3860008	1	44.75	
72	All w/C.A.C. (402)	3937787	1	12.90	PULLEY (3 groove)
72	All (402) (exc. C.A.C.)	3955290	1	9.20	PULLEY

**0.662 WASHER, Harmonic Balancer and Crankshaft Pulley**

72	All (402)	3864814	1	.63	balancer
----	-----------	---------	---	-----	----------

**0.666 FLYWHEEL, with Ring Gear**

72	All (402) (exc. A.T.)	3998281	1	68.25	
72	All w/A.T. (402)	340296	1	23.85	(repl. 3991403)

**0.669 BOLT, Flywheel to Crankshaft**

72	All (402) (exc. A.T.)	839756	6	.12	(7/16" — 20 x 1")
72	All w/A.T. (402)	3727207	6	.21	(7/16" — 20 x 45/64" — 290M steel)

**0.673 GEAR, Flywheel Ring**

72	All (402)	3991408	1	6.40	
----	-----------	---------	---	------	--

**0.679 UNDERPAN ASSY.— STUD— COVER, Flywheel**

72	All w/T.H. 400 (402)	3952661	1	4.85	trans. converter
72	All (402)	6270052 A.R.		.11	STUD, w/washer (1/4" — 20 x 37/64")
72	All (402)	3843943	1	3.05	COVER, clutch housing (contains large 27/8" dia. round hole)

**0.683 HOUSING, Flywheel and Clutch**

72	All (402)	3899621	1	37.50	clutch (cast 3899621)
----	-----------	---------	---	-------	-----------------------

**0.685 PIN, Clutch Housing**

72	All (402)	3712745	2	.50	(2 <sup>1</sup> / <sub>32</sub> " x 1 <sup>1</sup> / <sub>4</sub> ")
----	-----------	---------	---	-----	--

**0.724 CHAIN, Camshaft Timing**

72	All (402)	3902428	1	11.20	(link type)
----	-----------	---------	---	-------	-------------

**0.728 SPROCKET, Crankshaft Timing (Steel)**

72	All (402)	3902422	1	4.65	(19 teeth)
----	-----------	---------	---	------	------------

**0.736 SPROCKET, Camshaft Timing**

72	All (402)	330814	1	7.25	(38 teeth)
----	-----------	--------	---	------	------------

**0.738 PIN, Camshaft Sprocket**

72	All (402)	3836903 A.R.		.11	(1/4" dia. x 5/8" O.L.) (solid)
----	-----------	--------------	--	-----	---------------------------------

**0.787 ROD— SWIVEL, Clutch Fork Release**

72	Camaro (402)	340690	1	1.10	fork push adjusting (4 <sup>3</sup> / <sub>16</sub> " long)
72	Camaro (402)	3973076	1	1.95	fork push
72	Chevelle (402)	9779202	1	.88	fork push
72	Chevelle (402)	3840845	1	1.40	SWIVEL, fork adj. push rod

**402-ENGINE ASSEMBLY**

	<b>0.793</b>	<b>WASHER, Clutch Fork Push Rod</b>				
72	All (402)	3756694	1	.11	lever thrust (1" O.D. x 3/4" I.D.) pull rod lever	
	<b>0.795</b>	<b>FORK ASSY., Clutch Release</b>				
72	All (402)	3892632	1	7.15		
	<b>0.796</b>	<b>STUD— BRACKET, Clutch Fork</b>				
72	All (402)	3729000	1	1.05	(13/16"— 16 stud w/21/32" dia. ball)	
72	Chevelle (402)	3992305	1	.40	<b>BRACKET, pull back</b>	
	<b>0.797</b>	<b>BOOT, Clutch Fork</b>				
72	All (402)	3993851	1	.76		
	<b>0.799</b>	<b>BEARING, Clutch Throwout with Collar</b>				
72	All (402)	908093	1	13.56	(17/32" long)	
	<b>0.829</b>	<b>SEAL— BUMPER— COVER, Clutch</b>				
72	Camaro w/A.T. (402)	3903466	1	.15	clutch pedal push rod hole cover	
72	Chevelle (402)	399904	1	3.20	<b>SEAL ASSY., clutch pedal push rod</b>	
72	Camaro (402)	3973089	1	2.65	<b>SEAL ASSY., clutch pedal push rod</b>	
72	All (402)	340688	1	.21	<b>BUMPER, pedal</b>	
72	Camaro w/A.T. (402)	3886689	1	.21	<b>COVER, pedal push rod hole</b>	
	<b>0.830</b>	<b>PEDAL, Clutch</b>				
72	Chevelle (402)	3967783	1	5.30		
72	Camaro (402)	3998671	1	5.30		
	<b>0.844</b>	<b>SPRING, Clutch Pedal Pull Back</b>				
72	Chevelle (402)	3992306	1	.52	fork pull back	
72	Camaro (402)	3973088	1	.40	fork pull back	
	<b>0.851</b>	<b>STUD— SEAT— SEAL— SPRING— WASHER, Clutch Pedal Intermediate Lever Shaft Ball</b>				
72	All (402)	3866568	1	1.15	lever shaft ball to engine	
72	All (402)	3743349 A.R.		.18	<b>SEAT, lever shaft ball stud (7/8" dia.)</b>	
72	All (402)	382658	1	.19	<b>SEAL, lever shaft ball stud</b>	
72	All (402)	3750696	1	.13	<b>SPRING, stud seat retaining (1" O.D.)</b>	
72	All (402)	3743360	1	.18	<b>WASHER, stud dust seal (felt— 9/16" I.D. x 13/8" O.D.)</b>	
	<b>0.852</b>	<b>LEVER— BRACKET, Clutch Pedal Intermediate</b>				
72	Chevelle (402)	3920615	1	10.10	w/shaft	
72	Camaro (402)	3973082	1	12.25	w/shaft	
72	Chevelle (402) (exc. Monte Carlo)	3918098	1	.81	<b>BRACKET, lever and shaft frame</b>	
72	Monte Carlo (402)	3972641	1	.92	<b>BRACKET, lever and shaft</b>	
72	Camaro (402)	3973086	1	.94	<b>BRACKET, lever and shaft</b>	
	<b>0.854</b>	<b>ROD— BUSHING, Clutch Pedal</b>				
72	Chevelle (402)	3920618	1	2.10	push	
72	Camaro (402)	3998670	1	3.00	push	
72	Camaro (402)	406172	1	.88	<b>BUSHING, push rod</b>	
	<b>0.859</b>	<b>PLATE ASSY., Clutch Pressure with Cover</b>				
72	All (402)	3884598	1	69.00		
	<b>0.861</b>	<b>COVER ASSY., Clutch</b>				
72	All (402)	3860361	1	21.30	diaphragm spring type (11" O.D.)	
	<b>0.862</b>	<b>BOLT, Clutch Cover and Pressure Plate</b>				
72	All (402)	3962058 A.R.		.22	retracting spring (5/16"— 18 x 29/32" hex.)— (0.864)	
	<b>0.864</b>	<b>BOLT— SPRING, Clutch Pressure Plate</b>				
72	All (402)	3962058 A.R.		.22	retracting spring (9/16"— 18 x 29/32" hex.)	
72	All (402)	3788605	3	.13	<b>SPRING, retracting (13/32" dia. at wide end w/5/16" ctr. hole)</b>	
	<b>0.886</b>	<b>PLATE ASSY., with Facing, Clutch</b>				
72	All w/4-Spd. (402)	336720	1	41.75	driven (11" woven)	
72	Chevelle (402) (exc. 4-Spd.)	3908960	1	40.00	driven	
72	Chevelle (402) (exc. 4-Spd.)	3908960	1	40.00	driven	



**409-ENGINE ASSEMBLY**

**0.010 GASKET UNIT, Engine or Tune Up**

- 65 All (409) ..... **3998212** 1 5.35 engine .....
- NOTE The above Engine Small Parts Gasket Units together with Oil Pan Gasket Unit (Group 1.429) and Cylinder Head Gasket Unit (Group 0.289) provide all necessary Gaskets for complete engine overhaul.*

**0.027 MOUNTING UNIT, Engine**

**8 CYLINDER**

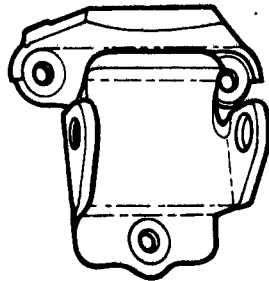

TYPE A

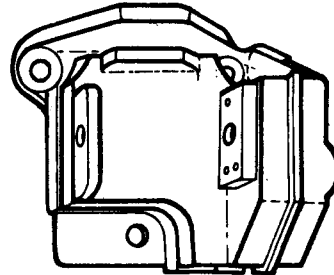

TYPE B

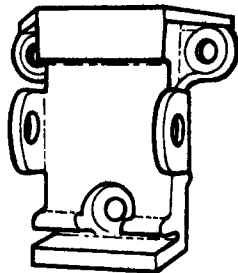

TYPE C

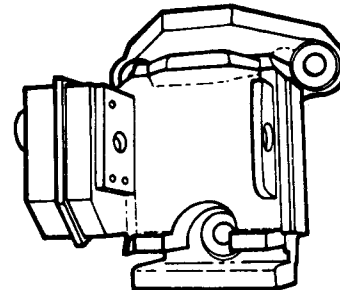

TYPE D

- 65 All (409) ..... **3990916** 2 16.10 .....
- NOTE Mount unit 3990916 include a mount, mount to frame bracket bolt, washers and nut.*

**0.029 BRACKET ASSY., Engine Mounting**

- 65 All (409) ..... **3954637** L.H. 2.00 frame .....
- 65 All (409) ..... **3977234** 1 3.25 right, frame .....
- 65 All (409) ..... **3977235** 1 3.20 left, frame .....

**0.033 BLOCK ASSY., Cylinder**

*NOTE CAUTION. Combination not appearing below should be checked in the Engine Series Number and Suffix Chart in front of catalog to determine if the combination was available in production. If not available, no attempt should be made to make the installation.*

**PARTIAL ENGINE**

- 65 All (409) (exc. H/Per., dual 4BC) **3839755** 1 733.00 (cast 3830814) (Note 1) .....
- 65 All w/H/Per., dual 4BC (409) ... **3865807** 1 755.00 (cast 3844422) .....

**FITTED CYLINDER BLOCK (Includes, Pistons, Pins, Rings and Bearings)**

- 65 All w/H/Per., dual 4BC (409) ... **3839752** 1 489.00 (cast 3844422) .....
- 65 All (409) ..... **3839754** 1 478.00 (cast 3830814) .....

**0.034 EXPANSION PLUGS, Cylinder Block (Also see 8.970)**

- 65 All (409) ..... **3738306** A.R. .46 (square socket water jacket hole) (1<sup>1</sup>/<sub>4</sub>" ) ...
- 65 All (409) ..... **3743389** 11 .24 water jacket hole (cup type— 1<sup>3</sup>/<sub>4</sub>" O.D.) ...
- 65 All (409) ..... **3736407** 4 .12 oil holes (cup type) (5/<sub>16</sub>" O.D.)— (1.531) ...



**409-ENGINE ASSEMBLY**

**0.093 PLASTIGAGE, Crankshaft Bearing**

65 All (409) ..... 1390274 A.R. 6.15 (green package-type PG-1) (12 pieces) .....

**0.096 BEARING UNIT, Crankshaft Front (1 Upper and 1 Lower)**

**See Chart for Model Application**

*NOTE: See Dealer Price Schedule for applicable prices.*

**CRANKSHAFT MAIN BEARING CHART**

	POSITION	STD.	.001 U.S.	.002 U.S.	.020 U.S.
65	All (409) ..... All (exc. Rear)	3832920(!)	—	—	—
65	All (409) (exc. P.G.) ..... Rear	3750720	3750721	—	—
65	All w/P.G. (409) ..... Rear	3750720(!)	3750721(!)	—	—

*NOTE Bearings having no supplementary notes are Durex 100.  
(!) Aluminum M-420.*

**0.107 DOWEL, Crankshaft Bearing Cap**

65 All (409) ..... 3836903 A.R. .11 rear cap (1<sup>1</sup>/<sub>32</sub>" O.D. x 5/8")— (0.738) .....

**0.137 SEAL, Crankshaft Rear Bearing and Cap Oil**

65 All (409) ..... 3748347 2 .31 cap (rubber-1<sup>23</sup>/<sub>32</sub>" O.L.) .....

65 All (409) ..... 3962863 2 2.60 rubber w/steel insert .....

65 All (409) ..... 3958001 2 2.60 SEAL ASSY., rear oil .....

**0.206 COVER— PIN, Crankcase Front End**

65 All (409) (exc. H/Per., dual 4BC) 3736357 1 5.80 w/oil seal .....

65 All (409) ..... 3836903 2 .11 PIN, dowel (1/8" x 5/8")— (0.738) .....

**0.207 GASKET, Crankcase Front End Cover**

65 All (409) ..... 3799600 1 .26 (fiber and rubber) (12 holes) .....

**0.213 SEAL, Crankcase Front End Cover**

65 All (409) ..... 3980267 1 3.35 (2<sup>7</sup>/<sub>16</sub>" O.D.— stamped 3980267) .....

**0.269 HEAD, Cylinder**

65 All (409) (exc. H/Per., dual 4BC) 3839747 2 110.00 (Ident. No. 3830817) .....

65 All w/H/Per., dual 4BC (409) ... 3852582 2 110.00 (Ident. No. 3852483) .....

**0.289 GASKET, Cylinder Head**

65 All (409) ..... 3814003 4 2.60 (20<sup>3</sup>/<sub>4</sub>" O.L.) .....

65 All (409) ..... 3829956 1 18.55 GASKET UNIT (contains 4 head gaskets)  
(Note 1, 2) .....

*NOTE 1 With dual 4BC use 561624 and with single 4BC use 3798388, air cleaner to carb. gaskets.  
NOTE 2 Consists of gaskets for cyl. heads, rocker cover, inlet manifold carburetor, water outlet, distributor, air cleaner, exhaust pipe packing and valve stem oil seals.*

**0.293 BOLT— PIN, Cylinder Head**

65 All (409) ..... 3735721 20 .40 long (7/16"— 14 x 4) .....

65 All (409) ..... 3735722 16 .28 short (7/16"— 14 x 3<sup>5</sup>/<sub>16</sub>") .....

65 All (409) ..... 585927 A.R. .16 PIN (5/16" x 9/16") .....

**0.296 VALVE, Inlet**

**Refer to following Chart for Model Application**

*NOTE: See Dealer Price Schedule for applicable prices.*

**VALVE CHART (Inlet)**

	STD.
65 All w/H/Per., dual 4BC (409) .....	3814691

**409-ENGINE ASSEMBLY**

**0.297 VALVE, Exhaust**

**Refer to following Chart for Model Application**

*NOTE: See Dealer Price Schedule for applicable prices.*

**VALVE CHART (Exhaust)**

		STD.	.003 O.S.	
65	All (409) .....	3817821	3817822	
<b>0.303 SPRING, Valve</b>				
65	All Pass. (409) (exc. H/Per.) ....	3836331 A.R.	1.10	outer (2 <sup>1</sup> / <sub>16</sub> " O.L. x 3 <sup>3</sup> / <sub>4</sub> " I.D.) (lt. pink, gray, lt. green, lavender, brown, med. blue) (Note 1) .....
<i>NOTE 1 Used with valves having full dia. stems only.</i>				
65	All (409) (exc. H/Per., dual 4BC)	3767744 16	1.10	inner (1 <sup>27</sup> / <sub>32</sub> " free length) (L.H. coil) .....
65	All w/H/Per., dual 4BC (409) ...	3858367 16	2.10	inlet and exhaust w/damper (stripe of yellow plus aluminum) .....
<b>0.308 SEAL— SHIELD, Valve Spring Cap</b>				
65	All (409) .....	3756314 16	.17	"O" ring, inlet and exhaust .....
65	All (409) (exc. H/Per., dual 4BC)	3836755 A.R.	.18	SHIELD (cup shape— <sup>7</sup> / <sub>8</sub> " I.D. x 1 <sup>3</sup> / <sub>8</sub> " O.D.) ...
65	All w/H/Per., dual 4BC (409) ...	3795664 16	.18	SHIELD (I.D. x 1 <sup>5</sup> / <sub>8</sub> " O.D.) .....
<b>0.309 CAP, Valve Spring</b>				
65	All (409) (exc. dual 4BC, H/Per.)	3776967 A.R.	.38	inlet and exhaust (1 <sup>13</sup> / <sub>64</sub> " O.D.) .....
65	All w/H/Per., dual 4BC (409) ...	3815520 16	.38	inlet and exhaust (1 <sup>15</sup> / <sub>32</sub> " O.D.) .....
<b>0.310 KEY, Valve Stem</b>				
65	All (409) .....	3947880 32	.12	(green) .....
<b>0.333 ARM, Valve Rocker with Adjusting Screw and Nut</b>				
65	All (409) .....	5723552 16	2.00	inlet and exhaust .....
<b>0.386 GROMMET, Valve Rocker Arm</b>				
65	All (409) .....	3894337 1	.11	cover to a/cl. (1 <sup>5</sup> / <sub>16</sub> " I.D. x 1 <sup>7</sup> / <sub>32</sub> " O.D.)— (1.745) (Note 1, 2) .....
<i>NOTE 1 May be used with or without closed vent.</i>				
<i>NOTE 2 When using on closed vent. equipped vehicles, it will be necessary to remove center from grommet to permit assembling of fresh air connector into side of cover.</i>				
<b>0.413 BOLT— REINFORCEMENT, Valve Rocker Cover and Support</b>				
65	All (409) .....	180016 1		( <sup>1</sup> / <sub>4</sub> "— 20 x <sup>1</sup> / <sub>2</sub> ")— (8.900) .....
65	All (409) .....	3877670 A.R.	.12	REINFORCEMENT (1 <sup>1</sup> / <sub>2</sub> " O.L.) (Note 1) ...
<i>NOTE 1 Use with Bolt 180016.</i>				
<b>0.423 GASKET, Valve Rocker Cover</b>				
65	All (409) .....	3795426 2	1.80	(cork rubber composition— <sup>5</sup> / <sub>32</sub> " thick) .....
<b>0.426 ROD, Valve Push</b>				
65	All (409) (exc. H/Per., dual 4BC)	3755545 8	1.30	inlet (8 <sup>11</sup> / <sub>16</sub> " O.L.— green stripe) (Note 1) ...
65	All (409) (exc. H/Per., dual 4BC)	3755543 8	1.30	exhaust (9 <sup>9</sup> / <sub>16</sub> " O.L.— yellow stripe) (Note 1) ...
65	All w/H/Per., dual 4BC (409) ...	3795627 8	2.20	inlet (8 <sup>53</sup> / <sub>64</sub> " O.L.— black stripe) (Note 1) ...
65	All w/H/Per., dual 4BC (409) ...	3822934 8	2.25	exhaust (9 <sup>1</sup> / <sub>8</sub> " O.L.— pink stripe) (Note 1) ...
<i>NOTE 1 Color marked end to be at valve rocker arm.</i>				
<b>0.429 BALL, Valve Push Rod Adjusting</b>				
65	All (409) .....	3992294 A.R.	.28	( <sup>15</sup> / <sub>16</sub> " dia.) valve rocker arm .....
<b>0.459 TAPPET, Valve (or Lifter)</b>				
65	All (409) .....	5232450 16	4.54	hydraulic type .....
65	All w/H/Per., dual 4BC (409) ...	5232695 16	2.95	mechanical type (2" O.L. x <sup>27</sup> / <sub>32</sub> " O.D.) .....
<b>0.519 CAMSHAFT, Engine</b>				
<i>NOTE Engine Camshaft Break-in Oil 1050800, Group 1.850, should be used when installing new camshafts.</i>				
65	All (409) (exc. H/Per., dual 4BC)	3744901 1	58.50	(Ident. No. 374430) .....
65	All w/H/Per., dual 4BC (409) ...	3837735 1	84.00	(Ident. No. 7736) .....
<b>0.539 BEARING, Camshaft (Front or No. 1)</b>				
65	All (409) .....	3750880 1	1.95	precision type (stamped 1) .....
<b>0.543 BEARING, Camshaft No. 2 (Front Intermediate)</b>				
65	All (409) .....	3723585 1	2.40	precision type (stamped 2) .....

**409-ENGINE ASSEMBLY**

	<b>0.546 BEARING, Camshaft (Center and Rear Intermediate)</b>			
65	All (409) .....	3750884 A.R.	2.40	(stamped 3-4) .....
	<b>0.549 BEARING, Camshaft Rear</b>			
65	All (409) .....	3750886 1	1.95	precision type (stamped 5) .....
	<b>0.553 PLUG, Camshaft Bearing Hole, cup type (in cylinder block)</b>			
65	All (409) .....	3704158 1	.22	(2 1/8" dia.) .....
	<b>0.603 ROD ASSY., Connecting, Less Dipper</b>			
65	All (409) .....	3814126 8	15.65	(lock-nut has only one end chamfered) .....
	<b>0.616 BEARING UNIT, Connecting Rod (1 Upper and 1 Lower)</b>			

**Refer to Chart for Model Application**

*NOTE: See Dealer Price Schedule for applicable prices.*

**CONNECTING ROD BEARING UNIT CHART**

MODEL USAGE .....	STD.			
65 All (409) .....	3832925(1)			
<i>(1) Aluminum M-420.</i>				
	<b>0.623 BOLT, Connecting Rod Bearing Cap</b>			
65 All (409) .....	3892670 A.R.	.70	(1 1/32" — 24 x 1 7/8")	.....
65 All (409) .....	3732718 16	.60	(3/8" — 24 x 2) (knurled shank)	.....
	<b>0.626 NUT, Connecting Rod Bearing Cap Bolt</b>			
65 All (409) .....	9422298 A.R.	.11	(3/8" — 24 x 5/16" thick) (one end chamfered)— (8.917)	.....

**0.629 PISTON ASSY., with Pin**

*NOTE Individual piston assemblies are available for warranty purposes and for replacement of pistons damaged when making repairs to engine assemblies. When ordering such parts it is necessary that you specify on your order the reason the parts are required and also that the following note appears on your order. Do not ship unit package quantity.*

ENGINE DISPLACEMENT	BASIC SIZE .....	SERVICE PISTON DIAMETER RANGE LIMITS ALUMINUM
40 cu. in.	4.3100— STD. ....	S-4-4.3100 to 4.3105, S-5-4.3105 to 4.3110 .....
409 cu. in.	4.3110— .001 .....	S-6— 4.3110 to 4.3115, S-7— 4.3115 to 4.3120 .....

*NOTE The above chart is for information purposes only.*

**(Refer to Chart for Model Application)**

*NOTE See Dealer Price Schedule (P&A 26) for applicable prices.*

**PISTON CHART**

	STD.	.060 O.S.
65 All (409) (exc. H/Per., dual 4BC) (cyl. 2 & 6) .	3834143	

## 409-ENGINE ASSEMBLY

### 0.643 RING UNIT, Piston (Service Sets)

NOTE: See Dealer Price Schedule for applicable prices.

		STD.	.020 O.S.	.030 O.S.	
65	All (409) .....	328546 <sup>(3)</sup>		328556 <sup>(1, 3)</sup>	1

(<sup>1</sup>) These are Molybdenum premium rings.

(<sup>3</sup>) Single cylinder replacement.

### 0.646 CRANKSHAFT, Engine

65	All (409) .....	3833147	1	167.00	(Ident. No. 3838416) .....
----	-----------------	---------	---	--------	----------------------------

### 0.649 BEARING, Crankshaft Clutch Pilot

65	All (409) .....	3752487	1	1.20	(bush type— <sup>19</sup> / <sub>32</sub> " I.D. x <sup>13</sup> / <sub>32</sub> " O.D. x <sup>3</sup> / <sub>4</sub> ") ..
----	-----------------	---------	---	------	---

### 0.659 BALANCER— PULLEY, Crankshaft

NOTE In some cases double groove pulleys may be used in place of single groove pulleys.

NOTE Crankshaft harmonic balancer is also referred to as "torsional damper".

65	All w/H/Per. dual 4BC (409) ...	3796769	1	26.50	w/o pulley (hub 5 <sup>1</sup> / <sub>4</sub> " O.D.) .....
65	All w/P.G. (409),				
65	All (409) (exc. P.G., H/Per., dual 4BC) .....	3838371	1	26.50	w/o pulley (hub 5 <sup>1</sup> / <sub>2</sub> " O.D.) .....
65	All (409) (exc. C.A.C.) .....	3858533	1	8.20	PULLEY, double 6 <sup>3</sup> / <sub>4</sub> " O.D. stamped (3766987) .....

### 0.662 WASHER— KEY, Harmonic Balancer and Crankshaft Pulley

65	All (409) (exc. dual 4BC) .....	3739422	1	.46	balancer .....
65	All w/key <sup>3</sup> / <sub>4</sub> " long x <sup>3</sup> / <sub>16</sub> " wide x <sup>1</sup> / <sub>4</sub> " high .....	3883206 A.R.		.16	KEY, crankshaft pulley hub (Note 1) .....
65	All w/key <sup>13</sup> / <sub>8</sub> " long x <sup>3</sup> / <sub>16</sub> " wide x <sup>11</sup> / <sub>32</sub> " high .....	3885092	1	.16	KEY, crankshaft pulley hub (Note 1) .....

NOTE 1: Used with pulleys and hubs having a shallow (<sup>1</sup>/<sub>16</sub>" deep) keyway only. All full depth (<sup>1</sup>/<sub>8</sub>") slots take standard Woodruff key (106751 two short or 144542 one long) in Group 8.960.

### 0.666 FLYWHEEL, with Ring Gear

65	All (409) (exc. A.T.) .....	3998281	1	68.25	w/11" coil sprg. clutch (12 <sup>5</sup> / <sub>8</sub> " bolt circle) solid type .....
65	All w/P.G. (409) .....	3781966	1	31.00	(2 <sup>15</sup> / <sub>32</sub> " ctr. hole) (Note 1) .....

NOTE 1 It is necessary to use shorter (<sup>45</sup>/<sub>64</sub>" O.L.) mounting bolt 3727207 with this flywheel Assy.

### 0.669 BOLT, Flywheel to Crankshaft

65	All (409) (exc. A.T.) .....	839756	6	.12	( <sup>7</sup> / <sub>16</sub> "— 20 x 1) .....
65	All w/A.T. (409) .....	3727207	6	.21	( <sup>7</sup> / <sub>16</sub> "— 20 x <sup>46</sup> / <sub>64</sub> "— 290M steel) .....

### 0.673 GEAR, Flywheel Ring

65	All (409) .....	3991408	1	6.40	
----	-----------------	---------	---	------	--

### 0.679 UNDERPAN— BOLT— COVER— SCREW ASSY., Flywheel

65	All w/P.G. (409) .....	3831527	1	8.60	transmission converter (Note 1) .....
----	------------------------	---------	---	------	---------------------------------------

NOTE 1 This part is also used as a replacement part with Rebuilt trans. Assy. 3832565 (P.G.) and (T.G.) conversion unit 3832566.

65	All w/T.H. 400 (409) .....	3868810	1	3.55	trans. converter .....
All	All (409) .....	3817006 A.R.		.12	BOLT, w/washer ( <sup>1</sup> / <sub>4</sub> "— 20 x <sup>7</sup> / <sub>16</sub> ") .....
65	All (409) .....	3843943	1	3.05	COVER, clutch housing .....
65	All w/P.G. (409) .....	3924780 A.R.		.16	SCREW ASSY., w/washer ( <sup>5</sup> / <sub>16</sub> "— 18 x <sup>7</sup> / <sub>8</sub> ") .....

### 0.683 HOUSING— BOLT, Flywheel and Clutch

65	All (409) (exc. A.T.) .....	3899621	1	37.50	clutch .....
All	All (409) .....	3736035 A.R.		.22	BOLT, clutch housing attach. ( <sup>9</sup> / <sub>8</sub> "— 16 x <sup>15</sup> / <sub>16</sub> ") (300M steel-plain)— (3.275) (Note 2) .....

NOTE 2 When using BOLT 3736035, it will be necessary to use washer 120394 (8.929).

All	All (409) .....	3733130	2	.24	BOLT, clutch housing attach. ( <sup>9</sup> / <sub>8</sub> "— 16 x <sup>2</sup> / <sub>4</sub> "— washer hd.) (300M steel)— (3.275)
-----	-----------------	---------	---	-----	---

### 0.685 DOWEL, Flywheel and Clutch Housing to Cylinder Block

65	All (409) .....	3712745	2	.50	clutch and flywheel ( <sup>21</sup> / <sub>32</sub> " x <sup>1</sup> / <sub>4</sub> " long) .....
----	-----------------	---------	---	-----	---

### 0.724 CHAIN, Camshaft Timing

65	All (409) .....	3777748	1	11.20	link type .....
----	-----------------	---------	---	-------	-----------------

### 0.728 SPROCKET, Crankshaft Timing (Steel)

65	All w/H/Per., dual 4BC (409) ...	3759980	1	4.65	(18 teeth— 2 <sup>7</sup> / <sub>8</sub> " O.D.) (early link type) .....
----	----------------------------------	---------	---	------	--

**409-ENGINE ASSEMBLY**

	<b>0.736</b>	<b>SPROCKET, Camshaft Timing</b>			
64-65	All (409)	3865964	1	7.55	(cast 3704214-36 teeth) (iron) (early link type)
	<b>0.738</b>	<b>PIN, Camshaft Sprocket</b>			
64-65	All (409)	3836903	1	.11	dowel (1/4" x 5/8") (solid)
	<b>0.787</b>	<b>ROD— CLIP— SWIVEL, Clutch Fork Release</b>			
65	All (409) (exc. Taxi)	3859863	1	1.25	fork push
65	All (409)	3749084 A.R.		.27	CLIP, push rod and swivel— (4.037)
65	All (409)	1455017	1	.13	CLIP, push rod— (3.425)
65	All (409)	3859839	1	.71	SWIVEL, pedal push
	<b>0.793</b>	<b>WASHER, Clutch Fork Push Rod</b>			
65	All (409)	3756694	1	.11	push rod lever thrust (2 3/4" dia. pedal shaft) pull rod lever
	<b>0.795</b>	<b>FORK ASSY., Clutch Release</b>			
65	All (409)	3860005	1	7.15	
	<b>0.796</b>	<b>STUD, Clutch Fork</b>			
65	All (409)	3790556	1	.84	ball (3/16"— 16 thds.)
	<b>0.797</b>	<b>BOOT, Clutch Fork</b>			
65	All (409)	3993851	1	.76	
65	Taxi (409)	3781385	1	1.65	black rubber
	<b>0.799</b>	<b>BEARING, Clutch throwout with Collar</b>			
65	All (409)	908093	1	13.56	(1 7/32" O.L.)
	<b>0.829</b>	<b>BUMPER— PLUG— SEAL, Clutch</b>			
		<b>(For COVERS see Group 4.630)</b>			
65	All (409)	340688	1	.21	pedal
65	All w/A.T. (409)	6256958	1		PLUG, pedal push rod hole (repl. 3872120)— (12.980)
65	All (409)	3857543	1	.65	SEAL, pedal push rod (Note 1)
		<i>NOTE 1 When using in place of 3819156 seal up to 1965, it will be necessary to replace 3825188 anchor plate with 3877244 plate. For attachment use 3877244 plate as template and drill necessary mounting holes.</i>			
	<b>0.830</b>	<b>PEDAL, Clutch</b>			
65	All (409)	3854325	1		
	<b>0.831</b>	<b>BUSHING, Clutch Pedal (See Group 4.626 for brake pedal bushing)</b>			
65	All (409)	1247439	2	.11	(3/8" dia. pedal shaft)— (4.626)
	<b>0.837</b>	<b>RETAINER— SPACER, Clutch and Brake Pedal Shaft (Also see Groups 4.634 and 4.648)</b>			
65	All (409)	3828428	1	.22	shaft— (4.634)
	<b>0.844</b>	<b>SPRING, Clutch Pedal Pull Back</b>			
65	All (409)	3849704	1	.34	fork pull back
65	All (409)	3879772	1	.22	clutch pull back
	<b>0.851</b>	<b>SEAT— SEAL— SPRING— STUD— WASHER, Clutch Pedal Intermediate Lever Shaft Ball</b>			
65	All (409)	3743349 A.R.		.18	stud (7/8" dia.)
65	All (409)	382658	1	.19	SEAL, lever shaft ball stud
65	All (409)	3750696	1	.13	SPRING, frame stud seat, retaining (1" O.D.)
65	All (409)	3898610	1	.81	STUD, to frame (3/8"— 24 x 1 13/16" O.L.)
65	All (409)	3859488	1	1.20	STUD, lever shaft ball to eng.
65	All (409)	3743360	1	.18	WASHER, stud dust seal, L.H. to frame (felt— 3/16" I.D. x 1 3/8" O.D.) lever assy. seal
	<b>0.852</b>	<b>BRACKET— SHAFT, Clutch Pedal, Intermediate (See Group 4.648 for brake)</b>			
65	All (409) (exc. Police, Taxi)	3859861	1	.28	clutch shaft frame
65	Taxi (409)	3869851	1	2.05	clutch shaft frame
65	All (409)	3954621	1	6.50	SHAFT, w/lever
	<b>0.854</b>	<b>ROD— CLIP, Clutch Pedal</b>			
65	All (409)	3859838	1	2.20	pedal push
65	All (409)	1455017	2	.13	CLIP, pedal pull rod— (3.425)

**409-ENGINE ASSEMBLY**

	<b>0.859</b>	<b>PLATE ASSY., Clutch Pressure with Cover</b>			
65	Pass. (409)	.....	<b>3884598</b>	<b>1</b>	<b>69.00</b>
	<b>0.861</b>	<b>COVER, Clutch</b>			
65	All (409)	.....	<b>3860361</b>	<b>1</b>	<b>21.30</b> diaphragm spring type (11" O.D.) .....
	<b>0.862</b>	<b>BOLT, Clutch Cover and Pressure Plate</b>			
65	All (409)	.....	<b>838653</b>	A.R.	.12 (3/8" — 16 x 1) .....
65	All (409)	.....	<b>3962058</b>	A.R.	.22 retrac. spring (5/16" — 18 x 29/32" hex.)— (0.864) .....
	<b>0.863</b>	<b>PLATE, Clutch Pressure</b>			
65	All (409)	.....	<b>3884630</b>	<b>1</b>	<b>32.50</b> (cast 3860363) (11" O.D.) .....
	<b>0.864</b>	<b>BOLT— SPRING, Clutch Pressure Plate</b>			
65	All (409)	.....	<b>3962058</b>	A.R.	.22 retrac. spring (9/16" — 18 x 29/32" hex.) .....
65	All (409)	.....	<b>3788605</b>	<b>3</b>	.13 <b>SPRING</b> , retracting (1 9/32" dia. at wide end w/5/16" ctr. hole) (Note 1) .....
	<i>NOTE 1 Replace only in sets of three.</i>				
	<b>0.886</b>	<b>DISC, with Facing, Clutch</b>			
65	All (409)	.....	<b>3908960</b>	<b>1</b>	<b>40.00</b> woven (11") .....



**427-ENGINE ASSEMBLY**

<b>0.010</b>	<b>GASKET UNIT, Engine or Tune Up</b>			
66-69	All (427)	328726	1	5.55 w/seal, engine
<b>0.027</b>	<b>MOUNTING UNIT, Engine</b>			

**8 CYLINDER**

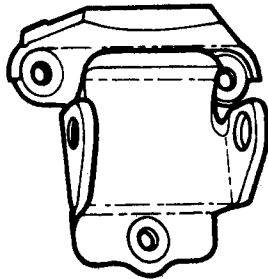

**TYPE A**

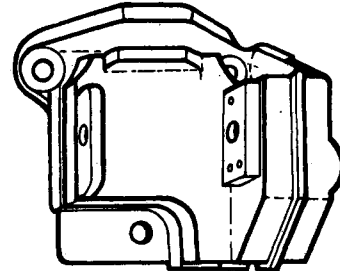

**TYPE B**

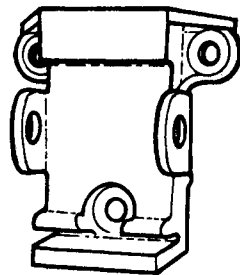

**TYPE C**

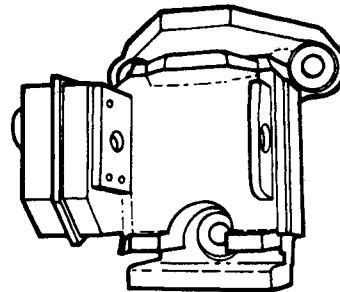

**TYPE D**

*NOTE Mount units 3990916 and 3990918 include a mount, mount to frame bracket bolt, washers and nut.*

65-67	All (427)	3990916	2	16.10 (Note 1)
<i>NOTE 1 Refer to illustration of mounting "Type C". This unit is to be used when replacing Type C mounting on R.H. and/or L.H. side 1967 Pass. (427).</i>				
67-69	All (427)	3990918	A.R.	11.05 (Note 2)
<i>NOTE 2 Refer to illustration of mounting "Type D". This unit is to be used when replacing Type D mounting on R.H. and/or L.H. side 1967 Pass. (427).</i>				

<b>0.029</b>	<b>BRACKET, Engine Mounting</b>			
66	All (427)	3954637	L.H.	2.00 BRACKET ASSY., frame
66	All (427)	3977234	R.H.	3.25 BRACKET ASSY., frame
67-69	All (427)	3977235	L.H.	3.20 BRACKET ASSY., frame
67-69	All (427)	3955186	R.H.	2.00 BRACKET ASSY., frame

**0.033 BLOCK ASSY., Cylinder**

*NOTE CAUTION. Combination not appearing below should be checked in the Engine Series Number and Suffix Chart in front of catalog to determine if the combination was available in production. If not available, no attempt should be made to make the installation.*

**PARTIAL ENGINE**

66-69	All w/Sp. H/Per. (427)	3970695	1	869.00 (Note 1)
66-69	All w/H/Per. (427) (exc. Police)	3970693	1	843.00 (Note 1) (repl. 3958669)
68-69	Police w/H/Per. (427)	3974198	1	843.00
69	All (427) (exc. Police, H/Per., Sp. H/Per.)	3970694	1	815.00
69	Police (427) (exc. H/Per.)	3974199	1	843.00

**FITTED CYLINDER BLOCK (Includes Pistons, Pins, Rings and Bearings)**

66-68	All (427) (exc. Sp. H/Per.),			
69	All (427) (exc. Police, Sp. H/Per.)	3970683	1	527.00 (Note 1, 2)



## 427-ENGINE ASSEMBLY

### 0.033 BLOCK ASSY., Cylinder (Con't)

66-69	All w/Sp. H/Per. (427)	3970685	1	565.00	(Note 1, 2)
69	Police w/H/Per. (427)	3970689	1	549.00	

*NOTE 1 On passenger models replace the four bearing cap studs with four 3864804 bolts.  
NOTE 2 When using on 1968 and past models, it is necessary to remove the two dowel pins from front of case when transfer ring front end cover from replaced engine.*

### 0.034 EXPANSION PLUGS, Cylinder Block (Also see 8.970)

66-69	All (427)	3743389	11	.24	water jacket hole (cup type— 1 <sup>9</sup> / <sub>4</sub> " O.D.)
66-69	All (427)	3864810	4	.22	(1" square socket) (cast iron heads)

### 0.056 BOLT— STUD, Crankshaft Bearing Cap

66-69	All w/Sp. H/Per. (427)				inboard,
66-69	All (427) (exc. Sp. H/Per.)	3909834	A.R.	.34	cap (3 <sup>11</sup> / <sub>32</sub> " long x 1 <sup>3</sup> / <sub>16</sub> " thread length)
66-69	All w/H/Per., Sp. H/Per. (427)	3859927	10	.28	outboard (2 <sup>39</sup> / <sub>64</sub> " long x <sup>53</sup> / <sub>64</sub> " thread)
66	All (427)	3902885	4	2.20	STUD, inboard crankshaft bearing cap

### 0.093 PLASTIGAGE, Crankshaft Bearing

66-69	All (427)	1390274	A.R.	6.15	(green package-type PG-1) (12 pieces)
-------	-----------	---------	------	------	---------------------------------------

### 0.095 CAP, Crankshaft Front Bearing

66-69	All (427) (exc. Sp. H/Per.)	3877462	4	5.60	(No. 1, 2, 3, 4)
66-69	All w/Sp. H/Per. (427)	3877470	4	7.65	(No. 1, 2, 3, 4)

### 0.096 BEARING UNIT, Crankshaft Front (1 Upper and 1 Lower)

See chart for Model Application

*NOTE: See Dealer Price Schedule for applicable prices.*

### CRANKSHAFT MAIN BEARING CHART

	POSITION	STD.	.001 U.S.	.002 U.S.	.010 U.S.	.020 U.S.
66-69	All (427) All (exc. Rear)	347013	3885379	3885378	347016	347017
66-69	All (427) Rear	347018	347019	347020	347021	347022

*NOTE Bearings having no supplementary notes are Durex 100.*

### 0.105 CAP, Crankshaft Rear Bearing

66-69	All (427)	3877464	1	5.75	(7 <sup>1</sup> / <sub>16</sub> " O.L. x 2 <sup>21</sup> / <sub>32</sub> " wide) (two <sup>17</sup> / <sub>32</sub> " holes)
-------	-----------	---------	---	------	--

### 0.107 PIN, Crankshaft Bearing Cap

66-69	All (427)	3836903	A.R.	.11	rear cap (1 <sup>4</sup> / <sub>32</sub> " O.D. x <sup>5</sup> / <sub>8</sub> "— (0.738)
-------	-----------	---------	------	-----	--

### 0.137 SEAL, Crankshaft Rear Bearing and Cap Oil

66-69	All (427)	3962863	2	2.60	rubber w/steel insert
-------	-----------	---------	---	------	-----------------------

### 0.153 SHIM UNIT, Crankshaft Bearing Cap

66-69	All (427)	3877476	A.R.	1.90	rear
66-69	All (427)	3877468	A.R.	1.90	front and intermediate

### 0.206 COVER— PIN, Crankcase Front End

66-69	All (427)	330850	1	7.15	
66-69	All (427)	3836903	2	.11	PIN, dowel (1 <sup>1</sup> / <sub>8</sub> " x <sup>5</sup> / <sub>8</sub> "— (0.738)

### 0.207 GASKET, Crankcase Front End Cover

66-68	All (427)	3860096	1	.34	(10 holes)
69	All (427)	3935449	1	.41	

### 0.213 SEAL, Crankcase Front End Cover

66-69	All (427)	3860095	1	2.30	(3" O.D.-stamped 3860095)
-------	-----------	---------	---	------	---------------------------

### 0.269 HEAD, Cylinder

66-69	All (427) (exc. Sp. H/Per.)	3931062	2	110.00	w/valve guide (Note 1)
66-69	All w/Sp. H/Per. (427)	3919839	2	124.00	w/valve guide (cast iron head) (Note 1)

*NOTE 1 When using on models prior to 1968 use pipe plug 444667 or 444746 to plug water temp. switch hole.*

### 0.289 GASKET, Cylinder Head

66-69	All (427)	330860	2	2.60	(22 <sup>1</sup> / <sub>2</sub> " O.L.)
66-69	All (427)	6259322	1	23.20	GASKET UNIT

## 427-ENGINE ASSEMBLY

### 0.293 BOLT— PIN, Cylinder Head

66-69	All (427)	3877668	24	.40	long (4 <sup>1</sup> / <sub>2</sub> " O.L.) (raised cross on top of head)
66-69	All (427)	3877669	A.R.	.32	short (2 <sup>1</sup> / <sub>16</sub> " O.L.) (raised cross)
66-69	All (427)	585927	A.R.	.16	PIN (9 <sup>9</sup> / <sub>16</sub> " x 9 <sup>9</sup> / <sub>16</sub> ")
66-69	All (427)	3894327	4	.16	PIN, special (1 <sup>1</sup> / <sub>2</sub> " I.D. x 5 <sup>5</sup> / <sub>8</sub> " diameter)

### 0.296 VALVE, Inlet

Refer to following Chart for Model Application

*NOTE: See Dealer Price Schedule for applicable prices.*

#### VALVE CHART (Inlet)

	STD.	.003 O.S.	.015 O.S.	.030 O.S.
66-69 All w/Sp. H/Per. (427)	3864808	3876813	3876814	3876815
66-69 All (427) (exc. Sp. H/Per.)	6263754	6263767	6263768	3931096

### 0.297 VALVE, Exhaust

Refer to following Chart for Model Application

*NOTE: See Dealer Price Schedule for applicable prices.*

#### VALVE CHART (Exhaust)

	STD.	.003 O.S.	.015 O.S.	.030 O.S.
66-69 All (427) (exc. Sp. H/Per.)	3931006	3931097	3931098	3931099
66-69 All w/Sp. H/Per. (427) (exc. Al. Head)	3860002	3863185	3863186	—

### 0.303 SPRING— SHIM, Valve

69	All (427) (exc. Police, H/Per., Sp. H/Per.)	3856860	16	1.85	w/damper (stripe of blue plus, aluminum, dk. green, purple or tan)
66-69	Pass. (427)	3970627	16	2.25	(Note 1)
<i>NOTE 1 When using 3970627 it is necessary to discard the valve spring cap and valve stem oil seal which were used with 1st design spring.</i>					
66-69	All (427)	3875916	16	.13	SHIM, spring (4 <sup>5</sup> / <sub>64</sub> " I.D. x 1 <sup>31</sup> / <sub>64</sub> " O.D. x 1 <sup>1</sup> / <sub>64</sub> " thick)

### 0.308 SEAL, Valve Spring Cap

66-69	All (427) (1st design)	3866612	16	.22	valve stem oil, inlet and exhaust (Note 1)
<i>NOTE 1 For 2nd design application see 3964264 Cap Assy. Group 0.309.</i>					

### 0.309 CAP, Valve Spring

66-69	All (427) (1st design)	3859909	16	.40	inlet and exhaust (1 <sup>13</sup> / <sub>32</sub> " O.D.) (stamped "T") (Note 1)
<i>NOTE 1 For 2nd design application see 3964264 Cap Assy.</i>					
69	All (427) (2nd design)	3964264	16	.47	CAP ASSY., w/deflector (Note 2)
<i>NOTE 2 1st design vehicles required a cap and seal, while 2nd design vehicles require 3964264 Cap Assy.</i>					

### 0.310 KEY, Valve Stem

66-69	All (427)	3947880	32	.12	(green)
-------	-----------	---------	----	-----	---------

### 0.333 ARM, Valve Rocker with Adjusting Screw and Nut

66-69	All (427)	6258611	16	3.30	inside rocker arm at pilot end
-------	-----------	---------	----	------	--------------------------------

### 0.386 COVER ASSY.— GROMMET, Valve Rocker Arm

66	All (427),				
67	All (427) (exc. Sp. H/Per., A.I.R.),				
68-69	All (427) (exc. S.S., Sp. H/Per.)	338262	R.H.	11.30	(painted)
66-69	All (427) (exc. Sp. H/Per.)	338261	L.H.	11.65	(painted)
67	All w/Sp. H/Per. (427) (exc. A.I.R.),				
68-69	All (427)	325174	R.H.	19.70	(chrome)
67	All w/Sp. H/Per. (427)	3908923	L.H.	20.80	(chrome) (aluminum head)
67	All w/Sp. H/Per., A.I.R. (427)	3902390	R.H.	20.80	(chrome plate) (w/aluminum head)

## 427-ENGINE ASSEMBLY

### 0.386 COVER ASSY.— GROMMET, Valve Rocker Arm (Con't)

68-69	All w/Sp. H/Per., S.S. Equip. (427) .....	325169 L.H.	19.70	(chrome) .....
66-69	All (427) .....	3894337 1	.11	GROMMET, cover to a/cl. ( $1\frac{15}{16}$ " I.D. x $1\frac{17}{32}$ " O.D.)— (1.745) (Note 1, 2) .....

NOTE 1 May be used with or without closed vent.

NOTE 2 When using on closed vent. equipped vehicles, it will be necessary to remove center from grommet to permit assembling of fresh air connector into side of cover.

### 0.413 BOLT— REINFORCEMENT, Valve Rocker Cover and Support

66-69	All (427) .....	180016 1		( $\frac{1}{4}$ "— 20 x $\frac{1}{2}$ ")— (8.900) .....
66-69	All (427) .....	3877670 A.R.	.12	REINFORCEMENT ( $1\frac{1}{2}$ " O.L.) (Note 1) .....

NOTE 1 Use with bolt 180016.

### 0.423 GASKET, Valve Rocker Cover

66-69	All (427) .....	3860315 2	1.80	( $21\frac{31}{32}$ " O.L. x $6\frac{11}{16}$ " wide) (6 tabs) .....
-------	-----------------	-----------	------	--

### 0.426 ROD, Valve Push

66	All (427),			
67	All (427) (2nd design) (exc. Sp. H/Per.),			
67-69	All w/Sp. H/Per. (427),			
68-69	Police (427) .....	3946067 8	1.70	inlet ( $8\frac{7}{32}$ " O.L.) .....
66	All (427),			
67	All (427) (2nd design) (exc. Sp./H/Per.),			
67-69	All w/Sp. H/Per. (427),			
68-69	Police (427) .....	3946069 8	1.70	exhaust ( $9\frac{3}{16}$ " O.L.) (Note 1) .....
67	All (427) (1st design) (exc. Sp. H/Per.),			
69	All (427) (exc. H/Per., Sp. H/Per., Police) .....	346282 8	1.30	exhaust ( $9\frac{3}{16}$ " O.L.) (Note 1) .....
67	All (427) (1st design) (exc. Sp. H/Per.),			
69	All (427) (exc. H/Per., Sp. H/Per., Police) .....	346280 8	1.30	inlet ( $8\frac{7}{32}$ " O.L.) (Note 1) .....

NOTE 1 1st design engines will be built prior to 9-1-66 and will be identified on the engine stamp pad by T08 plus the day built.

### 0.429 BALL— NUT— STUD, Valve Push Rod Adjusting

66-69	All (427) .....	3899622 16	.41	( $\frac{61}{64}$ " dia.) valve rocker arm .....
66-69	All (427) .....	3896648 16	.22	NUT, valve rocker arm (hex. lk. $\frac{7}{8}$ "— 20 cad.) .....
66-69	All (427) .....	3921912 16	.58	STUD, valve rocker arm ball (Note 1) .....

NOTE 1 When using 3921912 in place of 3904396 on aluminum head, it is mandatory to install 452716 helicoil.

### 0.439 GUIDE, Valve Push Rod

66	All (427),			
67	All (427) (2nd design) (exc. Sp. H/Per.),			
67	All w/Sp. H/Per. (427),			
68-69	All (427) .....	3860038 8	.71	(2 holes and 2 "U" slots) (Note 1) .....
67	All (427) (1st design) (exc. Sp. H/Per.),			
69	All (427) (exc. Police, H/Per., Sp. H/Per.) .....	3904378 8	.64	( $\frac{3}{16}$ " push rod slot— $\frac{3}{32}$ " thick) (Note 1) .....

NOTE 1 1st design engines will be built prior to 9-1-66 and will be identified on the engine stamp pad by T08 plus the day built.

### 0.459 TAPPET, Valve (or Lifter)

66-69	All w/Sp. H/Per. (427) .....	5232695 16	2.95	mechanical type (2" O.L. x $2\frac{27}{32}$ " O.D.) .....
66-69	All (427) (exc. Sp. H/Per.) .....	5232700 A.R.	4.68	

### 0.519 CAMSHAFT, Engine

NOTE Engine Camshaft Break-in Oil 1050800, Group 1.850, should be used when installing new camshafts.

66-69	All w/Sp. H/Per. (427) .....	3863143 1	61.25	(Ident. No. 3863143) .....
69	All (427) (exc. H/Per., Sp. H/Per.) .....	3874872 1	53.50	(Ident. No. 3874874) .....
66-68	All (427) (exc. Sp. H/Per.),			
69	All w/H/Per. (427) .....	3883986 1	61.25	

### 0.539 BEARING, Camshaft (Front or No. 1)

66-69	All (427) .....	3967808 1	2.50	precision type (stamped 1) .....
-------	-----------------	-----------	------	----------------------------------

## 427-ENGINE ASSEMBLY

<b>0.543 BEARING, Camshaft No. 2 (Front Intermediate)</b>					
66-69	All (427)	3967810	1	2.50	precision type (stamped 2)
<b>0.546 BEARING, Camshaft (Center and Rear Intermediate)</b>					
66-69	All (427)	3967809	2	2.50	center and rear inter. (stamped 3-4)
<b>0.549 BEARING, Camshaft Rear</b>					
66	All (427)	3876863	1	2.10	precision type (stamped 2)
67-69	All (427)	3967810	2	2.50	precision type (stamped 2)—(0.543)
<b>0.553 PLUG, Camshaft Bearing Hole, cup type (in cylinder block)</b>					
66-69	All (427)	3859926	1	.22	steel (27/32" dia. x 1 1/4" thk.)
<b>0.603 ROD ASSY., Connecting, Less Dipper</b>					
66-69	All (427) (exc. Sp. H/Per.)	3933174	8	13.30	(orange)
66-69	All w/Sp. H/Per. (427)	3856240	8	23.90	(Ident. rib on con. rod cap) (blue)
<b>0.616 BEARING UNIT, Connecting Rod (1 Upper and 1 Lower)</b>					

### Refer to chart for Model Application

*NOTE: See Dealer Price Schedule for applicable prices.*

### CONNECTING ROD BEARING UNIT CHART

MODEL USAGE	STD.	.001 U.S.	.002 U.S.	.010 U.S.	.020 U.S.
66-69 All (427)	347002	3876092	347004	347005	347006

<b>0.623 BOLT, Connecting Rod Bearing Cap</b>					
66-69	All (427)	3862720	16	.60	(3/8" — 24 x 2 1/2") (knurled shank)

### 0.629 PISTON ASSY., with Pin

*NOTE Individual piston assemblies are available for warranty purposes and for replacement of pistons damaged when making repairs to engine assemblies. When ordering such parts it is necessary that you specify on your order the reason the parts are required and also that the following note appears on your order. Do not ship unit package quantity.*

ENGINE DISPLACEMENT	BASIC SIZE	SERVICE PISTON DIAMETER RANGE LIMITS ALUMINUM			
427 cu. in.	4.2488— STD.	S-4— 4.2488 to 4.2493,	S-5— 4.2493 to 4.2498		
427 cu. in.	4.2498—.001	S-6— 4.2498 to 4.2503,	S-7— 4.2503 to 4.2508		

### (Refer to chart for model application)

*NOTE: See Dealer Price Schedule for applicable prices.*

### PISTON CHART

MODEL USAGE	STD.	.001 O.S.	.020 O.S.	.030 O.S.	.060 O.S.
66-69 All (427) (L.H.) (exc. Sp. H/Per.)	3888327	3888329	—	3888333	—
66-69 All (427) (R.H.) (exc. Sp. H/Per.)	3888328	—	—	3888334	—
66-69 All w/Sp. H/Per. (427)	3888342	3888343	—	3888344	3888345

**427-ENGINE ASSEMBLY**

**0.643 RING UNIT, Piston (Service Sets)**

NOTE: See Dealer Price Schedule for applicable prices.

**Original Equipment Type (complete set for one engine per container)**

	STD.	.030 O.S.	.060 O.S.	
66-69 All (427) . . . . .	—	328541	—	1

*(<sup>2</sup>) This part is eligible for wholesale compensation.*

**0.646 CRANKSHAFT, Engine**

66-69 All w/Sp. H/Per. (427) . . . . .	<b>3882842</b>	1	201.00	
66-68 All (427) (exc. Sp. H/Per.),				
69 Pass., Police w/H/Per. (427) . . .	<b>3882849</b>	1	167.00	(Note 1) . . . . .
69 All (427) (exc. H/Per., Sp. H/Per., Police) . . . . .	<b>3937739</b>	1	167.00	

NOTE 1 When used on A.T. it will be necessary to remove the pilot bearing.

**0.649 BEARING, Crankshaft Clutch Pilot**

66-69 All (427) . . . . .	<b>3752487</b>	1	1.20	(bush type— <sup>19</sup> / <sub>32</sub> " I.D. x <sup>13</sup> / <sub>32</sub> " O.D. x <sup>3</sup> / <sub>4</sub> ") . . .
---------------------------	----------------	---	------	--

**0.659 BALANCER— PULLEY— KEY, Crankshaft**

NOTE In some cases double groove pulleys may be used in place of single groove pulleys.

NOTE Crankshaft harmonic balancer is also referred to as "torsional damper".

66-69 All (427) (exc. Sp. H/Per.) . . . . .	<b>3860008</b>	1	44.75	w/o pulley ( <sup>7</sup> / <sub>16</sub> " O.D.) . . . . .
66-69 All w/Sp. H/Per. (427) . . . . .	<b>3860010</b>	1	44.75	w/o pulley (8" O.D.) . . . . .
66 All w/Sp. H/Per. (427),				
67-68 All w/P.S., Sp. H/Per. (427) . . . . .	<b>3869978</b>	1	25.25	PULLEY (3 grooves) . . . . .
66 All (427) (exc. Sp. H/Per., C.A.C., 62 amp., A.I.R.),				
67-68 All w/A.T. (427) (exc. 62 amp., C.A.C.) . . . . .	<b>3874412</b>	1	8.55	PULLEY (1 groove) . . . . .
66-67 All w/P/S (427) (exc. Sp. H/Per.)	<b>3874416</b>	1	9.80	PULLEY (1 groove) . . . . .
66-67 All (427) (exc. Sp. H/Per., T.H.),				
66-67 All w/C.A.C. (427) (exc. Sp. H/Per., T.H.),				
66-67 All w/62 amp. (C.A.C. w/T.H.) (427),				
68 All w/C.A.C. (427) (1st design) (exc. T.H.) . . . . .	<b>3874414</b>	1	9.00	PULLEY (2 grooves) ( <sup>7</sup> / <sub>16</sub> " O.D.) . . . . .
66 All w/62 amp. (427) (exc. Sp. H/Per., Air Cond.),				
66-67 All w/A.I.R. (427) (exc. Sp. H/Per., Air Cond.),				
68 All (427) (exc. C.A.C., A.T., Sp. H/Per.) . . . . .	<b>3874418</b>	1	8.20	PULLEY, front (2 grooves) . . . . .
66 All (Air Cond. w/T.H.) (427) (exc. 62 amp.),				
67 All (T.H. w/C.A.C.) (427) (exc. Sp. H/Per.),				
68 All w/C.A.C. (427) (2nd design) (exc. T.H.) . . . . .	<b>3876844</b>	1	5.70	PULLEY (2 grooves) ( <sup>7</sup> / <sub>16</sub> " O.D.) . . . . .
67 All w/Sp. H/Per. (427) (exc. P/S, A.I.R., 62 amp. gen.) . . . . .	<b>3862772</b>	1	22.15	PULLEY (1 groove) . . . . .
67 All (A.I.R. w/Sp. H/Per.) (427) (exc. P/S),				
67 All w/62 amp. A.C. Gen. (427 Sp. H/Per.) (exc. P/S) . . . . .	<b>3863108</b>	1	29.25	PULLEY (2 grooves) (cast) . . . . .
68 All w/Sp. H/Per. (427) (exc. P/S)	<b>3921923</b>	1	8.20	PULLEY (2 groove) (stamped) . . . . .
68 All w/P/S (427) (exc. Sp. H/Per.)	<b>3925525</b>	1	7.75	PULLEY, front (1 groove) . . . . .
69 All (427) (exc. C.A.C., P/S, Sp. H/Per.) . . . . .	<b>3955290</b>	1	9.20	PULLEY (1 groove) . . . . .
69 All w/Sp. H/Per. (427) . . . . .	<b>3955291</b>	1	9.20	PULLEY (2 groove) . . . . .
69 All w/Air Cond. (427) (exc. A.T.)	<b>3937787</b>	1	12.90	PULLEY (3 groove) (Note 1) . . . . .

NOTE 1 Not used on models having Acc. Air Cond. and 2.56 or 2.73 axle ratio.

69 All (Air Cond. w/T.H.) (427) . . . . .	<b>3946014</b>	1	12.90	PULLEY (3 groove) (Note 2) . . . . .
---	----------------	---	-------	--------------------------------------

NOTE 2 Used on models with Acc. Air Cond. and 2.56 or 2.73 axle ratio.

66 All w/key <sup>3</sup> / <sub>4</sub> " long x <sup>3</sup> / <sub>16</sub> " wide x <sup>1</sup> / <sub>4</sub> " high . . . . .	<b>3883206 A.R.</b>		.16	KEY, crankshaft pulley hub (Note 3) . . . . .
---	---------------------	--	-----	---

66 All w/key <sup>13</sup> / <sub>16</sub> " long x <sup>3</sup> / <sub>16</sub> " wide x <sup>11</sup> / <sub>32</sub> " high . . . . .	<b>3885092</b>	1	.16	KEY, crankshaft pulley hub (Note 3) . . . . .
---	----------------	---	-----	---

NOTE 3 Used with pulleys and hubs having a shallow (<sup>1</sup>/<sub>16</sub>" deep) keyway only. All full depth (<sup>1</sup>/<sub>8</sub>" slots take standard woodruff key (106751 two short or 144542 one long) in group 8.960.

**427-ENGINE ASSEMBLY**

<b>0.662</b>		<b>WASHER, Harmonic Balancer and Crankshaft Pulley</b>		
66-69	All (427)	3864814	1	.63 balancer
<b>0.666</b>		<b>FLYWHEEL, with Ring Gear</b>		
66-69	All (427) (exc. A.T.)	3998281	1	68.25
67	All w/T.H.,			
68	All w/T.H. (427) (1st design),			
69	All w/T.H. 400, Sp. H/Per. (427)	336763	1	32.00 (Note 1)
68	All w/T.H. (427) (2nd design),			
69	All w/T.H. 400 (427) (exc. Sp. H/Per.)	340296	1	23.85 (Note 1) (repl. 3991403)
<i>NOTE 1 On some application 3991401 and 3937736 are used optionally in production. These parts can be identified by their bolt hole mounting patterns. 3991401 contains a single bolt hole mounting pattern 1 1/2" in dia. 3937736 contains two (staggered) bolt hole mounting patterns. The inner pattern 10 3/4" in dia.</i>				
69	All w/T.H. 350 (427)	3991402	1	26.75
<b>0.669</b>		<b>BOLT, Flywheel to Crankshaft</b>		
66-69	All (427) (exc. A.T.)	839756	6	.12 (7/16"—20 x 1)
66-69	All w/A.T. (427)	3727207	6	.21 (7/16"—20 x 45/64"—290M steel)
<b>0.673</b>		<b>GEAR, Flywheel Ring</b>		
66-69	All (427)	3991408	1	6.40
<b>0.679</b>		<b>UNDERPAN— BOLT— COVER— SCREW, Flywheel</b>		
66-69	All w/T.H. 400 (427)	3868810	1	3.55 trans. converter
68-69	All w/T.H. 350 (427)	6261091	1	4.20 trans. converter
All	All (427)	3817006 A.R.		.12 BOLT, w/washer (1/4"—20 x 7/16")
66-69	All (427)	3843943	1	3.05 COVER, clutch housing
69	All w/T.H. 350 (427)	9420825	4	SCREW (5/16"—18 x 9/16")—(8.977) (Note 1)
<i>NOTE 1 Use with washer 120393 group (8.929).</i>				
66-69	All w/P.G. (427)	3924780 A.R.		.16 SCREW ASSY., w/washer (5/16"—18 x 7/8")
<b>0.683</b>		<b>HOUSING ASSY.— BOLT, Flywheel and Clutch</b>		
66-68	All (427) (exc. A.T.),			
69	All (427) (exc. reg. fuel)	3899621	1	37.50 clutch
All	All (427)	3736035 A.R.		.22 BOLT, clutch housing attach. (3/8"—16 x 1 5/16") (300M steel-plain)—(3.275) (Note 1)
<i>NOTE 1 When using Bolt 3736035, it will be necessary to use washer 120394 (8.929).</i>				
All	All (427)	3733130	2	.24 BOLT, clutch housing attach. (3/8"—16 x 2 1/4"—washer hd.) (300M steel)—(3.275)
<b>0.685</b>		<b>DOWEL, Flywheel and Clutch Housing to Cylinder Block</b>		
66-69	All (427)	3712745	2	.50 clutch and flywheel (2 1/32" x 1 1/4" long)
<b>0.724</b>		<b>CHAIN, Camshaft Timing</b>		
66	All (427),			
67-69	All w/Sp. H/Per. (427)	3860036	1	11.20 link type
67-69	All (427) (exc. Sp. H/Per.)	3902428	1	11.20 link type
<b>0.728</b>		<b>SPROCKET, Crankshaft Timing (Steel)</b>		
66	All (427),			
67-69	All w/Sp. H/Per. (427)	3860035	1	5.90 (19 teeth—3 1/32" O.D.)
67-69	All (427) (exc. Sp. H/Per.)	3902422	1	4.65 (19 teeth) (3 1/2" O.D.)
<b>0.736</b>		<b>SPROCKET, Camshaft Timing</b>		
66	All (427),			
67-69	All w/Sp. H/Per. (427)	330815	1	8.20 (cast 3856356-38 teeth) (aluminum)
67-69	All (427) (exc. Sp. H/Per.)	330814	1	7.25 (38 teeth) (aluminum)
<b>0.738</b>		<b>PIN, Camshaft Sprocket</b>		
66-69	All (427)	3836903	1	.11 dowel (1/4" x 5/8") (solid)
<b>0.787</b>		<b>ROD— CLIP— SWIVEL, Clutch Fork Release</b>		
66-69	All (427)	3859863	1	1.25 fork push
66-69	All (427)	3749084 A.R.		.27 CLIP, push rod and swivel—(4.037)
66-69	All (427)	1455017	1	.13 CLIP, push rod—(3.425)
66-69	All (427)	3859839	1	.71 SWIVEL, pedal push
<b>0.793</b>		<b>WASHER, Clutch Fork Push Rod</b>		
66-69	All (427)	3756694	1	.11 push rod lever thrust (2 3/4" dia. pedal shaft) pull rod lever

## 427-ENGINE ASSEMBLY

	<b>0.795</b>	<b>FORK ASSY., Clutch Release</b>			
66-69	All (427)	3860005	1	7.15	
	<b>0.796</b>	<b>STUD, Clutch Fork</b>			
66-69	All (427)	3790556	1	.84	ball ( <sup>9</sup> / <sub>16</sub> "— 16 thds.)
	<b>0.797</b>	<b>BOOT, Clutch Fork</b>			
66-69	All (427)	3993851	1	.76	black rubber
	<b>0.799</b>	<b>BEARING, Clutch throwout with Collar</b>			
66-69	All (427)	908093	1	13.56	(1 <sup>7</sup> / <sub>32</sub> " O.L.)
	<b>0.829</b>	<b>BUMPER— PLUG— SEAL, Clutch</b>			

(For COVERS see group 4.630)

66-69	All (427)	340688	1	.21	pedal
66-68	All w/A.T. (427)	6256958	1		PLUG, pedal push rod hole (repl. 3872120)— (12.980)
66-68	All (427)	3857543	1	.65	SEAL, pedal push rod
69	All (427)	3950007	1	1.30	SEAL, pedal push rod

### 0.830 PEDAL, Clutch

66	All (427)	3854325	1		
69	All (427)	3968745	1	5.50	

### 0.831 BUSHING, Clutch Pedal (see group 4.626 for brake pedal bushing)

66-68	All (427)	1247439	2	.11	( <sup>9</sup> / <sub>8</sub> " dia. pedal shaft)— (4.626)
-------	-----------	---------	---	-----	--

### 0.837 RETAINER— SPACER, Clutch and Brake Pedal Shaft— (Also see groups 4.634 and 4.648)

66-68	All (427)	3828428	1	.22	shaft— (4.634)
-------	-----------	---------	---	-----	----------------

### 0.844 SPRING, Clutch Pedal Pull Back

66-69	All (427)	3849704	1	.34	fork pull back
66-69	All (427)	3879772	1	.22	clutch pull back

### 0.851 SEAT— SEAL— SPRING— STUD— WASHER, Clutch Pedal Intermediate Lever Shaft Ball

66-69	All (427)	3743349 A.R.		.18	stud ( <sup>7</sup> / <sub>8</sub> " dia.)
66-69	All (427)	382658	1	.19	SEAL, lever shaft ball stud
66-69	All (427)	3750696	1	.13	SPRING, frame stud seat, retaining (1" O.D.)
66-69	All (427)	3898610	1	.81	STUD, to frame ( <sup>3</sup> / <sub>8</sub> "— 24 x 1 <sup>13</sup> / <sub>16</sub> " O.L.)
66-69	All (427)	3859488	1	1.20	STUD, lever shaft ball to eng.
66-69	All (427)	3743360	1	.18	WASHER, stud dust seal, L.H. to frame (felt— <sup>9</sup> / <sub>16</sub> " I.D. x 1 <sup>3</sup> / <sub>8</sub> " O.D.) lever assy. seal

### 0.852 BRACKET— SHAFT, Clutch Pedal, Intermediate (See Group 4.648 for brake)

66-69	Pass. (427) (exc. Police, Taxi)	3859861	1	.28	clutch shaft frame
66-69	Taxi (427),				
68-69	Police (427)	3869851	1	2.05	clutch shaft frame
66-69	All (427)	3954621	1	6.50	SHAFT, w/lever

### 0.854 ROD— CLIP, Clutch Pedal

66-69	All (427)	3859838	1	2.20	pedal push
66-69	All (427)	1455017	2	.13	CLIP, pedal pull rod— (3.425)

### 0.859 PLATE ASSY., Clutch Pressure with Cover

66-68	All (427),				
69	All (427) (exc. H.D. Clutch)	3884598	1	69.00	(111N-bent finger-Belleville)

### 0.861 COVER, Clutch

69	All (427) (exc. H.D. Clutch)	3860361	1	21.30	diaphragm spring type (11" O.D.)
66-68	All (427),				
69	All (427) (exc. H.D. Clutch)	3884626	1	18.90	

### 0.862 BOLT, Clutch Cover and Pressure Plate

66-69	All (427)	838653 A.R.		.12	( <sup>3</sup> / <sub>8</sub> "— 16 x 1)
66-69	All (427)	3962058 A.R.		.22	retrac. spring ( <sup>5</sup> / <sub>16</sub> "— 18 x 2 <sup>9</sup> / <sub>32</sub> " hex.)— (0.864)

### 0.863 PLATE, Clutch Pressure

66	All (427) (exc. Sp. H/Per.),				
67-68	All (427),				

**427-ENGINE ASSEMBLY**

---

**0.863 PLATE, Clutch Pressure (Con't)**

69 All (427) (exc. H.D., H.D. Clutch) 3884630 1 32.50 (cast 3860363) (11" O.D.) .....

**0.864 BOLT— SPRING, Clutch Pressure Plate**

66-69 All (427) ..... 3962058 A.R. .22 retrac. spring (<sup>5</sup>/<sub>16</sub>"— 18 x <sup>29</sup>/<sub>32</sub>" hex.) .....  
 66-69 All (427) ..... 3788605 3 .13 **SPRING**, retracting (1<sup>9</sup>/<sub>32</sub>" dia. at wide end  
 w/<sup>5</sup>/<sub>16</sub>" ctr. hole) (Note 1) .....

*NOTE 1 Replace only in sets of three.*

**0.886 DISC, with Facing, Clutch**

66-68 All (427),  
 69 All (427) (exc. H.D. Clutch) ..... 3908960 1 40.00 woven (11") .....





## 454-ENGINE ASSEMBLY

### 0.002 BOLT—SPACER, Engine Mounting (Small Attaching)

70-71	All (454),				
72	All (454) (exc. Taxi, Police) . . . . .	3980716	2	.34	( <sup>7</sup> / <sub>16</sub> "— 14 x 3 <sup>7</sup> / <sub>8</sub> ") . . . . .
73-75	All (454) . . . . .	334972	2	.34	to engine bracket ( <sup>7</sup> / <sub>16</sub> "— 14 x 5 <sup>1</sup> / <sub>8</sub> ") . . . . .
70	All (454) . . . . .	3826168	2	.18	SPACER, frt. mtg. eng. brkt. ("U" shape) (2 <sup>1</sup> / <sub>2</sub> " O.L.) (Note 1) . . . . .

NOTE 1 It may be necessary to reduce length to 2<sup>3</sup>/<sub>8</sub>".

### 0.010 GASKET UNIT, Engine or Tune-Up

70-75	All (454) . . . . .	328726	1	5.55	w/seal, engine . . . . .
-------	---------------------	--------	---	------	--------------------------

### 0.027 MOUNTING ASSY., Engine

## 8 CYLINDER

70	Chevelle w/4BC (454),				
70	Pass. (454),				
71	All (454),				
72	All (454) (exc. Police) . . . . .	3990918	2	11.05	(dk. green) . . . . .
72	Police (454),				
73-75	Pass. (Sta. Wag.) (454) . . . . .	3993721	2	12.70	
73-75	Chevelle (454),				
73-75	Pass. (454) (exc. Sta. Wag.) . . . . .	334941	2	9.80	

### 0.029 BRACKET— SHIELD, Engine Mounting

70	Pass. (454) . . . . .	3955186	R.H.	2.00	frame . . . . .
70-72	Chevelle (454) . . . . .	3980711	L.H.	5.00	frame . . . . .
70-72	Chevelle (454) . . . . .	3980712	R.H.	5.00	frame . . . . .
72	Police (454) . . . . .	334602	2	7.25	
70	Pass. (454) . . . . .	3977235	L.H.	3.20	BRACKET ASSY., frame . . . . .
71	Pass. (454),				
72	Pass. (454) (exc. Police) . . . . .	3988229	L.H.	2.25	BRACKET ASSY., frame . . . . .
71	Pass. (454),				
72	Pass. (454) (exc. Police) . . . . .	3988230	R.H.	3.40	BRACKET ASSY., frame . . . . .
73-75	Pass. (454) . . . . .	331287	2	2.40	BRACKET ASSY. . . . .
73-75	Chevelle (454) . . . . .	334962	2	5.00	BRACKET ASSY. . . . .
72	All (454) . . . . .	3989442	1	.84	SHIELD, heat . . . . .

### 0.033 BLOCK ASSY., Cylinder

NOTE CAUTION Combination not appearing below should be checked in the Engine Series Number and Suffix Chart in front of catalog to determine if the combination was available in production. If not available, no attempt should be made to make the installation.

## PARTIAL ENGINE

NOTE Includes block, crankshaft, camshaft, timing gears, pistons and connecting rods.

70	All (454) (exc. Police, H/Per., Sp. H/Per.) . . . . .	3981819	1	843.00	
70	Police (454) (exc. H/Per.) . . . . .	3981826	1	843.00	
70	All w/H/Per. (454) (exc. Police) . . . . .	3981818	1	924.00	
70	Police w/H/Per. (454) . . . . .	3981825	1	924.00	
70	All w/Sp. H/Per. (454) . . . . .	3981820	1	951.00	
71	All w/Sp. H/Per. (454) . . . . .	3997548	1	948.00	
71	All w/H/Per. (454),				
72	All (454) . . . . .	6272185	1	839.00	
73	All (454) . . . . .	6259224	1	968.00	
74	All (454) . . . . .	345016	1	839.00	
75	All (454) . . . . .	359072	1	843.00	

### FITTED CYLINDER BLOCK (Includes, Pistons, Pins, Rings and Bearings)

70	All (454) (exc. Sp. H/Per., Police)	3981808	1	549.00
70	Police (454) . . . . .	3981810	1	549.00
70	All w/Sp. H/Per. (454) . . . . .	3981806	1	614.00
71	All (454) (exc. Sp. H/Per., Police)	3997486	1	549.00
71	All w/Sp. H/Per. (454) . . . . .	3997547	1	613.00
71	Police (454),			
72-73	All (454) . . . . .	6259223	1	546.00
74	All (454) . . . . .	345014	1	546.00
75	All (454) . . . . .	359070	1	549.00

### 0.034 EXPANSION PLUGS, Cylinder Block (Also See Group 8.970)

70-75	All (454) . . . . .	3743389	11	.24	water jacket hole (cup type— 1 <sup>3</sup> / <sub>4</sub> " O.D.) . . . . .
70-75	All (454) . . . . .	3864810	4	.22	(1" square socket) (cast iron heads) . . . . .
75	All (454) . . . . .	361997	2	.27	cylinder case oil gallery hole front . . . . .
75	All (454) . . . . .	3826504	1	.96	water jacket . . . . .

## 454-ENGINE ASSEMBLY

### 0.056 BOLT— STUD, Crankshaft Bearing Cap

70	Chevelle w/H/Per., Sp. H/Per. (454),					
70	Pass. w/Sp. H/Per. (454),					
71	All w/Sp. H/Per. (454) . . . . .				inboard, . . . . .	
70-71	All (454) (exc. Sp. H/Per.),					
72-75	All (454) . . . . .	3909834 A.R.	.34		cap (3 <sup>11</sup> / <sub>32</sub> " long x 1 <sup>3</sup> / <sub>16</sub> " thread length) . . . .	
70	All w/H/Per., Sp. H/Per. (454),					
71	All w/Sp. H/Per. (454) . . . . .	3859927	10	.28	outboard (2 <sup>39</sup> / <sub>64</sub> " long x <sup>53</sup> / <sub>64</sub> " thread) . . . . .	
70-71	All w/Sp. H/Per. (454) . . . . .	3902885	4	2.20	STUD, inboard crankshaft bearing cap . . . .	

### 0.093 PLASTIGAGE, Crankshaft Bearing

70-75	All (454) . . . . .	1390274 A.R.	6.15		(green package-type PG-1) (12 pieces) . . . . .	
-------	---------------------	--------------	------	--	---	--

### 0.095 CAP, Crankshaft Front Bearing

70-71	All (454) (exc. Sp. H/Per.),					
72-75	All (454) . . . . .	3877462	4	5.60	(No. 1, 2, 3, 4) . . . . .	
70-71	All w/Sp. H/Per. (454) . . . . .	3877470	4	7.65	(No. 1, 2, 3, 4) . . . . .	

### 0.096 BEARING UNIT, Crankshaft Front (1 Upper and 1 Lower)

**See Chart for Model Application**

*NOTE: See Dealer Price Schedule for applicable prices.*

#### CRANKSHAFT MAIN BEARING CHART

	POSITION	STD.	.001 U.S.	.002 U.S.	.010 U.S.	.020 U.S.
70-72	All (454) . . . . . (exc. Rear)	347013	3885379	3885378	347016	347017
70-75	All (454) . . . . . (Rear)	347018	347019	347020	347021	347022
73	All (454) . . . . . All (exc. Rear)	347013	347014	3885378	—	347016
74-75	All (454) . . . . . All (exc. Rear)	347013	347014	347015	—	347016

*NOTE Bearings having no supplementary notes are Durex 100.*

### 0.099 BEARING UNIT, Crankshaft Front Intermediate (1 Upper and 1 Lower) See Chart Following Group 0.096 for Model Application.

*NOTE: See Dealer Price Schedule for applicable prices.*

### 0.101 BEARING UNIT, Crankshaft Center (1 Upper and 1 Lower) See Chart Following Group 0.096 for Model Application.

*NOTE: See Dealer Price Schedule for applicable prices.*

### 0.103 BEARING UNIT, Crankshaft Rear Intermediate (1 Upper and 1 Lower) See Chart Following Group 0.096 for Model Application.

*NOTE: See Dealer Price Schedule for applicable prices.*

### 0.105 CAP, Crankshaft Rear Bearing

70-75	All (454) . . . . .	3877464	1	5.75		
-------	---------------------	---------	---	------	--	--

### 0.106 BEARING UNIT, Crankshaft Rear (1 Upper and 1 Lower) See Chart Following Group 0.096 for Model Application.

*NOTE: See Dealer Price Schedule for applicable prices.*

### 0.107 PIN, Crankshaft Bearing Cap

70-75	All (454) . . . . .	3836903 A.R.	.11		rear cap (1 <sup>5</sup> / <sub>32</sub> " O.D. x <sup>5</sup> / <sub>8</sub> " )— (0.738) . . . . .	
-------	---------------------	--------------	-----	--	--	--

### 0.137 SEAL, Crankshaft Rear Bearing and Cap Oil

70-75	All (454) . . . . .	3962863	2	2.60	(Note 1) . . . . .	
-------	---------------------	---------	---	------	--------------------	--

*NOTE 1: Upper and lower seal must be replaced simultaneously.*

### 0.153 SHIM UNIT, Crankshaft Bearing Cap

70-71	All (454),					
75	All (454) . . . . .	3877476 A.R.	1.90		rear . . . . .	
70-71	All (454),					
75	All (454) . . . . .	3877468 A.R.	1.90		front and intermediate . . . . .	

### 0.206 COVER— PIN, Crankcase Front End

70-75	All (454) . . . . .	330850	1	7.15		
70-75	All (454) . . . . .	3836903	2	.11	PIN, dowel (1 <sup>1</sup> / <sub>8</sub> " x <sup>5</sup> / <sub>8</sub> " )— (0.738) . . . . .	

### 0.207 GASKET, Crankcase Front End Cover

70-75	All (454) . . . . .	3935449	1	.41		
-------	---------------------	---------	---	-----	--	--

## 454-ENGINE ASSEMBLY

<b>0.213 SEAL, Crankcase Front End Cover</b>					
70	All (454)	3980267	1	3.35	(2 <sup>7</sup> / <sub>16</sub> " O.D.— stamped 3980267)
70-75	All (454)	3860095	1	2.30	(3" O.D.— stamped 3860095)
<b>0.219 POINTER, Eng. Timing</b>					
71-75	All (454)	3992073	1	.46	
<b>0.269 HEAD, Cylinder</b>					
70	All (454) (exc. Sp. H/Per.)	3964286	2	127.00	w/valve guide
70	All w/Sp. H/Per. (454)	3964287	2	124.00	w/valve guide
71	All (454) w/Sp. H/Per.	6260482	2	127.00	w/valve guide
71-72	All (454) (2nd design)	3999240	2	127.00	w/valve guide
73	All (454)	353047	2	127.00	w/valve guide
74	All (454)	352625	2	127.00	w/guide
75	All (454)	343783	2	110.00	w/guide
<b>0.289 GASKET, Cylinder Head</b>					
70-75	All (454)	330860	2	2.60	(22 <sup>1</sup> / <sub>2</sub> " O.L.) (stamped 3863199)
70-72	All (454)	6259322	1	23.20	GASKET UNIT
73-74	All (454)	338381	1	20.60	GASKET UNIT
75	All (454)	358813	1	22.65	GASKET UNIT
<b>0.293 BOLT— PIN, Cylinder Head</b>					
70-75	All (454)	3877668	24	.40	long (4 <sup>1</sup> / <sub>2</sub> " O.L.) (raised cross)
70-75	All (454)	3877669	A.R.	.32	short (2 <sup>1</sup> / <sub>16</sub> " O.L.) (raised cross)
70-75	All (454)	3894327	4	.16	PIN, special (1 <sup>1</sup> / <sub>2</sub> " I.D. x 5 <sup>5</sup> / <sub>8</sub> " diameter)
<b>0.296 VALVE, Inlet</b>					

### Refer to Following Chart for Model Application

*NOTE: See Dealer Price Schedule for applicable prices.*

#### VALVE CHART (Inlet)

		STD.	.003 O.S.	.015 O.S.	.030 O.S.
70-71	All w/Sp. H/Per. (454)	3864808	3876813	3876814	3876815
70-71	All (454) (exc. Sp. H/Per.)	6263754	6263767	6263768	3931096
72-75	All (454)	6263754	6263767	6263768	6263769

### 0.297 VALVE, Exhaust

### Refer to Following Chart for Model Application

*NOTE: See Dealer Price Schedule for applicable prices.*

#### VALVE CHART (Exhaust)

		STD.	.003 O.S.	.015 O.S.	.030 O.S.
70-72	All (454) (exc. Sp. H/Per.)				
73-75	All (454)	3931006	3931097	3931098	3931099
70-71	All w/Sp. H/Per. (454)	3946077	3947872	3947873	3947874

### 0.303 SPRING— SHIM, Valve

70	Pass. (454) (exc. Police, H/Per., Sp. H/Per.)	3856860	16	1.85	w/damper (stripe of blue plus, aluminum, dk. green, purple or tan)
70	Chevelle (454),				
70	Police (454),				
70	Pass. w/H/Per. (454),				
71-72	All (454)	3970627	16	2.25	(Note 1)
<i>NOTE 1 When using 3970627 it is necessary to discard the valve spring cap and valve stem oil seal which were used with 1st design spring.</i>					
73-74	All (454)	353075	16	2.10	w/damper
75	All (454)	3887125	16	1.85	w/damper
70-75	All (454)	3875916	16	.13	SHIM, spring (4 <sup>5</sup> / <sub>64</sub> " I.D. x 1 <sup>31</sup> / <sub>64</sub> " O.D. x 1 <sup>1</sup> / <sub>64</sub> " thick)

## 454-ENGINE ASSEMBLY

### 0.308 SEAL, Valve Spring Cap

70	Pass. (454) (exc. H/Per., Police),				
73-75	All (454) .....	3866612	16	.22	valve stem oil, inlet and exhaust (Note 1) .....
70-75	All (454) .....	352698	1	5.35	SEAL UNIT, valve stem oil (std.) .....
73-75	All (454) .....	352698	1	5.35	SEAL UNIT, valve stem oil (std., .003 O.S.) .....
75	All (454) .....	361072	1	8.50	SEAL UNIT, valve stem oil (.015 O.S.) .....
75	All (454) .....	361073	1	8.50	SEAL UNIT, valve stem oil (.030 O.S.) .....

NOTE 1 For 2nd design application see 3964264 Cap Assy. Group 0.309.

### 0.309 CAP— ROTATOR ASSY., Valve Spring

70	Pass. (454) (exc. H/Per., Police) .	3859909	16	.40	inlet and exhaust ( $1\frac{13}{32}$ " O.D.) (stamped "T") .....
70	Pass. w/H/Per. (454),				
70	Chevelle (454) .....				CAP ASSY., inlet and exhaust, .....
71-72	All (454) .....	3964264	A.R.	.47	exhaust only .....
71-72	All (454) .....	3999199	8	.43	CAP ASSY., inlet .....
73-75	All (454) .....	3864900	16	.40	CAP ASSY. ....
73-75	All (454) .....	330848	8	3.25	ROTATOR ASSY., exh. valve .....

### 0.310 KEY, Valve Stem

70-75	All (454) .....	3947880	32	.12	(green) .....
-------	-----------------	---------	----	-----	---------------

### 0.333 ARM, Valve Rocker with Adjusting Screw and Nut

70-75	All (454) .....	6258611	16	3.30	inside rocker arm at pilot end w/ball and nut .....
73-75	All Police .....	360863	16	2.75	w/ball and nut .....

### 0.386 COVER ASSY.— GROMMET, Valve Rocker Arm

70-72	All (454) .....	338262	R.H.	11.30	w/oil filler cap R.H. ....
70-72	All (454) .....	338261	L.H.	11.65	w/oil filler cap L.H. ....
73	All (454),				
74	Chevelle (454),				
74	Pass. (454) (exc. NB2) .....	330891	L.H.	10.85	
73	All (454),				
74	Chevelle (454),				
74	Pass. (454) (exc. NB2) .....	330892	R.H.	10.00	
74	Pass. w/NB2 (454) .....	340273	L.H.	9.50	
74	Pass. w/NB2 (454) .....	340274	R.H.	9.50	
75	All (454) .....	346285	L.H.	12.15	
75	All (454) .....	346286	R.H.	12.15	
70	All (454) .....	3894337	A.R.	.11	GROMMET, cover to a/cl. ( $\frac{91}{32}$ " I.D. x $\frac{17}{32}$ " O.D.)— (1.745) .....

### 0.413 BOLT— REINFORCEMENT, Valve Rocker Cover and Support

70-75	All (454) .....	180016	1		( $\frac{1}{4}$ "— 20 x $\frac{1}{2}$ ")— (8.900) .....
70-75	All (454) .....	3877670	A.R.	.12	REINFORCEMENT ( $\frac{11}{2}$ " O.L.) (Note 1) .....

NOTE 1 Use with Bolt 180016.

### 0.423 GASKET, Valve Rocker Cover

70-75	All (454) .....	3860315	2	1.80	(2 $1\frac{31}{32}$ " O.L. x $6\frac{11}{16}$ " wide) (6 tabs) .....
-------	-----------------	---------	---	------	--

### 0.426 ROD, Valve Push

70	Police (454),				
70	Chevelle (454),				
70	Pass. w/H/Per. (454),				
71-72	All (454) .....	3946067	8	1.70	inlet ( $\frac{87}{32}$ " O.L.) .....
70	Police (454),				
70	Chevelle (454),				
70	Pass. w/H/Per. (454),				
71-72	All (454) .....	3946069	8	1.70	exhaust ( $\frac{93}{16}$ " O.L.) .....
70	Pass. (454) (exc. H/Per., Sp. H/Per., Police),				
73-75	All (454) .....	346282	8	1.30	exhaust ( $\frac{93}{16}$ " O.L.) .....
70	Pass. (454) (exc. H/Per., Sp. H/Per., Police),				
73-75	All (454) .....	346280	8	1.30	inlet .....

### 0.429 BALL— NUT— STUD, Valve Push Rod Adjusting

70-72	All (454) .....	3899622	16	.41	( $\frac{61}{64}$ " dia.) valve rocker arm .....
70	All (454) .....	3959142	A.R.	.38	( $\frac{13}{16}$ " dia.) .....
73-75	All (454) .....	5232762	16	.40	( $\frac{61}{64}$ " dia.) .....
70-75	All (454) .....	3896648	16	.22	NUT, valve rocker arm (hex. lk. $\frac{7}{8}$ "— 20 cad.) .....
70-75	All (454) .....	3921912	16	.58	STUD, valve rocker arm ball (Note 1) .....

NOTE 1 When using 3921912 in place of 3904396 on aluminum head, it is mandatory to install 452716 helicoil.

## 454-ENGINE ASSEMBLY

### 0.439 GUIDE, Valve Push ROD

70	Chevelle (454),					
70	Police (454),					
70	Pass. w/H/Per. (454),					
71-72	All (454) .....	3860038	8	.71	(2 holes and 2 "U" slots) .....	
70	Pass. (454) (exc. Police, H/Per., Sp. H/Per.),					
73-75	All (454) .....	3904378	8	.64	( <sup>3</sup> / <sub>16</sub> " push rod slot— <sup>3</sup> / <sub>32</sub> " thick) .....	

### 0.459 TAPPET, Valve (or Lifter)

70-71	All w/Sp. H/Per. (454) .....	5232695	16	2.95	mechanical type (2" O.L. x <sup>27</sup> / <sub>32</sub> " O.D.) .....	
70-72	All (454) (exc. Sp. H/Per.),					
73-75	All (454) .....	5232700	16	4.68		

### 0.519 CAMSHAFT, Engine

*NOTE Engine Camshaft Break-in Oil 1050800, Group 1.850, should be used when installing new camshafts.*

70-71	All w/Sp. H/Per. (454) .....	3863143	1	61.25	(Ident. No. 3863143) .....	
70	All w/H/Per. (454),					
71-72	All (454) (exc. Sp. H/Per.) .....	3883986	1	61.25		
70	All (454) (exc. H/Per., Sp. H/Per.) .....	3963544	1	61.25	(Ident. No. 3963545) .....	
73-75	All (454) .....	353040	1	53.50		

### 0.539 BEARING, Camshaft (Front or No. 1)

70-75	All (454) .....	3967808	1	2.50	precision type (stamped 1) .....	
-------	-----------------	---------	---	------	----------------------------------	--

### 0.543 BEARING, Camshaft No. 2 (Front Intermediate)

70-75	All (454) .....	3967810	1	2.50	precision type (stamped 2) .....	
-------	-----------------	---------	---	------	----------------------------------	--

### 0.546 BEARING, Camshaft (Center and Rear Intermediate)

70-75	All (454) .....	3967809	2	2.50	center and rear inter. (stamped 3-4) .....	
-------	-----------------	---------	---	------	--	--

### 0.549 BEARING, Camshaft Rear

70-75	All (454) .....	3967810	2	2.50	precision type (stamped 2)—(0.543) .....	
-------	-----------------	---------	---	------	--	--

### 0.553 PLUG, Camshaft Bearing Hole, Cup Type (In Cylinder Block)

70-72	All (454) .....	3859926	1	.22	steel (2 <sup>7</sup> / <sub>32</sub> " dia. x 1 <sup>1</sup> / <sub>4</sub> " thk.) .....	
73-75	All (454) .....	3999200	1	.16	rear brg. .....	

### 0.603 ROD ASSY., Connecting, Less Dipper

70-72	All (454) (exc. Sp. H/Per.),					
73-75	All (454) .....	3933174	8	13.30	(orange) .....	
70-71	All w/Sp. H/Per. (454) .....	3963552	8	34.75		

### 0.616 BEARING UNIT, Connecting Rod (1 Upper and 1 Lower)

**Refer to Chart for Model Application**

*NOTE: See Dealer Price Schedule for applicable prices.*

#### CONNECTING ROD BEARING UNIT CHART

MODEL USAGE .....	STD.	.001 U.S.	.002 U.S.	.010 U.S.	.020 U.S.	—
70-73 All (454) .....	347002	3876092	347004	347005	347006	—
74-75 All (454) .....	347002	347003	347004	347005	347006	—

### 0.623 BOLT, Connecting Rod Bearing Cap

70-72	(454) (exc. Sp. H/Per.),					
73-75	All (454) .....	3862720	16	.60	( <sup>3</sup> / <sub>8</sub> "—24 x 2 <sup>1</sup> / <sub>2</sub> ") (knurled shank) .....	
70-71	All w/Sp. H/Per. (454) .....	3981092	16	.60	( <sup>7</sup> / <sub>16</sub> "-20 x 2 <sup>9</sup> / <sub>32</sub> ") (knurled shank) .....	

### 0.626 NUT, Connecting Rod Bearing Cap Bolt

70-75	All (454) .....	3866766	A.R.	.12	( <sup>3</sup> / <sub>8</sub> "—24 x <sup>3</sup> / <sub>8</sub> " thick) (hex. nut) (both ends flat) (Note 1) .....	
-------	-----------------	---------	------	-----	--	--

*NOTE 1 Also used with bolts not requiring cotter pins.*

70-71	All w/Sp. H/Per. (454) .....	3942410	16	.24	( <sup>7</sup> / <sub>16</sub> "—20 x <sup>7</sup> / <sub>16</sub> " thick) .....	
-------	------------------------------	---------	----	-----	---	--

## 454-ENGINE ASSEMBLY

### 0.629 PISTON ASSY., with Pin

*NOTE Individual piston assemblies are available for warranty purposes and for replacement of pistons damaged when making repairs to engine assemblies. When ordering such parts it is necessary that you specify on your order the reason the parts are required and also that the following note appears on your order. Do not ship unit package quantity.*

ENGINE DISPLACEMENT	BASIC SIZE	SERVICE PISTON DIAMETER RANGE LIMITS ALUMINUM
---------------------	------------	---

*NOTE: The above chart is for information purposes only.*

**(Refer to Chart for Model Application)**

*NOTE: See Dealer Price Schedule for applicable prices.*

### PISTON CHART

		STD.	.001 O.S.	.010 O.S.	.020 O.S.	.030 O.S.	.040 O.S.
70	All (454) (exc. Sp. H/Per.) (L.H.)	3976015	3976019	3976023	3976027	—	—
70	All (454) (exc. Sp. H/Per.) (R.H.)	3976016	3976020	3976024	3976028	—	—
70	All w/Sp. H/Per. (454)	3976013	3976017	—	3976021	3976025	—
71	All (454) (exc. Sp. H/Per.)	353058	3993875	—	3993876	3993877	—
72	All (454)	353058	3993875	—	—	3993877	—
71	All w/Sp. H/Per. (454)	6262976	—	—	—	6262979	—
73	All (454)	353058	353059	—	—	353061	—
74-75	All (454)	340206	340207	—	—	340208	—

### 0.643 RING UNIT, Piston (Service Sets)

*NOTE: See Dealer Price Schedule for applicable prices.*

**Original Equipment Type (Complete Set for One Engine Per Container unless Otherwise Noted)**

		STD.	.020 O.S.	.030 O.S.	
70-72	All (454)	328536 <sup>(1)</sup>	3888309	328541 <sup>(1)</sup>	1
73-75	All (454)	328536 <sup>(1)</sup>	—	328541 <sup>(1)</sup>	—

<sup>(1)</sup> Single cylinder only.

### 0.646 CRANKSHAFT

70	Pass., Chevelle w/A.T. (454) (exc. Sp. H/Per.)				
73-75	All (454)	336782	1	167.00	(Note 1)
70	Chevelle (454) (exc. Sp. H/Per., Monte Carlo, A.T.)	3975945	1	167.00	
70-71	All w/Sp. H/Per. (454)	3963523	1	250.00	(Note 1)
71-72	All (454) (exc. Sp. H/Per.)	3993878	1	232.00	(Note 1)

*NOTE 1 When used on A.T. it will be necessary to remove the pilot bearing.*

### 0.649 BEARING, Crankshaft Clutch Pilot

70-74	All (454)	3752487	1	1.20	(bush type— <sup>19</sup> / <sub>32</sub> " I.D. x <sup>13</sup> / <sub>32</sub> " O.D. x <sup>3</sup> / <sub>4</sub> ")
-------	-----------	---------	---	------	--

### 0.659 BALANCER— PULLEY, Crankshaft

*NOTE In some cases double groove pulleys may be used in place of single groove pulleys.*

*NOTE Crankshaft harmonic balancer is also referred to as "torsional damper".*

70-72	All (454) (exc. Sp. H/Per.)				
73	All (454) (exc. A.T.)	3963529	1	44.75	
73-75	All w/A.T. (454)	330849	1	26.50	
70-71	All w/Sp. H/Per. (454)	3963530	1	44.75	
70-72	All (454) (exc. C.A.C., Sp. H/Per.)	3955290	1	9.20	PULLEY (2 groove)
70-71	All w/Sp. H/Per. (454)	3955291	1	9.20	PULLEY (2 groove)
70	Chevelle w/Air Cond. (454), Pass. w/C.A.C., A.T. (454), Pass. w/Air Cond. (454), Pass. w/Air Cond. (454), Pass. w/Air Cond. (454)				
71-72	All w/Air Cond. (454)				
73-75	All (454)	3937787	1	12.90	PULLEY (3 groove) (Note 1)
70	All w/P/S (454) (exc. C.A.C., Sp. H/Per.)	3956666	1	9.20	PULLEY ASSY. (2 groove)

*NOTE 1 Not used on models having Acc. Air Cond. and 2.56 or 2.73 axle ratio.*

**454-ENGINE ASSEMBLY**

<b>0.659 BALANCER— PULLEY, Crankshaft (Con't)</b>					
70	Pass., Chevelle w/Acc. Air Cond. (454) .....	3972180	1	15.95	PULLEY ASSY. (3 groove) (stamped 3972180) .....
<b>0.662 WASHER, Harmonic Balancer and Crankshaft Pulley</b>					
70-75	All (454) .....	3864814	1	.63	balancer .....
<b>0.666 FLYWHEEL, with Ring Gear</b>					
70-74	All (454) (exc. A.T.) .....	3993827	1	59.25	
70-72	All w/A.T. (454) (exc. Sp. H/Per.) .....				
73-75	All w/A.T. (454) (exc. Police) ...	3992069	1	40.25	
70-71	All w/A.T., Sp. H/Per. (454),				
73-75	Police w/A.T. (454) .....	336717	1	40.25	
<b>0.669 BOLT— DOWEL, Flywheel to Crankshaft</b>					
70-74	All (454) (exc. A.T.) .....	839756	6	.12	(7/16" — 20 x 1) .....
70-75	All w/A.T. (454) .....	3727207	6	.21	(7/16" — 20 x 45/64" — 290M steel) .....
70-75	All (454) .....	3701679	1	.16	DOWEL, flywheel (7/16" dia. x 7/8" long) .....
<b>0.673 GEAR, Flywheel Ring</b>					
70-75	All (454) .....	3991408	1	6.40	
<b>0.679 UNDERPAN— BOLT— COVER— STUD, Flywheel</b>					
70-74	All w/T.H. 400 (454) .....	3952661	1	4.85	trans. converter .....
75	All (454) .....	344249	1	4.55	trans. converter .....
All	All (454) .....	3817006	A.R.	.12	BOLT, w/washer (1/4" — 20 x 7/16") .....
70-75	All (454) .....	3843943	1	3.05	COVER, clutch housing .....
72	All (454) .....	6270052	A.R.	.11	STUD, w/washer (1/4" — 20 x 37/64") .....
<b>0.683 HOUSING— BOLT, Flywheel and Clutch</b>					
70-74	All (454) .....	3899621	1	37.50	clutch (cast 3899621) .....
All	Pass. (454) .....	3736035	A.R.	.22	BOLT, clutch housing attach. (3/8" — 16 x 1 5/16") (300M steel-plain)— (3.275) .....
All	Pass. (454) .....	3733130	2	.24	BOLT, clutch housing attach. (3/8" — 16 x 2 1/4" — washer hd.) (300M steel)— (3.275)
<b>0.685 DOWEL, Flywheel and Clutch Housing to Cylinder Block</b>					
70-75	All (454) .....	3712745	2	.50	clutch and flywheel (2 1/32" x 1 1/4" long) .....
<b>0.724 CHAIN, Camshaft Timing</b>					
70-71	All w/Sp. H/Per. (454) .....	3860036	1	11.20	link type .....
70-72	All (454) (exc. Sp. H/Per.),				
73-75	All (454) .....	3902428	1	11.20	link type .....
<b>0.728 SPROCKET, Crankshaft Timing (Steel)</b>					
70-71	All w/Sp. H/Per. (454) .....	3860035	1	5.90	(19 teeth— 3 1/32" O.D.) .....
70-72	All (454) (exc. Sp. H/Per.),				
73-75	All (454) .....	3902422	1	4.65	(19 teeth) (3 1/2" O.D.) .....
<b>0.736 SPROCKET, Camshaft Timing</b>					
70-71	All w/Sp. H/Per. (454) .....	330815	1	8.20	(38 teeth) (nylon) .....
70-72	All (454) (exc. Sp. H/Per.),				
73-75	All (454) .....	330814	1	7.25	(38 teeth) .....
<b>0.738 PIN, Camshaft Sprocket</b>					
70-75	All (454) .....	3836903	1	.11	dowel (1/4" x 5/8") (solid) .....
<b>0.787 ROD— SWIVEL, Clutch Fork Release</b>					
70	Pass. (454) .....	3859863	1	1.25	fork push .....
70-74	Chevelle (454),				
71	Pass. (454) .....	9779202	1	.88	fork push .....
70	Pass. (454) .....	3859839	1	.71	SWIVEL, pedal push .....
70-72	Chevelle (454),				
71	All (454) .....	3840845	1	1.40	SWIVEL, fork push rod (1 1/2" O.L.) (3/8" — 16 thds.) .....
73-74	Chevelle (454) .....	335380	1	1.40	SWIVEL, fork adj. push rod .....
<b>0.793 WASHER, Clutch Fork Push Rod</b>					
70-72	All (454) .....	3756694	1	.11	push rod lever thrust (2 3/4" dia. pedal shaft) pull rod lever .....
<b>0.795 FORK ASSY., Clutch Release</b>					
70	Chevelle (454),				
71-72	All (454) .....	3892632	1	7.15	



## 454-ENGINE ASSEMBLY

### 0.795 FORK ASSY., Clutch Release (Con't)

70	Pass. (454)	3860005	1	7.15	
73-74	All (454)	340278	1	11.70	

### 0.796 STUD— BRACKET, Clutch Fork

70	Pass. (454)	3790556	1	.84	ball ( <sup>3</sup> / <sub>16</sub> "— 16 thds.)
70	Chevelle (454),				
71-74	All (454)	3729000	1	1.05	ball ( <sup>13</sup> / <sub>16</sub> "— 16 w/ <sup>21</sup> / <sub>32</sub> " diameter ball)
71-72	Chevelle (454)	3992305	1	.40	BRACKET, pull back

### 0.797 BOOT, Clutch Fork

70-74	All (454)	3993851	1	.76	
-------	-----------	---------	---	-----	--

### 0.799 BEARING, Clutch Throwout with Collar

70	Police (454)	908092	1	15.94	ball bearing type ( <sup>17</sup> / <sub>8</sub> " long)
70	All (454) (exc. Police),				
71-74	All (454)	908093	1	13.56	( <sup>17</sup> / <sub>32</sub> " O.L.)

### 0.829 SEAT ASSY.— BRACKET— BUMPER— CLIP— COVER— SEAL, Clutch

(For COVERS See Group 4.630)

73-74	Chevelle (454)	3994485	1	3.20	clutch pedal push rod
73	Chevelle (454)	8264981	1	1.30	BRACKET, pedal bumper
74	Chevelle (454)	342435	1	1.30	BRACKET, bumper
70-74	All (454)	340688	1	.21	BUMPER, clutch pedal
73-74	Chevelle (454)	1243333	1	.16	CLIP, clutch arm stop
70	Pass. (454)	3950007	1	1.30	SEAL, pedal push rod
70-72	Chevelle (454)	399904	1	3.20	SEAL ASSY., clutch pedal push rod
71	Pass. (454)	3988202	1	3.40	SEAL ASSY., clutch pedal push rod

### 0.830 PEDAL, Clutch

70-72	Chevelle (454)	3967783	1	5.30	
70	Pass. (454)	3968745	1	5.50	
73-74	Chevelle (454)	3994483	1	8.85	

### 0.844 SPRING, Clutch Pedal Pull Back

70	Pass. (454)	3849704	1	.34	fork pull back
70	Pass. (454)	3879772	1	.22	clutch pull back
70	Chevelle (454)	3920614	1	.34	
71-72	Chevelle (454)	3992306	1	.52	fork pull back
71	Pass. (454)	3973088	1	.40	clutch fork push rod pull back
73-74	Chevelle (454)	3994494	1	1.75	fork pull back

### 0.851 SEAT— SEAL— SPRING— STUD— WASHER, Clutch Pedal Intermediate Lever Shaft Ball

70-74	All (454)	3743349	A.R.	.18	stud ( <sup>7</sup> / <sub>8</sub> " dia.)
70-74	All (454)	382658	1	.19	SEAL, lever shaft ball stud
70-74	All (454)	3750696	1	.13	SPRING, frame stud seat, retaining (1" O.D.)
70	Chevelle (454),				
71-74	All (454)	3866568	1	1.15	STUD, lever shaft ball to engine
70	Pass. (454)	3859488	1	1.20	STUD, lever shaft ball to eng.
70	Pass., Chevelle (454),				
71-74	All (454)	3935289	1	1.20	STUD, clutch lvr. & shaft ball to frame
70-74	All (454)	3743360	1	.18	WASHER, stud dust seal, L.H. to frame (felt— <sup>9</sup> / <sub>16</sub> " I.D. x <sup>13</sup> / <sub>8</sub> " O.D.) lever assy. seal

### 0.852 LEVER— BRACKET— SHAFT, Clutch Pedal, Intermediate (See Group 4.648 for Brake)

70-72	Chevelle (454)	3920615	1	10.10	w/shaft
71	Pass. (454)	3988203	1	12.05	w/shaft
73-74	Chevelle (454)	3994486	1	19.10	w/shaft
70	Pass. (454) (exc. Police)	3859861	1	.28	BRACKET, clutch shaft frame
70	Police (454)	3869851	1	2.05	BRACKET, clutch shaft frame
70-72	Chevelle (454) (exc. Monte Carlo)	3918098	1	.81	BRACKET, lever and shaft frame
70-72	Monte Carlo (454)	3972641	1	.92	BRACKET, lever and shaft
71	Pass. (454)	3988209	1	.83	BRACKET, clutch shaft frame
73-74	Chevelle (454)	3994491	1	1.25	BRACKET, clutch lever and shaft
70	Pass. (454)	3954621	1	6.50	SHAFT, w/lever

### 0.854 ROD— BUSHING, Clutch Pedal

70	Pass. (454)	3859838	1	2.20	pedal push
70-72	Chevelle (454)	3920618	1	2.10	pedal push
71	Pass. (454)	3988195	1	3.75	push

**454-ENGINE ASSEMBLY**

<b>0.854 ROD— BUSHING, Clutch Pedal (Con't)</b>					
73-74	Chevelle (454)	3994490	1	5.20	push
73	All (454)	406172	2	.88	BUSHING, pedal push rod
<b>0.859 PLATE ASSY., Clutch Pressure with Cover</b>					
70-74	All (454)	3884598	1	69.00	(111N-bent finger-Belleville)
<b>0.861 COVER, Clutch</b>					
70	All (454) (exc. Sp. H/Per.),				
72	Chevelle (454) (exc. Monte Carlo),				
73	Chevelle (454)	3860361	1	21.30	diaphragm spring type (11" O.D.)
70	All w/Sp. H/Per. (454)	3884626	1	18.90	
<b>0.862 BOLT, Clutch Cover and Pressure Plate</b>					
70-73	All (454)	3962058 A.R.		.22	retrac. spring ( <sup>5</sup> / <sub>16</sub> "— 18 x <sup>29</sup> / <sub>32</sub> " hex.)— (0.864)
<b>0.863 PLATE, Clutch Pressure</b>					
70-73	All (454)	3884630	1	32.50	(cast 3860363) (11" O.D.)
<b>0.864 BOLT— SPRING, Clutch Pressure Plate</b>					
70-72	All (454)	3962058 A.R.		.22	retrac. spring ( <sup>5</sup> / <sub>16</sub> "— 18 x <sup>29</sup> / <sub>32</sub> " hex.)
70-73	All (454)	3788605	3	.13	SPRING, retracting (1 <sup>9</sup> / <sub>32</sub> " dia. at wide end w/ <sup>3</sup> / <sub>16</sub> " ctr. hole)
<b>0.886 DISC, with Facing, Clutch</b>					
70-74	All (454)	336720	1	41.75	driven (11" woven)



# CHEVROLET CHASSIS GROUP 1.000



## COOLING — GRILLE — OIL SYSTEM

### ALPHABETICAL INDEX

<b>A</b>			
ADAPTER ASSY., Oil Filter.....	1.840	CONNECTOR, Oil Filter Fitting.....	1.855
ADAPTER, Crankcase.....	1.745	COOLER ASSY., Oil.....	1.540
ADAPTER, Oil (Also see Group 8.963).....	1.531	CORD ASSY., Engine Heater.....	1.152
ADAPTER, Oil Pressure.....	1.803	CORE, Radiator.....	1.219
ARRESTOR, Crankcase.....	1.745	COVER, Oil Pump.....	1.723
		CUSHION, Radiator Core.....	1.270
<b>B</b>		<b>D</b>	
BAFFLE, Oil Pan Upper.....	1.430	DEFLECTOR, Radiator Core Side and Lower..	1.272
BAFFLE, Radiator Core Side and Lower.....	1.272	DIAL, Coolant Temperature (Dash Unit).....	1.148
BAR ASSY., Radiator Support.....	1.271	DIAL, Oil Pressure.....	1.803
BAR, Radiator Grille.....	1.267		
BEARING, Fan-Idler Arm.....	1.060	<b>E</b>	
BELT, Fan, Gen. and Accessory Drive.....	1.066	ELBOW, Coolant Pump By-Pass.....	1.097
BLADE ASSY., Fan.....	1.064	ELBOW, Crankcase.....	1.745
BODY, Oil Filter.....	1.837	ELBOW, Oil Pressure.....	1.803
BOLT, Coolant Pump.....	1.073	ELBOW, Thermostat.....	1.251
BOLT, Oil.....	1.652	ELEMENT, Oil Filter.....	1.836
BOLT, Oil Filter.....	1.840	EMBLEM, Radiator Grille & Frt. End (Also See Group 8.055).....	1.303
BOLT, Oil Pan Attaching, with Lockwasher....	1.428	EXTENSION ASSY., Radiator Grille.....	1.267
BOLT, Radiator Core.....	1.270	EXTENSION, Radiator (Mouldings in group 1.268).....	1.266
BRACE, Radiator Grille.....	1.267	EXTENSION, Radiator and Grille Filler.....	1.287
BRACKET, Coolant Recovery Unit.....	1.240	EXTENSION, Radiator Fan.....	1.277
BRACKET, Fan-Idler Arm.....	1.060		
BRACKET, Front End and Close.....	1.263	<b>F</b>	
BRACKET, Oil Pressure.....	1.803	FASTENER, Radiator Grille and Engine Baffle Attaching.....	1.276
BRACKET, Radiator (Mouldings in group 1.268).....	1.266	FILLER, Front End and Close.....	1.263
BRACKET, Radiator and Grille Filler.....	1.287	FILLER, Radiator (Mouldings in group 1.268)	1.266
BRACKET, Radiator Core.....	1.270	FILTER UNIT, Oil (see group 3.163 for flexible pipes).....	1.835
BRACKET, Radiator Fan.....	1.277	FITTING, Oil Pressure (See group 9.748 for tell tale windows).....	1.800
BRACKET, Radiator Grille.....	1.267	FITTING, Oil Pressure.....	1.803
BRACKET, Radiator Support.....	1.271	FITTING, Radiator and Recovery Tank.....	1.203
BUMPER, Engine Air Cooling Control.....	1.035	FLANGE, Oil Pan Drain.....	1.453
BUSHING ASSY., Radiator Core.....	1.270		
<b>C</b>		<b>G</b>	
CAP, Coolant Pump.....	1.070	GASKET, Coolant Outlet.....	1.154
CAP, Coolant Recovery Unit.....	1.240	GASKET, Coolant Pump Assembly (to Block).	1.079
CAP, Oil Filler.....	1.758	GASKET, Crankcase.....	1.745
CAP, Radiator and Recovery Tank.....	1.203	GASKET, Oil Filler.....	1.758
CLAMP, Crankcase Ventilator Tube.....	1.750	GASKET, Oil Filter.....	1.844
CLAMP, Hose, with Nut and Bolt.....	1.166	GASKET, Oil Pan Drain Screw.....	1.456
CLEANER, Engine Concentrate.....	1.850	GASKET, Oil Pump Cover.....	1.724
CLIP, Coolant Recovery Unit.....	1.240	GASKET, Oil Pump.....	1.609
CLIP, Crankcase Ventilator-Outer.....	1.762		
CLIP, Crankcase.....	1.745		
CLIP, Radiator Grille and Engine Baffle Attaching.....	1.276		
CLIP, Radiator Grille Moulding.....	1.269		
CLUTCH ASSY., Engine Air Fan.....	1.050		
CONNECTOR, Coolant Pump By-Pass.....	1.097		
CONNECTOR, Crankcase.....	1.745		
CONNECTOR, Oil (Also see Group 8.963).....	1.531		

## ALPHABETICAL INDEX

GASKET, Thermostat Housing.....	1.252
GASKET UNIT, Oil Pan.....	1.429
GAUGE ASSY., Coolant Temperature (Dash Unit).....	1.148
GAUGE, Oil Level.....	1.516
GAUGE, Oil Pressure.....	1.803
GAUGE UNIT, Coolant Temperature (Engine Unit).....	1.150
GRILLE, Radiator (Mouldings in group 1.268).....	1.266
GROMMET, Crankcase.....	1.745
GROMMET, Oil (Also see Group 8.963).....	1.531
GUARD, Radiator Fan.....	1.277
GUSSET, Radiator Core.....	1.270

### H

HEATER UNIT, Engine Heater.....	1.152
HOSE, Coolant Pump By-Pass.....	1.097
HOSE, Coolant Recovery Unit.....	1.240
HOSE, Crankcase Ventilator-Outer.....	1.762
HOSE, Oil Pressure.....	1.803
HOSE, Radiator Inlet.....	1.159
HOSE, Radiator Outlet.....	1.173
HOUSING UNIT, Thermostat.....	1.251

### K

KIT, Crankcase.....	1.745
---------------------	-------

### L

LEAD ASSY., Engine Air Auxiliary Cooling.....	1.055
---	-------

### M

MODULE ASSY., Radiator and Recovery Tank.....	1.203
MOTOR, Engine Air Auxiliary Cooling.....	1.055
MOULDING, Radiator Grille.....	1.268
MOULDING UNIT, Radiator Grille & Frt. End (Also See Group 8.055).....	1.303
MOUNTING UNIT, Radiator Core.....	1.270

### N

NIPPLE, Crankcase.....	1.745
NUT, Oil (Also see Group 8.963).....	1.531
NUT, Radiator Core.....	1.270
NUT, Radiator Grille & Frt. End (Also See Group 8.055).....	1.303
NUT, Radiator Grille and Engine Baffle Attaching.....	1.276
NUT, Radiator Grille Moulding.....	1.269
NUT, Radiator Grille.....	1.267

### O

OIL, Engine Concentrate.....	1.850
ORNAMENT ASSY., Radiator Grille & Frt. End (Also See Group 8.055).....	1.303
OUTLET, Coolant.....	1.153

### P

PAD, Radiator Core.....	1.270
PAN ASSY., Oil.....	1.426
PANEL, Front End and Close.....	1.263
PANEL, Radiator (Mouldings in group 1.268).....	1.266
PANEL, Radiator and Grille Filler.....	1.287
PANEL, Radiator Core.....	1.270
PANEL, Radiator Fan.....	1.277
PIN, Oil Level.....	1.516
PIN, Oil Pump Shaft.....	1.639
PIN, Oil Pump.....	1.609
PIPE ASSY., Oil Pan Upper.....	1.430
PIPE ASSY., Oil Pressure.....	1.803
PIPE, Crankcase Ventilator-Outer.....	1.762
PLATE, Radiator and Grille Filler.....	1.287
PLATE, Radiator Grille & Frt. End (Also See Group 8.055).....	1.303
PLUG, Oil (Also see Group 8.963).....	1.531
PLUG, Oil Level.....	1.516
PLUG, Oil Pan Drain.....	1.453
PLUG, Oil Pump.....	1.609
PLUG, Rad. Core and Support.....	1.274
PROBE ASSY., Radiator and Recovery Tank..	1.203
PULLEY, Fan and Water Pump.....	1.062
PUMP ASSEMBLY, Oil.....	1.652
PUMP UNIT, Engine Coolant.....	1.069

### R

RECOVERY UNIT, Coolant Recovery Unit.....	1.240
REINFORCEMENT, Fan and Water Pump.....	1.062
REINFORCEMENT, Front End and Close.....	1.263
REINFORCEMENT, Radiator (Mouldings in group 1.268).....	1.266
REINFORCEMENT, Radiator and Grille Filler..	1.287
REINFORCEMENT, Radiator Core.....	1.270
REINFORCEMENT, Radiator Grille.....	1.267
REINFORCEMENT, Radiator Outlet.....	1.173
REPAIR KIT, Oil Filter.....	1.837
RETAINER, Coolant Recovery Unit.....	1.240
RETAINER, Oil Pressure.....	1.803
RETAINER, Oil Pump Shaft.....	1.639
RETAINER, Oil Pump.....	1.609
RETAINER, Radiator and Grille Filler.....	1.287
RETAINER, Radiator Grille & Frt. End (Also See Group 8.055).....	1.303
RETAINER, Radiator Grille Moulding.....	1.269
RIVET, Radiator Grille Moulding.....	1.269
ROTOR, Coolant Pump.....	1.109

### S

SCREEN, Oil Pump Intake.....	1.656
SCREW, Crankcase Ventilator Tube.....	1.750
SCREW, Oil Pan Attaching, with Lockwasher	1.428
SCREW, Oil Pan Drain.....	1.453
SCREW, Radiator Core.....	1.270
SCREW, Radiator Grille and Engine Baffle Attaching.....	1.276
SCREW, Radiator Grille Moulding.....	1.269
SCREW, Radiator Grille.....	1.267
SEAL, Coolant Pump.....	1.123
SEAL, Crankcase.....	1.745
SEAL, Oil Level.....	1.516
SEAL, Oil Pan.....	1.429
SEAL, Rad. Core and Support.....	1.274
SEAL, Radiator and Grille Filler.....	1.287
SEAL, Thermostat Housing.....	1.252
SENDER ASSY., Coolant Temperature (Engine Unit).....	1.150
SENSOR UNIT, Radiator and Recovery Tank..	1.203
SHAFT ASSY., Coolant Pump, with Bearing...	1.105
SHAFT, Oil Pump Shaft.....	1.639
SHIM, Radiator Core.....	1.270
SHROUD, Radiator Fan.....	1.277
SLEEVE, Oil Pump Shaft.....	1.639

## ALPHABETICAL INDEX

SPACER, Coolant Recovery Unit.....	1.240
SPACER, Fan .....	1.064
SPACER, Radiator Core.....	1.270
SPACER, Radiator Grille & Frt. End (Also See Group 8.055) .....	1.303
SPACER, Radiator Grille.....	1.267
SPRING, Oil Filter.....	1.837
SPRING, Oil Pump.....	1.609
STRAP, Radiator Outlet.....	1.173
STRIPE, Radiator Grille & Frt. End (Also See Group 8.055).....	1.303
STUD, Coolant Pump .....	1.073
STUD, Engine Air Fan.....	1.050
STUD, Oil .....	1.652
STUD, Radiator Grille Moulding.....	1.269
STUD, Thermostat Housing.....	1.252
SUPPORT ASSY., Oil Pump Intake .....	1.656
SUPPORT ASSY., Radiator Core.....	1.270
SUPPORT ASSY., Radiator Support .....	1.271
SUPPORT, Front End and Close.....	1.263
SUPPORT, Radiator Grille.....	1.267
SWITCH ASSY., Coolant Temperature (Engine Unit).....	1.150
SWITCH ASSY., Engine Air Auxiliary Cooling.....	1.055
SWITCH, Oil Pressure (See group 9.748 for tell tale windows).....	1.800

### T

TANK, Coolant Recovery Unit.....	1.240
TEE, Crankcase .....	1.745
TEE, Oil Pressure (See group 9.748 for tell tale windows).....	1.800
THERMOSTAT, Radiator and Hot Water Heater .....	1.246
TUBE ASSY., Crankcase .....	1.745
TUBE, Crankcase Ventilator-Outer.....	1.762
TUBE, Oil Level.....	1.516

### V

VALVE ASSEMBLY, Oil Filter.....	1.837
VALVE ASSY., Crankcase.....	1.745
VALVE ASSY., Oil Filter By-Pass.....	1.637
VALVE, Oil Pump.....	1.609
VENTILATOR, Crankcase.....	1.745

### W

WASHER, Crankcase.....	1.745
WASHER, Radiator Core.....	1.270



**COOLANT—GRILLE—OIL SYSTEM**

**1.035 BUMPER, Engine Air Cooling Control**

Not required in this group. See  
group 12.009 ..... 6257945 1 .12

**1.050 CLUTCH ASSY.— STUD, Engine Air Fan**

65-66	Pass. (6 cyl.),				
65	Pass. w/H/Per. (327) (1st design),				
65-67	Pass. (396, 409, 427),				
64-67	Chevelle (396),				
64-66	Chevy w/H.D. Rad.,				
67	Camaro (6 cyl.),				
67-68	Chevy w/Air Cond. (327),				
67	Camaro (396),				
67-68	Pass. w/Air Cond., fan drive (250, 283, 327),				
68	Camaro w/C.A.C. (350),				
68	Pass. w/C.A.C. (396) .....	3916141	1	36.75	(stamped CK) .....
65-67	Chevelle w/C.A.C. (6 cyl.),				
68	Chevy w/C.A.C. (6 cyl.) .....	3871278	1	38.00	fan blade .....
67-68	Pass. w/Sp. H/Per. (427),				
67-68	Chevelle w/Sp. H/Per. (396),				
67-68	Camaro (302),				
68	Camaro w/Sp. H/Per. (396),				
68	Camaro w/C.A.C. (396) .....	3927103	1	36.75	
69	Chevy w/C.A.C. (6 cyl.),				
74	Nova (6 cyl.) w/C.A.C. ....	3927783	1	36.75	fan blade .....
69-70	Camaro w/Sp. H/Per. (396, 454),				
69	Pass. w/C.A.C., Prod. fan drive (6 cyl.),				
69	Camaro w/C.A.C., Prod. Fan Drive (396),				
70	Pass. w/Acc. Fan Drive,				
70	Nova, Chevelle w/Acc. Fan Drive (8 cyl.) (exc. Monte Carlo, Estate Wagon),				
70	Camaro w/Acc. Fan Drive (396, 400 w/4BC) (exc. C.A.C., Sp. H/Per.) .....	3946050	1	38.00	fan blade .....
69	Pass., Chevelle w/Sp. H/Per. (396, 427),				
69	Camaro (302),				
69	Police w/Fan Drive (8 cyl.),				
70	Chevelle w/Sp. H/Per. (396, 454),				
69	Pass. w/Acc. Fan Drive (396, 427) (exc. C.A.C.),				
69	Pass. w/C.A.C., Prod. fan drive (8 cyl.),				
69	Chevelle w/acc. Fan Drive (396) (exc. C.A.C.),				
69	Chevelle w/C.A.C., Prod. Fan Drive,				
69	Chevy w/C.A.C. (8 cyl.),				
69	Camaro w/C.A.C. (6 cyl.),				
69	Camaro w/Prod. Fan Drive (exc. 396),				
70	All w/C.A.C. (8 cyl.)				
71	Camaro w/Sp. H/Per. (350),				
71	Pass., Nova, Monte Carlo, Camaro w/C.A.C. (exc. 454),				
71	Pass., Monte Carlo (454),				
72	All w/63 amp. (8 cyl.) (exc. 402, 454) .....	3991430	1	36.50	
71	Chevelle w/C.A.C. (8 cyl.) (exc. Monte Carlo) .....	3989096	1	35.25	
72-74	All (402, 454) .....	353021	1	37.00	
73-75	All w/61 amp. gen. (8 cyl.) (exc. 454),				
74-75	Nova (8 cyl.),				
74-75	Pass. (350, 400),				
74-75	Chevelle (exc. 454),				
75	Nova, Camaro (6 cyl.) w/C.A.C. .	342753	1	36.50	
75	All (454) .....	343719	1	43.00	fan blade .....

**COOLANT—GRILLE—OIL SYSTEM**

**1.050 CLUTCH ASSY.— STUD, Engine Air Fan (Con't)**

62-69 All ..... 333959 4 .18 **STUD, fan blade clutch to water pump pulley hub (<sup>5</sup>/<sub>16</sub>"— 18— 24 x 1<sup>11</sup>/<sub>16</sub>")— (3.288) .....**

**1.055 MOTOR— LEAD ASSY.— SWITCH ASSY., Engine Air Auxiliary Cooling**

75 Vega, Monza (8 cyl.) w/C.A.C. ... 5044825 1 32.80  
 75 Vega, Monza (8 cyl.) w/C.A.C. ... 4961761 1 .66 **LEAD ASSY. ....**  
 75 Vega, Monza (8 cyl.) w/C.A.C. ... 8992541 1 5.20 **SWITCH ASSY. ....**

**1.060 BEARING— BRACKET, Fan-Idler Arm**

65 Pass. w/Sp. H/Per. (396) ..... 908076 1 5.44 water pump and fan idler, pulley— (4.850) .  
 65 Pass. w/H/Per. (409) (exc. P/S),  
 65 Pass. (409) (exc. H/Per., P/S, C.A.C.) ..... 3786872 1 2.25 **BRACKET, idler— (6.606) .....**

**1.062 PULLEY— REINFORCEMENT, Fan and Water Pump**

*NOTE In some cases double groove pulleys may be used in place of single groove pulleys.*

62 Chevy (4 cyl.) (exc. P/S, C.A.C.),  
 62 Chevy (6 cyl.) (exc. C.A.C.),  
 63-65 Chevy (4 cyl.) (exc. 62 amp. A.C. Gen.),  
 63-65 Chevy (exc. 62 amp. A.C. Gen., P/S, C.A.C., 4 cyl.),  
 64-65 Chevelle (8 cyl.) (exc. Air Cond.),  
 65-66 Pass. (8 cyl.) (exc. 409, Air Cond., 62 amp. A.C. Gen., A.I.R.),  
 65-66 Pass., (6 cyl.) (exc. Air Cond., 62 amp. A.C. Gen., P/S, A.I.R.),  
 66 Chevy w/A.I.R. (6 cyl.) (exc. C.A.C., P.S., 62 amp. gen),  
 66 Chevy w/62 amp. gen., (exc. 8 cyl., C.A.C., P.S.),  
 67-68 Chevelle (8 cyl.) (exc. Air Cond., A.I.R.),  
 67-68 Chevy, Camaro (exc. Air Cond., A.I.R., P/S),  
 67 Pass. (exc. Air Cond., A.I.R., P/S),  
 68 Chevelle w/P.G. (exc. C.A.C.),  
 68 Camaro w/T.H. (exc. C.A.C.),  
 68 All w/T.H. 350 (exc. Air Cond.),  
 68 Chevy, Camaro w/Torque Drive . 3905995 1 11.85 (1 groove) (7<sup>1</sup>/<sub>8</sub>" O.D.) (Note 1) .....  
*NOTE 1 When using 3905995, on some models, it may be necessary to use reinforcement 3720616.*  
 62-67 Chevy w/C.A.C., Custom Air Cond.,  
 65-68 Pass. w/Custom Air Cond. (6 cyl.),  
 67-68 Camaro w/Air Cond. (6 cyl.),  
 68 Chevy, Chevelle w/Acc. Air Cond. (6 cyl.) ..... 3905989 1 11.85 double (5<sup>3</sup>/<sub>4</sub>" O.D.) .....  
 66-67 Chevelle w/A.I.R. (6 cyl.) (exc. C.A.C.),  
 64-67 Chevelle (6 cyl.) (exc. A.I.R., C.A.C.) ..... 3854031 1 12.90 (7<sup>5</sup>/<sub>32</sub>" O.D.) .....  
 65-66 Chevelle w/Air Cond. (6 cyl.) (2nd design),  
 67 Chevelle w/C.A.C. (6 cyl.),  
 68-69 Chevy w/C.A.C. (6 cyl.) ..... 3915975 1 8.20 (6<sup>5</sup>/<sub>16</sub>" O.D.) .....  
 65 Pass. w/Sp. H/Per. (396),  
 66 Pass. w/Sp. H/Per. (427),  
 66 Chevelle (396),  
 66 Chevelle w/62 amp. gen. (396) (exc. Sp. H/Per., C.A.C.) ..... 3765397 1 12.00 idler (4<sup>7</sup>/<sub>8</sub>" O.D.) (stamped 3765397)— (4.850) .....  
 65 Pass. (396) (exc. Sp. H/Per., 62 amp., A.C. Gen., C.A.C.),  
 65 Chevelle (396),  
 67 Chevelle w/Sp. H/Per. (396) (exc. A.I.R.),  
 67 Pass. w/Sp. H/Per. (427) (exc. 62 amp. AC gen., A.I.R.) ..... 3862774 1 16.45 single (7<sup>1</sup>/<sub>8</sub>" O.D.) (stamped 3862774) .....  
 65-67 Pass. (Air Cond. w/T.H.) (exc. A.I.R.),  
 67-68 Chevelle (T.H. 350 w/Air Cond.) (exc. A.I.R.),



**COOLANT—GRILLE—OIL SYSTEM**

**1.062 PULLEY— REINFORCEMENT, Fan and Water Pump (Con't)**

68	Camaro w/C.A.C., T.H. 350 (8 cyl.),				
68	Chevy w/P.G., T.H. 350, C.A.C. (8 cyl.),				
68	Pass. (C.A.C. w/T.H.) (8 cyl.),				
68	Pass. w/Acc. Air Cond. (8 cyl.),				
68	Pass. w/P/S (C.A.C. w/P.G.) (exc. 396),				
68	Pass. w/C.A.C. ....	<b>3995642</b>	1	9.80	double (stamped 3995642) .....
69-70	All (302),				
70-71	All w/Sp. H/Per. (350, 396, 454),				
72-74	All w/Sp. H/Per. (350) .....	<b>3995647</b>	1	7.75	water pump and fan .....
69	All w/Sp. H/Per. (396, 427) .....	<b>3995640</b>	1	8.20	water pump and fan .....
71-75	All w/61 amp. (8 cyl.) (exc. Sp. H/Per.),				
73-74	All (454) .....	<b>3995631</b>	1	7.75	water pump and fan .....
73-74	Chevelle, Nova, Camaro w/P.S. (6 cyl.),				
75	Nova (6 cyl.) w/P.S. ....	<b>329671</b>	1	6.95	water pump and fan (front) .....
75	Chevelle (6 cyl.) w/NB2, C.A.C.,				
75	Nova, Camaro (6 cyl.) (C.A.C. w/P.S.) .....	<b>355777</b>	1	6.95	water pump and fan (front) .....
64-67	Chevelle, Camaro (8 cyl.) (exc. T.H., A.I.R.),				
65	Chevy (327),				
65-66	Pass. w/Air Cond. (exc. T.H., 409),				
65-66	Pass. (396, 427) (exc. Sp. H/Per.),				
66-68	Pass. w/C.A.C. (8 cyl.) (exc. T.H., A.I.R.),				
66	Chevy w/C.A.C. (8 cyl.) (exc. A.I.R.),				
68	Chevy, Chevelle, Camaro (307, 327, 350) .....	<b>3995643</b>	1	9.20	<b>PULLEY ASSY.,</b> water pump and fan (Note 2) .....
65-66	Pass., Chevelle w/Sp. H/Per. (396, 427) .....	<b>3765393</b>	1	27.75	<b>PULLEY ASSY.,</b> w/support, water pump and fan idler— (4.850) .....
65-68	Pass., Chevelle w/Sp. H/Per. (396, 427),				
67	Camaro w/A.I.R. (396),				
68	Chevy, Camaro w/Sp. H/Per. (396) .....	<b>3906656</b>	1	25.75	<b>PULLEY ASSY.,</b> water pump and fan .....
66-68	Chevy, Camaro w/C.A.C. (8 cyl.),				
66-68	Pass., Chevelle (A.I.R. w/Air Cond.) (8 cyl.) (exc. Sp. H/Per.),				
67-68	Camaro (A.I.R. w/Air Cond.) (8 cyl.),				
67-68	Chevy w/A.I.R. (8 cyl.) .....	<b>3906657</b>	1	12.90	<b>PULLEY ASSY.,</b> water pump and fan .....
62-63	Chevy w/Access. C.A.C.,				
62	Chevy w/P/S (exc. Prod. C.A.C.),				
63-66	Chevy w/62 amp. A.C. Gen. (exc. P/S, 8 cyl.),				
63-65	Chevy w/P/S (exc. 4 cyl., C.A.C.),				
65-66	Pass. w/P/S (6 cyl.) (exc. A.I.R., C.A.C., Custom Air Cond.),				
65-66	Pass. w/62 amp. A.C. Gen. (exc. C.A.C., C/Deluxe, 409, P/S),				
66	Chevy w/A.I.R. (6 cyl.),				
66	Chevy w/A.I.R. (8 cyl.) (exc. C.A.C.),				
66	Chevelle, w/A.I.R. (396) (exc. C.A.C.),				
66	Chevelle w/62 amp. (396) (exc. Sp. H/Per., C.A.C.),				
66	Pass. w/A.I.R. (exc. C.A.C.),				
66	Chevelle w/A.I.R. (8 cyl.) (exc. 396),				
67-68	Pass. w/62 amp. (6 cyl.) (exc. P/S., C.A.C.),				
67-68	Pass. w/62 amp. (8 cyl.) (exc. C.A.C.),				

**COOLANT—GRILLE—OIL SYSTEM**

**1.062 PULLEY— REINFORCEMENT, Fan and Water Pump (Con't)**

67-68	Pass., Chevy, Camaro w/P/S (6 cyl.) (exc. A.I.R., C.A.C.),				
67-68	All w/A.I.R. (exc. Air Cond.),				
68	Chevy (exc. C.A.C., T.H., 396),				
68	Camaro w/P/S, P.G., Torque Drive (6 cyl.) (exc. C.A.C.) . . . . .	3900434	1	9.20	PULLEY ASSY. water pump and fan . . . . .
67-68	Camaro (302) . . . . .	3770245	1	16.45	PULLEY ASSY., w/pump and fan . . . . .
69	Pass., Chevelle, Camaro w/C.A.C. (6 cyl.),				
71	Taxi, Police (6 cyl.),				
72	Taxi (6 cyl.) . . . . .	3995648	1	8.50	PULLEY ASSY., water pump and fan . . . . .
69	Chevelle, Camaro (exc. C.A.C., A.T., 8.cyl.),				
69	Pass. w/P/S (6 cyl.) (exc. C.A.C.),				
69	All w/A.T. (6 cyl.) (exc. C.A.C., P/S),				
70	Nova w/Torque Drive, P.G. (exc. 8 cyl.),				
70	Nova (4 cyl.) . . . . .	3927796	1	10.05	PULLEY ASSY., water pump and fan . . . . .
69-70	All (8 cyl.) (exc. C.A.C., Sp. H/Per., 302),				
71-75	All (8 cyl.) (exc. Sp. H/Per., 61 amp., 454, Monza) . . . . .	330556	1	7.15	PULLEY ASSY., water pump and fan . . . . .
69	Chevelle w/Air Cond. (8 cyl.),				
69	Chevy, Camaro w/Acc. Air Cond. (396),				
69	Pass. w/Acc. Air Cond. (427),				
69	Pass., Chevy, Camaro w/C.A.C. (8 cyl.),				
70	All w/Air Cond. . . . .	3995631	1	7.75	PULLEY ASSY., water pump and fan . . . . .
69	All w/Acc. Air Cond. (6 cyl.),				
70	All (6 cyl.),				
71	All (6 cyl.) (exc. Taxi, Police),				
72	All (6 cyl.) (exc. Taxi, NB2),				
73-74	All (6 cyl.) (exc. C.A.C.) . . . . .	3995646	1	8.50	PULLEY ASSY., water pump and fan . . . . .
72	All w/NB2 (6 cyl.) . . . . .	326304	1	11.85	PULLEY ASSY., water pump and fan . . . . .
74	Nova (6 cyl.) w/C.A.C. . . . .	3915975	1	8.20	PULLEY ASSY. . . . .
75	All (6 cyl.) . . . . .	355776	1	8.50	PULLEY ASSY., water pump and fan . . . . .
75	All (454) . . . . .	351680	1	9.20	PULLEY ASSY., water pump and fan . . . . .
75	Monza (exc. Town Cpe.) (262) w/C.A.C.,				
75	Monza Town Cpe. (8 cyl.) . . . . .	360435	1	10.80	PULLEY ASSY., water pump and fan . . . . .
75	Monza (exc. Town Cpe.) (262) (exc. C.A.C.) . . . . .	354374	1	10.05	PULLEY ASSY., water pump and fan . . . . .
62-68	All . . . . .	3720616	1	.84	REINFORCEMENT (cup shape- <sup>1</sup> / <sub>4</sub> " deep- <sup>3</sup> / <sub>2</sub> " O.D. x <sup>5</sup> / <sub>8</sub> " I.D. w/four <sup>11</sup> / <sub>32</sub> " holes) (Note 3) . . . . .

NOTE 2: Used with (1st design) pump unit incorporating Shaft Assy. 954860-4<sup>11</sup>/<sub>16</sub>" O.L.-stamped 885118.  
 NOTE 3: Pumps having fan and pulley hub pressed to .348 dim. must use this reinforcement when replacing pump with pressed dim. of .288.

**1.064 BLADE ASSY.— SPACER, Fan**

NOTE Original equipment fans may be replaced by fans with additional blades, higher strength material or composite bolt circles.

62-68	Chevy (6 cyl.) (exc. C.A.C.),				
62-64	Chevy w/C.A.C. (4 cyl.),				
64-65	Pass., Chevy, Chevelle (exc. 327, Air Cond., fan drive equip., 4/BC),				
66-68	All (exc. C.A.C., Sp. H/Per. fan drive equip., 302, 396),				
68	Chevelle w/H.D. Rad. (exc. fan drive, 396, 327 w/Sp. H/Per.),				
68	Chevelle w/Sp. H/Per. (327) (exc. C.A.C., fan drive) . . . . .	3839282	1	5.60	(17 <sup>5</sup> / <sub>8</sub> " dia., 4 blades— 1 <sup>3</sup> / <sub>4</sub> " bolt circle— <sup>5</sup> / <sub>8</sub> " hub hole) . . . . .
62-67	Chevy w/C.A.C. (6 cyl.),				
64-65	Chevelle w/C.A.C. (6 cyl.) (1st design),				
65-68	Chevy, Chevelle w/Acc. Air Cond. (6 cyl.),				
68	Police,				
64	Chevelle w/Custom Deluxe (283) (exc. 4BC, fan drive equip.),				
62-67	Chevy w/C.A.C. (6 cyl.),				

**COOLANT—GRILLE—OIL SYSTEM**

**1.064 BLADE ASSY.— SPACER, Fan (Con't)**

64-65	Chevelle w/C.A.C. (6 cyl.) (1st design),				
65-68	Chevy, Chevelle w/Acc. Air Cond. (6 cyl.),				
68	Police,				
64-68	Chevy, Chevelle w/Custom Air Cond. (283, 307),				
65	Taxi,				
65-66	Pass. w/Custom (283),				
66-68	Pass.,				
68	Camaro,				
69-70	Police (exc. C.A.C., Fan Drive),				
69-70	All w/Acc. Fan Blade (exc. Police),				
69	Chevy (396),				
70	Nova (396) (exc. Sp. H/Per.) . . . . .	3990936	1	13.90	
64	Chevy, Chevelle w/4/BC, fan drive, Air Cond.,				
65-66	Chevy, Chevelle (327, 396),				
65-66	Chevy, Chevelle w/C.A.C. (exc. 327),				
65-68	Chevy, Chevelle, Camaro w/fan drive (8 cyl.),				
65-68	Pass. w/C.A.C., Cool Pack, Fan Drive Equip. (8 cyl.),				
65-66	Pass. (327, 409, 427),				
67-68	Chevy, Chevelle w/C.A.C. (8 cyl.),				
67-68	Camaro w/C.A.C.,				
67	Camaro (396),				
68	Chevelle w/C.A.C. (6 cyl.),				
68	Pass. w/C.A.C. (396, 427),				
68	Chevy w/C.A.C. (307),				
68	Camaro w/C.A.C. (8 cyl.) (exc. 396),				
68	Chevelle w/C.A.C. (8 cyl.) (exc. 327 w/Sp. H/Per.),				
68	Chevelle w/Sp. H/Per. (327) (exc. C.A.C.) . . . . .	3931002	1	15.00	(18" dia.— 7 blades) . . . . .
68	Chevelle (exc. C.A.C., H.D. Rad., fan drive, 396, 327 w/Sp. H/Per.) . . . . .	3927166	1	6.05	fan . . . . .
69	Chevy (exc. C.A.C., 396, 4 cyl.),				
69	Chevelle, Camaro (exc. C.A.C., fan drive),				
69	Pass. (6 cyl.) (exc. C.A.C., Fan Drive),				
69	Pass. (8 cyl.) (exc. Police, Sp. H/Per.),				
70	Pass. (8 cyl.) (exc. C.A.C., Police, H/Per. 454),				
70	Nova w/Sp. H/Per. (396),				
70-71	Nova (8 cyl.) (exc. C.A.C., 396),				
70	Chevelle, Camaro (8 cyl.) (exc. Monte Carlo, C.A.C., Sp. H/Per. 396, 454),				
70	Monte Carlo (exc. C.A.C., 454),				
71	Taxi, Police (6 cyl.),				
71	Monte Carlo (350) (exc. C.A.C.),				
72	Taxi (6 cyl.),				
72-73	Camaro (8 cyl.) (exc. C.A.C., Sp. H/Per.),				
72-73	Nova (8 cyl.) (exc. C.A.C.),				
72	Chevelle (402, 454),				
72	Monte Carlo (350) (exc. 4BC, C.A.C.) . . . . .	3927791	1	6.55	(17 <sup>5</sup> / <sub>8</sub> " dia. 4 blades) . . . . .
69-70	Chevy (153) . . . . .	487201	1	6.20	fan (16" dia.— 4 blades) . . . . .
65-67	Chevelle w/C.A.C. (6 cyl.) (2nd design),				
67-68	Camaro (302),				
68	Chevy w/C.A.C. (6 cyl.),				
68	Camaro w/C.A.C., fan drive (396),				
68	All w/Sp. H/Per. (396, 427),				
69	Pass. w/Acc. Air Cond. (6 cyl.),				

**COOLANT—GRILLE—OIL SYSTEM**

**1.064 BLADE ASSY.— SPACER, Fan (Con't)**

69	Chevelle w/C.A.C.,				
69	Chevy, Camaro w/C.A.C. (exc. Torque Drive, P.G., T.H. 350),				
69	Chevy, Camaro (Spt. Cpe., Conv.) w/C.A.C., A.T. (350),				
69	Chevelle w/fan drive (8 cyl.),				
69	Camaro w/Fan Drive (exc. 396),				
69	Chevelle, Camaro w/Acc. Fan Drive (396) (exc. C.A.C.),				
69	Pass., Chevelle, Camaro w/Sp. H/Per. (302, 396, 427),				
69	Pass. w/C.A.C., Fan Drive (327, 350, 427),				
70	All w/C.A.C. (8 cyl.),				
70	Chevelle, Camaro w/Sp. H/Per. (350, 396),				
70	Camaro w/Sp. H/Per. (454) . . . . .	<b>393996</b>	1	21.90	(18" dia.— 7 blades) . . . . .
69-70	Police (exc. C.A.C., Fan Drive),				
69-70	All w/Acc. Fan Blade (exc. Police),				
69	Chevy (396),				
70	Nova (396) (exc. Sp. H/Per.),				
70	Pass. (6 cyl.) (exc. Police),				
70	Nova, Chevelle, Camaro (6 cyl.),				
71-75	All (6 cyl.) (exc. Taxi, Police, C.A.C.) . . . . .	<b>483611</b>	1	6.95	(17 <sup>5</sup> / <sub>8</sub> " dia.— 4 blades) . . . . .
70	Pass., Monte Carlo w/H/Per. (454),				
70	Chevelle w/Sp. H/Per. (454),				
71	Nova, Monte Carlo, Camaro w/C.A.C. (8 cyl.),				
72	Camaro (C.A.C. w/4BC) (350, 402) (exc. Sp. H/Per.),				
72	Nova, Monte Carlo w/C.A.C. (8 cyl.) . . . . .	<b>3999266</b>	1	13.55	(18" dia.— 7 blades) . . . . .
71	Chevelle (307, 350, 400) (exc. C.A.C., Monte Carlo),				
71-72	Pass. (350, 400, 402) (exc. C.A.C., 63 amp. Taxi, Police),				
72	Chevelle (307, 350) (exc. 63 amp., Monte Carlo),				
73-75	Pass., Chevelle (8 cyl.) (exc. 61 amp., 454, Taxi, Police) . . . . .	<b>3989093</b>	1	6.20	19" dia.— 4 blades . . . . .
71-72	All w/Sp. H/Per. (350, 454) (exc. Monte Carlo),				
72-73	Camaro w/C.A.C. (307, 350) (exc. 4BC),				
73	Camaro w/4BC (350),				
74-75	Camaro w/flex fan . . . . .	<b>330533</b>	1	20.30	(18" dia.— 7 blades) . . . . .
71	Chevelle w/C.A.C. (8 cyl.) (exc. Monte Carlo) . . . . .	<b>3989095</b>	1	12.20	19 <sup>1</sup> / <sub>2</sub> " dia.— 7 blades . . . . .
71-74	Chevelle w/63 amp., C.A.C. (307, 350) (exc. Monte Carlo),				
71-74	Taxi, Police (8 cyl.) (exc. C.A.C.),				
71-74	Pass. w/C.A.C. (8 cyl.),				
73-74	Nova w/flex fan,				
75	Chevelle (350, 400) w/61 amp.,				
75	Pass. (350, 400) w/61 amp. (exc. 454, Taxi, Police),				
75	Pass., Chevelle (454),				
75	Taxi, Police (exc. 61 amp.),				
75	Nova w/engine fan clutch . . . . .	<b>3991431</b>	1	18.50	(19 <sup>1</sup> / <sub>2</sub> " dia.— 7 blades) . . . . .
71-75	Vega, Monza w/C.A.C., H.D. Rad. (exc. 262) . . . . .	<b>7811403</b>	1	15.75	fan (Note 1) . . . . .
71-75	Vega, Monza (exc. C.A.C., H.D. Rad., 262),				
75	Vega, Monza (122) . . . . .	<b>3994290</b>	1	6.70	fan (Note 1) . . . . .
74-75	All (6 cyl.) w/C.A.C. . . . . .	<b>3947772</b>	1	11.60	(18" dia.— 7 blades) . . . . .
74-75	Nova, Camaro (350) (exc. C.A.C., Sp. H/Per.) . . . . .	<b>3947890</b>	1	6.40	(18" dia.— 4 blades) . . . . .
75	Nova w/flex. fan . . . . .	<b>496249</b>	1	29.75	(19" dia.— 7 blades) (flexible type) . . . . .
75	Vega, Monza (262) . . . . .	<b>367138</b>	1	25.25	fan (Note 1) . . . . .
<i>NOTE 1: Original equipment fans may be replaced by fans with additional blades, higher strength material or composite bolt circles.</i>					
75	Vega, Monza (8 cyl.) w/C.A.C. . . . .	<b>4961755</b>	1	18.25	auxiliary engine cooling . . . . .

**COOLANT—GRILLE—OIL SYSTEM**

<b>1.064</b>		<b>BLADE ASSY.— SPACER, Fan</b>		<b>(Con't)</b>	
62	Chevy	3740523	1	.81	SPACER, fan pulley (27/16" O.D. x 41/64" I.D.)
65-67	Pass. (6 cyl.) (exc. Fan drive),				
68	Chevy, Camaro (8 cyl.) (exc. C.A.C., Fan Drive, 396),				
68	Chevelle (8 cyl.) (exc. C.A.C., fan drive, H.D. Rad. 396)	3857041	1	1.80	SPACER (2 3/8" O.D. x 1 45/64" thick)
65	Pass. (283) (exc. C.A.C., Fan Drive Equip.),				
66	Chevy (8 cyl.) (exc. Sp. H/Per., C.A.C., fan drive),				
66	Pass. w/A.I.R. (396) (2nd design) (exc. H.D. Rad.),				
66	Pass., Chevelle (283, 327) (exc. C.A.C., fan drive equip.),				
67	Pass. w/H.D. Rad. (396, 427),				
67	Pass. w/A.I.R. (396, 427) (exc. H.D. Rad., C.A.C.),				
67-68	Chevy (8 cyl.) (exc. C.A.C.),				
67-68	Camaro (exc. fan drive, 396),				
67-68	Pass., Chevelle (283, 327) (exc. C.A.C., A.I.R., fan drive equip.)	3814241	1	1.70	SPACER (2 3/8" O.D. x 2" thk.)
65-68	Pass., Chevelle (396, 427) (exc. Sp. H/Per., A.I.R., H.D. Rad., fan drive equip.),				
67-68	Camaro (6 cyl.),				
71-75	Vega, Monza (140)	3994248	1	2.15	SPACER (2 5/16")
65-67	Pass. (6 cyl.),				
65-66	Pass. w/P.G. (8 cyl.) (exc. C.A.C., Fan Drive),				
65-66	Pass. w/H.D. Rad. (396, 427) (exc. Sp. H/Per., Fan Drive),				
65	Chevy (exc. 8 cyl.),				
65	Chevelle (6 cyl.),				
66	Chevelle w/H.D. Rad., A.I.R. (396) (exc. fan drive),				
66	Pass. w/A.I.R. (396, 427) (1st design) (exc. Fan Drive, H.D. Rad.),				
67-68	Chevelle w/A.I.R. (396) (exc. H.D. Rad., Air Cond., fan drive),				
68	Camaro (396)	3857042	1	1.35	SPACER (1 19/64" thick)
68	Chevy (4 cyl.)	3775612	1	2.65	SPACER, fan blade
69	Pass. (6 cyl.) (exc. C.A.C. Fan Drive),				
69	Chevelle (307),				
69	Chevelle w/C.A.C., P.G., 2/BC, T.H. 350 (350),				
70	Pass., Camaro (6 cyl.),				
70	Chevelle (8 cyl.) (exc. C.A.C., A.T., 396, 400 w/4BC, 454),				
70	Camaro (307, 350) (exc. Sp. H/Per., C.A.C.),				
71-72	Camaro (6 cyl.),				
71	Pass. (8 cyl.) (exc. C.A.C., A.T., 63 amp., 454),				
71	Chevelle, Camaro (307, 350) (exc. Sp. H/Per., C.A.C., Monte Carlo),				
71	Monte Carlo (350, 400 w/2BC) (exc. A.T., C.A.C.),				
72	Camaro (307, 350) (exc. Sp. H/Per., C.A.C.),				
72	Chevelle (307),				
72	Monte Carlo (350 w/2BC),				
73	Chevelle (307) (exc. 61 amp.),				
73-74	Camaro (6 cyl.),				
75	Nova, Camaro (6 cyl.) (exc. fan clutch),				
75	Nova, Camaro (8 cyl.) (exc. Sp. H/Per., flexible engine fan)	3927794	1	2.40	SPACER
69-70	Chevy (exc. C.A.C. 153, 396),				
69	Camaro (exc. C.A.C., Fan Drive, 302, 396 w/Sp. H/Per.),				

**COOLANT—GRILLE—OIL SYSTEM**

**1.064 BLADE ASSY.— SPACER, Fan (Con't)**

69	Chevelle w/P.G., T.H. 350 (8 cyl.) (exc. C.A.C., Fan Drive, 396),				
69-70	Chevelle (396) (exc. C.A.C., Fan Drive, Sp. H/Per.),				
69	Pass. (8 cyl.) (exc. C.A.C., Fan Drive, Sp. H/Per.),				
70	Chevelle (400) (exc. C.A.C.),				
70	Malibu (454) (exc. Sp. H/Per., C.A.C.),				
70	Camaro w/H/Per. (396),				
70	Chevelle w/A.T., 2BC (350) (exc. C.A.C.),				
70	Pass. (8 cyl.) (exc. C.A.C.),				
71	Nova (exc. C.A.C.),				
71	Chevelle, Camaro (400) (exc. C.A.C.),				
71	Malibu (454) (exc. Sp. H/Per., C.A.C.),				
71	Pass. (8 cyl.) w/A.T. (exc. Taxi, C.A.C., 63 amp.),				
72	Nova (8 cyl.),				
72	Camaro (402) (exc. C.A.C.),				
72	Chevelle (8 cyl.) (exc. 307, Monte Carlo),				
72	Monte Carlo (exc. 350 w/2BC),				
72	Pass. w/A.T. (8 cyl.) (exc. Police, 454, Taxi, C.A.C., 63 amp.),				
73-75	Nova (8 cyl.) (exc. C.A.C., 4-Spd.),				
73-75	Chevelle (350, 400) (exc. 61 amp.),				
73-75	Pass. (8 cyl.) (exc. Police, 454, Taxi, 61 amp.)	3927792	1	2.65	SPACER
69	Chevy w/reg. fuel (350) (exc. C.A.C., A.T.),				
69	Chevelle (exc. C.A.C., A.T., Fan Drive, 396),				
70	Chevelle (6 cyl.),				
71	Pass., Chevelle (6 cyl.),				
72-74	Pass., Chevelle (6 cyl.) (exc. Taxi),				
75	Chevelle (6 cyl.) (exc. C.A.C.)	3927793	1	2.60	SPACER, fan blade
72	Taxi (6 cyl.) (exc. 63 amp.),				
75	Nova, Camaro w/flexible engine fan	3947132	1	2.25	SPACER
75	Vega, Monza (8 cyl.)	360476	1	3.05	SPACER, fan blade

## COOLANT—GRILLE—OIL SYSTEM

### 1.066 BELT, Fan, Gen. and Accessory Drive

*NOTE: See Dealer Price Schedule for applicable prices.*

Belt No.	Length	Belt No.	Length	Belt No.	Length
3880802	30	9433735	41 1/2*	3932330	52 1/4
3953733	31	9433737	42 1/2*	9433759	53 1/2*
3935420	32 1/2	9433738	43*	3845654	53 3/4*
9433716	32*	9433739	43 1/2*	9433760	54*
9433718	32 3/8*	3953778	43 1/4	9433761	54 1/2*
9433722	34 3/8	3953786	44	9433762	55*
9433723	35 1/2*	9433741	44 1/2*	3919824(1)	55
9433725	36 1/2*	9433742	45*	3847711	55 1/4*
—	—	3937790	45 1/2	9433764	56*
3962068	37 19/64	3999272	45 3/4*	3780981	55 3/4
9433728	37 1/2	3953787	47 1/4	3917208	56
6263721	38	9433746	47*	9433766	57*
3915962	38	9433748	47*	9433769	58 1/2*
9433730	39*	—	—	3946065	57*
—	—	3887104	48 1/2	9433766	57*
6262854	38 1/2*	9433750	49*	9433768	58*
3888458(1)	39	9433752	50*	3866956(1)	58 1/2
9433732	40*	3909819	49 1/2	9433769	58 1/2*
3849337	40 1/2	9433753	50	3879951	59
9433733	40 1/2*	9433756	51 1/2*	9433771	59
9433734	41*	3881871	52	9775522	60 1/2*
3849258	41	9433757	52 1/2*	—	—

(1) Belt Unit  
\*15/32" wide

*NOTE: Code letters shown under the heading Driven Pulleys indicate the pulleys which the belt drives. Codes are as follows:*

*W— Water Pump and Fan, G— Generator, P— Power Steering Pump, B— Blower  
A— Air Susp. Comp., C— Air Cond. Comp., I— Idler, X— Air Injection Reactor, F— Fan.*

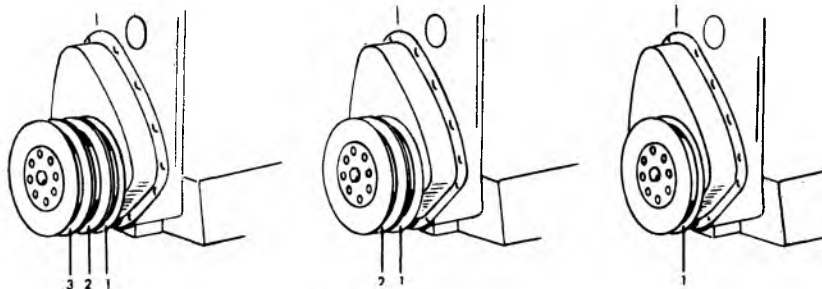

**(4 and 6 cylinder) Drive Pulley, (Crankshaft) Groove No. 1, (1, 2 or 3 pulley systems)**

	Dimensions	Driven Pulleys			
62	Chevy (exc. Air Cond.),				
62	Chevy w/Air Cond. (4 cyl.) (exc. P/S, AC gen.)	(15/32— 41)	G, W	9433734	1
62-63	Chevy w/42-52 amp. A.C. Gen. (6 cyl.) (exc. Air Cond., P/S),				
62	Chevy w/42-52 amp. A.C. Gen. (4 cyl.) (exc. P/S),				
62	Chevy (Taxi) w/42 amp. A.C. Gen. (6 cyl.) (exc. P/S),				
64-65	Chevy (4 cyl.) (exc. 62 amp.)				
66-67	Chevy (4 cyl.)	(3/8— 41)	G, W	3849258	1
62	Chevy (42-52 amp. A.C. Gen. w/P/S),				
63	Chevy w/P/S (4 cyl.),				

**COOLANT—GRILLE—OIL SYSTEM**

**1.066 BELT, Fan, Gen. and Accessory Drive (Con't)**

63	Chevy (P/S w/Prod. C.A.C.) (6 cyl.),				
63	Chevy (P/S w/62 amp.) (6 cyl.),				
64-67	Chevy, Chevelle, Camaro w/P/S (6 cyl.) (exc. A.I.R.)		G, P, W		
65-67	Pass. w/P/S (exc. 62 amp., A.I.R.)		F, P, G		
66-67	Chevy w/A.I.R. (6 cyl.),				
66-67	Chevelle, Camaro w/A.I.R. (6 cyl.) (exc. P/S),				
66-67	Pass. w/A.I.R. (6 cyl.) (exc. P/S)	( <sup>3</sup> / <sub>8</sub> — 49 <sup>1</sup> / <sub>2</sub> )	X, F, G	3909819	1
62	Chevy w/62 amp. A.C. Gen.,				
64	Chevy, Chevelle (6 cyl.) (exc. P/S, Air Cond., 62 amp. A.C. Gen.),				
65-66	Chevy, Chevelle (6 cyl.) (exc. 62 amp., C.A.C.),				
64-66	Chevelle w/Air Cond. (6 cyl.) (exc. P/S, 62 amp., A.I.R.),				
65-67	Pass. (exc. 62 amp., C.A.C.),				
65-66	Pass. w/Air Cond. (6 cyl.) (exc. 62 amp., P/S, A.I.R.),				
67	Chevelle, Camaro w/C.A.C. (6 cyl.) (exc. P/S, A.I.R.),				
67	Chevelle, Camaro, Chevy (6 cyl.) (exc. C.A.C.),				
67	Pass. w/C.A.C. (exc. A.I.R., P/S),				
67	Pass. (exc. C.A.C., 62 amp. gen.)	( <sup>3</sup> / <sub>8</sub> — 38 <sup>1</sup> / <sub>2</sub> )	G, W, C	9433730	1
62	Chevy w/P/S, (exc. 42-52 amp. A.C. Gen.),				
64-66	Chevelle (Access Air Cond. w/P/S),				
65-66	Pass. (Access. Air Cond. w/P/S)	( <sup>3</sup> / <sub>8</sub> — 48 <sup>1</sup> / <sub>2</sub> )	G, P, W	3887104	1
63-66	Chevy w/Access. Air Cond. (4 cyl.),				
63	Chevy w/Air Cond. (6 cyl.) (exc. P/S, 62 amp. A.C. Gen.)	( <sup>15</sup> / <sub>32</sub> — 40)	G, W	9433732	1
63	Chevy (62 amp. A.C. Gen. w/C.A.C.) (6 cyl.),				
64-66	Chevelle (62 amp. A.C. Gen. w/Air Cond.) (6 cyl.),				
65-66	Pass. (Air Cond., w/62 amp.) (6 cyl.) (exc. P/S, A.I.R.),				
67	Pass. (C.A.C. w/62 amp. gen.) (exc. P/S)	( <sup>15</sup> / <sub>32</sub> — 39)	G, W	9433730	1
63	Chevy w/P/S (6 cyl.) (exc. C.A.C.),				
66-67	Chevy, Chevelle, Camaro (A.I.R. w/P/S) (6 cyl.),				
65-66	Pass. (P/S w/Air Cond., A.I.R.) w/62 amp.,				
67-69	Pass. (P/S w/A.I.R.)	( <sup>3</sup> / <sub>8</sub> — 50)	G, P, W	9433753	1
63	Chevy w/62 amp. A.C. Gen. (exc. C.A.C., P/S),				
64-66	Chevy w/62 amp. A.C. Gen. (4 cyl.)	( <sup>3</sup> / <sub>8</sub> — 40 <sup>1</sup> / <sub>2</sub> )	G, W	3849337(1)	1
64-66	Chevy (62 amp. AC gen. w/C.A.C.) (6 cyl.)	( <sup>3</sup> / <sub>8</sub> — 38)	G, W	6263721	1
64-66	Chevy w/C.A.C. (6 cyl.) (exc. P/S, 62 amp. A.C. Gen.),				
65-67	Chevy, Chevelle, Camaro w/Air Cond.,				
67	Chevy, w/C.A.C. (6 cyl.) (exc. P/S),				
65	Pass. (exc. P/S)	( <sup>3</sup> / <sub>8</sub> — 37 <sup>1</sup> / <sub>2</sub> )	G, W	9433728	1
64-66	Chevy, Chevelle w/62 amp. A.C. Gen. (6 cyl.) (exc. C.A.C., P/S),				
65-67	Pass. w/62 amp. (exc. Air Cond., P/S)	( <sup>3</sup> / <sub>8</sub> — 39)	G, W	3888458(1)	1



**COOLANT—GRILLE—OIL SYSTEM**

**1.066 BELT, Fan, Gen. and Accessory Drive (Con't)**

<b>66-67</b>	Chevy, Chevelle, Camaro (A.I.R. w/P/S) (6 cyl.) . . . . .	( <sup>3</sup> / <sub>8</sub> — 30)	X	3880802 <sup>(?)</sup>	1
--------------	--	-------------------------------------	---	------------------------	---

*(<sup>1</sup>) Belt unit consists of two matched belts to be used on No. 1 and 2 crankshaft pulleys.*

*(<sup>2</sup>) Used on P/S and A.I.R. pumps.*

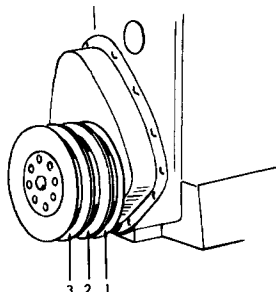

**(4 and 6 cylinder) Drive Pulley, (Crankshaft) Groove No. 2 (2 or 3 pulley systems)**

		Dimensions	Driven Pulleys		
<b>62</b>	Chevy w/P/S (exc. A.C. gen., Air Cond.) . . . . .	(1 <sup>15</sup> / <sub>32</sub> — 41)	G, W	9433734	1
<b>62</b>	Chevy (Taxi) (42 amp. A.C. Gen. w/P/S) (4 cyl.) . . . . .	(3/8— 41)	G, W	3849258	1
<b>62</b>	Chevy w/Access. C.A.C.,				
<b>63</b>	Chevy w/Access. C.A.C. (4 cyl.),				
<b>63</b>	Chevy w/Access. C.A.C. (6 cyl.) (1st design),				
<b>64-67</b>	Chevelle, Camaro w/Prod. Air Cond. (6 cyl.),				
<b>65-67</b>	Pass. w/Air Cond. . . . .	(1 <sup>15</sup> / <sub>32</sub> — 54 <sup>1</sup> / <sub>2</sub> )	W, C	9433761	1
<b>63</b>	Chevy w/Prod. Air Cond. (6 cyl.),				
<b>63</b>	Chevy w/Access Air Cond. (6 cyl.) (2nd design),				
<b>64-65</b>	Chevy w/C.A.C.,				
<b>64-67</b>	Chevy, Chevelle, Camaro w/Access. Air Cond.,				
<b>65-67</b>	Pass. w/Access. Air Cond. (exc. 62 amp.) . . . . .	(1 <sup>15</sup> / <sub>32</sub> — 53 <sup>3</sup> / <sub>4</sub> )	W, C	3845654	1
<b>63</b>	Chevy (62 amp. A.C. Gen. w/P/S) (6 cyl.) . . . . .	(1 <sup>15</sup> / <sub>32</sub> — 40 <sup>1</sup> / <sub>2</sub> )	G, W	9433733	1
<b>64-66</b>	Chevy (62 amp. A.C. Gen. w/P/S) (6 cyl.) (exc. C.A.C.),				
<b>65-67</b>	Pass. (P/S w/62 amp.) (exc. Air Cond.), . . . . .				
<b>64-66</b>	Chevy, Chevelle (6 cyl.) (exc. 62 amp. A.C. Gen., C.A.C.) . . . . .	(1 <sup>15</sup> / <sub>32</sub> — 39)	G, W	9433730	1
<b>66-67</b>	Chevy, Chevelle (A.I.R. w/P/S) (6 cyl.) . . . . .	(3/8— 30)	X	3880802 <sup>(1)</sup>	1

*(<sup>1</sup>) Used on P/S and A.I.R. pumps.*

**COOLANT—GRILLE—OIL SYSTEM**

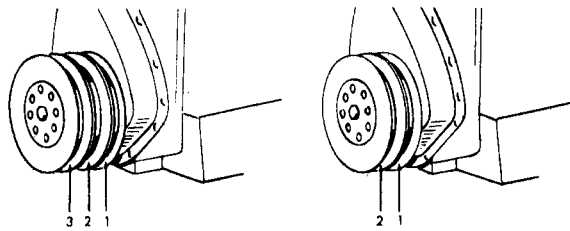

**(4 and 6 cylinder) Drive Pulley, (Crankshaft) Groove No. 3, (3 pulley systems)**

	Dimensions	Driven Pulleys		
<b>64-67</b> Chevelle, Camaro (C.A.C. w/P/S) (6 cyl.) (exc. A.I.R.),				
<b>66</b> Chevelle (A.I.R. w/C.A.C.) (6 cyl.) (exc. 62 amp., P/S),				
<b>67</b> Chevelle, Camaro (A.I.R. w/C.A.C.),				
<b>65-66</b> Pass. (Prod. Air Cond., C.A.C. w/P/S) (exc. 62 amp., A.I.R.),				
<b>67</b> Pass. (A.I.R. w/C.A.C.),				
<b>67</b> Pass. (P/S w/C.A.C.) (exc. A.I.R.)	( <sup>15</sup> / <sub>32</sub> — 32)	G	9433716	1
<b>66</b> Chevelle w/A.I.R. (62 amp. w/C.A.C.),				
<b>65-67</b> Pass. (Air Cond. w/P/S) w/62 amp.	( <sup>15</sup> / <sub>32</sub> — 32 <sup>3</sup> / <sub>4</sub> )	G	9433718	1
<b>66-67</b> Pass. (P/S w/A.I.R.) (6 cyl.)	( <sup>2</sup> / <sub>8</sub> — 30)	X, P	3880802	1

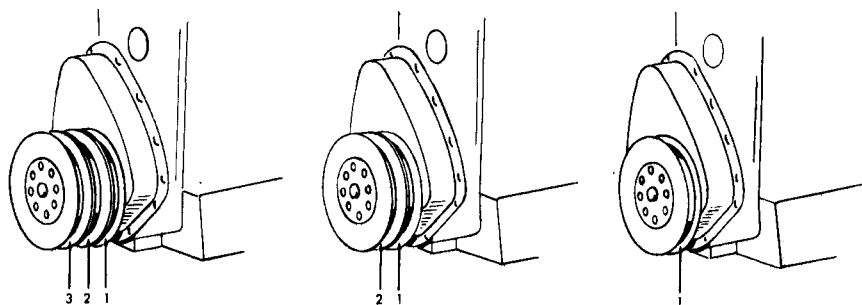

**(8 cylinder) Drive Pulley, (Crankshaft) Groove No. 1, (1, 2, or 3 pulley systems)**

**COOLANT—GRILLE—OIL SYSTEM**

**(8 cylinder) Drive Pulley, (Crankshaft) Groove No. 1, (1, 2, or 3 pulley systems)**

	Dimensions	Driven Pulleys		
64-66 Chevy (62 amp. A.C. Gen. w/C.A.C.) (283) . . . . .	( <sup>3</sup> / <sub>8</sub> — 55)	G, W	9433762	1
64 Chevelle w/Air Cond. (283) (exc. 62 amp. A.C. Gen.) . . . . .	( <sup>3</sup> / <sub>8</sub> — 54 <sup>1</sup> / <sub>2</sub> )	G, W	9433761	1
64-66 Chevelle w/62 amp. AC gen. (283, 327),				
65-66 Chevy (62 amp. AC gen. w/C.A.C.) (327),				
65-66 Pass. (Air Cond., w/62 amp.) (exc. 396, 409, 427) . . . . .	( <sup>15</sup> / <sub>32</sub> — 55 <sup>1</sup> / <sub>4</sub> )	G, W	3847711	1
64-65 Chevy w/62 amp. A.C. Gen. (283) (1st design) (exc. C.A.C., P/S),				
65 Pass. (396) (exc. C.A.C., 62 amp.),				
66 Pass. (427) (exc. Sp. H/Per.),				
66 Pass. w/Sp. H/Per. (427) (exc. 62 amp.),				
66 Chevelle w/Sp. H/Per. (396) (exc. 62 amp.),				
67 Camaro w/A.I.R. (396) . . . . .	( <sup>3</sup> / <sub>8</sub> — 55 <sup>1</sup> / <sub>2</sub> )	G, W	9433764	1
64-66 Chevy w/Air Cond. (283) (exc. 62 amp. Gen.) . . . . .	( <sup>3</sup> / <sub>8</sub> — 52 <sup>1</sup> / <sub>2</sub> )	G, W	3932330	1
64-66 Chevelle w/Air Cond. (exc. P/S, 62 amp. AC gen.),				
64-66 Chevy, Chevelle (283, 327) (exc. 62 amp. AC gen., Air Cond.),				
64-66 Chevelle (Air Cond. w/P/S) (283, 327) (exc. 62 amp. AC gen.),				
65-67 Pass. (exc. 62 amp., 396, 409, 427),				
67 Camaro (302) . . . . .		G, W		
65-66 Chevy w/C.A.C. (327) (exc. 62 amp.),				
67 Chevy, Chevelle, Camaro (exc. 396) . . . . .		G		
67 Chevy, Chevelle, Camaro w/Acc. Air Cond. (283, 327) . . . . .	( <sup>3</sup> / <sub>8</sub> — 53)	C, G	9433759	1
65 Pass. (62 amp. w/Air Cond., P/S) (409), . . . . .				
65 Pass. w/H/Per. (409) (exc. 62 amp.), . . . . .				
65 Pass. (409) (exc. H/Per., dual 4BC, 62 amp.), . . . . .				
66 Chevelle w/62 amp. (exc. 396), . . . . .				
66 Chevelle (62 amp. w/Sp. H/Per.) (396), . . . . .				
66 Pass. (62 amp. w/Sp. H/Per.) (396, 427) . . . . .	( <sup>3</sup> / <sub>8</sub> — 58)	G, W	9433769	1
65-67 Pass. (62 amp. w/C.A.C.) (396, 427),				
66 Chevelle (62 amp. w/C.A.C.) (396) (exc. Sp. H/Per.) . . . . .	( <sup>3</sup> / <sub>8</sub> — 59)	G, W	9433771	1
65 Pass. w/62 amp. (409) (exc. Air Cond.) . . . . .	( <sup>15</sup> / <sub>32</sub> — 57)	G, W	9433766	1
65 Pass. (396) (exc. 62 amp., C.A.C.),				
65 Pass. w/C.A.C. (396) (exc. 62 amp., T.H.),				
65-66 Pass. w/T.H. (exc. C.A.C., 62 amp.),				
66 Pass. w/C.A.C. (396, 427) (exc. 62 amp.),				
66 Chevelle w/C.A.C. (396) (exc. 62 amp., A.I.R.),				

**COOLANT—GRILLE—OIL SYSTEM**

**1.066 BELT, Fan, Gen. and Accessory Drive (Con't)**

67	Pass. w/C.A.C. (396, 427) (exc. T.H.),				
67	Pass. (62 amp. w/T.H.) (396, 427) (exc. C.A.C.),				
67	Pass. w/C.A.C. (exc. 62 amp.),				
67	Chevelle w/Air Cond. (396) (exc. T.H.),				
67	Chevelle w/T.H. (396) (exc. Air Cond.) . . . . .	( <sup>3</sup> / <sub>8</sub> — 55 <sup>3</sup> / <sub>4</sub> )	F, G	3780981	1
65-67	Pass. (396, 427) (exc. Sp. H/Per., C.A.C., T.H., 62 amp.),				
66	Chevelle (396) (exc. Sp. H/Per., 62 amp., C.A.C.),				
66	Chevelle w/C.A.C. (283, 327) (exc. 62 amp.) . . . . .	( <sup>15</sup> / <sub>32</sub> — 53 <sup>3</sup> / <sub>4</sub> )	F, G	3845654	1
67	Chevelle (396) (exc. C.A.C.) . . . . .	( <sup>3</sup> / <sub>8</sub> — 56)	G	3917208	1

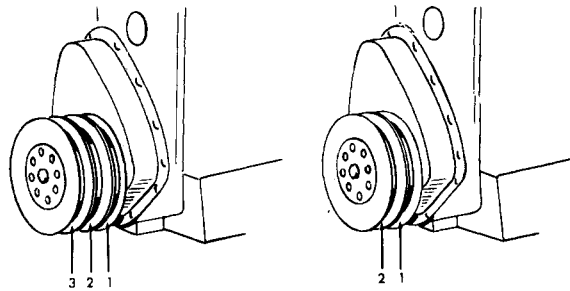

**(8 cylinder) Drive Pulley, (Crankshaft) Groove No. 2 (2, or 3 pulley systems)**

	Dimensions	Driven Pulleys			
64	Chevy w/Air Cond. (283),				
65	Chevy w/C.A.C. (327),				
66	Chevelle (62 amp. w/C.A.C.) (396) (exc. Sp. H/Per.),				
66-67	Chevy w/C.A.C. (8 cyl.) . . . . .	( <sup>15</sup> / <sub>32</sub> — 57)	W, C	9433766	1
64-67	Chevy, Camaro w/P/S (8 cyl.) (exc. Sp. H/Per., 350) . . . . .	( <sup>3</sup> / <sub>8</sub> — 34 <sup>3</sup> / <sub>8</sub> )	P	9433722	1
64-65	Chevelle w/P/S (283) . . . . .	( <sup>3</sup> / <sub>8</sub> — 41)	P	3849258	1
64-67	Chevelle, Camaro w/Air Cond. (283, 327),				
65	Chevy w/Air Cond. (283),				
65-67	Pass. w/C.A.C. (exc. 396, 409, 427) . . . . .	( <sup>15</sup> / <sub>32</sub> — 57)	W, C	3946065	1
65-66	Pass. (62 amp. w/C.A.C.) (396) . . . . .	( <sup>3</sup> / <sub>8</sub> — 59)	W, C	9433771	1
65	Pass. (409) (exc. P/S, C.A.C.),				
65-66	Pass., Chevelle w/Sp. H/Per. (396, 427) . . . . .	( <sup>3</sup> / <sub>8</sub> — 43)	I, W	9433739	1
65-67	Pass. w/Access. Air Cond. (exc. 409) . . . . .	( <sup>3</sup> / <sub>8</sub> — 53)	W, C	9433759	1
65-66	Pass., Chevelle w/Air Cond. (396, 409, 427) (exc. Sp. H/Per., T.H.),				
67	Pass. w/C.A.C. (396, 427) . . . . .	( <sup>15</sup> / <sub>32</sub> — 60 <sup>1</sup> / <sub>2</sub> )	W, C	9775522	1
65	Pass. (C.A.C. w/T.H.) (396),				
66	Pass. (C.A.C. w/T.H.) (396, 427) (exc. 62 amp. gen.) . . . . .	( <sup>15</sup> / <sub>32</sub> — 61 <sup>1</sup> / <sub>2</sub> )	W, C	9433775	1

**COOLANT—GRILLE—OIL SYSTEM**

<b>1.066 BELT, Fan, Gen. and Accessory Drive (Con't)</b>					
66	Chevelle w/P/S (396) . . . . .	$(\frac{3}{8}$ — 49 $\frac{1}{2}$ )	P	3909819	1
66	Chevy (P/S w/Sp. H/Per.) (327) . . . . .	$(\frac{15}{32}$ — 36 $\frac{1}{2}$ )	P	9433725	1
66	Chevy, Chevelle w/A.I.R. (283) (exc. Air Cond.),				
66-67	Pass. w/A.I.R. (283, 327) (exc. C.A.C.) . . . . .	$(\frac{3}{8}$ — 48 $\frac{1}{2}$ )	X, F	3887104	1
66	Chevelle w/A.I.R. (396) (exc. C.A.C.),				
66-67	Pass. w/A.I.R. (396, 427) (exc. C.A.C.) . . . . .	$(\frac{3}{8}$ — 52)	X, F	3881871	1

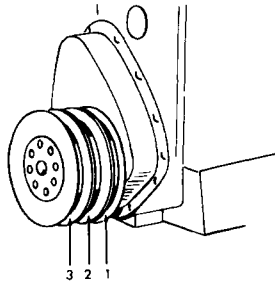

**(8 cylinder) Drive Pulley (Crankshaft) Groove No. 3 (3 pulley systems)**

		<b>Dimensions</b>	<b>Driven Pulleys</b>		
64-67	Chevelle w/P/S (exc. 396) . . . . .	$(\frac{3}{8}$ — 41)	P	3849258	1
65-67	Pass. w/P/S (exc. 396, 409, 427) . . . . .	$(\frac{3}{8}$ — 34 $\frac{3}{8}$ )	P	9433722	1
65	Pass. (P/S w/Air Cond.) (409) . . . . .	$(\frac{3}{8}$ — 44 $\frac{1}{2}$ )	P, W	9433742	1
65	Pass. w/P/S (409) (exc. Air Cond.) . . . . .	$(\frac{3}{8}$ — 44)	P, W	3953786	1
65-67	Pass. w/P/S (396, 427),				
66-67	Chevelle (Acc. Air Cond. w/P/S) (396),				
67	Camaro w/P/S (396) . . . . .	$(\frac{3}{8}$ — 37 $\frac{1}{2}$ )	P, W	9433728	1
66-67	Chevelle, Camaro (A.I.R. w/C.A.C.) (exc. 396),				
66-67	Pass. (C.A.C. w/A.I.R.) (283, 327) . . . . .	$(\frac{3}{8}$ — 31)	X, F	3953733	1
66	Chevy (A.I.R. w/C.A.C.) (283),				
67	Pass. (A.I.R. w/C.A.C.) w/T.H. (327) . . . . .	$(\frac{15}{32}$ — 32)	X, F	9433716	1
66-67	Chevelle (A.I.R. w/C.A.C.) (396),				
66-67	Pass. (A.I.R. w/C.A.C.) (396, 427) (exc. Sp. H/Per.) . . . . .	$(\frac{3}{8}$ — 32 $\frac{3}{4}$ )	X, F	3935420	1
67	Police w/61 amp. L.C.I. (427) . . . . .	$(\frac{3}{8}$ — 56)	G	3917208	1
67	Police w/61 amp. L.C.I. (427) . . . . .	$(\frac{3}{8}$ — 55)	G	3919824 <sup>(4)</sup>	1

<sup>(4)</sup> Belt Unit

**COOLANT—GRILLE—OIL SYSTEM**

**1967 FAN BELT CHART**

*NOTE See charts at beginning of group for belt dimensions and prices.*

Generator	Power Steering Pump	Air Conditioning Compressor	Air Injection Reactor Pump
-----------	---------------------	-----------------------------	----------------------------

**CHEVY II (4 CYLINDER)**

3849258			
---------	--	--	--

**CHEVY II (6 CYLINDER)**

(exc. C.A.C.) 9433730 (w/C.A.C.) 9433728	(exc. A.I.R.) 3909819 (w/A.I.R.)	3845654 9433753	(exc. P/S) 3909819 (w/P/S) 3880802
---	-------------------------------------	--------------------	---------------------------------------

**CHEVY II (8 CYLINDER)**

9433759	9433722	(Prod.) 9433766 (Access.) 9433759	(exc. C.A.C.) 3887104 (w/C.A.C.) 3935420
---------	---------	--------------------------------------	---

**CHEVELLE (6 CYLINDER)**

(exc. C.A.C.) 9433730 (w/C.A.C.) 9433716	(exc. A.I.R.) 3909819 (w/A.I.R.) 9433753	(Prod.) 9433761 (Access.) 3845654	(exc. P/S) 3909819 (w/P/S) 3880802
---	---	--------------------------------------	---------------------------------------

**CHEVELLE (8 CYLINDER)**

(exc. 396) 9433759 (396) (exc. C.A.C.) 3917208 (396 w/C.A.C.) 3780981 (T.H. w/C.A.C.) 9433766	(exc. 396) 3849258 (w/396) 9433728	(Prod.) (exc. 396) 3946065 (Prod.) (w/396) 9775522 (Access.) 9433759	(exc. 396, C.A.C.) 3887104 (C.A.C.) (exc. 396) 3953733 (396) (exc. C.A.C.) 3881871 (396 w/C.A.C.) 3935420
--	---------------------------------------	--	--

**CAMARO (6 CYLINDER)**

(exc. P/S) 3850801 (w/P/S) 9433728	(exc. A.I.R.) 3909819 (w/A.I.R.) 9433753	(Prod.) 9433761 (Access.) 3845654	(exc. P/S) 3909819 (w/P/S) 3880802
---------------------------------------	---	--------------------------------------	---------------------------------------

**CAMARO (8 CYLINDER)**

(exc. 396) 9433759 (w/396) 9433764	(302, 396) 9433728 (350) 9433725 (327) 9433722	(Prod.) 3946065 (Access.) 9433759	(exc. C.A.C.) 3887104 (w/C.A.C.) 3953733
---------------------------------------	--	--------------------------------------	---

**PASSENGER (6 CYLINDER)**

(exc. 62 amp.) 3850801 Access. C.A.C. 9433728 C.A.C. w/A.I.R. 9433716 (!)	(exc. A.I.R.) 3909819  (w/A.I.R.) 9433753	(w/Prod. C.A.C.) 9433761 (w/Access. C.A.C.)  3845654	(exc. P/S) 3909819  (w/P/S) 3880802
62 amp. (exc. P/S, C.A.C.) 3888458 62 amp. w/C.A.C. (exc. P/S) 1385181 62 amp. (P/S w/C.A.C.) 9433718			

(!) Gen. to Crankshaft—3rd track.

**PASSENGER (8 CYLINDER) (283, 327)**

**COOLANT—GRILLE—OIL SYSTEM**

**1.066 BELT, Fan, Gen. and Accessory Drive (Con't)**

(exc. 62 amp.) 9433759 62 amp. 3847711	9433722	3946065	(exc. C.A.C.) 3887104 (w/C.A.C.) 3953733
---	---------	---------	---

**PASSENGER (8 CYLINDER) (396, 427)**

(exc. 62 amp.) 3917208 62 amp. (exc. P/S, C.A.C.) 3879951(?) 62 amp. w/P/S, C.A.C. 3861956 62 amp. w/Sp. H/Per. 3866956(?)	9433728	9775522	(exc. C.A.C.) 3881871  (w/C.A.C.) 3935420
--	---------	---------	---

(?) Belt Units.

**1968 FAN BELT CHART**

<b>Generator</b>	<b>Power Steering Pump</b>	<b>Air Conditioning Compressor</b>	<b>Air Injection Reactor Pump</b>
------------------	----------------------------	------------------------------------	-----------------------------------

**CHEVY II (4 CYLINDER)**

3849258			
---------	--	--	--

**CHEVY II (6 CYLINDER)**

(exc. C.A.C.) 9433730 w/C.A.C. (exc. P.G.) 9433716 w/C.A.C. (P.G. w/P/S) 9433716 (C.A.C. w/P.G., T.H. 350) 9433730	(exc. P.G.) 9433753  (w/P.G.) 3909819	(Prod.) 9433761  (Access.) 3845654	(w/P/S) 3953733  (exc. P/S) 3909819
--	---	--	---

**CHEVY II (8 CYLINDER)**

(exc. 396, C.A.C.) 9433759  (396) (exc. Sp. H/Per. 61 amp.) 3917208  (C.A.C. w/61 amp.) 9433760 (396 w/61 amp.) 3917208 w/Sp. H/Per. (396) 9433764	(w/350, 327 Sp. H/Per.) 9433725  (exc. 350, 327 Sp. H/Per.) 9433722	3946065	(w/C.A.C.) 3953733   (exc. C.A.C.) 3909819
--	---	---------	---

**CHEVELLE (6 CYLINDER)**

(exc. C.A.C.) 9433730 w/C.A.C. (exc. P.G.) 9433716 w/C.A.C. (P.G. w/P/S) 9433716 (C.A.C. w/P.G., T.H. 350) 9433730	(exc. P.G.) 9433753  (w/P.G.) 3909819	(Prod.) 9433761  (Access.) 3845654	(w/P/S) 3953733  (exc. P/S) 3909819
--	---	--	---

**CHEVELLE (8 CYLINDER)**

(396) (exc. T.H., C.A.C.) 3917208 (396 w/C.A.C.)	(w/396) 9433753	(Prod.) (exc. 396) 3946065	(exc. 396, C.A.C.) 3909819 (396)
--	-----------------	----------------------------	-------------------------------------

**COOLANT—GRILLE—OIL SYSTEM**

**1.066 BELT, Fan, Gen. and Accessory Drive (Con't)**

(exc. T.H.) 3780981 (396 w/C.A.C., T.H.) (exc. 61 amp.) 9433766	(exc. 396) 3849258	(Prod.) (w/396) 9775522  (Access.) 9433759	(exc. C.A.C.) 9433753  w/C.A.C. (exc. 396) 3953733 (396 w/C.A.C.) 3935420
(exc. 396, C.A.C.) 9433759 (C.A.C.) w/61 amp. 9433760 (396 w/61 amp.) 3917208			

**CAMARO (6 CYLINDER)**

(exc. C.A.C.) 9433730 w/C.A.C. (exc. P.G.) 9433716 w/C.A.C. (P.G. w/P/S) 9433716 (C.A.C. w/P.G., T.H. 350) 9433730 (C.A.C. w/61 amp.) (exc. 396) 9433760	(exc. P.G.) 9433753  (w/P.G.) 3909819	(Prod.) 9433761  (Access.) 3845654	(w/P/S) 3953733  (exc. P/S) 3909819
---	---	--	---

**CAMARO (8 CYLINDER)**

(exc. 396) 9433759  (w/396) 9433764	(302) 9433725 (327) 9433722 (350) 9433725 (396) 9433728	(Prod.) (exc. 396) 3946065  (Prod.) (w/396) 9775522 (Access.) 9433759	(w/C.A.C.) 3953733  (exc. C.A.C.) 3909819
---	--	--	---

**PASSENGER (6 CYLINDER)**

(w/62 amp.) 3915962 (exc. 62 amp.) 9433730 w/P/S (P.G. w/C.A.C.) C.A.C. (exc. P.G.) 9433716 ( <sup>1</sup> ) (T.H. 350 w/C.A.C.) 9433730	9433753	(w/Prod. C.A.C.)  9433761	(w/P/S) 3953733  (exc. P/S) 9433753
--	---------	---------------------------------	---

<sup>(1)</sup> Gen. to Crankshaft—3rd track.

**PASSENGER (8 CYLINDER) (307, 327)**

(exc. 61 amp.) 9433759 (w/61 amp.) 3932330	9433722	3946065	(w/C.A.C.) 3953733 (exc. C.A.C.) 9433753
---	---------	---------	---

**PASSENGER (8 CYLINDER) (396, 427)**

w/T.H. 3917208	9433728	9775522	(w/C.A.C.) 3953733 (exc. C.A.C.) 9433753
----------------	---------	---------	---



**COOLANT—GRILLE—OIL SYSTEM**

**1969 FAN BELT CHART**

Generator	Power Steering Pump	Air Conditioning Compressor	Air Injection Reactor Pump
-----------	---------------------	-----------------------------	----------------------------

**CHEVY II (4 CYLINDER)**

w/C.A.C. (exc. 63 amp.) 9433730 (w/63 amp.) 3915962			9433753
---	--	--	---------

**CHEVY II (6 CYLINDER)**

(A.T. w/C.A.C.) (exc. P/S, 63 amp.) 9433730 (w/63 amp.) 3915962 w/C.A.C. (exc. A.T.) 3953733 w/P/S (C.A.C. w/A.T.) 3953733	3909819	(Prod.) 3845654 (Access.) 9433757	(exc. P/S) 9433753 (w/P/S) 3935420
---	---------	--------------------------------------	---------------------------------------

**CHEVY II (8 CYLINDER)**

(exc. A.T., C.A.C., 63 amp.) 9433748 w/A.T. (exc. 63 amp.)—9433741 (w/Acc. Air Cond.) 3847711 (C.A.C. w/A.T.) w/63 amp. 3953786 (Acc. Air Cond. w/H/Per.) (exc. A.I.R.) 3937790  (63 amp. w/A.T.) (exc. C.A.C.) 3953778 w/63 amp. (exc. A.T. 396) 3953787	(w/Sp. H/Per. 396)  9433732 (w/H/Per. 396) 3849258  (H/Per. w/A.I.R.) 3909819  (exc. H/Per. Sp. H/Per.) 9433725	(Access.) 9433757 (Prod.) 9433761	9433748
--	--	--------------------------------------	---------

**CHEVELLE (6 CYLINDER)**

(A.T. w/C.A.C.) (exc. P/S, 63 amp.) 3850801 w/C.A.C. (exc. A.T.) 3953733 w/P/S (C.A.C. w/A.T.) 3953733 (w/63 amp.) 3915962	(w/P.G.) 3909819  (exc. P.G.) 9433753	(Access.) 9433757  (Prod.) 9433761	(w/P/S) 3953733  (exc. P/S) 9433753
---	---	--	---

**CHEVELLE (8 CYLINDER)**

(w/Acc. Air Cond.) 3847711 C.A.C. w/A.T. w/63 amp. (exc. T.H. 400) 3953786 w/A.T. (exc. 63 amp.)—9433741  (exc. 396, 63 amp., A.T., C.A.C.) 9433748  (T.H. 400 w/H/Per.) w/63 amp. 3937790  (63 amp. w/A.T.)	(w/Sp. H/Per. 396) 9433732  (396 w/C.A.C.)  (exc. T.H. 400) 3849258  (396 w/Acc. Air Cond.) (exc. A.T.) 3909819  (exc. 396) 9433725 w/396 (C.A.C. w/T.H. 400) 9433737	(w/396)  (w/396) 3946065	9433748
--	--	--------------------------------	---------

**COOLANT—GRILLE—OIL SYSTEM**

**1.066 BELT, Fan, Gen. and Accessory Drive (Con't)**

(exc. C.A.C., T.H. 400) 3953778 w/63 amp. (exc. A.T., 396) 3953787			
---	--	--	--

**CAMARO (6 CYLINDER)**

w/C.A.C. (exc. A.T.) 3953733 (w/63 amp.) 3915962 w/P/S (C.A.C. w/A.T.) 3953733 (A.T. w/C.A.C.) (exc. P/S, 63 amp.) 3850801	(w/P.G.) 3909819 (exc. P.G.) 9433753	(Access.) 9433757 (Prod.) 3845654	(w/P/S) 3953733 (exc. P/S) 9433753
--	---	--------------------------------------	---------------------------------------

**CAMARO (8 CYLINDER)**

w/Air Cond. (exc. 63 amp.) 3847711  w/A.T. (C.A.C. w/63 amp.) 3953786 w/A.T. (exc. 63 amp.)— 9433741 (exc. 63 amp. A.T., C.A.C., 302, 396) 9433748  (396) (exc. Sp. H/Per.) 3909819 (302) 9433746 (396) (exc. A.I.R.) 3937790 (63 amp. w/A.T.) (exc. C.A.C.) 3953778 w/63 amp. (exc. A.T., 396) 3953787	(w/Sp. H/Per. 396) 9433732  (396) (exc. Sp. H/Per.)  3849258  w/396 (C.A.C. w/T.H. 400) 9433737  (exc. 302, 396) 9433725 (302) 9433722	(exc. 396) 9433762      (w/396) 3946065	9433748
--	---	---	---------

**PASSENGER (6 CYLINDER)**

(w/63 amp.) 3915962 (A.T. w/C.A.C.) (exc. P/S, 63 amp.) 3850801 w/C.A.C. (exc. P.G.) 3953733 P/S (P.G. w/C.A.C.) 3953733	(w/A.T.) 3909819   (exc. A.T.) 9433753	9433761	(w/P/S) 3953733   (exc. P/S) 9433753
---	---	---------	---

**PASSENGER (8 CYLINDER) (327, 350)**

w/A.T. (exc. 63 amp.)— 9433741 (exc. A.T., C.A.C., 63 amp.) 9433748 (63 amp. w/C.A.C.) w/A.T. 3953786 (C.A.C. exc. P/S) 3847711 (w/Acc. Air Cond.) 9433728 (63 amp. w/A.T.) (exc. C.A.C.) 3953778 w/63 amp. (exc. A.T.) 3953787 w/C.A.C. (exc. 63 amp., A.T.) 9433749	9433725	3847711	9433748
--	---------	---------	---------

**COOLANT—GRILLE—OIL SYSTEM**

**1.066 BELT, Fan, Gen. and Accessory Drive (Con't)**

**PASSENGER (8 CYLINDER) (396, 427)**

(C.A.C. exc. P/S) 3847711  (Acc. Air Cond. w/396) 9433728  (w/T.H. 400) 3937790	(exc. C.A.C., ) T.H. 400) 3849258  (C.A.C.) w/T.H. 400) 9433737 (w/Sp. H/Per.) 9433732	(exc. T.H. 400) 3946065 (w/T.H. 400) 3946065	(w/Acc. Air Cond.) 3909819
--	--	---	----------------------------

**1970 FAN BELT CHART**

**PASSENGER— FAN AND GENERATOR**

Usage	Part Number	Width Length
Taxi (6 cyl.)	3962068	$\frac{3}{8}$ "— $37\frac{19}{64}$ "
(6 cyl.) (exc. 63 amp., Taxi)	9433728	$\frac{3}{8}$ "— $37\frac{1}{2}$ "
w/63 amp. (6 cyl.) (exc. Taxi)	3962068	$\frac{3}{8}$ "— $37\frac{19}{64}$ "
(8 cyl.) (exc. 63 amp., 454)	9433741	$\frac{15}{32}$ X $44\frac{1}{2}$
w/63 amp. (8 cyl.) (exc. C.A.C., 454)	3953778	$\frac{3}{8}$ "— $43\frac{1}{4}$ "
(63 amp. w/C.A.C.) (8 cyl.) (exc. 454)	3953786	$\frac{3}{8}$ "— 44
(454)	3937790	$\frac{3}{8}$ "— $45\frac{1}{2}$ "

**PASSENGER— POWER STEERING PUMP**

(6 cyl.)	3909819	$\frac{3}{8}$ "— $49\frac{1}{2}$ "
(8 cyl.) (exc. 454)	9433725	$\frac{3}{8}$ "— 36
(454)	3849258	$\frac{3}{8}$ "— 41

**PASSENGER— AIR COND. COMPRESSOR**

(Access) (6 cyl.)	9433728	$\frac{3}{8}$ "— $37\frac{1}{2}$ "
(Access) (8 cyl.) (exc. 454)	3847711	$\frac{15}{32}$ "— $55\frac{1}{4}$ "
(Access) (454)	3909819	$\frac{3}{8}$ "— $49\frac{1}{2}$ "
*(Prod.) (8 cyl.) (exc. P/S, 454)	9433761	$\frac{15}{32}$ "— $54\frac{1}{2}$ "
(Prod.) w/P/S (8 cyl.) (exc. 454)	9433761	$\frac{15}{32}$ "— $54\frac{1}{2}$ "
(Prod.) (454)	3946065	$\frac{15}{32}$ "— 57

**NOVA— FAN AND GENERATOR**

(4 cyl.)	9433730	$\frac{3}{8}$ "— $38\frac{1}{2}$ "
(6 cyl.)	9433728	$\frac{3}{8}$ "— $37\frac{1}{2}$ "
(8 cyl.) (exc. 396)	3953786	$\frac{3}{8}$ "— 44
w/H/Per. (396)	3937790	$\frac{3}{8}$ "— $45\frac{1}{2}$ "
w/Sp. H/Per. (396)	9433748	$\frac{3}{8}$ "— $47\frac{1}{2}$ "

**NOVA— POWER STEERING PUMP**

(6 cyl.)	3887104	$\frac{3}{8}$ "— $48\frac{1}{2}$ "
(8 cyl.) (exc. 396)	9433725	$\frac{3}{8}$ "— 36
w/H/Per. (396)	3849258	$\frac{3}{8}$ "— 41
w/Sp. H/Per. (396)	9433734	$\frac{15}{32}$ "— 41

**NOVA— AIR COND. COMPRESSOR**

(Access) (6 cyl.)	9433728	$\frac{3}{8}$ "— $37\frac{1}{2}$ "
(Access) (8 cyl.) (exc. 396)	3847711	$\frac{15}{32}$ "— $55\frac{1}{4}$ "
(Access) (396)	3909819	$\frac{3}{8}$ "— $49\frac{1}{2}$ "
*(Prod.) (8 cyl.) (exc. P/S)	9433761	$\frac{15}{32}$ "— $54\frac{1}{2}$ "

**COOLANT—GRILLE—OIL SYSTEM**

**1.066 BELT, Fan, Gen. and Accessory Drive (Con't)**

(Prod.) w/P/S (8 cyl.)	9433761	$\frac{15}{32}$ "— 54 $\frac{1}{2}$ "
------------------------	---------	---------------------------------------

**NOVA— A.I.R. PUMP**

(4 cyl.)	9433753	$\frac{3}{8}$ "— 50
----------	---------	---------------------

**CHEVELLE— FAN AND GENERATOR**

(6 cyl.) (exc. 63 amp.)	9433728	$\frac{3}{8}$ "— 37 $\frac{1}{2}$ "
w/63 amp. (6 cyl.)	3962068	$\frac{3}{8}$ "— 37 $\frac{19}{64}$ "
(8 cyl.) (exc. 63 amp., 396, 400 w/4BC, 454)	3953786	$\frac{3}{8}$ "— 44
w/63 amp. (8 cyl.) (exc. C.A.C., 396, 400 w/4BC, 454)	3953778	$\frac{3}{8}$ "— 43 $\frac{1}{4}$ "
(63 amp. w/C.A.C.) (8 cyl.) (exc. 396, 400 w/4BC, 454)	3953786	$\frac{3}{8}$ "— 44
(396, 400 w/4BC, 454) (exc. Sp. H/Per.)	3937790	$\frac{3}{8}$ "— 45 $\frac{1}{2}$ "
w/Sp. H/Per. (396, 454)	9433748	$\frac{3}{8}$ "— 47 $\frac{1}{2}$ "

**CHEVELLE— POWER STEERING PUMP**

(6 cyl.)	3887104	$\frac{3}{8}$ "— 48 $\frac{1}{2}$ "
(8 cyl.) (exc. 396, 400 w/4BC, 454)	9433725	$\frac{3}{8}$ "— 36
(396, 400 w/4BC, 454) (exc. Sp. H/Per.)	3849258	$\frac{3}{8}$ "— 41
w/Sp. H/Per. (396, 454)	9433734	$\frac{15}{32}$ "— 41

**CHEVELLE— AIR COND. COMPRESSOR**

(6 cyl.)	9433728	$\frac{3}{8}$ "— 37 $\frac{1}{2}$ "
(Access) (8 cyl.) (exc. 396, 400 w/4BC, 454)	3847711	$\frac{15}{32}$ "— 55 $\frac{1}{4}$ "
(Access) (396, 400 w/4BC, 454)	3909819	$\frac{3}{8}$ "— 49 $\frac{1}{2}$ "
*(Prod.) (8 cyl.) (exc. P/S, 396, 400 w/4BC, 454)	9433761	$\frac{15}{32}$ "— 54 $\frac{1}{2}$ "
(Prod.) w/P/S (8 cyl.) (exc. 396, 400 w/4BC, 454)	9433761	$\frac{15}{32}$ "— 54 $\frac{1}{2}$ "
(Prod.) (396, 400 w/4BC, 454) (N) Notched belt	3946065	$\frac{15}{32}$ "— 57

**CAMARO— FAN AND GENERATOR**

(6 cyl.)	9433728	$\frac{3}{8}$ "— 37 $\frac{1}{2}$ "
(8 cyl.) (exc. 396, 454)	3953786	$\frac{3}{8}$ "— 44
w/H/Per. (396)	3937790	$\frac{3}{8}$ "— 45 $\frac{1}{2}$ "
w/Sp. H/Per. (396)	9433748	$\frac{3}{8}$ "— 47 $\frac{1}{2}$ "
(454)	9433748	$\frac{3}{8}$ "— 47 $\frac{1}{2}$ "

**CAMARO— POWER STEERING PUMP**

(6 cyl.)	3887104	$\frac{3}{8}$ "— 48 $\frac{1}{2}$ "
(8 cyl.) (exc. 396, Sp. H/Per. 350)	9433725	$\frac{3}{8}$ "— 36"
w/Sp. H/Per. (350)	9433722	$\frac{3}{8}$ "— 34 $\frac{3}{8}$ "
w/H/Per. (396)	3849258	$\frac{3}{8}$ "— 41
w/Sp. H/Per. (396, 454)	9433734	$\frac{15}{32}$ "— 41

**CAMARO— AIR COND. COMPRESSOR**

(Access) (6 cyl.)	9433728	$\frac{3}{8}$ "— 37 $\frac{1}{2}$ "
(Access) (8 cyl.) (exc. 396)	3847711	$\frac{15}{32}$ "— 55 $\frac{1}{4}$ "

**COOLANT—GRILLE—OIL SYSTEM**

<b>1.066</b>	<b>BELT, Fan, Gen. and Accessory Drive (Con't)</b>	
(Access) (396)	3909819	$\frac{3}{8}$ " — 49 $\frac{1}{2}$ "
*(Prod.) (8 cyl.) (exc. P/S)	9433761	$\frac{15}{32}$ " — 54 $\frac{1}{2}$ "

**1971 FAN BELT CHART**

**PASSENGER— FAN AND GENERATOR**

Usage	Part No.	Width	Length
71 Police, Taxi (6 cyl.)	9433730	4.95	$\frac{3}{8}$ " 38 $\frac{1}{2}$ "
71 (6 cyl.) (exc. 63 amp., Police, Taxi)	9433728	4.95	$\frac{3}{8}$ " 37 $\frac{1}{2}$ "
71 w/63 amp. (6 cyl.) (exc. Police, Taxi)	3962068	4.15	$\frac{3}{8}$ " 37 $\frac{19}{64}$ "
71 (8 cyl.) (exc. 63 amp., 454)	9433741	5.15	$\frac{15}{32}$ " x 44 $\frac{1}{2}$ "
71 w/63 amp. (8 cyl.) (exc. C.A.C., 454)	3953778	4.75	$\frac{3}{8}$ " 43 $\frac{1}{4}$ "
71 (63 amp. w/C.A.C.) (8 cyl.) (exc. 454)	3953786	4.75	$\frac{3}{8}$ " 44"
71 Taxi, Police (350)	9433742	5.15	$\frac{3}{8}$ " 44 $\frac{1}{4}$ "
71 (454, 400 w/4BC)	3937790	4.75	$\frac{3}{8}$ " 45 $\frac{1}{2}$ "

**PASSENGER— POWER STEERING PUMP**

71 (6 cyl.) (exc. Taxi, Police)	9433750	5.15	$\frac{15}{32}$ " 49"
71 (8 cyl.) (exc. 400 w/4BC, 454)	9433725	4.95	$\frac{3}{8}$ " 36"
71 (400 w/4BC, 454)	9433735	4.75	$\frac{3}{8}$ " 41"
71 Taxi, Police (6 cyl.)	9433752	6.05	$\frac{3}{8}$ " 49 $\frac{1}{2}$ "

**PASSENGER— AIR COND. COMPRESSOR**

71 (Prod.) (8 cyl.) (exc. 454, 400 w/4BC)	9433761	6.05	$\frac{15}{32}$ " 54 $\frac{1}{2}$ "
71 (Prod.) w/P/S (8 cyl.) (exc. 454)	9433761	6.05	$\frac{15}{32}$ " 54 $\frac{1}{2}$ "
71 (Prod.) (400, 454)	9433768	6.05	$\frac{15}{32}$ " 58"

**NOVA— FAN AND GENERATOR**

71 (6 cyl.)	9433728	4.95	$\frac{3}{8}$ " 37 $\frac{1}{2}$ "
71 (8 cyl.)	9433741	5.15	$\frac{15}{32}$ " x 44 $\frac{1}{2}$ "

**NOVA— POWER STEERING PUMP**

71 (6 cyl.)	9433750	5.15	$\frac{15}{32}$ " 49"
71 (8 cyl.)	9433725	4.95	$\frac{3}{8}$ " 36"

**NOVA— AIR COND. COMPRESSOR**

71 (Access) (6 cyl.)	9433728	4.95	$\frac{3}{8}$ " 37 $\frac{1}{2}$ "
71 (Prod.) (8 cyl.)	9433761	6.05	$\frac{15}{32}$ " 54 $\frac{1}{2}$ "

**CHEVELLE— FAN AND GENERATOR**

71 (6 cyl.) (exc. 63 amp.)	9433728	4.95	$\frac{3}{8}$ " 37 $\frac{1}{2}$ "
71 w/63 amp. (6 cyl.)	3962068	4.15	$\frac{3}{8}$ " 37 $\frac{19}{64}$ "
71 (8 cyl.) (exc. 63 amp., 400 w/4BC, 454)	9433741	5.15	$\frac{15}{32}$ " x 44 $\frac{1}{2}$ "
71 w/63 amp. (8 cyl.) (exc. C.A.C., 400 w/4BC, 454)	3953778	4.75	$\frac{3}{8}$ " 43 $\frac{1}{4}$ "
71 (63 amp. w/C.A.C.) (8 cyl.) (exc. 400 w/4BC, 454)	3953786	4.75	$\frac{3}{8}$ " 44"
71 (400 w/4BC, 454) (exc. Sp. H/Per.)	3937790	4.75	$\frac{3}{8}$ " 45 $\frac{1}{2}$ "
71 w/Sp. H/Per. (454)	3887104	4.75	$\frac{3}{8}$ " 48 $\frac{1}{2}$ "

**CHEVELLE— POWER STEERING PUMP**

71 (6 cyl.)	9433750	5.15	$\frac{15}{32}$ " 49"
71 (8 cyl.) (exc. 400, 454)	9433725	4.95	$\frac{3}{8}$ " 36"
71 (400 w/4BC, 454) (exc. Sp. H/Per.)	9433735	4.75	$\frac{3}{8}$ " 41"
71 w/Sp. H/Per. (454)	9433734	5.15	$\frac{15}{32}$ " 41"

**CHEVELLE— AIR COND. COMPRESSOR**

71 (6 cyl.)	9433728	4.95	$\frac{3}{8}$ " 37 $\frac{1}{2}$ "
71 (Access) (400 w/4BC, 454)	3909819	4.75	$\frac{3}{8}$ " 49 $\frac{1}{2}$ "
71 (Prod.) (8 cyl.) (exc. 400 w/4BC, 454)	9433761	6.05	$\frac{15}{32}$ " 54 $\frac{1}{2}$ "

**COOLANT—GRILLE—OIL SYSTEM**

**1.066 BELT, Fan, Gen. and Accessory Drive (Con't)**

71	(Prod.) w/P/S (8 cyl.) (exc. 400 w/4BC, 454) .....	<b>9433761</b>	6.05	15/32" 54 1/2"
71	(Prod.) (400 w/4BC, 454) .....	<b>9433768</b>	6.05	15/32" 58"

(N) Notched belt.

**CAMARO— FAN AND GENERATOR**

71	(6 cyl.) .....	<b>9433728</b>	4.95	3/8" 37 1/2"
71	(8 cyl.) (exc. 400 Sp. H/Per.) .....	<b>9433741</b>	5.15	15/32" x 44 1/2"
71	400 .....	<b>3937790</b>	4.75	3/8" 45 1/2"
71	w/Sp. H/Per. (350) .....	<b>9433746</b>	5.15	3/8" 46 1/2"

**CAMARO— POWER STEERING PUMP**

71	(6 cyl.) .....	<b>9433750</b>	5.15	15/32" 49"
71	(8 cyl.) (exc. 400, Sp. H/Per.) .....	<b>9433725</b>	4.95	3/8" 36"
71	w/Sp. H/Per. (350) .....	<b>9433723</b>	4.95	3/8" 35"
71	(400) .....	<b>9433735</b>	4.75	3/8" 41"

**CAMARO— AIR COND. COMPRESSOR**

71	(Access) (6 cyl.) .....	<b>9433728</b>	4.95	3/8" 37 1/2"
71	(Prod.) (400) .....	<b>9433768</b>	6.05	15/32" 58"
71	(Prod.) (8 cyl.) (exc. 400) .....	<b>9433761</b>	6.05	15/32" 54 1/2"

**1972 FAN BELT CHART**

**PASSENGER— FAN AND GENERATOR**

Usage .....	Part No.	Width	Length
72 Taxi (6 cyl.) .....	<b>6262854</b>	4.15	3/8" 38 1/2"
72 (6 cyl.) .....	<b>9433728</b>	4.95	3/8" 37 1/2"
72 (350, 400) (exc. Taxi, Police NB2) .....	<b>9433741</b>	5.15	15/32" x 44 1/2"
72 Taxi, Police (350, 400) (exc. NB2) .....	<b>9433742</b>	5.15	3/8" 44 1/4"
72 (454, 402) (exc. A.I.R.) .....	<b>3937790</b>	4.75	3/8" 45 1/2"
72 (454, 402) w/A.I.R. .....	<b>9433752</b>	6.05	3/8" 49 1/2"
72 w/NB2 (350, 400) .....	<b>9433748</b>	5.15	3/8" 47 1/2"

**PASSENGER— POWER STEERING PUMP**

72 Taxi (6 cyl.) .....	<b>9433752</b>	6.05	3/8" 49 1/2"
72 (6 cyl.) (exc. Taxi) .....	<b>9433750</b>	5.15	15/32" 49"
72 (350, 400) .....	<b>9433725</b>	4.95	3/8" 36"
72 (402, 454) .....	<b>9433735</b>	4.75	3/8" 41"

**PASSENGER— AIR COND. COMPRESSOR**

72 (350, 400) .....	<b>9433761</b>	6.05	15/32" 54 1/2"
72 (402, 454) .....	<b>9433768</b>	6.05	15/32" 58"
72 Police .....	<b>3999272</b>	5.15	15/32" 45 3/4"

**PASSENGER— AIR INJ. PUMP**

72 w/NB2 (6 cyl.) .....	<b>9433756</b>	6.05	3/8" 51 1/2"
-------------------------	----------------	------	--------------

**NOVA— FAN AND GENERATOR**

72 (6 cyl.) .....	<b>9433728</b>	4.95	3/8" 37 1/2"
72 (8 cyl.) (exc. NB2) .....	<b>9433741</b>	5.15	15/32" x 44 1/2"
72 w/NB2 (8 cyl.) .....	<b>9433748</b>	5.15	3/8" 47 1/2"

**NOVA— POWER STEERING PUMP**

72 (6 cyl.) .....	<b>9433750</b>	5.15	15/32" 49"
72 (8 cyl.) .....	<b>9433725</b>	4.95	3/8" 36"

**NOVA— AIR COND. COMPRESSOR**

72 (8 cyl.) .....	<b>9433761</b>	6.05	15/32" 54 1/2"
-------------------	----------------	------	----------------

**NOVA— AIR INJ. PUMP**

72 w/NB2 (6 cyl.) .....	<b>9433756</b>	6.05	3/8" 51 1/2"
-------------------------	----------------	------	--------------

**CHEVELLE— FAN AND GENERATOR**

72 (6 cyl.) .....	<b>9433728</b>	4.95	3/8" 37 1/2"
72 (307, 350) (exc. 63 amp., NB2) .....	<b>9433741</b>	5.15	15/32" x 44 1/2"
72 (63 amp. w/C.A.C.) (307, 350) .....	<b>3953786</b>	4.75	3/8" 44"
72 (402, 454) .....	<b>3937790</b>	4.75	3/8" 45 1/2"

**COOLANT—GRILLE—OIL SYSTEM**

**1.066 BELT, Fan, Gen. and Accessory Drive (Con't)**

72	w/NB2 (8 cyl.)	9433748	5.15	3/8" 47 1/2"
----	----------------	---------	------	--------------

**CHEVELLE— POWER STEERING PUMP**

72	(6 cyl.)	9433750	5.15	15/32" 49"
72	(307, 350)	9433725	4.95	3/8" 36"
72	(402, 454)	9433735	4.75	3/8" 41"

**CHEVELLE— AIR COND. COMPRESSOR**

72	(307, 350)	9433761	6.05	15/32" 54 1/2"
72	(402, 454)	9433768	6.05	15/32" 58"

**CHEVELLE— AIR INJ. PUMP**

72	w/NB2 (6 cyl.)	9433756	6.05	3/8" 51 1/2"
----	----------------	---------	------	--------------

**CAMARO— FAN AND GENERATOR**

72	(6 cyl.)	9433728	4.95	3/8" 37 1/2"
72	(8 cyl.) (exc. 402 Sp. H/Per., NB2)	9433741	5.15	15/32" x 44 1/2"
72	(402)	3937790	4.75	3/8" 45 1/2"
72	w/Sp. H/Per. (350)	9433746	5.15	3/8" 46 1/2"
72	w/NB2 (8 cyl.)	9433748	5.15	3/8" 47 1/2"

**CAMARO— POWER STEERING PUMP**

72	(6 cyl.)	9433750	5.15	15/32" 49"
72	(8 cyl.) (exc. 402, Sp. H/Per.)	9433725	4.95	3/8" 36"
72	w/Sp. H/Per. (350)	9433723	4.95	15/32" — 35 1/2"
72	(402)	9433735	4.75	3/8" 41"

**CAMARO— AIR COND. COMPRESSOR**

72	(402)	9433768	6.05	15/32" 58"
72	(8 cyl.) (exc. 402)	9433761	6.05	15/32" 54 1/2"

**CAMARO— AIR INJ. PUMP**

72	w/NB2 (6 cyl.)	9433756	6.05	3/8" 51 1/2"
----	----------------	---------	------	--------------

**1973-75 FAN BELT CHART**

**PASSENGER— FAN AND GENERATOR**

	USAGE	PART NO.		WIDTH— LENGTH
73-74	(6 cyl.)	9433728	1	4.95 15/32" — 38"
73-75	(454)	9433752	1	6.05 (15/32" — 50")
74	(350, 400) (exc. Sta. Wag.), Sta. Wag. (4BC w/NB2) (400)	9433748	1	5.15 (15/32" — 48")
74	Sta. Wag. w/4BC (400) (exc. NB2),			
75	w/2BC (350)	9433742	1	5.15 (15/32" — 45")
73	(350, 400) (exc. Taxi, Police, 61 amp.),			
75	w/4BC (350, 400) (exc. Taxi, Police, 61 amp.)	9433747	1	5.15 (18/32" — 47 1/2")
73	w/61 amp. (350, 400),			
73	Taxi, Police (350, 400),			
75	w/4BC (350, 400) w/61 amp. (exc. Taxi, Police),			
75	Taxi, Police w/4BC (350, 400)	9433749	1	4.75 (15/32" — 48 1/2")

**PASSENGER— POWER STEERING PUMP**

73-75	(350, 400)	9433725	1	4.95 3/8" — 36"
73	(454)	9433632	1	4.75 3/8" — 41"
73	(6 cyl.)	9433750	1	5.15 15/32" — 49"
74	(454)	9433735	1	4.75 15/32" — 41 1/2"
75	(454)	9433745	1	5.15 15/32" — 46 1/2"

**PASSENGER— AIR COND. COMPRESSOR**

73	(454)	9433768	1	6.05 15/32" — 58"
74	(350, 400)	9433762	1	6.05 15/32" — 55"
74-75	(454)	9433769	1	6.05 15/32" — 58 1/2"
73	(350, 400),			
75	(350, 400)	9433761	1	6.05 (15/32" — 54 1/2")

**PASSENGER— AIR INJ. PUMP**

73	(6 cyl.) (1st design)	9433756	1	6.05 3/8" — 51 1/2"
73	(6 cyl.) (2nd design)	9433728	1	4.95 15/32" — 38"

**COOLANT—GRILLE—OIL SYSTEM**

**1.066 BELT, Fan, Gen. and Accessory Drive (Con't)**

**NOVA— FAN AND GENERATOR**

73-74	(6 cyl.) (exc. C.A.C.),				
75	(6 cyl.)	9433728	1	4.95	3/8"—37 15/64"
74	(6 cyl.) (C.A.C. w/3-Spd.),				
74	(6 cyl.) w/A.T. (C.A.C. w/NB2),				
74	(6 cyl.) w/A.T. (C.A.C. w/P/S)				
	(exc. NB2)	9433715	1	4.95	15/32" x 31 1/2"
74	(6 cyl.) (A.T. w/C.A.C.) (exc. NB2,				
	P/S)	9433730	1	4.95	15/32" x 39"
74	(NB2 w/dual exh.) (350),				
74	(exc. dual exh.) (350)	9433748	1	5.15	15/32" x 48"
74	(350) w/dual exh. (exc. NB2),				
75	w/2BC (350)	9433742	1	5.15	(15/32"—45")
73-74	(8 cyl.) (exc. C.A.C.),				
75	w/4BC (350) (exc. C.A.C.),				
75	(262) (exc. C.A.C.)	9433747	1	5.15	(15/32"—47 1/2")
73	w/C.A.C.,				
75	(C.A.C. w/4BC) (350),				
75	(262) w/C.A.C.	9433749	1	4.75	(15/32"—48 1/2")

**NOVA— POWER STEERING PUMP**

73-75	(8 cyl.)	9433725	1	4.95	3/8"—36"
73-74	(6 cyl.) (exc. C.A.C.)	9433750	1	5.15	15/32"—49"
75	(6 cyl.)	9433751	1	4.95	BELT (15/32"—49 1/2")

**NOVA— AIR COND. COMPRESSOR**

73	(8 cyl.),				
75	(8 cyl.)	9433761	1	6.05	(15/32"—54 1/2")
75	(6 cyl.)	9433760	1	6.05	(15/32"—54")
74	All	9433762	1	6.05	15/32"—55"

**NOVA— AIR INJ. PUMP**

73	(6 cyl.) (1st design)	9433756	1	6.05	3/8"—51 1/2"
73	(6 cyl.) (2nd design),				
74	(6 cyl.)	9433728	1	4.95	15/32"—38"
75	(6 cyl.) (exc. C.A.C., P/S)	9433729	1	4.95	(15/32"—38 1/2")
75	(6 cyl.) w/C.A.C. (exc. P/S)	9433754	1	6.05	(15/32"—51")
75	(6 cyl.) (C.A.C. w/P/S)	9433767	1	6.05	(15/32"—57 1/2")

**CHEVELLE— FAN AND GENERATOR**

73-75	(6 cyl.)	9433728	1	4.95	3/8"—37 15/64"
73-75	(8 cyl.) w/A.I.R. (exc. 61 amp.,				
	454)	9433747	1	5.15	(15/32"—47 1/2")
73-75	(454)	9433752	1	6.05	15/32"—50"
73-75	w/61 amp., A.I.R. (8 cyl.) (exc.				
	454)	9433749	1	4.75	(15/32"—48 1/2")
73-75	(8 cyl.) (exc. A.I.R.)	9433742	1	5.15	(15/32"—45")

**CHEVELLE— POWER STEERING PUMP**

73-75	(8 cyl.) (exc. 454)	9433725	1	4.95	3/8"—36"
73	(454)	9433632	1	4.75	3/8"—41"
74	(454)	9433735	1	4.75	15/32"—41 1/2"
73-74	(6 cyl.)	9433750	1	5.15	15/32"—49"
75	(6 cyl.)	9433751	1	4.95	(15/32"—49 1/2")
75	(454)	9433745	1	5.15	(15/32"—46 1/2")

**CHEVELLE— AIR COND. COMPRESSOR**

74	(350, 400)	9433762	1	6.05	15/32"—55"
74	(454)	9433769	1	6.05	15/32"—58 1/2"
73	(454),				
75	(454)	9433768	1	6.05	(15/32"—58")
73	(8 cyl.) (exc. 454),				
75	(8 cyl.) (exc. 454)	9433761	1	6.05	(15/32"—54 1/2")
75	(6 cyl.)	9433760	1	6.05	(15/32"—54")

**CHEVELLE— AIR INJ. PUMP**

73	(6 cyl.) (1st design)	9433756	1	6.05	3/8"—51 1/2"
73	(6 cyl.) (2nd design),				
74	(6 cyl.)	9433728	1	4.95	15/32"—38"
75	(6 cyl.) (exc. C.A.C.)	9433729	1	4.95	(15/32"—38 1/2")
75	(6 cyl.) w/C.A.C.	9433767	1	6.05	(15/32"—57 1/2")

**CAMARO— FAN AND GENERATOR**



**COOLANT—GRILLE—OIL SYSTEM**

**1.066 BELT, Fan, Gen. and Accessory Drive (Con't)**

73-75	(6 cyl.)	9433728	1	4.95	$\frac{3}{8}$ "— $37\frac{19}{64}$ "
73-74	Sp. H/Per. (exc. C.A.C.)	9433746	1	5.15	$\frac{3}{8}$ "— $46\frac{1}{2}$ "
74	(350) (exc. Sp. H/Per., A.T.), (4BC w/Dual exh.) (NB2 w/T.H.) (exc. Sp. H/Per.)	9433748	1	5.15	$\frac{15}{32}$ "— $48$ "
74	(4BC w/dual exh.) w/T.H. (exc. NB2, Sp. H/Per.)				
75	w/2BC (350)	9433742	1	5.15	$(\frac{15}{32}$ "— $45$ ")
73-74	(Sp. H/Per. w/C.A.C.) (350),				
75	w/4BC (350) (exc. C.A.C.)	9433747	1	5.15	$(\frac{15}{32}$ "— $47\frac{1}{2}$ ")
73	(8 cyl.) (exc. Sp. H/Per., C.A.C.),				
73	w/C.A.C. (8 cyl.) (exc. Sp. H/Per.)				
75	w/4BC (350) w/C.A.C.	9433749	1	4.75	$(\frac{15}{32}$ "— $48\frac{1}{2}$ ")

**CAMARO— POWER STEERING PUMP**

73-75	(8 cyl.) (exc. Sp. H/Per.),				
73-74	Sp. H/Per. w/C.A.C.	9433725	1	4.95	$\frac{3}{8}$ "— $36$ "
73-74	w/Sp. H/Per. (350) (exc. C.A.C.)	9433723	1	4.95	$\frac{15}{32}$ "— $35\frac{1}{2}$ "
73-74	(6 cyl.)	9433750	1	5.15	$\frac{15}{32}$ "— $49$ "
75	(6 cyl.)	9433751	1	4.95	$(\frac{15}{32}$ "— $49\frac{1}{2}$ ")

**CAMARO— AIR COND. COMPRESSOR**

73	Sp. H/Per.	326090	1	7.35	$\frac{15}{32}$ "— $55\frac{1}{4}$ "
74	(8 cyl.) (exc. Sp. H/Per.)	9433762	1	6.05	$\frac{15}{32}$ "— $55$ "
74	w/Sp. H/Per. (350)	9433764	1	6.05	$\frac{15}{32}$ "— $56$ "
75	(6 cyl.)	9433757	1	6.05	$(\frac{15}{32}$ "— $52\frac{1}{2}$ ")
73	(8 cyl.) (exc. Sp. H/Per.),				
75	(8 cyl.)	9433761	1	6.05	$(\frac{15}{32}$ "— $54\frac{1}{2}$ ")

**CAMARO— AIR INJ. PUMP**

73	(6 cyl.) (1st design)	9433756	1	6.05	$\frac{3}{8}$ "— $51\frac{1}{2}$ "
73	(6 cyl.) (2nd design),				
74	(6 cyl.)	9433728	1	4.95	$\frac{15}{32}$ "— $38$ "
75	(6 cyl.) (exc. C.A.C.)	9433729	1	4.95	$(\frac{15}{32}$ "— $38\frac{1}{2}$ ")
75	(6 cyl.) w/C.A.C. (exc. P/S)	9433754	1	6.05	$(\frac{15}{32}$ "— $51$ ")
75	(6 cyl.) (P/S w/C.A.C.)	9433767	1	6.05	$(\frac{15}{32}$ "— $57\frac{1}{2}$ ")

**1971-75 VEGA, MONZA**

71-74	Vega,				
75	Vega, Monza (140) (exc. A.I.R.)	9433759	1	6.05	p/s drive ( $\frac{3}{8}$ "— $53\frac{1}{2}$ ")
71-75	Vega, Monza (exc. 8 cyl.)	3994231	1	4.95	comp. drive ( $\frac{15}{32}$ "— $36\frac{1}{4}$ ")
71-74	Vega,				
75	Vega, Monza (140) (exc. A.I.R., P/S)	9433725	1	4.95	gen. drive ( $\frac{15}{32}$ "— $36\frac{1}{2}$ ")
72-73	Vega	6270082	1	6.05	air inj. pump ( $\frac{3}{8}$ "— $50\frac{1}{4}$ ")
74	Vega	9433716	1	4.15	gen. drive ( $\frac{7}{16}$ "— $32$ ")
75	All (122)	334051	1	5.70	dist. drive
75	All (122)	9433714	1	4.15	gen. drive ( $\frac{7}{16}$ " x $31$ "
75	Monza (262) w/C.A.C.	9433768	1	6.05	p/s pump ( $\frac{15}{32}$ "— $58$ ")
75	Monza (262) (exc. C.A.C.)	9433662	1	4.90	p/s pump ( $\frac{3}{8}$ "— $56$ ")
75	Vega, Monza (8 cyl.) w/C.A.C.	9433747	1	5.15	gen. ( $\frac{15}{32}$ "— $47\frac{1}{2}$ ")
75	Vega, Monza (350) (exc. C.A.C.)	9433660	1	6.05	p/s pump ( $\frac{3}{8}$ "— $55$ ")
75	Vega, Monza w/2BC (140) w/A.I.R. (exc. C.A.C.)	9433766	1	6.05	p/s pump ( $\frac{15}{32}$ "— $57$ ")
75	Vega, Monza (140) w/A.I.R., P/S	9433715	1	4.95	gen. drive ( $\frac{15}{32}$ "— $31\frac{1}{2}$ ")
75	Monza (262) (exc. C.A.C.)	9433756	1	6.05	gen. drive ( $\frac{15}{32}$ "— $52$ ")
75	Monza (350) (exc. C.A.C.)	9433754	1	6.05	gen. drive ( $\frac{15}{32}$ "— $51$ ")
75	Monza (8 cyl.)	9433771	1	6.05	comp. drive ( $\frac{15}{32}$ "— $59\frac{1}{2}$ ")
75	Monza (350) (exc. C.A.C., P/S)	9433751	1	4.95	air inj. pump ( $\frac{15}{32}$ "— $49\frac{1}{2}$ ")
75	Vega, Monza (140) (exc. P/S),				
75	Monza (262) (exc. C.A.C., P/S)	9433752	1	6.05	air inj. pump ( $\frac{15}{32}$ "— $50$ ")
75	Vega, Monza w/2BC (140)	9433754	1	6.05	air inj. pump ( $\frac{15}{32}$ "— $51$ ")

**1.069 PUMP UNIT, Engine Coolant**

62-67	Pass., Chevy, Camaro (exc. 8 cyl.)				
68-69	All (153, 230, 250) (exc. Chevy),				
68-69	Chevy (exc. 8 cyl., C.A.C.),				
70-73	All (6 cyl.)				
74	All (6 cyl.) (exc. Nova),				
74	Nova (6 cyl.) (exc. C.A.C.)	357261	1	23.30	
74	Nova (6 cyl.) w/C.A.C.	358937	1	25.75	
64-65	Chevelle (6 cyl.) (exc. Taxi),				

**COOLANT—GRILLE—OIL SYSTEM**

**1.069 PUMP UNIT, Engine Coolant (Con't)**

65	Chevelle (Taxi) (194) (2nd design),				
66-67	Chevelle (6 cyl.) (exc. Air Cond.)	3876169	1	25.00	
65	Pass., Chevy (283, 327),				
65	Chevelle (327) (exc. Sp. H/Per.),				
68	Camaro (302) . . . . .	3998207	1	28.75	
65	Chevelle (283),				
65	Chevelle w/Sp. H/Per. (327),				
66-67	Pass., Chevy, Chevelle (283, 327),				
67	Camaro (8 cyl.),				
68	All (8 cyl.) (exc. 302) . . . . .	3998206	1	28.75	
65-67	Chevelle w/Air Cond. (6 cyl.),				
68-69	Chevy w/C.A.C. (6 cyl.) . . . . .	3960122	1	23.30	
65	Pass. (409) . . . . .	3857853	1	43.75	(less pulley) (Note 1) . . . . .
65-68	All (396, 427) . . . . .	3990993	1	54.50	(Note 1) . . . . .
	<i>NOTE 1 Includes pump to block gasket.</i>				
69-70	All (396, 400 w/4BC, 427, 454),				
71	All (400 w/4BC, 454),				
72-75	All (402, 454) . . . . .	6272159	1	43.00	
69	All (8 cyl.) (exc. 396, 427),				
70-71	All (307, 350),				
70-71	All w/2BC (400),				
72-75	All (262, 307, 350, 400) . . . . .	6272157	1	28.75	
75	All (6 cyl.) . . . . .	361054	1	23.30	
71-74	Vega,				
75	Vega, Monza (140) . . . . .	361053	1	29.75	w/pulley . . . . .
75	All (122) . . . . .	358175	1	29.75	
75	Monza (262, 350) . . . . .	359913	1	34.25	

**1.070 CAP, Coolant Pump**

64-69	All . . . . .	1191141	1	.40	heater hose pipe . . . . .
-------	---------------	---------	---	-----	----------------------------

**1.073 BOLT—STUD, Coolant Pump**

65-67	Pass. (8 cyl.) . . . . .				attach., . . . . .
65-67	Pass., Chevelle (w/C.A.C. (283, 327),				
67	Camaro w/C.A.C. (8 cyl.) . . . . .	3779940	1	.21	attach., lwr. hole, R.H.— (7.874) . . . . .
67	Camaro (A.I.R. w/Air Cond.) (8 cyl.) . . . . .	3785362	1	.32	upper right side— (0.002) . . . . .
64-65	Chevy, Chevelle (8 cyl.) (exc. Air Cond., Sp. H/Per.),				
65-68	Pass. (8 cyl.) (exc. C.A.C., A.I.R., Cool Pack 396, 409, 427),				
66	Chevy (8 cyl.) (exc. Air Cond., A.I.R.),				
66-67	Chevy, Chevelle (283, 327) (exc. Air Cond., A.I.R.),				
66-67	Chevelle, Camaro (396) (exc. A.I.R.),				
66-68	Pass. (396, 427) (exc. A.I.R.),				
67	Camaro (8 cyl.) (exc. A.I.R., Air Cond. 396),				
67	Camaro (302) . . . . .	3759755	1	.18	STUD, upper, R.H., pump attaching ( <sup>5</sup> / <sub>16</sub> "— 24 x <sup>2</sup> / <sub>8</sub> "— 16 x 2 <sup>9</sup> / <sub>16</sub> ") . . . . .
66-68	Pass. w/A.I.R. (396, 427),				
66-67	Chevelle w/A.I.R. (396) (exc. Sp. H/Per.),				
68	Chevelle (396) (exc. A.T., Sp. H/Per.),				
68-69	Chevy, Camaro (396) . . . . .	6272730	1	.34	STUD, upper R.H. . . . .
66	Chevy w/Sp. H/Per. (327) . . . . .	9418649	1	.25	STUD, water outlet ( <sup>2</sup> / <sub>8</sub> "— 16 x 2 <sup>7</sup> / <sub>8</sub> "— (8.900) . . . . .
66-67	Chevelle (8 cyl.) (exc. 396, 62 amp),				
67	Camaro (8 cyl.) (exc. A.I.R.) . . . . .	3903324	1	1.45	STUD, upper left ( <sup>5</sup> / <sub>8</sub> "— 16— 16 x 2 <sup>31</sup> / <sub>64</sub> "— (9.171) . . . . .
66	Pass., Chevelle w/A.I.R. (396, 427),				
67-68	All (396, 427) . . . . .	3877646	1	2.50	STUD, upper L.H. . . . .
69-71	All (302, 307, 327, 350),				
70-71	All w/2BC (400),				
72-75	All (307, 350, 400),				
75	Monza (262) (exc. Town Cpe.) . . . . .	3932368	1	.16	STUD, water outlet ( <sup>2</sup> / <sub>8</sub> "— 16 x 1 <sup>13</sup> / <sub>16</sub> " . . . . .

**COOLANT—GRILLE—OIL SYSTEM**

<b>1.073 BOLT— STUD, Coolant Pump (Con't)</b>					
75	Monza (262, 350) .....	3785362	1	.32	STUD, water outlet ( $\frac{3}{8}$ "— 16 x $2\frac{5}{8}$ ") .....
<b>1.079 GASKET, Coolant Pump Assembly (to Block)</b>					
62-72	All (exc. 8 cyl.),				
73-75	All (6 cyl.) .....	3788478	1	.17	
64-72	All (283, 302, 307, 327, 350),				
70-72	All w/2BC (400),				
73-75	All (8 cyl.) (exc. 454),				
75	Monza (262) .....	3754587	1	.17	left or right ( $\frac{13}{32}$ " large I.D.) (cork) (Note 1) ..
	<i>NOTE 1 When using as L.H. gasket trim off <math>\frac{1}{2}</math>" dia. hole.</i>				
65	Pass. (409) .....	3964224	2	.22	
65-72	All (396, 400 w/4BC, 402, 427, 454),				
73-75	All (454) .....	3860039	2	.17	( $\frac{17}{16}$ " I.D. x two $\frac{13}{32}$ " holes at ends) .....
71-75	Vega, Monza (exc. 262) .....	3973120	1	.19	
<b>1.097 CONNECTOR— ELBOW— HOSE, Coolant Pump By-Pass</b>					
65	Pass. (409) .....	3964228	2	.39	thermostat by-pass hose to water pump and inlet manifold (tube— $\frac{3}{8}$ " O.D. x $1\frac{5}{8}$ " long) .....
65-68	Chevelle (396),				
65-69	Pass. (396, 427),				
67-68	Camaro (396) (exc. A.I.R.) .....	3921915	2	.98	thermostat by-pass hose to inlet manifold and water pump ( $1\frac{39}{64}$ " O.L. x $\frac{49}{64}$ " O.D.) ..
67	Camaro w/A.I.R. (396) .....	3921916	2	1.65	therm, by-pass hose at water pump, inlet manifold .....
65-67	Chevy, Chevelle w/Sp. H/Per. (327),				
67-68	Camaro (302) .....	3829819	1	5.15	<b>ELBOW</b> , thermostat by-pass (at water pump) .....
75	Vega, Monza (122) .....	442407	1	3.90	<b>ELBOW</b> , therm. hsg. .....
65-68	All w/Sp. H/Per. (302, 327) .....	3794094	1	1.20	<b>HOSE</b> , thermostat by-pass— (8.846) .....
65	Pass. (409) .....	3760119	1	1.35	<b>HOSE</b> ( $\frac{5}{8}$ ") (Note 1) .....
65-68	Pass., Chevy, Chevelle (396, 427),				
67-68	Camaro (396) (exc. A.I.R.) .....	1485552	1	3.00	<b>HOSE</b> , thermostat by-pass ( $1\frac{1}{8}$ " O.D. x $\frac{3}{4}$ " I.D.) (Note 1) .....
67	Camaro w/A.I.R. (396) .....	3882829	1	1.25	<b>HOSE</b> , thermostat by-pass .....
	<i>NOTE 1 May be necessary to cut as required.</i>				
<b>1.105 SHAFT ASSY., Coolant Pump, with Bearing</b>					
65-68	All (396, 409, 427) .....	907738	1	12.06	( $4\frac{91}{64}$ " long) .....
<b>1.109 ROTOR, Coolant Pump</b>					
62-67	All (153, 194, 230, 250) (exc. Taxi),				
65	Chevy, Chevelle (Taxi) (194),				
65	Chevy (Taxi) (153),				
65-67	Pass. (Taxi) (230, 250),				
68-71	All (153, 230, 250) .....	3920917	1	3.00	w/pump .....
65-67	All (396, 427) .....	3863197	1	3.60	( $3\frac{55}{64}$ " O.D.) (stamped 3863197) .....
<b>1.123 SEAL, Coolant Pump</b>					
62-69	All (exc. 396, 427),				
69	Chevy (396),				
70	All,				
71	All (exc. 400 w/4BC, 454) .....	3927156	1	1.35	water pump .....
<b>1.148 GAUGE ASSY.— DIAL, Coolant Temperature (Dash Unit)</b>					
65	Malibu (S.S.) .....	6401598	1	9.60	
65	Impala (S.S.) .....	6401674	1	10.69	(less case, face plate and lens) .....
66-67	Chevelle (Spt. Cpe., Conv.),				
66-67	El Camino (Custom) .....	6402466	1	9.94	
67	Camaro (8 cyl.) .....	6402807	1	10.30	
68	Chevelle w/inst. panel gauges ..	6488813	1	8.10	
68-69	Camaro w/Console Instr. Cluster	6489836	1	10.08	
68-69	Chevy w/Console Instr. Cluster,				
70	Nova, Chevelle w/gauges,				
71-75	Nova w/console gauges .....	6489896	1	9.70	thermo .....
69	Chevelle w/inst. panel gauges ..	6489398	1	8.53	
70-72	Chevelle w/inst. panel gauges ..	6490087	1	12.36	thermo .....
70-75	Camaro w/inst. panel gauges ..	6489856	1	16.19	w/back plate (temp.) .....
71-74	Vega (G.T.) (140) .....	6489992	1	12.61	w/resistor .....
73-74	Chevelle w/inst. panel gauges ..	6490167	1	12.36	thermo. .....
75	Vega w/gauges (122) .....	8992569	1	13.80	w/resistor .....

**COOLANT—GRILLE—OIL SYSTEM**

**1.148 GAUGE ASSY.— DIAL, Coolant Temperature (Dash Unit) (Con't)**

75	Monza (Town Cpe.) . . . . .	<b>8987859</b>	1	27.02	temp. and volt . . . . .
75	Vega w/gauges (exc. 122),				
75	Monza (exc. Town Cpe.) . . . . .	<b>8992302</b>	1	14.44	w/resistor . . . . .
75	Pass. . . . .	<b>8992318</b>	1	14.56	coolant temp. (dash) . . . . .
75	Chevelle w/inst. panel gauges . . . . .	<b>8992361</b>	1	14.17	
73-74	Chevelle . . . . .	<b>6497327</b>	1	2.85	DIAL, temp. tell tale . . . . .

**1.150 GAUGE UNIT— SWITCH ASSY.— SENDER ASSY., Coolant Temperature (Engine Unit)**

68	Camaro, Chevelle w/inst. panel gauges (8 cyl.),				
68	Pass. w/inst. panel gauges, floor cluster (8 cyl.),				
63-65	All (S.S.),				
65	Pass. (409),				
66-67	Pass. (floor console w/gauges),				
66-68	Chevelle w/inst. panel gauges,				
67	Camaro w/console gauges,				
68	Chevy w/console gauges,				
69-75	All w/gauges . . . . .	<b>546702</b>	1	4.65	<b>GAUGE UNIT</b> . . . . .
62-66	Chevy, Chevelle . . . . .	<b>1993462</b>	1	5.60	<b>SWITCH ASSY.</b> (sending unit) . . . . .
65	Pass. (exc. S.S.),				
66	Pass. (exc. floor console w/gauges) . . . . .	<b>1993350</b>	1	5.70	<b>SWITCH ASSY.,</b> sending unit . . . . .
66-67	All (6 cyl.) (1st design),				
66-67	Chevy, Chevelle, Camaro (8 cyl.) (exc. gauges),				
67	Pass. (8 cyl.) (exc. inst. panel gauges),				
69	Chevy, Chevelle, Camaro (8 cyl.) (exc. gauges),				
69	Pass. (8 cyl.),				
69-70	Chevy (4 cyl.),				
70	Nova, Chevelle w/C.A.C., P.G., T.H. 350 (exc. gauges, Monte Carlo),				
70	Camaro w/C.A.C., A.T. (exc. gauges, 396),				
70	Monte Carlo w/C.A.C., P.G., T.H. 350 (exc. gauges, 400 w/2BC),				
70	Pass. w/C.A.C., P.G., T.H. 350 (350 w/2BC),				
70	Chevelle, Camaro (396, 400 w/4BC) (exc. gauges),				
70	Pass. w/A.T. (exc. 350 w/2BC),				
70	Monte Carlo w/T.H. 350 (400 w/2BC) (exc. gauges) . . . . .	<b>1993369</b>	1	5.05	<b>SWITCH ASSY.,</b> sending unit (stamped 369) (248 deg.) (Note 1) . . . . .
67	All (6 cyl.) (2nd design) . . . . .	<b>1993409</b>	1	5.55	<b>SWITCH ASSY.,</b> sending unit (stamped 409) (253 deg.) (Note 1) . . . . .
<i>NOTE 1 Part No. 1993409, 1993369 cannot be used in place of each other due to critical temp. range.</i>					
68-69	All (6 cyl.) . . . . .	<b>1993427</b>	1	5.15	<b>SWITCH ASSY.,</b> (253) (brown or red) . . . . .
68	All (8 cyl.) (exc. inst. panel gauges) . . . . .	<b>6489766</b>	1	6.15	<b>SWITCH ASSY.</b> (black) (248 degree switch)
70-72	All (6 cyl.) . . . . .	<b>6489903</b>	1	6.94	<b>SWITCH ASSY.</b> (stamped AC-82B-276M) . . . . .
70	Pass. (8 cyl.) (exc. C.A.C., A.T.),				
70	Nova (8 cyl.) (exc. C.A.C., gauges, 396),				
70	Chevelle, Camaro (exc. C.A.C., gauges, 396, 400 w/4BC, 454),				
71	All (8 cyl.) (exc. 400 w/4BC, 454),				
71-72	Vega,				
72	All (307, 350, 400, 454) . . . . .	<b>6489600</b>	1	6.17	<b>SWITCH ASSY.</b> (stamped A.C.-82B-260M on shell) (Note 4) . . . . .
70	Pass. w/T.H. 400 (400, 454) (2nd design),				
70	Nova (396) (exc. front comp. console inst. cluster),				
70	Chevelle (8 cyl.) (2nd design) (exc. 307, 350, inst. pnl. gauges),				
70	Camaro w/H/Per. (396) (2nd design) (exc. inst. pnl. gauges),				

**COOLANT—GRILLE—OIL SYSTEM**

**1.150 GAUGE UNIT— SWITCH ASSY.— SENDER ASSY., Coolant Temperature (Engine Unit) (Con't)**

70	Camaro w/Sp. H/Per. (396) (exc. inst. pnl. gauges) . . . . .	<b>1994095</b>	1	4.75	<b>SWITCH ASSY.</b> (stamped .095) . . . . .
70	Nova, Chevelle w/C.A.C., P.G., T.H. 350 (exc. gauges, Monte Carlo).				
70	Camaro (C.A.C. w/A.T.),				
70	Monte Carlo w/C.A.C., P.G., T.H. 350 (exc. gauges, 400 w/2BC),				
70	Pass. w/C.A.C., P.G., T.H. 350 (350 w/2BC),				
70	Chevelle, Camaro (396, 400 w/4BC) (exc. gauges),				
70	Pass. w/A.T. (exc. 350 w/2BC),				
70	Monte Carlo w/T.H. 350 (400 w/2BC) (exc. gauges),				
71	Camaro w/C.A.C. (400) . . . . .	<b>6489785</b>	1	6.62	<b>SWITCH ASSY.</b> (stamped A.C.-82B-232M) . . . . .
71-72	All (400 w/4BC, 402, 454) (exc. gauges) . . . . .	<b>6490094</b>	1	6.96	<b>SWITCH ASSY.</b> (2 terminals-stamped A.C.-82B-269M) (Note 2) . . . . .
73	Pass. (Sta. Wag.) (350, 400),				
73-74	Chevelle (307, 350) (exc. A.T. gauges) . . . . .				L.H.
73-74	Camaro (8 cyl.) (exc. A.T., Sp. instr.),				
73-74	Nova (8 cyl.) (exc. A.T., console gauges),				
73-74	Vega (exc. gauges, A.T.),				
75	Vega, Monza w/2BC (140),				
75	Vega, Monza w/1BC (140) w/A.T. . . . .	<b>6490452</b>	1	4.51	<b>SWITCH ASSY.</b> . . . . .
73-74	All (6 cyl.),				
73	Camaro w/gauges (exc. A.T.),				
73	Nova w/console gauges (exc. A.T.) . . . . .				1
73	Chevelle w/gauges (307, 350) (exc. A.T.),				
73-74	Vega w/gauges (exc. A.T.),				
74	All w/gauges (exc. A.T.) . . . . .	<b>6490454</b>	R.H.	6.42	<b>SWITCH ASSY.</b> . . . . .
73-74	Chevelle w/A.T. (350, 400) (exc. gauges),				
73-74	Pass. w/A.T. (350, 400) (exc. Sta. Wag.) . . . . .				L.H.
73-74	Camaro w/A.T. (350) (exc. Sp. instr.),				
73-74	Nova w/A.T. (350) (exc. console gauges),				
73-74	Vega w/A.T.,				
75	Vega, Monza (8 cyl.),				
75	Pass., Chevelle (350, 400) (exc. gauges),				
75	Nova, Camaro (262, 350) (exc. gauges),				
75	All (6 cyl.) . . . . .	<b>6490694</b>	1	4.99	<b>SWITCH ASSY.</b> . . . . .
73-74	All w/A.T. (454) (exc. gauges) . . . . .	<b>6490469</b>	L.H.	6.19	<b>SWITCH ASSY.</b> . . . . .
73-74	Chevelle (454) (exc. A.T.) . . . . .	<b>6490554</b>	L.H.	6.42	<b>SWITCH ASSY.</b> . . . . .
74	Chevelle (6 cyl.) . . . . .	<b>6490993</b>	1	6.42	<b>SWITCH ASSY.,</b> metal temp. . . . .
74	All (exc. Vega) . . . . .	<b>3030200</b>	1	7.95	<b>SWITCH ASSY.,</b> thermo. vac.— (3.670) . . . . .
75	All (454) . . . . .	<b>8992238</b>	L.H.	5.68	water temp. . . . .
75	Vega w/1BC (140) (exc. A.T.) . . . . .	<b>8992165</b>	1	8.09	<b>SWITCH ASSY.,</b> choke cont. and water temp. . . . .
75	Vega, Monza (122) . . . . .	<b>6490555</b>	1	6.42	<b>SWITCH ASSY.,</b> water temp. . . . .
75	Monza (8 cyl.) w/C.A.C. . . . .	<b>8992541</b>	1	5.20	<b>SWITCH ASSY.,</b> aux. coolant fan eng. temp. . . . .
75	Vega, Monza (122) . . . . .	<b>8992019</b>	1	8.98	<b>SENDER ASSY.,</b> water temp. . . . .

*NOTE 2 This switch is located on the right bank of the engine and used with 1993369 on the left bank.  
NOTE 4: These switches are located on the left bank of the engine with no other switch required on the right bank.*

**1.152 HEATER UNIT— CORD ASSY., Engine Heater**

71-75	All w/Engine Heater (exc. 402, 454) . . . . .	<b>994161</b>	1	8.75	
71-75	All w/Engine Heater (402, 454) . . . . .	<b>994162</b>	1	8.75	
74-75	Vega, Monza . . . . .	<b>992436</b>	1	10.50	(complete) engine block . . . . .
74-75	Vega, Monza . . . . .	<b>738667</b>	1	8.15	<b>HEATER ASSY.</b> (part of unit 992436) . . . . .

**COOLANT—GRILLE—OIL SYSTEM**

**1.152 HEATER UNIT— CORD ASSY., Engine Heater (Con't)**

69-70	All w/Prod. Engine Heater . . . . .	732546	1	3.60	CORD ASSY. (semi-circular receptacle) . . . . .
69-70	All w/Acc. Engine Heater . . . . .	732591	1	3.60	CORD ASSY. (rectangular receptacle) . . . . .
74-75	Vega, Monza . . . . .	740034	1	7.65	CORD ASSY. (part of unit 992436) . . . . .

**1.153 OUTLET, Coolant**

62-63	Chevy,				
64-67	Chevy (4 cyl.) . . . . .	3799344	1	2.30	(cast 3799344) . . . . .
64-67	Chevy (194, 230, 250),				
68-70	Chevy (4 cyl.),				
75	Vega, Monza (122) . . . . .	3841191	1	2.60	
64-65	Chevy (283),				
65	Pass. (8 cyl.) . . . . .	3837223	1	2.20	cast aluminum (cast 3837223) . . . . .
64-65	Chevelle (exc. Sp. H/Per.),				
65	Chevelle (Police) w/P.G.,				
65	Chevy (327),				
65-66	Pass. (6 cyl.),				
66-68	Chevelle, Camaro (6 cyl.),				
67-72	All (230, 250),				
73-75	All (6 cyl.) . . . . .	338117	1	2.75	
66-67	Chevelle, Camaro (396),				
66-67	Chevy, Chevelle, Camaro (283, 327, 350) (exc. Sp. H/Per.),				
66-67	Pass. (8 cyl.),				
68-73	All (8 cyl.) . . . . .	3877660	1	2.40	
74-75	All (8 cyl.) (exc. Monza) . . . . .	336790	1	2.60	
71-75	Vega, Monza (140) . . . . .	6270007	1	12.20	
75	Monza (8 cyl.) . . . . .	355957	1	10.90	

**1.154 GASKET, Coolant Outlet**

62-75	All . . . . .	3701777	1	.17	(2 holes <sup>13</sup> / <sub>16</sub> " I.D.) . . . . .
71-75	Vega, Monza (140) . . . . .	3977099	1	.13	
75	Vega, Monza (122) . . . . .	334033	1	.19	

**1.159 HOSE, Radiator Inlet**

*NOTE: "INLET" hose is used between top of radiator and engine coolant outlet. "OUTLET" hoses (group 1.173) are used between bottom of radiator and cylinder block.*

*NOTE Some hoses have been replaced with hoses of a different length or configuration. This replacement hose, in many instances will require cutting, using old part as guide.*

62-69	All w/ <sup>1</sup> / <sub>2</sub> " I.D. straight hose . . . . .	3701363 A.R.		3.80	( <sup>1</sup> / <sub>2</sub> " I.D. x 36 long) (moulded 3701363) . . . . .
62	Chevy (6 cyl.) (exc. C.A.C., alum. rad.),				
63	Chevy (6 cyl.) . . . . .	3842600	1	2.75	( <sup>1</sup> / <sub>32</sub> " I.D.) (moulded 3788533) . . . . .
62-67	Chevy (4 cyl.) . . . . .	3790492	1	2.40	( <sup>1</sup> / <sub>32</sub> " I.D.) (moulded 3790492) . . . . .
64	Chevelle (194),				
65	Chevelle (194) (exc. C.A.C., Taxi, Police),				
64-67	Chevy (6 cyl.) . . . . .	3852226	1	2.75	( <sup>1</sup> / <sub>32</sub> " I.D.) (moulded 3852226) . . . . .
64-65	Chevy (8 cyl.) (exc. C.A.C., H.D. Rad.) . . . . .	3790407	1	3.80	( <sup>1</sup> / <sub>2</sub> " I.D.) (moulded 3790407) . . . . .
64-65	Chevy w/C.A.C., H.D. Rad. (283),				
64-65	Chevelle (8 cyl.) (exc. Sp. H/Per. w/Hyd. lifters, Air Cond. H.D. Rad.),				
66	Chevy w/H.D. Rad. (283) (1st design) . . . . .	3788191	1	3.55	( <sup>1</sup> / <sub>2</sub> " I.D.) (moulded 3850687) . . . . .
64-65	Chevelle w/Air Cond. Equip., H.D. Rad. (8 cyl.) . . . . .	3850688	1	3.80	( <sup>1</sup> / <sub>2</sub> " I.D.) (moulded 3850688) . . . . .
64-66	Chevy w/Acc. Air Cond. (8 cyl.) (exc. S.S., H.D. Cooling) . . . . .	3754915	1	3.80	( <sup>1</sup> / <sub>2</sub> " I.D.) (moulded 3754915) . . . . .
64-65	Chevelle (230),				
65	Chevelle w/H.D. Rad., C.A.C., (194),				
65	Taxi, Police w/P.G.,				
66-67	Chevelle (6 cyl.) (exc. A.I.R.) . . . . .	3866781	1	4.90	( <sup>1</sup> / <sub>2</sub> " I.D.) (moulded 3866781) . . . . .
65-67	Pass. (6 cyl.) (exc. A.I.R.),				
68-70	Pass. (6 cyl.) . . . . .	3905057	1	4.90	( <sup>1</sup> / <sub>2</sub> " I.D.) (moulded 3905057) . . . . .
65	Pass. (283, 327) . . . . .	3860451	1	3.80	( <sup>1</sup> / <sub>2</sub> " I.D.) (moulded 3860451) (Note 1) . . . . .
	<i>NOTE 1 When using 3860451 in place of 3860447 cut approx. 2<sup>7</sup>/<sub>32</sub>" from rad. end and 1<sup>1</sup>/<sub>4</sub>" from eng. end.</i>				
65	Pass. w/C.A.C., H.D. Rad. (396) (exc. Sp. H/Per.),				
65	Pass. w/Sp. H/Per. (396),				
65	Chevelle (S.S.) w/Acc. Air Cond. (396),				

**COOLANT—GRILLE—OIL SYSTEM**

**1.159 HOSE, Radiator Inlet (Con't)**

66	Chevelle w/Acc. Air Cond. (396) (exc. Sp. H/Per.) . . . . .	<b>3863106</b>	1	3.80	(1½" I.D.) (moulded 3863106) . . . . .
66	Pass. w/H/Per., Sp. H/Per. (427),				
66	Pass. w/C.A.C., H.D. Rad. (396),				
67	Pass. (396) (exc. A.I.R.),				
67	Pass. w/C.A.C., H.D. Rad., H/Per. (427),				
68	Pass. w/C.A.C., H.D. Rad., H/Per. (396, 427),				
69	Pass. (C.A.C. w/427) (exc. 3 x 2),				
70	Pass. (454) . . . . .	<b>3768956</b>	1	4.05	(1½" I.D.) (moulded 3768956) . . . . .
66	Chevy, Chevelle w/C.A.C., H.D. Rad. (283, 327) (2nd design) (exc. Sp. H/Per.),				
66-68	Pass. w/C.A.C., H.D. Rad. (283, 307, 327),				
66-68	Pass. w/A.I.R. (327) (exc. C.A.C., H.D. Rad.),				
66	Pass. (8 cyl.) (exc. C.A.C., H.D. Rad., 327),				
66-67	Chevelle (283, 327) (exc. Sp. H/Per., C.A.C., H.D. Rad.),				
66-67	Chevy (283, 327) (exc. Sp. H/Per., C.A.C., H.D. Rad., A.I.R.),				
67-68	Pass. (307, 327) (exc. C.A.C., H.D. Rad., P.G.),				
67	Pass. w/A.I.R. (8 cyl.),				
67	Chevy, Chevelle w/Air Cond., H.D. Rad. (283),				
67	Chevy w/A.I.R. (283) (exc. H.D. Rad., Air Cond.),				
67	Chevelle w/A.I.R. (283, 327) (exc. H.D. Rad., Air Cond.),				
68	Pass. w/A.T. (307, 327) . . . . .	<b>3882883</b>	1	4.05	(1½" I.D.) (moulded 3882883) . . . . .
66-67	Pass. w/A.I.R. (6 cyl.) . . . . .	<b>3692230</b>	1	4.90	(1½" I.D.) (moulded 3692230)— (1.173) . . .
66-68	Pass. (396, 427) (exc. C.A.C., H.D. Rad.),				
67	Chevelle (396) (exc. H.D. Rad., Air Cond., A.T., H/Per.),				
69	Pass. w/H/Per. (427) (exc. C.A.C., H.D. Rad.) . . . . .	<b>3827366</b>	1	4.05	(1½" I.D.) (moulded 3827366) . . . . .
66	Chevelle (396),				
67	Chevelle w/C.A.C., H.D. Rad., A.T. (396) (exc. H/Per.),				
67	Chevelle w/H/Per. (396) . . . . .	<b>3880813</b>	1	3.55	(1½" I.D.) (moulded 3880813) . . . . .
66-67	Chevy w/C.A.C., H.D. Rad. (327) (exc. Sp. H/Per.),				
66	Chevelle w/C.A.C., H.D. Rad. (283, 327) (exc. Sp. H/Per.) . . .	<b>3882884</b>	1	3.80	(1½" I.D.) (moulded 3882884) . . . . .
66-67	Chevy w/Sp. H/Per. (327) (exc. H.D. Rad.) . . . . .	<b>3892682</b>	1	3.55	(1½" I.D.) (moulded 3892682) . . . . .
67	Camaro (8 cyl.) (exc. Air Cond., H.D. Rad., 302, 396) . . . . .	<b>3892626</b>	1	4.25	(1½" I.D.) (moulded 3892626) . . . . .
67	Camaro w/Air Cond., H.D. Rad. (327, 350) (exc. 2BC) . . . . .	<b>3892684</b>	1	5.35	(1½" I.D.) (moulded 3892684) . . . . .
67-69	Camaro (6 cyl.),				
68-70	Chevelle (6 cyl.),				
71-72	Pass., Chevelle (6 cyl.),				
73-75	Chevelle (6 cyl.) (exc. C.A.C.) . . .	<b>3905964</b>	1	3.55	(1½" I.D.) (moulded 3905964) . . . . .
67-68	Camaro (396) (exc. C.A.C.),				
68-69	Chevy (396),				
69	Camaro (396) (exc. C.A.C., H.D. Rad., P/Trac.),				
70	Nova (396) . . . . .	<b>3909866</b>	1	4.25	(1½" I.D.) (moulded 3909866) (Note 3) . . .
	<i>NOTE 3: It may be necessary to cut 2" from engine end of hose.</i>				
67-68	Camaro (302) . . . . .	<b>3892650</b>	1	5.35	(1½" I.D.) (moulded 3892650) . . . . .
68	Chevelle (396),				
69-70	Chevelle (396, 400 w/4BC, 454) (exc. C.A.C., H.D. Rad., P/Trac., 4.10 rear axle),				
69	Chevelle w/C.A.C., H.D. Rad., P/Trac., 4.10 rear axle (396, 400 w/4BC, 454),				

**COOLANT—GRILLE—OIL SYSTEM**

**1.159 HOSE, Radiator Inlet (Con't)**

71-72	Chevelle (400 w/4BC, 402, 454) (exc. Monte Carlo) . . . . .	<b>3942453</b>	1	5.35	(1½" I.D.) (moulded 3942453) . . . . .
68	Chevelle w/P.G., T.H. 350, C.A.C., H.D. Rad. (8 cyl.) (exc. 396),				
69	Chevelle w/P.G., T.H. 350 reg. fuel (350) (exc. C.A.C., H.D. Rad.),				
70	Chevelle w/A.T., 2BC (350) (exc. C.A.C., H.D. Rad., Monte Carlo)	<b>3932396</b>	1	5.35	(1½" I.D.) (moulded 3932396) . . . . .
68	Chevy (8 cyl.) (exc. 396),				
68	Camaro (8 cyl.) (exc. 302, 396, C.A.C., H.D. Rad.),				
68	Chevelle (8 cyl.) (exc. P.G., C.A.C., H.D. Rad., 327, 396 w/Sp. H/Per.),				
69	Chevelle (8 cyl.) (exc. C.A.C., H.D. Rad., 396),				
70	Chevelle (8 cyl.) (exc. Monte Carlo, C.A.C., H.D. Rad., P.G., T.H. 350, 396, 400 w/4BC, 454) . . . . .	<b>3923229</b>	1	4.25	(1½" I.D.) (moulded 3923229) . . . . .
68-70	Chevy (4 cyl.) . . . . .	<b>3983423</b>	1	3.80	(1 <sup>9</sup> / <sub>32</sub> " I.D.) (moulded 3983423) . . . . .
68-69	Chevy (6 cyl.) (exc. A.T.) . . . . .	<b>3920923</b>	1	2.70	(1½" I.D.) (moulded 3920923) . . . . .
68-69	Chevy w/A.T. (6 cyl.),				
70-73	Nova (6 cyl.),				
74	Nova (6 cyl.) (exc. C.A.C.) . . . . .	<b>3931054</b>	1	4.05	(1½" I.D.) (moulded 3931054) . . . . .
69	Camaro w/P/Trac., 3.73 ratio (396) (exc. Sp. H/Per.),				
69	Camaro w/C.A.C. (396),				
69	Camaro w/P/Trac., 4.10 ratio, H/Per., Sp. H/Per. (396) (exc. C.A.C.) . . . . .	<b>3946039</b>	1	5.35	(1½" I.D.) (moulded 3946039) . . . . .
69-70	Chevelle w/C.A.C., H.D. Rad. (8 cyl.) (exc. 396, 400 w/4BC, 454, Monte Carlo) . . . . .	<b>3942535</b>	1	5.35	(1½" I.D.) (moulded 3942535) . . . . .
69	Chevy, Camaro (8 cyl.) (exc. 396),				
70-72	Nova (8 cyl.) (exc. 396),				
70	Pass. w/H.D. Rad. (8 cyl.) (exc. 454),				
73-74	Nova (8 cyl.) (exc. H.D. Rad.) . . . . .	<b>3956662</b>	1	4.25	(moulded 3956662) . . . . .
69	Pass. (327, 350),				
70	Pass. (8 cyl.) (exc. 454) . . . . .	<b>3942515</b>	1	4.05	(1½" I.D.) (moulded 3942515) . . . . .
69	Pass. (396, 427) . . . . .	<b>3827366</b>	1	4.05	(1½" I.D.) (moulded 3827366) . . . . .
70-72	Monte Carlo w/C.A.C., H.D. Rad., 2BC (350) (exc. A.T.),				
70-72	Monte Carlo w/A.T., 2BC (350),				
70	Monte Carlo w/C.A.C., H.D. Rad. 4/BC (350),				
70-72	Monte Carlo (400, 402, 454),				
71-72	Monte Carlo w/4BC (350) . . . . .	<b>328943</b>	1	6.25	(1½" I.D.) (moulded 328943) . . . . .
70	Monte Carlo (350) (exc. C.A.C., H.D. Rad),				
71-72	Monte Carlo w/2BC (350) (exc. C.A.C., H.D. Rad., T.H. 350) . . . . .	<b>3972144</b>	1	6.25	(1½" I.D.) (moulded 3972144) . . . . .
70-72	Camaro (6 cyl.) . . . . .	<b>3967052</b>	1	3.55	(1½" I.D.) (moulded 3967052) . . . . .
70-75	Camaro (307, 350) (exc. C.A.C., H.D. Rad., Sp. H/Per.) . . . . .	<b>3970120</b>	1	4.25	(1½" I.D.) (moulded 3970120) . . . . .
70-75	Camaro w/Sp. H/Per. (350),				
70-75	Camaro w/C.A.C., H.D. Rad. (307, 350) . . . . .	<b>3970124</b>	1	5.15	(1½" I.D.) (moulded 3970124) . . . . .
70	Camaro (396, 454),				
71-72	Camaro (400 w/4BC, 402) . . . . .	<b>3973192</b>	1	5.15	(1½" I.D.) (moulded 3973192) . . . . .
71-73	Chevelle (307) (exc. C.A.C., H.D. Rad., Monte Carlo) . . . . .	<b>3989028</b>	1	4.25	(1½" I.D.) (moulded 3989028) . . . . .
71-73	Chevelle w/C.A.C., H.D. Rad (307) (exc. Monte Carlo),				
71-75	Chevelle (350, 400) (exc. Monte Carlo),				
71-75	Pass. (350, 400 w/2BC) . . . . .	<b>3986380</b>	1	5.70	(1½" I.D.) (moulded 3986380) . . . . .
71-72	Chevelle w/C.A.C. (400, 402, 454 w/H/Per.),				
71-72	Pass. (400 w/4BC, 402, 454) . . . . .	<b>3989342</b>	1	5.35	(1½" I.D.) (moulded 3989342) . . . . .



**COOLANT—GRILLE—OIL SYSTEM**

**1.159 HOSE, Radiator Inlet (Con't)**

71-75	Vega (140) (exc. C.A.C., H.D. Rad.)	3994253	1	2.20	
71-75	Vega (140) w/C.A.C., H.D. Rad.	6264398	1	2.20	
73-75	Pass., Chevelle (454) (exc. Monte Carlo)	328990	1	4.90	(1 1/2" I.D.)
73-74	Nova w/H.D. Rad. (8 cyl.)	327579	1	4.90	(1 1/2" I.D.)
73-75	Monte Carlo (350, 400)	328959	1	6.25	(1 1/2" I.D.)
73-75	Monte Carlo (454)	331781	1	7.30	(1 1/2" I.D.)
73-75	Camaro (6 cyl.) (exc. H.D. Rad.)	333746	1	4.05	(1 1/2" I.D.)
73	Pass. (6 cyl.)	335908	1	6.25	(1 1/2" I.D.)
74	Nova (6 cyl.) w/C.A.C.	333753	1	5.10	(1 1/2" I.D.)
75	Camaro (6 cyl.) w/H.D. Rad.	356614	1	3.35	
75	Chevelle (6 cyl.) w/C.A.C.	352097	1	4.25	
75	Nova (6 cyl.) (exc. H.D. Rad.)	345558	1	3.85	
75	Nova (8 cyl.) (exc. C.A.C., H.D. Rad.)	345513	1	4.05	
75	Nova (8 cyl.) w/C.A.C. (exc. H.D. Rad.)				
75	Nova (8 cyl.) w/H.D. Rad.	345514	1	5.35	
75	Nova (6 cyl.) w/H.D. Rad.	356608	1	4.05	
75	Monza (140) w/H.D. Rad.	358312	1	2.70	
75	Vega, Monza (8 cyl.) (exc. Notchback)	358318	1	4.65	
75	Vega, Monza (122)	336598	1	2.20	
75	Monza (Town Cpe.) (8 cyl.)	365280	1	3.65	
75	Monza (140) (exc. Town Cpe., H.D. Rad.)	358310	1	2.20	

**1.166 CLAMP, Hose, with Nut and Bolt**

All	All	1470029	A.R.	.73	for 13/16" dia. hose (stainless steel)
All	All	2468878	A.R.	.73	worm adj. type (1 3/8" x 2 1/4" I.D. range)
All	All	3749810	A.R.	.74	adjustable strap type (1" to 6")
All	All	2260846	A.R.	.80	rad. outlet (3 1/4" dia. open and 2 7/8" closed)
All	All	2494772	A.R.	.65	miniature worm drive type (1/4" x 5/8" dia. range)
All	All	1470030	A.R.	.73	worm adj. type (1 1/16" x 1 1/4" I.D.)
All	All w/C.A.C.	2471945	1	.73	evap. drain hose
All	All	1233754	2	.12	crankcase vent. hose (spring band) (7/8" x 1 1/16")
75	All (454)	451203	2	.18	therm. bypass hose

**1.173 HOSE— REINFORCEMENT— STRAP, Radiator Outlet**

*NOTE "Outlet" hoses are used between bottom of radiator and cyl. block. "Inlet" hose (group 1.159) is used between top of radiator and eng. coolant outlet.*

*NOTE Some hoses have been replaced with hoses of a different length or configuration. This replacement hose, in many instances, will require cutting, using old part as guide.*

62-67	Chevy (4 cyl.)	3790493	1	3.55	(1 3/4" I.D.) (moulded 3790493)
62	Chevy (6 cyl.) (exc. C.A.C., alum. rad.),				
63-67	Chevy (6 cyl.),				
64-65	Chevelle (230),				
65	Chevelle w/C.A.C., H.D. Rad., Trans. oil cooler (194),				
65	Police, Taxi w/P.G.,				
65-67	Chevelle (6 cyl.) (2nd design),				
64	Chevelle (194),				
65	Chevelle (194) (1st design) (exc. C.A.C., H.D. Rad., Taxi, Police),				
70	Pass. (6 cyl.)	3851680	1	5.35	(1 3/4" I.D.) (moulded 3851680)
64	Chevy (8 cyl.),				
64-66	Chevelle (283) (exc. Air Cond., H.D. Rad.),				
65-67	Chevy (8 cyl.) (exc. Sp. H/Per., A.I.R., H.D. Rad., C.A.C.),				
65-67	Pass. (283, 327) (exc. H.D. Rad., A.I.R.),				
66	Chevelle w/A.I.R. (283, 327) (2nd design) (exc. Sp. H/Per.),				
67	Chevelle (283, 327) (exc. C.A.C., Sp. H/Per., H.D. Rad., A.I.R.),				
68	Pass. (307, 327) (exc. C.A.C., A.T., H.D. Rad.)	3860448	1	3.80	(1 3/4" I.D.) (moulded 3860448)
64-65	Chevelle w/Air Cond., H.D. Rad. (283),				
64-65	Chevelle (327),				

**COOLANT—GRILLE—OIL SYSTEM**

<b>1.173 HOSE— REINFORCEMENT— STRAP, Radiator Outlet (Con't)</b>					
66	Chevelle (327) (exc. Sp. H/Per.) . . . . .	<b>3839303</b>	1	3.80	(1 <sup>3</sup> / <sub>4</sub> " I.D.) (moulded 3839303) . . . . .
65-69	Pass. (6 cyl.) . . . . .	<b>3857040</b>	1	5.35	(1 <sup>3</sup> / <sub>4</sub> " I.D.) (moulded 3857040) . . . . .
65-68	Pass. w/H.D. Rad., C.A.C. (283, 307, 327),				
66-68	Pass. w/A.I.R. (283, 327) (exc. H.D. Rad.),				
68	Pass. w/T.H. 350 (exc. C.A.C.) . . . . .	<b>3860452</b>	1	4.25	(1 <sup>3</sup> / <sub>4</sub> " I.D.) (moulded 3860452) . . . . .
66-67	Chevelle (396),				
66-68	Pass. (396, 427) . . . . .	<b>3881814</b>	1	3.80	(1 <sup>3</sup> / <sub>4</sub> " I.D.) (moulded 3881814) . . . . .
66-67	Chevy w/A.I.R. (283) (exc. H.D. Rad.),				
66-67	Chevy w/A.I.R. (327),				
66-67	Chevy w/H.D. Rad., C.A.C. (283),				
66	Chevy w/Sp. H/Per. (327) (exc. H.D. Rad.) . . . . .	<b>3881856</b>	1	4.25	(1 <sup>3</sup> / <sub>4</sub> " I.D.) (moulded 3881856) . . . . .
66	Chevelle w/A.I.R. (283, 327) (1st design) (exc. Sp. H/Per.),				
66-67	Chevelle w/Air Cond., H.D. Rad., (283, 327) (exc. Sp. H/Per.),				
67	Chevelle (A.I.R. w/P.G.) (283) (exc. C.A.C., H.D. Rad.) . . . . .	<b>3881857</b>	1	4.25	(1 <sup>3</sup> / <sub>4</sub> " I.D.) (moulded 3881857) . . . . .
67-69	Camaro (6 cyl.) . . . . .	<b>3891554</b>	1	4.65	(1 <sup>3</sup> / <sub>4</sub> " I.D.) (moulded 3891554) . . . . .
67-68	Camaro (8 cyl.) (exc. S.S.) . . . . .	<b>3892628</b>	1	4.25	(1 <sup>3</sup> / <sub>4</sub> " I.D.) (moulded 3892628) . . . . .
67-68	Camaro (396) . . . . .	<b>3909868</b>	1	3.80	(1 <sup>3</sup> / <sub>4</sub> " I.D.) (moulded 3909868) . . . . .
68-75	Chevelle (6 cyl.),				
71-72	Pass. (6 cyl.) . . . . .	<b>479236</b>	1	5.10	(1 <sup>3</sup> / <sub>4</sub> " I.D.) . . . . .
68	Chevelle (396) . . . . .	<b>3937733</b>	1	5.95	(1 <sup>3</sup> / <sub>4</sub> " I.D.) (moulded 3937733) . . . . .
68	Chevy, Chevelle (8 cyl.) (exc. 396) . . . . .	<b>3932394</b>	1	4.25	(1 <sup>3</sup> / <sub>4</sub> " I.D.) (moulded 3932394) . . . . .
68-70	Chevy (4 cyl.) . . . . .	<b>3920926</b>	1	3.55	(1 <sup>3</sup> / <sub>4</sub> " I.D.) (moulded 3920926) . . . . .
68-74	Chevy (6 cyl.) . . . . .	<b>3920924</b>	1	4.90	(1 <sup>3</sup> / <sub>4</sub> " I.D.) (moulded 3920924) . . . . .
69	Camaro (8 cyl.) (exc. 396) . . . . .	<b>3942561</b>	1	4.65	(1 <sup>3</sup> / <sub>4</sub> " I.D.) (moulded 3942561) . . . . .
69-74	Chevy (8 cyl.) (exc. 396) . . . . .	<b>3959490</b>	1	7.90	(1 <sup>3</sup> / <sub>4</sub> " I.D.) (moulded 3959490) . . . . .
69	Camaro (396) . . . . .	<b>3946044</b>	1	3.80	(1 <sup>3</sup> / <sub>4</sub> " I.D.) (moulded 3946044) . . . . .
69-70	Chevelle (396, 400 w/4BC, 454) (exc. Monte Carlo) . . . . .	<b>3959188</b>	1	4.65	(moulded 3959188SZ) . . . . .
69-70	Chevelle (8 cyl.) (exc. C.A.C., H.D. Rad., P.G., T.H. 350, 396, 454, Monte Carlo),				
71	Chevelle (307) (exc. C.A.C., H.D. Rad., Monte Carlo),				
71-72	Camaro (400, 402) (396, 454) . . . . .	<b>3959486</b>	1	4.65	(1 <sup>3</sup> / <sub>4</sub> " I.D.) (moulded 3959486) . . . . .
69	Chevelle w/P.G., T.H. 350 (350 w/reg. fuel),				
69-70	Chevelle w/C.A.C., H.D. Rad. (307, 350) (exc. Monte Carlo),				
71-72	Chevelle w/C.A.C., H.D. Rad. (307) (exc. Monte Carlo),				
71-72	Chevelle (350) (exc. Monte Carlo),				
71-73	Pass. (350, 400 w/2BC) . . . . .	<b>3959488</b>	1	4.65	
69	Pass. (327, 396) (exc. C.A.C., H.D. Rad., A.T., Police) . . . . .	<b>3902703</b>	1	4.25	(1 <sup>3</sup> / <sub>4</sub> " I.D.) (moulded 3942516) . . . . .
69	Pass. w/C.A.C., H.D. Rad., 4BC (350) (exc. A.T., reg. fuel),				
69	Pass. w/reg. fuel (350),				
69	Pass. w/P.G., T.H. 350 (8 cyl.) (exc. 350),				
69	Pass. w/T.H. 400 (327),				
69	Police (350) (exc. C.A.C., P.G., T.H.),				
70	Pass. (8 cyl.) (exc. 454) . . . . .	<b>3942517</b>	1	4.25	(1 <sup>3</sup> / <sub>4</sub> " I.D.) (moulded 3942517) . . . . .
69-70	Chevy (396) . . . . .	<b>3947809</b>	1	3.80	(1 <sup>3</sup> / <sub>4</sub> " I.D.) (moulded 3947809) . . . . .
69	Pass. (396, 427),				
70	Pass. (454) . . . . .	<b>3845442</b>	1	7.90	(1 <sup>3</sup> / <sub>4</sub> " I.D.) (moulded 3845442) . . . . .
70	Monte Carlo (350) (exc. C.A.C., H.D. Rad., A.T.),				
71-72	Monte Carlo w/2BC (350) (exc. C.A.C., H.D. Rad., A.T.) . . . . .	<b>3972146</b>	1	5.70	(1 <sup>3</sup> / <sub>4</sub> " I.D.) (moulded 3972146) . . . . .
70	Monte Carlo w/C.A.C., H.D. Rad., 2BC (350) (exc. A.T.),				
70	Monte Carlo w/C.A.C., H.D. Rad., 4BC (350),				
70-72	Monte Carlo w/A.T., 2BC (350),				
70-71	Monte Carlo w/2BC (400),				

**COOLANT—GRILLE—OIL SYSTEM**

**1.173 HOSE— REINFORCEMENT— STRAP, Radiator Outlet (Con't)**

71-72	Monte Carlo w/4BC (350) . . . . .	3972150	1	5.70	(1 <sup>3</sup> / <sub>4</sub> " I.D.) (moulded 3972150) . . . . .
70-72	Monte Carlo w/4BC (400, 402, 454) . . . . .	3969947	1	5.70	(1 <sup>3</sup> / <sub>4</sub> " I.D.) (moulded 3969947) . . . . .
70-74	Camaro (6 cyl.) . . . . .	3967054	1	4.90	(1 <sup>3</sup> / <sub>4</sub> " I.D.) (moulded 3967054) . . . . .
70	Camaro (8 cyl.) (exc. 396, 454),				
71-75	Camaro (8 cyl.) (exc. 400, 402) .	3970122	1	4.90	(1 <sup>3</sup> / <sub>4</sub> " I.D.) (moulded 3970122) . . . . .
71-72	Pass., Chevelle (400 w/4BC, 402, 454) (exc. Monte Carlo),				
73-75	Pass. (454) . . . . .	3992083	1	4.25	(1 <sup>3</sup> / <sub>4</sub> " I.D.) (moulded 3992083) . . . . .
71-75	Vega (exc. C.A.C., H.D. Rad.) . . .	3980262	1	5.15	
71-75	Vega w/C.A.C., H.D. Rad. . . . .	3980263	1	4.05	
73	Pass. (6 cyl.) . . . . .	335909	1	4.25	(1 <sup>3</sup> / <sub>4</sub> " I.D.) . . . . .
73	Chevelle w/C.A.C., H.D. Rad. (307),				
73-74	Chevelle (350, 400) (exc. Monte Carlo),				
74-75	Pass. (350, 400) . . . . .	331748	1	5.70	(1 <sup>3</sup> / <sub>4</sub> " I.D.) (moulded 331748) . . . . .
73-75	Monte Carlo (350, 400) . . . . .	328960	1	5.70	(1 <sup>3</sup> / <sub>4</sub> " I.D.) . . . . .
73	Chevelle (307) (exc. C.A.C., H.D. Rad.) . . . . .	328988	1	4.65	(1 <sup>3</sup> / <sub>4</sub> " I.D.) . . . . .
73-75	Chevelle (454) (exc. Monte Carlo) . . . . .	328989	1	5.70	(1 <sup>3</sup> / <sub>4</sub> " I.D.) . . . . .
73-75	Monte Carlo (454) . . . . .	331782	1	5.70	(1 <sup>3</sup> / <sub>4</sub> " I.D.) . . . . .
75	Chevelle (350, 400) (exc. Monte Carlo) . . . . .	345348	1	5.70	
75	Chevelle (6 cyl.) w/C.A.C. . . . .	352098	1	4.90	
75	Nova (8 cyl.) . . . . .	345521	1	5.70	
75	Nova (6 cyl.) . . . . .	356610	1	5.10	
75	Camaro (6 cyl.) . . . . .	356613	1	3.60	
75	Vega, Monza (8 cyl.) . . . . .	358319	1	4.05	
75	Monza Town Cpe. (140), Monza w/2BC (140) w/H.D. Rad. (exc. Town Cpe.),				
75	Monza w/1BC (140) . . . . .	358313	1	3.30	
75	Monza w/2BC (140) (exc. H.D. Rad. & Town Cpe.) . . . . .	358311	1	5.15	
70-73	Monte Carlo . . . . .	3981015	1	.63	<b>REINFORCEMENT, hose</b> . . . . .
70-75	Monte Carlo . . . . .	3999780	1	.13	<b>STRAP, hose</b> . . . . .

**1.203 CAP— SENSOR UNIT— FITTING— MODULE ASSY.— PROBE ASSY., Radiator and Recovery Tank**

62-64	Chevy, Chevelle (exc. Air Cond., H.D. Rad.) . . . . .	850800	1	2.30	pressure type (13 lb.) . . . . .
62-64	Chevy, Chevelle w/Air Cond., H.D. Rad.,				
65-71	All (exc. Vega),				
72	All (exc. Taxi, Police, Vega),				
71-72	Vega (exc. Recovery unit),				
73	All (exc. Recovery unit) . . . . .	861050	1	2.30	
72	Taxi, Police,				
72	Vega w/Recovery unit,				
73	All w/Recovery unit,				
74	All,				
75	All (exc. Vega, Monza) . . . . .	6410665	1	2.77	
75	Vega, Monza . . . . .	6410785	1	3.03	
71-74	Vega . . . . .	364002	1	12.65	<b>SENSOR UNIT, coolant level</b> . . . . .
75	All (122) . . . . .	356170	1		<b>SENSOR ASSY., water temp.— (3.320)</b> . . . . .
71-74	Vega . . . . .	364007	1	1.75	<b>FITTING, coolant level sensor</b> . . . . .
71-74	Vega . . . . .	364005	1	6.50	<b>MODULE ASSY., coolant level sensor (inst. panel)</b> . . . . .
75	Vega, Monza . . . . .	356135	1	6.50	<b>MODULE ASSY., coolant level sensor (inst. panel)</b> . . . . .
71-74	Vega . . . . .	364006	1	1.35	<b>PROBE ASSY., coolant level sensor (radiator)</b> . . . . .
75	Vega, Monza . . . . .	358375	1	1.35	<b>PROBE ASSY., coolant level sensor (radiator)</b> . . . . .

**1.219 CORE, Radiator**

*NOTE: For drain cocks see Standard Parts Group 8.951.*

*NOTE in some cases standard radiators are replaced by heavy duty radiators and radiators with oil coolers can be used in place of ones without oil coolers.*

*For 1972-75 usage see chart at end of group.*

**CHEVY**

**COOLANT—GRILLE—OIL SYSTEM**

**1.219 CORE, Radiator (Con't)**

*NOTE 1 Must also be used as a replacement for Aluminum Radiator. Inlet Hose, 3788533, and Outlet Hose, 3792813, must also be used when using this core as a replacement for Aluminum Radiator.*

62-70	Chevy (153) . . . . .	3003908	1	86.50	w/oil cooler, w/o finger guard (Note 3) . . . . .
	<i>NOTE 3 When using 3003908 in place of 3153508 it is necessary to remove trans. oil cooler line fittings to rad. and assy. fittings 137398.</i>				
	<i>NOTE 2 When using on models not equipped with Heavy Duty Radiator or Air Cond., it will be necessary to use hose 3850687.</i>				
64-66	Chevy (194) (exc. C.A.C., H.D. Rad., A.I.R., Taxi, Police),				
67	Chevy (194) (exc. C.A.C., P.G., H.D. Rad., A.I.R.),				
67	Chevy w/P.G. (194) (exc. A.I.R., C.A.C., H.D. Rad.),				
67	Chevy w/A.I.R. (194) (2nd design) (exc. C.A.C., H.D. Rad.)	3001012	1	82.00	w/o oil cooler and finger guard (stamped 112) . . . . .
66-67	Chevy w/P.G. (8 cyl.) (exc. H.D. Rad., A.I.R.) . . . . .	3007668	1	116.00	w/oil cooler . . . . .
	<i>NOTE 6 For 1st design see 3007651.</i>				
67	Chevy w/P.G. (250) (1st design) (exc. A.I.R., C.A.C., H.D. Rad.),				
67	Chevy w/P.G. (6 cyl.) (2nd design) (exc. C.A.C., H.D. Rad.)	3013509	1	111.00	
68-69	Chevy w/P.G., T.H. 350 (C.A.C., H.D. Rad.) (8 cyl.),				
70-71	Nova w/C.A.C., H.D. Rad. (307, 350) . . . . .	3022040	1	148.40	w/oil cooler . . . . .
68	Chevy (6 cyl.) (exc. P.G., Torque Drive),				
69	Chevy (6 cyl.) (exc. A.T.),				
68-69	Chevy w/C.A.C., H.D. Rad. (A.T. w/6 cyl.),				
70-71	Nova w/H.D. Rad., A.T. (6 cyl.) . .	3014714	1	119.60	w/oil cooler . . . . .
68	Chevy (8 cyl.) (exc. C.A.C., H.D. Rad., 396),				
68-69	Chevy w/A.T. (exc. C.A.C., H.D. Rad.),				
69	Chevy (8 cyl.) (exc. P.G., C.A.C., H.D. Rad., 396),				
70-71	Nova (307, 350) (exc. C.A.C., H.D. Rad.) . . . . .	3016670	1	80.45	w/oil cooler (Note 9) . . . . .
	<i>NOTE 9 Also appears in Chevelle section.</i>				
68-69	Chevy 400,				
70	Nova (396) . . . . .	3017838	1	144.00	w/oil cooler (Note 10) . . . . .
	<i>NOTE 10 Also appears in Camaro section.</i>				
69-70	Chevy w/A.T. (250) (exc. C.A.C., H.D. Rad.),				
71	Nova w/A.T. (6 cyl.) (exc. H.D. Rad.) . . . . .	3020210	1	95.25	w/oil cooler (Ident. No. 3020210) (code letters HH) . . . . .
69	Chevy w/A.T. (230) (exc. C.A.C., H.D. Rad.) . . . . .	3019102	1	80.75	w/oil cooler . . . . .
70-71	Nova (6 cyl.) (exc. A.T.) . . . . .	3021750	1	104.10	w/o oil cooler (Ident. No. 3021750— Code letters HO) . . . . .

**CHEVELLE**

65-66	Chevelle (194) (exc. Taxi, Police, C.A.C., P.G., H.D. Rad., oil cooler, A.I.R.),				
65	Chevelle (230) (exc. C.A.C., P.G., H.D. Rad., oil cooler, A.I.R.),				
65-66	Chevelle (230) (2nd design) (exc. Taxi, Police, H.D. Rad., trans. oil cooler, A.I.R.),				
66	Chevelle (P.G., w/A.I.R.) (230),				
67	Chevelle (6 cyl.) (exc. A.I.R., C.A.C., H.D. Rad.),				
67	Chevelle (230) (exc. H.D. Rad., C.A.C.) . . . . .	3005801	1	104.00	w/o oil cooler, w/finger guard . . . . .
65-66	Chevelle w/trans. oil cooler (194) (exc. A.I.R.),				
65	Chevelle (Taxi, Police) w/P.G. (6 cyl.),				
65-67	Chevelle (C.A.C., w/P.G.) (6 cyl.),				

**COOLANT—GRILLE—OIL SYSTEM**

**1.219 CORE, Radiator (Con't)**

65-66	Chevella (H.D. Rad. w/P.G.) (230),					
67	Chevella (H.D. Rad. w/P.G.) (6 cyl.)	3003906	1	121.00	w/oil cooler, w/o finger guard	
66-67	Chevella (396) (exc. Sp. H/Per., C.A.C., T.H., H.D. Rad., P.G.),					
66	Chevella w/Sp. H/Per. (H.D. Rad., C.A.C.) (327) (1st design) (exc. P.G.),					
67	Chevella w/Sp. H/Per. (C.A.C., H.D. Rad.) (327),					
67	El Camino w/C.A.C., H.D. Rad. (396, 327 w/Sp. H/Per.) (exc. P.G., H/Per.),					
67	Chevella (S.S.) w/C.A.C. (396) (exc. P.G., T.H.),					
66	Chevella w/A.T. (396)	3007621	1	151.00		
66-67	Chevella (C.A.C., H.D. Rad.) (A.T.) (396)	3010209	1	183.00		
66-67	Chevella w/P.G. (H.D. Rad., C.A.C.) (8 cyl.) (exc. 396)	3012519	1	135.00	w/oil cooler	
68	Chevella (A.T. w/396) (exc. C.A.C., H.D. Rad., H/Per.)	3014642	1	112.95	w/oil cooler	
68	Chevella (S.S.) w/C.A.C., H.D. Rad. (exc. A.T.)	3014608	1	104.65	w/o oil cooler	
68	Chevella (S.S.) w/C.A.C., H.D. Rad., A.T.	3014609	1	118.60	w/oil cooler	
68	Chevella w/C.A.C., H.D. Rad. (327 reg. fuel) (exc. P.G.),					
71	Chevella w/C.A.C., 4BC (350) (exc. A.T., H.D. Rad., Monte Carlo)	3023894	1	139.90	w/o oil cooler (Ident. No. 3023894-code letters SV)	
68	Chevella (exc. S.S., A.T., 327 reg. fuel),					
69-70	Chevella w/C.A.C., H.D. Rad. (307, 350) (exc. A.T.),					
71	Chevella w/C.A.C., H.D. Rad. (307) (exc. A.T.),					
71	Chevella (C.A.C. w/3 Spd.) (307),					
71	Monte Carlo (C.A.C. w/2BC) (400) (exc. A.T.),					
68	Chevella w/P.G., T.H. 350, reg. fuel (327) (exc. C.A.C., H.D. Rad.),					
68	Chevella w/P.G. (8 cyl.) (exc. 327, C.A.C., H.D. Rad.),					
68	Chevella w/Sp. H/Per. (327) (exc. C.A.C., H.D. Rad.),					
69	Chevella w/P.G., T.H. 350 reg. fuel (350) (exc. C.A.C., H.D. Rad.),					
70	Chevella w/A.T., C.A.C., H.D. Rad. (307, 350, 400),					
71	Monte Carlo w/A.T. (350, 400)					
71	Chevella A.T. w/C.A.C. (307, 350) (exc. 4BC, Monte Carlo)	3024632	1	138.10	w/oil cooler (Ident. No. 3014619 code letters SB)	
68	Chevella w/C.A.C. (H.D. Rad. w/P.G., T.H. 350) (8 cyl.) (exc. 396),					
70	Monte Carlo w/C.A.C., H.D. Rad., A.T. (400 w/2BC),					
71	Chevella w/H.D. Rad. (307, 350),					
71	Monte Carlo w/C.A.C., H.D. Rad., A.T. (400)	3017258	1	159.15	w/oil cooler (Ident. No. 3017258— Code letters SS)	
68-69	Chevella w/A.T. (C.A.C., H.D. Rad.) (6 cyl.),					
70	Chevella w/H.D. Rad., A.T. (6 cyl.)	3022040	1	148.40	w/oil cooler	
68-70	Chevella (6 cyl.) (exc. C.A.C., H.D. Rad.),					

**COOLANT—GRILLE—OIL SYSTEM**

**1.219 CORE, Radiator (Con't)**

68	Chevelle (327) (exc. C.A.C., H.D. Rad., req. fuel),				
69-70	Chevelle (307, 350) (exc. C.A.C., H.D. Rad.),				
71	Chevelle (6 cyl.),				
71	Chevelle w/A.T. (307, 350) (exc. C.A.C., H.D. Rad., Monte Carlo)	3016670	1	80.45	w/oil cooler (Ident. No. 3016670 code letters VB) (Note 15) .....
<i>NOTE 15 Also appears in Chevy section.</i>					
69	Chevelle (T.H. 400 w/396) (exc. C.A.C., H.D. Rad.),				
69-70	Chevelle (396, 400 w/4BC) (exc. C.A.C., H.D. Rad., T.H. 400, Sp. H/Per., P/Trac.),				
70	Chevelle w/A.T. (396, 400 w/4BC) (exc. C.A.C., H.D. Rad., Sp. H/Per.),				
70	Monte Carlo w/A.T. (454) (exc. C.A.C., H.D. Rad.),				
71	Chevelle w/Sp. H/Per. (454) (exc. A.T.),				
71	Chevelle (400 w/4BC) (exc. Monte Carlo, H.D. Rad.),				
71	Chevelle w/A.T. (454) (exc. C.A.C., H.D. Rad.) .....	3020143	1	137.70	w/oil cooler (Ident. No. 3020143 code letters BW) .....
69	Chevelle w/C.A.C., H.D. Rad. (T.H. 400 w/396),				
69	Chevelle w/Sp. H/Per. (396) (exc. T.H. 400),				
69	Chevelle w/C.A.C., H.D. Rad. (396) (exc. T.H. 400),				
70	Chevelle w/C.A.C., H.D. Rad., A.T. (400 w/4BC) (exc. Monte Carlo),				
70	Chevelle w/Sp. H/Per. (396),				
70	Chevelle (454) (exc. C.A.C., H.D. Rad., Monte Carlo),				
70	Monte Carlo w/A.T., C.A.C., H.D. Rad. (400 w/4BC),				
71	Monte Carlo w/A.T., C.A.C. (400 w/4BC),				
71	Chevelle w/Sp. H/Per. (454) (exc. A.T.),				
71	Chevelle w/C.A.C. (400 w/4BC) (exc. A.T.) .....	3019205	1	165.60	w/oil cooler (Ident. No. 3019205— Code letters BR) .....
70-71	Chevelle w/C.A.C., H.D. Rad. (396, 454) (exc. A.T., Monte Carlo) .....	3016678	1	187.00	w/o oil cooler (Ident. No. 3016678— Code letters PA) .....
70	Chevelle w/C.A.C., H.D. Rad., A.T. (396, 454),				
71	Chevelle w/C.A.C., A.T. (454),				
71	Chevelle w/H.D. Rad. (400 w/4BC, 454) .....	3017248	1	201.40	w/oil cooler (Ident. No. 3017248— Code letters PD) .....
71	Monte Carlo w/4BC (350) (exc. C.A.C., H.D. Rad., T.H. 350),				
71	Chevelle w/2BC (350) (exc. C.A.C., H.D. Rad., T.H. 350) ...	3023002	1	110.35	w/o oil cooler (Ident. No. 3023002— Code letter YG) .....

**CAMARO**

67-69	Camaro (396) (exc. T.H.),				
67-68	Camaro w/T.H. ....	3016689	1	163.00	w/oil cooler .....
67-68	Camaro w/P.G., T.H. 350 (6 cyl.) (exc. C.A.C., H.D. Rad.),				
67-69	Camaro w/P.G. (C.A.C., H.D. Rad.) (6 cyl.),				
67-68	Camaro w/P.G., T.H. 350 (8 cyl.) (exc. C.A.C., H.D. Rad.),				
67-69	Camaro (exc. 302, 396, A.T.),				
69	Camaro (350) (exc. reg. fuel, A.T., C.A.C., H.D. Rad.),				

**COOLANT—GRILLE—OIL SYSTEM**

**1.219 CORE, Radiator (Con't)**

69	Camaro (327) (exc. C.A.C., H.D. Rad., P.G., T.H. 350),					
69	Camaro w/A.T. (exc. T.H. 400, C.A.C., H.D. Rad., 350) . . . . .	3010176	1	97.75	w/oil cooler . . . . .	
67-68	Camaro w/C.A.C., H.D. Rad. (327) (exc. 4BC, A.T.),					
67-69	Camaro (302),					
68-69	Camaro w/C.A.C., H.D. Rad. (327, 350) (2nd design) (exc. P.G., T.H. 350),					
67-69	Camaro w/P.G. (C.A.C., H.D. Rad.) (327) (exc. 4BC),					
68-69	Camaro w/P.G., T.H. 350, reg. fuel (C.A.C., H.D. Rad.) (327, 350) . . . . .	3010179	1	119.00	w/oil cooler (Ident. No. 3010179) . . . . .	
67-68	Camaro (C.A.C., H.D. Rad.) (327, 350) (1st design) (exc. 2BC) . . . . .	3010181	1	136.00	w/oil cooler (Ident. No. 3010181) . . . . .	
69	Camaro w/C.A.C., H.D. Rad. (396) (exc. T.H. 400) . . . . .	3018624	1	169.00	w/o oil cooler . . . . .	
69	Camaro w/T.H. 400 (C.A.C., H.D. Rad.) . . . . .	3018623	1	163.00	w/oil cooler . . . . .	
69	Camaro (396) (exc. H.D. Rad., C.A.C.) . . . . .	3017838	1	144.00	w/oil cooler (Note 16) . . . . .	
	<i>NOTE 16 Also appears in Chevy section.</i>					
70-71	Camaro (6 cyl.) (exc. H.D. Rad.),					
70-71	Camaro (307, 350) (exc. C.A.C., H.D. Rad.) . . . . .	3016670	1	80.45	w/oil cooler (Ident. No. 3016670— Code letters VB) . . . . .	
70	Camaro w/H.D. Rad. (6 cyl.),					
70	Camaro (307, 350),					
71	Camaro w/C.A.C., H.D. Rad. (307, 350),					
71	Camaro (T.H. 400 w/Sp. H/Per.) (350) . . . . .	3021301	1	127.55	w/oil cooler (Ident. No. 3021301— Code letters LG) . . . . .	
70	Camaro (396) (exc. C.A.C., H.D. Rad.),					
71	Camaro w/4BC (400) (exc. C.A.C., H.D. Rad.) . . . . .	3021385	1	161.15	w/oil cooler (Ident. No. 3021385— Code letters LN) . . . . .	
70	Camaro w/C.A.C., H.D. Rad. (396),					
71	Camaro w/C.A.C., H.D. Rad. (400 w/4BC) . . . . .	3021775	1	190.10	w/oil cooler (Ident. No. 3021775— Code letters LS) . . . . .	

**PASSENGER**

65	Taxi, Police w/P.G.,					
65	Pass. w/C.A.C., H.D. Rad. (6 cyl.),					
66	Pass. (6 cyl.) (2nd design) (exc. Air Cond., P.G., H.D. Rad., Taxi, Police) . . . . .	3002312	1	130.00	w/oil cooler, finger guard . . . . .	
	<i>NOTE 17 Also appears in Chevelle section.</i>					
66	Pass. w/P.G. (C.A.C., H.D. Rad.) (283, 327) . . . . .	3007710	1	137.00	w/oil cooler, w/o finger guard . . . . .	
66-67	Pass. w/P.G. (283, 327) (exc. A.I.R., H.D. Rad.) . . . . .	3007707	1	113.00	w/oil cooler, w/finger guard . . . . .	
67	Pass. (283, 327) (exc. A.T., A.I.R., H.D. Rad., C.A.C.) . . . . .	3011405	1	95.25	w/out oil cooler, w/finger guard . . . . .	
67-68	Pass. (6 cyl.) (exc. P.G., H.D. Rad., C.A.C.),					
68	Pass. w/A.T. (6 cyl.) (exc. C.A.C., H.D. Rad., H.D. Chassis, Taxi) . . . . .	3017208	1	100.00	w/oil cooler (Ident. No. 3017208) . . . . .	
67	Pass. w/P.G. (6 cyl.) (exc. Taxi, Police, A.I.R., H.D. Rad., C.A.C.)	3012408	1	101.00	w/oil cooler, w/finger guard . . . . .	
67	Taxi, Police w/P.G. (6 cyl.),					
67	Pass. w/P.G. (H.D. Rad., C.A.C.) (6 cyl.),					
68	Pass. (6 cyl.) (C.A.C., H.D. Rad., H.D. Chassis, Taxi w/P.G.) . . . . .	3015512	1	105.30	w/oil cooler . . . . .	
67	Pass. w/P.G. (283, 327) (exc. A.I.R., H.D. Rad.),					
67	Pass. w/T.H. (327) (exc. C.A.C., A.I.R.) . . . . .	3011407	1	104.00	w/oil cooler . . . . .	

**COOLANT—GRILLE—OIL SYSTEM**

**1.219 CORE, Radiator (Con't)**

67	Pass. w/C.A.C., H.D. Rad., A.T. (8 cyl.) (exc. 427),				
67	Pass. w/A.I.R. (396, 427 w/A.T.) (exc. C.A.C., H.D. Rad.),				
68	Pass. w/C.A.C., H.D. Rad., A.T. (307, 327),				
68	Pass. w/A.T. (396, 427) (exc. C.A.C., H.D. Rad.)	3012410	1	114.25	w/oil cooler (Ident. No. 3012410)
67	Pass. w/C.A.C., H.D. Rad. (8 cyl.) (exc. A.T., 427),				
67-68	Pass. w/A.I.R. (396, 427) (exc. C.A.C., H.D. Rad.),				
67-68	Pass. w/A.I.R., Sp. H/Per., (427),				
68	Pass. (396) (exc. P.G.),				
68	Pass. (427) (exc. C.A.C., H.D. Rad., T.H.),				
68	Pass. w/C.A.C., H.D. Rad. (8 cyl.) (exc. 327, 427, A.T.)	3012409	1	98.70	w/out oil cooler
67	Pass. w/C.A.C., H.D. Cooling (396, 427 w/A.T.) (2nd design),				
68	Police (C.A.C. w/A.T.) (396) (1st design),				
68	Pass. w/C.A.C., H.D. Cooling (427 w/T.H.) (1st design),				
68	Pass. w/C.A.C., H.D. Cooling (396 w/T.H.) (exc. Police)	3014455	1	127.55	w/oil cooler (Ident. No. 3014455)
68	Police w/C.A.C. (396) (2nd design),				
68	Pass. w/C.A.C., H.D. Cooling w/427 (2nd design),				
69	Pass. w/A.T., reg. fuel (327, 350) (exc. C.A.C., H.D. Rad.),				
70	Pass. w/A.T., 2BC (350) (exc. C.A.C., H.D. Rad.)	3016804	1	191.00	w/oil cooler (Ident. No. 3016804)
68	Pass. w/A.T., reg. fuel (307, 327) (exc. H.D. Rad., C.A.C.),				
68	Pass. w/reg. fuel (327) (exc. C.A.C., H.D. Rad., A.T.)	3017031	1	99.00	w/oil cooler
69	Pass. w/P/S, Sp. H. Per. (427) (exc. H.D. Rad.),				
69	Pass. w/T.H. 400, Sp. H/Per. (396, 427) (exc. C.A.C., H.D. Rad.),				
69	Pass. w/Sp. H/Per. (427) (1st design) (exc. H.D. Rad., T.H. 400),				
69	Pass. w/C.A.C., H.D. Rad. (8 cyl.) (exc. 396, 427),				
69	Pass. (427) (exc. Sp. H/Per., C.A.C., H.D. Rad.),				
69	Pass. (396) (exc. C.A.C., H.D. Cooling, T.H. 400),				
70	Pass. w/A.T. (400) (exc. H.D. Rad.),				
70	Pass. w/A.T. (454) (exc. C.A.C., H.D. Rad.),				
70	Pass. w/C.A.C., A.T. (350),				
70	Pass. w/C.A.C. (8 cyl.) (exc. A.T., H.D. Rad.)	3018015	1	115.00	w/oil cooler
69-70	Pass. w/T.H., P.G., 4BC (350) (exc. C.A.C., H.D. Rad., reg. fuel)	3018026	1	96.00	w/oil cooler
69	Pass. w/Sp. H/Per. (427) (2nd Design) (exc. T.H. 400, H.D. Rad.),				
69	Pass. w/C.A.C., H.D. Rad. (396, 427),				
70	Pass. w/C.A.C., H.D. Rad., A.T. (454)	3018035	1	157.00	w/oil cooler
69	Pass. w/P.G. (6 cyl.) (exc. C.A.C., H.D. Cooling, Taxi),				
70	Pass. (250) (exc. H.D. Rad.)	3018045	1	89.50	w/oil cooler
69	Taxi w/P.G. (6 cyl.) (1st design),				



**COOLANT—GRILLE—OIL SYSTEM**

<b>1.219 CORE, Radiator (Con't)</b>						
69	Pass. w/C.A.C., H.D. Cooling (A.T. w/6 cyl.)					
70	Taxi w/A.T. (250)					
70	Pass. w/H.D. Rad., A.T. (250) . . .	<b>3020229</b>	1	107.00	w/oil cooler (code CN) . . . . .	
69	Pass. w/C.A.C., H.D. Rad. (6 cyl.) (exc. A.T.)					
70	Pass. w/H.D. Rad. (250) (exc. A.T.) . . . . .	<b>3020228</b>	1	95.50	w/o oil cooler . . . . .	
70	Pass. w/H.D. Rad. (350, 400) . . .	<b>3022526</b>	1	182.00	w/oil cooler (Ident. No. 3022526— Code letters CI) . . . . .	
71	Pass. (250) . . . . .	<b>3022831</b>	1	117.45	w/o oil cooler (Ident. No. 3022831) . . . . .	
71	Pass. w/4BC (350) (exc. C.A.C., H.D. Rad.)					
71	Pass. w/T.H., 2BC (400) (exc. C.A.C., H.D. Rad.) . . . . .	<b>3022999</b>	1	128.75	w/oil cooler (Ident. No. 3022999— Code letters YE) . . . . .	
71	Pass. w/P.G., T.H. 350, 2BC (350) (exc. C.A.C., H.D. Rad.)					
71	Pass. w/A.T., C.A.C. (8 cyl.) (exc. H.D. Rad., 400 w/4BC, 454) . .	<b>3023000</b>	1	134.90	(Ident. No. 3023000— Code letters YC) . . .	
71	Pass. w/H.D. Rad. (8 cyl.) (exc. 400 w/4BC, 454) . . . . .	<b>3023593</b>	1	162.75	w/oil cooler (Ident. No. 3023593— Code letters YK) . . . . .	
71	Pass. (400 w/4BC, 454) (exc. C.A.C., H.D. Rad.) . . . . .	<b>3020584</b>	1	136.70	(Ident. No. 3020584— Code letters NA) . . .	
71	Pass. w/H.D. Rad. (400 w/4BC, 454) . . . . .	<b>3023595</b>	1	200.25	w/oil cooler (Ident. No. 3023595— Code letters YK) . . . . .	
71	Pass. w/C.A.C. (400 w/4BC, 454) . . . . .	<b>3023005</b>	1	164.55	w/oil cooler (Ident. No. 3023005— Code letters ND) . . . . .	
71	Pass. w/3-Spd. (350) (exc. H.D. Rad.) . . . . .	<b>3024632</b>	1	138.10	w/o oil cooler (Ident. No. 3014612— Code letters SB) . . . . .	
<b>VEGA</b>						
71	Vega w/12" x 12" core . . . . .	<b>3023995</b>	1	82.85		
71	Vega w/12" x 20" core . . . . .	<b>3030141</b>	1	112.65		

**COOLANT—GRILLE—OIL SYSTEM**

**1972 USAGE**

*3025053	*3025068	*3025159	*3025166	*3025230
DD	DF	BK	BB	CB
DE	DG	BM	BE	CC
DU	DH	BQ	BW	CD
DX	DI	BR	NR	SP
DY	DM	NF	NS	SV
VK	DN	NG	NU	CE
VR	DO	NL		SS
	DP	NN		
	DQ	NX		
	DR			
	DT			
	DZ			
	LG			
	OX			
	VA			
	VB			
	VC			
	VD			
	VE			
	VG			
	VH			
	VI			
	VJ			
	VO			
	VS			

*3025243	*3025326	*3025387	*3025390	*3025415	*3025451	*3025827	
CJ	PA	LL	LR	LD	HA	LH	
CK	PD	LM	LS	LE	HN	LI	
CL	PK	LN	LV	LF	HO	LO	
CP	PN	LT	LW	LX	HS	LP	
CQ		LU		LY	HT		
CR					HV		
CS					HW		
SA							
SB							
SF							
SK							
YG							

*Check code letters on radiator, find code letters on chart and order number above code letters.*

**NOVA**

72	Nova (6 cyl.)	3025451	1	119.10	code letter HU
72	Nova (8 cyl.) (exc. C.A.C., H.D. Rad.)	3025068	1	147.00	code letter DP
72	Nova w/C.A.C., H.D. Rad. (8 cyl.)	3025053	1	157.40	code letter DY

**PASS.**

72	Pass. (6 cyl.)	3025068	1	147.00	code letter DP
72	Pass. (350, 400) (exc. H.D. Rad.)	3025243	1	136.70	code letter CQ
72	Pass. (402, 454) (exc. C.A.C., H.D. Rad.)	3025166	1	138.40	code letter NS
72	Pass. w/C.A.C. (402, 454)	3025159	1	166.85	code letter NL
72	Pass. w/H.D. Rad. (350, 400)	3025230	1	165.15	code letter CD
72	Pass. w/H.D. Rad. (402, 454)	3025326	1	203.45	code letter PK

**CAMARO**

72	Camaro (307, 350) (exc. C.A.C., H.D. Rad. Sp. H/Per.)				
72	Camaro (6 cyl.)	3025068	1	147.00	code letter DP
72	Camaro w/Sp. H/Per. (350) (exc. H.D. Rad.)				
72	Camaro (C.A.C., H.D. Rad.) (307, 350) (exc. 4BC)	3025415	1	129.25	code letter LX

**COOLANT—GRILLE—OIL SYSTEM**

**1.219 CORE, Radiator (Con't)**

72	Camaro (402) (exc. H.D. Rad., C.A.C.) .....	<b>3025387</b>	1	163.55	code letter LT .....
72	Camaro (C.A.C., H.D. Rad.) (402)	<b>3025390</b>	1	193.10	code letter LW .....
72	Camaro (H.D. Rad., C.A.C.) (350) (exc. 2BC) .....	<b>3025827</b>	1	200.90	code letter LP .....

**CHEVELLE**

72	Chevelle (6 cyl.),				
72	Chevelle (307) (exc. C.A.C., H.D. Rad.),				
72	Monte Carlo w/2BC (350) (exc. A.T., C.A.C., H.D. Rad.) .....	<b>3025068</b>	1	147.00	code letter DP .....
72	Chevelle (350) (exc. Monte Carlo),				
72	Chevelle (C.A.C. w/H.D. Rad.) (307),				
72	Monte Carlo w/A.T. (350) .....	<b>3025243</b>	1	136.70	code letter CQ .....
72	Chevelle (402) (exc. H.D. Rad., C.A.C.) .....	<b>3025166</b>	1	138.40	code letter NS .....
72	Chevelle (454) (exc. C.A.C.),				
72	Chevelle (C.A.C. w/H.D. Rad.) (402) .....	<b>3025159</b>	1	166.85	code letter NL .....
72	Chevelle w/H.D. Rad. (307, 350) (exc. Monte Carlo) .....	<b>3025230</b>	1	165.15	code letter CD, CE .....
72	Chevelle w/C.A.C. (454),				
72	Chevelle w/H.D. Rad. (402) (exc. C.A.C.) .....	<b>3025326</b>	1	203.45	code letter PK .....

**COOLANT—GRILLE—OIL SYSTEM**

**VEGA**

72 Vega w/12" x 12" core ..... 3023995 1 82.85  
 72 Vega w/12" x 20" core ..... 3030141 1 112.65

**1973— 1975 USAGE**

3030123	3030114	3030128	3030137
NC	YA YD YD YK YP	LA— LX LB— LQ LG LH— LN LI— LP LT	YT YF YG YJ

3030100	3030910	3027447	3030105	3030125	3030117
SA— DR SG— DW SH— DX SM— OA SQ— CY SS— CS ST— CU SV— OG SW— OF SY— CW CE— CI CR— CM	CB OC SR SX OH  CA	BA— NF BF— NJ BI— NE BM— NI BN— NG BO BP NZ	DU DE DF DG DH DI DJ DL DN	LJ LC LD LF LL  LH	HH HA HC HD HF

3030120	3031657	3031644
PG	DC DW DA DU DV DA DB	LS EE

*Check code letters on radiator, find code letters on chart and order number above code letters.*

**NOVA**

73-74 Nova (6 cyl.) (exc. C.A.C.) ..... 3030117 1 142.45 .code letter HD, HH .....  
 74 Nova (6 cyl.) w/C.A.C. .... 3030140 1 153.85 code letter YY .....  
 73-74 Nova (350) (exc. C.A.C., H.D.) ... 3030105 1 142.55 code letter DU .....  
 73 Nova (C.A.C. w/4BC) (350) (exc. H.D. Rad.),  
 73 Nova (C.A.C. w/2BC) (exc. H.D. Rad.),  
 74 Nova (C.A.C. w/2BC) (350) .... 3030137 1 149.70 code letter YT .....  
 74 Nova (C.A.C. w/4BC) (350),  
 73-74 Nova w/H.D. (8 cyl.) ..... 3030114 1 209.20 code letter YP .....  
 75 Nova (exc. H.D. Rad., C.A.C.) ... 3031657 1 153.90 code letter DB .....  
 75 Nova (6 cyl.) w/C.A.C., H.D. Rad. 3031644 1 158.05 code letter LS .....  
 75 Nova w/2BC (350) w/C.A.C., H.D. Rad.,  
 75 Nova w/4BC (350) w/C.A.C., H.D. Rad. (exc. A.T.),  
 75 Nova (262) w/C.A.C., H.D. Rad. . 3030125 1 162.15 code letter LJ .....  
 75 Nova w/4BC (350) w/C.A.C., H.D. Rad., A.T.,  
 75 Nova (8 cyl.) (C.A.C., w/H.D. Rad.) ..... 3030128 1 226.75 code letter LT .....

**PASS.**

73 Pass. (6 cyl.),  
 73 Pass. (350, 400 cyl.) (exc. H.D. Rad.),  
 74 Pass. (350, 2BC 400) (exc. H.D.),  
 75 Pass. (350, 400) (exc. C.A.C., H.D. Rad.),  
 75 Pass. (350) w/H.D. Rad., C.A.C.,

**COOLANT—GRILLE—OIL SYSTEM**

**1.219 CORE, Radiator (Con't)**

75	Pass. (400) w/H.D. Rad., C.A.C. (exc. Sta. Wag.)	3030100	1	180.05	code letter SQ, CR
73-74	Pass. w/H.D. Rad. (454),				
75	Pass. (454) (H.D. Rad. w/C.A.C.)	3030120	1	275.65	code letter PG
73-75	Pass. (454) (exc. H.D. C.A.C.)	3030123	1	173.80	code letter NC
73-74	Pass. (H.D. Rad. w/2BC) (400),				
73-74	Pass. (C.A.C. w/4BC) (400),				
73-74	Pass. w/H.D. Rad. (350, 400),				
75	Pass. (350, 400) (H.D. Rad. w/C.A.C.),				
75	Pass. (400) (Sta. Wag.) w/C.A.C., H.D. Rad.	3030910	1	237.35	code letter CB, SX, OH
73	Pass. w/C.A.C. (454) (exc. H.D. Rad.),				
74	Pass. w/C.A.C. (400),				
75	Pass. (454) w/C.A.C., H.D. Rad.	3027447	1	225.70	code letter NE, NZ

**CAMARO**

73-74	Camaro (6 cyl.),				
73	Camaro (307, 350) (exc. H.D. Rad., Sp. H/Per.),				
73-74	Camaro (350) (exc. C.A.C., Sp. H/Per.)	3030105	1	142.55	code letter DU
73-75	Camaro w/Sp. H/Per. (350),				
73-74	Camaro (4BC w/C.A.C.) (350) (exc. Sp. H/Per., 4-Spd.),				
75	Camaro w/4BC (350) w/C.A.C., H.D. Rad., A.T. (exc. Sp. H/Per.),				
75	Camaro (8 cyl.) (C.A.C. w/H.D. Rad.)	3030128	1	226.75	code letter LT
73	Camaro w/Sp. H/Per. (350),				
73	Camaro (H.D. Rad. w/4BC) (350) (exc. A.T. 350, Sp. H/Per.),				
73	Camaro w/H.D. Rad. (350) (exc. 4BC),				
74	Camaro (C.A.C. w/2BC) (350),				
74	Camaro (w/4-Spd.) (4BC w/C.A.C.) (350),				
75	Camaro w/2BC (350) w/C.A.C., H.D. Rad.,				
75	Camaro w/4BC (350) w/C.A.C., H.D. Rad. (exc. A.T., Sp. H/Per.)	3030125	1	162.15	code letter LJ
75	Camaro (exc. H.D. Rad. C.A.C., Sp. H/Per.)	3031657	1	153.90	code letter DB
75	Camaro (6 cyl.) w/C.A.C., H.D. Rad.	3031644	1	158.05	code letter LS

**CHEVELLE**

73	Chevelle (6 cyl.),				
73	Chevelle (307) (exc. H.D. Rad.),				
73-74	Chevelle (C.A.C., H.D. Rad.) (250)	3030105	1	142.55	code letter DU
73-74	Chevelle (C.A.C., H.D. Rad.) (307, 350),				
74	Chevelle w/C.A.C. (400),				
75	Laguna (400) (exc. H.D. Rad., C.A.C.),				
75	Chevelle (350, 400) w/H.D. Rad.,				
75	Chevelle (6 cyl.) (C.A.C., w/H.D. Rad.)	3030910	1	237.35	code letter CB, OH, SX
73-75	Chevelle (454)	3027447	1	225.70	code letter NE, NZ
74	Chevelle (250, 400) (exc. C.A.C., H.D. Rad.),				
75	Chevelle (400) (exc. H.D. Rad., C.A.C., Laguna),				
75	Chevelle (6 cyl.) w/C.A.C., H.D. Rad.,				
73-75	Chevelle (350) (exc. H.D. Rad.)	3030100	1	180.05	code letter CS, SQ
75	Chevelle (6 cyl.) w/H.D. Rad. (exc. C.A.C.)	3031657	1	153.90	code letter DB

**VEGA, MONZA**

73-74	Vega w/12" x 12" core	3023995	1	82.85	
-------	-----------------------	---------	---	-------	--

**COOLANT—GRILLE—OIL SYSTEM**

**1.219 CORE, Radiator (Con't)**

73-74	Vega w/12 x 20 core	3030141	1	112.65	
75	Vega (140) (exc. C.A.C., H.D. Rad.)	3033271	1	91.25	code letters UJ, UC, UM
75	Monza (8 cyl.) (exc. Town Cpe.)	3031734	1	183.75	code letters UQ, UP, UT, US, UR
75	Monza (Town Cpe.) (140) w/H.D. Rad.	3034009	1	91.45	code letters HU
75	Vega (140) w/C.A.C., H.D. Rad.,	3033283	1	117.25	code letters UO
75	Vega (122)				
75	Monza (140) w/H.D. Rad. (exc. Town Cpe.),				
75	Monza (Town Cpe.) (140) (exc. H.D. Rad.)	3031731	1	129.25	code letters UT, HT
75	Monza (Town Cpe.) (262)	3033825	1	159.30	code letters HQ, HP, HS, HR

**1.240 RECOVERY UNIT— BRACKET— CAP— CLIP— HOSE— RETAINER— SPACER— TANK, Coolant Recovery Unit**

72-73	Vega	994525	1	12.05	
72	Vega (140)	336526	1	1.20	BRACKET
73	Vega	336577	1	1.15	BRACKET ASSY.
73	All (exc. Vega)				
74	All (exc. Pass., Vega),				
75	Camaro	340194	1	.60	CAP
75	Nova	551304	1		CAP
74	Pass.,				
75	Pass., Chevelle	342343	1	.44	CAP
72-73	Vega	486546	1	.60	CAP, recovery tank
74-75	Vega, Monza (exc. Towne Cpe.)	1601187	1	.41	CAP, recovery tank
75	Monza (Towne Cpe.)	365272	1	.41	CAP
62-66	All	3863402	2	.12	CLIP (push in type 17/32" O.D. hose)
74	Chevelle	344719	1	.11	CLIP, coolant recovery tank hose
75	Vega (122)	486547	1	.36	CLIP, recovery tank to mtg. bracket
62-69	All	9432875	1	RL/.24	HOSE, supply tank to rad. radiator overflow (3/8" I.D. x 4 1/2" ft. long) (Butyl)— (8.962)
73-74	All (exc. Vega)	9432963	1	RL/.55	HOSE, cut as reqd.— (8.962)
73-74	Monte Carlo	336327	1	.16	SPACER, tank
72-73	Vega,				
75	Vega (122)	683087	1	4.55	TANK
73	Pass.	332389	1	3.35	TANK
73-75	Camaro	356615	1	4.55	TANK
73-74	Nova	344387	1	4.35	TANK
73	Chevelle,				
74	Monte Carlo	336320	1	3.20	TANK
74	Chevelle (exc. Monte Carlo)	340190	1	3.15	TANK
74-75	Pass.	342342	1	3.35	TANK
74-75	Vega (140)	336592	1	4.55	TANK
75	Monza (exc. Town Cpe.)	349516	1	4.65	TANK
75	Monza (Town Cpe.)	365271	1	4.10	TANK
75	Chevelle (exc. Monte Carlo)	347341	1	3.60	TANK
75	Nova	551448	1	3.55	TANK, w/cap
75	Monte Carlo	347333	1	4.65	TANK

**1.246 THERMOSTAT, Radiator and Hot Water Heater**

62	Chevy	3156279	1	4.88	170 degrees (poppet pellet type)
62-66	All (exc. A.I.R.),				
67-69	Chevy (4 cyl.),				
67-69	All (8 cyl.) (exc. A.I.R.),				
70-72	All w/Sp. H/Per. (350, 396, 454),				
73-74	All w/Sp. H/Per. (350)	3156280	1	4.88	180 degrees (poppet pellet type)
66-69	All w/A.I.R. (8 cyl.),				
66-69	All (6 cyl.),				
70-74	All (exc. Sp. H/Per.)	3028626	1	4.88	
75	All	3030055	1	5.17	

**1.251 HOUSING UNIT— ELBOW, Thermostat**

62-71	All (exc. 8 cyl., Vega)	328585	1	3.25	
72	All (6 cyl.)	6270014	1	3.25	
73	All (6 cyl.)	328584	1	3.25	
74	All (6 cyl.)	352705	1	4.00	
75	All (6 cyl.)	352161	1	9.05	
75	Vega (122)	348641	1	15.45	
75	Vega (122)	362753	1	7.15	ELBOW

**1.252 GASKET— SEAL— STUD, Thermostat Housing**

62-75	All (6 cyl.)	3789161	1	.12	(19/16" I.D.)
-------	--------------	---------	---	-----	---------------

**COOLANT—GRILLE—OIL SYSTEM**

<b>1.252 GASKET— SEAL— STUD, Thermostat Housing (Con't)</b>	
75 Vega (122)	334031 1 .44
73-75 All (6 cyl.)	406165 1 .22 STUD, therm. hsg. R.H. side
<b>1.263 FILLER— PANEL— BRACKET— REINFORCEMENT— SUPPORT, Front End and Close</b>	
73 Chevelle (exc. Laguna, Monte Carlo)	331703 1 14.55 rad. grille to frt. bumper
73 Chevelle (exc. Laguna, Monte Carlo)	331701 L.H. 11.25 fdr. to bumper
73 Chevelle (exc. Laguna, Monte Carlo)	331702 R.H. 11.25 fdr. to bumper
73 Monte Carlo	3996953 L.H. 8.70 frt. fdr. to bumper
73 Monte Carlo	3996954 R.H. 8.70 frt. fdr. to bumper
73 Monte Carlo	331705 1 14.55 rad. grille to frt. bumper
74 Pass.,	
75 Belair, Impala	339225 L.H. 6.70 frt. fdr. to bumper (paint as reqd.)
74 Pass.,	
75 Belair, Impala	339226 R.H. 6.70 frt. fdr. to bumper (paint as reqd.)
74-75 Monte Carlo	340151 L.H. 12.75 front fender to bumper
74-75 Monte Carlo	340152 R.H. 12.75 front fender to bumper
74-75 Malibu	340156 R.H. 12.60 frt. fdr. to bumper
74-75 Malibu	340155 L.H. 12.60 frt. fdr. to bumper
74 Nova	341008 1 7.35 frt. fdr. to bpr. (white) (11L) (Note 2)
74 Nova	341009 1 7.35 frt. fdr. to bpr. (bright blue met.) (26L) (Note 2)
74 Nova	341010 1 7.35 frt. fdr. to bpr. (dark blue met.) (29L) (Note 2)
74 Nova	341011 1 7.35 frt. fdr. to bpr. (bright aqua met.) (30L) (Note 2)
74 Nova	341012 1 7.35 frt. fdr. to bpr. (lime yellow) (40L) (Note 2)
74 Nova	341013 1 7.35 frt. fdr. to bpr. (bright green met.) (46L) (Note 2)
74 Nova	341014 1 7.35 frt. fdr. to bpr. (dark green met.) (49L) (Note 2)
74 Nova	341015 1 7.35 frt. fdr. to bpr. (cream beige) (50L) (Note 2)
74 Nova	341016 1 7.35 frt. fdr. to bpr. (bright yellow) (51L) (Note 2)
74 Nova	341017 1 7.35 frt. fdr. to bpr. (bright gold met.) (53L) (Note 2)
74 Nova	341018 1 7.35 frt. fdr. to bpr. (colonial gold) (55L) (Note 2)
74 Nova	341019 1 7.35 frt. fdr. to bpr. (golden brown met.) (59L) (Note 2)
74 Nova	341020 1 7.35 frt. fdr. to bpr. (silver taupe met.) (64L) (Note 2)
74 Nova	341021 1 7.35 frt. fdr. to bpr. (bronze metallic) (66L) (Note 2)
74 Nova	341022 1 7.35 frt. fdr. to bpr. (red met.) (74L) (Note 2)
74 Nova	341023 1 7.35 frt. fdr. to bpr. (red) (75L) (Note 2)
75 Nova	345589 1 6.85 frt. fdr. to bpr. vinyl (paint as reqd.) (Note 2)
75 Caprice	343521 L.H. 15.10 frt. fdr. to bumper (paint as reqd.)
75 Caprice	343522 R.H. 15.10 frt. fdr. to bumper (paint as reqd.)
<i>NOTE 2: Includes L.H. &amp; R.H.</i>	
73 Nova	337401 1 17.10 FILLER ASSY., rad. grille to frt. bpr. (paint as reqd.)
71 Pass.	3985615 L.H. 3.80 PANEL, frt. bumper filler L.H.
71 Pass.	3985616 R.H. 3.80 PANEL, frt. bumper filler R.H.
71-73 Camaro	3966861 L.H. 3.95 PANEL, frt. bumper filler L.H.
71-73 Camaro	3966862 R.H. 3.95 PANEL, frt. bumper filler R.H.
71-73 Vega	9657644 1 25.50 PANEL, front end
73 Pass.	335952 1 16.40 PANEL, frt. bumper filler
73 Pass.	332331 L.H. 6.30 PANEL, to bumper filler (paint as reqd.)
73 Pass.	332332 R.H. 6.30 PANEL, to bumper filler (paint as reqd.)
74-75 Vega	9728056 1 37.75 PANEL, front end
73 Vega	329706 1 14.25 PANEL, frt. bumper filler
74-75 Vega	342655 L.H. 3.90 PANEL, frt. bumper filler
74-75 Vega	342656 R.H. 3.90 PANEL, frt. bumper filler
74-75 Vega	342698 1 10.20 PANEL, frt. bumper filler (center)
74-75 Camaro	339425 L.H. 3.70 PANEL, frt. bpr. filler
74-75 Camaro	339426 R.H. 3.70 PANEL, frt. bpr. filler
74-75 Monte Carlo	340153 1 17.45 PANEL, rad. grille to frt. bpr. filler
74-75 Malibu, El Camino	340154 1 17.45 PANEL, rad. grille to frt. bpr. filler
74 Nova	341004 1 17.10 PANEL, frt. bpr. filler (steel) (paint as reqd.)
75 Caprice	343554 1 20.05 PANEL, frt. bpr. filler
75 Nova	345505 1 15.85 PANEL, frt. bpr. filler
73-75 Nova	6274349 L.H. 1.25 BRACKET, rad. grille to frt. bumper filler supt.

**COOLANT—GRILLE—OIL SYSTEM**

**1.263 FILLER— PANEL— BRACKET— REINFORCEMENT— SUPPORT, Front End and Close (Con't)**

73-75	Nova	6274350	R.H.	1.25	BRACKET, rad. grille to frt. bumper filler supt.
74	Nova	341005	2	.16	BRACKET, frt. bpr. filler panel (outer)
74	Nova	341006	1	.16	BRACKET, frt. bpr. filler panel (inner R.H.)
75	Nova	345575	L.H.	.52	BRACKET, rad. grille to frt. bumper filler supt.
75	Nova	345576	R.H.	.52	BRACKET, rad. grille to frt. bumper filler supt.
75	Nova	345547	L.H.	.81	BRACKET, frt. bpr. filler panel
75	Nova	345548	R.H.	.28	BRACKET, frt. bpr. filler panel
74-75	Pass.	339217	L.H.	.82	REINFORCEMENT, frt. fdr. to bumper filler
74-75	Pass.	339218	R.H.	.82	REINFORCEMENT, frt. fdr. to bumper filler
73	Nova	337469	1	2.25	SUPPORT ASSY., rad. grille to frt. bumper filler center
73	Nova	337468	R.H.	.98	SUPPORT ASSY., rad. grille to frt. bumper filler
73	Nova	337467	L.H.	1.05	SUPPORT ASSY., rad. grille to frt. bumper filler
74-75	Pass.	339224	1	20.05	SUPPORT ASSY., frt. bpr. face bar (black) (urethane)

**1.266 GRILLE— BRACKET— EXTENSION— PANEL— REINFORCEMENT— FILLER, Radiator (Mouldings in group 1.268)**

**PASSENGER**

65	Pass.	3850210	1	35.00	
66	Pass.	3869745	1	35.00	upper
66	Pass.	3869746	1	16.60	lower
67	Pass.	3885962	1	35.00	(Note 2)
<i>NOTE 2: When using 3885962 on 67 S.S. models, paint as required.</i>					
68	Pass.	3910612	1	35.00	upper
68	Pass.	3910613	1	19.65	lower
69	Pass. (exc. Caprice, Estate Wagon, retrac. hdlp. cover, S.S. 427)	3929895	1	35.00	upper (Note 3)
69	Caprice, Pass. w/retrac. hdlp. cover, S.S. 427 (exc. Caprice, Estate Wagon)	3929897	1	35.00	upper (Note 3)
69	Pass.	3934560	1	16.30	lower
70	Pass.	3972818	1	35.00	upper (Note 3)
70	Pass.	3950742	1	16.30	lower
71	Pass. (exc. Caprice, Estate Wagon)	3975308	1	51.25	
71	Caprice, Estate Wagon	3991138	1	51.25	
72	Caprice, Estate Wagon	3997319	1	25.25	upr.
72	Caprice, Estate Wagon	3997320	1	21.25	lwr.
72	Pass. (exc. Caprice, Estate Wagon)	3997323	1	23.70	upr.
72	Pass. (exc. Caprice, Estate Wagon)	3997324	1	20.00	lwr.
73	Caprice, Estate Wagon	337605	1	45.50	upr.
73	Pass. (exc. Caprice, Estate Wagon)	6273713	1	45.50	upr.
73	Pass. (exc. Caprice, Estate Wagon)	327163	L.H.	9.00	lwr.
73	Pass. (exc. Caprice, Estate Wagon)	327164	R.H.	9.00	lwr.
73	Caprice, Estate Wagon	327165	L.H.	9.00	lwr.
73	Caprice, Estate Wagon	327166	R.H.	9.00	lwr.
74	Caprice	335912	1	55.25	
74	Pass. (exc. Caprice) (exc. chrome grille)	360003	1	45.50	
74	Impala w/chrome grille	360004	1	45.50	
75	Pass. (exc. Caprice, Landau)	342344	1	42.00	
75	Caprice	342330	1	63.75	
75	Caprice	342395	L.H.	12.85	lower
75	Caprice	342396	R.H.	12.85	lower
75	Pass. w/Landau	364578	1	42.00	

**CHEVELLE**

64	Chevelle	3854130	1	20.30
65	Chevelle	3875756	1	40.25



**COOLANT—GRILLE—OIL SYSTEM**

**1.266 GRILLE— BRACKET— EXTENSION— PANEL— REINFORCEMENT— FILLER, Radiator (Mouldings in group 1.268) (Con't)**

66	Chevelle .....	3873795	1	40.25	(Note 1) .....
<i>NOTE 1: When using 3873795 it will be necessary to paint as required to match old part with black enamel.</i>					
67	Chevelle (exc. S.S., Concours) ..	3885980	1	40.25	
67	Concours .....	3907432	1	40.25	
67	Chevelle (S.S.) .....	3892182	1	40.25	
68	Chevelle .....	3915400	1	29.00	
69	Chevelle (exc. 396) .....	3942789	1	29.00	
70	Chevelle (exc. Monte Carlo) ....	3956117	1	43.75	
69	Malibu, Concours .....		1		(paint black as reqd.) .....
71	Chevelle (exc. Monte Carlo) ....	3982409	1	43.75	(stamped 3982409) (Note 3) .....
72	Chevelle (exc. Monte Carlo) ....	329000	1	43.75	(Note 3) .....
73	Chevelle (exc. Monte Carlo, Laguna) .....	3992688	1	43.75	
73	Laguna .....	331800	1	44.00	
74	Laguna .....	336378	1	74.75	
74	Malibu, El Camino .....	338511	1	69.50	
75	Laguna .....	347336	2	34.75	rad. and park. lamp bezel .....
75	Malibu, El Camino .....	345347	1	69.50	

**MONTE CARLO**

70	Monte Carlo .....	3958369	1	108.00	
71	Monte Carlo .....	3982444	1	108.00	
72	Monte Carlo .....	5964325	1	124.00	
73	Monte Carlo .....	3987079	1	86.00	upr. ....
73	Monte Carlo .....	325297	L.H.	10.70	lwr. ....
73	Monte Carlo .....	325298	R.H.	10.70	lwr. ....
74	Monte Carlo .....	338577	L.H.	10.70	lower ....
74	Monte Carlo .....	338578	R.H.	10.70	lower ....
74	Monte Carlo .....	336370	1	86.00	upper ....
75	Monte Carlo .....	345349	1	86.00	upper ....
75	Monte Carlo .....	345351	L.H.	8.60	lower ....
75	Monte Carlo .....	345352	R.H.	8.60	lower ....

**NOVA**

62	Chevy .....	3792544	1	23.30	radiator .....
63	Chevy .....	3833312	1	24.60	radiator .....
64	Chevy .....	3859082	1	24.60	radiator .....
65	Chevy .....	3867837	1	24.60	radiator .....
66	Chevy .....	3885299	1	24.60	radiator .....
67	Chevy .....	3886428	1	24.90	radiator .....
68-69	Chevy,				
70	Nova (exc. 4BC),				
71-72	Nova (exc. 4BC, Rally Package) .	3949721	1	26.00	(Note 3) .....
70	Nova w/4BC,				
71-72	Nova w/4BC, Rally Package ...	3962915	1	26.00	
73-74	Nova (exc. Rally Nova) .....	6274308	1	30.75	
73-74	Nova w/Rally Nova .....	327571	1	30.75	
75	Nova (LN) .....	344351	1	53.50	
75	Nova Custom (exc. S.S., LN) ....	344349	1	53.50	
75	Nova (exc. S.S., Nova Custom) ..	344348	1	37.75	
75	Nova (S.S.) .....	344350	1	53.50	

**CAMARO**

67	Camaro (exc. R.S.) .....	3891691	1	21.00	upper .....
67	Camaro (exc. R.S.) .....	3891692	1	21.00	lower .....
67	Camaro (exc. R.S.) .....	3891693	1	17.95	center .....
67	Camaro (exc. R.S.) .....	3905746	1	56.25	radiator .....
68	Camaro (exc. R.S.) .....	3914772	1	27.00	center .....
68	Camaro (exc. R.S.) .....	3914771	1	21.00	upper (Note 4) .....
<i>NOTE 4: Requires 6-121753 washers, 6-120375 nuts.</i>					
68	Camaro (exc. R.S.) .....	3914773	1	21.00	lower (Note 5) .....
<i>NOTE 5: Requres 8-3843001 nut assy.</i>					
67-68	Camaro w/R.S. ....	3898139	1	21.00	upper .....
67-68	Camaro w/R.S. ....	3919060	1	14.30	center .....
67-68	Camaro w/R.S. ....	3927420	1	31.50	lower .....
67-68	Camaro w/R.S. ....	3929281	1	67.50	radiator .....
69	Camaro w/R.S. ....	3938641	1	25.25	(black) .....
69	Camaro (exc. R.S.) .....	3957062	1	40.50	(black) .....
70-71	Camaro (exc. R.S.) .....	3967175	1	26.50	(Note 3) .....
70-72	Camaro w/R.S. ....	3962973	L.H.	13.20	
70-72	Camaro w/R.S. ....	3962974	R.H.	13.20	
72-73	Camaro (exc. R.S.) .....	333724	1	41.75	(paint as reqd.) .....
73	Camaro w/R.S. ....	3962973	L.H.	13.20	
73	Camaro w/R.S. ....	3962974	R.H.	13.20	

**COOLANT—GRILLE—OIL SYSTEM**

**1.266 GRILLE— BRACKET— EXTENSION— PANEL— REINFORCEMENT— FILLER, Radiator (Mouldings in group 1.268) (Con't)**

74	Camaro w/Sp. H/Per. (350)				
75	Camaro w/Sport Package	341003	1	13.35	lower
74	Camaro (exc. Sp. H/Per.)	333794	1	36.25	upper
74	Camaro w/Sp. H/Per. (350)	341001	1	36.25	upper
74-75	Camaro (exc. Sp. H/Per.)	341002	1	13.35	lower
75	Camaro w/Sport Package	347571	1	44.25	upper
75	Camaro (exc. Sport Package)	347570	1	44.25	upper

**VEGA, MONZA**

71-73	Vega (exc. Grille Mldg.)	3972026	1	20.45	
71-73	Vega w/Grille Mldg.	3984083	1	24.65	
74-75	Vega	339082	1	37.75	
75	Monza (Notchback)	358351	1	20.45	
68	Camaro (exc. R.S.)	3919180	2	.17	BRACKET, ctr. grille support
67	Chevelle	3893975	L.H.	7.30	EXTENSION, rad. grille
67	Chevelle	3893976	R.H.	7.30	EXTENSION, rad. grille
68	Chevelle (S.S.)	3926803	L.H.	2.55	EXTENSION, upper
68	Chevelle (S.S.)	3926804	R.H.	2.35	EXTENSION, upper
68	Chevelle	3926805	L.H.	3.00	EXTENSION, lower
68	Chevelle	3926806	R.H.	3.00	EXTENSION, lower
68	Chevelle (exc. S.S.)	3926807	L.H.	2.45	EXTENSION, upper
68	Chevelle (exc. S.S.)	3926808	R.H.	2.45	EXTENSION, upper
69	Chevelle	3938111	L.H.	2.30	EXTENSION, rad. grille (Note 3)
69	Chevelle	3938112	R.H.	2.30	EXTENSION, rad. grille (Note 3)
66-67	Chevy	3892288	R.H.	2.90	PANEL, front fender headlamp filler
66-67	Chevy	3892287	L.H.	2.90	PANEL, front fender headlamp filler
62-65	Chevy	3859255	L.H.	5.80	PANEL ASSY., front fender headlamp filler
62-65	Chevy	3859256	R.H.	5.80	PANEL ASSY., front fender headlamp filler
65	Pass.	3851248	1	17.65	PANEL ASSY., grille hdr. (above grille, below hood)
66	Pass.	3869757	1	22.95	PANEL ASSY., grille hdr.
68	Pass.	3907604	1	22.95	PANEL ASSY., grille header
68-69	Chevelle	3920862	1	22.25	PANEL ASSY., grille header
67-68	Camaro	3927907	1	22.25	PANEL ASSY., grille header
69	Camaro	3937529	1	22.25	PANEL ASSY., grille header
70-72	Camaro (exc. R.S.)	3962983	1	46.25	PANEL ASSY. (complete) grille header
70-72	Camaro w/R.S.	327539	1	68.25	PANEL ASSY. (complete) grille header
71	Pass.	3991178	1	26.50	PANEL ASSY., header
72	Pass.	327159	1	27.75	PANEL ASSY., header
73	Camaro (exc. R.S.)	3962983	1	46.25	PANEL ASSY. (complete)
73	Camaro w/R.S.	327539	1	68.25	PANEL ASSY. (complete)
73	Pass. (exc. Caprice)	327111	1	27.75	PANEL ASSY., header
73	Caprice	337607	1	27.75	PANEL ASSY., header
73	Chevelle (exc. Laguna, Monte Carlo)	325203	1	15.50	PANEL ASSY., header
74	Monte Carlo	338574	1	32.25	PANEL ASSY., header
74	Pass. (exc. Caprice)	332395	1	27.75	PANEL ASSY., header
74	Caprice	332396	1	39.50	PANEL ASSY., header
74	Camaro	337456	1	77.75	PANEL ASSY., header
74	El Camino Classic (exc. S.S.)				
74	Malibu Classic	345304	1	33.25	PANEL ASSY., header
75	Caprice	342368	1	50.75	PANEL ASSY., header
75	Pass. (exc. Caprice)	332396	1	39.50	PANEL ASSY., header
75	Camaro	347568	1	72.00	PANEL ASSY., header
73	Monte Carlo,				
75	Monte Carlo	345377	1	30.00	PANEL ASSY., header
74	El Camino (exc. Classic),				
74	El Camino Classic (S.S.),				
74	Malibu (exc. Classic),				
75	Chevelle (exc. Laguna, Monte Carlo)	360871	1	33.25	PANEL ASSY., header
75	Monza (Town Cpe.)	358347	1	18.45	PANEL ASSY., header
66	Chevelle	3876541	L.H.	1.05	REINFORCEMENT, rad. grille
67	Chevelle	3892113	L.H.	1.05	REINFORCEMENT, rad. grille
67	Chevelle	3892114	R.H.	1.05	REINFORCEMENT, rad. grille
68	Chevelle	3915497	L.H.	1.45	REINFORCEMENT
68	Chevelle	3915498	R.H.	1.45	REINFORCEMENT
69	Camaro	3949707	1	1.40	REINFORCEMENT, rad. grille
69	Chevelle	3940549	L.H.	1.35	REINFORCEMENT ASSY., rad. grille
69	Chevelle	3940550	R.H.	1.35	REINFORCEMENT ASSY., rad. grille
70-73	Camaro w/R.S.	3973942	1	30.25	FILLER, grille

NOTE 3 May be necessary to paint as required on certain models.

**COOLANT—GRILLE—OIL SYSTEM**

**1.267 SUPPORT— BAR— BRACE— BRACKET— EXTENSION ASSY.— NUT—  
REINFORCEMENT— SCREW— SPACER, Radiator Grille**

74-75	Camaro	337481	L.H.	1.95	left grille header panel
74-75	Camaro	344338	R.H.	1.95	right grille header panel
67	Chevy	3894501	L.H.	2.70	SUPPORT ASSY., rad. grille to bumper filler panel
67	Chevy	3894502	R.H.	2.70	SUPPORT ASSY., rad. grille to bumper filler panel
71-73	Vega	3982086	1	4.25	SUPPORT ASSY.
74-75	Vega	339079	L.H.	3.80	SUPPORT ASSY., header panel left
74-75	Vega	339080	R.H.	3.80	SUPPORT ASSY., header panel right
74-75	Vega	339078	1	3.80	SUPPORT ASSY., center
75	Monza (Town Cpe.)	358373	L.H.	3.80	SUPPORT ASSY., header panel left
75	Monza (Town Cpe.)	358374	R.H.	3.80	SUPPORT ASSY., header panel right
64	Chevelle	3837716	1	6.85	BAR, frt. fender tie
65	Chevelle	3857371	1	6.40	BAR, frt. fender tie
66	Chevelle	3874559	1	6.40	BAR, frt. fender tie
67	Chevelle	3891498	1	6.85	BAR, frt. fender tie
67	Pass.	3892116	1	6.95	BAR ASSY., front fender tie
69	Pass.	3942145	1	7.10	BAR ASSY., front fender tie
70-71	Pass.	3957229	1	7.25	BAR ASSY., front fender tie
70	Monte Carlo	3955032	1	6.90	BAR ASSY., front fender tie
70-72	Chevelle (exc. Monte Carlo)	3992652	1	6.85	BAR ASSY., front fender tie
71-72	Monte Carlo	6261996	1	7.15	BAR ASSY., front fender tie
73-75	Laguna	328994	1	6.40	BAR ASSY., front fender tie
75	Laguna	364459	3	3.55	BRACE, rad. grille
73-75	Laguna	328930	1	1.30	BRACE ASSY., frt. fender tie bar
62-65	Chevy	3790459	1	.21	BRACKET, grille center
66	Chevy	3876551	L.H.	.23	BRACKET, grille mtg.
66	Chevy	3876552	R.H.	.23	BRACKET, grille mtg.
68	Chevelle	3917482	2	.12	BRACKET, grille to hdr. panel
68	Pass.	3934831	1	.11	BRACKET, lower grille center
68	Pass.	3915450	1	.17	BRACKET, lower grille outer, right
68	Pass.	3915449	1	.17	BRACKET, lower grille outer, left
69	Chevelle	3938175	2	.12	BRACKET, grille to header panel
69	Impala, Caprice, Kingswood	3939343	1	.17	BRACKET, lower grille center
69	Impala, Caprice, Kingswood	3939341	2	.17	BRACKET, lower grille outer
63-64	Chevy	3792977	L.H.	1.40	BRACKET ASSY., outer
63-64	Chevy	3792978	R.H.	1.40	BRACKET ASSY., outer
65	Chevelle	3859721	L.H.	1.75	BRACKET ASSY., grille
66	Chevelle	3874597	L.H.	.85	BRACKET ASSY., grille
66	Chevelle	3874598	R.H.	.85	BRACKET ASSY., grille
66	Pass.	3874755	1	1.95	BRACKET ASSY., grille upper, left
66	Pass.	3874756	1	1.95	BRACKET ASSY., grille upper, right
67	Pass.	3895173	1	2.00	BRACKET ASSY., rad. grille, left
67	Pass.	3895174	1	2.00	BRACKET ASSY., rad. grille, right
68	Pass.	3915445	1	2.00	BRACKET ASSY., rad. grille, left
68	Pass.	3915446	1	2.00	BRACKET ASSY., rad. grille, right
68-72	Nova	3929919	L.H.	1.35	BRACKET ASSY., grille mtg.
68-72	Nova	3929920	R.H.	1.35	BRACKET ASSY., grille mtg.
69	Pass.	3955085	1	2.50	BRACKET ASSY., rad. grille, left
69	Pass.	3955086	1	2.50	BRACKET ASSY., rad. grille, right
70	Pass.	3957291	L.H.	2.55	BRACKET ASSY., rad. grille, L.H.
70	Pass.	3957292	R.H.	2.55	BRACKET ASSY., rad. grille, R.H.
70	Chevelle,				
71	Monte Carlo	3962329	L.H.	1.75	BRACKET ASSY., rad. grille, R.H., L.H.
70	Chevelle,				
71	Monte Carlo	3962330	R.H.	1.75	BRACKET ASSY., rad. grille, R.H.
71	Pass.	6262303	L.H.	3.25	BRACKET ASSY., L.H.
71	Pass.	6262304	R.H.	3.25	BRACKET ASSY., R.H.
72	Chevelle (exc. Monte Carlo)	6261969	L.H.	2.35	BRACKET ASSY., L.H.
71-72	Chevelle (exc. Monte Carlo)	6261970	R.H.	2.35	BRACKET ASSY., R.H.
72	Monte Carlo	6264803	L.H.	1.60	BRACKET ASSY., L.H.
72	Monte Carlo	6264804	R.H.	1.60	BRACKET ASSY., R.H.
73-74	Nova	3998887	L.H.	1.50	BRACKET ASSY., mounting L.H.
73-74	Nova	3998888	R.H.	1.50	BRACKET ASSY., mounting R.H.
75	Nova	345511	L.H.	2.00	BRACKET ASSY., mounting L.H.
75	Nova	345512	R.H.	2.40	BRACKET ASSY., mounting R.H.
73-75	Monte Carlo	340179	L.H.	2.15	BRACKET ASSY., L.H.
73-75	Monte Carlo	340180	R.H.	2.15	BRACKET ASSY., R.H.
71	Pass.	3991183	L.H.	2.85	EXTENSION ASSY., bracket L.H.
71	Pass.	3991184	R.H.	2.85	EXTENSION ASSY., bracket R.H.
68	Chevelle	3877254	2	.21	NUT, grille to frt. bumper filler panel— (7.800)
71-72	Vega	3919773	5	.12	NUT

**COOLANT—GRILLE—OIL SYSTEM**

**1.267 SUPPORT— BAR— BRACE— BRACKET— EXTENSION ASSY.— NUT— REINFORCEMENT— SCREW— SPACER, Radiator Grille (Con't)**

66	Chevy	3876505	L.H.	.12	REINFORCEMENT, rad. grille to bumper filler panel
66	Nova	3876506	R.H.	.12	REINFORCEMENT, rad. grille to bumper filler panel
68-72	Nova	3914798	1	1.05	REINFORCEMENT, upper

**1.268 MOULDING, Radiator Grille**

64	Chevelle	3837799	1	7.90	
64	Chevelle	3849638	1	7.55	grille to frt. bumper filler panel
70	Chevelle (exc. Monte Carlo)	3958326	4	4.70	inner
70	Chevelle (exc. Monte Carlo)	3958327	2	4.20	outer L.H.
70	Chevelle (exc. Monte Carlo)	3958328	2	4.20	outer R.H.
70	Malibu, El Camino (Custom) Concours (exc. 396, 454)	3958397	2	2.15	center
71-73	Vega	3984085	1	3.65	radiator grille upper
71-73	Vega	3984086	1	3.65	radiator grille lower
71-73	Vega	3984087	L.H.	4.95	radiator grille
71-73	Vega	3984088	R.H.	4.95	radiator grille
71	Pass.	3975305	1	7.25	header panel
71	Pass.	3986913	L.H.	2.40	bracket extension L.H.
71	Pass.	3986914	R.H.	2.40	bracket extension R.H.
71	Chevelle (Malibu, El Camino, Sta. Wag.)	3982431	3	4.70	rad. grille
71	Chevelle (Malibu, El Camino, Sta. Wag.)	3982433	1	4.60	rad. grille outer L.H.
71	Chevelle (Malibu, El Camino, Sta. Wag.)	3982434	1	4.60	rad. grille outer R.H.
72	Chevelle (exc. Monte Carlo)	6261909	1	6.50	rad. grille upr.
72	Chevelle (exc. Monte Carlo)	6261910	1	6.50	rad. grille lwr.
72	Chevelle (exc. S.S., Monte Carlo)	6261925	2	6.30	rad. grille ctr.
72	Pass.	6258042	1	7.65	rad. grille hdr. pnl.
73	Pass.	6258027	1	13.60	rad. grille hdr. pnl.
74-75	Camaro (L.T.)	6260915	1	6.10	valance pnl.
66	Chevy	3886274	1	15.70	MOULDING UNIT, grille to frt. bumper filler panel (Note 1)

*NOTE 1 Unit consists of 1 moulding, 10 screws, nuts and washers.*

66	Chevelle	3886260	1	6.85	MOULDING UNIT, grille to frt. bumper filler panel, center
66	Chevelle	3886263	L.H.	4.55	MOULDING UNIT, grille to frt. bumper filler panel
66	Chevelle	3886264	R.H.	4.55	MOULDING UNIT, grille to frt. bumper filler panel
68	Chevelle	3928471	L.H.	5.75	MOULDING UNIT, grille extension
68	Chevelle	3928472	R.H.	5.75	MOULDING UNIT, grille extension
68-69	Chevelle	3928474	1	8.80	MOULDING UNIT, center, hdr. panel
68	Chevelle (exc. Malibu, S.S.)	3928423	L.H.	5.45	MOULDING UNIT, grille
68	Chevelle (exc. Malibu, S.S.)	3928424	R.H.	5.45	MOULDING UNIT, grille
69	Chevelle	3952422	1	9.85	MOULDING UNIT, lower center
69	Chevelle	3952423	L.H.	4.25	MOULDING UNIT, lower outer
69	Chevelle	3952424	R.H.	4.25	MOULDING UNIT, lower outer
69	Malibu, Concours (396)	3952428	1	9.85	MOULDING UNIT, center inner
69	Camaro w/R.S.	3958637	1	13.30	MOULDING UNIT
69	Chevelle	3958644	2	4.75	MOULDING UNIT, header panel outer
73	Chevelle (exc. Laguna, Monte Carlo)	6258143	1	6.50	MOULDING UNIT, header panel
74	Caprice	6260496	1	13.60	MOULDING UNIT, header panel
74	Impala, Bel Air	6260820	1	6.80	MOULDING UNIT, w/name plate, header panel
75	Pass. (exc. Caprice)	358805	1	5.60	MOULDING UNIT, rad. grille header panel
75	Caprice	358807	1	7.60	MOULDING UNIT, rad. grille header panel
74-75	Vega	6260832	1	3.80	MOULDING UNIT, radiator grille header panel
74-75	Camaro (LT)	6260912	1	3.60	MOULDING UNIT, header panel lwr.
74-75	Camaro (LT)	344423	1	4.75	MOULDING UNIT, header panel upr.

**1.269 CLIP— RETAINER— RIVET— SCREW— STUD— NUT, Radiator Grille Moulding**

67	Camaro w/A.I.R. (6 cyl.) (exc. C.A.C.),				
67-69	Camaro (8 cyl.),				
67-69	Camaro w/C.A.C. (6 cyl.),				
67	Camaro w/A.I.R. (6 cyl.) (exc. C.A.C.),				

**COOLANT—GRILLE—OIL SYSTEM**

**1.269 CLIP— RETAINER— RIVET— SCREW— STUD— NUT, Radiator Grille Moulding (Con't)**

67-68	Camaro w/H.D. Rad. (6 cyl.) (exc. 250, P.G., Torque Drive),				
67-69	Camaro (exc. 396),				
67-69	Camaro w/C.A.C. (6 cyl.),				
68-70	Chevy (396)	3899881	R.H.	.23	shroud
69-70	Pass. (8 cyl.),				
70	Nova (396)	3899880	2	.11	shroud
73-74	Nova	3998897	1	5.60	RETAINER, rad. grille to frt. bpr. filler center
73-74	Nova	3998895	L.H.	3.70	RETAINER, rad. grille to frt. bpr. filler outer
73-74	Nova	3998896	R.H.	3.70	RETAINER, rad. grille to frt. bpr. filler outer
74-75	Camaro	339427	2	.39	RETAINER, frt. bpr. filler panel inner
74-75	Camaro	339429	L.H.	.31	RETAINER, frt. bpr. filler panel outer
74-75	Camaro	339430	R.H.	.31	RETAINER, frt. bpr. filler panel outer
74-75	Vega	346568	2	.42	RETAINER, frt. bpr. filler panel
75	Caprice	342390	2	.33	RETAINER, frt. fender to bumper filler upper
75	Caprice	343523	L.H.	.33	RETAINER, frt. fender bumper filler outer
75	Caprice	343524	R.H.	.33	RETAINER, frt. fender to bumper filler outer
75	Caprice	352566	2	.39	RETAINER, frt. fender filler
62-69	All	9418482	A.R.	.11	RIVET (1/8" x 5/16") (Aluminum)— (8.967)
64	Chevelle	3839463	5	.06	RIVET, grille moulding
65	Chevelle				RIVET, upper and lower
67	Camaro	3779647	A.R.	.05	headlamp
69	Chevelle	9423131	12	.05	SCREW, reinforcement (black plated)— (8.977)
69	Pass.	3942132	A.R.	.11	SCREW, to hood lock catch support, to rad. grille bracket (8— 18 x 3/4")
75	Monza	358357	6	.11	STUD, frt. bpr. impact bar upper cover ret.
62-69	All	3713542	A.R.	.12	NUT, attaching (14-10 "J" shape)
67-68	Chevelle,				
70-72	Camaro	3937957	AR	.16	NUT, rad. grille ext.
70-72	Camaro (R.S.)	3973944	6	.11	NUT, rad. grille filler (1/4"— 14 square plastic for 3/8" x 5/8" sheet metal hole)
70-73	Monte Carlo	3975436	3	.18	NUT, w/"U" shape spring, lower (1/4"— 20 x 1 1/16")
72	Pass.	3919773	1	.12	NUT (9.744)

**1.270 SUPPORT ASSY.— BRACKET— BOLT— BUSHING ASSY.— CUSHION— GUSSET— MOUNTING UNIT— NUT— PAD— PANEL— SCREW— SHIM— SPACER— WASHER— REINFORCEMENT, Radiator Core**

62-64	Chevy	3849959	1	30.75	
64	Chevelle	3853569	1	46.00	
65	Chevelle	3856901	1	46.00	
65	Chevy	3871342	1	30.75	
65-66	Pass.	3876582	1	51.25	(Note 1)
<i>NOTE 1 When using 3876582 on 65 models it will be necessary to drill two new holes to relocate battery tray support using old part as guide and replace rad. supt. mounting components with mounting unit 3887094.</i>					
66-67	Chevy	3899211	1	30.75	
66	Chevelle	3897533	1	46.00	
67	Chevelle	3907632	1	51.25	
67-69	Camaro	3962940	1	46.00	rad. (complete)
67	Pass.	3907635	1	61.50	rad.
68	Pass. (exc. retractable h/lamp)	3907651	1	61.50	rad.
68	Pass. w/retractable h/lamp	3917427	1	61.50	rad.
68	Chevy,				
69-72	Chevy (exc. 396)	327515	1	46.00	rad.
68	Chevelle (6 cyl.),				
68	Chevelle w/T.H. 350 (exc. C.A.C.),				
68	Chevelle (8 cyl.) (exc. P.G., 396, Sp. H/Per.),				
69	Chevelle	3956068	1	51.25	rad. (complete)
69-70	Nova (396)	3974533	1	46.00	
69	Pass. w/retrac. h/lamp	3926841	1	61.50	rad.
69	Pass. (exc. retrac. h/lamp)	3955038	1	61.50	rad.
70	Pass.	3957212	1	56.50	
70	Chevelle (307, 350) (exc. C.A.C., H.D. Rad.),				
70	Chevelle (6 cyl.) (exc. C.A.C., H.D. Rad.)	3958368	1	51.25	

**COOLANT—GRILLE—OIL SYSTEM**

**1.270 SUPPORT ASSY.— BRACKET— BOLT— BUSHING ASSY.— CUSHION— GUSSET— MOUNTING UNIT— NUT— PAD— PANEL— SCREW— SHIM— SPACER— WASHER— REINFORCEMENT, Radiator Core (Con't)**

70	Monte Carlo (exc. C.A.C., H.D. Rad., T.H. 350, 400 w/4BC, 454) . . . . .	3963347	1	51.25	
70	Monte Carlo w/C.A.C., H.D. Rad., A.T.,				
70	Monte Carlo (400 w/4BC),				
70	Monte Carlo (454) (exc. C.A.C., H.D. Rad., A.T.) . . . . .	3975439	1	51.25	
70	Chevelle w/C.A.C., H.D. Rad. (307, 350),				
70	Chevelle (400),				
70	Malibu, El Camino Custom w/H/Per. (454) (exc. H.D. Rad., C.A.C.),				
70	Malibu, El Camino Custom w/Sp. H/Per. (454) (exc. H.D. Rad., 4:10 rear axle),				
70	Malibu w/Sp. H/Per. (396) (exc. AL. H.D., 4:10 rear axle) . . . . .	3957351	1	51.25	
70	Malibu, El Camino Custom w/C.A.C., H.D. Rad., 4.10 rear axle (396, 454) . . . . .	3975388	1	51.25	
70	Camaro . . . . .	327533	1	51.25	
71-72	Monte Carlo w/C.A.C., H.D. Rad., A.T. (w/2BC 350),				
71-72	Monte Carlo (exc. 350 w/2BC) . . . . .	6261952	1	46.00	
71-72	Chevelle (6 cyl.),				
71-72	Chevelle (307) (exc. C.A.C., H.D. Rad., Monte Carlo) . . . . .	6264807	1	46.00	
71	Chevelle (exc. 250, 307, Monte Carlo),				
71	Chevelle (307) w/C.A.C., H.D. Rad.),				
72	Chevelle w/C.A.C. (454) (exc. Monte Carlo),				
72	Chevelle w/H.D. Rad. (402, 454) (exc. Monte Carlo) . . . . .	6264811	1	46.00	
71-73	Camaro . . . . .	327533	1	51.25	
71	Pass. (6 cyl.) . . . . .	6258529	1	61.50	
71	Pass. w/H.D. Rad. (454, 400 w/4BC) . . . . .	6258531	1	61.50	
71	Pass. (8 cyl.) (exc. H.D. Rad.) . . . . .	6258530	1	61.50	
72	Pass. (6 cyl.) . . . . .	327113	1	61.50	
72	Pass. (402, 454) . . . . .	327115	1	61.50	(reinf. 327101-2 must also be used) . . . . .
72	Pass. (350, 400) . . . . .	327114	1	61.50	(reinf. 327101-2 must also be used) . . . . .
71-72	Monte Carlo w/2BC (350) (exc. C.A.C., H.D. Rad., A.T.) . . . . .	6261948	1	46.00	
72	Chevelle w/C.A.C., H.D. Rad. (307) (exc. Monte Carlo),				
72	Chevelle (454) (exc. C.A.C., Monte Carlo),				
72	Chevelle (350),				
72	Chevelle (402, 454) (exc. H.D. Rad., Monte Carlo) . . . . .	6264809	1	46.00	
73-74	Nova (exc. C.A.C., H.D. Rad.) . . . . .	327515	1	46.00	
73	Nova w/H.D. Rad.,				
74	Nova (8 cyl.) w/H.D. Rad., C.A.C. . . . .	341045	1	46.00	
73-74	Chevelle . . . . .	359915	1	61.50	
74	Pass. (exc. 454),				
74	Pass. (454) (exc. H.D. Rad.) . . . . .	344490	1	66.75	
73	Pass.,				
74	Pass. w/H.D. Rad. (454) . . . . .	344491	1	66.75	(Note 1) . . . . .
	<i>NOTE 2: It may be necessary to order headlamp housings found in group 2.726.</i>				
74-75	Camaro . . . . .	337439	1	51.25	
75	Nova (exc. H.D. Rad., C.A.C.) . . . . .	344355	1	51.25	
75	Nova w/H.D. Rad., C.A.C. . . . .	344356	1	51.25	
75	Chevelle . . . . .	345355	1	61.50	
75	Pass. . . . .	343503	1	66.75	
75	Monza (140) . . . . .	1683710	R.H.	2.95	SUPPORT, mtg. rad. lwr. . . . .
75	Monza (140) . . . . .	1683711	L.H.	2.95	SUPPORT, mtg. rad. lwr. . . . .
71-72	Chevelle (exc. Monte Carlo) . . . . .	3975478	2	1.10	BRACKET, frt. fender to rad. support . . . . .
71-75	Vega w/C.A.C., H.D. Rad. . . . .	3982061	L.H.	.61	BRACKET, radiator upper mtg. . . . .
71-75	Vega w/C.A.C., H.D. Rad. . . . .	3982062	R.H.	.61	BRACKET, radiator upper mtg. . . . .

**COOLANT—GRILLE—OIL SYSTEM**

**1.270 SUPPORT ASSY.— BRACKET— BOLT— BUSHING ASSY.— CUSHION— GUSSET— MOUNTING UNIT— NUT— PAD— PANEL— SCREW— SHIM— SPACER— WASHER— REINFORCEMENT, Radiator Core (Con't)**

71-75	Vega w/C.A.C., H.D. Rad.	3982063	L.H.	.61	BRACKET, radiator lower mtg.
71-75	Vega	3982064	R.H.	.36	BRACKET, radiator lower mtg.
71-75	Vega (exc. C.A.C., H.D. Rad.)	3982055	L.H.	.36	BRACKET, radiator lower mtg.
73	Monte Carlo	6263679	2	1.55	BRACKET, rad. supt.
73-75	Chevelle (exc. Monte Carlo)	6271617	2	1.50	BRACKET, rad. supt. to frame
74	Caprice	337623	L.H.	1.70	BRACKET, rad. support
74	Caprice	337624	R.H.	1.70	BRACKET, rad. support
62-69	All	3980020	2	.22	BOLT, w/washer, rad. support to frame, rad. supt. mtg.
62-69	All	490067	2	.24	BOLT, rad. support (to rad. support cushion) (7/16"— 14 x 1 1/2")— (7.874)
66-68	Pass.	3926928	2	.46	BUSHING ASSY., rad. support
68-72	Chevelle,				
69-70	Pass.	3930745	2	.42	CUSHION, rad. support— (9.023)
68-72	Chevelle,				
69-70	Pass.	3920612	2	1.10	CUSHION ASSY., rad. support
70-73	Camaro	3962950	2	1.10	CUSHION ASSY., rad. supt. to frame bracket
72	Pass. (exc. Taxi, Police)	3989104	2	1.30	CUSHION ASSY., rad. supt. lwr.— (9.023)
72	Taxi, Police	3989105	2	1.10	CUSHION ASSY., rad. supt. lwr.— (9.023)
73	Pass.	331219	2	1.80	CUSHION ASSY., rad. supt. lwr.— (9.023)
74	Pass. (Sta. Wag.)	343258	2	1.55	CUSHION ASSY., rad. supt. (lower)
74	Pass. (Sta. Wag.)	343259	2	1.65	CUSHION ASSY., rad. supt. (upper)
69-70	Pass.	3934513	1	1.40	GUSSET, left, rad. support
69-70	Pass.	3934514	1	1.40	GUSSET, right, rad. support
70-72	Chevelle	3963327	L.H.	1.95	GUSSET, rad. support L.H.
70-72	Chevelle	3963328	R.H.	1.55	GUSSET, rad. support R.H.
71-72	Pass.	6273709	L.H.	.80	GUSSET, rad. support L.H.
71-72	Pass.	6273710	R.H.	.80	GUSSET, rad. support R.H.
65-67	Chevelle,				
65	Pass.	3887895	1	1.35	MOUNTING UNIT, rad. support
66	Pass.	3887894	1	1.35	MOUNTING UNIT, rad. support
64	Chevelle,				
67-72	Pass., Chevelle,				
71	Camaro,				
73-75	Chevelle	3750799	2	.11	NUT, radiator support to frame (7/16"— 14)
67-70	Camaro,				
68-70	Chevy (396)				NUT, rad. body,
69-70	All w/Air Cond.				baffle and support A/C condenser lower,
69	Camaro w/C.A.C.,				
73-75	Nova w/C.A.C.	3903539	2	.22	A/C compressor fitting, muffler and tube to rad. supt. clip (1/4"— 20 x 13/16")
68-70	Chevelle (396, 400 w/4BC, 454),				
70	Camaro (396, 400 w/4BC, 454),				
71	All (400 w/4BC, 454),				
72	Chevelle (402, 454),				
73-75	Pass., Chevelle (454)	6264100	2	.46	PAD, rad. ret.
68	Chevelle, Chevy (exc. 396),				
70-72	All (exc. 396, 400 w/4BC, 402, 454),				
73-75	All (exc. 454)	3966804	A.R.	.46	PAD, rad. ret.
71-75	Vega,				
75	Monza (exc. Town Cpe.) (140) (exc. H.D. Rad.)	3982058	2	.43	PAD, radiator retainer, R.H.
71-75	Vega,				
75	Monza (exc. Town Cpe.) (140) (exc. H.D. Rad.)	3982057	2	.43	PAD, radiator retainer, L.H.
75	Monza (exc. Town Cpe.) (262),				
75	Monza (exc. Town Cpe.) (140) w/H.D. Rad.	3966804	1	.46	PAD, radiator upper retainer
75	Monza (exc. Town Cpe.) (8 cyl.),				
75	Monza (exc. Town Cpe.) (140) w/H.D. Rad.,				
75	Monza (Town Cpe.)	356304	1	.55	PAD, radiator lower ret.
68-71	Chevy, Chevelle (6 cyl.),				
70	Camaro (6 cyl.),				
72-73	All (6 cyl.),				
74	All (6 cyl.) (exc. Nova),				
74	Nova (6 cyl.) (exc. C.A.C.),				
75	All (6 cyl.)	341100	1	1.75	PANEL, upper mtg.
68	Chevelle w/T.H. 350 (307, 327) (exc. C.A.C.),				

**COOLANT—GRILLE—OIL SYSTEM**

**1.270 SUPPORT ASSY.— BRACKET— BOLT— BUSHING ASSY.— CUSHION— GUSSET— MOUNTING UNIT— NUT— PAD— PANEL— SCREW— SHIM— SPACER— WASHER— REINFORCEMENT, Radiator Core (Con't)**

68	Chevelle w/C.A.C., H.D. Rad. (8 cyl.)	3917438	1	2.05	PANEL, upper mtg.
68	Chevelle (8 cyl.) (exc. C.A.C., H.D. Rad.),				
69	Chevelle w/C.A.C., H.D. Rad. (8 cyl.),				
70-71	Chevelle w/C.A.C., H.D. Rad. (307, 350),				
70-71	Chevelle (400 w/4BC),				
70-71	Monte Carlo (454),				
70-71	Malibu, El Camino Custom (396, 400 w/4BC, 454) (exc. C.A.C., H.D. Rad., 4.10 rear axle),				
71-74	Pass. (8 cyl.) (exc. H.D. Rad.),				
72-73	Chevelle w/C.A.C., H.D. Rad. (307),				
72-74	Chevelle (350),				
72-74	Chevelle (402, 454) (exc. C.A.C., H.D. Rad.),				
75	Pass. (350, 400),				
75	Pass. (454) (exc. H.D. Rad.),				
75	Chevelle (8 cyl.)	354074	1	2.75	PANEL, rad. upper mounting
68	Chevy (8 cyl.) (exc. 396),				
68	Chevelle (8 cyl.) (exc. C.A.C., H.D. Rad., P.G.),				
69	Chevy (8 cyl.),				
69	Chevelle (8 cyl.) (exc. C.A.C., H.D. Rad., A.T., 396),				
70-72	Nova (8 cyl.),				
70	Chevelle (8 cyl.) (exc. C.A.C., H.D. Rad., A.T., 396, 400 w/4BC, 454),				
71-73	Chevelle (307) (exc. C.A.C., H.D. Rad.),				
73	Nova (8 cyl.) (exc. C.A.C., H.D. Rad.),				
74	Nova (350) (exc. H.D. Rad., C.A.C.)	339457	1	1.95	PANEL, upper mounting
70-75	Camaro (307, 350) (exc. C.A.C., H.D. Rad., Sp. H/Per. 396)	3966856	1	1.80	PANEL, upper mtg.
70-72	Camaro w/C.A.C., H.D. Rad. (307, 350),				
70	Camaro (Sp. H/Per. 350, 396),				
71-72	Camaro (Sp. H/Per. 350, 400, 402),				
73-75	Camaro w/H.D. Rad. (307, 350) (exc. Sp. H/Per.),				
73-75	Camaro w/Sp. H/Per. 350	360638	1	2.85	PANEL, upper mounting
70	Malibu, El Camino Custom w/C.A.C., H.D. Rad., 4.10 rear axle (exc. 396, 454),				
71-72	Pass. w/H.D. Rad. (454, 400 w/4BC),				
71	Monte Carlo, Malibu, El Camino Custom w/C.A.C., H.D. Rad., 4.10 rear axle (exc. 400 w/4BC, 454),				
72	Chevelle w/C.A.C. (454),				
72	Chevelle w/H.D. Rad. (402, 454),				
73-74	Pass. w/H.D. Rad. (454),				
71-75	Vega (exc. H.D. Rad., C.A.C.)	3982054	1	2.15	PANEL, radiator upper mtg.
71-73	Vega	9619233	1	41.25	PANEL, motor compt.
73-74	Nova w/H.D. Rad. (8 cyl.)	339458	1	2.00	PANEL, upper
73	Pass. (6 cyl.)	335910	1	4.65	PANEL, upper mounting
74	Nova (6 cyl.) w/C.A.C.	352594	1	6.10	PANEL, upper mtg.
74-75	Vega	9676450	1	41.25	PANEL, motor compt.
75	Monza (Town Cpe.)	1696938	1	51.25	PANEL, motor compt. front
75	Monza (8 cyl.) (exc. Town Cpe.),				
75	Monza (140) w/H.D. Rad. (exc. Town Cpe.)	342692	1	3.30	PANEL, rad. upper mtg.
75	Monza (Town Cpe.)	365281	1	3.30	PANEL, rad. upper mtg.



**COOLANT—GRILLE—OIL SYSTEM**

<b>1.270</b>		<b>SUPPORT ASSY.— BRACKET— BOLT— BUSHING ASSY.— CUSHION— GUSSET— MOUNTING UNIT— NUT— PAD— PANEL— SCREW— SHIM— SPACER— WASHER— REINFORCEMENT, Radiator Core (Con't)</b>		
75	Monza (140) (exc. Town Cpe., H.D. Rad.)	356333	1 2.75	PANEL, rad. support filler
75	Monza (140) (exc. Town Cpe., H.D. Rad.)	356301	1 2.70	PANEL, rad. upper mtg.
75	Monza (262) w/C.A.C., H.D. Rad. (exc. Town Cpe.)	1697718	1 51.50	PANEL, motor compt. frt.
75	Monza (140) (exc. Town Cpe., H.D. Rad., C.A.C.)	1697717	1 51.50	PANEL, motor compt. frt.
75	Nova, Camaro (6 cyl.) (exc. H.D. Rad.)	3986525	1 1.75	PANEL, upr. mtg.
75	Nova, Camaro (6 cyl.) w/H.D. Rad.	356612	1 2.40	PANEL, radiator upper mounting
75	Nova (350) (exc. H.D. Rad., C.A.C.)	360633	1 1.95	PANEL, upper
75	Chevelle (6 cyl.) w/C.A.C.	352069	1 3.95	PANEL, upper mtg.
75	Nova (8 cyl.) w/H.D. Rad.	345519	1 2.25	PANEL, upper mtg.
75	Pass. w/H.D. Rad. (454)	354021	1 4.65	PANEL ASSY., upper mounting
75	Laguna w/H.D. Rad. (454)	327134	1 4.00	PANEL ASSY., upper mounting
75	Chevelle (6 cyl.) (exc. C.A.C.)			
67-73	All	3960314	A.R. .12	SCREW, rad. supt., rad. fan shroud, rad. grille ( <sup>5</sup> / <sub>16</sub> "— 18 x <sup>3</sup> / <sub>4</sub> ")— (1.276)
67-69	Camaro,			
68-70	Chevy (396)			SCREW, rad. body,
69	All w/Air Cond.,			
73-75	Nova w/C.A.C.			A/C condenser,
69	Camaro w/C.A.C.	3903536	2 .11	A/C compressor fitting, muffler and tube to rad. supt. clip ( <sup>1</sup> / <sub>4</sub> "— 20 x <sup>13</sup> / <sub>16</sub> ")
69	Chevelle (exc. Sta. Wag., El Camino)	3968523	A.R. .18	SCREW, rad. support to front fender skirt— (1.276)
74-75	Pass. (Sta. Wag.)	343280	2 .14	SCREW, rad. supt.
64-70	Chevelle,			
65	Pass.	3714962	A.R. .11	SHIM, rad. support to frame ( <sup>73</sup> / <sub>64</sub> " O.D. x <sup>3</sup> / <sub>64</sub> " thk.)
65	Pass.,			
65-67	Chevelle	3866425	2 .11	SPACER
65-66	Chevelle,			
66	Pass.	3818180	2 .11	WASHER, rad. supt. to frame ( <sup>1</sup> / <sub>4</sub> " O.D. x <sup>15</sup> / <sub>16</sub> " I.D. x <sup>3</sup> / <sub>16</sub> " thick)
67-68	Pass.	3913456	4 .06	WASHER, rad. supt. to frame ( <sup>15</sup> / <sub>32</sub> " I.D. x <sup>13</sup> / <sub>8</sub> " O.D. x <sup>3</sup> / <sub>16</sub> " thk.)
74-75	Chevelle	3833649	2 .12	WASHER, rad. supt. to frame ( <sup>15</sup> / <sub>32</sub> " x <sup>13</sup> / <sub>4</sub> ")
67-69	Camaro (Conv.)			WASHER, body dampener and bracket front,
68-69	Camaro w/C.A.C.	3909938	1 .11	A/C baffle ( <sup>13</sup> / <sub>32</sub> ")
70	Chevelle (exc. Monte Carlo)	3957389	L.H. .38	REINFORCEMENT, rad. support side L.H.
70	Chevelle (exc. Monte Carlo)	3957390	R.H. .38	REINFORCEMENT, rad. support side R.H.
72	Pass. (8 cyl.)	327101	L.H. .93	REINFORCEMENT, rad. supt. otr.
72	Pass. (8 cyl.)	327102	R.H. .93	REINFORCEMENT, rad. supt. otr.
70-71	Monte Carlo	3963363	2 .48	REINFORCEMENT ASSY., rad. support side
71-72	Chevelle (exc. Monte Carlo)	3975492	R.H. 3.70	REINFORCEMENT ASSY., frt. fdr. to rad. support L.H.
71-72	Chevelle (exc. Monte Carlo)	3975491	L.H. 3.70	REINFORCEMENT ASSY., frt. fdr. to rad. support R.H.
<b>1.271</b>		<b>BRACKET— BAR ASSY.— SUPPORT ASSY., Radiator Support</b>		
70-73	Camaro	3967167	L.H. 2.10	frame L.H.
70-73	Camaro	3967168	R.H. 2.10	frame R.H.
75	Monza (exc. Town Cpe.)	1705965	1 17.95	BAR ASSY., tie frt. end upper
75	Monza (Town Cpe.)	1699200	1 17.95	BAR ASSY., frt. end upper
75	Monza (exc. Town Cpe.)	1654700	1 12.40	SUPPORT ASSY., frt. end upper tie bar
75	Monza (Town Cpe.)	1698134	1 11.90	SUPPORT ASSY., frt. end upper tie bar
<b>1.272</b>		<b>BAFFLE— DEFLECTOR, Radiator Core Side and Lower</b>		
71	Nova w/C.A.C. (8 cyl.)	485129	R.H. .58	rad. to frt. fender
71	Nova w/C.A.C. (8 cyl.)	485130	L.H. .58	rad. to frt. fender
73-75	Pass. (exc. C.A.C.)	327127	L.H. .63	
73-75	Pass. (exc. C.A.C.)	327128	R.H. .63	
73	Chevelle w/H.D. Rad. (307) (exc. C.A.C.),			
73-75	Chevelle (350, 400, 454) (exc. C.A.C.)	331747	1 .61	
73-74	Chevelle (6 cyl.),			

**COOLANT—GRILLE—OIL SYSTEM**

**1.272 BAFFLE— DEFLECTOR, Radiator Core Side and Lower (Con't)**

73	Chevelle (307) (exc. H.D. Rad., C.A.C.)	331749 L.H.	1.60	
73-75	Chevelle (6 cyl.),			
73	Chevelle (307) (exc. H.D. Rad., C.A.C.)	331750 R.H.	.61	
74-75	Camaro w/H.D. Rad. (exc. C.A.C.)	337465	2	1.70
73-74	Nova w/C.A.C.	413489	1	8.75 lower, air
75	Nova	347507	1	8.00 lower, air
75	Nova (8 cyl.) w/H.D. Rad. (exc. C.A.C.)	344369	2	3.15 rad. support
75	Chevelle (6 cyl.) (exc. C.A.C.)	345397	1	1.75 rad. L.H.
75	Nova	347507	1	8.00 DEFLECTOR, rad. lower air

**1.274 SEAL— PLUG, Rad. Core and Support**

68	Chevy, Camaro w/C.A.C.	3937126	1	2.50 rad. supt. (Note 4)
<i>NOTE 4: On Chevy cut as required.</i>				
69-70	Chevy (396)	3947623	1	1.55 rad. support to rad. fan shroud
74-75	Vega, Monza (140, 122)	346569	1	.19 PLUG, rad. supt. air ind. hole

**1.276 NUT— CLIP— FASTENER— SCREW, Radiator Grille and Engine Baffle Attaching**

All	All	9431532 A.R.	.05	rad. fan shroud to rad. support (1/4" — 14, "J" shape)
69	Chevy, Camaro (8 cyl.) (exc. 396),			
69-70	Pass., Chevelle (8 cyl.),			
70	Nova, Camaro w/H.D. Rad. (8 cyl.),			
70	Nova (8 cyl.) (exc. 396),			
70	Camaro (8 cyl.),			
71-75	Nova w/H.D. Rad. (6 cyl.),			
71-75	All (8 cyl.),			
71-75	Vega, Monza w/C.A.C., H.D. Rad.,			
73-75	Camaro w/H.D. Rad. (6 cyl.)	3939394	2	.12 rad. fan shroud, upper (1/4" — 14 x 9/16")
67-68	Camaro (396)	3916638 R.H.	.18	CLIP
68-70	Chevelle (8 cyl.),			
68-70	Chevy (exc. 396),			
68-69	Chevy, Chevelle w/C.A.C., H.D. Rad. (6 cyl.),			
70	Nova, Chevelle, Camaro w/H.D. Rad. (6 cyl.),			
70	Camaro (8 cyl.),			
71-75	All (exc. Vega, Monza)	3920179	2	.16 CLIP, fan shroud
71-75	Vega, Monza (140) w/C.A.C., H.D. Rad.	3982085	2	.12 CLIP, radiator fan shroud
69-70	Chevy (396)	9792217	5	.13 FASTENER, rad. support to rad. fan shroud— (8.154)
65-67	Pass.,			
67	Chevy, Chevelle,			
70	Chevelle	3834926 A.R.	.11	SCREW, grille to frt. bumper filler panel (1/4" — 20 x 5/8" cad.)— (2.729)
67-75	All	3960314 A.R.	.12	SCREW, rad. supt., rad. fan shroud, rad. grille (5/16" — 18 x 3/4")
69	Chevelle (exc. Sta. Wag., El Camino),			
70	Chevelle			SCREW, rad. support to front fender skirt,
71-73	Chevelle	3968523 A.R.	.18	filler panel to grille bracket (5/16" — 18 x 1 1/2")

**1.277 SHROUD— BRACKET— GUARD— EXTENSION— PANEL, Radiator Fan**

62-67	Chevy (4 cyl.)	3791072 A.R.	17.80	(steel)
64-65	Chevelle (8 cyl.),			
66-67	Chevelle (8 cyl.) (exc. A.I.R., H.D. Rad., Sp. H/Per., 396)	3867783	1	16.10 rad. mounting (steel)
65-66	Pass. (283, 327) (exc. Air Cond., H.D. Rad.)	3867784	1	12.20 rad. mtg.
65-67	Pass. w/H.D. Rad., C.A.C. (8 cyl.) (exc. 396, 409, 427),			
65	Pass. w/Sp. H/Per. 396),			
66-67	Pass. w/A.I.R. (283, 327) (exc. H.D. Rad.),			
66-67	Pass. (396, 427)	3867785	1	6.05 rad. mtg.
65	Pass. w/Air Cond., H.D. Rad. (283, 327),			

**COOLANT—GRILLE—OIL SYSTEM**

**1.277 SHROUD— BRACKET— GUARD— EXTENSION— PANEL, Radiator Fan  
(Con't)**

66-67	Chevelle (8 cyl.) (exc. 396) . . . . .	3907199	1	10.60	(complete) . . . . .
65-66	Pass. w/Air Cond., H.D. Rad. (6 cyl.) (exc. A.I.R.),				
65	Taxi, Police (6 cyl.),				
65	Pass. w/C.A.C., H.D. Rad. (396) (exc. Sp. H/Per.),				
66-68	Taxi, Police w/P.G. (6 cyl.),				
68	Pass. w/C.A.C., H.D. Rad., (6 cyl.) . . . . .	3867788	1	11.35	(complete) . . . . .
66-67	Chevy (A.I.R. w/P.G.) (6 cyl.) (exc. 250, H.D. Rad., Trans. oil cooler),				
66-67	Chevy w/C.A.C., H.D. Rad. (6 cyl.),				
67	Chevy (A.I.R. w/P.G.) (250) (exc. H.D. Rad., C.A.C.) . . . . .	3878890	1	9.50	(plastic) . . . . .
66-67	Chevy w/C.A.C., H.D. Rad. (8 cyl.),				
66-67	Chevy w/A.I.R. (8 cyl.) (exc. Sp. H/Per., H.D. Rad., C.A.C.),				
66	Chevy w/Sp. H/Per. . . . .	3878892	1	10.10	(plastic) . . . . .
66	Taxi, Police (8 cyl.),				
66-68	Pass. w/H.D. Rad., C.A.C. (283, 307, 327),				
68	Pass. w/P.G. (307),				
68	Pass. w/T.H. 350 (307) (exc. Air Cond.) . . . . .	3926846	1	12.60	(plastic) . . . . .
66	Pass. w/A.I.R. (327) (exc. C.A.C., Taxi, H.D. Rad.),				
66	Pass. (A.I.R. w/P.G.) (283) (exc. H.D. Rad. C.A.C., Taxi),				
66-67	Chevelle w/A.I.R. (8 cyl.) (exc. H.D. Rad., 396, Sp. H/Per.),				
66-67	Chevelle w/C.A.C., H.D. Rad. (283, 327),				
67-68	Pass. w/A.I.R. (327) (exc. H.D. Rad., Air Cond.),				
67	Pass. (A.I.R. w/P.G.) (283) (exc. H.D. Rad., Air Cond.),				
68	Pass. w/A.T. (327) (exc. reg. fuel, C.A.C., H.D. Rad.) . . . . .	3903957	1	15.75	(plastic) . . . . .
66-67	Chevelle w/C.A.C., H.D. Rad. (396),				
66	Chevelle w/A.I.R. (396) (exc. H.D. Rad., C.A.C., A.T.),				
67	Chevelle (S.S.) w/A.I.R. (396) (exc. H.D. Rad., C.A.C., A.T.),				
67	El Camino (A.I.R. w/A.T.) (396) (exc. H.D. Rad., C.A.C.) . . . . .	3891464	1	9.30	(plastic) . . . . .
66-67	Pass. w/A.I.R. (396, 427),				
68	Pass. (396, 427) . . . . .	3934500	1	9.00	(plastic) . . . . .
66	Pass. w/A.I.R. (6 cyl.),				
66-67	Chevelle w/A.I.R. (6 cyl.),				
67-68	Pass. w/P.G. (6 cyl.) (exc. Taxi, C.A.C., H.D. Rad.),				
69	Pass. w/C.A.C., H.D. Rad. (6 cyl.),				
69-70	Taxi w/A.T. (6 cyl.),				
70	Pass. w/H.D. Rad. (6 cyl.) . . . . .	3939386	1	15.75	(plastic) . . . . .
	<i>NOTE 1 When using gussets 3860137 or 3860138 with this assy. spot weld as required using old part as guide.</i>				
67	Pass. (H.D. Rad. w/Air Cond.) (283, 327),				
67	Pass. w/A.I.R. (283, 327) (exc. Air Cond., H.D. Rad.),				
67	Pass. (396, 427),				
68	Pass. w/T.H. 350 (307, 327) (exc. Air Cond.),				
68	Pass. (327, 396, 427),				
68	Pass. w/H.D. Rad., C.A.C. (8 cyl.) (exc. 396, 427, P.G.),				
68	Pass. w/P.G. (307) . . . . .	3929278	1	19.90	mounting . . . . .
67-68	Camaro (8 cyl.) (exc. Air Cond., 396) . . . . .	3893812	1	10.45	(plastic) . . . . .

**COOLANT—GRILLE—OIL SYSTEM**

**1.277 SHROUD— BRACKET— GUARD— EXTENSION— PANEL, Radiator Fan  
(Con't)**

67-68	Camaro w/Air Cond., H.D. Rad. (327, 350) . . . . .	<b>3893814</b>	1	10.45	(plastic) . . . . .
67	Camaro w/A.I.R. (6 cyl.) (1st design) (exc. C.A.C.),				
67-69	Camaro w/Air Cond. (6 cyl.),				
67-68	Camaro w/H.D. Rad. (230) (exc. P.G., Torque Drive) . . . . .	<b>3893816</b>	1	9.05	(plastic) (Note 2) . . . . .
	<i>NOTE 2 For 2nd design see Guard, 3893892.</i>				
67-68	Camaro, Chevy (396) . . . . .	<b>3945789</b>	1	15.10	
67	Pass. (283, 327) (exc. A.I.R., H.D. Rad., Air Cond.),				
68	Pass. (307) (exc. C.A.C., A.T., H.D. Rad.) . . . . .	<b>3905778</b>	1	17.10	mounting . . . . .
68-69	Chevy w/C.A.C., H.D. Rad. (6 cyl.),				
70-74	Nova w/H.D. Rad. (6 cyl.) . . . . .	<b>3934189</b>	1	7.75	(plastic) . . . . .
68	Chevy (exc. 396) . . . . .	<b>3919167</b>	1	13.40	(plastic) . . . . .
68-70	Chevy (4 cyl.) . . . . .	<b>3927596</b>	1	16.70	
68-69	Chevelle w/C.A.C., H.D. Rad. (6 cyl.),				
70-75	Chevelle w/H.D. Rad. (6 cyl.),				
71-72	Pass. w/H.D. Rad. (6 cyl.) . . . . .	<b>6261915</b>	1	9.90	(plastic) . . . . .
68	Chevelle (396) . . . . .	<b>3920110</b>	1	13.85	(plastic) . . . . .
68	Chevelle (8 cyl.) (exc. C.A.C., P.G., H.D. Rad., 396, Sp. H/Per.) . . . . .	<b>3920108</b>	1	13.85	(plastic) . . . . .
68	Chevelle w/C.A.C., H.D. Rad. (8 cyl.) (exc. P.G., Sp. H/Per. 396),				
68	Chevelle w/T.H. 350 (307, 327) (exc. C.A.C.),				
68	Chevelle w/Sp. H/Per. (327),				
68	Chevelle w/P.G. (307) . . . . .	<b>3920109</b>	1	12.40	(plastic) . . . . .
69	Pass. (327) (1st design) (exc. C.A.C.),				
69	Pass. (4BC w/reg. fuel) (350) (1st design) (exc. H.D. Rad., A.T.),				
69	Pass. (327, 350 w/4BC) (2nd design) (exc. H.D. Rad., C.A.C.),				
70	Pass. (A.T. w/4BC) (350) (1st design) (exc. H.D. Rad., C.A.C.)	<b>3939387</b>	1	15.75	(plastic) (rounded bottom) . . . . .
69	Pass. w/2BC (350) (exc. H.D. Rad., C.A.C.),				
69	Pass. w/A.T. (327) (1st design) (exc. H.D. Rad., C.A.C.),				
69	Pass. (4BC w/reg. fuel) (350) (1st design) (exc. H.D. Rad., C.A.C.),				
69	Pass. (4BC w/reg. fuel) w/A.T. (350) (2nd design) (exc. H.D. Rad., C.A.C.),				
70	Pass. (8 cyl.) (1st design) (exc. H.D. Rad., C.A.C., A.T.),				
70	Pass. (A.T. w/2BC) (350) (1st design) (exc. H.D. Rad., C.A.C.),				
70	Pass. (350) (2nd design) (exc. H.D. Rad., C.A.C.) . . . . .	<b>3939388</b>	1	15.75	(plastic) (straight bottom) . . . . .
69	Pass. (396, 427) (exc. H/Per., Sp. H/Per., C.A.C., H.D. Rad.),				
69	Pass. w/H/Per. (427) (exc. C.A.C., Positraction),				
70	Pass. w/T.H. 400 (454) (exc. C.A.C., H.D. Rad.),				
70	Pass. (H.D. Rad. w/C.A.C.) (8 cyl.) . . . . .	<b>3939389</b>	1	15.75	(plastic) . . . . .
69	Pass. w/C.A.C. (327, 350),				
69	Pass. w/H.D. Rad. (327, 350),				
70	Pass. w/C.A.C. (350) (exc. H.D. Rad.),				
70	Pass. w/H.D. Rad. (350) (exc. C.A.C.),				
70	Pass. w/A.T. (400) (exc. H.D. Rad.) . . . . .	<b>3939390</b>	1	15.75	(plastic) . . . . .

**COOLANT—GRILLE—OIL SYSTEM**

**1.277 SHROUD— BRACKET— GUARD— EXTENSION— PANEL, Radiator Fan  
(Con't)**

69	Pass. w/C.A.C., H.D. Rad. (396, 427),				
69	Pass. w/Sp. H/Per. (427),				
69	Pass. w/P/Trac., H/Per. (427) (exc. C.A.C.),				
70	Pass. w/C.A.C., H.D. Rad., A.T. (454) . . . . .	3939391	1	15.75	(plastic) . . . . .
69	Chevelle w/C.A.C., H.D. Rad., P.G., T.H. 350 (8 cyl.) (exc. 350 w/2BC, 396),				
70	Chevelle w/C.A.C., H.D. Rad. (8 cyl.) (exc. A.T., 396, 400 w/4BC, 454),				
71-72	Monte Carlo, H.D. Rad., A.T. 2BC (350),				
71-72	Monte Carlo w/4BC (350) . . . . .	6261913	1	13.45	(plastic) . . . . .
69	Chevy, Camaro (396),				
70	Nova (396) . . . . .	3947619	1	14.15	(plastic) . . . . .
69	Chevelle (8 cyl.) (exc. C.A.C., H.D. Rad., P.G., T.H. 350, 396),				
70	Chevelle (307, 350) (exc. C.A.C., H.D. Rad., Monte Carlo),				
70	Monte Carlo (350, 400 w/2BC) (exc. C.A.C., H.D. Rad., T.H. 350),				
71-72	Monte Carlo w/2BC (350) (exc. C.A.C., H.D. Rad., A.T.) . . . . .	6261912	1	13.45	(plastic) . . . . .
69	Chevelle (396),				
70	Chevelle (400 w/4BC),				
70	Chevelle (396, 454),				
71-72	Monte Carlo (400 w/4BC, 402, 454) . . . . .	6261914	1	14.15	(plastic) . . . . .
69	Camaro (8 cyl.) (exc. 396) . . . . .	3938615	1	13.45	(plastic) . . . . .
69-72	Chevy (8 cyl.) (exc. 396) . . . . .	3938613	1	12.65	(plastic) . . . . .
70-75	Camaro (8 cyl.) (exc. C.A.C., H.D. Rad., Sp. H/Per. 396) . . . . .	3973900	1	7.55	upper half . . . . .
70-75	Camaro (8 cyl.) (exc. C.A.C., H.D. Rad., Sp. H/Per. 396) . . . . .	3973902	1	7.55	lower half . . . . .
70-75	Camaro w/C.A.C., H.D. Rad. (307, 350) (exc. Sp. H/Per.),				
70-75	Camaro w/Sp. H/Per. (350) . . . . .	3973910	1	7.05	upper half . . . . .
70-75	Camaro w/C.A.C., H.D. Rad. (307, 350) (exc. Sp. H/Per.),				
70-75	Camaro w/Sp. H/Per. (350) . . . . .	3973912	1	7.05	lower half . . . . .
70	Camaro (396),				
71-72	Camaro w/4BC (400, 402) . . . . .	3973920	1	7.05	
71-73	Chevelle (307) (exc. C.A.C., H.D. Rad.) . . . . .	3987013	1	6.95	upper . . . . .
71-73	Chevelle (307) (exc. C.A.C., H.D. Rad.) . . . . .	6261916	1	6.95	lower . . . . .
71-73	Chevelle w/C.A.C., H.D. Rad. (307),				
71-72	Chevelle (350) (exc. Monte Carlo),				
71-75	Pass. (350, 400),				
73-75	Chevelle (350, 400) . . . . .	3986905	1	7.50	upper half . . . . .
71-73	Chevelle w/C.A.C., H.D. Rad. (307),				
71-72	Chevelle (350) (exc. Monte Carlo),				
71-75	Pass. (350, 400),				
73-75	Chevelle (350, 400) . . . . .	6261917	1	7.50	lower half . . . . .
71	Chevelle (400 w/4BC) (exc. H.D. Rad., Monte Carlo),				
71-72	Chevelle (402, 454) (exc. C.A.C., H.D. Rad., Monte Carlo),				
71-72	Pass. (400 w/4BC, 402, 454) (exc. H.D. Rad.),				
73-75	Chevelle (454),				
73-75	Pass. (454) (exc. H.D. Rad.) . . . . .	3986907	1	6.95	upper half . . . . .
71	Chevelle (400 w/4BC) (exc. H.D. Rad., Monte Carlo),				
71-72	Chevelle (402, 454) (exc. C.A.C., H.D. Rad., Monte Carlo),				

**COOLANT—GRILLE—OIL SYSTEM**

**1.277 SHROUD— BRACKET— GUARD— EXTENSION— PANEL, Radiator Fan  
(Con't)**

71-72	Pass. (400 w/4BC, 402, 454) (exc. H.D. Rad.),				
73-75	Chevelle (454),				
73-75	Pass. (454) (exc. H.D. Rad.)	6261918	1	6.95	lower half
71-72	Chevelle w/H.D. Rad. (400 w/4BC, 402, 454) (exc. Monte Carlo),				
71-72	Chevelle w/C.A.C. (402, 454) (exc. Monte Carlo),				
71	Chevelle w/4.10 ratio,				
71-72	Pass. w/H.D. Rad. (400 w/4BC, 402, 454),				
73-75	Pass. w/H.D. Rad. (454)	3986974	1	6.95	upper half
71-72	Chevelle w/H.D. Rad. (400 w/4BC, 402, 454) (exc. Monte Carlo),				
71-72	Chevelle w/C.A.C. (454) (exc. Monte Carlo),				
71	Chevelle w/4.10 ratio,				
71-72	Pass. w/H.D. Rad. (400 w/4BC, 402, 454),				
73-75	Pass. w/H.D. Rad. (454)	6261919	1	6.95	lower half
73-74	Nova w/H.D. Rad. (8 cyl.)	6274372	1	13.45	lwr.
73-74	Nova (8 cyl.) (exc. H.D. Rad.)	6274373	1	13.45	lwr.
73-74	Nova (8 cyl.)	6274371	1	13.45	(upr.)
75	Chevelle (6 cyl.) w/C.A.C.	352099	1	11.10	
75	Nova (8 cyl.) (exc. H.D. Rad., C.A.C.)	345507	1	12.20	upper
75	Nova (8 cyl.)	345508	1	12.20	lower
75	Nova (8 cyl.) w/H.D. Rad.	345506	1	12.20	upper
75	Camaro (6 cyl.) w/H.D. Rad.	352600	1	13.65	
75	Nova (6 cyl.) w/H.D. Rad.	352593	1	8.00	
71-75	Vega w/C.A.C., H.D. Rad.	3982080	1	4.00	fan lower
71-75	Vega w/C.A.C., H.D. Rad.	3982079	1	4.00	fan upper
75	Monza (140) w/H.D. Rad.	356322	1	9.05	rad. fan
75	Monza (140) (exc. H.D. Rad., Town Cpe.)	358322	1	12.70	rad. fan
75	Vega, Monza (8 cyl.) w/C.A.C.	4961800	1	24.65	SHROUD ASSY., aux. engine cooling
69	Camaro (396)	3947622	1	.73	BRACKET, rad. fan shroud
69-70	Chevy (396)	3947621	1	.73	BRACKET, rad. fan shroud
67-68	Camaro (8 cyl.),				
69	Camaro (8 cyl.) (exc. 396)	3938612	1	.66	BRACKET, rad. fan shroud (Note 3)
	<i>NOTE 3 When using 3938612 in place of 3893831 use 1-3792259 nut, 1-9419967 screw, and 1-120386 washer.</i>				
67	Camaro (6 cyl.) (1st design) (exc. A.I.R., Air Cond.),				
67-68	Camaro (6 cyl.) (2nd design) (exc. C.A.C., H.D. Rad.),				
69	Camaro (6 cyl.) (exc. C.A.C.)	3893892	1	2.10	GUARD, rad. fan
67-69	Camaro w/C.A.C. (6 cyl.),				
67-68	Camaro w/H.D. Rad. (exc. 250 w/P.G.)	3914794	1	.80	GUARD, rad. fan
75	Monza (8 cyl.),				
75	Monza (140) (exc. H.D. Rad.)	353989	1	10.20	GUARD, rad. fan
70-72	Monte Carlo	3968571	1	6.65	EXTENSION, shroud upper
70-72	Monte Carlo	3968572	1	6.65	EXTENSION, shroud lower
73-75	Monte Carlo	3999701	1	6.65	EXTENSION, shroud upper
73-75	Monte Carlo	3999702	1	6.65	EXTENSION, shroud lower
73	Pass. (6 cyl.)	335911	1	1.85	PANEL, rad. upr. fan guard

**1.287 PANEL— BRACKET— EXTENSION— PLATE— REINFORCEMENT—  
RETAINER— SEAL, Radiator and Grille Filler**

62-65	Chevy	3858407	1	11.70	to front bumper filler (Note 1)
	<i>NOTE 1 When using 3858407 on 62-65 models without lower outer brackets, remove bracket as it is no longer required.</i>				
64	Chevelle	3839112	1	18.80	frt. bumper filler
65	Chevelle	3856904	1	14.10	rad. grille to front bumper filler
66	Chevelle	3871080	1	12.50	rad. grille to front bumper filler (Note 2)
	<i>NOTE 2 When using 3871080 in place of 3878487 drill 11 slots and 2 holes for attch. of mldg. Use old part as a guide.</i>				
66	Pass.	3869749	1	3.80	rad. grille to frt. bumper center filler
66	Pass.	3874549	1	6.60	rad. grille to front bumper outer filler L.H.
66	Pass.	3874550	1	6.60	rad. grille to front bumper outer filler R.H.
66-67	Chevy	3892293	1	11.95	rad. grille to front bumper filler

**COOLANT—GRILLE—OIL SYSTEM**

**1.287 PANEL— BRACKET— EXTENSION— PLATE— REINFORCEMENT—  
RETAINER— SEAL, Radiator and Grille Filler (Con't)**

67	Chevelle	3893903	1	11.95	rad. grille to front bumper filler
67	Pass.	3915401	1	2.60	rad. grille to front bumper filler, left
67	Pass.	3915402	1	2.60	rad. grille to front bumper filler, right
68	Pass.	3929816	1	2.15	rad. grille to front bumper filler
68-69	Chevelle	3966919	1	7.60	rad. grille to frt. bumper filler
68-72	Nova	3919083	1	7.30	rad. grille to frt. bumper filler
69	Pass.	3934575	L.H.	3.95	front bumper filler L.H.
69	Pass.	3934576	R.H.	3.95	front bumper filler R.H.
70	Pass.	3976655	1	4.95	rad. grille to front bumper filler
70	Chevelle,				
71-72	Monte Carlo	3962324	1	8.50	PANEL ASSY., rad. grille to front bumper filler
73	Chevelle (exc. Laguna, Monte Carlo)	325212		2.30	BRACKET, rad. grille to header pnl.
73	Chevelle (exc. Laguna, Monte Carlo)	325221	L.H.	.63	BRACKET, rad. grille
73	Chevelle (exc. Laguna, Monte Carlo)	325222	R.H.	.63	BRACKET, rad. grille
74	Malibu, El Camino	338569	L.H.	1.45	BRACKET, grille left
74	Malibu, El Camino	338570	R.H.	1.45	BRACKET, grille right
75	Malibu, El Camino	345345	L.H.	1.65	BRACKET, grille left
75	Malibu, El Camino	345346	R.H.	1.65	BRACKET, grille right
74-75	Malibu, El Camino	352094	1	3.00	BRACKET, rad. grille and header panel
65	Chevelle	3868713	L.H.	4.15	EXTENSION, grille to frt. bumper filler panel
65	Chevelle	3868714	R.H.	4.15	EXTENSION, grille to frt. bumper filler panel
73	Chevelle (exc. Laguna, Monte Carlo)	325217	L.H.	2.20	EXTENSION, rad. grille
73	Chevelle (exc. Laguna, Monte Carlo)	325218	R.H.	2.20	EXTENSION, rad. grille
75	Nova	345522	6	.12	PLATE, rad. grille ret.
66	Chevy	3876505	L.H.	.12	REINFORCEMENT, grille to bumper
66	Chevy	3876506	R.H.	.12	REINFORCEMENT, grille to bumper
68-72	Nova	3949797	1	5.95	REINFORCEMENT, rad. grille to frt. bumper filler panel
75	Camaro	341043	L.H.	.16	REINFORCEMENT, grille header panel
75	Camaro	341044	R.H.	.16	REINFORCEMENT, grille header panel
73-74	Monte Carlo	325249	L.H.	1.30	RETAINER, frt. fdr. to bumper filler inner
73-74	Monte Carlo	325250	R.H.	.76	RETAINER, frt. fdr. to bumper filler inner
73-75	Monte Carlo	325247	L.H.	.84	RETAINER, frt. fdr. to bumper filler outer
73-75	Monte Carlo	325248	R.H.	.84	RETAINER, frt. fdr. to bumper filler outer
75	El Camino	356419	L.H.	.84	RETAINER, frt. fdr. to bpr. filler outer
75	El Camino	356420	R.H.	.84	RETAINER, frt. fdr. to bpr. filler outer
68-72	Nova	3949680	2	.12	SEAL, rad. grille to front bumper filler panel

**1.303 EMBLEM— MOULDING UNIT— NUT— ORNAMENT ASSY.— PLATE—  
RETAINER— SPACER— STRIPE, Radiator Grille & Frt. End (Also See  
Group 8.055)**

65	Chevy	3863613	1	2.80	
65	Chevelle	3875758	1	3.25	
66	Chevy (S.S.)	3875713	1	2.85	
66	Chevelle (S.S.)	3891434	1	3.75	
68	Camaro w/R.S. (350, 396)	3921860	1	3.40	rad. grille (Note 1)
	<i>NOTE 1 Requires one 3927599 plate, two 9419761 nuts.</i>				
	<i>NOTE 2 Requires one 3916669 plate, two 9419761 nuts.</i>				
	<i>NOTE 3 Requires two 3874551 retainers, two 9417587 washers, two 3843001 nuts.</i>				
68	Chevelle (396)	3920802	1	2.95	rad. grille (Note 4)
	<i>NOTE 4 Requires one 3920803 retainer, two 9419764 nuts.</i>				
68	Camaro (exc. 350, 396, R.S.)	3916655	1	3.15	rad. grille (Note 5)
	<i>NOTE 5 Requires one 3916656 plate, two 9419761 nuts.</i>				
68	Pass. (exc. S.S. 427)	3926885	1	6.05	(Note 6)
	<i>NOTE 6 Requires two 9419764 nuts.</i>				
68	Pass. (S.S. 427)	3920800	1	3.50	(Note 7)
	<i>NOTE 7 Requires one 3920801 retainer, two 9419764 nuts.</i>				
65	Pass. (exc. Caprice)	3870783	1	4.65	EMBLEM UNIT, grille header panel (Note 8)
	<i>NOTE 8 Consists of 1 emblem, 1 bezel, 1 spacer and 4 nuts.</i>				
67	Camaro (exc. 350, 396, R.S.)	3902894	1	4.00	EMBLEM UNIT (Note 10)
67-68	Camaro w/R.S. (exc. 350, 396)	3907915	1	4.00	EMBLEM UNIT (Note 10)
	<i>NOTE 10 Unit consists of 1 emblem, 1 plate, 2 nuts.</i>				
67	Camaro (350, 396),				
68	Chevy (350),				
69	Chevy (396)	3918871	1	4.40	EMBLEM UNIT (Note 11)
	<i>NOTE 11 When used as replacement on Chevy discard plate 3899891.</i>				

**COOLANT—GRILLE—OIL SYSTEM**

**1.303 EMBLEM— MOULDING UNIT— NUT— ORNAMENT ASSY.— PLATE—  
RETAINER— SPACER— STRIPE, Radiator Grille & Frt. End (Also See  
Group 8.055) (Con't)**

*NOTE 13 Unit consists of 1 emblem, 2 retainers, 2 nuts.*

68	Camaro (350, 396) (exc. R.S.),				
72	Nova w/4BC (350),				
72	Camaro,				
72	Camaro w/4BC (350, 402) (exc.				
	Sp. H/Per.)	6263015	1	6.35	EMBLEM UNIT
69	Chevelle (exc. Nomad)	3952427	1	6.60	EMBLEM UNIT (Note 14)
	<i>NOTE 14 Unit consists of 1-emblem assy., 2-retainers, 2-nuts.</i>				
69	Chevelle (Spt. Cpe., El Camino				
	(396)	3952421	1	5.70	EMBLEM UNIT (Note 15)
	<i>NOTE 15 Unit consists of 1-emblem, 1-retainer, 2-nut assy.</i>				
69	Camaro (302)	3958642	1	8.75	EMBLEM UNIT (Z-28) (Note 16)
69	Camaro w/R.S.	3958641	1	5.15	EMBLEM UNIT (RS) (Note 16)
69	Camaro	3958639	1	6.90	EMBLEM UNIT (Chevrolet) (Note 16)
69	Camaro w/4BC (350, 396)	3958638	1	5.15	EMBLEM UNIT (SS) (Note 16)
	<i>NOTE 16 Units consist of 1-emblem, 1-plate, 2-nuts.</i>				
69	Pass. (exc. S.S. 427)	3953669	1	6.10	EMBLEM UNIT (Note 17)
69	Pass. (S.S. 427)	3958643	1	5.65	EMBLEM UNIT (Note 17)
70	Pass.	3977571	1	5.85	EMBLEM UNIT
70	Chevelle (exc. 396, 454, Monte				
	Carlo)	3977585	1	4.15	EMBLEM UNIT
70	Monte Carlo	3981934	1	4.15	EMBLEM UNIT
70	Chevelle (396, 454) (exc. Monte				
	Carlo)	3977563	1	4.15	EMBLEM UNIT
70-72	Nova w/4BC (350, 396)	3940538	1	4.35	EMBLEM UNIT
70-71	Camaro w/4BC (350, 396, 400)				
	(exc. Sp. H/Per.)	3981921	1	6.35	EMBLEM UNIT (S.S.)
70-71	Camaro w/Sp. H/Per. (350)	3981924	1	6.60	EMBLEM UNIT
71	Caprice	3995796	1	5.90	EMBLEM UNIT
71-72	Chevelle (exc. 454, Monte Carlo)	3991037	1	5.50	EMBLEM UNIT
71	Monte Carlo	3991038	1	4.35	EMBLEM UNIT
71	Chevelle (S.S.)	3991036	1	4.35	EMBLEM UNIT (S.S.)
70-72	Camaro	3996683	1	5.90	EMBLEM UNIT, header panel
72	Biscayne, Bel Air, Impala	6263032	1	2.05	EMBLEM UNIT
72	Biscayne, Bel Air, Impala,				
	Kingswood	6263034	1	3.15	EMBLEM UNIT, header pnl.
72	Caprice	6263035	1	3.15	EMBLEM UNIT, header pnl.
72	Caprice	6263033	1	2.40	EMBLEM UNIT
72	Chevelle (exc. S.S., Monte Carlo),				
	Monte Carlo	6263175	1	4.50	EMBLEM UNIT
72	Chevelle	6272090	1	4.65	EMBLEM UNIT, "S.S."
72	Camaro w/Sp. H/Per. (350)	6263014	1	6.60	EMBLEM UNIT
73	Bel Air, Impala	6258136	1	3.15	EMBLEM UNIT, grille
73	Bel Air, Impala	6258139	1	3.15	EMBLEM UNIT, rad. grille header pnl.
73	Caprice	338255	1	3.15	EMBLEM UNIT, rad. grille header pnl. and grille
73	Chevelle (exc. S.S., Monte Carlo)	6258024	1	5.50	EMBLEM UNIT, grille
73	Monte Carlo,				
	Monte Carlo	6258023	1	4.50	EMBLEM UNIT, grille
73	Chevelle w/S.S.	6258814	1	3.60	EMBLEM UNIT, "S.S." grille
73-74	Nova, S.S.	6258813	1	3.60	EMBLEM UNIT, grille
73-74	Camaro	3996683	1	5.90	EMBLEM UNIT, header panel
73	Camaro w/Sp. H/Per. (350)	338239	1	6.60	EMBLEM UNIT, grille (Z-28)
73	Camaro (LT)	6259662	1	3.60	EMBLEM UNIT, rad. grille
74	Chevelle (S.S.)	344453	1	4.35	EMBLEM UNIT, grille (S.S.)
74	Laguna	345214	1	4.35	EMBLEM UNIT, grille (shield, gold and black)
74	Impala, Bel Air	6260819	1	3.70	EMBLEM UNIT, grille
74	Camaro	6260836	1	4.10	EMBLEM UNIT, grille
74	Nova (exc. S.S.)	6260838	1	3.60	EMBLEM UNIT, grille
74	Caprice	6260495	1	3.15	EMBLEM UNIT, header panel
74	Monte Carlo	6260535	1	4.50	EMBLEM UNIT, header panel
75	Impala, Bel Air	358800	1	3.40	EMBLEM UNIT, header panel
75	Caprice	358808	1	5.35	EMBLEM UNIT, header panel
75	El Camino	358272	1	4.55	EMBLEM UNIT, rad. grille
75	El Camino Classic (S.S.)	358271	1	2.95	EMBLEM UNIT, rad. grille
75	Nova (exc. LN., S.S.)	358742	1	3.00	EMBLEM UNIT, rad. grille
75	Nova (exc. Nova Custom, S.S.)	358743	1	1.90	EMBLEM UNIT, rad. grille
75	Nova Custom (exc. LN., S.S.)	358744	1	3.00	EMBLEM UNIT, rad. grille
75	Nova (LN)	361006	1	3.55	EMBLEM UNIT, rad. grille
75	Nova (S.S.)	358746	1	2.95	EMBLEM UNIT, rad. grille
75	Camaro	358799	1	2.85	EMBLEM UNIT, rad. grille header panel



**COOLANT—GRILLE—OIL SYSTEM**

**1.303 EMBLEM— MOULDING UNIT— NUT— ORNAMENT ASSY.— PLATE—  
RETAINER— SPACER— STRIPE, Radiator Grille & Frt. End (Also See  
Group 8.055) (Con't)**

75	Monza (exc. Notchback) (262, 140) . . . . .	360813	1	4.20	EMBLEM UNIT, body front . . . . .
	<i>NOTE 17 Units consists of 1-emblem, 1-retainer, 2-nuts.</i>				
65	Pass. . . . .	3865253	1	5.70	MOULDING UNIT, left, headlamp opening— (8.132) . . . . .
65	Pass. . . . .	3865254	1	5.70	MOULDING UNIT, right, headlamp opng.— (8.132) . . . . .
64	All . . . . .	9419763	A.R.	.11	NUT, emblem assy. attaching ( <sup>3</sup> / <sub>16</sub> "— (8.921) . . . . .
67	Camaro . . . . .				NUT, head lamp bezel to grille header panel, . . . . .
67-68	Camaro . . . . .				headlamp bezel to fender, . . . . .
67-69	Camaro w/R.S. . . . .				headlamp bezel, . . . . .
68	Chevelle . . . . .	3899847	A.R.	.11	rad. grille ext. nut . . . . .
74-75	Malibu . . . . .	3952675	1	.12	NUT, rad. grille header pnl. orn. ( <sup>5</sup> / <sub>8</sub> "— 18)— (4.046) . . . . .
69	Chevelle (exc. Sta. Wag., El Camino) . . . . .	3958312	4	.05	NUT, rad. header panel name plate . . . . .
	Not required in this group. See group 9.190 . . . . .				
		3844999		.21	NUT . . . . .
71-74	Vega . . . . .	3844999	2	.21	NUT . . . . .
74	El Camino Classic (exc. S.S.), 74-75 Malibu (Classic) . . . . .	345303	1	6.20	ORNAMENT ASSY., rad. grille header panel . . . . .
65	Pass. (exc. S.S.) . . . . .	3855483	1	2.10	PLATE, name ("Chevrolet") . . . . .
66	Pass. (exc. S.S.) . . . . .	3874556	1	3.20	PLATE, name ("Chevrolet") . . . . .
66	Chevy . . . . .	3874540	1	2.30	PLATE, name . . . . .
67-68	Camaro w/R.S. (exc. 350, 396) . . . . .	3903440	1	.11	PLATE, emblem backing . . . . .
67	Camaro w/R.S. (350, 396) . . . . .	3899891	1	.18	PLATE, emblem backing . . . . .
68-69	Camaro . . . . .	3916654	1	3.50	PLATE, rad. grille hdr. panel name (Note 18) . . . . .
68-69	Chevelle . . . . .	3920825	1	3.00	PLATE, rad. grille hdr. panel (Note 18)— (8.147) . . . . .
	<i>NOTE 18 Requires four 3752642 nuts.</i>				
68	El Camino . . . . .	3920867	1	1.85	PLATE, rad. grille header panel name (Note 19) . . . . .
	<i>NOTE 19 Requires three 3752642 nuts.</i>				
68	Camaro (exc. 350, 396, R.S.) . . . . .	3916656	1	.70	PLATE, emblem backing . . . . .
68	Camaro (350, 396) (exc. R.S.) . . . . .	3916669	1	.16	PLATE, emblem backing . . . . .
68	Pass. w/S.S. . . . .	3920851	1	6.55	PLATE, name (Note 20) . . . . .
73	Camaro (LT) w/R.S. . . . .	333757	1	2.15	PLATE, rad. grille emblem backing . . . . .
	<i>NOTE 20 Requires one 3920852 retainer, two 9419761 nuts.</i>				
67	Pass. (exc. S.S.) . . . . .	3907067	1	4.00	PLATE UNIT, name (Note 21) . . . . .
	<i>NOTE 21 Unit consists of 1 plate, 2 retainers, 2 nuts.</i>				
67	S.S. (exc. 427) . . . . .	3904653	1	3.90	PLATE UNIT, name— (8.147) (Note 22) . . . . .
	<i>NOTE 22 Consists of 1 plate, 1 retainer, 5 nuts.</i>				
67	Chevy (exc. S.S.) . . . . .	3904672	1	3.20	PLATE UNIT, name (Note 23) . . . . .
	<i>NOTE 23 Unit consists of 1 plate, 2 retainers, 2 screws.</i>				
67	Chevy (S.S.) . . . . .	3907070	1	4.90	PLATE UNIT, name (Note 24) . . . . .
	<i>NOTE 24 Unit consists of 1 plate, 1 retainer, 2 nuts.</i>				
67	Camaro, 69 Chevelle (Sta. Wag.) . . . . .	3910000	1	4.15	PLATE UNIT (Chevrolet) rad. grille header panel . . . . .
67	Camaro . . . . .	3912192	1	2.85	PLATE UNIT (Camaro) rad. grille hdr. panel
69	Chevelle (exc. Sta. Wag., El Camino) . . . . .	3952431	1	4.35	PLATE UNIT, rad. grille header panel name
70	Chevelle . . . . .	3977632	1	4.15	PLATE UNIT, grille name "Chevelle" . . . . .
70	Chevelle (Sta. Wag., El Camino) . . . . .	3980825	1	3.80	PLATE UNIT, grille name "Chevrolet" . . . . .
71	Chevelle . . . . .	3991040	1	4.15	PLATE UNIT, grille name "Chevelle" . . . . .
71	Chevelle (Sta. Wag., El Camino) . . . . .	3991039	1	4.15	PLATE UNIT, grille name "Chevrolet" . . . . .
72	Chevelle (exc. Sta. Wag., El Camino, Monte Carlo) . . . . .	6272076	1	4.00	PLATE UNIT, grille name "Chevelle" . . . . .
72	Vega . . . . .	9870383	1	4.25	PLATE UNIT, frt. end outer panel (Chevrolet Vega 2300) . . . . .
73-74	Vega . . . . .	9614435	1	2.10	PLATE UNIT (Vega) front end header . . . . .
75	Monza . . . . .	358177	1	2.30	PLATE UNIT (Chevrolet) . . . . .
75	Vega . . . . .	1700895	1		PLATE UNIT, frt. end (Vega by Chevrolet)— (12.182) . . . . .
73	El Camino . . . . .	6258140	1	3.15	PLATE UNIT, rad. grille name (El Camino) . . . . .
73	Chevelle (exc. Laguna, Monte Carlo, El Camino, S.S.) . . . . .	6258313	1	4.00	PLATE UNIT, rad. grille name (Chevelle) . . . . .
73	Monte Carlo, 75 Monte Carlo . . . . .	6258144	1	4.00	PLATE UNIT, rad. grille header pnl. name . . . . .

**COOLANT—GRILLE—OIL SYSTEM**

**1.303 EMBLEM— MOULDING UNIT— NUT— ORNAMENT ASSY.— PLATE—  
RETAINER— SPACER— STRIPE, Radiator Grille & Frt. End (Also See  
Group 8.055) (Con't)**

74	El Camino (exc. S.S.)	344451	1	2.75	PLATE UNIT, grille name
74	Chevelle (exc. El Camino, S.S., Monte Carlo)	344452	1	2.75	PLATE UNIT, grille name
74	Caprice	6260821	1	1.70	PLATE UNIT, grille name (Chevrolet)
74	Laguna	345209	1	2.65	PLATE UNIT, rad. grille name (Laguna)
75	Pass.	358796	1	1.40	PLATE UNIT, grille name (Chevrolet)
75	Malibu	359022	1	2.45	PLATE UNIT, rad. grille (Chevelle)
75	Laguna	361007	1	2.40	PLATE UNIT, rad. grille name (Laguna S-3)
66	Chevelle (exc. S.S., El Camino)	3876137	1	3.60	PLATE ASSY., name
64	Chevy	3893998	3	.11	RETAINER, name plate— (8.133)
66	El Camino	3842013	2	.11	RETAINER, name plate— (8.133)
66	Chevy,				
67	Chevelle,				
68	Chevelle (exc. S.S.),				
71-72	El Camino	3874551	2	.12	RETAINER, name plate, emblem
67	Chevy (exc. S.S.)	3892274	2	.12	RETAINER, name plate
67	Chevy (S.S.)	3901997	1	.16	RETAINER, name plate
67	Pass. (exc. S.S.)	3899550	2	.11	RETAINER, name plate
67	S.S. (exc. 427)	3901923	1	.22	RETAINER, name plate
67	S.S. (427)	3901898	1	.18	RETAINER, emblem
68	Chevelle (S.S.)	3920803	1	.22	RETAINER, emblem
70	Nova (396),				
71-72	Nova w/4BC (350)	3938606	2	.40	RETAINER, rad. grille emblem
73	Deluxe, Malibu	328999	1	.40	RETAINER, rad. grille name plt.
73	Monte Carlo	325279	1	.11	RETAINER, rad. grille emblem
73	Chevelle (exc. Monte Carlo)	328905	1	.22	RETAINER, rad. grille emblem
73-74	Nova	333704	1	.18	RETAINER, rad. grille emblem
74	Chevelle (S.S.)	342182	1	.22	RETAINER, grille emblem
74	Chevelle (exc. S.S.)	342195	1	.22	RETAINER, rad. grille name plate
74	Laguna	342186	1	.22	RETAINER, grille emblem
75	El Camino Classic S.S.	352023	1	.23	RETAINER, rad. grille emblem
75	Nova	347581 A.R.		.17	RETAINER, rad. grille emblem
75	Laguna	347377	1	.27	RETAINER, rad. grille name
65	Pass.	3859554	1	.11	SPACER, header panel emblem
66	Pass.	3876539	1	.11	SPACER, name plate, upper
68-72	Nova	3938632 A.R.		.11	SPACER, rad. grille
68	Chevelle w/body side accent	3934101	1	11.95	STRIPE, black
68	Chevelle w/body side accent	3934102	1	12.50	STRIPE, white

**1.426 PAN ASSY., Oil**

62-67	Chevy (4 cyl.)	3927704	1	26.75	w/oil drain screw and baffle (18 holes)
62-67	Chevy (6 cyl.)	3793997	1	21.85	w/oil drain screw and baffle
64-67	Chevy (8 cyl.)	3869920	1	20.90	
64-67	Chevelle w/forged and modular crank (283, 327)	3830089	1	24.30	(contains two baffles)
64	Chevelle (6 cyl.)	3833058	1	22.65	
65-67	All (6 cyl.) (exc. Chevy),				
68-72	All (6 cyl.)	3988790	1	25.75	
65-66	Pass. (396, 427)	3902371	1	33.75	
67-69	Camaro (302),				
70-74	All w/Sp. H/Per. (350)	360009	1	23.95	
68-70	Chevy (4 cyl.)	3984147	1	24.85	
71-75	Vega, Monza (140, 122)	3977122	1	25.25	
73-75	All (6 cyl.)	352156	1	22.55	
75	All (454)	346232	1	30.75	
75	Vega, Monza (262)	360409	1	34.75	
65-70	Chevy, Chevelle, Camaro (396, 400 w/4BC, 454),				
71-72	All (400 w/4BC, 402, 454),				
73-74	All (454)	3985999	1	38.00	PAN UNIT
65-67	Pass. (283, 327),				
67	Camaro (327, 350),				
68	All (307, 327, 350),				
69	All (exc. 302, 396, 427),				
70-74	All (307, 350) (exc. Sp. H/Per.),				
70-74	All w/2BC (400)	3974252	1	24.25	PAN UNIT
67-70	Pass. (396, 427, 454)	3974328	1	41.25	PAN UNIT
75	All (262, 350, 400) (exc. Sp. H/Per.)	360010	1	19.50	PAN UNIT

**1.428 BOLT— SCREW, Oil Pan Attaching, with Lockwasher**

62-71	All (exc. Vega)	3817006 A.R.		.12	( <sup>1</sup> / <sub>4</sub> "— 20 x <sup>7</sup> / <sub>16</sub> ")— (0.679)
71-74	Vega,				

**COOLANT—GRILLE—OIL SYSTEM**

**1.428 BOLT— SCREW, Oil Pan Attaching, with Lockwasher (Con't)**

75	Vega, Monza (140) . . . . .	662421	2	.16	pipe and screen to block (5/16" — 18 x 3/4") . . . . .
All	All (exc. Vega, Monza) . . . . .	180075	4		(5/16" — 18 x 5/8") . . . . .
66	All (396, 427),				
73	Chevelle . . . . .	3856691	1	.05	<b>SCREW</b> , w/lockwasher (1/4" — 20 x 5/8") front center hole . . . . .

**1.429 GASKET UNIT— SEAL, Oil Pan**

62-70	Chevy (4 cyl.) . . . . .	3930961	1	2.50	(Note 1) . . . . .
	<i>NOTE 1: Unit consists of right and left gaskets and front and rear seals.</i>				
62-75	All (6 cyl.) . . . . .	3930962	1	3.65	(R.H. and L.H. gaskets and seals) . . . . .
64-67	All (283, 302, 327, 350) . . . . .		1		(left and right sides only) . . . . .
68-72	All (302, 307, 327, 350),				
70-72	All w/2BC (400),				
73-75	All (307, 350, 400) . . . . .	3931599	1	1.75	side . . . . .
64-70	All (8 cyl.) (exc. 396, 409, 427),				
71-72	All (307, 350),				
71-72	All w/2BC (400),				
73-74	All (307, 350, 400) . . . . .	3931597	1	4.55	(includes side gaskets, seals and packing) (Note 2) . . . . .
	<i>NOTE 2 When using on H/Per. (327) models, use (2) 3767556 exhaust pipe packing.</i>				
65	Pass. (409) . . . . .	3772597	1	2.85	(includes R.H. and L.H. gaskets, seals) . . . . .
65-70	All (396, 400 w/4BC, 427, 454),				
71-72	All (400 w/4BC, 402, 454),				
73-75	All (454) . . . . .	3931593	1	3.90	side . . . . .
65-70	All (396, 400 w/4BC, 427, 454),				
71-72	All (400 w/4BC, 402, 454),				
73-75	All (454) . . . . .	3958614	1	4.80	(includes side gaskets, seals and packing) . . . . .
71-75	Vega, Monza (122, 140) . . . . .	3977130	2	2.80	oil pan and oil pan baffle (part of Gasket Unit in Group 0.010) . . . . .
75	All (8 cyl.) (exc. 454) . . . . .	359936	1	4.95	
62-72	All (exc. 8 cyl.),				
73-75	All (6 cyl.) . . . . .	3921973	1	.48	<b>SEAL</b> , rear (57/64" end to end) . . . . .
64-69	All (8 cyl.) (exc. 396),				
70-72	All (307, 350),				
70-72	All w/2BC (400),				
73-74	All (8 cyl.) (exc. 454) . . . . .	3887151	1	.63	<b>SEAL</b> , front (Note 3) . . . . .
	<i>NOTE 3: If original oil pan has been replaced, part 357159 front seal may be required.</i>				
75	All (8 cyl.) (exc. 454) . . . . .	357159	1	.63	<b>SEAL</b> , front . . . . .
64-68	All (8 cyl.) (exc. 396, 409, 427),				
70-72	All (307, 350),				
70-72	All w/2BC (400),				
73-75	All (8 cyl.) (exc. 454) . . . . .	3887152	1	.83	<b>SEAL</b> , rear . . . . .
65-72	All (exc. 8 cyl.),				
73-75	All (6 cyl.) . . . . .	3923440	1	.83	<b>SEAL</b> , front . . . . .
65-72	All (396, 400 w/4BC, 402, 454),				
73-75	All (454) . . . . .	3909800	1	1.20	<b>SEAL</b> , front . . . . .
65-72	All (396, 400 w/4BC, 402, 427, 454),				
73-75	All (454) . . . . .	3955115	1	1.20	<b>SEAL</b> , rear . . . . .

**1.430 BAFFLE— PIPE ASSY., Oil Pan Upper**

64	Chevelle w/Sp. H/Per. (327) . . . . .	3769768	1	1.75	
67-69	Camaro (302),				
70-75	All w/Sp. H/Per. (350) . . . . .	3927136	1	7.30	
71-75	Vega, Monza (140) . . . . .	334036	1	4.35	
75	Vega, Monza (122) . . . . .	348680	1	54.25	
71-75	Vega, Monza (exc. 262) . . . . .	3992222	1	1.40	<b>PIPE ASSY.</b> , oil drain . . . . .

**1.453 FLANGE— PLUG— SCREW, Oil Pan Drain**

62-65	All,				
66-69	All w/R.G.,				
70-72	All (396, 400 w/4BC, 402, 454),				
73-75	All (454) . . . . .	3723008	1	.34	(1 3/8" x 7/8" w/1/2" — 20 hole in ctr.) . . . . .
62-75	All w/magnetic drain plug . . . . .	3866776	1	1.35	<b>PLUG</b> (1/2" — 20) . . . . .
62-75	All . . . . .	3923420 A.R.		.36	<b>SCREW</b> (1/2" — 20 x 13/16") (Non-magnetic) . . . . .

**1.456 GASKET, Oil Pan Drain Screw**

62-75	All . . . . .	3921989 A.R.		.20	(nylon 1/2" I.D. x 9/10" O.D.) . . . . .
-------	---------------	--------------	--	-----	--

**COOLANT—GRILLE—OIL SYSTEM**

**1.516 GAUGE—TUBE—SEAL—PIN—PLUG, Oil Level**

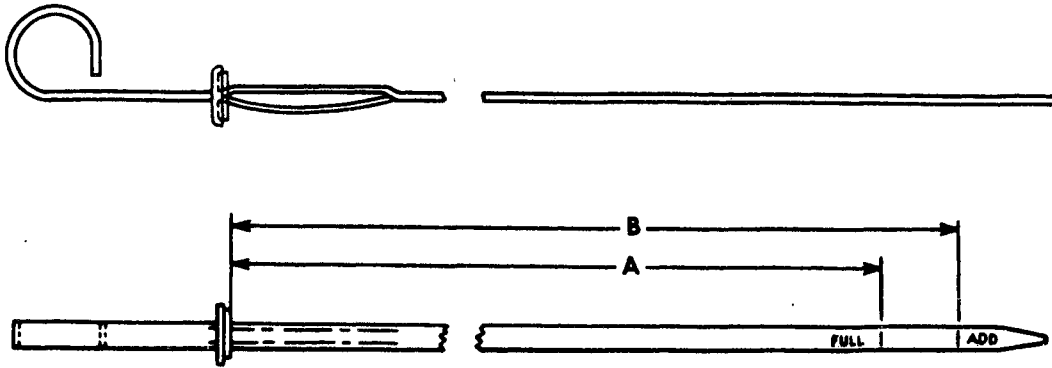

**OIL GAUGE STICK IDENTIFICATION**

		Dimensions			
		A	B		
63	Chevy w/Air Cond. (6 cyl.),				
64	Chevy w/C.A.C. (6 cyl.) . .	19 <sup>9</sup> / <sub>16</sub>	20	3846810	1
62	Chevy (4 cyl.) (exc. C.A.C.), . . . . .				
62	Chevy (6 cyl.), . . . . .				
63	Chevy (6 cyl.) (exc. C.A.C.), . . . . .				
64	Chevy (Std.) (4 cyl.), . . . .				
64	Chevy (6 cyl.) (exc. C.A.C. closed vent.), . . . . .				
64	Chevelle (194) (exc. closed vent.), . . . . .				
65	All (4 cyl., 6 cyl.) . . . . .	9 <sup>19</sup> / <sub>32</sub>	10 <sup>3</sup> / <sub>16</sub>	3860442	1
64	Chevelle w/H/Per. (230),				
64	Chevy w/H/Per. (230) (exc. C.A.C., closed vent.),				
64	Chevelle w/closed vent. (194, 230),				
64	Chevy w/closed vent. (exc. 230, 283, C.A.C.) .	9 <sup>19</sup> / <sub>32</sub>	10 <sup>3</sup> / <sub>16</sub>	3845768	1
64	Chevy (8 cyl.) . . . . .	19 <sup>3</sup> / <sub>8</sub>	20 <sup>7</sup> / <sub>32</sub>	3927194	1
64	Chevelle (8 cyl.) . . . . .	16 <sup>7</sup> / <sub>16</sub>	17 <sup>3</sup> / <sub>8</sub>	3846562	1
66-67	Chevy w/C.A.C. (6 cyl.) . .	20 <sup>1</sup> / <sub>8</sub>	20 <sup>3</sup> / <sub>4</sub>	3886083	1
65	Pass. (409),				
67	Camaro (8 cyl.) (exc. 396) . . . . .	17 <sup>25</sup> / <sub>32</sub>	18 <sup>7</sup> / <sub>16</sub>	3896912	1
65	Chevy w/Air Cond. (6 cyl.),				
65-67	Pass., Chevy (8 cyl.) (exc. 396, 409, 427) . . . . .	20 <sup>1</sup> / <sub>8</sub>	20 <sup>49</sup> / <sub>64</sub>	3862730	1
65-66	Pass. (396, 427),				
66-67	Chevelle, Camaro (396) . .	23 <sup>7</sup> / <sub>32</sub>	24	3981088 <sup>(2)</sup>	1
66-69	Chevy (exc. 8 cyl., C.A.C.),				
66-70	Pass., Chevelle, Camaro (6 cyl.),				
71-75	All (6 cyl.) . . . . .	11 <sup>15</sup> / <sub>32</sub>	12 <sup>15</sup> / <sub>16</sub>	3886082	1
67	Pass., Camaro (396, 427)	17 <sup>15</sup> / <sub>32</sub>	17 <sup>39</sup> / <sub>32</sub>	3902399	1
68	All (8 cyl.) (exc. 396, 427) . . . . .	17 <sup>17</sup> / <sub>32</sub>	18 <sup>7</sup> / <sub>16</sub>	3923239	1
68-69	Pass. (396, 427),				
70	Pass., Monte Carlo (454)	19 <sup>11</sup> / <sub>16</sub>	20 <sup>7</sup> / <sub>32</sub>	3928900	1
65-67	Chevelle (283, 327), . . . .				
69	All (8 cyl.) (exc. 396, 427),				
70	Camaro (8 cyl.) (exc. 396, 454),				
70	Pass., Nova, Chevelle (307, 350),				
70-72	All w/2BC (400),				
71-72	All (307, 350),				
73-74	All (307, 350, 400) . . . . .	17 <sup>5</sup> / <sub>16</sub>	18 <sup>9</sup> / <sub>32</sub>	3876869	1

**COOLANT—GRILLE—OIL SYSTEM**

**1.516 GAUGE— TUBE— SEAL— PIN— PLUG, Oil Level (Con't)**

70	Chevelle (454) (exc. Monte Carlo),					
68-69	Camaro, Chevelle, Chevy (396),					
70	All (396, 400 w/4BC),					
70	Camaro (454) . . . . .		19 <sup>35</sup> / <sub>64</sub>	20 <sup>23</sup> / <sub>64</sub>	3925599	1
71-72	All (400 w/4BC, 402, 454),					
73-75	All (454) . . . . .		19 <sup>13</sup> / <sub>32</sub>	20 <sup>3</sup> / <sub>8</sub>	3989391	1
71-75	Vega, Monza (140) . . . . .	3994266	1	1.80	oil level . . . . .	
75	Vega, Monza (122) . . . . .	3865665	1	1.25	oil level . . . . .	
75	Vega, Monza (8 cyl.) . . . . .	354367	1	1.90	oil level . . . . .	
75	Vega, Monza (122) . . . . .	3862730	1	.98	oil level . . . . .	
75	All (8 cyl.) (exc. 454) . . . . .	3951576	1	1.25		

62	Chevy,					
63-64	Chevy (exc. C.A.C., 8 cyl.),					
64-65	Chevelle (6 cyl.) (1st design),					
65-70	Chevy (4 cyl.),					
65	Chevy (6 cyl.) (exc. C.A.C.),					
68-71	Chevy (6 cyl.),					
66-71	Pass., Chevelle, Camaro (6 cyl.),					
72-75	All (6 cyl.) . . . . .	3828073	1	.46	TUBE (8 <sup>31</sup> / <sub>32</sub> " O.L.) . . . . .	
64	Chevy (283) . . . . .	3790733	1	.58	TUBE, gauge . . . . .	
65-67	Chevy (8 cyl.) . . . . .	3860339	1	2.60	TUBE . . . . .	
65	Chevelle w/Sp. H/Per. (327),					
66	Chevy w/Sp. H/Per. (327),					
69-72	All (302, 307, 327, 350),					
70-72	All w/2BC (400),					
73-75	All (8 cyl.) (exc. 454) . . . . .	3951600	1	.63	TUBE, lower . . . . .	
65	Pass. (6 cyl.),					
65	Chevelle (6 cyl.) (2nd design),					
66-67	Chevy (6 cyl.) (exc. C.A.C.) . . . . .	3906622	1	.40	TUBE . . . . .	
64	Chevelle (8 cyl.),					
65-66	Pass. (283, 327) . . . . .	3865664	1	.76	TUBE (Note 1) . . . . .	

*NOTE 1: When used on 1964 Chevelle (8 cyl.) cut 3<sup>7</sup>/<sub>8</sub>" from top end. When used on 65-66 Pass. (283, 327) cut 1<sup>1</sup>/<sub>4</sub>" from top end.*

65-66	Pass., Chevelle (396, 427) . . . . .	3981089	1	5.20	TUBE (Note 2) . . . . .	
65-69	Chevy, Chevelle, Camaro (8 cyl.) (exc. 396),					
68-69	Pass. (8 cyl.) (exc. 396, 427),					
70-72	All (307, 350) (exc. NB2),					
70-72	All w/2BC (400) (exc. NB2),					
73-75	All (8 cyl.) (exc. 454) . . . . .	3876870	1	.63	TUBE, curved . . . . .	
67	Pass. (283, 327) . . . . .	3900428	1	.58	TUBE . . . . .	
67	Pass., Chevelle (396, 427) (exc. H/Per.),					
68-72	All (396, 400 w/4BC, 402, 454)	3928901	1	.87	TUBE . . . . .	
73-75	All (454) . . . . .	329231	1	.87	TUBE . . . . .	
71-75	Vega, Monza (140) . . . . .	6273494	1	.55	TUBE ASSY., oil level gauge . . . . .	
75	Vega, Monza (122) . . . . .	348651	1	2.15	TUBE ASSY., oil level gauge . . . . .	
75	Vega, Monza (8 cyl.) . . . . .	354368	1	1.90	TUBE ASSY., oil level gauge . . . . .	
62-69	All . . . . .	274244	1	.11	SEAL, tube (7 <sup>1</sup> / <sub>16</sub> " O.D. x 1 <sup>11</sup> / <sub>32</sub> " I.D.)— (8.955) . . . . .	
62-69	All . . . . .	3837057	1	.11	PIN, gauge tube hole (7 <sup>1</sup> / <sub>16</sub> " O.D. x 7 <sup>1</sup> / <sub>16</sub> " long) (solid) . . . . .	
75	Vega, Monza (8 cyl.) . . . . .	3837057	1	.11	PLUG, cyl. to case oil level gauge tube hole . . . . .	

*NOTE 2 When using gauge assy. 3981088, tube assy. 3981089 must be used or when using 3981089 tube assy., 3981088 gauge assy. must be used.*

**1.531 PLUG— CONNECTOR— GROMMET— ADAPTER— NUT, Oil (Also see Group 8.963)**

62-68	All (exc. 8 cyl.) . . . . .	3835577 A.R.		.12	block main oil gallery frt. hole— (0.034) . . . . .
62-72	All (exc. 8 cyl.),				
73-75	All (6 cyl.) . . . . .	3930824	1	.11	oil pressure regulator hole . . . . .
64-69	All (8 cyl.) (exc. 396, 427),				
70-72	All (307, 350),				
70-72	All w/2BC (400),				
73-75	All (307, 350, 400),				
74	Vega,				
75	Vega, Monza (140) . . . . .	3701638 A.R.		.12	oil pressure and tappet gallery, cyl. and case oil gallery hole at frt. end and oil filter cavity (1 <sup>1</sup> / <sub>2</sub> " dia.— cup shape) . . . . .
65	Pass. (348, 409) . . . . .	3736407	4	.12	cyl. and case (cup type) (5 <sup>5</sup> / <sub>16</sub> " O.D.) . . . . .
64-65	Chevelle (S.S.) (8 cyl.) (exc. 396),				
65	S.S. (283, 327),				
66	Chevelle w/instr. panel gauges (exc. 396),				

**COOLANT—GRILLE—OIL SYSTEM**

**1.531 PLUG— CONNECTOR— GROMMET— ADAPTER— NUT, Oil (Also see Group 8.963) (Con't)**

66	Pass. (floor console w/gauges) (283, 327) . . . . .	<b>3853958</b>	1	.28	<b>CONNECTOR</b> , oil press. gauge pipe— engine end . . . . .
65	S.S. . . . . .	<b>442094</b>	1	1.95	<b>CONNECTOR</b> , threaded sleeve tube internal pipe thread (1/8"— 27— 5/16"— 24 x 29/32")— (8.963) . . . . .
73-75	Nova w/console gauges . . . . .	<b>6271248</b>	1	.11	<b>GROMMET</b> , oil pressure gauge hose . . . . .
67-68	Pass., Chevelle, Camaro w/instr. panel gauges (396, 427) . . . . .	<b>3906194</b>	1	.18	<b>ADAPTER</b> , oil press. gauge hose conn. at eng. . . . .
67-68	Chevelle w/instr. panel gauges (exc. S.S.),				
67-69	Camaro w/console gauges (8 cyl.) (exc. 396),				
67-68	Pass. w/instr. panel gauges (283, 327),				
68-75	Nova w/console gauges (8 cyl.) (exc. 396) . . . . .	<b>3904227</b>	1	.24	<b>ADAPTER</b> , oil press. gauge hose at eng. fitting (male) . . . . .
67	Camaro w/console gauges (8 cyl.),				
69	Chevy, Camaro w/console gauges (396) . . . . .	<b>3909520</b>	1	.12	<b>NUT</b> , oil press. gauge hose conn. . . . .

**1.540 COOLER ASSY., Oil**

65-66	Pass. (Spt. Cpe.) . . . . .	<b>3157804</b>	1	243.00	(stamped 3157804) . . . . .
-------	-----------------------------	----------------	---	--------	-----------------------------

**1.609 SPRING— GASKET— VALVE— RETAINER— PLUG— PIN, Oil Pump**

62-68	All (exc. 396, 409, 427),				
65	Pass. (409) (exc. H/Per., dual 4BC),				
69-72	All (exc. 8 cyl.),				
70-72	All (307, 350) (exc. Sp. H/Per.),				
70-72	All w/2BC (400),				
73-75	All (6 cyl.),				
73-75	All (307, 350, 400) . . . . .	<b>3814903 A.R.</b>		.16	pressure regulator valve (21 coils— 27/32" free length) . . . . .
65	Pass. (230),				
65	Pass. w/H/Per., dual 4BC (409),				
67-68	Camaro (302),				
70-72	All w/Sp. H/Per. (350) . . . . .	<b>3848911</b>	1	.38	pressure regulator valve (21 coils) (stripe of white) . . . . .
65	Pass. (396),				
66-71	Pass., Chevelle, Camaro w/Sp. H/Per. (396, 427, 454) . . . . .	<b>3876866</b>	1	.16	pressure regulator valve (24 coils, 5/16" O.D. x 27/16" free length) (Stripe of Lt. Green) . . . . .
66-71	Pass., Chevelle, Camaro (396, 400 w/4BC, 427, 454) (exc. Sp. H/Per.),				
72	All (402, 454),				
73-75	All (454) . . . . .	<b>3860378</b>	1	.16	pressure regulator valve (27/64" O.D. x 2 1/2" free length) . . . . .
71-75	Vega, Monza (140) . . . . .	<b>3988702</b>	1	.21	oil pressure regulator valve . . . . .
71-75	Vega, Monza (140) . . . . .	<b>3994264</b>	1	.13	oil pressure, regulator valve damping . . . . .
75	Vega, Monza (122) . . . . .	<b>334026</b>	1	.88	oil press. reg. valve . . . . .
71-74	Vega,				
75	Vega, Monza (140) . . . . .	<b>3870275</b>	1	.13	<b>GASKET</b> , oil pressure reg. valve plug . . . . .
62-75	All (6 cyl.),				
65-70	Chevy (4 cyl.) . . . . .	<b>3829433</b>	1	.59	<b>VALVE</b> , pressure regulator (used w/pump cast 3832182) (Note 1) . . . . .
64-69	All (8 cyl.) (exc. 396, 427),				
70-72	All (307, 350),				
70-72	All w/2BC (400),				
73-75	All (8 cyl.) (exc. 454) . . . . .	<b>3702366</b>	1	.59	<b>VALVE</b> , pressure regulator (1 1/32" I.D. x 7/16" O.D. x 1 3/16" O.L.) . . . . .
65-71	All (396, 400 w/4BC, 427, 454),				
72	All (402, 454),				
73-75	All (454) . . . . .	<b>3860377</b>	1	.64	<b>VALVE</b> , pressure regulator (1 49/64" O.L. x 7/16" O.D.) . . . . .
71-75	Vega, Monza (122, 140) . . . . .	<b>3988701</b>	1	.62	<b>VALVE</b> , oil pressure regulator . . . . .
65-71	All (396, 400 w/4BC, 427, 454),				
72	All (402, 454),				

**COOLANT—GRILLE—OIL SYSTEM**

**1.609 SPRING— GASKET— VALVE— RETAINER— PLUG— PIN, Oil Pump  
(Con't)**

73-75	All (454)	3701564	1	.06	RETAINER, pressure regulator, valve spring (7/16" O.D.)
64-67	Chevy (8 cyl.)	3774436	1	.11	PLUG, pump outlet by-pass hole— (1.516)
71-75	Vega, Monza (140)	6256614	1	.32	PLUG, oil pressure regulator valve
All	All	838839	1	.05	PIN, special groove

*NOTE 1 For 1962 thru 1967 Chevy with 283-327 V8, to be used in 3793310 pump asm. only.  
3793310 Ident. by GM Trademark and # 3793558 cast in pump body.*

**1.637 VALVE ASSY., Oil Filter By-Pass**

71-73	Vega (140)	5575416	1	1.57	
-------	------------	---------	---	------	--

**1.639 PIN— RETAINER— SHAFT— SLEEVE, Oil Pump Shaft**

65	Chevelle w/Sp. H/Per. (396),				
65-70	All w/Sp. H/Per. (396, 427, 454),				
71	All w/Sp. H/Per. (454)	3877674	1	.11	dist. to oil pump inter. sleeve retainer
72-75	All (8 cyl.)	3836903	2	.11	(0.738)
64-70	All (8 cyl.) (exc. 396, 427, 454)				
65-70	All (396, 427, 454) (exc. Sp. H/Per.),				
71-75	All (8 cyl.)	3764554	1	.11	RETAINER, dist. to pump inter. shaft (Note 1)
64-67	Chevy (8 cyl.)	3790872	1	2.20	SHAFT, dist. to pump, inter.— (2.372)
64-69	All (283, 302, 307, 327, 350),				
70-75	All (307, 350, 400 w/2BC)	3998287	1	2.80	SHAFT, dist. to pump inter.— (2.372) (Note 1)
65-69	All (396, 400 w/4BC, 427) (exc. Sp. H/Per.),				
70-71	All (454),				
71	All (396, 400 w/4BC) (exc. Sp. H/Per.),				
73-75	All (454)	3998289	1	2.25	SHAFT, dist. to pump inter.— (2.372)
65-70	All w/Sp. H/Per. (396, 427)	3865886	1	3.65	SHAFT, dist. to pump inter.— (2.372)
65	Chevelle (396),				
65-70	All w/Sp. H/Per. (396, 427, 454),				
71	All w/Sp. H/Per. (454)	3877672	1	1.05	SLEEVE, dist. to oil pump inter. shaft

*NOTE 1 For use with pump having retainer ring groove.*

**1.652 PUMP ASSEMBLY— BOLT— STUD, Oil**

64-67	Chevelle, Camaro (8 cyl.) (exc. 396),				
65-69	Pass. (283, 307, 327, 350),				
65	Pass. (409) (exc. H/Per., dual 4BC),				
68-69	Chevy, Chevelle, Camaro (307, 327, 350),				
70-72	All (307, 350) (exc. Sp. H/Per.),				
70-72	All w/2BC (400),				
73-75	All (8 cyl.) (exc. 454),				
75	Monza (8 cyl.)	3764547	1	21.50	
64-72	Chevelle, Camaro (6 cyl.),				
65-72	Pass., Chevy (exc. 8 cyl.),				
73-75	All (6 cyl.)	3832449	1	22.45	(cast 3832182)
64-67	Chevy (8 cyl.)	3793310	1	18.55	
65-69	Chevy (4 cyl.)	3832449	1	22.45	
65	Pass. w/H/Per., dual 4BC (409),				
67-69	Camaro (302),				
70-72	All w/Sp. H/Per. (350)	3848907	1	25.75	
65	Pass. w/Sp. H/Per. (396, 427),				
65	Chevelle (396),				
66-70	All w/Sp. H/Per. (396, 427, 454),				
71	Chevelle w/Sp. H/Per. (454)	3904826	1	25.00	(w/mechanical cam)
65-66	Pass. (396) (exc. Sp. H/Per.),				
66-70	All (396, 400 w/4BC 427, 454) (exc. Sp. H/Per.),				
71-72	All (400 w/4BC, 402, 454) (exc. Sp. H/Per.),				
73-75	All (454)	3904827	1	21.85	
71	Vega,				
72-75	Vega, Monza (140)	6263112	1	29.00	oil pump body (stamped 6262874)
75	Vega, Monza (122)	334024	1	47.00	
62-64	Chevy (6 cyl.)	3843243	1	25.75	PUMP UNIT

**COOLANT—GRILLE—OIL SYSTEM**

**1.652 PUMP ASSEMBLY— BOLT— STUD, Oil (Con't)**

62-66	All (8 cyl.) (exc. 396)	3754998	1	.24	BOLT, pump and screen (7/16" — 14 x 2 <sup>3</sup> /16")
65-69	All (396, 400 w/4BC 427, 454),				
71-72	All (400 w/4BC, 402, 454),				
73-75	All (454)	3860382	1	.27	BOLT, pump & screen assy. (7/16" — 14 x 2 <sup>23</sup> /64")
67-70	All (283, 302, 307, 327, 350),				
70-72	All w/2BC (400),				
71-72	All (307, 350),				
73-75	All (8 cyl.) (exc. 454),				
75	Monza (262)	3892678	1	.22	BOLT, pump and screen (7/16" — 14 x 2)
71	Vega	3992226	L.H.	.18	STUD, oil pump mtg., lower left
71-75	Vega, Monza (140)	3994292	R.H.	.18	STUD, oil pump mtg., upper right
71	Vega (1st design)	3903324	L.H.	1.45	STUD, oil pump mtg., at upper left (identification-1.32 from under side of hex. to end of stud)
71	Vega (2nd design),				
72-73	Vega	6262875	L.H.	.36	STUD, oil pump mtg., at upper left (identification-1.21 from under side of hex. to end of stud)
72-75	Vega, Monza	6270021	L.H.	.18	STUD, oil pump mtg., lower left

**1.656 SCREEN— SUPPORT ASSY., Oil Pump Intake**

62-64	Chevy (6 cyl.)	3788395	1	2.75	w/pipe (used w/pump cast 3788451)
62-67	Chevy (6 cyl.)	3904125	1	2.75	w/pipe
62-64	Chevy (4 cyl.)	3788531	1	2.85	w/pipe (used w/pump cast 3788451)
63-67	Chevy (4 cyl.)	3793919	1	2.85	(used w/pump cast 3832182)
64-65	Chevy (8 cyl.),				
66-67	Chevy (8 cyl.) (exc. Sp. H/Per.)	3790870	1	2.70	
64-65	Chevelle (8 cyl.)	3830080	1	2.30	(Note 1)
<i>NOTE 1 Identified by yellow stain mark on pipe close to screen assy.</i>					
65-67	Pass., Chevelle, Camaro (194, 230, 250),				
68-75	All (6 cyl.)	3859941	1	2.40	w/suction pipe
65-67	Chevelle (8 cyl.) (exc. 396)	3754942	1	2.40	w/pipe
65-70	Pass. (283, 307, 327, 350),				
67-70	Camaro (8 cyl.) (exc. 396),				
68-70	Chevy, Chevelle (307, 327, 350),				
70-72	All w/2BC (400),				
71-72	All (307, 350),				
73-75	All (8 cyl.) (exc. 454)	3855152	1	2.30	
65-66	Pass., Chevelle (396, 427)	3860366	1	2.30	
66	Chevy w/Sp. H/Per. (327)	3870327	1	3.60	
67-72	All (396, 400 w/4BC, 402, 427, 454),				
73-75	All (454)	3955281	1	2.40	
68-70	Chevy (4 cyl.)	3915988	1	4.35	w/pipe
71-75	Vega, Monza (140)	3994261	1	5.70	oil suction, w/pipe and support
75	Monza (8 cyl.)	3855152	1	2.30	oil pump
62-67	Chevy (4 cyl.)	3970417	1	1.75	SUPPORT ASSY., w/projection weld nut
71-75	Vega, Monza (122, 140)	3977133	1	.31	SUPPORT ASSY., oil pump suction pipe and screen

**1.723 COVER, Oil Pump**

62-72	All (exc. 8 cyl.),				
73-75	All (6 cyl.)	3788457	1	1.05	w/4 (17/64" dia.) holes
64-69	All (8 cyl.) (exc. 302, 396, 409, 427),				
65	Pass. (409) (exc. H/Per., dual 4BC),				
70-72	All (307, 350) (exc. Sp. H/Per.),				
70-72	All w/2BC (400),				
73-75	All (8 cyl.) (exc. 454)	3836980	1	5.20	
65-68	Pass. (396, 427) (exc. H/Per.),				
65-69	Chevy, Chevelle, Camaro w/Sp. H/Per. (396),				
69	Pass. w/Sp. H/Per. (427),				
70-71	All w/Sp. H/Per. (396, 454)	3906627	1	5.20	
67-72	All (396, 400 w/4BC, 402, 427, 454) (exc. Sp. H/Per.),				
73-75	All (454)	3906628	1	5.20	
67-68	Camaro (302),				
70-72	All w/Sp. H/Per. (350)	3848909	1	5.35	

**1.724 GASKET, Oil Pump Cover**

62-72	All (exc. 8 cyl.),				
-------	--------------------	--	--	--	--



**COOLANT—GRILLE—OIL SYSTEM**

**1.724 GASKET, Oil Pump Cover (Con't)**

<b>73-75</b>	All (6 cyl.)	<b>3789970</b>	1	.12	four 19/64" dia. holes)
<b>64-67</b>	Camaro, Chevy (8 cyl.)	<b>3793406</b>	1	.12	Note 1
<b>71-74</b>	Vega,				
<b>75</b>	Vega, Monza (122, 140)	<b>3973114</b>	1	.32	

*NOTE 1 For use only with oil pump asm. 3793310  
3793310 ident. by GM Trademark and # 3793558 case in pump body.*

**1.745 CONNECTOR— TUBE ASSY.— VENTILATOR— KIT— VALVE ASSY.—  
ADAPTER— ELBOW— ARRESTOR— GROMMET— NIPPLE— SEAL—  
TEE— GASKET— WASHER— CLIP, Crankcase**

*NOTE See Dealer Price Schedule (P&A 26) for applicable prices.*

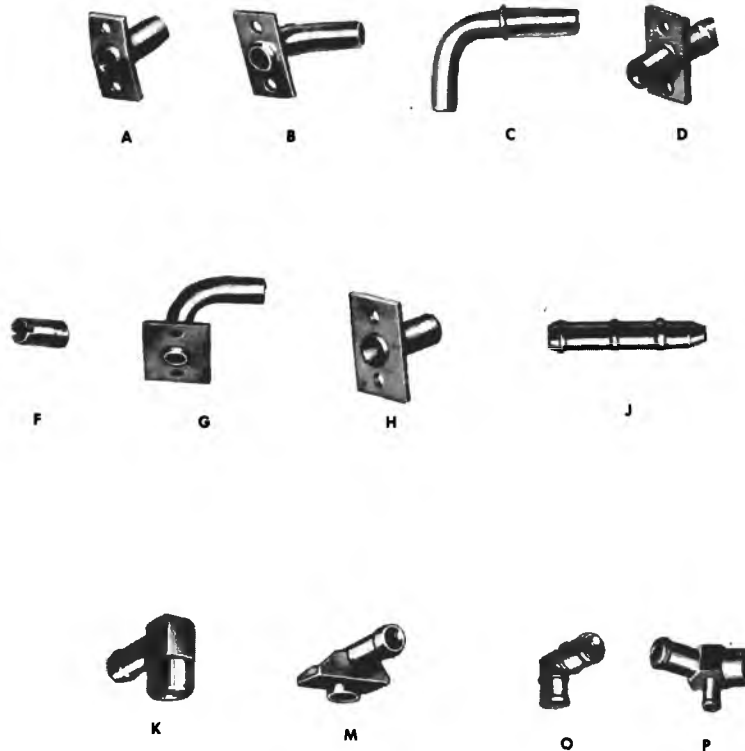

**CONNECTORS**

**CONNECTORS (Refer to Illustration)**

Part No.	Type	Dev. Length	Part No.	Type	Dev. Length
3715629	C	3 <sup>3</sup> / <sub>4</sub>	3890456	K	1 <sup>29</sup> / <sub>32</sub>
3778539	B	2 <sup>1</sup> / <sub>2</sub>	3902754	K	2 <sup>9</sup> / <sub>64</sub>
3825960	C	3 <sup>1</sup> / <sub>4</sub>	3905081	C	5
			3921916	O	2 <sup>7</sup> / <sub>16</sub>
3829150	F	1 <sup>1</sup> / <sub>2</sub>	3921983	J	2 <sup>1</sup> / <sub>2</sub>
3849816	J	1 <sup>7</sup> / <sub>8</sub>	3923213	J	1
3854567	J	2	3923254	O	2 <sup>3</sup> / <sub>8</sub>
3849985	K	1 <sup>5</sup> / <sub>16</sub>	3923260	O	3 <sup>1</sup> / <sub>4</sub>
580826	K	1 <sup>13</sup> / <sub>16</sub>	3927733	C	3 <sup>3</sup> / <sub>4</sub>
3856955	C	5 <sup>18</sup> / <sub>32</sub>	3927768	C	5
3859374	J	1 <sup>1</sup> / <sub>4</sub>	3928988	C	4
3868842	O	1 <sup>5</sup> / <sub>8</sub>	3942528	J	1 <sup>7</sup> / <sub>16</sub>
			3943670	C	3
			6262893	C	4 <sup>3</sup> / <sub>16</sub>

**COOLANT—GRILLE—OIL SYSTEM**

**1.745 CONNECTOR— TUBE ASSY.— VENTILATOR— KIT— VALVE ASSY.— ADAPTER— ELBOW— ARRESTOR— GROMMET— NIPPLE— SEAL— TEE— GASKET— WASHER— CLIP, Crankcase (Con't)**

*(<sup>3</sup>/<sub>16</sub>" orifice on small end.*

*(\*)When using in place of original part not requiring the extension beyond flange, cut tube as required for proper installation and reconnect hose.*

<b>73-75</b>	Vega, Monza w/1BC (140) . . . . .	<b>331144</b>	1	.55	c/case vent. hose in inlet manif. . . . .
<b>64-65</b>	Chevy, Chevelle (8 cyl.) (exc. Sp. H/Per., closed vent.),				
<b>65</b>	Pass. (409),				
<b>65</b>	All w/closed vent. (8 cyl.) . . . . .	<b>3846123</b>	1	3.95	<b>TUBE ASSY.</b> , filler . . . . .
<b>66-67</b>	Chevy, Chevelle w/Sp. H/Per. (327),				
<b>67</b>	Camaro (302) . . . . .	<b>3889316</b>	1	6.30	<b>TUBE ASSY.</b> , oil filler (chrome plated) . . . . .
<b>66</b>	Pass., Chevy, Chevelle (283, 327) (exc. closed vent., A.I.R., Sp. H/Per.),				
<b>67</b>	Chevy, Camaro, Chevelle (8 cyl.) (exc. 396, Sp. H/Per., closed pos. vent., 302),				
<b>67</b>	Pass. (283, 327) (exc. closed pos. vent.) . . . . .	<b>3881858</b>	1	4.60	<b>TUBE ASSY.</b> , oil filter . . . . .
<b>66</b>	Pass., Chevy, Chevelle w/A.I.R., closed vent. (283, 327) (exc. Sp. H/Per.),				
<b>67</b>	Chevy, Camaro, Chevelle w/closed pos. vent. (8 cyl.) (exc. 396),				
<b>67-68</b>	Pass. w/closed pos. vent. (283, 327) . . . . .	<b>3889311</b>	1	4.90	<b>TUBE ASSY.</b> , oil filler . . . . .
<b>68</b>	All (exc. 302, 396, 427) . . . . .	<b>3923234</b>	1	2.90	<b>TUBE ASSY.</b> , oil filler . . . . .
<b>69</b>	Camaro (302) . . . . .	<b>3937064</b>	1	4.15	<b>TUBE ASSY.</b> , oil filler . . . . .
<b>62</b>	Chevy (exc. closed vent.) . . . . .	<b>3792715</b>	1	2.15	<b>VENTILATOR</b> (brkt. w/ <sup>11</sup> / <sub>16</sub> " slot) . . . . .
<b>64-67</b>	All (283, 327) . . . . .	<b>3728502</b>	1	4.55	<b>VENTILATOR</b> (mtd. inside of engine— 5 <sup>3</sup> / <sub>4</sub> " ig.) . . . . .
<b>62</b>	Chevy . . . . .	<b>6421987</b>	1	8.45	<b>KIT</b> , positive vent. (CV-1) (Note 2) . . . . .
	<i>NOTE 2: When used on 4, 6 cyl. it is necessary to close adapter bolt hole. Also unit 6421785 must be used for all subsequent replacement assys. at inlet manifold.</i>				
<b>62</b>	Chevy mtd. at inlet manifold . . . . .	<b>6421785</b>	1	2.00	<b>VALVE ASSY.</b> , metering (CV-693-C) . . . . .
<b>63</b>	Chevy,				
<b>64-65</b>	Chevy (4 cyl.) (exc. closed vent.),				
<b>64-65</b>	Chevy, Chevelle (6 cyl.) (exc. closed vent.),				
<b>66</b>	Chevy, Chevelle (exc. 8 cyl., closed vent., A.I.R.),				
<b>67</b>	Chevy (153, 194) (exc. A.I.R.) . . . . .	<b>6422038</b>	1	2.08	<b>VALVE ASSY.</b> , vent. (CV-607-C) . . . . .
<b>64-65</b>	Chevy, Chevelle (8 cyl.) (exc. Sp. H/Per., closed vent.),				
<b>65</b>	Pass. (283, 327) (exc. closed pos. vent.),				
<b>66-67</b>	Pass., Chevy, Chevelle, Camaro (283) (exc. closed vent., A.I.R.),				
<b>67</b>	Pass. (283) (exc. closed pos. vent.) . . . . .	<b>6421934</b>	1	2.08	<b>VALVE ASSY.</b> , vent (CV-590) . . . . .
<b>65</b>	Chevy, Chevelle w/closed vent. (6 cyl.),				
<b>66</b>	Chevy, Chevelle w/closed vent. (230),				
<b>65-66</b>	Pass. (exc. Taxi, 8 cyl. A.I.R.),				
<b>67</b>	All (230, 250) (exc. A.I.R.) . . . . .	<b>6421971</b>	1	2.08	<b>VALVE ASSY.</b> , vent (CV-609C) . . . . .
<b>65-67</b>	Taxi (6 cyl.) (exc. A.I.R.) . . . . .	<b>6421980</b>	1	2.00	<b>VALVE ASSY.</b> , vent (CV-676C) . . . . .
<b>65-68</b>	Pass., Chevelle, Camaro (396) (exc. H/Per., Sp. H/Per.),				
<b>66</b>	El Camino w/H/Per., Sp. H/Per. (396) (1st design),				
<b>66-67</b>	Pass. (427) (1st design) (exc. Tri Carb.),				
<b>66-68</b>	Pass. w/Sp. H/Per. (427) (2nd design),				
<b>66-68</b>	Chevelle (S.S.) w/H/Per., Sp. H/Per. (396),				
<b>66-68</b>	El Camino w/H/Per., Sp. H/Per. (396) (2nd design),				
<b>68</b>	Pass., Chevelle, Camaro (8 cyl.) (exc. 396),				
<b>68-69</b>	Chevy (8 cyl.),				

**COOLANT—GRILLE—OIL SYSTEM**

**1.745 CONNECTOR— TUBE ASSY.— VENTILATOR— KIT— VALVE ASSY.—  
ADAPTER— ELBOW— ARRESTOR— GROMMET— NIPPLE— SEAL—  
TEE— GASKET— WASHER— CLIP, Crankcase (Con't)**

69	Pass., Chevelle, Camaro (8 cyl.) (exc. 302, H.D. 427),				
70-72	All (8 cyl.) (exc. Sp. H/Per. 350)	6423695	1	2.08	VALVE ASSY., vent. (CV-736C) .....
66	All (327) (exc. closed pos. vent., A.I.R., Sp. H/Per.),				
67	Chevy, Chevelle, Camaro w/4BC (327, 350) (exc. closed vent.),				
67	Pass. (8 cyl.) (exc. closed pos. vent.) .....	6487503	1	2.08	VALVE ASSY., vent (CV-768C) .....
66-67	Taxi w/A.I.R. (6 cyl.),				
68-71	Police, Taxi (6 cyl.),				
72	Taxi (6 cyl.) .....	6486885	1	1.94	VALVE ASSY., vent. (CV-757C) .....
66-67	All w/A.I.R. (194),				
68-70	Chevy (4 cyl.),				
71	All (6 cyl.) (exc. Taxi, Police),				
72	All (6 cyl.) (exc. Taxi) .....	6422717	1	2.08	VALVE ASSY., vent. (CV-722C) .....
66-68	All w/A.I.R. (230, 250) (exc. Taxi),				
69-70	All (6 cyl.) (exc. Taxi, Police) ...	6422718	1	2.08	VALVE ASSY., vent (CV-723C) .....
66	Pass. w/closed vent (283, 327),				
66	Pass. w/A.I.R. (283, 327),				
66	Chevy, Chevelle w/closed vent. A.I.R. (283, 327) (exc. Sp. H/Per.),				
66-67	Chevy, Chevelle w/Sp. H/Per. (327),				
67	Camaro (302, 396),				
67	All w/closed pos. vent (283, 327) .....	6422721	1	2.90	VALVE ASSY., vent (CV-726C) .....
68-69	Camaro (302),				
70-71	Camaro w/Sp. H/Per. (350) ....	6484525	1	2.00	VALVE ASSY., vent. (CV-746-C) .....
71-75	Vega, Monza (140) .....	6486964	1	2.08	VALVE ASSY. (CV-758C) (gold) .....
73	All (6 cyl.) .....	6487534	1	2.00	VALVE ASSY., vent. ....
73	All (8 cyl.) (exc. Sp. H/Per. 350)	6487532	1	2.00	VALVE ASSY., vent. ....
73	All w/Sp. H/Per. (350) .....	6484525	1	2.00	VALVE ASSY., vent. ....
74-75	All w/Sp. H/Per. (350) .....	6487945	1	2.33	VALVE ASSY., c/case vent. ....
74-75	All (8 cyl.) (exc. Sp. H/Per. 350)	6487779	1	2.33	VALVE ASSY., vent. ....
74-75	All (6 cyl.) .....	6487936	1	2.33	VALVE ASSY., vent. ....
75	Vega, Monza (122) .....	6488202	1	1.94	VALVE ASSY. PACKAGE, crankcase vent. .
64-67	All (283, 327) (exc. H.D. A/CL, closed pos. vent., A.I.R.) .....	3853194	1	.66	ADAPTER, vent hose to manifold .....
66-67	All w/closed pos. vent (283) ...	538570	1	1.10	ELBOW, c/case vent valve connector (3/8" hose to 1/4"-18 threaded pipe)— (3.163) ..
64-66	Chevy, Chevelle w/closed vent. A.I.R. (exc. 396),				
65-66	Pass. w/closed pos. vent. (6 cyl.)				
71-72	Camaro (Sp. H/Per. 350, 400 w/4BC),				
73	Camaro (Sp. H/Per. 350) .....				ARRESTOR, c/case vent. hose (a/cl. to valve rocker cover), .....
65-66	Pass. w/closed vent., A.I.R. (exc. F.I. 6 cyl.),				
66	Chevelle w/Sp. H/Per., H/Per. (396),				
67	Chevelle w/H/Per. (396),				
67	Chevy, Camaro w/closed pos. vent.,				
67-68	Chevelle w/Sp. H/Per. (327),				
67-69	Camaro (302, 396),				
67	Pass., Chevelle w/closed pos. vent.,				
69	Pass. w/Sp. H/Per. (427),				
70	Chevelle w/H/Per., Sp. H/Per. (396, 454) (exc. Monte Carlo),				
71	Chevelle w/Sp. Ducted Hood Air System (400, 454),				
71	Monte Carlo w/Sp. H/Per. (454)	3849856	1	.63	flame .....
65-66	Pass. closed pos. vent w/oil bath A/CL (6 cyl.),				
67	Pass. w/oil bath A/CL (6 cyl.) ..	3857476	1	1.20	ARRESTOR, flame c/case vent .....
68-69	All w/H.D. closed pos. vent. ....	6262992	1	1.65	ARRESTOR ASSY., flame .....

**COOLANT—GRILLE—OIL SYSTEM**

**1.745 CONNECTOR—TUBE ASSY.—VENTILATOR—KIT—VALVE ASSY.—  
ADAPTER—ELBOW—ARRESTOR—GROMMET—NIPPLE—SEAL—  
TEE—GASKET—WASHER—CLIP, Crankcase (Con't)**

62-72	All (exc. Vega)	3845783	1	.34	GROMMET, vent. hose conn. (at rocker cover) (for 1" dia. hole- <sup>23</sup> / <sub>64</sub> " I.D. x <sup>17</sup> / <sub>32</sub> " O.D. x <sup>7</sup> / <sub>16</sub> " thk.)
63	Chevy.				
64-65	All (exc. closed vent. H.D. A/CL, 8 cyl.),				
66-68	All (exc. 8 cyl.),				
70	Nova (exc. 8 cyl.)				GROMMET, vent. valve,
70	Chevelle (6 cyl.)				vent. rocket cover to carb. hose,
70	Pass., Camaro (6 cyl.)				vent.,
70	Pass., Nova (8 cyl.),				
70	Chevelle (8 cyl.) (exc. 396, 400 w/4BC, 454),				
71-75	All	3989344	A.R.	.22	vent. hose R.H. ( <sup>23</sup> / <sub>32</sub> " I.D. x <sup>17</sup> / <sub>32</sub> " O.D.)
64-69	All,				
69-70	All (6 cyl.),				
70	Nova,				
71	Chevelle, Camaro (exc. Sp. H/Per. 350)	3894337	A.R.	.11	GROMMET ( <sup>15</sup> / <sub>16</sub> " I.D. x <sup>17</sup> / <sub>32</sub> " O.D.)
64	Chevy (8 cyl.) (exc. closed vent.)	3831671	1	.34	GROMMET, vent., hose connector
65-67	Pass. (396, 427) (exc. Sp. H/Per.),				
66	Chevelle (396) (exc. Sp. H/Per., closed vent),				
67	Chevelle, Camaro (396),				
70	All (exc. 8 cyl.),				
70	Chevelle, Camaro (396, 400 w/4BC, 454),				
70	Nova (396)				GROMMET, vent. valve
66	Chevelle w/Sp. H/Per. (396),				
66-67	Pass. w/Sp. H/Per. (427),				
70	All (400 w/4BC, 454),				
71-75	All (exc. Vega, Monza)	3989347	1	.22	GROMMET ( <sup>23</sup> / <sub>32</sub> " I.D. x <sup>17</sup> / <sub>16</sub> " O.D.)
65	Pass. w/Sp. H/Per. (396)	3868838	1	.11	GROMMET, vent pipe
69	Camaro (302),				
71-75	All w/Sp. H/Per. (350)	3989348	1	.34	GROMMET, vent. hose
70	Pass., Nova, Camaro (307, 350),				
70	Pass. w/2BC (400)				GROMMET, vent. valve L.H.,
70	Chevelle (8 cyl.) (exc. 396, 400 w/4BC, 454)				vent. valve L.H., vent. hose
71-75	All	3989350	1	.34	( <sup>23</sup> / <sub>32</sub> " I.D. x <sup>13</sup> / <sub>16</sub> " O.D.)
71-75	Vega, Monza (140)	3994239	1	.24	GROMMET, crankcase vent. hose connector at cam cover front
71-75	Vega, Monza (140)	3977197	1	.18	GROMMET, vent. connector at cam cover rear
75	Vega, Monza w/2BC (140) (A.I.R. w/NB-2)	354537	1	.19	GROMMET, pulsair check valve tube
71	Nova, Chevelle, Camaro w/2BC (307, 350),				
71	Pass. w/2BC (350),				
72-75	All w/2BC (307, 350, 400),				
75	Vega, Monza (8 cyl.)	336018	1	.22	NIPPLE, inlet manifold to c/case vent. hose ( <sup>1</sup> / <sub>4</sub> "— 18)
75	Vega, Monza (122)	405143	1	2.00	NIPPLE, vent. hose
75	Vega, Monza (122)	348687	1	.61	SEAL, crankcase vent. pipe
73-75	Vega, Monza (C.A.C. w/2BC) (140)	338109	1	1.05	TEE, hot idle compensator valve
75	Vega, Monza (122)	343353	1	.98	TEE, crankcase vent. hose
70-73	All w/E.E.C.,				
74-75	Vega, Monza (140)	3970076	1	.98	TEE, crankcase vent. hose
64-65	All w/P.B., P.G., All Weather Air Cond. (8 cyl.) (exc. 396)	3863118	1	4.05	TEE ASSY., vac. inlet manifold
64-65	All w/P.G., All Weather Air Cond. (8 cyl.) (exc. P.B.)	336015	1	.80	TEE ASSY., vac. inlet manifold— (3.278)
65	Pass.,				
66-67	All,				
70-72	All (exc. Vega)	3989020	1	.59	TEE ASSY., c/case vent. hose ( <sup>3</sup> / <sub>8</sub> "— 18 pipe thds.)— (4.931)
66	Pass. (A.I.R., closed vent.) w/level control (283),				
66-70	Pass. w/level control (8 cyl.),				
67	Pass. (closed pos. vent. w/level control) (283),				

**COOLANT—GRILLE—OIL SYSTEM**

**1.745 CONNECTOR— TUBE ASSY.— VENTILATOR— KIT— VALVE ASSY.— ADAPTER— ELBOW— ARRESTOR— GROMMET— NIPPLE— SEAL— TEE— GASKET— WASHER— CLIP, Crankcase (Con't)**

71-72	All w/level control	406511	1	.67	TEE ASSY., vent. hose— (3.130)
67	Chevy, Chevelle w/Acc. Air Cond.,				
67-69	Pass. w/Acc. Air Cond. (6 cyl.)	3794176	1	3.70	TEE ASSY., c/case vent hose— (9.198)
62-69	All	5646135	A.R.	.10	GASKET, vent. valve adapter bolt, vent tube, hose adapter washer (CV-313) ( <sup>15</sup> / <sub>64</sub> " I.D. x <sup>5</sup> / <sub>64</sub> " O.D. x <sup>1</sup> / <sub>16</sub> " thk.)
68-69	All w/H.D. Closed pos. vent	3927732	1	1.35	GASKET, c/case vent hose connector
62-69	All	382105	1	.12	WASHER, vent. tube bracket ( <sup>25</sup> / <sub>64</sub> " I.D. x <sup>3</sup> / <sub>4</sub> " O.D.)— (4.037)

**1.750 CLAMP— SCREW, Crankcase Ventilator Tube**

62-69	All	1470029	2	.73	(1.166)
62-69	All	3785130	1	.11	SCREW, oil filler tube assy. ( <sup>1</sup> / <sub>4</sub> "— 20 x <sup>1</sup> / <sub>2</sub> ")

**1.758 CAP— GASKET, Oil Filler**

62-63	Chevy,				
64-66	All (exc. 8 cyl. closed vent., H.D. A/CL, A.I.R.),				
67	All (6 cyl.) (exc. closed pos. vent.)	1552232	1	2.30	type (FB7) painted (4 vent holes) ( <sup>2</sup> / <sub>4</sub> " O.D.) (Note 1)

*NOTE 1 Used on all models equipped with valve rocker cover without ventilation slots.*

64-66	Chevy, Chevelle w/closed vent. (exc. 230 H/Per., 8 cyl.),				
66-67	All w/A.I.R. (6 cyl.),				
68	All (4 cyl., 6 cyl.),				
68	Pass. (396, 427) (exc. Spec. H/Per.),				
69	All (exc. 302, 396),				
70	All,				
73-74	All (307, 350, 400) (exc. Sp. H/Per.),				
75	All (exc. Sp. H/Per.)	3835665	1	.84	w/gasket (on r/arm cover) (plain finish)
64-67	All (283, 327) (exc. H.D. A/CL, closed pos. vent)	6419440	1	2.30	(air breather type FB8)
64-65	All w/closed vent. (8 cyl.) (exc. 409),				
65	Chevelle (Sp. H/Per. w/Hyd. lifters) (327) (1st. design)	3714893	1	.87	( <sup>1</sup> / <sub>4</sub> " O.D.-w/4 ears)
65	Chevelle (Sp. H/Per. w/Hyd. lifters) (327) (2nd. design),				
65	Pass. (409)	3828373	1	1.65	(chrome)
64-65	Chevy, Chevelle (230) (exc. closed vent.)	6420359	1	6.49	CAP ASSY. (chrome) (FB-43)
64	Chevy, Chevelle w/closed vent (230),				
65-69	All (302, 396, 427),				
70	Nova, Chevelle, Camaro (Sp. H/Per. 350, 396, 454) (exc. Monte Carlo),				
73-75	All w/Sp. H/Per. (350)	3851735	1	1.35	CAP ASSY. (chrome)
65-66	Pass., Chevelle (396, 427) (exc. Sp. H/Per., closed vent.),				
67	Pass. (396, 427) (exc. S.S., A.I.R. closed pos. vent)	6421868	1	3.59	CAP ASSY., vent breather (plain)
66-67	Chevelle w/Sp. H/Per. (327),				
66	Chevy w/Sp. H/Per. (327) (exc. A.I.R.),				
67	Camaro w/closed pos. vent. (350),				
67	Camaro (302)	3882864	1	1.35	CAP ASSY.
66	All w/A.I.R., closed pos. vent. (283, 327) (exc. Sp. H/Per.),				
67-68	All w/closed pos. vent. (283, 307, 327)	3881834	1	1.05	CAP ASSY.
66	Chevelle (396) (exc. A.I.R., closed vent., H/Per., Sp. H/Per.),				
67	Chevelle (396) (exc. H/Per., closed pos. vent.),				
67	Impala (S.S.)	6423033	1	8.15	CAP ASSY., chrome

**COOLANT—GRILLE—OIL SYSTEM**

**1.758 CAP— GASKET, Oil Filler (Con't)**

67	Camaro (350) (exc. closed pos. vent.)	6419454	1	4.98	CAP ASSY. (type FB-39)
67	Chevy, Chevelle, Camaro w/closed vent. (exc. 327, 350, 396),				
67-68	Pass. w/closed pos. vent. (283),				
68	Chevy	6424994	1	2.27	CAP ASSY., vent breather (AC type FB-58)
71-75	Vega, Monza (122, 140)				
71	All (8 cyl.),				
72	All (6 cyl.),				
72	All (307, 350, 400),				
73-74	All (6 cyl., 454),				
75	Nova (6 cyl.) (exc. integrated cylinder head)	3980273	1	.71	CAP ASSY.
64-65	Chevy, Chevelle w/closed vent. (8 cyl.),				
65	Chevelle (w/Sp. H/Per.) (327) (exc. Hyd. lifters),				
65	Pass. (409),				
65	Pass. w/closed vent. (8 cyl.) (exc. 396, 409)	3723688	1	.12	GASKET (1 <sup>1</sup> / <sub>16</sub> " I.D. x 1 <sup>11</sup> / <sub>16</sub> " O.D.-cork)

**1.762 TUBE— HOSE— PIPE— CLIP, Crankcase Ventilator-Outer**

64-65	All w/closed vent. (8 cyl.) (exc. 409)	3846120	1	5.20	vent. to air cleaner
65	Chevelle w/Sp. H/Per. (327)	3849733	1	6.80	vent. to air cleaner
66	All w/closed vent. (327) (exc. Sp. H/Per.),				
66	Chevy, Chevelle w/Sp. H/Per. (327) (exc. A.I.R.),				
67	All w/closed pos. vent. (283, 327) (exc. A.I.R.)	3881848	1	2.95	
66	All w/A.I.R. (327),				
67	All w/A.I.R. (8 cyl.) (exc. Sp. H/Per., 302, 396)	3888364	1	5.35	w/bracket
62-69	All	9433154	A.R.	RL/.67	HOSE, vent. (1 <sup>1</sup> / <sub>2</sub> " x 18" O.L.-cut to desired length)— (8.962)
62-69	All w/pos. vent.	9432875	A.R.	RL/.24	HOSE (3 <sup>3</sup> / <sub>8</sub> " I.D.)— (8.962)
62-69	All	725615	A.R.	RL/.60	HOSE, vent. (5 <sup>5</sup> / <sub>8</sub> " I.D. x 1 <sup>15</sup> / <sub>16</sub> " O.D. x 25 ft.)— (8.962)
62-72	All (exc. Vega)	3981058	1	1.65	HOSE (1 <sup>11</sup> / <sub>32</sub> " x 29)
66	Pass., Chevelle (A.I.R., closed vent.) (327) (exc. Sp. H/Per.),				
67	Pass., Chevelle, Camaro w/closed pos. vent. (327, 350) (exc. Sp. H/Per.)	3883966	1	.83	HOSE, vent. to A/CL
66	Chevelle w/Sp. H/Per. (327),				
66	Chevy w/Sp. H/Per. (327) (exc. A.I.R.),				
66	All w/closed pos. vent. (327)		1		HOSE, c/case vent, carb. to oil fill tube
67	All (302, 327, 350) (exc. closed pos. vent., Sp. H/Per.)	3882870	1	1.30	c/case vent front
66	All (w/closed pos. vent., A.I.R.) (327),				
67	Pass., Chevelle, Camaro w/closed pos. vent. (327) (exc. A.I.R.)	3882871	1	1.00	HOSE, c/case vent carb. to oil fill tube
67	Chevy, Chevelle w/Sp. H/Per. (327)	3853386	1	1.90	HOSE, vent. to A/CL
67	All w/pos. closed vent., 2BC (283, 327),				
68	Chevy (8 cyl.)				HOSE, c/case vent. to A/CL,
67	Chevy, Chevelle w/pos. closed vent. (283)	3909889	1	2.35	c/case vent. tube to A/CL— (3.675)
67	Camaro (302),				
70	Chevelle, Camaro, Nova (396, 454),				
71	Chevelle (454)	3916380	1	1.85	HOSE, c/case vent. to a/cl.
68-70	Chevy (4 cyl.)	3921982	1	2.00	HOSE, c/case vent. A/CL to vlv. rocker cover
68	Chevy, Chevelle w/Sp. H/Per. (327),				
68-69	Camaro (302) (exc. Spec. ducted hood),				
71-72	All w/Sp. H/Per. (350)	3932336	1	2.30	HOSE, c/case vent. a/cl. to rocker cover

**COOLANT—GRILLE—OIL SYSTEM**

**1.762 TUBE— HOSE— PIPE— CLIP, Crankcase Ventilator-Outer (Con't)**

68	Pass., Chevelle (396, 427) (exc. H/Per., Sp. H/Per.)	3921978	1	2.70	HOSE, c/case vent left hand
68-69	All w/H.D. closed pos. vent. (exc. 396, 427)	3911029	1	3.25	HOSE, c/case vent. a/cl. to rocker cover or flame arrestor— (3.675)
68-69	All (6 cyl.) (exc. closed pos. vent. H.D.),				
70-74	All (6 cyl.),				
75	Nova (6 cyl.) (exc. integrated cylinder head)	3939005	1	1.35	HOSE, vent. a/cl. to valve
69	Chevelle (Deluxe) (396) (exc. H/Per., Sp. H/Per., engine block heater),				
69	Malibu (396) (exc. H/Per., Sp. H/Per., engine block heater),				
69	Pass. (396),				
69	Pass. (427) (exc. Sp. H/Per.)	3952306	1	1.70	HOSE, c/case vent to A/CL hose, c/case vent A/CL to rocker cover hose
68	All (8 cyl.) (exc. 302, 327 Sp. H/Per., 396, 427, H.D. closed pos. vent.),				
69	Chevy 307, 350,				
69	Camaro (327, 350),				
69	Chevelle (Deluxe, Nomad, Greenbrier) (307, 350) (exc. H.D. closed pos. vent.),				
69	Malibu, Concours (8 cyl.) (exc. H.D. closed pos. vent. 396),				
69	Pass. (327, 350) (exc. H.D. closed pos. vent.),				
71-72	Chevelle w/C.A.C. (307, 350, 400 w/2BC),				
73	All w/Sp. H/Per. (350)	3942524	1	1.70	HOSE, vent. a/cl. to rocker cover
69	Camaro (Spt. Cpe.) w/Spec. ducted hood (302, 350)	3951632	1	1.85	HOSE, A/CL to rocker cover
70	All (307),				
70	Chevelle w/C.A.C., 2BC (350)	3951407	1	1.15	HOSE, c/case vent. to a/cl.
72	Nova, Chevelle (350),				
73	All (8 cyl.) (exc. Sp. H/Per.),				
74-75	All (454)	3905067	1	4.05	HOSE, c/case vent. a/cl. to rocker cover
75	Vega, Monza (122)	9433154	1	RL/.67	HOSE, crankcase vent.
70-71	Pass., Nova (307, H/Per. 350),				
70	Camaro (307, 350),				
70	Nomad, Greenbrier, El Camino (307, H/Per. 350) (exc. Custom, C.A.C.),				
70	Malibu, Monte Carlo, Concours w/H/Per. (350),				
71-72	Camaro (307, 350) (exc. Sp. H/Per.),				
71	Chevelle (307, H/Per. 350) (exc. C.A.C.),				
72	Chevelle w/H/Per. (350),				
73-74	Camaro (307, 350),				
73-74	Pass., Nova, Chevelle w/4/BC (350),				
75	Pass., Nova, Chevelle w/4BC (350, 400),				
75	Camaro (8 cyl.)	3970072	1	.76	PIPE
70-71	Chevelle w/2BC (307, 350, 400) (exc. C.A.C.),				
70-71	Nova w/2BC (350),				
70-72	Pass. w/2BC (350, 400),				
72	Chevelle w/2BC (350, 402) (exc. C.A.C.),				
72	Nova (8 cyl.) (exc. 4BC),				
73-74	Nova, Chevelle w/2BC (307, 350),				
73-74	Pass. (350, 400),				
75	Pass., Nova, Chevelle w/2BC (350),				
75	Nova (262)	3970070	1	.76	PIPE
70	Monte Carlo (400 w/4BC, 454),				
70	Pass. (454),				

**COOLANT—GRILLE—OIL SYSTEM**

**1.762 TUBE— HOSE— PIPE— CLIP, Crankcase Ventilator-Outer (Con't)**

71-72	All (400 w/4BC, 402, 454) (exc. special ducted hood),				
73-75	All (454)	330523	1	2.20	PIPE
71-75	Vega (140)	3977193	1	.74	PIPE, crankcase vent. air cleaner to cam cover
75	Vega, Monza (122)	348686	1	4.90	PIPE, crankcase vent.
75	Vega, Monza (8 cyl.)	357017	1	1.90	PIPE, crankcase vent.
74	All (6 cyl.),				
75	Nova (exc. integrated cylinder head)	343319	1	1.75	PIPE
75	Chevelle, Camaro (6 cyl.),				
75	Nova w/integrated cylinder head	354545	1	10.05	PIPE
64-69	All,				
70	Nova	3877445	1	.12	CLIP, vent. hose
70	All w/E.E.C., 2BC (307, 350, 400),				
71	Chevelle, Camaro (307, 350) (exc. H/Per.)				CLIP, a/cl. fuel vapor canister hose
71	Camaro w/Sp. H/Per. (350)				a/cl. fuel vapor canister hose,
71	Chevelle w/Sp. H/Per. (454) (exc. Sp. ducted hood air system)	3972132	1	.16	a/cl. evap. emission hose (1 <sup>1</sup> / <sub>16</sub> " )

**1.800 SWITCH— TEE— FITTING, Oil Pressure (See group 9.748 for tell tale windows)**

62-65	All (exc. S.S.),				
66	Pass. (exc. floor console),				
66-69	Chevy, (exc. Console Gauges),				
66-69	Chevelle (exc. inst. panel gauges),				
67-69	Pass., Camaro,				
75	All (exc. Console Inst. Cluster)	3815936	1	2.75	(2 <sup>2</sup> <sup>1</sup> / <sub>32</sub> " O.L.)
65	Taxi	3818783	1	2.75	(2" O.L.)
69	Chevelle w/inst. panel gauges	6462137	1	25.21	gauge
70-74	All,				
75	Vega, Monza (122),				
76	X (250) (exc. integrated cylinder head)	3973617	1	2.75	SWITCH
71-75	Vega, Monza (exc. 122)	3986857	1	2.75	
75	All (6 cyl.) w/integrated cylinder head	356116	1	2.85	oil temp.
66	Chevelle (exc. S.S.)	3828680	1	3.95	TEE, switch to inlet pipe (1 <sup>1</sup> / <sub>8</sub> "— 27) internal and external pipe thread plus 90 degrees— (7 <sup>1</sup> / <sub>16</sub> "— 24) inv. flare threading (chrome plated)
67	Camaro (8 cyl.),				
68	Chevy	6461001	1	.84	FITTING, gauge adapter

**1.803 GAUGE— HOSE— FITTING— BRACKET— PIPE ASSY.— ADAPTER— DIAL— ELBOW— RETAINER, Oil Pressure**

67	Camaro (8 cyl.)	6460905	1	15.90	
68-75	Nova w/floor console cluster	6462896	1	19.83	
69	Chevelle w/inst. panel gauges (396)	6462069	1	8.90	
67-68	Pass., Chevelle w/instr. panel gauges (8 cyl.),				
67-68	Camaro, Chevy w/console gauges (8 cyl.) (exc. 396),				
69	Chevy, Camaro w/console gauges (8 cyl.) (exc. 396),				
70-75	Nova w/console gauges (exc. 396)	3906192	1	1.40	HOSE (5 <sup>5</sup> / <sub>64</sub> " I.D. x 1 <sup>1</sup> / <sub>8</sub> " O.D. w/5 <sup>5</sup> / <sub>16</sub> "— 24 int. thread nut, ea. end) (black nylon)
67-69	Camaro w/console gauges (396),				
70	Nova w/console gauges (396)	3909574	1	1.95	HOSE (87" O.L.)
69	Chevelle w/inst. panel gauges (exc. 396)	3954222	1	1.90	FITTING, gauge at engine
69-70	Chevy w/console gauges (396)	3954228	1	.22	BRACKET, gauge pipe
69	Chevy, Camaro w/console gauges (396),				
70	Nova w/console gauges (396)	3954225	1	6.15	PIPE ASSY., gauge
73-74	Chevelle	6497030	1	2.85	DIAL, oil press. tell tale
69-70	Pass. (396, 400 w/4BC, 427, 454) (exc. Sp. H/Per.),				



**COOLANT—GRILLE—OIL SYSTEM**

**1.803 GAUGE— HOSE— FITTING— BRACKET— PIPE ASSY.— ADAPTER— DIAL— ELBOW— RETAINER, Oil Pressure (Con't)**

69-70	Chevy, Camaro (396, 400 w/4BC, 454) (exc. Sp. H/Per., inst. panel gauges),				
69-70	Chevelle w/inst. panel gauges (396, 400 w/4BC, 454) (exc. Sp. H/Per.),				
71-72	All (400 w/4BC, 402, 454) (exc. Sp. H/Per.),				
73-75	All (454) . . . . .	3954219	1	1.30	ELBOW, switch . . . . .
69-70	Pass. w/Sp. H/Per. (427, 454),				
69-70	Chevy, Camaro w/Sp. H/Per. (396, 454) (exc. inst. panel gauges),				
69-70	Chevelle (inst. panel gauges w/Sp. H/Per.) (396, 454),				
71	All w/Sp. H/Per. (454) . . . . .	3954220	1	2.85	ELBOW, switch . . . . .
71-75	Nova w/console gauges . . . . .	6496636	1		RETAINER, fuel and oil pressure gauge . . .

**1.835 FILTER UNIT, Oil (see group 3.163 for flexible pipes)**

64-67	Pass., Chevelle, Camaro (8 cyl.),				
68-69	Taxi (8 cyl.),				
69	Police (8 cyl.) . . . . .	5574538	1	13.57	(AC type PM-16) (1 qt. cap) . . . . .

*IMPORTANT By-pass plug over front lower case connection must be driven in 5/8" when full flow oil filter is used. Must be flush when by-pass type or no filter is used.*

**1.836 ELEMENT, Oil Filter**

62-70	Chevy (4 cyl.) . . . . .	5578108	1	5.90	(type PF-12) (one piece throw-away type) . .
62-67	All (6 cyl.),				
64-67	Chevy (8 cyl.),				
68-75	All (exc. Taxi, Police, 4 cyl.),				
71-75	Vega, Monza . . . . .	6438261	1	5.74	(type PF-25) (one piece throw-away) (1 pint cap.) (Note 1) . . . . .

*NOTE 1 Some 1968 models used 1967 engines, refer to Note No. 4 in Group 0.033.*

70-75	Taxi, Police (8 cyl.) . . . . .	6438384	1	6.03	(AC Type PF-35) . . . . .
64-67	Pass., Chevelle, Camaro (8 cyl.),				
68-69	Taxi (8 cyl.),				
69	Police (8 cyl.) . . . . .	5574540	1	4.16	(AC-PF-141) (PM-16-1) (1 qt. cap) (replaceable element) . . . . .
65-67	Pass. All (8 cyl.),				
68	Chevy, Chevelle, Camaro (8 cyl.)	5576054	1	3.17	ELEMENT ASSY. (fleet pack) (type 12-141) (Note 3) . . . . .

*NOTE 3 Consists of 12 single elements.*

**1.837 VALVE ASSEMBLY— BODY— SPRING— REPAIR KIT, Oil Filter**

62-72	All (exc. 8 cyl.),				
64-67	Chevy (8 cyl.),				
71-75	Vega, Monza (140),				
73-75	All (6 cyl.) . . . . .	5575416	1	1.57	by-pass . . . . .
64-67	Pass., Chevelle, Camaro (8 cyl.),				
68-69	Taxi (8 cyl.),				
69	Police (8 cyl.) . . . . .	5573979	1	3.90	by pass (1 qt. cap) . . . . .
64-67	Pass., Chevelle, Camaro (8 cyl.),				
68-69	Taxi (8 cyl.),				
69	Police (8 cyl.) . . . . .	5574535	1	9.95	BODY, w/stud (1 qt. cap) . . . . .
68-69	Taxi (8 cyl.),				
69	Police (8 cyl.) . . . . .	5574536	1	.24	SPRING, element retainer . . . . .
68-69	Taxi (8 cyl.),				
69	Police (8 cyl.) . . . . .	5574574	1	.97	REPAIR KIT, stud gasket . . . . .

**1.840 BOLT— ADAPTER ASSY., Oil Filter**

68	All (8 cyl.) . . . . .	3933126	2	.13	filter adapter (5/16"— 18 x 1 1/4") . . . . .
69-75	All (8 cyl.) . . . . .	3951644	2	.18	adapter, fldg. hex head (5/16"— 18 x 1 1/4") . .
68	Police . . . . .	3951626	1	2.60	ADAPTER ASSY. . . . .
68-75	All (8 cyl.) . . . . .	3952301	1	3.15	ADAPTER ASSY., w/valve (Note 1 and 2) . .

*NOTE 1 Some early 1968 models used 1967 engines, refer to Note No. 4 in Group 0.033.*

*NOTE 2 When using 3952301 in place of 3916328 it is necessary to discard the attaching screws and use two 180080 screws.*

**1.844 GASKET, Oil Filter**

62	Chevy,				
63-70	Chevy (4 cyl.) . . . . .	5578878	1	.48	filter (type G-488) . . . . .
	Pass., Chevelle, Camaro (8 cyl.) .	3903322	1	.12	oil filter valve . . . . .
64-67	Pass., Chevelle (8 cyl.),				
68-70	Taxi, Police (8 cyl.),				

**COOLANT—GRILLE—OIL SYSTEM**

**1.844 GASKET, Oil Filter (Con't)**

69 All w/H.D. Oil Filter ..... **5573980** 1 .24 body or cavity cover .....

**1.850 OIL— CLEANER, Engine Concentrate**

62-70 All ..... **1051396** A.R. 2.25 camshaft break-in (1 pint can) ("E.O.S.")—  
(8.800) .....

62-70 All ..... **1051397** A.R. 3.10 camshaft break-in (32 oz. can) ("E.O.S.")—  
(8.800) .....

62-70 All ..... **1050002** A.R. 2.10 **CLEANER**, carb., combustion chamber and  
crankcase (16 oz. can) ("cleans")— (8.800)

62-70 All ..... **1050003** A.R. 4.75 **CLEANER**, carb., combustion chamber and  
crankcase (38 oz. can) ("cleans")— (8.800)

62-70 All ..... **1050690** 1 2.90 **CLEANER**, top eng. (19 oz., aerosol  
container)— (8.800) .....

62-70 All ..... **1050728** 1 2.70 **CLEANER**, top engine (24 oz. can)— (8.800)

**1.855 CONNECTOR, Oil Filter Fitting**

62-72 All (exc. 8 cyl.),

71-75 Vega, Monza (140),

73-75 All (6 cyl.) ..... **3853870** 1 .79 element to engine .....



# CHEVROLET CHASSIS GROUP 2.000



## CHASSIS WIRING — LAMPS

### ALPHABETICAL INDEX

<b>A</b>			
ACTUATOR ASSY., Direction Signal Lamp (See Group 9.748 Tell Tale Wind.) .....	2.895	BRACE, Generator (Bracket listed in Group 2.277) .....	2.317
ACTUATOR, Concealed Headlamp Control Drive .....	2.760	BRACE, Starting Motor (Internal) .....	2.077
ACTUATOR, Ignition Switch Warning .....	2.195	BRACE, Starting Motor to Engine Attaching ..	2.042
ADAPTER, Generator .....	2.313	BRACKET, Back-Up .....	2.698
ADAPTER, Horn Button and Blowing Ring .....	2.819	BRACKET, Battery .....	2.333
ADAPTER UNIT, Headlamp .....	2.726	BRACKET, Concealed Headlamp Control Drive .....	2.760
ALARM UNIT, Ignition Switch Warning .....	2.195	BRACKET, Concealed Headlamp Control Opening Cover .....	2.765
AMMETER, Electrical Output (See Group 9.748 for Telltale Windows) .....	2.515	BRACKET, Concealed Headlamp Motor .....	2.755
AMPLIFIER, Ignition Pulse (Transistorized) .....	2.383	BRACKET, Dist. Spark Advance Trans. Electric Control (Also See Group 4.075) ..	2.408
AMPLIFIER, Lighting .....	2.485	BRACKET, Distributor Vacuum Control .....	2.420
APPLIQUE, Tail and Stop Lamp .....	2.681	BRACKET, Distributor, with Bracket and Lead .....	2.393
ARMATURE, Generator .....	2.279	BRACKET, Generator (see 2.317 for brace) ...	2.277
ARMATURE, Starting Motor .....	2.043	BRACKET, Generator (Current Regulator Listed in Group 2.500) .....	2.319
ARM, Generator Brush .....	2.291	BRACKET, Headlamp (Rim or Door) .....	2.728
		BRACKET, Headlamp Lens and Sealed Beam Retaining .....	2.736
		BRACKET, Headlamp Moulding .....	2.729
		BRACKET, Ignition Coil Mounting .....	2.183
		BRACKET, Ignition Pulse (Transistorized) .....	2.383
		BRACKET, Instrument Panel Harness .....	2.482
		BRACKET, Lighting .....	2.485
		BRACKET, Parking Lamp Attaching .....	2.587
		BRACKET, Spark Plug Wire .....	2.251
		BRACKET, Stop Lamp .....	2.447
		BREAKER ASSY., Concealed Headlamp Motor .....	2.755
		BREAKER ASSY., Lighting .....	2.485
		BRIDGE, Generator (Current Regulator Listed in Group 2.500) .....	2.319
		BRUSH .....	2.051
		BRUSH, Distributor .....	2.368
		BRUSH, Generator .....	2.285
		BUMPER, Back-Up .....	2.697
		BUMPER, Battery .....	2.333
		BUMPER, Concealed Headlamp Motor .....	2.755
		BUMPER, Direction Signal Lamp (See Group 9.748 Tell Tale Wind.) .....	2.895
		BUMPER, Hazard Flasher .....	2.575
		BUMPER, Headlamp Control .....	2.775
		BUMPER, Parking Lamp Attaching .....	2.587
		BUSHING, Center Bearing .....	2.082
		BUSHING, Concealed Headlamp Control Opening Cover .....	2.765
		BUSHING, Generator (see 2.317 for brace) ...	2.277
		BUSHING, Generator (Current Regulator Listed in Group 2.500) .....	2.319
		BUSHING, Generator Commutator or Rotor Slip Ring End Frame .....	2.298
		BUSHING, Horn Button and Blowing Ring .....	2.819
		BUSHING, Starting Motor End .....	2.083
		BUTTON ASSY., Horn Blowing .....	2.820
		BUZZER ASSY., Automatic Headlamp Control .....	2.461
		BUZZER ASSY., Lighting .....	2.485
		BUZZER, Ignition Switch Warning .....	2.195
<b>B</b>			
BACKPLATE, Electrical Output (See Group 9.748 for Telltale Windows) .....	2.515		
BAR, Horn Blowing .....	2.830		
BEARING ASSY., Direction Signal Lamp (See Group 9.748 Tell Tale Wind.) .....	2.895		
BEARING ASSY., Distributor Mainshaft .....	2.375		
BEARING ASSY., Generator Commutator or Rotor Slip Ring End Frame .....	2.298		
BEARING, Generator Drive End .....	2.306		
BEZEL, Back-Up .....	2.697		
BEZEL, Hazard Flasher .....	2.575		
BEZEL, Headlamp (Rim or Door) .....	2.728		
BEZEL, Ignition Lock .....	2.198		
BEZEL, Lighting Switch Rod .....	2.487		
BEZEL, Lighting .....	2.485		
BEZEL, Parking Lamp .....	2.593		
BEZEL, Tail and Stop Lamp .....	2.681		
BLOCK ASSY., Battery to Starter Switch, with Terminals (Insulated) .....	2.342		
BLOCK, Fuse & Junction .....	2.483		
BOLT, Battery to Starter Switch, with Terminals (Insulated) .....	2.342		
BOLT, Battery Cable .....	2.343		
BOLT, Battery Hanger Clamp .....	2.334		
BOLT, Concealed Headlamp Control Opening Cover .....	2.765		
BOLT, Concealed Headlamp Opening Cover ..	2.770		
BOLT, Dist. Spark Advance Trans. Electric Control (Also See Group 4.075) .....	2.408		
BOLT, Generator (see 2.317 for brace) .....	2.277		
BOLT, Generator Through .....	2.316		
BOLT, Generator .....	2.313		
BOLT, Starting Motor (Internal) .....	2.077		
BOLT, Starting Motor to Engine Attaching ..	2.042		
BOOT, Distributor Vacuum Control Clamp ..	2.414		
BOOT, Electrical .....	2.530		
BRACE, Battery .....	2.333		

# ALPHABETICAL INDEX

## C

CABLE ASSY., Direction Signal Lamp (See Group 9.748 Tell Tale Wind.)	2.895
CABLE, Battery to Starter Switch, with Terminals (Insulated)	2.342
CABLE, Battery Ground, with Terminal	2.341
CABLE, Electrical	2.530
CAM, Direction Signal Lamp (Cancelling)	2.896
CAM, Distributor	2.381
CAPACITOR, Distributor, with Bracket and Lead	2.393
CAPACITOR, Generator (Current Regulator Listed in Group 2.500)	2.319
CAPACITOR, Ignition Pulse (Transistorized)	2.383
CAP ASSY., Horn Blowing	2.820
CAP, Distributor	2.367
CLAMP, Battery Top	2.335
CLAMP, Dist. Spark Advance Trans. Electric Control (Also See Group 4.075)	2.408
CLAMP, Distributor Housing	2.363
CLAMP, Generator Commutator or Rotor Slip Ring End Frame	2.298
CLIP, Chassis Wiring (segmented)	2.480
CLIP, Chassis Wiring Harness	2.559
CLIP, Concealed Headlamp Control Opening Cover	2.765
CLIP, Concealed Headlamp Motor	2.755
CLIP, Direction Signal Lamp	2.892
CLIP, Dist. Spark Advance Trans. Electric Control (Also See Group 4.075)	2.408
CLIP, Hazard Flasher	2.575
CLIP, Headlamp Dimmer	2.459
CLIP, Ignition Switch Warning	2.195
CLIP, Lighting Monitor	2.584
CLIP, Spark Plug Wire	2.251
CLIP, Stop Lamp	2.447
CLIP, Tail Lamp	2.688
CLUTCH PLATE, Concealed Headlamp Control Drive	2.760
COIL ASSY., Headlamp Washer	2.780
COIL ASSY., Starting Motor Field	2.049
COIL, Ignition	2.170
COIL UNIT, Generator Field	2.310
COLLAR, Generator Drive End	2.307
COLLAR, Starting Motor Thrust	2.063
CONDENSER, Distributor, with Bracket and Lead	2.393
CONDUCTOR, Lighting Monitor	2.580
CONNECTION BODY, Electrical	2.530
CONNECTOR, Direction Signal Lamp (See Group 9.748 Tell Tale Wind.)	2.895
CONNECTOR, Dist. Spark Advance Trans. Electric Control (Also See Group 4.075)	2.408
CONNECTOR, Distributor Terminal	2.400
CONNECTOR, Electrical	2.530
CONNECTOR, Horn Button and Blowing Ring	2.819
CONNECTOR, Lighting Monitor	2.584
CONTACT ASSY., Distributor (Consists of Breaker Arm and Support)	2.384
CONTACT, Horn Button and Blowing Ring	2.819
CONTACT, Starting Motor Solenoid	2.102
CONTACT UNIT, Direction Signal Lamp (See Group 9.748 Tell Tale Wind.)	2.895
CONTROL ASSY., Direction Signal Lamp (See Group 9.748 Tell Tale Wind.)	2.895
CONTROL, Distributor Vacuum	2.410
CONTROL UNIT, Dist. Spark Advance Trans. Electric Control (Also See Group 4.075)	2.408
CONVERSION UNIT, Direction Signal Lamp (Cancelling)	2.896
COVER, Concealed Headlamp Opening Cover	2.770
COVER, Direction Control Switch	2.906
COVER, Distributor Vacuum Control Clamp	2.414
COVER, Distributor	2.362
COVER, Distributor	2.368
COVER, Ignition Coil Mounting	2.183
COVER, Rear License Lamp	2.705
COVER, Rear License Lamp	2.706
COVER, Starting Motor	2.104
CUP, Direction Control Switch	2.906

CUP, Distributor Mainshaft	2.375
CUP, Generator Oil	2.301
CUP, Horn Button and Blowing Ring	2.819
CUSHION, Electrical Output (See 2.319 for Breaker)	2.500
CYLINDER ASSY., Ignition Switch	2.188

## D

DECAL, Headlamp (Rim or Door)	2.728
DIAL, Electrical Output (See Group 9.748 for Telltale Windows)	2.515
DIODE, Generator (Current Regulator Listed in Group 2.500)	2.319
DIODE, Ignition Pulse (Transistorized)	2.383
DISTRIBUTOR, Ignition	2.361
DRIVE ASSY., Starting Motor	2.086
DRIVE LINK, Concealed Headlamp Control Drive	2.760

## E

ELBOW, Distributor Lubricating	2.364
EMBLEM, Horn Blowing	2.820
ESCUTCHEON, Ignition Lock	2.198
ESCUTCHEON, Lighting Switch Rod	2.487
EXTENSION, Headlamp (Rim or Door)	2.728
EXTENSION, Ignition Pulse (Transistorized)	2.383

## F

FAN, Generator	2.274
FASTENER, Back-Up	2.698
FERRULE, Lighting Switch Rod	2.487
FILLER, Headlamp	2.726
FILTER ASSY., Concealed Headlamp Control Drive	2.760
FLAG, Hazard Flasher	2.575
FLARE ASSY., Hazard Flasher	2.575
FLASHER ASSY., Hazard Flasher	2.575
FLASHER, Direction Signal Lamp	2.892
FRAME ASSY., Tail and Stop Lamp	2.680
FRAME, Generator Commutator End, with Bushing	2.297
FRAME, Generator Drive End	2.305
FRAME, Starting Motor Commutator End, with Pins	2.067

## G

GASKET, Back-Up	2.697
GASKET, Distributor Housing	2.363
GASKET, Generator Drive End	2.307
GASKET, Hazard Flasher	2.575
GASKET, Horn Button and Blowing Ring	2.819
GASKET, Ignition Pulse (Transistorized)	2.383
GASKET, Parking Lamp Lens	2.590
GASKET, Rear License Lamp Lens	2.707
GASKET, Spark Plug Seat	2.271
GASKET, Tail Lamp	2.660
GASKET, Tail, Stop and Direction Signal Lamp Lens	2.684
GAUGE ASSY., Electrical Output (See Group 9.748 for Telltale Windows)	2.515
GEAR UNIT, Distributor	2.374
GENERATOR (less pulley)	2.275
GROMMET, Back-Up	2.697
GROMMET, Chassis Wiring (segmented)	2.480
GROMMET, Distributor Terminal	2.401
GROMMET, Distributor, with Weight Plate	2.372
GROMMET, Lighting Monitor	2.580
GROMMET, Rear License Lamp w/Wire	2.714

# ALPHABETICAL INDEX

GROMMET, Spark Plug Wire.....	2.251
GROMMET, Starting Motor Solenoid.....	2.102
GUIDE, Direction Control Switch.....	2.906

## H

HARNESS ASSY., Chassis Wiring (segmented).....	2.480
HARNESS ASSY., Dist. Spark Advance Trans. Electric Control (Also See Group 4.075).....	2.408
HARNESS ASSY., Electric Fuel Injection.....	2.225
HARNESS, Ignition Pulse (Transistorized).....	2.383
HARNESS, Starting, Ignition.....	2.525
HARNESS UNIT, Spark Plug.....	2.239
HEADLAMP ASSEMBLY, Complete with Sealed Beam.....	2.725
HEAT SINK ASSY., Generator (Current Regulator Listed in Group 2.500).....	2.319
HINGE, Concealed Headlamp Control Opening Cover.....	2.765
HOLDER, Generator Brush.....	2.291
HOLDER PKG., Electrical.....	2.530
HOLDER, Starting Motor Brush.....	2.052
HOLDER UNIT, Generator.....	2.313
HORN ASSEMBLY, Horn.....	2.810
HORN UNIT, Horn.....	2.810
HOSE, Concealed Headlamp Control Opening Cover.....	2.765
HOSE, Distributor Vacuum Control.....	2.420
HOUSING ASSY., Back-Up.....	2.697
HOUSING ASSY., Rear License Lamp.....	2.705
HOUSING ASSY., Tail and Stop Lamp.....	2.680
HOUSING, Direction Control Switch.....	2.906
HOUSING, Distributor.....	2.362
HOUSING, Fiber Optic Conductor.....	2.583
HOUSING, Headlamp.....	2.726
HOUSING, Parking Lamp.....	2.586
HOUSING, Starting Motor Drive, with Bushing.....	2.085

## I

INSERT, Lighting Monitor.....	2.584
INSERT, Parking Lamp.....	2.593
INSULATION, Starting Motor Field.....	2.049
INSULATOR, Electrical Output (See Group 9.748 for Telltale Windows).....	2.515
INSULATOR, Generator.....	2.313
INSULATOR, Horn Button and Blowing Ring.....	2.819
INSULATOR, Ignition Pulse (Transistorized).....	2.383

## K

KEY, Ignition-Door-Compartment-Trunk-Gas Tank Cap-Tire Locks.....	2.187
KNOB, Direction Signal Lamp.....	2.897
KNOB, Hazard Flasher.....	2.575

## L

LAMP ASSY., Back-Up.....	2.697
LAMP ASSY., Hazard Flasher.....	2.575
LAMP ASSY., Instrument Lamp.....	2.776
LAMP ASSY., Parking.....	2.585
LAMP ASSY., Rear License, Complete with Bulb.....	2.700
LAMP ASSY., Tail and Stop.....	2.679
LEAD ASSY., Dist. Spark Advance Trans. Electric Control (Also See Group 4.075).....	2.408
LEAD ASSY., Horn.....	2.859
LEAD, Distributor Terminal.....	2.400

LEAD, Generator.....	2.313
LEAD, Starting Motor Brush.....	2.055
LENS and ORNAMENT ASSY., Tail Lamp.....	2.682
LENS ASSY., Hazard Flasher.....	2.575
LENS, Back-Up.....	2.697
LENS, Fiber Optic Conductor.....	2.583
LENS, Parking Lamp.....	2.589
LENS, Rear License Lamp.....	2.709
LENS, Tail Lamp.....	2.682
LEVER, Direction Signal Lamp.....	2.897
LEVER, Starting Motor Drive Shaft.....	2.108
LINK, Concealed Headlamp Control Opening Cover.....	2.765
LOCK ASSY., Ignition Switch.....	2.188
LOCK, Distributor Housing.....	2.363
LOCK LEVER, Ignition Switch Warning.....	2.195
LOOM, Electrical.....	2.530
LUBRICATOR, Distributor Lubricating.....	2.364
LUG, Headlamp Lens and Sealed Beam Retaining.....	2.736

## M

MODULE, Ignition Pulse (Transistorized).....	2.383
MOLDING, Parking Lamp.....	2.586
MOTOR ASSY., Concealed Headlamp Control Drive.....	2.760
MOTOR ASSY., Starter.....	2.041
MOULDING, Concealed Headlamp Opening Cover.....	2.770
MOULDING, Headlamp (Rim or Door).....	2.728

## N

NIPPLE, Distributor Vacuum Control.....	2.420
NIPPLE, Spark Plug Wire.....	2.258
NOZZLE ASSY., Headlamp Washer.....	2.780
NUT ASSY., Lighting Switch Rod.....	2.487
NUT ASSY., Lighting Switch, with Knob.....	2.486
NUT, Back-Up.....	2.697
NUT, Concealed Headlamp Control Drive.....	2.760
NUT, Electrical Output (See 2.319 for Breaker).....	2.500
NUT, Generator (Current Regulator Listed in Group 2.500).....	2.319
NUT, Generator Armature.....	2.280
NUT, Generator Through.....	2.316
NUT, Hazard Flasher.....	2.575
NUT, Headlamp (Rim or Door).....	2.728
NUT, Headlamp to Fender.....	2.722
NUT, Headlamp Beam Adjusting.....	2.737
NUT, Headlamp Lens and Sealed Beam Retaining.....	2.736
NUT, Headlamp Moulding.....	2.729
NUT, Horn.....	2.812
NUT, Ignition Coil Mounting.....	2.183
NUT, Ignition Lock.....	2.198
NUT, Parking Lamp Attaching.....	2.587
NUT, Parking Lamp Door or Lens.....	2.594
NUT, Rear License Lamp.....	2.708
NUT, Starting Motor.....	2.104
NUT, Stop Lamp.....	2.447
NUT, Tail Lamp.....	2.688

## O

OCTANE ADJ. UNIT, Dist. Spark Advance Trans. Electric Control (Also See Group 4.075).....	2.408
ORNAMENT, Back-Up.....	2.697
ORNAMENT, Parking Lamp.....	2.586
ORNAMENT, Tail and Stop Lamp.....	2.680

# ALPHABETICAL INDEX

## P

PAD, Back-Up .....	2.697
PAWL, Direction Signal Lamp (See Group 9.748 Tell Tale Wind.) .....	2.895
PIN, Concealed Headlamp Control Drive .....	2.760
PIN, Concealed Headlamp Control Opening Cover .....	2.765
PIN, Distributor Housing .....	2.363
PIN, Starting Motor Brush .....	2.052
PIN, Starting Motor Commutator End, with Pins .....	2.067
PIPE, Distributor Housing .....	2.363
PIPE, Distributor Vacuum Control .....	2.420
PIVOT, Horn Button and Blowing Ring .....	2.819
PLATE ASSY., Concealed Headlamp Control Opening Cover .....	2.765
PLATE ASSY., Tail and Stop Lamp .....	2.681
PLATE, Center Bearing .....	2.082
PLATE, Direction Signal Lamp (See Group 9.748 Tell Tale Wind.) .....	2.895
PLATE, Distributor Breaker .....	2.385
PLATE, Distributor Weight and Cam, with Stop .....	2.390
PLATE, Generator Drive End .....	2.307
PLATE, Headlamp .....	2.726
PLATE, Horn Button and Blowing Ring .....	2.819
PLATE, Ignition Coil Mounting .....	2.183
PLATE, Ignition Switch Warning .....	2.195
PLATE, Lighting Switch Rod .....	2.487
PLUG, Battery .....	2.345
PLUG, Generator Commutator or Rotor Slip Ring End Frame .....	2.298
PLUG, Generator Oil .....	2.301
PLUG, Spark .....	2.270
PLUG, Tail Lamp .....	2.688
PLUNGER, Starting Motor Drive Shaft .....	2.113
POINT UNIT, Distributor (Consists of Breaker Arm and Support) .....	2.384
POLE PIECE, Distributor, with Weight Plate .....	2.372
POLE PIECE, Starting Motor (Internal) .....	2.077
PROTECTOR, Spark Plug Wire .....	2.258
PULLEY, Generator .....	2.274

## R

RACK, Ignition Switch Warning .....	2.195
REFLEX ASSY., Back-Up .....	2.697
REGULATOR, Electrical Output (See 2.319 for Breaker) .....	2.500
RELAY ASSY., Concealed Headlamp Motor .....	2.755
RELAY ASSY., Dist. Spark Advance Trans. Electric Control (Also See Group 4.075) .....	2.408
RELAY, Ignition Switch Warning .....	2.195
RELAY, Matched Horn .....	2.815
RESISTOR, Electrical Output (See Group 9.748 for Telltale Windows) .....	2.515
RESISTOR, Generator (Current Regulator Listed in Group 2.500) .....	2.319
RESISTOR, Ignition Coil .....	2.173
RESISTOR, Ignition Pulse (Transistorized) .....	2.383
RETAINER, Back-Up .....	2.697
RETAINER, Battery Top .....	2.335
RETAINER, Chassis Wiring Harness .....	2.559
RETAINER, Concealed Headlamp Control Opening Cover .....	2.765
RETAINER, Distributor Breaker .....	2.385
RETAINER, Distributor Contact Point Support Clamp .....	2.387
RETAINER, Distributor Housing .....	2.363
RETAINER, Distributor Lubricating .....	2.364
RETAINER, Fiber Optic Conductor .....	2.583
RETAINER, Generator Drive End .....	2.307
RETAINER, Hazard Flasher .....	2.575
RETAINER, Headlamp Moulding .....	2.729
RETAINER, Horn Blowing .....	2.820
RETAINER, Ignition Pulse (Transistorized) .....	2.383
RETAINER, Ignition Switch Warning .....	2.195
RETAINER, Parking Lamp Door or Lens .....	2.594
RETAINER, Spark Plug Wire .....	2.251

RETAINER, Tail and Stop Lamp .....	2.681
RETAINER, Tail Lamp .....	2.688
RING ASSY., Generator .....	2.279
RING, Direction Signal Lamp (See Group 9.748 Tell Tale Wind.) .....	2.895
RING, Headlamp .....	2.726
RING, Horn Blowing .....	2.830
RING, Horn Button and Blowing Ring .....	2.819
RING, Ignition Switch .....	2.188
RING, Sealed Beam Retaining .....	2.731
RING, Starting Motor Thrust .....	2.063
RING, Tail and Stop Lamp .....	2.680
ROD ASSY., Ignition Switch Warning .....	2.195
ROD, Back-Up .....	2.698
ROD, Lighting Switch, with Knob .....	2.486
ROLLER, Direction Signal Lamp (Detent) .....	2.910
ROTOR ASSY., Generator .....	2.279
ROTOR, Distributor, with Weight Plate .....	2.372
ROTOR, Distributor .....	2.382

## S

SCREW ASSY., Battery .....	2.333
SCREW, Automatic Headlamp Control .....	2.461
SCREW, Back-Up .....	2.697
SCREW, Back-Up .....	2.698
SCREW, Battery Cable .....	2.343
SCREW, Chassis Wiring Harness .....	2.559
SCREW, Concealed Headlamp Control Opening Cover .....	2.765
SCREW, Concealed Headlamp Motor .....	2.755
SCREW, Direction Control Switch .....	2.906
SCREW, Direction Signal Lamp (See Group 9.748 Tell Tale Wind.) .....	2.895
SCREW, Distributor Contact Point Support Clamp .....	2.387
SCREW, Distributor Vacuum Control Clamp .....	2.414
SCREW, Distributor, with Bracket and Lead .....	2.393
SCREW, Distributor .....	2.362
SCREW, Distributor .....	2.368
SCREW, Distributor .....	2.382
SCREW, Electrical Output (See 2.319 for Breaker) .....	2.500
SCREW, Generator (Current Regulator Listed in Group 2.500) .....	2.319
SCREW, Generator Brush .....	2.291
SCREW, Generator Drive End .....	2.307
SCREW, Generator .....	2.313
SCREW, Hazard Flasher .....	2.575
SCREW, Headlamp Beam Adjusting .....	2.737
SCREW, Headlamp Lens and Sealed Beam Retaining .....	2.736
SCREW, Headlamp Moulding .....	2.729
SCREW, Ignition Coil Mounting .....	2.183
SCREW, Ignition Pulse (Transistorized) .....	2.383
SCREW, Ignition Switch .....	2.188
SCREW, Parking Lamp Attaching .....	2.587
SCREW, Parking Lamp Door or Lens .....	2.594
SCREW, Parking Lamp .....	2.589
SCREW, Rear License Lamp .....	2.708
SCREW, Starting Motor (Internal) .....	2.077
SCREW, Starting Motor to Engine Attaching .....	2.042
SCREW, Starting Motor Brush .....	2.052
SCREW, Tail and Stop Lamp .....	2.680
SCREW, Tail Lamp .....	2.688
SEAL, Distributor Mainshaft .....	2.375
SEALED BEAM, Headlamp .....	2.727
SEAL, Generator Commutator or Rotor Slip Ring End Frame .....	2.298
SEAL, Ignition Coil Mounting .....	2.183
SEAL, Lighting Monitor .....	2.584
SEAL, Parking Lamp .....	2.599
SEAL, Tail Lamp .....	2.660
SECTOR, Ignition Switch Warning .....	2.195
SHAFT ASSY., Distributor Mainshaft .....	2.375
SHAFT, Concealed Headlamp Control Opening Cover .....	2.765
SHAFT, Distributor, with Weight Plate .....	2.372
SHAFT, Ignition Switch Warning .....	2.195
SHAFT, Starting Motor Drive Shaft .....	2.108
SHIELD ASSY., Chassis Wiring Harness .....	2.559

# ALPHABETICAL INDEX

SHIELD, Back-Up.....	2.698	SWITCH ASSY., Distributor Vacuum .....	2.410
SHIELD, Battery Cable.....	2.343	SWITCH ASSY., Hazard Flasher.....	2.575
SHIELD, Concealed Headlamp Control Drive.....	2.760	SWITCH ASSY., Horn Button and Blowing	
SHIELD, Direction Control Switch.....	2.906	Ring .....	2.819
SHIELD, Distributor.....	2.362	SWITCH ASSY., Ignition Switch Warning.....	2.195
SHIELD, Parking Lamp .....	2.593	SWITCH ASSY., Ignition Switch.....	2.188
SHIELD, Spark Plug Wire .....	2.251	SWITCH ASSY., Starting Motor (on Motor)....	2.100
SHIELD, Starting Motor.....	2.104	SWITCH ASSY., Stop Lamp.....	2.447
SHIELD UNIT, Distributor, with Bracket and		SWITCH, Back-Up.....	2.698
Lead.....	2.393	SWITCH, Headlamp Dimmer .....	2.459
SHIM, Distributor Gear .....	2.379	SWITCH, Lighting .....	2.485
SHIM, Headlamp Control.....	2.775	SWITCH UNIT, Horn .....	2.810
SHROUD, Generator Commutator or Rotor			
Slip Ring End Frame .....	2.298		
SLEEVE, Distributor Breaker.....	2.385	<b>T</b>	
SLEEVE, Ignition Switch .....	2.188		
SLINGER, Generator Drive End .....	2.307		
SOCKET ASSY., Hazard Flasher .....	2.575	TANK ASSY., Concealed Headlamp Control	
SOCKET ASSY., Lighting Monitor.....	2.584	Drive .....	2.760
SOCKET ASSY., Parking Lamp .....	2.596	TEE, Concealed Headlamp Control Drive.....	2.760
SOCKET ASSY., Rear License Lamp w/Wire..	2.714	TERMINAL, Electrical .....	2.530
SOCKET, Back-Up .....	2.697	TERMINAL, Generator.....	2.313
SOCKET, Instrument Lamp.....	2.776	TERMINAL UNIT, Generator (Current	
SOCKET, Tail and Stop Lamp .....	2.694	Regulator Listed in Group 2.500) .....	2.319
SOLENOID ASSY., Dist. Spark Advance		TRANSISTOR, Ignition Pulse (Transistorized)	2.383
Trans. Electric Control (Also See Group		TRANSISTOR, Voltage Regulator Output .....	2.505
4.075) .....	2.408	TRAY ASSY., Battery.....	2.333
SPACER, Concealed Headlamp Control Drive	2.760	TUBING, Electrical .....	2.530
SPACER, Concealed Headlamp Control		TUNE .....	2.270
Opening Cover .....	2.765		
SPACER, Direction Signal Lamp (See Group			
9.748 Tell Tale Wind.).....	2.895	<b>U</b>	
SPACER, Generator (see 2.317 for brace).....	2.277		
SPACER, Generator (Bracket listed in Group		UP KITS.....	2.270
2.277) .....	2.317		
SPACER, Generator.....	2.274		
SPACER, Lighting Switch Rod .....	2.487	<b>V</b>	
SPACER, Parking Lamp.....	2.586		
SPACER, Starting Motor to Engine Attaching	2.042		
SPRING, Concealed Headlamp Control		VALVE ASSY., Concealed Headlamp Control	
Opening Cover .....	2.765	Drive .....	2.760
SPRING, Direction Control Switch.....	2.906	VALVE ASSY., Concealed Headlamp Motor...	2.755
SPRING, Direction Signal Lamp (Cancelling)..	2.896	VALVE, Headlamp Washer.....	2.780
SPRING, Direction Signal Lamp (Detent) .....	2.910		
SPRING, Distributor Breaker.....	2.385	<b>W</b>	
SPRING, Distributor Contact Point Support			
Clamp.....	2.387	WASHER, Back-Up .....	2.698
SPRING, Distributor Weight.....	2.389	WASHER, Battery.....	2.345
SPRING, Generator (Current Regulator Listed		WASHER, Concealed Headlamp Control	
in Group 2.500) .....	2.319	Drive .....	2.760
SPRING, Headlamp Beam Adjusting .....	2.737	WASHER, Distributor Breaker.....	2.385
SPRING, Headlamp Control.....	2.775	WASHER, Distributor Gear.....	2.379
SPRING, Horn Button and Blowing Ring .....	2.819	WASHER, Distributor Lubricating .....	2.364
SPRING, Ignition Switch Warning .....	2.195	WASHER, Generator (see 2.317 for brace)....	2.277
SPRING, Starting Motor Brush.....	2.053	WASHER, Generator (Current Regulator	
SPRING, Starting Motor Drive Shaft .....	2.108	Listed in Group 2.500) .....	2.319
SPROCKET, Distributor.....	2.374	WASHER, Generator Armature .....	2.280
Starting Motor .....	2.051	WASHER, Generator Brush .....	2.291
STATOR ASSY., Generator Field .....	2.310	WASHER, Generator Drive End.....	2.307
STRAP ASSY., Ignition Switch .....	2.188	WASHER, Generator.....	2.313
STRAP, Chassis Wiring Harness .....	2.559	WASHER, Horn Button and Blowing Ring .....	2.819
STRAP, Lighting.....	2.485	WASHER, Horn .....	2.812
STRIKER, Stop Lamp.....	2.447	WASHER, Ignition Switch Warning.....	2.195
STUD, Distributor Housing .....	2.363	WASHER, Ignition Switch.....	2.188
STUD, Generator (see 2.317 for brace).....	2.277	WASHER, Starting Motor Solenoid .....	2.102
STUD, Generator .....	2.313	WASHER, Starting Motor Thrust.....	2.063
STUD, Starting Motor Drive Shaft.....	2.108	WEIGHT, Distributor .....	2.388
STUD, Starting Motor Solenoid .....	2.102	WICK, Starting Motor Commutator End, with	
SUB BODY, Headlamp .....	2.726	Pins.....	2.067
SUPPORT ASSY., Direction Control Switch....	2.906	WIRE ASM., Horn.....	2.859
SUPPORT, Battery.....	2.333	WIRE ASSY., Back-Up .....	2.697
SUPPORT, Concealed Headlamp Control		WIRE ASSY., Hazard Flasher.....	2.575
Opening Cover .....	2.765	WIRE ASSY., Ignition Coil .....	2.171
SUPPORT, Generator (see 2.317 for brace)....	2.277	WIRE ASSY., Parking Lamp .....	2.596
SUPPORT, Horn Blowing .....	2.820	WIRE ASSY., Rear License Lamp w/Wire .....	2.714
SUPPORT, Parking Lamp Attaching.....	2.587	WIRE ASSY., Spark Plug, with Terminals	
SUPPORT, Rear License Lamp .....	2.705	(Single Wire Replacement).....	2.240
SUPPORT, Spark Plug Wire.....	2.251		
SUPPORT UNIT, Starting Motor Brush .....	2.052		
SWITCH ASSY., Concealed Headlamp Motor	2.755		
SWITCH ASSY., Direction Signal Lamp (See			
Group 9.748 Tell Tale Wind.) .....	2.895		
SWITCH ASSY., Dist. Spark Advance Trans.			
Electric Control (Also See Group 4.075) ..	2.408		

## ALPHABETICAL INDEX

---

WIRE ASSY., Starting, Ignition .....	2.525
WIRE, Chassis Wiring (segmented) .....	2.480
WIRE, Electrical .....	2.530
WIRE UNIT, Spark Plug .....	2.239
WRENCH, Spark Plug .....	2.273

### Y

YOKE ASSY., Direction Signal Lamp (Detent)	2.910
--	-------



## CHASSIS—ELECTRICAL SYSTEM

### 2.041 MOTOR ASSY., Starter

65-67	Pass., Chevy, Chevelle (327),				
67	Camaro (exc. 350),				
68	Pass. (327) (exc. H.D. clutch,				
	T.H.),				
68	Chevy, Chevelle (327),				
69	Chevy (350) (exc. T.H. 350, reg.				
	fuel),				
69	Chevy, Chevelle, Camaro (4 BC				
	w/reg. fuel) (350),				
69	Chevelle, Camaro w/P.G. (350)				
	(exc. reg. fuel),				
69	Chevelle, Camaro w/T.H. 350				
	(350) (1st design) (exc. reg.				
	fuel),				
69	Pass. w/A.T. (350) (exc. T.H.	1108361	1	105.50	w/switch (stamped 1107320-1108361) . . .
	400) . . . . .				
62-64	Chevy, Chevelle,				
65-67	Chevy, Chevelle, Camaro (exc.				
	327, 396),				
65-66	Pass. (230, 283) (exc. H.D.				
	Clutch),				
66-69	Pass. (6 cyl.) (exc. Taxi),				
66-67	Pass. (250, 283) (exc. A.I.R.				
	C.A.C., H.D. Clutch),				
68-69	Pass. (307, 327) (exc. T.H. 400,				
	H.D. Clutch),				
68	Chevy (exc. 250, 327, 350),				
68	Chevelle (exc. H.D. Clutch),				
68-69	Camaro (exc. 350, 396),				
68-69	Chevy (4 cyl.) w/torque drive,				
70-72	All (4 cyl., 6 cyl.) (exc. Taxi,				
	Police),				
70-73	All (307),				
73-74	All (6 cyl.),				
75	Nova (262),				
75	All (6 cyl.) (exc. A.T.) . . . . .	1108366	1	101.25	w/switch (stamped 1108365-66-67-8512) .
65-68	Pass. w/H.D. Clutch (6 cyl.),				
68-69	Police (6 cyl.) (exc. P.G.),				
70-71	Taxi, Police (6 cyl.) . . . . .	1108425	1	121.25	w/switch (stamped 1108425) . . . . .
65-68	Pass. (396, 427),				
65	Pass. (409),				
66-68	Chevy, Chevelle, Camaro (350,				
	396),				
67-68	Pass. w/T.H. (307, 327),				
68	Chevelle w/H.D. clutch,				
68-69	Pass. w/T.H. 400,				
69	Chevelle, Camaro (350) (exc.				
	reg. fuel P.G., T.H. 350),				
69	Pass. w/T.H. 350 (350) (1st				
	design) (exc. reg. fuel),				
69	Pass. (4BC w/reg. fuel) (350),				
69	Pass. w/P.G. (350) (exc. reg.				
	fuel),				
69	All (396, 427),				
70-72	Pass. (exc. A.T.),				
70-75	Nova, Chevelle, Camaro (8 cyl.)	1108788	1	124.00	w/switch (repl. 1108400) . . . . .
	(exc. 307, 262 A.T.) . . . . .				
69	All w/H.D. batt. (396, 427) . . . . .	1108350	1	135.75	w/switch (stamped 1108350) . . . . .
69	Chevy w/T.H. 350 (350) (exc.				
	reg. fuel),				
69	Chevelle, Camaro w/T.H. 350				
	(2nd design) (exc. reg. fuel),				
69	Pass. w/T.H. 350 (350) (2nd	1108420	1	96.75	w/switch(stamped 1108420) (w/12 <sup>3</sup> / <sub>4</sub> " ring
	design) (exc. reg. fuel . . . . .				gear) . . . . .
70-75	All w/A.T. (8 cyl.) (exc. 262,				
	307),				
75	All w/A.T. (6 cyl.) . . . . .	1109025	1	120.75	w/switch (stamped 1108427-28-29-30) . . .
71-75	Vega, Monza (140) . . . . .	1108196	1	97.50	w/switch . . . . .
75	Vega (122) . . . . .	1108773	1	160.50	
75	Monza (262) . . . . .	1108366	1	101.25	

### 2.042 BOLT— BRACE— SPACER— SCREW, Starting Motor to Engine Attaching

62-70	All,
71	Pass. w/2BC (250) (exc. A.T.),

**CHASSIS—ELECTRICAL SYSTEM**

**2.042 BOLT— BRACE— SPACER— SCREW, Starting Motor to Engine Attaching (Con't)**

72-75	Chevelle, Nova, Camaro (8 cyl.) (exc. 307, A.T.)	3733289	2	.40	attach. ( $\frac{3}{8}$ "— 16 x $3\frac{5}{8}$ ")
62-69	Chevy, Chevelle, Camaro (exc. 396),				
65-70	Pass. (exc. 396, 409, 427 Taxi, H.D. Clutch, T.H.),				
65-67	Biscayne (6 cyl.) (exc. Taxi, P.G.),				
71	Pass. (exc. Taxi, Police),				
72-73	All (307),				
72	Pass. (6 cyl.),				
73-75	All	1366042	1	.28	BOLT, at outboard hole ( $\frac{3}{8}$ "— 16 x $1\frac{27}{32}$ ")
65-70	Pass. (exc. 396, 409, 427, Taxi, H.D. Clutch, T.H.),				
71-72	All w/A.T.,				
73-75	All	1366043	1	.64	BOLT, at inboard hole ( $\frac{3}{8}$ "— 16 x $4\frac{27}{32}$ ")
62-68	Chevy, Chevelle, Camaro (6 cyl.),				
65-68	Pass. (6 cyl.) (exc. Taxi, H.D. Clutch),				
69-71	All (6 cyl.) (exc. Taxi, Police),				
71-74	All (6 cyl.),				
75	All (6 cyl.) (exc. A.T.)	3941029	1	1.10	BRACE
65-68	Pass. w/H.D. Clutch (6 cyl.),				
68-69	Police (6 cyl.),				
71	Taxi, Police (exc. A.T.)	3866634	1	1.35	BRACE
65-68	Pass. (396, 427),				
66-69	Chevelle, Camaro, Chevy (396)	3864972	1	.28	BRACE
66-68	Pass. w/H.D. Clutch,				
66-68	Chevelle, Camaro w/H.D. Clutch (8 cyl.),				
67-69	All (350),				
69	Pass. (T.H. 400 w/reg. fuel) (327, 350)	3932398	1	1.20	BRACE
70	Nova, Chevelle, Camaro (396, 400 w/4BC),				
70	All (454),				
71	Chevelle, Camaro (400),				
71	Pass., Chevelle (454),				
72-75	All (402, 454)	3965588	1	.22	BRACE
70	Nova, Chevelle, Camaro (350) (exc. Sp. H/Per.),				
70	Monte Carlo (400),				
70	Pass. (8 cyl.) (exc. 454),				
70	Camaro (exc. 350, 396 Sp. H/Per.),				
71	All (350),				
72-73	All (350, 400)	3965589	1	.58	BRACE
71-75	Vega, Monza (140)	3980269	1	1.10	BRACE, starting mtr. attach.
64-69	Chevy, Chevelle, Camaro (exc. 350, 396),				
65-69	Pass. (283, 307, 327, 350),				
71-72	All (307),				
73	All (307),				
75	All (262)	354353	1	1.05	BRACE
62-63	Chevy	3819824	1	.42	SPACER
70-75	All (8 cyl.)	3973388	1	.11	SCREW, w/lock washer str. mtr. brkt.

**2.043 ARMATURE, Starting Motor**

62-67	Chevy, Chevelle, Camaro (exc. 396)		1		w/1107237-43-47-59-60-7320,
65	Pass. (exc. 396, 409)		1		(w/1107660-7664-7694-7687-7688
66-67	Pass. (exc. 396, 427, T.H., H.D. Clutch)	1955937	1	27.20	7273-7274-7315-7320-7336-7353-7369-7370-7374-7383-7497-7889-7890-7891-7892-7895 (Exchange Item— Note 1)
65-69	All (396, 427),				
66-68	Chevy, Chevelle, Camaro (350),				
70-75	All (exc. Vega, Monza)	1965724	1	29.70	w/1107365-8385-8400-18 (Exchange Item— Note 1)
66-68	Pass. w/H.D. Clutch,				
67-69	Pass. (307, 350, 396, 427),				
68	Chevy, Chevelle, Camaro (exc. 350, 396),				
69	Chevy, Chevelle, Camaro (8 cyl.) (exc. 396),				

**CHASSIS—ELECTRICAL SYSTEM**

**2.043 ARMATURE, Starting Motor (Con't)**

70-75	All (exc. Vega, Monza) . . . . .	1966228	1	27.45	w/1107372-8338-8350-8357 thru 8382 (Exchange Item— Note 1) . . . . .
70-75	Vega (exc. 122) . . . . .	1971568	1	27.50	w/1108425-27-28-8512-8745-64-78-90 (Exchange Item— Note 1) . . . . .
70-75	All (exc. Vega, Monza) . . . . .	1970548	1	28.35	w/1108429-30-8775-76 (Exchange Item— Note 1) . . . . .
75	Vega (122) . . . . .	830842	1	28.10	(Exchange Item— Note 1) . . . . .

*NOTE 1 List price shown does not include exchange charge. Refer to Dealer Parts Price Schedule for exchange price.*

**2.049 COIL ASSY.— INSULATION, Starting Motor Field**

62-64	Chevy, Chevelle,				
65-69	Chevy, Chevelle (exc. 327, 396),				
65-69	Pass. (230, 250, 283, 307) (exc. H.D. Clutch),				
68-69	Camaro (exc. 350, 396),				
70-75	All (exc. Vega, Monza) . . . . .	1967968	1	10.10	consists of 4 coils (w/1107237-43-47- 7259-7260-7273-7399-7400-7496-7497- 7652-7660-7664-7888-89-8365-66-67- 8428-8512-45) . . . . .
65-69	All (327, 396, 427),				
65	Pass. w/H.D. Clutch (6 cyl.),				
66-69	Pass. (6 cyl.),				
70-74	All (exc. Vega, Monza),				
75	All (262) . . . . .	1877291	1	10.70	consists of 3 coils (w/1107242-7274-7315- 7320-7336-7353-7369-7372-7374-7388- 7687-7688-8338-8361-8425-27-30) . . . . .
65-69	All (327, 396, 427),				
65	Pass. w/H.D. clutch (6 cyl.),				
66-69	Pass. (6 cyl.),				
70-75	All . . . . .	1935131	1	3.71	shunt (one coil) (w/1107687-7688-7233- 7369-7372-7374-7388-8338-8425-27-30)
65	Pass. (409) . . . . .	1952304	1	7.30	shunt (w/1107286-7289-7342) (1 coil) . . . . .
65	Pass. (409) . . . . .	1949332	1	12.60	w/1107286-7289-7342 (3 coils) . . . . .
65-69	Pass. (396, 427),				
66-69	Chevelle, Camaro, Chevy (350, 396),				
70-75	All (exc. Vega, Monza) . . . . .	1877306	1	12.85	field (4 coils) (w/1117352-7365-832-8400- 8418-8420-8430-8552) . . . . .
69	Pass. w/H.D. Starter (396, 427) .	1957375	1	21.75	w/1107369-7370-7375-7383-8350-63- 8372 . . . . .
71-74	Vega . . . . .	1851420	1	8.70	w/1108195-96-8523 . . . . .
75	All (exc. Vega, Monza) . . . . .	1891487	1	11.50	field w/1108773 . . . . .
75	All . . . . .	1891314	1	11.70	field w/1108774-8365-8770-8778 . . . . .
75	Vega, Monza (140) . . . . .	1891316	1	10.45	w/1108771-72 . . . . .
75	All . . . . .	1927853	1	.10	INSULATION, str. mtr. field coil . . . . .

**2.051 BRUSH— Starting Motor**

62-75	All . . . . .	1906945	4	.36	(stamped 945) ( <sup>13</sup> / <sub>64</sub> " hole) . . . . .
65-72	Taxi, Police (6 cyl.) (exc. A.T.) . .	1946400	4	.64	(stamped 400) ( <sup>11</sup> / <sub>64</sub> " hole) . . . . .

**2.052 HOLDER— PIN— SCREW— SUPPORT UNIT, Starting Motor Brush**

62-75	All . . . . .	1926618	2	.67	(insulated) . . . . .
62-75	All . . . . .	1940477	2	1.01	(ground) . . . . .
66-69	Pass. w/H.D. Clutch (6 cyl.),				
66-69	Chevelle, Camaro, Chevy (350, 396),				
67-69	Pass. (396, 427),				
70-75	All (exc. Vega, Monza) . . . . .	1938058	1	.09	PIN, holder (w/1107388-8338-8425-27-28- 29-30) . . . . .
67-69	Pass. (6 cyl.) (exc. Taxi),				
67-68	Pass. (250, 283, 307) (exc. A.I.R., C.A.C., H.D. Clutch),				
67-69	Chevy, Camaro, Chevelle (exc. 327, 396),				
69	Pass. (327),				
70-75	All . . . . .	1966923	2	.09	PIN, support (w/1108365-66-67-8400- 8418-8430-8512) . . . . .
62-69	All (12 volt) . . . . .	448015	4	.06	SCREW (tapping— <sup>3</sup> / <sub>16</sub> "— 32 x <sup>5</sup> / <sub>8</sub> ")— (8.977) . . . . .
62-75	All . . . . .	1928015	2	1.09	SUPPORT UNIT, holder (Note 1) . . . . .

*NOTE 1 Consists of 1 ea. support, lead, pin and 2 ea. screws, nuts, washers.*

**2.053 SPRING, Starting Motor Brush**

62-75	All . . . . .	1926622	2	.25	(hair pin type— <sup>1</sup> / <sub>2</sub> " wide) . . . . .
-------	---------------	---------	---	-----	---

**CHASSIS—ELECTRICAL SYSTEM**

<b>2.055 LEAD, Starting Motor Brush</b>					
62-75	All	1960864	2	.21	ground (2 terminals— 2 <sup>3</sup> / <sub>8</sub> " long)
<b>2.063 COLLAR— RING— WASHER, Starting Motor Thrust</b>					
62-75	All	1927849	1	.61	(1 <sup>5</sup> / <sub>32</sub> " I.D. x 1 <sup>1</sup> / <sub>16</sub> " O.D. x 3 <sup>3</sup> / <sub>16</sub> " wide)
62-75	All	1927848	1	.07	RING, pinion stop retainer (lock type— 7 <sup>7</sup> / <sub>16</sub> " I.D.)
62-75	All	818265	1	.08	WASHER, comm. end (leather— 9 <sup>9</sup> / <sub>16</sub> " I.D. x 1 <sup>5</sup> / <sub>16</sub> " O.D.)
62-75	All	1927850	1	.13	WASHER, drive end (1 <sup>5</sup> / <sub>32</sub> " I.D. x 1 <sup>1</sup> / <sub>16</sub> " O.D.) (7 <sup>7</sup> / <sub>64</sub> " thk.)
<b>2.067 FRAME— WICK— PIN, Starting Motor Commutator End, with Pins</b>					
71-74	Vega	1946745	1	3.68	
62-74	All (exc. Vega, Monza),				
75	All	1928966	1	3.67	w/bushing (4 <sup>1</sup> / <sub>4</sub> " O.D.)
65-69	Pass.	1947350	A.R.	.15	WICK, oil commutator end (felt-7 <sup>7</sup> / <sub>32</sub> " dia. x 3 <sup>1</sup> / <sub>2</sub> " lo)— (2.364)
75	Vega (140)	809062	1	.07	PIN, comm. end dowel
<b>2.077 SCREW— BOLT— BRACE— POLE PIECE, Starting Motor (Internal)</b>					
62-75	All (exc. Vega, Monza)	1949653	1	.03	field lead (No.10-32 x 3 <sup>3</sup> / <sub>8</sub> ")
62-75	All	1970469	A.R.	.11	pole shoe (3 <sup>3</sup> / <sub>8</sub> " x 24 x 1 <sup>1</sup> / <sub>16</sub> " O.L.) (Cad.)
62-70	All (12 volt),				
71	All (307),				
71	All (350, 400, 454) (exc. A.T.),				
72	Taxi, Police (6 cyl.) (exc. A.T.),				
72-75	All (8 cyl.) (exc. Monza)	1941111	2	.61	BOLT, through (1 <sup>1</sup> / <sub>4</sub> "— 20 x 5 <sup>7</sup> / <sub>8</sub> " w/ <sup>5</sup> / <sub>8</sub> " ext.)
66-69	Pass. (6 cyl.),				
66-69	Pass. (396, 427),				
66-70	Chevelle, Camaro (350, 396),				
71	Taxi, Police (exc. A.T.),				
71	All (350, 400, 454) w/A.T.,				
72-75	All (4 cyl., 6 cyl.) (exc. Taxi, Police)	1939970	1	.43	BOLT, through
75	Vega (122)	343351	1	7.35	BRACE, starter mtr.
75	All (6 cyl.),				
75	Monza (262)	1931129	4	1.31	POLE PIECE, str. mtr. shoe
75	All (8 cyl.) (exc. Monza)	810601	4	1.44	POLE PIECE, str. mtr. shoe
75	Vega, Monza (140)	1954947	4	1.75	POLE PIECE, str. mtr. shoe
<b>2.082 BUSHING— PLATE, Center Bearing</b>					
75	Vega (122)	1957017	1	.44	center bearing plate
75	Vega (122)	1891488	1	5.55	PLATE, center bearing
<b>2.083 BUSHING, Starting Motor End</b>					
62-75	All	1923907	1	.32	drive housing (1 <sup>5</sup> / <sub>32</sub> " I.D. x 3 <sup>3</sup> / <sub>64</sub> " O.D. 2 <sup>3</sup> / <sub>32</sub> " long)
70-75	All	1932190	1	.26	drive end w/1108425-27-28-30-8512-8195
<b>2.085 HOUSING, Starting Motor Drive, with Bushing</b>					
62-68	Chevy, Camaro, Chevelle (exc. 350, 396),				
65-69	Pass. (exc. 396, 409, 427, H.D. clutch),				
69	All w/T.H. 350 (350) (exc. reg. fuel),				
70-75	All (exc. Vega, Monza)	1968122	1	12.20	w/1107237-7242-7247-7259-7260-7320-7352-7399-7496-8351-61-65-66-67-8420-8512
65-67	Pass. w/H.D. clutch,				
65-69	Taxi, Police (6 cyl.) (exc. P.G.),				
70-72	All (exc. Vega, Monza)	801191	1	24.45	w/1107353-7372-8425
65-69	Pass. (396, 409, 427),				
66-69	Chevelle, Camaro, Chevy (350, 396) (exc. H.D. 4-Spd.),				
70-75	All (exc. Vega, Monza)	1969309	1	20.00	w/1107289-7342-7365-7385-7687-7694-8338-8382-8400-8418
70-75	All (exc. Vega, Monza)	801188	1	12.15	w/1108427-28-29-30-8513-8745-76
71-75	Vega, Monza (140)	801783	1	15.15	
75	Monza (262)	1876881	1	11.70	(w/1103366-8790)
<b>2.086 DRIVE ASSY., Starting Motor</b>					
62-75	All	1954842		13.10	(Exchange Item— Note 1)

*NOTE 1 List price shown does not include exchange charge. Refer to Dealer Parts Price Schedule for exchange price.*

**CHASSIS—ELECTRICAL SYSTEM**

**2.100 SWITCH ASSY., Starting Motor (on Motor)**

65-75	All	1114356	1	15.75	solenoid (stamped 1107365-7388-7497-7712-8338-8400-1114356-4339-1108195-96)
74	Vega	1114388	1	32.30	solenoid (w/1108523)
75	All	1114395	1	15.35	solenoid (w/1108366-8429-8774-78-90)
75	Vega (122)	1114460	1	38.75	solenoid (w/1108373)

**2.102 CONTACT— GROMMET— STUD— WASHER, Starting Motor Solenoid**

62-75	All (exc. Vega, Monza)	1956226	1	1.33	w/push rod
62-75	All	1935645	1	.11	switch
65	Pass. (327),				
65-69	Pass. w/H.D. clutch,				
66-69	All (327),				
70-75	All	1966391	1	.12	<b>GROMMET</b> , field frame ( $7/16$ " I.D. x $3/4$ " O.D. w/slot and ident. recesses) (w/1107233-7242-7274-7315-7320-7336-7687-7688-8338-65-66-67-8425-27-28-8790)
65-69	All (396, 409, 427),				
66-68	Chevelle, Camaro (350, 396),				
70-75	All (exc. Vega, Monza)	1949327	1	.18	<b>GROMMET</b> , field frame (w/1108400-18-25)
70-75	All (exc. Vega, Monza)	1846097	1	.17	<b>GROMMET</b> , field frame (w/1108430)
71-74	Vega, Monza (140)	1945827	1	.09	<b>GROMMET</b> (w/1108195-96-8771-72)
62-64	All (exc. Pass.)	1927344	1	.33	<b>STUD</b> , switch terminal (copper— $3/8$ "— 16 x $1/16$ " )
62-72	All (exc. Vega)	1923935	2	.10	<b>WASHER</b> , switch cover and terminal stud (nylon— $3/16$ " I.D. x $7/16$ " O.D.)
73-75	All (exc. Vega, Monza)	3961507	2	.05	<b>WASHER</b> , switch cover and terminal stud— (9.647)

**2.104 SHIELD— COVER— NUT, Starting Motor**

69	All (396, 427) (exc. T.H. 400),				
70	All (396, 400, 454),				
71	Camaro (400),				
71	Chevelle w/Sp. H/Per. (454)	3954224	1	3.60	solenoid (stainless steel)
75	Vega, Monza	1935167	1	1.16	<b>COVER</b> , switch
69	All (396) (exc. T.H. 400),				
70	All (396, 400, 454),				
71	Camaro (400),				
71	Chevelle w/Sp. H/Per. (454)	3943648	1	1.25	<b>NUT</b> , sol. heat shield

**2.108 LEVER— SHAFT— STUD— SPRING, Starting Motor Drive Shaft**

62-64	Chevy, Chevelle,				
65-67	Pass. (exc. 396, 427),				
65-75	All (exc. Vega, Monza)	1951567	1	2.13	( $3^{17}/32$ " between end holes) (w/1108338-65-66-67-8400-18-25-8512)
62-69	All (exc. Pass., 396),				
65-67	Pass. (exc. 396, 409, 427, H.D. Clutch),				
68-69	Pass. (307, 327) (exc. H.D. clutch T.H.),				
70-75	All (exc. 140)	801433	1	2.34	<b>SHAFT</b> , w/1108427-28-29-30
71-75	Vega, Monza	1951658	1	2.13	<b>SHAFT</b>
68-69	Pass. (6 cyl.) (exc. Taxi),				
70-75	All	1945804	1	.13	<b>SHAFT</b> , lever
65-69	Pass. (396, 409, 427),				
65-69	Pass. w/H.D. Clutch,				
66-69	Chevelle, Camaro, Chevy (350, 396),				
70-75	All (exc. Vega, Monza)	1932197	1	.17	<b>STUD</b> , lever ( $5/16$ "— 18 x $13/16$ " O.L.)
69-75	All (exc. Vega, Monza)	1960244	1	.36	<b>STUD</b> , solenoid terminal
62-67	All (exc. Pass., 396),				
65-67	Pass. (230, 250, 283) (exc. H.D. clutch)	1951002	1	.47	<b>SPRING</b> , lever assist. ( $15/16$ " I.D.— $6^{1}/2$ " coils)
62-75	All	1958679	1	.69	<b>SPRING</b> , plunger

**2.113 PLUNGER, Starting Motor Drive Shift**

62-75	All	1941113	1	4.81	w/link
-------	-----	---------	---	------	--------

**2.170 COIL, Ignition**

64-70	All (exc. T. Ign.),				
71-74	All (140),				
71-75	All (6 cyl.)	1115202	1	16.25	w/1.8 OHM wire (stamped 202-12-V)
65-66	All w/T. Ign.	1115207	1	19.10	(embossed 176-12-V)
67-71	All,				

## CHASSIS—ELECTRICAL SYSTEM

<b>2.170 COIL, Ignition (Con't)</b>					
72-74	All (8 cyl.) (exc. H.E.I.)	1115238	1	16.40	w/1.3 OHM wire (stamped 238-BR)
74-75	All (8 cyl.) w/H.E.I.	1875894	1	27.80	w/H.E.I.
75	All (140, 250)	1115444	1	32.90	w/H.E.I.
75	All (122)	1115207	1	19.10	w/H.E.I.
<b>2.171 WIRE ASSY., Ignition Coil</b>					
62-74	All (exc. Vega)	2985954	1	1.11	to distributor (high tension) (16 <sup>39</sup> / <sub>64</sub> " O.L.)
71-74	Vega (140)	2985971	1	2.78	to distributor (high tension)
75	All (122, 140)	8914045	1	4.95	(12" O.L.)
75	All (250)	8914040	1	5.05	(14" O.L.)
<b>2.173 RESISTOR, Ignition Coil</b>					
65	Pass. (409) (exc. T. Ign., Caprice),				
65	Pass. (396) (exc. T. Ign.),				
66	Pass. w/H/Per. (427)	1957154	1	3.09	primary (blue stripe) (1.8 ohms)
<b>2.183 BRACKET—COVER—NUT—PLATE—SCREW—SEAL, Ignition Coil Mounting</b>					
62-63	Chevy (4 cyl.)	1909326	1	.62	ignition coil
62-64	Chevy, Chevelle (exc. 8 cyl.),				
65-74	All (6 cyl.),				
66	Pass. (327),				
71-74	Vega (140)	1846736	1	.78	
64	Chevelle, w/T. Ign.,				
65	Pass. (409)	1929496	1	.65	w/Screw
64-65	Chevy, Chevelle (8 cyl.) (exc. Sp. H/Per.),				
65-67	All (8 cyl.) (exc. 409),				
68	Pass. (8 cyl.) (exc. P.G.),				
68	Chevy, Chevelle (exc. Sp. H/Per. 327, 350, S.S.),				
68	Chevelle (S.S.) (exc. Sp. H/Per. 327, P.G.),				
68-70	Camaro (exc. 302),				
69-70	Chevy, Chevelle, Pass. (8 cyl.),				
71-72	Pass. (8 cyl.) (exc. 400, 454),				
71-72	Nova, Chevelle, Camaro (8 cyl.) (exc. Monte Carlo),				
71-72	Monte Carlo (exc. 454)	1970344	1	.62	w/1115293
66-67	All (327) (exc. Sp. H/Per.),				
67	All (350),				
69-70	Camaro w/spec. ducted hood,				
72	Camaro w/Sp. H/Per. (350)	1966876	1	.98	
67-68	Chevelle w/P.G.,				
67-68	El Camino (396),				
67-68	Pass. w/P.G. (396),				
71	Monte Carlo (454)	1968323	1	1.35	
68	Chevy, Chevelle w/Sp. H/Per. (327),				
68-69	Camaro (302) (exc. sp. ducted hood),				
70	All w/Sp. H/Per. (350)	1971011	1	.83	
71-72	Pass. (400, 454),				
73-74	All (8 cyl.)	1846538	1	.84	
75	All (140, 250)	1880083	1	1.52	
75	All (6 cyl.)	8917609	1	3.65	COVER, ign. coil
75	All (122)	3953056	1	.24	NUT, ign. mtg.— (7.833)
64-69	Chevy, Chevelle, Camaro w/Air Cond. (6 cyl.),				
65-69	Pass. w/C.A.C. (6 cyl.),				
70	All w/Air Cond. (6 cyl.) (exc. Camaro),				
74	Nova (6 cyl.) w/C.A.C.	3843253	1	.28	PLATE, mounting
65-68	All (exc. 3/2BC)	1945901	1	.05	SCREW, bracket (No. 10— 32 x 1 <sup>1</sup> / <sub>2</sub> ")
74-75	All (8 cyl.) w/H.E.I.	1875961	4	.20	SCREW, dist. ign. coil attach.
75	All (140, 250)	830762	4	.29	SCREW, w/washer, ign. coil bracket
74-75	All (8 cyl.) w/H.E.I.	1875962	1	2.51	SEAL, dist. ign. coil (rubber)
<b>2.187 KEY, Ignition—Door—Compartment—Trunk—Gas Tank Cap—Tire Locks</b>					
62-66	All	3694624 A.R.		.16	(octagon hd.— w/knockout plug-ignition, door and tire locks) (series 8000-9499)
67	All	7033454 A.R.		.16	octagon hd., ignition and door lock
67	All	7033455 A.R.		.16	round head, instrument panel
68	All	7034680 A.R.		.16	hexagon hd., uncoded

**CHASSIS—ELECTRICAL SYSTEM**

**2.187 KEY, Ignition— Door— Compartment— Trunk— Gas Tank Cap— Tire Locks (Con't)**

68	All	7034702 A.R.	.16	round hd.
69	All,			
73	All	7025019 A.R.	.33	oval hd., uncoded
69	All,			
73	All	7025014 A.R.	.33	square hd., uncoded
70	All,			
74	All	7025288 A.R.	.33	oval hd., uncoded
70	All,			
74	All	7025282 A.R.	.33	square hd., uncoded
71	All,			
75	All	7027275 A.R.	.27	sq. hd. uncoded
71	All,			
75	All	7027281 A.R.	.27	oval hd. uncoded
72	All	7024229 A.R.	.33	sq. hd. uncoded
72	All	7024235 A.R.	.33	oval hd. uncoded

**2.188 CYLINDER ASSY.— LOCK ASSY.— RING— SCREW— SLEEVE— STRAP ASSY.— SWITCH ASSY.— WASHER, Ignition Switch**

*NOTE: See group 10.553 for cylinder tumblers.*

62-64	All	3772085	1	1.90	less tumblers, spring and retainers, uncoded
65	All	3869215	1	1.50	uncoded
66	All	7031272	1	1.05	uncoded
67	All	695450	1	3.15	less tumblers, spring and retainer uncoded
68	All (exc. Pass.)	7023261	1	2.45	less tumblers, spring and retainers uncoded
68	Pass.	7023262	1	2.75	less tumblers, spring and retainers uncoded (B&S 603956)
69	All	7025216	1	4.45	uncoded
70	All	7042761 A.R.		6.50	uncoded
71	All	3990946	1	7.90	uncoded (B & S 604909)
72	All	7044844	1	7.90	CYLINDER UNIT, uncoded (B & S 605192) (Note 1)

*NOTE 1: This unit consists of 1 each - cyl. & sleeve assy., guard, washer, anti-rattle washer, adapter stop.*

73	All	7047678	1	7.45	CYLINDER UNIT (uncoded)
74-75	All	345083	1	7.65	LOCK ASSY., ign. (coded w/key) (B&S 605529)
69	All,				
71-72	Vega	7024780	1	.24	RING, cyl. anti-theft
69-75	All	7806433	1	.34	SCREW, ign. switch
69	All	7024624	1	1.20	SLEEVE, cyl.
62-64	Chevy	1116626	1	6.85	SWITCH ASSY., ignition and starting
64	Chevelle	1116656	1	7.00	SWITCH ASSY., ignition and starting
65	Chevy, Chevelle	1116661	1	6.60	SWITCH ASSY., ignition and starting
65	Pass.	1116660	1	6.60	SWITCH ASSY., less cyl. and keys
66	Pass.	1116686	1	6.55	SWITCH ASSY.
66-67	All (exc. Pass.),				
67	Pass.	1116685	1	6.35	SWITCH ASSY.
68	All (exc. Chevelle, Pass.)	1116694	1	6.90	SWITCH ASSY., ignition and starting
68	Chevelle	1116703	1	6.80	SWITCH ASSY., ignition and starting
68	Pass.	1116702	1	6.90	SWITCH ASSY.
69-75	All w/T.W.,				
71	Camaro w/A.T. (exc. floor console, T.W.)	1990099	1	6.90	SWITCH ASSY., ign.
69-75	All (exc. T.W.)	1990098	1	6.15	SWITCH ASSY., ign.
69-71	All	7025198	1	.31	WASHER, ing. lk. cyl. ring anti/R

**2.195 RELAY— ACTUATOR— ALARM UNIT— BUZZER— SWITCH ASSY.— CLIP— LOCK LEVER— PLATE— ROD ASSY.— SHAFT— SECTOR— RACK— SPRING— RETAINER— WASHER, Ignition Switch Warning**

68-71	All (exc. Vega)	1115889	1	6.25	w/buzzer— (2.815)
69-74	Chevelle, Camaro, Nova w/T.W.	7819754	1		ACTUATOR & RACK ASM., ign. sw.
71-74	Pass. w/T.W.	7819749	1	7.80	ACTUATOR & RACK ASM., ign. sw.
75	Pass. w/T.W.	7818778	1	3.00	ACTUATOR, ign. sw.
75	Chevelle, Camaro	7818776	1	3.00	ACTUATOR, ign. switch
75	Nova	7819038	1	3.00	ACTUATOR, ign. switch
75	Vega, Monza w/T.W.	7826073	1	3.00	ACTUATOR, ign. switch (Note 1)
75	Vega, Monza w/T.W.	7816819	1		ACTUATOR, ign. sw. (Note 2)
72-75	All	994354	1	30.80	ALARM UNIT, burglar
72	All,				
73-74	Vega,				
74-75	All (exc. Vega, Monza)	6262663	1	3.30	BUZZER, key warning
73	All (exc. Vega)	6270699	1	3.15	BUZZER
74-75	All	6258257	1	3.40	BUZZER, seat belt warning
75	Vega, Monza	356137	1	2.95	BUZZER, key and temp. warning
69-75	All (exc. T.W.)	7804414	1	2.70	SWITCH ASSY., ign. key warning buzzer

**CHASSIS—ELECTRICAL SYSTEM**

**2.195 RELAY— ACTUATOR— ALARM UNIT— BUZZER— SWITCH ASSY.— CLIP— LOCK LEVER— PLATE— ROD ASSY.— SHAFT— SECTOR— RACK— SPRING— RETAINER— WASHER, Ignition Switch Warning (Con't)**

69-70	All w/T.W.	7804514	1	1.95	SWITCH ASSY., ign. key warning buzzer
71-75	All w/T.W.	7811092	1	1.90	SWITCH ASSY., ign. key warning buzzer
69-75	All (exc. T.W.)	7804419	1	.74	CLIP, ign. key warning buzzer switch
69-70	All w/T.W.,				
71-72	All w/T.W. (exc. Pass.),				
73-75	All w/T.W.	7804518	1	.38	CLIP, ign. key warning buzzer switch
70-72	All (exc. Vega)	3986825	1	.12	CLIP, dir. sig. lamp flasher— (2.892)
71-72	Pass. w/T.W.	7804513	1	.78	CLIP, ign. key warning buzzer switch
71-75	Vega, Monza (exc. T.W.)	7810253	1	1.40	LOCK LEVER, stg. col.
72	Pass.	6270655	1	1.80	PLATE, anti-theft switch
75	Vega, Monza	7819320	1	.98	PLATE, inhibitor ret.
72-75	All	6258507	1	26.00	RELAY CONTROL, burglar alarm
69-70	Pass. w/T.W.	7805377	1	3.70	ROD ASSY., ign. switch actuator
69-70	Pass. (exc. T.W.)	7806115	1	4.95	ROD ASSY., w/rack ign. switch actuator
69-71	Chevy, Chevelle, Camaro (exc. T.W.),				
72-75	All w/col. shift (exc. T.W., Vega, Monza)	7806114	1	5.20	ROD ASSY., w/rack ign. switch actuator
70	Camaro (exc. T.W., A.T.),				
71-75	All w/floor shift (exc. T.W., Pass., Vega, Monza)	7807282	1	6.05	ROD ASSY., w/rack, strg. column
71-75	Vega, Monza (exc. T.W.)	7810387	1	3.10	ROD ASSY., switch actuator
71-74	Pass. w/T.W.	7805376	1	3.80	ROD ASSY., ign. switch
71-74	Pass. (exc. T.W.)	7806117	1	6.75	ROD ASSY., w/rack ign. switch
73-74	Camaro w/A.T. (exc. floor console, T.W.)	7803646	1	3.55	ROD ASSY., ign. switch actuator
75	Pass. (exc. T.W.)	7807284	1	5.70	ROD ASSY., w/rack, ign. switch
69	All (exc. T.W.)	7804412	1	1.30	SHAFT, ign. switch actuator sector
69	All w/T.W.,				
70	All w/T.W. (exc. Camaro)	7804917	1	3.55	SHAFT, ign. switch sector door
70	Camaro w/T.W.,				
71-75	All w/T.W.	7809368	1	3.45	SHAFT, ign. switch selector door
69-75	All w/T.W.	7805158	1	.64	SECTOR, ign. switch actuator
69	Police,				
71-75	All (exc. T.W.)	7812526	1	1.40	SECTOR, ign. switch actuator
71	All w/T.W. (exc. Pass., Vega)	7807284	1	5.70	RACK, ign. switch
73	Camaro w/T.W.	7807283	1	6.75	RACK, ign. switch actu. rod
75	All w/T.W.	7818721	1	3.80	RACK, ign. switch actu. rod
69	Police,				
69-75	All (exc. T.W.)	7804410	1	.62	SPRING, ign. switch rack preload
69-75	All w/T.W.	7804908	1	.59	SPRING, ign. switch rack preload
71-75	Vega, Monza (exc. T.W.)	7810516	1	.57	SPRING, steering col. lock lever
69-75	All w/T.W.	7804911	1	.59	RETAINER, ign. switch actuator sector
69-70	All w/T.W.	7804910	1	.59	WASHER, ign. switch sector door shift

NOTE 1: Rod has engagement end length of 11/16".

NOTE 2: Rod has engagement end length of 5/8".

**2.198 NUT— BEZEL— ESCUTCHEON, Ignition Lock**

62-64	Chevy,				
65	Chevy, Pass. (exc. Impala)	3902185	1	.54	ignition and starting switch
64	Chevelle	3839493	1	.38	mounting
65	Chevelle,				
65-66	Impala, Caprice,				
66-67	Chevelle, Chevy	3879549	1	.80	mounting
66	Biscayne, Bel Air,				
67	Chevy, Chevelle, Camaro,				
68	Camaro	3897349	1	.55	ignition and starting switch
67	Biscayne, Bel Air	3886982	1	.46	ignition and starting switch
67	Impala, Caprice	3886991	1	.55	ignition and starting switch
68	Chevy	3921400	1	.98	ignition and starting switch
65-66	Pass. (exc. Impala, Caprice),				
65	Chevy (exc. Nova),				
66-67	Chevy	3861406	1	.46	BEZEL, switch
66-67	Chevelle (Std.)	3878138	1	.67	BEZEL
67-68	Camaro	3923942	1	.64	BEZEL ASSY., ignition and starting
68	Chevelle	3934229	1	2.40	BEZEL ASSY., ignition and starting
68	Pass.	3923945	1	1.20	BEZEL ASSY., ign. and str. switch
62-64	Chevy	3791655	1	.18	ESCUTCHEON

**2.225 HARNESS ASSY., Electric Fuel Injection**

75	Vega (122)	8914616	1	158.00	
----	------------	---------	---	--------	--



## CHASSIS—ELECTRICAL SYSTEM

### 2.239 WIRE UNIT— HARNESS UNIT, Spark Plug

62-70	Chevy (4 cyl.)	2986603	1	5.82	glass interbraid
64-67	All (327),				
64-67	All (283) (exc. Chevelle),				
68-69	Pass. (307, 327, 350)	8912437	1	21.92	glass interbraid w/rams horn exh. (Note 2)
65	All (348, 409)	2978261	1	14.91	glass interbraid (Note 2)
65-69	All (194, 230, 250)	2986606	1	7.94	glass interbraid (Note 1)
65-70	All (396, 427, 454),				
71-73	All (402, 454)	8909665	1	19.31	glass interbraid (Note 2-4)
70-72	All (6 cyl.),				
73-74	Nova (250) (exc. C.A.C.)	8909903	1	8.14	glass interbraid (Note 1)
64-67	Chevelle (283),				
67	Camaro (302, 350),				
68	Camaro (302, 327, 350),				
68	Chevy (8 cyl.) (exc. 396),				
68	Chevelle (307, 327),				
69-73	All (302, 307, 327, 350),				
72-73	All (400),				
74	All (350, 400) (exc. Sp. H/Per.)	8912493	1	19.85	glass interbraid w/small block eng. (Note 2)
71-74	Vega	8906932	1	9.08	
74	Nova w/C.A.C. (250)	6298659	1	8.55	
74	Chevelle (454),				
74	Pass. (454) (exc. NB-2)	8909665	1	19.31	glass interbraid (Note 2)
74	Camaro w/Sp. H/Per. (350)	8908551	1	42.75	HARNESS UNIT (H.E.I.)
74	All w/H.E.I. (400),				
75	Nova (262),				
75	All (350, 400)	8908551	1	42.75	HARNESS UNIT (H.E.I.)
74	Pass. w/NB-2 (454),				
74	Chevelle w/H.E.I. (454),				
75	All (454)	8919646	1	43.18	HARNESS UNIT (H.E.I.)
75	All (6 cyl.)	8908517	1	25.75	HARNESS UNIT (H.E.I.)
75	Vega, Monza (140)	8908545	1	26.35	HARNESS UNIT (H.E.I.)
75	Monza (262)	8916133	1	38.63	HARNESS UNIT (H.E.I.)

NOTE 1: Consists of 6 spark plug wires, 1 coil high tension wire, 8 nipples and clips.

NOTE 2: Consists of 8 spark plug wires and 1 coil high tension wire with nipples and clips.

NOTE 4: Used with tapered seat spark plug.

### 2.240 WIRE ASSY., Spark Plug, with Terminals (Single Wire Replacement)

62	Chevy, F.C.,				
64-69	Pass., Chevy, Chevelle w/Air Cond. (6 cyl.),				
64-70	All (283, 302, 327, 350),				
74	Nova w/C.A.C. (6 cyl.)	2979302 A.R.		3.51	glass interbraid (36 <sup>1</sup> / <sub>4</sub> " O.L.) (Note 1)
	NOTE 1. Universal length unit for all applications 36 inches and shorter.				
63-68	Chevy, Chevelle (exc. 8 cyl.),				
65-67	All (exc. 8 cyl.)	2979304 A.R.		3.60	glass interbraid (34" O.L.)
64-67	Chevy, Chevelle (283, 327),				
65-69	Pass. (8 cyl.) (exc. 396, 427),				
68-70	All (327, 350)	2979303 A.R.		3.83	glass interbraid (54 <sup>1</sup> / <sub>2</sub> " long) (Note 2)
	NOTE 2 Universal length unit 37 to 53 inches as required.				
65	All (409)	2979570 A.R.		3.05	glass interbraid (41 <sup>1</sup> / <sub>2</sub> " O.L.)
65-68	All w/C.A.C. (396, 427),				
69	Chevelle, Camaro w/C.A.C. (396),				
69	Pass. w/C.A.C.(427)	2989406	1	4.28	(No. 2 wire) (34" O.L.-glass interbraid, 90 degree boot)
65-69	All (396, 427)	2989404 A.R.		3.71	(No. 5-6-7-8 wires) (28" O.L.-glass interbraid, 135 degree boot)
65-69	All (396, 427) (exc. C.A.C.)	2989400 A.R.		3.86	(No. 1-2-3-4 wires) (34" O.L.-glass interbraid, 135 degree boot)
70-71	All (6 cyl.)	8907609	1	3.04	glass interbraid (34" O.L.)
70-71	All (396, 400, 454)	8903191	1	4.24	glass interbraid (32" O.L.)
71	All (307, 350, 400)	8907292 A.R.		4.61	glass interbraid (50" O.L.)
71-72	Vega	8906933	1	3.88	
74	All (400),				
75	All (8 cyl.) (exc. 454)	8914092 A.R.		5.59	WIRE, #1 (28" O.L.)
74	All (400),				
75	All (8 cyl.) (exc. 454)				WIRE, #2,
75	Chevelle (8 cyl.) (exc. 454)	8914035 A.R.		5.73	WIRE, #6 (31" O.L.)
74	All (400),				
75	All (8 cyl.) (exc. 454)	8914038 A.R.		5.97	WIRE, #3 (36" O.L.)
74	All (400),				
75	All (8 cyl.) (exc. 454)	8914091 A.R.		5.44	WIRE, #4 (25" O.L.)
74	All (400),				
75	All (8 cyl.) (exc. 454)				WIRE, #5, 7, 8,

**CHASSIS—ELECTRICAL SYSTEM**

**2.240 WIRE ASSY., Spark Plug, with Terminals (Single Wire Replacement)  
(Con't)**

75	Pass., Nova, Camaro (8 cyl.) (exc. 454)	8914031 A.R.	5.30	WIRE, #6 (22" O.L.)
74-75	All (454)	8914072 A.R.	5.19	WIRE, #1 (30" O.L.)
74-75	All (454)			WIRE, #2,
74-75	Chevelle (454)	8914053 A.R.	5.48	WIRE, #6 (36" O.L.)
74-75	All (454)	8914066 A.R.	5.38	WIRE, #3 (34" O.L.)
74-75	All (454)	8914080 A.R.	5.09	WIRE, #4, 5 (28" O.L.)
74-75	Pass. (454)	8914055 A.R.	4.99	WIRE, #6 (26" O.L.)
74-75	All (454)	8914057 A.R.	4.80	WIRE, #7, 8 (22" O.L.)
75	All (250)	8914051 A.R.	4.70	WIRE, #1, 2, 3 (12" O.L.)
75	All (250)	8914096 A.R.	4.61	WIRE, #4 (18" O.L.)
75	All (250)	8914057 A.R.	4.80	WIRE, #5 (22" O.L.)
75	All (250)	8914012 A.R.	4.90	WIRE, #6 (24" O.L.)
75	Monza (262)	12002029 A.R.		WIRE, No. 1
75	Monza (262)	8914035 A.R.	5.73	WIRE, No. 2 (31" O.L.)
75	Monza (262)	8914093 A.R.	6.26	WIRE, No. 3 (42" O.L.)
75	Monza (262)	12002030 A.R.		WIRE, No. 4 (25" O.L.)
75	Monza (262)	8914038 A.R.	5.97	WIRE, No. 5 (36" O.L.)
75	Monza (262)	8914031 A.R.	5.30	WIRE, No. 6-7-8 (22" O.L.)
75	Vega, Monza (140)	12002010 A.R.	5.98	WIRE, No. 1 (18½" O.L.) (repl. 8914046)
75	Vega, Monza (140)	12002012 A.R.	5.80	WIRE, No. 3-4 (14½" O.L.) (repl. 8914078)
75	Vega, Monza (140)	12002011 A.R.	5.91	WIRE, No. 2 (17" O.L.) (repl. 8914047)
75	Vega (122)	12002015 A.R.	6.60	WIRE, No. 1 (16" O.L.)
75	Vega (122)	12002016 A.R.	6.91	WIRE, No. 2-3 (24" O.L.)
75	Vega (122)	12002017 A.R.	7.52	WIRE, No. 4 (34" O.L.) (repl. 12002000)

**2.251 SUPPORT—RETAINER—SHIELD—CLIP—GROMMET—BRACKET, Spark Plug Wire**

64-69	All (283, 327)	3864899 A.R.	.50	lower left rear
64-67	Chevy (8 cyl.) (exc. P.G.),			
65-68	Pass. (283, 307, 327)	3744404 R.H.	.21	rear, upper
64-67	Chevy (8 cyl.)	3790731 1	.21	
64-67	Chevelle (283, 327)	3841567 L.H.	.80	rear upper
64-67	Chevelle, Camaro (283, 327, 350) (exc. A.I.R.)	3841568 R.H.	.80	rear upper
64-67	Chevy (8 cyl.),			
65-70	Pass. (283, 307, 327, 350, 400),			
71	Pass. (8 cyl.) (exc. 400, 454)	3744408 2	.21	side
64-67	Chevy (8 cyl.),			
65	Pass. (8 cyl.) (exc. 396, 409),			
66-67	Pass. (8 cyl.) (exc. 396, 427)	3814499 L.H.	.53	rear, upper
67	Camaro (8 cyl.),			
67-68	Chevy (8 cyl.),			
67-68	Pass. (283, 307, 327) (1st design),			
70	Pass. (8 cyl.) (exc. 454)	3900407 1	.50	lower left rear
67	Pass. (283, 327)	3906613 1	.59	upper left rear
67-68	Pass. (283, 327) (2nd design)	3932450 1	.80	lower left rear
67	Chevy (8 cyl.)	3906611 R.H.	.71	rear upper
67	Chevelle, Camaro (283, 302, 327, 350),			
68-70	Chevy, Chevelle, Camaro (8 cyl.) (exc. 396),			
71-74	All (307, 350),			
72-74	All (400)	3923266 4	.21	side
68	Chevy, Chevelle, Camaro (8 cyl.) (exc. 396)	3923287 L.H.	.80	rear upper
68-70	All (396, 427, 454),			
71-72	All (402, 454)	3928902 R.H.	.36	frt.
68-70	All (8 cyl.) (exc. 396, 427, 454),			
71-72	All (307, 350),			
72	All (400),			
74	Camaro w/Sp. H/Per. (350)	3927104 1	.23	upper rear right
69-70	Chevy, Chevelle, Camaro (302, 307, 350, 400),			
69-70	Pass., Camaro w/C.A.C. (396, 427, 454) (exc. Sp. H/Per.),			
71	All w/C.A.C. (400, 454),			
71-72	All (307, 350, 400)	3932485 L.H.	.25	rear upper
69-70	Chevy, Chevelle, Camaro (302, 307, 350, 400),			
71-72	All (307, 350),			
72	All (400)	3947766 L.H.	.36	front side
70	All (8 cyl.) (exc. 454),			

## CHASSIS—ELECTRICAL SYSTEM

### 2.251 SUPPORT—RETAINER—SHIELD—CLIP—GROMMET—BRACKET, Spark Plug Wire (Con't)

71-72	All (307, 350),				
72	All (400) .....	3973366	1	.36	rear upper, left .....
71-73	Vega .....	3980274	1	.23	
74	All (350, 400) .....	342740	1	.36	frt. left .....
74-75	All (350, 400) (exc. Sp. H/Per.)	340653	1	.79	rear upper, left .....
74	All w/Sp. H/Per. (350) .....	340281	4	.25	side .....
74	All w/2BC (350, 400) .....	340636	1	1.15	accel. cable and pull back spring .....
75	Monza (262) .....	351693	1	.54	
62-74	All (6 cyl.),				
74-75	Vega, Monza (140) .....	3702799	A.R.	.52	RETAINER (3-wire ret.) (black nylon) .....
62-74	All .....	2965950	A.R.	.26	RETAINER, spark plug wires (rear) (2-wire) .....
65-68	Pass. (396, 427),				
66-68	Chevelle w/A.I.R. (exc. 396),				
66-69	Chevelle, Camaro (302, 396),				
69	Chevy, Camaro (396 Sp. H/Per.),				
69	Chevelle (8 cyl.),				
69	Pass. (427) (exc. H/Per. Sp. H/Per.),				
70-74	All (8 cyl.),				
71-73	Vega .....	2977555	R.H.	.30	RETAINER, spark plug wires, rear side .....
67-70	Pass. (396, 400, 427, 454),				
67-68	Camaro (396) (exc. H/Per., Sp. H/Per.),				
68-70	Chevy, Chevelle (396, 400, 454),				
71	All (400, 454),				
75	All (122) .....	2977417	A.R.	.52	RETAINER (Note 1) .....
	<i>NOTE 1 Two wire-3/4" in between centers.</i>				
74	Nova w/C.A.C. (6 cyl.),				
74	Pass., Chevelle w/H.E.I.,				
75	All (8 cyl.) (exc. 454) .....	8911429	1	1.30	RETAINER (H.E.I.) (4-wire) (L.H.) .....
74	Camaro w/Sp. H/Per. (350),				
75	All (122) .....	8911948	8	1.30	RETAINER (H.E.I.) .....
74-75	All (8 cyl.) H.E.I. .....	8911889	A.R.	4.40	RETAINER, plug wire to dist. .....
74-75	All (4 & 6 cyl.) H.E.I. .....	8917298	A.R.	2.25	RETAINER, coil wire .....
75-77	H (122) .....	367111	1	.28	RETAINER .....
75	All (4 & 6 cyl.) H.E.I. .....	8917297	A.R.	4.50	RETAINER, plug wire .....
75	All (8 cyl.) (exc. 454) .....	8911960	4	1.30	RETAINER (2-wire) .....
75	All (8 cyl.) (exc. 454) .....	367111	1	.28	RETAINER (4-wire) (R.H.) .....
75	All (8 cyl.) .....	8911429	A.R.	1.30	RETAINER .....
75	All (454),				
75	Monza (262) .....	357125	2	.16	RETAINER, splg. wire R.H. .....
75-77	Monza (262) .....	8911554	L.H.	.56	RETAINER, rear .....
75-77	Vega (262) .....	8911952	L.H.	2.40	RETAINER, plug wire .....
75-77	Vega (262) .....	8911953	R.H.		RETAINER, plug wire .....
75	All V-8 (exc. 262) .....	367111	R.H.	.28	RETAINER, plug wire .....
64-70	Chevy, Chevelle, Camaro (8 cyl.) (exc. 396, 400),				
71-72	All (8 cyl.) (exc. 400 w/4BC, 454) .....	357039	A.R.		SHIELD, L.H. and R.H. .....
64-68	Chevy (8 cyl.),				
65-69	Pass. (8 cyl.) (exc. 396, 409, 427, 454) .....	3917663	A.R.	.88	SHIELD, left rear and right front .....
64-68	Chevy (8 cyl.),				
65-67	Pass. (8 cyl.) (exc. 396, 409, 427),				
68	Pass. (exc. 427),				
69	Pass. (8 cyl.) (exc. 396, 427),				
70	Pass. (8 cyl.) .....	3917664	A.R.	.79	SHIELD, right rear and left front .....
65	Pass. w/Sp. H/Per. (396),				
66	Chevelle (396),				
66-67	Pass. (396, 427) .....	3871266	8	1.20	SHIELD .....
68	Chevy,				
68	Chevy,				
68-70	Pass. (8 cyl.) (exc. 396, 427, 454) .....				SHIELD, left frt. .....
70	Pass. w/A.T. (8 cyl.) .....	3919807	1	.79	rear right .....
72-75	All (402, 454) .....	336716	8	.36	SHIELD, spark plug heat .....
73-75	All (8 cyl.) (exc. 454) .....	330517	L.H.	.47	SHIELD, left .....
73-75	All (8 cyl.) (exc. 454) .....	357039	R.H.		SHIELD, right .....
73-75	All (8 cyl.) (exc. 454) .....	330518	R.H.	.62	SHIELD .....
73-75	All (8 cyl.) (exc. 454) .....	330519	L.H.	.62	SHIELD .....
75	Monza (262) .....	357047	1	1.80	SHIELD, splg. heat .....
64-66	Chevy (283, 327),				
64	Chevelle (327),				

**CHASSIS—ELECTRICAL SYSTEM**

**2.251 SUPPORT—RETAINER—SHIELD—CLIP—GROMMET—BRACKET, Spark Plug Wire (Con't)**

65-70	Pass. (283, 307, 327, 350, 400)	3744409	2	.23	CLIP ( <sup>9</sup> / <sub>32</sub> " wide-one <sup>19</sup> / <sub>64</sub> " hole)
75	Monza (262)	351694	1	.27	GROMMET, splg. wire L.H. side
64-67	Chevy (8 cyl.)	3790731	L.H.	.21	BRACKET, rear lower
64-67	Chevelle, Camaro (283, 302, 327, 350),				
68-70	Chevy, Chevelle, Camaro (8 cyl.) (exc. 396, 454),				
71-72	All (8 cyl.) (exc. 400 w/4BC, 454),				
73-75	All (307, 350, 400),				
75	All (262)	330521	2	.15	BRACKET, shield, right frt. and rear left
75	Vega (122)	362716	1	3.85	BRACKET, plug wire ret.
75	Vega (122)	362717	1	3.60	BRACKET, plug wire ret.

**2.258 NIPPLE—PROTECTOR, Spark Plug Wire**

65-69	Pass. (exc. 8 cyl.)	5289527	A.R.	.11	distributor (plastic— <sup>13</sup> / <sub>16</sub> " long)
65-69	Pass. (6 cyl.)	5297132	6	.45	PROTECTOR (bellows type) (Packard 286)

**2.270 PLUG, Spark**

**RECOMMENDED SERVICE**

62-68	All (153, 194, 230, 250)	5612630	A.R.	1.62	standard AC-46N (14 MM)
64-68	Chevy, Chevelle, Camaro w/4BC (exc. 396)				
65-68	Pass. (327)	1559492	A.R.	1.62	standard plug AC-44 (14 MM) (Note 1)
64-68	Chevy, Chevelle w/4BC (exc. H/Per.),				
65-68	Pass. (327) (exc. H/Per., Sp. H/Per., F.I.),				
66-68	Chevelle, Camaro (327, 350)	5612386	A.R.	1.62	town and country (extended shield) AC-44S (14 MM) (Note 1)
64-67	Chevy, Chevelle (8 cyl.) (exc. 4BC),				
65-68	Pass. (283, 307),				
68	Chevy, Chevelle (307)	1559493	A.R.	1.62	standard AC-45 (14 MM)
64-68	Chevy, Chevelle (283, 307) (exc. 4BC),				
65-68	Pass. (283, 307)	5612371	A.R.	1.62	standard (extended shield) AC-45S (14 MM)
65-68	All (396, 409, 427)	5612241	A.R.	1.62	hot plug, city type driving AC-43N (14 MM)
65-67	Pass. w/Sp. H/Per. (396, 427),				
66	Chevelle w/Sp. H/Per. (396)	5612235	A.R.	1.62	normal service AC-42N (14 MM)
67	Chevy (194)	5612437	A.R.	1.62	(AC-45N)
67-68	Camaro (302)	5569857	A.R.	1.62	(AC-43)
68	Chevy (396) w/aluminum cyl. hd.,				
68-69	Camaro (396) w/aluminum cyl. hd.,				
70	Chevelle w/Al. Cyl. Hd. (396, 400 w/4BC, 454)	5613312	A.R.	1.95	normal service (AC-R43XL)
69	All (exc. 8 cyl.),				
70	Nova (4 cyl.)	5612826	A.R.	1.95	normal service (AC-R46N)
69-70	Chevelle, Nova, Camaro (307),				
69	Pass., Camaro (327)	5569834	A.R.	1.95	normal service AC R-45
69	All (350),				
70	All (350, 400) (exc. Sp. H/Per.)	5569993	A.R.	1.95	(AC-R-44)
69	All (396, 427) (exc. H/Per. Sp. H/Per.)	5612321	8	1.95	(AC-R44N)
69	All w/H/Per., Sp. H/Per. (396, 427)	5612425	8	1.95	hotplug (AC-R43N)
69	Camaro (302),				
70	All w/Sp. H/Per. (350)	5569992	A.R.	1.95	(AC-R43)
70-74	All (6 cyl.)	5613357	6	1.95	(AC-R46T)
70	All (396, 454) (exc. H/Per., Sp. H/Per.),				
71	All w/4BC (350, 400) (exc. Sp. H/Per.),				
72-74	All (8 cyl.)	5613355	8	1.95	(AC-R44T)
70	All w/Sp. H/Per. (396, 400 w/4BC, 454) (exc. Al. Cyl. Hd.),				
71	Camaro w/Sp. H/Per. (350),				
71-73	Vega (140),				
74	Vega w/1BC (140)	5613324	4	1.95	(AC-R42-TS)
71	All (454) (exc. Sp. H/Per.)	5613354	8	1.95	(AC-R43T)

## CHASSIS—ELECTRICAL SYSTEM

### 2.270 PLUG, Spark (Con't)

71	All w/2BC (307, 350)	5613356	8	1.95	(AC-R45T)
71-72	All (6 cyl.)	5613326	6	1.95	(AC-R46TS) (Hot Plug)
71	All w/2BC (307, 350)	5613303	8	1.95	(AC-R-45TS) (Hot Plug)
71	All w/4BC (350, 400) (exc. Sp. H/Per.)	5613302	8	1.95	(AC-R-44TS) (Hot Plug)
74	Vega w/2BC (140)	5613557	4	1.95	(AC-R42TSM)
75	Vega, Monza (140)	5613578	4	1.95	(AC-R43TSX)
75	All (6 cyl.)	5613579	6	1.95	(AC-R46TX)
75	All (8 cyl.)	5613572	8	1.95	(AC-R44TX)
75	All (122)	5613600	4	1.80	(AC-R43LTSX)

*When individual driving conditions warrant, different heat range plugs may be used by selecting higher type Nos. for hotter and lower type Nos. for colder plugs as necessary.*

*NOTE 1. May be used on previous models using 14MM plugs not equipped with boots.*

### 2.270 TUNE-UP KITS

*The GM Merchandising Line of Tune-Up Kits, Shock Absorbers, and Brake Sets are shipped direct to dealers from the source, and are not stocked at GM Parts Division Distribution Centers.*

*There is a required minimum order quantity. Combination Tune-Up Kits, Brake Sets and Shocks orders may qualify based on weight.*

*All orders are shipped freight prepaid.*

*Orders must be written on a special order form which allows scheduling of four dealer shipments. Specific weights and qtys. are specified on order form.*

*All purchases accrue toward Dealer's parts return reserve.*

*Purchases are not eligible for wholesale compensation or stock order allowance.*

*GM Merchandising Line Parts are not returnable to GM Parts Division.*

*Merchandising Line Parts are warranted in accordance with current GM Parts Division parts policy.*

57-60	Pass. (265, 283) (exc. dual 4BC & fuel inj.)	1154025 A.R.	N.L.	KIT (No. 25) (incl. spark plug 8-45)
59-61	Pass. (348) (exc. Highlift Cam, H.P. & Spec. H.P.)	1154027 A.R.	N.L.	KIT (No. 27) (incl. spark plug 8-44N)
61-64	Pass. (283) (exc. Transistorized Ign.)	1154025 A.R.	N.L.	KIT (No. 25) (incl. spark plug 8-45)
62-64	Pass. (327) (exc. Transistorized Ign.)	1154022 A.R.	N.L.	KIT (No. 22) (incl. spark plug 8-44)
63-68	All (153, 194, 230, 250)	1154026 A.R.	N.L.	KIT (No. 26) (incl. spark plug 6-46N)
64-67	Chevy II, Chevelle (V-8) (2BC)	1154025 A.R.	N.L.	KIT (No. 25) (incl. spark plug 8-45)
64-68	Chevy II, Chevelle, Camaro (V-8) 4BC (exc. 302, 396, 427)	1154022 A.R.	N.L.	KIT (No. 22) (incl. spark plug 8-44)
65-68	Pass. (283, 307)	1154025 A.R.	N.L.	KIT (No. 25) (incl. spark plug 8-45)
65-68	Pass. (327)	1154022 A.R.	N.L.	KIT (No. 22) (incl. spark plug 8-44)
69	All (153, 194, 230, 250)	1154007 A.R.	N.L.	KIT (No. 6R) (incl. spark plug 6-R46N)
69	Pass., Camaro (327)	1154006 A.R.	N.L.	KIT (No. 5R) (incl. spark plug 8-R45)
69	All (350) (exc. Corvette Spec. H.P.)	1154002 A.R.	N.L.	KIT (No. 1R) (incl. spark plug 8-R44)
69	All (396) (exc. H.P. & Spec. H.P.)	1154008 A.R.	N.L.	KIT (No. 7R) (incl. spark plug 8-R44N)
69	Pass. (427) (exc. H.P. & Spec. H.P.)	1154008 A.R.	N.L.	KIT (No. 7R) (incl. spark plug 8-R44N)
69-70	Chevelle, Nova, Camaro (307)	1154006 A.R.	N.L.	KIT (No. 5R) (incl. spark plug 8-R45)
70	All (350, 400) (exc. Spec. H.P.)	1154002 A.R.	N.L.	KIT (No. 1R) (incl. spark plug 8-R44)
70	All (396, 454 w/345 H.P. Eng.) (exc. H.P. & Spec. H.P.)	1154015 A.R.	N.L.	KIT (No. 14R) (incl. spark plug 8-R44T)
70-74	All (230, 250)	1154014 A.R.	N.L.	KIT (No. 13R) (incl. spark plug 6-R46T)
71	All (307)	1154070 A.R.	N.L.	KIT (No. 21R) (incl. spark plug 8-R45T)
71	All (350 2BC)	1154070 A.R.	N.L.	KIT (No. 21R) (incl. spark plug 8-R45T)
71	All (350, 400 4BC) (exc. Spec. H.P.)	1154015 A.R.	N.L.	KIT (No. 14R) (incl. spark plug 8-R44T)
71-74	Vega (140)	1154164 A.R.	N.L.	KIT (No. 36R) (incl. spark plug 4-R42TSM)
72-74	All (V-8) (exc. Uni-Point Set, Spec. H.P. 350)	1154015 A.R.	N.L.	KIT (No. 14R) (incl. spark plug 8-R44T)
73	All (350, 454 Spec. H.P.) (exc. Uni-Point Set)	1154110 A.R.	N.L.	KIT (No. 30R) (incl. spark plug 8-R44T)
74	All (V-8)	1154111 A.R.	N.L.	KIT (No. 31R) (incl. spark plug 8-R44T)
75	All (140)	1154272 A.R.	N.L.	KIT (No. 37R) (incl. spark plug 4-R43TSX)
75	All (250)	1154273 A.R.	N.L.	KIT (No. 38R) (incl. spark plug 6-R46TX)
75	All (262, 350, 400, 454) (exc. Spec. H.P.)	1154278 A.R.	N.L.	KIT (No. 43R) (incl. spark plug 8-R44TX)
75	350 w/Spec. H.P.	1154279 A.R.	N.L.	KIT (No. 44R) (incl. spark plug 8-R44TX)

### 2.271 GASKET, Spark Plug Seat

62-69	Chevy, Chevelle, Camaro	5612328 A.R.	.02	( <sup>9</sup> / <sub>16</sub> " I.D. x <sup>25</sup> / <sub>32</sub> " O.D.) (14MM-chrome) (w/retention dimple)
62-69	All	1555475 A.R.	.02	(14 MM-chrome) (less retention dimple)

### 2.273 WRENCH, Spark Plug

62-66	All	3708444	1	.90	( <sup>13</sup> / <sub>16</sub> " hex.— 4 <sup>1</sup> / <sub>4</sub> " length)
-------	-----	---------	---	-----	---

**CHASSIS—ELECTRICAL SYSTEM**

**2.274 PULLEY— FAN— SPACER, Generator**

*NOTE In some cases double groove pulleys may be used in place of single groove pulleys.  
NOTE: See Dealer Price Schedule for applicable prices.*

	FAN	OUTSIDE DIA.	SHAFT DIA.	GROOVE NO.	WIDTH		
62	Chevy w/35 amp.,						
62	Chevy w/42 amp. AC gen.,						
63	Chevy w/42-52 amp. AC gen. (exc. P/S),						
63	Chevy w/C.A.C. (6 cyl.) (exc. 62 amp. AC gen.),						
64-66	Chevelle w/62 amp. (283, 327) (1st design),						
65-66	Chevy w/62 amp. (327) (1st design),						
65-66	Pass. w/62 amp. (8 cyl.) (1st design) (exc. 396, 409, Caprice),						
66	Pass. w/62 amp. (283, 327) . . . . .	No	2 <sup>7</sup> / <sub>8</sub>	4 <sup>5</sup> / <sub>64</sub>	1	3 <sup>3</sup> / <sub>8</sub>	1949358 1
62	Chevy w/52 amp. AC gen. (exc. P/S),						
62	Chevy (42 amp. AC gen. w/P/S) (exc. Taxi),						
62	Chevy (52 amp. AC gen. w/P/S) . . . . .	No	2 <sup>7</sup> / <sub>8</sub>	4 <sup>3</sup> / <sub>64</sub>	2	3 <sup>3</sup> / <sub>8</sub>	3792460 1
62	Chevy (Taxi) w/42 amp. AC gen. . . . .	No	2 <sup>7</sup> / <sub>8</sub>	4 <sup>3</sup> / <sub>64</sub>	2	3 <sup>3</sup> / <sub>8</sub>	3815463 1
62-66	Chevy, Chevelle w/62 amp. AC gen. (1st design) (exc. 8 cyl.),						
64-65	Chevy w/62 amp. (283),						
64-66	Pass. w/62 amp. (6 cyl.) (1st design) (exc. P/S w/Air Cond.) . . . . .	No	2 <sup>7</sup> / <sub>8</sub>	4 <sup>3</sup> / <sub>64</sub>	2	3 <sup>3</sup> / <sub>8</sub>	3815461 1
62-63	Chevy (exc. C.A.C., P/S, 52-62 amp., 35 amp.) . . .	Yes	3	1 <sup>1</sup> / <sub>16</sub>	1	3 <sup>3</sup> / <sub>8</sub>	3830422 1
64	Chevy (exc. 62 amp.)						
64-67	Chevelle (exc. 62 amp., Air Cond., 6 cyl. w/P/S, A.I.R.),						
65-67	Chevy (exc. 8 cyl., 62 amp., P/S, A.I.R.),						
65-67	Chevy (8 cyl.) (exc. 62 amp., C.A.C. w/327),						
65-67	Pass. (6 cyl.) (exc. 62 amp., P/S, Air Cond., A.I.R.),						
65-67	Pass. (396) (exc. Sp. H/Per., C.A.C., 62 amp., T.H.),						
65-67	Pass. (8 cyl.) (exc. 396, 409, 62 amp., Air Cond., T.H.) . . . . .	Yes	2 <sup>13</sup> / <sub>16</sub>	4 <sup>3</sup> / <sub>64</sub>	1	3 <sup>3</sup> / <sub>8</sub>	3909815 1
64-68	Chevy, Chevelle, Camaro w/P/S (exc. Air Cond., 8 cyl.),						
65-68	Pass. w/P/S (6 cyl.) (exc. 62 amp., Air Cond.),						
68	Chevy, Chevelle, Camaro w/42 amp. (exc. 8 cyl.),						
69	All (exc. 63 amp. 8 cyl.),						
70	All (6 cyl.) (exc. 63 amp.),						
71	Ail w/P/S (6 cyl.) (exc. 63 amp.) . . . . .	No	2 <sup>13</sup> / <sub>16</sub>	2 <sup>1</sup> / <sub>32</sub>	2	1 <sup>7</sup> / <sub>16</sub>	3947155 1
64-68	Chevelle, Camaro (P/S w/Air Cond.) (6 cyl.),						
65-67	Pass. (P/S w/Air Cond.) (6 cyl.) (exc. 62 amp.),						
68-69	Chevy, Chevelle, Camaro (6 cyl.),						
70	Pass., Nova, Chevelle w/Acc. Air Cond. (6 cyl.),						
72	Chevelle, Nova, Camaro (NB/2 w/P/S) (6 cyl.) (exc. 63 amp.) . . . . .	No	2 <sup>9</sup> / <sub>16</sub>	2 <sup>1</sup> / <sub>32</sub>	3	3 <sup>3</sup> / <sub>8</sub>	1970832 1
64-65	Chevelle w/Air Cond. (exc. 62 amp. P/S),						
65	Chevy w/Air Cond. (exc. 62 amp., 327),						

**CHASSIS—ELECTRICAL SYSTEM**

**2.274 PULLEY— FAN— SPACER, Generator (Con't)**

66	Chevy w/C.A.C. (327) (exc. 62 amp. Sp. H/Per.),							
66	Chevelle w/Air Cond. (6 cyl.) (exc. A.I.R., 62 amp.),							
66	Chevelle w/Air Cond. (396),							
66-67	Pass. w/Air Cond. (396, 427) (exc. 62 amp.),							
67	Chevelle (396) . . . . . Yes	2 <sup>31</sup> / <sub>32</sub>	4 <sup>3</sup> / <sub>64</sub>	1	3/ <sub>8</sub>	3909817	1	
65	Pass., w/H/Per., dual 4BC (409),							
65	Pass. w/62 amp. (409) (exc. C.A.C., H/Per.),							
65	Pass. (62 amp. w/C.A.C.) (396),							
65	Pass. w/Sp. H/Per. (396),							
65	Pass. (396) (exc. S.S., Sp. H/Per.),							
65	Caprice (396) (exc. Sp. H/Per.),							
65-67	Chevelle (C.A.C. w/62 amp.) (396) (1st design),							
66	Pass. w/62 amp. (396, 427) (1st design),							
67	Pass. w/Sp. H/Per. (427),							
67	Camaro (396),							
72	Camaro (402, Sp. H/Per. 350) (exc. C.A.C.),							
72	Pass., Chevelle (402, 454) (exc. C.A.C., 63 amp., Police),							
72	Taxi, Police (6 cyl.) (exc. 63 amp.),							
72	Taxi, Police (8 cyl.) (exc. 63 amp., C.A.C.) . . . . . No	3 <sup>7</sup> / <sub>32</sub>	4 <sup>3</sup> / <sub>64</sub>	1	1/ <sub>2</sub>	3844100	1	
65-66	Pass., w/Sp. H/Per. (396),							
66	Chevelle w/Sp. H/Per. (396),							
67	Camaro (302) . . . . . No	3 <sup>5</sup> / <sub>8</sub>	4 <sup>3</sup> / <sub>64</sub>	1	1/ <sub>2</sub>	3829387	1	
65	Pass. (409) (exc. 62 amp., Air Cond., H/Per., dual 4BC) . . . . . No	3 <sup>3</sup> / <sub>64</sub>	4 <sup>3</sup> / <sub>64</sub>	1	1/ <sub>2</sub>	3846180	1	
66-67	Pass. w/62 amp. (8 cyl.) (2nd design) (exc. 396, 409),							
66	Chevy, Chevelle w/62 amp. gen. (283, 327) (2nd design),							
67-68	Chevy w/62 amp. . . . . No	3 <sup>3</sup> / <sub>64</sub>	6 <sup>1</sup> / <sub>64</sub>	1	9/ <sub>32</sub>	3892614	1	
66-67	Pass. w/62 amp., C.A.C. (6 cyl.) (exc. P/S) (2nd design),							
66-67	Pass. w/62 amp., P/S (6 cyl.) (exc. C.A.C.) (2nd design),							
66	Chevelle (C.A.C. w/62 amp.) (396) (2nd design) . . . . . No	3 <sup>11</sup> / <sub>32</sub>	6 <sup>1</sup> / <sub>64</sub>	1	1/ <sub>2</sub>	3888168	1	
66	Pass. w/62 amp. (6 cyl.) (2nd design) (exc. P/S w/Air Cond.),							
66	Chevy, Chevelle w/62 amp. AC gen. (2nd design) (exc. 8 cyl.) . . . . . No	3	6 <sup>1</sup> / <sub>64</sub>	2	3/ <sub>8</sub>	3888186	1	
67	Police w/61 amp. . . . . No	2 <sup>1</sup> / <sub>8</sub>	4 <sup>3</sup> / <sub>64</sub>	1	3/ <sub>8</sub>	1969432	1	
68	Pass. w/61 amp. (exc. P/S),							
68	Chevy, Chevelle, Camaro,							
69-70	All w/Acc. Air Cond.,							
71	All w/C.A.C.,							
72	Chevelle, Nova, Camaro (6 cyl.) (exc. 63 amp., P/S, NB2),							
72	Pass. (6 cyl.) (exc. P/S, 63 amp.),							
72	Pass. (350, 400) (exc. 63 amp., C.A.C., Taxi, Police),							
72	Nova, Camaro (8 cyl.) (exc. 402, Sp. H/Per.),							
72	Chevelle (307, 350) (exc. 63 amp.),							
72	All w/63 amp.,							
72	Pass. w/C.A.C., Auto. Temp. Control (8 cyl.) (exc. 63 amp.),							
73-75	All (6 cyl.) (exc. 61 amp.),							
71-74	Vega (140),							
73-75	All (8 cyl.),							
75	Vega, Monza w/P/S . . . . . No	2 <sup>1</sup> / <sub>2</sub>	2 <sup>1</sup> / <sub>32</sub>	1	1/ <sub>2</sub>	1949355		
68-69	All w/61, 63 amp., P/S (6 cyl.),							

**CHASSIS—ELECTRICAL SYSTEM**

**2.274 PULLEY— FAN— SPACER, Generator (Con't)**

68-69	Chevy w/61, 63 amp. (4 cyl.),							
69	Pass. w/C.A.C., A.T. (exc. P/S,							
	63 amp.),							
70	Pass. w/63 amp. (8 cyl.),							
70	Nova w/63 amp. (4 cyl.),							
70	Taxi (6 cyl.) . . . . .	No	2 <sup>7</sup> / <sub>16</sub>	3 <sup>1</sup> / <sub>32</sub>	2	3/8	1969433	1
68	Pass. w/42 amp.,							
70-71	All w/1100834-39-42,							
73-75	Pass., Chevelle . . . . .	No	2 <sup>3</sup> / <sub>8</sub>	4 <sup>3</sup> / <sub>64</sub>	1	3/8	1949357	1
68	Pass. (8 cyl.) w/42 amp.,							
68	Chevelle (S.S.), Camaro,							
69-70	Chevelle, Camaro w/396 Sp.							
	H/Per.,							
69-70	Camaro (302),							
69	Pass. w/Sp. H/Per. (427),							
71	Camaro w/Sp. H/Per.							
	(350) . . . . .	No	3 <sup>3</sup> / <sub>16</sub>	1 <sup>1</sup> / <sub>16</sub>	1	1/2	1970831	1
70	Pass., Chevelle w/63							
	amp. (6 cyl.) . . . . .	No	2 <sup>11</sup> / <sub>32</sub>	1	2	3/8	1944312	1
70	Camaro w/63 amp., P/S							
	(6 cyl.) . . . . .	No	2 <sup>3</sup> / <sub>8</sub>	4 <sup>3</sup> / <sub>64</sub>	2	3/8	3816753	1
67	Police w/61 amp.,							
69-70	All w/C.A.C. (6 cyl.),							
74-75	Nova w/C.A.C., P/S (6							
	cyl.) . . . . .	No	2 <sup>11</sup> / <sub>32</sub>	4 <sup>3</sup> / <sub>64</sub>	3	3/8	800260	1
71	All w/P/S, 63 amp. (6 cyl.),							
71	Taxi (exc. 63 amp.),							
72	Chevelle, Nova, Camaro w/P/S							
	(6 cyl.) (exc. 63 amp., NB2),							
72	Chevelle, Nova, Camaro w/NB2							
	(6 cyl.) (exc. 63 amp., P/S),							
72	Pass. (6 cyl.) (exc. 63							
	amp., Taxi) . . . . .	No	2 <sup>1</sup> / <sub>2</sub>	1 <sup>1</sup> / <sub>16</sub>	2	3/8	1846787	
74	Nova w/C.A.C. (6 cyl.)							
	(exc. P/S) (Federal) . . . . .	No	2 <sup>7</sup> / <sub>16</sub>	1 <sup>1</sup> / <sub>16</sub>	3	3/8	—	1949355
75	Camaro w/Sp. H/Per.							
	(350) (exc. C.A.C.) . . . . .	No	3 <sup>3</sup> / <sub>16</sub>	1 <sup>1</sup> / <sub>16</sub>	1	1/2	—	1970831
74	Nova w/C.A.C. (6 cyl.) (w/P/S) . .		<b>800260</b>		1	8.95	<b>PULLEY</b>	
75	Vega (122) . . . . .		<b>3844100</b>		1	7.45	<b>PULLEY</b>	
75	Vega (exc. P/S) . . . . .		<b>1891066</b>		1	9.25	<b>PULLEY</b>	
75	Vega 140/P/S & A.I.R. exc. A.C.		<b>1891654</b>		1	13.85	<b>PULLEY</b>	

- 62-63 Chevy w/P/S (exc. AC gen.),
- 62-63 Chevy w/45-52 amp. AC gen.
- 35 amp. DC gen.,
- 64-66 Chevy, Chevelle w/P/S (exc. Air
- Cond., 8 cyl.),
- 64-66 Chevelle w/Air Cond. (6 cyl.),
- 65 Chevy w/C.A.C. (327) (exc. 62
- amp.),
- 65 Chevelle w/C.A.C. (exc. 62
- amp.),
- 65 Chevelle (6 cyl.),
- 65 Pass. w/Sp. H/Per. (396) (exc.
- 62 amp.),
- 65 Pass. w/P.S. (6 cyl.) (exc. 62
- amp.),
- 65 Pass. w/C.A.C. (exc. 409),
- 65 Pass. (409) (exc. C.A.C., 62
- amp.),
- 66 Pass. w/Air Cond. (exc. Caprice),
- 66-68 Caprice w/Air Cond. (exc. Spt.
- Cpe.),
- 66-67 Pass. w/A.I.R. (6 cyl.),
- 66 Pass. (327, 396),
- 66-68 Pass. w/A.T. (427),
- 67-68 Pass. w/P/S (6 cyl.) (exc. A.I.R.
- 62 amp.),
- 67-68 Chevy, Chevelle, Camaro w/P/S
- (6 cyl.) (exc. C.A.C.),
- 67-68 Chevelle, Camaro (302, 396),
- 68 All w/42 amp. 61 amp. (exc.
- Pass.),
- 67 Police w/61 amp.,



**CHASSIS—ELECTRICAL SYSTEM**

**2.274 PULLEY— FAN— SPACER, Generator (Con't)**

68-69	All w/1100796-0810-18-45-47-49,				
70	All w/1100834-36-37-39-41-42-43-45-46-47-49-96,				
71-77	All .....	800594	1	2.26	FAN (11 blades) .....
65-67	Pass. (396, 427) (exc. Sp. H/Per., 62 amp.) .....	3846589	1	.26	SPACER, pulley— (5.056) .....

**2.275 GENERATOR (less pulley)**

*NOTE. Mountings on rebuilt generators are the same as those used on new generators. Refer to type numbers for similarity.*

*NOTE. For Generators acceptable for exchange credit see exchange section of the Dealer Price Schedule.*

62-65	All .....	1100694	1	102.25	52-55 amp. A.C. (Delcotron) (less pulley and fan) (Exchange Item— Note 1) .....
62-66	All (1st design) .....	1117765	1	220.50	62 amp. A.C. (Delcotron) (shaft, <sup>43</sup> / <sub>64</sub> " O.D.) (also used as replmt. for 32 and 37 amp. Delcotron) (less pulley and fan) .....
62-71	All (exc. Vega) .....	1100842	1	87.45	42 amp. (Delcotron) (less pulley and fan) (Exchange Item— Note 1) .....
66-71	All (exc. Vega) .....	1100849	1	94.00	61 amp. (Delcotron) (less pulley and fan) (Exchange Item— Note 1) .....
66	All (2nd design),				
71	All (exc. Vega) .....	1100742	1	100.25	63 amp. (Delcotron) (less pulley and fan) (Exchange Item— Note 1) .....
72	All (exc. Vega) .....	1102459	1	96.00	37 amp. (Delcotron) (less pulley and fan) (Exchange Item— Note 1) .....
72	All (exc. Vega) .....	1102451	1	97.10	63 amp. (Delcotron) (less pulley and fan) (Exchange Item— Note 1) .....
73-75	All .....	1102848	1	102.50	42 amp. (Delcotron) (less pulley and fan) (Exchange Item— Note 1) .....
73-75	All .....	1102849	1	113.50	63 amp. (Delcotron) (less pulley and fan) (Exchange Item— Note 1) .....

**GENERATOR (Rebuilt for General Motors)**

62	Chevy .....	1102195	1	36.10	(35 amp.) (Exchange Item— Note 1) (38-U) .
----	-------------	---------	---	-------	--

**GENERATOR (Rebuilt by General Motors)**

63-72	All (exc. Vega) .....	1963778	1	49.65	(55 amp.) (Exchange Item— Note 1) .....
63-72	All (exc. Vega) .....	1846935	1	44.40	(42 amp.) (Exchange Item— Note 1, 2) .....
66-72	All (exc. Vega) .....	1846936	1	49.65	(61 amp.) (less pulley and fan) (Exchange Item— Note 1) .....

*NOTE 1 List price shown does not include exchange charge. Refer to Dealer Parts Price Schedule for exchange price.*

*NOTE 2: Replaced 37 amp. generator 1963776.*

**2.277 BRACKET— BOLT— STUD— WASHER— SPACER— BUSHING— SUPPORT, Generator (see 2.317 for brace)**

63-66	Chevy (4 cyl.) (exc. 62 amp.) ...	3842014	1	1.70	
63	Chevy (6 cyl.) w/42-52 amp. A.C. gen.,				
65	Pass. (409) (exc. 62 amp.) .....	3825447	1	1.50	
64-67	Chevy (8 cyl.) (exc. 62 amp., A.I.R.),				
67	Chevy (8 cyl.) (exc. A.I.R.) .....	3849727	1	5.15	
64-65	Chevelle w/P/S (8 cyl.) (exc. 62 amp.) .....	3840084	1	2.95	
64-69	Chevy, Pass. (6 cyl.) (exc. 62 amp.),				
64	Chevelle (exc. 62 amp., P/S),				
65-66	Chevelle (exc. 62 amp., 8 cyl. w/P/S),				
67-69	Chevy, Chevelle, Camaro (6 cyl.),				
70-75	All (6 cyl.) .....	3838441	1	1.70	
65-66	Pass. w/62 amp. (8 cyl.) (exc. 396, 409, 427) .....	3892968	1	5.05	
65	Pass. (396) (exc. 62 amp.) .....	3863138	1	4.55	
65-67	Chevelle, Pass. w/62 amp. (396, 427) (1st design) .....	3878267	1	10.40	
66-67	Chevy w/A.I.R. (8 cyl.) .....	3878248	1	10.40	
66-67	Pass. (427) (exc. 62 amp.),				
66-67	Pass. (396) (exc. 62 amp., Sp. H/Per.),				
66-68	Chevelle, Camaro (396) (exc. 62 amp.),				
68	Pass. (396, 427) (exc. 62 amp.) .	3925526	1	5.05	

**CHASSIS—ELECTRICAL SYSTEM**

**2.277 BRACKET— BOLT— STUD— WASHER— SPACER— BUSHING— SUPPORT, Generator (see 2.317 for brace) (Con't)**

65	Pass. w/62 amp. A.C. gen. (409),				
66	Chevy, Chevelle w/62 amp. (6 cyl.) (2nd design),				
66-67	Pass. w/62 amp. (6 cyl.) . . . . .	3888196	1	2.75	
69-70	All (396, 400, 427, 454),				
71-75	All (400, 454) . . . . .	338496	1	1.35	
69-70	All (8 cyl.) (exc. Pass. 396, 400, 454),				
69-70	Pass. (exc. 396, 400, 427, 454),				
71-75	All (8 cyl.) (exc. 400, 454) . . . . .	342737	1	1.10	
69	All (396, 427),				
71-72	All (400, 454) . . . . .	3940942	1	.24	rear . . . . .
71-75	Vega, Monza (140) w/P/S . . . . .	3983420	1	6.20	
72-74	Vega (140) (exc. P/S) . . . . .	326303	1	3.45	
74-75	All V-8 (exc. 454) . . . . .	342737	1	1.10	
75	All (122) . . . . .	348628	1	39.75	
75	Vega, Monza (140) (exc. P/S) . . . . .	354607	1	3.60	
75	Monza w/C.A.C. (262) . . . . .	354362	1	19.60	
75	Monza (262) (exc. C.A.C.) . . . . .	357003	1	6.45	
66-67	Chevelle (283, 327) (exc. 62 amp.),				
67-68	Camaro (8 cyl.) (exc. 396),				
68	Chevy, Chevelle (exc. 396) . . . . .	3878256	1	1.55	<b>BRACKET ASSY.</b> . . . . .
65-67	All w/40-45-50 amp. L.C.I. . . . .	3707480	2	.18	<b>BOLT, brkt. to gen. (<math>7/16"</math>— <math>20 \times 17/16"</math>)— (6.172)</b> . . . . .
65-67	Pass.,				
68	All . . . . .	3792380	1	.31	<b>BOLT, brkt. to gen. (<math>3/8"</math>— <math>16 \times 33/4"</math>)— (6.606)</b> . . . . .
69-75	All (8 cyl.) . . . . .	3951572	1	.11	<b>BOLT, rr. brkt. to gen. (<math>5/16"</math>— <math>18 \times 5/8"</math>)</b> . . . . .
69	All (8 cyl.) (exc. Pass., 396),				
69	Pass. (327, 350),				
70-75	All (exc. 396, 400, 454) . . . . .	3932414	1	.40	<b>BOLT, pivot (<math>3/8"</math>— <math>16 \times 6"</math>)</b> . . . . .
71-73	Vega w/P/S . . . . .	3779940	1	.21	<b>BOLT, gen. to bracket</b> . . . . .
69	All (396, 400, 427, 454),				
71-72	All (400, 454) . . . . .	3940944	1	.92	<b>STUD, gen. (<math>3/8"</math>— <math>16 \times 6"</math>)</b> . . . . .
62-63	All . . . . .	3954735	1	.13	<b>WASHER, bracket (<math>7/16"</math>)</b> . . . . .
62-72	All (exc. Vega) . . . . .	3933941	A.R.	.15	<b>WASHER, generator to bracket (<math>11/32"</math>)— (5.110)</b> . . . . .
62-63	Chevy w/52-62 amp. A.C. gen. . . . .	6255782	1	.12	<b>WASHER, to bracket— (5.428)</b> . . . . .
62-69	All . . . . .	3792381	1	.14	<b>WASHER, brkt. spacer (<math>3/4"</math> O.D. x <math>3/8"</math> I.D. x <math>1/4"</math> thick)— (6.606)</b> . . . . .
70-71	All (exc. Vega) . . . . .	382105	A.R.	.12	<b>WASHER (<math>13/32"</math> I.D. x <math>3/4"</math> O.D. x <math>1/32"</math> thk.)— (4.037)</b> . . . . .
73-75	All (exc. Vega) . . . . .	3933941	1	.15	<b>WASHER, gen. frt. brkt. to gen.</b> . . . . .
63-68	Chevy, Chevelle, Camaro,				
65-69	Pass. (exc. 62 amp.),				
70-75	All (6 cyl.) . . . . .	3825451	1	.13	<b>SPACER, bracket</b> . . . . .
71-75	Vega, Monza w/P/S (exc. C.A.C.)	3983422	1	.31	<b>SPACER, gen. brace</b> . . . . .
62-66	All w/62 amp. gen. (1st design) . . . . .	1957249	1	.07	<b>BUSHING, drive end hinge</b> . . . . .
75	Vega, Monza (P/S w/2BC) (140) (exc. C.A.C.),				
75	All (122) . . . . .	360432	2	1.75	<b>BUSHING, gen. brkt.</b> . . . . .
75	Vega, Monza (140) w/A.I.R. & P/S exc. A.C. . . . .	355720	2	5.55	<b>BUSHING, alt. brkt.</b> . . . . .
64	Chevelle (327),				
65-68	All (283, 307, 327) (exc. 62 amp.) . . . . .	3846565	1	1.30	<b>SUPPORT, gen. mounting (on exh. man.)</b> . . . . .
65	Pass. (409) . . . . .	3826452	1	4.85	<b>SUPPORT, bracket</b> . . . . .
65-66	All w/62 amp. (8 cyl.) (exc. 396, 409, 427) . . . . .	3894008	1	1.90	<b>SUPPORT, bracket</b> . . . . .
66-68	Pass. w/62 amp. (283, 307, 327),				
66	Chevy, Chevelle (exc. 396) . . . . .	3892612	1	1.75	<b>SUPPORT, bracket</b> . . . . .
75	Monza (262) (exc. C.A.C.) . . . . .	357037	1	2.05	<b>SUPPORT, gen. frt.</b> . . . . .
75	Monza (262) (exc. C.A.C.) . . . . .	357038	1	2.05	<b>SUPPORT, gen. rear</b> . . . . .
<b>2.279 ARMATURE— ROTOR ASSY.— RING ASSY., Generator</b>					
62	Chevy w/1100326 . . . . .	1928952	1	37.80	$9^{13/32}"$ O.L. (Exchange Item-Note 1) . . . . .
62	Chevy w/1102096 . . . . .	1932900	1	37.30	$10^{13/32}"$ O.L. (Exchange Item-Note 1) . . . . .

**CHASSIS—ELECTRICAL SYSTEM**

**2.279 ARMATURE— ROTOR ASSY.— RING ASSY., Generator (Con't)**

62-71	All w/1100600-0601-0613-0615-0618-0620-0628-0629-0633-0665-0668-0669-0670-0693-0694-0695-0696-0742-0750-94-95-96-0810 thru 0818-34 thru 0849,				
72	All (exc. Vega)	1958565	1	29.15	ROTOR ASSY., w/shaft
65-66	All w/1117765	1955497	1	75.65	ROTOR ASSY., w/shaft
66-68	All w/1117754-82	1955679	1	80.25	ROTOR ASSY., w/shaft
73-75	All	1876163	1	25.10	ROTOR ASSY., w/shaft
65-68	All w/1117754-65-82	1955412	1	5.35	RING ASSY., rotor shaft slip

**2.280 NUT— WASHER, Generator Armature**

62-75	All	1915172	1	.41	( <sup>5</sup> / <sub>8</sub> "— 20 thd. <sup>1</sup> / <sub>4</sub> " thick)
65-71	Pass.	3947121	1	.28	( <sup>5</sup> / <sub>8</sub> " x 1" x <sup>1</sup> / <sub>2</sub> " thick)
65-72	Pass.	3947122	1	.58	( <sup>5</sup> / <sub>8</sub> " x 1" x <sup>1</sup> / <sub>2</sub> " thick)
68	Chevy, Chevelle w/61 amp. (6 cyl.) (exc. P/S),				
70-71	All w/63 amp. (6 cyl.)	3816757	1	2.85	
69-70	All w/63 amp. (6 cyl.)	1969206	1	2.50	w/1100849
74-75	Nova w/C.A.C. (6 cyl.)	1969206	1	2.50	shaft (drive end)
62-75	All	1941978	1	.07	WASHER, spring (wave) (drive end)
68-71	All w/61-63 amp. (6 cyl.)	1944314	1	.30	WASHER, pulley

**2.285 BRUSH, Generator**

62-63	Chevy w/1100357-2096-2226-2227-2274	1932506	2	.83	w/lead (stamped 956)
62-64	Chevy, Chevelle w/1100600-0601-0613-0615-0618-0620-0628-0629-0630-0633-0665-0668-0669-0670	1958197	1	1.77	BRUSH UNIT
65-68	All w/1117754-7765-82	1958827	1	2.30	BRUSH UNIT

**2.291 ARM— HOLDER— SCREW— WASHER, Generator Brush**

64-66	Chevy, Chevelle w/1117765,				
65-68	All w/1117754-65-82	1961890	1	2.21	HOLDER
62-64	All w/1100357-2096-2174-2226-2227-2274-2336	1925378	1	2.65	HOLDER UNIT, w/brush (ground)
62-66	All w/1117765	1962608	1	5.60	HOLDER UNIT (Note 1)
<i>NOTE 1. Unit contains 4 screws, 2 studs, 2 terminals, 1 adapter, 1 brush holder, 4 nuts and 11 washers.</i>					
62-71	All w/1100600-0601-0613-0615-0618-0620-0628-0629-0633-0665-0668-0669-0670-0693-0694-0695-0696-0697-0742-0750-0834 thru 0849 (exc. Vega)	1964682	1	3.05	HOLDER UNIT, w/brush
72-75	All (exc. Vega, Monza)	801466	1	4.89	HOLDER UNIT, w/brush
71	All (exc. Vega)	9420489	2	.05	SCREW, brush holder
72-75	All	1876682	2	.07	SCREW, brush holder atch. grd.
72-75	All	1876681	1	.14	SCREW, brush holder atch.
68-72	All (exc. Vega)	9419392	1	.05	WASHER, brush holder screw— (8.928)
73-75	All	1970149	2	.11	WASHER, gen. brush holder attach. (insul.)

**2.297 FRAME, Generator Commutator End, with Bushing**

62-71	All w/1100615-0618-0620-0628-0629-0633-0665-0668-0669-0670-0693-0694-0695-0696-0697-750-834-36-37-38-39-41-42-43-45-46-47	1852934	1	23.60	slip ring end
66	Chevy, Chevelle w/1117754,				
68	All w/1117782	1950674	1	15.20	slip ring end
71	Vega	1846523	1	7.50	slip ring end
72-75	All	1852101	1	10.75	slip ring end

**2.298 BEARING ASSY.— BUSHING— SHROUD— PLUG— CLAMP— SEAL, Generator Commutator or Rotor Slip Ring End Frame**

62-71	All w/1100639-93-94-95-96-98-750-94-95-96-0810 thru 0818-1102020-2025-2041-2043-2059-2084-2115-5947-6982-2173-2174-2268-5116-5123-5124-0693-94-95-96-97-950-1117754-65-82 (12 volt)				
		905429	1	4.42	rotor shaft end
62-75	All	7451931	1	2.68	rotor slip ring end

**CHASSIS—ELECTRICAL SYSTEM**

**2.298 BEARING ASSY.— BUSHING— SHROUD— PLUG— CLAMP— SEAL,  
Generator Commutator or Rotor Slip Ring End Frame (Con't)**

66-68	All w/1117754-82	1965145	1	3.04	BUSHING, slip ring
66-68	All w/1117754-82	1955667	1	1.49	SHROUD, slip ring
66-68	All w/1117754-82	1955520	1	.25	PLUG, bearing
66-68	All w/1117754-82	1963355	1	1.41	CLAMP, ball bearing
62-75	All (exc. 61, 63 amp. gen.)	1961323	1	.31	SEAL, gen. slip ring end brg.

**2.301 CUP— PLUG, Generator Oil**

65-69	Pass.	125609	A.R.	.11	( <sup>3</sup> / <sub>16</sub> " )— (8.984)
60-64	Chevy w/1102174-5135	1948326	1	.16	PLUG, hole (steel 1 <sup>1</sup> / <sub>8</sub> " dia. x 7 <sup>1</sup> / <sub>16</sub> " long)

**2.305 FRAME, Generator Drive End**

62-66	All w/1117765	1955492	1	9.95	
66-68	All w/1117754-82	1961866	1	19.75	
62-71	All w/1100600-0601-0613- 0615-0618-0620-0628-0629- 0633-0665-0668-0669-0670- 0693-0694-0695-0696-0697- 0742-0750-0834 thru 0849,				
72-75	All	800135	1	7.55	
62	Chevy w/1102096	1910404	1	8.55	FRAME UNIT

**2.306 BEARING, Generator Drive End**

62-69	All (exc. w/1006976-6981- 6982-6985-1117765)	905429	1	4.42	(2.298)
72-75	All	907998	1	4.20	

**2.307 PLATE— GASKET— WASHER— COLLAR— RETAINER— SLINGER—  
SCREW, Generator Drive End**

62-66	All w/1117765	1944964	1	1.33	brg. ret.
65-69	Pass. (exc. w/1106981-6982)	1911263	1	.23	brg. ret. ( <sup>13</sup> / <sub>32</sub> " I.D. x 2" O.D.)
66-68	All w/1117754-82	1955664	1	.16	washer retainer
62-71	All w/1100600-601-613-615- 618-620-628-629-633-665- 668-669-670-693-694-695- 696-697-742-750-0834 thru 0849,				
72-75	All	1971993	1	.61	brg. ret.
62-71	All w/1100357-0615-0618- 0620-0628-0629-0630-0633- 0639-0665-0668-0669-0670- 693-0694-695-696-698-750- 981-982-6982-0742-50-0834 thru 0849-226-227-2274- 2336-5135-1117765	1912008	1	.06	GASKET, brg. ret., plate inner ( <sup>13</sup> / <sub>32</sub> " I.D. x 2" O.D.)
62-66	All w/1117765	1945070	1	.06	GASKET, brg. ret. plate
66-68	All w/1117754-82	1955663	1	.06	GASKET, ball brg. retainer (2 <sup>1</sup> / <sub>16</sub> " I.D. x 2 <sup>9</sup> / <sub>16</sub> " O.D.)
62-69	All w/1117765	809961	1	.08	WASHER, felt, outside ( <sup>29</sup> / <sub>32</sub> " I.D. x 1 <sup>9</sup> / <sub>16</sub> " O.D.)
62-69	All	809945	1	.07	WASHER, metal, spacer (1 <sup>1</sup> / <sub>16</sub> " I.D. x <sup>15</sup> / <sub>16</sub> " O.D. x <sup>3</sup> / <sub>32</sub> " thk.)
66-68	All w/1117754-82	1962276	3	.04	WASHER ( <sup>9</sup> / <sub>16</sub> " O.D. x <sup>3</sup> / <sub>16</sub> " I.D.)— (2.082) (*1)
66-69	All w/1117754-82	810794	1	.07	WASHER ( <sup>5</sup> / <sub>16</sub> " O.D. x <sup>9</sup> / <sub>64</sub> " I.D.)— (2.401)
66-68	All w/1117754-82	1955660	1	.11	WASHER (1 <sup>11</sup> / <sub>16</sub> " O.D. x 1 <sup>5</sup> / <sub>16</sub> " I.D.)
71	All w/1100742-917-44,				
72-75	All	800832	1	.08	WASHER, ball brg. grease
62-64	Chevy, Chevelle w/1100600- 0601-0613-0615-0618-0620- 0628-0629-0630-0633	1843015	1	.43	COLLAR, ball brg. spacer (inside)
62-71	All w/1100600-0601-613-615- 618-620-628-629-633-665- 668-669-693-694-695-696- 697-742-750-794-795-813 thru 818-825-826-833-834- 836-837-838-839-841-842- 845-846-849-859-896-917- 934,				
72-75	All	1959991	1	.28	COLLAR, brg. spacer (outside)
62-66	All w/1117765	1955490	1	.28	COLLAR, ball brg. spacer (inside)

**CHASSIS—ELECTRICAL SYSTEM**

**2.307 PLATE— GASKET— WASHER— COLLAR— RETAINER— SLINGER—  
SCREW, Generator Drive End (Con't)**

64-71	All w/1100639-665-668-669-670-693-694-695-696-697-742-750-0825-26-33-0834-0849-0859,				
72-75	All	1963139	1	.79	COLLAR, brg. spacer (inside)
66-68	All w/1117754-82	1961870	1	3.40	COLLAR, brg. spacer (inside)
66-68	All w/1117754-82	1961869	1	1.46	COLLAR, brg. spacer (outside)
62-69	All	819104	1	.06	RETAINER, felt washer (1" I.D. x 1 <sup>9</sup> / <sub>16</sub> " O.D.)
66-68	All w/1117754-82	1961867	1	2.36	RETAINER, ball brg.
62-71	All w/1100600-601-613-615-618-620-628-629-633-639-665-668-669-670-693-694-695-696-697-698-742-750-0834 thru 0849	1947344	1	.11	SLINGER, ball bearing grease
62-66	All w/1100357-2096-2226-2227-2274-2336-5135-7754-1117765,				
65-68	All w/1117754-65	1914580	3	.04	SCREW, brg. retainer plate (No. 10— 32 x 7 <sup>7</sup> / <sub>16</sub> " )
62-69	All w/1100639-693-694-695-696-698-0742-750-94-95-96-0813 thru 18-0834 thru 0849,				
65-71	All w/1100665-668-669-670-693-694-695-696-697-742-750-94-95-96-0818-0825-33-0849-0859,				
72-75	All	1965104	3	.05	SCREW, brg. retainer plate

**2.310 COIL UNIT— STATOR ASSY., Generator Field**

62	Chevy w/1102096-2174-2274	1922701	1	18.30	
62-68	All w/1117754-65-82	1958822	1	55.05	STATOR ASSY.
62-71	All w/1100615-620-628-629-630-639-668-669-670-693-695-696-0834 thru 0843-0896-0944	1959381	1	21.45	STATOR ASSY.
65	Pass. w/1100697	1964122	1	27.50	STATOR ASSY.
66-71	All w/1100742-750-796-0843-45-46-47-48-49-917	1962025	1	20.70	STATOR ASSY.
72-75	All w/C.A.C., 63 amp. (8 cyl.)	1971639	1	21.30	STATOR ASSY.
72-75	All (exc. 63 amp., C.A.C.)	1971986	1	21.10	STATOR ASSY.

**2.313 STUD— BOLT— SCREW— WASHER— INSULATOR— TERMINAL—  
HOLDER UNIT— LEAD— ADAPTER, Generator**

62-64	Chevy w/1100357-2096-2226-2227-2274-2336-5135	1923284	1	.46	armature terminal (7 <sup>7</sup> / <sub>32</sub> "— 24 x 1 <sup>35</sup> / <sub>64</sub> " O.L.)
66-68	All w/1117754-82	1961889	2	.51	adapter
73-74	Vega	3952222	1	.66	BOLT, spark control pipe clamp to bracket
66-68	All w/1117754-82	1956030	2	.07	SCREW, terminal (5 <sup>5</sup> / <sub>32</sub> "— 32 x 3 <sup>3</sup> / <sub>4</sub> " O.L.)
62-64	Chevy w/1100357-2096-2226-2227-2274-2336-5135	1905125	2	.07	WASHER, steel term. stud outside (1 <sup>1</sup> / <sub>4</sub> " I.D. x 9 <sup>9</sup> / <sub>16</sub> " O.D. x 1 <sup>1</sup> / <sub>32</sub> " thk.)
64-71	All w/1100639-668-670-693-694-695-696-697-698-742-750-0834 thru 0849	1959523	1	.04	WASHER, condenser terminal insulator screw
67	All	1905406	1	.36	WASHER (5 <sup>5</sup> / <sub>8</sub> "— 1 <sup>1</sup> / <sub>4</sub> " x 3 <sup>3</sup> / <sub>32</sub> ")
68-71	All w/1100794-95-96-0813 thru 0818-0825-26-590834 thru 0848,				
72	All	9419392	6	.05	WASHER, capacitor, gen. brush, diode junction term.— (8.928)
62-64	Chevy w/1100357-2096-2226-2227-2274-2336-5135	1921362	1	.08	INSULATOR, terminal stud (plastic— 2 <sup>1</sup> / <sub>32</sub> " O.D. x 1 <sup>1</sup> / <sub>4</sub> " thk.)
64-71	All w/1100639-668-670-693-694-695-696-697-698-742-750-0834 thru 0849	1959389	1	.08	INSULATOR, condenser terminal screw
65-68	All w/1117754-65-82	1955543	1	.31	INSULATOR, heat sink
66-68	All w/1117754-82	1961887	1	.39	TERMINAL
66-68	All w/1117754-82	1961888	1	.39	TERMINAL, relay

**CHASSIS—ELECTRICAL SYSTEM**

**2.313 STUD— BOLT— SCREW— WASHER— INSULATOR— TERMINAL—  
HOLDER UNIT— LEAD— ADAPTER, Generator (Con't)**

62-71	All w/1100615-618-620-628-629-630-633-639-665-668-669-670-693-694-695-696-697-698-742-750-0834 thru 0849	1959832	1	.85	TERMINAL UNIT, battery
62-71	All w/1100615-618-620-628-629-630-633-665-668-669-670-693-694-695-696-697-742-750-0834 thru 0849	1959833	1	.85	TERMINAL UNIT, ground (Note 1)
<i>NOTE 1 Consists of 1 stud, 1 insulator, 2 washers, 2 lockwashers and 2 nuts.</i>					
65-67	All w/1117754-65	1958828	1	.98	TERMINAL UNIT, battery (Note 2)
<i>NOTE 2 Consists of 1 terminal, 1 bushing, 2 washers, 2 nuts, 2 lockwashers.</i>					
68-69	All w/1117782	1970470	1	1.60	TERMINAL UNIT, battery
72-75	All	1846900	1	1.55	TERMINAL UNIT, batt.
72*	All	1852097	1	1.71	TERMINAL UNIT, field and ind. lgt.
75	All (122)	1971704	1	1.94	TERMINAL UNIT
62-66	Chevy, Chevelle w/1117765	1962608	1	5.60	HOLDER UNIT, brush (Note 3)— (2.291)
<i>NOTE 3 Unit contains 4 screws, 2 studs, 2 terminals, 1 adapter, 1 brush holder, 4 nuts and 11 washers.</i>					
66-68	All w/1117754-82	1961257	1	1.66	LEAD, diode term
66-68	All w/1117754-82	1961803	1	1.38	ADAPTER, terminal

**2.316 BOLT— NUT, Generator Through**

62-64	All w/1102096-2174-2226-2227-2336	809763	2	.45	( <sup>5</sup> / <sub>16</sub> "— 18 x <sup>7</sup> / <sub>8</sub> " )
65-75	All	1956975	4	.16	( <sup>3</sup> / <sub>16</sub> "— 24 x <sup>2</sup> / <sub>64</sub> " )
62-68	All w/1117765-82	1961871	A.R.	.41	NUT, slip ring end frame and drive end frame attach. ( <sup>1</sup> / <sub>4</sub> "— 28 off square)

**2.317 BRACE— SPACER, Generator (Bracket listed in Group 2.277)**

*NOTE Original equipment braces may be replaced by service braces which will require drilling of attaching hole and forming.*

*NOTE: See Dealer Price Schedule for applicable prices.*

**PASS., CHEVELLE, NOVA, CAMARO**

	Length	Slot	Offset	Shape		
62	Chevy (exc. 42-52 amp. A.C. gen.)	7 <sup>5</sup> / <sub>32</sub>	2 <sup>15</sup> / <sub>32</sub>	1 <sup>9</sup> / <sub>32</sub>	Curved	3788503 1
62	All (283, 327) (exc. 50 amp. L.C.I. AC gen.)	14	4 <sup>1</sup> / <sub>2</sub>	5 <sup>5</sup> / <sub>8</sub>	Curved	3760364 1
62-63	Chevy w/62 amp. A.C. gen.,					
64-66	Chevy w/62 amp. (4 cyl.)	7 <sup>5</sup> / <sub>8</sub>	2 <sup>1</sup> / <sub>4</sub>	—	Straight	3791941 1
63-67	Chevy (4 cyl.) (exc. 62 amp.)	8 <sup>13</sup> / <sub>16</sub>	3	1 <sup>1</sup> / <sub>4</sub>	Curved	3793629 1
63	Chevy w/42-52 amp. A.C. gen. (6 cyl.),					
64-66	Chevy (w/C.A.C.) (6 cyl.),					
65	Chevy (153)	9 <sup>3</sup> / <sub>16</sub>	2 <sup>11</sup> / <sub>16</sub>	1 <sup>1</sup> / <sub>4</sub>	Curved	3825450 1
64-69	Pass. (exc. 8 cyl., 62 amp., A.I.R. w/P/S),					
64	Chevy (6 cyl.) (exc. 62 amp., P/S w/Air Cond.),					
64-65	Chevelle (194, 230) (exc. 62 amp.),					
65	Chevy (194) (exc. 62 amp., P/S),					
65-66	Chevy (230) (exc. P/S w/C.A.C.),					
66	Chevelle (194) (exc. 62 amp.),					
66	Chevelle (230) (exc. 62 amp., A.I.R. w/P/S),					
66	Chevy (194) (exc. A.I.R. w/C.A.C.),					
67-68	Chevy, Chevelle, Camaro (6 cyl.) (exc. P/S w/A.I.R.),					
67-68	Chevy (194, 230) (exc. P/S, A.I.R. w/C.A.C.),					
69	Chevy w/A.T. (153),					
69	Chevelle, Camaro (6 cyl.),					
70-71	All (exc. 8 cyl.)	6 <sup>13</sup> / <sub>32</sub>	3 <sup>3</sup> / <sub>8</sub>	4 <sup>5</sup> / <sub>64</sub>	Curved	3838444 1
64-66	All w/62 amp. (6 cyl.) (1st design)	6 <sup>23</sup> / <sub>64</sub>	2 <sup>9</sup> / <sub>16</sub>	None	Straight	3843420 1
64-65	Chevelle w/P/S (8 cyl.) (1st design) (exc. Sp. H/Per., 62 amp.),					

**CHASSIS—ELECTRICAL SYSTEM**

<b>2.317 BRACE— SPACER, Generator (Bracket listed in Group 2.277) (Con't)</b>							
65-67	Chevy (8 cyl.) (exc. 62 amp., Sp. H/Per.) . . . . .	11 <sup>29</sup> / <sub>32</sub>	2 <sup>3</sup> / <sub>4</sub>	1 <sup>3</sup> / <sub>4</sub>	Curved	3846865	1
64	Chevy (8 cyl.) (exc. 62 amp.),						
64-66	Chevy w/62 amp. (8 cyl.) (1st design) . . . . .	13 <sup>3</sup> / <sub>16</sub>	2 <sup>5</sup> / <sub>8</sub>	2 <sup>1</sup> / <sub>2</sub>	Straight	3998338	1
64-66	All w/62 amp. (283, 327) (1st design) . . . . .	10	2 <sup>13</sup> / <sub>64</sub>	1 <sup>1</sup> / <sub>8</sub>	Curved	3879936	1
64-65	Chevelle (8 cyl.) (3rd design) (exc. P/S, Sp. H/Per., 62 amp.),						
65	Pass. (8 cyl.) (exc. 396, S.S., Caprice),						
65	S.S., Caprice (8 cyl.) (exc. 62 amp., 409),						
66-67	All (283, 327) (exc. 62 amp.),						
68	Pass. (307, 327) . . . . .	13 <sup>7</sup> / <sub>8</sub>	3 <sup>25</sup> / <sub>64</sub>	1 <sup>3</sup> / <sub>4</sub>	Curved	3885040	1
65	Chevelle w/Sp. H/Per. (327) (exc. 62 amp.) . . . . .	12 <sup>3</sup> / <sub>4</sub>	2 <sup>27</sup> / <sub>64</sub>	1 <sup>7</sup> / <sub>32</sub>	Curved	3884547	1
65	Chevelle (8 cyl.) (2nd design) (exc. P/S, Sp. H/Per., 62 amp.),						
66-67	Chevelle, Camaro (8 cyl.) (exc. 396, 62 amp.),						
66	Chevelle (exc. 327),						
68	Chevelle (8 cyl.) (exc. Concours),						
68	Camaro, Chevy (exc. 302, 396) . . . . .	14 <sup>57</sup> / <sub>64</sub>	4 <sup>21</sup> / <sub>64</sub>	1 <sup>37</sup> / <sub>64</sub>	Curved	3888104	1
65	Pass. (396) (exc. 62 amp.) . . . . .	8 <sup>5</sup> / <sub>8</sub>	1 <sup>9</sup> / <sub>16</sub>	1 <sup>3</sup> / <sub>4</sub>	Curved	3873864	1
65-67	Pass. w/62 amp. (396, 427),						
66	Chevelle w/62 amp. (396) . . . . .	13 <sup>25</sup> / <sub>64</sub>	3 <sup>11</sup> / <sub>64</sub>	3 <sup>1</sup> / <sub>2</sub>	Curved	3888170 (1)	1
	<i>(1) This is a brace assy. consisting of one 3888172 brace and one 3884510 bracket.</i>						
65	Pass. (409) (exc. 62 amp., Caprice) . . . . .	12 <sup>1</sup> / <sub>8</sub>	3 <sup>1</sup> / <sub>2</sub>	1 <sup>9</sup> / <sub>16</sub>	Curved	3826928	1
65	Chevelle w/P/S (8 cyl.) (2nd design) (exc. Sp. H/Per., 62 amp.) . . . . .	14 <sup>21</sup> / <sub>64</sub>	2 <sup>25</sup> / <sub>32</sub>	1 <sup>1</sup> / <sub>4</sub>	Curved	3873816	1
66-67	All w/62 amp. (283, 307, 327) (2nd design) . . . . .	12 <sup>57</sup> / <sub>64</sub>	2 <sup>13</sup> / <sub>64</sub>	2 <sup>35</sup> / <sub>64</sub>	Curved	3892610	1
66-68	All (396, 427) (exc. 62 amp.) . . . . .	12	2 <sup>29</sup> / <sub>32</sub>	1 <sup>7</sup> / <sub>16</sub>	Curved	3884506	1
66-67	Chevy (A.I.R. w/C.A.C.) (6 cyl.),						
66-67	Chevy (P/S w/C.A.C.) (exc. A.I.R.),						
67	Chevy (6 cyl.) w/Access. C.A.C. . . . .	9 <sup>15</sup> / <sub>64</sub>	—	5 <sup>1</sup> / <sub>32</sub>	Curved	3880805	1
66	Chevy w/Sp. H/Per. (327) (exc. 62 amp.),						
66-67	Chevelle w/Sp. H/Per. (327) (Front) (exc. 62 amp.),						
67-68	Camaro (302) (Front),						
68	Chevy w/Sp. H/Per. (327) . . . . .	12 <sup>9</sup> / <sub>16</sub>	2 <sup>55</sup> / <sub>64</sub>	2 <sup>7</sup> / <sub>64</sub>	Curved	3870388	1
66	Chevy, Chevelle w/62 amp. (6 cyl.) (2nd design),						
66-67	Pass. w/62 amp. (6 cyl.) . . . . .	6 <sup>13</sup> / <sub>64</sub>	2 <sup>1</sup> / <sub>8</sub>		Straight	3998339	1
66-67	Chevelle w/Sp. H/Per. (327) (Rear) (exc. 62 amp.),						
67-68	Camaro (302) (Rear) . . . . .	11 <sup>31</sup> / <sub>32</sub>	3	2	Curved	3899619	1
66-67	Pass. (250) (exc. P/S w/A.I.R.) . . . . .	5 <sup>1</sup> / <sub>4</sub>	3	1 <sup>9</sup> / <sub>32</sub>	Curved	3824404	1
69	All (396, 427),						
71-72	All w/4BC (400, 454) frt. . . . .	6 <sup>9</sup> / <sub>4</sub>	3 <sup>11</sup> / <sub>32</sub>	—	Curved	338497	1
69-75	All (8 cyl.) (exc. 4BC, 396, 400, 427, 454) (frt.) . . . . .	5 <sup>1</sup> / <sub>4</sub>	3 <sup>1</sup> / <sub>4</sub>	—	Curved	6262956	1
70	All (396, 400, 454) (exc. 2BC) (rear) . . . . .	2 <sup>5</sup> / <sub>8</sub>	2	—	Straight	3940942	1
69	All (8 cyl.) (exc. Pass., 396) (rear), . . . . .						
69	Pass. (exc. 396, 427) (rear), . . . . .						
70	All (8 cyl.) (exc. 396, 400, w/4BC, 454) (rear), . . . . .						
71	All (8 cyl.) (exc. 400, 454) (rear) . . . . .	3 <sup>1</sup> / <sub>4</sub>	2	—	Straight	3951574	1

**CHASSIS—ELECTRICAL SYSTEM**

**2.317 BRACE— SPACER, Generator (Bracket listed in Group 2.277) (Con't)**

72-74	All (6 cyl.)	7	2 <sup>7</sup> / <sub>16</sub>	1 <sup>29</sup> / <sub>32</sub>	Curved	6270047	1
72*	All (402, 454) (rear)	—	—	—	—	6262938	1
72*	All (307, 350, 400) (rear),						
73-74	All (8 cyl.) (rear),						
75	All (8 cyl.) (exc. 262) (rear)	—	—	—	—	6262934	1
73-74	All (454) (frt.)	6 <sup>13</sup> / <sub>16</sub>	3 <sup>27</sup> / <sub>32</sub>	—	Curved	338497	
75	All (6 cyl.)	7	3 <sup>3</sup> / <sub>4</sub>	5/ <sub>8</sub>	Curved	354524	
75	All (454) (frt.)	7	3	3/ <sub>4</sub>	Curved	354446	
75	All (350, 400) (frt.)	7	3	1 <sup>1</sup> / <sub>4</sub>	Curved	354424	
<hr/>							
71	Vega (exc. P/S)	3977191	1	3.05			
71-75	Vega (140) w/P/S	3983421	1	2.20	front		
71-75	Vega (140) w/P/S	3992256	1	1.10	rear		
72-75	Vega (140) (exc. P/S)	6270084	1	2.75			
74	Vega (122)	333919	1	9.30			
75	Vega w/C.A.C. (262, 350)	354360	1	2.05	frt.		
75	Vega w/C.A.C. (262, 350)	354361	1	2.05	rear		
75	Vega (262, 350) (exc. C.A.C.)	357006	1	2.85			
75	Vega (122)	348691	1	8.35			
75	Vega (8 cyl.) (exc. C.A.C.)	357036	1	2.85			
69-70	All (396, 400, 427, 454),						
71-72	All w/4BC (400, 454)	3940943	1	.63	SPACER, gen. to cyl. hd. (2 <sup>7</sup> / <sub>8</sub> " long)		
74	Vega w/P/S	3955204	1	.35	SPACER, gen. to brkt.— (3.655)		

**2.319 DIODE— HEAT SINK ASSY.— NUT— BUSHING— SPRING— BRACKET— BRIDGE— CAPACITOR— RESISTOR— TERMINAL UNIT— WASHER— SCREW, Generator (Current Regulator Listed in Group 2.500)**

62-71	All w/1100615-618-620-628-629-630-633-639-665-668-669-670-693-694-695-696-697-698-742-750-0834 thru 0849	1852929	3	3.10	positive (42-52-61 amp.) (red)		
62-71	All (exc. Vega) w/1100615-618-620-628-629-630-633-639-665-668-669-670-693-694-695-696-697-698-742-750-0834 thru 0849	1852928	3	3.13	negative (42-52-61 amp.) (black) (repl. 1959830)		
62-68	All w/1117754-65-82	1852931	3	4.59	positive (62 amp.)		
62-68	All w/1117754-65-82	1852930	3	4.63	negative (62 amp.)		
71-75	Vega, Monza	1971528	1	2.96	negative		
62-71	All w/1100615-618-620-628-629-630-633-639-665-668-669-670-693-694-695-696-697-698-742-750-0834 thru 0849	1959828	1	16.80	HEAT SINK ASSY.		
62-68	All w/1117754-65-82	1852933	1	17.35	HEAT SINK ASSY., positive		
62-68	All w/1117754-65-82	1852932	1	15.80	HEAT SINK ASSY., negative		
66-68	All w/1117754-82	1961878	2	.98	NUT (No. 12— 24)		
65-68	All w/1117765-82	1961877	3	.29	BUSHING, heat sink insulator		
62-71	All w/1100615-618-620-628-629-630-633-639-665-669-670-693-694-695-696-697-698-742-750-0834 thru 0849	1960750	1	.06	SPRING, condenser retaining		
62-68	All w/1117754-65-82	1956279	1	.31	BRACKET, condenser		
72-75	All	1875627	1	13.65	BRIDGE, diode (positive)		
72-75	All	801824	1	2.59	CAPACITOR		
62-71	All w/1100615-618-620-628-629-630-633-639-665-668-669-670-693-694-695-696-697-698-742-750-0834 thru 0849	1959455	1	1.34	CAPACITOR		
66-69	All w/1117754-82	1961891	1	2.23	CAPACITOR		
74	Nova (C.A.C. w/P/S) (6 cyl.),						
75	All (exc. Vega, Monza)	830478	1	.27	RESISTOR, reg. to brush grd.		
70-71	All	1959834	1	.37	TERMINAL UNIT, junc.— (2.313)		
70	All	815540	2	.07	WASHER, capac.		
71	All	9419392	6	.05	WASHER, capac. and diode junc. term		
72-75	All (exc. Vega, Monza)	1851612	1	.07	SCREW, w/washer, capac. brkt.		
73-75	All (exc. Vega, Monza)	1876688	1		SCREW, diode bridge attach.		

**2.333 TRAY ASSY.— SUPPORT— BRACE— BRACKET— BUMPER— SCREW ASSY., Battery**

64-65	Pass., Chevelle	3848270	1	3.75			
-------	-----------------	---------	---	------	--	--	--



**CHASSIS—ELECTRICAL SYSTEM**

**2.333 TRAY ASSY.— SUPPORT— BRACE— BRACKET— BUMPER— SCREW ASSY., Battery (Con't)**

66	Pass., Chevelle,				
67-69	Camaro .....	3893882	1	6.15	
68	Pass.,				
68-72	Chevelle .....	3915471	1	4.55	
68-74	Nova .....	3916658	1	4.20	
69	Pass. ....	3938000	1	4.70	
70	Pass. ....	3957233	1	4.55	
70-75	Camaro .....	3967157	1	4.25	
71-72	Pass. ....	3972889	1	4.50	
73-75	Pass. ....	327172	1	4.70	
73-75	Chevelle .....	338566	1	5.90	
75	Nova .....	344385	1	4.80	
71-75	HV (140) .....	9845074	1	4.40	
75	HR (206, 262) .....	1695487	1	5.25	
75	H (140) .....	1684802	1	5.45	
75	HM .....	1704871	1	6.85	
65	Pass. ....	3858968	1	1.75	SUPPORT, tray .....
70-72	Monte Carlo .....	3963317	1	.98	SUPPORT, tray .....
75	Monza .....	1706591	L.H.	4.35	BRACE, tray to abs. hsg. ....
71	Pass. ....	6270166	1	1.10	BRACKET, battery supt. ....
71	Pass. ....	6270167	2	.52	BUMPER, battery supt. brkt.— (8.024) ....
73	Nova .....	3945712	2	.16	SCREW ASSY., w/washer— (8.143) ....

**2.334 BOLT, Battery Hanger Clamp**

62-67	Chevy, Chevelle .....	325053	A.R.	1.25	( <sup>5</sup> / <sub>16</sub> "— 18 x 10 <sup>1</sup> / <sub>2</sub> " O.L.— hook end) .....
64	Chevelle (exc. C.A.C., Taxi, Police),				
65	Pass., Chevelle (exc. Air Cond., Taxi, Police, 327, 396, 409, H.D. Batt., Caprice) .....	3848488	1	.34	rear ( <sup>5</sup> / <sub>16</sub> "— 18 x 7 <sup>5</sup> / <sub>8</sub> ") .....
64-65	Chevelle w/H.D. Batt.,				
65	Pass. (409) (exc. H/Per., dual 4BC),				
65	Pass. (T.H. w/C.A.C.),				
65	Pass. w/H.D. Bat.,				
65	Pass. (396) .....	3848495	1	.40	rear ( <sup>5</sup> / <sub>16</sub> "— 18 x 9 <sup>1</sup> / <sub>4</sub> ") .....
64-65	Chevelle (Taxi, Police),				
64	Chevelle w/Air Cond.,				
65	Chevelle (exc. H.D. Batt.),				
65	Pass. w/Air Cond. (exc. H.D. Bat., 327, 409),				
65	Pass. (327) (exc. H.D. Bat.),				
65	Pass. w/H/Per., dual 4BC (409) (exc. H.D. Bat.),				
65	Taxi, Police (exc. H.D. Bat., 327),				
65	Pass. w/T.H. (exc. C.A.C.),				
65	Pass. w/Sp. H/Per. (396),				
66	Chevelle (327) (exc. H.D. Batt.) .	6263004	1	.77	rear ( <sup>5</sup> / <sub>16</sub> "— 18 x 8 <sup>1</sup> / <sub>4</sub> ") .....

**2.335 RETAINER— CLAMP, Battery Top**

62-63	Chevy (Taxi, Police) (exc. H.D. Batt.),				
64-65	Chevy (Taxi) (exc. H.D. Batt.),				
65-66	Chevy (327) (exc. H.D. Batt.),				
67	Nova (327) .....	3795405	1	2.00	
64-65	Chevelle .....	3848484	1	1.70	
65	Taxi, Police w/H.D. Bat.,				
65	Pass. (409) (exc. H/Per.),				
65	Pass. w/H.D. Bat.,				
65	Pass. (T.H. w/C.A.C.),				
65	Pass. (396) .....	3859505	1	1.70	
65	Pass. w/Air Cond. (exc. H.D. Bat.),				
65	Pass. (327, 396) (exc. H.D. Bat.),				
65	Pass. w/H/Per. (409) (exc. H.D. Bat.),				
65	Pass. w/T.H. (exc. C.A.C., H.D. Bat.),				
65	Taxi, Police (exc. H.D. Bat.) .....	3859507	1	2.45	
65	Pass. (exc. 327, 396, 409, Taxi, Police, H.D. Bat., Air Cond.) . . .	3859509	1	2.45	
63-67	Chevy (6 cyl.) (exc. Taxi, H.D. Batt.),				

## CHASSIS—ELECTRICAL SYSTEM

### 2.335 RETAINER— CLAMP, Battery Top (Con't)

64-65	Chevy (283) (exc. Taxi, H.D. Batt.)	3830594	1	.16	CLAMP
66	Pass. (exc. S.S.),				
67-75	All (exc. Monza)	6270159	1	.55	CLAMP
75	Monza (140)	358328	1	1.00	CLAMP
75	Monza (262)	353929	1	.55	CLAMP

### 2.341 CABLE, Battery Ground, with Terminal

62-70	All	8907363	1	9.40	(36" ctr. to ctr. holes) (universal)
62-70	All	8907362	1	8.61	(30" ctr. to ctr. holes) (universal)
62-70	All	8907361	1	7.86	(22" ctr. to ctr. holes) (universal)— (2.342)
65	Pass. w/Air Cond. (6 cyl.),				
66-68	Chevy w/C.A.C. (6 cyl.),				
67	Camaro w/C.A.C. (6 cyl.) (exc. H.D. Batt.),				
68	Camaro w/C.A.C. (6 cyl.)	8907359	1	7.38	batt. (15" ctr. to ctr. holes)
70	Police (454) (exc. H.D. Batt.)	8907353	1	5.42	(22" ctr. to ctr. holes)
70	Pass. w/H.D. Batt. (6 cyl.)	8901374	1	9.10	(26 1/2" ctr. to ctr. holes) (side terminals)
70	Nova w/H.D. Batt. (6 cyl.) (exc. C.A.C.)				
70	Monte Carlo	8907027	1	9.10	(28" ctr. to ctr. holes) (side terminals)
69	Camaro w/C.A.C. (6 cyl.) (2nd design) (exc. H.D. Batt.),				
70	Nova (350),				
70	Chevelle w/H.D. Batt. (exc. Monte Carlo),				
70	Pass. w/H.D. Batt.,				
70	Camaro (8 cyl.),				
71-75	Vega (122, 140),				
71-74	Nova,				
71-75	Camaro, Chevelle (8 cyl.) (exc. Monte Carlo)	8907026	1	8.28	(25" ctr. to ctr. holes) (side terminals)
70	Camaro (6 cyl.),				
71-74	Chevelle (6 cyl.),				
71-75	Pass., Monte Carlo	8907027	1	9.10	(30" ctr. to ctr. holes) (side terminals)
70	Nova w/H.D. Batt. (4 cyl.),				
71-74	Camaro (6 cyl.),				
75	Monza (262)	8907028	1	9.77	(35" ctr. to ctr. holes) (side terminals)
All	All	6296304	1	7.14	universal

### 2.342 CABLE— BLOCK ASSY.— BOLT, Battery to Starter Switch, with Terminals (Insulated)

62-63	Chevy (exc. 42-52-62 amp., 8 cyl., Air Cond.),				
64-65	Chevy (exc. H.D. Batt., C.A.C., 8 cyl., 55-62 amp.),				
64	Chevy w/H.D. Batt.,				
64-65	Chevelle w/H.D. Batt., Air Cond., Taxi, Police (6 cyl.),				
65-66	Chevy w/61-62 amp. (exc. 8 cyl.),				
65	Chevelle (6 cyl.) (exc. H.D. Batt., C.A.C., Taxi, Police),				
66	Chevelle (6 cyl.) (exc. H.D. Batt.),				
66	Chevy (exc. 61-62 amp., 8 cyl.)	8907363	1	9.40	(35" ctr. to ctr. holes)
62	Chevy w/AC gen.,				
63	Chevy (exc. C.A.C., 52-62 amp., AC gen.),				
63-64	Chevy w/52-62 amp. AC gen. (2nd design) (exc. H.D. Batt., 8 cyl.),				
63-64	Chevy w/C.A.C. (6 cyl.),				
64	Chevy (8 cyl.) (exc. C.A.C., H.D. Batt.),				
65-66	Chevy (327) (exc. Sp. H/Per.),				
64	Chevelle (Air Cond. w/H.D. Batt.) (283),				
64	Chevelle (327),				
64	Chevelle (6 cyl.) (exc. H.D. Batt., Air Cond., Taxi, Police),				
64	Chevelle (283) (exc. C.A.C., H.D. Batt.),				
65	Pass. (6 cyl.),				
65	Chevelle (8 cyl.) (exc. C.A.C., H.D. Batt., 327),				

**CHASSIS—ELECTRICAL SYSTEM**

**2.342 CABLE— BLOCK ASSY.— BOLT, Battery to Starter Switch, with Terminals (Insulated) (Con't)**

66	Pass. (6 cyl.) (exc. H.D. Batt., Taxi, Police),				
67	Chevy, Chevelle, Camaro (6 cyl.),				
67	Chevy (exc. 327),				
69-70	Taxi,				
69	Pass. (8 cyl.),				
70	Nova (350, 396) (exc. H.D. Batt.)	8909815	1	11.38	(48" ctr. to ctr. holes) .....
63	Chevy w/52-62 amp. AC gen. (1st design) (exc. C.A.C.),				
65-66	Chevelle w/H.D. Batt. (8 cyl.) (exc. C.A.C., 327, 396),				
65-66	Chevelle (327, 396),				
66	Chevelle w/C.A.C. (396),				
65-66	Pass. (8 cyl.),				
66	Chevelle (283) (exc. H.D. Batt.),				
67-68	Pass. (6 cyl.),				
67-69	Nova, Chevelle, Camaro (8 cyl.),				
68	Pass. (8 cyl.),				
68-69	Chevelle (6 cyl.) (exc. H.D. Batt.),				
70	Pass. (8 cyl.) (exc. 454, H.D. Batt.),				
70	Nova (8 cyl.) (exc. 350, 396, H.D. Batt.),				
70	Chevelle (8 cyl.) (exc. H.D. Batt., Monte Carlo) .....	8907366	1	11.55	(54" ctr. to ctr. holes) .....
67	Chevy (327),				
70	Pass. (8 cyl.) (exc. H.D. Batt.) ...	8907364	1	9.89	(41" ctr. to ctr. holes) .....
67	Pass. (8 cyl.) .....	8907367	1	12.90	(57" ctr. to ctr. holes) .....
69	Camaro (6 cyl.) (exc. H.D. Batt.),				
70	Nova w/H.D. Batt.,				
70	Camaro,				
71-75	All (6 cyl.),				
71-72	Camaro, Chevelle (8 cyl.) (exc. Monte Carlo),				
73-75	Camaro, Nova (8 cyl.) .....	8907029	1	10.65	(40" ctr. to ctr. holes) .....
70	Pass., Chevelle w/H.D. Batt. (6 cyl.) .....	8901397	1	11.20	(37" ctr. to ctr. holes) .....
70	Monte Carlo (exc. H.D. Batt.) ...	8901072	1	8.90	(57" ctr. to ctr. holes) .....
69	Camaro (8 cyl.),				
70	Chevelle w/H.D. Batt.,				
71-72	Nova, Pass. (8 cyl.),				
71-72	Monte Carlo,				
73-75	Pass., Chevelle (8 cyl.) .....	8907030	1	11.13	(45" ctr. to ctr. holes) .....
71-72	Vega .....	8907028	1	9.77	pos. (35") .....
73-75	Vega (122, 140) .....	8907027	1	9.10	battery pos. (30") .....
75	Monza (262) .....	8907033	1	14.29	battery pos. (30") .....
75	Monza w/C.A.C. (262) .....	8919885	1	18.98	battery pos. (30") .....
65-74	All .....	340409	1	.36	<b>BLOCK ASSY.</b> , batt. pos. cable junction ...
69-70	Camaro,				
70	Pass., Nova, Chevelle w/H.D. Batt.,				
71-75	All .....	8905400	1	.75	<b>BOLT</b> , batt. cable (positive cable) used with side term. batt. cable— (2.343) .....

**2.343 BOLT— SCREW— SHIELD, Battery Cable**

62-69	All .....	1846534	1	.22	w/nut for bolt type clamp .....
69-70	Camaro,				
70	Pass., Nova, Chevelle w/H.D. Batt. ....	8900304	1	1.03	<b>SCREW</b> , batt. cable ( <sup>5</sup> / <sub>16</sub> " ), used with side term. batt. cable (neg.) .....
75	Monza (262) .....	344886	1	2.10	<b>SHIELD</b> , pos. batt. cable .....

**2.345 WASHER— PLUG, Battery**

62-69	All .....	378082	1	.05	pos. term. ( <sup>11</sup> / <sub>16</sub> " I.D. x <sup>15</sup> / <sub>16</sub> " O.D. x <sup>3</sup> / <sub>16</sub> " ) ...
62-69	All .....	1876506	1	1.38	<b>PLUG</b> , filler (Delco Eye), push on type .....

**2.361 DISTRIBUTOR, Ignition**

62-67	Chevy, Chevelle (194) .....	1110388	1	46.60	
62-67	Chevy (4 cyl.) .....	1110323	1	46.50	
64	Chevelle (327) .....	1111016	1	56.45	
64-67	All (283),				
67	Pass. (327),				
68	Chevelle, Chevy (283, 327) (exc. H/Per., Sp. H/Per.),				

**CHASSIS—ELECTRICAL SYSTEM**

**2.361 DISTRIBUTOR, Ignition (Con't)**

68	Pass. (327 w/reg. fuel) . . . . .	1111500	1	53.05	
65	Pass. (409) (exc. H/Per., T. Ign.) .	1111023	1	60.35	(w/vacuum advance, single contact) . . . . .
65-67	All (230) (exc. A.I.R.) . . . . .	1110362	1	38.65	
65-67	Chevelle w/Sp. H/Per. (327) (exc. T. Ign.) . . . . .	1111195	1	56.25	
65-67	All (327) (exc. A.I.R.) . . . . .	1111249	1	55.55	
65	Pass. (396) (exc. Sp. H/Per., T. Ign.),				
66	Pass. (396) (exc. T. Ign., A.T.)				
66	Chevelle (396) (exc. H/Per., Sp. H/Per., T. Ign., P.G.),				
67-69	Chevelle, Nova, Camaro (396) (exc. H/Per., Sp. H/Per.),				
67-69	Pass. (396, 427),				
70	All (T.H. 400 w/H/Per.) (396),				
70	Chevelle (400) (exc. 2BC) . . . . .	1111998	1	55.90	
65-66	Pass. w/Sp. H/Per. (396, 427) (exc. T. Ign.),				
66	Chevelle w/Sp. H/Per. (396) (exc. T. Ign.) . . . . .	1111100	1	57.75	
66-67	All (250) . . . . .	1110351	1	40.85	
66	Pass. (427) (exc. Sp. H/Per. T. Ign., T.H.),				
66-68	Chevelle, Camaro w/H/Per., Sp. H/Per. (396) (exc. T. Ign.),				
67	Pass. (427),				
68-69	Pass. w/Sp. H/Per. (427),				
69	Chevy, Chevelle, Camaro w/Sp. H/Per. (396) . . . . .	1111499	1	43.25	
67	Camaro (exc. 327, 4BC, 350) . . .	1111101	1	52.90	
67	Camaro (302) HD Z28 . . . . .	1111267	1	130.00	
67-69	Camaro (302) . . . . .	1111480	1	54.30	
68	Chevelle, Camaro w/Sp. H/Per. (327) . . . . .	1111478	1	44.45	
68	Chevy (4 cyl.) (exc. A.T.),				
69-70	Chevy (4 cyl.) (exc. P.G., Torque Drive) . . . . .	1110457	1	49.30	
68	Chevy, Camaro (350) (exc. P.G.),				
69	All (350) (exc. reg. fuel, A.T.),				
70	Nova, Chevelle, Camaro w/H/Per. (350) (exc. A.T.) . . . . .	1111996	1	55.00	
68	Camaro (A.T. w/2BC) . . . . .	1111443	1	45.10	
68	Camaro w/2BC (exc. P.G.),				
69	Camaro (327) w/reg. fuel (exc. A.T.) . . . . .	1111482	1	50.90	
68-70	Chevy w/A.T. (4 cyl.) . . . . .	1110458	1	50.05	
68-70	All (250) (exc. A.T., Taxi, Police)	1110465	1	43.60	
68-70	Taxi, Police w/A.T. (6 cyl.) . . . . .	1110482	1	43.60	
68-70	Taxi, Police (6 cyl.) (exc. A.T.) . .	1110483	1	43.60	
68	All w/A.T. (327) . . . . .	1111297	1	53.20	
68-69	All (230) (exc. A.T.),				
70	Nova (6 cyl.) (exc. 250, A.T.) . . .	1110459	1	45.25	
68-70	All w/A.T. (250) . . . . .	1110466	1	43.60	
68-69	All w/A.T. (230),				
70	Nova w/A.T. (6 cyl.) (exc. 250) . .	1110460	1	42.15	
68	All (307),				
69	All (307, 327),				
70	Nova, Chevelle, Camaro (307) (exc. A.T.) . . . . .	1111995	1	49.95	
69	All w/2BC (350) (exc. A.T.),				
70	All (350) (exc. A.T., H/Per.) . . . .	1112001	1	54.35	
69	All (2BC w/A.T.) (350),				
69	Pass. w/T.H. 400 (8 cyl.) (exc. 396),				
70	All w/A.T. (350) (exc. H/Per.) . . .	1112002	1	52.75	
69	Pass. (427) (exc. H/Per., Sp. H/Per.) . . . . .	1111925	1	51.55	
69	All (A.T. w/4BC) (350 w/reg. fuel) . . . . .	1111955	1	51.60	
69	All w/4BC (350 w/reg. fuel) (exc. A.T.) . . . . .	1111956	1	55.75	
69	Camaro w/P.G., T.H. 350 (327, 350 w/reg. fuel),				
70	Nova, Chevelle, Camaro w/A.T. (307),				

**CHASSIS—ELECTRICAL SYSTEM**

**2.361 DISTRIBUTOR, Ignition (Con't)**

71-72	All (307) (exc. A.T.),				
71	All (A.T. w/2BC) (350),				
72	All w/2BC (350) . . . . .	1112005	1	53.75	
67	Camaro (350),				
68	Chevy, Camaro w/P.G. (350),				
69	All w/A.T. (350) (exc. reg. fuel),				
70	All (A.T. w/H/Per.) (350) (exc. T.H. 400) . . . . .	1111997	1	54.45	
70	All w/Sp. H/Per. (396),				
70	Camaro w/2BC (400) . . . . .	1112000	1	56.85	
69	Chevy, Chevelle, Camaro w/H/Per. (396) (exc. T.H. 400),				
70	All w/H/Per. (396) (exc. T.H. 400) . . . . .	1111999	1	56.05	
70	Pass., Monte Carlo (A.T. w/2BC) (400) . . . . .	1111494	1	55.10	
70	Monte Carlo w/2BC (400) (exc. A.T.) . . . . .	1111492	1	56.25	
70	Pass. (454) (exc. H/Per.) . . . . .	1111436	1	58.40	
70	All w/H/Per. (454) . . . . .	1111963	1	58.40	
70	Chevelle w/Sp. H/Per. (454) . . . . .	1111437	1	58.85	
70	Camaro w/Sp. H/Per. (350) . . . . .	1112019	1	54.95	
71-72	All (6 cyl.) . . . . .	1110489	1	39.50	
71	Camaro w/Sp. H/Per. (350) (exc. A.T.),				
71-72	All w/A.T. (307) . . . . .	1112039	1	51.90	
71	All w/2BC (350) (exc. A.T.) . . . . .	1112042	1	53.35	
71-72	All (350 w/4BC) (exc. A.T., Sp. H/Per.) . . . . .	1112044	1	53.35	
71	All (A.T. w/4BC) (350) (exc. Sp. H/Per.) . . . . .	1112045	1	51.90	
72	All (A.T. w/Sp. H/Per.) (350) . . . . .	1112049	1	56.30	
71	All (A.T. w/2BC) (400) . . . . .	1112056	1	53.85	
71-72	All w/4BC (400, 402) . . . . .	1112057	1	51.15	
71-72	All (454) (exc. Sp. H/Per.) . . . . .	1112052	1	49.85	
71	Camaro (A.T. w/Sp. H/Per.) (350) . . . . .	1112074	1	62.45	
71-72	Vega w/A.T.,				
72	Vega (NB-2 w/2BC) w/A.T. . . . .	1110435	1	54.10	
71-72	Vega (exc. A.T.) . . . . .	1110492	1	46.50	
72	All (400) . . . . .	1112099	1	53.05	
72	All (A.T. w/4BC) (350) (exc. Sp. H/Per.) . . . . .	1112045	1	51.90	w/Integral breaker point capacitor assy. . . . .
72-73	All w/Sp. H/Per. (350) (exc. A.T.) . . . . .	1112095	1	59.05	
73-74	All (6 cyl.) . . . . .	1110499	1	40.70	
73	All w/4BC (350) (exc. A.T., Sp. H/Per.),				
74	Pass. (4BC w/NB2) (350),				
74	Chevelle w/4BC (350),				
74	Camaro, Nova (4BC w/dual exh.) (350) (exc. NB2, Sp. H/Per.) . . . . .	1112093	1	54.85	
73	All (A.T. w/4BC) (350) (exc. Sp. H/Per.),				
74	Pass. (Sta. Wag.) w/4BC (350) (exc. NB2) . . . . .	1112094	1	54.85	
73	All (307) (exc. A.T.) . . . . .	1112227	1	52.90	
73	All (307) w/A.T. . . . .	1112102	1	53.35	
73-74	All (454) (exc. H.E.I.) . . . . .	1112113	1	58.30	
73	All (400) . . . . .	1112166	1	54.50	
73	Camaro (A.T. w/Sp. H/Per.) (350) . . . . .	1112148	1	61.15	
73	All w/2BC (350) (exc. Pass., Sta. Wag.) . . . . .	1112168	1	51.40	
73	Pass. (Sta. Wag.) w/2BC (350) . . . . .	1112230	1	52.85	
73	Vega (140),				
74	Vega w/1BC (140) . . . . .	1110496	1	49.60	
74	Vega w/2BC (140) . . . . .	1110532	1	45.50	
74	Pass. w/4BC (400) (exc. NB2) . . . . .	1112250	1	55.60	
74	All (4BC w/single exh.) (350) (exc. Pass., A.T.),				
74	All w/NB2 (4BC w/dual exh.) (350) (exc. A.T., Sp. H/Per.) . . . . .	1112543	1	49.10	
74	All (4BC w/NB2) (400) . . . . .	1112545	1	56.50	
74	Camaro w/Sp. H/Per. (350) . . . . .	1112528	1	170.50	(H.E.I.) . . . . .
74	Pass. w/2BC (350) (exc. NB-2),				

**CHASSIS—ELECTRICAL SYSTEM**

**2.361 DISTRIBUTOR, Ignition (Con't)**

74	Nova, Chevelle, Camaro w/2BC (350)	1112844	1	55.00	
74	Pass. w/2BC (400) (exc. NB-2), Chevelle (A.T. w/2BC) (400)	1112846	1	54.05	
74	Pass. w/NB-2 (454)	1112527	1	170.50	(H.E.I.)
74	Pass. (Sta. Wag.) (400)	1112864	1	180.00	(H.E.I.)
74	All w/4BC (400) (exc. Sta. Wag.)	1112865	1	180.00	(H.E.I.)
74	All w/2BC (400)	1112866	1	180.00	(H.E.I.)
75	All w/NB-2 (6 cyl.)	1110650	1	140.00	(H.E.I.)
75	All w/integrated cyl. hd. (6 cyl.) (exc. NB-2)	1112863	1	138.75	(H.E.I.)
75	All (6 cyl.) (exc. integrated cyl. hd.)	1110652	1	140.00	(H.E.I.)
75	Nova (262)	1112933	1	180.00	(H.E.I.)
75	Camaro w/Sp. H/Per. (350)	1112883	1	180.00	(H.E.I.)
75	All w/2BC (350), Pass., Chevelle w/4BC (350), Chevelle exc. Sta. Wag. w/4BC (350) Nova, Camaro (NB-2 w/4BC) (350)	1112959	1	172.25	(H.E.I.)
75	Pass., Chevelle w/4BC (350)	1112880	1	170.50	(H.E.I.)
75	Nova, Camaro w/4BC (350) (exc. NB-2)	1112888	1	170.50	(H.E.I.)
75	All (400)	1112882	1	180.00	(H.E.I.)
75	All (454)	1112886	1	170.50	(H.E.I.)
75	All (122)	1110649	1	149.00	(H.E.I.)
75	Vega, Monza (140)	1112862	1	149.00	(H.E.I.)
75	Monza (262)	1112933	1	180.00	(H.E.I.)

**2.362 HOUSING— COVER— SHIELD— SCREW, Distributor**

62-70	All (exc. 8 cyl., Taxi, Police)	1954539	1	7.75	(0351-0360-0361-0362-0363-0307-0439 thru 0466)
64-74	All (8 cyl.) (exc. 409 H.E.I.)	1966407	1	14.80	(w/1111073-74-96-98-1100-07-09-12-14-16-20-32-37-40-1257-1439-69-97-98)
68-69	Taxi, Police (6 cyl.)	800043	1	8.75	(w/1110469-70) (perma-lube housing)
70	Taxi, Police				w/1110482-83,
71-74	All (6 cyl.)	1846069	1	11.00	(Note 1)
71-74	All (140)	1846284	1	11.15	
75	All (122)	1892189	1	16.30	base
75	All (122)	360147	1	95.00	drive
75	Vega, Monza (140)	1880018	1	14.90	w/1112862
75	Monza (262)	1876222	1	20.25	w/1112933
<i>NOTE 1: When using with mainshafts having spiral oil groove remove seal from top of housing.</i>					
74-75	All (8 cyl.) w/H.E.I.	1876222	1	20.25	(H.E.I.)
75	(6 cyl.)	1880038	1	14.90	w/1110650-52-2863
75	All (122)	334048	1	.81	COVER, dist. drive hsg.
62-66	Chevy	1960325	1	1.15	SHIELD, dust
75	All (122)	546575	A.R.	.11	SCREW, dist. drive hsg. cvr.— (10.152)

**2.363 GASKET— CLAMP— PIN— RETAINER— STUD— PIPE— LOCK, Distributor Housing**

62-75	All (140, 250)	6256636	1	.13	mounting (1 <sup>3</sup> / <sub>32</sub> " I.D. x 1 <sup>19</sup> / <sub>32</sub> " O.D.)
64-75	All (8 cyl.) (exc. 409, F.I.)	3932344	1	.12	ign. timer dist. (1 <sup>13</sup> / <sub>16</sub> " O.D. x 1 <sup>9</sup> / <sub>32</sub> " I.D.)
65	Pass. w/F.I.	3745181	A.R.	.12	mounting (1 <sup>9</sup> / <sub>32</sub> " I.D. x 1 <sup>13</sup> / <sub>16</sub> " O.D.) (3 <sup>3</sup> / <sub>32</sub> " slot)
65	Pass. (409)	3737047	1	.12	mounting (1 <sup>1</sup> / <sub>2</sub> " I.D. x 2 <sup>1</sup> / <sub>8</sub> " O.D.)
75	All (122)	2359870	1	.51	ign. timer dist. ("O" ring)
75	All (122)	334049	1	.81	dist. drive hsg. cover
75	All (6 cyl.)	355780	1	.40	
62-69	All	2494772	A.R.	.65	CLAMP (1/4" to 5/8")— (1.166)
64-75	All (8 cyl.)	3704912	1	.53	CLAMP, mounting
62-75	All (6 cyl.)	3998172	1	.40	CLAMP, mounting
71-75	Vega (140)	3980255	1	.50	CLAMP, mounting
62-70	All,				
75	All (122)	141192	1	.28	PIN, dist. drive shaft
75	All (122)	360149	1	.40	PIN, dist. drive ret.
71	All (6 cyl.)	3770598	1	.12	RETAINER, ignition timer clamp
71-75	All	1950569	1	.09	SEAL, housing oil
70	Taxi, Police (6 cyl.)	1876413	1	1.66	SEAL, hsg., oil
75	All (122)	334001	1	.45	SEAL, drive shaft
75	All (122)	348626	1	.16	SEAL, dist. drive hsg.
75	All (122)	352119	1	.29	STUD, clamp
71-75	Vega (140)	3980253	1	.18	STUD, clamp
75	All (122)	334058	1	.31	LOCK, drive hsg.

**CHASSIS—ELECTRICAL SYSTEM**

**2.364 LUBRICATOR— ELBOW— RETAINER— WASHER, Distributor Lubricating**

70	Taxi, Police,				
71-74	Vega	1963555	1	.06	rotor lubricating
62-74	All	1852935	1	.57	LUBRICATOR UNIT, cam
75	All (122)	190338	1	2.65	ELBOW, dist. dr. hsg. oil drain pipe at dist. hsg.— (8.963)
75	All (122)	442411	1	10.25	ELBOW, dist. dr. hsg. oil drain pipe at oil pump— (8.963)
64-70	All (8 cyl.),				
71-73	All	1935621	1	.10	RETAINER, felt wick
74	All	1963858	1	.33	RETAINER, felt wick
64-70	All (8 cyl.),				
64-70	All (8 cyl.),				
71-75	All	1951099	1	.08	WASHER, housing oil seal

**2.367 CAP, Distributor**

62-70	Chevy (4 cyl.),				
71-74	All (140)	1962446	1	4.15	
62-74	All (6 cyl.)	1971324	1	4.07	
64-74	All (8 cyl.) (exc. H.E.I.)	800061	1	6.75	
74-75	All (8 cyl.) w/H.E.I.	1875963	1	11.65	
75	All (140)	1880022	1	7.82	
75	All (6 cyl.)	1880042	1	8.63	

**2.368 BRUSH— COVER— SCREW, Distributor**

74-75	All	1875967	1	1.80	dist. cap resistor (H.E.I.)
74-75	All	1875960	1	3.09	COVER, cap (H.E.I.)
74-75	All	1876153	1	.11	SCREW, dist. cap cover attach. (H.E.I.)

**2.372 SHAFT— POLE PIECE— ROTOR— GROMMET, Distributor, with Weight Plate**

62-68	Chevy (4 cyl.),				
64	Chevy, Chevelle,				
69-70	Chevy (4 cyl.) (exc. P.G., Torque Drive)	800094	1	7.40	w/weight plate (w/1110268-0292-0321-0457)
62-65	Chevy, Chevelle (194),				
66	Chevy, Chevelle (194) (exc. A.I.R., P.G.)	1961215	1	6.40	w/weight plate (w/1110267-0293-0360)
64-66	Chevy, Chevelle (283) (exc. A.I.R.),				
65-66	Pass. (283) (exc. A.I.R.)	1960377	1	6.05	w/1110920-0947-1015-1096
64-67	Chevy (8 cyl.)	3790872	1	2.20	intermediate, to oil pump
64-67	All (230)	1957385	1	6.70	w/1110280-0336
65	Chevelle w/Sp. H/Per. (327) (exc. T. Ign.),				
66-67	Chevy, Chevelle (327) (exc. A.I.R., T. Ign.),				
67	Chevy, Chevelle w/A.I.R. (250, 283),				
67	Pass. w/A.I.R. (283) (exc. P.G.)	1964371	1	7.00	main, w/auto. cam (w/1111071-1107-1108-1256)
65	Pass. (409)	3764553	1	2.00	intermediate, to oil pump (Note 1)
65	All (327),				
68	All (307) (exc. P.G.)	1964913	1	5.90	w/automatic cam (w/1111074-75)
65-66	All (Sp. H/Per. w/T. Ign.) (396, 427),				
65-69	All w/Sp. H/Per., (396, 427),				
67-68	Pass. (427),				
70	Nova, Chevelle, Camaro w/Sp. H/Per. (396, 400 w/4BC, 454),				
71	All w/Sp. H/Per. (454)	3865886	1	3.65	intermediate to oil pump
65-70	All (396, 427, 454) (exc. Sp. H/Per.),				
71	All w/4BC (400, 454) (exc. Sp. H/Per.)	3998289	1	2.25	intermediate, to oil pump
65-66	All w/Sp. H/Per. (396) (exc. T. Ign.),				
71	Camaro w/Sp. H/Per. (350) (exc. A.T.)	1965891	1	6.55	main, w/auto. cam (w/1111100, 1112049)
66-70	All w/A.T. (250)	1966436	1	7.00	main, w/weight plate (w/1110351-0464-66)
66-67	All w/A.I.R. (283),				
68-69	Pass. (327 w/reg. fuel),				
68	Chevelle w/reg. fuel (327),				
69	All w/2BC (350) (exc. A.T.),				

**CHASSIS—ELECTRICAL SYSTEM**

**2.372 SHAFT— POLE PIECE— ROTOR— GROMMET, Distributor, with Weight Plate (Con't)**

70	All (350) (exc. A.T., H/Per.),					
71	All w/2BC (350) (exc. A.T.) . . . . .	<b>1967196</b>	1	6.45	main, w/auto. cam (w/1111150-1482-86-1500-2001-42) . . . . .	
66-67	Pass. (327) (exc. A.I.R.),					
67	Chevy, Chevelle, Camaro (327) (exc. A.I.R., P.G.),					
68	Chevy, Camaro w/P.G. (350),					
69	Chevy, Chevelle, Camaro w/A.T. (350) (exc. reg. fuel),					
69-70	Pass. w/A.T. (350) (exc. reg. fuel) . . . . .	<b>1968076</b>	1	5.80	main, w/auto. cam (w/1111193-95-97-1489) . . . . .	
67-68	All (396, 427),					
69	Pass. (427),					
69	Chevelle, Chevy, Camaro,					
70	All w/Sp. H/Per. (396),					
70	All (T.H. 400 w/H/Per.) (396),					
70	Chevelle (400) (exc. 2BC) . . . . .	<b>1968535</b>	1	6.65	main, w/auto. cam (w/1111169-70-1497-99-1925-98-2000) . . . . .	
67-69	Camaro (302) . . . . .	<b>1969762</b>	1	7.25	main auto. cam (w/1111266) . . . . .	
68-70	All w/A.T. (230) . . . . .	<b>1970578</b>	1	7.10	main, w/weight plate (w/1110433-0460) . .	
68-70	All (250) (exc. A.T.) . . . . .	<b>1970840</b>	1	6.35	main, w/weight plate (w/1110439-63) . . . .	
68	All w/A.T. (307),					
69	Chevy, Chevelle (exc. 350, 396),					
70	Nova, Chevelle, Camaro (307) (exc. A.T.) . . . . .	<b>1970575</b>	1	6.65	main, w/auto. cam (w/1111257-1481-1995) . . . . .	
68	Camaro w/2BC (exc. P.G.),					
69	Chevy, Chevelle (A.T. w/2BC) (350),					
70	All w/A.T. (350) (exc. H/Per.) . . .	<b>1970863</b>	1	6.55	main, w/weight plate (w/1111440-2002) . .	
68	Chevy, Camaro (350) (exc. P.G.),					
68	Chevelle, Camaro w/Sp. H/Per. (327),					
69	All (350) (exc. reg. fuel, A.T.),					
70	Nova, Chevelle, Camaro w/H/Per. (350) (exc. A.T.) . . . . .	<b>1966928</b>	1	6.65	main, w/cam (1111264-1444-88-1996) . . . .	
69-70	Chevy (4 cyl.) w/P.G., Torque Drive . . . . .	<b>800263</b>	1	7.35	main, w/weight plate (w/1110458) . . . . .	
69-70	All w/H/Per. (396) (exc. T.H. 400) . . . . .	<b>1970915</b>	1	6.05	main, w/auto. cam (w/1111498-1999) . . . .	
69	Camaro w/A.T. (327, 350 w/reg. fuel),					
70	Nova, Chevelle, Camaro w/A.T. (307),					
71-72	All (307) (exc. A.T.),					
71-72	All (A.T. w/2BC) (350) . . . . .	<b>1941361</b>	1	5.80	main, w/auto. cam (w/1110912-1483-2005) . . . . .	
69	Pass. w/A.T. (350 w/reg. fuel) . .	<b>800643</b>	1	6.70	main, w/auto cam (w/1111955) . . . . .	
69	Pass. w/T.H. 400,					
69	Pass. (A.T. w/2BC) (350) . . . . .	<b>1970863</b>	1	6.55	main, w/weight plate (w/1111487) . . . . .	
65-66	All w/Sp. H/Per. (396),					
70	Pass., Monte Carlo (A.T. w/2BC) (400) . . . . .	<b>1846052</b>	1	6.15	main w/auto. cam (w/1111494) . . . . .	
70	Pass., Monte Carlo (454) . . . . .	<b>1846010</b>	1	8.00	main w/auto. cam (w/1111436-1963) . . . .	
70	Chevelle (454) (exc. Monte Carlo) . . . . .	<b>1846239</b>	1	7.25	main w/auto. cam (w/1111437) . . . . .	
64-69	Pass., Chevelle, Camaro (283, 307, 327, 350),					
68-69	Chevy (8 cyl.) (exc. 396),					
70	All (307, 350, 400),					
71-72	All w/2BC (400),					
71-75	All (307, 350, 400) . . . . .	<b>3998287</b>	1	2.80	intermediate, to oil pump (Note 1) . . . . .	
70	Camaro w/Sp. H/Per. (350) . . . . .	<b>1846553</b>	1	6.90	main w/auto. cam (w/1112019) . . . . .	
71-74	All (6 cyl.) . . . . .	<b>1876248</b>	1	7.50	main, w/weight plate (w/1110489) . . . . .	
71-73	All w/A.T. (307),					
73	All w/2BC (350, 400) . . . . .	<b>1851705</b>	1	6.50	main, w/auto. cam (w/1112039-1112102-47-66-68-2230) . . . . .	
71-72	All (350 w/4BC) (exc. A.T., Sp. H/Per.) . . . . .	<b>1851631</b>	1	6.45	main, w/auto. cam (w/1112044-1112152) . .	
71	All (A.T. w/4BC) (350) (exc. Sp. H/Per.) . . . . .	<b>1851126</b>	1	5.05	main, w/auto. cam (w/1112045) . . . . .	
71	Camaro (A.T. w/Sp. H/Per.) (350) . . . . .	<b>1851357</b>	1	6.45	main w/auto. cam (w/1112074) . . . . .	



**CHASSIS—ELECTRICAL SYSTEM**

**2.372 SHAFT— POLE PIECE— ROTOR— GROMMET, Distributor, with Weight Plate (Con't)**

71-72	All (454) (exc. Sp. H/Per.)	1851159	1	10.35	main, w/auto. cam (w/1112052)
71	All (A.T. w/Sp. H/Per.) (454)	1851217	1	8.80	main, w/auto. cam (w/1112054)
71-72	All (A.T. w/2BC) (400)	1851201	1	6.35	main, w/auto. cam (w/1112056)
71-72	All w/4BC (400, 402)	1851210	1	6.35	main, w/auto. cam (w/1112057)
71	Vega (exc. 2BC w/A.T.),				
72	Vega (exc. NB-2 w/2BC and w/A.T.)	1851066	1	8.50	
71	Vega (2BC w/A.T.),				
72	Vega (NB-2 w/2BC) w/A.T.	1851064	1	8.90	
72	All (A.T. w/4BC) (350) (exc. Sp. H/Per.)	1851629	1	6.60	main, w/auto. cam (w/1112154)
72	All w/Sp. H/Per. (350) (exc. A.T.)	1852673	1	8.25	main, w/auto. cam (w/1112153)
72	All (A.T. w/Sp. H/Per.) (350)	1965891	1	6.55	main, w/auto. cam (w/1112156)
73	All (A.T. w/4BC) (350) (exc. Sp. H/Per.),				
74	Pass. (Sta. Wag.) w/4BC (350) (exc. NB2)	1870658	1	9.80	main, w/auto. cam (w/1112094)
73-74	All (454) (exc. H.E.I.)	1870670	1	10.15	main, w/auto. cam (w/1112113)
73	Camaro w/Sp. H/Per. (350)	1870722	1	10.85	main, w/auto. cam (w/1112148)
73	All (307) (exc. A.T.)	1941361	1	5.80	main w/weight plate (w/1112227)
73-74	All w/4BC (350) (exc. Sp. H/Per., A.T.)	1851629	1	6.60	main, w/auto. cam (w/1112093)
73-75	All (454)	3998289	1	2.25	intermediate to oil pump
74	Pass. (Sta. Wag.) (400) (exc. NB-2)	1851628	1	17.55	main (w/1112250)
74	All (w/1112543)	1851630	1	17.80	main
74	All (w/1112545)	1876879	1	17.90	main
74	Camaro w/Sp. H/Per. (350)	1876331	1	23.50	main (w/1112528) (H.E.I.)
74	Pass. w/NB-2 (454)	1876404	1	23.50	main (w/1112527) (H.E.I.)
74	All w/2BC (350, 400) (exc. A.T., NB-2)	1851704	1	17.85	main (w/1112844-46)
74	Pass. (Sta. Wag.) (400)	1876324	1	23.50	main (w/1112864) (H.E.I.)
74	All w/4BC (400) (exc. Sta. Wag.)	1880115	1	23.50	main (w/1112865) (H.E.I.)
74	All w/2BC (400)	1880113	1	23.50	main (w/1112866) (H.E.I.)
73-74	All (140)	1852772	1	8.50	
75	All (140)	1891103	1	23.50	w/1112862
75	All (6 cyl.) (exc. integrated cyl. hd.)	1891145	1	23.50	main (w/1110652)
75	All (6 cyl.)	1891100	1	23.30	main (w/1110650-2863)
75	All (262)	1891248	1	23.50	main (w/1112933)
75	Pass., Chevelle (350),				
75	Nova, Camaro w/2BC (350)	830072	1	23.50	main (w/1112880)
75	Nova, Camaro w/4BC (350) (exc. NB-2)	830165	1	23.50	main (w/1112888)
75	Camaro w/Sp. H/Per. (350)	830110	1	23.50	main (w/1112883) (H.E.I.)
75	All (400)	830136	1	25.50	main (w/1112882)
75	All (454)	830121	1	23.50	main (w/1112886)
65	All w/T. Ign. (396, 409),				
66	All w/T. Ign. (396) (exc. P.G., T.H.),				
66	Pass. w/T. Ign. (427) (exc. Sp. H/Per., A.I.R., T.H.)	1960779	1	26.10	POLE PIECE, w/plate (w/1111059-1060-1074-1086-88-93-98-1125-26-37-40-42-1927-28-1954)
65	Pass., Chevelle w/T. Ign. (396),				
66	Chevy w/T. Ign. (exc. A.I.R.)	1964272	1	14.10	POLE PIECE, w/weight base (w/1111074-1088-1093-1098)
74-75	All (8 cyl.) w/H.E.I.	1875981	1	20.70	POLE PIECE, w/plate (H.E.I.) (pick-up coil)
75	All (140)	1880020	1	15.70	POLE PIECE, w/plate assy. (w/1112862) (pick-up coil)
75	All (122)	1891767	1	15.45	POLE PIECE, w/plate assy. (w/plate assy. (w/1110649)
75	All (6 cyl.)	1880040	1	15.70	POLE PIECE, w/plate (w/1110650-52-2863) (pick-up coil)
65	All w/T. Ign. (396, 409),				
66	All w/T. Ign. (396) (exc. P.G., T.H.),				
66-67	Pass. w/T. Ign. (427) (exc. Sp. H/Per., A.I.R., T.H.)	1932023	1	.09	GROMMET, pole piece and plate— (2.401)

NOTE 1: For use with pump having retainer ring groove.

**2.374 GEAR UNIT— SPROCKET, Distributor**

62-74	All (6 cyl.)	1962052	1	5.15
64-75	All (8 cyl.) (exc. 262)	1958599	1	5.35

**CHASSIS—ELECTRICAL SYSTEM**

**2.374 GEAR UNIT— SPROCKET, Distributor (Con't)**

71-75	All (140) .....	1963136	1	7.15	
75	All (6 cyl.) .....	1955676	1	9.00	
75	All (262) .....	801200	1	7.05	
75	All (122) .....	352134	1	5.55	SPROCKET, dist. drive shaft .....

**2.375 BEARING ASSY.— CUP— SEAL— SHAFT ASSY., Distributor Mainshaft**

62-74	All (4 cyl., 6 cyl.) (exc. Vega) ...	3792286	1	.28	
71-75	All (140) .....	1846279	1	2.02	CUP, hyd. braking .....
75	All (122) .....	360145	1	54.25	SHAFT ASSY., dist. dr. ....

**2.379 SHIM— WASHER, Distributor Gear**

65	Pass. w/Sp. H/Per. (396),				
66	Pass. w/H/Per. (427) .....	1927529	A.R.	.07	(1/2" I.D. x 1" O.D. x .005" thick) .....
62-74	All (4 cyl., 6 cyl.) .....	3792285	1	.12	WASHER (1/2" I.D. x 1" O.D. x 3/8" thick) ...
64-66	All (8 cyl.),				
75	All .....	1837617	1	.07	WASHER, undergear .....
66-75	All (8 cyl.) .....	1965864	1	.41	WASHER, dist. tang (Note 1) .....
71-74	All (140) .....	1960478	1	.32	WASHER, housing (tang-under gear) .....
71-74	All (140) .....	1959714	1	.07	WASHER, weight base .....
75	All (140) .....	811912	1	.07	WASHER, plain under gear .....
75	All (140) .....	1877308	1	.32	WASHER, tang-under gear .....

NOTE 1. Used between gear and housing.

**2.381 CAM, Distributor**

62-65	Chevy, Chevelle (194) .....	1954584	1	7.40	w/auto. breaker (w/1110267-69-93-94-0310-30-0434-52) .....
62-67	Chevy (4 cyl.) .....	1954610	1	7.40	w/auto. breaker (1110292) .....
64-65	All (327),				
65	Pass. (409) (exc. T. Ign.),				
66-67	All w/P.G. (327) (exc. A.I.R.),				
68	Chevy, Camaro w/P.G. (350),				
69	Chevy w/A.T. (350) (exc. reg. fuel),				
70	All w/A.T. (307),				
70	All (A.T. w/H/Per.) (350),				
71-72	All (307) (exc. A.T.),				
71-72	All (A.T. w/2BC) (350),				
71-72	All (350 w/4BC) (exc. A.T., Sp. H/Per.),				
71-72	Camaro w/Sp. H/Per. (350),				
71-72	All (A.T. w/2BC) (400),				
70	Malibu, Monte Carlo (Spt. Cpe., Conv.) w/H/Per. (454),				
71-72	All (454) (exc. Sp. H/Per.) .....	1966686	1	7.00	w/weight plate (w/1110122-0907-0912-0927-0930-0948-0985-0987-1006-1016-1023-1024-1062-1063-1075-1085-1152-1489-1963-1997-2005-44-49-52-56-2152-2156-2161-2163 .....
65	All (230) .....	1961236	1	7.85	w/1110280-0336 .....
65	Pass. (396) (exc. Sp. H/Per., 62 amp.),				
71-72	All w/4BC (400, 402) .....	1965976	1	6.95	w/weight plate (w/1111073-2057) .....
66	Pass. (250) (exc. A.I.R., P.G.),				
67	All (250) .....	1966621	1	7.35	advance w/breaker (w/1110351) .....
66	Chevy w/Sp. H/Per. (327) (exc. A.I.R., T. Ign.),				
66	All (283) (exc. A.I.R.),				
67-68	Pass. (396, 427),				
67	All w/A.I.R. (283) (exc. P.G.),				
69	Chevy, Chevelle, Camaro (396),				
69	Pass. w/H/Per., Sp. H/Per. (427),				
70	All w/Sp. H/Per. (396),				
70	All (T.H. 400 w/H/Per.) (396),				
70	Chevelle (400) (exc. 2BC) .....	1935632	1	7.35	w/1110874-1069-1070-1096-1169-1170-1256-1297-1497-98-99-2000 .....
66	All w/A.I.R. (327) (exc. Sp. H/Per.),				
67	Camaro w/2BC (327),				
68	All (307) (exc. P.G.),				
69	All (327),				
69	Pass. w/T.H. 400,				
69	Pass. (A.T. w/2BC) (350) (exc. T.H. 400),				

## CHASSIS—ELECTRICAL SYSTEM

<b>2.381 CAM, Distributor (Con't)</b>					
70	Monte Carlo (400) (exc. T.H. 350, 4BC),				
70	All w/A.T. (350) (exc. H/Per.) . . .	<b>1967005</b>	1	6.90	aut. and breaker (w/1111101-16-1443-1492-2002) . . . . .
67-69	Camaro (302),				
69	All w/A.T. (350 w/reg. fuel),				
71	All w/2BC (350) (exc. A.T.),				
72	All w/Sp. H/Per. (350) (exc. A.T.)	<b>1969763</b>	1	5.40	w/weight plate (w/1111246-1480-83-1955-2003-42-2153) . . . . .
68-70	All (230) (exc. A.T.) . . . . .	<b>1970834</b>	1	7.85	advance w/breaker (w/1110436-0459) . . . . .
68	Chevelle, Camaro w/H/Per. (396) (exc. A.T.),				
69-70	All w/H/Per. (396) (exc. T.H. 400) . . . . .				w/weight plate (w/1111445-1498-1999), . . .
68	Camaro w/2BC (exc. P.G.),				
69	Chevy, Chevelle w/2BC (350) (exc. A.T.),				
70	All (350) (exc. A.T., H/Per.) . . . . .	<b>1966740</b>	1	7.55	w/weight plate (w/1111440-1486-2001) . .
68-70	All (250) (exc. A.T.) . . . . .	<b>1970841</b>	1	7.05	w/advance breaker (w/1110439-63-83) . . .
68-70	All w/A.T. (250) . . . . .	<b>1970537</b>	1	7.50	w/breaker advance (w/1110399-0464-82) . .
65-66	All w/Sp. H/Per. (396, 427) (exc. T. Ign.),				
66	All (396, 427) (exc. Sp. H/Per., T. Ign., T.H.),				
65-67	All w/A.I.R. (283),				
66-67	All (327) (exc. A.I.R.),				
68-69	All (327, 350, w/reg. fuel),				
68-69	All (307),				
70	All (307) (exc. A.T.),				
70	Pass., Monte Carlo w/T.H. 350 (400) (exc. 4BC),				
71	All w/A.T. (307),				
67-68	Chevy, Chevelle w/Sp. H/Per. (327),				
69	Pass. (427) (exc. H/Per. Sp. H/Per.),				
70	Pass., Chevelle (454) (exc. Monte Carlo, H/Per.),				
68	Chevy, Camaro (350),				
69	All (350) (exc. reg. fuel, A.T.),				
70	Nova, Chevelle, Camaro w/H/Per. (350) (exc. A.T.) . . . . .	<b>1967002</b>	1	7.00	w/plate (w/1110920-0946-0947-1111015-1071-76-87-50-51-1100-07-09-12-41-50-53-56-94-1257-1436-37-81-88-90-93-94-1500-1925-26-95-96-2039-54) . . . . .
69-70	Chevy (4 cyl.) w/P.G. Torque Drive . . . . .	<b>1970539</b>	1	7.50	auto. and breaker (w/1110458) . . . . .
71-74	All (6 cyl.) . . . . .	<b>1966901</b>	1	9.20	advance w/breaker (w/1110489) . . . . .
71-72	All (A.T. w/4BC) (350) (exc. Sp. H/Per.),				
73-74	(454),				
73-74	w/4BC (350) (exc. A.T., Sp. H/Per.) . . . . .	<b>1963492</b>	1	7.00	w/weight plate (w/1112045-50-93-2113) . .
71-72	All (140) . . . . .	<b>1851224</b>	1	9.75	
72-73	All w/A.T. (307),				
73-74	Camaro w/Sp. H/Per. (350),				
73	All w/2BC (350, 400),				
74	All w/2BC (350, 400) (exc. NB-2) . . . . .	<b>1851057</b>	1	7.30	auto. w/breaker (w/1112147-66-68-2230) . .
73	All (307) (exc. A.T.) . . . . .	<b>1966686</b>	1	7.00	w/weight plate (w/1112227) . . . . .
73-74	All (A.T. w/4BC) (350) (exc. Sp. H/Per.) . . . . .	<b>1870644</b>	1	7.40	w/weight plate (1112094) . . . . .
73-74	All (140) . . . . .	<b>1870662</b>	1	9.75	w/weight plate . . . . .
<b>2.382 ROTOR—SCREW, Distributor</b>					
62-74	All (exc. 8 cyl.) . . . . .	<b>800056</b>	1	1.35	
64-74	All (8 cyl.) (exc. H.E.I.) . . . . .	<b>1852722</b>	1	2.31	
74	All (8 cyl.) w/H.E.I. . . . .	<b>1891080</b>	1	3.65	(H.E.I.) (repl. 1875943) . . . . .
75	All (122, 140, 250) . . . . .	<b>1880011</b>	1	3.60	w/1110650-52-2862-63 . . . . .
75	All (122) . . . . .	<b>333929</b>	1	6.25	(magnetic) . . . . .
75	All (8 cyl.) . . . . .	<b>1891080</b>	1	3.65	
74-75	All . . . . .	<b>1875948</b>	1	.11	<b>SCREW, rotor attach.</b> . . . . .

## CHASSIS—ELECTRICAL SYSTEM

### 2.383 AMPLIFIER— HARNESS— EXTENSION— BRACKET— TRANSISTOR— CAPACITOR— INSULATOR— DIODE— GASKET— RESISTOR— MODULE— RETAINER— SCREW, Ignition Pulse (Transistorized)

64-68	All w/T. Ign. ....	1115006	1	88.05	contact triggered (std. dist. point) .....
74-75	All (122) .....	3955511	1	148.00	
64	Chevelle w/T. Ign.,				
65-67	Pass. w/T. Ign. (396, 427),				
66	Chevelle (Sp. H/Per. w/T. Ign.) (396) .....	2988218	1	15.45	HARNESS, amplifier .....
64-66	Chevy, Chevelle w/T. Ign.,				
65-67	Pass., w/T. Ign. ....	2986672	1	4.25	HARNESS, amplifier (5" O.L.) .....
74-75	All (8 cyl.) w/H.E.I. ....	1876018	1	9.80	HARNESS (H.E.I.) .....
75	All (140, 250) .....	1880021	1	9.80	HARNESS (H.E.I.) .....
75	All (122) .....	800127	1	16.55	HARNESS, ign. impulse .....
66-67	Pass. w/T. Ign. ....	6287841	1	21.75	EXTENSION, amplifier harness .....
64-66	All w/T. Ign.,				
75	All (122) .....	1960632	1	29.65	TRANSISTOR (2.505) .....
64-69	All w/T. Ign.,				
75	All (122) .....	1960643	1	7.00	TRANSISTOR, trigger .....
64-69	All w/T. Ign.,				
75	All (122) .....	1960584	1	10.20	TRANSISTOR, drive .....
64-69	All w/T. Ign.,				
75	All (122) .....	1960483	1	2.46	CAPACITOR (2 <sup>1</sup> / <sub>64</sub> ") .....
64-69	All w/T. Ign.,				
75	All (122) .....	1962104	1	.19	CAPACITOR (1/200) .....
64-69	All w/T. Ign.,				
75	All (122) .....	1962715	1	.12	INSULATOR (Mica) .....
64-69	All w/T. Ign.,				
75	All (122) .....	1960642	1	13.40	DIODE (Sensor) .....
64-69	All w/T. Ign.,				
75	All (122) .....	1970226	1	1.27	GASKET, bottom plate .....
64-69	All w/T. Ign.,				
75	All (122) .....	1960640	1	.17	RESISTOR (10 ohm) .....
64-69	All w/T. Ign.,				
75	All (122) .....	1963873	1	.45	RESISTOR (15 ohm) .....
64-69	All w/T. Ign.,				
75	All (122) .....	1965254	1	.16	RESISTOR (150 ohm) .....
64-69	All w/T. Ign.,				
75	All (122) .....	1960638	1	.51	RESISTOR (680 ohm) .....
64-69	All w/T. Ign.,				
75	All (122) .....	1960641	1	.19	RESISTOR (1500 ohm) .....
64-69	All w/T. Ign.,				
75	All (122) .....	1960639	1	.17	RESISTOR (1800 ohm) .....
74-75	All w/H.E.I. ....	1875990	1	53.10	MODULE, dist. elec. ....
75	All (140, 250) .....	1891074	1	.25	RETAINER, harness .....
74-75	All w/H.E.I. ....	1891234	1	.21	SCREW, dist. module attach. ....

### 2.384 POINT UNIT— CONTACT ASSY., Distributor (Consists of Breaker Arm and Support)

62-69	All (8 cyl.) (exc. 427),				
70	All (8 cyl.) (exc. Sp. H/Per., 396),				
71-73	All (8 cyl.) (exc. 454, Sp. H/Per. 350) .....	1931988	1	4.90	pre-assembled (clip on type) .....
64-67	All (8 cyl.) (exc. 427) .....	1966289	1	4.90	pre-assembled (w/screw terminal) .....
62-74	All (exc. 8 cyl.) .....	1954557	1	3.68	
66	Pass. (427) (exc. Sp. H/Per. A.I.R., T. Ign., T.H.),				
66	Chevelle w/H/Per. (396) (exc. A.I.R., T. Ign. P.G.),				
67	Chevelle w/H/Per. (396) (exc. T. Ign.),				
67-69	Camaro (302),				
68-70	Chevelle, Camaro w/Sp. H/Per. (396),				
68-69	Pass. w/Sp. H/Per. (427),				
71-73	All w/Sp. H/Per. (350),				
71-73	All (454) .....	1966294	1	5.60	
72	All (8 cyl.) (exc. 454, Sp. H/Per. 350) .....	1876065	1	7.30	CONTACT ASSY., w/capacitor .....
74	All (8 cyl.) .....	1876600	1	8.40	CONTACT ASSY., w/capacitor .....

### 2.385 PLATE— RETAINER— SPRING— SLEEVE— WASHER, Distributor Breaker

62-74	All (153, 250) .....	1961428	1	3.00	
64-69	All (8 cyl.) .....	1962141	1	3.33	
70-71	All (8 cyl.) .....	1846122	1		
71-74	All (140) .....	1846456	1	4.17	

**CHASSIS—ELECTRICAL SYSTEM**

**2.385 PLATE— RETAINER— SPRING— SLEEVE— WASHER, Distributor Breaker (Con't)**

74-75	All w/H.E.I. . . . .	830446	1	.25	RETAINER, pole piece . . . . .
62-74	All (153, 250) . . . . .	1956213	1	.04	SPRING, plate retaining . . . . .
64-74	All (8 cyl.) . . . . .	1932024	1	.11	SPRING, plate retaining (w/1110874- 1110890-0907-15-20-47-48-84-87- 1111006-1015-16-23-59-60-62-63-64-69- 70-85-86-87-88-96-107-09-12-14- 16-17-19-20-25-26-32-37-38-39- 41-42-1111346- thru 1111956) . . . . .
67	Pass. (396, 427) . . . . .	1882774	2	.48	SPRING, w/1111169-70-1247 . . . . .
71-74	All (140) . . . . .	1846002	1	.11	SPRING, vib. damper . . . . .
71-74	All (140) . . . . .	1956213	1	.04	SPRING, plastic retainer . . . . .
65	Pass. (396) (exc. T. Ign.),				
65	Pass. (Sp. H/Per. w/T. Ign.) (396),				
66-68	All (327) (exc. A.I.R.),				
66	All (396) (exc. P.G., T.H.),				
66	All (427) (exc. Sp. H/Per., A.I.R., T.H.),				
70-74	All (8 cyl.) . . . . .	1961234	1	.21	SLEEVE, spring post (plastic 1/4" O.D. x 3/16" O.L.) . . . . .
65-66	All w/T. Ign. . . . .	1961927	1	.80	WASHER, advance plate . . . . .

**2.387 SCREW— RETAINER— SPRING, Distributor Contact Point Support Clamp**

64-65	All (8 cyl.) . . . . .	453418	2	.04	contact attaching w/lock washer (No. 8— 32 x 5/16")— (8.906) . . . . .
64-65	All (8 cyl.) . . . . .	1938376	1	.09	RETAINER, contact adjusting . . . . .
62-65	All . . . . .	1931995	1	.05	SPRING, contact adj. screw . . . . .

**2.388 WEIGHT, Distributor**

62-65	Chevy, Chevelle (194),				
67-68	Camaro (exc. 327, 4BC, 350),				
71	Vega (2BC w/A.T.),				
71	All w/A.T. (307) . . . . .	1880902	2	.84	
64-70	All (230, 250, 283, 327, 350, 396, 400),				
67-68	Pass. w/Sp. H/Per. (427),				
71	All (exc. A.T. w/307),				
71	Vega (exc. 2BC, A.T.),				
72-74	All . . . . .	1881371	A.R.	.80	
65	Pass. (409),				
67	All (327) (exc. A.I.R.) . . . . .	1924737	1	.77	
66	All w/A.I.R. (250) (exc. Sp. H/Per., P.G.),				
66	Pass. (396) (exc. P.G., T.H.),				
66	All (427) (exc. Sp. H/Per., A.I.R., T.H.),				
68	Chevy, Camaro (350) (exc. P.G.),				
68	Chevy, Camaro w/Sp. H/Per. (327),				
70	Nova, Chevelle, Camaro w/H/Per. (350) . . . . .	1965843	2	.86	

**2.389 SPRING, Distributor Weight**

63-67	Chevy (4 cyl.),				
64	Chevelle w/4BC . . . . .	1912189	1	.48	w/1110292 . . . . .
63-65	Chevy, Chevelle (194) . . . . .	1885636	2	.48	w/1110293-324 . . . . .
64	Chevy, Chevelle (230),				
65-66	All (327) (exc. A.I.R.) . . . . .	1884094	2	.42	(49/64" free length) . . . . .
64-66	All (283) (exc. A.I.R.),				
68-70	All (230) (exc. A.T.) . . . . .	1883779	2	.48	(3/8" free length) (w/1110458-59) . . . . .
65	Chevelle (230),				
65-67	Pass. (230, 250) . . . . .	1922426	2	.48	(1 11/16" free length) (w/1110336-71) . . . . .
65	Pass. w/T. Ign. (409) (exc. H/Per.),				
66	Chevy w/A.I.R. (Sp. H/Per. w/T. Ign.) (327) . . . . .	1941524	2	.46	(47/64" free length) . . . . .
65	Pass. (409) (exc. T. Ign.) . . . . .	1943041	2	.48	(3/4" free length) . . . . .
65	Pass. (H/Per. w/T. Ign.) . . . . .	1884610	2	.46	
65-66	Pass. (Sp. H/Per. w/T. Ign.) (396, 427),				
69	Pass. (396) (exc. T.H.) . . . . .	1965903	2	.47	(17/32" free length) (w/1111074-93-95-1240- 1949) . . . . .
65	Pass. (396) (exc. Sp. H/Per., 62 amp.) . . . . .	1965978	2	.46	(47/64" free length) . . . . .

## CHASSIS—ELECTRICAL SYSTEM

### 2.389 SPRING, Distributor Weight (Con't)

65-66	All w/Sp. H/Per. (396, 427) (exc. T. Ign.)	1916848	2	.48	( <sup>1</sup> / <sub>16</sub> " free length)
65	Chevelle w/T. Ign.,				
65-66	Pass. w/T. Ign. (396) (exc. Sp. H/Per.),				
66-67	Chevy, Chevelle (230),				
66	Chevy (Sp. H/Per. w/T. Ign.) (327) (exc. A.I.R.)	1964950	2	.48	w/1111072-1146 ( <sup>45</sup> / <sub>64</sub> " free length)
66	Chevy, Chevelle (194) (exc. A.I.R., P.G.)	1886508	2	.46	w/1110360
66	Pass. (427) (exc. Sp. H/Per., A.I.R., T. Ign., T.H.),				
66-67	Chevelle w/H/Per. (396) (exc. A.I.R., T. Ign., A.T.)	1911484	2	.45	
66	Pass. (427),				
66	All w/T. Ign. (396) (exc. Sp. H/Per.),				
68-70	Chevy (4 cyl.) (exc. A.T.)	1884929	2	.48	w/1110457
66	All w/A.I.R. (327)	1903693	2	.46	
66-67	All w/A.I.R. (283),				
68	Pass., Chevelle (327 w/reg. fuel)	1908587	2	.48	
66	All w/P.G. (327),				
68	Camaro (P.G. w/2BC)	1923139	2	.42	
66-67	All (250)	1928363	2	.48	
66	All w/P.G. (327) (exc. A.I.R.),				
67	Chevy w/Sp. H/Per. (327)		2		w/1111193-95,
69	Camaro (A.T. w/reg. fuel) (327, 350)	1951743	2	.48	w/1111483-90
67	Chevy, Chevelle, Camaro w/A.I.R. (6 cyl.),				
70	Pass., Monte Carlo (454)	1968543	2	.52	w/1110390-1436-1963
67	Camaro (350) (exc. T. Ign.),				
68	Chevy, Camaro w/P.G. (350),				
69-70	All w/A.T. (350) (exc. reg. fuel),				
70	All w/A.T. (307),				
71-72	All (307) (exc. A.T.),				
71-72	All (A.T. w/2BC) (350)	1963965	2	.46	w/1110912-1168-1489-1997-2005
67-69	All (396),				
69	Pass. (427),				
70	Chevelle (454) (exc. Monte Carlo),				
70	Chevelle (400) (exc. 2BC)	1882774	2	.48	w/1111169-70-1437-97-99-1925-26-98- 2000
67	Camaro (exc. 327 4/BC, 350),				
68	Camaro P.G. w/2BC	1968847	1	.48	w/1111101
67-68	Camaro (302)	1969107	2	.56	w/1111266
67	All (327) (exc. A.I.R.),				
71-72	All w/4BC (400, 402)	1967517	2	.48	w/1112057
68	All w/P.G. (230),				
68	Chevy, Chevelle (8 cyl.) (exc. P.G. 327, 350)	1968533	2	.52	w/1110389
68	Chevy, Camaro (350) (exc. P.G.)				w/1111264,
68	Chevelle, Camaro w/Sp. H/Per. (327),				
69	All (350) (exc. A.T., reg. fuel),				
70	Nova, Chevelle, Camaro w/H/Per. (350) (exc. A.T.)	1967643	1	.52	w/1111438-88-1996
68	All (327) (exc. A.T.)	1923140	2	.50	w/1111298
68-70	All w/A.T. (230),				
71-72	All (454) (exc. Sp. H/Per.)	1882956	2	.48	w/1110433-0460-2052
68-69	Pass. (250) (exc. A.T.)	1929319	2	.46	( <sup>1</sup> / <sub>16</sub> " free length)
68-70	All w/A.T. (250)	1970536	2	.43	w/1110399-0464-66-69-82
68	All w/A.T. (327)	1925574	2	.48	w/1111297-1441
68	Pass. w/P.G. (307),				
69-70	All (307, 327),				
69	All (350 w/reg. fuel) (exc. 2BC)	1884615	2	.48	w/1111257-1481-1995
70	Monte Carlo (400) w/A.T.,				
70	Pass. (400)	1966509	2	.36	w/1111494
68	Taxi, Police (exc. P.G.),				
69-70	All (250) (exc. A.T.)	1922381	2	.48	w/1110470-0463-65-70-83
69	Pass., Camaro (327, 350 w/reg. fuel) (exc. A.T.)	1931257	2	.46	w/1111482
69-70	All w/2BC (350) (exc. A.T.)	1935546	2	.46	w/1111486-2001
69	All w/4BC (350 w/reg. fuel) (exc. A.T.)	1937291	2	.46	w/1111956

**CHASSIS—ELECTRICAL SYSTEM**

**2.389 SPRING, Distributor Weight (Con't)**

69-70	All (A.T. w/2BC) (350)	1887743	2	.46	( <sup>3</sup> / <sub>4</sub> " free length) (w/1111487-2002)
69-70	Camaro (302),				
69	All (A.T. w/4BC) (350 w/reg. fuel)	1885787	2	.48	w/1111955-2003
69-70	Chevy, Chevelle, Camaro w/H/Per. (396) (exc. T.H. 400)	1900371	2	.46	w/1111498-1999
69	Pass. w/T.H. (396)	1915231	2	.48	w/1111479-1111950
71-74	All (6 cyl.),				
72-73	All w/A.T. (307),				
73	All w/2BC (8 cyl.) (exc. 307),				
74	All w/2BC (350, 400) (exc. NB-2)	1912886	2	.48	w/1110489-2102-47-66-68-2230)
71*	All w/A.T. (307)	1946990	2	.46	w/1112039
71	All w/2BC (350) (exc. A.T.)	1916297	2	.48	w/1112042
71*	All (350 w/4BC) (exc. A.T., Sp. H/Per.)	1883373	2	.46	w/1112044
71*	All (A.T. w/4BC) (350) (exc. Sp. H/Per.)	1846319	2	.48	w/1112045
71-72	Camaro w/Sp. H/Per. (350) (exc. A.T.)	1846802	2	.43	w/1112049
71	Camaro (A.T. w/Sp. H/Per.) (350),				
73-74	All w/Sp. H/Per. (350)	1851056	2	.48	w/1112074-2148
71	All (A.T. w/Sp. H/Per.) (454)	1939480	2	.46	w/1112054
71	All w/Sp. H/Per. (454) (exc. A.T.)	1887553	2	.48	w/1112075
71-72	All w/2BC (400) (exc. A.T.)	1851173	2	.46	w/1112056
71	Vega (2BC w/A.T.),				
72	Vega (NB-2 w/2BC) w/A.T.	1851446	2	.48	
72	All w/4BC (350) (exc. A.T., Sp. H/Per.)	1965353	2	.48	w/1112152
72	Vega (exc. NB-2 w/2BC and w/A.T.)	1946276	2	.48	
72	All (A.T. w/4BC) (350) (exc. Sp. H/Per.),				
73-74	All w/4BC (350) (exc. A.T., Sp. H/Per.),				
73-74	All (454)	1851764	2	.48	w/1112093-2113-54)
72	All w/Sp. H/Per. (350) (exc. A.T.)	1970572	2	.43	w/1112153
73-74	All (A.T. w/4BC) (350) (exc. Sp. H/Per.)	1870640	2	.46	w/1112094
73	All (307) (exc. A.T.)	1851823	2	.48	w/1112227
73-74	All (140)	1870661	2	.46	

**2.390 PLATE, Distributor Weight and Cam, with Stop**

62-74	All (exc. 8 cyl.)	1954548	1	.66	
-------	-------------------	---------	---	-----	--

**2.393 CONDENSER— CAPACITOR— BRACKET— SHIELD UNIT— SCREW, Distributor, with Bracket and Lead**

62-74	All (exc. 8 cyl.)	1928111	1	1.71	spade type terminal
64-74	All (8 cyl.) (exc. H.E.I.)	1932004	1	1.71	
74-75	All w/H.E.I.	1876154	1	2.67	CAPACITOR, dist.
62-74	All (exc. 8 cyl.)	1944118	1	.08	BRACKET, condenser
64-74	All (8 cyl.),				
71-75	All (140)	1869573	1	.08	BRACKET, condenser
70-74	All (8 cyl.)	1846216	1	2.20	SHIELD UNIT, radio frequency interference
70-74	All (8 cyl.)	1846215	2	.06	SCREW, w/lock washer, radio frequency
74-75	All	1876639	1	.10	SCREW, capac. brkt. attach.

**2.400 LEAD— CONNECTOR, Distributor Terminal**

62-74	All (exc. 8 cyl.)	1954563	1	.55	
64-74	All (8 cyl.)	1932002	1	.34	breaker plate ground (w/1110874-0890-0915-0946-0947-0948-0984-0987-1006-1015-16-22-23-24-62-63-60-70-73-75-76-85-87-96-100-109-114-117-119-120-132-141-149-150-1931-194-196-249-1480 thru 1500)
70-72	All (8 cyl.)	1846199	1	.74	
73-74	All w/A.T. (8 cyl.) (exc. H.E.I.),				
64-69	All (8 cyl.)	1942518	1	.72	
73-74	All (8 cyl.) (exc. A.T., H.E.I.)	1875613	1	.79	
73-75	All w/H.E.I.	1876155	1	.58	
65-66	All w/T. lgn.	2984883	1	.22	CONNECTOR, male (2-way <sup>1</sup> / <sub>32</sub> " O.L.)— (2.530)

**CHASSIS—ELECTRICAL SYSTEM**

**2.401 GROMMET, Distributor Terminal**

62-74	All (exc. 8 cyl.)	1954564	1	.09	housing
64-74	All (8 cyl.)	1932023	1	.09	housing

**2.408 SWITCH ASSY.— BRACKET— BOLT— CLAMP— CLIP— CONNECTOR— HARNESS ASSY.— LEAD ASSY.— RELAY ASSY.— SOLENOID ASSY.— OCTANE ADJ. UNIT— CONTROL UNIT, Dist. Spark Advance Trans. Electric Control (Also See Group 4.075)**

70-71	All w/A.T. (exc. T.H. 400),				
72	All w/P.G.,				
72	Nova w/T.H. 350	6462549	1	1.95	trans. spark control— (4.075)
70-71	All (exc. A.T.)	3961567	1	3.00	trans. spark control— (4.075)
70-71	All w/T.H. 400	6462286	1	2.21	trans. spark control— (4.075)
72	Pass., Chevelle, Camaro w/T.H. 350	3996287	1	3.00	trans. control spark— (4.075)
72	All w/T.H. 400	8627332	1	7.00	trans. control spark— (4.075)
72	All (exc. A.T., 140)	3996286	1	2.85	trans. control spark— (4.075)
71-75	All (140)	3992247	1	.31	BRACKET, spark control pipe
71-73	All (140)	3952222	1	.66	BOLT, spark control pipe clamp to bracket
70-71	All (6 cyl.)	3824400	1	.23	CLAMP, spark control sol.— (3.405)
71-75	All (140)	3998135	1	.13	CLAMP, spark cont. pipe
70-72	Nova, Chevelle, Camaro (exc. A.T.)	3983960	1	.11	CLIP, trans. control spark ( <sup>3</sup> / <sub>4</sub> " x <sup>5</sup> / <sub>16</sub> " w/ <sup>1</sup> / <sub>2</sub> " hole)— (4.075)
70-72	Pass., Camaro w/T.H. 400 (exc. 396)	8626597	1	2.89	CONNECTOR, trans. control spark
74-75	Vega, Monza (exc. A.T.)	8908347	1	10.25	HARNESS ASSY., trans.
70-72	Pass., Camaro w/T.H. 400 (exc. 396)	8626426	1	1.68	LEAD ASSY., w/conn. trans. cont. spark switch— (4.075)
70	All,				
71	Chevelle	3961573	1	2.85	RELAY ASSY., trans. spark control— (4.075)
71	All	3990842	1	2.45	RELAY ASSY., trans. control switch reversing— (4.075)
71	All	3990843	1	3.00	RELAY ASSY., trans. control switch delay— (4.075)
70	All (6 cyl.)	1114431	1	9.15	SOLENOID ASSY., spark control
70-71	All (8 cyl.) w/2BC	1114432	1	8.45	SOLENOID ASSY., spark control
70	All (396, 400 w/4BC, 454)	1114434	1	9.35	SOLENOID ASSY., spark control
71-72	All (6 cyl.)	1114444	1	13.70	SOLENOID ASSY., spark control
72	All w/NB2 (307, 350, 400)	1114451	1	9.85	SOLENOID ASSY., spark control
71-73	All (140)	1114439	1	8.75	SOLENOID ASSY., spark control
72	All (402, 454)	1114453	1	10.25	SOLENOID ASSY., spark control
73-74	Chevelle w/4-Spd. (454)	1997411	1	9.20	SOLENOID ASSY., trans. spark cont.
73	Pass. (Sta. Wag.) w/2BC,				
73	Nova, Chevelle, Camaro (307) (exc. A.T.),				
74	Nova, Chevelle, Camaro (350) (exc. A.T., Sp. H/Per.)	1997410	1	8.60	SOLENOID ASSY., trans. spark cont.
73-75	All (140) (exc. A.T.)	1997412	1	9.00	SOLENOID ASSY., cont. spark vac.
74	All (6 cyl.) (exc. A.T.)	1997433	1	8.55	SOLENOID ASSY., trans. spark cont.
66	All (283 w/2BC),				
67	All (283 w/2BC) (exc. Air Cond. w/Manual Trans.),				
68-69	All (307 w/2BC),				
70	All w/Manual Trans. (307 w/2BC)	1851798	1	4.09	OCTAIN ADJ. UNIT
67	All (350 w/4BC),				
68-70	All w/A.T. (350 w/4BC),				
70	All w/A.T. (307 w/2BC)	1851780	1	2.03	OCTANE ADJ. UNIT
68-70	All (250) (exc. A.T.)	1851775	1	.94	OCTANE ADJ. UNIT
68	All (327 w/4BC),				
69	All w/A.T. (327 w/2BC)	1851794	1	.94	OCTANE ADJ. UNIT
69-70	All w/A.T. (350 w/2BC)	1851795	1	2.82	OCTANE ADJ. UNIT
69	All (350 w/4BC)	1851799	1	4.09	OCTANE ADJ. UNIT
70	All w/A.T. (400 w/2BC)	1851797	1	.98	OCTANE ADJ. UNIT
62-67	Chevy (exc. 8 cyl.)	3023802	1	14.45	CONTROL UNIT, exh. emission
62-67	All (exc. Chevy)	3023803	1	14.45	CONTROL UNIT, exh. emission

**2.410 CONTROL— SWITCH ASSY., Distributor Vacuum**

62-65	All (153, 194, 230),				
66-67	All (6 cyl.)	1116195	1	4.06	
65	Pass. w/Sp. H/Per. (396) (exc. T. Ign.),				
66-67	Chevy (327) (exc. T. Ign.),				



**CHASSIS—ELECTRICAL SYSTEM**

**2.410 CONTROL— SWITCH ASSY., Distributor Vacuum (Con't)**

66-67	All (427) (exc. Sp. H/Per., A.I.R., T.H.),				
66-67	Chevelle w/Sp. H/Per. (396) (exc. T. Ign.),				
68	All w/A.T. (307),				
69	All (307)				
69-70	All w/Sp. H/Per. (396, 427),				
70	Pass., Monte Carlo w/2BC (400),				
70	All (307) (exc. A.T.) . . . . .	1115355	1	3.62	w/1111100-12-17-40-41-42-53-94-1257-1481-92-94-99-1949-50-95-2000 . . . . .
64	Chevy, Chevelle (8 cyl.),				
65-67	All (283, 409) (exc. H/Per.),				
65	Pass. (Sp. H/Per. w/T. Ign.) (396),				
66-68	All (327) (exc. A.I.R.),				
66-68	All w/A.I.R. (327) (exc. P.G.),				
67-68	All (396),				
69-70	Camaro (302),				
69	All (396, 427) (exc. Sp. H/Per.),				
70	Pass. (400, 454),				
70	All w/H/Per. (396),				
70	Monte Carlo (400, 454) (exc. 2BC) . . . . .	1116163	1	3.37	1111436-1963-1998-99-2003 . . . . .
65	Pass. w/H/Per. (409),				
65	Chevelle w/Sp. H/Per. (327),				
66	Chevy w/Sp. H/Per. (327) . . . . .	1116236	1	4.02	w/1111060-62-63-64-69-70-85-86-87-88-119-125-156-157-196 . . . . .
65	Pass. (396) (exc. Sp. H/Per.),				
65	All (327) (exc. Sp. H/Per., F.I.),				
66	All (396) (exc. P.G., T.H.),				
69	All (327),				
69	All (350) (exc. reg. fuel),				
70	All w/A.T. (307),				
70	All (A.T. w/H/Per.) (350),				
71-72	All (307) (exc. A.T.),				
71-72	All (A.T. w/2BC) (350) . . . . .	1115357	1	3.64	w/1110912-1109-37-73-75-76-98-109-120-126-137-1482-88-89-90-1997-2005 . . . . .
66	All (396) (exc. P.G., T.H.),				
66-68	Pass. w/Sp. H/Per. (427) (exc. T. Ign.),				
67	Chevelle, Camaro (396) (exc. T. Ign.) . . . . .	1115360	1	3.62	w/1111093-1170-1247-48-1493-1926-1954 . . . . .
68-70	All (exc. 8 cyl.) . . . . .	1116217	1	4.02	
68	Pass. w/A.T. (327),				
68	Chevy, Camaro (8 cyl.) (exc. 396),				
68	Chevy, Chevelle, Camaro w/P.G. (327),				
70	Nova, Chevelle, Camaro w/H/Per. (350) (exc. A.T.) . . . . .	1968861	1	3.72	w/1111297-1996 . . . . .
74	All (140) . . . . .	1973506	1	3.65	
69	All (4BC w/reg. fuel) (350),				
69-70	All w/2BC (350) . . . . .	1973421	1	3.62	w/1111486-7-2001-02 . . . . .
71-72	All (6 cyl.) . . . . .	1973434	1	4.07	w/1110489 . . . . .
71-72	All w/A.T. (307),				
71*	All w/2BC (350) (exc. A.T.),				
71-72	All w/4BC (400, 402),				
71-72	All (454) (exc. Sp. H/Per.) . . . . .	1973436	1	3.59	w/1112039-42-51-57 . . . . .
71-72	All w/4BC (350),				
73	Pass. (400),				
74	All (NB-2 w/4BC) (400) . . . . .	1973437	1	3.59	w/1112044-45-49-2166 . . . . .
71	All w/Sp. H/Per. (454) . . . . .	1973439	1	3.54	w/1112054 . . . . .
71	All (A.T. w/2BC) (400) . . . . .	1973438	1	3.65	w/1112056 . . . . .
73-74	All (454) (exc. H.E.I.) . . . . .	1116212	1	4.00	w/1112113 . . . . .
73-74	All w/4BC (350) (exc. Sp. H/Per.) . . . . .	1973446	1	3.59	w/1112093-2094 . . . . .
73	All (307),				
73	Camaro w/Sp. H/Per. (350) . . . . .	1973448	1	3.65	w/1112102-2148-2227 . . . . .
73	All w/2BC (350) (exc. Pass., Sta. Wag.) . . . . .	1973469	1	4.02	w/1112168 . . . . .
73	Pass. (Sta. Wag.) w/2BC (350) . . . . .	1973472	1	4.08	w/1112230 . . . . .
71-73	All (140),				
73-74	All (6 cyl.) . . . . .	1973428	1	4.01	

**CHASSIS—ELECTRICAL SYSTEM**

**2.410 CONTROL— SWITCH ASSY., Distributor Vacuum (Con't)**

74	Pass. w/NB-2 (454)	1973481	1	4.66	w/1112527 (H.E.I.)
74-75	Camaro w/Sp. H/Per. (350)	1973482	1	4.48	w/1112528-2883 (H.E.I.)
74	All w/2BC (350)	1973502	1	4.12	w/1112844
74	All w/2BC (400) (exc. NB-2)	1973503	1	3.68	w/1112846
74	All (NB-2 w/2BC) (400)	1973508	1	5.85	
74	All (140)	1973506	1	3.65	
74	Pass. (Sta. Wag.) w/4BC (400) (exc. NB-2)	1973507	1	5.85	w/1112864 (H.E.I.)
74	Pass. (Sta. Wag.) w/4BC (400) (exc. NB-2)	1973459	1	3.74	w/1112250
75	All w/NB-2 (6 cyl.)	1973549	1	6.00	w/1110650
75	All (6 cyl.) (exc. NB-2)	1973505	1	5.85	w/1110652-2863
75	All (140)	1973533	1	5.85	w/1112862
75	All (262, 350) (exc. Sp. H/Per.)	1973517	1	5.85	w/1112863-80-88-2933
75	All (400)	1973492	1	5.85	w/1112882
75	All (454)	1973519	1	5.85	w/1112886
70	Nova, Chevelle w/C.A.C., P.G., T.H. 350 (exc. gauges, Monte Carlo),				
70	Camaro (C.A.C. w/A.T.),				
70	Monte Carlo w/C.A.C., P.G., T.H. 350 (exc. gauges, 400 w/2BC),				
70	Pass. w/C.A.C., P.G., T.H. 350 (350 w/2BC),				
70	Chevelle, Camaro (396, 400 w/4BC) (exc. gauges),				
70	Pass. w/A.T. (exc. 350 w/2BC),				
70	Monte Carlo w/T.H. 350 (400 w/2BC) (exc. gauges),				
71	Camaro w/C.A.C. (400)	6489785	1	6.62	SWITCH ASSY. (stamped A.C.-82B- 232M)— (1.150)
71-72	All (400 w/4BC, 402, 454) (exc. gauges)	6490094	1	6.96	SWITCH ASSY. (2 terminals-stamped A.C.- 82B-269M)— (1.150) (Note 1)

*NOTE 1 This switch is located on the right bank of the engine and used with 1993369 on the left bank.*

**2.414 BOOT— COVER— SCREW, Distributor Vacuum Control Clamp**

67	All (250)	1963610	1	.75	control arm
75	All (140)	354619	1	.90	COVER
75	All	1891239	2	.08	SCREW, vac. control

**2.420 NIPPLE— BRACKET— HOSE— PIPE, Distributor Vacuum Control**

66-67	Pass. w/A.I.R. (6 cyl.),				
67	Camaro (C.A.C. w/A.I.R.) (8 cyl.)	3749168	1	.22	spark control hose at inlet manifold (1/8"— 27) (for 1/4" I.D. hose)— (3.278)
75	All (262)	1891188	1	.97	BRACKET, dist. vac. cont.
62-72	All	3982953	1	CL/.60	HOSE, spark control, at carb. end (5/32" I.D. x 25 ft.)— (8.962)
66	Chevy, Chevelle w/Sp. H/Per. (327)	3696822	1	RL/.17	PIPE (chrome)— (8.964)

**2.447 SWITCH ASSY.— BRACKET— STRIKER— NUT— CLIP, Stop Lamp**

62-69	Pass., Chevy, Camaro (exc. Speed and Cruise Control),				
70	Pass. (exc. Speed Cruise Control),				
70-75	Nova, Vega, Monza,				
73-75	Camaro,				
73-75	Pass., Chevelle (exc. Cruise Control)	3886906	1	2.10	
64-69	Chevelle (exc. Speed Cruise Control),				
70	Chevelle, Camaro,				
71-72	All (exc. Nova, Speed and Cruise Control)	1362835	1	1.82	
67-75	All w/Speed and Cruise Control	9794682	1	3.73	(3.887)
73-75	Chevelle	1239108	1	.44	BRACKET, brake pedal stop lamp switch
74-75	Pass.	1236462	1	.38	BRACKET, stoplight switch mtg.
67-72	Chevelle	3936272	1	.16	STRIKER, brake pedal
67-69	Camaro,				
68-74	Nova	3917957	1	.12	STRIKER, brake pedal switch
69-71	Pass. (exc. P.B.)	3939192	1	.16	STRIKER, brake peda1
69-71	Pass. w/P.B.	3939193	1	.34	STRIKER, brake pedal
70	Camaro w/P.B.,				

**CHASSIS—ELECTRICAL SYSTEM**

**2.447 SWITCH ASSY.— BRACKET— STRIKER— NUT— CLIP, Stop Lamp  
(Con't)**

71-74	Camaro	347449	1	.17	STRIKER, brake pedal switch (repl. 3965694)
75	Nova (exc. P.B.)	347425	1	.17	STRIKER, brake pedal switch
75	Nova w/P.B.	347426	1	.17	STRIKER, brake pedal switch
75	Camaro w/P.B.	347449	1	.17	STRIKER, brake pedal switch
66	Pass.	9420171	2	.05	NUT (1/2"— 20, type R-ZC)— (8.921)
64-70	Chevelle, Camaro,				
68	Pass.,				
71-75	All	1361699	1	.18	CLIP

**2.459 SWITCH— CLIP, Headlamp Dimmer**

62-67	Chevy,				
71-74	Vega	1997043	1	2.94	
64-67	Chevelle, Camaro,				
65-67	Pass.,				
68-74	All (exc. Vega),				
75	All	1997037	1	2.65	
65	Pass.	1997030	1	5.30	headlamp automatic beam control
67	Pass.	1361699	1	.18	CLIP, stop lamp switch

**2.461 SCREW— BUZZER ASSY., Automatic Headlamp Control**

65-66	Pass.	3748777	1	.11	beam— (4.217)
75	Nova w/aux. lighting	364079	1	3.50	BUZZER ASSY., hldp. warning (repl. 344835)

**2.480 HARNESS ASSY.— WIRE— GROMMET— CLIP, Chassis Wiring  
(segmented)**

62	Chevy (6 cyl.)	2980868	1	12.65	A.C. gen. jumper wire (cover 5 15/16" O.L.)
----	----------------	---------	---	-------	---

**INSTRUMENT PANEL**

63-64	Chevy (exc. S.S.)	2986044	1	41.50	
63-64	Chevy (S.S.)	2983739	1	41.25	
64	Chevelle (exc. S.S.)	2988205	1	52.50	
65	Chevelle (exc. S.S.)	2989048	1	40.75	(Note 1, 2)
65	Pass. (exc. Air Cond. S.S.)	2989090	1	49.00	(Note 4)
65	Pass. w/Air Cond. (exc. S.S.)	2989292	1	50.50	
66	Pass. (exc. Astro bucket, S.S., C.A.C.)	6290693	1	45.25	
66	Pass. w/Astro bucket, S.S. (exc. A.T., C.A.C.)	6290691	1	44.00	
66	Pass. w/C.A.C. (exc. Astro bucket, Auto Temp. Cont., S.S.)	6290694	1	45.50	
66	Pass. (B.S. w/A.T.)	6290695	1	52.00	
66	Chevy	6287813	1	52.00	(Note 3)
66	Chevelle (exc. S.S., C.A.C.)	6287026	1	51.25	(Note 3)
66	Malibu (S.S.) (exc. C.A.C.)	6287027	1	57.75	
67	Chevelle w/inst. panel gauges	6290401	1	56.25	
67	Camaro (A.T. w/floor console) (exc. inst. cluster)	6290650	1	55.00	instrument panel
67	Chevy	6290699	1	55.50	instrument panel
67	Camaro (exc. floor console)	6290159	1	53.75	instrument panel
67	Camaro w/Floor Compartment Console (exc. A.T. Inst. Cluster Console)	6291285	1	55.25	inst. panel
67	Camaro w/Inst. Cluster Console (exc. A.T.)	6291286	1	62.75	inst. panel
67	Pass. (exc. Inst. pnl. gauges, B.S.),				
67	S.S. w/Strato bench seat (exc. Inst. pnl. gauges)	6291895	1	59.00	(Note 3)
68	Pass. (exc. courtesy lights, inst. pnl. gauges),				
68	Impala (Conv.) (exc. S.S., Inst pnl. gauges),				
68	Caprice (exc. B.S., inst. pnl. gauges)	6295005	1	67.00	
68	Pass. w/A.T. (B.S.w/inst. pnl. gauges)	6295024	1	65.75	
68	Chevelle w/Inst. panel gauges (8 cyl.)	6295036	1	63.25	
68	Camaro w/Inst. Cluster Console (8 cyl.) (exc. A.T.)	6295063	1	60.25	
68	Camaro w/floor console (exc. A.T. inst. cluster)	6295061	1	56.00	

**CHASSIS—ELECTRICAL SYSTEM**

**2.480 HARNESS ASSY.— WIRE— GROMMET— CLIP, Chassis Wiring (segmented) (Con't)**

68	Camaro w/floor console, A.T. (exc. inst. cluster) . . . . .	<b>6295062</b>	1	58.25	
68	Camaro (exc. floor console),				
68	Camaro w/T.H. 350 . . . . .	<b>6295244</b>	1	63.50	
68	Chevelle w/floor console (exc. inst. panel gauges) . . . . .	<b>6295032</b>	1	59.75	
68	Chevelle (exc. floor console),				
68	Chevelle w/T.H. 350 (exc. C.A.C.) . . . . .	<b>6295031</b>	1	48.75	
69	Chevelle (exc. Floor Console, Gauges) . . . . .	<b>6297504</b>	1	49.00	
69	Chevelle w/inst. panel gauges . .	<b>6297531</b>	1	71.00	
69	Chevelle w/floor console (exc. gauges) . . . . .	<b>6297507</b>	1	56.25	
69	Chevy (exc. floor console, C.A.C.)	<b>6297570</b>	1	97.75	
69	Camaro w/instr. cluster console (exc. A.T.) . . . . .	<b>6297663</b>	1	73.25	
69	Camaro w/Tach. (exc. floor console),				
69	Camaro w/Tach. (console w/A.T.),				
69	Camaro (console w/A.T.) w/C.A.C. (6 cyl.),				
69	Camaro w/floor console, A.T. (8 cyl.) (exc. instrument cluster console, Tach. C.A.C.) . . . . .	<b>6297659</b>	1	80.25	
69	Camaro w/floor console (exc. C.A.C., A.T. instrument cluster console, Tach.),				
69	Camaro (exc. floor console, Tach.),				
69	Camaro (Tach. w/floor console) (exc. A.T.) . . . . .	<b>6297658</b>	1	80.25	
69	Chevy w/C.A.C. (exc. floor console) . . . . .	<b>6297597</b>	1	56.50	
69	Camaro w/floor console (C.A.C. w/A.T.) (exc. console inst. cluster, Tach.) . . . . .	<b>6297600</b>	1	65.50	
69	Pass. (exc. B.S.) . . . . .	<b>6297510</b>	1	80.25	(Note 3) . . . . .
69	Pass. w/A.T. (B.S. w/C.A.C.) . . .	<b>6297626</b>	1	80.25	
70	Pass. . . . .	<b>8901515</b>	1	81.75	(Note 5) . . . . .
<i>NOTE 5: It may be necessary to cut off ctsy. lamp sockets and tape back wires.</i>					
70	Chevelle (307, 350) (exc. C.A.C., inst. pnl. gauges, frt. comp. fir. console, Monte Carlo, El Camino),				
70	El Camino (307, 350) (exc. Custom, inst. pnl. gauges, frt. comp. fir. console, C.A.C.) . . . .	<b>8901324</b>	1	66.25	
70	Chevelle w/inst. panel gauges . .	<b>8901478</b>	1	78.25	
70	Chevelle w/C.A.C. (8 cyl.) (exc. Monte Carlo) . . . . .	<b>8901331</b>	1	78.25	
70	Malibu, El Camino w/floor console (exc. inst. pnl. gauges),				
70	Malibu, Estate Wag. (exc. C.A.C.),				
70	El Camino (Custom) (exc. C.A.C.)	<b>8901327</b>	1	66.00	
70	Malibu, El Camino, Monte Carlo (2-Dr.) (exc. inst. panel gauges)	<b>8901481</b>	1	69.50	(Note 6) . . . . .
<i>NOTE 6: It may be necessary to remove 14 ga. brown wire from heater control connector and use for A/C Feed. Add conn. body pin, 2977253-tape unused wires out of the way.</i>					
70	Nova (exc. C.A.C., inst. console cluster) . . . . .	<b>8901341</b>	1	68.25	
70	Nova (A.T. w/floor console) (exc. inst. console cluster) . . . . .	<b>8901343</b>	1	66.50	
70	Nova w/C.A.C. (exc. floor console) . . . . .	<b>8901344</b>	1	68.25	
70	Camaro w/inst. pnl. gauges . . . .	<b>8901444</b>	1	28.75	ext. . . . .
70	Camaro (exc. inst. pnl. gauges)	<b>8901440</b>	1	37.00	ext. . . . .
70	Camaro w/A.T. (8 cyl.) (exc. C.A.C. floor console),				
70	Camaro w/P.G. (6 cyl.) (exc. floor console) . . . . .	<b>8901449</b>	1	83.75	
70	Camaro (exc. A.T.) . . . . .	<b>8901543</b>	1	91.25	

**CHASSIS—ELECTRICAL SYSTEM**

**2.480 HARNESS ASSY.— WIRE— GROMMET— CLIP, Chassis Wiring  
(segmented) (Con't)**

70	Camaro (A.T. w/floor console) . . .	8901544	1	80.75	
70	Camaro (A.T. w/C.A.C.) (8 cyl.) (exc. floor console) . . . . .	8901546	1	72.75	
71	Nova w/console inst. cluster . . .	8907789	1	81.25	
71	Nova (exc. console inst. cluster) .	8907788	1	81.25	
71	Camaro . . . . .	8907781	1	81.25	
71	Chevelle w/inst. panel gauges . .	8901718	1	71.50	
71	Malibu (S.S. Package) (8 cyl.) (exc. inst. pnl. gauges), Monte Carlo (exc. inst. pnl. gauges) . . . . .	8901717	1	71.50	
71	Chevelle (exc. 454, S.S. Package inst. pnl. gauges) . . . . .	8907793	1	82.50	
71	Pass. . . . .	8901910	1	59.50	
71-72	Pass. . . . .	8901706	1	36.50	wiring ext. . . . .
72	Nova w/console inst. cluster . . .	8912235	1	111.00	w/st. belt warning sys. . . . .
71	Vega w/A.T. . . . .	8901687	1	66.25	instr. panel . . . . .
71	Vega (exc. A.T.) . . . . .	8901881	1	111.00	instr. panel . . . . .
72	Vega w/A.T. . . . .	8908170	1	100.00	instr. panel . . . . .
72	Vega (exc. A.T.) . . . . .	8908104	1	93.25	instr. panel . . . . .
72-73	Vega (exc. A.T., G.T.) . . . . .	8908256	1	93.25	instr. panel . . . . .
72-73	Vega (G.T.) (exc. A.T.) . . . . .	8908319	1	86.75	instr. panel (repl. 8908257) . . . . .
72	Nova (exc. console inst. cluster) .	8912234	1	111.00	w/st. belt warning sys. . . . .
72	Camaro . . . . .	8912225	1	151.00	w/st. belt warning sys. . . . .
72	Chevelle w/inst. panel gauges . .	8908150	1	81.25	
72	Malibu (S.S. Package w/frt. compartment floor console) (8 cyl.) (exc. inst. pnl. gauges), Monte Carlo w/frt. compartment floor console (exc. inst. pnl. gauges) . . . . .	8908149	1	128.00	
72	Chevelle (exc. 454, S.S. Package inst. pnl. gauges) . . . . .	8912222	1	82.50	
72	Pass. . . . .	8908140	1	71.25	(Note 7) . . . . .
73	Nova (exc. Console Inst. Cluster)	8912638	1	73.75	
73	Nova w/Console Inst. Cluster . . .	8908208	1	79.25	
73	Chevelle (exc. Inst. Panel gauges) . . . . .	8901963	1	68.75	
73	Chevelle w/Inst. Panel gauges . .	8901964	1	68.75	
73	Pass. . . . .	8908211	1	59.50	
73	Camaro (exc. Instr. Panel gauges, L.T.) . . . . .	8908214	1	151.00	
73	Camaro w/Instr. Panel gauges . .	8908215	1	151.00	
73	Vega w/A.T. (exc. G.T.) . . . . .	8908254	1	100.00	instr. panel . . . . .
73	Vega w/A.T. (G.T.) . . . . .	8908255	1	100.00	instr. panel . . . . .
74	Vega (122) . . . . .	8908426	1	100.00	instr. panel . . . . .
74	Vega (exc. A.T., gauges) . . . . .	8908427	1	93.25	instr. panel . . . . .
74	Vega w/A.T. (exc. gauges) . . . .	8908428	1	100.00	instr. panel . . . . .
74	Vega (140) w/gauges (exc. A.T.)	8908429	1	93.25	instr. panel . . . . .
74	Vega w/A.T., gauges . . . . .	8908430	1	103.00	instr. panel . . . . .
74	Pass. . . . .	8908374	1	125.00	
74	Nova (exc. Console Inst. Cluster)	8918810	1	122.00	
74	Nova w/Console Inst. Cluster . . .	8908352	1	122.00	
74	Chevelle (S.S.) (exc. gauges), Laguna, Monte Carlo (exc. gauges) . . . . .	8908383	1	133.00	
74	Chevelle (exc. S.S., gauges, Laguna, Monte Carlo) . . . . .	8908381	1	133.00	
74	Chevelle w/gauges . . . . .	8908384	1	123.00	
74	Camaro (exc. gauges) . . . . .	8908354	1	151.00	
74	Camaro w/gauges . . . . .	8908355	1	151.00	
75	Camaro (exc. gauges) . . . . .	12001663	1	147.00	
75	Camaro w/gauges . . . . .	8908499	1	147.00	
75	Nova w/Console Inst. Cluster . . .	12001667	1	97.75	
75	Nova (exc. Console Inst. Cluster)	8919397	1	67.75	
75	Chevelle w/gauges . . . . .	12001662	1	165.00	
75	Chevelle (exc. gauges, S.S.) . . . .	12001660	1	165.00	
75	Chevelle S.S. (exc. gauges) . . . .	12001661	1	165.00	
75	Pass. . . . .	8919802	1	136.00	
75	Vega, Monza (exc. Notchback) w/gauges (exc. A.T.) . . . . .	12001669	1	143.00	
75	Vega, Monza (A.T. w/gauges) . .	12001671	1	180.00	
75	Vega (exc. A.T., gauges) . . . . .	12001668	1	175.00	
75	Vega w/A.T. (exc. gauges) . . . .	12001670	1	175.00	

**CHASSIS—ELECTRICAL SYSTEM**

**2.480 HARNESS ASSY.— WIRE— GROMMET— CLIP, Chassis Wiring  
(segmented) (Con't)**

75	Monza Notchback (exc. A.T., gauges) .....	8916141	1	114.00
75	Monza Notchback (w/M.T. & gauges) .....	8916142	1	150.00
75	All (122) .....	8908534	1	168.00

*NOTE 7: When 8908140 is used in place of the first design harness it will be necessary to discard the steering column harness on the vehicle and replace it with 8908140.*

*NOTE 1 It may be necessary to cut the neutral safety switch connector off and strip, splice, solder, and tape wires for insulation.*

*On models prior to 1964 transfer light switch connector from old harness.*

*NOTE 2 When using on models without C.A.C. equip., glove box terminal should be taped for installation.*

*NOTE 3 It may be necessary to coil and tape excess wire.*

*NOTE 4 When using on models without powerglide it will be necessary to cut off neutral safety switch terminals, strip wires and splice together or use jumper terminal 2984503.*

*Solder and tape for proper insulation.*

**GENERATOR AND FORWARD LAMP**

63-64	Chevy .....	2986045	1	28.75	
64	Chevelle .....	2988125	1	37.50	
65	Chevelle .....	6286877	1	38.25	
65	Pass. (6 cyl.) .....	2989093	1	41.25	
65	Pass. (8 cyl.) .....	2989094	1	36.75	
66	Pass. (8 cyl.) .....	6286977	1	38.25	
66	Pass. (6 cyl.) .....	6289420	1	37.75	
66	Chevy .....	6287819	1	25.75	
66	Chevelle .....	6289374	1	38.25	
67	Chevelle .....	6293164	1	40.75	
67	Chevy .....	6292081	1	30.75	w/fusible link .....
67	Camaro (8 cyl.) w/R.S. ....	6292098	1	72.50	w/fusible link .....
67	Camaro (6 cyl.) (exc. R.S.) ..	6292093	1	35.00	w/fusible link .....
67	Camaro (8 cyl.) (exc. R.S.) ..	6292095	1	43.50	w/fusible lamp .....
67	Pass. (8 cyl.) .....	6293383	1	46.25	(Note 1) .....
<i>NOTE 1 Includes wires for front fender running lamps. If not used with running lamps cut and tape wires.</i>					
68	Pass. (8 cyl.) (exc. frt. fender lamps, Caprice) .....	6295041	1	52.25	
<i>NOTE 2 Tape back fender light wires if necessary. DO NOT CUT.</i>					
68	Pass. (6 cyl.) (exc. frt. fender lamps) .....	6295043	1	49.25	
68	Caprice, Pass. w/frt. fender lamps (exc. Caprice) .....	6295042	1	51.25	
68	Chevelle (6 cyl.) .....	6295034	1	40.75	
68	Chevelle (8 cyl.) (exc. inst. panel gauges),				
68	Chevelle w/inst. panel gauges ..	6295050	1	52.00	
68	Camaro (8 cyl.) (exc. R.S.) .....	6295058	1	49.25	
68	Chevy (8 cyl.) .....	6295230	1	45.25	
68	Chevy (exc. 8 cyl.) .....	6295228	1	40.50	
69	Chevelle (8 cyl.) .....	6297520	1	54.25	
69	Chevelle (6 cyl.) .....	6297518	1	47.50	
69	Chevy (exc. 8 cyl.) .....	6297544	1	48.00	
69	Chevy (8 cyl.) .....	6297536	1	48.00	
69	Camaro (6 cyl.) .....	6297540	1	48.00	
69	Camaro (8 cyl.) .....	6297542	1	50.50	
69	Pass. (396, 427) (exc. retrac. H/lamp cover) .....	6297566	1	48.00	
69	Pass. (6 cyl.) (exc. retrac. H/lamp cover) .....	6297577	1	48.00	
69	Pass. (327, 350) (exc. retrac. H/lamp cover) .....	6297565	1	43.75	
70	Pass. (8 cyl.) .....	8901454	1	49.50	
70	Chevelle w/inst. panel gauges (8 cyl.) (exc. Monte Carlo) .....	8901302	1	55.00	
70	Monte Carlo w/C.A.C. (exc. inst. panel gauges) .....	8901452	1	55.00	
70	Monte Carlo w/inst. panel gauges .....	8901453	1	55.00	
70	Monte Carlo (exc. C.A.C., inst. panel gauges) .....	8901540	1	55.00	
70-71	Nova (exc. 8 cyl.) .....	8908093	1	44.50	
70	Nova w/inst. console cluster ..	8901465	1	49.50	
70	Nova (8 cyl.) (exc. inst. console cluster) .....	8901466	1	49.50	
70	Camaro (6 cyl.) .....	8901392	1	47.00	

## CHASSIS—ELECTRICAL SYSTEM

### 2.480 HARNESS ASSY.— WIRE— GROMMET— CLIP, Chassis Wiring (segmented) (Con't)

70	Camaro (8 cyl.) (exc. inst. pnl. gauges) . . . . .	8907785	1	67.75
70	Camaro w/inst. pnl. gauges . . . . .	8901394	1	45.75
70	Chevelle (8 cyl.) (exc. inst. pnl. gauges, Monte Carlo) . . . . .	8901539	1	55.00
71	Nova (8 cyl.) . . . . .	8907792	1	67.75
71	Camaro (6 cyl.) . . . . .	8901915	1	46.00
71	Camaro (8 cyl.) . . . . .	8907785	1	67.75
71	Chevelle (6 cyl.) . . . . .	8901719	1	46.00
71	Chevelle (8 cyl.) (exc. Monte Carlo) . . . . .	8907797	1	53.25
71	Monte Carlo . . . . .	8907798	1	49.25
71	Pass. (6 cyl.) . . . . .	8908096	1	49.25
71	Pass. (8 cyl.) . . . . .	8908097	1	44.50
71	Vega . . . . .	8907055	1	47.50
72-73	Vega . . . . .	8908301	1	47.50
72	Nova . . . . .	8908028	1	67.75
72	Camaro . . . . .	8908010	1	42.25
72	Chevelle (exc. Monte Carlo) . . . . .	8908068	1	54.50
72	Monte Carlo . . . . .	8908189	1	54.50
72	Pass. . . . .	8901952	1	66.50
73	Nova . . . . .	8908209	1	67.75
73	Camaro . . . . .	8908212	1	42.25
73	Chevelle (exc. Monte Carlo) . . . . .	8908358	1	54.25
73	Monte Carlo . . . . .	8901995	1	54.25
73	Pass. . . . .	8908224	1	44.50
74	Caprice . . . . .	8908337	1	56.50
74	Pass. (exc. Caprice) . . . . .	8908336	1	44.50
74	Nova . . . . .	8908353	1	67.75
74	Camaro . . . . .	8908312	1	40.25
74	Chevelle (exc. Laguna, Monte Carlo) . . . . .	8908371	1	54.25
74	Chevelle (Laguna) . . . . .	8908372	1	54.25
74	Monte Carlo . . . . .	8908373	1	54.25
74	Vega . . . . .	8908334	1	47.50
75	Monza (Notchback) . . . . .	8908500	1	46.00
75	Monza (exc. Notchback) . . . . .	8908507	1	51.25
75	Pass. (exc. Caprice) . . . . .	8908464	1	65.50
75	Caprice . . . . .	8908465	1	55.25
75	Nova . . . . .	8908490	1	66.25
75	Camaro . . . . .	8908497	1	41.00
75	Chevelle (exc. Monte Carlo, Laguna) . . . . .	8908493	1	53.25
75	Monte Carlo . . . . .	8908494	1	53.25
75	Laguna . . . . .	8908571	1	79.75

### INSTRUMENT CLUSTER

71	Camaro (8 cyl.) (exc. inst. panel gauges) . . . . .	8901808	1	23.65
71	Camaro w/inst. panel gauges . . . . .	8901809	1	27.25
71	Pass. . . . .	8901698	1	65.50
71	Vega (exc. G.T.) . . . . .	8901685	1	80.00
71-72	Vega (G.T.) . . . . .	8908167	1	53.25
72	Vega (exc. G.T.) . . . . .	8908168	1	41.25
72	Pass. . . . .	8908141	1	43.50
72	Camaro (exc. inst. panel gauges) . . . . .	8908156	1	30.50
72	Camaro w/inst. panel gauges . . . . .	8908157	1	34.50
73	Chevelle w/Aux. lighting (exc. S.S., Inst. Panel gauges, Monte Carlo) . . . . .	8901967	1	55.00
73	Chevelle (S.S.) (exc. Inst. Panel gauges), . . . . .			
73	Monte Carlo (exc. Inst. Panel gauges) . . . . .	8901969	1	52.25
73	Chevelle w/Inst. Panel gauges . . . . .	8901970	1	54.50
73	Pass. . . . .	8908279	1	41.50
73	Vega (G.T.) . . . . .	8908285	1	53.25
73	Vega (exc. G.T.) . . . . .	8908284	1	53.25
74	Vega w/gauges . . . . .	8908432	1	53.25
74	Vega (exc. gauges) . . . . .	8908431	1	53.25

### PARTS

71-74	Vega . . . . .	8916194	1	7.85	HARNESS ASSY., coolant level sensor . . . . .
-------	----------------	---------	---	------	---

**CHASSIS—ELECTRICAL SYSTEM**

**2.480 HARNESS ASSY.— WIRE— GROMMET— CLIP, Chassis Wiring (segmented) (Con't)**

62-72	All (exc. Vega)	8903488	A.R.	RL/10.71	WIRE, fusible (14 gauge) (50 ft. coil)— (2.530)
62-72	All (exc. Vega)	8903489	A.R.	RL/8.92	WIRE, fusible (16 gauge) (50 ft. coil)— (2.530)
62-72	All (exc. Vega)	8903490	A.R.	RL/7.86	WIRE, fusible (20 gauge) (50 ft. coil)— (2.530)
67-68	Camaro	6291184	1	3.40	WIRE ASSY., gas tank extension
67	Camaro w/R.S.	6291830	1	13.40	WIRE ASSY., inst. panel wiring harness extension w/diode
69-71	Camaro	8901600	1	3.65	WIRE ASSY., gas tank extension
70-72	Nova	8901580	1	.98	WIRE ASSY., inst. pnl. wrg. harness ext.
71-74	Vega	8916195	1	6.05	WIRE ASSY., coolant level sensor
71	Pass., Camaro,				
73-75	Nova	8901772	1	3.65	WIRE ASSY., fuel tank ext.
72-73	Pass.	8908138	1	2.25	WIRE ASSY., fuel tank ext.
74	Pass. (exc. Sta. Wag.),				
75	Camaro	8908397	1	2.75	WIRE ASSY., fuel tank ext.
73	El Camino,				
74-75	Chevelle (Spt. Cpe., Sed.)	8908402	1	3.65	WIRE ASSY., fuel tank ext.
75	Pass. Chevelle	8908496	1	20.05	WIRE ASSY., wsw
75	Monza (Notchback)	8916119	1	4.05	WIRE ASSY., fuel tank ext.
73-74	Chevelle	8905981	A.R.	.43	CLIP, inst. cluster printed wiring circuit
68	Malibu, Concours, S.S.,				
70	Chevelle, Camaro,				
74-75	Pass.	6258275	2	.11	GROMMET, fwd. lamp horn relay wiring

**2.482 BRACKET, Instrument Panel Harness**

74	Vega	340477	1	.28	
----	------	--------	---	-----	--

**2.483 BLOCK, Fuse & Junction**

*NOTE Fuse Panel Assy. is part of wiring harness.*

65-69	All, w/1100615-0618-0620- 0628-0629-0633-0665-0668- 0669-0670-0693-0694-0695- 0696-0697-742-750-0834 thru 0849	1959834	3	.37	generator junction— (2.313)
65-67	Chevelle,				
65	Pass.,				
67	Chevy,				
67-68	Camaro	340409	1	.36	batt. positive cable— (2.342)

**2.485 SWITCH— AMPLIFIER— BEZEL— BRACKET— BREAKER ASSY.— BUZZER ASSY.— STRAP, Lighting**

62-63	Chevy	1995096	1	10.00	
64-67	All,				
68-69	Chevy, Chevelle,				
68	Camaro (exc. R/S),				
70-73	Nova,				
71-74	Vega,				
72-73	Chevelle	1995179	1	6.50	(4 amp. fuse)
66	Caprice w/Bucket Seats	1995142	1	5.75	
68	Pass. (exc. Retracc. H/Lamp cvr.)	1995165	1	6.90	(6 amp. fuse)
68	Pass. w/Retrac. H/Lamp cvr.	1995191	1	11.40	
68	Camaro w/R.S.,				
69	Camaro w/R.S. (exc. Console inst. cluster)	1995176	1	12.05	
69	Pass. (exc. Retracc. H/Lamp cvr.),				
69	Camaro w/Console inst. cluster (exc. R.S.),				
70-72	All (exc. Nova, Chevelle),				
73-75	Pass., Camaro	1995192	1	7.05	
69	Pass. w/Retrac. H/Lamp cvr.	1995174	1	12.05	
69	Camaro (exc. R.S. console inst. cluster)	1995175	1	7.65	
69	Camaro w/console inst. cluster	1995177	1	11.55	
70-71	Pass. w/hdip. time delay	3973678	1	4.00	
74-75	Nova, Chevelle,				
75	Vega, Monza	1995193	1	7.10	
70-71	Pass. w/hdip. time delay	917042	1	26.25	AMPLIFIER, light watch
70	Pass. w/hdip. time delay	3973679	1	.71	BEZEL, light watch
71*	Pass. w/hdip. time delay	3990897	1	.63	BEZEL, light watch
71	Pass. w/hdip. time delay	3986835	1	.36	BRACKET, light watch ampf.



**CHASSIS—ELECTRICAL SYSTEM**

**2.485 SWITCH—AMPLIFIER—BEZEL—BRACKET—BREAKER ASSY.—BUZZER ASSY.—STRAP, Lighting (Con't)**

72-75	Pass., Chevelle	2474055	1	1.90	BREAKER ASSY., inst. panel wrg. harness. circ.
71	Camaro	3973681	1	1.30	STRAP ASSY., windshield washer and light switch guard

**2.486 ROD—NUT ASSY., Lighting Switch, with Knob**

64	Nova	3782624	1	.84	
65-66	All	3860104	1	.84	
67	All,				
68	Camaro	3886987	1	.76	
68	Pass.	3943623	1	1.10	
68	Chevy	3916711	1	.76	
68	Chevelle	3943624	1	1.10	
71	Camaro,				
71	Chevelle (S.S.);				
71-75	Vega, Monza (exc. Notchback),				
72-75	Chevelle, Nova, Camaro	3986886	1	1.15	
69-70	All	3954210	1	1.20	
71	Nova,				
71	Chevelle (exc. S.S.)	3986888	1	.98	
71-75	Pass.	3996284	1	.98	
75	Monza (Notchback)	366484	1	1.20	
68	Chevy	3916710	1	.46	NUT ASSY.

**2.487 FERRULE—ESCUTCHEON—BEZEL—NUT ASSY.—PLATE—SPACER, Lighting Switch Rod**

62-65	Chevy,				
65-66	Pass.	1959820	1	.56	
	<i>Note 1. Paint as required.</i>				
71-75	Pass.	3996237	1	.59	ESCUTCHEON, light switch
67-68	Camaro	3904861	1	.82	NUT ASSY.
68-69	All (exc. Camaro),				
70	All,				
71-72	All (exc. Pass.),				
71-75	Vega, Monza,				
73-75	Nova, Camaro	3919021	1	.47	NUT ASSY.
71-74	Pass.	3996236	1	.19	NUT ASSY.
73-75	Chevelle	6258213	1	.55	NUT ASSY.
75	Pass.	344857	1	.71	NUT ASSY.
69	Camaro w/deluxe interior (exc. power top, rr. window defrost)	3945971	1	.71	PLATE, inst. pnl. light switch trim
71-75	Pass.	3996256	1	.11	SPACER, light switch
74-75	Nova	3918894	1	.61	SPACER, light switch

**2.500 REGULATOR—CUSHION—SCREW—NUT, Electrical Output (See 2.319 for Breaker)**

62	Chevy w/35 amp. (exc. L.C.I.)	1119305	1	24.95	(exchange item-Note 1)
62-67	All (exc. 62 amp., T. Ign.),				
68-70	All,				
71-72	All (exc. Vega) (exc. 63 amp.)	1119515	1	21.20	
63-66	Chevy, Chevelle w/62 amp.,				
65	Pass., Chevelle (T. Ign. w/C.A.C.) (exc. 62 amp.),				
66-67	Pass. w/62 amp.	1116378	1	48.90	(Exchange Item—Note 1)
66-67	Pass. (C.A.C. w/T.H.);				
71-72	All w/63 amp.	1119519	1	22.60	
71-75	Vega	1116387	1	22.00	
63	Chevy (exc. 62 amp. AC gen.)	3840533	3	.58	CUSHION, regulator mtg. w/1119512) (rubber—2 1/4" x 5/8" x 3/4")
63-75	All (exc. 62. amp., T. Ign.)	3876129	3	.11	SCREW, voltage and current reg. assy. attaching (No. 10-24 x 1) (w/1119515)
62-75	All	3876130	A	.16	NUT, w/grommet regulator (No. 10-24)

*NOTE 1 List price shown does not include exchange charge. Refer to Dealer Parts Price Schedule for exchange price.*

**2.505 TRANSISTOR, Voltage Regulator Output**

65-66	Pass., Chevelle (T. Ign. w/C.A.C.) (exc. 62 amp., F.I.),				
75	All (122)	1960632	1	29.65	

**2.515 AMMETER—GAUGE ASSY.—BACKPLATE—DIAL—INSULATOR—RESISTOR, Electrical Output (See Group 9.748 for Telltale Windows)**

63-65	Nova (S.S.)	1502728	1	7.91	
64	Malibu (S.S.)	1502873	1	8.83	

**CHASSIS—ELECTRICAL SYSTEM**

**2.515 AMMETER— GAUGE ASSY.— BACKPLATE— DIAL— INSULATOR— RESISTOR, Electrical Output (See Group 9.748 for Telltale Windows) (Con't)**

65	Malibu (S.S.)	1503013	1	6.93	
65	S.S.	1503038	1	6.93	
66-67	Malibu, S.S.	1503251	1	9.46	GAUGE ASSY., ammeter
67	Camaro	1503499	1	7.08	GAUGE ASSY., ammeter
68-69	Camaro w/inst. cluster console	6473265	1	8.78	GAUGE ASSY., ammeter
69	Chevelle w/inst. panel gauges	6473402	1	7.79	GAUGE ASSY., ammeter
70-72	Chevelle w/inst. console cluster	6473843	1	10.45	GAUGE ASSY., ammeter
70-75	Camaro w/inst. panel gauges	6473741	1	10.45	GAUGE ASSY., ammeter
68-70	Chevy w/inst. cluster console,				
71-75	Nova w/inst. panel gauges	6473840	1	8.28	GAUGE ASSY., ammeter
71-74	Vega w/gauges	6473831	1	11.19	GAUGE ASSY., ammeter
73-74	Chevelle w/inst. panel gauges	6473890	1	10.45	GAUGE ASSY., ammeter
75	Chevelle w/inst. panel gauges	6474254	1	18.62	GAUGE ASSY., voltmeter
75	Vega, Monza (exc. 122)	6474139	1	9.77	GAUGE ASSY., ammeter
75	Vega, Monza (140)	8987859	1	27.02	GAUGE ASSY., voltmeter (incl. temp. ga.)— (1.148)
75	Vega (122)	6474333	1	15.71	GAUGE ASSY., voltmeter
75	Camaro w/inst. panel gauges	6473744	1	2.17	BACKPLATE, ammeter & full ga. mtg.
73-74	Chevelle	6497031	1	2.85	DIAL, gen. telltale
70	Nova w/inst. console cluster	6430382	1	.44	INSULATOR, ammeter
63-65	Nova (S.S.)				
64	Malibu (S.S.)	1961149	1	3.69	RESISTOR, ammeter shunt

**2.525 HARNESS— WIRE ASSY., Starting, Ignition**

**AMMETER TO STARTING SWITCH**

62-64	Chevy (exc. 8 cyl.),				
65	Chevy (exc. 8 cyl., S.S.),				
66	Chevy (exc. 8 cyl.)	2986047	1	12.45	(cover 53 O.L.)
64-66	Chevy (8 cyl.)	2982837	1	10.30	(cover 58 <sup>7</sup> / <sub>32</sub> " O.L.)
64	Chevelle (8 cyl.)	2988122	1	17.85	(cover 33 <sup>13</sup> / <sub>32</sub> " O.L.)
65	Chevelle (8 cyl.) (exc. 396),				
66	Chevelle (8 cyl.) (exc. C.A.C.)	2989052	1	15.75	(cover 41 <sup>1</sup> / <sub>2</sub> " O.L.) (Note 1)
<i>NOTE 1 When using on S.S. models, remove temp. sender plastic connector.</i>					
65	Pass. (8 cyl.) (exc. S.S., C.A.C., 396, 409),				
66	Pass. (8 cyl.) (exc. C.A.C., Floor console w/gauges, 396, 427),				
66	Pass. w/Auto Temp. Cont. (8 cyl.) (exc. floor console w/gauges, 396, 427)	2989096	1	13.60	
65	S.S. (8 cyl.) (exc. C.A.C., 396, 409),				
66	Pass. w/B.S., Auto Temp. Cont. (8 cyl.) (exc. C.A.C., 396, 427)	2989099	1	11.90	
65-66	Pass. w/C.A.C. (8 cyl.) (exc. S.S. Caprice, 396, 409, 427)	6286761	1	21.15	
65-66	S.S., Caprice w/C.A.C. (8 cyl.) (exc. 396, 409, 427)	6286764	1	17.95	
66	Pass. (396, 427) (exc. C.A.C.)	6287144	1	14.75	
66	Chevelle w/C.A.C. (283, 327) (exc. Sp. H/Per.),				
66	Chevelle (S.S.) (396)	6287156	1	20.55	(cover 39 <sup>45</sup> / <sub>64</sub> " O.L.)
66	Chevelle (396) (exc. C.A.C.)	6287855	1	14.75	(cover 57 <sup>45</sup> / <sub>64</sub> " O.L.)
<i>NOTE 4 When using in place of 6290481 replace temp. sender conn. 2984275 with 2962965.</i>					
<i>NOTE 2 When using on models equipped with instrument panel gauges replace sender connector with 2962965.</i>					
67	Chevelle (396)	6290411	1	20.70	(55 <sup>23</sup> / <sub>32</sub> " O.L.) (Note 3)
67	Chevelle (8 cyl.) (2nd design) (exc. 396)	6291979	1	20.30	(41 <sup>23</sup> / <sub>32</sub> " O.L.) (Note 3)
<i>NOTE 3 On El Camino, S.S. models it may be necessary to change temp. sender terminals to connector 2962965 and terminal 2973369 and tape back oil pressure switch wire.</i>					
67	Chevy (6 cyl.)	6291931	1	11.50	(53 <sup>19</sup> / <sub>32</sub> " O.L.)
67	Chevy (8 cyl.) (1st design)	6291164	1	12.65	(58 <sup>13</sup> / <sub>16</sub> " O.L.)
67	Chevy (8 cyl.) (2nd design)	6291973	1	11.85	(63 <sup>5</sup> / <sub>16</sub> " O.L.)
67	Camaro (396) (exc. Inst. Cluster Gauges)	6291985	1	17.15	(60 <sup>13</sup> / <sub>16</sub> " O.L.)
67	Camaro w/inst. panel gauges (exc. 396)	6291982	1	18.20	
67	Camaro (exc. inst. panel gauges, 396)	6291981	1	17.05	
67	Camaro (6 cyl.)	6291938	1	19.05	(58 O.L.)

**CHASSIS—ELECTRICAL SYSTEM**

**2.525 HARNESS— WIRE ASSY., Starting, Ignition (Con't)**

67	Pass. (283, 327) (exc. Inst. Pan. Gauges) . . . . .	6290487	1	13.85	
67	Pass. w/C.A.C. (exc. Auto Temp. Control) . . . . .	6290675	1	19.85	
68	Pass. (8 cyl.) (exc. 396, 427, Inst. panel gauges) . . . . .	6295007	1	15.00	
68	Pass. (396, 427) (exc. Inst. panel gauges),				
69	Pass. (8 cyl.) . . . . .	6297634	1	22.35	
68-69	Pass. (6 cyl.) . . . . .	6295192	1	15.95	
68-69	Chevelle w/inst. panel gauges . . . . .	6297631	1	22.45	
68-69	Chevelle (8 cyl.) (exc. inst. panel gauges) . . . . .	6297630	1	25.25	
68-69	Chevelle (6 cyl.) . . . . .	6295188	1	20.90	
68-69	Chevy, Camaro (exc. 8 cyl.) . . . . .	6295189	1	18.20	
68-69	Chevy, Camaro (8 cyl.) w/inst. cluster console . . . . .	6297639	1	19.05	
68-69	Chevy, Camaro (exc. inst. cluster console) . . . . .	6297638	1	20.70	
70	Pass. w/P.G., T.H. 350 (350, 400) . . . . .	8901364	1	31.00	
70	Pass. w/A.T. (350) (exc. C.A.C., 4BC) . . . . .	8901588	1	21.65	
70	Pass. (C.A.C. w/T.H. 400) (350, 400) . . . . .	8901589	1	24.95	(rod type linkage) (Note 4) . . . . .
<i>NOTE 4 When using in place of 8901619 cut off Transmission Kickdown Switch Conn. and replace with Series 56 Type Female Terminals and Conn. Body.</i>					
70	Chevelle w/P.G., T.H. 350 (8 cyl.) . . . . .	8901304	1	26.00	
70	Chevelle w/T.H. 400 . . . . .	8901495	1	26.00	
70	Chevelle (396, 400, 454) (exc. T.H. 400) . . . . .	8901494	1	26.00	
70	Nova 6 cyl. (exc. A.T.) . . . . .	8901398	1	20.05	
70	Nova w/A.T. (exc. 8 cyl.) . . . . .	8901400	1	19.90	
70	Nova w/P.G., T.H. 350 (8 cyl.) (exc. inst. console cluster) . . . . .	8901401	1	19.05	
70	Nova w/T.H. 400 (8 cyl.) (exc. inst. console cluster) . . . . .	8901402	1	21.95	
<i>NOTE 1 When using 8901407 in place of 8901622, cut off kick down switch conn. and splice to old conn. or install new term. and conn. body 2977647.</i>					
70	Nova w/inst. console cluster (307, 350) (exc. A.T.) . . . . .	8901405	1	17.35	
70	Nova w/inst. console cluster (396) (exc. T.H. 400) . . . . .	8901406	1	18.40	
70	Nova (8 cyl.) (exc. 396, A.T., inst. console cluster) . . . . .	8901403	1	19.90	
70	Nova (396) (exc. A.T., inst. console cluster) . . . . .	8901404	1	18.55	
70	Nova (A.T. w/inst. console cluster) (exc. T.H. 400) . . . . .	8901399	1	18.90	
70	Camaro (8 cyl.) (exc. A.T., 396) . . . . .	8901409	1	20.00	
70	Camaro w/P.G. (6 cyl.) . . . . .	8901410	1	22.80	
70	Camaro (396) (exc. T.H. 400) . . . . .	8901412	1	26.00	
70	Camaro w/A.T. (8 cyl.) (exc. T.H. 400) . . . . .	8901413	1	22.80	
70	Camaro (T.H. 400 w/Sp. H/Per.) (350) . . . . .	8901707	1	35.25	
71	Nova (6 cyl.) . . . . .	8907790	1	22.35	
71	Camaro (6 cyl.) . . . . .	8907782	1	35.25	
71	Chevelle (6 cyl.) . . . . .	8907794	1	35.25	
71	Pass. (6 cyl.) . . . . .	8907786	1	22.50	
71	Nova (8 cyl.) . . . . .	8907791	1	22.35	
71	Camaro w/T.H. 400 (350 Sp. H/Per.),				
71	Camaro (400) . . . . .	8907784	1	35.25	
71	Camaro (8 cyl.) (exc. 400, T.H. 400) . . . . .	8907783	1	35.25	
71	Chevelle (8 cyl.) (exc. 400, 454) . . . . .	8907795	1	25.75	
71	Chevelle (400, 454) . . . . .	8907796	1	27.50	
71	Pass. (8 cyl.) (exc. T.H. 400) . . . . .	8907787	1	30.50	
71	Pass. w/T.H. 400 (8 cyl.) . . . . .	8901888	1	64.00	
71	Vega . . . . .	8907054	1	68.00	engine wiring . . . . .
72	Vega w/P/S . . . . .	8909990	1	76.25	engine and generator . . . . .
72	Vega (exc. P/S) . . . . .	8909991	1	68.00	engine and generator . . . . .
72	Nova (6 cyl.) . . . . .	8908024	1	43.25	

## CHASSIS—ELECTRICAL SYSTEM

### 2.525 HARNESS— WIRE ASSY., Starting, Ignition (Con't)

72	Camaro (6 cyl.)	8908002	1	35.25	
72	Pass. (6 cyl.)	8901947	1	26.25	
72	Chevelle (6 cyl.)	8908061	1	18.65	
72	Nova (8 cyl.)	8909948	1	35.25	
72	Camaro w/T.H. 400 (350 Sp. H/Per.)	8908007	1	35.25	
72	Camaro w/T.H. 400 (402)	8909989	1	136.00	
72	Camaro (402) (exc. T.H. 400)	8909988	1	126.00	
72	Camaro (8 cyl.) (exc. T.H. 400, 402)	8909987	1	86.25	
72	Pass. w/T.H. (402, 454)	8901950	1	64.00	
72	Pass. w/T.H. (350, 400)	8909986	1	65.25	
72	Chevelle (307, 350)	8909984	1	74.25	
72	Chevelle (402, 454)	8909985	1	35.25	
73	All (6 cyl.)	8912790	1	67.75	
73	Nova (307, 350) (exc. console inst. cluster),				
73	Chevelle, Camaro (307, 350) (exc. Gauges, Sp. H/Per.),				
73	Camaro (Sp. H/Per. w/4-Spd.) (exc. Gauges),				
73	Pass. w/T.H. 350	8901986	1	65.25	
73-74	Chevelle w/4-Spd. (454) (exc. Gauges)	8901987	1	74.25	
73-74	Pass., Chevelle (454) (exc. Gauges)	8919363	1	74.25	
73-74	Chevelle (4-Spd. w/Gauges) (exc. H.E.I.)	8901991	1	74.25	
73-74	Chevelle (T.H. 400 w/Gauges) (exc. H.E.I.)	8901992	1	74.25	
73	Camaro w/T.H. 400 (exc. Gauges),				
73	Pass. (Sta. Wag.) w/2BC,				
73	Pass. w/T.H. 400 (400) (exc. Sta. Wag.)	8908222	1	42.25	
73	Camaro w/Gauges (exc. T.H. 400),				
73	Nova w/console instrument cluster,				
73	Chevelle (307, 350) w/gauges	8901990	1	126.00	
73	Camaro (T.H. 400, w/Gauges)	8908237	1	42.25	
73	Vega (exc. P/S)	8914919	1	68.00	engine and generator
73	Vega w/P/S	8908263	1	76.25	engine and generator
74	Vega w/P/S (140)	8908560	1	72.00	engine and generator
74	Vega (exc. A.T., P/S, gauges)	8908328	1	61.50	engine and generator
74	Vega w/gauges (exc. P/S, A.T.)	8908558	1	61.50	engine and generator
74	All (6 cyl.)	8908359	1	67.75	
74	All (350) (exc. A.T.)	8918592	1	126.00	
74	All w/A.T. (350, 400)	8918593	1	74.25	
75	Vega (122)	8916239	1	70.25	engine and generator
75	Vega, Monza (140) (exc. P/S)	8908524	1	60.25	engine and gen.
75	Vega, Monza (P/S) (140)	8916191	1	70.25	engine and gen.
75	Monza (262) w/M.T.	8916113	1	83.75	engine and gen.
75	All w/integrated cyl. hd. (6 cyl.)	8908440	1	66.25	
75	All (6 cyl.) (exc. integrated cyl. hd.)	8916150	1	67.75	
75	Chevelle (8 cyl.) w/T.H. 400, w/gauges,				
75	Pass. (454) w/gauges	8908448	1	65.50	
75	Chevelle, Pass. Camaro, Nova (350-400) w/A.T. (exc. H.E.I.)	8919314	1	101.00	engine and gen.
75	Nova, Camaro (8 cyl.) (w/M.T. & gauges)	8908596	1	66.25	engine and gen.
75	Pass. w/T.H. 400 (exc. 454)	8908538	1	44.50	

### TRANSMISSION OVERDRIVE

65-66	Pass. (8 cyl.)	2988803	1	8.45	
68	Chevy, Camaro	6401499	1	.44	thermo. gauge
64-68	Chevelle	2985594	1	4.65	WIRE ASSY., extension

### 2.530 CABLE— LOOM— TERMINAL— TUBING— CONNECTOR— CONNECTION BODY— BOOT— WIRE— HOLDER PKG., Electrical

NOTE For illustration on terminals and connectors see Standard Parts Catalog (P&A 24).

62-69	All	3829905 A.R.	FT/.12	LOOM (3/16" x 50 ft. coil)	
71-73	All	3991025 A.R.	FT/.26	LOOM, battery cable protective (50 ft. roll)	

**CHASSIS—ELECTRICAL SYSTEM**

<b>2.530</b>		<b>CABLE— LOOM— TERMINAL— TUBING— CONNECTOR— CONNECTION BODY— BOOT— WIRE— HOLDER PKG., Electrical (Con't)</b>		
62-69	All	2962650 A.R.	.12	TERMINAL (used w/14 and 16 gauge wire) (1 <sup>1</sup> / <sub>32</sub> " O.L.— stamped 6)
62-69	All	2984123 A.R.	.12	TERMINAL, male (used w/14-16 and 18 gauge wire) (3 <sup>1</sup> / <sub>32</sub> " O.L.)
62-69	All	2965078 A.R.	.13	TERMINAL, female (used w/14 and 16 gauge wire) (4 <sup>9</sup> / <sub>64</sub> " O.L.— stamped 6)
62-69	All	2962958 A.R.	.10	TERMINAL, male (used w/14 and 16 gauge wire) (2 <sup>3</sup> / <sub>32</sub> " O.L.— stamped 6)
62-69	All	2962141 A.R.	.09	TERMINAL, male (used w/18 and 20 gauge wire) (4 <sup>7</sup> / <sub>64</sub> " O.L.)
62-69	All	2977615 A.R.	.39	TERMINAL, female (used w/14-16-18 and 20 gauge wire) (4 <sup>7</sup> / <sub>64</sub> " O.L.)
62-69	All	5640018	3	TERMINAL (1 <sup>1</sup> / <sub>4</sub> " O.L.)
62-69	All	2962987	1	TERMINAL, male (used w/14 and 16 gauge wire) (1 <sup>1</sup> / <sub>32</sub> " O.L.)
62-69	All	2965272 A.R.	.08	TERMINAL, male (used w/18 gauge wire) (1 <sup>7</sup> / <sub>32</sub> " O.L.)
62-69	All	2962915	1	TERMINAL, side type female (used w/14-16-18 and 20 gauge wire) (1 <sup>3</sup> / <sub>8</sub> " O.L.)
62-69	All	5640012 A.R.	.18	TERMINAL, temp., ammeter, and gasoline gauge
62-69	All	5289848 A.R.	.25	TERMINAL (male terminal— for welded joint— 2 <sup>1</sup> / <sub>32</sub> " O.L.)
62-69	All	1503092	1	TERMINAL, ammeter
62-70	All	6401499	1	TERMINAL, thermo. gauge (L.H. bend)
62-70	All	6401500	1	TERMINAL, thermo. gauge (R.H. bend)
65-68	Chevy, Chevelle (exc. P.G.),			
65-68	Pass. (exc. P.G.),			
71	All	2984503	1	TERMINAL, instr. panel neutral safety switch connector (jumper clip)
68-69	Chevy, Camaro w/gauges,			
70	Nova w/inst. console cluster	6430189	1	TERMINAL, gas gauge (R.H. bend)
69-70	Chevy			TERMINAL, inst. cluster tach. ground,
68-69	Chevy, Camaro w/gauges,			
70	Nova w/inst. console cluster	6430190	1	gas gauge (L.H. bend)
69	Camaro	6431192	1	TERMINAL, gas gauge (right side)— (9.735)
69	Camaro	6431201	1	TERMINAL, gas gauge (center)— (9.735)
69	Chevelle w/inst. panel gauges	1503092	1	TERMINAL, oil gauge
74-75	Nova, Vega	6402685	1	TERMINAL, a/c blower mtr.
72	All	8911077 A.R.	.71	TUBING, fusible link wire protective
62-66	Chevy,			
65	Chevelle w/tach.,			
66	Chevelle (exc. Malibu, P.G., 4-Spd.),			
66	Malibu,			
65-69	Pass.	2962964	1	CONNECTOR, male (2 way— 1 <sup>1</sup> / <sub>2</sub> " O.L.)
62-72	All	2965979 A.R.	.92	CONNECTOR, male (8 way)
62-69	Chevy, Chevelle, Camaro w/32-37-42-52 amp. AC gen.,			
65-69	Pass.	2977373	1	CONNECTOR, front extension wiring harness (female— 2 way)
62-64	Chevy	2973871	1	CONNECTOR, light switch (56 series) (7-female terms)
63-64	Chevy	2977268	1	CONNECTOR, ign. switch (56 series) (lock type-5 female terms)
63	Chevy,			
65-69	Pass.	2965017	1	CONNECTOR, male (6 way— 1 <sup>19</sup> / <sub>32</sub> " O.L.)
64-65	Chevy, Chevelle (Taxi),			
65-69	Pass.	2965981	1	CONNECTOR, clear (2 way— 3 <sup>1</sup> / <sub>32</sub> " O.L.)
64	Chevelle w/tach. (exc. P.G.),			
65-66	Chevy, Chevelle w/tach. (exc. T.W.),			
65-69	Pass.	2962510	1	CONNECTOR, headlamp, tach. wiring (female— 3 way)
64-65	Chevy, Chevelle,			
65-69	Pass.	2977607	1	CONNECTOR, frt. extension wiring harness (female— 4 way)
64-65	Chevy, Chevelle,			
67	Pass.	2984170	1	CONNECTOR, ignition switch, 56 series lock type (6 female terminals)
65-69	Pass.	2977668	1	CONNECTOR, dir. sig. control switch (female-4 way)
65-72	Pass.	2965490	1	CONNECTOR (2 contact) series 58
65-69	Pass.	2965478 A.R.	.13	CONNECTOR, single (2 <sup>9</sup> / <sub>32</sub> " O.L.)

**CHASSIS—ELECTRICAL SYSTEM**

<b>2.530</b>		<b>CABLE— LOOM— TERMINAL— TUBING— CONNECTOR— CONNECTION</b>		<b>BODY— BOOT— WIRE— HOLDER PKG., Electrical (Con't)</b>	
65-69	Pass. ....	2977253 A.R.	.15	CONNECTOR, single (clear plastic— <sup>31</sup> / <sub>32</sub> " O.L.)	
65-69	Pass. ....	2973603	1	CONNECTOR, male (4 way— <sup>19</sup> / <sub>64</sub> " O.L.—black)	
65-66	Chevy, Chevelle w/T. Ign.,				
65-69	Pass. w/T. Ign. ....	2984883	1	.22	CONNECTOR, dist. terminal lead, male (2 way— <sup>121</sup> / <sub>32</sub> " O.L.)
65	All,				
66-69	Pass. ....	6294730	1	.82	CONNECTOR, light switch, 56 series
65-69	Pass. ....	2973453	5	.16	CONNECTOR, female, single (black— <sup>27</sup> / <sub>32</sub> " O.L.)
67	Pass., Chevelle (exc. El Camino)	6288471	2	.21	CONNECTOR, body headlamp, 3-way
67	Pass., Chevelle (exc. El Camino)	6288472	1	.20	CONNECTOR, body headlamp, 2-way
67	Chevelle w/Tach. ....	2977864	1	.21	CONNECTOR, dir. sign. control
68	Pass. ....	6294221	1	1.70	CONNECTOR, ign. switch 56 series, lock type (7 female terminals)
68	Chevy, Chevelle, Camaro (exc. Conv.),				
68	Pass. (exc. Spt. Cpe., Conv.)				CONNECTOR, body wiring (1 female terminal) (188 Series),
68-70	Chevelle w/courtesy lights,				
69-70	Pass. (exc. Conv.),				
71-72	All	2977360	1	.23	dr. jam. switch lead conn.
69-70	Pass., Chevy w/C.A.C.	2965164	1	.53	CONNECTOR, air cond. switch
69-70	Chevelle	2977646	1	.27	CONNECTOR, air cond. switch and w/s/w mtr.
70-71	Nova (T.H. 400 w/inst. console cluster),				
72	All	2977647	1	.27	CONNECTOR, ammeter harness
70	Pass., Chevelle, Nova,				
71-75	All	3927320	1	.50	CONNECTOR, stop lamp switch
74-75	Bel Air (Taxi)	2973781	1	.19	CONNECTOR, door opening warning lamp wire
74-75	Nova 4-Dr.	2965981	1	.25	CONNECTOR, door opng. warn. lamp wire (2 female term.)
74	All	8911813	1	2.10	CONNECTOR, seat belt intlk. override relay
74	All	8911774	1	1.35	CONNECTOR, seat belt intlk. relay
All	All	2977253 A.R.		.15	CONNECTOR, single (clear plastic <sup>31</sup> / <sub>32</sub> O.L.)
All	All	6288702 A.R.		.23	CONNECTOR, used where a 7 term. conn. body with two locking arms are reqd. for panel mounted ign. switch
All	All	2984570 A.R.		.55	CONNECTION BODY (4-contact)
All	All	2984958 A.R.		1.01	CONNECTION BODY (3-contact)
62-63	Chevy,				
65-69	Pass. ....	2984033 A.R.		.38	BOOT, ring terminal (black neoprene)
All	All	8903490 A.R.		RL/7.86	WIRE, fusible (20 gauge) (Note 1)
All	All	8903489 A.R.		RL/8.92	WIRE, fusible (16 gauge) (Note 1)
All	All	8903488 A.R.		RL/10.71	WIRE, fusible (14 gauge) (Note 1)
					<i>NOTE 1 Qty. of 1 when ordering denotes one 50 ft. roll.</i>
62-69	All	2961631	1	1.25	HOLDER, fuse (universal) (inline type)—(8.965)
75	All	1684873 A.R.		N.L.	KIT, alum. wire term. repair
<b>2.559</b>		<b>CLIP— RETAINER— SCREW— SHIELD ASSY.— STRAP, Chassis Wiring</b>		<b>Harness</b>	
71-72	Chevelle, Camaro (400, 402, 454)	3784832	1	.16	oil pressure switch gauge pipe
65-69	Pass., Camaro w/C.A.C. (exc. auto. temp. control),				
70	Pass. w/C.A.C.	3781398	1	.16	engine wiring harness to air cond. blower and evap.
67-68	Camaro w/floor console	3909586	1	.11	seat separator compt. wiring harness
67-68	All	3815761	1	.22	batt. to start switch
62-69	All	2965457	1	.39	fuse
62-75	All	3954218 A.R.		.27	( <sup>1</sup> / <sub>16</sub> " sheet metal edge-wire clip)
62-69	All	3750695 A.R.		.12	(sheet metal end type clip— can retain wire up to <sup>3</sup> / <sub>8</sub> " dia. and be used on panels up to <sup>1</sup> / <sub>8</sub> " thk.)— (3.162)
62-70	All				ammeter to starter switch wiring harness ( <sup>3</sup> / <sub>16</sub> " )
68-70	All w/A.T. (8 cyl.),				
71	Nova w/A.T.	367701 A.R.		.16	engine wire harness
62-69	All,				

**CHASSIS—ELECTRICAL SYSTEM**

<b>2.559 CLIP— RETAINER— SCREW— SHIELD ASSY.— STRAP, Chassis Wiring Harness (Con't)</b>					
71-74	Vega	3844390	A.R.	.18	push in type (for cables <sup>19</sup> / <sub>64</sub> " to <sup>33</sup> / <sub>64</sub> " dia.) (rubber coated)
64-70	All (8 cyl.) (exc. 396)	3853786	2	.11	eng. heater core
65-69	Pass.,				
73-75	All	6270410	A.R.	.11	bolt on type (coated) (2" O.L.)
65-69	Pass. (6 cyl.),				
68-70	Chevelle (6 cyl.)				battery positive cable to engine front mounting frame bracket,
68-70	Chevy, Chevelle, Camaro, 70 Pass. (8 cyl.) (exc. 454),				
71-75	All (6 cyl.)	3866187	1	.16	battery positive cable to engine clip
65-69	Pass. (8 cyl.),				
66-67	Chevelle (8 cyl.),				
71-74	Vega,				
71	Camaro	3866188	1	.18	bat. pos. cable to side member ext.
67-69	Camaro,				
68-69	Chevy, Chevelle,				
70-75	Nova	3903405	1	.16	inst. panel harness
68	Pass.		1		stop lamp switch wire,
69	Chevelle w/C.A.C. (6 cyl.)	3927327	1	.16	a/c wiring harness
68	Chevelle (exc. Sta. Wag., El Camino)	4576889	1	.06	radio ant. lead in cable
68	Chevelle (exc. Sta. Wag., El Camino),				
72-73	Camaro	581084	1	.12	radio ant. lead in cable
69	Pass.,				
74-75	All (122)	3943626	1	.18	instr. panel harness
70	Camaro w/C.A.C.	3983946	1	.11	heater and A/C temp.
70-75	Camaro	3983950	1	.16	inst. pnl. wrg. to inst. cluster
72	Camaro (307, 350),				
73-74	Camaro (307, 350),				
75	All (exc. Pass.)	6273314	1	.13	battery positive cable to fuel pump
73-75	Pass. w/C.A.C.	9798433	1	.16	a/c wrg. harn.
74-75	All	3979352	A.R.	.05	closed ( <sup>7</sup> / <sub>8</sub> " x <sup>5</sup> / <sub>16</sub> ")
74-75	Pass., Chevelle	478007	1	.11	eng. block htr. cord.
75	All (8 cyl.)	355930	1	.65	pos. cable to oil pan
75	All (exc. 140)	3853786	1	.11	eng. & gen. wrg. harn.
75	All (140)	333913	1	.18	eng. wiring harness
75	Pass. (exc. Sta. Wag.)	3927327	1	.16	license plate lamp wrg.
62	Chevy,				
65-69	Pass.,				
71	Malibu,				
72-75	All	3816659	A.R.	.31	RETAINER, adjustable (plastic push-in) (for 2" dia. cables)
65-70	All,				
71	All (exc. Pass.)				RETAINER, firewall wiring (13" O.L.) gen. and forward lamp harness to rad. tie bar,
71-72	Pass.	3990810	1	.62	eng. wrg. harness (Note 1)
64	Chevy, Chevelle	9776916	1	.12	SCREW, inst. pnl. wrg. harness
73-74	All (8 cyl.) (exc. 307),				
75	All (8 cyl.) (exc. Nova),				
75	Nova (350) (exc. 2BC)	6258203	1	.62	SHIELD ASSY., eng. wrg. harn.
73	All (307),				
75	Nova w/2BC (262, 350)	6258204	1	.62	SHIELD ASSY., eng. wrg. harn.
73-75	All	1239007	1	.12	STRAP, binding

*NOTE 1 Loose trough type wire and hose retainer (rubber) use at cowl or radiator tie-bar locations as service replacement for similar retainers which are part of wiring harnesses.*

**2.575 SWITCH ASSY.— FLASHER ASSY.— CLIP— NUT— KNOB— FLARE ASSY.— FLAG— LAMP ASSY.— LENS ASSY.— BEZEL— GASKET— NUT— SOCKET ASSY.— BUMPER— RETAINER— SCREW— WIRE ASSY., Hazard Flasher**

**LAMP SOCKET REPLACEMENT**

*It is necessary to carefully check the parts catalogs for correct model application when replacing lamp socket assemblies. If incorrect sockets are used for replacement, the bulb filament will be in the wrong location with respect to the lens and/or reflector. As a result, the lamp may fail to meet the required lighting standards.*

64-65	Chevy, Chevelle	3843700	1	11.05	w/harness (traffic hazard lamp)
67-68	All	7800482	1	12.15	dir. sig. and traffic hazard (Delco-Remy)— (2.895)
67	All	5698520	1	20.60	dir. sig. and traffic hazard (Boyne)— (2.895)
67-68	Camaro (A.T. w/T.W.)	7800006	1	23.80	dir. sig. and traffic hazard (Boyne)— (2.895)

**CHASSIS—ELECTRICAL SYSTEM**

**2.575 SWITCH ASSY.— FLASHER ASSY.— CLIP— NUT— KNOB— FLARE ASSY.— FLAG— LAMP ASSY.— LENS ASSY.— BEZEL— GASKET— NUT— SOCKET ASSY.— BUMPER— RETAINER— SCREW— WIRE ASSY., Hazard Flasher (Con't)**

69-72	All	1997963	1	12.35	hazard lamp
62-63	Chevy	2415204	1	3.10	FLASHER ASSY., hazard lamp (3 prong)
64-75	All	491391	1	3.60	FLASHER ASSY., hazard lamp w/986639
66	All	2973342	2	.33	CLIP, lamp switch harness
64-66	All	3843744	1	.19	NUT, hazard lamp switch and harness
68	Pass.	9784284	2	.12	NUT, rr. qtr. marker
70	Camaro	8797130	8	.12	NUT, side mkr. lamp retainer
<i>NOTE 2. Bullet type lens.</i>					
65-66	All	3929510	1	.59	KNOB, traffic hazard lamp switch control
67-75	All	411525	1	.52	KNOB, traffic hazard warning
62-72	All	3891442	2	1.35	FLARE ASSY., distress— (8.821)
70	All	3943606	1	.93	FLARE ASSY., distress— (8.821)
62-72	All	3891443	1	.83	FLAG, distress— (8.821)
68	All	916581	2	5.15	LAMP ASSY., frt. fdr. marker
68	Pass. (exc. Sta. Wag.)	916754	1	4.65	LAMP ASSY., rr. qtr. side marker
68	Sta. Wag., El Camino, Chevy, Camaro,				
69	Chevy,				
69	Chevelle (Sta. Wag., El Camino)	916632	2	5.15	LAMP ASSY., rr. qtr. marker
69	Pass.	910959	2	3.20	LAMP ASSY., rr. qtr. side marker
69	Pass., Chevy	911045	2	4.55	LAMP ASSY., frt. fdr. side marker (Note 5)
<i>NOTE 5 When using in place of 911052 remove the bezel and two studs and discard.</i>					
69	Camaro, Chevelle (exc. Sta. Wag., El Camino)	916847	2	3.20	LAMP ASSY., rear qtr. side marker
69	Camaro, Chevelle	916813	2	2.90	LAMP ASSY., frt. fdr. marker
70	Pass.	917653	L.H.	4.50	LAMP ASSY., frt. fdr. marker, left
70	Pass. (exc. Sta. Wag.)	917119	2	5.10	LAMP ASSY., rear qtr. side marker
70	Pass. (Sta. Wag.)	917127	2	5.15	LAMP ASSY., rear qtr. side marker
70	Pass.	917654	R.H.	4.50	LAMP ASSY., frt. fdr. marker, right
70	Chevelle (exc. Monte Carlo)	917093	L.H.	5.15	LAMP ASSY., frt. fdr. marker, left
70	Chevelle (exc. Monte Carlo)	917094	R.H.	5.15	LAMP ASSY., frt. fdr. marker, right
70-72	Monte Carlo	917031	L.H.	6.25	LAMP ASSY., frt. fdr. marker, left
70-72	Monte Carlo	917032	R.H.	6.25	LAMP ASSY., frt. fdr. marker, right
70-72	Monte Carlo	917107	L.H.	5.15	LAMP ASSY., rear qtr. side marker, left
70-72	Monte Carlo	917108	R.H.	5.15	LAMP ASSY., rear qtr. side marker, right
70-72	Chevelle (exc. Sta. Wag., El Camino, Monte Carlo)	917101	L.H.	5.10	LAMP ASSY., rear qtr. side marker, left
70-72	Chevelle (exc. Sta. Wag., El Camino, Monte Carlo)	917102	R.H.	5.10	LAMP ASSY., rear qtr. side marker, right
70-74	Nova	897170	2	5.15	LAMP ASSY., frt. fdr. marker
70-74	Nova	917441	2	5.10	LAMP ASSY., rear qtr. side marker
70-75	Camaro	912143	L.H.	4.50	LAMP ASSY., left, front fdr. side marker
70-75	Camaro	912144	R.H.	4.50	LAMP ASSY., right, front fdr. side marker
70-73	Camaro	917165	L.H.	5.15	LAMP ASSY., rear quarter side marker
70-73	Camaro	917166	R.H.	5.15	LAMP ASSY., rear quarter side marker
71	Biscayne, Bel Air,				
72-73	Pass. (exc. Sta. Wag.)	917611	L.H.	8.25	LAMP ASSY., rear qtr. side marker
71	Biscayne, Bel Air,				
72-73	Pass. (exc. Sta. Wag.)	917612	R.H.	8.25	LAMP ASSY., rear qtr. side marker
71	Brookwood, Townsman,				
72-73	Pass. (Sta. Wag.)	917585	L.H.	5.10	LAMP ASSY., rear qtr. side marker
71	Brookwood, Townsman,				
72-73	Pass. (Sta. Wag.)	917586	R.H.	5.10	LAMP ASSY., rear qtr. side marker
71	Impala, Caprice	917583	L.H.	8.25	LAMP ASSY., rear qtr. side marker
71	Impala, Caprice	917584	R.H.	8.25	LAMP ASSY., rear qtr. side marker
71-75	Vega (exc. Monza)	927986	2	3.10	side marker rear qtr.
71-75	Vega (exc. Monza)	927920	2	3.80	side marker frt. fender
72	Pass.	911733	L.H.	6.25	LAMP ASSY., frt. fdr. side marker
72	Pass.	911734	R.H.	6.25	LAMP ASSY., frt. fdr. side marker
73-75	Chevelle (exc. Monte Carlo)	911723	L.H.	3.65	LAMP ASSY., frt. fdr. side marker
73-75	Chevelle (exc. Monte Carlo)	911724	R.H.	3.65	LAMP ASSY., frt. fdr. side marker
73	Pass.	911937	L.H.	3.65	LAMP ASSY., frt. fdr. side marker
73	Pass.	911938	R.H.	3.65	LAMP ASSY., frt. fdr. side marker
73	Monte Carlo	911967	L.H.	4.90	LAMP ASSY., frt. fdr. side marker
73	Monte Carlo	911968	R.H.	4.90	LAMP ASSY., frt. fdr. side marker
73-75	Chevelle (Sta. Wag., El Camino)	911691	L.H.	4.70	LAMP ASSY., rr. qtr. side marker
73-75	Chevelle (Sta. Wag., El Camino)	911692	R.H.	4.70	LAMP ASSY., rr. qtr. side marker
73-75	Chevelle (exc. Sta. Wag., El Camino, Monte Carlo)	911725	L.H.	4.70	LAMP ASSY., rr. qtr. side marker
73-75	Chevelle (exc. Sta. Wag., El Camino, Monte Carlo)	911726	R.H.	4.70	LAMP ASSY., rr. qtr. side marker
73-75	Monte Carlo	911975	L.H.	4.90	LAMP ASSY., rr. qtr. side marker



**CHASSIS—ELECTRICAL SYSTEM**

**2.575 SWITCH ASSY.— FLASHER ASSY.— CLIP— NUT— KNOB— FLARE ASSY.— FLAG— LAMP ASSY.— LENS ASSY.— BEZEL— GASKET— NUT— SOCKET ASSY.— BUMPER— RETAINER— SCREW— WIRE ASSY., Hazard Flasher (Con't)**

73-75	Monte Carlo	911976 R.H.	4.90	LAMP ASSY., rr. qtr. side marker
74	Monte Carlo	912219 L.H.	15.20	LAMP ASSY., park and side marker— (2.585)
74	Monte Carlo	912220 R.H.	15.20	LAMP ASSY., park and side marker— (2.585)
74	Pass. (exc. Caprice)	912225 L.H.	12.70	LAMP ASSY., park and side marker— (2.585)
74	Pass. (exc. Caprice)	912226 R.H.	12.70	LAMP ASSY., park and side marker— (2.585)
74	Caprice,			
75	Pass. (exc. Caprice)	912171 L.H.	6.50	LAMP ASSY., frt. fdr. side marker
74	Caprice,			
75	Pass. (exc. Caprice)	912172 R.H.	6.50	LAMP ASSY., frt. fdr. side marker
74-75	Pass. (exc. Sta. Wag.)	912235 L.H.	8.60	LAMP ASSY., rear qtr. side marker
74-75	Pass. (exc. Sta. Wag.)	912236 R.H.	8.60	LAMP ASSY., rear qtr. side marker
74-75	Pass. (Sta. Wag.)	912185 L.H.	3.50	LAMP ASSY., rear qtr. side marker
74-75	Pass. (Sta. Wag.)	912186 R.H.	3.50	LAMP ASSY., reqr qtr. side marker
75	Caprice	911887 L.H.	3.45	LAMP ASSY., frt. fdr. side marker
75	Caprice	911888 R.H.	3.45	LAMP ASSY., frt. fdr. side marker
75	Nova	912099 2	5.15	LAMP ASSY., rear qtr. side marker
75	Nova	912100 2	5.15	LAMP ASSY., frt. fdr. side marker
75	Monza	912363 L.H.	4.10	LAMP ASSY., frt. fdr. side marker
75	Monza	912364 R.H.	4.10	LAMP ASSY., frt. fdr. side marker
75	Monza (Notchback)	912819 2	3.55	LAMP ASSY., rear qtr. side marker
71	Pass.	5963985 L.H.	6.05	LENS ASSY., park and side marker— (2.589)
71	Pass.	5963986 R.H.	6.05	LENS ASSY., park and side marker— (2.589)
71	Chevlelle (Sta. Wag., El Camino)	5963821 L.H.	7.15	LENS ASSY., park and side marker— (2.589)
71	Chevlelle (Sta. Wag., El Camino)	5963822 R.H.	7.15	LENS ASSY., park and side marker— (2.589)
71	Chevlelle (exc. Sta. Wag., El Camino, Monte Carlo)	5963817 L.H.	6.55	LENS ASSY., park and side marker— (2.589)
71	Chevlelle (exc. Sta. Wag., El Camino, Monte Carlo)	5963818 R.H.	6.55	LENS ASSY., park and side marker— (2.589)
72	Nomad, Greenbrier, El Camino (exc. Custom),			
72	Concours, El Camino Custom (1st design)	5965275 L.H.	7.15	LENS ASSY., park. and side marker— (2.589) (Note 2)
72	Nomad, Greenbrier, El Camino (exc. Custom),			
72	Concours, El Camino Custom (1st design)	5965276 R.H.	7.15	LENS ASSY., park. and side marker— (2.589) (Note 2)
72	Chevlelle (Std.) (exc. Sta. Wag., El Camino),			
72	Malibu (1st design)	5965269 L.H.	7.45	LENS ASSY., park. and side marker— (2.589) (Note 2)
72	Chevlelle (Std.) (exc. Sta. Wag., El Camino),			
72	Malibu (1st design)	5965270 R.H.	7.45	LENS ASSY., park. and side marker— (2.589) (Note 2)
72	Malibu (2nd design)	5965683 L.H.	7.45	LENS ASSY., park. and side marker (Note 3)
72	Malibu (2nd design)	5965684 R.H.	7.45	LENS ASSY., park. and side marker (Note 3)
72	Concours, El Camino Custom (2nd design)	5965687 L.H.	7.15	LENS ASSY., park. and side marker (Note 3)
72	Concours, El Camino Custom (2nd design)	5965688 R.H.	7.15	LENS ASSY., park. and side marker (Note 3)
74-75	Pass. (exc. Sta. Wag.)	5949591 L.H.	6.15	LENS, rear qtr. side marker
74-75	Pass. (exc. Sta. Wag.)	5949592 R.H.	6.15	LENS, rear qtr. side marker
	<i>NOTE 2: Amber lens.</i>			
	<i>NOTE 3: White lens.</i>			
68	Sta. Wag., El Camino	1384373 2	1.30	BEZEL, rr. qtr. side marker lamp
68-69	Pass., Chevy (exc. 8 cyl.),			

**CHASSIS—ELECTRICAL SYSTEM**

**2.575 SWITCH ASSY.— FLASHER ASSY.— CLIP— NUT— KNOB— FLARE ASSY.— FLAG— LAMP ASSY.— LENS ASSY.— BEZEL— GASKET— NUT— SOCKET ASSY.— BUMPER— RETAINER— SCREW— WIRE ASSY., Hazard Flasher (Con't)**

68	Chevelle (6 cyl.)					
68	Camaro				BEZEL, frt. fdr. marker lamp.	
68-69	Chevy,					
68	Camaro	3927459	2	1.15	rear qtr. side marker lamp	
68	Pass. (exc. Sta. Wag.)	3921403	1	1.10	BEZEL, rr. qtr. side marker lamp L.H.	
68	Pass. (exc. Sta. Wag.)	3921404	1	1.10	BEZEL, rr. qtr. side marker lamp R.H.	
68	Pass., Chevelle (396)	3935901	1	3.75	BEZEL, frt. fdr. marker L.H.	
68	Pass., Chevelle (396)	3935902	1	3.75	BEZEL, frt. fdr. marker R.H.	
68	Pass., Chevelle (307)	3935903	1	3.90	BEZEL, frt. fdr. marker L.H.	
68	Pass., Chevelle (307)	3935904	1	3.90	BEZEL, frt. fdr. marker R.H.	
68	Pass., Chevelle (327)	3935907	1	3.75	BEZEL, frt. fdr. marker L.H.	
68	Pass., Chevelle (327)	3935908	1	3.75	BEZEL, frt. fdr. marker R.H.	
68	Pass. (427)	3935909	1	3.75	BEZEL, frt. fdr. marker L.H.	
68	Pass. (427)	3935910	1	3.90	BEZEL, frt. fdr. marker R.H.	
68-69	Chevy (307)	3929993	L.H.	4.45	BEZEL, frt. fdr. marker	
68-69	Chevy (307)	3929994	R.H.	4.45	BEZEL, frt. fdr. marker	
68	Chevy (327)	3929995	L.H.	4.25	BEZEL, frt. fdr. marker	
68	Chevy (327)	3929996	R.H.	4.25	BEZEL, frt. fdr. marker	
68-69	Chevy (350)	3929997	L.H.	3.80	BEZEL, frt. fdr. marker	
68-69	Chevy (350)	3929998	R.H.	3.80	BEZEL, frt. fdr. marker	
68-69	Chevy (396)	3937593	L.H.	3.95	BEZEL, frt. fdr. side marker	
68-69	Chevy (396)	3937594	R.H.	3.95	BEZEL, frt. fdr. side marker	
69	Chevelle (Sta. Wag., El Camino)	3954599	2	1.25	BEZEL, rr. qtr. side marker	
69	Camaro	3945715	2	.83	BEZEL, rr. qtr. side marker	
69	Chevelle (230),					
69	Chevelle (396)	3942749	2	.63	BEZEL, frt. fdr. marker	
69	Camaro	3943269	2	.94	BEZEL, frt. fdr. side marker	
69	Chevelle (307)	3945291	L.H.	1.90	BEZEL, frt. fdr. side marker	
69	Chevelle (307)	3945292	R.H.	1.90	BEZEL, frt. fdr. side marker	
69	Chevelle (350)	3945293	L.H.	1.90	BEZEL, frt. fdr. side marker	
69	Chevelle (350)	3945294	R.H.	1.90	BEZEL, frt. fdr. side marker	
69	Chevelle (250)	3954541	L.H.	2.05	BEZEL, frt. fdr. side marker	
69	Chevelle (250)	3954542	R.H.	2.05	BEZEL, frt. fdr. side marker	
69	Pass. (exc. Sta. Wag.)	3939347	1	1.10	BEZEL, rr. qtr. side marker L.H.	
69	Pass. (exc. Sta. Wag.)	3939348	1	1.10	BEZEL, rr. qtr. side marker R.H.	
69	Sta. Wag. (exc. Estate Wag.)	3955035	1	1.85	BEZEL, rr. qtr. side marker L.H.	
69	Sta. Wag. (exc. Estate Wag.)	3955036	1	1.85	BEZEL, rr. qtr. side marker R.H.	
69	Estate Wag.	3950605	1	1.90	BEZEL, rr. qtr. side marker L.H.	
69	Estate Wag.	3950606	1	1.90	BEZEL, rr. qtr. side marker R.H.	
69	Pass. (350) (exc. Estate Wag.)	3949287	2	2.05	BEZEL, frt. fender marker	
69	Pass. (427) (exc. Estate Wag.)	3949288	1	2.05	BEZEL, frt. fender marker	
69	Estate Wag.	3950720	2	2.80	BEZEL, frt. fender marker	
69	Pass. (327) (exc. Estate Wag.)	3950773	2	2.05	BEZEL, frt. fender marker	
69	Pass. (396) (exc. Estate Wag.)	3950774	2	2.05	BEZEL, frt. fender marker	
70	Pass. (Sta. Wag.)	3945609	L.H.	1.65	BEZEL, rear qtr. side marker, left	
70	Pass. (Sta. Wag.)	3945610	R.H.	1.65	BEZEL, rear qtr. side marker, right	
70	Pass. (exc. Sta. Wag.)	3955083	L.H.	1.20	BEZEL, rear qtr. side marker, left	
70	Pass. (exc. Sta. Wag.)	3955084	R.H.	1.20	BEZEL, rear qtr. side marker, right	
70-72	Chevelle (exc. Sta. Wag., El Camino, Monte Carlo)	3972899	L.H.	1.15	BEZEL, rr. qtr. side marker, left	
70-72	Chevelle (exc. Sta. Wag., El Camino, Monte Carlo)	3972900	R.H.	1.15	BEZEL, rr. qtr. side marker, right	
70-75	Nova	3962934	2	1.10	BEZEL, rr. qtr. side marker	
70-73	Nova	3962933	2	1.10	BEZEL, frt. fdr. side marker	
71	Biscayne, Bel Air,					
72-73	Pass. (exc. Sta. Wag.)	3991185	L.H.	1.10	BEZEL, rear qtr. side marker	
71	Biscayne, Bel Air,					
72-73	Pass. (exc. Sta. Wag.)	3991186	R.H.	1.10	BEZEL, rear qtr. side marker	
71	Kingswood Estate,					
71	Brookwood, Townsman,					
72-73	Pass. (Sta. Wag.)	6262397	L.H.	.97	BEZEL, rear qtr. side marker	
71-73	Kingswood Estate,					
71-73	Brookwood, Townsman	6262398	R.H.	.97	BEZEL, rear qtr. side marker	
71	Pass.	5964085	L.H.	7.95	BEZEL, park sig. and marker lamp— (2.593)	
71	Pass.	5964086	R.H.	7.95	BEZEL, park sig. and marker lamp— (2.593)	
71	Chevelle (exc. Sta. Wag., El Camino, Monte Carlo)	3998271	L.H.	3.05	BEZEL, park lamp and side marker— (2.593)	
71	Chevelle (exc. Sta. Wag., El Camino, Monte Carlo)	3998272	R.H.	3.05	BEZEL, park lamp and side marker— (2.593)	

**CHASSIS—ELECTRICAL SYSTEM**

**2.575 SWITCH ASSY.— FLASHER ASSY.— CLIP— NUT— KNOB— FLARE ASSY.— FLAG— LAMP ASSY.— LENS ASSY.— BEZEL— GASKET— NUT— SOCKET ASSY.— BUMPER— RETAINER— SCREW— WIRE ASSY., Hazard Flasher (Con't)**

71	Chevelle (Sta. Wag., El Camino) .	3998273 L.H.	3.60	BEZEL, park lamp and side marker— (2.593) . . . . .
71	Chevelle (Sta. Wag., El Camino) .	3998274 R.H.	3.60	BEZEL, park lamp and side marker— (2.593) . . . . .
72	Chevelle (exc. Sta. Wag., El Camino, Monte Carlo) . . . . .	6261959 L.H.	3.50	BEZEL, park. lamp and side marker— (2.593) . . . . .
72	Chevelle (exc. Sta. Wag., El Camino, Monte Carlo) . . . . .	6261960 R.H.	3.50	BEZEL, park. lamp and side marker— (2.593) . . . . .
72	Chevelle (Sta. Wag., El Camino) .	6261961 L.H.	3.50	BEZEL, park. lamp and side marker— (2.593) . . . . .
72	Chevelle (Sta. Wag., El Camino) .	6261962 R.H.	3.50	BEZEL, park. lamp and side marker— (2.593) . . . . .
73-75	Chevelle (Sta. Wag.) . . . . .	331765 L.H.	1.85	BEZEL, rear quarter side marker . . . . .
73-75	Chevelle (Sta. Wag.) . . . . .	331766 R.H.	1.85	BEZEL, rear quarter side marker . . . . .
73-75	El Camino . . . . .	3996969 L.H.	1.85	BEZEL, rear quarter side marker . . . . .
73-75	El Camino . . . . .	3996970 R.H.	1.60	BEZEL, rear quarter side marker . . . . .
73	Pass. . . . .	327151 L.H.	2.40	BEZEL, frt. fdr. side marker . . . . .
73	Pass. . . . .	327152 R.H.	2.40	BEZEL, frt. fdr. side marker . . . . .
73-75	Chevelle (exc. Monte Carlo) . . . . .	325295 L.H.	1.05	BEZEL, frt. fdr. side marker (paint as reqd.) . . . . .
73-75	Chevelle (exc. Monte Carlo) . . . . .	325296 R.H.	1.05	BEZEL, frt. fdr. side marker (paint as reqd.) . . . . .
73-75	Chevelle (exc. Sta. Wag., El Camino, Monte Carlo) . . . . .	3996989 L.H.	1.05	BEZEL, left, rear qtr. side marker (paint as reqd.) . . . . .
73-75	Chevelle (exc. Sta. Wag., El Camino, Monte Carlo) . . . . .	3996990 R.H.	1.05	BEZEL, right, rear qtr. side marker (paint as reqd.) . . . . .
74-75	Nova . . . . .	3962934 2	1.10	BEZEL, frt. fdr. mkr. . . . .
74-75	Pass. (exc. Sta. Wag.) . . . . .	337639 L.H.	3.10	BEZEL, rear qtr. side marker lamp . . . . .
74-75	Pass. (exc. Sta. Wag.) . . . . .	337640 R.H.	3.10	BEZEL, rear qtr. side marker lamp . . . . .
74-75	Pass. (Sta. Wag.) . . . . .	337653 L.H.	.43	BEZEL, rear qtr. side marker lamp . . . . .
74-75	Pass. (Sta. Wag.) . . . . .	337654 R.H.	.43	BEZEL, rear qtr. side marker lamp . . . . .
74	Caprice, . . . . .			
75	Pass. (exc. Caprice) . . . . .	337625 L.H.	1.65	BEZEL, front fender side marker lamp . . . . .
74	Caprice, . . . . .			
75	Pass. (exc. Caprice) . . . . .	337626 R.H.	1.65	BEZEL, front fender side marker lamp . . . . .
75	Caprice . . . . .	343547 L.H.	1.80	BEZEL, frt. fdr. side marker lamp . . . . .
75	Caprice . . . . .	343548 R.H.	1.80	BEZEL, frt. fdr. side marker lamp . . . . .
68	Chevy, Chevelle, Camaro (exc. Sta. Wag., El Camino), . . . . .			
69	Pass., Chevy (exc. Sta. Wag.) . . . . .	5960511 4	.18	GASKET, rr. qtr., side . . . . .
68-69	Sta. Wag., El Camino . . . . .	7765668 2	.18	GASKET, rr. fdr. marker . . . . .
69	Camaro, . . . . .			
69	Chevelle (exc. Sta. Wag., El Camino) . . . . .	3945721 1	.18	GASKET, rear qtr. side marker . . . . .
70	Pass. (exc. Sta. Wag.) . . . . .	3973631 2	.31	GASKET, rear qtr. side marker . . . . .
70-72	Monte Carlo . . . . .	5962878 2	.25	GASKET, rear qtr. side marker . . . . .
70-72	Chevelle (exc. Sta. Wag., El Camino, Monte Carlo) . . . . .	3972898 2	.31	GASKET, rr. qtr. side marker . . . . .
70-75	Nova . . . . .	3962935 2	.31	GASKET, rear qtr. side marker . . . . .
70-73	Camaro . . . . .	5963185 1	1.35	GASKET, rr. qtr. side mkr. mtg. . . . .
71-72	Chevelle (exc. Sta. Wag., El Camino, Monte Carlo) . . . . .	5963816 2	1.35	GASKET, park and side marker— (2.590) . . . . .
71-72	Chevelle (Sta. Wag., El Camino) .	5963820 2	1.45	GASKET, park and side marker— (2.590) . . . . .
71-75	Vega . . . . .	5963170 2	.40	GASKET, side marker lamp mounting . . . . .
71	Pass. . . . .	5964083 2	.97	GASKET, park and side marker— (2.590) . . . . .
71-73	Brookwood, Townsman . . . . .	5964262 2	1.10	GASKET, rear qtr. side marker lamp . . . . .
72-73	Pass. (exc. Sta. Wag.) . . . . .	3991197 2	.62	GASKET, rear qtr. side marker lamp . . . . .
73	Chevelle (Sta. Wag., El Camino) .	3996968 2	.18	GASKET, rear quarter side marker lamp . . . . .
73	Chevelle (Spt. Cpe., Sed.) . . . . .	3996984 2	.31	GASKET, rear qtr. side marker lamp . . . . .
73-75	Monte Carlo . . . . .	6264833 2	.31	GASKET, rear quarter side marker lamp . . . . .
74-75	Pass. (Sta. Wag.) . . . . .	5947214 2	1.10	GASKET, rear qtr. side marker lamp . . . . .
74-75	Pass. (exc. Sta. Wag.) . . . . .	337617 2	.62	GASKET, rear qtr. side marker lamp . . . . .
74-75	Chevelle (Sta. Wag., El Camino) .	5953121 2	1.05	GASKET, rear qtr. side marker lamp . . . . .
74-75	Chevelle (Spt. Cpe., Sed.) . . . . .	5953138 2	.99	GASKET, rear qtr. side marker lamp . . . . .
75	Monza (Notchback) . . . . .	5967518 2	.60	GASKET, rear side marker lamp . . . . .
69	Sta. Wag. . . . .	8779101 4	.19	NUT, rear qtr. side marker lamp bezel . . . . .
70-75	Camaro, . . . . .			
75	Monza . . . . .	8797130 A.R.	.12	NUT, side marker lamp ret. . . . .
62-72	All, . . . . .			
73-74	Chevelle . . . . .			side marker, . . . . .

**CHASSIS—ELECTRICAL SYSTEM**

**2.575 SWITCH ASSY.— FLASHER ASSY.— CLIP— NUT— KNOB— FLARE ASSY.— FLAG— LAMP ASSY.— LENS ASSY.— BEZEL— GASKET— NUT— SOCKET ASSY.— BUMPER— RETAINER— SCREW— WIRE ASSY., Hazard Flasher (Con't)**

74	Pass. (exc. Sta. Wag.)				rear qtr. side marker,
74	Pass., Camaro,				
75	Caprice	6298886	1.95		<b>SOCKET ASSY.</b> , frt. side marker (Note 1)
	<i>NOTE 1: Cut away old side marker lamp socket and splice in new socket leads. Old socket is part of fwd. and rear wrg. harness.</i>				
74	Belair, Impala				rear side marker,
74	Monte Carlo	8912750	A.R.	3.00	<b>SOCKET ASSY.</b> , side marker lamp
73-74	Vega				rear lic. plate lamp,
74	Pass. (Sta. Wag.),				
75	Nova	8901283	2	2.00	<b>SOCKET ASSY.</b> , rear qtr. side marker
62-72	All,				
71-74	Vega,				
75	Monza	6298886	A.R.	1.95	<b>SOCKET ASSY.</b> , side marker lamp (Note 4)
70-71	Chevelle (exc. Monte Carlo)	3841098	2	.11	<b>BUMPER</b> , frt. fdr. marker— (7.800)
70-75	Camaro,				
75	Monza	3974545	2	.12	<b>RETAINER</b> , frt. fdr. and rr. qtr. side mkr. lamp
70	Pass.	3961572	4	.28	<b>SCREW</b> , frt. fdr. marker (10— 16 x 5/8")
67-73	All	9433331	1	.39	<b>SCREW</b> (ov. hd. rec. mach.) (6— 32 x 8)— (8.909)
73	Pass. (exc. Sta. Wag.),				
75	Nova	8901283	1	2.00	<b>WIRE ASSY.</b> , rear quarter side marker lamp
	<i>NOTE 4 Cut away old side marker lamp socket and splice in new socket leads. Old socket is part of fwd. and rr. wrg. harness. Use with molded on socket.</i>				

**2.580 CONDUCTOR— GROMMET, Lighting Monitor**

68-69	Pass. (exc. Sta. Wag., Conv.)	6295138	1	30.75	w/housing, tail, stop and lic. lamp fiber optic
68	Pass.,				
68	Chevelle (exc. Sta. Wag., El Camino),				
69	Chevelle (exc. El Camino)	6297564	R.H.	13.90	w/housing, headlamp and park lamp fiber optic
68	Pass.,				
68	Chevelle (exc. Sta. Wag., El Camino)	6297563	1	13.90	w/housing headlamp and park lamp fiber optic L.H.
68-69	Camaro	6297575	L.H.	12.70	w/housing, h/lamp and park lamp fiber optic
68-69	Camaro (Spt. Cpe.)	6297612	1	22.10	w/housing, tail, stop and lic. lamp fiber optic
69	Chevelle (exc. El Camino)	6297563	L.H.	13.90	w/housing, headlamp and park lamp fiber optic
69	Pass. (exc. Sta. Wag.)	6297550	1	13.60	w/housing headlamp and park lamp fiber optic L.H.
69	Pass. (exc. Sta. Wag.)	6297551	1	13.60	w/housing headlamp and park lamp fiber optic R.H.
70	Pass.	8901419	L.H.	13.75	w/housing, hdlp. and park. lamp fiber optic
70	Pass.	8901420	R.H.	13.75	w/housing, hdlp. and park. lamp fiber optic
70	Pass.	8901490	2	2.90	hdlp. fiber optic ext.
70-71	All	8901484	1	5.20	ws/w jar fluid level fiber optic
70	Monte Carlo	8901377	L.H.	13.90	w/housing, hdlp. and park. lamp fiber optic
67-68	Pass.,				
68	Chevelle, Camaro, Chevy,				
69	Camaro	6295090	1	2.60	<b>CONDUCTOR ASSY.</b> , ash tray lamp and ign. switch fiber optic
69-75	All	6293975	1	4.25	<b>CONDUCTOR ASSY.</b> , ash tray lamp fiber optic
73-74	Pass.	332060	1	.19	w/s/w switch light
75	Pass.	346737	1	.16	w/s/w switch light
	<i>NOTE 1 May be necessary to cut lead to size reqd. using old part as guide.</i>				
68-69	All (Sta. Wag.)	6298664	1	22.70	<b>CONDUCTOR HARNESS</b> , univ. fiber optic, frt.
68-69	Pass., Chevelle, Camaro (exc. Sta. Wag.)	6298667	1	12.50	<b>CONDUCTOR HARNESS</b> , univ. fiber optic, frt.

**2.583 LENS— HOUSING— RETAINER, Fiber Optic Conductor**

68-69	Pass., Chevelle, Camaro,				
70	Pass., Chevelle	5959740	2	.68	parking lamp
68-69	Pass., Chevelle, Camaro,				
70	Pass., Chevelle	5960480	3	.43	frt., rr. and lic. lamps

**CHASSIS—ELECTRICAL SYSTEM**

**2.583 LENS— HOUSING— RETAINER, Fiber Optic Conductor (Con't)**

67	Pass. (Conv.),				
67-69	Chevelle (exc. Sta. Wag., Conv., El Camino),				
68-69	Pass. (exc. Sta. Wag., Conv.),				
70	All w/lamp monitor (exc. Sta. Wag.)	<b>6288728</b>	1	.52	<b>HOUSING</b> , tail, stop and lic. lamp
	<i>NOTE 1. Houses the retainer and lens assy.</i>				
68-69	Pass.,				
68	Chevelle (exc. Sta. Wag., El Camino)	<b>8917239</b>	2	3.35	<b>HOUSING</b> , headlamp and park lamp
	<i>NOTE 2. Used with accessory unit.</i>				
	<i>NOTE 3. Used with R.P.O. unit.</i>				
68	Chevelle (exc. Sta. Wag., El Camino)	<b>6294182</b>	L.H.	2.35	<b>RETAINER</b> , headlamp and park lamp fiber optic

**2.584 CONNECTOR— INSERT— SOCKET ASSY.— SEAL— CLIP, Lighting Monitor**

**LAMP SOCKET REPLACEMENT**

*It is necessary to carefully check the parts catalogs for correct model application when replacing lamp socket assemblies. If incorrect sockets are used for replacement, the bulb filament will be in the wrong location with respect to the lens and/or reflector. As a result, the lamp may fail to meet the required lighting standards.*

67	Pass.	<b>6288471</b>	2	.21	body headlamp, 3-way
67	Pass.	<b>6288472</b>	2	.20	body headlamp, 2-way
68-71	Pass., Chevelle, Camaro,				
70	Pass., Chevelle	<b>5959734</b>	2	.43	<b>INSERT</b> , parking lamp fiber optic conductor
68-69	Pass., Chevelle, Camaro,				
70	Pass., Chevelle	<b>5960542</b>	3	.43	<b>INSERT</b> , tail, stop and license lamp fiber optic conductor
67	Pass., Chevelle (exc. Sta. Wag., El Camino)	<b>8912698</b>	2	3.10	<b>SOCKET ASSY.</b> , tail lamp body
67-75	All	<b>6288601</b>	1	1.30	<b>SOCKET ASSY.</b> , ign. switch fiber optic
67-70	Pass., Chevelle (exc. El Camino),				
68-69	Camaro	<b>1601794</b>	4	.19	<b>SEAL</b> , headlamp fiber optic conductor conn.
74-75	Nova, Chevelle	<b>1382116</b>	1	.13	<b>CLIP</b> , ash tray lamp fibre optic conductor

**2.585 LAMP ASSY., Parking**

62-64	Chevy	<b>897287</b>	R.H.	7.90	(amber lens)
62-64	Chevy	<b>897286</b>	L.H.	7.90	(amber lens)
64	Chevelle	<b>910850</b>	2	9.20	
65	Chevelle	<b>910659</b>	L.H.	9.20	
65	Chevelle	<b>910660</b>	R.H.	9.20	
65	Chevy	<b>910663</b>	L.H.	11.90	
65	Chevy	<b>910664</b>	R.H.	11.90	
65	Pass.	<b>910657</b>	2	11.90	
66	Pass.	<b>910968</b>	1	9.20	includes direction signal
66	Chevelle	<b>911243</b>	L.H.	9.20	
66	Chevelle	<b>911244</b>	R.H.	9.20	
66-67	Chevy	<b>910977</b>	L.H.	11.90	
66-67	Chevy	<b>910978</b>	R.H.	11.90	
67	Chevelle	<b>911271</b>	L.H.	10.60	
67	Chevelle	<b>911272</b>	R.H.	10.60	
67	Camaro (exc. R.S.)	<b>911259</b>	L.H.	11.85	
67	Camaro (exc. R.S.)	<b>911260</b>	R.H.	11.85	
67	Camaro w/R.S.	<b>911473</b>	L.H.	11.05	
67	Camaro w/R.S.	<b>911474</b>	R.H.	11.05	
67	Pass.	<b>911161</b>	2	9.20	w/direction signal
68	Pass. (exc. lamp monitor)	<b>916257</b>	1	12.05	L.H.
68	Pass.	<b>916258</b>	1	11.90	R.H. (Note 1)
68	Camaro w/R.S.	<b>916619</b>	L.H.	9.60	
68	Camaro w/R.S.	<b>916620</b>	R.H.	9.60	
68	Camaro (exc. R.S.)	<b>916896</b>	2	8.60	
68	Chevelle (exc. lamp monitor)	<b>916173</b>	2	10.60	
68-69	Chevy	<b>916211</b>	2	10.60	
69	Chevelle (exc. 396)	<b>916791</b>	L.H.	11.90	
69	Chevelle (exc. 396)	<b>916792</b>	R.H.	11.90	
69	El Camino	<b>916795</b>	L.H.	11.25	
69	El Camino	<b>916796</b>	R.H.	10.25	
69	Chevelle (396)	<b>916901</b>	L.H.	9.20	(Note 1)
69	Chevelle (396)	<b>916902</b>	R.H.	9.20	(Note 1)
69	Camaro	<b>916911</b>	2	10.60	(Note 1)
70	Monte Carlo	<b>911320</b>	2	16.60	

**CHASSIS—ELECTRICAL SYSTEM**

**2.585 LAMP ASSY., Parking (Con't)**

70-73	Camaro (R.S.)	917034	2	15.55	
70	El Camino	917194	2	13.10	
71	Monte Carlo	910662	2	14.00	
73-74	Nova	897087	2	6.25	
73	Laguna	911993	L.H.	12.10	w/side marker
73	Laguna	911994	R.H.	12.10	
74-75	Malibu, El Camino	912177	2	14.05	
74	Laguna	912179	L.H.	12.10	
74	Laguna	912180	R.H.	12.10	
74	Monte Carlo	912219	L.H.	15.20	w/side marker
74	Monte Carlo	912220	R.H.	15.20	w/side marker
74	Caprice,				
75	Pass. (exc. Caprice)	912211	L.H.	9.10	
74	Caprice,				
75	Pass. (exc. Caprice)	912212	R.H.	9.10	
74	Pass. (exc. Caprice)	912225	L.H.	12.70	w/side marker
74	Pass. (exc. Caprice)	912226	R.H.	12.70	w/side marker
74-75	Camaro	928168	2	5.75	
74-75	Vega (exc. G.T.)	912189	L.H.	10.80	(Note 1)
74-75	Vega (exc. G.T.)	912190	R.H.	10.80	(Note 1)
74-75	Vega (G.T.)	912191	L.H.	10.80	(Note 1)
74-75	Vega (G.T.)	912192	R.H.	10.80	(Note 1)
75	Monza (exc. Towne Cpe.)	912329	L.H.	10.80	(Note 1)
75	Monza (exc. Towne Cpe.)	912330	R.H.	10.80	(Note 1)
75	Monza (Towne Coupe)	912810	R.H.	8.65	
75	Monza (Towne Coupe)	912809	L.H.	8.65	

*NOTE 1: Parking lamp is serviced as a complete unit only for 1974-75.*

75	Nova (exc. S.S., L.N.)	911879	2	6.25	
75	Nova (S.S., L.N.)	912008	2	6.25	
75	Laguna	912371	L.H.	14.05	w/side marker
75	Laguna	912372	R.H.	12.10	w/side marker
75	Monte Carlo	912373	L.H.	16.95	w/side marker
75	Monte Carlo	912374	R.H.	16.95	w/side marker
75	Caprice	912395	L.H.	9.95	
75	Caprice	912396	R.H.	9.95	

*NOTE 1 It may be necessary to drill hole in Hsg. for fiber optic lead as a guide and add collector lens 5959740 and insert 5959734.*

**2.586 HOUSING— MOLDING— ORNAMENT— SPACER, Parking Lamp**

67	Pass.	5959501	1	19.50	L.H. front fdr. lamp
67	Pass.	5959502	1	19.50	R.H. front fdr. lamp
68	Pass.	5961631	1	14.70	L.H. front fdr. lamp
68	Pass.	5961632	1	14.70	R.H. front fdr. lamp
69	Pass.	5958699	2	8.65	HOUSING ASSY., parking and directional signal
70	Pass.	5962254	2	10.60	HOUSING ASSY., park and dir. sig.
70	Chevelle (exc. Monte Carlo)	5962103	2	10.60	HOUSING ASSY., park and dir. sig.
70-72	Nova	5962264	1	6.60	HOUSING ASSY., park lamp
70-72	Camaro (exc. R.S.)	5962637	L.H.	16.70	HOUSING ASSY., park. and dir. sig.
70-72	Camaro (exc. R.S.)	5962638	R.H.	16.70	HOUSING ASSY., park. & dir. sig.
71	Pass.	5964091	1	14.40	HOUSING ASSY., park, signal and marker L.H.
71	Pass.	5964092	1	14.40	HOUSING ASSY., park, signal and marker R.H.
71-73	Vega	5963123	1	8.65	HOUSING ASSY., park. lamp
72	Pass.	5964672	2	5.80	HOUSING ASSY., park. lamp
73	Chevelle (exc. Monte Carlo)	5965529	2	6.50	
73	Pass.	5965583	2	5.80	
73	Monte Carlo	5965631	L.H.	7.00	
73	Monte Carlo	5965632	R.H.	7.00	
73	Camaro (exc. R.S.)	5962637	L.H.	16.70	park. and dir. sig.
73	Camaro (exc. R.S.)	5962638	R.H.	16.70	
74	BL57	5966234	R.H.	3.80	MOLDING, frt. fdr. park. & sig. lamp-lwr.
74	BL57	5966233	L.H.	3.80	MOLDING, frt. fdr. park. & sig. lamp-lwr.
74-75	Camaro	337452	2	1.40	ORNAMENT
75	El Camino	356424	2	.27	SPACER, park. & dir. sig. lamp

**2.587 BRACKET— BUMPER— NUT— SCREW— SUPPORT, Parking Lamp Attaching**

70	Monte Carlo, El Camino	3968562	1	.96	
65	Chevy,				
66	Pass.	3841098	2	.11	BUMPER (7.800)
66-70	Chevy, Chevelle, Camaro,				
67-69	Pass.,				
68	Camaro w/R.S.,				

**CHASSIS—ELECTRICAL SYSTEM**

**2.587 BRACKET— BUMPER— NUT— SCREW— SUPPORT, Parking Lamp Attaching (Con't)**

71-72	Nova,				
72	Camaro	3938600	2	.11	BUMPER (7.800)
70	Chevelle	3973636	1	.11	BUMPER, parking lamp
69	Camaro w/R.S.	3849124	1	.15	NUT, attach. (No. 10-16)
65	Chevy, Chevelle,				
66-67	Chevy,				
67	Chevelle (exc. Sta. Wag., El Camino)	5956445	4	.16	SCREW, parking and dir. sig. lamp— (2.697)
67	Camaro w/R.S.	3906185	L.H.	1.35	SUPPORT
67	Camaro w/R.S.	3906186	R.H.	1.65	SUPPORT

**2.589 LENS— SCREW, Parking Lamp**

62	Chevy	5953435	L.H.	1.85	
62	Chevy	5953436	R.H.	1.85	
63-64	Chevy	5954493	L.H.	1.85	(amber)
63-64	Chevy	5954494	R.H.	1.85	(amber)
64	Chevelle	5954926	2	1.85	(amber)
65	Chevy	5956557	L.H.	2.15	
65	Chevy	5956558	R.H.	2.15	
65	Chevelle	5956671	L.H.	2.40	
65	Chevelle	5956672	R.H.	2.40	
65	Pass.	5956277	2	2.15	(amber)
66	Pass.	5957569	2	2.40	parking and direction signal lamp
66-67	Chevy	5957479	L.H.	2.15	
66-67	Chevy	5957480	R.H.	2.15	
66	Chevelle	5957799	L.H.	2.40	
66	Chevelle	5957800	R.H.	2.40	
67	Chevelle	5958639	L.H.	2.15	
67	Chevelle	5958640	R.H.	2.15	
67	Camaro (exc. R.S.)	5958775	2	2.85	
67-68	Camaro w/R.S.	5959233	L.H.	2.40	
67-68	Camaro w/R.S.	5959234	R.H.	2.40	
67	Pass.	5958804	2	3.20	parking and direction signal lamp
67	Pass. w/Running Lamp	5959509	1	5.35	front fender lamp, L.H.
67	Pass. w/Running Lamp	5959510	1	5.35	front fender lamp, R.H.
68	Pass.	5960941	1	3.20	frt. fdr. lamp L.H.
68	Pass.	5960942	1	3.20	frt. fdr. lamp R.H.
68	Pass.	5960368	1	1.60	park and direction signal lamp, R.H.
68	Pass.	5960367	1	1.60	park and direction signal lamp, L.H.
68	Camaro (exc. R.S.)	5960200	2	3.25	
68	Chevelle	5959619	2	1.85	
68-69	Chevy	5959688	2	1.60	
69	Camaro w/lamp monitor (exc. R.S.)	5961467	2	2.85	
69	Camaro w/lamp monitor, R.S.	5961469	2	4.00	
69	Chevelle (exc. 396, El Camino)	5961641	L.H.	1.85	
69	Chevelle (exc. 396, El Camino)	5961642	R.H.	1.85	
69	Chevelle (396) (exc. El Camino)	5961623	L.H.	4.25	
69	El Camino	5961045	L.H.	2.15	
69	El Camino	5961046	R.H.	2.15	
69	Pass. (exc. Caprice, Est. Wag.)	5961196	2	2.40	
69	Caprice, Estate Wag.	5961032	2	2.40	
70	Caprice, Estate Wag.	5962390	2	4.00	park. and dir. sig.
70	Pass. (exc. Caprice, Estate Wag.)	5962258	2	4.00	park. and dir. sig.
70	Chevelle (exc. 396, Monte Carlo, El Camino)	5962107	2	4.25	park and dir. sig.
70	Chevelle (396)	5961555	2	4.25	park and dir. sig.
70	Monte Carlo	5962691	2	7.00	park. and dir. sig.
70	El Camino	5963284	2	3.40	park
70	Nova	5962268	2	2.30	park. and dir. sig.
70-72	Camaro (exc. R.S., ext. mldg.)	5962635	L.H.	4.00	park. and dir. sig.
70-72	Camaro (exc. R.S., ext. mldg.)	5962636	R.H.	4.00	park. & dir. sig.
70	Camaro w/ext. mldg. (exc. lamp monitor),				
71-73	Camaro w/ext. mldg. (exc. R.S.)	5963345	L.H.	5.25	left, park and dir. signal
70	Camaro w/ext. mldg. (exc. lamp monitor),				
71-73	Camaro w/ext. mldg. (exc. R.S.)	5963346	R.H.	5.25	right, park and dir. signal
70	Camaro (R.S.) (exc. lamp monitor),				
71-73	Camaro w/R.S.	5962882	2	9.30	park and dir. signal (round)
70	Camaro (exc. lamp monitors, R.S., ext. mldg.),				

**CHASSIS—ELECTRICAL SYSTEM**

**2.589 LENS— SCREW, Parking Lamp (Con't)**

71-73	Camaro (exc. R.S., ext. mldg.)	5962635 L.H.	4.00	left, park and dir. signal
70	Camaro (exc. lamp monitors, R.S., ext. mldg.)			
71-73	Camaro (exc. R.S., ext. mldg.)	5962636 R.H.	4.00	right, park and dir. signal
71-72	Nova	5963490 2	2.15	park and dir. sig.
71	Monte Carlo	5963566 2	6.05	
71	Chevelle (exc. Sta. Wag., El Camino, Monte Carlo)	5963817 L.H.	6.55	park and side marker
71	Chevelle (exc. Sta. Wag., El Camino, Monte Carlo)	5963818 R.H.	6.55	park and side marker
71	Chevelle (Sta. Wag., El Camino)	5963821 L.H.	7.15	park and side marker
71	Chevelle (Sta. Wag., El Camino)	5963822 R.H.	7.15	park and side marker
71	Pass.	5963985 L.H.	6.05	park and side marker
71	Pass.	5963986 R.H.	6.05	park and side marker
71-73	Vega (exc. G.T.)	5963166 2	2.00	park
71-73	Vega (G.T.)	5963131 2	2.00	park
72	Monte Carlo	5964317 L.H.	7.45	park. and dir. sig.
72	Monte Carlo	5964318 R.H.	7.45	park. and dir. sig.
73	Chevelle (exc. Monte Carlo)	5965533 2	4.80	park. and dir. sig.
73	Pass.	5965595 2	4.15	park. and dir. sig.
73	Monte Carlo	5965635 L.H.	5.50	park. and dir. sig.
73	Monte Carlo	5965636 R.H.	5.50	park. and dir. sig.
72	Chevelle (Std.) (exc. Sta. Wag., El Camino, Monte Carlo), Malibu (1st design)	5965269 L.H.	7.45	LENS ASSY., park. and side marker (Note 1)
72	Chevelle (Std.) (exc. Sta. Wag., El Camino, Monte Carlo), Malibu (1st design)	5965270 R.H.	7.45	LENS ASSY., park. and side marker (Note 1)
72	Malibu (2nd design)	5965683 L.H.	7.45	LENS ASSY., park. and side marker (Note 2)
72	Malibu (2nd design)	5965684 R.H.	7.45	LENS ASSY., park. and side marker (Note 2)
72	Nomad, Greenbrier, El Camino (exc. Custom), Concours, El Camino Custom (1st design)	5965275 L.H.	7.15	LENS ASSY., park. and side marker (Note 1)
72	Nomad, Greenbrier, El Camino (exc. Custom), Concours, El Camino Custom (1st design)	5965276 R.H.	7.15	LENS ASSY., park. and side marker (Note 1)
72	Concours, El Camino Custom (2nd design)	5965687 L.H.	7.15	LENS ASSY., park. and side marker (Note 2)
72	Concours, El Camino Custom (2nd design)	5965688 R.H.	7.15	LENS ASSY., park. and side marker (Note 2)
72	Pass.	5964676 2	4.15	LENS ASSY., park. and dir. sig.
71-73	Vega	5959089 A.R.	.22	SCREW, park. lens

NOTE 1: Amber lens.

NOTE 2: White lens.

**2.590 GASKET, Parking Lamp Lens**

67	Pass.			
69	Pass.	5958805 2	.52	parking and direction, signal lamp lens
67	Pass. w/Running Lamp	5959506 2	.45	front fender lamp lens
67	Camaro w/R.S.	5959235 2	.35	
68	Camaro	5960199 2	.35	
68-69	Chevy	5960206 2	.40	
68	Pass.	5960399 1	.45	frt. fdr. lamp lens, L.H.
68	Pass.	5960400 1	.45	frt. fdr. lamp lens, R.H.
69	Camaro	5961316 1	1.35	
70	Pass.	5962257 2	.55	park. and dir. sig.
70	Chevelle (exc. Monte Carlo, El Camino)	5962106 2	.63	park. and dir. sig.
70	Monte Carlo, El Camino,			
71-73	Camaro w/R.S.	5962690 2	.58	park. and dir. sig.
70-72	Nova	5962267 2	.68	park. and dir. sig.
70	Camaro,			
71-73	Camaro (exc. R.S.)	5962633 L.H.	1.65	left, park. and dir. signal
70	Camaro,			
71-73	Camaro (exc. R.S.)	5962634 R.H.	1.65	right, park and dir. signal



**CHASSIS—ELECTRICAL SYSTEM**

<b>2.590 GASKET, Parking Lamp Lens</b>		<b>(Con't)</b>		
71-72	El Camino, Monte Carlo	5963816	2	1.35 park and side marker
71-72	Chevelle (Sta. Wag., El Camino)	5963820	2	1.45 park and side marker
71	Monte Carlo	5963565	2	.68
71	Pass.	5964083	2	.97 park and side marker
71-73	Vega	5963129	4	.97
72	Monte Carlo	5964321	2	.85
72-73	Pass.	5964675	2	.80 park. and dir. sig.
72-73	Camaro w/R.S.	5961809	1	1.35 park. and dir. sig.
73	Chevelle (exc. Monte Carlo)	5965532	2	1.10 park and dir. sig.
73	Monte Carlo	5965630	2	1.10 park and dir. sig.
<b>2.593 BEZEL— INSERT— SHIELD, Parking Lamp</b>				
62	Chevy	3790351	L.H.	2.70
62	Chevy	3790352	R.H.	2.70
63-64	Chevy	3792987	L.H.	2.30
63-64	Chevy	3792988	R.H.	2.30
67	Pass. w/Running Lamp	5959507	1	19.50 front fender lamp, L.H.
67	Pass. w/Running Lamp	5959508	1	19.50 front fender lamp, R.H.
68	Pass.	5960323	1	8.45 frt. fender lamp, L.H.
68	Pass.	5960324	1	8.45 frt. fender lamp, R.H.
71	Pass.	5964085	L.H.	7.95 park sig. and side marker
71	Pass.	5964086	R.H.	7.95 park sig. and side marker
71	Chevelle (exc. Sta. Wag., El Camino, Monte Carlo)	3998271	L.H.	3.05 park and side marker
71	Chevelle (exc. Sta. Wag., El Camino, Monte Carlo)	3998272	R.H.	3.05 park and side marker
71	Chevelle (Sta. Wag., El Camino)	3998273	L.H.	3.60 park and side marker
71	Chevelle (Sta. Wag., El Camino)	3998274	R.H.	3.60 park and side marker
72	Monte Carlo	5964319	L.H.	4.50 park. lamp
72	Monte Carlo	5964320	R.H.	4.50 park. lamp
72	Chevelle (exc. Sta. Wag., El Camino, Monte Carlo)	6261959	L.H.	3.50 park. and side marker
72	Chevelle (exc. Sta. Wag., El Camino, Monte Carlo)	6261960	R.H.	3.50 park. and side marker
72	Chevelle (Sta. Wag., El Camino)	6261961	L.H.	3.50 park. and side marker
72	Chevelle (Sta. Wag., El Camino)	6261962	R.H.	3.50 park. and side marker
73-74	Nova	327558	2	1.10
71	Chevelle (exc. Monte Carlo)	3998270	2	.66 INSERT, park and side marker
69	Impala, Caprice, Kingswood, Estate Wag.	3957259	2	.77 SHIELD
<b>2.594 SCREW— NUT— RETAINER, Parking Lamp Door or Lens</b>				
62-65	Chevy,			
67	Camaro w/R.S.,			
68	Pass.,			
70	El Camino	5953438	4	.12 (No. 8-32 x 5/8" cr. recess)
66	Chevelle, Chevy,			
67-69	Chevy	5957808	4	.16 park and dir. sig. lamp lens attach.
66	Pass.,			
71-72	Vega (2-Dr.)			backing lamp lens,
71-73	Camaro w/R.S.	5961749	4	.33 (No. 8— 32 x 7/8") (shoulder type)
66	Sta. Wag. (exc. Caprice)	5957931	A.R.	.12 (No. 8— 32 x 59/64" chrome plated)— (2.688)
67	Camaro (exc. R.S.)	5955349	4	.11 park and dir. sig. lamp lens
67-69	Pass.,			
67-69	Chevelle,			
68-69	Camaro,			
70-72	Nova,			
71-73	Vega,			
72	Pass.,			
72	Monte Carlo	5958894	4	.33 park. and dir. sig. lamp lens, and backing lamp (No. 8— 32 x 41/64")
68-69	Chevy,			
70	Pass.	5959383	4	.33 parking and dir. signal lamp lens
70	Chevelle (exc. Monte Carlo)	5959107	2	.33 park and dir. sig.
71-72	Vega (2-Dr.)			tail and stop lamp assy.,
70	Monte Carlo, El Camino,			
71-73	Camaro (exc. R.S.)	5962696	2	.33 park and dir. sig.
71	Monte Carlo	5963622	4	.16
71	Pass.	5956880	4	.33 park sig. and marker lamp
73	Vega (2-Dr.)	5966002	2	.33 tail and stop lamp assy.
62-63	Chevy (Deluxe)	3780673	4	.12 NUT, park and direction lamp bezel extension assy. (10— 24)— (8.133)
71-72	Monte Carlo	3961571	2	.11 RETAINER, park lamp— (2.688)

**CHASSIS—ELECTRICAL SYSTEM**

**2.596 SOCKET ASSY.— WIRE ASSY., Parking Lamp**

**LAMP SOCKET REPLACEMENT**

*It is necessary to carefully check the parts catalogs for correct model application when replacing lamp socket assemblies. If incorrect sockets are used for replacement, the bulb filament will be in the wrong location with respect to the lens and/or reflector. As a result, the lamp may fail to meet the required lighting standards.*

69-73	All,				
74	Nova,				
74-75	Vega,				
74-75	Pass., Camaro,				
74-75	Monte Carlo, Laguna	8914822	A.R.	3.90	(twist lock-socket) (gray-focal length 7/8")
69-73	All,				
74-75	Vega,				
74-75	Malibu, El Camino	8914823	A.R.	3.90	(twist lock-socket) (cream-focal length 1 1/4")
75	Pass., Nova	8914823	A.R.	3.90	(twist lock-socket) (cream-focal length 1 1/4")
74	Caprice	8909517	2	4.65	tail and stop lamp (use w/912237-38)
75	Nova	8919916	2	6.30	
75	Monza	12001470	2	6.50	tail and stop (w/912109-10)
71-73	Vega	8902526	A.R.	2.60	connector (for repair of forward lamp harness)
72	Pass.,				
73	Malibu, Deluxe	8901974	2	8.20	<b>WIRE ASSY.</b> , park., direct. sig. and side mkr. (ext.)

**2.599 SEAL, Parking Lamp**

67	Camaro w/R.S.	3897347	2	.48	parking lamp
----	---------------	---------	---	-----	--------------

**2.660 GASKET— SEAL, Tail Lamp**

68-69	Chevy	7730113	2	1.65	lamp opening
68	Chevelle (exc. Sta. Wag., El Camino)	7739830	2	.66	lamp opening
69	Chevelle (exc. Sta. Wag., El Camino)	8737611	L.H.	2.25	sealing
70-72	Chevelle (Sta. Wag., El Camino)	5962743	L.H.	2.30	L.H., tail, stop and dir. sig. lamp mtg.
70-72	Chevelle (Sta. Wag., El Camino)	5962744	R.H.	2.75	R.H., tail, stop and dir. sig. lamp mtg.
70-72	Nova	5963118	2	2.00	tail, stop and backing lamp mtg.
70-73	Camaro	5963583	L.H.	1.60	left, tail, stop and backing lamp
70-73	Camaro	5963584	R.H.	1.60	right, tail, stop and backing lamp
71-73	Camaro	5963060	2	1.65	tail and stop mtg. (inboard)
71-73	Pass. (Sta. Wag.)	5963535	L.H.	1.95	tail and stop mtg.
71-73	Pass. (Sta. Wag.)	5963536	R.H.	1.95	tail and stop mtg.
71	Pass. (exc. Sta. Wag.)	9843300	2	.79	tail lamp sealing— (12.943)
71-75	Vega (Sta. Wag., Panel)	5962773	L.H.	2.70	tail and stop lamp to body outer
71-75	Vega (Sta. Wag., Panel)	5962774	R.H.	1.70	tail and stop lamp to body outer
71-75	Vega (Sta. Wag., Panel)	5962623	L.H.	1.70	tail and stop lamp inner
71-75	Vega (Sta. Wag., Panel)	5962624	R.H.	1.70	tail and stop lamp, inner
73	Chevelle (exc. Sta. Wag.)	5964914	4	2.30	tail, stop, and backing mtg.
73	Monte Carlo	5965053	L.H.	2.30	tail and stop mtg.
73	Monte Carlo	5965054	R.H.	2.30	tail and stop mtg.
73	Nova	5950233	4	8.25	tail stop and backing lamp
74-75	Camaro	5954135	L.H.	3.35	tail, stop and backing mtg.
74-75	Camaro	5954136	R.H.	3.35	tail, stop and backing mtg.
74-75	Pass. (Sta. Wag.)	5949277	L.H.	1.95	tail, stop and backing mtg.
74-75	Pass. (Sta. Wag.)	5949278	R.H.	1.95	tail, stop and backing mtg.
74	Chevelle (Spt. Cpe., Sed.) (exc. Monte Carlo)	342190	2	1.35	rear lamp
74-75	Monte Carlo	5950145	L.H.	2.30	tail and stop mtg.
74-75	Monte Carlo	5950146	R.H.	2.30	tail and stop mtg.
74-75	Pass. (exc. Sta. Wag.)	5952919	A.R.	.97	tail, stop and backing mtg.
74	Nova	5950233	1	8.25	tail, stop and backing mtg.
75	Nova	5966241	L.H.	8.25	tail, stop and backing mtg.
75	Nova	5966242	R.H.	8.25	tail, stop and backing mtg.
75	Chevelle (Spt. Cpe., Sedan) (exc. Monte Carl)	347343	2	1.30	rear lamp
75	Caprice (exc. Sta. Wag.)	5966316	6	.93	comb. tail and backing mtg.
69	Chevelle (exc. Sta. Wag., El Camino)	5961111	L.H.	1.70	<b>SEAL</b> , tail, stop and direction sig.
69	Chevelle (exc. Sta. Wag., El Camino)	5961112	R.H.	1.70	<b>SEAL</b> , tail, stop and direction sig.

**2.679 LAMP ASSY., Tail and Stop**

62-64	Chevy (exc. Sta. Wag.)	899439	2	16.95	<b>L.H. and R.H.</b>
62-64	Chevy (Sta. Wag.)	898614	2	16.85	<b>L.H. and R.H.</b>

**CHASSIS—ELECTRICAL SYSTEM**

**2.679 LAMP ASSY., Tail and Stop (Con't)**

64	Chevelle (exc. Sta. Wag., El Camino) . . . . .	910267 L.H.	13.10	
64	Chevelle (exc. Sta. Wag., El Camino) . . . . .	910268 R.H.	13.10	
64	Chevelle (Sta. Wag., El Camino) . . . . .	910442 R.H.	24.30	
65	Chevy (exc. Sta. Wag.) . . . . .	910731 L.H.	13.10	
65	Chevy (exc. Sta. Wag.) . . . . .	910732 R.H.	13.10	
65	Chevelle (exc. Sta. Wag., El Camino, Malibu) . . . . .	910723 L.H.	13.75	
65	Chevelle (Malibu) (exc. Sta. Wag., El Camino) . . . . .	910725 L.H.	15.55	
65	Chevelle (Malibu) (exc. Sta. Wag., El Camino) . . . . .	910726 R.H.	15.55	
65	Chevelle (Sta. Wag., El Camino) . . . . .	910863 L.H.	24.10	
65	Chevelle (Sta. Wag., El Camino) . . . . .	910864 R.H.	24.10	
65	Impala (exc. Sta. Wag.) . . . . .	910667	2 14.25	L.H., w/direction signal . . . . .
65	Impala (exc. Sta. Wag.) . . . . .	910668	2 14.25	R.H., w/direction signal . . . . .
65	Bel Air (exc. Sta. Wag.) . . . . .	910701	1 15.55	L.H., w/direction signal . . . . .
65	Bel Air (exc. Sta. Wag.) . . . . .	910702	1 15.55	R.H., w/direction signal . . . . .
66	Biscayne, Bel Air (exc. Sta. Wag.) . . . . .	911037	1 32.50	L.H., tail, stop, dir. and backing . . . . .
66	Biscayne, Bel Air (exc. Sta. Wag.) . . . . .	911038	1 32.50	R.H., tail, stop, dir. and backing . . . . .
66	Caprice (exc. Sta. Wag.) . . . . .	911429	1 48.75	L.H., tail, stop and direction . . . . .
66	Caprice (exc. Sta. Wag.) . . . . .	911430	1 48.75	R.H., tail, stop and direction . . . . .
66	Impala (exc. Sta. Wag.) . . . . .	911427	1 46.00	L.H., tail, stop and direction . . . . .
66	Impala (exc. Sta. Wag.) . . . . .	911428	1 46.00	R.H., tail stop and direction . . . . .
66-67	Chevy . . . . .	910970	2 21.70	
67	Bel Air, Impala (exc. Sta. Wag.) . . . . .	911287	1 43.00	L.H. w/dir. sig. . . . .
67	Bel Air, Impala (exc. Sta. Wag.) . . . . .	911288	1 43.00	R.H. w/dir. sig. . . . .
67	Biscayne, (exc. Sta. Wag.) . . . . .	911277	1 18.05	L.H., stop and dir. signal . . . . .
67	Caprice (exc. Sta. Wag.) . . . . .	911293	1 40.50	L.H., stop and dir. signal . . . . .
67	Caprice (exc. Sta. Wag.) . . . . .	911294	1 40.50	R.H., stop and dir. signal . . . . .
67	Camaro w/R.S. . . . .	911475	L.H. 48.75	
67	Camaro w/R.S. . . . .	911476	R.H. 46.50	
67	Camaro (exc. R.S.) . . . . .	916539	L.H. 46.50	
67	Camaro (exc. R.S.) . . . . .	916540	R.H. 46.50	
68	Camaro (exc. R.S.) . . . . .	916523	L.H. 46.50	
68	Camaro (exc. R.S.) . . . . .	916524	R.H. 46.50	
68	Camaro w/R.S. . . . .	916525	L.H. 46.50	
68	Camaro w/R.S. . . . .	916526	R.H. 46.50	
68-69	Chevy . . . . .	916277	L.H. 27.75	
68-69	Chevy . . . . .	916278	R.H. 27.75	
69	Biscayne, Bel Air . . . . .	916879	1 20.55	L.H., tail and stop (Note 1) . . . . .
69	Biscayne, Bel Air . . . . .	916880	1 20.55	R.H., tail and stop (Note 1) . . . . .
69	Impala . . . . .	916865	1 23.00	L.H., tail and stop outer (Note 1) . . . . .
69	Impala . . . . .	916866	1 23.00	R.H., tail and stop outer (Note 1) . . . . .
69	Caprice . . . . .	916869	1 23.35	L.H., tail and stop outer (Note 1) . . . . .
69	Caprice . . . . .	916870	1 23.35	R.H., tail and stop outer (Note 1) . . . . .
<i>NOTE 1 It may be necessary to drill hole in Hsg. for fiber optic lead as a guide and add Collector Lens 5960480 and insert 5960542.</i>				
69	Impala . . . . .	916867	1 21.80	L.H., tail and stop inner . . . . .
69	Impala . . . . .	916868	1 21.80	R.H., tail and stop inner . . . . .
69	Caprice . . . . .	916871	1 22.70	L.H., tail and stop inner . . . . .
69	Caprice . . . . .	916872	1 22.70	R.H., tail and stop inner . . . . .
70	Biscayne, Bel Air . . . . .	917675	L.H. 38.75	L.H., tail and stop . . . . .
70	Biscayne, Bel Air . . . . .	917676	R.H. 38.75	R.H., tail and stop . . . . .
70	Impala . . . . .	917673	L.H. 46.00	L.H., tail and stop . . . . .
70	Impala . . . . .	917674	R.H. 46.00	R.H., tail and stop . . . . .
70	Caprice . . . . .	917671	L.H. 53.75	L.H., tail and stop . . . . .
70	Caprice . . . . .	917672	R.H. 53.75	R.H., tail and stop . . . . .
71	Malibu (1st design) . . . . .	917575	L.H. 23.75	(Note 2) . . . . .
71	Malibu (1st design) . . . . .	917576	R.H. 23.75	(Note 2) . . . . .
71	Chevelle (Deluxe) . . . . .	911543	L.H. 24.00	
71	Chevelle (Deluxe) . . . . .	911544	R.H. 24.00	
74-75	Vega (Coupe) . . . . .	912193	L.H. 12.75	backing . . . . .
74-75	Vega (Coupe) . . . . .	912194	R.H. 12.75	backing . . . . .
75	Monza (exc. Notchback) . . . . .	912109	L.H. 46.50	tail, stop and backing . . . . .
75	Monza (exc. Notchback) . . . . .	912110	R.H. 46.50	tail, stop and backing . . . . .
75	Monza (Notchback) . . . . .	912621	L.H. 13.85	rear . . . . .
75	Monza (Notchback) . . . . .	912622	R.H. 13.85	rear . . . . .
<i>NOTE 2 Pointed Back-Up Lens.</i>				

## CHASSIS—ELECTRICAL SYSTEM

### 2.680 FRAME ASSY.— ORNAMENT— HOUSING ASSY.— RING— SCREW, Tail and Stop Lamp

*NOTE For 1966-69 Chevelle Housing Assy. See Extension in Group 12.940.*

66-67	Chevy	5957442	2	1.20	ORNAMENT
68-69	Chevy	5960130	1	1.85	ORNAMENT
68	Pass.	5959802	A.R.	2.05	ORNAMENT, tail and stop (middle ring)
69	Kingswood, Estate Wag.	5961564	6	1.35	ORNAMENT, tail, stop and dir. lamp
73	Laguna (exc. Sta. Wag.)	5966033	L.H.	13.95	ORNAMENT, tail, stop and bkg. lamp
73	Laguna (exc. Sta. Wag.)	5966034	R.H.	13.95	ORNAMENT, tail, stop and bkg. lamp
74-75	Vega (Coupe)	5949348	R.H.	5.50	ORNAMENT, tail, stop & backup Imp.
74-75	Vega (Coupe)	5949347	L.H.	5.50	ORNAMENT, tail, stop & backup Imp.
66	Biscayne, Bel Air (Sta. Wag.)	5958305	1	19.55	HOUSING ASSY., inner tail and backing, L.H.
66	Biscayne, Bel Air (Sta. Wag.)	5958306	1	19.20	HOUSING ASSY., inner tail and backing R.H.
66	Sta. Wag.	5958301	1	20.55	HOUSING ASSY., outboard tail, stop direction backing L.H.
66	Sta. Wag.	5958302	1	20.55	HOUSING ASSY., outboard, tail, direction backing R.H.
66	Impala, Caprice (Sta. Wag.)	5958303	1	19.90	HOUSING ASSY., inner tail, stop direction L.H.
66	Impala, Caprice (Sta. Wag.)	5958304	R.H.	19.90	HOUSING ASSY., inner tail, stop, direction
66	Chevelle (Sta. Wag., El Camino)	5958367	L.H.	19.65	HOUSING ASSY., backing
66	Chevelle (Sta. Wag., El Camino)	5958368	R.H.	19.65	HOUSING ASSY., backing
67	Chevelle (Sta. Wag., El Camino)	5959063	L.H.	23.35	HOUSING ASSY.
67	Chevelle (Sta. Wag., El Camino)	5959064	R.H.	23.35	HOUSING ASSY.
67	Sta. Wag.	5958765	1	14.70	HOUSING ASSY., tail stop direction, R.H. (inner)
67	Sta. Wag.	5958766	1	14.70	HOUSING ASSY., tail stop, direction, L.H. (inner)
67	Caprice (Sta. Wag.)	5958897	2	10.85	HOUSING ASSY., tail stop direction
67	Sta. Wag.	5959187	1	10.70	HOUSING ASSY., tail, stop, direction left (outer)
67	Sta. Wag.	5959188	1	10.70	HOUSING ASSY., tail, stop, direction, right (outer)
68	Pass. w/lamp monitor (exc. Sta. Wag.),				
68	Pass. (exc. Sta. Wag.)	5959795	A.R.	11.05	HOUSING ASSY., tail and stop, L.H.
68	Pass. w/lamp monitor				HOUSING ASSY., tail and stop, right
68	Pass. (exc. Sta. Wag.)	5959796	A.R.	11.05	HOUSING ASSY., tail, stop and dir. signal, R.H.
68	Sta. Wag. w/lamp monitor				HOUSING ASSY., tail and stop, otr.
68	Sta. Wag.	5959899	2	5.90	HOUSING ASSY., tail, stop and dir. signal otr.
68	Impala, Caprice (Sta. Wag.)	5959990	2	14.70	HOUSING ASSY., tail, stop and dir. signal lamp, inner
68	Nomad,				
68	El Camino (Deluxe)	5960313	L.H.	18.05	HOUSING ASSY.
68	Nomad,				
68	El Camino (Deluxe)	5960314	R.H.	18.05	HOUSING ASSY.
68	Malibu, Concours (Sta. Wag.),				
68	El Camino (exc. Deluxe)	5959945	L.H.	28.75	HOUSING ASSY.
68	Malibu, Concours (Sta. Wag.),				
68	El Camino (exc. Deluxe)	5959946	R.H.	28.75	HOUSING ASSY.
69	Nomad, Greenbrier	5961041	L.H.	18.05	HOUSING ASSY.
69	Nomad, Greenbrier	5961042	R.H.	18.05	HOUSING ASSY.
69	Concours	5961545	L.H.	28.75	HOUSING ASSY.
69	Concours	5961546	R.H.	28.75	HOUSING ASSY.
69	El Camino (Deluxe)	5961647	L.H.	28.75	HOUSING ASSY.
69	El Camino (Deluxe)	5961648	R.H.	28.75	HOUSING ASSY.
69	El Camino (Custom)	5961651	L.H.	28.75	HOUSING ASSY.
69	El Camino (Custom)	5961652	R.H.	28.75	HOUSING ASSY.
69	Camaro w/R.S.	5961747	L.H.	11.60	HOUSING ASSY.
69	Camaro w/R.S.	5961748	R.H.	11.60	HOUSING ASSY.
69	Camaro (exc. R.S.)	5961565	L.H.	11.60	HOUSING ASSY.
69	Camaro (exc. R.S.)	5961566	R.H.	11.60	HOUSING ASSY.
69-70	Kingswood	5961583	2	14.70	HOUSING ASSY., tail and stop, inner
69	Sta. Wag.,				
70	Pass. (Sta. Wag.)	5961575	L.H.	14.70	HOUSING ASSY., L.H., tail and stop outer
69	Sta. Wag.,				
70	Pass. (Sta. Wag.)	5961576	R.H.	14.70	HOUSING ASSY., R.H., tail and stop outer
70	Impala, Caprice (exc. Sta. Wag.)	5962309	L.H.	29.00	HOUSING ASSY., left, tail, stop and backing
70	Impala, Caprice (exc. Sta. Wag.)	5962310	R.H.	29.00	HOUSING ASSY., right, tail, stop and backing

**CHASSIS—ELECTRICAL SYSTEM**

<b>2.680 FRAME ASSY.— ORNAMENT— HOUSING ASSY.— RING— SCREW, Tail and Stop Lamp (Con't)</b>				
70	Biscayne, Bel Air (4-Dr. Sed.) . . .	5962337 L.H.	21.15	HOUSING ASSY., left, tail, stop and backing . . . . .
70	Biscayne, Bel Air (4-Dr. Sed.) . . .	5962338 R.H.	21.15	HOUSING ASSY., right, tail, stop and backing . . . . .
70-72	Concours, El Camino (Custom) . . .	5964203 L.H.	35.25	HOUSING ASSY., L.H., tail and stop . . . . .
70-72	Concours, El Camino (Custom) . . .	5964204 R.H.	35.25	HOUSING ASSY., R.H., tail and stop . . . . .
70	Chevelle (exc. Sta. Wag., El Camino, Monte Carlo) . . . . .	5962793 L.H.	17.90	HOUSING ASSY., L.H., tail and stop . . . . .
70	Chevelle (exc. Sta. Wag., El Camino, Monte Carlo) . . . . .	5962794 R.H.	17.90	HOUSING ASSY., R.H., tail and stop . . . . .
70-72	Nova . . . . .	5961269 L.H.	22.55	HOUSING ASSY., tail, stop and backing . . . . .
70-72	Nova . . . . .	5961270 R.H.	22.55	HOUSING ASSY., tail, stop and backing . . . . .
70-73	Camaro . . . . .	5963049 L.H.	11.65	HOUSING ASSY., left, tail, stop and backing . . . . .
70-73	Camaro . . . . .	5963050 R.H.	11.65	HOUSING ASSY., right, tail, stop and backing . . . . .
70-72	Nomad, Greenbrier, El Camino (exc. Custom) . . . . .	5964197 L.H.	35.25	HOUSING ASSY. . . . .
70-72	Nomad, Greenbrier, El Camino (exc. Custom) . . . . .	5964198 R.H.	35.25	HOUSING ASSY. . . . .
72	Pass. (exc. Sta. Wag.) . . . . .	5964837 L.H.	17.40	HOUSING ASSY. . . . .
72	Pass. (exc. Sta. Wag.) . . . . .	5964838 R.H.	17.40	HOUSING ASSY. . . . .
71	Biscayne, Bel Air . . . . .	5964019 L.H.	11.80	HOUSING ASSY. . . . .
71	Biscayne, Bel Air . . . . .	5964020 R.H.	11.80	HOUSING ASSY. . . . .
71-73	Pass. (Sta. Wag.) . . . . .	5963529 L.H.	32.50	HOUSING ASSY. . . . .
71-73	Pass. (Sta. Wag.) . . . . .	5963530 R.H.	32.50	HOUSING ASSY. . . . .
71	Impala, Caprice . . . . .	5963915 L.H.	14.70	HOUSING ASSY. . . . .
71	Impala, Caprice . . . . .	5963916 R.H.	14.70	HOUSING ASSY. . . . .
71-72	Chevelle (exc. Sta. Wag., El Camino, Monte Carlo) . . . . .	5963421 L.H.	13.50	HOUSING ASSY., tail, stop and backing . . . . .
71-72	Chevelle (exc. Sta. Wag., El Camino, Monte Carlo) . . . . .	5963422 R.H.	13.50	HOUSING ASSY., tail, stop and backing . . . . .
71-73	Vega (Coupe) . . . . .	5965979 2	5.70	HOUSING ASSY., backing lamp . . . . .
71-73	Vega (Coupe) . . . . .	5965972 1	5.70	HOUSING ASSY., tail and stop lamp (Note 1) . . . . .
<i>NOTE 1: Includes mounting and lens gasket.</i>				
71-75	Vega (Sta. Wag., Panel) . . . . .	5962127 L.H.	15.55	HOUSING ASSY., tail and stop lamp . . . . .
71-75	Vega (Sta. Wag., Panel) . . . . .	5962128 R.H.	15.55	HOUSING ASSY., tail and stop lamp . . . . .
73	Monte Carlo . . . . .	5965047 L.H.	13.95	HOUSING ASSY. . . . .
73	Monte Carlo . . . . .	5965048 R.H.	13.95	HOUSING ASSY. . . . .
73	Deluxe, Malibu, Laguna (exc. Sta. Wag.) . . . . .	5964905 L.H.	17.90	HOUSING ASSY. . . . .
73	Deluxe, Malibu, Laguna (exc. Sta. Wag.) . . . . .	5964906 R.H.	17.90	HOUSING ASSY. . . . .
73	Chevelle (El Camino, Sta. Wag.), El Camino . . . . .	5965159 L.H.	13.50	HOUSING ASSY. . . . .
74-75	El Camino . . . . .	5965160 R.H.	13.50	HOUSING ASSY. . . . .
73	Impala, Caprice (exc. Sta. Wag.) . . . . .	5965695 L.H.	17.40	HOUSING ASSY. . . . .
73	Impala, Caprice (exc. Sta. Wag.) . . . . .	5965696 R.H.	17.40	HOUSING ASSY. . . . .
73	Bel Air (Sedan) . . . . .	5965737 L.H.	13.95	HOUSING ASSY. . . . .
73	Bel Air (Sedan) . . . . .	5965738 R.H.	13.95	HOUSING ASSY. . . . .
73-74	Nova . . . . .	5965741 L.H.	11.85	HOUSING ASSY. . . . .
73-74	Nova . . . . .	5965742 R.H.	11.85	HOUSING ASSY. . . . .
74-75	Pass. (Sta. Wag.) . . . . .	5949271 L.H.	22.30	HOUSING ASSY. . . . .
74-75	Pass. (Sta. Wag.) . . . . .	5949272 R.H.	22.30	HOUSING ASSY. . . . .
74-75	Camaro . . . . .	5954109 L.H.	18.80	HOUSING ASSY. . . . .
74-75	Camaro . . . . .	5954110 R.H.	18.80	HOUSING ASSY. . . . .
74	Monte Carlo . . . . .	5949871 L.H.	13.95	HOUSING ASSY. . . . .
74	Monte Carlo . . . . .	5949872 R.H.	13.95	HOUSING ASSY. . . . .
74	Malibu, Laguna (exc. Sta. Wag.) . . . . .	5953007 L.H.	16.95	HOUSING ASSY. . . . .
74	Malibu, Laguna (exc. Sta. Wag.) . . . . .	5953008 R.H.	16.95	HOUSING ASSY. . . . .
74-75	Chevelle (Sta. Wag.) . . . . .	5948605 L.H.	16.60	HOUSING ASSY. . . . .
74-75	Chevelle (Sta. Wag.) . . . . .	5948606 R.H.	16.60	HOUSING ASSY. . . . .
74-75	Bel Air (Sedan) . . . . .	5950791 L.H.	30.50	HOUSING ASSY. . . . .
74-75	Bel Air (Sedan) . . . . .	5950792 R.H.	30.50	HOUSING ASSY. . . . .
74	Caprice (exc. Sta. Wag.) . . . . .	5951193 L.H.	30.50	HOUSING ASSY. . . . .
74	Caprice (exc. Sta. Wag.) . . . . .	5951194 R.H.	30.50	HOUSING ASSY. . . . .
74-75	Impala (exc. Sta. Wag.) . . . . .	5951567 L.H.	30.50	HOUSING ASSY. . . . .
74-75	Impala (exc. Sta. Wag.) . . . . .	5951568 R.H.	30.50	HOUSING ASSY. . . . .
75	Nova . . . . .	5966235 L.H.	11.65	HOUSING ASSY., tail, stop and backing . . . . .
75	Nova . . . . .	5966236 R.H.	11.65	HOUSING ASSY., tail, stop and backing . . . . .
75	Monte Carlo . . . . .	5966511 L.H.	26.75	HOUSING ASSY. . . . .
75	Monte Carlo . . . . .	5966512 R.H.	26.75	HOUSING ASSY. . . . .

**CHASSIS—ELECTRICAL SYSTEM**

**2.680 FRAME ASSY.— ORNAMENT— HOUSING ASSY.— RING— SCREW, Tail and Stop Lamp (Con't)**

75	Chevelle (Spt. Cpe. Sed.) (exc. Monte Carlo)	5966679	L.H.	17.45	HOUSING ASSY., comb.
75	Chevelle (Spt. Cpe., Sed.) (exc. Monte Carlo)	5966680	R.H.	17.45	HOUSING ASSY., comb.
75	Caprice (exc. Sta. Wag.)	5966497	L.H.	30.50	HOUSING ASSY., comb.
75	Caprice (exc. Sta. Wag.)	5966498	R.H.	30.50	HOUSING ASSY., comb.
65	Pass. (exc. Sta. Wag.),				
67	Pass.	5959530	A.R.		SCREW, retaining (No. 8— 32 x 11/32")
66-69	Chevy	5958143	4	.16	SCREW, ornament
74	Nova w/Spirit of America	347529	2	1.90	TAPE ASSY., tail and stop lamp vinyl

**2.681 BEZEL— PLATE ASSY.— APPLIQUE— RETAINER, Tail and Stop Lamp**

66	Biscayne, Bel Air (exc. Sta. Wag.)	5957949	1	17.70	L.H., w/dir. signal
66	Biscayne, Bel Air (exc. Sta. Wag.)	5957950	1	17.70	R.H., w/dir. signal
66	Impala (exc. Sta. Wag.)	5958919	1	22.75	L.H., w/dir. signal
66	Impala (exc. Sta. Wag.)	5958920	1	22.75	R.H., w/dir. signal
66	Caprice (exc. Sta. Wag.)	5958921	1	27.25	L.H., w/dir. signal
66	Caprice (exc. Sta. Wag.)	5958922	1	27.25	R.H., w/dir. signal
66	Malibu (exc. Sta. Wag., El Camino)	3876560	2	7.45	outer
66	Chevelle (exc. Sta. Wag., El Camino)	3876559	2	7.30	inner
67	Chevelle (Sedan) (exc. Malibu)	3887593	L.H.	7.30	
67	Chevelle (Sedan) (exc. Malibu)	3887594	R.H.	7.30	
67	Camaro	5959263	L.H.	30.75	
67	Camaro	5959264	R.H.	30.75	
67	Pass. (exc. Biscayne, Sta. Wag.)	5958789	1	29.00	L.H., w/dir. signal
67	Pass. (exc. Biscayne, Sta. Wag.)	5958790	1	27.00	R.H., w/dir. signal
68	Sta. Wag.	5959907	1	5.80	w/dir. signal— (2.697)
70-72	Monte Carlo	3945395	2	3.80	
70	Monte Carlo	3963380	2	4.60	lens
71-72	Monte Carlo	3982426	2	4.60	lens
73	Monte Carlo	9667271	L.H.	20.90	left
73	Monte Carlo	9667270	R.H.	20.90	right
74	Monte Carlo	9677436	R.H.	18.65	right— (12.940)
74	Monte Carlo	9677437	L.H.	18.65	left— (12.940)
75	Monte Carlo	9632859	R.H.	13.80	right— (12.940)
75	Monte Carlo	9632860	L.H.	13.80	left— (12.940)
75	Nova	344395	L.H.	10.00	left
75	Nova	344396	R.H.	10.00	right
67	Malibu, S.S. (exc. Sta. Wag., El Camino)	3907493	L.H.	10.70	BEZEL ASSY.
67	Malibu, S.S. (exc. Sta. Wag., El Camino)	3907494	R.H.	10.70	BEZEL ASSY.
68	Chevelle (Std. Deluxe) (exc. Sta. Wag.)	5960513	L.H.	23.05	BEZEL ASSY.
68	Chevelle (Std. Deluxe) (exc. Sta. Wag.)	5960514	R.H.	23.05	BEZEL ASSY.
68	Malibu (exc. Sta. Wag.),				
68	Chevelle (S.S.)	5960517	L.H.	23.05	BEZEL ASSY.
68	El Camino (Custom),				
68	Malibu (exc. Sta. Wag.),				
68	Chevelle (S.S.)	5960518	R.H.	23.05	BEZEL ASSY.
68	Camaro	5959941	L.H.	30.75	BEZEL ASSY.
68	Camaro	5959942	R.H.	30.75	BEZEL ASSY.
69	Malibu (exc. Sta. Wag., El Camino)	3948069	L.H.	23.05	BEZEL ASSY.
69	Malibu (exc. Sta. Wag., El Camino)	3948070	R.H.	23.05	BEZEL ASSY.
69	Chevelle (Deluxe) (exc. Sta. Wag., El Camino)	3948071	L.H.	23.05	BEZEL ASSY.
69	Chevelle (Deluxe) (exc. Sta. Wag., El Camino)	3948072	R.H.	23.05	BEZEL ASSY.
71-75	Vega (Sta. Wag., Panel)	5962671	L.H.	10.45	BEZEL ASSY.
71-75	Vega (Sta. Wag., Panel)	5962672	R.H.	10.45	BEZEL ASSY.
74	Impala (exc. Sta. Wag.)	5966145	L.H.	21.70	PLATE, rear lamp trim
74	Impala (exc. Sta. Wag.)	5966146	R.H.	21.70	PLATE, rear lamp trim
74	Caprice (exc. Sta. Wag.)	5966147	L.H.	31.00	PLATE ASSY., rear lamp trim
74	Caprice (exc. Sta. Wag.)	5966148	R.H.	31.00	PLATE ASSY., rear lamp trim
75	Impala (exc. Sta. Wag.)	5967065	L.H.	25.75	APPLIQUE, rear lamp
75	Impala (exc. Sta. Wag.)	5967066	R.H.	25.75	APPLIQUE, rear lamp
75	Caprice (exc. Sta. Wag.)	5966647	L.H.	23.05	APPLIQUE, rear lamp (Note 1)

**CHASSIS—ELECTRICAL SYSTEM**

**2.681 BEZEL— PLATE ASSY.— APPLIQUE— RETAINER, Tail and Stop Lamp  
(Con't)**

75	Caprice (exc. Sta. Wag.)	5966648 R.H.	23.05	APPLIQUE, rear lamp (Note 1)
	<i>NOTE 1: It may be necessary to paint to match.</i>			
66	Malibu (exc. Sta. Wag., El Camino)	3876561 8	.18	RETAINER, outer bezel

**2.682 LENS— LENS and ORNAMENT ASSY., Tail Lamp**

62-64	Chevy (exc. Sta. Wag.)	5953465 2	1.85	upper (Guide 62)
62-64	Chevy (Sta. Wag.)	5953458 2	1.55	w/o reflex lens and gasket (Note 1)
	<i>NOTE 1 5953458 lens, 5953459 lens, 5953460 gasket and 5953461 ring used on 2nd design models in place of 5953457.</i>			
64	Chevelle (exc. Sta. Wag., El Camino)	5954963 L.H.	2.80	
64	Chevelle (exc. Sta. Wag., El Camino)	5954964 R.H.	2.80	
64	Chevelle (Sta. Wag., El Camino)	5955055 L.H.	1.85	outer (red)
64	Chevelle (Sta. Wag., El Camino)	5955056 R.H.	1.85	outer (red)
64	Chevelle (Sta. Wag., El Camino)	5955149 L.H.	4.35	lamp reflex ornament
64	Chevelle (Sta. Wag., El Camino)	5955150 R.H.	4.35	lamp reflex ornament
65	Chevy (Sta. Wag.)	5956467 L.H.	6.50	
65	Chevy (exc. Sta. Wag.)	5956827 L.H.	2.40	
65	Chevy (exc. Sta. Wag.)	5956828 R.H.	2.40	
65	Chevelle (exc. Sta. Wag., El Camino, Malibu)	5956717 L.H.	3.10	
65	Chevelle (exc. Sta. Wag., El Camino, Malibu)	5956718 R.H.	3.10	
65	Chevelle (Sta. Wag., El Camino)	5956339 L.H.	5.00	outer (red)
65	Chevelle (Sta. Wag., El Camino)	5956340 R.H.	5.00	outer (red)
65	Chevelle (Sta. Wag., El Camino)	5956341 L.H.	2.85	inner (crystal)
65	Chevelle (Sta. Wag., El Camino)	5956342 R.H.	2.85	inner (crystal)
65	Impala (exc. Sta. Wag.)	5956328 4	4.95	w/direction signal
65	Biscayne (exc. Sta. Wag.)	5956415 2	2.80	w/direction signal
65	Bel Air (exc. Sta. Wag.)	5956424 2	5.60	w/direction signal
65	Biscayne (Sta. Wag.)	5956533 2	2.10	w/direction signal
65	Bel Air (Sta. Wag.)	5956494 2	5.00	w/direction signal
65	Impala (Sta. Wag.)	5956532 4	5.75	w/direction signal
66	Pass. (Sta. Wag.) (exc. Biscayne, Bel Air)	5957920 2	4.95	w/direction signal inner
66	(Sta. Wag.)	5957659 1	9.15	L.H. w/direction signal outer
66	(Sta. Wag.)	5957660 1	9.15	R.H. w/direction signal outer
66	Impala (exc. Sta. Wag.)	5957717 1	16.20	L.H. w/direction signal
66	Impala (exc. Sta. Wag.)	5957718 1	16.20	R.H. w/direction signal
66	Caprice (exc. Sta. Wag.)	5957983 1	16.20	L.H. w/direction signal
66	Caprice (exc. Sta. Wag.)	5957984 1	16.20	R.H. w/direction signal
66-67	Chevy	5957440 2	3.90	
66	Chevelle (exc. Sta. Wag., El Camino)	5957814 2	1.70	inner
66	Chevelle (exc. Sta. Wag., El Camino)	5957812 2	3.30	outer
66	Chevelle (Sta. Wag., El Camino)	5957819 L.H.	5.00	outer
66	Chevelle (Sta. Wag., El Camino)	5957820 R.H.	5.00	outer
66	Chevelle (Sta. Wag., El Camino)	5957823 L.H.	1.85	inner
66	Chevelle (Sta. Wag., El Camino)	5957824 R.H.	1.85	inner
67	Chevelle (exc. Sta. Wag., El Camino)	5958449 2	5.00	
67	Chevelle (Sta. Wag., El Camino) (exc. Deluxe)	5959069 L.H.	6.50	
67	Chevelle (Sta. Wag., El Camino) (exc. Deluxe)	5959070 R.H.	6.50	
67	Chevelle (Deluxe) (Sta. Wag., El Camino)	5959071 L.H.	5.60	
67	Chevelle (Deluxe) (Sta. Wag., El Camino)	5959072 R.H.	5.60	
67	Chevelle (Sta. Wag., El Camino)	5959074 1	2.35	inner
67	Camaro (exc. R.S.)	5959294 2	2.80	
67	Camaro w/R.S.	5959298 2	5.95 <sup>f</sup>	
67	Biscayne, (exc. Sta. Wag.)	5958523 L.H.	3.25	L.H. w/direction signal
67	Biscayne (exc. Sta. Wag.)	5958524 R.H.	3.25	R.H. w/direction signal
67	Impala, Bel Air (exc. Sta. Wag.)	5958791 L.H.	7.15	L.H. w/direction signal
67	Impala, Bel Air (exc. Sta. Wag.)	5958792 R.H.	7.15	R.H. w/direction signal
67	Caprice (exc. Sta. Wag.)	5958799 L.H.	6.90	L.H. w/direction signal
67	Caprice (exc. Sta. Wag.)	5958800 R.H.	6.90	R.H. w/direction signal
67	Pass. (Sta. Wag.)	5958895 1	2.05	L.H. w/direction signal (Note 2)
	<i>NOTE 2 Used as direction signal right inner or left outer.</i>			
67	Sta. Wag.	5958896 1	2.05	R.H. w/direction signal (Note 3)

**CHASSIS—ELECTRICAL SYSTEM**

**2.682 LENS— LENS and ORNAMENT ASSY., Tail Lamp (Con't)**

*NOTE 3 Used as direction signal left inner or right outer.*

67	Caprice (Sta. Wag.)	5958899	2	2.80	tail lamp
68	Biscayne (exc. Sta. Wag.)	5959800	2	3.60	w/direction signal
68	Biscayne (Sta. Wag.)	5959906	2	2.60	w/direction signal
68	Pass. (Sta. Wag.) (exc. Biscayne, Caprice)	5959967	2	4.25	w/direction signal
68	Camaro (exc. R.S.)	5959934	1	2.70	
68	Camaro w/R.S.	5959940	1	5.95	
68-69	Chevy	5960133	L.H.	3.10	
68-69	Chevy	5960134	R.H.	3.10	
68-69	Chevelle (Sta. Wag., El Camino)	5961794	R.H.	6.15	
68-69	Chevelle (Sta. Wag., El Camino)	5961793	L.H.	6.15	
68	Chevelle (Deluxe)	5959993	L.H.	7.15	
68	Chevelle (Deluxe)	5959994	R.H.	7.15	
68	Malibu (exc. Sta. Wag.), Chevelle (S.S.)	5959995	L.H.	5.10	
68	Malibu (exc. Sta. Wag.), Chevelle (S.S.)	5959996	R.H.	5.10	
69	Chevelle (exc. Sta. Wag., El Camino)	5961097	L.H.	7.05	(Note 4)
69	Chevelle (exc. Sta. Wag., El Camino)	5961098	R.H.	7.05	(Note 4)
69	Camaro	5961567	L.H.	18.40	(Note 4)
69	Camaro	5961568	R.H.	18.40	(Note 4)
<i>NOTE 4 Includes red and clear lens.</i>					
69	Camaro w/R.S.	5960963	L.H.	23.85	
69	Camaro w/R.S.	5960964	R.H.	23.85	
69	Estate Wag.	5961587	2	4.95	tail and stop inner
69	Kingswood	5961731	2	3.70	tail and stop inner
69	Sta. Wag. (exc. Estate Wag.)	5961511	2	3.70	tail and stop outer
65	Malibu (exc. Sta. Wag., El Camino)	5956889	L.H.	8.15	LENS ASSY., w/ornaments
65	Malibu (exc. Sta. Wag., El Camino)	5956890	R.H.	8.15	LENS ASSY., w/ornaments
66	Biscayne, Bel Air (exc. Sta. Wag.)	5957725	1	9.10	LENS ASSY., L.H., w/direction signal
66	Biscayne, Bel Air (exc. Sta. Wag.)	5957726	1	9.10	LENS ASSY., R.H., w/direction signal
68	Caprice (Sta. Wag.)	5959905	2	6.50	LENS ASSY., w/direction signal
69	Estate Wag.	5961581	2	4.95	LENS ASSY., tail and stop outer
69	Caprice	5961191	1	7.30	LENS ASSY., tail and stop outer, L.H.
69	Caprice	5961192	1	7.30	LENS ASSY., tail and stop outer, R.H.
69	Biscayne, Bel Air	5961185	1	4.85	LENS ASSY., tail and stop L.H.
69	Biscayne, Bel Air	5961186	1	4.85	LENS ASSY., tail and stop, R.H.
69	Impala	5960878	2	5.75	LENS ASSY., tail and stop inner
69	Caprice	5960884	2	7.90	LENS ASSY., tail and stop inner
69	Impala	5961183	1	5.00	LENS ASSY., tail and stop outer, L.H.
69	Impala	5961184	1	5.00	LENS ASSY., tail and stop outer, R.H.
70	Caprice	5962331	L.H.	7.00	LENS ASSY., L.H., tail and stop inner
70	Caprice	5962332	R.H.	4.70	LENS ASSY., R.H., tail and stop inner
70	Caprice	5962315	L.H.	4.70	LENS ASSY., L.H., tail and stop outer
70	Caprice	5962316	R.H.	4.70	LENS ASSY., R.H., tail and stop outer
70	Brookwood, Townsman	5960065	2	3.75	LENS ASSY., tail and stop
70	Biscayne, Bel Air	5962343	L.H.	5.75	LENS ASSY., L.H., tail and stop
70	Biscayne, Bel Air	5962344	R.H.	5.75	LENS ASSY., R.H., tail and stop
70	Impala	5962411	L.H.	5.75	LENS ASSY., L.H., inner
70	Impala	5962412	R.H.	5.75	LENS ASSY., R.H., inner
70	Impala	5962401	L.H.	5.75	LENS ASSY., L.H., tail and stop outer
70	Impala	5962402	R.H.	5.75	LENS ASSY., R.H., tail and stop outer
70	Kingswood	5961320	2	4.40	LENS ASSY., tail and stop inner
70	Kingswood	5961256	2	4.40	LENS ASSY., tail and stop outer
70-72	Chevelle (Sta. Wag., El Camino)	5964151	L.H.	2.25	LENS ASSY., L.H., tail and stop, reflex
70-72	Chevelle (Sta. Wag., El Camino)	5964152	R.H.	2.25	LENS ASSY., R.H., tail and stop, reflex
70-72	El Camino	5964159	L.H.	8.75	LENS ASSY., L.H., tail and stop w/side marker (outboard)
70-72	(El Camino)	5964160	R.H.	8.75	LENS ASSY., w/side marker (outboard)
70	Malibu (exc. El Camino)	5964287	L.H.	13.00	LENS ASSY., L.H., tail and stop
70	Malibu (exc. El Camino)	5964288	R.H.	13.00	LENS ASSY., R.H., tail and stop
70	Chevelle (Standard) (exc. El Camino)	5964361	L.H.	7.30	LENS ASSY., left, tail and stop
70	Chevelle (Standard) (exc. El Camino)	5964362	R.H.	7.30	LENS ASSY., right, tail and stop
70-71	Monte Carlo	5962761	2	6.15	LENS ASSY., tail and stop
70-73	Camaro (exc. R.S.)	5963051	L.H.	8.05	LENS ASSY., left, tail, stop rear
70-73	Camaro (exc. R.S.)	5963052	R.H.	8.05	LENS ASSY., right, tail, stop rear



**CHASSIS—ELECTRICAL SYSTEM**

**2.682 LENS— LENS and ORNAMENT ASSY., Tail Lamp (Con't)**

70-73	Camaro (R.S.)	5963061 L.H.	9.95	LENS ASSY., left, tail and stop rear
70-73	Camaro (R.S.)	5963062 R.H.	9.95	LENS ASSY., right, tail and stop rear
70-71	Nova	5964171 L.H.	5.90	LENS ASSY., w/dir. sig.
70-71	Nova	5964172 R.H.	5.90	LENS ASSY., w/dir. sig.
71	Chevelle (Deluxe)	5963427 L.H.	5.10	LENS ASSY.
71	Chevelle (Deluxe)	5963428 R.H.	5.10	LENS ASSY.
71	Malibu (exc. El Camino)	5963426 R.H.	7.30	LENS ASSY.
71	Malibu (exc. El Camino)	5963425 L.H.	7.30	LENS ASSY.
70-72	Chevelle (Sta. Wag.)	5964153 L.H.	8.75	LENS ASSY., w/side marker (outboard)
70-72	Chevelle (Sta. Wag.)	5964154 R.H.	8.75	LENS ASSY., w/side marker (outboard)
71-73	Pass. (Sta. Wag.)	5963537 L.H.	14.25	LENS ASSY.
71-73	Pass. (Sta. Wag.)	5963538 R.H.	14.25	LENS ASSY.
71	Biscayne, Bel Air	5964491 L.H.	11.05	LENS ASSY.
71	Biscayne, Bel Air	5964492 R.H.	11.05	LENS ASSY.
71	Impala, Caprice	5964487 L.H.	23.35	LENS ASSY.
71	Impala, Caprice	5964488 R.H.	23.35	LENS ASSY.
71-72	Vega (Coupe) (1st design)	5963105 2	6.25	LENS ASSY.
71-75	Vega (Sta. Wag., Panel)	5962627 L.H.	4.35	LENS ASSY.
71-75	Vega (Sta. Wag., Panel)	5962628 R.H.	4.35	LENS ASSY.
72	Vega (Coupe) (2nd design)	5965681 1	5.10	LENS ASSY.
72	Nova	5964513 L.H.	5.90	LENS ASSY., w/dir. sig. back lamp
72	Nova	5964514 R.H.	5.90	LENS ASSY., w/dir. sig. back lamp
72	Malibu (exc. El Camino)	5964497 L.H.	7.45	LENS ASSY.
72	Malibu (exc. El Camino)	5964498 R.H.	7.45	LENS ASSY.
72	Chevelle (Std.) (exc. El Camino)	5964503 L.H.	4.95	LENS ASSY.
72	Chevelle (Std.) (exc. El Camino)	5964504 R.H.	4.95	LENS ASSY.
72	Monte Carlo	5962761 2	6.15	LENS ASSY.
72	Impala, Caprice (exc. Sta. Wag.)	5964841 L.H.	24.80	LENS ASSY.
72	Impala, Caprice (exc. Sta. Wag.)	5964842 R.H.	24.80	LENS ASSY.
72	Biscayne, Bel Air	5964951 L.H.	19.95	LENS ASSY.
72	Biscayne, Bel Air	5964952 R.H.	19.95	LENS ASSY.
73	Vega (Coupe)	5966017 2	5.15	LENS ASSY.
73	Malibu (S.S.) (exc. Sta. Wag.)	5965103 L.H.	10.30	LENS ASSY.
73	Malibu (S.S.) (exc. Sta. Wag.)	5965104 R.H.	10.30	LENS ASSY.
73	Deluxe (exc. Sta. Wag., aux. lighting)	5965157 L.H.	9.10	LENS ASSY.
73	Deluxe (exc. Sta. Wag., aux. lighting)	5965158 R.H.	9.10	LENS ASSY.
73	Deluxe w/aux. lighting (exc. Sta. Wag.)			
73	Laguna (exc. Sta. Wag.)	5965937 L.H.	9.10	LENS ASSY.
73	Deluxe w/aux. lighting (exc. Sta. Wag.)			
73	Laguna (exc. Sta. Wag.)	5965938 R.H.	9.10	LENS ASSY.
73	Chevelle (Sta. Wag., El Camino)			
74-75	El Camino	5965169 L.H.	4.65	LENS ASSY.
73	Chevelle (Sta. Wag., El Camino)			
74-75	El Camino	5965170 R.H.	4.80	LENS ASSY.
73	Monte Carlo	5965055 L.H.	9.10	LENS ASSY.
73	Monte Carlo	5965056 R.H.	9.10	LENS ASSY.
73	Impala, Caprice (exc. Sta. Wag.)	5965700 2	5.75	LENS ASSY., tail and stop rear, inner
73	Bel Air (Sedan)	5965913 L.H.	5.15	LENS ASSY., tail and stop rear, outer
73	Bel Air (Sedan)	5965914 R.H.	5.15	LENS ASSY., tail and stop rear, outer
73	Impala, Caprice (exc. Sta. Wag.)	5965701 L.H.	5.75	LENS ASSY., tail and stop rear, outer
73	Impala, Caprice (exc. Sta. Wag.)	5965702 R.H.	5.75	LENS ASSY., tail and stop rear, outer
73	Chevelle (Sta. Wag., El Camino)	5965165 L.H.	6.05	LENS ASSY., back-up w/reflex
73	Chevelle (Sta. Wag., El Camino)	5965166 R.H.	6.05	LENS ASSY., back-up w/reflex
73-74	Nova (exc. S.S., Custom)	5965743 L.H.	12.70	LENS ASSY., tail, stop and back-up
73-74	Nova (exc. S.S., Custom)	5965744 R.H.	12.70	LENS ASSY., tail, stop and back-up
73-74	Nova w/S.S. Custom	5965833 L.H.	15.20	LENS ASSY., w/ornament, tail, stop and back-up
73-74	Nova w/S.S., Custom	5965834 R.H.	15.20	LENS ASSY., w/ornament, tail, stop and back-up
74-75	Camaro	5954137 L.H.	30.50	LENS ASSY., w/back-up lamp
74-75	Camaro	5954138 R.H.	30.50	LENS ASSY., w/back-up lamp
74-75	Pass. (Sta. Wag.)	5949279 L.H.	14.25	LENS ASSY., w/back-up lamp
74-75	Pass. (Sta. Wag.)	5949280 R.H.	14.25	LENS ASSY., w/back-up lamp
74-75	Impala (exc. Sta. Wag.)	5951649 L.H.	17.25	LENS ASSY., w/back-up lamp
74-75	Impala (exc. Sta. Wag.)	5951650 R.H.	17.25	LENS ASSY., w/back-up lamp
74	Caprice (exc. Sta. Wag.)	5951421 L.H.	17.25	LENS ASSY., w/back-up lamp
74	Caprice (exc. Sta. Wag.)	5951422 R.H.	17.25	LENS ASSY., w/back-up lamp
74-75	Bel Air (exc. Sta. Wag.)	5951047 L.H.	8.80	LENS ASSY.
74-75	Bel Air (exc. Sta. Wag.)	5951048 R.H.	8.80	LENS ASSY.
74-75	Chevelle (Sta. Wag.)	5948695 L.H.	13.95	LENS ASSY., w/back-up lamp
74-75	Chevelle (Sta. Wag.)	5948696 R.H.	13.95	LENS ASSY., w/back-up lamp

**CHASSIS—ELECTRICAL SYSTEM**

**2.682 LENS— LENS and ORNAMENT ASSY., Tail Lamp (Con't)**

74	Malibu w/exterior decor (exc. Sta. Wag.)	5953053 L.H.	26.75	LENS ASSY., w/back-up lamp
74	Malibu w/exterior decor (exc. Sta. Wag.)	5953054 R.H.	26.75	LENS ASSY., w/back-up lamp
74	Malibu (exc. Sta. Wag., Classic, exterior decor),			
74	Laguna	5956773 L.H.	20.05	LENS ASSY., w/back-up lamp
74	Malibu (exc. Sta. Wag., Classic, exterior decor),			
74	Laguna	5956774 R.H.	20.05	LENS ASSY., w/back-up lamp
74	Monte Carlo	5950147 L.H.	16.70	LENS ASSY.
74	Monte Carlo	5950148 R.H.	16.70	LENS ASSY.
75	Nova w/L.N.	5966357 L.H.	13.75	LENS ASSY., w/back-up lamp
75	Nova w/L.N.	5966358 R.H.	13.75	LENS ASSY., w/back-up lamp
75	Nova (exc. L.N.)	5966237 L.H.	12.70	LENS ASSY., w/back-up lamp
75	Nova (exc. L.N.)	5966238 R.H.	12.70	LENS ASSY., w/back-up lamp
75	Chevle (Spt. Cpe. Sed.) (exc. ext. Decor, Monte Carlo)	5966683 L.H.	27.00	LENS ASSY., comb.
75	Chevle (Spt. Cpe. Sed.) (exc. ext. Decor, Monte Carlo)	5966684 R.H.	27.00	LENS ASSY., comb.
75	Chevle (Spt. Cpe. Sed.) w/ext. Decor (exc. Monte Carlo)	5966687 L.H.	26.75	LENS ASSY., comb.
75	Chevle (Spt. Cpe. Sed.) w/ext. Decor (exc. Monte Carlo)	5966688 R.H.	26.75	LENS ASSY., comb.
75	Monte Carlo	5966517 L.H.	22.50	LENS ASSY.
75	Monte Carlo	5966518 R.H.	22.50	LENS ASSY.
75	Caprice (exc. Sta. Wag.)	5966505 L.H.	19.30	LENS ASSY.
75	Caprice (exc. Sta. Wag.)	5966506 R.H.	19.30	LENS ASSY.
68	Impala (Spt. Cpe.) w/lamp monitor,			
68	Caprice (exc. Sta. Wag.)	5959799 2	9.55	LENS AND ORNAMENT ASSY., w/direction signal
68	Bel Air (exc. Sta. Wag.),			
68	Impala (exc. Sta. Wag., S.S.)	5959865 A.R.	5.10	LENS AND ORNAMENT ASSY., w/direction signal

**2.684 GASKET, Tail, Stop and Direction Signal Lamp Lens**

66-67	Chevy	5957443 2	1.95	
67	Chevle (exc. Sta. Wag., El Camino)	5958442 2	1.20	
67	Chevle (Sta. Wag., El Camino)	5959067 2	1.25	
68	Pass. (exc. Sta. Wag.)	5959804 A.R.	1.15	tail, stop and dir signal— (2.697)
68-69	Chevy	5960131 L.H.	2.25	
68-69	Chevy	5960132 R.H.	2.25	
68-69	Chevle (Sta. Wag., El Camino)	5959957 1	.97	
69	Camaro	5962505 L.H.	5.70	
69	Camaro	5962506 R.H.	5.70	
69-70	Pass. (Sta. Wag.)	5962027 1	2.20	L.H., tail and stop, outer lens mtg.
69-70	Pass. (Sta. Wag.)	5962028 1	2.20	R.H., tail and stop, outer lens mtg.
69-70	Pass. (Sta. Wag.)	5961579 2	1.10	tail and stop outer
69	Impala, Caprice	5960876 2	1.20	tail and stop inner
70	Pass. (exc. Sta. Wag.)	5961917 A.R.	1.50	inner
70-72	Chevle (Sta. Wag., El Camino)	5962647 L.H.	1.35	L.H., tail and stop
70-72	Chevle (Sta. Wag., El Camino)	5962648 R.H.	1.35	R.H., tail and stop
70	Malibu	5962673 2	1.55	tail and stop
70-72	Monte Carlo	5962762 2	2.60	tail and stop
70-72	Nova	5961830 2	2.00	tail, stop and dir. sig.
71-72	Chevle (exc. Sta. Wag., El Camino, Monte Carlo)	5963400 2	1.05	
71-73	Pass. (Sta. Wag.)	5963533 L.H.	1.20	
71-73	Pass. (Sta. Wag.)	5963534 R.H.	1.20	
71	Pass. (exc. Sta. Wag.)	9843300 2	.79	tail & stop— (12.943)
71-72	Vega (Coupe)	5963110 4	.92	backing lamp assy. mounting
71-72	Vega (Coupe)	5963109 4	.68	backing lamp assy. lens
71-75	Vega (Sta. Wag., Panel)	5962625 L.H.	2.30	tail and stop lamp lens
71-75	Vega (Sta. Wag., Panel)	5962626 R.H.	2.30	tail and stop lamp lens
72	Pass. (exc. Sta. Wag.)	5964847 2	4.20	
73	Monte Carlo	5965051 L.H.	1.95	
73	Monte Carlo	5965052 R.H.	1.95	
73	Chevle (Sta. Wag., El Camino),			
74-75	El Camino	5965163 4	1.10	tail, stop and back-up lens
73	Impala, Caprice (exc. Sta. Wag.),			
73	Bel Air (Sedan)	5965699 A.R.	1.10	tail, stop and back-up lens
73	Vega (Coupe)	5965976 A.R.	1.70	tail, and stop lens
74-75	Bel Air (Sedan)	5947632 4	.97	tail, stop and back-up lens

**CHASSIS—ELECTRICAL SYSTEM**

**2.684 GASKET, Tail, Stop and Direction Signal Lamp Lens (Con't)**

74	Impala, Caprice (exc. Sta. Wag.),				
75	Impala (exc. Sta. Wag.)	5947958	2	6.55	tail, stop and back-up lens
74-75	Pass. (Sta. Wag.)	5949275	L.H.	1.20	tail, stop and back-up lens
74-75	Pass. (Sta. Wag.)	5949276	R.H.	1.20	tail, stop and back-up lens
74-75	Camaro	5954113	L.H.	2.85	tail, stop and back-up lens
74-75	Camaro	5954114	R.H.	2.85	tail, stop and back-up lens
74	Monte Carlo	5950143	L.H.	1.95	
74	Monte Carlo	5950144	R.H.	1.95	
74-75	Chevelle (Sta. Wag.)	5948619	2	3.20	tail, stop and back-up lens
74-75	Vega (Coupe)	339069	2	.58	tail, stop and backing lamp hsg.
75	Monza	5966336	2	1.35	tail, stop and backing lamp hsg. mtg. and side marker
75	Monte Carlo	5966515	L.H.	1.85	
75	Monte Carlo	5966516	R.H.	1.85	
75	Caprice (exc. Sta. Wag.)	5966503	L.H.	6.55	tail, stop and back-up
75	Caprice (exc. Sta. Wag.)	5966504	R.H.	6.55	tail, stop and back-up

**2.688 SCREW—CLIP—RETAINER—NUT—PLUG, Tail Lamp**

62-69	All	9417096	A.R.	.05	tail, stop, directional sig. and reflex ornament (No. 8-32 x 1/2" st. steel)—(8.903)
62-64	Chevy (Sta. Wag.)	3792034	A.R.	.11	lens (pan head cross recess tapping No. 8-15 x 1 1/4" steel)
64	Chevy (Sta. Wag.)	3792033	A.R.	.12	lens (pan head cross recess tapping No. 8-15 x 3/4" steel)
65	Chevy (Sta. Wag.)		6		lens retaining,
67	Biscayne, (exc. Sta. Wag.)	5953654	4	.11	tail, stop direction signal, rear ornament and backing lamp lens (8— 32 x 21/32")
66	Biscayne, Bel Air (exc. Sta. Wag.)	5957810	8	.16	tail, stop, dir. signal, and backing lamp lens
66	Sta. Wag. (exc. Caprice)	5957931	A.R.	.12	tail, stop, and dir. signal (No. 8— 32 x 59/64" chrome plated)
66	Sta. Wag. (exc. Caprice),				
71-72	El Camino	5953438	A.R.	.12	lens (No. 8— 32 x 5/8" cr. recess)—(2.594)
67	Camaro	5959164	12	.16	lens
67	Pass. (exc. Sta. Wag., Biscayne),				
68	Camaro	5958793	16	.16	tail, stop, dir. signal, and backing lamp lens
68	Pass. (exc. Sta. Wag.)	3919004	A.R.	.12	tail and stop lamp—(2.697)
69	Pass. (exc. Sta. Wag.),				
70	Chevelle (exc. Sta. Wag.)	5961749	4	.33	tail and stop inner lamp
70-72	Nova	5961225	8	.22	tail, stop and dir. sig.
70	Pass. (exc. Sta. Wag.)	5962272	A.R.	.33	tail and stop
71-72	Chevelle (exc. Sta. Wag., El Camino, Monte Carlo)	5963437	6	.16	tail and stop lamp lens
72	Pass. (exc. Sta. Wag.),				
73-75	Chevelle (Sta. Wag.),				
73-75	Bel Air (Sedan)	5964883	A.R.	.33	tail, stop and parking lamp lens
73	Monte Carlo,				
74-75	Camaro	5960507	A.R.	.27	tail and stop
73-75	Chevelle (Sta. Wag., El Camino),				
73	Impala, Caprice (exc. Sta. Wag.),				
73	Bel Air (4-Dr.)	5965736	A.R.	.22	tail and stop
75	Monte Carlo	5966729	10	.33	tail lamp
62-69	All	171031	A.R.	.06	SCREW ASSY., tail, stop, direction, rear ornament and backing lamp (1/4"— 20 x 3/4")
75	Camaro	5949351	2	.33	CLIP, tail, stop, back-up and sidemarker
68	Pass. (exc. Sta. Wag.)	3937618	A.R.	.22	RETAINER, tail and stop lamp
68-70	Pass. (exc. Sta. Wag.)	3916701	A.R.	.11	RETAINER, tail and stop wire
70	Pass., Chevelle (exc. Sta. Wag.),				
71-75	Chevelle (Deluxe, Malibu)	3961571	A.R.	.11	RETAINER, tail and stop
73-74	Chevelle, Camaro (2-Dr.),				
73	Pass. (exc. Sta. Wag.)	3916701	2	.11	RETAINER, rear lamp wiring harness
68	Pass. (exc. Sta. Wag.)	3982098	A.R.	.12	NUT, tail and stop (1/4")
68-69	Biscayne, Bel Air (Sed.)	4744981	2	.12	PLUG, tail and stop lamp grommet hole

**2.694 SOCKET, Tail and Stop Lamp**

**LAMP SOCKET REPLACEMENT**

*It is necessary to carefully check the parts catalogs for correct model application when replacing lamp socket assemblies. If incorrect sockets are used for replacement, the bulb filament will be in the wrong location with respect to the lens and/or reflector. As a result, the lamp may fail to meet the required lighting standards.*

64-65 Chevy,

## CHASSIS—ELECTRICAL SYSTEM

<b>2.694 SOCKET, Tail and Stop Lamp</b>		<b>(Con't)</b>		
65-68	Pass. (exc. Sta. Wag.) . . . . .	8912698 A.R.	3.10	(6 O.L.— w/terminal) (double contact) . . . . .
68	Chevelle (Sta. Wag., El Camino),			
72	Chevelle (Sta. Wag., El Camino) . . . . .	6300060 1	2.70	
69	Pass. (exc. Sta. Wag.) . . . . .	5961031 1	10.05	w/wire assy. (crimp type) . . . . .
69-73	All,			
74-75	Chevelle (exc. Sta. Wag.) . . . . .	8914822 A.R.	3.90	(twist lock-socket) (gray-focal length 7/8")— (2.596) . . . . .
69-73	All,			
74	Pass., Camaro,			
75	Pass., Nova . . . . .	8914823 A.R.	3.90	(twist lock-type) (cream-focal length 1 1/4")— (2.596) . . . . .
69	Pass (exc. Sta. Wag.) . . . . .	5961031 1	10.05	w/wire assy. (crimp type) . . . . .
<b>2.697 LAMP ASSY.— HOUSING ASSY.— LENS— ORNAMENT— BEZEL—</b>				
<b>GASKET— SCREW— SOCKET— NUT— RETAINER— BUMPER— REFLEX</b>				
<b>ASSY.— PAD— GROMMET— WIRE ASSY., Back-Up</b>				

### LAMP SOCKET REPLACEMENT

*It is necessary to carefully check the parts catalogs for correct model application when replacing lamp socket assemblies. If incorrect sockets are used for replacement, the bulb filament will be in the wrong location with respect to the lens and/or reflector. As a result, the lamp may fail to meet the required lighting standards.*

64	Chevelle (exc. Sta. Wag., El Camino) . . . . .	910531 L.H.	9.55	
65	Chevelle (Sta. Wag., El Camino),			
67	Chevelle (Sta. Wag., El Camino) . . . . .	910798 2	9.55	
65	Chevy (exc. Sta. Wag.) . . . . .	910903 L.H.	11.05	
65	Chevelle (exc. Sta. Wag., El Camino) . . . . .	910729 2	8.25	
65	Impala (exc. Sta. Wag.) . . . . .	910707 1	14.90	L.H. . . . .
66	Biscayne, Bel Air (exc. Sta. Wag.) . . . . .	911037 1	32.50	L.H.— (2.679) . . . . .
66	Biscayne, Bel Air (exc. Sta. Wag.) . . . . .	911038 1	32.50	R.H.— (2.679) . . . . .
66	Impala, Caprice (Sta. Wag.),			
67	Caprice (Sta. Wag.) . . . . .	911486 2	9.55	
66	Impala (exc. Sta. Wag.),			
67	Caprice (exc. Sta. Wag.) . . . . .	911485 2	9.55	
66-67	Chevy . . . . .	910970 2	21.70	(2.679) . . . . .
67	Chevelle (exc. Sta. Wag., El Camino) . . . . .	911417 2	9.55	
67	Camaro (exc. R.S.) . . . . .	916539 L.H.	46.50	(2.679) . . . . .
67	Camaro (exc. R.S.) . . . . .	916540 R.H.	46.50	(2.679) . . . . .
67-68	Camaro w/R.S. . . . .	911479 L.H.	15.80	
67-68	Camaro w/R.S. . . . .	911480 R.H.	15.80	
67	Impala (exc. Sta. Wag.) . . . . .	911287 1	43.00	L.H.— (2.679) . . . . .
67	Impala (exc. Sta. Wag.) . . . . .	911288 1	43.00	R.H.— (2.679) . . . . .
67	Biscayne (exc. Sta. Wag.) . . . . .	911282 1	12.10	R.H. backing . . . . .
68	Chevelle . . . . .	916535 2	9.55	
68	Chevy . . . . .	916277 L.H.	27.75	(2.679) . . . . .
68	Chevy . . . . .	916278 R.H.	27.75	(2.679) . . . . .
68	Camaro (exc. R.S.) . . . . .	916523 L.H.	46.50	(2.679) . . . . .
68	Camaro (exc. R.S.) . . . . .	916524 R.H.	46.50	(2.679) . . . . .
70	Biscayne, Bel Air . . . . .	917675 L.H.	38.75	L.H.— (2.679) . . . . .
70	Biscayne, Bel Air . . . . .	917676 R.H.	38.75	R.H.— (2.679) . . . . .
70	Impala . . . . .	917673 L.H.	46.00	L.H.— (2.679) . . . . .
70	Impala . . . . .	917674 R.H.	46.00	R.H.— (2.679) . . . . .
70	Caprice . . . . .	917671 L.H.	53.75	L.H.— (2.679) . . . . .
70	Caprice . . . . .	917672 R.H.	53.75	R.H.— (2.679) . . . . .
70-73	Monte Carlo . . . . .	911510 2	9.55	
71	Malibu . . . . .	917575 L.H.	23.75	(2.679) . . . . .
71	Malibu . . . . .	917576 R.H.	23.75	(2.679) . . . . .
74-75	Monte Carlo . . . . .	912400 2	5.25	(repl. 928066) . . . . .
66	Pass. (Sta. Wag.) . . . . .	5958301 1	20.55	<b>HOUSING ASSY., outboard tail, stop, dir., backing, L.H.— (2.680) . . . . .</b>
66	Pass. (Sta. Wag.) . . . . .	5958302 1	20.55	<b>HOUSING ASSY., outboard tail, stop, dir., backing, R.H.— (2.680) . . . . .</b>
66	Biscayne, Bel Air (Sta. Wag.) . . . . .	5958305 1	19.55	<b>HOUSING ASSY., inner tail and backing L.H.— (2.680) . . . . .</b>
66	Biscayne, Bel Air (Sta. Wag.) . . . . .	5958306 1	19.20	<b>HOUSING ASSY., inner tail and backing R.H.— (2.680) . . . . .</b>
66	Sta. Wag., El Camino . . . . .	5958367 L.H.	19.65	<b>HOUSING ASSY., tail, stop, dir. signal, backing lamp— (2.680) . . . . .</b>

**CHASSIS—ELECTRICAL SYSTEM**

**2.697 LAMP ASSY.— HOUSING ASSY.— LENS— ORNAMENT— BEZEL—  
GASKET— SCREW— SOCKET— NUT— RETAINER— BUMPER— REFLEX  
ASSY.— PAD— GROMMET— WIRE ASSY., Back-Up (Con't)**

66	Sta. Wag., El Camino	5958368 R.H.	19.65	HOUSING ASSY., tail, stop, dir. signal, backing lamp— (2.680)
67	Pass. (Sta. Wag.)	5958902 2	11.05	HOUSING ASSY., backing lamp
68	Pass. (Sta. Wag.)	5959984 2	10.10	HOUSING ASSY.
68	Pass. (exc. Sta. Wag.)	5960018 2	11.35	HOUSING ASSY.
69	Pass. (exc. Sta. Wag.)	5961657 1	10.30	HOUSING ASSY., backing, L.H.
69	Pass. (exc. Sta. Wag.)	5961658 1	10.30	HOUSING ASSY., backing R.H.
69-70	Pass. (Sta. Wag.)	5961589 2	12.45	HOUSING ASSY., backing
69	Camaro w/R.S.	5961535 L.H.	24.95	HOUSING ASSY., backing
69	Camaro w/R.S.	5961536 R.H.	24.95	HOUSING ASSY., backing
69-72	Chevelle (Sta. Wag., El Camino)	5960885 2	22.30	HOUSING ASSY., backing
70	Malibu	5962793 L.H.	17.90	HOUSING ASSY., backing— (2.680)
70	Malibu	5962794 R.H.	17.90	HOUSING ASSY., backing— (2.680)
71	Chevelle (Deluxe),			
72	Chevelle (exc. Sta. Wag., El Camino, Monte Carlo)	5963422 R.H.	13.50	HOUSING ASSY., tail, stop, backing— (2.680)
71-72	Camaro	5963049 L.H.	11.65	HOUSING ASSY., tail, stop, backing— (2.680)
71-72	Camaro	5963050 R.H.	11.65	HOUSING ASSY., tail, stop, backing— (2.680)
72	Concours,			
72	El Camino (Custom)	5964203 L.H.	35.25	HOUSING ASSY., tail, stop, backing— (2.680)
72	Concours,			
72	El Camino (Custom)	5964204 R.H.	35.25	HOUSING ASSY., tail, stop, backing— (2.680)
72	Chevelle (exc. Sta. Wag., El Camino, Monte Carlo)	5963421 L.H.	13.50	HOUSING ASSY., tail, stop, backing— (2.680)
62-64	Chevy (exc. Sta. Wag.)	5953466 2	1.80	LENS, back-up lamp, lower (Guide R-62)
62-64	Chevy (Sta. Wag.)	5953456 2	1.90	LENS
64	Chevelle (exc. Sta. Wag., El Camino)	5955884 R.H.	3.85	LENS
64	Chevelle (exc. Sta. Wag., El Camino)	5955883 L.H.	3.85	LENS
64	Chevelle (Sta. Wag., El Camino)	5955059 L.H.	2.60	LENS
64	Chevelle (Sta. Wag., El Camino)	5955060 R.H.	2.60	LENS
65	Chevy (exc. Sta. Wag.)	5956821 L.H.	2.20	LENS
65	Chevy (exc. Sta. Wag.)	5956822 R.H.	2.20	LENS
65	Chevelle,			
67	Chevelle	5956582 2	1.60	LENS
65	Impala (exc. Sta. Wag.)	5956430 2	7.50	LENS
65	Impala (Sta. Wag.)	5956541 2	3.55	LENS
66	Biscayne, Bel Air (Sta. Wag.)	5957930 2	3.15	LENS
66	Impala, Caprice,			
67	Caprice	5957876 2	1.80	LENS
66-67	Chevy	5957441 2	2.00	LENS
66	Chevelle (exc. Sta. Wag., El Camino)	5957813 2	2.20	LENS
66	Chevelle (Sta. Wag., El Camino)	5957825 L.H.	2.70	LENS
66	Chevelle (Sta. Wag., El Camino)	5957826 R.H.	2.70	LENS
67-68	Camaro w/R.S.	5959251 2	2.20	LENS
67	Camaro (exc. R.S.)	5959297 2	3.30	LENS
67	Biscayne, (exc. Sta. Wag.)	5958535 1	2.50	LENS, L.H.
67	Biscayne, (exc. Sta. Wag.)	5958536 1	2.50	LENS, R.H.
68	Camaro (exc. R.S.)	5959939 2	3.25	LENS
68	Malibu, S.S.,			
68	Chevelle (Sta. Wag., El Camino)	5960079 2	1.60	LENS
68-69	Chevy	5960135 L.H.	1.80	LENS
68-69	Chevy	5960136 R.H.	1.80	LENS
68	Chevelle (Deluxe)	5959993 L.H.	7.15	LENS (2.682)
68	Chevelle (Deluxe)	5959994 R.H.	7.15	LENS (2.682)
69-71	El Camino	5961725 2	2.70	LENS, rear bumper reflex reflector
69	Camaro w/R.S.	5961500 2	3.55	LENS
69-71	Chevelle (Sta. Wag., El Camino)	5960888 2	2.15	LENS
70	Brookwood, Townsman	5960946 2	5.45	LENS, backing
70	Monte Carlo	5964338 2	3.15	LENS, backing
68	Pass. (S.S.) (Conv.),			
68	Caprice (Spt. Mdls.)	5959825 2	8.55	LENS and ORNAMENT ASSY., complete
68	Bel Air, Impala (exc. Sta. Wag.)	5959866 2	5.20	LENS and ORNAMENT ASSY., complete
66	Biscayne, Bel Air (Sta. Wag.)	5957924 2	5.25	LENS ASSY., lamp reflex

**CHASSIS—ELECTRICAL SYSTEM**

**2.697 LAMP ASSY.— HOUSING ASSY.— LENS— ORNAMENT— BEZEL— GASKET— SCREW— SOCKET— NUT— RETAINER— BUMPER— REFLEX ASSY.— PAD— GROMMET— WIRE ASSY., Back-Up (Con't)**

66	Biscayne, Bel Air (exc. Sta. Wag.)	5957725	1	9.10	LENS ASSY., L.H.— (2.682)
66	Biscayne, Bel Air (exc. Sta. Wag.)	5957726	1	9.10	LENS ASSY., R.H.— (2.682)
67	Bel Air, Impala (exc. Sta. Wag.)	5958791	1	7.15	LENS ASSY., L.H.— (2.682)
67	Bel Air, Impala (exc. Sta. Wag.)	5958792	1	7.15	LENS ASSY., R.H.— (2.682)
67	Pass. (Sta. Wag.) (exc. Caprice)	5958904	2	2.20	LENS ASSY.
68	Biscayne (exc. Sta. Wag.)	5959826	2	4.35	LENS ASSY.
68	Bel Air, Impala (Sta. Wag.)	5959992	2	7.30	LENS ASSY., complete
68	Caprice (Sta. Wag.)	5959986	2	6.70	LENS ASSY., complete
68	Biscayne (Sta. Wag.)	5959987	2	3.35	LENS ASSY.
69	Caprice	5960871	2	10.30	LENS ASSY., backing
69	Estate Wag.	5961591	2	6.70	LENS ASSY., backing
69	Impala	5960877	2	10.30	LENS ASSY., backing
69	Biscayne, Bel Air (exc. Sta. Wag.)	5961475	2	5.15	LENS ASSY., backing
69	Pass. (Sta. Wag.) (exc. Estate Wag.)	5961733	2	5.15	LENS ASSY., backing
69	Malibu (exc. Sta. Wag., El Camino),				
69	Chevelle (Deluxe) (exc. Sta. Wag., El Camino)	5961097	L.H.	7.05	LENS ASSY. (2.682)
69	Malibu (exc. Sta. Wag., El Camino),				
69	Chevelle (Deluxe) (exc. Sta. Wag., El Camino)	5961098	R.H.	7.05	LENS ASSY. (2.682)
69	Camaro (exc. R.S.)	5961567	L.H.	18.40	LENS ASSY. (2.682)
69	Camaro (exc. R.S.)	5961568	R.H.	18.40	LENS ASSY. (2.682)
70	Biscayne, Bel Air	5964231	L.H.	6.50	LENS ASSY., L.H., backing
70	Biscayne, Bel Air	5964232	R.H.	6.50	LENS ASSY., R.H., backing
70	Impala	5964229	L.H.	6.50	LENS ASSY., L.H., backing
70	Impala	5964230	R.H.	6.50	LENS ASSY., R.H., backing
70	Kingswood	5961347	2	7.15	LENS ASSY., backing
70	Caprice	5964223	L.H.	5.00	LENS ASSY., L.H., backing
70	Caprice	5964224	R.H.	5.00	LENS ASSY., R.H., backing
70	Malibu	5964287	L.H.	13.00	LENS ASSY., L.H. backing— (2.682)
70	Malibu	5964288	R.H.	13.00	LENS ASSY., R.H. backing— (2.682)
70	Chevelle (Standard) (exc. El Camino)	5964361	L.H.	7.30	LENS ASSY., left, backing— (2.682)
70	Chevelle (Standard) (exc. El Camino)	5964362	R.H.	7.30	LENS ASSY., right, back— (2.682)
70	Camaro (exc. R.S.),				
71	Camaro (exc. R.S.) (1st design)	5963055	L.H.	10.85	LENS ASSY., backing (circular optics)
70	Camaro (exc. R.S.),				
71	Camaro (exc. R.S.) (1st design)	5963056	R.H.	10.85	LENS ASSY., backing (circular optics)
70	Camaro w/R.S.,				
71	Camaro w/R.S. (1st design)	5963067	L.H.	11.85	LENS ASSY., backing (circular optics)
70	Camaro w/R.S.,				
71	Camaro w/R.S. (1st design)	5963068	R.H.	11.85	LENS ASSY., backing (circular optics)
71-73	Camaro (exc. R.S.) (2nd design)	5964523	L.H.	9.55	LENS ASSY., backing (pillow optics)
71-73	Camaro (exc. R.S.) (2nd design)	5964524	R.H.	9.55	LENS ASSY., backing (pillow optics)
71-73	Camaro w/R.S. (2nd design)	5964531	L.H.	11.05	LENS ASSY., backing (pillow optics)
71-73	Camaro w/R.S. (2nd design)	5964532	R.H.	11.05	LENS ASSY., backing (pillow optics)
70-71	Nova	5964171	L.H.	5.90	LENS ASSY., backing— (2.682)
70-71	Nova	5964172	R.H.	5.90	LENS ASSY., backing— (2.682)
71	Chevelle (Deluxe)	5964071	L.H.	7.80	LENS ASSY., backing
71	Chevelle (Deluxe)	5964072	R.H.	7.80	LENS ASSY., backing
71	Malibu	5963431	L.H.	7.80	LENS ASSY., backing
71	Malibu	5963432	R.H.	7.80	LENS ASSY., backing
71-73	Monte Carlo	5964338	2	3.15	LENS ASSY., backing
71-72	Pass. (Sta. Wag.)	5963537	L.H.	14.25	LENS ASSY., tail, stop, backing— (2.682)
71-72	Pass. (Sta. Wag.)	5963538	R.H.	14.25	LENS ASSY., tail, stop, backing— (2.682)
71	Biscayne, Bel Air	5964491	L.H.	11.05	LENS ASSY., tail, stop, backing— (2.682)
71	Biscayne, Bel Air	5964492	R.H.	11.05	LENS ASSY., tail, stop, backing— (2.682)
71	Impala, Caprice	5964487	L.H.	23.35	LENS ASSY., tail, stop, backing— (2.682)
71	Impala, Caprice	5964488	R.H.	23.35	LENS ASSY., tail, stop, backing— (2.682)
71-73	Vega (Coupe)	5966018	2	6.25	LENS ASSY., backing
72	El Camino	5961725	2	2.70	LENS ASSY., rear bumper reflex
72	Chevelle (Sta. Wag., El Camino)	5960888	2	2.15	LENS ASSY., backing
72	Chevelle (Std.)	5964511	L.H.	6.25	LENS ASSY., backing
72	Chevelle (Std.)	5964512	R.H.	6.25	LENS ASSY., backing
72	Malibu	5964505	L.H.	7.45	LENS ASSY., backing
72	Malibu	5964506	R.H.	7.45	LENS ASSY., backing

**CHASSIS—ELECTRICAL SYSTEM**

<b>2.697</b>		<b>LAMP ASSY.— HOUSING ASSY.— LENS— ORNAMENT— BEZEL—</b>		<b>GASKET— SCREW— SOCKET— NUT— RETAINER— BUMPER— REFLEX</b>		<b>ASSY.— PAD— GROMMET— WIRE ASSY., Back-Up (Con't)</b>	
72	Nova	5964513	L.H.	5.90	LENS ASSY., backing— (2.682)		
72	Nova	5964514	R.H.	5.90	LENS ASSY., backing— (2.682)		
73	Deluxe (exc. Sta. Wag., aux. lighting)	5965153	L.H.	10.55	LENS ASSY., back-up		
73	Deluxe (exc. Sta. Wag., aux. lighting)	5965154	R.H.	10.55	LENS ASSY., back-up		
73	Pass. (exc. Sta. Wag.)	5965499	2	6.50	LENS ASSY., back-up		
73	Deluxe w/aux. lighting (exc. Sta. Wag.)						
73	Malibu (exc. S.S., Sta. Wag.)						
73	Laguna (exc. Sta. Wag.)	5965933	L.H.	10.30	LENS ASSY., back-up		
73	Deluxe w/aux. lighting (exc. Sta. Wag.)						
73	Malibu (exc. S.S., Sta. Wag.)						
73	Laguna (exc. Sta. Wag.)	5965934	R.H.	10.30	LENS ASSY., back-up		
73	Malibu (S.S.) (exc. Sta. Wag.)	5964910	R.H.	11.60	LENS ASSY., back-up lamp— (2.682)		
73	Malibu (S.S.) (exc. Sta. Wag.)	5964909	L.H.	11.60	LENS ASSY., back-up lamp— (2.682)		
73	Chevelle (Sta. Wag., El Camino)						
74-75	El Camino	5965165	L.H.	6.05	LENS ASSY., back-up w/reflex— (2.682)		
73	Chevelle (Sta. Wag., El Camino)						
74-75	El Camino	5965166	R.H.	6.05	LENS ASSY., back-up w/reflex— (2.682)		
74-75	Bel Air (Sedan)	5947866	2	3.75	LENS ASSY., back-up lamp		
74-75	Bel Air (Sedan)	5947788	2	5.60	LENS ASSY., rear lamp reflex		
66-67	Chevy	5957442	2	1.20	ORNAMENT (2.680)		
68-69	Chevy	5960130	2	1.85	ORNAMENT (2.680)		
69	Pass. (Sta. Wag.)	5961564	6	1.35	ORNAMENT, backing— (2.680)		
68	Pass.	5959802	A.R.	2.05	ORNAMENT, backing (middle ring)— (2.680)		
73	Deluxe w/aux. lighting (exc. Sta. Wag.)	5964915	4	7.60	ORNAMENT, back-up lens		
66	Biscayne, Bel Air (exc. Sta. Wag.)	5957949	1	17.70	BEZEL, L.H.— (2.681)		
66	Biscayne, Bel Air (exc. Sta. Wag.)	5957950	1	17.70	BEZEL, R.H.— (2.681)		
68	Pass. (Sta. Wag.)	5959907	2	5.80	BEZEL		
66-67	Impala, Caprice,						
68	Malibu,						
68	Chevelle (Sta. Wag., El Camino)		R.H.		GASKET, lens		
69-72	El Camino	5964089	2	1.80	rear bumper reflector		
66-67	Chevy	5957443	2	1.95	GASKET, lens— (2.684)		
67-68	Camaro w/R.S.	3899800	2	.41	GASKET, inner		
68	Pass. (exc. Sta. Wag.)	5959804	2	1.15	GASKET, lamp lens		
69-70	Pass. (Sta. Wag.)	5961586	2	1.15	GASKET, backing		
68-69	Chevy	5960131	L.H.	2.25	GASKET, lens— (2.684)		
68-69	Chevy	5960132	R.H.	2.25	GASKET, lens— (2.684)		
69-72	Chevelle (Sta. Wag., El Camino)	5960887	2	1.55	GASKET, lens		
69	Camaro w/R.S.	5961539	2	1.55	GASKET, lens		
69	Pass. (exc. Sta. Wag.)	5961760	2	1.45	GASKET, backing		
70	Pass. (exc. Sta. Wag.)	5961917	A.R.	1.50	GASKET, lamp lens— (2.684)		
70	Malibu	5962673	2	1.55	GASKET, lamp lens— (2.684)		
70-73	Monte Carlo	5961099	2	1.15	GASKET, lamp lens		
70	Nova	5961830	2	2.00	GASKET, lamp lens— (2.684)		
71-72	Nova	5963118	2	2.00	GASKET, backing lamp mtg.— (2.660)		
71-72	Camaro	5963060	2	1.65	GASKET, backing lamp mtg. (inboard)— (2.660)		
71-72	Camaro	5963583	L.H.	1.60	GASKET, tail, stop, backing lamp mtg.— (2.660)		
71-72	Camaro	5963584	R.H.	1.60	GASKET, tail, stop, backing lamp mtg.— (2.660)		
73	Chevelle (Sta. Wag., El Camino)	5965163	4	1.10	GASKET, tail, stop and back-up lens— (2.684)		
73	Impala, Caprice (exc. Sta. Wag.)						
73	Bel Air (Sedan)	5965699	A.R.	1.10	GASKET, tail, stop and back-up lens— (2.684)		
62-69	All	9414752	4	.13	SCREW, attaching hole cover (No. 8-18 x 1/2")— (8.977)		
62-63	Chevy (Sta. Wag.)	3792033	A.R.	.12	SCREW, lens attach. (No. 8-32 x 5/8")— (2.688)		
64	Chevelle,						
65	Chevy (Sta. Wag.)	9420489	4	.05	SCREW, lens attach. (No. 8-32 x 19/16") (stainless steel)		
65-67	Chevy, Chevelle,						
68	Pass. (exc. Sta. Wag.)	3919004	2	.12	SCREW, lamp (No. 10-64 x 3/4")		

**CHASSIS—ELECTRICAL SYSTEM**

**2.697 LAMP ASSY.— HOUSING ASSY.— LENS— ORNAMENT— BEZEL— GASKET— SCREW— SOCKET— NUT— RETAINER— BUMPER— REFLEX ASSY.— PAD— GROMMET— WIRE ASSY., Back-Up (Con't)**

66-69	Chevy	5958143	4	.16	SCREW, ornament— (2.680)
66	Biscayne, Bel Air (exc. Sta. Wag.)	5957810	8	.16	SCREW, lens— (2.688)
66-67	Impala, Caprice	5956445	4	.16	SCREW, lamp
67-68	Camaro w/R.S.	5957653	4	.17	SCREW, lens
69	Pass. (exc. Sta. Wag.)	5961875	4	.27	SCREW, backing
70	Pass. (exc. Sta. Wag.)	5962272	A.R.	.33	SCREW, backing lens— (2.688)
70	Chevelle (exc. Sta. Wag.)	5961749	8	.33	SCREW, inner lamp— (2.688)
70-73	Monte Carlo	5958894	4	.33	SCREW, backing— (2.594)
70	Nova	5961225	8	.22	SCREW, backing lens— (2.688)
62-64	Chevy	6292182	1	2.50	SOCKET, w/wire (black-6" O.L.)
64	Chevelle (Std.) (exc. Sta. Wag., El Camino)	6292182	A.R.	2.50	SOCKET (repl. 2973973)
69	Pass.	5959814	1	4.40	SOCKET, w/wire assy. (backing)
69-72	All	8904437	1	3.70	SOCKET, back-up lamp with twist lock
73-75	Nova	8904257	A.R.	8.50	SOCKET ASSY., back-up lamp
73-75	Vega,				
73-74	Pass. (Sta. Wag.),				
74	Camaro, Monte Carlo,				
74-75	Chevelle (exc. Sta. Wag.)	8909518		3.90	SOCKET ASSY., back-up
74-75	Pass. (exc. Sta. Wag.)	8918646		3.75	SOCKET ASSY., back-up
64-73	All	3885999	A.R.	.04	NUT (J-shape spring No. 10— 12)
68	Pass. (exc. Sta. Wag.)	3937618	2	.22	RETAINER, backing lamp— (2.688)
68-72	Pass. (exc. Sta. Wag.),				
72	All,				
73	Pass. (exc. Sta. Wag.)	3916701	A.R.	.11	RETAINER, backing lamp wire— (2.688)
70	Pass., Chevelle (exc. Sta. Wag.)	3961571	A.R.	.11	RETAINER, backing— (2.688)
65	Malibu,				
66	Impala (exc. Sta. Wag.),				
66	Caprice,				
70-72	El Camino	3841098	2	.11	BUMPER, lamp— (7.800)
70	Monte Carlo	3973636	2	.11	BUMPER, backing lamp— (2.587)
72	El Camino	910883	2	5.00	REFLECTOR ASSY., rear bumper
69-72	Chevelle (Sta. Wag., El Camino)	5961840	2	.71	PAD, mtg.
67	Caprice (exc. Sta. Wag.)	6437746	2	.44	GROMMET, back-up lamp— (9.775)
67-68	All w/4-Spd.	6290554	1	2.35	WIRE ASSY., backing lamp extension

**2.698 SWITCH— BRACKET— FASTENER— ROD— SHIELD— SCREW— WASHER, Back-Up**

62-66	All (exc. A.T., 4-Spd.)	3745921	1	4.00	lamp (w/column shift)
62-66	All w/P.G. (exc. S.S.)	1993659	1	3.45	lamp— (4.054)
63-64	Nova (S.S.) w/P.G.	1993618	1	18.55	trans., control safety— (4.054)
63-64	Chevy, Chevelle w/4-Spd.	1993661	1	12.25	
64	Malibu (S.S.) w/P.G.	1993658	1	9.85	trans. control safety— (4.058)
65-67	S.S. w/P.G.	1993696	1	5.65	lamp— (4.054)
65-67	S.S. w/T.H. (8 cyl.)	1993321	1	9.80	lamp— (4.054)
65-66	Pass. w/T.H. (exc. B.S.)	1993320	1	8.15	lamp— (4.054)
65-67	All w/4-Spd.,				
68	Chevy, Chevelle, Camaro	1993420	1	13.20	lamp
66-68	Chevelle w/H.D. 3-Spd. (396),				
67-68	Camaro w/floor console (exc. T.H.),				
68	Chevy w/floor console (exc. T.H.),				
68-72	Nova (T.H. w/floor console)	3948538	2	4.65	neutral saf. lamp— (4.054)
66-68	Chevelle w/3-Spd.,				
67-68	Camaro w/H.D. 3-Spd.,				
68	Chevy (w/H.D. 3-Spd.)	1993364	1	21.85	lamp
67-68	All w/A.T. (exc. B.S.)	1993404	1	3.35	SWITCH ASSY., backing— (4.054)
67	Camaro (floor console w/A.T.),				
67-68	All w/3-Spd.	3909537	1	3.50	SWITCH ASSY., backing
68-69	Pass. (A.T. w/B.S.),				
68-72	Chevelle, Camaro (floor console w/A.T.)	1993434	1	4.26	SWITCH ASSY., backing— (4.054)
68	Pass. w/4-Spd.	1993431	1	6.90	SWITCH ASSY., backing
69-73	All w/A.T.	1994158	1	4.62	SWITCH ASSY., backing— (4.054)
69-75	Camaro, Chevelle, Nova (exc. A.T.)	6270695	1	2.40	SWITCH ASSY., backing
71-72	Vega w/3-Spd.	8955983	1	4.15	SWITCH ASSY., back-up lamp (Opel-1720866)
71-72	Vega w/4-Spd.	8969775	1	3.90	SWITCH ASSY., trans. back-up lamp
73-74	Vega	3902194	1	3.75	SWITCH ASSY., backing lamp
75	Vega, Monza w/M.T.	3938481	1	3.05	SWITCH ASSY., back-up lamp



**CHASSIS—ELECTRICAL SYSTEM**

**2.698 SWITCH— BRACKET— FASTENER— ROD— SHIELD— SCREW—  
WASHER, Back-Up (Con't)**

65-68	All w/Muncie 4-Spd. . . . .	3864296	1	1.10	BRACKET, switch mtg. . . . .
66-68	All w/4-Spd. (283, 307, 327) (exc. Camaro) . . . . .	3886923	1	.96	BRACKET, switch mtg. . . . .
75	Vega w/5-Spd. . . . .	361182	1	.96	BRACKET, back-up lamp switch . . . . .
71-75	All . . . . .	3981828	1	1.20	FASTENER, seat belt warning and backing lamp switch . . . . .
64	Chevy, Chevelle w/4-Spd. . . . .	3846427	1	1.90	ROD, switch control (4 <sup>3</sup> / <sub>8</sub> " O.L.) . . . . .
65-68	All w/Muncie 4-Spd. . . . .	3861440	1	.96	ROD, switch control . . . . .
66-68	All w/4-Spd. (283, 307, 327) (exc. Camaro) . . . . .	3886922	1	1.25	ROD, switch control . . . . .
66-68	Chevelle, Camaro w/H.D. 3-Spd., 68 Chevy (w/H.D. 3-Spd., Sp. H/Per., 327, 350, 396) . . . . .	3878489	1	2.85	ROD, back-up lamp switch . . . . .
67-68	Camaro (floor console w/3- Spd.), 68-69 Chevy w/floor shift . . . . .	3895264	1	1.25	ROD, switch control . . . . .
67-68	Camaro w/4-Spd. (exc. 350, 396), 68 Chevy w/4-Spd. (exc. 396, Sp. H/Per. 327) . . . . .	3895265	1	1.25	ROD, switch control . . . . .
64-68	All w/4-Spd. . . . .	3706355	1	.22	SHIELD, switch— (4.054) . . . . .
73-74	All . . . . .	7806573	2	.06	SCREW, seat belt warning and backing lamp switch . . . . .
69-70	All w/A.T. (exc. B.S.), 66 Chevy . . . . .	3826178	1	.38	WASHER, switch hole plug gasket— (4.105) . . . . .

**2.700 LAMP ASSY., Rear License, Complete with Bulb**

62-65	Chevy . . . . .	926742	1	6.10	
64-65	Chevelle . . . . .	910575	1	6.10	
65	Pass. . . . .	910700	1	6.10	
66-69	Pass., Chevy (exc. Sta. Wag.), 66-68 Chevelle (exc. Sta. Wag., El Camino), 69 Camaro, 70-72 Nova, Monte Carlo . . . . .	911576	1	6.10	
66-69	Sta. Wag., El Camino, 70 Pass., Chevelle (exc. Monte Carlo), 71 Pass. (exc. Sta. Wag.), 71-72 Chevelle (exc. Monte Carlo), 73 Chevelle (Sta. Wag., El Camino) . . . . .	911556	1	6.10	
67-68	Camaro . . . . .	911242	1	6.10	
69	Chevelle (exc. Sta. Wag., El Camino) . . . . .	916855	1	6.10	
70-73	Camaro . . . . .	917053	2	6.10	
71-73	Vega . . . . .	911576	1	6.10	
71-73	Pass. (Sta. Wag.), 74-75 El Camino . . . . .	911547	1	6.10	
73-74	Nova . . . . .	897081	1	6.10	
73	Chevelle (exc. Sta. Wag., El Camino) . . . . .	911716	1	6.10	
74-75	Chevelle (Sta. Wag.) . . . . .	899794	1	4.35	
74-75	Camaro . . . . .	928543	1	6.10	
74-75	Pass., 74-75 Chevelle (Spt. Cpe., Sed.) . . . . .	928802	1	6.10	
74-75	Vega (Coupe) . . . . .	928192	2	6.10	
74-75	Vega (Sta. Wag., Panel) . . . . .	928482	2	6.10	
75	Monza . . . . .	912094	1	6.10	
75	Nova . . . . .	897192	1	6.10	

**2.705 HOUSING ASSY.— COVER— SUPPORT, Rear License Lamp**

72-73	Pass. (exc. Sta. Wag.) . . . . .	5964930	1	3.80	
74-75	Vega (Sta. Wag., Panel) . . . . .	336579	1	1.10	COVER . . . . .
75	Chevelle (Spt. Cpe., Sed.) (exc. Monte Carlo) . . . . .	1668454	1	2.50	SUPPORT, lic. plate lamp . . . . .

**2.706 COVER, Rear License Lamp**

75	Monza (Notchback) . . . . .	1699244	1	2.60	
----	-----------------------------	---------	---	------	--

**2.707 GASKET, Rear License Lamp Lens**

64-65	Chevelle . . . . .	5954938	1	.35	
66-72	All, 73-74 Pass., Chevelle,				

**CHASSIS—ELECTRICAL SYSTEM**

**2.707 GASKET, Rear License Lamp Lens (Con't)**

75	El Camino	5955194	1	.35	
71-73	Vega	5955194	1	.35	
73-74	Nova	5965831	1	1.10	
74-75	Camaro	5941173	2	.45	mtg. ....
74-75	Vega (Sta. Wag., Panel)	5947326	2	.45	
74-75	Vega (Coupe)	5947948	2	.45	
75	Nova	5947529	1	.35	

**2.708 SCREW— NUT, Rear License Lamp**

64-65	Chevelle	5954939	4	.11	oval hd. cr. recess (No. 8— 32 x 9/16")
64	Chevelle	3858749	4	.11	NUT, "J" shape (No. 8— 18)

**2.709 LENS, Rear License Lamp**

62-65	Chevy	5953152	1	.93	
64-65	Chevelle	5947312	2	1.30	
65	Pass.	5956396	1	.93	
66-70	All,				
71-73	Vega,				
71-72	Nova,				
72	Chevelle (Sta. Wag., El Camino)	5955195	1	.98	
69	Chevelle (exc. Sta. Wag.),				
71-73	Pass. (Sta. Wag.),				
75	El Camino	5959244	1	.93	
70-72	Pass., Chevelle (exc. Sta. Wag., El Camino),				
73	Chevelle (exc. Sta. Wag., El Camino)	5958467	1	.93	
72-73	Pass. (exc. Sta. Wag.)	5964932	1	1.90	
73-74	Nova	5965830	1	3.05	

**2.714 WIRE ASSY.— GROMMET— SOCKET ASSY., Rear License Lamp w/Wire**

68	Chevy (250)	6291458	1	1.95	
73	Monte Carlo	6258217	1	.08	GROMMET, license plate lamp wire
74-75	Camaro, Chevelle (Sta. Wag.),				
75	Monza (exc. Notchback)	6298886	1	1.95	SOCKET ASSY., lic. plate lamp— (2.575)
74-75	Chevelle (exc. Sta. Wag.),				
74-75	Pass.	8918527	2	3.75	SOCKET ASSY., lic. plate lamp
75	Nova, Monza (Notchback)	8901283	1	2.00	SOCKET ASSY., lic. lamp

**2.722 NUT, Headlamp to Fender**

65	Chevy	3696396	4	.16	to front fender headlamp filler panel
----	-------	---------	---	-----	---------------------------------------

**2.725 HEADLAMP ASSEMBLY, Complete with Sealed Beam**

62-64	Chevy	5955711	L.H.	19.50	
62-64	Chevy	5955712	R.H.	19.50	
64	Chevelle	5955227	L.H.	31.75	
64	Chevelle	5955228	R.H.	31.75	
65	Chevy	5958073	L.H.	19.50	
65	Chevy	5958074	R.H.	19.50	
65	Chevelle	5956097	L.H.	31.75	
65	Chevelle	5956098	R.H.	31.75	
65	Pass.	5956095	1	43.50	L.H. ....
65	Pass.	5956096	1	43.50	R.H. ....
66	Pass.	5957585	1	43.50	L.H. ....
66	Pass.	5957586	1	43.50	R.H. ....
66	Chevy	5958437	L.H.	31.75	
66	Chevy	5958438	R.H.	31.75	
66	Chevelle	5957583	L.H.	31.75	
66	Chevelle	5957584	R.H.	31.75	
67-69	Camaro,				
68-74	Nova,				
70	Monte Carlo	5963071	L.H.	13.20	
67	Chevy	5958957	L.H.	13.20	
67	Chevy	5958958	R.H.	13.20	
68-74	Nova	5963905	R.H.	13.20	
67-69	Chevelle				R.H., L.H. inner, ....
67-68	Pass.				R.H., L.H. inner, ....
69-71	Pass.				R.H. inner, ....
70	Chevelle,				
72-75	Pass.	5963837	1	12.75	L.H. inner
67-69	Chevelle				R.H., L.H. outer, ....
67-68	Pass.				R.H., L.H. outer, ....
70	Chevelle,				
69-75	Pass.	5963839	1	12.75	L.H. outer
69-71	Pass.				L.H. inner, ....

## CHASSIS—ELECTRICAL SYSTEM

### 2.725 HEADLAMP ASSEMBLY, Complete with Sealed Beam (Con't)

70	Chevelle,				
72-75	Pass. ....	5963838	1	12.75	R.H. inner .....
69-75	Pass.,				
70	Chevelle .....	5963840	1	12.75	R.H. outer .....
70-73	Camaro,				
71-73	Vega,				
71-72	Chevelle .....	5963119	R.H.	13.20	.....
70-73	Camaro,				
71-73	Vega,				
71-72	Chevelle .....	5963120	L.H.	13.20	.....
67-69	Camaro,				
70	Monte Carlo .....	5963072	1	13.20	R.H. ....
73-74	Laguna .....	5962996	2	13.20	head .....
73-74	Chevelle (exc. Laguna),				
74	Camaro, Vega,				
75	All (exc. Pass.) .....	5964573	2	12.80	head .....
75	Monza (exc. Twn. Cpe.) .....	5966076	L.H.	18.70	outboard .....
75	Monza (exc. Twn. Cpe.) .....	5966077	R.H.	18.70	outboard .....
75	Monza (exc. Twn. Cpe.) .....	5966078	R.H.	18.70	inboard .....
75	Monza (exc. Twn. Cpe.) .....	5966079	L.H.	18.70	inboard .....

### 2.726 SUB BODY— HOUSING— PLATE— FILLER— RING— ADAPTER UNIT, Headlamp

62-64	Chevy .....	5953440	R.H.	5.95	
66	Chevelle .....	5958086	R.H.	11.95	
70	Pass. ....	3977587	L.H.	10.05	HOUSING, w/bracket .....
70	Pass. ....	3977588	R.H.	10.05	HOUSING, w/bracket .....
74-75	Vega .....	336511	L.H.	21.70	HOUSING .....
74-75	Vega .....	336512	R.H.	21.70	HOUSING .....
67	Camaro w/R.S. ....	3898179	L.H.	15.60	HOUSING ASSY. ....
67	Camaro w/R.S. ....	3898180	R.H.	15.60	HOUSING ASSY. ....
67	Camaro (exc. R.S.) .....	3891653	L.H.	7.90	HOUSING ASSY. ....
67	Camaro (exc. R.S.) .....	3891654	R.H.	7.90	HOUSING ASSY. ....
68	Camaro w/R.S. ....	3925445	L.H.	15.60	HOUSING ASSY. ....
68	Camaro w/R.S. ....	3925446	R.H.	15.60	HOUSING ASSY. ....
68	Camaro (exc. R.S.) .....	3919175	L.H.	15.60	HOUSING ASSY. ....
68	Camaro (exc. R.S.) .....	3919176	R.H.	15.60	HOUSING ASSY. ....
69	Camaro (exc. R.S.) .....	3937541	L.H.	15.60	HOUSING ASSY. ....
69	Camaro (exc. R.S.) .....	3937542	R.H.	15.60	HOUSING ASSY. ....
69	Camaro w/R.S. ....	3945701	L.H.	15.60	HOUSING ASSY. (compl.) .....
69	Camaro w/R.S. ....	3945702	R.H.	15.60	HOUSING ASSY. (compl.) .....
70-72	Camaro .....	3967163	L.H.	8.75	HOUSING ASSY. ....
70-72	Camaro .....	3967164	R.H.	8.75	HOUSING ASSY. ....
72	Pass. ....	3997321	L.H.	17.35	HOUSING ASSY. ....
72	Pass. ....	3997322	R.H.	17.35	HOUSING ASSY. ....
73	Camaro .....	3967163	L.H.	8.75	HOUSING ASSY. ....
73	Camaro .....	3967164	R.H.	8.75	HOUSING ASSY. ....
73	Pass. ....	6273731	L.H.	16.45	HOUSING ASSY. ....
73	Pass. ....	6273732	R.H.	16.45	HOUSING ASSY. ....
73	Monte Carlo .....	3996939	L.H.	23.70	HOUSING ASSY. ....
73	Monte Carlo .....	3996940	R.H.	23.70	HOUSING ASSY. ....
73	Chevelle (exc. Laguna, Monte Carlo) .....	3992689	L.H.	18.35	HOUSING ASSY. ....
73	Chevelle (exc. Laguna, Monte Carlo) .....	3992690	R.H.	17.90	HOUSING ASSY. ....
74	Chevelle (exc. Laguna, Monte Carlo) .....	352095	L.H.	24.05	HOUSING ASSY. ....
74	Chevelle (exc. Laguna, Monte Carlo) .....	352096	R.H.	24.05	HOUSING ASSY. ....
74-75	Camaro .....	333789	L.H.	30.50	HOUSING ASSY. ....
74-75	Camaro .....	333790	R.H.	30.50	HOUSING ASSY. ....
74	Caprice .....	335917	L.H.	17.35	HOUSING ASSY. ....
74	Caprice .....	335918	R.H.	17.35	HOUSING ASSY. ....
74	Pass. (exc. Caprice) .....	335987	L.H.	17.35	HOUSING ASSY. ....
74	Pass. (exc. Caprice) .....	335988	R.H.	17.35	HOUSING ASSY. ....
74	Monte Carlo .....	336363	L.H.	35.25	HOUSING ASSY., front fender headlamp and park. lamp .....
74	Monte Carlo .....	336364	R.H.	35.25	HOUSING ASSY., front fender headlamp and park. lamp .....
75	Monza (Twn. Cpe.) .....	358338	R.H.	16.00	HOUSING ASSY. ....
75	Monza (Twn. Cpe.) .....	358337	L.H.	16.00	HOUSING ASSY. ....
75	Monte Carlo .....	345357	L.H.	37.00	HOUSING ASSY., frt. fdr. hdlp. and park. lamp .....
75	Monte Carlo .....	345358	R.H.	37.00	HOUSING ASSY., frt. fdr. hdlp. and park. lamp .....

**CHASSIS—ELECTRICAL SYSTEM**

**2.726 SUB BODY— HOUSING— PLATE— FILLER— RING— ADAPTER UNIT,  
Headlamp (Con't)**

75	Malibu (Classic)	345373	L.H.	35.00	HOUSING ASSY., frt. fdr. hdip.
75	Malibu (Classic)	345374	R.H.	35.00	HOUSING ASSY., frt. fdr. hdip.
75	Malibu (exc. Classic)	352095	L.H.	24.05	HOUSING ASSY., frt. fdr. hdip.
75	Malibu (exc. Classic)	352096	R.H.	24.05	HOUSING ASSY., frt. fdr. hdip.
75	Bel Air, Impala	342391	L.H.	25.75	HOUSING ASSY.
75	Bel Air, Impala	342392	R.H.	25.75	HOUSING ASSY.
75	Caprice	342393	L.H.	20.35	HOUSING ASSY.
75	Caprice	342394	R.H.	20.35	HOUSING ASSY.
71	Vega (1st design)	9860142	R.H.	2.50	PLATE, motor compt. mtg. (Note 3)
71	Vega (1st design)	9860143	L.H.	2.35	PLATE, motor compt. mtg. (Note 3)
71-73	Vega (2nd design)	9878386	R.H.	2.35	PLATE, headlamp mtg. (Note 1)
71-73	Vega (2nd design)	9878387	L.H.	2.35	PLATE, headlamp mtg. (Note 1)
73	Monte Carlo	3996953	L.H.	8.70	FILLER, frt. fdr. to bumper— (1.287)
73	Monte Carlo	3996954	R.H.	8.70	FILLER, frt. fdr. to bumper— (1.287)
62-66	Chevy	5942079	2	4.15	RING
64	Chevelle	922540	L.H.	2.30	RING, inner
64	Chevelle	5954293	R.H.	2.30	RING, inner
64	Chevelle	5954294	L.H.	2.30	RING, outer
64	Chevelle	5954295	R.H.	2.30	RING, outer
65-66	Pass., Chevelle	5948825	1	2.30	RING, left inner (L-1 on flange)
65-70	Pass., Chevelle (exc. Monte Carlo),				
71-73	Pass.,				RING, left outer (L-2 on flange),
67-68	Pass.,				
67-69	Chevelle	5950507	1	3.90	right outer (repl. 5963889)
65-66	Pass., Chevelle,				
69-73	Pass.,				
70	Chevelle (exc. Monte Carlo)	5963890	1	2.30	RING, right outer (R-2 on flange)
66-67	Chevy	5957683	L.H.	4.35	RING, sealed beam mtg.
66-67	Chevy				RING, R.H.
67-69	Camaro,				
68-70	Chevy, Monte Carlo,				
71-74	Nova	5957684	1	4.35	L.H., sealed beam mtg.
72	Chevy				RING, body inner mounting,
67-69	Camaro,				
68-73	Nova,				
70	Monte Carlo	924535	A.R.	4.50	R.H. body inner mtg.
70-73	Camaro,				
71-73	Vega,				
71-72	Chevelle	5961886	R.H.	4.65	RING, right, mtg.
70-73	Camaro,				
71-73	Vega,				
71-72	Chevelle	5961887	L.H.	4.65	RING, left, mtg.
67-69	Pass.,				
70	Pass., Chevelle (exc. Monte Carlo),				
71	Pass.,				RING, L.H. inner,
72-75	Pass.	5950506	1	3.90	R.H. inner
65-70	Pass., Chevelle (exc. Monte Carlo),				
71	Pass.,				RING, R.H. inner,
67-69	Chevelle,				
72-73	Pass.	5963887	1	2.30	L.H. inner
73-74	Laguna	5963209	1	4.15	RING, mounting
73-74	Chevelle (exc. Laguna),				
74-75	Vega (exc. Monza),				
75	All (exc. Pass., Vega)	5964577	1	4.65	RING, hdtp. mtg.
71-73	Vega	5961887	L.H.	4.65	RING, headlamp mounting
71-73	Vega	5961886	R.H.	4.65	RING, headlamp mounting
75	Monza	5966080	R.H.	6.50	RING, outer
75	Monza	5966081	L.H.	6.50	RING, outer
75	Monza	5966082	R.H.	6.50	RING, inner
75	Monza	5966083	L.H.	6.50	RING, inner
74-75	Pass.	5950500	1	3.90	RING UNIT, L.H. inner mtg.
74-75	Pass.	5950507	1	3.90	RING UNIT, L.H. outer mtg.
74-75	Pass.	5950513	1	3.90	RING UNIT, R.H. outer mtg.
67-70	Pass., Chevelle	5961999	A.R.	10.85	ADAPTER UNIT, hdip.

**2.727 SEALED BEAM, Headlamp**

62-69	Chevy, Camaro,				
70	Nova, Monte Carlo,				
71-75	Vega (exc. Monza),				
73-75	Nova, Chevelle, Camaro	5962548	2	4.90	
65-69	Pass., Chevelle,				

**CHASSIS—ELECTRICAL SYSTEM**

**2.727 SEALED BEAM, Headlamp (Con't)**

70	Pass., Chevelle (exc. Monte Carlo),				
71-75	Pass. ....	5965416	2	4.35	inner (single filament) .....
65-69	Pass., Chevelle,				
70	Pass., Chevelle (exc. Monte Carlo),				
71-75	Pass. ....	5964600	2	4.35	outer (double filament) .....
71-72	Nova, Chevelle, Camaro .....	5962548	1	4.90	
75	Monza .....	5966200	1	7.00	outer .....
75	Monza .....	5966201	1	7.00	inner .....

**2.728 MOULDING— BEZEL— DECAL— EXTENSION— BRACKET— NUT, Headlamp (Rim or Door)**

62-64	Chevy .....	3790349	L.H.	9.20	
64	Chevelle .....	3830723	L.H.	17.45	
64	Chevelle .....	3830724	R.H.	17.45	
65	Pass. ....	3851257	1	9.20	left, outer .....
65	Pass. ....	3851258	1	9.20	right, outer .....
65	Pass. ....	3855653	1	9.20	left, inner .....
65	Pass. ....	3855654	1	9.20	right, inner .....
66	Pass. ....	3869747	1	17.45	left .....
66	Pass. ....	3869748	1	17.45	right .....
66	Chevy .....	3866885	2	9.20	left and right .....
66	Chevelle .....	3874589	L.H.	17.45	
66	Chevelle .....	3874590	R.H.	17.45	
67	Pass. ....	3885963	1	17.45	
72	Pass. ....	3996931	2	1.10	housing .....
73	Malibu, Deluxe .....	6258331	L.H.	2.30	MOULDING UNIT, head lamp hsg. lower .....
73	Malibu, Deluxe .....	6258332	R.H.	2.30	MOULDING UNIT, headlamp hsg. lower .....
73	Malibu, Deluxe .....	6258333	L.H.	2.65	MOULDING UNIT, headlamp hsg. side .....
73	Malibu, Deluxe .....	6258334	R.H.	2.65	MOULDING UNIT, headlamp hsg. side .....
74-75	Malibu, El Camino .....	6260589	L.H.	2.30	MOULDING UNIT, head lamp housing .....
74-75	Malibu, El Camino .....	6260590	R.H.	2.30	MOULDING UNIT, head lamp housing .....
74	Caprice .....	6260492	2	3.00	MOULDING UNIT, hdlp. housing .....
74-75	Vega w/L.X.,				
74-75	Vega w/G.T. ....	6260833	L.H.	3.40	MOULDING UNIT, housing .....
74-75	Vega w/L.X.,				
74-75	Vega w/G.T. ....	6260834	R.H.	3.40	MOULDING UNIT, housing .....
75	Bel Air, Impala .....	358803	L.H.	1.95	MOULDING UNIT, hdlp. hsg. lower .....
75	Bel Air, Impala .....	358804	R.H.	1.95	MOULDING UNIT, hdlp. hsg. lower .....
75	Bel Air, Impala .....	358801	L.H.	6.50	MOULDING UNIT, hdlp. hsg. inner .....
75	Bel Air, Impala .....	358802	R.H.	6.50	MOULDING UNIT, hdlp. hsg. inner .....
75	Caprice .....	358806	2	6.50	MOULDING UNIT, hdlp. hsg. inner .....
65	Chevy .....	3858391	2	9.20	BEZEL, left and right .....
65	Chevelle .....	3856899	L.H.	17.45	BEZEL .....
65	Chevelle .....	3856900	R.H.	17.45	BEZEL .....
67	Chevelle .....	3885991	L.H.	17.45	BEZEL .....
67	Chevelle .....	3885992	R.H.	17.45	BEZEL .....
67	Camaro (exc. R.S.) .....	3886613	L.H.	9.20	BEZEL .....
67	Camaro (exc. R.S.) .....	3886614	R.H.	9.20	BEZEL .....
67-68	Camaro w/R.S. ....	3898149	L.H.	9.20	BEZEL .....
67-68	Camaro w/R.S. ....	3898150	R.H.	9.20	BEZEL .....
67	Chevy .....	3892281	L.H.	11.30	BEZEL .....
67	Chevy .....	3892282	R.H.	11.30	BEZEL .....
68	Camaro (exc. R.S.) .....	3914769	L.H.	9.20	BEZEL .....
68	Camaro (exc. R.S.) .....	3914770	R.H.	9.20	BEZEL .....
68	Chevelle .....	3942115	L.H.	9.20	BEZEL .....
68	Chevelle .....	3942116	R.H.	9.20	BEZEL .....
68	Chevy .....	3914759	L.H.	11.30	BEZEL (Note 1) .....
68	Chevy .....	3914760	R.H.	11.30	BEZEL (Note 1) .....
<i>NOTE 1 May be necessary to paint as required.</i>					
68	Pass. ....	3917467	1	18.45	BEZEL, L.H. ....
68	Pass. ....	3917468	1	18.45	BEZEL, R.H. ....
69	Camaro (exc. exterior mldgs.) .....	3935927	L.H.	7.15	BEZEL (plastic) (painted) .....
69	Camaro (exc. exterior mldgs.) .....	3935928	R.H.	7.15	BEZEL (plastic) (painted) .....
69	Camaro w/interior mldgs. ....	3962901	L.H.	9.20	BEZEL (chrome ring) .....
69	Camaro w/interior mldgs. ....	3962902	R.H.	9.20	BEZEL (chrome ring) .....
69	Chevelle .....	3938187	L.H.	9.20	BEZEL, inboard .....
69	Chevelle .....	3938188	R.H.	9.20	BEZEL, inboard .....
69	Chevelle w/hdip. washer .....	3957035	L.H.	9.20	BEZEL, outboard .....
69	Chevelle w/hdip. washer .....	3957036	R.H.	9.20	BEZEL, outboard .....
69	Chevelle (exc. hdip. washer) .....	3938185	L.H.	9.20	BEZEL, outboard .....
69	Chevelle (exc. hdip. washer) .....	3938186	R.H.	9.20	BEZEL, outboard .....
69-72	Chevy (exc. hdip. washer) .....	3949789	L.H.	11.30	BEZEL .....
69-72	Chevy (exc. hdip. washer) .....	3949790	R.H.	11.30	BEZEL .....

**CHASSIS—ELECTRICAL SYSTEM**

**2.728 MOULDING— BEZEL— DECAL— EXTENSION— BRACKET— NUT,  
Headlamp (Rim or Door) (Con't)**

69	Chevy w/hdlp. washer (exc. 350, 396)	3957033 L.H.	11.30	BEZEL
69	Chevy w/hdlp. washer (exc. 350, 396)	6264046 R.H.	.29	BEZEL
69	Chevy w/hdlp. washer (350, 396)	3957049 L.H.	11.30	BEZEL
69	Chevy w/hdlp. washer (350, 396)	3957034 R.H.	6.40	BEZEL (repl. 3957050)
70	Pass.	3955081 L.H.	18.45	BEZEL, left
70	Pass.	3955082 R.H.	18.45	BEZEL, right
70	Monte Carlo	3965957 L.H.	9.20	BEZEL, left
70	Monte Carlo	3965958 R.H.	9.20	BEZEL, right
70	Chevelle (exc. Monte Carlo)	3965973 L.H.	9.20	BEZEL, left
70	Chevelle (exc. Monte Carlo)	3965974 R.H.	9.20	BEZEL, right
70-72	Camaro	3962943 L.H.	9.20	BEZEL, left
70-72	Camaro	3962944 R.H.	9.20	BEZEL, right
71	Pass.	3975311 2	17.45	BEZEL
71-73	Vega	3974499 L.H.	5.50	BEZEL
71-73	Vega	3974500 R.H.	5.50	BEZEL
72	Pass.	3996933 1	9.20	BEZEL, L.H.
72	Pass.	3996934 1	9.20	BEZEL, R.H.
73	Camaro	3962943 L.H.	9.20	BEZEL
73	Camaro	3962944 R.H.	9.20	BEZEL
73-74	Laguna	325225 L.H.	9.20	BEZEL
73-74	Laguna	325226 R.H.	9.20	BEZEL
73	Deluxe, Malibu	3996945 L.H.	9.20	BEZEL
73	Deluxe, Malibu	3996946 R.H.	9.20	BEZEL
73	Caprice	6273783 L.H.	17.45	BEZEL
73	Caprice	6273784 R.H.	17.45	BEZEL
73-74	Nova	6274309 L.H.	9.20	BEZEL
73-74	Nova	6274310 R.H.	9.20	BEZEL
74	Bel Air, Impala (exc. Chrome Grille)	335923 L.H.	17.45	BEZEL
74	Bel Air, Impala (exc. Chrome Grille)	335924 R.H.	17.45	BEZEL
74	Impala w/Chrome Grille	342349 L.H.	17.45	BEZEL
74	Impala w/Chrome Grille	342350 R.H.	17.45	BEZEL
74	Camaro	371034 R.H.	9.60	BEZEL (exc. rally spt. opt.) (chrome)
74	Camaro	371033 L.H.	9.60	BEZEL (exc. rally spt. opt.) (chrome)
74-75	Camaro	333791 L.H.	9.20	BEZEL (w/rally spt. opt.-brushed alum.)
74-75	Camaro	333792 R.H.	9.20	BEZEL (w/rally spt. opt.-brushed alum.)
74	Chevelle (exc. Laguna, Monte Carlo)			
75	Malibu (exc. Classic)	338509 L.H.	9.20	BEZEL
74	Chevelle (exc. Laguna, Monte Carlo)			
75	Malibu (exc. Classic)	338510 R.H.	9.20	BEZEL
74	Caprice,			
75	Bel Air, Impala	335915 L.H.	17.45	BEZEL
74	Caprice,			
75	Bel Air, Impala	335916 R.H.	17.45	BEZEL
74-75	Vega (exc. G.T.),			
74-75	Vega (Sta. Wag., Panel)	336513 L.H.	9.20	BEZEL
74-75	Vega (exc. G.T.),			
74-75	Vega (Sta. Wag., Panel)	336514 R.H.	9.20	BEZEL
74-75	Vega w/G.T.	336569 L.H.	9.20	BEZEL
74-75	Vega w/G.T.	336570 R.H.	9.20	BEZEL
75	Monza (Notchback)	358350 R.H.	10.75	BEZEL
75	Monza (Notchback)	358349 L.H.	10.75	BEZEL
75	Monza (exc. Notchback)	356319 L.H.	17.45	BEZEL
75	Monza (exc. Notchback)	356320 R.H.	17.45	BEZEL
71	Chevelle (exc. Monte Carlo)	3982449 1	9.20	BEZEL ASSY., L.H.
71	Chevelle (exc. Monte Carlo)	3982450 1	9.20	BEZEL ASSY., R.H.
71-72	Monte Carlo	3982445 1	9.20	BEZEL ASSY., L.H.
71-72	Monte Carlo	3982446 1	9.20	BEZEL ASSY., R.H.
72	Chevelle (ex c. Monte Carlo)	328933 1	9.20	BEZEL ASSY., L.H.
72	Chevelle (exc. Monte Carlo)	328934 1	9.20	BEZEL ASSY., R.H.
73	Impala, Bel Air	327167 L.H.	17.45	BEZEL ASSY.
73	Impala, Bel Air	327168 R.H.	17.45	BEZEL ASSY.
73-75	Monte Carlo	3996987 L.H.	9.20	BEZEL ASSY.
73-75	Monte Carlo	3996988 R.H.	9.20	BEZEL ASSY.
75	Nova (exc. S.S.)	345533 L.H.	11.30	BEZEL ASSY.
75	Nova (exc. S.S.)	345534 R.H.	11.30	BEZEL ASSY.
75	Nova (S.S.)	360607 L.H.	11.30	BEZEL ASSY.

**CHASSIS—ELECTRICAL SYSTEM**

**2.728 MOULDING— BEZEL— DECAL— EXTENSION— BRACKET— NUT, Headlamp (Rim or Door) (Con't)**

75	Nova (S.S.)	360608	R.H.	11.30	BEZEL ASSY.
75	Laguna, El Camino	347335	2	6.70	BEZEL ASSY.
75	Malibu (Classic)	345385	L.H.	9.20	BEZEL ASSY.
75	Malibu (Classic)	345386	R.H.	9.20	BEZEL ASSY.
75	Caprice	342333	L.H.	17.45	BEZEL ASSY.
75	Caprice	342334	R.H.	17.45	BEZEL ASSY.
69	Pass. (exc. retr. hdlp.)	3964555	1	17.45	BEZEL UNIT, L.H.
69	Pass. (exc. retr. hdlp.)	3964556	1	17.45	BEZEL UNIT, R.H.
69	Pass. w/retr. hdlp.	3964557	1	17.45	BEZEL UNIT, L.H.
69	Pass. w/retr. hdlp.	3964558	1	17.45	BEZEL UNIT, R.H.
66	Chevelle	3876423	L.H.	2.65	EXTENSION, moulding
66	Chevelle	3876424	R.H.	2.65	EXTENSION, moulding
66	Chevy	3888229	L.H.	4.35	EXTENSION, moulding
66	Chevy	3888230	R.H.	4.35	EXTENSION, moulding
70	Chevelle (Sta. Wag., El Camino)	3958391	L.H.	9.95	EXTENSION, left front fender— (8.131)
70	Chevelle (Sta. Wag., El Camino)	3958392	R.H.	9.95	EXTENSION, right front fender— (8.131)
70	Chevelle (exc. Monte Carlo, Sta. Wag., El Camino)	3962327	L.H.	9.95	EXTENSION, left frt. fender— (8.131)
70	Chevelle (exc. Monte Carlo, Sta. Wag., El Camino)	3962328	R.H.	9.95	EXTENSION, right frt. fender— (8.131)
69	Chevelle	3940548	2	.38	BRACKET, bezel to fil. pnl. (inner)
69	Chevelle	3938189	2	.45	BRACKET, bezel to fil. pnl. (outer)
70	All,				
74-75	Vega (exc. Monza)	3919773	A.R.	.12	NUT, bezel ext.— (2.729)
70	Camaro	3967142	6	.16	NUT, head lamp bezel

**2.729 SCREW— NUT— RETAINER— BRACKET, Headlamp Moulding**

62-69	All	9414752	A.R.	.13	headlamp bezel attach. (No. 8-6— 18 x 1/2")— (8.977)
65-69	Pass., Chevy,				
68-69	Chevelle	3834926	A.R.	.11	headlamp assy., and mldg. attach (1/4" — 20 x 3/8")
69	Camaro (exc. R.S.)	3943203	6	.18	w/washer (8— 18 x 5/8")
74	Nova, Camaro w/S.S.	9414754	6	.11	hdlp. bezel— (8.977)
74-75	Camaro (exc. S.S.)	3942132	6	.11	hdlp. bezel— (1.267)
65	Pass.	3863669	2	.11	NUT, headlamp assy. to rad. grille (No. 8 or No. 10)
66	Pass.,				
67-68	All,				
68	Chevy	3937957	4	.16	NUT
66	All	3877248	4	.11	NUT, headlamp opening mldg. ext.
68-72	Chevelle, Pass.,				
73	Malibu, Deluxe,				
73-75	Pass.,				
74	Monte Carlo	3919773	A.R.	.12	NUT, plastic (No. 8)— (9.744)
71-74	Camaro,				
73-74	Nova	3967142	6	.16	NUT
74-75	Chevelle	338565	8	.11	NUT
66-67	Pass.	3874710	4	.11	RETAINER
67	Chevelle	3892184	4	.11	RETAINER, bezel
66-67	Pass.	3874516	2	.22	BRACKET
69	Pass.	3938049	4	.24	BRACKET, bezel
71	Pass.	3986898	2	1.15	BRACKET, inner
71	Pass.	3986899	2	1.15	BRACKET, outer

**2.731 RING, Sealed Beam Retaining**

62-69	Chevy, Camaro,				
70	Nova, Monte Carlo,				
71-75	Nova,				
71-73	Vega,				
73-75	Camaro,				
74-75	Laguna	5952000	2	3.25	(one pc. construction) (chrome— 7 <sup>3</sup> / <sub>16</sub> " O.D.— three attach. ears 1 <sup>1</sup> / <sub>16</sub> " wide)
64-70	Chevelle,				
65-75	Pass.	5954892	A.R.	2.15	
73	Laguna	5963210	2	3.25	
73	Chevelle (exc. Laguna),				
74	Vega,				
75	All (exc. Pass., Monza)	5964574	2	3.60	
75	Monza	5966170	1	4.15	retaining

**2.736 SCREW— LUG— NUT— BRACKET, Headlamp Lens and Sealed Beam Retaining**

62-75	All	5947955	A.R.	.22	(cr. rec. hd. 8— 32 x 1 <sup>1</sup> / <sub>32</sub> ") (repl. 5959530)
-------	-----	---------	------	-----	---

**CHASSIS—ELECTRICAL SYSTEM**

**2.736 SCREW— LUG— NUT— BRACKET, Headlamp Lens and Sealed Beam Retaining (Con't)**

70	All	3848539	A.R.	.11	(No. 10— 32 x 5/8")
65	Pass.	5956598	4	.16	LUG, headlamp bezel retainer (nylon)
65	Pass.	3863669	2	.11	NUT, rod. grl. to hdlp. (No. 8-10)

**2.737 SCREW— NUT— SPRING, Headlamp Beam Adjusting**

62-67	Chevy, Chevelle, Camaro,				
65-69	Pass.,				
68-71	All (exc. Vega)	9432523	A.R.	.16	use w/3921446 nut— (8.907)
65	Pass.,				
66-67	Chevelle,				
67	Pass.	5956686	8	.48	w/nut
68	Pass.	3928758	1	.33	w/nut L.H.
71-75	Vega	9432645	4	.18	(1/4"— 28 x 2)
75	Monza (exc. Notchback)	5966249	4	.19	
75	Monza (Notchback)	343544	4		w/nut
75	Caprice	365266	4	.33	w/nut
65-74	All,				
75	Camaro, Vega	3921446	A.R.	.18	NUT, use w/3996200
75	Pass., Chevelle	343555	A.R.	.19	NUT
75	Nova	343556	1	.36	NUT
62-74	Nova				SPRING, L.H.
67-69	Camaro,				
70	Monte Carlo	5953168	A.R.	.33	adjusting L.H.
67	Pass., Chevelle	5949989	4	.34	SPRING
68-70	Pass., Chevelle (exc. Monte Carlo),				
71-75	Pass.	3923948	4	.22	SPRING
68-74	Chevy	3929918	A.R.	.40	SPRING, R.H.
70-73	Camaro,				
71-73	Vega,				
71-72	Monte Carlo	342684	2	.31	SPRING (repl. 3945882)
71-72	Chevelle (exc. Monte Carlo),				
73	Chevelle, Monte Carlo (exc. Laguna)	3987016	2	.22	SPRING
74	Camaro, Chevelle (exc. Laguna),				
75	Chevelle, Camaro	345559	2	.23	SPRING
75	Caprice	364590	4	.21	SPRING
73-74	Laguna	478943	2	.46	SPRING
74-75	Vega, Monza	342684	2	.31	SPRING
75	Nova	345510	2	.29	SPRING

**2.755 SWITCH ASSY.— BRACKET— BREAKER ASSY.— BUMPER— CLIP— RELAY ASSY.— SCREW— VALVE ASSY., Concealed Headlamp Motor**

67	Camaro	3906179	4	4.05	limited
67	Camaro w/R.S.	4749164	1	3.35	BREAKER ASSY., headlamp cover— (13.095)
68	Pass.	3926835	2	.70	BUMPER, upper outer
68	Pass.	3929844	4	.11	CLIP, upper cvr.
67	Camaro w/R.S.	1115858	3	11.15	RELAY ASSY., headlamp cover— (9.277)
68-69	Pass., Camaro	5638498	1	13.00	RELAY ASSY., headlamp cover
68	Pass.	3920831	4	.12	SCREW, lwr. cvr. to otr. brkt.
68	Camaro w/R.S.	393688	1	2.05	VALVE ASSY., vac. cont. check

**2.760 MOTOR ASSY.— ACTUATOR— BRACKET— DRIVE LINK— VALVE ASSY.— TANK ASSY.— SHIELD— SPACER— PIN— FILTER ASSY.— TEE— NUT— CLUTCH PLATE— WASHER, Concealed Headlamp Control Drive**

67	Camaro w/R.S.	4918344	1	37.75	return (L.H. or R.H.)
68-69	Pass.	5638409	2	18.85	ACTUATOR, retainer cvr.
68-69	Camaro w/R.S.	5638486	2	18.85	ACTUATOR, retainer cvr.
67	Camaro w/R.S.	4917699	R.H.	2.50	BRACKET, return
67	Camaro w/R.S.	4917700	L.H.	2.50	BRACKET, return
67	Camaro w/R.S.	3909542	1	1.80	BRACKET ASSY., relay
67	Camaro w/R.S.	4917702	1	4.38	DRIVE LINK
68-69	Pass., Camaro	3926296	1	1.70	VALVE ASSY., resv. chk.
68	Camaro w/R.S.	3929937	1	21.35	TANK ASSY., vac. cont. cover
69	Camaro w/R.S.	3949631	1	22.25	TANK ASSY., vac. cont. cover
69	Pass.	3934572	1	22.25	TANK ASSY., vacuum resv.
67	Camaro w/R.S.	3919165	L.H.	.78	SHIELD, return
68	Camaro w/R.S.	3925475	L.H.	2.45	SHIELD, return
69	Camaro w/R.S.	3943283	L.H.	3.30	SHIELD, return
69	Camaro w/R.S.	3943284	R.H.	2.30	SHIELD, return
68-69	Pass., Camaro	5638432	1	1.25	FILTER ASSY., air (check valve type)
67-69	Pass.,				
68-69	Camaro w/R.S.	3926844	1	.34	TEE, hdlp. retainer cover vacuum hose



**CHASSIS—ELECTRICAL SYSTEM**

**2.760 MOTOR ASSY.— ACTUATOR— BRACKET— DRIVE LINK— VALVE ASSY.— TANK ASSY.— SHIELD— SPACER— PIN— FILTER ASSY.— TEE— NUT— CLUTCH PLATE— WASHER, Concealed Headlamp Control Drive (Con't)**

68-69	Pass., Camaro	3926812	2	.27	TEE, vac. relay to actu.
67	Camaro w/R.S.	4917705	1	.11	NUT
67	Camaro w/R.S.	4917706	1	.83	CLUTCH PLATE
67	Camaro w/R.S.	4917701	1	.10	WASHER ( <sup>5</sup> / <sub>16</sub> " I.D. x <sup>1</sup> <sup>23</sup> / <sub>64</sub> " O.D.)
67	Camaro w/R.S.	4917703	1	.11	WASHER ( <sup>13</sup> / <sub>32</sub> " I.D. x <sup>1</sup> <sup>3</sup> / <sub>64</sub> " O.D.)

**2.765 SUPPORT— LINK— BRACKET— SCREW— PLATE ASSY.— SPACER— PIN— SPRING— HOSE— BOLT— BUSHING— CLIP— HINGE— RETAINER— SHAFT, Concealed Headlamp Control Opening Cover**

68	Camaro w/R.S.	3925456	2	.72	cvr. shaft lwr.
68-69	Camaro w/R.S.	3925460	2	.21	cvr. actuator
69	Camaro w/R.S.	3949625	L.H.	1.35	cvr. shaft lwr.
69	Camaro w/R.S.	3949626	R.H.	1.35	cvr. shaft lwr.
68	Pass.	3920143	2	.41	LINK, lwr. cvr.
68	Pass.	3920136	2	.52	LINK, upr. cvr.
68	Pass.	3920116	1	7.15	BRACKET, upper cvr. R.H.
68	Pass.	3920115	1	7.15	BRACKET, upper cvr. L.H.
68	Pass.	3920141	1	12.35	BRACKET, lwr. otr. L.H.
68	Pass.	3920142	1	12.35	BRACKET, lwr. otr. R.H.
68	Pass.	3920133	2	3.35	BRACKET, lwr. cvr. mtg. plate inner
68	Pass.	3920832	2	1.15	BRACKET, lwr. cvr. bpr. inner
69	Pass.	3934570	1	4.65	BRACKET, cvr. mtg. plate, R.H.
69	Pass.	3934568	2	5.70	BRACKET, cvr. inner
68	Camaro w/R.S.	3925461	L.H.	3.25	BRACKET ASSY., cvr. actuator
68	Camaro w/R.S.	3925462	R.H.	3.25	BRACKET ASSY., cvr. actuator
68	Camaro w/R.S.	3927394	2	.27	BRACKET ASSY., cvr. bumper
69	Camaro w/R.S.	3943285	L.H.	3.10	BRACKET ASSY., cvr. actuator
69	Camaro w/R.S.	3943286	R.H.	3.10	BRACKET ASSY., cvr. actuator
69	Camaro w/R.S.	3945780	2	.27	BRACKET ASSY., cvr. bumper
68	Pass.	3920137	4	.21	SCREW, upper cover link
69	Pass.	3934594	4	.21	SCREW, cvr. bumper
67-68	Camaro w/R.S.	3914747	L.H.	11.50	PLATE ASSY.
67-68	Camaro w/R.S.	3914748	R.H.	11.50	PLATE ASSY.
68	Pass.	3926881	1	15.15	PLATE ASSY., lower, L.H.
68	Pass.	3926882	1	15.15	PLATE ASSY., lower, R.H.
69	Camaro w/R.S.	3945713	L.H.	11.30	PLATE ASSY.
69	Camaro w/R.S.	3945714	R.H.	11.30	PLATE ASSY.
67-69	Camaro w/R.S.	3903451	4	.27	SPACER, hdlp. retainer cover mtg. plate to hdlp. retainer cover hinge
67-69	Camaro w/R.S.	3903454	4	.27	SPACER, hdlp. retainer cover hinge to hdlp. housing
68-69	Camaro w/R.S.	3925465	2	.27	SPACER, cvr. actuator to support
68	Pass.	3926896	2	.23	SPACER, lower mtg. to inner bracket
68	Pass.	3920119	4	.15	SPACER, upper cover brkt.
68-69	Camaro w/R.S.	3925459	2	.15	PIN, cvr. actuator to shaft lwr. lvr.
68-69	Camaro w/R.S.	3925466	2	.15	PIN, cvr. actuator to supt. pin
68	Pass.	3920135	2	.39	PIN, lwr. cvr. to inner brkt.
68	Pass.	3929845	2	1.90	PIN, upper cover
68	Pass. w/retr. h/lamp covers	3945628	2	.27	SPRING, lwr. cover to otr. brkt.
68-69	Camaro w/R.S.	3925477	2	.21	SPRING, cvr. shaft lwr.
68-69	All	3945335	1	1.70	HOSE ( <sup>9</sup> / <sub>32</sub> " I.D.)
69	All	3987364	1	RL/14	HOSE ( <sup>7</sup> / <sub>32</sub> " I.D.)
67-69	Camaro w/R.S.	3903453	2	2.95	BOLT (hex. <sup>1</sup> / <sub>4</sub> " x 20)
68-69	Camaro w/R.S.	3925457	A.R.	.31	BUSHING, upper and lower
68-69	Camaro w/R.S.	3925458	2	.14	BUSHING, cvr. actuator
Not Required in this Group. See Group 10.156					
67-68	Camaro w/R.S.	9793032	2	.87	CLIP
67-68	Camaro w/R.S.	3918873	2	6.70	HINGE
69	Camaro w/R.S.	3945711	2	4.50	HINGE
68	Camaro w/R.S.	3925473	2	.21	RETAINER, spring L.H.
68	Camaro w/R.S.	3925474	2	.21	RETAINER, spring R.H.
68	Camaro w/R.S.	3929949	L.H.	6.80	SHAFT, w/lever
68	Camaro w/R.S.	3929950	R.H.	4.20	SHAFT, w/lever
69	Camaro w/R.S.	3943289	L.H.	5.15	SHAFT w/lever
69	Camaro w/R.S.	3943290	R.H.	5.15	SHAFT w/lever

**2.770 COVER— BOLT— MOULDING, Concealed Headlamp Opening Cover**

67-68	Camaro w/R.S.	3919064	R.H.	2.95	(Note 1)
67-68	Camaro w/R.S.	3919063	L.H.	2.95	(Note 1)
68	Pass.	3934293	1	10.60	upper, L.H.
68	Pass.	3934294	1	10.60	upper, R.H.
68	Pass.	3934261	1	11.70	lower, L.H. (Note 1)

**CHASSIS—ELECTRICAL SYSTEM**

**2.770 COVER— BOLT— MOULDING, Concealed Headlamp Opening Cover (Con't)**

68	Pass.	3934262	1	11.70	lower, R.H. (Note 1)
<i>NOTE 1 Paint as required.</i>					
69	Camaro w/R.S.	3958003	L.H.	5.85	outer
69	Camaro w/R.S.	3958004	R.H.	3.90	outer
69	Camaro w/R.S.	3958005	L.H.	5.30	inner
69	Camaro w/R.S.	3958006	R.H.	5.30	inner
69	Pass.	3934563	1	13.05	retr., L.H.
69	Pass.	3934564	1	13.05	retr., R.H.
67-69	Camaro w/R.S.	4405522	A.R.	.11	BOLT (1/4" x 20)— (10.556)
67-68	Camaro w/R.S.	3919155	L.H.	12.50	MOULDING
67-68	Camaro w/R.S.	3919156	R.H.	12.50	MOULDING
68	Pass.	3934291	2	3.80	MOULDING, upper cover

**2.775 SHIM— BUMPER— SPRING, Headlamp Control**

67-69	Camaro w/R.S.	3903452	1	.11	between housing and radiator
-------	---------------	---------	---	-----	------------------------------

**2.776 SOCKET— LAMP ASSY., Instrument Lamp**

66-67	Pass.,				
67-68	Camaro	3882798	A.R.	.58	bayonet type, park brake alarm bulb— (4.589)
67-68	Pass., Camaro,				
68	Chevy	5655006	A.R.	.81	bayonet type— (9.744)
75	Pass., Chevelle	8910572	1	3.55	LAMP ASSY., courtesy

**2.780 NOZZLE ASSY.— COIL ASSY.— VALVE, Headlamp Washer**

69	Chevy, Chevelle, Camaro	3957029	4	2.40	washer spray
69	All	4919674	1	9.75	COIL ASSY., sol.
69	All	4919503	1	1.56	VALVE, washer check
69	All	4919676	1	6.50	VALVE ASSY., sol.

**2.810 HORN ASSEMBLY— HORN UNIT— SWITCH UNIT, Horn**

65-68	All,				
72-73	All,				
74-75	Pass., Chevelle	9000236	1		low note
73-75	Pass., Chevelle w/dual horns	9000239		11.70	(high note)
62-70	All,				
71-73	Vega,				
73-75	Camaro w/dual horns	9000011	1	11.70	HORN UNIT (hi note)
74	All	9000062	1	18.65	HORN ASSY. (low decibel)
74	All	345147	1	13.90	SWITCH UNIT, w/wire (low decibel)

*NOTE On some models it will be necessary to use the mounting bracket from the replaced horn and enlarge the hose to 1 1/2" dia., also to rework trumpet by cutting 1/2 inch off end.*

**2.812 NUT— WASHER, Horn**

65-66	Chevy, Chevelle (Std.)	1965698	1	.07	vibrator horn bracket (7/8"— 20)
66-69	Chevy	3886974	A.R.	.12	WASHER, reinforcement

**2.815 RELAY, Matched Horn**

62	Chevy	1116920	1	4.10	
63-65	Chevy, Chevelle	1115824	1	4.10	
65	Pass.,				
66-71	All	1115889	1	6.25	
72-73	All	6273328	1	4.70	
74	All	344813	1	4.15	
75	All	370113	1	4.15	

**2.819 CONTACT— ADAPTER— BUSHING— CUP— INSULATOR— BUSHING— RING— GASKET— WASHER— PIVOT— SWITCH ASSY.— SPRING— CONNECTOR— PLATE— RING, Horn Button and Blowing Ring**

64-66	Chevy,				
65-66	Pass.	5955202	1	.48	
65-66	Pass. w/wood grained wheel	769609	1	2.85	
67-68	All w/wood wheel	3901330	1	3.30	
67	Pass., Camaro	9746517	2	3.15	
67	Chevelle (Malibu, Concours, S.S.),				
67	Pass., Chevy	9746525	1	3.30	w/insulator
69-70	All w/wood wheel,				
70	All w/cushion rim wheel	3937897	1	5.35	
69	All (exc. wood wheel),				
70	All (exc. Cushion rim wheel)	3939746	1	3.65	
70	Camaro	3983012	2	.11	blowing
64-66	Chevelle,				
66	Chevy,				

**CHASSIS—ELECTRICAL SYSTEM**

**2.819 CONTACT— ADAPTER— BUSHING— CUP— INSULATOR— BUSHING— RING— GASKET— WASHER— PIVOT— SWITCH ASSY.— SPRING— CONNECTOR— PLATE— RING, Horn Button and Blowing Ring (Con't)**

67-69	All,				
70	All w/cushion rim wheel,				
71-72	All w/Sport Wheel,				
73-75	Vega w/Sport Wheel,				
73-75	Camaro, Laguna	3916047	1	1.20	CONTACT UNIT, w/eyelet and spring
71	All (exc. Sport, Vinyl Wheel),				
73-74	Pass., Chevelle, Nova	9752569	1	3.55	CONTACT ASSY.
62-67	Chevy,				
67	Chevelle (Std.) (exc. deluxe, wood wheel)	770904	1	1.10	ADAPTER, cap
75	All w/cust. whl.	9754764	1	.24	BUSHING, horn but. cap. adapter
67-69	Camaro (exc. deluxe, wood wheel),				
68	Chevy (exc. 350, 396, deluxe, wood wheel)	9740532	1	.53	CUP, cap
67-68	Pass.,				
67	Camaro w/deluxe wheel,				
68	Chevelle (exc. Malibu, Concours, S.S.)	9746151	1	.71	CUP, horn button cap
71-73	All w/Sport Wheel	9748190	1	1.69	CUP, cap
62-65	Chevy,				
65-66	Pass. (exc. T.W., wood grained wheel)	768233	1	.84	INSULATOR, horn blowing contact
67	Biscayne, Bel Air,				
68	All,				
69	Camaro	9741653	1	.78	INSULATOR, horn blowing spring
68	Chevy, Camaro w/Tel. W.,				
69	Chevy, Malibu, Camaro (exc. deluxe, wood wheel),				
69	Biscayne, Bel Air (exc. deluxe, wood wheel)	9747057	1	.18	INSULATOR, cap clip
68	Chevy, Camaro (exc. deluxe wheel),				
68	Chevelle (exc. Malibu, S.S.),				
68	Biscayne, Bel Air (exc. deluxe wheel),				
68	Chevy w/wood wheel,				
69	All w/wood wheel,				
69	Camaro w/cushion rim wheel,				
70	Pass. w/cushion rim wheel,				
71-73	Vega	382117	1	.12	INSULATOR, contact
70	Camaro	3983014	2	.11	INSULATOR, blowing contact
71-73	All w/Sport Wheel	770855	1	1.05	INSULATOR, strg. whl.
71-72	All w/Sport Wheel,				
73-75	Camaro,				
74-75	Vega w/Spt. Wheel,				
74	Laguna	409190	1	.12	INSULATOR, horn blowing contact (eyelet type)
75	All w/Spt. Whl.	9755872	1	.84	INSULATOR, horn blow. spr.
62-63	Chevy (exc. Std.),				
64-65	Nova	764761	1	.53	BUSHING, strg. wheel adapter
62-65	Chevy (Std.),				
71-73	All w/Sport Wheel	764402	1	.27	BUSHING, stg. whl. insulator
64-65	Chevelle,				
65-66	Pass. (exc. T.W., wood grained wheel),				
70	Camaro	764762	1	.56	BUSHING, blowing ring
65	Chevelle (Std.),				
66	Chevy (Std.),				
67-69	Chevy, Chevelle, Camaro,				
67-69	Biscayne, Bel Air	9740172	1	.36	BUSHING, button cap adapter
67-68	Pass. w/horn ring	9745089	1	.53	BUSHING, strg. whl.
68	Chevy, Chevelle w/deluxe wheel,				
68	Impala, Caprice (exc. wood wheel),				
68	Camaro w/int. decor. pkg. (exc. wood wheel),				
68	Biscayne, Bel Air w/deluxe wheel	9747689	1	1.75	BUTTON ASSY., switch right (black)
68	Chevy, Chevelle w/deluxe wheel,				
68	Impala, Caprice (exc. wood wheel),				

**CHASSIS—ELECTRICAL SYSTEM**

**2.819 CONTACT— ADAPTER— BUSHING— CUP— INSULATOR— BUSHING— RING— GASKET— WASHER— PIVOT— SWITCH ASSY.— SPRING— CONNECTOR— PLATE— RING, Horn Button and Blowing Ring (Con't)**

68	Camaro w/int. decor. pkg. (exc. wood wheel),				
68	Biscayne, Bel Air w/deluxe wheel	9747590	1	1.75	BUTTON ASSY., left (black)
69	All	3939753	1	1.65	BUTTON ASSY., left (Note 3)
69	All	3939754	1	1.65	BUTTON ASSY., right (Note 3)
70	All	3973021	L.H.	1.75	BUTTON ASSY., left (Note 3)
70	All	3973022	R.H.	1.75	BUTTON ASSY., right (Note 3)
<i>NOTE 3: Paint as required.</i>					
65-66	Pass. (exc. wood wheel),				
65	Nova, Chevelle (exc. Malibu),				
66	Nova (exc. wood wheel, Tel. W.)	763323	1	.44	RING, pivot (1 <sup>13</sup> / <sub>16</sub> " O.D.)
66	Pass. w/T.W. (exc. Caprice),				
66	Caprice w/T.W. (exc. Sta. Wag.),				
73-75	Camaro	5697735	1	.78	RING, carrier locking
67-68	All w/horn ring	810794	1	.07	WASHER, strg. whl.— (8.929)
67-68	All w/horn ring	9745191	1	.38	PIVOT, inst. strg. whl.
67	Chevy, Malibu, Concours, S.S.,				
67	Caprice	9746461	2	1.95	SWITCH ASSY.
<i>NOTE 2 Includes Ring.</i>					
68	All	9748128	1	2.85	SWITCH ASSY.
62-69	Chevy,				
67-69	Biscayne, Bel Air,				
65-69	Chevelle, Camaro (Std.),				
70	Camaro,				
71-73	Vega w/Spt. Wheel	9741644	1	.61	SPRING, pivot (Belleville-coned height)
65-66	Pass. (exc. T.W., wood grained wheel)	765631	1	.48	SPRING, pivot (Belleville-coned height)
65-66	Chevelle (exc. T.W.),				
66	Chevy	5955237	1	.11	SPRING, horn contact brush
71-72	All w/Sport Wheel,				
71-75	Vega, Monza,				
73-75	Camaro,				
74	Laguna	404234	1	.12	SPRING, horn blowing contact
62	Chevy	759037	1	1.05	CONNECTOR, contact w/spring
70	Camaro	3982390	1	2.25	PLATE, blowing contact
73-75	Camaro	5697735	1	.78	RING, stg. column horn contact carrier lock

**2.820 CAP ASSY.— RETAINER— SUPPORT— EMBLEM— BUTTON ASSY., Horn Blowing**

**ACTUATING TYPE**

62-65	Chevy (exc. Nova)	3929758	1	3.40	
62-64	Chevy (Deluxe) (exc. S.S.),				
65	Nova	3858192	1	4.55	shield type
64-65	Chevelle (exc. wood wheel)	3858821	1	3.90	
65	Bel Air (exc. wood grained wheel)	3840112	1	2.95	
65	Biscayne (exc. wood grained wheel, Police)	3853908	1	3.40	
65-66	Impala (exc. wood grained wheel, T.W.)	3874620	1	3.25	
66-68	All w/wood grained wheel,				
69	Camaro, Chevelle w/wood wheel,				
69	Camaro w/cushion rim wheel,				
69	Pass. w/wood wheel	3945461	1	6.20	
66	Biscayne, Bel Air (exc. T.W., wood grained wheel)	3874627	1	3.40	
66	Chevelle (exc. Std., wood wheel)	3878016	1	3.65	
66	Chevy (exc. Nova)	3873627	1	3.35	
66	Nova	3873655	1	3.20	
67	Chevelle (exc. wood wheel),				
67	Chevelle (300) w/Deluxe Wheel (exc. Deluxe)	3905578	1	3.95	
67	Chevy w/Deluxe wheel (exc. S.S.)	3905560	1	6.90	
67	Nova (S.S.) (exc. Deluxe wheel, wood wheel)	3905521	1	4.35	
67	Camaro (Deluxe) (exc. 350, 396, R.S., Deluxe wheel, wood wheel)	3905583	1	7.20	(Camaro)

**CHASSIS—ELECTRICAL SYSTEM**

**2.820 CAP ASSY.— RETAINER— SUPPORT— EMBLEM— BUTTON ASSY., Horn Blowing (Con't)**

67-68	Camaro (R.S.) (exc. 350, 396 deluxe wheel, wood wheel) . . .	3935718	1	11.85	(R.S.) . . . . .
67	Chevelle (Concours, S.S.) (exc. Sta. Wag., wood wheel),				
67	Chevy (exc. wood wheel) . . . . .	3898279	1	3.75	
67	Nova (exc. S.S., wood wheel) . . .	3901341	1	3.80	
67	Camaro w/Deluxe wheel . . . . .	3908382	1	3.80	
67	Camaro (396) (exc. int. decor pkg., wood wheel),				
68	Chevy, Camaro (350, 396) (exc. int. decor. pkg., wood wheel) . .	3935712	1	13.35	
67-68	Camaro (Std.) (exc. 350, 396, Deluxe wheel, wood grained wheel, R.S.) . . . . .	3928351	1	3.90	
67-68	Bel Air (exc. wood grained wheel, Deluxe Wheel) . . . . .	3925143	1	3.75	
67	Impala, Caprice (exc. wood grained wheel),				
67	Biscayne, Bel Air w/deluxe wheel . . . . .	3898270	1	3.75	
67	Biscayne (exc. wood grained wheel, T.W.),				
68	Biscayne (exc. Deluxe wheel, wood wheel) . . . . .	3925142	1	3.80	
68	Nomad (Custom),				
68	Chevelle (Deluxe) (exc. Deluxe wheel, wood wheel) . . . . .	3926977	1	3.80	
68	Chevy (8 cyl.) (exc. 350),				
68	Chevy (6 cyl.) (exc. Deluxe, wood wheel) . . . . .	3928352	1	7.35	
71-75	All w/sport wheel . . . . .	329736	1	5.60	
73-75	Camaro, Laguna . . . . .	329736	1	5.60	horn button . . . . .
74	Camaro (L.T.) . . . . .	340378	1	2.05	horn button (midnight neutral) . . . . .
74	Camaro (L.T.), Laguna . . . . .	340379	1	2.05	horn button (dark saddle) . . . . .
74	Camaro (L.T.) . . . . .	340380	1	2.05	horn button (dark taupe) . . . . .
74	Laguna,				
75	Camaro, Monza . . . . .	339750	1	6.65	horn button (dark oxblood) . . . . .

**NON-ACTUATING TYPE**

**PARTS, Horn Blowing Cap**

62-66	Chevy (Std.),				
65-67	Chevelle (Std.) (exc. deluxe equip.),				
67-68	Camaro (exc. deluxe wheel, wood wheel),				
68	Chevy (exc. deluxe wheel, wood wheel) . . . . .	3931568	1	.34	RETAINER, horn button . . . . .
67-68	Pass.,				
67	Chevelle,				
67-68	Camaro w/deluxe wheel,				
67-68	Chevy (exc. wood wheel),				
68	Chevelle (exc. Malibu, Concours, S.S., deluxe, wood wheel) . . . .	3931574	1	.38	RETAINER, cap . . . . .
71-75	All w/sport wheel,				
73-75	Camaro, Laguna . . . . .	329738	1	.50	RETAINER, horn button cap . . . . .
68	Impala (exc. S.S., S.S. 427, wood grained wheel, Sta. Wag.) . . . . .	3925146	1	1.75	EMBLEM, strg. whl. shrd. . . . .
69	Camaro w/R.S. (exc. 350, 396, wood cushion rim wheel) . . . .	3939756	1	1.65	EMBLEM, strg. whl. shroud . . . . .
69-70	Malibu (exc. Sta. Wag., Spec. Spt. Sedan, wood wheel, 396, 454),				
69	Chevelle (Deluxe) (8 cyl.) (exc. Sta. Wag., wood wheel) . . . . .	3939780	1	1.65	EMBLEM, strg. whl. shroud . . . . .
69-70	Impala (exc. S.S. 427, wood wheel, vinyl wheel) . . . . .	3939209	1	1.65	EMBLEM, strg. wheel shrd. . . . .
69-70	Caprice (exc. wood wheel, vinyl wheel) . . . . .	3958931	1	2.95	EMBLEM, strg. wheel shroud . . . . .
69	Chevy, Chevelle, Camaro (350, 396) (exc. wood wheel),				

**CHASSIS—ELECTRICAL SYSTEM**

**2.820 CAP ASSY.— RETAINER— SUPPORT— EMBLEM— BUTTON ASSY., Horn Blowing (Con't)**

69	Impala (S.S. 427) (exc. wood wheel) . . . . .	3939758	1	1.65	EMBLEM, strg. wheel shroud . . . . .
69	Chevy, Chevelle, Camaro (exc. wood wheel, 396),				
69	Biscayne, Bel Air w/deluxe wheel,				
69	Brookwood, Townsman w/deluxe wheel,				
69	Kingswood, Estate Wag. (exc. wood wheel) . . . . .	3939755	1	1.65	EMBLEM, strg. whl. shroud . . . . .
70	Nova (exc. 350, 396, vinyl wheel),				
70	All (Sta. Wag.) (exc. vinyl wheel),				
70	Concours, El Camino (Custom) (exc. Estate Wag., 396, 454, vinyl wheel) . . . . .	3968705	1	2.30	EMBLEM, strg. wheel shrd. . . . .
70	Nova (350, 396),				
70	Chevelle (396) . . . . .	3973852	1	2.30	EMBLEM, strg. wheel shrd. . . . .
70	Malibu (396, 454) . . . . .	3939780	1	1.65	EMBLEM, strg. wheel shrd. . . . .
70	Monte Carlo (exc. vinyl wheel) . . . . .	3973851	1	1.40	EMBLEM, strg. wheel shrd. . . . .
70	Camaro (exc. 350, 396) . . . . .	3981974	1	1.85	EMBLEM, strg. wheel shrd. . . . .
71-75	Vega w/G.T. . . . .	329740	1	1.85	EMBLEM, strg. wheel shrd. . . . .
71-72	All w/Sport Wheel,				
73-75	Camaro (L.T.) . . . . .	340315	1	1.85	EMBLEM, button cap . . . . .
73-75	Vega w/Spt. Wheel (exc. G.T.),				
73	Camaro (exc. L.T.),				
75	Nova (exc. S.S., L.N.) . . . . .	329737	1	1.85	EMBLEM, horn button cap . . . . .
74-75	Camaro (exc. L.T.) . . . . .	332649	1	1.85	EMBLEM, horn button cap . . . . .
74-75	Laguna . . . . .	339749	1	2.20	EMBLEM, horn button cap . . . . .
75	Vega w/Cosworth . . . . .	336582	1	1.85	EMBLEM, horn button cap . . . . .
75	Monza . . . . .	356351	1	1.90	EMBLEM, horn button cap . . . . .
75	Nova (S.S.) . . . . .	352886	1	1.90	EMBLEM, horn cap . . . . .

**2.830 RING— BAR, Horn Blowing**

62-63	Chevy Deluxe,				
64-65	Nova . . . . .	768293	1	10.30	
64-65	Chevelle . . . . .	9740962	1	8.00	
65	Biscayne, Bel Air . . . . .	9741000	1	7.55	
65-66	Pass. (exc. wood grained wheel)	3882985	1	10.65	(w/wood grain vinyl film) . . . . .
66	Nova . . . . .	3873652	1	10.30	
66	Chevelle . . . . .	3878015	1	8.10	
67-68	All w/horn ring . . . . .	9749044	1	28.50	BAR (Note 1) . . . . .

NOTE 1 Also order 3 each of 9745089 bushing and 9745191 pivot.

**2.859 LEAD ASSY.— WIRE ASM., Horn**

70	Camaro . . . . .	9752670	1	2.85	horn contact lead wire . . . . .
71	Camaro, Nova (exc. Sport Wheel),				
71	Chevelle, Pass.,				
72-75	All . . . . .	9752246	1	.42	WIRE ASSY. . . . .

**2.892 FLASHER— CLIP, Direction Signal Lamp**

62-63	Chevy . . . . .	3713382	1	1.95	
65	Impala,				
66-69	Impala, Caprice,				
67	Biscayne, Bel Air . . . . .	491160	1	1.95	(3 bulb) (Stat. Co. No. 145, Tung. Sol. No. 323) (repl. 383637) . . . . .
66	Impala, Caprice (exc. Sta. Wag., S.S.) . . . . .	491391	1	3.60	(4 bulb) (Tung. Sol.) . . . . .
73	Impala, Caprice (exc. Sta. Wag.)	6273331	1	1.80	dir. sig. lamp . . . . .
74-75	Impala, Caprice (exc. Sta. Wag.),				
74-75	Chevelle (exc. El Camino) . . . . .	491160	1	1.95	dir. sig. lamp . . . . .
64-72	All,				
73	Chevelle,				
73-75	Camaro, Nova, El Camino, Vega, Monza,				
73-75	Pass. (Sta. Wag.), Bel Air . . . . .	491392	1	2.20	dir. signal lamp . . . . .
65-73	All . . . . .	3986825	1	.12	CLIP, dir. sig. lamp flasher . . . . .
74-75	All . . . . .	3866440	1	.06	CLIP, dir. sig. lamp flasher . . . . .

**CHASSIS—ELECTRICAL SYSTEM**

**2.895 SWITCH ASSY.— ACTUATOR ASSY.— BUMPER— CONNECTOR— CONTROL ASSY.— RING— CONTACT UNIT— SCREW— PLATE— CABLE ASSY.— SPACER— BEARING ASSY.— PAWL, Direction Signal Lamp (See Group 9.748 Tell Tale Wind.)**

62	Chevy	3765110	1	1.80	
63-64	Chevy (1st design)	898197	1	13.60	
64-66	Chevelle (exc. T.W.)				
66	Chevy	387115	1	13.60	(cast "BPC")
64-66	Chevelle (exc. T.W.)				
66	Chevy	911051	1	13.60	(cast "Guide")
64-66	Pass., Chevelle w/Tel. W., T.W.	1993624	1	8.00	
64-65	Chevy (2nd design)				
65-66	Pass. (exc. T.W., Tel. W.)	910821	1	14.05	
67-68	All	7800482	1	12.15	dir. sig. and traffic hazard (Delco-Remy)
67-68	All	5698520	1	20.60	dir. sig. and traffic hazard (Boyne)
67-68	Chevy, Camaro w/A.T. (exc. T.W.)	5698897	1	23.80	(Delco-Remy), bulb socket w/hazard flasher
67-68	Camaro (A.T. w/T.W.)	7800006	1	23.80	(Boyne) bulb socket w/hazard flasher
69-75	All	1997963	1	12.35	dir. sig. and traffic hazard
66	Pass. (T.W. w/Tel. W.)	5695301	1	17.65	ACTUATOR ASSY., less housing switch
65-66	Pass.				
65-66	Chevy	5954457	1	.11	BUMPER, control switch
63	Chevy	2965017	1	.22	CONNECTOR, hazard lamp switch— (2.530)
62	Chevy (exc. P.G.)	3816391	1	13.65	CONTROL ASSY. (Note 1)
62	Chevy w/P.G.	3816390	1	16.50	CONTROL ASSY. (Note 1)
	<i>NOTE 1 Paint as required.</i>				
62	Chevy	5953236	1	3.35	RING, control
65-66	All (exc. T.W.)	5956608	1	.16	RING, control ("O")
63-64	Chevy	5954706	1	.55	CONTACT UNIT, control switch
64-66	All	5957066	1	.65	CONTACT UNIT, control switch contact
64-66	Chevy,				
65-67	Pass. (exc. T.W., Tel. W.)				
67-70	Camaro	3841575	1	.12	SCREW, control (10— 32 x 1/2")
65-68	Pass., Chevelle, Camaro	7801514	2	.71	SCREW (12— 24 thd. x 7/8")
67-68	All	5698392	3	.32	SCREW (12— 28 thd., 1/2" lg. shldr.)
67-68	Pass., Chevelle, Camaro	7801513	1	.71	SCREW (12— 24 x 1/2")
69-75	All	7809128	1	.34	SCREW, sig. switch mtg.
62	Chevy	3713031	1	.32	PLATE, control locking— (6.512)
63-64	Chevy	5954159	1	4.25	PLATE, switch w/wiring
63-64	Chevy	5954456	1	1.40	PLATE, actuating
64	Chevy,				
65-66	Pass. (exc. Tel. W.)	5955189	1	1.40	PLATE, control switch
65	Chevy	5957015	1	1.40	PLATE, control switch
64-66	Chevelle (exc. T.W.)				
66	Chevy	5957063	1	1.40	PLATE, actuating
65	Chevy	3785211	1	1.45	CABLE ASSY., switch
64-66	Chevelle w/T.W.	1963518	1	1.38	CABLE ASSY., yoke assy. actuator
65-66	Pass. w/T.W.	1965039	1	2.61	CABLE ASSY., yoke assy. actuator
62-67	Chevy,				
65-67	Pass.	3745292	1	.11	SPACER (17/16" O.D. x 1 1/8" I.D. x 1" G" thick)
64-66	Chevelle (exc. T.W.)				
66	Chevy	383871	1	1.75	BEARING ASSY., control switch— (6.521)
64-66	Chevy, Pass.	5679205	1	2.70	BEARING ASSY., control switch— (6.521)
62	Chevy	5950164	1	.16	PAWL, switch

**2.896 CAM— CONVERSION UNIT— SPRING, Direction Signal Lamp (Cancelling)**

62-65	Chevy	3831338	1	.38	without integral spacer
64-66	Chevelle (exc. T.W.)	382931	1	1.10	
65-66	Pass. (exc. T.W.)	3813945	1	.56	(w/integral spacer) (Note 1)
	<i>NOTE 1 When using 3813945 on past models it will be necessary to also use 1— 3708146 seal "O" ring as a spacer to build up inner boss approx. 3/32".</i>				
65-66	Pass. w/T.W.	3832618	1	.39	
66	Chevy	3878117	1	1.45	
67-68	All (exc. T.W.)	399292	1	.65	
67-68	All w/T.W.	399294	1	.95	
71-73	Vega	7810712	1	2.15	
74	Vega,				
75	Vega, Monza w/T.W.	7812051	1	2.25	CAM ASSY.
75	Vega, Monza (exc. T.W.)	7816849	1	2.40	CAM ASSY.
69-75	All w/T.W.	7812211	1	2.25	CONVERSION UNIT
69-75	All (exc. T.W.)	7812210	1	2.25	CONVERSION UNIT
64-66	Pass., Chevelle	1966522	1	.14	SPRING, cancel cam right
64-66	Pass., Chevelle	1966523	1	.14	SPRING, cancel cam left
64-66	Pass., Chevelle w/T.W.	1921885	2	.12	SPRING, yoke assy. trigger
67-68	All w/T.W.	3900514	1	.14	SPRING, cancel cam

**CHASSIS—ELECTRICAL SYSTEM**

**2.896 CAM— CONVERSION UNIT— SPRING, Direction Signal Lamp (Cancelling)  
(Con't)**

67-75	All	1964785	1	.12	SPRING, cancelling L.H.
67-75	All	1964784	1	.12	SPRING, cancelling R.H.
67-75	All	1967685	1	.11	SPRING, lane change
69-70	All w/T.W.	7805554	1	.39	SPRING, cancel cam

**2.897 LEVER— KNOB, Direction Signal Lamp**

63-65	Chevy				
65-66	Pass. (exc. T.W.)	3854303	1	.57	control
64-67	Chevelle (exc. T.W.),				
66	Chevy	3840903	1	.63	control
67-68	All (exc. Cruise Control)	3909580	1	.74	control
67-75	All w/Spd. Cruise Control	6465256	1	20.65	w/switch
69-70	All (exc. Spd. Cruise Control)	3961517	1	.68	control
71-74	Vega,				
75	Vega, Monza (exc. T.W.)	3990866	1	1.25	w/knob
71-75	All (exc. Speed Cruise Control),				
75	Vega, Monza w/T.W.	3990858	1	1.45	w/knob (black)
62-65	Chevy,				
64-66	Chevelle w/T.W.,				
65-66	Pass. w/T.W.	3783459	1	1.75	LEVER ASSY., control (w/knob)
62-66	Chevy, Chevelle,				
65-66	Pass. w/Tel. W. (exc. Caprice, S.S.)	3782965	1	.46	KNOB, control lever, release lever
65-67	Caprice, S.S. w/T.W.,				
68	Pass., Chevelle (exc. S.S. 427, Speed Cruise Cont.),				
69-70	All	3973060	1	.24	KNOB, control and release lever (black)
67	All,				
68	Camaro w/T.W.	3898283	1	.46	KNOB (black)
68	All (exc. Speed Cruise Cont.)	3923903	1	.50	KNOB (dk. gold w/chrome)

**2.906 HOUSING— COVER— GUIDE— SPRING— CUP— SUPPORT ASSY.—  
SCREW— SHIELD, Direction Control Switch**

64-65	Chevy (exc. P.G.),				
64-65	Chevy (S.S.) w/P.G.	3873162	1	2.00	
65-67	Pass. (exc. T.W.)	3840851	1	2.10	
67-68	All	5698373	1	5.70	w/round hole
67-68	All	7800436	1	4.00	w/slotted hole
	<i>NOTE 1 Used with boyne switch.</i>				
66	Pass. (T.W. w/Tel. W.)	5694942	1	45.50	HOUSING ASSY., w/actuator, turn signal— (6.514)
67-68	Chevelle, Chevy, Camaro (exc. T.W.),				
67-68	Pass. (exc. T.W., 3-Spd.)	5698375	1	9.10	HOUSING ASSY., turn sig. switch
69-75	All w/T.W.	7805986	1	20.15	HOUSING ASSY., turn signal and ign. switch
69	Chevy, Chevelle, Camaro (exc. T.W.),				
69	Pass. (col. shift w/3-Spd.),				
70-75	All (exc. T.W., Vega, Monza)	7811172	1	18.80	HOUSING ASSY., turn signal switch
71-75	Vega, Monza (exc. T.W.)	7810575	1	18.15	HOUSING ASSY., turn signal switch
67-68	All	5699961	1	1.80	COVER, signal switch and horn wire
67-68	Pass., Chevelle, Camaro w/T.W.	7800499	1	9.00	COVER, strg. column switch actuator (Note 1)
	<i>NOTE 1 Used with Delco switch.</i>				
69-75	All (exc. T.W.)	7804558	1	1.35	COVER, signal switch and horn wire
69-75	All w/T.W.	7815106	1	1.90	COVER, signal switch and horn wire
73-75	Pass., Camaro (exc. T.W.)	7806901	1	1.90	COVER, strg. col. sig. switch and horn wire
73	Chevelle (exc. T.W.)	7814784	1	2.25	COVER, strg. col. sig. switch and horn wire
73-75	Camaro (exc. T.W.)	7805987	1	25.75	COVER ASSY., w/lock strg. sol. strg. shaft
67-68	Chevy, Chevelle, Camaro	7801578	1	1.90	GUIDE, sig. switch and horn wire
67-68	All (exc. T.W.)	7800151	1	.32	SPRING, upper brg. hsg. retainer
69-75	All (exc. T.W.)	7804413	1	.44	CUP, turn signal switch hsg. thrust
67-68	Pass., Chevelle, Camaro w/floor shift	5698847	1	12.50	SUPPORT ASSY., strg. col.— (6.514)
67-68	Pass., Chevelle, Camaro w/column shift	5698649	1	14.85	SUPPORT ASSY., strg. col.— (6.514)
69	Pass., Chevelle, Camaro w/T.W.,				
70	All,				
71	All w/T.W.	7807635	1	17.20	SUPPORT ASSY., turn sig. hsg.— (6.514)
69-75	All (exc. T.W.)	7806867	4	.13	SCREW, signal switch hsg.
73-75	Camaro (exc. T.W.)	7806057	1	2.75	SHIELD, strg. col. turn sig. lever opening



**CHASSIS—ELECTRICAL SYSTEM**

---

**2.910 ROLLER— SPRING— YOKE ASSY., Direction Signal Lamp (Detent)**

<b>62</b>	Chevy .....	<b>5950163</b>	<b>1</b>	<b>.16</b>	<b>SPRING, tension</b> .....
<b>64-66</b>	Pass., Chevelle w/T.W. ....	<b>1964461</b>	<b>1</b>	<b>.14</b>	<b>SPRING, yoke assy. detent</b> .....
<b>67-70</b>	All .....	<b>1967684</b>	<b>1</b>	<b>.10</b>	<b>SPRING</b> .....
<b>63-66</b>	Pass. w/T.W. ....	<b>1966809</b>	<b>1</b>	<b>2.15</b>	<b>YOKE ASSY., actuator</b> .....
<b>64-66</b>	Chevelle w/T.W. ....	<b>1967311</b>	<b>1</b>	<b>2.15</b>	<b>YOKE ASSY., turn sign. actuator</b> .....
<b>67-68</b>	Chevy, Chevelle, Camaro .....	<b>1967674</b>	<b>1</b>	<b>.58</b>	<b>YOKE ASSY., turn sign. actuator</b> .....



# CHEVROLET CHASSIS GROUP 3.000



## FUEL — EXHAUST — CARBURETION

### ALPHABETICAL INDEX

<b>A</b>			
ACTUATOR, Air Cleaner Intake Valve .....	3.415	BRACE, Engine Intake .....	3.265
ACTUATOR, Air Cleaner .....	3.417	BRACE, Muffler .....	3.704
ACTUATOR, Exhaust Manifold Heat Control Valve .....	3.640	BRACE, Speed and Cruise Control .....	3.880
ADAPTER, Air Cleaner to Carb. ....	3.407	BRACKET, Accelerator Pedal .....	3.452
ADAPTER, Air Cleaner .....	3.417	BRACKET, Accelerator Pull Back .....	3.459
ADAPTER, Air Injection Reactor .....	3.675	BRACKET, Accelerator .....	3.454
ADAPTER, Manifold Vacuum Take-Off .....	3.278	BRACKET, Air Cleaner Intake Valve .....	3.415
ADAPTER, Speed and Cruise Control Power..	3.885	BRACKET, Air Cleaner .....	3.405
ADAPTER UNIT, Carburetor and Fuel Meter Fuel Inlet .....	3.740	BRACKET, Air Cleaner .....	3.417
AIR CLEANER, Air Injection Reactor .....	3.672	BRACKET, Air Injection Reactor Pump Mounting .....	3.655
ANTI SQUEAK, Accelerator .....	3.451	BRACKET, Air Injection Reactor Pump .....	3.665
ARM, Carburetor Idle Vapor Vent .....	3.852	BRACKET, Air Injection Reactor Valve .....	3.670
ARM, Carburetor Pump .....	3.845	BRACKET ASSY., Carburetor .....	3.755
ARM, Carburetor Throttle .....	3.762	BRACKET, Automatic Choke Control .....	3.750
		BRACKET, Carburetor and Fuel Meter Intake (w/seat and gasket) .....	3.814
		BRACKET, Carburetor Air .....	3.730
		BRACKET, Carburetor Throttle Return Check .....	3.440
		BRACKET, Carburetor Throttle Return Check .....	3.444
		BRACKET, Carburetor Vacuum .....	3.765
		BRACKET, Carburetor .....	3.890
		BRACKET, Catalytic Converter .....	3.685
		BRACKET, Catalytic Converter .....	3.690
		BRACKET, Fuel Feed Pipe .....	3.162
		BRACKET, Fuel Injection .....	3.302
		BRACKET, Fuel Injector .....	3.330
		BRACKET, Fuel Pump Mounting .....	3.901
		BRACKET, Fuel Tank Evaporative Control .....	3.120
		BRACKET, Fuel Tank Evaporative Control .....	3.130
		BRACKET, Hand Control Wires and Tubes .....	3.483
		BRACKET, Manifold Heat Control Valve .....	3.641
		BRACKET, Manifold .....	3.602
		BRACKET, Muffler Tail Pipe .....	3.706
		BRACKET, Muffler .....	3.704
		BRACKET, Speed and Cruise Control Power..	3.885
		BRACKET, Speed and Cruise Control .....	3.880
		BRAKE ASSY., Carburetor .....	3.755
		BREATHER, Air Cleaner .....	3.410
		BUMPER, Air Cleaner .....	3.417
		BUMPER, Fuel Pump .....	3.903
		BUSHING, Carburetor and Fuel Injection Choke .....	3.752
		BUSHING, Carburetor Fast Idle Cam .....	3.767
		BUSHING, Carburetor Throttle .....	3.762
		BUSHING, Exhaust Manifold .....	3.647
		BUSHING, Throttle Control Rod .....	3.425
		BUTTON, Speed and Cruise Selector .....	3.883
		<b>C</b>	
		CABLE ASSY., Carburetor to Accelerator Lever .....	3.430
		CABLE ASSY., Speed and Cruise Control .....	3.880
		CAM, Carburetor and Fuel Injection Fast Idle .....	3.766
		CAM, Carburetor Pump .....	3.842
		CAM, Fuel Tank Gauge .....	3.107
		CANISTER, Fuel Tank Evaporative Control .....	3.130
		CAP, Air Injection Reactor Valve .....	3.670
		CAP, Carburetor and Fuel Meter Float Lever .	3.747

## ALPHABETICAL INDEX

CAP, Carburetor Float.....	3.734	DIAPHRAGM ASSY., Carburetor.....	3.755
CAP, Carburetor Idle Vapor Vent.....	3.852	DIAPHRAGM ASSY., Screw Carburetor	
CAP, Fuel Tank Evaporative Control.....	3.130	Throttle.....	3.758
CAP, Fuel Tank Filler Cap.....	3.028	DIAPHRAGM UNIT, Fuel and Vacuum Pump	
CARBURETORS.....	3.725	Repair.....	3.925
CATALYST PKG., Catalytic Converter.....	3.685	DIAPHRAGM, Fuel Pump Pulsator.....	3.910
CHAIN ASSY., Speed and Cruise Control		DOME, Fuel and Vacuum Pump Repair.....	3.925
Power.....	3.885	DOOR, Air Cleaner.....	3.417
CLAMP, Air Cleaner.....	3.405	DUCT, Air Cleaner.....	3.417
CLAMP, Air Cleaner.....	3.417		
CLAMP, Air Injection Reactor.....	3.680	<b>E</b>	
CLAMP, Carburetor Air Valve.....	3.757	ELBOW, Air Cleaner.....	3.417
CLAMP, Carburetor Throttle Return Check....	3.444	ELBOW, Air Injection Reactor.....	3.680
CLAMP, Carburetor.....	3.890	ELBOW, Fuel Lines.....	3.163
CLAMP, Catalytic Converter.....	3.685	ELBOW, Fuel Pump Mounting.....	3.901
CLAMP, Exhaust Pipe Support.....	3.616	ELEMENT, Air Cleaner.....	3.410
CLAMP, Fuel Feed Pipe.....	3.162	ELEMENT, Air Injection Reactor.....	3.672
CLAMP, Fuel Tank Filler.....	3.003	ELEMENT, Carburetor.....	3.890
CLAMP, Hand Control Wires and Tubes.....	3.483	ELEMENT, Speed and Cruise Control.....	3.887
CLAMP, Manifold.....	3.273	EXTENSION, Air Cleaner.....	3.417
CLAMP, Muffler Exhaust Pipe and Tail Pipe...	3.708	EXTENSION, Air Injection Reactor.....	3.675
CLAMP, Muffler Tail Pipe.....	3.706	EXTENSION, Engine to Muffler Exhaust.....	3.609
CLAMP UNIT, Muffler Exhaust Pipe and Tail		EXTENSION, Fuel Injector.....	3.330
Pipe.....	3.708	EXTENSION, Muffler Tail.....	3.705
CLAMP UNIT, Muffler.....	3.704		
CLEANER, Carburetor Air.....	3.402	<b>F</b>	
CLIP, Air Injection Reactor.....	3.675	FAN, Air Injection Reactor Pump.....	3.665
CLIP, Air Injection Reactor.....	3.680	FASTENER, Throttle Control Rod.....	3.425
CLIP, Carburetor (with Leather and Shaft)....	3.838	FILTER ASSY., Carburetor Idle Air	
CLIP, Carburetor and Fuel Injection Choke....	3.752	Compensator.....	3.820
CLIP, Carburetor and Fuel Meter Intake (w/		FILTER, Carburetor and Fuel Meter Fuel	
seat and gasket).....	3.814	Inlet.....	3.740
CLIP, Carburetor Pump.....	3.842	FILTER, Carburetor Air.....	3.402
CLIP, Carburetor Throttle.....	3.762	FILTER, Fuel Tank Evaporative Control.....	3.130
CLIP, Fuel Feed Pipe.....	3.162	FILTER, NUT, Carburetor and Fuel Meter	
CLIP, Fuel Tank Evaporative Control.....	3.120	Fuel Inlet.....	3.740
CLIP, Fuel Tank Evaporative Control.....	3.130	FITTING, Air Injection Reactor.....	3.680
CLIP, Fuel Tank Filler.....	3.003	FITTING ASSY., Speed and Cruise Control....	3.880
CLIP, Fuel Tank.....	3.015	FITTING, Carburetor and Fuel Meter Fuel	
CLIP, Speed and Cruise Control Power.....	3.885	Inlet.....	3.740
CLIP, Speed and Cruise Control.....	3.887	FITTING, Carburetor Pump.....	3.842
CLIP, Throttle Control Rod.....	3.425	FITTING, Manifold Vacuum Take-Off.....	3.278
COIL, Automatic Choke Control.....	3.750	FITTING, Oil Pressure Gauge.....	3.374
COMPENSATOR KIT, Carburetor Idle Air		FLANGE, Air Cleaner.....	3.417
Compensator.....	3.820	FLANGE, Exhaust Pipe Packing.....	3.610
CONNECTOR, Air Injection Reactor.....	3.675	FLOAT, Carburetor and Fuel Meter.....	3.745
CONNECTOR, Carburetor and Fuel Meter		FRAME, Air Cleaner Intake Valve.....	3.415
Fuel Inlet.....	3.740	FUEL FILTER ASSY., Carburetor.....	3.890
CONNECTOR, Carburetor.....	3.755	FUEL RAIL, Fuel Injector.....	3.330
CONNECTOR, Fuel Lines.....	3.163		
CONNECTOR, Fuel Pump Mounting.....	3.901	<b>G</b>	
CONNECTOR, Fuel Tank Evaporative Control		GASKET, Accelerator Rod Linkage.....	3.469
Control Assy., Carburetor Vacuum.....	3.765	GASKET, Air Cleaner Oil.....	3.406
CONTROL ASSY., Carburetor.....	3.755	GASKET, Air Cleaner.....	3.403
CONTROL ASSY., Speed and Cruise Control....	3.880	GASKET, Air Cleaner.....	3.417
CONTROL, Fuel Injection.....	3.300	GASKET, Air Injection Reactor Valve.....	3.670
CONVERTER, Catalytic Converter.....	3.685	GASKET, Air Injection Reactor.....	3.680
COVER, Air Cleaner.....	3.410	GASKET, Automatic Choke Control.....	3.750
COVER, Air Cleaner.....	3.417	GASKET, Carburetor and Fuel Meter Fuel	
COVER ASSY., Carburetor Idle Air		Inlet.....	3.740
Compensator.....	3.820	GASKET, Carburetor to Manifold.....	3.726
COVER ASSY., Carburetor Pump.....	3.844	GASKET, Carburetor Float Bowl to Cover (or	
COVER, Automatic Choke Control.....	3.750	Air Horn).....	3.738
COVER, Carburetor (with Leather and Shaft)...	3.838	GASKET, Carburetor Idle Air Compensator....	3.820
COVER, Carburetor Power.....	3.858	GASKET, Carburetor.....	3.890
COVER, Carburetor.....	3.755	GASKET, Exhaust Pipe.....	3.611
COVER, Fuel Tank Evaporative Control.....	3.120	GASKET, Fuel Pump Bowl and Mounting.....	3.904
COVER, Fuel Tank Filler Neck.....	3.008	GASKET, Fuel Pump.....	3.903
COVER, Speed and Cruise Control.....	3.880	GASKET, Fuel Tank Evaporative Control.....	3.120
COVER, Speed and Cruise Control.....	3.887	GASKET, Fuel Tank Evaporative Control.....	3.130
CUSHION, Air Cleaner.....	3.417	GASKET, Fuel Tank Filler Neck.....	3.008
		GASKET, Fuel Tank Gauge.....	3.112
<b>D</b>			
DAMPENER, Exhaust Pipe Support.....	3.616		
DASH POT ASSY., Carburetor Throttle			
Return Check.....	3.440		
DELAYER ASSY., Carburetor and Fuel			
Injection Choke.....	3.752		
DIAPHRAGM ASSY., Carburetor (with			
Leather and Shaft).....	3.838		

# ALPHABETICAL INDEX

GASKET, Intake to Exhaust Manifold.....	3.272
GASKET, Intake Manifold.....	3.270
GASKET KIT, Carburetor.....	3.724
GASKET PKG., Intake Manifold.....	3.270
GASKET, Speed and Cruise Control.....	3.887
GASKET, Venturi Cluster.....	3.790
GAUGE, Fuel Tank Gauge.....	3.107
GAUGE, Instrument Panel Fuel.....	3.108
GREASE, Air Injection Reactor Pump.....	3.665
GROMMET, Air Cleaner Intake Valve.....	3.415
GROMMET, Air Injection Reactor Valve.....	3.670
GROMMET, Automatic Choke Control.....	3.750
GROMMET, Fuel Injection.....	3.300
GROMMET, Fuel Injector.....	3.330
GROMMET, Fuel Tank Filler Neck.....	3.008
GROMMET, Speed and Cruise Control.....	3.880
GUARD, Engine Intake.....	3.265
GUIDE, Carburetor Pump Outlet Valve.....	3.825
GUIDE, Speed and Cruise Control Power.....	3.885

## H

HANDLE, Fuel Tank Filler Cap.....	3.028
HANGER ASSY., Exhaust Pipe Support.....	3.616
HANGER ASSY., Muffler Tail Pipe.....	3.706
HANGER ASSY., Muffler.....	3.704
HANGER, Catalytic Converter.....	3.685
HANGER, Catalytic Converter.....	3.690
HARNESS ASSY., Speed and Cruise Control.....	3.887
HOLDER UNIT, Carburetor Metering.....	3.806
HORN ASSY., Carburetor Air.....	3.730
HOSE, Air Cleaner to Carb.....	3.407
HOSE, Air Cleaner.....	3.417
HOSE, Air Injection Reactor.....	3.675
HOSE, Carburetor and Fuel Injection Choke.....	3.752
HOSE, Carburetor Idle Air Compensator.....	3.820
HOSE, Carburetor Throttle Return Check.....	3.444
HOSE, Carburetor.....	3.755
HOSE, Fuel Injector.....	3.330
HOSE, Fuel Lines.....	3.163
HOSE, Fuel Pump Mounting.....	3.901
HOSE, Fuel Tank Filler.....	3.003
HOSE, Speed and Cruise Control Power.....	3.885
HOUSING, Automatic Choke Control.....	3.750
HOUSING, Carburetor and Fuel Injection Choke.....	3.752
HOUSING, Carburetor Power.....	3.858

## I

INSERT, Carburetor Float.....	3.734
INSULATOR, Carburetor and Fuel Injection Choke.....	3.752
INSULATOR, Carburetor to Manifold.....	3.726
INSULATOR, Fuel Tank.....	3.022
INSULATOR, Muffler Tail Pipe.....	3.706
INSULATOR, Muffler.....	3.704

## J

JET, Carburetor Idle.....	3.798
JET, Carburetor Metering Rod, with Gasket.....	3.792

## K

KIT, Fuel and Vacuum Pump Repair.....	3.925
---------------------------------------	-------

## L

LEVER, Accelerator.....	3.454
LEVER ASSY., Carburetor Throttle Valve and Throttle Lever Adjusting.....	3.761
LEVER ASSY., Speed and Cruise Control.....	3.887
LEVER, Carburetor and Fuel Injection Choke.....	3.752
LEVER, Carburetor and Fuel Injection Fast Idle.....	3.766
LEVER, Carburetor Air Valve.....	3.757
LEVER, Carburetor Power.....	3.858
LEVER, Carburetor Pump Connector.....	3.843
LEVER, Carburetor Pump.....	3.842
LEVER, Carburetor Throttle.....	3.762
LIMITER, Carburetor and Fuel Injection Idle Adjusting Screw.....	3.823
LINK, Carburetor and Fuel Injection Choke.....	3.752
LINK, Carburetor Power.....	3.858
LINK, Carburetor Pump Connector.....	3.843
LINK, Carburetor.....	3.755
LOCK, Air Injection Reactor Valve.....	3.670
LOCK, Exhaust Manifold Bolt.....	3.604
LOCK, Exhaust Pipe.....	3.613
LOOM, Fuel Lines.....	3.163

## M

MAGNET ASSY., Speed and Cruise Control.....	3.887
MANIFOLD, Engine Exhaust.....	3.601
MANIFOLD, Engine Intake.....	3.265
MANIFOLD, Fuel Injector.....	3.330
METER, Fuel Tank Gauge.....	3.107
MOTOR ASSY., Speed and Cruise Control.....	3.887
MOUNT, Fuel Injection.....	3.300
MOUNTING ASSY., Fuel Pump Mounting.....	3.901
MUFFLER ASSY., Engine to Muffler Exhaust.....	3.609
MUFFLER, Engine Exhaust.....	3.701

## N

NECK, Fuel Tank Filler.....	3.003
NEEDLE, Carburetor Pump Outlet Valve.....	3.825
NEEDLE UNIT, Carburetor and Fuel Injection Idle Adjusting.....	3.822
NEEDLE UNIT, Carburetor and Fuel Meter Intake (w/seat and gasket).....	3.814
NIPPLE, Carburetor.....	3.755
NOZZLE, Carburetor.....	3.774
NUT, Air Cleaner.....	3.403
NUT, Air Injection Reactor Pump Mounting.....	3.655
NUT, Carburetor and Fuel Injection Choke.....	3.752
NUT, Carburetor and Fuel Meter Fuel Inlet.....	3.740
NUT, Carburetor and Fuel Meter Intake (w/seat and gasket).....	3.814
NUT, Carburetor Idle Vapor Vent.....	3.852
NUT, Carburetor Throttle.....	3.762
NUT, Catalytic Converter.....	3.685
NUT, Exhaust Pipe.....	3.613
NUT, Fuel Lines.....	3.163
NUT, Fuel Tank Strap.....	3.023
NUT, Muffler Tail Pipe.....	3.706
NUT, Muffler.....	3.704

## P

PACKING, Automatic Choke Control.....	3.750
PACKING, Exhaust Pipe.....	3.611
PEDAL, Accelerator.....	3.451
PIN, Accelerator Intermediate.....	3.463
PIN, Accelerator Pedal.....	3.452
PIN, Carburetor and Fuel Injection Choke.....	3.752
PIN, Carburetor and Fuel Meter Float Lever.....	3.747
PIN, Carburetor Throttle Return Check.....	3.440
PIN, Manifold Heat Control Valve.....	3.641

## ALPHABETICAL INDEX

PIN, Throttle Control Rod.....	3.425
PIPE, Air Injection Reactor.....	3.675
PIPE ASSY., Automatic Choke Control.....	3.750
PIPE, Carburetor and Fuel Meter Fuel Inlet...	3.740
PIPE, Catalytic Converter.....	3.685
PIPE, Engine to Muffler Exhaust.....	3.609
PIPE, Exhaust Manifold.....	3.647
PIPE, Fuel Injector.....	3.330
PIPE, Fuel Lines.....	3.163
PIPE, Fuel Tank Evaporative Control.....	3.120
PIPE, Intake & Exhaust Manifold.....	3.275
PIPE, Muffler Tail.....	3.705
PISTON, Carburetor and Fuel Injection Choke.....	3.752
PISTON, Carburetor Power.....	3.858
PLATE, Accelerator.....	3.451
PLATE, Air Cleaner.....	3.417
PLATE, Automatic Choke Control.....	3.750
PLATE, Carburetor Float.....	3.734
PLATE, Carburetor Power.....	3.858
PLATE, Fuel Meter Enrichment.....	3.320
PLATE, Fuel Pump Mounting.....	3.901
PLATE, Speed and Cruise Control.....	3.880
PLUG, Air Injection Reactor Valve.....	3.670
PLUG, Air Injection Reactor.....	3.680
PLUG, Automatic Choke Control.....	3.750
PLUG, Carburetor and Fuel Meter Float Lever.....	3.747
PLUG, Carburetor Idle Vapor Vent.....	3.852
PLUG, Carburetor Nozzle Passage.....	3.775
PLUG, Carburetor Pump Outlet Valve.....	3.825
PLUG, Engine Intake.....	3.265
PLUNGER, Carburetor (with Leather and Shaft).....	3.838
PROTECTOR, Speed and Cruise Control.....	3.887
PULLEY, Air Injection Reactor.....	3.650
PUMP ASM., Carburetor (with Leather and Shaft).....	3.838
PUMP ASSY., Air Injection Reactor Pump.....	3.660
PUMP ASSY., Fuel with Gasket.....	3.900
PUMP, Fuel Tank Gauge.....	3.107

### R

REGULATOR ASSY., Fuel Pump Pulsator.....	3.910
REGULATOR ASSY., Speed and Cruise Control Power.....	3.885
REINFORCEMENT, Accelerator Pedal.....	3.452
REINFORCEMENT, Accelerator.....	3.454
REINFORCEMENT, Exhaust Pipe Support.....	3.616
RELAY, Air Cleaner Intake Valve.....	3.415
RELAY ASSY., Carburetor Throttle Return Check.....	3.440
RELAY ASSY., Speed and Cruise Control.....	3.887
REPAIR KITS.....	3.725
REPAIR PKG., Catalytic Converter.....	3.685
REPAIR PKG., Fuel Tank Evaporative Control	3.130
RESERVOIR, Fuel Lines.....	3.163
RESONATOR ASSY., Muffler Tail.....	3.702
RESONATOR, Muffler Tail.....	3.705
RESTRICTOR, Fuel Tank Evaporative Control	3.130
RESTRICTOR, Fuel Tank Filler.....	3.003
RETAINER, Accelerator.....	3.454
RETAINER, Air Cleaner Intake Valve.....	3.415
RETAINER, Air Cleaner.....	3.410
RETAINER, Air Injection Reactor.....	3.675
RETAINER, Air Injection Reactor.....	3.680
RETAINER, Automatic Choke Control.....	3.750
RETAINER, Carburetor and Fuel Injection Choke.....	3.752
RETAINER, Carburetor and Fuel Injection Fast Idle.....	3.766
RETAINER, Carburetor and Fuel Meter Intake (w/seat and gasket).....	3.814
RETAINER, Carburetor Idle Vapor Vent.....	3.852
RETAINER, Carburetor Idle.....	3.798
RETAINER, Carburetor Power.....	3.858
RETAINER, Carburetor Pump Inlet Valve.....	3.826
RETAINER, Carburetor Pump Outlet Valve.....	3.825
RETAINER, Carburetor Pump.....	3.841
RETAINER, Carburetor Throttle.....	3.762

RETAINER, Fuel Pump Bowl and Mounting....	3.904
RETAINER, Fuel Pump Mounting.....	3.901
RETAINER, Muffler Tail Pipe.....	3.706
RETAINER, Muffler.....	3.704
RETAINER, Speed and Cruise Control.....	3.880
RETAINER, Throttle Control Rod.....	3.425
RING, Accelerator Pedal.....	3.452
RING, Accelerator.....	3.454
RING, Automatic Choke Control.....	3.750
RING, Carburetor and Fuel Meter Fuel Inlet..	3.740
RING, Carburetor Pump.....	3.842
RING, Exhaust Pipe.....	3.611
RING, Fuel Tank Filler.....	3.003
ROD, Accelerator Pedal to Lever.....	3.431
ROD, Carburetor and Fuel Injection Choke....	3.752
ROD, Carburetor to Accelerator Lever.....	3.430
ROD, Carburetor Air Valve.....	3.757
ROD, Carburetor Fast Idle.....	3.768
ROD, Carburetor Metering.....	3.806
ROD, Carburetor Power.....	3.858
ROD, Carburetor Pump Connector.....	3.843
ROD, Carburetor Throttle.....	3.762
ROD, Carburetor.....	3.755
ROD, Fuel Pump.....	3.935
ROD, Hand Choke with Button, Wire and Tube.....	3.480
ROD, Speed and Cruise Control Power.....	3.885

### S

SCREEN, Air Cleaner Intake Valve.....	3.415
SCREEN, Air Cleaner.....	3.417
SCREEN, Carburetor and Fuel Meter Fuel Inlet.....	3.740
SCREEN, Carburetor Pump.....	3.841
SCREW, Air Cleaner.....	3.403
SCREW, Air Cleaner.....	3.417
SCREW, Air Injection Reactor Pump.....	3.665
SCREW, Air Injection Reactor.....	3.680
SCREW ASSY., Carburetor Pump.....	3.845
SCREW, Automatic Choke Control.....	3.750
SCREW, Carburetor (with Leather and Shaft)	3.838
SCREW, Carburetor and Fuel Injection Choke.....	3.752
SCREW, Carburetor and Fuel Injection Fast Idle.....	3.766
SCREW, Carburetor and Fuel Injection Idle Adjusting.....	3.822
SCREW, Carburetor and Fuel Meter Intake (w/seat and gasket).....	3.814
SCREW, Carburetor Air Valve.....	3.757
SCREW, Carburetor Air.....	3.730
SCREW, Carburetor Body.....	3.741
SCREW, Carburetor Choke.....	3.751
SCREW, Carburetor Fast Idle Cam.....	3.767
SCREW, Carburetor Idle Air Compensator.....	3.820
SCREW, Carburetor Idle Vapor Vent.....	3.852
SCREW, Carburetor Power.....	3.858
SCREW, Carburetor Pump Outlet Valve.....	3.825
SCREW, Carburetor Pump.....	3.841
SCREW, Carburetor Pump.....	3.842
SCREW, Carburetor Throttle Return Check ...	3.440
SCREW, Carburetor Throttle Return Check ...	3.444
SCREW, Carburetor Throttle Valve and Throttle Lever Adjusting.....	3.761
SCREW, Carburetor Throttle.....	3.762
SCREW, Carburetor.....	3.755
SCREW, Carburetor.....	3.786
SCREW, Fuel Pump Mounting.....	3.901
SCREW, Fuel Tank Filler Cap.....	3.028
SCREW, Fuel Tank Strap.....	3.023
SCREW, Muffler Exhaust Pipe and Tail Pipe..	3.708
SCREW, Muffler Tail Pipe.....	3.706
SCREW, Muffler.....	3.704
SCREW, Venturi Cluster.....	3.790
SEAL, Air Cleaner Intake Valve.....	3.415
SEAL, Air Cleaner.....	3.417
SEAL, Air Injection Reactor Pump.....	3.665
SEAL, Carburetor and Fuel Injection Choke...	3.752
SEAL, Carburetor Float.....	3.734
SEAL, Carburetor Idle Air Compensator.....	3.820

## ALPHABETICAL INDEX

<p>SEAL, Fuel Pump Bowl and Mounting..... 3.904</p> <p>SEAL, Fuel Tank Filler Neck..... 3.008</p> <p>SEAL, Injection Valve to Intake Manifold..... 3.304</p> <p>SENDER, Fuel Tank Gauge..... 3.107</p> <p>SENSOR ASSY., Fuel Meter Enrichment..... 3.320</p> <p>SENSOR UNIT, Air Cleaner Intake Valve..... 3.415</p> <p>SEPARATOR, Fuel Tank Evaporative Control..... 3.120</p> <p>SERVO ASSY., Speed and Cruise Control Power..... 3.885</p> <p>SHAFT ASSY., Speed and Cruise Control..... 3.880</p> <p>SHAFT, Carburetor and Fuel Injection Choke..... 3.752</p> <p>SHAFT, Carburetor and Fuel Meter..... 3.745</p> <p>SHAFT, Carburetor Air Valve..... 3.757</p> <p>SHAFT UNIT, Carburetor Choke..... 3.751</p> <p>SHIELD, Automatic Choke Control..... 3.750</p> <p>SHIELD, Carburetor Idle Vapor Vent..... 3.852</p> <p>SHIELD, Carburetor Throttle Return Check..... 3.444</p> <p>SHIELD, Fuel Lines..... 3.163</p> <p>SHIELD, Fuel Meter Enrichment..... 3.320</p> <p>SHIELD, Fuel Tank..... 3.015</p> <p>SHIELD, Manifold..... 3.602</p> <p>SHIELD, Muffler Tail..... 3.705</p> <p>SHOE, Air Injection Reactor Pump..... 3.665</p> <p>SILENCER ASSY., Air Injection Reactor..... 3.672</p> <p>SILENCER, Carburetor Air..... 3.402</p> <p>SLEEVE, Accelerator Intermediate..... 3.463</p> <p>SLEEVE, Fuel Lines..... 3.163</p> <p>SLEEVE, Speed and Cruise Control..... 3.880</p> <p>SLEEVE, Throttle Control Rod..... 3.425</p> <p>SOLENOID ASSY., Carburetor Idle Air Compensator..... 3.820</p> <p>SOLENOID ASSY., Carburetor..... 3.755</p> <p>SOLENOID, Air Cleaner Intake Valve..... 3.415</p> <p>SOLENOID, Carburetor and Fuel Injection Choke..... 3.752</p> <p>SOLENOID, Carburetor Throttle Return Check..... 3.440</p> <p>SOLENOID, Engine Fuel or Air Inlet Shut Down..... 3.485</p> <p>SOLENOID, Exhaust Manifold Heat Control Valve..... 3.640</p> <p>SOLENOID, Heat Valve..... 3.140</p> <p>SPACER, Air Cleaner..... 3.417</p> <p>SPACER, Air Injection Reactor Pump Mounting..... 3.655</p> <p>SPACER, Carburetor and Fuel Injection Choke..... 3.752</p> <p>SPACER, Carburetor and Fuel Meter Fuel Inlet..... 3.740</p> <p>SPACER, Catalytic Converter..... 3.685</p> <p>SPACER, Exhaust Manifold..... 3.647</p> <p>SPACER, Fuel Tank Strap..... 3.023</p> <p>SPRING, Accelerator Pull Back..... 3.459</p> <p>SPRING, Air Injection Reactor Pump..... 3.665</p> <p>SPRING, carburetor Metering Rod..... 3.810</p> <p>SPRING, Carburetor and Fuel Injection Choke..... 3.752</p> <p>SPRING, Carburetor and Fuel Injection Fast Idle..... 3.766</p> <p>SPRING, Carburetor and Fuel Injection Idle Adjusting Screw..... 3.823</p> <p>SPRING, Carburetor and Fuel Meter Float Lever..... 3.747</p> <p>SPRING, Carburetor and Fuel Meter Fuel Inlet..... 3.740</p> <p>SPRING, Carburetor Air Valve..... 3.757</p> <p>SPRING, Carburetor Choke..... 3.753</p> <p>SPRING, Carburetor Idle Vapor Vent..... 3.852</p> <p>SPRING, Carburetor Power Piston..... 3.859</p> <p>SPRING, Carburetor Pump Outlet Valve..... 3.825</p> <p>SPRING, Carburetor Pump..... 3.841</p> <p>SPRING, Carburetor Throttle Return Check.... 3.440</p> <p>SPRING, Carburetor Throttle Shaft..... 3.763</p> <p>SPRING, Carburetor Throttle Valve and Throttle Lever Adjusting..... 3.761</p> <p>SPRING, Carburetor..... 3.755</p> <p>SPRING, Fuel Pump Rocker Arm..... 3.927</p> <p>SPRING, Manifold Heat Control Valve..... 3.641</p> <p>SPRING, Speed and Cruise Control Power..... 3.885</p> <p>STOVE, Air Cleaner..... 3.417</p> <p>STRAINER, Carburetor and Fuel Meter Fuel Inlet..... 3.740</p> <p>STRAINER, Fuel Tank Gauge..... 3.110</p> <p>STRAP, Air Cleaner..... 3.417</p>	<p>STRAP, Air Injection Reactor Valve..... 3.670</p> <p>STRAP, Fuel Tank..... 3.022</p> <p>STRAP, Muffler Tail Pipe..... 3.706</p> <p>STRIKER, Speed and Cruise Control..... 3.880</p> <p>STUD, Accelerator Intermediate..... 3.463</p> <p>STUD, Accelerator Pedal..... 3.452</p> <p>STUD, Air Cleaner..... 3.403</p> <p>STUD, Air Cleaner..... 3.417</p> <p>STUD, Air Injection Reactor..... 3.680</p> <p>STUD, Exhaust Pipe..... 3.613</p> <p>STUD, Intake &amp; Exhaust Manifold..... 3.275</p> <p>STUD, Intake Manifold to Carburetor..... 3.288</p> <p>STUD, Manifold..... 3.602</p> <p>STUD, Speed and Cruise Control..... 3.880</p> <p>STUD, Throttle Control Rod..... 3.425</p> <p>SUPPORT, Accelerator Pedal to Lever..... 3.431</p> <p>SUPPORT, Accelerator Pedal..... 3.452</p> <p>SUPPORT, Accelerator..... 3.454</p> <p>SUPPORT, Air Cleaner..... 3.417</p> <p>SUPPORT, Carburetor Throttle Return Check..... 3.444</p> <p>SUPPORT, Carburetor..... 3.890</p> <p>SUPPORT, Catalytic Converter..... 3.685</p> <p>SUPPORT, Catalytic Converter..... 3.690</p> <p>SUPPORT, Exhaust Pipe Support..... 3.616</p> <p>SUPPORT, Fuel Injection..... 3.302</p> <p>SUPPORT, Fuel Tank Evaporative Control..... 3.130</p> <p>SUPPORT, Fuel Tank..... 3.015</p> <p>SUPPORT, Muffler..... 3.704</p> <p>SUPPORT, Speed and Cruise Control..... 3.880</p> <p>SWITCH, Air Cleaner Intake Valve..... 3.415</p> <p>SWITCH, Air Injection Reactor Valve..... 3.670</p> <p>SWITCH ASSY., Carburetor Throttle Return Check..... 3.440</p> <p>SWITCH ASSY., Carburetor..... 3.755</p> <p>SWITCH ASSY., Heat Valve..... 3.140</p> <p>SWITCH, Fuel Injector Air..... 3.335</p> <p>SWITCH, Speed and Cruise Control..... 3.887</p> <p>SWITCH, Speed and Cruise Selector..... 3.883</p> <p>SWIVEL, Throttle Control Rod..... 3.425</p>
<b>T</b>	
	<p>TANK ASSY., Fuel Tank..... 3.001</p> <p>TEE, Air Injection Reactor..... 3.680</p> <p>TEE ASSY., Speed and Cruise Control..... 3.880</p> <p>TEE, Carburetor Idle Air Compensator..... 3.820</p> <p>TEE, Carburetor..... 3.755</p> <p>TEE, Fuel Lines..... 3.163</p> <p>TEE, Manifold Vacuum Take-Off..... 3.278</p> <p>TEE, Speed and Cruise Control Power..... 3.885</p> <p>THERMOSTAT ASSY., Automatic Choke Control..... 3.750</p> <p>THERMOSTAT, Exhaust Manifold Heat Control Valve..... 3.640</p> <p>TUBE, Air Cleaner..... 3.417</p> <p>TUBE, Air Injection Reactor..... 3.675</p> <p>TUBE, Air Injection Reactor..... 3.680</p> <p>TUBE ASSY., Automatic Choke Control..... 3.750</p> <p>TUBE, Carburetor Idle..... 3.818</p> <p>TUBE, Carburetor..... 3.786</p> <p>TUBE, Exhaust Manifold Choke Heat..... 3.603</p>
<b>U</b>	
	<p>U BOLT, Muffler Exhaust Pipe and Tail Pipe.. 3.708</p>
<b>V</b>	
	<p>VACUUM MOTOR PKG., Air Cleaner Intake Valve..... 3.415</p> <p>VALVE, Air Cleaner Intake Valve..... 3.415</p> <p>VALVE ASSY., Air Injection Reactor Check.... 3.670</p> <p>VALVE ASSY., Air Injection Reactor..... 3.650</p> <p>VALVE ASSY., Carburetor Idle Air Compensator..... 3.820</p>

## ALPHABETICAL INDEX

VALVE ASSY., Carburetor Pump Inlet Valve..	3.826
VALVE ASSY., Carburetor Throttle Return Check.....	3.440
VALVE ASSY., Exhaust Gas Recirculation.....	3.670
VALVE ASSY., Exhaust Manifold.....	3.647
VALVE ASSY., Fuel Mixture Control.....	3.670
VALVE ASSY., Speed and Cruise Control Power.....	3.885
VALVE, Carburetor Air Valve.....	3.757
VALVE, Carburetor Choke.....	3.751
VALVE, Carburetor Idle Vapor Vent.....	3.852
VALVE, Carburetor Throttle Return Check.....	3.440
VALVE, Fuel Injection.....	3.302
VALVE, Screw Carburetor Throttle.....	3.758
VALVE UNIT, Carburetor Power.....	3.858
VANE, Air Injection Reactor Pump.....	3.665
VEGA, MONZA.....	3.725
VENTURI, Carburetor.....	3.786

### W

WASHER, Automatic Choke Control.....	3.750
WASHER, Carburetor and Fuel Injection Choke.....	3.752
WASHER, Carburetor Air Valve.....	3.757
WASHER, Carburetor Fast Idle.....	3.768
WASHER, Carburetor Pump.....	3.842
WASHER, Carburetor Throttle Valve and Throttle Lever Adjusting.....	3.761
WASHER, Carburetor Throttle.....	3.762
WASHER, Exhaust Pipe.....	3.613
WASHER, Fuel Feed Pipe.....	3.162
WASHER, Fuel Tank Strap.....	3.023
WASHER, Intake Manifold to Carburetor.....	3.288
WASHER, Muffler.....	3.704
WASHER, Speed and Cruise Selector.....	3.883
WIRE ASSY., Air Cleaner Intake Valve.....	3.415
WIRE ASSY., Carburetor Throttle Return Check.....	3.440
WIRE ASSY., Engine Fuel or Air Inlet Shut Down.....	3.485
WIRE ASSY., Fuel Tank Extension.....	3.115
WIRE ASSY., Fuel Tank Gauge.....	3.107



**FUEL—EXHAUST—CARBURETION**

**3.001 TANK ASSY., Fuel Tank**

62-63	Chevy (exc. 3 Seat Sta. Wag.)				
64-67	Chevy	3793946	1	52.25	(16 gal.)
64	Chevle (Sta. Wag., El Camino) (exc. 3 Seat Sta. Wag.)				
65-67	Chevle (Sta. Wag., El Camino)	3857231	1	69.60	complete (20 gal.)
64-67	Chevle (exc. Sta. Wag., El Camino)				
65-66	Pass. (exc. Sta. Wag.)	3867745	1	65.25	(20 gal. inc. filler neck)
65-70	Pass. (Sta. Wag.)	3972571	1	59.15	complete (25 gal.)
67	Pass. (exc. Sta. Wag.)	3930952	1	75.00	complete (24 gal.) (Note 1)
<i>NOTE 1: Includes 3926931 Tank Assy. and 3930734, 8<sup>5</sup>/<sub>16</sub>" Long Neck Assy.</i>					
67-68	Camaro	3912377	1	56.50	complete (18 gal.)
68-70	Chevle (Sta. Wag.) (exc. E.E.C.)	398168	1	52.25	complete (20 gal.)
68-69	Chevle (exc. Sta. Wag., El Camino)				
		3940133	1	65.25	complete (20 gal.)
68-70	El Camino (exc. E.E.C.)	3930806	1	65.00	complete (20 gal.)
68-70	Chevy (exc. E.E.C.)	3998317	1	60.00	complete (18 gal.)
68-70	Pass. (exc. Sta. Wag., E.E.C.)	3968731	1	59.15	complete (25 gal.)
69	Camaro	3953844	1	56.50	complete (18 gal.)
70	Pass. w/E.E.C. (exc. Sta. Wag.)	3982841	1	73.25	complete (25 gal.)
70	Pass. (Sta. Wag.) w/E.E.C.	3972572	1	70.00	complete (25 gal.)
70	Chevle (Sta. Wag.) w/E.E.C.,				
71-72	Chevle (Sta. Wag.)	409384	1	57.75	complete (20 gal.)
70-71	El Camino w/E.E.C.,				
72	El Camino	3995767	1	65.00	complete
70	Chevle w/E.E.C. (exc. Sta. Wag., El Camino)	3998310	1	73.25	complete (20 gal.)
70	Chevle (exc. Sta. Wag., El Camino, Monte Carlo, E.E.C.)	3998309	1	65.25	complete (20 gal.)
70	Monte Carlo (exc. E.E.C.)	3998308	1	65.25	complete
70-71	Nova w/E.E.C.,				
72	Nova	3995720	1	45.00	complete
70	Camaro (exc. E.E.C.)	6263025	1	56.50	complete
71-72	Pass. (exc. Sta. Wag.)	3991011	1	72.90	complete
71	Chevle (exc. Sta. Wag., Monte Carlo, El Camino)	3995766	1	63.25	complete
71	Vega	3987345	1	44.00	complete
71	Monte Carlo	325172	1	63.25	complete (repl. 3995765)
71-74	Pass. (Sta. Wag.)	416062	1	57.75	complete (22½ gal.)
72	Chevle (exc. El Camino, Sta. Wag., Monte Carlo)	325173	1	60.00	complete
72	Monte Carlo	325172	1	63.25	complete
70-71	Camaro w/E.E.C.,				
72-73	Camaro	6272127	1	56.50	complete
72-73	Vega	6263069	1	32.50	complete
73	Pass. (exc. Sta. Wag.)	6259307	1	73.25	complete
73	Chevle (exc. El Camino, Sta. Wag.)	415418	1	58.60	(complete)
73	El Camino	6259308	1	65.00	(complete)
74	Chevle (exc. El Camino, Sta. Wag.)	344417	1	60.00	complete
73-74	Chevle (Sta. Wag.)	416366	1	57.75	complete (22 gal.)
73-74	Nova	344416	1	52.00	complete
74	El Camino	344486	1	65.00	(complete)
74	Pass. (exc. Sta. Wag.)	344418	1	63.25	(complete)
74	Camaro	344427	1	60.00	(complete)
74-75	Vega (140)	376765	1	37.50	(complete)
75	Vega (122)	345084	1	37.50	(complete)
75	Pass. (exc. Sta. Wag.)	357388	1	63.25	(complete)
75	Monza	360948	1	37.50	(complete)
75	Pass. (Sta. Wag.)	553835	1	58.00	less sender (repl. 419531)
75	Camaro	357392	1	57.20	complete
75	El Camino	357385	1	57.20	complete
75	Chevle (exc. Sta. Wag., El Camino)	357387	1	57.20	complete
75	Chevle (Sta. Wag.)	553834	1	58.00	less sender (22 gal.) (repl. 419530)
75	Nova	357393	1	53.50	complete

**3.003 NECK— CLAMP— CLIP— HOSE— RESTRICTOR— RING, Fuel Tank Filler**

63-66	Chevy	3777689	1	2.35	lower
64-67	Chevle (El Camino, Sta. Wag.) (exc. 3 Seat Sta. Wag.)	3851756	1	5.95	
65-67	Pass., Chevle (exc. Sta. Wag., El Camino)	3858955	1	4.90	w/3907183 (Note 1)

*NOTE 1 It will be necessary to cut off 1½" before installing into tank.*



**FUEL—EXHAUST—CARBURETION**

**3.003 NECK— CLAMP— CLIP— HOSE— RESTRICTOR— RING, Fuel Tank Filler**  
(Con't)

67-68	Camaro	3893113	1	5.60	upper
67	Chevy,				
67-68	Camaro	3912556	1	.32	lower
67	Pass. (exc. Sta. Wag.)	3930734	1	8.00	w/3930952
68	Pass. (exc. Sta. Wag.)	3923301	1	8.00	
68-69	Chevelle (exc. Sta. Wag., El Camino)	3937810	1	5.00	(has convolutions and spacing on neck end)
68-70	El Camino	3923359	1	5.95	
68-70	Chevy (exc. E.E.C.)	3914864	1	2.60	
69	Camaro	3939790	1	2.25	
69-70	Pass. (exc. Sta. Wag., E.E.C.)	3950291	1	4.80	
70	Pass. w/E.E.C. (exc. Sta. Wag.)	3968744	1	3.25	
70	Pass. (Sta. Wag.) w/E.E.C.	3972594	1	2.65	
70	Chevelle (exc. Sta. Wag., El Camino)	3967794	1	3.25	
70	Camaro (exc. E.E.C.)	3965634	1	2.15	
71-73	Camaro	6264049	1	2.30	
71-73	Vega	3992924	1	1.35	
74	Vega (Coupe)	339044	1	6.10	
74	Vega (exc. Coupe)	339047	1	6.10	
75	Vega (Coupe)	353922	1	8.15	
75	Vega (exc. Coupe, Export)	353921	1	8.15	
75	Vega (exc. Coupe) Export	360329	1	6.10	
75	Monza (Towne Coupe)	360310	1	6.10	
75	Monza (exc. Towne Coupe)	349520	1	6.10	
74-75	Vega, Monza	1470029	A.R.	.73	CLAMP, fuel filter pipe hose
71-73	Vega	2359058	2	.10	CLIP, fuel vent. frt. pipe to w/h (5/16" strap type)
74-75	Vega (Coupe) (122)	343442	1	.11	CLIP, fuel return pipe
62-70	All	3834073	1	5.65	HOSE, filler neck (2" I.D. x 16 3/4" O.L.)
62-70	All	9433154	A.R.	RL/.67	HOSE, vent. pipe (1/2" I.D. x 25 ft. long)—(8.962)
62-70	All	3848526	1	3.60	HOSE, filler neck (2 1/4" I.D. x 15 1/2" long)
62-70	All	328003	A.R.	2.30	HOSE, filler neck (1 3/8" I.D. x 12) (Note 2)
62-70	All	3758062	A.R.	RL/.34	HOSE (7/32" I.D.) (10 ft. roll) (gas resistant)—(8.962)
71	Vega	3988091	1	.67	HOSE, fuel vent. pipe (5/16" I.D. x 27 7/8" dev. length)
74	Pass. (Sta. Wag.)	416575	1	1.30	HOSE, vent. rear pipe
68	Chevelle (exc. Sta. Wag., El Camino)	398339	1	.12	RESTRICTOR, fuel tank vent. pipe hose
69	Chevelle (exc. Sta. Wag., El Camino)	403844	1	.11	RESTRICTOR, fuel tank vent. pipe hose
71-75	Vega, Monza	3991301	1	.18	RESTRICTOR, fuel vent. rear pipe
69-70	Pass. (exc. Sta. Wag.)	3947528	1	.64	RING, filler neck hose

**3.008 COVER— SEAL— GASKET— GROMMET, Fuel Tank Filler Neck**

71	Vega	6263026	1	1.20	(field fix)
62	Chevy (Sedan)	3792277	1	5.15	SEAL, used as tank vent. lower pipe shield—(7.833)
64-67	Chevelle (El Camino, Sta. Wag.)	580531	1	.23	SEAL
62-67	Chevy	3792459	1	.31	GASKET, flange
74-75	Vega, Monza	339071	1	.20	GASKET, filler neck
75	Monza (Towne Coupe)	360312	1	.55	GASKET, filler neck
65-68	Pass., Chevelle (exc. Sta. Wag., El Camino),				
70	Pass. (exc. Sta. Wag., E.E.C.)	3853970	1	.16	GROMMET, vent. pipe—(9.775)

**3.015 SUPPORT— CLIP— SHIELD, Fuel Tank**

64-67	Chevelle (Sta. Wag., El Camino)	383948	1	4.65	front
64-67	Chevelle (Sta. Wag., El Camino)	383961	1	4.80	rear
65-68	Pass.,				
66-68	Chevelle	540160	11	.12	CLIP, gas tank stone shield—(8.154)
75	Monza	356349	1	.37	CLIP, gas tank stone shield
68-72	Chevelle (Sta. Wag.)	398994	1	6.50	SHIELD
69-70	Pass. (Sta. Wag.)	3938074	1	3.55	SHIELD
71-72	Pass. (Sta. Wag.)	408526	1	8.20	SHIELD
74-75	Vega	353987	1	1.15	SHIELD, rear
75	Monza	356347	1	5.85	SHIELD, front
75	Monza	356348	1	5.80	SHIELD, rear

**3.022 STRAP— INSULATOR, Fuel Tank**

62-67	Chevy (1st design)	3790593	2	1.10	(27 13/16" O.L.)
-------	--------------------	---------	---	------	------------------

**FUEL—EXHAUST—CARBURETION**

**3.022 STRAP— INSULATOR, Fuel Tank (Con't)**

64-66	Chevelle (exc. Sta. Wag., El Camino),				
65-66	Pass. (exc. Sta. Wag.),				
67	Chevelle (exc. Sta. Wag.)	396711	2	2.25	(43 <sup>51</sup> / <sub>64</sub> " dev. length)
64-67	Chevelle (Sta. Wag., El Camino)	384655	2	2.10	top (Note 1)
65-70	Pass. (Sta. Wag.)	3857541	1	1.55	(13 <sup>19</sup> / <sub>32</sub> " O.L.) (w/hook bolt)
67	Pass. (exc. Sta. Wag.)	3909618	2	1.90	
67	Chevelle (Sta. Wag., El Camino)	397621	1	3.85	front (Note 1)
67-69	Camaro	3908341	2	1.35	
67	Chevy (2nd design) (exc. Sta. Wag.)	3908367	2	1.35	
68-70	Pass. (Sta. Wag.)	3931422	1	1.65	(17 <sup>5</sup> / <sub>8</sub> " dev. length)
68-70	Pass. (exc. Sta. Wag.)	3958907	2	1.95	
68-72	Chevelle (Sta. Wag.)	400676	1	2.10	lower and front strap
68-72	Chevy	3914867	2	1.45	
68-72	Chevelle (exc. Sta. Wag.)	401794	2	1.55	
70-73	Camaro	3965632	2	1.65	
71-75	Pass. (exc. Sta. Wag.),				
73-75	El Camino	411828	2	2.40	
71	Pass. (Sta. Wag.)	408013	1	1.80	frt. inner
71-72	Pass. (Sta. Wag.)	418337	1	1.55	lower (repl. 408014)
71-72	Pass. (Sta. Wag.)	418335	1	4.00	front outer
71	Vega	3978038	1	1.35	
72-73	Vega	3997278	1	1.30	
73-74	Pass., Chevelle (Sta. Wag.)	418337	1	1.55	lwr. (repl. 408014)
73-75	Chevelle (exc. Sta. Wag., El Camino)	411834	2	1.60	
73	Nova	6264093	L.H.	2.60	
73	Nova	6264094	R.H.	2.60	
74-75	Vega	339005	2	1.45	
74-75	Camaro	340304	R.H.	1.65	
74-75	Nova, Camaro	340397	L.H.	1.55	
74-75	Nova	340398	R.H.	1.55	
74-75	Chevelle (Sta. Wag.)	418341	1	2.10	
73-75	Pass. (Sta. Wag.)				front outer,
73-75	Chevelle (Sta. Wag.)	418335	1	4.00	front inner
73	Chevelle (Sta. Wag.)	408013	1	1.80	
74-75	Chevelle (Sta. Wag.)	418341	1	2.10	frt. inner
74-75	Pass. (Sta. Wag.)	418338	1	1.80	frt. inner
75	Pass., Chevelle (Sta. Wag.)	418337	1	1.55	lower
75	Monza	346587	2	1.35	
65-74	All	3785997	1	3.35	INSULATOR (16.585)

NOTE 1 On 1967 jobs use two 384655 across top of tank and one 297621 in front of tank.

**3.023 BOLT— NUT— SCREW— SPACER— WASHER, Fuel Tank Strap**

62-70	All,				
71-73	Vega,				
72	Chevy, Camaro,				
73	Camaro	3913468	2	.31	rd. head sq. neck ( <sup>3</sup> / <sub>8</sub> "— 16 x 3 <sup>3</sup> / <sub>8</sub> "— 280M steel)
65-70	Pass. (Sta. Wag.)	9777719	1	.65	( <sup>3</sup> / <sub>8</sub> "— 16 x 7 <sup>21</sup> / <sub>32</sub> ") (hook type)
68-70	Chevelle,				
71-72	Chevelle (Sta. Wag.)	399739	A.R.	.36	( <sup>3</sup> / <sub>8</sub> "— 16 x 3 <sup>1</sup> / <sub>4</sub> ") (hex. head)
68-75	Chevelle (Sta. Wag.),				
71-75	Pass. (Sta. Wag.)	402476	1	1.00	hook
74-75	All	427559	2		( <sup>3</sup> / <sub>8</sub> "— 16 x 1.70")
75	Monza (exc. Towne Coupe)	3921688	2	.21	( <sup>3</sup> / <sub>8</sub> "— <sup>1</sup> / <sub>4</sub> " x <sup>7</sup> / <sub>8</sub> ")
64-67	Chevelle (Sta. Wag., El Camino)	1372369	4	.23	NUT, support ( <sup>5</sup> / <sub>16</sub> "— 18) "J" Type
68-70	Chevelle (exc. Sta. Wag.),				
71-72	Pass., Chevelle (exc. Sta. Wag.)	399862	2	.23	NUT, front
73-74	Pass., Chevelle, Nova (exc. Sta. Wag.)	413051	2	.23	NUT
74	Vega	9414034	4		NUT, fuel tank strap— (8.915)
75	Chevelle (exc. Sta. Wag.)	492709	2	.47	NUT, <sup>3</sup> / <sub>8</sub> "— 16 x 1 <sup>3</sup> / <sub>4</sub> "
75	All	416574	2	.21	NUT
68-72	Chevelle (exc. Sta. Wag.)	399782	2	.14	SCREW, rear ( <sup>1</sup> / <sub>4</sub> "— 14 x 1)
69-71	Chevy, Camaro,				
71	Vega,				
72	Chevy	3949718	2	.42	SPACER
74-75	Pass. (Sta. Wag.)	413201	1	.75	SPACER, strap bolt (plastic)
63	All	3792381	A.R.	.14	WASHER ( <sup>3</sup> / <sub>4</sub> " x <sup>3</sup> / <sub>8</sub> " x <sup>1</sup> / <sub>4</sub> " thk.)— (6.606)
67-68	Pass. (exc. Sta. Wag.),				
68	Chevy, Chevelle, Camaro,				

**FUEL—EXHAUST—CARBURETION**

**3.023 BOLT— NUT— SCREW— SPACER— WASHER, Fuel Tank Strap (Con't)**

75 Vega, Monza (140) . . . . . 3916493 2 .11 WASHER (5.418) . . . . .

**3.028 CAP— HANDLE— SCREW, Fuel Tank Filler Cap**

62-64 Chevy . . . . . 3792252 1 5.65 chrome plated . . . . .  
 64-67 Chevelle (El Camino, Sta. Wag.),  
 65-67 Pass. (Sta. Wag.) . . . . . 3843698 1 2.30 vented . . . . .  
 64-67 Pass., Chevelle (exc. Sta. Wag.),  
 68-69 Pass., Chevelle (exc. Sta. Wag.,  
 El Camino),  
 70 Pass. (exc. E.E.C., Sta. Wag.) . . . . . 405373 1 2.30 (not vented) . . . . .  
 65-67 Chevy . . . . . 3867853 1 4.40 chrome plated . . . . .  
 66-67 Chevelle (El Camino) w/P.S.  
 (396) . . . . . 3914958 1 2.30  
 67-68 Camaro . . . . . 3910043 1 3.35 complete (Note 1) . . . . .  
*NOTE 1 Paint to match car color.*  
 68-69 Chevy . . . . . 3914863 1 2.30 vented . . . . .  
 75 All . . . . . 7470051 1 4.40 (new departure) . . . . .  
 75 Pass. (Sta. Wag.) . . . . . 337160 1 locking . . . . .  
 68-69 Pass., Chevelle (Sta. Wag., El  
 Camino),  
 69-70 Camaro (exc. E.E.C.),  
 70 Pass. (Sta. Wag.) (exc. E.E.C.),  
 70 Nova, Chevelle (exc. E.E.C.) . . . . . 3931449 1 2.30 CAP ASSY. (vented) . . . . .  
 70 All w/E.E.C. (exc. Nova) . . . . . 3997480 1 3.35 CAP ASSY. (vented) . . . . .  
 70 Nova w/E.E.C.,  
 71-74 All . . . . . 413755 1 3.35 CAP ASSY. (vented) . . . . .  
 74 Vega w/wood grain . . . . . 342644 1 7.15 CAP ASSY. . . . .  
 74-75 Vega (exc. wood grain) . . . . . 345088 1 4.55 CAP ASSY. . . . .  
 75 Vega w/wood grain . . . . . 358329 1 7.15 CAP ASSY. . . . .  
 75 Monza (Towne Cpe.) . . . . . 370364 1 4.65 CAP . . . . .  
 67-68 Camaro (350, 396) . . . . . 3910045 1 16.10 CAP UNIT (letters S.S. shown on cap top) . . . . .  
 67-68 Camaro (exc. 350, 396) . . . . . 3910189 1 16.10 CAP UNIT (letters R.S. shown on cap top) . . . . .  
 71-73 All,  
 74 All (exc. Vega) . . . . . 994171 1 7.75 CAP PKG., locking . . . . .  
 74-75 Vega, Monza . . . . . 995213 1 7.75 CAP PKG., locking . . . . .  
 75 All (exc. Vega, Monza) . . . . . 983493 1 9.85 CAP PKG., locking . . . . .  
 75 Vega . . . . . 360313 1 1.75 HANDLE, cap . . . . .  
 62-64 Chevy . . . . . 9417639 A.R. .07 SCREW, cap handle (No. 10— 24 x 1/2")—  
 (8.977) . . . . .

**3.107 GAUGE— CAM— METER— PUMP— SENDER— WIRE ASSY., Fuel Tank Gauge**

64 Chevelle (3 Seat Sta. Wag.) (exc.  
 327) . . . . . 6425457 1 14.64  
 64 Chevelle (327) (exc. 3 Seat Sta.  
 Wag.) . . . . . 6425600 1 13.65  
 65-67 Chevelle w/4BC,  
 65-66 Pass. (283, 327, 396) (exc. Sta.  
 Wag., 2BC),  
 67 Chevelle (396) . . . . . 6426973 1 13.46 tank unit . . . . .  
 66-67 Chevy (exc. 4BC) . . . . . 6426499 1 13.04 tank unit . . . . .  
 66-67 Chevy w/4BC . . . . . 6426500 1 11.90 tank unit . . . . .  
 67-68 Pass. (250, 283, 307) (exc. Sta.  
 Wag.),  
 69-70 Pass. (6 cyl.) (exc. Sta. Wag.) . . . . . 6428094 1 16.63 tank unit . . . . .  
 67 Camaro w/4BC . . . . . 6428068 1 17.44 tank unit . . . . .  
 62-70 Chevy, Chevelle, Camaro,  
 65-66 Pass.,  
 67-70 Pass. (Sta. Wag.),  
 71-72 Nova, Chevelle,  
 73 Nova,  
 74-75 Nova, Camaro . . . . . 3774937 1 .24 CAM . . . . .  
 67-72 Pass. (exc. Sta. Wag.),  
 70-72 Camaro,  
 71-74 Vega,  
 73 Pass., Chevelle, Camaro,  
 74-75 Pass., Chevelle,  
 75 Vega, Monza . . . . . 413899 1 .59 CAM . . . . .  
 62-63 Chevy (exc. 3 Seat Sta. Wag.),  
 64 Chevy,  
 65 Chevy (exc. 4BC) . . . . . 6428066 1 13.10 METER ASSY., w/gasket . . . . .  
 64 Chevelle (exc. 3 Seat Sta. Wag.,  
 327) . . . . . 6426932 1 14.21 METER ASSY., w/gasket . . . . .

**FUEL—EXHAUST—CARBURETION**

**3.107 GAUGE—CAM—METER—PUMP—SENDER—WIRE ASSY., Fuel Tank  
Gauge (Con't)**

65-66	Pass. (230, 250, 283) (exc. Sta. Wag., 4BC),					
65-67	Chevelle (exc. 4BC) . . . . .	6428067	1	13.73	METER ASSY., w/gasket . . . . .	
65-67	Pass. (Sta. Wag.) w/4BC (1st design),					
68	Pass. (Sta. Wag.) (327),					
68	Pass. (Sta. Wag.) (396) (exc. Police),					
69-70	Pass. (Sta. Wag.) (8 cyl.) (exc. C.A.C. w/4BC 350, 427, 454 Police) . . . . .	6427637	1	20.71	METER ASSY., w/gasket (w/1 tube) . . . . .	
65-68	Pass. (Sta. Wag.) (exc. 4BC),					
69	Pass. (Sta. Wag.) (6 cyl.) . . . . .	6428064	1	19.22	METER ASSY., w/gasket . . . . .	
65	Pass. (Sta. Wag.) (409),					
67-69	Pass. (Sta. Wag.) (427) (2nd design),					
68	Police (Sta. Wag.) (350, 396) (exc. C.A.C.),					
69-70	Pass. (Sta. Wag.) (4BC w/C.A.C.) (350),					
69	Police w/4BC (350),					
69	Pass. (Sta. Wag.) w/C.A.C. (396),					
69	Police (396) (exc. C.A.C.),					
70	Pass. (Sta. Wag.) (454),					
70	Police (Sta. Wag.) w/4BC (350) (exc. C.A.C.) . . . . .	6427638	1	26.20	METER ASSY., w/gasket (w/2 tubes) . . . . .	
67	Pass. (427) (1st design) (exc. Sta. Wag.),					
67	Pass. (327, 396) (exc. Sta. Wag.),					
68	Pass. (327) (exc. Sta. Wag.),					
68	Pass. (396) (exc. Sta. Wag., Police),					
69	Pass. w/4BC (350) (exc. C.A.C., Sta. Wag.),					
69	Pass. (8 cyl.) (exc. Sta. Wag., 4BC, 350 w/C.A.C., 427, Police),					
70	Pass. w/4BC (350) (exc. Sta. Wag. Police, C.A.C.),					
70	Pass. w/2BC (350, 400) (exc. Sta. Wag. Police) . . . . .	6428084	1	16.45	METER ASSY., w/gasket (w/1 tube) . . . . .	
67	Pass. (427) (2nd design) (exc. Sta. Wag.),					
68	Police (396) (exc. Sta. Wag.),					
69-70	Pass. (427, 454) (exc. Sta. Wag.),					
69	Pass. w/C.A.C. (396),					
69-70	Pass. (4BC w/C.A.C.) (350) (exc. Sta. Wag.),					
70	Police w/4BC (350) (exc. Sta. Wag., C.A.C.) . . . . .	6428177	1	23.73	METER ASSY., w/gasket . . . . .	
67	Camaro (exc. 4BC) . . . . .	6428069	1	19.40	METER ASSY., w/gasket . . . . .	
68-69	Camaro (6 cyl.),					
68	Chevy (exc. 327, 350),					
69-70	Chevy (exc. 350, 396) . . . . .	6428844	1	20.09	METER ASSY., w/gasket . . . . .	
68	Sta. Wag.,					
69	Chevelle (Sta. Wag.) w/4BC (350) (exc. C.A.C.),					
69	Chevelle (Sta. Wag.) (exc. 4BC),					
70	Chevelle (Sta. Wag.) (exc. C.A.C., 400) . . . . .	6428036	1	17.36	METER ASSY., w/gasket . . . . .	
68	Chevelle (exc. Sta. Wag.),					
69	Chevelle w/4BC (350) (exc. C.A.C., Sta. Wag.),					
69	Chevelle (exc. Sta. Wag., 4BC),					
69	Chevelle w/Sp. H/Per. (396),					
70	Chevelle (exc. Sta. Wag., C.A.C. w/4BC 350, 400 w/4BC, 454) . . . . .	6428034	1	12.79	METER ASSY., w/gasket . . . . .	
68	Camaro (8 cyl.),					
68	Chevy (327, 350),					
69-70	Chevy w/2BC (350),					
69	Chevy, Camaro w/Sp. H/Per. (396),					

**FUEL—EXHAUST—CARBURETION**

**3.107 GAUGE—CAM—METER—PUMP—SENDER—WIRE ASSY., Fuel Tank**  
**Gauge (Con't)**

69	Camaro w/2BC,				
69	Camaro (302),				
70	Nova w/Sp. H/Per. (396),				
70	Chevelle (Sta. Wag.) w/C.A.C. (8 cyl.)	6428845	1	20.15	METER ASSY., w/gasket
69-70	Chevelle (4BC w/C.A.C.) (350) (exc. Sta. Wag.),				
69-70	Chevelle (396) (exc. Sp. H/Per.),				
70	Chevelle (454),				
70	Chevelle w/4BC (400) (exc. Sta. Wag.)	6428035	1	14.16	METER ASSY., w/gasket
69-70	Chevelle (Sta. Wag.) (4BC w/C.A.C.) (350),				
70	Chevelle (Sta. Wag.) w/4BC (400)	6428037	1	19.16	METER ASSY., w/gasket
69	Chevy, Camaro w/4BC (350, 396) (exc. Sp. H/Per.),				
70	Nova w/4BC (350, 396) (exc. Sp. H/Per.)	6428846	1	25.04	METER ASSY., w/gasket (2 tubes)
70	Camaro (exc. H/Per. 350 H/Per. 396, Sp. H/Per. 454)	6428843	1	20.26	METER ASSY., w/gasket
70	Camaro w/H/Per. (350, 396),				
70	Camaro w/Sp. H/Per. (454)	6428842	1	22.92	METER ASSY., w/gasket
71-73	Vega	6428767	1	20.64	METER ASSY., w/gasket
75	Chevelle (250, 350-4BC) (exc. Sta. Wag., El Camino)	6429285	1	15.08	METER ASSY.
75	Vega (122)	6429744	1	26.44	METER ASSY., w/gasket
74-75	Vega (140),				
75	Monza (140)	6429678	1	20.64	METER ASSY., w/gasket
75	Monza (262, 350)	6429878	1	31.56	METER ASSY., w/gasket
74	Vega (140)	6470967	1	20.92	PUMP AND FILTER UNIT, fuel (in tank)
74	Vega (122)	6470894	1	22.71	PUMP AND FILTER UNIT, fuel (in tank)
66	Pass. (396, 427)	6427151	1	16.74	SENDING UNIT, gas tank
70	Pass. (exc. Sta. Wag.),				
71-72	Chevelle (exc. Sta. Wag., El Camino)	8908138	1	2.25	WIRE ASSY., ext.

**FUEL—EXHAUST—CARBURETION**

**1971 METER ASSY. CHART**

*NOTE: See Dealer Price Schedule for applicable prices.*

ENGINE	PASSENGER	NOVA	CHEVELLE	CAMARO
6 Cyl.	6428630	6428844	6428838	6428843
307	—	6428844	6428838-A 6428036-B	6428843
350 w/2BC	6428630-A 6428943-B	6428845	6428838-A 6428036-B	6428843
350 w/4BC	6428630-ACE 6428629-AD 6428629-ACF 6428943-BEC 6428944-BD 6428944-BCF	6428667	6428837-AD 6428838-AC 6428036-BC 6428037-BD	6428843-H 6428842-G
400 w/2BC	6428630-AC 6428629-AD 6428943-BC 6428944-BD	—	6428837-D 6428838-C	—
400 w/4BC	6428629-A 6428944-B	—	6428837-A 6428037-B	6428842
454	6428629-A 6428944-B	—	6428837	6428800

- A. (exc. Sta. Wag.)
- B. Sta. Wag.
- C. exc. C.A.C.
- D. w/C.A.C.
- E. exc. Police
- F. Police
- G. exc. Sp. H/Per.
- H. Sp. H/Per.

**FUEL—EXHAUST—CARBURETION**

**1972 METER ASSY. CHART**

*NOTE: See Dealer Price Schedule for applicable prices.*

ENGINE	PASSENGER	NOVA	CHEVELLE	CAMARO
6 Cyl.	6428630	6428844	6428838	6428843
307	—	6428844	6428838-A 6428036-B	6428843
350 w/2BC	6428630-A 6428943-B	6428845	6428838-A 6428036-B	6428843
350 w/4BC	6428630-ACE 6428629-AD 6428629-ACF 6428943-BEC 6428944-BD 6428944-BCF	6428846	6428837-AD 6428838-AC 6428036-BC 6428037-BD	6428842-G 6428842-G  6428843-H
400 w/2BC	6428630-AC 6428629-AD 6428943-BC 6428944-BD	—		—
400 w/4BC	6428629-A 6428944-B	—	6428837-A 6428037-B	6428842
454	6428629-A 6428944-B	—	6428837	—

- A. (exc. Sta. Wag.)
- B. Sta. Wag.
- C. exc. C.A.C.
- D. w/C.A.C.
- E. exc. Police
- F. Police
- G. exc. Sp. H/Per.
- H. Sp. H/Per.

**1973 METER ASSY. CHART**

*NOTE: See Dealer Price Schedule for applicable prices.*

ENGINE	PASS.	NOVA	CHEVELLE	CAMARO
(6 cyl.)	6429288	6429284	6429252 B 6429285 A	6428843
(307)	—	6429284	6429252 B 6429285 A	6428843
350 w/2BC	6428943 B 6429288 A	6429282	6429252 B 6429285 A	6428843
350 w/4BC	6429288 CEA 6429289 ADE 6429289 ACF	6429283	6429251 BD 6429252 CB 6429285 CAG 6429286 DAG 6429289 DH 6429288 CH	6428842
400	6428943 BEC 6428944 BDE 6428944 BCF 6429289 ADE 6429289 ACF 6429288 CEA	—	—	—
454	6428944 B 6429289 A	—	6429251 B 6429286 AG 6429289 H	—

- A. (exc. Sta. Wag.)
- B. Sta. Wag.
- C. (exc. C.A.C.)
- D. w/C.A.C.

**FUEL—EXHAUST—CARBURETION**

**3.107 GAUGE—CAM— METER— PUMP— SENDER— WIRE ASSY., Fuel Tank Gauge (Con't)**

*E. (exc. Police)  
F. Police  
G. exc. El Camino  
H. El Camino*

**1974-1975 METER ASSY. CHART**

ENGINE	PASS.	CHEVELLE	NOVA	CAMARO
6 cyl.	—	6429252	6429284	6429282
350 w/2BC	6428944 B 6429288 A	6429252 B 6429285 AG 6429288 H	6429282	6429282
350 w/4BC	6428944 B 6429288 ACE 6429289 FAC 6429289 DA	6429251 BD 6429252 BC 6429285 ACG 6429286 AGD 6429288 HC 6429289 HD	6429283	6429283
400 w/2BC	6428944 B 6429288 ACE 6429289 FAC 6429289 DA	6429251 BD 6429252 BC 6429285 ACG 6429286 AGD 6429288 HC 6429289 HD	—	—
400 w/4BC	6428944 B 6429289 A	6429251 B 6429286 AG 6429289 H	—	—
454	6428944 B 6429289 A	6429251 B 6429286 AG 6429289 H	—	—

*A. (exc. Sta. Wag.)  
B. Sta. Wag.  
C. (exc. C.A.C.)  
D. w/C.A.C.  
E. (exc. Police)  
F. Police  
G. (exc. El Camino)  
H. El Camino*

**3.108 GAUGE, Instrument Panel Fuel**

<b>63-65</b>	Chevy (exc. S.S.)	<b>5644638</b>	1	10.82	
<b>63-65</b>	Nova (S.S.)	<b>5644539</b>	1	10.69	
<b>64</b>	Malibu (S.S.)	<b>5644954</b>	1	9.77	
<b>64</b>	Chevelle (exc. S.S.)	<b>5644870</b>	1	11.00	
<b>65</b>	Chevelle (exc. S.S.)	<b>6430164</b>	1	10.93	
<b>65</b>	Chevelle (S.S.)	<b>6430197</b>	1	9.50	
<b>65</b>	Pass. (exc. S.S., Caprice)	<b>6430118</b>	1	12.11	
<b>65</b>	Pass. (S.S.)	<b>6430122</b>	1	10.56	
<b>66</b>	Pass.	<b>6430461</b>	1	11.25	
<b>66-67</b>	Chevelle w/gauges	<b>6430628</b>	1	11.55	gas gauge dash unit
<b>66-67</b>	Chevelle (exc. gauges)	<b>6430420</b>	1	12.98	fuel gauge and back plate assy.
<b>66-67</b>	Chevy (exc. speed warning ind.)	<b>6430436</b>	1	11.74	
<b>67</b>	Camaro (exc. console)	<b>6480802</b>	1	19.16	
<b>67</b>	Camaro w/console	<b>6430797</b>	1	10.80	
<b>67</b>	Pass. (exc. gauges)	<b>6430721</b>	1	14.53	
<b>67</b>	Pass. w/gauges (8 cyl.)	<b>6430798</b>	1	13.10	
<b>68</b>	Pass. w/gauges	<b>6430921</b>	1	9.58	
<b>68</b>	Chevelle w/gauges	<b>6428077</b>	1	7.84	w/resistor
<b>68</b>	Chevelle (exc. gauges)	<b>6480638</b>	1	20.45	w/tell-tale assy., oil temp. and fuel
<b>68</b>	Chevy (exc. console gauges)	<b>6430814</b>	1	9.21	
<b>68-69</b>	Camaro w/floor console gauges	<b>6431423</b>	1	9.70	
<b>68-69</b>	Chevy w/floor console gauges	<b>6430929</b>	1	8.60	
<b>68</b>	Camaro (exc. console gauges)	<b>6431002</b>	1	18.79	
<b>69</b>	Camaro (exc. console gauges)	<b>6431172</b>	1	12.30	
<b>69</b>	Chevelle (Spt. Cpe.)	<b>6431250</b>	1	8.03	w/res. unit, tach.
<b>69</b>	Chevelle	<b>6431251</b>	1	11.00	w/tell-tale assy., generator, oil, thermo., gas
<b>69-70</b>	Pass.	<b>6431147</b>	1	10.13	



**FUEL—EXHAUST—CARBURETION**

**3.108 GAUGE, Instrument Panel Fuel (Con't)**

69	Camaro w/Tachometer . . . . .	6431307	1	21.69	
70	Chevelle (396, 454) (exc. gauges), Monte Carlo (exc. gauges),				
71-72	Chevelle (454) (exc. gauges, Monte Carlo),				
71-72	Monte Carlo (exc. gauges) . . . . .	6431586	1	11.80	
70-72	Camaro w/gauges . . . . .	6431506	1	13.92	
70	Chevelle (exc. gauges, 396, 454),				
71-72	Chevelle (exc. 454, Monte Carlo)	6431584	1	11.80	
70-72	Chevelle w/gauges . . . . .	6431581	1	11.80	
69-74	Nova (exc. console gauges) . . . . .	6431585	1	12.06	GAUGE ASSY. . . . .
70-75	Nova w/Console gauges . . . . .	6431582	1	9.89	GAUGE ASSY. . . . .
70-72	Camaro (exc. gauges) . . . . .	6431496	1	14.53	GAUGE ASSY. . . . .
71-75	Pass. . . . .	6431560	1	11.80	GAUGE ASSY., w/resistor . . . . .
71-74	Vega (exc. gauges) . . . . .	6431459	1	13.22	GAUGE ASSY. . . . .
71-73	Vega w/gauges . . . . .	6431534	1	12.06	GAUGE ASSY., w/resistor . . . . .
73-74	Malibu, El Camino (exc. gauges)	6431622	1	14.22	GAUGE ASSY. . . . .
73-75	Monte Carlo (exc. gauges),				
73-75	Malibu, El Camino (S.S.) (exc. gauges) . . . . .	6431626	1	11.80	GAUGE ASSY. . . . .
73-74	Chevelle w/gauges . . . . .	6431630	1	11.80	GAUGE ASSY. . . . .
73-74	Camaro (exc. gauges) . . . . .	6431496	1	14.53	GAUGE ASSY. . . . .
73-74	Camaro w/gauges . . . . .	6431506	1	13.92	GAUGE ASSY. . . . .
74	Vega w/gauges . . . . .	6431854	1	12.06	GAUGE ASSY., w/resistor . . . . .
75	Monte Carlo . . . . .	6431971	1	15.05	GAUGE ASSY., instrument panel . . . . .
75	Pass. . . . .	6431979	1	12.79	GAUGE ASSY., w/resistor . . . . .
75	Camaro (exc. elec. clock, inter. decor.) . . . . .	6432040	1	12.43	GAUGE ASSY. . . . .
75	Camaro w/gauges . . . . .	6432041	1	13.00	GAUGE ASSY. . . . .
75	Malibu, El Camino (exc. gauges)	6431969	1	15.22	GAUGE ASSY. . . . .
75	Malibu, El Camino w/gauges . . . . .	6432027	1	12.35	GAUGE ASSY. . . . .
75	Laguna (exc. gauges) . . . . .	6431971	1	15.05	GAUGE ASSY. . . . .
75	Nova w/fuel ecno. (exc. console gauges) . . . . .	6432086	1	10.89	GAUGE ASSY. . . . .
75	Nova (exc. fuel ecno., console gauges) . . . . .	6432087	1	10.89	GAUGE ASSY. . . . .
75	Vega (exc. gauges) . . . . .	6432015	1	14.43	GAUGE ASSY., w/resistor . . . . .
75	Vega, Monza w/gauges (exc. Towne Cpe.) . . . . .	6432070	1	13.60	GAUGE ASSY., w/resistor . . . . .
75	Monza (Towne Cpe.) w/gauges . . . . .	6432096	1	14.03	GAUGE ASSY. . . . .
75	Monza (Towne Cpe.) (exc. gauges) . . . . .	6432092	1	15.16	GAUGE ASSY. . . . .

**3.110 STRAINER, Fuel Tank Gauge**

62-66	Chevy,				
65	Pass. (Sta. Wag.) . . . . .	3714812	1	.87	tank pipe (2 1/2" lg.) (5/16" pipe) . . . . .

**3.112 GASKET— BOLT, Fuel Tank Gauge**

62-69	Chevy, Chevelle, Camaro,				
65-66	Pass.,				
67-70	Pass. (Sta. Wag.),				
70-72	Nova, Chevelle,				
73	Nova,				
74-75	Nova, Camaro . . . . .	3825206	1	.29	
65-69	Pass. . . . .	105450 A.R.		.07	gauge screw (3/16"— type A)— (8.955) . . . . .
67-71	Pass. (exc. Sta. Wag.),				
70-72	Camaro,				
71-75	Vega, Monza,				
72	Pass.,				
73	All (exc. Nova, Vega),				
74-75	Pass., Chevelle . . . . .	3893116	1	.32	gas-meter . . . . .
65-70	Pass. . . . .	132908 A.R.			BOLT, rd. hd. sl. mach. (10— 32 x 1/2")— (8.906) . . . . .

**3.115 WIRE ASSY., Fuel Tank Extension**

71-75	Vega, Monza (140) . . . . .	8908335	1	5.95	
74	Vega (122) . . . . .	8908349	1	20.30	

**3.120 SEPARATOR— BOLT— BRACKET— CLIP— COVER— GASKET— PIPE, Fuel Tank Evaporative Control**

70	Pass., Chevelle w/E.E.C. (exc. Sta. Wag., El Camino) . . . . .	7028021	1	10.25	fuel vapor . . . . .
70	Chevelle (El Camino) w/E.E.C.,				

FUEL—EXHAUST—CARBURETION

**3.120 SEPARATOR— BOLT— BRACKET— CLIP— COVER— GASKET— PIPE,  
Fuel Tank Evaporative Control (Con't)**

70	Nova, Camaro w/E.E.C.	7043728	1	11.10	fuel vent.
71	Nova, Chevelle, Camaro, Pass. (exc. Sta. Wag.),				
72	All (exc. Sta. Wag., El Camino, Vega),				
73	Camaro	407742	1	16.10	fuel vent.
71	Vega	408302	1	19.15	
72-73	Vega	6264327	1	2.90	
70	All (exc. Sta. Wag., El Camino)	407303	2		<b>BOLT</b> , fuel vapor separator (rd. hd. square neck) (1/4" — 20 x 7/8") — (8.903)
70-71	El Camino w/E.E.C.,				
72	El Camino	3974678	1	2.65	<b>BRACKET ASSY.</b> , fuel vapor separator
73-74	All (6 cyl.) (exc. Vega)	331118	1	.16	<b>CLIP</b> , evap. emission hose
73-75	Nova, Camaro	6264031		.07	<b>CLIP</b> , fuel meter pipe, liquid separator tank pipe — (3.162)
75	All (6 cyl.) (exc. Vega)	354575	1	.29	<b>CLIP</b> , evap. emission hose
75	All	2459769	1	.35	<b>CLIP</b> , fuel feed pipe, vent. pipe
71	Vega	3992945	1	1.55	<b>COVER</b> , fuel vent. separator
71-72	All (exc. Sta. Wag., El Camino, Vega)	9837479	1	1.15	<b>GASKET</b> , gas tank fuel emission separator
71	Vega	3992943	1	.32	<b>GASKET</b> , gas tank fuel emission separator
73	Nova, Camaro	6264084	1	1.35	<b>PIPE ASSY.</b> , lqd. sep. tank
74	A, F, X (250)		1		<b>CLIP</b> , evap. emission hose
75	X (250) (exc. integrated cyl. hd.)	340396	1	.28	<b>CLIP</b> , evap. emission hose

**3.130 CANISTER— CAP— BRACKET— CLIP— CONNECTOR— FILTER—  
GASKET— REPAIR PKG.— RESTRICTOR— SUPPORT, Fuel Tank  
Evaporative Control**

70	All w/E.E.C. (6 cyl.),				
70	All (E.E.C. w/2BC) (exc. Monte Carlo)	7036964	1	29.10	fuel vapor
70	Camaro (E.E.C. w/Sp. H/Per.) (350, 454),				
70	Nova (E.E.C. w/Sp. H/Per.) (350, 396)				fuel vent.
70	Chevelle (E.E.C. w/Sp. H/Per.) (396, 454)	7036968	1	32.20	fuel vapor
70	Nova, Camaro (E.E.C. w/4BC) (350, 396) (exc. Sp. H/Per.)				fuel vent.
70	Pass., Monte Carlo (E.E.C. w/4BC),				
70	Chevelle (E.E.C. w/4BC) (350, 396) (exc. Sp. H/Per.),				
71-75	Vega, Monza (140)	7030758	1	27.90	
71-73	All,				
73	All,				
74-75	All (6 cyl.)	7030605	1	27.90	fuel vapor
74-75	All (8 cyl.) (exc. Monza),				
75	Monza (262)	7028131	1	23.25	fuel vapor
75	Monza (206),				
75	Nova	7043715	1	23.25	
71-74	Vega	7021739	1	3.50	<b>CAP ASSY.</b> , w/filter
72	Pass. (8 cyl.) (exc. Caprice, Estate Wag.),				
73-74	Chevelle, Nova	7028046	1	2.65	<b>CAP</b> , fuel vapor canister drain
70	Chevelle w/E.E.C. (exc. Monte Carlo)	3974652	1	2.40	<b>BRACKET ASSY.</b> , fuel vapor canister
70	Pass., Nova w/E.E.C.				<b>CLIP</b> , fuel vapor hose canister to engine,
70	Chevelle w/E.E.C.				<b>CLIP</b> , fuel vapor pipe to canister hose,
70	Camaro w/E.E.C. (6 cyl.)				<b>CLIP</b> , fuel vent. hose,
70	Camaro w/E.E.C. (8 cyl.),				
71-75	All	3977988	A.R.	.16	<b>CLIP</b> , fuel vapor hose canister to engine, to L.H. fender skirt cup
70	Pass., Camaro w/E.E.C.				<b>CONNECTOR</b> , fuel vapor purge hose at a/cl.
70	Nova, Chevelle w/E.E.C.	3967086	1	.31	<b>CONNECTOR</b> , fuel vapor purge pipe hose
70-75	All	7026014	1	1.10	<b>FILTER</b> , fuel vent. and vapor air inlet
70	All w/E.E.C.,				
72	Chevy,				
73-75	All	7021739	1	3.50	<b>FILTER ASSY.</b> , w/drain cap, fuel vapor canister
71-73	Vega	3997290	1	.88	<b>GASKET</b> , canister

**FUEL—EXHAUST—CARBURETION**

**3.130 CANISTER— CAP— BRACKET— CLIP— CONNECTOR— FILTER—  
GASKET— REPAIR PKG.— RESTRICTOR— SUPPORT, Fuel Tank  
Evaporative Control (Con't)**

70	All (E.E.C. w/4BC) (350, 396, 400, 454) (exc. Sp. H/Per.) . . .	7041344	1	2.50	REPAIR PKG., fuel vapor canister purge valve . . . . .
70	Pass., Chevelle (Sta. Wag.) w/E.E.C. . . . .	3977213	1	.16	RESTRICTOR, fuel vapor pipe to canister hose . . . . .
71	Camaro, Nova,				
72	Pass., Nova, Chevelle,				
73	Pass. (Sta. Wag.), Camaro . . . . .	3992372	1	.11	RESTRICTOR, fuel vent. pipe hose . . . . .
70-71	Nova w/E.E.C.,				
72-74	Nova . . . . .	3973069	1	3.60	SUPPORT ASSY., fuel vent. canister . . . . .
71-72	Chevelle . . . . .	3992371	1	2.15	SUPPORT ASSY., fuel vapor canister . . . . .
73-75	Chevelle . . . . .	3994453	1	2.15	SUPPORT ASSY., fuel vapor canister . . . . .
75	Nova . . . . .	344696	1	3.25	SUPPORT ASSY., fuel vent. canister . . . . .
71-75	Vega . . . . .	3988276	1	1.10	SUPPORT ASSY., fuel vapor canister (repl. 3978187) . . . . .
71-75	Pass., Camaro . . . . .	3988276	1	1.10	SUPPORT ASSY., fuel vent. canister . . . . .
75	Monza (Towne Coupe) . . . . .	3978187	1	1.30	SUPPORT ASSY., fuel vent. canister . . . . .
75	Monza (262, 350-2BC) . . . . .	349556	1	3.75	SUPPORT ASSY., fuel vent. canister . . . . .
75	Monza (140) (1st design) . . . . .	356367	1	3.75	SUPPORT ASSY., fuel vent. canister . . . . .
75	Monza (140) (2nd design) . . . . .	366152	1	3.75	SUPPORT ASSY., fuel vent. canister (Note 1) . . . . .

NOTE 1: Used with fresh air inlet L.H. motor compartment extension.

**3.140 SWITCH ASSY.— SOLENOID, Heat Valve**

75	All (8 cyl.) (exc. 454) . . . . .	3031386	1	9.35	thermostatic vac. (in water outlet hsg.) . . . . .
75	All (454) . . . . .	356115	1	4.25	heat valve control oil temp. . . . .
75	Monza . . . . .	355963	1		exh. heat valve actuator . . . . .
75	Chevelle (454) . . . . .	1997447	1	10.45	SOLENOID, carb. choke . . . . .

**3.162 CLIP— BRACKET— CLAMP— WASHER, Fuel Feed Pipe**

62-70	All . . . . .	1380949	A.R.	.12	gas feed pipe, double pipe clip (for 1/4"— 3/8" pipe) . . . . .
62-70	All,				
71	Camaro w/Sp. H/Per. (350),				
72	Pass. (6 cyl.) . . . . .	3931078	A.R.	.11	gas rtn. pipe frt. (1/8"—1/4" pipe) . . . . .
62	Chevy (3-Seat Sta. Wag.) . . . . .	3750695	1	.12	rear hose . . . . .
65-66	Pass. . . . .				rr. bracket pipe assy., . . . . .
66-69	Chevy, Camaro . . . . .	3825340	A.R.	.11	gas feed pipe . . . . .
67-69	Camaro . . . . .				gas feed pipe, . . . . .
68-74	Chevy,				
73-75	Camaro . . . . .	3912538	1	.11	fuel feed pipe . . . . .
68-71	All (4 cyl., 6 cyl.),				
72	Pass. (6 cyl.) . . . . .	3918968	1	.11	carb. gas pipe . . . . .
68	Pass. . . . .	3927977	1	.26	gas feed pipe, strap type (for 5/16"—3/8" pipe)— (4.686) . . . . .
69-72	Chevelle . . . . .	1231003	1	.16	fuel feed pipe ret. . . . .
69-74	All . . . . .	343464	A.R.	.11	use with 5/16" pipe with 23/32" reach (dark green) . . . . .
70-72	Camaro . . . . .	3984506	1	.16	fuel feed rr. pipe . . . . .
71	Pass.,				
72	Pass. (Sta. Wag.) . . . . .	1347654	1	.11	vent. rear pipe . . . . .
71	Chevelle (exc. Sta. Wag.),				
72	Pass., Chevelle (exc. Sta. Wag., El Camino) . . . . .	407886	1	.16	fuel tank to separator pipe support . . . . .
71	Pass. w/4BC (350),				
71	Nova, Chevelle, Camaro w/4BC (350) . . . . .	3991412	1	.12	spark cont. pipe at No. 3 R.H. inlet manifold hole . . . . .
71-72	Nova, Chevelle, Camaro (307) . . . . .	3991415	1	.12	spark control pipe at No. 4 R.H. inlet manifold hole . . . . .
71	All (6 cyl.),				
71	All w/2BC (350, 400),				
75	Chevelle, Nova (6 cyl. w/NB-2) (exc. C.A.C.) . . . . .		1		air inj. diverter valve . . . . .
75	Chevelle (6 cyl.) . . . . .	3931078	2	.11	A.I.R. diverter valve signal pipe . . . . .
72-75	Pass.,				
74	Vega (122) . . . . .	343442	1	.11	fuel return pipe . . . . .
74-75	Vega (140) . . . . .	342677	A.R.		fuel feed pipe . . . . .
74-75	Nova w/4BC (350) . . . . .	342676	1	.16	fuel feed pipe . . . . .
74-75	Camaro . . . . .	340392	A.R.	.11	fuel feed pipe . . . . .
74-75	Camaro . . . . .	478600	A.R.	.11	fuel feed pipe . . . . .

**FUEL—EXHAUST—CARBURETION**

**3.162 CLIP— BRACKET— CLAMP— WASHER, Fuel Feed Pipe (Con't)**

74-75	Camaro, Nova				fuel mtr. & tank pipe
74-75	Camaro, Nova	6264031	1	.07	cannister pipe
74-75	All	343464	A.R.	.11	fuel vent. frt. pipe, fuel vapor pipe, fuel feed (blue) (4 tangs)
75	See Group 4.686	343450	1	.11	
75	All	343463	A.R.	.11	fuel feed pipe (natural-4 tang)
75	Pass.	343448	A.R.	.28	fuel feed pipe (yellow)
75	Camaro, Chevelle, Nova, Monza (8 cyl.)	340392	A.R.	.11	fuel rtn. and feed, vapor pipes (5 tangs)
75	Pass., Chevelle, Camaro	540029	2	.11	emission pipe to fuel return pipe
75	Vega, Monza	340815	1	.34	fuel vent. pipe
74-75	Camaro, Nova (350)	340391	7	.11	fuel feed pipe
74-75	Pass.	342676	2	.16	fuel feed pipe
75	All (140)	328157	1	.11	eng. valve pipe (black)— (4.686)
69-70	Camaro,				
71-72	Camaro w/Sp. H/Per. (350)	3959444	1	1.25	<b>BRACKET</b> , carb. fuel pipe
71	Chevelle w/Sp. H/Per. (454)	3994043	1	.40	<b>BRACKET</b> , fuel pipe
62-69	All	2494772	A.R.	.65	<b>CLAMP</b> , spring type for 9/16" dia. hose— (1.166)
75	Vega (122)	3892948	1	.12	<b>CLAMP</b> (6.672)
75	Monza (262)	342711	1	.63	<b>CLAMP</b> , carb. fuel pipe — (1.516)
74-75	Vega w/P.S.	1361756	1	.57	<b>STRAP</b> , wiring harness
62-66	Chevy	3755763	A.R.	.06	<b>WASHER</b> , fuel line and heater pipe clip— (8.133)

**3.163 PIPE— CONNECTOR— ELBOW— HOSE— LOOM— NUT— RESERVOIR— SHIELD— SLEEVE— TEE, Fuel Lines**

65-70	Pass.	3706968	1	2.50	(8" O.L.— 1/2"— 20 int. thd. end free to turn— 1/2"— 20 ext. thd. end solid)
65	Chevelle w/Sp. H/Per. (327)	3854796	1	3.40	pump to filter (chrome)
66-67	Chevy, Chevelle w/Sp. H/Per. (327) (2nd design)	603827	1	RL/.18	carb. gas (1/4" O.D.)— (8.964) (Note 1)
67-69	Camaro (327)	3932446	1	1.45	carb. gas
62-67	Pass., Chevy	3750685	1	.27	<b>CONNECTOR</b> , at fuel pump, gas feed pipe (5/16" I.D. at hose end)
64	Chevelle w/4BC	3853192	1	1.15	<b>CONNECTOR</b> , to fuel pump hose
65-67	Pass.,				
66-67	Chevy, Chevelle	582093	1	.59	<b>CONNECTOR</b> , carb. gas hose at fuel filter, gas feed pipe
65-70	Pass.	3751207	1	1.15	<b>CONNECTOR</b> , gas feed pipe (3/8" I.D. at hose end— 1 9/16" O.L.)
	Not required in this group. See group 4.931	3751206	1	.67	<b>CONNECTOR</b>
65-67	Chevelle, Camaro,				
66-67	Pass.	538570	1	1.10	<b>ELBOW</b> , gas feed (1/4"— 18 thds. 3/8" I.D.)
65	Chevelle w/Sp. H/Per.	9409919	1	.52	<b>ELBOW</b> , auto 45 pipe— (8.963)
65-70	Pass.	9432963	A.R.	RL/.55	<b>HOSE</b> , gas feed pipe front or rear (10 ft. roll) (3/8" hose)— (8.962) (Note 1)
65-70	Pass.	3749394	A.R.	2.95	<b>HOSE ASSY.</b> , oil filter outlet (15" O.L.— 7/16"— 24 end free to turn, 1/8" pipe thd. end solid)
65-70	Pass.	3654629	A.R.	3.35	<b>HOSE ASSY.</b> , oil filter inlet (19" O.L.— 7/16"— 24 end free to turn, 1/8" pipe thd. end solid)
65-70	Pass.	3745516	A.R.	2.90	<b>HOSE ASSY.</b> , oil filter inlet (22" O.L.— 7/16"— 24 end free to turn, 1/8" pipe thd. end solid)
65-70	Pass.	3758984	1	3.90	<b>HOSE ASSY.</b> , oil filter outlet (28" O.L.)
62-70	All	3926960	A.R.	FT/.22	<b>LOOM</b> , gas feed pipe shield (3/8")
62-70	Chevy, Chevelle, Camaro	137398	A.R.	.24	<b>NUT</b> , gas and carb. pipes (5/16")— (8.963)
69	Chevelle (exc. Sta. Wag., El Camino)	403846	1	.87	<b>RESERVOIR</b> , gas tank breather
65-70	Pass.,				
71	Vega	3792505	1	3.75	<b>SHIELD</b> , gas feed rear pipe (for 5/16" O.D. pipe) (95 1/8" O.L.— 11 coils per in.)
75	Vega	366140	1	3.60	<b>SHIELD</b> , fuel rear hose heat
67-68	Camaro				<b>SLEEVE</b> , feed pipe rear hose,
71-72	Camaro (exc. H/Per. 350, 400),				
71-75	Vega, Monza	3908307	1	.16	<b>SLEEVE</b> , fuel meter tank unit

**FUEL—EXHAUST—CARBURETION**

**3.163 PIPE—CONNECTOR—ELBOW—HOSE—LOOM—NUT—RESERVOIR—SHIELD—SLEEVE—TEE, Fuel Lines (Con't)**

<b>69-72</b>	Camaro w/4BC (350, 396, 402) (exc. Sp. H/Per.) . . . . .	<b>3955791</b>	<b>1</b>	<b>.31</b>	<b>SLEEVE, fuel meter tank unit . . . . .</b>
<b>65-68</b>	Pass. (427),				
<b>66-68</b>	All w/Sp. H/Per. (396),				
<b>67-70</b>	Camaro (302) (Sp. H/Per. 350) .				<b>TEE, fuel filter pipe to carb. gas pipe, . . . . .</b>
<b>69-70</b>	Nova, Chevelle, Camaro w/Sp. H/Per. (396, 427, 454),				
<b>71-72</b>	Camaro w/Sp. H/Per. (350) . . . . .	<b>545294</b>	<b>1</b>	<b>4.15</b>	<b>TEE, carb. fuel pipe . . . . .</b>

*NOTE 1 Cut to required length using old part as guide.*

**FUEL—EXHAUST—CARBURETION**

**3.265 MANIFOLD— BRACE— GUARD— PLUG, Engine Intake**

*NOTE: See Group 3.601 for Exhaust Manifold.  
See end of listings for Vega, Monza.*

**1962— 1963 CHEVY II Intake Manifold**

ENGINE	CHEVY II	
4 cyl.	3828271	
6 cyl.	3929253	

**1964 CHEVY II, CHEVELLE Intake Manifold**

ENGINE	CHEVY II	CHEVELLE
4 cyl.	3828271	—
6 cyl.	3929253-A 3929253-B	3929253-A 3929253-B
283 w/2BC	3852585	3852585
283 w/4BC	—	3852568
327	—	3852568-C 3852569-D

*A. 194 (6 cyl.)  
B. 230, 250 (6 cyl.)  
C. Exc. H/Per.  
D. w/H/Per.*

**1965 PASSENGER, CHEVY II, CHEVELLE Intake Manifold**

ENGINE	PASSENGER	CHEVY II	CHEVELLE
4 cyl.	—	3828271	—
6 cyl.	3929253	3929253-A 3929253-B	3929253-A 3929253-B
283 w/2BC	3852585	3852585	3852585
283 w/4BC	3870394	3870394	3870394
327	3852569-E 3870394-F	3852569-E 3870394-F	3852570-C 3870394-DF 3852569-E
396	3876818-DH 3957996-DI	—	—
409	384444-F 3844462-E	—	—

*A. 194 (6 cyl.)  
B. 230, 250 (6 cyl.)  
C. w/Sp. H/Per.  
D. Exc. Sp. H/Per.  
E. w/H/Per.  
F. Exc. H/Per.  
H. Holley  
I. Rochester*

**FUEL—EXHAUST—CARBURETION**

**1966 PASSENGER, CHEVY II, CHEVELLE Intake Manifold**

ENGINE	PASSENGER	CHEVY II	CHEVELLE
4 cyl.	—	3828271	—
6 cyl.	3929253	3929253-A/ 3929253-B	3929253-A 3929253-B
283 w/2BC	3888899-J	3888899-J	3888899-J
283 w/4BC	3888885	3888885	3888885
327	3888886-EI 3931575-FJ	3888886-DE 3931575-DFJ 3893594-C	3888886-DE 3931575-DFJ 3893594-C
396	3876818-DE 3957996-DF 3933163-CE	—	3876818-DE 3957996-DGFH 3933163-CEH
427	3876818-DE 3957996-DF 3933163-CE	—	—

A. 194 (6 cyl.)

B. 230, 250 (6 cyl.)

C. w/Sp. H/Per.

D. Exc. Sp. H/Per.

E. Holley

F. Rochester

G. Exc. H/Per.

H. It may be necessary to remove thermostat by-pass hose connector and install connector 3882830. Also it may be necessary to plug the water temp. switch hole with a (1/2— 14) pipe plug.

I. Carter

J. It may be necessary to plug water temp. switch hole with a 1/2— 14 plug.

**1967 PASSENGER, CHEVY II, CHEVELLE, CAMARO Intake Manifold**

ENGINE	PASSENGER	CHEVY II	CHEVELLE	CAMARO
4 cyl.	—	3828271	—	—
6 cyl.	3929253	3929253-A 3929253-B	3929253-A 3929253-B	3929253-B
283	3888899-J	3888899-J	3888899-J	—
327 w/2BC	—	—	—	3888899-J
327 w/4BC	3931575	3931575-H 3893594-G	3931575-HJ 3893594-G	3931575
350	—	—	—	3931575-F
396	3957996	—	3876818-CE 3957996-DHFI 3933163-EGI	3876818-CE 3957996-DFHI 3933163-EGI
302	—	—	—	3958627
427	3957996-H 3933163-G	—	—	—

A. 194 (6 cyl.)

B. 230, 250 (6 cyl.)

C. w/H/Per.

D. Exc. H/Per.

E. Holley

F. Rochester

G. w/Sp. H/Per.

H. Exc. Sp. H/Per.

I. It may be necessary to remove thermostat by-pass hose connector and install connector 3882830. Also it may be necessary to plug the water temp. switch hole with a 1/2— 14 pipe plug.

J. It may be necessary to plug water temp. switch hole with 1/2— 14 plug.

**FUEL—EXHAUST—CARBURETION**

**1968 PASSENGER, CHEVY II, CHEVELLE, CAMARO Intake Manifold**

ENGINE	PASSENGER	CHEVY II	CHEVELLE	CAMARO
4 cyl.	—	3828271	—	—
6 cyl.	3929253	3929253	3929253	3929253
307	3888899	3888899	3888899	—
327 w/2BC	—	—	—	3888899
327 w/4BC	3931575	3931575	3931575	3931575
350	—	3931575	—	3931575
396	3957996	3957996-B 3933163-A	3957996-B 3933163-A	3957996-B 3933163-A
302	—	—	—	3972114
427	3957996-B 3933163-A	—	—	—

A. w/Sp. H/Per.  
B. Exc. Sp. H/Per.

**1969 PASSENGER, CHEVY II, CHEVELLE, CAMARO Intake Manifold**

ENGINE	PASSENGER	CHEVY II	CHEVELLE	CAMARO
4 cyl.	—	3828271	—	—
6 cyl.	3929253	3929253	3929253	3929253
307	—	3958622	3958622	3958622
327	3958626	—	—	3958622
350 w/2BC	3958626	3958626	3958626	3958626
350 w/4BC	3987361	3987361	3987361	3987361
396 w/2BC	3957995	—	—	—
396 w/4BC	—	3957996-B 3933163-A	3957996-B 3933163-A	3957996-B 3933163-A
302	—	—	—	3972114
427	3957996-B 3933163-A	—	—	—

A. w/Sp. H/Per.  
B. Exc. Sp. H/Per.



**FUEL—EXHAUST—CARBURETION**

**1970 INTAKE MANIFOLD**

*NOTE: See Dealer Price Schedule for applicable prices.*

ENGINE	PASS.	NOVA	CHEVELLE	CAMARO
4 cyl.	—	3828271	—	—
6 cyl.	3929253	3929253	3929253	3929253
307	—	3958622	3958622	3958622
350 w/2BC	3958626	3958626	3958626	3958626
350 w/4BC	3987361	3987361	3987361	3972114-A 3987361-B
396	—	3977609-A 3977608-B	3977609-A 3977608-B	3977608
400 w/2BC	3958626	—	3958626	—
400 w/4BC	—	—	3977608	—
454 (exc. H/Per., Sp.)				
H/Per.	3977608	—	3977608	—
454 H/Per.	3977608	—	3977608	—
454 Sp. H/Per.	—	—	3977609	3977609

*A. w/Sp. H/Per.  
B. Exc. Sp. H/Per.*

**1971 INTAKE MANIFOLD**

ENGINE	PASS.	NOVA	CHEVELLE	CAMARO
6 cyl.	3929253	3929253	3929253	3929253
307	—	3991005	3991005	3991005
350 w/2BC	3990948	3990948	3990948	3990948
350 w/4BC	6262932	6262932	6262932	6262932-A 3991004-B
400 w/2BC	3990948	—	3990948	—
400 w/4BC	3977608	—	3977608	3977608
454 (exc. Sp. H/Per.)	3977608	—	3977608	—
454 Sp. H/Per.	—	—	3977609	—

*A. Exc. Sp. H/Per.  
B. w/Sp. H/Per.*

**FUEL—EXHAUST—CARBURETION**

**1972 INTAKE MANIFOLD**

*NOTE: See Dealer Price Schedule for applicable prices.*

ENGINE	PASS.	NOVA	CHEVELLE	CAMARO
6 Cyl. 307	343304 —	329603 6262928	329603 6262928	329603 6262928
350 w/2BC	6262930	6262930	6262930	6262930
350 w/4BC	6262932	6262932	6262932	6262932-A 3991004-B
400 w/2BC 402	6262930 6262901	— —	— 6262901	— 6262901
454	6262901	—	6262901	—

A. exc. Sp. H/Per.  
B. w/Sp. H/Per.

**1973 INTAKE MANIFOLD**

*NOTE: See Dealer Price Schedule for applicable prices.*

ENGINE	PASS.	NOVA	CHEVELLE	CAMARO
6 Cyl. 307	6270042 —	6270042 6271060	6270042 6271060	6270042 6271060
350 w/2BC	340265	3997772	340265	340265
350 w/4BC	340260	340260	340260	340260 A 3991004 B
400 w/2BC 454	340265 353068	— —	— 353068	— —

A. exc. Sp. H/Per.  
B. w/Sp. H/Per.

**1974 INTAKE MANIFOLD**

ENGINE	PASS.	NOVA	CHEVELLE	CAMARO
6 cyl.	—	343303	343303	343303
350 w/2BC	340265	340265	340265	340265
350 w/4BC	340260	340260	340260	340260
400 w/2BC	340265	—	340265	—
400 w/4BC	340260	—	340260	—
454	336788	—	336788	—

**1975 INTAKE MANIFOLD**

ENGINE	PASS.	NOVA	CHEVELLE	CAMARO
6 cyl.	—	343303*		
262 w/2BC	—	355942	—	—
350 w/2BC	343755	343755	343755	343755
350 w/4BC	343756	343756	343756	343756
350 w/4BC-Z28				
400 w/4BC	343756		343756	
454 w/4BC	346241	—	346241	—

\*NOTE: Less integrated cyl. hd.

- 64-67 Chevy, Chevelle (8 cyl.) (exc. H/Per., Sp. H/Per.),
- 65-66 Pass. (283, 327) (exc. F.I., dual 4BC, H/Per.),
- 66 Chevy, Chevelle w/Sp. H/Per. (327),

**FUEL—EXHAUST—CARBURETION**

**3.265 MANIFOLD— BRACE— GUARD— PLUG, Engine Intake (Con't)**

- 67-68 Pass. (283, 307),
- 67-69 All w/2BC (8 cyl.) (exc. 350),
- 67 Chevelle w/Sp. H/Per. (327),
- 69-71 Camaro (302) (Sp. H/Per. 350),

**VEGA— MONZA**

*NOTE: Exhaust manifold in 3.601.*

71-72	Vega (1BC) .....	6272112	1	29.75	
71-72	Vega (2BC) .....	6272114	1	32.25	
73	Vega (1BC) .....	6258339	1	29.75	
73	Vega (2BC) .....	6259600	1	29.75	
74-75	Vega (140-1BC) .....	6260825	1	32.25	
74-75	Vega (140-2BC) .....	6260824	1	32.25	
75	Vega (122) .....	361082	1	141.00	
75	Monza (262) .....	355942	1	53.50	
75	Vega (122) .....	343339	1	6.70	<b>BRACE</b> , inlet manif. ....
70	All (307),				
72	Camaro w/Sp. H/Per. (350) .....	3758369	1	1.20	<b>GUARD</b> , inlet manifold oil splash .....
64-65	Chevy, Chevelle w/H/Per. (327),				
65	Pass. w/H/Per. (327),				
66-68	All (327, 350) (exc. Sp. H/Per.),				
69	All (327, 350),				
70	Pass., Nova, Camaro (350, 400)				
	(exc. Sp. H/Per.),				
70	Chevelle (350),				
70	Chevelle w/2BC (400),				
71-72	All (307, 350) (exc. Sp. H/Per.) ..	3946830		1.45	<b>GUARD</b> , oil splash .....
70	Nova, Chevelle w/Sp. H/Per.				
	(396),				
70-71	Chevelle, Camaro w/Sp. H/Per.				
	(454) .....	3964247		5.05	<b>GUARD</b> , inlet manifold oil splash .....
70-71	Pass., Chevelle (454) (exc. Sp.				
	H/Per.),				
70	All w/4BC (396, 400) (exc. Sp.				
	H/Per.),				
71	Pass., Chevelle, Camaro w/4BC				
	(400),				
72	All (402, 454) .....	3919853		2.70	<b>GUARD</b> , oil splash .....
73	All (307, 350, 400) (exc. Sp.				
	H/Per.),				
74-75	All (350, 400),				
75	Monza (262) .....	6271071	1	1.55	<b>GUARD</b> , oil splash .....
73-74	All (454) .....	346243	1	2.70	<b>GUARD</b> , oil splash (repl. 353069) .....
75	All (454) .....	346243	1	2.70	<b>GUARD</b> , oil splash .....
69	Camaro (302) .....	3941142	1	.27	<b>PLUG</b> , inlet man. oil filter tube hole .....

**3.270 GASKET PKG.— GASKET, Intake Manifold**

*NOTE: Gasket Package contains 1 center, 2 end gaskets and 1 exh. pipe packing.*

64-68	Chevy (8 cyl.) (exc. 396),				
65-68	All (283, 307, 327) .....	3931600	1	2.95	intake .....
65	Pass. (409) (exc. H/Per., dual				
	4BC) .....	3750620	1	3.10	intake (Note 1) .....
	<i>NOTE 1 Consists of 1 front, 1 rear, 1 distributor, and 2 side gaskets.</i>				
65	Pass. (H/Per. w/dual 4BC) (409)				
	(exc. RPO Z11) .....	3822650	1	4.05	intake .....
65-69	All w/Sp. H/Per. (396, 427),				
70-71	Nova, Chevelle, Camaro w/Sp.				
	H/Per. (396, 454) .....	3955527	1	4.05	inlet manifold .....
65-69	All (396, 427) (exc. Sp. H/Per.),				
70-71	Pass., Chevelle (454) (exc. Sp.				
	H/Per.),				
70-71	All w/4BC (396, 400) (exc. Sp.				
	H/Per.),				
72	All (402, 454),				
75	All (454) .....	6259379	1	3.20	inlet manifold .....
69	All (8 cyl.) (exc. 396, 427),				
70-71	All (8 cyl.) (exc. 396, 4BC, 400,				
	454),				
72	All (307, 350, 400) .....	356802	1	3.20	inlet manifold .....
73	All (454) .....	6259316	1	3.20	inlet .....
73	All (8 cyl.) (exc. 454),				
74	All w/2BC (350, 400) .....	6258833	1	3.20	inl. manif. ....
74	All (454) .....	6260996	1	3.20	inlet manif. ....
74	All w/4BC (350, 400) .....	345195	1	3.20	inlet manif. ....
75	All (262, 350, 400) .....	356801	1	3.75	inlet manifold .....

**FUEL—EXHAUST—CARBURETION**

**3.270 GASKET PKG.— GASKET, Intake Manifold (Con't)**

62-69	Chevy (4 cyl.)	3788539	1	.80	GASKET, inlet and exhaust
71-75	All (140)	3977151	1	.77	GASKET, intake manif.
62-71	All (6 cyl.),				
72	Pass. (6 cyl.),				
73-74	All (6 cyl.),				
75	Nova (6 cyl.) (exc. integrated cyl. head)	338115	1	1.80	GASKET, inlet and exhaust
75	All (6 cyl.) w/integrated cyl. head	352176	1	5.35	GASKET, exhaust manifold
75	All (122)	333903	1	.77	GASKET, intake manif.
75	All (122)	348618	1	3.75	GASKET, exhaust

**3.272 GASKET, Intake to Exhaust Manifold**

62-71	All (4 cyl., 6 cyl.),				
72	Pass., Nova, Chevelle (6 cyl.),				
73-74	All (6 cyl.)	329604	1	.29	
75	All (6 cyl.) (exc. integrated cyl. hd.)	343386	1	.29	

**3.273 CLAMP, Manifold**

62-70	All (4 cyl.),				
71-75	All (6 cyl.)	3792519	1	.32	inlet & exhaust
62-75	All (6 cyl.)	3823035	2	.32	at exhaust ports

**3.275 STUD— BOLT— PIPE, Intake & Exhaust Manifold**

62-75	All	483543 A.R.		.11	exh. mfl'd. ends to hd., intake manifold (3/8" — 16 — 16 x 2 3/16")
62-70	All (4 cyl.),				
71-75	All (6 cyl.)	3835487	2	.40	1 end threaded— other end used as dowel to line up manifold (3/8" — 16 x 2 9/32")
62-71	All	344996 A.R.		.23	inlet mfl'd. to exh. mfl'd. (3/8" — 16 — 16 x 3 5/16")
62-64	Chevy,				
71-75	All (6 cyl.)	3792369 A.R.		.16	inlet and exhaust manifold clamp (3/8" — 16 — 24 x 1 1/16")
62-67	Chevy (8 cyl.)	3771064	2	.34	exhaust L.H. (3/8" — 16 — 15/16" — 18 x 2 7/8")
64-65	Chevelle w/Air Cond. (8 cyl.),				
65-66	Pass. w/Air Cond. (283, 327, 427),				
67	Pass., Chevelle, Camaro (8 cyl.),				
68	All (307, 327, 350)	3932448	1	.64	(3/8" — 16 — 16 x 4 1/8")
65	Pass. (409)	3774029	1	1.70	(5/16" — 18 — 3/16" — 16 x 2 9/16")
65	Chevy (327) (exc. H/Per.)				exh. manifold assy. at rt. front center hole (3/8" — 16 — 16 x 3 1/2")
66-67	Pass. (327)				exh. manifold, at left center front hole (Rochester carbs.),
67	Chevy (327)	3814568	1	.34	left center front hole
68	Pass., Chevelle, Camaro w/C.A.C. (396, 427)				exh. manifold, front right,
68-69	Chevelle w/P.S. (396),				
69	Camaro w/P.S. (8 cyl.)	3928906	1	.52	exh. manifold front L.H.
69	All (A.T. w/Sp. H/Per.) (396, 427),				
70	All (396, 454),				
71	All (400, 454) (exc. Sp. H/Per.),				
72-75	All (402, 454)	3959168	1	.34	inlet manifold (3/8" — 16 — 5/16" — 18 x 2 1/4")
70	Pass. (350, 400)	3937247	1	1.70	exh. manifold R.H. No. 4 hole
71	All	333959 A.R.		.18	(3/16" — 18 — 24 x 1 11/16") — (3.288)
71-73	Vega (1BC)	3980285	1	.31	intake manif. to cyl. head
74-75	All (exc. Vega)	3975998	1	.38	inlet manifold #1 R.H. hole, #3 L.H. hole (3/8" — 16)
75	All (6 cyl.)	6272730	4	.34	exhaust manifold
75	All (6 cyl.)	9784982	2	.11	intake and exh. mfl'd. clamp
75	Vega (122)	147664	1		inlet manif. brace
75	Monza (262)	3932448	1	.64	exhaust manifold #1 and 2 R.H.
75	Monza (262)	3993345	1	.28	inlet manifold #1 R.H.
75	Monza (262)	3932368	1	.16	inlet manifold #3 R.H.
62-70	All	3733130 A.R.		.24	BOLT, at end holes (3/8" — 16 x 2 1/4") (300M steel)
62-70	All	3909830 A.R.		.52	BOLT, exh. manifold at end holes (3/8" — 16 x 2 1/16")
64-67	Chevy (283, 327),				
64-67	Chevelle (327),				
65-68	Pass. (283, 307, 327),				

**FUEL—EXHAUST—CARBURETION**

**3.275 STUD— BOLT— PIPE, Intake & Exhaust Manifold (Con't)**

70	Pass. (350, 400) . . . . .	3733134 A.R.	.28	BOLT, at center holes ( $\frac{3}{8}$ "— 16 x $2\frac{27}{32}$ " (300M steel)— (8.900) . . . . .
64-68	Chevelle, Camaro w/Air Cond. (8 cyl.),			
65-68	Pass. w/Air Cond. (283, 307, 327, 427),			
67	Chevelle (8 cyl.) . . . . .			BOLT, exhaust— R.H. 3rd hole ( $\frac{3}{8}$ "— 16 x $3\frac{21}{32}$ "), . . . . .
68	All (307, 327, 350),			
69	All w/Air Cond. (8 cyl.),			
70	Pass., Nova, Chevelle,			
70	Camaro w/C.A.C. (exc. 396),			
71-75	All w/C.A.C. (8 cyl.) (exc. 400, 454) . . . . .	3841724 A.R.	.46	exh. man. 2nd and 3rd holes L.H. . . . .
67-69	Pass., Chevelle, Camaro (396, 427),			
70	Pass., Monte Carlo (454),			
70	Nova, Chevelle, Camaro (396),			
71	All (400, 454) . . . . .	3909821 A.R.	.22	BOLT, exh. manifold ( $\frac{3}{8}$ "— 16 x $1\frac{3}{16}$ " ) . . . . .
67	Chevy (283, 327) (exc. Sp. H/Per.),			
67	Chevy (283, 327) (exc. A.I.R., C.A.C.) . . . . .	3909831	1 .28	BOLT, exh. manifold at L.H. side rear, exh. manifold at R.H. side front ( $\frac{3}{8}$ "— 16 x $1\frac{5}{16}$ " ) . . . . .
74-75	All (454) . . . . .	3909821	8 .22	BOLT, exh. manifold at end holes (hex. $\frac{3}{8}$ "— 16 x $1\frac{3}{16}$ " ) . . . . .
71-75	Vega, Monza . . . . .	3921953	2 .31	BOLT, exhaust manifold, upper ends ( $\frac{3}{8}$ "— 16 x $1\frac{1}{2}$ " ) . . . . .
71-72	Vega . . . . .	3977152	2 .31	BOLT, exhaust manifold, lower ends ( $\frac{3}{8}$ "— 16 x $2\frac{1}{4}$ " ) . . . . .
73-75	Vega, Monza (140) . . . . .	329699	2 .31	BOLT, exhaust manifold, lower ends . . . . .
75	Vega (122) . . . . .	334047	16 .31	BOLT, exhaust manifold— (0.662) . . . . .
75	Vega, Monza . . . . .	3841724	2 .46	BOLT, exhaust manifold ( $\frac{3}{8}$ "— 16 x $3\frac{11}{16}$ " ) . . . . .
73-75	Vega, Monza (140) . . . . .	331101	1 1.85	PIPE, exhaust gas recirculation exhaust manif. to inlet manifold . . . . .

**3.278 ADAPTER— FITTING— TEE, Manifold Vacuum Take-Off**

65-68	Pass.,			
65-66	Chevelle w/level ride (8 cyl.) . . . . .	3871227	1 2.10	inlet manifold to air hose . . . . .
65	All . . . . .	3989020	1 .59	FITTING, vac. inlet manif. ( $\frac{3}{8}$ "— 18)— (4.931) . . . . .
67-69	Pass., Chevelle, Camaro,			
70	Pass. (Speed and Cruise Control w/P.B.) w/C.A.C. (8 cyl.),			
70	Chevelle (Spec. Duct Hood w/P.B.) (C.A.C. w/A.T.) (454),			
70	Camaro (R.S. Package w/Disc Brake, P.B.) (C.A.C. w/A.T.) . . . . .	3905376	1 1.75	FITTING, vac. inlet manifold . . . . .
70	Chevelle (8 cyl.) . . . . .	3905374	1	FITTING (4.931) . . . . .
70-71	Pass. (6 cyl.) . . . . .	3977106	1 1.40	FITTING ( $1\frac{27}{32}$ " O.L.) ( $\frac{3}{8}$ "— 18) (2 hose connector) . . . . .
70	All w/P.B. (6 cyl.),			
71	Nova, Chevelle, Camaro w/P.B. (6 cyl.),			
72	All (6 cyl.) . . . . .	330138	1 2.35	FITTING, inlet manifold ( $\frac{3}{8}$ "— 18 x $1\frac{5}{16}$ " O.L.) (1 hose conn.) . . . . .
70	All . . . . .	3981049	1 1.75	FITTING, inlet manifold vacuum ( $\frac{3}{8}$ "— 18 x $1\frac{5}{16}$ " ) (2 hose connector)— (4.931) . . . . .
70	Pass. w/C.A.C. (8 cyl.) (exc. P.B.),			
71-75	Vega, Monza . . . . .	336015	1 .80	FITTING, inlet manifold (two hose take off) ( $\frac{3}{8}$ "— 18 pipe thd.) . . . . .
71-75	Vega, Monza . . . . .	336013	1 1.05	FITTING, inlet manifold (one hose take off) ( $\frac{3}{8}$ "— 18 pipe thd.) . . . . .
74-75	All (Speed & Cruise Cont. w/C.A.C.) . . . . .	336016	1 1.30	FITTING, incl. manif. vac. (3-way— $\frac{5}{16}$ " dia.) . . . . .
73-75	Nova w/A.T. (exc. C.A.C.),			
73-75	Pass., Chevelle (8 cyl.),			
74-75	Nova w/C.A.C. (8 cyl.) (exc. A.T.),			
74-75	Camaro (8 cyl.) . . . . .	336013	1 1.05	FITTING, ini. manif. vac. (2-way for $\frac{1}{4}$ " hole) . . . . .
73-75	Nova (A.T. w/C.A.C.),			
73-75	Pass., Chevelle,			
74-75	Camaro . . . . .	336015	1 .80	FITTING, ini. manif. vac. ( $\frac{3}{8}$ "— 18 thds. and two $\frac{1}{4}$ " hose take-off) . . . . .

**FUEL—EXHAUST—CARBURETION**

**3.278 ADAPTER— FITTING— TEE, Manifold Vacuum Take-Off (Con't)**

75	Chevelle (6 cyl.) (exc. C.A.C., NB-2),					
75	Camaro, Nova (6 cyl.) (exc. C.A.C., NB-2)	354513	1	1.10	FITTING, inlet manifold vac.	
75	All (A.T. w/C.A.C.) (6 cyl.)	343350	1	.27	FITTING, inlet manifold vac.	
75	All (3-Spd. w/C.A.C.) (6 cyl.)	355787	1		FITTING, inlet manifold vac.	
75	Monza (C.A.C. w/fuel econ. gauge) (262)	336016	1	1.30	FITTING, inlet manifold vac.	
75	Vega w/P.B. (140) (exc. A.I.R. fuel econ. gauges)	357616	1	2.10	FITTING, inlet manifold vac.	
75	Vega (1BC w/P.B. econo. gauges) (140)	357615	1	3.20	FITTING, inlet manifold vac.	
75	Vega (2BC w/P.B. econo. gauges) (140)	357614	1	3.20	FITTING, inlet manifold vac.	
63-64	Chevy w/C.A.C. (exc. 8 cyl.)	3794176	A.R.	3.70	TEE, air bleed valve and fast idle— (9.189)	
75	All (454)	6272769	1	.50	TEE, diverter vlv. vent. vlv. hose	
75	Pass., Chevelle	3752621	1	.22	TEE, speed and cruise control vac. hose	
64	Chevy, Chevelle (8 cyl.),					
65	Chevelle (level ride w/P.B.) (exc. Air Cond., P.G.),					
65-66	Chevy,					
65-67	Pass.,					
65-66	Chevelle (P.G. w/C.A.C.) w/P.B.,					
65-67	Pass. (level control w/P.B.) (C.A.C. w/P.G.),					
65-67	All,					
70	Nova					inlet manifold
67-68	Camaro	3891528	1	1.70	TEE ASSY., vac. inlet manifold (one 3/8" hose take-off and one 1/4" hose take-off) (3/8" — 18 thds.)— (7.447)	
65-69	All (level control w/P.B.)	3891526	1	.87	TEE ASSY., inlet manifold (3/8" — 18 one take-off)	
64-69	Chevelle, Camaro,					
65-69	Pass.,					
66-69	Chevy,					
70	Pass. (8 cyl.),					
72	Nova (A.T. w/C.A.C.),					
72	Pass., Chevelle	336015	1	.80	TEE ASSY., vac. inlet manifold (3/8" — 18 thds. and two 1/4" hose take-off)	
65-69	All,					
72	Nova w/A.T. (exc. C.A.C.),					
72	Pass., Chevelle	336013	1	1.05	TEE ASSY., inlet mfld. (2-way for 1/4" hose)	
65	Pass. w/level ride (Air Cond. w/P.G.) (409) (exc. P.B., H/Per.),					
65	Chevelle w/level ride (Air Cond. w/P.G.) (exc. P.B.),					
65-67	Pass. w/level ride (Air Cond. w/P.G.) w/T.H. (396) (exc. P.B., Sp. H/Per.)	3894339	1	3.85	TEE ASSY., spl. vac.— (7.447)	
65-67	Chevy w/P.B. (8 cyl.)	3794177	1	1.80	TEE ASSY., c/case vent. hose— (1.745)	
65-67	Pass., Chevelle, Camaro	3891526	1	.87	TEE ASSY., vac. inlet manifold (3/8" — 18 thd. and 3/8" hose take-off)— (7.447)	
69	Pass.	3894339	1	3.85	TEE ASSY., vac. inlet manifold (3/8" — 18 thd. and four 3/8" take off— (7.447)	
75	Chevelle, Pass., Nova, Camaro	352252	1	3.40	TEE, cruise control vac. hose	

**3.288 STUD— BOLT— WASHER, Intake Manifold to Carburetor**

62	Chevy (2nd design),					
63-70	All (4 cyl., 6 cyl.)	3792369	A.R.	.16	inlet and exhaust (3/8" — 16— 24 x 1 13/16")— (3.275)	
62-70	All	3731702	A.R.	.34	left side front hole, adapter, right side, frt. (3/8" — 16 x 1 49/64") right side, front, right side, rear	
70	All w/E.E.C. (6 cyl.)	3967070	2	.52	(5/8" — 24 one end 3/8" — 16 x 1 9/16" other end)	
70	All w/Sp. H/Per. (350, 396, 454),					
71	Chevelle w/Sp. H/Per. (454),					
72	Camaro w/Sp. H/Per. (350)	3967475	4	.40	(5/16" — 18— 24 x 1 7/8")	
71-72	Vega,					
72-75	All (6 cyl.)	3973169	2	.22		
73-75	Vega, Monza w/1BC (140)	3983491	2	.24	carb. (3/8" — 16— 24 x 1 3/4")	
62-71	All					(5/16" — 18— 24 x 1 11/16"),
73-75	Vega, Monza w/2BC (140)					carb.,

**FUEL—EXHAUST—CARBURETION**

**3.288 STUD— BOLT— WASHER, Intake Manifold to Carburetor (Con't)**

74	Vega (122),				
75	Vega, Monza	333959	A.R.	.18	inlet manifold (5/16" — 18 — 24 x 1 5/16")
75	All (6 cyl.) (exc. integrated cyl. hd.)	347183	1	.52	exh. manifold to inlet manifold
70	Monte Carlo w/4BC (400),				
70	Pass. (4BC w/E.E.C.),				
70	Nova, Chevelle, Camaro w/4BC (exc. Sp. H/Per.),				
71-72	All w/4BC (350) (exc. Sp. H/Per.)	9432450	2	.33	<b>BOLT</b> (1/2" — 18 x 3 3/4")— (8.900)
64-66	All (283) (exc. 4BC, dual 4BC, RPO Z11)	3719427	2	.11	<b>WASHER</b> , frt. mtg. stud (1 1/32" I.D. x 1 1/32" O.D.)

**3.300 CONTROL— GROMMET— MOUNT, Fuel Injection**

75	Vega (122)	354819	1	380.00	<b>CONTROL</b> , elec. (rebuilt)
74-75	Vega (122)	336500	2	.12	<b>GROMMET</b> , elec. fuel inj. control
75	Vega (122)	361096	1	5.35	<b>MOUNT</b> , M.A.P. valve

**3.302 VALVE— BRACKET— SUPPORT, Fuel Injection**

74-75	Vega (122)	345130	1	40.75	eng. fuel inj.
75	Vega (122)	361085	1	43.25	fuel inj. fast idle
74-75	Vega (122)	336497	L.H.	1.25	<b>BRACKET</b> , control
74-75	Vega (122)	336498	R.H.	1.50	<b>BRACKET</b> , control
74-75	Vega (122)	336499	1	1.15	<b>SUPPORT</b> , control

**3.304 SEAL— "O" RING, Injection Valve to Intake Manifold**

75	Vega (122)	345141	1	.27	inj. valve to intake mfl.
75	Vega (122)	1606772	1	.27	"O" RING, E.F.I. injector

**3.320 SENSOR ASSY.— PLATE— SHIELD, Fuel Meter Enrichment**

75	Vega (122)	345133	1	26.50	ini. manif. air temp.
75	Vega (122)	361090	1	95.00	intake mfl. air press.
75	Vega (122)	334039	1	26.50	speed switch
75	Vega (Hatchback Cpe.) (122)	361089	1	17.10	water temp.
75	Vega (122)	361091	1	12.20	<b>PLATE</b> , sensor mtg.
75	Vega (122)	334038	1	2.70	<b>SHIELD</b> , water temp. heat sensor

**3.330 MANIFOLD— PIPE— BRACKET— EXTENSION— FUEL RAIL— GROMMET— HOSE, Fuel Injector**

75	Vega (122)	360189	1	20.40	<b>MANIFOLD</b> , pulsair valve
75	Vega (122)	360186	1	3.60	<b>PIPE</b> , dist. drain hsg. oil drain
75	Vega (122)	360187	1	26.50	<b>PIPE</b> , pulsair
75	Vega (122)	361088	1	5.35	<b>BRACKET</b> , fuel rail
75	Vega (122)	360188	1	1.90	<b>EXTENSION</b> , pulsair pipe
75	Vega (122)	361087	1	35.25	<b>FUEL RAIL</b>
75	Vega (122)	345143	1	.27	<b>GROMMET</b> , fuel pipe bracket
75	Vega (122)	360190	4	.76	<b>HOSE</b> , pulsair mfl. to valve
75	Vega (122)	360124	1	2.05	<b>HOSE</b> , fuel inj. fast idle valve to t/body

**3.335 SWITCH, Fuel Injector Air**

75	Vega (122)	345132	1	26.50	<b>SWITCH</b> , throt. position
----	------------	--------	---	-------	---------------------------------

**3.374 FITTING, Oil Pressure Gauge**

67	Pass. (8 cyl.)	3886605	A.R.	.84	hose (Note 1)
----	----------------	---------	------	-----	---------------

*NOTE 1 Used with RPO U-14 oil pressure gauge.*

**FUEL—EXHAUST—CARBURETION**

**3.402 CLEANER— FILTER— SILENCER, Carburetor Air**

*NOTE When using certain cleaners on non-closed vent systems, it will be necessary to pinch shut closed system tube.*

*NOTE: See end of listing for Vega-Monza.*

**1962— 1963 CHEVY II AIR CLEANER CHART**

ENGINE	CHEVY II
4 cyl.	6484490-A
6 cyl.	5649855-A

*A. When using on early models, it is necessary to pinch shut 1/2" dia. tube in the top cover. (1 1/8" O.D. at intake horn).*

**1964 CHEVY II, CHEVELLE AIR CLEANER CHART**

ENGINE	CHEVY II	CHEVELLE
4 cyl.	6484490	—
6 cyl.	64235 16-B 648444 1-E	648444 1-E 64235 17-AG
283 w/2BC	6484445	6484445
283 w/4BC	6484455-A 6420903-BF	6484455-A 6420903-B
327	6484455-AD 6420903-BF	6484455-A 6420903-B

*A. w/Closed Vent*

*B. Exc. Closed Vent*

*C. w/Sp. H/Per.*

*D. Exc. Sp. H/Per.*

*E. 230 Engine*

*F. Pinch shut the 1/4" Connector on the bottom when used in place of 6420901.*

*G. It may be necessary to use A/cl. 5353824.*



**FUEL—EXHAUST—CARBURETION**

**1965 PASSENGER, CHEVY II, CHEVELLE AIR CLEANER CHART**

ENGINE	PASSENGER	CHEVY II	CHEVELLE
4 cyl.	—	6484490	—
6 cyl.	— 6423517-LN 6422819-IF	6423516-F 6484441-O	6423517-EN 6484441-O
283 w/2BC	6484445	6484445	6484445
283 w/4BC	6484455-ENG 6420903-FDM	6420903-F 6484455-EB	6420903-F 6484455-E
327	6420903-EDM	6420903-F 6484455-EB	6420903-F 6484420-A 6484455-E
396	6484409-CGH	—	—

A. w/Sp. H/Per.

B. Exc. Sp. H/Per.

C. w/Level Ride.

D. Exc. Level Ride.

E. w/Closed Vent.

F. Exc. Closed Vent.

G. When used with Level Ride use Compressor A/c. 5353826.

H. It may be necessary to Drill a Hole in the Snorkel for Heat Tube.

I. w/Oil Bath.

J. Exc. Oil Bath.

K. w/A.I.R.

L. Exc. A.I.R.

M. Pinch shut the 1/4" Connector on Bottom of A/c. on Models not used with Level Ride.

N. It may be necessary to use A/c. 5353824.

O. 230 Engine.

**FUEL—EXHAUST—CARBURETION**

**1966 PASSENGER, CHEVY II, CHEVELLE AIR CLEANER CHART**

ENGINE	PASSENGER	CHEVY II	CHEVELLE
4 cyl.	—	6484490	—
6 cyl.	6424433-A 6423516-F 6423517-BD 6484421-NF	6424433-A 6423517-B	6424433-A
283 w/2BC	6484445-D	6484445	6484445-D
283 w/4BC	6484455-AC 6484455-E 6420903-BS	6484455-A 6484455-E	6484455-A 6484455-E
327	6421966-FG 6484410-ACG 6484410-EH 6422191-EI	6422182-AJ 6484417-AK 6421964-JB 6421916-EB 6484410-EHK 6484410-AKR	6422182-AJ 6421964-BJ 6421966-BFK 6484410-AK 6422191-EKI
396	6484409	—	6423907-JPB 6423269-JPA 6484411-KQ 6484409-EP
427	6421958-AEKG 6484409-KIF 6423260-HEKM 6484409-HKFL 6484415-JIH		

- A. w/A.I.R.
- B. Exc. A.I.R.
- C. When used with Level Ride use Compressor A/cl. 5353826.
- D. When used with Level Ride use Compressor A/cl. 5353824.
- E. w/Closed Vent.
- F. Exc. Closed Vent.
- G. It may be necessary to drill a Hole in the Snorkel for Heat Tube.
- H. w/Level Ride.
- I. Exc. Level Ride.
- J. w/Sp. H/Per.
- K. Exc. Sp. H/Per.
- L. w/Holley Carb.
- M. w/Rochester Carb.
- N. w/Oil Bath
- P. w/H/Per.
- Q. Exc. H/Per.
- R. Exc. Air Cond.
- S. Pinch shut the 1/4" Connector on Bottom of A/cl. on Models not used w/level.

**FUEL—EXHAUST—CARBURETION**

**1967 PASSENGER, CHEVY II, CHEVELLE, CAMARO AIR CLEANER CHART**

ENGINE	PASSENGER	CHEVY II	CHEVELLE	CAMARO
4 cyl.	—	6484490	—	—
6 cyl.	6424488-AD 6424489-AC 6423516-BD 6424433-E 6423517-JBISC	6424433-E 6423517-CI 6423516-D	6424433-E 6423516-D 6423517-CIS	6423517-CI 6424433-E 6423516-DW
283	6423927-FC 6424491-CGI  6484489-DJEGCHI  6424803-EH	— 6424803-EH 6424491-CIG  6484489-DEGCHI	6424803-EH  6424491-CIG 6484489-DEGCHI	—
327 w/2BC	—	—	—	6424490-D 6424491-CG 6484489-EGCH 6424803-EH
327 w/4BC	6421966-DP 6484410-EOP 6422191-CI	6484498-L 6484417-EQ 6421916-CI 6422191-CI	6423507-EL 6423506-LI 6484410-EQ  6421966-D	6484410-E 6422191-CI
350	—	—	—	6424486-CI 6484493-E 6424485-D
396	6484409-OP	—	6423907-KLI 6423269-KLE 6484411-QR	6423269-KLE 6423907-KLI 6483656-QRD 6424436-EQRV 6424435-CIQR 6424434-DQRV
302	—	—	—	6484665-T 6484413-E 6423907-I
427	6424482-KD 6424483-KCI 6423269-LE 6423907-LI 6424484-ME 6484409-EN 6484409-LJD			

- A. w/Oil Bath
- B. Exc. Oil Bath
- C. w/Closed Vent.
- D. Exc. Closed Vent.
- E. w/A.I.R.
- F. w/Level Ride
- G. 1st Design w/Two Tubes
- H. 2nd Design w/One Tube
- I. Exc. A.I.R.
- J. Exc. Level Ride
- K. w/H/Per.
- L. w/Sp. H/Per.
- M. w/SS 427
- N. Exc. SS 427
- O. When used with Level Ride use Compressor A/cl. 5353826
- P. It may be necessary to drill a hole in the snorkel for heat tube
- Q. Exc. Sp. H/Per.
- R. Exc. H/Per.
- S. It may be necessary to use A/cl. 5353824
- T. w/Spec. exh. plenum air
- U. 1st Design w/Cover 6422356
- V. 2nd Design w/Cover 6483656
- W. 230 Engine

**FUEL—EXHAUST—CARBURETION**

**1968 PASSENGER, CHEVY II, CHEVELLE, CAMARO AIR CLEANER CHART**

ENGINE	PASSENGER	CHEVY II	CHEVELLE	CAMARO
4 cyl.	—	6485884	—	—
6 cyl.	6483657-BD 6484217-CB 6424424-AC 6424423-AD	6424423-A 6483657-B	6424423-A 6483657-B	6424423-A 6483657-B
307	6483655-LB 6424425-LA 6484218-MA	6424425-A 6483655-B	6484218-NA 6483655-BO 6424425-AO	—
327 w/2BC	—	—	—	6483655-B 6424425-A
327 w/4BC	6484220-A	6423272-I 6484220-AJ	6484220-AJ 6423272-K	6484220-A
350	—	6484223-B 6484222-A	—	6484222-A 6484223-B
396	6484225-A	6423907	6484226-BP 6484227-AP 6423907-IK	6423907
302	—	—	—	6484665-Q 6423272-R
427	6424810-EG 6424809-EH 6483663-IFH 6483664-GFJ 6423907-K	—	—	—

- A. w/A.T.
- B. Exc. A.T.
- C. w/H.D. A/cl.
- D. Exc. H.D. A/cl.
- E. w/T.H.
- F. Exc. T.H.
- G. w/SS 427
- H. Exc. SS 427
- I. w/H/Per.
- J. Exc. Sp. H/Per.
- K. w/Sp. H/Per.
- L. Biscayne, Bel Air
- M. Impala, Caprice
- N. Malibu, Concours
- O. Exc. Malibu, Concours
- P. Exc. H/Per., Sp. H/Per.
- Q. w/Spec. exh., plenum air (black)
- R. Chrome cover

**FUEL—EXHAUST—CARBURETION**

**1969 PASSENGER, CHEVY II, CHEVELLE, CAMARO AIR CLEANER CHART**

ENGINE	PASSENGER	CHEVY II	CHEVELLE	CAMARO
4 cyl.	—	6485884	—	—
6 cyl.	6484661-BD 6487200-AD 6484663-CB 6484664-AC	6484661-B 6487200-A	6484661-B 6487200-A	6484661-B 6487200-A
307	—	6484597-B 6484578-A	6484597-NB 6484580-AO 6484579-BO 6485902-AN	6487430 6484597-B
327	6484668-A 6484667-B	—	—	6487430-A 6484597-B
350 w/2BC	6484668-A 6484667-B	6484674-A	6484668-A 6484667-B	6484674-A
350 w/4BC	6485240-A 6484581-B	6485244-A 6484583-B	6484581-B 6485240-A	6484583-BS 6485244-AS 6485233-RB 6485234-RA
396 w/2BC	6484671-B	—	—	—
396 w/4BC	—	6423907	6423907-EF 6484589-GI 6484592-GH	6423907-S 6485891-R
302	—	—	—	6423907-QS 6423272-PS 6485891-R
427	6423907-E 6484596-FHL 6484595-FLI 6484594-FHM 6484593-FIM 6484592-HG 6484591-GI	—	—	—

- A. w/A.T.
- B. Exc. A.T.
- C. w/H.D. A/cl.
- D. Exc. H.D. A/cl.
- E. w/Sp. H/Per.
- F. w/H/Per.
- G. Exc. H/Per., Sp. H/Per.
- H. w/T.H. 400
- I. Exc. T.H. 400
- L. w/SS 427
- M. Exc. SS 427
- N. Deluxe, Nomad, Greenbrier
- O. Malibu, Concours
- P. 1st Design
- Q. 2nd Design
- R. w/Spec. Duct Hood
- S. Exc. Spec. Duct Hood

**FUEL—EXHAUST—CARBURETION**

**1970 AIR CLEANER CHART**

*NOTE: See Dealer Price Schedule for applicable prices.*

ENGINE	PASS.	NOVA	CHEVELLE	CAMARO
(4 cyl.)	—	6485884	—	—
(6 cyl.)	6487200	6487200	6487200	6485886
(307)	—	6487430	6487430-F 6487428	6487430
350 w/2BC	6484668	6484674	6484668	6485894
350 w/4BC	6485240	6485242	6485240	6485241-C 6485242-B
396	—	6485239-B 6485257-C	6485891-A 6485257-CE 6485239-BE	6485239
400 w/2BC	6484668	—	6484668-H	—
400 w/4BC	—	—	6485252	—
454 (exc. H/Per. Sp. H/Per.)	6485252	—	—	—
454 H/Per.	6485248	—	6485891-A 6485248-H 6485239-JE	—
454 Sp. H/Per.	—	—	6485235-A 6485257-E	6485257

A. w/Spec. Duct Hood  
 B. Exc. Sp. H/Per.  
 C. Sp. H/Per.  
 D. (Exc. Spec. Duct Hood  
 E. Exc. Spec. Duct Hood  
 F. Nomad, Greenbrier, El Camino (exc. Custom)  
 G. Used on Malibu and Concours, El Camino (Custom)  
 H. Monte Carlo  
 J. Exc. Monte Carlo  
 K. Exc. T.H. 400  
 L. w/T.H. 400  
 M. w/A.T.  
 N. Exc. A.T.

**1971 AIR CLEANER CHART**

*NOTE: See Dealer Price Schedule for applicable prices.*

ENGINE	PASS.	NOVA	CHEVELLE	CAMARO
(6 cyl.)	6487200	6487200	6487200	6485886
(307)	—	6487428	6487430-A 6487428-B	6487430
350 w/2BC	6484668	6484674	6484668	6485894
350 w/4BC	6485240	6485242	6485240	6485242-C 6485241-D
400 w/2BC	6484668	—	6484668	—
402 w/4BC	6485252	—	6485252	6485254I 6485904J
454	6485248	—	6485248-EC 6485254-CFH 6485236-CGH 6485257-DF 6485891-DGH 6485904 FCH	—

A. Nomad, Greenbrier, El Camino (exc. Custom)  
 B. Malibu, Concours, El Camino Custom  
 C. Exc. Sp. H/Per.  
 D. w/Sp. H/Per.  
 E. Monte Carlo  
 F. Exc. Spec. Duct Hood  
 G. w/Spec. Duct Hood  
 H. Exc. Monte Carlo  
 I. (exc. C.A.C.)  
 J. w/C.A.C.

**FUEL—EXHAUST—CARBURETION**

**1972 AIR CLEANER CHART**

*NOTE: See Dealer Price Schedule for applicable prices.*

ENGINE	PASS.	NOVA	CHEVELLE	CAMARO
(6 Cyl.) (307)	6487200	6487200 6487430	6487200 6487430-A 6487428-B	6487201 6487430
350 w/2BC 350 w/4BC	6484668	6484674 6485242	6484668 6485240	6485894 6485242-C 6485241-D
400 w/2BC 402 w/4BC 454	6484668 6485252 6485248		6485252 6485248-E.C. 6487394-F.H. 6485236-G.H.	6487394

- A. *Nomad, Greenbrier, El Camino (exc. Custom)*
- B. *Malibu, Concours, El Camino (Custom)*
- C. *exc. Sp. H/Per.*
- D. *w/Sp. H/Per.*
- E. *Monte Carlo*
- F. *exc. Spec. Duct Hood*
- G. *w/Spec. Duct Hood*
- H. *exc. Monte Carlo*

**1973 AIR CLEANER CHART**

*NOTE: See Dealer Price Schedule for applicable prices.*

ENGINE	PASS.	NOVA	CHEVELLE	CAMARO
(6 cyl.)	6487925	6487925	6487925	6487562
(307)	—	6487563	6487560	6487564
(350 w/2BC)	8994024	6487556	8994024	6487559
(350 w/4BC)	8994025	6487558	8994025	6487558 A 6487699 B
(400 w/2BC)	8994024	—	—	—
(454)	6487536	—	6487536	—

- A. *(exc. Sp. H/Per.)*
- B. *(w/Sp. H/Per.)*

**1974 AIR CLEANER CHART**

ENGINE	PASS.	NOVA	CHEVELLE	CAMARO
(6 cyl.)	—	6487925 6488248 H.D.	6487925	6487926
(350 w/2BC)	8994024	6487556	8994024	6487559
(350 w/4BC)	8994025	6488064	8994025	6488064* 6488412#
(400 w/2BC)	8994024	—	8994024	—
(400 w/4BC)	8994025	—	8994025	—
(454)	6487536	—	6487536	—

- NOTE \*: (exc. Sp. H/Per.)*
- NOTE #: w/Sp. H/Per.*

**FUEL—EXHAUST—CARBURETION**

**1975 AIR CLEANER CHART**

ENGINE	PASS.	CHEVELLE	NOVA	CAMARO
(6 cyl.)		8994431	8994431	8994431
(262 w/2BC)			8994415	
(350 w/2BC)	8994306	8994306	8994415	8994022
(350 w/4BC)	8994307	8994307	6487557	8994023* 8994282#
(400 w/4BC)	8994307	8994468		
(454 w/4BC)	8994030	8994030		

NOTE \*: exc. Sp. H/Per.

NOTE #: w/Sp. H/Per.

**VEGA— MONZA**

71-72	Vega,				
73-74	Vega (1BC) .....	8995315	1	13.85	AIR CLEANER ASSY. ....
73-74	Vega (2BC) .....	8994874	1	12.98	AIR CLEANER ASSY. (repl. 6487668) ....
75	Vega (122) .....	8994368	1	167.00	AIR CLEANER ASSY. ....
75	Vega (140-1BC) .....	6487282	1	11.89	AIR CLEANER ASSY. ....
75	Vega (140) .....	6487351	1	10.50	AIR CLEANER ASSY. ....
75	Monza (262, 350) .....	8994417	1	80.25	AIR CLEANER ASSY. ....

75	All (140-2BC) .....	8995350	1	12.98	FILTER, air .....
71-75	Vega (140) .....	6487351	1	10.50	SILENCER ASSY. ....

**3.403 GASKET— NUT— SCREW— STUD, Air Cleaner**

64-71	All,				
72-75	All (exc. 350, 400, 402, 454) ..	3970102 A.R.		.20	to carb. and silencer, carb. to a/cl. hose, a/cl. and sil. to carb. air ini. tube (2 <sup>5</sup> / <sub>8</sub> " I.D. x 3 <sup>1</sup> / <sub>16</sub> " x 1 <sup>1</sup> / <sub>16</sub> " thk.) .....
64-66	Chevy, Chevelle w/4BC (exc. Sp. H/Per.),				
65	Pass. (8 cyl.) (exc. 283) .....	1463468 A.R.		.17	to carb. (4 <sup>1</sup> / <sub>4</sub> " I.D. x 4 <sup>5</sup> / <sub>8</sub> " O.D. x 1 <sup>1</sup> / <sub>16</sub> " thk.) ..
65	Chevelle w/Sp. H/Per. (327),				
65	Pass. (396, 409),				
66	Chevy, Chevelle (327, 396),				
66	Pass. (8 cyl.),				
67-68	All w/4BC (exc. A.I.R.),				
67-69	Chevy, Chevelle, Camaro (302, 327, 350, 396) (exc. H/Per., Sp. H/Per., 2BC),				
67-69	Pass. (4BC w/A.I.R.),				
70	Pass. w/H/Per. (350),				
70	Chevelle, Camaro (454),				
70	Chevelle w/Spec. Duct Hood,				
70	Nova, Chevelle, Camaro w/4BC (350, 400, 396),				
71-75	All w/4BC (exc. Monza),				
75	Monza w/A.I.R. (262) .....	3969843	1	.29	air cleaner and silencer (5 <sup>1</sup> / <sub>2</sub> " I.D. x 5 <sup>9</sup> / <sub>16</sub> " x 1 <sup>1</sup> / <sub>8</sub> " thk.) .....
69	Pass. (8 cyl.) (exc. 427),				
69-71	Chevy, Chevelle, Camaro w/2BC (350),				
70	Monte Carlo,				
70-71	Pass. w/2BC,				
71	Monte Carlo (exc. 4BC, 350, 454),				
72-75	All w/2BC (350, 400),				
75	Monza, Nova (262) .....	3970104	1	.17	a/cl. and silencer (3 <sup>1</sup> / <sub>16</sub> " I.D. x 3 <sup>9</sup> / <sub>16</sub> " O.D. x 1 <sup>1</sup> / <sub>16</sub> " thk.) .....
75	Nova (250, 350) .....	347519	1	.29	snorkel adapter .....
75	Camaro (8 cyl.) .....	347509	1	.32	snorkel adapter .....
75	Chevelle, Nova (6 cyl.) .....	354521	1	1.25	o/cleaner and sil. ....
62-70	All .....	1385852	1	.16	NUT, wing (1 <sup>1</sup> / <sub>4</sub> "— 20 serrated) (repl. 3752760) .....
68-75	All w/Roch. 1BC .....	7038913	2	.28	SCREW, carb. air cleaner bracket .....
71-75	Vega, Monza .....	7042813	2	.30	SCREW, carb. air cleaner bracket .....
62-71	All,				



**FUEL—EXHAUST—CARBURETION**

**3.403 GASKET— NUT— SCREW— STUD, Air Cleaner (Con't)**

72	Nova,				
72	Camaro w/4BC (350, 402) (exc. Sp. H/Per.)	3921975	1	.12	STUD (1/4"— 20— 20 x 3 1/2")
65-69	Pass. w/Sp. H/Per. (396, 427),				
65-67	Chevelle w/H/Per., Sp. H/Per. (396),				
67	Chevelle w/Sp. H/Per. (327),				
67-68	Camaro w/Sp. H/Per. (396),				
67-69	Camaro (302) (exc. Spec. Duct Hood),				
68-69	Chevy, Chevelle w/Sp. H/Per. (396)	3873852	1	.55	STUD (1/4"— 20— 20 x 1 1/32")
69-70	All w/2BC (307, 327, 350, 400),				
62-75	All (exc. Vega, Monza)	3785256	1	.59	STUD, air cleaner (1/4"— 20 x 9) (Note 1)
70-72	Camaro (6 cyl.),				
74	Nova (6 cyl.),				
75	All (6 cyl.) (exc. Vega, Monza)	3785256	1	.59	STUD (1/4"— 20— 20 x 1 1/4")
75	Pass., Chevelle w/2BC (350),				
75	Nova (262)	3942532	1	.28	STUD (1/4"— 20 x 3 31/64")
75	Monza (262)	3785256	1	.59	STUD, a/cl. and silencer (repl. 3928914)

*NOTE 1: This is a universal stud that must be cut to required length. If excess length is not removed, damage to the hood panel or carburetor can result upon closing the hood.*

**3.405 BRACKET— CLAMP, Air Cleaner**

63-66	Chevy (4 cyl.),				
66	All w/A.I.R. (6 cyl.),				
67	All w/Carter 1BC	3832250	1	.57	stud mtg. (2 3/8" O.L.)
69-74	All w/Roch. 1BC	7037774	1	1.00	carb. a/cl. stud
71-75	Vega, Monza (1BC)	7043656	1	1.45	carb. a/cl. stud
75	All w/1BC	7043588	1	2.20	a/cl. stud
65-67	Pass. w/oil bath (6 cyl.)	3824400	1	.23	CLAMP, support

**3.406 BASE— GASKET, Air Cleaner Oil**

65-67	Pass. (396, 427)				(w/6421816-3240-3907),
66	Chevelle w/H/Per., Sp. H/Per. (396) (exc. A.I.R.)				w/6423240,
67	Camaro (396),				
69	All (302, 396) (exc. Spec. Duct Hood)				w/6424435,
69	Pass. w/Sp. H/Per. (427)	6422188	1	14.50	
64-66	Chevy, Chevelle (8 cyl.) (exc. 396),				
65-66	Pass. (8 cyl.),				
67	Chevy (8 cyl.)	1554094	1	2.00	GASKET (5649128-6419181-9509-10-11-9182-9469-70-6420164-0901-2-3-4-5-6-7)
73-75	Vega, Monza (140-2BC)	348612	1	.24	GASKET, a/cl. to carb.
74-75	Vega, Monza (140-2BC)	348658	1	.17	GASKET, a/cl. silencer to a/cl.
75	Vega	6488143	1		GASKET

**3.407 ADAPTER— HOSE, Air Cleaner to Carb.**

75	Monza (exc. Towne Coupe)	356339	1	9.80	a/cl. and silencer
65-68	All	3845512	1	10.70	HOSE (3" I.D.— 26 1/4" O.L.)

**3.410 COVER— BREATHER— ELEMENT— RETAINER, Air Cleaner**

66-68	Pass. (327, 427)				(w/6421963-2286-7-3240-69-3520-3689-3907-8-9),
66-69	Chevy, Chevelle (327, 396),				
67-69	Camaro (396)				(w/6423269-3908-64836-56),
69	Pass. w/Sp. H/Per. (427)	6421832	1	21.65	(w/6423907)
67	Camaro (396)	6422356	1	11.25	(w/6424434-35-36)
64	Chevy, Chevelle (exc. 230, 283, pos. vent.),				
65-66	All (4 cyl., 6 cyl.)	6419318	1	11.30	COVER ASSY. (w/6418735-6420500-17-1573-74-2100)
65-67	Chevelle, Camaro (396),				
65-67	Pass. (327, 396) (exc. lever ride, Sp. H/Per.)	6422184	1	12.40	COVER ASSY. (w/6421213-63-1775-1970)
67	All (6 cyl.)	6485193	1	8.20	COVER ASSY. (w/6423274-3514-15-16-17)
68	Pass. (S.S.) (427) (exc. T.H., Sp. H/Per.)				COVER ASSY. (w/6483664),
69	Pass. w/H/Per. (427, S.S. 427),				

**FUEL—EXHAUST—CARBURETION**

**3.410 COVER—BREATHER—ELEMENT—RETAINER, Air Cleaner (Con't)**

69	Chevelle (396) (exc. H/Per., Sp. H/Per.)				w/6484589-90-95-96,
70	Camaro w/Sp. H/Per. (350)	6483843	1	25.75	w/6485887
74	Nova, Camaro (350) (exc. Sp. H/Per.)	6483610	1	25.75	<b>COVER ASSY.,</b> a/cl. and silencer
68-75	All	6484966	1	2.13	<b>BREATHER,</b> air cleaner and silencer (painted gray or brown) (Fb 59)
62-70	All (4 cyl., 6 cyl.) (exc. H.D. A/Cl.),				
67	All w/2BC (283, 327),				
68	Pass. w/T.H. 350,				
68	Biscayne, Bel Air (307),				
68	All w/2BC (307, 327) (exc. Malibu, Concours),				
69	Chevelle (Deluxe) (307),				
69	Nomad, Greenbrier (307),				
69-70	Chevy, Camaro (307, 327)				<b>ELEMENT</b> (polyurethane) (AC No. A-169CW),
70	Chevelle (Nomad, Greenbrier, El Camino) (307) (exc. El Camino Custom)				w/6484578,
71-75	All (6 cyl.)				w/6484662-5886,
71	Nova, Camaro (307),				
71	Chevelle (Nomad, Greenbrier, El Camino) (307) (exc. El Camino Custom)	5649797	1	4.83	<b>ELEMENT,</b> w/6485898
64-67	Chevy, Chevelle (8 cyl.) (exc. level ride),				
65-66	Pass. (8 cyl.) (exc. level ride, 327, 396)	6420690	1	7.22	<b>ELEMENT,</b> oil paper w/6420716-0857-901-2-3-4-5-6-7-1577-8-9-80-2-3-4-2099-2102-2887-2968-9-3275-3927 (A86CW)
68-69	Pass. w/H.D. A/Cl. (6 cyl.)	6483864	1	9.98	<b>ELEMENT</b> (A333C)
68-69	Impala, Caprice, Malibu, Concours (307),				
68	All w/4BC (327, 350) (exc. Sp. H/Per.),				
69	Pass. (8 cyl.),				
69	Chevelle (350)				<b>ELEMENT</b> (wetted paper) (A-348C),
70-71	Chevelle (Malibu, Concours, El Camino (Custom) (307)				w/6485892-6485900,
70-71	Pass., Chevelle (350, 400),				
70-72	Pass., Monte Carlo (454),				
72	Chevelle (307, 350, 402) (exc. spec. duct hood),				
72	Pass., Monte Carlo (454),				
73-74	Pass., Chevelle w/2BC (350),				
75	All w/4BC	6484235	1	7.73	<b>ELEMENT,</b> w/6484668-5240-48-52
68	Pass. (H.D. A/Cl. w/P.G.) (6 cyl.),				
68-69	All (396, 427) (exc. Sp. H/Per.),				
68	Chevelle (396) (exc. H/Per., Sp. H/Per.),				
69	Chevy, Camaro w/2BC (350),				
69	Chevelle w/T.H. 400 (396) (exc. H/Per. Sp. H/Per.),				
70-73	Nova, Camaro (350) (exc. Sp. H/Per.),				
72-73	Nova (307),				
72	Camaro (402),				
72	Chevelle (454) (exc. spec. duct hood, Monte Carlo),				
74	Nova, Camaro (350),				
75	Monza, Nova, Camaro w/2BC (262, 350)	6483645	1	7.17	<b>ELEMENT</b> (wetted paper) w/6484674-5242-5896
65-67	Pass. (327, 396),				
66-67	Chevy, Chevelle, Camaro (8 cyl.),				
68-69	Pass. w/Sp. H/Per. (427),				
68	Chevy, Camaro (302, 396) (exc. plenum air, spec. exh.),				
68	Chevelle w/H/Per., Sp. H/Per. (327, 396) (exc. A.T.)				<b>ELEMENT ASSY.</b> (w/6421213-14-16-63-1775-1914-66-70-2191-3269-3506-7-39-7-8-4434-5-6-867) (A212-CW),

**FUEL—EXHAUST—CARBURETION**

**3.410 COVER— BREATHER— ELEMENT— RETAINER, Air Cleaner (Con't)**

69	Camaro w/Spec. Duct Hood . . . . .				(w/6423272-6423907), . . . . .
70-71	Camaro w/Sp. H/Per. (350),				
70	Nova, Chevelle, Camaro (396,				
	454) . . . . .				(w/6485235-5239-5241-5257), . . . . .
71	Chevelle (454) (exc. Monte				
	Carlo) . . . . .				w/6485236-54-57-5891, . . . . .
71	Camaro w/4BC (400),				
72-74	Camaro w/Sp. H/Per. (350),				
72	Chevelle w/spec. duct hood . . . . .	6421746	1	8.85	ELEMENT ASSY., w/6485254 . . . . .
66	Chevelle (327),				
67-68	Camaro w/plenum air, spec. exh.				
	(302) . . . . .	6422544	1	13.26	ELEMENT ASSY. . . . .
75	All (122) . . . . .	6488289	1	7.45	ELEMENT ASSY. . . . .
72-73	Camaro (307) . . . . .	6422866	1	8.77	ELEMENT ASSY. . . . .
68	All . . . . .	6420265	1	.41	RETAINER, air cleaner and silencer breather . . . . .

**3.415 VACUUM MOTOR PKG.— ACTUATOR— BRACKET— FRAME—  
GROMMET— RELAY— RETAINER— SCREEN— SEAL— SENSOR UNIT—  
SOLENOID— SWITCH— VALVE— WIRE ASSY., Air Cleaner Intake Valve**

68	All w/T.H. 350,				
68	Chevy, Chevelle, Camaro (2BC				
	w/P.G.) (307, 327) (exc.				
	Malibu, Concours),				
68	Biscayne, Bel Air (8 cyl.) . . . . .	6484248	1	4.90	A/CL diaphragm (w/6424425) . . . . .
68	All (4BC w/A.T.) (327, 350),				
68	Impala, Caprice, Malibu,				
	Concours w/A.T. (307),				
69	Pass. w/A.T. (6 cyl.),				
69	Chevy, Camaro w/A.T. (307,				
	327),				
69	Chevelle (Deluxe) w/A.T. (307),				
69	Nomad, Greenbrier w/A.T. (307)				w/6424809-60-6483572-3700-4164-4218- 20-22-4578-4662-64-4866, . . . . .
70-72	All (6 cyl.),				
70-72	Nova, Camaro (307),				
70-72	Chevelle (Nomad, Greenbrier, El				
	Camino) (307) (exc. El Camino				
	Custom) . . . . .	6484245	1	4.75	w/6484578-4662-5886-5898 . . . . .
68	Pass. w/P.G. (6 cyl.),				
68	Pass. w/T.H. 350,				
68	Chevy, Chevelle, Camaro w/A.T.				
	(6 cyl.) (exc. H.D. A/CL),				
68	Chevelle w/A.T. (396),				
68-69	Pass. w/A.T. (350, 396, 427)				
	(exc. S.S. w/427),				
69	Malibu, Concours w/A.T. (307),				
69	Chevy, Camaro w/A.T. (350),				
69	Chevelle (8 cyl.) . . . . .				a/cl. diaphragm, . . . . .
70-72	Chevelle (Malibu, Concours, El				
	Camino Custom) (307),				
70	All (350, 400) (exc. Sp. H/Per.) .				w/6484668-4674-5240-42-48-52-5892-96,
70-72	Pass., Monte Carlo (454),				
71-72	All (350) (exc. Sp. H/Per.),				
72	Pass., Chevelle (400, 402) . . . . .	6484247	1	4.75	w/6485248-5252 . . . . .
73	All (6 cyl.),				
74	Camaro (6 cyl.) . . . . .	6487368	1	11.05	
73	All (exc. 6 cyl.),				
74	All (8 cyl.) (exc. Sp. H/Per.),				
75	Pass. (8 cyl.),				
75	Chevelle (454),				
75	Nova, Camaro (exc. Sp. H/Per.),				
75	Monza (262, 350) . . . . .	6487370	1	7.05	
74	Chevelle, Nova (6 cyl.) . . . . .	6487366	1		
70	Chevelle w/Spec. Duct Hood . . . . .	1998970	1	10.00	ACTUATOR, hood panel cowl induction door . . . . .
72	Chevelle w/Spec. Duct Hood . . . . .	3972676		1.75	BRACKET, carb. air cont. valve sol. switch— (4.060) . . . . .
69-70	Chevelle, Camaro w/Spec. Duct				
	Hood . . . . .	3955225	1	5.55	FRAME ASSY., carb. air cont. valve . . . . .
70-72	Chevelle w/Spec. Duct Hood				
	(396, 454) . . . . .	3975984	1	5.45	FRAME ASSY., carb. air control valve . . . . .
70-71	Chevelle w/Spec. Duct Hood . . . . .	3922580	1	1.75	GROMMET, carb. air control valve vacuum— (4.047) . . . . .
69	Camaro w/Spec. Duct Hood,				

**FUEL—EXHAUST—CARBURETION**

**3.415 VACUUM MOTOR PKG.— ACTUATOR— BRACKET— FRAME— GROMMET— RELAY— RETAINER— SCREEN— SEAL— SENSOR UNIT— SOLENOID— SWITCH— VALVE— WIRE ASSY., Air Cleaner Intake Valve (Con't)**

72	Chevelle w/Spec. Duct Hood . . .	7729602	1	5.00	RELAY ASSY. (13.095) . . . . .
69-70	Chevelle, Camaro w/Spec. Duct Hood,				
71-72	Chevelle w/Spec. Duct Hood . . .	3955227	3	.39	RETAINER, carb. air cont. valve . . . . .
70-72	Chevelle w/Spec. Duct Hood (396, 454) . . . . .	3972919	1	2.90	SCREEN ASSY., hood mtg. . . . .
69-71	Chevelle, Camaro w/Spec. Duct Hood (396, 454),				
70	Camaro,				
72	Chevelle w/Spec. Duct Hood (454) . . . . .	3969803	2	.13	SEAL ASSY., carb. air control valve frame— (9.262) . . . . .
68	Camaro w/P.G. T.H. 350,				
68-69	Pass.,				
68-69	Chevy, Chevelle w/A.T. (exc. 4 cyl.),				
69	Camaro w/Spec. Duct Hood,				
70-72	All . . . . .	6484242	1	6.10	SENSOR UNIT, a/cl thermal . . . . .
73	All,				
74	All (exc. Sp. H/Per.),				
75	Pass., Chevelle (8 cyl.) (exc. Sp. H/Per.),				
75	Monza (262, 350) . . . . .	6484244	1	3.54	SENSOR UNIT, thermal . . . . .
69-70	Chevelle, Camaro w/Spec. Duct Hood,				
71-72	Chevelle w/Spec. Duct Hood . . .	1114427	1	14.25	SOLENOID ASSY., carb. air cont. . . . .
69-70	Chevelle, Camaro w/Spec. Duct Hood . . . . .	3959115	1	2.80	SWITCH, carb. air cont. valve sol. . . . .
72	Chevelle w/Spec. Duct Hood . . .	1242101	1	3.00	SWITCH, carb. air cont. valve sol.— (4.057)
69-72	Chevelle, Camaro w/Spec. Duct Hood . . . . .	3955226	1	4.75	VALVE, carb. air cont. . . . .
70-72	Chevelle w/Spec. Duct Hood . . .	6440776	1	5.65	VALVE, hood panel cowl induction door . . .
70-72	Chevelle w/Spec. Duct Hood . . .	8901587	1	14.10	WIRE ASSY., carb. air control valve . . . . .

**3.417 HOSE— ACTUATOR— ADAPTER— BOLT— BOOT— BRACKET— BUMPER— CLAMP— COVER— CUSHION— DOOR— DUCT— ELBOW— EXTENSION— FLANGE— GASKET— PLATE— SCREEN— SCREW— SEAL— SPACER— STOVE— STRAP— STUD— SUPPORT— TUBE, Air Cleaner**

68	Pass. (A.T. w/H/Per.) (396, 427),				
68	Chevelle w/A.T. (396) (exc. H/Per., Sp. H/Per.),				
69	Chevelle (396) (exc. H/Per., Sp. H/Per.),				
69	Pass. w/A.T. (396, 427) (exc. Sp. H/Per.),				
70	Pass. (454),				
70	Chevelle w/4BC (400),				
71	Pass., Chevelle, Camaro (400, 454) (exc. Sp. H/Per.),				
72	All (402, 454) . . . . .	3952317	1	1.55	carb. air heater duct ext. . . . .
75	Monza (262) . . . . .	357016	1	2.95	carb. air heat . . . . .
72	Chevelle w/Spec. Duct Hood . . .	1998970	1	10.00	ACTUATOR, hood panel cowl induction door . . . . .
72-75	Vega (140) w/2BC . . . . .	6264325	1	8.95	ADAPTER, air cleaner . . . . .
75	Monza (Towne Coupe) (140-2BC) . . . . .	6264325	1	8.95	ADAPTER, air cleaner . . . . .
75	Monza (exc. Towne Coupe) . . . .	356339	1	9.80	ADAPTER, a/cl. and silencer— (3.407) . . . .
72	Chevelle w/Spec. Duct Hood . . .	3945359	1	.53	BOLT, actuator to door— (10.130) . . . . .
75	All (122) . . . . .	342662	1	3.50	BOOT, a/cl. . . . .
75	All (122) . . . . .	356303	2	3.50	BOOT, a/cl. . . . .
71-75	Vega, Monza w/1BC . . . . .	3977195	1	1.70	BRACKET, air cleaner and heat tube . . . . .
71-72	Vega w/2BC (1st design) . . . . .	3983477	1	1.80	BRACKET, air cleaner and heat tube, and carb. idle cont. . . . .
72	Vega w/2BC (2nd design) . . . . .	326313	1	1.95	BRACKET, a/cl. and heat tube and carb. idle cont. solenoid . . . . .
73-75	Vega, Monza (140) w/2BC . . . . .	331162		1.95	BRACKET, a/cl. and heat tube . . . . .
75	All (122) . . . . .	342661	1	1.70	BRACKET, a/cl. . . . .

**FUEL—EXHAUST—CARBURETION**

**3.417 HOSE— ACTUATOR— ADAPTER— BOLT— BOOT— BRACKET—  
BUMPER— CLAMP— COVER— CUSHION— DOOR— DUCT— ELBOW—  
EXTENSION— FLANGE— GASKET— PLATE— SCREEN— SCREW—  
SEAL— SPACER— STOVE— STRAP— STUD— SUPPORT— TUBE, Air  
Cleaner (Con't)**

70	Chevelle w/Spec. Duct Hood . . .	3968560	2	.26	BUMPER, hood pnl. cowl induction door stop . . . . .
62-69	All,				
75	All (122) . . . . .	3749810	A.R.	.74	CLAMP, air cleaner hoses— (1.166) . . . . .
68	Pass. w/A.T. (307, 327) . . . . .	3982954	1	3.15	COVER, carb. air heater stove . . . . .
69	Pass. w/A.T. (327, 350),				
70	Pass. (350, 400) . . . . .	3946842	1	1.35	COVER, carb. air heat stove . . . . .
75	Pass. . . . .	354062	3	.19	CUSHION, air intake duct . . . . .
70-72	Chevelle w/Spec. Duct Hood . . .	3968539	1	11.65	DOOR, hood pnl. cowl induction . . . . .
68-69	Chevelle w/A.T. (396) (exc. H/Per., Sp. H/Per.),				
68	Pass. w/A.T. (396, 427),				
70	Pass. (454),				
71-72	All (400, 402, 454) (exc. Sp. H/Per., Monte Carlo) . . . . .	3916177	1	5.35	DUCT, carb. air heater . . . . .
67-68	Camaro w/plenum air, w/spec. exh. (302) . . . . .	3916621	1	26.00	DUCT ASSY., A/CL to dash . . . . .
70	Chevelle w/4BC (400),				
70-72	Monte Carlo (454),				
71-72	Monte Carlo (400) . . . . .	3976061	1	5.95	DUCT ASSY., carb. air heater (w/extension)
72-73	Vega (2BC) . . . . .	3997296	1	2.90	DUCT ASSY., carb. air intake . . . . .
73-75	All (454) . . . . .	360414	1	5.95	DUCT ASSY., carb. air heater (repl. 353079) . . . . .
74-75	Vega (140) . . . . .	339086	1	2.90	DUCT ASSY., air intake . . . . .
75	Camaro (122) w/C.A.C. . . . .	364914	1	5.45	DUCT, air intake (flexible) . . . . .
75	Camaro (350) . . . . .	360630	1		DUCT, air intake (flexible) . . . . .
75	Monza (140) (exc. Towne Coupe)	356340	1	2.70	DUCT ASSY., air intake . . . . .
75	Monza (140-2BC) . . . . .	1694312	L.H.	2.90	DUCT ASSY., air intake . . . . .
75	Monza (262, 350) . . . . .	356336	1	2.90	DUCT ASSY., air intake . . . . .
75	Camaro (350) . . . . .	347582	1	3.80	DUCT ASSY., air intake (flexible) . . . . .
75	Chevelle (6 cyl.) (exc. C.A.C.) . . .	347301	1	5.35	DUCT ASSY., air intake (flexible) . . . . .
75	Chevelle w/C.A.C. (6 cyl.) . . . . .	356405	1	5.35	DUCT ASSY., air intake . . . . .
75	Chevelle w/C.A.C. (6 cyl.) . . . . .	356406	1	5.35	DUCT ASSY., air intake (flexible) . . . . .
75	Pass. . . . .	354001	1	8.30	DUCT ASSY., air intake . . . . .
75	Pass., Chevelle (exc. 6 cyl.) . . . .	364592	1	8.45	DUCT ASSY., air intake (flexible) (repl. 353890) . . . . .
75	Nova (6 cyl.) . . . . .	347578	1	3.70	DUCT ASSY., air intake (flexible) . . . . .
75	Nova (6 cyl.) . . . . .	347577	1	3.70	DUCT ASSY., air cleaner snorkel adapter . .
75	Nova (350) . . . . .	347542	1	1.60	DUCT ASSY., snorkel adapter— (3.410) . . .
75	Nova (262, 350) . . . . .	356447	1	5.95	DUCT ASSY., air intake flex. . . . .
75	Nova (262, 350) . . . . .	360632	1	2.30	DUCT, air intake . . . . .
75	Camaro (350) . . . . .	345539	1	3.70	DUCT ASSY., a/cl. snorkel adapter . . . . .
75	Camaro (350) (1st design) . . . . .	347582	1	3.80	DUCT ASSY., air intake flex. . . . .
75	Camaro (350) . . . . .	360639	1	3.80	DUCT, air intake (2nd design) . . . . .
75	Camaro (6 cyl.) . . . . .	347583	1	5.60	DUCT ASSY., air intake (flexible) . . . . .
75	Nova w/4BC (350) . . . . .	347584	1	5.60	DUCT ASSY., air intake (flexible) . . . . .
75	Chevelle (8 cyl.) . . . . .	352064	1	8.50	DUCT ASSY., air intake outer (flexible) . . . .
75	Chevelle (8 cyl.) (exc. Monte Carlo) . . . . .	356437	1	3.35	DUCT ASSY., air intake . . . . .
75	Camaro (Sp. H/Per. 350) . . . . .	356606	1	4.85	DUCT ASSY., air intake (flexible) . . . . .
75	Monte Carlo . . . . .	356437	1	3.35	DUCT ASSY., air intake outer front . . . . .
75	Pass., Chevelle (454) . . . . .	360414	1	5.95	DUCT ASSY., carb. air heater . . . . .
69	Chevelle w/T.H. 400 (396) (exc. H/Per., Sp. H/Per.),				
69	Pass. w/A.T. (396, 427) (exc. Sp. H/Per.),				
70	Pass. (454),				
70	Chevelle w/4BC (400) (exc. Monte Carlo),				
71	Pass., Camaro w/4BC (400, 454),				
71	Chevelle (454) (exc. Sp. H/Per.),				
72	All (402, 454) . . . . .	3946083	1	.58	ELBOW, carb. air heater duct ext. hose . . . .
68	Chevelle w/A.T. (exc. H/Per. 396),				
68	Pass. w/A.T. (396),				
69-70	Chevelle w/A.T. (396) (exc. H/Per., Sp. H/Per.),				

**FUEL—EXHAUST—CARBURETION**

**3.417 HOSE— ACTUATOR— ADAPTER— BOLT— BOOT— BRACKET— BUMPER— CLAMP— COVER— CUSHION— DOOR— DUCT— ELBOW— EXTENSION— FLANGE— GASKET— PLATE— SCREEN— SCREW— SEAL— SPACER— STOVE— STRAP— STUD— SUPPORT— TUBE, Air Cleaner (Con't)**

69	Pass. w/A.T. (396, 427) (exc. Sp. H/Per.),				
70	Pass., Monte Carlo (454),				
71-72	All (400, 402, 454) (exc. Sp. H/Per., Monte Carlo) . . . . .	3964265	1	2.15	EXTENSION ASSY., carb. air heater duct . . .
70-71	Chevelle w/Spec. Duct Hood (396, 454),				
72	Chevelle w/Spec. Duct Hood . . .	3975977	1	7.50	EXTENSION ASSY., a/cl. . . . .
69	Camaro w/Spec. Duct Hood,				
70-72	Chevelle w/Spec. Duct Hood (396, 454) . . . . .	3975986	1	7.05	FLANGE, seal . . . . .
75	Camaro (8 cyl.) . . . . .	347509	1	.32	GASKET, a/cl. snorkel adap. . . . .
75	All (8 cyl.) (exc. 454) . . . . .	343663	1	.31	GASKET, carb. choke heat tube . . . . .
75	All (454) . . . . .	343794	1	.32	GASKET, carb. choke heat tube . . . . .
69	Pass. w/A.T. (8 cyl.) (exc. 396, 427),				
70	Pass. (350, 400) . . . . .	3946840	1	.43	PLATE, carb. air heat stove base . . . . .
68	Pass. w/A.T. (307, 327) . . . . .	3946832	1	1.40	PLATE ASSY., carb. air heater . . . . .
72-75	All (140) . . . . .	3997295	1	1.75	SCREEN, air intake . . . . .
75	Camaro (6 cyl.) . . . . .	347554	1	1.85	SCREEN, air intake duct . . . . .
70-72	Chevelle w/Spec. Duct Hood . . .	3968558	2	.31	SCREW, hood pnl. cowl induction door pivot . . . . .
70-71	Chevelle w/Spec. Duct Hood . . .	3968559	1	.31	SCREW, hood pnl. cowl induction door stop . . . . .
69-71	Chevelle, Camaro w/Spec. Duct Hood,				
72	Chevelle w/Spec. Duct Hood . . .	3955231	1	8.75	SEAL, a/cl. to hood . . . . .
70-72	Chevelle w/Spec. Duct Hood . . .	3968556	A.R.	.17	SPACER, hood pnl. cowl induction door actuator, support . . . . .
70-72	Chevelle w/Spec. Duct Hood . . .	3968557	2	.17	SPACER, hood pnl. cowl induction door pivot screw . . . . .
75	Pass. . . . .	354063	3	1.45	SPACER, air inj. duct . . . . .
68-75	All (6 cyl.) (exc. integrated cyl. head) . . . . .	331116	1	3.40	STOVE, carb. air heater . . . . .
68	Chevy, Chevelle, Camaro w/A.T. (8 cyl.) . . . . .	3916302	1	2.35	STOVE, carb. air heater . . . . .
69	Chevy, Chevelle, Camaro w/P.G., T.H. 350 (8 cyl.),				
70	Monte Carlo w/2BC (400),				
70	Nova, Chevelle, Camaro (307, 350),				
71	Pass., Nova (8 cyl.) (exc. 454),				
71	Chevelle, Camaro (8 cyl.) (exc. 400, 454),				
72	All (exc. 402, 454) . . . . .	3941196	1	.55	STOVE, carb. air heater (upper) . . . . .
69	Chevy, Chevelle, Camaro w/P.G., T.H. 350 (8 cyl.),				
70	Monte Carlo w/2BC (400),				
70	Nova, Chevelle, Camaro (307, 350),				
71	Pass., Nova (8 cyl.) (exc. 454),				
71	Chevelle, Camaro (8 cyl.) (exc. 400, 454),				
72	All (exc. 402, 454) . . . . .	338473	1	.87	STOVE, carb. air heater (lower) (repl. 3941198) (Note 1) . . . . .
72	All (exc. 402, 454) . . . . .				STOVE, carb. air heater (upper) (repl. 3941198) . . . . .
73-75	All (8 cyl.) (exc. 454) . . . . .	338471	1	.77	STOVE, carb. air heater (upper) . . . . .
71-74	Vega (140) . . . . .	3980250	1	2.50	STOVE, carb. air heater (upper) . . . . .
73	All (exc. 454),				
74-75	All (8 cyl.) (exc. 454) . . . . .	338473	1	.87	STOVE, carb. air heater (lower) . . . . .
75	All (140) . . . . .	348650	1	2.50	STOVE, carb. air heater (lower) . . . . .
75	All (6 cyl.) . . . . .	354515	1	6.80	STOVE, carb. air heat. . . . .
75	All (262) . . . . .	354488	1	5.35	STOVE, carb. air heat. . . . .
70	Chevelle w/4BC (400),				
70	Monte Carlo (454),				
71-72	Monte Carlo (400, 402, 454) . . .	3976063	1	.17	STRAP, carb. air heater duct and extension . . . . .
75	Camaro (6 cyl.) . . . . .	409797	1	.32	STRAP, air int. duct (nylon) . . . . .
68	All w/A.T. (6 cyl.),				

**FUEL—EXHAUST—CARBURETION**

**3.417 HOSE— ACTUATOR— ADAPTER— BOLT— BOOT— BRACKET—  
BUMPER— CLAMP— COVER— CUSHION— DOOR— DUCT— ELBOW—  
EXTENSION— FLANGE— GASKET— PLATE— SCREEN— SCREW—  
SEAL— SPACER— STOVE— STRAP— STUD— SUPPORT— TUBE, Air  
Cleaner (Con't)**

70-71	All (6 cyl.),				
70	Nova, Chevelle (307, 350),				
70	Camaro,				
71	Nova, Camaro (307, 350),				
71	Pass. (8 cyl.) (exc. 454),				
71	Chevelle (8 cyl.) (exc. 4BC, 400, 454),				
72	All (exc. 402, 454),				
73-75	All (exc. Vega, Monza) . . . . .	3959544	1	.06	STUD, carb. air heat. stove . . . . .
74-75	Chevelle (6 cyl.),				
74-75	Nova (6 cyl.),				
75	Vega,				
75	Camaro (305) . . . . .	9780558	1	.18	STUD, a/cl. & silencer . . . . .
70-72	Chevelle w/Spec. Duct Hood . . .	3968554	1	2.50	SUPPORT, hood pnl. cowl induction door actuator . . . . .
70-72	Chevelle w/Spec. Duct Hood . . .	3968555	1	2.50	SUPPORT, hood pnl. cowl induction door . .
68	All w/A.T. (6 cyl.),				
69	Chevy, Chevelle, Camaro w/T.H. 350 (6 cyl.) . . . . .	3915952	1	3.60	TUBE, carb. air heater stove . . . . .
68	Pass. w/A.T. (307) . . . . .	3917661	1	2.10	TUBE, carb. air heater . . . . .
68	Pass. w/A.T. (327) . . . . .	3917659	1	2.20	TUBE, carb. air heater . . . . .
69-70	All (6 cyl.),				
71-75	Pass., Nova, Chevelle (6 cyl.) . . .	3941030	1	3.60	TUBE, carb. air heater stove . . . . .
69	Chevy, Chevelle, Camaro w/A.T. (350) (exc. Spec. Duct Hood),				
69	Biscayne, Bel Air, Brookwood, Townsmen w/A.T. (350),				
69	Camaro w/P.G. (6 cyl.),				
70-71	Nova, Camaro (350) (exc. Sp. H/Per.),				
70-71	Chevelle (Std.), Nomad, Greenbrier, El Camino (350) (exc. Custom),				
70-71	Camaro w/2BC (350),				
70-71	Chevelle, (Malibu, Monte Carlo, El Camino Custom, Concours) (307, 350, 400) (exc. 400 w/4BC),				
72	Pass. (350, 400),				
72	Nova, Chevelle, Camaro (307),				
72	Nova, Chevelle, Camaro (350) (exc. Sp. H/Per.) . . . . .	3942531	1	3.40	TUBE, carb. air heat . . . . .
69	Chevy, Chevelle, Camaro w/A.T. (307, 327, 396),				
70-71	Nova, Camaro (307),				
70	Chevelle (Std.), Nomad, El Camino, Greenbrier (8 cyl.) (exc. Custom, 350, 400),				
70	Camaro (396),				
70	Camaro w/Sp. H/Per. (350),				
71	Pass. (8 cyl.) (exc. 400 w/4BC, 454),				
71	Chevelle (Deluxe) Nomad, El Camino, Greenbrier (8 cyl.) (exc. Custom 350, 400),				
73	Camaro (350) (exc. Sp. H/Per.),				
73-74	Pass., Nova, Chevelle (307, 350, 400) . . . . .	6272719	1	3.85	TUBE, carb. air heat. . . . .
69	Camaro w/Spec. Duct Hood . . . . .	3951636	1	7.60	TUBE, carb. air heat . . . . .
70-74	Camaro (6 cyl.) . . . . .	3973098	1	2.25	TUBE, carb. air heat stove . . . . .
73	Camaro (307) . . . . .	6272718	1	2.65	TUBE, carb. air heat. . . . .
75	All (6 cyl.) . . . . .	355781	1	3.50	TUBE, carb. air heat stove . . . . .
68	Chevy, Camaro (2BC w/A.T.) (307, 327),				
68	Chevelle w/P.G. (307) (exc. Malibu, Concours, S.S.),				
69	Chevelle (Deluxe) (8 cyl.) (exc. 350),				
69	Nomad, Greenbrier (8 cyl.) (exc. 350) . . . . .	3917680	1	3.25	TUBE ASSY., carb. air heater . . . . .

**FUEL—EXHAUST—CARBURETION**

**3.417 HOSE— ACTUATOR— ADAPTER— BOLT— BOOT— BRACKET— BUMPER— CLAMP— COVER— CUSHION— DOOR— DUCT— ELBOW— EXTENSION— FLANGE— GASKET— PLATE— SCREEN— SCREW— SEAL— SPACER— STOVE— STRAP— STUD— SUPPORT— TUBE, Air Cleaner (Con't)**

68	Chevy, Chevelle, Camaro (A.T. w/4BC) (327, 350),				
68	Malibu, Concours w/A.T. (8 cyl.)	3916309	1	3.35	TUBE ASSY., carb. air heater . . . . .
69	Pass. w/A.T. (327, 350),				
70-71	Pass. (350, 400) . . . . .	3946846	1	2.75	TUBE ASSY., carb. air heater . . . . .
73-74	Pass., Chevelle (454) . . . . .	353078		3.85	TUBE ASSY., carb. air heat. . . . .
71-75	All (140) . . . . .	331123	1	3.10	TUBE ASSY., carb. air heat. . . . .
75	Chevelle, Camaro, Nova (250) . .	362785	1	3.50	TUBE, carb. air heat stove . . . . .
75	Pass., Chevelle (454) . . . . .	354440	1	3.50	TUBE ASSY., carb. air heat. . . . .
75	All (454) . . . . .	343793	1	3.50	TUBE ASSY., carb. choke heat. . . . .
75	Pass., Chevelle, Nova (262, 350, 400) . . . . .	373522	1	1.85	TUBE ASSY., carb. air heat (repl. 354320) .
75	Monza (262) . . . . .	343769	1	3.15	TUBE, carb. choke heat . . . . .
75	Nova, Camaro (8 cyl.) . . . . .	373522	1	1.85	TUBE ASSY., carb. air heat (repl. 354321) .
75	All (350, 400) . . . . .	343769	1	3.15	TUBE ASSY., carb. choke heat. . . . .

NOTE 1: When replacing original production part with 338473 you must also order 1-338471 upper stove.

**3.425 SWIVEL— BUSHING— CLIP— FASTENER— PIN— RETAINER— SLEEVE— STUD, Throttle Control Rod**

62	Chevy,				
65-71	All (exc. Vega) . . . . .	3711199	A.R.	.29	carb. to accel. lever rod . . . . .
62-63	Chevy . . . . .	6255916	A.R.	.23	accel. control cross shaft rod . . . . .
65-66	All,				
67	Pass., Chevelle w/speed control,				
68-69	Chevy (4 cyl.),				
70	Pass.,				
70	Nova (8 cyl.) . . . . .	3892880	1	.28	accel. control rod . . . . .
67	Camaro (8 cyl.) (exc. 302, 396),				
68-69	Chevy (8 cyl.),				
68	Camaro (8 cyl.),				
69	Camaro (8 cyl.) (exc. 302, 396) .	3899075	1	.46	accel. control rod . . . . .
71-75	Vega, Monza . . . . .	6270002	1	.40	carb. choke rod . . . . .
62-65	All,				
66-68	Pass. . . . .	3710620	2	.16	BUSHING, accel. control lever shaft . . . . .
62	Chevy . . . . .	3794377	A.R.	.16	BUSHING, accel. control rod, throttle cont. lever . . . . .
62	Chevy . . . . .	3792439	A.R.	.16	BUSHING, accel. control rod (at cont. rod and carb. lever end) . . . . .
62-63	Chevy (exc. 8 cyl.),				
64-71	Pass., Chevelle (6 cyl.),				
68-71	Chevy, Camaro (6 cyl.),				
72-75	All (6 cyl.),				
71-75	All (140) . . . . .	330668	A.R.	.19	CLIP, accel. control rod . . . . .
62-67	All (6 cyl.) . . . . .	3790816	1	.12	CLIP, carb. to accel. control lever rod . . . . .
62-69	All . . . . .	3749084	A.R.	.27	CLIP, throttle valve control lower rod, accelerator control rod, throttle lever rod swivel retaining— (4.037) . . . . .
65	Chevy, Chevelle,				
65-69	Pass.,				
70	All,				
71	Pass., Nova, Chevelle . . . . .	3700188	A.R.	.29	CLIP, carb. to accel. lever rod, carb. to cont. lever, carb. to accel. lever rod swivel . . . . .
65	Chevy, Chevelle,				
65-69	Pass.,				
70-71	All . . . . .				CLIP, accel. control rod swivel, carb. to accel. rod carb. to accel. rod lever, . . . . .
71-73	Vega . . . . .	3711177	A.R.	.28	trans. throttle valve control rod . . . . .
71	All (exc. Sp. H/Per. 454, Vega),				
72-75	All . . . . .	3989067	1	.12	CLIP, rod end auto. choke rod to carb. . . . .
74-75	All (6 cyl.),				
75	All (140) . . . . .	3962782	1	.13	CLIP, carb. to accel. cont. lever rod . . . . .
70	Pass.,				
70	Nova (exc. T.H. 400) . . . . .	1383809	2	.12	FASTENER, accel. cont. rod retainer . . . . .
75	All w/flr. shift . . . . .	9791366	1	.05	PIN, control cable to shifter . . . . .
68-69	Chevy, Chevelle, Camaro (6 cyl.),				
69	Chevy (4 cyl.),				
70	All,				
71	All (exc. Camaro),				
71	Camaro (8 cyl.),				
72-75	All . . . . .	403929	1	.06	RETAINER, accel. cont. cable . . . . .
71-74	Camaro (6 cyl.) . . . . .	404087	1	.12	RETAINER, accel. control cable . . . . .



**FUEL—EXHAUST—CARBURETION**

**3.425 SWIVEL— BUSHING— CLIP— FASTENER— PIN— RETAINER— SLEEVE— STUD, Throttle Control Rod (Con't)**

71-75	All (6 cyl.)	3998634	1	.13	RETAINER, carb. to accel. cont. lever rod . . .
73-74	All	3863558	1	.27	RETAINER, accel. cont. cable— (7.529) . . .
75	Monza (262)	1247878	1		RETAINER, accel. cont. cable— (7.529) . . .
75	All	1247872	1	.12	RETAINER, accel. control cable . . . . .
75	All w/Cruise Control	1383809	1	.12	RETAINER, accel. cont. cable . . . . .
75	Pass., Chevelle, Nova	1247872	1	.12	RETAINER, cruise control cable . . . . .
62-69	All	3866271	A.R.	.12	SLEEVE, accel. control lever rod, accel. control rod, accel. rod (1/4" I.D. x 3/8" O.L.— nylon) . . . . .
62	Chevy	3791100	2	.18	SLEEVE, accel. control rod . . . . .
71-73	All (6 cyl.)	3909973	1	.12	SLEEVE, accel. control lever stud— (3.463) . . . . .
68-69	Chevelle (8 cyl.),				STUD, accel. lever ball, . . . . .
70	Pass., Chevelle				
70	Nova, Camaro,				
71-73	Nova	3924414	1	.23	accel. control cable . . . . .
71	Pass., Chevelle,				
71	Camaro,				
72-73	Pass., Chevelle (8 cyl.),				
72-73	Camaro (8 cyl.)	3991261	1	1.25	STUD, accel. lever ball . . . . .
71-72	All w/Speed and Cruise Control,				
73-74	Pass., Monte Carlo w/4BC	3990838		.60	STUD, accel. lever ball . . . . .
73-75	Pass., Monte Carlo w/2BC	3990837	1	.36	STUD, accel. lever ball . . . . .
74	Pass., Chevelle	342413	1	3.75	STUD, control cable . . . . .
75	Pass., Chevelle	368016	1	.72	STUD, control cable . . . . .

**3.430 ROD— CABLE ASSY., Carburetor to Accelerator Lever**

62-67	All (4 cyl., 6 cyl.)	3790814	1	.28	carb. to accel. cont. lever . . . . .
65-66	Pass. (6 cyl.)	3827696	1	1.15	accel. control . . . . .
65-67	Pass., Chevelle (396, 427) (1st design)	3884868	1	.53	accel. control (developed length 14 <sup>23</sup> / <sub>32</sub> " ) . . . . .
66-67	Chevelle, w/2BC,				
66-68	Pass. (283, 307) (exc. 4BC)	3913497	1	.92	accel. cont. . . . .
66	Pass., Chevelle w/4BC (283, 327)	3878399	1	.82	accel. control . . . . .
67	Chevelle w/Sp. H/Per. (327),				
67	Camaro w/4BC (327, 350)	3909981	1	1.00	accel. control (developed length 12 <sup>31</sup> / <sub>32</sub> " ) . . . . .
67	Camaro (6 cyl.)	3909939	1	1.35	accel. control . . . . .
67	Camaro (396)	3912600	1	.92	accel. control . . . . .
67	Chevy (283)	3901368	1	.82	accel. control . . . . .
68-69	Chevy, Camaro w/2BC (307, 327)	3923502	1	1.10	accel. control . . . . .
68-69	Chevy (4 cyl.)	3923516	1	3.60	accel. control . . . . .
68-69	Chevy, Camaro w/4BC (327, 350) (exc. Sp. H/Per.)	3923539	1	1.10	accel. control . . . . .
68-69	Chevy, Camaro (396)	3923549	1	1.70	accel. control . . . . .
68-69	Camaro (302)	3923551	1	2.35	accel. control . . . . .
68	Pass. (327),				
69-70	Pass. w/4BC (350)	3968780	1	1.35	accel. control . . . . .
68	Pass. (396),				
68-69	Pass. (427) (exc. Sp. H/Per)	3924417	1	1.35	accel. control . . . . .
68-69	Pass. (6 cyl.)	3924413	1	1.35	accel. control . . . . .
68-70	All (4 cyl., 6 cyl.)	400158	1	.65	carb. to accel. cont. lever . . . . .
69-70	Pass. w/2BC	3968778	1	.98	accel. control . . . . .
69	Chevy, Camaro w/2BC (350)	3955761	1	.88	accel. control . . . . .
70	Nova (307)	3975515	1	1.10	accel. control . . . . .
70	Nova w/4BC (350)	3975518	1	1.75	accel. control . . . . .
70	Nova w/2BC (350)	3975517	1	.98	accel. control . . . . .
70	Nova (396) (exc. Sp. H/Per.)	3975519	1	1.30	accel. control . . . . .
70	Nova w/Sp. H/Per. (396)	3975522	1	1.70	accel. control . . . . .
71-73	Vega (1BC)	338917	1	.38	accel. control (repl. 3978132) . . . . .
71-72	Vega (2BC)	3978149	1	.39	accel. control . . . . .
71-75	All (6 cyl.)	6261779	1	.50	carb. to accel. lever . . . . .
73-75	All (140-2BC)	338959	1	.38	carb. to accel. cont. lever . . . . .
73-75	All (140-1BC)	338914	1	.38	accel. control . . . . .
74-75	All (140-1BC)	338917	1	.38	carb. to accel. cont. lever . . . . .
63-67	Chevy,				
64-66	Chevelle w/4BC	3827696	1	1.15	ROD ASSY., accel. control . . . . .
67-69	Chevy, Camaro (302, 396),				
68	Chevy, w/Sp. H/Per. (327)	3912601	1	5.50	ROD ASSY., accel. control adj. . . . .
67	Camaro,				
68-69	Chevy, Camaro (6 cyl.),				
70-72	Nova (6 cyl.)	3998633	1	3.40	CABLE ASSY., accel. control . . . . .
68-72	Chevelle w/2BC	3973863	1	4.05	CABLE ASSY., accel. control (black) . . . . .
68-69	Chevelle (396),				

**FUEL—EXHAUST—CARBURETION**

**3.430 ROD— CABLE ASSY., Carburetor to Accelerator Lever (Con't)**

70-72	Chevelle (6 cyl.),				
70-72	Chevelle w/4BC (396, 400, 402, 454) (exc. Sp. H/Per.)	3972679	1	4.05	CABLE ASSY., accel. control (black) (2 1 <sup>31</sup> / <sub>32</sub> " )
68-69	Chevelle (6 cyl.)	3949068	1	4.05	CABLE ASSY., accel. control (black)
68	Chevelle (327),				
69-72	Chevelle w/4BC (350)	3973862	1	4.05	CABLE ASSY., accel. control (orange)
69-70	Chevy (4 cyl.)	3962734	1	3.90	CABLE ASSY., accel. control (cable type linkage)
70	Pass. (6 cyl.),				
70	Pass. w/4BC (350)	3996341	1	3.75	CABLE ASSY., accel. control
70	Pass. w/2BC (350, 400)	3993662	1	3.65	CABLE ASSY., accel. control
70	Pass. (454)	3996342	1	3.75	CABLE ASSY., accel. control (2 1 <sup>3</sup> / <sub>8</sub> " )
70-72	Nova w/2BC	3998627	1	3.75	CABLE ASSY., accel. control (1 8 <sup>7</sup> / <sub>8</sub> " )
70	Nova w/4BC,				
71-72	Nova w/4BC (2nd design)	3998632	1	3.75	CABLE ASSY., accel. control (20 <sup>5</sup> / <sub>16</sub> " O.L.)
70-73	Camaro (6 cyl.),				
71-72	Camaro (400, 402)	336967	1	4.40	CABLE ASSY., accel. cont. (22 <sup>1</sup> / <sub>2</sub> " O.L.) (stamped WA)
70-72	Chevelle w/Sp. H/Per. (396, 454),				
70	Camaro w/4BC,				
71-73	Camaro w/4BC (350)	336969	1	4.40	CABLE ASSY., accel. control (21" O.L.)
70-71	Camaro w/2BC (307, 350),				
72-73	Camaro w/2BC	336968	1	4.40	CABLE ASSY., accel. control (20 <sup>3</sup> / <sub>32</sub> " )
71-73	Pass. (6 cyl.)	336975	1	4.50	CABLE ASSY., accel. control (22 <sup>7</sup> / <sub>16</sub> " ) (stamped WB)
71-72	Pass. w/4BC (350)	3989173	1	4.20	CABLE ASSY., accel. control
71-72	Pass. (400, 402, 454),				
73	Pass. w/4BC	336966	1	4.20	CABLE ASSY., accel. control (21 <sup>7</sup> / <sub>16</sub> " O.L.) (stamped WD)
71-72	Pass. w/2BC (350, 400)	336965	1	4.20	CABLE ASSY., accel. control (19 <sup>1</sup> / <sub>4</sub> " O.L.) (coded WC)
71-73	Vega	336976	1	3.80	CABLE ASSY., accel. control
73	Pass. w/2BC (350, 400)	336965	1	4.20	CABLE ASSY., accel. control (19 <sup>1</sup> / <sub>4</sub> " O.L.) (coded WC)
73	Chevelle (6 cyl.)	336962	1	4.50	CABLE ASSY., accel. control
73	Chevelle (8 cyl.)	336961	1	4.40	CABLE ASSY., accel. cont.
73	Nova (6 cyl.)	336923	1	3.75	CABLE ASSY., accel. cont.
73	Nova w/2BC (307, 350)	336921	1	3.75	CABLE ASSY., accel. cont.
73	Nova w/4BC (350)	336922	1	3.75	CABLE ASSY., accel. cont.
74	Chevelle (6 cyl.)	1244124	1	4.50	CABLE ASSY., accel. cont.
74	Nova (exc. 4BC)	1244463	1	3.75	CABLE ASSY., accel. cont.
74-75	Nova w/4BC	1244464	1	3.75	CABLE ASSY., accel. cont.
74	Chevelle w/2BC	1244125	1	4.50	CABLE ASSY., accel. cont.
74	Chevelle w/4BC (350, 400)	1244126	1	4.50	CABLE ASSY., accel. cont.
74	Chevelle (454)	1244127	1	4.50	CABLE ASSY., accel. cont.
74	Pass. w/2BC	1244129	1	4.20	CABLE ASSY., accel. cont.
74	Pass. w/4BC	1244130	1	4.20	CABLE ASSY., accel. cont.
74	Camaro (6 cyl.)	1244136	1	4.40	CABLE ASSY., accel. cont.
74	Camaro w/2BC	1244137	1	4.40	CABLE ASSY., accel. cont.
74	Camaro w/4BC	1244138	1	4.40	CABLE ASSY., accel. cont.
74	All (140)	340644	1	3.80	CABLE ASSY., accel. cont.
74	All (122)	340658	1	10.75	CABLE ASSY., accel. cont.
75	All (140)	354712	1	5.80	CABLE ASSY., accel. cont.
75	All (122)	361679	1	8.10	CABLE ASSY., accel. cont.
75	Monza (262)	1248094	1	4.80	CABLE ASSY., accel. cont.
75	Nova (6 cyl.) (exc. integrated cyl. hd.)	1247966	1	3.75	CABLE ASSY., accel. cont.
75	Chevelle (6 cyl.)	1248075	1	4.50	CABLE ASSY., accel. cont.
75	Chevelle (350, 400)	1248077	1	4.50	CABLE ASSY., accel. cont.
75	Pass. w/2BC (350)	1248079	1	4.20	CABLE ASSY., accel. cont.
75	Pass. w/4BC	1248080	1	4.20	CABLE ASSY., accel. cont.
75	Camaro (6 cyl.)	1248084	1	4.40	CABLE ASSY., accel. cont.
75	Camaro w/4BC	1248086	1	4.40	CABLE ASSY., accel. cont.
75	Nova w/integrated cyl. hd. (6 cyl.)	1246650	1	3.55	CABLE ASSY., accel. cont.
75	Chevelle (454)	1248078	1	4.00	CABLE ASSY., accel. cont.

**3.431 ROD— SUPPORT, Accelerator Pedal to Lever**

63-65	Chevy	3793644	1	.88	(dev. length 9 <sup>1</sup> / <sub>2</sub> " )
64-67	Chevelle	3853563	1	.98	accel. pedal
65-70	Pass.	3864599	1	.80	accel. pedal
67	Camaro,				
68-69	Chevy, Camaro (exc. 6 cyl.),				

**FUEL—EXHAUST—CARBURETION**

**3.431 ROD— SUPPORT, Accelerator Pedal to Lever (Con't)**

70	Nova (8 cyl.)	3909980	1	2.40	accel. pedal (rod type linkage) (Note 1)
<i>NOTE 1 It may be necessary to use 3912540 lever.</i>					
67-69	Camaro (6 cyl.),				
68-70	Chevy (6 cyl.),				
69-70	Chevy (4 cyl.),				
71-75	Nova	3998616	1	4.50	accel. pedal
68-69	Chevelle	3930790	1	2.80	accel pedal
70	Pass.	3982817	1	3.10	ROD ASSY.
70-72	Chevelle	3972675	1	2.40	ROD ASSY.
70	Nova (8 cyl.)	3983077	1	7.90	ROD ASSY., cable type linkage
70-71	Camaro (exc. Sp. H/Per. 350),				
72-75	Camaro	6264915	1	2.85	ROD ASSY.
70-71	Camaro w/Sp. H/Per. (350)	3980989	1	4.20	ROD ASSY.
71-73	Vega	6264922	1	4.55	ROD ASSY.
71-73	Pass.	6264911	1	1.90	ROD ASSY.
74-75	Vega	342418	1	4.20	ROD ASSY.
75	Monza	347412	1	3.60	ROD ASSY.
70	Nova w/E.E.C. (4 cyl.)	3975498	1	6.80	SUPPORT, accel. pedal cont. cable

**3.440 VALVE— BRACKET— DASH POT ASSY.— PIN— RELAY ASSY.—  
SCREW— SOLENOID— SPRING— SWITCH ASSY.— VALVE ASSY.—  
WIRE ASSY., Carburetor Throttle Return Check**

64-65	Chevy, Chevelle (P.G. w/4BC) (exc. H/Per., Sp. H/Per.),				
65	Pass. w/A.T. (327) (exc. H/Per.)	3758594	1	2.90	
65	Pass., Chevelle (P.G. w/H/Per.) (327)	3828485	1	2.90	
65	Pass. w/P.G. (8 cyl.),				
66	Chevy, Chevelle w/A.T. (8 cyl.) (exc. 283, A.I.R.),				
66	Pass. w/A.T. (327, 396),				
67	Chevelle (A.T. w/H/Per.) (396),				
70	All w/2BC (exc. A.T., Monte Carlo),				
70	Monte Carlo (exc. P.G., T.H. 350, H/Per. 350, 400),				
71	Nova, Chevelle (307)	3970060	1	2.90	VALVE ASSY., w/Holley or Carter
75	All w/Roch. 4BC	7042682	1	1.50	BRACKET, carb. solenoid
70	Nova, Chevelle, Camaro w/Roch. 4BC	7038765	1	7.15	DASHPOT ASSY., slow idle
75	All (350, 400)	7042654	1	1.15	NUT, solenoid brkt.
65	Pass. (396) (exc. Sp. H/Per.),				
66-72	All w/Roch. 4BC	9428787	1	.24	PIN, slotted, carb. valve & pump lever hinge, carb. dashpot— (8.940)
71	All (8 cyl.) w/C.A.C.	6273301		6.90	RELAY ASSY., anti-dieseling
75	All (140-2BC)	360979	1	.70	ROD
74	All w/2BC	7044722	2		SCREW, carb. idle adjusting
74	All w/1BC	7042427	1	.93	SCREW, carb. idle adjusting
75	All w/Roch. 4BC	7043682	1	.27	SCREW
68-70	All,				
71	Vega (2BC) (1st design),				
71-72	Vega (1BC)	1114421	1	8.85	SOLENOID, carb. idle control
72	Camaro w/Holley 4BC	6273914	1	13.00	SOLENOID ASSY., carb. (CEC)
71	All,				
72-73	All w/Rochester 1BC	1114444	1	13.70	SOLENOID ASSY., carb. emission cont.
71	Vega (2BC) (2nd design),				
72	All w/Roch. w/2BC, 4BC,				
72	Vega (2BC),				
73-74	All w/Roch. 2BC, 4BC (exc. 454) <i>NOTE 1: Used on 1st design carb. on Vega.</i>	1997409	1	10.75	SOLENOID ASSY., carb. idle cont. (Note 1)
72	All w/Roch. 1BC,				
73-75	Vega, Monza (140-1BC),				
74	All (6 cyl.)	7040219	1	13.40	SOLENOID ASSY., carb. idle cont.
72	Vega (2BC)	1997403	1	11.65	SOLENOID ASSY., carb. idle cont. (Note 2)
<i>NOTE 2: Used on 2nd design carb. on Vega.</i>					
73-74	All w/Roch. 4BC (454)	1997417	1	11.30	SOLENOID ASSY., carb. idle stop
73	All w/Roch. 1BC	7040316	1	13.40	SOLENOID ASSY., carb. idle control
73-74	All (140-2BC)	335146	1	12.00	SOLENOID ASSY., carb.
75	All (140-2BC)	360163	1	13.00	SOLENOID ASSY., choke pull off
75	All (454)	1997447	1	10.45	SOLENOID ASSY., carb. choke
75	All w/1BC	7043575	1	16.00	SOLENOID ASSY., carb. idle

**FUEL—EXHAUST—CARBURETION**

**3.440 VALVE— BRACKET— DASH POT ASSY.— PIN— RELAY ASSY.—  
SCREW— SOLENOID— SPRING— SWITCH ASSY.— VALVE ASSY.—  
WIRE ASSY., Carburetor Throttle Return Check (Con't)**

73-75	All (140-1BC) .....	7040519	1	.39	SPRING, sol. lock .....
75	All (454) .....	354762	1	20.70	SWITCH ASSY., carb. choke sol. timer .....
75	All (140-2BC) w/NB-2 .....	354618	1	5.70	VALVE ASSY., thermal check and delay .....
75	All (140-2BC) (exc. NB-2) .....	357620	1	6.75	VALVE ASSY., thermal check and delay .....
74-75	Vega, Monza (140-2BC) .....	413429	1	3.60	VALVE ASSY., thermal check and delay .....
68	Pass. w/P.G. (6 cyl.),				
68	Pass. w/A.T. (327) .....	6298952	1	6.30	WIRE ASSY., anti-dieseling solenoid— (3.485) .....

**3.444 BRACKET— BRACE— CLAMP— HOSE— SCREW— SHIELD— SUPPORT,  
Carburetor Throttle Return Check**

68-70	All (6 cyl.) .....	3967067	1	1.35	carb. idle control solenoid .....
69	All (T.H. 400 w/Sp. H/Per.) (396, 427) .....	3967426	1	1.70	carb. idle cont. sol. ....
69	Chevy, Chevelle, Camaro w/A.T. (307) .....	3959420	1	1.65	carb. idle cont. sol. ....
68	All w/2BC (307, 327) (exc. P.G.),				
69	All .....	3927163	1	5.15	BRACKET ASSY., carb. idle cont. solenoid (w/1114421) .....
69	All (2BC w/A.T.) (327, 350) .....	3959496	1	1.65	BRACKET ASSY., carb. idle cont. solenoid .....
70	All w/2BC (350, 400) .....	3973304	1	1.65	BRACKET ASSY., carb. idle cont. solenoid .....
70	Nova, Chevelle (307) (exc. A.T.),				
70	Camaro (8 cyl.) .....	3970062	1	1.45	BRACKET ASSY., valve .....
70	Nova, Chevelle, Camaro w/A.T. (307) .....	3973306	1	1.90	BRACKET ASSY., carb. idle cont. solenoid .....
70	Camaro (Holley 4BC w/A.T.) w/Sp. H/Per. (350) .....	3979533	1	3.10	BRACKET ASSY., carb. solenoid .....
71	All w/Roch. 1BC .....	7042667	1	1.65	BRACKET ASSY., carb. solenoid .....
71	All w/Roch. 2BC (307) .....	7042811	1	1.95	BRACKET ASSY., carb. solenoid (w/7041101-107-110-1) .....
71-72	Vega (1BC) .....	329640	1	1.35	BRACKET ASSY., carb. solenoid .....
71	All w/Roch. 2BC (350, 400),				
72-74	All w/Roch. 2BC .....	7042818	1	2.25	BRACKET ASSY., carb. solenoid (w/7041102-13-14-17-18-27-7104) (Note 1) .....
<i>NOTE 1: Used on Vega 1st design carb.</i>					
71-73	All w/Roch. 4BC .....	7042682	1	1.50	BRACKET ASSY., carb. solenoid— (3.440) .....
71-72	All w/Holley 4BC .....	3979663	1	2.15	BRACKET ASSY., carb. solenoid .....
72	All w/Roch. 1BC .....	7030584	1	1.95	BRACKET ASSY., carb. solenoid .....
72	Vega (2BC) .....	7030757	1	2.25	BRACKET ASSY., carb. solenoid (Note 2) .....
<i>NOTE 2: Used on Vega 2nd design carb.</i>					
73	All w/Roch. 1BC .....	7040378	1	1.65	BRACKET ASSY., carb. solenoid .....
74-75	All w/1BC .....	17050025	1	1.00	BRACKET ASSY., inner .....
69-70	All (6 cyl.) .....	3967068	1	.44	BRACE, carb. idle control solenoid bracket .....
72	Vega (2BC) .....	326302	1	1.05	BRACE, carb. idle control solenoid bracket .....
68-70	All w/2BC .....	3927165	1	2.65	CLAMP, carb. idle control solenoid .....
69	Pass., Chevelle (T.H. 400 w/Sp. H/Per.) (396, 427) .....	3940917	1	3.35	CLAMP, carb. idle cont. solenoid .....
71-72	Vega (2BC) .....	3983481	1	.32	CLAMP, carb. idle cont. solenoid .....
71	All w/Roch. 4BC .....	7026907	1	.84	HOSE, carb. solenoid vacuum .....
74-75	All w/1BC .....	7041287	2	.28	SCREW, throttle return bracket (long) .....
74	All w/1BC .....	17050024	1	.28	SCREW, throttle return bracket (short) .....
75	Camaro, Nova (6 cyl.) .....	354590	1	2.65	SHIELD, choke pull off switch .....
72	Vega (1BC) .....	333976	1	1.05	SUPPORT, solenoid bracket .....

**3.451 PEDAL— ANTI SQUEAK— PLATE, Accelerator**

62-67	Chevy .....	3820328	1	3.05	
64-67	Chevelle,				
65-70	Pass.,				
70-71	Camaro w/Sp. H/Per. (350) .....	3864740	1	3.00	(Note 1) .....
<i>NOTE 1 Used as standard equipment on Caprice, Super Sport, and Custom Sport truck models and as optional equip. on other models.</i>					
67	Camaro,				
68-71	Chevy, Chevelle, Camaro (exc. Sp. H/Per. 350),				

**FUEL—EXHAUST—CARBURETION**

**3.451 PEDAL— ANTI SQUEAK— PLATE, Accelerator (Con't)**

71-75	Vega,				
72	Nova, Chevelle, Camaro,				
73-75	Nova, Camaro	3920296	1	1.70	
71-73	Pass.	332546	1	1.65	
73	Chevelle,				
74-75	Pass., Chevelle	6271501	1	1.70	
75	Monza	368079	1	1.65	
62-64	Chevy	3825201	1	.11	ANTI-SQUEAK (pedal plastic insert)
65-70	Pass.	3958933	1	.22	ANTI-SQUEAK, pedal rod
65-70	Pass.	3864742	1	.84	PLATE, pedal trim
67	Camaro,				
68-69	Chevy, Camaro,				
70	Nova w/B.S., Custom interior, Interior Convenience Package	3923611	1	.98	PLATE, accel. pedal trim

**3.452 BRACKET— PIN— REINFORCEMENT— RING— STUD— SUPPORT, Accelerator Pedal**

68-69	Chevelle (exc. T.H. 400)	3922516	1	.15	pedal rod
67	Camaro,				
68-71	Chevy, Chevelle, Camaro (exc. Sp. H/Per. 350),				
71-74	Vega,				
72	Chevelle,				
72-75	Pass., Nova, Camaro	346324	1	.22	PIN
75	Nova, Camaro, Vega, Monza	346324	1	.22	PIN, to rod
70-72	Camaro (exc. T.H. 400)	3972288	1	.74	REINFORCEMENT, accel. pedal rod support
70-72	Camaro w/T.H. 400	3972298	1	.61	REINFORCEMENT, accel. pedal rod support
71-72	Pass.	3993656	1	2.85	REINFORCEMENT, accel. pedal rod support
70	Pass. (6 cyl.),				
70	Nova	9421540	1	.18	RING, accel. pedal rod retainer— (8.934)
62-67	Chevy,				
65-69	Pass.,				
65-67	Chevelle,				
71	Camaro w/Sp. H/Per. (350)	3748971	1	.35	STUD, ball (1/4"— 20 x 1 1/2") (Note 1)
	<i>NOTE 1 If required use 120392 washer to obtain proper height.</i>				
70	Camaro,				
71-72	Pass., Camaro	3993087	1	.80	SUPPORT, accel. pedal rod
68-72	Chevelle	3949066	1	.61	SUPPORT ASSY., pedal rod
70-71	Camaro w/Sp. H/Per. (350)	3980987	1	3.30	SUPPORT ASSY., accel. control pedal

**3.454 LEVER— BEARING— BRACKET— RING— SUPPORT— REINFORCEMENT— RETAINER, Accelerator**

63-65	Chevy (exc. 8 cyl.),				
64-65	Chevy (8 cyl.)	3790773	1	.71	accel. control rod
63	Chevy,				
64-65	Chevy (exc. P.G., 8 cyl.),				
64-66	Chevelle (6 cyl.) (1st design) (exc. P.G.),				
66	Chevy (4 cyl.)	3832784	1	.78	accel. control
65	Pass. (396),				
66	Pass. (8 cyl.) (exc. 396),				
67-70	Pass.	3924411	1	1.55	accel. control rod
66-67	Pass., Chevy, Chevelle (6 cyl.)	3909969	1	1.60	accel. cont.
66-67	Chevy	3901383	1	1.05	accel. control rod
67	Camaro (exc. 396)	3912540	1	1.30	accel. control rod
68-70	Pass. (6 cyl.) (exc. T.H. 350)	3925081	1	1.30	accel. pedal (Note 1)
	<i>NOTE 1 No pin above D slot.</i>				
68-69	Chevy, Camaro (8 cyl.) (exc. Spec. Duct Hood),				
70	Nova	3975516	1	1.45	accel. control rod
73-75	Vega, Monza (140-2BC)	332511	1	2.85	accel. control rod
68	Chevy, Camaro (6 cyl.),				
68	Chevelle (6 cyl.) (exc. O.D.),				
69	Chevy, Chevelle, Camaro (6 cyl.) (exc. T.H. 350)	3928327	1	2.30	LEVER ASSY., accel. cont.
69	Camaro w/Spec. Duct Hood	3959113	1	2.70	LEVER ASSY., accel. cont. rod
70	Pass. (6 cyl.) (exc. T.H. 350),				
70	Pass. (8 cyl.),				
70	Chevelle, Camaro (6 cyl.),				
71	Pass., Chevelle, Camaro,				
72	Pass., Chevelle, Camaro (6 cyl.),				
73-75	Pass., Chevelle (6 cyl.),				
73-75	Camaro w/3-Spd. (6 cyl.)	3972293	1	1.75	LEVER ASSY., accel. control
70	Pass. w/T.H. 350 (6 cyl.) (2nd design),				

FUEL—EXHAUST—CARBURETION

**3.454 LEVER— BEARING— BRACKET— RING— SUPPORT— REINFORCEMENT—  
RETAINER, Accelerator (Con't)**

70	Chevelle w/T.H. 350 (6 cyl.),				
73-74	Camaro w/A.T. (6 cyl.)	3974082	1	3.50	LEVER ASSY., accel. cont.
70-71	Nova (6 cyl.) (exc. T.H. 350),				
72	Nova (6 cyl.),				
73-75	Nova (6 cyl.) (exc. A.T.),				
73	Nova (8 cyl.)	3973092	1	2.20	LEVER ASSY., accel. control
70	Nova w/T.H. 350 (6 cyl.),				
73-75	Nova w/A.T. (6 cyl.)	3974078	1	3.40	LEVER ASSY., accel. cont.
71-75	Vega, Monza (1BC)	3978130	1	1.45	LEVER ASSY., accel. cont.
71-72	Vega (2BC)	3978148	1	2.85	LEVER ASSY., accel. cont.
73-75	Vega, Monza (2BC)	332508	1	2.85	LEVER ASSY., accel. cont.
73-74	Chevelle	1239963	1	10.00	LEVER ASSY., accel. pedal
74-75	Pass. (8 cyl.)	477593	1	2.25	LEVER ASSY., accel. pedal
75	Chevelle, Camaro (6 cyl.)	354667	1	3.30	LEVER ASSY., accel. control
75	Chevelle (8 cyl.)	355532	1	4.00	LEVER ASSY., accel. pedal
75	Nova w/A.T. (6 cyl.)	355586	1	4.80	LEVER ASSY., accel. pedal
70-72	Chevelle (exc. T.H. 400, Spec. Duct Hood)	399613	1	.27	BEARING, accel. and trans. throttle valve
67	Camaro (6 cyl.),				
68-69	Chevy, Chevelle, Camaro (6 cyl.)	3928330	1	.36	BRACKET, accel. cont. cable
71-75	Vega, Monza (1BC)	3978129	1	.56	BRACKET, accel. cont. cable
71-72	Vega (2BC)	3978147	1	1.20	BRACKET, accel. cont. cable
73-75	Vega, Monza (2BC)	338937	1	1.65	BRACKET, accel. cont. cable
73-75	Chevelle	1241016	1	2.70	BRACKET, accel. ped. rod
70	Pass. (6 cyl.)	9421540	1	.18	RING, accel. control lever retainer— (8.934)
64-67	Chevelle,				
65-70	Pass.,				
67-69	Camaro,				
68-72	Chevy	346394	1	.58	SUPPORT, rod
68	Chevelle (327, 396) (exc. Sp. H/Per. 396)	3943667	1	.61	SUPPORT, accel. cont. cable
68	Chevelle (307)	3930789	1	1.15	SUPPORT, accel. cont. cable
68	Chevelle w/Sp. H/Per. (396)	3930794	1	.66	SUPPORT, accel. cont. cable
69	Chevelle (307),				
70	Chevelle, Nova, Camaro (307) (exc. E.E.C.),				
71	Nova (307)	3949058	1	1.35	SUPPORT, accel. pedal control cable
69	Chevy, Chevelle, Camaro (6 cyl.),				
70-73	Nova (6 cyl.)	3949069	1	.65	SUPPORT, accel. control cable
69	Chevelle (350, 396) (exc. reg. fuel, Sp. H/Per.),				
70	Chevelle, Nova, Camaro w/H/Per. (396),				
70	Pass., Nova w/4BC (350),				
70	Pass., Chevelle w/4BC (400, 454) (exc. Sp. H/Per.),				
71	All w/4BC (exc. Sp. H/Per.),				
72	All w/4BC (exc. Sp. H/Per. NB- 2),				
73	All w/4BC	326564	1	1.15	SUPPORT, accel. pedal control cable
69-70	Chevelle w/Sp. H/Per. (396)	3949088	1	.73	SUPPORT, accel. cont. cable
69	Chevelle w/Roch. 2BC (350),				
70	All w/2BC (350, 400) (exc. E.E.C.),				
71	Nova w/2BC (350)	334923	1	18.15	SUPPORT, accel. pedal control cable
70-75	Pass., Chevelle, Camaro (6 cyl.)	3972291	1	.61	SUPPORT, accel. control cable
70	All w/E.E.C. (307),				
70	Nova, Chevelle (2BC w/E.E.C.) (350, 400),				
70	Camaro w/2BC (350),				
71	Pass., Chevelle, Camaro w/2BC (350, 400),				
71	Chevelle, Camaro (307),				
72-73	All (8 cyl.) (exc. 402, 454, Sp. H/Per.)	6261813	1	1.10	SUPPORT, accel. control cable
70	Camaro w/Sp. H/Per. (350, 454),				
71	Chevelle, Camaro w/Sp. H/Per. (350, 454),				
72	All w/Sp. H/Per.	6261814	1	1.10	SUPPORT, accel. control cable
70	Nova, Chevelle w/Sp. H/Per. (396, 454)	3972619	1	.80	SUPPORT, accel. pedal control cable
71-75	Vega, Monza,				
73-75	Pass., Camaro, Chevelle	3993087	1	.80	SUPPORT, accel. pedal rod

**FUEL—EXHAUST—CARBURETION**

**3.454 LEVER— BEARING— BRACKET— RING— SUPPORT— REINFORCEMENT—  
RETAINER, Accelerator (Con't)**

74	All w/2BC	340636	L.H.	1.15	SUPPORT, spark plug wire, accel. cable and prim. pull back spring
74-75	Nova	346394	1	.58	SUPPORT, accel. pedal rod
75	All (6 cyl.) w/integrated cyl. hd.	354671	1	2.40	SUPPORT, accel. control cable
74-75	All (6 cyl.) (exc. integrated cyl. hd.)	340626	1	.61	SUPPORT, accel. cont. cable
74-75	All w/4BC	340651	1	1.15	SUPPORT, accel. cont. cable
75	All (122)	340649	1	1.35	SUPPORT, accel. cont. cable
75	Monza	355553	1	.85	SUPPORT, accel. pedal rod
75	Monza (262) (exc. NB-2)	352286	1	1.30	SUPPORT, accel. cont. cable
75	Monza (262 w/NB-2)	352279	1	2.40	SUPPORT, accel. cont. cable
75	Pass., Camaro, Chevelle (350)	352286	1	1.30	SUPPORT, accel. cont. cable
73-75	Pass.	3993656	1	2.85	REINFORCEMENT, accel. pedal rod support
71-73	Vega,				
73-75	Camaro (exc. T.H. 400)	3972288	1	.74	REINFORCEMENT, accel. pedal rod support
73-75	Camaro w/T.H. 400	3972298	1	.61	REINFORCEMENT, accel. pedal rod support
74-75	Chevelle	1241016	1	2.70	REINFORCEMENT, accel. pedal rod support
74-75	Vega	336908	1	.65	REINFORCEMENT, accel. pedal rod
75	Monza (Towne Coupe)	336908	1	.65	REINFORCEMENT, accel. pedal rod
75	Monza (exc. Towne Coupe)	355554	1		REINFORCEMENT, accel. pedal rod
75	Camaro w/T.H. 350	352229	1	2.70	REINFORCEMENT, accel. pedal rod supt.
73-74	Chevelle, Camaro	3863558	1	.27	RETAINER, accel. cont. cable— (7.529)

**3.459 SPRING— BRACKET, Accelerator Pull Back**

62-64	Chevy, Chevelle (283) (exc. 4BC),				
65	All (8 cyl.) (exc. 396)	3785404	1	.48	(5 <sup>11</sup> / <sub>16</sub> " free length— 31" coils) (two hook ends) (blue)
62-67	Chevy (exc. 8 cyl.),				
64	Chevelle (6 cyl.)	3791577	1	.40	(2 <sup>13</sup> / <sub>16</sub> " free length— 37 coils) (black)
64	Chevelle w/4BC	3821966	1	.40	(6 <sup>1</sup> / <sub>4</sub> " free length) (white)
65	Chevelle w/Sp. H/Per.	3830222	1	.65	(4 <sup>13</sup> / <sub>32</sub> " free length— 30 coils)
65-67	Pass., Chevelle, Camaro (6 cyl.)	3839720	1	.40	(2 <sup>1</sup> / <sub>4</sub> " free length) (dk. blue)
65-66	Pass., Chevelle (396, 427)	3871197	1	.48	(6 <sup>3</sup> / <sub>4</sub> " free length— 25" coils)
66	Chevy w/2BC,				
66	Pass., Chevelle w/2BC (283),				
67	Chevelle (283) (exc. P.G.)	3878397	1	.48	
66	All w/4BC (283, 327),				
67	Chevelle w/P.G. (327)	3878379	1	.48	
67	Pass. w/P.G. (283),				
67	Chevy, Chevelle, Camaro w/P.G. (283, 327) (exc. 4BC)	3952107	1	.48	pink
67-70	Camaro (exc. Sp. H/Per. 350),				
68-70	Chevy, Chevelle,				
71	All (exc. Sp. H/Per. 350),				
67	Camaro (327)	3888697	1	.48	(orange)
67	Pass. (283) (exc. P.G.),				
67	Chevy, Chevelle, Camaro w/2BC (exc. P.G.)	3908780	1	.53	(2 <sup>15</sup> / <sub>16</sub> " free length— 31" coils) (white)
67	Pass. w/P.G. (327),				
67	Chevy, Chevelle, Camaro w/P.G. (327, 350) (exc. 2BC, Sp. H/Per.)	3904245	1	.48	(lime)
67	Chevy (327) (exc. P.G., Sp. H/Per.),				
67	Camaro (327, 350) (exc. P.G.),				
67	Camaro (302),				
67	Chevelle (327),				
67	Pass. (327)	3908781	1	.48	(gold)
67	All (396, 427) (exc. P.G.)	3913415	1	.48	(black)
67-68	Pass., Chevelle w/P.G. (396)	3928245	1	.36	(blue) (50" coils)
68	All (307, 327) (exc. P.G.),				
69	Chevy (8 cyl.) (exc. P.G., 396)	3923504	1	.48	(brown)
68	Pass., Chevy, Camaro (302, 396, 427),				
68	Chevelle (S.S.) (396) (exc. P.G.)	3923501	1	.66	(green) (58" coils)
68	All (4 cyl., 6 cyl.),				
69-71	All (4 cyl., 6 cyl.) (exc. A.T.),				
71-73	Vega (1BC) (exc. A.T.),				
72	Pass., Chevelle, Camaro (6 cyl.) (exc. P.G., NB2),				
72	Nova (6 cyl.) (exc. P.G., Torque Drive, NB2)	336924	1	.24	
68	All (4BC w/P.G.) (327, 350)	3928312	1	.36	(purple)

**FUEL—EXHAUST—CARBURETION**

**3.459 SPRING— BRACKET, Accelerator Pull Back (Con't)**

68-69	All (2BC w/P.G.) (307, 327),				
69	Pass. w/P.G. (8 cyl.),				
69	Pass. (396) (exc. P.G.),				
70	All w/P.G. (8 cyl.),				
71	All (2BC w/P.G.)	3953999	1	.36	
68	Pass. w/T.H. 350 (8 cyl.),				
69-70	Chevelle w/4BC (350) (exc. P.G.),				
69-70	Pass. w/4BC (350),				
70	Nova w/4BC (350) (exc. P.G.)	3947518	1	.48	(white)
69	Pass. (427),				
69	Chevy, Chevelle, Camaro (302, 396)	3950210	1	.36	(light green)
69-71	All w/A.T. (4 cyl., 6 cyl.),				
71-73	Vega (1BC w/A.T.),				
71-72	Vega	330122	1	.20	pedal tension (repl. 3909982)
72	All w/P.G. (6 cyl.) (exc. NB2),				
72	Nova w/Torque Drive (6 cyl.) (exc. NB-2),				
73	Nova w/A.T. (6 cyl.)	3953206	1	.53	
69	Pass., Chevelle w/2BC (327, 350) (exc. P.G.),				
69	Camaro (327, 350) (exc. P.G.),				
70-71	Pass., Monte Carlo w/2BC (350, 400) (exc. P.G.),				
70-71	Nova w/2BC (307, 350) (exc. P.G.),				
70-71	Chevelle, Camaro w/2BC (exc. P.G.),				
72	Pass. w/2BC (exc. P.G.)	3952776	1	.48	(light brown)
72	All (307, 350) (exc. 4BC),				
73	All w/2BC	6261815	1	.66	accel. pull back
70	Pass., Chevelle (454),				
70	Nova, Chevelle, Camaro w/4BC (396, 400),				
70	Camaro w/Sp. H/Per. (350),				
71-72	All w/4BC	3970274	1	.17	
71-72	Vega (exc. A.T.)	3996326	1	.31	pull back
71-72	Vega w/A.T.	3996327	1	.55	pull back
73	Vega (1BC)	332509	1	.32	pull back
73	Pass., Camaro, Nova,				
72	All,				
73-75	Vega, Monza,				
74-75	Nova, Camaro	330122	1	.20	accel. ped. tens.
73	Chevelle,				
74-75	Pass., Chevelle	336989	1	.22	accel. ped. tens.
71-73	Vega (1BC) (exc. A.T.),				
73	Pass., Chevelle, Camaro (6 cyl.),				
73	Nova w/A.T. (6 cyl.),				
73	Nova w/3-Spd. (6 cyl.) (exc. NB-2)	336924	1	.24	accel. pull back
73	All w/4BC	6261811	1	.23	accel. pull back
74-75	Vega (140-2BC)	340650	1	.31	accel. pull back
74-75	Vega (1BC),				
74-75	All (6 cyl.),				
75	All (122)	342484	1	1.05	accel. pull back (inner)
74-75	Vega (1BC),				
74-75	All (6 cyl.),				
74-75	All (122)	342485	1	.50	accel. pull back (outer)
74-75	All (8 cyl.)	340637	1	.22	accel. pull back (outer)
74-75	All (8 cyl.)	340638	1	.22	accel. pull back (inner)
62-67	All (4 cyl., 6 cyl.)	3842719	1	2.05	BRACKET, spring
65	Chevelle w/Sp. H/Per. (327)	3824300	1	.96	BRACKET, spring
67	Pass., Chevelle, Camaro (exc. 396, 427),				
67	Chevy (exc. 327)	3904249	1	.48	BRACKET, spring
68	All (4 cyl., 6 cyl.),				
68	All (327, 350),				
68	Chevy, Camaro w/P.G. (307),				
69-70	All w/4BC (350) (exc. Sp. H/Per. 350)	3930791	1	.48	BRACKET, spring
69-71	All w/2BC (327, 350, 400),				
72	Pass. w/2BC (350, 400),				
72	All w/2BC (350)	3952778	1	.12	BRACKET, spring
70	Nova w/Sp. H/Per. (396)	3975520	1	.23	BRACKET, spring



**FUEL—EXHAUST—CARBURETION**

**3.459 SPRING— BRACKET, Accelerator Pull Back (Con't)**

70	Nova (4 cyl.)	3973099	1	.28	BRACKET, spring
73	Vega (1BC)	336925	1	.77	BRACKET, spring
69-72	All (6 cyl.),				
73	All (6 cyl.)	331198	1	.24	BRACKET, spring
74-75	Vega (1BC)	340645	1	.77	BRACKET, spring

**3.463 STUD— SLEEVE— PIN, Accelerator Intermediate**

65-75	All (6 cyl.),				
71-75	All (140)	3997258	1	.78	accel. control lever (5/8" "B"— 18 x 2 1/16" O.L. x 1/2")
67-71	All (4 cyl., 6 cyl.),				
72-75	All (6 cyl.)	3909973	1	.12	SLEEVE, accel. control lever stud
73-75	All (140-1BC)	336959	1	.42	PIN, carb. to accel. cont. lever

**3.469 GASKET, Accelerator Rod Linkage**

62-67	Chevy	3792913	1	.23	rod support to dash
75	Vega (Hatchback)	364618	1	4.65	SHIELD, accel. cont. cable

**3.480 ROD, Hand Choke with Button, Wire and Tube**

68-69	Chevy (4 cyl.)	1991853	1	8.50	w/tube
-------	----------------	---------	---	------	--------

**3.483 BRACKET— CLAMP, Hand Control Wires and Tubes**

68-69	Chevy (4 cyl.)	7035725	1	1.00	carb. choke wire
62-64	Chevy (4 cyl.)	3127015 A.R.		.17	CLAMP, choke rod and tube— (9.787)

**3.485 SOLENOID— WIRE ASSY., Engine Fuel or Air Inlet Shut Down**

68-69	All	1114421	1	8.85	anti-dieseling— (3.440)
68	Pass. w/P.G. (6 cyl.),				
68	Pass. w/A.T. (327)	6298952	1	6.30	WIRE ASSY., anti-dieseling solenoid

**3.601 MANIFOLD, Engine Exhaust**

*NOTE: See end of listings for Vega-Monza manifold.*

**1962— 1963 CHEVY II Exhaust Manifold**

*NOTE: See Dealer Price Schedule for applicable prices.*

ENGINE	CHEVY II	
4 cyl.	3977556	
6 cyl.	328599-B	

A. (1962)  
B. (1963)

**1964 CHEVY II, CHEVELLE Exhaust Manifold**

*NOTE: See Dealer Price Schedule for applicable prices.*

ENGINE	CHEVY II	CHEVELLE
4 cyl.	3977556	—
6 cyl.	328599	328599
283 w/2BC	3790729 (L.H.) 3890424 (R.H.)	3893608 (R.H.) 3892679 (L.H.)
283 w/4BC	3890424 (R.H.) 3790729 (L.H.)	3893608 (R.H.) 3892679 (L.H.)
327	3890424 (R.H.) 3790729 (L.H.)	3893608 (R.H.) 3892679 (L.H.)

**FUEL—EXHAUST—CARBURETION**

**1965 PASSENGER, CHEVY II, CHEVELLE Exhaust Manifold**

*NOTE: See Dealer Price Schedule for applicable prices.*

ENGINE	PASSENGER	CHEVY II	CHEVELLE
4 cyl.	—	3977556	—
6 cyl.	328599	328599	328599
283 w/2BC	336711 (R.H.) 3855163 (L.H.)	3790729 (L.H.) 3890424 (R.H.)	3892679 (L.H.) 3893608 (R.H.)
283 w/4BC	3817806 (R.H.) 3855163 (L.H.)	3890424 (R.H.) 3790729 (L.H.)	3893608 (R.H.) 3892679 (L.H.)
327	3817806 (R.H.) 3855163 (L.H.)	3890424 (R.H.) 3790729 (L.H.)	3893608 (R.H.) 3892679 (L.H.)
396	3904399 (L.H.) A 3884504 (R.H.) A 3880833 (L.H.) B	—	— 340293 (L.H.)

*A. Exc. Sp. H/Per.*

*B. w/Sp. H/Per.*

**1966 PASSENGER, CHEVY II, CHEVELLE Exhaust Manifold**

*NOTE: See Dealer Price Schedule for applicable prices.*

ENGINE	PASSENGER	CHEVY II	CHEVELLE
4 cyl.	—	3977556	—
6 cyl.	328599	328599	328599
283 w/2BC	336711 (R.H.) A 3855163 (L.H.) A 3872741 (L.H.) B 3932461 (R.H.) B	3790729 (L.H.) A 3872738 (R.H.) B 3890424 (R.H.) A	3893608 (R.H.) A 3892683 (L.H.) B 3892679 (L.H.) A 3872730 (R.H.) B
283 w/4BC	3817806 (R.H.) A 3855163 (L.H.) A 3872741 (L.H.) B	3890424 (R.H.) A 3790729 (L.H.) A	3893608 (R.H.) A 3892679 (L.H.) A 3892683 (L.H.) B
327	336711 (R.H.) A 3855163 (L.H.) A 3872741 (L.H.) B 3932461 (R.H.) B	3790729 (L.H.) A 3890424 (R.H.) A 3872738 (R.H.) B	3893608 (R.H.) A 3892679 (L.H.) A 3872730 (R.H.) B 3892683 (L.H.) B
396	3884504 (R.H.) AD 3904399 (L.H.) AD	—	340293 (L.H.) A 340293 (L.H.) B 353028 (R.H.)
427	3884504 (R.H.) AD 3880827 (L.H.) C 3880834 (R.H.) C 3904399 (L.H.) AD	—	—

*A. Exc. A.I.R.*

*B. w/A.I.R.*

*C. w/Sp. H/Per.*

*D. Exc. Sp. H/Per.*

**FUEL—EXHAUST—CARBURETION**

**1967 PASSENGER, CHEVY II, CHEVELLE, CAMARO Exhaust Manifold**

*NOTE: See Dealer Price Schedule for applicable prices.*

ENGINE	PASSENGER	CHEVY II	CHEVELLE	CAMARO
4 cyl.	—	3977556	—	—
6 cyl.	328599	328599	328599	328599
283	336711 (R.H.) A 3855163 (L.H.) A 3872741 (L.H.) B 3932461 (R.H.) B	3790729 (L.H.) A 3890424 (R.H.) A 3872738 (R.H.) B	3893608 (R.H.) A 3892679 (L.H.) A 3872730 (R.H.) B 3892683 (L.H.) B	
327 w/2BC	—	—	—	3893608 (R.H.) A 3892679 (L.H.) A 3872730 (R.H.) B 3892683 (L.H.) B
327 w/4BC	336711 (R.H.) A 3855163 (L.H.) A 3872741 (L.H.) B 3932461 (R.H.) B	3790729 (L.H.) A 3890424 (R.H.) A 3872738 (R.H.) B	3893608 (R.H.) A 3892679 (L.H.) A 3872730 (R.H.) B 3892683 (L.H.) B	3893608 (R.H.) A 3892679 (L.H.) A 3872730 (R.H.) B 3892683 (L.H.) B
350	—	—	—	3893608 (R.H.) A 3892679 (L.H.) A 3872730 (R.H.) B 3892683 (L.H.) B
396	3904399 (L.H.) A  3884504 (R.H.) A	—	340293 (L.H.) A 340293 (L.H.) B 353028 (R.H.)	340293 (L.H.) A 340293 (L.H.) B 353028 (R.H.)
302	—	—	—	3892683 (L.H.) B 3893608 (R.H.) A 3892679 (L.H.) A 3872730 (R.H.) B
427	3904399 (L.H.) A 3884504 (R.H.) A			

A. Exc. A.I.R.  
B. w/A.I.R.

**FUEL—EXHAUST—CARBURETION**

**1968 PASSENGER, CHEVY II, CHEVELLE, CAMARO Exhaust Manifold**

*NOTE: See Dealer Price Schedule for applicable prices.*

ENGINE	PASSENGER	CHEVY II	CHEVELLE	CAMARO
4 cyl.	—	3977556	—	—
6 cyl.	328599	328599	328599	328599
307	336711 (R.H.) A 3855163 (L.H.) A 3872741 (L.H.) D 3932461 (R.H.) D	3892683 (L.H.) D 3893608 (R.H.) A 3892679 (L.H.) A 3872730 (R.H.) D	3893608 (R.H.) A 3892679 (L.H.) A 3872730 (R.H.) D 3892683 (L.H.) D	—
327 w/2BC	—	—	—	3893608 (R.H.) A 3892679 (L.H.) A 3872730 (R.H.) D 3892683 (L.H.) D
327 w/4BC	336711 (R.H.) A 3855163 (L.H.) A 3932461 (R.H.) D 3872741 (L.H.) D	3892683 (L.H.) D 3893608 (R.H.) A 3872730 (R.H.) D 3892679 (L.H.) A	3892683 (L.H.) D 3893608 (R.H.) A 3872730 (R.H.) D 3892679 (L.H.) A	3892683 (L.H.) D 3893608 (R.H.) A 3872730 (R.H.) D 3892679 (L.H.) A
350	—	3892679 (L.H.) A 3893608 (R.H.) A 3872730 (R.H.) D 3892683 (L.H.) D	—	3892683 (L.H.) D 3893608 (R.H.) A 3892679 (L.H.) A 3872730 (R.H.) D
396	3914617 (L.H.) 353028 (L.H.)	340293 (L.H.)	340293 (L.H.) AB 353028 (R.H.) 340293 (L.H.) D 353028 (L.H.) AE 353028 (R.H.)	3989345 (L.H.)
302	—	—	—	3872730 (R.H.) 3892683 (L.H.)
427	353028 (R.H.) A 3914617 (L.H.) 353028 (R.H.) D			

A. w/A.T.  
 B. Exc. H/Per. Sp. H/Per.  
 D. Exc. A.T.  
 E. w/H/Per.

**FUEL—EXHAUST—CARBURETION**

**1969 PASSENGER, CHEVY II, CHEVELLE, CAMARO Exhaust Manifold**

*NOTE: See Dealer Price Schedule for applicable prices.*

ENGINE	PASSENGER	CHEVY II	CHEVELLE	CAMARO
4 cyl.	—	3977556	—	—
6 cyl.	328599	328599	328599	328599
307	—	336710 (L.H.) C 336709 (R.H.) C 336706 (L.H.) B 346222 (R.H.) B	336710 (L.H.) C 336709 (R.H.) C 336706 (L.H.) B 346222 (R.H.) B	336710 (L.H.) C 336709 (R.H.) C 336706 (L.H.) B 346222 (R.H.) B
327	3932461 (R.H.) C 336711 (R.H.) B 3932469 (L.H.) C 3989055 (L.H.) B	—	—	336710 (L.H.) C 336709 (R.H.) C 336706 (L.H.) B 346222 (R.H.) B
350 w/2BC	3932461 (R.H.) C 336711 (R.H.) B 3932469 (L.H.) C 3989055 (L.H.) B	336710 (L.H.) C 336709 (R.H.) C 336706 (L.H.) B 346222 (R.H.) B	346222 (L.H.) C 336709 (R.H.) C 336706 (L.H.) B 346222 (R.H.) B	346222 (L.H.) C 336709 (R.H.) C 336706 (L.H.) B 346222 (R.H.) B
350 w/4BC	3932461 (R.H.) C 336711 (R.H.) B 3932469 (L.H.) C 3989055 (L.H.) B	336710 (L.H.) C 336709 (R.H.) C 336706 (L.H.) B 346222 (R.H.) B	336710 (L.H.) C 336709 (R.H.) C 336706 (L.H.) B 346222 (R.H.) B	336710 (L.H.) C 336709 (R.H.) C 336706 (L.H.) B 346222 (R.H.) B
396 w/2BC	3914617 (L.H.) 353028 (R.H.)	—	—	—
396 w/4BC	—	340293 (L.H.) 353028 (R.H.)	340293 (L.H.) AB 340293 (L.H.) C 340293 (L.H.) BD 353028 (R.H.)	340293 (L.H.) 353028 (R.H.)
302	—	—	—	336710 (L.H.) C 336709 (R.H.) C 336706 (L.H.) B 346222 (R.H.) B
427	353028 (R.H.) B 3914617 (L.H.) 353028 (R.H.) C	—	—	—

A. Exc. H/Per. Sp. H/Per.  
 B. w/A.T.  
 C. Exc. A.T.  
 D. w/H/Per., Sp. H/Per.

**FUEL—EXHAUST—CARBURETION**

**1970 EXHAUST MANIFOLD CHART**

*NOTE: See Dealer Price Schedule for applicable prices.*

ENGINE	PASSENGER	NOVA	CHEVELLE	CAMARO
4 cyl.	—	3977556	—	—
6 cyl.	328599	328599	328599	328599
307	—	336706 (L.H.) 346222 (R.H.)	336706 (L.H.) 346222 (R.H.)	336706 (L.H.) 346222 (R.H.)
350 w/2BC	3989055 (L.H.) 336711 (R.H.)	336706 (L.H.) 346222 (R.H.)	336706 (L.H.) 346222 (R.H.)	336706 (L.H.) A 346222 (R.H.)
350 w/4BC	3989055 (L.H.) 336711 (R.H.)	336706 (L.H.) 346222 (R.H.)	336706 (L.H.) 346222 (R.H.)	336706 (L.H.) A 346222 (R.H.) A 336710 (L.H.) B 336709 (R.H.) B
—	—	340293 (L.H.) A 340293 (L.H.) B	340293 (L.H.) A 353028 (R.H.) 340293 (L.H.)	340293 (L.H.) 353028 (R.H.)
400 w/2BC	3989055 (L.H.) 336711 (R.H.)	—	336706 (L.H.) 353028 (R.H.)	—
400 w/4BC	—	—	340293 (L.H.) 353028 (R.H.)	—
454 (exc. H/Per., Sp. H/Per.)	3914617 (L.H.) 353028 (R.H.)	—	353028 (R.H.) 340293 (L.H.)	—
454 H/Per.	3914617 (L.H.) 353028 (R.H.)	—	353028 (R.H.) 340293 (L.H.)	—
454 Sp. H/Per.	—	—	340293 (L.H.) 353028 (R.H.)	340293 (L.H.) 353028 (R.H.)

**1971 EXHAUST MANIFOLD CHART**

*NOTE: See Dealer Price Schedule for applicable prices.*

ENGINE	PASS.	NOVA	CHEVELLE	CAMARO
6 cyl.	328599	328599	328599	328599
307	—	336706 (L.H.) 346222 (R.H.)	336706 (L.H.) 346222 (R.H.)	336706 (L.H.) 346222 (R.H.)
350 w/2BC	336706 (L.H.) 346222 (R.H.)	336706 (L.H.) 346222 (R.H.)	336706 (L.H.) 346222 (R.H.)	336706 (L.H.) 346222 (R.H.)
350 w/4BC	336706 (L.H.) 346222 (R.H.)	336706 (L.H.) 346222 (R.H.)	336706 (L.H.) 346222 (R.H.)	336706 (L.H.) A 346222 (R.H.) A 336710 (L.H.) B 336709 (R.H.) B
400 w/2BC	336706 (L.H.) 346222 (R.H.)	—	336706 (L.H.) 346222 (R.H.)	—
400 w/4BC	340293 (L.H.) 353028 (R.H.)	—	340293 (L.H.) 353028 (R.H.)	340293 (L.H.) 353028 (R.H.)
454 (exc. Sp. H/Per.)	340293 (L.H.) 353028 (R.H.)	—	340293 (L.H.) 353028 (R.H.)	—
454 Sp. H/Per.	—	—	340293 (L.H.) 353028 (R.H.)	—

A. Exc. Sp. H/Per.  
B. w/Sp. H/Per.

**FUEL—EXHAUST—CARBURETION**

**1972 EXHAUST MANIFOLD CHART**

ENGINE	PASS.	NOVA	CHEVELLE	CAMARO
6 Cyl.	328599	328599	328599	328599
307	—	336706 L.H. 346222 R.H.	336706 L.H. 346222 R.H.	336706 L.H. 346222 R.H.
350 w/2BC	336706 L.H. (C) 346222 R.H. 336710 L.H. (D)	336706 L.H. (C) 346222 R.H. 336710 L.H. (D)	336706 L.H. (C) 346222 R.H. 336710 L.H. (D)	336706 L.H. (C) 346222 R.H. 336710 L.H. (D)
350 w/4BC	336706 L.H. (C) 346222 R.H. 336710 L.H. (D)	336706 L.H. (C) 346222 R.H. 336710 L.H. (D)	336706 L.H. (C) 346222 R.H. 336710 L.H. (D)	336706 L.H. (C, A) 346222 R.H. (A) 336710 L.H. (A, D) 336709 R.H. (B) 336710 L.H. (B)
400 w/2BC	336706 L.H. (C) 346222 R.H. 336710 L.H. (D)	—	—	—
402	3989343 L.H.(C) 3989345 L.H.(D) 353028 R.H.	— —	3989343 L.H.(C) 3989345 L.H.(D) 353028 R.H.	3989343 L.H.(C) 3989345 L.H.(D) 353028 R.H.
454	3989310 R.H. (C) 353028 R.H. (D) 3989343 L.H.(C) 340293 L.H. (D) 353028 R.H.	—	3989310 R.H. (C) 353028 R.H. (D) 3989343 L.H.(C) 340293 L.H. (D) 353028 R.H.	353028 R.H.

A. exc. Sp. H/Per.  
 B. w/Sp. H/Per.  
 C. exc. NB2  
 D. w/NB2

**FUEL—EXHAUST—CARBURETION**

**1973 EXHAUST MANIFOLD CHART**

ENGINE	PASS.	NOVA	CHEVELLE	CAMARO
(250)	328599	328599	328599	328599
(307)	—	336710 (L.H.) 346222 (R.H.)	336710 (L.H.) 346222 (R.H.)	336710 (L.H.) 346222 (R.H.)
(350 w/2BC)	336710 (L.H.) 346222 (R.H.)	336710 (L.H.) 346222 (R.H.)	336710 (L.H.) 346222 (R.H.)	336710 (L.H.) 346222 (R.H.)
(350 w/4BC)	336710 (L.H.) 346222 (R.H.)	336710 (L.H.) 346222 (R.H.)	336710 (L.H.) 346222 (R.H.)	336710 (L.H.) 346222 (R.H.) (B) 336709 (R.H.) (A)
(400 w/2BC)	336710 (L.H.) 346222 (R.H.)	—	—	—
(454)	340293 (L.H.) D 353028(R.H.)D 343787(L.H.)C 353030(R.H.)C	— — — —	340293 (L.H.) 353028(R.H.) — —	— — — —

A-w/Sp. H/Per.  
B-exc. Sp. H/Per.  
C-Police  
D-exc. Police

**1974 EXHAUST MANIFOLD CHART**

ENGINE	PASS.	NOVA	CHEVELLE	CAMARO
250 350 w/2BC	336710-L.H. 346222 R.H.	328599 336710-L.H. 346222 R.H.	328599 336710-L.H. 346222 R.H.	328599 336710-L.H. 346222 R.H.
350 w/4BC	336710-L.H. 346222 R.H.	336710-L.H.* 346222 R.H. 346222 R.H. (F)	336710-L.H. 346222 R.H.	336710-L.H.* 346222 R.H. 346222 R.H. (F)
400 w/2BC	336710-L.H. 346222 R.H.		336710-L.H. 346222 R.H.	
400 w/4BC	336710-L.H.* 346222 R.H. 346222 R.H. (FG)		336710-L.H. 346222 R.H.	
454	333846-R.H. (CF) 340293-L.H. (D) 353028-R.H. (D) 353030-R.H. (CE) 3994045-L.H. (CF) 343787-L.H. (CE)		340293-L.H. 353028-R.H.	

\*It is necessary to plug A.I.R. holes with four (4) 1/4" 18 pipe plugs

A  
C Police  
D (exc. Police)  
E w/NB-2  
F (exc. NB-2)  
G Sta. Wag.  
H (exc. Sta. Wag.)

**1975 EXHAUST MANIFOLD CHART**

ENGINE	PASS.	NOVA	CHEVELLE	CAMARO
250	— —	352191(F) 348608(F)	352191(F) —	352191(F) —
262 w/2BC	— —	346222(R.H.) 336710(L.H.)	— —	— —
350 w/2BC	346222(R.H.) 336710(L.H.)	346222(R.H.) 336710(L.H.)	346222(R.H.) 336710(L.H.)	346222(R.H.) 336710(L.H.)



**FUEL—EXHAUST—CARBURETION**

<b>3.601 MANIFOLD, Engine Exhaust (Con't)</b>				
350 w/4BC	346222(R.H.) 336710(L.H.)	346222(R.H.) 336710(L.H.)	346222(R.H.) 336710(L.H.)	346222(R.H.) 336710(L.H.)
350 w/4BC Z-28	— —	— —	— —	346222(R.H.) 336710(L.H.)
400 w/4BC	346222(R.H.) 336710(L.H.)	— —	346222(R.H.) 336710(L.H.)	— —
454 w/4BC	357102(R.H.) (A, B) 340293(L.H.) (A, C) 340293(L.H.) (D, B) 353030(R.H.) (D, B) 343787(L.H.) (D)	— — — — —	357102(R.H.) 340293(L.H.)	— — — — —

- A. (exc. Police)
- B. (exc. A.I.R.)
- C. w/A.I.R.
- D. Police
- E. (exc. Integrated Cyl. Hd.)
- F. (w/Integrated Cyl. Hd.)

**VEGA— MONZA**

71-72	All (140)	333994	1	39.25	MANIFOLD
73-74	All (140)	329695	1	39.25	MANIFOLD
75	All (140)	343378	1	36.75	MANIFOLD
75	All (262)	354432	R.H.	39.25	MANIFOLD
75	All (262)	354433	L.H.	39.25	MANIFOLD
75	All (122)	360193	1	444.00	MANIFOLD

**3.602 BRACKET— BOLT— SHIELD— STUD, Manifold**

65	Pass. (396) (exc. Sp. H/Per., dual exh.)	3876556	2	2.00	exh. crossover pipe
75	Vega (122)	443899	16	.11	BOLT, exh. manifold
72	Nova w/NB2	6274352	1	2.65	SHIELD, underbody exhaust pipe
72	Pass. (exc. Sta. Wag.)	6270711	L.H.	4.55	SHIELD, left exhaust
72	Pass. (exc. Sta. Wag.)	6270712	R.H.	4.55	SHIELD, right exhaust
72	Camaro,				
73-74	Camaro w/Sp. H/Per. (350)	6274353	L.H.	3.05	SHIELD, left, underbody exhaust pipe
72	Camaro,				
73-74	Camaro w/Sp. H/Per. (350)	6274354	R.H.	5.70	SHIELD, right, underbody exhaust pipe
73-74	Police (454)	336774	1	2.00	SHIELD, exhaust manifold
74-75	Pass., Chevelle (454)	340288	1	2.30	SHIELD, exh. manifold heat.
75	Nova (8 cyl.)	345568	1	4.20	SHIELD, underbody exhaust pipe
75	Camaro	345578	R.H.	4.20	SHIELD, underbody exhaust pipe
75	Vega, Monza	3937247	L.H.	1.70	STUD (1.153)

**3.603 TUBE, Exhaust Manifold Choke Heat**

64	Chevelle w/4BC (exc. H/Per.),				
65	Pass. (8 cyl.) (exc. 283),				
65	Chevelle (327),				
66	Pass. w/4BC (283) (exc. A.I.R.),				
66	Chevy, Chevelle w/4BC (283)	3814026	1	1.50	

**3.604 LOCK, Exhaust Manifold Bolt**

64-65	Chevy, Chevelle (8 cyl.),				
65	Pass. w/Air Cond. (8 cyl.) (exc. 396, 409),				
66-70	All (283, 302, 307, 327, 350, 400),				
71	All (8 cyl.) (exc. 4BC),				
72-75	All (307, 350, 400)	3880844	4	.11	end bolt (2 <sup>7</sup> / <sub>16</sub> " ctr. to ctr. of holes) (w/locking tangs)
65	Pass. (409)	3736032	4	.12	end bolt
65-67	All (396, 427)	3860351	4	.12	end bolt

**3.609 PIPE— EXTENSION— MUFFLER ASSY., Engine to Muffler Exhaust**

NOTE Refer to group 3.701 for chart containing 1968-71 Exh. Pipes and Crossovers.

**PASSENGER**

65-66	(6 cyl.)	3863591	1	14.15	w/flange
65-66	(283) (exc. dual exh.)	3860260	1	25.50	

**FUEL—EXHAUST—CARBURETION**

**3.609 PIPE— EXTENSION— MUFFLER ASSY., Engine to Muffler Exhaust  
(Con't)**

65-66	(327) (exc. dual exh.)	3860261	L.H.	25.50	
65-66	(283, 327) (exc. dual exh. H/Per.)	3860262	1	12.90	crossover
65-66	w/dual exh. (283, 327)	3861807	L.H.	22.30	
65-66	w/dual exh. (283, 327)	3861808	R.H.	22.30	
65-67	(396) (exc. dual exh.)	3871109	1	20.30	
65-67	(396) (exc. dual exh.)	3882914	1	13.85	crossover
65-67	w/dual exh. (396), 66 w/H/Per. (427), 67 (427)	3866521	L.H.	15.60	
65-67	w/dual exh. (396), 66 w/H/Per. (427), 67 (427)	3866522	R.H.	15.60	
65-66	w/Sp. H/Per. (396, 427)	3866523	L.H.	15.90	
67	(6 cyl.)	3904261	1	14.45	(horizontal length 87 <sup>3</sup> / <sub>8</sub> " )
67	w/dual exh. (327)	3928293	L.H.	31.00	
67	w/dual exh. (327)	3910744	R.H.	31.00	
67	(327) (exc. dual exh.)	3976490	1	22.95	
67	(327) (exc. dual exh.)	3976509	1	31.25	crossover
67	(283)	3954691	1	28.75	crossover
67	(283)	3928289	1	14.35	

**CHEVY**

62-67	(6 cyl.)	3792274	1	12.90	(85 <sup>11</sup> / <sub>16</sub> " dev. length) (stamped 3792274)
62-67	(4 cyl.)	3792271	1	13.40	(83" dev. length) (stamped 3792271)
64	w/4BC	3792281	L.H.	17.45	
64-67	(283) (exc. 4BC)	3792276	1	8.15	(stamped 3792276)
64	w/4BC	3792282	R.H.	17.45	
64-67	(8 cyl.) (exc. H/Per., dual exh.)	3908340	1	13.55	exh. crossover
65	w/dual exh. (8 cyl.), 66 w/dual exh. (283, 327)	3886583	L.H.	23.90	
65-66	w/dual exh. (283, 327)	3872288	R.H.	23.05	
65-67	(327) (exc. dual exh.)	3872289	1	15.90	
67	w/dual exh.	3914818	R.H.	23.40	
67	w/dual exh.	3914817	L.H.	23.05	

*NOTE Refer to group 3.701 for chart containing 1968-71 Exh. Pipes.*

**CHEVELLE**

64	(8 cyl.) (exc. dual exh.), 65-66 w/2BC (8 cyl.), 67 (283, 327) (exc. dual exh., Sp. H/Per.)	3840876	1	10.55	(exhaust crossover)
64-67	(6 cyl.)	3849834	1	13.40	(exhaust)
64	(283) (exc. 4BC)	3849836	1	16.00	(exhaust)
64	w/4BC (exc. H/Per.)	3851353	L.H.	16.00	
64	w/4BC (exc. H/Per.)	3851354	R.H.	16.90	
64-65	w/H/Per. (327), 65-66 w/dual exh. 4BC, 66-67 w/Sp. H/Per. (327), 67 w/dual exh. (exc. Sta. Wag., El Camino, 396, Sp. H/Per.)	3909619	L.H.	25.25	
64-65	w/H/Per. (327), 65-67 w/dual exh. (exc. 396)	3930740	R.H.	23.05	
65-67	(396)	3930743	L.H.	24.70	
65-67	(396), 67 w/Sp. H/Per. (327)	3930744	R.H.	23.05	
65-67	(283) (exc. 4BC)	3869466	1	16.55	
65-67	(327) (exc. dual exh.)	3909617	1	23.40	

*NOTE Refer to group 3.701 for chart containing 1968-71 Exh. Pipes.*

**CAMARO**

67	(6 cyl.)	3892765	1	13.55	assy., frt. w/attaching flange
67	(6 cyl.)	3892766	1	9.75	rear
67	(327) (exc. dual exh.)	3916070	1	23.40	front
67	(327)	3983029	L.H.	9.90	rear
67	w/dual exh. (8 cyl.)	3983030	R.H.	9.65	rear
67	w/deep tone muffler (exc. 396)	3923571	L.H.	23.40	exh.
67	w/deep tone muffler (exc. 396)	3901334	R.H.	25.25	exhaust, front
67	w/deep tone muffler (396)	3923573	L.H.	30.75	exhaust, front
67	w/deep tone muffler (396)	3912596	R.H.	23.05	exhaust, front
67	w/dual exh. (350) (exc. deep tone muffler)	3934871	L.H.	23.90	exhaust
67	w/dual exh. (327, 350) (exc. deep tone muffler)	3909958	R.H.	25.25	exhaust

**FUEL—EXHAUST—CARBURETION**

**3.609 PIPE— EXTENSION— MUFFLER ASSY., Engine to Muffler Exhaust  
(Con't)**

67	(396) .....	3914847 L.H.	26.25	exhaust .....
67	(396) .....	3914848 R.H.	23.05	exhaust .....

*NOTE Refer to group 3.701 chart containing 1968-70 Exh. Pipes.*

**EXTENSION— MUFFLER ASSY., Engine to Muffler Exhaust**

62-70	All w/A.T.,			
71	All (exc. 4BC 400, 454),			
72	Pass. (8 cyl.) (exc. 4BC, NB2),			
72	Nova, Camaro (exc. 402, Sp. H/Per. 350) .....			left, .....
72	Camaro w/Sp. H/Per. (350) .....			right, .....
72	Chevelle (6 cyl.) (exc. NB2),			
72	Nova, Camaro (6 cyl.) .....	3748781 1	.41	(1 <sup>13</sup> / <sub>32</sub> " O.L. x 2" O.D.) (steel) .....
62-70	All,			
71-72	All (400, 402, 454) .....	3890689 A.R.	1.50	(1 <sup>13</sup> / <sub>32</sub> " O.L. x 2 <sup>1</sup> / <sub>2</sub> " O.D.) (steel) .....
62-70	All (exc. A.T.),			
72	Pass. w/NB2 (8 cyl.) (exc. 4BC) .			<b>EXTENSION, crossover, left, .....</b>
72	Chevelle w/NB2 (exc. 402, 454)	3890382 1	1.90	(1 <sup>13</sup> / <sub>32</sub> " O.L. x 2" O.D.) (stainless steel) .....
62-70	All .....	3890383 1	2.00	(2 <sup>3</sup> / <sub>8</sub> " O.L. x 2" O.D.) (stainless steel) .....
71	All (exc. 4BC 400, 454),			
72	Nova, Chevelle, Camaro (307, 350) (exc. Sp. H/Per.) .....			<b>EXTENSION, right, .....</b>
72	Camaro w/Sp. H/Per. (350) .....			left, .....
72	Pass. (350, 400) .....	3992363 1	.60	right .....
65-67	Chevelle w/dual exh. (396) (exc. El Camino) .....	335219 L.H.	31.25	<b>MUFFLER ASSY., w/exh. pipe— (3.701) ...</b>

**3.610 FLANGE, Exhaust Pipe Packing**

64-66	Chevelle (8 cyl.) (exc. H/Per., Sp. H/Per., dual exh., 283, 396),			
65-66	Pass. (283) (exc. O.D., A.I.R.),			
67	Pass., Chevelle (283, 327) (exc. dual exh.) .....	3734402 A.R.	.53	crossover pipe assy. .....
65	Pass. ....	3915125 1	2.25	(2 <sup>1</sup> / <sub>2</sub> " w/3 holes) .....

**3.611 PACKING— GASKET— RING, Exhaust Pipe**

62-71	All,			
72	Pass., Nova, Chevelle (exc. 402, 454, NB2, Sp. H/Per.) .....	6271611 A.R.	.61	exhaust pipe (2 <sup>1</sup> / <sub>32</sub> " I.D. x 2 <sup>1</sup> / <sub>2</sub> " O.D.) .....
65-66	Pass. ....	593606 A.R.	.40	(1 <sup>7</sup> / <sub>8</sub> " I.D. x 2 <sup>3</sup> / <sub>8</sub> " O.D. x <sup>5</sup> / <sub>8</sub> " thick) .....
65-69	Pass., Chevelle, Camaro,			
68-71	Chevy,			
70-71	Chevelle,			
71	Camaro,			
72	All (402, 454) .....	6271612 2	.40	exhaust pipe (2 <sup>17</sup> / <sub>32</sub> " I.D. x 3" O.D.) .....
64-69	Chevy, Chevelle, Camaro (8 cyl.) (exc. 396),			
65-66	Pass. (327, 427) (exc. Sp. H/Per.),			
67-69	Pass. (283, 307, 327, 350),			
69	Pass. (8 cyl.) (exc. 396, 427),			
70	Pass., Monte Carlo w/2BC (400),			
70	All (307, 350),			
71	Chevelle (454),			
71-72	Camaro w/Sp. H/Per. (350) .....	3946828 A.R.	.29	<b>GASKET, exh. manifold valve, exh. pipe to manifold spacer .....</b>
65-69	All (396, 409, 427) .....			<b>GASKET, outlet pipe flange, exhaust manifold valve, .....</b>
70	Pass., Monte Carlo (454) .....			exh. manifold spacer, .....
70	Camaro (454),			
70	Nova, Chevelle, Camaro w/4BC (396, 400),			
71	Pass. (454) .....	3981068 1	.29	<b>GASKET, exh. manifold valve .....</b>
72	Camaro w/4BC (402, 454) (exc. Sp. H/Per.) .....	3989379 1	.29	<b>GASKET (exh. pipe spacer) .....</b>
66-69	Pass., Chevelle,			
70	Chevelle,			
71	Chevelle, Camaro w/4BC (400, 454) (exc. Sp. H/Per.),			
71	Camaro,			
72	Pass., Chevelle w/NB2 (exc. 402, 454),			
72	Camaro w/Sp. H/Per. (350),			

**FUEL—EXHAUST—CARBURETION**

**3.611 PACKING— GASKET— RING; Exhaust Pipe (Con't)**

72	Camaro w/NB2,				
72	Nova (350),				
72	Nova, Camaro (6 cyl.)	3731062 A.R.	.63	RING, crossover pipe (2 1/2" O.D. x 2" I.D.) (cast iron)	
66-69	Pass., Chevelle,				
70-71	Chevelle,				
72	All (402, 454)	3768711 A.R.	1.20	RING, exh. pipe to manifold, sealing	

**3.613 STUD— LOCK— NUT— WASHER, Exhaust Pipe**

62-75	All	483543 A.R.	.11	exh. pipe and muffler, exh. crossover pipe to exh. manifold (3/8"— 16 x 16 x 2 3/16")— (3.275)	
62-71	All			exh. pipe and muffler, exh. crossover pipe to exh. manifold (3/8"— 16— 16 x 2 1/8")— (3.275),	
75	Monza (262)	A.R.		exhaust pipe,	
75	Chevelle, Pass. (454)	344996	3	exh. crossover frt. pipe	
75	All (6 cyl.)	355778	2	LOCK, exh. mfl. end bolt	
62-70	All	838780 A.R.	.16	NUT, exhaust pipe and muffler (3/8"— 16 x 3/8" thick) (brass)	
62-75	All	3829086 A.R.	.12	NUT, exh. pipe to exh. manifold (3/8"— 16) (zinc plated anti-seize coated)	
62-69	All	3754153 A.R.	.21	WASHER, exh. pipe to exh. manifold (3/8" I.D. x 3/4" O.D. x 1/8" thick)— (5.383)	

**3.616 HANGER ASSY.— CLAMP— DAMPENER— REINFORCEMENT— SUPPORT, Exhaust Pipe Support**

*NOTE Refer to group 3.701 Chart for 1968-71 Exhaust pipe Hanger Assemblies.*

67	Camaro	3930087	2	2.30	
71	Vega	3991377	1	1.85	
68-70	Chevelle (6 cyl.) (exc. A.T.),				
72	Chevelle (6 cyl.)	3926907	1	3.80	CLAMP, exh. pipe hanger
75	All (122)	1240745	1	1.35	CLAMP, exh. pipe (repl. 3857547)
74	Nova w/A.T. (6 cyl.)	488974	2	2.95	DAMPENER, exh. pipe
71-75	Pass. (Sta. Wag.)	1236947	2	.28	REINFORCEMENT, muffler and exhaust pipe
68	Chevy, Camaro	3930032	1	1.25	SUPPORT, hanger, R.H.
69	Chevy (exc. dual exh.)				SUPPORT, hanger,
70-71	Nova w/2BC (exc. dual exh.),				
72	Nova (exc. 4BC)	3953210	1	.87	SUPPORT, muff. and tail pipe hanger
69	Camaro (exc. dual exh.)	3953246	1	.71	SUPPORT, hanger
72-73	All w/A.T. (140)	325745	1	1.95	SUPPORT ASSY.
71-73	All w/2BC (140) (exc. A.T.),				
74	All (140) (exc. A.T.)	342674	1	1.55	SUPPORT ASSY.
75	All w/A.T. (140)	353937	1	2.05	SUPPORT ASSY., exhaust pipe
75	All (140) (exc. A.T.)	349514	1	2.10	SUPPORT ASSY., exhaust pipe

**3.640 THERMOSTAT— ACTUATOR— SOLENOID, Exhaust Manifold Heat Control Valve**

62-65	Chevy, Chevelle (exc. 6 cyl.),				
65	Pass. (6 cyl.)	838573	1	1.20	
65-72	All (6 cyl.),				
70-74	Chevy (4 cyl.)	3881831	1	1.30	
75	All (6 cyl.)	1996526	1	11.15	ACTUATOR, vacuum-w/rod
75	All (8 cyl.) (exc. Monza, 454)	1996523	1	11.75	ACTUATOR ASSY., w/rod, exh. heat
75	Monza (8 cyl.)	1996542	1	11.80	ACTUATOR ASSY., w/rod, exh. heat
75	All (454)	1996533	1	11.75	ACTUATOR ASSY., w/rod, exh. heat
75	All (6 cyl.)	1997449	1	10.45	SOLENOID, exh. heat valve
75	All (454)	1997446	1	10.45	SOLENOID, exh. heat valve

**3.641 SPRING— BRACKET— PIN, Manifold Heat Control Valve**

62-65	All (4 cyl., 6 cyl.),				
66-69	Chevy (4 cyl.)	602799	1	.53	rear, anti-rattle (1/4" wide stock— coiled)
63-65	All (4 cyl., 6 cyl.),				
66-69	Chevy (4 cyl.)	3792818	1	.16	front, anti-rattle
64-70	All (8 cyl.),				
71	Chevelle, Camaro w/Sp. H/Per. (350, 454),				
72	Chevelle (exc. 454),				
72-74	Camaro w/Sp. H/Per. (350)	3746600	1	.24	anti-rattle
66-74	All (6 cyl.),				
70	Nova (4 cyl.),				
75	Nova (6 cyl.) (exc. integrated cyl. hd.)	3895015	1	.11	exh. mfl. valve stop
75	All (454)	354428	1	1.60	BRACKET, exhaust heat valve-actr.

**FUEL—EXHAUST—CARBURETION**

**3.641 SPRING— BRACKET— PIN, Manifold Heat Control Valve (Con't)**

75	All (8 cyl.) (exc. 262, 454) . . . . .	343770	1	1.60	BRACKET, heat valve actuator . . . . .
75	All (262) . . . . .	355959	1	1.60	BRACKET, heat valve actuator . . . . .

**3.647 VALVE ASSY.— BUSHING— PIPE— SPACER, Exhaust Manifold**

64-67	Chevy (8 cyl.),				
66	Chevelle (A.I.R. w/Sp. H/Per.) (327) . . . . .	3887022	1	8.15	
64-69	Chevelle, Camaro (283, 302, 307, 327, 350),				
68	Chevy (8 cyl.) (exc. Sp. H/Per. 327, 396),				
69	Chevy, Chevelle, Camaro (exc. 396),				
70	Nova, Chevelle, Camaro (307, 350),				
70	Monte Carlo w/2BC (400),				
71-75	Camaro w/Sp. H/Per. (350),				
72	Chevelle (exc. 454) . . . . .	3887023	1	9.75	
65-69	Pass. (283, 307, 327, 350),				
70	Pass. (8 cyl.) (exc. 454),				
71	Chevelle w/Sp. H/Per. (454) . . .	3887024	1	9.15	
65-68	Pass. (396, 409, 427) . . . . .	3887034	1	11.45	
65-70	Chevy, Chevelle, Camaro (396),				
69-70	Pass. (396, 427),				
70	Chevelle, Camaro w/4BC (400, 454) . . . . .	3969903	1	10.00	
75	Pass., Chevelle (454) . . . . .	343742	1	16.15	exh. heat . . . . .
75	All (6 cyl.) . . . . .	343368	1	24.80	exhaust manifold heat . . . . .
75	Chevelle, Camaro, Nova, Monza, Vega (8 cyl.) (exc. 454) . . . . .	355915	1	15.75	exhaust heat . . . . .
64-71	All (4 cyl., 6 cyl.),				
66	Pass., Chevelle (396, 427),				
70	Nova, Chevelle, Camaro w/4BC (396, 400, 454),				
72-74	All (6 cyl.),				
75	Nova (6 cyl.) (exc. integrated cyl. hd.) . . . . .	3848282	2	.22	BUSHING, exh. mfl'd. valve shaft . . . . .
66	Pass., Chevelle w/A.I.R. (283, 327),				
67	Pass. (283, 327),				
67-69	Chevy, Chevelle, Camaro (8 cyl.) (exc. 396),				
70	All (307, 350),				
70	Pass., Monte Carlo w/2BC (400),				
71	Chevelle, Camaro w/Sp. H/Per. (350, 454),				
72	Chevelle (exc. 454),				
72-74	Camaro w/Sp. H/Per. (350) . . . . .	3887032	1	.24	BUSHING, exh. manifold valve shaft . . . . .
66	Pass. (283, 327) (exc. Sp. H/Per.) . . . . .	3877484	4	1.05	PIPE, center and end . . . . .
66	Pass. (327, 396, 427) (exc. Sp. H/Per.) . . . . .	3880887	1	.48	PIPE . . . . .
70	Pass., Monte Carlo (454) . . . . .	3845304	1	6.20	SPACER, exh. pipe . . . . .
71-72	Chevelle, Camaro w/4BC (400, 402, 454) . . . . .	3989380	1	3.80	SPACER, exh. pipe . . . . .

**3.650 PULLEY— VALVE ASSY., Air Injection Reactor**

66-67	Pass. (exc. 283, 327, Air Cond.),				
66	Chevy (8 cyl.),				
66	Chevelle (6 cyl.),				
66-67	Chevelle (396) (exc. Air Cond., Sp. H/Per.),				
67	Chevy, Chevelle, Camaro (6 cyl.),				
67	Camaro (302, 396) . . . . .	3880800	1	7.85	
66-67	All (283, 327, 350) (exc. Air Cond.) . . . . .	3881885	1	4.05	
68	Chevy, Camaro (396) (exc. Sp. H/Per., C.A.C.) . . . . .	3917234	1	5.90	(3 hole atch.) . . . . .
68	All (307, 327, 350),				
68	All w/C.A.C. (8 cyl.) (exc. A.T.),				
68	Chevelle (S.S.) w/C.A.C. . . . .	3917238	1	1.75	
68	All w/Sp. H/Per. (396, 427) . . . .	3925522	1	4.40	pump (3 hole attachment) . . . . .
68-69	Pass. (exc. C.A.C., A.T., 427 Sp. H/Per.),				

**FUEL—EXHAUST—CARBURETION**

**3.650 PULLEY— VALVE ASSY., Air Injection Reactor (Con't)**

68	Chevy, Chevelle, Camaro (exc. A.T., C.A.C. 396),				
69	Chevy (exc. P.G., 396),				
69	Camaro (exc. P.G., Sp. H/Per. 396),				
70	Nova (4 cyl.),				
72-75	All w/NB2 (exc. Vega)	3927116	1	.92	pump
69-70	All w/Sp. H/Per. (302, 350, 396, 427, 454),				
72-74	Camaro w/Sp. H/Per. (350)	3932458	1	1.75	
72-75	Vega	6270081	1	1.95	
73	All (exc. Sp. H/Per. 350),				
75	All	6270081	1	1.95	(5.17" O.D.)
75	All w/C.A.C. (140)	354605	1	1.95	
73	Camaro w/Sp. H/Per. (350)	3887023	1	9.75	VALVE ASSY., exh. manifold

**3.655 BRACE— BOLT— BRACKET— NUT— SPACER, Air Injection Reactor Pump Mounting**

66	Pass. (283, 327),				
66	Chevy, Chevelle (283, 327) (exc. Sp. H/Per., Air Cond.),				
67	Pass. (396, 427) (exc. Sp. H/Per.),				
67	Chevy (8 cyl.) (exc. C.A.C.)	3900432	1	.73	adjusting
66-67	All (6 cyl.) (exc. P.S.)	3998341	1	1.70	adjusting— (2.317)
67	Camaro w/P/S (6 cyl.),				
68-69	All w/P/S (6 cyl.) (exc. A.T.)	3901803	1	1.10	
67	Chevelle, Camaro (283, 327, 350),				
68	All (307, 327, 350) (exc. A.T.)	3951340	1	1.05	
68	Pass. (396, 427) (exc. Sp. H/Per., A.T.),				
68	Chevy, Chevelle, Camaro (396)	3917230	1	.73	
68-69	All (4 cyl., 6 cyl.) (exc. A.T., P/S),				
70	Nova (4 cyl.)	3918950	1	1.15	pump and generator
68-69	All w/P/S (6 cyl.) (exc. A.T.)	3918962	1	.85	pump, adjusting
72	All w/NB2 (6 cyl.)	3998150	1	1.55	air inj. pump
73-74	All (6 cyl.)	329664	1	1.55	air inj. pump
75	All (6 cyl.) (exc. C.A.C.)	354564	1	3.20	air inj. pump
75	All w/C.A.C. (6 cyl.)	355726	1	.99	air inj. pump
66-69	All	3877606	1	.28	BOLT (3/8" — 16 x 5 1/4")
66-67	Pass., Chevy, Chevelle w/P/S (6 cyl.)	3877432	1	14.50	BRACKET, pump
66-68	All (283, 302, 307, 327, 350)	3917642	1	7.05	BRACKET, pump
67	Camaro (396),				
67	Chevelle w/Sp. H/Per. (396)	3882831	1	12.75	BRACKET, pump
67	All (283, 302, 327, 350)	3919806	1	4.20	BRACKET, air inj. pump a/cl.
68-69	All (4 cyl., 6 cyl.) (exc. A.T., P/S),				
70	Nova (4 cyl.)	3918948	1	3.45	BRACKET, pump
68-69	All w/P/S (6 cyl.) (exc. A.T.)	3918960	1	13.55	BRACKET, pump
69	All (396, 427) (exc. A.T.),				
70-71	All w/Sp. H/Per. (396, 454),				
72-75	All (402, 454)	6272780	1	2.85	BRACKET
69	Chevy, Chevelle, Camaro (8 cyl.) (exc. 396),				
69	Pass. (327, 350) (exc. A.T.),				
70-72	Camaro w/Sp. H/Per. (350),				
72	All w/NB2 (8 cyl.)	354311	1	4.75	BRACKET, pump (repl. 3956674)
72	Vega	6270083	1	15.45	BRACKET, pump
73	All (6 cyl.)	328579	1	4.25	BRACKET, air inj. pump
73-74	All (8 cyl.) (exc. 454)	354311	1	4.75	BRACKET, pump (repl. 3956674)
75	All (6 cyl.) (C.A.C.)	355727	1	5.10	BRACKET, air injection pump
75	Nova, Camaro (C.A.C.) (6 cyl.)	352192	1	.66	BRACKET
75	All w/C.A.C. (6 cyl.)	355728	1	4.05	BRACKET, air inj. pump adjust.
75	All (8 cyl.) (exc. Monza, 454)	354311	1	4.75	BRACKET, air inj. pump
75	All (454)	355976	1	7.05	BRACKET, air inj. pump
75	All (2BC w/NB-2) (140),				
75	All w/NB-2 (262)	354363	1	6.35	BRACKET, air inj. pump
75	All (262, 350) (exc. C.A.C.)	354388	1	2.75	BRACKET, rear
75	All (262, 350) (exc. C.A.C.)	354364	1	3.95	BRACKET, front
66-69	All	9422297	1	.17	NUT, pump (3/8" — 16) — (3.706)
66-69	All (283, 302, 307, 327, 350)	3877600	1	.12	SPACER (13/32" I.D. x 21/32" O.D. x 1/2" long)
69	All (8 cyl.) (exc. A.T.),				
70-71	All w/Sp. H/Per. (350, 396, 454),				

**FUEL—EXHAUST—CARBURETION**

**3.655 BRACE— BOLT— BRACKET— NUT— SPACER, Air Injection Reactor Pump Mounting (Con't)**

71-73	Vega w/P.S.,				
72	All (8 cyl.),				
73	All,				
74-75	Pass. (454),				
75	Vega, Monza w/P.S. ....	3955204	1	.35	SPACER .....
75	All w/C.A.C. (6 cyl.) .....	355729	1	.40	SPACER, air inj. pump adj. brkt. ....

**3.660 PUMP ASSY., Air Injection Reactor Pump**

66	Chevy (327) (exc. Air Cond.),				
66	Pass., Chevy, Chevelle w/P/S (6 cyl.),				
66-67	Chevy, Chevelle (283) (exc. Air Cond.),				
66-67	Pass. (8 cyl.) (exc. 327),				
67	Camaro w/2BC (327),				
67	Chevelle (283) .....	5696104	1	61.25	
66-67	Pass., Chevelle, Camaro w/4BC (327, 350) .....	5696468	1	66.75	
66	All (6 cyl.) (exc. P/S) .....	5697628	1	61.25	
66-67	Chevy w/Air Cond. (8 cyl.) .....	5697527	1	66.75	
67	Camaro (396) .....	7800308	1	66.75	
67	All (6 cyl.) (exc. P/S) .....	7800306	1	58.00	
67	All w/P/S (6 cyl.) .....	7800307	1	58.00	
66	Chevy (exc. 327),				
66-67	Pass., Chevelle (exc. 327),				
67	Chevy (8 cyl.),				
67	Camaro w/2BC (327),				
70-71	All .....	7806686	1	60.00	
72-75	All (8 cyl.) .....	7817809	1	68.50	(repl. 7803948) .....
72	All (6 cyl.) .....	7817807	1	65.25	(repl. 7817574) .....
72	Vega,				
73	All (250) .....	7817815	1	53.00	
73-75	All (6 cyl.),				
74	Pass. (exc. Sta. Wag.) .....	7817809	1	68.50	(repl. 7817575) .....
74	Pass. (Sta. Wag.) (400-4BC) .....	7817809	1	68.50	(repl. 7817575) .....
75	Vega, Monza .....	7817807	1	65.25	
68	All,				
69	Pass.,				
69	Chevy, Chevelle, Camaro (exc. A.T.),				

**3.665 BEARING— BRACKET— FAN— GREASE— SCREW— SEAL— SHOE— SPRING— VANE, Air Injection Reactor Pump**

66-67	All .....	5696030	1	8.15	housing rot. rr. ....
75	HV w/2BC (140) .....	6270083	1	15.45	BRACKET, air injector pump .....
75	H (262, 350) .....	354363	1	6.35	BRACKET, air injector pump .....
68	All,				
72	Vega .....	7813409	1	2.45	FAN (centrifugal filter) .....
66-67	All .....	1050525	1	1.30	GREASE (2 oz. container)— (8.800) .....
66-67	All .....	5697026	6	.78	SCREW, housing rot. end plate .....
66-67	All .....	7801092	1	1.75	SEAL, rear housing .....
66-67	All .....	5695846	6	1.15	SHOE, vane .....
66-67	All .....	5695845	3	.74	SPRING, vane shoe .....
66-67	All .....	5696594	1	12.00	VANE, w/bearing (symmetrical type) .....
66-67	All .....	5696599	2	12.00	VANE, w/bearing (offset type) .....

**3.670 VALVE ASSY., Fuel Mixture Control**

66-67	Pass. (283),				
66-67	Chevy, Chevelle, Camaro w/2BC	7033545	1	11.70	fuel mixture control .....
66-67	All (6 cyl.) .....	7027093	1	11.70	fuel mixture control .....
66	All (327),				
67	All (283, 327, 350) (exc. 2BC 327) .....	7033546	1	11.70	fuel mixture control .....
66	Chevelle (396),				
66-67	Pass. (396, 427),				
67	Chevelle, Camaro (396) (exc. H/Per.) .....	7033547	1	11.70	fuel mixture control .....
66-67	All .....	5696639	1	2.60	pump relief .....

**3.670 VALVE ASSY., Air Injection Reactor Diverter**

68	Pass. (327) (exc. A.T.),				
68	Chevy, Chevelle, Camaro w/4BC (327, 350) .....	7036452	1	17.15	relief valve div. (stamped 35004) .....

**FUEL—EXHAUST—CARBURETION**

**3.670 VALVE ASSY., Air Injection Reactor Diverter (Con't)**

68	Biscayne, Bel Air (307) (exc. P.G.),				
68	Chevy, Chevelle, Camaro w/2BC (307, 327) (exc. Malibu, Concourse)	7036451	1	16.15	relief valve div. (stamped 35002)
68	Pass. (396, 427) (exc. A.T.),				
68	Chevelle (exc. A.T., H/Per., Sp. H/Per.),				
68	Camaro (302, 396)	7803286	1	2.75	pump relief
68	Impala, Caprice (307) (exc. A.T.),				
68	Malibu, Concourse (307) (exc. P.G.)	7036453	1	17.15	relief div. (stamped 35005)
68	Chevy (4 cyl.)	7036444	1	15.30	diverter (stamped 28095)
68	All w/Sp. H/Per. (327),				
68	Camaro (302)	7036449	1	15.30	diverter (stamped 28469)
68	All (6 cyl.) (exc. P.G.)	7036450	1	16.15	relief valve div. (stamped 35001)
68	Pass. (396, 427) (exc. A.T.),				
68	Chevy, Chevelle, Camaro (396)	7036448	1	15.30	relief valve div. (stamped 28299)
69-70	Chevy (4 cyl.)	7029290	1	14.45	relief div.
69	Pass. (6 cyl.) (exc. A.T.),				
69	Chevy, Chevelle, Camaro (6 cyl.)	7029198	1	15.30	diverter
69	Pass. (396, 427) (exc. A.T.),				
69	Chevy, Chevelle, Camaro (396),				
70	Nova, Chevelle, Camaro w/Sp. H/Per. (396, 454),				
71	Chevelle w/Sp. H/Per. (454),				
72	All (402, 454)	7029297	1	15.30	diverter
69	All (302, 350) (exc. A.T.),				
70-72	Camaro w/Sp. H/Per. (350),				
72	All w/NB-2 (8 cyl.) (exc. 402, 454),				
73-74	All (8 cyl.) (exc. 454)	7029295	1	15.30	diverter
69	All (307, 327) (exc. A.T.)	7029293	1	15.30	diverter
72-74	All (6 cyl.) (exc. Vega)	7045625	1	15.30	diverter
72	Vega	17052771	1	13.85	diverter (repl. 7046171)
74	Chevelle, Camaro, Nova (6 cyl.)	7040349	1	12.30	diverter
75	All (6 cyl.) (exc. Vega, Monza)	7043229	1	14.00	diverter (Calif.)
75	Chevelle (454)	7046328	1	15.30	diverter
75	All (350) w/2BC (exc. Vega, Monza),				
75	Nova (262),				
75	Nova, Camaro (350) w/4BC	7043427	1	13.15	diverter
75	Vega, Monza w/2BC, 140 (exc. C.A.C.)	7030884	1	12.30	diverter
75	Monza w/262, A.I.R.	7043372	1	14.00	diverter
75	Vega, Monza w/2BC, 140, C.A.C.	7030885	1	12.70	diverter
75	Monza (Hatchback) (262, 350)	17052263	1	14.00	diverter
75	Pass. (V8)	7040150	1	11.15	diverter
73-75	Chevelle (454),				
73-75	Pass. (454)	17052768	1	13.85	KIT, diverter valve

**3.670 VALVE ASSY., Air Injection Reactor Check**

66-67	All	5354987	L.H.	3.95	check
66-67	All Pass. (8 cyl.),				
67	All (6 cyl.)	5354988	R.H.	4.95	check
68-70	All,				
71	Chevelle, Camaro w/Sp. H/Per. (350, 454),				
72	Nova,				
72	All (402, 454),				
72	Camaro w/Sp. H/Per. (350),				
73-74	All (8 cyl.),				
75	Nova, Chevelle (6 cyl.),				
75	All (8 cyl.)	4974265	1	4.80	air inj. check
75	Vega	4993435	4		pulsair check valve
75	Vega, Monza (140)	4974196	1	5.25	check
75	All (350) w/2BC,				
75	All (454)	5361992	A.R.	4.80	air inj. check
75	All (8 cyl.)	497853	1	1.40	(E.F.E.) vac. check

**3.670 VALVE ASSY., Exhaust Gas Recirculation**

73	All (250) (exc. Vega)	17051807	1	18.05	(E.G.R.)
73	Pass. (Sta. Wag.) (400),				



**FUEL—EXHAUST—CARBURETION**

**3.670 VALVE ASSY., Exhaust Gas Recirculation (Con't)**

73	All (A.T. w/2BC) (350) (exc. Vega),				
74	All w/A.T. (350) (exc. Sp. H/Per., Vega)	7040437	1	16.85	(E.G.R.)
73	All w/2BC (350) (exc. A.T., Vega)	7040042	1	16.85	(E.G.R.)
73-74	Camaro w/Sp. H/Per. (350) (exc. A.T.)	7040299	1	16.85	(E.G.R.)
73	Camaro (A.T. w/Sp. H/Per.) (350)	7047065	1	16.85	(E.G.R.)
73	All w/4BC (350) (exc. A.T., Vega)	7040318	1	16.85	(E.G.R.)
73	All (307),				
74	Nova, Chevelle (3-Spd. w/2BC) (350)	7035170	1	16.85	(E.G.R.)
73	Pass. w/2BC (400) (exc. Sta. Wag.),				
73	All (A.T. w/4BC (350) (exc. Sp. H/Per., Vega),				
74	Pass.,				
74	Chevelle w/2BC (400)	7035172	1	16.85	(E.G.R.)
73	All (454) (exc. Vega)	7047066	1	16.85	(E.G.R.)
73	All w/3-Spd. (6 cyl.) (exc. Vega)	17051809	1		(E.G.R.)
73-74	All w/A.T. (6 cyl.) (exc. Vega)	17051807	1	18.05	(E.G.R.) (repl. 7035169)
73	Vega w/2BC (exc. A.T.)	7046498	1	16.85	(E.G.R.)
73	Vega w/2BC, A.T.	7030880	1	16.85	(E.G.R.)
73	Vega w/1BC (exc. A.T.),				
74	Vega w/1BC, 140 (exc. NB-2, A.T.)	17051876	1	18.05	(E.G.R.)
73	Vega w/1BC, A.T.,				
74	Vega w/1BC, 140, NB-2, A.T.	7049875	1	16.85	(E.G.R.)
74	Nova, Chevelle, Camaro w/4BC (350) (exc. A.T.)	7040599	1	16.85	(E.G.R.)
74	All (6 cyl.) (exc. A.T., Vega)	7043042	1	16.85	(E.G.R.)
74	Nova, Camaro w/4BC (350) (exc. NB-2, Sp. H/Per.)	7041409	1	16.85	(E.G.R.) (Federal)
74	Pass., Chevelle (4BC w/NB-2) (400)	17051840	1	18.05	(E.G.R.) (Calif.)
74	Pass. (454),				
74	Chevelle w/T.H. 400 (454) (exc. NB-2)	7049867	1	16.85	(E.G.R.) (Federal)
74	Vega w/1BC (140) NB-2, M.T.,				
74	Vega w/1BC (140) A.T. (exc. NB-2)	17051875	1	18.05	(E.G.R.) (Federal)
74-75	Vega, Monza w/2BC (140) (exc. A.T.)	17051860	1	18.05	(E.G.R.)
74-75	Vega, Monza w/2BC (140) A.T., NB-2	7043279	1	18.35	(E.G.R.) (Calif.)
74-75	Vega, Monza w/2BC (140) A.T. (exc. NB-2)	7048270	1	17.85	(E.G.R.) (Federal)
74-75	Vega, Monza w/2BC (140) M.T.	17051860	1	18.05	(E.G.R.)
74	Vega w/1BC (140)	7049873	1	16.85	(E.G.R.)
75	All A.T. (6 cyl.) (exc. Vega, Monza)	17052663	1	18.05	(E.G.R.)
75	Chevelle w/T.H. 400 (454) (exc. NB-2)	370721	1	8.20	(E.G.R.) (Federal)
75	All w/NB-2 (400) (exc. Vega, Monza)	17052703	1	30.65	(E.G.R.) (Calif.)
75	All A.T. w/NB-2 (6 cyl.) (exc. Vega, Monza)	17052664	1	18.05	(E.G.R.) (Calif.)
75	Chevelle (400) (exc. NB-2)	17052670	1	18.05	(E.G.R.) (Federal)
75	All (2BC w/3-Spd.) (350) (exc. Pass.)	17052669	1	18.05	(E.G.R.)
75	Camaro, Nova w/3-Spd. (6 cyl.) (exc. A.I.R.)	17052668	1	18.05	(E.G.R.)
75	Monza (Hatchback) w/4-Spd. (262) NB-2				(E.G.R.) (Calif.)
75	Camaro, Nova (A.T. w/2BC) (350),				
75	Camaro, Nova w/NB-2 (A.T. w/4BC) (350)				(E.G.R.) (Calif.)
75	Pass. (Sta. Wag.) (400) (exc. NB-2)	17052671	1	18.05	(E.G.R.) (Federal)
75	Chevelle (350) (A.T. w/2BC) (exc. Sta. Wag.),				

**FUEL—EXHAUST—CARBURETION**

**3.670 VALVE ASSY., Exhaust Gas Recirculation (Con't)**

75	Pass. w/2BC (350) .....	17052693	1	18.05	(E.G.R.) .....
75	Pass. (350) w/4BC (exc. Sta. Wag.),				
75	Chevelle (Sta. Wag.) (350) w/4BC .....	17052716	1	30.65	(E.G.R.) .....
75	All (A.T. w/A.I.R.) (6 cyl.) (exc. NB-2, Vega, Monza) .....	17052702	1	18.05	(E.G.R.) (Federal) .....
75	Chevelle, Camaro, Nova w/A.T. (6 cyl.) (exc. A.I.R., NB-2) .....	7043058	1		(E.G.R.) (Federal) .....
75	All (262) .....	17052660	1		(E.G.R.) .....
75	Vega, Monza (262),				
75	Nova (262) (exc. A.T.) .....	17052749	1	18.05	(E.G.R.) .....
75	Pass., Chevelle (454) .....	17052700	1	18.05	(E.G.R.) .....
75	Nova w/A.T. (262) .....	17052742	1	18.05	(E.G.R.) .....
75	Chevelle (400) w/NB-2,				
75	Police (400) w/NB-2 (exc. Sta. Wag.) .....	17052704	1	18.05	(E.G.R.) (Calif.) .....
75	Monza (Hatchback) w/4-Spd., NB-2, 140 .....	17052682	1	18.05	(E.G.R.) (Calif.) .....
75	Vega, Monza w/1BC, A.T. .....	17052672	1	18.05	(E.G.R.) .....
75	Vega, Monza w/1BC (exc. A.T.) .....	17052673	1	18.05	(E.G.R.) .....
75	Vega, Monza w/2BC (262, 350) .....	3031549	1	9.35	(E.G.R.) .....
75	Vega, Monza (140) (exc. A.T., NB-2) .....	17052680	1	18.05	(E.G.R.) (Federal) .....
75	Vega, Monza (140) w/2BC, A.T., (NB-2) .....	17052681	1	18.05	(E.G.R.) (Calif.) .....
75	Vega, Monza (350) w/2BC, NB-2 .....	17052693	1	18.05	(E.G.R.) (Calif.) .....

**3.670 BRACKET—CAP—GASKET—GROMMET—LOCK—PLUG—STRAP—SWITCH, Air Injection Reactor Valve**

75	Monza (262, 350) .....	357018	1	14.70	BRACKET, diverter valve .....
69	Pass. (427) (exc. T.H. 400, Sp. H/Per.),				
70	Nova (4 cyl.) .....	3928101	1	.17	CAP, diverter valve sig. hose— (3.734) .....
75	All (6 cyl.) .....	354403	1	.95	GASKET, (E.G.R. valve) .....
67	All (6 cyl.) .....	3901808	1	.12	GROMMET, cont. valve .....
73-74	All (exc. Vega) .....	3855524	1	.11	LOCK, E.G.R. valve— (5.425) .....
66-68	Pass. (327, 396, 427),				
66-67	All (327, 350, 396),				
68	Camaro (302),				
68	All w/Sp. H/Per. (327),				
68	All (396) (2nd design) .....	7801659	1	.68	PLUG, pressure setting (black) .....
66-67	Pass. (283),				
66-67	Chevy, Chevelle, Camaro (exc. 327, 396),				
68	Pass. (396) (exc. A.T.),				
68	Chevy, Chevelle, Camaro (396) (1st design) .....	7801660	1	.68	PLUG, pump pressure setting (green) .....
67	Chevy, Chevelle, Camaro (6 cyl.),				
68	Chevy (4 cyl.) .....	7801662	1	.74	PLUG, pressure setting (blue) .....
68	All (307, 327, 350) (exc. A.T.) ..	7801663	1	.40	PLUG, pressure setting (red) .....
74	All,				
75	All (140, 250, 454) .....	370721	1	8.20	SWITCH, E.G.R. (1/2" w/dry seal)— (1.150) ..
75	All (8 cyl.) (exc. 454) .....	3031385	1	8.40	SWITCH ASSY. (E.G.R.) (3/8"— 18 x 50") ..

**3.672 SILENCER ASSY.—AIR CLEANER—ELEMENT, Air Injection Reactor**

66-67	All (exc. 4 cyl.) .....				air injector pump, .....
68	All .....	1492575	1	2.25	by-pass valve, diverter valve, relief diverter valve (Note 1) .....
<i>NOTE 1 It may be necessary to use Tube 7035403 for proper fit of muffler and valve.</i>					
69	Pass., Chevy .....	3938790	1	2.10	air injector pump .....
66-67	All (194, 230, 250, 283, 327) (exc. Sp. H/Per.) .....	6422732	1	6.10	AIR CLEANER, w/silencer .....
66-67	All (194, 230, 250, 283, 327) (exc. Sp. H/Per.) .....	6422750	1	3.34	ELEMENT, a/cl. w/silencer .....

**3.675 HOSE—ADAPTER—CLIP—CONNECTOR—EXTENSION—PIPE—TUBE—RETAINER, Air Injection Reactor**

66-67	Pass., Chevelle (327),				
67	Camaro w/4BC (327, 350) .....	3877612	1	1.90	pump inlet .....
66	Pass. (283),				
66	Chevy, Chevelle (283) (exc. 4BC),				
67	Chevy (327),				

**FUEL—EXHAUST—CARBURETION**

**3.675 HOSE— ADAPTER— CLIP— CONNECTOR— EXTENSION— PIPE— TUBE—  
RETAINER, Air Injection Reactor (Con't)**

67	Camaro (396)	3909889	1	2.35	injection pump inlet
66-67	Pass., Chevelle (396, 427)	3902346	1	2.45	pump to a/cl.
66	Pass. (8 cyl.) (exc. 396, 427)	3884657	1	2.70	pump outlet (L.H.)
66-67	Pass. (283, 327)	3884658	1	1.80	pump outlet (R.H.)
66-67	Chevy, Chevelle w/Sp. H/Per. (327),				
66-67	All (396, 427),				
67	Camaro (302)	3902340	1	2.70	pump outlet (R.H.)
66	All w/4BC (283)	3884655	1	1.90	pump inlet
66-67	Pass. (396, 427),				
66-67	Chevy, Chevelle, Camaro (396) (exc. H/Per., Sp. H/Per.)	3889354	1	2.70	fuel mixture control valve to check vlv.
67	All (8 cyl.) (exc. 396, 427),				
68	All (8 cyl.) (exc. A.T., 396, 427)	3911029	1	3.25	pump to check valve, pump to outlet (L.H.) (Note 1)
66-67	Pass. (283, 327),				
66-67	All (8 cyl.) (exc. 302, Sp. H/Per. 327, 396)	3891387	1	2.85	fuel mixture cont. valve to check valve
66-67	Chevelle (283, 327) (exc. Sp. H/Per.),				
67	Camaro (8 cyl.) (exc. 302, 396)	3890442	1	2.45	pump outlet R.H.
66-67	Chevy (8 cyl.) (exc. Sp. H/Per.),				
66	Chevelle w/Sp. H/Per. (327)	8884503	R.H.	1.45	pump outlet
66	Chevy, Chevelle (283, 327)	3890441	L.H.	2.70	pump outlet
66-67	Pass. (283, 327),				
66-67	Chevy, Chevelle, Camaro (283, 327, 350) (exc. Sp. H/Per.)	3890404	1	1.90	fuel mixture cont. valve by-pass.
67	Chevy, Chevelle w/Sp. H/Per. (327),				
67	Camaro (396)	3889356	1	2.45	injection pump outlet
67	Pass. (6 cyl.) (exc. P/S),				
68-69	All w/P/S (6 cyl.) (exc. A.T.)	3918964	1	2.20	diverter to check valve (5/8" I.D.)
68-69	All (6 cyl.) (exc. P/S, A.T.)	3918958	1	1.80	diverter to check valve (5/8" I.D.)
68	Pass. (396, 427) (exc. A.T.),				
68	Chevy, Chevelle, Camaro (396)	3951457	1	7.80	diverter to check valve R.H.
68	Pass. (396, 427) (exc. A.T.),				
68	Chevy, Chevelle, Camaro (396)	3917249	1	3.10	diverter to check valve L.H.
68	Chevy, Chevelle, Camaro (6 cyl.)	3905067	1	4.05	pump to check valve
73-75	All (140)	3943638	1	1.70	valve E.G.R.
75	Monza (262)	357033	1	1.65	air inj. check
75	Monza (262)	357048	1		exhaust emission control
75	Nova w/A.I.R. (262)	360448	1	2.40	diverter valve
75	Camaro (6 cyl.) w/C.A.C.	354314	1	1.65	air diverter valve to check valve
75	Pass., Chevelle w/A.I.R. (454)	357101	1	2.75	diverter valve
75	All (454) w/A.I.R.	357101	1	2.75	air inj. diverter valve
75	All (8 cyl.) (exc. Vega, Monza)	354314	1	1.65	ctltc. conv. air pipe (rubber)
75	All (454)	355979	1	2.10	ctltc. conv. (rubber)
72	All w/NB-2 (6 cyl.),				
73-74	All (6 cyl.)	6270049	1	1.40	ADAPTER, div. valve
68-72	Chevelle, Camaro w/C.A.C. (396, 400, 454),				
73-75	Chevelle (454)	353085	2	1.30	ADAPTER, air inj. pipe
75	All w/NB-2 (6 cyl.) (exc. C.A.C.)	354569	1	1.50	ADAPTER, air inj. dvtr. valve
74-75	All (140-2BC)	3984517	1	.11	CLIP, E.G.R. valve hose
75	Pass. (A.I.R. w/NB-2),				
75	Chevelle w/4BC, 350, 400, NB-2	354400	1	.55	CONNECTOR, exhaust emission cont. hose
66-69	All (6 cyl.),				
70	Nova (4 cyl.),				
73	All (6 cyl.)	3880812	6	.29	EXTENSION, air inj. pipe
73-74	All (8 cyl.) (exc. Monza),				
75	All (454)	3882805	8	.97	EXTENSION, air inj. pipe
75	All (140)	6270023	4	.29	EXTENSION, air inj. pipe
66-67	All (396, 427),				
68	Chevelle, Camaro (396),				
68	Pass. (396, 427) (exc. A.T.),				
69	Chevy, Camaro (396),				
69	Chevelle (396) (exc. H/Per., Sp. H/Per., A.T.),				
69	Chevelle (A.T. w/H/Per., Sp. H/Per.) (396),				
70	Nova, Chevelle, Camaro w/Sp. H/Per. (396, 454),				
71	Chevelle w/Sp. H/Per. (454)	3880887	1	.48	PIPE, injection

**FUEL—EXHAUST—CARBURETION**

**3.675 HOSE— ADAPTER— CLIP— CONNECTOR— EXTENSION— PIPE— TUBE—  
RETAINER, Air Injection Reactor (Con't)**

66-67	Chevelle, Camaro (283, 327, 350),				
68	All (302, 307, 327, 350) (exc. A.T.),				
70-71	Camaro w/Sp. H/Per. (350),				
72	Camaro w/Sp. H/Per. (350),				
72	Pass., Chevelle (454),				
72	All (402) (exc. Police)	3882805	1	.97	PIPE (extension)
75	Nova (262)	357183	1	9.95	PIPE, air injection
66-67	Chevy (8 cyl.)	3890410	R.H.	25.50	PIPE ASSY., injection
66-67	Chevelle (283, 327)	3890413	L.H.	9.25	PIPE ASSY., injection
66-67	Chevelle (283, 327),				
68	Chevelle (8 cyl.) (exc. P.G.),				
68	Chevy, Camaro (8 cyl.) (exc. 396, P.G., C.A.C.)	3890414	R.H.	9.25	PIPE ASSY., injection
66-67	Chevy (8 cyl.)	3887135	L.H.	4.55	PIPE ASSY., injection (rear)
66-67	Chevy (8 cyl.)	3890409	L.H.	38.25	PIPE ASSY., injection (front)
66-67	Pass. (396, 427),				
66-67	Chevelle, Camaro (302, 396)	3889348	1	11.75	PIPE ASSY., injection (R.H.)
66-69	All (396, 427)	3889377	1	11.75	PIPE ASSY., injection (L.H.)
66-67	All (6 cyl.)	3901800	1	14.35	PIPE ASSY., check valve connector
66	Pass. (6 cyl.),				
66-68	Pass. (283, 307, 327)	333832	A.R.	6.20	PIPE ASSY., exh. gas combustion
66-69	Pass. (283, 307, 327, 350)	3877484	A.R.	1.05	PIPE ASSY., exh. gas comb. end and ctr. pipe
67	Pass. (8 cyl.) (exc. 283),				
67	Chevy, Camaro w/4BC (327, 350, 396),				
67	Chevelle (327, 396) (exc. H/Per., Sp. H/Per.)	3900413	1	1.30	PIPE ASSY., control valve signal hose
67	Chevelle, Camaro (8 cyl.) (exc. 396),				
68	Chevy, Chevelle, Camaro (8 cyl.) (exc. 396, P.G.)	3927119	L.H.	9.75	PIPE ASSY., air inj.
67	Chevelle, Camaro (8 cyl.) (exc. 396),				
68	Chevy w/C.A.C. (8 cyl.),				
68	Camaro w/C.A.C. (8 cyl.) (exc. A.T., 396)	3903382	R.H.	9.25	PIPE ASSY., air injection
68-70	Chevy (4 cyl.)	3918996	1	13.45	PIPE ASSY., w/conn., check valve
68	Chevelle, Camaro w/C.A.C. (396)	3921910	R.H.	13.85	PIPE ASSY., air inj.
68-69	All (6 cyl.) (exc. A.T.)	3918952	1	8.85	PIPE ASSY., w/conn., check valve
68	Pass. (396, 427) (exc. A.T.),				
68	Chevy, Chevelle, Camaro (396) (exc. A.T., C.A.C.)	3917252	R.H.	10.75	PIPE ASSY., injection
69	Pass. (8 cyl.) (exc. A.T., 396, 427)	3932492	R.H.	9.90	PIPE ASSY.
69	Pass. (396, 427) (exc. C.A.C., A.T.),				
69	Chevy, Chevelle, Camaro (396) (exc. C.A.C.)	3940933	L.H.	11.30	PIPE ASSY.
69	Pass. (396, 427) (exc. A.T.),				
69	Chevy, Chevelle, Camaro (396) (exc. C.A.C.),				
70-71	All w/Sp. H/Per. (396, 454)	333822	R.H.	9.25	PIPE ASSY.
69	Chevy, Camaro w/C.A.C. (8 cyl.) (exc. P.G., T.H. 350, 396)	3932488	R.H.	9.90	PIPE ASSY.
69	Chevy, Chevelle, Camaro (8 cyl.) (exc. A.T., 396),				
70-72	Camaro w/Sp. H/Per. (350)	330537	L.H.	9.00	PIPE ASSY.
69	Chevy, Camaro (8 cyl.) (exc. C.A.C., A.T., 396),				
69	Chevelle (8 cyl.) (exc. A.T., 396),				
70-72	Camaro w/Sp. H/Per. (350)	3932490	R.H.	9.00	PIPE ASSY.
69	Camaro w/C.A.C. (396) (exc. Sp. H/Per.),				
69	Chevelle (396) (exc. A.T., H/Per., Sp. H/Per.),				
69	Chevelle w/H/Per. (396)	3940936	R.H.	11.75	PIPE ASSY.
69	Pass. (8 cyl.) (exc. A.T. 427)	3947757	L.H.	9.00	PIPE ASSY.
70-71	All w/Sp. H/Per. (396, 454)	333823	L.H.	9.10	PIPE ASSY.
72	Chevelle, Camaro (402, 454)	333827	L.H.	9.25	PIPE ASSY.
72	Chevelle, Camaro w/C.A.C. (402, 454)	6271028	R.H.	9.25	PIPE ASSY.

**FUEL—EXHAUST—CARBURETION**

**3.675 HOSE— ADAPTER— CLIP— CONNECTOR— EXTENSION— PIPE— TUBE—  
RETAINER, Air Injection Reactor (Con't)**

72	Pass., Chevelle, Camaro (307, 350, 400) (exc. Sp. H/Per.),				
72	Nova w/C.A.C. (8 cyl.)	6271050 R.H.	10.85	PIPE ASSY.	
73	All (6 cyl.)	331169 1	16.10	PIPE ASSY.	
73-74	All (8 cyl.) (exc. 454)	330537 L.H.	9.00	PIPE ASSY.	
73-74	All (8 cyl.) (exc. 454)	330508 R.H.	9.25	PIPE ASSY.	
73-75	Pass. (454)	333827 L.H.	9.25	PIPE ASSY.	
72	Chevelle, Camaro (402, 454) (exc. C.A.C.),				
73-74	Pass. (454)	333822 R.H.	9.25	PIPE ASSY.	
73-75	Chevelle (454)	353081 L.H.	9.25	PIPE ASSY.	
73-74	Chevelle (454)	353082 R.H.	9.25	PIPE ASSY.	
74	All (6 cyl.)	333909 1	1.30	PIPE ASSY., spark control and air inj. diverter valve signal	
74	All (6 cyl.)	338121 1	16.10	PIPE ASSY., air inj.	
75	All w/NB-2 (6 cyl.) (exc. C.A.C.)	354565 1	6.65	PIPE ASSY., air inj.	
75	All (C.A.C. w/NB-2) (6 cyl.)	355735 1	9.60	PIPE ASSY., diverter	
75	All (6 cyl.) (exc. integrated cyl. hd.)	360137 1	3.55	PIPE ASSY., diverter	
75	All w/A.I.R. (350, 400)	343690 1	5.70	PIPE ASSY., converter	
75	Monza (262)	360415 1	6.80	PIPE ASSY., converter air	
75	Pass., Chevelle w/4BC (350, 400)	346279 1	6.65	PIPE ASSY., c/tlc. conv. air	
75	Chevelle (454)	357104 1	16.20	PIPE ASSY., air inject.	
75	Pass. (454)	357106 1	9.55	PIPE ASSY., air inject.	
75	All (8 cyl.) (exc. 454)	355972 R.H.	9.95	PIPE ASSY., air inject.	
75	All (8 cyl.) (exc. 454)	355973 L.H.		PIPE ASSY., air inject.	
75	Camaro, Nova (350)	354319 1	9.95	PIPE ASSY., catalytic cont. air	
75	Vega, Monza (262)	355932 R.H.	6.30	PIPE ASSY.	
75	Monza (Hatchback) (262)	355931 L.H.	6.30	PIPE ASSY.	
73-75	Vega, Monza (140)	331101 1	1.85	PIPE ASSY., E.G.R. exh. manif. to inlet manif.	
73-75	All (454)	353043 1	.90	TUBE (E.G.R.)	
73-75	Chevelle (454)	353083 L.H.	.61	RETAINER, air inj. pipe	
73-75	Chevelle (454)	329228 R.H.	.58	RETAINER, air inj. pipe	

**3.680 BOLT— CLIP— CLAMP— ELBOW— FITTING— GASKET— PLUG—  
RETAINER— SCREW— STUD— TEE— TUBE, Air Injection Reactor**

75	All (6 cyl.)	354591 1	.11	E.G.R. valve	
68	Pass. (307, 327, 350) (exc. A.T.)	3900412 1	.28	CLIP, diverter valve hose	
74-75	Vega, Monza w/1BC, 140	3984517 1	.11	CLIP, E.G.R. valve hose	
73-75	Vega, Monza (140)	331102 1	.32	CLAMP, E.G.R. pipe	
73-75	All (6 cyl.)	329606 1	1.40	CLAMP (E.G.R.) valve	
73-74	All (8 cyl.) (exc. 454)	353090 1	1.40	CLAMP (E.G.R.) valve	
73-74	All (454)	353087 1	1.40	CLAMP (E.G.R.) valve	
75	Nova (6 cyl.)	360109 1	1.40	CLAMP (E.G.R.) valve	
68	Pass. (396, 427) (exc. A.T.),				
68	Chevy, Chevelle, Camaro w/4BC	7801154 1	.76	ELBOW, pump	
71	Chevelle, Camaro w/Sp. H/Per. (350-454),				
72-75	All	3942533 1	4.15	ELBOW, diverter valve mtg.	
75	All (8 cyl.) (exc. 454)	354313 1	4.90	ELBOW, air inj. div. valve	
75	Monza (262, 350)	357042 1	1.65	FITTING, air inj. pump	
68	All,				
69	Chevy, Chevelle, Camaro (4 cyl., 6 cyl.) (exc. A.T.),				
69	All (8 cyl.) (exc. A.T.),				
70	All (exc. Pass.),				
71	Chevelle, Camaro w/Sp. H/Per. (350, 454),				
72-75	All	3942534 1	.13	GASKET, div. to elbow	
73-74	All	353086 1	.12	GASKET (E.G.R.) valve	
73-75	All (140)	329700 1	.20	GASKET (E.G.R.) valve	
73-75	All (140)	333978 1	.13	GASKET (E.G.R.) valve	
75	All (8 cyl.) (exc. 454)	343752 1	.95	GASKET (E.G.R.) valve	
66-67	Chevelle,				
66-69	Pass. (6 cyl.) (exc. A.T.),				
69	Pass. (327, 350) (exc. A.T.),				
69	Chevy, Camaro (8 cyl.) (exc. P.G., T.H. 350),				
69	Chevelle (8 cyl.) (exc. A.T.)	3889330 A.R.	.12	PLUG, air inj. pipe hole, check valve conn. in cyl. head (1/4" — 18) (Note 1)	

**FUEL—EXHAUST—CARBURETION**

**3.680 BOLT— CLIP— CLAMP— ELBOW— FITTING— GASKET— PLUG—  
RETAINER— SCREW— STUD— TEE— TUBE, Air Injection Reactor  
(Con't)**

*NOTE 1 For use when converting Air Injection engine to standard engine.*

73	All (6 cyl.) (exc. Pass., NB-2) . . .	3889330	6	.12	PLUG, air inj. pipe hole . . . . .
73-74	All (454) . . . . .	9427697	1	.13	PLUG (E.G.R.) . . . . .
72	Chevelle, Camaro w/C.A.C. (402, 454) . . . . .	329228	1	.58	RETAINER, air inj. pipe (repl. 6271029) . . .
73-75	All . . . . .	331141	A.R.	.28	SCREW, diverter valve elb. . . . .
73	All w/P.B. (6 cyl.) . . . . .	331200	1	.26	STUD (E.G.R.) vlv. clamp . . . . .
75	All (140), 75 All (6 cyl.) . . . . .	382919	4	.16	STUD, exh. mfl'd. heat valve . . . . .
71-73	All (140) . . . . .				TEE, vac. signal hose, . . . . .
72	All w/NB2 (6 cyl.) . . . . .	3760758	1	.49	diverter valve sig. pipe— (10.155) . . . . .
73-75	All . . . . .	6272766	1	1.10	TEE, air inj. div. valve . . . . .
75	All (6 cyl.) . . . . .	352187	1	1.05	TUBE, throt. bore . . . . .

**3.685 CONVERTER— BRACKET— BOLT— CLAMP— HANGER— NUT— PIPE—  
SPACER— SUPPORT— CATALYST PKG.— REPAIR PKG., Catalytic  
Converter**

75	Nova, Camaro . . . . .	8998163	1	161.25	(260) . . . . .
75	Pass., Chevelle . . . . .	6498987	1	157.75	(260) . . . . .
75	Vega, Monza . . . . .	8998163	1	161.25	(260) (Calif.) . . . . .
75	Vega, Monza . . . . .	8998210	1	143.75	(175) (Federal) . . . . .
75	Chevelle T.H. 350 . . . . .	1250764	1	4.25	BRACKET, resonator hanger-rear . . . . .
75	Chevelle T.H. 350 . . . . .	1250764	1	4.25	BRACKET, converter hanger-rear . . . . .
75	Chevelle w/3-Spd. . . . .	356940	1	6.35	BRACKET, converter hanger . . . . .
75	Chevelle (exc. 454) . . . . .	1247008	1	4.05	BRACKET, rear converter hanger . . . . .
75	Chevelle (454) . . . . .	1247009	1	4.25	BRACKET, rear converter hanger— (3.690) .
75	Pass. w/T.H. 350 (exc. Sta. Wag.) . . . . .	1247011	1	4.05	BRACKET, rear converter hanger . . . . .
75	All (122, 140) . . . . .	356383	1	4.25	BRACKET, converter . . . . .
75	Monza (262) (exc. A.T.) . . . . .	356387	1	4.90	BRACKET, converter . . . . .
75	Monza (262, 350) . . . . .	356386	1	4.05	BRACKET, converter . . . . .
75	Pass., Chevelle . . . . .	1250024	1	3.10	BOLT-U, conv. to hanger brkt. . . . .
75	Monza (262) . . . . .	360416	1	2.65	CLAMP, ctyct. pipe to oil pan . . . . .
75	Camaro, Nova . . . . .	352899	1	1.65	HANGER, exhaust converter . . . . .
75	Chevelle w/3-Spd. Nova, 75 Vega, Monza . . . . .	356940	1	6.35	HANGER, converter . . . . .
75	All (140) . . . . .	356384	1	5.70	HANGER, converter (160) . . . . .
75	All . . . . .	8998221	1	1.75	PLUG, converter . . . . .
75	Vega, Monza . . . . .	356385	1	.81	SPACER, converter . . . . .
75	Camaro, Nova . . . . .	352898	1	3.25	SUPPORT, exhaust converter hanger . . . . .
75	All (160) . . . . .	6498994	1	52.50	CATALYST PKG. (175 cu. in. of material) . .
75	All (260) . . . . .	6498995	1	62.75	CATALYST PKG. (285 cu. in. of material) . .
75	All (260) . . . . .	8998244	1	33.75	REPAIR PKG., converter bottom cover repair . . . . .
75	All (160) . . . . .	8998300	1	29.00	KIT, converter bottom cover repair . . . . .

**3.690 BRACKET— HANGER— SUPPORT, Catalytic Converter**

75	All (6 cyl.) . . . . .	354512	1	1.25	BRACKET, exh. heat actuator . . . . .
75	Chevelle T.H. 400 . . . . .	1250765	1	4.25	BRACKET, resonator hanger-rear . . . . .
75	Chevelle T.H. 400 . . . . .	1250765	1	4.25	BRACKET, converter hanger-rear . . . . .
75	Chevelle S.T. . . . .	356940	1	6.35	BRACKET, resonator or converter . . . . .
75	Chevelle (454) . . . . .	1247009	1	4.25	BRACKET, rear converter hanger . . . . .
75	Pass. . . . .	1247011	1	4.05	BRACKET, resonator or converter . . . . .
75	Camaro, Nova . . . . .	352899	1	1.65	HANGER, exh. converter hanger . . . . .
75	Camaro, Nova . . . . .	352898	1	3.25	SUPPORT, exh. converter hanger . . . . .

**3.701 MUFFLER, Engine Exhaust**

62-64	Chevy, Chevelle (exc. 327),				
65-66	Chevy (153, 194, 283),				
65-66	Chevelle (194),				
65-67	Pass., Chevelle (6 cyl.),				
67	Chevy (exc. 327),				
67	Chevelle (230) . . . . .	3981942	L.H.	20.15	
64	Chevelle w/H/Per. (327),				

**FUEL—EXHAUST—CARBURETION**

**3.701 MUFFLER, Engine Exhaust (Con't)**

65	Pass. (Sta. Wag.) w/dual exh. (327, 396, 409),				
65-66	Chevelle (Sta. Wag., El Camino) w/dual exh. (exc. 2BC),				
67	Chevelle (Sta. Wag., El Camino) w/dual exh. ....	3931392	L.H.	27.50	
64	Chevelle w/H/Per. (327),				
65	Pass. (Sta. Wag.) w/dual exh. (327, 396, 409),				
65-66	Chevelle (Sta. Wag., El Camino) w/dual exh. (exc. 2BC),				
67	Chevelle (Sta. Wag., El Camino) w/dual exh. ....	3952874	L.H.	38.00	aluminized w/stainless steel .....
64	Chevelle w/4BC (exc. H/Per.) ...	3851351	L.H.	38.00	
64	Chevelle w/4BC (exc. H/Per.) ...	3851352	R.H.	38.00	aluminized w/stainless steel .....
65	Pass. w/dual exh. (exc. Sta. Wag.),				
65-67	Pass., Chevelle w/2BC (283) ...	3981947	1	27.25	.....
65	Pass. (exc. dual exh.) .....		R.H.		aluminized w/stainless steel .....
65-66	Chevelle w/dual exh. (exc. Sta. Wag.),				
66-67	Pass. w/dual exh. (exc. Sta. Wag.),				
67	Chevelle w/dual exh. (327) (exc. Sta. Wag.),				
65-67	Pass. w/dual exh. (exc. Sta. Wag.),				
65-67	Chevelle w/dual exh. (exc. Sta. Wag., El Camino),				
66-67	Pass. w/dual exh. ....	335219	1	31.25	aluminized w/stainless steel .....
65	Pass. w/Sp. H/Per. (396) (exc. Sta. Wag.),				
65	Chevelle w/H/Per. (396),				
66-67	Chevelle (396),				
66-67	Chevelle w/Sp. H/Per. (327),				
66-67	Pass. w/H/Per., Sp. H/Per. (427),				
67	Chevelle (283) .....	3884800	R.H.	30.75	
65-66	Chevy w/dual exh. (283, 327) ..	3872286	R.H.	34.00	aluminized w/stainless steel .....
65-66	Chevy w/4BC (283, 327),				
65-67	Chevy w/dual exh. ....	3908399	L.H.	34.00	
67	Pass. (327) (exc. dual exh.),				
67	Pass. (396) (exc. dual exh.),				
67	Chevelle (327) (exc. dual exh., Sp. H/Per.) .....	3931392	1	27.50	
67	Camaro (327) (exc. dual exh.) ..	3910563	1	24.10	
67	Camaro (350, 396) (exc. deep tone muffler),				
67	Camaro w/dual exh. ....	3981951	1	25.75	.....
67	Camaro w/deep tone muffler ...	3910566	1	28.75	.....
67	Camaro (6 cyl.) .....	3981952	1	24.85	.....
67	Chevy w/dual exh. ....	3914830	R.H.	30.75	

**FUEL—EXHAUST—CARBURETION**

**1968 PASSENGER EXHAUST SYSTEM**

NOTE: See Dealer Price Schedule for Applicable Prices.

ENGINE	MUFFLER 3.701	EXHAUST PIPES 3.609	CROSS- OVER 3.609	RESONATOR W/TAILOPIPE 3.702	TAILPIPES 3.705	HANGER EXHAUST PIPE 3.616	HANGERS TAILPIPE 3.706
16 Cyl.)	3931358	3904261A 3931889B	—	—	3934014C 3934016D	3934033	3913417(frnt.) 3884857(r.r.)
307	3981947	3928289	3954691	—	3934014C 3934016D	—	3913417(frnt.) 3884857(r.r.)
327 (exc. dual exh.)	3931392	3976490	3976509	—	3934018C	—	3913417(frnt.) 3884857(r.r.)
327 w/dual exh.	3904077(L.H.) 3866582(R.H.)	3928293(L.H.) 3910744(R.H.)	—	3934023(L.H.)C 3930708(R.H.)C 3939239(L.H.)D 3939240(R.H.)D	—	—	3913417(frnt.) 3904014(R.H.)CE 3904013(L.H.)CE 3884858(R.H.)DE 3884857(L.H.)DE
396 (exc. dual exh.)	3931392	3976493	3972593	—	3923317C 3930707D	—	3904014C 3884858D
396 w/dual exh.	3904077(L.H.) 3866582(R.H.)	3923315(L.H.) 3923370(R.H.)	—	3934023(L.H.)C 3930708(R.H.)C 3939239(L.H.)D 3939240(R.H.)D	—	—	3904014(R.H.)CE 3913417(frnt.) 3904013(L.H.)CE 3884858(R.H.)DE 3884857(L.H.)DE
427 H/Per.	3928215(L.H.) 3884800(R.H.)	3923315(L.H.) 3923370(R.H.)	—	3934013(L.H.)C 3930706(R.H.)C 3939239(L.H.)D 3939240(R.H.)D	—	—	3913417(frnt.) 3904014(R.H.)CE 3904013(L.H.)CE 3884858(R.H.)DE 3884857(L.H.)DE
427 Sp. H/per.	3928215(L.H.) 3884800(R.H.)	3923315(L.H.) 3923370(R.H.)	—	3939239(L.H.)D 3939240(R.H.)D	3934021(L.H.)C 3930704(R.H.)C	—	3913417(frnt.) 3884857(L.H.)DE 3884858(R.H.)DE 3883693(R.H.)C 3883694(L.H.r.r.)C

A 1st design - horizontal length 87 3/8 "      C (exc. sta. wag.)      E Resonator tailpipe  
B 2nd design - horizontal length 83 5/16"      D Sta. wag.

**1968 CHEVY II EXHAUST SYSTEM**

NOTE: See Dealer Price Schedule for Applicable Prices.

ENGINE	MUFFLER 3.701	EXHAUST PIPE 3.609	CROSSOVER 3.609	TAILPIPE 3.705	RESONATOR 3.702	HANGER ASSY. EXHAUST 3.616	HANGER ASSY. TAILPIPE 3.706
4 Cyl.	3981952	3975692	—	3934870	—	3930034	3938904
6 Cyl.	3981952	3998692	—	3934870	—	3930034	3938904
307 exc. dual exh.)	3928342	3975694	—	3934874	—	3930034	3938904
307 w/dual exh.	3981951	3983030(R.H.) (r.r.) 3983029(L.H.) (r.r.) 3972279(L.H.) (frnt.) 3972280(R.H.) (frnt.)	—	3932747(L.H.) 3934874(R.H.)	3909959	3930033(L.H.) 3920204(R.H.)	3938903(L.H.) 3938904(R.H.)
327 exc. Sp. H/Per. dual exh.)	3928342	3975694	—	3934874	—	3930034	3938904
327 w/dual exh. Sp. H/Per	3981951	3983030(R.H.) (r.r.) 3983029(L.H.) (r.r.) 3972279(L.H.) (frnt.) 3972280(R.H.) (frnt.)	—	3932747(L.H.) 3934874(R.H.)	3909959	3930033(L.H.) 3920204(R.H.)	3938903(L.H.) 3938904(R.H.)
350	3981951	3983030(R.H.) (r.r.) 3983029(L.H.) (r.r.) 3972279(L.H.) (frnt.) 3972280(R.H.) (frnt.)	—	3932747(L.H.) 3934874(R.H.)	3909959	3930033(L.H.) 3920204(R.H.)	3938903(L.H.) 3938904(R.H.)
396	3910566	3972279(L.H.) (frnt.) 3972280(R.H.) (frnt.) 3983030(R.H.) (r.r.) 3983829(L.H.) (r.r.)	—	3932747(L.H.) 3934874(R.H.)	—	3930033(L.H.) 3920204(R.H.)	3938903(L.H.) 3938904(R.H.)



**FUEL—EXHAUST—CARBURETION**

**1968 CHEVELLE EXHAUST SYSTEM**

NOTE: See Dealer Price Schedule for Applicable Prices.

ENGINE	MUFFLER 3.701	EXHAUST PIPE 3.609	CROSS- OVER 3.609	TAILPIPE 3.705	RESONATOR 3.702	HANGER ASM. EXHAUST 3.616	HANGER ASM. TAILPIPE 3.706
6 Cyl.	3981942	3930753-A 3930754-BCD	—	6263696-AB 3925112-CD	—	3926900	9790493(frnt.) 3853659(r.r.)
307	3981947	3930769-A 3930770-BCD	3973853	3943309-AB 3925114-CD	—	—	9790492(frnt.) 3853660(r.r.)
327 (exc. dual exh., Sp. H/Per.)	3931392	3930772-BCD 3983321-A	3973853	3925114-CD 3943309-AB	—	—	9790492(frnt.) 3853660(r.r.)
327 w/dual exh. (exc. Sp. H/Per.)	3904077(L.H.) AB 3866582(R.H.) AB 3931392(L.H.) CD 3952874 (R.H.) CD	3930757(L.H.) A 3930758(R.H.) A 3930761(L.H.) BCD 3930762(R.H.) BCD	—	3925103(L.H.) CD 3925104(R.H.) CD	3925105(L.H.) ABE 3925106(R.H.) ABE	—	9790492(R.H.)(frnt.) 9790493(L.H.)(frnt.) 3853659(L.H.)(r.r.) CD 3853660(R.H.)(r.r.) CD 3925121(L.H.)ABF 3925122(R.H.)ABF
327 w/Sp. H/Per.	3930752 (L.H.) 3930752 (R.H.)	3930757(L.H.) A 3930758(R.H.) A 3930761(L.H.) BCD 3930762(R.H.) BCD	—	3925103(L.H.) CD 3925104(R.H.) CD 3928265(L.H.) AB 3928266(R.H.) AB	—	—	9790492(R.H.)(frnt.) 9790493(L.H.)(frnt.) 3853660(r.r.)CD 3925111(r.r.)AB
396	3930752 (R.H.) 3930752 (L.H.)	3930765(L.H.) A 3930766(R.H.) A 3930767(L.H.) D 3930768(R.H.) D	—	3925103(L.H.) D 3925104(R.H.) D 3928265(L.H.) A 3928266(R.H.) A	—	—	9790493(frnt.) 3853659(L.H.)(r.r.) D 3853660(R.H.)(r.r.) D 3925111(r.r.)A

A. Coupe, Cohv.  
B. Sedan  
C. Sta. Wag.

D. El Camino  
E. w/Tailpipe  
F. Resonator Tailpipe

**FUEL—EXHAUST—CARBURETION**

**1968 CAMARO EXHAUST SYSTEM**

NOTE: See Dealer Price Schedule for Applicable Prices.

ENGINE	MUFFLER 3.701	EXHAUST PIPE 3.609	CROSS- OVER 3.609	TAILPIPE 3.705	RESONATOR 3.702	HANGER ASM. EXHAUST 3.616	HANGER ASM. TAILPIPE 3.706
6 Cyl.	3981952	3930058	—	3934870	—	3930034	3938904
327 (exc. dual) exh., deep tone muffler)	3928342	3962792	—	3934874	—	3930034	3938904
327 w/dual exh.	3981951	3909958(R.H.) (frt.)A 3934871(L.H.) (frt.)A 3923571(frnt.)B 3930085(L.H.) (r.r.) 3930086(R.H.) (r.r.)	—	3934874(R.H.) 3932747(L.H.)	3909959-A	3930087	3938903(L.H.) 3938904(R.H.)
350	3981951-A 3910566-B	3923571(L.H.) (frt.)B 3901334(R.H.) (frt.)B 3909958(R.H.) (frt.)A 3934871(L.H.) (frt.)A 3930085(L.H.) (r.r.) 3930086(R.H.) (r.r.)	—	3932747(L.H.) 3934874(R.H.)	3909959-A	3930087	3938903(R.H.) 3938904(L.H.)
396	3981951-A 3910566-B	3934873(L.H.) (frt.)A 3914848(R.H.) (frt.)A 3923573(L.H.) (frt.)B 3912596(R.H.) (frt.)B 3930085(L.H.) (r.r.) 3930086(R.H.) (r.r.)	—	3932747(L.H.) 3934874(R.H.)	3909959-A	3930087	3938903(L.H.) 3938904(R.H.)
302	3910566	3923571(L.H.) (frt.) 3901334(R.H.) (frt.) 3930085(L.H.) (r.r.) 3930086(R.H.) (r.r.)	—	3932747(L.H.) 3934874(R.H.)	—	3930087	3938903(L.H.) 3938904(R.H.)

A. Exc. Deep Tone Muffler  
B. w/Deep Tone Muffler

**FUEL—EXHAUST—CARBURETION**

**1969 PASSENGER EXHAUST SYSTEM**

NOTE: See Dealer Price Schedule for Applicable Prices.

ENGINE	MUFFLER 3.701	EXHAUST PIPES 3.609	CROSSOVER 3.609	RESONATOR W/TAILPIPE 3.702	TAILPIPES 3.705	EXH. PIPE HANGERS 3.616	TAILPIPE HANGERS 3.706
6 Cyl.	3931358	3931889	—	—	3939233 (Sta. Wag.) 3939231 (exc. Sta. Wag.)	3934033	3961906 (frt.) 3964035 (rr.)
327	3981947	3928289	3954691	—	3939231 (exc. Sta. Wag., N.R.E.) 3939233 (Sta. Wag.) (exc. N.R.E.)	—	3961906 (frt.) 3964035 (rr.)
350 (exc. dual exh.)	3931392	3976490	3976509	—	3939233 (Sta. Wag.) (exc. N.R.E.) 3939231 (exc. Sta. Wag., N.R.E.) 3961994 w/N.R.E. (exc. Sta. Wag.)	—	3961906 (frt.) 3964035 (rr.)
350 w/dual exh.	3904077 (L.H.) 3866582 (R.H.)	3928293 (L.H.) 3910744 (R.H.)	—	3939239 (L.H.) (Sta. Wag.) 3939240 (R.H.) (Sta. Wag.) 3954673 (L.H.) (exc. Sta. Wag.) 3954674 (R.H.) (exc. Sta. Wag.)	—	—	3961906 (frt.) 3964035 (L.H.) (Sta. Wag.) 3964036 (R.H.) (Sta. Wag.) 3954681 (L.H.) (exc. Sta. Wag.) 3954682 (R.H.) (exc. Sta. Wag.)
396 (exc. dual exh.)	3931392	3976493	3972593	—	3939234 (Sta. Wag.) (exc. N.R.E.) 3954672 (exc. Sta. Wag. N.R.E.) 3958959 w/N.R.E. (exc. Sta. Wag.)	—	3961906 (frt.) 3964036 (rr.) (Sta. Wag.) 3947554 (rr.) (exc. Sta. Wag.)

**FUEL—EXHAUST—CARBURETION**

**1969 PASSENGER EXHAUST SYSTEM (Cont'd.)**

<b>ENGINE</b>	<b>MUFFLER 3.701</b>	<b>EXHAUST PIPES 3.609</b>	<b>CROSSOVER 3.609</b>	<b>RESONATOR W/TAIPIPE 3.702</b>	<b>TAILPIPES 3.705</b>	<b>EXH. PIPE HANGERS 3.616</b>	<b>TAILPIPE HANGERS 3.706</b>
396 w/dual exh.	3904077 (L.H.) 3866582 (R.H.)	3923315 (L.H.) 3923370 (R.H.)	—	3939239 (L.H.) (Sta. Wag.) 3939240 (R.H.) (Sta. Wag.) 3954673 (L.H.) (exc. Sta. Wag.) 3954674 (R.H.) (exc. Sta. Wag.)	—	—	3961906 (frt.)  3964035 (L.H.) (Sta. Wag.)  3964036 (R.H.) (Sta. Wag.)  3954681 (L.H.) (exc. Sta. Wag.) 3954682 (R.H.) (exc. Sta. Wag.)
427 (exc. dual exh.)	3931392	3976493	3972593	—	3939234 (Sta. Wag.) (exc. N.R.E.)  3954672 (exc. Sta. Wag., N.R.E.)  3958959 w/N.R.E. (exc. Sta. Wag.)	—	3964036 (rr.) (Sta. Wag.)  3947554 (rr.) (exc. Sta. Wag.)
427 w/dual exh.  (exc. H/Per. Sp. H/Per.)	3904077 (L.H.) 3866582 (R.H.)	3923315 (L.H.) 3923370 (R.H.)	—	3939239 (L.H.) (Sta. Wag.)  3939240 (R.H.) Sta. Wag.)  3954673 (L.H.) (exc. Sta. Wag.)  3954674 (R.H.) (exc. Sta. Wag.)	—	—	3961906 (frt.)  3964035 (L.H.) (Sta. Wag.)  3964036 (R.H.) (Sta. Wag.)  3954681 (L.H.) (exc. Sta. Wag.) 3954682 (R.H.) (exc. Sta. Wag.)
427 (H/Per.)	3930752 (L.H.) 3884800 (R.H.)	3923315 (L.H.) 3923370 (R.H.)	—	3939239 (L.H.) Sta. Wag. 3939240 (R.H.) Sta. Wag.  3954674 (R.H.) (exc. Sta. Wag.)	— —	—	3961906 (frt.)  3964035 (L.H.) (Sta. Wag.)  3964036 (R.H.) (Sta. Wag.)  3954681 (L.H.) (exc. Sta. Wag.) 3954682 (R.H.) (exc. Sta. Wag.)

**FUEL—EXHAUST—CARBURETION**

**1969 PASSENGER EXHAUST SYSTEM (Cont'd.)**

ENGINE	MUFFLER 3.701	EXHAUST PIPES 3.609	CROSSOVER 3.609	RESONATOR W/TAIPIPE 3.702	TAILPIPES 3.705	EXH. PIPE HANGERS 3.616	TAILPIPE HANGERS 3.706
427 Sp. H/Per.	3928215 (L.H.)  3884800 (R.H.)	3923315 (L.H.)  3923370 (R.H.)	—	3939239 (L.H.) Sta. Wag.  3939240 (R.H.) Sta. Wag.		—	3961906 (frt.)  3964035 (L.H.) (Sta. Wag.) 3964036 (R.H.) (Sta. Wag.) 3954681 (L.H.) (exc. Sta. Wag.) 3954682 (R.H.) (exc. Sta. Wag.)

**1969 CHEVY EXHAUST SYSTEM**

NOTE: See Dealer Price Schedule for Applicable Prices.

ENGINE	MUFFLER 3.701	EXHAUST PIPE 3.609	TAIPIPES 3.705	RESONATOR 3.702	HANGER ASSY. EXH. 3.616	HANGER ASSY. TAILPIPE 3.706
4 Cyl.	3962700	3975692	3958492	—	3967826	3964858
6 Cyl.	3962700	3975693	3958492	—	3967826	3964858
307 (exc. dual exh.)	3928342	3975694	3934874	—	3967826	3964858
307 w/dual exh.	3981951	3972279(frnt. R.H.) 3972280(frnt. L.H.) 3983029(r.r. L.H.) 3983030(r.r. R.H.)	3934873(R.H.) 3932747(L.H.)	3909959	3920204(R.H.) 3930033(L.H.)	3955749(L.H.) 3955750(R.H.)
350 w/2BC (exc. dual exh.)	3928342	3975694	3934874	—	3967826	3964858
350 (2BC w/dual exh.)	3981951	3972279(frnt. R.H.) 3972280(frnt. L.H.) 3983029(r.r. L.H.) 3983030(r.r. R.H.)	3934874(R.H.) 3932747(L.H.)	3909959	3920204(R.H.) 3930033(L.H.)	3965633(L.H.) 3955750(R.H.)
350 w/4BC	3981951	3935714(frnt. R.H.)A 3928344(frnt. R.H.)B 3928343(frnt. L.H.) 3983029(r.r. L.H.) 3983030(r.r. R.H.)	3934874(R.H.) 3932747(L.H.)	3909959	3920204(R.H.) 3930033(L.H.)	3955749(L.H.) 3955750(R.H.)
396 H/Per.	3981951	3972280(frnt. R.H.) 3972279(frnt. L.H.) 3983029(r.r. L.H.) 3983030(r.r. R.H.)	3934874(R.H.) 3932747(L.H.)	—	3920204(R.H.) 3930033(L.H.)	3955749(L.H.) 3955750(R.H.)
396 Sp.H/Per.	3981951	3972280(frnt. R.H.) 3972279(frnt. L.H.) 3925837(r.r. L.H.) 3983030(r.r. R.H.)	3934874(R.H.) 3932747(L.H.)	—	3920204(R.H.) 3930033(L.H.)	3955749(L.H.) 3955750(R.H.)

A. 1st design (91 3/32" Dev. length)

B. 2nd design (75 9/32" Dev. length)

**FUEL—EXHAUST—CARBURETION**

**1969 CHEVELLE EXHAUST SYSTEM**

NOTE: See Dealer Price Schedule for Applicable Prices.

ENGINE	MUFFLER 3.701	EXHAUST PIPE 3.609	CROSS- OVER T 3.609	TAILPIPE 3.705	RESONATOR w/TAILPIPE 3.702	HANGER ASM. EXH. PIPE 3.616	HANGER ASM. TAILPIPE 3.706
6 Cyl.	3931358	6262201-A 6262202 BCD	—	3925112-CD 3943307-AB	—	3926900	3853659(r.r.) 1382595(frnt.)
307	3981947	3930769-A 3930770-BCD	3973853	3943309-AB 3925114-CD	—	—	9790492(frnt.) 3853660(r.r.)AB 3925111(r.r.)CD
350 (exc. dual exh.)	3931392	3930772-BCD 3983321-A	3973853	3943309-BE 3925114-CDE 3949748-CDF 3949750-ABF	— —	— —	9790492(frnt.) 3853660(r.r.) ABE 3925111(r.r.) CDE 3949752(r.r.)F
350 w/dual exh.	3904077(L.H.) AB 3931392(L.H.) CD 3866582(R.H.) AB 3952874(R.H.) CD	3952875(L.H.) A 3930758(R.H.) A 3952877(L.H.) BCD 3930762(R.H.) BCD	—	3925112(L.H.) CD 3925114(R.H.) CD	3925105(L.H.) AB 3925106(R.H.) AB	—	9790492(frnt. R.H.) 9790493(frnt. L.H.) 3853659(r.r.)CD 3925121(L.H.)AB 3925122(R.H.)AB
396 (exc. cham- bered pipe exh.)	3930752	3930768(R.H.)D 3930767(L.H.)D 3930765(L.H.)A 3930766(R.H.)A	—	3925103(L.H.) D 3925104(R.H.) D 3956757(L.H.) A 3956758(R.H.) A	—	—	9790493(frnt.) 3853659(r.r.) 3974671(L.H.) 3974672(R.H.)
396 with cham- bered pipe exh.	3956749(frnt. L.H.) 3956750(frnt. R.R.) 3956751(r.r. L.H.) G 3956752(r.r. R.H.) G	3956747(frnt. L.H.) 3956748(frnt. R.H.)	—	3956751(L.H.) H 3956752(R.H.) H	—	9790493(r.r. L.H.) 9790492(r.r. R.H.)	3974671(L.H.) 3974672(R.H.)

A. Coupe, Conv.  
B. Sed.  
C. Sta. Wag.

D. El Camino  
E. (exc. N.R.E.)  
F. w/N.R.E.

G. w/Pipe  
H. w/Rear Muffler

**FUEL—EXHAUST—CARBURETION**

**1969 CAMARO EXHAUST SYSTEM**

NOTE: See Dealer Price Schedule for Applicable Prices.

ENGINE	MUFFLER 3.701	EXHAUST PIPE 3.609	TAILPIPE 3.705	RESONATOR 3.702	HANGER ASM. EXH. PIPE 3.616	HANGER ASM. TAILPIPE 3.706
6 Cyl.	3962700	3930058	3958492	—	3967825	3964858
307, 327 (exc. dual exh.)	3928342	3962792	3934874	—	3967825	3964858
307, 327 w/dual exh.	3981951	3934871(fr. L.H.) 3909958(fr. R.H.) 3930086(r.r. R.H.) 3930085(r.r. L.H.)	3961397(R.H.)E 3958459(L.H.)E 3965627(L.H.)F 3974213(R.H.)F	3909959	3930087	3965633(L.H.) 3964858(R.H.)
350 w/2BC (exc. dual exh.)	3928342	3962792	3934874	—	3967825	3964858
350 (2BC w/dual exh.)	3981951	3934871(fr. L.H.) 3909958(fr. R.H.) 3930086(r.r. R.H.) 3930085(r.r. L.H.)	3961397(R.H.)E 3958459(L.H.)E 3965627(L.H.)F 3974213(R.H.)F	3909959	3930087	3964858(R.H.) 3965633(L.H.)
350 w/4BC	3981951	3909958(fr. R.H.) 3934871(fr. L.H.) 3930086(r.r. R.H.) 3930085(r.r. L.H.)	3961397(R.H.)E 3958459(L.H.)E 3965627(L.H.)F 3974213(R.H.)F	3909959	3930087	3964858(R.H.) 3965633(L.H.)
396 (exc. chambered pipe exh.)	3981951	3914848(fr. R.H.) 3934873(fr. L.H.) 3930086(r.r. R.H.) 3930085(r.r. L.H.)	3961397(R.H.)E 3958459(L.H.)E 3965627(L.H.)F 3974213(R.H.)F	3909959	3930087	3965633(L.H.) 3964858(R.H.)
396 w/chambered pipe exh.	3958412(fr. R.H.)A 3958411(fr. L.H.)A 3958458(r.r.)C 3958415(r.r.)ABE	3958410(fr. R.H.) 3958409(fr. L.H.)	3958417(L.H.)DE	3909959	3965181(L.H.) 3965182(R.H.)	3964858(R.H.) 3965637(L.H.)
302 (exc. chambered pipe exh.)	3981951	3909958(fr. R.H.) 3934871(fr. L.H.) 3930086(r.r. R.H.) 3930085(r.r. L.H.)	3961397(R.H.)E 3958459(L.H.)E 3965627(L.H.)F 3974213(R.H.)F	3909959	3930087	3965633(L.H.) 3964858(R.H.)
302 w/chambered pipe exh.	3958412(fr. R.H.)A 3958411(fr. L.H.)A 3958458(r.r. R.H.)C 3958415(r.r. L.H.)ABE	3958408(fr. R.H.) 3958407(fr. L.H.)	3958417(L.H.)DE	3909959	3965181(L.H.) 3965182(R.H.)	3965637(L.H.) 3964858(R.H.)

A. w/tailpipe

B. Used as upper rear muffler and tailpipe asm.

C. Used as rear lower muffler asm.

D. Used with muffler 3958458.

E. 1st design not chrome plated.

F. 2nd design tailpipe chrome plated.

**FUEL—EXHAUST—CARBURETION**

**1970 PASSENGER EXHAUST CHART**

NOTE: See Dealer Price Schedule for Applicable Prices.

ENGINE	MUFFLER 3.701	EXHAUST 3.609	CROSSOVER 3.609	RESONATOR w/tailpipe 3.702	TAILPIPES 3.705	EXH. PIPE HANGERS 3.616	TAILPIPE HANGERS 3.706
6 cyl.	3977205	3931889	—	—	3972558	3934033	3961906 (frt.) 3972515 (r.r.)
350, 400 (exc. dual exh.)	3983320	3976490	3976509	—	3972558 (Exc Sta. Wag.) CD 3972561 (Sta. Wag.) B 3972557 (Sta. Wag.) AC 3972506 (exc. Sta. Wag.) BD 3972506 (exc. Sta. Wag.) E	—	3961906 (frt.) 3972515 (rr.) (exc. Sta. Wag.) 3964035 (rr.) (Sta. Wag.)
350, 400 w/dual exh.	3983317 (L.H.) 3983318 (R.H.)	3928293 (L.H.) 3910744 (R.H.)	—	3988271 (L.H.) (Sta. Wag.) 3988272 (R.H.) (Sta. Wag.) 3972513 (L.H.) (exc. Sta. Wag.) 3972514 (R.H.) (exc. Sta. Wag.)	—	—	3961906 (frt.) 3972515 (rr.) (exc. Sta. Wag.) 3964036 (rr. R.H.) (Sta. Wag.) 3964035 (rr. L.H.) (Sta. Wag.)
454 (exc. H/Per. dual exh.)	3983320	3976493	3972593	—	3984699 (exc. Sta. Wag.) 3972576 (Sta. Wag.) A	—	3961906 (frt.) 3972515 (rr.) (exc. Sta. Wag.) 3964036 (rr.) (Sta. Wag.)
454 w/dual exh. (exc. H/Per.)	3976483 (L.H.) 3976484 (R.H.)	3923315 (L.H.) 3923370 (R.H.)	—	3988271 (L.H.) (Sta. Wag.) 3988272 (R.H.) (Sta. Wag.) 3972513 (L.H.) (exc. Sta. Wag.) 3972514 (R.H.) (Exc. Sta. Wag.)	—	—	3961906 (frt.) 3972515 (rr.) (exc. Sta. Wag.) 3964036 (rr. R.H.) (Sta. Wag.) 3964035 (rr. L.H.) (Sta. Wag.)
454 H/Per.	3976483 (L.H.) 3976484 (R.H.)	3923315 (L.H.) 3923370 (R.H.)	—	3988271 (L.H.) (Sta. Wag.) 3988272 (R.H.) (Sta. Wag.) 3972553 (L.H.) (exc. Sta. Wag.) 3972514 (R.H.) (exc. Sta. Wag.)	—	—	3947543 (frt.) 3972515 (rr.) (exc. Sta. Wag.) 3964036 (rr. R.H.) (Sta. Wag.) 3964035 (rr. L.H.) (Sta. Wag.)

A. w/extension  
B. w/H.D. Suspension  
C. exc. H.D. Suspension

D. 350  
E. 400



**FUEL—EXHAUST—CARBURETION**

**1970 CHEVELLE EXHAUST CHART**

NOTE: See Dealer Price Schedule for Applicable Prices.

ENGINE	MUFFLER 3.701	EXHAUST PIPE 3.609	CROSS- OVER 3.609	TAILPIPE 3.705	RESONATOR w/TAILPIPE 3.702	HANGER ASM. EXHAUST 3.616	HANGER ASM. TAILPIPE 3.706
6 Cyl.	3977205	6262201-A 6262202-BCD	—	3973803-AB 3977973-CD	—	3926900	3980767(r.r.)AB 3853659(r.r.)CD 9790493(fr.)
307	3983309	3983311-A 3983310-BCD	3973853	3973804-AB 3977974-CD	—	—	9790492(fr.) 3980768(r.r.)AB 3853660(r.r.)CD
350 w/2BC (exc. dual exh.)	3983320	3983321-AE 3983322-BCD	3973853	3973835-CDIN 3973804-ABERS 3973838-ABEPQ 3977974-CDO	—	—	3853660(r.r.)CD 3980768(r.r.)ABERS 3949752(r.r.)ABEPQ 9790492(fr.)
350 (2BC w/dual exh.)	3983315(L.H.) CD 3983316(R.H.) CD 3983317(L.H.) AB 3983318(R.H.) AB	3930762(R.H.) BCD 3952877(L.H.) BCD 3952875(L.H.)A 3930758(R.H.)A	—	3977973(L.H.) CD 3977974(R.H.) CD	3973827(L.H.) AB 3973828(R.H.) AB	—	9790492(fr.) 3853660(r.r. R.H.) CDE 3853659(r.r. L.H.) CD 9790493(fr. L.H.) 3980768(r.r. R.H.) AB 3980767(r.r. L.H.) AB
350 w/4BC (exc. dual exh.)	3983320	3983322-BCD 3983321-AE	3973853	3973835-CDIN 3973804-ABERS 3973838-ABEPQ 3977974-CDO	—	—	1382594(fr.) 3853660(r.r.)CD 3980768(r.r.)ABERS 3949752(r.r.)ABEPQ
350 (4BC w/dual exh.)	3983315(L.H.) CD 3983316(R.H.) CD 3983317(L.H.) AB 3983318(R.H.) AB	3930762(R.H.) BCD 3952877(L.H.) BCD 3952875(L.H.)A 3930758(R.H.)A	—	3977973(L.H.) CD 3977974(R.H.) CD	3973827(L.H.) ABE 3973828(R.H.) ABE	—	3853660(r.r. R.H.) CDE 3853659(r.r. L.H.) CD 9790493(fr. L.H.) 9790492(fr. R.H.) 3980768(r.r. R.H.) AB 3980767(r.r. L.H.) AB
396	3983320	3930765(L.H.)A 3930766(R.H.)A 3930767(L.H.)D 3930768(R.H.)D	—	3983387(L.H.) DU 3983388(R.H.) DU 3982173(L.H.) DW 3982174(R.H.) DW	3973857(L.H.)A 3973858(R.H.)A 3983386-D	—	3853660(r.r. R.H.) CDE 3853659(r.r. L.H.)D 3974672(r.r. R.H.)A 3974671(r.r. L.H.)A 9790493(fr. L.H.) 9790492(fr. R.H.)
400 w/2BC (exc. dual exh.)	3983320	3983321	— 3973853	— 3973838	—	—	9790493(fr.) 3949752(r.r.)
400 (2BC w/dual)	3983317(L.H.) 3983318(R.H.)	3930758(R.H.) 3952875(L.H.)	—	—	3973827(L.H.)E 3973828(R.H.)E	—	3853660(r.r. R.H.) CDE 9790492(fr. R.H.) 9790493(fr. L.H.) 3980768(r.r. R.H.) AB 3980767(r.r. L.H.) AB
400 w/4BC	3983320	3930765(L.H.) AE 3930766(R.H.) AE 3930767(L.H.) BCD 3930768(R.H.) BCD	—	3983387(L.H.) CDU 3983388(R.H.) CDU 3982173(L.H.) CDW 3982174(R.H.) CDW	3974755(L.H.) ABE 3974756(R.H.) ABE 3983386-CD	—	9790492(fr. R.H.) 9790493(fr. L.H.) 3980767(L.H. r.r.) ABE 3980768(R.H. r.r.) ABE 3853660(r.r.)CD
454	3983320	3930765(L.H.)A 3930766(R.H.)A 3930767(L.H.)D 3930768(R.H.)D	—	3983387(L.H.)DU 3983388(R.H.)DU 3982173(L.H.)DW 3982174(R.H.)DW	3973857(L.H.)A 3973858(R.H.)A 3983386-D	—	9790493(fr. L.H.) 3925121(L.H.)JE 3974671(r.r. L.H.)L 3974672(r.r. R.H.)L 3853660(r.r. R.H.)

A. Coupe, Conv.  
B. Sedan  
C. Sta. Wag.  
D. El Camino

E. Monte Carlo  
I. w/E extension  
K. exc. Monte Carlo  
L. Muffler and exh. pipe r.r. hanger asm.

N. exc. P.G.  
O. w/P.G.  
P. w/H.D. Suspension  
Q. w/4-Spd.

R. exc. 4-Spd.  
S. exc. H.D. Suspension  
T. without Pipes  
U. reso. tail  
W. muff. to reso.

**FUEL—EXHAUST—CARBURETION**

**1970 NOVA EXHAUST CHART**

NOTE: See Dealer Price Schedule for Applicable Prices.

ENGINE	MUFFLER 3.701	EXHAUST PIPE 3.609	TAILPIPE 3.705	RESONATOR 3.705	HANGER ASM. EXHAUST 3.616	HANGER ASM. TAILPIPE 3.706
4 Cyl.	3984559	3975692	3975586	—	3900033	3964858
6 Cyl.	3984559	3975693	3975586	—	3967826	3964858
307 (exc. dual exh.)	344616	3975694	3975586	—	3967826	3964858
307 w/dual exh.	3983035	3972279(frnt. L.H.) 3972280(frnt. R.H.) 3983029(r.r. L.H.) 3983030(r.r. R.H.)	3975585(L.H.) 3975586(R.H.)	3909959 —	3920204(R.H.) 3930033(L.H.)	3964858(R.H.) 3965633(L.H.)
350 w/2BC (exc. dual exh.)	344616	3975694	3975586	—	3967826	3964858
350 (2BC w/dual exh.)	3983035	3972279(frnt. L.H.) 3972280(frnt. R.H.) 3983029(r.r. L.H.) 3983030(r.r. R.H.)	3975585(L.H.) 3975586(R.H.)	3909959	3920204(R.H.) 3930033(L.H.)	3964858(R.H.) 3965633(L.H.)
350 w/4BC	3983035	3972279(frnt. L.H.) 3972280(frnt. R.H.) 3983029(r.r. L.H.) 3983030(r.r. R.H.)	3975585(L.H.) 3975586(R.H.)	3909959	3920204(R.H.) 3930033(L.H.)	3964858(R.H.) 3965633(L.H.)
396	3983035	3972279(frnt. L.H.) 3972280(frnt. R.H.) 3983029(r.r. L.H.) 3983030(r.r. R.H.)	3975585(L.H.) 3975586(R.H.)	3909959	3920204(R.H.) 3930033(L.H.)	3964858(R.H.) 3965633(L.H.)

**1970 CAMARO EXHAUST CHART**

NOTE: See Dealer Price Schedule (P&A 26) for Applicable Prices.

ENGINE	MUFFLER 3.701	EXHAUST PIPE 3.609	TAILPIPE 3.705	HANGER ASM. 3.616	HANGER ASM. 3.706
(6 cyl.)	3984559	3972209	3984558		3972214-A 3983053-B
307	344616	3972222	3984558		3972214-A 3983053-B
350 w/2BC	344616	3972222	3984558		3972214-A 3983053-B
350 w/4BC	3983066	3972229 (L.H.) 340360 (R.H.)	3984569 (L.H.) 3984570 (R.H.)		3972214-A 3983053-B
396, 454	3983066	3972227 (L.H.) 3972228 (R.H.)	3984569 (L.H.) 3984570 (R.H.)		3972214-A 3983053-B

A. Muffler

B. Tailpipe

**FUEL—EXHAUST—CARBURETION**

**1971 PASSENGER EXHAUST CHART**

NOTE: See Dealer Price Schedule for Applicable Prices.

ENGINE	MUFFLER 3.701	EXHAUST PIPE 3.609	CROSS- OVER 3.609	RESONATOR w/TAILPIPE 3.702	TAILPIPE 3.705	EXHAUST PIPE HANGER 3.616	TAILPIPE HANGERS 3.706
6 Cyl.	3996381	3993796	—	—	3988165	1235535	1237363
350 w/2BC	1240538	331248	3993787	—	3988166-A 3993702-B	1238326-B 1242421-A	1235537-B 1241562-A
350 w/4BC	1240538	331248	3993787	—	3988166-A 3993702-B	1238326-B 1242421-A	1235537-B 1241562-A
400 w/2BC	1240538	331248	3993787	—	3988166-A 3993702-B	1238326-B 1242421-A	1235537-B 1241562-A
400 w/4BC	1240538-AE 3993688-B 3993688-AD	3996387(L.H.)A 3996388(R.H.)A 3992946-B 3992946-AD	—	3996391(L.H.)A 3996392(R.H.)A 3992948-B 3993719-AD	1242725-B 3993718-AD 3996389-AE 3996390-AE	1238326-B 1242421-A	1237363(L.H.)AC 1241562-A 1235537-B 1236948-BC
454	1240538-A 3993688-B	3996387(L.H.)A 3996388(R.H.)A 3992946-B	—	3996391(L.H.)A 3996392(R.H.)A 3992948-B	1242725-B 3996389-AE 3996390-AE	1238326-B 1242421-A	1237363(L.H.)A 1235537-B 1236948-BC

A. exc. Sta. Wag.  
D. exc. Dual Exhaust

B. Sta. Wag.  
E. w/Dual Exhaust

C. Resonator Tailpipe

**1971 NOVA EXHAUST CHART**

NOTE: See Dealer Price Schedule for Applicable Prices.

ENGINE	MUFFLER 3.701	EXHAUST PIPE 3.609	RESONATOR 3.702	TAILPIPE 3.705	HANGER ASM. EXHAUST 3.616	HANGER ASM. TAILPIPE 3.706
6 Cyl.	3984559	3975693	—	3998631	3967826	3964858 (frt.) 3996375 (r.r.)
307, 350 w/2BC	344616	344603	—	3998631	3967826	3964858 (frt.) 3996375 (r.r.)
350 w/4BC	3983035	3972280 (frt. L.H.) 3972279 (frt. R.H.) 3983029 (r.r. L.H.) 3983030 (r.r. R.H.)	3909959	3998257 (L.H.) 3998256 (R.H.)	3930033 (L.H.) 3992507 (R.H.)	3965633 (L.H.) 3964858 (frt.) 3996375 (R.H. r.r.) 3996376 (L.H. r.r.)

**FUEL—EXHAUST—CARBURETION**

**1971 CHEVELLE EXHAUST CHART**

NOTE: See Dealer Price Schedule for Applicable Prices.

ENGINE	MUFFLER 3.701	EXHAUST PIPE 3.609	CROSS- OVER 3.609	TAILPIPE 3.705	RESONATOR w/TAILPIPE 3.702	HANGER ASM. EXHAUST 3.616	HANGER ASM. TAILPIPE 3.706
6 Cyl.	3977205	6262202-BCD 6262201-A	—	3977973-CD 3973803-AB	—	—	3853659 (r.r.)CD 3980767 (r.r.)AB 9790493 (frt.)
307	3983309	3983311-AL 3983310-BCD	3993787	3977974-CD 3973804-AB	—	—	9790492 (frt.) 3853660 (r.r.)CD 3980768 (r.r.)AB
350 w/2BC	3983320	3983321-AEL 3983322-BCD	3993787	3973835-CDF 3973804-ABEIJ 3973838-ABEGH	—	—	3949752 (r.r.) ABEGH 3980768 (r.r.) ABEIJ 3853660 (r.r.)CD 9790492 (frt.)
350 w/4BC	3983320	3983321-AEL 3983322-BCD	3993787	3973835-CDF 3973804-ABEIJ 3973838-ABEGH	—	—	3949752 (r.r.) ABEGH 3980768 (r.r.) ABEIJ 3853660 (r.r.)CD 9790492 (frt.)
400 w/2BC	3983320	3983321	3993787	3973838	—	—	3949752 (r.r.) 9790493 (frt.)
400 w/4BC	3983320	3930765 (L.H.) AE 3930766 (R.H.) AE 3930767 (L.H.) BCD 3930768 (R.H.) BCD	—	3983387 (L.H.) CDU 3983388 (R.H.) CDU 3982173 (L.H.) CDW 3982174 (R.H.) CDW	3974755 (L.H.) ABE 3974756 (R.H.) ABE 3983386-CDK	—	9790493 (L.H. frt.) 9790492 (R.H. frt.) 3980767 (L.H. r.r.) ABE 3980768 (R.H. r.r.) ABE
454 (exc. Sp.)	3983320	3930765 (L.H.) AE 3930766 (R.H.) AE 3930767 (L.H.) C 3930768 (R.H.) C	—	3983387 (L.H.) CU 3983388 (R.H.) CU 3982173 (L.H.) CW 3982174 (R.H.) CW	3974755 (L.H.) E 3974756 (L.H.) E 3983386-CK 3973857 (L.H.) A 3973858 (R.H.) A	—	9790493 (L.H. frt.) 9790492 (R.H. frt.) 3980767 (L.H.)E 3980768 (R.H.)E 3974671 (L.H. r.r.) A 3974672 (R.H. r.r.) A
454 Sp. H/Per.	3983320	3930765 (L.H.) AE 3930766 (R.H.) AE 3930767 (L.H.) C 3930768 (R.H.) C	—	3983387 (L.H.) CU 3983388 (R.H.) CU 3982173 (L.H.) CW 3982174 (R.H.) CW	3973857 (L.H.) A 3973858 (R.H.) A 3983386-CK	—	9790493 (L.H. frt.) 9790492 (R.H. frt.) 3974671 (L.H. r.r.) A 3974672 (R.H. r.r.) A

A. Spt. Cpe.  
B. Sedan  
C. El Camino

D. Sta. Wag.  
E. Monte Carlo  
F. w/Extension

G. w/H.D. Suspension  
H. w/4-Spd.  
I. (exc. H.D. Suspension)

J. (exc. 4-Spd.)  
K. without Pipes  
L. Conv.

U. reso. tail  
W. muff to reso.

**FUEL—EXHAUST—CARBURETION**

**1971 CAMARO EXHAUST CHART**

NOTE: See Dealer Price Schedule for Applicable Prices.

ENGINE	MUFFLER 3.701	EXHAUST PIPE 3.609	TAILPIPE 3.705	HANGER ASM. TAILPIPE 3.706
6 Cyl.	3984559	3972209	3992575	3983053
307, 350 w/2BC	3984561	340357	3992575	3983053
350 w/4BC	3996331	3998604 (R.H.)D 3998603 (L.H.) 340359 (R.H.)C	3992573 (L.H.) 3992574 (R.H.)	3983053
400 w/4BC	3996331	3998601 (L.H.) 3998602 (R.H.)	3992573 (L.H.) 3992574 (R.H.)	3983053

C. exc. Sp. H/Per.

D. Sp. H/Per.

**1972 PASSENGER EXHAUST CHART**

NOTE: See Dealer Price Schedule for Applicable Prices.

ENGINE	MUFFLER 3.701	EXHAUST PIPE 3.609	CROSS- OVER 3.609	RESONATOR w/TAILPIPE 3.702	TAILPIPE 3.705	EXHAUST PIPE HANGER 3.616	TAILPIPE HANGERS 3.706
6 Cyl.	3996381	3993796	—	—	3988165	1242421	1241563
350	1240538	331248	3993787	—	3988166-A 3993702-B	1238326-B 1242421-A	1235537-B 1241562-A
400 w/2BC		331248	3993787	—	3988166-A 3993702-B	1238326-B 1242421-A	1235537-B 1241562-A
402 w/4BC	1240538-D 3993688-E	3996387 (L.H.)A 3996388 (R.H.)A 3992946-E	—	3996391 (L.H.)AD 3996392 (R.H.)AD 3992948-B 3993719-AE	1242725-B 3996389-AD 3996390-AD	1238326-B 1242421-A	1241563 (L.H.)AC 1241562-A 1235537-B 1236948-BC
454	1240538-AD 3993688-B	3996387 (L.H.)AD 3996388 (R.H.)AD 3992946-E	—	3996391 (L.H.)A 3996392 (R.H.)A 3992948-B	1242725-B 3996389-AD 3996390-AD	1238326-B 1242421-A	1241563 (L.H.)A 1235537-B 1236948-BC
A. exc. Sta. Wag. D. w/dual exh.		B. Sta. Wag. E. Single exh.		C. Resonator Tailpipe			

**FUEL—EXHAUST—CARBURETION**

**1972 NOVA EXHAUST CHART**

NOTE: See Dealer Price Schedule for Applicable Prices.

<b>ENGINE</b>	<b>MUFFLER 3.701</b>	<b>EXHAUST PIPE 3.609</b>	<b>RESONATOR 3.702</b>	<b>TAILPIPE 3.705</b>	<b>HANGER ASM. EXHAUST 3.616</b>	<b>HANGER ASM. TAILPIPE 3.706</b>
6 Cyl.	3984559	332640	—	3998631	3967826	3964858 (frt.) 3996376 (r.r.)
307, 350 w/2BC	344616	344603	—	3998631	3967826	3964858 (frt.) 3996376 (r.r.)
350 w/4BC	6264040	6264035 (L.H.) 6264036 (R.H.)	—	3998257 (L.H.) 3998256 (R.H.)	3930033 (L.H.) 3992507 (R.H.)	3965633 (L.H.) 3964858 (frt.) 3996375 (R.H. r.r.) 3996376 (L.H. r.r.)

**FUEL—EXHAUST—CARBURETION**

**1972 CHEVELLE EXHAUST CHART**

NOTE: See Dealer Price Schedule for Applicable Prices.

ENGINE	MUFFLER 3.701	EXHAUST PIPE 3.609	CROSS- OVER 3.609	TAILPIPE 3.705	RESONATOR w/TAIPIPE 3.702	HANGER ASM. EXHAUST 3.616	HANGER ASM. TAILPIPE 3.706
6 Cyl.	3996381	6262201-A 6262202-BCD	—	3977973-CD 3973803-AB	—	3926900	3853659 (r.r.)CD 3980767 (r.r.)AB 9790493 (frt.)
307	3983309	3983311-AL 3983310-BCD	3993787	3977974-CD 3973804-AB	—	—	9792594 (frt.) 3853660 (r.r.) CD 3980768 (r.r.)AB
350 w/2BC	3983320	3983321-AEL 3983322-BCD	3993787	3973835-CDF 3973804-ABEIJ 3973833-ABEGH	—	—	3949752 (r.r.) ABEGH 3980768 (r.r.) ABEIJ 3853660 (r.r.)CD 9790492 (frt.)
350 w/4BC	3983320	3983321-AEL 3983322-BCD	3993787	3973835-CDF 3973804-ABEIJ 3973838-ABEGH	—	—	3949752 (r.r.) ABEGH 3980768 (r.r.) ABEIJ 3853660 (r.r.)CD 9790492 (frt.)
*402 w/4BC	3983320 (L.H.) 6271628 (R.H.)	3930765 (L.H.) AE 3930766 (R.H.) AE 3930767 (L.H.) BCD 3930768 (R.H.) BCD	—	3983387 (L.H.) CDU 3983388 (R.H.) CDU 3982173 (L.H.) CDW 3982174 (R.H.) CDW	3974755 (L.H.) ABEN 3974756 (R.H.) ABEN 3983386-CDK 3973857 (L.H.) ALM 3973858 (R.H.) ALM	—	9790493 (L.H. frt.) 9790492 (R.H. frt.) 3980767 (L.H. r.r.) ABEN 3980768 (R.H. r.r.) ABEN 3974671 (L.H. r.r.) ALM 3974672 (R.H. r.r.) ALM
454	3983320 (L.H.) 6271628 (R.H.)	3930765 (L.H.) AE 3930766 (R.H.) AE 3930767 (L.H.) C 3930768 (R.H.) C	—	3933387 (L.H.) CU 3983388 (R.H.) CU 3982173 (L.H.) CW 3982174 (R.H.) CW	3974755 (L.H.) E 3974756 (L.H.) E 3983336-CK 3973857 (L.H.) AL 3973858 (R.H.) AL	—	9790493 (L.H. frt.) 9790492 (R.H. frt.) 3980767 (L.H.)E 3980768 (R.H.)E 3974671 (L.H. r.r.) AL 3974672 (R.H. r.r.) AL

A. Spt. Cpe.  
B. Sedan  
C. El Camino

D. Sta. Wag.  
E. Monte Carlo  
F. w/extension

G. W/H.D. Suspension  
H. w/4-Spd.  
I. (exc. H.D. Suspension)

J. (exc. 4-Spd.)  
K. without Pipes  
L. Conv.

M. SS  
N. (exc. SS)  
U. reso. tail  
W. muff. to reso.

**1972 CAMARO EXHAUST CHART**

NOTE: See Dealer Price Schedule for Applicable Prices.

<b>ENGINE</b>	<b>MUFFLER 3.701</b>	<b>EXHAUST PIPE 3.609</b>	<b>TAILPIPE 3.705</b>	<b>HANGER ASM. TAILPIPE 3.706</b>
6 Cyl. 307, 350 w/2BC	3984559 3984561	3972209 340357	3992575 3992575	3983053 3983053
350 w/4BC	3996331	3998604 (R.H.)D 3998603 (L.H.) 340359 (R.H.)C	6272115 (L.H.) 6272116 (R.H.)	3983053
402 w/4BC	3996331	3998601 (L.H.) 3998602 (R.H.)	6272115 (L.H.) 6272116 (R.H.)	3983053

C. exc. Sp. H/Per.

D. Sp. H/Per.



**FUEL—EXHAUST—CARBURETION**

**1973 PASSENGER EXHAUST CHART**

ENGINES .....	6 Cyl.	350/400 w/2BC (exc. Sta. Wag.) 345 150 A	350/400 w/2BC (Sta. Wag.)	350 w/4BC	454 (exc. Sta. Wag.)	454 (Sta. Wag.)
<b>3.609</b> EXTENSION, exhaust pipe .....	3890382	3890382	3890382	3890382	3890689	3890689
<b>3.611</b> PACKING, exhaust pipe .	3731062	3731062	3731062	3731062	3768711	3768711
<b>3.609</b> EXHAUST PIPE .....	3993796	3993787 A 331248	3993787 A 331248	331249 LH 331250 RH	3996387 LH 3996388 RH	3992946
<b>3.708</b> CLAMP UNIT, exhaust pipe to hanger .....	1240744		3857547			
<b>3.704</b> BRACKET, exhaust pipe .	3993697					
<b>3.704</b> SUPPORT, exhaust pipe .	3993699					
<b>3.708</b> CLAMP UNIT, exhaust pipe to muffler .....	1240744	1240745	1240745	1240745	3857547	3633128
<b>3.708</b> CLAMP UNIT, crossover to exhaust pipe .....		1240744	1240744			
<b>3.616</b> HANGER ASSY., exhaust pipe .....			1238326			1238326
<b>3.616</b> REINFORCEMENT, exhaust pipe hanger ...			1236947			1236947
<b>3.701</b> MUFFLER .....	1242700	351208	351208	331251 LH 331252 RH	1240538 LH 1240538 RH	3993688
<b>3.708</b> CLAMP UNIT, muffler to tailpipe .....	1240744	1240744	3754883 B	1240744	1240744	1240745
<b>3.706</b> BRACKET, tailpipe (front)	1243532	1243532	1236950 RH	1243532	1243532	1236950 RH
<b>3.706</b> HANGER, tailpipe (front) .	1242421	1242421	1235537 LH 1236948 RH	1242421	1242421	1235537 LH 1236948 RH
<b>3.705</b> SHIELD, tailpipe right side .....			410020			410020
<b>3.702</b> RESONATOR .....					3996391 LH 3996392 RH	3992948
<b>3.706</b> HANGER, tailpipe (rear) .	1241562	1241562		1241562 RH 1241563 LH	1241562 RH 1241563 LH	
<b>3.706</b> BRACKET, tailpipe (rear)	1237366	1237366		1237366	1237366	
<b>3.708</b> CLAMP, tailpipe hanger (rear) .....	1240744	1240744		1240744	1240744	
<b>3.705</b> TAILPIPE .....	331300	1242684	325894	331211 LH 331212 RH	3996389 LH 3996390 RH	1242725

*A-El Camino*

**1973 CHEVELLE EXHAUST CHART**

*A-Crossover*

ENGINES .....	6 CYL.	307, 350 w/2BC	350 w/4BC	454
<b>3.611</b> PACKING, exhaust pipe .	3731062	3731062	3731062	3768711
<b>3.609</b> EXTENSION, exhaust pipe .....	3890382	3890382	3890382	3890689

**FUEL—EXHAUST—CARBURETION**

<b>3.701 MUFFLER, Engine Exhaust (Con't)</b>				
<b>3.609</b>		334983 LH A, D	345183 LH A, D	345185 LH A, B, E, D
	1242698 B	338014 C	334984 RH A, D	334990 RH A, D
		1240346 A, D	334985 LH B, E	334991 LH B, E
		1240347 B, E	334986 RH B, E	334992 RH B, E
<b>3.708</b>	CLAMP UNIT, crossover to exhaust pipe .....	1240745		
<b>3.708</b>	CLAMP UNIT, exhaust pipe to muffler .....	1240744	1240745	1240745
<b>3.701</b>	MUFFLER .....	1242700	338736	345187
<b>3.708</b>	CLAMP UNIT, muffler to tailpipe .....	1240744	1240744	1240744
<b>3.706</b>	BRACKET, muffler to tailpipe .....	1243532	1243532	1243532
<b>3.706</b>	HANGER ASSY., muffler to tailpipe .....	1242421	326739	1242421
<b>3.702</b>	RESONATOR, w/pipe ...			330909 LH A, F 330910 RH A, F 330911 LH D 330912 RH D
<b>3.708</b>	CLAMP, resonator to frame .....			330916 H
<b>3.706</b>	BRACKET, resonator to frame .....			330919 LH H 330920 RH H
<b>3.706</b>	HANGER, resonator to frame .....			1238742 H
	<i>A-Spt. Cpe. B-4-Dr. C-Crossover D-Monte Carlo E-El Camino F-Spt. Sed. G-Sta. Wag. H(exc. Sta. Wag.) J-2nd design pipe is 2 1/4" dia. the last 8" of pipe K-1st design pipe is a 2" dia. M-Tailpipe replaces production pipe and resonator asm.</i>			
<b>3.708</b>	CLAMP UNIT, hanger to tailpipe .....	1240642 G 1240744 A, F	1240642 G, E 1240744 A, F, D	1240744
<b>3.706</b>	BRACKET, hanger to tailpipe .....	1240641 G 1241093 A, F	1240640 G, E 1241093 A, F, D	1241093
<b>3.706</b>	HANGER ASSY., hanger to tailpipe .....	1238742 G 1240616 A, F	1238742 G, E 1240616 A, F, D	1240616
<b>3.705</b>	TAILPIPE .....	1240899 G 330925 A, F	334910 G, E 330926 A, F 1240506 D	1240506 RH D 1240507 LH D 330925 LH A, F 330926 RH A, F 330913 LH E 330914 RH E
<b>3.705</b>				330913 LH E 330914 RH E 330918 RH G, M 330917 LH G, M
<b>3.708</b>	CLAMP UNIT, pipe to resonator .....			1240744 G
	<i>A-Spt. Cpe. B-4-Dr. C-Crossover</i>			

**FUEL—EXHAUST—CARBURETION**

**3.701 MUFFLER, Engine Exhaust (Con't)**

*D-Monte Carlo  
E-El Camino  
F-Spt. Sed.  
G-Sta. Wag.  
H-(exc. Sta. Wag.)*

**1973 NOVA EXHAUST CHART**

ENGINE .....	6 Cyl.	307 350 w/2BC	350 w/4BC
<b>3.611</b> PACKING, exhaust pipe .	3731062	3731062	3731062
<b>3.609</b> EXTENSION, exhaust pipe .....	3748781	3748781	3748781
<b>3.609</b> EXHAUST PIPE .....	332640	344603	6264035 LH 6264036 RH
<b>3.708</b> U-BOLT & CLAMP UNIT, exhaust pipe to muffler	1240744	1240744	3857547
<b>3.701</b> MUFFLER .....	332624	332626	6264040
<b>3.704</b> SUPPORT, muffler .....	3983052	3983052	
<b>3.706</b> BRACKET, muffler & tailpipe to support .....	330232	330232	330232
<b>3.706</b> INSULATOR, muffler & tailpipe to bracket .....	3996318	3996318	3996318
<b>3.708</b> CLAMP, tailpipe .....	3992572 332607	3992572 332607	3992572 332607
<b>3.705</b> TAILPIPE .....	1246224	1246224	1246224 RH 344607 LH
<b>3.706</b> HANGER, tailpipe .....	3983053	3983053	3983053

**FUEL—EXHAUST—CARBURETION**

**1973 CAMARO EXHAUST CHART**

ENGINE .....	6 Cyl.	307 350 w/2BC	350 w/4BC	
<b>3.611</b> PACKING, exhaust pipe . . .	3731062	3731062	3731062	
<b>3.609</b> EXTENSION, exhaust pipe .....	3748781	3748781	3748781	
<b>3.609</b> EXHAUST PIPE .....	3972209	340357	340358 LH 340359 RH	
<b>3.701</b> MUFFLER .....	3984559	344616	3996331	
<b>3.708</b> U-BOLT & CLAMP UNIT, exhaust pipe to muffler	1240744	1240744	3857547	
<b>3.706</b> BRACKET, muffler & tailpipe to support ....	3996317	3996317	3996317	
<b>3.706</b> SUPPORT MUFFLER ....	3983052	3983052		
<b>3.706</b> INSULATOR, muffler & tailpipe to bracket ....	3996318	3996318	3996318	
<b>3.708</b> CLAMP, tailpipe .....	332607 3992572	332607 3992572	332607 3992572	
<b>3.705</b> TAILPIPE .....	3992575	344619	344620 RH	LH
<b>3.706</b> HANGER, tailpipe .....	3983053	3983053	3983053	

**1971-1973 VEGA EXHAUST CHART**

ENGINE .....	140
<b>3.609</b> EXHAUST PIPE .....	325176
<b>3.701</b> MUFFLER .....	6258546
<b>3.705</b> TAILPIPE .....	6263050(1½ O.D.)
<b>3.706</b> HANGER, tailpipe .....	339035(A) 6264311(B)

*NOTE A: When used in place of 3997246 it is necessary to use 1-9425369 Bolt and 1-187119 Washer.*

*NOTE B: Muffler and Tailpipe.*

**FUEL—EXHAUST—CARBURETION**

**1974 PASSENGER EXHAUST CHART**

ENGINE . . . . .	350 w/2BC	350 w/4BC	400 w/2BC	400 w/4BC	454
<b>3.609</b> EXTENSION, exhaust pipe . . . . .	3890382	3890382	3890382	3890382	3890689
<b>3.611</b> PACKING, exhaust pipe . . . . .	3731062	3731062	3731062	3731062	3768711
<b>3.609</b> EXHAUST PIPE . . . . .	343291 A	343291 A	343291 A	343291 A	338713 LH D 3996387 LH E 3996388 RH 454
<b>3.704</b> BRACKET, Hanger . . . . .	350 w/2BC 1243880	350 w/4BC 1243880	400 w/2BC	400 w/4BC 1243880	
<b>3.708</b> CLAMP UNIT, exhaust pipe to hanger . . . . .	1240744	1240744	1240744	1240744	1240744
<b>3.708</b> CLAMP UNIT, exhaust pipe to muffler . . . . .	1240745	1240745	1240745	1240745	1240745
<b>3.708</b> CLAMP UNIT, crossover to exhaust pipe . . . . .	1240744	1240744	1240744	1240744	
<b>3.704</b> HANGER ASSY., exhaust pipe . . . . .	1238326 B		1238326 B		1238326 RH B 1243905 LH B
<b>3.616</b> REINFORCEMENT, exhaust pipe hanger . . . . .				1236947 B	1236947 B
<b>3.701</b> MUFFLER . . . . .	338736	338736	338758 C 338736 B	338758 C 338736 B	343239
<b>3.708</b> CLAMP UNIT, muffler to tail pipe . . . . .	1240744	1240744	1240744	1240744	1240744 C 1240745 B
<b>3.706</b> BRACKET, tailpipe (front) . . . . .	1243532 C 1236950 B	1243532 C	1243532 C 1236950 B	1243532 C	1243532 C 1236950 B
<b>3.706</b> HANGER, tailpipe (front) . . . . .	1242421	1242421	1242421	1235537 LH B 1236948 RH B 1242421 C	1242421 C 1245533 C
<b>3.705</b> SHIELD, tailpipe right side . . . . .		1243881 B		1243881 B	1243881 B
<b>3.702</b> RESONATOR . . . . .				343251 B	338767 LH B 338768 RH B 338769 LH C 338770 RH C
<b>3.706</b> HANGER, tailpipe (rear) . . . . .	1245533 C 1235537 B	1245533 C 1235537 B	1245533 C 1235537 B	1245533 C 1235537 B	1245533 C
<b>3.706</b> BRACKET, tailpipe (rear) . . . . .	1243880 C 1243882 B	1243880 C 1243882 B	1243880 C 1243882 B	1243880 C 1243882 B	1243880 C 1243882 B
<b>3.708</b> CLAMP, tailpipe hanger (rear) . . . . .	1240744	1240744	1240744	1240744	1240744
<b>3.705</b> TAILPIPE . . . . .	1243644 C	1243644 C	1243644 C	1242725 B 1243644 C	343289 B

A-w/Crossover      C-exc. Sta. Wag.      E-exc. Police  
B-Sta. Wag.      D-Police

**FUEL—EXHAUST—CARBURETION**

**1974 CHEVELLE EXHAUST CHART**

ENGINE	6 Cyl.	350 w/2BC	350 w/4BC	400 w/2BC	400 w/4BC	454
<b>3.611</b> PACKING, exhaust pipe	3731062	3731062	3731062	3731062	3731062	3731062
<b>3.609</b> EXTENSION, exhaust pipe	3890382	3890382	3890382	3890382	3890382	3890689
<b>3.609</b> EXHAUST PIPE	1242698 C 1242699 A	345150 C, D 345152 A, B	345150 C, D 345152 A, B	345150 C, D 345152 A, B	345150 C, D 345152 A, B	345183 LH A, B 334990 RH A, B 345185 LH C, D 345186 RH C, D
<b>3.708</b> CLAMP UNIT, crossover to exhaust pipe		1240745	1240745	1240745	1240745	
<b>3.708</b> CLAMP UNIT, exhaust pipe to muffler	1240744	1240745	1240745	1240745	1240745	1240745
<b>3.701</b> MUFFLER	1242700	338736 F	338736 F	340823	340823	345187
<b>3.705</b> PIPE	340890	340890	340890	340890	340890	340890
<b>3.708</b> CLAMP UNIT, muffler to tailpipe	1240744	1240744	1240744	1240744	1240744	1240744
<b>3.706</b> BRACKET, muffler to tailpipe	1243532	1243532	1243532	1243532	1243532	1243532
<b>3.706</b> HANGER ASSY., muffler to tailpipe	357220	357220	357220	357220	357220	357220
<b>3.702</b> RESONATOR, w/pipe						340883 LH 340884 RH
<b>3.708</b> CLAMP, resonator to frame						1240744
	6 Cyl.	350 w/2BC	350 w/4BC	400 w/2BC	400 w/4BC	454
<b>3.706</b> HANGER, resonator to frame	360023	360023	360023	360023	360023	1244015
<b>3.708</b> CLAMP UNIT, hanger to tailpipe	1240744	1240744	1240744	1240744	1240744	1240744
<b>3.706</b> BRACKET, hanger to tailpipe	1241093 A, C	1241093 A, C	1241093			
<b>3.706</b> HANGER ASSY., hanger to tailpipe	1244015 A, C	1242907 H	1242907 H	1242907 H	1242907 H	1242906 RH H
<b>3.705</b> TAILPIPE	340881	340810 H 340890 D 340882 B, J	340890 D 340811 H 340882 B, J	340810 H 340890 D 340882 B, J	340835 D 340811 H 361066 B, J	
<b>3.705</b> PIPE, muffler to resonator						330913 D LH 330917 LH H 330918 RH H
<b>3.708</b> CLAMP UNIT, pipe to resonator						1240744
<b>3.616</b> CLAMP, exhaust pipe hanger	340899					
<b>3.616</b> HANGER ASSY., exhaust pipe	340895					

**FUEL—EXHAUST—CARBURETION**

**3.701 MUFFLER, Engine Exhaust (Con't)**

A-2 Dr.	D-El Camino	F-Single Exhaust	H-Sta. Wag.
B-exc. El Camino	E-Crossover	G-Dual Exhaust	J-exc. Sta. Wag.
C-4 Dr.			

**1974 NOVA EXHAUST CHART**

ENGINE .....	6 Cyl.	350 w/2BC	350 w/4BC
<b>3.611</b> PACKING, exhaust pipe .	3731062	3731062	3731062
<b>3.609</b> EXTENSION, exhaust pipe .....	3748781	3748781	3748781
<b>3.609</b> EXHAUST PIPE .....	332640	344603	344603 A 6264035 LH B 6264036 RH B
<b>3.708</b> U-BOLT & CLAMP UNIT, exhaust pipe to muffler	7240744	1240744	1240744
<b>3.701</b> MUFFLER .....	332624	1245082	1245082 A 6264040 B
<b>3.704</b> SUPPORT, muffler .....	3983052 A	3983052 A	
<b>3.706</b> BRACKET, muffler & tailpipe to support .....	330232	330232	330232
<b>3.706</b> INSULATOR, muffler & tailpipe to bracket .....	340364	340364	340364
<b>3.708</b> CLAMP, tailpipe .....	332607 3992572	332607 3992572	332607 3992572
<b>3.705</b> TAILPIPE .....	344608	1246224	1246224 A 344607 LH B 344608 RH B
<b>3.705</b> SHIELD, underbody exh. pipe heat .....	6 Cyl. —	350 w/2BC 6274352	350 w/4BC 6274352
<b>3.706</b> HANGER, tailpipe .....	340361	340361	340361

*A-Single exhaust  
B-Dual exhaust*

**FUEL—EXHAUST—CARBURETION**

**1974 CAMARO EXHAUST CHART**

ENGINE .....	6 Cyl.	350 w/2BC	350 w/4BC
<b>3.611</b> PACKING, exhaust pipe ..	3731062	3731062	3731062
<b>3.609</b> EXTENSION, exhaust pipe .....	3748781	3748781	3748781
<b>3.609</b> EXHAUST PIPE .....	340356	340357	340357 A 340358 LH B 340359 RH B, D 340360 RH B, C
<b>3.701</b> MUFFLER .....	344314	344616	344616 A 3996331 B
<b>3.708</b> U-BOLT & CLAMP UNIT, exhaust pipe to muffler	1240744	1240744	1240745
<b>3.706</b> BRACKET, muffler & tailpipe to support .....	330232	330232	330232
<b>3.706</b> SUPPORT, muffler .....	3983052	3983052	
<b>3.706</b> INSULATOR, muffler & tailpipe to bracket .....	340364	340364	340364
<b>3.708</b> CLAMP, tailpipe .....	332607 3992572	332607 3992572	332607 3992572
<b>3.705</b> TAILPIPE .....	344620	344620	344620 A 344619 LH B 344620 RH B
<b>3.706</b> HANGER, tailpipe .....	340361	340361	340361

*A-Single exhaust  
B-Dual exhaust  
C-w/Spec. H/Per.  
D-exc. Spec. H/Per.*



**FUEL—EXHAUST—CARBURETION**

**1974 VEGA EXHAUST CHART**

ENGINE .....	140
<b>3.609</b> EXHAUST PIPE .....	339028
<b>3.701</b> MUFFLER .....	342686
<b>3.704</b> BRACKET .....	339036
<b>3.705</b> TAILPIPE .....	342689
<b>3.706</b> HANGER, Tailpipe .....	339035 (A, B) 339040 (C)

*NOTE A: When used in place of 3997246 it is necessary to use 1-9425369 Bolt and 1-187119 Washer.  
NOTE B: Attaches to tailpipe (used w/1½ in. tailpipe).*

**1975 PASSENGER EXHAUST CHART**

ENGINE .....	350 w/2BC	350 w/4BC	400 w/4BC	454 w/4BC
<b>3.609</b> EXHAUST PIPE .....	358062 A 344997 C, D 345000 C, E	358062 A 344997 C	358062 344997 C, D 345000 C, E	344990 H 344988 F 351272 G
<b>3.609</b> EXTENSION, exhaust pipe .....	3890382	3890382	3890382	3890689
<b>3.611</b> PACKING, exhaust pipe ..	3731062	3731062	3731062	3768711
<b>3.701</b> MUFFLER .....	358060 A	358060 A	358061	344991 LH 344992 RH
<b>3.702</b> RESONATOR .....		351223 A, J	351229 B 344998 A, J	351219 LH B 351220 RH B 344993 LH A, J 344994 RH A, J
<b>3.705</b> TAILPIPE .....	351226		351251 B	343289 B
<b>3.705</b> SHIELD, tailpipe (rear) ..			1243881 B	1243881 B
<b>3.706</b> BRACKET, tailpipe hanger .....	1247748 A 360022 L	1247748 A 360022 L	1247748 A 360022 L	1247748 A 360022 L
<b>3.706</b> BRACKET, reso. hanger ..			1236948 B	1236948 B
<b>3.706</b> RETAINER, tailpipe insulation .....	1247746 A	1247746 A	1247746 A	1247746 A
<b>3.706</b> BRACKET, resonator tailpipe .....			1236950 B	1243882 B
<b>3.706</b> HANGER, tailpipe .....	1235537 B 1245533 A 360023 K	1235537 B 1245533 A 360023 K	1235537 B 1245533 A 360023 K	1235537 B 1245533 A 360023 K
<b>3.704</b> HANGER, intermediate pipe .....			1247722 B	1238326 RH B 1243905 LH B
<b>3.616</b> BRACKET, tailpipe .....	351206 A	351206 A	351206 A	351206 A

*A-exc. Sta. Wag.  
B-Sta. Wag.  
C-w/Crossover  
D-w/A.I.R.  
E-exc. A.I.R.  
F-exc. Police  
G-Police  
H-Intermediate exhaust  
J-w/Tailpipe  
K-Universal Hanger for resonator tailpipe.  
L-Bracket Unit for muffler tailpipe hanger.*

**FUEL—EXHAUST—CARBURETION**

**1975 CHEVELLE EXHAUST CHART**

ENGINE . . . . .	6 Cyl.	350 w/2BC	350 w/4BC	400 w/4BC	454 w/4BC
<b>3.609</b> EXHAUST PIPE . . . . .	356876 C, F 358887 E	358887 E 356828 A, C, F	358887 E 356828 A, C, F	358887 E, J 356828 A, C, F	1248348 A, C, F 1248349 E 1248349 E, H
<b>3.609</b> CROSSOVER PIPE, exh. . . . .	339787	351557	351559	351559	351530
<b>3.609</b> EXTENSION, exhaust pipe . . . . .		3890382 G	3890382 G	3890382 G	3890689
<b>3.611</b> PACKING . . . . .	3731062	3731062	3731062	3731062	3768711
<b>3.701</b> MUFFLER . . . . .	356896	358888	358888	358888	351565
<b>3.702</b> RESONATOR . . . . .				351538 A, C 356901 E, F	
<b>3.705</b> TAILPIPE . . . . .	351526 C 361066 RH E, F	367931 A, C 351531 E, F 361066 RH E, F 367931 A, C			351527 LH A 351528 RH A 351525 LH C 351526 RH C, J 361092 LH E, F 361066 RH E, F
<b>3.706</b> INSULATOR . . . . .	1247747	1247747	1247747	1247747	1247747
<b>3.706</b> RETAINER, tailpipe insulation . . . . .	1247746	1247746	1247746	1247746	1247746
<b>3.706</b> BRACKET, tailpipe hanger . . . . .	1247748 360022 L	1247748 360022 L	1247748 360022 L	1247748 360022 L	1247748 360022 L
<b>3.706</b> HANGER ASSY., tailpipe . . . . .	1244015	1247728 A, C 1244015	1247728 A, C 1244015	1248459 RH A, C 1244015	1248459 RH A, C 1247728 A, C
<b>3.706</b> HANGER ASSY., resonator . . . . .			1247728 A	1247728 A, C	
<b>3.706</b> HANGER ASSY., coverover . . . . .	339795				
<b>3.706</b> HANGER UNIT, tailpipe . . . . .	357221 360023 K	357221 360023 K	357221 360023 K	357221 360023 K	357221 360023 K
<b>3.708</b> CLAMP, tailpipe . . . . .				A A, H	338001 A 338002 A, H
<b>3.616</b> CLAMP, exhaust pipe . . . . .	339794				

*A—Sta. Wag.  
 B—exc. Sta. Wag.  
 C—El Camino  
 D—exc. El Camino  
 E—Spt. Cpe.  
 F—Sed.  
 G—C/Over  
 H—w/A.i.R.  
 J—exc. A.I.R.  
 K—Universal hanger for resonator tailpipe.  
 L—Bracket Unit for muffler tailpipe hanger.*

**FUEL—EXHAUST—CARBURETION**

**1975 NOVA EXHAUST CHART**

ENGINE .....	6 Cyl.	262 w/2BC	350 w/2BC	350 w/4BC
<b>3.609</b> EXHAUST PIPE .....	356535 Rr. 367983 Frt. C 357705 Frt. D	356535 Rr.	356535 Rr.	356535 Rr.
<b>3.609</b> EXHAUST, crossover pipe .....		352897	352897	352896 A 352897 B
<b>3.701</b> MUFFLER .....	1250144 356537	1250144 359909	1250144	1250144
<b>3.704</b> SUPPORT, muffler & tailpipe .....	359946 356538 RH 3983052 LH	359946	359946	359946
<b>3.704</b> BRACKET, muffler hanger .....	330232	330232	330232	330232
<b>3.704</b> MUFFLER, support unit ..	359946	359946	359946 356507	359946 356507
<b>3.705</b> TAILPIPE .....	356509 LH	356508 RH 356509 LH	356508 RH 356509 LH	356508 RH 356509 LH
<b>3.706</b> HANGER ASSY., tailpipe	340361	340361	340361	340361
<b>3.706</b> INSULATOR, muffler & tailpipe .....	340364	340364	340364	340364
<b>3.708</b> CLAMP, muffler hanger ..	332607	332607	332607	332607
<b>3.708</b> U BOLT, muffler & tailpipe support .....	3890616	3890616	3890616	3890616

A-w/A.I.R.  
B-exc. A.I.R.  
C-w/Integrated Cyl. Hd.  
D-exc. Integrated Cyl. Hd.

**1975 CAMARO EXHAUST CHART**

ENGINE .....	6 Cyl.	350 w/2BC	350 w/4BC	Sp. H/Per.
<b>3.609</b> EXHAUST PIPE .....	356512	356526	356526	356526 352896 C
<b>3.609</b> EXTENSION, exhaust pipe .....	3748781	3748781	3748781	3748781
<b>3.609</b> BRACKET, muffler & tailpipe supt. ....	330232	330232	330232	330232
<b>3.701</b> MUFFLER .....	369134	1250144	1250144	1250144
<b>3.704</b> MUFFLER SUPPORT UNIT .....	359946	359946	359946	359946
<b>3.704</b> SUPPORT, muffler & tailpipe .....	356538 359946	359946 356504	356504	
<b>3.705</b> TAILPIPE .....	356503	356503 372248	356503 372248	
<b>3.706</b> HANGER, tailpipe .....	340361	340361	340361	340361
<b>3.706</b> INSULATOR, muffler hanger .....	340364	340364	340364	340364
<b>3.708</b> U-BOLT, muffler & tailpipe support .....	3890616	3890616	3890616	3890616

**FUEL—EXHAUST—CARBURETION**

**3.701 MUFFLER, Engine Exhaust (Con't)**

*A-Single exhaust  
B-Dual exhaust  
C-Crossover*

**1975 VEGA EXHAUST CHART**

ENGINE .....	1BC 140	2BC 140	122
3.609 EXHAUST PIPE .....	348271 (A) (F) 353986 (B) (D) 348273 (B, E) 373238 (A, G)	348271 (A, F) 353986 (B, D) 348273 (B, E) 373238 (A, G)	360341 (A) 360342 (B) 342691 (C)
3.609 EXHAUST PIPE .....		369470	
3.701 MUFFLER .....	348279	348275	361056
3.704 BRACKET .....	339036	339036	339036
3.705 TAILPIPE .....	348275	348275	342691
3.705 TAILPIPE .....		1250096	
3.706 HANGER, Tailpipe .....	349515	349515	339058

*NOTE A: Front  
NOTE B: Rear  
NOTE C: Muffler Tail  
NOTE D: 260 Converter  
NOTE E: 160 Converter  
NOTE F: (exc. A.I.R.)  
NOTE G: w/A.I.R.*

**1975 MONZA EXHAUST CHART**

ENGINE .....	140	262
3.609 EXHAUST PIPE .....	373238 (A, G) 348271 (A, F)	353969 (A, D) 353974 (A, E) 353971 (B, D)
3.701 MUFFLER .....	353972	353972
3.702 RESONATOR ASSY. ....	353991	360381
3.706 HANGER, Tailpipe .....	356376	356376

*NOTE A: Front  
NOTE B: Rear  
NOTE D: 260 Converter  
NOTE E: 160 Converter  
NOTE F: (exc. A.I.R.)  
NOTE G: w/A.I.R.*

**3.702 RESONATOR ASSY., Muffler Tail**

*NOTE: See Group 3.701 chart containing 1972 Resonator Assy.*

65-67 Pass. (Sta. Wag.) w/dual exh. (8 cyl.) .....	3939239 L.H.	45.25	w/pipes .....
65-66 Pass. (Sta. Wag.) (327) (2nd design) (exc. H/Per., Sp./H/Per., dual exh.),			
65-66 Pass. (Sta. Wag.) (396) (exc. Sp. H/Per., dual exh.) .....	3874245 L.H.	34.00	w/pipes .....
65-66 Pass. (Sta. Wag.) (8 cyl.),			
67 Pass. (Sta. Wag.) (dual exh. w/4BC) .....	3939240 R.H.	45.25	w/pipes .....
65 Pass. (327) (1st design) (exc. Sta. Wag.),			
65-66 Pass. w/dual exh. (exc. Sta. Wag., 427) .....	3861813 L.H.	34.50	(3861813 stamped on assy.), w/pipes .....
65-66 Pass. w/dual exh. (exc. Sta. Wag., 427) .....	3861814 R.H.	34.50	w/pipes .....
65 Chevelle (Sta. Wag., El Camino) (327, 396) (exc. H/Per., Sp./H/Per.),			
66 Chevelle (Sta. Wag., El Camino) (327) (exc. dual exh.) .....	3878304 1	29.25	w/pipes .....
65 Chevy w/dual exh. (327) (exc. Sta. Wag.),			
66 Chevy w/4BC (exc. Sta. Wag.),			
66-67 Chevy w/dual exh. (exc. Sta. Wag.) .....	3884862 R.H.	34.50	w/pipes .....
65 Pass. (327) (2nd design) (exc. Sta. Wag., dual exh.),			
65-66 Pass. (327, 396) (exc. Sta. Wag., Sp. H/Per., dual exh.) .....	3874241 L.H.	34.50	(3874241 stamped on assy.) w/pipes .....
66-67 Pass. w/4BC (427) (exc. Sta. Wag.) .....	3934013 L.H.	30.75	w/pipes .....

**FUEL—EXHAUST—CARBURETION**

**3.702 RESONATOR ASSY., Muffler Tail (Con't)**

66-67	Pass. w/H/Per. (427) (exc. Sta. Wag.)	3930706 R.H.	38.00	w/pipes
67	Pass. w/dual exh. (exc. Sta. Wag.)	3934023 L.H.	35.50	w/pipes
67	Pass. w/dual exh. (exc. Sta. Wag.)	3930708 R.H.	35.50	w/pipes

*NOTE: Refer to Group 3.701 Chart for 1968-75 Resonators.*

**3.704 BRACE— BRACKET— CLAMP UNIT— HANGER ASSY.— INSULATOR— NUT— RETAINER— SCREW— SUPPORT— WASHER, Muffler**

*NOTE: See Group 3.701 for chart containing Brackets.*

71-72	Pass. (exc. Sta. Wag.)	1243532	1	1.15	BRACKET, muffler and exhaust pipe hanger
71-72	Vega, Monza	339036	1	2.20	BRACKET, muffler and tailpipe
75	Monza	353979	1	2.10	BRACKET, muffler hanger
75	Monza (Hatchback)	349554	1	2.80	BRACKET, resonator and tail
71-74	Vega	2378615	1	.90	CLAMP UNIT, exhaust system (1 <sup>3</sup> / <sub>4</sub> " )
65	Chevelle (327)	3864749	L.H.	2.10	HANGER ASSY., resonator tailpipe (L.H.)
65	Chevelle w/dual exh.	3864750	R.H.	1.85	HANGER ASSY., resonator tailpipe (R.H.)
71-72	Pass. (Sta. Wag.)	1238326	1	1.95	HANGER ASSY., muff. & exh. pipe
62-66	Chevy (exc. 327),				
67	Chevy	3791989	A.R.	.22	INSULATOR, tailpipe front and rear
65-68	Pass.	3782302	A.R.	.16	INSULATOR (rubber-1 <sup>3</sup> / <sub>4</sub> " x 3 <sup>3</sup> / <sub>8</sub> " x 9/ <sub>32</sub> " )
69	Chevy, Camaro (exc. dual exh.),				
70-71	Nova (6 cyl., 8 cyl.) (exc. 4BC, dual exh.),				
72	Nova (exc. 4BC)	3953214	1	.25	INSULATOR, muffler and tailpipe hanger support
67-75	Chevy, Camaro	3792287	A.R.	.34	NUT, muffler and tailpipe front insul. body bracket exh. pipe hanger (5/ <sub>16</sub> "— 18)
62-67	Chevy,				
64	Chevy w/4BC (exc. Sta. Wag.),				
66-67	Chevelle w/A.I.R. (6 cyl.)	3791991	2	.16	RETAINER, tailpipe
64-71	Chevelle,				
72	Chevelle (402, 454)	1323935	A.R.	.16	RETAINER, tailpipe front hanger
70	Pass. (6 cyl.) (exc. A.T.)	3751443	1	.36	RETAINER, exh. pipe insul.
70-75	Camaro	3983051	1	.05	SCREW, muffler hanger clamp
70-72	Camaro (exc. 4BC)	3983052	1	.63	SUPPORT, muffler
75	All (exc. C.A.C.)	3966556	A.R.		WASHER

**3.705 PIPE— EXTENSION— RESONATOR— SHIELD, Muffler Tail**

*NOTE: Refer to Group 3.701 for Chart containing 1968-75 Tailpipes and Shields.*

**PASSENGER**

65-67	(230, 250, 283, 327) (exc. Sta. Wag.)	3934014	1	10.90
65-66	Sta. Wag. (230, 250, 283),			
67	(327) (exc. dual exh., Sta. Wag.)	3934016	1	11.60
65	Sta. Wag. w/dual exh. (327, 396, 409),			
65	w/H/Per. (327)	3859817	L.H.	10.75
65	Sta. Wag. w/dual exh. (327, 396, 409),			
65	w/H/Per. (327)	3861854	R.H.	10.45
65	w/Sp. H/Per. (396) (exc. Sta. Wag.),			
66	(427) (exc. Sta. Wag.),			
67	w/Sp. H/Per. (427) (exc. Sta. Wag.)	3934021	L.H.	22.35
67	(396) (exc. dual exh., Sta. Wag.)	3908045	1	25.25
67	Sta. Wag. (396) (exc. dual exh.)	3908051	1	25.25
67	w/Sp. H/Per. (427) (exc. Sta. Wag.)	3930704	R.H.	22.35

**CHEVY**

62-63	(exc. 9-Pass. Sta. Wag.),			
64-67	(exc. 4BC)	3883670	1	9.75
62-63	(9-Pass. Sta. Wag.)	3793916	1	9.15
64	w/4BC	3793918	R.H.	11.00
65	(Sta. Wag.) (H/Per. w/dual exh.),			
66	(Sta. Wag.) (Sp. H/Per. w/dual exh.),			
67	(Sta. Wag.) w/dual exh. (exc. 327 Sp. H/Per.)	3883676	R.H.	20.50
67	w/dual exh. (exc. Sta. Wag.)	3909984	R.H.	11.90

*NOTE: Refer to Group 3.701 Chart containing 1968-75 Tailpipe.*

**FUEL—EXHAUST—CARBURETION**

**3.705 PIPE— EXTENSION— RESONATOR— SHIELD, Muffler Tail (Con't)**

**CHEVELLE**

64	(exc. Sta. Wag., H/Per., 327),			
65-66	(exc. Sta. Wag., 4BC),			
67	(exc. Sta. Wag., dual exh.) . . . . .	3878301	L.H.	9.75
64-66	(Sta. Wag.) (exc. 4BC),			
67	(Sta. Wag.) (283, 327) (exc. dual exh., Sp. H/Per.) . . . . .	3918056	1	8.65
64	w/4BC (exc. Sta. Wag., H/Per.) .	3853652	R.H.	9.50
64-67	(Sta. Wag.) w/dual exh. . . . .	3918059	L.H.	15.25 (Note 1) . . . . .
64-65	(Sta. Wag.) w/H/Per., Sp. H/Per.,			
66	(Sta. Wag.) w/dual exh. (283, 396) (exc. 2BC),			
67	(Sta. Wag.) w/dual exh. . . . .	3918060	R.H.	15.25 (Note 1) . . . . .
66-67	(S.S.) (396),			
67	w/Sp. H/Per. (327) . . . . .	3901731	L.H.	15.55
66-67	(S.S.) (396),			
67	w/Sp. H/Per. (327) . . . . .	3901732	R.H.	15.55

*NOTE 1 When used on early 67 models it will be necessary to use hanger 3853656.*  
*NOTE: Refer to Group 3.701 Chart containing 1968-75 Tailpipe.*

**CAMARO**

67	(8 cyl.) . . . . .	3932747	L.H.	9.20
67	(8 cyl.) . . . . .	3934874	R.H.	9.20
67	(6 cyl.) . . . . .	3910560	1	7.15

*NOTE: Refer to Group 3.701 Chart for 1968-75 Tailpipes.*

**EL CAMINO**

64	(exc. 4BC),			
65	(283),			
66	(exc. 4BC),			
67	(230, 250, 283, 327) (exc. dual exh., Sp. H/Per.) . . . . .	3918056	1	8.65 (Note 2) . . . . .

*NOTE 2 When used on early 1967 models it will be necessary to use hanger 3853655 or 3853656.*

64-67	w/dual exh. . . . .	3918059	L.H.	15.25
64-65	w/H/Per., Sp. H/Per.,			
64-67	w/dual exh. . . . .	3918060	R.H.	15.25

*NOTE Refer to group 3.701 Chart for 1968-71 Tailpipes.*

**EXTENSION— RESONATOR ASSY.— SHIELD, Muffler Tail**

69	Chevelle w/N.R.E.,			
69	Pass. w/N.R.E. (exc. Sta. Wag.),			
70	Pass., Chevelle w/H.D. Suspension (350),			
70	Pass., Chevelle (400, 454) (exc. Sta. Wag. H/Per., Sp. H/Per.),			
70	Pass. (exc. Sta. Wag., P.G., dual exh.),			
71-72	Chevelle (Deluxe, Malibu, Monte Carlo) w/4-Spd. (350),			
71	Monte Carlo w/2BC (400),			
71-72	Chevelle (Deluxe, Malibu) w/H.D. Suspension (350) (exc. 4-Spd.),			
72	Monte Carlo w/4BC (350) . . . . .	3958961	1	8.85 EXTENSION . . . . .
69-70	Chevelle (396, 454),			
71-72	Chevelle w/Spec. Duct Hood (402),			
71	Chevelle w/Sp. H/Per. (454),			
72	Chevelle (454) . . . . .	3956756	1	9.75 EXTENSION, rear muffler . . . . .
65	Pass. (Sta. Wag.) (327) (2nd design) (exc. H/Per., Sp. H/Per., dual exh.),			
65	Pass. (Sta. Wag.) (396) (exc. Sp. H/Per., dual exh.) . . . . .	3874245	L.H.	34.00 RESONATOR ASSY., w/pipes— (3.702) . . . . .
65-66	Pass. (Sta. Wag.) (8 cyl.),			
67	Pass. (Sta. Wag.) (dual exh. w/4BC) . . . . .	3939240	R.H.	45.25 RESONATOR ASSY., w/pipes— (3.702) . . . . .
65	Pass. (327)(1st design)(exc. Sta. Wag.),			
65-66	Pass. w/dual exh. (exc. Sta. Wag.),			
65	Pass. (409) (exc. Sta. Wag.) . . . . .	3861813	L.H.	34.50 RESONATOR ASSY., w/pipes (3861813 stamped on assy.)— (3.702) . . . . .

**FUEL—EXHAUST—CARBURETION**

**3.705 PIPE— EXTENSION— RESONATOR— SHIELD, Muffler Tail (Con't)**

65-66	Pass. w/dual exh. (exc. Sta. Wag.)	3861814 R.H.	34.50	RESONATOR ASSY., w/pipes— (3.702) . . .
65	Pass. (327) (2nd design) (exc. Sta. Wag., dual exh.)			
65	Pass. (396)(exc. Sta. Wag., Sp./H/Per., dual exh.)	3874241 L.H.	34.50	RESONATOR ASSY., w/pipes (3874241 stamped on assy.)— (3.702) . . . . .
65-67	Pass. (Sta. Wag.) w/dual exh. (8 cyl.)	3939239 L.H.	45.25	RESONATOR ASSY., w/pipes— (3.702) . . .
65	Chevelle (Sta. Wag., El Camino) (327, 396) (exc. H/Per., Sp. H/Per.),			
66	Chevelle (Sta. Wag., El Camino) (327) (exc. dual exh.)	3878304 1	29.25	RESONATOR ASSY., w/pipes— (3.702) . . .
65	Chevy w/dual exh. (327) (exc. Sta. Wag.),			
66	Chevy w/4BC (exc. Sta. Wag.),			
66-67	Chevy w/dual exh. (exc. Sta. Wag.)	3884862 R.H.	34.50	RESONATOR ASSY., w/pipes— (3.702) . . .
66-67	Pass. w/4BC (427) (exc. Sta. Wag.)	3934013 L.H.	30.75	RESONATOR ASSY., w/pipes— (3.702) . . .
66-67	Pass. w/H/Per. (427) (exc. Sta. Wag.)	3930706 R.H.	38.00	RESONATOR ASSY., w/pipes— (3.702) . . .
67	Pass. w/dual exh. (exc. Sta. Wag.)	3934023 L.H.	35.50	RESONATOR ASSY., w/pipes— (3.702) . . .
67	Pass. w/dual exh. (exc. Sta. Wag.)	3930708 R.H.	35.50	RESONATOR ASSY., w/pipes— (3.702) . . .
71-72	Pass. (Sta. Wag.)	410020 1	2.65	SHIELD, tailpipe to u/b . . . . .

**3.706 BRACKET— CLAMP— HANGER ASSY.— INSULATOR— NUT— RETAINER— SCREW— STRAP, Muffler Tail Pipe**

62-64	Chevy,			
64	Chevy w/4BC (exc. Sta. Wag.)	3792994 1	1.35	frt. insulator body, R.H. muff. tail pipe frt. insul. body . . . . .
67	Chevy w/dual exh. (exc. Sta. Wag.)	3792972 1	1.90	rear insulator body . . . . .
69-70	Pass. (8 cyl.)	3947542 A.R.	1.60	tail pipe front hanger to frame . . . . .
62-71	All (exc. Vega)	3996543 A.R.	1.65	BRACKET ASSY., w/insul., exh. pipe, tailpipe . . . . .
62-65	Chevy (exc. 327),			
66-67	Chevy	3791122 1	.84	BRACKET ASSY., rear clamp . . . . .
65-66	Chevy (exc. 327),			
66	Chevy w/Sp. H/Per. (327),			
67	Chevy	3912545 A.R.	2.60	BRACKET ASSY., front . . . . .
65-66	Chevy (dual exh. w/4BC),			
67	Chevy w/dual exh.	3869886 A.R.	2.00	BRACKET ASSY., front . . . . .
65	Chevy (Sta. Wag.) (H/Per., w/dual exh.),			
66	Chevy (Sta. Wag.) w/Sp. H/Per. (283, 327),			
67	Chevy (Sta. Wag.) w/dual exh. . .	3870189 L.H.	1.65	BRACKET ASSY., inter. (L.H.) . . . . .
65	Chevy (Sta. Wag.) (H/Per., w/dual exh.),			
66-67	Chevy (Sta. Wag.) w/Sp. H/Per. (283, 327),			
67	Chevy (Sta. Wag.) w/dual exh. . .	3870194 R.H.	1.25	BRACKET ASSY., rear . . . . .
70-72	Chevelle (Sta. Wag., El Camino) (396, 400, 402, 454)	3982179 L.H.	4.55	BRACKET ASSY., resonator tail pipe . . . . .
70-72	Chevelle (Sta. Wag., El Camino) (396, 400, 402, 454)	3982180 R.H.	4.55	BRACKET ASSY., resonator tail pipe . . . . .
70-72	Camaro	3996317 2	.58	BRACKET ASSY., muffler hanger . . . . .
71	Pass. (exc. Sta. Wag.)			
71	Pass. w/4BC (400) (exc. Sta. Wag.)			reso. tailpipe hanger, . . . . .
71	Pass. (454) (exc. Sta. Wag.)			muffler tailpipe hanger, left, . . . . .
71	Pass. w/dual exh. (exc. Sta. Wag.),			
72	Pass. w/2BC (350, 400)			tailpipe hanger, . . . . .
72	Pass. (402),			
72	Pass. w/dual exhaust	1237366	.46	reso. tailpipe hanger, left . . . . .
71	Pass. (Sta. Wag.)			BRACKET ASSY., tailpipe, right, . . . . .
71	Pass. (Sta. Wag.) w/4BC	1236950	1.45	tailpipe to resonator . . . . .
72-73	Vega	6264307 1	2.80	BRACKET ASSY. . . . .
74-75	Vega	339036 1	2.20	BRACKET ASSY. . . . .
75	Monza	360022 1	2.30	BRACKET . . . . .

**FUEL—EXHAUST—CARBURETION**

**3.706 BRACKET— CLAMP— HANGER ASSY.— INSULATOR— NUT—  
RETAINER— SCREW— STRAP, Muffler Tail Pipe (Con't)**

69	Pass. w/N.R.E. (396, 427) (exc. Sta. Wag.),				
70	Pass. (400) (exc. Sta. Wag., dual exh.),				
70	Pass. w/H.D. Suspension (350),				
70	Pass. (8 cyl.) (exc. Sta. Wag., dual exh., P.G.)	<b>3958978</b>	1	2.20	<b>CLAMP</b> , extension
72	Chevelle				<b>CLAMP</b> , muffler tailpipe frt. hanger,
72	Malibu w/H.D. Susp. (350) (exc. 4-Spd.),				
72	Monte Carlo w/2BC (400)				muffler tailpipe extension,
72	Chevelle (exc. 400, 454)				exh. crossover pipe to connector,
72	Chevelle (Sta. Wag., El Camino) w/4BC (400, 454)	<b>1240744</b>	A.R.	.97	<b>CLAMP</b> , muffler to resonator pipe
64-67	Chevelle w/dual exh.	<b>9783845</b>	R.H.	1.65	<b>HANGER ASSY.</b> , tail pipe front
64-67	Chevelle	<b>9783634</b>	L.H.	1.65	<b>HANGER ASSY.</b> , front
64	Chevelle (Sta. Wag., El Camino) (exc. 4/BC),				
65-66	Chevelle (Sta. Wag., El Camino) (exc. 327, 396),				
67	Chevelle (Sta. Wag., El Camino)	<b>3853659</b>	L.H.	.84	<b>HANGER ASSY.</b> , rear
64-66	Chevelle (exc. Sta. Wag., El Camino, 327, 396),				
67	Chevelle (exc. dual exh.),				
65-66	Chevelle (396) (1st design),				
66	Chevelle w/Sp. H/Per. (327)	<b>3876973</b>	L.H.	1.95	<b>HANGER ASSY.</b> , rear
64	Chevelle w/4BC (1st design) (exc. Sta. Wag., El Camino),				
65-66	Chevelle (396) (1st design),				
66	Chevelle w/Sp. H/Per. (327),				
67	Chevelle (Sta. Wag., El Camino) w/H/Per., Sp. H/Per. (327, 396)	<b>3876974</b>	R.H.	1.95	<b>HANGER ASSY.</b> , rear
64	Chevelle w/4BC (2nd design) (exc. Sta. Wag., El Camino),				
64-66	Chevelle (Sta. Wag., El Camino) w/4BC	<b>3853660</b>	R.H.	.76	<b>HANGER ASSY.</b> , rear
65-66	Chevelle (283, 327) (exc. El Camino, Sta. Wag.),				
67	Chevelle w/dual exh. (exc. Sta. Wag.)	<b>3864749</b>	L.H.	2.10	<b>HANGER ASSY.</b> , resonator
65	Chevelle w/dual exh. (283, 327, 396) (exc. Sp. H/Per., Sta. Wag., El Camino),				
66	Chevelle w/dual exh. (283) (exc. Sta. Wag., El Camino),				
67	Chevelle w/dual exh.	<b>3864750</b>	R.H.	1.85	<b>HANGER ASSY.</b> , resonator
65-66	Chevelle (396) (1st design),				
66	Chevelle w/Sp. H/Per. (327)	<b>3876974</b>	R.H.	1.95	<b>HANGER ASSY.</b> , rear
65-67	Pass. (230, 250, 283, 307),				
65-67	Pass. (Sta. Wag.) w/dual exh.	<b>3884857</b>	L.H.	2.15	<b>HANGER ASSY.</b> , rear
65-66	Pass. w/4BC (exc. Sta. Wag.)	<b>3867375</b>	L.H.	1.75	<b>HANGER ASSY.</b> , resonator
65-66	Pass. w/dual exh. (327, 396, 409, 427) (exc. Sta. Wag.)	<b>3867376</b>	R.H.	1.75	<b>HANGER ASSY.</b> , resonator
65-67	Pass. (Sta. Wag.) w/dual exh. (327, 396, 427)	<b>3884858</b>	R.H.	2.65	<b>HANGER ASSY.</b> , rear
65	Pass. (8 cyl.)(exc. 283),				
65-66	Pass. w/dual exh.	<b>3877508</b>	R.H.	2.20	<b>HANGER ASSY.</b> , front
65-66	Pass.	<b>3877507</b>	L.H.	2.00	<b>HANGER ASSY.</b> , front
65	Pass. w/Sp. H/Per. (396) (exc. Sta. Wag.),				
66-67	Pass. w/Sp. H/Per. (427)(exc. Sta. Wag.)	<b>3883693</b>	L.H.	3.25	<b>HANGER ASSY.</b> , rear
65	Pass. w/Sp. H/Per. (396)(exc. Sta. Wag.),				
66-67	Pass. w/Sp. H/Per. (427)(exc. Sta. Wag.)	<b>3883694</b>	R.H.	2.20	<b>HANGER ASSY.</b> , rear
65-67	Pass. w/Sp. H/Per. (396, 427)(exc. Sta. Wag.),				
67	Pass. w/sgl. exh.		L.H.		<b>HANGER ASSY.</b> , front
67	Pass. w/dual exh.	<b>3913417</b>	R.H.	1.75	<b>HANGER ASSY.</b> , front
66	Chevy (283, 327) (exc. 2BC, Sta. Wag.)	<b>3893183</b>	L.H.	1.90	<b>HANGER ASSY.</b> , resonator



**FUEL—EXHAUST—CARBURETION**

**3.706 BRACKET— CLAMP— HANGER ASSY.— INSULATOR— NUT—  
RETAINER— SCREW— STRAP, Muffler Tail Pipe (Con't)**

66	Chevy w/dual exh. (exc. Sta. Wag.)	3893184 R.H.	1.90	HANGER ASSY., resonator
66-67	Chevelle (396) (2nd design),			
67	Chevelle w/Sp. H/Per. (327)	3901727 L.H.	1.95	HANGER ASSY., rear (Note 1)
66-67	Chevelle (396) (2nd design),			
67	Chevelle w/Sp. H/Per. (327)	3901728 R.H.	2.95	HANGER ASSY., rear (Note 1)
	<i>NOTE 1 Used with tailpipes 3901731-32.</i>			
67	Camaro w/dual exh.	3892789 L.H.	1.75	HANGER ASSY.
67	Camaro	3892790 R.H.	1.75	HANGER ASSY.
67	Pass. (396, 427) (exc. Sta. Wag.)	3904013 L.H.	1.75	HANGER ASSY., resonator
67	Pass. w/dual exh. (exc. Sta. Wag.)	3904014 R.H.	1.75	HANGER ASSY., resonator
	<i>NOTE: Refer to Group 3.701 Chart containing 1968-75 Hanger Assys.</i>			
70-73	Camaro	3996318 2	1.20	INSULATOR, muffler hanger
74-75	Nova, Camaro	340364 2	1.10	INSULATOR, muff. and tail pipe hanger
	Not required in this group. See group 3.655			
64-67	Chevelle	9422297 R.H.	.17	NUT
68-69	Chevelle,	1361728 A.R.	.18	RETAINER, tail pipe rear hanger
70-71	Chevelle (6 cyl.),			
70-72	Chevelle (Sta. Wag., El Camino) (8 cyl.) (exc. 400, 402, 454)	1384485 A.R.	.11	RETAINER, tail pipe rear hanger
69	Camaro w/H/Per., Sp. H/Per. (302, 396),			
69	Camaro w/chambered pipe exh.	3958420 2	.11	RETAINER, exh. pipe hanger
70	Camaro	3983051 1	.05	SCREW, muffler hanger clamp (5/16" — 18 x 1 1/4") — (8.977)
75	Monza	356391 1	4.25	STRAP ASSY., muffler hanger

**3.708 CLAMP UNIT— CLAMP— U BOLT— SCREW, Muffler Exhaust Pipe and Tail Pipe**

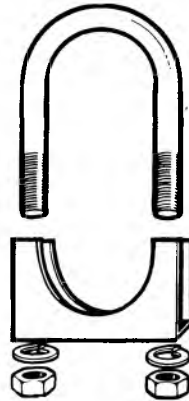
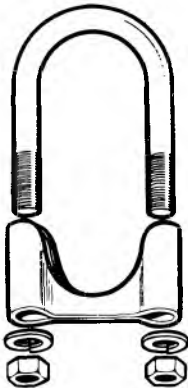

OPEN ..... ENCLOSED .....

ALL	w/2 1/4"	3857547	ALL	w/1 1/2"	3837878
ALL	w/2 1/2"	3633128	ALL	w/1 3/4"	2378615
			ALL	w/1 7/8"	3754882
			ALL	w/2"	1240744
			ALL	w/2 1/4"	1240745
			ALL	w/2 1/2"	2414398
			ALL	w/3"	2378617
			ALL	w/3 1/2"	2378618
			ALL	w/4"	2378620

62-64	Chevy	3791093 1	.59	CLAMP, muffler to tail pipe
65-69	Pass. w/Sp. H/Per. (396, 427) (exc. Sta. Wag.),			
65-69	Chevelle (396),			
66-68	Chevelle w/Sp. H/Per. (327),			
67-69	Camaro (302) (exc. chambered exh.)			CLAMP, tail pipe hanger (2 1/4" closed),
68-69	Camaro w/dual exh.,			
68-69	Chevy w/dual exh.	1240745 A.R.	1.35	CLAMP, muffler to rear exh. pipe, muffler to exh. pipe

**FUEL—EXHAUST—CARBURETION**

<b>3.708</b>		<b>CLAMP UNIT— CLAMP— U BOLT— SCREW, Muffler Exhaust Pipe and Tail Pipe (Con't)</b>			
70	Pass. (6 cyl.)	3782033	1	.71	CLAMP, muff. to tail pipe
70-72	Camaro				CLAMP, muffler hanger (lower half)
70-71	Camaro w/4BC (350, 396, 454),				
72	Camaro w/4BC (350, 402)	332607	1	.28	CLAMP, upper half
70-75	Camaro				CLAMP, muffler hanger (upper half)
70	Camaro w/4BC (350, 396, 454),				
71	Camaro w/4BC (350, 400),				
72-74	Camaro w/4BC (350, 402)	3992572	1	.53	CLAMP, lower half
71-72	Pass.	1235854	AR	.84	CLAMP, muffler and exh. pipe tailpipe hanger
75	All	3633128	A.R.	1.20	CLAMP PKG. (repl. 1249618)
64-69	All,				
75	All (122)	1240744	A.R.	.97	CLAMP (w/bolt 2")
75	All (122)	339059		1.30	CLAMP (holds two pipes)
64-66	Chevelle (exc. 327),				
65-69	Pass. w/sgl. exh.,				
67-69	Chevelle (6 cyl.)	3754882	1	.81	"U" BOLT, tail pipe (5/16"— 18) (use w/17/8" pipe)
55-75	All	352731	A.R.	1.05	"U" BOLT PKG. (2 1/2")
65-69	Pass.,				
69-72	Chevelle	3815306	2	1.30	"U" BOLT, muff. to exh. pipe (5/16"— 18), exh. cross over pipe (use w/2 11/16" pipe)
66-67	Pass. w/A.I.R. (6 cyl.),				
68-70	Pass. (6 cyl.)	3890616	1	.98	"U" BOLT, exh. pipe (5/16"— 18) (use w/2 5/16" pipe)
62-70	All	9429462	1	.18	SCREW, hanger clamp No. 9— 20 x 2"— (8.977)
70-74	Camaro	3972221	2	.16	SCREW, w/lockwasher muffler hanger

**3.724 GASKET KIT, Carburetor**

*NOTE. See the gasket unit component chart in the supplementary data section for a breakdown of each unit.*

62-66	Chevy (4 cyl.)				w/3792945-3019-3891591-2,
66	All w/A.I.R. (6 cyl.)				w/3880860-1-3891595-6,
66	Taxi (6 cyl.)				w/3886193-4-3891593-4,
67	All w/Carter 1BC	3914065	1	1.75	w/3905071-2-5-6-5973-4-5-6-8463-4-5-6-7-8-9405
63-67	Chevy, Chevelle, Camaro				w/7023000-03-3105-08-4000-01-5000-3-105-8-6027-8,
65-67	Pass., Taxi (6 cyl.) w/Econ. Carb.	7016351	1	1.75	w/7023000-3003-3004-3005-5000-03-04-05-6027-8
64	Chevy, Chevelle (exc. 4BC),				w/7024100-01-02-06-08-10-12-3007-08-
65-66	Chevy, Chevelle w/A.I.R. (283)				18-0007-08-18-5103-7036101-03-10-12,
65-66	Pass. (283)	7015952	1	3.00	w/7010647-48-0719-1131-49-1224-2133
64-65	All w/4BC (283, 327) (exc. H/Per., Sp. H/Per.),				
66	Chevy (327) (exc. Sp. H/Per.),				
66	All (283) (exc. 2BC)	7033076	1	4.35	w/7023006-12-4120-21-22-25-26-4220-25-26-5121-22-25-26-7-8-6121-7125-7036118-19-20-21
65	Pass. w/Sp./H/Per. (396)				w/3869933,
66-67	Pass. w/Sp. H/Per. (427)				w/3885067-6101-3916143-5-3923289,
65-67	All (Holley 4BC w/Sp. H/Per.) (302, 327, 396)	3896609	1	5.00	w/3923289-3877413-3890497-3229-3916143-5-392328
65-66	Pass. (396, 427) (exc. Sp. H/Per., A.I.R.)				w/3868864-3874898-5964-6747,
66	Chevy, Chevelle (327, 396)	3896610	1	4.10	w/3868864-3876747-4898-5964-3886087-8-3892338-9
65	Pass. (396) (exc. Sp. H/Per.)				w/7025200-1-20-21,
66	Pass. (8 cyl.) (exc. 283 Sp. H/Per.)				w/7026200-1-2-3-4-5-7036200-1-2-3-4-5,
66-67	Chevelle (396) (exc. H/Per.),				
66-67	All w/4/BC (327) (exc. Sp. H/Per.)				w/7026200-1-2-3-7200-1-2-3-10-11-12-13-7036200-1-2-3-7200-1-2-3-10-11-12-13,
67	Pass. w/Roch. 4BC	7031430	1	5.50	w/7027200-1-2-3-10-11-12-13-7037200-1-2-3-10-12-13
67	All w/Holley 4BC (396)	3914106	1	4.70	w/3908956-7-8-9 (Holley 85G-2731)
67	All w/Roch. 2BC	7016752	1	2.65	w/7027101-3-10-12-7037101-3-10-12-7016818-19

*NOTE: See Group 3.725 for chart containing 1968-75 Carburetor Gasket Units.*

**FUEL—EXHAUST—CARBURETION**

**3.725 CARBURETORS— REPAIR KITS**

*NOTE: For Vega, Monza carburetor Gasket Units See End of Group 3.725.  
 NOTE: For Vega, Monza carburetor and Repair Units See End of Group 3.725.  
 NOTE: A.C. denotes Automatic Choke.  
 NOTE: All 1966 thru 1967 Rochester Carb. with 4-BC are "Quadra-Jets".*

**ROCHESTER CARBURETORS**

62	Chevy (6 cyl.)	7016205	1	54.75	unit
63-67	All (6 cyl.)	7036680	1	55.00	unit
64-66	All (283) (exc. P.G., A.I.R., 4BC)	7016559	1	56.00	unit
66	All (327) (exc. A.I.R., P.G.),				
66-67	Pass. w/A.I.R. (327) (exc. A.T.),				
66-67	Chevy, Chevelle (A.I.R. w/4BC) (327, 350) (exc. P.G., Sp. H/Per.),				
66	All w/P.G. (327),				
66	Pass. w/A.I.R. (396) (exc. A.T.),				
66	Pass. (A.I.R. w/H/Per.) (427) (exc. T.H.),				
66	Chevelle w/A.I.R. (396) (exc. P.G., H/Per.),				
67	Chevy, Chevelle, Camaro (P.G. w/4BC) (327, 350) (exc. Sp. H/Per.),				
67	Pass. w/A.T. (exc. A.I.R.)	7046902	1	118.00	unit
66	All w/A.I.R. (283) (exc. P.G., 4BC),				
67	Pass. (283),				
67	Chevy, Chevelle, Camaro w/2BC (283, 327)	7041833	1	70.00	unit
64-66	All (w/P.G.) (283) (exc. 4BC)	7041832	1	70.00	assy.
66	Pass. (396, 427),				
66	Chevelle w/P.G. (396) (exc. H/Per.),				
67	Pass. w/A.T. (396, 427) (2nd design) (exc. A.I.R.),				
67	Chevelle, Camaro (396) w/A.T. (2nd design) (exc. A.I.R., H/Per., Sp. H/Per.),				
67	Pass. (A.I.R. w/A.T.) (396, 427) (2nd design),				
67	Pass. w/A.T. (396, 427) (1st design) (exc. A.I.R.),				
67	Chevelle w/A.T. (396) (1st design) (exc. A.I.R., H/Per., Sp. H/Per.),				
67	Chevelle (A.I.R. w/A.T.) (396) (2nd design) (exc. H/Per., Sp. H/Per.),				
67	Camaro (A.I.R. w/T.H.) (396) (exc. Sp. H/Per.)	7046903	1	118.00	unit
67	Pass. w/A.I.R. (283) (exc. P.G.),				
67	Chevy, Chevelle, Camaro (A.I.R. w/2BC) (283, 327) (exc. P.G.)	7037103	1	56.75	assy.

**ROCHESTER MAJOR REPAIR KIT**

*NOTE: Repair Kits consist of necessary parts to overhaul one carburetor - including jets, nozzles, intake needle and seat, pump lever, etc.*

63-66	Chevy, Chevelle (6 cyl.),				
65	Pass. (6 cyl.),				
67	Chevy (194) (exc. A.I.R.)	7016458	1	10.75	w/7023000-03-3105-08-4000-01-510-8-5000-03
64-66	Chevy, Chevelle (8 cyl.) w/Air Cond. (exc. P.G., 4BC),				
65-66	Pass. w/2BC (283) (exc. P.G.)	7026433	1	12.50	w/7013007-9007-7020007-3007-4101-5103
64	Chevelle w/4BC,				
64-65	Chevy, Chevelle w/4BC (exc. H/Per., Sp. H/Per.),				
65	Pass. w/4BC (283, 327) (exc. H/Per.),				
66	All w/A.I.R. (283) (exc. 2BC)	7033075	1	18.90	w/7023006-3012-4120-21-22-25-26-4220-25-26-5121-22-26-27-28-6121-7036118-19-20-21
64-66	Chevy, Chevelle w/P.G. (283) (exc. 4BC, A.I.R.)				w/7024110-12,

**FUEL—EXHAUST—CARBURETION**

**3.725 CARBURETORS— REPAIR KITS (Con't)**

65-66	Pass. (2BC w/P.G.)	7026433	1	12.50	w/7013008-3018-7020008-0018-3008-3018-4100-02-06-08-10-12
65-66	Pass. w/econ. carb. (6 cyl.)				w/7025004-5005,
67	Taxi w/econ. carb. (6 cyl.)				w/7026027-28,
67	Pass. (6 cyl.) (exc. Taxi, A.I.R.)				
67	Chevy, Chevelle, Camaro (230, 250) (exc. A.I.R.)	7016553	1	10.25	w/7025000-3-6027-8
65	Pass. w/A.T. (396) (exc. Sp. H/Per.)				w/7025200-5220,
66	Chevelle w/P.G. (396) (exc. H/Per.)				
66	Pass. w/A.T. (396)				w/7026200-7036200,
67	Chevelle w/A.T. (396) (exc. A.I.R., H/Per., Sp. H/Per.)				
67	Pass. w/A.T. (396, 427) (exc. A.I.R.)	7031428	1	20.15	w/7027200
66	All (P.G. w/4BC) (327) (exc. A.I.R.)				w/7026202,
67	Pass. A.T./4BC (327),				
67	Chevy, Chevelle, Camaro w/4BC (327, 350) (exc. Sp. H/Per.)	7033070	1	19.70	w/7027202-7037202

**ROCHESTER MINOR REPAIR KIT**

*NOTE. Repair Kits (Minor) consist of pump, needle and seat unit, air horn gasket, thermostat housing cover gasket, clip and gauge.*

62	Chevy (exc. 8 cyl.)	7039030	1	5.15	w/7020103-05-0104-08-0114-0115 (Viton)
63-66	Pass., Taxi, Chevy, Chevelle (6 cyl.)				w/7023000-03-04-05-3105-08-4000-1,
67	Chevy, Chevelle, Camaro (6 cyl.)				w/7025000-3-5105-8-6017-27-8-9-7009-11-29-7037009,
67	Pass. (6 cyl.) (exc. A.I.R., Taxi)	7039062	1	5.05	w/7026027-28
64-66	Chevy, Chevelle w/C.A.C.,				
66	Chevy, Chevelle w/A.I.R. (283) (exc. 4BC)				w/7036101-03-10-12
65-66	Pass. w/2BC (283)		1		(Viton) w/carb. 7012133-2451-2452-2500-3007-3008-3018-9007-9008-9018-7020007-0008-0018-3007-3008-3018-4100-4101-4102-4106-4108-4110-4112-4103-7036101-6103-6110-6112,
67	Chevy, Chevelle, Camaro w/2BC (307, 327),				
67	Pass. w/2BC	7039109	1	7.10	(Viton) w/7024120-22-25-26-4220-25-26-5121-22-26-27-28
64-65	Chevy, Chevelle w/4BC,				
65-66	Pass. (P.G. w/4BC) (283, 327) (exc. H/Per., Sp. H/Per.)				w/7023006-12-4121-22-5121-2-6-7-8-6121-7036118-6119-6120-6121,
66	Chevy, Chevelle w/A.I.R. (283) (exc. 2BC)	7039107	1	9.45	w/7036118-19-20-21 (Viton)
65	Pass. w/H.D. 3-Spd. (396) (exc. Sp. H/Per.)				(Viton) w/7025200-01-20-21,
65-66	Pass. (327, 396, 427),				
66	Chevelle (327, 396) (exc. H/Per.)				w/7026200-01-02-03-04-05-7036200-0102-03-04-05,
66	Chevy (327) (exc. Sp. H/Per.)				w/7027200-1-2-3-7037200-1-2-3
67	All w/4BC	7039074	1	9.45	
67	Chevy, Chevelle, Camaro (396) (exc. H/Per., Sp. H/Per.)	7039115	1	9.45	(Viton) w/7027210-11-16-7037210-11-16
67	Pass. (396, 427)				
67	Chevy, Chevelle, Camaro w/4BC (327, 350) (exc. Sp. H/Per.)	7039116	1	9.45	(Viton) w/7027212-13-18-7037212-13-18
67	Pass. (327)				
67	Chevy, Chevelle, Camaro w/A.T. (396) (exc. A.I.R.)	7039126	1	9.45	w/7028210-11-17-18

**CARTER CARBURETORS**

62-67	Chevy (4 cyl.)	3908464	1	43.50	assy. (YF-43745)
64-65	Pass., Chevelle w/H/Per. (327),				
65	Chevy w/H/Per. (327)	3851761	1	80.00	assy. (AF-B3721SB)
65	Pass. w/H/Per. (409) (exc. dual 4BC)	3855581	1	86.25	assy. (AFB3783-S)
66-67	Chevy, Chevelle, Camaro w/A.I.R. (6 cyl.)				
66-67	Taxi w/A.I.R. (6 cyl.)				

**FUEL—EXHAUST—CARBURETION**

**3.725 CARBURETORS— REPAIR KITS (Con't)**

67	Pass. w/A.I.R. (6 cyl.) . . . . .	3998378	1	44.75	assy. (YF4203-A, 4377-S) . . . . .
66	Pass. w/P.G. (327) (exc. A.I.R.),				
66	Chevy, Chevelle w/P.G. (327)				
	(exc. A.I.R., Sp. H/Per.) . . . . .	3875966	1	93.50	assy. (AVS-40285) . . . . .
66	Pass. (327) (exc. P.G., A.I.R.),				
66	Chevelle, Chevy (327) (exc.				
	A.I.R., P.G. Sp. H/Per.) . . . . .	3876749	1	82.25	assy. (AVS-4027S) . . . . .

**CARTER MAJOR REPAIR KIT**

*NOTE Repair kits consist of necessary parts to overhaul one carburetor-including jets, nozzles, intake needle and seat, pump lever, ect.*

65	Pass. (327) (exc. H/Per., Sp.				
	H/Per.) . . . . .	3833363	1	13.65	w/3788245-8246-3826003-6005- 3846246-6247 (No. 5071-N) . . . . .

**CARTER MINOR REPAIR KIT**

*NOTE Repair kits (minor consist of pump, needle and seat unit, air horn gasket, thermostat housing cover, gasket, clip and gauge.*

63-66	Chevy (153) . . . . .	7039607	1	6.50	w/3792945-3019-3891591-2 (repl. 3886346) . . . . .
64-65	All (P.G. w/H/Per.) (327) . . . . .	3857359	1	10.65	w/3851762 (900-140) . . . . .
64-65	All w/H/Per. (exc. P.G.) . . . . .	3857360	1	10.65	w/3851761 (900-141) . . . . .
65	Pass. (327) (exc. H/Per.) . . . . .	7039576	1	10.50	w/3756677-8-3779179-80-3788245-6- 3826003-5-3846246-7 (No. 900-132) . . . . .
66	Pass. (327) (exc. A.I.R.),				
66	Chevy, Chevelle (327) (exc.				
	A.I.R., Sp. H/Per.) . . . . .	3889727	1	9.50	w/3876749-5966 (900-145) . . . . .
66	All w/A.I.R. (6 cyl.) . . . . .				w/3880860-1-6193-4-3891593-4-1595-6, . . . . .
67	All w/1BC . . . . .	7039615	1	6.75	(900-147) . . . . .

**HOLLEY CARBURETORS**

65	Pass. w/Sp. H/Per. (396) . . . . .	3869933	1	127.00	assy. (R-3130A) . . . . .
65-66	Pass. (396, 427) (exc. A.T., Sp.				
	H/Per.),				
66	Chevelle (396) (exc. P.G., A.I.R.,				
	H/Per.) . . . . .	3874898	1	114.00	assy. (4-3139A) . . . . .
65-66	Pass. w/A.T. (396, 427) (exc. Sp.				
	H/Per., A.I.R.),				
66	Chevelle w/P.G. (396) (exc.				
	A.I.R., H/Per.) . . . . .	3868864	1	114.00	assy. (R-3140A) . . . . .
65	Chevelle (396) . . . . .	3878261	1	114.00	assy. (R-3310A) . . . . .
66-67	Chevy, Chevelle w/Sp. H/Per.				
	(327) (exc. A.I.R.) . . . . .	3903389	1	149.00	assy. (R-3806A) . . . . .
66	Pass. w/P.G. (327) (exc. A.I.R.),				
66	Chevy, Chevelle w/P.G. (327)				
	(exc. A.I.R., Sp. H/Per.) . . . . .	3875964	1	82.00	assy. (R-3230A) . . . . .
66	Pass. w/Sp. H/Per. (427) . . . . .	3885067	2	125.00	assy. (R-3246A) . . . . .
66	Chevelle w/H/Per. (396) (exc.				
	A.I.R., P.G.) . . . . .	3886087	1	110.00	assy. (R-3419A) . . . . .
66	Chevelle (A.I.R. w/H/Per.) (396)				
	(exc. P.G.) . . . . .	3892339	1		assy. (R-3609A) . . . . .
66	Chevelle w/Sp. H/Per. (396) . . . . .	3893229	1	125.00	assy. (R-3613A) . . . . .
67	Chevelle, Camaro (A.T.				
	w/H/Per.) (396) (exc. A.I.R.) . . . . .	3908956	1	127.00	assy. (R-3836A) . . . . .
67	Camaro, Chevelle w/H/Per.				
	(396) (exc. A.T., A.I.R.) . . . . .	3908957	1	125.00	assy. (R-3837A) . . . . .
67	Chevelle (A.I.R. w/H/Per.) (396)				
	(exc. A.T.),				
67	Camaro (A.I.R. w/H/Per.) (396) . . . . .	3908959	1	127.00	assy. (R-3839A) . . . . .
67	All w/Sp. H/Per. (302, 396,				
	427) (exc. A.I.R.) . . . . .	3916143	1	125.00	assy. (R-3901A) . . . . .
67	All (A.I.R. w/Sp. H/Per.) (302,				
	396, 427) . . . . .	3916145	1	131.00	assy. (R-3911A) . . . . .

**HOLLEY MAJOR REPAIR KIT**

*NOTE Repair Kits consist of necessary parts to overhaul one carburetor-including jets, nozzles, intake needle and seat, pump lever, ect.*

65-66	Chevelle w/Sp. H/Per. (327)				
	(exc. A.I.R.) . . . . .				w/3863150-3877413, . . . . .
66	Chevy, Chevelle w/A.I.R. (327)				
	(exc. H/Per.) . . . . .	3905846	1	16.65	w/3890497 . . . . .
65-66	Pass. (396) (exc. Sp. H/Per.,				
	A.I.R.),				
66	Chevy, Chevelle (327, 396) (exc.				
	H/Per., A.I.R., Sp. H/Per.) . . . . .	3905850	1	16.05	w/3868864-3874898-5964 (85R1669) . . . . .

**FUEL—EXHAUST—CARBURETION**

**3.725 CARBURETORS— REPAIR KITS (Con't)**

**67** Chevy, Chevelle, Camaro w/4BC  
(396) ..... **3914108** 1 15.65 w/3908956-7-8-9 (85R-2733) .....

**HOLLEY MINOR REPAIR KIT**

*NOTE Repair Kits (Minor) consist of pump, needle and seat unit, air horn gasket, thermostat housing cover gasket, clip and gauge.*

<b>65</b>	Chevelle (396) .....				w/3878261 (85R-2509), .....
<b>65</b>	Pass. w/Sp. H/Per. (396) .....				w/3869933, .....
<b>66</b>	Pass. w/Sp. H/Per. (327, 427) (exc. P.G., A.I.R.) .....				w/3876247-3885067, .....
<b>66</b>	Chevelle w/Sp. H/Per. (396) .....				w/3893229, .....
<b>66</b>	Chevy, Chevelle (327) (exc. A.I.R., P.G., H/Per.) .....				w/3876747, .....
<b>65</b>	Chevelle w/Sp. H/Per. (327),				
<b>66</b>	Chevy, Chevelle (327) .....	<b>7039594</b>	1	13.20	w/3877413-3890497 .....
<b>65-66</b>	Pass. (396) (exc. Sp. H/Per., A.I.R.),				
<b>66</b>	Pass. (327, 396) (exc. A.I.R.),				
<b>66</b>	Chevy, Chevelle (327, 396) (exc. H/Per., A.I.R., Sp. H/Per.) .....	<b>3905849</b>	1	13.50	w/3868864-3874898-5964 (85R-1698) ...
<b>66</b>	Chevelle w/H/Per. (396) .....	<b>7039604</b>	1	11.30	w/3892338-9-3886087-8 .....
<b>67</b>	Chevy, Chevelle, Camaro w/4BC (327),				
<b>67</b>	All w/4BC (396) .....	<b>7039686</b>	1	11.95	w/3903389-91 (85R-2728) .....
<b>67</b>	All (Sp. H/Per. w/4BC) (302, 396, 427) .....	<b>3924121</b>	1	13.25	w/3916143-5 .....

ENGINE	CARBU- RETOR 3.725	MAJOR REPAIR KIT 3.725	MINOR REPAIR KIT 3.725	GASKET UNIT 3.724	BODY ASM. 3.729	HORN ASM. 3.730	BOWL ASM. 3.734	NEEDLE UNIT 3.814	PUMP 3.838
--------	--------------------------	---------------------------------	---------------------------------	-------------------------	-----------------------	-----------------------	-----------------------	-------------------------	---------------

## 1975 NOVA CARBURETOR CHART

6 Cyl.	7047522(2)(3)(5) 7047523(4) 17052544(3)(6) 7047524(1)(3)	17051892(2) 17051891(1)	7039248	7046679	17052059(5) 17053010(6)	17050834(5) 17052206(6)	17050697(2)(3)(5) 17052727(2)(4) 17051894(1)(3) 17052718(3)(6)	7035133	7037595(5) 7037597(6)
262 w/2BC	17052569(2)(4) 17052566(2)(3)	17052787(2)	7039284	17052657	17052788	17052652	17052785	7035132	7037561
350 w/2BC	7047505(4) 7047506(3)	17052658	7039282	17052657	17052723	17052652	17052659	7035132	7046028
350 w/4BC	7047536(2)(3) 7047537(2)(4) 7047538(1)(3) 7047539(1)(4)	17051931	7039272	17051913	17051921(3) 17051923(4)	17052228	17051919	7035134	17051374

(1) w/NB-2

(2) (exc. NB-2)

(3) w/A.T.

(4) (exc. A.T.)

(5) w/intergrated cyl. hd.  
(6) exc. intergrated cyl. hd.

## 1975 CAMARO CARBURETOR CHART

6 Cyl.	7047522(2)(3) 7047523(4) 7047524(1)(3)	17051892(2) 17051891(1)	7039248	7046679	17052059	17050834	17050697(2)(3) 17052727(2)(4) 17051894(1)(3)	7035133	7037595
350 w/2BC	7047505(4) 7047506(3)	17052658	7039282	17052657	17052723	17052652	17052653	7035132	7046028
350 w/4BC	7047536(2)(3) 7047537(2)(4) 7047538(1)(3) 7047539(1)(4)	17051931	7039272	17051913	17051921(3) 17051923(4)	17052228	17051919	7035134	17051374
Sp. H/Per. 350 w/4BC	17052563(2)(4) 17052564(2)(3)	17051931	7039272	17051913	17052628(2)(4) 17052627(2)(3)	17052228	17052630	7035134	17051374

(1) w/NB-2

(3) w/A.T.

(2) (exc. NB-2)

(4) (exc. A.T.)

ENGINE	CARBURETOR 3.725	MAJOR REPAIR KIT 3.725	MINOR REPAIR KIT 3.725	GASKET UNIT 3.724	BODY ASM. 3.729	HORN ASM. 3.730	BOWL ASM. 3.734	NEEDLE UNIT 3.814	PUMP 3.838
--------	---------------------	---------------------------------	---------------------------------	-------------------------	-----------------------	-----------------------	-----------------------	-------------------------	---------------

## 1975 PASSENGER CARBURETOR CHART

350 w/2BC	7047506	17052658	7039282	17052657	17052723	17052652	17052653	7035132	7046028
350 w/4BC	17052594	17051931	7039272	17051913	17051923	17052228	17052630	7035134	17051374
400 w/4BC	17052582(1) 17052584(2)	17051931(1) 17052635(2)	7039272	17051913	17052061	17052053	17052634	7035134	17051374
454 w/4BC	17052604	17052644	7039272	17051913	17052643	17051362	17052641	7035134	17051374

(1) w/NB-2

(2) (exc. NB-2)

## 1975 CHEVELLE CARBURETOR CHART

6 Cyl.	7047522(2)(3) 7047523(4) 7047524(1)(3)	17051892(2) 17051891(1)	7039248	7046679	17052059	17050834	17050697(2)(3) 17052727(2)(4) 17051894(1)(3)	7035133	7037595
350 w/2BC	7047505(4) 7047506(3)	17052658	7039282	17052657	17052723	17052652	17052653(3) 17052659(4)	7035132	7046028
350 w/4BC	17052594(3)	17051931	7039272	17051913	17051923	17052228	17051919(4) 17052630(3)	7035134	17051374
400 w/4BC	17052582(1) 17052584(2)	17051931(1) 17052635(2)	7039272	17051913	17052061	17052053	17052634	7035134	17051374
454 w/4BC	17052604	17052644	7039272	17051913	17052643	17051362	17052641	7035134	17051374

(1) w/NB-2

(2) (exc. NB-2)

(3) w/A.T.

(4) (exc. A.T.)



ENGINE	CARBU- RETOR 3.725	MAJOR REPAIR KIT 3.725	MINOR REPAIR KIT 3.725	GASKET UNIT 3.724	BODY ASSY. 3.729	HORN ASSY. 3.730	BOWL ASSY. 3.734	NEEDLE UNIT 3.815	PLUNGER 3.838
--------	--------------------------	---------------------------------	---------------------------------	-------------------------	------------------------	------------------------	------------------------	-------------------------	------------------

## 1974 CHEVELLE CARBURETOR CHART (Cont'd.)

350 w/4BC	17050580(2) 17050581(1)	17050544	7039268	17050525	17050572(2) 17050573(1)	7048938	17050542(1) 17050565(2)	7035140	7047080
400 w/2BC	7047418	17050518	7039267	17050519	17050812	7046712	7046911	7035132	7046028
400 w/4BC	7047407	17050524	7039268	17050525	17050523	7048988	17050521	7035140	7047080
454	7047401(1) 7047403(2)(3) 7047405(2)(4)	17050563(2) 17050564(1)	7039268	17050525	17050558(2) 17050559(1)	7048880	17050539(1) 17050521(2)	7035140	7047080

(1) (exc. A.T.) (3) (exc. NB-2)  
 (2) w/A.T. (4) w/NB-2

## 1974 CAMARO CARBURETOR CHART

6 Cyl.	7047404(2)(6) 7047417(1) 7047414(2)(5)	7046950(2)(5) 7046951(1) 7046952(2)(6)	7039248	7046679	7048266(1) 7048267(2)	7049919	7046944	7035133	7037597
350 w/2BC	7047402(2) 7047415(1)	17050518	7039267	17050519	17050535(1) 17050536(2)	17050543(1) 7046712(2)	7046713(1) 7046714(2)	7035132	7046028
350 w/4BC (exc. Sp. H/Per.)	17050578(2)(5) 17050579(1)(5) 17050580(2)(6) 17050581(1)(6)	17050544	7039268	17050525	17050572(2)(6) 17050570(2)(5) 17050571(1)(5) 17050573(1)(6)	7048938	17050541(1)(5) 17050542(1)(6) 17050520(2)	7035140	7047080
350 (4BC w/Sp. H/Per.)	17050590(2) 17050591(1)	17050545	7039268	17050525	17050586(2) 17050587(1)	7044884	17050583(1) 17050582(2)	7035140	7047080

(1) (exc. A.T.) (5) (exc. NB-2)  
 (2) w/A.T. (6) w/NB-2

ENGINE	CARBU- RETOR 3.725	MAJOR REPAIR KIT 3.725	MINOR REPAIR KIT 3.725	GASKET UNIT 3.724	BODY ASSY. 3.729	HORN ASSY. 3.730	BOWL ASSY. 3.734	NEEDLE UNIT 3.814	PLUNGER 3.838
--------	--------------------------	---------------------------------	---------------------------------	-------------------------	------------------------	------------------------	------------------------	-------------------------	------------------

## 1974 PASSENGER CARBURETOR CHART

350 w/2BC	7047402	17050518	7039267	17050519	17050536	17050543	7046714	7035132	7046028
350 w/4BC	17050625	17050544	7039268	17050525	17050572	7048938	17050520(3) 17050565(4)	7035140	7047080
400 w/2BC	7047418	17050518	7039267	17050519	7048132	7046712	7046911	7035132	7046028
400 w/4BC	7047406(1) 7047407(2)	17050524(3)(1) 17050524(3)(2) 17050524(4)	7039268	17050525	17050523(4) 17050523(2)(3) 17050558(1)(3)	7048988	17050521(4) 17050521(3)(2) 17050520(3)(1)	7035140	7047080
454	7047403(1) 7047405(2)	17050563	7039268	17050525	17050558	7048880	17050521	7035140	7047080

(1) (exc. NB-2) (2) w/NB-2 (3) Sta. Wag. (4) (exc. Sta. Wag.)

## 1974 NOVA CARBURETOR CHART

6 Cyl.	7047404(2)(4) 7047417(1) 7047414(2)(3)	7046950(2)(3) 7046951(1) 7046952(2)(4)	7039248	7046679	7048266(1) 7048267(2)	7049919	7046944	7035133	7037597
350 w/2BC	7047415(2) 7047402(2)	17050518	7039267	17050519	17050535(1) 17050536(2)	17050543(1) 7046712(2)	7046713(1) 7046714(2)	7035132	7046028
350 w/4BC	17050578(2)(3) 17050579(1)(3) 17050580(2)(4) 17050581(1)(4)	17050544	7039268	17050525	17050572(2)(4) 17050570(2)(3) 17050571(1)(3) 17050573(1)(4)	7048938	17050541(1)(3) 17050542(1)(4) 17050520(2)(5)(3) 17050565(2)(6) 17050565(2)(5)(4)	7035140	7047080

(1) (exc. A.T.) (2) w/A.T. (3) (exc. NB-2) (4) w/NB-2 (5) w/dual exh. (6) (exc. dual exh.)

## 1974 CHEVELLE CARBURETOR CHART

6 Cyl.	7047404(2)(4) 7047417(1) 7047414(2)(3)	7046950(2)(3) 7046951(1) 7046952(2)(4)	7039248	7046679	7048266(1) 7048267(2)	7049919	7046944	7035133	7037597
350 w/2BC	7047415(1) 7047402(2)	17050518	7039267	17050519	17050535(1) 17050536(2)	17050543(1) 7046712(2)	7046713(1) 7046714(2)	7035132	7046028

**FUEL—EXHAUST—CARBURETION**

ENGINE	CARBURETOR 3.725	MAJOR REPAIR KIT 3.725	MINOR REPAIR KIT 3.725	GASKET UNIT 3.724	BODY ASSY. 3.729	HORN ASSY. 3.730	BOWL ASSY. 3.734	NEEDLE UNIT 3.814	PLUNGER 3.838
--------	---------------------	---------------------------	---------------------------	----------------------	---------------------	---------------------	---------------------	----------------------	------------------

**1973 PASSENGER CARBURETOR CHART**

6 Cyl.	7047317	7046677-A 7046883-B	7039248	7046679	7046673	7049919	7046670	7035133	7037597
350 w/2BC	7047302	7046716	7039251	7046717	7047368	7046712	7046714	7035132	7046028
350 w/4BC	7047303	7046828	7039259	7046779	7046827	7044884	7046826	7035140	7040691
400 w/2BC	7047318	7046716	7039251	7046717	7046715	7046712	7046911	7035132	7046028
454	7047316	7046777	7039259	7046779	7046774	7047613	7046772	7035140	7040691

A—w/A.T.  
B—exc. A.T.

**1973 NOVA CARBURETOR CHART**

6 Cyl.	7047314-A 7047317-B	7046677-A 7046883-B	7039248	7046679	7046671-A 7046673-B	7049919	7046669-A 7046670-B	7035133	7037597
307	7047300-A 7047301-B	7046884	7039250	7046706	7046704	7046702	7046893	7035132	7045908
350 w/2BC	7047302-A 7047311-B	7046716	7039251	7046717	7047368	7046711-B 7046712-A	7046714-A 7046713-B	7035132	7046028
350 w/4BC	7047303	7046828	7039259	7046779	7046827	7044884	7046826	7035140	7040691

A—w/A.T.                      B—exc. A.T.

**1973 CHEVELLE CARBURETOR CHART**

6 Cyl.	7047314-A 7047317-B	7046677-A 7046883-B	7039248	7046679	7046671-A 7046464	7049919	7046669-A 7046670-B	7035133	7037597
307	7047300-A 7047301-B	7046884	7039250	7046706	7047295	7046702	7046893 7046714-A	7035132	7045908
350 w/2BC	7047302-A 7047311-B	7046716	7039251	7046717	7047368	7046711-B 7046712-A	7046893-A 7046713-B	7035132	7046028
350 w/4BC	7047303	7046828	7039259	7046779	7046827	7044884	7046826	7035140	7040691
454	7047316-A 7047315-B	7046777-A 7046778-B	7039259	7046779	7046774	7047613	7046772-A 7046773-B	7035140	7040691

A—w/A.T.                      B—exc. A.T.

**1973 CAMARO CARBURETOR CHART**

6 Cyl.	7047314-A 7047317-B	7046677-A 7046883-B	7039248	7046679	7046671-A 7046673-B	7049919	7046669-A 7046670-B	7035133	7037597
307	7047300-A 7047301-B	7046884	7039250	7046706	7046704	7046702	7046893	7035132	7045908
350 w/2BC	7047302-A 7047311-B	7046716	7039251	7046717	7047368	7046711-B 7046712-A	7046714-A 7046713-B	7035132	7046028
350 w/4BC	7047303-D 7047328-C	7046828	7039259	7046779	7046847-C 7046827-D	7044884	7046846-C 7046826-D	7035140	7040691

A—w/A.T.                      C—w/Sp. H/Per.  
B—exc. A.T.                      D—exc. Sp. H/Per.

**FUEL—EXHAUST—CARBURETION**

**1972 CHEVELLE CARBURETOR CHART**

NOTE: See Dealer Price Schedule for applicable prices.

ENGINE	CARBU- RETOR 3.725	MAJOR REPAIR KIT 3.725	MINOR REPAIR KIT 3.725	GASKET UNIT 3.724	BODY ASSY. 3.729	HORN ASSY. 3.730	BOWL ASSY. 3.734	NEEDLE UNIT 3.814	PLUNGER 3.838
6 Cyl.	7047222-CA 7047223-DA 7046577-BC 7046578-BD	7046538-C 7046537-D	7039236	7046536	7045951-C 7041956-D	7045886	7041953-C 7041954-D	7035133	7037597
307	7047210-C 7047203-D	7041905-C 7046565-D	7039224	7041906	7041904-C 7041903-D	7041600	7041902-C 7041901-D	7023809	7045908
350 w/2BC	7047204-CA 7047213-DA 7046587-BC 7046586-BD	7041928-C 7041975-D	7039226-C 7039229-D	7041929	7041927-C 7041926-D	7041923	7041925-C 7041924-D	7023813	7036282-C 7046028-D
350 w/4BC	7046589-B 7047221-A	7041881	7039223	7041872	7041878	7044884	7041876	7035130	7037327
402 w/4BC	7046908	7041871	7039222	7041872	7041870	7044883	7041869	7035140	7037327
454	7046908	7041871	7039222	7041872	7041870	7044883	7041869	7035140	7037327

A. w/NB-2  
C. w/A.T.

B. exc. NB-2  
D. exc. A.T.

**1972 CAMARO CARBURETOR CHART**

NOTE: See Dealer Price Schedule for applicable prices.

ENGINE	CARBU- RETOR 3.725	MAJOR REPAIR KIT 3.725	MINOR REPAIR KIT 3.725	GASKET UNIT 3.724	BODY ASSY. 3.729	HORN ASSY. 3.730	BOWL ASSY. 3.734	NEEDLE UNIT 3.814	PLUNGER 3.838
6 Cyl.	7047222-CA 7047223-DA 7046577-BC 7046578-BD	7046538-C 7046537-D	7039236	7046536	7041955-C 7041956-D	7045886	7041953-C 7041954-D	7035133	7037597
307	7047210-C 7047203-D	7041905	7039224	7041906	7041904-C 7047213-D	7041600	7041902-C 7041901-D	7023809	7045908
350 w/2BC	7047212-CA 7047227-DB 7046585-BC 7046584-BD	7041928-C 7041975-D	7039226-C 7039229-D	7041929	7041927-C 7041926-D	7041923	7041925-C 7041924-D	7023813	7036282-C 7046028-D
350 w/4BC	7046589-BF 7047221-AF 3997788-EC 3999263-ED	7041881-F 6273916-E	7039223-F 6273915-E	7041872-F 3979667-E	7041878-F 6273906-E	7044884	7041876-F 3889781-EG 3898992-EH	7035130-F 3877165-E	7037327
402 w/4BC	7046908	7041871	7039222	7041872	7041870	7044883	7041869	7035140	7037327

A. w/NB-2  
B. exc. NB-2

C. w/A.T.  
D. exc. A.T.

E. w/SP, H/Per.  
F. exc. SP, H/Per.

G. Secondary  
H. Primary

**FUEL—EXHAUST—CARBURETION**

**1972 PASSENGER CARBURETOR CHART**

NOTE: See Dealer Price Schedule for applicable prices.

ENGINE	CARBU-RETOR 3.725	MAJOR REPAIR KIT 3.725	MINOR REPAIR KIT 3.725	GASKET UNIT 3.725	BODY ASSY. 3.729	HORN ASSY. 3.730	BOWL ASSY. 3.734	NEEDLE UNIT 3.814	PLUNGER 3.838
6 Cyl.	7047222-CA 7047223-DA 7046577-BC 7046578-BD	7046538-C 7046537-D	7039236	7046536	7041955-C 7041956-D	7045886	7041953-C 7041954-D	7035133	7037597
350 w/2BC	7047204-A 7046587-B	7041938-C 7041975-D	7039226-C 7039229-D	7041929	7041927-C 7041926-D	7041923	7041925-C 7041924-D	7023813	7036282-C 7046028-D
350 w/4BC	7047221-A 7046589-B	7041881	7039223	7041872	7041878	7044884	7041876	7035130	7037327
400 w/2BC	7047218-A 7046588-B	7041928	7039226	7041929	7041936	7041923	7041935	7023813	7036282
402 w/4BC	7046908	7041871	7039222	7041872	7041870	7044883	7041869	7035140	7037327
454	7046908	7041871	7039222	7041872	7041870	7044883	7041869	7035140	7037327

- A. w/NB-2
- B. exc. NB-2
- C. w/A.T.
- D. exc. A.T.

**1972 NOVA CARBURETOR CHART**

ENGINE	CARBU-RETOR 3.725	MAJOR REPAIR KIT 3.725	MINOR REPAIR KIT 3.725	GASKET UNIT 3.724	BODY ASSY. 3.729	HORN ASSY. 3.730	BOWL ASSY. 3.734	NEEDLE UNIT 3.824	PLUNGER 3.838
6 Cyl.	7047222-CA 7047223-DA 7046577-BC 7046578-BD	7046538-C 7046537-D	7039236	7046536	7041955-C 7041956-D	7045886	7041953-C 7041954-D	7035133	7037597
307	7047210-C 7047203-D	7041905	7039224	7041906	7041904-C 7041903-D	7041600	7041902-C 7041901-D	7023809	7045908
350 w/2BC	7047204-CA 7047213-DA 7046587-BC 7046586-BD	7041928-C 7041975-D	7039226-C 7039229-D	7041929	7041927-C 7041926-D	7041923	7041925-C 7041924-D	7023813	7036282-C 7046028-D
350 w/4BC	7046589-B 7047221-A	7041881	7039223	7041872	7041878	7044884	7041876	7035100	7037327

- A. w/NB-2
- B. Exc. NB-2
- C. w/A.T.
- D. Exc. A.T.

## FUEL—EXHAUST—CARBURETION

### 1971 NOVA CARBURETOR CHART

NOTE: See Dealer Price Schedule for applicable prices.

ENGINE	CARBU-RETOR 3.725	MAJOR REPAIR KIT 3.725	MINOR REPAIR KIT 3.725	GASKET UNIT 3.724	BODY ASSY. 3.729	HORN ASSY. 3.730	BOWL ASSY. 3.734	NEEDLE UNIT 3.814	PLUNGER 3.838
6 Cyl.	7047114-A 7047117-B	7041598-A 7041597-B	7039196	7041599	7041594-A 7048235-B	7042482-A 7042480-B	7041591-A 7041592-B	7035133	7037597
307	7047111-B 7047110-A	7041605	7039197	7041606	7041604-A 7041603-B	7041600	7041602-A 7041601-B	7023809	7042819
350 w/2BC	7047113-B 7047104-A	7041613	7039198	7041614	7041724-A 7041611-B	7041607	7041608-A 7041609-B	7023813	7036282
350 w/4BC	7047120	7041667	7039202	7041872	7041665	7042746	7041664	7035130	7037337

A. w/A.T.

B. exc. A.T.

### 1971 CHEVELLE CARBURETOR CHART

NOTE: See Dealer Price Schedule for applicable prices.

ENGINE	CARBU-RETOR 3.725	MAJOR REPAIR KIT 3.725	MINOR REPAIR KIT 3.725	GASKET UNIT 3.724	BODY ASSY. 3.729	HORN ASSY. 3.730	BOWL ASSY. 3.734	NEEDLE UNIT 3.814	PLUNGER 3.838
6 Cyl.	7047114-A 7047117-B	7041598-A 7041597-B	7039196	7041599	7041594-A 7048235-B	7042482-A 7042480-B	7041591-A 7041592-B	7035133	7037597
307	7047111-B 7047110-A	7041605	7039197	7041606	7041604-A 7041603-B	7041600	7041602-A 7041601-B	7023809	7042819
350 w/2BC	7047113-B 7047104-A	7041613	7039198	7041614	7041724-A 7041611-B	7041607	7041608-A 7041609-B	7023813	7036282
350 w/4BC	7046984	7041667	7039202	7041872	7041665	7042746	7041664	7035130	7037337
400 w/2BC	7047118-A 7047113-B	7041613	7039198	7041614	7041610-A	7041607	7041616-A	7023813	7036282
400 w/4BC	7047116	7041661	7039222	7041872	7041870	7042745	7041658	7035140	7037327
454	7047116-C 3986196-DA 3986195-DB	7041661-C 3979669-D	7039201-C 3979668-D	7041872 3979667	7041659-C 3979655-DA 3979694-DB	7042745-C	7041658-C 3898992-DE 3889781-DE	7035140-C 3979656-D	7037327-C

A. w/A.T.

C. exc. Sp. H/Per.

E. Sec'd.

B. exc. A.T.

D. Sp. H/Per.

F. Primary

### 1971 CAMARO CARBURETOR CHART

NOTE: See Dealer Price Schedule for Applicable Prices.

ENGINE	CARBU-RETOR 3.725	MAJOR REPAIR KIT 3.725	MINOR REPAIR KIT 3.725	GASKET UNIT 3.724	BODY ASSY. 3.729	HORN ASSY. 3.730	BOWL ASSY. 3.734	NEEDLE UNIT 3.814	PLUNGER 3.838
6 Cyl.	7047114-A 7047117-B	7041598-A 7041597-B	7039196	7041599	7041594-A 7048235-B	7042482-A 7042480-B	7041591-A 7041592-B	7035133	7037597
307	7047111-B 7047110-A	7041605	7039197	7041606	7041604-A 7041603-B	7041600	7041602-A 7041601-B	7023809	7042819
350 w/2BC	7047112-A 7047127-B	7041613	7039198	7041614	7041724-A 7041611-B	7041607	7041608-A 7041609-B	7023813	7036282
350 w/4BC	7046984-F 3989021-BD 3989022-AD	7041667 3971669-D	7039202-F 3979668-D	7041872 3979667-D	7041665-F 3979694-BD 3979655-AD	7042746-F	7041664-F 3898992-DE 3889781-DC	7035130-F 3969656-D	7037337-F
400 w/4BC	7047116	7041661	7039201	7041872	7041870	7042745	7041658	7035140	7037327

A. w/A.T.

C. Sec'd.

E. Primary

B. exc. A.T.

D. Sp. H/Per.

F. exc. Sp. H/Per.

**FUEL—EXHAUST—CARBURETION**

**1970 CAMARO CARBURETOR CHART**

NOTE Rochester parts can be identified by the part number. All 7000000 part numbers are considered Rochester. All 3000000 part numbers are to be considered Holley parts.  
 NOTE Major Repair Kits consist of necessary parts to overhaul one carburetor-including jets, nozzles, intake needle and seat, pump lever etc.  
 NOTE Minor Repair Kits consist of pump, needle and seat unit, air horn gasket, thermostat housing cover gasket, clip and gauges.  
 NOTE: See Dealer Price Schedule for applicable prices.

ENGINE	CARBU-RETOR 3.725	MAJOR REPAIR KIT 3.725	MINOR REPAIR KIT 3.725	GASKET UNIT 3.724	BODY ASSY. 3.729	HORN ASSY. 3.730	BOWL ASSY. 3.734	NEEDLE UNIT 3.814	PLUNGER 3.838
6 Cyl.	7047014-A 7047015-B	7036782-A 7036783-B	7039166	7036784	7040696-B 7040631-A	7038554-A 7038556-B	7036785-A 7041348-B	7035133	7037597
307	7047002-A 7047013-B	7036796	7039167	7036797	7026285-BH 7038467-AG 7038466-AH 7026150-BG	7036790	7036791-AH 7036792-AG 7036920-BH 7036921-BG	7023809	7040996-A 7042819-B
350 w/2BC	7047004-A 7047029-B	7036800	7039169	7036801	7038461-A 7038785-B	7036793	7036794-B 7036799-A	7023813	7036282
350 w/4BC	7047006-K 3972121-DFB 3972123-DEB 3972120-DAF 3972122-DAE	7036843-K 3979474-DF 3979638-DE	7039174-K 3979473-DF 3979637-DE	7036814-K 3979472-DF 3979636-DE	3979497-DEB 3979534-DFB 7036841-K 3979469-DAF 3979495-DAE	7038704-K	3889781-DFI 3889781-DAE 3979540-DBE 7036839-K 3898992-DFJ 3979502-DEJ	7035130-K 3877165-D	7037337-K
396, 454	7046906-C 3967477-DBF 3967479-DBE 3969894-DAE 3969898-DAF	7036860-C 3979474-DF 3979688-DE	7039171-C 3979473-DF 3979637-DE	7036814-C 3979472-DF 3979636-DE	3979529-DE 3979531-DF 7036812-BC 7041303-AC	7038702-C	3889781-DAE 3898992-DFJ 3979502-DEJ 7036811-C 3889781-DBF 3979540-DBE	3877165-D 7035140-C	7037327-C

A. w/A.T.      C. H/Per.      E. w/E.E.C.      G. w/C.A.C.      I. Sec'd.      K. exc. Sp. H/Per.  
 B. exc. A.T.      D. Sp. H/Per.      F. exc. E.E.C.      H. exc. C.A.C.      J. Primary

**1971 PASSENGER CARBURETOR CHART**

NOTE: See Dealer Price Schedule for Applicable Prices.

ENGINE	CARBU-RETOR 3.725	MAJOR REPAIR KIT 3.725	MINOR REPAIR KIT 3.725	GASKET UNIT 3.724	BODY ASSY 3.729	HORN ASSY. 3.730	BOWL ASSY. 3.734	NEEDLE UNIT 3.814	PLUNGER 3.838
6 Cyl.	7047117-B 7047114-A	7041598-A 7041597-B	7039196	7041599	7042489-A 7048235-B	7042482-A 7042480-B	7041591-A 7041592-B	7035133	7037597
350 w/2BC	7047113-B 7047104-A	7041613	7039198	7041614	7041724-A 7041611-B	7041607	7041608-A 7041609-B	7023813	7036282
350 w/4BC	7047120	7041667	7039202	7041872	7041665	7042746	7041664	7035130	7037337
400 w/2BC	7047118-A 7047113-B	7041613	7039198	7041614	7041610-A	7041607	7041616-A	7023813	7036282
400 w/4BC	7047116	7041661	7039222	7041872	7041870	7042745	7041658	7035140	7037327
454	7047116	7041661	7039222	7041872	7041870	7042745	7041658	7035140	7037327

A. w/A.T.      B. exc. A.T.

## FUEL—EXHAUST—CARBURETION

### 1970 NOVA CARBURETOR CHART

NOTE Rochester parts can be identified by the part number. All 7000000 part numbers are considered Rochester. All 3000000 part numbers are to be considered Holley parts.

NOTE Major Repair Kits consist of necessary parts to overhaul one carburetor-including jets, nozzles, intake needle and seat, pump lever etc.

NOTE Minor Repair Kits consist of pump, needle and seat unit, air horn gasket, thermostat housing cover gasket, clip and gauges.

NOTE: See Dealer Price Schedule for Applicable Prices.

ENGINE	CARBU- RETOR 3.725	MAJOR REPAIR KIT 3.725	MINOR REPAIR KIT 3.725	GASKET UNIT 3.724	BODY ASSY. 3.729	HORN ASSY. 3.730	BOWL ASSY. 3.734	NEEDLE UNIT 3.814	PLUNGER 3.838
4 Cyl.	7047008	7036789	7039166	7036784	7040769	7038553	7036786	7035133	7037596
6 Cyl.	7047014-A 7047015-B	7036782-A 7036783-B	7039166	7036784	7040631-A 7040696-B	7038554-A 7038556-B	7036785-A 7041348-B	7035133	7037597
307	7047002-A 7047013-B	7036796 7036796	7039167	<b>7036797</b>	7026285-BH 7038467-AG 7038466-AH 7026150-BG	7036790	7036791-AH 7036792-AG 7036920-BH 7036921-BG	7023809	7040996-A 7042819-B
350 w/2BC	7047016-A 7047005-B	7036800	7039169	7036801	7038461-A 7038785-B	7036793	7036794-B 7036799-A	7023813	7036282
350 w/4BC	7047006	7036843	7039174	7036814	7036841	7038704	7036839	7035130	7037337
396	7046906-C 3967477-DBF 3967479-DBE 3969894-DAE 3969898-DAF	7036860-C 3979474-DF 3979638-DE	7039171-C 3979473-DF 3979637-DE	7036814-C 3979472-DF 3979636-DE	7041303-AC 7036812-BC 3979529-DE 3979531-DF	7038702-C	7036811-C 3889781-DAE 3898992-DFJ 3979696-DEJ 3889781-DBFI 3979540-DBEI	7035140-C 3877165-D	7037327-C

A. w/A.T.  
B. exc. A.T.

C. H/Per.  
D. Sp. H/Per.

E. w/E.E.C.  
F. exc. E.E.C.

G. w/C.A.C.  
H. exc. C.A.C.

I. Sec'd.  
J. Primary



**FUEL—EXHAUST—CARBURETION**

**1970 PASSENGER CARBURETOR CHART**

NOTE Rochester parts can be identified by the part number. All 7000000 part numbers are considered Rochester. All 3000000 part numbers are to be considered Holley parts.

NOTE Major Repair Kits consist of necessary parts to overhaul one carburetor-including jets, nozzles, intake needle and seat, pump lever etc.

NOTE Minor Repair Kits consist of pump, needle and seat unit, air horn gasket, thermostat housing cover gasket, clip and gauges.

NOTE: See Dealer Price Schedule for Applicable Prices.

ENGINE	CARBU- RETOR 3.725	MAJOR REPAIR KIT 3.725	MINOR REPAIR KIT 3.725	GASKET UNIT 3.724	BODY ASSY. 3.729	HORN ASSY. 3.730	BOWL ASSY. 3.734	NEEDLE UNIT 3.814	PLUNGER 3.838
6 Cyl.	7047014-A 7047015-B	7036782-A 7036783-B	7039166	7036784	7040631-A 7040696-B	7038554-A 7038556-B	7036785-A 7041348-B	7035133	7037597
350 w/2BC	7047005-B 7047016-A	7036800	7039169	7036801	7038461-A 7038785-B	7036793	7036794-B 7036799-A	7023813	7036282
350 w/4BC	7047006	7036843	7039174	7036814	7036841	7038704	7036839	7035130	7037337
400 w/2BC	7047020	7036800	7039169	7036801	7038461	7036793	7036802	7023813	7036282
454	7046906	7036860	7039171	7036814	7036812	7040689	7036811	7035140	7037327

A. w/A.T.

B. exc. A.T.

**1970 CHEVELLE CARBURETOR CHART**

NOTE Rochester parts can be identified by the part number. All 7000000 part numbers are considered Rochester. All 3000000 part numbers are to be considered Holley parts.

NOTE Major Repair Kits consist of necessary parts to overhaul one carburetor-including jets, nozzles, intake needle and seat, pump lever etc.

NOTE Minor Repair Kits consist of pump, needle and seat unit, air horn gasket, thermostat housing cover gasket, clip and gauges.

NOTE: See Dealer Price Schedule for Applicable Prices.

ENGINE	CARBU- RETOR 3.725	MAJOR REPAIR KIT 3.725	MINOR REPAIR KIT 3.725	GASKET UNIT 3.724	BODY ASSY. 3.729	HORN ASSY. 3.730	BOWL ASSY. 3.734	NEEDLE UNIT 3.814	PLUNGER 3.838
6 Cyl.	7047014-A 7047015-B	7036782-A 7036783-B	7039166	7036784	7040696-B 7040631-A	7038554-A 7038556-B	7036785-A 7041348-B	7035133	7037597
307	7047002-A 7047013-B	7036796 7036796	7039167	7036797	7026285-BH 7038467-AG 7038466-AH 7026150-BG	7036790	7036791-AH 7036792-AG 7036920-BH 7036921-BG	7023809	7040996-A 7042819-B
350 w/2BC	7047016-A 7047005-B	7036800	7039169	7036801	7038461-A 7038785-B	7036793	7036794-B 7036799-A	7023813	7036282
350 w/4BC	7047006	7036843	7039174	7036814	7036841	7038704	7036839	7035130	7037337
396	7046906-C 3967477-DBF 3967479-DBE 3969894-DAE 3969898-DAF	7036860-C 3979474-DF 3979638-DE	7039171-C 3979473-DF 3979637-DE	7036814-C 3979472-DF 3979636-DE	7041303-AC 7036812-BC 3979529-DE 3979531-DAF 3979534-DBF	7038702-C	7036811-C 3889781-DAEK 3898992-DFL 3979502-DEL 3889781-DBFK	3877165-D 7035140-C	7037327-C
400 w/2BC	7047019-B 7047020-A	7036800	7039169	7036801	7038461-A 7038462-B	7036793	7036802-A 7036803-B	7023813	7036282
400 w/4BC	7046906	7036813-B 7036860-A	7039171	7036814	7036812	7038702-B 7040689-A	7036811-A 7036922-B	7035140	7037327
454	7046906-CI 3967477-DBF 3967479-DBE 3969894-DAE 3969898-DAF 7047009-J	7036860-C 3979474-DF 3979638-DE	7039171-C 3979473-DF 3979637-DE	7036814-C 3979472-DF 3979636-DE	7041303-ACI 7036812-BCI 7036812-J 3979529-DE 3979531-DF	7040689-ACI 7038702-BCI 7040689-J	7036811-C 3889781-DBFK 3889781-DAEIK 3898992-DFL 3979696-DEL 3979540-DBEK	7035140-C 3877165-D	7037327-C

A. w/A.T.

C. H/Per.

E. w/E.E.C.

G. w/C.A.C.

I. exc. Monte Carlo

K. Sec'd.

B. exc. A.T.

D. Sp. H/Per.

F. exc. E.E.C.

H. exc. C.A.C.

J. Monte Carlo

L. Primary

## 1969 CAMARO CARBURETOR CHART

- NOTE Rochester parts can be identified by the part number. All 7000000 part numbers are considered Rochester. All 3000000 part numbers are to be considered Holley parts.
- NOTE Major Repair Kits consist of necessary parts to overhaul one carburetor including jets, nozzles, intake needle and seat, pump lever etc.
- NOTE Minor Repair Kits consist of pump, needle and seat unit, air horn gasket, thermostat housing cover gasket, clip and gauges.
- NOTE See Dealer Price Schedule for Applicable Prices.

ENGINE	CARBU- RETOR 3.725	MAJOR REPAIR KIT 3.725	MINOR REPAIR KIT 3.725	GASKET UNIT 3.724	BODY ASSY. 3.729	HORN ASSY. 3.730	BOWL ASSY. 3.734	NEEDLE UNIT 3.814	PLUNGER 3.838
6 Cyl.	7016901-B 7016902-A	7036548-A 7036549-B	7039147	7036546	7037033-A 7037036-B	7037776-A 7037799-B	7036666-B 7036667-A	7035133	7037597
307,327	7016912-A 7016903-B	7016740	7039109	7016752	7037938-E 7037937-F	7036550	7036404-AF 7036405-AE 7036403-BE 7036402-BF	7023809	7031824
350 w/2BC	7016915-B 7016916-A	7036552	7039148	7036533	7037939-A 7036288-B	7036551	7036555	7023813	7037562
350 w/4BC	7046904-A 7016923-B	7036562-A 7036563-B	7039149	7036565	7036559-A 7036773-B	7037347	7036557-A 7036558-B	7035130	7037337
396	7046904-C 3959164-D	7036571-BC 7036572-AC 3960396-D	7039150-C 7039594-D	7036565-C 3960394-D	7036569-BC 7036620-AC - 3931643-D	7037948-AC 7037306-BC	7036567-BC 7036643-AC 3960393-DG 3889781-DH	3877165-D 7035140-C	7037327-C
302	3923289	3936249	3936248	3896609	3931643		3898992-G 3889781-H	3877165	

- A. w/A.T.                      C. exc. Sp. H/Per.                      E. w/C.A.C.                      G. Primary
- B. exc. A.T.                      D. Sp. H/Per.                      F. exc. C.A.C.                      H. Secondary

## 1969 NOVA CARBURETOR CHART

- NOTE Rochester parts can be identified by the part number. All 7000000 part numbers are considered Rochester. All 3000000 part numbers are to be considered Holley parts.  
 NOTE Major Repair Kits consist of necessary parts to overhaul one carburetor-including jets, nozzles, intake needle and seat, pump lever etc.  
 NOTE Minor Repair Kits consist of pump, needle and seat unit, air horn gasket, thermostat housing cover gasket, clip and gauges.  
 NOTE See Dealer Price Schedule for Applicable Prices.

ENGINE	CARBU- RETOR 3.725	MAJOR REPAIR KIT 3.725	MINOR REPAIR KIT 3.725	GASKET UNIT 3.724	BODY ASSY. 3.729	HORN ASSY. 3.730	BOWL ASSY. 3.734	NEEDLE UNIT 3.814	PLUNGER 3.838
4 Cyl.	7016900	7036545	7039147	7036546	7037458	7037041	7036377	7035133	7037597
6 Cyl.	7016901-B 7016902-A	7036548-A 7036549-B	7039147	7036546	7037033-A 7037036-B	7037776-A 7037799-B	7036666-B 7036667-A	7035133	7037597
307	7016912-A 7016903-B	7016740	7039109	7016752	7037938-E 7037937-F	7036550	7036404-AF 7036405-AE 7036403-BE 7036402-BF	7023809	7031824
350 w/2BC	7016915-B 7016916-A	7036552	7039148	7036533	7037939-A 7036288-B	7036551	7036555	7023813	7037562
350 w/4BC	7046904-A 7016923-B	7036562-A 7036563-B	7039149	7036565	7036559-A 7036773-B	7037347	7036557-A 7036558-B	7035130	7037337
396	7046904-C 3959164-D	7036571-BC 7036572-AC 3960396-D	7039150-C 7039594-D	3960394-D 7036565-C	7036569-BC 7036620-AC 3931643-D	7037948-AC 7037306-BC	7036567-BC 7036643-AC 3960393-DG 3889781-DH	3877165-D 7035140-C	7037327-C

A. w/A.T.  
B. exc. A.T.

C. exc. Sp. H/Per.  
D. Sp. H/Per.

E. w/C.A.C.  
F. exc. C.A.C.

G. Primary  
H. Secondary

## 1969 CHEVELLE CARBURETOR CHART

- NOTE Rochester parts can be identified by the part number. All 7000000 part numbers are considered Rochester. All 3000000 part numbers are to be considered Holley parts.
- NOTE Major Repair Kits consist of necessary parts to overhaul one carburetor-including jets, nozzles, intake needle and seat, pump lever etc.
- NOTE Minor Repair Kits consist of pump, needle and seat unit, air horn gasket, thermostat housing cover gasket, clip and gauges.
- NOTE See Dealer Price Schedule for Applicable Prices

ENGINE	CARBU- RETOR 3.725	MAJOR REPAIR KIT 3.725	MINOR REPAIR KIT 3.725	GASKET UNIT 3.724	BODY ASSY. 3.729	HORN ASSY. 3.730	BOWL ASSY. 3.734	NEEDLE UNIT 3.814	PLUNGER 3.838
6 Cyl.	7016901-B 7016902-A	7036548-A 7036549-B	7039147	7036546	7037033-A 7037036-B	7037776-A 7037799-B	7036666-B 7036667-A	7035133	7037597
307	7016912-A 7016903-B	7016740	7039109	7016752	7037938-G 7037937-H	7036550	7036404-AH 7036405-AG 7036403-BG 7036402-BH	7023809	7031824
350 w/2BC	7016915-B 7016916-A	7036552	7039148	7036533	7037939-A 7036288-B	7036551	7036555	7023813	7037562
350 w/4BC	7046904-A 7016923-B	7036562-A 7036563-B	7039149	7036565	7036559-A 7036773-B	7037347	7036557-A 7036558-B	7035130	7037337
396	7046904-CD 7046904-E 3959164-F	7036570-ACD 7036571-BD 7036572-AE 3960396-F	7039150-D 7039594-F	7036565-D 3960394-F	7036568-ACD 7036569-BD 3931643-F 7036620-AE	7037340-ACD 7037306-BD 7037948-AE	7036566-ACD 7036567-BD 3960393-FI 7036643-AE	3877165-F 7035140-D	7037327-C

A. w/A.T.  
B. exc. A.T.

C. exc. H/Per.  
D. exc. Sp. H/Per.

E. H/Per.  
F. Sp. H/Per.

G. w/C.A.C.  
H. exc. C.A.C.

I. Primary  
J. Secondary

## 1969 PASSENGER CARBURETOR CHART

- NOTE Rochester parts can be identified by the part number. All 7000000 part numbers are considered Rochester. All 3000000 part numbers are to be considered Holley parts.  
 NOTE Major Repair Kits consist of necessary parts to overhaul one carburetor-including jets, nozzles, intake needle and seat, pump lever etc.  
 NOTE Minor Repair Kits consist of pump, needle and seat unit, air horn gasket, thermostat housing cover gasket, clip and gauges.  
 NOTE See Dealer Price Schedule for Applicable Prices.

ENGINE	CARBU- RETOR 3.725	MAJOR REPAIR KIT 3.725	MINOR REPAIR KIT 3.725	GASKET UNIT 3.724	BODY ASSY. 3.729	HORN ASSY. 3.730	BOWL ASSY. 3.734	NEEDLE UNIT 3.814	PLUNGER 3.838
6 Cyl.	7016901-B 7016902-A	7036548-A 7036549-B	7039147	7036546	7037033-A 7037036-B	7037776-A 7037799-B	7036666-B 7036667-A	7035133	7037597
327 w/2BC	7016904-A 7016915-B	7036552	7039148	7036553	7036288	7036551	7036554-B 7036697-A	7023813	7037562
350 w/2BC	7016915-B 7016916-A	7036552	7039148	7036553	7037939-A 7036288-B	7036551	7036555	7023813	7037562
350 w/4BC	7046904-A 7016923-B	7036562-A 7036563-B	7039149	7036565	7036559-A 7036773-B	7037347	7036557-A 7036558-B	7035130	7037337
396	7016918-A 7016919-B	7036552	7039148	7036553	7036290-A 7037940-B	7036551	7036700-B 7036713-A	7023813	7037562
427	7046904-C 3959164-D	7036570-AC 7036571-BC 3960396-D	7039150-C 7039594	7036565-C 3960394-D	7036568-AC 7036569-BC 3931643-D	7037340-AC 7037306-BC	7036566-AC 7036567-BC 3960393-DE 3889781-DF	3877165-D 7035140-C	7037327-C

A. w/A.T.  
B. exc. A.T.

C. exc. Sp. H/Per.  
D. Sp. H/Per.

E. Primary  
F. Secondary

## 1968 CAMARO CARBURETOR CHART

- NOTE Rochester parts can be identified by the part number. All 7000000 part numbers are considered Rochester. All 3000000 part numbers are to be considered Holley parts.
- NOTE Major Repair Kits consist of necessary parts to overhaul one carburetor-including jets, nozzles, intake needle and seat, pump lever etc.
- NOTE Minor Repair Kits consist of pump, needle and seat unit, air horn gasket, thermostat housing cover gasket, clip and gauges.
- NOTE See Dealer Price Schedule for Applicable Prices.

ENGINE	CARBU- RETOR 3.725	MAJOR REPAIR KIT 3.725	MINOR REPAIR KIT 3.725	GASKET UNIT 3.724	BODY ASSY. 3.729	HORN ASSY. 3.730	BOWL ASSY. 3.734	NEEDLE UNIT 3.814	PLUNGER 3.838
6 Cyl.	7016901-A 7016902-B	7016824-B 7016825-A	7039147	7036546	7034136-I 7037033-E	7036439-I 7036314-E	7036400-E 7036401-I	7035133	7037595-B 7037597-A
307,327 w/2BC	7041833-A 7046904-E 7016912-F	7016740	7039109	7016752	7035428-AG 7035429-AH 7035426-BG 7035427-BH	7036550	7036402-AG 7036403-AH 7036404-BG 7036405-BH	7023809	7031824
327 w/4BC	7016923-A 7046904-B	7016851	7039133	7016843	7036406-A 7036407-B	7034898	7036318-E 7036319-I	7035130	7034111
350	7046904-B 7016923-A	7016851	7039133	7016843	7036406-A 7036407-B	7034898	7036318-E 7036319-I	7035130	7034111
396	7016125-AC 7016925-BC 3923289-D	7016839-AC 7036325-BC 3936249-D	7039126-C 3936248-D	7016843-C 3896609-D	7036409-BC 7036410-AC 3931643-D	7034897-C	7036309-C 3898992-DJ 3889781-DK	7035140-C 3877165-D	7036140-C
302	3923289	3936249	7039594	3896609	3931643	--	3898992-J 3889781-K	3877165	

- A. exc. A.T.                      D. Sp. H/Per.                      G. exc. C.A.C.                      J. Primary
- B. w/A.T.                          E. w/P.G.                          H. w/C.A.C.                      K. Secondary
- C. exc. Sp. H/Per.                F. w/T.H. 350                      I. e&c. P.G.

## 1968 NOVA CARBURETOR CHART

- NOTE Rochester parts can be identified by the part number. All 7000000 part numbers are considered Rochester. All 3000000 part numbers are to be considered Holley parts.
- NOTE Major Repair Kits consist of necessary parts to overhaul one carburetor-including jets, nozzles, intake needle and seat, pump lever etc.
- NOTE Minor Repair Kits consist of pump, needle and seat unit, air horn gasket, thermostat housing cover gasket, clip and gauges.
- NOTE: See Dealer Price Schedule for Applicable Prices.

ENGINE	CARBU- RETOR 3.725	MAJOR REPAIR KIT 3.725	MINOR REPAIR KIT 3.725	GASKET UNIT 3.724	BODY ASSY. 3.729	HORN ASSY. 3.730	BOWL ASSY. 3.734	NEEDLE UNIT 3.814	PLUNGER 3.838
4 Cyl.	7016900	7036363	7039147	7036546	7034006-E 7034757-I	7035937	7036377	7035133	
6 Cyl.	7016901-A 7016902-B	7016824-B 7016825-A	7039147	7036546	7037033-E 7034136-I	7036439-I 7036314-E	7036400-E 7036401-I	7035133	7037595-B 7037597-A
307 w/2BC	7041833-A 7046904-E 7016912-F	7016740	7039109	7016752	7035428-AG 7035429-AH 7035426-BG 7035427-BH	7036550	7036402-AG 7036403-AH 7036404-BG 7036405-BH	7023809	7031824
327 w/4BC	7016923-AC 7016927-D 7046904-BC	7016851-C 7036455-D	7039133	7016843	7036406-AC 7036407-BC 7036412-D	7034898-C 7035919-D	7036318-CE 7036319-CI	7035130	7034111
350	7016923-A 7046904	7016851	7039133	7016843	7036406-A 7036407-B	7034898	7036318-E 7036319-I	7035130	7034111
396	7016125-AC 7016925-CB 3923289-D	7016839-AC 7036325-BC 3936249-D	7039126-C 7039594-D	7016843-C 3896609-D	7036409-BC 7036410-AC 3931643-D	7034897-C	3898992-DJ 7036309-C 3889781-DK	7035140-C 3877165-D	7036140-C

- A. exc. A.T.                      E. w/P.G.                      I. exc. P.G.  
 B. w/A.T.                         F. w/T.H. 350                J. Primary  
 C. exc. Sp. H/Per.               G. exc. C.A.C.               K. Secondary  
 D. Sp. H/Per.                    H. w/C.A.C.

## 1968 CHEVELLE CARBURETOR CHART

- NOTE Rochester parts can be identified by the part number. All 7000000 part numbers are considered Rochester. All 3000000 part numbers are to be considered Holley parts.  
 NOTE Major Repair Kits consist of necessary parts to overhaul one carburetor-including jets, nozzles, intake needle and seat, pump lever etc.  
 NOTE Minor Repair Kits consist of pump, needle and seat unit, air horn gasket, thermostat housing cover gasket, clip and gauges.  
 NOTE See Dealer Price Schedule for Applicable Prices.

ENGINE	CARBU- RETOR 3.725	MAJOR REPAIR KIT 3.725	MINOR REPAIR KIT 3.725	GASKET UNIT 3.724	BODY ASSY. 3.729	HORN ASSY. 3.730	BOWL ASSY. 3.734	NEEDLE UNIT 3.814	PLUNGER 3.838
6 Cyl.	7016901-A 7016902-B	7016824-B 7016825-A	7039147	7036546	7034136-K 7037033-G	7036439-K 7036314-G	7036400-G 7036401-K	7035133	7037595-B 7037597-A
307 w/2BC	7041833-A 7016912-H	7016740	7039109	7016752	7035428-AI 7035429-AJ 7035426-BI 7035427-BJ	7036550	7036402-AI 7036403-AJ 7036404-BI 7036405-BJ	7023809	7031824
327 w/4BC	7016923-AC 7046904-BCD	7016851-C 7036455-D	7039133	7016843	7036406-BC 7036407-AC 7036412-D	7034898-C 7035919-D	7036318-GC 7036319-KC	7035130	7034111
396	7016925-CB 3923289-DA	7016839-AC 7036325-BF 7016838-BCE 3936249-D	7039126-C 7039594-D	7016843-C 3896609-D	7036409-BC 7036410-AC 3931643-D	7034896-BCE 7034897-F 7034897-ACE	7036309-AC 7036308-BC 3898992-DL 3889781-DM	7035140-C 3877165-D	7036140-C

A. exc. A.T.  
 B. w/A.T.  
 C. exc. Sp. H/Per.  
 D. Sp. H/Per.

E. exc. H/Per.  
 F. H/Per.  
 G. w/P.G.

H. w/T.H. 350  
 I. exc. C.A.C.  
 J. w/C.A.C.

K. exc. P.G.  
 L. Primary  
 M. Secondary



## 1968 PASSENGER CARBURETOR CHART

- NOTE Rochester parts can be identified by the part number. All 7000000 part numbers are considered Rochester. All 3000000 part numbers are to be considered Holley parts.
- NOTE Major Repair Kits consist of necessary parts to overhaul one carburetor-including jets, nozzles, intake needle and seat, pump lever etc.
- NOTE Minor Repair Kits consist of pump, needle and seat unit, air horn gasket, thermostat housing cover gasket, clip and gauges.
- NOTE See Dealer Price Schedule for applicable prices.

ENGINE	CARBU- RETOR 3.725	MAJOR REPAIR KIT 3.725	MINOR REPAIR KIT 3.725	GASKET UNIT 3.724	BODY ASSY. 3.729	HORN ASSY. 3.730	BOWL ASSY. 3.734	NEEDLE UNIT 3.814	PLUNGER 3.838
6 Cyl.	7016901-A 7016902-B	7016824-B 7016825-A	7039147	7036546	7034136-I 7037033-E	7036439-I 7036314-E	7036400-E 7036401-I	7035133	7037595-B 7037597-A
307	7041833-A 7016904-E 7016912-F	7016740	7039109	7016752	7035428-AG 7035429-AH 7035426-BG 7035427-BH	7036550	7036402-AG 7036403-AH 7036405-BH 7036404-BG	7023809	7031824
327	7016923-A 7046904-B	7016851	7039133	7016843	7036406-A 7036407-B	7034898-	7036318-B 7036319-A	7035130	7034111
396	7016925-	7016839-A 7016838-B	7039126	7016843	7036409-B 7036410-A	7034896-B 7034897-A	7036308-B 7036309-A	7035140	7036140
427	7016925-C 3923289-D	7016839-AC 7016838-BC 3936249-D	7039126-C 7039594-D	7016843-C 3896609-D	7036409-BC 7036410-AC 3931643-D	7034896-BC 7034897-AC	7036308-BC 7036309-AC 3898992-DJ 3889781-DK	7035140-C 3877165-D	7036140-C

- A. exc. A.T.                      E. w/P.G.                      I. exc. P.G.  
 B. w/A.T.                         F. w/T.H. 350                J. Primary  
 C. exc. Sp. H/Per.               G. exc. C.A.C.               K. Secondary  
 D. Sp. H/Per.                    H. w/C.A.C.

**FUEL—EXHAUST—CARBURETION**

**3.725 VEGA, MONZA**

**GASKET UNIT, CARBURETOR**

71-72	Vega w/1BC .....	7041582	1	3.35
71	Vega w/2BC .....	7041588	1	4.50
72	Vega w/2BC .....	7041922	1	4.50
73-75	Vega, Monza w/1BC .....	7046683	1	3.35
73-74	Vega, Monza w/2BC .....	335147	1	4.65
75	Vega, Monza w/2BC (140) .....	360994	1	6.80
75	Vega, Monza w/A.T. (262) .....	17052657	1	5.15

**3.725 VEGA, MONZA**

**CARBURETOR—REPAIR UNIT**

71	Vega w/1BC (exc. A.T.) .....	7047123	1	59.00	
71	Vega (1BC w/A.T.) .....	7047124	1	56.00	
71	Vega w/2BC (exc. A.T.) .....	7041911	1	78.00	
71	Vega (2BC w/A.T.) .....	7041910	1	70.00	
72	Vega w/1BC (NB-2 w/A.T.) .....	7047254	1	59.00	
72	Vega (1BC w/NB-2) (exc. A.T.) ..	7047257	1	59.00	
72	Vega w/1BC (exc. A.T., NB-2) ..	7046579	1	59.00	
72	Vega (1BC w/A.T.) (exc. NB-2) ..	7046580	1	59.00	
72	Vega w/2BC (NB-2 w/A.T.) .....	7046632	1	78.00	
72	Vega (2BC w/NB-2) (exc. A.T.) ..	7046633	1	78.00	
72	Vega (2BC w/A.T.) (exc. NB-2) ..	7046630	1	78.00	
72	Vega w/2BC (exc. A.T., NB-2) ..	7046631	1	78.00	
72	Vega (2BC w/A.T.) (exc. NB-2) ..	6259026	1	70.50	
73	Vega w/2BC (exc. A.T., NB-2) ..	6259025	1	70.50	
73	Vega w/2BC (A.T. w/NB-2) .....	6259027	1	70.50	
73	Vega w/1BC (exc. A.T.) .....	7047333	1	61.00	
73	Vega (1BC w/A.T.) .....	7047334	1	61.00	
73	Vega (2BC w/NB-2) (exc. A.T.) ..	6259028	1	70.50	
74	Vega w/1BC (140) (exc. A.T.) ..	7047443	1	61.00	
74	Vega (1BC w/A.T.) (140) .....	17050660	1	61.00	
74	Vega w/2BC (140) (exc. A.T.) ..	345652	1	70.00	
74	Vega (2BC w/A.T.) (140) (exc. NB-2) .....	345653	1	70.00	
74	Vega w/2BC (140) (A.T. w/NB- 2) .....	345655	1	73.50	
74	Vega w/2BC (exc. A.T.) .....	345652	1	70.00	
75	Vega, Monza (A.T. w/1BC) (140)	7047528	1	79.00	
75	Vega, Monza (1BC w/4-Spd.) (140) .....	7047529	1	79.00	
75	Vega, Monza (3-Spd. w/1BC) (140) .....	17052833	1	79.00	
75	Vega, Monza w/2BC (140) (exc. A.T., C.A.C., NB-2) .....	378049	1	104.00	(repl. 361008) .....
75	Vega, Monza (A.T. w/2BC) (140) (exc. NB-2, C.A.C.) .....	361015	1	104.00	
75	Vega, Monza (2BC w/C.A.C.) (140) (exc. A.T., NB-2) .....	378053	1	104.00	(repl. 361011) .....
75	Vega, Monza w/A.T. (2BC w/C.A.C.) (140) (exc. NB-2) ..	378054	1	104.00	(repl. 361012) .....
75	Vega, Monza (NB-2 w/2BC) (140) (exc. A.T., C.A.C.) .....	361009	1	104.00	
75	Vega, Monza w/NB-2 (2BC w/A.T.) (140) (exc. C.A.C.) .....	361010	1	104.00	
75	Vega, Monza w/NB-2 (C.A.C. w/2BC) (140) (exc. A.T.) .....	361013	1	104.00	
75	Vega, Monza (A.T. w/2BC) (NB-2 w/C.A.C.) (140) .....	361014	1	104.00	
75	Vega, Monza (262) (exc. A.T.) ..	17052567	1	97.00	
75	Vega, Monza w/A.T. (262) .....	17052566	1	97.00	
71	Vega w/1BC .....	7041581	1	13.55	REPAIR UNIT, carb. (major) .....
71	Vega w/1BC .....	7039194	1	5.15	REPAIR UNIT, carb. (minor) .....
71	Vega w/2BC .....	7041866	1	26.90	REPAIR UNIT, carb. (major) .....
71	Vega w/2BC .....	7039195	1	7.10	REPAIR UNIT, carb. (minor) .....
72	Vega w/1BC .....	7046524	1	12.65	REPAIR UNIT, carb. (major) .....
72	Vega w/1BC .....	7039235	1	5.15	REPAIR UNIT, carb. (minor) .....
72	Vega w/2BC .....	7041921	1	26.90	REPAIR UNIT, carb. (major) .....
72	Vega w/2BC .....	7039225	1	8.10	REPAIR UNIT, carb. (minor) .....
73-75	Vega, Monza w/1BC .....	7046682	1	12.65	REPAIR UNIT, carb. (major) .....
73-75	Vega, Monza w/1BC .....	7039249	1	5.15	REPAIR UNIT, carb. (minor) .....
73	Vega, Monza w/2BC .....	335148	1	28.50	REPAIR UNIT, carb. (major) .....

**FUEL—EXHAUST—CARBURETION**

<b>3.725 VEGA, MONZA (Con't)</b>					
74	Vega, Monza w/2BC (140) (exc. A.T.)	345649	1	21.70	REPAIR UNIT, carb. (major)
74	Vega, Monza (2BC w/A.T.) (140)	345651	1	21.70	REPAIR UNIT, carb. (major)
75	Vega, Monza w/2BC (140) (exc. A.T., NB-2)	360990	1	21.70	REPAIR UNIT, carb. (major) (85R4840)
75	Vega, Monza (2BC w/A.T.) (140) (exc. NB-2)	360992	1	21.70	REPAIR UNIT, carb. (major) (85R4899)
75	Vega, Monza (NB-2 w/2BC) (140) w/A.T.	361022	1	24.45	REPAIR UNIT, carb. (major) (85R4826)
75	Vega, Monza w/M.T. (NB-2 w/2BC) (140)	360991	1	24.45	REPAIR UNIT, carb. (major) (85R4898)
75	Monza (262)	7039284	1	10.65	REPAIR UNIT, carb. (minor)
75	Monza (262)	17052787	1	15.50	REPAIR UNIT, carb. (major)
<b>3.726 GASKET—BAFFLE—INSULATOR, Carburetor to Manifold</b>					
62	Chevy	3795179	1	.22	
62-69	All (exc. 8 cyl.),				
70	All (4 cyl., 6 cyl.) (exc. E.E.C.)	3953732	1	.45	carb. (two 2 <sup>7</sup> / <sub>64</sub> " holes 1 <sup>25</sup> / <sub>64</sub> " I.D. x 2 <sup>15</sup> / <sub>16</sub> " O.L.)
64-69	Chevy, Chevelle, Camaro (283, 307, 327) (exc. 4BC),				
65-68	Pass. w/2BC,				
70	All (307) (exc. E.E.C.)	3704952	1	.19	(two 1 <sup>1</sup> / <sub>2</sub> " holes— 4 <sup>7</sup> / <sub>8</sub> " O.L.) (w/3 head passage cutouts)
64-65	Chevy, Chevelle (327) (exc. H/Per., Sp. H/Per.),				
65	Pass. (327) (exc. H/Per., Sp. H/Per.),				
65-66	Pass. w/4BC (283),				
66	Chevy, Chevelle, Camaro w/4BC (283)	3743282	1	.38	
64-65	All w/H/Per. (327),				
65	Pass. (409) (exc. H/Per., dual 4BC)	3829012	1	.29	
65	Chevelle w/Sp. H/Per.,				
66-67	Chevy, Chevelle w/Sp./H/Per. (327)	3849825	1	.36	
65	Pass. w/H/Per., dual 4BC	3798352	1	.36	
65	Pass. w/Sp. H/Per. (396),				
66-69	Pass. w/Sp. H/Per. (427),				
66-67	Chevelle w/Sp. H/Per. (396),				
67-69	Camaro w/Sp. H/Per. (396, 302),				
68-69	Chevy, Chevelle w/Sp. H/Per. (396),				
70	All (4BC w/Sp. H/Per.) (exc. E.E.C.)	682914	1	.30	carburetor
65	Pass. (396),				
66	Pass. (327, 396, 427) (exc. Sp. H/Per.),				
66-67	Chevy, Chevelle, Camaro w/4BC (327, 396) (exc. Sp./H/Per.),				
67	Pass. (327, 396) (exc. A.I.R.)	3890495	1	.36	carburetor (Holley and Carter)
65	Pass. (396) (exc. Sp. H/Per.),				
66	Pass. (327, 396, 427) (exc. Sp. H/Per.),				
66-69	Chevy, Chevelle, Camaro (327, 350, 396) (exc. Sp./H/Per.),				
67	Pass. (427) (exc. Sp. H/Per.),				
68	Concours w/Sp. H/Per. (327),				
68	Pass. (327, 396) (exc. Sp. H/Per.),				
68-69	Pass. (427),				
69	Pass. w/4BC (350)	3884574	1	.36	carb. (Roch.)
69	Pass. w/2BC,				
69	Chevy, Chevelle, Camaro w/2BC (350),				
70	All w/2BC (350, 400) (exc. E.E.C.),				
71-72	Nova w/2BC (350)	3942470	1	.66	carb.
70	All w/E.E.C. (4 cyl., 6 cyl.),				
71	Pass. (6 cyl.),				
72	All (6 cyl.)	3967065	1	.46	(Note 1)

NOTE 1 Part of 3967077 Shield Assy.

**FUEL—EXHAUST—CARBURETION**

**3.726 GASKET—BAFFLE—INSULATOR, Carburetor to Manifold (Con't)**

70	All (4BC w/E.E.C.) (exc. Sp. H/Per.)				
71	Chevelle w/4BC (350) (exc. Monte Carlo)	3972192	1	.46	
70	All w/4BC (exc. Sp. H/Per.)	3967470	1	.33	
71	Pass. (6 cyl.)	3953732	1	.45	
75	All w/4BC (exc. 454)	354308	1		carb. to manifold
75	All (454)	419047	1	3.80	carb. to manifold
71-75	Vega, Monza w/1BC	3983440	1	.67	carb. flange
71-72	Vega, Monza w/2BC	3988778	1	.86	carb. flange
73-75	Vega, Monza w/2BC (140)	331161	2	.88	carb. air heat
75	All (122)	361083	1	1.65	throttle body
64-65	All w/H/Per. (327)	3799354	1	1.10	BAFFLE, heat radiation
65	Pass. w/A.T. (396) (exc. Sp. H/Per.)				
66	Chevy, Chevelle (327, 396) (exc. H/Per., Sp./H/Per., A.I.R.)				
66	Pass. (327, 396, 427) (exc. Sp. H/Per.)				
67	Chevelle (S.S.) (396) (exc. A.I.R., H/Per.)				
67	El Camino (396) (exc. A.I.R., H/Per., P.G.)				
67	All w/4BC (327, 350) (exc. A.I.R., Sp. H/Per.)				
67	Pass. (327, 396) (exc. A.I.R.)	3884575	1	1.25	BAFFLE, heat radiation (Holley or Carter)
65	Pass. (396) (exc. Sp. H/Per.)				
66-68	Pass. (327, 396, 427) (exc. Sp. H/Per.)				
66-67	Chevy, Chevelle, Camaro w/4BC (327, 350, 396) (exc. Sp./H/Per.)				
68-69	Chevy, Chevelle, Camaro w/4BC (327, 350, 396)				
69	Pass. (427) (exc. Sp. H/Per.)	3884576	1	1.25	BAFFLE, heat radiation (Roch.)
67-68	Pass. (396, 427)				
67	Camaro, Chevelle w/A.T. (396) (exc. H/Per., Sp. H/Per.)				
68-69	Chevelle (396) (exc. H/Per., Sp. H/Per.)				
69	Pass. (427) (exc. Sp. H/Per.)	7035494	1	.43	BAFFLE, carb. airhorn (Roch.)
64-65	All w/H/Per. (327)	3828231	1	2.95	INSULATOR (w/1—1/4" x 3/8" ext. tab)
70	All (2BC w/E.E.C.) (350, 400)	3973302	1	1.80	INSULATOR
70	All (4BC w/E.E.C.) (exc. Sp. H/Per.)	3972190	1	2.05	INSULATOR, carb. heat
70	Nova w/E.E.C.				INSULATOR, carb.
70	Pass., Chevelle w/E.E.C.				INSULATOR, carb. stud
70	Camaro w/E.E.C.	3967466	A.R.	.17	INSULATOR, carb. heat
71	All w/2BC (350, 400)	3998976	1	1.75	INSULATOR, carb. heat
71	All (307)	3998975	1	1.45	INSULATOR, carb. heat
71-75	Vega, Monza w/1BC	331124	1	1.10	INSULATOR, carb. flange (asbestos)
71-72	Vega, Monza w/2BC	3983482	1	1.65	INSULATOR, carb. flange
71	All w/4BC (exc. Sp. H/Per.)				
72-73	Pass. (400, 454)				
72-73	All w/4BC (exc. Sp. H/Per., NB-2, Pass.)	3998912	1	1.75	INSULATOR, carb. heat
72-75	All (250)	333977	1	.75	INSULATOR, carb. heat
73-75	Vega, Monza w/2BC (140)	331160	1	1.60	INSULATOR, carb. heat
75	All w/2BC	6271058	1	1.75	INSULATOR, flange
75	All w/4BC (350, 400, 454)	354310	1	1.85	INSULATOR, carb. heat
70	All (6 cyl.)	3967077	1	4.95	INSULATOR ASSY., carb. heat
70	All w/E.E.C. (4 cyl., 6 cyl.)	3967075	1	12.15	INSULATOR ASSY., carb. heat
70	All w/E.E.C. (307)	3970038	1	3.20	INSULATION ASSY., carb. heat
70	All (2BC w/E.E.C.) (350, 400)	3970048	1	3.30	INSULATION ASSY., carb. heat
70	All (4BC w/E.E.C.) (exc. Sp. H/Per.)				
71	Chevelle w/4BC (350) (exc. Monte Carlo)	3969837	1	3.30	INSULATION ASSY., carb. heat
70	All (E.E.C. w/Sp. H/Per.) (396, 454)	3969835	1	3.70	INSULATION ASSY., carb. heat
70	Camaro (E.E.C. w/Sp. H/Per.) (350)				
71	Chevelle, Camaro w/Sp. H/Per. (350, 454)	3999198	1	3.50	INSULATION ASSY., carb. heat
72-73	All (307)	6262904	1	1.45	INSULATOR ASSY., carb. heat

**FUEL—EXHAUST—CARBURETION**

**3.726 GASKET—BAFFLE—INSULATOR, Carburetor to Manifold (Con't)**

72-73	All w/2BC (350, 400) . . . . .	6262906	1	1.75	INSULATOR ASSY., carb. heat . . . . .
74	All w/4BC (350, 400, 454) . . . . .	342705		1.75	INSULATOR ASSY., carb. heat . . . . .
74	All w/2BC (350) . . . . .	336060	1	1.60	INSULATOR ASSY., carb. heat . . . . .

**3.729 BODY, Carburetor**

*NOTE: See Group 3.725 for Chart containing 1969-75 Carburetor Throttle Body Assemblies.*

*NOTE: For Vega, Monza carburetor throttle body see end of Group 3.729.*

64-66	Chevy, Chevelle w/P.G. (8 cyl.) (exc. 4BC),				
65	Pass. w/P.G. (283),				
66	Pass. w/P.G. Air Cond. (283) (exc. A.I.R.) . . . . .	7027743	1	16.00	throttle (w/7024100-06-10) . . . . .
65	Chevelle w/Sp. H/Per. . . . .	3867985	1	34.25	w/3863150 . . . . .
65-66	Pass. (396) (exc. A.T., Sp./H/Per.),				
66	All (327) (exc. A.I.R., Sp./H/Per.)	3889763	1	35.50	BODY ASSY., throttle (w/3876747-5964) . . . . .
66	Chevelle w/Sp. H/Per. (396),				
66	Pass. w/Sp. H/Per. (427) . . . . .	3889766	1	35.50	BODY ASSY., throttle (w/3885067-6101- 3893229) . . . . .
67	All (P.G. w/2BC) (283) (exc. A.I.R., C.A.C.) . . . . .	7033896	1	21.35	BODY ASSY., throttle (w/7027110-14) . . . . .
67	Chevy, Chevelle (P.G. w/Roch. 4BC) (327) (exc. A.I.R.),				
67	Camaro w/P.G. (327, 350) (exc. A.I.R.),				
67	Pass. w/A.T. (327) (exc. A.I.R.),				
68	Concours (Roch. 2BC w/P.G.) (327) (exc. A.I.R.) . . . . .	7036303	1	38.75	BODY ASSY., throttle (w/7027218) . . . . .

**VEGA, MONZA CARBURETOR THROTTLE BODY**

71-72	Vega w/1BC (exc. NB-2) . . . . .	7048969	1	18.40	
71-72	Vega w/2BC . . . . .	7047260	1	23.05	
72	Vega (1BC w/NB-2) . . . . .	7046603	1	17.80	
73	Vega w/1BC . . . . .	7046383	1	17.80	
73	Vega w/2BC . . . . .	6259086	1	35.50	
74	Vega w/1BC (140) . . . . .	7048968	1	18.40	
74	Vega w/2BC (140) . . . . .	345642	1	55.25	
75	Vega, Monza w/2BC (140) (exc. A.T., C.A.C., NB-2) . . . . .	361198	1	62.00	w/plugs (12R6508A) (repl. 361016) . . . . .
75	Vega, Monza (A.T. w/2BC) (140) (exc. NB-2, C.A.C.) . . . . .	361199	1	62.00	w/plugs (12R6513A) (repl. 361017) . . . . .
75	Vega, Monza (NB-2 w/2BC) (140) (exc. A.T., C.A.C.) . . . . .	361196	1	62.00	w/plugs (12R6510A) (repl. 361018) . . . . .
75	Vega, Monza w/NB-2 (2BC w/A.T.) (140) (exc. C.A.C.) . . . . .	361197	1	60.50	w/plugs (12R6511A) (repl. 361019) . . . . .
75	Vega, Monza (A.T. w/2BC) (NB-2 w/C.A.C.) (140) . . . . .	360961	1		w/plugs (12R6514A) . . . . .
75	Vega, Monza (262) . . . . .	17052788	1	45.45	
75	Vega, Monza (1BC w/4-Spd.) . . . . .	17052469	1	25.80	
75	Vega, Monza w/1BC (exc. 4- Spd.) . . . . .	17052478	1	25.80	
75	Vega, Monza w/2BC (140) . . . . .	360970	1	4.65	
75	Vega, Monza (122) . . . . .	372354	1		(repl. 361084) . . . . .
75	Vega, Monza w/NB-2 (C.A.C. w/2BC) (140) (exc. A.T.) . . . . .	361193	1	62.00	
75	Vega, Monza w/A.T. (C.A.C. w/2BC) (140) (exc. NB-2) . . . . .	361194	1	62.00	
75	Vega, Monza (2BC w/C.A.C.) (140) (exc. A.T., NB-2) . . . . .	361195	1	62.00	
75	Vega, Monza (2BC w/NB-2) (140) (exc. A.T., C.A.C.) . . . . .	361196	1	62.00	
75	Vega, Monza (2BC w/NB-2) (140) A.T. (exc. C.A.C.) . . . . .	361197	1	60.50	
75	Vega, Monza (2BC) (140) (exc. A.T., C.A.C., NB-2) . . . . .	361198	1	62.00	
75	Vega, Monza (2BC) (140) A.T. (exc. C.A.C., NB-2) . . . . .	361199	1	62.00	

*NOTE See group 3.725 for chart containing 1968-71 Carburetor Throttle Body Assemblies.*

**3.730 HORN ASSY.—BOLT—BRACKET—SCREW, Carburetor Air**

*NOTE: See end of Group 3.730 for Vega, Monza horn, bracket, screw carburetor air.*

*NOTE: See Group 3.725 for Chart containing 1969-75 Carburetor Air Horn Assemblies.*

63-66	Chevy, Chevelle (6 cyl.) (exc. P.G., 230),				
67	Chevy (194) (exc. P.G., A.I.R.) . . . . .	7029753	1	13.65	w/7023105-5105 . . . . .

**FUEL—EXHAUST—CARBURETION**

**3.730 HORN ASSY.— BOLT— BRACKET— SCREW, Carburetor Air (Con't)**

63-65	Chevy, Chevelle w/P.G. (6 cyl.) (exc. 230).					
66	Chevy w/P.G. (194),					
67	Chevy w/P.G. (194) (exc. A.I.R.)	7029754	1	13.65	w/7023108-5108	
63-64	Chevy, Chevelle (6 cyl.) (exc. P.G.),					
65-66	Chevy, Chevelle (230) (exc. P.G.),					
65	Pass. (230) (exc. P.G.),					
67	Chevelle, Camaro (230) (exc. P.G., A.I.R.)	7029749	1	13.65	w/7023003-7025003	
64-67	Chevy, Chevelle, Camaro w/P.G. (230) (exc. A.I.R.),					
65	Pass. w/P.G. (6 cyl.),					
67	Chevy w/P.G. (250) (exc. A.I.R.)	7029748	1	13.65	w/7023000-5000	
64-66	Chevy, Chevelle w/Air Cond. (283),					
65-66	Pass. (283)	7027742	1	9.50	w/7024100-01-02-06-08-10-12-5103- 7036101-03-10-12	
66-67	Pass. (6 cyl.) (exc. P.G., Taxi, A.I.R.),					
67	Chevy, Chevelle, Camaro (250) (exc. P.G., A.I.R.)	7031467	1	17.45	w/7026027	
67	Pass. (283) (exc. A.I.R.)		1		w/7027100-3-10-12-14-16,	
67	Chevy, Chevelle, Camaro w/Roch. 2BC	7036550	1	12.55	w/7028101-03-10-12-7037101-3-10-12	
<i>NOTE See group 3.725 for chart containing 1968-71 Carburetor Air Horn Assemblies.</i>						
62-67	All w/Roch. 1BC	7003823	4	.11	<b>BOLT</b> , air horn attach., w/l/washer (No. 12— 28 x 15/16")	
62	Chevy,					
63-65	Chevy, Chevelle (194)	7010001	1	.40	<b>BRACKET</b> , car. a/cl. stud mounting (2 <sup>3</sup> / <sub>8</sub> " O.L.)	
63-66	Chevy (4 cyl.),					
65	Pass. w/P.G. (327),					
66	All w/A.I.R. (6 cyl.),					
67	All w/Carter 1BC	1346866	A.R.	.17	<b>SCREW</b> (w/3880860-1-3905973-4-5-6- 846-3-4-5-6-7-8)	
64-66	Chevy, Chevelle w/Air Cond. (283),					
65-68	Pass. (283, 307) (exc. 4BC, dual 4BC),					
67-75	All w/Roch. 2BC	7006119	A.R.	.11	<b>SCREW</b> , air horn attach. (No. 10— 32 x 15/16")	
65	Pass. w/H.D. 3-Spd., 4-Spd. (396) (exc. Sp. H/Per.)					<b>SCREW</b> , to air horn (w/7025200-1),
66	Chevy (327) (exc. Sp. H/Per.),					
66	Chevelle (327, 396) (exc. H/Per.),					
66	Pass. (8 cyl.) (exc. 283)					w/7026200-1-2-3-4-5-7036300-1-2-3-4-5,
67-72	All w/Roch. 4BC,					
73-74	All w/Roch. 1BC	7029912	A.R.	.41	w/7027200-1-2-3-10-11-12-13-7037200-1- 2-3-10-11-12-13 (10— 32 x 3)	
65	Pass. w/H.D. 3-Spd., 4-Spd. (396) (exc. Sp. H/Per.)					<b>SCREW</b> , to air horn (w/7025200-1),
66	Chevy (327) (exc. Sp. H/Per.),					
66	Chevelle (327, 396) (exc. H/Per.),					
66	Pass. (8 cyl.) (exc. 283)					w/7026200-1-2-3-4-5-7036200-1-2-3-4-5,
67-75	All w/Roch. 4BC	7031105	2	.16	w/7027200-1-2-3-10-11-12-13-7037200-1- 2-3-10-11-12-13 (8— 32 x 1/2")	
66	Pass. (396) (exc. A.I.R.)					<b>SCREW</b> , to air horn (w/3849804- 3868826),
66	Pass. w/H.D. (396, 427)					w/3887147,
67-72	All w/Holley 4BC	2367996	A.R.	.05	w/3935215	
68-71	All (6 cyl.),					
71-74	Vega, Monza 1BC	7038912	3	.33	<b>SCREW</b> , carb. air horn (long)	
72	All w/Roch. 1BC	7038912	3	.33	<b>SCREW</b> , carb. air horn	
68	All w/Roch. 1BC,					
69	Pass. w/Roch. 1BC	7038913	2	.28	<b>SCREW</b> , carb. a/cl. bracket (w/7029014- 15-17-20-22)— (3.403)	
72	All w/Roch. 1BC	7030917	A.R.	.24	<b>SCREW</b> , horn (repl. 7024278)	
73-74	All w/Roch. 1BC	7040135	A.R.	.24	<b>SCREW</b> , horn	
75	Vega, Monza 1BC	7043088	1	.39	<b>SCREW</b> , carb. air horn	
75	All w/1BC	7043089	A.R.	.41	<b>SCREW</b> , carb. air horn (long)	
75	All w/2BC	7010432	1	.11	<b>SCREW</b> , carb. air horn (long)	
75	All w/1BC	7030917	A.R.	.24	<b>SCREW</b> , carb. air horn (short)	

**FUEL—EXHAUST—CARBURETION**

**3.730 HORN ASSY.— BOLT— BRACKET— SCREW, Carburetor Air (Con't)**

**VEGA, MONZA**

**HORN, SCREW CARBURETOR AIR**

71	Vega (1BC w/A.T.)	7044851	1	12.75	
71	Vega w/1BC (exc. A.T.)	7043878	1	11.45	
71-72	Vega w/2BC	7041919	1	13.65	
72	Vega w/1BC (exc. A.T.)	7044850	1	12.75	
72	Vega (1BC w/A.T.)	7044851	1	12.75	
73	Vega w/1BC	7047643	1	12.55	
73	Vega w/2BC	6259155	1	19.95	
74	Vega w/1BC (140)	7048721	1	12.55	
74	Vega w/2BC (140)	345601	1	20.75	
75	Vega, Monza w/1BC	17050828	1	20.10	
75	Vega, Monza (262)	17052652	1	21.55	
75	Vega, Monza (2BC w/A.T.) w/NB-2 (140)	371396	1	20.75	
75	Vega, Monza w/2BC (140) (exc. NB-2)	372012	1	23.45	
75	Vega, Monza (2BC w/M.T.) w/NB-2 (140)	372206	1	23.45	
75	Vega, Monza (262)	7010432	1	.11	SCREW, carb. air horn (long)
75	Vega, Monza (262)	7006119	7	.11	SCREW, carb. air horn (short)
73-74	Vega, Monza w/2BC	335094	5	.12	SCREW ASSY., carb. air horn w/lockwasher

**3.734 BOWL— BODY ASSY.— CAP— INSERT— PLATE— SEAL, Carburetor Float**

*NOTE: See Group 3.725 for Chart containing 1968-75 Carburetor Float Bowl Assemblies.*

*NOTE: See end of Group 3.734 for carburetor float bowl & insert.*

62-66	All (6 cyl.),				
67	Chevy, Chevelle, Camaro (6 cyl.),				
67	Pass. (6 cyl.) (exc. Taxi, A.I.R.)	7021778	1	11.10	w/7023000-03-3105-3108-7025000-3- 105-8-6027-8
65	Pass. Sp. H/Per. (396)				primary (Holley No. 34R-4460A) (w/3868826-9933),
67	Pass. w/H.D. (396, 427)				w/3887147,
67	Pass. w/Sp. H/Per. (427)	3898992	1	19.45	w/3916143-5-3923289-3955205
65-66	Pass. (396) (exc. Sp./H/Per.),				
66	Chevy (327) (exc. A.I.R., Sp. H/Per.),				
66	Chevelle (327, 396)	3966915	1	9.55	secondary (w/3868864-3874898-5964- 6747-3886087-8-3892338-9-3229)
65-66	Pass. (396) (exc. Sp. H/Per.),				
66	Chevy (327) (exc. A.I.R.),				
66	Chevelle (327, 396)	3966916	1	11.75	prim. (w/3868864-3874898-6747-5964- 7413-3886087-8-3892338-9-3229) (w/3869933-8826),
65	Pass., w/Sp. H/Per. (396)				w/3887147,
66	Pass. w/H.D. (396, 427)				secondary (w/3885067-6101) (Holley 34R- 4652),
66	Pass. w/Sp./H/Per. (427)				w/3916143-5-3923289-5519-3955205
67	Pass. w/Sp. H/Per. (427)	3889781	1	9.20	primary (w/3885067-6101) (Holley 34R- 4703)
66	Pass., w/Sp. H/Per. (427)	3889784	1	11.60	
67	All (A.I.R. w/A.T.) (327, 350) (exc. Sp. H/Per.)	7035328	1	50.00	w/7037202-12-18
67	All (A.I.R. w/4BC) (327, 350) (exc. A.T., Sp. H/Per.)	7035329	1	48.50	w/7037203-13
67	Chevy, Chevelle, Camaro (4BC w/P.G.) (327, 350) (exc. A.I.R., Sp. H/Per.),				
67	Pass. w/A.T. (327) (exc. A.I.R.)	7035328	1	50.00	w/7027202-12
67	Pass., Chevelle w/P.G. (396) (exc. A.I.R., H/Per., Sp. H/Per.)	7033092	1	39.00	w/7027200
67	Chevy, Chevelle, Camaro w/Holley 4BC (exc. 302, Sp. H/Per. 396)	3966917	1	13.85	primary (w/3903389-91-8956-7-8-9)
67	Chevy, Chevelle, Camaro w/Holley 4BC (exc. 302, Sp. H/Per. 396)	3966913	1	9.55	secondary (w/3903389-91-8956-7-8-9)
67	Chevy, Chevelle, Camaro w/Holley 4BC (302, 396)	3889781	1	9.20	secondary (w/3916143-5-3923289)
67	Camaro w/Sp. H/Per. (396)	3889784	1	11.60	primary (w/3916143-5)

**FUEL—EXHAUST—CARBURETION**

**3.734 BOWL— BODY ASSY.— CAP— INSERT— PLATE— SEAL, Carburetor Float (Con't)**

67	Chevy, Chevelle, Camaro (Holley 4BC w/Sp. H/Per.) (302, 396) .	<b>3898992</b>	1	19.45	primary (w/3916143-5-3923289) . . . . .
	<i>NOTE See group 3.725 for chart containing 1968-71 Carburetor Float Bowl Assemblies.</i>				
65-67	Chevy, Chevelle w/Sp. H/Per. (327) (exc. A.I.R.) . . . . .	<b>3852473</b>	1	8.65	<b>BODY ASSY.</b> , w/plugs, main metering (secondary) (w/3863150-3877413-3903389) (Note 1) . . . . .
65-66	Pass. w/Sp. H/Per. (396),				
66	Chevelle w/Sp. H/Per. (396),				
67-69	Chevy, Chevelle, Camaro w/Holley 4BC,				
67-69	Pass. (Holley 4BC w/Sp. H/Per.) (427) . . . . .				<b>BODY ASSY.</b> , w/plugs, carb. main metering secondary (w/3868826-9933-3885067-6101-3916143-5-3923289) (Note 1), . . . . .
70	All (Holley 4BC w/Sp. H/Per.) (350, 396, 454) (exc. E.E.C.),				
71	All w/Holley 4BC . . . . .	<b>3877171</b>	1	10.20	(secondary) (w/3967477-9898-3972120-21) . . . . .
68-69	All w/Sp. H/Per. (302, 396, 427) . . . . .				<b>BODY ASSY.</b> , w/plugs, carb. main metering primary (w/3923289) (Note 1), . . . . .
70	Camaro (Holley 4BC w/Sp. H/Per.) (350) (exc. A.T., E.E.C.)	<b>3934274</b>	1	13.25	<b>BODY ASSY.</b> , w/plugs (primary) (w/3972121) . . . . .
70	Camaro (Holley 4BC w/A.T.) (Sp. H/Per. w/E.E.C.) (350),				
70	All (Holley 4BC w/Sp. H/Per.) w/E.E.C. (396, 454) . . . . .	<b>3979505</b>	1	18.05	<b>BODY ASSY.</b> , w/plugs (primary) (w/3967479-9894-3972122) . . . . .
70	Camaro (Holley 4BC w/Sp. H/Per.) w/E.E.C. (350) exc. A.T.,				
71	Camaro w/Holley 4BC,				
71	Chevelle w/Holley 4BC (exc. A.T.) . . . . .	<b>3979564</b>	1	13.30	<b>BODY ASSY.</b> , w/plugs (primary) (w/3972123-3989021-22-6195) . . . . .
71	Chevelle (Holley 4BC w/A.T.) . . . . .	<b>3995822</b>	1	16.10	<b>BODY ASSY.</b> , w/plugs (primary) (w/3986196) . . . . .
72	All (Holley 4BC w/A.T.) . . . . .	<b>6273955</b>	1	13.30	<b>BODY ASSY.</b> , w/plugs (primary) . . . . .
72	All w/Holley 4BC (exc. A.T.) . . . . .	<b>6273957</b>	1	13.30	<b>BODY ASSY.</b> , w/plugs (primary) . . . . .
72	All w/Holley 4BC . . . . .	<b>6273956</b>	1	11.60	<b>BODY ASSY.</b> , w/plugs (secd.) . . . . .
69	Chevy, Camaro (396),				
69	Chevy (4 cyl.) . . . . .	<b>3928101</b>	1	.17	<b>CAP</b> , diverter valve sig. hose . . . . .
62-63	Chevy (6 cyl.),				
64-66	Chevy, Chevelle (8 cyl.) (exc. H/Per.),				
65-69	Pass. (8 cyl.) (exc. 4BC, 3/2BC),				
66	Pass. w/4BC (283),				
67-69	Chevy, Chevelle, Camaro w/Roch. 2BC,				
70-75	All w/Roch. 2BC (307) . . . . .	<b>7021528</b>	2	.37	<b>INSERT</b> , mainwell (w/7041101-10-7110-11) . . . . .
65-66	Pass. (396) (exc. Sp./H/Per.) . . . . .				<b>INSERT</b> , bowl (w/7025200-01-20-21-6200-1-2-3-4-5-7036200-1-2-3-4-5), . . . . .
66	Chevy (327) (exc. Sp. H/Per.),				
66	Chevelle (327, 396) (exc. H/Per.),				
67	All w/Roch. 4BC . . . . .	<b>7034666</b>	1	1.85	w/7027200-1-2-3-7037200-1-2-3 . . . . .
67	Pass. w/Roch. 4BC,				
68	All w/Roch. 4BC . . . . .	<b>7034361</b>	1	1.70	<b>INSERT</b> , bowl (w/7027210-11-12-13-7028207-08-09-10-11-12-13-16-19-7037210-11-12-13) . . . . .
69-75	All w/Roch. 4BC . . . . .	<b>7041471</b>	1	1.70	<b>INSERT</b> , bowl (repl. 7037319) . . . . .
73-75	All w/2BC . . . . .	<b>7040320</b>	1	.63	<b>INSERT</b> , carb. main well . . . . .
70	All w/Roch. 4BC . . . . .	<b>17052246</b>	1	1.45	<b>SEAL</b> , carb. float bowl secondary well (rubber) (repl. 7041342) . . . . .

**VEGA, MONZA BOWL, INSERT CARBURETOR FLOAT**

71	Vega w/1BC . . . . .	<b>7041398</b>	1	22.35	
71	Vega w/2BC . . . . .	<b>7041585</b>	1	16.95	
72	Vega w/2BC . . . . .	<b>7041920</b>	1	16.95	(used w/1st design carb.) . . . . .
72	Vega w/2BC . . . . .	<b>7046634</b>	1	19.65	(used w/2nd design carb.) . . . . .
72	Vega w/1BC . . . . .	<b>7041947</b>	1	22.35	



**FUEL—EXHAUST—CARBURETION**

**3.734 BOWL— BODY ASSY.— CAP— INSERT— PLATE— SEAL, Carburetor Float (Con't)**

73	Vega w/1BC	7046680	1	22.35	
74	Vega w/1BC,				
75	Vega, Monza (A.T. w/1BC)	17050666	1	22.35	
75	Vega, Monza w/1BC (exc. A.T.)	7046966	1	22.35	
75	Vega, Monza (262)	17052785	1	23.90	
71-72	Vega w/2BC	7021528	1	.37	INSERT, carb. main well
75	Vega, Monza (262)	7040320	1	.63	INSERT, carb. main well

*NOTE 1 All BODY.ASSY. for Holley Carbs are fuel metering bodies located between the fuel bowl and the air horn.*

**3.738 GASKET, Carburetor Float Bowl to Cover (or Air Horn)**

*NOTE: For Vega, Monza Carburetor Air Horn Gasket, See end of Group 3.738.*

64-66	Chevy, Chevelle w/4BC (exc. H/Per., Sp. H/Per.),				
65	Pass. w/P.G., 4BC (283, 327) (exc. H/Per., Sp. H/Per.),				
66	Chevy (327) (exc. Sp. H/Per.)	7015173	1	1.25	to air horn (w/7024120-22-25-26-7025121-22-25-26-27-28-6121-7125-7036118-19-20-21)
65	Pass. dual 4BC (409),				
65	All w/H/Per. (327)	1179331 A.R.		1.30	(Carter 121-292) (w/3760264-4593-3772600-3795566-3797698-7699-3815403-5404-9207-3820580-6004-96-3851761-62-5581-6580)
67-68	All w/Roch. 2BC,				
69	Chevy, Chevelle, Camaro w/Roch. 2BC (307, 327)	7021008	1	.89	carb. to air horn (w/7016818-19-7027101-3-10-12-9101-3-10-12-7037101-3-10-12)
70-72	All w/1BC	7037591	1	.74	carb. air horn
73-75	All w/Roch. 1BC (exc. Vega)	7035166	1	.74	carb. air horn
73	All (307)	7032888	1	.89	carb. air horn
75	All w/2BC (exc. Vega)	7045671	1	.57	carb. air horn
75	All w/4BC	7042998	1	.91	carb. air horn

**VEGA, MONZA**

**GASKET, CARBURETOR AIR HORN**

71-72	Vega w/2BC	7045879	1	.89
73-75	Vega, Monza w/1BC	7040137	1	.74

**3.740 CONNECTOR— ADAPTER UNIT— BAFFLE— FILTER— FILTER NUT— FITTING— GASKET— NUT— PIPE— RING— SCREEN— SPACER— SPRING— STRAINER, Carburetor and Fuel Meter Fuel Inlet**

62-66	Chevy, Chevelle,				
65-66	Pass. (exc. Carter 4BC),				
67	All w/Roch. 1BC,				
67	All w/Roch. 4BC (327)	7040952	1	1.95	gas pipe (carb. end) (Rochester)
65-67	All w/4BC (396, 427)				ADAPTER UNIT (w/7025200-01-20-21-7026200-01-04-05-7027200-01-10-11-16-7036200-01-04-05-7037200-01-10-11-16),
67	All w/4BC (327, 350)				(w/7027212-13-18-7037212-13-18),
68-70	All	7041634	1	6.75	(w/7028207-08-09-10-11-12-13-14-16-17-18-19-23-24-29-7029200-01-02-03-04-07-15-7040200-01-02-03-04-05-06-08-13-21-7040500-01-02-03-04-05-07-09-11-13-21)
66	All w/4BC (327)				ADAPTER UNIT (w/7026202-03-10-7036202-03-10),
67	All w/4BC (327, 350)	7041635	1	6.75	(w/7027202-03-7037202-03)
65-66	Pass. (327, 396) (exc. A.I.R.),				
66	Chevy, Chevelle (327, 396)	3912154	1	.23	BAFFLE, carb. fuel bowl (secondary) (Holley No. 59R-35) (w/3849804-3868864-3874898-5964-6747-6749-7413-3882835-4505-6087-8-3890497-99-2338-9-41-3229)
65-66	Pass. (327, 396) (exc. A.I.R.),				
66	Chevy, Chevelle (327, 396),				

**FUEL—EXHAUST—CARBURETION**

**3.740 CONNECTOR— ADAPTER UNIT— BAFFLE— FILTER— FILTER NUT— FITTING— GASKET— NUT— PIPE— RING— SCREEN— SPACER— SPRING— STRAINER, Carburetor and Fuel Meter Fuel Inlet (Con't)**

67	Chevy, Chevelle, Camaro w/Holley 4BC (exc. 302, Sp. H/Per. 396) .....	<b>3912152</b>	1	.23	<b>BAFFLE</b> , fuel bowl primary (w/3868864-3874898-5964-6747-7413-3886087-8-3890497-2338-9-3229-3903389-91-8956-7-8-9) .....
66-69	Pass. (396, 427) (exc. Sp. H/Per.),				
66-67	Chevelle (396) (exc. H/Per.),				
67	Camaro (396),				
68	Chevelle, Camaro (396) (exc. Sp. H/Per.),				
69	Chevy, Chevelle, Camaro (396),				
70-75	All w/Roch. 4BC .....	<b>7031365</b>	1	.56	<b>BAFFLE</b> , carb. float bowl (w/7026200-1-4-5-7200-1-10-11-7036200-1-4-5-7200-1-10-11-7028210-11-17-18-7029200-01-15) .....
66-67	Pass. (327) .....				<b>BAFFLE</b> , carb. float bowl (w/7026202-3-7202-3-12-13-7036202-3-7202-3-12-13), ..
66-68	All w/4BC (327, 350) (exc. Sp. H/Per.),				
68	Chevy, Chevelle w/Sp., H/Per. (327),				
68	Pass. (327) .....				w/7028212-13-19-29, .....
69	All w/Roch. 4BC (350) .....	<b>7032324</b>	1	1.80	w/7029202-03-07-23 .....
67	Chevy, Chevelle, Camaro w/Holley 4BC (exc. 302, Sp. H/Per. 396) .....	<b>3912154</b>	1	.23	<b>BAFFLE</b> , fuel bowl (secondary) (w/3903389-91-8956-7-8-9) .....
62-66	Chevy, Chevelle (exc. 4 cyl.),				
65-66	Pass. (exc. H/Per., Sp. H/Per.),				
65-66	Pass. (396) (exc. Sp. H/Per., A.I.R.),				
66	Pass. w/H.D. (396, 427),				
67	All w/Holley 4BC,				
67	All w/Roch. 1BC, 2BC,				
67	Pass. w/Roch. 4BC (327),				
68-69	Chevy, Chevelle, Camaro w/Roch. 2BC,				
68-69	Pass. (Holley 4BC w/Sp. H/Per.) (427),				
69	Pass. w/Roch. 2BC (396),				
70	Nova, Chevelle, Camaro w/Roch. 2BC (307),				
70	Camaro (Roch. 2BC w/A.T.) (350),				
70-71	All w/Holley 4BC,				
71-72	Vega w/2BC,				
71	Nova, Chevelle, Camaro w/Roch. 2BC (307),				
71	Camaro w/Roch. 2BC (350),				
72	All (exc. Vega),				
73	All 2BC (307),				
73	Pass. (400),				
73-75	Camaro w/Roch. 2BC (350),				
75	All w/2BC (262) .....	<b>7013404</b>	A.R.	1.10	<b>FILTER</b> , carb. fuel inlet .....
67	All w/Roch. 4BC,				
68-69	All w/Roch. 1BC, 4BC,				
69	Pass. w/Roch. 2BC (exc. 396),				
70	All w/Roch. Carb.,				
71	All w/Roch. 1BC, 4BC,				
75	Vega, Monza w/2BC (140) .....	<b>335143</b>		1.00	<b>FILTER</b> , fuel inlet .....
71-72	Vega w/1BC,				
71	Pass., Nova, Chevelle w/Roch. 2BC (350, 400),				
73-74	Vega w/2BC,				
73-75	All w/Roch. 1BC, 4BC,				
74-75	All w/2BC (exc. Camaro, 262) ..	<b>5651393</b>	1	1.09	<b>FILTER</b> , carb. fuel inlet .....
68-71	All (6 cyl.),				
69	Chevy (4 cyl.),				
71-72	Vega w/1BC,				
73-75	All w/Roch. 1BC .....	<b>7038946</b>	1	1.95	<b>FILTER NUT</b> , carb. fuel inlet .....
71-72	Vega w/2BC .....	<b>7040953</b>		1.95	<b>FILTER NUT</b> , carb. fuel inlet .....

**FUEL—EXHAUST—CARBURETION**

**3.740 CONNECTOR— ADAPTER UNIT— BAFFLE— FILTER— FILTER NUT— FITTING— GASKET— NUT— PIPE— RING— SCREEN— SPACER— SPRING— STRAINER, Carburetor and Fuel Meter Fuel Inlet (Con't)**

75	Vega, Monza (262) . . . . .	7040958	1.95	FILTER NUT, carb. fuel inlet . . . . .
71-75	Vega, Monza w/1BC,			
65	Chevelle (396) . . . . .			FITTING (w/3878261), . . . . .
66	Pass. (327, 427) (exc. H/Per.) . . . . .			w/3875964-6747-3885067, . . . . .
66	Pass. w/H.D. (396, 427) . . . . .			w/3887147, . . . . .
67	All w/Sp. H/Per. (327),			
67	All (A.I.R. w/Sp. H/Per.)			
	w/Holley 4BC (302, 396),			
68-69	All w/Holley 4/BC (302, 396),			
67-69	Pass. w/Sp. H/Per. (427) . . . . .			w/3903389-91-3916143-5-3923289, . . . . .
70	All w/Holley 4BC,			
71-72	Camaro w/Holley 4BC . . . . .	3889776	1	1.55 FITTING, carb. fuel inlet (w/3989021-22) . . . . .
65	Chevelle w/Sp. H/Per. (327),			
65	Pass. w/Sp. H/Per. (396) . . . . .	3877142	1	.73 FITTING, carb. inlet (w/3869933) . . . . .
65-66	Pass. (396) (exc. Sp. H/Per.,			
	A.I.R.),			
66	Chevelle (396) (exc. A.I.R.,			
	H/Per.),			
67	Chevelle, Camaro (Holley 4BC			
	w/H/Per.) (396) . . . . .	3890124	1	1.80 FITTING, carb. fuel inlet (Holley 19R-343) . . . . .
71	Chevelle w/Holley 4BC . . . . .	3960299	2	3.60 FITTING, carb. fuel inlet (w/3986195-96) . . . . .
73-75	Vega, Monza 2BC . . . . .	335107	1	1.65 FITTING, carb. fuel inlet . . . . .
65-70	All,			
71	All w/Roch. 2BC, 4BC . . . . .			GASKET, gas pipe conn., carb. end, . . . . .
71-75	All w/Roch. 1BC,			
71-72	Vega w/2BC,			
73-75	All w/Roch. 2BC . . . . .	7032508	1	.29 GASKET, filter nut (7/8" I.D.— 1 1/16" O.D. x 1/2" thk.) . . . . .
65	Pass. w/Roch. 4BC (409) . . . . .	7001597	1	.11 GASKET, strainer nut . . . . .
65-66	Pass. (exc. Carter 4BC),			
67	All w/Rochester Carb.,			
68	All w/Roch. 2BC,			
69	Pass. (396),			
69-71	Chevy, Chevelle, Camaro			
	w/Roch. 2BC (307, 327),			
70-71	Camaro (Roch. 2BC w/A.T.)			
	(350) (exc. E.E.C.),			
72	All w/Roch. 2BC,			
72	Nova, Chevelle, Camaro w/Roch.			
	2BC (307),			
72	Pass. (400),			
72	Camaro w/Roch. 2BC (350),			
73	All w/Roch. 2BC,			
73	Nova, Chevelle, Camaro w/Roch.			
	2BC (307),			
73	Pass. (400),			
73-75	Camaro w/Roch. 2BC (350),			
75	All w/2BC (262) . . . . .	7013584	1	.15 GASKET, gas pipe conn. strainer (carb. end) (Rochester) (w/7041101-02-10-27-7110-11-12-27) . . . . .
75	Vega, Monza A.T. w/2BC,			
72-75	All w/Roch. 4BC . . . . .	7024281	1	.15 GASKET, gas pipe conn. (car bend) (7042202-03-15-20, 7042902-03) . . . . .
62-63	Chevy . . . . .	7015233	A.R.	.90 NUT, carb. end (7/84"— 24 int. 7/8"— 20 ext. thds.) . . . . .
65-66	Pass. (327) (exc. A.I.R.),			
66	Chevy, Chevelle (327) (exc. A.I.R., Sp. H/Per.) . . . . .	3759759	1	2.20 NUT, w/gasket (Carter 15-705), w/3846246-7-3875966-6749 . . . . .
65	Pass. (396) (exc. Sp. H/Per.) . . . . .			NUT, carb. fuel inlet filter (w/7025200-1-20-21), . . . . .
66-67	Chevelle (396) (exc. H/Per., Sp. H/Per.),			
67	Camaro (396) (exc. Sp. H/Per.),			
66-67	Pass. (396, 427) . . . . .	7040954	1	1.90 w/7026200-1-4-5-7200-1-7036200-1-4-5-7200-1) . . . . .
66	Pass. (409) (exc. H/Per.) . . . . .	7002862	1	.90 NUT, strainer . . . . .
67	All w/Roch. Carb. (283),			
68-69	Chevy, Chevelle, Camaro			
	w/Roch. 2BC (307, 327),			
68	Pass. w/Roch. 2BC (307),			
70	All w/Roch. 2BC,			

**FUEL—EXHAUST—CARBURETION**

**3.740 CONNECTOR— ADAPTER UNIT— Baffle— FILTER— FILTER NUT— FITTING— GASKET— NUT— PIPE— RING— SCREEN— SPACER— SPRING— STRAINER, Carburetor and Fuel Meter Fuel Inlet (Con't)**

71-73	Nova, Chevelle, Camaro w/Roch. 2BC (307) . . . . .	7040953	1	1.95	NUT, carb. fuel inlet filter (w/7041101-10-7110-11) . . . . .
67-71	All w/Roch. 4BC,				
69-70	All w/Roch. 2BC,				
71-72	Pass., Nova, Chevelle w/Roch. 2BC (350, 400),				
71-72	All w/Roch. 4BC,				
73	Pass., Nova, Chevelle w/Roch. 2BC (350),				
74-75	Pass., Chevelle w/2BC . . . . .	7040955	1	2.05	NUT, carb. fuel filter inlet, w/7041113-14-87-18-7104-07-13-18 . . . . .
69	Pass. w/Roch. 2BC (396),				
70-75	Camaro w/Roch. 2BC (350),				
72	Pass. (400),				
74-75	Nova, Camaro w/2BC . . . . .	7040958	1	1.95	NUT, carb. fuel inlet . . . . .
72-75	All w/Roch. 4BC . . . . .	7045605	1	2.05	NUT, filter carb. fuel inlet (7042203-04-15-20, 7042902-03) . . . . .
73	Chevelle, Nova (307) . . . . .	7040952	1	1.95	NUT, fuel filter inlet . . . . .
75	All (250) w/1BC . . . . .	7038946	1	1.95	NUT, fuel filter inlet . . . . .
75	All w/Roch. 2BC . . . . .	7045878	1		NUT, fuel filter inlet . . . . .
65	Chevelle w/Sp. H/Per. . . . .				PIPE, carb. primary to secondary float bowl (w/3863150), . . . . .
66	Chevy, Chevelle (A.I.R. w/Sp. H/Per.) (327) . . . . .				w/3877413-3883939-3890497, . . . . .
67	Chevy, Chevelle w/Sp. H/Per. (327) . . . . .	2367995	1	1.20	w/3903389-91 . . . . .
65-66	Pass. (396) (exc. Sp. H/Per., A.I.R.),				
66	Pass. w/H.D. (396, 427),				
66	Chevy, Chevelle (327, 396),				
67-68	Pass. w/Sp. H/Per. (427),				
69-70	All w/Holley 4BC . . . . .	3881433	1	.12	RING, retaining (Holley 36R-284) . . . . .
65	Chevelle w/Sp. H/Per. . . . .	3852482	1	.57	SCREEN, carb. fuel filter (w/3863150-3878261) . . . . .
70	All (Holley 4BC w/E.E.C.) w/Sp. H/Per. (396, 454),				
70	Camaro (Holley 4BC w/A.T.) (Sp. H/Per. w/E.E.C.) (350),				
71-72	All w/Holley 4BC . . . . .	3979503	2	2.25	SPACER, carb. fuel bowl (w/3967479-9894-3972122) . . . . .
70	All (Holley 4BC w/E.E.C.) w/Sp. H/Per. (396, 454),				
70	Camaro (Holley 4BC w/A.T.) (Sp. H/Per. w/E.E.C.) (350),				
71-72	All w/Holley 4BC . . . . .	3979504	2	2.25	SPACER, carb. mtr. body (w/3967479-9894-3972122) . . . . .
62-66	Chevy, Chevelle,				
65-66	Pass. (6 cyl.),				
65-66	All (8 cyl.) (exc. Carter 4BC),				
67	All w/Rochester 1BC . . . . .	7010007	1	.29	SPRING, inlet filter (Rochester) . . . . .
63-66	Chevy (4 cyl.),				
65-66	Pass. w/Carter 4BC,				
66	All w/A.I.R. (6 cyl.),				
66	Chevy, Chevelle (8 cyl.),				
67	All w/Carter 1BC . . . . .	3759765	1	.31	SPRING, strainer (Carter 61-6 No. 6) . . . . .
65	Pass. (396) (exc. Sp. H/Per.) . . . . .				SPRING, carb. fuel filter (w/7025200-1-20-21), . . . . .
65-66	Pass. (396) (exc. Sp. H/Per., A.I.R.) . . . . .				w/3868864-3874898, . . . . .
66	Chevy (327) (exc. Sp. H/Per.),				
66	Chevelle (327, 396) (exc. H/Per.),				
67-69	Chevy, Chevelle, Camaro (exc. Roch. 1BC),				
67	Pass. w/Sp. H/Per. (427) . . . . .				w/3916143-5, . . . . .
67-72	All w/2BC, 4BC,				
75	Vega, Monza (262) . . . . .	7034356	A.R.	.37	
68-75	All w/Roch. 1BC . . . . .	7031539	1	.29	SPRING, fuel filter . . . . .
73-75	Vega w/2BC . . . . .	335131	1	.38	SPRING, carb. fuel inlet filter return . . . . .
72-75	All w/Roch. 4BC . . . . .	7030588	1	.20	SPRING, carb. fuel filter (7042202-03-15-20, 7042902-03) . . . . .
63-66	Chevy (4 cyl.),				

**FUEL—EXHAUST—CARBURETION**

**3.740 CONNECTOR— ADAPTER UNIT— BAFFLE— FILTER— FILTER NUT— FITTING— GASKET— NUT— PIPE— RING— SCREEN— SPACER— SPRING— STRAINER, Carburetor and Fuel Meter Fuel Inlet (Con't)**

65-66	Pass. w/Carter 4BC,				
66	Chevy, Chevelle (327) (exc. A.I.R., Sp. H/Per.),				
66	All w/A.I.R. (6 cyl.),				
67	All w/Carter 1BC	<b>3759764</b>	1	1.55	<b>STRAINER</b> (Carter 30-87)
65	Pass. w/Roch. 4BC (409)	<b>7003083</b>	1	.37	<b>STRAINER</b> (w/7025123-4-5-7125-7036125-7125)

**3.741 BOLT— SCREW, Carburetor Body**

64-70	All (8 cyl.),				
71	All w/Roch. 2BC	<b>7015105</b>	3	.14	throttle body to airhorn (12-28 x 13/16")
70	All	<b>3967476</b>	2	.22	carb. frt. (5/16"— 18 x 35/8") (280M)
64-66	All w/Roch. 4BC	<b>7004324</b>	1	.36	<b>SCREW</b> , w/washer, large (3/8"— 24 x 1 1/8")
65	Pass., Chevelle (396),				
66	All (327) (exc. A.I.R.),				
66	All (396) (exc. Sp. H/Per.),				
66	Pass. w/Sp. H/Per. (427)				<b>SCREW</b> , w/lockwasher (body to airhorn) (Holley 5R-567) (w/3868826-8868864-9933-3874898-5904-6747-3882835-5067-6101-3890499-2341),
66	Pass. w/H.D. (396, 427)				w/3887147,
67-72	All w/Holley 4BC	<b>2368004</b>	8	.89	<b>SCREW</b> , throttle (w/7025200-01),
65	All (396)				w/7026200-1-2-3-4-5-7036200-1-2-3-4-5,
66	All (327, 396, 427) (exc. Sp. H/Per.)				w/7027200-1-2-3-10-11-12-13-7037200-1-2-3-10-11-12-13
67-68	All w/Roch. 4BC	<b>7029891</b>	2	.16	<b>SCREW</b> , carb. throttle body
68-74	All w/Roch. 1BC	<b>7038875</b>	2	.34	<b>SCREW</b> , throttle body
69-75	All w/Roch. 4BC	<b>7035790</b>	A.R.	.16	<b>SCREW</b> , throttle body to bowl (12— 28 x 3/16")
72-75	All w/Roch. 2BC	<b>7015105</b>	3	.14	<b>SCREW</b> , carb. throttle body
75	All w/1BC	<b>7043087</b>	1	.34	

**3.745 FLOAT— SHAFT, Carburetor and Fuel Meter**

62	Chevy (4 cyl.),				
62-67	Chevy, Chevelle, Camaro w/Roch. 1BC (6 cyl.),				
65-66	Pass. w/Roch. (6 cyl.),				
66-67	Pass. (6 cyl.) (exc. Taxi, A.I.R.)	<b>7002672</b>	1	3.25	w/7020103-04-05-08-3000-03-3105-08-4000-01-5000-03-105-08-6027-28-7027011-29
64-66	Chevy, Chevelle w/Air Cond. (283),				
65-68	All w/Roch. (8 cyl.) (exc. 4BC)	<b>7012974</b>	1	1.95	w/lever (7024101-10-12-5103-7103-10-12-14-16-7036101-3-10-12-7101-3-10-12)
65	Pass. w/H/Per., Dual 4BC (409),				
65	All w/H/Per. (327),				
66	All (327) (exc. A.I.R., Sp H/Per.)	<b>7011148</b>	A.R.	4.10	w/3851761-62-3875966-6749
65	Pass. w/Carter 4BC	<b>3759758</b>	A.R.	6.50	w/lever, primary and secondary (Carter 21-197S)
65	Pass. (396) (exc. Sp. H/Per.)				w/lever (w/7025200-01),
66	All (327, 396, 427)				w/7026200-1-2-3-4-5-7036200-1-2-3-4-5,
67	All w/Roch. 4BC	<b>7029854</b>	1	4.15	w/7027200-1-2-3-7037200-1-2-3
64-66	Chevy, Chevelle w/4BC (exc. H/Per., Sp. H/Per.),				
65	Pass. w/Roch. 4BC	<b>7017488</b>	2	3.90	<b>FLOAT ASSY.</b> (w/7015010-5012-9004-9006-9010-9014-702006-0012-0022-4120-22-25-26-4220-25-26-7025126-27-28-6121-7036118-19-20-21-25-4121-22-5121-2-5-6-7-8-6121-7125)
65	Chevelle (396) (exc. H/Per.),				
66	Chevy, Chevelle (327, 396)				<b>FLOAT ASSY.</b> (w/3868864-3874898-5964-6747-7413-3886087-88-3890497-2338-39),
65	Chevelle w/Sp. H/Per.	<b>3916048</b>	1	1.65	secondary (w/3863150)
65	Pass. (396)				
66	Pass., Chevelle w/Sp. H/Per. (396, 427)				<b>FLOAT ASSY.</b> (Holley 16R-420A) (w/3868826-3869933-3886101),
66	Pass. w/H.D. (396, 427)				w/3887147,
67-72	All w/Holley 4BC	<b>3877164</b>	2	1.70	

**FUEL—EXHAUST—CARBURETION**

**3.745 FLOAT— SHAFT, Carburetor and Fuel Meter (Con't)**

65-66	Pass. (396) (exc. Sp. H/Per., A.I.R.) .....				FLOAT ASSY. (Holley 16R-420A) (w/3868864-3874898) .....
66	Pass. (327) (exc. A.I.R.) .....				w/3875964-6747, .....
67	Chevy, Chevelle, Camaro (exc. 302, Sp. H/Per. 396) .....	<b>3905843</b>	2	1.60	w/3903389-91-8956-7-8-9 .....
67	Pass. (396, 427) .....				FLOAT ASSY., w/7027210-11-7037210-11, .....
68	Chevy, Chevelle, Camaro (396) (exc. H/Per., Sp. H/Per.),				
68	Pass. (396, 427) (exc. Sp. H/Per.) .....	<b>7033752</b>	1	3.70	w/7028210-11 .....
67	All w/Roch. 4BC (327, 350) (exc. Sp. H/Per.) .....				FLOAT ASSY., w/7027212-13-7037212-13, .....
68	All w/Roch. 4BC (327, 350) ...	<b>7034454</b>	1	3.70	w/7028207-08-12-13-19 .....
68-75	All w/Roch. 1BC .....	<b>7037022</b>	1	3.25	FLOAT ASSY., w/lever .....
69-74	All w/Roch. 4BC .....	<b>7037316</b>	1	2.85	FLOAT ASSY. ....
69-72	All w/Roch. 2BC (350, 396, 400),				
73-75	All w/Roch. 2BC (exc. Vega, Monza),				
75	Vega, Monza (262) .....	<b>7037512</b>	1	2.25	FLOAT ASSY. ....
69-71	All w/Roch. 2BC (307, 327),				
71-72	Vega w/2BC,				
72	All w/Roch. 2BC (307) .....	<b>7037519</b>	1	2.25	FLOAT ASSY., w/lever (w/7041101-10-7110-11) .....
73-75	Vega 2BC .....	<b>335106</b>	1	3.10	FLOAT ASSY. ....
75	All w/4BC .....	<b>7041468</b>	1	3.70	FLOAT ASSY., carb. ....
65-66	Pass. w/Sp. H/Per. (396) (exc. A.I.R.),				
66	Pass. w/Sp. H/Per. (427) .....				SHAFT (w/3869933) .....
66	Chevelle w/Sp. H/Per. (396),				
66	Pass. w/H.D. (396, 427) .....				w/3887147, .....
67-72	All w/Holley 4BC .....	<b>3881417</b>	2	.15	

**3.747 PIN— PLUG— CAP— SPRING, Carburetor and Fuel Meter Float Lever**

62	Chevy,				
63-66	Chevy, Chevelle (exc. 4 cyl.),				
65-67	Pass. w/Roch. Carb. (exc. 4BC),				
67	Chevy, Chevelle, Camaro w/Roch. 1BC, 2BC,				
68-69	Pass. w/Roch. 2BC,				
68	All w/Roch. 2BC,				
69-71	All w/Roch. 2BC (307, 327),				
73-75	Vega w/2BC .....	<b>335116</b>	1	.26	
72-75	All w/Roch. 2BC (exc. Vega, Monza) .....	<b>7002081</b>	1	.11	
75	Vega, Monza w/A.T. (262),				
64-65	Chevy, Chevelle (exc. H/Per., Sp. H/Per.),				
64	Chevy, Chevelle w/A.I.R. (283) (exc. 2BC),				
65	All w/Roch. 4BC,				
66	Pass. w/A.I.R. (283) (exc. 2BC) .	<b>7001595</b>	2	.09	w/7025121-2-3-4-6-7-8-6121-7036118-19-20-21 .....
65	Pass. (396) .....				w/7025200-1-20-21, .....
66	All (327, 396, 427) .....				w/7026200-1-2-3-4-5-7036200-1-2-3-4-5, .
67-69	All w/Roch. 4BC .....	<b>7029856</b>	1	.45	
68-75	All w/Roch. 1BC .....	<b>7034032</b>	1	.24	float lever .....
71-75	Vega, Monza 1BC,				
69-70	Chevy, Chevelle, Camaro w/Roch. 2BC (350, 400),				
69-70	Pass. w/Roch. 2BC (327, 350, 396, 400),				
71	All w/Roch. 2BC (350, 400) ...	<b>7010037</b>	1	.11	hinge (w/7041102-13-14-17-18-27-7104-07-12-13-18-27) .....
69-75	All w/Roch. 4BC .....	<b>7037317</b>	1	.45	hinge .....
65	Chevelle w/Sp. H/Per.,				
66	Chevy, Chevelle (327, 396) ....				PLUG, w/3868864-3874898-5964-6747-7413-8261-3886087-88-3892338-9-3229-0497, .....
66	Pass. w/H.D. (396, 427),				
66	Pass. (396) (exc. A.I.R.),				
67-72	All w/Holley 4BC .....	<b>3852466</b>	2	.23	fuel level check (Holley 7R-225) .....

**FUEL—EXHAUST—CARBURETION**

**3.747 PIN— PLUG— CAP— SPRING, Carburetor and Fuel Meter Float Lever  
(Con't)**

70-71	All w/Holley 4BC	3928101	1	.17	CAP, carb. tee connector— (3.734)
64-65	Chevy, Chevelle w/4BC (exc. H/Per., Sp. H/Per.),				
65	Pass. w/Roch. 4BC (396, 409),				
66	All w/A.I.R. (283) (exc. 2BC)	7017486	2	.18	SPRING, float torsion (w/7015010-12-9004-6-10-14-7020006-12-22-4121-2-5121-22-25-26-27-28-6121-7125-7036118-19-20-21-71-25)
65	Chevelle w/Sp. H/Per.				SPRING (w/3863150),
65-66	Pass. (327, 396) (exc. A.I.R.)				w/3868864-3874898-5964-6747,
66	Chevy, Chevelle (327, 396),				
67	Chevy, Chevelle, Camaro w/Holley 4BC	3867993	2	.23	
65-66	Pass. w/Sp. H/Per. (396),				
66	Chevelle w/Sp. H/Per. (396),				
66	Pass. w/H.D. (396, 427),				
67-71	All w/Holley 4BC	3877173	1	.23	SPRING, float

**3.750 THERMOSTAT ASSY.— BAFFLE— BRACKET— COIL— COVER— GASKET— GROMMET— HOUSING— PACKING— PIPE ASSY.— PLATE— PLUG— RETAINER— SCREW— SHIELD— TUBE ASSY.— WASHER, Automatic Choke Control**

*NOTE: For Vega, Monza Thermostat assy. & parts see end of Group 3.750.*

63-67	All (6 cyl.)	3821564	1	3.15	w/cover
64-66	Chevy, Chevelle w/2BC (283),				
65-68	Pass. (283, 307),				
67-70	Chevy, Chevelle, Camaro w/2BC (283, 302, 307, 327)	3908966	1	1.90	
65	Chevelle w/Sp. H/Per. (327),				
65-67	Pass. (396, 427) (exc. Sp. H/Per.),				
66	Pass. w/Sp. H/Per. (327),				
66-67	Chevy, Chevelle w/Sp. H/Per. (327, 396),				
66-69	Pass. w/Sp. H/Per. (427),				
67	Chevelle, Camaro (302, 396),				
68-69	Camaro (302),				
68	All w/Sp. H/Per. (396),				
70	Camaro w/Sp. H/Per. (350) (exc. E.E.C.)	3887148	1	3.05	
66	All (327) (exc. Sp. H/Per.)	3887109	1	3.25	w/Rochester and Holley carbs.
66	All (327) (exc. A.I.R., Sp. H/Per.)	3887110	1	3.25	w/Carter carb.
66-67	All w/A.I.R. (6 cyl.) (exc. P.G.)	3888108	1	3.15	w/cover
67	All w/4BC (327, 350) (exc. Sp. H/Per.)				w/3903312-3916353,
68	Chevy, Chevelle, Camaro w/4BC,				
68	All (327, 396, 427)	3927190	1	3.20	auto. choke
68-71	All (6 cyl.) (exc. A.T.),				
70	Nova (4 cyl.)	3927770	1	3.40	w/cover (2 holes on tab)
68-71	All w/A.T. (6 cyl.)	3927772	1	2.85	w/cover (1 hole on tab)
69	Chevy, Chevelle, Camaro w/2BC (350),				
69	Pass. w/2BC				w/3959172-73,
70	Pass. (2BC, w/E.E.C.),				
70	Nova, Chevelle, Camaro (2BC w/E.E.C.) (350)	3951638	1	2.75	w/3970056
69	Chevy, Chevelle, Camaro w/4BC (350, 396) (exc. Sp. H/Per.),				
69	All w/4BC (350, 396, 427) (exc. Sp. H/Per.)	3946093	1	3.25	
72	All w/4BC (350) (exc. Sp. H/Per.)	3998940	1	3.40	
70	Pass., Chevelle w/4BC (400, 454),				
70	Nova, Chevelle, Camaro w/H/Per. (396)	3969825	1	3.40	w/3967468-71
70	All w/4BC (350) (exc. Sp. H/Per.)	3973497	1	2.65	w/3972134-40
70	Pass. w/2BC (exc. E.E.C.),				
70	Nova, Chevelle, Camaro w/2BC (350) (exc. E.E.C.)	3972186	1	3.45	w/3972184
70	Nova, Chevelle, Camaro w/Sp. H/Per. (396, 454)	3977103	1	3.05	w/3967492-94
71	All w/2BC,				
73	All (307),				

FUEL—EXHAUST—CARBURETION

**3.750 THERMOSTAT ASSY.— BAFFLE— BRACKET— COIL— COVER— GASKET— GROMMET— HOUSING— PACKING— PIPE ASSY.— PLATE— PLUG— RETAINER— SCREW— SHIELD— TUBE ASSY.— WASHER, Automatic Choke Control (Con't)**

73-74	All (A.T. w/2BC) (350, 400) . . . . .	3989058	1	3.55	
71	All w/4BC (350) (exc. Sp. H/Per.) . . . . .	3989060	1	3.25	
71	All w/Sp. H/Per. (350), Camaro w/Sp. H/Per. (350) . . . . .	3989061	1	3.55	
71	All w/4BC (400, 454) (exc. Sp. H/Per.) . . . . .	3992082	1	3.25	
72	All w/4BC (402, 454) (exc. Sp. H/Per.) . . . . .	6272732	1	3.40	(repl. 3999279) . . . . .
72	All (6 cyl.) . . . . .	3998143	1	3.40	
72	All w/2BC, All w/2BC (exc. A.T.) . . . . .	6262984	1	3.50	
73-74	All w/4BC (350, 400) . . . . .	326079	1	7.55	
73-74	All (454) . . . . .	6272736	1	3.40	
73-74	All (6 cyl.) . . . . .	333992	1	3.40	
75	All (6 cyl.) (exc. integrated cyl. hd.) . . . . .	362710	1	3.40	
75	All (6 cyl.) w/integrated cyl. hd. . . . .	17052651	1	10.40	w/cover . . . . .
75	All w/2BC (350) . . . . .	7037239	1	.62	BAFFLE, choke cont. . . . .
69	All w/Roch. 4BC . . . . .	7037501	1	6.55	BRACKET, choke control . . . . .
75	All w/2BC, 4BC (exc. 262) . . . . .	17052654	1	5.95	COIL, w/gasket, stat. cover . . . . .
75	All w/2BC (262) . . . . .	17052784	1	5.95	COIL, w/gasket, stat. cover . . . . .
62	Chevy w/P.G. (6 cyl.) . . . . .	7021438	1	5.70	COVER, thermostat, w/gasket . . . . .
64-70	Chevy, Chevelle, Camaro w/2BC (283, 307, 327), Pass. (283, 307) . . . . .	3840906	1	.48	COVER, thermostat . . . . .
64-65	Chevy, Chevelle w/4BC (exc. H/Per., Sp. H/Per.), Pass. w/Roch. 4BC (exc. 396, 409), Chevy, Chevelle w/A.I.R. (283) (exc. 2BC) . . . . .	7013588	1	6.85	COVER, w/coil thermostat . . . . .
64-65	Chevy, Chevelle w/H/Per., Pass. w/H/Per. (327), Pass. w/H/Per., dual 4BC (409) . . . . .	3759946	1	15.45	COVER, w/coil, thermostat . . . . .
65	Pass. (327) (exc. P.G.) . . . . .	3816379	1	8.45	COVER, w/coil (Carter 170-AD-588S) (w/3846247) . . . . .
65	Pass. w/Sp. H/Per. (396) . . . . .	3852481	1	3.75	COVER (w/3849804, Holley R-2818A) . . . . .
65	Pass. w/Sp. H/Per. (396) . . . . .	3886265	1	3.80	COVER, w/coil (w/3868826-3869933) . . . . .
70	Pass. (454), Nova, Chevelle, Camaro w/4BC (396, 400), All (8 cyl.), All (exc. integrated cyl. hd.) . . . . .	3998944	1	.73	COVER (w/3967468-7471-7492-94) . . . . .
72-75	All (6 cyl.) w/integrated cyl. hd. . . . .	17051424	1	2.40	COVER . . . . .
75	All w/4BC (exc. 454) . . . . .	17051918	1	6.05	COVER . . . . .
75	All (454) . . . . .	17052640	1	6.05	COVER . . . . .
65	Pass. (396) (exc. Sp. H/Per.), Pass. (8 cyl.) (exc. 283), Chevy, Chevelle (327, 396), Camaro (302, 396), All (327, 350) (exc. Sp. H/Per.), Camaro (302, 396) (exc. Sp. H/Per.), Chevelle w/Sp. H/Per. (327, 396), All (327, 396), Pass. (8 cyl.), All (350) . . . . .	3864866	1	.66	COVER ASSY., auto. choke therm. . . . .
62	Chevy (6 cyl.), Chevy, Chevelle (8 cyl.) (exc. H/Per., Sp. H/Per.), Pass. w/4BC (exc. H/Per.), Pass. (409) (exc. H/Per., dual 4BC), Chevy, Chevelle w/A.I.R. (283) (exc. 2BC) . . . . .	7002760	1	.11	GASKET, thermostat housing cover . . . . .
64-65	Chevy, Chevelle w/H/Per., Pass. w/4BC, dual 4BC . . . . .	7000610	1	.17	GASKET, coil hsg. (Carter 121-78) . . . . .
64-65	Chevy, Chevelle w/H/Per., Pass. w/Carter 4BC, H/Per. (327),				



**FUEL—EXHAUST—CARBURETION**

**3.750 THERMOSTAT ASSY.— BAFFLE— BRACKET— COIL— COVER—  
GASKET— GROMMET— HOUSING— PACKING— PIPE ASSY.— PLATE—  
PLUG— RETAINER— SCREW— SHIELD— TUBE ASSY.— WASHER,  
Automatic Choke Control (Con't)**

65	Pass. w/dual 4BC (409) . . . . .	1423131	2	.36	GASKET, choke housing (Carter 20-43) . . . . .
65	Pass. (409) (exc. H/Per., dual 4BC) . . . . .	7007502	1	.11	GASKET, choke hsg. to airhorn (w/7013004-06-07-08-10-12-16-18-20-26- 3974-7024123-24-27-28) . . . . .
75	All w/2BC (350) . . . . .	17050961	1	.20	GASKET, stat. cover . . . . .
75	All w/2BC . . . . .	7043291	1	.18	GASKET, choke hsg. to throttle body . . . . .
66	Pass. (327, 396, 427) (exc. Sp. H/Per.) . . . . .				
67	Pass. (396, 427) . . . . .	3890476	1	.40	GROMMET, carb. air heater tube (Rochester Carbs.) . . . . .
64	Chevy, Chevelle (P.G. w/4BC),				
65	Pass. w/Roch. 4BC, P.G. (exc. 409 H/Per.) . . . . .				
65-66	Chevy, Chevelle w/P.G. 4BC (283, 327) (exc. H/Per., Sp. H/Per.) . . . . .	7021208	1	3.60	HOUSING, w/plugs . . . . .
64-65	All w/H/Per. (327) . . . . .	3830752	1	7.25	HOUSING . . . . .
64	Chevelle w/4BC (exc. P.G.),				
65	Chevy, Chevelle w/4BC (exc. P.G., H/Per., Sp. H/Per.) . . . . .				
65	Pass. w/4BC (283, 327) (exc. P.G.) . . . . .				
66	Pass. w/A.I.R. (283) (exc. P.G., 2BC) . . . . .				
66	Chevy, Chevelle w/A.I.R. (283) (exc. 2BC) . . . . .	7016573	1	3.60	HOUSING, w/plug . . . . .
65	Pass. w/Carter 4BC . . . . .	3759936	1	5.90	HOUSING (Carter 170-585S) (w/3846246- 7) . . . . .
75	All w/2BC . . . . .	17050876	1	4.40	HOUSING, choke . . . . .
75	All w/4BC (exc. 454) . . . . .	17051917	1	6.10	HOUSING, choke . . . . .
75	All (454) . . . . .	17051908	1	6.10	HOUSING, choke . . . . .
62	Chevy (6 cyl.) . . . . .	7002883	1	.05	PACKING, suction tube . . . . .
75	Chevelle (6 cyl.) . . . . .	354519	1	.71	PIPE, auto. choke heat front . . . . .
75	All (350) . . . . .	355918	1	.67	PIPE, auto. choke heat . . . . .
75	All 2BC (350) . . . . .	355921	1	.42	PIPE, auto. choke air . . . . .
75	All 4BC (350, 400) . . . . .	355922	1	.42	PIPE, auto. choke air . . . . .
62-64	Chevy (8 cyl.) . . . . .	603827	1	RL/.18	PIPE ASSY., heat air intake (repl. 3792709)
62	Chevy (6 cyl.) . . . . .				
64-65	Chevy, Chevelle w/4BC (exc. H/Per., Sp. H/Per.) . . . . .				
65-66	Pass. w/4BC (exc. H/Per.) . . . . .				
65	Pass. (409) (exc. H/Per., dual 4BC) . . . . .				
66	Chevy, Chevelle w/A.I.R. (283) (exc. 2BC) . . . . .	7006643	1	.37	PLATE, choke baffle . . . . .
64-65	Chevy, Chevelle w/H/Per.,				
65	Pass. w/Carter 4BC, H/Per. (409) . . . . .				
65	Pass. w/H/Per. (327, 409) . . . . .	3759939	1	.39	PLATE, thermostat baffle (Carter 186-79) . .
75	All (262) . . . . .	7037239	1	.62	PLATE, therm. cvr. baffle . . . . .
64-65	Chevy, Chevelle w/4BC,				
65-66	Pass. w/Roch. 4BC (283, 327) (exc. H/Per.) . . . . .				
66	Chevy, Chevelle w/A.I.R. (283) (exc. 2BC) . . . . .	7007893	1	.07	PLUG, choke hsg. expansion ( <sup>9</sup> / <sub>16</sub> " dia.) . . . . .
65	Pass. w/Carter 4BC (327) (2nd design) (exc. Sp. H/Per.) . . . . .				
65	Chevy, Chevelle w/H/Per.,				
65	Pass. (409) . . . . .	1172236	1	.17	PLUG, choke hsg. (Carter 47-30) ( <sup>5</sup> / <sub>8</sub> " dia. alum.) (expansion) . . . . .
62	Chevy (6 cyl.) . . . . .				
64-65	Chevy, Chevelle w/4BC (exc. H/Per., Sp. H/Per.) . . . . .				
65	Pass. w/4BC (exc. H/Per., Sp. H/Per.) . . . . .				
66	Chevy, Chevelle w/A.I.R. (283) (exc. 2BC) . . . . .				RETAINER, thermostat housing cover, . . . . .
66	Pass. w/A.I.R. (283) (exc. 2BC) . . . . .				
65	All w/2BC . . . . .	7000614	A.R.	.15	A.M. cold enrichment cover (Carter 63-58) .
64-65	Chevy, Chevelle w/4BC (exc. H/Per., Sp. H/Per.) . . . . .				

**FUEL—EXHAUST—CARBURETION**

**3.750 THERMOSTAT ASSY.— BAFFLE— BRACKET— COIL— COVER— GASKET— GROMMET— HOUSING— PACKING— PIPE ASSY.— PLATE— PLUG— RETAINER— SCREW— SHIELD— TUBE ASSY.— WASHER, Automatic Choke Control (Con't)**

65-66	Pass. w/4BC (283, 327) (exc. H/Per.)				
65	Pass. (409) (exc. H/Per., dual 4BC)				
66	Chevy, Chevelle w/A.I.R. (283) (exc. 2BC)	<b>7006846</b>	1	.07	<b>RETAINER, cover</b> .....
65	Chevelle w/Sp. H/Per. (327)	<b>3852461</b>	3	.12	<b>SCREW, w/L/washer, housing (w/3863150)</b> .....
65	Pass. (409)	<b>1179316</b>	3	.18	<b>SCREW, piston housing (Carter 101-436) (w/3760264-4593-3772600-3795566-7698-7699-3815403-5404-9207-3820580-7324-3855581-6580)</b> .....
72	All (6 cyl.) (exc. NB-2)	<b>6270074</b>	1	3.60	<b>SHIELD, auto. choke air</b> .....
73	All (6 cyl.)	<b>331115</b>	1	3.20	<b>SHIELD, auto. choke air.</b> .....
74-75	All (6 cyl.) (exc. integrated cyl. hd.)	<b>338193</b>	1	3.20	<b>SHIELD, auto. choke air</b> .....
75	Camaro w/2BC	<b>7013704</b>	1	.11	<b>SCREW, choke hsg.</b> .....
75	All w/2BC (exc. Camaro)	<b>7043296</b>	1		<b>SCREW, choke hsg.</b> .....
75	All w/4BC	<b>7038808</b>	1	.21	<b>SCREW, choke hsg. bowl</b> .....
65-66	Pass. (396, 427)				
66-69	Chevelle (396)	<b>3876794</b>	1	.11	<b>WASHER (1/8" I.D. x 3/4" O.D. x 1/16" thick) automatic choke thermostat cover</b> .....

**3.750 THERMOSTAT ASSY.— COVER— GASKET— HOUSING— RETAINER— RING— SCREW, Automatic Choke Control**

71-72	Vega (1BC w/A.T.)				
73-74	Vega w/1BC	<b>3998170</b>	1	3.35	
71-72	Vega w/1BC (exc. A.T.)				
71-72	Vega w/2BC	<b>6273474</b>	1	3.35	
75	Vega, Monza 1BC (140)	<b>348643</b>	1	3.15	
71-73	Vega,				
74-75	Vega, Monza w/1BC (140)	<b>348646</b>	1	.60	<b>COVER (repl. 3980240)</b> .....
75	Vega, Monza w/A.T. (262)	<b>17052784</b>	1	5.95	<b>COVER, stat., coil and gasket assy.</b> .....
73-75	Vega, Monza w/2BC	<b>335099</b>	1	.38	<b>GASKET, carb. choke housing</b> .....
73	Vega w/2BC	<b>335140</b>	1	5.75	<b>HOUSING ASSY., carb. thermostat</b> .....
74	Vega w/2BC (140)	<b>345648</b>	1	5.75	<b>HOUSING ASSY., carb. therm.</b> .....
75	Vega, Monza w/2BC (140)	<b>360987</b>	1	4.90	<b>HOUSING ASSY., carb. therm.</b> .....
75	Vega, Monza w/A.T. (262)	<b>7000614</b>	3	.15	<b>RETAINER, stat. cover</b> .....
73-75	Vega, Monza w/2BC	<b>335142</b>	1	.32	<b>RING, carb. thermostat housing retainer</b> .....
75	Vega, Monza w/2BC (140)	<b>360958</b>	1	.38	<b>SCREW, choke water hsg. ret.</b> .....

**3.751 VALVE— SCREW— SHAFT UNIT, Carburetor Choke**

*NOTE: For Vega, Monza valve-screw carburetor choke see end of Group 3.751.*

62	Chevy,				
64-66	All (6 cyl.)				
66-67	Pass. (6 cyl.) (exc. Taxi, A.I.R.)				
67	Chevy, Chevelle, Camaro w/Roch. 1BC	<b>7011651</b>	1	.63	
63-65	Chevy (4 cyl.)				
66	All w/A.I.R. (6 cyl.)				
67	All w/Carter 1BC	<b>1875233</b>	1	.76	(Carter 7-107) .....
64-66	Chevy, Chevelle w/A.I.R. (283)				
65-66	Pass. (283)				
67-68	All w/Roch. 2BC				w/7024100-1-2-6-8-10-12-5103-7101-3-10-12-14-16-7036101-03-10-12-7101-3-10-12, .....
69	All w/Roch. 2BC (307, 327)				
73	All w/Roch. 2BC (307)	<b>7025955</b>	1	.62	w/7029101-03-10-12 .....
65	Chevelle w/Sp. H/Per. (327)				
66	Pass. (327, 396) (exc. A.I.R., Sp. H/Per.)				
66	Chevy, Chevelle (327, 396)				
66	Pass. w/H.D. (396, 427)				
67-70	Pass. w/Holley 4BC				
71-72	All w/Holley 4BC	<b>3852460</b>	1	.23	(Holley 2R-388) .....
68-71	All (4 cyl., 6 cyl.)				
72-73	All w/Roch. 1BC	<b>7034012</b>	1	.72	carb. choke .....
69	All w/Roch. 2BC				
70-75	All w/Roch. 2BC (262, 350, 400)	<b>7033443</b>	1	.65	w/7040102-4-13-15-16-17-18-19-20-27-29-0402-4-13-14-15-16-17-18-19-20-27-28-7004-5-16-19-20-29 .....

**FUEL—EXHAUST—CARBURETION**

**3.751 VALVE— SCREW— SHAFT UNIT, Carburetor Choke (Con't)**

70-72	All w/Roch. 2BC (307) . . . . .	7025955	1	.62	w/7040101-3-10-12-0401-3-10-12-7002-13
70-74	All w/Roch. 4BC . . . . .	7036021	1	.87	
74	All w/1BC,				
75	Vega, Monza w/1BC . . . . .	7049918	1	.72	
75	All w/1BC (exc. Vega, Monza) . .	17052251	1	1.15	carb. choke . . . . .
75	All w/4BC . . . . .	7048904	1	1.25	carb. choke . . . . .
62-64	Chevy, Chevelle,				
65-70	All w/Roch. Carb.,				
71-75	All w/Roch. 2BC . . . . .	7007627	A.R.	.11	SCREW, choke valve attach (16— 32 x 17/64") . . . . .
62-69	All . . . . .	342146	2	.11	SCREW, choke valve attach. (No. 3— 45 x 7/32") (w/3817245)— (3.761) . . . . .
65	Chevelle w/Sp. H/Per. (327),				
66	Pass. w/H.D. (396, 427),				
66	Chevy, Chevelle (327, 396),				
66	Pass. (396) (exc. A.I.R., Sp. H/Per.),				
67-72	All w/Holley 4BC . . . . .	2285775	2	.10	SCREW, valve (Holley 5R-4) . . . . .
65	Pass. (396) (exc. Sp. H/Per.),				
66	Chevy (327) (exc. Sp. H/Per.),				
66	Pass. (327, 396, 427),				
66	Chevelle (327, 396) (exc. H/Per.),				
67-75	All w/Roch. 4BC . . . . .	7029866	2	.15	SCREW, valve . . . . .
65-66	Pass. (396) (exc. Sp. H/Per.),				
66	Chevy, Chevelle (327, 396),				
66	Pass. w/H.D. (396, 427),				
67-72	All w/Holley 4BC . . . . .	2292693	2	.11	SCREW, diaph. brkt. . . . .
68-71	All w/Roch. 1BC,				
73	All w/Roch. 1BC, A.T.,				
74-75	All w/1BC . . . . .	7020926	2	.11	SCREW, carb. choke vlv.— (3.820) . . . . .
65	Pass. (396) (exc. Sp. H/Per.) . . . .				SHAFT UNIT, carb. choke w/lever and valve (w/7025200-01), . . . . .
66	Chevy (327) (exc. Sp. H/Per.),				
66	Pass. (327, 396, 427),				
66	Chevelle (327, 396) (exc. H/Per.)				w/7026200-1-2-3-4-5-7036200-1-2-3-4-5, .
67-69	Pass. w/Roch. 4BC . . . . .	7036430	1	2.50	(3.752) . . . . .

**3.751 VALVE— SCREW, Carburetor Choke**

71-72	Vega w/1BC . . . . .	7026656	1	.74	
71-72	Vega w/2BC . . . . .	7025955	1	.62	
73-74	Vega w/2BC . . . . .	335081	2	.65	
73	Vega w/1BC . . . . .	7034012	1	.72	
75	Vega, Monza w/1BC . . . . .	7049918	1	.72	
75	Vega, Monza w/A.T. (262) . . . . .	7033443	1	.65	
71-73	Vega w/1BC . . . . .	7020926	2	.11	SCREW, carb. choke valve . . . . .
71-72	Vega w/2BC,				
75	Vega, Monza w/A.T. (262) . . . . .	7007627	2	.11	SCREW, carb. choke valve . . . . .
73-75	Vega, Monza w/2BC . . . . .	335088	4	.12	SCREW, carb. choke valve . . . . .
73-75	Vega, Monza w/2BC . . . . .	335090	3	.12	SCREW, carb. choke housing ret. ring . . . . .
73-75	Vega, Monza w/2BC . . . . .	335092	3	.12	SCREW ASSY., carb. choke housing w/lockwasher . . . . .

**3.752 BUSHING— CLIP— DELAYER ASSY.— HOUSING— HOSE— INSULATOR— LEVER— LINK— NUT— PIN— PISTON— RETAINER— ROD— SCREW— SEAL— SHAFT— SOLENOID— SPACER— SPRING— WASHER, Carburetor and Fuel Injection Choke**

73-75	Vega, Monza (140-2BC) . . . . .	335102	1	.32	carb. oper. lever (secondary) . . . . .
62	Chevy,				
66-69	Chevelle, Camaro,				
67-69	Pass., Chevy,				
70	Nova . . . . .	7003137	A.R.	.11	CLIP, choke rod, pump connector . . . . .
67-70	All . . . . .				CLIP, thermo. modifier link rod end, L.H. auto. choke upper rod end, auto. choke rod at carb., . . . . .
72-73	Vega . . . . .	6255773	A.R.	.19	auto. choke rod . . . . .
71	Vega,				
72	All (exc. 402, 454) . . . . .	3989067	1	.12	CLIP, auto. choke rod— (3.425) . . . . .
71	Chevelle (Holley 4BC w/A.T.),				
71	Camaro w/Holley 4BC . . . . .	3979658	1	9.10	DELAYER ASSY. (w/3989021-22-6196) . .
73-75	Vega w/2BC . . . . .	335122	1	4.15	HOUSING, carb. choke cover . . . . .
75	Monza w/A.T. (262) . . . . .	17050876	1	4.40	HOUSING, carb. choke . . . . .
73-74	Vega w/2BC . . . . .	335120	1	4.15	HOUSING ASSY., carb. choke . . . . .
75	Vega, Monza (2BC-140) . . . . .	360970	1	4.65	HOUSING ASSY., w/plugs choke . . . . .
73-75	Vega w/1BC . . . . .	331124	1	1.10	INSULATOR, carb. heat (3.726) . . . . .

**FUEL—EXHAUST—CARBURETION**

**3.752 ■ BUSHING— CLIP— DELAYER ASSY.— HOUSING— HOSE— INSULATOR— LEVER— LINK— NUT— PIN— PISTON— RETAINER— ROD— SCREW— SEAL— SHAFT— SOLENOID— SPACER— SPRING— WASHER, Carburetor and Fuel Injection Choke (Con't)**

62	Chevy (4 cyl.)	7022952	1	.78	LEVER, choke (w/7020103-0104-0114-0115)
62-66	Chevy, Chevelle (6 cyl.),				
65-66	Pass. (6 cyl.),				
67	Chevelle, Camaro w/P.G. (230) (exc. A.I.R.),				
67	Chevy w/P.G. (250) (exc. A.I.R.)	7009262	1	.64	LEVER, choke (w/collar) (1/4" I.D.)
64-66	Chevy, Chevelle (6 cyl.),				
65-67	Pass. (6 cyl.) (exc. Taxi, A.I.R.),				
67	All w/Roch. 1BC (6 cyl.)	7022550	1	.62	LEVER, choke shaft (w/7023000-03-4-5-3105-08-4000-01-5000-3-4-5105-8-6027-8)
64-65	Chevy, Chevelle w/Air Cond. (283) (exc. 4BC),				
65-67	Pass. w/Roch. 2BC (283),				
66	Chevy, Chevelle w/A.I.R. (283) (exc. 4BC),				
67-68	Chevy, Chevelle, Camaro w/Roch. 2BC,				
68	Pass. (307),				
70	All w/Roch. 2BC	7038612	1	.79	LEVER, carb. choke rod
64-65	Chevy, Chevelle w/Air Cond. (283) (exc. 4BC),				
65-67	Pass. w/Roch. 2BC (283),				
66	Chevy, Chevelle w/A.I.R. (283) (exc. 4BC),				
67-69	Chevy, Chevelle, Camaro w/Roch. 2BC,				
68	Pass. (307),				
69	Pass. w/2BC,				
70-74	All w/Roch. 2BC (exc. Vega),				
71-72	Vega w/2BC	7026239	1	.82	LEVER, w/collar, carb. choke
64-65	Chevy, Chevelle w/4BC, P.G. (exc. H/Per., Sp. H/Per.),				
65-66	Pass. w/Roch. 4BC, P.G. (283, 327) (exc. H/Per.),				
66	Pass. w/A.I.R. (283) (exc. 2BC),				
66	Chevy, Chevelle w/4BC (283)	7012748	1	.66	LEVER, w/link, choke and piston (w/7024120-21-22-26-4220-26-5121-2-6-7-8-5126-7-8-6121-7036118-19-20-21)
64-65	Chevy, Chevelle w/4BC (exc. H/Per., Sp. H/Per.),				
65-66	Pass. w/Roch. 4BC,				
66	Pass. w/A.I.R. (283) (exc. 2BC),				
66	Chevy, Chevelle w/4BC (283)	7027897	1	.69	LEVER, choke w/collar (w/7024120-22-25-26-4220-25-26-5121-2-3-4-6-7-8-6121-7036118-19-20-21)
64-65	Chevy, Chevelle w/H/Per.,				
65	Pass. w/Carter 4BC,				
65	Pass. w/dual 4BC, H/Per. (409)	1472184 A.R.		1.80	LEVER, w/link and pin, piston (Carter 14-609S)
64-65	Chevy, Chevelle w/H/Per.,				
65	Pass. w/H/Per. (327)	1173247 A.R.		.46	LEVER, choke outer (Carter 14-512)
65-66	Pass. w/4BC (exc. P.G., H/Per.),				
66	Chevy, Chevelle w/4BC (283) (exc. P.G.),				
66	Pass. w/A.I.R. (283) (exc. 2BC, P.G.)	7009852	1	.66	LEVER, w/link, piston (w/7024123-4-5-7-8-5123-4-7-6121-7036118-19-21)
65	Pass. (396) (exc. Sp./H/Per.)				LEVER, sec"d. lock-out (w/7025200-01-20-21),
66	Chevy (327) (exc. Sp. H/Per.),				
66	Pass. (8 cyl.) (exc. 283),				
66	Chevelle (327, 396) (exc. H/Per.),				
67	Pass. (8 cyl.) (exc. 283, A.T.),				
67-69	Chevy, Chevelle, Camaro w/Roch. 4BC,				
68-69	Pass. w/Roch. 4BC				w/7026200-1-2-3-5-7036200-1-2-3-5-7027201-11-13-7037201-11-13,
70-75	All w/Roch. 4BC	7027270	1	.88	LEVER, inter. (w/7025200-01-20-21),
65	Pass. (396) (exc. Sp./H/Per.)				

**FUEL—EXHAUST—CARBURETION**

**3.752 ■BUSHING— CLIP— DELAYER ASSY.— HOUSING— HOSE— INSULATOR— LEVER— LINK— NUT— PIN— PISTON— RETAINER— ROD— SCREW— SEAL— SHAFT— SOLENOID— SPACER— SPRING— WASHER, Carburetor and Fuel Injection Choke (Con't)**

166	Chevelle (327, 396) (exc. H/Per.),					
66	Pass. (8 cyl.) (exc. 283)				w/7026200-1-2-3-4-5-7036200-1-2-3-4-5,	
67-75	All w/Roch. 4BC	7031231	1	.63		
68	Chevy (4 cyl.)	7034078	1	.65	LEVER, carb. choke cam	
69	All w/Roch. 2BC	7006596	1	.22	LEVER, carb. choke trip	
69	Chevy w/Roch. 1BC (4 cyl.)	7037007	1	.65	LEVER, carb. choke	
71	All w/Roch. 1BC (exc. Vega)	7026277	1	.62	LEVER, carb. choke	
71	All w/Roch. 2BC (exc. Vega)	7028164	1	.81	LEVER, carb. choke shaft	
71	Vega w/2BC (exc. A.T.) (1st design)	7043760	1	.81	LEVER, carb. stat.	
71	Vega (2BC w/A.T.) (1st design)	7038612	1	.79	LEVER, carb. stat.	
71-72	Vega w/2BC (2nd design)	7030632	1	.81	LEVER, carb. stat.	
71-72	Vega w/1BC	7043764	1	.58	LEVER, carb. choke	
72	All w/Roch. 2BC (exc. Vega)	7024266	1	.75	LEVER, shaft	
72-74	All w/Roch. 1BC	7030719	1	.71	LEVER, carb. choke	
73-74	All w/2BC (exc. Vega)	7040002	1	.78	LEVER, shaft	
73-75	Vega, Monza (2BC-140)	335083	1	.84	LEVER, carb. choke	
75	Vega, Monza (2BC-140)	360989	1	.84	LEVER, choke pull off int.	
75	All w/2BC (exc. Vega, Monza),					
75	Monza w/A.T. (262)	17050766	1	.86	LEVER, choke	
73	Vega w/1BC	7040489	1	1.50	LEVER ASSY., carb. choke w/link	
74-75	Vega, Monza w/1BC	7041238	1	1.50	LEVER ASSY., carb. choke w/link	
75	All (1BC w/integrated cyl. hd.)	17051769	1	2.00	LEVER ASSY., carb. choke w/link	
75	All w/2BC (exc. Vega, Monza),					
75	Monza w/A.T. (262)	17050271	1	.82	LEVER ASSY., carb. choke shaft	
75	All w/4BC	7041542	1		LEVER ASSY., carb. choke shaft	
75	Vega, Monza w/2BC (140)	360917	1	.22	LEVER ASSY., choke pull off int.	
65-66	Pass. (396) (exc. Sp. H/Per., A.I.R.),					
66	Pass. (327) (exc. A.I.R.),					
66	Chevy, Chevelle (327, 396),					
66	Pass. w/H.D. (396, 427),					
67-70	All w/Holley 4BC	3881422	1	.57	LINK, diaph. (Holley 33R-475)	
71-72	All w/Holley 4BC	3979657	1	.80	LINK, delayer	
75	Vega, Monza w/2BC (140)	360976	1	.16	NUT, choke shaft	
62	Chevy (6 cyl.),					
65	Pass. w/4BC (409)	7010746	1	.03	PIN, piston (center carb.) (w/7013016-20-26-3974-7020000-03-07-23-24-27-28-0105-0108-5123-4)	
64-65	Chevy, Chevelle w/H/Per.,					
65	Pass. w/Carter 4BC,					
65	Pass. w/dual 4BC (409)	1172252	1	.15	PIN, choke piston (Carter 150-190)	
64-65	Chevy, Chevelle w/4BC (exc. H/Per., Sp. H/Per.),					
65	Pass. (8 cyl.) (exc. Carter 4BC),					
66	Pass. w/A.I.R. (283) (exc. 2BC),					
66	Chevy, Chevelle w/4BC (283)	7004748	1	.03	PIN, choke piston ( <sup>5</sup> / <sub>32</sub> " long) (Carter 150-62)	
64-65	Chevy, Chevelle w/4BC (exc. H/Per., Sp. H/Per.)					
65-66	Pass. w/Roch. 4BC (283, 327)					
66	Chevy, Chevelle w/4BC (283),					
66	Pass. w/A.I.R. (283) (exc. 2BC)	7015887	1	1.05	w/7026121-7036118-19-20-21	
65	Pass. (327) (exc. H/Per., Sp. H/Per., F.I.)	3764577	1	1.30	PISTON, choke (Carter 160-136)	
64-65	Chevy, Chevelle w/H/Per.,					
65	Pass. w/H/Per. (327)	7013765	1	1.55	PISTON, choke (w/3797699-3815404-3851761-2)	
65	Pass. w/P.G. (409)	7012294	1	.64	PISTON, choke (w/7020024-4124-28-5124)	
62-66	Chevy (4 cyl.)					
68-69	Chevy (4 cyl.)	838884	1	.16	RETAINER, lever (w/7019100-9101-9107-9110-9111-9117-7020103-0104-0114-0115),	
65	Chevelle w/Sp. H/Per. (327)	3877147	1	.12	RETAINER, idle vent valve (w/3863150)	
65	Chevelle w/Sp. H/Per.,					
65	Pass. w/Sp. H/Per. (396)					
66	Pass. w/H.D. (396, 427)	2315470	1	.22	RETAINER, choke rod (Holley 48R-31) (w/3869933-3863150),	
73-75	Vega, Monza w/2BC (140)	335141	2	.22	w/3887147	
					RETAINER, carb. choke rod	

**FUEL—EXHAUST—CARBURETION**

**3.752 ■ BUSHING— CLIP— DELAYER ASSY.— HOUSING— HOSE— INSULATOR— LEVER— LINK— NUT— PIN— PISTON— RETAINER— ROD— SCREW— SEAL— SHAFT— SOLENOID— SPACER— SPRING— WASHER, Carburetor and Fuel Injection Choke (Con't)**

75	Vega, Monza w/2BC (140) . . . . .	360973	2	.55	RETAINER, E- ring . . . . .
62-65	Chevy, Chevelle w/4BC (exc. H/Per.) . . . . .				ROD, choke (w/702006-12-22-7023006-12-7024120-22-25-26-4220-25-26-5126-27-28), . . . . .
65-66	Pass. w/4BC (283, 327) (exc. H/Per.) . . . . .				w/7025121-2-6-7-8, . . . . .
66	Pass. w/A.I.R. (283) (exc. 2BC),				
66	Chevy, Chevelle w/4BC (283) . . . . .	7009776	1	1.35	w/7026121-7036118-19-20-21 . . . . .
62	Chevy (6 cyl.) . . . . .	7020653	1	.67	ROD, choke (w/7020105-0108) . . . . .
63-65	Chevy, Chevelle (6 cyl.),				
65-66	All (230),				
65-66	Pass., Taxi w/econ. carb. (6 cyl.)	7028996	1	.69	ROD, choke (Rochester) . . . . .
63-67	Chevy (4 cyl.) . . . . .	3843944	2	.57	ROD, choke (w/3792945-3019-3905971-2)
63-67	All (6 cyl.) . . . . .	3830922	1	.73	ROD, automatic choke . . . . .
64-69	Chevy, Chevelle, Camaro w/2BC (283, 307, 327),				
65-68	Pass. w/2BC (283, 307),				
70	Nova, Chevelle, Camaro (307) (exc. E.E.C.) . . . . .	3840907	1	.57	ROD, auto. choke . . . . .
64-65	Chevy, Chevelle w/Air Cond. (283) (exc. 4BC),				
65-67	Pass. (283),				
66	Chevy, Chevelle w/A.I.R. (283) (exc. 4BC),				
67-68	Chevy, Chevelle, Camaro w/Roch. 2BC,				
69	Chevy, Chevelle, Camaro w/Roch. 2BC (307, 327),				
70-71	All w/Roch. 2BC (307) . . . . .	7026559	1	.78	ROD, carb. choke (w/7041101-10-7110-11)
65-66	Pass. (396, 427) (exc. Sp./H/Per.),				
67	Camaro (396),				
67	Pass. (396, 427) (exc. A.I.R.) . . . . .	3874890	1	.39	ROD, auto. choke . . . . .
65	Pass. w/A.T. (396) (exc. Sp./H/Per.),				
66	Chevelle (396) (exc. A.I.R.),				
66	Pass. w/H/Per. (396, 427) . . . . .	3899614	1	.84	ROD, auto choke (Holley) . . . . .
65-66	Pass. (396) (exc. Sp. H/Per., A.I.R.) . . . . .				ROD, carb. choke (Holley 43R-363) (w/3868864-3874898), . . . . .
66	Pass. (327) (exc. A.I.R.) . . . . .				w/3875964-6747, . . . . .
66-69	Pass. w/Sp. H/Per. (427) . . . . .				w/3885067-3916143-5-3923289, . . . . .
66	Chevy, Chevelle (327, 396) . . . . .				w/3868864-3875964-6747-4898-7413-3886087-8-3890497-3892338-9-3229, . . . . .
67-69	Chevy, Chevelle, Camaro w/Holley 4BC . . . . .				w/3903389-91-8956-7-8-9-3916143-5-3923289, . . . . .
70	All w/Holley 4BC . . . . .	3881440	1	.39	ROD, choke (w/7025200-01) (Roch.), . . . . .
65	Pass. (396) (exc. Sp. H/Per.) . . . . .				
66	Chevy (327) (exc. Sp. H/Per.),				
66	Chevelle (327, 396) (exc. H/Per.),				
66	Pass. (8 cyl.) (exc. 283) . . . . .				w/7026200-1-2-3-4-5-7036200-1-2-3-4-5, . . . . .
67	All w/Roch. 4BC . . . . .	7031394	1	1.05	w/7027200-1-2-3-10-11-12-13-7037200-1-2-3-10-11-12-13 . . . . .
65	Chevelle w/Sp. H/Per. (327) . . . . .	3877150	1	1.40	ROD, idle vent. valve (w/3863150) . . . . .
66-67	Chevelle, Camaro w/Sp. H/Per. (396),				
67-69	Pass. w/Sp. H/Per. (427),				
68-69	Chevy, Chevelle, Camaro w/Sp. H/Per. (396) . . . . .	3947803	1	1.85	ROD, auto choke . . . . .
66	Pass. w/A.I.R. (6 cyl.) . . . . .				ROD, carb. choke conn. (w/3880860-1-3891595-6), . . . . .
66	Taxi (6 cyl.) . . . . .				(w/3886193-4-3891593-4), . . . . .
66-67	All w/A.I.R. (6 cyl.) . . . . .				w/3880860-1-3891595-6-3905975-6-9405
67	Pass., Taxi w/Carter 1BC . . . . .	3888030	1	.35	w/3905973-4-5-6 . . . . .
66	All (327) (exc. A.I.R., Sp. H/Per.)	3881867	1	.55	ROD, auto. choke (Carter) (w/3893242) . . . . .
66	Pass. (327) (exc. A.I.R.),				
66	Chevy, Chevelle w/A.I.R. (327),				
67-68	Pass. (327),				

**FUEL—EXHAUST—CARBURETION**

**3.752 ■ BUSHING— CLIP— DELAYER ASSY.— HOUSING— HOSE— INSULATOR— LEVER— LINK— NUT— PIN— PISTON— RETAINER— ROD— SCREW— SEAL— SHAFT— SOLENOID— SPACER— SPRING— WASHER, Carburetor and Fuel Injection Choke (Con't)**

67- 69	Chevy, Chevelle, Camaro w/4BC (327, 350),				
69	Pass. w/4BC (350) .....	3896970	1	1.60	ROD, auto. choke therm. cover and rod assy. ....
67-69	Camaro (302) .....				ROD, auto. choke, .....
70	Camaro (E.E.C. w/Sp. H/Per.) (350) .....	3917616	1	3.20	(w/3917614) .....
67	Chevelle (396) .....	3906641	1	3.00	ROD, auto. choke .....
68	All w/Roch. 1BC .....	7034057	1	.65	ROD, carb. choke actuator .....
68-69	All (6 cyl.) .....	3918984	1	.88	ROD, auto. choke .....
68-69	All w/Roch. 4BC .....	7036067	1	1.05	ROD, carb. choke .....
68-69	Chevy, Chevelle, Camaro w/4BC (396, 427) (exc. Sp. H/Per.) ...	3927193	1	.38	ROD, auto. choke (nickel plated) .....
69	Chevy, Chevelle, Camaro w/Roch. 2BC (350),				
69	Pass. w/Roch. 2BC (327, 350) ..				ROD, auto. choke, .....
70	All w/2BC (350, 400) (exc. E.E.C.) .....	3947724	1	.65	(w/3972184) .....
69	Pass. w/Roch. 2BC (396) .....	3952308	1	.53	ROD, auto. choke .....
69	All w/Roch. 2BC,				
70	Pass., Monte Carlo (Roch. 2BC w/A.T.) (400),				
70	All w/Roch. 2BC (350),				
71-74	All w/Roch. 2BC (350, 400) ...	7043370	1	.71	ROD, carb. choke (repl. 7036186) .....
69-71	All w/Roch. 1BC (6 cyl.),				
72-75	All w/Roch. 1 BC (exc. Vega, Monza, integrated cyl. hd.) ...	7037000	1	.67	ROD, carb. choke .....
70	Monte Carlo w/Roch. 2BC (400) (exc. A.T.) .....	7026141	1	.71	ROD, carb. choke .....
70-71	All (6 cyl.) .....	3967069	1	.65	ROD, auto. choke .....
70	Pass., Chevelle (4BC w/E.E.C.) (400, 454),				
70	All (H/Per. w/E.E.C.) (396) .....	3967469	1	1.05	ROD, auto. choke (w/3967468) .....
70	Pass., Monte Carlo w/4BC (400, 454) (exc. E.E.C.),				
70	All w/H/Per. (396) (exc. E.E.C.) .	3967472	1	.71	ROD, auto. choke (w/3967471) .....
70	Nova, Chevelle, Camaro (E.E.C. w/Sp. H/Per.) (396, 454) .....	3967495	1	.71	ROD, auto. choke (w/3967494) .....
70	Nova, Chevelle w/E.E.C. (307) ..	3970046	1	.48	ROD, auto. choke .....
70	All (2BC w/E.E.C.) (350, 400) ..	3970058	1	.99	ROD, auto. choke (w/3970056) .....
70	All (4BC w/E.E.C.) (350) (exc. Sp. H/Per.) .....	3970084	1	.93	ROD, auto. choke (w/3972140) .....
70	All w/4BC (350) (exc. Sp. H/Per., E.E.C.) .....	3970080	1	.93	ROD, auto. choke (w/3972134-3475) .....
70-74	All w/Roch. 4BC .....	7037557	1	.71	ROD, carb. choke .....
70	Nova (4 cyl.) .....	3973179	1	6.35	ROD, auto. choke (upper) .....
70	Nova, Chevelle, Camaro w/Sp. H/Per. (396, 454) (exc. E.E.C.) .	3967493	1	.71	ROD, auto. choke (w/3967492) .....
70	Camaro w/Sp. H/Per. (350) (exc. E.E.C.) .....	3972124	1	1.55	ROD, auto. choke (w/3972118) .....
71	All w/4BC (350) (exc. Sp. H/Per.) .....	3989046	1	.57	ROD, auto. choke .....
71-72	Camaro w/Sp. H/Per. (350) .....	3989057	1	.87	ROD, auto. choke .....
71	All w/4BC (400, 454) (exc. Sp. H/Per.) .....	3989382	1	.80	ROD, auto. choke .....
71	All w/Holley 4BC .....	3979661	1	.80	ROD .....
71	All (307),				
72-73	Nova, Chevelle (307) .....	3989042	1	1.40	ROD, auto. choke .....
71-74	All w/2BC (350, 400) .....	3989044	1	.60	ROD, auto. choke .....
71-73	Vega w/1BC .....	7041173	1	.74	ROD, carb. choke .....
71-72	Vega w/2BC .....	7043761	1	.81	ROD, carb. choke .....
71	Vega w/2BC .....	6262858	1	.93	ROD, carb. auto. choke (3.96" O.L.) .....
71	Vega w/2BC,				
71-74	Vega w/1BC (exc. NB-2) .....	6262856	1	.62	ROD, carb. auto. choke (4.97" O.L.) .....
72	Vega w/2BC .....	6270001	1	.84	ROD, carb. auto. choke (4.24" O.L.) .....
72	Vega (1BC w/NB-2) .....	6270000	1	.84	ROD, carb. auto. choke .....
72-73	All w/Roch. 2BC (307) .....	7030521	1	.71	ROD .....
72-74	All w/Roch. 4BC .....	7024256	1	.71	ROD, inter. choke .....
72	All w/4BC (350) (exc. Sp. H/Per.),				
73-74	All w/4BC (350, 400) .....	3998966	1	1.80	ROD, auto. choke .....

**FUEL—EXHAUST—CARBURETION**

**3.752 ■BUSHING— CLIP— DELAYER ASSY.— HOUSING— HOSE— INSULATOR— LEVER— LINK— NUT— PIN— PISTON— RETAINER— ROD— SCREW— SEAL— SHAFT— SOLENOID— SPACER— SPRING— WASHER, Carburetor and Fuel Injection Choke (Con't)**

172	All w/4BC (400, 454) (exc. Sp. H/Per.)				
73-74	All (454)	3999278	1	.38	ROD, auto. choke
72-74	Pass., Chevelle, Camaro (6 cyl.)				
72-74	Nova (6 cyl.) (exc. A.T.)				
73-74	Vega (1BC w/NB-2)	333945	1	.96	ROD, carb. auto. choke
73-74	Vega w/2BC	335134	1	.84	ROD, carb. choke
74	Vega w/1BC (140)	7041173	1	.74	ROD, carb. choke
75	Vega, Monza w/1BC (140)	348645	1	1.15	ROD, auto. choke
75	Vega, Monza w/1BC	17053085	1	2.45	ROD, carb. choke (repl. 7043097)
75	Vega, Monza w/2BC (140)	360978	1	1.55	ROD, choke
75	Vega, Monza w/2BC (140)	360980	1	.84	ROD, choke pull off rod
75	All w/2BC (exc. Vega, Monza)				
75	Monza w/A.T. (262)	7043370	1	.71	ROD, choke
75	All w/1 BC w/integrated cyl. hd. (exc. Vega, Monza)	7043131	1	.86	ROD, choke
75	All w/4BC	7041472	1	1.75	ROD, choke
75	All (6 cyl.)	7043516	1	1.90	ROD, thermostat
70	Nova (4 cyl.)	3973178	1	6.15	ROD ASSY., auto. choke (lower)
62-69	All (exc. 4 cyl.)				
70	All w/Roch. 2BC,				
71-75	All				SCREW, trip lever, choke rod,
71-72	Vega w/2BC	7019709	1	.05	carb. choke lever (6-32 x 5/16")
65	Pass.	7010434	1	.18	SCREW, attach. choke valve, trip lever (16— 32 x 5/16")— (3.740)
66	Chevy, Chevelle w/A.I.R. (283) (exc. 4BC),				
66	Pass. w/A.I.R. (283),				
67	All w/Roch. 2BC	131954	1	.04	SCREW, lever swivel— (8.907)
68	All w/Roch. 2BC,				
71	All (Roch. 2BC w/A.T.) (307)	7019707	1	.05	SCREW, carb. choke rod and tube
75	Vega, Monza w/2BC (140)	360959	1		SCREW, w/lock washer
75	Monza w/A.T. (262)	7011270	3		SCREW, stat. cover
75	Monza w/A.T. (262)	7043292	2	.19	SCREW, choke housing
75	Vega, Monza w/2BC (140)	360958	1	.38	SCREW, carb. water hsg. ret.
65-66	Pass. w/Sp. H/Per. (396, 427)				SEAL, choke rod (w/3869933-3885067),
65-66	Chevelle w/Sp. H/Per.				w/3861150-3893229,
66	Pass. w/H.D. (396, 427)				w/3887147,
66	Chevy (327)				w/3877413-3890497,
67-72	All w/Holley 4BC	3852471	1	.12	
73-75	Vega, Monza w/2BC (140)	335115	1	.13	SEAL, carb. choke rod
75	All w/2BC, 4BC	7037569	1	.38	SEAL, inter. choke sht. dust
75	All w/4BC	7043367	1	.38	SEAL, choke hsg. bowl
62	Chevy (4 cyl.)	7019230	1	1.45	SHAFT, w/lever (w/7020103-104-114-115)
63-67	Chevy (4 cyl.)	3832223	1	1.75	SHAFT, w/lever (w/3829476-38330-19-38-2945-3905971-2)
63-66	Chevy, Chevelle (6 cyl.)				
65-67	Pass. (6 cyl.) (exc. A.I.R., Taxi)				
67	Chevy, Chevelle, Camaro (6 cyl.)	7022548	1	3.35	SHAFT, w/lever (w/7023000-03-4-5-3 105-3108-4000-01-5000-3-5 105-8-6027-8)
64-66	Chevy, Chevelle w/Air Cond. (283) (exc. 4BC)				SHAFT, w/lever and link (w/7024100-1-2-6-8-19-12-51-3-7041101-10-7110-11),
65-68	Pass. (283, 307),				
66	Chevy, Chevelle w/A.I.R. (283) (exc. 4BC),				
67-68	All w/Roch. 2BC,				
69-71	All w/Roch. 2BC (307, 327),				
72	All w/Roch. 2BC (307)	7024464	1	1.80	SHAFT, w/lever (w/7024120-22-25-26-4220-25-26-5125-27-28),
64-65	Chevy, Chevelle w/4BC				w/7026121-7036118-19-20-21,
65-66	Pass. w/Roch. 4BC				w/7025121-2-6-7-8),
66	Pass. w/A.I.R. (283) (exc. 2BC)				w/7026121-7036118-19-20-21
66	Chevy, Chevelle w/4BC (283)	7013175	1	1.45	
64-65	Chevy, Chevelle w/H/Per.,				
65	Pass. w/H/Per. (327)	1472185	1	1.45	SHAFT, w/lever (piston housing) (Carter 14-612S) w/3760264-4593-3772600-3795566-7699-9207-3815404-3816004-06-3851761-62-6580)
65	Chevy, Chevelle w/Sp. H/Per.	2367952	1	1.10	SHAFT (w/3863150)
65	Pass. (409) (exc. H/Per., dual 4BC)	7010048	1	.84	SHAFT, w/lever



**FUEL—EXHAUST—CARBURETION**

**3.752 BUSHING— CLIP— DELAYER ASSY.— HOUSING— HOSE— INSULATOR— LEVER— LINK— NUT— PIN— PISTON— RETAINER— ROD— SCREW— SEAL— SHAFT— SOLENOID— SPACER— SPRING— WASHER, Carburetor and Fuel Injection Choke (Con't)**

65-66	Pass. (8 cyl.) (exc. 283),					
66	Chevy, Chevelle (327, 396),					
67	Pass. w/Holley 4BC					SHAFT, carb. choke (w/3868864-3875964-6747-4898-7413-3886087-8-3890497-3893229-2338-9-3906631-3-5-7-3916143-5,.....)
67-69	Chevy, Chevelle, Camaro w/Holley 4BC,					
68	Pass. w/Sp. H/Per. (427),					
70-72	All w/Holley 4BC	3877160	1	1.70		
68	All w/Roch. 1BC	7034056	1	.46	SHAFT, w/lever carb. choke	
69-70	All w/Roch. 1BC	7036973	1	2.35	SHAFT, w/lever carb. choke	
68-69	Chevy (4 cyl.)	7028177	1	2.15	SHAFT, w/lever, carb. choke	
69	Chevy, Chevelle, Camaro w/Roch. 2BC (350),					
69	Pass. w/Roch. 2BC	7037175	1	2.15	SHAFT, w/lever and link, w/7029109-4-13-14-15-16-17-18-19-20	
70-72	All w/Roch. 2BC (350, 400)	7036177	1	2.35	SHAFT ASSY., w/lever and link (w/7041102-13-14-17-18-27-7104-07-12-13-18-27)	
70-72	All w/Roch. 4BC,					
73-74	All w/4BC (350, 400)	7038855	1	2.45	SHAFT ASSY., w/lever	
71-72	Vega w/2BC	7043757	1	1.80	SHAFT ASSY., carb. choke	
71-74	All w/Roch. 1BC (exc. Vega),					
75	Nova (1BC) (exc. integrated cyl. hd.)	7028175	1	2.25	SHAFT ASSY., w/lever	
73	All (307)	7047839	1	2.35	SHAFT ASSY.	
73-75	All w/2BC (262, 350, 400) (exc. Monza),					
75	Monza w/A.T. (262)	7047797	1	2.35	SHAFT ASSY.	
73-75	All (454)	7047614	1	2.45	SHAFT ASSY., w/lever	
75	All w/2BC (exc. Monza),					
75	Monza w/A.T. (262)	7043289	1	1.50	SHAFT ASSY., inter. choke	
75	All w/1BC w/integrated cyl. hd. (exc. Vega, Monza)	7043099	1	3.60	SHAFT ASSY., carb. choke	
75	All w/4BC	7038259	1	5.00	SHAFT ASSY., choke	
75	Vega, Monza	7043083	1	4.00	SHAFT ASSY., w/lever	
65	Pass. (396) (exc. Sp. H/Per.)					SHAFT UNIT, carb. choke w/lever and valve (w/7025200-01),
71-73	Vega w/1BC	7041843	1	3.00	SHAFT AND LEVER ASSY., carb. choke	
73-74	Vega w/2BC	6259042	1	2.40	SHAFT AND LEVER ASSY., carb. choke	
73-75	Vega, Monza w/2BC (140)	6259047	1	2.40	SHAFT AND LEVER ASSY., carb. choke housing	
74	Vega w/1BC (140)	7043765	1	2.25	SHAFT AND LEVER ASSY., carb. choke	
75	Vega, Monza w/2BC (140)	360916	1	4.65	SHAFT AND LEVER ASSY., choke	
66	Chevy (327) (exc. Sp. H/Per.),					
66	Pass. (327, 396, 427),					
66	Chevelle (327, 396) (exc. H/Per.)					w/7026200-1-2-3-4-5-703-6200-1-2-3-4-5,
67-69	All w/Roch. 4BC	7036430	1	2.50		
64-65	Chevy, Chevelle w/H/Per.,					
65	Pass. w/H/Per. (327)	1875354	1	.15	SPACER, choke trip lever (w/3760264-4593-3772600-3795566-7699-3815404-9207-3826004-06-3851761-62-6580)	
71	All w/Roch. 4BC	836159	1	.07	SPRING, carb. choke rod	
75	Vega, Monza (2BC-140)	360986	1	.11	SPRING, retainer washer	
75	Vega, Monza (2BC-140)	360974	1	.16	SPRING, choke closure	
75	Vega, Monza (2BC-140)	360984	1	.11	WASHER, lock-choke shaft	
75	Vega, Monza (2BC-140)	360981	1	.11	WASHER, choke lever	
75	Vega, Monza (2BC-140)	360985	1	.11	WASHER, seal	

**3.753 SPRING, Carburetor Choke**

68	Pass. w/Roch. 2BC (307)	7019892	1	.29	
68-69	Chevy (4 cyl.)	7035700	1	.26	valve

**3.755 CONTROL ASSY.— BRACKET ASSY.— BRAKE ASSY.— CONNECTOR— COVER— DIAPHRAGM ASSY.— HOSE— LINK— NIPPLE— ROD— SCREW— SOLENOID ASSY.— SPRING— SWITCH ASSY.— TEE, Carburetor**

63-66	Chevy, Chevelle (6 cyl.),
65-66	Pass., Taxi w/Econ. Carb. (6 cyl.),

**FUEL—EXHAUST—CARBURETION**

**3.755 CONTROL ASSY.— BRACKET ASSY.— BRAKE ASSY.— CONNECTOR—  
COVER— DIAPHRAGM ASSY.— HOSE— LINK— NIPPLE— ROD—  
SCREW— SOLENOID ASSY.— SPRING— SWITCH ASSY.— TEE,  
Carburetor (Con't)**

67	Chevy, Chevelle, Camaro w/Roch. 1BC (6 cyl.) . . . . .				w/7025000-3-105-8-3000-03-3 105-08- 4000-01-6027-8, . . . . .
67	Pass. (6 cyl.) (exc. Taxi, A.I.R.) . .	<b>7025091</b>	1	3.20	w/7023000-03-04-05-5000-03-04-05-6027- 8 . . . . .
64-66	Chevy, Chevelle (283) . . . . .				w/7024100-1-2-6-8-10-12-5 103-8101-03- 10-12, . . . . .
67	Pass. (283) (exc. A.I.R.) . . . . .				w/7027101-3-10-12-14-16, . . . . .
67-68	All w/Roch. 2BC,				
69	Chevy, Chevelle, Camaro w/Roch. 2BC (307, 327) . . . . .				(w/7029102-3-10-12), . . . . .
70	All Roch. 2BC w/A.T. (307),				
71	Vega w/2BC (1st design) . . . . .	<b>7036768</b>	1	3.55	w/bracket (w/7040110-12-0410-12-7002) .
65-66	Pass. (283),				
67	Pass. (A.I.R. w/P.G.) (283) . . . . .	<b>7041822</b>	1	3.55	w/7024100-1-2-6-8-10-12-5 103-7036110- 12-7119-12 . . . . .
65	Pass. (396) (exc. Sp. H/Per., A.T.) . . . . .	<b>7031929</b>	1	3.20	w/7025201 . . . . .
65-66	Pass. w/A.T. (396, 427) (exc. Sp. H/Per.),				
66	Pass. w/P.G. (327),				
66	Chevy, Chevelle w/P.G. (396) (exc. H/Per.),				
66	Chevy, Chevelle w/P.G. (327) . . .	<b>7031388</b>	1	3.20	w/7025200-20-7026200-2-4-7036200-2-4
66	Chevy (327) (exc. P.G., Sp. H/Per.),				
66	Pass. w/H/Per. (427) (exc. T.H.),				
66	Chevelle (327, 396) (exc. P.G., H/Per.),				
66	Pass. (327, 396) (exc. A.T.) . . . .	<b>7032425</b>	1	3.30	w/7026201-3-7036201-2-3 . . . . .
66-67	All w/A.I.R. (283) (exc. P.G., 4BC) . . . . .	<b>7041822</b>	1	3.55	w/7036101-3-7101-3 . . . . .
67-68	All w/Roch. 4BC . . . . .	<b>7038960</b>	1	3.85	w/7027200-1-2-3-10-11-12-13-7037200-1- 2-3-10-11-12-13 . . . . .
68	All w/P.G. (6 cyl.) . . . . .	<b>7035877</b>	1	1.05	w/7028014 . . . . .
68-69	All (6 cyl.) (exc. A.T.) . . . . .	<b>7035878</b>	1	1.05	w/7028015-17-9017 . . . . .
69	Pass. w/Roch. 2BC,				
69	Chevy, Chevelle, Camaro w/Roch. 2BC (350) . . . . .	<b>7027649</b>	1	3.20	w/bracket . . . . .
69	All w/Roch. 4BC . . . . .	<b>7038239</b>	1	4.25	
69	All (Roch. 1BC w/A.T.) . . . . .	<b>7037778</b>	1	1.05	w/7029014 . . . . .
69	Chevy, Chevelle, Camaro w/Roch. 2BC (307, 327) . . . . .				(w/7029101-3-10-12) . . . . .
70	All (Roch. 2BC w/A.T.) (307),				
71	Vega w/2BC (1st design) . . . . .	<b>7036769</b>	1	3.20	choke vac. (w/7040110-12-0410-12-7002)
69	Pass. w/Roch. 2BC,				
69	Chevy, Chevelle, Camaro w/Roch. 2BC (350) . . . . .	<b>7037953</b>	1	2.55	
70	Nova w/Roch. 1BC (4 cyl.),				
70-71	All (Roch. 1BC w/A.T.) (6 cyl.) (exc. Vega),				
71-72	Vega w/1BC (exc. A.T.) . . . . .	<b>7040606</b>	1	1.05	w/7040014-7014 . . . . .
70-71	All w/Roch. 1BC (6 cyl.) (exc. A.T.) . . . . .	<b>7040646</b>	1	1.05	w/7040017-7015 . . . . .
70	All w/Roch. 2BC (307) (exc. A.T.) . . . . .	<b>7026278</b>	1	3.55	w/bracket, choke (w/7040101-3-0401-3- 7013) . . . . .
70	All w/Roch. 2BC (307) (exc. A.T.) . . . . .	<b>7040849</b>	1	3.20	choke vacuum (w/7040101-3-0401-3-7013)
70	All w/Roch. 2BC (350, 400) . . . .	<b>7038037</b>	1	2.85	choke vacuum (w/7040102-4-13-14-15-16- 17-18-19-20-27-29-0402-4-13-14- 15-16-17-18-19-20-27-29-7004-5- 16-19-20-29) . . . . .
70	All w/Roch. 2BC (350, 400) . . . .	<b>7027662</b>	1	3.20	w/bracket, choke vacuum (w/7040102-4- 13-14-15-16-17-18-19-20-27-29- 0402-4-13-14-15-16-17-18-19-20- 27-29-7004-5-16-19-20-29) . . . . .
71-72	Vega (1BC w/A.T.) . . . . .	<b>7043737</b>	1	1.35	carb. vac. break link . . . . .
71-72	Vega w/2BC (2nd design) . . . . .	<b>7030627</b>	1	3.20	carb. vac. break . . . . .
71-72	All w/Roch. 2BC,				
73	All (307) . . . . .	<b>7042715</b>	1	10.00	w/bracket . . . . .
71-72	Vega w/2BC (2nd design) . . . . .	<b>7045971</b>	1	3.55	w/bracket carb. vac. break . . . . .

**FUEL—EXHAUST—CARBURETION**

**3.755 CONTROL ASSY.— BRACKET ASSY.— BRAKE ASSY.— CONNECTOR—  
COVER— DIAPHRAGM ASSY.— HOSE— LINK— NIPPLE— ROD—  
SCREW— SOLENOID ASSY.— SPRING— SWITCH ASSY.— TEE,  
Carburetor (Con't)**

70-71	All w/Roch. 4BC	7043674	1	9.00	w/brkt. choke vacuum
70	All w/Roch. 4BC	7043676	1	5.20	vacuum brake
72	All w/Roch. 1BC	7030713	1	9.25	
72	All w/Roch. 4BC	7044903	1	5.20	choke vacuum (7042202-03-15-20, 7042902-03)
72	All w/Roch. 4BC	7044901	1	9.00	w/brkt. vacuum
73	Vega w/1BC (140)	7040139	1	8.80	carb. bac. break link
73-75	All w/Roch. 1BC (exc. integrated cyl. hd.)	7030918	1	9.25	
73-74	All w/2BC (350, 400)	7040238	1	10.00	
73	All w/4BC (350)	7040181	1	5.25	
73	All (454)	7040384	1	5.25	
73	All w/Roch. 4BC (454)	7047872	2	9.00	w/bracket, vacuum
73	All w/4BC (350)	7047878	1	9.00	w/bracket
74	All (454)	7048200	1	5.25	
74	All w/4BC (350, 400) (exc. Sp. H/Per.)	7048206	1	5.25	
74	All w/Sp. H/Per. (350)	7048211	1	5.25	
74	Vega w/1BC (140)	17050210	1	8.80	carb. vac. brkt.
75	All w/2BC (262, 350)	17052732	1	9.35	w/brkt.-vac. brk.
75	Vega w/1BC	7043098	1	6.90	vac. brake
75	All (1BC w/integrated cyl. hd.) (exc. Vega, Monza)	17052250	1	9.25	vac. brake
75	Monza w/A.T. (262) (exc. Towne Coupe)	17052732	1	9.35	carb. vac. brkt.
75	Pass. (350, 400) (4BC)	17050759	1	9.00	w/bracket, vac. brk.
75	Pass. (454) (4BC)	7041534	1	9.00	w/bracket, vac. brk.
67	Chevelle, Camaro w/Roch. 4BC (396) (exc. H/Per., Sp. H/Per.),				
67	Pass. w/Roch. 4BC (396, 427)	7036313	1	4.40	BRACKET ASSY., control (w/7027200-1- 10-11-7037200-1-10-11)
67	All (327, 350) (exc. Sp. H/Per.)	7036310	1	4.40	BRACKET ASSY., carb. choke vac. cont. (w/7027202-3-12-13-7037212-13-18)
68	All w/Roch. 4BC	7036367	1	4.40	BRACKET ASSY., carb. choke vac. control
75	All w/1BC, integrated cyl. hd. (exc. Vega, Monza)	7043127	1	9.10	BRAKE ASSY., carb. vac. (sec'd.)
75	Vega, Monza w/1BC	7043090	1	7.30	BRAKE ASSY., carb. vac. (sec'd.)
68-70	All (6 cyl.),				
71-72	Vega w/1BC				CONNECTOR, carb. vac. brake link,
71	All w/Roch. 1BC	7034013	1	.58	carb. choke
70	All w/Holley 4BC	3979424	1	.81	CONNECTOR, fuel inlet
68-70	All (6 cyl.),				
71	All w/Roch. 1BC				COVER, carb. choke,
71-72	Vega w/1BC	7034018	1	.65	carb. vac. brake
73-74	Vega w/2BC	335121	1	1.55	COVER ASSY., carb. choke diaph.— (3.750)
75	Vega, Monza w/2BC (140)	360969	1	4.20	COVER ASSY., carb. choke diaph.— (3.750)
65-66	Pass. (396) (exc. Sp. H/Per.)				DIAPHRAGM ASSY. (w/3868864-6747),
66	Chevy, Chevelle (327, 396)				w/3868864-3874898-5964-6747-7413- 3886076-8-3890497-2338-9-3229,
66	Pass. w/Sp. H/Per. (427),				
66	Pass. (327) (exc. A.I.R.),				
66	Pass. w/H.D. (396, 427)				w/3887147,
67-70	All w/Holley 4BC	3912092	1	3.10	
66	All (327) (exc. A.I.R., Sp. H/Per.)	3889755	1	5.30	DIAPHRAGM ASSY. (w/3875966-6749) (Carter 202-2545)
66	All w/A.I.R. (6 cyl.)				DIAPHRAGM ASSY., w/bracket,
66	Taxi (6 cyl.) (exc. A.I.R.)				w/3891593-4,
67	All Taxi w/Carter 1BC (6 cyl.)	3888037	1	5.20	w/3905973-4-5-6
68-70	All (6 cyl.),				
71	All w/Roch. 1BC				DIAPHRAGM ASSY., carb. choke,
71-72	Vega w/1BC	7034017	1	1.25	carb. vac. brake
72	All w/Holley 4BC	6273911	1	11.90	DIAPHRAGM, carb. choke
73	Vega w/2BC,				
74	Vega w/2BC (140) (exc. A.T.)	335124	1	4.65	DIAPHRAGM ASSY., carb. choke w/shaft
74	Vega (A.T. w/2BC) (140)	345644	1	4.65	DIAPHRAGM ASSY., carb. choke w/shaft
75	Vega, Monza (A.T. w/2BC) (140) (exc. NB-2)	360972	1	3.90	DIAPHRAGM ASSY., carb. choke w/shaft
75	Vega, Monza (2BC w/NB-2) (140)	360971	1	3.90	DIAPHRAGM ASSY., carb. choke w/shaft
75	Vega, Monza (A.T. w/2BC) (140) (exc. NB-2, C.A.C.)	361020	1	20.60	DIAPHRAGM ASSY., w/hsg. carb. choke
64-66	Chevy, Chevelle (283),				

**FUEL—EXHAUST—CARBURETION**

**3.755 CONTROL ASSY.— BRACKET ASSY.— BRAKE ASSY.— CONNECTOR—  
COVER— DIAPHRAGM ASSY.— HOSE— LINK— NIPPLE— ROD—  
SCREW— SOLENOID ASSY.— SPRING— SWITCH ASSY.— TEE,  
Carburetor (Con't)**

65	Pass. (8 cyl.) (exc. 4BC),					
66	Pass. w/A.I.R. (283) (exc. 4BC),					
67-68	Chevy, Chevelle, Camaro w/Roch. 2BC,					
67-69	Pass. w/Roch. 2BC,					
69	Chevy, Chevelle w/Roch. 2BC (350) .....	7026685	1	.84	LINK (w/7024100-1-2-6-8-10-12-5103- 7100-3-10-12-14-16-8101-03-10-12- 7029102-04-13-14-15-16-17-18-19-20- 21-27-29-7036101-03-10-12-7101-3-10- 12) .....	
69	Chevy, Chevelle, Camaro w/Roch. 2BC (307, 327) .....				LINK (w/7029101-3-10-12), .....	
70	All w/Roch. 2BC .....	7037770	1	.84	choke vacuum control .....	
71	Vega w/2BC (1st design) .....	7043762	1	.86	LINK, carb. vacuum brake .....	
71-72	Vega w/2BC (2nd design) .....	7030631	1	.83	LINK, carb. vacuum brake .....	
72	All w/Roch. 1BC .....	7024277	1	.83	LINK, vac. control .....	
73-74	All w/Roch. 1BC .....	7035207	1	.83	LINK, vac. control .....	
73-75	All w/2BC .....				LINK, choke vac., .....	
71-72	All w/Roch. 2BC,					
75	Monza w/A.T. (262) (exc. Towne Coupe) .....	7040239	1	.86	LINK, vac. brake .....	
75	All w/1BC, integrated cyl. hd. (exc. Vega, Monza) .....	7043122	1	.86	LINK, vac. brk. (sec.) .....	
75	All w/4BC (exc. 454) .....	7043447	1	1.85	LINK, aux. vac. brake .....	
75	All (454) .....	7041496	1	2.55	LINK, aux. vac. brake .....	
75	Vega, Monza w/1BC .....	7043086	1	1.30	LINK, vac. brake (secd.) .....	
66	Pass. w/A.I.R., level ride (6 cyl.) (exc. Air Cond.) .....	3749168	1	.22	NIPPLE, air inlet door— (3.278) .....	
63-66	Chevy, Chevelle (6 cyl.),					
65-67	Pass. (6 cyl.) (exc. A.I.R., Taxi),					
67	Chevy, Chevelle, Camaro w/Roch. 1BC (6 cyl.) .....	7022554	1	.67	ROD, choke actuating .....	
65	Pass. (396) (exc. Sp. H/Per.),					
66	Chevy (327) (exc. Sp. H/Per.),					
66	Pass. (327, 396, 427),					
66	Chevelle (327, 396) (exc. H/Per.)	7029880	1	1.35	ROD, vac. control (w/7025200-01-20-21- 6200-1-2-3-4-5-7036200-1-2-3-4-5) .....	
67-69	All w/Roch. 4BC .....	7038167	1	.62	ROD, vac. control .....	
70-71	All w/Roch. 4BC .....	7029075	1	.72	ROD, choke vacuum control .....	
72-74	All w/Roch. 4BC .....	7024257	1	.72	ROD, vacuum control .....	
75	All w/4BC .....	7041527	1	1.30	ROD, vac. brk. .....	
75	Vega, Monza w/2BC (140) .....	360979	1	.70	ROD, choke pull off solenoid .....	
65	Pass. (396) (exc. Sp. H/Per.) .....				SCREW, vac. cont. assy. (w/7025200-1-10- 21), .....	
66	Chevy (327) (exc. Sp. H/Per.),					
66	Pass. (8 cyl.) (exc. 283),					
66	Chevelle (327, 396) (exc. H/Per.)				w/7026200-1-2-3-4-5-7036200-1-2-3-4-5, .....	
67-75	All w/Roch. 4BC .....	7031925	1	.19		
65	Chevelle w/Sp. H/Per. (327),					
66	Chevelle (396) (exc. H/Per.),					
66	Chevy, Chevelle w/Sp. H/Per. (327),					
66	Pass. (396) (exc. Sp. H/Per.),					
66	Pass. (327) (exc. A.I.R.),					
66	Pass. w/Sp. H/Per. (427),					
66	Pass. w/H.D. (396, 427),					
67-72	All w/Holley 4BC .....	2285812	4	.08	SCREW, secondary diaphragm cover (repl. 2285811) .....	
69	All w/Roch. 2BC .....				SCREW, vac. cont. assy., .....	
70-75	All w/Roch. 2BC (262, 350, 400) .....	7037570	1	.14	(w/7040102-4-13-14-15-16-17-18-19-20- 27-29-0402-4-13-14-15-16-17-18- 19-20-27-29-7004-5-16-19-20-29) .....	
75	All w/1BC .....	7043095	2	.33	SCREW, vac. brake .....	
75	Vega, Monza w/1BC (140) .....	1997439	1	9.75	SOLENOID ASSY., choke pull off .....	
75	Vega, Monza w/2BC (140) .....	335146	1	12.00	SOLENOID ASM., choke pull off .....	
72	All w/2BC .....	328756	1	.55	SPRING, carb. vac. brake control .....	
75	All (6 cyl.) .....	3031548	1	9.20	SWITCH ASSY., choke pull off .....	
68-69	Chevy, Chevelle, Camaro w/Holley 4BC,					
68-69	Pass. w/Sp. H/Per. (427) .....	6272766	1	1.10	TEE, carb. vac. sig. conn. .....	

**FUEL—EXHAUST—CARBURETION**

**3.757 BEARING— BODY ASSY.— CLAMP— LEVER— ROD— SCREW— SHAFT—  
SPRING— VALVE— WASHER, Carburetor Air Valve**

70	All (Holley 4BC w/E.E.C.) w/Sp. H/Per. (396, 454) .....	3979695	1	.55	<b>BODY ASSY.</b> , carb. vent. valve (w/3967479-9894) .....
66-67	Chevelle w/A.T. (396) (exc. H/Per., Sp. H/Per.),				
66-67	Pass. w/A.T. (327, 396, 427),				
67	Chevy, Chevelle, Camaro (A.T. w/4BC) (327, 350, 396) (exc. Sp. H/Per.) .....	7031393	1	.46	<b>LEVER</b> , lockout (w/7026200-04-7200-2-10- 12-7036200-04-7200-2-10-12) .....
70	All (Holley 4BC w/Sp. H/Per.) (396, 454) (exc. E.E.C., A.T.) ...	3979627	1	.92	<b>ROD</b> , carb. air valve (w/3967477) .....
66-75	All w/Roch. 4BC .....	7035344	1	2.50	<b>SPRING</b> , w/cam air valve .....
65	Pass. w/H.D. 3-Spd., 4-Spd. (396) (exc. Sp. H/Per.) .....				<b>VALVE</b> , carb. (Roch.) (w/7025200-1-20-21),
66	Chevelle w/A.I.R. (327, 396) (exc. H/Per.),				
66	Chevy w/A.I.R. (327) (exc. Sp. H/Per.),				
66	Pass. w/A.I.R. (327, 396, 427) ..	7032503	1	2.70	w/7026200-1-2-3-7036200-1-2-3-4-5) ....

**3.758 VALVE— DIAPHRAGM ASSY., Screw Carburetor Throttle**

65	Chevelle w/Sp. H/Per. (327) ...				secondary (w/3863150), .....
66	Chevy, Chevelle (396) .....				w/3868864-6874898-5964-6747- 3883921-39-6087-88-3890497-2338-9, ..
66	Pass. (396) (exc. Sp. H/Per., A.I.R.) .....				w/3868864-3874898, .....
66	Pass. (327) (exc. A.I.R.) .....				w/3875964-6747, .....
67	Chevy, Chevelle, Camaro w/Holley 4BC .....	3867984	2	.46	w/3903389-91-8956-7-8-9 .....
70	All w/Holley 4BC .....	3979471	1	7.30	<b>DIAPHRAGM ASSY.</b> , carb. secondary throttle .....
65	Chevelle w/Sp. H/Per.,				
65-66	Pass. (396) (exc. Sp. H/Per.),				
66	Chevelle (327, 396),				
66	Pass. (327) (exc. A.I.R.),				
66	Pass. w/Sp. H/Per. (427),				
66	Pass. w/H.D. (396, 427),				
67	All w/Holley 4BC (exc. H.D. 427),				
68-69	Chevy, Chevelle, Camaro w/Holley 4BC,				
68-69	Pass. (Holley 4BC w/Sp. H/Per.) (427),				
70-72	All w/Holley 4BC .....	3852474	1	2.05	<b>DIAPHRAGM ASSY.</b> , w/rod (secondary) w/3849804-3868826-64-9933-3874898- 5964-6741-3882835-4505-6101-7147 ..
73-74	Vega w/2BC .....	335093	1	.13	<b>SCREW</b> , carb. diaph. adj. ....
73	Vega w/2BC .....	335117	1	.37	<b>SCREW</b> , carb. secondary return spring ....
75	Vega, Monza w/2BC (140) .....	335070	1	.19	<b>SCREW</b> , choke diaph. adj. ....
73-75	Vega, Monza w/2BC .....	335091	3	.13	<b>SCREW ASSY.</b> , carb. diaph. cover w/lockwasher .....

**3.761 LEVER ASSY.— SCREW— SPRING— WASHER, Carburetor Throttle Valve  
and Throttle Lever Adjusting**

73-75	Vega, Monza w/2BC (140) .....	335144	1	.84	carb. oper. (sec%d.) .....
62	Chevy (4 cyl.) .....	7001619	1	.11	<b>SCREW</b> , fast idle lever adjusting (w/7019100-9101-9107-9110-9111- 9117-7020103-0104-0114-0115) .....
62-69	All .....	342146	1	.11	<b>SCREW</b> , throttle valve attaching (No. 3-45 x 7/32") (w/3817245-3829180-9476- 3833038-3793019-2945-3856713- 3873818-5966-6749-3880860-1-0786) ..
65	Chevelle w/Sp. H/Per. ....				w/3863150, .....
66	All (327, 396),				
67	Chevy, Chevelle, Camaro w/Holley 4BC,				
72	All w/Holley 4BC .....	2368018	A.R.	.03	<b>SCREW</b> , w/3868864-3874898-5964-6747- 7413-8261-3886087-8-3890497-2338-9- 3229-3903389-91-8956-7-8-9 .....
65	Pass. w/Roch. 1BC (6 cyl.),				
65	Pass. (396),				
67-75	All w/Roch. 4BC .....	3960392	1	.12	<b>SCREW</b> , throttle shaft and lever, air meter idle adj. (10-32 x 19/32") .....

**FUEL—EXHAUST—CARBURETION**

**3.761 LEVER ASSY.— SCREW— SPRING— WASHER, Carburetor Throttle Valve and Throttle Lever Adjusting (Con't)**

66	Chevelle w/Sp. H/Per. (396),					
66	Pass. w/H.D. (396, 427) . . . . .				w/lockwasher (Holley 5R-1016) (w/3887147-3893229), . . . . .	
66	Pass. w/Sp. H/Per. (427),					
67-72	All w/Holley 4BC . . . . .	<b>3877162</b>	2	.12	<b>SCREW</b> . . . . .	
66	Pass. (exc. 396, 427),					
66	Chevy, Chevelle w/A.I.R. (6 cyl.),					
66	Pass., Taxi (6 cyl.),					
67	All w/Carter 1BC . . . . .	<b>3888029</b>	2	.12	<b>SCREW</b> , w/3880860-1-3876749-5966- 3891595-6-3905971-2-5-6-9405 . . . . .	
73-75	Vega, Monza w/2BC (140) . . . . .	<b>335087</b>	1	.35	<b>SCREW</b> , carb. throttle lever . . . . .	
75	Vega, Monza (122) . . . . .	<b>7010434</b>	1	.18	<b>SCREW</b> (6-32 x 5/16") . . . . .	
65	Chevelle w/Sp. H/Per.,					
66	All (327, 396, 427) . . . . .				<b>SPRING</b> , adjusting screw (w/3863150), . . . . .	
66	Pass. w/H.D. (396, 427),					
67-72	All w/Holley carb. . . . .				primary, . . . . .	
73-74	Vega w/2BC . . . . .	<b>2285846</b>	1	.26	carb. throttle lever return . . . . .	
75	Vega, Monza w/2BC (140) . . . . .	<b>347087</b>	1	.14	<b>SPRING</b> , throttle lever and brush . . . . .	
65	Chevelle w/Sp. H/Per. (327),					
66	All (327, 396, 427),					
66	Chevy, Chevelle (327, 396) . . . . .	<b>810794</b>	1	.07	<b>WASHER</b> , connecting rod (Holley 46R-25) . . . . .	

**3.762 ARM— BUSHING— CLIP— LEVER— NUT— RETAINER— ROD— SCREW— WASHER, Carburetor Throttle**

65-66	Pass. (396) (exc. Sp. H/Per.),					
66	Pass. (327) (exc. A.I.R.),					
66	Chevy, Chevelle (327, 396),					
66	Pass. w/Sp. H/Per. (427),					
66	Pass. w/H.D. (396, 427),					
67-69	All w/Holley 4BC . . . . .	<b>3888871</b>	1	.29	<b>BUSHING</b> , throttle shaft (Holley 13R-600) . . . . .	
65-66	Pass. . . . .	<b>7010773</b>	1	.08	<b>CLIP</b> (front to center carb. rod) (at center carb. end) . . . . .	
68	Chevy (4 cyl.) . . . . .	<b>3908243 A.R.</b>		.63	<b>CLIP</b> , carb. to accel. control lever rod— (4.054) . . . . .	
65-66	Pass. (396) (exc. Sp. H/Per.),					
66	Pass. w/Sp. H/Per. (427),					
66	Chevy, Chevelle (327, 396),					
66	Pass. w/H.D. (396, 427),					
67-69	All w/Holley carbs. . . . .				<b>LEVER</b> , choke control, . . . . .	
70	Camaro (Holley 4BC w/Sp. H/Per.) (350) . . . . .	<b>3881408</b>	1	.46	(w/3972120-21-22-23) . . . . .	
71	All w/Holley 4BC . . . . .	<b>3979654</b>	1	.73	<b>LEVER</b> , carb. choke control . . . . .	
72	All w/Holley 4BC . . . . .	<b>6273903</b>	1	.73	<b>LEVER</b> , carb. choke control . . . . .	
73	Vega w/2BC . . . . .	<b>6259097</b>	1	2.30	<b>LEVER</b> , carb. throttle (primary) . . . . .	
74-75	Vega, Monza w/2BC (140) . . . . .	<b>345640</b>	1	2.05	<b>LEVER</b> , carb. throttle . . . . .	
75	Vega, Monza w/2BC (140) . . . . .	<b>360975</b>	1	.16	<b>NUT</b> , throttle lever retainer . . . . .	
<i>NOTE 1 In most applications retainer 7002140 must also be used.</i>						
65	Pass. (396) (exc. Sp. H/Per.),					
66	Pass. (327) (exc. A.I.R.),					
66	Chevelle w/Sp. H/Per. (327),					
66	Pass. w/Sp. H/Per. (427),					
66	Chevy, Chevelle (327, 396),					
66	Pass. w/H.D. (396, 427),					
67-69	Pass. w/Holley 4BC,					
70	All w/Holley 4BC . . . . .	<b>3867995</b>	1	.46	<b>ROD</b> , connector (Holley No. 43R-205) . . . . .	
71	All w/Holley 4BC . . . . .	<b>3979662</b>	1	.80	<b>ROD</b> , carb. throttle connector . . . . .	
72	All w/Holley 4BC . . . . .	<b>6273913</b>	1	.65	<b>ROD</b> , carb. throttle connector . . . . .	
65	Pass. (396),					
66	Chevy (327) (exc. Sp. H/Per.),					
66	Chevelle (327, 396) (exc. H/Per.),					
67	All w/Roch. 4BC,					
68-75	All w/Roch. 1BC . . . . .	<b>7010435 A.R.</b>		.11	<b>SCREW</b> (front carb.) shaft return spring lever, carb. throttle shaft retainer spring lever . . . . .	
73-75	Vega, Monza w/2BC (140) . . . . .	<b>6259096</b>	1	.13	<b>WASHER</b> , carb. throttle lever nut primary (locking) . . . . .	
75	Vega, Monza w/2BC (140) . . . . .	<b>360982</b>	1	.11	<b>WASHER</b> , shaft lever . . . . .	
75	Vega, Monza w/2BC (140) . . . . .	<b>360983</b>	1	.11	<b>WASHER</b> , operating sel. . . . .	
75	Vega, Monza . . . . .	<b>335138</b>	1	.13	<b>WASHER</b> , fast idle lever spring . . . . .	

**3.763 SPRING, Carburetor Throttle Shaft**

73-74	Vega w/2BC . . . . .	<b>335127</b>	1	.50	carb. diaph. return . . . . .
73	Vega w/2BC . . . . .	<b>335132</b>	1	.38	carb. throttle lever return (primary) . . . . .

**FUEL—EXHAUST—CARBURETION**

**3.763 SPRING, Carburetor Throttle Shaft (Con't)**

74-75 Vega, Monza w/2BC (140) . . . . . 345645 1 .26 carb. throttle lever return (primary) . . . . .

**3.765 BRACKET— CONTROL ASSY., Carburetor Vacuum**

75 All w/4BC (exc. 454) . . . . . 17050759 1 9.00 w/bracket, vac. brk. . . . .  
 75 All (454) . . . . . 7041534 1 9.00 w/bracket, vac. brk. . . . .  
 75 All w/4BC (exc. 454) . . . . . 17050756 1 8.75 w/brkt. assy.-aux. vac. break . . . . .  
 75 All (454) . . . . . 17051155 1 8.50 w/brkt. assy.-aux. vac. break . . . . .

68 Pass., Chevelle w/reg. fuel (327),  
 69 All . . . . . 3932356 1 2.85 BRACKET, carb. idle control solenoid . . . . .

**3.766 CAM— LEVER— RETAINER— SCREW— SPRING, Carburetor and Fuel Injection Fast Idle**

63-65 All (6 cyl.),  
 66-67 All (6 cyl.) (exc. Taxi, P.G., A.I.R.) . . . . . 7025345 1 .99 (w/7023000-108-5003-105-6027) . . . . .

64-65 Chevy, Chevelle w/4BC (exc. H/Per., Sp. H/Per.) . . . . .  
 w/7025126-27-28, . . . . .

65-66 Pass. w/Roch. 4BC (283) . . . . . w/7025121-22-26-28-6121, . . . . .

66 Chevy, Chevelle (283) (exc. 2BC) 7028500 1 .96 w/7026121-7036118-19-20-21 . . . . .

64-65 Chevy, Chevelle w/Air Cond. (283) (exc. 4BC),

65-66 Pass. (283),

66 Chevy, Chevelle (283) (exc. 4BC) w/7024100-01-02-06-08-10-12-5103-7036101-3-10-12), . . . . .

67 Chevy, Chevelle, Camaro w/Roch. 2BC (exc. A.I.R.) . . . . . w/7027101-3-10-12-14-16, . . . . .

68-69 Chevy, Chevelle, Camaro w/Roch. 2BC (307, 327) (exc. A.T.),

68 Pass. (307) (exc. A.T.) . . . . . w/7028101-3, . . . . .

69 Pass. (Roch. 2BC w/A.T.) (327, 350, 396),

69 Chevy, Chevelle, Camaro (350),

71 All w/Roch. 2BC (307) (exc. A.T.) . . . . . 7029979 1 .90 w/7041101-7111 . . . . .

65-66 Pass. (283) . . . . . w/7024100-01-02-06-08-10-12-5103, . . . . .

67 Pass. w/Roch. 2BC (exc. A.I.R.) . . . . . w/7027101-3-10-12-14-16, . . . . .

68 Pass. (307) (exc. A.T.) . . . . . w/7028101-3, . . . . .

69 Pass. (Roch. 2BC w/A.T.) (327, 350, 396),

70 All w/Roch. 2BC (307, 350) (exc. A.T.),

72 All w/Roch. 2BC (307) (exc. A.T.) . . . . . 7029979 1 .90 w/7040101-3-13-15-27-29-0401-3-13-15-27-29-700-5-13-29 . . . . .

65 Pass. (396) (exc. Sp./H/Per.),

66 Pass. w/Sp. H/Per. (427) . . . . . w/3868864-3874893-3885067-6101), . . . . .

66 Pass. w/H.D. (396, 427) . . . . . w/3887147, . . . . .

67 Chevy, Chevelle w/Sp. H/Per. (327) . . . . . (w/3903389-91), . . . . .

67 All (Holley 4BC w/Sp. H/Per.) (396) . . . . . w/3916143-5, . . . . .

68-69 Chevy, Chevelle, Camaro w/Holley 4BC (302, 396) . . . . . w/3923289-3959164, . . . . .

67-69 Pass. w/Sp. H/Per. (427) . . . . . w/3916143-5-3923289, . . . . .

70 All w/Holley 4BC . . . . . 3881438 1 .46

65-67 All w/P.G. (6 cyl.) . . . . . 7029554 1 .99 fast idle (w/7025000-04-6028) . . . . .

66 Chevy, Chevelle w/A.I.R. (6 cyl.),

66 Pass. (6 cyl.),

66 Taxi (6 cyl.) (exc. A.I.R.) . . . . . fast idle (Carter 181-376) (w/3880860-1-6193-94-3891593-4-5-6), . . . . .

67 Pass., Taxi w/Carter 1BC,

67 Chevy, Chevelle, Camaro w/A.I.R. (6 cyl.) . . . . . 3888036 1 .35 w/3905973-4-5-6-9405 . . . . .

66 Pass. (327) (exc. A.I.R.),

66 Pass. (396) (exc. Sp. H/Per.) . . . . . fast idle (w/3868864-3874898-5964-6747-3882835-4505-3890499-2341), . . . . .

66 Chevy, Chevelle (327, 396) . . . . . (w/3868864-6874898-5964-6747-7413-3886087-8-3890497-3892338-9), . . . . .

67 Chevelle, Camaro w/Holley 4BC (396) (exc. Sp. H/Per.) . . . . . 3888875 1 .57 w/3908956-7-8-9 . . . . .

66 Pass. (396, 427),

66 Chevelle (396) (exc. H/Per.) . . . . . fast idle (w/7026200-1-7036200-1), . . . . .

67 All w/Roch. 4BC (396, 427) . . . . . 7031259 1 .78 w/7027200-1-10-11-7037200-1-10-11 . . . . .

**FUEL—EXHAUST—CARBURETION**

**3.766 CAM— LEVER— RETAINER— SCREW— SPRING, Carburetor and Fuel Injection Fast Idle (Con't)**

66	Chevy, Chevelle (327) (exc. Sp. H/Per.),				
66	Pass. w/A.I.R. (327) . . . . .	<b>7032252</b>	1	1.05	fast idle (w/7026202-3-7036202-3) . . . . .
66-67	All w/A.I.R. (283) (exc. 4BC) . . .				fast idle (w/7036101-03-10-12-7101-3-10-12), . . . . .
67	Chevy, Chevelle, Camaro (A.I.R., w/Roch. 2BC),				
69	Pass. w/Roch. 2BC (327, 350, 396) (exc. A.T.),				
69	Chevy, Chevelle, Camaro w/Roch. 2BC (350) (exc. A.T.) . . . . .				w/7029113-15-17-19-21-27-29, . . . . .
70	Monte Carlo w/Roch. 2BC (400) (exc. A.T.) . . . . .	<b>7033376</b>	1	.90	w/7040117-19-0417-19-7019 . . . . .
67	Chevy, Chevelle, Camaro (P.G. w/Roch. 4BC) (327, 350) (exc. Sp. H/Per.),				
67	Pass. w/A.T. (327) . . . . .	<b>7033859</b>	1	1.10	w/7027202-12-7037202-12 . . . . .
67	Chevy, Chevelle, Camaro w/Roch. 4BC (327, 350) (exc. P.G., Sp. H/Per.),				
67	Pass. w/Roch. 4BC (327) (exc. A.T.) . . . . .	<b>7033814</b>	1	1.10	w/7027203-13-7037203-13 . . . . .
68	Chevy, Chevelle, Camaro w/Roch. 4BC (327, 350) (exc. P.G.),				
68	Pass. w/Roch. 4BC (327) (exc. A.T.) . . . . .				fast idle (w/7028207-13-19), . . . . .
69	Chevelle (396) (exc. T.H. 400, Sp/ H/Per.),				
69	All w/Roch. 4BC (350, 427) (exc. A.T., Sp. H/Per.) . . . . .	<b>7038844</b>	1	1.35	
68	Chevelle, Camaro w/Roch. 4BC (396),				
68	Pass. (Roch. 4BC w/A.T.) (327), Chevy, Chevelle, Camaro (Roch. 4BC w/P.G.) (327, 350) . . . . .				fast idle (w/7028208-10-11-12-17-18), . . . . .
69	All (Roch. 4BC w/A.T.) (350, 427) (exc. Sp. H/Per.) . . . . .	<b>7038845</b>	1	.99	w/7029200-2-4-14-15-23-24 . . . . .
68	All (6 cyl.) . . . . .	<b>7036239</b>	1	.65	fast idle (w/7028014-15-17) . . . . .
68	Chevy, Chevelle, Camaro (Roch. 2BC w/A.T.) (307, 327),				
68	Pass. w/A.T. (307) . . . . .	<b>7035923</b>	1	.95	fast idle (w/7028110-12-9105) . . . . .
68	Chevy (4 cyl.) . . . . .	<b>7034068</b>	1	.69	fast idle (w/7028008-9) . . . . .
69-70	All (Roch. 1BC w/A.T.) (6 cyl.),				
70	Nova w/Roch. 1BC (4 cyl.) . . . . .	<b>7040633</b>	1	.79	fast idle (w/7029014-7040008-14-7008-14) . . . . .
69	Chevy (4 cyl.) . . . . .	<b>7037005</b>	1	.74	fast idle (w/7029008) . . . . .
69	All w/Roch. 1BC (exc. A.T.) . . . . .	<b>7040635</b>	1	.79	w/7029015-17 . . . . .
69	Chevy, Chevelle, Camaro (Roch. 2BC w/A.T.) (307, 327) . . . . .	<b>7037947</b>	1	.95	fast idle (w/7029110-12) . . . . .
70-71	All w/Roch. 1BC (6 cyl.) (exc. A.T.) . . . . .	<b>7038956</b>	1	.74	w/7040017-7015 . . . . .
70	All (Roch. 2BC w/A.T.) (307, 350, 400),				
71-72	All (Roch. 2BC w/A.T.) (307),				
72	All w/Roch. 2BC (350, 400) . . . . .	<b>7026140</b>	1	.99	w/7040102-4-10-12-14-16-18-20-0402-4-10-12-14-16-18-20-7002-4-16-20-7041110-7110 . . . . .
71	All w/Roch. 2BC (350, 400) . . . . .	<b>7026111</b>	1	.91	w/7041102-13-14-17-18-27-7104-07-12-13-18-27 . . . . .
70	All w/Roch. 4BC . . . . .	<b>7040800</b>	1	3.75	
71-72	All w/Roch. 4BC . . . . .	<b>7042723</b>	1	3.75	
71	All w/Holley 4BC . . . . .	<b>3979660</b>	1	.80	
71-72	Vega w/2BC (exc. A.T.) . . . . .	<b>7042798</b>	1	.99	
71	Vega (2BC w/A.T.) (1st design) . . . . .	<b>7042799</b>	1	.96	
71-72	Vega (2BC w/A.T.) (2nd design) . . . . .	<b>7024273</b>	1	.98	
71-73	Vega w/1BC . . . . .	<b>7048549</b>	1	.81	
72-73	All w/Roch. 1BC . . . . .	<b>7045905</b>	1	.74	
72	All w/Holley 4BC . . . . .	<b>6273912</b>	1	.73	
73	All (307) . . . . .	<b>7040295</b>	1	.95	
73	All w/2BC (350, 400) . . . . .	<b>7040296</b>	1	.91	
73-74	Vega w/2BC . . . . .	<b>6259046</b>		1.35	w/hub . . . . .
74	Vega w/1BC (140) . . . . .	<b>7048773</b>	1	.74	



FUEL—EXHAUST—CARBURETION

**3.766 CAM— LEVER— RETAINER— SCREW— SPRING, Carburetor and Fuel Injection Fast Idle (Con't)**

74-75	All w/1BC (exc. integrated cyl. hd.)	7048770	1	.74	
74	All w/2BC	17050019	1	.91	
75	All w/2BC,				
75	Monza w/A.T. (262)	7043369	1	1.20	
75	All w/1BC, integrated cyl. hd. (exc. Vega, Monza)	17052358	1	1.00	
75	Vega, Monza w/1BC	17053085	1	2.45	(repl. 17050833)
75	All w/4BC (exc. 454)	17051176	1	3.75	
75	All (454)	7042922	1	5.10	
75	Vega w/1BC	17053085	1	2.45	w/link
75	Vega, Monza w/2BC (140) (exc. A.T.)	360977	1	1.35	w/hub
64-65	Chevy, Chevelle w/4BC (exc. H/Per., Sp. H/Per.),				LEVER, cam trip,
65-66	Pass. w/Roch. 4BC				
66	Chevy, Chevelle w/A.I.R. (283) (exc. 2BC),				
66	Pass. w/A.I.R. (exc. 2BC)	7000196	1	.55	air meter (w/7025121-2-3-4-6-7-8-6121-7036118-19-20-21)
65	Pass. (396) (exc. Sp. H/Per.)				LEVER, cam trip (w/7025200-01),
66	Chevy, Chevelle (327, 396),				
66	Pass. (8 cyl.) (exc. 283, Sp. H/Per.)				w/7026200-1-2-3-4-5-7036200-1-2-3-4-5,
67	All w/Roch. 4BC	7031933	1	1.05	w/7027200-1-2-3-10-11-12-13-7037200-1-2-3-10-11-12-13
65-66	Pass. (396) (exc. Sp. H/Per.),				LEVER, cam (w/3869861-3874898-5964-6747-3882835-4505-5067-6091-6101),
66	Pass. (327) (exc. A.I.R.),				w/3887147,
66	Chevy, Chevelle (327, 396),				center
66	Pass. w/H.D. (396, 427)				LEVER, fast idle cam
67-70	All w/Holley 4BC	3881409	1	.46	LEVER, fast idle cam trip
68-70	All w/Roch. 4BC	7035409	1	.65	LEVER, wide open kick
68-70	All w/Roch. 4BC	7035806	1	.87	LEVER, carb. wide open kick
68-69	All w/Roch. 4BC	7035840	1	.58	LEVER, cam follower
70	All w/Roch. 4BC	7040805	1	.71	LEVER, cam
71-74	All w/Roch. 4BC	7043634	1	.91	LEVER, cam trip
71*	All w/Holley 4BC	3979653	1	.46	LEVER, cam
72-74	All w/Roch. 4BC	7030677	1	1.25	LEVER, cam follower
72	All w/Holley 4BC	6273904	1	.57	LEVER, fast idle
75	All w/2BC	7038298	1		LEVER, cam follower
75	All w/2BC	7035998	1		LEVER, fast idle
75	All w/4BC	7041497	1	1.00	LEVER, cam follower
75	All w/4BC	7041498	1	1.40	LEVER, fast idle
73-74	Vega w/2BC,				LEVER, carb.fast idle cam adj.
74	Vega w/2BC (140)	345639	1	1.80	LEVER, carb. idle stop
73-75	Vega, Monza w/2BC (140)	335145	1	.38	LEVER, fast idle adj. (repl. 335085)
75	Vega, Monza w/2BC (140)	345639	1	1.80	LEVER ASSY., fast idle adj.
75	Vega, Monza w/2BC (140)	360918	1	1.65	RETAINER, carb. fast idle spring
73-75	Vega, Monza w/2BC (140)	6259044	1	.20	
62-67	All (6 cyl.) (exc. A.I.R., Corvair),				
65	Chevy, Chevelle w/Air Cond.(283),				
65-66	Pass. w/2BC, 3/2BC,				
65-66	Pass. (6 cyl.),				
66	Chevy, Chevelle (283),				
67	Pass. (6 cyl.) (exc. Taxi, A.I.R.)	7013347	1	.21	SCREW, throttle idle adjustment (w/7023000-03-04-05-4101-10-12-5000-03-04-05-4103-6027-28-7105-7036101-03-7105)
65-69	Pass.	7019709	A.R.	.05	SCREW, choke rod throttle lever— (3.752)
65	Pass. (396) (exc. Sp. H/Per.),				
66	Chevy (327) (exc. Sp. H/Per.),				
66	Pass. (exc. 283),				
66	Chevelle (327, 396) (exc. H/Per.)				SCREW, cam adj. (w/7025200-1-20-21-7026200-1-2-3-4-5-7036200200-1-2-3-4-5),
67-74	All w/Roch. 4BC	7029899	1	.24	SCREW, shaft and lever cam (w/7036110-11-12-7101-3-10-12),
66	All (A.I.R., w/P.G.) (283)				
67-75	All w/Roch. 2BC	7029427	1	.27	SCREW, fast idle lever
68-74	All w/Roch. 4BC	7035523	1	.33	SCREW, throttle adj.
69-72	All w/Holley 4BC	3960392	1	.12	

**FUEL—EXHAUST—CARBURETION**

**3.766 CAM— LEVER— RETAINER— SCREW— SPRING, Carburetor and Fuel Injection Fast Idle (Con't)**

71-72	Vega w/2BC	7048549	1	.81	SCREW, carb. idle stop
74-75	Vega w/1BC	17050381	1	.27	SCREW, carb. idle stop
73-75	Vega, Monza w/2BC (140)	335097	1	.27	SCREW, carb. idle stop
75	Vega, Monza w/2BC (140)	360960	1	.65	SCREW, idle adj. sel.
75	Monza (exc. Towne Coupe) w/A.T. (262)	7049427	1		SCREW, idle stop
75	Vega, Monza w/2BC	335093	1	.13	SCREW, fast idle adj.
62	Chevy (4 cyl.)	7001690	2	.11	SPRING, adjusting screw (w/7015300-10-11-12-13-19-9100-01-07-10-11-17-7020103-04-14-15-4022-23-24-25-5023-24-25-6023-24-7036023-24-14-15)
65-66	Pass. w/Roch. (6 cyl.) (exc. A.C.)	7002102	1	.37	SPRING, fast idle
65	Pass. (396) (exc. Sp. H/Per.),				
66	Chevy (327) (exc. Sp. H/Per.),				
66	Pass. (8 cyl.) (exc. 283, Sp. H/Per.),				
66	Chevelle (327, 396) (exc. H/Per.)				SPRING, fast idle screw (w/7025200-1-20-21-7026200-1-2-3-4-5-7036200-1-2-3-4-5),
67-75	All w/Roch. 4BC	7029900	1	.28	SPRING, throttle shf. and lvr. cam (w/7036110-12-7101-3-10-12),
66	Pass. (A.I.R., w/P.G.) (283)				
67-73	All w/Roch. 2BC	7029428	1	.41	
68-74	All w/Roch. 4BC	7035772	1	.33	SPRING, fast idle cam lever
71-72	Vega w/2BC	7029428	1	.41	SPRING, carb. idle stop
72-75	All w/Roch. 4BC	7003176	1	.11	SPRING, stop screw (1/2" O.L., 3/16" I.D., 2 coils)
73-75	Vega, Monza w/2BC	2285797	1	.06	SPRING, carb. idle adj. needle
73-74	Vega w/2BC	335126	1	.43	SPRING, carb. idle stop screw
73-75	Vega, Monza w/2BC	6259045	1	.58	SPRING, carb. fast idle cam
74-75	Vega, Monza w/1BC	7041519	1	.41	SPRING, carb. idle stop screw
74-75	All w/2BC	7037131	1	.41	SPRING, throttle and lever cam
75	All w/4BC	17051494	1	.33	SPRING, cam lever

**3.767 SCREW— BUSHING, Carburetor Fast Idle Cam**

62-64	Chevy, Chevelle (6 cyl.)				throttle lever,
65	Pass.				carb. fast idle cam,
65-70	Pass. w/Roch. carb.				A.M. fast idle cam,
67-70	Camaro w/Roch. Carb.,				
68-69	Chevy, Chevelle, Camaro (4 cyl., 6 cyl.),				
69	Chevy, Chevelle w/Roch. 2BC,				
71-75	All w/1BC	7003561	1	.37	(12— 28 x 3/8" x 3/16" dia. shldr.) (attach.)
64-65	All w/H/Per. (327),				
65	Pass. w/H/Per., dual 4BC (409),				
66	All (327) (exc. A.I.R., Sp. H/Per.)	7011620	1	.55	SCREW, fast idle cam (Carter 101-323) (w/3760264-4593-3772600-3795566-7699-3815404-9207-3820580-6004-06-7324-3851761-62-5581-6580-3875966-6749)
65	Pass. w/Sp. H/Per. (396)	3852464	1	.12	SCREW, fast idle cam lever adj. (w/3849804-3868826-9933)
66	Taxi (6 cyl.)				SCREW, fast idle cam (w/3886193-4-3891593-4),
66	All w/A.I.R. (6 cyl.),				
67	Chevy, Chevelle, Camaro w/A.I.R. (6 cyl.)				w/3880860-1-3891595-6,
67	Pass., Taxi w/Carter 1BC	1875343	1	.55	w/3905973-4-5-6
73-75	Vega, Monza w/2BC (140)	335095	1	.38	SCREW ASSY., carb. fast idle lever
74-75	All w/2BC (exc. 400)	7036222	1	.34	SCREW
75	All w/4BC	7036079	1	.33	SCREW, attach.
75	All w/4BC	7044794	1	.23	SCREW, adjust.
73-75	Vega, Monza w/2BC (140)	335101	1	2.85	BUSHING, carb. fast idle lever

**3.768 ROD— WASHER, Carburetor Fast Idle**

73	Vega w/2BC	335135	1	1.00	
74-75	Vega, Monza w/2BC (140)	345647	1	.95	
73-75	Vega, Monza w/2BC (140)	6259098	1	.13	WASHER, carb. fast idle adj. lever
73-75	Vega, Monza w/2BC (140)	335138	1	.13	WASHER, carb. fast idle lever spring

**3.774 NOZZLE, Carburetor**

65-66	Pass. w/A.T. (396) (exc. A.I.R.),				
-------	-----------------------------------	--	--	--	--

**FUEL—EXHAUST—CARBURETION**

**3.774 NOZZLE, Carburetor (Con't)**

66	Pass. w/P.G. (327) (exc. A.I.R.) . . .				pump discharge (Holley No. 21R-572-25) (w/3868826-8864-3875964-3884505- 2835-3890499), . . . . .
66	Chevy, Chevelle (327, 396) . . . . .				w/3868864-3875964-7413-8261- 3886088-3892338, . . . . .
67	Chevy, Chevelle w/Holley 4BC . . .				w/3903389-91-8956-8, . . . . .
69	All (Holley 4BC w/Sp. H/Per.) (396, 427),				
70-71	All w/Holley 4BC . . . . .	2367980	1	1.00	
65-66	Pass. (396),				
66	Chevy, Chevelle (327, 396) . . . . .				pump discharge (Holley No. 21R-572-21) (w/3868826-9933-3874898-5964- 3885067-6747-3892341-2339-3229), . . . . .
66	Pass. w/H.D. (396, 427) . . . . .				w/3887147, . . . . .
67	Chevelle, Camaro w/H/Per. (396) (exc. A.T.) . . . . .				w/3908957-9, . . . . .
67-68	Chevy, Chevelle, Camaro w/Holley 4BC (302, 396) . . . . .				w/3916143-5-3923289, . . . . .
67-69	Pass. w/Sp. H/Per. (427) . . . . .	3881419	1	.88	w/3916143-5-3923289 . . . . .
69	All (Holley 4BC w/Sp. H/Per.) (396, 427),				
72	All w/Holley 4BC . . . . .	3963831	A.R.	1.25	pump discharge . . . . .
73-74	Vega w/2BC,				
75	Vega, Monza w/2BC (140) (exc. A.T., NB-2) . . . . .	6259087	1	2.05	carb. pump discharge (w/348659-663) . . . . .
75	Vega, Monza w/2BC (140) . . . . .	361021	1	2.10	carb. pump discharge (w/348660-61-64-65)
75	Vega, Monza w/2BC (140) . . . . .	360965	1	2.10	carb. pump discharge (w/348662-66) . . . . .

**3.775 PLUG, Carburetor Nozzle Passage**

63-65	Chevy (4 cyl.),				
65	Pass. (327) (exc. H/Per., Sp. H/Per.),				
66	All w/A.I.R. (6 cyl.),				
66	Taxi (6 cyl.) (exc. A.I.R.),				
67	All w/Carter 1BC . . . . .	7002439	A.R.	.16	(Carter 11B-35) (1 <sup>3</sup> / <sub>64</sub> " O.D. x 1 <sup>3</sup> / <sub>64</sub> " shaft length) (w/3792945-3019-3846246-47- 3868468-69-3876213-14-3880303-0860- 0861-5439-40-41-42-3891593-4-5-6- 3905973-4-5-6-8463-4-5-6) . . . . .

**3.786 VENTURI— SCREW— TUBE, Carburetor**

69	Pass. (Roch. 2BC w/A.T.) (327) . . .	7038306	1	10.20	w/7029102-04 . . . . .
70	All (Roch. 2BC w/A.T.) (307) . . .	7038867	1	9.10	w/7040110-12-0410-12-7002 . . . . .
70	All w/Roch. 2BC (307) (exc. A.T.) . . . . .	7040694	1	9.10	w/7040101-3-0401-3-7013 . . . . .
70	All (Roch. 2BC w/A.T.) (350) . . .	7041352	1	10.55	w/7040102-4-14-16-0402-4-14-16-7004-16
71-72	All w/Roch. 2BC (307) (exc. A.T.) . . . . .	7043791	1	11.40	w/7041101-7111 . . . . .
71-72	All (Roch. 2BC w/A.T.) (307) . . .	7042627	1	10.65	w/7041110-7110 . . . . .
71	All w/Roch. 2BC (350) (exc. A.T.) . . . . .	7042623	1	10.65	w/7041113-27-7113-27 . . . . .
71	All (Roch. 2BC w/A.T.) (350) . . .	7042622	1	10.65	w/7041102-14-7104-12 . . . . .
71	Pass., Monte Carlo (Roch. 2BC w/A.T.) . . . . .	7042625	1	10.65	w/7041118-7118 . . . . .
71	Vega w/2BC (exc. A.T.) . . . . .	7044671	1	10.55	
71	Vega (2BC w/A.T.) . . . . .	7045977	1	10.55	
72	Vega w/2BC . . . . .	7046140	1	10.55	
72	All w/Roch. 2BC (350) (exc. A.T.) . . . . .	7046096	1	10.65	
72	All (Roch. 2BC w/A.T.) (350) . . .	7046101	1	10.65	
72	Pass. w/Roch. 2BC (400) . . . . .	7046331	1	10.65	
73	All w/2BC (350) (exc. A.T.) . . . . .	7047645	1	12.15	carb. fuel . . . . .
73	All w/A.T. (307) . . . . .	7047707	1	10.65	carb. fuel . . . . .
73	Pass. (400),				
74	All w/2BC (400) . . . . .	7047820	1	12.15	carb. fuel . . . . .
73-74	All (T.H. 350 w/2BC) (350) . . . . .	7047828	1	12.15	carb. fuel . . . . .
73	All (307) (exc. A.T.) . . . . .	7047925	1	10.65	carb. fuel . . . . .
74	All w/2BC (350) (exc. A.T.) . . . . .	17050045	1	12.15	carb. fuel . . . . .
75	All w/2BC . . . . .	17051435	1	13.00	carb. fuel . . . . .
75	Nova (262) A.T. (exc. NB-2) . . . . .	17053145	1	15.50	
75	Vega w/A.T. (262) . . . . .	17053145	1	15.50	
75	Vega w/M.T. (262) . . . . .	17053234	1	15.50	
71-72	Vega w/2BC . . . . .	7000293	1	.11	<b>SCREW</b> , carb. venturi cluster outer (8— 32 x 1 <sup>3</sup> / <sub>16</sub> " ) . . . . .

**FUEL—EXHAUST—CARBURETION**

**3.786 VENTURI— SCREW— TUBE, Carburetor (Con't)**

75	Monza (exc. Notchback) w/A.T. (262) .....	7045762	2	.11	SCREW, venturi cluster outer .....
75	Monza (exc. Notchback) w/A.T. (262) .....	7009077	1	.21	SCREW, venturi cluster center .....
73-75	Vega, Monza w/2BC (140) .....	335103	1	1.50	TUBE, carb. main well (sec% d) .....
73-75	Vega, Monza w/2BC (140) .....	335104	1	1.50	TUBE, carb. main well (primary) .....

**3.790 GASKET— SCREW— BLEED RESET, Venturi Cluster**

62-69	All w/2BC, 3/2BC .....				SCREW, venturi at outer holes (8-32 x 1 <sup>3</sup> / <sub>16</sub> " .....
70-73	All w/Roch. 2BC (307) .....	7000293 A.R.		.11	fuel venturi at outer holes (w/7040101-3- 10-12-0401-3-10-12-7002-13-7041101- 10-7110-11) .....
69	Pass. w/Roch. 2BC .....				SCREW, fuel outlet outer (w/7029121-22- 23), .....
69	Chevy, Chevelle, Camaro w/Roch. 2BC (350) .....				w/7029113-14-15-16, .....
69	Pass. w/Roch. 2BC .....				SCREW, fuel outlet center (w/7029121-22- 23), .....
69	Chevy, Chevelle, Camaro w/Roch. 2BC (350) .....				w/7029113-14-15-16, .....
70-72	All w/Roch. 2BC (350, 400), .....				
73-75	All w/Roch. 2BC .....	7009077	1	.21	fuel venturi center (w/7040102-4-13-14-15- 16-17-19-20-27-29-0402-4-13-14- 15-16-17-18-19-20-27-29-7004-5- 16-19-20-29-7041102-13-14-17-18-27- 7104-07-12-13-18-27) .....
71	All w/Roch. 2BC (350, 400) ...	7008502	2	.11	fuel venturi outer (w/7041102-13-14-17-18- 27-7104-07-12-13-18-27) .....
72	All w/Roch. 2BC (350, 400), .....				
73-75	All w/2BC .....	7045762	2	.11	fuel venturi outer .....
73-75	Vega, Monza w/2BC .....	6259093	2	.77	BLEED RESET, carb. high speed .....

**3.792 JET, Carburetor Metering Rod, with Gasket**

62	Chevy w/P.G. (4 cyl.) .....				main (60 degree approach) (w/7020104- 4025), .....
68	Pass. (307) (exc. A.T.), .....				
68	Chevy, Chevelle, Camaro w/Roch. 2BC (307, 327) (exc. P.G.) .....	7002653	1	1.05	w/7028101-3 .....
62	Chevy w/P.G. (4 cyl.) .....				main (60 degree approach) (stamped 54) (w/7020103-0114), .....
67	All w/2BC (283, 327) .....	7002654	1	1.05	w/7027101-3703710-1-3-7037110-12 .....
62	Chevy w/P.G. (6 cyl.), .....				
62	Chevy (4 cyl.) (exc. P.G.), .....				
64-66	All w/P.G. (283) (exc. 4BC, A.I.R.) .....				main (60 degree approach) (stamped 55) w/7020103-0108-4100-2-6-8-4110-12, .....
67	All (P.G. w/2BC) (283, 327) (2nd design) .....	7002655 A.R.		1.05	w/7027101-3-10-12-14-16-7037101-3 .....
62	Chevy (4 cyl.) (exc. P.G.), .....				
64-66	All (283) (exc. P.G., A.I.R., 4BC) ..	7002656	1	1.05	main (60 degree approach) (stamped 56) (w/7020115-4101-5103) .....
62	Chevy (6 cyl.) (exc. P.G.), .....				
63-64	Chevy, Chevelle (230) (exc. P.G.) .....				main (60 degree approach) (stamped 59), ..
65	Pass. (230) (exc. P.G.) .....				1 step rich (w/7002051-3060-3864), .....
65	Chevy, Chevelle (6 cyl.), .....				
67	Chevy w/P.G. (6 cyl.) (exc. A.I.R.) ..				(w/7020105-7023108-5108), .....
66	All w/A.I.R. (283) (exc. P.G., 2BC) .....				w/7036118-19-21, .....
66	Pass. (6 cyl.) (exc. Taxi, P.G., A.I.R.) .....				w/7026027, .....
67	Chevelle, Camaro (230) (exc. P.G., A.I.R.) .....				w/7025003, .....
67	Chevy w/P.G. (194) (exc. A.I.R.) ..				w/7025108, .....
70	All w/Roch. 2BC (350) (exc. A.T.) .....	7002659	1	1.05	(w/7040113-15-27-29-7005-29) .....
63	Chevy (6 cyl.) (exc. P.G.), .....				
64-66	Chevy, Chevelle w/P.G. (6 cyl.) (exc. A.I.R.) .....				main (60 degree approach) (stamped 58), ..
65	Pass. w/P.G. (230) .....				w/7026011-7011, .....
66-67	Pass. w/P.G. (6 cyl.) (exc. Taxi, A.I.R.) .....				w/7026028, .....
67	Chevy, Chevelle, Camaro w/P.G. (230, 250) (exc. A.I.R.) .....				w/7023108-5108-6028, .....

**FUEL—EXHAUST—CARBURETION**

**3.792 JET, Carburetor Metering Rod, with Gasket (Con't)**

69	Pass. (Roch. 2BC w/A.T.) (327),				
71	All w/Roch. 2BC (350) . . . . .	<b>7002658</b>	A.R.	1.05	w/7029102-04-7041102-13-14-18-7104-12-13-18) . . . . .
63-66	Chevy, Chevelle (6 cyl.) (exc. P.G.) . . . . .				main (60 degree approach) (stamped 60), . .
65	Pass. (6 cyl.) (exc. P.G., econ. carb., Taxi),				
67	Chevy (194) (exc. P.G., A.I.R.) . . .				(w/7023003-3105-5105), . . . . .
70	All (Roch. 2BC w/A.T.) (350) . . .	<b>7002660</b>	1	1.05	(w/7040102-4-14-16-0402-4-16-7004-16) . . . . .
63	Chevy w/P.G. (6 cyl.) . . . . .				main (60 degree approach) (stamped 57), . .
64	Chevy, Chevelle w/4BC,				
72	All w/Roch. 2BC (350) . . . . .	<b>7002657</b>	2	1.05	(w/7023108-7024120-22-25-26-4220-25-26) . . . . .
63-66	Chevy (4 cyl.) . . . . .	<b>7002494</b>	1	1.45	main (stamped 94) (w/3792945-3019) . . . . .
64	Chevelle w/H/Per. (327) . . . . .				primary (w/3851761-62) used w/Carter 3720S-3721S, . . . . .
66	All w/A.I.R. (6 cyl.) (exc. P.G.) . . .	<b>3815049</b>	A.R.	1.30	w/3880861-3891595 . . . . .
64	Chevy, Chevelle w/P.G. (230) . . .	<b>7008670</b>	1	1.05	main (60 degree approach) (w/7024000) . .
64	Chevy, Chevelle w/H/Per. (230) (exc. P.G.) . . . . .	<b>7008672</b>	1	1.05	main (60 degree approach) (w/7024001) . .
64	Chevy, Chevelle w/4BC . . . . .				main (w/7024120-21-22-25-26-4220-25-26), . . . . .
66	All w/A.I.R. (283) (exc. 2BC) . . .				w/7036118-19-20-21, . . . . .
69	Chevy, Chevelle, Camaro w/Roch. 2BC (350),				
69	Pass. (Roch. 2BC w/A.T. (396) . . .	<b>7008667</b>	2	1.05	
64-65	All (P.G. w/H/Per.) (327) . . . . .	<b>563131</b>	2	1.55	secondary (w/3851762) (Carter 120-176) . .
64-65	Chevy, Chevelle w/H/Per. (327) (exc. P.G.) . . . . .				secondary (w/3851761) (Carter 120-222), . .
65	Pass. (327) (exc. H/Per., Sp. H/Per., Air Cond.),				
66	All (327) (exc. A.I.R., Sp. H/Per.)	<b>1465397</b>	2	1.55	secondary (Carter 120-222) (w/3846246-47-3875966-6749) . . . . .
64-65	All w/H/Per. (327) . . . . .				primary (w/3851761-62) (approx. 3/32"), . . . . .
64-65	Pass. w/H/Per., dual 4BC (409) . . .	<b>7009575</b>	A.R.	1.55	primary (w/3855581) (Carter 120-224) . . . .
64-65	Chevy, Chevelle w/P.G. (230),				
65	Pass. w/P.G. (6 cyl.) (exc. econ. carb., Taxi) . . . . .	<b>7002959</b>	1	1.05	main (w/7023000) (stamped 59) . . . . .
65-66	Chevy, Chevelle w/4BC (exc. H/Per., Sp. H/Per., A.I.R.),				
65-66	Pass. w/4BC (283, 327) (exc. H/Per., A.I.R.) . . . . .				main 60 degree approach (w/7025121-2-6-7-8-6121), . . . . .
70	Pass., Monte Carlo (Roch. 2BC w/A.T.) (400) . . . . .	<b>7008666</b>	1	1.05	(w/7040118-20-0418-20-7020) . . . . .
65-66	Chevy, Chevelle w/4BC (283, 327) (exc. H/Per., Sp. H/Per.),				
65-66	Pass. w/4BC (283) . . . . .				main 60 degree approach (w/7025126-8-7036118-19-20-21), . . . . .
66-67	Pass. (6 cyl.) (exc. Taxi, P.G., A.I.R.),				
67	Chevelle (250) (exc. P.G.),				
67	Camaro, Chevy (250) (exc. P.G., A.I.R.) . . . . .	<b>7008660</b>	1	1.05	w/7026027 . . . . .
65-66	Pass. w/4BC (283) (exc. P.G.),				
65-66	Chevy, Chevelle w/4BC (exc. H/Per., Sp. H/Per., P.G., A.I.R.) . .	<b>7008662</b>	2	1.05	main (60 degree approach) (approx. 5/8" opening) (w/7025127-6121) . . . . .
65	Chevelle w/Sp. H/Per. (327) . . . . .				secondary (w/3863150) (Holley 22R-4094),
66	Chevy w/Sp. H/Per. (327) (exc. A.I.R.) . . . . .				w/3877413, . . . . .
67	Chevy, Chevelle w/Sp. H/Per. (327) (exc. A.I.R.) . . . . .	<b>2359509</b>	2	.41	w/3903389 . . . . .
65-66	Pass. w/A.T. (396) (exc. Sp. H/Per., A.I.R.) . . . . .				main metering primary (w/3868864), . . . . .
65	Chevelle w/Sp. H/Per. (327),				
66	Chevelle w/P.G. (396) (exc. A.I.R., H/Per.) . . . . .				(w/3863150, 3868864), . . . . .
66-67	Chevy, Chevelle w/Sp. H/Per. (327) . . . . .	<b>2364451</b>	2	.41	w/3877413-3890497-3903339-91 (Holley 22R-4067) . . . . .
65	Pass. (327) (exc. H/Per., Sp. H/Per.) . . . . .	<b>1346577</b>	1	.92	primary (Carter 120-165) . . . . .
65-66	Taxi . . . . .	<b>3815050</b>	1	1.55	primary (std.) (w/3857523-3886193-4-3891593-4) (7/64" opening)A.R. . . . .

**FUEL—EXHAUST—CARBURETION**

**3.792 JET, Carburetor Metering Rod, with Gasket (Con't)**

65	Pass. w/P.G. (409) (exc. H/Per., dual 4BC) .....	<b>7008680</b>	2	1.05	main (w/7024124-4128) .....
65	Pass. (P.G. w/econ. carb) (6 cyl.) .....	<b>7002643</b>	1	1.05	standard, 60 degree approach (w/7023004) (.043 orifice) .....
65	Pass. w/econ. carb. (6 cyl.) (exc. P.G.) .....	<b>7002644</b>	1	1.05	standard, 60 degree approach (w/7023005) .....
65	Pass. w/Sp. H/Per. (396),				main metering (secondary) (Holley No. 22R-40-76) (w/3849804-3868826-9933-5067-6091-6101), .....
66	Pass. w/Sp. H/Per. (427) .....				
66	Pass. w/H.D. (396, 427) .....				w/3887147, .....
66	Chevelle w/Sp. H/Per. (396) .....				secondary (w/3893229), .....
67	All (A.I.R. w/Sp. H/Per.) (327) .....				w/3903391, .....
67-71	All w/Holley 4BC .....	<b>2337493</b>	2	.41	secondary .....
65-66	Pass. (396) (exc. A.T., Sp. H/Per.),				main (w/3874898-3892338), .....
66	Chevelle (396) .....				
67	Chevelle (A.I.R. w/A.T.) w/Per. (396) .....				w/3908958, .....
68-69	Pass. w/Sp. H/Per. (427),				primary (w/3869933) (Holley 22R-40-72), .....
68-69	All w/Holley 4BC (302, 396),				
72	All w/Holley 4BC .....	<b>2339559</b>	2	.41	
65	Pass. w/Sp. H/Per. (396) .....				(w/3890497) .....
66	Chevy, Chevelle (A.I.R. w/Sp. H/Per.) (327) .....	<b>2359504</b>	2	.41	
65	Pass. (396) (exc. Sp. H/Per.) .....				main (90 degree approach) (w/7025200-01-20-21), .....
66	Chevy, Chevelle (327, 396) .....				w/7026200-1-2-3-7036200-1-2), .....
66	Pass. (8 cyl.) (exc. 283, Sp. H/Per.) .....				w/7026200-01-02-03-04-05-7036200-01-02-03-04-05), .....
67	All w/Roch. 4BC .....				w/7027200-1-2-3-10-11-12-13-7037200-1-2-3-10-11-12-13, .....
68-69	All w/Roch. 4BC (exc. 327 Sp. H/Per., 350) .....	<b>7031971</b>	2	1.05	
66	All (A.I.R. w/P.G.) (6 cyl.) .....	<b>3841359</b>	1	1.30	carb. metering rod (w/3880860-5440-5442-3891596) (Carter 120-170) .....
66	All (327) (exc. A.I.R., Sp. H/Per.)	<b>3721035</b>	2	1.55	primary (w/3876749-5966) .....
66	All (327) (exc. A.I.R., P.G., Sp. H/Per.) .....	<b>2292685</b>	2	.41	primary (w/3876747) .....
66	Chevelle w/H/Per. (396) (exc. A.I.R., P.G.) .....				primary (w/3886087), .....
66	Chevelle w/H/Per. (396) .....				primary (w/3886088-3892339), .....
67	Chevelle (A.T. w/H/Per.) (396) (exc. A.I.R.) .....	<b>2337804</b>	A.R.	.35	w/3908956 .....
66	All w/P.G. (327) (exc. A.I.R., Sp. H/Per.) .....	<b>2193738</b>	2	.37	primary (w/3875964) .....
66	Chevelle, A.I.R. w/P.G. (396, H/Per.) .....	<b>2370787</b>	2	.67	primary (w/3892338) .....
66	All A.I.R. w/P.G. (283) (exc. 4BC)	<b>7002955</b>	2	1.05	main (square approach) (w/7036110-12) ..
66	All w/A.I.R. (283) (exc. P.G., 4BC) .....	<b>7002956</b>	2	1.05	main (square approach) (w/7036101-3) ...
66	Chevelle w/Sp. H/Per. (396),				primary (w/3893229-3892339-3908959), ..
66-67	Chevelle, Camaro w/A.I.R. (396, H/Per.) (exc. A.T.) .....				
67	Pass. w/Sp. H/Per. (427),				w/3916143-5 .....
67	Chevelle, Camaro (302, Sp. H/Per. 396) .....	<b>3896615</b>	2	.46	
66	Pass. w/Sp. H/Per. (427),				primary (w/3885067) (Holley 22R-40-73) ..
72	All w/Holley 4BC .....	<b>3889777</b>	2	.46	
67	All (P.G. w/Roch. 2BC) (283, 327) (1st design) .....				main (60 degree approach) (w/7027110-12-7037110-12), .....
68	Chevy, Chevelle, Camaro (Roch. 2BC w/P.G.) (307, 327),				w/7028110-12, .....
68	Pass. w/A.T. (307) .....				
69	Chevy, Chevelle, Camaro w/Roch. 2BC (307, 327) (exc. A.T.),				
72	Vega w/2BC .....	<b>7002652</b>	2	1.05	w/7029101-03 .....
68-69	Chevy (4 cyl.) .....	<b>7034195</b>	1	1.05	main (45 degree approach) (w/7028008-9)
68	Chevy, Chevelle w/Sp. H/Per. (327) .....	<b>7031966</b>	2	1.05	primary (90 degree approach) (w/7028229) (w/7028014-15-17), .....
68	All (6 cyl.) .....				

**FUEL—EXHAUST—CARBURETION**

**3.792 JET, Carburetor Metering Rod, with Gasket (Con't)**

69	All w/Roch. 4BC (350) . . . . .	<b>7031967</b>	1	1.05	main metering (90 degree approach) (w/7029202-03-23-24) . . . . .
69	All (Roch. 1BC w/A.T.) (6 cyl.) . .	<b>7034203</b>	1	1.05	main metering (45 degree approach) (w/7029014) . . . . .
69	All (w/Roch. 1BC) (exc. A.T.) . . .				main metering (45 degree approach) (w/7029015-17), . . . . .
70	All (Roch. 1BC w/A.T.) (6 cyl.) . .	<b>7034204</b>	1	1.05	(w/7040014-7014) . . . . .
69	Pass. w/Roch. 2BC (327) (exc. A.T.) . . . . .	<b>7008663</b>	2	1.05	main (60 degree approach) (w/7029127- 29) . . . . .
69	Pass. w/Roch. 2BC (350),				main metering (60 degree approach) (w/7029113-14-15-16-17-19-7041117- 7107), . . . . .
69	Pass. w/Roch. 2BV (396) (exc. A.T.) . . . . .				
70-71	Monte Carlo w/Roch. 2BC (400) (exc. A.T.),				
71	Pass. w/Roch. 2BC (400) (exc. A.T.) . . . . .	<b>7008669</b>	1	1.05	
69	Chevy, Chevelle, Camaro (Roch. 2BC w/A.T.) (307, 327) . . . . .				main (60 degree approach) (w/7029110- 12), . . . . .
70	All w/Roch. 2BC (307),				
71-72	All w/Roch. 2BC (307) (exc. A.T.),				
73-74	All w/2BC (350) (exc. A.T.) . . . .	<b>7002651</b>	2	1.05	(w/7040101-3-10-12-0401-3-10-12-7002- 13-7041101-7-111) . . . . .
70	Nova w/Roch. 1BC (4 cyl.) . . . . .	<b>7034192</b>	1	1.05	main (45 degree approach) (w/7040008- 7008) . . . . .
70	All w/Roch. 1BC (6 cyl.) (exc. A.T.) . . . . .	<b>7034205</b>	1	1.05	main (45 degree approach) (w/7040017- 7015) . . . . .
70	Chevelle w/Roch. 4BC (400),				
70	Pass., Monte Carlo w/Roch. 4BC (454),				
70	Nova, Chevelle, Camaro (Roch. 4BC w/H/Per.) (396, 454),				
73	All w/4BC (350) (exc. Sp. H/Per.) . . . . .	<b>7031978</b>	1	1.05	main (90 degree approach) (w/7040200-1- 4-5-21-0500-1-4-5-21-7000-9) . . . . .
70	All w/Roch. 4BC (350) (exc. Sp. H/Per.) . . . . .	<b>7031976</b>	1	1.05	main (90 degree approach) (w/7040202-3- 13-0502-3-13-7006) . . . . .
70-71	All w/Holley 4BC . . . . .	<b>2334344</b>	2	.41	primary . . . . .
71	Pass., Monte Carlo (Roch. 2BC w/A.T.) (400),				
72	Pass. (Roch. 2BC w/NB2) (400) .	<b>7008665</b>	2	1.05	main (60 degree approach) (w/7041118- 7118) . . . . .
71	All (Roch. 2BC w/A.T.) (307),				
71	Vega w/2BC (exc. A.T.) (1st design),				
71	Vega (2BC w/A.T.),				
73	All (A.T. w/2BC) (350),				
73-74	All (307, 400),				
75	All w/2BC (350) . . . . .	<b>7002650</b>	2	1.05	main (60 degree approach) (w/7041110- 7110) . . . . .
71-75	All (250) w/1BC, integrated cyl. hd. . . . .	<b>7034206</b>	1	1.05	main (45 degree approach) . . . . .
75	Nova (250) w/1BC, A.T. (exc. integrated cyl. hd.) . . . . .	<b>7034204</b>	1	1.05	main . . . . .
71-72	All w/Roch. 4BC (350) . . . . .	<b>7031974</b>	2	1.05	main (90 degree approach) (w/7041202- 03-7120) . . . . .
71-72	All w/Roch. 4BC (400, 402, 454),				
73	All w/Roch. 4BC (454) . . . . .	<b>7031977</b>	2	1.05	main (90 degree approach) (w/7041200- 01-7116) . . . . .
71	Vega w/1BC,				
72	Vega (1BC w/NB-2) . . . . .	<b>7034154</b>	1	1.05	
72	Vega w/1BC (exc. NB-2),				
73-75	Vega, Monza w/1BC (140) . . . . .	<b>7034153</b>	1	1.05	
72	All (Roch. 2BC w/A.T.) (307) (exc. NB2) . . . . .	<b>7002648</b>	2	1.05	main (60 degree approach) . . . . .
73-74	Vega w/2BC (exc. A.T.) . . . . .	<b>6259090</b>	1	1.10	(secondary) . . . . .
73-74	Vega w/2BC,				
75	Vega, Monza w/2BC (140) . . . . .	<b>6259088</b>	1	1.10	(primary) (348660-664) . . . . .

**FUEL—EXHAUST—CARBURETION**

**3.792 JET, Carburetor Metering Rod, with Gasket (Con't)**

73-74	Vega (2BC w/A.T.),				
75	Vega, Monza w/2BC (140) . . . . .	6259089	1	1.10	(secondary) . . . . .
73	Camaro w/Sp. H/Per. (350),				
75	All (454) . . . . .	7031974	1	1.05	main (90 degree approach) . . . . .
74	All w/4BC (400) . . . . .	7031973	1	1.05	main (90 degree approach) . . . . .
74	All w/4BC (350, 454) . . . . .	7031975	1	1.05	main (90 degree approach) . . . . .
75	Nova w/2BC (262) . . . . .	7002646	1	1.05	(std.-prod. No. 7045101-05) . . . . .
75	All w/4BC (exc. 454) . . . . .	7031972	1	1.05	main . . . . .
75	All w/2BC (262) w/A.T. . . . .	7002645	1	1.05	main . . . . .
75	Vega, Monza (2BC w/M.T.)				
	(140) (exc. NB-2) . . . . .	360966	1	.43	(primary) (348659-663) . . . . .
75	Vega, Monza w/2BC (140)				
	w/NB-2 . . . . .	360967	1	.55	(primary) (348661-62-665-666) . . . . .
75	Vega, Monza w/2BC (262)				
	w/M.T. . . . .	7002646	1	1.05	(std. prod. No. 7045101-05) . . . . .
75	Vega, Monza (2BC w/A.T.) (exc.				
	NB-2) . . . . .	6259088	1	1.10	(primary) . . . . .
75	Vega, Monza w/1BC A.T. (140) .	7034150	1	1.05	
75	Vega, Monza (1BC w/M.T.)				
	(140) . . . . .	7034151	1	1.05	main . . . . .

*NOTE Stamp on top or side of jet denotes orifice diameter in thousands.*

**3.798 JET— RETAINER, Carburetor Idle**

73-74	Vega w/2BC . . . . .	6259091	1	1.15	(secondary) . . . . .
73-74	Vega w/2BC . . . . .	6259092	1	1.15	(primary) . . . . .
73-74	Vega w/2BC . . . . .	335111	2	.50	RETAINER, carb. idle jet . . . . .

**3.806 ROD— HOLDER UNIT, Carburetor Metering**

65	Pass. w/A.T. (396) (exc. Sp.				
	H/Per.) . . . . .				primary (w/7025200-20), . . . . .
66	Chevelle w/P.G. (396) (exc.				
	H/Per.) . . . . .				primary (w/7026200-7036200), . . . . .
66	Pass. w/A.T. (396) . . . . .				
67	Chevelle w/A.T. (396) (exc.				
	A.I.R., H/Per., Sp. H/Per.),				
67	Pass. w/A.T. (396, 427) (exc.				
	A.I.R.) . . . . .	7031844	2	1.35	w/7027200 . . . . .
65	Pass. (396) (exc. A.T., Sp.				
	H/Per.),				
66	Chevelle (396) (exc. P.G.,				
	H/Per.);				
66	Pass. (396, 427) (exc. A.T.) . . . . .				primary (w/7026201-5-7036201-5), . . . . .
67	Chevy, Chevelle, Camaro (396)				
	(exc. H/Per., Sp. H/Per.),				
67	Pass. (396, 427) (exc. A.T.) . . . . .	7031841	2	1.35	w/7027201-10-11-7037201-11 . . . . .
66	All w/P.G. (327) (exc. A.I.R., Sp.				
	H/Per.) . . . . .	3890958	2	.78	standard (Carter 16-426) (w/3875966) . . . . .
66	Pass. (396, 427) (exc. Sp.				
	H/Per.) . . . . .				secondary (w/7026200-01-4-5-7036200-
					01-4-5), . . . . .
67-68	Pass. w/Roch. 4BC (396, 427) . . . . .				w/7027200-1-10-11-8209-10-11-16-
					7037200-1-10-11, . . . . .
67-68	Chevelle, Camaro w/Roch. 4BC				
	(396) (exc. Sp. H/Per.) . . . . .				w/7028210-11-17-18, . . . . .
69	Chevy, Camaro (396) . . . . .				w/7029204-15, . . . . .
69	Chevelle (Roch. 4BC w/H/Per.)				
	(396) (exc. T.H. 400) . . . . .				w/7029215, . . . . .
70	Nova, Chevelle, Camaro (Roch.				
	4BC w/H/Per.) (396, 454) (exc.				
	Monte Carlo) . . . . .	7033549	2	2.65	secondary (w/7040204-5-0504-5-7000) . . . . .
66	All (327) (exc. Sp. H/Per.) . . . . .	7033104	2	2.65	secondary (w/7022602-3-7036202-3) . . . . .
66	Pass. w/T.H. (427) (exc. Sp.				
	H/Per.) . . . . .				primary (w/7026204-7036204), . . . . .
67	Chevy, Chevelle, Camaro (A.I.R.				
	w/A.T.) (396) (exc. H/Per., Sp.				
	H/Per.),				
67	Pass. (A.I.R. w/A.T.) (396, 427) .	7031846	2	1.35	w/7037200-10 . . . . .
66-67	Chevy, Chevelle, Camaro (P.G.				
	w/Roch. 4BC) (327, 350) (exc.				
	Sp. H/Per.),				
66-67	Pass. w/A.T. (327) . . . . .	7031845	2	1.35	primary (w/7026202-7202-12-7037202-12)
66-67	Chevy, Chevelle, Camaro (P.G.				
	w/A.I.R.) (327, 350) (exc. Sp.				
	H/Per., 2BC),				
66	Pass. (A.T. w/A.I.R.) (327) . . . . .	7031847	2	1.35	primary (w/7036202-7202) . . . . .



**FUEL—EXHAUST—CARBURETION**

**3.806 ROD— HOLDER UNIT, Carburetor Metering (Con't)**

66	Chevy (327) (exc. P.G., Sp. H/Per.),					
66	Chevelle (327) (exc. P.G.),					
66-67	Pass. (327) (exc. A.T.),					
67	Chevy, Chevelle, Camaro w/Roch. 4BC (327, 350) (exc. A.T., Sp. H/Per.)	7031843	2	1.35	primary (w/7026203-7203-13-7036203-7203-13)	
67-69	Chevy, Chevelle, Camaro w/Roch. 4BC (327, 350) (exc. Sp. H/Per.),					
67	Pass. w/Roch. 4BC (327)				secondary (w/7027202-3-12-13-8212-13-7037202-3-12-13-7029202-3),	
68	Pass. w/Roch. 4BC (427) (exc. Sp. H/Per.)				w/7028207-8-12-13,	
69	Pass. (350)	7034320	2	2.65	w/7029202-03-23	
68	All (6 cyl.) (exc. P.G.)	7035930	1	1.70	w/7028015-17	
68	All w/P.G. (6 cyl.)	7035931	1	1.70	w/7028014	
68	Chevy, Chevelle w/Sp. H/Per. (327)	7034836	2	1.35	primary (w/7028229)	
68	Pass. (Roch. 4BC w/A.T.) (396, 427)				primary (w/7028210),	
68-69	Chevelle (Roch. 4BC w/A.T.) (396) (exc. H/Per.),					
69	Pass. (Roch. 4BC w/T.H. 400) (427) (exc. Sp. H/Per.)				w/7029200,	
70	Pass. w/Roch. 4BC (454),					
70	Chevelle (Roch. 4BC w/A.T.) (400),					
70	Monte Carlo (Roch. 4BC w/A.T.) (400, 454),					
70	Nova, Chevelle, Camaro (Roch. 4BC w/H/Per.) (396, 454),					
71	All w/Roch. 4BC (400, 454)	7034849	1	1.35	primary (w/7040200-04-05-0500-04-05-7000-09-7041200-01-7116)	
68	Pass. w/Roch. 4BC (427) (exc. Sp. H/Per.),					
68	Chevy, Chevelle, Camaro w/Roch. 4BC (327, 350) (exc. Sp. H/Per.)	7034846	1	1.35	primary (w/7028207-8-12-13-19)	
68-69	All w/Roch. 4BC (396, 427) (exc. Sp. H/Per., A.T.),					
72	All w/Roch. 4BC (350)	7034845	1	1.35	primary (w/7028209-11-17-7029201-15)	
68	Chevy, Chevelle w/Sp. H/Per. (327),					
69	All w/Roch. 4BC,					
70	Pass. w/Roch. 4BC (454),					
70	Chevelle w/Roch. 4BC (400),					
70	Monte Carlo (Roch. 4BC w/A.T.) (454),					
71	All w/Roch. 4BC (400, 454)	7034822	1	3.20	secondary (w/7040200-1-21-0500-1-21-7009-7041200-01-7116)	
68	Chevelle (Roch. 4BC w/A.T.) (396 H/Per.),					
68	Camaro (Roch. 4BC w/T.H.) (396)		1		primary (w/7028218),	
69	Chevy, Camaro (Roch. 4BC w/T.H. 400)	7034847	1	1.35		
69-70	Chevy (4 cyl.) (2nd design)	7040770	1	1.70	w/7028008-09-7040008-7008 (.048 throttle step)	
69	Pass. (427) (exc. Sp. H/Per.),					
69	Chevelle w/Roch. 4BC (396) (exc. H/Per.)	7034300	2	2.65	secondary (w/7029200-1)	
69	All w/Roch. 4BC (350) (exc. A.T.)	7034838	2	1.35	w/7029203	
69	All (Roch. 4BC w/A.T.) (350)	7034842	1	1.35	primary (w/7029202)	
70-71	All w/Roch. 4BC (350),					
73	All (350)	7034844	A.R.	1.35	primary (w/7040202-03-13-0502-03-13-7006-7041202-03-7130)	
70	All w/Roch. 4BC (350)	7034337	1	3.00	secondary (w/7040202-3-13-0502-3-13-7006)	
70	Chevelle w/Roch. 4BC (400) (exc. A.T.),					
73	All (454) (exc. A.T.)	7034848	1	1.35	primary (w/7040201-21-0501-21-7009)	
72	All w/Roch. 4BC (400, 454)	7034849	A.R.	1.35	ROD ASSY., primary (w/7042215-20)	

**FUEL—EXHAUST—CARBURETION**

**3.806 ROD— HOLDER UNIT, Carburetor Metering (Con't)**

72	All w/Roch. 4BC (350) . . . . .	7046010	2	3.00	ROD ASSY., secondary (w/7042202-03, 7042902-03) . . . . .
72	All w/Roch. 4BC (402, 454) . . . . .	7045840	2	3.00	ROD ASSY., secondary (w/7042215-20) . . . . .
70-72	All (Roch. 1BC) (6 cyl.) (exc. A.T.) . . . . .	7040630	1	1.70	ROD ASSY. (w/7040017-7017-7041017-7117) . . . . .
70	All (Roch. 1 BC w/A.T.) (6 cyl.) . . . . .	7042534	1	1.70	ROD ASSY. (w/7040014-7014) . . . . .
71-72	All (Roch. 1BC w/A.T.) . . . . .	7044791	1	1.70	ROD ASSY., w/7041014-7114 . . . . .
71	All w/Roch. 4BC (350) . . . . .	7033171	2	3.00	ROD ASSY., secondary (w/7041202-03-7120) . . . . .
73	All (Roch. 1BC w/A.T.) . . . . .	7037782	1	1.35	ROD ASSY. . . . .
73-75	All w/Roch. 4 BC,				
75	Nova (250) w/A.T. (exc. integrated cyl. hd.) . . . . .	7037974	1	1.70	ROD ASSY. . . . .
74-75	Camaro w/Sp. H/Per. (350) . . . . .	7046010	2	3.00	ROD ASSY., secondary . . . . .
73	All w/A.T. (454) . . . . .	7034850	2	1.35	ROD ASSY., primary . . . . .
74	All w/1BC (exc. A.T.) . . . . .	7048987	1	1.35	ROD ASSY. . . . .
74	All (1BC w/A.T.) w/NB-2 . . . . .	7048984	1	1.35	ROD ASSY. . . . .
74	All (1BC w/A.T.) (exc. NB-2) . . . . .	7042534	1	1.70	ROD ASSY. . . . .
75	Nova (350) . . . . .	7043543	1	1.80	ROD, primary . . . . .
74-75	All w/4BC (350) (exc. Sp. H/Per.) . . . . .	7045779	2	2.65	ROD ASSY., secondary . . . . .
74-75	All w/4BC (400, 454) . . . . .	7048992	2	3.00	ROD ASSY., secondary . . . . .
75	All w/1BC w/integrated cyl. hd. . . . .	17052051	1	1.75	ROD ASSY., w/spring, A.P.T. . . . .
75	Nova w/4BC (350) (exc. NB-2) . . . . .	17052060	1	6.55	ROD, A.P.T. aneroid . . . . .
75	Nova w/4BC (350) NB-2 . . . . .	17052235	1	14.95	ROD, A.P.T. aneroid . . . . .
75	All w/4BC (exc. NB-2, 454) . . . . .	17053049	1	6.35	ROD ASSY., A.P.T. . . . .
75	All (4BC w/NB-2) . . . . .	17052235	1	14.95	ROD ASSY., A.P.T. . . . .
75	All (454) . . . . .	17052178	1	6.35	ROD ASSY., A.P.T. . . . .
66	Chevy (327) (exc. Sp. H/Per.),				
66	Pass. (8 cyl.) (exc. 283, Sp. H/Per.),				
66	Chevelle (327, 396) (exc. H/Per.)				HOLDER UNIT, carb. metering rod secondary (w/7026200-1-2-3-4-5-7036200-1-2-3-4-5), . . . . .
67-75	All w/Roch. 4BC . . . . .	7034522	1	.99	

**3.810 SPRING, carburetor Metering Rod**

65	Pass. (396) . . . . .				prim. (w/7025200-01-20-21), . . . . .
66	Chevelle (327, 396) (exc. H/Per.),				
66	Pass. (8 cyl.) (exc. 283, Sp. H/Per.),				
66	Chevy (327) (exc. Sp. H/Per.) . . . . .				primary (w/7026200-1-2-3-4-5-7036200-1-2-3-4-5), . . . . .
67-68	Pass. w/Roch. 4BC,				
69-75	All w/Roch. 4BC . . . . .	7029862	1	.53	

**3.814 NEEDLE UNIT— BAFFLE— BRACKET— CLIP— NUT— RETAINER— SCREW, Carburetor and Fuel Meter Intake (w/seat and gasket)**

*NOTE: See Group 3.725 for chart containing 1969-75 Carburetor and Fuel Meter Intake Needle Units.*

62-66	Chevy, Chevelle (6 cyl.),				
65-67	Pass. w/Roch. 1BC,				
67	Chevy, Chevelle, Camaro (6 cyl.) (exc. A.I.R.) . . . . .	7023801	1	3.20	w/7020103-0104-0105-0108-4000-01 . . . . .
64-65	Chevy, Chevelle w/4BC . . . . .				secondary w/seat and gasket (w/7024120-22-25-26-4220-25-26-5126-27-28), . . . . .
65	Pass. w/P.G. (327) (exc. Sp. H/Per.),				
65	Pass. w/4BC (exc. H/Per., dual 4BC),				
66	Chevy, Chevelle w/A.I.R. (283) (exc. 2BC),				
66	Pass. (283) (exc. 2BC) . . . . .	7023807	1	3.20	(w/7025121-2-3-4-5-6-7-8-6121-7125-7036118-19-20-21-6125-7125) . . . . .
64-65	Chevy, Chevelle w/H/Per. (327),				
65-66	Pass. (327) (exc. A.I.R.),				
66	Chevy, Chevelle (327) (exc. A.I.R., Sp. H/Per.) . . . . .	543070	2	4.00	w/seat and seal (w/3851761-62-3875966-6749) . . . . .
64-65	Chevy, Chevelle (283) (exc. 4BC),				
65	Pass. (283) . . . . .				w/seat and gasket, . . . . .
66	Chevy, Chevelle w/A.I.R. (283) (exc. 4BC),				

**FUEL—EXHAUST—CARBURETION**

**3.814 NEEDLE UNIT— BAFFLE— BRACKET— CLIP— NUT— RETAINER— SCREW, Carburetor and Fuel Meter Intake (w/seat and gasket) (Con't)**

66	Pass. (283) (exc. 4BC) .....			w/7024101-10-12-5103-7036101-03-10-12, .....
67	All w/Roch. 2BC .....	<b>7023809</b>	1	3.20
65	Pass. (327) (exc. H/Per., Sp. H/Per.) .....	<b>3850048 A.R.</b>		4.00 w/seat and gasket (Carter 25-280S, 728S) primary and secondary .....
65	Pass. (409) (exc. H/Per., dual 4BC) .....	<b>7023811</b>	1	3.20 primary w/seat and gasket (Roch.) .....
65	Pass. w/Sp. H/Per. (396),			w/seat assy. (Holley 18R-135A)
66-67	Pass. w/Sp. H/Per. (427) .....			(w/3868826-9933-3885067-6101-3916143-5-3923289), .....
66	Chevelle w/Sp. H/Per. (396) ...			w/3893229, .....
66	Pass. w/H.D. (396, 427) .....			w/3887147, .....
67	Chevy, Chevelle, Camaro w/Holley 4BC .....	<b>3877165</b>	2	4.00
65	Chevelle w/Sp. H/Per. (327) ...			w/seat and seal (w/3863150), .....
65-66	Pass. (327, 396) (exc. Sp. H/Per.),			
66	Chevy, Chevelle (327, 396) ....	<b>3877141</b>	2	4.75 w/3868864-3874898-5964-6747) (Holley 18R-96A) .....
65	Pass. (396) (exc. Sp. H/Per.) ...			float, less gasket (w/7025200-01), .....
66	Chevelle (327, 396) (exc. H/Per.),			
66	Pass. (8 cyl.) (exc. 283, Sp. H/Per.),			
66	Chevy (327) (exc. Sp. H/Per.) ...			w/7026200-1-2-3-4-5-7036200-1-2-3-4-5, .
67	All w/Roch. 4BC .....	<b>7023889</b>	1	4.60 w/7027200-1-2-3-7037200-1-2-3 .....
66	Chevy, Chevelle w/Sp. H/Per. (327) (exc. A.I.R.) .....	<b>3889775</b>	2	4.00 w/seat and gasket (w/3877413) (Holley 18R-123A) .....
66	Chevy w/A.I.R. (327) (exc. H/Per.) .....			w/3890497, .....
66	Chevelle w/A.I.R. (396, H/Per.) (exc. P.G.) .....	<b>3896614</b>	1	4.00 w/3892339 .....
66	Chevy, w/Sp. H/Per. (327) (exc. A.I.R.) .....	<b>3889775</b>	2	4.00 w/3877413 .....
67	Chevy, Chevelle, Camaro w/Holley 4BC (exc. 302, Sp. H/Per. 396) .....	<b>3912070</b>	2	4.00 w/3903389-91-8956-7-8-9 .....
67	All w/Carter 1BC .....	<b>3912226</b>	1	4.00 w/3905971-2-3-4-5-6-8463-4-5-6-7-8-9405
67	Chevy, Chevelle, Camaro (396) (exc. H/Per., Sp. H/Per.),			
67	Pass. (396, 427) .....	<b>7035140</b>	1	3.80 w/7027210-11-7028209-10-11-16-7037210-11 .....
67	Chevy, Chevelle, Camaro w/4BC (327, 350) (exc. Sp. H/Per.),			
67	Pass. (327) .....	<b>7035130</b>	1	3.20 w/7027212-13-7028207-08-12-13-19-7037212-13 .....
71-72	Vega w/2BC .....	<b>7023803</b>	1	3.20 w/seat .....
71-75	Vega, Monza w/1BC (140) .....	<b>7035149</b>	1	3.40 w/seat .....
74-75	Vega, Monza w/2BC (140) .....	<b>6260706</b>	1	4.00 w/seat .....
75	Monza (exc. Towne Coupe) ....	<b>7035132</b>	1	3.20 w/seat .....
75	Vega, Monza w/1BC exc. NB-2 .	<b>7048964</b>	1	.90 w/seat .....
<i>NOTE: See Group 3.725 for chart containing 1968-72 Carburetor and Fuel Meter Intake Needle Units.</i>				
70-71	All (Roch. 2BC w/A.T.) (350),			
72	All (Roch. 2BC w/A.T.) (350, 400) .....	<b>7026257</b>	1	.33 <b>BAFFLE</b> , carb. high speed bleed (w/7040102-14-16-0402-14-16-7004-16-7041102-14-7104-12) .....
65	Pass. w/Sp. H/Per. (396),			
66-69	Pass. w/Sp. H/Per. (427) .....			<b>BRACKET</b> , float shf. ret. (Holley 59R-79) (w/3868826-9933-3885067-6101-3916143-5-3923289), .....
66	Chevelle w/Sp. H/Per. (396),			
66	Pass. w/H.D. (396, 427),			
67-69	Chevy, Chevelle, Camaro w/Holley 4BC .....			w/3916143-3923289, .....
70-72	All w/Holley 4BC .....	<b>3877174 A.R.</b>		.16
65-67	All w/Roch. 2BC, 4BC (8 cyl.) (exc. Quadrajet),			
68-70	All w/Roch. 2BC (8 cyl.) .....	<b>7006474</b>	1	.05 <b>CLIP</b> , carb. float needle valve .....
67-75	All w/Roch. 4BC .....	<b>7033751</b>	1	.45 <b>CLIP</b> , carb. float needle pull .....
65	Chevelle w/Sp. H/Per. (327),			

**FUEL—EXHAUST—CARBURETION**

**3.814 NEEDLE UNIT— BAFFLE— BRACKET— CLIP— NUT— RETAINER— SCREW, Carburetor and Fuel Meter Intake (w/seat and gasket) (Con't)**

65-66	Pass. (396) (exc. Sp. H/Per.),				
66	Chevy, Chevelle (327, 396),				
66	Pass. (327) (exc. A.I.R.),				
66-69	Pass. w/Sp. H/Per. (427) . . . . .				NUT, needle adjusting (w/3849804-3868826-8864-9933-3874898-5964-6741-3882835-4505-6091-6101-3916143-5-3923289), . . . . .
66	Pass. w/H.D. (396, 427) . . . . .				w/3887147, . . . . .
67-69	Chevy, Chevelle, Camaro w/Holley 4BC . . . . .				w/3916143-5-3923289, . . . . .
70	Camaro (Holley 4BC w/A.T.) (Sp. H/Per. w/E.E.C.) (350),				
71-72	All w/Holley 4BC . . . . .	3852477	2	.29	
66	Chevy (327) (exc. Sp. H/Per.),				
66	Pass. (8 cyl.) (exc. 283) . . . . .				RETAINER, carb. float needle (w/7026200-1-2-3-4-5-7036200-1-2-3-4-5), . . . . .
66	Chevelle (327, 396) (exc. H/Per.),				
67	All w/Roch. 4BC . . . . .	7031377	1	.35	w/7027200-1-2-3-7037200-1-2-3 . . . . .
65	Chevelle w/Sp. H/Per. (327),				
65-66	Pass. (396) (exc. Sp. H/Per.),				
66	Chevy, Chevelle (327, 396),				
66	Pass. (327) (exc. A.I.R.),				
66-69	Pass. w/Sp. H/Per. (427) . . . . .				SCREW, needle lock (w/3849804-.3868826-8864-9933-3874898-5964-6741-3882835-4505-6091-6101-3916143-5-3923289), . . . . .
66	Pass. w/H.D. (396, 427) . . . . .				w/3887147, . . . . .
67-69	Chevy, Chevelle, Camaro w/Holley 4BC . . . . .				w/3916143-5-3923289, . . . . .
70-72	All w/Holley 4BC . . . . .	3852465	A.R.	.17	
65	Pass. (396),				
66	Chevy, Chevelle w/A.I.R. (327, 396),				
66	Pass. (327, 396, 427) (exc. Sp. H/Per.) . . . . .				SCREW (w/7025200-01-7026200-1-2-3-4-5-7036200-1-2-3-4-5, . . . . .
67	All w/Roch. 4BC . . . . .	7007090	2	.04	w/7027200-1-2-3-7037200-1-2-3 . . . . .

**3.818 TUBE, Carburetor Idle**

68	All w/P.G. (6 cyl.),				
69	All (6 cyl.) . . . . .	7033940	1	1.25	
68	All (6 cyl.) (exc. P.G.),				
71	All (Roch. 1BC w/A.T.) . . . . .	7033942	1	1.25	
70	All w/Roch. 1BC (6 cyl.) (exc. A.T.) . . . . .	7033946	1	1.25	w/7040017-7015-17 . . . . .
70	All (Roch. 1BC w/A.T.) (6 cyl.) . . . . .	7033945	1	1.25	w/7040014-7014 . . . . .
71	All w/Roch. 1BC (exc. A.T.) . . . . .	7033943	1	1.25	w/7041017-7117 . . . . .
71	Vega w/1BC . . . . .	7033929	1	1.25	
72-74	Vega w/1BC (140),				
75	Vega, Monza (1BC w/A.T.) (140) . . . . .	17052329	1	1.60	
72-73	All (Roch. 1BC w/A.T.) . . . . .	7046025	1	1.25	
72-73	All w/Roch. 1BC (exc. A.T.) . . . . .	7046040	1	1.25	
74	All w/1BC . . . . .	7048983	1	1.25	
75	Vega, Monza (1BC w/M.T.) (140) . . . . .	17052332	1	1.60	
75	All (1BC w/A.T.) . . . . .	17052344	1	1.60	(repl. 17051328) . . . . .
75	All (250 w/M.T.) . . . . .	17052340	1	1.60	
75	All (250 w/A.T., integrated cyl. hd.) . . . . .	17052344	1	1.60	
75	Nova (250 w/A.T.) (exc. integrated cyl. hd.) . . . . .	17052347	1	1.60	

**3.820 COMPENSATOR KIT— COVER ASSY.— GASKET— SCREW— TEE— SEAL— SOLENOID ASSY.— VALVE ASSY.— FILTER ASSY.— HOSE, Carburetor Idle Air Compensator**

64-65	Chevy, Chevelle (P.G. w/Air Cond.) (8 cyl.) (exc. 4BC),				
65	Pass. w/Air Cond. (exc. 409) . . . . .				w/7024102-8-12-20-22-220-5122, . . . . .
66	Chevy, Chevelle w/A.I.R.,				
66	Pass. w/A.I.R. (283) (exc. C.A.C.)				w/7036103-12-20-21, . . . . .
67-68	Chevy, Chevelle, Camaro (C.A.C. w/Roch. 2BC) (283, 307, 327),				
67-68	Pass. w/C.A.C. (283, 307) . . . . .	7028925	1	4.45	w/7027103-12-8103-12-7037103-12-16 . . . . .

**FUEL—EXHAUST—CARBURETION**

**3.820 COMPENSATOR KIT— COVER ASSY.— GASKET— SCREW— TEE— SEAL— SOLENOID ASSY.— VALVE ASSY.— FILTER ASSY.— HOSE, Carburetor Idle Air Compensator (Con't)**

65	Pass. (396) (exc. Sp. H/Per.) . . . . .				w/7025200-01, . . . . .
66	Chevelle (327, 396) (exc. H/Per.),				
66	Pass. (8 cyl.) (exc. 283, Sp. H/Per.),				
66	Chevy w/A.I.R. (327) (exc. Sp. H/Per.) . . . . .				(w/7026200-1-2-3-4-5-7036200-1-2-3-4-5),
67	All w/Roch. 4BC . . . . .				w/7027200-1-2-3-7037200-1-2-3, . . . . .
69	Chevy, Chevelle (Roch. 4BC w/T.H. 400) w/H/Per. (396),				
69	Camaro (Roch. 4BC w/T.H. 400) (396) . . . . .	<b>7034461</b>	1	3.45	w/7029204 . . . . .
68	All w/C.A.C. (6 cyl.) (exc. P.G.) . . . . .				w/7028015, . . . . .
69	All w/Roch. 1BC (6 cyl.) . . . . .				w/7029014-15, . . . . .
70-75	All (Roch. 1BC) . . . . .	<b>7035870</b>	1	2.25	w/7040014-7014-7041014-7114) . . . . .
75	Vega, Monza (1BC w/A.T.) . . . . .	<b>7035667</b>	1	3.45	
75	Vega, Monza (1BC w/M.T.) . . . . .	<b>7035288</b>	1	3.30	
70	All (Roch. 2BC w/C.A.C.) . . . . .	<b>7036644</b>	1	3.80	w/7040103-4-12-15-16-19-20-29-7040403-4-12-15-16-19-20-29-7002-4-5-13-16-19-20-29 . . . . .
64-65	Chevy, Chevelle (P.G. w/Air Cond.) (8 cyl.) (exc. 4BC),				
65-66	Pass. (A.I.R. w/C.A.C.) (283) . . . . .				<b>COVER ASSY.</b> , compensator (w/7013018-26-7024102-08-12-5103-7036103-17), . . . . .
66	Chevy, Chevelle w/A.I.R. (283) (exc. 4BC) . . . . .				w/7036103-12, . . . . .
67-68	Pass. w/C.A.C. (283, 307),				
67-70	Chevy, Chevelle, Camaro (C.A.C. w/Roch. 2BC) (283, 307, 327)	<b>7013937</b>	1	1.80	w/7027103-12-16-8103-12-7037103-12-7040103-12-0403-12-7002-13 . . . . .
65	Pass. (396) (exc. Sp. H/Per.) . . . . .				<b>COVER ASSY.</b> , compensator (w/7025200-01), . . . . .
66	Chevy (327) (exc. Sp. H/Per.),				
66	Chevelle (327, 396) (exc. H/Per.),				
66	Pass. (8 cyl.) (exc. 283, Sp. H/Per.) . . . . .				(w/7026200-1-2-3-4-5-7036200-1-2-3-4-5),
67	All w/Roch. 4BC . . . . .				w/7027200-1-2-3-10-11-12-13-7037200-1-2-3-10-11-12-13, . . . . .
69	Chevy, Chevelle (Roch. 4BC w/T.H. 400) w/H/Per. (396),				
69	Camaro (Roch. 4BC w/T.H. 400) (396) . . . . .	<b>7029865</b>	1	.63	w/7029204 . . . . .
74-75	Vega, Monza w/1BC (140) . . . . .	<b>7035667</b>	1	3.45	
75	Vega, Monza w/2BC (140) w/C.A.C. . . . .	<b>360988</b>	1	3.20	(w/348663-664-65-66) . . . . .
68-69	All (6 cyl.) . . . . .				<b>COVER ASSY.</b> , compensator (w/7028014-15), . . . . .
70-73	All (Roch. 1BC w/A.T.) (6 cyl.) . . . . .	<b>7035670</b>	1	.46	(w/7040014-7014-7041014-7114) . . . . .
74-75	Vega, Monza w/1BC . . . . .	<b>7041512</b>	1	.46	<b>COVER</b> , compensator . . . . .
64-65	Chevy, Chevelle (P.G. w/Air Cond.) (8 cyl.),				
65	Pass. w/Air Cond. (283, 327) . . . . .				<b>GASKET</b> , compensator (w/7020012-0018-0022-4102-08-10-12-22-5103-8-121), . . . . .
65	Pass. (409) (exc. H/Per. dual 4BC) . . . . .				(w/7020023-0024-4123-24-27-28-5123-24), . . . . .
66	Chevy, Chevelle w/A.I.R. (283) (exc. 4BC),				
66	Pass. (283) . . . . .				w/7025126-7-6121-7036103-12-18-19-20-21, . . . . .
67-68	Chevy, Chevelle, Camaro (C.A.C. w/Roch. 2BC) (283, 307, 327),				
67-68	Pass. w/C.A.C. (283, 307) . . . . .				w/7027103-12-16-8103-12-7037103-12, . . . . .
69	All w/Roch. 2BC . . . . .	<b>7013341</b>	1	.29	w/7029103-4-12-14-15-19-20-29 . . . . .
75	All w/1BC . . . . .	<b>7027970</b>	1	.29	<b>GASKET</b> , carb. idle comp. . . . .
64-65	Chevy, Chevelle (P.G. w/Air Cond.) (8 cyl.),				
65	Pass. w/Air Cond. (283, 327) . . . . .				<b>SCREW</b> , idle compensator (w/7020012-0018-0022-4102-08-22), . . . . .
65	Pass. w/Roch. 4BC (409) . . . . .				(w/7020023-0024-4112-23-24-27-28), . . . . .
66	Chevy, Chevelle w/A.I.R. (283) (exc. 4BC),				

**FUEL—EXHAUST—CARBURETION**

**3.820 COMPENSATOR KIT— COVER ASSY.— GASKET— SCREW— TEE— SEAL— SOLENOID ASSY.— VALVE ASSY.— FILTER ASSY.— HOSE, Carburetor Idle Air Compensator (Con't)**

66	Pass. (283) .....				w/7025 128-5 103-6121-7036103-12-20-21, .....
67-68	All (C.A.C. w/2BC) (283, 307) ..				w/7027 103-12-16-8103-12-7037 103-12, ..
69	All w/Roch. 2BC,				
70	All (Roch. 2BC w/C.A.C.) .....	<b>7015127</b>	1	.14	(w/7040103-4-12-15-16-19-20-29-7040403-4-12-15-16-19-20-29-7002-4-5-13-16-19-20-29) .....
65	Pass. (396) (exc. Sp. H/Per.) .....				<b>SCREW</b> , comp. cover (w/7025200-01), .....
66	Chevy (327) (exc. Sp. H/Per.),				
66	Pass. (8 cyl.) (exc. 283, Sp. H/Per.) .....				w/7026200-1-2-3-4-5-7036200-1-2-3-4-5), ..
67	All w/Roch. 4BC .....				w/7027200-1-2-3-10-11-12-13-7037200-1-2-3, .....
68-75	All w/Roch. 1BC,				
69	Chevy, Chevelle (Roch. 4BC w/T.H. 400) w/H/Per. (396),				
69	Camaro (Roch. 4BC w/T.H. 400) (396),				
74-75	Vega, Monza w/1BC (140) .....	<b>7020926</b>	2	.11	
68-69	Pass. w/Roch. 1BC,				
68-69	Chevy, Chevelle, Camaro .....				<b>SCREW</b> , idle compensator, .....
70-73	All (Roch. 1BC w/A.T.) (6 cyl.) ..	<b>7034030</b>	2	.21	(w/7040014-7014-7041014-7114) .....
74-75	Vega, Monza w/1BC .....	<b>7041272</b>	2	.28	<b>SCREW</b> , comp. cover .....
75	All w/1BC .....	<b>7041287</b>	1	.28	<b>SCREW</b> , carb. idle comp. cvr. ....
63-64	Chevy, Chevelle w/C.A.C. (exc. 8 cyl.) .....	<b>3794176</b>	1	3.70	<b>TEE</b> , air bleed— (9.198) .....
75	Vega, Monza w/2BC (140) w/C.A.C. ....	<b>360968</b>	1	.16	<b>SEAL</b> , carb. idle comp. vlv. ....
73-75	Vega, Monza (C.A.C. w/2BC) (140) .....	<b>338108</b>	1	6.50	<b>VALVE ASSY.</b> , hot idle compensator .....
75	Vega, Monza (122) .....	<b>361085</b>	1	43.25	<b>VALVE</b> , fast idle .....
75	Vega, Monza (122) .....	<b>361086</b>	1	38.00	<b>VALVE</b> , air solenoid .....

**3.822 SCREW— NEEDLE UNIT, Carburetor and Fuel Injection Idle Adjusting**

62	Chevy,				
63-66	Chevy, Chevelle (6 cyl.),				
65	Pass., Taxi w/econ. carb. (6 cyl.),				
67	Chevy (194) (exc. A.I.R.) .....	<b>7001669</b>	1	.78	adjustment needle (No. 10-32 x 1 <sup>5</sup> / <sub>32</sub> " O.L.) (w/7017380-7020103-0104-0105-0108-0114-0115-3000-03-105-8-4000-01-5000-3-105-8-7036009) .....
63-66	Chevy (4 cyl.),				
66	All w/A.I.R. (6 cyl.),				
66	Taxi (6 cyl.),				
67	All w/Carter 1BC .....	<b>1458268</b>	1	.85	Carter 30A-44 .....
64-65	Chevy, Chevelle (8 cyl.) (exc. H/Per.),				
65	All w/Roch. (8 cyl.) (exc. 396),				
65-66	Pass. w/Roch. (283) .....				w/7024 101-10-12-5 103-21-22-23-24-26-27-28-6121-7101-3-5-6-10-12-14-16, .....
66	Chevy, Chevelle w/A.I.R. (283) ..				w/7026 121-7036102-12-20-21, .....
67-70	All w/Roch. 2BC,				
68	Chevy (4 cyl.),				
70	All w/Roch. 4BC .....	<b>7048858</b>	A.R.	.90	
64-65	All w/H/Per. (327) .....				(w/3851761-62) (Carter 30A-81), .....
66	All (327) (exc. A.I.R., Sp. H/Per.)	<b>1470451</b>	2	.97	w/3875966-6749 .....
65	Pass. (6 cyl.),				
66-67	Pass. (6 cyl.) (exc. Taxi, A.I.R.),				
67	Chevy, Chevelle, Camaro (230, 250) (exc. A.I.R.) .....	<b>7002357</b>	1	.90	
65	Pass. w/H/Per., dual 4BC (409) .	<b>7011583</b>	2	.85	(Carter 30A-80) .....
65	Chevelle w/Sp. H/Per. (327),				
65-66	Pass. (396) (exc. Sp. H/Per.),				
66	Chevy, Chevelle (327, 396),				
66	Pass. (327) (exc. A.I.R.),				
66	Pass. w/Sp. H/Per. (427) .....				(Holley 15R-40) (w/3849804-3863150-3868826-8864-9933-3874898-5964-6741-3882835-4505-6091-6101), .....
66	Pass. w/H.D. (396, 427) .....				w/3887147, .....
67	Pass. w/Holley 4BC .....				w/3886091-3906631-3-5-7-3916143-5, .....
67-69	Chevy, Chevelle, Camaro w/Holley 4BC,				
70	Nova, Chevelle w/Holley 4BC,				

**FUEL—EXHAUST—CARBURETION**

**3.822 SCREW— NEEDLE UNIT, Carburetor and Fuel Injection Idle Adjusting (Con't)**

70	Camaro (Holley 4BC w/Sp. H/Per.) w/E.E.C. (350) (exc. A.T.),				
70	Camaro (Holley 4BC w/Sp. H/Per.) w/A.T. (350),				
70	Camaro w/Holley 4BC (396),				
71	All w/Holley 4BC	2367986	2	.25	
65	Pass. (396) (exc. Sp. H/Per.)				(w/7025200-01),
66	Chevy, Chevelle (327) (exc. Sp. H/Per.),				
66	Pass. (327)				(w/7026202-3-7036202-3),
66	Chevelle (396) (exc. H/Per.),				
66	Pass. (396, 427) (exc. Sp. H/Per.)				(w/7026200-1-4-5-7036200-1-4-5),
67-68	All w/Roch. 4BC,				
68	Chevy, Chevelle (Roch. 1BC w/A.T.)				w/7028014,
69	Chevy, Chevelle, Camaro w/Roch. 4BC				
70	All (Roch. 1BC w/A.T.) (6 cyl.)				w/7040014-7014,
68-69	Chevy (4 cyl.)				w/7029008,
68-70	All (6 cyl.) (exc. A.T.)				w/7028015-17-9015-17-7040017-7015
69	Chevy, Chevelle, Camaro w/Roch. 4BC (396) (exc. A.T., Sp. H/Per.),				
69	Pass. w/Roch. 4BC (350, 427) (exc. A.T., Sp. H/Per.)	7041864	1	1.30	w/7029201-03-07-15
68-69	All w/Roch. 1BC (6 cyl.),				
69-70	Chevy (4 cyl.)				slow idle,
70-71	All (Roch. 1BC w/A.T.) (6 cyl.),				
72	Vega w/1BC	7034034	1	.43	slow idle (w/7040008-14-7008-7014)
71-74	Vega w/1BC	7048964	1	.90	(repl. 7043887)
72	All w/Holley 4BC	6273907	2	.37	
73-74	Vega w/2BC	335089	1	.13	(secd.)
73-75	Vega, Monza w/2BC (140)	6259043	1	.47	
71-73	All w/Roch. 2BC	7041612	1	2.00	NEEDLE UNIT, w/screw
71-72	Vega w/2BC	7048861	1	.90	NEEDLE UNIT, w/screw
71-73	All w/Roch. 1BC	7041596	1	1.15	NEEDLE UNIT, w/screw
71-72	All w/Roch. 4BC	7041660	1	1.95	NEEDLE UNIT, w/screw
73	All w/Roch. 4BC	7042457	1	.90	NEEDLE UNIT, w/screw
75	All w/2BC	7048860	1	.90	NEEDLE UNIT
74	Vega,				
75	All w/1BC	7048964	1	.90	NEEDLE UNIT
75	All w/4BC (exc. 454)	7048531	2	.90	NEEDLE UNIT
75	All (454)	7048532	2	.90	NEEDLE UNIT

**3.823 SPRING— LIMITER, Carburetor and Fuel Injection Idle Adjusting Screw**

62	Chevy,				
63-67	All (6 cyl.)	7003190	1	.11	lock spring (5½" coils— ½" free length)
64-65	Chevy, Chevelle w/H/Per. (327),				
65	Pass. w/H/Per., dual 4BC				carb. idler (w/3846246-47-3851761-62-5581-3875966-6749),
66	Chevy, Chevelle w/A.I.R. (327) (exc. Sp. H/Per.),				
66	Pass. (327) (exc. A.I.R.)	563887	A.R.	.25	(Carter 61-84)
64-65	Chevy, Chevelle (8 cyl.),				
65-66	Pass. w/Roch. (8 cyl.) (exc. H/Per., Sp. H/Per.),				
67-75	All w/Roch. Carb.	7011479	2	.11	adjusting screw
67	Chevy, Chevelle, Camaro (230.250) (exc. A.I.R.),				
68	All w/Roch. 1BC (6 cyl.)	7001666	1	.07	lock spring
68-69	All w/Holley 4BC,				
70	Camaro (Holley 4BC w/Sp. H/Per.) (350) (exc. A.T., E.E.C.)	3934263	2	1.05	
71-75	All w/Roch. 1BC	7038989	1	.33	
75	Vega, Monza w/2BC (140)	2285797	1	.06	SPRING, needle adj.— (3.766)
71-73	All w/Roch. 1BC	7043677	1	.54	LIMITER (contains 2 caps)
71-73	All w/Roch. 2BC	7043684	1	.54	LIMITER (contains 2 caps)
71-75	All w/Roch. 4BC	7042801	2	.54	LIMITER (contains 1 cap)
72	All w/Holley 4BC	6273918	1	.81	LIMITER (Holley 34R-6790-3)
73	Vega w/2BC	335118	1	.65	LIMITER CAP, carb. idle needle

**FUEL—EXHAUST—CARBURETION**

**3.825 BALL— GUIDE— NEEDLE— PLUG— RETAINER— SCREW— SPRING, Carburetor Pump Outlet Valve**

62-64	Chevy, Chevelle,					
65-70	Pass. w/Roch.,					
71-75	All w/Roch. carb.,					
71-75	All w/1BC .....	7002117	1	.05	check valve ( <sup>3</sup> / <sub>16</sub> " ) .....	
73-75	Vega, Monza w/2BC (140) .....	453627	2	.10		
75	Monza w/A.T. (262) (exc. Towne Coupe) .....	7002120	1	.05	inlet check .....	
64-65	Chevy, Chevelle (8 cyl.) (exc. 4BC),					
65-66	Pass. (8 cyl.) (exc. 4BC, dual 4BC),					
66	Chevy, Chevelle w/A.I.R. (283) (exc. 4BC),					
67-70	All w/Roch. 2BC (exc. 396),					
71-75	All w/Roch. 2BC,					
75	Monza w/A.T. (262) (exc. Towne Coupe) .....	7000286	1	.07	GUIDE, spring (flat) .....	
65	Pass. (exc. 283) .....				GUIDE, spring (flat), .....	
66	Pass. (6 cyl.) .....				w/7026027-8, .....	
66	Chevy, Chevelle w/A.I.R. (283) (exc. 2BC),					
66	Pass. w/4BC (283) .....				w/7025126-7-8-6121-7036118-19-20-21, .	
67-75	All w/Roch. 1BC .....	7003838	1	.21		
64-65	Chevy, Chevelle w/H/Per.,					
65	Pass. w/H/Per., Dual 4BC (409),					
65	Pass. w/H/Per. (327) .....	7000711	A.R.	.76	NEEDLE (Carter 17-51) .....	
65	Pass. (396) (exc. Sp. H/Per.) .....				PLUG, discharge (w/7025200-1-20-21), ...	
66	Chevy (327) (exc. Sp. H/Per.),					
66	Pass. (8 cyl.) (exc. 283, Sp. H/Per.),					
66	Chevelle (327, 396) (exc. H/Per.)				w/7026200-1-2-3-4-5-7036200-1-2-3-4-5, .	
67-75	All w/Roch. 4BC .....	7029849	1	.78		
73-75	Vega, Monza w/2BC (140) .....	335096	1	.20	SCREW .....	
62	Chevy,					
63-65	All w/Roch. (exc. 4BC),					
65	Pass. (409),					
66	Chevy, Chevelle w/A.I.R.,					
66	Pass. (6 cyl.) (exc. Taxi, A.I.R.),					
66	Pass. w/2BC (283),					
67-75	All w/Roch. 1BC, 2BC .....	7002118	1	.29	SPRING, check valve .....	
64-66	Chevy, Chevelle w/4BC .....				SPRING, discharge ball (w/7024120-22-5-6-4220-5-6-5126-78, .....	
65	Pass. w/Roch. 4BC (283, 327),					
66	Chevy, Chevelle w/A.I.R. (283) (exc. 2BC),					
66	Pass. w/4BC (283) .....	7006059	1	.29	w/7025125-6-7-8-6121-7125-7036118-19-20-21-7125 .....	

**3.826 VALVE ASSY.— BALL— RETAINER, Carburetor Pump Inlet Valve**

64-65	All w/H/Per. (327),					
65	Pass. w/H/Per., dual 4BC (409) .	7013735	A.R.	1.60	check (Carter 122-108S) .....	
64-65	Chevy, Chevelle,					
65	Pass. w/Air Cond.,					
65	Pass. w/4BC (283, 327, 409) (exc. H/Per., dual 4BC) .....				BALL, valve check ( <sup>5</sup> / <sub>16</sub> " dia.) (aluminum), . .	
66	Chevy, Chevelle w/A.I.R. (283) (exc. 2BC),					
66	Pass. w/4BC (283),					
73-75	All w/2BC .....	7002120	1	.05		
65	Pass. (exc. 409, H/Per., Sp. H/Per., Air Cond.) .....	1875237	A.R.	.17	BALL, check ( <sup>5</sup> / <sub>32</sub> " ) (Carter 116-13) (stainless steel) .....	

**3.838 PLUNGER— BOOT— CLIP— COVER— DIAPHRAGM ASSY.— PUMP ASM.— SCREW, Carburetor (with Leather and Shaft)**

*NOTE: See Group 3.725 for chart containing 1968-75 Carburetor Plungers.*

62	Chevy (6 cyl.) .....	7010012	1	3.50	w/rod (w/7020105-0108) .....	
63-66	Chevy, Chevelle (6 cyl.),					
65	Pass. (6 cyl.),				w/7026027-8, .....	
66-67	Pass. (6 cyl.) (exc. Taxi, A.I.R.) . .					
67	Chevy, Chevelle, Camaro (6 cyl.) (exc. A.I.R.) .....	7025530	1	3.50	w/rod (7023000-03-3105-08-4000-01-5000-3-5105-8-6027-8) .....	



**FUEL—EXHAUST—CARBURETION**

**3.838 PLUNGER— BOOT— CLIP— COVER— DIAPHRAGM ASSY.— PUMP  
ASM.— SCREW, Carburetor (with Leather and Shaft) (Con't)**

64-66	Chevy, Chevelle (8 cyl.) (exc. P.G., 4BC) . . . . .				w/7024101, . . . . .
65-66	Pass. (283) (exc. A.T., A.I.R.) . . . . .				w/7019007-7020007-3007-9-10-22-4101-5103, . . . . .
66	All w/A.I.R. (283) (exc. P.G., 4BC) . . . . .				w/7036100-1-3-5-6, . . . . .
67	All w/Roch. 2BC (exc. P.G.) . . . . .				w/7027101-3-8100-03-05-06-07-11-25-27-7037101-3, . . . . .
64-65	Chevy, Chevelle w/P.G. (8 cyl.),				w/return spring and rod (w/7013008-18-9008-18-7020008-18-4100-02-06-08-7036110-12), . . . . .
65	Pass. (2BC w/A.T.) (exc. A.I.R.) . . . . .				w/7024110-12, . . . . .
66	Pass. w/2BC (283) (exc. A.I.R.) . . . . .				w/7036110-12, . . . . .
66	Chevy, Chevelle w/P.G. (283) (exc. 4BC) . . . . .				
67	Pass. (P.G. w/Roch. 2BC),				
67	Chevy, Chevelle, Camaro (P.G. w/Roch. 2BC) (283, 307, 327)	<b>7031824</b>	1	3.25	w/7027110-12-8110-12-14-16-7037110-12-14-16-7037110 . . . . .
64-65	Chevy, Chevelle w/4BC,				
65	Pass. w/4BC (283, 327) (exc. H/Per.),				
66	Pass. w/4BC (283),				
66	Chevy, Chevelle w/A.I.R. (283) (exc. 2BC) . . . . .	<b>7026826</b>	1	3.50	(w/7024120-21-22-25-26-4220-25-26-5125-26-27-28-6121-7125-7036118-19-20-21-25-7125) . . . . .
64-65	Chevy, Chevelle w/H/Per. (327) (exc. P.G.),				
65	Pass. w/H/Per. (327) . . . . .	<b>1172261</b>	1	4.85	w/spring and rod (Carter 64-209S) . . . . .
65	Pass. (396) (exc. Sp. H/Per.) . . . . .				w/7025200-01, . . . . .
66	Chevelle (327, 396) (exc. H/Per.) . . . . .				w/7026200-1-2-3, . . . . .
66	Chevy (327) (exc. Sp. H/Per.) . . . . .				w/7036200-1-2-3, . . . . .
66-67	Pass. w/Roch. 4BC,				
67	Chevy, Chevelle, Camaro w/4BC	<b>7034111</b>	1	3.25	
65	Pass. (327) (exc. H/Per., Sp. H/Per.) . . . . .	<b>3751523</b>	1	4.85	w/rod (Carter 64-214S) . . . . .
66	All (327) (exc. A.I.R., Sp. H/Per.)	<b>1180436</b>	1	4.85	w/spring and rod (Carter 64-205S) (w/3875966-6749) . . . . .
64-66	Chevy, Chevelle w/4BC,				
65	Pass. w/Roch. 4BC,				
65	Pass. w/4BC (283, 327) (exc. H/Per.),				
66	Pass. w/4BC (283) . . . . .	<b>7006372</b>	1	.29	<b>BOOT</b> , pump rod (rubber) w/1025125-6-7-8-6121-7125-70361170180290210612506125 . . . . .
75	All w/2BC . . . . .	<b>7018186</b>	1	.22	<b>CLIP</b> , carb. pump rod . . . . .
65	Chevelle w/Sp. H/Per. (327) . . . . .				fuel pump (w/3863150-3878261) . . . . .
65	Pass. (396),				
66	Pass. w/Sp. H/Per. (427) . . . . .				pump diaphragm (w/3849804-3868826-9933-3885067-6101), . . . . .
66	Chevy, Chevelle (327, 396) . . . . .				w/3877413-3890497-3229, . . . . .
66	Pass. w/H.D. (396, 427) . . . . .				w/3887147, . . . . .
67-72	All w/Holley 4BC . . . . .	<b>6263029</b>	A.R.	.35	<b>COVER ASSY.</b> , fuel pump . . . . .
67	Chevy, Chevelle, Camaro w/Holley 4BC,				
70	All (Holley 4BC w/Sp. H/Per.) (396, 454) (exc. E.E.C., A.T.) . . . . .	<b>2368959</b>	1	1.45	<b>COVER</b> , carb. diaph. (w/3967477) . . . . .
63-66	Chevy (4 cyl.),				
66	All w/A.I.R. (6 cyl.),				
66	Taxi (6 cyl.) . . . . .				<b>DIAPHRAGM ASSY.</b> , pump (w/3792945-3019-3868468-3876213-14-3880303-0860-61-5439-40-41-42-6193-4-3891593-4-5-6-3895393-4-5-6-7-8), . . . . .
67	All w/Carter 1BC . . . . .	<b>3857769</b>	1	4.85	w/3905973-4-5-6-8463-4-5-6-7-8 . . . . .
65	Chevelle w/Sp. H/Per. (327),				
65-66	Pass. (396) (exc. Sp. H/Per.),				
66	Chevy, Chevelle (327, 396),				
66	Pass. (327) (exc. A.I.R.) . . . . .				<b>DIAPHRAGM ASSY.</b> , fuel pump (w/3849804-3863150-8826-8864-9933-3874898-5964-6741-3882835-4505-6091-6101), . . . . .
66	Pass. w/Sp. H/Per. (427),				
66	Pass. w/H.D. (396, 427) . . . . .				w/3887147, . . . . .

**FUEL—EXHAUST—CARBURETION**

**3.838 PLUNGER— BOOT— CLIP— COVER— DIAPHRAGM ASSY.— PUMP ASM.— SCREW, Carburetor (with Leather and Shaft) (Con't)**

67-72	All w/Holley 4BC	2414214	A.R.	.82	
73-75	Vega, Monza w/2BC (140)	335123	1	5.75	DIAPHRAGM ASM., carb. accel. pump
71	Vega w/1BC	7037597	1	3.15	PUMP ASSY.
71	Vega w/2BC	7042819	1	3.25	PUMP ASSY.
72	Vega w/2BC	7045908	1	3.25	PUMP ASSY.
72-75	Vega, Monza w/1BC	7045943	1	3.15	PUMP ASSY.
75	Monza (262) (exc. Towne Coupe, NB-2)	7037561	1	4.25	PUMP ASSY.
65-66	Pass. (396) (exc. Sp. H/Per.),				
65	Chevelle w/Sp. H/Per. (327),				
66	Pass. (327) (exc. A.I.R.),				
66	Chevy, Chevelle (327, 396),				
66	Pass. w/Sp. H/Per. (427)				SCREW, diaphragm lever adj. (w/3849804-3863150-8826-8864-9933-3874894898-5964-6741-3882835-4505-6091-6101), w/3887147,
66	Pass. w/H.D. (396, 427)				
67-72	All w/Holley 4BC	2367998	1	.12	
65	Chevelle w/Sp. H/Per. (327),				
65-66	Pass. (396),				
66	Chevy, Chevelle (327, 396),				
66	Pass. (327) (exc. A.I.R.),				
66	Pass. w/Sp. H/Per. (427)				SCREW, w/lockwasher, pump cover (w/3849804-3863150-8826-8864-9933-3874898-5964-6741-3882835-4505-6091-6101-3890499-2341), w/3887147,
66	Pass. w/H.D. (396, 427)				
67-71	All w/Holley 4BC	3852462	4	.12	
<b>3.841 RETAINER— SCREEN— SCREW— SPRING, Carburetor Pump</b>					
65	Chevelle w/Sp. H/Per. (327)	9431762	1	.08	fuel pump operating lever— (8.934)
73-74	All w/2BC	7004557	1	.40	SCREEN, inlet
65	Chevelle w/Sp. H/Per. (327),				
65-66	Pass. (396) (exc. Sp. H/Per.),				
66	Pass. (327) (exc. A.I.R.),				
66	Pass. w/Sp. H/Per. (427)				SCREW, cam lock (w/3849804-3863150-3868826-8864-9933-3874898-5964-6741-3882835-4505-6091-6101), w/3887147,
66	Pass. w/H.D. (396, 427)				w/3868864-3874898-5964-6747-7413-8261-3886087-8-3890497-2338-9-3229,
66	Chevy, Chevelle (327, 396)				
67-69	Pass. w/Holley 4BC,				
70-72	All w/Holley 4BC	3852463	A.R.	.12	
65	Chevelle w/Sp. H/Per. (327),				
65-66	Pass. (396) (exc. Sp. H/Per.),				
66	Pass. (327) (exc. A.I.R.),				
66	Pass. w/Sp. H/Per. (427)				SCREW, discharge nozzle (w/3849804-3863150-3868826-8864-9933-3874898898-5964-6741-3882835-4505-6091-6101), w/3887147,
66	Pass. w/H.D. (396, 427)				w/3868864-3874898-5964-6747-7413-8261-3886087-8-3890497-2338-9-3229229,
66	Chevy, Chevelle (327, 396)				
67-69	Pass. w/Holley 4BC	2368034	1	.05	
69	Chevy, Chevelle, Camaro (Holley 4BC w/Sp. H/Per.) (302, 396),				
69	Pass. w/Holley 4BC,				
70-72	All w/Holley 4BC	3960391	1	.17	SCREW, carb. pump discharge nozzle
62	Chevy (exc. 8 cyl.),				
63-66	Chevy, Chevelle (6 cyl.),				
65	Pass. w/Roch. 1BC (6 cyl.),				
66	Pass. (6 cyl.) (exc. Taxi, A.I.R.),				
67	All w/Roch. 1BC (6 cyl.)	7005954	1	.21	SPRING, pump reteturn
64-66	Chevy, Chevelle (327) (exc. H/Per., Sp. H/Per.),				
65	Pass. w/A.T. (8 cyl.) (exc. Carter 4BC, dual 4BC),				
66	Pass. (283) (exc. A.I.R.),				
67-70	All w/Roch. 2BC,				
67	Chevy, Chevelle, Camaro w/Roch. 4BC,				
71-75	Vega, Monza w/1BC,				
73	All w/Roch. 4BC	7004597	1	.37	SPRING, pump return
65	Chevelle w/Sp. H/Per. (327)	2368957	1	.09	SPRING, fuel pump lever adj. (w/3863150)

**FUEL—EXHAUST—CARBURETION**

**3.841 RETAINER— SCREEN— SCREW— SPRING, Carburetor Pump (Con't)**

65-67	All w/Carter 1BC .....	836159 A.R.	.07	SPRING, retainer, arm (hairpin type) (Carter 150-A-10) .....
65	Chevelle w/Sp. H/Per. (327),			
65-66	Pass. (396) (exc. Sp. H/Per.),			
66	Chevy, Chevelle (327, 396),			
66	Pass. (327) (exc. A.I.R.),			
66-67	Pass. w/Sp. H/Per. (427) .....			SPRING, diaphragm return (Holley 38R-569) (w/3849804-3868826-8864-9933-3874898-5964-6741-3882835-4505-6091-6101), .....
66	Pass. w/H.D. (396, 427),			
67	All w/Holley 4BC .....	2367992	1	.46 w/3887147 .....
65-68	Pass. w/Roch. 4BC,			
68	Chevy, Chevelle, Camaro			
	w/Roch. 4BC .....	7035672	1	.37 SPRING, pump .....
65-66	Pass. w/A.T. (396) (exc. Sp.			
	H/Per.) .....			SPRING, diaph. secd. (Holley 38R-477), ...
66	Chevelle (396),			
66	All (327) (exc. A.I.R., Sp. H/Per.)	3881434	1	.16 (w/3868864-3875964-6747) .....
65-66	Pass. (396) (exc. A.T. Sp.			
	H/Per.),			
66	Chevelle (396) (exc. H/Per., P.G.,			
	A.I.R.) .....	2386320	1	.33 SPRING, diaph. sec. (Holley 38R-684)
				(w/3874898) .....
65-66	Pass. (396) (exc. Sp. H/Per.) .....			SPRING, pump lever (Holley 38R-782), ...
66	Chevy, Chevelle (327, 396),			
66	Pass. (327) (exc. A.I.R.),			
66	Pass. w/Sp. H/Per. (427) .....			w/3849804-3868826-8864-9933-3874898-5964-6741-3882835-4505-6091-6101, .....
				w/3887147, .....
66	Pass. w/H.D. (396, 427) .....			
67-72	All w/Holley 4BC .....	3888872	1	.22
68-72	All w/Holley 4BC .....	3918878	1	.22 SPRING, diaphragm return .....
68-73	All w/Roch. 1BC .....	7008694	1	.21 SPRING, pump return (stained yellow) .....
69-72	All w/Roch. 4BC .....	7037314	1	.37 SPRING, pump .....
71-73	All w/Roch. 2BC .....	7043600	1	.18 SPRING, pump .....
73-75	Vega, Monza w/2BC (140) .....	335130	1	.38
74	All w/4BC,			
75	All w/2BC (262) .....	7041169	1	.37 SPRING, pump return .....
74-75	All w/1BC .....	7041176	1	.21 SPRING, pump return .....
75	All w/2BC (350) .....	17050241	1	.46 SPRING, carb. pump return .....
75	All w/4BC .....	7042979	1	.37 SPRING, carb. pump return .....
75	Monza w/A.T. (262) (exc. Towne			
	Coupe) .....	7041141	1	.29 SPRING, carb. pump return .....
75	Vega, Monza w/2BC (140) .....	345646	1	.12 SPRING, diaph. ret. ....

**3.842 LEVER— CAM— CLIP— FITTING— RING— SCREW— WASHER, Carburetor Pump**

64-66	Chevy, Chevelle w/A.I.R. (283)				air horn pump inside (w/7024100-1-2-6-8-10-12-5103-7036101-3-10-12), .....
	(exc. 4BC) .....				
65-66	Pass. w/2BC, 3/2BC (283),				
67-68	All w/Roch. 2BC,				
75	All w/2BC .....	7032377	1	.78	
64-66	Chevy, Chevelle (8 cyl.) (exc.				air horn pump outside w/lever
	4BC) .....				(w/7024100-1-2-6-8-10-12-5103), .....
66	Pass. w/H.D. (396, 427) .....				w/3887147, .....
67-69	All w/Roch. 2BC .....	7036764	1	2.40	actuating— outside, w/shaft .....
65	Pass. (396) (exc. Sp. H/Per.) .....				actuating (w/7025200-01), .....
66	Chevelle (327, 396) (exc.				
	H/Per.),				
66	Pass. (8 cyl.) (exc. 283, Sp.				
	H/Per.),				
66	Chevy (327) (exc. Sp. H/Per.) ...				w/7026200-01-02-03-04-05-7036200-01-02-03-04-05, .....
67-69	All w/Roch. 4BC,				
70	All w/Roch. 2BC, 4BC,				
71-72	All w/Holley 4BC,				
73-75	All w/4BC .....	7048169	1	.75	pump actuator .....
67-69	All w/Holley 4BC .....				pump operating (center) w/3906631-3-5-7-3916143-5-3923289, .....
70	All (Holley 4BC w/Sp. H/Per.)				
	w/E.E.C. (350, 396, 454),				
71-72	All w/Holley 4BC .....	3907115 A.R.		1.35	operating .....

**FUEL—EXHAUST—CARBURETION**

**3.842 LEVER—CAM—CLIP—FITTING—RING—SCREW—WASHER,  
Carburetor Pump (Con't)**

68-70	All w/Roch. 1BC	7038049	1	.57	carb. pump and power rod
70	All w/Roch. 1BC	7038596	1	.98	actuator
70-73	All w/Roch. 2BC	7038630	1	.99	carb. to airhorn pump
70-73	All w/Roch. 2BC (exc. Vega),				
71	Vega w/2BC (1st design)	7038788	1	1.25	w/shaft
71	Vega w/2BC (2nd design),				
72	Vega w/2BC	7046602	1	1.30	w/shaft
71-75	All w/Roch. 1BC (exc. Vega, Monza)	7024216	1	.57	pump and power rod
71-75	All w/Roch. 1BC	7042670	1	1.20	pump actuator
68-69	All w/Roch. 1BC	7034048	1	.72	LEVER ASSY., pump actuating
70	All (Holley 4BC w/Sp. H/Per.) (350, 396, 454) (exc. E.E.C.)	3979428	1	1.80	LEVER ASSY., operating
75	All w/2BC	17050230	1	1.45	LEVER ASSY., w/pump shaft
75	Monza w/A.T. (262) (exc. Towne Coupe)	7032377	1	.78	LEVER, pump inside
65-66	Pass. (396) (exc. Sp. H/Per.),				
66	Chevy, Chevelle (327, 396),				
66	Pass. (327) (exc. A.I.R.),				
66-69	Pass. w/Sp. H/Per. (427)				CAM, pump (w/3849804-3868826-8864- 9933-3874898-5964-674 1-3882835- 3916143-5-3923289),
67-69	Chevy, Chevelle, Camaro w/Holley 4BC,				
71-72	All w/Holley 4BC	3852480	A.R.	.39	
65-66	Pass. (396) (exc. A.T., Sp./H/Per.),				
66	Chevy, Chevelle (327, 396),				
66	Pass. (327) (exc. P.G., A.I.R.)				CAM, pump (w/3874898-6747-3882835- 4505-6091-3896499-234 1),
67	Chevy, Chevelle, Camaro w/Holley 4BC	3881437	1	1.35	
64-65	Chevy, Chevelle w/4BC,				
65	Pass. (P.G. w/Air Cond.) (327),				
65	Pass. w/Roch. 4BC,				
66	Chevy, Chevelle w/A.I.R. (283) (exc. 2BC),				
66	Pass. w/4BC (283)	7007616	1	.03	CLIP, pump shaft and lever (w/7025 125-6- 7-8-6121-7125-7036 118-19-20-21-6125- 7125)
65	Chevelle w/Sp. H/Per. (327),				
65-66	Pass. (396) (exc. Sp. H/Per.),				
66	Chevy, Chevelle (327, 396),				
66	Pass. (327) (exc. A.I.R.),				
66	Pass. w/Sp. H/Per. (427)				FITTING, lever adjusting (w/3849804- 3868826-8864-9933-3874898-5964- 6741-3882835-4505-6091-6101), w/3887147,
66	Pass. w/H.D. (396, 427)				
67-72	All w/Holley 4BC	2368958	A.R.	.18	
67-71	All w/Holley 4BC	230207	A.R.	.17	RING, pump operating lever (center)
65	Chevelle w/Sp. H/Per. (327),				
65-66	Pass. (396) (exc. Sp. H/Per.),				
66	Chevy, Chevelle (327, 396),				
66	Pass. (327) (exc. A.I.R.),				
66	Pass. w/Sp. H/Per. (427)				SCREW, lever adjusting (w/3849804- 3868826-8864-9933-3874898-5964- 6746741-3882835-4505-6091-6101), w/3887147,
66	Pass. w/H.D. (396, 427)				
67-72	All w/Holley 4BC	2368956	1	.13	
68	All w/Roch. 1BC	7010435	1	.11	SCREW, pump lever— (3.762)
75	Monza w/A.T. (262) (exc. Towne Coupe)	7011270	1		SCREW, pump lever
75	Vega, Monza w/2BC (140)	335098	4	.19	SCREW, w/lockwasher, pump cover
68	All w/Roch. 2BC (307, 327),				
69-75	All w/Roch. 2BC	7019568	1	.33	WASHER, pump shaft and lever
<b>3.843 LINK—LEVER—ROD, Carburetor Pump Connector</b>					
63-66	Chevy, Chevelle (6 cyl.),				
65	Pass. w/Econ. Carb. (6 cyl.)				w/7023000-3003-3004-3005-5003-4-5,
66-67	Pass. (6 cyl.) (exc. Taxi, A.I.R.),				
67	Chevy, Chevelle, Camaro (6 cyl.) (exc. A.I.R.)	7029787	1	.69	w/7026027-8
64-66	Chevy, Chevelle (283) (exc. 4BC),				

**FUEL—EXHAUST—CARBURETION**

**3.843 LINK— LEVER— ROD, Carburetor Pump Connector (Con't)**

65	Pass. w/2BC, 3/2BC (283) (exc. dist. cont. gov.),				
66-67	Pass. w/2BC (283, 307),				
67-69	Chevy, Chevelle, Camaro w/Roch. 2BC (283, 307, 327)	<b>7036759</b>	1	1.20	w/clip lever actuating (flat in ctr. 2 <sup>15</sup> / <sub>16</sub> " end to end) (Rochester)
64-65	All w/H/Per. (327),				
65	Pass. w/H/Per., dual 4BC (409)	<b>7015137</b>	1	.27	arm connector (Carter 117-182)
68	Pass. (6 cyl.) (exc. P.G.)				pump lever,
70	All w/Roch. 1BC (6 cyl.),				
72-75	All w/Roch. 1BC	<b>7037855</b>	1	.65	carb. pump lever (w/7040014-17-7014-15)
68	Chevy (4 cyl.),				
68	All w/P.G. (6 cyl.),				
69	All w/Roch. 1BC,				
70	Nova (4 cyl.)	<b>7037981</b>	1	.65	pump lever
69	Chevy, Chevelle w/Roch. 2BC (350),				
69	Pass. w/Roch. 2BC	<b>7036760</b>	1	.99	pump connector
70-71	All w/Roch. 2BC (307)	<b>7038802</b>	1	.71	w/7040101-3-10-12-0401-3-10-12-7002-13
70-71	All w/Roch. 2BC (350, 400),				
72-73	All w/Roch. 2BC	<b>7038799</b>	1	.71	w/7040102-4-13-14-15-16-17-18-19-20-27-29-0402-4-13-14-15-16-17-18-19-20-27-29-7004-5-16-19-20-29
73-74	All w/Roch. 1BC	<b>7024214</b>	1	.65	carb. pwr. piston rod
75	All 6 cyl.	<b>7035267</b>	1	.85	carb. pump lever
71-75	Vega, Monza w/1BC	<b>7040900</b>	1	.65	carb. pump lever
71	Vega w/2BC (1st design)	<b>7042804</b>	1	.74	carb. pump connector
71-72	Vega w/2BC (2nd design)	<b>7030635</b>	1	.74	carb. pump connector
71-75	Vega, Monza w/1BC	<b>7027005</b>	1	.57	LEVER, carb. pump rod
66	Chevy (327) (exc. Sp. H/Per.),				
66	Pass. (8 cyl.) (exc. 283, Sp. H/Per.)				ROD (w/7026200-1-2-3-4-5-7036200-1-2-3-4-5),
66	Chevelle (327, 396) (exc. H/Per.),				
67-69	All w/Roch. 4BC				w/7027200-1-2-3-10-11-12-13-7037200-1-2-3-10-11-12-13,
70-75	All w/Roch. 4BC	<b>7026138</b>	1	1.25	ROD
75	All w/2BC	<b>17050277</b>	1	1.25	ROD, carb. pump

**3.844 COVER ASSY., Carburetor Pump**

73-75	Vega, Monza w/2BC (140)	<b>335119</b>	1	1.60	COVER ASSY. (34R-6995A)
-------	-------------------------	---------------	---	------	-------------------------

**3.845 ARM— SCREW ASSY., Carburetor Pump**

73-75	Vega, Monza w/2BC (140)	<b>335098</b>	4	.19	SCREW ASSY., carb. accel. pump cover, w/lockwasher
-------	-------------------------	---------------	---	-----	--

**3.852 ARM— BAFFLE— CAP— NUT— PLUG— RETAINER— SCREW— SHIELD— SPRING— VALVE, Carburetor Idle Vapor Vent**

65	Chevelle w/Sp. H/Per. (327),				
65-66	Pass. (396) (exc. Sp. H/Per.),				
66	Pass. (327) (exc. A.I.R.),				
66	Chevy, Chevelle (327, 396),				
66	Pass. w/Sp. H/Per. (427)				BAFFLE, metering body vent (w/3849804-3868826-8864-9933-3874898-5964-6741-3882835-4505-6091-6101),
66	Pass. w/H.D. (396, 427)				w/3887147,
67-72	All w/Holley 4BC	<b>3852483</b>	1	.73	
70	All w/Roch. 2BC	<b>7038814</b>	1	.32	PLUG, carb. idle vent. hole (1/4") (brass) (Note 2)

*NOTE 2 This part for California use only.*

64-65	Chevy, Chevelle (283, 327),				
65	Pass. w/Roch. (8 cyl.) (exc. 3/2BC),				
66	Pass. (283) (exc. A.I.R.),				
67-70	All w/Roch. 2BC, 4BC	<b>7012548</b>	1	.11	SCREW, idle valve arm
68-70	All w/Roch. 4BC (exc. E.E.C.)	<b>7035431</b>	1	.58	SHIELD, idle vent
69	All w/Roch. 2BC				SHIELD, idle vent,
70	All w/Roch. 2BC (350, 400)	<b>7037718</b>	1	.48	(w/7040102-4-13-14-15-16-17-18-19-20-27-29-0402-4-13-14-15-16-17-18-19-20-27-29-7004-5-16-19-20-29)
65	Chevelle w/Sp. H/Per.	<b>3852475</b>	1	.16	SPRING (w/3863150)
64-66	Chevy, Chevelle (8 cyl.),				
65-66	Pass. (283) (exc. A.I.R.),				
66	Pass. w/4BC (283),				

**FUEL—EXHAUST—CARBURETION**

**3.852 ARM— BAFFLE— CAP— NUT— PLUG— RETAINER— SCREW— SHIELD—  
SPRING— VALVE, Carburetor Idle Vapor Vent (Con't)**

67-70	Pass. w/Roch. 2BC,				
67-70	Chevy, Chevelle, Camaro w/Roch. 2BC (283, 307, 327, 350, 400) .....				VALVE (w/7024 101-10-12-5023-4-5-5103- 26-27-28-6023-24-6121-7036014-15-23- 24-6101-03-10-12-6118-19-20-21-7125) (w/7025200-01), .....
65	Pass. (396) (exc. Sp./H/Per.) ...				
66	Chevelle (327, 396) (exc. H/Per.),				
66	Pass. (8 cyl.) (exc. 283, Sp. H/Per.),				
66	Chevy (327) (exc. Sp. H/Per.) ...				w/7026200-01-02-03-04-05-7036200-01- 02-03-04-05, .....
67-70	All w/Roch. 4BC (exc. E.E.C.) ...	<b>7029993</b>	1	.33	
65	Chevelle w/Sp. H/Per. (327) ...	<b>3877144</b>	1	.33	VALVE (w/3863150) .....
63-66	Chevy, Chevelle (6 cyl.),				
65-66	Pass. (6 cyl.) (exc. A.I.R.),				
67	Pass. w/Roch. 1BC,				
67	Chevy, Chevelle, Camaro (6 cyl.) (exc. A.I.R.) .....	<b>7025599</b>	1	.78	VALVE KIT (Note 1) .....
64-65	Chevy, Chevelle (8 cyl.) (exc. 4BC, P.G., Air Cond.),				
65-66	Pass. w/2BC (283),				
66	Chevy, Chevelle w/A.I.R. (283),				
67-68	Pass. w/Roch. 2BC,				
67-68	Chevy, Chevelle, Camaro w/Roch. 2BC (283, 307, 327) .				VALVE KIT (Note 1), .....
70	All w/Roch. 2BC (307) .....	<b>7012252</b>	1	.84	(w/7040101-3-10-12-0401-3-10-12-7002- 13) .....
64-65	All w/Roch. 4BC,				
66	Chevy, Chevelle w/A.I.R. (283) (exc. 2BC),				
66	Pass. w/4BC (283) .....	<b>7012188</b>	1	.84	VALVE KIT (w/7025 125-6-7-8-6121-7125- 7036118-19-20-21-6125-7125) (Note 1) .
65	Pass. (396) (exc. Sp./H/Per.) ...				VALVE KIT (w/7025200-01), .....
66	Chevelle (327, 396) (exc. H/Per.),				
66	Pass. (8 cyl.) (exc. 283, Sp. H/Per.),				
66	Chevy (327) (exc. Sp. H/Per.) ...				w/7026200-01-02-03-04-05-7036200-01- 02-03-04-05, .....
67	All w/Roch. 4BC .....	<b>7031423</b>	1	.90	w/7027200-1-2-3-10-11-12-13-7037200-1- 2-3-10-11-12-13 (Note 1) .....
68-69	All w/Roch. 1BC .....	<b>7046639</b>	1	.58	VALVE KIT .....
68-70	All w/Roch. 4BC (exc. E.E.C.) ...	<b>7036425</b>	1	1.25	VALVE KIT .....
69	All w/Roch. 2BC .....				VALVE KIT, .....
70	All w/Roch. 2BC (350, 400) ...	<b>7036556</b>	1	1.00	(w/7040102-4-13-14-15-16-17-18-19-20- 27-29-0402-4-13-14-15-16-17-18- 19-20-27-29-7004-5-16-19-20-29) .....

NOTE 1 Consists of arm, valve, and screw.

**3.858 VALVE UNIT— COVER— HOUSING— LEVER— LINK— PISTON— PLATE—  
RETAINER— ROD— SCREW, Carburetor Power**

62-63	Chevy (4 cyl.) .....	<b>7025554</b>	1	.62	w/7020103-0104-0114-0115 .....
63-66	Chevy, Chevelle (6 cyl.),				
65-66	Pass. (6 cyl.) (exc. Taxi, A.I.R.),				
67	Chevy, Chevelle, Camaro (6 cyl.) (exc. A.I.R.) .....	<b>7026961</b>	1	.67	w/7023000-03-3100-05-08-4000-01-5000- 03-105-108-6027-8 .....
64-66	Chevy, Chevelle (8 cyl.) (exc. 4BC),				
65-66	Pass. (283) (exc. A.I.R. 4BC),				
73	All w/A.T. (307) .....	<b>7006331</b>	1	1.85	w/7024100-1-2-6-8-10-12-5103 .....
64-65	Chevelle w/H/Per. (327) .....				discharge needle (w/3863150-8864- 3874898-8261), .....
65-66	Pass. (396) (exc. Sp. H/Per.),				
66	Pass. (327) (exc. A.I.R.),				
66	Pass. w/Sp. H/Per. (427) .....				pump disc. needle (w/3849804-3868826- 8864-9933-3874898-5964-6741- 3882835-4505-6101), .....
66	Pass. w/H.D. (396, 427) .....				w/3887147, .....
66	Chevelle (327, 396) .....				w/3868864-3874898-5974-6747-7413- 3886087-8-3890497-2338-9-3229, .....
67-72	All w/Holley 4BC .....	<b>3852485</b>	A.R.	.33	

**FUEL—EXHAUST—CARBURETION**

**3.858 VALVE UNIT— COVER— HOUSING— LEVER— LINK— PISTON— PLATE—  
RETAINER— ROD— SCREW, Carburetor Power (Con't)**

64-66	Chevy, Chevelle w/4BC			w/7024120-22-25-26-4220-25-26-5126-7-8, .....
65	Pass. w/Roch. 4BC,			
66	Chevy, Chevelle w/A.I.R. (283) (exc. 2BC),			
66	Pass. w/4BC (283)			w/7025126-7-8-6121-7125-7036118-19-20-21-7125, .....
69	Pass. w/Roch. 2BC,			
69-71	All w/Roch. 2BC (350, 400),			
72	All w/Roch. 2BC, A.T. (350, 400)	7011989	1	1.85
65-66	Pass. w/Sp. H/Per. (396),			
65-66	Pass. (396, 427) (exc. Sp. H/Per., A.I.R.)			(Holley 25R-219A-45) (w/3868864-3874898), w/3893229, .....
66	Chevelle w/Sp. H/Per. (396)			
68-69	Pass. (Holley 4BC w/Sp. H/Per.) (427),			
68-69	Chevy, Chevelle, Camaro w/Holley 4BC (302, 396)			w/3923289, .....
70-72	All w/Holley 4BC	3877167	A.R.	1.85 secondary
65	Chevelle w/Sp. H/Per. (327)			power (w/3863150), .....
66	Chevy (327)			w/3877413-3890497, .....
66	Chevelle (396)			w/3886087-8-3892338-9, .....
67	Chevy, Chevelle, Camaro w/Holley 4BC	3852470	1	1.70 w/3903389-91-8956-7-8-9
66	Chevy, Chevelle w/A.I.R. (283)			w/7036101-3-10-12, .....
67	All w/Roch. 2BC	7009349	1	1.85 w/7027100-1-03-10-12-14-16-7037100-1-03-10-12 w/7027100-5-6-7036101-3-10-12-7100-5, ..
66	Pass. w/A.I.R. (283) (exc. 4BC)			
68	Chevy, Chevelle, Camaro w/Roch. 2BC,			
68	Pass. w/Roch. 2BC (307),			
69-70	Chevy, Chevelle, Camaro w/Roch. 2BC (307, 327),			
71-72	All w/Roch. 2BC (307)	7010918	1	1.85 (w/7028101-03-05-06-07-10-11-12-25-27-7040101-3-10-12-0401-3-10-12-7002-13)
67-69	Chevy, Chevelle, Camaro w/Holley 4BC (302, 396),			
67-69	Pass. w/Sp. H/Per. (427)			w/3916143-5-3923289, .....
70	All (Holley 4BC w/A.T.) w/Sp. H/Per. (396, 454) (exc. E.E.C.),			
72	All w/Holley 4BC	3898991	A.R.	1.70 primary (w/3969898) .....
72	All w/Roch. 2BC (350) (exc. A.T.)	7037812	1	1.80 carb. power .....
73	All (307) (exc. A.T.)	7037115	1	1.80 carb. pwr. .....
73-75	All w/2BC (350, 400)	7011989	1	1.85 carb. power .....
75	All w/2BC (262)	7022777	1	1.85 carb. power .....
71-72	Vega w/2BC	7030507	1	14.55 VALVE ASSY. ....
71	Vega w/1BC,			
72	Vega (1BC w/NB-2)	7026660	1	.99 VALVE ASSY. ....
72-73	Vega w/1BC,			
75	Vega, Monza w/1BC	7030668	1	.99 VALVE ASSY. ....
73-75	Vega, Monza w/2BC	335113	1	1.60 VALVE ASSY. ....
73-74	Vega w/2BC	335114	1	2.70 VALVE ASSY., carb. power oper. rod .....
74	Vega w/1BC (140)	7042849	1	.99 VALVE ASSY. ....
75	Monza w/A.T. (exc. Towne Cpe.) (262)	7022777	1	1.85 VALVE ASSY. ....
65	Chevelle w/Sp. H/Per.,			
65-66	Pass. (396) (exc. Sp. H/Per.),			
66	Pass. (327) (exc. A.I.R.),			
66	Chevelle (327, 396),			
66	Pass. w/Sp. H/Per. (427)			HOUSING, carb. diaphragm (secondary) (Holley No. 79R-389) (w/3849804-3868826-8864-9933-3874898-5964-6741-3882835-4505-6101), w/3887147, .....
66	Pass. w/H.D. (396, 427)			
67-72	All w/Holley 4BC	2368960	1	2.20
70	All w/Roch. 1BC,			
71-74	Vega w/1BC	7042670	1	1.20 LEVER, pump actuator .....
65	Chevelle w/Sp. H/Per. (327),			
65-66	Pass. (396) (exc. Sp./H/Per.),			
65-66	Pass. (327) (exc. A.I.R.),			
65-66	Pass. w/Sp. H/Per. (427),			

**FUEL—EXHAUST—CARBURETION**

**3.858 VALVE UNIT— COVER— HOUSING— LEVER— LINK— PISTON— PLATE—  
RETAINER— ROD— SCREW, Carburetor Power (Con't)**

66	Chevy, Chevelle (327, 396) . . . . .				<b>LEVER ASSY.</b> , carb. diaph. (Holley No. 63R-354A) (w/3849804-3868826-64-9933-3874898-5964-6741-3882835-4505-6091-6101), . . . . .
					w/3887147, . . . . .
66	Pass. w/H.D. (396, 427) . . . . .				
67-69	Chevy, Chevelle, Camaro w/Holley 4BC,				
68-69	Pass. (Holley 4BC w/Sp. H/Per.) (427),				
70	All (Holley 4BC w/Sp. H/Per.) (396, 454) (exc. E.E.C., A.T.),				
71-72	All w/Holley 4BC . . . . .	<b>3869001</b>	1	.42	
68-70	All w/Roch. 1BC . . . . .	<b>7035502</b>	1	.65	<b>LINK</b> , power piston rod . . . . .
71-73	All w/Roch. 1BC (6 cyl.) . . . . .	<b>7024214</b>	1	.65	<b>LINK</b> , carb. pump lever . . . . .
62	Chevy,				
63-66	Chevy, Chevelle (6 cyl.),				
65	Pass. (6 cyl.),				
67	Chevelle, Camaro (230) (exc. A.I.R.),				
67	Chevy (194) (exc. A.I.R.),				
67	Chevy w/P.G. (250) (exc. A.I.R.) . . . . .	<b>7010002</b>	1	1.40	<b>PISTON</b> , w/bleed tube (w/7020103-04-05-08-14-15-3000-03-3105-08-4000-01-5000-3-105-08-7027009-7037009) . . . . .
64-66	Chevy, Chevelle w/Air Cond. (283) (exc. P.G., 4BC) . . . . .				<b>PISTON</b> (w/7024101-5103), . . . . .
65-67	Pass. (283) (exc. P.G., A.I.R. 4BC),				
67	All w/2BC (283) (exc. A.I.R., P.G.),				
68	All w/Roch. 2BC,				
69	All w/Roch. 2BC (307, 327),				
70	All (Roch. 2BC w/A.T.) (307) . . . . .				(w/7040110-12-0410-12-7002), . . . . .
70	All w/Roch. 2BC (350) (exc. A.T.),				
73-74	All (A.T. w/2BC) (350) . . . . .	<b>7006323</b>	1	.78	(w/7040113-15-27-29-0413-15-27-29-7005-29) . . . . .
64-65	Chevy, Chevelle w/H/Per. (327) . . . . .				<b>PISTON</b> (w/3851761-62), . . . . .
65	Pass. w/H/Per., Dual 4BC (409),				
65	Pass. w/H/Per. (327),				
66	All (327) (exc. A.I.R., Sp. H/Per.)	<b>1195596 A.R.</b>		1.30	(w/3760264-4593-3772600-3795596-7699-3815403-04-9207-3820580-6004-06-7324-3851761-62-5581-6580-3875966-6749) . . . . .
64-65	Chevy w/P.G. (8 cyl.) (exc. 4BC),				
64-66	Chevy, Chevelle w/4BC, Air Cond. (8 cyl.) . . . . .				<b>PISTON</b> (w/7024100-2-6-8-10-11-12-4220-22-25-26-56-5126-7-8, . . . . .
65	Pass. w/P.G. (283),				
65	Pass. w/Roch. 4BC (exc. 409),				
66	Pass. w/4BC (283),				
66	Chevy, Chevelle w/A.I.R. (283) (exc. 2BC) . . . . .				w/7025126-7-8-6121-7036118-19-20-21, . . . . .
69	Pass. w/Roch. 2BC,				
69	Chevy, Chevelle, Camaro w/Roch. 2BC (350),				
70	All (Roch. 2BC w/A.T.) (350),				
70-71	All w/Roch. 2BC (400) (exc. A.T.),				
72	All (Roch. 2BC w/A.T.) (350, 400) . . . . .				(w/7040102-4-14-16-17-18-19-20-0402-4-14-16-17-18-19-20-7004-16-19-20), . . . . .
73	All w/A.T. (307),				
75	All w/2BC (350) . . . . .	<b>7009718</b>	1	.78	carb. power valve . . . . .
65	Pass. (396) (exc. Sp. H/Per.) . . . . .				<b>PISTON</b> , valve prim. (w/7025200-01-20-21), . . . . .
66-67	Chevy, Chevelle w/A.I.R. (283) (exc. 4BC),				
66	Chevy (327) (exc. Sp. H/Per.),				
66	Pass. (8 cyl.) (exc. 283, Sp. H/Per.) . . . . .				w/7026200-1-2-3-4-5-7036200-1-2-3-4-5, . . . . .
67	All w/Roch. 4BC . . . . .	<b>7032979</b>	1	2.45	w/7027200-1-2-3-10-11-12-13-7037200-1-2-3-10-11-12-13 . . . . .
66-67	Pass. (6 cyl.) (exc. Taxi, A.I.R.) . . . . .	<b>7027765</b>	1	1.40	<b>PISTON</b> , w/bleed tube (w/7026027-8) . . . . .



FUEL—EXHAUST—CARBURETION

**3.858 VALVE UNIT— COVER— HOUSING— LEVER— LINK— PISTON— PLATE— RETAINER— ROD— SCREW, Carburetor Power (Con't)**

66-67	All w/A.I.R. (283) (exc. 4BC) . . .	7009054	1	.78	PISTON (w/7036101-03-10-12-7101-3-10-12-7027110-12-14-16-7037101-03-10-12) . . . . .
67	Chevy, Chevelle, Camaro (250) (exc. A.I.R.) . . . . .	7027765	1	1.40	PISTON, w/tube (w/7026027-8) . . . . .
68-74	All w/Roch. 4BC . . . . .	7034903	1	1.75	PISTON . . . . .
68-70	Chevy (4 cyl.),				
68-69	All w/A.T. (6 cyl.) . . . . .	7035295	1	1.85	PISTON (w/7028006-8-9-10-12-13-14-7029008-7040008-7008) . . . . .
68	All (6 cyl.) (exc. P.G.) . . . . .	7036066	1	1.85	PISTON (w/7028007-8011-15-17) . . . . .
69-70	All (Roch. 1BC w/A.T.) (6 cyl.),				
71-72	All w/Roch. 1BC . . . . .	7037780	1	1.85	PISTON (w/7029014-7040014-7014) . . . . .
69	All w/Roch. 1BC (exc. A.T.),				
74-75	All (1BC w/A.T.) w/NB-2 . . . . .	7035889	1	1.70	PISTON (w/7029015-17) . . . . .
70	All w/Roch. 2BC (307) (exc. A.T.),				
71	All w/Roch. 2BC (307),				
71	All (Roch. 2BC w/A.T.) (350),				
71	All (2BC w/A.T.) (400),				
71-72	Vega w/2BC,				
72-73	All w/Roch. 2BC (307) . . . . .	7006011	1	.78	PISTON ASSY. (w/7040101-3-7013-7041101-02-10-14-17-18-7104-07-10-11-12-18) . . . . .
71	All w/Roch. 2BC (350) (exc. A.T.) . . . . .	7006323	1	.78	PISTON ASSY., carb. power valve (w/7041113-27-7113-27) . . . . .
72	All w/Roch. 2BC (350) (exc. A.T.),				
75	All w/2BC (262) . . . . .	7037811	1	1.80	PISTON ASSY., carb. power valve . . . . .
73	All (307) (exc. A.T.) . . . . .	7034359	1	1.75	PISTON ASSY., vlv. . . . .
73-74	All w/2BC (350) (exc. A.T.) . . . . .	7009054	1	.78	PISTON ASSY., vlv. . . . .
73-75	All w/1BC (exc. NB-2) . . . . .	7037804	1	1.80	PISTON ASSY. . . . .
75	All w/1BC (w/NB-2) . . . . .	7035512	1	1.85	PISTON ASSY., carb. power . . . . .
75	All w/4BC . . . . .	7041460	1	1.90	PISTON ASSY., carb. power . . . . .
65	Pass. (396) (exc. Sp. H/Per.) . . . . .				RETAINER, power piston (w/7025200-1-20-21), . . . . .
66	Chevelle (327, 396) (exc. H/Per.),				
66	Pass. (8 cyl.) (exc. 283, Sp. H/Per.),				
66	Chevy (327) (exc. Sp. H/Per.),				
67	All w/Roch. 4BC . . . . .	7034339	1	.21	w/7026200-1-2-3-4-5-7036200-1-2-3-4-5 . . . . .
68-70	All w/Roch. 1BC . . . . .	7035297	1	.58	ROD, piston . . . . .
71-75	All w/Roch. 1BC, integrated cyl. hd. . . . .	7024215	1	.58	ROD, piston . . . . .
64-65	All w/H/Per. (327),				
72	All w/Holley 4BC . . . . .	2285779	4	.04	SCREW, w/lockwasher fuel pump cover . . . . .
73-74	Vega w/2BC . . . . .	2285812	3	.08	SCREW, carb. power valve oper. rod to air horn . . . . .

**3.859 SPRING, Carburetor Power Piston**

62-66	Chevy, Chevelle (6 cyl.) (exc. 230),				(41 coils-2 <sup>17</sup> / <sub>64</sub> " free length) (red), . . . . .
65	Pass. w/econ. carb. (230) . . . . .				(w/7020105-0108-3105-8-5105-8) . . . . .
67	Chevy (194) (exc. A.I.R.) . . . . .	7002366	1	.29	
64-66	Chevy, Chevelle (230),				
65-67	Pass. (6 cyl.) (exc. Taxi, A.I.R.),				
67	All (230, 250) (exc. A.I.R.) . . . . .	7002896	1	.29	(power vac. piston/33 coils) (blue) . . . . .
65	Pass. (396) (exc. Sp. H/Per.) . . . . .				(w/7025200-01), . . . . .
66	Chevelle (327, 396) (exc. H/Per.),				
66	Pass. (8 cyl.) (exc. 283, Sp. H/Per.),				
66	Chevy (327) (exc. Sp. H/Per.) . . . . .				w/7026200-1-2-3-4-5-7036200-1-2-3-4-5, . . . . .
67	All w/Roch. 4BC . . . . .	7029922	1	.20	w/7027200-1-2-3-10-11-12-13-7037200-1-2-3-10-11-12-13 . . . . .
65-67	Chevelle w/Sp. H/Per. (327) . . . . .				diaphragm secondary (w/3863150-3903389-91), . . . . .
66	Pass. w/H.D. (396, 427) . . . . .				w/3887147, . . . . .
66	Chevy, Chevelle w/Sp. H/Per. (327),				
67	Pass. w/Sp. H/Per. (427) (exc. A.I.R.) . . . . .				w/3916143-3890497, . . . . .

**FUEL—EXHAUST—CARBURETION**

**3.859 SPRING, Carburetor Power Piston (Con't)**

67-69	Chevy, Chevelle, Camaro w/Holley 4BC,				
68-69	Pass. (Holley 4BC w/Sp. H/Per.) (427) .....				w/3923289-55 19-3955205, .....
70-72	All w/Holley 4BC .....	3877148	1	.48	carb. diaph. secondary .....
66	Chevelle w/H/Per. (396) .....				diaphragm, secondary (w/3886087-8- 3892338-9), .....
67	Chevy, Chevelle w/Sp. H/Per. (327) (exc. A.I.R.) .....				w/3903389, .....
67	Chevelle, Camaro w/Holley 4BC (396) .....	3867992	1	.76	w/3908956-7-8-9 .....
68-71	All (6 cyl.),				
72	All w/Roch. 1BC,				
73	All w/Roch. 1BC,				
74-75	All (1BC w/A.T.) w/NB-2 .....	7012515	1	.29	vacuum piston .....
68-74	All w/Roch. 4BC .....	7036019	1	.28	(power piston) .....
68-70	Chevy (4 cyl.),				
68	Chevy, Chevelle, Camaro w/P.G. (6 cyl.),				
73	All w/Roch. 1BC (exc. A.T.),				
74-75	All (1BC w/A.T.) (exc. NB-2),				
74	All w/1BC (exc. A.T.) .....	7034360	1	.43	carb. pwr. piston .....
75	All w/1BC w/M.T. ....	7036280			
75	All w/4BC (exc. 454) .....	17052057	1	.37	power piston .....
75	All (454) .....	7041477	1	.28	SPRING, power piston .....

**3.880 CONTROL ASSY.— BRACE— BRACKET— BOLT— CABLE ASSY.—  
COVER— FITTING ASSY.— GROMMET— PLATE— RETAINER— SHAFT  
ASSY.— SLEEVE— STRIKER— STUD— SUPPORT— TEE ASSY., Speed and  
Cruise Control**

75	Chevelle (exc. Monte Carlo) ....	994947	1		CRUISE CONTROL PKG. ....
75	Pass. ....	CRUISE CO	1		CRUISE CONTROL PKG. ....
70	Chevelle (396, 400, 454) .....	3974005	1	2.25	BRACE, accel. pedal cable .....
71-72	Pass., Chevelle w/2BC .....	3990822	1	.38	BRACE, accel. pedal cable .....
71-72	Pass., Chevelle w/4BC .....	3990823	1	.16	BRACE, accel. pedal cable .....
71-72	Pass., Chevelle w/2BC,				
73	Pass., Monte Carlo .....	3990822	1	.38	BRACE, accel. pedal cable .....
71-72	Pass., Chevelle w/2BC,				
73	Pass., Monte Carlo .....	3990823	1	.16	BRACE, accel. pedal cable .....
74	Pass., Chevelle w/2BC .....	342406	1	.42	BRACKET, speed cruise control cable .....
74-75	All w/4BC .....	342407	1	.42	BRACKET, speed cruise control cable .....
75	Pass., Chevelle w/2BC (350) ...	354668	1	2.20	BRACKET, speed cruise cont. cable .....
75	Chevelle, Nova .....	355587	1	.23	BOLT, speed cruise cont. carb. bracket .....
69-70	Chevelle .....	3943641	1	7.25	CABLE ASSY., w/casing (selector)— (4.342) .....
70	Pass. w/2BC .....	3990847	1	7.75	CABLE ASSY. (w/994004) .....
70	Pass. w/4BC .....	3990848	1	5.15	CABLE ASSY. (w/994004) .....
71-72	Chevelle .....	3990881	1	6.90	CABLE ASSY. ....
71-72	Pass. ....	3990836	1	5.15	CABLE ASSY. ....
73	Pass. ....	3990836	1	5.15	CABLE ASSY. ....
73-74	Monte Carlo .....	342456	1	10.05	CABLE ASSY. ....
73-74	Chevelle (exc. Monte Carlo),				
74	Pass. ....	342457	1	8.60	CABLE ASSY. ....
75	Pass., Chevelle (exc. Monte Carlo) .....	354696	1	9.65	CABLE ASSY. ....
75	Monte Carlo .....	354697	1	10.05	CABLE ASSY. ....
71-73	Pass., Chevelle .....	3990896	1	.84	COVER, servo bracket .....
67	Chevelle .....	3875822	1	.52	GROMMET, vacuum release hose— (9.775)
74-75	Chevelle .....	1238731	1	.48	PLATE, cruise vac. release .....
71-73	Pass., Chevelle .....	3990839	1	.18	RETAINER, servo cable .....
65-66	Pass., Chevelle .....	3852599	1	13.10	SHAFT ASSY., w/casing, control regulator to transmission (72" O.L.)— (4.342) .....
65-66	Chevelle .....	6478121	1	6.42	SHAFT ASSY., regulator to speedometer (w/casing) (40")— (4.342) .....
65-69	Chevelle,				
67-68	Pass. ....	3919007	1	4.95	SHAFT ASSY., w/casing (37")— (4.342) ...
67	Pass. ....	6478132	1	10.83	SHAFT ASSY., w/casing, regulator to trans.— (4.342) .....
68	Chevelle .....	6478123	1	6.74	SHAFT ASSY., less casing (48") (repl. 3928703)— (4.342) .....
69-70	Pass. ....	6477264	1	2.06	SHAFT ASSY., less casing (to speedo shaft) (29 <sup>7</sup> / <sub>16</sub> ")— (4.342) .....
69	Pass. ....	6478168	1	6.87	SHAFT ASSY., w/casing (29") (repl. 6477528)— (4.342) .....

**FUEL—EXHAUST—CARBURETION**

**3.880 CONTROL ASSY.— BRACE— BRACKET— BOLT— CABLE ASSY.— COVER— FITTING ASSY.— GROMMET— PLATE— RETAINER— SHAFT ASSY.— SLEEVE— STRIKER— STUD— SUPPORT— TEE ASSY., Speed and Cruise Control (Con't)**

71	Pass.	6478170	1	6.44	SHAFT ASSY., regulator to speedometer— (4.342)
71	Pass.	6478125	1	7.13	SHAFT ASSY., regulator to transmission
73-74	Pass.	6478124	1	7.10	SHAFT ASSY., flex. (52") (HC #507)
68-70	Chevelle				SLEEVE, cable cover,
70	Pass.	3934220	1	2.25	w/994004
68	Chevelle w/Disc Brakes,				
68-72	Chevelle	3928702	1	1.60	STRIKER, vacuum release valve
69-70	Pass. w/P.B.	3948925	1	.82	STRIKER, vacuum release valve
73-74	Monte Carlo,				
75	Chevelle	1238731	1	.48	STRIKER, vacuum release valve
65-66	All	3731702 A.R.		.34	STUD, inlet manifold (3/8" x 1 1/8")— (3.288)
71-72	All w/Speed and Cruise Control,				
73-74	Pass., Monte Carlo w/2BC	3990837	1	.36	STUD, accel. lever ball— (3.425)
73-74	Pass., Monte Carlo w/4BC	3990838	1	.60	STUD, accel. lever ball— (3.425)
68	Chevelle (327, 396)	3943667	1	.61	SUPPORT, cable bracket— (3.454)
69	Chevelle (8 cyl.) w/A.T. (exc. T.H. 350),				
70	Pass.				SUPPORT (w/994004),
70	Chevelle w/4BC (350)	3951291	1	2.40	accel. pedal cont. cable
70	Pass. w/C.A.C. (8 cyl.) (exc. P.B.)	3894339	1	3.85	TEE ASSY., vacuum inlet manifold (repl. 3891527)— (7.447)

**3.883 SWITCH— BUTTON— WASHER, Speed and Cruise Selector**

67-68	Pass., Chevelle, Camaro,				
69-71	All	6466018	1	5.28	SWITCH, actuating
70	Pass. (8 cyl.),				
71-72	Pass., Chevelle	6465701	1	17.17	SWITCH ASSY., activating
73-74	Pass., Chevelle (exc. Monte Carlo),				
75	Pass., Chevelle	6499310	1	17.17	SWITCH ASSY., activating
74	Pass., Chevelle	6466018	1	5.28	SWITCH ASSY., actuating (spring loaded)
70-71	Pass., Chevelle	6465300	1	.78	BUTTON, activating switch

**3.885 REGULATOR ASSY.— ADAPTER— BRACKET— CHAIN ASSY.— CLIP— GUIDE— HOSE— ROD— SERVO ASSY.— SPRING— TEE— VALVE ASSY., Speed and Cruise Control Power**

67-68	Pass., Chevelle, Camaro	6465116	1	62.73	
69-70	Pass.,				
70-72	Chevelle	6466184	1	63.66	(repl. 6465641)
69	Chevelle, Camaro	6465574	1	55.30	
71-72	Pass.,				
73-74	Pass., Monte Carlo,				
75	All	6465795	1	71.56	
74-75	All	3963229	1	.88	ADAPTER, cruise control vac. hose
70-72	Chevelle	3974002	1	7.65	BRACKET
71-72	Chevelle	3990879	1	2.30	BRACKET, servo
67-68	Chevelle,				
67-70	Pass.	3917989	1	2.20	BRACKET ASSY., servo
67-70	Pass.,				
68	Chevelle, Camaro,				
69	Chevelle	3927351	1	1.70	BRACKET ASSY., regulator
67-70	Pass.	3948926	1	.28	BRACKET ASSY., vacuum release valve
68-70	Camaro	3929820	1	6.50	BRACKET ASSY., servo
69	Camaro	6465381	1	2.75	BRACKET ASSY., regulator
71-73	Pass.	3990832	1	2.05	BRACKET ASSY., servo
71-75	Pass.	3990834	1	1.55	BRACKET ASSY., regulator
73-75	Monte Carlo	6258202	1	5.35	BRACKET ASSY., regulator
73-75	Monte Carlo	6258201	1	3.00	BRACKET ASSY., servo
74	Pass.	330127	1	1.75	BRACKET ASSY., speed cruise control servo
67	Chevelle,				
67-70	Pass., Camaro	3901773	1	.28	CHAIN ASSY., control ball
68-70	Chevelle				CHAIN ASSY., control ball,
70	Pass.	3934222	1	.36	(w/994004)
67-70	Pass.,				
67	Chevelle	3961539	1	.42	CLIP, ball chain
67	Pass. (exc. level ride),				
67	Chevelle w/A.T. (8 cyl.) (exc. level ride),				
67-70	Camaro,				

**FUEL—EXHAUST—CARBURETION**

**3.885 REGULATOR ASSY.— ADAPTER— BRACKET— CHAIN ASSY.— CLIP— GUIDE— HOSE— ROD— SERVO ASSY.— SPRING— TEE— VALVE ASSY., Speed and Cruise Control Power (Con't)**

67-72	Chevelle,					
68	Camaro w/A.T. (exc. level ride),					
68	Pass.,					
71-75	Pass. ....					CLIP, vacuum release valve, .....
69	Camaro w/Spec. Duct Hood . . . .	9788460	1	.14		carb. air cont. valve solenoid switch . . . . .
75	All (exc. Vega, Monza) . . . . .	9796744	1	.23		CLIP, cruise release valve to switch mtg. bracket . . . . .
						CLIP, control cable, .....
68	Chevelle . . . . .					
69	Chevelle (Roch. 2BC w/A.T.) (exc. T.H. 350),					
70	Chevelle (exc. Monte Carlo),					
70	Monte Carlo (8 cyl.) (exc. 4BC, 400, 454) . . . . .	3934221	1	1.65		ball chain clip . . . . .
68	Chevelle,					
69-70	Pass. . . . .	3928701	1	3.75		CLIP, vacuum release valve . . . . .
70	Pass., Chevelle . . . . .	9787740	1	.15		CLIP, ball chain to throttle (w/994004) . . . . .
71*	Chevelle w/4BC . . . . .	3986864	1	.36		CLIP, ball chain . . . . .
68-69	Camaro . . . . .	3929822	1	.36		GUIDE, ball chain . . . . .
69	Chevelle . . . . .					HOSE, servo to reg. air input, .....
74-75	Vega, Monza w/2BC (140) . . . . .	3943638	1	1.70		E.G.R., valve (7/32" long) . . . . .
69	Pass., Chevelle . . . . .	3943639	1	.36		HOSE, servo to reg. vacuum input (9/32") . . . . .
71-72	Chevelle . . . . .	3990880	1	.36		HOSE, servo to tee (1 1/4") . . . . .
67-68	Pass., Chevelle, Camaro . . . . .	6465142	1	14.59		SERVO ASSY. . . . .
69-70	Pass., Chevelle, Camaro . . . . .	6465480	1	15.46		SERVO ASSY. . . . .
71-73	Pass., Chevelle . . . . .	6465796	1	17.99		SERVO ASSY. . . . .
73-74	Monte Carlo,					
74-75	Pass.,					
75	Chevelle, Nova . . . . .	6494922	1	17.99		SERVO ASSY. . . . .
69-70	Pass., Chevelle, Camaro,					
71-72	Chevelle . . . . .	6465399	1	.51		TEE, servo hose . . . . .
71	Pass. (exc. C.A.C.) . . . . .	3752621	1	.22		TEE, vac. hose— (9.281) . . . . .
73-74	Pass., Monte Carlo . . . . .	352252	1	3.40		TEE, vac. . . . .
75	Pass., Chevelle . . . . .	3963228	1	.32		TEE, vac. . . . .
75	All (exc. Vega, Monza) . . . . .	352252	1	3.40		TEE, vac. hose . . . . .
67-70	Pass., Chevelle, Camaro,					
71-75	All (exc. Vega, Monza) . . . . .	6465213	1	5.58		VALVE ASSY., vacuum release . . . . .

**3.887 HARNESS ASSY.— BLOCK UNIT— CLIP— COVER— ELEMENT— GASKET— LEVER ASSY.— MAGNET ASSY.— MOTOR ASSY.— PROTECTOR— RELAY ASSY.— SWITCH, Speed and Cruise Control**

*NOTE 1 Use 6290647 with production installed RPO K-30, use 6290674 with dealer installed accessory.*

68-70	Pass., Chevelle, Camaro,					
72	Chevelle . . . . .	6297641	1	9.95		
71-73	Pass. . . . .	8901779	1	9.75		wiring . . . . .
73-74	Monte Carlo,					
75	Chevelle . . . . .	8908253		10.05		wiring . . . . .
74-75	Pass. . . . .	8908417	1	20.40		wiring . . . . .
65-66	Pass. . . . .	1484810	1	5.90		BLOCK UNIT, reg. terminal . . . . .
67	Chevelle,					
67-70	Pass. . . . .	3901794	2	.23		CLIP, harness . . . . .
67-68	Pass., Chevelle,					
67	Camaro . . . . .	6465056	1	.38		ELEMENT, filter . . . . .
67-68	Chevelle,					
67-69	Pass.,					
67	Camaro . . . . .	6465055	1	.21		GASKET, solenoid and filter cover . . . . .
67-68	Chevelle, Camaro,					
67	Pass.,					
68-71	Pass., Chevelle, Camaro . . . . .	6465256	1	20.65		LEVER ASSY., actuator— (2.895) (Note 2) . . . . .
						<i>NOTE 2 Also used as lever to actuate directional signals.</i>
65-66	Pass., Chevelle . . . . .	1484804	1	36.75		MOTOR ASSY., reg. . . . .
69	Pass. (8 cyl.),					
70-75	All (exc. Vega, Monza) . . . . .	7806271	1	.43		PROTECTOR, tilt steering wheel (7 1/16" black) . . . . .
65-66	Chevelle . . . . .	1484810	1	5.90		SWITCH, w/board, regulator terminal . . . . .
65-66	Chevelle,					
65-67	Pass. . . . .	3772117	A.R.	2.80		SWITCH ASSY., control brake release and control clutch release . . . . .
67-71	Pass., Chevelle, Camaro,					
72-74	Pass., Chevelle . . . . .	9794682	1	3.73		SWITCH ASSY., control . . . . .

**3.890 FUEL FILTER ASSY.— BOWL— BRACKET— CLAMP— ELEMENT— GASKET— SUPPORT, Carburetor**

64-65	All w/H/Per. (327) . . . . .	854444	1	5.23		(AC-GF-48) (carb. mtg.) . . . . .
-------	------------------------------	--------	---	------	--	-----------------------------------

FUEL—EXHAUST—CARBURETION

**3.890 FUEL FILTER ASSY.— BOWL— BRACKET— CLAMP— ELEMENT— GASKET— SUPPORT, Carburetor (Con't)**

65	Chevelle w/Sp. H/Per. . . . .	5650899	1	8.24	(Note 1) . . . . .
	<i>NOTE 1 If 1/8" vent opening is not required, crimp and solder.</i>				
65	Pass. w/Sp. H/Per. (396),				
66	Chevelle w/Sp. H/Per. (396),				
66	Pass. w/Sp. H/Per. (427) . . . . .	5651146	1	5.16	(AC-GF-416) . . . . .
66	All w/Roch. Carb. (327) . . . . .	854583	1	3.80	inline (AC-GF-61) . . . . .
66	Pass. (396, 427),				
71-72	Monte Carlo (4BC w/C.A.C.)				
	(350),				
71	Monte Carlo (C.A.C. w/2BC)				
	(400),				
71	Camaro w/4BC (400),				
71-72	Nova w/4BC (350) . . . . .	5650829	1	5.17	
66	Chevelle w/Roch. Carb. (396),				
67	Pass. w/Roch. Carb. (396, 427) .	854619	1	3.73	in line (AC-GF-61P) . . . . .
67-69	Pass. (427) (exc. Sp. H/Per.),				
68-69	Police,				
69	Chevy, Camaro (396) (exc. Sp.				
	H/Per.),				
69	Chevelle (exc. Sp. H/Per. 396),				
69	Camaro (350),				
70	Pass. (454),				
70	Police w/4BC (350) (exc. C.A.C.),				
70	Nova, Camaro w/H/Per. (396),				
70	Nova w/4BC (350),				
70	Camaro w/Sp. H/Per. (454),				
70	Pass., Monte Carlo (4BC				
	w/C.A.C.) (350),				
72	Camaro (402) . . . . .	5651480	1	7.94	fuel (AC-GF-432) . . . . .
75	Vega, Monza (122) . . . . .	342603	1	5.30	
64-65	All w/H/Per. (327),				
65	Pass. (409) . . . . .	854237	1	.88	<b>BOWL</b> (AC-CF-20) (glass) . . . . .
71-72	Camaro (400) . . . . .	3992006	1	.85	<b>BRACKET</b> , filter . . . . .
69	Pass. (396, 427),				
69	Police (396) (exc. C.A.C.) . . . . .	3952309	1	.97	<b>BRACKET ASSY.</b> . . . . .
70-72	Nova w/4BC (350),				
70	Pass., Monte Carlo (4BC				
	w/C.A.C.) (350),				
70	Police w/4BC (350) (exc. C.A.C.),				
71-72	Monte Carlo (4BC w/C.A.C.)				
	(350),				
71	Monte Carlo w/2BC (400) . . . . .	3965599	1	.55	<b>BRACKET ASSY.</b> , filter . . . . .
75	Vega, Monza (122) . . . . .	339076	1	.92	<b>BRACKET</b> , fuel filte . . . . .
71-72	Camaro (400) . . . . .	3992007	1	.23	<b>CLAMP</b> , filter . . . . .
64-65	All w/H/Per. (327) . . . . .	854347	1	2.42	<b>ELEMENT</b> , w/gasket (AC-GF-124) . . . . .
65	Pass. (409) . . . . .	854567	1	2.50	<b>ELEMENT</b> , w/gasket . . . . .
64-65	All w/H/Per. (327) . . . . .	854390	1	.11	<b>GASKET</b> , strainer (AC-CF-132) (cork) . . . . .
64-65	All w/H/Per. (327),				
65	Pass. (409) . . . . .	854389	1	.16	<b>GASKET</b> , filter bowl (AC-106) (cork) . . . . .
70	Pass. (454),				
70	Nova, Camaro (396, 454) . . . . .	3967498	1	.17	<b>SUPPORT</b> , filter . . . . .

**3.900 PUMP ASSY., Fuel with Gasket**

62-66	All (exc. 8 cyl., A.I.R.) . . . . .	6415725	1	15.65	(stamped 5656790) . . . . .
64-66	Chevy, Chevelle w/4BC (exc. Sp.				
	H/Per.),				
65-66	Pass. w/4BC (283, 327, 409) . .	6415616	1	14.84	
64-66	All (283) (exc. 4BC) . . . . .	6415824	1	14.95	
65	Pass. (409) (exc. RPO Z11) . . . .	5621887	1	13.74	
65-66	Chevy, Chevelle w/A.I.R. (6 cyl.),				
66	Pass. w/A.I.R. (6 cyl.),				
67	All (6 cyl.),				
68-70	All (4 cyl., 6 cyl.),				
71-74	All (6 cyl.) . . . . .	6416502	1	14.79	(type 40446) . . . . .
65-66	Chevelle w/Sp. H/Per. (327) . . .	6415563	1	20.27	
65	Pass. (396, 427),				
66	Chevelle (396) (exc. H/Per., Sp.				
	H/Per.),				
66	Pass. (396, 427) (exc. Sp.				
	H/Per.) . . . . .	6415961	1	13.58	
66	Chevelle w/H/Per. (396),				
66	Pass. w/Sp. H/Per. (427) . . . . .	6416459	1	13.48	
67	Pass. (396) (exc. Sp. H/Per.),				
67-69	Pass. (427),				

**FUEL—EXHAUST—CARBURETION**

**3.900 PUMP ASSY., Fuel with Gasket (Con't)**

67-68	Chevy, Chevelle, Camaro (396),				
68	Pass. (396),				
69	All (396),				
70	Pass. (454),				
70	Nova, Camaro (396),				
70	Chevelle w/Sp. H/Per. (396,				
	454),				
71-72	Camaro w/4BC (400) . . . . .	<b>6470424</b>	1	15.28	(type 40727) . . . . .
67	Chevy, Chevelle w/Sp. H/Per.				
	(327),				
67	Pass. (283),				
67	Pass. (327) (1st design),				
67	Chevy, Chevelle, Camaro (327,				
	350) (1st design),				
67	Chevy, Chevelle (283) (exc. dual				
	exh.),				
67	Chevy w/dual exh. (283) (2nd				
	design),				
68-69	All (307),				
70-72	Nova, Chevelle (307) . . . . .	<b>6416712</b>	1	12.21	(type 40503) . . . . .
67	Pass. (327) (2nd design),				
67	Chevy, Chevelle, Camaro (327,				
	350) (2nd design),				
67	Camaro (302),				
67	Chevy w/dual exh. (283) (1st				
	design),				
68	Pass. (327),				
68	Chevy, Chevelle, Camaro (327,				
	350),				
68	All (327, 350),				
69-71	Camaro (307, 327),				
72-73	Camaro (307) . . . . .	<b>6470422</b>	1	13.68	(type 40725) . . . . .
69	All (327, 350),				
70	Pass. (350, 400),				
70	Nova, Chevelle, Camaro w/2BC				
	(350),				
70	Chevelle w/4BC (350) (exc.				
	C.A.C.),				
70	Nova w/4BC (350),				
70	Monte Carlo (exc. 400 w/4BC,				
	454),				
70-71	Camaro w/Sp. H/Per. (350),				
71	All w/2BC (350, 400),				
71	Nova, Monte Carlo w/4BC				
	(350),				
71-72	Chevelle w/4BC (350) (exc.				
	Monte Carlo, C.A.C.),				
72-75	All w/2BC (350),				
72-75	Pass. (400) (exc. C.A.C., Police),				
72	Camaro w/Sp. H/Per. (350),				
73	Bel Air, Impala w/4BC (350)				
	(exc. Sta. Wag., Police, C.A.C.),				
73-75	Chevelle w/4BC (350) (exc.				
	C.A.C.),				
75	Nova (262),				
74	Chevelle w/2BC (400) (exc.				
	C.A.C.) . . . . .	<b>6470779</b>	1	16.58	(type 40726) . . . . .
70	Chevelle w/4BC (396, 400) (exc.				
	Sp. H/Per.),				
70	Chevelle (454) . . . . .	<b>6470307</b>	1	18.12	(type 40768) . . . . .
70	Chevelle (4BC w/C.A.C.) (350)				
	(exc. Monte Carlo) . . . . .	<b>6470306</b>	1	17.95	(type 40767) . . . . .
70-72	Camaro w/4BC (350) (exc. Sp.				
	H/Per.) . . . . .	<b>6470310</b>	1	17.95	(type 40777) . . . . .
71	Pass., Chevelle w/4BC (400,				
	454) (exc. Sp. H/Per.),				
72	Pass., Chevelle w/4BC (402,				
	454) . . . . .	<b>6470570</b>	1	17.47	
71	Police w/4BC (350),				
71-72	Pass. (C.A.C. w/2BC) (400),				
71	Pass., Chevelle (4BC w/C.A.C.)				
	(350) (exc. Monte Carlo),				
72	Police (400) (exc. C.A.C.),				
72	Chevelle (4BC w/C.A.C.) (350)				
	(exc. Monte Carlo) . . . . .	<b>6470869</b>	1	16.96	(type 40867) . . . . .

**FUEL—EXHAUST—CARBURETION**

**3.900 PUMP ASSY., Fuel with Gasket (Con't)**

72	Nova w/4BC (350),				
72	Monte Carlo (C.A.C. w/4BC (350),				
73-75	Police (400) (exc. C.A.C.),				
73-75	Police w/4BC (350) (exc. C.A.C.),				
73-75	Bel Air, Impala (4BC w/C.A.C.) (350) (exc. Sta. Wag.),				
73-75	Pass. w/C.A.C. (400),				
74-75	Chevelle w/4BC (400),				
73-75	Nova w/4BC (350),				
73-75	Chevelle (4BC w/C.A.C.) (350),				
74-75	Chevelle (2BC w/C.A.C.) (400) . . .	<b>6470777</b>	1	18.12	(type 40986) (w/inlet, outlet and vent. opening) . . . . .
73-75	Chevelle (454) . . . . .	<b>6470761</b>	1	17.84	
73-75	Pass. (454) . . . . .	<b>6470775</b>	1	20.66	
73-75	Camaro w/4BC (350) . . . . .	<b>6470310</b>	1	17.95	
73	Chevelle, Nova (307) . . . . .	<b>6470778</b>	1	16.74	
75	All (6 cyl.) . . . . .	<b>6470871</b>	1	15.07	
75	Vega, Monza (122) . . . . .	<b>1608783</b>	1	97.75	
75	Vega, Monza (140) . . . . .	<b>6470967</b>	1	20.92	
75	Vega, Monza (262, 350) . . . . .	<b>6470994</b>	1	22.69	
71-74	Vega (140) . . . . .	<b>6470550</b>	1	19.69	<b>PUMP AND FILTER UNIT, fuel (in tank) . . .</b>

**3.901 PLATE— BAIL— BRACKET— CONNECTOR— ELBOW— HOSE— MOUNTING ASSY.— RETAINER— SCREW, Fuel Pump Mounting**

64-69	Chevy, Chevelle, Camaro (8 cyl.) (exc. 396),				
65-66	Pass. (8 cyl.) (exc. 396),				
67-69	Pass. (283, 307, 327, 350),				
70	Camaro (8 cyl.) (exc. H/Per. 396),				
70	Pass., Monte Carlo w/2BC (400),				
70	Pass., Nova, Chevelle (307, 350),				
71	Nova, Camaro,				
71	Pass., Chevelle (exc. 400 w/4BC, 454),				
72-75	All (exc. 402, 454) . . . . .	<b>3719599</b>	1	.84	(4 attach. holes-one large slot) . . . . .
75	Vega, Monza (122) . . . . .	<b>339077</b>	1	3.05	<b>BRACKET</b> . . . . .
75	Vega, Monza (122) . . . . .	<b>1608784</b>	1	1.35	<b>BRACKET, fuel pump</b> . . . . .
62-66	All . . . . .	<b>3750685</b>	1	.27	<b>CONNECTOR, hose (Note.1)</b> . . . . .
	<i>NOTE 1 Use fuel pump 6415824.</i>				
65-66	Pass. . . . .	<b>3758062</b>	1	RL/.34	<b>HOSE, vacuum pump exhaust (7/32")— (8.962)</b> . . . . .
75	Vega, Monza (122) . . . . .	<b>345137</b>	1	3.20	<b>MOUNT ASSY., fuel pump vibration</b> . . . . .
75	Vega (122) . . . . .	<b>1741603</b>	1	.55	<b>RETAINER, fuel pump shield</b> . . . . .
64	Chevy, Chevelle (8 cyl.),				
65-66	Pass. (8 cyl.) . . . . .	<b>3751842</b>	2	.16	<b>SCREW, w/lockwasher (3/8"— 16 x 1 1/8") (washer hd.)</b> . . . . .
65	Pass. . . . .	<b>3862716</b>	1	.16	<b>SCREW, lw. asm. (3/8"— 16 x 1)</b> . . . . .
65-68	Chevelle,				
65-70	Pass., Camaro,				
70	Nova,				
71	All,				
72-75	All (402, 454) . . . . .	<b>3874876</b>	2	.16	<b>SCREW (3/8"— 16 x 1 1/8") w/lockwasher</b> . . .
66-71	All,				
72-75	All (6 cyl.) . . . . .	<b>3888192 A.R.</b>		.11	<b>SCREW, w/sealing washer (5/16"— 18 x 1 3/8")</b> . . . . .
72-75	All (8 cyl.) (exc. 402, 454) . . . . .	<b>3895411</b>	2	.11	<b>SCREW ASSY., w/lockwasher (3/8"— 16 x 1 7/16")</b> . . . . .

**3.903 BUMPER— GASKET, Fuel Pump**

75	Vega, Monza (122) . . . . .	<b>339100</b>	2	.13	<b>BUMPER, fuel pump</b> . . . . .
75	Monza (262) (exc. Towne Coupe)	<b>3705044</b>	1	.12	<b>GASKET, fuel pump mounting plate</b> . . . . .

**3.904 GASKET— RETAINER— SEAL, Fuel Pump Bowl and Mounting**

62-68	Chevy, Chevelle, Camaro,				
65-66	Pass. w/elect. wiper (6 cyl.),				
67-69	Pass.,				
70-75	All . . . . .	<b>9776705</b>	1	.05	mtg., flange (2 attach. holes— one small slot) . . . . .
64-65	Chevy, Chevelle (8 cyl.),				
65	Pass. (8 cyl.) (exc. 396),				
66	Pass. (8 cyl.) (exc. 396, 427),				

**FUEL—EXHAUST—CARBURETION**

**3.904 GASKET— RETAINER— SEAL, Fuel Pump Bowl and Mounting (Con't)**

66-69	Chevy, Chevelle, Camaro (8 cyl.) (exc. 396),				
67-69	Pass. (283, 307, 327, 350),				
70	Pass., Monte Carlo w/2BC (400),				
70	Camaro (8 cyl.) (exc. H/Per. 396),				
70	Pass., Nova, Chevelle (307, 350),				
72	All (8 cyl.) (exc. 400 w/4BC, 454),				
73-75	All (8 cyl.) (exc. 454) . . . . .	3705044	1	.12	mounting plate (4 attach. holes— one large slot) . . . . .
71	Nova (8 cyl.),				
71	Pass., Chevelle, Camaro (8 cyl.) (exc. 400 w/4BC, 454),				
64-66	All (8 cyl.) . . . . .	5620995 A.R.		.10	RETAINER, fuel ( <sup>15</sup> / <sub>32</sub> " I.D. x 1" O.D.) ( <sup>5</sup> / <sub>32</sub> " thick) . . . . .
64-66	All . . . . .	5592331 A.R.		.29	SEAL, fuel and vacuum diaphragm pull rods

**3.910 DIAPHRAGM— REGULATOR ASSY., Fuel Pump Pulsator**

64-66	Chevy, Chevelle (283) (exc. 4BC),				
65-66	Pass. (283) . . . . .	5593898	1	.26	(rubber— <sup>1</sup> / <sub>4</sub> " I.D. x 3" O.D.) . . . . .
75	Vega, Monza (122) . . . . .	1608785	1	19.00	REGULATOR KIT, fuel pressure (w/nut) . . .

**3.925 KIT— DIAPHRAGM UNIT— DOME, Fuel and Vacuum Pump Repair**

62-66	All (4 cyl., 6 cyl.) . . . . .	5593568	1	7.07	(AC-R-271) . . . . .
62-66	Chevy, Chevelle (exc. 8 cyl.) . . . . .	5593569	1	3.53	diaphragm, (w/5623540-5656760-6790) (AC-D-278) . . . . .
64-66	Chevy, Chevelle (8 cyl.),				
65-66	Pass. (283, 327) . . . . .	5622175	1	6.25	(AC-R-467) . . . . .
64-66	Chevy, Chevelle (8 cyl.) . . . . .	5622176	1	5.32	diaphragm . . . . .

**DIAPHRAGM UNIT**

65-66	Pass. (230) . . . . .	5593569	1	3.53	fuel pump (Note 5) . . . . .
	<i>NOTE 5 5593569 consists of. diaphragm w/pull rod, 1 pulsator diaphragm, 2 valves, 2 valve gaskets and 1 flange gasket.</i>				
65-66	All (283, 327) . . . . .	5622176	1	5.32	fuel pump (type AC-D-337) . . . . .
74-75	Pass., Chevelle w/4BC (350) . . . . .	1523319	1	1.34	DOME, fuel pump— (3.163) . . . . .

**3.927 SPRING, Fuel Pump Rocker Arm**

64-66	Chevy, Chevelle (8 cyl.) (exc. Sp. H/Per.),				
65-66	Pass. (8 cyl.) . . . . .	5621566	1	.15	(15 coils) ( <sup>13</sup> / <sub>4</sub> " free length) (painted yellow)

**3.935 ROD, Fuel Pump**

64-75	All . . . . .	3704817	1	2.20	( <sup>1</sup> / <sub>2</sub> " dia. x 5 <sup>3</sup> / <sub>4</sub> " long) . . . . .
-------	---------------	---------	---	------	--





# CHEVROLET CHASSIS GROUP 4.000



## TRANSMISSION — BRAKES

### ALPHABETICAL INDEX

<b>A</b>			
ACTUATOR ASSY., Transmission Parking Brake.....	4.290	BOLT, Transmission Mounting Support.....	4.085
ACTUATOR ASSY., Transmission Parking Lock.....	4.220	BOLT, Transmission Overdrive.....	4.495
ADAPTER ASSY., Speedometer.....	4.329	BOLT, Transmission.....	4.115
ADAPTER, Transmission Overdrive.....	4.455	BOLT, Wheel Brake (Also See Group 4.667).....	4.665
ADAPTER UNIT, Speedometer.....	4.329	BOOT, Gearshift Linkage.....	4.067
APPLIQUE, Underbody Trim (floor mounted).....	4.017	BOOT, Lever Hand (Floor Mounted).....	4.015
ARM, Transmission Rail End.....	4.302	BOOT, Main Cylinder (Rubber).....	4.659
		BOOT, Parking Brake.....	4.592
		BOOT, Transmission Control Lever.....	4.015
		BOOT, Wheel Cylinder.....	4.670
		BOWL, Gearshift Hand Lever.....	4.010
		BRACE, Gearshift Control Hand Lever.....	4.008
		BRACE, Gearshift Hand Lever.....	4.010
		BRACE, Transmission Gearshift Control Shaft or Tube.....	4.027
		BRACE, Vacuum Power Brake Cylinder Air....	4.913
		BRACE, Vacuum Power Brake.....	4.898
		BRACKET ASSY., Brake Pedal.....	4.634
		BRACKET ASSY., Gearshift Hand Lever.....	4.010
		BRACKET ASSY., Transmission Control Safety.....	4.054
		BRACKET ASSY., Transmission Gearshift.....	4.004
		BRACKET ASSY., Transmission Throttle Valve Control (T.V.).....	4.050
		BRACKET, Brake Hose or Pipe.....	4.681
		BRACKET, Brake Press Ind.....	4.874
		BRACKET, Gearshift Control (Hand).....	4.006
		BRACKET, Gearshift Control Hand Lever.....	4.008
		BRACKET, Gearshift Hand Lever.....	4.010
		BRACKET, Hydraulic Brake.....	4.686
		BRACKET, Parking Brake Cable.....	4.785
		BRACKET, Rear Brake Pressure Regulator.....	4.690
		BRACKET, Transmission Control Idler.....	4.040
		BRACKET, Transmission Control Safety.....	4.054
		BRACKET, Transmission Control Switch.....	4.060
		BRACKET, Transmission Gearshift Control Cable.....	4.047
		BRACKET, Transmission Gearshift Shaft or Tube (Lower).....	4.030
		BRACKET, Transmission Mounting.....	4.083
		BRACKET, Transmission Oil.....	4.128
		BRACKET, Transmission Overdrive.....	4.480
		BRACKET, Transmission Overdrive.....	4.495
		BRACKET, Transmission Parking Brake.....	4.290
		BRACKET, Transmission Parking Lock.....	4.220
		BRACKET, Transmission Throttle valve Operating Parts.....	4.275
		BRACKET, Transmission Throttle Valve Control (T.V.).....	4.050
		BRACKET, Underbody Trim (floor mounted)....	4.017
		BRACKET, Vacuum Power Brake.....	4.898
		BRACKET, Wheel Brake (Also See Group 4.667).....	4.665
		BRAKE UNIT, Vacuum Power Brake.....	4.901
		BUMPER, Vacuum Power Brake Cyl. Reaction.....	4.934
		BUSHING, Brake Pedal.....	4.626
		BUSHING, Forward Cone Freewheel.....	4.168
		BUSHING, Gearshift Control (Hand).....	4.006
		BUSHING, Gearshift Control Hand Lever.....	4.008
		BUSHING, Gearshift Shaft Lever.....	4.032
		BUSHING, Low Sun Gear and Clutch.....	4.162
		BUSHING, Oil Supply Pump.....	4.203
		BUSHING, Planet Carrier.....	4.176

## ALPHABETICAL INDEX

BUSHING, Transmission Case.....	4.104
BUSHING, Transmission Clutch.....	4.169
BUSHING, Transmission Control Idler Attaching .....	4.042
BUSHING, Transmission Control Safety .....	4.054
BUSHING, Transmission Extension.....	4.319
BUSHING, Transmission Front Servo.....	4.226
BUSHING, Transmission Gearshift Rod to Lever.....	4.037
BUSHING, Transmission Low and Drive Valve .....	4.265
BUSHING, Transmission Overdrive.....	4.455
BUSHING, Transmission Planet.....	4.161
BUSHING, Transmission Rear Main Bearing..	4.319
BUSHING, Transmission Reverse .....	4.431
BUSHING, Transmission .....	4.256
BUSHING UNIT, Transmission Main Valve.....	4.216
BUSHING, Wheel Brake (Also See Group 4.667).....	4.665
BUTTON, Gearshift Control (Hand).....	4.006

### C

CABLE ASSY., Transmission Gearshift Control Cable .....	4.047
CABLE ASSY., Transmission Throttle Valve Control (T.V.).....	4.050
CABLE, Gearshift Control (Hand).....	4.006
CABLE, Parking Brake .....	4.779
CABLE, Transmission Gearshift Control.....	4.020
CAGE ASSY., Transmission Overdrive.....	4.470
CAGE, Transmission, Overdrive.....	4.467
CALIPER ASSY., Wheel Brake (Also See Group 4.667).....	4.665
CAM ASSY., Transmission Overdrive.....	4.465
CAM, Gearshift Detent.....	4.311
CAM, Transmission Forward Cone Freewheel.....	4.167
CAM, Transmission Internal Shift .....	4.302
CAP.....	4.651
CAP, Gearshift Level Selector and Indicator..	4.022
CAP, Transmission Case .....	4.104
CAP, Transmission Gearshift Control.....	4.020
CAP, Transmission .....	4.256
CARRIER ASSY., Transmission Planet.....	4.175
CASE ASSY., Transmission .....	4.103
CASE, Transmission Overdrive.....	4.455
CASE, Transmission .....	4.103
CLAMP, Transmission Gearshift Rod to Lever.....	4.037
CLAMP, Transmission Oil.....	4.128
CLAMP, Vacuum Power Brake Cylinder .....	4.930
CLEVIS, Main Cylinder Adjusting .....	4.662
CLEVIS, Transmission Gearshift Rod to Lever.....	4.037
CLIP, Brake Hose or Pipe .....	4.681
CLIP, Gearshift Control (Hand).....	4.006
CLIP, Hydraulic Brake.....	4.685
CLIP, Hydraulic Brake.....	4.686
CLIP, Parking Brake Cable Pulley .....	4.790
CLIP, Parking Brake Cable.....	4.785
CLIP, Parking Brake Lever Release.....	4.595
CLIP, Parking Brake.....	4.765
CLIP, Speedometer without Casing .....	4.342
CLIP, Speedometer Drive Gear.....	4.345
CLIP, Speedometer .....	4.342C
CLIP, Transmission Control Safety .....	4.054
CLIP, Transmission Control Switch .....	4.060
CLIP, Transmission Gearshift Control .....	4.020
CLIP, Transmission Gearshift Control Cable..	4.047
CLIP, Transmission Gearshift Control .....	4.020
CLIP, Transmission Gearshift Rod to Lever....	4.037
CLIP, Transmission Oil.....	4.128
CLIP, Transmission Overdrive.....	4.495
CLIP, Transmission Throttle valve Operating Parts .....	4.275
CLIP, Transmission Throttle Valve Control....	4.052
CLIP, Transmission, Smog Control.....	4.075
CLIP, Vacuum Power Brake Cylinder.....	4.930
CLIP, Vacuum .....	4.205

CLUTCH ASSY., Transmission Forward Cone Freewheel.....	4.167
CLUTCH ASSY., Transmission RearRing Gear.....	4.180
CLUTCH ASSY., Transmission 1st & Rev. ....	4.380
CLUTCH ASSY., Transmission .....	4.164
CONNECTOR, Hydraulic Brake .....	4.686
CONNECTOR, Parking Brake Cable .....	4.785
CONNECTOR, Parking Brake.....	4.765
CONNECTOR, Transmission Low and Drive Valve .....	4.265
CONNECTOR, Transmission Oil.....	4.128
CONNECTOR, Vacuum Power Brake Cyl.....	4.931
CONTROL ASSY., Transmission Gearshift.....	4.004
COUNTERGEAR UNIT, Transmission .....	4.421
COVER .....	4.651
COVER ASSY., Oil Supply Pump.....	4.203
COVER ASSY., Transmission Oil .....	4.224
COVER, Brake and Clutch Pedal .....	4.630
COVER, Gearshift Control (Hand).....	4.006
COVER, Gearshift Hand Lever.....	4.010
COVER, Lever Hand (Floor Mounted).....	4.015
COVER, Low Servo .....	4.228
COVER, Main Cylinder (Rubber).....	4.659
COVER, Main Cylinder Push.....	4.658
COVER, Parking Brake Lever.....	4.615
COVER, Reverse Servo.....	4.241
COVER, Servo.....	4.212
COVER, Transmission Case.....	4.105
COVER, Transmission .....	4.256
COVER, Wheel Cylinder .....	4.666
CUP, Gearshift Control Hand Lever .....	4.008
CUP, Main Cylinder Piston.....	4.654
CUP, Speedometer Adapter .....	4.330
CUP, Vacuum Power Brake.....	4.910
CUP, Wheel Cylinder Piston (Also See Group 4.665).....	4.667
CYLINDER ASSEMBLY, Vacuum Power Brake.....	4.901
CYLINDER ASSY., Wheel Brake (Also See Group 4.667).....	4.665
CYLINDER ASSY.....	4.650

### D

DAMPER ASSY., Transmission Main Valve....	4.216
DAMPER, Transmission Output Shaft.....	4.404
DECLENE, Hydraulic Brake .....	4.683
DETENT, Gearshift Hand Lever Housing .....	4.012
DIAL, Transmission Gearshift Control.....	4.020
DIAPHRAGM, Vacuum Power Brake Cylinder ..	4.922
DISC, Vacuum Power Brake Cyl. Reaction.....	4.934
DIVIDER, Vacuum Power Brake Cylinder .....	4.904
DRUM ASSY., Transmission Clutch.....	4.169
DRUM, Transmission Clutch .....	4.169

### E

EQUALIZER, Parking Brake.....	4.765
EXTENSION ASSY., Transmission Rear Main Bearing .....	4.317
EXTENSION, Brake Pull Back .....	4.760
EXTENSION, Gearshift Hand Lever .....	4.010
EXTENSION, Underbody Trim (floor mounted).....	4.017

### F

FASTENER, Gearshift Control Hand Lever .....	4.008
FASTENER, Gearshift Level Selector and Indicator.....	4.022
FASTENER, Transmission Control Switch .....	4.060
FILTER ASSY., Oil Pan Pump Suction.....	4.197
FILTER, Gearshift Level Selector and Indicator.....	4.022

# ALPHABETICAL INDEX

FILTER UNIT, Oil Pan Pump Suction .....	4.197
FILTER, Vacuum Power Brake Cylinder Air .....	4.913
FITTING ASSY., Vacuum Power Brake Cyl. ....	4.931
FITTING, Speedometer Driven Gear .....	4.338
FLANGE ASSY., Low Sun Gear and Clutch.....	4.162
FLANGE, Gearshift Control Hand Lever .....	4.008
FLANGE, Transmission Oil .....	4.195
FLUID, Hydraulic Brake.....	4.683
FORK, Gearshift .....	4.303
FORK, Transmission Overdrive Shifting .....	4.490

## G

GASKET.....	4.651
GASKET, Brake Cyl. and Pedal Shaft (Also See Group 0.847 for pedal shaft bracket) .....	4.648
GASKET, Gearshift Detent.....	4.311
GASKET, Oil Pan Pump Suction .....	4.197
GASKET, Oil Supply Pump.....	4.203
GASKET, Parking Brake Apply.....	4.591
GASKET, Reverse Servo.....	4.241
GASKET, Servo .....	4.212
GASKET, Transmission Case Cover.....	4.109
GASKET, Transmission Front Servo .....	4.226
GASKET, Transmission Low and Drive Valve.....	4.265
GASKET, Transmission Main Drive Gear Bearing Retainer.....	4.358
GASKET, Transmission Main Valve Body Accumulator.....	4.217
GASKET, Transmission Oil Pan.....	4.196
GASKET, Transmission Oil .....	4.128
GASKET, Transmission Overdrive .....	4.460
GASKET, Transmission Rear Bearing Retainer.....	4.318
GASKET, Transmission Throttle Valve.....	4.278
GASKET, Transmission, Smog Control .....	4.075
GASKET, Transmission .....	4.256
GASKET UNIT, Transmission.....	4.005
GASKET, Vacuum Power Brake Cylinder .....	4.922
GASKET, Vacuum Power Brake.....	4.898
GASKET, Vacuum Power Brake.....	4.901
GASKET, Vacuum Power Brake.....	4.910
GASKET, Vacuum.....	4.205
GATE, Transmission Gearshift Control Shaft or Tube .....	4.027
GAUGE, Transmission Oil Filler .....	4.133
GEAR ASSY., Transmission Front Drive .....	4.158
GEAR, Fifth Speed .....	4.416
GEAR, Speedometer Drive .....	4.343
GEAR, Transmission (1st and Reverse Sliding) .....	4.417
GEAR, Transmission Countershaft .....	4.422
GEAR, Transmission First Speed .....	4.417
GEAR, Transmission Main Drive (Clutch) .....	4.351
GEAR, Transmission Overdrive .....	4.470
GEAR, Transmission Overdrive.....	4.485
GEAR, Transmission Planet.....	4.175
GEAR, Transmission Rear Unit.....	4.187
GEAR, Transmission Reverse Idler (with bushings) .....	4.430
GEAR, Transmission Second Speed .....	4.395
GEAR, Transmission Speedometer Driven Gears (only).....	4.337
GEAR, Transmission Sun Gear and Parts .....	4.159
GEAR, Transmission Third & Fifth Speed.....	4.415
GEAR, Transmission 1st and Reverse Sliding .....	4.417
GEAR, Transmission 2nd Speed .....	4.395
GEAR, Transmission 3rd Speed.....	4.415
GEAR, Transmission .....	4.421
GEAR UNIT, Transmission .....	4.256
GOVERNOR ASSY., Transmission Overdrive ..	4.485
GOVERNOR ASSY., Transmission .....	4.256
GROMMET, Gearshift Control Hand Lever .....	4.008
GROMMET, Hydraulic Brake.....	4.685
GROMMET, Lever Hand (Floor Mounted) .....	4.015
GROMMET, Oil Pan Pump Suction .....	4.197
GROMMET, Parking Brake Lever Release .....	4.594
GROMMET, Speedometer without Casing.....	4.342
GROMMET, Speedometer Driven Gear.....	4.338
GROMMET, Transmission Control Lever.....	4.015

GROMMET, Transmission Gearshift Control Cable.....	4.047
GROMMET, Transmission Gearshift Rod to Lever.....	4.037
GROMMET, Transmission Gearshift Shaft Tube Lever.....	4.032
GROMMET, Transmission Overdrive .....	4.495
GROMMET, Vacuum Power Brake Check.....	4.955
GROMMET, Vacuum Power Brake Cyl. ....	4.931
GUARD, Main Cylinder (Rubber).....	4.659
GUARD, Vacuum Power Brake Cylinder .....	4.922
GUIDE, Gearshift Control Hand Lever .....	4.008
GUIDE, Manual Valve.....	4.218
GUIDE, Parking Brake Cable .....	4.785
GUIDE, Transmission Gearshift Control .....	4.020
GUIDE, Transmission.....	4.164

## H

HANDLE ASSY., Parking Brake Lever Release .....	4.594
HANDLE, Gearshift Control (Hand) .....	4.006
HANDLE, Parking Brake .....	4.592
HANGER, Parking Brake Cable Pulley .....	4.790
HARNESS ASSY., Transmission Control Safety.....	4.054
HEAD, Gearshift.....	4.303
HOSE ASSY., Hydraulic Brake .....	4.680
HOSE, Vacuum Power Brake Cyl. ....	4.931
HOSE, Vacuum .....	4.205
HOUSING, Gearshift Hand Lever.....	4.010
HOUSING, Lever Hand (Floor Mounted).....	4.015
HOUSING, Parking Brake Apply.....	4.591
HOUSING, Transmission Clutch .....	4.169
HOUSING, Transmission Gearshift Control.....	4.020
HOUSING, Transmission Gearshift Shaft or Tube (Lower).....	4.030
HOUSING, Wheel Brake (Also See Group 4.667) .....	4.665
HUB, Transmission .....	4.164
HYDRAMATIC (250, 350, 375, 400) .....	4.003
Hydraulic Brake Main .....	4.650

## I

INDICATOR, Transmission Gearshift Control ..	4.020
INSERT, Brake Connector.....	4.671
INSERT, Hydraulic Brake.....	4.686
INSERT, Main Cylinder Outlet Fitting .....	4.661
INSULATOR ASSY., Transmission Control Lever.....	4.004
INSULATOR, Brake Caliper.....	4.668
INSULATOR, Brake Pedal.....	4.634
INSULATOR, Lever Hand (Floor Mounted) .....	4.015
INTERLOCK, Gearshift .....	4.307
INTERLOCK, Transmission Gearshift Control Shaft or Tube .....	4.027
ISOLATOR, Gearshift Control Hand Lever .....	4.008
ISOLATOR, Transmission Gearshift.....	4.004

## K

KEY, Speedometer Adapter.....	4.330
KEY, Transmission Synchronizer .....	4.384
KEY, Vacuum Power Brake Cylinder Air Valve (See Group 4.658 for Valve and Push Rod Assy.).....	4.918
KIT, Transmission Gearshift.....	4.004
KNOB, Gearshift Control (Hand).....	4.006

# ALPHABETICAL INDEX

## L

LENS ASSY., Transmission Control Pedal Rod .....	4.260
LENS, Parking Brake Alarm .....	4.589
LENS, Transmission Gearshift Control .....	4.020
LEVER ASSY., Manual Valve .....	4.218
LEVER ASSY., Parking Brake Apply .....	4.591
LEVER ASSY., Parking Brake .....	4.792
LEVER ASSY., Transmission Control .....	4.006
LEVER ASSY., Transmission Detent .....	4.279
LEVER ASSY., Transmission Gearshift .....	4.004
LEVER ASSY., Transmission Inter. Shift .....	4.302
LEVER ASSY., Transmission Mounted Gearshift (External) .....	4.045
LEVER ASSY., Transmission Throttle Valve .....	4.278
LEVER, Gearshift Control (Hand) .....	4.006
LEVER, Parking Brake .....	4.592
LEVER, Transmission Control Idler .....	4.040
LEVER, Transmission Control Safety .....	4.054
LEVER, Transmission Control Switch .....	4.060
LEVER, Transmission Gearshift Anti-Theft .....	4.070
LEVER, Transmission Gearshift Shaft or Tube (Lower) .....	4.030
LEVER, Transmission Internal Shift .....	4.302
LEVER, Transmission Mounted Gearshift (External) .....	4.045
LEVER, Transmission Overdrive .....	4.495
LEVER, Transmission Rail End .....	4.302
LEVER, Transmission Throttle Valve Control (T.V.) .....	4.050
LEVER, Vacuum Power Brake Cyl. Reaction .....	4.934
LINK, Gearshift .....	4.303
LINK, Transmission Throttle valve Operating Parts .....	4.275
LOCK, Gearshift .....	4.307
LOCKOUT ASSY., Gearshift Control Hand Lever .....	4.008
LOCK OUT UNIT, Gearshift Control Hand Lever .....	4.008
LOCK, Transmission Control Idler Attaching .....	4.042
LOCK, Transmission Main Drive Gear Bearing .....	4.356

## M

MAGNET UNIT, Transmission Case .....	4.105
MEMBER ASSY., Transmission Mounting .....	4.081
MODULATOR, Vacuum .....	4.205
MOUNTING ASSY., Transmission Mounting .....	4.081

## N

NUT ASSY., Parking Brake .....	4.765
NUT, Brake Band Adjusting .....	4.253
NUT, Gearshift Control Hand Lever .....	4.008
NUT, Hydraulic Brake .....	4.686
NUT, Main Cylinder Push .....	4.658
NUT, Parking Brake Lever Release .....	4.594
NUT, Transmission Control Idler Attaching .....	4.042
NUT, Transmission Gearshift External Control Lever .....	4.046
NUT, Transmission Gearshift Rod to Lever .....	4.037
NUT, Transmission Main Drive Gear Bearing .....	4.356
NUT, Transmission Main Valve Body Accumulator .....	4.217
NUT, Transmission Overdrive .....	4.480
NUT, Transmission Throttle Valve Control (T.V.) .....	4.050
NUT, Transmission Throttle Valve Control .....	4.052
NUT, Underbody Trim (floor mounted) .....	4.017

## P

PAD, Gearshift .....	4.303
PAN, Transmission Oil .....	4.195
PAWL, Transmission Gearshift Control Shaft or Tube .....	4.027
PAWL, Transmission Interlock .....	4.307
PAWL, Transmission Overdrive Shifting .....	4.490
PAWL, Transmission Parking Brake .....	4.294
PAWL, Transmission Parking Lock .....	4.220
PEDAL ASSY., Brake .....	4.625
PEDAL ASSY., Parking Brake Apply .....	4.591
PIN, Gear Shifter Shaft & Fork (Yoke) .....	4.312
PIN, Gearshift Control (Hand) .....	4.006
PIN, Gearshift Control Hand Lever .....	4.008
PIN, Gearshift Detent .....	4.311
PIN, Gearshift Hand Lever Housing .....	4.012
PIN, Gearshift .....	4.307
PINION, Transmission Planet .....	4.175
PINION UNIT, Transmission Planet .....	4.175
PIN, Main Cylinder Adjusting .....	4.662
PIN, Manual Valve .....	4.218
PIN, Oil Supply Pump .....	4.203
PIN, Reverse Servo .....	4.241
PIN, Transmission Control Idler Attaching .....	4.042
PIN, Transmission Control Safety .....	4.054
PIN, Transmission Front Servo .....	4.226
PIN, Transmission Gearshift Control Cable .....	4.047
PIN, Transmission Gearshift Control Shaft or Tube .....	4.027
PIN, Transmission Gearshift External Control Lever .....	4.046
PIN, Transmission Gearshift Rod to Lever .....	4.037
PIN, Transmission Low and Drive Valve .....	4.265
PIN, Transmission Overdrive Shifting .....	4.490
PIN, Transmission Overdrive .....	4.495
PIN, Transmission Parking Lock .....	4.220
PIN, Transmission Reverse Idler Shaft .....	4.435
PIN, Transmission Selector .....	4.046
PIN, Transmission Throttle valve Operating Parts .....	4.275
PIN, Transmission Throttle Valve Control (T.V.) .....	4.050
PIN, Transmission .....	4.256
PIN, Wheel Brake (Also See Group 4.667) .....	4.665
PIPE ASSY., Oil Pan Pump Suction .....	4.197
PIPE ASSY., Transmission Case .....	4.104
PIPE ASSY., Vacuum Power Brake Cylinder .....	4.930
PIPE ASSY., Vacuum .....	4.205
PIPE, Hydraulic Brake .....	4.685
PIPE, Transmission Case .....	4.104
PIPE, Transmission Oil .....	4.248
PISTON ASSY., Brake Caliper .....	4.668
PISTON, Brake Main Cylinder .....	4.653
PISTON, Low Servo .....	4.228
PISTON, Reverse Servo .....	4.241
PISTON, Transmission Clutch .....	4.166
PISTON, Vacuum Power Brake Cylinder .....	4.922
PIVOT, Transmission Rail End .....	4.302
PLATE, Brake and Clutch Pedal .....	4.630
PLATE, Gearshift Hand Lever Housing .....	4.012
PLATE, Gearshift Hand Lever .....	4.010
PLATE, Oil Supply Pump .....	4.203
PLATE, Parking Brake Cable Pulley .....	4.790
PLATE, Planet Carrier .....	4.176
PLATE, Transmission Clutch Drive and Driven .....	4.163
PLATE, Transmission Gearshift Control .....	4.020
PLATE, Transmission Gearshift Control Shaft or Tube .....	4.027
PLATE, Transmission Gearshift Control .....	4.020
PLATE, Transmission Gearshift Shaft or Tube (Lower) .....	4.030
PLATE, Transmission Low and Drive Valve .....	4.265
PLATE, Transmission Overdrive Sun Gear .....	4.472
PLATE, Transmission Overdrive .....	4.495
PLATE, Transmission Rail End .....	4.302
PLATE, Transmission Synchronizing .....	4.384
PLATE, Transmission .....	4.215
PLATE, Underbody Trim (floor mounted) .....	4.017
PLATE, Vacuum Power Brake Cyl. Reaction .....	4.934
PLATE, Vacuum Power Brake Cylinder .....	4.922
PLUG, Gearshift Control Hand Lever .....	4.008

## ALPHABETICAL INDEX

PLUG, Gearshift Detent .....	4.311	RETAINER, Transmission Main Drive Gear Bearing .....	4.356
PLUG, Gearshift Hand Lever .....	4.010	RETAINER, Transmission Overdrive Shifting ..	4.490
PLUG, Transmission Case .....	4.105	RETAINER, Transmission Overdrive .....	4.467
PLUG, Transmission Low and Drive Valve .....	4.265	RETAINER, Transmission Overdrive .....	4.485
PLUG, Transmission Main with Gear .....	4.172	RETAINER, Transmission Rear Main Bearing ..	4.317
PLUG, Transmission Overdrive .....	4.455	RETAINER, Transmission Rear Servo .....	4.247
PLUG, Transmission Parking Brake .....	4.294	RETAINER, Transmission Synchronizing .....	4.383
PLUG, Wheel Cylinder .....	4.666	RETAINER, Transmission Throttle Valve Control (T.V.) .....	4.050
PLUNGER ASSY., Vacuum Power Brake Cylinder Air Valve (See Group 4.658 for Valve and Push Rod Assy.) .....	4.918	RETAINER, Transmission .....	4.164
PLUNGER, Gearshift Detent .....	4.311	RETAINER, Transmission .....	4.256
PLUNGER, Transmission Gearshift Control Shaft or Tube .....	4.027	RETAINER, Vacuum Power Brake Cyl. Reaction .....	4.934
PLUNGER, Transmission Overdrive Shifting ..	4.490	RETAINER, Vacuum Power Brake Cyl. Relay Valve .....	4.935
PLUNGER, Vacuum .....	4.205	RETAINER, Vacuum Power Brake Cylinder Air Valve (See Group 4.658 for Valve and Push Rod Assy.) .....	4.918
POINTER, Transmission Gearshift Control .....	4.020	RETAINER, Vacuum Power Brake Cylinder Air .....	4.913
POPET ASM., Vac. Pwr. Brake Cyl. ....	4.940	RETAINER, Vacuum Power Brake Cylinder Piston .....	4.924
POWERGLIDE TRANSMISSION .....	4.003	RETAINER, Vacuum Power Brake Cylinder .....	4.922
PROTECTOR, Main Cylinder Piston .....	4.654	RETAINER, Vacuum Power Brake .....	4.910
PUMP ASSY., Transmission Oil Supply .....	4.200	RETAINER, Vacuum .....	4.205
		RETAINER, Wheel Brake (Also See Group 4.667) .....	4.665
<b>R</b>		RING, Fifth Speed .....	4.416
RACE ASSY., Low Sun Gear and Clutch .....	4.162	RING, Forward Cone Freewheel .....	4.168
RACE, Forward Cone Freewheel .....	4.168	RING, Gearshift Control (Hand) .....	4.006
RACE, Transmission Clutch Gear .....	4.352	RING, Gearshift Control Hand Lever .....	4.008
RACE, Transmission Rear Ring Gear .....	4.180	RING, Gearshift .....	4.309
RAIL ASSY., Transmission Overdrive Shifting RAIL, Gearshift .....	4.490	RING GEAR, Transmission Planet .....	4.175
	4.303	RING, Low Servo .....	4.228
REBUILT CONVERTER ASSY., Transmission (Rebuilt for General Motors) .....	4.115	RING, Low Sun Gear and Clutch .....	4.162
RELAY ASSY., Transmission Overdrive .....	4.480	RING, Main Cylinder (Rubber) .....	4.659
RELAY ASSY., Transmission, Smog Control ...	4.075	RING, Main Cylinder Stop .....	4.656
REPAIR UNIT, Hydraulic Brake Main Cylinder .....	4.649	RING, Manual Valve .....	4.218
REPAIR UNIT, Vacuum Power Brake .....	4.898	RING, Planet Carrier .....	4.176
REPAIR UNIT, Wheel Brake (Also See Group 4.667) .....	4.665	RING, Reverse Servo .....	4.241
REPAIR UNIT, Wheel Cylinder Piston (Also See Group 4.665) .....	4.667	RING, Speedometer Drive Gear .....	4.345
RETAINER, Brake Pedal .....	4.634	RING, Speedometer Driven Gear .....	4.338
RETAINER, Cyl. Poppet .....	4.942	RING, Transmission Clutch .....	4.169
RETAINER, Cyl. Push Rod .....	4.926	RING, Transmission Control Safety .....	4.054
RETAINER, Gearshift Control Hand Lever .....	4.008	RING, Transmission Forward Cone Freewheel .....	4.167
RETAINER, Gearshift Hand Lever .....	4.010	RING, Transmission Front Drive .....	4.158
RETAINER, Gearshift Level Selector and Indicator .....	4.022	RING, Transmission Front Servo Piston Parts ..	4.229
RETAINER, Gearshift Shaft Lever .....	4.032	RING, Transmission Front Servo .....	4.226
RETAINER, Gearshift .....	4.307	RING, Transmission Gearshift Control Shaft or Tube .....	4.027
RETAINER, Hydraulic Brake .....	4.680	RING, Transmission Input .....	4.123
RETAINER, Lever Hand (Floor Mounted) .....	4.015	RING, Transmission Main with Gear .....	4.172
RETAINER, Low Servo .....	4.228	RING, Transmission Main Drive Gear Bearing .....	4.376
RETAINER, Main Cylinder (Rubber) .....	4.659	RING, Transmission Main Shaft Front Pilot to Main Drive Gear .....	4.353
RETAINER, Main Cylinder Adjusting .....	4.662	RING, Transmission Main Valve .....	4.216
RETAINER, Main Cylinder Piston .....	4.654	RING, Transmission Overdrive Snap .....	4.477
RETAINER, Main Cylinder Push .....	4.658	RING, Transmission Overdrive Sun Gear .....	4.472
RETAINER, Main Cylinder Return .....	4.655	RING, Transmission Parking Brake .....	4.290
RETAINER, Main Cylinder Stop .....	4.656	RING, Transmission Parking Lock .....	4.220
RETAINER, Manual Valve .....	4.218	RING, Transmission Rear Bearing and Mainshaft .....	4.412
RETAINER, Parking Brake Cable .....	4.785	RING, Transmission Rear Main Bearing .....	4.317
RETAINER, Parking Brake Lever Release .....	4.594	RING, Transmission Rear Servo .....	4.242
RETAINER, Parking Brake Lever Release .....	4.595	RING, Transmission Rear Unit .....	4.187
RETAINER, Speedometer without Casing .....	4.342	RING, Transmission Rear Ring Gear .....	4.180
RETAINER, Speedometer Driven Gear .....	4.338	RING, Transmission Reverse Idler Shaft .....	4.435
RETAINER, Transmission (Rebuilt for General Motors) .....	4.115	RING, Transmission Synchronizer .....	4.383
RETAINER, Transmission Control Idler Attaching .....	4.042	RING, Transmission Synchronizer .....	4.384
RETAINER, Transmission Control Lever Boot ..	4.017	RING, Transmission Synchronizing .....	4.383
RETAINER, Transmission Forward Cone Freewheel .....	4.167	RING, Transmission Synchronizing .....	4.384
RETAINER, Transmission Front Servo .....	4.233	RING, Transmission Throttle Valve Control (T.V.) .....	4.050
RETAINER, Transmission Gearshift Control ..	4.020	RING, Transmission .....	4.164
RETAINER, Transmission Gearshift Control Shaft or Tube .....	4.027	RING, Transmission .....	4.256
RETAINER, Transmission Gearshift Control ..	4.020	RING, Transmission .....	4.421
RETAINER, Transmission Gearshift Rod to Lever .....	4.037	RING UNIT, Transmission .....	4.005
RETAINER, Transmission Gearshift Shaft Tube Lever .....	4.032	RING, Vacuum Power Brake Cyl. Relay Valve ..	4.935
		RING, Vacuum Power Brake Cylinder Air Valve (See Group 4.658 for Valve and Push Rod Assy.) .....	4.918

## ALPHABETICAL INDEX

RING, Vacuum Power Brake Cylinder Air.....	4.913	SEAL, Transmission Gearshift Control Shaft	
RING, Vacuum Power Brake Cylinder Piston..	4.924	or Tube.....	4.027
RING, Vacuum Power Brake Cylinder.....	4.922	SEAL, Transmission Internal Selector Shaft...	4.313
RING, Wheel Cylinder.....	4.666	SEAL, Transmission Main Drive Gear	
ROD ASSY., Vacuum Power Brake Cylinder		Bearing.....	4.354
Piston.....	4.924	SEAL, Transmission Oil Filler.....	4.133
ROD, Gearshift Control (Hand).....	4.006	SEAL, Transmission Overdrive.....	4.460
ROD, Gearshift Control Hand Lever.....	4.008	SEAL, Transmission Overdrive.....	4.485
ROD, Low Servo.....	4.228	SEAL, Transmission Parking Brake.....	4.294
ROD, Main Cylinder Push.....	4.658	SEAL, Transmission Parking Lock.....	4.220
ROD, Parking Brake Lever Release.....	4.594	SEAL, Transmission Rear Bearing Retainer...	4.318
ROD, Transmission Control Safety.....	4.054	SEAL, Transmission Rear Servo.....	4.242
ROD, Transmission Gearshift Anti-Theft.....	4.070	SEAL, Transmission Throttle valve Operating	
ROD, Transmission Gearshift.....	4.035	Parts.....	4.275
ROD, Transmission Throttle Valve Control		SEAL, Transmission.....	4.256
(T.V.).....	4.050	SEAL UNIT, Transmission Clutch.....	4.166
ROD, Wheel Cyl. to Brake Shoe Thrust.....	4.675	SEAL UNIT, Transmission.....	4.005
ROLLER ASSY., Transmission Forward Cone		SEAL, Vacuum Power Brake Cylinder Air	
Freewheel.....	4.167	Valve (See Group 4.658 for Valve and	
ROLLER ASSY., Transmission Reverse		Push Rod Assy.).....	4.918
Shifter Crank.....	4.293	SEAL, Vacuum Power Brake Cylinder.....	4.922
ROLLER, Gear Shifter Shaft and Fork (Yoke)..	4.312	SEAL, Vacuum Power Brake.....	4.910
ROLLER, Planet Carrier.....	4.176	SEAL, Vacuum.....	4.205
ROLLER, Transmission Clutch Gear.....	4.352	SEAL, Wheel Cylinder Piston (Also See	
ROLLER, Transmission Countershaft Gear.....	4.422	Group 4.665).....	4.667
ROLLER, Transmission Main Shaft Front		SEAT, Main Cylinder Outlet Fitting.....	4.661
Pilot to Main Drive Gear.....	4.352	SEAT, Transmission Front Servo.....	4.233
ROLLER, Transmission Overdrive.....	4.467	SEAT, Transmission.....	4.164
ROLLER, Transmission Reverse Idler Gear.....	4.431	SELECTOR, Transmission Rail End.....	4.302
ROLLER UNIT, Transmission Rear Ring Gear..	4.180	SHAFT ASSEMBLY with Casing.....	4.342A
		SHAFT ASSY., Speed and Cruise Control.....	4.342B
		SHAFT ASSY., Speedometer.....	4.342C
		SHAFT ASSY., Gear Shifter.....	4.309
		SHAFT ASSY., Speedometer without Casing..	4.342
		SHAFT ASSY., Transmission Gearshift Rod	
		to Lever.....	4.037
		SHAFT ASSY., Transmission Internal Shift....	4.302
		SHAFT ASSY., Transmission Planet.....	4.161
		SHAFT ASSY., Transmission Planet.....	4.175
		SHAFT, Brake Pedal.....	4.634
		SHAFT, Gear Shifter.....	4.309
		SHAFT, Gearshift Control Hand Lever.....	4.008
		SHAFT, Gearshift Control.....	4.025
		SHAFT, Gearshift Detent.....	4.311
		SHAFT, Gearshift Hand Lever.....	4.010
		SHAFT, Gearshift.....	4.309
		SHAFT, Transmission Control Idler.....	4.040
		SHAFT, Transmission Counter.....	4.428
		SHAFT, Transmission Gearshift Control	
		Shaft or Tube.....	4.027
		SHAFT, Transmission Input.....	4.123
		SHAFT, Transmission Main with Gear.....	4.172
		SHAFT, Transmission Main.....	4.403
		SHAFT, Transmission Overdrive.....	4.465
		SHAFT, Transmission Overdrive.....	4.495
		SHAFT, Transmission Parking Brake.....	4.294
		SHAFT, Transmission Parking Lock.....	4.220
		SHAFT, Transmission Planet.....	4.175
		SHAFT, Transmission Reverse Idler Gear.....	4.433
		SHAFT, Transmission Throttle valve	
		Operating Parts.....	4.275
		SHAFT, Transmission Throttle Valve Control	
		(T.V.).....	4.050
		SHAFT, Transmission.....	4.256
		SHAFT, Transmission.....	4.403
		SHAFT UNIT, Speedometer without Casing...	4.342
		SHELL ASSY., Vacuum Power Brake	
		Cylinder.....	4.906
		SHELL, Transmission Planet.....	4.175
		SHIELD, Gearshift Level Selector and	
		Indicator.....	4.022
		SHIELD, Gearshift Linkage.....	4.067
		SHIELD, Hydraulic Brake.....	4.685
		SHIELD, Transmission Control Safety.....	4.054
		SHIFT FINGER, Gearshift Control (Hand).....	4.006
		SHIM, Gearshift Control Hand Lever.....	4.008
		SHIM, Transmission Mounting Support.....	4.085
		SHIM UNIT, Transmission Case.....	4.104
		SHROUD, Gearshift Hand Lever.....	4.010
		SILENCER, Vacuum Power Brake Cylinder	
		Air.....	4.913
		SLEEVE, Gearshift Control Hand Lever.....	4.008
		SLEEVE, Gearshift.....	4.307
		SLEEVE, Speedometer Driven Gear.....	4.338

### S

SCREEN ASSY., Oil Pan Pump Suction.....	4.197
SCREEN ASSY., Transmission Case.....	4.105
SCREEN ASSY., Transmission Low and Drive	
Valve.....	4.265
SCREEN ASSY., Transmission Oil.....	4.224
SCREEN ASSY., Transmission Oil.....	4.248
SCREEN UNIT, Oil Pan Pump Suction.....	4.197
SCREW ASSY., Wheel Brake (Also See	
Group 4.667).....	4.665
SCREW, Brake Band Adjusting.....	4.253
SCREW, Brake Cyl. and Pedal Shaft (Also	
See Group 0.847 for pedal shaft	
bracket).....	4.648
SCREW, Brake Press Ind.....	4.874
SCREW, Gearshift Control Hand Lever.....	4.008
SCREW, Gearshift Hand Lever Housing.....	4.012
SCREW, Lever Hand (Floor Mounted).....	4.015
SCREW, Low Sun Gear and Clutch.....	4.162
SCREW, Main Cylinder Stop.....	4.656
SCREW, Oil Supply Pump.....	4.203
SCREW, Planet Carrier.....	4.176
SCREW, Transmission Control Safety.....	4.054
SCREW, Transmission Front Servo.....	4.226
SCREW, Transmission Gearshift Control	
Shaft or Tube.....	4.027
SCREW, Transmission Gearshift Rod to	
Lever.....	4.037
SCREW, Transmission Oil.....	4.195
SCREW, Transmission.....	4.256
SEAL ASSY., Transmission Extension Oil.....	4.318
SEAL ASSY., Transmission Gearshift Control	
SEAL ASSY., Transmission Rear Bearing	
Retainer.....	4.318
SEAL, Gearshift Control Hand Lever.....	4.008
SEAL, Lever Hand (Floor Mounted).....	4.015
SEAL, Main Cylinder Piston.....	4.654
SEAL, Main Cylinder Stop.....	4.656
SEAL, Oil Pan Pump Suction.....	4.197
SEAL, Oil Supply Pump.....	4.203
SEAL, Parking Brake Apply.....	4.591
SEAL, Parking Brake Lever Housing.....	4.612
SEAL, Servo.....	4.212
SEAL, Speedometer Driven Gear.....	4.338
SEAL, Transmission Case.....	4.104
SEAL, Transmission Clutch Gear Oil.....	4.354
SEAL, Transmission Front Servo Piston Parts	
SEAL, Transmission Front Servo.....	4.226
SEAL, Transmission Gearshift Control Cable.	4.047

## ALPHABETICAL INDEX

SLEEVE, Transmission (1st and Reverse Gear).....	4.419	SPRING, Transmission Throttle Valve Control.....	4.052
SLEEVE, Transmission Gearshift Rod to Lever.....	4.037	SPRING, Transmission.....	4.164
SLEEVE, Transmission Rear Bearing Retainer.....	4.318	SPRING, Transmission.....	4.256
SLEEVE, Transmission Throttle Valve Control.....	4.052	SPRING, Vacuum Power Brake Cyl. Reaction Valve (See Group 4.658 for Valve and Push Rod Assy.).....	4.918
SLEEVE, Wheel Brake (Also See Group 4.667).....	4.665	SPRING, Vacuum Power Brake Cylinder Piston.....	4.924
SLINGER, Transmission Main Drive Gear Bearing.....	4.374	SPRING, Vacuum.....	4.205
SOCKET ASSY., Gearshift Level Selector and Indicator.....	4.022	SPRING, Wheel Cylinder Piston.....	4.669
SOCKET ASSY., Parking Brake Alarm.....	4.589	STOP, Brake Main Cylinder.....	4.653
SOLENOID ASSY., Transmission Low and Drive Valve.....	4.265	STRAP, Parking Brake Alarm.....	4.589
SOLENOID, Transmission Overdrive.....	4.480	STRAP, Transmission Gearshift Control Shaft or Tube.....	4.027
SPACER, Brake Pedal.....	4.634	STRIKER, Parking Brake Alarm.....	4.589
SPACER, Fifth Speed.....	4.416	STRUT, Transmission Brake.....	4.251
SPACER, Gearshift Control Hand Lever.....	4.008	STUD, Gearshift Hand Lever Housing.....	4.012
SPACER, Gearshift Hand Lever Housing.....	4.012	STUD, Gearshift.....	4.307
SPACER, Low Sun Gear and Clutch.....	4.162	STUD, Parking Brake Apply.....	4.591
SPACER, Parking Brake Cable Pulley.....	4.790	STUD, Transmission Main Valve.....	4.216
SPACER, Planet Carrier.....	4.176	STUD, Transmission Throttle Valve Control.....	4.052
SPACER, Rear Brake Pressure Regulator.....	4.690	SUPPORT ASSY., Gearshift Hand Lever.....	4.010
SPACER RING, Transmission Main Shaft Front Pilot to Main Drive Gear.....	4.353	SUPPORT ASSY., Low Sun Gear and Clutch.....	4.162
SPACER, Transmission Control Idler Attaching.....	4.042	SUPPORT ASSY., Transmission Control Idler.....	4.040
SPACER, Transmission Counter Gear Bearing.....	4.423	SUPPORT ASSY., Transmission Gearshift Anti-Theft.....	4.070
SPACER, Transmission Gearshift Shaft Tube Lever.....	4.032	SUPPORT ASSY., Transmission.....	4.081
SPACER, Transmission Main Shaft Front Pilot to Main Drive Gear.....	4.353	SUPPORT, Gearshift Hand Lever Housing.....	4.012
SPACER, Transmission Oil.....	4.128	SUPPORT, Gearshift Hand Lever.....	4.010
SPACER, Transmission Overdrive.....	4.495	SUPPORT, Parking Brake Cable.....	4.785
SPACER UNIT, Transmission (Rebuilt for General Motors).....	4.115	SUPPORT, Transmission Control Idler Attaching.....	4.042
SPACER UNIT, Transmission Low and Drive Valve.....	4.265	SUPPORT, Transmission Low and Drive Valve.....	4.265
SPRAG ASSEMBLY, Transmission Forward Cone Freewheel.....	4.167	SUPPORT, Transmission Mounting.....	4.081
SPRAG ASSY., Transmission Rear Ring Gear.....	4.180	SUPPORT, Transmission.....	4.403
SPRING ASSY., Transmission Throttle Valve Operating Parts.....	4.275	SUPPORT, Vacuum Power Brake Cylinder.....	4.922
SPRING, Brake Hose or Pipe.....	4.681	SUPPORT, Vacuum Power Brake Cylinder.....	4.930
SPRING, Brake Pedal Return.....	4.639	SWITCH ASSY., Brake Press Ind.....	4.874
SPRING, Brake Pedal.....	4.634	SWITCH ASSY., Hydraulic Brake.....	4.686
SPRING, Brake Pull Back.....	4.760	SWITCH ASSY., Rear Brake Pressure Regulator.....	4.690
SPRING, Gearshift Control Hand Lever.....	4.008	SWITCH ASSY., Transmission Control Safety.....	4.054
SPRING, Gearshift Detent.....	4.311	SWITCH ASSY., Transmission Throttle Control (Electric).....	4.057
SPRING, Gearshift Hand Lever.....	4.010	SWITCH ASSY., Transmission, Smog Control.....	4.075
SPRING, Main Cylinder Return.....	4.655	SWITCH, Parking Brake Alarm.....	4.589
SPRING, Manual Valve.....	4.218	SWITCH, Transmission Overdrive.....	4.480
SPRING, Oil Supply Pump.....	4.203	SWIVEL, Transmission Control Safety.....	4.054
SPRING, Parking Brake Cable Pulley.....	4.790	SWIVEL, Transmission Gearshift Rod to Lever.....	4.037
SPRING, Parking Brake Lever.....	4.606	SWIVEL, Transmission Throttle Valve Control.....	4.052
SPRING, Parking Brake Release.....	4.597	SYNCHRONIZER, Transmission 1st & Rev.....	4.380
SPRING, Reverse Brake Band.....	4.246		
SPRING, Speedometer without Casing.....	4.342	<b>T</b>	
SPRING, Speedometer.....	4.342C		
SPRING, Transmission (1st and Reverse Gear).....	4.419	TEE ASSY., Vacuum Power Brake Cyl.....	4.931
SPRING, Transmission Clutch Drive and Driven.....	4.163	TEE ASSY., Vacuum.....	4.205
SPRING, Transmission Control Idler Attaching.....	4.042	TEE, Hydraulic Brake.....	4.686
SPRING, Transmission Front Servo.....	4.226	TRANSMISSION ASSY. (less hand brake).....	4.003
SPRING, Transmission Front Servo.....	4.233	TUBE ASSY., Gearshift Control.....	4.025
SPRING, Transmission Gearshift Control.....	4.020	TUBE ASSY., Transmission Oil Filler.....	4.133
SPRING, Transmission Gearshift Control Shaft or Tube.....	4.027	TUBE, Gearshift Control Hand Lever.....	4.008
SPRING, Transmission Gearshift Control.....	4.020	TUBE, Transmission Main Valve.....	4.216
SPRING, Transmission Low and Drive Valve.....	4.265	TURBO, 350, 375, 400).....	4.003
SPRING, Transmission Main Valve.....	4.216		
SPRING, Transmission Overdrive.....	4.467	<b>V</b>	
SPRING, Transmission Parking Brake.....	4.295	VALVE ASSY., Brake Press Ind.....	4.874
SPRING, Transmission Parking Lock.....	4.220	VALVE ASSY., Main Cylinder Push.....	4.658
SPRING, Transmission Rear Ring Gear.....	4.180	VALVE ASSY., Rear Brake Pressure Regulator.....	4.690
SPRING, Transmission Synchronizer.....	4.384	VALVE ASSY., Vacuum Power Brake Check.....	4.955
SPRING, Transmission Synchronizing.....	4.413	VALVE, Main Cylinder.....	4.657

## ALPHABETICAL INDEX

VALVE, Oil Supply Pump.....	4.203
VALVE, Transmission Front Servo.....	4.226
VALVE, Transmission Low and Drive Valve....	4.265
VALVE, Transmission Main Valve.....	4.216
VALVE, Transmission Oil Supply.....	4.200
VALVE, Transmission.....	4.256
VALVE UNIT, Oil Supply Pump.....	4.203
VALVE UNIT, Transmission Main Valve.....	4.216
VALVE UNIT, Vacuum Power Brake Cyl. Relay Valve.....	4.935
VALVE, Vacuum.....	4.205
VALVE, Wheel Cylinder.....	4.666
VENT ASSY., Transmission Case.....	4.104
VENT, Transmission Case.....	4.104

### W

WASHER, Brake Connector.....	4.671
WASHER, Brake Pedal.....	4.634
WASHER, Fifth Speed.....	4.416
WASHER, Gear Shifter Shaft and Fork (Yoke).....	4.312
WASHER, Gearshift Control Hand Lever.....	4.008
WASHER, Gearshift Hand Lever Housing.....	4.012
WASHER, Gearshift Level Selector and Indicator.....	4.022
WASHER, Gearshift Shaft Lever.....	4.032
WASHER, Low Servo.....	4.228
WASHER, Low Sun Gear and Clutch.....	4.162
WASHER, Main Cylinder (Rubber).....	4.659
WASHER, Main Cylinder Adjusting.....	4.662
WASHER, Parking Brake.....	4.765
WASHER, Planet Carrier.....	4.176
WASHER, Reverse Servo.....	4.241
WASHER, Transmission (1st and Reverse Gear).....	4.419
WASHER, Transmission Clutch Gear.....	4.352
WASHER, Transmission Clutch.....	4.169
WASHER, Transmission Control Idler Attaching.....	4.042
WASHER, Transmission Control Idler.....	4.040
WASHER, Transmission Counter Gear Bearing.....	4.423
WASHER, Transmission Front Drive.....	4.158
WASHER, Transmission Gearshift Control Cable.....	4.047
WASHER, Transmission Gearshift Control Shaft or Tube.....	4.027
WASHER, Transmission Gearshift Rod to Lever.....	4.037
WASHER, Transmission Gearshift Shaft Tube Lever.....	4.032
WASHER, Transmission Low and Drive Valve.....	4.265
WASHER, Transmission Main Drive Gear Bearing.....	4.376
WASHER, Transmission Planet.....	4.175
WASHER, Transmission Reverse Idler Gear Thrust.....	4.437
WASHER, Transmission Selector.....	4.046
WASHER, Transmission Shaft and 2nd Speed Gear Thrust.....	4.398
WASHER, Transmission Throttle Valve Control.....	4.052
WASHER, Transmission Throttle Valve.....	4.278
WASHER, Transmission 1st Reverse Gear.....	4.419
WASHER, Transmission.....	4.164
WASHER, Transmission.....	4.256
WEIGHT ASSY., Transmission.....	4.256
WIRE ASSY., Transmission Control Safety.....	4.054
WIRE ASSY., Transmission Throttle Control (Electric).....	4.057
WIRE ASSY., Transmission, Smog Control.....	4.075
WIRE, Transmission Throttle valve Operating Parts.....	4.275



### 3-SPEED TRANSMISSION

#### 4.003 TRANSMISSION ASSY.

64-65	Chevelle (8 cyl.) (exc. O/D) . . . . .	3866689	1	228.00	(Saginaw) . . . . .
64-65	Chevy (327),				
65	Pass. (327) . . . . .	3854724	1	228.00	(Saginaw) (Note 1) . . . . .
	<i>NOTE 1 When using in place of 3866694 transfer cover assy.</i>				
65	Pass. (6 cyl.) (exc. Taxi, Police, O/D, 3.55 axle) . . . . .	3854720	1	228.00	(Saginaw) . . . . .
66-67	All (327, 350) (exc. Pass.),				
66-67	Pass. (327) (exc. 3.55, 3.70 axle),				
68	Pass. (8 cyl.) (exc. 2.73, 3.55, 3.70 axle, O/D, Police, Taxi),				
68	Chevy, Camaro (350) (exc. O.D., 3.55 axle),				
69	Chevy, Chevelle, Camaro w/reg. fuel (350),				
69	Pass. (8 cyl.) (exc. Police, 2.73 axle),				
70	All (350),				
70	Taxi, Police . . . . .	6273289	1		Saginaw w/ext. . . . .
73-74	All (250, 307) . . . . .	6273288	1	236.00	(2.85 low gear ratio) . . . . .
73-74	All w/2BC (350) . . . . .	346313	1	288.00	(2.54 low gear ratio) . . . . .
75	All (250, 262) . . . . .	355543	1	304.00	(2.73 low gear ratio) . . . . .
75	All (350) w/2BC . . . . .	355542	1	304.00	
71-72	Vega (Opel) . . . . .	8977926	1	347.00	w/extension (Note 1) . . . . .
73-74	Vega (Saginaw) . . . . .	6261881	1	304.00	
75	Vega (Saginaw) . . . . .	352251	1	304.00	
75	Monza (140-2BC) . . . . .	368081	1	309.00	(3.42 low gear ratio) . . . . .

#### H.D. 3-SPD. TRANSMISSION

65-68	All (exc. Pass., 3.55, 3.73 axle),				
65-68	Pass. . . . .	3890533	1	284.00	(Warner) . . . . .
69	Chevy, Chevelle, Camaro (350),				
69	Pass. (P/Trac. w/3.73 axle (350, 396) . . . . .	3911938	1	301.00	(Muncie) . . . . .
69	Chevy, Chevelle, Camaro (P/Trac. w/H/Per., Sp. H/Per., 396),				
69	Pass. w/Sp. H/Per. (427) . . . . .	3932262	1	327.00	(Muncie) . . . . .
69	Chevelle w/3.36 axle (exc. 350, 396) . . . . .	3932264	1	327.00	(Muncie) . . . . .
72	Chevelle w/Muncie . . . . .	3952657	1	321.00	Muncie . . . . .

#### 4.004 KIT— CONTROL ASSY.— LEVER ASSY.— ISOLATOR, Transmission Gearshift

62-63	Chevy w/3-Spd. . . . .	3838375	1	14.20	thrust washer and needle bearing . . . . .
64-65	Pass., Chevy, Chevelle w/3-Spd.	3858809	1	12.45	thrust washer and needle brg. . . . .
66-72	All, w/3-Spd. (exc. H.D.) . . . . .	3886339	1	7.85	thrust washer and needle bearing . . . . .
69	All w/Muncie H.D. 3-Spd. (exc. Police),				
69	Police w/Muncie H.D. 3-Spd. (350, 396, 427),				
70-72	Chevelle w/Muncie 3-Spd. . . . .	3958615	1	13.10	thrust washer and needle bearing . . . . .
66-67	Chevelle w/H.D. 3-Spd. . . . .	3890614	1	42.50	CONTROL ASSY., bracket . . . . .
67	Camaro (3-Spd. w/floor control),				
68-70	Chevy, Camaro (3-Spd. w/floor control),				
71-72	Nova w/floor console . . . . .	3934284	1	40.75	CONTROL ASSY., w/lever and bracket . . . . .
68-69	Chevelle w/H.D. 3-Spd.,				
71-72	Chevelle w/floor controls . . . . .	3922526	1	62.50	CONTROL ASSY., w/lever and bracket . . . . .
68-72	Chevy (3-Spd. w/floor shift) (exc. floor console) . . . . .	3930045	1	41.00	CONTROL ASSY., w/lever and bracket . . . . .
70-72	Camaro w/3-Spd.,				
73	Nova, Camaro,				
74-75	Nova (floor controls w/floor console),				
74-75	Camaro . . . . .	494575	1	41.00	CONTROL ASSY. . . . .
74-75	Nova w/floor controls (exc. floor console) . . . . .	494573	1	72.00	CONTROL ASSY. . . . .
73-74	Vega (Saginaw) . . . . .	325746	1	43.50	LEVER ASSY. . . . .
75	Monza . . . . .	348201	1	43.50	LEVER ASSY. . . . .
73-75	Vega (Saginaw) . . . . .	325749	1	2.65	ISOLATOR, trans. control lever . . . . .

#### 4.005 GASKET UNIT, Transmission

62-65	Chevy, Chevelle w/3-Spd. (exc. H.D.),				
-------	--	--	--	--	--

### 3-SPEED TRANSMISSION

#### 4.005 GASKET UNIT, Transmission (Con't)

65	Pass. w/3-Spd. (exc. O/D, H.D.)	3719636	1	.54	(Note 1)	.....
<i>NOTE 1 Consists of 1 transmission cover gasket, 1 clutch gear bearing retainer gasket, 1 transmission extension gasket and 1 "O" ring seal, shifter lever shaft oil, and (1) instruction sheet.</i>						
64-68	Pass., Chevelle w/O.D.	3910117	1	2.70	over drive— (4.460) (Note 2)	.....
<i>NOTE 2: Consists of (2) gaskets, trans. overdrive, (1) gasket, overdrive adapter rear (1) seal, trans. overdrive solenoid oil, overdrive control shaft oil, shifter lever shaft oil, and (1) instruction sheet.</i>						
65-68	All w/3-Spd. H.D.	3870814	1	1.35	(Note 3)	.....
<i>NOTE 3: Consists of 3 gaskets for the clutch gear brg. retainer and 1 each for trans. cover, and extension.</i>						
71-72	Vega (Opel)	6272080	1	11.60	trans. (Note 1)	.....
<i>NOTE 1: Consists of (2 each) seal assy., trans. shift selector shaft (1 each) seal assy., trans. extension oil, trans. clutch gear, "O" ring-used as speedo. driven gear fitting seal (1 each) gasket, trans. case cover 3-Spd., trans. extension, trans. to clutch housing, clutch release bearing support.</i>						
70-75	All w/Saginaw	3886338	1	1.10	(Note 4)	.....
<i>NOTE 4: Consists of 1 trans. extension gasket, 1 trans. cover gasket, 1 clutch gear bearing retainer gasket, and 1 "O" ring seal.</i>						
69	All w/Muncie H.D. 3-Spd.,					
71-74	All w/Muncie	3958616	1	2.75	(Note 8)	.....
<i>NOTE 8 Consists of (1) "O" ring seal and (1 each) gasket trans. cover, clutch gear bearing retainer, and trans. extension.</i>						

#### 4.006 LEVER— KNOB— PIN— SHIFT FINGER, Gearshift Control (Hand)

62-65	Chevy	3790080	1	2.70		
64-65	Chevelle w/3-Spd.	383836	1	3.90	control	.....
65	Pass. (3-Spd. w/column shift)	3816227	1	3.65	control	.....
66	All w/3-Spd.	3879746	1	4.00		
67-68	Pass., Chevelle, Chevy w/3-Spd. (exc. H.D.)	3928317	1	3.75	control	.....
67	Chevy, Camaro w/3-Spd. (exc. H.D., floor console),					
68	Camaro w/3-Spd. (column shift)	3928321	1	4.10	control	.....
67-68	Camaro (floor shift),					
68	Chevy (3-Spd. w/floor console),					
69-71	Chevy w/floor console,					
69	Camaro w/H.D. 3-Spd.	3934288	1	20.95	control	.....
68-70	Chevy w/H.D. 3-Spd. (exc. floor console),					
71-72	Nova w/floor shift	3920248	1	25.00	control	.....
68-70	Chevelle (floor shift w/B.S.),					
71-72	Chevelle (Muncie w/floor console)	3973866	1	10.50	control upper	.....
68-69	Chevelle w/floor shift (exc. B.S.)	3924422	1	10.25	control, upper	.....
69	Pass. w/3-Spd.,					
69	Chevy, Camaro w/3-Spd. (exc. floor shift),					
69	Chevelle w/3-Spd. (exc. H.D.),					
70	All w/Saginaw 3-Spd. (exc. floor shift),					
71-75	Pass., Nova, Chevelle w/Saginaw (exc. floor controls)	3958445	1	4.00	control	.....
70	Camaro w/3-Spd.	3989400	1	6.60	control	.....
71-72	Camaro w/Saginaw (exc. floor controls)	3992595	1	6.60		
71	Vega (Opel)	3460292	1	27.75	trans. control (Opel— 738067)	.....
72	Vega (Opel)	8967343	1	27.75	trans. control	.....
71-72	Chevelle w/Muncie (exc. floor console)	3973865	1	10.40		
73-75	Camaro	332606	1	6.60		
73	Nova w/floor controls (exc. B.S.)	6264077	1	25.00	control	.....
73-75	Nova (floor controls w/B.S.)	6264078	1	20.95	control	.....
74-75	Nova (exc. floor console)	340348	1	18.75	control	.....
73-75	Vega (Saginaw)	325747	1	26.75	trans. control	.....
75	Vega w/floor shift (Saginaw)	9794506	1		control lever	.....
64-65	Chevelle w/T.W. (exc. S.S.),					
65	Pass. (exc. S.S., Caprice),					
65	Pass. w/3-Spd.	3782694	1	1.35	KNOB (2 <sup>13</sup> / <sub>32</sub> " O.L.— black plastic)	.....
66-67	Chevelle w/floor console	3857160	1	5.75	KNOB, control lever	.....
65-66	Caprice (exc. B.S.)	3882907	1	1.55	KNOB, cont. lever	.....
66	Chevelle w/H.D. 3-Spd. (exc. floor console)	3904035	1	3.60	KNOB, control (black)	.....
67	Pass.,					
67	Concours (exc. H.D. 3-Spd.)	3898254	1	1.75	KNOB, turquoise w/chrome	.....
67	Concours (exc. H.D. 3-Spd.),					
67	Pass.,					
67	Camaro (Deluxe) w/3-Spd. (exc. H.D.),					

### 3-SPEED TRANSMISSION

#### 4.006 LEVER— KNOB— PIN— SHIFT FINGER, Gearshift Control (Hand) (Con't)

67	Chevelle (Spt. Cpe., Conv.) w/3-Spd. (exc. H.D.),				
67	Nova (S.S.) w/3-Spd. (exc. H.D.),				
67	Pass.,				
67	Nova, Malibu (exc. H.D., 3-Spd.),				
67	Conv., Sta. Wag., El Camino,				
67-70	All w/column shift	3973042	1	2.10	KNOB, control lever (black) (paint as required)
68	Pass.,				
68	Chevelle (Spt. Sed.) w/3-Spd. (exc. H.D.),				
68	Pass.,				
68	Chevelle w/3-Spd. (exc. H.D., floor console)	3928282	1	1.90	KNOB, dark saddle w/chrome
69	All	3945523	1	1.20	KNOB, midnight green
71-75	All w/column shift	3990592	1	2.40	KNOB, control lever (black)
68	Camaro w/floor console,				
68-70	Chevelle (H.D. 3-Spd. w/floor console),				
69	Camaro (H.D. 3-Spd. w/floor console),				
69	Chevy (3-Spd., w/floor console)	390749	1	4.40	KNOB ASSY., control lever
69-70	Camaro w/floor console (exc. H.D. 3-Spd.)	9793565	1	2.25	KNOB ASSY., control lever (black)
71-72	Chevelle w/floor console	3992308	1	3.65	KNOB ASSY., control lever (black)
71	Chevelle w/floor shift (exc. floor console),				
71-72	Nova w/floor shift, floor console	3992554	1	3.85	KNOB ASSY., control lever (black)
71-72	Vega (Opel)	3988097	1	1.90	KNOB, trans. control lever
71	Camaro w/floor console	3992558	1	3.65	KNOB ASSY., control lever
71-75	Nova, Camaro, Vega w/floor shift	357702	1	6.10	KNOB ASSY., control lever
67	Camaro (3-Spd. w/floor controls),				
68-69	Camaro (3-Spd. w/floor shift) (exc. floor console),				
68-70	Chevy (3-Spd., w/floor controls),				
68-69	Chevelle w/3-Spd. (exc. fir. console)	3921146	1	4.80	KNOB UNIT, control (black) (w/shift pattern)
70	Camaro (3-Spd. w/floor shift)	3981892	1	5.05	KNOB UNIT, control lever
73-75	All	402196	1	.16	PIN, trans. control lever pivot
71-72	Vega (Opel)	3460287	1	15.35	SHIFT FINGER, trans. gearshift control (Opel— 738321)

#### 4.008 BRACKET— BOLT— BRACE— FLANGE— GROMMET— NUT— PIN— RING— SHAFT— SHIM— SPACER— SPRING— WASHER, Gearshift Control Hand Lever

71-72	Chevelle w/floor shift	3922532	1	.83	control lever and bracket stabilizer shaft
71-72	Vega (Opel)	8961295	1	6.55	trans. gearshift control
72	Camaro	454950	1	.28	BOLT, control lever and bracket ( $7/16"$ — 14 x 3)— (8.900)
73-74	Vega (Saginaw)	329787	3	.31	BOLT, control lever ( $5/16"$ — 18 x $21/32"$ )
72	Chevelle w/floor controls	3922522	1	.94	BRACE, control lever and bracket
66-67	Chevelle w/H.D. 3-Spd.	3845747		5.35	FLANGE, control lower lever (w/studs)
62-65	Chevy	3793046	1	.11	GROMMET, inner
62-65	Chevy	3790083	1	.26	GROMMET, outer
65	Pass. w/3-Spd. (exc. T.W.)	3779108	1	.12	GROMMET, control lever (rubber)
66-67	Chevelle w/H.D. 3-Spd.	3852444	1	.16	GROMMET, control lever and reverse release cable ( $7/16"$ )
71-72	Vega (Opel)	2865032	1	.24	GROMMET, trans. control lever, lower
71-72	Vega (Opel)	2865035	1	.31	GROMMET, trans. control lever, upper (Opel— 738900)
71-72	Vega (Opel)	3991370	1	2.10	INSULATOR, trans. control lever
67-69	Camaro (3-Spd. w/floor controls) (exc. H.D.),				
67-69	Camaro w/H.D. 3-Spd.,				
68-72	Chevy w/floor shift	3901371	1	.78	NUT, special anchor ( $5/16"$ — 18) (2 holes)
67-69	Camaro (3-Spd. w/floor console) (exc. H.D.),				
67-69	Camaro w/H.D. 3-Spd.,				
68-72	Chevy w/floor shift	3901372	1	.53	NUT, anchor ( $5/16"$ — 18) (1 hole)
71-72	Nova, Chevelle w/floor controls	3992309	1	.18	NUT, control lever knob ( $5/16"$ — 18)
73-75	All	9794299	1	.18	NUT, trans. cont. lever knob
73-75	Vega (Saginaw)	9794299	1	.18	NUT

**3-SPEED TRANSMISSION**

**4.008 BRACKET— BOLT— BRACE— FLANGE— GROMMET— NUT— PIN— RING— SHAFT— SHIM— SPACER— SPRING— WASHER, Gearshift Control Hand Lever (Con't)**

62-65	Chevy,					
67-71	All w/3-Spd. (exc. H.D.)	3793014	1	1.05	PIN, fulcrum ( $7/32$ " dia. x $1^{11}/32$ " O.L.)	
64-66	Chevelle w/3-Spd. (exc. H.D.),					
66	Chevy w/3-Spd.	9425112	1	.16	PIN, control lever pivot— (8.939)	
66-67	Chevelle w/H.D., 3-Spd.	3845746	1	.59	PIN, lower lever	
67	Camaro w/floor shift,					
68-69	Chevy, Chevelle, Camaro w/floor shift,					
69	Chevy, Chevelle, Camaro w/Muncie H.D. 3-Spd.,					
70-72	Nova, Chevelle w/floor controls	3895254	1	.53	PIN, control lever	
71-72	Vega (Opel)	3978193	1	.42	PIN, trans. control lever ( $1^{47}/64$ " O.L. x $1^{15}/16$ " O.D.)	
62-69	All	9431762	1	.08	RING, control lever pin retaining ( $1^{13}/64$ "— (8.934)	
67-68	Camaro (floor shift w/floor console),					
71-72	Vega (Saginaw)	11057501	1	.13	RING, trans. lower grommet retainer	
71-72	Vega (Saginaw)	11060801	1	.27	RING, trans. gearshift control tube retaining, lower	
71-72	Vega (Opel)	2886929	1	.15	SEAT, trans. lower grommet (Opel— 738528)	
68-69	Chevy, Camaro w/floor shift,					
68	Chevelle (S.S.),					
70-71	Nova w/floor controls,					
72	Nova, Chevelle w/floor controls	3895256	1	.84	SHAFT, control lever	
71-72	Chevelle w/floor shift	3922531	1	1.55	SHAFT, control lever and bracket stabilizer	
73-75	Vega (Saginaw)	325757	1	.91	SHAFT, trans. control shaft lever	
65	Pass.	3758998	1	.26	SHIM, control lever	
67-69	Camaro (3-Spd. w/floor shift),					
68-71	Chevy (3-Spd. w/floor shift),					
68-60	Chevelle w/H.D. 3-Spd.,					
72	Nova, Chevelle w/floor controls	3901385	1	5.05	SPACER, cont. shift lever	
73-75	Vega (Saginaw)	325755	1	5.35	SPACER, control shaft lever	
73-74	Vega (Saginaw)	329721	1	5.35	SPACER, control shaft lever	
64-66	Chevelle (exc. T.W., S.S., floor console)	391537	1	.40	SPRING, shift lever	
65	Chevy w/3-Spd.	3653114	1	.63	SPRING, pull back (50 coils— $5^{43}/64$ " free length)— (0.844) (Note 1)	
<i>NOTE 1 When using in place of 3786560 discard original spring extension 3780837.</i>						
65	Pass. (exc. T.W.)	3719853	1	.16	SPRING (5 coils— $1^{9}/32$ " long)	
66-67	Chevelle w/B.S. (8 cyl.)	3845716	1	.44	SPRING, reverse release cable retaining	
67-68	All w/3-Spd.	7800604	1	.38	SPRING, strg. col. shift lever secondary	
69-74	All w/column shift	7804624	1	.71	SPRING, lever	
75	Monza	348231	1	.40	SPRING, trans. control lever lock out lower	
69-70	All (column shift w/T.W.) (exc. Chevy)	7812853	1	.92	SPRING, gearshift lever housing	
70	All w/floor controls	7808017	1	.64	SPRING, lever	
66-67	Chevelle w/H.D. 3-Spd.,					
67-68	Camaro w/floor shift,					
68	Chevy, Chevelle w/floor shift,					
71	Nova w/floor controls,					
72	Nova, Chevelle w/floor controls	3841726	1	.12	WASHER, control lever spring	
66-67	Chevelle w/H.D. 3-Spd.,					
68	Chevy	3852446	2	.11	WASHER, control lever and reverse release cable ( $2^{1}/64$ " I.D.)	
71-72	Vega (Opel)	3460500	1	.24	WASHER, trans. lower grommet (Opel— 738533)	
71-72	Vega (Opel)	9428369	1	.12	WASHER, trans. control lever pin ( $2^{1}/64$ " I.D. x $4^{1}/64$ " O.D. x $1/64$ " thk.)— (8.928)	
71-72	Vega (Opel)	3460499	1	.24	WASHER, trans. upper grommet (Opel— 738532)	

**4.010 SUPPORT ASSY.— BRACE— BRACKET— COVER— HOUSING— PLATE— PLUG— SHAFT— SHROUD, Gearshift Hand Lever**

*For floor shift models not using strg. column shift lever housing, see group 6.518 for equivalent part, listed as a cover, jacket extension, housing, etc.*

67-70	Camaro w/floor shift,					
68-72	Chevy w/floor shift	3895261	1	7.50	lever and bracket	
68-72	Chevelle w/H.D. 3-Spd.	3918063	1	5.20	lever and bracket	
70-75	Camaro w/3-Spd. (exc. 454)	3975595	1	3.50	lever and bracket	
73-75	Nova w/floor controls	6264086	1	8.05	control lever	
68-71	Chevelle w/H.D. 3-Spd.	3922522	1	.94	BRACE, control lever and bracket (Note 1)	

### 3-SPEED TRANSMISSION

#### 4.010 SUPPORT ASSY.— BRACE— BRACKET— COVER— HOUSING— PLATE— PLUG— SHAFT— SHROUD, Gearshift Hand Lever (Con't)

*NOTE 1 1969 Chevelle H.D. 3-Spd. is interchangeable between M13 and MC1.*

67	Camaro (3-Spd. w/floor console) (exc. H.D.),				
68-69	Chevy, Camaro (3-Spd. w/floor shift) (exc. H.D.),				
70-72	Nova (Saginaw 3-Spd. w/floor controls) . . . . .	3920249	1	2.00	BRACKET, control lever and stabilizer shaft
67	Camaro w/H.D. 3-Spd.,				
68	Camaro, Chevy w/H.D. 3-Spd. . .	3920250	1	.57	BRACKET, control lever . . . . .
69	Chevy, Camaro, Chevelle w/Muncie H.D. 3-Spd.,				
71-72	Chevelle w/Muncie . . . . .	3945462	1	.83	BRACKET, control lever and stabilizer shaft
66	Chevelle w/H.D. 3-Spd. . . . .	3890614	1	42.50	BRACKET ASSY., control lever . . . . .
67-69	Camaro w/floor shift,				
68-70	Chevy, Chevelle w/floor shift,				
71	Nova w/floor controls,				
72	Nova, Chevelle w/floor controls .	325050	1	25.50	BRACKET ASSY., control shaft lever . . . . .
67-68	Camaro w/floor shift console,				
68	Chevy, Chevelle w/floor shift, console,				
69	Chevy, Camaro, Chevelle w/floor shift (8 cyl.),				
70	Nova, Chevelle w/floor controls,				
71	Nova w/floor controls,				
72	Nova, Chevelle w/floor controls .	3895248	1	7.55	BRACKET ASSY., control lever . . . . .
73-75	Vega (Saginaw) . . . . .	325748	1	.99	trans. control lever . . . . .
68	Chevelle w/floor console . . . . .	3934819	1	.40	COVER, control lever seal . . . . .
62	Chevy w/3-Spd. . . . .	3790084	1	5.05	HOUSING, lever . . . . .
63-65	Chevy w/3-Spd. . . . .	3793785	1	5.05	HOUSING, lever . . . . .
64	Chevelle w/3-Spd. . . . .	382082	1	6.35	HOUSING, lever . . . . .
66	Pass. w/3-Spd. . . . .	3882939	1	5.30	HOUSING, cont. lever . . . . .
66	Chevy w/3-Spd. . . . .	3879745	1	4.85	HOUSING, lever . . . . .
67-68	Pass. w/3-Spd. . . . .	7800596	1	17.60	HOUSING, lever . . . . .
69-70	All w/floor shift (exc. T.W.) . . . .	7804436	1	14.25	HOUSING, control lock tube . . . . .
69-75	All w/column shift (exc. T.W.) . . .	7812064	1	18.35	HOUSING, control lock tube (Note 1) . . . . .
73-75	Vega (Saginaw) . . . . .	325751	1	12.50	HOUSING, trans. control shaft . . . . .
67-68	Camaro (3-Spd. w/column shift)	5698563	1	21.95	HOUSING ASSY., w/shroud, control lever . .
67	Chevy (3-Spd. w/column shift) . .	7800608	1	23.80	HOUSING ASSY., shroud assy., gear shift lever . . . . .
68	Chevelle w/3-Spd. (column shift)	7802980	1	27.75	HOUSING ASSY., w/shroud . . . . .
68	Chevy w/3-Spd. (column shift) . .	7803115	1	27.75	HOUSING ASSY., w/shroud . . . . .
69-70	Pass., Chevelle (Column Shift w/3-Spd.),				
69-70	Pass., Chevelle w/floor shift (exc. T.W.) . . . . .	7807691	1	1.10	PLATE, strg. column shift tube lock . . . . .
73-75	All (350) . . . . .	3906448	1	.92	PLUG, trans. tower . . . . .
67-68	Camaro (3-Spd. w/floor shift) (exc. H.D.),				
68	Chevy (3-Spd. w/floor shift) (exc. H.D.),				
69-70	Chevy, Camaro (3-Spd. w/floor shift),				
71	Nova w/floor controls . . . . .	3901377	1	1.55	SHAFT, lever and bracket stabilizer . . . . .
67-68	Camaro w/H.D. 3-Spd. (302, 350),				
68	Chevelle w/H.D. 3-Spd.,				
68	Chevy (H.D. 3-Spd. w/Sp. H/Per.) (327, 350),				
70	Nova (3-Spd. w/floor controls) . .	3922531	1	1.55	SHAFT, lever and bracket stabilizer . . . . .
67-68	Camaro w/H.D. 3-Spd.,				
68-69	Chevy w/H/Per., Sp. H/Per. (396) . . . . .	3913710	1	2.25	SHAFT, lever and bracket stabilizer . . . . .
69	Pass., Chevelle (exc. T.W.),				
70	Pass., Nova, Chevelle (exc. Tel., T.W.),				
71	Chevelle (exc. T.W.),				
73-74	All w/column shift (exc. T.W.) . .	7811352	1	7.75	SHROUD, strg. col. gearshift housing bowl .
69-70	Chevy, Camaro (exc. T.W.),				
71	Pass., Nova, Camaro (exc. T.W.),				
73-75	Camaro (exc. column shift, T.W.)	7811350	1	7.90	SHROUD, strg. col. G/S hsg. bowl . . . . .
73-74	Vega (Saginaw) . . . . .	7810336	1	7.15	SHROUD, strg. col. . . . .

*NOTE 1: When used on jobs having plate and screws, discard these parts.*

### 3-SPEED TRANSMISSION

#### 4.012 BOLT— DETENT— SCREW— SPACER— WASHER, Gearshift Hand Lever Housing

67-69	Camaro w/floor shift,				
68-72	Chevelle w/H.D. 3-Spd.,				
68-71	Chevy w/floor shift,				
72	Nova, Chevelle w/floor shift . . . .	3922533	1	.28	control lever and bracket stabilizer shaft . . .
67-69	All (w/T.W.) . . . . .	7800639	1	.24	SCREW, shift detent plate . . . . .
69-70	All (exc. T.W.) . . . . .	7810242	2	.78	SCREW, strg. column shift tube lock plate . . .
69-75	All (exc. T.W.) . . . . .	7804407	1	.24	SCREW, strg. column shift lever detent plate . . . . .
68-69	Chevy, Chevelle, Camaro w/floor shift,				
70-72	Nova, Chevelle (3-Spd. w/floor controls) . . . . .	3941824	3	.24	SPACER, control rod . . . . .
62-65	Chevy,				
65	Pass. (exc. T.W.) . . . . .	3793124	1	.16	WASHER, lever housing (1 <sup>5</sup> / <sub>16</sub> " ) . . . . .
64-65	Chevelle w/3-Spd.,				
66	All . . . . .	388757	1	.18	WASHER, lever housing retainer . . . . .
64-67	Chevelle,				
66-67	Chevy w/3-Spd. . . . .	3745292	1	.11	WASHER, control lever housing thrust, control lever housing upper— (2.895) . . . . .
64-66	Chevelle w/3-Spd. . . . .	382085	1	.11	WASHER, cont. lever housing spring . . . . .
66	Pass. w/3-Spd.,				
66	Chevy,				
66	Chevelle . . . . .	3879747	1	.11	WASHER, lever housing . . . . .
66	All w/3-Spd. . . . .	3879748	1	.24	WASHER, cont. lever hsg. thrust . . . . .
66	Chevy, Chevelle w/H.D. 3-Spd. . . . .	3879778	1	.12	WASHER, cont. lever hsg. thrust . . . . .
67-68	All w/3-Spd. (exc. floor shift) . . . . .	7800579	1	.38	WASHER, lever hsg. to bearing hsg. . . . .
67-68	All w/T.W. . . . .	5698413	1	.53	WASHER, steering column support thrust . . .
72-75	Vega . . . . .	7811188	1	.57	strg. col. shift lever hsg. brg. wave . . . . .
67-68	All w/T.W. . . . .	5699618	1	.53	WASHER, steering column support wave . . .
67-75	All (exc. T.W.) . . . . .	7800580	1	.34	WASHER, steering shaft upper retainer ring thrust . . . . .
67-68	All (exc. T.W.) . . . . .	7800581	1	.38	WASHER, steering shaft upper retainer ring wave . . . . .
69-74	All, w/T.W. . . . .	3886319	1	.32	WASHER, strg. column supt. thrust . . . . .
69-73	All, w/T.W. . . . .	3884595	1	.20	WASHER, strg. column supt. wave . . . . .
69-72	All, w/3-Spd.,				
73-74	Nova, Chevelle w/column shift . . . . .	7806732	1	.38	WASHER, strg. col. shift lever hsg. brg. wave . . . . .

#### 4.015 SEAL— BEZEL— BOOT— COVER— GROMMET— INSULATOR— RETAINER— SCREW, Lever Hand (Floor Mounted)

66	Chevelle w/H.D. 3-Spd. (exc. floor console) . . . . .	3842926	1	4.85	control lever and lower . . . . .
66-67	Chevelle (floor console w/H.D. 3- Spd.) . . . . .	3907663	1	3.05	control lever upper . . . . .
66-67	Chevelle (floor console w/H.D. 3- Spd.) . . . . .	3903917	1	3.20	control lever lower . . . . .
67-68	Camaro w/3-Spd. (exc. flr. console),				
69	Camaro w/H.D. 3-Spd.,				
69	Camaro (floorshift w/3-Spd.) (exc. floor console) . . . . .	3893853	1	3.20	underbody trans. control lever (boot) . . . . .
67-69	Camaro w/floor console,				
68-73	Chevy w/floor console . . . . .	3974526	1	2.95	underbody trans. control lever . . . . .
67	Chevelle w/H.D. 3-Spd. (exc. floor console) . . . . .	3903961	1	3.90	control lever . . . . .
67	Camaro w/floor console,				
68-69	Chevy, Camaro w/floor console . . . . .	3921896	1	2.50	control lever . . . . .
68	Chevy (H.D. 3-Spd. w/H/Per., Sp. H/Per.) (327, 350, 396),				
68-72	Chevy w/floor shift (exc. floor console) . . . . .	3974568	1	2.60	underbody control lever . . . . .
68-72	Chevelle w/3-Spd. (exc. floor console) . . . . .	3975405	1	2.75	control lever . . . . .
68-69	Chevelle (H.D. 3-Spd. w/floor console) . . . . .	3922820	1	.57	control lever . . . . .
68	Camaro w/floor console . . . . .	3929984	1	1.15	control lever . . . . .
68-72	Chevelle (H.D. 3-Spd. w/floor console) . . . . .	3975356	1	2.05	control lever (boot) . . . . .
70-75	Camaro w/3-Spd. . . . .	3973966	1	3.20	underbody control lever . . . . .
71-75	Camaro . . . . .	3990467	1	2.75	underbody trans. control lever lower . . . . .
73	Nova w/floor shift,				
74-75	Nova (floor shift w/floor console) . . . . .	327545	1	3.20	underbody control lever upper . . . . .

### 3-SPEED TRANSMISSION

#### 4.015 SEAL— BEZEL— BOOT— COVER— GROMMET— INSULATOR— RETAINER— SCREW, Lever Hand (Floor Mounted) (Con't)

73-74	Nova	327544	1	3.15	underbody trans. control lever lower
74	Nova w/floor shift (exc. floor console)	341070	1	3.20	u/b trans. control lever upper
75	Nova	332235	1	3.40	underbody trans. control lever lower
67	Chevelle w/H.D. 3-Spd. (exc. floor console)	3903960	1	8.80	BEZEL, control lever seal
68-72	Chevelle w/H.D. 3-Spd. (exc. flr. console)	3926747	1	4.75	BEZEL, control lever seal
71-72	Vega (Opel)	3988056	1	2.75	BEZEL, trans. control lever boot (chrome)
73-75	Vega (Saginaw)	329732	1	2.75	BEZEL, trans. control lever boot
67-69	Camaro w/floor console	3929982	1	.47	COVER; underbody control lever seal
71-72	Vega (Opel)	3978154	1	3.30	BOOT, trans. control lever, upper
71-72	Vega (Opel)	3991299	1	4.25	BOOT, trans. control lever, lower
73-74	Vega (Saginaw)	325779	1	3.30	BOOT, trans. control lever (upper)
73-75	Vega (Saginaw)	336520	1	4.25	BOOT, trans. control lever (lower)
75	Monza	348207	1	4.50	BOOT, trans. control lever (lower)
66-67	Chevelle (3-Spd. w/floor console)	3903962	1	.70	RETAINER, control lever and lower seal
73-75	Vega (Saginaw)	329788	3	.22	GROMMET, trans. control lever to floor pan
75	Monza	348300	1	.43	GROMMET, trans. control lever
73-75	Vega (Saginaw)	360303	1	4.25	INSULATOR, trans. control lever
75	Monza	348203	1	3.70	INSULATOR, trans. control lever
66-67	Chevelle (floor console w/H.D. 3-Spd.)	3878413	1	3.65	RETAINER, cont. lever upper seal
67	Camaro w/floor console,				
68	Chevy w/floor console	3899870	L.H.	.14	RETAINER, control lever seal, left
67	Camaro w/floor console,				
68	Chevy w/floor console	3893872	R.H.	.19	RETAINER, control lever seal, right
67-68	Camaro w/flr. console,				
68-72	Chevy w/floor console,				
69	Camaro (3-Spd. w/floor console)	3893877	1	.63	RETAINER, underbody trans. lever seal
67-69	Camaro w/3-Spd. (exc. floor console)	3893854	1	.63	RETAINER, underbody trans. control lever seal
68-72	Chevelle w/H.D. 3-Spd. (exc. floor console)	3926745	1	2.30	RETAINER, control lever seal
68-72	Chevy (exc. floor console)	3921898	1	1.55	RETAINER, underbody control lever seal
68	Camaro w/flr. console	3919159	1	.42	RETAINER, control lever seal
68-72	Chevelle (H.D. 3-Spd. w/floor console)	3975358	1	1.25	RETAINER, control lever seal
71-74	Camaro w/floor controls	3973970	1	2.70	RETAINER, underbody control lever seal
71-72	Vega (Opel)	331963	1	2.15	RETAINER, trans. control lever boot
73	Nova w/floor console	327548	1	.63	RETAINER, underbody lever seal
74-75	Nova w/floor controls	339459	1	.78	RETAINER, u/b control lever seal
70	Camaro w/floor controls	9415952	3	.05	SCREW, lever seal front and rear guide, boot ret. and hsg. trim cover brkt.— (8.977)

#### 4.017 PLATE— EXTENSION— NUT, Underbody Trim (floor mounted)

67-68	Camaro w/3-Spd. (exc. floor console),				
69	Camaro w/H.D. 3-Spd.,				
69	Camaro (floor shift w/3-Spd.) (exc. floor console)	3893855	1	3.30	underbody lever seal trim
67	Camaro w/floor console,				
68-72	Chevy w/floor console	3921895	1	10.15	control lever hole trim
68-72	Chevy w/floor shift	3921899	1	4.35	underbody control lever seal trim
69	Camaro (3-Spd. w/floor console)	3949537	1	8.75	control lever hole trim
70	Camaro (3-Spd./floor console) (exc. Deluxe Interior)	3975874	1	8.65	control lever hole trim (chrome)
70	Camaro w/Deluxe Interior	3975876	1	8.65	control lever hole trim (wood grain)
73-74	Nova w/floor console	327549	1	7.50	control lever trim plate
73-75	Camaro w/floor console	478571	1	2.95	control lever trim hole
75	Monza w/console	332236	1	1.55	PLATE, seat separator trim
69	Camaro (3-Spd. w/floor console)	3949540	1	2.45	EXTENSION, control lever hole trim plate
70-72	Nova w/floor console	3974524	1	2.25	EXTENSION, lever hole trim plate
70-72	Camaro w/floor console	3973964	1	2.25	EXTENSION, lever hole trim plate
71-72	Chevelle (Muncie w/floor console)	3975357	1	.98	EXTENSION, trans. control lever hole trim plate
73-75	Camaro w/floor console	480133	4	.07	NUT, seat sep. trim plate ("U" shape)

### 3-SPEED TRANSMISSION

#### 4.020 PLATE, Transmission Gearshift Control

68-72	Chevelle (H.D. 3-Spd. w/floor console)	3919910	1	3.30	control selector (3 x 1 <sup>1</sup> / <sub>2</sub> )
68-69	Camaro (3-Spd. w/floor console)	3919121	1	2.00	control selector
70-72	Camaro (3-Spd. w/floor console)	3975882	1	2.00	control selector

#### 4.025 TUBE ASSY., Gearshift Control

62-65	Chevy w/3-Spd.	3830773	1	9.00	
64	Chevelle w/3-Spd.	382068	1	8.85	
64-66	Chevelle,				
70-75	Camaro w/T.W.	7808908	1	27.25	shift
65	Pass. w/3-Spd. (exc. H.D.)	3859439	1	11.05	shifter
65	Chevelle w/3-Spd.	3864591	1	11.05	
66	Pass. w/3-Spd.	3879735	1	10.85	shifter
66	Chevy w/3-Spd.	3886541	1	8.55	
66	Chevelle w/3-Spd.	3879797	1	10.75	
67-68	Pass. w/3-Spd.	7803663	1	26.50	shifter
67	Chevy w/3-Spd.	7803666	1	26.50	
67	Camaro w/3-Spd.	7803667	1	26.50	
67	Chevelle w/3-Spd.	5699802	1	25.50	
68	Chevelle w/3-Spd. (exc. T.W., H.D.)	7802218	1	31.25	
68	Chevy, Camaro w/3-Spd. (column shift)	7801439	1	24.85	
69-70	Pass. w/T.W.	7805265	1	26.25	strg. column trans. control lock
69-70	Pass. w/3-Spd.	7805118	1	25.75	shifter
69-70	Chevelle w/floor shift (exc. T.W.)	7804493	1	32.50	
69-72	Chevelle (column shift w/3-Spd.)	7805114	1	26.25	
69	Chevelle (floor shift w/T.W.)	7806838	1	26.25	lock
69-70	Chevelle w/floor shift (exc. T.W.)	7806814	1	25.75	lock
<i>NOTE 1 Can be used as steering column control lock tube on floor shift models.</i>					
69	Chevy, Camaro (column shift w/3-Spd.),				
70-74	Nova (3-Spd. w/col. shift)	7805117	1	26.25	
69	Chevy, Camaro (exc. T.W.),				
70-71	Nova w/floor controls (exc. T.W.)	7804745	1	25.75	
70-71	Camaro (exc. T.W.),				
72-75	Camaro (exc. floor console, T.W.)	7808563	1	37.75	strg. col. shift
71-73	Pass. (exc. T.W.)	7810774	1	29.00	shift
73-75	Chevelle	7812570	1	26.25	shift
73-74	Nova w/T.W.	7815214	1	26.25	shift
75	Nova	7817850	1	26.25	shift

#### 4.027 INTERLOCK— GATE— PLATE— PLUNGER— RETAINER— RING— SCREW— SEAL— SHAFT— SPRING— WASHER, Transmission Gearshift Control Shaft or Tube

64-67	Chevelle	3841485	1	1.65	control reverse lever (3/32" thk.)
68	Chevy, Chevelle (3-Spd. w/floor shift)	3901387	1	1.70	trans. control shaft lever
69-70	All w/column shift (exc. T.W.)	7804406	1	1.70	PLATE, strg. col. gearshift lever detent
69	All (floor shift w/T.W.) (exc. Chevelle)	7806055	1	2.95	PLATE, strg. col. shroud index detent
69-75	All w/column shift	7804761	1	1.25	PLATE, strg. col. rack guide
71-72	Pass., Nova, Chevelle w/column shift	7806352	1	3.15	PLATE, strg. col. G/S lever detent
69	All (floor shift w/T.W.) (exc. Chevy)	7806056	1	1.30	PLUNGER, strg. col. shroud index detent
64-67	Chevy, Chevelle,				
73-74	Vega (Saginaw)	3841725	1	.42	RETAINER, trans. control shift lever shaft
67-68	All w/T.W.	5698409	1	.39	RING, steering column support retainer
69-70	All w/T.W.	7804907	1	.47	RING, column support retainer
65-66	Pass. w/3-Spd.,				
65-67	Chevelle w/3-Spd. (exc. H.D.)	3872057	1	1.90	RING ASSY., shifter tube adj.
69	Chevy, Camaro (column shift w/3-Spd.),				
69-70	Pass., Chevelle (exc. T.W.)	7806109	1	1.15	SCREW, column shift tube index
62-67	Chevy, Chevelle,				
65-67	Pass.	3711055	1	.28	SEAL, tube (felt) (1 <sup>1</sup> / <sub>8</sub> " I.D. x 1 <sup>15</sup> / <sub>16</sub> " O.D.)
70	Chevelle w/T.W.,				
71-73	Pass., Camaro	7807007	1	.50	SEAL, strg. col. shifter tube
69-72	Chevelle w/Muncie H.D. 3-Spd.	3945460	1	2.15	SHAFT, control lever and bracket stabilizer
73-74	Chevelle	488451	1	5.35	SHAFT ASSY., control equalizer
64	Malibu (S.S.)	3874236	1	.11	SPRING, lever release button— (4.008)
67	All (exc. T.W.)	5698381	1	.65	SPRING, shift tube thrust
67-69	Camaro (3-Spd. w/floor shift),				



**3-SPEED TRANSMISSION**

**4.027 INTERLOCK— GATE— PLATE— PLUNGER— RETAINER— RING— SCREW— SEAL— SHAFT— SPRING— WASHER, Transmission Gearshift Control Shaft or Tube (Con't)**

68-71	Chevy (3-Spd., w/floor shift),				
68-69	Chevelle w/H.D. 3-Spd.,				
68	Concours,				
72	Nova, Chevelle w/floor controls .	3895250	1	.98	SPRING, lever . . . . .
69-70	All (exc. T.W.) . . . . .	7804446	1	.88	SPRING, shift tube thrust . . . . .
71-75	All . . . . .	7810567	1	.98	SPRING, strg. col. shift tube return lower . . . . .
71-72	Vega (Opel) . . . . .	3978195	1	.23	trans. control lever bias . . . . .
73-75	Vega (Saginaw) . . . . .	325750	1	1.90	SPRING, trans. control lever . . . . .
69-75	All (exc. T.W.) . . . . .	7807427	1	.47	WASHER, shift tube thrust . . . . .

**4.030 LEVER— BRACKET— HOUSING, Transmission Gearshift Shaft or Tube (Lower)**

62-65	Chevy w/3-Spd. . . . .	3790830	1	2.75	1st and reverse . . . . .
62-65	Chevy w/3-Spd. . . . .	3790831	1	1.30	2nd and 3rd . . . . .
64	Chevelle w/3-Spd. . . . .	3841360	1	1.85	1st and reverse . . . . .
64	Chevelle w/3-Spd. . . . .	3841361	1	1.35	2nd and 3rd . . . . .
64-67	Chevy, Chevelle w/H.D. 3-Spd. . . . .	3841488	1	4.45	control shaft (1st & rev.) . . . . .
64-67	Chevelle w/H.D. 3-Spd. . . . .	3841489	1	4.45	control shaft (2nd & 3rd) . . . . .
65-66	Pass. w/3-Spd. . . . .	3886469	1	2.20	shifter tube 1st and reverse . . . . .
66	Chevy w/3-Spd. . . . .	3886547	1	1.35	1st and reverse . . . . .
66	Chevy w/3-Spd. . . . .	3886545	1	2.75	2nd and 3rd . . . . .
66	Chevelle w/3-Spd. (exc. H.D.) . . . . .	3864593	1	2.35	2nd and 3rd . . . . .
67-69	Camaro w/3-Spd. (floor shift),				
68-69	Chevy, Chevelle (3-Spd. w/floor shift),				
69	Chevy, Chevelle, Camaro w/H.D. 3-Spd.,				
70	Nova (3-Spd. w/floor controls) . . . . .	3980718	1	4.35	2nd and 3rd . . . . .
67-68	Camaro w/3-Spd. (exc. floor console, H.D.),				
68	Chevy w/3-Spd. (column shift) . . . . .	5698809	1	3.60	1st and reverse . . . . .
67	Chevelle w/3-Spd. (exc. H.D., S.S.) . . . . .	5698811	1	2.40	1st and reverse . . . . .
67	Chevy w/3-Spd. . . . .	5698821	1	4.00	1st and reverse . . . . .
67-68	Pass. w/3-Spd. . . . .	5699066	1	3.15	1st and reverse . . . . .
68-69	Chevy, Chevelle (3-Spd. w/floor shift),				
69	Chevy, Chevelle, Camaro w/H.D. 3-Spd.,				
71	Nova w/floor controls,				
72	Nova, Chevelle w/floor controls .	3895258	1	4.25	1st and reverse . . . . .
68	Chevelle w/3-Spd. (column shift)	7802499	1	4.50	1st and reverse . . . . .
69	Chevy, Camaro (column shift w/3-Spd.),				
70-75	Nova (3-Spd. w/column shift) . . . . .	7805083	1	2.50	1st and reverse . . . . .
69-72	Chevelle (column shift w/3-Spd.)	7805082	1	2.50	1st and reverse . . . . .
73-75	Chevelle w/column shift . . . . .	7812799	1	2.50	control 1st and reverse . . . . .
69-75	Pass. w/3-Spd. . . . .	7804740	1	2.50	1st and reverse . . . . .
70	Nova (3-Spd. w/floor controls) . . . . .	3895288	1	5.75	reverse . . . . .
71	Nova w/floor controls,				
72	Nova, Chevelle w/floor controls .	3980718	1	4.35	2nd and 3rd . . . . .
73-75	Vega (Saginaw) . . . . .	325754	1	4.60	2nd and 3rd . . . . .
73-75	Vega (Saginaw) . . . . .	325753	1	4.55	1st and reverse . . . . .
68-69	Chevelle w/H.D. 3-Spd. . . . .	3922517	1	7.85	LEVER ASSY., control . . . . .
71	All (exc. T.W.) . . . . .	7812064	1	18.35	HOUSING, strg. col. gearshift lever . . . . .

**4.032 GROMMET— SPACER— WASHER, Transmission Gearshift Shaft Tube Lever**

69-70	Pass., Chevelle,				
73-75	Vega (Saginaw) . . . . .	1234418	2	.64	control shift lever . . . . .
73-75	Vega (Saginaw) . . . . .	325756	1	1.55	SPRING, trans. control lever . . . . .
72	Chevelle w/column shift . . . . .	391312	1	.34	control rod . . . . .
62-66	Chevy w/3-Spd. . . . .	3790091	1	.16	SPACER . . . . .
64	Chevelle w/3-Spd. . . . .	382081	1	.22	SPACER, shifter tube lever . . . . .
65-68	All w/3-Spd.,				
65-67	Chevelle w/3-Spd. (exc. H.D.) . . . . .	3873130	1	.34	SPACER, shifter tube lever . . . . .
67-68	Pass. w/3-Spd.,				
67-68	Chevy, Chevelle, Camaro w/3-Spd. (exc. H.D., floor console) . . . . .	5698382	1	1.45	SPACER, 1st and reverse . . . . .
69-75	All w/3-Spd. . . . .	7805818	1	.38	SPACER, strg. column lower shift lever . . . . .
62-66	Chevy w/3-Spd.,				
64	Chevelle w/3-Spd. . . . .	3884595	1	.20	WASHER (1 <sup>5</sup> / <sub>32</sub> " 1st and rev.— (4.419) . . . . .

**3-SPEED TRANSMISSION**

**4.032 GROMMET— SPACER— WASHER, Transmission Gearshift Shaft Tube Lever (Con't)**

**67-68** Pass. w/3-Spd. (exc. floor shift) . **7800579** 1 .38 **WASHER, lever housing to bearing housing— (4.012)** .....

**4.035 ROD, Transmission Gearshift**

**62-65** Chevy w/3-Spd. (exc. H.D.) ..... **3790834** 4 1.80 1st and reverse .....

**62-65** Chevy w/3-Spd. (exc. H.D.) ..... **3792973** 1 1.45 2nd and 3rd .....

**67-68** Pass. w/3-Spd. (exc. H.D.) ..... **3906763** 1 2.70 2nd and 3rd .....

**67-68** Pass. w/3-Spd. (exc. H.D.) ..... **3893375** 1 2.50 1st and reverse .....

**67** Camaro w/3-Spd. (column shift) **3895245** 1 2.10 1st and reverse .....

**67** Camaro w/3-Spd. (column shift) **3895247** 1 2.10 2nd and 3rd .....

**67** Camaro w/H.D. 3-Spd. (350),  
**68** Chevy, Camaro w/H.D. 3-Spd.  
(327 Sp. H/Per. 350) ..... **3930055** 1 4.10 1st and reverse .....

**67** Camaro w/H.D. 3-Spd. (350),  
**68** Chevy, Camaro w/H.D. 3-Spd.  
(327 Sp. H/Per. 350) ..... **3930057** 1 2.35 2nd and 3rd .....

**67-69** Camaro (3-Spd. w/floor shift)  
(exc. H.D.),  
**68-69** Chevy (3-Spd. w/floor shift) (exc.  
H.D.),  
**70-72** Nova (Saginaw 3-Spd. w/floor  
controls) ..... **3930051** 1 1.90 1st and reverse .....

**67-69** Camaro (3-Spd. w/floor shift)  
(exc. H.D.),  
**68-69** Chevy (3-Spd. w/floor shift) (exc.  
H.D.),  
**71-72** Vega (Opel) ..... **3455208** 1 4.55 trans. shift selector (Opel— 761704) .....

**70-72** Nova (Saginaw 3-Spd. w/floor  
controls) ..... **3930053** 1 2.35 2nd and 3rd .....

**68-69** Chevy, Camaro w/3-Spd. (exc.  
floor shift),  
**70-74** Nova w/column shift ..... **332662** 1 1.95 2nd and 3rd .....

**68** Chevelle w/3-Spd. (exc. H.D.) ... **3931611** 1 9.70 1st and reverse .....

**68** Chevelle w/3-Spd. (exc. H.D.) ... **3931427** 1 8.70 2nd and 3rd .....

**69** Chevy w/floor shift,  
**69** Camaro w/floor shift,  
**69** Chevy, Camaro w/Muncie H.D.  
3-Spd. .... **3972256** 1 1.65 control upper .....

**69** Chevy w/3-Spd. (exc. floor  
console) ..... **3895294** 1 1.25 control lower .....

**69-70** Pass. w/3-Spd. .... **3981251** 1 2.90 2nd and 3rd .....

**69** Pass. w/3-Spd. (exc. Muncie) ... **3981250** 1 2.80 1st and reverse .....

**69-72** Chevelle w/3-Spd. (exc. H.D.) ... **3945405** 1 2.15 2nd and 3rd .....

**69-72** Chevelle w/Muncie H.D. 3-Spd. . **3945466** 1 2.80 1st and reverse .....

**69-72** Chevelle w/Muncie H.D. 3-Spd. . **3945467** 1 2.80 2nd and 3rd .....

**69-70** Chevy, Camaro w/Muncie H.D.  
3-Spd. (350) ..... **3950171** 1 2.80 2nd and 3rd .....

**69-72** Chevelle w/3-Spd. (exc. H.D.) ... **3945403** 1 2.10 1st and reverse .....

**69** Chevy, Camaro (floor shift w/3-  
Spd.),  
**70-74** Nova (Saginaw 3-Spd. w/floor  
controls) ..... **332605** 1 2.35 control lower lock .....

**70-75** Camaro w/Saginaw 3-Spd. .... **3975603** 1 2.10 control lower lock .....

**70-75** Camaro w/3-Spd. .... **3975607** 1 1.25 control, upper lock .....

**70-75** Camaro w/3-Spd. .... **3975611** 1 2.10 1st and rev. ....

**70-75** Camaro w/3-Spd. .... **3975612** 1 2.40 2nd and 3rd .....

**70-71** Nova (3-Spd. w/floor controls) .. **3972256** 1 1.65 control upper .....

**69** Chevy, Camaro w/3-Spd. (exc.  
H.D., floor shift),  
**70-75** Nova w/3-Spd. (exc. floor  
controls) ..... **3982315** 1 2.35 control 1st and reverse .....

**73-75** Chevelle (exc. floor shift, H.D. 3-  
Spd.) ..... **488321** 1 7.55 1st and rev. ....

**73-75** Chevelle (exc. floor shift, H.D. 3-  
Spd.) ..... **488322** 1 7.80 2nd and 3rd .....

**71-72** Chevelle w/floor shift ..... **3931439** 1 2.10 1st and rev. ....

**71-72** Chevelle w/floor shift ..... **3924419** 1 2.50 2nd and 3rd .....

**72-74** Nova w/floor controls ..... **6264006** 1 1.35 control upper lock .....

**72** Pass. .... **3988219** 1 4.00 control 1st and rev. ....

**72** Pass. .... **3988220** 1 2.80 control 2nd and 3rd .....

**75** Nova ..... **357711** 1 8.15 control lock upper .....

**73-75** Nova w/floor shift ..... **6264079** 1 1.90 1st and rev. ....

**73-75** Nova w/floor shift ..... **6264088** 1 2.35 2nd and 3rd .....

**73-75** Vega (Saginaw) ..... **325760** 1 2.20 1st and rev. ....

### 3-SPEED TRANSMISSION

<b>4.035 ROD, Transmission Gearshift (Con't)</b>					
73-75	Vega (Saginaw)	325761	1	2.95	2nd and 3rd
<b>4.037 BUSHING— CLAMP— CLEVIS— CLIP— GROMMET— NUT— PIN— RETAINER— SCREW— SHAFT ASSY.— SLEEVE— SWIVEL— WASHER, Transmission Gearshift Rod to Lever</b>					
64-75	All	382102	A.R.	.11	control rod, lever ( $\frac{3}{8}$ " I.D.— $\frac{1}{2}$ " O.D.)
65-66	Pass. w/3-Spd.	3710401	A.R.	.18	2nd and 3rd idler lever ( $\frac{1}{2}$ " I.D. x $\frac{3}{4}$ " O.D.)
73-75	Chevelle	9776337	2	.16	trans. control rod
All	All	382103	1	.16	CLAMP, cup shade and rod control ( $\frac{13}{32}$ " I.D. x $\frac{25}{32}$ " O.D. x $\frac{7}{32}$ " thk.)
62-66	Chevy,				
65-66	Pass. w/3-Spd.	3790231	1	.22	CLAMP, 1st and reverse 2nd and 3rd rod to lower shift tube
66-67	Chevelle w/H.D. 3-Spd.	3841496	1	1.20	CLEVIS, 1st and reverse
62-75	All	3749084	A.R.	.27	CLIP, control rod (all locations) (Note 1)
All	All	3975131	1	.16	GROMMET, control shifter tube lever ( $\frac{3}{4}$ " O.D. x $\frac{1}{2}$ " I.D. x $\frac{5}{16}$ " thk.— rubber)
All	All	3833107	1	.12	GROMMET, bell crank, control rod lever ( $\frac{5}{16}$ " I.D.) (Note 1)
62-65	All w/3-Spd.	3975132	A.R.	.17	GROMMET, cont. rod ( $\frac{5}{16}$ " )
62-66	Chevy w/3-Spd.,				
65-66	Pass.	3834139	1	.11	GROMMET, control rod to shifter tube lever ( $\frac{3}{4}$ " )
65	Pass. w/3-Spd.	3852837	1	.11	GROMMET, cont. 2nd and 3rd rod
68	Chevelle w/3-Spd.,				
69-72	Chevelle w/H.D. 3-Spd.	391312	1	.34	GROMMET, control rod ( $\frac{31}{32}$ " I.D.)— (4.032)
67	Camaro w/floor shift				GROMMET, cont. lever and bracket stab. shaft,
68-69	Chevy, Chevelle w/H.D. 3-Spd.				cont. rod tube link to rod assy.,
72-74	Pass. (6 cyl.)	1394293	1	.27	control lock rod col. end
62-68	All	3840137	1	.13	NUT, control rod clevis ( $\frac{7}{16}$ "— 20)— (4.253)
All	All	472668	A.R.	.48	PIN, clevis (use wherever $\frac{5}{16}$ " dia. x $\frac{5}{8}$ " effective length pin must be used)
67-70	Chevelle,				
71-74	All	1244707	1	.12	RETAINER, control rod, control eqlzr., and control rod lock
67-69	Camaro w/floor shift, console,				
68-71	Chevy w/floor shift, console,				
68	Chevelle w/floor shift,				
69	Chevelle w/H.D. 3-Spd.,				
72	Nova, Chevelle w/floor controls	3895252	1	.38	RETAINER, control lever spring
67	Camaro w/floor shift,				
68-69	Chevy, Chevelle, Camaro w/floor shift,				
70-71	Nova w/floor controls,				
72	Nova, Chevelle w/floor controls	3923544	1	1.35	RETAINER, control shift lever shaft
69-74	Chevelle w/Muncie H.D. 3-Spd.	3929844	2	.11	RETAINER, control lock lower rod
71-75	Pass.	3989433	2	.16	SCREW, control rod swivel
68	Chevelle w/3-Spd. (exc. H.D.)	3931612	1	11.50	SHAFT ASSY., control equalizer
69-72	Chevelle w/3-Spd. (exc. H.D.)	3945407	1	3.20	SHAFT ASSY., control equalizer
71-72	Pass.	3988216	1	3.20	SHAFT ASSY., control equalizer
64-65	Chevelle,				
65-70	Pass.,				
67-69	Camaro,				
68-75	Chevy	3852838	1	.16	SLEEVE, shifter tube lever and upper rod ( $\frac{3}{8}$ " O.L. x $\frac{15}{32}$ " O.D. x $\frac{3}{16}$ " I.D.)
All	All	382104	1	.24	SWIVEL ( $\frac{3}{8}$ " x 16" threads, 1 $\frac{1}{2}$ " long w/ $\frac{5}{8}$ " dia. hole)
62-65	Chevy w/3-Spd.				SWIVEL, control rod to shifter tube,
65-66	Pass. w/3-Spd.	3790230	1	.59	1st and reverse, 2nd and 3rd rod to lower shift tube
66-67	Chevelle w/H.D. 3-Spd.	3843014	A.R.	.59	SWIVEL, 3rd and 4th reverse rod
67-68	Camaro w/floor shift,				
68	Chevelle w/H.D. 3-Spd.,				
68	Chevy (H.D. 3-Spd. w/Sp. H/Per. 327),				
69	Chevy, Chevelle, Camaro w/floor shift,				
70-72	Nova, Chevelle w/floor controls	3895244	3	1.20	SWIVEL, control rod
71-75	Pass.	1385607	A.R.	.71	SWIVEL, control rod lock
71-75	Camaro	477721	1	1.10	SWIVEL, control rod rear end
70-75	Camaro w/3-Spd.	3975600	1	.63	SWIVEL ASSY., control rod rear end 1st and rev.

### 3-SPEED TRANSMISSION

#### 4.037 BUSHING— CLAMP— CLEVIS— CLIP— GROMMET— NUT— PIN— RETAINER— SCREW— SHAFT ASSY.— SLEEVE— SWIVEL— WASHER, Transmission Gearshift Rod to Lever (Con't)

73-74	Nova w/floor shift	491086	1	1.05	SWIVEL, control rod rear end
73-75	Vega (Saginaw)	325762	1	.50	SWIVEL, trans. control rod
All	All	9415113A.R.		.11	WASHER, control rod swivel (to shifter tube lever) ( $3/16$ " I.D. x $7/8$ " O.D.) (wave type)
All	All	3772165A.R.		.11	WASHER, 1st and reverse rod (to shifter tube lever), trans. control rod swivel ( $17/32$ " I.D. x $7/8$ " O.D.) (flat type)
All	All	382105A.R.		.12	WASHER, control upper rod to trans. control shifter tube lever ( $25/32$ " I.D. x $3/4$ " O.D.)
64-72	All	580379A.R.		.11	WASHER, cont. rod to trans. cont. counter shaft cont. upper, rod to cont. idler lever ( $23/32$ " O.D. x $21/32$ " I.D. x $1/2$ " thk.)
67-69	Camaro w/3-Spd. (column shift) (exc. H.D.)				WASHER, control rod front end, col. end, trans. end,
67-70	Chevy w/3-Spd.				control rod front end, col. end, trans. end, control rod front and rear end,
67-70	Pass. w/3-Spd.,				control rod ( $3/8$ " I.D. x 1" O.D. x $1/2$ " thk.)
67-70	Chevelle w/3-Spd. (exc. H.D.)	120395A.R.			WASHER, cross shaft lever,
68-71	Chevelle (exc. H.D.)				control 2nd and 3rd,
72	Chevelle				control equalizer shaft
72-74	Pass.	492346	1	.34	WASHER, control upper lock rod ( $5/32$ " x $13/64$ " free height) ( $21/64$ " x $11/16$ "
74-75	Chevelle	334533	1	.11	WASHER, control rod ( $5/16$ " I.D. x $23/32$ " O.D. x $1/32$ " thk.)
73-75	Pass., Chevelle	580379A.R.		.11	WASHER, trans. control rod swivel
73	Pass., Chevelle, Camaro	3989434	2	.11	

#### 4.040 LEVER— BRACKET— SHAFT— SUPPORT ASSY., Transmission Control Idler

64-65	Chevelle w/3-Spd.	3841368	1	1.65	2nd and 3rd rod idler
65-67	Chevelle w/3-Spd. (exc. H.D.)	3880554	1	2.85	2nd and 3rd rod idler
69-70	Chevy, Camaro w/floor shift,				
71-74	Nova w/floor controls	3895290	1	1.65	control lock rod idler
70-75	Camaro w/3-Spd.	3975606	1	1.70	control lock rod idler
71-72	Chevelle w/floor controls	3945491	1	1.35	control lock rod idler— (4.070)
71-72	Vega (Opel)	3460267	1	12.55	trans. shift idler (Opel— 761504)
68-72	Chevelle w/3-Spd. (exc. H.D.)	1230115	1	.88	BRACKET, control equalizer shaft frame
71-74	Pass.	3988221	1	.80	BRACKET, control equalizer shaft
75	Pass., Chevelle	488450	1		BRACKET, control equal. shaft frame
73	Pass.	3988216	1	3.20	SHAFT ASSY., control equalizer
73-75	Chevelle	488451	1	5.35	SHAFT ASSY., control equalizer
71-72	Vega (Opel)	2874880	1	5.35	SHAFT, trans. shift idler lever (Opel— 761550)
65-66	Pass. w/3-Spd. (exc. H.D.)	3859446	1	3.50	SHAFT, control 2nd and 3rd
66	Pass. w/3-Spd.,				
67-68	Pass. w/H.D. 3-Spd.	3880577	1	4.65	SHAFT, cont. 2nd and 3rd
69-70	Pass. w/3-Spd.	3939278	1	4.65	SHAFT, control 2nd and 3rd
65-70	Pass. w/3-Spd.	3856992	1	4.65	SUPPORT ASSY., 2nd and 3rd rod idler lever
69	Chevy, Camaro w/floor shift,				
70-74	Nova w/Saginaw 3-Spd.	3895291	1	2.25	SUPPORT ASSY., control rod idler lever
70-75	Camaro w/Saginaw 3-Spd.	3975604	1	1.30	SUPPORT ASSY., control lock rod idler lever

#### 4.042 LOCK— BUSHING— NUT— RETAINER— SPACER— SPRING, Transmission Control Idler Attaching

65-66	Pass.,				
65-67	Chevy, Chevelle w/3-Spd.,				
68-70	Chevy, Chevelle, Camaro,				
71	Nova,				
72-75	Nova, Chevelle w/floor controls	3685801	1	.16	control 2nd and 3rd rod idler lever ( $13/16$ " O.D.)
73-75	Vega (Saginaw)	336530	2	.18	shifter shaft control lever
73-74	Vega (Saginaw)	7800580	1	.34	strg. col. strg. shaft upper ret. ring thrust
64-67	Chevelle w/3-Spd. (exc. H.D.)				BUSHING, lever shaft,
69-70	Chevy w/H.D. 3-Spd.,				
69-70	Chevy, Chevelle, Camaro,				
71-75	Nova, Chevelle	3792168A.R.		.22	trans. cont. rod idler lever
64-74	All	382102A.R.		.11	BUSHING, control rod ( $3/8$ " I.D.— $1/2$ " O.D.)— (4.037)
68-75	Chevelle (3-Spd.) (exc. H.D.)				BUSHING, 2nd and 3rd control,

### 3-SPEED TRANSMISSION

<b>4.042</b>		<b>LOCK— BUSHING— NUT— RETAINER— SPACER— SPRING, Transmission Control Idler Attaching (Con't)</b>			
71-75	Pass. ....	1377083	1	.16	control equalizer shaft .....
71-72	Vega (Opel) .....	2893967	1	7.20	<b>BUSHING</b> , trans. int. shift lever (Opel— 761602) .....
67-69	Chevy, Camaro .....	3792287	1	.34	<b>NUT</b> , cont. rod idler lever supt.— (3.704) ..
65-70	Pass. w/3-Spd. ....	3842902	2	.11	<b>RETAINER</b> , cross shaft anti-rattle spring, trans. cross shaft .....
65-66	Pass. ....	3698237	1	.12	<b>SPRING</b> , cross shaft (idler inner and outer levers— 6 <sup>1</sup> / <sub>2</sub> " coils— <sup>11</sup> / <sub>16</sub> " I.D.) .....
71-72	Vega (Opel) .....	2888545	1	.31	<b>SPRING</b> , trans. shift idler lever (Opel— 761625) .....
70	Pass. w/3-Spd. ....	3755663	1	.11	<b>BUSHING</b> , control rod idler lever .....
68-72	Chevelle (3-Spd.) (exc. H.D.) .....				<b>SPRING</b> , cross shaft (2nd and 3rd), .....
71-75	Pass. ....	1380549	1	.11	control equalizer shaft .....
<b>4.045</b>		<b>LEVER, Transmission Mounted Gearshift (External)</b>			
62-65	Chevy w/3-Spd. (exc. H.D.) .....	3790269	1	1.80	1st and reverse shifter shaft .....
62-65	Chevy w/3-Spd. (exc. H.D.) .....	3790273	1	1.80	2nd and 3rd shifter shaft .....
64-65	Chevelle w/3-Spd. ....	3840458	1	1.75	1st and reverse .....
65	Pass. w/3-Spd. (exc. H.D.) .....	3860335	1	1.45	1st and reverse shifter shaft .....
66-70	Pass. w/3-Spd. (exc. H.D.) .....	3939280	1	2.15	2nd and 3rd shifter shaft .....
66	Chevelle w/3-Spd. (exc. H.D.) .....	3880559	1	1.30	1st and reverse .....
67-68	Pass. w/3-Spd. (exc. H.D.) .....	3904098	1	1.35	1st and reverse shifter shaft .....
67	Chevy w/3-Spd. ....	3905555	1	1.30	1st and reverse .....
67-68	Camaro w/H.D. 3-Spd.,				
68	Chevy, Chevelle w/H.D. 3-Spd. ...	3899045	1	1.40	1st and reverse .....
67-68	Camaro w/H.D. 3-Spd.,				
68	Chevy, Chevelle w/H.D. 3-Spd. ...	3899047	1	1.40	2nd and 3rd .....
67-68	Camaro w/3-Spd. (exc. floor shift, H.D.),				
68	Chevy w/3-Spd. (exc. floor shift, console, H.D.) .....	3895241	1	1.40	1st and reverse .....
67	Camaro w/3-Spd. (exc. floor shift) .....	3895243	1	2.60	2nd and 3rd .....
67-69	Camaro (3-Spd. w/floor shift) (exc. H.D.),				
68-75	Chevy (3-Spd. w/floor shift) .....	3895251	1	1.20	2nd and 3rd .....
67	Camaro (3-Spd. w/floor shift) (exc. H.D.),				
68	Chevy, Camaro w/3-Spd. (exc. H.D.) .....	3922528	1	.92	1st and reverse .....
68-69	Chevelle w/3-Spd. (exc. H.D.) .....	3922544	1	3.90	
68-69	Chevy, Camaro w/3-Spd. (exc. H.D., floor console),				
70-75	Nova w/3-Spd. (exc. floor controls) .....	3920289	1	1.45	control shifter shaft 2nd and 3rd .....
68-70	Chevelle w/3-Spd. (exc. H.D.),				
71-75	Pass., Chevelle (exc. H.D.) .....	1375434	1	1.45	control shifter shaft 2nd and 3rd .....
69-70	Pass. w/3-Spd. (exc. Muncie) .....	3939281	1	1.30	1st and reverse .....
69-72	Chevy (floor shift w/3-Spd.) (exc. H.D.),				
69-74	Camaro (floor console w/3-Spd.) (exc. H.D.) .....	3955783	1	1.60	control shifter shaft 1st and reverse .....
69-72	Chevelle w/3-Spd. (exc. H.D.) .....	3945411	1	1.40	control shifter shaft 1st and reverse .....
69	Chevy, Camaro w/3-Spd. (exc. Muncie, floor console),				
70-75	Nova w/3-Spd. (exc. floor controls) .....	3939717	1	1.60	control shifter shaft 1st and reverse .....
69-72	Chevy, Chevelle, Camaro w/Muncie H.D. 3-Spd. ....	3945465	1	.92	control shifter shaft 2nd and 3rd .....
69-72	Chevelle w/Muncie H.D. 3-Spd. ....	3952892	1	1.45	control shifter shaft 1st and rev. ....
70-74	Camaro w/3-Spd. ....	479687	1	1.30	shifter shaft 1st and rev. ....
70-75	Camaro w/3-Spd. ....	3975609	1	1.10	shift shaft 2nd and 3rd .....
71-73	Pass. ....	3988215	1	1.20	shift shaft 1st and rev. ....
71	Chevelle w/floor shift (exc. H.D.) .....	3994320	1	4.65	1st and rev. ....
71-72	Chevelle w/floor shift (exc. H.D.) .....	3922529	1	.92	2nd and 3rd .....
71-72	Vega (Opel) .....	3455204	1	3.45	trans. shift selector (Opel— 761101) .....
73-75	Vega (Saginaw) .....	325759	2	1.05	trans. shift shaft control .....
73-75	Chevelle w/column shift .....	6262257	1	1.60	shift shaft, 1st and rev. ....
75	Nova w/column shift .....	344674	1	3.80	shifter shaft, 2nd and 3rd .....
75	Nova w/column shift .....	344671	1	3.25	shifter shaft, 1st and rev. ....
75	Nova w/floor controls .....	352880	1	1.45	shifter shaft 1st and rev. ....
71-72	Vega (Opel) .....	52501	2	1.00	<b>LOCK RING</b> , trans. shift selector .....

### 3-SPEED TRANSMISSION

#### 4.046 PIN— WASHER, Transmission Selector

71-72	Vega (Opel)	3455655	1	.39	trans. selector lever pivot (9X.25MM) (Opel— 761351)
71-72	Vega (Opel)	2875721	1	.15	WASHER, trans. shift selector shaft (Belleville) (Opel— 761325)

#### 4.047 CLIP— GROMMET— WASHER, Transmission Gearshift Control Cable

69	Chevy, Camaro w/Muncie 3-Spd.	3772324 A.R.		.13	(in tunnel) (1 <sup>5</sup> / <sub>16</sub> " long)
66-67	Chevelle w/H.D. 3-Spd.	3852444	2	.16	GROMMET, reverse release (7 <sup>7</sup> / <sub>16</sub> "— (4.008)
66-67	Chevelle w/H.D. 3-Spd.	3852446 A.R.		.11	WASHER, reverse release (2 <sup>1</sup> / <sub>64</sub> " I.D.)— (4.008)

#### 4.054 SWITCH ASSY.— BRACKET— BUSHING— CLIP— PIN— ROD— SCREW, Transmission Control Safety

69	Chevelle	1993490	1	11.40	clutch operated
69	Pass.	1993491	1	11.25	clutch operated (neutral start)
69	Chevy, Camaro	1993494	1	11.30	clutch operated
70	Pass., Nova, Camaro,				
71-75	Nova, Camaro	3983965	1	2.25	clutch operated neutral start
70	Chevelle	3983966	1	2.50	clutch operated neutral start
71-72	Pass., Chevelle	3986841	1	2.25	clutch operated neutral start
73	Pass., Chevelle	3996277	1	2.50	clutch oper. neutral start
74-75	Chevelle	6258273	1	2.50	clutch oper. neutral start
71-75	Vega	6273381	1	2.40	clutch operated neutral start
75	Monza	356113	1	2.35	clutch operated neutral start
73-74	Vega	3902194	1	3.75	backing lamp— (2.698)
71-75	Vega	3990895	1	.31	BRACKET, clutch operated neutral starting switch
70	Pass., Nova	3961588	1	.38	BRACKET, clutch operated start switch
70-72	Chevelle	3961590	1	.38	BRACKET, clutch operated neutral start switch
70-75	Camaro	3961589	1	.36	BRACKET, clutch oper. neutral start switch
71-73	Pass.	3986842	1	.31	BRACKET, clutch oper. start switch
71-75	Nova	3996249	1	.28	BRACKET, clutch oper. start switch
73-75	Chevelle	3996278	1	.36	BRACKET, clutch oper. start switch
69	Chevy, Camaro	3954290	1	.16	BUSHING, clutch operated neutral start switch
	Not required in this group. See group 3.762, 9.787	3908243	1	.63	CLIP
69	Pass., Chevelle	3954288	1	.53	PIN, clutch operated neutral start switch
69	Chevy, Camaro	3954282	1	1.10	ROD, clutch operated

#### 4.067 BOOT, Gearshift Linkage

65-70	Pass. w/3-Spd.	3852836	1	.22	cont. 2nd and 3rd rod
-------	----------------	---------	---	-----	-----------------------

#### 4.070 ROD— LEVER— SUPPORT ASSY., Transmission Gearshift Anti-Theft

69-72	Chevelle	3952888	1	2.95	control lock upper
69-72	Chevelle	3952890	1	2.00	control lock lower
71-72	Chevelle	3945491	1	1.35	LEVER, control lock
69-72	Chevelle	3949005	1	1.80	SUPPORT ASSY., control lock

#### 4.075 SWITCH ASSY.— CLIP— GASKET— RELAY ASSY.— WIRE ASSY., Transmission, Smog Control

*NOTE See 2.408 group for electrical parts.*

70-71	All	3961567	1	3.00	trans. control spark
72-75	All	3996286	1	2.85	trans. control spark
70-72	Nova, Chevelle, Camaro	3983960	1	.11	CLIP, trans. control (3 <sup>3</sup> / <sub>4</sub> " x 1 <sup>5</sup> / <sub>16</sub> ", w/1 <sup>1</sup> / <sub>2</sub> " hole)
70-72	All,				
71-75	Vega	3929530	1	.39	GASKET, trans. control spark switch— (2.698)
70	All,				
71-75	Chevelle, Vega	3961573	1	2.85	RELAY ASSY., trans. control spark
71	All	3990842	1	2.45	RELAY ASSY., control switch reversing
71	All	3990843	1	3.00	RELAY ASSY., control switch delay
71	All w/C.A.C.	6273301	1	6.90	RELAY ASSY., anti-dieseling
71-72	Pass., Chevelle w/C.A.C.	3996204	1	2.70	RELAY ASSY., anti-dieseling blocking
72	All (8 cyl.) (exc. 402, 454)	3996297	1	3.65	RELAY ASSY., control vac. advance delay
72	All (6 cyl.)	3996296	1	2.25	RELAY ASSY., control spark delay (20 second)
73-75	All	6270698	1	2.15	RELAY ASSY., control spark delay (20 second)
73-74	Vega (exc. NB-2)	3906448	1	.92	PLUG, control spark hole
74-75	Vega	8908346	1	3.05	WIRE ASSY., trans. control spark
72	Nova, Camaro,				
73-75	All	8908033	1	5.70	WIRE ASSY., control spark

### 3-SPEED TRANSMISSION

#### 4.081 SUPPORT— MOUNTING ASSY.— MEMBER ASSY., Transmission Mounting

67	Pass. (327, 396, 427) (2nd design) (exc. Conv.)	3906954	1	14.10	(w/1 square and 1 round hole)
68	Pass. (250, 307) (exc. Conv.),				
69	Pass. (Sta. Wag.)	3950232	1	14.25	
70	Pass. (Conv.)	3947536	1	14.25	
64-67	Chevelle (exc. Conv., El Camino),				
68	Chevelle (exc. H.D. 3-Spd., Conv., El Camino),				
68	Chevelle w/Warner H.D. 3-Spd. (exc. El Camino, Conv.),				
69-70	Chevelle (exc. El Camino, Conv.),				
71-72	Chevelle w/floor shift (exc. Conv., El Camino),				
72	Chevelle w/column shift (exc. El Camino, Conv.)	6272136	1	17.90	SUPPORT ASSY., trans.
64-67	Chevelle (Conv., El Camino)	3838043	1	11.60	SUPPORT ASSY.
67-69	Camaro w/3-Spd. (exc. H.D., 396),				
68-74	Chevy (exc. 396)	3899006	1	10.50	SUPPORT ASSY.
68	Chevelle (El Camino, Conv.) w/Warner H.D. 3-Spd.,				
69	Chevelle (El Camino, Conv.),				
70-72	Chevelle (El Camino, Conv.) w/3-Spd.	6272134	1	17.35	SUPPORT ASSY.
68-69	Pass. (exc. Sta. Wag., Conv., 4-Spd.),				
70	Pass. (exc. Sta. Wag., Conv., C.A.C.)	3947535	1	10.20	SUPPORT ASSY. (code letter "S") (Note 4)
<i>NOTE 4 When using in place of 3928222 it will be necessary to add a hole in support bracket for trans. mtg. Use old part as guide.</i>					
69	Pass. (Sta. Wag.),				
70	Pass. (Sta. Wag.) (exc. C.A.C.)	3984771	1	18.25	SUPPORT ASSY.
70-72	Camaro	3964816	1	13.65	SUPPORT ASSY.
71	Pass. (exc. Sta. Wag., Conv.),				
72	Pass.	6270765	1	16.85	SUPPORT ASSY.
71	Pass. (Conv.)	3947536	1	14.25	SUPPORT ASSY.
71	Vega	3988033	1	10.05	SUPPORT ASSY., trans.
73-75	Vega	329708	1	5.85	SUPPORT ASSY., trans.
73	Pass.	331288	1	16.75	SUPPORT ASSY.
73-74	Chevelle w/column shift (exc. El Camino)	6273806	1	20.95	SUPPORT ASSY., trans.
73-74	Chevelle (El Camino)	6273808	1	21.50	SUPPORT ASSY., trans.
62-65	Chevy w/3-Spd. (4 cyl.)	3792474	2	4.05	MOUNTING ASSY., support
65-70	Pass. (6 cyl.),				
65-67	Chevelle (8 cyl.),				
67	Camaro,				
68-69	Chevy (4 cyl.),				
68	Chevelle (8 cyl.) (exc. 327) (1st design),				
68	Chevelle (exc. 396),				
70	Camaro w/Sp. H/Per. (350)	3870182	1	4.50	MOUNTING ASSY. (daub of orange paint) (molded 3870182) (Note 2)
65	Pass. (8 cyl.),				
66	Pass. (283, 327),				
67	Pass. (283, 327) (1st design),				
68	Impala, Caprice (307),				
68	Biscayne, Bel Air (307),				
69	Impala, Caprice (327),				
69	Biscayne, Bel Air (327),				
70	Pass. (350) (exc. 4BC)	3870184	1	4.50	MOUNTING ASSY. (no paint ident.) (molded 3870184) (4 holes) (Note 1, 2)
66	Pass. (396, 427),				
68-70	Camaro, Chevy (396),				
68-69	Camaro (302)	3895830	1	4.40	MOUNTING ASSY. (daub of white paint) (Note 1)
67	Pass. (396, 427),				
68	Chevelle (396) (1st design)	3904078	1	5.35	MOUNTING ASSY. (daub of white paint)
67-68	Pass. (327),				
68	Chevelle (327) (1st design)	3906957	1	4.75	MOUNTING ASSY., trans. supt. (3 holes, 2 oblong) (Note 1, 2)
62-70	Chevy, Chevelle (exc. 4 cyl.),				
68-69	Camaro (exc. 302, 396),				
70-72	Chevelle (6 cyl.),				
70	Camaro w/Sp. H/Per. (350),				

**3-SPEED TRANSMISSION**

**4.081 SUPPORT— MOUNTING ASSY.— MEMBER ASSY., Transmission Mounting (Con't)**

71-75	Nova, Camaro	3913498	1	4.65	MOUNTING ASSY., support
68	Chevelle (8 cyl.) (2nd design) (exc. 327),				
69	Chevelle (307),				
70	Chevelle (307) (exc. Monte Carlo),				
70	Concours, Estate Wag. (exc. 350, 400),				
71	Chevelle (8 cyl.) (exc. Monte Carlo),				
72	Chevelle (307)	3935704	1	4.60	MOUNTING ASSY., support (orange)
69-70	Chevelle (350) (exc. Monte Carlo),				
69	Chevelle (396),				
70	Monte Carlo,				
70	Chevelle (396, 400, 454),				
72	Chevelle (350, 402, 454)	3945476	1	6.80	MOUNTING ASSY., support
69	Pass. (350),				
70	Pass. w/H/Per. (350),				
70	Pass. (400)	3947534	1	8.65	MOUNTING ASSY.
69	Pass. (396, 427)	3950234	1	8.65	MOUNTING ASSY.
70	Pass. (exc. C.A.C.)	3872247	1	5.25	MOUNTING ASSY., support (orange paint marking, part number molded on piece)
71-75	Pass.	331239	1	4.40	MOUNTING ASSY.
71-72	Vega	329741	1	8.50	MOUNTING ASSY.
73-75	Vega	329768	1	8.50	MOUNTING ASSY.
73-75	Chevelle	3989125	1	10.55	MOUNTING ASSY., support

NOTE 1 3<sup>3</sup>/<sub>4</sub>" between center lines of bolt holes.  
 NOTE 2 Part number moulded on part.  
 NOTE 3 4<sup>1</sup>/<sub>4</sub>" between center lines of bolt holes.

**4.083 BRACKET, Transmission Mounting**

65	Pass.,				
68	Pass. (exc. Taxi),				
69	Pass. (exc. Taxi),				
70	Pass. (exc. C.A.C.)	3855908	1	4.50	support (Budd frame)

**4.085 BOLT, Transmission Mounting Support**

62-66	Chevy (exc. 4 cyl.),		2		( <sup>3</sup> / <sub>8</sub> "— 16 x 3 <sup>3</sup> / <sub>8</sub> ")— (7.874)
71-72	Vega	3779940	1	.21	( <sup>3</sup> / <sub>8</sub> "— 16 x 3 <sup>3</sup> / <sub>8</sub> ")

**4.103 CASE, Transmission**

64-65	All (exc. O/D, H.D.)	3866696	1	47.00	w/plugs
65-68	All	3870787	1	69.75	w/magnet (Warner AT16-1)
66-67	Chevy, Chevelle, Camaro w/3-Spd. (2nd design) (exc. O.D., H.D.)	3890566	1	44.25	w/magnet (cast 3890564) (iron) (Note 2, 3)

NOTE 2 It may be necessary to use 2 each of the following. 9414511 1/2— 13 hex. nut, 455001 1/2— 13 x 2 hex. bolt, and 131101 1/2 lock washer.

71-72	H	8977844	1	45.00	(Opel— 702072) (Note 1)
-------	---	---------	---	-------	-------------------------

NOTE 1: When using in place of 1971 case also use 8977912 extension, 8977852 counter gear shaft, 8977851 reverse idler shaft, 6264343 support, and 6272080 gasket & seal unit.  
 NOTE 3 Used with magnet No. 3890564.

66-67	Pass. (exc. O.D., H.D.),				
68	All (exc. O.D., H.D.),				
70-75	All w/Saginaw	6273247	1	52.25	w/magnet (Note 1)

NOTE 1 When using in place of 3925642 run a <sup>7</sup>/<sub>32</sub> drill bit thru both lower tapped holes on front mtg. face.

69-71	All w/Muncie	6273263	1	47.00	w/magnet
-------	--------------	---------	---	-------	----------

**4.104 SHIM UNIT— VENT, Transmission Case**

64-70	All	3887055	A.R.	.66	to clutch hsg. (4-002, 2-005 and 1-010 shims)
65-68	Pass. (exc. H.D.)	3820840	1	.36	VENT ASSY. (5.387)

**4.105 COVER— BOLT— MAGNET UNIT— PLUG, Transmission Case**

62-65	Chevy (exc. H.D.)	3731900	1	23.20	(cast 3731911)
65-68	All H.D.	3870808	1	9.30	(Warner T16-148)
66-69	Pass. w/3-Spd. (1st design) (exc. H.D.),				
66-69	Chevy, Chevelle, Camaro w/Saginaw 3-Spd.	3919365	1	10.55	(stamped 3919365)
70-75	All w/Saginaw	338287	1	15.05	trans.
69-72	All w/Muncie (8 cyl.)	3977508	1	11.45	COVER ASSY.
71-72	Vega (Opel)	8957632	1	3.45	COVER ASSY., trans. case (Opel— 730113)



### 3-SPEED TRANSMISSION

#### 4.105 COVER— BOLT— MAGNET UNIT— PLUG, Transmission Case (Con't)

73-75	Vega	338288	1	12.95	COVER ASSY.
62-64	Chevy, Chevelle	369122	1	4.25	MAGNET UNIT, case chip collector
62-69	All	3930923	1	1.30	PLUG, trans. case magnet (1/2")
71-72	Vega (Opel)	8984672	10	1.45	SCREW ASSY., trans. case cover (Opel— 2034775)

#### 4.109 GASKET, Transmission Case Cover

62-65	All (exc. H.D., O.D.)	591513	1	.23	(fiber)
65-68	All H.D.	3870806	1	.28	(Warner T-16-115)
71-72	Vega (Opel)	6667448	1	.54	(Opel— 730888)
66-75	All w/Saginaw	3858990	1	.33	(8 7/32" O.L. 8 hole)
71-72	Chevelle w/Muncie	3952621	1	.31	

#### 4.302 LEVER ASSY., Transmission Inter. Shift

71-72	Vega (Opel)	2875017	2	6.65	trans. inter. shift (Opel— 732192) (Note 1)
-------	-------------	---------	---	------	---

*NOTE 1: 1 used as 1st and reverse, 1 used as 2nd and 3rd.*

#### 4.303 FORK, Gearshift

62-65	Chevy, Chevelle (exc. H.D.),				
65	Pass. (2nd design) (exc. H.D.)	3731918	1	5.95	1st and reverse (less shaft)
62-65	Chevy, Chevelle w/3-Spd. (exc. H.D.),				
65	Pass. (2nd design) (exc. H.D.)	3785217	1	2.83	2nd and 3rd (less shaft)
65-68	All w/H.D.	3746272	1	12.40	2nd and 3rd
65-68	Pass. H.D.	3870795	1	10.95	1st and reverse (Warner T16-24)
66-69	Pass. (exc. H.D.),				
66-69	Chevy, Chevelle, Camaro (exc. H.D.),				
70-74	All w/Saginaw	3858997	A.R.	6.90	1st and reverse, 2nd and 3rd
68-69	Chevy, Chevelle, Camaro (exc. H.D., O/D)	3884610	1	6.90	1st and 2nd
71-72	Vega (Opel)	6667469	1	6.15	trans. 1st and reverse shift (Opel— 734156)
71-72	Vega (Opel)	6667468	1	7.25	trans. 2nd and 3rd shift (Opel— 734183)
69-75	All w/H.D.	3831717	2	12.45	1st and 2nd, 3rd and 4th

#### 4.307 INTERLOCK— SLEEVE— LOCK— PIN— RETAINER— STUD, Gearshift

65	Pass. (exc. H.D.)	3686833	1	.82	(3 1/32" x 7/32" x 4 5/64" — "S" shape)
65-68	All H.D.	3709311	1	1.20	SLEEVE, trans. interlock (1.0185 long)
62-65	All	591539	2	.05	LOCK, interlock ret. stud nut
66-68	Chevelle	3709315	1	.23	PIN, interlock (1/4" O.D. x 5/16" O.L.)
62-65	All (exc. H.D.)	591538	1	.23	RETAINER (1/2" x 4 1/6" O.L.)
62-65	All (exc. H.D.)	591537	2	.31	STUD, retainer (1 1/2" O.L. w/2 thd. ends)

#### 4.309 SHAFT, Gear Shifter

64-65	Pass., Chevelle (exc. H.D.)	3840456	1	11.30	SHAFT ASSY., w/plate, second and third
64-65	Chevelle	3840454	1	10.30	SHAFT ASSY., w/plate, first and reverse
65-68	All w/H.D.	3893612	1	9.25	SHAFT ASSY., w/plate, 1st and reverse (Warner AT16-40)
65-68	All H.D.	3893611	1	6.60	SHAFT ASSY., w/plate, 2nd and 3rd (Warner AT16-40)
66-67	All w/O/D				SHAFT ASSY., 2nd and 3rd
66-67	All (exc. H.D., O.D.)	3858994	A.R.	4.90	1st and reverse, 2nd and 3rd
68	Pass. w/Saginaw				
68-69	Chevy, Chevelle, Camaro (exc. O.D.),				
69	Pass. w/Saginaw (exc. H.D.)				SHAFT ASSY., reverse 1st, 2nd, and 3rd, 2nd and 3rd,
68-69	All w/O.D.				
69-72	All w/Muncie,				
70-72	Chevelle w/Saginaw		2		(Note 1)
73-75	All	3932234	1	5.35	SHAFT ASSY., 1st and rev.
70-75	All w/Saginaw	3952649	1	5.75	SHAFT ASSY., 2nd and 3rd
71-72	Vega (Opel)	6667420	1	5.60	SHAFT ASSY., trans. 1st and reverse shift (Opel— 732032)
71-72	Vega (Opel)	3460270	1	5.55	SHAFT ASSY., trans. 2nd and 3rd shift (Opel— 732059)
71-72	All w/Muncie	3952650	1	5.40	SHAFT ASSY., 2nd and 3rd
71-72	Vega (Opel)	3455183	1	9.10	SHAFT ASSY., trans. shift selector (Opel— 732384)
71-72	Vega (Opel)	2874888	1	.63	RING, trans. shift selector shaft (Opel— 761175)
71-72	Vega (Opel)	2877475	1	.32	WASHER, trans. mainshaft rear main bearing (Belleville) (Opel— 722151)

*NOTE 1 Use one as 1st and reverse shift shaft assy. Use one as 2nd and 3rd shift shaft assy.*

### 3-SPEED TRANSMISSION

#### 4.311 CAM— PIN— SHAFT— SPRING, Gearshift Detent

62-65	Pass. (exc. H.D.)	3869906	1	.82	2nd and 3rd
62-65	Pass. (exc. H.D.)	3869904	1	.82	1st and reverse detent
66-68	Pass. w/O.D.	3911918	1	.76	1st and reverse detent
66	All w/O.D.				2nd and 3rd,
66-67	Chevelle w/O.D.				3rd and 4th,
66-75	All (exc. H.D., O.D.)	346399	A.R.	.25	detent
68	Chevelle w/H.D. 3-Spd.,				
69-72	All w/H.D.	3911948	2	.88	detent
71-72	Vega (Opel)	11011286	2	.15	trans. shift shaft detent (8 mm dia.) (315) (Opel— 2088004)
71-72	Vega (Opel)	11030002	1	.44	PLUG, trans. oil fill
71-72	Vega (Opel)	6696393	2	.32	PLUG, trans. shift shaft detent hole (Opel— 734604)
66-70	All w/Saginaw (exc. H.D., O.D.),				
71-75	All	3831715	1	.20	PIN, detent cam
62-65	All (exc. H.D.)	3731912	1	.23	SHAFT, cam detent (scissors type) (5/16" O.L.)
62-65	Chevy, Chevelle w/3-Spd. (exc. H.D.),				
65	Pass. (exc. H.D.)	3737068	1	.18	SPRING, cam detent (scissors type) (1 1/8" long— 14 coils)
71-72	Vega (Opel)	6667617	2	.15	SPRING, trans. shift shaft detent (Opel— 73436)
66-75	All	3831718	1	.20	SPRING, detent cam

#### 4.312 ROLLER— PIN— WASHER, Gear Shifter Shaft and Fork (Yoke)

62-65	All	3731920	2	.18	shifter fork (scissors type) (3/16" I.D. x 5/16" O.D.)
71-72	Vega (Opel)	11054211	4	.13	PIN, trans. shaft shift lever and shift shaft spiral (Opel— 2086000)
65	Pass.	3731921	2	.12	WASHER, shaft (scissors type) (2/16" I.D. x 3/4" O.D.)

#### 4.313 SEAL, Transmission Internal Selector Shaft

62-68	All (exc. Pass.),				
65-66	Pass.,				
68-69	All w/H.D.	3845164	2	.21	"O" ring, rubber (7/16" I.D. x 17/32" O.D.)
71-72	Vega (Opel)	8984672	2	1.45	trans. shift selector shaft
64-75	All	3831716	2	.54	shifter shaft, all locations (steel) (.031 thk.)
66-69	All (exc. H.D.),				
69-70	All w/H.D. (350, 396) (exc. req. fuel),				
71-75	All	3844036	A.R.	.14	shifter shaft, all locations (3/8" dia. x 1/16" thk.)

#### 4.317 EXTENSION ASSY., Transmission Rear Main Bearing

62-65	All (exc. O.D., H.D.)	3855709	1	27.80	w/bushing (cast 3707195)
71-72	Vega w/Opel (1st design)	3455569	1	26.50	(Opel— 724188) (Note 1)
<i>NOTE 1: When using 3455569 in place of 3455570 plug bu. sw. hole in extension with plug 3906448 and gasket 3906462.</i>					
72	Vega w/Opel (2nd design)	8977912	1	26.50	
66-70	All w/Saginaw 3-Spd.,				
71-72	All w/Saginaw (exc. Pass. Sta. Wag.)				
73-75	Vega w/Saginaw	352253	1		
69	Pass. w/H.D. 3-Spd.,				
71-72	Pass. (Sta. Wag.)	3993044	1	23.90	
73-75	All w/Saginaw	360002	1	34.75	
69-71	All w/H.D. 3-Spd. (350, 396) (exc. reg. fuel, Pass.),				
72	Chevelle w/Muncie,				
73	All w/Muncie	3911941	1	43.50	
71-72	Vega w/Opel	11048332	5	.13	BOLT ASSY., trans. extension to case

#### 4.318 GASKET— SEAL, Transmission Rear Bearing Retainer

62-65	All (exc. O.D., H.D.)	3707172	1	.05	extension (5 holes 15/16" I.D.)
65-68	All H.D.	3870807	1	.31	extension (Warner T16-145)
66-75	All w/Saginaw	3876752	1	.14	extension
69-72	All w/Muncie H.D.	3911943	1	.31	trans. ext.
71	Vega w/Opel	8977853	1	.13	trans. extension (Opel— 724535)
72	Vega w/Opel	8977853	1	.13	trans. extension
65	All w/H.D.	3769588	1	2.63	SEAL, oil (2 7/32" I.D. x 3" O.D. x 7/16" thick)
62-69	All (exc. Pass.),				
66-69	All,				
71-75	All	1243402	1	2.95	SEAL ASSY., extension oil
70	Pass.,				

### 3-SPEED TRANSMISSION

#### 4.318 GASKET— SEAL, Transmission Rear Bearing Retainer (Con't)

70	Nova, Chevelle, Camaro . . . . .	3932255	1	4.02	SEAL ASSY., extension oil . . . . .
71-72	Vega w/Opel . . . . .	8961248	1	2.83	trans. extension oil (Opel— 724508) . . . . .

#### 4.319 BUSHING, Transmission Rear Main Bearing

71-72	Vega w/Opel . . . . .	325087	1	2.27	trans. rear main extension (1 <sup>1</sup> / <sub>2</sub> " I.D. x 1 <sup>5</sup> / <sub>8</sub> " O.D.) . . . . .
62-75	All (exc. Opel) . . . . .	6260048	1	.74	extension (1 <sup>1</sup> / <sub>2</sub> " I.D. x 1 <sup>5</sup> / <sub>8</sub> " O.D.) . . . . .

#### 4.329 ADAPTER ASSY.— ADAPTER UNIT, Speedometer

68	(For application refer to chart in group 4.337) . . . . .	6451928	1	36.59	
68	(For application refer to chart in group 4.337) . . . . .	1585657	1	28.80	
68	(For application refer to chart in group 4.337) . . . . .	1565452	1	30.15	
68	(For application refer to chart in group 4.337) . . . . .	1583624	1	25.28	
69	(For application refer to chart in group 4.337) . . . . .	3950348	1	18.10	
69	(For application refer to chart in group 4.337) . . . . .	3950350	1	18.10	
69	(For application refer to chart in group 4.337) . . . . .	3950352	1	18.10	
69	(For application refer to chart in group 4.337) . . . . .	3950354	1	18.10	
65-66	(For models and comb. see group 4.337) . . . . .				ADAPTER UNIT, ratio 17.16 (stamped 1563871), . . . . .
68	(For application refer to chart in group 4.337) . . . . .	1565812 A.R.		26.70	(Note 2) . . . . .
65-66	(For models and comb. see group 4.337) . . . . .				ADAPTER UNIT, ratio 17.15 (stamped 1563872), . . . . .
68	(For application refer to chart in group 4.337) . . . . .	1565813 A.R.		26.70	(Note 2) . . . . .
68	(For application refer to chart in group 4.337) . . . . .	1565814 A.R.		28.80	ADAPTER UNIT, ratio 16.17 (stamped 1564409) (Note 2) . . . . .

*NOTE 2 Above adapters used as required in combination with speedometer gears to correct odometer reading for various tire sizes, transmission and rear axle gear ratio combinations— See group 4.337.*

68	(For application refer to chart in group 4.337) . . . . .	1584275	1	28.80	ADAPTER UNIT . . . . .
68	(For application refer to chart in group 4.337) . . . . .	1584277	1	28.80	ADAPTER UNIT . . . . .
69	(For application refer to chart in group 4.337) . . . . .	3925673	1	18.10	ADAPTER UNIT . . . . .

#### 4.330 KEY— CUP, Speedometer Adapter

62-69	All . . . . .	867209	1	1.14	(also included w/adapters 1565811-12-13-14-1580273-3876) . . . . .
62-69	All . . . . .	860187	1	1.88	CUP, drive (1/4"— 32 x 1 <sup>3</sup> / <sub>16</sub> " nickel bright) . . . . .

*For application refer to chart in Group 4.337.*

#### 4.337 GEAR, Transmission Speedometer Driven Gears (only)

62	Chevy w/3.55 axle . . . . .				(6.00 x 13), . . . . .
64	Chevelle w/3.70 axle . . . . .				(6.50 x 14), . . . . .
65-66	Chevy, Chevelle w/2.73 axle . . . . .	3987917	1	1.05	(6.95, 7.35, 7.75 x 14) . . . . .
62-65	Chevy w/3.08 axle . . . . .				(6.00 x 13), . . . . .
62-66	Chevy (Sta. Wag.) w/3.36 axle . . . . .				(6.95 x 14, 7.00 x 13), . . . . .
64	Chevelle (Sta. Wag., El Camino) w/3.36 axle (6 cyl.) . . . . .				(6.50, 7.00 x 14), . . . . .
65-66	Pass. w/3.36, 3.31 axle . . . . .				(7.35 x 14), . . . . .
65-66	Pass. w/3.55 axle . . . . .				(7.75 x 14, 8.25 x 14, 7.75 x 15, 8.15 x 15, 8.55 x 14) (red-21 teeth), . . . . .
65-66	Chevelle w/3.36, 3.31 axle . . . . .				(6.95, 7.35 x 14), . . . . .
66	Chevelle w/3.55 axle . . . . .				(7.75 x 14), . . . . .
66	Chevy w/3.31 axle . . . . .				(6.95 x 14), . . . . .
67	Pass. w/3.55 axle . . . . .				(8.55 x 14, 8.15 x 15, 8.45 x 15, 8.25 x 14), . . . . .
67	Pass. w/3.70 axle . . . . .				(8.45 x 15), . . . . .
67	Chevelle w/3.36 axle . . . . .				(7.00, 7.35, 7.75 x 14), . . . . .
67	Chevelle, Camaro w/3.31 axle . . . . .	3987921	1	1.15	(7.00, 7.35 x 14) (red— 21 teeth) . . . . .
62-66	Chevy w/3.07, 3.08 axle . . . . .				(6.50, 7.00 x 13, 6.95 x 14), . . . . .
64	Chevelle w/3.08 axle (exc. Sta. Wag., El Camino) . . . . .				(6.50 x 14), . . . . .

### 3-SPEED TRANSMISSION

#### 4.337 GEAR, Transmission Speedometer Driven Gears (only) (Con't)

64-66	Chevelle (Sta. Wag., El Camino) w/3.36 axle (6 cyl.)				(7.50, 7.75 x 14),
65-66	Pass. w/3.36, 3.31 axle				(7.75 x 14, 8.25 x 14, 7.75 x 15, 8.15 x 15, 8.55 x 14) (blue— 20 teeth),
65-66	Chevelle w/3.31 axle				(7.75 x 14),
65-66	Chevelle w/3.07, 3.08 axle				(6.95 x 14),
67	Pass. w/3.36 axle				(8.25 x 14, 8.55 x 14, 8.15 x 15, 7.75 x 15, 8.45 x 15),
67	Pass. w/3.31 axle				(8.25 x 14, 8.55 x 14, 8.15 x 15),
67	Chevelle w/3.07, 3.08, 2.73 axle				(7.35 x 14),
67	Chevelle w/3.31 axle				(7.75 x 14),
67	Chevy w/3.07, 3.08 axle				(6.95, 7.35 x 14),
67	Camaro w/2.73, 3.07, 3.08 axle	3987920	1	.98	(7.00, 7.35 x 14)
62-66	Chevy w/3.36 axle				(6.50 x 13),
64	Chevelle w/3.70 axle				(7.50 x 14),
65-66	Pass. w/3.55 axle				(7.35 x 14),
65-66	Pass. w/3.70, 3.73 axle				(7.75 x 14, 8.25 x 14, 7.75 x 15, 8.15 x 15, 8.55 x 14),
65-66	Chevelle w/3.70 axle				(7.75 x 14),
67	Pass. w/3.55 axle				(8.25 x 14, 7.75 x 15),
67	Pass. w/3.70 axle				(8.25 x 14, 8.55 x 14, 7.75 x 15),
67	Pass. w/3.73 axle				(8.55 x 14, 8.15 x 15, 8.45 x 15) (green— 22 teeth),
67	Chevelle w/3.55 axle				(7.00, 7.75, F70 x 14),
67	Chevy w/3.31, 3.36 axle				(6.95 x 14),
67	Camaro w/4.10 axle	3860345	1	1.05	(7.00, 7.35 x 14)
62-65	Chevy w/3.36 axle				(6.00 x 13),
62-66	Chevy w/3.55 axle				(6.50, 7.00 x 13, 6.95 x 14),
64	Chevelle w/3.70 axle				(7.00 x 14),
65-66	Pass. w/3.70 axle				(7.35 x 14),
65-66	Pass. w/3.73 axle				(7.35 x 14, 7.75 x 14),
65-66	Chevelle w/3.70 axle				(7.35 x 14),
65-66	Chevelle w/3.73 axle				(7.35, 7.75 x 14),
67	Pass. w/3.73 axle				(8.25 x 14),
67	Chevelle w/3.70 axle				(7.00, 7.75 x 14),
67	Chevelle w/3.73 axle				(7.00, 7.75 x 14),
67	Chevy w/3.55 axle				(6.95, E70 x 14),
67	Camaro w/3.55 axle	3860346	1	1.10	(7.00, 7.35 x 14) (black— 23 teeth)
63-65	Chevy w/3.55 axle				(6.00 x 13),
67	Pass. w/4.10 axle				(7.75 x 14, 8.25 x 14, 7.75 x 15),
67	Chevelle w/4.10, 4.88 axle				(7.00, 7.75 x 14),
67	Camaro w/4.88 axle	3860348	1	1.05	(7.00, 7.35 x 14) (orange— 25 teeth)
64	Chevelle (Sta. Wag., El Camino) w/3.08 axle (8 cyl.) (exc. S.S.),				
64	Chevelle w/3.08 axle (exc. Sta. Wag., El Camino)				(7.00, 7.50 x 14),
65-66	Pass. w/3.07, 3.08, 3.31 axle				(7.35 x 14, 7.75 x 14, 8.25 x 14, 8.15 x 15, 8.55 x 14),
65	Chevelle w/3.07, 3.08 axle				(7.35, 7.775 x 14),
67	Pass. w/3.07 axle				(8.25 x 14),
67	Pass. w/3.08 axle				(8.25 x 14, 7.75 x 15),
67	Pass. w/3.31 axle				(8.45 x 15),
67	Pass. w/2.73 axle				(8.25 x 14),
67	Chevelle w/3.07, 3.08 axle				(7.00, 7.75 x 14),
67	Chevelle w/2.73 axle	3987919	1	.98	(7.75, 7.35 x 14) (natural— 19 teeth)
65-66	Pass. w/4.89 axle	3860033	1	4.70	(8.25 x 14, 8.15 x 15, 8.55 x 14) (21 teeth)
65-66	Pass. w/4.10 axle				(8.25 x 14, 7.75 x 15, 8.15 x 15, 8.55 x 14) (yellow— 24 teeth),
65-66	Chevelle w/3.70, 3.73 axle,				
66	Chevy w/3.55 axle				(6.95 x 14),
67	Chevelle w/3.70 axle				(7.35 x 14),
67	Chevelle w/3.73 axle				(7.75 x 14),
67	Chevelle w/4.56 axle				(7.00, 7.75 x 14),
67	Chevy w/3.73 axle				(6.95 x 14),
67	Camaro w/3.73, 4.56 axle				(7.00, 7.35 x 14),
67	Pass. w/4.10 axle	3860347	1	1.10	(8.55 x 14, 8.15 x 15, 8.45 x 15)
65-66	Pass. w/4.56 axle	3860329	1	2.20	(8.25 x 14, 8.15 x 15, 8.55 x 14) (20 teeth— steel)
65-66	Pass. w/3.08 axle				(8.00 x 14, 6.70 x 15, 7.10 x 15, 7.75-15, 8.25-14, 8.55-14),
65-66	Pass. w/3.07 axle				(8.25 x 14, 8.15 x 15, 8.55 x 14),
65	Pass. w/3.08 axle				(7.75 x 15, 8.15 x 15, 8.25 x 15),
67	Pass. w/3.07 axle				(8.55 x 14, 8.15 x 15, 8.45 x 15, 6.70 x 15),
67	Pass. w/3.08 axle				(8.15 x 15, 8.45 x 15, 8.55 x 14),

### 3-SPEED TRANSMISSION

#### 4.337 GEAR, Transmission Speedometer Driven Gears (only) (Con't)

67	Pass. w/2.73 axle .....	3987918	1	1.05	(8.55 x 14, 8.15 x 15, 8.45 x 15) (brown— 18 teeth) .....
----	-------------------------	---------	---	------	--

NOTE 1 Used selectively.

#### 1968 PASSENGER SPEEDOMETER GEAR CHART

NOTE: To order Speedometer Gears or Parts, Transmission Type, Rear Axle Ratio and Tire Size must be known.

REAR AXLE RATIO	TIRE SIZE .....	4.343 GEAR, SPEEDO. DRIVE	4.337 GEAR, SPEEDO. DRIVEN	4.329 ADAPTER, SPEEDO.
--------------------	-----------------	------------------------------------	-------------------------------------	------------------------------

#### 3-SPEED, H.D. 3-SPEED (exc. O/D)

2.73	8.55 x 14, 8.15 x 15, 8.45 x 15, G70 x 15 ...	3905494	3987918	—
2.73	8.25 x 14 .....	3905494	3987919	—
3.07	8.55 x 14, 8.15 x 15, 8.45 x 15, G70 x 15 ...	6261794	3987918	—
3.07	8.25 x 14, F70 x 15 .....	6261794	3987919	—
3.08	8.55 x 14, 8.15 x 15, 8.45 x 15, G70 x 15 ...	6261794	3987918	—
3.08	8.25 x 14, F70 x 15 .....	6261794	3987919	—
3.31	8.45 x 15 .....	6261794	3987919	—
3.31	8.25 x 14, 8.55 x 14, 8.15 x 15, F70 x 15, G70 x 15 .....	6261794	3987920	—
3.36	8.25 x 14, 8.55 x 14, 8.15 x 15, F70 x 15, G70 x 15 .....	6261794	3987920	—
3.55	8.25 x 14, 8.55 x 14, 8.15 x 15, 8.45 x 15, G70 x 15 .....	6261794	3987921	—
3.55	F70 x 15 .....	3924097	3860345	—
3.70	8.25 x 14, 8.55 x 14, 8.15 x 15, F70 x 15, G70 x 15 .....	3924097	3860345	—
3.70	8.45 x 15 .....	6261794	3987921	—
3.73	8.55 x 14, 8.15 x 15, 8.45 x 15, G70 x 15 ...	3924097	3860345	—
3.73	8.25 x 14, F70 x 15 .....	3924097	3860348	—
4.10	8.55 x 14, 8.15 x 15, 8.45 x 15, G70 x 15 ...	3924097	3860347	—
4.10	8.25 x 14 .....	3924097	3860348	—
4.11	F70 x 15 .....	3924097	3860348	—
4.56	8.55 x 14, 8.45 x 15 ...	3924097	3860345	3890575
4.56	8.25 x 14, 8.15 x 15, G70 x 15 .....	3924097	3860346	3890575
4.56	F70 x 15 .....	3845079	3860033	—
4.89	8.55 x 14, 8.15 x 15, 8.45 x 15, G70 x 15 ...	3924097	3860347	3890575
4.89	8.25 x 14 .....	3924097	3860348	3890575

#### 3-SPEED TRANSMISSION w/O/D

3.70	8.25 x 14, 8.55 x 14, 8.45 x 15, G70 x 15 ...	3924097	3860345	—
------	--	---------	---------	---

### 3-SPEED TRANSMISSION

#### 1968 CHEVY, CHEVELLE, CAMARO SPEEDOMETER GEAR CHART

*NOTE: To order Speedometer Gears or Parts, Transmission Type, Rear Axle Ratio and Tire Size must be known.*

REAR AXLE RATIO	TIRE SIZE	4.343 GEAR, SPEEDO. DRIVE	4.337 GEAR, SPEEDO. DRIVEN	4.329 ADAPTER SPEEDO.
<b>3-SPEED, H.D. 3-SPEED TRANSMISSION (exc. O/D)</b>				
2.56	7.35 x 14	3905494	3860341	—
2.56	E70 x 14, F70 x 14	3905494	3987919	—
2.73	7.35 x 14, 7.75 x 14, E70 x 14, F70 x 14	3905494	3987919	—
3.07	7.35 x 14, 7.75 x 14, F70 x 14, G70 x 14, E70 x 15	6261794	3987919	—
3.07	E70 x 14	6261794	3987920	—
3.08	7.75 x 14, F70 x 14, G70 x 14	6261794	3987919	—
3.08	7.35 x 14, E70 x 14	6261794	3987920	—
3.31	7.75 x 14, G70 x 14, E70 x 15	6261794	3987920	—
3.31	7.35 x 14, E70 x 14, F70 x 14	6261794	3987921	—
3.36	7.35 x 14, 7.75 x 14, F70 x 14, G70 x 14	6261794	3987921	—
3.36	E70 x 14	3924097	3860345	—
3.55	7.35 x 14, 7.75 x 14, F70 x 14, G70 x 14, E70 x 15	3924097	3860345	—
3.55	E70 x 14	3924097	3860346	—
3.70	7.35 x 14, 7.75 x 14, F70 x 14, G70 x 14	3924097	3860346	—
3.73	7.75 x 14, F70 x 14, G70 x 14, E70 x 15	3924097	3860346	—
3.73	7.35 x 14, E70 x 14	3924097	3860347	—
4.10	7.35 x 14	3924097	3860345	3890575
4.10	7.75 x 14, F70 x 14, G70 x 14	3924097	3860348	—
4.10	7.35 x 14, F70 x 14	6261794	3987920	6476736
4.10	E70 x 14	3924097	3860345	6476735
4.10	E70 x 15	3924097	3860348	—
4.56	7.75 x 14, G70 x 14	3924097	3860346	3890575
4.56	7.35 x 14, F70 x 14	3924097	3860347	3890575
4.56	7.35 x 14	3924097	3860347	6476735
4.56	F70 x 14, E70 x 15	3924097	3860346	6476735
4.56	E70 x 14	3924097	3860346	6476736
4.89	7.75 x 14, F70 x 14, G70 x 14	3924097	3860348	3890575
4.89	7.35 x 14	3924097	3860348	3905497
4.89	E70 x 14, E70 x 15	3924097	3860346	6476736
4.89	7.35 x 14, F70 x 14	3924097	3860347	6476736
<b>3-SPEED TRANSMISSION w/O/D</b>				
3.70	7.35 x 14, 7.75 x 14, F70 x 14, G70 x 14	3924097	3860346	—

### 3-SPEED TRANSMISSION

#### 1969 PASSENGER SPEEDOMETER GEAR CHART

*NOTE: To order Speedometer Gears or Parts, Transmission Type, Rear Axle Ratio and Tire Size must be known.*

REAR AXLE RATIO	TIRE SIZE	4.343 GEAR, SPEEDO. DRIVE 3-SPD.	4.337 GEAR, SPEEDO. DRIVEN	4.329 ADAPTER, SPEEDO.
<b>3-SPEED, H.D. 3-SPEED TRANSMISSION</b>				
2.56	7.35 x 14, 7.75 x 14, E78 x 14, F70 x 14, F78 x 14, G78 x 14 . . .	3905494	3987918	—
2.56	8.25 x 14, E70 x 14, F70 x 15, G70 x 15, G78 x 15 . . . . .	3905494	3987919	3925673
2.73	8.55 x 14, G70 x 15, G78 x 15, 8.85 x 14, 8.25 x 15, 8.55 x 15 . .	3905494	3987918	—
2.73	7.35 x 14, 7.75 x 14, 8.25 x 14, F70 x 14, F70 x 15, F78 x 14, G78 x 14 . . . . .	3905494	3987919	—
2.73	E70 x 14, E78 x 14 . . . .	3905494	3987920	—
3.07	8.55 x 14, 8.85 x 14, 8.25 x 15, G70 x 15, G78 x 15 . . . . .	6261794	3987918	—
3.07	7.35 x 14, 7.75 x 14, F70 x 14, F78 x 14, G70 x 14 . . . . .	6261794	3987919	—
3.07	8.55 x 15 . . . . .	3905494	3987920	—
3.07	E70 x 14, E78 x 14 . . . .	6261794	3987920	—
3.07	8.25 x 14, E70 x 15, F70 x 15, G78 x 14 . . . . .	3905494	3987921	—
3.08	8.55 x 14, 8.85 x 14, 8.55 x 15, G70 x 15, G78 x 15 . . . . .	6261794	3987918	—
3.08	7.75 x 14, F70 x 14, F78 x 14 . . . . .	6261794	3987919	—
3.08	7.35 x 14, E70 x 14, E78 x 14 . . . . .	6261794	3987920	—
3.08	8.25 x 14, 8.25 x 15, F70 x 15, G78 x 14 . . .	3924099	3987921	—
3.31	8.55 x 15 . . . . .	6261794	3987919	—
3.31	7.75 x 14, 8.25 x 14, 8.55 x 14, 8.85 x 14, 8.25 x 15, E70 x 15, F70 x 15, G70 x 14, G70 x 15, G78 x 14, G78 x 15 . . . . .	6261794	3987920	—
3.31	7.35 x 14, E70 x 14, E78 x 14, F70 x 14, F78 x 14 . . . . .	6261794	3987921	—
3.36	8.25 x 14, 8.55 x 14, 8.85 x 14, 8.25 x 15, 8.55 x 15, F70 x 15, G70 x 15, G78 x 15 . . .	6261794	3987920	—
3.36	7.35 x 14, 7.75 x 14, E78 x 14, F70 x 14, F78 x 14, G78 x 14 . . .	6261794	3987921	—
3.36	E70 x 14 . . . . .	3924097	3860345	—
3.55	8.25 x 14, 8.55 x 14, 8.85 x 14, 8.25 x 15, 8.55 x 15, G70 x 15, G78 x 15 . . . . .	6261794	3987921	—
3.55	7.35 x 14, 7.75 x 14, E70 x 15, F70 x 14, F70 x 15, F78 x 14, G70 x 14, G78 x 14 . . .	3924097	3860345	—
3.55	E70 x 14, E78 x 14 . . . .	3924097	3860346	—

**3-SPEED TRANSMISSION**

**1969 PASSENGER SPEEDOMETER GEAR CHART (CONT.)**

REAR AXLE RATIO	TIRE SIZE .....	4.343 GEAR, SPEEDO. DRIVE 3-SPD.	4.337 GEAR, SPEEDO. DRIVEN	4.329 ADAPTER, SPEEDO.
-----------------------	-----------------	--	-------------------------------------	------------------------------

**3-SPEED, H.D. 3-SPEED TRANSMISSION (CONT.)**

3.70	E70 x 14 .....	3924097	3860347	—
3.73	8.25 x 14, 8.55 x 14, 8.85 x 14, 8.25 x 15, 8.55 x 15, G70 x 15, G78 x 15 .....	3924097	3860345	—
3.73	E70 x 15, F70 x 14, F70 x 15, G70 x 14, G78 x 14 .....	3924097	3860346	—
3.73	E70 x 14 .....	3924097	3860347	—
4.10	F70 x 14 .....	6261794	3987919	3932220
4.10	8.55 x 14, 8.85 x 14, 8.25 x 15, 8.55 x 15, G70 x 15, G78 x 15 ...	3924097	3860347	—
4.10	8.25 x 14, G70 x 14, G78 x 14 .....	3924097	3860348	—



### 3-SPEED TRANSMISSION

#### 1969 CHEVY, CHEVELLE, CAMARO SPEEDOMETER GEAR CHART

*NOTE: To order Speedometer Gears or Parts, Transmission Type, Rear Axle Ratio and Tire Size must be known.*

REAR AXLE RATIO	TIRE SIZE .....	4.343 GEAR, SPEEDO. DRIVE 3, 4-SPD., POWER- GLIDE	4.337 GEAR, SPEEDO. DRIVEN	4.329 ADAPTER, SPEEDO.
--------------------	-----------------	---	-------------------------------------	------------------------------

#### 3-SPEED, H.D. 3-SPEED TRANSMISSION

2.73	8.25 x 14, 7.75 x 14, F70 x 14, 7.35 x 14, 5.78 x 14 .....	6261794	3987919	—
2.73	E78 x 14, E70 x 14 .....	6261794	3987920	—
3.07	8.25 x 14, E70 x 15 .....	3905494	3987921	—
3.07	7.75 x 14, G70 x 14, F70 x 14, F78 x 14 .....	3905494	3987919	—
3.07	E70 x 14 .....	3905494	3987920	—
3.08	8.25 x 14 .....	3905494	3987921	—
3.08	7.75 x 14, F70 x 14, F78 x 14 .....	3905494	3987919	—
3.08	7.35 x 14, E78 x 14, E70 x 14 .....	3905498	3987920	—
3.31	8.25 x 14, 7.75 x 14, G70 x 14, E90 x 15 .....	3905494	3987920	—
3.31	F70 x 14, F78 x 14, E70 x 14 .....	3905494	3987921	—
3.36	8.25 x 14 .....	3905494	3987920	—
3.36	7.75 x 14, F70 x 14, 7.35 x 14, E78 x 14, F78 x 14 .....	3905494	3987921	—
3.36	E70 x 14 .....	3924097	3860345	—
3.55	8.25 x 14 .....	3905494	3987921	—
3.55	7.75 x 14, G70 x 14, F70 x 14, 7.35 x 14, F78 x 14, E70 x 15 .....	3924097	3860345	—
3.55	E70 x 14 .....	3924097	3860346	—
3.70	E70 x 14 .....	3924097	3860347	—
3.73	8.25 x 14 .....	3924097	3860345	—
3.73	7.75 x 14, G70 x 14, F70 x 14, F78 x 14, E70 x 15 .....	3924097	3860346	—
3.73	E70 x 14 .....	3924097	3860347	—
2.56	8.25 x 14 .....	3905494	3987919	3925673
2.56	G78 x 14, 7.75 x 14, F70 x 14, 7.35 x 14, E78 x 14, F78 x 14 .....	3905494	3987918	—
2.56	E70 x 14 .....	3905494	3987919	—

**3-SPEED TRANSMISSION**

**1969 CHEVY, CHEVELLE, CAMARO SPEEDOMETER GEAR CHART (CONT.)**

*NOTE: To order Speedometer Gears or Parts, Transmission Type, Rear Axle Ratio and Tire Size must be known.*

REAR AXLE RATIO	TIRE SIZE .....	4.343 GEAR, SPEEDO. DRIVE 3, 4-SPD., POWER- GLIDE	4.337 GEAR, SPEEDO. DRIVEN	4.329 ADAPTER, SPEEDO.
--------------------	-----------------	---	-------------------------------------	------------------------------

**3-SPEED, H.D. 3-SPEED TRANSMISSION**

4.10	8.55 x 14 .....	3924097	3860347	—
4.10	8.25 x 14, G78 x 14, 7.75 x 14, G70 x 14, E78 x 14 .....	3924097	3860348	—
4.10*	F70 x 14 .....	6261794	3987919	3932220
4.10	F70 x 14 .....	6261794	3987920	6476736
4.10	E70 x 14 .....	6261794	3987921	6476736
4.10	E70 x 15 .....	3924097	3860348	6476736
4.55	8.55 x 14, 8.25 x 14, G78 x 14, 7.75 x 14 ...	6261794	3987920	3932220
4.55*	G70 x 14, F70 x 14, F78 x 14 .....	6261794	3987921	3932220
4.55	F70 x 14, E70 x 15 .....	3924097	3860345	6476736
4.55	E70 x 15 .....	3924097	3860346	6476736
4.88	8.55 x 14 .....	6261794	3987921	3932220
4.88*	8.25 x 14, G78 x 14, 7.75 x 14, G70 x 14, F70 x 14, F78 x 14 ...	3924097	3860345	3932220
4.88	F70 x 14, E70 x 14 .....	3924097	3860347	6476736
4.88	E70 x 15 .....	3924097	3860346	6476736

*\*NOTE: Chevelle (3-Spd., 4-Spd.)*

**3-SPEED TRANSMISSION**

**1970 PASSENGER, NOVA, CHEVELLE, CAMARO SPEEDOMETER GEAR CHART**

REAR AXLE RATIO	REAR TIRE SIZE	4.337 GEAR, SPEEDO. DRIVEN	4.343 GEAR, SPEEDO. DRIVE
--------------------	----------------	-------------------------------------	------------------------------------

**ALL w/3-SPEED (EXC. TAXI, POLICE, CAMARO)**

3.07	F70 x 14, E70 x 14, E78 x 14, F78 x 14, G78 x 14, F78 x 15, 7.35 x 14, 7.75 x 14, 8.25 x 14	3987919	6261794
3.07	G70 x 15, G78 x 15, H78 x 15, 8.25 x 15	3987918	6261794
3.08	E70 x 14, E78 x 14, 7.35 x 14	3987920	6261794
3.08	F70 x 14, F78 x 14, G78 x 15, H70 x 15, F78 x 15, 7.75 x 14, 8.25 x 14	3987919	6261794
3.08	G70 x 15, G78 x 15, H78 x 15, 8.25 x 15	3987918	6261794
3.31	F70 x 14, F78 x 14	3987921	6261794
3.31	G78 x 14, 8.25 x 14	3987920	6261794
3.31	H78 x 15	3987919	6261794
3.36	F70 x 14, F78 x 14, G78 x 14	3987921	6261794
3.36	H70 x 15, H78 x 15, 8.25 x 14	3987920	6261794

**CAMARO w/3-SPEED**

3.07	F70 x 14, E78 x 14, F70 x 15, 7.35 x 14	3987919	6261794
3.08	F70 x 14	3987919	6261794
3.08	E78 x 14, 7.35 x 14	3987920	6261794

REAR AXLE RATIO	REAR TIRE SIZE	4.337 GEAR, SPEEDO. DRIVEN	4.343 GEAR, SPEEDO. DRIVE 3-SPD. (EXC. 350 w/4/BC)	4.329 ADAPTER, SPEEDO.
--------------------	----------------	-------------------------------------	--	------------------------------

**POLICE AND TAXI**

2.73	F78 x 15	3987920	3708144	3950348
2.73	G78 x 15, G70 x 15, H78 x 15	3987919	3708144	3950348
3.07	G70 x 15, G78 x 15, H78 x 15	3987918	3708144	—
3.07	F78 x 15	3987919	3708144	—
3.31	G70 x 15, F78 x 15, G78 x 15	3987920	3708144	—
3.31	H78 x 15	3987919	3708144	—

### 3-SPEED TRANSMISSION

#### 1971 SPEEDOMETER GEAR CHART

##### DRIVE GEARS

PART NUMBER	COLOR	NUMBER OF TEETH
6261794	Natural	8

##### DRIVEN GEARS

*3987918	Brown	18
*3987919	Natural	19
*3987920	Blue	20
*3987921	Red	21

*NOTE To order speedometer gears and parts, transmission type, rear axle ratio, and tire size must be known.*

REAR AXLE RATIO	REAR TIRE SIZE	4.337 GEAR SPEEDO. DRIVEN	4.343 GEAR SPEEDO. DRIVE	4.329 ADAPTER ASSY.
2.733	G78-15	3987921	6261794	3950350
2.733	L78-15	3987920	6261794	3950350
3.083	E70-14, E78-14	3987920	6261794	
3.083	F70-14, F78-14, F78-15	3987919	6261794	
3.083	G70-15, G78-15, H78-15	3987918	6261794	
3.308	E78-14, F78-14	3987921	6261794	
3.308	G78-14	3987920	6261794	
3.364	E78-14, G78-14	3987921	6261794	

#### 1972 SPEEDOMETER GEAR CHART

##### DRIVE GEARS

Part Number	Color	Number of Teeth
6261794	Natural	8

##### DRIVEN GEARS

3987918	Brown	18
3987919	Natural	19
3987920	Blue	20
3987921	Red	21
3987922	Solid Silver	22

*NOTE: To order speedometer gears & parts transmission type, rear axle ratio, & tire size must be known.*

### 3-SPEED TRANSMISSION

#### 3 SPEED (SAGINAW)

AXLE RATIO REAR TIRE SIZE . . . . .	GEAR SPEEDO. DRIVEN	GEAR SPEEDO. DRIVE	ADAPTER ASSY.	SLEEVE DRIVEN GEAR
3.083 E78-14, F60-15, E70-14 . . . . .	3987920	6261794		3869914
3.083 F78-14, F70-14, G78-14, F70-15, F78-15, G70-14 . . . . .	3987919	6261794		3869914
3.083 G70-15, G78-15, H78-15, 8:55-15 . . . . .	3987918	6261794		3869914
3.083 L78-15 . . . . .	3987922	6261794	3950350	3869914
3.308 E78-14, F78-14, F70-14, F60-15, E70-14 . . . . .	3987921	6261794		3869914
3.308 G78-14, G70-15, G78-15, F78-15, G70-15 . . . . .	3987920	6261794		3869914
3.308 H78-15, L78-15, 8:55-15 . . . . .	3987919	6261794		3869914
3.364 E78-15, F78-14, F70-14, G78-14, F60-15, E70-14, G70-14 . . . . .	3987921	6261794		3869914
3.364 G70-15, F78-15, H78-15, F78-15, 8:55-15 . . . . .	3987920	6261794		3869914
3.364 L78-15 . . . . .	3987919	6261794		3869914

#### 3 SPEED (MUNCIE)

AXLE RATIO REAR TIRE SIZE . . . . .	GEAR SPEEDO. DRIVEN	GEAR SPEEDO. DRIVE	ADAPTER ASSY.	SLEEVE DRIVEN GEAR
3.308 E78-14, F78-14, F70-14, F60-15, E70-14 . . . . .	3987921	6261794		3869912
3.308 G78-14, G70-15, G78-15, F70-15, F78-15, G70-14 . . . . .	3987920	6261794		3869912
3.308 H78-15, L78-15, 8:55-15 . . . . .	3987919	6261794		3869912

#### 1973 ALL 3-SPD.

CODE	DRIVEN GEAR		SLEEVE ASM.	CODE	ADAPTER
A	3987920	20T	6258100	F	3950354
B	3987921	21T	6258100	G	326569
C	3987922	22T	6258100		
D	3987919	19T	6258100		
E	3987918	18T	6258100		

TIRE SIZE	3.08 DRIVE GEAR 6261794		3.42 DRIVE GEAR 6261794	
	Driven	Adapt	Driven	Adapt
Pass.	A	F	—	—
G78-15	A	—	—	—
H78-15	A	—	—	—
Chevelle	A	—	—	—
E-78-14	D	—	B	—
G70-14	D	—	B	—
G78-14	E	F	A	F
H78-14	E	—	—	—
GR70-15	E	F	—	—
G78-15	E	—	—	—
Camaro	A	—	C	—
E78-14	D	G	B	G
F70-14	D	—	B	—
GR70-14	D	—	—	—
Nova	A	—	—	—
E78-14	A	—	—	—
E70-14	A	—	—	—

**3-SPEED TRANSMISSION**

**1974 ALL w/3-SPD.**

CODE	DRIVEN GEAR	TEETH	COLOR	CODE	ADAPTER	CODE	SLEEVE ASM.
A	3987920	20	Blue	F	3950354	H	345215
B	3987921	21	Red	G	326569	I	3869912
C	3987922	22	Silver				
D	3987919	19	Natural				
E	3987918	18	Brown				

TIRE SIZE		3.08 RATIO DRIVE GEAR 6261794*			3.42 RATIO DRIVE GEAR 6261794*		
		Driven	Adapt.	Sleeve	Driven	Adapt.	Sleeve
Chevelle		A	—	H	—	—	—
E78-14		A	—	H	—	—	—
G70-14		D	—	H	B	—	H
G78-14		D	—	H	B	—	H
H78-14		E	F	H	A	F	H
GR70-15		D	—	H	—	—	—
G78-15		E	F	H	—	—	—
Camaro							
E78-14		D	G	I	C	—	H
F70-14		D	G	I	B	G	I
FR78-14		D	G	I	C	—	H
Nova							
E78-14		A	—	H	—	—	—
E70-14		A	—	H	—	—	—

\*8 Tooth Natural

**1975 ALL w/3-SPD.**

CODE	DRIVEN GEAR	TEETH	COLOR	CODE	ADAPTER	CODE	SLEEVE ASM.
A	3987920	20	Blue	F	3950354	H	345215
B	3987921	21	Red	G	326569	I	3869912
C	3987922	22	Silver	—	—	—	—
D	3987919	19	Natural	—	—	—	—
E	3987918	18	Brown	—	—	—	—

TIRE SIZE		3.08 RATIO DRIVE GEAR 6261794*			3.42 RATIO DRIVE GEAR 6261794*		
		Driven	Adapter	Sleeve	Driven	Adapter	Sleeve
Chevelle		A	—	H	—	—	—
E78-14		A	—	H	—	—	—
G70-14		D	—	H	B	—	H
G78-14		D	—	H	B	—	H
H78-14		E	F	H	A	F	H
GR70-15		D	—	H	—	—	—
G78-15		E	F	H	—	—	—
Camaro							
E78-14		D	G	I	C	—	H
F70-14		D	G	I	B	G	I
FR78-14		D	G	I	C	—	H
Nova							
E78-14		A	—	H	—	—	—
E70-14		A	—	H	—	—	—

\*8 Tooth Natural

**4.338 FITTING— RETAINER— SEAL, Speedometer Driven Gear**

62-64	Chevy, Chevelle,					
65-67	Pass. w/3-Spd. (exc. H.D.),					
65-66	Chevy,					
65-68	Chevelle,					
67-69	Chevy, Camaro,					
68-69	Pass.,					
69	Chevelle,					
70-71	All	3869914	1	2.75	w/seal	.....
74	Vega w/Saginaw	345215	1	2.45	w/seal speedo. driven gear	.....

**3-SPEED TRANSMISSION**

**4.338 FITTING— RETAINER— SEAL, Speedometer Driven Gear (Con't)**

65-69	Pass.,				
70	All,				
71	Pass.,				
75	All	3708148	1	.12	RETAINER, gear fitting (9/16" I.D.)
74-75	All	1361618	1	.13	RING, speedo. driven gear sleeve seal ret.
62-75	All	6264903	1	.20	SEAL, speedo. gear fitting (rubber)
65-74	Chevy w/3-Spd. H.D.	3869910	1	1.05	SEAL ASSY., pinion (5/32")
71-75	All w/Muncie	345215	1	2.45	SEAL ASSY., w/fitting

**4.342 SHAFT ASSY.— SHAFT UNIT— CLIP— GROMMET— RETAINER— SPRING, Speedometer without Casing**

65-68	Pass.,				
67	Camaro (exc. 350, 396),				
68	Chevy, Camaro w/3-Spd. (exc. H.D., P/Trac., floor shift),				
69	Camaro w/floor shift (302, 350, 396) (exc. P/Trac.)	6452474	1	2.08	(62 1/8")
66-67	Chevy, Chevelle,				
68	Chevy (8 cyl.)	1564778	1	2.20	(56 1/8" O.L.)
67	Camaro w/H.D. 3-Spd. (exc. 350, 396),				
68	Chevy, Camaro w/3-Spd. (exc. 327 Sp. H/Per., 350, 396),				
69	Chevy, Camaro w/floor shift (exc. 302, 350, 396)	6478071	1	2.68	lower flex (24 3/4" O.L.)
68	Chevelle w/cruise control	6478123	1	6.74	(48" O.L.)
69	Chevy, Camaro (Spt. Cpe.) (exc. floor shift, 302, 350, 396),				
69	Pass. (exc. H.D. 3-Spd.)	6477306	1	2.35	(61 7/16")
69	Pass. w/H.D. 3-Spd.	6477751	1		(80 7/16")
69	Chevelle w/Muncie 3-Spd.	6478057	1		(70 7/16") (left hand wound)
69	Chevy, Camaro (Spt. Cpe.) w/floor shift (exc. 302, 350, 396)	6477297	1	1.80	upper flex (37 7/16")
69	Camaro (Conv.) (exc. floor shift, 302, 350, 396)	6478073	1	2.40	(67 7/16")
62-74	All	6477499	1	3.70	SHAFT UNIT (consists of shaft, tip) (AC-615) (70" O.L.) (Note 1)
<i>NOTE 1 For models requiring maximum length of 81" cut to required length.</i>					
62-70	All	6478825	1	6.70	SHAFT UNIT (171" O.L.) (Note 2)
73-74	Camaro w/E78-14 tires	6478175	1	6.97	(60") (AC #CC-534)
73-74	Pass.	6478174	1	7.36	(55")
73	Nova, Camaro	6478071	1	2.68	lower flex (less casing)
75	Nova, Camaro	6478179	1	9.28	SHAFT UNIT (76")
73-75	All	6454481	1	10.92	SHAFT UNIT, lower flex. (24")
75	Nova w/floor controls	6479292	1	11.62	SHAFT UNIT (27")
<i>NOTE 2 For models requiring length of 81" to 172" cut to required length.</i>					
69	Pass. w/Muncie 3-Spd.	3918968	1	.11	CLIP, speedo flex shaft (1/2" dia. mounting hole, 3/4" width)
69	Pass. w/Muncie 3-Spd.	3958981	1		CLIP, speedo flex shaft (9/32" dia. mounting hole, 1/2" width)
69-72	All w/quick release cable	6491006	1	.35	CLIP, instr. cluster cable release
72	Nova	3772324	3	.13	CLIP, speedo. flex. shaft— (4.047)
72	Camaro	401164	1	.16	CLIP, speedo. flex. shaft (Nylon)
73-75	Camaro	401164	1	.16	CLIP, speedo. flex shaft (nylon)
73-74	Pass.	3993616	1	.11	CLIP, speedo. flex shaft to u/b
73-75	Chevelle	6271678	1	.11	CLIP, speedo. flex. shaft
75	Camaro	487120	1	.16	CLIP, speedo. flex. shaft to cross shaft bracket
73-74	Chevelle,				
73-74	Pass. (exc. speed & cruise control)	6271679	1	.40	GROMMET, speedo. flex. shaft— (9.775)
73-75	Chevelle	334963	1	.11	RETAINER ASSY., flex shaft clip
73-74	Camaro w/F70-14 tires	3816659	1	.31	RETAINER ASSY., flex. shaft
75	Camaro	481730	1		RETAINER, flex. shaft
72-73	Pass.	6478373	1	.70	SPRING, inst. cluster speedo. cable lock

**4.342A SHAFT ASSEMBLY with Casing**

*NOTE Shaft length is generally 1 1/8" longer than casing dimension listed.*

62-69	All	6478125	1	7.13	(55" casing)
62-69	All	6478128	1	8.91	(67 1/2" casing)
65-69	Pass.	6478131	1	9.62	(77 1/2" casing O.L.)
65-66	Pass.	6478193	1	11.88	(120" casing)
65-69	All	6478134	1	11.85	(92 1/2" casing)
67-70	All	6478132	1	10.83	(84" casing)

### 3-SPEED TRANSMISSION

#### 4.342A SHAFT ASSEMBLY with Casing (Con't)

67	Camaro w/H.D. 3-Spd. ....	6478121	1	6.42	(48" O.L.) .....
67-69	Chevy, Camaro w/floor console (exc. 350, 396) .....	6454481	1	10.92	lower flex .....
68	Camaro (Conv.) w/floor shift (exc. 350, 396) .....	6478122	1	6.59	(casing 40" O.L.) .....
69	Pass. w/Muncie H.D. 3-Spd. ....	6478180	1	9.33	flex (80 <sup>1</sup> / <sub>2</sub> " O.L.) .....
69-74	All .....	6478176	1	7.28	(64" O.L.) .....
69	Taxi .....	6478125	1	7.13	lower .....
64-65	Chevelle w/O.D.,				(55 <sup>1</sup> / <sub>8</sub> " ), .....
65	Chevelle w/H.D. ....				upper flex, .....
69	Chevy, Camaro w/floor console (exc. 350, 396), .....				
73-75	Vega,				
73-74	Nova w/floor controls,				
73-75	Camaro w/F70-14 tires .....	6478171	1	6.58	(44") (AC #CC-530) (upper) .....

#### 4.342B SHAFT ASSY., Speed and Cruise Control

65-69	All .....	3919007	1	4.95	w/casing (37" O.L.) .....
65-66	Pass., Chevelle .....	3852599	1	13.10	w/casing (control regulator to transmission) (72" O.L.) .....
65-66	Chevelle .....	6478121	1	6.42	w/casing (regulator to speedometer) (40" O.L.) .....
67	All .....	6478132	1	10.83	w/casing (84") (regulator to transmission) ..
68	Chevelle .....	6478123	1	6.74	w/o casing (48" O.L.) .....
69	Pass. ....	6477264	1	2.06	w/o casing (to speedometer shaft) (29 <sup>7</sup> / <sub>16</sub> " O.L.) .....
69	Pass., Chevelle .....	6478168	1	6.87	w/casing (29" O.L.) .....
69	Chevelle .....	3943641	1	7.25	w/casing (selector) .....



### 3-SPEED TRANSMISSION

#### 4.342C SHAFT ASSY.— CLIP, Speedometer

70 PASSENGER	WITH CASING	WITHOUT CASING
(exc. Taxi)	6478176 (64" O.L.)	6477306 (61 <sup>7</sup> / <sub>16</sub> " O.L.)
Taxi (upper)	6477857	—
Taxi (lower)	6476587	—
w/Speed and Cruise Control	—	6477264

70 NOVA		
w/4/BC	6478176	6451067 (Note 1)
(exc. Floor Shift)	6478176	6451067 (Note 1)
w/Floor Shift (exc. 4/BC)		
(upper)	6478176	6451067 (Note 1)
w/Floor Shift (exc. 4/BC)		
(lower)	6454481 (24 <sup>3</sup> / <sub>4</sub> " O.L.)	6453991 (24 <sup>3</sup> / <sub>4</sub> " O.L.)

70 CHEVELLE		
(w/3-Spd.)	6478176 (64" O.L.)	6451067 (Note 1)
w/Speed and Cruise Control	3943641	—

70 CAMARO		
w/3-Spd. (upper)	6478170 (40")	
w/3-Spd. (lower)	6478225 (18")	

NOTE: 1 Shaft Unit-consists of shaft and tip (81" O.L.-cut to required length).

NOTE: See Dealer Price Schedule (P&A 26) for Applicable Prices.

NOTE: For Cables less casing refer to old book for universal casings.

71 PASSENGER	With Casing	O.L.
exc. Taxi	6478514	53"

71 NOVA		
w/floor control	6454481 lower	24 <sup>3</sup> / <sub>4</sub> "
w/floor control	6478171 upper	44"
exc. floor control	6478176	64"

71 CHEVELLE		
exc. H.D.	6478175	60"
w/H.D.	6478178	72"

71 CAMARO		
	6478170 (Upper)	40"
	6478225 (Lower)	18"

72 PASSENGER	With Casing	O.L.
exc. Taxi	6478514	53"

72 NOVA		
w/floor control	6454481 (lower)	24 <sup>3</sup> / <sub>4</sub> "
w/floor control	6478171 (upper)	44"
exc. floor control	6478176	64"

72 CHEVELLE		
exc. H.D.	6478175	60"
w/H.D.	6478178	72"

### 3-SPEED TRANSMISSION

#### 4.342C SHAFT ASSY.— CLIP, Speedometer (Con't)

72 CAMARO		
	6478170 (Upper)	40"
	6478225 (Lower)	18"

#### 4.343 GEAR, Speedometer Drive

62-65	Chevy w/3.36, 3.55 axle,				(7.00 x 13 tires), .....
65	Chevelle w/3.55, 3.70, 3.73 axle				(7.00 x 14 tires), .....
65	Pass. (3-Spd.) (3.55 axle) .....				
66-67	Pass. w/3.31, 3.36, 3.55, 3.70,				
	3.73 axle .....				(6.95 x 14 tires), .....
66-67	Pass. w/3.55, 3.70, 3.73, 4.10,				
	4.89 axle .....				(7.35 x 14, 7.75 x 14, 7.75 x 15, 8.25 x 14
					tires), .....
66-67	Pass. w/3.70, 3.73, 4.10, 4.89				
	axle .....				(8.15 x 15, 8.55 x 14 tires), .....
66-67	Pass. w/3.73, 4.10, 4.89 axle ..				(8.45 x 15 tires), .....
66-67	All w/3.31, 3.36, 3.55, 3.70,				
	3.73 axle .....				(6.95 x 14 tires), .....
66-67	All w/3.55, 3.70, 3.73, 4.10,				
	4.56, 4.89 axle, .....				
67	Pass. w/4.56 axle .....	3708145	1	3.15	8 teeth (1 <sup>9</sup> / <sub>4</sub> " O.D. x 1 <sup>7</sup> / <sub>32</sub> " thick) (7.35 x 14,
					7.75 x 14, 7.75 x 15, 7.35 x 15 tires) ....
62-65	Chevy, Chevelle w/3.08 axle,				
64-65	Chevelle w/3.36 axle,				
65	Chevy, Chevelle w/2.73, 3.07,				
	3.31 axle .....				(7.00 x 13 tires), .....
65	Pass. w/3.08, 3.36 axle,				
65	Pass. (3.55 axle) (exc. 7.00-14				
	tires), .....				
65	Pass. w/H.D. 3-Spd.,				
66-67	Pass. w/3.07, 3.08, 3.31, 3.36				
	axle .....				(7.35 x 14, 7.75 x 14, 8.25 x 14), .....
66-67	Pass. w/3.07, 3.08 axle .....				(6.95 x 14 tires), .....
66-67	Pass. w/3.07, 3.08, 3.31, 3.36,				
	3.55 axle .....				(8.55 x 14, 8.45 x 15, 15), .....
66-67	Pass. w/3.70 axle .....	3708144	1	2.11	(8.45 x 15) .....
65-66	All w/4.56, 4.89 axle .....	3845079	1	3.14	6 teeth (1 <sup>59</sup> / <sub>64</sub> " O.D. x 2 <sup>9</sup> / <sub>64</sub> " thick) .....
67-68	Pass. w/2.73 axle .....	3905494	1	2.94	9 teeth (1 <sup>27</sup> / <sub>32</sub> " O.D. x 5 <sup>5</sup> / <sub>8</sub> " thick) .....
71-72	Vega w/Opel .....	3987908	1	.69	(8 teeth) (blue) .....
73-75	Vega w/Saginaw .....	6261794	1	.54	speedo. drive .....

#### 4.345 CLIP, Speedometer Drive Gear

71-75	All .....	6261781	1	.13	retainer .....
-------	-----------	---------	---	-----	----------------

#### 4.351 GEAR, Transmission Main Drive (Clutch)

64-65	Chevy, Chevelle (283) w/3-Spd.				(1st design) (exc. H.D.),
64-65	Chevy, Chevelle (8 cyl.) w/3-Spd.				(exc. 283, H.D.),
65	Pass. w/3-Spd. (327, 409) (exc.				
	H.D.) .....	3848100	1	28.75	w/synchronizer spring (20 teeth) .....
64-65	Chevy, Chevelle (6 cyl.) w/3-Spd.				
	(exc. H.D.),				
64-65	Chevy, Chevelle (283) w/3-Spd.				
	(exc. H.D.) (2nd design),				
65	Pass. w/3-Spd. (exc. 327, 409,				
	H.D.) .....	3848101	1	28.75	w/synchronizer spring (19 teeth) .....
65-68	Pass. w/3-Spd. H.D.,				
65	Chevy w/3-Spd. H.D.,				
66-68	Chevy, Chevelle, Camaro w/3-				
	Spd. H.D. (exc. 250, 307) .....	3870794	1	52.50	(Helical teeth 21, clutch teeth 36) (Warner
					T16B-16) (grooved) .....
66-67	Pass. w/3-Spd. (exc. H.D., 327),				
66-69	Chevy, Chevelle, Camaro				
	w/Saginaw 3-Spd. (exc. H.D.,				
	327, 350),				
68-69	Pass. w/3-Spd. (exc. Taxi, 327,				
	H.D.),				
69-70	Pass. w/3-Spd. (6 cyl.),				
70	Nova, Chevelle, Camaro				
	w/Saginaw 3-Spd. (exc. 350),				

### 3-SPEED TRANSMISSION

#### 4.351 GEAR, Transmission Main Drive (Clutch) (Con't)

71-75	All w/column shift (exc. 350, H.D.)	3859030	1	28.50	(19 teeth)
66-68	Pass. w/3-Spd. (327) (exc. H.D.),				
66-67	Chevy, Chevelle w/3-Spd. (327),				
67	Camaro w/3-Spd. (8 cyl.) (exc. H.D.),				
68-69	Police w/3-Spd. (6 cyl.),				
68	Taxi (6 cyl.),				
68-69	Chevy, Chevelle, Camaro w/3-Spd. (327, 350) (exc. H.D.),				
69	Pass., Police w/3-Spd. (8 cyl.),				
70-75	All w/Saginaw 3-Spd. (350),				
71-72	Chevelle w/floor shift (exc. H.D.)	3859035	1	28.50	(19 teeth)
75	All (6-cyl.)	346354	1	59.84	(18 teeth)
71-72	Vega w/Opel	3455154	1	36.25	trans. (clutch) (Opel— 712075)
73-74	Vega w/Saginaw	3885095	1	63.00	
67	Chevelle w/3-Spd., H.D.,				
68	Chevelle w/H.D. 3-Spd. (250, 307)	3912392	1	41.75	(Helical teeth— 19, clutch teeth-36) (Warner T16A-16)
69	Pass. w/H.D. 3-Spd.,				
69	All w/H.D. 3-Spd. (350, 396) (exc. Pass.),				
71-72	All w/Muncie	3932210	1	53.75	w/slinger assy. (21 teeth)
69	Chevelle w/H.D. 3-Spd. (exc. 350, 396)	3932211	1	53.75	w/slinger (18T)

#### 4.352 ROLLER, Transmission Main Shaft Front Pilot to Main Drive Gear

65-68	All w/3-Spd., H.D.,				
69	Chevy, Camaro w/Muncie H.D. 3-Spd.,				
71-72	Chevelle w/Muncie 3-Spd.	9423039	16	.30	main shaft bearing
62-65	All w/3-Spd. (exc. H.D.)	435844	14	.12	front pilot bearing ( $\frac{3}{16}$ " dia. $\frac{33}{64}$ ")
62-65	All w/3-Spd. (exc. H.D.)	7450247	A.R.	.12	rear bearing ( $\frac{1}{8}$ " dia. x $\frac{1}{2}$ ")
66-69	Chevy, Chevelle, Camaro (283, 307, 327, 350) (exc. Sp. H/Per. Pass.),				
66-69	All w/3-Spd. (exc. H.D.),				
71-72	Vega w/Opel	9280339	1	2.63	(needle point) (Opel— 8931793)
70-75	All w/Saginaw 3-Spd.	3743449	A.R.	.26	( $\frac{7}{16}$ " dia. x $\frac{5}{16}$ ")

#### 4.353 SPACER— RING, Transmission Main Shaft Front Pilot to Main Drive Gear

62-65	All w/3-Spd. (exc. H.D.)	591851	1	.12	front roller ( $\frac{5}{16}$ " I.D. x 1" O.D. x $\frac{7}{64}$ " thk.)
62-65	All w/3-Spd. (exc. H.D.)	591852	1	.12	rear roller ( $\frac{7}{8}$ " I.D. x $1\frac{1}{16}$ " O.D. x $\frac{7}{64}$ " thk.)
65-68	Pass. w/3-Spd., H.D.	389677	1	.28	(Warner T85G-25)
71-72	Vega w/Opel	6681770	1	.08	SPACER RING, trans. mainshaft front pilot brg. assy.
71-72	Vega w/Opel	3455155	1	.31	RING, trans. 1st and rev. synch. key stop (Opel— 720303)

#### 4.354 SEAL, Transmission Main Drive Gear Bearing

71-72	Vega w/Opel	3978794	1	2.25	trans. clutch gear
65	Pass. w/3-Spd. H.D.,				
65-69	Chevy, Chevelle,				
66-68	Pass. w/3-Spd. (exc. H.D.),				
66-68	Pass.,				
67-69	Camaro (exc. 350, 396),				
69	Pass. (8 cyl.) w/H.D. 3-Spd.,				
70	Pass., Chevelle w/Muncie 3-Spd.,				
70	Nova, Chevelle, Camaro w/Saginaw 3-Spd.,				
71-75	All	3987936	1	1.50	oil

#### 4.355 BEARING, Transmission Main Drive Gear (Ball)

62-65	Chevy, Chevelle w/3-Spd. (exc. 8 cyl. O.D.),				
65-67	Pass. w/3-Spd. (exc. O.D., H.D.),				
65-69	Chevy, Chevelle, Camaro w/3-Spd. (exc. H.D. 327),				
68-69	Pass. w/Saginaw 3-Spd. (exc. H.D.),				
70-74	All w/Saginaw 3-Spd.	907929	1	16.80	single row w/snap ring (ND 47507-51773A)
64	Chevelle w/3-Spd. (exc. O.D.),				

### 3-SPEED TRANSMISSION

#### 4.355 BEARING, Transmission Main Drive Gear (Ball) (Con't)

64	Chevy (8 cyl.),				
65	Pass. (8 cyl.),				
65	Pass. w/O.D. (6 cyl.),				
65	Chevelle (3-Spd. w/O.D.) (6 cyl.),				
66	Pass. (327),				
66	Pass. w/3-Spd. (327) (2nd design),				
66-67	Chevy w/3-Spd. (327 Sp. H/Per.),				
68-69	Police, Taxi w/3-Spd.,				
68-69	Chevy, Camaro w/3-Spd. (350),				
70	All w/Saginaw 3-Spd. (350) . . . . .	907930	1	20.04	(single row) w/snap ring (ND 47207) . . . . .
65-68	All w/H.D. 3-Spd. . . . .	907372	1	14.16	(4.408) . . . . .
69-72	All w/Muncie 3-Spd. H.D. . . . .	907913	1	15.66	clutch gear— (4.408) . . . . .
71-72	Vega w/Opel . . . . .	908058	1	13.78	(Conrad) (NDH-47606) . . . . .

#### 4.356 RETAINER, Transmission Main Drive Gear Bearing

62-63	Chevy w/3-Spd. . . . .	604932	1	5.75	
64-65	All w/3-Spd. (exc. H.D.) . . . . .	3741458	1	6.60	(cast 3741458) (4 <sup>11</sup> / <sub>16</sub> " O.D. x 3 <sup>3</sup> / <sub>16</sub> " O.L.) . .
65-68	All w/3-Spd., H.D. . . . .	3786024	1	9.70	(4 <sup>11</sup> / <sub>16</sub> " O.L.-Warner T89C-6A) . . . . .
66-69	Chevy, Chevelle, Camaro w/3-Spd. (exc. H.D.),				
66-69	Pass. w/3-Spd. (exc. H.D.),				
71-75	All (exc. H.D.) . . . . .	3859032	1	7.40	RETAINER ASSY. (4 <sup>3</sup> / <sub>4</sub> " O.D. x 3 <sup>1</sup> / <sub>4</sub> " O.L.) . .
69-72	All w/H.D. 3-Spd. . . . .	3911976	1	11.25	RETAINER ASSY., clutch gear brg. . . . .

#### 4.358 GASKET, Transmission Main Drive Gear Bearing Retainer

62-65	All w/3-Spd. (exc. H.D.) . . . . .	591022	1	.16	(3 <sup>3</sup> / <sub>8</sub> " I.D. x 4 <sup>5</sup> / <sub>32</sub> " O.D. w/4 holes 1 <sup>1</sup> / <sub>32</sub> " dia.)
65-68	All w/3-Spd. H.D. . . . .	1359473	A.R.	.13	(.010) (4 holes 3 <sup>3</sup> / <sub>8</sub> "— 4 <sup>2</sup> / <sub>32</sub> " O.D.) . . . . .
66-67	Pass. w/3-Spd. (exc. H.D.),				
68-69	All w/3-Spd. (exc. H.D.),				
70-75	All w/Saginaw 3-Spd. . . . .	3916113	1	.33	
69-72	All w/Muncie H.D. 3-Spd. . . . .	3915017	1	.31	(3 <sup>7</sup> / <sub>16</sub> " I.D. x 4 <sup>5</sup> / <sub>8</sub> " O.D. x 4 holes) . . . . .

#### 4.374 SLINGER, Transmission Main Drive Gear Bearing

69	Pass. w/H.D. 3-Spd.,				
69	Chevelle w/H.D. 3-Spd.,				
69	Chevy, Camaro w/H.D. 3-Spd. (350, 396) (exc. reg. fuel),				
71-72	All w/Muncie . . . . .	3932213	1	.31	clutch gear bearing oil . . . . .

#### 4.376 RING— WASHER, Transmission Main Drive Gear Bearing

62-68	All w/3-Spd. (exc. Pass.),				
65-69	Pass. w/3-Spd. (exc. H.D.),				
70	All w/Saginaw 3-Spd. (350),				
71-75	All w/Saginaw . . . . .	590849	1	.33	locating (2 <sup>11</sup> / <sub>16</sub> " I.D. x 2 <sup>23</sup> / <sub>32</sub> " O.D. x 1 <sup>1</sup> / <sub>2</sub> " thk.)
65-75	All . . . . .	3709351	A.R.	.20	retaining (.087 thk.) (Note 1) . . . . .
65-75	All . . . . .	3709352	A.R.	.18	snap (.09) (Note 1) . . . . .
65-75	All . . . . .	3709354	A.R.	.18	snap (.096) (Note 1) . . . . .
65-75	All . . . . .	3709355	A.R.	.18	snap (.099 thk.) (Note 1) . . . . .
65-75	All . . . . .	3709356	A.R.	.18	snap (.102) (Note 1) . . . . .
<i>NOTE 1 Use selectively, but only 1 used to obtain proper fit.</i>					
70	Chevelle w/Muncie 3-Spd. . . . .	2830050	1	.38	locating (3 <sup>13</sup> / <sub>32</sub> " O.D.)— (4.412) . . . . .
70	All w/Saginaw 3-Spd. . . . .	3707174	2	.33	locating (2 <sup>11</sup> / <sub>16</sub> " I.D.)— (4.412) . . . . .
71-72	Vega w/Opel . . . . .	11057029	1	.63	trans. clutch gear bearing locking . . . . .
65-68	All w/3-Spd. H.D. . . . .	3709350	2	.36	WASHER (1 <sup>3</sup> / <sub>8</sub> " I.D. x 1 <sup>13</sup> / <sub>16</sub> " O.D. x 1 <sup>1</sup> / <sub>16</sub> " thick) . . . . .

#### 4.380 CLUTCH ASSY.— SYNCHRONIZER, Transmission 1st & Rev.

62-63	Chevy w/3-Spd. . . . .	3774720	1	44.00	2nd and 3rd . . . . .
64-65	All w/3-Spd. (exc. H.D.) . . . . .	3848090	1	44.25	2nd and 3rd w/synchronizer . . . . .
65-68	All w/3-Spd., H.D. . . . .	3870789	1	39.25	SYNCHRONIZER, 2nd and 3rd (Warner AT16-2 <sup>1</sup> / <sub>2</sub> ") . . . . .
65-68	Pass. w/3-Spd., H.D. . . . .	3870785	1	56.50	SYNCHRONIZER, 1st and reverse (Warner 1AT1-6-80) . . . . .
66-67	Pass. w/3-Spd. (exc. H.D.),				
66-69	All w/3-Spd. (exc. H.D., Pass.),				
68-69	Pass. w/3-Spd.,				
70-75	All w/Saginaw 3-Spd. . . . .	3924766	1	35.50	SYNCHRONIZER . . . . .
69-72	All w/Muncie 3-Spd. . . . .	3911968	1	41.00	SYNCHRONIZER, reverse 1st, 2nd and 3rd
71-72	Vega w/Opel . . . . .	3443722	1	28.50	trans. 1st and reverse (Opel-3443722) (Note 1) . . . . .
71-72	Vega w/Opel . . . . .	3443721	1	18.25	trans. 2nd and 3rd (Opel-3443721) (Note 1)

NOTE 1: Consists of sleeve, hub, spring and keys.

### 3-SPEED TRANSMISSION

#### 4.383 RING— RETAINER, Transmission Synchronizing

62-65	All w/3-Spd. (exc. H.D.)	3845039	2	4.60	(2 <sup>3</sup> / <sub>32</sub> " O.D. at small end)
65-68	All w/H.D. 3-Spd.	3709348	2	9.70	blocking (2 <sup>13</sup> / <sub>16</sub> " I.D. x 3 <sup>7</sup> / <sub>32</sub> " O.D. w/3 inside slots)
65-68	All w/3-Spd., H.D.	3870811	1	.23	1st and reverse, retaining (Warner 4816D) (brown) (Note 1)
65-68	All w/3-Spd., H.D.	3870813	1	.31	1st and reverse retaining (Warner 4816F) (red) (Note 1)
65-68	All w/3-Spd., H.D.	3870812	1	.36	1st and reverse retaining (Warner 4816E) (lt. blue) (Note 1)
<i>NOTE 1 Use selectively to obtain proper fit.</i>					
65-68	Pass. w/H.D. 3-Spd.	3870805	1	9.90	1st speed (Warner T16-83)
71-72	Vega w/Opel	6667181	3	7.10	trans. synchronizing blocking (Opel-718904) (Note 1)

*NOTE 1: Used on 1st, 2nd and 3rd.*

66-69	All w/3-Spd. (exc. H.D.),				
70-75	All w/Saginaw 3-Spd.	3859027	A.R.	8.10	blocking
69	Pass. w/Muncie H.D. 3-Spd.,				
69	Chevelle w/H.D. 3-Spd.,				
69	Chevy, Camaro w/H.D. 3-Spd. (350, 396) (exc. reg. fuel),				
71-72	All w/H.D.	3911974	3	10.00	synchronizer blocking
62-65	All w/3-Spd. (exc. H.D.)	3845202	2	.23	RETAINER (2 <sup>3</sup> / <sub>32</sub> " I.D.)

#### 4.384 RING— PLATE— KEY, Transmission Synchronizing

66-69	All w/3-Spd. (exc. H.D.),				
70-75	All w/Saginaw 3-Spd.	3859025	2	.13	all clutch hub retaining
69	Pass. w/Muncie H.D. 3-Spd.,				
69	Chevelle w/H.D. 3-Spd.,				
69	Chevy, Camaro w/H.D. 3-Spd. (350, 396) (exc. reg. fuel),				
71-72	All w/H.D.	3911973	2	.31	synchronizer retainer
70	All w/Saginaw 3-Spd.	3831741	1	.18	3rd clutch hub retaining
71-72	Vega w/Opel	2877400	1	.13	trans. synch. assy. retaining (Opel—718753)
65-68	Pass. w/3-Spd. H.D.	3870804	3	.61	PLATE, 1st and reverse shifting (Warner T16-82)
65-68	All w/3-Spd. H.D.	3870793	3	.51	PLATE, shifting (Warner T16-13)
66-69	All w/3-Spd. (exc. H.D.),				
70-75	All w/Saginaw 3-Spd.	3871250	6	.54	KEY, all clutch
69-72	All w/Muncie H.D. 3-Spd.	3911972	6	.51	KEY, synchronizer
71-72	Vega w/Opel	6667472	3	.32	KEY, trans. 1st and rev. synchronizer (Opel—734101)
71-72	Vega w/Opel	6667478	3	.25	KEY, trans. synch. (Opel—734182)

#### 4.395 GEAR, Transmission 2nd Speed

62-63	Chevy w/3-Spd.	3737859	1	25.00	w/energizing spring
64-65	All w/3-Spd. (exc. H.D.)	3834224	1	26.00	w/energizing spring
65-68	Pass. w/3-Spd. H.D.,				
65-68	Chevy, Chevelle, Camaro w/3-Spd. H.D. (1st design)	3870823	1	61.25	(clutch teeth-36, helical teeth 28) (Warner T16B-11)
66-75	All w/3-Spd. (exc. H.D.)	3859019	1	22.25	(24 teeth)
67	Chevelle w/3-Spd. H.D. (2nd design),				
68	Chevelle w/H.D. 3-Spd. (250, 307)	3912390	1	56.75	(Helical teeth-27, Clutch teeth-36) (Warner T16D-11)
69	Pass. w/H.D. 3-Spd.,				
69	All w/H.D. 3-Spd. (350, 396) (exc. Pass.),				
71-72	All w/H.D.	3911962	1	41.00	2nd speed (27 teeth)
71-72	Vega w/Opel	8961417	1	18.50	
69	Chevelle w/H.D. 3-Spd. (exc. 350, 396)	3911988	1	41.00	(25 teeth)

#### 4.398 WASHER, Transmission Shaft and 2nd Speed Gear Thrust

62-65	All w/3-Spd. (exc. H.D.)	3736753	1	.99	gear thrust (1 <sup>3</sup> / <sub>16</sub> " I.D. x 1 <sup>25</sup> / <sub>32</sub> " O.D. x 3 <sup>3</sup> / <sub>16</sub> " thick-steel)
-------	--------------------------	---------	---	-----	---

#### 4.403 SHAFT, Transmission Main

62-63	Chevy w/3-Spd.	3740860	1	45.00	(22 <sup>1</sup> / <sub>32</sub> " long-6 splines)
64-65	All w/3-Spd. (exc. O.D., H.D.)	3870774	1	39.50	
65-68	All w/H.D. 3-Spd.	3870788	1	77.00	(21" O.L.) (27-splines) (Warner T16-2)
66-67	All w/3-Spd. (exc. O.D., H.D.),				
68-69	Pass. w/Saginaw 3-Spd.,				

### 3-SPEED TRANSMISSION

#### 4.403 SHAFT, Transmission Main (Con't)

68-69	Chevy, Chevelle, Camaro w/3-Spd. (exc. H.D., O.D.),				
70	All w/Saginaw 3-Spd.,				
71-75	All (exc. H.D., Pass. Sta. Wag.) . . . . .	3915014	1	38.00	
71-72	Vega w/Opel . . . . .	3455181	1	41.50	(Opel— 716046) . . . . .
66-69	All w/O.D. . . . .	3876748	1	58.50	
69	Pass. w/Muncie H.D. 3-Spd.,				
69-72	Chevelle w/H.D. 3-Spd.,				
69	Chevy, Camaro w/H.D. 3-Spd. (350, 396) (exc. reg. fuel) . . . . .	3911960	1	83.25	main . . . . .
71-72	Pass. (Sta. Wag.) . . . . .	3993046	1	51.25	

#### 4.408 BEARING, Transmission Main Shaft Rear

62-64	Chevy w/3-Spd.,				
64	Chevelle w/3-Spd. (6 cyl.) (exc. O.D.),				
65-68	Pass. w/3-Spd. (exc. H.D., 327),				
65	Chevy, Chevelle (exc. O.D. 327),				
66-67	Chevy, Chevelle, Camaro w/3-Spd. (exc. H.D., 327),				
70	All w/Saginaw 3-Spd. (exc. 350),				
71-75	All (exc. H.D.) . . . . .	907763	1	15.36	(ND 476006V) . . . . .
64-65	Chevelle w/3-Spd. (8 cyl.) (exc. O.D.),				
65	Taxi w/3-Spd.,				
65	Pass. w/3-Spd. (exc. H.D.),				
65	Police (6 cyl.) . . . . .				rear, . . . . .
64-65	Pass., Chevelle w/O.D.,				
65	Pass. w/3-Spd. (8 cyl.) (exc. H.D.),				
65	Chevy, Chevelle w/3-Spd. (8 cyl.) (exc. H.D.),				
66-67	Pass. (327),				
66	Chevy, Chevelle w/3-Spd. (327) . . . . .	907765	1	20.26	(ND 47306-1961A) . . . . .
65-68	All w/H.D. 3-Spd. . . . .	907372	1	14.16	rear . . . . .
65-69	All w/O.D. . . . .	954862	1	8.20	output shaft bearing (ND 43206) . . . . .
71-72	Vega w/Opel . . . . .	908058	1	13.78	ball (Conrad) (NDH-47606) (Note 1) . . . . .

*NOTE 1: When used as a main shaft rear bearing install with shielded side towards rear of trans. snap ring groove nut used at this location.*

73-75	Vega w/Saginaw . . . . .	907763	1	15.36	
69-72	All w/Muncie H.D. 3-Spd.,				
69	Chevy, Camaro w/H.D. 3-Spd. (350, 396) (exc. reg. fuel) . . . . .	907913	1	15.66	BEARING ASSY., new departure ball . . . . .

#### 4.412 RING, Transmission Rear Bearing and Mainshaft

62-69	All w/3-Spd. (exc. Pass.),				
65-69	Pass., w/3-Spd. (exc. O.D., H.D.) . . . . .				locating (in case), . . . . .
65-69	All w/G.D.,				
70	All w/Saginaw 3-Spd. (350),				
71-75	All (exc. H.D.) . . . . .	3707174	1	.33	retainer (2 <sup>11</sup> / <sub>16</sub> " I.D.) . . . . .
62-69	All w/3-Spd. (exc. H.D., Pass.),				
65-67	Pass. w/3-Spd. (exc. O.D., H.D.),				
65-69	Pass. w/O.D.,				
67-69	Pass. w/3-Spd. (exc. H.D.),				
70	All w/Saginaw 3-Spd. (350),				
71-75	All (exc. H.D.) . . . . .	3707189	1	.20	snap (.089-.091 thick) (Note 1) . . . . .

*NOTE 1 Use selectively to obtain minimum end play.*

65-72	All w/3-Spd. H.D. . . . .	2830050	1	.38	snap (3 <sup>1</sup> / <sub>2</sub> " x 3 <sup>13</sup> / <sub>16</sub> " thk.) . . . . .
65-66	Pass. w/H.D. 3-Spd.,				
66	All w/3-Spd. (exc. H.D.) . . . . .				locating, . . . . .
66-68	All w/H.D. 3-Spd. (exc. Pass.),				
68	Pass. w/H.D. 3-Spd.,				
69-72	All w/Muncie H.D. 3-Spd. . . . .	3911967	1	.51	rear bearing lock (.073 thk.) . . . . .
71-72	Vega w/Opel . . . . .	6634858	2	.25	trans. clutch gear bearing retaining (Opel— 714275) . . . . .
71-72	Vega w/Opel . . . . .	2877384	1	.52	trans. main shaft rear bearing locating (Opel) . . . . .
71-72	Vega w/Opel . . . . .	2877480	1	.19	trans. mainshaft rear bearing rear (Opel— 722276) . . . . .
65-66	Pass. w/H.D. 3-Spd. . . . .	3998393	2	.50	RING UNIT, bearing snap (Note 2) . . . . .

*NOTE 2 Consists of 1 each ring, .088, .091, .094, .097, .100 thk.*

62-65	Chevy, Chevelle w/3-Spd.,				
65-66	Pass. w/3-Spd. (exc. O.D., H.D.),				
65-69	Pass. w/O.D. . . . .	3998394	1	.62	RING UNIT, bearing snap (Note 3) . . . . .

### 3-SPEED TRANSMISSION

#### 4.412 RING, Transmission Rear Bearing and Mainshaft (Con't)

NOTE 3 Consists of (1) one each ring .087 Green, .090 dark blue .093 yellow, .096 white.

#### 4.413 SPRING, Transmission Synchronizing

62-65	All w/3-Spd. (exc. H.D.)	3737448	2	.31	energizing
65-68	All w/3-Spd. H.D.	3870810	2	.31	2nd and 3rd (Warner 4682-AJ)
65-68	All w/3-Spd. H.D.	3870809	2	.31	1st and reverse (Warner 4682AE)
66-69	All w/Saginaw 3-Spd. (exc. H.D.),				
70-75	All w/Saginaw 3-Spd.	3924768	4	.33	1st and rev., 2nd and 3rd
69-72	All w/Muncie H.D. 3-Spd.	3911971	4	.31	synchronizing (2 <sup>1</sup> / <sub>2</sub> " I.D. x 2 <sup>3</sup> / <sub>4</sub> " O.D.)
71-72	Vega w/Opel	8953909	4	.08	(Opel— 718938)

#### 4.417 GEAR, Transmission 1st and Reverse Sliding

64-65	All w/3-Spd. (exc. H.D.)	3848091	1	20.50	1st and reverse
65-68	Pass. w/H.D. 3-Spd.	3870798	1	71.75	1st speed (Clutch teeth-27, Helical teeth-30) (Warner T16-31)
65-68	Pass. w/H.D. 3-Spd.,				
66-68	Chevelle, Camaro w/3-Spd., H.D.	3870803	1	51.25	reverse (Warner AT 16-46)
66-75	All w/3-Spd. (exc. H.D.)	3859014	1	23.00	1st speed (29 teeth)
66-75	All w/3-Spd. (exc. H.D.)	3859015	1	23.00	reverse (28 teeth)
69	Pass. w/Muncie H.D. 3-Spd.,				
69-72	Chevelle w/H.D. 3-Spd.,				
69	Chevy, Camaro w/H.D. 3-Spd. (350, 396) (exc. reg. fuel)	3911961	1	41.00	1st speed
71-72	Vega w/Opel	8961416	1	23.00	
69	Pass. w/Muncie H.D. 3-Spd.,				
69-72	Chevelle w/H.D. 3-Spd.,				
69	Chevy, Camaro w/H.D. 3-Spd. (350, 396) (exc. reg. fuel)	3911964	1	41.00	GEAR ASSY., reverse

#### 4.419 WASHER, Transmission 1st Reverse Gear

66-69	Pass. w/Saginaw 3-Spd.,				
69	All w/Saginaw 3-Spd. (exc. Pass.),				
70	All w/Saginaw 3-Spd. (exc. 350),				
71-75	All (exc. H.D.)	3869940	1	.38	reverse thrust (1 <sup>3</sup> / <sub>16</sub> " I.D. x 2 <sup>1</sup> / <sub>2</sub> " O.D.)
66-69	All w/Saginaw 3-Spd.,				
71-75	All (exc. H.D.)	3884595	1	.20	reverse thrust (1 <sup>7</sup> / <sub>32</sub> " I.D. x 1 <sup>27</sup> / <sub>32</sub> " O.D.) (wavey)
69	Pass. w/Muncie H.D. 3-Spd.,				
69-72	Chevelle w/H.D. 3-Spd.,				
69	Chevy, Camaro w/H.D. 3-Spd. (350, 396) (exc. reg. fuel)	3911963	1	.36	reverse gear thrust

#### 4.421 GEAR— COUNTERGEAR UNIT— RING, Transmission

64-65	Chevy, Chevelle (6 cyl.) w/3-Spd. (exc. H.D.),				
64-65	Chevy, Chevelle w/3-Spd. (283) (2nd design) (exc. H.D.),				
65	Pass. w/3-Spd. (exc. 327, 409 H.D.)	3834207	1	45.75	(27-14-22T) (5 <sup>27</sup> / <sub>32</sub> " O.L.)
64-65	Chevy, Chevelle w/3-Spd. (283) (1st design) (exc. H.D.),				
64-65	Chevy, Chevelle (8 cyl.) w/3-Spd. (exc. 283, H.D.),				
65	Pass. w/3-Spd. (327, 409) (exc. H.D.)	3834208	1	46.50	(25-14-22T) (5 <sup>27</sup> / <sub>32</sub> " O.L.)
65-68	Pass. w/H.D. 3-Spd.,				
66-68	Chevy, Chevelle, Camaro w/H.D. 3-Spd. (327, 350, 396)	3870784	1	95.00	(Warner 1AT 16B-8)
66-67	All w/3-Spd. (exc. H.D. 327, Pass.),				
66-67	Chevy, Chevelle w/3-Spd. (327),				
68-69	Pass. w/3-Spd. (250, 307) (exc. H.D., O.D.),				
68	Chevy, Chevelle w/3-Spd. (153, 230, 250, 307) (exc. H.D., O.D.),				
69	Chevy, Camaro, Chevelle w/3-Spd. (exc. 350 w/2BC),				
70	All w/Saginaw 3-Spd. (exc. 350 2BC, Police, Taxi),				
71-75	All (exc. 350, floor shift, H.D.)	3858998	1	53.75	(28-21-15-14 teeth)
66-69	Pass. w/3-Spd.,				

### 3-SPEED TRANSMISSION

#### 4.421 GEAR— COUNTERGEAR UNIT— RING, Transmission (Con't)

68	Taxi w/3-Spd. (8 cyl.),				
68	Pass. w/O.D.,				
68	Police w/3-Spd.,				
68	All w/3-Spd. (exc. H.D. Pass.),				
69	All (2BC w/3-Spd.) (327, 350)				
	(exc. Pass.),				
70	All w/Saginaw 3-Spd. (350				
	w/2BC),				
71-75	All (350) (exc. H.D.),				
71-72	Chevelle w/floor shift (exc. H.D.)	3859036	1	40.75	(25 teeth) . . . . .
71-75	All (4 cyl.) . . . . .	3461931	1	42.50	GEAR (Opel) . . . . .
73-75	All (6 cyl.) (262) . . . . .	3859951	1	46.50	GEAR . . . . .
66-68	Chevelle w/3-Spd. H.D. (exc.				
	327, 396) . . . . .	3912391	1	85.25	GEAR ASSY., counter (Warner 1AT 16D-8)
69	Pass. w/H.D. 3-Spd.,				
69	All w/H.D. 3-Spd. (350, 396)				
	(exc. Pass.),				
71-72	All w/H.D. . . . .	3911950	1	88.00	GEAR ASSY., counter . . . . .
69	All w/H.D. 3-Spd. (exc. 350,				
	396, Pass.),				
71	All w/H.D. . . . .	3911985	1	88.00	GEAR ASSY., counter . . . . .
62-63	Chevy w/3-Spd. . . . .	3817960	1	49.75	COUNTERGEAR UNIT, countershaft
					w/bearing (27T-14T-22T) (5 <sup>23</sup> / <sub>32</sub> " O.L.) . . .
65-68	All w/H.D. 3-Spd. . . . .	3924195	1	1.25	RING, trans. counter gear damper plate . . .

#### 4.422 BEARING— ROLLER, Transmission Countershaft Gear

65-69	All w/H.D. 3-Spd. . . . .	9423051	A.R.	.12	roller (Warner 47410) . . . . .
62-69	All w/3-Spd. (exc. H.D.),				
65-69	All w/4-Spd.,				
70	All w/3-Spd.,				
71-75	All (exc. H.D.) . . . . .	435847	A.R.	.13	ROLLER, brg. (1/8" dia. x 3/4" O.L.) (not used
					w/bushed type countergear) . . . . .
71-72	Vega w/Opel . . . . .	3469848	1	2.50	trans. counter gear bearing roller (Note 1) . .
	<i>NOTE 1: Consists of 48 bearing rollers.</i>				

#### 4.423 WASHER— SPACER, Transmission Counter Gear Bearing

62-65	Pass. w/3-Spd. (exc. H.D.) . . . . .	3737814	2	.23	roller brg. thrust (7/8" I.D. x 1 <sup>5</sup> / <sub>32</sub> " O.D.) . . . . .
62-63	Chevy w/3-Spd. . . . .	3740819	2	.68	(1 <sup>5</sup> / <sub>8</sub> " O.D.) . . . . .
64-65	All w/3-Spd. (exc. H.D.) . . . . .	3834209	2	.23	thrust (1 <sup>5</sup> / <sub>16</sub> " I.D. x 1 <sup>5</sup> / <sub>8</sub> " O.D. x 1 <sup>9</sup> / <sub>64</sub> " thick) . .
65-68	All w/3-Spd. H.D. . . . .	3870799	1	1.40	rear thrust (Warner T16-32) . . . . .
65-68	All w/3-Spd. H.D. . . . .	3870797	1	1.25	front thrust (Warner T16-30) . . . . .
66-68	Chevelle, Camaro w/3-Spd.,				
	H.D.,				
68	Pass. w/H.D. 3-Spd. . . . .	3709324	6	.23	brg. (7/8" I.D. x 1 <sup>5</sup> / <sub>32</sub> " thick) . . . . .
66-69	All w/3-Spd. (exc. H.D.),				
67-68	Camaro (exc. 350, 396),				
70-75	All w/Saginaw 3-Spd. . . . .	3859006	2	.26	bearing (31/64" I.D. x 1 <sup>15</sup> / <sub>64</sub> " O.D.) . . . . .
67-68	Camaro (exc. 302, 350, 396),				
70-75	All w/Saginaw 3-Spd. . . . .	3890565	2	.71	thrust (1 <sup>1</sup> / <sub>64</sub> " I.D. x 1 <sup>3</sup> / <sub>8</sub> " O.D.) . . . . .
69	Chevy, Camaro w/H.D. 3-Spd.				
	(350, 396) (exc. reg. fuel),				
69-72	All w/Muncie H.D. 3-Spd. . . . .	3924786	1	.31	center shaft bearing . . . . .
69	Chevy, Camaro w/H.D. 3-Spd.				
	(350, 396) (exc. reg. fuel),				
69-72	All w/Muncie H.D. 3-Spd. . . . .	3911955	1	.68	center gear thrust . . . . .
71-72	Vega (Opel) . . . . .	3442446	2	1.20	trans. counter gear thrust (Opel— 708286) . .
71-72	Vega (Opel) . . . . .	3775063	4	.18	trans. counter gear bearing (Opel—
					712200) . . . . .

#### 4.428 SHAFT, Transmission Counter

62-65	All w/3-Spd. (exc. H.D.) . . . . .	3707179	1	5.75	(7/8" dia. x 7 <sup>1</sup> / <sub>8</sub> " O.L.) (for use only w/needle
					type countergear) . . . . .
65	Chevy w/3-Spd., H.D.,				
65-68	Pass. w/H.D. 3-Spd.,				
66-68	Chevelle, Camaro w/3-Spd., H.D.	3870790	1	7.75	(7/8" dia. x 10 <sup>1</sup> / <sub>2</sub> " O.L.) (Wagner T16-3) . . . .
66-69	Pass. w/Saginaw 3-Spd. (exc.				
	H.D.),				
67-68	Camaro (exc. H.D., 302, 350,				
	396),				
70-75	All w/Saginaw 3-Spd. . . . .	3859005	1	7.80	(6 <sup>1</sup> / <sub>64</sub> " dia. x 9 <sup>19</sup> / <sub>32</sub> " O.L.) . . . . .
69	Pass. w/Muncie H.D. 3-Spd.,				
69-72	Chevelle w/H.D. 3-Spd.,				
69	Chevy, Camaro w/H.D. 3-Spd.				
	(350, 396) (exc. reg. fuel) . . . . .	3911954	1	14.95	(1" dia. x 11" O.L.) . . . . .
71-72	Vega (1st design) . . . . .	6666526	1	3.75	(Opel— 710011) (used w/3455090 trans.) . .



### 3-SPEED TRANSMISSION

<b>4.428 SHAFT, Transmission Counter (Con't)</b>					
72	Vega (2nd design) . . . . .	8977852	1	3.75	(used w/8977926 trans.) . . . . .
<b>4.429 BALL, Transmission Locking</b>					
71-72	Vega w/Opel . . . . .	11011168	2	.08	(6 mm dia.) (.236) (Opel— 2088003) (Note 1) . . . . .
<i>NOTE 1: 1 used to lock rev. idler gear shaft to case. 1 used to lock counter gear shaft to case.</i>					
<b>4.430 GEAR, Transmission Reverse Idler (with bushings)</b>					
62-63	Chevy w/3-Spd. . . . .	3743358	1	26.25	(Note 1) . . . . .
<i>NOTE 1 If clash is experienced in first gear, also use 3725646, 1st and reverse gear.</i>					
65-70	All w/3-Spd. (exc. 8 cyl., O.D.),				
64-65	Chevy, Chevelle w/3-Spd. (8 cyl.) (1st design) . . . . .	3834233	1	25.25	for use w/pushing . . . . .
71-72	Vega w/Opel . . . . .	8961526	1	11.70	
64-65	All w/3-Spd. (8 cyl.) (2nd design) (exc. H.D.) . . . . .	3851228	1	27.00	GEAR ASSY., for use w/roller bearing . . . . .
66-75	All w/3-Spd. (exc. H.D.) . . . . .	3859007	1	18.05	GEAR ASSY. (17 teeth) . . . . .
69	Pass. w/Muncie H.D. 3-Spd.,				
69-72	Chevelle w/H.D. 3-Spd.,				
69	Chevy, Camaro w/H.D. 3-Spd. (350, 396) (exc. reg. fuel) . . . . .	3911956	1	26.75	GEAR ASSY., rev. idler . . . . .
<b>4.431 ROLLER, Transmission Reverse Idler Gear</b>					
64-65	All w/3-Spd. (8 cyl.) (exc. H.D.) . . . . .	9421574	40	.25	bearing . . . . .
65-68	All w/3-Spd. H.D. . . . .	9423491	25	.12	bearing . . . . .
<b>4.433 SHAFT, Transmission Reverse Idler Gear</b>					
62	Chevy w/3-Spd.,				
64-65	All w/3-Spd. (2nd design) (exc. 8 cyl. H.D.) . . . . .	3820058	1	4.25	w/oil flat, use w/bushing . . . . .
63	All w/3-Spd.,				
64-65	All w/3-Spd. (6 cyl.) (1st design) (exc. O.D.),				
64-65	Chevy, Chevelle w/3-Spd. (2nd design) (8 cyl.),				
65	Pass. w/3-Spd. (1st design) (exc. H.D.),				
65	Pass. w/3-Spd. (8 cyl.) (2nd design) (exc. H.D.) . . . . .	590831	1	3.55	w/o oil flat, use w/bearing . . . . .
66-75	All w/3-Spd. (exc. H.D.) . . . . .	3998253	1	2.60	(3 <sup>27</sup> / <sub>32</sub> " O.L. x 3/4" O.D.) . . . . .
69	Pass. w/Muncie H.D. 3-Spd.,				
69-72	Chevelle w/H.D. 3-Spd.,				
69	Chevy, Camaro w/H.D. 3-Spd. (350, 396) (exc. reg. fuel) . . . . .	3911959	1	4.20	reverse idler . . . . .
71-72	Vega w/Opel (1st design) . . . . .	6667457	1	2.80	(Opel— 706011) . . . . .
72	Vega w/Opel (2nd design) . . . . .	8977851	1	2.80	
<b>4.435 PIN— RING, Transmission Reverse Idler Shaft</b>					
62-65	All w/3-Spd. (exc. H.D.),				
66	Chevy w/3-Spd. . . . .	590832	1	.12	lock (1/4" tapered x 11/16" length) . . . . .
66-71	All w/3-Spd. (exc. H.D.),				
67	Chevy, Chevelle, Camaro (exc. H/Per., Sp. H/Per., 350) . . . . .	9414486	1	.16	RING, gear retainer— (8.934) . . . . .
<b>4.437 WASHER— BEARING, Transmission Reverse Idler Gear Thrust</b>					
62-63	Chevy w/3-Spd. . . . .	3746442	1	.18	rear (1 <sup>11</sup> / <sub>16</sub> " O.D. x 3/4" to 29/64" I.D.) . . . . .
62-64	Chevy, Chevelle w/3-Spd. (1st design) . . . . .	591091	1	.18	front (49/64" I.D.— 4 notches x 1 1/4" O.D. x 1/2" thk.) . . . . .
64-65	All w/3-Spd. (6 cyl.) (2nd design) . . . . .	3820060	1	.23	front (53/64" I.D. x 1 <sup>21</sup> / <sub>64</sub> " O.D. x 1/16" thk.) . . . . .
64-65	All w/3-Spd. (exc. H.D.) . . . . .	3854026	1	.27	rear (1 <sup>11</sup> / <sub>16</sub> " O.D.) . . . . .
64-65	All w/3-Spd. (8 cyl.) (2nd design) (exc. H.D.) . . . . .	3854027	1	.32	front (1 1/2" O.D.) . . . . .
65-68	All w/H.D. 3-Spd. . . . .	3876160	2	2.70	
66-67	All w/3-Spd. (exc. H.D.) . . . . .	3859011	1	.23	(49/64" I.D. x 1 1/2" O.D.) . . . . .
62-65	All w/3-Spd. (exc. H.D.) . . . . .	457202	1	1.15	BEARING, rear (Torrington FA 10077) . . . . .
<b>4.455 CASE— ADAPTER— Baffle— BUSHING— PLUG, Transmission Overdrive</b>					
66-69	All . . . . .	3886321	1	52.50	(Warner AR10Q-1) . . . . .
66-69	All . . . . .	3886323	1	25.25	ADAPTER (Warner R10Q-3) . . . . .
64-67	All . . . . .	6260048	1	.74	BUSHING, case (1 1/2" I.D. x 1 5/8" O.D.)— (4.319) . . . . .

**3-SPEED TRANSMISSION**

<b>4.460 GASKET— SEAL, Transmission Overdrive</b>				
64-65	All	3707135	1	.12 adapter front
64-68	All	3785633	1	.17 adapter rear (Warner R10K-146)
64-69	All	3910117	1	2.70 <b>GASKET UNIT</b>
64-65	All	5696537	1	1.10 SEAL, control shaft oil— (6.806)
64-69	All	3712726	1	.96 SEAL, solenoid oil
66-68	All	3845164	1	.21 SEAL, control shaft oil— (4.313)
64-69	All	3932255	1	4.02 SEAL ASSY., case oil— (4.318)
<b>4.465 SHAFT— CAM ASSY., Transmission Overdrive</b>				
66-69	All	3886322	1	50.50 output (Warner AR10Q-2)
64-69	All	3712713	1	23.55 CAM ASSY., overdrive free wheeling (Warner AR-10-46)
<b>4.467 CAGE— RETAINER— ROLLER— SPRING, Transmission Overdrive</b>				
64-69	All	3712715	1	.99 free wheeling brg. roller (Warner R-10-47)
64-69	All	3712714	1	.43 RETAINER, free wheeling pinion cage (Warner R-10-29)
64-69	All	3712717	1	.18 RETAINER, free wheeling cam (Warner R10-46 <sup>1/2</sup> )
64-69	All	3712718	12	.18 ROLLER, free wheel cam (Warner R6-177)
64-69	All	3712716	2	.18 SPRING, free wheeling roller cage (Warner R4-178)
<b>4.470 CAGE ASSY.— GEAR, Transmission Overdrive</b>				
64-69	All	3712712	1	70.00 overdrive pinion (includes gears) (Warner AR-10B-30A)
64-69	All	3712711	1	20.40 GEAR, shifting collar and sun (Warner AR-10B-4)
64-69	All	3712720	1	28.75 GEAR, output shaft ring (Warner R10-6)
<b>4.472 PLATE— RING, Transmission Overdrive Sun Gear</b>				
64-68	All	3785630	1	7.15 (Warner 10 AR-10B-9) sun gear cover
64-69	All	3712704	1	24.25 w/blocking ring end gear (Warner AR-10B-13)
64-69	All	3712707	1	.51 RING, blocking and cover plate snap (.0625) (Warner R10-11)
64-69	All	3712721	1	.31 RING, ring gear to output shaft snap (.062) (Warner R10-19)
<b>4.477 RING, Transmission Overdrive Snap</b>				
64-69	All	3712723	1	.66 output shaft brg. snap (.073 thick) (Warner R10H-7 <sup>1/2</sup> )
65-69	Pass.	3707189	1	.20 speedo. drive gear retainer (.089 thick)— (4.412)
65-69	Pass.,			
66-68	Chevelle	3998394	1	.62 RING UNIT, bearing snap— (4.412) (Note 1)
<i>NOTE 1: Consists of one each ring .087 green, .090 dark blue, .093 yellow, .096 white.</i>				
<b>4.480 SOLENOID— BRACKET— NUT— RELAY ASSY.— SWITCH, Transmission Overdrive</b>				
<i>NOTE See group 4.495 for overdrive kickdown switch brackets.</i>				
64-65	All	3850094	1	31.75
66-69	All	3886326	1	34.25 (Warner AR10Q-62)
64-69	All	826198	2	.08 NUT, overdrive kickdown switch assy. (hex. <sup>7/16</sup> "— 20)
64-69	All	1115812	1	9.20 RELAY ASSY.
64-69	All	1998130	1	4.08 SWITCH, kickdown (4 term. brass) (carb.)
<b>4.485 GOVERNOR ASSY.— GEAR— RETAINER— SEAL, Transmission Overdrive</b>				
64-65	Chevelle (1st design)	3852437	1	29.50 (Warner AR10-M72) (3 <sup>3/4</sup> " O.L.) (Note 1)
65	Pass.,			
65	Chevelle (2nd design)	3871529	1	28.25 (Warner AR10P-72) (3 <sup>11/32</sup> " O.L.) (Note 1)
<i>NOTE 1 1st design Governor used with 3852431 Case. 2nd design Governor used with 3871531 Case.</i>				
66-69	All	3916080	1	28.00 (Warner AR10Q-72A) (3 <sup>3/32</sup> " O.L.)
65-69	Pass.,			
65-68	Chevelle (2nd design)	3871530	1	5.55 GEAR, gov. driven (Warner R10P-73)
<b>4.490 FORK— RAIL ASSY.— PAWL— PIN— RETAINER— PLUNGER, Transmission Overdrive Shifting</b>				
64-69	All	3741421	1	3.75 (Warner R11-23C)
66-69	All	3886324	1	7.10 RAIL ASSY. (Warner AR 10Q-20)
64-68	All	3785631	1	3.70 PAWL (1 <sup>55/64</sup> " O.L.) (Warner R 10K-15)

**3-SPEED TRANSMISSION**

**4.495 BOLT— BRACKET— CLIP— GROMMET— LEVER— PIN— PLATE—  
SHAFT— SPACER, Transmission Overdrive**

64-69	All	3712722	1	.18	control cable to lever ( $\frac{5}{16}$ "— 24 x $\frac{7}{8}$ ") (Warner 4737)
67-68	All (8 cyl.)	3902230	1	.46	BRACKET, kickdown switch
64-68	All	3711622	1	.12	CLIP, control cable hsg. to overdrive ( $\frac{17}{64}$ " I.D.)
66-69	All	3886329	1	.23	CLIP, control cable ( $1\frac{17}{64}$ " hole, $1\frac{21}{64}$ " hole) (Warner 4738M)
66-69	All	3886320	1	2.40	LEVER ASSY., control (Warner 1AR10L- 105)
62-69	All	103565 A.R.		.22	PIN, control shaft to case ( $\frac{5}{32}$ " x $1\frac{1}{4}$ " taper)— (8.940)
64-69	All	3712740	1	.17	SPACER, control shaft lever ( $\frac{21}{64}$ " I.D. x $\frac{11}{16}$ " O.D.) (Warner 4736)



**4-SPEED TRANSMISSION**

**4.003 TRANSMISSION ASSY. (less hand brake)**

**4-SPD. TRANSMISSION**

63-64	Chevelle	3867265	1	450.00	(Muncie) (2.56 to 1)
65	Pass. (exc. close ratio),				
65	Chevy, Chevelle (exc. close ratio, 3.55 axle),				
66	Chevy (exc. close ratio),				
66-67	Pass. (exc. close ratio),				
66-68	Chevelle, Camaro (327 Sp. H/Per., 396) (exc. close ratio, H.D.),				
67	Camaro (350, 396),				
68	Camaro, Chevy (4-Spd. w/H/Per., Sp. H/Per.) (w/3.07, 3.31, P/Trac. rear axle) (302, 350, 396),				
68	Chevy (4-Spd. w/H/Per., Sp. H/Per.) (327, 350, 396) (exc. P/Trac., 3.55, 3.73, 4.10 rear axles),				
68	Pass. (396, 427) (exc. 3.55, 3.73 axle, close ratio),				
68	Pass. (8.15 x 15 tires w/3.55 axle) (396, 427) (exc. S.S., close ratio)	3964502	1	537.00	(2.52 to 1) (aluminum) (Muncie)
65-66	Pass. (close ratio) w/4.10, 3.73 axle,				
65-67	Pass. (close ratio) w/P/Trac. (exc. 8.15 x 15 tires),				
66-67	Chevelle (close ratio) (396) (exc. C.A.C., 3.31 axle),				
66-67	Chevy (close ratio w/3.73, 3.55 axle),				
67	Camaro (close ratio) (exc. 3.07, 3.31 axle),				
68	Chevelle (close ratio) w/H/Per., Sp. H/Per. (396) (exc. C.A.C., 307, 3.31 axles),				
68	Chevelle (close ratio) (Sp. H/Per. w/P/Trac., 3.55, 3.73 axles) (327),				
68	Camaro (close ratio) (Sp. H/Per. w/3.31, 3.07 axles) (302, 396),				
68	Camaro (close ratio) (H/Per. w/P/Trac., 3.55, 3.73 axles) (396) (exc. C.A.C.),				
68	Chevy (close ratio) w/H/Per., Sp. H/Per. (327, 396) (exc. 3.07, 3.31 rear axles),				
68	Pass. (close ratio) (3.55, 3.73 axle, w/P/Trac.) (exc. 8.15 x 15 tires)	3964506	1	453.00	(2.20 to 1) (Muncie)
65	Pass. (close ratio) (exc. P/Trac.),				
66-67	Pass. (close ratio) (exc. P/Trac., 3.73 axle),				
66	Chevy (close ratio) w/3.31 axle,				
66-67	El Camino (close ratio) (396) (exc. 3.73, 4.56, 4.88 axle),				
66-67	Chevelle (327 Sp. H/Per.) (exc. 3.55, 3.73 axle),				
66-67	Chevelle (close ratio) (396) (exc. 3.55, 3.73, 4.56, 4.88 axle),				
67	Camaro (close ratio w/3.07, 3.31 axle) (302, 396 Sp. H/Per.) (exc. P/Trac.),				
68	Chevy, Chevelle, Camaro (close ratio) w/Sp. H/Per. (327, 396) (exc. 3.55, 3.73, rear axle, P/Trac.),				
68	Camaro (302) (close ratio) w/3.07, 3.31 rear axle,				
68	Pass. (close ratio) (exc. P/Trac., 3.55, 3.73 rear axle),				

**4-SPEED TRANSMISSION**

**4.003 TRANSMISSION ASSY. (less hand brake) (Con't)**

68	Pass. (close ratio) 3.55 axle w/8.15 x 15 tires) (exc. S.S.) . . .	3964505	1	512.00	(2.20 to 1) (aluminum) (Muncie) . . . . .
66	Chevy (327) (exc. C.A.C., H/Per.),				
66	Chevelle (327) (exc. H/Per., 3.70 rear axle),				
66	Pass. (327) . . . . .	6271515	1	513.00	(2.54 to 1) (cast iron) (Saginaw) . . . . .
66-67	Pass. (283) (exc. 3.55 axle, close ratio),				
66-67	Chevelle (283) (exc. 3.55, 3.70 axle),				
66-67	Chevy (283) (exc. C.A.C., 3.55 axle),				
66-67	Pass. (3.55 axle, w/8.15 x 15 tires) (exc. close ratio) . . . . .	3916103	1	460.00	(3.11 to 1) (cast iron) (Saginaw) . . . . .
67	Camaro w/3.08 axle (327),				
67-68	Pass. (327) (exc. 2.73, 3.73 rear axle),				
67-68	Chevy, Chevelle, Camaro (327) (exc. Sp. H/Per., 2.73, 3.55, 3.70, 3.73 rear axles),				
69	Chevy, Chevelle w/reg. fuel (350),				
69	Pass. w/2BC (350) . . . . .	3933853	1	475.00	(Saginaw) . . . . .
68	Pass. (307) (exc. 3.55, 3.70 axle),				
68	Pass. (8.45 x 15-4 w/3.70 axle),				
68-69	Chevelle (307) (exc. 2.73, 3.55, 3.70 axles),				
68-69	Camaro (6 cyl.),				
68-69	Chevy (307),				
69	Pass. (327) . . . . .	3919384	1	486.00	(2.85 to 1) (Saginaw) . . . . .
69	Pass. (close ratio w/P/Trac., 3.73 axle),				
69	Chevy, Chevelle, Camaro (close ratio) w/3.55, 3.73 axles (302, 396) . . . . .	3946798	1	475.00	(2.20 to 1) (Muncie) . . . . .
69	Pass. (close ratio) (exc. P/Trac.),				
69	Chevy, Chevelle, Camaro (close ratio) w/3.07, 3.31 axles (302, 396) . . . . .	3950316	1	475.00	(2.20 to 1) (Muncie) . . . . .
69	Pass. (exc. reg. fuel, P/Trac.),				
69	Chevy, Chevelle, Camaro w/3.07, 3.31 axles (302, 350, 396) (exc. reg. fuel) . . . . .	3950356	1	475.00	(2.52 to 1) (Muncie) . . . . .
69	Camaro w/reg. fuel (exc. 2.73 axle, 350) . . . . .	3950376	1	480.00	(2.85 to 1) (Saginaw) . . . . .
69	Camaro (2.73 axle w/2BC) (327, 350) . . . . .	3950379	1	480.00	(2.54 to 1) (Saginaw) . . . . .
70	Chevelle (350),				
70	Nova (8 cyl.) . . . . .	3952658	1	480.00	w/ext. (Saginaw) . . . . .
71-72	All w/Saginaw . . . . .	6271515	1	513.00	w/ext. . . . .

**H.D. 4-SPD. TRANSMISSION**

65-68	Pass. (P/Trac. w/3.55, 3.73, 4.10, 4.56, 4.88 axles) (8 cyl.) . . . . .	3964508	1	648.00	(2.20 to 1) (Muncie) . . . . .
69	Chevy, Camaro (H.D.) (exc. P/Trac., 3.07, 3.31 axles),				
69	Pass. w/P/Trac., 3.73 axle . . . . .	3950318	1	608.00	(2.20 to 1) (Muncie) . . . . .
70	Chevelle w/H.D. (454),				
71-72	All w/Muncie H.D. . . . . .	6271517	1	480.00	(2.20 to 1) . . . . .
71-72	Vega w/Opel . . . . .	3455091	1	439.00	w/extension . . . . .
73-74	Vega (140) w/Saginaw . . . . .	6261882	1	385.00	3.11 to 1 ratio . . . . .
74	Vega (122) w/Saginaw . . . . .	326554	1		w/ext. . . . .
75	Monza (140) w/Saginaw . . . . .	346341	1	385.00	w/ext. . . . .
75	Monza (8 cyl.) w/Saginaw . . . . .	354714	1	385.00	w/ext. . . . .
75	Vega (140) w/Saginaw . . . . .	361631	1	385.00	w/ext. . . . .
75	Vega (122) w/Saginaw . . . . .	361671	1	385.00	w/ext. . . . .
73	All w/Saginaw,				
74-75	Camaro (350) (exc. Sp. H/Per.),				
74-75	Nova . . . . .	6273271	1	480.00	
74-75	Camaro w/Warner close ratio (2nd design) . . . . .	369182	1	565.00	
74-75	Camaro w/Warner (350) Sp. H/Per. (exc. close ratio) (2nd design) . . . . .	360836	1	464.00	

## 4-SPEED TRANSMISSION

### 4.003 TRANSMISSION ASSY. (less hand brake) (Con't)

75 Camaro, Nova w/Saginaw (2.54  
1st gear) ..... 6273271 1 480.00

### 4.004 CONTROL ASSY.— INSULATOR ASSY., Transmission Gearshift

64-65 Chevy, Chevelle w/4-Spd.,  
65-67 Pass. w/4-Spd.,  
66-67 Chevelle w/4-Spd.,  
66-67 Chevy (4-Spd. w/Sp. H/Per.)  
(327),  
66 Chevy w/Muncie 4-Spd. (1st  
des.) (exc. 327 w/Sp. H/Per.) .. 3841472 1 43.25 bracket .....  
67-68 Camaro w/4-Spd.,  
68-72 Chevy (4-Spd. w/floor console) . 6264025 1 41.25 w/bracket and lever .....  
68-72 Pass., Chevelle w/4-Spd. .... 6271625 1 41.25 w/lever and bracket .....  
69 Camaro w/4-Spd. .... 9792437 1 77.75 w/bracket and lever ("HURST") (Note 1) ...  
68-72 Nova w/4-Spd. (exc. floor  
console) ..... 6264024 1 47.00 w/lever and bkt. (Note 2) .....  
*NOTE 2: It may be necessary to purchase and install lever 3992595 and knob 6262264.*  
70-72 Camaro ..... 340332 1 75.75 w/lever and bracket .....  
73-74 Nova w/floor console,  
73-75 Camaro ..... 340332 1 75.75 trans. control .....  
74 Nova (exc. floor console),  
75 Nova,  
73-75 Chevelle w/close ratio ..... 494574 1 81.00 trans. control .....  
73-75 Vega ..... 325764 1 54.50 trans. control .....  
75 Monza ..... 348202 1 49.00 trans. control .....  
75 Vega ..... 348203 1 3.70 INSULATOR ASSY., trans. control lever ...  
*NOTE 1 No components serviced.*

### 4.005 GASKET UNIT, Transmission

64-66 Chevy, Chevelle w/4-Spd.,  
65-68 Pass., w/Muncie 4-Spd.,  
67-68 Chevy, Chevelle, Camaro w/4-  
Spd. (327 Sp. H/Per., 302,  
350, 396),  
69 Pass., w/4-Spd. (350, 396, 427)  
(exc. reg. fuel),  
69 Chevy, Chevelle, Camaro w/4-  
Spd. (302, 350, 396) (exc. reg.  
fuel),  
70-72 All w/Muncie 4-Spd. .... 3917763 1 2.90 (Note 1) .....  
*NOTE 1: Consists of (1 each) gasket rear bearing retainer front, and rear, trans. cover, clutch gear bearing  
retainer, and (1) "O" ring seal.*  
71-72 Vega w/Opel ..... 6272080 1 11.60 trans. (Note 3) .....  
*NOTE 3: Consists of (2 each) seal assy., trans. shift selector shaft (1 each) seal assy., trans. extension oil,  
trans. clutch gear, "O" ring-used as speedo. driven gear fitting seal. (1 each) gasket, trans. case cover 3  
and 4-Spd., trans. extension, trans. to clutch housing, clutch release bearing support.*  
66-69 Pass. w/Saginaw 4-Spd. (283,  
327),  
66-68 Chevy, Chevelle w/Saginaw 4-  
Spd. (283, 307, 327),  
67-68 Camaro (exc. 350, 396),  
69 Chevy, Chevelle, Camaro  
w/Saginaw 4-Spd. (307, 327,  
350 w/regular fuel),  
70-75 All w/Saginaw 4-Spd. .... 3886338 1 1.10 (Note 2) .....  
*NOTE 2: Consists of 1 trans. extension gasket, 1 trans. cover gasket, 1 clutch gear bearing retainer gasket,  
and 1 "O" ring seal.*  
73-74 All w/Muncie ..... 3958616 1 2.75 (Note 4) .....  
*NOTE 4: Consists of (1) "O" ring seal and (1 each) gasket trans. cover, clutch gear bearing retainer and  
trans. extension.*

### 4.006 LEVER— CABLE— HANDLE— KNOB, Gearshift Control (Hand)

64-66 Chevy, Chevelle w/4-Spd. (exc.  
bucket seats) ..... 3853134 1 31.50 w/cable, reverse release .....  
64-66 Malibu (S.S.) w/4-Spd.,  
65-66 El Camino 4-Spd. (w/B.S.) ..... 3853137 1 33.00 w/cable, reverse release .....  
64-66 All w/4-Spd.,  
67 Pass., Chevelle w/4-Spd.,  
67 Chevy, w/4-Spd. (327 Sp.  
H/Per.) ..... 3841476 1 10.65 lower .....  
65-67 Pass. w/4-Spd. (exc. B.S.) ..... 3859883 1 27.25 w/cable, cont. reverse release .....  
65 Impala (S.S.) w/4-Spd. .... 3859890 1 27.75 w/cable reverse release .....  
66 Chevy (exc. close ratio, S.S.),  
66 Chevy (S.S.) (exc. 6 cyl.),

## 4-SPEED TRANSMISSION

4.006 LEVER—CABLE—HANDLE—KNOB, Gearshift Control (Hand) (Con't)					
66	Chevy (S.S.) (6 cyl.)	3879746	1	4.00	
67-68	Camaro (floor shift),				
69-70	Chevy w/floor console	3934288	1	20.95	control
67	Chevelle w/4-Spd. (exc. B.S.)	3903077	1	31.00	w/cable reverse release
67	Chevelle w/4-Spd.	3917728	1	30.25	w/cable reverse release
67	Chevelle (4-Spd. w/floor console)	3917764	1	27.00	control
68-69	Pass. w/4-Spd.	3924463	1	10.50	control upper
68	Chevy w/floor shift,				
69-70	Chevy w/4-Spd. (exc. floor console),				
71-72	Nova	3920248	1	25.00	control
68-71	Chevelle (Floor shift w/B.S.),				
72	Chevelle w/floor console	3973866	1	10.50	control upper
68-69	Chevelle w/floor shift (exc. B.S.)	3924422	1	10.25	control, upper
69	Camaro w/4-Spd.	9792435	1	27.50	control
70-71	Chevelle w/4-Spd. (exc. B.S.),				
72	Chevelle (exc. floor console)	3973865	1	10.40	
70	Camaro (4-Spd. w/floor shift),				
71-72	Camaro	3992596	1	28.00	
73-74	Chevelle	488947	1	10.40	upper
73-75	Camaro	332606	1	6.60	
73	Nova (exc. B.S.)	6264077	1	25.00	
73-75	Nova w/floor console	6264078	1	20.95	
74-75	Nova (exc. floor console)	340348	1	18.75	
73-74	Vega	6259654	1	26.25	LEVER UNIT, trans. control
73-75	Vega, Monza	6258816	1	4.00	BRACKET UNIT, trans. control lever
64-67	All w/4-Spd. (exc. Camaro)	3883686	1	2.80	CABLE, control reverse release
71-72	Vega	8953216	1	1.80	CABLE ASSY., trans. reverse lock out
64-67	All w/4-Spd. (exc. Camaro)	3901033	1	4.70	HANDLE, reverse release lever, w/retainer & sleeve (Note 2)
71-72	Vega	8967342	1	27.75	HANDLE, trans. control
73-74	Vega	329727	1	5.05	HANDLE, transmission reverse lockout w/cable
75	Vega, Monza	348218	1	4.70	HANDLE, transmission control reverse release
<i>NOTE 2 It may be necessary to enlarge the cable hole in the reverse release handle to 3/32" diameter.</i>					
64-65	Chevelle w/T.W. (exc. S.S.)	3782694	1	1.35	KNOB (2 <sup>13</sup> / <sub>32</sub> " O.L.—black plastic)
64	Chevy (S.S.) w/4-Spd.,				
65-67	Pass. w/4-Spd. (exc. B.S.),				
65-67	Chevy, Chevelle w/4-Spd. (exc. floor console)	3857524	1	2.25	KNOB, control lever
67	Pass.	3898254	1	1.75	KNOB, turquoise w/chrome
67-68	Pass.,				
67	Conv., Sta. Wag., El Camino	3973042	1	2.10	KNOB, black
68	Pass.	3928282	1	1.90	KNOB, dark saddle w/chrome
69	All	3945523	1	1.20	KNOB, midnight green
71	Camaro (exc. floor console)	9794505	1	3.50	KNOB, control lever (upper and lower half)
67	Camaro w/4-Spd.,				
68-69	Pass. w/4-Spd. (exc. S.S., B.S.),				
68-71	Chevy, Chevelle, w/4-Spd. (exc. floor console),				
68	Camaro w/4-Spd. (exc. floor console)	390768	1	5.55	KNOB UNIT (black) (w/shift pattern)
69-70	Camaro w/4-Spd. (exc. floor console)	3961437	1	4.90	KNOB UNIT (black)
68-69	Pass. (4-Spd. w/B.S.),				
68	Camaro w/floor console,				
68-70	Chevelle (4-Spd. w/floor console),				
69	Chevy (4-Spd. w/floor console)	390749	1	4.40	KNOB ASSY., control lever
69-70	Camaro w/floor console	9793565	1	2.25	KNOB ASSY., control lever (black)
71-72	Chevelle w/floor console	3992308	1	3.65	KNOB ASSY., control lever
71-72	Nova, Chevelle (exc. floor console)	3992307	1	3.85	KNOB ASSY., control lever (black)
71	Camaro w/floor console	3992558	1	3.65	KNOB ASSY., control lever
71	Camaro (exc. floor console)	3992556	1	4.70	KNOB ASSY., control lever (black)
72-73	Camaro	6262264	1	4.70	KNOB, control lever
71-72	Vega	3991303	1	1.90	KNOB, trans. control lever
71-72	Vega	8967339	1	.77	KNOB, trans. reverse lock out
73-75	All (exc. Vega, Monza)	494367	1	3.10	KNOB ASSY., control lever
73-75	Vega, Monza	329729	1	1.30	KNOB, trans. control lever
73-75	All	402196	1	.16	PIN, trans. control lever pivot
71-72	Vega	8967340	1	15.20	SHIFT FINGER, trans. gearshift control



**4-SPEED TRANSMISSION**

**4.008 BUSHING— BRACE— BRACKET— FLANGE— GROMMET— ISOLATOR—  
LOCK OUT UNIT— LOCKOUT ASSY.— NUT— PIN— RETAINER— RING—  
SCREW— SEAL— SHAFT— SLEEVE— SPACER— SPRING— TUBE—  
WASHER, Gearshift Control Hand Lever**

64-67	Pass., Chevy, Chevelle w/4-Spd.	3845636	A.R.	.93	reverse release cable handle
72	Chevelle	3922522	1	.94	BRACE, lever and bracket
72	Chevelle w/Saginaw	3922532	1	.83	BRACKET, control lever and bracket stab. shaft
73-75	All	329723	1	1.45	BRACKET, trans. control lever spring reverse lock-out
73-74	Vega	329787	3	.31	BOLT, control lever (5/16" — 18 x 2 1/32")
75	Vega	348299	3	.55	BOLT, control lever (5/16" — 18 x 1 1/16")
64-67	Pass., Chevy, Chevelle w/4-Spd.	3845747	1	5.35	FLANGE, control lower lever (w/studs)
64-67	Pass., Chevy, Chevelle w/4-Spd.	3852444	1	.16	GROMMET, control lever and reverse release cable (7/16")
65	Chevelle w/T.W. (exc. S.S.)	568018	1	.11	GROMMET, control lever
70-72	Camaro	1234418	3	.64	GROMMET, shift lever
71-72	Vega	2865035	1	.31	GROMMET, trans. control lever upper (Opel— 738900)
71-72	Vega	2865032	1	.24	GROMMET, trans. control lever lower
72-74	Camaro	483381	1	2.45	ISOLATOR, control lever (Inland 1086-0)
70-71	Camaro	325051	1	1.65	ISOLATOR UNIT, w/retainer, shift control lever
71-72	Vega	3991370	1	2.10	INSULATOR, trans. control lever
70-72	Nova, Chevelle w/4-Spd.	325050	1	25.50	LOCKOUT UNIT, reverse
67-69	All w/4-Spd.,				
70-72	Nova, Chevelle w/4-Spd.	6271627	1	8.55	LOCKOUT ASSY., control rev. lever (inhibitor)
67-69	Camaro w/4-Spd.,				
68-72	Chevy w/floor shift	3901371	1	.78	NUT, special anchor (5/16" — 18) (2 holes)
67-69	Camaro w/4-Spd.,				
68-72	Chevy w/floor shift	3901372	1	.53	NUT, anchor (5/16" — 18) (1 hole)
69	Camaro w/4-Spd. (exc. 396)	9791886	1	.57	NUT, control lever and bracket to support
71-72	Nova, Chevelle	3992309	1	.18	NUT, control lever knob (3/16" — 18 x 1/2" thk.)
73-75	Vega, Monza	329739	1	.40	NUT, lever knob
73-75	All	9794299	1	.18	NUT, trans. control lever knob
64-67	All w/4-Spd.	3845746	1	.59	PIN, lower lever
66	El Camino w/4-Spd. (close ratio)	9425112	1	.16	PIN, control lever pivot— (8.939)
67	Camaro w/floor shift,				
68-69	Chevy, Chevelle, Camaro w/floor shift, 4-Spd.,				
69	Pass. w/4-Spd.,				
70	Chevelle w/4-Spd.,				
70	Nova w/floor controls,				
71-72	Nova, Chevelle w/floor console	3895254	1	.53	PIN, control lever
71-72	Vega	3978193	1	.42	PIN, trans. control lever (1 47/64" O.L. x 15/16" O.D.)
71-72	Vega	11064732	1	.14	PIN, trans. gearshift control (4 x 26 mm) (roll)
73-74	H	329725	1	.57	PIN, trans. control lever
65-66	All w/4-Spd. (1st design)	3861020	1	.59	RETAINER, reverse release cable (Use 8— 32 set screw)
66-67	All w/4-Spd. (2nd design) (exc. Camaro),				
67-68	Camaro w/4-Spd.	3898236	1	.71	RETAINER, reverse release cable (Use 6— 32 set screw)
68-69	All w/4-Spd.	2358524	1	.98	RETAINER, control reverse lever
71-72	Vega	11057501	1	.13	RING, trans. lower grommet retainer
71-72	Vega	11060801	1	.27	RING, trans. gearshift control tube retaining, lower
65-66	Pass. w/4-Spd.	427721	A.R.	.16	SCREW (8— 32)— (8.975)
66	Pass. w/4-Spd.	147462	A.R.	.27	SCREW (6— 32)— (8.975)
71-72	Vega	11064721	1	.14	SCREW, trans. reverse lock out cable lock
65-67	All w/4-Spd.	2402029	1	.34	SEAL, "O" ring control lever handle
71-72	Vega	2886929	1	.15	SEAT, trans. lower grommet (Opel— 738528)
67-68	Camaro (floor shift w/floor console),				
68-69	Chevy, Camaro w/floor shift,				
68	Chevelle (S.S.),				
69	Pass., Chevelle w/4-Spd.,				
70	Chevelle w/4-Spd.,				
70	Nova w/floor controls,				
71-74	Nova, Chevelle w/floor console	3895256	1	.84	SHAFT, control lever
72-74	Camaro	6273921	1	.84	SHAFT, control lever (Inland 1031-D)

## 4-SPEED TRANSMISSION

### 4.008 BUSHING— BRACE— BRACKET— FLANGE— GROMMET— ISOLATOR— LOCK OUT UNIT— LOCKOUT ASSY.— NUT— PIN— RETAINER— RING— SCREW— SEAL— SHAFT— SLEEVE— SPACER— SPRING— TUBE— WASHER, Gearshift Control Hand Lever (Con't)

73-75	Vega, Monza	325757	1	.91	SHAFT, trans. control shaft lever
73-75	Vega, Monza	325774	1	5.35	SPACER, 1st and 2nd lever to rev.
75	Vega, Monza	348225	1	5.00	SPACER, 1st and 2nd lever to rev.
73-75	Vega, Monza	325752	1	5.35	SPACER, rev. lever to bracket
75	Vega, Monza	348221	1	5.00	SPACER, reverse lever to bracket
66-67	Chevy w/4-Spd. (exc. close ratio, 327 Sp. H/Per.)	3886564	3	.53	SPACER, cont. lever w/bracket support
64-67	All w/4-Spd. (exc. Camaro),				
66-67	Chevelle w/B.S. (8 cyl.)	3845716	1	.44	SPRING, reverse release cable retaining
66	Pass. (T.W. w/B.S.)	3719853	1	.16	SPRING (5 coils— 1 <sup>9</sup> / <sub>32</sub> " long)
70	All w/floor controls	7808017	1	.64	SPRING, lever
70-72	Nova, Chevelle w/4-Spd.	3984549	1	1.75	SPRING, control reverse lever lockout (Note 1)
71-72	Vega	3991304	1	.12	SPRING, trans. control reverse lever lockout
73-75	Vega, Monza	3921641	1	.24	SPRING, control rev. release retainer
71-72	Vega	8953223	1	.82	SLEEVE, trans. reverse lockout cable clamping
NOTE 1 3984549 may also be used for replacement purposes on 1967 thru 1970 models which have been previously serviced with reverse inhibitor unit 3988379 or 325050.					
64-67	Chevy, Chevelle w/4-Spd. (2nd design),				
65-67	Pass. w/4-Spd.	3859193	1	.71	TUBE, cont. reverse release cable
64-67	All w/4-Spd. (exc. Camaro),				
67-68	Camaro w/floor shift,				
68	Chevy, Chevelle w/floor shift,				
69-70	All w/4-Spd. (exc. Chevelle),				
71-72	Nova, Chevelle	3841726	1	.12	WASHER, control lever spring
64-67	All w/4-Spd. (exc. Camaro),				
68	Chevy	3852446	2	.11	WASHER, control lever and reverse release cable (2 <sup>1</sup> / <sub>64</sub> " I.D.)
65-67	Pass. w/4-Spd.	3851780	1	.18	WASHER, control lever spring
68	Chevy w/floor console	2390395	1	.20	WASHER, control lever & bracket shaft
71-72	Vega	3460499	1	.24	WASHER; trans. upper grommet (Opel— 738532)
71-72	Vega	9428369	1	.12	WASHER, trans. control lever pin (2 <sup>1</sup> / <sub>64</sub> " I.D. x 4 <sup>1</sup> / <sub>64</sub> " O.D. x 1 <sup>1</sup> / <sub>64</sub> " thk.)— (8.928)
71-72	Vega	3460500	1	.24	WASHER, trans. lower grommet (Opel— 738533)

### 4.010 SUPPORT— BRACE— BRACKET— COVER— HOUSING— PLATE— RETAINER— SHAFT— SHROUD— SPRING, Gearshift Hand Lever

*For floor shift models not using strg. column shift lever housing, see group 6.518 for equivalent part, listed as a cover, jacket extension, housing, etc.*

65-67	Pass. w/4-Spd.	3866260	1	3.40	lever
66-67	Chevy w/Saginaw 4-Spd. (exc. 327 w/Sp. H/Per.)	3886566	1	1.80	cont. lever and bracket
68-69	Pass. w/4-Spd.	3918065	1	5.25	control lever and bracket
73	Chevelle (exc. close ratio)	6262275	1	4.05	control shaft
73-74	Chevelle w/close ratio	6263677	1	3.90	control shaft
73-75	Nova	6264086	1	8.05	lever and bracket
67-70	Camaro w/floor shift,				
68-72	Chevy w/floor shift	3895261	1	7.50	SUPPORT ASSY., lever and bracket
68-72	Chevelle w/4-Spd.	3918063	1	5.20	SUPPORT ASSY., lever and bracket
69	Camaro w/4-Spd. (396)	3955772	1	7.10	SUPPORT ASSY., lever and bracket
69	Camaro w/4-Spd. (exc. 396)	9791899	1	3.65	SUPPORT ASSY., lever and bracket
70-71	Camaro w/4-Spd. (exc. 454),				
72-75	Camaro w/Saginaw	3975595	1	3.50	SUPPORT ASSY., lever and bracket
70	Camaro w/Muncie H.D., 4-Spd. (454),				
71-75	Camaro w/Muncie	3989410	1	4.50	SUPPORT ASSY., lever and bracket
68-71	Chevelle w/4-Spd.	3922522	1	.94	BRACE, control lever and bracket
67	Camaro w/4-Spd. (exc. 350, 396),				
68	Chevy, Camaro w/4-Spd. (exc. 302, 327 Sp. H/Per., 350, 396),				
69	Chevy, Camaro w/4-Spd.,				
70	Nova (Saginaw 4-Spd. w/floor controls),				
71-72	Nova	3920249	1	2.00	BRACKET, control lever and stabilizer shaft
67	Camaro w/4-Spd. (350),				
67	Camaro w/4-Spd. (close ratio),				

**4-SPEED TRANSMISSION**

**4.010 SUPPORT— BRACE— BRACKET— COVER— HOUSING— PLATE—  
RETAINER— SHAFT— SHROUD— SPRING, Gearshift Hand Lever (Con't)**

68	Chevy, Camaro w/4-Spd. (8 cyl.),				
68-69	Pass. w/4-Spd. (396, 427),				
69-70	Chevy w/4-Spd. (exc. reg. fuel),				
71	Nova	3920250	1	.57	BRACKET, control lever
68	Pass. w/4-Spd. (exc. 396, 427),				
69	Pass. w/4-Spd. (exc. 4BC., 396)	3924474	1	.83	BRACKET, control lever and stabilizer, shaft
68	Chevelle w/4-Spd. (exc. 327 Sp. H/Per.),				
69-70	Chevelle w/4-Spd. (exc. 4BC)	3922532	1	.83	BRACKET, control lever and stabilizer shaft
68	Chevelle w/4-Spd. (327 Sp. H/Per., 396),				
69-70	Chevelle (4-Spd. w/4BC),				
71-72	Chevelle w/Muncie	3922538	1	.34	BRACKET, control lever and stabilizer shaft
67-69	Camaro w/floor shift,				
68-70	Chevy, Chevelle w/floor shift,				
69	Pass. w/4-Spd.,				
71	Nova w/floor console	325050	1	25.50	BRACKET ASSY., control shaft lever
67-68	Camaro w/floor shift console,				
68	Chevy, Chevelle w/floor shift, console,				
69	Chevy, Camaro, Chevelle w/floor shift (8 cyl.),				
69	Pass. w/4-Spd.,				
70-72	Nova, Chevelle w/floor controls	3895248	1	7.55	BRACKET ASSY., control lever
68-69	Pass. (4-Spd. w/B.S.) (S.S.)	3920397	1	.76	COVER, control lever upper
68	Chevelle w/floor console	3934819	1	.40	COVER, control lever seal
69-70	All w/floor shift (exc. T.W.)	7804436	1	14.25	HOUSING, control lock tube
72-74	Camaro	6273922	1	11.75	HOUSING, control lever (Inland 1038-D)
73-75	Vega	325751	1	12.50	HOUSING, trans. control shaft
75	Monza	348212	1	24.45	HOUSING, trans. control shaft
69-70	Pass., Chevelle w/floor shift (exc. T.W.)	7807691	1	1.10	PLATE, strg. column shift tube lock
67-68	Camaro w/4-Spd. (exc. 302, 350, 396, close ratio),				
68	Chevy w/4-Spd. (exc. 327 Sp. H/Per., 350),				
69	Chevy, Camaro (4-Spd. w/reg. fuel),				
70	Nova w/Saginaw 4-Spd.,				
72	Nova	3901377	1	1.55	SHAFT, lever and bracket stabilizer
72-74	Camaro	6273923	1	3.40	PLATE, control lever housing support (Inland 1346)
75	All	3906448	1	.92	PLUG, trans. tower
72	Camaro,				
73-74	All	6273924	1	1.75	RETAINER, rev. lever lockout spring (lower) (Inland 1114-A)
72	Camaro,				
73-74	All	6273925	1	1.70	RETAINER, rev. lever lockout spring (upper) (Inland 1115-A)
67-68	Camaro w/4-Spd. (302, 350),				
68	Chevy (4-Spd. w/Sp. H/Per.) (327, 350),				
68	Chevelle w/4-Spd.,				
69	Chevy, Chevelle (4-Spd. w/4BC),				
70-71	Nova w/Muncie 4-Spd.,				
70-72	Chevelle w/Saginaw 4-Spd.	3922531	1	1.55	SHAFT, lever and bracket stabilizer
67-69	Camaro w/4-Spd. (302, 396),				
68-69	Chevy w/H/Per., Sp. H/Per. (396)	3913710	1	2.25	SHAFT, lever and bracket stabilizer
69	Pass., Chevelle (exc. T.W.),				
70	Pass., Nova, Chevelle (exc. Tel., T.W.),				
71	Chevelle (exc. T.W.)	7811352	1	7.75	SHROUD, strg. col. gearshift hsg. bowl
71-75	Nova, Camaro (exc. T.W.)	7811350	1	7.90	SHROUD, strg. col. gearshift housing bowl
72	Chevelle (T.W. w/floor console)	7806003	1	28.25	SHROUD, strg. col. trans. control lock tube
73-75	Vega, Monza	7810336	1	7.15	SHROUD, strg. col.
73-75	Vega	329724	1	2.25	SPRING, trans. control lever reverse lockout
75	Monza	353936	1	1.80	SPRING, trans. control lever
72-75	Camaro	6273926	1	1.80	SPRING, rev. lever lockout (Inland 3011)

**4.012 BOLT— DETENT— PIN— SCREW— SPACER— SUPPORT— WASHER,  
Gearshift Hand Lever Housing**

68-69 Pass. w/4-Spd.,

**4-SPEED TRANSMISSION**

**4.012 BOLT— DETENT— PIN— SCREW— SPACER— SUPPORT— WASHER,  
Gearshift Hand Lever Housing (Con't)**

67-69	Camaro w/floor shift,					
68-72	Chevelle w/4-Spd.,					
68-72	Chevy w/floor shift	3922533	1	.28	control lever and bracket stabilizer shaft (3 <sup>5</sup> / <sub>16</sub> " O.L.)	
65-67	Pass. w/4-Spd.	3866261	4	.16	SCREW, trans. control lever and bracket support (3 <sup>5</sup> / <sub>8</sub> "— 16 x 1 <sup>5</sup> / <sub>64</sub> ")	
67-69	All (w/T.W.)	7800639	1	.24	SCREW, shift detent plate	
69-70	All (exc. T.W.)	7810242	2	.78	SCREW, strg. column shift tube lock plate	
69-75	All (exc. T.W.)	7804407	1	.24	SCREW, strg. column shift lever detent plate	
68-69	Pass. w/4-Spd.,					
68-69	Chevy, Chevelle, Camaro w/floor shift,					
70-72	Nova, Chevelle (4-Spd. w/floor controls)	3941824	3	.24	SPACER, control rod	
62-65	Chevy,					
65	Pass. (exc. T.W.)	3793124	1	.16	WASHER, lever housing (1 <sup>5</sup> / <sub>16</sub> ")	
66	Chevy,					
66	Chevelle	3879747	1	.11	WASHER, lever housing	
66	Chevy, Chevelle w/4-Spd.	3879778	1	.12	WASHER, cont. lever hsg. thrust	
67-68	All w/T.W.	5698413	1	.53	WASHER, steering column support thrust	
67-68	All w/T.W.	5699618	1	.53	WASHER, steering column support wave	
67-75	All (exc. T.W.)	7800580	1	.34	WASHER, steering shaft upper retainer ring thrust	
67-68	All (exc. T.W.)	7800581	1	.38	WASHER, steering shaft upper retainer ring wave	
69-74	All w/T.W.	3886319	1	.32	WASHER, strg. column supt. thrust	
69-72	All w/T.W.	3884595	1	.20	WASHER, strg. column supt. wave	
69-70	All (exc. T.W.)	7804447	1	.59	WASHER, strg. column shift lever housing brg. wave	

**4.015 SEAL— BEZEL— COVER— GROMMET— INSULATOR— RETAINER—  
SCREW, Lever Hand (Floor Mounted)**

64-65	Chevelle w/4-Spd.,					
66	Chevelle w/4-Spd. (exc. floor console)	3842926	1	4.85	control lever and lower	
64-65	Malibu (S.S. w/4-Spd.),					
64	El Camino (Deluxe) w/4-Spd.	3849668	1	1.30	control lever upper	
64-66	Chevy w/4-Spd. (exc. close ratio),					
67	Chevy w/4-Spd. (close ratio)	3849850	1	4.35	control lever	
65	S.S. w/4-Spd.	3860109	1	5.55	control lever	
65-67	Pass. w/4-Spd. (exc. B.S.)	3860183	1	6.05	control lever (black) (Note 1)	
	<i>NOTE 1 Used with vinyl ring in carpet.</i>					
65-67	Nova (S.S.) w/4-Spd.	3863574	1	1.90	control lever upper	
66-67	Pass. (4-Spd. w/B.S.)	3877251	1	3.55	control lever lower	
66-67	Pass. (4-Spd. w/B.S.)	3877252	1	3.55	control lever upper	
66-67	Chevelle (floor console w/4- Spd.)	3907663	1	3.05	control lever upper	
66-67	Chevelle (floor console w/4- Spd.)	3903917	1	3.20	control lever lower	
67-68	Camaro w/4-Spd. (exc. fir. console)	3893853	1	3.20	underbody trans. control lever	
67-69	Camaro w/floor console,					
68-71	Chevy w/floor console	3974526	1	2.95	underbody trans. control lever	
67	Chevelle w/4-Spd. (exc. floor console)	3903961	1	3.90	control lever	
67	Camaro w/floor console,					
68-69	Chevy, Camaro w/floor console	3921896	1	2.50	control lever	
68-69	Pass. w/4-Spd. (exc. S.S., B.S.)	3922871	1	3.80	control lever	
68-69	Pass. (4-Spd. w/B.S.) (S.S.)	3920377	1	3.85	control lever upper	
68-69	Pass. (4-Spd. w/B.S.) (S.S.)	3920375	1	4.00	control lever lower	
68-71	Chevy w/floor shift (exc. floor console)	3974568	1	2.60	underbody control lever	
68-72	Chevelle w/4-Spd. (exc. floor console)	3975405	1	2.75	control lever	
68-69	Chevelle (4-Spd., w/floor console)	3922820	1	.57	control lever	
68	Camaro w/floor console	3929984	1	1.15	control lever	
68-71	Chevelle (4-Spd., w/floor console)	3975356	1	2.05	control lever (boot) (Note 1)	
	<i>NOTE 1 When using in place of 3931688 also use retainer 3975358.</i>					
69	Camaro w/4-Spd.	9795407	1	5.65	underbody shift lever rod (boot)	
70-72	Camaro w/4-Spd.	3973966	1	3.20	underbody control lever upper	

**4-SPEED TRANSMISSION**

**4.015 SEAL— BEZEL— COVER— GROMMET— INSULATOR— RETAINER—  
SCREW, Lever Hand (Floor Mounted) (Con't)**

71-72	Camaro	3990467	1	2.75	underbody control lever lower
72	Chevelle w/floor console	3975356	1	2.05	control lever (boot) (Note 1)
<i>NOTE 1 When using in place of 3931688 also use retainer 3975358</i>					
67	Chevelle w/4-Spd. (exc. floor console)	3903960	1	8.80	BEZEL, control lever seal
68-72	Chevelle w/4-Spd. (exc. flr. console)	3926747	1	4.75	BEZEL, control lever seal
71-72	Vega	3988056	1	2.75	BEZEL, control lever boot (chrome)
73-75	Vega, Monza	329732	1	2.75	BEZEL, control lever boot
71-72	Vega	3978154	1	3.30	BOOT, control lever, upper
71-72	Vega	3991299	1	4.25	BOOT, control lever, lower
73-75	Vega	349580	1	3.40	BOOT, control lever (upper)
75	Monza	332240	1	7.90	BOOT, control lever (upper)
73-74	Vega	336520	1	4.25	BOOT, control lever (lower)
75	Monza	348207	1	4.50	BOOT, control lever (lower)
67-69	Camaro w/floor console, 70 Chevelle (4-Spd. w/floor console)	3929982	1	.47	COVER, underbody control lever seal
64-67	Chevelle w/4-Spd.	3903962	1	.70	RETAINER, control lever and lower seal
73-75	Vega	329788	3	.22	GROMMET, control lever floor pan mounting
75	Vega	348300	3	.43	GROMMET, control lever
73-75	Vega	329730	1		INSULATOR, control lever
64-66	Chevy w/4-Spd. (exc. close ratio),				
67	Chevy w/4-Spd.	3849851	1	1.20	RETAINER, control lever
65-67	Pass. w/4-Spd.	3860108	1	.76	RETAINER, cont. lever seal lower
66-67	Chevelle (floor console w/4-Spd.)	3878413	1	3.65	RETAINER, cont. lever upper seal
67	Camaro w/floor console,				
68	Chevy w/floor console	3899870	L.H.	.14	RETAINER, control lever seal, left
67	Camaro w/floor console,				
68	Chevy w/floor console	3893872	R.H.	.19	RETAINER, control lever seal, right
67-68	Camaro w/flr. console,				
68-71	Chevy w/floor console	3893877	1	.63	RETAINER, underbody trans. lever seal
67-69	Camaro w/4-Spd. (exc. floor console)	3893854	1	.63	RETAINER, underbody trans. control lever seal
68-72	Chevelle w/4-Spd. (exc. floor console)	3926745	1	2.30	RETAINER, control lever seal
68-71	Chevy (exc. floor console)	3921898	1	1.55	RETAINER, underbody control lever seal
68	Camaro w/flr. console	3919159	1	.42	RETAINER, control lever seal
68-72	Chevelle (4-Spd. w/floor console)	3975358	1	1.25	RETAINER, control lever seal
71-72	Vega	3978155	1	1.20	RETAINER, control lever boot
75	Vega	332239	1	2.35	RETAINER, control lever boot
73	Nova	327548	1	.63	RETAINER, u/b trans. control lever seal
73-74	Chevelle	3994505	1	1.55	RETAINER, u/b trans. control lever (paint as reqd.)
74-75	Nova	339459	1	.78	RETAINER, u/b trans. control lever
74	Camaro	3973970	1	2.70	RETAINER, u/b trans. control lever
73	Chevelle (exc. floor console)	3975405	1	2.75	SEAL, control lever
73-75	Camaro	3973966	1	3.20	SEAL, u/b trans. control lever upper
73-75	Camaro	3990467	1	2.75	SEAL, u/b trans. control lever lower
73	Nova w/floor console	3974526	1	2.95	SEAL, control lever
73	Nova,				
74-75	Nova w/floor console	327545	1	3.20	SEAL, u/b control lever upper
75	Nova	332235	1	3.40	SEAL, underbody trans. control lever lower
73-74	Nova	327544	1	3.15	SEAL, u/b control lever lower
73-74	Chevelle	3994501	1	3.20	SEAL, u/b control lever upper
73-74	Chevelle	3994502	1	4.00	SEAL, u/b control lever lower
74	Nova (exc. floor console)	341070	1	3.20	SEAL, u/b control lever upper
70	Camaro w/floor controls	9415952	3	.05	SCREW, lever seal front and rear guide, boot ret. and hsg. trim cover brkt.— (8.977)

**4.017 PLATE— EXTENSION— NUT, Underbody Trim (floor mounted)**

66-67	Nova (S.S.) w/4-Spd.	3872256	1	14.10	trans. cont. hsg.
67-68	Camaro w/4-Spd. (exc. floor console)	3893855	1	3.30	underbody lever seal trim
67	Camaro w/floor console,				
68-72	Chevy w/floor console	3921895	1	10.15	control lever hole trim
68-70	Chevy w/floor shift,				
71-72	Nova (exc. floor console)	3921899	1	4.35	underbody control lever seal trim

## 4-SPEED TRANSMISSION

### 4.017 PLATE— EXTENSION— NUT, Underbody Trim (floor mounted) (Con't)

69	Camaro (4-Spd. w/floor console)	9780054	1	1.65	underbody lever seal plate
69	Camaro (4-Spd. w/floor console)	3949537	1	8.75	trans. control lever hole trim
69	Camaro w/4-Spd. (exc. floor console)	9780055	1	3.35	underbody control lever seal plate
70-71	Camaro (4-Spd. w/floor console) (exc. Deluxe Interior)	3975874	1	8.65	control lever hole trim (chrome)
70-71	Camaro w/Deluxe Interior (exc. floor console)	3975876	1	8.65	PLATE ASSY., control lever hole trim (wood grain)
73-74	Nova w/floor console	327549	1	7.50	trans. control lever hole trim
73-75	Camaro w/floor console	478571	1	2.95	PLATE ASSY., control lever trim hole
75	Monza	332236	1	1.55	PLATE, seat separator trim
69	Camaro (4-Spd. w/floor console)	3949539	1	3.70	EXTENSION, control lever hole trim plate
70-72	Chevelle (4-Spd. w/floor console)	3975357	1	.98	EXTENSION, lever hole trim plate
70-72	Nova w/floor console	3974524	1	2.25	EXTENSION, lever hole trim plate
70-72	Camaro w/floor console	3973964	1	2.25	EXTENSION, lever hole trim plate
	<i>NOTE 1 Paint as required.</i>				
64-65	Nova, Malibu (S.S.),				
64-65	El Camino (Deluxe) w/4-Spd.	9422836	A.R.	.05	NUT, trans. trim plate (No. 10-16)
73-74	Camaro w/floor console	480133	1	.07	NUT, seat sep. trim plate ("U" shape)

### 4.020 PLATE, Transmission Gearshift Control

68-69	Camaro (4-Spd. w/floor console)	3919122	1	1.95	control selector
70-72	Chevelle w/floor console	3919914	1	3.25	control selector
70-72	Camaro w/floor console	3975881	1	2.00	control selector

### 4.025 TUBE ASSY.— SHAFT, Gearshift Control

69	Pass. w/floor shift (exc. T.W.)	7804497	1	25.75	control lock tube
69-70	Chevelle w/floor shift (exc. T.W.)	7804493	1	32.50	
69	Chevelle (floor shift w/T.W.),				
71-72	Chevelle w/T.W.	7806838	1	26.25	lock
69-72	Chevelle w/floor shift (exc. T.W.)	7806814	1	25.75	lock
	<i>NOTE 1 Can be used as steering column control lock tube on floor shift models.</i>				
69	Chevy, Camaro (exc. T.W.),				
70-71	Nova w/floor controls (exc. T.W.),				
72	Monte Carlo (350) (exc. T.W.)	7804745	1	25.75	
70-71	Camaro (exc. T.W.),				
72	Camaro (exc. floor console, T.W.)	7808563	1	37.75	strg. col. shift
64-67	Chevy, Chevelle,				
70-72	Camaro w/T.W.	7808908	1	27.25	shift
65-67	Pass. w/4-Spd.	3841490	1	2.20	SHAFT, control lever

### 4.027 BRACE— INTERLOCK— GATE— PLATE— PLUNGER— RETAINER— RING— SEAL— SHAFT— SPRING— WASHER, Transmission Gearshift Control Shaft or Tube

68-69	Pass. w/4-Spd.	3924475	1	1.30	control lever and bracket
64-67	Chevelle,				
64-66	Chevy w/4-Spd.,				
65-67	Pass. w/4-Spd.,				
67	Chevy w/4-Spd. (327 Sp. H/Per.)	3841485	1	1.65	INTERLOCK, control reverse lever ( <sup>3</sup> / <sub>32</sub> " thk.)
67	Camaro w/4-Spd.,				
68	All w/4-Spd. (exc. Pass.),				
69	All w/4-Spd.,				
70-72	Nova, Chevelle w/4-Spd.	3901387	1	1.70	INTERLOCK, trans. control shaft lever
73-75	All (exc. T.W.)	7804761	1	1.25	GATE, strg. col. rack guide
69	All (floor shift w/T.W.) (exc. Chevelle)	7806055	1	2.95	PLATE, strg. col. shroud index detent
69	All (floor shift w/T.W.) (exc. Chevy)	7806056	1	1.30	PLUNGER, strg. col. shroud index detent
64-67	Chevy, Chevelle,				
65-67	Pass. w/4-Spd.	3841725	1	.42	RETAINER, control shifter lever shaft
73-75	Vega	3841725	1	.42	RETAINER, trans. control shift lever shaft
67-68	All w/T.W.	5698409	1	.39	RING, steering column support retainer
69-75	All w/T.W.	7804907	1	.47	RING, column support retainer
65-66	Pass. w/4-Spd.,				
67-68	Pass. w/4-Spd.	3872057	1	1.90	RING ASSY., shifter tube adj.
71-72	Camaro	7807007	1	.50	SEAL, strg. col. shift tube
68-72	Chevelle w/4-Spd.	3922537	1	1.85	SHAFT, control lever and bracket stabilizer
67	Camaro w/4-Spd., floor console,				
68	Chevelle w/4-Spd.,				
70	Chevelle, Nova w/4-Spd.	3923546	1	1.35	SPRING, lever (ends open)
69-70	All (exc. T.W.)	7804446	1	.88	SPRING, shift tube thrust

## 4-SPEED TRANSMISSION

### 4.027 BRACE— INTERLOCK— GATE— PLATE— PLUNGER— RETAINER— RING— SEAL— SHAFT— SPRING— WASHER, Transmission Gearshift Control Shaft or Tube (Cont)

71-72	Chevelle	7808481	1	1.10	SPRING, shift tube thrust
72-75	All	7810567	1	.98	SPRING, strg. col. shift tube return lower
71-72	Vega	3978196	1	.23	SPRING, trans. control lever bias
69-72	All (exc. T.W.)	7807427	1	.47	WASHER, shift tube thrust

### 4.030 LEVER— BRACKET— PLATE, Transmission Gearshift Shaft or Tube (Lower)

64-67	Chevy, Chevelle w/4-Spd., 65-67 Pass. w/4-Spd.	3841488	1	4.45	control shaft (1st and 2nd)
64-67	Chevelle w/4-Spd., 64-66 Chevy w/4-Spd., 65-67 Pass. w/4-Spd., 67 Chevy w/4-Spd. (327 Sp. H/Per.)	3841489	1	4.45	control shaft (3rd and 4th)
64-67	All w/4-Spd. (exc. Camaro)	3841487	1	3.60	reverse
66-67	Chevy w/4-Spd. (exc. close ratio)	3850111	1	3.05	3rd and 4th
67-69	Camaro (4-Spd. w/floor console), 68-69 Chevy (4-Spd. w/floor console), 68 Chevy, Chevelle w/4-Spd., 70 Nova, Chevelle w/4-Spd., 71-72 Nova w/floor console	3895288	1	5.75	reverse
67-69	Camaro (4-Spd., w/floor console), 68-72 Chevy, Chevelle w/4-Spd., 69 Pass. w/4-Spd.	3895258	1	4.25	control shaft 1st and 2nd
68-72	Chevelle w/4-Spd.	3922518	1	7.85	control, reverse
67-69	Camaro (4-Spd., w/floor console), 68-69 Chevy, Chevelle w/4-Spd., 67-69 Chevy (4-Spd. w/floor console), 70 Nova, Chevelle w/4-Spd., 71-72 Nova, Chevelle	3980718	1	4.35	3rd and 4th
72	Camaro,	6273927	1	5.80	reverse (Inland #3051)
73-74	All	6273928	1	4.35	1st and 2nd (Inland #1050D)
72	Camaro,	6273929	1	4.40	3rd and 4th (Inland #1049-D)
73-74	All	6273929	1	4.40	3rd and 4th (Inland #1049-D)
73-75	Vega, Monza	325754	1	4.60	control shaft 3rd and 4th
73-75	Vega	325773	1	6.10	reverse
75	Monza	348215	1	4.20	reverse
73-75	Vega, Monza	325753	1	4.55	1st and 2nd shift
68-72	Chevelle w/4-Spd.	3922517	1	7.85	LEVER ASSY., control
72*	Camaro,	6273920	1	21.85	LEVER ASSY., w/bracket control inter. (Inland #3130)
73-74	Nova, Camaro	6273920	1	21.85	LEVER ASSY., w/bracket trans. control inter.
75	Vega, Monza	1234418	1	.64	GROMMET, trans. control shaft lever
73-75	All	1234418	A.R.	.64	GROMMET, control shift lever
73-74	All	6273931	1	1.60	PLATE, shift lever spring (Inland #1109-B)
73-74	All	6273932	1	4.10	PLATE, shift lever interlock (Inland #3083)
72	Camaro	6273931	1	1.60	PLATE, shift lever spring (Inland #1109-B)
72	Camaro	6273932	1	4.10	PLATE, shift lever interlock (Inland #3083)
73-75	Vega, Monza	325756	1	1.55	SPRING, control lever

### 4.032 GROMMET— RETAINER, Transmission Gearshift Shaft Tube Lever

69-71	Pass., Chevelle	391312	1	.34	control rod
65-67	Pass. w/4-Spd.	3841725	1	.42	RETAINER, control lever— (4.027)

### 4.035 ROD, Transmission Gearshift

64	Chevy w/4-Spd.				1st and 2nd, 3rd and 4th,
64-65	Chevelle w/4-Spd., 66-67 Chevelle w/4-Spd. (396), 66 Chevelle w/Muncie 4-Spd. (283, 327) (1st design)	3841494	1	3.00	1st and 2nd
64-65	Chevelle w/4-Spd., 66-67 Chevelle w/4-Spd. (396), 66 Chevelle w/Muncie 4-Spd. (283, 327) (1st design)	3841495	1	2.40	3rd and 4th
65	Pass. w/4-Spd., 66-67 Pass. w/4-Spd. (exc. 283, 327),				

## 4-SPEED TRANSMISSION

4.035 ROD, Transmission Gearshift		(Con't)	
66	Pass. w/Muncie 4-Spd. (283, 327) (1st design) . . . . .	3859892	1 1.70 1st and 2nd . . . . .
65	Pass. w/4-Spd.,		
66-67	Pass. w/4-Spd. (exc. 283, 327),		
66	Pass. w/Muncie 4-Spd. (283, 327) (1st design) . . . . .	3859893	1 2.15 3rd and 4th . . . . .
65	Pass. w/4-Spd.,		
66-67	Pass. w/4-Spd. (exc. 283, 327),		
66	Pass. w/Muncie 4-Spd. (283, 327) (1st design) . . . . .	3859894	1 .80 reverse . . . . .
65	Chevelle w/4-Spd.,		
66-67	Chevelle w/4-Spd. (396),		
66	Chevelle w/Muncie 4-Spd. (283, 327) (1st design) . . . . .	3862915	1 .80 control reverse . . . . .
65-67	Chevy w/4-Spd. . . . .	3869816	1 1.25 control reverse . . . . .
66-67	Chevy w/Saginaw 4-Spd. (2nd design) (exc. 327 w/Sp. H/Per.) . . . . .	3886575	1 1.90 1st and 2nd . . . . .
66-67	Chevy w/Saginaw 4-Spd. (2nd design) (exc. 327 w/Sp. H/Per.) . . . . .	3886579	1 1.45 reverse . . . . .
67	Camaro w/4-Spd. (327),		
68	Chevy, Camaro w/4-Spd. (250, 307, 327) (exc. Sp. H/Per.),		
68	Camaro w/4-Spd. (exc. 350, 396),		
69-70	Chevy w/4-Spd. (exc. 4BC) . . . . .	3930069	1 2.45 control reverse . . . . .
67	Camaro w/4-Spd. (302, 350),		
68	Chevy, Camaro w/4-Spd. (302, 327 Sp. H/Per., 350, 396),		
69	Chevy (4-Spd. w/4BC),		
70-71	Nova w/Muncie 4-Spd. (350) . . . . .	3930073	1 1.90 3rd and 4th . . . . .
67	Camaro w/4-Spd. (302, 350),		
68	Chevy, Camaro w/4-Spd. (302, 327 Sp. H/Per., 350, 396),		
69	Chevy (4-Spd. w/4BC),		
70-71	Nova w/Muncie 4-Spd. (350) . . . . .	3930071	1 1.35 1st and 2nd . . . . .
67-68	Chevy, Camaro w/4-Spd. (396),		
69-70	Chevy w/4-Spd. (396) . . . . .	3913715	1 1.65 reverse . . . . .
67	Camaro w/4-Spd. (396),		
68	Chevy, Camaro w/4-Spd. (396),		
69	Chevy w/4-Spd. (396),		
70	Nova w/Muncie 4-Spd. (350) . . . . .	3913713	1 1.95 1st and 2nd . . . . .
67	Camaro w/4-Spd. (302, 350),		
68	Chevy, Camaro w/4-Spd. (302, 327, Sp. H/Per. 350, 396),		
69	Chevy (4-Spd. w/4BC),		
70-71	Nova w/Muncie 4-Spd. (350) . . . . .	3930075	1 1.35 reverse . . . . .
67	Camaro w/4-Spd. (exc. 350, 396),		
68	Chevy, Camaro w/4-Spd. (250, 307, 327) (exc. Sp. H/Per.),		
69	Camaro w/4-Spd. (exc. 4BC),		
70	Nova w/Saginaw 4-Spd.,		
72	Nova . . . . .	3930051	1 1.90 1st and 2nd . . . . .
67	Camaro w/4-Spd. (exc. 350, 396),		
68	Chevy, Camaro w/4-Spd. (250, 307, 327) (exc. Sp. H/Per.),		
69	Chevy w/4-Spd. (exc. 4BC),		
70	Nova w/Saginaw 4-Spd.,		
72	Nova . . . . .	3930053	1 2.35 3rd and 4th . . . . .
68	Pass. w/4-Spd. (307, 327),		
69	Pass. w/4-Spd. (exc. 4BC, 396) . . . . .	3928252	1 3.40 3rd and 4th . . . . .
68	Pass. w/4-Spd. (307, 327),		
69	Pass. w/4-Spd. (exc. 4BC, 396) . . . . .	3928253	1 reverse control . . . . .
68-69	Pass. w/4-Spd. (396, 427),		
69	Pass. (4-Spd. w/4BC) (350) . . . . .	3931436	1 2.40 1st and 2nd . . . . .
69	Chevy w/floor shift,		
69	Camaro w/floor shift,		
69	Chevy, Camaro (4-Spd. w/2BC) . . . . .	3972256	1 1.65 control upper . . . . .
68-69	Chevelle w/4-Spd. (327 Sp. H/Per., 350, 396) (exc. 2BC),		
70-72	Chevelle w/Muncie 4-Spd. . . . .	3931437	1 2.10 1st and 2nd . . . . .



**4-SPEED TRANSMISSION**

<b>4.035 ROD, Transmission Gearshift</b>		<b>(Con't)</b>	
68-69	Chevelle w/4-Spd. (327 Sp. H/Per., 350, 396) (exc. 2BC),		
70-72	Chevelle w/Muncie 4-Spd. . . . .	3922535	1 2.40 3rd and 4th . . . . .
68-69	Chevelle w/4-Spd. (327 Sp. H/Per., 350, 396) (exc. 2BC),		
70-72	Chevelle w/Muncie 4-Spd. . . . .	3931438	1 1.55 reverse control . . . . .
68-69	Chevelle w/4-Spd. (307, 327, 350) (exc. Sp. H/Per., 4BC),		
70-72	Chevelle w/Saginaw 4-Spd. . . . .	3931439	1 2.10 1st and 2nd . . . . .
68-69	Chevelle w/4-Spd. (307, 327, 350) (exc. Sp. H/Per., 4BC),		
70-72	Chevelle w/Saginaw 4-Spd. . . . .	3924419	1 2.50 3rd and 4th . . . . .
68-69	Chevelle w/4-Spd. (307, 327, 350) (exc. Sp. H/Per., 4BC),		
70-72	Chevelle w/Saginaw 4-Spd. . . . .	3924420	1 1.45 reverse control . . . . .
69	Camaro (4-Spd. w/4BC) (302, 350) . . . . .	3955773	1 2.35 control lower lock . . . . .
69	Chevy, Camaro w/4-Spd. (exc. 4BC),		
69-70	Chevy w/4-Spd. (396) . . . . .	3955795	1 2.25 control lower lock . . . . .
69-71	Chevy (4-Spd. w/4BC) (350) . . . . .	3955793	1 2.35 control lower lock . . . . .
69	Camaro (4-Spd. w/4BC) (302, 350) . . . . .	3955771	1 1.65 reverse . . . . .
69	Camaro w/4-Spd. (396) . . . . .	3955776	1 4.10 control lower lock . . . . .
69	Camaro w/4-Spd. (exc. 4BC) . . . . .	3955765	1 1.35 reverse . . . . .
69	Camaro w/4-Spd. (exc. 396) . . . . .	9791876	1 3.95 1st and 2nd . . . . .
69	Camaro w/4-Spd. (396) . . . . .	3955779	1 1.65 reverse . . . . .
69	Camaro w/4-Spd. (396) . . . . .	3955777	1 2.10 3rd and 4th . . . . .
69	Camaro w/4-Spd. (396) . . . . .	3955775	1 2.80 1st and 2nd . . . . .
69	Camaro w/4-Spd. (exc. 396) . . . . .	9791885	1 4.50 3rd and 4th . . . . .
70-75	Camaro w/4-Spd. (exc. 4BC) . . . . .	3975611	1 2.10 control 1st and 2nd . . . . .
70-75	Camaro w/4-Spd. (exc. 2BC) . . . . .	3975617	1 2.10 control 1st and 2nd . . . . .
70-75	Camaro w/4-Spd. (exc. 2BC) . . . . .	3975618	1 2.10 control, lower lock . . . . .
70-75	Camaro w/4-Spd. (exc. 4BC) . . . . .	3975612	1 2.40 control 3rd and 4th . . . . .
70-75	Camaro w/4-Spd. (exc. 2BC) . . . . .	3975619	1 4.60 control, 3rd and 4th . . . . .
70-75	Camaro w/4-Spd. (exc. 4BC) . . . . .	3975613	1 2.30 control rev. . . . .
70-72	Camaro w/4-Spd. (exc. 2BC) . . . . .	3975621	1 1.25 control rev. . . . .
70-75	Camaro w/4-Spd. (exc. 2BC) . . . . .	3975624	1 1.25 control upper lock . . . . .
70-75	Camaro w/Saginaw 4-Spd. . . . .	3975603	1 2.10 control lower lock . . . . .
70-75	Camaro w/Saginaw 4-Spd. . . . .	3975607	1 1.25 control upper lock . . . . .
70	Nova (4-Spd. w/floor controls) . . . . .	3972256	1 1.65 control upper . . . . .
70-71	Nova w/Muncie 4-Spd. . . . .	3958490	1 2.10 control, upper lock . . . . .
72	Nova w/Muncie . . . . .	3930055	1 4.10 reverse . . . . .
72	Monte Carlo (350) (exc. T.W.) . . . . .	7804745	1 25.75 shift . . . . .
72	Camaro (exc. floor console, T.W.) . . . . .	7808563	1 37.75 shift . . . . .
72	Nova . . . . .	3930069	1 2.45 rev. . . . .
73-75	Nova . . . . .	6264099	1 1.45 rev. . . . .
73-75	Nova . . . . .	6264079	1 1.90 1st and 2nd . . . . .
73-75	Nova . . . . .	6264088	1 2.35 3rd and 4th . . . . .
73-74	Nova . . . . .	6264006	1 1.35 control upper lock . . . . .
70	Nova, . . . . .		
73-74	Nova . . . . .	332605	1 2.35 control lower lock . . . . .
75	Nova . . . . .	357711	1 8.15 control lower lock . . . . .
73-74	Chevelle w/Muncie (close ratio) . . . . .	477709	1 2.40 1st and 2nd . . . . .
73-74	Chevelle w/Muncie (close ratio) . . . . .	477710	1 2.95 3rd and 4th . . . . .
73-74	Chevelle w/Muncie (close ratio) . . . . .	6262266	1 1.55 reverse . . . . .
73	Chevelle (exc. close ratio) . . . . .	6262272	1 1.95 1st and 2nd . . . . .
73	Chevelle (exc. close ratio) . . . . .	6262273	1 2.40 3rd and 4th . . . . .
73	Chevelle (exc. close ratio) . . . . .	6262274	1 1.45 reverse . . . . .
73-74	Chevelle w/close ratio . . . . .	6262269	1 1.35 control upper lock . . . . .
73	Chevelle (exc. close ratio) . . . . .	6262279	1 1.35 control upper lock . . . . .
73-74	Chevelle w/close ratio . . . . .	6262267	1 2.05 control lower lock . . . . .
73	Chevelle (exc. close ratio) . . . . .	6262276	1 2.10 control lower lock . . . . .
75	Camaro w/Muncie . . . . .	493450	1 2.10 1st and 2nd . . . . .
75	Camaro w/Muncie . . . . .	493451	1 4.05 3rd and 4th . . . . .
73-75	Camaro w/Muncie (w/close ratio) . . . . .	493452	1 2.15 reverse . . . . .
74-75	Camaro w/Muncie (w/close ratio) . . . . .	493453	1 2.00 control lower lock . . . . .
75	Camaro w/Muncie . . . . .	356556	1 2.40 reverse . . . . .
71-72	Vega . . . . .	3460273	1 4.65 trans. shift control (Opel— 761703) . . . . .
73-75	Vega . . . . .	325777	1 2.80 reverse . . . . .
73-75	Vega . . . . .	325760	1 2.20 1st and 2nd . . . . .
73-75	Vega . . . . .	325761	1 2.95 3rd and 4th . . . . .

**4-SPEED TRANSMISSION**

**4.035 ROD, Transmission Gearshift (Con't)**

75	Monza (8 cyl.)	356330	1	2.95	reverse
75	Monza (8 cyl.)	356331	1	2.95	1st and 2nd
75	Monza (8 cyl.)	356332	1	2.95	3rd and 4th
75	Monza (140)	348220	1	2.60	1st and 2nd
75	Monza (140)	348222	1	2.60	3rd and 4th
75	Monza (140)	348223	1	2.60	reverse

**4.037 BUSHING— CLAMP— CLEVIS— CLIP— GROMMET— NUT— PIN—  
RETAINER— SLEEVE— SWIVEL— WASHER, Transmission Gearshift Rod  
to Lever**

64-75	All	382102	A.R.	.11	control rod, lever ( <sup>3</sup> / <sub>8</sub> " I.D. - <sup>1</sup> / <sub>2</sub> " O.D.)
All	All	382103	1	.16	CLAMP, cup shade and rod control ( <sup>13</sup> / <sub>32</sub> " I.D. x <sup>25</sup> / <sub>32</sub> " O.D. x <sup>7</sup> / <sub>32</sub> " thk.)
64-67	All w/4-Spd. (exc. Camaro)				CLEVIS, control rod (1st and 2nd),
66-67	Pass. w/4-Spd. (283, 327)	3841496	1	1.20	reverse rod,
62-68	All	3749084	A.R.	.27	CLIP, control rod (all locations) (Note 1)
All	All	3975131	1	.16	GROMMET, control shifter tube lever ( <sup>3</sup> / <sub>4</sub> " O.D. x <sup>1</sup> / <sub>2</sub> " I.D. x <sup>5</sup> / <sub>16</sub> " thk.— rubber)
All	All	3833107	1	.12	GROMMET, bell crank, control rod lever ( <sup>5</sup> / <sub>16</sub> " I.D.) (Note 1)
69	Pass. w/4-Spd. (exc. close ratio, H.D.)				GROMMET, control rod front end, control upper rod/column end,
69	Chevy, Camaro,				control rod ( <sup>5</sup> / <sub>16</sub> " I.D.)
69	Pass. w/H.D., close ratio 4-Spd.	3852837	1	.11	GROMMET, control rod ( <sup>31</sup> / <sub>32</sub> " I.D.)— (4.032)
69-72	Chevelle w/4-Spd.	391312	1	.34	GROMMET ASSY., w/sleeve trans. control upper lock rod
73-74	Chevelle	1394293	1	.27	NUT, control rod clevis ( <sup>7</sup> / <sub>16</sub> "— 20)— (4.253)
62-68	All	3840137	1	.13	PIN, clevis (use wherever <sup>5</sup> / <sub>16</sub> " dia. x <sup>5</sup> / <sub>8</sub> " effective length pin must be used)
All	All	472668	A.R.	.48	RETAINER, control rod
67-70	Chevelle,				RETAINER, control lever spring
69-70	Pass. w/4-Spd.,				
73-74	Vega,				
74	Nova, Chevelle	1351769	1		RETAINER, control shift lever shaft
67-69	Camaro w/floor shift, console,				RETAINER, trans. control rod
68-70	Chevy w/floor shift, console,				
68	Chevelle w/floor shift	3895252	1	.38	RETAINER, control lower lock rod (hair pin type)
67	Camaro w/floor shift,				
68-69	Chevy, Chevelle, Camaro w/floor shift,				
70-72	Chevelle w/4-Spd.,				
70-72	Nova w/floor controls	3923544	1	1.35	SLEEVE, shifter tube lever and upper rod ( <sup>3</sup> / <sub>8</sub> " O.L. x <sup>15</sup> / <sub>32</sub> " O.D. x <sup>3</sup> / <sub>16</sub> " I.D.)
73-74	Vega	3749084	3	.27	SCREW, control rod lower ( <sup>5</sup> / <sub>16</sub> "— 18 x <sup>1</sup> / <sub>2</sub> "
69	Chevelle w/Muncie 4-Spd.,				SWIVEL ( <sup>3</sup> / <sub>8</sub> " x 16" threads, 1 <sup>1</sup> / <sub>2</sub> " long w/ <sup>1</sup> / <sub>8</sub> " dia. hole)
74	Nova	3929844	2	.11	
64-69	Chevelle,				
65-70	Pass.,				
67-69	Camaro,				
68-70	Chevy	3852838	1	.16	
73-75	Chevelle	3989433	1	.16	
All	All	382104	1	.24	
64-65	Chevy, Chevelle w/4-Spd.,				
65-67	Pass. w/4-Spd.,				
66-67	Chevelle w/4-Spd.,				
66-67	Chevy (4-Spd. w/Sp. H/Per. 327),				
66	Chevy w/Muncie 4-Spd. (1st design) (exc. 327 w/Sp. H/Per.)	3843014	A.R.	.59	SWIVEL, 3rd and 4th reverse rod
66-67	Chevy w/Saginaw 4-Spd. (2nd design) (exc. 327 w/Sp. H/Per.)	3886562	2	1.35	SWIVEL, cont. rod
67-68	Camaro w/floor shift,				
68	Chevelle w/4-Spd.,				
68	Chevy w/4-Spd.,				
68-69	Pass. w/4-Spd.,				
69	Chevy, Chevelle, Camaro w/floor shift,				
70-72	Nova, Chevelle w/floor controls	3895244	3	1.20	SWIVEL, control rod

**4-SPEED TRANSMISSION**

**4.037 BUSHING— CLAMP— CLEVIS— CLIP— GROMMET— NUT— PIN—  
RETAINER— SLEEVE— SWIVEL— WASHER, Transmission Gearshift Rod  
to Lever (Con't)**

69	Camaro w/4-Spd. ....	9786896	1	.58	SWIVEL, reverse, rear end .....
69	Camaro w/4-Spd. ....	9788242	1	.71	SWIVEL, 1st and 2nd, rear end .....
69	Camaro w/4-Spd. ....	9791887	1	.81	SWIVEL, 3rd and 4th, rear end .....
70-72	Camaro w/4-Spd. ....	477721	1	1.10	SWIVEL, control rod 3rd and 4th, rear end ..
70-72	Camaro w/4-Spd. ....				SWIVEL ASSY., control rod rev., rear end, ..
70-72	Camaro w/Muncie 4-Spd. ....	491086	2	1.05	control rod 1st and 2nd, rear end .....
70-72	Camaro w/Saginaw .....	3975600	1	.63	SWIVEL ASSY., control rod rear end .....
73-75	Vega .....	325762	1	.50	SWIVEL, trans. control rod .....
75	Monza .....	329757	1	.50	SWIVEL, trans. park. lock and range selector outer .....
73-75	Chevelle .....	1385607	1	.71	SWIVEL, upper control rod .....
73-75	Camaro, Nova .....	3975600	1	.63	SWIVEL ASSY., control rod rear end .....
73-75	Camaro, Nova .....				SWIVEL, control rod 1st and 2nd, rev. rear end, .....
74-75	Chevelle .....	491086	1	1.05	SWIVEL, control rod 1st and 2nd, 3rd and 4th ( <sup>29</sup> / <sub>64</sub> " opening <sup>3</sup> / <sub>8</sub> " pin) .....
73-75	Camaro .....				SWIVEL, control rod rev. 3rd and 4th rear end, .....
74-75	Chevelle .....	477721	1	1.10	control rod reverse .....
All	All .....	9415113	A.R.	.11	WASHER, control rod swivel (to shifter tube lever) ( <sup>9</sup> / <sub>16</sub> " I.D. x <sup>7</sup> / <sub>8</sub> " O.D.) (wave type) ...
All	All .....	3772165	A.R.	.11	WASHER, 1st and reverse rod (to shifter tube lever), trans. control rod swivel ( <sup>17</sup> / <sub>32</sub> " I.D. x <sup>7</sup> / <sub>8</sub> " O.D.) (flat type) .....
All	All .....	382105	A.R.	.12	WASHER, control upper rod to trans. control shifter tube lever ( <sup>25</sup> / <sub>32</sub> " I.D. x <sup>3</sup> / <sub>4</sub> " O.D.) .....
64-72	All .....	580379	A.R.	.11	WASHER, cont. rod to trans. cont. counter shaft cont. upper, rod to cont. idler lever ( <sup>23</sup> / <sub>32</sub> " O.D. x <sup>21</sup> / <sub>16</sub> " I.D. x <sup>1</sup> / <sub>2</sub> " thk.) .....
73-74	Vega .....	382105	1	.12	WASHER, plain .....
73-75	Nova, Chevelle, Camaro .....	382105	A.R.	.12	WASHER, upper lock rod, front end ( <sup>13</sup> / <sub>32</sub> " I.D. x <sup>3</sup> / <sub>4</sub> " O.D. x <sup>1</sup> / <sub>32</sub> " thk.) .....
74-75	Chevelle, Nova, Camaro .....	334533	1	.11	WASHER, control rod (spring type) ( <sup>5</sup> / <sub>32</sub> "— <sup>13</sup> / <sub>64</sub> " free height <sup>21</sup> / <sub>64</sub> " x <sup>11</sup> / <sub>16</sub> ") .....

**4.040 LEVER— SUPPORT ASSY., Transmission Control Idler**

69	Chevy, Camaro w/4-Spd. (exc. 4BC),				
69-70	Chevy, Camaro w/floor shift ...	3895290	1	1.65	
69	Chevy, Camaro (4-Spd. w/4BC) (302, 350, 396),				
70	Nova w/Muncie 4-Spd. (350, 396),				
71-72	Nova .....	3955780	1	1.25	control lock rod idler .....
70-75	Camaro w/4-Spd. (exc. 2BC) ...	3975623	1	1.25	control lock rod idler .....
70-75	Camaro w/Saginaw .....	3975606	1	1.70	control lock rod idler .....
71	Chevelle .....	3945491	1	1.35	lock rod idler .....
71-72	Vega .....	3460269	1	11.50	trans. shift idler (Opel— 761505) .....
73-74	Chevelle w/close ratio .....	6262268	1	1.80	lock rod idler .....
73	Chevelle (exc. close ratio) .....	6262278	1	1.70	lock rod idler .....
73-74	Nova .....	3895290	1	1.65	lock rod idler .....
68-69	Chevy, Camaro w/4-Spd. (exc. 4BC),				
69	Chevy, Camaro w/floor shift,				
70-74	Nova w/Saginaw 4-Spd. ....	3895291	1	2.25	SUPPORT ASSY., control rod idler lever ...
69	Chevy, Camaro (4-Spd. w/4BC) (302, 350, 396),				
70-72	Nova w/4-Spd. ....	3945595	1	1.25	SUPPORT ASSY., control lock rod idler ...
70-75	Camaro w/Saginaw .....	3975604	1	1.30	SUPPORT ASSY., control lock rod idler lever .....
70-75	Camaro w/4-Spd. (exc. 2BC) ...	3975620	1	1.65	SUPPORT ASSY., control lock rod .....

**4.042 LOCK— BUSHING— NUT— SPACER— SPRING— SUPPORT, Transmission  
Control Idler Attaching**

71	Nova, Chevelle,				
72	Chevelle,				
73-75	All (exc. Vega) .....	3685801	1	.16	control lock rod idler lever .....
74-75	Vega .....	336530	2	.18	shift shaft control lever .....
69-70	Chevy, Chevelle, Camaro,				
71	Nova, Chevelle,				
72-75	All (exc. Vega) .....	3792168	A.R.	.22	BUSHING, trans. cont. rod idler lever .....

## 4-SPEED TRANSMISSION

### 4.042 LOCK— BUSHING— NUT— SPACER— SPRING— SUPPORT, Transmission Control Idler Attaching (Con't)

64-74	All (exc. Vega)	382102 A.R.	.11	BUSHING, control rod ( $\frac{3}{8}$ " I.D.- $\frac{1}{2}$ " O.D.)— (4.037)
71-72	Vega	2893967	1	7.20 BUSHING, trans. int. shift lever (Opel— 761602)
67-69	Chevy, Camaro	3792287	1	.34 NUT, cont. rod idler lever supt.— (3.704)
65-66	Pass.	3698237	1	.12 SPRING, cross shaft (idler inner and outer levers— 6 $\frac{1}{2}$ " coils— $\frac{11}{16}$ " I.D.)
71-72	Vega	2888545	1	.31 SPRING, trans. shift idler lever
73-74	Chevelle	488454	1	4.25 SUPPORT ASSY., control lock

### 4.045 LEVER, Transmission Mounted Gearshift (External)

64-65	Chevy, Chevelle w/4-Spd.,			
66-67	Chevy, Chevelle w/4-Spd. (327 w/Sp. H/Per., 396),			
66	Chevy, Chevelle w/Muncie 4-Spd. (1st design) (exc. 327 w/Sp. H/Per., 396),			
67-68	Camaro (4-Spd. w/H/Per., Sp. H/Per.) (302, 350, 396),			
68	Chevy (4-Spd. w/H/Per., Sp. H/Per.) (327, 350, 396)	3859942	1	1.10 1st and 2nd
64-65	Chevelle w/4-Spd.,			
65	Chevy w/4-Spd.,			
66-67	Chevy, Chevelle w/4-Spd. (327 w/Sp. H/Per., 396),			
66	Chevy, Chevelle w/Muncie 4-Spd. (1st design) (exc. 327 w/Sp. H/Per., 396),			
68	Chevy (4-Spd. w/H/Per., Sp. H/Per.) (327, 350, 396),			
68	Camaro w/4-Spd. (302, 396) (exc. close ratio, Sp. H/Per., H.D.),			
68	Camaro w/4-Spd. (close ratio) (302, H/Per., Sp. H/Per. 396),			
68	Pass. w/4-Spd. (396, 427)	3859943	1	1.10 3rd and 4th
65	Pass. w/4-Spd.,			
66-67	Pass. w/4-Spd. (exc. 283, 327),			
66	Pass. w/Muncie 4-Spd. (283, 327) (1st design)	3857410	1	.92 1st and 2nd shifter
65	Pass. w/4-Spd.,			
66-67	Pass. w/4-Spd. (exc. 283, 327),			
66	Pass. w/Muncie 4-Spd. (283, 327) (1st design)	3857411	1	1.15 3rd and 4th shifter
65	Pass. w/4-Spd.,			
66-68	Pass. w/4-Spd. (exc. 283, 307, 327),			
66	Pass. w/Muncie 4-Spd. (283, 327) (1st design),			
66	Chevy, Chevelle w/Muncie 4-Spd. (1st design) (exc. 327 w/Sp. H/Per., 396),			
67	Chevelle, Camaro w/4-Spd. (327 Sp. H/Per., 302, 350, 396),			
68	Chevy (4-Spd. w/H/Per., Sp. H/Per.) (327, 350, 396),			
68	Camaro (4-Spd. w/H/Per., Sp. H/Per.) (302, 350, 396),			
68	Camaro w/H.D. 4-Spd. (2nd design)	3857412	1	.92 reverse $\frac{3}{16}$ " offset
65	Chevy, Chevelle w/4-Spd.,			
66	Chevy, Chevelle w/4-Spd. (327 w/Sp. H/Per., 396),			
66-67	Pass., Chevelle w/Saginaw 4-Spd. (283, 327) (2nd design)	3888771	1	.92 reverse
66-67	Pass., Chevelle w/Saginaw 4-Spd. (283, 327) (2nd design)	3886407	1	1.00 1st and 2nd shifter shaft
66-67	Pass., Chevelle w/Saginaw 4-Spd. (283, 327) (2nd design)	3886417	1	1.00 3rd and 4th shifter shaft
66-67	Chevy w/Saginaw 4-Spd. (2nd design) (exc. 327 w/Sp. H/Per.)	3886569	1	1.30 1st and 2nd

## 4-SPEED TRANSMISSION

### 4.045 LEVER, Transmission Mounted Gearshift (External) (Con't)

66-67	Chevy w/Saginaw 4-Spd. (2nd design) (exc. 327 w/Sp. H/Per.)	3886571	1	1.30	3rd and 4th
67-68	Camaro w/4-Spd. (exc. 4BC),				
68	Chevy w/4-Spd. (exc. Sp. H/Per. 327, 396),				
70	Nova w/Saginaw 4-Spd.,				
73-75	Nova	3895251	1	1.20	shifter shaft, 3rd and 4th
68	Pass. w/4-Spd. (396, 427)	3924469	1	1.65	control shifter shaft 1st and 2nd
68	Pass. w/4-Spd. (exc. 396, 427),				
69	Pass. w/4-Spd. (exc. 4BC)				control shifter shaft,
67	Camaro w/4-Spd. (exc. 350, 396),				
68	Chevy, Chevelle, Camaro w/4-Spd. (exc. 302, 327 Sp. H/Per., 350, 396),				
69	Chevy, Chevelle w/4-Spd. (exc. 4BC),				
70	Nova, Chevelle w/Saginaw 4-Spd. (307, 350),				
71-72	Chevelle w/Saginaw,				
73-74	Nova w/Saginaw	3922528	1	.92	shifter shaft 1st and 2nd
68	Pass. w/4-Spd. (exc. 4BC),				
68	Chevelle w/4-Spd. (exc. Sp. H/Per. 327),				
69	Chevy, Chevelle w/4-Spd. (exc. 4BC),				
70-72	Chevelle w/Saginaw 4-Spd. (307, 350)	3922529	1	.92	control shifter shaft 3rd and 4th
68	Pass. w/4-Spd. (307, 327),				
68	Chevelle w/4-Spd. (exc. Sp. H/Per. 327)	3922530	1	.92	control shifter shaft reverse
68	Pass. w/4-Spd. (396, 427),				
68	Chevelle w/4-Spd. (327 Sp. H/Per., 396),				
68	Camaro w/H.D. 4-Spd. (1st design)	3922521	1	.98	control shifter shaft reverse (straight piece)
68	Chevelle w/4-Spd. (327 Sp. H/Per., 396)	3922519	1	1.10	control shifter shaft 1st and 2nd
69	Pass. w/4-Spd. (exc. 4BC)	3953597	1	1.30	reverse shifter
69-71	Chevy (4-Spd. w/4BC) (350, 396)	3950199	1	.92	control shifter shaft reverse
69	Chevy (4-Spd. w/4BC) (350, 396) (exc. reg. fuel),				
70-72	Nova w/Muncie 4-Spd.	3950195	1	.92	control shifter shaft 1st and 2nd
69	Chevy (4-Spd. w/4BC) (350, 396),				
70-71	Nova w/Muncie 4-Spd.	3950197	1	5.95	control shifter shaft 3rd and 4th
69	Camaro w/4-Spd. (exc. 4BC)	3955764	1	1.30	control shifter shaft reverse
69	Chevelle w/4-Spd. (exc. 4BC),				
70-71	Chevelle w/Saginaw 4-Spd. (307, 350)	3949001	1	1.00	control shifter shaft reverse
69-72	Chevelle (4-Spd. w/4BC)	3952891	1	2.15	control shifter shaft reverse
69-72	Chevelle (4-Spd. w/4BC)	3949180	1	1.70	control shifter shaft 1st and 2nd
69-72	Chevelle (4-Spd. w/4BC)	3949192	1	1.15	control shaft 3rd and 4th
69	Camaro (4-Spd. w/4BC) (302, 350, 396)	3955769	1	2.00	control shifter shaft reverse
69-70	Chevy w/4-Spd. (exc. 4BC),				
73-74	Nova	3955785	1	1.65	shifter shaft, reverse
70-72	Camaro w/4-Spd. (exc. 4BC),				
73-75	Chevelle, Camaro w/Saginaw	3975609	1	1.10	shifter shaft 1st and 2nd, 3rd and 4th
69	Camaro,				
70-72	Camaro w/4-Spd. (exc. 2BC),				
73-75	Chevelle, Camaro w/Muncie	409870	1	3.40	shifter shaft 1st and 2nd, 3rd and 4th
70-75	Camaro w/4-Spd. (exc. 4BC)	3975610	1	1.60	shift shaft, rev.
70-72	Camaro w/4-Spd. (exc. 2BC),				
73-74	Chevelle, Camaro w/Muncie	3975616	1	1.20	shifter shaft reverse
71-72	Vega	2874890	1	3.30	trans. shift selector (Opel— 761100)
73	Chevelle w/Saginaw	6262277	1	1.10	shifter shaft, reverse
73-74	Vega	325759	2	1.05	trans. shift shaft control
73-74	Vega	325776	1	1.20	trans. control shaft
75	Vega w/140	348224	1	6.80	trans. control shaft
75	Monza (exc. Towne Cpe.)	348289	1	1.20	trans. control shaft
75	Camaro w/Muncie	486392	1	1.05	shifter shaft reverse
75	Camaro w/Muncie	486391	1	.80	1st and 2nd, 3rd and 4th

## 4-SPEED TRANSMISSION

### 4.045 LEVER, Transmission Mounted Gearshift (External) (Con't)

75 Nova ..... 352881 1 1.25 shifter shaft, reverse .....

### 4.046 PIN, Transmission Gearshift External Control Lever

71-72 Vega ..... 3455655 1 .39 trans. selector lever pivot (9 x .25 mm)  
(Opel— 761351) .....

### 4.047 CLIP— GROMMET— WASHER, Transmission Gearshift Control Cable

67 Camaro w/4-Spd.,  
68-69 Chevy w/4-Spd. (327 Sp. H/Per.,  
350, 396, Sp. H/Per., P/Trac.),  
68-69 Camaro w/4-Spd. (Sp. H/Per.  
327, 396 P/Trac.) ..... 3772324 A.R. .13 (in tunnel) (1<sup>5</sup>/<sub>16</sub>" long) .....

64-67 All w/4-Spd. (exc. Camaro) .... 3852444 2 .16 GROMMET, reverse release (7/<sub>16</sub>"— (4.008)  
64-67 All w/4-Spd. (exc. Camaro) .... 3852446 A.R. .11 WASHER, reverse release (2<sup>1</sup>/<sub>64</sub>" I.D.)—  
(4.008) .....

### 4.054 SWITCH ASSY.— BRACKET— BUSHING— CLIP— PIN— ROD— RING— SHIELD, Transmission Control Safety

69 Chevelle ..... 1993490 1 11.40 clutch operated .....

69 Pass. .... 1993491 1 11.25 clutch operated (neutral start) .....

69 Chevy, Camaro ..... 1993494 1 11.30 clutch operated .....

70-72 Pass., Nova, Camaro,  
73-75 Nova, Camaro ..... 3983965 1 2.25 clutch oper. neutral start .....

70 Chevelle ..... 3983966 1 2.50 clutch operated neutral start .....

72 Chevelle ..... 3986841 1 2.25 clutch oper. neutral start .....

71-72 Vega ..... 8955983 1 4.15 trans. back-up lamp— (2.698) .....

71-72 Vega ..... 6273381 1 2.40 clutch operated neutral start .....

73 Chevelle ..... 3996277 1 2.50 clutch oper. neutral start .....

74-75 Chevelle ..... 6258273 1 2.50 clutch oper. neutral start .....

73-75 Vega ..... 6273381 1 2.40 clutch operated neutral start .....

75 Monza ..... 356113 1 2.35 clutch operated neutral start .....

73-74 Vega ..... 3902194 1 3.75 backing lamp— (2.698) .....

73-75 Vega, Monza ..... 3990895 1 .31 BRACKET, clutch operated neutral starting  
switch .....

73-75 Chevelle ..... 3996278 1 .36 BRACKET, clutch oper. neutral start .....

71-72 Vega ..... 3990895 1 .31 BRACKET, clutch operated neutral starting  
switch .....

70 Pass., Nova ..... 3961588 1 .38 BRACKET, clutch operated start switch .....

70-72 Chevelle ..... 3961590 1 .38 BRACKET, clutch operated neutral start  
switch .....

70-75 Camaro ..... 3961589 1 .36 BRACKET, clutch oper. neutral start switch .....

72-75 Nova ..... 3996249 1 .28 BRACKET, clutch oper. neutral start .....

69 Chevy, Camaro ..... 3954290 1 .16 BUSHING, clutch operated neutral start  
switch .....

Not required in this group. See  
group 3.762, 9.787 ..... 3908243 1 .63 CLIP .....

69 Chevy, Camaro ..... 3954282 1 1.10 ROD, clutch operated .....

69 Pass., Chevelle ..... 3954288 1 .53 PIN, clutch operated neutral start switch .....

71-72 Vega ..... 11017691 1 .17 RING, trans. back-up switch seal— (2.698) .....

64-68 Chevy w/4-Spd.,  
64-65 Chevelle w/4-Spd.,  
65 Pass. w/4-Spd.,  
66-68 Pass. w/4-Spd. (396, 427),  
66-68 Chevelle, Camaro w/4-Spd.  
(302, 327 w/Sp. H/Per. 350,  
396) ..... 3706355 1 .22 SHIELD, switch .....

### 4.070 LEVER— ROD— SUPPORT ASSY., Transmission Gearshift Anti-Theft

69-72 Pass., Chevelle w/Saginaw 4-  
Spd. .... 3945491 1 1.35 control lock rod idler .....

69-72 Pass., Chevelle w/Muncie 4-Spd. .... 3945493 1 1.25 control lock rod idler .....

69-72 Chevelle w/Muncie 4-Spd. .... 3952889 1 1.95 ROD, control lock upper .....

69-72 Chevelle w/Muncie 4-Spd. .... 3945497 1 2.00 ROD, control lock lower .....

69-72 Chevelle w/Saginaw 4-Spd. .... 3952888 1 2.95 ROD, control lock upper .....

69-72 Chevelle w/Saginaw 4-Spd. .... 3952890 1 2.00 ROD, control lock lower .....

69-72 Chevelle w/4-Spd. .... 3949005 1 1.80 SUPPORT ASSY., control lock .....

### 4.075 SWITCH ASSY.— CLIP— RELAY ASSY.— WIRE ASSY., Transmission, Smog Control

NOTE See 2.408 group for electrical parts.

70 All ..... 3961567 1 3.00 trans. control spark .....

71-75 All ..... 3996286 1 2.85 control spark .....

71-72 Vega ..... 3961567 1 3.00 trans. control spark .....

70-72 Nova, Chevelle, Camaro ..... 3983960 1 .11 CLIP, trans. control (3/<sub>4</sub>" x 1<sup>5</sup>/<sub>16</sub>", w/1/<sub>2</sub>"  
hole) .....

## 4-SPEED TRANSMISSION

4.075 SWITCH ASSY.— CLIP— RELAY ASSY.— WIRE ASSY., Transmission, Smog Control (Con't)					
71-72	Vega	3929530	1	.39	GASKET, trans. control spark switch— (2.698)
73-75	Vega	3929530	1	.39	GASKET, trans. control spark hole plug— (2.698)
73-74	Vega (exc. NB-2)	3906448	1	.92	PLUG, control spark hole
70-75	All	3961573	1	2.85	RELAY ASSY., trans. control spark
71	All	3990842	1	2.45	RELAY ASSY., trans. control switch reversing
71	All	3990843	1	3.00	RELAY ASSY., control spark delay
72	All (307, 350, 400)	3996297	1	3.65	RELAY ASSY., trans. control spark
72	All (6 cyl.)	3996296	1	2.25	RELAY ASSY., trans. control vacuum advance
71-72	Vega	3961573	1	2.85	RELAY ASSY., trans. control spark
73-75	All (exc. 454)	6270698	1	2.15	RELAY ASSY., trans. control vacuum advance
73-74	Vega	1997412	1	9.00	SOLENOID, trans. control spark— (2.408)
72	Nova, Camaro	8908033	1	5.70	WIRE ASSY., trans. control switch
73	Chevelle	8908033	1	5.70	WIRE ASSY., trans. control spark
74-75	Vega	8908346	1	3.05	WIRE ASSY., trans. control spark
4.081 SUPPORT— MOUNTING ASSY.— MEMBER ASSY., Transmission Mounting					
67	Pass. (327, 396, 427) (2nd design) (exc. Conv.)	3906954	1	14.10	(w/1 square and 1 round hole)
68	Pass. w/4-Spd. (8 cyl.) (exc. 307, Conv.)				
68	Pass. (250, 307) (exc. Conv.)				
69	Pass. w/4-Spd. (exc. Conv., Sta. Wag.)	3950232	1	14.25	
70	Pass. (Conv.)	3947536	1	14.25	
64-67	Chevelle (exc. Conv., El Camino)				
68	Chevelle w/4-Spd. (exc. H.D., El Camino, Conv.)				
69-72	Chevelle (exc. El Camino, Conv.)	6272136	1	17.90	SUPPORT ASSY.
64-67	Chevelle (Conv., El Camino)	3838043	1	11.60	SUPPORT ASSY.
68-74	Chevy (exc. 396),				
67	Camaro w/4-Spd.,				
68-69	Camaro (396),				
68-70	Chevy w/H/Per., Sp. H/Per. (396)	3899006	1	10.50	SUPPORT ASSY.
68	Chevelle (El Camino, Conv.) w/4-Spd.,				
69	Chevelle (El Camino, Conv.)				
70-72	Chevelle (El Camino, Conv.) w/4-Spd.	6272134	1	17.35	SUPPORT ASSY.
70	Pass. (exc. Sta. Wag., Conv., C.A.C.)	3947535	1	10.20	SUPPORT ASSY. (code letter S)
70	Pass. (Sta. Wag.) (exc. C.A.C.)	3984771	1	18.25	SUPPORT ASSY.
70-72	Camaro	3964816	1	13.65	SUPPORT ASSY.
71-72	Vega	3988034	1	7.45	SUPPORT ASSY., trans.
73-75	Vega	329708	1	5.85	SUPPORT ASSY., trans.
75	Monza (140)	356344	1	34.00	SUPPORT ASSY., trans.
73-74	Chevelle (exc. El Camino)	6273806	1	20.95	SUPPORT ASSY.
73-74	Chevelle (El Camino)	6273808	1	21.50	SUPPORT ASSY.
62-64	Chevy, Chevelle (exc. 4 cyl.),				
65-70	Pass. (6 cyl.),				
65-67	Chevelle (8 cyl.),				
67	Camaro,				
68-69	Chevy (4 cyl.),				
68	Chevelle (8 cyl.) (exc. 327) (1st design),				
68	Chevelle (exc. 396),				
70-75	Camaro w/Sp. H/Per. (350)	3870182	1	4.50	MOUNTING ASSY. (daub of orange paint) (molded 3870182) (Note 2)
65	Pass. (8 cyl.),				
66	Pass. (283, 327),				
67	Pass. (283, 327) (1st design),				
68	Impala, Caprice (307),				
68	Biscayne, Bel Air (307),				
69	Impala, Caprice (327),				
69	Biscayne, Bel Air (327),				
70	Pass. (350) (exc. 4BC)	3870184	1	4.50	MOUNTING ASSY. (no paint ident.) (molded 3870184) (4 holes) (Note 1, 2)
66	Pass. (396, 427),				

## 4-SPEED TRANSMISSION

### 4.081 SUPPORT— MOUNTING ASSY.— MEMBER ASSY., Transmission Mounting (Con't)

68-70	Camaro, Chevy (396),					
68-69	Camaro (302) . . . . .	3895830	1	4.40	MOUNTING ASSY. (daub of white paint) (Note 1) . . . . .	
67	Pass. (396, 427),					
68	Chevelle (396) (1st design) . . . . .	3904078	1	5.35	MOUNTING ASSY. (daub of white paint) . . . . .	
67-68	Pass. (327),					
68	Chevelle (327) (1st design) . . . . .	3906957	1	4.75	MOUNTING ASSY., trans. supt. (3 holes, 2 oblong) (Note 1, 2) . . . . .	
70	Pass. (exc. C.A.C.) . . . . .	3872247	1	5.25	MOUNTING ASSY., support (orange paint marking, part number molded on piece) . . . . .	
65-67	Chevy,					
66-67	Chevelle (6 cyl.),					
68-69	Camaro (exc. 302, 396),					
68-69	Chevelle, Chevy (6 cyl.),					
68-72	Chevy (exc. 4 cyl.),					
70	Chevelle (6 cyl.),					
70-75	Camaro w/Sp. H/Per. (350) . . . . .	3913498	1	4.65	MOUNTING ASSY., support . . . . .	
68	Chevelle (8 cyl.) (2nd design) (exc. 327),					
69	Chevelle (307),					
70	Chevelle (307) (exc. Monte Carlo),					
70	Concours, Estate Wag. (exc. 350, 400) . . . . .	3935704	1	4.60	MOUNTING ASSY., support . . . . .	
69-70	Chevelle (350) (exc. Monte Carlo),					
69	Chevelle (396),					
70	Monte Carlo,					
70	Chevelle (396, 400, 454),					
71-72	Chevelle (350, 400, 402, 454) . . . . .	3945476	1	6.80	MOUNTING ASSY., support . . . . .	
69	Pass. (396, 427) . . . . .	3950234	1	8.65	MOUNTING ASSY. . . . .	
71-72	Vega . . . . .	329741	1	8.50	MOUNTING ASSY., trans. . . . .	
73-74	Chevelle . . . . .	331239	1	4.40	MOUNTING ASSY., support (white) . . . . .	
73-75	Vega . . . . .	329768	1	8.50	MOUNTING ASSY. . . . .	
75	Monza (8 cyl.) . . . . .	356312	1	56.50	MOUNTING ASSY. . . . .	
73-74	Vega . . . . .	3779940	1	.21	BOLT, trans. support ( $\frac{3}{8}$ "— 16 x $\frac{3}{4}$ "— (7.874) . . . . .	
73-74	Vega . . . . .	3954735	1	.13	WASHER, trans. mtg. to trans.— (14.875) . . . . .	

NOTE 1  $3\frac{3}{4}$ " between center lines of bolt holes.

NOTE 2 Part number moulded on part.

NOTE 3  $4\frac{1}{4}$ " between center lines of bolt holes.

### 4.083 BRACKET, Transmission Mounting

65	Pass.,					
68-69	Pass. (exc. Taxi),					
70	Pass. (exc. C.A.C.) . . . . .	3855908	1	4.50	support (Budd frame) . . . . .	

### 4.085 BOLT, Transmission Mounting Support

62-66	Chevy (exc. 4 cyl.) . . . . .	3779940	2	.21	( $\frac{3}{8}$ "— 16 x $\frac{3}{8}$ "— (7.874) . . . . .
71-72	Vega . . . . .	3779940	1	.21	trans. support ( $\frac{3}{8}$ "— 16 x $\frac{3}{8}$ " . . . . .

### 4.103 CASE, Transmission

64-65	All w/4-Spd. (exc. H.D.) . . . . .	3851324	1	75.50	w/plugs . . . . .
66-74	All w/Muncie 4-Spd. . . . .	3925659	1	82.00	w/plugs . . . . .
66	Pass. w/Saginaw 4-Spd. (2nd design) (exc. 396, 427),				
66-67	Chevy, Chevelle, Camaro w/4-Spd. Saginaw (1st design) (exc. 327 Sp. H/Per., 350, 396),				
67	Pass. w/Saginaw 4-Spd. (1st design) (exc. 396, 427) . . . . .	3890566	1	44.25	w/magnet (cast 3890564) (iron) (Note 1, 2) on piece) . . . . .

NOTE 1 It may be necessary to use 2 each of the following. 9414511  $\frac{1}{2}$ "— 13 hex. nut, 455001  $\frac{1}{2}$ "— 13 x 2 hex. bolt, and 131101  $\frac{1}{2}$  lock washer.

NOTE 2 Used with magnet No. 3890564.

67-69	Pass. w/Saginaw 4-Spd. (2nd design) (exc. 350, 396, 427),				
67-69	Chevy, Chevelle, Camaro w/Saginaw 4-Spd. (2nd design) (exc. 327 Sp. H/Per., 350, 396),				
70-75	All w/Saginaw 4-Spd. . . . .	3925654	1	52.25	w/magnet . . . . .
71-72	Vega . . . . .	3455917	1	46.50	trans. (Opel— 702073) . . . . .
74-75	All w/Warner . . . . .	6260710	1	99.75	(Warner #13-04-065-003) . . . . .



## 4-SPEED TRANSMISSION

<b>4.104 CAP, Transmission Case</b>					
71-72	Vega	3442140	1	2.10	trans. ext. vent. (Opel— 416541)
<b>4.105 COVER— PLUG, Transmission Case</b>					
66	All w/Saginaw 4-Spd. (283, 327)	3890527	1	23.80	
67-69	Pass. w/4-Spd. (exc. 396, 427),				
67-69	Chevy, Chevelle, Camaro w/Saginaw 4-Spd. (exc. 302, 327 Sp. H/Per., 350, 396)	3927919	1	24.30	
70	All w/Saginaw 4-Spd. (8 cyl.),				
71-75	All w/Saginaw (exc. Vega)	3952647	1	26.75	trans.
64-65	Chevy, Chevelle w/4-Spd.,				
65-66	Pass. w/Muncie 4-Spd. (283, 327) (1st design),				
66-68	Pass. w/4-Spd. (396, 427),				
66-68	Chevy, Chevelle, Camaro w/4-Spd. (327 Sp. H/Per., 302, 350, 396),				
66	Chevy, Chevelle w/Muncie 4-Spd. (283, 327) (1st design) (exc. Sp. H/Per.),				
69	Pass. w/4-Spd. (350, 427),				
69	Chevy, Chevelle, Camaro w/4-Spd. (302, 350, 396),				
70-75	All w/Muncie 4-Spd.	3977618	1	11.05	trans.
71-72	Vega	8957606	1	3.75	trans. case (Opel— 730114)
73-75	Vega	6258040	1	28.50	w/pin, trans.
74-75	All w/Warner	360811	1	21.25	trans.
73-75	All w/Muncie, Warner	3968034	1	.93	PLUG, trans. filler
71-72	Vega	8984077	10	.15	SCREW ASSY., trans. case cover (Opel— 2034775)
62-69	All	3930923	1	1.30	PLUG, trans. case magnet (1/2")
<b>4.109 GASKET, Transmission Case Cover</b>					
64-65	All w/4-Spd.,				
66-69	Pass. w/4-Spd. (350, 396, 427),				
66-69	Pass. w/Muncie 4-Spd. (283, 327) (1st design),				
66-69	All w/4-Spd. (302, 327 w/Sp. H/Per., 350, 396),				
66	Chevy, Chevelle w/Muncie 4-Spd. (283, 327) (1st design) (exc. Sp. H/Per.),				
70-75	All w/Muncie	3831705	1	.18	
66	All w/Saginaw 4-Spd. (283, 327) (2nd design),				
67-70	Pass. w/Saginaw 4-Spd. (283, 307, 327, 350),				
67-69	All w/Saginaw 4-Spd. (exc. 302, 327 Sp. H/Per., 350, 396),				
71-75	All w/Saginaw	3858990	1	.33	(87/32" — 20 x 13/16")— (1.453)
71-72	Vega	6681783	1	.58	trans. case cover (Opel— 730890)
74-75	All w/Warner	3709316	1	.24	(Warner #T85B-115)
<b>4.195 SCREW, Transmission Oil</b>					
62-69	All w/4-Spd.	3923420 A.R.		.36	pan drain plug (1/2" — 20 x 13/16")— (1.453)
<b>4.196 GASKET, Transmission Oil Pan</b>					
62-69	All	3921989 A.R.		.20	(1/2" I.D. x 9/10" O.D. x 3/32" thk.)
<b>4.302 SHAFT ASSY.— CAM— LEVER, Transmission Internal Shift</b>					
74-75	All w/Warner	360086	1	11.30	3rd and 4th
74-75	All w/Warner	360087	1	10.20	1st and 2nd
71-72	Vega	6680423	1	6.15	CAM, trans. 1st and 2nd spd. inter. shift lever (L-shaped) (Opel— 732282)
71-72	Vega	6696089	1	6.15	LEVER, trans. 1st and 2nd inter. shift (Opel— 732189)
71-72	Vega	6680414	1	7.25	LEVER, trans. 3rd and 4th inter. shift (Opel— 732196)
71-72	Vega	8952416	1	6.90	LEVER, trans. reverse inter. shift (Opel— 732195)
<b>4.303 FORK, Gearshift</b>					
64-65	Chevy, Chevelle w/4-Spd.,				
65-69	Pass. w/Muncie 4-Spd.,				

## 4-SPEED TRANSMISSION

### 4.303 FORK, Gearshift (Con't)

66-69	Chevy, Chevelle w/4-Spd. (327 Sp. H/Per., 350, 396),				
66	Chevy, Chevelle w/Muncie 4-Spd. (283, 327) (1st design) (exc. Sp. H/Per.),				
67-69	Camaro w/4-Spd. (302, 350, 396),				
66	Pass. w/Muncie 4-Spd. (283, 327) (1st design),				
70-75	All w/Muncie 4-Spd. ....	3831717	2	12.45	1st and 2nd, 3rd and 4th .....
64-65	Chevy, Chevelle w/4-Spd.,				
67-69	Pass. w/Muncie 4-Spd.,				
67-69	Chevy, Chevelle (Muncie 4-Spd.) (w/H/Per., Sp. H/Per. 327, 350, 396),				
67-69	Camaro w/4-Spd. (302, 350, 396),				
70-75	All w/Muncie 4-Spd. ....	3832786	1	8.00	reverse shifter .....
66-69	Pass. w/Saginaw 4-Spd. (283, 307, 327) (2nd design),				
66-69	Chevy, Chevelle w/Saginaw 4-Spd. (283, 307, 327) (2nd design) (exc. Sp. H/Per.),				
67-69	Camaro w/4-Spd. (exc. 302, 350, 396),				
70-75	All w/Saginaw (4-Spd.) .....	3858997	A.R.	6.90	3rd and 4th .....
66-67	Pass. w/Saginaw 4-Spd. (283, 327) (2nd design),				
66-67	Chevy, Chevelle w/Saginaw 4-Spd. (283, 327) (2nd design) (exc. Sp. H/Per.),				
68-69	Chevy, Chevelle, Camaro w/4-Spd. (exc. 302, 327 Sp. H/Per., 350, 396),				
68-75	All w/Saginaw 4-Spd. ....	3884610		6.90	1st and 2nd .....
71-72	Vega .....	6680425	1	6.65	trans. reverse shift (Opel— 734032) .....
71-72	Vega .....	2897723	1	6.50	trans. 1st and 2nd shift (Opel— 734134) .....
71-72	Vega .....	6667468	1	7.25	trans. 3rd and 4th (Opel— 734183) .....
74	All w/Warner .....	3746272	1	12.40	1st, 2nd, 3rd, 4th (Warner #T10-23) .....
74	All w/Warner .....	3743478	1	8.15	reverse (Warner #T10-24) .....
75	All w/Warner .....	360088	1	10.85	FORK, 1st, 2nd, 3rd, 4th .....

### 4.307 PIN— SLEEVE, Gearshift

71-72	Vega .....	6680418	1	.37	trans. reverse inter. shift lever pivot (Opel— 732311) .....
74-75	All w/Warner .....	3709315	1	.23	interlock (Warner #T85B-87) (1/4" O.D. x 5/16" O.L.) .....
74	All w/Warner .....	3709311	1	1.20	SLEEVE, interlock (Warner #T85B-86) (1.0185 O.L.) .....
74	All w/Warner .....	3709313	1	1.15	SLEEVE, interlock (Warner #T85B-86B) (1.0085 O.L.) .....
74-75	All w/Warner .....	360089	1	1.45	SLEEVE, interlock (1.01025 O.L.) .....
74-75	All w/Warner .....	360090	1	1.45	SLEEVE, interlock (1.01175 O.L.) .....
74-75	All w/Warner .....	360091	1	1.45	SLEEVE, interlock (1.01325 O.L.) .....
74-75	All w/Warner .....	360092	1	1.45	SLEEVE, interlock (1.01475 O.L.) .....
74-75	All w/Warner .....	360093	1	1.45	SLEEVE, interlock (1.01625 O.L.) .....
74-75	All w/Warner .....	360094	1	1.45	SLEEVE, interlock (1.01775 O.L.) .....
74-75	All w/Warner .....	360095	1	1.45	SLEEVE, interlock (1.01925 O.L.) .....
74-75	All w/Warner .....	360096	1	1.45	SLEEVE, interlock (1.02075 O.L.) .....
74-75	All w/Warner .....	360097	1	1.45	SLEEVE, interlock (1.02225 O.L.) .....
74-75	All w/Warner .....	360098	1	1.45	SLEEVE, interlock (1.02375 O.L.) .....

### 4.309 SHAFT ASSY., Gear Shifter

64-65	Chevy, Chevelle w/4-Spd.,				
65	Pass. w/Muncie 4-Spd.,				
66-68	Pass. w/4-Spd. (396, 427),				
66	Pass. w/Muncie 4-Spd. (283, 327) (1st design),				
66-68	Chevy, Chevelle (4-Spd. w/H/Per., Sp. H/Per. 327, 350, 396),				
67-68	Camaro w/4-Spd. (302, 350, 396) .....	3831709	A.R.	8.10	1st, 2nd, 3rd, 4th .....
63-65	Chevy, Chevelle w/4-Spd.,				
65	Pass. w/Muncie 4-Spd.,				

**4-SPEED TRANSMISSION**

**4.309 SHAFT ASSY., Gear Shifter (Con't)**

66	Chevy, Chevelle w/Muncie 4-Spd. (283, 327) (1st design) (exc. Sp. H/Per.),					
66-68	Pass. w/4-Spd. (396, 427),					
66	Pass. w/Muncie 4-Spd. (283, 327) (1st design),					
66-68	Chevy, Chevelle w/4-Spd. (327 Sp. H/Per., 350, 396),					
66	Chevy, Chevelle w/Muncie 4-Spd. (283, 327) (1st design) (exc. Sp. H/Per.),					
67-68	Camaro w/4-Spd. (302, 350, 396) .....	<b>3850086</b>	1	7.35	reverse .....	
66	Pass. w/Saginaw 4-Spd. (283, 327) (2nd design),					
66-67	Chevy, Chevelle w/Saginaw 4-Spd. (283, 327) (2nd design) (exc. Sp. H/Per.),					
67	Pass. w/Saginaw 4-Spd. (283, 327),					
67	Camaro w/4-Spd. (exc. 350) ...	<b>3858994 A.R.</b>		4.90	3rd and 4th .....	
66	Pass. w/Saginaw 4-Spd. (283, 327) (2nd design),					
66	Chevy, Chevelle w/Saginaw 4-Spd. (283, 327) (2nd design) (exc. Sp. H/Per.),					
67	Chevelle, Camaro w/4-Spd. (1st design) (exc. 327 Sp. H/Per., 350, 396) .....	<b>3887061</b>	1	7.85	w/plate, 1st and 2nd .....	
66-67	Pass. w/Saginaw 4-Spd. (283, 327) (2nd design),					
66-67	Chevy, Chevelle w/Saginaw 4-Spd. (283, 327) (2nd design) (exc. Sp. H/Per.),					
67	Pass. w/4-Spd. (1st design) (exc. 396, 427),					
67	Camaro w/4-Spd. (exc. 350, 396),					
68	Pass. w/4-Spd. (exc. 396, 427),					
68-69	Chevy, Chevelle, Camaro w/Saginaw 4-Spd.,					
69	Pass. w/Saginaw 4-Spd. (exc. 4BC),					
70	All w/Saginaw 4-Spd. (8 cyl.),					
71-73	All w/Saginaw .....	<b>3915047</b>	1	8.70	w/lever reverse .....	
67-69	Pass. w/Saginaw 4-Spd. (2nd design) (exc. 4BC),					
67	Chevy w/4-Spd. (2nd design),					
67	Camaro, Chevelle (2nd design) (exc. 327 Sp. H/Per., 350, 396),					
68-69	Chevy, Chevelle, Camaro w/4-Spd. (exc. 302, 327 Sp. H/Per., 350, 396),					
70	All w/Saginaw 4-Spd. (8 cyl.),					
71-73	All w/Saginaw .....	<b>3915044</b>	1	9.10	1st and 2nd .....	
68-69	Pass. w/Saginaw 4-Spd. (307, 327),					
68-69	Chevy, Chevelle, Camaro w/Saginaw 4-Spd. (exc. 302, 327 Sp. H/Per., 350, 396) .....	<b>3932234</b>	1	5.35	3rd and 4th .....	
69-72	All w/Muncie 4-Spd. ....	<b>3950312</b>	1	8.35	reverse shaft .....	
69	All w/Muncie 4-Spd. ....	<b>3950308</b>	2	8.35	(Note 1) .....	
70-72	All w/Muncie 4-Spd. ....				1st and 2nd, 3rd and 4th, .....	
72	All w/Saginaw .....	<b>3952649</b>	1	5.75	3rd and 4th .....	
71-72	Vega .....	<b>6695978</b>	1	5.45	trans. 1st and 2nd shift (Opel— 732035) ..	
71-72	Vega .....	<b>8961917</b>	1	4.46	trans. 3rd and 4th shift (Opel— 8961917) ..	
71-72	Vega .....	<b>3442082</b>	1	5.77	trans. reverse shift (Opel— 732132) .....	
71-72	Vega .....	<b>3460271</b>	1	9.10	trans. shift selector (Opel— 732385) .....	
73-75	All w/Saginaw (2nd design) ....	<b>342425</b>	1	7.55	w/lever, reverse (Note 2) .....	
73-75	All w/Saginaw (2nd design) ....	<b>342422</b>	1	5.45	1st and 2nd (Note 2) .....	
	<i>NOTE 2: Identified by "U" shaped interlock located on reverse shifter shaft assy.</i>					
73-74	All w/Muncie .....				1st and 2nd, .....	
73-75	All w/Saginaw, Muncie .....	<b>3952649</b>	1	5.75	3rd and 4th .....	
73-74	All w/Muncie .....	<b>3950312</b>	1	8.35	reverse .....	

## 4-SPEED TRANSMISSION

### 4.309 SHAFT ASSY., Gear Shifter (Con't)

74-75	All w/Warner	6260716	1	7.75	rev. shift (Warner #13-04-598-003)
73-75	Vega (140)	330125	1	8.60	trans. 3rd and 4th shift
73	Vega (1st design)	6261887	1	8.10	trans. 1st and 2nd shift (Note 1)
73	Vega (1st design)	6261889	1	7.75	w/lever trans. reverse shift (Note 1)
<i>NOTE 1: Identified by "U" shaped interlock located on 1-2 shifter shaft assy.</i>					
73-75	Vega (2nd design)	342423	1	8.45	trans. 1st and 2nd shift (Note 2)
73-75	Vega (2nd design)	342426	1	8.05	w/lever trans. reverse shift (Note 2)
<i>NOTE 2: Identified by "U" shaped interlock located on reverse shifter shaft assy.</i>					
74	Vega (122)	342459	1	8.95	trans. 3rd and 4th shift
71-72	Vega	6667468	1	7.25	<b>FORK</b> , trans. 3rd and 4th shift (Opel—734183)
71-72	Vega	11043292	1	.07	<b>NUT</b> , trans. adj. ring lock
71-72	Vega	8953235	1	.45	<b>RING</b> , trans. shift selector shaft adj. (Opel—761176)
71-72	Vega	2877475	1	.32	<b>WASHER</b> , trans. mainshaft rear bearing (Belleville) (Opel—722151)

*NOTE 1 Use one as 1st and reverse shift shaft assy. Use one as 2nd and 3rd shift shaft assy.*

### 4.311 CAM— SPRING— PIN— SHAFT— GASKET, Gearshift Detent

64	Chevy, Chevelle w/4-Spd.,				
65-74	All w/Muncie 4-Spd.	3905462	2	.82	detent
66-69	Pass. w/Saginaw 4-Spd. (283, 307, 327, 350) (2nd design),				
66-70	Chevy, Chevelle w/Saginaw 4-Spd. (283, 307, 327) (2nd design) (exc. Sp. H/Per.),				
67-70	Camaro w/Saginaw 4-Spd. (exc. 4BC),				
71-75	All w/Saginaw	346399	A.R.	.25	3rd and 4th
66-70	Pass. w/Saginaw 4-Spd. (exc. 396, 427),				
66-72	Chevy, Chevelle, Camaro w/Saginaw 4-Spd.	3911925	1		1st and 2nd detent
73	All w/Saginaw	336937	1	.83	1st and 2nd detent
75	All w/Saginaw	346399	1	.25	3rd and 4th detent
71-72	Vega	11011286	3	.15	<b>BALL</b> , trans. shift shaft detent (8 mm dia.) (.315) (Opel—2088004)
64-65	All w/4-Spd.,				
66-75	All w/Muncie 4-Spd.	3773017	1	.23	<b>SPRING</b> , lever poppet ( <sup>13</sup> / <sub>16</sub> " O.D.—6 <sup>1</sup> / <sub>2</sub> " active coils) detent ball, reverse
64-75	All 4-Spd.	3831718	1	.20	<b>SPRING</b> , detent cam
66-67	Pass. w/Saginaw, 4-Spd. (283, 327) (2nd design),				
66-67	Chevy, Chevelle w/Saginaw 4-Spd. (283, 327) (2nd design) (exc. Sp. H/Per.),				
67	Camaro w/4-Spd. (exc. 350, 396),				
74-75	All w/Warner	3709310	1	.17	<b>SPRING</b> , reverse lever poppet ( <sup>13</sup> / <sub>16</sub> " O.L.—7 active coils) detent ball (all locations)
68-70	Pass. w/Saginaw 4-Spd.,				
68-75	Chevy, Chevelle, Camaro w/Saginaw 4-Spd. (exc. 4BC)	3920799	1	.12	<b>SPRING</b> , reverse shift lever detent ball ( <sup>31</sup> / <sub>32</sub> " O.L., 10 coils)
66-70	Pass. w/Saginaw 4-Spd. (283, 307, 327) (2nd design),				
71-75	All w/Saginaw	3831715	1	.20	<b>PIN</b> , detent cam
66-70	Pass. w/Saginaw 4-Spd. (283, 307, 327),				
71-72	All w/Saginaw	141198	1	.11	<b>PIN</b> , rev. shift lever—(8.939)
71-72	Vega	11030002	1	.44	<b>PLUG</b> , trans. oil filler
71-72	Vega	6696393	2	.32	<b>PLUG</b> , trans. shift shaft detent hole (Opel—734604)
71-72	Vega	2874102	1	.32	<b>SEAT</b> , trans. reverse shift shaft detent spring (Opel—734576)
71-72	Vega	6667617	3	.15	<b>SPRING</b> , trans. shift shaft detent (Opel—734360)
66	Chevy, Chevelle w/Saginaw 4-Spd. (283, 327) (2nd design) (exc. Sp. H/Per.),				
66-69	Chevy, Chevelle w/Saginaw 4-Spd. (283, 307, 327) (exc. Sp. H/Per.),				
67-69	Camaro w/4-Spd. (exc. 302, 350, 396),				

**4-SPEED TRANSMISSION**

**4.311 CAM— SPRING— PIN— SHAFT— GASKET, Gearshift Detent (Con't)**

67-69	Chevy, Chevelle, Camaro w/Saginaw 4-Spd. . . . .	3731912	1	.23	SHAFT, cam detent (scissors type) (5/8" O.L.)
62-69	All w/4-Spd. . . . .	3921989 A.R.		.20	GASKET, 1st, 2nd, 3rd and 4th detent spring— (1.456) . . . . .

**4.312 PIN, Gear Shifter Shaft & Fork (Yoke)**

71-72	Vega . . . . .	11054211 A.R.		.13	trans. gearshift control (5 x 24 mm) (spiral) (Opel— 2086000) . . . . .
-------	----------------	---------------	--	-----	--

**4.313 SEAL, Transmission Internal Selector Shaft**

64-75	All w/Muncie 4-Spd. . . . .	3831716	2	.54	shifter shaft, all locations (steel) (.031 thk.) .
66-70	Pass. w/Saginaw 4-Spd. (283, 307, 327) (2nd design),				
66-70	Chevy, Chevelle w/Saginaw 4- Spd. (283, 307, 327) (2nd design) (exc. Sp. H/Per.),				
67-70	Camaro w/4-Spd. (exc. 302, 350, 396),				
71-75	All w/Saginaw . . . . .	3844036 A.R.		.14	shifter shaft (5/8" dia. x 1/16" thk.) (Note 1) . .
71-72	Vega . . . . .	8987853	2	38.74	trans. shift selector shaft . . . . .
73-75	Vega . . . . .	6255517	1	.14	reverse shift shaft . . . . .
74-75	All w/Warner . . . . .	6260717	1	.23	shift lever shaft, oil (Warner #3-188) . . . . .

*NOTE 1 1 Used as 1st and 2nd shaft seal, 1 used as rev. shaft seal.*

**4.317 EXTENSION ASSY.— RETAINER, Transmission Rear Main Bearing**

65	All w/4-Spd.,				
66-69	All w/Muncie 4-Spd.,				
70	All w/Muncie 4-Spd. (exc. H.D.),				
70	Camaro w/Muncie H.D. 4-Spd. . .	3857583	1	56.90	
66-72	All w/Saginaw,				
73-75	Vega . . . . .	6261883	1		
71-72	Vega . . . . .	3455569	1	26.50	trans. (Opel— 724189) (Note 1) . . . . .

*NOTE 1: When using 3455569 in place of 3455570, plug back-up switch hole in extension with plug 3906448 and gasket 3906462.*

74-75	All w/Warner . . . . .	360809	1	59.25	
73-74	All w/Saginaw (exc. Vega) . . . . .	360002	1	34.75	
70-75	Chevelle w/Muncie H.D. 4-Spd. . .	3978763	1	56.90	
71-72	Vega . . . . .	11048332	5	.13	BOLT ASSY., trans. ext. to case . . . . .
74-75	All w/Warner . . . . .	3931531	1	36.80	RETAINER ASSY., w/pin, rear bearing (Warner #AT10-107A) . . . . .
64-75	All w/Muncie 4-Spd. . . . .	3831752	1	38.90	RETAINER . . . . .

**4.318 GASKET— SEAL ASSY., Transmission Rear Bearing Retainer**

64-66	All w/4-Spd.,				
67-75	All w/Muncie 4-Spd. . . . .	3911900	1	1.20	front . . . . .
64-70	All w/4-Spd.,				
71-75	All w/Muncie . . . . .	3911901	1	1.20	rear . . . . .
66-75	All w/Saginaw 4-Spd. . . . .	3876752	1	.14	extension . . . . .
71-72	Vega . . . . .	8977853	1	.13	trans. extension . . . . .
73-74	Vega . . . . .	3876752	1	.14	trans. extension . . . . .
74-75	All w/Warner . . . . .	3787720	1	1.10	rear bearing ret. front . . . . .
74-75	All w/Warner . . . . .	3787722	1	1.00	rear bearing ret. rear . . . . .
62-69	All (exc. Pass.),				
71-75	All . . . . .	1243402	1	2.95	SEAL ASSY., ext. oil . . . . .
70	Pass.,				
70	Nova, Chevelle, Camaro,				
73	Vega . . . . .	3932255	1	4.02	SEAL ASSY., extension oil . . . . .
71-75	All w/Muncie . . . . .	8626009	1	3.07	SEAL ASSY., ext. rear oil . . . . .
71-72	Vega . . . . .	8961248	1	2.83	SEAL ASSY., trans. ext. oil (Opel— 724508)
74-75	All w/Warner . . . . .	6260707	1	4.55	SEAL ASSY., ext. (Warner #T22-110A) . . .

**4.319 BUSHING, Transmission Rear Main Bearing**

62-69	All,				
70-75	All (exc. H.D.) . . . . .	6260048	1	.74	extension (1 1/2" I.D. x 1 5/8" O.D.) . . . . .
70	Chevelle, Camaro w/Muncie H.D. 4-Spd.,				
71-75	All w/Muncie . . . . .	3978765	1	1.25	extension . . . . .
71-72	Vega . . . . .	325087	1	2.27	trans. rear main ext. (1 1/2" I.D. x 1 5/8" O.D.) .
74-75	All w/Warner . . . . .	3774911	1	.83	

**4.329 ADAPTER ASSY.— ADAPTER UNIT, Speedometer**

66-67	All (4-Spd. w/4.56, 4.89 axle) . .	3890575	1	27.30	(7.75 x 14, 7.75 x 15, 8.25 x 14, 8.55 x 14, 8.15 x 15 tires) (21/32" O.L., 10 coils) . . . . .
67	Camaro (4-Spd. w/P/Trac.) (4.88, 4.56 axle) . . . . .	6476736	1	30.04	driven gear (Note 1) . . . . .

**4-SPEED TRANSMISSION**

**4.329 ADAPTER ASSY.— ADAPTER UNIT, Speedometer (Con't)**

67	Camaro 4-Spd. w/4.10, 4.88 axle	<b>6476735</b>	1	27.51	driven gear (7.35 x 15 tires) (Note 1)
	<i>NOTE 1 For additional model application refer to chart in 4.337 group.</i>				
68	(For application refer to chart in group 4.337)	<b>6451928</b>	1	36.59	
68	(For application refer to chart in group 4.337)	<b>1585657</b>	1	28.80	
68	(For application refer to chart in group 4.337)	<b>1565452</b>	1	30.15	
68	(For application refer to chart in group 4.337)	<b>1583624</b>	1	25.28	
69	(For application refer to chart in group 4.337)	<b>3950348</b>	1	18.10	
69	(For application refer to chart in group 4.337)	<b>3950350</b>	1	18.10	
69	(For application refer to chart in group 4.337)	<b>3950352</b>	1	18.10	
69	(For application refer to chart in group 4.337)	<b>3950354</b>	1	18.10	
65-66	(For models and comb. see group 4.337)				<b>ADAPTER UNIT, ratio 17.16 (stamped 1563871),</b>
68	(For application refer to chart in group 4.337)	<b>1565812</b>	A.R.	26.70	(Note 2)
65-66	(For models and comb. see group 4.337)				<b>ADAPTER UNIT, ratio 17.15 (stamped 1563872),</b>
68	(For application refer to chart in group 4.337)	<b>1565813</b>	A.R.	26.70	(Note 2)
68	(For application refer to chart in group 4.337)	<b>1565814</b>	A.R.	28.80	<b>ADAPTER UNIT, ratio 16.17 (stamped 1564409) (Note 2)</b>
	<i>NOTE 2 Above adapters used as required in combination with speedometer gears to correct odometer reading for various tire sizes, transmission and rear axle gear ratio combinations— See group 4.337.</i>				
68	(For application refer to chart in group 4.337)	<b>1584275</b>	1	28.80	<b>ADAPTER UNIT</b>
68	(For application refer to chart in group 4.337)	<b>1584277</b>	1	28.80	<b>ADAPTER UNIT</b>
69	(For application refer to chart in group 4.337)	<b>3925673</b>	1	18.10	<b>ADAPTER UNIT</b>

**4.330 KEY— CUP, Speedometer Adapter**

62-69	All	<b>867209</b>	1	1.14	(also included w/adapters 1565811-12-13-14-1580273-3876)
62-69	All	<b>860187</b>	1	1.88	<b>CUP, drive (1/4"— 32 x 1<sup>3</sup>/<sub>16</sub>" nickel bright)</b>

**4.337 GEAR, Transmission Speedometer Driven Gears (only)**

62	Chevy w/3.55 axle				(6.00 x 13),
64	Chevelle w/3.70 axle				(6.50 x 14),
65-66	Chevy, Chevelle w/2.73 axle	<b>3987917</b>	1	1.05	(6.95, 7.35, 7.75 x 14)
62-65	Chevy w/3.08 axle				(6.00 x 13),
62-66	Chevy (Sta. Wag.) w/3.36 axle				(6.95 x 14, 7.00 x 13),
64	Chevelle (Sta. Wag., El Camino) w/3.36 axle (6 cyl.)				(6.50, 7.00 x 14),
65-66	Pass. w/3.36, 3.31 axle,				(6.95, 7.35 x 14),
65-66	Chevelle w/3.36, 3.31 axle				(7.75 x 14),
66	Chevelle w/3.55 axle				(6.95 x 14),
66	Chevy w/3.31 axle				(8.55 x 14, 8.15 x 15, 8.45 x 15, 8.25 x 14),
67	Pass. w/3.55 axle				(8.45 x 15),
67	Pass. w/3.70 axle				(7.00, 7.35, 7.75 x 14),
67	Chevelle w/3.36 axle				(7.00, 7.35 x 14) (red— 21 teeth)
62-66	Chevy w/3.07, 3.08 axle	<b>3987921</b>	1	1.15	(6.50, 7.00 x 13, 6.95 x 14),
64	Chevelle w/3.08 axle (exc. Sta. Wag., El Camino)				(6.50 x 14),
64-66	Chevelle (Sta. Wag., El Camino) w/3.36 axle (6 cyl.)				(7.50, 7.75 x 14),
65-66	Pass. w/3.36, 3.31 axle				(7.75 x 14, 8.25 x 14, 7.75 x 15, 8.15 x 15, 8.55 x 14) (blue— 20 teeth),
65-66	Chevelle w/3.31 axle				(7.75 x 14),
65-66	Chevelle w/3.07, 3.08 axle				(6.95 x 14),
67	Pass. w/3.36 axle				(8.25 x 14, 8.55 x 14, 8.15 x 15, 7.75 x 15, 8.45 x 15),
67	Pass. w/3.31 axle				(8.25 x 14, 8.55 x 14, 8.15 x 15),

**4-SPEED TRANSMISSION**

**4.337 GEAR, Transmission Speedometer Driven Gears (only) (Con't)**

67	Chevelle w/3.07, 3.08, 2.73 axle				(7.35 x 14),
67	Chevelle w/3.31 axle				(7.75 x 14),
67	Chevy w/3.07, 3.08 axle				(6.95, 7.35 x 14),
67	Camaro w/2.73, 3.07, 3.08 axle	<b>3987920</b>	1	.98	(7.00, 7.35 x 14)
62-66	Chevy w/3.36 axle				(6.50 x 13),
64	Chevelle w/3.70 axle				(7.50 x 14),
65-66	Pass. w/3.55 axle				(7.35 x 14),
65-66	Pass. w/3.70, 3.73 axle				(7.75 x 14, 8.25 x 14, 7.75 x 15, 8.15 x 15, 8.55 x 14),
65-66	Chevelle w/3.70 axle				(7.75 x 14),
67	Pass. w/3.55 axle				(8.25 x 14, 7.75 x 15),
67	Pass. w/3.70 axle				(8.25 x 14, 8.55 x 14, 7.75 x 15),
67	Pass. w/3.73 axle				(8.55 x 14, 8.15 x 15, 8.45 x 15) (green— 22 teeth),
67	Chevelle w/3.55 axle				(7.00, 7.75, F70 x 14),
67	Chevy w/3.31, 3.36 axle				(6.95 x 14),
67	Camaro w/4.10 axle	<b>3860345</b>	1	1.05	(7.00, 7.35 x 14)
62-65	Chevy w/3.36 axle				(6.00 x 13),
62-66	Chevy w/3.55 axle				(6.50, 7.00 x 13, 6.95 x 14),
64	Chevelle w/3.70 axle				(7.00 x 14),
65-66	Pass. w/3.70 axle				(7.35 x 14),
65-66	Pass. w/3.73 axle				(7.35 x 14, 7.75 x 14),
65-66	Chevelle w/3.70 axle				(7.35 x 14),
65-66	Chevelle w/3.73 axle				(7.35, 7.75 x 14),
67	Pass. w/3.73 axle				(8.25 x 14),
67	Chevelle w/3.70 axle				(7.00, 7.75 x 14),
67	Chevelle w/3.73 axle				(7.00, 7.75 x 14),
67	Chevy w/3.55 axle				(6.95, E70 x 14),
67	Camaro w/3.55 axle	<b>3860346</b>	1	1.10	(7.00, 7.35 x 14) (black— 23 teeth)
63-65	Chevy w/3.55 axle				(6.00 x 13),
67	Pass. w/4.10 axle				(7.75 x 14, 8.25 x 14, 7.75 x 15),
67	Chevelle w/4.10, 4.88 axle				(7.00, 7.75 x 14),
67	Camaro w/4.88 axle	<b>3860348</b>	1	1.05	(7.00, 7.35 x 14) (orange— 25 teeth)
64	Chevelle (Sta. Wag., El Camino) w/3.08 axle (8 cyl.) (exc. S.S.),				
64	Chevelle w/3.08 axle (exc. Sta. Wag., El Camino)				(7.00, 7.50 x 14),
65-66	Pass. w/3.07, 3.08, 3.31 axle				(7.35 x 14, 7.75 x 14, 8.25 x 14, 8.15 x 15, 8.55 x 14),
65	Chevelle w/3.07, 3.08 axle				(7.35, 7.775 x 14),
67	Pass. w/3.07 axle				(8.25 x 14),
67	Pass. w/3.08 axle				(8.25 x 14, 7.75 x 15),
67	Pass. w/3.31 axle				(8.45 x 15),
67	Pass. w/2.73 axle				(8.25 x 14),
67	Chevelle w/3.07, 3.08 axle				(7.00, 7.75 x 14),
67	Chevelle w/2.73 axle	<b>3987919</b>	1	.98	(7.75, 7.35 x 14) (natural— 19 teeth)
65-66	Pass. w/4.89 axle	<b>3860033</b>	1	4.70	(8.25 x 14, 8.15 x 15, 8.55 x 14) (21 teeth)
65	Pass. w/2.73	<b>1359273 A.R.</b>		1.20	(7.75 x 15, 8.25 x 14, 8.15 x 15, 8.55 x 14) (brown— 39 teeth) (Note 1)
65-66	Pass. w/4.10 axle				(8.25 x 14, 7.75 x 15, 8.15 x 15, 8.55 x 14) (yellow— 24 teeth),
65-66	Chevelle w/3.70, 3.73 axle,				
66	Chevy w/3.55 axle				(6.95 x 14),
67	Chevelle w/3.70 axle				(7.35 x 14),
67	Chevelle w/3.73 axle				(7.75 x 14),
67	Chevelle w/4.56 axle				(7.00, 7.75 x 14),
67	Chevy w/3.73 axle				(6.95 x 14),
67	Camaro w/3.73, 4.56 axle				(7.00, 7.35 x 14),
67	Pass. w/4.10 axle	<b>3860347</b>	1	1.10	(8.55 x 14, 8.15 x 15, 8.45 x 15)
65-66	Pass. w/4.56 axle	<b>3860329</b>	1	2.20	(8.25 x 14, 8.15 x 15, 8.55 x 14) (20 teeth— steel)
65-66	Pass. w/3.08 axle				(8.00 x 14, 6.70 x 15, 7.10 x 15, 7.75-15, 8.25-14, 8.55-14),
65-66	Pass. w/3.07 axle				(8.25 x 14, 8.15 x 15, 8.55 x 14),
65	Pass. w/3.08 axle				(7.75 x 15, 8.15 x 15, 8.25 x 15),
67	Pass. w/3.07 axle				(8.55 x 14, 8.15 x 15, 8.45 x 15, 6.70 x 15),
67	Pass. w/3.08 axle				(8.15 x 15, 8.45 x 15, 8.55 x 14),
67	Pass. w/2.73 axle	<b>3987918</b>	1	1.05	(8.55 x 14, 8.15 x 15, 8.45 x 15) (brown— 18 teeth)
71-74	Vega w/2.92 rr. axle	<b>3987918</b>	1	1.05	transmission speedometer driven (18 teeth) (brown)
71-74	Vega w/3.36 rr. axle	<b>3987921</b>	1	1.15	trans. speedo. driven (21 teeth) (red)
74	Vega w/3.70 rear axle	<b>3860346</b>	1	1.10	trans. speedometer driven (33 teeth) (black)

NOTE 1 Used selectively.

**4-SPEED TRANSMISSION**

**1968 PASSENGER SPEEDOMETER GEAR CHART**

*NOTE: To order Speedometer Gears or Parts, Transmission Type, Rear Axle Ratio and Tire Size must be known.*

REAR AXLE RATIO	TIRE SIZE	4.343 GEAR, SPEEDO. DRIVE	4.337 GEAR, SPEEDO. DRIVEN	4.329 ADAPTER, SPEEDO.
<b>4-SPEED TRANSMISSION (exc. O/D)</b>				
2.73	8.55 x 14, 8.15 x 15, 8.45 x 15, G70 x 15 ...	3905494	3987918	—
2.73	8.25 x 14	3905494	3987919	—
3.07	8.55 x 14, 8.15 x 15, 8.45 x 15, G70 x 15 ...	6261794	3987918	—
3.07	8.25 x 14, F70 x 15	6261794	3987919	—
3.08	8.55 x 14, 8.15 x 15, 8.45 x 15, G70 x 15 ...	6261794	3987918	—
3.08	8.25 x 14, F70 x 15	6261794	3987919	—
3.31	8.45 x 15	6261794	3987919	—
3.31	8.25 x 14, 8.55 x 14, 8.15 x 15, F70 x 15, G70 x 15	6261794	3987920	—
3.36	8.25 x 14, 8.55 x 14, 8.15 x 15, F70 x 15, G70 x 15	6261794	3987920	—
3.55	8.25 x 14, 8.25 x 14, 8.15 x 15, 8.45 x 15, G70 x 15	6261794	3987921	—
3.55	F70 x 15	3924097	3860345	—
3.70	8.25 x 14, 8.55 x 14, 8.15 x 15, F70 x 15, G70 x 15	3924097	3860345	—
3.70	8.45 x 15	6261794	3987921	—
3.73	8.55 x 14, 8.15 x 15, 8.45 x 15, G70 x 15 ...	3924097	3860345	—
3.73	8.25 x 14, F70 x 15	3924097	3860348	—
4.10	8.55 x 14, 8.15 x 15, 8.45 x 15, G70 x 15 ...	3924097	3860347	—
4.10	8.25 x 14	3924097	3860348	—
4.11	F70 x 15	3924097	3860348	—
4.56	8.55 x 14, 8.45 x 15	3924097	3860345	3890575
4.56	8.25 x 14, 8.15 x 15, G70 x 15	3924097	3860346	3890575
4.56	F70 x 15	3845079	3860033	—
4.89	8.55 x 14, 8.15 x 15, 8.45 x 15, G70 x 15 ...	3924097	3860347	3890575
4.89	8.25 x 14	3924097	3860348	3890575



## 4-SPEED TRANSMISSION

### 1968 CHEVY, CHEVELLE, CAMARO SPEEDOMETER GEAR CHART

*NOTE: To order Speedometer Gears or Parts, Transmission Type, Rear Axle Ratio and Tire Size must be known.*

REAR AXLE RATIO	TIRE SIZE .....	4.343 GEAR, SPEEDO. DRIVE	4.337 GEAR, SPEEDO. DRIVEN	4.329 ADAPTER, SPEEDO.
<b>4-SPEED TRANSMISSION (exc. O/D)</b>				
2.56	7.35 x 14 .....	3905494	3987918	—
2.56	E70 x 14, F70 x 14 ....	3905494	3987919	—
2.73	7.35 x 14, 7.75 x 14, E70 x 14, F70 x 14 ....	3905494	3987919	—
3.07	7.35 x 14, 7.75 x 14, F70 x 14, G70 x 14, E70 x 15 .....	6261794	3987919	—
3.07	E70 x 14 .....	6261794	3987920	—
3.08	7.75 x 14, F70 x 14, G70 x 14 .....	6261794	3987919	—
3.08	7.35 x 14, E70 x 14 ....	6261794	3987920	—
3.31	7.75 x 14, G70 x 14, E70 x 15 .....	6261794	3987920	—
3.31	7.35 x 14, E70 x 14, F70 x 14 .....	6261794	3987921	—
3.36	7.35 x 14, 7.75 x 14, F70 x 14, G70 x 14 ....	6261794	3987921	—
3.36	E70 x 14 .....	3924097	3860345	—
3.55	7.35 x 14, 7.75 x 14, F70 x 14, G70 x 14, E70 x 15 .....	3924097	3860345	—
3.55	E70 x 14 .....	3924097	3860346	—
3.70	7.35 x 14, 7.75 x 14, F70 x 14, G70 x 14 ....	3924097	3860346	—
3.73	7.75 x 14, F70 x 14, G70 x 14, E70 x 15 .....	3924097	3860346	—
3.73	7.35 x 14, E70 x 14 ....	3924097	3860347	—
4.10	7.35 x 14 .....	3924097	3860345	3890575
4.10	7.75 x 14, F70 x 14, G70 x 14 .....	3924097	3860348	—
4.10	7.35 x 14, F70 x 14 ....	6261794	3987920	6476736
4.10	E70 x 14 .....	3924097	3860345	6476735
4.10	E70 x 15 .....	3924097	3860348	—
4.56	7.75 x 14, G70 x 14 ....	3924097	3860346	3890575
4.56	7.35 x 14, F70 x 14 ....	3924097	3860347	3890575
4.56	7.35 x 14 .....	3924097	3860347	6476735
4.56	F70 x 14, E70 x 15 ....	3924097	3860346	6476735
4.56	E70 x 14 .....	3924097	3860346	6476736
4.89	7.75 x 14, F70 x 14, G70 x 14 .....	3924097	3860348	3890575
4.89	7.35 x 14 .....	3924097	3860348	3905497
4.89	E70 x 14, E70 x 15 ....	3924097	3860346	6476736
4.89	7.35 x 14, F70 x 14 ....	3924097	3860347	6476736

**4-SPEED TRANSMISSION**

**1969 PASSENGER SPEEDOMETER GEAR CHART**

*NOTE: To order Speedometer Gears or Parts, Transmission Type, Rear Axle Ratio and Tire Size must be known.*

REAR AXLE RATIO	TIRE SIZE	4.343 GEAR, SPEEDO. DRIVE 4-SPD.	4.337 GEAR, SPEEDO. DRIVEN	4.329 ADAPTER, SPEEDO.
<b>4-SPEED TRANSMISSION</b>				
2.56	7.35 x 14, 7.75 x 14, E78 x 14, F70 x 14, F78 x 14, G78 x 14 . . .	3905494	3987919	—
2.56	8.25 x 14, E70 x 14, F70 x 15, G70 x 15, G78 x 15 . . . . .	3905494	3987919	3925673
2.73	8.55 x 14, G70 x 15, G78 x 15, 8.85 x 14, 8.25 x 15, 8.55 x 15 . .	3905494	3987919	—
2.73	7.35 x 14, 7.75 x 14, 8.25 x 14, F70 x 14, F70 x 15, F78 x 14, G78 x 14 . . . . .	3905494	3987919	—
2.73	E70 x 14, E78 x 14 . . . .	3905494	3987920	—
3.07	8.55 x 14, 8.85 x 14, 8.25 x 15, G70 x 15, G78 x 15 . . . . .	6261794	3987919	—
3.07	7.35 x 14, 7.75 x 14, F70 x 14, F78 x 14, G70 x 14 . . . . .	6261794	3987919	—
3.07	8.55 x 15 . . . . .	3905494	3987920	—
3.07	E70 x 14, E78 x 14 . . . .	6261794	3987920	—
3.07	8.25 x 14, E70 x 15, F70 x 15, G78 x 14 . . . . .	3905494	3987921	—
3.08	8.55 x 14, 8.85 x 14, 8.55 x 15, G70 x 15, G78 x 15 . . . . .	6261794	3987919	—
3.08	7.75 x 14, F70 x 14, F78 x 14 . . . . .	6261794	3987919	—
3.08	7.35 x 14, E70 x 14, E78 x 14 . . . . .	6261794	3987920	—
3.08	8.25 x 14, 8.25 x 15, F70 x 15, G78 x 14 . . .	3924099	3987921	—
3.31	8.55 x 15 . . . . .	6261794	3987919	—
3.31	7.75 x 14, 8.25 x 14, 8.55 x 14, 8.85 x 14, 8.25 x 15, E70 x 15, F70 x 15, G70 x 14, G70 x 15, G78 x 14, G78 x 15 . . . . .	6261794	3987920	—
3.31	7.35 x 14, E70 x 14, E78 x 14, F70 x 14, F78 x 14 . . . . .	6261794	3987921	—
3.36	8.25 x 14, 8.55 x 14, 8.85 x 14, 8.25 x 15, 8.55 x 15, F70 x 15, G70 x 15, G78 x 15 . . .	6261794	3987920	—
3.36	7.35 x 14, 7.75 x 14, E78 x 14, F70 x 14, F78 x 14, G78 x 14 . . .	6261794	3987921	—
3.36	E70 x 14 . . . . .	3924097	3860345	—
3.55	8.25 x 14, 8.55 x 14, 8.85 x 14, 8.25 x 15, 8.55 x 15, G70 x 15, G78 x 15 . . . . .	6261794	3987921	—
3.55	7.35 x 14, 7.75 x 14, E70 x 15, F70 x 14, F70 x 15, F78 x 14, G70 x 14, G78 x 14 . . .	3924097	3860345	—

**4-SPEED TRANSMISSION**

**1969 PASSENGER SPEEDOMETER GEAR CHART (CONT.)**

REAR AXLE RATIO	TIRE SIZE	4.343 GEAR, SPEEDO. DRIVE 4-SPD.	4.337 GEAR, SPEEDO. DRIVEN	4.329 ADAPTER, SPEEDO.
<b>4-SPEED TRANSMISSION (CONT.)</b>				
3.55	E70 x 14, E78 x 14	3924097	3860346	—
3.70	E70 x 14	3924097	3860347	—
3.73	8.25 x 14, 8.55 x 14, 8.85 x 14, 8.25 x 15, 8.55 x 15, G70 x 15, G78 x 15	3924097	3860345	—
3.73	E70 x 15, F70 x 14, F70 x 15, G70 x 14, G78 x 14	3924097	3860346	—
3.73	E70 x 14	3924097	3860347	—
4.10	F70 x 14	6261794	3987919	3932220
4.10	8.55 x 14, 8.85 x 14, 8.25 x 15, 8.55 x 15, G70 x 15, G78 x 15	3924097	3860347	—
4.10	8.25 x 14, G70 x 14, G78 x 14	3924097	3860348	—
4.56	8.55 x 15	6261794	3987919	3932220
4.56	8.25 x 14, 8.55 x 14, 8.85 x 14, G70 x 15, G78 x 14, G78 x 15	6261794	3987920	3932220
4.56	8.25 x 15	6261794	3987920	3932220
4.56	F70 x 14, G70 x 14	6261794	3987921	3932220
4.88	8.55 x 14, 8.85 x 14, 8.25 x 15, 8.55 x 15, G70 x 15, G78 x 15	6261794	3987921	3932220
4.88	8.25 x 14, F70 x 14, G70 x 14, G78 x 14	3924097	3860345	3932220

**4-SPEED TRANSMISSION**

**1969 CHEVY, CHEVELLE, CAMARO SPEEDOMETER GEAR CHART**

*NOTE: To order Speedometer Gears or Parts, Transmission Type, Rear Axle Ratio and Tire Size must be known.*

REAR AXLE RATIO	TIRE SIZE	4.343 GEAR, SPEEDO. DRIVE 4-SPD.	4.337 GEAR, SPEEDO. DRIVEN	4.329 ADAPTER, SPEEDO.
<b>4-SPEED TRANSMISSION</b>				
2.73	8.25 x 14, 7.75 x 14, F70 x 14, 7.35 x 14, 5.78 x 14	6261794	3987919	—
2.73	E78 x 14, E70 x 14	6261794	3987920	—
3.07	8.25 x 14, E70 x 15	3905494	3987921	—
3.07	7.75 x 14, G70 x 14, F70 x 14, F78 x 14	3905494	3987919	—
3.07	E70 x 14	3905494	3987920	—
3.08	8.25 x 14	3905494	3987921	—
3.08	7.75 x 14, F70 x 14, F78 x 14	3905494	3987919	—
3.08	7.35 x 14, E78 x 14, E70 x 14	3905498	3987920	—
3.31	8.25 x 14, 7.75 x 14, G70 x 14, E90 x 15	3905494	3987920	—
3.31	F70 x 14, F78 x 14, E70 x 14	3905494	3987921	—
3.36	8.25 x 14	3905494	3987920	—
3.36	7.75 x 14, F70 x 14, 7.35 x 14, E78 x 14, F78 x 14	3905494	3987921	—
3.36	E70 x 14	3924097	3860345	—
3.55	8.25 x 14	3905494	3987921	—
3.55	7.75 x 14, G70 x 14, F70 x 14, 7.35 x 14, F78 x 14, E70 x 15	3924097	3860345	—
3.55	E70 x 14	3924097	3860346	—
3.70	E70 x 14	3924097	3860347	—
3.73	8.25 x 14	3924097	3860345	—
3.73	7.75 x 14, G70 x 14, F70 x 14, F78 x 14, E70 x 15	3924097	3860346	—
3.73	E70 x 14	3924097	3860347	—
2.56	8.25 x 14	3905494	3987919	3925673
2.56	G78 x 14, 7.75 x 14, F70 x 14, 7.35 x 14, E78 x 14, F78 x 14	3905494	3987918	—
2.56	E70 x 14	3905494	3987919	—
4.10	8.55 x 14	3924097	3860347	—
4.10	8.25 x 14, G78 x 14, 7.75 x 14, G70 x 14, E78 x 14	3924097	3860348	—
4.10*	F70 x 14	6261794	3987919	3932220
4.10	F70 x 14	6261794	3987920	6476736
4.10	E70 x 14	6261794	3987921	6476736
4.10	E70 x 15	3924097	3860348	6476736
4.55	8.55 x 14, 8.25 x 14, G78 x 14, 7.75 x 14	6261794	3987920	3932220
4.55*	G70 x 14, F70 x 14, F78 x 14	6261794	3987921	3932220
4.55	F70 x 14, E70 x 15	3924097	3860345	6476736
4.55	E70 x 15	3924097	3860346	6476736
4.88	8.55 x 14	6261794	3987921	3932220
4.88*	8.25 x 14, G78 x 14, 7.75 x 14, G70 x 14, F70 x 14, F78 x 14	3924097	3860345	3932220
4.88	F70 x 14, E70 x 14	3924097	3860347	6476736
4.88	E70 x 15	3924097	3860346	6476736

\*NOTE: Chevelle (3-Spd., 4-Spd.)

**4-SPEED TRANSMISSION**

**1970 PASSENGER, NOVA, CHEVELLE, CAMARO SPEEDOMETER GEAR CHART**

REAR AXLE RATIO	REAR TIRE SIZE .....	4.337 GEAR, SPEEDO. DRIVEN	4.343 GEAR, SPEEDO. DRIVE	4.329 ADAPTER, SPEEDO.	4.330 KEY, SPEEDO. ADAPTER
--------------------	----------------------	-------------------------------------	------------------------------------	------------------------------	-------------------------------------

**NOVA w/4-SPEED (EXC. CLOSE RATIO)**

3.07	E70 x 14, E78 x 14, 7.35 x 14 .....	3987919	6261794	—	—
3.08	E70 x 14, E78 x 14, 7.35 x 14 .....	3987920	6261794	—	—
3.08	F70 x 15 .....	3987919	6261794	—	—
3.31	E70 x 14 .....	3987921	6261794	—	—
3.36	F70 x 15 .....	3987920	6261794	—	—
3.55	E70 x 14 .....	3987919	6261794	6477965	867209
3.55	F70 x 15 .....	3987918	6261794	6477965	867209
3.70	F70 x 15 .....	3987919	6261794	6477965	867209
4.11	F70 x 15 .....	3987921	6261794	6477965	867209
4.56	F70 x 15 .....	3987920	6261794	6477964	867209

**NOVA w/CLOSE RATIO 4-SPEED**

3.08	F70 x 15 .....	3860346	3924097	6477966	867209
3.31	E70 x 14 .....	3860348	3924097	6477966	867209
3.36	F70 x 15 .....	3860348	3924097	6477966	867209
3.55	E70 x 14, F70 x 15 .....	3860345	3924097	—	—
3.70	F70 x 15 .....	3860345	3924097	—	—
4.11	F70 x 15 .....	3860348	3924097	—	—

### 4-SPEED TRANSMISSION

REAR AXLE RATIO	REAR TIRE SIZE	4.337 GEAR, SPEEDO. DRIVEN	4.343 GEAR, SPEEDO. DRIVE (EXC. H.D.)	4.343 GEAR, SPEEDO. DRIVE (w/H.D.)	4.329 ADAPTER, SPEEDO.
<b>CHEVELLE, CAMARO w/4-SPEED (EXC. CLOSE RATIO)</b>					
3.07	F70 x 14, E78 x 14, F60 x 15, F70 x 15, 7.35 x 14	3987919	6261794	3978758	—
3.08	F70 x 14	3987919	6261794	3978758	—
3.08	E78 x 14, 7.35 x 14	3987920	6261794	3978758	—
3.31	F70 x 14, E78 x 14, F78 x 14, F60 x 15, 7.35 x 14	3987921	6261794	3978758	—
3.31	G70 x 14, G78 x 14, F70 x 15, G70 x 15, G78 x 15, 7.75 x 14, 8.25 x 14	3987920	6261794	3978758	—
3.36	F70 x 14, E78 x 14, F78 x 14, G78 x 14, 7.35 x 14, 7.75 x 14	3987921	6261794	3978758	—
3.36	G70 x 15, G78 x 15, 8.25 x 14	3987920	6261794	3978758	—
3.55	F70 x 14, G70 x 14, F70 x 15	3987918	6261794	3978758	3950352
3.55	F60 x 15	3987919	6261794	3978758	3950352
3.73	F60 x 15	3987919	6261794	3978758	3950352
4.10	F70 x 14, G70 x 14	3987921	6261794	3978758	3950352
4.10	F60 x 15	3987919	6261794	3978758	3932220
4.10	F70 x 15	3987918	6261794	3978758	3932220

### 1970 PASSENGER, NOVA, CHEVELLE, CAMARO SPEEDOMETER GEAR CHART (CONT.)

REAR AXLE RATIO	REAR TIRE SIZE	4.337 GEAR, SPEEDO. DRIVEN	4.343 GEAR, SPEEDO. DRIVE	4.329 ADAPTER, SPEEDO.
<b>CHEVELLE, CAMARO w/CLOSE RATIO 4-SPEED</b>				
3.31	F70 x 14, G70 x 14, F60 x 15	3860348	3924097	3950348
3.31	F70 x 15	3860347	3924097	3950348
3.55	F70 x 14, G70 x 14, F60 x 15, F70 x 15	3860345	3924097	—
3.73	F60 x 15	3860347	3924097	—
4.10	F70 x 14, G70 x 14, F70 x 15	3860348	3924097	—
4.10	F60 x 15	3860345	3924097	3950352

**4-SPEED TRANSMISSION**

**1971 SPEEDOMETER GEAR CHART**

**DRIVE GEAR**

PART NUMBER	COLOR	NUMBER OF TEETH
6261794	Natural	8

**DRIVEN GEARS**

*3987919	Natural	19
*3987920	Blue	20
*3987921	Red	21

*NOTE To order speedometer gears and parts, transmission, rear axle ratio, and tire, size must be known.*

**NOVA**

REAR AXLE RATIO	REAR TIRE SIZE	4.337 GEAR, SPEEDO. DRIVEN	4.343 GEAR, SPEEDO. DRIVE
3.308	E78-14, E70-14	3987921	6261794

**CHEVELLE, CAMARO**

REAR AXLE RATIO	REAR TIRE SIZE	GEAR, SPEEDO. DRIVEN	4.337 GEAR, SPEEDO. DRIVE	4.329 ADAPTER ASSY.
3.083	E78-14	3987920	6261794	—
3.083	F70-14, F78-14	3987919	6261794	—
3.308	E78-14, F78-14, F60-15	3987921	6261794	—
3.308	G78-14, G70-15, G78-15	3987920	6261794	—
3.364	E78-14, F78-14, G78-14	3987921	6261794	—
3.417	F70-14	3987921	6261794	—
3.727	F60-15	3987919	6261794	3950352
4.100	F78-14, F60-15	3987921	6261794	3950352

**1972 SPEEDOMETER GEAR CHART**

**DRIVE GEARS**

PART NUMBER	COLOR	NUMBER OF TEETH
6261794	Natural	8
3978758	Steel	8

**DRIVEN GEARS**

3987918	Brown	18
3987919	Natural	19
3987920	Blue	20
3987921	Red	21
3987922	Solid Silver	22

*NOTE: To order speedometer gears & parts, transmission type, rear axle ratio, & tire size must be known.*

## 4-SPEED TRANSMISSION

### 4 SPEED (SAGINAW) CHEVELLE, CAMARO

REAR AXLE RATIO	REAR TIRE SIZE	GEAR SPEEDO. DRIVEN	GEAR SPEEDO. DRIVE	ADAPTER ASSY.	SLEEVE DRIVEN GEAR
3.083	E78-14, F60-15	3987920	6261794		3869914
3.083	F78-14, F70-14, G78-14	3987919	6261794		3869914
3.083	G70-15, G78-15	3987918	6261794		3869914
3.308	E78-14, F78-14, F70-14, F60-15	3987921	6261794		3869914
3.308	G78-14, G70-15, G78-15	3987920	6261794		3869914
3.364	E78-14, F78-14, F70-14, G78-14, F60-15	3987921	6261794		3869914
3.364	G70-15, G78-15	3987920	6261794		3869914
3.417	E78-14, F60-15	3987922	6261794		3869914
3.417	F78-14, F70-14, G78-14	3987921	6261794		3869914
3.417	G70-15, G78-15	3987920	6261794		3869914

### NOVA

3.308	E78 x 14, E70 x 14	3987921	6261794		3869914
3.417	E78 x 14, E70 x 14	3987922	6261794		3869914

### CHEVELLE, CAMARO 4 SPEED (MUNCIE)

REAR AXLE RATIO	REAR TIRE SIZE	GEAR SPEEDO. DRIVEN	GEAR SPEEDO. DRIVE	ADAPTER ASSY.	SLEEVE DRIVEN GEAR
3.308	E78-14, F78-14, F70-14, F60-15, E70-14	3987921	3978758		3869912
3.308	G78-14, G70-15, G78-15	3987920	3978758		3869912
3.417	E78-14, F60-15, E70-14	3987922	3978758		3869912
3.417	F78-14, F70-14, G78-14	3987921	3978758		3869912
3.417	G70-15, G78-15	3987920	3978758		3869912
3.727	F78-14, F70-14, G78-14	3987919	3978758	3950352	3869912
3.727	G70-15, G78-15	3987922	3978758		3869912
3.727	F60-15	3987920	3978758	3950352	3869912
4.100	E78-14, F78-14, F70-14, G78-14, F60-15, E70-14	3987921	3978758	3950352	3869912
4.100	G70-15, G78-15	3987920	3978758	3950352	3869912

### 1973

#### Camaro, Chevelle, Nova 4-Spd. (exc. Close Ratio)

CODE	DRIVEN GEAR		SLEEVE ASM.	CODE	ADAPTER
A	3987921	21T	6258100	F	326569
B	3987922	22T	6258100		
C	3987919	19T	6258100		
D	3987920	20T	6258100		



### 4-SPEED TRANSMISSION

TIRE SIZE	3.08 DRIVE GEAR 6261794	3.42 DRIVE GEAR 6261794
Chevelle	Driven	Adapt
G70-14	—	—
G78-14	—	—
Camaro		
E78-14	D	—
F70-14	C	F
Nova		
E78-14	—	—
E70-14	—	—

#### 1973 Chevelle, Camaro w/Close Ratio 4-Spd.

CODE	DRIVEN GEAR	TEETH	SLEEVE ASSY.	CODE	ADAPTER
A	3987921	21T	6258100	D	3950352
B	3987922	22T	6258100		
C	3987920	20T	6258100		

TIRE SIZE	3.42 DRIVE GEAR 3978758	3.73 DRIVE GEAR 3978758
G78-14	Driven	Adapt
G70-14	A	—
F60-15	A	—
	B	—
		Driven
		C
		Adapt
		D

#### 1974 NOVA, CHEVELLE, CAMARO w/4-SPD. (exc. Close Ratio)

CODE	DRIVEN GEAR	TEETH	COLOR	CODE	ADAPTER	CODE	SLEEVE ASSY.
A	3987921	21	Red	F	326569	H	345215
B	3987922	22	Silver	G	3950352	I	3869912
C	3987919	19	Natural				
D	3987920	20	Blue				

TIRE SIZE	3.08 DRIVE	RATIO GEAR	6261794*	3.42 DRIVE	RATIO GEAR	6261794*	3.73 DRIVE	RATIO GEAR	
	Driven	Adapter	Sleeve	Driven	Adapter	Sleeve	Driven	Adapter	Sleeve
Chevelle									
G78-14	—	—		A	—	H			
G78-14	—	—		A	—	H			
Camaro									
E78-14	C	F	I	B		H			
E70-14	C	F	I	A	F	I			
FR78-14	C	F	I	B		H			
F60-15				B		H	D	G	I
Nova									
E78-14	—	—		B	—	H			
E70-14	—	—		B	—	H			

\*8 Tooth Natural

#### 1974 CHEVELLE, CAMARO w/Close Ratio 4-Spd.

DRIVEN	SLEEVE

### 4-SPEED TRANSMISSION

#### 4.337 GEAR, Transmission Speedometer Driven Gears (only) (Con't)

CODE	GEAR	TEETH	COLOR	CODE	ADAPTER	CODE	ASSY.
A	3987921	21	Red	D	3950352	E	3869912
B	3987922	22	Silver			F	345215
C	3987920	20	Blue				

TIRE SIZE		3.42 RATIO DRIVE GEAR 3978758*			3.73 RATIO DRIVE GEAR 3978758*	
G78-14 G70-14 F60-15	Driven A A	Adapt.	Sleeve F F	Driven  C	Adapt.  D	Sleeve  E

\* 8 Tooth Natural (Steel)

#### 1975 NOVA, CHEVELLE, CAMARO w/4-SPD. (Exc. Close Ratio)

CODE	DRIVEN GEAR	TEETH	COLOR	CODE	ADAPTER	CODE	SLEEVE ASSY.
A	3987921	21	Red	F	326569	H	345215
B	3987922	22	Silver	G	3950352	I	3869912
C	3987919	19	Natural	—	—	—	—
D	3987920	20	Blue	—	—	—	—

TIRE SIZE	3.08 DRIVE	RATIO GEAR 6261794*		3.42 DRIVE	RATIO GEAR 6261794*		3.73 DRIVE	RATIO GEAR 6261794*	
	Driven	Adapter	Sleeve	Driven	Adapter	Sleeve	Driven	Adapter	Sleeve
Chevelle									
G-78-14	—	—	—	A	—	H	—	—	—
G-78-14	—	—	—	A	—	H	—	—	—
Camaro									
E78-14	C	F	I	B	—	H	—	—	—
E70-14	C	F	I	A	F	I	—	—	—
FR78-14	C	F	I	B	—	H	—	—	—
F60-15	—	—	—	B	—	H	D	G	I
Nova									
E78-14	—	—	—	B	—	H	—	—	—
E70-14	—	—	—	B	—	H	—	—	—

\* 8 Tooth Natural

**4-SPEED TRANSMISSION**

**1975 CHEVELLE, CAMARO w/Close RATIO 4-SPD.**

CODE	DRIVEN GEAR	TEETH	COLOR	CODE	ADAPTER	CODE	SLEEVE ASSY.
A	3987921	21	Red	D	3950352	E	3869912
B	3987922	22	Silver	—	—	F	345215
C	3987920	20	Blue	—	—	—	—

**1975 CHEVELLE, CAMARO w/Close RATIO 4-SPD.**

CODE	DRIVEN GEAR	TEETH	COLOR	CODE	ADAPTER	CODE	SLEEVE ASSY.
A	3987921	21	Red	D	3950352	E	3869912
B	3987922	22	Silver	—	—	F	345215
C	3987920	20	Blue	—	—	—	—

TIRE SIZE	DRIVEN GEAR	ADAPTER	SLEEVE	DRIVEN GEAR	ADAPTER	SLEEVE
	<b>3.42 RATIO DRIVE GEAR</b> 3978758* 6260705(1) 361002(2)			<b>3.73 RATIO DRIVE GEAR</b> 3978758* 6260705(1) 361002(2)		
G78-14	Driven A	Adapter —	Sleeve F	Driven —	Adapter —	Sleeve —
G70-14	A	—	F	—	—	—
F60-15	—	—	—	C	D	E

\* 8 Tooth Natural (Steel)  
(1) 8 Tooth Blue-Warner 4 Spd.  
(2) 7 Tooth 2nd design Warner

**4.338 FITTING— RETAINER— RING— SEAL, Speedometer Driven Gear**

65-73	All w/4-Spd. ....	345215	1	2.45	w/seal .....
65-69	Pass.,				
70-74	All .....	3708148	1	.12	RETAINER, gear fitting (9/16" I.D.) .....
70	Pass., Nova, Chevelle w/4-Spd. .	1361618	1	.13	RING, oil seal retaining .....
70-74	All .....	6264903	1	.20	SEAL, gear fitting "O" ring, hole plug (11/16" I.D.) .....
65-67	All w/4-Spd.,				
68	Pass. w/4-Spd. (exc. H.D.),				
68	All w/4-Spd. (exc. Pass.),				
71-74	All w/4-Spd. ....	3869910	1	1.05	SEAL ASSY., pinion (5/32") .....

**4.342 SHAFT ASSY.— SHAFT UNIT— CLIP, Speedometer without Casing**

64	Chevelle w/4-Spd. ....	6478171	1	6.58	(55 1/8") .....
66	Pass. w/4-Spd.,				
66	Chevy, Chevelle w/4-Spd. (327 Sp. H/Per.) (396),				
67	Chevelle w/4-Spd. (327 Sp. H/Per.) (396),				
68	Camaro w/Muncie 4-Spd. (exc. P/Trac.),				
69	Camaro w/floor shift (302, 350, 396) (exc. P/Trac.) .....	6452474	1	2.08	(62 1/8") .....
66	Chevy, Chevelle w/4-Spd. (283, 327) (exc. Sp. H/Per.),				
67-68	Camaro w/4-Spd. (350, 396),				
68	Chevy (8 cyl.) .....	1564778	1	2.20	(56 1/8" O.L.) .....
67	Camaro w/4-Spd. (exc. 350, 396),				
68	Chevy, Camaro w/4-Spd. (exc. 327 Sp. H/Per., 350, 396),				
69	Chevy, Camaro w/floor shift (exc. 302, 350, 396) .....	6478071	1	2.68	lower flex (24 3/4" O.L.) .....
68	Chevelle w/cruise control .....	6478123	1	6.74	(48" O.L.) .....
69	Pass. (exc. H.D. close ratio 4-Spd.) .....	6477306	1	2.35	(61 7/16") .....

## 4-SPEED TRANSMISSION

### 4.342 SHAFT ASSY.— SHAFT UNIT— CLIP, Speedometer without Casing (Con't)

69	Pass. w/4-Spd. (exc. H.D. 4-Spd.)	6477751	1		(80 <sup>7</sup> / <sub>16</sub> " ) . . . . .
69	Camaro (P/Trac. w/4-Spd.) (350, 396)	6477499	1	3.70	(70") (AC-615) . . . . .
69	Pass. w/Muncie 4-Spd. (exc. close ratio, H.D.),				
69	Chevelle w/4-Spd. . . . .	6478057	1		(70 <sup>7</sup> / <sub>16</sub> " ) (left hand wound) . . . . .
69	Chevy, Camaro (Spt. Cpe.) w/floor shift (exc. 302, 350, 396)	6477297	1	1.80	upper flex (37 <sup>7</sup> / <sub>16</sub> " ) . . . . .
62-70	All,				
71-75	Vega . . . . .	6477499	1	3.70	SHAFT UNIT (consists of shaft, tip) (AC-615) (70" O.L.) (Note 1) . . . . .
<i>NOTE 1 For models requiring maximum length of 81" cut to required length.</i>					
62-72	All . . . . .	6478825	1	6.70	SHAFT UNIT (171" O.L.) (Note 2) . . . . .
71-72	Vega . . . . .	6478514	1		speedo. flex (AC pkg. No. CC-541) (53") . . . . .
73-75	Vega . . . . .	6478175	1	6.97	speedo. flex (60") . . . . .
73	Camaro . . . . .	6478170	1	6.44	(40") (AC #CC-529) . . . . .
73-74	Camaro w/E78-14 tires . . . . .	6478225	1	10.72	(18") (AC #CC-413) (lower) . . . . .
73-75	Nova, Camaro . . . . .	6478171	1	6.58	(44") (AC #CC-530) (upper) . . . . .
73	Chevelle . . . . .	6478176	1	7.28	(64") (AC #CC-535) . . . . .
73-74	Camaro w/Sp. H/Per. (350),				
73-75	Chevelle w/close ratio,				
75	Camaro w/Sp. H/Per. (350) . . . . .	6478179	1	9.28	SHAFT ASM. (76") . . . . .
73-75	Camaro w/F70-14 tires,				
73-74	Nova, Chevelle . . . . .	6454481	1	10.92	SHAFT UNIT, speedo. flex (lower) (24") . . . . .
<i>NOTE 2 For models requiring length of 81" to 172" cut to required length.</i>					
64-69	Chevy w/4-Spd. (8 cyl.),				
67-69	Camaro w/4-Spd. (350, 396),				
70-72	Nova w/4-Spd. . . . .	3772324	1	.13	CLIP, flexible shaft (1 <sup>5</sup> / <sub>16</sub> " long)— (4.047) . . . . .
68-69	Chevelle w/4-Spd. (327 Sp. H/Per., 396),				
69	Pass. w/4-Spd. (exc. 327, 350 w/2BC) . . . . .	3958981	1		CLIP, speedo flex shaft ( <sup>9</sup> / <sub>32</sub> " dia. mounting hole, <sup>1</sup> / <sub>2</sub> " width) . . . . .
69-72	All w/quick release cable . . . . .	6491006	1	.35	CLIP, instr. cluster cable release . . . . .
72	Camaro . . . . .	401164	1	.16	CLIP, speedo. flex. shaft (nylon) . . . . .
74-75	Chevelle . . . . .	6271678	1	.11	CLIP, speedo. flex. shaft . . . . .
75	HR . . . . .	6478373	1	.70	CLIP, speedo. cable locking . . . . .
73	Chevelle,				
73	Pass. (exc. speed & cruise control) . . . . .	6271679	1	.40	GROMMET, speedo. flex. shaft— (9.775) . . . . .
74-75	Chevelle . . . . .	334963	1	.11	RETAINER, speedo. flex. shaft clip . . . . .
75	Camaro . . . . .	481730	1		RETAINER, flex. shaft . . . . .
73-74	Chevelle (exc. I.P.G., Monte Carlo) . . . . .	6478343	1	.28	SPRING, inst. cluster speedo. cable lock . . . . .

### 4.342A SHAFT ASSEMBLY with Casing

*NOTE Shaft length is generally 1<sup>1</sup>/<sub>8</sub>" longer than casing dimension listed.*

62-69	All . . . . .	6478125	1	7.13	(55" casing) . . . . .
62-69	All . . . . .	6478128	1	8.91	(67 <sup>1</sup> / <sub>2</sub> " casing) . . . . .
65-69	Pass. . . . .	6478131	1	9.62	(80" casing O.L.) . . . . .
65-66	Pass. . . . .	6478193	1	11.88	(120" casing) . . . . .
65-69	All . . . . .	6478134	1	11.85	(92 <sup>1</sup> / <sub>2</sub> " casing) . . . . .
67-69	All . . . . .	6478132	1	10.83	(84" casing) . . . . .
67	Camaro w/4-Spd. . . . .	6478121	1	6.42	(38" O.L.) . . . . .
67-72	Chevy, Camaro w/floor console (exc. 350, 396) . . . . .	6454481	1	10.92	lower flex (24") . . . . .
68	Camaro (Conv.) w/floor shift (exc. 350, 396) . . . . .	6478122	1	6.59	(casing 43" O.L.) . . . . .
69	Pass. w/Muncie 4-Spd. (exc. H.D.) . . . . .	6478180	1	9.33	flex (80 <sup>1</sup> / <sub>2</sub> " O.L.) . . . . .
69-70	All . . . . .	6478176	1	7.28	(64" O.L.) . . . . .
69	Taxi . . . . .	6478125	1	7.13	lower . . . . .
69	Chevy, Camaro w/floor console (exc. 350, 396) . . . . .	6478171	1	6.58	upper flex . . . . .
73-75	Monte Carlo w/Speed and Cruise Control . . . . .	6478180	1	9.33	(80") (AC #CC-539) . . . . .
75	Nova, Camaro . . . . .	6479292	1	11.62	speedo. flex. lower . . . . .
75	Chevelle, Camaro, Nova . . . . .	6478178	1	7.96	(72") . . . . .
75	Vega (122) . . . . .	356359	1	13.80	speedo. flex. . . . .

### 4.342B SHAFT ASSY., Speed and Cruise Control

65-69	All . . . . .	3919007	1	4.95	w/casing (37" O.L.) . . . . .
-------	---------------	---------	---	------	-------------------------------

## 4-SPEED TRANSMISSION

### 4.342B SHAFT ASSY., Speed and Cruise Control (Con't)

65-66	Pass., Chevelle	3852599	1	13.10	w/casing (control regulator to transmission) (72" O.L.)
65-66	Chevelle	6478121	1	6.42	w/casing (regulator to speedometer) (40 <sup>1</sup> / <sub>4</sub> " O.L.)
67-69	All	6478132	1	10.83	w/casing (regulator to transmission) (84" O.L.)
69	Pass.	6477264	1	2.06	w/o casing (to speedometer shaft) (29 <sup>7</sup> / <sub>16</sub> " O.L.)
69	Pass., Chevelle	6478168	1	6.87	w/casing (29" O.L.)
69	Chevelle	3943641	1	7.25	w/casing (selector)

70 PASSENGER	WITH CASING	WITHOUT CASING
(exc. Taxi)	6478176 (64" O.D.)	6477306 (61 <sup>7</sup> / <sub>16</sub> " O.L.)
Taxi (upper)	6477857 (7 <sup>1</sup> / <sub>2</sub> " O.L.)	—
Taxi (lower)	6476587	—
w/Speed and Cruise Control	—	6477264

70 NOVA	WITH CASING	WITHOUT CASING
w/4/BC	*6477953	6451067 (Note 1)
(exc. Floor Shift)	*6477953	6451067 (Note 1)
w/Floor Shift (exc. 4/BC) (upper)	*6477953	6451067 (Note 1)
w/Floor Shift (exc. 4/BC) (lower)	6454481 (24 <sup>3</sup> / <sub>4</sub> " O.L.)	6453991 (24 <sup>3</sup> / <sub>4</sub> " O.L.)

70 CHEVELLE	WITH CASING	WITHOUT CASING
w/4-Spd.	*6477552 (70" O.L.)	6477365 (70 <sup>7</sup> / <sub>16</sub> " O.L.)
w/Speed and Cruise Control	3943641	—

70 CAMARO	WITH CASING	WITHOUT CASING
w/4-Spd.	6478179 (76" O.L.)	—

NOTE 1 Shaft Unit— consists of shaft and tip (81" O.L.— cut to required length).

NOTE See Dealer Price Schedule (P&A 26) for Applicable Prices.

NOTE For Cables less casing refer to old book for universal cables.

71 NOVA	WITH CASING	O.L.
	6478171 (upper)	44"
	6454481 (lower)	24"

71 CHEVELLE	WITH CASING	O.L.
	6478178	72"

71 CAMARO	WITH CASING	O.L.
	6478179	76"

72 NOVA	WITH CASING	O.L.
	6478171 (upper)	44"
	6454481 (lower)	24"

72 CHEVELLE	WITH CASING	O.L.
	6478178	72"

72 CAMARO	WITH CASING	O.L.
	6478179	76"

## 4-SPEED TRANSMISSION

### 4.343 GEAR, Speedometer Drive

62-65	Chevy w/3.36, 3.55 axle,				
65	Chevelle w/3.55, 3.70, 3.73 axle				(7.00 x 13 tires), .....
65	Pass. (4-Spd. w/3.70, 4.11 axle)				(6.00-16, 670-15, 710-15 tires), .....
66-67	Pass. w/3.31, 3.36, 3.55, 3.70,				
	3.73 axle .....				(6.95 x 14 tires), .....
66-67	Pass. w/3.55, 3.70, 3.73, 4.10,				
	4.89 axle .....				(7.35 x 14, 7.75 x 14, 7.75 x 15, 8.25 x 14 tires), .....
66-67	Pass. w/3.70, 3.73, 4.10, 4.89				
	axle .....				(8.15 x 15, 8.55 x 14 tires), .....
66-67	Pass. w/3.73, 4.10, 4.89 axle ..				(8.45 x 15 tires), .....
66-67	All w/3.31, 3.36, 3.55, 3.70,				
	3.73 axle .....				(6.95 x 14 tires), .....
66-67	All w/3.55, 3.70, 3.73, 4.10,				
	4.56, 4.89 axle,				
67	Pass. w/4.56 axle .....	3708145	1	3.15	8 teeth (1 <sup>3</sup> / <sub>4</sub> " O.D. x 1 <sup>7</sup> / <sub>32</sub> " thick) (7.35 x 14, 7.75 x 14, 7.75 x 15, 7.35 x 15 tires) ....
62-65	Chevy, Chevelle w/3.08 axle,				
64-65	Chevelle w/3.36 axle,				
65	Chevy, Chevelle w/2.73, 3.07,				
	3.31 axle .....				(7.00 x 13 tires), .....
65	Pass. w/3.08, 3.36 axle,				
65	Pass. (3.55 axle) (exc. 7.00-14				
	tires),				
66-67	Pass. w/3.07, 3.08, 3.31, 3.36				
	axle .....				(7.35 x 14, 7.75 x 14, 8.25 x 14), .....
66-67	Pass. w/3.07, 3.08 axle .....				(6.95 x 14 tires), .....
66-67	Pass. w/3.07, 3.08, 3.31, 3.36,				
	3.55 axle .....				(8.55 x 14, 8.45 x 15, 15), .....
66-67	Pass. w/3.70 axle .....	3708144	1	2.11	(8.45 x 15) .....
65-66	All w/4.56, 4.89 axle .....	3845079	1	3.14	6 teeth (1 <sup>59</sup> / <sub>64</sub> " O.D. x 2 <sup>9</sup> / <sub>64</sub> " thick) .....
67-68	Pass. w/2.73 axle .....	3905494	1	2.94	9 teeth (1 <sup>27</sup> / <sub>32</sub> " O.D. x 5 <sup>5</sup> / <sub>8</sub> " thick) .....
71-72	Vega .....	3987907	1	.69	speedo. drive (7 teeth) (red) .....
73-75	Vega (140) .....	6261797	1	3.55	
74	Vega (122) .....	326555	1	3.45	

### 4.345 CLIP— RING, Speedometer Drive Gear

71-75	All .....	6261781	1	.13	gear retainer .....
74	All .....	3709351	1	.20	RING, speedo. drive gear ret.— (4.376) ....

### 4.351 GEAR, Transmission Main Drive (Clutch)

63	Chevy w/4-Spd. (327),				
65-69	Pass. (Muncie 4-Spd. w/2.20 to				
	1 1st gear),				
68	Chevy, Chevelle, Camaro				
	w/close ratio 4-Spd.,				
69	Chevelle, Camaro w/close ratio				
	4-Spd.,				
70	All w/Muncie close ratio 4-Spd. .	3925690	1		(26 teeth) slinger assy. ....
65	All w/H.D. 4-Spd.,				
70	Camaro (H.D. 4-Spd. w/Sp.				
	H/Per.) (350) .....	3925691	1	75.75	w/slinger (26 teeth) (10 splines) .....
65	Pass. (Muncie 4-Spd. w/2.56 to				
	1 1st gear) .....	357240	1	68.95	(24 teeth) .....
66-68	Pass. w/Saginaw 4-Spd. (327,				
	350),				
66-69	Chevy, Chevelle w/Saginaw 4-				
	Spd. (327) (2nd design),				
67-69	Camaro w/Saginaw 4-Spd. (exc.				
	302, 350, 396),				
70	All w/Saginaw 4-Spd. (350),				
71-72	All w/Saginaw 4-Spd. ....	3859035	1	28.50	(19 teeth) .....
66-69	Pass. w/Muncie 4-Spd. (396,				
	427) (exc. H.D., close ratio),				
66-69	Pass. w/Muncie 4-Spd. (283,				
	327) (1st design),				
66-68	Chevy, Chevelle, Camaro				
	w/Muncie 4-Spd. (302, 327				
	Sp. H/Per. 350, 396),				
66	Chevy, Chevelle w/Muncie 4-				
	Spd. (283, 327) (1st design)				
	(exc. Sp. H/Per.),				
69	Chevelle, Camaro w/H.D. 4-Spd.,				
70	All w/Muncie 4-Spd. (exc. close				
	ratio, H.D.) .....	357241	1	74.75	(21 teeth) w/slinger .....

## 4-SPEED TRANSMISSION

### 4.351 GEAR, Transmission Main Drive (Clutch) (Con't)

66-67	Pass. w/Saginaw 4-Spd. (283) (2nd design),				
66-67	Chevy, Chevelle w/Saginaw 4- Spd. (283) (2nd design),				
67	Camaro w/4-Spd. (6 cyl.),				
73-74	Vega (140) .....	3885095	1	63.00	(18 teeth) .....
68-69	Pass. w/Saginaw 4-Spd. (307, 327, 350),				
68-69	Chevy, Chevelle, Camaro w/Saginaw 4-Spd. (250, 307, 350, 396),				
70	All w/Saginaw 4-Spd. (exc. 350)	3859030	1	28.50	(19 teeth) .....
70	Chevelle w/H.D. 4-Spd.,				
70	Camaro w/H.D. 4-Spd. (454),				
71-72	All w/H.D. 4-Spd. ....	3978761	1	62.00	w/slinger (26 teeth 26 spline) .....
71-72	All Muncie (exc. close ratio H.D.)	3978772	1	59.25	
71-72	All w/close ratio .....	3978773	1		
71-72	Vega .....	8931652	1	37.75	trans. clutch (Opel— 712066) .....
74	Vega (122) .....	340621	1	63.09	
75	Vega, Monza .....	346354	1	59.84	(18 teeth) .....
73-75	All w/Saginaw .....	3859035	1	28.50	(19 teeth) .....
73-74	All w/Muncie (exc. close ratio H.D.) .....	3978772	1	59.25	
73-74	All w/close ratio .....	357244	1	85.00	
74-75	All w/Warner (close ratio) .....	360807	1	66.50	
74-75	All w/Warner (exc. close ratio) .	360814	1	54.25	

### 4.352 BEARING— ROLLER, Transmission Main Shaft Front Pilot to Main Drive Gear

64-69	Chevy, Chevelle w/Muncie 4- Spd. (exc. 283, 307),				
65-69	Pass. w/Muncie 4-Spd. (283, 307, 327, 350),				
67-69	Camaro w/Muncie 4-Spd. (302, 350, 396),				
69	Police (Sta. Wag.) w/Muncie 4- Spd. (427),				
70-74	All w/Muncie 4-Spd. ....	9419248	1	1.85	mainshaft front (17 roller w/cage) .....
71-72	Vega .....	8931793	1		trans. mainshaft front pilot (needle type) (Opel— 8931793) .....
75	All w/Warner .....	907930	1	20.04	new departure ball, single row .....
66-69	Pass. w/Saginaw 4-Spd. (283, 307, 327),				
66-69	Chevy, Chevelle, Camaro (283, 307, 327, 350) (exc. Sp. H/Per. Pass.),				
70-75	All w/Saginaw 4-Spd. ....	3743449	A.R.	.26	ROLLER (7/16" dia. x 5/8") .....
74-75	All w/Warner .....	389677	1	.28	SPACER, mainshaft brg. (Warner #T856- 25) .....

### 4.353 SPACER RING, Transmission Main Shaft Front Pilot to Main Drive Gear

71-72	Vega .....	6681770	1	.08	trans. mainshaft front pilot brg. assy. (Opel— 716251) .....
-------	------------	---------	---	-----	---

### 4.354 SEAL, Transmission Main Drive Gear Bearing

65-69	Chevy, Chevelle,				
66-68	Pass.,				
67-69	Camaro (exc. 350, 396),				
69	Pass. w/Saginaw 4-Spd. (327, 350 w/reg. fuel),				
70	Nova, Chevelle, Camaro w/Saginaw 4-Spd.,				
71-75	All w/Saginaw .....	3987936	1	1.50	oil .....
71-72	Vega .....	3978794	1	2.25	trans. clutch gear .....

### 4.355 BEARING, Transmission Main Drive Gear (Ball)

66-67	Pass. w/Saginaw 4-Spd. (283, 327) (2nd design),				
66-69	Chevy, Chevelle w/Saginaw 4- Spd. (283, 307, 350) (2nd design),				
67-69	Camaro w/Saginaw 4-Spd.,				
68-69	Pass. w/Saginaw 4-Spd. (307),				
70-75	All w/Saginaw 4-Spd. (307) ....	907929	1	16.80	single row w/snap ring (ND 47507- 51773A) .....

## 4-SPEED TRANSMISSION

### 4.355 BEARING, Transmission Main Drive Gear (Ball) (Con't)

64	Chevy (8 cyl.),				
65	Pass. (8 cyl.),				
66	Pass. (327),				
66-69	Chevy, Chevelle, Camaro w/4-Spd. (327) (exc. Sp. H/Per., 2BC),				
67-69	Pass. w/4-Spd. (327, 350),				
70	All w/Saginaw 4-Spd. (350),				
71-74	All w/Saginaw	907930	1	20.04	(single row) w/snap ring (ND47207)
64-65	All w/4-Spd.,				
66-69	Pass. w/4-Spd. (396, 427),				
66	Pass. w/Muncie 4-Spd. (283, 327) (1st design),				
66-68	Chevy, Chevelle w/4-Spd. (327 Sp. H/Per., 350, 396),				
66	Chevy, Chevelle w/Muncie 4-Spd. (283, 327) (1st design) (exc. Sp. H/Per.),				
67-69	Camaro w/4-Spd. (302, 350, 396),				
69	Chevelle w/Muncie 4-Spd.,				
70-74	All w/Muncie 4-Spd.	907572	1	24.06	(single row) w/snap ring (ND41307B)
71-72	Vega	908058	1	13.78	trans. mainshaft rear ball (Conrad) (NDH-47606) (Note 1)
<i>NOTE 1: When used as a main shaft rear bearing install with shielded side towards rear of transmission.</i>					
74-75	All w/Warner	908216	1	18.85	(single row) with snap rings

### 4.356 RETAINER— LOCK— NUT, Transmission Main Drive Gear Bearing

64-65	All w/4-Spd.,				
66	Pass. w/Muncie 4-Spd. (283, 327) (1st design),				
66-69	Pass. w/Muncie 4-Spd. (350, 396, 427),				
66-69	Chevy, Chevelle, Camaro w/4-Spd. (302, 327 Sp. H/Per. 350, 396),				
70-74	All w/Muncie 4-Spd.	3915020	1	9.20	(Note 1)
74-75	All w/Warner	360806	1	14.83	
<i>NOTE 1 When using 3915020, use 4 each 186678 bolts (3/8"— 16 x 1) in place of present ones.</i>					
66-69	Pass. w/Saginaw 4-Spd. (283, 307, 327, 350) (2nd design),				
66-69	Chevy, Chevelle w/Saginaw 4-Spd. (283, 307, 327) (2nd design) (exc. Sp. H/Per.),				
67-69	Camaro w/4-Spd. (exc. 302, 350, 396),				
70	All w/Muncie 4-Spd.,				
71-75	All w/Saginaw	3859032	1	7.40	RETAINER ASSY. (4 <sup>3</sup> / <sub>4</sub> " O.D. x 3 <sup>1</sup> / <sub>4</sub> " O.L.)
64-65	All w/4-Spd.,				
66-69	Pass. w/Muncie 4-Spd. (350, 396, 427),				
66	Pass. w/Muncie 4-Spd. (283, 327) (1st design),				
66-69	Chevy, Chevelle w/4-Spd. (327 Sp. H/Per., 350, 396),				
66	Chevy, Chevelle w/Muncie 4-Spd. (283, 327) (1st design) (exc. Sp. H/Per.),				
67-69	Camaro w/4-Spd. (302, 350, 396),				
70-74	All w/Muncie 4-Spd.	3849937	L.H.	.36	LOCK, retainer bolt, left
64-65	All w/4-Spd.,				
64-69	Chevy, Chevelle w/4-Spd. (327 Sp. H/Per., 350, 396),				
66-69	Pass. w/Muncie 4-Spd. (350, 396, 427),				
66	Pass. w/Muncie 4-Spd. (283, 327) (1st design),				
66	Chevy, Chevelle w/Muncie 4-Spd. (283, 327) (1st design) (exc. Sp. H/Per.),				
67-69	Camaro w/4-Spd. (302, 350, 396),				
70-74	All w/Muncie 4-Spd.	3849938	R.H.	.36	LOCK, retainer bolt, right
62-65	All w/4-Spd.,				



## 4-SPEED TRANSMISSION

### 4.356 RETAINER— LOCK— NUT, Transmission Main Drive Gear Bearing (Con't)

66-69	Pass. w/Muncie 4-Spd. (350, 396, 427),				
66	Pass. w/Muncie 4-Spd. (283, 327) (1st design),				
66-68	Chevy, Chevelle w/4-Spd. (327 Sp. H/Per., 350, 396),				
66	Chevy, Chevelle w/Muncie 4-Spd. (283, 327) (1st design) (exc. Sp. H/Per.),				
67-68	Camaro w/4-Spd. (302, 350, 396),				
69	Police (Sta. Wag.) w/Muncie 4-Spd. (427),				
69	All w/Muncie 4-Spd. (exc. Pass.),				
71-74	All w/Muncie 4-Spd. . . . .	591150	1	1.15	NUT (1 <sup>3</sup> / <sub>4</sub> "— 12 L.H. thread) . . . . .

### 4.358 GASKET, Transmission Main Drive Gear Bearing Retainer

64-65	Chevy, Chevelle w/4-Spd.,				
66-69	Pass. w/Muncie 4-Spd. (350, 396, 427),				
66	Pass. w/Muncie 4-Spd. (283, 327) (1st design),				
66-68	Chevy, Chevelle, Camaro w/4-Spd. (302, 327 Sp. H/Per., 350, 396),				
66	Chevy, Chevelle w/Muncie 4-Spd. (283, 327) (1st design) (exc. Sp. H/Per.),				
69	All w/Muncie 4-Spd. (exc. Pass.),				
70-74	All w/Muncie 4-Spd. . . . .	3915019	1	.31	
66-67	Pass. w/Saginaw 4-Spd. (283, 327) (2nd design),				
66-67	Chevy, Chevelle w/Saginaw 4-Spd. (283, 327) (2nd design) (exc. Sp. H/Per.),				
67	Camaro w/4-Spd. (exc. 302, 350),				
68-69	Pass. w/4-Spd. (307, 327),				
68-69	All w/Saginaw 4-Spd. (exc. Pass.),				
70-75	All w/Saginaw 4-Spd. . . . .	3916113	1	.33	
74-75	All w/Warner . . . . .	1359473	1	.13	(Warner #T85B-145C) . . . . .

### 4.374 SLINGER, Transmission Main Drive Gear Bearing

68-69	Pass. w/Muncie 4-Spd.,				
70-74	All w/Muncie 4-Spd. . . . .	3925692	1	.82	clutch gear bearing oil . . . . .

### 4.376 RING, Transmission Main Drive Gear Bearing

66-69	Pass. w/Muncie 4-Spd. (283, 307, 327, 350),				
66-68	Chevy, Chevelle, Camaro w/Saginaw 4-Spd. (exc. 302, 327 Sp. H/Per., 350, 396),				
69	All w/Saginaw 4-Spd.,				
70-75	All w/Saginaw 4-Spd. (350) . . . .	590849	1	.33	locating (2 <sup>11</sup> / <sub>16</sub> " I.D. x 2 <sup>23</sup> / <sub>32</sub> " O.D. x 1/2" thk.)
66-67	All (exc. H.D.),				
66-69	Pass. w/Saginaw 4-Spd. (283, 307, 327) . . . . .				snap (.087 thk.), . . . . .
66-67	Chevy, Chevelle w/Saginaw 4-Spd.,				
67	Camaro w/4-Spd. (exc. 350, 396),				
69	All w/Saginaw 4-Spd. (exc. Pass.),				
71-75	All w/Saginaw . . . . .	3709351	A.R.	.20	retaining (.087 thk.) . . . . .
65-68	Pass. w/4-Spd.,				
66-68	Chevy, Chevelle w/4-Spd. (327 Sp. H/Per., 350, 396),				
67-68	Camaro w/4-Spd. (302, 350, 396),				
70	Chevelle w/Muncie 4-Spd. . . . .	2830050	1	.38	locating (3 <sup>13</sup> / <sub>32</sub> " O.D.)— (4.412) . . . . .
70	All w/Saginaw 4-Spd. (exc. 350)	3707174	2	.33	locating (2 <sup>11</sup> / <sub>16</sub> " I.D.)— (4.412) . . . . .
71-72	Vega . . . . .	11057029	1	.63	trans. clutch gear bearing locking . . . . .

NOTE 1: Used as 2nd and 3rd synch. Assy. retaining ring.

## 4-SPEED TRANSMISSION

### 4.376 RING, Transmission Main Drive Gear Bearing (Con't)

73-75	All w/Warner	3709352	1	.18	retaining (.089-.091 thk.) (dark blue)
73-75	All w/Warner	3709353	1	.18	retaining (.092-.094 thk.) (orange)
73-75	All w/Warner	3709354	1	.18	retaining (.095-.097 thk.) (green)
73-75	All w/Warner	3709355	1	.18	retaining (.098-.100 thk.)
73-75	All w/Warner	3709356	1	.18	retaining (.101-.103 thk.)
74-75	All w/Warner	3709350	1	.36	SPACER, clutch gear brg. (1 <sup>3</sup> / <sub>8</sub> " I.C. x 1 <sup>13</sup> / <sub>16</sub> " O.D. x 1 <sup>1</sup> / <sub>16</sub> " thk.) (Warner #4652U)

### 4.380 SYNCHRONIZER, Transmission 2nd-3rd and 3rd-4th Speeds

66	Pass. w/Saginaw 4-Spd. (283, 327) (2nd design),				
66	Chevy, Chevelle w/Saginaw 4-Spd. (283, 327) (2nd design) (exc. Sp. H/Per.),				
67	Pass. w/4-Spd. (283, 327)	3924769	1	35.00	1st and 2nd
66-67	Pass. w/Saginaw 4-Spd. (283, 327) (2nd design),				
66-67	Chevy, Chevelle w/Saginaw 4-Spd. (283, 327) (2nd design) (exc. Sp. H/Per.),				
67	Camaro w/4-Spd. (exc. 350, 396),				
68-69	Pass. w/4-Spd. (307, 327, 350),				
68	All w/4-Spd. (exc. 302, 327 Sp. H/Per., Pass.),				
69	All w/Saginaw 4-Spd. (exc. Pass.),				
70-75	All w/Saginaw	3924766	1	35.50	3rd and 4th
67-69	Pass. w/Saginaw 4-Spd. (307, 327, 350),				
67	Chevy, Chevelle w/4-Spd. (283, 327) (2nd design) (exc. Sp. H/Per.),				
67	Camaro w/4-Spd. (exc. 350, 396) (2nd design),				
68	Chevy, Chevelle, Camaro w/Saginaw 4-Spd. (exc. 327 Sp. H/Per., 350, 396),				
69	Chevy, Chevelle, Camaro w/Saginaw 4-Spd.,				
70-75	All w/Saginaw 4-Spd.	3924771	1	37.00	1st and 2nd
63-68	Chevy, Chevelle, Camaro w/Muncie 4-Spd. (302, 327 Sp. H/Per., 350, 396, 427),				
65-67	Pass. w/Muncie 4-Spd.,				
68-69	Pass. w/Muncie 4-Spd. (327 Sp. H/Per., 350, 396, 427),				
69	All w/Muncie 4-Spd. (exc. Pass.),				
70-72	All w/Muncie 4-Spd.	357239	1	73.50	SYNCHRONIZER UNIT, 3rd and 4th
63-68	Chevy, Chevelle, Camaro w/Muncie 4-Spd. (302, 327 Sp. H/Per., 350, 396, 427),				
65-69	Pass. w/Muncie 4-Spd. (327 Sp. H/Per., 350, 396, 427),				
69	All w/Muncie 4-Spd. (exc. Pass.),				
70-74	All w/Muncie 4-Spd.	357238	1	70.50	SYNCHRONIZER UNIT, 1st and 2nd
71-72	Vega	3443720	1	35.50	trans. 1st and 2nd (w/3455091) (Opel—3443720) (Note 1)
71-72	Vega	3443719	1	28.50	trans. 3rd and 4th (w/3455091) (Opel—3443719) (Note 1)

NOTE 1: Consists of sleeve, hub, spring and keys.

74-75	All w/Warner	360801	1	40.50	1st and 2nd
74-75	All w/Warner	360100	1	46.00	3rd and 4th

### 4.383 RING, Transmission Synchronizing

64-65	All w/Muncie 4-Spd.	3831742	4	8.85	blocking
70	All w/Muncie 4-Spd.	3831741	1	.18	3rd and 4th clutch hub retaining
66-69	Pass. w/Saginaw 4-Spd. (283, 327, 350) (2nd design),				
66-69	Chevy, Chevelle w/Saginaw 4-Spd. (283, 307, 327) (2nd design) (exc. Sp. H/Per.),				
67-69	Camaro w/4-Spd. (exc. 302, 350, 396),				
70-75	All w/Saginaw 4-Spd.	3859027 A.R.		8.10	blocking

## 4-SPEED TRANSMISSION

### 4.383 RING, Transmission Synchronizing (Con't)

66-69	Pass. w/4-Spd. (396, 427),				
66	Pass. w/Muncie 4-Spd. (283, 327) (1st design),				
66-69	Chevy, Chevelle w/4-Spd. (327 Sp. H/Per.) (350, 396),				
66	Chevy, Chevelle w/Muncie 4-Spd. (283, 327) (1st design) (exc. Sp. H/Per.),				
67-68	Camaro w/4-Spd. (302, 350, 396),				
70-74	All w/Muncie 4-Spd. . . . .	3880850	4	10.15	blocking . . . . .
71-72	Vega . . . . .	2897710	2	8.10	trans. 1st and 2nd synch. (Opel— 718909)
71-72	Vega . . . . .	6667181	2	7.10	trans. synch. blocking (Opel— 718904) (Note 1) . . . . .
<i>NOTE 1: Used as 3rd and 4th synch. blocking ring.</i>					
74-75	All w/Warner . . . . .	360812	4	6.10	blocking (2 <sup>13</sup> / <sub>16</sub> " I.D. x 3 <sup>7</sup> / <sub>32</sub> " O.D., w/3 inside slots) (Warner #T91A-14A) . . . . .

### 4.384 RING— PLATE— KEY, Transmission Synchronizing

64-65	All w/Muncie 4-Spd.,				
66-69	Pass. w/4-Spd. (396, 427),				
66	Pass. w/Muncie 4-Spd. (283, 327) (1st design),				
66-68	Chevy, Chevelle w/4-Spd. (327 Sp. H/Per., 350, 396),				
66	Chevy, Chevelle w/Muncie 4-Spd. (283, 327) (1st design) (exc. Sp. H/Per.),				
67-68	Camaro w/4-Spd. (302, 350, 396),				
69	All w/Muncie 4-Spd. (exc. Pass.),				
70	All w/Saginaw 4-Spd.,				
71-74	All w/Muncie . . . . .	3831741	1	.18	3rd & 4th clutch hub retaining . . . . .
66-69	Pass. w/Saginaw 4-Spd. (283, 307, 327) (2nd design),				
66-69	Chevy, Chevelle w/Saginaw 4-Spd. (283, 307, 327) (2nd design) (exc. Sp. H/Per.),				
67-69	Camaro w/4-Spd. (exc. 302, 350, 396),				
70-75	All w/Saginaw 4-Spd. . . . .	3859025	2	.13	all clutch hub retaining . . . . .
74-75	All w/Warner . . . . .	3709351	1	.20	RING, 3-4 syn. ret. (.086-.088 thk.) (plain)— (4.376) . . . . .
74-75	All w/Warner . . . . .	3709352	1	.18	RING, 3-4 syn. ret. (.089-.091 thk.) (dark blue)— (4.376) . . . . .
74-75	All w/Warner . . . . .	3709353	1	.18	RING, 3-4 syn. ret. (.092-.094 thk.) (orange)— (4.376) . . . . .
74-75	All w/Warner . . . . .	3709354	1	.18	RING, 3-4 syn. ret. (.095-.097 thk.) (green)— (4.376) . . . . .
74-75	All w/Warner . . . . .	3709355	1	.18	RING, 3-4 syn. ret. (.098-.100 thk.)— (4.376) . . . . .
74-75	All w/Warner . . . . .	3709356	1	.18	RING, 3-4 syn. ret. (.101-.103 thk.)— (4.376) . . . . .
64-65	Chevy, Chevelle w/4-Spd.,				
65-66	Pass. w/Muncie 4-Spd.,				
66-68	Chevy, Chevelle w/4-Spd. (327 Sp. H/Per., 350, 396),				
67-69	Pass. w/Muncie 4-Spd. (350, 396, 427),				
67-68	Camaro w/4-Spd. (302, 350, 396),				
69	All w/Muncie 4-Spd. (exc. Pass.),				
70-74	All w/Muncie 4-Spd. . . . .	3915050	6	.51	PLATE, shifter . . . . .
66-69	Pass. w/Saginaw 4-Spd. (283, 307, 327),				
66-69	Chevy, Chevelle w/Saginaw 4-Spd. (283, 307, 327) (exc. Sp. H/Per.),				
67-69	Camaro w/4-Spd. (exc. 302, 350, 396),				
70-75	All w/Saginaw 4-Spd. . . . .	3871250	6	.54	KEY, all clutch . . . . .
71-72	Vega . . . . .	6667478	3	.25	KEY, trans. synch. (Opel— 734182) (Note 1)
<i>NOTE 1: Used as 3rd and 4th.</i>					
71-72	Vega . . . . .	6695985	3	.32	KEY, trans. 1st and 2nd synch. (Opel— 734133) . . . . .

## 4-SPEED TRANSMISSION

### 4.384 RING— PLATE— KEY, Transmission Synchronizing (Con't)

74-75 All w/Warner ..... 3870793 3 .51 KEY, 1st and 2nd, 3rd and 4th (Warner #T16-13) .....

### 4.395 GEAR, Transmission 2nd Speed

64-65 All w/Muncie 4-Spd.,  
 66-69 Pass. w/4-Spd. (396, 427) (exc. H.D.),  
 66 Pass. w/Muncie 4-Spd. (283, 327) (1st design),  
 66-68 Chevy, Chevelle w/4-Spd. (327 Sp. H/Per., 350, 396) (exc. H.D.),  
 66 Chevy, Chevelle w/Muncie 4-Spd. (283, 327) (1st design) (exc. Sp. H/Per.),  
 67-68 Camaro w/4-Spd. (302, 350, 396),  
 69 Chevy, Chevelle, Camaro w/Muncie 4-Spd. (exc. H.D.),  
 70-74 All w/Muncie 4-Spd. (exc. H.D.) . 357226 1 73.75 (30 teeth) .....  
 65-72 All w/Muncie H.D. 4-Spd. .... 3879999 1 80.75 (30 teeth) .....  
 66 Pass. w/Saginaw 4-Spd. (283, 327) (2nd design),  
 66 Chevy, Chevelle w/Saginaw 4-Spd. (283, 327) (2nd design) (exc. Sp. H/Per.),  
 67-69 Pass. w/Saginaw 4-Spd. (exc. 396, 427),  
 67-68 Chevy, Chevelle w/Saginaw 4-Spd. (283, 307, 327) (exc. Sp. H/Per.),  
 67-68 Camaro w/4-Spd. (exc. 302, 350, 396),  
 69 All w/Saginaw (exc. Pass.),  
 70-74 All w/Saginaw ..... 3915055 1 23.00 (26 teeth) (Note 1) .....  
 75 All w/Saginaw ..... 352239 1 23.00  
 71-72 Vega ..... 8961423 1 30.00 trans. 2nd speed .....  
 74-75 All w/Warner ..... 360802 1 55.50

NOTE 1 2nd design part has a 3/16" notch on face of gear.

### 4.403 SHAFT, Transmission Main

64-65 Chevy, Chevelle w/4-Spd.,  
 65-69 Pass. w/Muncie 4-Spd.,  
 66-67 Chevy, Chevelle w/4-Spd. (327 Sp. H/Per.) (396),  
 66 Chevy, Chevelle w/Muncie 4-Spd. (283, 327) (1st design) (exc. Sp. H/Per.),  
 67 Camaro w/4-Spd. (302, 350, 396),  
 68-69 Chevy, Chevelle, Camaro w/Muncie 4-Spd. (302, 327 Sp. H/Per., 350, 396),  
 70 All w/Muncie 4-Spd. .... 3915087 1 68.00  
 66-67 Pass. w/Saginaw 4-Spd. (283, 327) (2nd design),  
 66-67 Chevy, Chevelle w/Saginaw 4-Spd. (283, 327) (2nd design) (exc. Sp. H/Per.),  
 67 Camaro w/4-Spd. (exc. 350, 396),  
 68-69 Pass. w/Saginaw 4-Spd. (exc. 396, 427),  
 68 Chevy, Chevelle, Camaro w/Saginaw 4-Spd. (exc. 302, 327, Sp. H/Per., 350, 396),  
 69 Chevy, Chevelle, Camaro w/Saginaw 4-Spd.,  
 70-75 All w/Saginaw 4-Spd. .... 3915014 1 38.00  
 70-72 Chevelle w/Muncie H.D. 4-Spd.,  
 73-74 All w/Muncie ..... 3978759 1 83.25 (32-6T) (21 3/4" O.L.) .....  
 71-72 Vega ..... 3455289 1 46.00 trans. main (Opel— 716047) .....  
 74-75 All w/Warner ..... 6260713 1 101.00 (Warner #13-04-171-005) .....  
 75 All w/Warner ..... 360088 1 10.85

## 4-SPEED TRANSMISSION

### 4.408 BEARING, Transmission Main Shaft Rear

65	Chevy, Chevelle (exc. O.D. 327),				
66-68	Pass. w/Saginaw 4-Spd.,				
66-67	Pass. (327) (exc. A.T.),				
70	All w/Saginaw 4-Spd. (exc. 350)	907763	1	15.36	(ND 476006V) .....
66-67	Pass. (327) (exc. A.T.),				
66-67	Chevy, Chevelle, Camaro				
	w/Saginaw 4-Spd. (327),				
70-74	All w/Saginaw 4-Spd. (350) .....	907765	1	20.26	(ND47306-1961A) .....
64-69	All w/Muncie 4-Spd.,				
69	Police (Sta. Wag.) w/Muncie 4-				
	Spd. (427),				
71-75	All w/Muncie .....	907474	1	17.52	(ND 43308) .....
74-75	All w/Warner .....	907458	1	19.90	
73-75	Vega .....	907763	1	15.36	

### 4.412 RING, Transmission Rear Bearing and Mainshaft

66-69	Pass. w/Saginaw 4-Spd. (283, 307, 327, 350) (2nd design),				
66-68	Chevy, Chevelle w/Saginaw 4-				
	Spd. (283, 307, 327) (2nd				
	design) (exc. Sp. H/Per.) .....				locating (in case), .....
67-68	Camaro w/4-Spd. (exc. 302, 350, 396),				
69	Chevy, Chevelle, Camaro				
	w/Saginaw 4-Spd.,				
70	All w/Saginaw 4-Spd. (350),				
71-75	All w/Saginaw .....	3707174	1	.33	retainer (2 <sup>11</sup> / <sub>16</sub> " I.D.) .....
66-69	Pass. w/Saginaw 4-Spd. (283, 307, 327, 350) (2nd design),				
67-68	Camaro w/4-Spd. (exc. 302, 350, 396),				
69	Chevy, Chevelle, Camaro				
	w/Saginaw 4-Spd.,				
70	All w/Saginaw 4-Spd. (350),				
71-75	All w/Saginaw .....	3707189	1	.20	snap (.089-.091 thick) .....
64-65	All w/Muncie 4-Spd.,				
66-69	Pass. w/4-Spd. (396, 427),				
66	Pass. w/Muncie 4-Spd. (283, 327) (1st design),				
66-68	Chevy, Chevelle (4-Spd. w/H/Per., Sp. H/Per.) (327, 350, 396),				
66	Chevy, Chevelle w/Muncie 4-				
	Spd. (283, 327) (1st design)				
	(exc. Sp. H/Per.),				
67-68	Camaro w/4-Spd. (302, 350, 396) (exc. H.D.),				
69	Police (Sta. Wag.) w/Muncie 4-				
	Spd. (427),				
69	All w/Muncie 4-Spd. (exc. Pass.),				
70-74	All w/Muncie 4-Spd. ....	3831749	1	.99	locating .....
66-68	Pass. w/4-Spd. (396, 427),				
66-68	Chevy, Chevelle, Camaro w/4-				
	Spd. (302, 327 Sp. H/Per., 350, 396),				
68-69	Pass. w/Muncie 4-Spd. (exc. 307),				
69	All w/Muncie 4-Spd. (exc. Pass.),				
70-74	All w/Muncie 4-Spd. ....	2830050	1	.38	snap (3 <sup>1</sup> / <sub>2</sub> " x 3 <sup>13</sup> / <sub>16</sub> " thk.) .....
64-65	All w/Muncie 4-Spd.,				
66-68	Pass. w/4-Spd. (396, 427),				
66	Pass. w/Muncie 4-Spd. (283, 327) (1st design),				
66-68	Chevy, Chevelle w/4-Spd. (327 Sp. H/Per., 350, 396),				
66	Chevy, Chevelle w/Muncie 4-				
	Spd. (283, 327) (1st design)				
	(exc. Sp. H/Per.),				
67-68	Camaro w/4-Spd. (302, 350, 396),				
69-74	All w/Muncie .....	3998395	1	.40	RING UNIT (Note 1) .....
	<i>NOTE 1 Consists of 1 each ring. 097, .093, .090, .087 thk.</i>				
75	Monza (exc. Towne Coupe) ....	3915033	1	54.25	GEAR ASSY., counter (Note 3) .....
71-72	Vega .....	2877384	1	.52	trans. mainshaft rear bearing locating (Opel— 720091) .....

## 4-SPEED TRANSMISSION

### 4.412 RING, Transmission Rear Bearing and Mainshaft (Con't)

71-72	Vega	6634858	2	.25	trans. clutch gear bearing retaining
74-75	All w/Muncie, Warner	3911967	1	.51	rear brg. locating
71-72	Vega	2877382	1	1.35	SPACER, trans. mainshaft rear bearing, front (Opel— 716104)
71-72	Vega	2877480	1	.19	SPACER, trans. mainshaft rear bearing, rear (Opel— 722276)
74-75	All w/Warner	3709350	1	.36	SPACER, mainshaft rear brg. (1 <sup>3</sup> / <sub>8</sub> " I.D. x 1 <sup>13</sup> / <sub>16</sub> " O.D. x 1 <sup>1</sup> / <sub>16</sub> " thk.) (Warner #4652U)— (4.376)

### 4.413 SPRING, Transmission Synchronizing

64	Chevy, Chevelle w/4-Spd.,				
65-67	All w/Muncie 4-Spd.	591914	4	.18	(3 <sup>9</sup> / <sub>32</sub> " O.D.) energizing
64-65	Chevy, Chevelle w/4-Spd.,				
65	Pass. w/Muncie 4-Spd. (2nd design),				
66-69	Pass. w/Muncie 4-Spd.,				
66	Pass. w/Muncie 4-Spd. (283, 327) (1st design),				
66-67	Chevy, Chevelle w/4-Spd. (327 Sp. H/Per., 396),				
66	Chevy, Chevelle w/Muncie 4-Spd. (283, 327) (1st design) (exc. Sp. H/Per.),				
67	Camaro w/4-Spd. (302, 350, 396),				
68	All w/4-Spd. (302, 327 Sp. H/Per., 350, 396),				
69	All w/Muncie 4-Spd. (exc. Pass.),				
70-74	All w/Muncie 4-Spd.	3920775	4	.31	1st and 2nd, 3rd and 4th
66-69	Pass. w/Saginaw 4-Spd. (283, 307, 327, 350) (2nd design),				
66-68	All w/4-Spd. (exc. 302, 327 Sp. H/Per., 350, 396),				
69	All w/Saginaw 4-Spd. (exc. Pass.),				
70-75	All w/Saginaw 4-Spd.	3924768	4	.33	1st and 2nd, 3rd and 4th
71-72	Vega	8953908	2	.08	trans. 1st and 2nd synch. (Opel— 718937)
71-72	Vega	8953909	2	.08	trans. 3rd and 4th synch. (Opel— 718938)
74-75	All w/Warner	3870810	2	.31	1st and 2nd, 3rd and 4th (Warner #4682 AJ)

### 4.415 GEAR, Transmission 3rd Speed

64-65	Chevy, Chevelle w/4-Spd.,				
65-69	Pass. w/Muncie 4-Spd.,				
66	Pass. w/Muncie 4-Spd. (283, 327) (1st design),				
66-68	Chevy, Chevelle w/4-Spd. (327 Sp. H/Per., 350, 396) (exc. H.D.),				
66	Chevy, Chevelle w/Muncie 4-Spd. (283, 327) (1st design) (exc. Sp. H/Per.),				
67-68	Camaro w/4-Spd. (302, 396) (exc. H.D.),				
69	All w/Muncie 4-Spd. (exc. H.D., Pass.),				
70-74	All w/Muncie 4-Spd. (exc. H.D.)	3831747	1	53.00	3rd (27 teeth)
65-69	Pass. w/H.D. 4-Spd.,				
66-69	Chevelle w/H.D. 4-Spd.,				
68-69	Camaro, Chevy w/H.D. 4-Spd.,				
70-72	All w/Muncie H.D. 4-Spd.	3880845	1	76.25	3rd speed (27 teeth)
66	All w/Saginaw 4-Spd. (327) (2nd design) (exc. Sp. H/Per.)	3884617	1	18.10	3rd speed
66-68	Pass., Chevy, Chevelle w/Saginaw 4-Spd. (283, 307) (2nd design),				
67-68	Camaro w/4-Spd. (6 cyl.),				
69	Chevy, Chevelle w/Saginaw 4-Spd. (307),				
69	Chevy, Chevelle w/Saginaw 4-Spd. (350 w/reg. fuel) (exc. 2BC),				
70	All w/Saginaw 4-Spd. (307),				
73-75	Vega w/Saginaw	3859986	1	19.20	3rd speed

## 4-SPEED TRANSMISSION

### 4.415 GEAR, Transmission 3rd Speed (Con't)

67-68	Pass. w/4-Spd. (327),				
67-68	All w/4-Spd. (327) (exc. Sp. H/Per., Pass.),				
69	Pass. w/Saginaw 4-Spd.,				
69	Camaro w/Saginaw 4-Spd.,				
69	Chevy, Camaro w/Saginaw 4- Spd. (350 reg. fuel) (exc. 4BC),				
70	All w/Saginaw 4-Spd. (350 w/2BC),				
71-75	All w/Saginaw (exc. Vega) . . . . .	3890552	1	20.15	3rd speed (23 teeth) . . . . .
71-72	Vega . . . . .	8961339	1	28.50	trans. 3rd speed . . . . .
74-75	All w/Warner . . . . .	360099	1	58.50	

### 4.417 GEAR, Transmission (1st and Reverse Sliding)

64-66	All w/Muncie 4-Spd.,				
67-68	Pass. w/4-Spd. (396, 427),				
67-68	Chevy, Chevelle (4-Spd. w/H/Per. Sp. H/Per. 327, 350, 396),				
67-68	Camaro w/4-Spd. (302, 350, 396),				
69	All w/Muncie 4-Spd.,				
71-74	All w/Muncie . . . . .	357228	1	80.25	reverse (35 teeth) . . . . .
64-65	All w/4-Spd.,				
66-68	Pass. w/Muncie 4-Spd. (396, 427) (exc. H.D.),				
66	Pass. w/Muncie 4-Spd. (283, 327) (1st design),				
66-68	Chevy, Chevelle w/4-Spd. (327 Sp. H/Per., 350, 396) (exc. H.D.),				
66	Chevy, Chevelle w/Muncie 4- Spd. (283, 327) (1st design) (exc. Sp. H/Per.),				
67-68	Camaro w/4-Spd. (302, 350, 396) (exc. H.D.),				
69	All w/Muncie 4-Spd.,				
70-74	All w/Muncie 4-Spd. (exc. H.D.) . . . . .	3849388	1		1st speed (36 teeth) . . . . .
65-67	Pass. w/H.D. 4-Spd.,				
66-67	Chevelle, Camaro w/H.D. 4-Spd.,				
68-72	All w/H.D. 4-Spd. . . . .	3924796	1	89.50	1st speed (36 teeth) . . . . .
66-68	Pass. w/Saginaw 4-Spd. (283, 307, 327, 350) (2nd design),				
66-68	Chevy, Chevelle w/Saginaw 4- Spd. (283, 307, 327) (2nd design) (exc. Sp. H/Per.),				
67-68	Camaro w/4-Spd. (exc. 302, 350, 396),				
69-75	All w/Saginaw 4-Spd. . . . .	3859981	1	23.00	1st speed (29 teeth) . . . . .
71-72	Vega . . . . .	2897722	1	46.25	trans. 1st speed (Opel— 718341) . . . . .
74-75	All w/Warner . . . . .	360804	1	36.25	reverse . . . . .
74-75	All w/Warner . . . . .	360803	1	54.25	1st speed . . . . .

### 4.419 SLEEVE— SPRING— WASHER, Transmission (1st and Reverse Gear)

64-66	Pass. w/4-Spd.,				
66-68	Chevy, Chevelle w/4-Spd. (327 Sp. H/Per., 350, 396) (exc. H.D.),				
67	Pass. w/4-Spd. (396, 427),				
67-68	Camaro w/4-Spd. (302, 350, 396) (exc. H.D.),				
68	Pass. w/4-Spd. (396, 427) (exc. H.D.),				
69	All w/Muncie 4-Spd. (exc. H.D.),				
70-74	All w/Muncie 4-Spd. . . . .	3978781	1	9.50	1st speed . . . . .
68	All w/H.D. 4-Spd.,				
69	All w/H.D. 4-Spd. (exc. Pass.) . . . . .	3932228	1	15.15	(1st speed) . . . . .
71-72	Vega . . . . .	2888315	1	6.65	trans. mainshaft 1st gear (needle type) (Opel— 716350) . . . . .
74-75	All w/Warner . . . . .	6260712	1	9.50	1st speed (Warner #13-04-103-001) . . . . .
66-69	Pass. w/4-Spd. (396, 427) (exc. H.D., close ratio),				
68-69	Camaro w/4-Spd. (302, 350, 396) (exc. close rao, H.D.),				

## 4-SPEED TRANSMISSION

### 4.419 SLEEVE— SPRING— WASHER, Transmission (1st and Reverse Gear) (Con't)

68-69	Chevy, Chevelle w/4-Spd. (327 Sp. H/Per. 350, 396) (exc. close ratio, H.D.),				
70-74	All w/Muncie 4-Spd. (exc. H.D., close ratio) . . . . .	3890532	2	.10	SPRING, reverse gear anti-lash . . . . .
66-68	Chevy, Chevelle w/Saginaw 4-Spd. (283, 307, 327) (exc. Sp. H/Per.),				
66-69	Pass. w/Saginaw 4-Spd. (283, 307, 327, 350),				
67-68	Camaro w/4-Spd. (exc. 302, 350, 396),				
69	All w/Saginaw 4-Spd. (exc. Pass.),				
70	All w/Saginaw 4-Spd. (exc. 350),				
71-75	All w/Saginaw . . . . .	3869940	1	.38	WASHER, reverse thrust (1 <sup>3</sup> / <sub>16</sub> " I.D. x 2 <sup>1</sup> / <sub>2</sub> " O.D.) . . . . .
66-69	Pass. w/Saginaw 4-Spd. (283, 307, 327, 350),				
67-69	Camaro w/4-Spd. (exc. 302, 350, 396),				
69	All w/Saginaw 4-Spd. (exc. Pass.),				
70	All w/Saginaw 4-Spd. (350),				
71-75	All w/Saginaw . . . . .	3884595	1	.20	WASHER, reverse thrust (17/ <sub>16</sub> " I.D. x 1 <sup>27</sup> / <sub>32</sub> " (wavery) . . . . .
74-75	All w/Warner . . . . .	6260715	1	3.20	WASHER, thrust 1st speed gear (Warner # 13-04-193-002) . . . . .
66-68	Chevy, Chevelle w/4-Spd. (327 Sp. H/Per., 350, 396) (exc. close ratio, H.D.) . . . . .	3911963	1	.36	WASHER, reverse gear thrust . . . . .

### 4.421 GEAR, Transmission

64-65	All (Muncie 4-Spd. w/2.56 to 1 1st gear) . . . . .	3831728	1	79.50	(29 teeth) . . . . .
65	Pass. (Muncie 4-Spd. w/2.20 to 1 1st gear) w/H/Per., F.I. . . . .	3831727	1	79.50	(1 <sup>3</sup> / <sub>16</sub> " I.D.) (27T-22T-19T-17T) . . . . .
65-69	Pass., Chevelle w/H.D. 4-Spd.,				
68-69	Chevy, Camaro w/H.D. 4-Spd.,				
70-72	All w/Muncie H.D. 4-Spd. . . . .	3905466	1	138.00	(27T-22T-19T-17T) . . . . .
66-74	All w/Muncie 4-Spd. close ratio . . . . .	357236	1	115.25	counter (27T-22T-19T-17T) . . . . .
65-68	Pass. w/Saginaw 4-Spd. (307, 350),				
68	Chevy, Chevelle, Camaro w/Saginaw 4-Spd. (exc. 327, 350, 396),				
69	All w/Saginaw 4-Spd. (exc. 350 w/2BC, Pass.),				
70	All w/Saginaw 4-Spd. (307) . . . . .	3924708	1	50.00	GEAR ASSY., counter . . . . .
66	Chevy, Chevelle w/4-Spd. (327 Sp. H/Per.) (396),				
66	Chevy, Chevelle w/Muncie 4-Spd. (283, 327) (1st design) (exc. Sp. H/Per.),				
66-68	Pass. w/4-Spd. (exc. H.D.),				
66	Pass. w/Muncie 4-Spd. (283, 327) (1st design),				
67-68	Chevy, Chevelle w/4-Spd. (327 Sp. H/Per., 350, 396) (exc. close ratio, H.D.),				
67-68	Camaro w/4-Spd. (350, 396) (exc. close ratio, H.D.),				
69-73	All w/Muncie 4-Spd. (exc. close ratio, H.D.) . . . . .	3905463	1		GEAR ASSY., counter (25T-22T-19T-17T) . . . . .
66	Pass. w/Saginaw 4-Spd. (327) (2nd design),				
66	Chevy, Chevelle w/Saginaw 4-Spd. (327) (2nd design) (exc. Sp. H/Per.) . . . . .	3884614	1	78.25	GEAR ASSY., counter (Note 1) . . . . .
66	<i>NOTE 1: Consists of counter gear, counter gear damper plate, plate, pin and spring.</i>				
66	Pass. w/Saginaw 4-Spd. (283) (2nd design),				



## 4-SPEED TRANSMISSION

### 4.421 GEAR, Transmission (Con't)

67	Pass. w/4-Spd. (327) (1st design),					
67	Chevy, Chevelle, Camaro w/4-Spd. (327) (exc. Sp. H/Per.) (1st design)	3890549	1	51.25	GEAR ASSY., counter	
66	Chevy, Chevelle w/Saginaw 4-Spd. (283) (2nd design),					
67	All w/4-Spd. (283) (1st design),					
67	Camaro w/4-Spd. (6 cyl.) (1st design)	3859970	1	51.25	GEAR ASSY., counter (29T-23T-19T-15T) (Note 2)	
<i>NOTE 2: Lube hole forward of reverse gear section.</i>						
67-68	Pass. w/4-Spd. (327) (2nd design),					
67-68	All w/4-Spd. (327) (2nd design) (exc. Sp. H/Per., Pass.),					
70	All (2BC w/Saginaw 4-Spd.) (327, 350),					
71-75	All w/Saginaw	3915034	1	51.25	GEAR ASSY., counter (25T-21T-19T-15T) (Note 3)	
67	All w/4-Spd. (283) (2nd design),					
67	Camaro w/4-Spd. (6 cyl.) (2nd design),					
71-72	Vega	2877408	1	57.00	GEAR ASSY., trans. countershaft (Opel—708079)	
73-75	Vega, Monza (140)	3915033	1	54.25	GEAR ASSY.	
74	Vega (122)	340622	1	79.75	GEAR ASSY., counter	
<i>NOTE 3: Oiling hole rearward of reverse gear section.</i>						

### 4.422 ROLLER, Transmission Countershaft Gear

64-65	All w/4-Spd.	3709328	80	.12	brg. (frt. and rear) ( $\frac{3}{4}$ " O.L.)
66-75	All w/4-Spd.	435847	A.R.	.13	brg. ( $\frac{1}{8}$ " dia. x $\frac{3}{4}$ " O.L.) (Note used w/bushed type countergear)
71-72	Vega	3469848	1	2.50	trans. gear bearing roller (Opel—1607042) (Note 1)

*NOTE 1: Consists of 48 bearing rollers.*

### 4.423 WASHER— SPACER, Transmission Counter Gear Bearing

64-65	All w/4-Spd.	3709324	6	.23	brg. ( $\frac{7}{8}$ " I.D. x $1\frac{5}{32}$ " thick)
64-65	All w/Muncie 4-Spd.	3831729	1	.82	thrust ( $\frac{57}{64}$ " I.D. x $1\frac{5}{8}$ " O.D. x $\frac{1}{16}$ " thick)
66-69	Pass. w/Saginaw 4-Spd. (283, 327, 350) (2nd design),				
66-68	Chevy, Chevelle w/Saginaw 4-Spd. (283, 307, 327) (2nd design) (exc. Sp. H/Per.),				
67-68	Camaro (exc. 302, 350, 396),				
69	All w/Saginaw 4-Spd. (exc. Pass.),				
70-75	All w/Saginaw 4-Spd.	3890565	2	.71	thrust ( $1\frac{1}{64}$ " I.D. x $1\frac{3}{8}$ " O.D.)
69-70	Pass. w/4-Spd. (396, 427),				
66	Pass. w/Muncie 4-Spd. (283, 327) (1st design),				
66-68	Chevy, Chevelle (4-Spd. w/H/Per., Sp. H/Per.) (327, 350, 396),				
66	Chevy, Chevelle w/Muncie 4-Spd. (283, 327) (1st design) (exc. Sp. H/Per.),				
67-68	Camaro w/4-Spd. (302, 350, 396) (exc. H.D.),				
69	All w/Muncie 4-Spd. (exc. 396),				
70-74	All w/Muncie 4-Spd.	3864860	A.R.	.82	thrust (1" I.D. x $1\frac{25}{32}$ " O.D.)
66-69	Pass. w/Saginaw 4-Spd. (283, 307, 327, 350) (2nd design),				
66-68	Chevy, Chevelle w/Saginaw 4-Spd. (283, 307, 327) (2nd design) (exc. Sp. H/Per.),				
67-68	Camaro (exc. 350, 396),				
69	All w/Saginaw 4-Spd. (exc. Pass.),				
70-75	All w/Saginaw 4-Spd.	3859006	2	.26	bearing ( $\frac{31}{64}$ " I.D. x $1\frac{15}{64}$ " O.D.)
66-68	Pass. w/4-Spd. (396, 427),				
66	Pass. w/Muncie 4-Spd. (283, 327) (1st design),				

## 4-SPEED TRANSMISSION

### 4.423 WASHER— SPACER, Transmission Counter Gear Bearing (Con't)

66-68	Chevy, Chevelle w/4-Spd. (327 Sp. H/Per., 350, 396),				
66	Chevy, Chevelle w/Muncie 4-Spd. (283, 327) (1st design) (exc. Sp. H/Per.),				
67-68	Camaro w/4-Spd. (302, 350, 396),				
69-74	All w/Muncie 4-Spd. ....	3864856	4	.23	bearing (1" I.D. x 1 <sup>3</sup> / <sub>16</sub> " O.D.) .....
71-72	Vega .....	3442446	2	1.20	trans. counter gear thrust (Opel— 708286) .
71-72	Vega .....	6638457	4		trans. counter gear bearing (Opel— 712200) .....
74-75	All w/Warner .....	6260709	6	.82	countershaft brg. (Warner #13-04-053-002)
74-75	All w/Warner .....	6260714	1	.82	countershaft gear rear thrust (Warner #13-04-193-001) .....
74-75	All w/Warner .....	3870799	1	1.40	reverse idler gear rear thrust .....
64-65	Chevy, Chevelle w/4-Spd.,				
65	Pass. w/Muncie 4-Spd. ....	3831726	1	2.25	SPACER, brg. (7/8" I.D. x 5 <sup>7</sup> / <sub>64</sub> " O.L.) .....
66	Pass. w/4-Spd.,				
66-68	Chevy, Chevelle, Camaro (4-Spd. w/H/Per., Sp. H/Per.) (302, 327, 350, 396),				
67-68	Pass. w/4-Spd. (396, 427),				
69-74	All w/Muncie 4-Spd. ....	3912195	1	2.05	SPACER, bearing, w/washer (1" I.D. x 5 <sup>3</sup> / <sub>32</sub> " O.L.) .....
74-75	All w/Warner .....	6260708	1	1.35	SPACER, countershaft brg. (Warner #13-04-053-001) .....

### 4.428 SHAFT, Transmission Counter

63-65	All w/Muncie 4-Spd. ....	357222	1	10.50	(7/8" dia. x 10" O.L.) .....
73-74	All w/Muncie .....	357233	1	13.00	(1 <sup>1</sup> / <sub>2</sub> " dia. x 10" O.L.) .....
66-69	Pass. w/Saginaw 4-Spd. (283, 307, 327, 350) (2nd design),				
66-68	Chevy, Chevelle w/Saginaw 4-Spd. (283, 307, 327) (2nd design) (exc. Sp. H/Per.),				
67-68	Camaro (exc. H.D., 302, 350, 396),				
69	All w/Saginaw 4-Spd. (exc. Pass.),				
70-75	All w/Saginaw .....	3859005	1	7.80	(6 <sup>1</sup> / <sub>64</sub> " dia. x 9 <sup>19</sup> / <sub>32</sub> " O.L.) .....
66-68	Pass. w/4-Spd. (396, 427),				
66	Pass. w/Muncie 4-Spd. (283, 327) (1st design),				
66-68	Chevy, Chevelle (4-Spd. w/H/Per., Sp. H/Per. 327, 350, 396),				
66	Chevy, Chevelle w/Muncie 4-Spd. (283, 327) (1st design) (exc. Sp. H/Per.),				
67-68	Camaro w/4-Spd. (302, 350, 396),				
69	All w/Muncie 4-Spd.,				
71-72	All w/Muncie .....	3864850	1		(1" dia. x 10" O.L.) .....
71-72	Vega .....	3442445	1	4.25	trans. counter gear (Opel— 712200) .....
74-75	All w/Warner .....	6260711	1	7.75	(Warner #13-04-068-001) .....

### 4.429 BALL, Transmission Countershaft Gear

71-72	Vega .....	11011168	2	.08	trans. (6 mm dia.) (.236) (Opel— 2088003) (Note 1) .....
-------	------------	----------	---	-----	--

NOTE 1: 1 used to lock rev. idler gear shaft to case. 1 used to lock counter gear shaft to case.

### 4.430 GEAR, Transmission Reverse Idler (with bushings)

64-65	All w/Muncie 4-Spd.,				
66-67	Pass. w/Muncie 4-Spd. (396, 427) (exc. H.D.),				
66	Pass. w/Muncie 4-Spd. (283, 327) (1st design),				
66-68	Chevy, Chevelle w/4-Spd. (327, Sp. H/Per., 350, 396) (exc. H.D.),				
66	Chevy, Chevelle w/Muncie 4-Spd. (283, 327) (1st design) (exc. Sp. H/Per.),				
67-68	Camaro w/4-Spd. (302, 350, 396) (exc. H.D.),				

## 4-SPEED TRANSMISSION

### 4.430 GEAR, Transmission Reverse Idler (with bushings) (Con't)

68	Pass. w/4-Spd. (327 Sp. H/Per., 396, 427),				
70-74	All w/Muncie 4-Spd. (exc. H.D.)	3831762	1	13.45	front
65-69	Pass. w/H.D. 4-Spd.,				
66-72	Chevelle w/4-Spd. H.D.,				
68-72	Chevy, Camaro w/H.D. 4-Spd.	3879997	1	14.85	front
64-65	All w/Muncie 4-Spd.,				
66-68	Pass. w/Muncie 4-Spd. (396, 427),				
66	Pass. w/Muncie 4-Spd. (283, 327) (1st design),				
66-68	Chevy, Chevelle w/4-Spd. (327 Sp. H/Per., 350, 396),				
66	Chevy, Chevelle w/Muncie 4-Spd. (283, 327) (1st design) (exc. Sp. H/Per.),				
67-68	Camaro w/4-Spd. (302, 350, 396),				
69-74	All w/Muncie 4-Spd.	357231	1	29.75	rear (17 teeth)
66	Pass. w/Saginaw 4-Spd. (283, 327) (2nd design),				
66	Chevy, Chevelle w/Saginaw 4-Spd. (283, 327) (2nd design) (exc. Sp. H/Per.),				
67	Chevy, Chevelle w/4-Spd. (283, 327) (1st design),				
67	Camaro w/4-Spd. (exc. 302, 350, 396) (1st design),				
67	Pass. w/4-Spd. (283, 327) (1st design)	3859975	1	14.80	(1½")
67-68	Pass. w/4-Spd. (283, 307, 327) (2nd design),				
67-68	Chevy, Chevelle w/4-Spd. (283, 307, 327) (exc. Sp. H/Per.) (2nd design),				
67-68	Camaro w/4-Spd. (exc. 302, 350, 396) (2nd design),				
69-75	All w/Saginaw 4-Spd.	3915037	1	17.40	(2⅛")
74-75	All w/Warner	3774905	1	57.50	rear (Warner #AT10-34C)
74-75	All w/Warner	3936254	1	43.25	front (Warner #T10T-10) (16 tooth)

### 4.433 SHAFT, Transmission Reverse Idler Gear

64-65	All w/Muncie 4-Spd.,				
66-68	Pass. w/Muncie 4-Spd. (396, 427),				
66	Pass. w/Muncie 4-Spd. (283, 327) (1st design),				
66-68	Chevy, Chevelle w/4-Spd. (327 Sp. H/Per. 350, 396),				
66	Chevy, Chevelle w/Muncie 4-Spd. (283, 327) (1st design) (exc. Sp. H/Per.),				
67-68	Camaro w/4-Spd. (302, 350, 396),				
69-72	All w/Muncie 4-Spd.	3831761	1		
67-69	Pass. w/Saginaw 4-Spd. (283, 307, 327, 350) (2nd design),				
67-69	Chevy, Chevelle w/4-Spd. (283, 307, 327) (exc. Sp. H/Per.) (2nd design),				
67-69	Camaro w/4-Spd. (exc. 302, 350, 396) (2nd design),				
70-75	All w/Saginaw 4-Spd.	3915039	1	3.35	w/o stop ring (4 <sup>7</sup> / <sub>32</sub> ")
71-72	Vega	2877404	1	14.55	trans. reverse idler w/bushing (Opel—704025) (18 teeth)
73-74	All w/Muncie	357229	1	8.75	
74-75	All w/Warner	3746277	1	6.10	( <sup>7</sup> / <sub>8</sub> " dia. x 5½" O.L.) (Warner #T10-35)
66	Pass. w/Saginaw 4-Spd. (283, 327) (2nd design),				
66	Chevy, Chevelle w/4-Spd. (283, 327) (2nd design) (exc. Sp. H/Per.),				

## 4-SPEED TRANSMISSION

### 4.433 SHAFT, Transmission Reverse Idler Gear (Con't)

67	Chevy, Chevelle w/4-Spd. (283, 327) (1st design) (exc. Sp. H/Per.),					
67	Camaro w/4-Spd. (exc. 302, 350, 396) (1st design),					
67-68	Pass. w/4-Spd. (283, 307, 327) (1st design) .....	3910029	1	3.15	SHAFT UNIT, w/stop ring (3 <sup>27</sup> / <sub>32</sub> " ) .....	

### 4.435 PIN— RING, Transmission Reverse Idler Shaft

62-65	All w/4-Spd. (exc. H.D.) .....	590832	1	.12	lock (1/4" tapered x 11/16" length) .....	
67	Chevy, Chevelle, Camaro (exc. H/Per., Sp. H/Per., 350) .....	9414486	1	.16	RING, gear retainer— (8.934) .....	
74-75	All w/Warner .....	3774910	1	.36	gear ret. (1 <sup>5</sup> / <sub>8</sub> " O.D.) (Warner #4821A) .....	

### 4.437 WASHER, Transmission Reverse Idler Gear Thrust

64-66	All w/Muncie 4-Spd.,					
67	Pass. w/4-Spd. (396, 427),					
67-68	Chevy, Chevelle w/4-Spd. (327 Sp. H/Per., 350, 396),					
67-68	Camaro w/4-Spd. (302, 350, 396),					
68-70	Pass. w/Muncie 4-Spd.,					
69-75	All w/Muncie, Warner 4-Spd. (exc. Pass.) .....	3774909	1	1.60	rear (1 <sup>5</sup> / <sub>8</sub> " O.D.) .....	
64-66	All w/Muncie 4-Spd.,					
67-68	Pass. w/4-Spd. (396, 427),					
67-68	Chevy, Chevelle w/4-Spd. (327 Sp. H/Per. 350) (396),					
67-68	Camaro w/4-Spd. (302, 350, 396),					
69-74	All w/Muncie 4-Spd. ....	3834739	1	.68	front .....	

## 5 SPEED TRANSMISSION

<b>4.003 TRANSMISSION ASSY.</b>					
75	Vega, Monza w/140	361664	1		
<b>4.004 INSULATOR ASSY., Transmission Control Lever</b>					
75	Vega	360303	1	4.25	INSULATOR
75	Monza	348203	1	3.70	INSULATOR
<b>4.006 LEVER ASSY., Transmission Control</b>					
75	Monza w/140	366101	1	49.00	
75	Vega	366175	1	49.00	
<b>4.008 RETAINER—SPRING—BOLT, Gearshift Control Hand Lever</b>					
75	Vega, Monza	366113	1	3.70	trans. control lever
75	Vega, Monza	366116 R.H.		1.25	SPRING, trans. control lever neutral bypass
75	Vega, Monza	366115 L.H.		1.25	SPRING, trans. control lever neutral bypass
75	Vega, Monza	386117	1	3.55	SPRING, trans. control lever pin
75	Vega, Monza	366114	1	1.40	BOLT, trans. control lever neutral bypass spring retaining
<b>4.015 BOOT—GROMMET, Transmission Control Lever</b>					
75	Vega	349544	1	7.90	
75	Monza	353976	1	4.25	trans. control lever inner
75	Vega	366119	1	7.90	trans. control lever lower
75	Monza	348207	1	4.50	trans. control lever lower
75	Vega	329788	1	.22	GROMMET, trans. control lever
75	Monza	348300	1	.43	GROMMET, trans. control lever
<b>4.017 BEZEL—RETAINER, Transmission Control Lever Boot</b>					
75	Vega, Monza	349545	1	7.15	
75	Monza (Hatchback)	332239	1	2.35	RETAINER
<b>4.054 SWITCH ASSY.—BRACKET, Transmission Control Safety</b>					
75	Vega, Monza	356113	1	2.35	clutch operated neutral start
75	Vega, Monza	3990895	1	.31	BRACKET, clutch operated neutral start switch
<b>4.081 SUPPORT ASSY.—MOUNTING ASSY., Transmission</b>					
75	Vega	366141	1	34.00	
75	Vega, Monza (140)	329768	1	8.50	MOUNTING ASSY.
<b>4.103 CASE ASSY., Transmission</b>					
75	Vega, Monza	361183	1	88.50	
<b>4.104 VENT ASSY., Transmission Case</b>					
75	Vega, Monza	3786022	1	.20	
<b>4.302 SELECTOR—ARM—LEVER—PIVOT—PLATE, Transmission Rail End</b>					
75	Vega, Monza	361158	1	13.85	
75	Vega, Monza	361156	1		ARM, selector
75	Vega, Monza	361168	1	14.15	LEVER, selector
75	Vega, Monza	361171	1	5.10	PIVOT, selector lever
75	Vega, Monza	361157	1	1.00	PLATE, selector arm retaining
<b>4.303 FORK—HEAD—LINK—PAD—RAIL, Gearshift</b>					
75	Vega, Monza	361153	1	10.80	first & reverse shift
75	Vega, Monza	361151	1	10.80	second & third shift
75	Vega, Monza	361149	1	10.80	fourth & fifth shift
75	Vega, Monza	361170	1	7.20	HEAD, gearshift
75	Vega, Monza	361154	1	4.90	LINK, first & reverse shift fork
75	Vega, Monza	361152	1	5.95	LINK, second & third shift fork
75	Vega, Monza	361150	1	5.95	LINK, fourth & fifth shift fork
75	Vega, Monza	361155	1	.16	PAD, shift fork
75	Vega, Monza	361169	1	7.90	RAIL, gearshift
<b>4.307 PAWL, Transmission Interlock</b>					
75	Vega, Monza	361167	1	7.90	
<b>4.309 SHAFT—RING, Gearshift</b>					
75	Vega, Monza	361166	1	30.40	trans. shifter
75	Vega, Monza	3881433	1	.12	RING, shift rail retaining
<b>4.311 PLUNGER—PLUG—SPRING, Gearshift Detent</b>					
75	Vega, Monza	361172	1	.69	trans. mesh lock
75	Vega, Monza	361174	1	.42	PLUG, poppet spring
75	Vega, Monza	361173	1	.12	SPRING, poppet

**5 SPEED TRANSMISSION**

<b>4.317 EXTENSION ASSY., Transmission</b>					
75	Vega, Monza	361163	1	68.50	
<b>4.318 SEAL ASSY., Transmission Extension Oil</b>					
75	Vega, Monza	361165	1	3.14	
<b>4.319 BUSHING, Transmission Extension</b>					
75	Vega, Monza	6260048	1	.74	
<b>4.342 SHAFT ASSY., Speedometer Flex</b>					
75	HM (262)	6478176	1	7.28	64" long
<b>4.343 GEAR, Speedometer Drive</b>					
75	Vega, Monza	6261797	1	3.55	
<b>4.351 GEAR, Transmission Main Drive (Clutch)</b>					
75	Vega, Monza w/140	361128	1	97.75	
75	Vega, Monza w/262	369118	1	106.00	
<b>4.352 ROLLER— BEARING— RACE— WASHER, Transmission Clutch Gear</b>					
75	Vega, Monza	361124	1	.26	clutch gear bearing
75	Vega, Monza	361122	1		BEARING, clutch gear needle
75	Vega, Monza	361126	1	1.85	BEARING, clutch gear needle thrust
75	Vega, Monza	361127	1	1.50	RACE, clutch gear needle thrust brg.
75	Vega, Monza	361125	1	.71	WASHER, clutch gear needle brg. thrust
<b>4.354 SEAL, Transmission Clutch Gear Oil</b>					
75	Vega, Monza	361120	1	2.21	
<b>4.380 SYNCHRONIZER, Transmission</b>					
75	Vega, Monza	361146	1	35.50	trans. first & reverse
75	Vega, Monza	361132	1	35.50	trans. second & third
75	Vega, Monza	361142	1	38.75	trans. fourth & fifth
<b>4.383 RING, Transmission Synchronizer</b>					
75	Vega, Monza	361131	1	8.10	synchronizer blocking
<b>4.384 KEY— BEARING— RING— SPRING, Transmission Synchronizer</b>					
75	Vega, Monza	361133	1	.54	
75	Vega, Monza	361143	1	1.55	BEARING, fourth & fifth synch. needle thrust
75	Vega, Monza	361147	1	.31	RING, first & reverse synch. retainer
75	Vega, Monza	361135	1	.31	RING, second & third synch. retainer
75	Vega, Monza	361134	1	.33	SPRING, trans. synch.
<b>4.395 GEAR, Transmission Second Speed</b>					
75	Vega, Monza	361136	1	42.25	
<b>4.403 SHAFT— SUPPORT, Transmission</b>					
75	Vega, Monza	361129	1	90.75	SHAFT
75	Vega, Monza	361177	1	84.25	SUPPORT, center
<b>4.404 DAMPER, Transmission Output Shaft</b>					
75	H	347415	1	12.50	DAMPER (5.544)
<b>4.415 GEAR, Transmission Third &amp; Fifth Speed</b>					
75	Vega, Monza	361130	1	42.25	third speed
75	Vega, Monza w/262	369119	1	40.25	fifth speed
<b>4.416 GEAR— BEARING— RING— SPACER— WASHER, Fifth Speed</b>					
75	Vega, Monza	361140	1	42.25	fifth speed
75	Vega, Monza	361176	1	.16	BEARING, fifth speed gear needle
75	Vega, Monza	361137	1	.33	RING, fifth speed gear brg. retainer
75	Vega, Monza	361141	1	.49	SPACER, fifth speed gear needle brg.
75	Vega, Monza	361138	1	.36	WASHER, fifth speed gear thrust
<b>4.417 GEAR, Transmission First Speed</b>					
75	Vega, Monza	361148	1	46.50	
<b>4.422 GEAR— BEARING, Transmission Countershaft</b>					
75	Vega, Monza w/262	369121	1	157.75	counter
75	Vega, Monza w/140	361179	1		counter
75	Vega, Monza	451973	1		BEARING, counter gear front needle
75	Vega, Monza	374625	1		BEARING, counter gear center needle
75	Vega, Monza	361181	1	4.35	BEARING, counter gear rear needle

**5 SPEED TRANSMISSION**

---

**4.430 GEAR, Transmission Reverse**

75	Vega, Monza .....	361144	1	40.25	reverse .....
75	Vega, Monza w/140 .....	361159	1	23.85	reverse idler .....

**4.431 BUSHING, Transmission Reverse**

75	Vega, Monza .....	361144	1	40.25	reverse gear .....
75	Vega, Monza .....	361159	1	23.85	reverse idler gear .....





**250-350-375-400 TURBO-HYDRAMATIC**

**4.003 TURBO-HYDRAMATIC (250, 350, 375, 400)**

*The Turbo Hydra-Matic Section of this catalogue includes two types of three-speed automatic transmission, the T.H. 350 and the T.H. 400.*

*To Identify the Transmission use the following:*

*T.H. 350— The carburetor to transmission throttle control is CABLE ACTIVATED.*

*The cable runs from the accelerator control lever to the RIGHT side of the transmission.*

*T.H. 400— The carburetor to transmission throttle control is ELECTRICALLY ACTIVATED.*

*The cable runs from the switch at the carburetor to the LEFT side of the transmission.*

**4.003 TRANSMISSION ASSY. (less hand brake)**

**TURBO-HYDRAMATIC 375, 400 TRANSMISSION**

65-67	Pass. (396),				
68	Pass. (396) (exc. Police, 2.29 rear axle),				
69	Pass. (350, 396),				
67	Pass. (327),				
68-69	Pass. (327) (exc. Police),				
70	Pass. (400 w/2BC) . . . . .	<b>8626648</b>	1	515.00	
71	Pass. (400) . . . . .	<b>8627039</b>	1	552.00	
71	Chevelle w/H/Per. (454) . . . . .	<b>8627048</b>	1	572.00	
72	Pass. w/T.H. 400 (exc. Police, 454) . . . . .	<b>8627258</b>	1	552.00	
73	Pass. w/T.H. 400 (454) . . . . .	<b>8627515</b>	1	552.00	
73	Chevelle w/T.H. 400 . . . . .	<b>8627516</b>	1	552.00	
73	Pass. (2BC w/T.H. 375) (350, 400) . . . . .	<b>8627579</b>	1	552.00	
74	Pass. (454) . . . . .	<b>8627726</b>	1	552.00	
74	Chevelle . . . . .	<b>8627728</b>	1	552.00	
74	Camaro . . . . .	<b>8627730</b>	1	745.00	
74	Chevelle w/T.H. 400 (3.08 rear axle),				
74	Pass. w/2BC (400) (exc. Sta. Wag.),				
74	Pass. (Sta. Wag.) w/4BC (400) (exc. NB-2) . . . . .	<b>8627725</b>	1	552.00	(Note 1) . . . . .
74	Pass. w/2BC (400) (exc. Sta. Wag.),				
74	Pass. (Sta. Wag.) w/4BC (400) (exc. NB-2) . . . . .	<b>8627887</b>	1	552.00	(Note 2) . . . . .
75	Chevelle w/T.H. 400 . . . . .	<b>8629015</b>	1	745.00	
75	Pass. (454) Police (350) w/T.H. 400 . . . . .	<b>8629020</b>	1	745.00	
75	Pass. w/T.H. 400 (400) 4BC (exc. NB-2) (3.08-3.42 rear axle) . . . . .	<b>8629014</b>	1	745.00	
75	Pass. w/T.H. 400 (400) 4BC (exc. NB-2) (2.56-2.73 rear axle) . . . . .	<b>8629062</b>	1	745.00	

*NOTE 1: Outer spline dia. 1.175.*

*NOTE 2: Outer spline dia. 1.375.*

**TURBO-HYDRAMATIC 250, 350 TRANSMISSION**

68	Pass. (307) (exc. C.A.C.),				
68	Chevy, Chevelle, Camaro w/2BC (exc. C.A.C.),				
69	Chevy, Chevelle, Camaro (2BC w/2.56, 2.73 axles) (307, 327),				
70-72	All (307),				
68	Pass., Chevelle, w/C.A.C. (327),				
69	Pass. (2BC w/3.07, 3.08 axles) (350),				
69	Chevy, Chevelle, Camaro w/3.07, 3.08 axles (350),				
68	Pass., Chevelle (327) (exc. C.A.C.),				
68	Chevy, Camaro w/4BC (327),				
69	Pass. w/2BC (350) (exc. 3.07, 3.08 axles, Police),				
69	Chevy, Chevelle, Camaro w/reg. fuel (350),				
70	All (350) (exc. 4BC),				
71	All (350) (exc. Pass.),				
72	Nova, Chevelle, Camaro w/T.H. 350 (350) . . . . .	<b>340662</b>	1	673.00	



**250-350-375-400 TURBO-HYDRAMATIC**

**4.003 TRANSMISSION ASSY. (less hand brake) (Con't)**

68	Chevy, Camaro (350),			
69	Chevelle (350) (exc. reg. fuel, 3.07 axle),			
69	Chevy, Camaro w/2.73 axle (350) (exc. reg. fuel),			
69	Pass. w/4BC (350) (exc. 3.07 axle, Police),			
69	Pass. (3.07 axle w/4BC) (350),			
69	Chevelle w/3.07 axle (350) (exc. reg. fuel),			
69	Chevy, Camaro (350) (exc. reg. fuel, 2.73 axle),			
70	All (350 w/4BC),			
70	All (400 w/2BC),			
71	Monte Carlo (400) . . . . .	325108	1	664.00
69	Pass. (8 cyl.) (exc. 350, C.A.C., 3.07, 3.08 axle, Taxi, Police) . .	6261417	1	585.00
71-73	Pass. w/T.H. 350 (400) (exc. Sta. Wag.) . . . . .	332568	1	
72	Pass. (Sta. Wag.) w/T.H. 350 (350, 400) . . . . .	6261847	1	673.00
71-72	Pass. (350) (exc. Sta. Wag.),			
73-74	Pass. w/T.H. 350 (350) (exc. Taxi, Police) . . . . .	340663	1	673.00
72-74	Vega (140) T.H. 250 . . . . .	345188	1	639.00
74	Chevelle (T.H. 350 w/2BC) (400)	340683	1	
75	Chevelle w/T.H. 350 (400) 4BC .	347482	1	688.00
73-74	Nova, Chevelle, Camaro w/T.H. 350 (350),			
75	Monte Carlo, Chevelle w/T.H. 350 (350) . . . . .	347497	1	688.00
75	Chevelle, Camaro (350) w/T.H. 350,			
75	Nova (350) w/T.H. 350, 4BC . . .	8640081	1	688.00
74-75	All w/T.H. 250 (6 cyl.) . . . . .	346350	1	688.00
75	Pass. w/T.H. 350 (400) (exc. Sta. Wag.),			
75	Police w/T.H. 350 (350) . . . . .	347484	1	688.00
75	Pass. w/T.H. 350 (350) (exc. Sta. Wag., Police) . . . . .	347483	1	688.00
75	Vega, Monza (140) T.H. 250 . . .	8640014	1	688.00
75	Monza (8 cyl.) . . . . .	347498	1	688.00

**4.004 CONTROL ASSY., Transmission Gearshift**

66-67	Pass. (T.H. w/B.S.) . . . . .	3904027	1	52.25	w/lever and bracket . . . . .
67-68	Camaro (T.H. w/floor console),				
68	Chevy (T.H. w/floor console) . . .	3912607	1	55.00	w/lever and bracket . . . . .
68-70	Pass. (A.T. w/B.S.) . . . . .	3954623	1	62.50	w/lever and bracket . . . . .
68-72	Chevelle (A.T. w/floor console) . .	3952863	1	41.00	w/bracket and lever . . . . .
69-73	Nova (T.H. w/floor console) . . . .	3998651	1	39.00	w/bracket and lever . . . . .
68-72	Camaro (A.T. w/floor console) . . .	3972240	1	42.50	w/lever and bkt. . . . .
73-75	Camaro w/floor console . . . . .	351300	1	25.50	trans. control . . . . .
73-75	Chevelle w/floor console . . . . .	6262290	1	42.00	trans. control . . . . .
73	Nova w/floor console . . . . .	3998651	1	39.00	trans. control . . . . .
74	Nova w/floor console . . . . .	340305	1	40.00	trans. control (hypodermic type shifter) . . . .
75	Nova w/floor controls . . . . .	352872	1	23.00	trans. control . . . . .
72	Vega (2nd design) . . . . .	329754	1	14.55	trans. control w/bracket . . . . .
73-74	Vega . . . . .	325790	1	14.55	trans. control w/bracket . . . . .
75	Vega . . . . .	356361	1	18.20	trans. control w/bracket . . . . .
75	Monza (exc. Towne Cpe.) w/console . . . . .	348208	1	25.00	trans. control w/bracket . . . . .
76	Towne Coupe (exc. console) . . . .	349592	1		trans. control w/bracket . . . . .

**4.005 GASKET UNIT— RING UNIT, Transmission**

65-75	All w/T.H. 375, 400 . . . . .	8625967	1	60.80	overhaul (Note 1) . . . . .
<i>NOTE 1 Consists of 1 front servo piston oil seal ring, 2 pump oil seal rings, 4 center support oil seal rings, 3 intermediate clutch drive plate assemblies, 5 forward clutch drive plate assemblies, 1 front pump seal, 1 extension housing seal, 2 forward and direct clutch piston seal kits, 1 intermediate clutch piston seal kit, 1 overhaul gasket and seal kit.</i>					
68-72	All w/T.H. 350 (exc. Taxi),				
73-75	All w/T.H. 350 . . . . .	347126	1	9.80	w/seals (Note 2) . . . . .

**250-350-375-400 TURBO-HYDRAMATIC**

**4.005 GASKET UNIT— RING UNIT, Transmission (Con't)**

*NOTE 2: Consists of 1 each seal assy. park lock and range selector shift, inter. clutch accum. piston cover, extension to case governor cover, low and reverse clutch piston, lower, outer, and center inter., clutch piston outer and inner, direct clutch piston inner, outer and center forward clutch piston outer and inner, output shaft, oil pump outer and inner oil filler tube, and detent cable. Also 8 seals, oil pump to transmission case bolt, 1 each "O" rings speedo. driven gear fitting, and vacuum modulator. Also 1 each gasket valve body to spacer plate, oil pan to trans. case, oil pump screen, oil to case and valve body spacer plate.*

65-66	Pass. w/T.H.,				
67-75	All w/T.H. 375, 400	8625905	1	9.50	w/seals (Note 5)
	<i>NOTE 5 Consists of 1 ring pump to case seal, 8 "O" ring pump body bolt seals, 8 pump body bolt washers, 1 pump cover to case gasket, 1 "O" ring output shaft seal, 1 reverse servo piston seal, 1 rear servo cover gasket, 1 governor cover gasket, 1 "O" ring parking pawl shaft seal, 2 manual shaft "O" rings, 1 manual shaft seal assy., 2 vacuum modulator and connector seals, 1 valve body to spacer gasket, 1 case to spacer gasket, 1 solenoid valve gasket, 1 "O" ring strainer seal, 1 trans. oil pan gasket, 1 case extension to case gasket 1<sup>23</sup>/<sub>64</sub>" dia. parking shaft plug, 1 filler tube "O" ring seal.</i>				
69-75	All w/T.H. 250, T.H. 350	358045	1	80.25	complete overhaul (Note 3)
	<i>NOTE 3: Consists of (1 each) gasket and seal unit, oil seal ring unit, seal assy. extension oil (5 each) plate assy., low and reverse drive (faced), forward clutch driven (faced) (3 each) plate assy., low and reverse drive (faced) (4 each) plate assy. direct clutch drive.</i>				
65-71	All w/T.H. 400	3928594	1	9.15	RING UNIT, trans. oil seal (Note 4)
	<i>NOTE 4 Consists of 6 center support and pump cover seals, 1 front servo piston seal, 1 front accumulator piston seal, 1 accumulator piston seal, 1 rear accumulator piston seal.</i>				
69-72	All w/T.H. 350 (exc. Taxi),				
73-74	All w/T.H. 250, 350	338202	1	9.20	RING UNIT, trans. oil seal
73-75	All w/T.H. 375, 400	8623979	1	1.81	RING UNIT, snap

**4.006 LEVER— BRACKET— BUTTON— CABLE— COVER— CLIP— HANDLE— KNOB— RING— ROD, Gearshift Control (Hand)**

65-66	Pass. w/A.T. (exc. B.S., T.W.)	3816227	1	3.65	(9 <sup>13</sup> / <sub>32</sub> " O.L.)
67	Pass., Chevelle w/A.T. (exc. T.W., B.S.),				
68	Pass. w/A.T. (exc. B.S., S.S., T.W.),				
68	Chevy, Chevelle, w/A.T. (exc. T.W., floor console)	3928319	1	3.75	control
69	Pass. w/A.T. (exc. B.S., T.W.),				
69	Chevy, Chevelle, Camaro w/A.T. (exc. T.W., floor shift),				
70	All w/A.T. (exc. T.W.)	3939741	1	6.65	control
69	Pass. (A.T. w/T.W.) (exc. B.S.),				
69	Chevelle, Camaro (A.T. w/T.W.) (exc. floor console),				
70-71	All (A.T. w/T.W.) (exc. Nova, floor console),				
72-74	All w/T.W. (exc. floor console)	6272366	1	5.90	control
71	Nova (exc. floor console),				
71-75	All (exc. T.W., floor console)	6272365	1	5.85	
67	Camaro (floor console w/A.T.),				
68-72	Chevy (A.T. w/floor console),				
68	Camaro (T.H. 400 w/floor shift) (exc. floor console)	6263121	1	22.20	LEVER UNIT, control
68-69	Pass. (A.T. w/B.S.),				
68-72	Chevelle, Camaro (A.T. w/floor console)	3922577	1	4.20	LEVER ASSY., control
64-67	Nova, Malibu (S.S.) w/A.T.,				
75	Nova w/T.H. w/T.W. (exc. floor console)	352867	1	6.15	LEVER ASSY., control
73-74	Nova w/floor console	360853	1	41.00	LEVER ASSY., w/cable
72	Vega (1st design)	6264380	1	6.10	LEVER ASSY., trans. cont. shaft (Note 1)
72	Vega (2nd design)	329765	1	6.10	LEVER ASSY., trans. cont. shaft (Note 1)
73-74	Vega	325782	1	14.55	LEVER ASSY., trans. cont. shaft (Note 1)
75	Vega	356361	1	18.20	LEVER ASSY., trans. control shaft
75	Vega	349596	1	5.10	LEVER ASSY., control detent
75	Monza	348235	1	.43	LEVER ASSY., control detent
75	Monza	348227	1	16.75	LEVER ASSY., trans. control shaft
72	Vega (1st design)	6264383	1	4.20	BRACKET ASSY., control lever mtg. (Note 1)
72	Vega (2nd design)	329762	1	4.20	BRACKET ASSY., control lever mtg. (Note 1)
73-74	Vega	325791	1	4.20	BRACKET ASSY., control lever mtg. (Note 1)
75	Monza	348237	1	3.55	BRACKET ASSY., control lever mtg.
65	S.S. w/A.T.,				
66-67	Spt. Cpe., Conv. w/A.T.	3843125	1	.22	BUTTON, control lever release
67	Camaro (floor console w/A.T.),				

**250-350-375-400 TURBO-HYDRAMATIC**

**4.006 LEVER— BRACKET— BUTTON— CABLE— COVER— CLIP— HANDLE—  
KNOB— RING— ROD, Gearshift Control (Hand) (Con't)**

68-72	Chevy (A.T. w/floor console),					
68-69	Camaro (T.H. 400 w/floor shift)	3914825	1	.74	BUTTON, control lever	
68-69	Pass., Chevelle, Camaro (A.T. w/floor console),					
70-72	Chevelle, Camaro (A.T. w/floor console)	3920271	1	1.35	BUTTON, control lever	
73-75	Chevelle w/floor console	6262282	1	1.25	BUTTON, control lever	
73-75	Camaro w/floor console,					
75	Nova w/floor console	332617	1	.99	BUTTON, control lever knob	
72-75	Vega, Monza	3992925	2	.91	BUSHING, trans. cont. rod lever	
72-75	Vega, Monza	3988009	1	.15	BUSHING, trans. cont. rod lever	
75	Monza	348233	1	1.40	CABLE ASSY., trans. control	
68-69	Pass., Chevelle, Camaro (A.T. w/floor console),					
70-72	Chevelle, Camaro (A.T. w/floor console)	3920270	1	1.35	COVER, control lever handle	
73-75	Chevelle, Camaro w/floor console	9797188	1	.33	CLIP, control lever knob	
68-69	Pass., Chevelle, Camaro (A.T. w/floor console),					
70-72	Chevelle, Camaro (A.T. w/floor console)	3920269	1	9.60	HANDLE, control lever	
70-72	Nova (A.T. w/floor console)	3895274	1	4.80	HANDLE, control lever	
74	Nova w/floor console	325769	1	4.80	HANDLE, control lever	
65	Pass. (exc. S.S., Caprice)	3782694	1	1.35	KNOB (2 <sup>13</sup> / <sub>32</sub> " O.L.— black plastic)	
65	Caprice	3877518	1		KNOB, control lever	
66	Caprice (exc. B.S.)	3882907	1	1.55	KNOB, cont. lever	
67	Pass.	3898254	1	1.75	KNOB, turquoise w/chrome	
67	Pass.	3973042	1	2.10	KNOB, gold w/chrome	
68	Pass.	3928282	1	1.90	KNOB, dark saddle w/chrome	
69	All	3945523	1	1.20	KNOB, midnight green	
67-70	All w/column shift	3973042	1	2.10	KNOB, control lever (black) (paint as required)	
71-75	All w/column shift	3990592	1	2.40	KNOB, control lever (black)	
72-74	Vega	3978178	1	1.15	KNOB, trans. control lever	
75	Vega, Monza (140)	349589	1	3.60	KNOB, trans. control lever	
75	Monza (8 cyl.)	330237	1	3.85	KNOB, trans. control lever	
73-75	Nova w/floor console	330237	1	3.85	KNOB, control lever	
73-75	Camaro w/floor console,					
75	Nova w/floor console	332616	1	.99	KNOB, control lever	
73-75	Chevelle w/floor console	481172	1	1.85	KNOB ASSY., control lever	
73-74	Chevelle, Camaro w/floor console	9418564	1	.11	RING, control lever (1/2" dia.)— (8.934)	
75	Monza	348234	1	.24	RETAINER, trans. control cable	
75	Vega, Monza	3992926	1	.14	WASHER, trans. cont. rod lever	

*NOTE 1: 1st design is identified by threaded type park lock and range selector outer rod. 2nd design is identified by slotted type park lock and range selector outer rod.*

**4.008 BUSHING— BRACKET— CUP— FASTENER— GROMMET— GUIDE—  
NUT— PIN— PLUG— RING— ROD— SEAL— SHAFT— SHIM— SLEEVE—  
SPACER— SPRING— TUBE— WASHER, Gearshift Control Hand Lever**

67	Camaro (floor console w/A.T.),					
68-71	All (A.T. w/floor console),					
72	Chevelle, Camaro w/floor console,					
73	All w/floor console	3859797	2	.92	control lever	
73-75	Chevelle w/floor console	6263601	1	1.05	BRACKET, control shaft	
68-70	All (A.T. w/floor console)	564708	2	.16	FASTENER, snap, control cable retainer— (4.060)	
65	Pass. w/A.T. (exc. T.W.),					
66	Pass. w/A.T. (exc. T.W., B.S.)	3779108	1	.12	GROMMET, control lever (rubber)	
65-66	Pass. (T.W. w/A.T.) (exc. B.S.)	568018	1	.11	GROMMET, control lever	
67	Camaro (floor console w/A.T.),					
68	Camaro (T.H. 400 w/floor shift) (exc. floor console),					
68-71	Chevy (A.T. w/floor console)	3895275	1	1.05	NUT, control lever handle	
71-72	Nova w/floor console	3992309	1	.18	NUT, control lever knob (9/16"— 18)	
72	Vega	3909593	2	.11	trans. cont. lever and bracket (8— 18)— (9.743)	
73-74	Vega	325822	2	.11	trans. cont. lever and bracket (8— 18)— (9.743)	
67-69	Chevelle (S.S. w/A.T.),					
71-74	Nova, Chevelle, Camaro (exc. floor console)	3793014	1	1.05	PIN, fulcrum (7/32" dia. x 1 <sup>11</sup> / <sub>32</sub> " O.L.)	

**250-350-375-400 TURBO-HYDRAMATIC**

**4.008 BUSHING— BRACKET— CUP— FASTENER— GROMMET— GUIDE—  
NUT— PIN— PLUG— RING— ROD— SEAL— SHAFT— SHIM— SLEEVE—  
SPACER— SPRING— TUBE— WASHER, Gearshift Control Hand Lever  
(Con't)**

75	All (exc. floor console) . . . . .	402196	1	.16	PIN, trans. control lever pivot . . . . .
67	Camaro (floor console w/A.T.) . . .	3859792	1	4.05	PLUG, control lever . . . . .
62-69	All . . . . .	9431762	1	.08	RING, control lever pin retaining ( <sup>13</sup> / <sub>64</sub> "— (8.934) . . . . .
67	Camaro (A.T. w/floor console),				
68-70	Chevy (A.T. w/floor console) (6 cyl.),				
68	Camaro (T.H. 400 w/floor shift) (exc. floor console),				
71-72	Nova w/floor console . . . . .	3895278	1	6.30	ROD, control lever release . . . . .
67	Camaro (T.H. w/floor console),				
68	Camaro (T.H. w/floor shift) (exc. floor console),				
68-74	Nova (T.H. w/floor console) . . . .	3912612	1	1.90	SEAL, control lever w/bracket . . . . .
68-69	All (A.T. w/floor console) (exc. Chevy),				
71-72	Chevelle, Camaro w/floor console . . . . .	3920281	1	1.95	SHAFT, control lever and bracket . . . . .
65	Pass. (exc. S.S. w/A.T.),				
66	Pass. w/A.T. (exc. T.W., B.S.) . . .	3758998	1	.26	SHIM, control lever . . . . .
67	Camaro (A.T. w/floor console),				
68	Camaro (T.H. 400 w/floor shift) (exc. floor console),				
68-72	Chevy (A.T. w/floor console) . . . .	3905504	1	1.40	SLEEVE, control lever release rod . . . . .
68-72	All (A.T. w/floor console) (exc. Chevy) . . . . .	3920282	1	.53	SPACER, control lever 2nd bracket shaft . . .
64-67	Chevy, Chevelle (S.S.) w/A.T.,				
65-67	Pass. w/A.T. . . . .	3874236	1	.11	SPRING, cont. lever release button . . . . .
66	Pass. (T.W. w/B.S.) . . . . .	3719853	1	.16	SPRING (5 coils— <sup>19</sup> / <sub>32</sub> " long) . . . . .
67-68	All w/A.T. (exc. floor console, T.W.) . . . . .	7800605	1	.38	SPRING, lever . . . . .
67-68	All (A.T. w/column shift) (exc. Chevy),				
73-75	Pass. w/T.W. . . . .	7800670	1	.53	SPRING, gearshift lever housing . . . . .
67	Camaro (floor console w/A.T.),				
68	Camaro (T.H. 400 w/floor shift) (exc. floor console),				
68-71	Chevy (A.T. w/floor console) . . . .	3895277	1	1.05	SPRING, control lever upper . . . . .
67	Camaro (floor console w/A.T.) (1st design) . . . . .	3899023	1	.32	SPRING, control lever lower ( <sup>15</sup> / <sub>32</sub> " O.L.) . . .
67	Camaro (A.T. w/floor console) (2nd design),				
68-72	Chevy (A.T. w/floor console),				
68	Camaro (T.H. 400 w/floor shift) (exc. floor console) . . . . .	3917592	1	.92	SPRING, control lever lower ( <sup>11</sup> / <sub>2</sub> " O.L.) . . .
69	Pass. (A.T. w/column shift) (exc. T.W., B.S.),				
70	All w/floor controls,				
70-71	All (A.T. w/column shift),				
73	All (exc. floor console, T.W.) . . . .	7808017	1	.64	SPRING, lever . . . . .
69-70	All (column shift w/T.W.) (exc. Chevy),				
71-72	All w/T.W. (exc. floor console),				
73-75	All w/T.W. (exc. floor console pass.) . . . . .	7812853	1	.92	SPRING, gearshift lever housing . . . . .
73-74	Nova w/floor console . . . . .	3845716	1	.44	SPRING, lever lower . . . . .
75	Vega, Monza . . . . .	349597	1	.58	SPRING, control detent lever . . . . .
72-75	Vega (2nd design) . . . . .	329764	1	.14	SPRING, trans. cont. shift lever (Note 1) . . .
75	Monza . . . . .	348243	1	.14	SPRING, trans. control lever lockout upper . .
75	Monza . . . . .	348231	1	.40	SPRING, trans. control lever lockout lower . .
<i>NOTE 1: 1st design is identified by threaded type park lock and range selector outer rod, 2nd design is identified by slotted type park lock and range selector outer rod.</i>					
73-74	Nova w/floor console . . . . .	3859193	1	.71	TUBE, control lever seal . . . . .
64-66	Nova, Malibu (S.S.) w/A.T.,				
65-67	Pass. (A.T. w/B.S.) . . . . .	3843131	1	.12	WASHER, control lever spring . . . . .
68-70	Camaro, Chevelle (A.T. w/floor console),				
68	Chevy w/floor console,				
68-69	Pass. (A.T. w/B.S.),				
71-73	All w/floor console . . . . .	2390395	1	.20	WASHER, control lever & bracket shaft . . . .

**4.010 BRACKET— BOWL— COVER— EXTENSION— HOUSING— PLATE— SHROUD, Gearshift Hand Lever**

*For floor shift models not using strg. column shift lever housing, see group 6.518 for equivalent part, listed as a cover, jacket extension, housing, etc.*

67	Camaro (T.H. w/floor console),				
68	Camaro (T.H. 400 w/floor shift) (exc. floor console),				
68-70	Chevy (T.H. 400 w/floor console),				
71-72	Nova w/floor console . . . . .	3912608	1	15.95	BRACKET ASSY., control lever . . . . .
68-72	Chevelle (A.T. w/floor console) .	3952864	1	15.00	BRACKET ASSY., w/detent control lever . .
70-72	Camaro (A.T. w/floor console) . .	3984550	1	12.10	BRACKET ASSY., control lever . . . . .
74	Nova w/floor console . . . . .	340309	1	9.00	BRACKET ASSY., control lever . . . . .
76	Monza (140, 262) . . . . .	348237	1	3.55	BRACKET ASSY., lever mounting . . . . .
69	Pass. w/column shift (exc. T.W.),				
69-70	Chevy, Chevelle, Camaro w/column shift (exc. T.W.) . . . .	7810216	1	26.25	BOWL, strg. col. G/S lever . . . . .
72	Vega, Monza . . . . .	3999482	1	4.50	COVER, trans. control lever and bracket . .
73-74	Vega, Monza . . . . .	6264741	1	3.95	COVER, trans. control lever and bracket (black) . . . . .
74	Vega . . . . .	336594	1	.43	COVER, detent plate . . . . .
75	Monza (140, 262) . . . . .	348236	1	.84	COVER, detent plate . . . . .
75	Vega, Monza (exc. Console) . . . .	349564	1	.44	COVER, detent plate . . . . .
75	Vega, Monza . . . . .	346640	1	4.15	COVER, trans. control lever and bracket (black) . . . . .
71-75	Camaro (exc. T.W., floor console) . . . . .	7808409	1	7.50	EXTENSION, strg. col. control lock tube . .
67-68	Camaro (A.T. w/T.W.) (exc. floor console) . . . . .	5698984	1	16.85	HOUSING, lever . . . . .
68	Camaro (T.H. 400 w/floor shift) (exc. floor console) . . . . .	3893847	1	9.85	HOUSING, control . . . . .
69-70	All w/floor shift (exc. T.W.) . . . .	7804436	1	14.25	HOUSING, control lock tube . . . . .
69-72	All w/column shift (exc. T.W.),				
73	All (exc. T.W.) . . . . .	7812064	1	18.35	HOUSING, control lock tube (Note 1) . . . .
69-72	Camaro (A.T. w/T.W.) (exc. floor console),				
73-75	Nova, Chevelle, Camaro w/T.W. (exc. floor console) . . . . .	7805991	1	33.75	HOUSING, strg. column . . . . .
67-68	Camaro w/A.T. (exc. T.W., floor console) . . . . .	5699058	1	25.00	HOUSING ASSY., w/shroud assy., gear shift lever . . . . .
68	Pass. w/A.T. Column shift (exc. T.W.) . . . . .	7800595	1	19.20	HOUSING ASSY., w/shroud gearshift lever
68	Chevy w/A.T. (exc. floor console)	7803114	1	27.75	HOUSING ASSY., w/shroud . . . . .
72	Pass., Chevelle w/T.W. . . . .	7805996	1	16.60	HOUSING, strg. col. gearshift lever . . . . .
73-74	Pass. w/T.W.,				
69-70	All w/A.T. (exc. T.W., floor console) . . . . .	7804401	1	1.75	PLATE, strg. column shift tube lock . . . . .
69-70	Pass., Chevelle w/floor shift (exc. T.W.) . . . . .	7807691	1	1.10	PLATE, strg. column shift tube lock . . . . .
69	Pass., Chevelle (exc. T.W.),				
70	Pass., Nova, Chevelle (exc. Tel., T.W.),				
71	Pass., Chevelle (exc. T.W.),				
73-74	Pass., Monte Carlo (exc. T.W.) . .	7811352	1	7.75	SHROUD, strg. col. gearshift hsg. bowl . . . .
69-71	Nova, Camaro (exc. T.W.),				
73-75	Nova, Chevelle, Camaro (exc. T.W.) . . . . .	7811350	1	7.90	SHROUD, strg. col. gearshift hsg. bowl . . . .
72	Chevelle (T.W. w/floor console) .	7806003	1	28.25	SHROUD, strg. col. tran. control lock tube .
73-75	Vega, Monza . . . . .	7810336	1	7.15	strg. col. . . . .

NOTE 1: When used on jobs having plate and screw discard these parts.

**4.012 PLATE— DETENT— SCREW— STUD— WASHER, Gearshift Hand Lever Housing**

73	Nova (exc. floor console, T.W.) . .	7806352	1	3.15	strg. col. g/s lever detent . . . . .
68-70	All (A.T. w/floor console) (exc. Chevy, Monte Carlo),				
71-72	Chevelle, Camaro w/floor console . . . . .	3920280	1	1.90	DETENT, control lever . . . . .
67-75	All w/T.W. . . . .	7800639	1	.24	SCREW, shift detent plate . . . . .
69-70	All (exc. T.W.) . . . . .	7810242	2	.78	SCREW, strg. column shift tube lock plate .
69-75	All (exc. T.W.) . . . . .	7804407	A.R.	.24	SCREW, str. column shift lever detent plate
65	Pass. (exc. T.W.),				
66	Pass. w/A.T. (exc. T.W., B.S.) . . .	3793124	1	.16	WASHER, lever housing (1 <sup>5</sup> / <sub>16</sub> " ) . . . . .
66	Caprice (Spt. Cpe.) (A.T. w/B.S.),				
66	Chevy,				

**250-350-375-400 TURBO-HYDRAMATIC**

**4.012 PLATE— DETENT— SCREW— STUD— WASHER, Gearshift Hand Lever Housing (Con't)**

66	Chevelle	3879747	1	.11	WASHER, lever housing
66	Caprice (Spt. Cpe.) (B.S. w/A.T.)	3879778	1	.12	WASHER, cont. lever hsg. thrust
67-68	All w/T.W.	5698413	1	.53	WASHER, steering column support thrust
67-68	All w/T.W.	5699618	1	.53	WASHER, steering column support wave
67-75	All (exc. T.W.)	7800580	1	.34	WASHER, steering shaft upper retainer ring thrust
67-68	All (exc. T.W.)	7800581	1	.38	WASHER, steering shaft upper retainer ring wave
69-75	All w/T.W.	3886319	1	.32	WASHER, strg. column supt. thrust— (5.453)
69-74	All w/T.W.	3884595	1	.20	WASHER, strg. column supt. wave
69-70	All (exc. T.W.)	7804447	1	.59	WASHER, strg. column shift lever housing brg. wave

**4.015 SEAL— HOUSING— BOOT— RETAINER, Lever Hand (Floor Mounted)**

67	Camaro w/A.T.,				
68-74	Chevy (A.T. w/floor console)	345527	1	.65	control lever
68	Camaro (T.H. w/floor shift) (exc. floor console)	3893849	1	3.75	control
68-72	Chevelle (A.T. w/floor console)	3922817	2	.59	control lever outer
68-72	Chevelle (A.T. w/floor console)	3922816	2	1.10	control lever inner
68-72	Camaro (A.T. w/floor console)	3975880	1	.71	control lever
73-75	Chevelle, Camaro, Nova w/floor console	9797193	1	.93	control lever
65-67	S.S. w/A.T. (exc. Strato bench),				
66-67	Caprice (A.T. w/B.S.),				
73-75	Vega	331941	1	2.15	HOUSING, trans. cont. indicator
75	Monza	332230	1	4.80	HOUSING, trans. cont. indicator
67	Caprice w/A.T. (exc. B.S.)	3859856	1	1.00	BOOT, control actuating lever
67	Camaro w/A.T.,				
68	Chevy w/floor console,				
70-74	Nova (A.T. w/floor console)	3893872	R.H.	.19	RETAINER, control lever seal, right
67-74	Camaro (A.T. w/floor console),				
68	Camaro (T.H. w/floor shift) (exc. floor console),				
68	Nova (A.T. w/floor console)	3895282	1	.83	RETAINER, control lever w/bracket
67	Chevelle w/T.H.	3923618	1	1.20	RETAINER, control cable seal
68-69	Camaro (A.T. w/floor console)	3919162	1	.34	RETAINER, control indicator dial
68-72	Chevelle (A.T. w/floor console)	3922818	1	.28	RETAINER, control lever outer seal
73-74	Nova w/floor console	3898236	1	.71	RETAINER, control lever cable
68	Camaro (T.H. w/floor shift) (exc. floor console)	3893848	1	7.10	RETAINER, underbody control housing

**4.017 PLATE— BRACKET— APPLIQUE— NUT, Underbody Trim (floor mounted)**

67	Camaro w/A.T.,				
68-72	Chevy (A.T. w/floor console)	3925417	L.H.	3.65	control lever hole trim, left
67	Camaro w/A.T.,				
68-74	Chevy (A.T. w/floor console)	3925418	R.H.	3.65	control lever hole trim, right
68-69	Camaro (A.T. w/floor console)	3921804	1	4.20	control lever hole trim lower
68	Camaro (A.T. w/floor console)	3921805	1	8.75	control lever hole trim upper
70	Camaro (A.T. w/floor console) (exc. Deluxe Interior),				
71	Camaro w/floor console,				
72	Camaro w/floor console (exc. Deluxe interior)	3975877	1	8.20	control lever hole trim (upper)
70	Camaro (A.T. w/floor console) (exc. Deluxe Interior),				
71	Camaro w/floor console,				
72-73	Camaro w/floor console (exc. Deluxe interior)	3975879	1	4.40	control lever hole trim (lower)
73	Chevelle w/floor console	3994517	1	9.55	trans. control and seat sep. trim
73-74	Nova w/floor console	6264749	L.H.	3.65	control lever hole trim left
74-75	Chevelle w/floor console	332158	1	10.05	trans. control and seat sep. trim
68-72	Chevelle (A.T. w/floor console) (exc. Monte Carlo)	3926729	1	9.55	PLATE ASSY., control indicator dial trim
69	Camaro (floor console w/A.T.)	3921805	1	8.75	PLATE ASSY., control lever hole trim upper
70-72	Camaro (floor console w/Deluxe Interior)	3975886	1	8.20	PLATE ASSY., control lever hole trim (upper)
70-72	Camaro (floor console w/Deluxe Interior)	3975887	1	4.40	PLATE ASSY., control lever hole trim (lower)
70-72	Monte Carlo (A.T. w/floor console)	3975361	1	9.55	PLATE ASSY., control indicator dial

**250-350-375-400 TURBO-HYDRAMATIC**

**4.017 PLATE— BRACKET— APPLIQUE— NUT, Underbody Trim (floor mounted)  
(Con't)**

73-75	Camaro w/floor console . . . . .	6264779	1	8.20	PLATE ASSY., seat sep. trim . . . . .
75	Monza (exc. Towne Cpe.) . . . . .	332227	1	8.15	PLATE ASSY., trans. cont. lever and bracket cover . . . . .
73-74	Vega, Monza . . . . .	6264798		2.00	APPLIQUE, trans. cont. lever and bracket cover . . . . .
75	Vega . . . . .	346683	1	2.00	APPLIQUE, trans. cont. lever and bracket cover . . . . .
75	Monza (Towne Cpe.) . . . . .	346764	1	3.20	APPLIQUE, trans. cont. lever and bracket cover (paint as req.) . . . . .
73-75	Camaro w/floor console . . . . .	478920	1	1.40	BRACKET, control lever seat . . . . .
65-66	Pass. (A.T. w/B.S.) . . . . .	9422836	A.R.	.05	NUT, trans. trim plate (No. 10-16) . . . . .

**4.020 INDICATOR— CABLE— CAP— CLIP— DIAL— LENS— PLATE— POINTER—  
RETAINER— SPRING, Transmission Gearshift Control**

65-66	Pass. w/A.T. (exc. B.S., T.W.) . . . . .	3861888	1	.22	
67	Pass. w/A.T. (exc. B.S.) . . . . .	3913419	1	.34	control . . . . .
67	Chevelle w/A.T. (exc. floor console) . . . . .	3900563	1	.84	
67-68	Camaro (T.H. w/T.W.) (exc. floor console) . . . . .	3912618	1	1.20	(pointer) . . . . .
68	Chevelle w/T.H. . . . .	6480928	1	6.99	INDICATOR ASSY., shift . . . . .
69	Chevelle w/T.H. . . . .	6483425	1	6.80	INDICATOR ASSY., shift . . . . .
69	Camaro w/T.H. (exc. floor console) . . . . .	6483161	1	14.71	INDICATOR ASSY. . . . .
69-72	Nova . . . . .	6496316	1	5.98	INDICATOR ASSY., shift . . . . .
70-72	Monte Carlo, Chevelle (S.S.) w/T.H. (exc. floor console), Chevelle (T.H. w/gages) (exc. floor console) . . . . .	6496776	1	5.79	INDICATOR ASSY., shift . . . . .
70-72	Chevelle w/A.T. (exc. Monte Carlo, S.S., gages, floor console) . . . . .	6492183	1	5.29	INDICATOR ASSY., shift inst. cluster . . . . .
71-75	Pass. . . . .	6496066	1	4.61	INDICATOR ASSY., shift . . . . .
73-74	Nova (exc. console gauges) . . . . .	6499641	1	4.27	INDICATOR ASSY., shift . . . . .
73-75	Nova (exc. console gauges) . . . . .	6499640	1	3.99	INDICATOR ASSY. . . . .
73-75	Chevelle (exc. console, console gauges) . . . . .	6497295	1	4.81	INDICATOR ASSY., shift . . . . .
68	Pass. w/T.H. (exc. B.S., S.S.) . . . . .	6481829	1	3.38	CABLE ASSY., instrument cluster shift indicator . . . . .
69-70	Pass. w/A.T., 71-74 Camaro . . . . .	6492011	1	2.30	CABLE ASSY., instrument cluster shift indicator . . . . .
69	Chevelle w/A.T. . . . .	6483430	1	2.24	CABLE ASSY., indicator . . . . .
71-74	Pass. . . . .	6496537	1	1.91	CABLE ASSY., inst. cluster trans. ind. . . . .
71	Nova (exc. floor console) . . . . .	6492504	1	1.89	CABLE ASSY., shift ind. . . . .
72	Nova . . . . .	6499550	1	1.64	CABLE ASSY., shift ind. . . . .
72	Chevelle (exc. floor console) . . . . .	6493285	1	1.88	CABLE ASSY., shift ind. . . . .
73-75	Monte Carlo (exc. console, console gauges) . . . . .	6497953	1	1.49	CABLE ASSY., shift ind. . . . .
73-75	Chevelle (exc. console gauges Monte Carlo) . . . . .	6497381	1	2.15	CABLE ASSY., shift ind. . . . .
67-68	Chevy, Camaro w/A.T. (exc. floor console, T.W.), 68 Camaro w/T.H. 350 . . . . .	3925885	1	.71	CAP, lever housing . . . . .
69	Camaro w/A.T. . . . .	6481602	2	.07	CLIP, indicator dial . . . . .
65-66	Pass. (A.T. w/B.S.) . . . . .	3864183	1	.64	DIAL, indicator, left . . . . .
68	Chevy (T.H. 350 w/floor console) . . . . .	3893874	1	.93	DIAL, indicator . . . . .
67	Camaro w/T.H. (exc. T.W., floor console), 68 Camaro w/T.H. (exc. T.W., floor shift, console) . . . . .	3909588	1	.67	DIAL, indicator . . . . .
67	Camaro (T.H. w/floor console), 68 Chevy (floor console w/T.H. 400), 69-72 Chevy (T.H. w/floor console) . . . . .	3986833	1	.74	DIAL, indicator . . . . .
68-69	Pass. (T.H. w/B.S.) . . . . .	3934232	1	1.65	DIAL, control indicator . . . . .
68	Pass. w/T.H. (exc. B.S., S.S.) . . . . .	6480709	1	1.79	DIAL, instrument cluster shift indicator . . . . .
68-69	Camaro (T.H. w/floor console) . . . . .	3919161	1	.93	DIAL, control indicator . . . . .
68-70	Chevelle (T.H. w/floor console) . . . . .	3921428	1	1.30	DIAL, control indicator . . . . .
71-72	Chevelle w/floor console . . . . .	3990815	1	1.35	DIAL, control indicator . . . . .
70-75	Camaro w/T.H. . . . .	6496185	1	6.67	DIAL ASSY., indicator . . . . .
73-75	Vega . . . . .	346684	1	.41	GUIDE, trans. cont. indicator pointer . . . . .
75	Monza . . . . .	348230	1	.41	GUIDE, trans. control indicator pointer . . . . .



**250-350-375-400 TURBO-HYDRAMATIC**

**4.020 INDICATOR— CABLE— CAP— CLIP— DIAL— LENS— PLATE— POINTER— RETAINER— SPRING, Transmission Gearshift Control (Con't)**

68	Camaro (T.H. w/floor shift) (exc. floor console) . . . . .	3893850	1	1.75	LENS, control indicator . . . . .
69-70	Pass. w/T.H. . . . .	6482737	1	3.92	LENS, indicator . . . . .
69	Camaro (A.T. w/clock) (exc. floor shift) . . . . .	3943617	1	1.50	LENS, control indicator dial (Note 1)— (9.772) . . . . .
<i>NOTE 1 For models with clock and with floor shift, see Group 9.772 for lens.</i>					
71-75	Pass. . . . .	8987229	1		LENS, shift ind. . . . .
73-74	Chevelle w/floor console . . . . .	3994514	1	1.35	LENS, control ind. . . . .
73-75	Chevelle (exc. floor console gauges) . . . . .	6497379	1	1.86	LENS, shift ind. . . . .
73-75	Chevelle . . . . .	6499525	1	.61	LINK, shift ind. . . . .
72	Vega . . . . .	6273335	1	.60	LENS, trans. control pointer . . . . .
72	Vega . . . . .	6273338	1	1.05	LENS, trans. cont. indicator . . . . .
73-74	Vega . . . . .	336465	1	.66	LENS, control indicator . . . . .
75	Vega, Monza . . . . .	346682	1	.68	LENS, control indicator . . . . .
67	Camaro (floor console w/A.T.),				
68-72	Chevy (A.T. w/floor console) . . . . .	3893875	1	.11	PLATE, indicator dial . . . . .
68	Chevy w/A.T. (exc. floor console),				
68	Chevy, Camaro w/T.H. 350 . . . . .	6481616	1	.60	PLATE, indicator . . . . .
68-69	Camaro (A.T. w/floor console) . . . . .	3921803	1	.27	PLATE, control indicator dial . . . . .
68	Camaro (T.H. w/floor shift) (exc. floor console) . . . . .	3893851	1	.93	PLATE, control indicator lens backing . . . . .
68-72	Chevelle (A.T. w/floor console) . . . . .	3921414	1	.22	PLATE, control indicator dial . . . . .
72	Vega . . . . .	3984442	1	.18	PLATE, trans. cont. indicator . . . . .
73-74	Vega . . . . .	331938	1	.18	PLATE, trans. cont. indicator . . . . .
68	Pass. w/A.T. (exc. B.S., S.S.) . . . . .	6481641	1	.84	POINTER, instrument cluster shift indicator
68	Chevy w/A.T. (exc. floor console),				
68	Chevy, Camaro w/T.H. 350 . . . . .	6481614	1	.84	POINTER, indicator instrument cluster . . . . .
69-70	Pass. w/A.T. . . . .	6482739	1	.55	POINTER, instrument cluster shift indicator
73	Chevelle (exc. console gauges),				
74-75	Monte Carlo (exc. floor console, I.P.G.) . . . . .	6499524	1	1.64	POINTER, shift ind. . . . .
74-75	Chevelle (exc. I.P.G., Monte Carlo) . . . . .	6497380	1	1.05	POINTER, inst. cluster shift ind. . . . .
70-74	Camaro w/A.T. . . . .	6496267	1	1.64	POINTER, shift indicator . . . . .
73-74	Vega . . . . .	331939	1	.24	POINTER, trans. cont. indicator . . . . .
75	Vega, Monza . . . . .	332231	1	.25	POINTER, control indicator . . . . .
69-70	Chevy w/T.H. 350,				
71-74	Nova w/T.H. (exc. floor console) . . . . .	6496631	1	6.04	RETAINER, inst. cluster indicator . . . . .
73-74	Chevelle w/floor console . . . . .	3994516	1	.71	RETAINER, control ind. dial . . . . .
68	Pass. w/A.T. (exc. B.S., S.S.) . . . . .	6480711	1	.40	SPRING, instrument cluster shift indicator return . . . . .
68	Chevy w/A.T. (exc. floor console),				
68	Chevy, Camaro w/T.H. 350 . . . . .	6481615	1	.54	SPRING, indicator pointer return . . . . .
69-74	Pass. w/A.T. . . . .	6482740	1	.40	SPRING, instrument cluster shift indicator pointer return . . . . .
70-75	Camaro w/A.T. . . . .	6496268	1	.62	SPRING, indicator pointer retainer . . . . .
72-74	Vega . . . . .	3943203	2	.18	SCREW ASSY., trans. control cover (8— 18 x 5/8")— (2.729) . . . . .
72	Vega . . . . .	3969803	1	.13	SEAL ASSY., trans. cont. ind. light leak (cut as reqd.)— (9.262) . . . . .

**4.022 RETAINER— SOCKET ASSY.— WASHER, Gearshift Lever Selector and Indicator**

67	Camaro (A.T. w/floor console),				
68-72	Chevy (A.T. w/floor console) . . . . .	3893876	1	.46	control indicator dial . . . . .
68-72	Chevelle (A.T. w/floor console) . . . . .	3921415	1	.67	control indicator dial . . . . .
67	Camaro (floor console w/A.T.) (1st design) . . . . .	3859790	1	.53	WASHER, control lever (13/32" O.D., 1/16" thick) . . . . .
67	Camaro (A.T. w/floor console) (2nd design),				
68-72	Chevy (A.T. w/floor console),				
68-69	Camaro (T.H. w/floor shift) (exc. floor console) . . . . .	3917594	1	.38	WASHER, control lever . . . . .

**4.025 TUBE ASSY., Gearshift Control**

67-68	Pass. (A.T. w/T.W.) . . . . .	7803830	1	15.05	shifter . . . . .
67-68	Pass. w/A.T. (exc. T.W., floor shift) . . . . .	7803279	1	15.60	shifter . . . . .

**250-350-375-400 TURBO-HYDRAMATIC**

**4.025 TUBE ASSY., Gearshift Control (Con't)**

67	Camaro w/A.T. (exc. T.W.),				
68	Camaro (A.T. w/column shift) (exc. T.W.),				
68	Chevy w/A.T. (exc. floor console)	7802486	1	23.40	
69-70	Pass. w/A.T. (exc. T.W.)	7804497	1	25.75	shifter
69-70	Pass. w/T.W.	7805265	1	26.25	strg. column trans. control lock
69-70	Chevelle w/A.T. (exc. T.W.)	7804493	1	32.50	
70	Pass. w/A.T. (exc. floor shift, T.W.)	7806814	1	25.75	lock
69	Chevelle (A.T. w/T.W.),				
70	All (A.T. w/T.W.) (exc. Camaro),				
71-72	Chevelle w/T.W.	7804960	1	32.50	(Note 1)
<i>NOTE 1 Can be used as steering column control lock tube on floor shift models.</i>					
69	Chevy, Camaro (exc. T.W.),				
70-71	Nova w/floor controls (exc. T.W.),				
70-71	Nova (A.T. w/col. shift) (exc. T.W.)	7804745	1	25.75	
70-75	Camaro w/T.W.	7808908	1	27.25	shift
70-75	Camaro (exc. T.W.)	7808563	1	37.75	strg. col. shift
71	Chevelle (exc. T.W.)	7807020	1	29.50	shift
71-75	Pass. (exc. T.W.)	7809589	1	29.00	shift
71-75	Pass. w/T.W.	7809800	1	32.75	shift
72	Chevelle (exc. T.W.)	7807020	1	29.50	shift
72	Camaro (exc. T.W.),				
73	Camaro (exc. floor console, T.W.)	7805702	1	39.25	strg. col. trans. control lock
73-74	Nova w/T.W.	7815214	1	26.25	shift
75	Nova (exc. T.W.)	7817847	1	26.25	shift
75	Nova w/T.H.	7818105	1	26.25	shift
73-75	Chevelle w/T.W.	7812650	1	32.50	strg. col. shift
73-75	Chevelle (exc. T.W.)	7812502	1	32.50	strg. col. shift
73-74	Nova (exc. T.W.)	7813674	1	25.75	strg. col. shift

**4.027 GATE— PAWL— PLATE— PLUNGER— RETAINER— RING— SCREW— SEAL— SPRING— STRAP— WASHER, Transmission Gearshift Control Shaft or Tube**

71-75	All (exc. floor console, T.W.)	7811592	1	1.70	strg. col. gearshift lever
71-75	All w/T.W. (exc. floor console)	7811691	1	2.70	strg. col. gearshift lever
73-75	All w/floor console (exc. T.W.)	7804761	1	1.25	strg. col. rack guide
68-72	All (A.T. w/floor shift) (exc. Chevy)	3920276	1	2.40	PAWL, control lever
67-68	Pass. (w/A.T. column shift) (exc. Tilt Whl.)	7801037	1	2.45	PLATE, shift detent & hsg. lock
69-70	Pass. (column shift w/T.W.),				
69-70	Chevelle (column shift w/A.T.) w/T.W.,				
69-70	Camaro w/T.W.	7804916	1	2.10	PLATE, strg. col. gear shift lever detent
69-70	All w/column shift (exc. T.W.)	7804406	1	1.70	PLATE, strg. col. gearshift lever detent
69	All (floor shift w/T.W.) (exc. Chevelle)	7806055	1	2.95	PLATE, strg. col. shroud index detent
69	All (floor shift w/T.W.) (exc. Chevy)	7806056	1	1.30	PLUNGER, strg. col. shroud index detent
68-70	All (A.T. w/floor console),				
71-72	Chevelle, Camaro w/floor console	3920275	1	.14	RETAINER, control lever detent spring
67-68	All w/T.W.	5698409	1	.39	RING, steering column support retainer
69-75	All w/T.W.	7804907	1	.47	RING, column support retainer
65-66	Pass. w/A.T.	3872057	1	1.90	RING ASSY., shifter tube adj.
69-70	Pass., Chevelle (exc. T.W.)	7806109	1	1.15	SCREW, column shift tube index
62-67	Chevy, Chevelle,				
65-67	Pass.	3711055	1	.28	SEAL, tube (felt) (1 <sup>1</sup> / <sub>8</sub> " I.D. x 1 <sup>15</sup> / <sub>16</sub> " O.D.)
70	Chevelle w/T.W.,				
71-73	Pass., Camaro	7807007	1	.50	SEAL, strg. col. shifter tube
67	All (exc. T.W.)	5698381	1	.65	SPRING, shift tube thrust
68	All (A.T. w/floor console),				
70-72	Chevelle, Camaro (A.T. w/floor console)	3920273	1	.26	SPRING, control lever button
68-69	All (A.T. w/floor console),				
70-72	Chevelle, Camaro (A.T. w/floor console)	3920274	2	.15	SPRING, control lever detent
69-70	All (exc. T.W.)	7804446	1	.88	SPRING, shift tube thrust
71-75	All	7810567	1	.98	SPRING, strg. col. shift tube return lower
71-73	Nova, Camaro (exc. floor console)	7808481	1	1.10	SPRING, shift tube thrust

**250-350-375-400 TURBO-HYDRAMATIC**

**4.027 GATE— PAWL— PLATE— PLUNGER— RETAINER— RING— SCREW— SEAL— SPRING— STRAP— WASHER, Transmission Gearshift Control Shaft or Tube (Con't)**

68-70	All (A.T. w/floor console),				
71-72	Chevelle, Camaro w/floor console	3920272	1	1.00	STRAP, control lever release
67-68	All w/A.T. (exc. T.W., floor console)	5698379	1	.65	WASHER, shift tube thrust
68-70	All (A.T. w/floor console),				
71-72	Chevelle, Camaro w/floor console	3920277	1	.15	WASHER, control lever pawl spring
69-75	All (exc. T.W.)	7807427	1	.47	WASHER, shift tube thrust

**4.030 LEVER— HOUSING, Transmission Gearshift Shaft or Tube (Lower)**

69-72	Chevy (T.H. w/floor console)	3950180	1	16.90	LEVER ASSY., control
72	Vega	6264382	1	2.65	LEVER ASSY., trans. cont. rod
73-74	Vega	325784	1	2.60	LEVER ASSY., trans. cont. shaft
75	Vega	348242	1	1.10	LEVER ASSY., trans. control rod
69	Pass. w/A.T. (exc. floor shift),				
69-70	Chevelle (A.T. w/T.W.),				
71	Pass., Chevelle w/T.W. (exc. floor console)	7805996	1	16.60	HOUSING, column gear shift lever
71	All (exc. T.W.)	7812064	1	18.35	HOUSING, steering col. gearshift lever
75	Camaro w/console	357701	1	16.60	HOUSING ASSY., control shaft

**4.032 BUSHING— RETAINER— WASHER, Gearshift Shaft Lever**

72-75	Vega, Monza	3992925	2	.91	BUSHING, trans. cont. rod lever
72-75	Vega, Monza	3988009	1	.15	BUSHING, trans. cont. rod lever
72-74	Vega	3988005	1	.27	RETAINER, trans. cont. shift lever
75	Vega	3992926	1	.14	WASHER, control rod lever

**4.035 ROD, Transmission Gearshift**

65-66	Pass. w/A.T. (exc. B.S.)	3869824	1	.98	control
67	Pass. (T.H. w/B.S.)	3904004	1	3.05	control
67-68	Pass. w/A.T. (exc. B.S.)	3898243	1	1.55	control
67	Camaro (T.H. w/floor console),				
68	Camaro (T.H. w/floor shift)	3912613	1	1.65	control
67-68	Camaro w/T.H. (exc. floor shift),				
68	Chevy w/T.H. (exc. floor console),				
68	Chevy, Camaro w/T.H. 350,				
69	Chevy, Camaro w/T.H.	3972257	1	1.80	control upper
67-68	Camaro w/T.H. (exc. floor shift),				
68	Chevy w/T.H. (exc. floor console),				
69	Chevy, Camaro w/T.H. 400,				
70	Nova w/T.H. 400	3914805	1	1.55	control lower
69	Chevy w/floor shift,				
69	Camaro w/floor shift (exc. T.H. 400)	3972256	1	1.65	control upper
68	Chevelle (S.S.) w/T.H. (exc. floor console),				
68	Chevelle w/T.H. 350	1382860	1	1.45	control
68-69	Chevy, Camaro w/T.H. 350,				
70-72	Nova w/T.H. 350	3945511	1	2.15	control lower
69-74	Chevy (T.H. w/floor console),				
69	Camaro (T.H. 400 w/floor shift)	3950178	1	2.35	control lever and bracket
69	Chevelle w/A.T. (exc. floor console)				control,
69	Chevelle (A.T. w/floor console),				
70-72	Chevelle w/A.T.	3945415	1	1.35	control lock
70-72	Nova w/T.H.	3972257	1	1.80	control upper lock
70-75	Camaro	3975630	1	1.35	control
71-75	Pass.	3988225	1	1.55	control
72-74	Nova	3998697	1	1.35	control
72	Vega (1st design)	6264387	1	2.25	trans. park lock and range selector (threaded)
72	Vega (2nd design)	6258617	1	2.60	trans. park. lock and range selector (slotted)
73-74	Vega	325796	1	2.25	trans. park. lock and range selector
75	Monza (140)	356323	1	2.75	trans. park. lock and range selector
75	Vega (140)	356365	1	2.25	trans. park. lock and range selector
75	Monza (8 cyl.)	356329	1	2.75	trans. park. lock and range selector
75	Vega	356363	1	1.30	trans. control detent
73-74	Chevelle	493469	1	1.45	control
75	Chevelle	497678	1	1.15	control
75	Nova	352868	1	1.30	control

**250-350-375-400 TURBO-HYDRAMATIC**

<b>4.035</b>		<b>ROD, Transmission Gearshift</b>	<b>(Con't)</b>		
75	Nova	352869	1	2.50	control
<b>4.037</b>		<b>BUSHING— CLAMP— CLIP— GROMMET— NUT— PIN— RETAINER— SCREW— SLEEVE— SWIVEL— WASHER, Transmission Gearshift Rod to Lever</b>			
64-75	All (exc. Vega)	382102	A.R.	.11	control rod, lever ( <sup>3</sup> / <sub>8</sub> " I.D.— <sup>1</sup> / <sub>2</sub> " O.D.)
All	All (exc. Vega)	382103	1	.16	CLAMP, cup shade and rod control ( <sup>13</sup> / <sub>32</sub> " I.D. x <sup>25</sup> / <sub>32</sub> " O.D. x <sup>7</sup> / <sub>32</sub> " thk.)
65-66	Pass. w/A.T. (2nd design) (exc. B.S.)	3725298	A.R.	.22	CLAMP, control rod ( <sup>11</sup> / <sub>32</sub> " I.D.)
62-68	All	3749084	A.R.	.27	CLIP, control rod (all locations) (Note 1)
All	All	3975131	1	.16	GROMMET, control shifter tube lever ( <sup>3</sup> / <sub>4</sub> " O.D. x <sup>1</sup> / <sub>2</sub> " I.D. x <sup>5</sup> / <sub>16</sub> " thk.— rubber)
All	All	3833107	1	.12	GROMMET, bell crank, control rod lever ( <sup>5</sup> / <sub>16</sub> " I.D.) (Note 1)
65-66	Pass.	3834139	1	.11	GROMMET, control rod to shifter tube lever ( <sup>3</sup> / <sub>4</sub> " )
65-68	Pass. w/A.T. (exc. B.S.)				GROMMET, control rod front end, control upper rod/column end,
67	Camaro w/A.T. (exc. floor console),				
68	Chevy, Camaro w/A.T. (exc. floor shift),				
68	Chevy, Camaro w/T.H. 350,				
69	Chevy, Camaro	3852837	1	.11	control rod
66-67	Chevelle w/A.T. (exc. floor console),				
68	Chevelle (S.S.) w/A.T. (exc. floor console),				
69-70	Chevelle w/T.H. 350,				
69-70	Pass. w/A.T.,				
71	Chevelle w/floor console	391312	1	.34	GROMMET, control rod ( <sup>31</sup> / <sub>32</sub> " I.D.)— (4.032)
67	Camaro w/floor shift				GROMMET, cont. lever and bracket stab. shaft,
70	Camaro (A.T. w/floor console)				control lock rod, col. end,
70	Camaro w/A.T. (exc. floor console),				
71	Pass., Camaro,				
72-74	Pass., Nova, Camaro	1394293	1	.27	control rod, col. end
62-68	All	3840137	1	.13	NUT, control rod clevis ( <sup>7</sup> / <sub>16</sub> "— 20)— (4.253)
All	All	472668	A.R.	.48	PIN, clevis (use wherever <sup>5</sup> / <sub>16</sub> " dia. x <sup>5</sup> / <sub>8</sub> " effective length pin must be used)
67-70	Chevelle,				
69-70	Pass. w/A.T.,				
71-74	All	1351769	1		RETAINER, control rod, control eq'lzr., and control rod lock
67-69	Camaro w/floor shift, console	3895252	1	.38	RETAINER, control lever spring
72-74	Vega	3988005	1	.27	RETAINER, trans. cont. shift lever
72-74	Vega	1244707	2	.12	RETAINER, trans. park lock and range selector outer— (4.662)
74-75	Nova w/floor console	3749084	1	.27	RETAINER, trans. control rod
67-72	Chevelle w/A.T.,				
69-72	Pass. w/A.T.,				
70-75	Camaro (A.T. w/floor console),				
72	Nova	3989433	1	.16	SCREW, control rod swivel ( <sup>5</sup> / <sub>16</sub> "— 18 x <sup>1</sup> / <sub>2</sub> " )
64-69	Chevelle,				
65-70	Pass.,				
67-69	Camaro,				
68-70	Chevy	3852838	1	.16	SLEEVE, shifter tube lever and upper rod ( <sup>3</sup> / <sub>8</sub> " O.L. x <sup>15</sup> / <sub>32</sub> " O.D. x <sup>3</sup> / <sub>16</sub> " I.D.)
All	All	382104	1	.24	SWIVEL ( <sup>3</sup> / <sub>8</sub> " x 16" threads, 1 <sup>1</sup> / <sub>2</sub> " long w/ <sup>15</sup> / <sub>8</sub> " dia. hole)
65-67	Pass. w/A.T. (2nd design) (exc. B.S.)	3772164	1	.53	SWIVEL, control rod, upper to shift tube lever (1 <sup>3</sup> / <sub>8</sub> " O.L.)
66-67	Chevelle, Camaro (A.T. w/floor console),				
68	Camaro (T.H. 400 w/floor shift) (exc. floor console),				
68-69	Chevy w/floor console,				
70-73	Nova (A.T. w/floor console)	3843142	1	.59	SWIVEL, control lower rod, control rod

**250-350-375-400 TURBO-HYDRAMATIC**

**4.037 BUSHING— CLAMP— CLIP— GROMMET— NUT— PIN— RETAINER—  
SCREW— SLEEVE— SWIVEL— WASHER, Transmission Gearshift Rod to  
Lever (Con't)**

67	Chevelle w/T.H. (exc. floor console),					
68-71	Chevelle w/A.T.,					
70	Pass. w/A.T.,					
70-71	Camaro (A.T. w/floor console),					
72-75	Chevelle, Camaro					<b>SWIVEL, control rod lock, control rod idler lever end</b>
72-75	Nova	1385607	1	.71		
72	Vega (1st design)	3996334	1	.50		<b>SWIVEL, trans. park lock and range selector outer</b>
72-75	Vega (2nd design)	329757	1	.50		<b>SWIVEL, trans. park lock and range selector outer</b>
<i>NOTE 1: 1st design is identified by threaded type park lock and range selector outer rod, 2nd design is identified by slotted type park lock and range selector outer rod.</i>						
All	All	9415113	A.R.	.11		<b>WASHER, control rod swivel (to shifter tube lever (<sup>9</sup>/<sub>16</sub>" I.D. x <sup>7</sup>/<sub>8</sub>" O.D.) (wave type)</b>
All	All	3772165	A.R.	.11		<b>WASHER, 1st and reverse rod (to shifter tube lever), trans. control rod swivel (<sup>17</sup>/<sub>32</sub>" I.D. x <sup>7</sup>/<sub>8</sub>" O.D.) (flat type)</b>
All	All	382105	A.R.	.12		<b>WASHER, control upper rod to trans. control shifter tube lever (<sup>25</sup>/<sub>32</sub>" I.D. x <sup>3</sup>/<sub>4</sub>" O.D.)</b>
72-74	Vega	3992926	1	.14		<b>WASHER, trans. cont. rod lever</b>
74-75	All	334533	A.R.	.11		<b>WASHER, control rod swivel, arched spring (<sup>5</sup>/<sub>32</sub>"—<sup>13</sup>/<sub>64</sub>" free height, <sup>21</sup>/<sub>64</sub>" x <sup>1</sup>/<sub>16</sub>" )</b>
64-71	All	580379	A.R.	.11		<b>WASHER, cont. rod to trans. cont. counter shaft cont. upper, rod to cont. idler lever (<sup>23</sup>/<sub>32</sub>" O.D. x <sup>21</sup>/<sub>32</sub>" I.D. x <sup>1</sup>/<sub>2</sub>" thk.)</b>
67-68	Chevelle w/T.H. (exc. floor console),					
68-73	Chevelle w/A.T.,					
70-73	Pass. w/A.T.,					
70-73	Camaro (A.T. w/floor console)					<b>WASHER, control rod lock swivel (<sup>11</sup>/<sub>32</sub>" I.D. x <sup>27</sup>/<sub>32</sub>" O.D.),</b>
72-73	Nova	3989434	1	.11		control rod spring idler lever end
68-72	Chevelle w/A.T.,					
69-70	Pass. w/A.T.,					
70-74	Camaro (A.T. w/floor console)					<b>WASHER, cross shaft lever,</b>
72-74	Nova	492346	1	.34		control rod idler lever

*NOTE 1 The above parts are also used as replacement parts with rebuilt trans. assy. 3832565 (P.G.)*

**4.040 LEVER— BRACKET— SHAFT— SUPPORT ASSY., Transmission Control Idler**

67-69	Chevy, Camaro w/T.H.,					
70-71	Nova w/T.H.	3912619	1	2.35		
70-71	Camaro w/T.H. (exc. floor console)					<b>LEVER ASSY., control rod idler, control lock rod idler</b>
70-75	Camaro (T.H. w/floor console)	3982391	1	4.75		
72-74	Nova	332652	1	2.70		<b>LEVER ASSY., control rod idler</b>
75	Vega, Monza	349578	1	6.15		neutral start switch trans. control shaft
75	Nova	352869	1	2.50		control rod idler
67	Chevelle w/T.H. (exc. flr. console)	1379767	1	1.30		<b>BRACKET, cross shaft frame</b>
68-70	Chevelle w/T.H. 400 (exc. floor console),					
72	Chevelle	1230115	1	.88		<b>BRACKET, control equalizer shaft frame</b>
69-70	Pass. w/A.T.	3939282	1	1.20		<b>BRACKET, control equalizer shaft</b>
70-72	Camaro w/A.T. (exc. floor console),					
73-75	Nova					<b>BRACKET, control rod idler lever</b>
70-75	Camaro (A.T. w/floor console)	3998691	1	1.65		control lock rod idler lever
73-74	Pass., Chevelle	3988221	1	.80		<b>BRACKET, control equalizer shaft frame</b>
75	Pass., Chevelle	488450	1			<b>BRACKET, control equalizer shaft frame</b>
65-68	Pass. w/A.T. (exc. B.S., S.S.)	3859849	1	1.45		<b>BRACKET ASSY., control shaft frame</b>
65-66	Pass. w/T.H. (exc. B.S.)	3869825	1	2.90		<b>SHAFT, control cross</b>
67-68	Pass. w/T.H. (exc. B.S., S.S.)	3898249	1	3.20		<b>SHAFT, control cross</b>
67	Chevelle w/T.H. (exc. floor console)	1379766	1	3.45		<b>SHAFT, control cross</b>
69-70	Pass. w/T.H.	3939286	1	4.05		<b>SHAFT, control equalizer</b>
68	Chevelle w/T.H. (exc. flr. console),					
69-72	Chevelle w/T.H.	1382861	1	3.05		<b>SHAFT ASSY., control cross w/lever</b>
71-72	Pass.	492495	1	3.30		<b>SHAFT ASSY., control equalizer</b>
73-75	Pass.	492495	1	3.30		<b>SHAFT ASSY., control equalizer</b>

**250-350-375-400 TURBO-HYDRAMATIC**

**4.040 LEVER— BRACKET— SHAFT— SUPPORT ASSY., Transmission Control Idler (Con't)**

73-75	Chevelle	488452	1	3.05	SHAFT ASSY., control equal.
67-69	Camaro w/T.H.,				
68-72	Chevy w/T.H.	3914801	1	2.80	SUPPORT ASSY., control rod idler lever
72-75	Vega, Monza	3984038	1	.44	WASHER, trans. cont. rod lever

**4.042 LOCK— BUSHING— NUT— RETAINER— SPACER— SPRING, Transmission Control Idler Attaching**

62-69	Chevy, Camaro w/A.T. (exc. floor console),				
65-66	Pass.,				
71-72	Nova	3685801	1	.16	control rod idler lever ( <sup>13</sup> / <sub>16</sub> " O.D.)
62-69	Chevy w/T.H. 400 (exc. floor console),				
67-68	Camaro w/T.H. (exc. floor control),				
68	Camaro, Chevy w/T.H. 350,				
69-70	Chevy, Chevelle, Camaro,				
71	Nova	3792168	A.R.	.22	trans. cont. rod idler lever
64-70	All	382102	A.R.	.11	BUSHING, control rod ( <sup>3</sup> / <sub>8</sub> " I.D.— <sup>1</sup> / <sub>2</sub> " O.D.)— (4.037)
67-68	Chevelle w/T.H. (exc. floor console),				
69-70	Chevelle w/A.T.				BUSHING, control cross shaft,
69-70	Pass. w/A.T. (exc. B.S.),				
71-75	Pass., Chevelle, Camaro				equalizer shaft,
72-75	Nova	1377083	1	.16	control rod idler lever
67-74	Chevy, Camaro	3792287	1	.34	NUT, cont. rod idler lever supt.— (3.704)
65-69	Pass. w/A.T. (exc. B.S.)	3842902	2	.11	RETAINER, cross shaft anti-rattle spring, trans. cross shaft
65-66	Pass.	3698237	1	.12	SPRING, cross shaft (idler inner and outer levers— 6 <sup>1</sup> / <sub>2</sub> " coils— <sup>11</sup> / <sub>16</sub> " I.D.)
65-69	Pass.				SPRING, parking lock and range selector lever shaft, anti-rattle,
68-69	Pass. w/A.T.	3755663	1	.11	control cross shaft
67-68	Chevelle w/T.H. (exc. floor console),				
69-70	Chevelle w/A.T.,				
71-72	Chevelle, Camaro				SPRING, cross shaft,
69-70	Pass. w/A.T.,				
70	Camaro (A.T. w/floor console)				equalizer shaft,
72-75	Nova	1380549	1	.11	control rod idler lever
75	All	351239	1	.16	SPRING, control cross shaft

**4.045 LEVER, Transmission Mounted Gearshift (External)**

65-68	Pass. w/T.H. 400 (exc. B.S., S.S.)				parking lock and range selector,
68	Pass. w/T.H. 350	1365182	1	1.65	actuator
65-67	Pass. (T.H. w/B.S.),				
67	Camaro (T.H. w/floor console),				
68	Camaro (T.H. w/floor controls) (exc. floor console),				
68	Chevy (T.H. w/floor console)	3904028	1	.95	park and range selector
67-69	Chevy, Camaro w/T.H. (exc. floor shift),				
70-71	Nova w/T.H. (exc. floor console)	3914807	1	.98	park lock and range selector
67-68	Chevelle w/T.H. (exc. floor console),				
69	Chevelle w/T.H.,				
69-75	Pass. w/T.H. (exc. B.S.),				
70-75	Chevelle w/T.H. (exc. floor console)	9795470	1	1.40	range selector
68	Pass. (T.H. 400 w/B.S.),				
68	Chevelle, Camaro (T.H. w/floor console),				
69	Camaro (T.H. w/floor console)	3950176	1	1.45	park lock and range selector
69	Pass. (T.H. w/B.S.),				
69-72	Chevelle (T.H. w/floor console)	3945488	1	1.20	control shift shaft
69-72	Chevy (T.H. w/floor console)	3950177	1	1.30	parking lock and range selector actuator
70-75	Camaro w/T.H.,				
72-75	Vega	6264386	1	1.15	trans. park lock and range selector outer
73-74	Nova	344627	1	.96	park. lock and range sel.
75	Nova w/floor console	352874	1	2.90	park lock and range selector
74-75	Camaro w/floor console	480565	1	1.20	park lock and range sel.
75	Nova (exc. floor console)	352870	1	1.20	park lock and range sel.
75	Monza (exc. Rotary)	356328	1	1.15	trans. park lock and range selector outer

**250-350-375-400 TURBO-HYDRAMATIC**

**4.045 LEVER, Transmission Mounted Gearshift (External) (Con't)**

72	Nova (exc. floor console) . . . . .	3998695	1	1.80	park lock and range . . . . .
67	Chevelle (T.H. 400 w/floor console) . . . . .	3949083	1	2.15	LEVER ASSY., trans. control park lock and range selector . . . . .

**4.047 CABLE ASSY.— BOLT— BRACKET— GROMMET— PIN— SEAL— WASHER, Transmission Gearshift Control Cable**

67	Chevelle (T.H. w/floor console) . . . . .	3913443	1	9.70	trans. control . . . . .
68-69	Pass. (A.T. w/B.S.) . . . . .	3956767	1	12.00	control . . . . .
68-72	Chevelle, Camaro (A.T. w/floor console) . . . . .	3956765	1	12.00	trans. control . . . . .
69-70	Chevy (A.T. w/floor console) . . . . .	6491944	1	1.91	shift control . . . . .
73-75	Chevelle w/floor console . . . . .	6262289	1	10.95	trans. control . . . . .
73-75	Camaro w/floor console . . . . .	478839	1	11.55	trans. control . . . . .
75	Nova w/floor console . . . . .	352873	1		trans. control . . . . .
68-70	Impala, Caprice w/A.T.,				
68-70	All (A.T. w/floor console) (exc. Pass.) . . . . .	443899 A.R.		.11	BOLT, control cable bracket ( <sup>5</sup> / <sub>16</sub> "— 18 x <sup>7</sup> / <sub>8</sub> ")— (8.900) . . . . .
68	Camaro,				
68	Chevelle (T.H. w/floor console) . . . . .	9788709	1	2.05	BRACKET, control cable . . . . .
68-69	All (T.H. 400 w/floor console) (exc. Chevy),				
70-72	Chevelle, Camaro (T.H. 400 w/floor console) . . . . .	3945494	1	2.60	BRACKET, control cable . . . . .
69	All (T.H. 350 w/floor console) (exc. Chevy),				
70-72	Chevelle, Camaro (T.H. 350 w/floor console) . . . . .	3945490	1	1.75	BRACKET, control cable . . . . .
73-74	Camaro (T.H. 400 w/floor console),				
74-75	Chevelle (T.H. 400 w/floor console) . . . . .	9793193	1	1.35	BRACKET, control cable . . . . .
73-75	Chevelle, Camaro (T.H. 350 w/floor console) . . . . .	9795915	1	.88	BRACKET, control cable . . . . .
68-69	All (A.T. w/floor console),				
70-72	Chevelle, Camaro (A.T. w/floor console) . . . . .	3922580	1	1.75	GROMMET, control cable . . . . .
73	Chevelle, Camaro w/floor console,				
74	Chevelle w/floor console . . . . .	480076	1	1.55	GROMMET, control cable . . . . .
67	Chevelle (T.H. w/floor console),				
68-69	All (A.T. w/floor console),				
70	Chevelle (A.T. w/floor console),				
71-75	Chevelle, Camaro w/floor console . . . . .	9779348	1	.73	PIN, control cable . . . . .
72	Nova . . . . .	6264901	1	.28	SEAL, detent control cable . . . . .
73-75	Camaro w/floor console . . . . .	478841	1	.81	RETAINER, control cable . . . . .
68-69	Impala, Caprice w/A.T.,				
73-75	All w/T.H. 250, 350 . . . . .	6264901	1	.28	SEAL, detent control cable . . . . .
73-74	Chevelle, Camaro w/floor console . . . . .	334961	1	.19	SPRING, control cable yoke— (4.681) . . . . .

**4.050 BRACKET ASSY.— CABLE ASSY.— NUT— PIN— RETAINER— RING, Transmission Throttle Valve Control (T.V.)**

68	Pass. (T.H. 350 w/2BC),				
68-69	All (T.H. 350) (exc. 307, 327, 350 Pass.),				
69	Pass. w/T.H. 350 (327) . . . . .	3947512	1	.81	detent control cable . . . . .
68-69	Pass. w/T.H. (350 w/4BC),				
68-69	All w/T.H. 350 (350) (exc. Pass.)	3947514	1	.70	detent control cable . . . . .
70-75	All w/T.H. 350 (6 cyl.) . . . . .	3972998	1	.98	detent control cable (stamped 3972998) . . . . .
70-73	All (T.H. 350 w/4BC) . . . . .	3973000	1	1.10	detent control cable (stamped 3973000) . . . . .
70-73	All w/T.H. 350 (exc. 4BC) . . . . .	3972999	1	.71	detent control cable (stamped 3972999) . . . . .
72-75	Vega . . . . .	6273234	1	1.15	BRACKET, trans. detent control cable . . . . .
74	All w/T.H. 350 . . . . .	340657	1	.92	BRACKET, detent control cable . . . . .
68-70	Pass. w/T.H. 350,				
73-74	Nova, Camaro w/T.H. 350 . . . . .	342487	1	8.45	CABLE ASSY., detent control (4 1 <sup>13</sup> / <sub>64</sub> " O.L.) black (Note 1, 4) . . . . .

*NOTE 1: When using it is also necessary to use bracket assy. 3972998.*

68-69	Pass. (T.H. 350 w/4BC) (327, 350),				
68-69	All w/T.H. 350 (exc. Pass.),				
70-71	All w/T.H. 350,				
72	All w/T.H. 350 (exc. Pass.),				

**250-350-375-400 TURBO-HYDRAMATIC**

**4.050 BRACKET ASSY.— CABLE ASSY.— NUT— PIN— RETAINER— RING, Transmission Throttle Valve Control (T.V.) (Con't)**

73-75	Nova, Camaro w/T.H. 250 (6 cyl.)	342486	1	8.45	CABLE ASSY., detent control (37 <sup>1</sup> / <sub>2</sub> " O.L.) (orange) (Note 3, 4)
<i>NOTE 3: When using it is also necessary to use bracket assy. 3973000.</i>					
<i>NOTE 4: When used on certain past models, use a 1/4"— 20 x 5/8" bolt and washer and torque to 60-90 inch pounds.</i>					
75	Nova, Camaro, Monza w/T.H. 350	1249236	1	7.85	detent control (37 <sup>1</sup> / <sub>2</sub> " (orange)
75	Camaro, Nova (6 cyl.)	1248361	1	7.85	detent control
73-74	Chevelle w/T.H. 250, 350	1241109	1	9.75	detent control
72-74	Pass. w/T.H. 350	1241110	1	6.65	detent control
75	Pass. w/T.H. 350	1245641	1	7.45	detent control
75	Chevelle w/T.H. 350	1245640	1	10.85	detent control
72-75	Vega	342488	1	8.90	detent control (orange)
68-74	All w/T.H. 350	271184	A.R.	.11	NUT, detent cable (5/16"— 18)— (8.917)
68-74	All w/T.H. 350	3947517	1	.28	PIN, detent control cable
74	Chevelle, Camaro w/floor console	9791327	1	.27	PIN, control cable (1/4" x 33/64")
73-74	Pass., Chevelle w/T.H. 400	1233424	1	.17	PLUG, trans. detent cable hole
74	All w/T.H. 350	3816659	1	.31	RETAINER, detent control cable
72	Pass. w/T.H. 350	403993	1	.16	RETAINER, detent control cable
68-71	All w/T.H. 350	6264901	1	.28	RING, detent control cable (rubber, 11/32" dia.)
68-70	All	9416094	A.R.	.11	RING, detent valve (zinc, 3/16" dia.)— (8.934)

**4.052 CLIP— STUD— SWIVEL— WASHER, Transmission Throttle Valve Control**

62-69	All	3711177	A.R.	.28	lower and upper, front rod— (3.425)
62-69	All	3700188	1	.29	special— (3.425)
62-69	All	1455017	A.R.	.13	upper rod— (3.425)
62-69	All (6 cyl.)	3997258	1	.78	STUD, throttle valve control intermediate rod lever (5/16"— 18 thds. x 2 <sup>3</sup> / <sub>8</sub> " O.L. 1/2" hex. nut)— (3.463)
62-67	All,				
70	Pass., Chevelle, Camaro	3711199	A.R.	.29	SWIVEL, throttle valve control (use w/1/4" rod)— (3.425)

**4.054 SWITCH ASSY.— CLIP— LEVER— SCREW— WIRE ASSY., Transmission Control Safety**

65-67	Pass. (T.H. w/B.S.),				
67	Chevelle (T.H. w/floor console)	1993321	1	9.80	safety and back-up lamp
65-66	All w/T.H. (exc. B.S.)	1993320	1	8.15	also back-up lamp
67-69	Pass. w/A.T. (exc. B.S.),				
67-68	All w/A.T. (exc. Pass. floor console)	1993404	1	3.35	also back-up lamp
67-69	Pass. (A.T. w/B.S.),				
68-71	Chevelle, Camaro (A.T. w/floor console)	1993434	1	4.26	control and back-up lamp
68-70	Chevy (Spt. Cpe.) w/flr. console	3900503	1	5.60	neutral safety and back-up lamp
67-68	Chevy, Camaro (T.H. w/floor console),				
69-71	Chevy (T.H. w/floor console)	3948538	1	4.65	safety and back-up lamp
69-71	All w/A.T. (exc. floor console),				
72-73	All	1994158	1	4.62	control safety and backing lamp
74-75	All	1994163	1	4.99	control safety, backing lamp, seat belt warning and t/gate unlock
72-73	Vega	1994155	1	9.05	trans. safety, back-up lamp and seat belt warning
74-75	Vega, Monza	1994165	1	8.85	safety, back-up and seat belt warning
	Not required in this group. See group 3.762, 9.787	3908243	1	.63	CLIP
67	Camaro (A.T. w/floor console),				
68-69	Camaro (T.H. 400 w/floor shift) (exc. floor console),				
68-72	Chevy (A.T. w/floor console)	3895280	1	.78	LEVER, neutral safety switch
68-72	All (A.T. w/floor console) (exc. Chevy)	3920283	1	.12	LEVER, neutral safety switch
67	Chevelle w/T.H.,				
68-69	Chevy, Camaro w/T.H. 400,				
70	Nova w/T.H. 400	2989365	1	5.35	WIRE ASSY., switch
68-70	Chevelle w/T.H. 400	6295151	1	5.95	WIRE ASSY., switch

**4.057 SWITCH ASSY.— WIRE ASSY., Transmission Throttle Control (Electric)**

67	All w/T.H. (exc. Pass.),				
65-68	Pass. w/T.H. (exc. 307),				



**250-350-375-400 TURBO-HYDRAMATIC**

**4.057 SWITCH ASSY.— WIRE ASSY., Transmission Throttle Control (Electric)  
(Con't)**

68-69	Chevy, Camaro w/T.H.,				
69	Pass. (T.H. 400 w/4BC) (350,				
	427) . . . . .	1993388	1	9.00	
68	Pass. w/T.H. (307),				
69	Pass. (T.H. 400 w/2BC) (327,				
	350, 396) . . . . .	1998130	1	4.08	(4.480) . . . . .
68-69	Chevelle w/T.H. . . . .	1993424	1	5.30	trans. control . . . . .
70-75	All w/T.H. 400 . . . . .	1242101	1	3.00	control . . . . .
75	All (6 cyl.) . . . . .	3031548	1	9.20	choke pull off . . . . .
71-74	All w/T.H. 400 . . . . .	8901896	1	7.15	WIRE ASSY., kickdown switch . . . . .

**4.060 LEVER— BRACKET— CLIP— FASTENER, Transmission Control Switch**

68	Pass. w/T.H. (exc. 307),				
68-69	Chevy, Camaro w/T.H. 400				
	(396) (exc. Sp. H/Per.),				
69	Pass. w/T.H. 400 (350) (exc.				
	2BC),				
69	Pass. w/T.H. 400 (427) (exc. Sp.				
	H/Per.) . . . . .	3924412	1	.16	actuator . . . . .
68	Pass. w/T.H. (307),				
69	Pass. (T.H. 400 w/2BC) . . . . .	3930733	1	.32	control switch . . . . .
70	Nova (T.H. 400 w/Sp. H/Per.)				
	(396) . . . . .	3975534	1	1.20	control actuator switch . . . . .
65-67	Pass. w/T.H.,				
67	All (exc. Pass.),				
69	Pass. (T.H. 400 w/Sp. H/Per.)				
	(427),				
69	Chevy, Camaro (T.H. 400 w/Sp.				
	H/Per.) (396) . . . . .	3909630	1	.58	BRACKET . . . . .
68	Pass. w/T.H. (exc. 307),				
68-69	Chevy, Camaro w/T.H. 400				
	(396) (exc. Sp. H/Per.),				
69	Pass. w/T.H. 400 (350) (exc.				
	2BC),				
69	Pass. w/T.H. 400 (427) (exc. Sp.				
	H/Per.) . . . . .	3924410	1	.34	BRACKET, control switch . . . . .
68-69	Pass. w/T.H. 400 (307, 327) . . . . .	3950212	1	.63	BRACKET . . . . .
68-69	Chevelle w/T.H. 400 . . . . .	3930796	1	1.85	BRACKET, control kick down switch . . . . .
69	Pass. (T.H. 400 w/4BC),				
70	Pass. w/T.H. 400 (400) . . . . .	3950213	1	.95	BRACKET, control switch . . . . .
70	Nova (T.H. 400 w/Sp. H/Per.)				
	(396) . . . . .	3975533	1	2.90	BRACKET, control actuator switch . . . . .
70-72	Chevelle w/T.H. 400 . . . . .	3972676	1	1.75	BRACKET, control kick down switch . . . . .
70	Pass. w/T.H. 400 (454) . . . . .				BRACKET, control switch, . . . . .
70	Nova w/T.H. 400 (396) (exc. Sp.				
	H/Per.) . . . . .	3972455	1	.70	control actuator switch . . . . .
71-72	Pass., Chevelle, Camaro w/T.H.				
	400 . . . . .	9787673	1	.16	CLIP, cont. switch wire (nylon 2 <sup>13</sup> / <sub>16</sub> " O.L.)— (8.950) . . . . .
70-72	Chevelle, Camaro (A.T. w/floor				
	console) . . . . .	564708	1	.16	FASTENER, snap control cable retainer . . . . .

**4.067 BOOT, Gearshift Linkage**

65-69	Pass. w/A.T. (exc. B.S.) . . . . .	3852836	1	.22	control cross shaft . . . . .
65-66	Pass. w/T.H. . . . .	8624975	1	.22	trans. shaft shift lever— (4.275) . . . . .

**4.075 SWITCH ASSY.— CLIP— WIRE ASSY.— RELAY ASSY., Transmission, Smog Control**

*NOTE See 2.408 group for electrical parts.*

70-71	All w/T.H. 400 . . . . .	6462286	1	2.21	trans. control spark . . . . .
70-73	All w/T.H. 350 . . . . .	6462549	1	1.95	trans. control spark . . . . .
72-74	All w/T.H. 400 . . . . .	8627332	1	7.00	control spark . . . . .
73	All w/T.H. 350 (307, 350) . . . . .	3996287	1	3.00	control spark . . . . .
72-74	Nova, Chevelle, Camaro w/T.H.				
	400,				
72-74	Pass. w/T.H. 400 (454) . . . . .	8623766	1	.20	CLIP, trans. control switch wire lead . . . . .
70	Pass., Camaro w/T.H. 400 (exc.				
	396),				
71-74	All w/T.H. 400 . . . . .	8626426	1	1.68	WIRE ASSY., w/conn., control spark switch to case conn. . . . .
70	All,				
72-75	Vega, Monza . . . . .	3961573	1	2.85	RELAY ASSY., trans. control spark . . . . .
73-74	Pass. w/T.H. 350 . . . . .	6270698	1	2.15	RELAY ASSY., control vac. advance delay . . . . .

**250-350-375-400 TURBO-HYDRAMATIC**

**4.075 SWITCH ASSY.— CLIP— WIRE ASSY.— RELAY ASSY., Transmission, Smog Control (Con't)**

71	All	3990842	1	2.45	RELAY ASSY., trans. control switch reversing
71	All	3990843	1	3.00	RELAY ASSY., control spark delay
72-73	All (8 cyl.) (exc. 402, 454)	3996297	1	3.65	RELAY ASSY., control vac. adv. delay (60 seconds)
72-73	All w/250	3996296	1	2.25	RELAY ASSY., control spark delay (20 seconds)

**4.081 SUPPORT— MOUNTING ASSY.— MEMBER ASSY., Transmission Mounting**

67	Pass. (327, 396, 427) (2nd design) (exc. Conv.)	3906954	1	14.10	(w/1 square and 1 round hole)
68	Pass. (250, 307) (exc. Conv. T.H. 350),				
69	Pass. (Sta. Wag.)	3950232	1	14.25	
68	Pass. (Conv.) w/T.H. 350,				
70	Pass. (Conv.) (exc. T.H. 400)	3947536	1	14.25	
64-67	Chevelle (Conv., El Camino)	3838043	1	11.60	SUPPORT ASSY.
68-72	Chevy (exc. 396),				
68-69	Camaro (396) (exc. T.H. 400),				
68-70	Chevy w/H/Per., Sp. H/Per. (396) (exc. T.H. 400),				
73-74	Nova	3899006	1	10.50	SUPPORT ASSY.
67-69	Camaro w/T.H. 400,				
68-70	Chevy w/T.H. 400	3912573	1	14.95	SUPPORT ASSY.
69-72	Chevelle (El Camino, Conv.)	6272134	1	17.35	SUPPORT ASSY.
68-69	Pass. (exc. Sta. Wag., Conv.),				
70	Pass. (exc. Sta. Wag., Conv., C.A.C., T.H. 400)	3947535	1	10.20	SUPPORT ASSY. (code letter "S") (Note 4)
<i>NOTE 4 When used in place of 3928222 it will be necessary to add a hole in support bracket for trans. mtg. use old part as guide.</i>					
70-72	Monte Carlo w/A.T. (exc. Conv.)	3967773	1	10.65	SUPPORT ASSY.
70	Pass. (C.A.C. w/T.H. 350) (8 cyl.) (exc. Conv., Sta. Wag.),				
70	Pass. w/T.H. 400 (exc. Conv., Sta. Wag.)	3953528	1	13.00	SUPPORT ASSY.
69	Pass. (Sta. Wag.),				
70	Pass. (Sta. Wag.) (exc. C.A.C., T.H. 400)	3984771	1	18.25	SUPPORT ASSY.
70	Pass. (Sta. Wag.) w/T.H. 400,				
70	Pass. (Sta. Wag.) (C.A.C. w/T.H. 350)	3984772	1	17.25	SUPPORT ASSY.
70-73	Camaro (exc. T.H. 400)	3964816	1	13.65	SUPPORT ASSY.
70-74	Camaro w/T.H. 400	3964819	1	13.65	SUPPORT ASSY.
71	Pass. w/T.H. 350 (exc. Sta. Wag.),				
72-74	Caprice w/T.H. 350	331288	1	16.75	SUPPORT ASSY.
71-74	Pass. w/T.H. 400 (exc. Sta. Wag.),				
72-74	Caprice w/T.H. 400	331230	1	16.75	SUPPORT ASSY.
71	Pass. (Sta. Wag.) w/T.H. 400,				
72	Pass. w/T.H. 400 (exc. Caprice)	6270768	1	16.75	SUPPORT ASSY.
72	Pass. w/T.H. 350 (exc. Caprice)	6270765	1	16.85	SUPPORT ASSY., trans.
72	Chevelle (exc. El Camino, Conv.)	6272136	1	17.90	SUPPORT ASSY., trans.
72-75	Vega	6264361	1	12.95	SUPPORT ASSY., trans.
75	Monza (8 cyl.)	356309	1	56.50	SUPPORT ASSY., trans.
75	Monza (140)	356341	1	27.00	SUPPORT ASSY., trans.
75	Camaro	344677	1	13.65	SUPPORT ASSY., trans.
73-74	Chevelle (exc. El Camino, Conv.)	6273806	1	20.95	SUPPORT ASSY., trans.
73-74	Chevelle (El Camino, Conv.)	6273808	1	21.50	SUPPORT ASSY., trans.
75	Chevelle (El Camino) (454)	348091	1	34.00	SUPPORT ASSY.
75	Chevelle (El Camino) (350)	348084	1	34.00	SUPPORT ASSY., trans.
75	Chevelle (350) (exc. El Camino),				
75	Malibu (exc. Estate), Malibu (Estate) (350, 400)	356983	1	34.00	SUPPORT ASSY., trans.
75	Chevelle (454) (exc. El Camino)	348089	1	21.80	SUPPORT ASSY., trans.
75	Malibu (exc. Estate), Monte Carlo, Malibu (Estate) (454)	348393	1	37.25	SUPPORT ASSY., trans.
75	Pass. (exc. Sta. Wag.)	344955	1	26.25	SUPPORT ASSY., trans.
75	Pass. (Sta. Wag.)	351264	1	16.75	SUPPORT ASSY., trans.
75	Pass. w/T.H. 400 (exc. Sta. Wag.)	344958	1	26.25	SUPPORT ASSY., trans.
68-69	Chevy (4 cyl.),				

**250-350-375-400 TURBO-HYDRAMATIC**

**4.081 SUPPORT— MOUNTING ASSY.— MEMBER ASSY., Transmission Mounting (Con't)**

68	Chevelle (8 cyl.) (exc. 327) (1st design),					
70	Pass. (6 cyl.)	3870182	1	4.50	MOUNTING ASSY. (daub of orange paint) (moulded 3870182) (Note 2)	
68	Biscayne, Bel Air (307),					
69	Impala, Caprice (327) (exc. T.H. 400),					
69	Biscayne, Bel Air (327),					
70	Pass. (350) (exc. 4BC)	3870184	1	4.50	MOUNTING ASSY. (no paint ident.) (molded 3870184) (4 holes) (Note 1, 2)	
65-66	Pass. w/T.H. (1st design)	334529	1	5.55	MOUNTING ASSY. (no paint ident.) (Note 3)	
68-70	Camaro, Chevy (396) (exc. T.H. 400),					
68-69	Camaro (302)	3895830	1	4.40	MOUNTING ASSY. (daub of white paint) (Note 1)	
66-67	Pass. w/T.H.,					
67	Camaro w/T.H. (8 cyl.) (2nd design),					
68	Impala w/T.H. (307) (exc. Sed.),					
68	Caprice w/T.H. (307),					
68-70	Camaro, Chevy w/T.H. 400 (8 cyl.),					
69	Pass. w/T.H. 400 (327)	3895831	1	5.55	MOUNTING ASSY. (daub of white paint) (Note 3)	
67-68	Pass. w/T.H. (327, 396, 427),					
68	Chevelle (396) w/T.H. (1st design)	3904079	1	6.25	MOUNTING ASSY. (daub of green paint)	
68	Chevelle (327) (1st design)	3906957	1	4.75	MOUNTING ASSY., trans. supt. (3 holes, 2 oblong) (Note 1, 2)	
67	Chevelle w/T.H. (8 cyl.),					
67	Camaro w/T.H. (8 cyl.) (1st design),					
70-75	Camaro (T.H. 400 w/Sp. H/Per.) (350)	3872247	1	5.25	MOUNTING ASSY., support (orange paint marking, part number molded on piece)	
65-67	Chevy,					
66-67	Chevelle (6 cyl.),					
68-70	Camaro (exc. T.H. 400, 302, 396),					
68-69	Chevelle, Chevy (6 cyl.),					
68-70	Chevy (exc. 4 cyl.),					
70	Chevelle (6 cyl.),					
71	Nova, Camaro (exc. T.H. 400),					
72-75	Nova	3913498	1	4.65	MOUNTING ASSY., support (part number moulded on piece)	
68	Pass. w/T.H. 350 (327),					
69	Pass. (350) (exc. T.H. 400),					
69	Malibu w/T.H. 400,					
70	Pass. w/H/Per. (350),					
70	Pass. (400) (exc. T.H. 400),					
70-72	Chevelle w/T.H. 400	3947534	1	8.65	MOUNTING ASSY.	
68	Chevelle (396) w/T.H. (2nd design)	3935708	1	5.45	MOUNTING ASSY., support (moulded 3935708)	
68	Chevelle (8 cyl.) (2nd design) (exc. 327),					
69	Chevelle (307),					
70	Chevelle (307) (exc. Monte Carlo),					
70	Concours, Estate Wag. (exc. 350, 400)	3935704	1	4.60	MOUNTING ASSY., support	
68	Chevelle w/T.H. 350 (327),					
69-70	Chevelle (350) (exc. Monte Carlo),					
69	Chevelle (396) (exc. T.H. 400),					
70	Monte Carlo (exc. T.H. 400),					
70	Chevelle (396, 400, 454),					
71-72	Chevelle w/T.H. 350	3945476	1	6.80	MOUNTING ASSY., support	
69	Pass. (396, 427),					
69	Pass. w/T.H. 400 (350),					
70	Pass. w/T.H. 400 (400, 454)	3950234	1	8.65	MOUNTING ASSY.	
71	Camaro (T.H. 400 w/4BC) (400)	9788736	1	5.30	MOUNTING ASSY.	
71-73	Pass. w/T.H. 350, 400,					

**250-350-375-400 TURBO-HYDRAMATIC**

**4.081 SUPPORT— MOUNTING ASSY.— MEMBER ASSY., Transmission Mounting (Con't)**

73	Pass. (exc. Sta. Wag., Conv.),				
74	Pass. (Sta. Wag., Conv.) w/T.H. 400,				
74-75	Pass. (Cpe.),				
73-75	Pass. (Conv.) w/T.H. 350	357748	1	2.70	MOUNTING ASSY., support (coded black)
72	Camaro (T.H. 400 w/4BC) (402)	9788736	1	5.30	MOUNTING ASSY.
73-74	Chevelle w/T.H. 400	3989137	1	5.85	MOUNTING ASSY., support (lt. brown)
73-75	Chevelle w/T.H. 250, 350	3989125	1	10.55	MOUNTING ASSY., support (gold)
75	Chevelle w/T.H. 250, 350	356999	1	9.40	MOUNTING ASSY., support
74	Pass. (Sed.)	343253	1	4.50	MOUNTING ASSY., support
75	Nova, Camaro,				
75	Pass. (Sed., Sta. Wag.)	352893	1	6.80	MOUNTING ASSY., support
72	Vega	329741	1	8.50	MOUNTING ASSY., trans.
73-75	Vega	329768	1	8.50	MOUNTING ASSY., trans.

NOTE 1 3<sup>3</sup>/<sub>4</sub>" between center lines of bolt holes.  
 NOTE 2 Part number moulded on part.  
 NOTE 3 4<sup>1</sup>/<sub>4</sub>" between center lines of bolt holes.

**4.083 BRACKET, Transmission Mounting**

65	Pass.,				
66-68	Pass. w/T.H.,				
68	Pass. (exc. Taxi),				
69	Pass. (exc. Taxi, T.H. 400),				
69	Pass. w/T.H. 400 (exc. 427),				
70	Camaro (T.H. 400 w/Sp. H/Per.) (350),				
70	Pass. (exc. C.A.C., T.H. 400)	3855908	1	4.50	support (Budd frame)
70	Pass. (C.A.C. w/T.H. 350),				
70	Pass. w/T.H. 400	3982835	2	.87	support

**4.085 SHIM— BOLT, Transmission Mounting Support**

65-70	Pass. w/T.H.	3750050	A.R.	.18	(3 long)
62-66	Chevy (exc. 4 cyl.)	3779940	2	.21	BOLT (2 <sup>3</sup> / <sub>8</sub> "— 16 x 3 <sup>3</sup> / <sub>8</sub> ")— (7.874)

**4.103 CASE, Transmission**

65-75	All w/T.H. 400	8626953	1	188.35	(Note 3)
	<i>NOTE 3: Includes governor driven gear.</i>				
69-75	All w/T.H. 350	6261756	1	170.00	w/bushings (Note 2)
72-74	Vega w/T.H. 350	6260536	1	185.00	(vent. located in extension) (Note 1)
	<i>NOTE 1: When using case 6260536 on models with vent. in case, you must also order extension 6260477.</i>				
73-75	All w/T.H. 250	345036	1	162.00	
75	Monza (8 cyl.) T.H. 350	359986	1	162.00	CASE ASSY.
75	All w/T.H. 375, 400	8611710	1	.22	PLUG, trans. case

*NOTE 2 When using in place of case with 6261165 case number, purchase and install 6261516 vacuum mod. valve assy.*

**4.104 BUSHING— PIPE, Transmission Case**

65-75	All w/T.H. 400	8623941	1	1.94	
69-75	All w/T.H. 350	6261016	1	1.85	
65-72	All w/T.H. 400	8623425	1	1.08	PIPE, vent. (w/sleeve)
69-72	All w/T.H. 350	3820840	1	.36	PIPE ASSY., vent.
74-75	Monte Carlo	6261289	1	.26	PIPE ASSY., trans. vent.
72-73	Vega (1st design)	3820840	1	.36	VENTILATOR ASSY., trans.— (5.387) (Note 1)

*NOTE 1: Located on left hand side of center line.*  
*NOTE 2: Located on right hand side of center line. The tube section of vent. extends forward and to the right.*

**4.115 REBUILT CONVERTER ASSY.— BOLT, Transmission**

**REBUILT BY GENERAL MOTORS**

65-69	Pass. w/T.H. 400 (396, Sp. H/Per. 427),				
67-69	All w/T.H. 400 (exc. Pass., Sp. H/Per., 396),				
70-72	Pass. w/T.H. 400 (454),				
70	Nova, Chevelle, Camaro w/T.H. 400 (396, 400, 454) (exc. Sp. H/Per.),				
71-72	Police w/T.H. 400 (400),				
71-72	Chevelle w/T.H. 400 (400, 402, 454) (exc. Sp. H/Per.),				

**250-350-375-400 TURBO-HYDRAMATIC**

**4.115 REBUILT CONVERTER ASSY.— BOLT, Transmission (Con't)**

75	Camaro w/T.H. 400,				
73-75	Pass., Chevelle w/T.H. 400	8623990	1	82.50	(Exchange Item— Note 1)
67-69	Pass. w/T.H. 400 (307, 327),				
70	Pass. w/T.H. 400 (400),				
71-72	Pass., Camaro w/T.H. 400 (400,				
	402) (exc. Police)	8623964	1	82.50	torque (Exchange Item, Note 1)
73-75	Pass. w/T.H. 375	8623964	1	82.50	(Exchange Item— Note 1)
69	Pass. (T.H. 400 w/Sp. H/Per.,				
	H.D.) (427),				
69	All (T.H. 400 w/Sp. H/Per.)				
	(396) (exc. Pass.),				
70	All (T.H. 400 w/Sp. H/Per.)				
	(396, 454),				
71-72	Chevelle, Camaro (T.H. 400				
	w/Sp. H/Per.) (350, 454)	8625982	1	157.00	(Exchange Item, Note 1)
73-74	Camaro w/T.H. 400	8625982	1	157.00	(Exchange Item— Note 1)

**REBUILT FOR GENERAL MOTORS**

69-72	All w/T.H. 350 (350) (exc. 2BC),				
69-75	All w/T.H. 350 (400)	3948963	1	55.00	rebuilt (Exchange Item— Note 1)
69-75	All (T.H. 350 w/2BC) (250, 307,				
	350)	3963871	1	50.75	rebuilt (Exchange Item— Note 1)
69-70	All w/T.H. 350 (6 cyl.) (exc. Taxi,				
	Police)	3966923	1	55.00	rebuilt (Exchange Item— Note 1)
71	All w/T.H. 350 (6 cyl.)	3998276	1	54.00	rebuilt (Exchange Item— Note 1)
72-73	Vega w/T.H. 250, 350 (1st				
	design)	328749	1	57.50	(11" converter) (10 <sup>3</sup> / <sub>4</sub> " mtg. bolt circle)
					(rebuilt by GM)
73	Monte Carlo w/T.H. 350				
	(Canadian Built)	1394144	1	88.00	rebuilt (Exchange Item— Note 1)
73-75	Vega (2nd design) T.H. 250	328750	1	64.50	(10" converter) (9 <sup>3</sup> / <sub>4</sub> " mtg. bolt circle) (a
					portion rebuilt for GM)
75	Monza w/T.H. 350 (8 cyl.)	3963871	1	50.75	rebuilt for General Motors
	<i>NOTE 1 List price shown does not include exchange charge. Refer to dealer parts price schedule for</i>				<i>exchange charge.</i>
69	All w/T.H. 350,				
70-75	All	3799830	3	.16	<b>BOLT</b> , trans. assy. to engine or flywheel
					( <sup>3</sup> / <sub>8</sub> "— 24 x <sup>9</sup> / <sub>16</sub> " (Note 2)
	<i>NOTE 2 The above part is also used as a replacement with rebuilt trans. assy. 3832565 (P.G.)</i>				
65-69	All w/T.H. 400	1484645	A.R.	.40	<b>BOLT</b> , converter to flywheel ( <sup>3</sup> / <sub>8</sub> "— 16 x
					<sup>1</sup> / <sub>2</sub> "

**4.123 SHAFT, Transmission Input**

65-69	Pass. w/T.H. 400,				
67-68	All w/T.H. (exc. Pass.),				
70-75	All w/T.H. 400	8624772	1	23.15	(30 teeth) (9 <sup>1</sup> / <sub>4</sub> " O.L.)
75	All w/T.H. 250, 350	360941	1	19.00	<b>SHAFT UNIT</b> , trans. input

**4.128 CLAMP— CLIP— CONNECTOR— GASKET— SPACER, Transmission Oil**

70-75	All	3997718	1	1.30	oil cooler pipe to oil pan
74-75	Camaro w/T.H. 250	6271699	1	.98	oil cooler pipe
62-75	All w/A.T.	3710497	A.R.	.11	<b>CLIP</b> , inlet and outlet pipe assy.
70	Nova w/A.T. (8 cyl.)	3984503	1	.16	<b>CLIP</b> , oil cooler pipe (1 <sup>1</sup> / <sub>4</sub> "
65-66	Pass. w/T.H.,				
67-69	Pass. w/T.H. 400,				
67-68	All w/T.H. (exc. Pass.)	386297	1	.40	<b>CONNECTOR</b> , cooler inlet and outlet pipe
					assy. to trans.
69-75	All w/T.H. 350	3974421	1	.42	<b>CONNECTOR</b> , oil cooler pipe to case
70-75	All w/T.H. 400,				
75	Vega, Monza	8626632	2	1.53	<b>CONNECTOR</b> , oil cooler inverted flared
					tube
65-75	All w/T.H. 350	8625422	2	.14	<b>GASKET</b> , cooler fitting (steel) ( <sup>28</sup> / <sub>32</sub> " O.D.—
					<sup>7</sup> / <sub>32</sub> " I.D. x <sup>1</sup> / <sub>16</sub> " thk.)

**4.133 TUBE ASSY.— GAUGE— SEAL, Transmission Oil Filler**

65-73	All w/T.H. 400	330120	1	2.15	(23")
68-70	Pass. w/T.H. 350,				
69-70	All w/T.H. 350 (exc. Pass.),				
72-73	All w/T.H. 350	330119	1	2.20	(dev. length 24 <sup>13</sup> / <sub>32</sub> "
71	All w/T.H. 350	6261696	1	1.85	(dev. length 24 <sup>13</sup> / <sub>32</sub> "
73	Chevelle w/T.H. 350	330121	1	2.50	(dev. length 23 <sup>3</sup> / <sub>4</sub> "
74-75	Chevelle w/T.H. 400	338938	1	2.15	
74-75	Chevelle w/T.H. 250, 350	340625	1	2.00	
74-75	Pass., Camaro w/T.H. 375, 400	340659	1	1.75	

**250-350-375-400 TURBO-HYDRAMATIC**

**4.133 TUBE ASSY.— GAUGE— SEAL, Transmission Oil Filler (Con't)**

74	Pass., Nova, Camaro w/T.H. 250, 350,				
75	Pass., Camaro w/T.H. 250, 350,				
75	Nova w/T.H. 250, 350	355555	1	2.30	
72-74	Vega	6273221	1	2.45	trans. oil filler
75	Vega, Monza (140)	354702	1	1.95	trans. oil filler
75	Monza (8 cyl.)	354634	1	1.95	trans. oil filler
65-66	Pass. w/A.T. (exc. 409),				
68-73	All	1387568	1	1.15	GAUGE ASSY., cap and level
75	Vega	3981714	1	2.40	GAUGE ASSY., trans. oil level, w/cap
75	Monza w/Rotary	346355	1	.98	GAUGE ASSY., trans. oil level
74-75	All	1244421	1	.93	GAUGE ASSY., w/cap oil level
62-75	All w/A.T.	6264902	1	.22	SEAL, oil filler tube (Note 1)

*NOTE 1 The above parts also are used as replacement parts with rebuilt trans. assy. 3832565 (aluminum P.G.) and T.G. conversion trans. 3832566.*

**4.158 GEAR ASSY.— RING— WASHER, Transmission Front Drive**

69-75	All w/T.H. 350	6261397	1	31.40	input ring
69-70	All w/T.H. 350	6261049	1	.71	RING, snap (7/16" O.D.)— (4.187)
69-75	All w/T.H. 350	6260374	1	1.45	WASHER, input ring gear rear trans.

**4.159 GEAR— BEARING UNIT, Transmission Sun Gear and Parts**

65-75	All w/T.H. 400	8626807	1	18.95	
68-75	All w/T.H. 250, 350	6260185	1	19.20	
65-75	All w/T.H. 400	8623921	1	2.45	BEARING UNIT, w/race sun gear rear intermediate gear thrust
65-75	All w/T.H. 400	8623920	1	2.31	BEARING UNIT, w/race center supt. to sun gear thrust

**4.161 BUSHING— SHAFT ASSY., Transmission Planet**

65-75	All w/T.H. 400	8623944	4	2.45	sun gear shaft
65-75	All w/T.H. 400	8623177	1	22.90	SHAFT ASSY., sun gear

**4.162 BOLT— BUSHING— RING— SCREW— SPACER— SUPPORT ASSY.— WASHER, Low Sun Gear and Clutch**

65-75	All w/T.H. 400	8624009	1	.84	case to center support
65-74	All w/T.H. 400	8623942	1	6.90	BUSHING, center supt.
69-75	All w/T.H. 350	1381366	1	.65	BUSHING, stator shaft front
65-75	All w/T.H. 400	8623437	1	2.01	RING, center supt. to case snap
65-75	All w/T.H. 400	8626356	4	.55	RING, counter supt. oil seal
65-69	All w/T.H. 400	8623498	1	.77	SCREW, case to center support lock
70-75	All w/T.H. 400	8626816	1	1.54	SPACER, case center
65	Pass. w/T.H.,				
66-75	All w/T.H. 400	8625990	1	79.30	SUPPORT ASSY., center w/race assy. (Note 1)
69-75	All w/T.H. 350	6261118	1	27.30	SUPPORT ASSY. (Note 1)
65-75	All w/T.H. 400	8624783	1	.72	WASHER, center support to reaction carrier thrust

*NOTE 1 Used with Roller type low clutch.*

**4.163 PLATE— SPRING, Transmission Clutch Drive and Driven**

65-66	Pass. w/T.H. 375	8623113	5	1.70	direct drive
65-75	All w/T.H. 375	8623122	1	7.95	direct clutch backing
65-75	All w/T.H. 375, 400	8623150 A.R.		2.50	intermediate clutch driven
65-75	All w/T.H. 375, 400	8623151	3	2.69	intermediate clutch driving
65-75	All w/T.H. 375, 400	8623152	1	8.55	intermediate clutch backing
65-70	All w/T.H. 375, 400,				
71	Pass. w/T.H. 375, 400 (400) (exc. Police),				
71	Chevelle, Camaro (350, 400, 454) (exc. H/Per.),				
72-75	All w/T.H. 375, 400 (exc. 454)	8623849	4	1.69	forward clutch driven (.078" thk.)
65-72	All w/T.H. 375, 400	8623851	2	2.85	forward clutch driven wave
66	Pass. w/T.H.,				
67-70	All w/T.H. 375, 400,				
71-75	All w/T.H. 375, 400 (exc. Sp. H/Per.)	8624199	1	2.85	intermediate clutch reaction wave
67-75	All w/T.H. 375, 400	8625197	4	2.77	forward and direct clutch driven (.092" thk.)
69-75	All w/T.H. 350	6261450 A.R.		2.65	inter. reaction (Note 2)
69-75	All w/T.H. 350	6261010	1	5.55	inter. press
69-75	All w/T.H. 350	6261071 A.R.		2.65	direct clutch driven and forward clutch drive (steel w/tangs)
69-75	All w/T.H. 350	6261072	1	5.35	forward clutch press (1/4")
69-75	All w/T.H. 350	6261350	1	5.35	direct clutch press (5/16") (2 tangs)
69-75	All w/T.H. 350	6260236 A.R.		2.65	low and rev. clutch reaction

**250-350-375-400 TURBO-HYDRAMATIC**

**4.163 PLATE— SPRING, Transmission Clutch Drive and Driven (Con't)**

75	All w/T.H. 350	6261349	1	5.20	fwd. clutch driven
65-75	All w/T.H. 400	8623483	A.R.	2.12	PLATE ASSY., forward and direct clutch drive (42 teeth)
69	All w/T.H. 350,				
70	All w/A.T. (exc. T.H. 400, Floor Shift),				
70-75	All w/T.H. 350	3832386	A.R.	2.65	PLATE ASSY., low and reverse clutch drive
69-75	All w/T.H. 350	6261277	A.R.	5.35	PLATE ASSY., inter. clutch drive
69-75	All w/T.H. 350	6261278	A.R.	5.35	PLATE ASSY., direct clutch drive (lined plate)
69	Pass. w/T.H. 400, Sp. H/Per., H.D. (427),				
69	All (T.H. 400 w/Sp. H/Per.) (396) (exc. Pass.),				
70	All (T.H. 400 w/Sp. H/Per.) (396),				
71-75	Chevelle, Camaro (T.H. 400 w/Sp. H/Per.) (350, 454)	8626363	3	7.40	PLATE ASSY., inter. clutch
70-75	All w/T.H. 350	6261532	A.R.	5.35	PLATE ASSY., forward clutch driven
69	All w/T.H. 350	6261222	1	2.25	SPRING, forward, piston cushion

*NOTE 1 Use selectively.*  
*NOTE 2 When using on models with Part No. 6261043-44 stamped on inner of inter clutch piston, purchase and install new piston.*

**4.164 BEARING ASSY.— HUB— GUIDE— RETAINER— RING— SEAT— SPRING— WASHER, Transmission**

69-75	All w/T.H. 350	9428864	1	3.20	rear trans. clutch drum
75	All w/T.H. 350	9436851	1	2.65	direct clutch drum to pump cover
65	Pass. w/T.H.,				
66-67	All w/T.H.	8624197	1	13.80	HUB, forward clutch
65-75	All w/T.H. 400	8625718	1	16.60	HUB, direct clutch
68-75	All w/T.H. 400	8625717	1	16.20	HUB, forward clutch
74-75	All w/T.H. 375, 400	8627385	1	2.63	GUIDE, trans. inter. clutch spring
65-75	All w/T.H. 400	8623104	1	.54	RETAINER, forward or direct clutch piston release spring
65-75	All w/T.H. 400	8623146	1	1.32	RETAINER, intermediate clutch spring
69-75	All w/T.H. 350	6261041	1	.20	RETAINER, lower and reverse clutch piston return
65-75	All w/T.H. 400	8623105	2	.24	RING, forward or direct clutch piston release spring retaining snap (1 <sup>5</sup> / <sub>8</sub> " I.D.)
65-75	All w/T.H. 400	8623112	1	1.77	RING, forward or direct clutch ret. snap
65-75	All w/T.H. 400	8623149	1	1.38	RING, inter. clutch ret. snap (7 <sup>7</sup> / <sub>8</sub> " I.D.)
65-75	All w/T.H. 400	8623153	1	.38	RING, intermediate clutch release spring retaining snap (3" I.D.)
69-75	All w/T.H. 350	6261037	2	.20	RING, clutch piston return, forward and direct
69-75	All w/T.H. 350	6261011	2	.71	SEAT, clutch piston return, forward and direct
69-75	All w/T.H. 350	1243126	1	2.25	SEAT, intermediate clutch piston return
69-75	All w/T.H. 350	6260382	1	2.25	SEAT ASSY., w/springs low and reverse clutch
65-69	All w/T.H. 400	8623103	16	.23	SPRING, direct clutch piston release
65-75	All w/T.H. 400	8623145	A.R.	.14	SPRING, intermediate clutch release
65-75	All w/T.H. 400	8624101	16	.14	SPRING, forward clutch piston release
69-75	All w/T.H. 350	6261309	1	2.25	SPRING, inter. clutch piston cushion
69-74	All w/T.H. 350	6261457	1	1.90	SPRING, direct clutch piston cushion
69-73	All w/T.H. 350	6260311	17		SPRING, direct clutch piston return (violet)
69-75	All w/T.H. 350	6261681	21	.13	SPRING, forward clutch piston return (green)
69-70	All w/T.H. 350	6261024	30	.18	SPRING, inter. clutch piston return
69-75	All w/T.H. 350	6261222	1	2.25	SPRING, forward clutch piston cushion
71-73	All w/T.H. 350	6260294	20	.23	SPRING, inter. clutch piston return (yellow)
69-70	Pass. w/T.H. 400,				
69-70	All (T.H. 400 w/Sp. H/Per.) (396) (exc. Pass.),				
71-75	All w/T.H. 400	8624073	16	.23	SPRING, direct clutch release (red)
74	Vega	1242723	1	2.25	SPRING UNIT, w/seat direct clutch piston return (Note 1)

*NOTE 1: Consists of 17 springs permanently attached to seat.*

65-75	All w/T.H. 400	8624196	1	.92	WASHER, forward clutch hsg. to forward clutch hub thrust
69	All w/T.H. 350	6261382	1	.36	WASHER, direct clutch drum thrust (Note 1)
69-75	All w/T.H. 400	8624781	1	.42	WASHER, forward clutch hub to direct clutch hub thrust

**250-350-375-400 TURBO-HYDRAMATIC**

**4.164 BEARING ASSY.— HUB— GUIDE— RETAINER— RING— SEAT— SPRING— WASHER, Transmission (Con't)**

*NOTE 1: See model usage clarification section in front of catalog for illustration of first and second design parts.*

**4.166 PISTON— BALL— SEAL UNIT, Transmission Clutch**

65-66	Pass. w/T.H. ....	<b>8623034</b>	1	8.85	direct clutch .....
65	Pass. w/T.H. ....	<b>8623142</b>	1	7.05	intermediate clutch .....
65-66	Pass. w/T.H. (396),				
67-70	Pass. w/T.H. 400 (exc. H/Per. 454),				
71	Chevelle, Camaro w/T.H. 400 (400),				
71	Pass. w/T.H. 400 (400) (exc. Police),				
71	Chevelle, Camaro (T.H. 400 w/Sp. H/Per.) (350, 454),				
72	All w/T.H. 400 (exc. 454, Police),				
73-75	Camaro w/T.H. 400 .....	<b>8624016</b>	1	12.70	fwd. clutch .....
66-75	All w/T.H. 400 .....	<b>8624210</b>	1	8.45	intermediate clutch .....
68	Pass. w/T.H. 400 (307) .....	<b>8625518</b>	1	14.40	direct clutch .....
69	Pass. w/T.H. 350 (8 cyl.),				
69-70	All w/T.H. 350 (350) (exc. Pass., Monte Carlo),				
70	Pass., Monte Carlo w/T.H. 350 (8 cyl.),				
70	Taxi, Police w/T.H. 350 (6 cyl.),				
71-74	All w/T.H. 350 (350, 400) .....	<b>6260264</b>	1	8.35	intermediate clutch (Note 2) .....
	<i>NOTE 2: When using 6260264 in place of 6261449 discard old return springs, qty. of 30, and install 20 return springs 6260294.</i>				
69-70	Pass. w/T.H. 350 (8 cyl.),				
69-70	All w/T.H. 350 (350) (exc. Pass.),				
70	Taxi, Police w/T.H. 350 (6 cyl.),				
71-75	All w/T.H. 350 (350, 400) .....	<b>6261105</b>	1	8.50	lower and reverse clutch .....
73-75	All w/T.H. 375, 400 .....	<b>8626938</b>	1	8.45	inter. clutch .....
75	All w/T.H. 350 .....	<b>1239836</b>	1	2.99	inter. clutch accum. (w/2 teflon seals) .....
75	All w/T.H. 350 (exc. 6 cyl.) .....	<b>1243383</b>	1	1.05	direct clutch .....
69-70	Pass., Camaro w/T.H. 350 (6 cyl.) (exc. Taxi, Police),				
69-70	Chevy, Chevelle w/T.H. (350) (exc. 350),				
71-75	All w/T.H. 350 (exc. 350, 400) .....	<b>344212</b>	1	8.05	lower and reverse clutch .....
73-75	Pass. w/T.H. 375, 400 C.G. ....	<b>8624021</b>	1	12.95	fwd. clutch .....
69-75	All w/T.H. 350 (exc. 350, 400) .....	<b>6261115</b>	1	8.15	forward clutch (1.415" thk.) .....
69	All w/T.H. 350 (350),				
70	Nova, Camaro, Chevelle w/T.H. 350 (350) (exc. Monte Carlo),				
70	Pass., Monte Carlo w/T.H. (350) (8 cyl.),				
70	Taxi, Police w/T.H. 350 (6 cyl.),				
71-75	All w/T.H. 350 (350, 400) .....	<b>6261116</b>	1	8.15	forward clutch (1.233" thk.) .....
69	Pass., Camaro w/T.H. 350 (6 cyl.) (exc. Taxi),				
69	Chevy, Chevelle w/T.H. 350 (exc. 350) .....	<b>6261102</b>	1	8.55	direct clutch .....
70	All (T.H. 400 w/H/Per.) (454),				
71-72	Police w/T.H. 400 (400, 402),				
71-75	Pass., Chevelle w/T.H. 400 (454) (exc. Sp. H/Per.) .....	<b>8625505</b>	1	14.20	forward clutch .....
72-75	Vega, Monza .....	<b>6271551</b>	1	8.95	trans. low and rev. clutch .....
72-75	Vega .....	<b>6271552</b>	1	8.65	trans. fwd. clutch .....
72-75	Vega, Monza .....	<b>6271558</b>	1	8.95	trans. direct clutch .....
69-73	All w/T.H. 350 (exc. 350, 400) .....	<b>6260265</b>	1	8.60	inter. clutch (Note 3) .....
	<i>NOTE 3 When using in place of 6261448 discard old return springs (Qty. 30) purchase and install 20 return springs 6260294.</i>				
67-68	Pass. w/T.H. 400 (exc. 307),				
69	All w/T.H. 400 (exc. Sp. H/Per.),				
70	All w/T.H. 400 (exc. 302, 454),				
70	All w/T.H. 400 (454) (exc. H/Per.),				
71	All w/T.H. 400 (400) (exc. Police),				
72-75	All w/T.H. 400 (exc. Police, 454)	<b>8625514</b>	1	14.00	<b>PISTON ASSY., direct clutch</b> .....



**250-350-375-400 TURBO-HYDRAMATIC**

**4.166 PISTON— BALL— SEAL UNIT, Transmission Clutch (Con't)**

69	Pass. w/T.H. 400, Sp. H/Per. (396, 427),				
71-75	Chevelle, Camaro (T.H. 400 w/Sp. H/Per.) (350, 454) . . . . .	8626544	1	25.95	PISTON ASSY., direct clutch . . . . .
69-70	Pass., Monte Carlo w/T.H. 350 (8 cyl.),				
69-70	Nova, Chevelle, Camaro w/T.H. 350 (350),				
70	Taxi, Police w/T.H. 350 (6 cyl.),				
71-75	All w/T.H. 350 (350, 400) . . . . .	6260197	1	8.90	PISTON ASSY., direct clutch . . . . .
70	Pass. w/T.H. 350 (6 cyl.) (exc. Taxi),				
70	Nova, Chevelle, Camaro w/T.H. 350 (exc. 350),				
71-75	All w/T.H. 350 (exc. 350, 400) . . . . .	6260196	1	8.50	PISTON ASSY., direct clutch . . . . .
70	All (T.H. 400 w/H/Per.) (454),				
71-72	Police w/T.H. 400 (400, 402),				
71-75	Pass., Chevelle w/T.H. 400 (454) (exc. Sp. H/Per.) . . . . .	8625384	1	14.70	PISTON ASSY., direct clutch . . . . .
62-69	All . . . . .	7002117	1	.05	BALL, pressure relief valve (3/16")— (3.825) . . . . .
65-75	All w/T.H. 400 . . . . .	8623917	1	3.90	SEAL UNIT, forward or direct cl. piston . . . . .
65-75	All w/T.H. 400 . . . . .	8623918	1	2.81	SEAL UNIT, intermediate clutch piston . . . . .
69-75	All w/T.H. 350 . . . . .	3947088	1	3.00	SEAL UNIT, intermediate clutch piston . . . . .
69-75	All w/T.H. 350 . . . . .	3947089	1	.54	SEAL UNIT, reverse clutch piston . . . . .
69-75	All w/T.H. 350 . . . . .	3947087	1	2.45	SEAL UNIT, direct clutch piston . . . . .
69-75	All w/T.H. 350 . . . . .	3947086	1	2.25	SEAL UNIT, forward clutch piston . . . . .

**4.167 SPRAG ASSEMBLY— CLUTCH ASSY.— CAM— RETAINER— RING— ROLLER ASSY., Transmission Forward Cone Freewheel**

65-74	All w/T.H. 400 . . . . .	8623116	1	18.50	w/bushing . . . . .
69-75	All w/T.H. 350 . . . . .	6261298	1	12.50	CLUTCH ASSY., intermediate clutch o/run . . . . .
75	Vega, Monza . . . . .	356826	1	10.50	CLUTCH ASSY., trans. inter. clutch o/run . . . . .
72-73	Monte Carlo . . . . .	6260318	1	12.15	CAM, inter. o/run clutch (Note 1) . . . . .
65-75	All w/T.H. 400 . . . . .	8623119	1	2.18	RETAINER, intermediate clutch sprag . . . . .
69-75	All w/T.H. 350 . . . . .	6261143	1	1.40	RETAINER, intermediate o/run clutch . . . . .
65-75	All w/T.H. 400 . . . . .	8623120	1	.30	RING, inter. cl. sprag ret. snap (2 3/4" I.D.) . . . . .
69-75	All w/T.H. 350 . . . . .	6261048	2	.26	RING, clutch pressure plate retainer, forward and direct . . . . .
72-75	All w/T.H. 400 . . . . .	8625814	1	13.55	ROLLER ASSY., inter. clutch . . . . .

*NOTE 1: Used with Buick type trans. identified by 2" dia. speedo, driven gear bore in extension.*

**4.168 RACE— BUSHING— RING, Forward Cone Freewheel**

65-75	All w/T.H. 400 . . . . .	8623117	1	27.15	intermediate clutch sprag outer . . . . .
69-75	All w/T.H. 350 . . . . .	6261021	1	12.95	intermediate o/run clutch outer . . . . .
65-74	All w/T.H. 400 . . . . .	8623945	2	1.94	BUSHING, intermediate sprag assy. . . . .
69-75	All w/T.H. 350 . . . . .	6261038	1	.20	RING, inter. o/run clutch retainer . . . . .

**4.169 DRUM ASSY.— HOUSING— BUSHING— RING— WASHER, Transmission Clutch**

69-75	All w/T.H. 350 . . . . .	6261404	1	38.00	direct clutch . . . . .
73-75	All w/T.H. 250 . . . . .	330151	1	38.00	direct clutch . . . . .
65-69	All w/T.H. 400 (exc. Sp. H/Per.),				
70	All w/T.H. 400 (exc. Sp. H/Per. 396, 302),				
72	All w/T.H. 400 (400, 402) (exc. Police) . . . . .	8623061	1	47.35	HOUSING ASSY., direct clutch (w/race) (w/inter. spring type) . . . . .
69	Pass. (T.H. 400 w/Sp. H/Per.) (427),				
69	All (T.H. 400 w/Sp. H/Per.) (396) (exc. Pass.),				
70	All (T.H. 400 w/Sp. H/Per.) (396),				
70	Camaro w/T.H. 400 (302),				
72	All w/T.H. 400 (454),				
72-74	Camaro (T.H. 400 w/Sp. H/Per.) (350) . . . . .	8625756	1	48.65	HOUSING ASSY., direct (w/race) (w/inter. spring type) . . . . .
71	All w/T.H. 400 (454),				
71	All (T.H. 400 w/Sp. H/Per.) (350) . . . . .	8625817	1		HOUSING ASSY., w/cam direct clutch (6 plate clutch) (Note 5) . . . . .
65-70	Pass. w/T.H. 400,				
71-75	All w/T.H. 400 . . . . .	8624908	1	33.75	HOUSING UNIT, forward clutch . . . . .
75	Pass. w/T.H. 375 . . . . .	8627387	1	60.90	HOUSING UNIT, w/cam, direct clutch . . . . .

**250-350-375-400 TURBO-HYDRAMATIC**

**4.169 DRUM ASSY.— HOUSING— BUSHING— RING— WASHER, Transmission Clutch (Con't)**

71-75	Pass., Chevelle w/T.H. 400	8627388	1	60.90	HOUSING UNIT, w/cam, direct clutch
69-75	All w/T.H. 350	360943	1	29.75	HOUSING UNIT, forward clutch (note 1)
<i>NOTE 1: Use together with shaft unit #360941 located in Group 4.123.</i>					
69-75	All w/T.H. 350	6261026	1	1.10	BUSHING, direct clutch drum
69-75	All w/T.H. 350	6261570	2	1.50	RING, forward clutch housing oil seal
69-75	All w/T.H. 350	6261746	1	1.65	RING, direct clutch drum oil seal
65-75	All w/T.H. 400	8623300	1	1.02	WASHER, oil pump cover to forward clutch hsg. thrust (.060-.064 thk.) (yellow)
65-75	All w/T.H. 400	8623301	1	1.02	WASHER, oil pump cover to forward clutch hsg. thrust (.071-.075" thk.)
65-75	All w/T.H. 400	8623302	1	1.02	WASHER, oil pump cover to forward clutch hsg. thrust (.082-.086 thk.) (red)
65-75	All w/T.H. 400	8623303	1	1.02	WASHER, oil pump cover to forward clutch hsg. thrust (.093-.097 thk.) (brown)
65-75	All w/T.H. 400	8623304	1	1.02	WASHER, oil pump cover to forward clutch hsg. thrust (.104-.108 thk.) (green)
65-75	All w/T.H. 400	8623305	1	1.02	WASHER, oil pump cover to forward clutch hsg. thrust (.115-.119 thk.) (black)
65-75	All w/T.H. 400	8623306	1	1.02	WASHER, oil pump cover to forward clutch hsg. thrust (.126-.130 thk.) (purple)
69-75	All w/T.H. 350	6261015	1	1.20	WASHER, direct drum front thrust (.065-.067) (Note 3)
69-75	All w/T.H. 350	6261014	1	1.25	WASHER, direct drum front thrust (.099-.101) (Note 3)
69-75	All w/T.H. 350	6261013	1	1.25	WASHER, direct drum front thrust (.082-.084) (Note 3)

*NOTE 2 See models usage clarification section in front of catalog for illustration of first and second design parts.*

*NOTE 3 Use selectively.*

*NOTE 4 When using in place of models using a thrust washer between the direct and forward clutch drums, discard thrust washer, purchase and install 6261404 together with 9428864.*

*NOTE 5 Used with inter. roller type clutch.*

**4.172 SHAFT— PLUG— RING, Transmission Main with Gear**

65-67	All w/T.H.	8623321	1	19.70	w/plug
68-75	All w/T.H. 400	8625736	1	21.05	w/plugs trans. main
65-74	All w/T.H. 400	8623484	2	.19	PLUG, main shaft or shaft and bushing output (1 <sup>1</sup> / <sub>32</sub> " dia.)
67-75	All w/T.H. 400	8625221	1	.24	RING, main shaft retaining snap

**4.175 CARRIER ASSY.— PINION UNIT— RING GEAR— SHAFT ASSY.— SHELL— WASHER, Transmission Planet**

65-75	All w/T.H. 400	8625957	1	96.65	output (complete)
65-67	All w/T.H.	8624971	1	94.45	roller clutch and reaction
68-75	All w/T.H. 400	8625859	1	93.30	reaction (complete)
69-74	All w/T.H. 350	6261643	1	54.50	output
69-75	All w/T.H. 350	6261645	1	57.00	reaction planet
75	All w/T.H. 250, 350	1250023	1	57.50	CARRIER PKG., output w/thrust roller bearings
65-67	All w/T.H.	8623951	2	29.40	PINION UNIT, reaction or output carrier planetary
68-75	All w/T.H. 400	8625913	1	31.05	PINION UNIT, reaction and output carrier
75	All w/T.H. 350	1250022	1	28.25	RING GEAR & BEARINGS, output
65-70	All w/T.H. 400,				
71-74	All w/T.H. 400 (exc. Pass.)	8625961	1	53.80	SHAFT ASSY., output
69-70	All w/T.H. 350 (exc. Taxi, Police),				
71-75	All w/T.H. 350 (exc. Pass.)	6260182	1	34.75	SHAFT ASSY., output
71	Pass. w/T.H. 350 (exc. Sta. Wag.),				
72	Pass. w/T.H. 350 (350, 400) (exc. Sta. Wag.)	6261639	1		SHAFT ASSY., output
71	Pass. (Sta. Wag.) w/T.H. 350,				
72-73	Pass. (Sta. Wag.) w/T.H. 350 (350, 400)	6261640	1	31.00	SHAFT ASSY., output
71-75	Pass. w/T.H. 400	8627451	1	70.75	SHAFT ASSY., w/plug output
75	Vega, Monza,				
75	Chevelle, Camaro, Nova w/T.H. 250, 350	1245379	1	28.00	SHAFT ASSY., output, short
73	Pass. w/T.H. 350 (exc. Sta. Wag., Taxi),				
74-75	Pass. w/T.H. 350	354649	1	36.00	SHAFT ASSY., output
73-75	Pass. w/T.H. 375	8626918	1	60.70	SHAFT ASSY., w/bushing trans. output
75	Chevelle w/T.H. 400	8627453	1	67.20	SHAFT ASSY., output

**250-350-375-400 TURBO-HYDRAMATIC**

**4.175 CARRIER ASSY.— PINION UNIT— RING GEAR— SHAFT ASSY.— SHELL— WASHER, Transmission Planet (Con't)**

69-73	All w/T.H. 350	1241726	1	15.05	SHELL, sun gear drive
74-75	All w/T.H. 250, 350	342470	1	14.15	SHELL, sun gear drive
65-74	All w/T.H. 400	8626372	1	2.80	WASHER, reaction carrier to output carrier, thrust— (4.176)

**4.176 BEARING ASSY.— BUSHING— RING— WASHER, Planet Carrier**

69	All w/T.H. 350,				
70	All w/A.T.,				
71-75	All w/T.H. 350	9427759	1	2.65	output ring gear rear thrust
69-75	All w/T.H. 350	3789034	1	.74	BUSHING, output shaft
65-75	All w/T.H. 400	8624988	1	2.68	BUSHING, output shaft
69-75	All w/T.H. 350	6261033	3	.74	BUSHING, reaction planet carrier, sun gear (Note 1)

*NOTE 1: 2 used as trans. sun gear bushing 1 used as reaction planet carrier bushing.*

69-75	All w/T.H. 350	6261029	1	.33	BUSHING, input ring gear
65-68	All w/T.H.	8623203	1	1.39	RING, output carrier snap
65-75	All w/T.H. 400	8626112	1	2.61	RING, front internal gear
69-75	All w/T.H. 400	8626173	1	1.30	RING, snap output front internal gear
69-75	All w/T.H. 350	6261039	1	.20	RING, trans. output carrier ret. to output shaft
69-75	All w/T.H. 350	6261040	1	.20	RING, trans. output ring gear supt. to output shaft
69-75	All w/T.H. 350	6261066	2	.20	RING, trans. sun gear drive shell retainer
65-75	All w/T.H. 400	8626372	AR	2.80	WASHER, reaction and output shaft to case front thrust
65-75	All w/T.H. 400	8625401	1	2.97	WASHER, output shaft to case rear thrust (.074-.078 thk.) (Note 4)
65-75	All w/T.H. 400	8625405	1	2.97	WASHER, output shaft to case rr. thrust (.110-.114 thk.) (2 notch-tab side O.D.)
65-75	All w/T.H. 400	8625406	1	2.97	WASHER, output shaft to case rr. thrust (.118-.122 thk.) (3 notch-tab side O.D.)
65-75	All w/T.H. 400	8625403	1	2.97	WASHER, output shaft to case rear thrust (.090-.094 thk.) (2 notch-tab side) (Note 4)
68-75	All w/T.H. 400	8625402	1	2.97	WASHER, output shaft to case rear thrust (.082-.086 thk.) (1 notch-tab side) (Note 4)
68-75	All w/T.H. 400	8625404	1	2.97	WASHER, output shaft to case rear thrust (.098-.102 thk.) (1 notch-tab side O.D.) (Note 4)
69-75	All w/T.H. 350	6261184	1	.74	WASHER, sun gear shell rear thrust
69-72	All w/T.H. 350	6261034	1	.71	WASHER, sun gear thrust
69-75	All w/T.H. 350	6261124	1	.57	WASHER, output ring gear front thrust
69-75	All w/T.H. 350	6261027	1	.74	WASHER, input ring gear front thrust
75	All w/T.H. 350	1241725	1	.72	WASHER, sun gear thrust

*NOTE 4 Use selectively.*

**4.180 SPRAG ASSY.— CLUTCH ASSY.— RACE— RING— ROLLER UNIT— SPRING, Transmission RearRing Gear**

65-66	Pass. w/T.H. 400	8623497	1	23.15	low clutch (Note 1)
<i>NOTE 1 Use with sprag type low clutch.</i>					
66-75	All w/T.H. 400	8623842	1	14.55	low clutch w/16 rollers (Note 2)
<i>NOTE 2 Use with roller type low clutch.</i>					
69-75	All w/T.H. 350	6261305	1	12.50	CLUTCH ASSY., low and reverse o/run
69-75	All w/T.H. 350	6261125	1	12.95	RACE, low and reverse o/run clutch retainer
69-75	All w/T.H. 350	6261051	2	.33	RING, low and reverse o/run clutch retainer
69-75	All w/T.H. 350	6261416	1	.33	RING, low and reverse clutch support retainer
71-75	All w/T.H. 400	8624960	1	.92	ROLLER UNIT, low clutch
69-75	All w/T.H. 350	6261415	1	1.05	SPRING, low and reverse clutch support retainer

**4.187 GEAR— BEARING UNIT— RING, Transmission Rear Unit**

65-75	All w/T.H. 400	8623202	1	29.20	rear internal mainshaft
69-75	All w/T.H. 250, 350	6261275	1	25.50	output ring
65-75	All w/T.H. 400	8623922	1	2.31	BEARING UNIT, w/race, rear intermediate gear output thrust
69-75	All w/T.H. 350	6261049	2	.71	RING, snap, input, and output ( $\frac{7}{16}$ " O.D.)

**4.195 PAN, Transmission Oil**

65-67	All w/T.H. (1st design)	8623778	1	10.20	
67-75	All w/T.H. 400 (2nd design)	8625766	1	11.00	(Note 1)
<i>NOTE 1 Pan has two stamped bosses for identification.</i>					
69-75	All w/T.H. 350	335339	1		

**250-350-375-400 TURBO-HYDRAMATIC**

**4.196 GASKET, Transmission Oil Pan**

62-69	All,				
72-74	Vega	3921989	1	.20	trans. oil pan drain plug— (1.456)
65-72	All w/T.H. 400	8623266	1	.74	
69-75	All w/T.H. 350	6261649	1	.68	oil pan to trans. case (cork)
73-75	All w/T.H. 375, 400	8626931	1	.98	
75	Monza w/T.H. 350 (8 cyl.)	8640054	1	1.90	trans. oil pan to trans. case

**4.197 PIPE ASSY.— BOLT— FILTER ASSY.— FILTER UNIT— GASKET— GROMMET— SCREEN UNIT— SEAL, Oil Pan Pump Suction**

67-75	All w/T.H. 400	8626886	1	2.49	oil filter inlet (Note 1)
67-75	All w/T.H. 400	8625769	1	.46	BOLT, shoulder (Note 1)
67-70	All w/T.H. 400 (2nd design),				
71-75	All w/T.H. 400	6259423	1	N.L.	FILTER ASSY., less pipe oil pump (Note 2)

*NOTE 2 Use with 2nd design oil pan 8625766 which has two stamped bosses.*

65-67	All w/T.H. (1st design)	6259422	1	N.L.	FILTER UNIT, w/pipe oil pump
69-75	All w/T.H. 350	6261235	1	.14	GASKET, screen
67-75	All w/T.H. 400	6437746	1	.44	GROMMET, oil pump filter assy. (Note 1)
69-74	All w/T.H. 350	6258504	1	N.L.	SCREEN UNIT, w/gaskets oil pump (Note 3)

*NOTE 3: Consists of 1 screen, trans., 1 gasket, trans. screen 1 gasket trans. oil pan, and one instruction sheet.*

65-75	All w/T.H. 400	1363951	1	.31	SEAL, oil pump filter intake pipe to case ("O" ring)
-------	----------------	---------	---	-----	--

*NOTE 1 For use with 2nd design filter assy. 6437741.*

**4.203 BOLT— SCREW— SEAL— SPRING— VALVE, Oil Supply Pump**

65-69	All w/T.H.	3826039 A.R.		.14	front pump (5/16" — 18 x 1 3/4")— (8.900)
62-69	All w/A.T.	6261374 A.R.		.20	SCREW, pump to trans. case (5/16" — 18 x 1 7/16")— (4.226)
69-71	All w/T.H. 350	8626916	1	3.43	SEAL, oil pump body inner— (4.226)
69-71	All w/T.H. 350	3850850	1	.05	SPRING, front oil pump priming valve— (4.226)
69	All w/T.H. 350	3850849	1	.51	VALVE, front oil pump priming— (4.226)

**4.205 MODULATOR— CLIP— HOSE— PIPE ASSY.— RETAINER— SEAL— TEE ASSY.— VALVE, Vacuum**

69	All w/T.H. 350,				
70	All w/T.H. 350 (exc. 350, 396),				
70	All w/T.H. 350 (350) (exc. 4BC),				
71-72	All w/T.H. 350 (307, 350),				
72	Vega,				
74	Pass. w/T.H. 350 (400),				
74	Taxi, Police w/T.H. 350 (350)	3027223	1	12.90	
70	All (T.H. 350 w/4BC) (350),				
70-72	All w/T.H. 350 (400),				
65-75	All w/T.H. 400	3027222	1	12.90	absolute
73-75	All w/T.H. 375,				
74	All w/T.H. 350 (350) (exc. Taxi, Police)	3027842	1	19.20	trans. abs. press (3022714 stamped on case)
73	Monte Carlo w/T.H. 350	3027843	1	17.75	
73-75	Vega, Monza,				
73	All w/T.H. 250, 350,				
74-75	All w/T.H. 250,				
75	Camaro, Nova w/T.H. 350,				
75	Pass., Chevelle w/T.H. 350 (350),				
75	Pass., Chevelle w/T.H. 350 (400) w/NB-2,				
75	Pass. (Sta. Wag.) w/T.H. 350 (NB-2)	6259799	1	21.50	
75	Pass., Chevelle w/T.H. 350 (400) (exc. NB-2),				
75	Pass. (Sta. Wag.) w/T.H. 350 (exc. NB-2),				
75	Police w/T.H. 350	3032144	1	5.60	
73-74	All w/T.H. 250, 350	6271699	1	.98	CLAMP, trans. oil cooler pipe
73-74	All w/T.H. 375, 400	2381318	1	.21	CLIP, vac. mod. pipe
68-70	Pass. w/T.H. 350,				
71-72	All w/T.H. 350	3905427	1	.20	CLIP, vac. pipe (3/8")
69	All w/A.T. (6 cyl.)	3945472	1	.27	CLIP, transmission oil cooler pipe
62-71	All	3987364 A.R.		RL/.14	HOSE, vacuum modulator (7/32" I.D.)— (8.962)
73-75	All	336919	1	.61	HOSE, vac. mod. pipe (1/4" I.D. x 1 5/16" O.L.)
72-73	Vega,				

**250-350-375-400 TURBO-HYDRAMATIC**

**4.205 MODULATOR— CLIP— HOSE— PIPE ASSY.— RETAINER— SEAL— TEE ASSY.— VALVE, Vacuum (Con't)**

66-69	All,				
70	Pass., Nova, Chevelle w/A.T.,				
72	Pass. (402, 454),				
73-75	Vega	3937972	1	7.45	PIPE ASSY., vacuum modulator (cut as required 62" long)
70-72	Camaro (T.H. 400 w/Sp. H/Per. 350)	3952693	1	9.15	PIPE ASSY., modulator (37 1/2" dev. length)
65-75	All w/T.H. 400	8627650	1	.33	RETAINER, vacuum mod.
69-75	All w/T.H. 350	6261285	1	.26	RETAINER, absolute press
65-74	All	6264903	1	.20	SEAL, vacuum modulator to case
65-67	All	336013	1	1.05	TEE ASSY., vacuum modulator front pipe (3/8"— 18 thds.)— (7.447)
65-75	All w/T.H. 400	8623983	1	4.95	VALVE
69-75	All w/T.H. 350	6261516	1	2.78	VALVE ASSY., vacuum mod.

**4.216 VALVE UNIT, Transmission Main Valve**

72-73	Vega	3977543	1	.26	trans. oil cooler by-pass
-------	------	---------	---	-----	---------------------------

**4.218 PIN, Manual Valve**

65	Pass. w/T.H. 400,				
73	Pass. w/T.H. 400	8623232	1	.23	manual shift (1 7/8" O.L.)— (4.256)

**4.224 BODY ASSY.— COVER ASSY.— SCREEN ASSY., Transmission Oil**

65-75	All w/T.H. 400	8625954	1	66.60	oil pump
69-75	All w/T.H. 350	6264919	1	69.00	w/priming valve unit, oil pump
73-74	Vega w/T.H. 250,				
75	Vega, Monza	6271567	1	69.80	oil pump
67-75	All w/T.H. 400	8625955	1	77.70	COVER ASSY., front oil pump
69-75	All w/T.H. 350	6258819	1	46.60	COVER ASSY., w/seal ring, oil pump
73-75	All w/T.H. 250	338382	1	40.70	COVER ASSY., w/seal oil pump
69-74	All w/T.H. 350	6261323	1	.54	SCREEN ASSY., oil pump press.

*NOTE 1 When using 3974332-3 on models with part No. 6261043-4 stamped on inner side of inter. clutch piston, discard inter. clutch reaction plates, purchase and install 3 each of 6261450 inter. clutch reaction plates.*

**4.226 VALVE— BUSHING— GASKET— PIN— RING— SCREW— SEAL— SPRING, Transmission Front Servo**

69-71	All w/T.H. 350	3850849	1	.51	front oil pump priming
65-71	All w/T.H.	8623944	1	2.45	BUSHING, conv. stator shaft— (4.161)
65-75	All w/T.H. 400	8623940	1	1.70	BUSHING, oil pump body
69-75	All w/T.H. 350	6261022	2	.54	BUSHING, transmission stator
65-75	All w/T.H. 400	8623978	1	1.19	GASKET, front oil pump to case
69-75	All w/T.H. 350	6261584	2	.54	GASKET, oil pump to case
65-75	All w/T.H. 400	8623078	2	.10	PIN, front oil pump pressure regulator valve plug retaining
65-74	All w/T.H. 400	8626356	2	.55	RING, front oil pump oil seal— (4.162)
62-75	All w/A.T.	6261374	1	.20	SCREW, oil pump lower to case (5/16"— 18 x 1 7/16")
65-69	All w/T.H. 400,				
69	All w/T.H. (350) (exc. Pass.),				
70	All w/T.H. 350,				
71-75	All	6261413	1	.76	SEAL, "O" ring (8 17/32" I.D.)
65-67	Pass. w/A.T. (2nd design),				
67-71	All w/A.T. (exc. T.H. 350),				
68-69	Pass. w/A.T.,				
72-74	All	3884683	A.R.	.06	SEAL, front oil pump to trans. case bolt
65-75	All w/T.H.	8626916	1	3.43	SEAL ASSY., front oil pump, oil pump body inner
73-75	All w/T.H. 350	332505	1	.21	SPACER, trans. oil pump thrust
69-70	All w/T.H. 350	3850850	1	.05	SPRING, front oil pump priming valve

**4.228 PISTON— COVER— RETAINER— RING— ROD— WASHER, Low Servo**

65-69	All w/T.H. 400	8623649	1	2.75	front servo
65-69	All w/T.H. 400	8623652	1	3.78	front accumulator
71-75	All w/T.H. 400	8626878	1	3.02	front servo
71-75	All w/T.H. 400	8626883	1	5.60	front accum.
73-74	All w/T.H. 250	330155	1	3.81	inter. servo.
73-75	All w/T.H. 250	330154	1	3.81	inter. servo. cushion
73-75	All	342494	1	2.63	PISTON ASSY., w/seal, inter. servo.
69-75	All w/T.H. 350	1243383	1	1.05	PISTON UNIT, w/rings direct clutch accum.
69-72	All w/T.H. 350	6261141	1	2.52	COVER, intermediate clutch accumulator piston
69-72	All w/T.H. 350	6260138	1	.20	RETAINER, intermediate accumulator piston cover

**250-350-375-400 TURBO-HYDRAMATIC**

**4.228 PISTON— COVER— RETAINER— RING— ROD— WASHER, Low Servo  
(Con't)**

71-72	All w/T.H. 400	8626884	1	.30	RING, front servo spring retain.
65-70	All w/T.H. 400	8623651	1	2.37	ROD, front servo piston
69-72	All w/T.H. 350	6261008	1	2.32	ROD, intermediate servo apply (O.L. 2 <sup>27</sup> / <sub>32</sub> " )
71-72	All w/T.H. 400	8626879	1	1.27	ROD, front servo piston (2 <sup>1</sup> / <sub>4</sub> " O.L.)
73-74	Vega	330153	1	2.32	ROD, trans. inter. servo. apply
75	Vega w/T.H. 250	347469	1	2.16	ROD, trans. inter. servo. apply
65-72	All w/T.H.	8623362	1	.23	WASHER, frt. inter. servo piston
73-75	Vega, Monza w/T.H. 250	336918	1	.20	WASHER, inter. servo. apply rod

**4.229 RING— SEAL, Transmission Front Servo Piston Parts**

65	Pass. w/T.H. 400	9431762	1	.08	front accumulator piston retaining (1 <sup>3</sup> / <sub>64</sub> " ) (Type T.E.)
65-75	All w/T.H. 400	8623653	1	.61	front accumulator piston oil seal
65-75	All w/T.H. 400	8623131	1	1.00	front servo piston oil seal
69-75	All w/T.H. 350	6261322	1	.13	direct clutch accumulator piston retainer
73-74	All w/T.H. 250	9434076	2	.12	inter. servo apply rod— (8.934)
69-75	All w/T.H. 350	338926	1	.22	SEAL, inter. clutch accumulator piston cover
69-74	All w/T.H. 350	6261150	1	.54	SEAL, direct clutch accumulator piston
69-74	All w/T.H. 350	342494	1	2.63	SEAL, intermediate servo piston
75	All w/T.H. 350	6260320	1	.51	SEAL, direct clutch accum. piston
73-74	All w/T.H. 250	330164	1	1.00	SEAL, inter. servo piston inner
73-74	All w/T.H. 250	330159	1	.22	SEAL, inter. servo piston pilot

**4.233 SPRING— RETAINER— SEAT, Transmission Front Servo**

65-70	Pass. w/T.H. 400,				
71-75	All w/T.H. 400	8623489	1	.74	front servo piston
65-66	Pass. w/T.H. (396),				
68-69	Pass. w/T.H. 400 (327) (exc. Police),				
73-74	Camaro w/T.H. 400	8623674	1	1.40	front accum. piston
66	Pass. w/T.H.,				
67	Pass. w/T.H. (427),				
68-69	Police w/T.H. 400 (327),				
68-70	All w/T.H. 400 H/Per. (396) (exc. Pass.),				
71	Chevelle w/T.H. 400 (400, 454) (exc. Sp. H/Per.),				
72	Chevelle w/T.H. 400	8623676	1	1.94	front accumulator piston
67-68	Pass. w/T.H. 400 (327, 396),				
69	Pass. w/T.H. 400, (427) (exc. H/Per., Sp. H/Per.),				
67-69	All w/T.H. 400 (396) (exc. H/Per., Sp. H/Per., Pass.),				
71	Pass. w/T.H. 400,				
72-75	Pass. w/T.H. 400 (400, 402, 454)	8623654	1	1.24	front accumulator piston
68-69	Pass. w/T.H. 400 (327, 350 2BC)	8625426	1	2.49	front accumulator piston
68-69	Pass. w/T.H. 400, H/Per. (427) (exc. Police),				
68-69	Police w/T.H. 400 (396, 427),				
70	Pass. w/T.H. 400 (454) (exc. H/Per.),				
71-72	Camaro w/T.H. 400 (400, 402)	8624358	1	2.10	front accumulator piston
69	Pass., Camaro w/T.H. 350 (8 cyl.) (exc. 350),				
70	All (T.H. 350 w/4BC) (350) (exc. Police),				
70	Taxi, Police w/T.H. 350 (6 cyl.),				
71	All w/T.H. 350 (350) (exc. Taxi),				
75	Chevelle w/T.H. 350 (350)	6261231	1	1.05	intermediate clutch accumulator piston (green)
69	Chevy, Chevelle w/T.H. 350 (8 cyl.) (exc. 350),				
70	Nova, Chevelle, Camaro w/T.H. 350 (8 cyl.) (exc. 350),				
70	Taxi, Police w/T.H. 350,				
73-75	Camaro w/T.H. 350	6261333	1	1.05	intermediate clutch accumulator piston (plain) (3 <sup>1</sup> / <sub>32</sub> " free length)
69-70	All w/T.H. 350 (6 cyl.),				
69-75	All w/T.H. 350 (350)	6261140	1	1.05	inter. clutch accum. piston (orange)
69	Pass. Camaro w/T.H. 350 (8 cyl.) (exc. 350),				

**250-350-375-400 TURBO-HYDRAMATIC**

**4.233 SPRING— RETAINER— SEAT, Transmission Front Servo (Con't)**

69	All w/T.H. 350 (6 cyl.)	6261360	1	1.05	direct clutch accumulator piston (green)
69-70	All w/T.H. 350 (350),				
71	All w/T.H. 350 (307),				
75	All w/T.H. 350, Sp. H/Per.	6261617	1	.69	direct clutch accum. piston
69-75	All w/T.H. 350	6261229	1	.30	intermediate servo piston
70	Pass. (T.H. 400 w/H/Per.) (454),				
72	Camaro (T.H. 400 w/Sp. H/Per.) (350)	8626775	1	1.80	front accumulator piston
70	All w/T.H. 350 (350) (exc. 4BC),				
70	All w/T.H. 350 (6 cyl.),				
71	Nova, Camaro w/T.H. 350 (8 cyl.) (exc. 350),				
71	Chevelle w/T.H. 350 (exc. 350, Monte Carlo),				
71	Pass., Monte Carlo w/T.H. 350 (400),				
72-73	All w/T.H. 350 (307, 400)	6261612	1	.94	direct clutch accum. piston
70	Pass. w/T.H. 350 (400),				
71-75	Pass., Monte Carlo w/T.H. 350 (400)	6261629	1	.88	inter. clutch accum. piston
70	Nova, Chevelle, Camaro w/T.H. 350 (350) (exc. 2BC),				
70	Monte Carlo w/T.H. 350 (400),				
70	Pass. w/T.H. 350 (350) (exc. Taxi, 2BC),				
71	All w/T.H. 350 (exc. Taxi, Police, 400),				
72-75	All w/T.H. 350 (350) (exc. Taxi)	6261615	1	.71	direct clutch accum. piston
65-70	All w/T.H. 400	8623704	1	.61	RETAINER, front servo spring
71-75	All w/T.H. 400	8626881	1	.39	RETAINER, front servo spring (1 <sup>7</sup> / <sub>32</sub> " dia.)
69-75	All w/T.H. 350	6261178	1	.20	SEAT, intermediate servo piston spring

**4.241 PISTON— COVER— GASKET— PIN— WASHER, Reverse Servo**

65-75	All w/T.H. 400	8626902	1	9.25	rear accumulator (w/teflon and aluminum seal rings)
65-75	All w/T.H. 400	8624138	1	7.95	rear servo
65-75	All w/T.H. 400	8624136	1	4.89	COVER, rear servo
65-75	All w/T.H. 400	8623174	1	.33	GASKET, rear servo cover
65-75	All w/T.H. 400	8624139	1	3.19	PIN, rear servo piston-1 ring (3 <sup>5</sup> / <sub>16</sub> " O.L.)
65-66	Pass. w/T.H. 400,				
70-75	All w/T.H. 400	8624140	1	3.19	PIN, rear servo piston-2 rings (3 <sup>3</sup> / <sub>16</sub> " O.L.)
65-66	Pass. w/T.H. 400,				
70-75	All w/T.H. 400	8624141	1	3.19	PIN, rear servo piston-3 rings (3 <sup>7</sup> / <sub>16</sub> " O.L.)
65-75	All w/T.H. 400	8623744	1	.37	WASHER, rear servo piston

**4.242 SEAL— RING, Transmission Rear Servo**

65-75	All w/T.H. 400	8623430	1	.46	rear servo piston
69-75	All w/T.H. 350	6261139	1	1.40	intermediate clutch accumulator piston outer (aluminum)
72-73	Vega	6261138	1		trans. inter. clutch accum. piston inner
65-75	All w/T.H. 400	8623671	1	1.37	RING, rear accum. piston inner oil seal (1 <sup>5</sup> / <sub>8</sub> " O.D.)
65-71	All w/T.H. 400	8623672	1	1.24	RING, rear accum. piston outer oil seal
72-75	All w/T.H. 400	8627153	1	.78	RING, rear accum. piston outer seal (teflon)
75	All w/T.H. 250, 350	6260258	1	1.35	RING, inter. clutch accum. piston seals

**4.246 SPRING, Reverse Brake Band**

65-75	All w/T.H. 400	8623666	1	.74	rear servo
65	Pass. w/T.H. 400,				
68	Pass. w/T.H. 400 (307)	8623667	1	.86	rear servo accumulator piston
66	Pass. w/T.H. 400,				
67-69	Pass. w/T.H. 400 (327, 396),				
67-69	All w/T.H. 400 (exc. Pass., 454),				
70	All w/T.H. 400 (400, 454) (exc. H/Per.),				
70	All w/T.H. 400 (396) (exc. Sp. H/Per.),				
71-75	All w/T.H. 400 (400, 402) (exc. Police)	8624256	1	.74	rear accumulator
67-70	Pass. w/T.H. 400 (427, 454),				
70	All w/T.H. 400 (302 Sp. H/Per. 396),				
71	All w/T.H. 400 (exc. 400),				
71	Police w/T.H. 400 (400, 402),				
72	All w/T.H. 400 (454),				

**250-350-375-400 TURBO-HYDRAMATIC**

**4.246 SPRING, Reverse Brake Band (Con't)**

72	Camaro (T.H. 400 w/Sp. H/Per.) (350),				
73-75	All w/T.H. 400 .....	8624391	1	.92	rear accumulator .....

**4.247 RETAINER, Transmission Rear Servo**

65-75	All w/T.H. 400 .....	8623664	1	.46	rear servo piston spring .....
-------	----------------------	---------	---	-----	--------------------------------

**4.248 PIPE— SCREEN ASSY., Transmission Oil**

65-75	All w/T.H. 400 .....	8623157	2	1.24	governor oil .....
67-68	Pass. w/T.H.,				
67-69	All w/T.H. 400 (exc. Pass.),				
70	All w/T.H. 400 .....	8626288	1		SCREEN ASSY., trans. governor .....
69-75	All w/T.H. 350 .....	6273269	1	.33	SCREEN ASSY., gov. press (5/16" dia. x 3/4") .....
71-75	All w/T.H. 400 .....	8627509	1	.57	SCREEN ASSY., gov. .....

**4.251 BAND ASSY., Transmission Brake**

65-75	All w/T.H. 400 .....	8623123	1	12.85	trans. front. ....
65-75	All w/T.H. 400 .....	8623155	1	26.25	trans. rear .....
69-75	All w/T.H. 350 .....	6261132	1	15.05	intermediate o/run brake .....
73-75	All w/T.H. 250 .....	338929	1	10.95	inter. ....

**4.253 NUT, Brake Band Adjusting**

70-71	All .....	3840137	A.R.	.13	brake screw (7/16"— 20 x 1/4") .....
73-75	All w/T.H. 250 .....	330152	1	.87	inter. band .....

**4.256 GOVERNOR ASSY.— CAP— COVER— GASKET— GEAR UNIT— PIN— RETAINER— SEAL, Transmission**

65	Pass. w/T.H.,				
66	Pass. w/T.H. (2nd design),				
67-69	Pass. w/T.H. (exc. 427),				
68-69	Police w/T.H. ....	8623852	1	24.20	w/out stop pin .....
66	All w/T.H. (1st design) .....	8624213	1	20.85	w/stop pin .....
67-69	All w/T.H. 400,				
70	All (T.H. 400 w/H/Per.) (454),				
70	All (T.H. 400 w/4BC) (396, 400) (exc. Sp. H/Per.) .....	8625622	1	25.75	w/out stop pin .....
69-75	All w/T.H. 350 .....	6261706	1	21.95	
69	Pass. w/T.H. 400 (Sp. H/Per., H.D. 427),				
69	All w/T.H. 400, Sp. H/Per. (396) (exc. Pass.),				
70	Chevelle (T.H. 400 w/Sp. H/Per.) (454) .....	8626612	1	23.70	complete .....
70	Pass. w/T.H. 400 (400, 454) (exc. H/Per.),				
71	Pass., Chevelle w/T.H. 400 (400) (exc. Police),				
72	Pass. w/T.H. 400 (400, 402) (exc. Police),				
72	Chevelle w/T.H. 400 (402) .....	8627442	1	24.75	
71-72	Police w/T.H. 400 (400, 402),				
71-75	Pass. w/T.H. 400 (454) .....	8627441	1	24.65	
70	All w/T.H. 400 (350),				
71	Camaro w/T.H. 400 (400),				
71	Chevelle w/T.H. 400 (454) (exc. Sp. H/Per.),				
72	Camaro w/T.H. 400 (402),				
72	Chevelle w/T.H. 400 (454),				
75	Pass. w/T.H. 400,				
75	Chevelle w/T.H. 400 (3.08, 3.42 ratio) .....	8627443	1	24.70	
70	All (T.H. 400 w/Sp. H/Per.) (396),				
71	Chevelle, Camaro (T.H. 400 w/Sp. H/Per.) (350, 454),				
72-74	Camaro (T.H. 400 w/Sp. H/Per.) (350) .....	8627444	1	24.75	
75	Camaro w/Sp. H/Per., T.H. 350 ..	6261738	1	25.00	
75	All w/T.H. 350 (350) .....	370366	1	18.55	
75	Chevelle w/T.H. 400 (2.73 ratio)	8629073	1	25.45	
72-75	Vega w/T.H. 250 .....	8640000	1	21.75	trans. ....
69-75	All w/T.H. 350 .....	6261239	1	.33	CAP, thrust .....
65-75	All w/T.H. 400 .....	8623262	1	1.08	COVER, governor .....
69-75	All w/T.H. 350 .....	6261067	1	1.10	COVER, governor .....
65-75	All w/T.H. 400 .....	8623263	1	.19	GASKET, gov. cover .....



**250-350-375-400 TURBO-HYDRAMATIC**

**4.256 GOVERNOR ASSY.— CAP— COVER— GASKET— GEAR UNIT— PIN—  
RETAINER— SEAL, Transmission (Con't)**

69	All w/T.H. 350 (exc. Pass.)	6261213	1	.49	GASKET, valve body to spacer plate
65	Pass. w/T.H.,				
66-75	All w/T.H. 400 <i>NOTE 5 Contains gear 8623925.</i>	8623924	1	3.57	GEAR UNIT, w/pin, gov. driven (Note 5)
66-68	All w/T.H. <i>NOTE 6 Contains gear 8624219.</i>	8624912	1	1.32	GEAR UNIT, w/pin, gov. driven (Note 6)
69-75	All w/T.H. 350	6261660	1	.79	GEAR UNIT, driven
65-75	All w/T.H.	8623232	3	.23	PIN, governor (17/8" O.L.)
69-75	All w/T.H. 350	6260040	1	.20	RETAINER, governor cover
69-75	All w/T.H. 350	1241734	1	.26	SEAL, trans. gov. cover

**4.260 LENS ASSY., Transmission Control Pedal Rod**

Not required in this group. See  
group 10.275

		5939863	1	1.85	cover
--	--	---------	---	------	-------

**4.265 BODY ASSY.— VALVE— PLATE— SOLENOID ASSY.— BUSHING—  
PLUG— GASKET— CONNECTOR— PIN— SPACER UNIT— SPRING—  
SUPPORT— BALL— WASHER— SCREEN ASSY., Transmission Low and  
Drive Valve**

**TURBO-HYDRAMATIC**

69-70	All w/T.H. 350 (6 cyl.)	6261720	1	60.50	
69	All w/T.H. 350 (350),				
69	All w/T.H. 350 (exc. 350),				
70	Taxi (8 cyl.),				
70	All (8 cyl.) (exc. 350),				
70	All (350) (exc. 4BC, Taxi, Police),				
71-72	All (307),				
71	Monte Carlo (400),				
71	Pass.,				
72	Pass. w/T.H. 350 (400)	6261693	1	65.65	valve (Note 1)
	<i>NOTE 1 When using 6261693 in place of 6261616 or 6261613 discard new manual valve and transfer old manual valve assy. from old valve body.</i>				
70	All w/4BC (350),				
71	Nova, Chevelle, Camaro (350),				
72-75	All (350)	6261692	1	57.15	valve (Chev. built trans.)
73-74	All w/T.H. 250	330172	1	63.35	valve
74	Monte Carlo w/T.H. 350,				
75	Monte Carlo w/T.H. 350 (350, 400)	1242324	1	56.70	valve (Buick built trans.)
75	All w/T.H. 350 (6 cyl.)	6271591	1	57.15	valve
69-75	All w/T.H. 350	6261179	4	.26	BALL, oil check valve
67	Pass. (327),				
68	Pass. w/2.29 axle,				
68	Police,				
69-75	All w/T.H. 400	8625902	1	6.05	BUSHING, w/valve regulator booster
65-67	All	8623915	1	6.15	BUSHING UNIT, hydraulic mod. booster
65-75	All	8626252	1	2.17	CONNECTOR, solenoid sleeve
70-75	All w/T.H. 400	8626597	1	2.89	CONNECTOR, control switch
65-75	All	8623561	1	.72	GASKET, trans. control valve body to transfer plate
65-75	All w/T.H. 400	8623563	1	.72	GASKET, case to transfer plate upper
65-72	All w/T.H. 400	8623741	1	.20	GASKET, solenoid valve
69	All w/T.H. 350	6261212	1	.49	GASKET, valve body case to spacer plate upper
69	All w/T.H. 350	6261213	1	.49	GASKET, valve body to spacer plate lower
70-72	All w/T.H. 350	6261676	1		GASKET, valve body spacer plate (upper)
70-75	All w/T.H. 250, 350	330190	1	.57	GASKET, valve body spacer plate (lower)
65-67	All	8624483	1	.26	PIN, valve 1-2 accumulator valve slotted spring
65-75	All w/T.H. 400	8625324	1	.30	PIN, valve 3-2 valve
65-75	All w/T.H. 400	8623507	1	.30	PIN, detent reg. valve
65-75	All w/T.H. 400	8624482	2	.30	PIN, control valve body detent
65-74	All w/T.H. 400	8623078	1	.10	PIN, valve 2-3 spring retention— (4.226)
67-75	All	8625544	1	.30	PIN, valve body plug retainer (27/32" O.L.)
65	Pass. (396)	8623562	1	3.24	PLATE, valve body spacer
66-68	Pass. (427),				
69	Pass. (350, 396, 427),				
70	All (T.H. 400 w/H/Per. 454),				
70	All w/T.H. 400 (302, Sp. H/Per. 396),				
71-74	Chevelle, Camaro (T.H. 400 w/Sp. H/Per.) (350, 454)	8624461	1	4.09	PLATE, valve body spacer

250-350-375-400 TURBO-HYDRAMATIC

**4.265 BODY ASSY.— VALVE— PLATE— SOLENOID ASSY.— BUSHING— PLUG— GASKET— CONNECTOR— PIN— SPACER UNIT— SPRING— SUPPORT— BALL— WASHER— SCREEN ASSY., Transmission Low and Drive Valve (Con't)**

67-69	Pass. (327).				
72	Pass., Chevelle (454),				
72	Police (402).				
73-74	Camaro	8625663	1	4.11	PLATE, valve body spacer
67-68	All w/T.H. 400 (exc. Pass.),				
68	Police (327),				
68	Pass. (396) (exc. Police),				
69	Pass. (350, 396, 427),				
70	All w/T.H. 400 (396, 400) (exc. Sp. H/Per.),				
71-73	All w/T.H. 400 (400, 402) (exc. Police)	8625652	1	4.11	PLATE, valve body spacer
70	Pass. w/T.H. 400 (454) (exc. H/Per.)	8625899	1	4.11	PLATE, valve body spacer
69-75	All w/T.H. 350	6261679	1	6.20	PLATE ASSY., w/gasket valve body spacer
65-75	All w/T.H. 400	8623292	1	.37	PLUG, pressure regulator bore (11/16" O.D.)
74	All w/T.H. 250	330146	1	1.45	PLATE, valve body spacer plate
73-75	Pass., Chevelle	8626036	1		PLATE, valve body spacer
73-75	Vega w/T.H. 250	330145	1	1.60	PLATE, valve body spacer
74	Vega w/T.H. 350	335327	1	1.50	PLATE, valve body spacer
65-72	All w/T.H. 400	8623295	1	.36	PLUG, valve body detent valve bore
65-75	All w/T.H. 400	8623298	1	.38	PLUG, valve body 3-2 valve bore (7/16")
69-75	All w/T.H. 350	6261206	1	.33	PLUG, manual low control valve
72-74	All w/T.H. 400	8625546	1	.36	PLUG, valve body bore (9/16" O.D.)
65-75	All w/T.H. 400	1993620	1	8.70	SOLENOID ASSY.
65-75	All w/T.H. 400	8623368	A.R.	.11	SPACER UNIT, press. regulator spring
75	All w/T.H. 400	8624461	1	4.09	SPACER, plate valve body
65-66	All,				
67-68	Pass. (exc. 327),				
68	Police (327),				
67-68	All (exc. Pass.)	8623090	1	1.01	SPRING, front oil pump pressure regulator valve
67-70	Pass. w/T.H. 400,				
68	Police (327),				
71-75	All w/T.H. 400	8625648	1	1.78	SPRING, front oil pump pressure regulator valve (Note 4)
	<i>NOTE 4 Use with 2nd design Filter Assy. 6437741.</i>				
69	Pass. w/T.H. 350	6261229	1	.30	SPRING, intermediate servo piston
69-75	All w/T.H. 350	338905	1	1.10	SUPPORT, spacer plate
65-75	All w/T.H. 400	8623422	1	3.42	VALVE, pressure regulator (w/plug)
65-75	All w/T.H. 400	8623592	1	2.10	VALVE, manual control
67-68	Pass. (327, 350)	8625979	1	95.90	VALVE ASSY., oil control
	<i>NOTE 2 Must include tapped hole for strainer.</i>				
68	All (exc. H/Per. Pass.),				
68	Police (327),				
69	Camaro, Chevelle w/T.H. 400 (396) (exc. H/Per., Sp. H/Per.)	8626084	1	102.15	VALVE ASSY., oil control
68	All w/T.H. 350	6261480	1	2.83	VALVE ASSY., manual
68	Camaro w/H/Per. (396),				
65-71	All (T.H. 400 w/H/Per. 396) (exc. Pass.)	8626093	1	102.15	VALVE ASSY.
69	Pass. w/T.H. 400 (350, 396) (exc. 2BC)	8626311	1	102.15	VALVE ASSY., control
69	Pass. w/T.H. 400, Sp. H/Per. (427)	8626367	1	95.90	VALVE ASSY., control (complete)
69-70	All w/T.H. 350	6260148	1	2.63	VALVE ASSY., manual
70	Chevelle (396) (exc. H/Per., Sp. H/Per., Monte Carlo),				
70	Monte Carlo w/4BC (400)	8626762	1	113.10	VALVE ASSY., control
70	Pass. (exc. 454)	8626760	1	113.10	VALVE ASSY., control
70	All w/H/Per. (454)	8626766	1	105.85	VALVE ASSY., control
71	Pass. w/T.H. 400 (400) (exc. Police)	8627161	1	113.10	VALVE ASSY., control
71-72	Chevelle w/T.H. 400 (400, 402)	8627162	1	113.10	VALVE ASSY., control
71	Camaro w/T.H. 400 (400)	8627164	1	113.10	VALVE ASSY., control
71	Police w/T.H. 400 (400),				
71	Pass., Chevelle w/T.H. 400 (454) (exc. Sp. H/Per.)	8627166	1	105.85	VALVE ASSY., control
71-72	Chevelle, Camaro (T.H. 400 w/Sp. H/Per.) (350, 454)	8627360	1	105.75	VALVE ASSY., control
72	Pass. (400, 402) (exc. Police)	8627364	1	105.75	VALVE ASSY., control
72	Camaro (402)	8627366	1	113.10	VALVE ASSY., control

**250-350-375-400 TURBO-HYDRAMATIC**

**4.265 BODY ASSY.— VALVE— PLATE— SOLENOID ASSY.— BUSHING— PLUG— GASKET— CONNECTOR— PIN— SPACER UNIT— SPRING— SUPPORT— BALL— WASHER— SCREEN ASSY., Transmission Low and Drive Valve (Con't)**

72	Police (402),					
72	Pass. (454)	8627365	1	105.75	VALVE ASSY., control	
69-75	All w/T.H. 350	1394763	1	5.55	VALVE UNIT, trans. manual valve (Note 5)	
	<i>NOTE 5 Contains spring, link, valve, and lever.</i>					
69-75	All w/T.H. 350	3977543	1	.26	VALVE UNIT, oil cooler by-pass	
72-74	Vega w/T.H. 350	6271575	1	69.70	VALVE ASSY., trans. valve	
73-75	Vega w/T.H. 250	330171	1	60.50	VALVE ASSY., trans. valve	
73-74	All w/T.H. 250	330172	1	63.35	VALVE ASSY., valve	
74-75	Monte Carlo w/T.H. 350	1242324	1	56.70	VALVE ASSY., valve	
75	All w/T.H. 350 (6 cyl.)	6271591	1	57.15	VALVE ASSY., valve	
73	Pass. w/T.H. 375	8627633	1	105.85	VALVE ASSY., control	
73-74	Chevelle	8627655	1	105.85	VALVE ASSY., control	
73	Pass. w/T.H. 400	8627617	1	105.85	VALVE ASSY., control	
73	Camaro	8627603	1	105.85	VALVE ASSY., control	
74	Pass. w/T.H. 375	8627811	1	105.85	VALVE ASSY., control	
74	Pass. w/T.H. 400	8627807	1	105.85	VALVE ASSY., control	
74	Camaro	8627836	1	98.45	VALVE ASSY., control	
75	Chevelle (2.73 rear axle)	8629143	1	105.85	VALVE ASSY., control	
75	Chevelle (3.08 rear axle)	8629142	1	105.85	VALVE ASSY., control	
75	Pass. w/T.H. 375	8629145	1	105.85	VALVE ASSY., control	
75	Pass. w/T.H. 400	8629113	1	105.85	VALVE ASSY., control	
65-75	All w/T.H. 400	8623039	1	.23	WASHER, front oil pump pressure regulator valve spring retaining	

**4.275 SHAFT— BRACKET— CLIP— LINK— PIN— SEAL— SPRING ASSY.— WIRE, Transmission Throttle valve Operating Parts**

65-66	Pass. w/T.H.	8624972	1	6.35	shifter and "O" ring	
69-75	All w/T.H. 350	6260216	1	1.91	park lock and range sel.	
73-75	All w/T.H. 375, 400	8626935	1	5.30	w/seal trans. man.	
69-75	All w/T.H. 350	6261187	1	.20	BRACKET, detent actuator lever	
69-70	All w/T.H. 350	6260113	1	.12	CLIP, manual valve control link	
71-75	All w/T.H. 250, 350	6260155	1	.45	LINK, manual valve control	
69-75	All w/T.H. 350	6261288	1	.13	PIN, detent actuator lever	
73-75	All w/T.H. 375, 400	8623232	1	.23	PIN, manual shaft— (4.256)	
65-74	All w/T.H. 400	8621767	2	.31	SEAL, parking brake lock and range selector shaft	
66-75	All w/T.H.	8623056	1	.67	SEAL ASSY., manual shaft	
69-70	All w/T.H. 350	6261161	1	1.00	SPRING ASSY., trans. detent	
71-75	All w/T.H. 350	6260153	1	.92	SPRING ASSY., detent (3 <sup>31</sup> / <sub>32</sub> " from hole to pin)	
69-75	All w/T.H. 350	1243133	1	.39	WIRE, detent valve control	

**4.279 LEVER ASSY., Transmission Detent**

65-69	Pass. w/T.H. 400,					
67-72	Chevy, Chevelle, Camaro w/T.H. 400,					
73-75	All w/T.H. 400	8624336	1	2.62	parking brake and range selector inside detent (w/pin)	
69-75	All w/T.H. 350	6261186	1	.33	detent valve actuator	
69-70	All w/T.H. 350	6260144	1	1.00	park lock and range selector	
71-75	All w/T.H. 350	330136	1	1.50	park lock and range sel.	

**4.290 ACTUATOR ASSY.— BRACKET— RING, Transmission Parking Brake**

65-75	All w/T.H. 400	8624091	1	4.89		
69-75	All w/T.H. 350	6260224	1	2.83	park lock	
65-75	All w/T.H. 400	8623042	1	3.83		
69-75	All w/T.H. 350	1377861	1	1.05	BRACKET, park lock reaction	
69-75	All w/T.H. 350	6261347	1	.20	RING, park lock and range selector shift retainer	

**4.293 ROLLER ASSY., Transmission Reverse Shifter Crank**

65-67	All w/T.H. 400	8623617	1	1.05	w/spring, manual detent	
68-75	All w/T.H. 400	8625773	1	1.53	w/spring manual detent	

**4.294 PAWL— PLUG— SHAFT— SEAL, Transmission Parking Brake**

65-75	All w/T.H. 400	8623037	1	4.56		
69-75	All w/T.H. 350	3977619	1	.26	park, shaft and plug	
69-75	All w/T.H. 350	6261657	1	2.99	park lock (2 hole)	
72-75	All	8620318	1	.23	PLUG, park pawl shaft	
65-75	All w/T.H. 400	8624976	1	.76	SHAFT, w/plug park pawl	
72-75	All w/T.H. 350	6260216	1	1.91	SHAFT, park lock and range sel. outer	
65-66	Pass. w/T.H. 400	8623040	1	.19	SEAL, pawl shaft ("O" ring)— (4.220)	

**250-350-375-400 TURBO-HYDRAMATIC**

**4.294 PAWL— PLUG— SHAFT— SEAL, Transmission Parking Brake (Con't)**

70 All w/T.H. 400 ..... **8616504** 1 .21 SEAL, output shaft "O" ring .....

**4.295 SPRING, Transmission Parking Brake**

65-75 All w/T.H. 400 ..... **8623041** 1 .46 pawl return .....

69 All w/T.H. 350 (1st design) .... **6261145** 1 .36 lock pawl disengaging (10 coils, 1<sup>3</sup>/<sub>4</sub>" long) .....

69-75 All w/T.H. 350 (2nd design) ... **6261528** 1 .38 lock pawl disengaging (8 coils, 1" long) .....

(Note 1) (w/Chev. type trans.) .....

*NOTE 1 Use with 2nd design Pawl in group 4.294.*

72 Monte Carlo w/T.H. 350 ..... **6260253** 1 .31 park lock pawl disengaging (w/Buick type trans.) .....

**4.317 EXTENSION ASSY., Transmission Rear Main Bearing**

65-67 Pass. w/T.H. .... **8623213** 1 21.45 trans. case .....

67-70 All w/T.H. 400,

71 Pass. w/T.H. 400 (454),

71 Police w/T.H. 400 (400),

71-75 Nova, Chevelle, Camaro w/T.H.

400 ..... **8626785** 1 21.60

69-70 All w/T.H. 350,

71-75 Nova, Chevelle, Camaro w/T.H.

350 ..... **6261369** 1 20.20 w<sup>7</sup>/<sub>8</sub>" dia. speedo driven bore .....

71 Pass. w/T.H. 350 (exc. Sta.

Wag.),

72 Pass. (T.H. 350 w/2BC) (350)

(exc. Taxi, Sta. Wag.),

72-75 Pass. w/T.H. 350 (400) (exc.

Sta. Wag.) ..... **6261607** 1 20.05

71 Pass. (Sta. Wag.) w/T.H. 350

(2nd design),

72-75 Pass. (Sta. Wag.) w/T.H. 350

(350, 400) ..... **6261632** 1 24.40 (Note 1) .....

*NOTE 1 Use with Chev. type small speedometer driven gear hole (7/8" dia.).*

71 Pass. (Sta. Wag.) w/T.H. 350

(1st design) ..... **6260239** 1 24.05 (Note 2) .....

*NOTE 2 Use with Buick type large speedo. driven gear hole (2" dia.).*

71-75 Pass. w/T.H. 375, 400 w/2 BC . **8627005** 1 41.60

72 Monte Carlo w/T.H. 350 ..... **6260035** 1 16.60

w/bushing (w/2" dia. speedo driven bore . . .

72-75 Vega T.H. 250 ..... **347123** 1 19.15

trans. includes ventilator assembly

3820840 .....

75 Vega, Monza w/T.H. 350 ..... **8640021** 1 17.95

EXTENSION ASSY., w/bushing .....

73-75 Pass. w/T.H. 375, 400 w/4 BC . **8627407** 1 41.60

**4.318 GASKET— SEAL— SLEEVE, Transmission Rear Bearing Retainer**

65-75 All w/T.H. 400 ..... **8624709** 1 .30 trans. case extension to case .....

65-66 Pass. w/T.H. .... **8625892** 1 2.91 SEAL, rear bearing oil (2<sup>1</sup>/<sub>2</sub>" O.D.) .....

67-71 All w/T.H. 400,

72 Pass., Chevelle w/T.H. 400,

72-75 Camaro w/T.H. 400 (exc. 402) . . **8616504** 1 .21

SEAL, output shaft "O" ring .....

69-75 All w/T.H. 350 ..... **1358899** 1 .54

SEAL, extension to case .....

69 All w/T.H. 350 ..... **3764601** 1 .18

SEAL, O-ring output shaft yoke .....

67-75 All w/T.H. 400 ..... **8626009** 1 3.07

SEAL ASSY., ext. rear oil .....

75 Vega, Monza ..... **347123** 1 19.15

SEAL ASSY., trans. ext. to case .....

66-75 All (350) w/T.H. 350, 400 ..... **1243402** 1 2.95

SEAL ASSY., extension .....

69 All w/T.H. 350 ..... **6261062** 1 1.30

SLEEVE, output shaft yoke seal .....

**4.319 BUSHING, Transmission Rear Main Bearing**

65-66 Pass. w/T.H. 400 ..... **8619943** 1 2.64 extension .....

67-69 All w/T.H. 400,

68 Police w/T.H.,

71-75 All w/T.H. 400 ..... **8626901** 1 2.69

trans. case extension .....

69-75 All w/T.H. 350 ..... **6260048** 1 .74

extension (1<sup>1</sup>/<sub>2</sub>" I.D. x 1<sup>5</sup>/<sub>8</sub>" O.D.) .....

75 All w/T.H. 350 ..... **1602499** 2 .11

BOLT, ext. to case .....

**4.329 ADAPTER ASSY.— ADAPTER UNIT, Speedometer**

68 (For application refer to chart in group 4.337) ..... **6451928** 1 36.59

68 (For application refer to chart in group 4.337) ..... **1585657** 1 28.80

68 (For application refer to chart in group 4.337) ..... **1565452** 1 30.15

68 (For application refer to chart in group 4.337) ..... **1583624** 1 25.28

69 (For application refer to chart in group 4.337) ..... **3950348** 1 18.10

**250-350-375-400 TURBO-HYDRAMATIC**

**4.329 ADAPTER ASSY.— ADAPTER UNIT, Speedometer (Con't)**

69	(For application refer to chart in group 4.337) .....	3950350	1	18.10	
69	(For application refer to chart in group 4.337) .....	3950352	1	18.10	
69	(For application refer to chart in group 4.337) .....	3950354	1	18.10	
65-66	(For models and comb. see group 4.337) .....				ADAPTER UNIT, ratio 17.16 (stamped 1563871), .....
68	(For application refer to chart in group 4.337) .....	1565812 A.R.		26.70	(Note 2) .....
65-66	(For models and comb. see group 4.337) .....				ADAPTER UNIT, ratio 17.15 (stamped 1563872), .....
68	(For application refer to chart in group 4.337) .....	1565813 A.R.		26.70	(Note 2) .....
68	(For application refer to chart in group 4.337) .....	1565814 A.R.		28.80	ADAPTER UNIT, ratio 16.17 (stamped 1564409) (Note 2) .....
<i>NOTE 2 Above adapters used as required in combination with speedometer gears to correct odometer reading for various tire sizes, transmission and rear axle gear ratio combinations— See group 4.337.</i>					
68	(For application refer to chart in group 4.337) .....	1584275	1	28.80	ADAPTER UNIT .....
68	(For application refer to chart in group 4.337) .....	1584277	1	28.80	ADAPTER UNIT .....
69	(For application refer to chart in group 4.337) .....	3925673	1	18.10	ADAPTER UNIT .....

**4.330 KEY— CUP, Speedometer Adapter**

62-69	All .....	867209	1	1.14	(also included w/adapters 1565811-12-13-14-1580273-3876) .....
62-69	All .....	860187	1	1.88	CUP, drive (1/4"— 32 x 1 <sup>3</sup> / <sub>16</sub> " nickel bright) .....

**4.337 GEAR, Transmission Speedometer Driven Gears (only)**

65-66	Pass. w/3.36, 3.31 axle .....				(7.35 x 14), .....
65-66	Pass. w/3.55 axle .....				(7.75 x 14, 8.25 x 14, 7.75 x 15, 8.15 x 15, 8.55 x 14) (red-21 teeth), .....
65-66	Chevelle w/3.36, 3.31 axle .....				(6.95, 7.35 x 14), .....
66	Chevelle w/3.55 axle .....				(7.75 x 14), .....
62-66	Chevy w/3.31 axle .....	3987921	1	1.15	(6.95 x 14) (red— 21 teeth) .....
62-66	Chevy w/3.07, 3.08 axle .....				(6.50, 7.00 x 13, 6.95 x 14), .....
64	Chevelle w/3.08 axle (exc. Sta. Wag., El Camino) .....				(6.50 x 14), .....
64-66	Chevelle (Sta. Wag., El Camino) w/3.36 axle (6 cyl.) .....				(7.50, 7.75 x 14), .....
65-66	Pass. w/3.36, 3.31 axle .....				(7.75 x 14, 8.25 x 14, 7.75 x 15, 8.15 x 15, 8.55 x 14) (blue — 20 teeth), .....
65-66	Chevelle w/3.31 axle .....				(7.75 x 14), .....
65-66	Chevelle w/3.07, 3.08 axle .....				(6.95 x 14), .....
67	Chevy w/3.07, 3.08 axle .....	3987920	1	.98	(6.95, 7.35 x 14), .....
62-66	Chevy w/3.36 axle .....				(6.50 x 13), .....
64	Chevelle w/3.70 axle .....				(7.50 x 14), .....
65-66	Pass. w/3.55 axle .....				(7.35 x 14), .....
65-66	Pass. w/3.70, 3.73 axle .....				(7.75 x 14, 8.25 x 14, 7.75 x 15, 8.15 x 15, 8.55 x 14), .....
65-66	Chevelle w/3.70 axle .....				(7.75 x 14), .....
67	Chevy w/3.31, 3.36 axle .....	3860345	1	1.05	(6.95 x 14) (green— 22 teeth), .....
62-65	Chevy w/3.36 axle .....				(6.00 x 13), .....
62-66	Chevy w/3.55 axle .....				(6.50, 7.00 x 13, 6.95 x 14), .....
64	Chevelle w/3.70 axle .....				(7.00 x 14), .....
65-66	Pass. w/3.70 axle .....				(7.35 x 14), .....
65-66	Pass. w/3.73 axle .....				(7.35 x 14, 7.75 x 14), .....
65-66	Chevelle w/3.70 axle .....				(7.35 x 14), .....
65-66	Chevelle w/3.73 axle .....				(7.35, 7.75 x 14), .....
67	Chevy w/3.55 axle .....	3860346	1	1.10	(6.95, E70 x 14) (black— 23 teeth) .....
64	Chevelle (Sta. Wag., El Camino) w/3.08 axle (8 cyl.) (exc. S.S.), .....				(7.00, 7.50 x 14), .....
64	Chevelle w/3.08 axle (exc. Sta. Wag., El Camino) .....				(7.35 x 14, 7.75 x 14, 8.25 x 14, 8.15 x 15, 8.55 x 14), .....
65-66	Pass. w/3.07, 3.08, 3.31 axle .....				(7.35 x 14, 7.75 x 14) (natural— 19 teeth) .....
65	Chevelle w/3.07, 3.08 axle .....	3987919	1	.98	(8.25 x 14, 8.15 x 15, 8.55 x 14) (21 teeth) .....
65-66	Pass. w/4.89 axle .....	3860033	1	4.70	
65	Pass. w/2.73,				

**250-350-375-400 TURBO-HYDRAMATIC**

**4.337 GEAR, Transmission Speedometer Driven Gears (only) (Con't)**

66-67	Pass. (T.H. w/2.73) (1st design) .				(7.75 x 15, 8.25 x 14, 8.15 x 15, 8.55 x 14) (brown— 39 teeth), . . . . .
67	Camaro (T.H. w/2.73) . . . . .	1359273 A.R.	1.20		(7.00, 7.35 x 14) (Note 1) . . . . .
65-66	Pass. w/4.10 axle . . . . .				(8.25 x 14, 7.75 x 15, 8.15 x 15, 8.55 x 14) (yellow— 24 teeth), . . . . .
65-66	Chevelle w/3.70, 3.73 axle,				
66	Chevy w/3.55 axle . . . . .				(6.95 x 14), . . . . .
67	Chevy w/3.73 axle . . . . .	3860347	1	1.10	(6.95 x 14) . . . . .
65-66	Pass. w/3.08 axle . . . . .				(8.00 x 14, 6.70 x 15, 7.10 x 15, 7.75-15, 8.25-14, 8.55-14), . . . . .
65-66	Pass. w/3.07 axle . . . . .				(8.25 x 14, 8.15 x 15, 8.55 x 14), . . . . .
65	Pass. w/3.08 axle . . . . .	3987918	1	1.05	(7.75 x 15, 8.15 x 15, 8.25 x 15) (brown— 18 teeth) . . . . .
66-67	Pass. (T.H. w/2.72) (2nd design)	1359271	1	1.45	(7.75 x 8.25 x 14, 8.15 x 15, 8.55 x 14) (red— 37 teeth) (Note 1) . . . . .
66-67	Pass. (T.H. w/2.73) (1st design) .	1362048	1	1.25	(7.75 x 14) (black— 40 teeth) (Note 1) . . . . .
66-67	Pass. (T.H. w/2.73) (2nd design)				(7.75 x 14) (blue— 38 teeth) (Note 1), . . . . .
67	Chevelle (T.H. w/2.73) . . . . .	1359272 A.R.	1.20		(7.00, 7.75 x 14) . . . . .
66	Pass. (T.H. w/3.07) (1st design) .				(8.55 x 14, 8.15 x 15) (drk. gray-44 teeth) (Note 1), . . . . .
67	Camaro (T.H. w/3.07) . . . . .	9780470	1	.92	(7.00, 7.35 x 14) . . . . .
66-67	Pass. (T.H. w/3.07) (2nd design)				(8.55 x 14, 8.15 x 15, 8.45 x 15) (yellow— 41 teeth) (Note 1), . . . . .
67	Chevelle (T.H. w/3.31) . . . . .	1362195 A.R.	2.20		(7.00 x 14) . . . . .
66-67	Pass. (T.H. w/3.31) . . . . .				(7.75 x 14, 7.75 x 15, 8.25 x 14, 8.55 x 14, 8.15 x 15), . . . . .
66	Pass. (T.H. w/3.07) (1st design) .				(7.75 x 14, 7.75 x 15, 8.25 x 14) (lt. blue— 45 teeth) (Note 1), . . . . .
67	Chevelle (T.H. w/3.31) . . . . .	9775187	1	2.05	(7.75 x 14) . . . . .
66-67	Pass. (T.H. w/3.07) (2nd design)				(7.75 x 14, 7.75 x 15, 8.25 x 14) (green— 42 teeth) (Note 1), . . . . .
67	Chevelle (T.H. w/3.07) . . . . .	1362049	1	1.40	(7.75 x 14) . . . . .
67	Pass. (T.H. w/3.31 axle) . . . . .				(8.45 x 15) (purple-43 teeth) (Note 1), . . . . .
67	Chevelle (T.H. w/3.07) . . . . .	1362196 A.R.	1.55		(7.00 x 14) . . . . .
67	Pass. (T.H. w/2.73 axle) (P/Trac.) . . . . .				(8.45 x 15), . . . . .
67	Chevelle (T.H. w/2.56) . . . . .	1359270 A.R.	1.20		(7.00, 7.75 x 14) (36 teeth— white) (Note 1)
	<i>NOTE 1 Used selectively.</i>				
72-75	Vega w/2.92 rr. axle . . . . .	3987918	1	1.05	trans. speedometer driven (18 teeth) (brown) . . . . .
72-75	Vega w/3.36 rr. axle . . . . .	3987921	1	1.15	trans. speedometer driven (21 teeth) (red) . .

**250-350-375-400 TURBO-HYDRAMATIC**

**1968 PASSENGER SPEEDOMETER GEAR CHART**

*NOTE: To order Speedometer Gears or Parts, Transmission Type, Rear Axle Ratio and Tire Size must be known.*

<b>REAR AXLE RATIO</b>	<b>TIRE SIZE</b> .....	<b>4.343 GEAR, SPEEDO. DRIVE</b>	<b>4.337 GEAR, SPEEDO. DRIVEN</b>
----------------------------	------------------------	--	---

**TURBO-HYDRAMATIC TRANSMISSION**

<b>2.29</b>	8.45 x 15 .....	8623316	9780628
<b>2.29</b>	8.25 x 14, 8.55 x 14, 8.15 x 15, G70 x 15 ...	8623316	1359270
<b>2.56</b>	8.55 x 14, 8.15 x 15, 8.45 x 15, G70 x 15 ...	8623313	9774413
<b>2.56</b>	8.25 x 14 .....	8623313	9780628
<b>2.73</b>	8.45 x 15 .....	8623313	1359270
<b>2.73</b>	8.25 x 14, 8.55 x 14, 8.15 x 15, F70 x 15, G70 x 15 .....	8623313	1359271
<b>3.07</b>	8.55 x 14, 8.15 x 15, 8.45 x 15, G70 x 15 ...	8623313	1362195
<b>3.07</b>	8.25 x 14 .....	8623313	1362049
<b>3.08</b>	8.55 x 14, 8.15 x 15, 8.45 x 15, G70 x 15 ...	8623313	1362195
<b>3.08</b>	8.25 x 14, F70 x 15 ...	8623313	1362049
<b>3.31</b>	8.45 x 15 .....	8623313	1362196
<b>3.31</b>	8.25 x 14, 8.55 x 14, 8.15 x 15, G70 x 15 ...	8623313	9775187
<b>3.36</b>	8.45 x 15 .....	8623313	1362196
<b>3.36</b>	8.25 x 14, 8.55 x 14, 8.15 x 15, G70 x 15 ...	8623313	9775187

**250-350-375-400 TURBO-HYDRAMATIC**

**1968 CHEVY, CHEVELLE, CAMARO SPEEDOMETER GEAR CHART**

*NOTE: To order Speedometer Gears or Parts, Transmission Type, Rear Axle Ratio and Tire Size must be known.*

REAR AXLE RATIO	TIRE SIZE .....	4.343 GEAR, SPEEDO. DRIVE	4.337 GEAR, SPEEDO. DRIVEN	4.329 ADAPTER, SPEEDO.
-----------------------	-----------------	------------------------------------	-------------------------------------	------------------------------

**TURBO-HYDRAMATIC TRANSMISSION (396) (exc. H/Per.)**

2.56	7.75 x 14, F70 x 14, G70 x 14 .....	8623312	9774413	—
2.56	7.35 x 14, E70 x 14 .....	8623312	9780628	—
2.73	7.75 x 14, F70 x 14, G70 x 14 .....	8623312	1359270	—
2.73	7.35 x 14, E70 x 14 .....	8623312	1359271	—
3.07	7.75 x 14, G70 x 14 .....	8623312	1362048	—
3.07	F70 x 14 .....	8623312	1362195	—
3.07	7.35 x 14, E70 x 14 .....	8623312	1362049	—
3.31	7.75 x 14, G70 x 14 .....	8623312	1362196	—
3.31	F70 x 14 .....	8623312	9780470	—
3.31	7.35 x 14 E70 x 14 .....	8623312	9775187	—

**TURBO-HYDRAMATIC TRANSMISSION w/H/Per. (396)**

2.73	E70 x 14 .....	8623311	9774413	—
2.73	F70 x 14 .....	8623311	9780628	—
3.07	7.75 x 14, F70 x 14, G70 x 14 .....	8623311	1359272	—
3.07	E70 x 14 .....	8623311	1359273	—
3.31	7.75 x 14, F70 x 14, G70 x 14 .....	8623311	1362195	—
3.31	E70 x 14 .....	8623311	1362196	—
3.55	7.75 x 14, F70 x 14, G70 x 14 .....	8623311	9780470	—
3.55	E70 x 14 .....	8623311	9775187	—
3.73	7.75 x 14, F70 x 14, G70 x 14 .....	8623311	9774413	3932220
3.73	E70 x 14 .....	8623311	9780628	3932220
4.10	7.75 x 14, G70 x 14 .....	8623311	1359271	3932220
4.10	F70 x 14 .....	8623311	1359272	3932220
4.10	E70 x 14 .....	8623311	1359273	3932220
4.56	7.75 x 14, G70 x 14 .....	8623311	1362195	3932220
4.56	F70 x 14 .....	8623311	1362049	3932220
4.56	E70 x 14 .....	8623311	1362196	3932220
4.89	7.75 x 15, G70 x 14 .....	8623311	9780470	3932220
4.89	E70 x 14, F70 x 14 .....	8623311	9775187	3932220



**250-350-375-400 TURBO-HYDRAMATIC**

**1969 PASSENGER SPEEDOMETER GEAR CHART**

*NOTE: To order Speedometer Gears or Parts, Transmission Type, Rear Axie Ratio and Tire Size must be known.*

REAR AXLE RATIO	TIRE SIZE .....	4.343 GEAR, SPEEDO. DRIVE 350 TURBO- HYDRA- MATIC	4.337 GEAR, SPEEDO. DRIVEN	4.329 ADAPTER, SPEEDO.
<b>T.H. 350</b>				
2.56	7.35 x 14, 7.75 x 14, E78 x 14, F70 x 14, F78 x 14, G78 x 14 ...	6261076	3987918	—
2.56	8.25 x 14, E70 x 14, F70 x 15, G70 x 15, G78 x 15 .....	6261076	3987919	3925673
2.73	8.55 x 14, G70 x 15, G78 x 15, 8.85 x 14, 8.25 x 15, 8.55 x 15 ..	6261076	3987918	—
2.73	7.35 x 14, 7.75 x 14, 8.25 x 14, F70 x 14, F70 x 15, F78 x 14, G78 x 14 .....	6261076	3987919	—
2.73	E70 x 14, E78 x 14 .....	6261076	3987920	—
3.07	8.55 x 14, 8.85 x 14, 8.25 x 15, G70 x 15, G78 x 15 .....	6261078	3987918	—
3.07	7.35 x 14, 7.75 x 14, F70 x 14, F78 x 14, G70 x 14 .....	6261078	3987919	—
3.07	8.55 x 15 .....	6261076	3987920	—
3.07	E70 x 14, E78 x 14 .....	6261078	3987920	—
3.07	8.25 x 14, E70 x 15, F70 x 15, G78 x 14 .....	6261076	3987921	—
3.08	8.55 x 14, 8.85 x 14, 8.55 x 15, G70 x 15, G78 x 15 .....	6261078	3987918	—
3.08	7.75 x 14, F70 x 14, F78 x 14 .....	6261078	3987919	—
3.08	7.35 x 14, E70 x 14, E78 x 14 .....	6261078	3987920	—
3.08	8.25 x 14, 8.25 x 15, F70 x 15, G78 x 14 ...	6261076	3987921	—
3.31	8.55 x 15 .....	6261078	3987919	—
3.31	7.75 x 14, 8.25 x 14, 8.55 x 14, 8.85 x 14, 8.25 x 15, E70 x 15, F70 x 15, G70 x 14, G70 x 15, G78 x 14, G78 x 15 .....	6261078	3987920	—
3.31	7.35 x 14, E70 x 14, E78 x 14, F70 x 14, F78 x 14 .....	6261078	3987919	—
3.36	8.25 x 14, 8.55 x 14, 8.85 x 14, 8.25 x 15, 8.55 x 15, F70 x 15, G70 x 15, G78 x 15 ...	6261078	3987920	—
3.36	7.35 x 14, 7.75 x 14, E78 x 14, F70 x 14, F78 x 14, G78 x 14 ...	6261078	3987919	—
3.36	E70 x 14 .....	6261077	3860345	—

**250-350-375-400 TURBO-HYDRAMATIC**

REAR AXLE RATIO	TIRE SIZE .....	4.343 GEAR, SPEEDO. DRIVE 350 TURBO- HYDRA- MATIC	4.337 GEAR, SPEEDO. DRIVEN	4.329 ADAPTER, SPEEDO.
<b>T.H. 350</b>				
3.55	8.25 x 14, 8.55 x 14, 8.85 x 14, 8.25 x 15, 8.55 x 15, G70 x 15, G78 x 15 .....	6261078	3987919	—
3.55	7.35 x 14, 7.75 x 14, E70 x 15, F70 x 14, F70 x 15, F78 x 14, G70 x 14, G78 x 14 ...	6261077	3860345	—
3.55	E70 x 14, E78 x 14 .....	6261077	3860346	—
3.70	E70 x 14 .....	6261077	3860347	—
3.73	8.25 x 14, 8.55 x 14, 8.85 x 14, 8.25 x 15, 8.55 x 15, G70 x 15, G78 x 15 .....	6261077	3860345	—
3.73	E70 x 15, F70 x 14, F70 x 15, G70 x 14, G78 x 14 .....	6261077	3860346	—
3.73	E70 x 14 .....	6261077	3860347	—
4.10	F70 x 14 .....	6261794	3987919	3932220
4.10	8.55 x 14, 8.85 x 14, 8.25 x 15, 8.55 x 15, G70 x 15, G78 x 15 ...	3924097	3860347	—
4.10	8.25 x 14, G70 x 14, G78 x 14 .....	3924097	3860348	—
4.56	8.55 x 15 .....	6261794	3987919	3932220
4.56	8.25 x 14, 8.55 x 14, 8.85 x 14, G70 x 15, G78 x 14, G78 x 15 ...	6261794	3987920	3932220
4.56	8.25 x 15 .....	6261078	3987920	3932220
4.56	F70 x 14, G70 x 14 .....	6261794	3987921	3932220
4.88	8.55 x 14, 8.85 x 14, 8.25 x 15, 8.55 x 15, G70 x 15, G78 x 15 ...	6261794	3987921	3932220
4.88	8.25 x 14, F70 x 14, G70 x 14, G78 x 14 .....	3924097	3860345	3932220

**250-350-375-400 TURBO-HYDRAMATIC**

**1969 PASSENGER SPEEDOMETER GEAR CHART (Contd.)**

REAR AXLE TIRE SIZE RATIO	4.343 GEAR, SPEEDO. DRIVE	4.337 GEAR, SPEEDO. DRIVEN	4.338 SLEEVE, SPEEDO. DRIVEN GEAR
<b>TURBO HYDRAMATIC TRANSMISSION (T.H. 400) (exc. H.D., Sp. H/Per. 427)</b>			
2.294 8.55 x 14, 8.85 x 14, G70 x 15, 8.25 x 15, 8.25 x 14, G78 x 15 . . .	8623316	1359270	1485025
2.294 8.55 x 15 . . . . .	8623316	9780628	1485025
2.294 G78 x 14 . . . . .	8623316	1359271	1485025
2.56 8.55 x 15, 8.55 x 14, 8.85 x 14, G70 x 15, 8.25 x 15, G78 x 14 . . .	8623313	9774413	1485025
2.56 8.25 x 14, G78 x 14 . . . .	8623313	9780628	1485025
2.73 8.55 x 15, 8.55 x 14, 8.85 x 14, G78 x 15 . . .	8623313	1359270	1435025
2.73 G70 x 15, 8.25 x 15, 8.25 x 14, G78 x 14 . . .	8623313	1359270	1485025
2.73 F70 x 15 . . . . .	8624738	1359271	1485025
3.07 8.55 x 15 . . . . .	8623313	1362048	1485026
3.07 8.55 x 14, 8.85 x 14, G70 x 15, 8.25 x 15, G78 x 15 . . . . .	8623313	1362195	1485026
3.07 8.25 x 14, G78 x 14 . . . .	8623313	1362049	1485026
3.08 8.55 x 15 . . . . .	8623313	1362048	1485026
3.08 8.55 x 14, 8.85 x 14, G70 x 15, 8.25 x 15, G78 x 15 . . . . .	8623313	1362195	1485026
3.08 8.25 x 14, G78 x 14 . . . .	8623313	1362049	1485026
3.08 F70 x 15 . . . . .	8624738	1362049	1485026
3.30 8.55 x 15 . . . . .	8623313	1362196	1485026
3.30 8.55 x 14, 8.85 x 14, G70 x 15, 8.25 x 15, G78 x 15 . . . . .	8623313	9780470	1485026
3.30 8.25 x 14, G78 x 14 . . . .	8623313	9775187	1485026

**250-350-375-400 TURBO-HYDRAMATIC**

**1969 PASSENGER SPEEDOMETER GEAR CHART (Contd.)**

REAR AXLE RATIO	TIRE SIZE	4.343 GEAR, SPEEDO. DRIVE	4.337 GEAR, SPEEDO. DRIVEN	4.338 SLEEVE, SPEEDO. DRIVEN GEAR
<b>TURBO HYDRAMATIC TRANSMISSION (T.H. 400) (H.D. Sp. H/Per. 427)</b>				
2.73	F70 x 15	8623311	9774413	1485025
3.07	8.55 x 15, 8.55 x 14, 8.85 x 14, G78 x 15	8623311	1359270	1485025
3.07	G70 x 15, 8.25 x 15, 8.25 x 14, G78 x 14	8623311	1359271	1485025
3.08	F70 x 15	8623311	1359271	1485025
3.30	8.55 x 15	8623311	1359272	1485025
3.30	8.55 x 14, 8.85 x 14, G70 x 15, 8.25 x 15, G78 x 15	8623311	1359273	1485025
3.30	8.25 x 14, G78 x 14	8623311	1362048	1485026
3.36	F70 x 15	8623311	1362195	1485026
3.54	8.55 x 15	8623311	1362195	1485026
3.54	8.55 x 14, 8.85 x 14, G70 x 15, 8.25 x 15, G78 x 15	8623311	1362049	1485026
3.54	8.25 x 14, G78 x 14	8623311	1362196	1485026
3.72	8.55 x 15	8623311	1362196	1485026
3.72	8.55 x 14, 8.85 x 14, G70 x 15, 8.25 x 15, G78 x 15	8623311	9780470	1485026
3.72	8.25 x 14, G78 x 14	8623311	9775187	1485026
4.10	8.55 x 15	8623311	9780628	1485025
4.10	8.55 x 14, 8.85 x 14, G70 x 15, 8.25 x 15, 8.25 x 14, G78 x 15	8623311	1359270	1485025
4.10	G78 x 14	8623311	1359271	1485025
4.55	8.55 x 15, 8.55 x 14, G78 x 15	8623311	1359273	1485025
4.55	8.85 x 14, G70 x 15, 8.25 x 15, 8.25 x 14	8623311	1362048	1485026
4.55	G78 x 14	8623311	1362195	1485026
4.87	8.55 x 15, 8.55 x 14, 8.85 x 14, G70 x 15, G78 x 15	8623311	1362049	1485026
4.87	8.25 x 15, 8.25 x 14	8623311	1362196	1485026
4.87	G78 x 14	8623311	9780470	1485026

**250-350-375-400 TURBO-HYDRAMATIC**

**1969 CHEVY, CHEVELLE, CAMARO SPEEDOMETER GEAR CHART**

*NOTE: To order Speedometer Gears or Parts, Transmission Type, Rear Axle Ratio and Tire Size must be known.*

REAR AXLE RATIO	TIRE SIZE .....	4.343 GEAR, SPEEDO. DRIVE (T.H. 350)	4.337 GEAR, SPEEDO. DRIVEN	4.329 ADAPTER, SPEEDO.
<b>TURBO-HYDRAMATIC (T.H. 350)</b>				
2.73	8.25 x 14, 7.75 x 14, F70 x 14, 7.35 x 14, 5.78 x 14 .....	6261078	3987919	—
2.73	E78 x 14, E70 x 14 .....	6261078	3987920	—
3.07	8.25 x 14, E70 x 15 .....	6261076	3987921	—
3.07	7.75 x 14, G70 x 14, F70 x 14, F78 x 14 .....	6261076	3987919	—
3.07	E70 x 14 .....	6261076	3987920	—
3.08	8.25 x 14 .....	6261076	3987921	—
3.08	7.75 x 14, F70 x 14, F78 x 14 .....	6261076	3987919	—
3.08	7.35 x 14, E78 x 14, E70 x 14 .....	6261076	3987920	—
3.31	8.25 x 14, 7.75 x 14, G70 x 14, E90 x 15 .....	6261076	3987920	—
3.31	F70 x 14, F78 x 14, E70 x 14 .....	6261076	3987921	—
3.36	8.25 x 14 .....	6261076	3987920	—
3.36	7.75 x 14, F70 x 14, 7.35 x 14, E78 x 14, F78 x 14 .....	6261076	3987921	—
3.36	E70 x 14 .....	6261077	3860345	—
3.55	8.25 x 14 .....	6261076	3987921	—
3.55	7.75 x 14, G70 x 14, F70 x 14, 7.35 x 14, F78 x 14, E70 x 15 .....	6261077	3860345	—
3.55	E70 x 14 .....	6261077	3860346	—
3.70	E70 x 14 .....	6261077	3860347	—
3.73	8.25 x 14 .....	6261077	3860345	—
3.73	7.75 x 14, G70 x 14, F70 x 14, F78 x 14, E70 x 15 .....	6261077	3860346	—
3.73	E70 x 14 .....	6261077	3860347	—
2.56	8.25 x 14 .....	6261076	3987919	3925673
2.56	G78 x 14, 7.75 x 14, F70 x 14, 7.35 x 14, E78 x 14, F78 x 14 .....	6261076	3987918	—
2.56	E70 x 14 .....	6261076	3987919	—
4.10	8.55 x 14 .....	—	3860347	—
4.10	8.25 x 14, G78 x 14, 7.75 x 14, G70 x 14, E78 x 14 .....	—	3860348	—
4.10*	F70 x 14 .....	—	3987919	3932220
4.10	F70 x 14 .....	—	3987920	6476736
4.10	E70 x 14 .....	—	3987921	6476736
4.10	E70 x 15 .....	—	3860348	6476736
4.55	8.55 x 14, 8.25 x 14, G78 x 14, 7.75 x 14 .....	—	3987920	3932220
4.55*	G70 x 14, F70 x 14, F78 x 14 .....	—	3987921	3932220
4.55	F70 x 14, E70 x 15 .....	—	3860345	6476736
4.55	E70 x 15 .....	—	3860346	6476736
4.88	8.55 x 14 .....	—	3987921	3932220
4.88*	8.25 x 14, G78 x 14, 7.75 x 14, G70 x 14, F70 x 14, F78 x 14 .....	—	3860345	3932220
4.88	F70 x 14, E70 x 14 .....	—	3860347	6476736
4.88	E70 x 15 .....	—	3860346	6476736

\*NOTE: Chevelle (3-Spd., 4-Spd.)

**250-350-375-400 TURBO-HYDRAMATIC**

**1969 CHEVY, CHEVELLE, CAMARO SPEEDOMETER GEAR CHART (Contd.)**

<b>REAR</b>		<b>4.338</b>	<b>4.343</b>	<b>4.337</b>	<b>4.329</b>
<b>AXLE</b>		<b>SLEEVE</b>	<b>GEAR,</b>	<b>GEAR,</b>	<b>ADAPTER,</b>
<b>TIRE SIZE</b> .....		<b>ASSY.</b>	<b>SPEEDO.</b>	<b>SPEEDO.</b>	<b>SPEEDO.</b>
<b>RATIO</b>		<b>SPEEDO.</b>	<b>DRIVE</b>	<b>DRIVEN</b>	
Size	8623313		8623313		8623313

**TURBO-HYDRAMATIC TRANSMISSION (396) (exc. H/Per. Sp. H/Per.)**

<b>2.56</b>	F70 x 14 .....	1485025	8623312	9774413	—
<b>2.73</b>	7.75 x 14, G70 x 14, F70 x 14, F78 x 14 .....	1485025	8623312	1359270	—
<b>2.73</b>	E70 x 14 .....	1485025	8623312	1359271	—
<b>3.07</b>	7.75 x 14, G70 x 14, F78 x 14 .....	1485026	8623312	1362048	—
<b>3.07</b>	F70 x 14 .....	1485026	8623312	1362195	—
<b>3.07</b>	E70 x 14 .....	1485026	8623312	1362049	—
<b>3.31</b>	7.75 x 14, G70 x 14 .....	1485026	8623312	1362196	—
<b>3.31</b>	F70 x 14, F78 x 14 .....	1485026	8623312	9780470	—
<b>3.31</b>	E70 x 14 .....	1485026	8623312	9775187	—

**TURBO-HYDRAMATIC TRANSMISSION w/H/Per. Sp. H/Per. (396)**

<b>2.73</b>	F70 x 14 .....	1485025	8623311	9774413	—
<b>2.73</b>	E70 x 14 .....	1485025	8623311	9780628	—
<b>3.07</b>	8.55 x 14 .....	1485025	8623311	1359270	—
<b>3.07</b>	8.25 x 14, G78 x 14 .....	1485025	8623311	1359271	—
<b>3.07</b>	7.75 x 14, G70 x 14, F70 x 14, F78 x 14 .....	1485025	8623311	1359272	—
<b>3.07</b>	E70 x 14 .....	1485026	8623311	1362048	—
<b>3.31</b>	8.55 x 14 .....	1485025	8623311	1359273	—
<b>3.31</b>	8.25 x 14, G78 x 14 .....	1485026	8623311	1362048	—
<b>3.31</b>	7.75 x 14, G70 x 14, F70 x 14, F78 x 14 .....	1485026	8623311	1362195	—
<b>3.31</b>	E70 x 14 .....	1485026	8623311	1362196	—
<b>3.55</b>	8.55 x 14 .....	1485026	8623311	1362049	—
<b>3.55</b>	8.25 x 14, G78 x 14, 7.75 x 14 .....	1485026	8623311	1362196	—
<b>3.55</b>	G70 x 14, F70 x 14, F78 x 14 .....	1485026	8623311	9780470	—
<b>3.55</b>	E70 x 14 .....	1485026	8623311	9775187	—
<b>3.73</b>	8.55 x 14 .....	1485026	8623311	9780470	—
<b>3.73</b>	8.25 x 14, G78 x 14, 7.75 x 14, G70 x 14 ...	1485026	8623311	9775187	—
<b>3.73</b>	F70 x 14, F78 x 14 .....	1485025	8623311	9774413	3932220
<b>3.73</b>	E70 x 14 .....	1485025	8623311	9780628	3932220
<b>4.10</b>	8.55 x 14, 8.25 x 14 .....	1485025	8623311	1359270	3932220
<b>4.10</b>	G78 x 14, 7.75 x 14, F78 x 14 .....	1485025	8623311	1359271	3932220
<b>4.10</b>	F70 x 14 .....	1485025	8623311	1359272	3932220
<b>4.10</b>	E70 x 14 .....	1485025	8623311	1359273	3932220
<b>4.55</b>	8.55 x 14 .....	1485025	8623311	1359273	3932220
<b>4.55</b>	8.25 x 14 .....	1485026	8623311	2362048	3932220
<b>4.55</b>	G78 x 14, 7.75 x 14, G70 x 14, F78 x 14 ...	1485026	8623311	1362195	3932220
<b>4.55</b>	F70 x 14 .....	1485026	8623311	1362049	3932220
<b>4.55</b>	E70 x 14 .....	1485026	8623311	1362196	3932220
<b>4.88</b>	8.55 x 14 .....	1485026	8623311	1362049	3932220
<b>4.88</b>	8.25 x 14 .....	1485026	8623311	1362196	3932220
<b>4.88</b>	G78 x 14, 7.75 x 14, G70 x 14, F78 x 14 ...	1485026	8623311	9780470	3932220
<b>4.88</b>	F70 x 14, E70 x 14 .....	1485026	8623311	9775187	3932220

**250-350-375-400 TURBO-HYDRAMATIC**

**1970 PASSENGER, NOVA, CHEVELLE, CAMARO SPEEDOMETER GEAR CHART**

REAR AXLE RATIO	REAR TIRE SIZE	4.337 GEAR, SPEEDO. DRIVEN	4.343 GEAR, SPEEDO. DRIVE	4.329 ADAPTER, SPEEDO.
<b>ALL w/TURBO-HYDRAMATIC TRANSMISSION (T.H. 350) (exc. TAXI, POLICE, CAMARO)</b>				
2.56	E70 x 14, F70 x 14, E78 x 14, F78 x 14, G78 x 14, 7.35 x 14, 7.75 x 14	3987920	6261785	—
2.56	G70 x 15, F78 x 15, G78 x 15, H78 x 15, H70 x 15, 8.25 x 15, 8.25 x 14	3987919	6261785	—
2.73	F70 x 14, F78 x 14, G78 x 14, F78 x 15, 7.75 x 14, 8.25 x 14	3987921	6261785	—
2.73	E78 x 14, 7.35 x 14	3974422	6261785	—
2.73	G70 x 15, G78 x 15, H78 x 15, 8.25 x 15	3987920	6261785	—
3.07	E70 x 14, F70 x 14, F78 x 14	3987920	6261785	3950352
3.07	G78 x 14, 8.25 x 14	3987919	6261785	3950352
3.08	F70 x 14, F78 x 14	3987920	6261785	3950352
3.08	G78 x 14, 8.25 x 14	3987919	6261785	3950352
3.31	E70 x 14, E78 x 14, 7.35 x 14	3987919	6261785	3932220
3.36	F70 x 14, F78 x 14, G78 x 14, F78 x 15, 7.75 x 14	3987921	6261785	3950352
3.31	G70 x 15, H70 x 15, H78 x 15	3987920	6261785	3950352
3.31	G78 x 15, 8.25 x 14, 8.25 x 15	3987918	6261785	3932220
3.36	E70 x 14, E78 x 14, 7.35 x 14	3974422	6261785	3950352

REAR AXLE RATIO	REAR TIRE SIZE	4.337 GEAR, SPEEDO. DRIVEN	4.343 GEAR, SPEEDO. DRIVE	4.329 ADAPTER, SPEEDO.	4.330 KEY, SPEEDO. ADAPTER
<b>CAMARO w/TURBO-HYDRAMATIC TRANSMISSION (T.H. 350)</b>					
2.56	F70 x 14, E78 x 14, 7.35 x 14	3987920	6261785	—	—
3.07	F70 x 14	3987920	6261785	6477965	867209
3.07	F70 x 15	3987919	6261785	6477965	867209
3.31	F70 x 14	3987919	6261785	6477964	867209
3.31	E78 x 14, 7.35 x 14	3974422	6261785	6477965	867209
3.31	F70 x 15	3987921	6261785	6477965	867209
3.36	F70 x 14	3987919	6261785	6477964	867209
3.36	E78 x 14, 7.35 x 14	3974422	6261785	6477965	867209

**250-350-375-400 TURBO-HYDRAMATIC**

REAR AXLE RATIO	REAR TIRE SIZE .....	4.337	4.343	4.338	4.329
		GEAR, SPEEDO. DRIVEN	GEAR, SPEEDO. DRIVE	SLEEVE, SPEEDO. DRIVEN GEAR	ADAPTER, SPEEDO.
<b>NOVA, CHEVELLE w/TURBO-HYDRAMATIC TRANSMISSION (T.H. 400) (H/PER. 396, SP. H/PER. 396, 454)</b>					
2.73	F70 x 15 .....	9774413	8623311	1362294	—
3.08	F70 x 15 .....	1359271	8623311	1362294	—
3.31	E70 x 14 .....	1362049	8623311	1362293	—
3.31	F70 x 14, G70 x 14 .....	1362195	8623311	1362293	—
3.36	F70 x 15 .....	1362195	8623311	1362293	—
3.55	E70 x 14 .....	9775187	8623311	1362293	—
3.55	F70 x 14, G70 x 14 .....	9780470	8623311	1362293	—
4.10	F70 x 14 .....	1362049	8623311	1362293	3950352
4.10	G70 x 14 .....	1359271	8623311	1362294	3932220

REAR AXLE RATIO	REAR TIRE SIZE .....	4.337	4.343	4.338	4.329	4.330
		GEAR, SPEEDO. DRIVEN	GEAR, SPEEDO. DRIVE	SLEEVE, SPEEDO. DRIVEN GEAR	ADAPTER, SPEEDO.	KEY, SPEEDO. ADAPTER
<b>CAMARO w/TURBO-HYDRAMATIC TRANSMISSION (T.H. 400) (302, 396)</b>						
3.31	F70 x 14 .....	1362195	8623311	1362293	—	—
3.31	F60 x 15 .....	1362049	8623311	1362293	—	—
3.31	F70 x 15 .....	1362048	8623311	1362293	—	—
3.55	F70 x 14 .....	9780470	8623311	1362293	—	—
3.55	F60 x 15 .....	9775187	8623311	1362293	—	—
3.55	F70 x 15 .....	1362196	8623311	1362293	—	—
3.73	F60 x 15 .....	1359273	8623311	1362294	6477965	867209
4.10	F70 x 14 .....	1359271	8623311	1362294	6477964	867209
4.10	F60 x 15 .....	1359272	8623311	1362294	6477964	867209
4.10	F70 x 15 .....	1362049	8623311	1362293	6477965	867209



**250-350-375-400 TURBO-HYDRAMATIC**

**1970 PASSENGER, NOVA, CHEVELLE, CAMARO SPEEDOMETER GEAR CHART (Contd.)**

REAR AXLE RATIO	REAR TIRE SIZE	4.337 GEAR, SPEEDO. DRIVEN	4.343 GEAR, SPEEDO. DRIVE w/T.H. 350 (EXC. POLICE w/8 CYL.)	4.343 GEAR, SPEEDO. DRIVE w/T.H. 350 (8 CYL.)	4.329 ADAPTER, SPEEDO.
-----------------	----------------	-------------------------------	--	--	---------------------------

**POLICE AND TAXI**

2.73	F78 x 15	3987920	6261435	6261078	3950348
2.73	G78 x 15, G70 x 15, H78 x 15	3987919	6261435	6261078	3950348
3.07	G70 x 15, G78 x 15, H78 x 15	3987918	6261435	6261078	—
3.07	F78 x 15	3987919	6261435	6261078	—
3.31	G70 x 15, F78 x 15, G78 x 15	3987920	6261435	6261078	—
3.31	H78 x 15	3987919	6261435	6261078	—

REAR AXLE RATIO	REAR TIRE SIZE	4.337 GEAR, SPEEDO. DRIVEN	4.343 GEAR, SPEEDO. DRIVE	4.338 SLEEVE, SPEEDO. DRIVEN GEAR	4.329 ADAPTER, SPEEDO.
-----------------	----------------	-------------------------------	------------------------------	--------------------------------------	---------------------------

**PASSENGER, CHEVELLE w/TURBO-HYDRAMATIC TRANSMISSION (T.H. 400)**

**(350, 400 w/2BC, 454)**

2.56	G78 x 15, H78 x 15, H70 x 15, 8.25 x 15	9774413	8623313	1362294	—
2.73	F70 x 15, 8.25 x 15	1359271	8623313	1362294	—
2.73	H78 x 15, H70 x 15	1359270	8623313	1362294	—
3.07	H78 x 15, H70 x 15	1362048	8623313	1362293	—
3.07	8.25 x 15	1362195	8623313	1362293	—
3.08	F70 x 15	1362049	8623313	1362293	—
3.31	F70 x 14	1359272	8623313	1362294	3950352
3.31	G70 x 14	9775187	8623313	1362293	—
3.31	G70 x 15, H70 x 15, 8.25 x 15	9780470	8623313	1362293	—
3.31	H78 x 15	1362196	8623313	1362293	—
3.36	F70 x 15	9775187	8623313	1362293	—

**CHEVELLE w/TURBO-HYDRAMATIC TRANSMISSION (T.H. 400) (400 w/4/BC)**

3.31	F70 x 14, F78 x 14	9780470	8623312	1362293	—
3.31	G78 x 14, 7.75 x 14	1362196	8623312	1362293	—
3.31	G70 x 15	1362195	8623312	1362293	—
3.31	G78 x 15	1362049	8623312	1362293	—
3.31	7.35 x 14	9775187	8623312	1362293	—
3.31	8.25 x 14	1362049	8623312	1362293	—

**250-350-375-400 TURBO-HYDRAMATIC**

**1971 SPEEDOMETER GEAR CHART (T.H. 350)**

**DRIVE GEARS**

PART NUMBER	COLOR	NUMBER OF TEETH
-------------	-------	-----------------

**DRIVE GEARS**

6260037	Green	18
6261785	Purple	10

**DRIVEN GEARS**

1359273	Brown	39
1362196	Purple	43
3987919	Natural	19
3987920	Blue	20
3987921	Red	21
3987922	Silver	22
9780628	Pink	35

*NOTE: To order speedometer gears and parts, transmission type, rear axle ratio and tire size must be known.*

**1971 T.H. 350 (exc. Camaro)**

REAR AXLE RATIO	REAR TIRE SIZE	4.337 GEAR SPEEDO. DRIVEN	4.343 GEAR SPEEDO. DRIVE	4.329 ADAPTER ASSY.
2.563	E70-14, E78-14, F78-14, G78-14	3987920	6261785	—
2.733	F78-14, G78-14, F78-15	3987921	6261785	—
2.733	E78-14	3987922	6261785	—
2.733	G70-15, G78-15, H78-15	3987920	6261785	—
2.733	L78-15	3987919	6261785	—
3.071	E70-14	3987920	6261785	3950352
3.083	G78-14, F78-15, G78-15	3987919	6261785	3950352
3.083	E78-14, F78-14	3987920	6261785	3950352
3.083	H78-15, L78-15	3987922	6261785	—
3.308	E70-14, E78-14	3987922	6261785	3950352
3.308	F78-14, G78-14	3987921	6261785	3950352
3.308	G70-15, G78-15	3987920	6261785	3950352
3.364	E70-14, E78-14	3987922	6261785	3950352
3.417	G78-14, F78-15, G78-15	3987921	6261785	3950352
3.417	H78-15, L78-15	3987920	6261785	3950352

**1971 T.H. 350 CAMARO**

REAR AXLE RATIO	REAR TIRE SIZE	4.337 GEAR SPEEDO. DRIVEN	4.343 GEAR SPEEDO. DRIVE	4.329 ADAPTER ASSY.	4.330 KEY SPEEDO. ADAPTER
2.733	E78-14	3987922	6261785	—	—
2.733	F70-14, F78-14	3987921	6261785	—	—
3.083	F70-14	3987920	6261785	6477965	867209
3.417	E78-14	3987920	6261785	6477964	867209
3.417	F78-14, F70-14	3987922	6261785	6477965	867209

**250-350-375-400 TURBO-HYDRAMATIC**

**1971 PASS. (STA. WAG.) TH350 (W/2" SPEEDO. DRIVEN GEAR HOLE)**

REAR AXLE RATIO	REAR TIRE SIZE	4.337 GEAR SPEEDO. DRIVEN	4.343 GEAR SPEEDO. DRIVE	4.338 SLEEVE SPEEDO. DRIVEN GEAR
2733	L78-15	9780628	6260037	1362284
3083	L78-15	1359273	6260037	1362284
3417	L78-15	1362196	6260037	1362285

**1971 T.H. 400 DRIVE GEARS**

PART NUMBER	COLOR	NUMBER OF TEETH
8623311	Orange	16
8623313	Yellow	18

**DRIVEN GEARS**

9780628	Pink	35
1359270	White	36
1359271	Red	37
1359272	Blue	38
1359273	Brown	39
1362048	Black	40
1362195	Yellow	41
1362049	Green	42
1362196	Purple	43
9780470	Dark Gray	44
9775187	Light Blue	45

*NOTE: To order speedometer gears, and parts, transmission type, rear axle ratio and tire size must be known.*

**250-350-375-400 TURBO-HYDRAMATIC**

**1971 SPEEDOMETER GEAR CHART (Contd.)**

**T.H. 400 (w/400, 454) (exc. Sp. H/Per., Camaro)**

REAR AXLE RATIO	REAR TIRE SIZE	4.337 GEAR SPEEDO. DRIVEN	4.343 GEAR SPEEDO. DRIVE	4.329 ADAPTER ASSY.	4.338 SLEEVE DRIVEN GEAR
2.733	G78-14, F78-15, G70-15, G78-15	1359271	8623313	—	1362294
2.733	F78-14	1359272	8623313	—	1362294
2.733	H78-15	1359270	8623313	—	1362294
2.733	L78-15	9780628	8623313	—	1362294
3.083	F78-15	1362049	8623313	—	1362293
3.083	G78-15	1362195	8623313	—	1362293
3.083	H78-15	1362048	8623313	—	1362293
3.083	L78-15	1359273	8623313	—	1362294
3.308	F78-14	1359272	8623313	3950352	1362294
3.308	G78-14	9775187	8623313	—	1362293
3.308	F60-15	1359273	8623313	3950352	1362294
3.308	G70-15	9780470	8623313	—	1362293
3.417	F78-15	1359272	8623313	3950352	1362294
3.417	G78-15, H78-15	9775187	8623313	—	1362293
3.417	L78-15	1362196	8623313	—	1362293

**1971 T.H. 400 (w/Sp. H/Per.) (454)**

REAR AXLE RATIO	REAR TIRE SIZE	4.337 GEAR SPEEDO. DRIVEN	4.343 GEAR SPEEDO. DRIVE	4.329 ADAPTER ASSY.	4.338 SLEEVE DRIVE GEAR
3.308	F60-15	1362049	8623311	—	1362293
3.308	G70-15	1359273	8623311	—	1362294
4.100	F60-15	1362049	8623311	3950352	1362293

**1971 T.H. 400 CAMARO**

REAR AXLE RATIO	REAR TIRE SIZE	4.337 GEAR SPEEDO. DRIVEN	4.343 GEAR SPEEDO. DRIVE	4.329 ADAPTER ASSY.	4.338 SLEEVE DRIVEN GEAR	4.330 KEY SPEEDO. ADAPTER
3.417	F70-14	1362049	8623311	—	1362293	—
3.727	F60-15	1359273	8623311	6477965	1362294	867209
4.100	F60-15	1362196	8623311	6477965	1362293	867209

**250-350-375-400 TURBO-HYDRAMATIC**

**1972 SPEEDOMETER GEAR CHART (T.H. 350)**

**DRIVE GEARS**

PART NUMBER	COLOR	NUMBER OF TEETH
6260037	Green	18
6261785	Purple	10

**DRIVEN GEARS**

1359271	Red	37
1362049	Green	42
3987918	Brown	18
3987919	Natural	19
3987920	Blue	20
3987921	Red	21
3987922	Solid Silver	22
9774413	Light Green	34
9775187	Light Blue	45

*NOTE To order speedometer gears & parts, transmission type, rear axle ratio, & tire size must be known.*

**1972 T.H. 350 (EXC. CAMARO, MONTE CARLO)**

**T.H. 350 (1st Design Monte Carlo)**

**(With 7/8" Speedo Driven Gear Hole)**

REAR AXLE RATIO	REAR TIRE SIZE	GEAR SPEEDO. DRIVEN	GEAR SPEEDO. DRIVE	ADAPTER ASSY.	SLEEVE DRIVEN GEAR
2.733	E78-14, F60-15, E70-14	3987922	6261785	—	3869912
2.733	F78-14, G78-14, F78-15	3987921	6261785	—	3869912
2.733	G70-15, G78-15, H78-15, 8:55-15	3987920	6261785	—	3869912
2.733	L78-15	3987919	6261785	—	3869912
3.083	E78-14, F78-14, F60-15, E70-14	3987920	6261785	3950352	3869912
3.083	G78-14, G78-15, F78-15, 8:55-15	3987919	6261785	3950352	3869912
3.083	H78-15, L78-15	3987922	6161785	—	3869912
3.417	E78-14, F78-14, G78-14, F60-15, E70-14	3987922	6261785	3950352	3869912
3.417	G70-15, G78-15, H78-15, F78-15, 8:55-15	3987921	6261785	3950352	3869912
3.417	L78-15	3987920	6261785	3950352	3869912

**1972 T.H. 350**

**(2nd Design Monte Carlo)**

**(w/2" Buick Type Speedo Driven Gear Hole)**

REAR AXLE RATIO	TIRE SIZE	GEAR SPEEDO. DRIVEN	GEAR SPEEDO. DRIVE	ADAPTER ASSY.	SLEEVE DRIVEN GEAR
2.733	G70-15, G78-15	1359271	6260037	—	1362284
3.083	G70-15, G70-15	1362049	6260037	—	1362285
3.308	G70-15, G78-15	9775187	6260037	—	1362285
3.364	G70-15, G78-15	9775187	6260037	—	1362285
3.417	G70-15, G78-15	9774413	6260037	3932220	1362284

**250-350-375-400 TURBO-HYDRAMATIC**

**1972 CAMARO T.H. 350**

REAR AXLE RATIO REAR TIRE SIZE .....	GEAR SPEEDO. DRIVEN	GEAR SPEEDO. DRIVE	ADAPTER ASSY.	SLEEVE DRIVEN GEAR
2.733 E78-14, F60-15 .....	3987922	6261785	—	3869912
2.733 F70-14 .....	3987921	6261785	—	3869912
3.083 E78-14, F60-15 .....	3987918	6261785	6477964	3869912
3.083 F70-14 .....	3987920	6261785	6477965	3869912
3.417 E78-14, F60-15 .....	3987920	6261785	6477964	3869912
3.417 F70-14 .....	3987922	6261785	6477965	3869912

**1972 SPEEDOMETER GEAR CHART (T.H. 400)**

**DRIVE GEARS**

PART NUMBER	COLOR	NUMBER OF TEETH
8623313	Steel-Yellow	18

**DRIVEN GEARS**

1359270	White	36
1359271	Red	37
1359272	Blue	38
1359273	Brown	39
1362048	Black	40
1362049	Green	42
1362195	Yellow	41
1362196	Purple	43
9775187	Light Blue	45
9780470	Dark Gray	44
9780628	Pink	35

*NOTE To order speedometer gears & parts, transmission type, rear axle ratio, & tire size must be known.*

**1972 CAMARO T.H. 400**

REAR AXLE RATIO REAR TIRE SIZE .....	GEAR SPEEDO. DRIVEN	GEAR SPEEDO. DRIVE	ADAPTER ASSY.	SLEEVE DRIVEN GEAR
3.417 E78-14, F60-15 .....	1359270	8623313	6477964	1362294
3.417 F70-14 .....	1362048	8623313	6477965	1362293
3.727 E78-14, F60-15 .....	1359273	8623313	6477964	1362294
3.727 F70-14 .....	9780470	8623313	6477965	1362293
4.100 E78-14, F60-15 .....	1362196	8623313	6477964	1362293
4.100 F70-14 .....	1362049	8623313	6477964	1362293

**1972 PASS., CHEVELLE T.H. 400**

REAR AXLE RATIO REAR TIRE SIZE .....	GEAR SPEEDO. DRIVEN	GEAR SPEEDO. DRIVE	ADAPTER ASSY.	SLEEVE DRIVEN GEAR
2.733 E78-14, F60-15 .....	1359273	8623313	—	1362294
2.733 F78-14, G78-14, G70-15, G78-15 .....	1359272	8623313	—	1362294
2.733 F78-15 .....	1359271	8623313	—	1362294
2.733 H78-15, 8:55-15 .....	1359270	8623313	—	1362294
2.733 L78-15 .....	9780628	8623313	—	1362294
3.083 E78-14, F60-15 .....	9780470	8623313	—	1362293
3.083 F78-14, G78-14, G70-15 .....	1362196	8623313	—	1362293
3.083 F78-15 .....	1362049	8623313	—	1362293
3.083 G78-15, 8:55-15 .....	1362195	8623313	—	1362293
3.083 H78-15 .....	1362048	8623313	—	1362293
3.083 L78-15 .....	1359273	8623313	—	1362294

**250-350-375-400 TURBO-HYDRAMATIC**

**4.337 GEAR, Transmission Speedometer Driven Gears (only) (Con't)**

<b>3.308</b>	E78-14, F60-15, F78-14, F70-14 .....	1359273	8623313	3950352	1362294
<b>3.308</b>	G78-14, G70-15 .....	1359272	8623313	3950352	1362294
<b>3.308</b>	F78-15 .....	9775187	8623313	—	1362293
<b>3.308</b>	G78-15, 8:55-15 .....	9780470	8623313	—	1362293
<b>3.308</b>	H78-15 .....	1362196	8623313	—	1362293
<b>3.308</b>	L78-15 .....	1362049	8623313	—	1362293
<b>3.417</b>	E78-14, F70-14, F60-15 .	1362048	8623313	3950352	1362293
<b>3.417</b>	F78-14, G78-14, F78-15	1359273	8623313	3950352	1362294
<b>3.417</b>	G70-15, 8:55-15, G78- 15, H78-15 .....	9775187	8623313	—	1362293
<b>3.417</b>	L78-15 .....	1362196	8623313	—	1362293

**250-350-375-400 TURBO-HYDRAMATIC**

**1973 Pass. TH-350**

Code	Driven Gear		Sleeve Assy.	Code	Adapter
A	3987921	21T	345215	E	3950354
B	3987920	20T	345215	F	3932220
C	3987919	19T	345215	G	3950352
D	3987922	22T	345215		

Tire Size	3.73 Drive Gear 6261785#		3.08 Drive Gear 6261785#		3.42 Drive Gear 6261785#	
G78-15 H78-15	Driven A B	Adapt — —	Driven C D	Adapt G E	Driven C A	Adapt F G

#purple 10 tooth.

**1973 Chevelle w/TH 250, 350 (Exc. Monte Carlo)**

Code	Driven Gear		Sleeve Assy.	Code	Adapter
A	3987921	21T	345215	E	3950354
B	3987920	20T	345215	F	3950352
C	3987922	22T	345215	G	3932220
D	3987919	19T	345215	H	6273218

Tire Size	2.73 Drive Gear 6261785#		3.08 Drive Gear 6261782*		3.42 Drive Gear 6261782*	
G70-14 G78-14 H78-14 E78-14	Driven A A B —	Adapt — — E —	Driven — A — C	Adapt — E — —	Driven — — D —	Adapt — — F —

Tire Size	3.08 Drive Gear 6261785#		3.42 Drive Gear 6261785#	
G70-14 G78-14 H78-14 E78-14	Driven A A D —	Adapt H H F —	Driven C C D —	Adapt F F G —

\* Green 9 Tooth  
# Purple 10 Tooth

**1973 MONTE CARLO w/TH 350**

Code	Driven Gear		Sleeve Assy.
A	9780628	35T	1362284
B	1362048	40T	1362285
C	1359273	39T	1362284
D	9780470	44T	1362285

Tire Size	2.73 Drive Gear 6260037*		3.08 Drive Gear 6260037*		3.42 Drive Gear 6260037*	
GR70-15 G78-15	Driven A A	Adapt — —	Driven B C	Adapt — —	Driven D D	Adapt — —



**250-350-375-400 TURBO-HYDRAMATIC**

**4.337 GEAR, Transmission Speedometer Driven Gears (only) (Con't)**

*\*18 Tooth Green*

**1973 NOVA w/TH 250, 350**

Code	Driven Gear		Sleeve Assy.	Code	Adapter
A	3987920	20T	345215	E	3932220
B	3987922	22T	345215		
C	3987918	18T	345215		

Tire Size	2.73 Drive Gear 6261782*		2.73 Drive Gear 6261785#		3.08 Drive Gear 6261785#		3.42 Drive Gear 6261785#	
E78-14	Driven A	Adapt —	Driven B	Adapt —	Driven C	Adapt E	Driven A	Adapt E
E70-14	A	—	B	—	C	E	A	E

*\* Green 9 Tooth  
# Purple 10 Tooth*

**1973 CAMARO w/TH 250, 350**

Code	Driven Gear		Sleeve Assy.	Code	Driven Gear		Sleeve Assy.	Code	Adapter
A	6258100	22T	3869912	E	3987918	18T	3869912	F	326569
B	6258100	21T	3869912					G	330192
C	6258100	20T	3869912					H	332537
D	6258100	19T	3869912						

Tire Size	2.73 Drive Gear 6261785#		2.73 Drive Gear 6261782*		3.08 Drive Gear 6261785#		3.42 Drive Gear 6261785#	
E78-14	Driven A	Adapt —	Driven C	Adapt —	Driven E	Adapt G	Driven C	Adapt G
F70-14	B	F	D	—	E	G	C	G
GR70-14	B	—	—	—	C	H	A	H

*# Purple 10 Tooth  
\* Green 9 Tooth*

**1973 PASS. TH 375, 400**

Code	Driven Gear		Sleeve Assy.	Code	Driven Gear		Sleeve Assy.	Code	Adapter
A	1359271	37T	1362294	F	1359273	39T	1362294	J	3932220
B	1359270	36T	1362294	G	9774413	34T	1362294		
C	9780628	35T	1362294	H	9775187	45T	1362293		
D	1362049	42T	1362293	I	9780470	44T	1362293		
E	1362195	41T	1362293						

Tire Size	2.73 Drive Gear 8623313		3.08 Drive Gear 8623313		3.42 Drive Gear 8623313	
G78-15	Driven A	Adapt —	Driven D	Adapt —	Driven G	Adapt J
H78-15	B	—	E	—	H	—
L78-15	C	—	F	—	I	—

**250-350-375-400 TURBO-HYDRAMATIC**

**1973 CHEVELLE TH 400**

Code	Driven Gear		Sleeve Assy.
A	1359270	36T	1362294
B	9780628	35T	1362294
C	9775187	45T	1362293
D	1362196	43T	1362293
E	9780470	44T	1362293

Tire Size	2.73 Drive Gear 8623312		3.42 Drive Gear 8623312	
	Driven	Adapt	Driven	Adapt
G70-14	A	—	C	—
G78-14	A	—	C	—
H78-14	B	—	D	—
GR70-15	B	—	E	—
G78-15	B	—	E	—

**1973 CAMARO TH 400**

Code	Driven Gear		Sleeve Assy.
A	1362195	41T	1362293
B	9775187	45T	1362293

Tire Size	3.42 Drive Gear 8624735		3.73 Drive Gear 8624735	
	Driven	Adapt	Driven	Adapt
F60-15	A	—	B	—

**1974 Pass. w/TH 350**

Code	Driven Gear	Teeth	Color	Code	Adapter	Code	Sleeve Assy.
A	3987919	19	Natural	E	3950354	H	345215
B	3987920	20	Blue	F	3950352	I	345213
C	3987921	21	Red	G			
D	3987922	22	Silver				

Tire Size	2.73 Drive Ratio Gear 6261785*			3.08 Drive Ratio Gear 6261785*			3.42 Drive Ratio Gear 6261785*		
	Driven	Adapter	Sleeve	Driven	Adapter	Sleeve	Driven	Adapter	Sleeve
G78-15	C	—	H	A	F	I	C	F	I
H78-15	B	—	H	D	E	I	C	F	I
L78-15	—	—	—	D	—	H	B	F	I
HR78-15	B	—	H	D	E	I	C	F	I
LR78-15	—	—	—	D	—	H	B	F	I

\*Purple 10 Tooth.

**250-350-375-400 TURBO-HYDRAMATIC**

**1974 NOVA w/TH 250, 350**

Code	Driven Gear	Teeth	Color	Code	Adapter	Code	Sleeve Assy.
A	3987920	20	Blue	D	3932220	E	345215
B	3987922	22	Silver				
C	3987918	18	Brown				

Tire Size	2.73 Ratio Driven Gear 6261785 #			3.08 Ratio Driven Gear 6261782*		
E78-14 E70-14	Driven B B	Adapt — —	Sleeve E E	Driven B B	Adapt — —	Sleeve E E

Tire Size	3.08 Ratio Driven Gear 6261785 #			3.42 Ratio Driven Gear 6261785 #		
E78-14 E70-14	Driven C C	Adapt D D	Sleeve E E	Driven A A	Adapt D D	Sleeve E E

#purple 10 tooth.  
\*green 9 tooth.

**1974 Camaro w/TH 250, 350**

Code	Driven Gear	Teeth	Color	Code	Driven Gear	Teeth	Color
A	3927922	22	Silver	D	3997919	19	Natural
B	3987921	21	Red	E	3987918	18	Brown
C	3987922	20	Blue				

Code	Adapter	Code	Sleeve
F	326569	I	345215
G	330192	J	345215
H	332537		

Tire Size	2.73 Ratio Driven Gear 6261785 #			3.08 Ratio Driven Gear 6261782*		
E78-14 F70-14 FR78-14	Driven A B A	Adapt — I F —	Sleeve A J I	Driven — — A	Adapt I — —	Sleeve — — I

Tire Size	3.08 Ratio Driven Gear 6261785 #			3.42 Ratio Driven Gear 6261785 #		
E78-14 F70-14 FR78-14	Driven E E E	Adapt G G G	Sleeve J J J	Driven C A C	Adapt G H G	Sleeve J J J

#purple 10 tooth.  
\*green 9 tooth.

**250-350-375-400 TURBO-HYDRAMATIC**

**1974 Chevelle with 250, 350 (exc. Monte Carlo)**

Code	Driven Gear	Teeth	Color	Code	Adapter	Code	Sleeve Assy.
A	3987921	21	Red	G	3950354	K	345215
B	3987920	20	Blue	H	3950352		
C	3987922	22	Silver	I	3932220		
D	3987919	19	Natural	J	6273218		
E	9775187	45	Lt. Blue				
F	1362196	43	Purple				

Tire Size	2.73 Drive	Ratio Gear 6261785†		3.08 Drive	Ratio Gear 6261782*		3.42 Drive	Ratio Gear 6261782*	
	Driven	Adapt	Sleeve	Driven	Adapt	Sleeve	Driven	Adapt	Sleeve
G70-14	A	—	K	—	—	—	—	—	—
G70-14	A	—	K	A	G	K	—	—	—
G78-14	A	—	K	A	—	K	—	—	—
H78-14	B	G	K	A	—	K	D	H	K
E78-14	—	—	K	C	—	K	—	—	—

Tire Size	3.08 Ratio Drive Gear 6261785†			3.42 Ratio Drive Gear 6261785†		
	Driven	Adapt	Sleeve	Driven	Adapt	Sleeve
G70-14	—	—	—	—	—	—
G70-14	A	J	K	C	H	K
G78-14	A	J	K	C	H	K
H78-14	D	H	K	D	I	K
E78-14	—	—	—	—	—	—

†Purple 10 tooth.  
\*green 9 tooth.

**1974 Monte Carlo with/TH 350**

Code	Driven Gear	Teeth	Color	Code	Sleeve Assy.
A	9780628	35	Pink	F	1362285
B	1362048	40	Black	G	1362284
C	1359273	39	Brown		
D	9780470	44	Dk. Gray		

Tire Size	2.73 Drive	Ratio Gear 6260037*		3.08 Drive	Ratio Gear 6260037*		3.42 Drive	Ratio Gear 6260037*	
	Driven	Adapter	Sleeve	Driven	Adapter	Sleeve	Driven	Adapter	Sleeve
GR70-15	A	—	G	G	—	—	D	—	F
G78-15	A	—	G	D	—	G	D	—	F

\*18 Tooth Green

**1974 Pass. w/TH 375, 400**

Code	Driven Gear	Teeth	Color	Code	Adapter	Code	Sleeve Assy.
A	1359271	37	Red	K	3932220	L	1362293
B	1359270	36	White			M	1362294
C	9780628	35	Pink				
D	1362049	42	Green				
E	1362195	41	Yellow				
F	1359273	39	Brown				
G	9774413	34	Lt. Green				
H	9775187	45	Lt. Blue				
I	9780470	44	Dk. Gray				
J	1362048	40	Black				

**250-350-375-400 TURBO-HYDRAMATIC**

Tire Size	2.73 Drive	Ratio Gear 8624738		3.08 Drive	Ratio Gear 8624738		3.42 Drive	Ratio Gear 8624738	
G78-15	Driven A	Adapter —	Sleeve M	Driven D	Adapter —	Sleeve L	Driven G	Adapter K	Sleeve M
H78-15	B	—	M	E	—	L	H	—	L
L78-15	C	—	M	F	—	M	I	—	L
HR78-15	B	—	M	E	—	L	H	—	L
LR78-15	C	—	M	J	—	L	I	—	L

*10 Tooth Purple*

**1974 CAMARO TH 400**

Code	Driven Gear	Teeth	Color	Sleeve Assy.
A	1362195	41	Yellow	1362293
B	9775187	45	Lt. Blue	1362293

Tire Size	3.42 Ratio Drive Gear 8623310		3.73 Ratio Drive Gear 8623310	
F60-15	Driven A	Adapter —	Driven B	Adapter —

**1974 CHEVELLE W/TH 400**

Code	Driven Gear	Teeth	Color	Sleeve Assy.
A	1359270	36	White	1362294
B	9780628	35	Pink	1362294
C	9775187	45	Lt. Blue	1362293
D	1362196	43	Purple	1362293
E	9780470	44	Dk. Gray	1362293

Tire Size	2.73 Ratio Drive Gear 8623312		3.42 Ratio Drive Gear 8623312	
G70-14	Driven A	Adapter —	Driven C	Adapter —
G78-14	A	—	C	—
H78-14	B	—	D	—
GR70-15	B	—	E	—
G78-15	B	—	E	—

**1975 PASS. W/TH 375, 400**

Code	Driven Gear	Teeth	Color	Code	Adapter	Code	Sleeve Assy.
A	1359271	37	Red	M	3932220	L	1362293
B	1359270	36	White			M	1362294
C	9780628	35	Pink				
D	1362049	42	Green				
E	1362195	41	Yellow				
F	1359273	39	Brown				
G	9774413	34	Lt. Green				
H	9775187	45	Lt. Blue				
I	9780470	44	Dk. Gray				
J	1362048	40	Black				

**250-350-375-400 TURBO-HYDRAMATIC**

Tire Size	2.73 Drive			3.08 Drive			3.42 Drive		
	Driven	Adapter	Sleeve	Driven	Adapter	Sleeve	Driven	Adapter	Sleeve
678-15	A	—	M	D	—	L	G	K	M
H78-15	B	—	M	E	—	L	H	—	L
L78-15	C	—	M	F	—	M	I	—	L
HR78-15	B	—	M	E	—	L	H	—	L
LR78-15	C	—	M	J	—	L	I	—	L

**1975 PASS. W/TH 350**

Code	Driven Gear	Teeth	Color	Code	Adapter	Code	Sleeve Assy.
A	3987919	19	Natural	E	3950354	H	1362293
B	3987920	20	Blue	F	3950352	I	1362294
C	3987921	21	Red	G	—	—	—
D	3987922	22	Silver	—	—	—	—

Tire Size	2.73 Drive			3.08 Drive			3.42 Drive		
	Driven	Adapter	Sleeve	Driven	Adapter	Sleeve	Driven	Adapter	Sleeve
G78-15	C	—	H	A	F	I	C	F	I
H78-15	B	—	H	D	E	I	C	F	I
L78-15	—	—	—	D	—	H	B	F	I
HR78-15	B	—	H	D	E	I	C	F	I
LR78-15	—	—	—	D	—	H	B	F	I

**1975 CAMARO T.H. 350**

CODE	DRIVEN GEAR	TEETH	COLOR	CODE	DRIVEN GEAR	TEETH	COLOR	CODE	ADAPTER	CODE	SLEEVE
A	3927922	22	Silver	D	3997919	19	Natural	F	326569	I	345215
B	3987921	21	Red	E	3987918	18	Brown	G	330192	J	345215
C	3987922	20	Blue	F	3987920			H	332537		

TIRE SIZE	2.73 RATIO DRIVE GEAR 6261785#			3.08 RATIO DRIVE GEAR 6261782*			3.08 RATIO DRIVE GEAR 6261785#			3.42 RATIO DRIVE GEAR 6261785#		
	DRIVEN	ADAPT	SLEEVE	DRIVEN	ADAPT	SLEEVE	DRIVEN	ADAPT	SLEEVE	DRIVEN	ADAPT	SLEEVE
E60-15	F	—	J	F	—	J	F	—	J	F	—	J
E78-14	A	—	I	A	—	I	E	G	J	C	G	J
F70-14	B	F	J	—	—	—	E	G	J	A	H	J
FR78-14	A	—	I	A	—	I	E	G	J	C	G	J

#purple 10 tooth.

\* green 9 tooth.

**250-350-375-400 TURBO-HYDRAMATIC**

**1975 NOVA W/TH 250/350**

Code	Driven Gear	Teeth	Color	Code	Adapter	Code	Sleeve Assy.
A	3987920	20	Blue	D	3932220	E	345215
B	3987922	22	Silver	—	—	—	—
C	3987918	18	Brown	—	—	—	—

Tire Size	2.73 Ratio Drive Gear 6261782			3.8 Ratio Drive Gear 6261785		
E78-14 E70-14	Driven B B	Adapter — —	Sleeve E E	Driven B B	Adapter — —	Sleeve E E

Tire Size	3.08 Ratio Drive Gear 6261785			3.42 Ratio Drive Gear 6261785		
E78-14 E70-14	Driven C C	Adapter D D	Sleeve E E	Driven A A	Adapter D D	Sleeve E E

**1975 Chevelle w/250, 350 (exc. Monte Carlo)**

Code	Driven Gear	Teeth	Color	Code	Adapter	Code	Sleeve Asm.
A	3987921	21	Red	G	3950354	K	345215
B	3987920	20	Blue	H	3950352		
C	3987922	22	Silver	I	3932220		
D	3987919	19	Natural	J	6273218		
E	9775187	45	Lt. Blue				
F	1362196	43	Purple				

Tire Size	2.73 Drive	Ratio Gear 6261785†		3.08 Drive	Ratio Gear 6261782*		3.42 Drive	Ratio Gear 6261782*	
G70-14 G70-14 G78-14 H78-14 E78-14	Driven A A A B —	Adapt — — — G —	Sleeve K K K K K	Driven — A A C	Adapt — G — —	Sleeve — K K K	Driven — — D —	Adapt — — H —	Sleeve — — K —

Tire Size	3.08 Ratio Drive Gear 6261785#			3.42 Ratio Drive Gear 6261785#		
G70-14 G70-14 G78-14 H78-14 E78-14	Driven A A D —	Adapt J J H —	Sleeve K K K —	Driven C C D —	Adapt H H I —	Sleeve K K K —

#purple 10 tooth.  
\*green 9 tooth.

**250-350-375-400 TURBO-HYDRAMATIC**

**1975 CHEVELLE W/T.H. 400**

Code	Driven Gear	Teeth	Color	Sleeve Assy.
A	1359270	36	White	1362294
B	9780628	35	Pink	1362294
C	9775187	45	Lt. Blue	1362293
D	1362196	43	Purple	1362293
E	9780470	44	Dk. Gray	1362293

Tire Size	2.73 Ratio Drive Gear 8623312		3.42 Ratio Drive Gear 8623312	
	Driven	Adapter	Driven	Adapter
G70-14	A	—	C	—
G78-14	A	—	C	—
H78-14	B	—	D	—
GR70-15	B	—	E	—
G78-15	B	—	E	—

**1975 MONTE CARLO T.H. 350**

Code	Driven Gear	Teeth	Color	Code	Sleeve Assy.	Code	Adapter
A	9780628	35	Pink	F	1362285	H	3950352
B	1362048	40	Black	G	1362284		
C	1359273	39	Brown				
D	9780470	44	Dk. Gray				

Tire Size	2.73 Drive	Ratio Gear 6261785		3.08 Drive	Ratio Gear 6261785		Ratio Gear 6261785	
	Driven	Sleeve	Adapter	Driven	Sleeve	Adapter	Sleeve	Adapter
GR70-15	A	G	H	C		H	F	H
G78-15	B	G	H	D	G	H	F	H



**250-350-375-400 TURBO-HYDRAMATIC**

**1975 CAMARO w/T.H. 400**

Code	Driven Gear	Teeth	Color	Sleeve Assy.
A	1362195	41	Yellow	1362293
B	9775187	45	Lt. Blue	1362293

Tire	3.42 Ratio Drive Gear 8623310		3.73 Ratio Drive Gear 8623310	
F-60	Driven A	Adapter —	Driven B	Adapter —

**4.338 FITTING— RETAINER— SLEEVE— SEAL— RING, Speedometer Driven Gear**

70-75	All w/T.H. 350	345215	1	2.45	w/seal
65-69	Pass. (exc. T.H. 400),				
70-75	All (exc. T.H. 400)	3708148	1	.12	RETAINER, gear fitting ( <sup>9</sup> / <sub>16</sub> " I.D.) (w/Chev. type trans.)
65-72	All w/T.H. 400,				
72-75	Monte Carlo w/T.H. 350 (2nd design)	1362215	1	.22	RETAINER, gear sleeve ( <sup>11</sup> / <sub>32</sub> " I.D.) (Note 1)
	<i>NOTE 1 Used on Monte Carlo w/Buick type 2" dia. speedo gear hole.</i>				
65-66	Pass. w/T.H.,				
68	Pass. w/T.H. (exc. C.A.C., 3.07, 3.08, 3.31, 3.36 axle),				
68	Camaro w/T.H. (exc. R.S., 3.07 axle),				
68	Chevelle w/T.H. (exc. C.A.C., 3.07, 3.08, 3.31, H/Per.),				
72	Camaro (T.H. 400 w/3.73 ratio)	1362294	1	4.60	SLEEVE, w/seal
66-69	Pass. w/T.H.,				
67-68	All (T.H. 3.07 axle) (exc. Pass.),				
68	Pass. (T.H. w/C.A.C., 3.36, 3.08, 3.31, 3.07 axle),				
72-73	Camaro (T.H. 400 w/4.10 ratio)	1362293	1	3.70	SLEEVE ASSY., speedo driven gear
72-75	Monte Carlo w/T.H. 350	1362284	1	5.05	SLEEVE ASSY., speedo driven gear (use w/Buick type 2" speedo driven gear hole)
75	Monte Carlo w/T.H. 350 (3.08 ratio)	1362285	1	5.35	SLEEVE ASSY., speedo. driven gear
62-69	All (exc. T.H. 400),				
70	All,				
71	All w/T.H. 400,				
72-75	All	6264903	2	.20	SEAL, fitting ( <sup>21</sup> / <sub>32</sub> " I.D. x <sup>3</sup> / <sub>32</sub> ")— (4.205)
	<i>NOTE 2: Used with Chev. type trans. w/<sup>7</sup>/<sub>8</sub>" speedo driven gear bore.</i>				
65	All w/T.H. 400,				
71	Pass. (Sta. Wag.),				
72-75	Monte Carlo w/T.H. 350	6264904	1	.51	SEAL, gear fitting "O" ring, hole plug ( <sup>13</sup> / <sub>4</sub> " O.D.) (Note 3)
	<i>NOTE 3 Used with Buick type trans. w/2" speedo driven gear bore.</i>				
65	Pass. w/T.H.,				
71-75	Pass., Nova, Chevelle w/T.H. 350	3869910	1	1.05	SEAL ASSY., pinion ( <sup>9</sup> / <sub>32</sub> ")
66-69	Pass. w/T.H. 400,				
70	Pass., Nova, Chevelle w/T.H. 350	1361618	1	.13	RING, oil seal retaining

**4.342 SHAFT ASSY.— SHAFT UNIT— CLIP, Speedometer without Casing**

65-68	Pass.,				
67	Camaro (exc. 350, 396),				
69	Camaro w/floor shift (302, 350, 396) (exc. P/Trac.)	6452474	1	2.08	( <sup>62</sup> / <sub>8</sub> " )
66-67	Chevy, Chevelle,				
68	Chevy (8 cyl.)	1564778	1	2.20	( <sup>56</sup> / <sub>8</sub> " O.L.)
69	Chevy, Camaro w/floor shift (exc. 302, 350, 396)	6478071	1	2.68	lower flex ( <sup>24</sup> / <sub>4</sub> " O.L.)
69	Chevy, Camaro (Spt. Cpe.) (exc. floor shift, 302, 350, 396),				
69	Pass.	6477306	1	2.35	( <sup>61</sup> / <sub>16</sub> " )
69	Chevy, Camaro (Spt. Cpe.) w/floor shift (exc. 302, 350, 396)	6477297	1	1.80	upper flex ( <sup>37</sup> / <sub>16</sub> " )

**250-350-375-400 TURBO-HYDRAMATIC**

**4.342 SHAFT ASSY.— SHAFT UNIT— CLIP, Speedometer without Casing (Con't)**

69	Camaro (Conv.) (exc. floor shift, 302, 350, 396) .....	6478073	1	2.40	(67 <sup>7</sup> / <sub>16</sub> " ) .....
62-75	All .....	6477499	1	3.70	SHAFT UNIT (consists of shaft, tip) (AC-615) (70" O.L.) (Note 1) .....
<i>NOTE 1 For models requiring maximum length of 81" cut to required length.</i>					
62-75	All .....	6478825	1	6.70	SHAFT UNIT (171" O.L.) (Note 2) .....
<i>NOTE 2 For models requiring length of 81" to 172" cut to required length.</i>					
69	All w/quick release cable .....	6491006	1	.35	CLIP, instr. cluster cable release .....

**4.342A SHAFT ASSEMBLY with Casing**

*NOTE Shaft length is generally 1<sup>1</sup>/<sub>2</sub>" longer than casing dimension listed.*

62-69	All .....	6478125	1	7.13	(55" casing) .....
62-69	All .....	6478128	1	8.91	(67 <sup>1</sup> / <sub>2</sub> " casing) .....
65-69	Pass. ....	6478131	1	9.62	(77 <sup>1</sup> / <sub>2</sub> " casing O.L.) .....
65-66	Pass. ....	6478193	1	11.88	(120" casing) .....
65-69	All .....	6478134	1	11.85	(92 <sup>1</sup> / <sub>2</sub> " casing) .....
67	Pass. ....	6478132	1	10.83	(82" casing) .....
75	Vega (122) .....	356359	1	13.80	
73-75	Camaro (T.H. 350 w/2.73 ratio) w/F70 x 14 tires .....	6478171	1	6.58	speedo flex (44") (AC#CC530) .....
73	Camaro (2BC w/3.42 ratio),				
73-75	Pass. (exc. speed & cruise control),				
73-75	Camaro w/4BC .....	6478174	1	7.36	speedo flex upper (56") (AC#CC553) .....
73-74	Camaro (T.H. 350 w/3.42, 3.08 ratio),				
73-74	Camaro (T.H. 350 w/2.73 ratio) w/E78 x 14 tires,				
74	Camaro w/T.H. 400 .....	6478175	1	6.97	speedo flex (60") (AC#CC-534) .....
73-74	Nova,				
73-74	Chevelle (exc. Monte Carlo),				
73-75	Monte Carlo (exc. speed cruise control),				
75	Chevelle (exc. speed and cruise control, Monte Carlo) .....	6478176	1	7.28	speedo flex (64") (AC#CC-535) .....
75	Chevelle w/speed & cruise control .....	6478130	1	9.44	speedo. flex (76") .....
73-75	Monte Carlo w/speed & cruise control .....	6478180	1	9.33	speedo flex (80") (AC#539) .....
73-75	Monte Carlo w/speed and cruise control .....	6478131	1	9.62	lower (AC#CC514) (80") .....
73	Pass. w/speed and cruise control,				
75	Pass. w/speed and cruise control .....	6478124	1	7.10	speedo flex .....
73-75	Taxi .....	6478488	1	14.11	(20") speedo. flex upper .....
73-75	Taxi .....	6478489	1	10.70	(37") speedo. flex lower .....
73-75	Camaro w/T.H. 350 .....	6454481	1	10.92	lower (24") .....
73	Nova, Camaro .....	6453991	1		lower flex, less casing .....
74	Pass. w/speed & cruise control .....	6478124	1	7.10	reg. to trans. (52") (AC #507) .....
75	Camaro (3.08 ratio) (exc. Cruise),				
75	Chevelle (exc. Monte Carlo) .....	6478179	1	9.28	speedo. flex. (76") .....
75	Nova, Camaro .....	6479292	1	11.62	lower speedo. flec. (27") .....
69	Taxi .....	6478125	1	7.13	lower .....

**4.342B SHAFT ASSY., Speed and Cruise Control**

65-69	All .....	3919007	1	4.95	w/casing (37" O.L.) .....
65-66	Pass., Chevelle .....	3852599	1	13.10	w/casing (control regulator to transmission) (72" O.L.) .....
65-66	Chevelle .....	6478121	1	6.42	w/casing (regulator to speedometer) (40" O.L.) .....
67	Pass. ....	6478132	1	10.83	w/casing (regulator to transmission) (82" O.L.) .....
69	Pass. ....	6477264	1	2.06	w/o casing (to speedometer shaft) (29 <sup>7</sup> / <sub>16</sub> " O.L.) .....
69	Pass., Chevelle .....	6477528	1		w/casing (29" O.L.) .....
69	Chevelle .....	3943641	1	7.25	w/casing (selector) .....

**250-350-375-400 TURBO-HYDRAMATIC**

**4.342C SHAFT ASSY.— CLIP— SPRING, Speedometer**

<b>70 PASSENGER</b>	<b>WITH CASING</b>	<b>WITHOUT CASING</b>
(exc. Taxi) Taxi (upper) Taxi (lower) w/Speed and Cruise Control	6478176 (64" O.L.) 6477857 (7½" O.L.) 6476587 —	6477306 (61 <sup>7</sup> / <sub>16</sub> " O.L.) — — 6477264

<b>70 NOVA</b>		
w/T.H.	6478176	6451067 (Note 1)

<b>70 CHEVELLE</b>		
w/T.H. w/Speed and Cruise Control	6478176 (64" O.L.) 3943641	6451067 (Note 1)

<b>70 CAMARO</b>		
w/T.H.	6478175 (60")	

*NOTE: 1 Shaft Unit-consists of shaft and tip (81" O.L.-cut to required length).  
NOTE: See Dealer Price Schedule (P&A 26) for Applicable Prices.  
NOTE: For Cables less casing refer to old book for universal cables.*

<b>71 PASSENGER</b>	<b>WITH CASING</b>	<b>O.L.</b>
exc. Taxi, Speed. Cruise Control w/Spd. Cruise Control w/Spd. Cruise Control	6478174 6478170-A 6478124-B	56" 40" 52"

<b>71 NOVA</b>		
w/Floor Controls exc. Floor Controls	6478171 6478176	44" 64"

<b>71 CHEVELLE</b>		
exc. Spd. Cruise Control w/Spd. Cruise Control w/Spd. Cruise Control	6478175 6478126 (Lower) 6478171 (Upper)	60" 60" 44"

<b>71 CAMARO</b>		
w/T.H. 350	6478175	60"
w/T.H. 400 (exc. 3.08, 3.31, 3.73, 4.10 ratio)	6478175	60"
(T.H. 400 w/3.08, 3.31, 3.73, 4.10 ratio)	6428174	56"

<b>72 PASSENGER</b>	<b>WITH CASING</b>	<b>O.L.</b>
exc. Taxi, Spd. Cruise Control w/Spd. Cruise Control w/Spd. Cruise Control	6478174 6478170-A 6478124-B	56" 40" 52"

<b>72 NOVA</b>		
w/Floor Controls exc. Floor controls	6478171 6478176	44" 64"

**250-350-375-400 TURBO-HYDRAMATIC**

<b>72 CHEVELLE</b>		
exc. Spd. Cruise Control	6478175	60"
w/Spd. Cruise Control	6478126 (Lower)	60"
w/Spd. Cruise Control	6478171 (Upper)	44"

<b>72 CAMARO</b>		
w/T.H. 350	6478175	60"
w/T.H. 400 (exc. 3.08, 3.31, 3.73, 4.10 ratio)	6478175	60"
(T.H. 400 w/3.08, 3.31, 3.73, 4.10 ratio)	6428174	56"

*A. Regulator to Speedometer.*

*B. Regulator to transmission.*

<b>75</b>	Chevelle w/Speed & Cruise Control	<b>6478130</b>	1	9.44	speedo. flex. (76")
<b>72-75</b>	Vega, Monza	<b>6478175</b>	1	6.97	speedo. flex. (w/casing) (60" long)
<b>75</b>	Nova, Camaro	<b>6479292</b>	1	11.62	speedo. flex. (27")
<b>72-75</b>	Vega, Monza	<b>6477499</b>	1	3.70	speedo. flex. (less casing) (70") (Note 1)
<i>NOTE 1: Consists of shaft and tip, cut as required.</i>					
<b>73-75</b>	Monte Carlo w/speed & cruise control	<b>6478180</b>	1	9.33	speedo. flex. (80") (AC#539)
<b>73-75</b>	Monte Carlo w/speed and cruise control	<b>6478131</b>	1	9.62	lower (AC#CC514) (80")
<b>73</b>	Pass. w/speed and cruise control,				
<b>75</b>	Pass. w/speed and cruise control	<b>6478170</b>	1	6.44	reg. to speedometer (37" to 40") (AC #CC-529)
<b>75</b>	Pass. w/speed and cruise control	<b>6478124</b>	1	7.10	speedo. flex.
<b>73-75</b>	Taxi	<b>6478488</b>	1	14.11	(20") speedo. flex. upper
<b>73-75</b>	Taxi	<b>6478489</b>	1	10.70	(37") speedo. flex. lower
<b>73-75</b>	Camaro w/T.H. 350	<b>6454481</b>	1	10.92	lower (24")
<b>74</b>	Pass. w/speed & cruise control	<b>6478124</b>	1	7.10	reg. to trans. (52") (AC #507)
<b>75</b>	Chevelle (exc. Monte Carlo)	<b>6478179</b>	1	9.28	speedo. flex. (76")
<b>71-75</b>	Pass. w/T.H. 350	<b>3993616</b>	1	.11	CLIP, speedo. to underbody
<b>72-74</b>	All w/quick release cable	<b>6491006</b>	1	.35	CLIP, spring, inst. cstr. speedo. cable release
<b>73-75</b>	Chevelle	<b>334963</b>	1	.11	RETAINER ASSY., speedo. flex. shaft clip
<b>75</b>	Camaro	<b>481730</b>	1		RETAINER, flex. shaft
<b>75</b>	Vega (122)	<b>369481</b>	1	6.55	SHIELD, speedo. shaft
<b>73-74</b>	Chevelle,				
<b>73-74</b>	Pass. (exc. speed and cruise control)	<b>6271679</b>	1	.40	GROMMET, speedo. flex. shaft— (9.775)
<b>72</b>	Pass.	<b>6478373</b>	1	.70	SPRING, inst. cluster speedo. cable lock

**4.343 GEAR, Speedometer Drive**

<b>65-66</b>	All w/4.56, 4.89 axle	<b>3845079</b>	1	3.14	6 teeth (1 <sup>59</sup> / <sub>64</sub> " O.D. x 2 <sup>29</sup> / <sub>64</sub> " thick)
<b>65-66</b>	Pass. w/T.H. (1st design)	<b>8623314</b>	1	2.75	19 teeth (clear white)
<b>66-69</b>	Pass. w/T.H. 400 (2nd design),				
<b>68</b>	Police w/T.H. (396, 427)	<b>8623313</b>	1	2.71	18 teeth
<b>68</b>	All w/T.H. 400 (exc. Pass.),				
<b>68</b>	Police w/T.H. (327)	<b>8623312</b>	1	2.75	17 teeth
<b>68-69</b>	Pass., T.H. 400 w/2.29 axle (427)	<b>8623316</b>	1	3.64	(21 teeth)
<b>69</b>	Taxi (T.H. 350 w/3.07 axle)	<b>6261435</b>	1	5.41	(8 teeth)
<b>69</b>	Taxi (T.H. 350 w/2.73 axle)	<b>6261456</b>	1	5.25	(9 teeth)

**4.345 CLIP, Speedometer Drive Gear**

<b>69</b>	All w/T.H. 350,				
<b>70</b>	All w/T.H. 350 (exc. Taxi, 400 w/2BC)	<b>6261059</b>	1	.12	drive gear retainer
<b>71-75</b>	All w/T.H. 350	<b>6261781</b>	1	.13	retainer
<b>74</b>	Monte Carlo	<b>6478373</b>	1	.70	RETAINER, speedo. cable

**POWERGLIDE AND TORQUE DRIVE TRANSMISSION**

**4.003 POWERGLIDE TRANSMISSION**

64	Chevelle (194) (exc. Taxi, Police),			
65	Nova (S.S.) (6 cyl.) (exc. C.A.C.),			
65	Chevelle (6 cyl.) (exc. Taxi, Police, C.A.C.),			
66-67	Nova (S.S.) (194) (exc. C.A.C.),			
66	Chevelle (194) (exc. C.A.C.) . . . .	3887077	1	460.00
64-65	Chevelle (230) (exc. oil cooler),			
65	Nova (S.S.) (230) (exc. oil cooler),			
65	Pass. (6 cyl.) (exc. oil cooler, 3.55 axle) . . . . .	3848977	1	460.00
64-66	Chevelle (283),			
65-67	Pass. (283),			
65-66	Chevy (283),			
67	Chevy (S.S.) (283) (exc. C.A.C., 3.55 axle),			
67	Chevelle (283) (exc. 3.55, 3.70 axles),			
67	Camaro w/Floor Console (396),			
68	Chevelle (307) (exc. Floor Console, 2.73, 3.55, 3.70 axles),			
68	Chevy (Floor Console w/C.A.C.) (307),			
68	Pass. (307) (exc. H.D. Chassis, Taxi, Police 2.73, 3.70 axles),			
68	Pass. (8.15 x 15" tires 3.70 axle) (307) . . . . .	3977622	1	433.00
65	Pass. w/H/Per. (327) (exc. Police),			
65	Taxi (327),			
65-66	Chevelle (327),			
66	Pass., Chevy (327),			
67	Chevy (S.S.) (327) (exc. A.I.R., C.A.C.),			
67	Chevelle (327) (exc. A.I.R.),			
67	Camaro (floor console w/C.A.C.) (327) (exc. A.I.R., 3.55 axle),			
67	Pass. (327) (exc. A.I.R.),			
68	Pass. (327) (exc. S.S., Police 2.73, 3.55, 3.70 axles),			
68	Pass. (8.45 x 15-4 tires w/3.70 rear axle) (327),			
68	Chevelle (327) (exc. floor console, 2.73, 3.55, 3.70 axles),			
68	Chevy (floor console w/C.A.C.) (327) (exc. 3.55 rear axle) . . . .	6258385	1	450.00
66-67	Pass. (6 cyl.) (exc. 3.70 axle),			
67	Nova (S.S.) (250) (exc. C.A.C., 3.36, 3.55 axles),			
67	Chevelle (250) (exc. 3.55, 3.77 axles),			
67	Camaro (floor console, w/C.A.C.) (6 cyl.) (exc. 3.55 axle),			
68	Chevelle (250) (exc. floor console, 2.73, 3.55, 3.70 axles),			
68	Chevy w/floor console (6 cyl.),			
68	Pass. (6 cyl.) (exc. S.S., H.D. Chassis, Taxi, Police, 2.73, 3.70 axle),			
69	Pass. w/2.73 axle (6 cyl.),			
69	Chevelle w/2.73 axle (250),			
67	Pass. (396) . . . . .	3887076	1	443.00
67	Chevy (250) (exc. C.A.C., 3.55 axle, S.S.),			
67	Camaro w/C.A.C. (250) (exc. floor console, 3.55 axle) . . . . .	3901102	1	396.00
67	Chevy (283) (exc. S.S., C.A.C.) . .	3887080	1	443.00
67	Camaro w/3.07, 3.31 axle (350) (exc. floor console) . . . . .	3895797	1	443.00
68	Pass. (396) (exc. S.S., Police, 2.73, 3.73 axles) . . . . .	3919344	1	411.00

**POWERGLIDE AND TORQUE DRIVE TRANSMISSION**

**4.003 POWERGLIDE TRANSMISSION (Con't)**

68	Chevy, Camaro (230) (exc. C.A.C., floor console, 3.55 axle)	3966978	1	460.00
68	Chevy, Camaro (250) (exc. C.A.C., floor console, 3.55 axle)	3919304	1	411.00
68	Chevy (307) (exc. C.A.C., floor console 3.55 axle)	3919310	1	411.00
68	Camaro w/4BC 327 (exc. reg. fuel, floor console, C.A.C., 3.55 axle)			
68	Chevy (327) (exc. Sp. H/Per., C.A.C., floor console, 3.55 axle)	3919312	1	411.00
68	Camaro w/2BC (exc. C.A.C., floor console, 3.55 axle)	3919317	1	460.00
68	Chevy, Camaro (350) (exc. 2.73, 3.55, 3.73 axles, floor console)	3919327	1	411.00
68	Chevelle w/H/Per. 396 (exc. P/Trac., flr. console, 3.55, 3.73 axles)	3919342	1	411.00
68	Chevelle (396) (exc. H/Per., P/Trac., 2.73, 3.55, 3.73 axles, floor console)	3919339	1	460.00
69	Pass. w/reg. fuel (350) (exc. 2.73 axle, Police)			
69	Chevelle (2BC w/3.07, 3.08 axles) (350)	328838	1	454.00
69	Pass. (6 cyl.) (exc. 2.73 axle, Police, Taxi)			
69	Chevelle (250) (exc. 2.73 axles)	3950313	1	460.00
69	Pass. (8 cyl.) (exc. 350)	3950331	1	454.00
69	Chevelle (8 cyl.) (exc. 2.73, 3.55 axles, 350)	3950317	1	450.00
69	Chevelle w/3.55 axle (8 cyl.) (exc. 350)			
69	Chevelle w/C.A.C. (8 cyl.) (exc. 350, 3.31, 3.36 axles)	3950319	1	460.00
69	Chevelle w/2.73 axle (8 cyl.) (exc. 350)	3950321	1	460.00
69	Chevy (4 cyl.) (exc. 2.73 axle)	3950301	1	460.00
70	All (350) (w/4BC) (exc. Police)	3978707	1	454.00
70	All (8 cyl.) (exc. 4BC Pass., Nova)	3968022	1	454.00
70-71	All (6 cyl.) (exc. Taxi, Police)	6264966	1	454.00
71	Nova, Chevelle, Camaro (8 cyl.) (exc. Monte Carlo)	3987903	1	454.00
71	Pass., Monte Carlo (8 cyl.)	6264967	1	454.00
72	All w/P.G. (6 cyl.) (exc. Taxi, Police)	6261821	1	454.00
72	Nova, Chevelle, Camaro w/P.G. (8 cyl.) (exc. Monte Carlo)	6261823	1	454.00
70	Pass. (350) (exc. 4BC)			
72	Monte Carlo w/P.G.	6261822	1	454.00
71	Vega (P.G. w/2BC)	6261825	1	432.00
71-72	Vega (P.G. w/1BC) (exc. NB-2)	6261826	1	481.00
73	Vega w/1BC	332581	1	481.00
73	Vega w/2BC	332582	1	481.00

**TORQUE DRIVE TRANSMISSION**

68-69	Chevy (4 cyl.)	3950340	1	417.00
70	All	3968026	1	392.00
71-72	Vega w/Torque Drive	3993051	1	419.00

**4.004 CONTROL ASSY.— BRACKET ASSY.— LEVER ASSY., Transmission Gearshift**

66-67	Chevelle (floor console w/P.G.)	3880851	1	52.25	w/lever and bracket
67	Camaro (P.G. w/floor console)				
68-70	Chevy (P.G. w/floor console)	3895200	1	45.25	w/lever and bracket
68-70	Pass. (A.T. w/B.S.)	3954623	1	62.50	w/lever and bracket
68-72	Chevelle (A.T. w/floor console)	3952863	1	41.00	w/bracket and lever
70-72	Camaro (A.T. w/floor console)	3972240	1	42.50	w/lever and bkt.
71-72	Vega w/Torque Drive	3978174	1	14.55	trans. cont. w/bracket (used with unlighted trans. cont. indicator pointer)
71-72	Vega w/P.G.	3988010	1		<b>BRACKET ASSY.,</b> trans. cont. lever mtg.
72	Vega w/P.G. (1st design)	325198	1	4.20	<b>BRACKET ASSY.,</b> trans. control lever mtg. (Note 1)

**POWERGLIDE AND TORQUE DRIVE TRANSMISSION**

**4.004 CONTROL ASSY.— BRACKET ASSY.— LEVER ASSY., Transmission Gearshift (Con't)**

72	Vega w/P.G. (2nd design) . . . . .	329760	1	4.20	BRACKET ASSY., trans. control lever mtg. (Note 1) . . . . .
72	Vega w/Torque Drive . . . . .	328702	1	4.20	BRACKET ASSY., trans. control lever mtg. . . . .
73	Vega . . . . .	325785	1	4.20	BRACKET ASSY., trans. cont. lever mtg. . . . .
71-72	Vega w/P.G. (1st design) . . . . .	325197	1	14.55	LEVER ASSY., trans. control w/bracket (Note 1) . . . . .
72	Vega w/P.G. (2nd design) . . . . .	329753	1	12.65	LEVER ASSY., trans. control w/bracket (Note 1) . . . . .
72	Vega w/Torque Drive . . . . .	328701	1	14.55	LEVER ASSY., trans. control w/brkt. . . . .
73	Vega . . . . .	325781	1	14.55	LEVER ASSY., trans. control w/bracket . . . . .
73	Vega . . . . .	325782	1	14.55	LEVER ASSY., trans. control shaft . . . . .

*NOTE 1: 1st design is identified by threaded type park lock and range selector outer rod, 2nd design is identified by slotted type park lock and range selector outer rod.*

**4.005 GASKET UNIT— RING UNIT— SEAL UNIT, Transmission**

62-68	All, w/P.G. . . . .	3910040	1	14.00	(Note 1) . . . . .
<i>NOTE 1 Consists of (1 each) gasket, trans. low servo cover, front oil pump body, governor support body, trans. upper valve body plate, trans. transfer plate to upper, and lower valve body, trans. vacuum modulator, trans. oil pan, trans. oil pump suction screen, trans. governor. (1 each) seal, rear oil pump, low servo cover, front oil pump body oil, throttle valve control shaft oil ring, speedometer driven gear fitting, trans. clutch piston outer, and inner (7) front oil pump to trans. case bolt, clutch piston outer. (1) seal unit, trans. reverse clutch piston (1) seal assy. trans. parking lock and range selector (2) gaskets for transfer plate to valve body (upper and lower) (1) seal, filler tube.</i>					
69-73	All w/P.G. . . . .	3958686	1	22.05	w/seals (Note 2) . . . . .
<i>NOTE 2 Consists of (1 each) gasket, low servo cover, front oil pump body upper valve body plate, vacuum modulator, oil pan, oil pump suction screen, governor (1 each) seal assy. parking lock and range sel. (1 each) seal unit, reverse clutch piston. (1 each) seal, rear oil pump low servo cover (2 each) seal, front oil pump body oil. (1 each) throttle valve control shaft oil ring, speedometer driven gear fitting, trans. clutch piston outer, and inner (7 each) seal front oil pump to trans. case bolt. (2 each) gasket, transfer plate to valve body (upper and lower) (1 each) gasket trans. to governor support body. (1 each) seal, clutch piston outer, filler tube "O" ring.</i>					
62-71	All w/P.G. . . . .	3914196	1	57.25	overhaul . . . . .
62-72	All w/P.G. (aluminum) . . . . .	3928592	1	9.70	RING UNIT, trans. oil seal (Note 3) . . . . .
<i>NOTE 3 Consists of 2 input shaft seals, 2 clutch drum seals, 2 governor seals, 2 low servo seals.</i>					
68-72	All w/Torque Drive . . . . .	3955593	1	10.60	SEAL UNIT, w/gaskets (Note 4) . . . . .
<i>NOTE 4 Consists of (1 each) gasket, trans. low servo cover, front oil pump body, oil pan, oil pump suction screen. (2 each) gasket, transfer plate valve body. (1 each) seal, extension to case, low servo cover, oil pump body oil, speedometer driven gear fitting, clutch piston inner and outer. (7 each) oil pump to trans. case bolt. (1 each) seal unit reverse clutch piston. Seal assy. parking lock and range selector. (1 each) seal.</i>					

**4.006 LEVER— BUSHING— BUTTON— COVER— HANDLE— KNOB— ROD, Gearshift Control (Hand)**

62-65	Chevy (exc. S.S.) . . . . .	3790080	1	2.70	
<i>NOTE 1 Enlarge hole in steering column housing with No. 1 drill (.228) when necessary.</i>					
65-66	Pass. w/A.T. (exc. B.S., T.W.) . . . . .	3816227	1	3.65	(9 <sup>13</sup> / <sub>32</sub> " O.L.) . . . . .
66	Chevelle (S.S.) w/P.G. (exc. floor console, T.W.),				
66	Chevy (exc. S.S.),				
66	Chevy (S.S.) (exc. 6 cyl.) . . . . .	3879746	1	4.00	
67	Pass., Chevelle w/A.T. (exc. T.W., B.S.),				
68	Pass. w/A.T. (exc. B.S., S.S., T.W.),				
68	Chevy, Chevelle w/A.T. (exc. T.W., floor console) . . . . .	3928319	1	3.75	control . . . . .
67	Camaro (floor console w/A.T.),				
68-70	Chevy (A.T. w/floor console) . . . . .	6263121	1	22.20	control . . . . .
68-69	Pass. (A.T. w/B.S.),				
68-72	Chevelle, Camaro (A.T. w/floor console) . . . . .	3922577	1	4.20	control . . . . .
68-70	Chevelle (Floor shift w/B.S.) . . . . .	3973866	1	10.50	control upper . . . . .
69	Pass. w/A.T. (exc. B.S., T.W.),				
69	Chevy, Chevelle, Camaro w/A.T. (exc. T.W., floor shift),				
70	All w/A.T. (exc. T.W.),				
72	Nova w/Torque Drive . . . . .	3939741	1	6.65	control . . . . .
69	Pass. (A.T. w/T.W.) (exc. B.S.),				
69	Chevelle, Camaro (A.T. w/T.W.) (exc. floor console),				
70-72	All (A.T. w/T.W.) (exc. Nova, floor console) . . . . .	6272366	1	5.90	control . . . . .
71-72	All (exc. T.W.) . . . . .	6272365	1	5.85	

**POWERGLIDE AND TORQUE DRIVE TRANSMISSION**

**4.006 LEVER— BUSHING— BUTTON— COVER— HANDLE— KNOB— ROD,  
Gearshift Control (Hand) (Con't)**

71-72	Vega (1st design) . . . . .	6264380	1	6.10	trans. cont. shaft (Note 1) . . . . .
72	Vega w/P.G. (2nd design) . . . . .	329766	1	6.10	trans. control shaft (Note 1) . . . . .
71-73	Vega . . . . .	3988009	1	.15	<b>BUSHING</b> , trans. control rod lever . . . . .
64-67	Nova, Malibu (S.S.) w/A.T., 65 S.S. w/A.T.,				
66-67	Spt. Cpe., Conv. w/A.T. . . . .	3843125	1	.22	<b>BUTTON</b> , control lever release . . . . .
67	Camaro (floor console w/A.T.),				
68-70	Chevy (A.T. w/floor console) . . . . .	3914825	1	.74	<b>BUTTON</b> , control lever . . . . .
68-69	Pass., Chevelle, Camaro (A.T. w/floor console),				
70-72	Chevelle, Camaro (A.T. w/floor console) . . . . .	3920271	1	1.35	<b>BUTTON</b> , control lever . . . . .
68-69	Pass., Chevelle, Camaro (A.T. w/floor console),				
70-72	Chevelle, Camaro (A.T. w/floor console) . . . . .	3920270	1	1.35	<b>COVER</b> , control lever handle . . . . .
68-69	Pass., Chevelle, Camaro (A.T. w/floor console),				
70-72	Chevelle, Camaro (A.T. w/floor console) . . . . .	3920269	1	9.60	<b>HANDLE</b> , control lever . . . . .
70	Nova (A.T. w/floor console) . . . . .	3895274	1	4.80	<b>HANDLE</b> , control lever . . . . .
63-64	Nova (S.S. w/P.G.) . . . . .	390749	1	4.40	<b>KNOB</b> (white plastic) . . . . .
64-65	Chevelle w/T.W. (exc. S.S.),				
65	Pass. (exc. S.S., Caprice) . . . . .	3782694	1	1.35	<b>KNOB</b> (2 <sup>13</sup> / <sub>32</sub> " O.L.— black plastic) . . . . .
65	Caprice . . . . .	3877518	1		<b>KNOB</b> , control lever . . . . .
66	Caprice (exc. B.S.) . . . . .	3882907	1	1.55	<b>KNOB</b> , cont. lever . . . . .
67	Pass.,				
67	Concours . . . . .	3898254	1	1.75	<b>KNOB</b> , turquoise w/chrome . . . . .
67	Pass.,				
67	Concours . . . . .	3898255	1		<b>KNOB</b> , gold w/chrome . . . . .
68	Pass. . . . .	3928282	1	1.90	<b>KNOB</b> , dark saddle w/chrome . . . . .
69	All . . . . .	3945523	1	1.20	<b>KNOB</b> , midnight green . . . . .
67-71	All w/column shift . . . . .	3973042	1	2.10	<b>KNOB</b> , control lever (black) (paint as required) . . . . .
71	Chevelle, Camaro (P.G. w/column shift),				
72-73	All (P.G. w/column shift) . . . . .	3990592	1	2.40	<b>KNOB</b> , control lever (black) . . . . .
71-73	H . . . . .	3978178	1	1.15	<b>KNOB</b> , trans. control lever . . . . .

*NOTE 1: 1st design is identified by threaded type park lock and range selector outer rod, 2nd design is identified by slotted type park lock and range selector outer rod.*

**4.008 BUSHING— CUP— FASTENER— GROMMET— GUIDE— NUT— PIN—  
PLUG— RING— ROD— SHAFT— SHIM— SLEEVE— SPACER— SPRING—  
WASHER, Gearshift Control Hand Lever**

67	Camaro (floor console w/A.T.),				
68-72	All (A.T. w/floor console) (exc. Vega) . . . . .	3859797	2	.92	control lever . . . . .
71-72	Vega . . . . .	3992925	2	.91	trans. control lever . . . . .
68-70	All (A.T. w/floor console) . . . . .	564708	2	.16	<b>FASTENER</b> , snap, control cable retainer— (4.060) . . . . .
62-65	Chevy (exc. S.S.) . . . . .	3793046	1	.11	<b>GROMMET</b> , inner . . . . .
62-65	Chevy (exc. S.S.) . . . . .	3790083	1	.26	<b>GROMMET</b> , outer . . . . .
65	Pass. w/A.T. (exc. T.W.),				
66	Pass. w/A.T. (exc. T.W., B.S.) . . . . .	3779108	1	.12	<b>GROMMET</b> , control lever (rubber) . . . . .
65-66	Pass. (T.W. w/A.T.) (exc. B.S.),				
65	Chevelle w/T.W. (exc. S.S.),				
66	Chevelle (T.W. w/P.G.) (exc. floor console) . . . . .	568018	1	.11	<b>GROMMET</b> , control lever . . . . .
67	Camaro (floor console w/A.T.),				
68-70	Chevy (A.T. w/floor console) . . . . .	3895275	1	1.05	<b>NUT</b> , control lever handle . . . . .
62-65	Chevy (exc. S.S.),				
67-68	Pass. w/P.G.,				
67-69	Chevelle (S.S. w/A.T.),				
71-72	Vega . . . . .	3909593	2	.11	<b>NUT</b> , trans. control lever and brkt. (8-18)— (9.743) . . . . .
73	Vega . . . . .	325822	2	.11	<b>NUT</b> , trans. control lever and brkt. (8-18)— (9.743) . . . . .
71-73	All w/P.G. (exc. floor console) . . . . .	3793014	1	1.05	<b>PIN</b> , fulcrum (7/32" dia. x 1 <sup>11</sup> / <sub>32</sub> " O.L.) . . . . .
66	Chevelle (S.S.) w/P.G. . . . .	9425112	1	.16	<b>PIN</b> , control lever pivot— (8.939) . . . . .
67	Camaro (floor console w/A.T.) . . . . .	3859792	1	4.05	<b>PLUG</b> , control lever . . . . .
62-69	All . . . . .	9431762	1	.08	<b>RING</b> , control lever pin retaining (1 <sup>13</sup> / <sub>64</sub> "— (8.934) . . . . .
67	Camaro (A.T. w/floor console),				



**POWERGLIDE AND TORQUE DRIVE TRANSMISSION**

**4.008 BUSHING— CUP— FASTENER— GROMMET— GUIDE— NUT— PIN—  
PLUG— RING— ROD— SHAFT— SHIM— SLEEVE— SPACER— SPRING—  
WASHER, Gearshift Control Hand Lever (Con't)**

68-70	Chevy (A.T. w/floor console) (6 cyl.)	3895278	1	6.30	ROD, control lever release
71-73	Vega	3943203	2	.18	SCREW, trans. control cover (8-18 x 5/8")— (2.729)
68-69	All (A.T. w/floor console) (exc. Chevy),				
71-72	Chevelle, Camaro (P.G. w/floor console)	3920281	1	1.95	SHAFT, control lever and bracket
65	Pass. (exc. S.S.),				
66	Pass. w/A.T. (exc. T.W., B.S.)	3758998	1	.26	SHIM, control lever
67	Camaro (A.T. w/floor console),				
68-70	Chevy (A.T. w/floor console)	3905504	1	1.40	SLEEVE, control lever release rod
68-70	All (A.T. w/floor console) (exc. Chevy),				
71	Chevelle, Camaro (P.G. w/floor console)	3920282	1	.53	SPACER, control lever and bracket shaft
63	Nova (S.S.) w/P.G.,				
63	Chevy w/P.G. (4 cyl.)	3760384	1	1.05	SPRING, control (8 coils— 1 1/2" free length)
66-67	Chevelle w/B.S. (8 cyl.)	3845716	1	.44	SPRING, reverse release cable retaining
64-67	Chevy, Chevelle (S.S.) w/A.T.,				
65-67	Pass. w/A.T.	3874236	1	.11	SPRING, cont. lever release button
64-66	Chevelle (exc. T.W., S.S., floor console),				
64-65	Chevelle (T.W. w/P.G.) (exc. S.S.),				
66	Chevelle (T.W. w/P.G.) (exc. floor console)	391537	1	.40	SPRING, shift lever
66	Pass. (exc. T.W.),				
66	Pass. (T.W. w/B.S.),				
66	Chevelle (S.S.) w/P.G. (exc. T.W.)	3719853	1	.16	SPRING (5 coils— 1 9/32" long)
67-68	All w/A.T. (exc. floor console, T.W.)	7800605	1	.38	SPRING, lever
67-68	All (A.T. w/column shift) (exc. Chevy)	7800670	1	.53	SPRING, gearshift lever housing
67	Camaro (floor console w/A.T.),				
68-70	Chevy (A.T. w/floor console)	3895277	1	1.05	SPRING, control lever upper
67	Camaro (floor console w/A.T.) (1st design)	3899023	1	.32	SPRING, control lever lower (1 5/32" O.L.)
67	Camaro (A.T. w/floor console) (2nd design),				
68-70	Chevy (A.T. w/floor console)	3917592	1	.92	SPRING, control lever lower (1 1/2" O.L.)
69	Pass. (A.T. w/column shift) (exc. T.W., B.S.),				
70	All w/floor controls,				
70-71	All (A.T. w/column shift)	7808017	1	.64	SPRING, lever
69-70	All (column shift w/T.W.) (exc. Chevy),				
71-72	All w/T.W. (exc. floor console)	7812853	1	.92	SPRING, gearshift lever housing
72-73	Vega w/P.G.	329764	1	.14	SPRING, trans. control shift lever (Note 1)
64-66	Nova, Malibu (S.S.) w/A.T.,				
65-67	Pass. (A.T. w/B.S.),				
67	Chevy, Chevelle (floor console w/P.G.)	3843131	1	.12	WASHER, control lever spring
68-70	Camaro, Chevelle (A.T. w/floor console),				
68	Chevy w/floor console,				
68-69	Pass. (A.T. w/B.S.),				
71-72	All (P.G. w/floor console) (exc. Vega)	2390395	1	.20	WASHER, control lever & bracket shaft (5/8" I.D.)

**4.010 BRACKET ASSY.— BOWL— COVER— EXTENSION— HOUSING— PLATE— SHROUD, Gearshift Hand Lever**

*For floor shift models not using strg. column shift lever housing, see group 6.518 for equivalent part, listed as a cover, jacket extension, housing, etc.*

67	Camaro (floor console w/P.G.),				
68	Chevy (P.G. w/floor console)	3895269	1	8.30	control lever
68-72	Chevelle (A.T. w/floor console)	3952864	1	15.00	w/detent control lever
68-69	Camaro (A.T. w/floor console)	3920278	1		control lever
70-72	Camaro (A.T. w/floor console)	3984550	1	12.10	control lever
69	Pass. w/column shift (exc. T.W.),				
69-70	Chevy, Chevelle, Camaro w/column shift (exc. T.W.)	7810216	1	26.25	BOWL, strg. col. g/s lever

**POWERGLIDE AND TORQUE DRIVE TRANSMISSION**

**4.010 BRACKET ASSY.— BOWL— COVER— EXTENSION— HOUSING— PLATE— SHROUD, Gearshift Hand Lever (Con't)**

71-72	Vega	3999482	1	4.50	COVER, trans. control lever and bracket
73	Vega	6264741	1	3.95	COVER, trans. control lever and bracket
71	Camaro (exc. T.W. floor console)	7808409	1	7.50	EXTENSION, strg. col. control lock tube
67	Pass.	7800596	1	17.60	HOUSING, lever
67-68	Camaro (A.T. w/T.W.) (exc. floor console)	5698984	1	16.85	HOUSING, lever
69-70	All w/floor shift (exc. T.W.)	7804436	1	14.25	HOUSING, control lock tube
69-72	All w/column shift (exc. T.W.)	7812064	1	18.35	HOUSING, control lock tube
69-72	Camaro (A.T. w/T.W.) (exc. floor console),				
73	Nova w/T.W.	7805991	1	33.75	HOUSING, strg. column
72	Pass., Chevelle w/T.W.	7805996	1	16.60	HOUSING, strg. col. gear shift lever
67	Chevy w/P.G.	5698796	1	25.00	HOUSING ASSY., w/shroud, control lever
67-68	Camaro w/A.T. (exc. T.W., floor console)	5699058	1	25.00	HOUSING ASSY., w/shroud assy., gear shift lever
68	Pass. w/A.T. column shift (exc. T.W.)	7800595	1	19.20	HOUSING ASSY., w/shroud gearshift lever
68	Chevy w/A.T. (exc. floor console)	7803114	1	27.75	HOUSING ASSY., w/shroud
69-70	All w/A.T. (exc. T.W., floor console)	7804401	1	1.75	PLATE, strg. column shift tube lock
69-70	Pass., Chevelle w/floor shift (exc. T.W.)	7807691	1	1.10	PLATE, strg. column shift tube lock
69	Pass., Chevelle (exc. T.W.),				
70	Pass., Nova, Chevelle (exc. Tel., T.W.),				
71	Pass., Chevelle (exc. T.W.)	7811352	1	7.75	SHROUD, strg. col. gearshift hsg. bowl
69-73	Nova, Camaro (exc. A.T.)	7811350	1	7.90	SHROUD, strg. col. gearshift hsg. bowl
72	Chevelle (T.W. w/floor console)	7806003	1	28.25	SHROUD, strg. col. trans. control lock tube

**4.012 PLATE— DETENT— SCREW— STUD— WASHER, Gearshift Hand Lever Housing**

69-70	Chevy, Camaro w/Torque Drive,				
73	Nova	7806352	1	3.15	lever detent
68-70	All (A.T. w/floor console) (exc. Chevy, Monte Carlo),				
71-72	Chevelle, Camaro (P.G. w/floor console)	3920280	1	1.90	DETENT, control lever
67-73	All w/T.W.	7800639	1	.24	SCREW, shift detent plate
69-70	All (exc. T.W.)	7810242	2	.78	SCREW, strg. column shift tube lock plate
69-73	All (exc. T.W., Vega)	7804407	1	.24	SCREW, str. column shift lever detent plate
62-65	Chevy,				
65	Pass. (exc. T.W.),				
66	Pass. w/A.T. (exc. T.W., B.S.)	3793124	1	.16	WASHER, lever housing (1 <sup>5</sup> / <sub>16</sub> " )
64-67	Chevelle	3745292	1	.11	WASHER, control lever housing thrust, control lever housing upper— (2.895)
66	Caprice (Spt. Cpe.) (A.T. w/B.S.),				
66	Chevy,				
66	Chevelle	3879747	1	.11	WASHER, lever housing
66-67	Chevelle (S.S.) w/P.G. (exc. floor console)	3879748	1	.24	WASHER, cont. lever hsg. thrust
66	Caprice (Spt. Cpe.) (B.S. w/A.T.),				
66	S.S. (P.G. w/floor console)	3879778	1	.12	WASHER, cont. lever hsg. thrust
67-68	All w/T.W.	5698413	1	.53	WASHER, steering column support thrust
67-68	All w/T.W.	5699618	1	.53	WASHER, steering column support wave
67-73	All (exc. T.W., Vega)	7800580	1	.34	WASHER, steering shaft upper retainer ring thrust
67-68	All (exc. T.W.)	7800581	1	.38	WASHER, steering shaft upper retainer ring wave
69-73	All w/T.W.	3886319	1	.32	WASHER, strg. column supt. thrust
69-73	All w/T.W.	3884595	1	.20	WASHER, strg. column supt. wave
69-70	All (exc. T.W.)	7804447	1	.59	WASHER, strg. column shift lever housing brg. wave

**4.015 SEAL— BOOT— COVER— HOUSING— RETAINER— SCREW, Lever Hand (Floor Mounted)**

63-64	Nova (S.S.) w/P.G.	3830457	1	4.85	control selector
64-67	S.S. w/P.G. (exc. Pass.),				
65-67	Pass. w/A.T.	3878480	1	1.45	control lever
67	Camaro w/A.T.,				
68-70	Chevy (A.T. w/floor console)	3925419	1		control lever
67	Camaro w/P.G.,				
68-69	Chevy (P.G. w/floor console)	3895281	1	2.50	control lever w/bracket
68-72	Chevelle (A.T. w/floor console)	3922817	2	.59	control lever outer

**POWERGLIDE AND TORQUE DRIVE TRANSMISSION**

**4.015 SEAL— BOOT— COVER— HOUSING— RETAINER— SCREW, Lever Hand  
(Floor Mounted) (Con't)**

68-72	Chevelle (A.T. w/floor console) . . .	3922816	2	1.10	control lever inner . . . . .
68-72	Camaro (A.T. w/floor console) . . .	3975880	1	.71	control lever . . . . .
65-67	S.S. w/A.T. (exc. Strato bench),				
65-67	Chevy w/P.G.,				
66-67	Caprice (A.T. w/B.S.),				
67	Caprice w/A.T. (exc. B.S.) . . . . .	3859856	1	1.00	BOOT, control actuating lever . . . . .
71	Vega . . . . .	3978179	1	.43	COVER, trans. detent pit. . . . .
72	Vega . . . . .	6273336	1	.43	COVER, trans. detent pit. . . . .
73	Vega . . . . .	336594	1	.43	COVER, trans. detent plate . . . . .
71	Vega . . . . .	3984439	1	1.80	RETAINER, trans. cont. indicator . . . . .
72	Vega . . . . .	331963	1	2.15	RETAINER, trans. cont. indicator . . . . .
67	Camaro w/A.T.,				
68	Chevy w/floor console,				
70	Nova (A.T. w/floor console) . . . . .	3893872	R.H.	.19	RETAINER, control lever seal, right . . . . .
67	Camaro (A.T. w/floor console),				
68-70	Chevy (A.T. w/floor console) . . . . .	3895282	1	.83	RETAINER, control lever w/bracket . . . . .
68-69	Camaro (A.T. w/floor console) . . . . .	3919162	1	.34	RETAINER, control indicator dial . . . . .
68-72	Chevelle (A.T. w/floor console) . . . . .	3922818	1	.28	RETAINER, control lever outer seal . . . . .
73	Vega . . . . .	331941	1	2.15	HOUSING, trans. cont. indicator . . . . .
64-65	Malibu (S.S.) w/P.G. . . . .	9415952	3	.05	SCREW, lever seal front and rear guide, boot ret. and hsg. trim cover brkt.— (8.977) . . . . .

**4.017 PLATE— APPLIQUE— NUT, Underbody Trim (floor mounted)**

67	Camaro w/A.T.,				
68-70	Chevy (A.T. w/floor console) . . . . .	3925417	L.H.	3.65	control lever hole trim, left . . . . .
67	Camaro w/A.T.,				
68-70	Chevy (A.T. w/floor console) . . . . .	3925418	R.H.	3.65	control lever hole trim, right . . . . .
68-69	Camaro (A.T. w/floor console) . . . . .	3921804	1	4.20	control lever hole trim lower . . . . .
68-69	Camaro (A.T. w/floor console) . . . . .	3921805	1	8.75	control lever hole trim upper . . . . .
70-72	Camaro (A.T. w/floor console) (exc. Deluxe Interior) . . . . .	3975877	1	8.20	control lever hole trim (upper) . . . . .
70-72	Camaro (A.T. w/floor console) (exc. Deluxe Interior) . . . . .	3975879	1	4.40	control lever hole trim (lower) . . . . .
68-72	Chevelle (A.T. w/floor console) (exc. Monte Carlo) . . . . .	3926729	1	9.55	PLATE ASSY., control indicator dial trim . . . . .
70-72	Camaro (floor console w/Deluxe Interior) w/A.T. . . . .	3975886	1	8.20	PLATE ASSY., control lever hole trim (upper) . . . . .
70-72	Camaro (floor console w/Deluxe Interior) w/A.T. . . . .	3975887	1	4.40	PLATE ASSY., control lever hole trim (lower) . . . . .
70-72	Monte Carlo (A.T. w/floor console) . . . . .	3975361	1	9.55	PLATE ASSY., control indicator dial . . . . .
73	Vega . . . . .	6264798	1	2.00	APPLIQUE, trans. control lever and bracket cover . . . . .

*NOTE 1 Paint as required.*

64-65	Nova, Malibu (S.S.),				
65-66	Pass. (A.T. w/B.S.) . . . . .	3840110	A.R.		NUT, trans. trim plate (No. 10-16) . . . . .

**4.020 INDICATOR— CABLE— CAP— CLIP— DIAL— GUIDE— HOUSING—  
LENS— PLATE— POINTER— RETAINER— SEAL ASSY.— SPRING,  
Transmission Gearshift Control**

64-65	Chevelle w/T.W. (exc. S.S.),				
67-68	Camaro (T.W. w/P.G.) (exc. floor console) . . . . .	9775619	1	1.05	
65-66	Pass. w/A.T. (exc. B.S., T.W.) . . . . .	3861888	1	.22	
66	Chevy w/P.G. (exc. S.S.) . . . . .	3886581	1		
66	Chevelle w/P.G. (exc. floor console) . . . . .	3888772	1	.53	
67	Pass. w/A.T. (exc. B.S.) . . . . .	3913419	1	.34	control . . . . .
67	Chevelle w/A.T. (exc. floor console),				
68	Chevelle w/P.G. (exc. floor console) . . . . .	3900563	1	.84	
68	Chevelle w/P.G. . . . .	6480927	1	6.99	INDICATOR ASSY., shift . . . . .
69	Chevelle w/P.G. . . . .	6483424	1	6.80	INDICATOR ASSY., shift . . . . .
69	Camaro w/P.G. (exc. floor console) . . . . .	6483160	1	14.71	INDICATOR ASSY. . . . .
69-72	Nova . . . . .	6496316	1	5.98	INDICATOR ASSY., shift . . . . .
70	Monte Carlo, Chevelle (S.S.) w/P.G. (exc. floor console),				
70	Chevelle (P.G. w/gages) (exc. floor console),				

**POWERGLIDE AND TORQUE DRIVE TRANSMISSION**

**4.020 INDICATOR— CABLE— CAP— CLIP— DIAL— GUIDE— HOUSING— LENS— PLATE— POINTER— RETAINER— SEAL ASSY.— SPRING, Transmission Gearshift Control (Con't)**

71-72	Monte Carlo w/P.G. (exc. console),				
71-72	Chevelle (S.S.) (P.G. w/gauges) (exc. floor console) . . . . .	6496777	1	5.63	INDICATOR ASSY., shift instr. cluster . . . . .
70-72	Chevelle w/A.T. (exc. Monte Carlo, S.S., gages, floor console) . . . . .	6492183	1	5.29	INDICATOR ASSY., shift instr. cluster . . . . .
71-72	Pass. . . . .	6496066	1	4.61	INDICATOR ASSY., shift . . . . .
73	Nova . . . . .	6499640	1	3.99	INDICATOR ASSY., inst. cluster . . . . .
68	Pass. w/P.G. (exc. B.S., S.S.) . . . . .	6481558	1	3.16	CABLE ASSY., instrument cluster shift indicator . . . . .
69-70	Pass. w/A.T.,				
71-72	Camaro . . . . .	6492011	1	2.30	CABLE ASSY., instrument cluster shift indicator . . . . .
69	Chevelle w/A.T. . . . .	6483430	1	2.24	CABLE ASSY., indicator . . . . .
71-72	Pass. . . . .	6496537	1	1.91	CABLE ASSY., inst. cluster trans. ind. . . . .
71-72	Nova (exc. floor console) . . . . .	6492504	1	1.89	CABLE ASSY., shift ind. . . . .
72	Chevelle (exc. floor console) . . . . .	6493285	1	1.88	CABLE ASSY., shift ind. . . . .
73	Nova . . . . .	6499638	1	1.61	CABLE ASSY., shift ind. (black) . . . . .
67-68	Chevy, Camaro w/A.T. (exc. floor console, T.W.) . . . . .	3925885	1	.71	CAP, lever housing . . . . .
69	Camaro w/A.T. . . . .	6481602	2	.07	CLIP, indicator dial . . . . .
65-66	Pass. (A.T. w/B.S.) . . . . .	3864183	1	.64	DIAL, indicator left . . . . .
65-66	Pass. (P.G. w/B.S.) . . . . .	3864184	1	1.25	DIAL, indicator right . . . . .
67	Camaro (floor console w/P.G.),				
68	Chevy (P.G. w/floor console),				
69	Chevy (P.G. w/floor console) . . . . .	3893874	1	.93	DIAL, indicator . . . . .
68-69	Pass. (P.G. w/B.S.) . . . . .	3934231	1	1.70	DIAL, control indicator . . . . .
68	Pass. w/P.G. (exc. B.S., S.S.) . . . . .	6480708	1	1.75	DIAL, instrument cluster shift indicator . . . . .
68-69	Camaro (P.G. w/floor console) . . . . .	3919160	1	.58	DIAL, control indicator . . . . .
68-72	Chevelle (P.G. w/floor console) . . . . .	3990804	1	1.35	DIAL, control indicator . . . . .
70-72	Camaro w/P.G. . . . .	6496184	1	6.67	DIAL ASSY., indicator . . . . .
73	Vega . . . . .	331940	1		GUIDE, trans. cont. indicator pointer . . . . .
69-70	Pass. w/P.G. . . . .	6482736	1	3.92	LENS, indicator . . . . .
69	Camaro w/A.T. (exc. floor console, tach., clock) . . . . .	3943615	1		LENS, control indicator dial (Note 1) . . . . .
69	Camaro (A.T. w/clock) (exc. floor shift) . . . . .	3943617	1	1.50	LENS, control indicator dial (Note 1)— (9.772) . . . . .
	<i>NOTE 1 For models with clock and with floor shift, or 3-Spd. transmission, see group 9.772 for lens.</i>				
71-72	Pass. . . . .	6496292	1	2.89	LENS, shift indicator assy. . . . .
71-72	Vega w/P.G. . . . .	3984441	1	.74	LENS, trans. cont. indicator . . . . .
71-72	Vega w/Torque Drive . . . . .	3984440	1	.74	LENS, trans. cont. indicator . . . . .
72	Vega . . . . .	6273335	1	.60	LENS, trans. control pointer . . . . .
73	Vega . . . . .	336464	1	.66	LENS, trans. control indicator . . . . .
67	Camaro (floor console w/A.T.),				
68-70	Chevy (A.T. w/floor console) . . . . .	3893875	1	.11	PLATE, indicator dial . . . . .
68	Chevy w/A.T. (exc. floor console) . . . . .	6481616	1	.60	PLATE, indicator . . . . .
68-69	Camaro (A.T. w/floor console) . . . . .	3921803	1	.27	PLATE, control indicator dial . . . . .
68-72	Chevelle (A.T. w/floor console) . . . . .	3921414	1	.22	PLATE, control indicator dial . . . . .
71-72	Vega . . . . .	3984442	1	.18	PLATE, trans. cont. indicator . . . . .
73	Vega . . . . .	331938	1	.18	PLATE, trans. cont. indicator . . . . .
68	Pass. w/A.T. (exc. B.S., S.S.) . . . . .	6481641	1	.84	POINTER, instrument cluster shift indicator . . . . .
68	Chevy w/A.T. (exc. floor console) . . . . .	6481614	1	.84	POINTER, indicator instrument cluster . . . . .
69-70	Pass. w/A.T. . . . .	6482739	1	.55	POINTER, instrument cluster shift indicator . . . . .
70-72	Camaro w/A.T. . . . .	6496267	1	1.64	POINTER, shift indicator . . . . .
73	Vega . . . . .	331939	1	.24	POINTER, trans. cont. indicator . . . . .
69-71	Nova w/P.G. . . . .	6483034	1	5.49	RETAINER, instrument cluster indicator . . . . .
69-72	Nova w/Torque Drive . . . . .	6496632	1	8.83	RETAINER, inst. cluster ind. . . . .
72-73	Nova w/P.G. . . . .	6496630	1	6.04	RETAINER, inst. cluster ind. . . . .
72	Vega . . . . .	3969803	1	.13	SEAL ASSY., trans. cont. ind. light leak (cut as reqd.)— (9.262) . . . . .
68	Pass. w/A.T. (exc. B.S., S.S.) . . . . .	6480711	1	.40	SPRING, instrument cluster shift indicator return . . . . .
68	Chevy w/A.T. (exc. floor console) . . . . .	6481615	1	.54	SPRING, indicator pointer return . . . . .
69-71	Pass. w/A.T. . . . .	6482740	1	.40	SPRING, instrument cluster shift indicator pointer return . . . . .
70-72	Camaro w/A.T. . . . .	6496268	1	.62	SPRING, indicator pointed retainer . . . . .

**4.022 CAP— FASTENER— FILTER— RETAINER— SHIELD— SOCKET ASSY.— WASHER, Gearshift Level Selector and Indicator**

64-65 Chevy, Chevelle w/P.G. (exc. S.S.),

**POWERGLIDE AND TORQUE DRIVE TRANSMISSION**

**4.022 CAP— FASTENER— FILTER— RETAINER— SHIELD— SOCKET ASSY.— WASHER, Gearshift Level Selector and Indicator (Con't)**

67-68	Camaro (T.W. w/P.G.) (exc. floor console) . . . . .	3779994	1	.12	FILTER, indicator dial lamp . . . . .
67	Camaro (A.T. w/floor console),				
68-70	Chevy (A.T. w/floor console) . . .	3893876	1	.46	RETAINER, control indicator dial . . . . .
67	Camaro (T.W. w/P.G.) (exc. floor console) . . . . .	9787711	1	5.80	RETAINER, indicator dial . . . . .
68	Camaro (P.G. w/T.W.) (exc. floor console) . . . . .	3923986	1	1.70	RETAINER, control indicator dial . . . . .
68-72	Chevelle (A.T. w/floor console) . .	3921415	1	.67	RETAINER, control indicator dial . . . . .
63	Nova (S.S.) w/P.G. . . . .	6293344	1	4.55	SOCKET ASSY., rr. trim plate— (2.694) . . .
67	Camaro (floor console w/A.T.) (1st design) . . . . .	3859790	1	.53	WASHER, control lever ( <sup>13</sup> / <sub>32</sub> " O.D., <sup>1</sup> / <sub>16</sub> " thick) . . . . .
67	Camaro (A.T. w/floor console) (2nd design),				
68-70	Chevy (A.T. w/floor console) . . .	3917594	1	.38	WASHER, control lever ( <sup>15</sup> / <sub>32</sub> " O.D., <sup>1</sup> / <sub>2</sub> " thick) . . . . .

**4.025 TUBE ASSY., Gearshift Control**

67-68	Pass. (A.T. w/T.W.) . . . . .	7803830	1	15.05	shifter . . . . .
67-68	Pass. w/A.T. (exc. T.W., floor shift) . . . . .	7803279	1	15.60	shifter . . . . .
67	Camaro w/A.T. (exc. T.W.),				
68	Camaro (A.T. w/column shift) (exc. T.W.),				
68	Chevy w/A.T. (exc. floor console)	7802486	1	23.40	
68	Chevelle w/P.G. (exc. T.W., floor console) . . . . .	7802669	1	15.60	
69-70	Pass. w/A.T. (exc. T.W.) . . . . .	7804497	1	25.75	shifter . . . . .
69-70	Pass. w/T.W. . . . .	7805265	1	26.25	strg. column trans. control lock . . . . .
69-70	Chevelle (column shift w/A.T.) (exc. T.W.),				
69-70	Chevelle w/floor shift (exc. T.W.)	7804493	1	32.50	
70	Pass. w/A.T. (exc. floor shift, T.W.) . . . . .	7806814	1	25.75	lock . . . . .
69	Chevelle (A.T. w/T.W.),				
70	All (A.T. w/T.W.) (exc. Camaro),				
71-72	Chevelle w/T.W. . . . .	7804960	1	32.50	(Note 1) . . . . .
	<i>NOTE 1 Can be used as steering column control lock tube on floor shift models.</i>				
69	Chevy, Camaro (exc. T.W.),				
70	Nova w/floor controls (exc. T.W.),				
70	Nova (A.T. w/col. shift) (exc. T.W.),				
71	Nova . . . . .	7804745	1	25.75	
70-71	Camaro (exc. T.W.) . . . . .	7808563	1	37.75	strg. col. shift . . . . .
70-72	Camaro w/T.W. . . . .	7808908	1	27.25	shift . . . . .
71-72	Pass. w/T.W. . . . .	7809800	1	32.75	shift . . . . .
71-72	Chevelle (exc. T.W.) . . . . .	7807020	1	29.50	shift . . . . .
71-72	Pass. (exc. T.W.) . . . . .	7809589	1	29.00	shift . . . . .
73	All w/T.W. (exc. Vega) . . . . .	7815214	1	26.25	shifter . . . . .

**4.027 GATE— PAWL— PIN— PLATE— PLUNGER— RETAINER— RING— SCREW— SEAL— SPRING— STRAP— WASHER, Transmission Gearshift Control Shaft or Tube**

71-73	All (exc. floor console, T.W.) . . .	7811592	1	1.70	GATE, strg. col. gearshift lever . . . . .
71-73	All w/T.W. (exc. floor console) . .	7811691	1	2.70	GATE, strg. col. gearshift lever . . . . .
68-72	All (A.T. w/floor shift) (exc. Chevy) . . . . .	3920276	1	2.40	PAWL, control lever . . . . .
63	Nova (S.S.) w/P.G. . . . .	3783860	1	1.55	PIN, control lever (beveled ends-3 grooves) ( <sup>1</sup> / <sub>4</sub> " x 1) . . . . .
69-70	Pass. (column shift w/T.W.),				
69-70	Chevelle (column shift w/A.T.) w/T.W.,				
69-70	Camaro w/T.W. . . . .	7804916	1	2.10	PLATE, strg. col. gearshift lever detent . . . .
69-70	All w/column shift (exc. T.W.) . .	7804406	1	1.70	PLATE, strg. col. gearshift lever detent . . . .
69	All (floor shift w/T.W.) (exc. Chevelle) . . . . .	7806055	1	2.95	PLATE, strg. col. shroud index detent . . . . .
69	All (floor shift w/T.W.) (exc. Chevy) . . . . .	7806056	1	1.30	PLUNGER, strg. col. shroud index detent . . .
68-70	All (A.T. w/floor console),				
71-72	Chevelle, Camaro (P.G. w/floor console) . . . . .	3920275	1	.14	RETAINER, control lever detent spring . . . .
67-68	All w/T.W. . . . .	5698409	1	.39	RING, steering column support retainer . . . .

**POWERGLIDE AND TORQUE DRIVE TRANSMISSION**

**4.027 GATE— PAWL— PIN— PLATE— PLUNGER— RETAINER— RING—  
SCREW— SEAL— SPRING— STRAP— WASHER, Transmission Gearshift  
Control Shaft or Tube (Con't)**

69-73	All w/T.W. ....	7804907	1	.47	RING, column support retainer .....
65-66	Pass. w/A.T. ....	3872057	1	1.90	RING ASSY., shifter tube adj. ....
69-70	Pass., Chevelle (exc. T.W.) ....	7806109	1	1.15	SCREW, column shift tube index .....
62-67	Chevy, Chevelle, 65-67 Pass. ....	3711055	1	.28	SEAL, tube (felt) (1 <sup>1</sup> / <sub>8</sub> " I.D. x 1 <sup>15</sup> / <sub>16</sub> " O.D.) ...
70	Chevelle w/T.W.,				
71-72	Pass., Camaro ....	7807007	1	.50	SEAL, strg. col. shifter tube .....
64	Malibu (S.S.),				
65	Impala (S.S.) w/P.G. ....	3874236	1	.11	SPRING, lever release button— (4.008) ....
67	All (exc. T.W.) ....	5698381	1	.65	SPRING, shift tube thrust .....
68	All (A.T. w/floor console),				
70-72	Chevelle, Camaro (A.T. w/floor console) .....	3920273	1	.26	SPRING, control lever button .....
68-69	All (A.T. w/floor console),				
70-72	Chevelle, Camaro (A.T. w/floor console) .....	3920274	1	.15	SPRING, control lever detent .....
69-70	All (exc. T.W.) ....	7804446	1	.88	SPRING, shift tube thrust .....
71-72	Nova, Camaro (exc. floor console) .....	7808481	1	1.10	SPRING, shift tube thrust .....
73	All (exc. T.W.) ....	7810567	1	.98	SPRING, strg. col. shaft tube return lever ..
68-70	All (A.T. w/floor console),				
71-72	Chevelle, Camaro (P.G. w/floor console) .....	3920272	2	1.00	STRAP, control lever release .....
67-68	All w/A.T. (exc. T.W., floor console) .....	5698379	1	.65	WASHER, shift tube thrust .....
68-70	All (A.T. w/floor console),				
71-72	Chevelle, Camaro (P.G. w/floor console) .....	3920277	1	.15	WASHER, control lever pawl spring .....
69-70	All (exc. T.W.),				
71-73	All .....	7807427	1	.47	WASHER, shift tube thrust .....

**4.030 LEVER— HOUSING, Transmission Gearshift Shaft or Tube (Lower)**

69	Pass. w/A.T. (exc. floor shift),				
69-70	Chevelle (A.T. w/T.W.),				
71	Pass., Chevelle w/T.W. (exc. floor console) .....	7805996	1	16.60	HOUSING, column gearshift lever .....
71	All (exc. T.W.) .....	7812064	1	18.35	HOUSING, strg. col. gearshift lever .....

**4.035 ROD, Transmission Gearshift**

62-66	Chevy w/P.G. (exc. S.S.) .....	3792062	1	.88	upper .....
62-67	Chevy w/P.G. (exc. S.S.) .....	3792432	1	2.15	lower .....
64-65	Malibu (S.S.) w/P.G.,				
66-67	Chevelle (P.G. w/floor console) .	3843290	1	3.70	control lower .....
64-66	Chevelle w/P.G. (2nd design) (exc. S.S., floor console),				
66	Chevelle (S.S.) w/P.G. (exc. floor console) .....	3850232	1	1.95	control w/bolted on bracket .....
65-67	Pass. (P.G. w/B.S.) .....	3859855	1	2.35	control .....
65-66	Pass. w/A.T. (exc. B.S.) .....	3869824	1	.98	control .....
67-68	Pass. w/A.T. (exc. B.S.) .....	3898243	1	1.55	control .....
67	Camaro (floor console w/P.G.),				
68-69	Chevy (floor console w/P.G.) ...	3895268	1	1.85	control .....
67-68	Camaro w/P.G., Torque Drive (exc. floor console),				
68	Chevy w/P.G., Torque Drive (exc. floor console),				
69	Chevy, Camaro w/Torque Drive,				
70-71	Nova w/Torque Drive .....	3895294	1	1.25	control lower .....
68-69	Chevy, Camaro w/P.G. (exc. floor console),				
68-69	Chevy, Camaro w/Torque Drive, 69 Chevy w/floor shift,				
69	Camaro w/floor shift,				
70-71	Nova w/P.G., Torque Drive .....	3972256	1	1.65	control upper .....
68	Chevelle w/P.G. (1st design) ...	1382860	1	1.45	control .....
69-70	Pass. w/A.T. ....	3954651	1	1.70	control .....
69	Chevy, Camaro w/P.G.,				
70-71	Nova w/P.G. ....	3939743	1	1.35	control lower .....
69	Chevelle w/A.T. (exc. floor console) .....				control, .....
69	Chevelle (A.T. w/floor console),				
70-72	Chevelle w/A.T. ....	3945415	1	1.35	control lock .....
70-72	Camaro w/A.T. ....	3975630	1	1.35	control .....

**POWERGLIDE AND TORQUE DRIVE TRANSMISSION**

<b>4.035 ROD, Transmission Gearshift</b>		<b>(Con't)</b>		
71-72	Pass. w/P.G. ....	3988225	1	1.55 control .....
71-72	Vega (1st design) .....	3978175	1	3.60 trans. park lock and range selector outer (threaded) .....
72-73	Vega (2nd design) .....	325795	1	2.20 trans. park lock and range selector outer (slotted) .....
72-73	Nova .....	3998688	1	1.35 control .....
<b>4.037 BUSHING— CLAMP— CLIP— GROMMET— NUT— PIN— RETAINER— SCREW— SLEEVE— SWIVEL— WASHER, Transmission Gearshift Rod to Lever</b>				
64-72	All (exc. Vega) .....	382102	A.R.	.11 control rod, lever ( <sup>3</sup> / <sub>8</sub> " I.D.— <sup>1</sup> / <sub>2</sub> " O.D.) .....
65-66	Pass. w/P.G. (exc. B.S.) .....	3710401	A.R.	.18 control upper and lower rod idler lever ( <sup>1</sup> / <sub>2</sub> " I.D. x <sup>3</sup> / <sub>4</sub> " O.D.) (Note 1) .....
64-70	All .....	382103	1	.16 <b>CLAMP</b> , cup shade and rod control ( <sup>13</sup> / <sub>32</sub> " I.D. x <sup>25</sup> / <sub>32</sub> " O.D. x <sup>7</sup> / <sub>32</sub> " thk.) .....
62-66	Chevy w/P.G.,			
65-66	Pass. w/A.T. (2nd design) (exc. B.S.) .....	3725298	A.R.	.22 <b>CLAMP</b> , control rod ( <sup>11</sup> / <sub>32</sub> " I.D.) .....
65	Pass. w/P.G. (exc. S.S.) (1st design) .....			
62-66	Chevy .....	3790231	1	.22 <b>CLAMP</b> , control rod to shifter tube, 1st and reverse 2nd and 3rd rod to lower shift tube .....
62-68	All .....	3749084	A.R.	.27 <b>CLIP</b> , control rod (all locations) (Note 1) ..
All	All .....	3975131	1	.16 <b>GROMMET</b> , control shifter tube lever ( <sup>3</sup> / <sub>4</sub> " O.D. x <sup>1</sup> / <sub>2</sub> " I.D. x <sup>5</sup> / <sub>16</sub> " thk.— rubber) .....
All	All .....			<b>GROMMET</b> , bell crank, control rod lever ( <sup>5</sup> / <sub>16</sub> " I.D.) (Note 1) .....
71-73	H .....	3833107	2	.12 trans. park lock and range selector outer ( <sup>5</sup> / <sub>16</sub> " I.D. x <sup>11</sup> / <sub>16</sub> " O.D.) .....
65-66	Pass. ....	3834139	1	.11 <b>GROMMET</b> , control rod to shifter tube lever ( <sup>3</sup> / <sub>4</sub> ") .....
64-66	Chevelle (exc. S.S., floor console),			
67	Chevelle w/P.G. (exc. floor console) .....			<b>GROMMET</b> (shifter tube lever) ( <sup>5</sup> / <sub>16</sub> " I.D.), ..
65-68	Pass. w/A.T. (exc. B.S.) .....			control rod front end, control upper rod/column end, .....
67	Chevy w/P.G. (exc. S.S.) .....			control upper rod idler, .....
67	Chevelle w/P.G. ....			lever end, .....
67	Camaro w/A.T. (exc. floor console),			
68	Chevy, Camaro w/A.T. (exc. floor shift),			
69	Chevy, Camaro .....	3852837	1	.11 control rod .....
66-67	Chevelle w/A.T. (exc. floor console),			
68	Chevelle (S.S.) w/A.T. (exc. floor console),			
69-70	Chevelle w/P.G.,			
69-70	Pass. w/A.T. ....	391312	1	.34 <b>GROMMET</b> , control rod ( <sup>21</sup> / <sub>32</sub> " I.D.)— (4.032) .....
73	Nova .....	1394293	1	.27 <b>GROMMET</b> , control rod col. end. ....
62-68	All .....	3840137	1	.13 <b>NUT</b> , control rod clevis ( <sup>7</sup> / <sub>16</sub> "— 20)— (4.253) .....
All	All .....	472668	A.R.	.48 <b>PIN</b> , clevis (use wherever <sup>5</sup> / <sub>16</sub> " dia. x <sup>5</sup> / <sub>8</sub> " effective length pin must be used) .....
67-70	Chevelle,			
69-70	Pass. w/A.T.,			
71	All (exc. Vega),			
72-73	Nova .....			<b>RETAINER</b> , control rod, control eqlzr., and control rod lock (hairpin type), .....
71-73	Vega .....	1351769	A.R.	<b>RETAINER</b> , trans. throttle valve control lever rod, park lock and range sel. outer ..
71-73	Vega .....	3988005	1	.27 <b>RETAINER</b> , trans. control shift lever .....
67-71	Chevelle w/A.T.,			
69-72	Pass. w/A.T.,			
70-71	Camaro (A.T. w/floor console) ..			<b>SCREW</b> , control rod swivel, .....
72	Chevelle (P.G. w/floor console) ..			control lock, .....
72-73	Nova, Camaro w/P.G. ....	3989433	A.R.	.16 control lock rod swivel idler lever end .....
64-69	Chevelle,			
65-70	Pass.,			
67-69	Camaro,			
68-70	Chevy .....	3852838	1	.16 <b>SLEEVE</b> , shifter tube lever and upper rod ( <sup>3</sup> / <sub>8</sub> " O.L. x <sup>15</sup> / <sub>32</sub> " O.D. x <sup>3</sup> / <sub>16</sub> " I.D.) .....

**POWERGLIDE AND TORQUE DRIVE TRANSMISSION**

**4.037 BUSHING— CLAMP— CLIP— GROMMET— NUT— PIN— RETAINER— SCREW— SLEEVE— SWIVEL— WASHER, Transmission Gearshift Rod to Lever (Con't)**

70-72	Camaro (A.T. w/floor console) . . .				<b>SLEEVE UNIT</b> , w/bushing control lock rod, col. end, . . . . .
70-71	Camaro w/A.T. (exc. floor console),				
72	Pass., Nova, Camaro w/A.T. (exc. floor console) . . . . .	<b>1394293</b>	1	.27	control rod, col. end . . . . .
All	All . . . . .	<b>382104</b>	1	.24	<b>SWIVEL</b> ( <sup>9</sup> / <sub>8</sub> " x 16" threads, 1 <sup>1</sup> / <sub>2</sub> " long w/1 <sup>5</sup> / <sub>8</sub> " dia. hole) . . . . .
62-66	Chevy w/P.G.,				
64-66	Malibu (S.S.) w/P.G.,				
65-67	Pass. w/A.T. (2nd design) (exc. B.S.) . . . . .	<b>3772164</b>	1	.53	<b>SWIVEL</b> , control rod, upper to shift tube lever (1 <sup>3</sup> / <sub>8</sub> " O.L.) . . . . .
65	Pass. w/P.G. (1st des.) (exc. S.S.)	<b>3790230</b>	1	.59	<b>SWIVEL</b> , control rod to shifter tube . . . . .
64-65	Chevelle (B.S. w/P.G.),				
65-67	Nova (S.S.) w/P.G.,				
66-67	Chevelle, Camaro (A.T. w/floor console),				
68-69	Chevy w/floor console,				
70	Nova (A.T. w/floor console) . . . . .	<b>3843142</b>	1	.59	<b>SWIVEL</b> , control lower rod, control rod . . . . .
71-72	Vega (1st design) . . . . .	<b>3996334</b>	1	.50	<b>SWIVEL</b> , trans. park lock and range selector outer (Note 2) . . . . .
72-73	Vega (2nd design) . . . . .	<b>329757</b>	1	.50	<b>SWIVEL</b> , trans. park lock and range selector outer (Note 2) . . . . .
68-72	Chevelle w/A.T.,				
70	Pass. w/A.T.,				
70	Camaro (A.T. w/floor console),				
72-73	Nova,				
71-72	Camaro w/P.G. . . . .	<b>1385607</b>	1	.71	control rod idler lever end . . . . .
All	All . . . . .	<b>9415113</b>	A.R.	.11	<b>WASHER</b> , control rod swivel (to shifter tube lever) ( <sup>9</sup> / <sub>16</sub> " I.D. x <sup>7</sup> / <sub>8</sub> " O.D.) (wave type) . . . . .
All	All . . . . .	<b>3772165</b>	A.R.	.11	<b>WASHER</b> , 1st and reverse rod (to shifter tube lever) trans. control rod swivel ( <sup>17</sup> / <sub>32</sub> " I.D. x <sup>7</sup> / <sub>8</sub> " O.D.) (flat type) . . . . .
All	All . . . . .	<b>382105</b>	A.R.	.12	<b>WASHER</b> , control upper rod to trans. control shifter tube lever ( <sup>25</sup> / <sub>32</sub> " I.D. x <sup>3</sup> / <sub>4</sub> " O.D.) . . . . .
64-70	All,				
71	Chevelle . . . . .	<b>580379</b>	A.R.	.11	<b>WASHER</b> , cont. rod to trans. cont. counter shaft cont. upper, rod to cont. idler lever ( <sup>23</sup> / <sub>32</sub> " O.D. x <sup>21</sup> / <sub>16</sub> " I.D. x <sup>1</sup> / <sub>2</sub> " thk.) . . . . .
68-72	Chevelle w/A.T.,				
70-72	Pass. w/A.T.,				
70-72	Camaro (A.T. w/floor console),				
72	Nova . . . . .	<b>3989434</b>	1	.11	<b>WASHER</b> , control rod lock swivel ( <sup>11</sup> / <sub>32</sub> " I.D. x <sup>27</sup> / <sub>32</sub> " O.D.) . . . . .
68-70	Chevelle w/A.T.,				
69-70	Pass. w/A.T.,				
70	Camaro (A.T. w/floor console) . . .				<b>WASHER</b> , cross shaft lever, . . . . .
72	Pass. w/P.G. . . . .				control equal. shaft spring, . . . . .
72	Chevelle w/P.G. . . . .				control cross shaft and lever, . . . . .
72	Camaro w/P.G. (exc. floor console) . . . . .				control rod idler lever, . . . . .
72-73	Nova,				
72	Camaro (P.G. w/floor console) . . .	<b>492346</b>	1	.34	control lock rod idler lever . . . . .
71-73	Vega . . . . .	<b>3992926</b>	1	.14	<b>WASHER</b> , trans. control rod lever . . . . .

*NOTE 1 The above parts are also used as replacement parts with rebuilt trans. assy. 3832565 (P.G.).*

*NOTE 2: 1st design is identified by threaded type park lock and range selector outer rod, 2nd design is identified by slotted, type park lock and range selector outer rod.*

**4.040 LEVER— BRACKET— SHAFT— SUPPORT ASSY.— WASHER, Transmission Control Idler**

62-66	Chevy w/P.G. (exc. S.S.) . . . . .	<b>3792433</b>	1	1.55	
65-67	Chevy (S.S.) w/P.G.,				
65	Malibu (S.S.) w/P.G.,				
65-67	Chevelle, Camaro (P.G. w/floor console),				
65-68	Pass. (P.G. w/B.S.),				
68	Chevy (P.G. w/floor console) . . . . .	<b>3842090</b>	1	4.50	range selector actuating . . . . .
67-69	Camaro w/P.G. (exc. floor console),				
68-69	Chevy w/P.G. (exc. floor console),				



**POWERGLIDE AND TORQUE DRIVE TRANSMISSION**

**4.040 LEVER— BRACKET— SHAFT— SUPPORT ASSY.— WASHER,  
Transmission Control Idler (Con't)**

68-70	Chevy, Camaro w/Torque Drive,				
69-70	Chevy, Camaro w/floor shift,				
71-72	Nova	3895290	1	1.65	
70-72	Camaro w/P.G.	3975632	1	3.30	LEVER ASSY., control rod idler
72-73	Nova	3998689	1	3.30	LEVER ASSY., control rod idler
72	Vega (1st design)	3988006	1	2.50	LEVER ASSY., trans. cont. rod (Note 1)
72	Vega w/P.G. (2nd design)	329759	1	2.60	LEVER ASSY., trans. cont. rod (Note 1)
73	Vega	325784	1	2.60	LEVER ASSY., trans. cont. shaft
64-65	Chevelle w/P.G. (2nd design) (exc. S.S., floor console),				
66-67	Chevelle w/P.G. (exc. floor console)	3850235	1	1.70	BRACKET, cross shaft frame
68	Chevelle w/P.G. (exc. floor console)	3925061	1	1.80	BRACKET, control cross shaft frame
69-70	Pass. w/A.T.	3939282	1	1.20	BRACKET, control equalizer shaft
70-72	Chevelle	1230115	1	.88	BRACKET, control equalizer shaft frame
70-71	Camaro w/A.T. (exc. floor console),				
72-73	Nova				BRACKET, control rod idler lever,
70-72	Camaro (A.T. w/floor console)	3998691	1	1.65	control lock rod idler lever
65-68	Pass. w/A.T. (exc. B.S., S.S.)	3859849	1	1.45	BRACKET ASSY., control shaft frame
64-66	Chevelle w/P.G. (exc. floor console)	3857183	1	4.80	SHAFT, control cross, bolt on bracket (Note 1)
<i>NOTE 1 When using in place of 1st design, 3850232 (2nd design) trans. control rod must also be used.</i>					
65-68	Pass. w/P.G. (exc. B.S., S.S.)	3898245	1	2.40	SHAFT, control cross
67-68	Chevelle w/P.G. (exc. fir. console)	3898257	1	4.10	SHAFT, control cross
69-70	Pass. w/P.G.	3939284	1	2.85	SHAFT, control equalizer
70-73	All w/P.G.	3952622	1	2.95	SHAFT, outer, park lock and range sel.
70-71	Nova w/Torque Drive,				
71-72	Vega w/Torque Drive	6261792	1	4.70	SHAFT, park lock and range selector outer
69-72	Chevelle w/P.G.	3945417	1	3.25	SHAFT ASSY., control cross w/lever
71-72	Pass. w/P.G.	3984797	1	2.85	SHAFT ASSY., control equal.
62-67	Chevy w/P.G. (exc. S.S.)	3792066	1	1.65	SUPPORT ASSY., lever
67-69	Camaro w/P.G. (exc. floor console),				
68-69	Chevy w/P.G. (exc. floor console),				
68-69	Chevy, Camaro w/Torque Drive,				
69	Chevy, Camaro w/floor shift,				
70-71	Nova w/A.T.	3895291	1	2.25	SUPPORT ASSY., control rod idler lever
71-73	H	3984038	1	.44	WASHER, trans. control rod lever

*NOTE 1: 1st design is identified by threaded type park lock and range selector outer rod, 2nd design is identified by slotted type park lock and range selector outer rod.*

**4.042 LOCK— BUSHING— NUT— PIN— RETAINER— SPRING— WASHER,  
Transmission Control Idler Attaching**

62-69	Chevy, Camaro w/A.T. (exc. floor console),				
65-66	Chevelle w/P.G.,				
71-72	Nova	3685801	1	.16	control rod idler lever ( <sup>13</sup> / <sub>16</sub> " O.D.)
62-69	Chevy w/P.G. (exc. floor console),				
67-68	Camaro w/P.G. (exc. floor control),				
68	Camaro, Chevy w/Torque Drive,				
69-70	Chevy, Chevelle, Camaro,				
71	Nova	3792168	A.R.	.22	BUSHING, trans. cont. rod idler lever
64-65	Malibu (S.S.) w/P.G.,				
66-67	Chevelle (P.G. w/floor console)	3843140	2	.15	BUSHING, actuating lever pin
64-70	All	382102	A.R.	.11	BUSHING, control rod ( <sup>3</sup> / <sub>8</sub> " I.D.— <sup>1</sup> / <sub>2</sub> " O.D.)— (4.037)
69-71	Chevelle w/A.T.				BUSHING, control cross shaft,
69-70	Pass. w/A.T. (exc. B.S.)				equalizer shaft,
71-72	Camaro (P.G. w/floor console)				control lock rod idler lever,
71-72	Camaro w/P.G. (exc. floor console),				
72-73	Nova	1377083	1	.16	control rod idler lever
67-72	Chevy, Camaro	3792287	1	.34	NUT, cont. rod idler lever supt.— (3.704)
64-65	Malibu (S.S.) w/P.G.,				
66-67	Chevelle (P.G. w/floor console)	3843267	1	.49	PIN, actuating lever
64-68	Chevelle w/P.G. (exc. B.S. w/floor console),				

**POWERGLIDE AND TORQUE DRIVE TRANSMISSION**

**4.042 LOCK— BUSHING— NUT— PIN— RETAINER— SPRING— WASHER,  
Transmission Control Idler Attaching (Con't)**

65-69	Pass. w/A.T. (exc. B.S.)	3842902	2	.11	<b>RETAINER</b> , cross shaft anti-rattle spring, trans. cross shaft
65-66	Chevelle w/P.G.	3698237	1	.12	<b>SPRING</b> , cross shaft (idler inner and outer levers— 6½" coils-11/16" I.D.)
65-69	Pass.				<b>SPRING</b> , parking lock and range selector lever shaft, anti-rattle,
65-67	Chevelle w/P.G. (exc. B.S. w/floor console),				
68-69	Pass. w/A.T.	3755663	1	.11	control cross shaft
69-72	Chevelle w/A.T.				<b>SPRING</b> , cross shaft,
69-70	Pass. w/A.T.,				
70	Camaro (A.T. w/floor console)				equalizer shaft,
71-72	Camaro w/P.G.,				
72-73	Nova	1380549	1	.11	control lock rod idler

**4.045 LEVER ASSY., Transmission Mounted Gearshift (External)**

63-68	Chevy w/P.G. (exc. S.S.),				
67-68	Camaro w/P.G. (exc. floor console)	3829989	1	9.60	w/shaft parking lock and range selector outer
63-64	Nova (S.S.) w/P.G.	3829987	1	9.10	w/shaft, parking lock and range selector outer
64-68	Chevelle w/P.G. (exc. floor console),				
65-68	Pass. w/P.G. (exc. B.S.),				
65-67	Chevy (S.S.) w/P.G.,				
68	Chevy, Camaro (P.G. w/floor console)	3842074	1	9.60	w/shaft, lock and range selector
68	Chevelle, Camaro (P.G. w/floor console),				
68	Pass. (P.G. w/B.S.),				
69	Chevy, Camaro w/P.G.	3946735	1	10.30	w/shaft park. lock and range selector
68-69	Chevy, Camaro w/Torque Drive	3946702	1	9.05	w/shaft, trans. park. lock and range selector outer
69	Pass., Chevelle w/P.G.	3946733	1	9.05	parking lock and range selector outer
70-72	Pass., Chevelle w/P.G.	3952625	1	1.15	park. lock and range sel. outer
70-72	Nova	3952626	1	1.20	park. lock and range sel. outer
70-72	Camaro	3982395	1	1.25	park. lock and range sel.
72-73	Nova	3998690	1	1.25	park. lock and range sel. actuating
71-73	Vega	3978177	1	1.05	trans. park lock and range selector outer

**4.046 NUT, Transmission Gearshift External Control Lever**

70-73	All w/A.T.	3952675	1	.12	park lock and range sel. (5/8" — 18)
-------	------------	---------	---	-----	--------------------------------------

**4.047 CABLE ASSY.— BOLT— BRACKET— GROMMET— PIN— WASHER,  
Transmission Gearshift Control Cable**

68-69	Pass. (A.T. w/B.S.)	3956767	1	12.00	control
68-72	Chevelle, Camaro (A.T. w/floor console)	3956765	1	12.00	trans. control
69-70	Chevy (A.T. w/floor console)	6491944	1	1.91	shift control
68-70	Impala, Caprice w/A.T.,				
68-70	All (A.T. w/floor console) (exc. Pass.)	443899	A.R.	.11	<b>BOLT</b> , control cable bracket (5/16" — 18 x 7/8") — (8.900)
68-69	All (P.G. w/floor console) (exc. Chevy),				
70-72	Chevelle (P.G. w/floor console)	3953578	1	1.05	<b>BRACKET</b> , control cable
68	Camaro	9788709	1	2.05	<b>BRACKET</b> , control cable
70-72	Camaro (P.G. w/floor console)	3982397	1	1.70	<b>BRACKET</b> , control cable
68-69	All (A.T. w/floor console),				
70-72	Chevelle, Camaro (A.T. w/floor console)	3922580	1	1.75	<b>GROMMET</b> , control cable
68-69	All (A.T. w/floor console),				
70	Chevelle (A.T. w/floor console),				
71-72	Chevelle, Camaro (P.G. w/floor console)	9779348	1	.73	<b>PIN</b> , control cable
68-69	Impala, Caprice w/A.T.,				
68-70	All (A.T. w/floor console) (exc. Pass.)	120638	A.R.		<b>WASHER</b> , control cable bracket (5/16") — (8.931)

**4.050 ROD— BRACKET— LEVER— RING— SHAFT, Transmission Throttle Valve Control (T.V.)**

63-66	Chevy, Chevelle w/P.G. (6 cyl.),				
-------	----------------------------------	--	--	--	--

**POWERGLIDE AND TORQUE DRIVE TRANSMISSION**

**4.050 ROD— BRACKET— LEVER— RING— SHAFT, Transmission Throttle Valve Control (T.V.) (Con't)**

65-66	Pass. w/P.G. (6 cyl.)	3837310	1	1.45	throttle valve control
67-70	All w/P.G. (283, 307) (exc. Camaro),				
67-70	Camaro w/P.G. (327 w/2BC),				
69-70	Pass. (P.G. w/2BC) (327, 350)				throttle valve control cross shaft
71-72	Chevelle w/P.G. (8 cyl.)				throttle valve control rod
71-72	Pass., Camaro w/P.G. (8 cyl.)				throttle valve control upper
71-72	Nova w/P.G. (8 cyl.)	3904254	1	1.25	throttle valve control cross shaft
67-68	All w/P.G. (327),				
69-70	All (P.G. w/4BC) (350)	3904060	1	1.25	throttle valve control cross shaft
71-73	Vega	3978133	1	1.10	trans. throttle valve control, trans. to brkt.
71-73	Vega	3991310	1	1.90	trans. throttle valve control lever, trans. brkt. to carb. at trans.
71-73	Vega	3978143	1	1.25	trans. throttle valve control lever, trans. brkt. to carb., at carb., slotted
71-73	Vega	3978134	1	1.50	<b>BRACKET</b> , trans. throttle valve control rod
62-69	Chevy w/P.G. (4 cyl.)	3830219	1	2.70	<b>ROD ASSY.</b>
64-66	Chevy, Chevelle w/P.G. (8 cyl.) (exc. 4BC),				
65-66	Pass. w/P.G. (283) (exc. 4BC)	3830308	1	1.45	<b>ROD ASSY.</b> , throttle valve control cross shaft
64-65	Chevy, Chevelle w/P.G. 4BC (exc. H/Per.),				
65	Pass. w/P.G. (327) (exc. H/Per.),				
66	Chevy, Chevelle (283 w/4BC),				
67-68	Camaro (floor console w/P.G.),				
67	Pass. w/P.G. (283),				
68	Nova (P.G. w/floor console),				
69	Chevy, Camaro w/P.G.	3830309	1	1.45	<b>ROD ASSY.</b> , throttle valve control cross shaft
64-67	Chevy, Chevelle, Camaro w/P.G. (8 cyl.) (exc. 396),				
65-69	Pass. w/P.G. (8 cyl.) (exc. 396, 427),				
68-70	Chevy, Chevelle, Camaro w/P.G. (8 cyl.),				
71-72	Pass., Chevelle w/P.G. (8 cyl.)				<b>ROD ASSY.</b> , throttle valve control
71-72	Nova, Camaro w/P.G. (8 cyl.)	3830310	1	.93	throttle valve control lower
65-69	Pass. w/P.G. (396),				
66-67	Chevelle w/P.G. (396),				
68	Chevelle (S.S.) w/P.G. (396)	3868694	1	.76	<b>ROD ASSY.</b> , throttle valve cont.
65-66	All w/P.G. (396)	3881488	1	2.20	<b>ROD ASSY.</b> , throttle valve control cross shaft adjuster
66	Pass. w/P.G. (327),				
66	Chevy, Chevelle w/P.G. (327) (exc. Sp. H/Per.)	3876964	1	1.45	<b>ROD ASSY.</b> , throttle valve cont. cross shaft
67-72	All w/P.G. (6 cyl.),				
73	All	3901360	1	1.25	<b>ROD ASSY.</b> , valve control
67-68	Pass., Chevelle w/P.G. (396)	3904257	1	1.25	<b>ROD ASSY.</b> , throttle valve cont. cross shaft adj.
67-69	All w/P.G. (exc. 8 cyl.),				
70	All w/P.G. (exc. Camaro, 8 cyl.),				
71-72	All w/P.G. (6 cyl.),				
73	All	3972248	1	.46	<b>LEVER</b> , throttle valve control
70	Nova w/Torque Drive,				
70-73	All w/P.G. (exc. Vega)	3952617	1	1.15	<b>LEVER</b> , throttle valve control outer
71-73	Vega	3997231	1	.36	<b>LEVER</b> , trans. throttle valve control
63-64	Chevy w/P.G.,				
65-68	Chevy w/P.G. (exc. S.S.),				
67-68	Camaro w/P.G. (exc. floor console)	3829992	1	5.35	<b>LEVER ASSY.</b> , outer
65-67	Nova (S.S.) w/P.G.,				
65-69	Chevelle w/P.G.,				
65-69	Pass. w/P.G. (2nd design),				
67-68	Camaro (floor console w/P.G.),				
68	Nova (P.G. w/floor console),				
69	Chevy, Camaro w/P.G.	3842077	1	4.65	<b>LEVER ASSY.</b> , outer
71-73	Vega	3978135	1	1.35	<b>LEVER ASSY.</b> , trans. throttle valve control rod
68-70	All	9416094	A.R.	.11	<b>RING</b> , detent valve (zinc, 3/16" dia.)— (8.934)
64-70	Pass. w/P.G. (8 cyl.),				
71-72	All w/P.G. (8 cyl.)	3830304	1	2.30	<b>SHAFT</b> , bracket, throttle valve cross w/bracket
70	All w/A.T.,				

**POWERGLIDE AND TORQUE DRIVE TRANSMISSION**

**4.050 ROD— BRACKET— LEVER— RING— SHAFT, Transmission Throttle Valve Control (T.V.) (Con't)**

71-73 All w/P.G. . . . . 3952672 1 2.20 SHAFT, throttle valve control . . . . .

**4.052 CLIP— NUT— SLEEVE— SPRING— STUD— SWIVEL— WASHER, Transmission Throttle Valve Control**

62-72 All . . . . . 3711177 A.R. .28 lower and upper, front rod— (3.425) . . . . .  
 62-72 All . . . . . 3700188 1 .29 special— (3.425) . . . . .  
 62-69 All . . . . . 1455017 A.R. .13 upper rod— (3.425) . . . . .  
 70-73 All w/P.G. . . . . 1498443 1 .11 NUT, control shaft (<sup>7</sup>/<sub>16</sub>"— 20) . . . . .  
 71-73 Vega . . . . . 3992929 1 .53 SLEEVE, trans. throttle valve control lever  
 rod . . . . .  
 67 Camaro w/P.G. (327, 350),  
 67 Pass., Chevelle w/P.G. (327) . . . 3904245 1 .48 SPRING, throttle valve pull back, throttle  
 valve cont. cross shaft— (3.459) . . . . .  
 67 Pass. w/P.G. (283) . . . . .  
 67 Chevy, Chevelle w/P.G. (327) . . . 3952107 1 .48 SPRING, throttle valve cont. cross shaft, . . .  
 cross shaft pull back— (3.459) . . . . .  
 67-68 Pass., Chevelle w/P.G. (396) . . . 3928245 1 .36 SPRING, also back-up lamp . . . . .  
 68 Pass. w/P.G. (307),  
 68 Chevy, Chevelle, Camaro (P.G.  
 w/2BC) (307, 327),  
 69-72 All w/P.G. (8 cyl.) . . . . . 3953999 1 .36 SPRING, throttle valve control rod pull  
 back— (3.459) . . . . .  
 68 Pass. w/P.G. (327),  
 68 Chevy, Chevelle, Camaro w/P.G.  
 (327 w/4BC, 350) . . . . . 3928312 1 .36 SPRING, throttle valve control rod pull  
 back— (3.459) . . . . .  
 69-72 All w/P.G. (6 cyl.),  
 71-72 Vega,  
 73 All w/P.G. . . . . 3953208 1 .21 SPRING, throttle valve control rod pull back  
 62-69 All (6 cyl.) . . . . . 3997258 1 .78 STUD, throttle valve control intermediate  
 rod lever (<sup>5</sup>/<sub>16</sub>"— 18 thds., x 2<sup>3</sup>/<sub>8</sub>" O.L. <sup>1</sup>/<sub>2</sub>"  
 hex. nut)— (3.463) . . . . .  
 69-70 All w/P.G. (8 cyl.),  
 71-72 Chevelle w/P.G. (8 cyl.) . . . . .  
 71-72 Nova w/P.G. (8 cyl.) . . . . .  
 71-72 Pass., Camaro w/P.G. (8 cyl.) . . . 3949065 1 .16 STUD, c/shaft ball, . . . . .  
 control upper rod, . . . . .  
 control upper rod ball . . . . .  
 62-67 All,  
 70-72 Pass., Chevelle, Camaro . . . . . 3711199 A.R. .29 SWIVEL, throttle valve control (use w/<sup>1</sup>/<sub>4</sub>"  
 rod)— (3.425) . . . . .  
 70 All w/A.T.,  
 71-73 All w/P.G. . . . . 3978774 1 .12 WASHER, shaft . . . . .  
 71-73 All w/P.G. (6 cyl.),  
 73 Vega . . . . . 3998635 1 .13 WASHER, control rod (reinforced plastic) . .

**4.054 SWITCH ASSY.— BRACKET ASSY.— CLIP— HARNESS ASSY.— LEVER— ROD— SCREW— SWIVEL, Transmission Control Safety**

62-66 Chevy, Chevelle w/P.G. (exc.  
 S.S., floor console),  
 65-66 Pass. w/P.G. (exc. B.S.) . . . . . 1993659 1 3.45 also back-up lamp . . . . .  
 63 Nova (S.S.) w/P.G. . . . . 1993618 1 18.55 also back-up lamp . . . . .  
 64 Malibu (S.S.) w/P.G. . . . . 1993658 1 9.85 also back-up lamp . . . . .  
 65 S.S. w/P.G.,  
 65-67 Chevy, Chevelle (P.G. w/floor  
 console),  
 66-67 Pass. (P.G. w/B.S.),  
 68 Pass. (P.G. w/B.S.) (exc. S.S.) . . . 1993696 1 5.65 also back-up lamp . . . . .  
 67-68 Pass. w/A.T. (exc. B.S.),  
 67-68 All w/A.T. (exc. Pass. floor  
 console) . . . . . 1993404 1 3.35 also back-up lamp . . . . .  
 67-69 Pass. (A.T. w/B.S.),  
 68-72 Chevelle, Camaro (A.T. w/floor  
 console) . . . . . 1993434 1 4.26 control and back-up lamp . . . . .  
 67 Camaro (floor console w/P.G.),  
 68-70 Chevy (Spt. Cpe.) w/flr. console . 3900503 1 5.60 neutral safety and back-up lamp . . . . .  
 69-71 All w/A.T. (exc. floor console),  
 72-73 All (exc. Vega) . . . . . 1994158 1 4.62 control safety and backing lamp . . . . .  
 71 Vega . . . . . 1994105 1 6.25 trans. control safety and backing lamp . . . . .  
 72-73 Vega . . . . . 1994155 1 9.05 trans. safety back-up lamp, and seat belt  
 warning . . . . .  
 71-72 Vega w/Torque Drive . . . . . 3991373 1 4.20 BRACKET ASSY., trans. control lever . . . . .  
 Not required in this group. See  
 group 3.762, 9.787 . . . . . 3908243 1 .63 CLIP . . . . .  
 67 Camaro (A.T. w/floor console),  
 68-70 Chevy (A.T. w/floor console) . . . 3895280 1 .78 LEVER, neutral safety switch . . . . .

**POWERGLIDE AND TORQUE DRIVE TRANSMISSION**

**4.054 SWITCH ASSY.— BRACKET ASSY.— CLIP— HARNESS ASSY.— LEVER— ROD— SCREW— SWIVEL, Transmission Control Safety (Con't)**

68-70	All (A.T. w/floor console) (exc. Chevy),				
71-72	All (P.G. w/floor console) (exc. Vega)	3920283	1	.12	LEVER, neutral safety switch
63-64	Nova (S.S.) w/P.G.	3829470	1	.53	ROD, and backing lamp switch
63-64	Nova (S.S.) w/P.G.	3947382	1	.81	SWIVEL, switch rod

**4.060 FASTENER, Transmission Control Switch**

71-72	Chevelle, Camaro (P.G. w/floor console)	564708	2	.16	control cable retainer
-------	---	--------	---	-----	------------------------

**4.067 BOOT— SHIELD, Gearshift Linkage**

64-67	Chevelle w/P.G. (exc. B.S. w/floor console),				
65-69	Pass. w/A.T. (exc. B.S.),				
68	Chevelle w/P.G. (exc. floor console)	3852836	1	.22	control cross shaft
68-69	Pass., Chevelle w/P.G.	3953637	1	1.70	SHIELD, trans. control splash

**4.075 SWITCH ASSY.— RELAY ASSY., Transmission, Smog Control**

*NOTE See 2.408 Group for electrical parts.*

70-72	All w/A.T. (exc. Vega),				
71-73	Vega (exc. NB-2)	6462549	1	1.95	trans. control spark
72	Vega w/NB-2	6273237	1	2.70	trans. control spark
73	All w/P.G. (exc. Vega)	3996287	1	3.00	trans. control spark
70	All,				
71-73	Vega	3961573	1	2.85	RELAY ASSY., trans. control spark
71	All (exc. Vega)	3990842	1	2.45	RELAY ASSY., trans. control switch reversing
72	All (8 cyl.) (exc. 402, 454)	3996297	1	3.65	RELAY ASSY., control vac. adv. delay (60 seconds)
72	All (6 cyl.)	3996296	1	2.25	RELAY ASSY., control spark delay (20 seconds)

**4.081 SUPPORT— MOUNTING ASSY.— MEMBER ASSY., Transmission Mounting**

67	Pass. (327, 396, 427) (2nd design) (exc. Conv.)	3906954	1	14.10	(w/1 square and 1 round hole)
68	Pass. (250, 307) (exc. Conv.),				
69	Pass. (Sta. Wag.)	3950232	1	14.25	
70	Pass. (Conv.)	3947536	1	14.25	
64-72	Chevelle (exc. El Camino, Conv.)	6272136	1	17.90	SUPPORT ASSY.
64-67	Chevelle (Conv., El Camino)	3838043	1	11.60	SUPPORT ASSY.
67-69	Camaro w/P.G. (exc. 396),				
68-72	Chevy (exc. 396),				
68-69	Camaro (396)	3899006	1	10.50	SUPPORT ASSY.
69-72	Chevelle (El Camino, Conv.)	6272134	1	17.35	SUPPORT ASSY.
68-69	Pass. (exc. Sta. Wag., Conv.),				
70	Pass. (exc. Sta. Wag., Conv., C.A.C.)	3947535	1	10.20	SUPPORT ASSY. (code letter "S") (Note 4)

*NOTE 4 When used in place of 3928222 it will be necessary to add a hole in support bracket for trans. mounting. Use old part as guide.*

70-72	Monte Carlo w/A.T. (exc. Conv.)	3967773	1	10.65	SUPPORT ASSY.
70	Pass. (C.A.C. w/P.G.) (8 cyl.) (exc. Conv., Sta. Wag.)	3953528	1	13.00	SUPPORT ASSY.
69	Pass. (Sta. Wag.),				
70	Pass. (Sta. Wag.) (exc. C.A.C.)	3984771	1	18.25	SUPPORT ASSY.
70	Pass. (Sta. Wag.) (C.A.C. w/P.G.)	3984772	1	17.25	SUPPORT ASSY.
70-72	Camaro	3964816	1	13.65	SUPPORT ASSY.
71	Pass. w/P.G. (exc. Sta. Wag.)	331288	1	16.75	SUPPORT ASSY.
72	Pass. w/P.G.	6270765	1	16.85	SUPPORT ASSY. (stamped X)
73	Nova	3899006	1	10.50	SUPPORT ASSY.
71-72	Vega	3978138	1	10.55	SUPPORT ASSY., trans.
73	Vega	329708	1	5.85	SUPPORT ASSY., trans.
65-70	Pass. (6 cyl.),				
65-67	Chevelle (8 cyl.),				
67	Camaro,				
68-69	Chevy (4 cyl.),				
68	Chevelle (8 cyl.) (exc. 327) (1st design),				
68	Chevelle (exc. 396)	3870182	1	4.50	MOUNTING ASSY. (daub of orange paint) (molded 3870182) (Note 2)
65	Pass. (8 cyl.),				
66	Pass. (283, 327),				

**POWERGLIDE AND TORQUE DRIVE TRANSMISSION**

**4.081 SUPPORT— MOUNTING ASSY.— MEMBER ASSY., Transmission Mounting (Con't)**

67	Pass. (283, 327) (1st design),				
68	Impala, Caprice (307),				
68	Biscayne, Belair (307),				
69	Impala, Caprice (327),				
69	Biscayne, Bel Air (327),				
70	Pass. (350) (exc. 4BC) . . . . .	<b>3870184</b>	1	4.50	<b>MOUNTING ASSY.</b> (no paint ident.) (molded 3870184) (4 holes) (Note 1, 2) . .
66	Pass. (396, 427),				
68-70	Camaro, Chevy (396) . . . . .	<b>3895830</b>	1	4.40	<b>MOUNTING ASSY.</b> (daub of white paint) (Note 1) . . . . .
67	Pass. (396, 427),				
68	Chevelle (396) (1st design) . . . .	<b>3904078</b>	1	5.35	<b>MOUNTING ASSY.</b> (daub of white paint) . .
67-68	Pass. (327),				
68	Chevelle (327) (1st design) . . . .	<b>3906957</b>	1	4.75	<b>MOUNTING ASSY., trans. supt.</b> (3 holes, 2 oblong) (Note 1, 2) . . . . .
70	Pass. (exc. C.A.C.) . . . . .	<b>3872247</b>	1	5.25	<b>MOUNTING ASSY., support</b> (orange paint marking, part number molded on piece) . .
65-67	Chevy,				
66-67	Chevelle (6 cyl.),				
68-69	Camaro (exc. 396),				
68-69	Chevelle, Chevy (6 cyl.),				
68-70	Chevy (exc. 4 cyl.),				
70-72	Chevelle (6 cyl.),				
71	Nova, Camaro,				
72-73	Nova . . . . .	<b>3913498</b>	1	4.65	<b>MOUNTING ASSY., support</b> . . . . .
69	Pass. (350),				
70	Pass. w/H/Per. (350) . . . . .	<b>3947534</b>	1	8.65	<b>MOUNTING ASSY.</b> . . . . .
68	Chevelle (8 cyl.) (2nd design) (exc. 327),				
69	Chevelle (307),				
70-72	Chevelle (307) (exc. Monte Carlo),				
70	Concours, Estate Wag. (exc. 350, 400) . . . . .	<b>3935704</b>	1	4.60	<b>MOUNTING ASSY., support</b> . . . . .
69-70	Chevelle (350) (exc. Monte Carlo),				
69	Chevelle (396),				
70	Monte Carlo,				
70	Chevelle (396, 400, 454) . . . . .	<b>3945476</b>	1	6.80	<b>MOUNTING ASSY., support</b> . . . . .
71-72	Vega . . . . .	<b>329741</b>	1	8.50	<b>MOUNTING ASSY., trans.</b> . . . . .
73	Vega . . . . .	<b>329768</b>	1	8.50	<b>MOUNTING ASSY., trans.</b> . . . . .

*NOTE 1 3<sup>3</sup>/<sub>4</sub>" between center lines of bolt holes.  
NOTE 2 Part number moulded on part.  
NOTE 3 4<sup>1</sup>/<sub>4</sub>" between center lines of bolt holes.*

**4.083 BRACKET, Transmission Mounting**

65	Pass.,				
68-69	Pass. (exc. Taxi),				
70	Pass. (exc. C.A.C.) . . . . .	<b>3855908</b>	1	4.50	support (Budd frame) . . . . .
70	Pass. (C.A.C. w/P.G.) . . . . .	<b>3982835</b>	2	.87	support . . . . .

**4.085 BOLT, Transmission Mounting Support**

62-66	Chevy (exc. 4 cyl.),				
71-72	Vega . . . . .	<b>3779940</b>	2	.21	( <sup>3</sup> / <sub>8</sub> "— 16 x <sup>3</sup> / <sub>8</sub> ")— (7.874) . . . . .

**4.103 CASE, Transmission**

62-73	All w/P.G. (exc. Vega) . . . . .	<b>3981855</b>	1	87.75	w/bushing and low servo piston (Note 1) . .
<i>NOTE 1 Includes governor driven gear.</i>					
68-72	Chevy, Camaro w/Torque Drive . .	<b>3981856</b>	1	84.50	<b>CASE ASSY., w/bushing</b> . . . . .
71-72	Vega w/Torque Drive . . . . .	<b>3981723</b>	1	90.25	<b>CASE ASSY., trans. w/bushing</b> . . . . .
71-73	Vega w/P.G. . . . .	<b>3974410</b>	1	90.75	<b>CASE ASSY., trans. w/bushing</b> . . . . .

**4.104 BUSHING— PIPE ASSY.— SEAL— VENT ASSY., Transmission Case**

62-69	All w/P.G.,				
68-70	Chevy, Camaro w/Torque Drive,				
71-73	All . . . . .	<b>3789009</b>	1	1.25	( <sup>17</sup> / <sub>64</sub> " bore dia. x <sup>17</sup> / <sub>32</sub> " wide) . . . . .
62-73	All . . . . .	<b>3789056</b>	1	.33	<b>SEAL, ext. to case— (4.203)</b> . . . . .
71-73	Vega . . . . .	<b>3978756</b>	1	.98	<b>PIPE ASSY., trans. vent</b> . . . . .
62-73	All . . . . .	<b>3820840</b>	1	.36	<b>VENT ASSY. (5.387)</b> . . . . .
71-73	Vega . . . . .	<b>3820840</b>	1	.36	<b>VENT. ASSY., trans. case— (5.387)</b> . . . . .

**4.105 BAFFLE— PLUG— SCREEN ASSY., Transmission Case**

62-73	All w/P.G. . . . .	<b>3816920</b>	1	.20	oil drain back . . . . .
62-69	All . . . . .	<b>3930923</b>	1	1.30	<b>PLUG, trans. case magnet (<sup>1</sup>/<sub>2</sub>"</b> ) . . . . .

**POWERGLIDE AND TORQUE DRIVE TRANSMISSION**

**4.105 Baffle— Plug— Screen Assy., Transmission Case (Con't)**

67-73 All ..... 3921124 1 .54 SCREEN ASSY., trans. case .....

**4.115 REBUILT CONVERTER ASSY.— BOLT— RETAINER— SPACER UNIT, Transmission (Rebuilt for General Motors)**

62-68 Chevy, Chevelle w/P.G. (exc. 8 cyl.),  
 69 Chevy w/Torque Drive, P.G. (4 cyl.),  
 70 Nova w/Torque Drive (4 cyl.) ... 3793984 1 55.00 torque (rebuilt) (Exchange item, Note 1) ...  
 62-69 Chevy, Chevelle w/P.G. (8 cyl.) (exc. Sp. H/Per., 396),  
 65-69 Pass. w/P.G. (283, 307, 327),  
 67-69 Camaro w/P.G. (8 cyl.) (exc. 350, 396),  
 68-69 All w/Torque Drive (exc. 4 cyl.),  
 70 Pass., Nova, Chevelle w/P.G. (exc. 4BC, Taxi, Police) ..... 3852880 1 55.00 torque (Exchange Item, Note 1) .....  
 64-69 Chevy, Chevelle w/P.G. (230, 250) (exc. Taxi, Police),  
 65-69 Pass. w/P.G. (6 cyl.) (exc. Taxi, Police),  
 67-69 Camaro w/P.G. (6 cyl.),  
 70 All w/A.T. (6 cyl.) (exc. T.H., Taxi, Police) ..... 3964587 1 55.00 torque (rebuilt) (Exchange Item, Note 2) .....  
 64-65 Chevelle (Taxi, Police) w/P.G. (6 cyl.),  
 65-70 Pass. (Police, Taxi) w/P.G. (6 cyl.),  
 68-69 Pass. (Police) w/P.G. (exc. 396) . 3858967 1 55.00 torque (Exchange Item, Note 1) .....  
 65-66 Pass., Chevelle w/P.G. (396, 409) ..... 3834108 1 59.75 torque (Exchange Item, Note 1) .....  
 67 Pass. w/P.G. (396, 427 H/Per.),  
 67-69 Chevy, Chevelle, Camaro w/P.G. (350, 396),  
 68-69 Pass. w/P.G. (350, 396, 427 H/Per.) (exc. Police),  
 70 Taxi w/P.G.,  
 70 All (P.G. w/4BC) (350) (exc. Police) ..... 3905861 1 59.75 torque (Exchange Item, Note 1) .....  
 71-72 Taxi, Police w/P.G. (6 cyl.),  
 71-72 All w/P.G. (8 cyl.) ..... 3991015 1 61.75 (Exchange Item, Note 1) .....  
 71-72 All (6 cyl.) (exc. Taxi, Police),  
 73 All ..... 3998276 1 54.00 (Exchange Item, Note 1) .....

*NOTE 1 List price shown does not include exchange charge. Refer to dealer parts price schedule for exchange charge.*

71-73 Vega ..... 3998277 1 61.75 torque (rebuilt) .....  
 62-71 All (exc. Vega) ..... 3799830 3 .16 BOLT, trans. assy. to engine or flywheel (3/8" — 24 x 9/16") (Note 2) .....

*NOTE 2 The above part is also used as a replacement with rebuilt trans. assy. 3832565 (P.G.).*

72-73 All (exc. Vega) ..... 3987930 A.R. .22 BOLT, trans. to flywheel (3/8" — 16 x 1 1/32) ...  
 65-66 Pass. w/P.G. (396, 409),  
 66 Chevelle w/P.G. (396) ..... 3785104 1 .36 RETAINER, trans. to flywheel (3/8" — 24) ...  
 62-71 All w/P.G. (exc. Vega) ..... 6272162 1 .97 SPACER UNIT, conv. to flywheel (used to adapt 71 models to older trans. asm's. (Note 3) .....

*NOTE 3 Contains 3 washers, 4 screw and washer assys., 1 hex lock nut, 1 hex jam nut, 1 instruction sheet.*

**4.123 SHAFT— RING, Transmission Input**

62-69 Chevy, Chevelle, Camaro w/P.G. (exc. 327, 350, 396),  
 65 Pass. w/P.G. (exc. 327, 396, 409),  
 66-68 Pass. w/P.G. (250, 283, 307, 350) (exc. Taxi, Police),  
 68-72 Chevy, Camaro w/Torque Drive,  
 69 Pass. w/P.G. (exc. Taxi, Police 350),  
 69 All w/P.G. (6 cyl.) (exc. Pass.),  
 70 All w/A.T. (exc. 350, Taxi, Police),  
 71-72 Pass., Nova, Chevelle w/P.G. (6 cyl.) (exc. Taxi, Police),  
 71 Nova, Chevelle w/P.G. (8 cyl.),  
 71-73 Vega,  
 72-73 Nova, Camaro (8 cyl.),

**POWERGLIDE AND TORQUE DRIVE TRANSMISSION**

**4.123 SHAFT— RING, Transmission Input (Con't)**

72	Pass. (Sta. Wag.),				
72	Chevelle (8 cyl.) (exc. Monte Carlo) . . . . .	<b>3946732</b>	1	16.85	input (12 <sup>5</sup> / <sub>8</sub> " O.L.) (Note 2) . . . . .
	<i>NOTE 2 Use on 66 and 67 Pass., Chevelle with small gear set.</i>				
64-68	Chevy, Chevelle, Camaro w/P.G. (327, 350, 396),				
65-69	Pass. w/P.G. (327, 396, 409),				
66-68	Taxi, Police w/P.G. (6 cyl.),				
69	All w/P.G. (8 cyl.),				
70-72	Taxi, Police w/P.G. (6 cyl.),				
70	All w/P.G. (350),				
71	Pass. w/P.G. (8 cyl.),				
72	Monte Carlo,				
72	Pass. (8 cyl.) (exc. Sta. Wag.) . . . . .	<b>3950385</b>	1	15.60	(12 <sup>27</sup> / <sub>32</sub> " O.L.) . . . . .
	<i>NOTE 1 Use on 66 and 67 Pass., Chevy, Chevelle with large gear set.</i>				
62-73	All . . . . .	<b>3817715</b>	2	.68	<b>RING</b> , input shaft oil seal . . . . .

**4.128 BRACKET— CLAMP— CLIP— SPACER, Transmission Oil**

69	All (6 cyl.),				
70-71	All w/A.T. (6 cyl.) (exc. Taxi, Police) . . . . .	<b>3945470</b>	1	.70	cooler pipe . . . . .
71-72	Pass. (6 cyl.) . . . . .	<b>3993600</b>	1	.70	oil cooler pipe . . . . .
70-72	All (8 cyl.) . . . . .	<b>3997718</b>	1	1.30	<b>CLAMP</b> , oil cooler pipe to oil pan . . . . .
72	All (6 cyl.),				
73	All . . . . .	<b>6271699</b>	1	.98	<b>CLAMP</b> , oil cooler pipe . . . . .
62-73	All w/A.T. . . . .	<b>3710497</b>	A.R.	.11	<b>CLIP</b> , inlet and outlet pipe assy. . . . .
70	Nova w/P.G. (8 cyl.) . . . . .	<b>3984503</b>	1	.16	<b>CLIP</b> , oil cooler pipe (1 <sup>1</sup> / <sub>4</sub> ") . . . . .
70-71	All w/A.T. (6 cyl.) . . . . .	<b>3945472</b>	2	.27	<b>CLIP</b> , oil cooler pipe . . . . .
69-71	All (6 cyl.) . . . . .	<b>3945475</b>	1	.16	<b>SPACER</b> , cooler pipe . . . . .

**4.133 TUBE ASSY.— GAUGE— SEAL, Transmission Oil Filler**

62-67	All w/P.G. (exc. 396, 409, Taxi, Police),				
68	Pass. w/P.G. (exc. 396),				
68	All w/P.G. (exc. Pass.),				
68-69	Chevy, Camaro w/Torque Drive,				
69-70	All w/P.G. (exc. Taxi),				
70	Nova w/Torque Drive,				
71-73	All (exc. Vega) . . . . .	<b>3789688</b>	1	2.30	(dev. length 22") . . . . .
65-69	Taxi, Police w/P.G. (6 cyl.),				
70	Taxi w/P.G. . . . .	<b>3857239</b>	1	2.95	
65-68	Pass., Chevelle w/P.G. (396) . . . . .	<b>3866785</b>	1	2.80	
71-73	Vega . . . . .	<b>3981711</b>	1	2.00	trans. oil filler . . . . .
62-66	Chevy, Chevelle w/P.G. (exc. 230 H/Per.),				
65-66	Pass. w/A.T. (exc. 409),				
67-69	All w/P.G. (exc. Taxi, Police),				
71-73	All . . . . .	<b>1387568</b>	1	1.15	<b>GAUGE</b> , cap and level . . . . .
65-69	Taxi, Police w/P.G.,				
70	Taxi w/P.G. . . . .	<b>3857241</b>	1	1.85	<b>GAUGE</b> , cap and level . . . . .
62-73	All w/A.T. . . . .	<b>6264902</b>	1	.22	<b>SEAL</b> , oil filler tube (Note 1) . . . . .
	<i>NOTE 1 The above parts also are used as replacement parts with rebuilt trans. assy. 3832565 (aluminum P.G.) and T.G. conversion trans. 3832566.</i>				

**4.161 BUSHING, Transmission Planet**

69	All w/P.G. (exc. Pass.) . . . . .	<b>8623944</b>	4	2.45	sun gear shaft . . . . .
----	-----------------------------------	----------------	---	------	--------------------------

**4.162 FLANGE ASSY.— BEARING ASSY.— RACE ASSY.— RING— WASHER, Low Sun Gear and Clutch**

62-69	All w/P.G. (exc. 307, 327, 350, 396, 409, Taxi, Police),				
68-72	Chevy, Camaro w/Torque Drive,				
70-71	Pass. w/P.G. (6 cyl.) (exc. Taxi, Police),				
70-71	Nova, Chevelle, Camaro w/P.G. (exc. 350),				
71-73	Vega,				
72	All w/P.G. (6 cyl.) (exc. Taxi, Police),				
72	Nova, Camaro w/P.G. (8 cyl.),				
72	Pass. (Sta. Wag.),				
73	Nova . . . . .	<b>3854333</b>	1	13.45	(Note 1) . . . . .
	<i>NOTE 1 Used on 66 and 67 Pass. with small gear set.</i>				
64-71	Pass. w/P.G. (307, 327, 350, 396, 409),				



**POWERGLIDE AND TORQUE DRIVE TRANSMISSION**

**4.162 FLANGE ASSY.— BEARING ASSY.— RACE ASSY.— RING— WASHER,  
Low Sun Gear and Clutch (Con't)**

66-72	Taxi, Police w/P.G. (6 cyl.),				
70	Chevelle, Nova w/P.G. (350),				
72	Monte Carlo,				
72	Pass. w/P.G. (8 cyl.) (exc. Sta. Wag.)	3843443	1	12.00	(Note 2)
	<i>NOTE 2 Use with large gear set on 66 thru 69 Chevy, Chevelle.</i>				
73	Nova,				
63-73	All	3771838	1	2.15	BEARING ASSY., w/race, low sun gear needle thrust
62-73	All	3779911	1	.33	RING, clutch flange retainer
62-63	Chevy w/P.G.	3755412	1	1.35	WASHER, thrust (1 1/2" O.D. x 31/32" I.D.)
62-73	All	3758781	1	3.00	WASHER UNIT, thrust w/bushing (Note 4)
	<i>NOTE 4 Consists of 1 low sun gear thrust washer and 1 low sun gear bushing.</i>				

**4.163 PLATE, Transmission Clutch Drive and Driven**

62	Chevy w/P.G.	3799212	1	2.30	reverse clutch reaction (.102 thk.) (Note 1)
62-63	Chevy w/P.G.	6256553	A.R.	1.80	reverse clutch driven (wavy)
62-73	All	1379373	1	1.50	reverse clutch reaction (.070 thk.) (5 3/4" I.D., 6 tabs) (Note 1)
62-64	Chevy, Chevelle w/P.G.,				
65	All w/P.G.,				
66-70	All w/P.G. (exc. 350, 396, 427),				
69-70	Chevy w/Torque Drive (4 cyl.),				
71	Pass. w/P.G. (6 cyl.) (exc. Taxi, Police),				
71	Nova, Chevelle, Camaro w/P.G.,				
71-73	Vega,				
72	All w/P.G. (6 cyl.) (exc. Taxi, Police),				
72	Nova, Chevelle, Camaro w/P.G. (exc. Monte Carlo),				
72	Pass. (Sta. Wag.),				
73	Nova	3783287	A.R.	2.65	driven (12 tangs) (flat) (3/32" thk.)
66-70	All w/P.G. (350, 396),				
68-72	All w/Torque Drive,				
71	Pass. w/P.G. (8 cyl.),				
71-72	Taxi, Police w/P.G. (6 cyl.),				
71-72	Monte Carlo w/P.G.,				
72	Pass. w/P.G. (8 cyl.) (exc. Sta. Wag.)	3883903	A.R.	2.10	driven (1/16" thk.) (Note 1)
66	Pass., Chevelle w/P.G. (396)	3883904	A.R.	2.10	driven (3/32" thk.) (Note 1)
62-73	All w/P.G., Torque Drive	3779904	A.R.	2.30	PLATE ASSY., drive (Ident. by green mark)
62-73	All	6257025	1	3.90	PLATE ASSY., reverse clutch pressure (.325 thk.)
65-69	Pass. w/P.G.,				
69	All w/Torque Drive,				
70-73	All	3832386	A.R.	2.65	PLATE ASSY., low and reverse clutch drive
71-73	Vega	1379373	A.R.	1.50	PLATE ASSY., trans. reverse clutch reaction (.070 thk.)

*NOTE 1 Use selectively.*

**4.164 CLUTCH ASSY.— HUB— RING— SEAT— SPRING— WASHER,  
Transmission**

64-68	All w/P.G. (exc. 8 cyl. Pass.),				
65	Pass. w/P.G. (6 cyl.) (exc. Taxi, Police),				
67-68	Chevy w/P.G. (8 cyl.),				
69	Chevy w/P.G. (153),				
71-73	Vega w/P.G.	3901119	1	62.00	(stamped 1119)
64-66	Chevy, Chevelle w/P.G. (283),				
65	Pass. w/P.G. (283),				
66-69	Pass. w/P.G. (250, 283, 307) (exc. Taxi, Police),				
67-69	Chevy, Chevelle, Camaro w/P.G. (250, 283, 307, 350 w/reg. fuel),				
69-70	Chevy w/Torque Drive (4 cyl.),				
70	All w/P.G. (8 cyl.) (exc. 350),				
70	Pass., Chevelle w/P.G. (6 cyl.) (exc. Taxi, Police),				
71-72	All w/P.G. (6 cyl.) (exc. Taxi, Police),				
71-72	Nova, Chevelle, Camaro w/P.G. (8 cyl.) (exc. Monte Carlo),				

**POWERGLIDE AND TORQUE DRIVE TRANSMISSION**

**4.164 CLUTCH ASSY.— HUB— RING— SEAT— SPRING— WASHER,  
Transmission (Con't)**

71-72	Vega w/Torque Drive,					
72	Pass. (Sta. Wag.),					
73	Nova	3901121	1	63.85	(stamped 1121) (Note 1)	
	<i>NOTE 1 Not used on 283 engine when the transmission code ends with the letter L.</i>					
64-66	All w/P.G. (283, 327),					
67-69	Pass. w/P.G. (8 cyl.) (exc. 396, 427, 4BC),					
67-69	All w/P.G. (283, 307, 327) (exc. Pass.),					
70	All (P.G. w/2BC) (8 cyl.)	3901122	1	58.50	(stamped 1122) (Note 2)	
	<i>NOTE 2 When using Clutch Assy. on the 283 engine the transmission code must end with the letter L.</i>					
65	Pass. w/P.G. (396, 409),					
66-69	Taxi, Police w/P.G. (6 cyl.),					
68-69	Police, Taxi w/P.G. (307),					
70	Taxi, Police w/P.G.	3901123	1	59.75	(stamped 4906)	
66	All w/P.G. (396),					
67-69	All w/P.G. (350, 396, 427) (exc. 2BC),					
70	All w/P.G. (350) (exc. 2BC, Police),					
71-72	Taxi, Police w/P.G. (6 cyl.),					
71	Pass., Monte Carlo w/P.G. (8 cyl.),					
72	Monte Carlo,					
72	Pass. w/P.G. (8 cyl.) (exc. Sta. Wag.)	3901124	1	58.50	(stamped 1124)	
68-69	Chevy, Camaro w/Torque Drive, P.G.,					
70	Nova w/P.G. (6 cyl.),					
72	All w/Torque Drive	3950346	1	66.25		
62-69	All w/P.G. (exc. 350, 396, Pass.),					
65	Pass. w/P.G. (exc. 327 H/Per., 396, 409, Taxi, Police),					
66-69	Pass. w/P.G. (8 cyl.) (exc. 350, 396, 427 Taxi, Police),					
69-70	Chevy w/Torque Drive (4 cyl.),					
70	All w/P.G. (exc. 350, Taxi, Police),					
71-72	Pass. w/P.G. (6 cyl.) (exc. Taxi, Police),					
71-72	Nova, Chevelle, Camaro w/P.G. (exc. Monte Carlo),					
71-73	Vega,					
72	Pass. (Sta. Wag.),					
73	Nova	3792701	1	8.75	HUB, clutch (cast 3792701)	
65-69	Taxi, Police w/P.G. (6 cyl.),					
65-69	Pass. w/P.G. (350, 396, 409) (exc. 2BC),					
66-69	All w/P.G. (350, 396) (exc. Pass.),					
68	Taxi, Police w/P.G. (8 cyl.),					
68-72	All w/Torque Drive,					
70	All w/P.G. (350) (exc. 2BC),					
70	Taxi, Police w/P.G.,					
71-72	Taxi, Police w/P.G. (6 cyl.),					
71	Pass., Monte Carlo w/P.G. (8 cyl.),					
72	Pass., Monte Carlo w/P.G. (8 cyl.) (exc. Sta. Wag.)	3826047	1	5.50	HUB, clutch	
62-73	All w/P.G., Torque Drive	6255698	1	.13	RING, reverse clutch piston return spring snap (1 <sup>31</sup> / <sub>32</sub> " dia.)	
62-73	All w/P.G., Torque Drive	3779908	1	.13	RING, high clutch piston return spring snap	
62-73	All w/P.G., Torque Drive	3796576	1	1.05	RING, snap, reverse clutch pack (7 <sup>1</sup> / <sub>4</sub> " dia.)	
62-73	All w/P.G., Torque Drive	3789072	1	.71	SEAT, clutch spring	
62-73	All w/P.G., Torque Drive	3789062	1	.71	SEAT, reverse clutch piston retaining spring	
62-73	All w/P.G., Torque Drive	3783288	A.R.	.13	SPRING, hi clutch (stained orange)	
62-73	All w/P.G., Torque Drive	3789061	17	.13	SPRING, reverse clutch piston return (stained green)	
64-73	All w/P.G., Torque Drive	3845858	1	2.10	SPRING, reverse clutch cushion	
64-70	All w/P.G., Torque Drive (exc. Pass.),					
65-70	Pass. w/P.G. (exc. 396, 409, Taxi, Police),					

**POWERGLIDE AND TORQUE DRIVE TRANSMISSION**

**4.164 CLUTCH ASSY.— HUB— RING— SEAT— SPRING— WASHER,  
Transmission (Con't)**

71-73	All	3862232	1	1.40	SPRING, clutch cushion (wave type) (light green)
62-73	All w/P.G., Torque Drive	3783286	1	.38	WASHER, clutch hub thrust
71-73	Vega	3783285	1	.26	WASHER, clutch hub rear thrust

**4.166 PISTON— BALL— SEAL UNIT, Transmission Clutch**

64-66	Chevy, Chevelle w/P.G. (exc. 8 cyl. Taxi, Police),				
65	Pass. w/P.G. (6 cyl.) (exc. Taxi, Police),				
67-68	Chevy w/P.G. (153, 194, 230),				
67-68	Chevelle, Camaro w/P.G. (230),				
69	Chevy w/P.G. (153),				
71-73	Vega w/P.G.	3844205	1	6.20	(1 <sup>1</sup> / <sub>2</sub> " thk.)
64-66	Chevy, Chevelle w/P.G. (8 cyl.) (exc. 396),				
65	Chevelle (Taxi, Police w/P.G.),				
65-69	Pass. w/P.G. (8 cyl.) (exc. 350, 396, 409),				
66-70	Pass. w/P.G. (6 cyl.) (exc. Taxi, Police),				
67-69	Chevy w/P.G. (exc. 153, 194, 350),				
67-69	Chevelle, Camaro w/P.G. (exc. 230, 350, 396),				
69-70	Chevy w/Torque Drive,				
69-70	Chevelle, Chevy, Camaro w/P.G. (exc. 350),				
71-72	Pass. w/P.G. (6 cyl.) (exc. Taxi, Police),				
71-72	Nova, Chevelle, Camaro w/P.G. (exc. Monte Carlo),				
71-72	Vega w/Torque Drive,				
72	Pass. (Sta. Wag.),				
73	Nova	3844206	1	6.20	( <sup>27</sup> / <sub>32</sub> " thk.)
64-66	Chevy, Chevelle w/P.G. (283),				
65-66	Pass. w/P.G. (283, 292) (1st design),				
67-68	All w/P.G. (8 cyl.) (exc. 396)	3845855	1	8.15	reverse clutch ( <sup>29</sup> / <sub>32</sub> " thk.)
64-66	All w/P.G. (327, 396, 409, 427),				
67-68	Pass., Chevelle w/P.G. (396, 427)	3845856	1	8.15	reverse clutch ( <sup>23</sup> / <sub>32</sub> " thk.)
64-66	Chevy, Chevelle w/P.G. (exc. 8 cyl.),				
65-69	Pass. w/P.G. (6 cyl.),				
66-67	Pass. (283) (2nd design),				
67	Chevy, Chevelle, Camaro w/P.G. (exc. 327, 350, 396),				
68-69	Chevy, Chevelle, Camaro w/P.G., Torque Drive,				
69	Pass. w/P.G. (8 cyl.),				
70-73	All w/A.T. (exc. Vega),				
71-72	Vega w/Torque Drive	3845857	1	8.65	reverse (1 <sup>5</sup> / <sub>64</sub> " thk.)
65-69	Taxi, Police w/P.G. (6 cyl.),				
65	Pass. w/P.G. (396, 409),				
68-69	Taxi, Police w/P.G. (327) (exc. low comp.),				
70	Taxi, Police w/P.G.	3844181	1	5.85	
66-69	All w/P.G. (350, 396) (exc. Pass. reg. fuel),				
66-68	Pass. w/P.G. (396, 427) (exc. Police),				
68-72	All w/Torque Drive (6 cyl.),				
69-70	All w/P.G. (350) (exc. 2BC),				
71-72	Taxi, Police w/P.G. (6 cyl.),				
71	Pass., Monte Carlo w/P.G. (8 cyl.),				
72	Pass., Monte Carlo w/P.G. (8 cyl.) (exc. Sta. Wag.)	3883902	1	5.65	high
71-73	Vega w/P.G.	3974411	1	8.20	trans. reverse clutch
62-69	All	7002117	1	.05	BALL, pressure relief valve ( <sup>3</sup> / <sub>16</sub> "— (3.825)
62	Chevy w/P.G.	3815148	1	2.20	SEAL UNIT, piston
62-73	All w/P.G., Torque Drive	3799008	1	.39	SEAL UNIT, reverse piston (Note 3)

NOTE 3 Consists of 1 inner and 1 outer seal.

**POWERGLIDE AND TORQUE DRIVE TRANSMISSION**

**4.166 PISTON— BALL— SEAL UNIT, Transmission Clutch (Con't)**

63-73 All w/P.G., Torque Drive . . . . . **3794123** 1 2.35 **SEAL UNIT**, piston (inner and outer seal) . .

**4.169 DRUM— BUSHING— RING— WASHER, Transmission Clutch**

64-73 All w/P.G., Torque Drive . . . . . **3844252** 1 22.95 w/bushing . . . . .  
 63 Chevy w/P.G. (327) . . . . . **3859477** 1 30.25 **DRUM UNIT**, w/bushing (Note 4) . . . . .

*NOTE 4 Consists of trans. clutch piston, seal unit, drive and driven plate and spring.*

62-73 All w/P.G., Torque Drive . . . . . **3840760** 1 .71 **BUSHING**, clutch drum . . . . .  
 62-73 All w/P.G., Torque Drive . . . . . **3689808** 2 1.40 **RING**, clutch drum oil sealing . . . . .  
 62-73 All w/P.G., Torque Drive . . . . . **3845835** 1 1.25 **WASHER**, drum thrust (.061) (Note 3) . . . . .  
 62-73 All w/P.G., Torque Drive . . . . . **3845836** 1 1.25 **WASHER**, drum thrust (.078) (Note 3) . . . . .  
 62-73 All w/P.G., Torque Drive . . . . . **3845838** 1 1.25 **WASHER**, drum thrust (.106) (Note 3) . . . . .  
 62-73 All w/P.G., Torque Drive . . . . . **3845837** 1 1.25 **WASHER**, drum thrust (.092) (stamped "8")  
 (Note 3) . . . . .

62-73 All w/P.G., Torque Drive (exc. Vega) . . . . . **3783285** 1 .26 **WASHER**, hub front thrust . . . . .  
*NOTE 3 Use selectively.*

**4.175 CARRIER ASSY.— GEAR— PINION— SHAFT, Transmission Planet**

62-63 Chevy w/P.G. . . . . **3830539** 1 110.00 (16 tooth spline) . . . . .

64-70 All w/P.G. (exc. Taxi, Police, 327, 350, 396),

71-72 Pass. w/P.G. (6 cyl.) (exc. Taxi, Police),

71-72 Nova, Chevelle, Camaro w/P.G. (exc. Monte Carlo),

71-73 Vega w/P.G.,

72 Pass. (Sta. Wag.),

73 Nova . . . . . **3920785** 1 109.00 (27 tooth spline) . . . . .

65-67 Pass. (8 cyl.) w/P.G. (exc. 283),

65-67 Chevy, Chevelle, Camaro (8 cyl.),

66 Taxi, Police w/P.G. (6 cyl.),

68-69 Police, Taxi w/P.G.,

68-70 All w/P.G. (8 cyl.) (exc. Taxi),

70 Taxi, Police w/P.G. (exc. 350 w/4BC),

70 Nova, Chevelle, Camaro w/P.G. (350),

71-72 Taxi, Police w/P.G. (6 cyl.),

71 Pass., Monte Carlo w/P.G. (8 cyl.),

72 Pass., Monte Carlo w/P.G. (8 cyl.) (exc. Sta. Wag.) . . . . . **3920786** 1 103.00 (27 tooth spline) (Note 2) . . . . .

*NOTE 2 Includes rear pump drive pin hole and provides for installing steel drive gear.*

68-72 Chevy, Camaro, Vega w/Torque Drive . . . . . **3987974** 1 107.00

62 Chevy w/P.G. . . . . **3790778** 1 5.65 **GEAR**, input sun . . . . .

63-65 All w/P.G. (2nd design) (exc. 327, 396, 409),

66-69 Pass. w/P.G., Torque Drive (exc. 327, 350, 396, Taxi, Police),

70 Chevelle (Sta. Wag.) w/P.G. (8 cyl.) (exc. 350),

70 Nova, Camaro w/P.G. (exc. 350),

70 Pass., Chevelle w/P.G. (6 cyl.) (exc. Taxi, Police),

70 Nova w/Torque Drive,

71-73 Vega,

72 All (6 cyl.) (exc. Taxi, Police),

72 Nova, Camaro (8 cyl.),

72 Pass. (Sta. Wag.),

72 Chevelle (8 cyl.) (exc. Monte Carlo),

72-73 Nova . . . . . **3756797** 1 5.95 **GEAR**, input sun (1<sup>1</sup>/<sub>16</sub>" wide) . . . . .  
 63-65 All w/P.G. (exc. 327, 409),  
 66-70 All w/P.G., Torque Drive (exc. 327, 350, 396, Taxi, Police),  
 71-73 Vega,  
 72 Nova w/Torque Drive,  
 72 All (6 cyl.) (exc. Taxi, Police),  
 72 Nova, Chevelle, Camaro w/P.G. (8 cyl.) (exc. Monte Carlo),  
 72 Pass. (Sta. Wag.) w/P.G.,  
 73 Nova . . . . . **3790163** 3 6.85 **PINION**, w/needle thrust bearing, short  
 (Note 1) . . . . .

**POWERGLIDE AND TORQUE DRIVE TRANSMISSION**

**4.175 CARRIER ASSY.— GEAR— PINION— SHAFT, Transmission Planet (Con't)**

63-65	All w/P.G. (2nd design) (exc. 327, 409),				
66-70	All w/P.G., Torque Drive (exc. 327, 350, 396, Taxi, Police),				
71-73	Vega,				
71-72	Nova w/Torque Drive,				
71-72	Pass. w/P.G. (6 cyl.) (exc. Taxi, Police),				
71-72	Nova, Chevelle, Camaro w/P.G. (exc. Monte Carlo),				
72	Pass. (Sta. Wag.),				
73	Nova	3790164	3	5.95	PINION, w/needle thrust bearing, long (Note 1)
62-65	All w/P.G. (exc. 327, 409),				
66-70	All w/P.G., Torque Drive (exc. 327, 350, 396, Taxi, Police),				
71-73	Vega,				
71-72	Nova w/Torque Drive,				
71-72	Pass. w/P.G. (6 cyl.) (exc. Taxi, Police),				
71-72	Nova, Chevelle, Camaro w/P.G. (exc. Monte Carlo),				
72	Pass. (Sta. Wag.),				
73	Nova	3694427	6	1.75	SHAFT, pinion (Note 1)

*NOTE 1 Used on 66 and 67 Pass. with small gear set.*

**4.176 BEARING ASSY.— BUSHING— PLATE— ROLLER— SCREW— SPACER— WASHER, Planet Carrier**

62-73	All w/P.G., Torque Drive	3742922	1	3.00	output shaft needle thrust
70	All w/A.T.	9427759	1	2.65	output ring gear rear thrust
62-73	All w/P.G., Torque Drive	3789034	1	.74	BUSHING, output shaft
62-65	All w/P.G. (exc. 327, 409),				
66-70	All w/P.G., Torque Drive (exc. 327, 396, Taxi, Police),				
71-72	Nova w/Torque Drive,				
71-72	Pass. w/P.G. (6 cyl.) (exc. Taxi, Police),				
71-72	Nova, Chevelle, Camaro w/P.G. (exc. Monte Carlo),				
71-73	Vega,				
72	Pass. (Sta. Wag.),				
73	Nova	3694428	1	.26	PLATE, pinion shaft lock (3— 1/4" holes) (Note 1)
62-65	All w/P.G. (exc. 327, 396, 409),				
66-69	All w/P.G. (exc. 327, 350, 396, Taxi, Police),				
68-73	All w/Torque Drive,				
71-73	Vega	7450410 A.R.		.01	ROLLER, long and short pinion needles (Note 1)
65-68	Pass. w/P.G.	9417317	180	.01	ROLLER, pinion needle
62-69	Chevy w/P.G. (exc. 327),				
65-70	Chevelle, Camaro w/P.G. (exc. 327, 350, 396),				
65-70	Pass. w/P.G. (exc. 327, 396, 409, Taxi, Police),				
68-70	Chevy, Camaro w/Torque Drive,				
71-73	All	3694432	3	.06	SCREW, lock plate w/lockwasher (12— 24 x 1/4") (Note 1)
62-63	Chevy w/P.G. (1st design)	3751043	18	.12	SPACER, pinion needle bearing (1/2" I.D. x 11/16" O.D. x 3/32" thk.) (Note 2)
63-70	Chevy w/P.G. (2nd design) (exc. 327, 350),				
64-70	Chevelle, Camaro w/P.G. (exc. 327, 350, 396),				
65	Pass. w/P.G. (exc. 327, 396, 409),				
66-70	Pass. w/P.G. (exc. 327, 350, 396, Taxi, Police),				
68-72	All w/Torque Drive,				
71-73	All w/P.G.	3790162	1	.13	SPACER, pinion needle bearing (Note 2)

*NOTE 2 Use with carrier with low sun gear needle thrust bearing.*

65-68	Pass. w/P.G.	3789037	12	.12	SPACER, pinion needle bearing (thin)
62-65	All w/P.G. (exc. 327, 396, 409),				

**POWERGLIDE AND TORQUE DRIVE TRANSMISSION**

**4.176 BEARING ASSY.— BUSHING— PLATE— ROLLER— SCREW— SPACER— WASHER, Planet Carrier (Con't)**

66-70	All w/P.G. (exc. 327, 350, 396, Taxi, Police),				
68-70	All w/Torque Drive,				
71-73	All	3790777	A.R.	.26	WASHER, pinion thrust (1½" ctr. to ctr. holes)
65-68	Pass. w/P.G.	3789036	6	.23	WASHER, planet pinion front thrust
65-68	Pass. w/P.G.	3789035	6	.23	WASHER, planet pinion rear thrust (Note 4)
67-73	All w/P.G., Torque Drive	3689834	1	.71	WASHER, input sun gear thrust (½" x 1½") (Note 3)

NOTE 3 Use with planet carriers with pinion shafts retained by removable type lock plate.

NOTE 1 Use on 66 and 67 Pass. w/small gear set.

NOTE 4 Use selectively.

**4.187 GEAR, Transmission Rear Unit**

62-69	Chevy, Chevelle, Camaro w/P.G. (exc. 327, 350, 396),				
65	Pass. w/P.G. (exc. 327, 396, 409),				
66-69	Pass. w/P.G. (exc. 327, 350, 396, Taxi, Police),				
68-69	Chevy, Camaro w/Torque Drive,				
70	All w/A.T. (exc. 350, Taxi, Police),				
71-72	Nova, Chevelle, Camaro w/P.G. (exc. Monte Carlo),				
71-72	Pass. w/P.G. (6 cyl.) (exc. Taxi, Police),				
71-73	Vega,				
72	Nova w/Torque Drive,				
72	Pass. (Sta. Wag.) w/P.G.,				
73	Nova	3790168	1	27.25	reverse ring (Note 1)

NOTE 1 Not used on 283 engine when the transmission code ends with the letter L.

64-69	Chevelle w/P.G. (8 cyl.),				
65-69	Chevy, Camaro w/P.G. (283, 327, 350, 396),				
65-69	Pass. w/P.G. (8 cyl.),				
66-72	Taxi, Police w/P.G. (6 cyl.),				
70	All w/P.G. (350),				
71	Pass., Monte Carlo w/P.G. (8 cyl.),				
72	Monte Carlo,				
72	Pass. (8 cyl.) (exc. Sta. Wag.)	3843441	1	22.10	reverse ring (Note 2)

NOTE 2 When using Gear ring on the 283 engine the transmission code must end with the letter L.

**4.195 PAN— FLANGE— SCREW, Transmission Oil**

62-73	All w/P.G., Torque Drive	3789146	1	5.75	
65-68	All w/P.G. (exc. Camaro)	3723008	1	.34	FLANGE, pan drain— (1.453)
65-68	All w/P.G. (exc. Camaro)	3923420	1	.36	SCREW, pan drain plug (½"— 20 x 13/16")— (1.453)

**4.196 GASKET, Transmission Oil Pan**

62-69	All	3921989	A.R.	.20	(½" I.D. x 9/10" O.D. x 3/32" thk.)
62-73	All w/P.G., Torque Drive	3789148	1	.39	

**4.197 GASKET— SCREEN ASSY., Oil Pan Pump Suction**

62-73	All w/P.G., Torque Drive	3795990	1	.14	screen
62-73	All w/P.G., Torque Drive	6263005	1	1.85	SCREEN ASSY.

**4.200 PUMP ASSY.— VALVE, Transmission Oil Supply**

62-67	All w/P.G. (exc. A.I.R., Pass.),				
65-67	Pass. w/P.G.,				
68-73	All w/P.G., Torque Drive	3828786	1	65.65	front (less cover)
62-66	All w/P.G.	3818871	1	30.40	rear (cast 3818872)
62-66	All w/P.G.	6256323	1	.31	VALVE, pump check

**4.203 BOLT— BUSHING— COVER ASSY.— GASKET— PIN— PLATE— SCREW— SEAL— VALVE UNIT, Oil Supply Pump**

62-63	Chevy w/P.G.	193940	5		front pump cover to pump body (5/16"— 18 x 1 1/8")— (8.900)
62-73	All w/P.G.	3789877	1	.39	BUSHING, rear oil pump body
62-63	Chevy w/P.G.,				
64-68	All w/P.G. (exc. Taxi, Police),				
65-69	Taxi, Police w/P.G. (6 cyl.),				
69-73	All w/P.G.,				

**POWERGLIDE AND TORQUE DRIVE TRANSMISSION**

**4.203 BOLT— BUSHING— COVER ASSY.— GASKET— PIN— PLATE— SCREW— SEAL— VALVE UNIT, Oil Supply Pump (Con't)**

69-72	Chevy, Camaro, Vega w/Torque Drive	3988907	1	45.30	COVER ASSY., w/shaft stator
62-73	All w/P.G., Torque Drive	3789022	1	.54	GASKET, front pump body (7 <sup>3</sup> / <sub>16</sub> " I.D. x .015 thk.)
62-66	All w/P.G.	3709063	1	.05	PIN, rear pump drive (3 <sup>3</sup> / <sub>4</sub> " x 3 <sup>3</sup> / <sub>16</sub> ")
62-66	All w/P.G.	3789055	1	.82	PLATE, rear pump wear (5" O.D. x 1 <sup>1</sup> / <sub>32</sub> " thk.)
62-69	All w/A.T.	6261374	A.R.	.20	SCREW, pump to trans. case (5 <sup>5</sup> / <sub>16</sub> "— 18 x 1 <sup>7</sup> / <sub>16</sub> ")— (4.226)
62-68	All w/P.G.				
69-71	All w/A.T. (exc. Vega)	8626916	1	3.43	SEAL, oil pump body inner— (4.226)
62-73	All w/P.G., Torque Drive	3789056	1	.33	SEAL, rear pump square ring (4 <sup>27</sup> / <sub>32</sub> " dia. x .090 thk.)
62-73	All w/P.G., Torque Drive	3789013	1	.26	SEAL, front oil pump
62-65	All w/P.G.	3798153	1	.83	SEAL UNIT, front pump (consists of 7 bolt seals and one 8 <sup>1</sup> / <sub>4</sub> " dia. large seal)
66-73	All w/P.G., Torque Drive	3886384	1	.88	SEAL UNIT, front pump (consists of 7 bolt seals and 1 oil pump seal)
62-69	Chevy, Chevelle, Camaro w/P.G.		1		VALVE UNIT, frt. and rear oil pump priming,
65-73	All w/P.G.				rear pump priming,
62-65	All w/P.G.				
69-73	Chevy, Camaro w/Torque Drive	3871500	1	.74	frt. oil pump priming

**4.205 MODULATOR— CLIP— GASKET— HOSE— PIPE ASSY.— PLUNGER— SPRING— TEE ASSY.— VALVE, Vacuum**

62-63	Chevy w/P.G. (1st design)	3812741	1		(1 piece design)
63-64	Chevy, Chevelle w/P.G. (230, 283) (2nd design) (exc. Taxi),				
65-66	All w/P.G. (230, 283, 327, 396),				
67-69	All w/P.G. (exc. Chevy),				
67-69	Chevy w/P.G. (250, 283, 327),				
71-72	Vega,				
70-73	All w/P.G.	5638205	1	7.55	
64-69	Chevy, Chevelle w/P.G. (153, 194),				
73	Vega	5638206	1	5.35	(white stripe)
62-64	Chevy	2459769	1	.35	CLIP, tube attach.
64-66	All w/P.G. (8 cyl.) (exc. 396, 409)	3826932	1		CLIP, pipe assy. to engine (1 <sup>1</sup> / <sub>16</sub> "
66-72	All w/P.G. (8 cyl.)	3905427	1	.20	CLIP, vac. pipe (3 <sup>9</sup> / <sub>8</sub> ")
68	All w/P.G. (exc. 8 cyl.)	3920793	1	.31	CLIP, vacuum modulator pipe
69	All w/A.T. (6 cyl.)	3945472	1	.27	CLIP, transmission oil cooler pipe
62-73	All w/P.G.	6257218	1	.22	GASKET (2 <sup>3</sup> / <sub>32</sub> " I.D. x 1" O.D. x 1 <sup>1</sup> / <sub>64</sub> " thk.)
62-72	All (exc. Vega)	3987364	A.R.	RL/.14	HOSE, vacuum modulator (7 <sup>7</sup> / <sub>32</sub> " I.D.)— (8.962)
73	All w/P.G.	336919	1	.61	HOSE, vac. mod. pipe (1 <sup>1</sup> / <sub>4</sub> " I.D. x 1 <sup>9</sup> / <sub>16</sub> " O.L.)
66-69	All,				
70	Pass., Nova, Chevelle w/A.T.	3937972	1	7.45	PIPE ASSY., vac. modulator (62")
63-73	All w/P.G.,				
71-73	Vega	3830311	1	.13	PLUNGER
63-73	All w/P.G. (exc. 194),				
71-73	Vega	3839599	1	.15	SPRING, damping
65-67	All	336013	1	1.05	TEE ASSY., trans. vacuum modulator front pipe (3 <sup>9</sup> / <sub>8</sub> "— 18 thds.)— (7.447)
63-64	Chevy w/P.G. (2nd design),				
64	Chevelle (8 cyl.) w/P.G. (2nd design),				
65-69	All w/P.G. (230, 250, 283, 307),				
65	Chevelle (Taxi, Police) (6 cyl.),				
70	All w/P.G. (exc. 350),				
71-72	All w/P.G. (6 cyl.) (exc. Taxi, Police),				
71-72	Nova, Chevelle, Camaro w/P.G. (8 cyl.) (exc. Monte Carlo),				
71-73	Vega,				
72	Pass. (Sta. Wag.) w/P.G.,				
73	Nova	3830276	1	1.65	VALVE (2 <sup>15</sup> / <sub>32</sub> " O.L.)
64	Chevy w/P.G.,				
64	Chevelle w/P.G. (1st design),				
64	Chevelle w/P.G. (6 cyl.) (2nd design),				
65-69	All w/P.G. (194, 327, 396, 409, 427),				
65-69	Chevy w/P.G. (153, 194, 327),				

**POWERGLIDE AND TORQUE DRIVE TRANSMISSION**

**4.205 MODULATOR— CLIP— GASKET— HOSE— PIPE ASSY.— PLUNGER—  
SPRING— TEE ASSY.— VALVE, Vacuum (Con't)**

65-68	Chevelle w/P.G. (194, 327, 396) (exc. Taxi, Police),				
67-68	Camaro w/P.G. (327 w/4BC),				
69	All (P.G. w/2BC) (350),				
70	All w/P.G. (350),				
71-72	Taxi, Police w/P.G. (6 cyl.),				
71	Pass., Monte Carlo w/P.G. (8 cyl.),				
71-73	Vega,				
72	Pass., Monte Carlo w/P.G. (8 cyl.) (exc. Sta. Wag.)	3847870	1	1.65	VALVE (2 <sup>15</sup> / <sub>32</sub> " O.L.)
71-72	Vega w/Torque Drive	3986000	1	2.68	VALVE UNIT, trans. hyd. mod. w/sleeve
73	Vega w/P.G.	6258670	1	2.32	VALVE UNIT, w/sleeve, trans. hyd. mod.

**4.212 COVER— GASKET— SEAL, Servo**

62-73	All w/P.G., Torque Drive	3789085	1	3.19	low
62-73	All w/P.G., Torque Drive	3789086	1	.14	GASKET, low servo cover
62-73	All w/P.G., Torque Drive	3789087	1	.20	SEAL, low servo cover

**4.215 PLATE, Transmission**

67-69	Pass. w/P.G. (307, 327, 350) (exc. A.I.R., 4BC),				
67-69	Chevy, Chevelle w/P.G. (307, 327) (exc. A.I.R.),				
70	All w/P.G. (350) (exc. 4BC),				
73	Nova	3978784	1	5.55	PLATE ASSY., transfer w/gasket
67	All w/P.G. (230, 250, 283) (exc. Chevy),				
67-69	Chevy w/P.G. (250, 283),				
68-69	Pass. w/P.G. (6 cyl.),				
68-69	Chevelle, Camaro w/P.G. (230, 250, 283),				
70	All w/P.G. (exc. 350),				
71	Pass. (6 cyl.) (exc. Taxi, Police),				
71	Nova, Chevelle, Camaro w/P.G. (exc. Monte Carlo),				
72	All (6 cyl.) (exc. Taxi, Police)	3981738	1	5.35	PLATE ASSY., transfer w/gasket
70	All w/P.G. (350) (exc. 2BC),				
71-72	Taxi, Police w/P.G. (6 cyl.),				
71	Pass., Monte Carlo w/P.G. (8 cyl.),				
72	Pass., Monte Carlo w/P.G. (8 cyl.) (exc. Sta. Wag.)	3981739	1	5.55	PLATE ASSY., transfer w/gasket
68-72	H, X w/P.G.,				
68-72	All w/Torque Drive	3981740	1	5.55	PLATE ASSY., transfer w/gasket (stamped U)
72	Pass. (Sta. Wag.)	6261772	1	5.75	PLATE ASSY., w/gasket, transfer
71-72	Vega (P.G. w/1BC) (exc. NB-2)	3993084	1	5.40	w/gasket transfer
72	Vega (P.G. w/1BC) w/NB-2,				
72	Vega (P.G. w/2BC)	6273276	1	5.40	w/gasket transfer
73	Vega	335392	1	5.40	w/gasket transfer

**4.216 BODY ASSY.— BUSHING UNIT— DAMPER ASSY.— RING— SPRING—  
STUD— TUBE— VALVE, Transmission Main Valve**

**POWERGLIDE BODY ASSY., Complete**

*NOTE 1 On early 1963 models, vacuum modulator valve 3830276 must be replaced by the valve from the old valve body or use the new modulator valve 3789122.*

64-66	All (283)	3895785	1	59.45	complete
64-66	All (327)	3895742	1	59.45	complete
68-70	Chevy, Camaro w/Torque Drive	3981740	1	5.55	transfer plate valve
65-66	Chevy, Chevelle (230),				
65	Chevelle (Taxi, Police) (6 cyl.),				
65	Pass. (6 cyl.),				
64-66	Chevy, Chevelle (153, 194)	3847809	1	64.60	complete
66	Pass. (6 cyl.) (exc. Taxi, Police)	3885099	1	63.35	complete
67-69	Pass. (327) (exc. Police),				
67-68	Chevy, Chevelle, Camaro w/4BC (327) (exc. A.I.R.),				
69	All w/reg. fuel (350) (exc. 2BC, Police),				
69	Pass. w/3.08 ratio	3932208	1	58.45	complete
67-69	Police, Taxi (6 cyl.),				



**POWERGLIDE AND TORQUE DRIVE TRANSMISSION**

**4.216 BODY ASSY.— BUSHING UNIT— DAMPER ASSY.— RING— SPRING— STUD— TUBE— VALVE, Transmission Main Valve (Con't)**

67-69	Chevy, Chevelle, Camaro (230),				
70	Taxi, Police (6 cyl.) . . . . .	3968065	1	58.95	
67	Police, Taxi (exc. 327),				
67-69	Chevy (153, 194, 230) . . . . .	3905468	1	53.05	complete . . . . .
67	All (283),				
68	All (307) (exc. Camaro),				
69	All (307) (exc. Pass.),				
70	All (8 cyl.) (exc. 350) . . . . .	3968064	1	58.95	
67-69	Camaro (307, 327) (exc. 4BC),				
69	Pass. (396) (exc. 4BC) . . . . .	3911924	1	61.00	
68-69	Pass. (6 cyl.) (exc. Police, Taxi),				
68-69	Chevy, Chevelle, Camaro (250),				
70	All (6 cyl.) (exc. Taxi, Police) . . . . .	3968062	1	58.95	
70	All (350) (exc. 2BC) . . . . .	3968063	1	56.65	
69	Pass. (8 cyl.) (exc. 4BC),				
69	Chevelle (350) (exc. 4BC), . . . . .		1		
70	All (350) (exc. 4BC) . . . . .	3981761	1	55.60	
71-72	All (6 cyl.) (exc. Taxi, Police) . . . . .	3987996	1	58.95	
71-72	Nova, Chevelle, Camaro (8 cyl.) (exc. Monte Carlo),				
72	Pass. (Sta. Wag.) . . . . .	3987997	1	58.95	
71-72	Pass. (8 cyl.) (exc. Sta. Wag.),				
71-72	Monte Carlo . . . . .	3993001	1	58.95	
73	All . . . . .	332585	1	58.95	
71-72	Vega (P.G. w/1BC) (exc. NB-2) . . . . .	3993086	1	56.40	(complete) . . . . .
72	Vega (P.G. w/1BC) w/NB-2 . . . . .	326531	1	56.40	
71	Vega (P.G. w/2BC) . . . . .	3993097	1	54.35	
72	Vega (P.G. w/2BC) . . . . .	6273275	1	51.25	
73	Vega w/2BC . . . . .	335393	1	58.95	(complete) . . . . .
73	Vega w/1BC . . . . .	335391	1	58.95	(complete) . . . . .

**POWERGLIDE BODY ASSY., Upper**

64-69	All (283, 327) (exc. Pass.),				
65-68	Pass. (283, 307),				
70	Nova, Camaro, Chevelle (8 cyl.) (exc. 350) . . . . .	3968068	1	28.55	upper valve . . . . .
67-70	All (exc. 8 cyl.) . . . . .	3968067	1	28.55	upper valve . . . . .
68-69	Chevy (Spt. Cpe.) (350) (2nd design) (exc. reg. fuel),				
68-69	Camaro (350) (2nd design) (exc. reg. fuel),				
68-69	Pass. (350),				
69	Chevelle (350) (exc. reg. fuel),				
70	Nova, Camaro, Chevelle (350),				
70	Pass. (8 cyl.) . . . . .	3968069	1	33.55	upper valve . . . . .
71-72	All (6 cyl.) (exc. Taxi, Police),				
73	All . . . . .	3992998	1	28.55	
71	Nova, Chevelle, Camaro (8 cyl.) (exc. Monte Carlo),				
72	Pass. (Sta. Wag.) . . . . .	3992999	1	28.55	
71	Pass. (8 cyl.),				
71-72	Monte Carlo,				
72	Pass. (8 cyl.) (exc. Sta. Wag.) . . . . .	3993002	1	28.60	
71-73	Vega (P.G. w/1BC) . . . . .	3974406	1	35.35	
71-72	Vega (P.G. w/2BC) . . . . .	3993055	1	28.55	
73	Vega (P.G. w/2BC) . . . . .	336903	1	28.50	
71-72	Vega w/Torque Drive . . . . .	3950334	1	26.75	

**POWERGLIDE BODY ASSY., Lower**

64	Chevy, Chevelle (230),				
66-68	Taxi, Police (6 cyl.) (1st design),				
66-68	All (230) (1st design) (exc. Pass.),				
69	Pass. (327, 350) (exc. 4BC),				
69	All (327, 350) (exc. Pass.),				
70	All (8 cyl.) . . . . .	3968073	1	36.30	lower valve (Note 2) . . . . .
	<i>NOTE 2 Contains component regulator valve 3792247 w/25/32" O.D.</i>				
64-67	All (283),				
68	Pass. (307),				
68-69	All (307) (exc. Pass.) . . . . .	3924702	1	58.45	lower valve . . . . .
65	Pass. (8 cyl.),				
65	Chevy, Chevelle (327) (exc. Sp. H/Per.),				
66	All (327, 396),				

**POWERGLIDE AND TORQUE DRIVE TRANSMISSION**

**4.216 BODY ASSY.— BUSHING UNIT— DAMPER ASSY.— RING— SPRING—  
STUD— TUBE— VALVE, Transmission Main Valve (Con't)**

67-68	Pass. (8 cyl.) (exc. 283, 307),				
67-68	Camaro (327, 350),				
67-68	Chevy, Chevelle (327, 350, 396)	<b>3895744</b>	1	37.60	lower valve .....
68-70	Pass. (6 cyl.) (2nd design) (exc. Police, Taxi),				
68-69	Chevy, Chevelle, Camaro (250) (2nd design),				
71-72	All (6 cyl.) (exc. Taxi, Police),				
71	Nova, Chevelle, Camaro (8 cyl.) (exc. Monte Carlo) (1st design),				
73	All .....	<b>3968071</b>	1	38.35	lower valve (Note 3) .....
68-70	Taxi, Police (6 cyl.) (2nd design),				
68-69	Chevy, Chevelle, Camaro (230) (2nd design),				
71-72	Nova, Chevelle, Camaro (8 cyl.) (exc. Monte Carlo) (2nd design),				
72	Pass. (Sta. Wag.) .....	<b>3968072</b>	1	36.80	lower valve (Note 3, 4) .....
	<i>NOTE 3 Contains component regulator valve 3838472 w/<sup>27</sup>/<sub>32</sub>" O.D.</i>				
	<i>NOTE 4 Use on 1971 models beginning with trans. serial #C-1T01-D.</i>				
71-72	Taxi, Police (6 cyl.),				
71	Pass., Monte Carlo (8 cyl.),				
72	Pass., Monte Carlo (8 cyl.) (exc. Sta. Wag.) .....	<b>3981743</b>	1	64.90	
71-72	Vega (P.G. w/1BC) (exc. NB-2) ..	<b>3978797</b>	1	40.70	
73	Vega (P.G. w/2BC) .....	<b>336904</b>	1	40.70	
71-72	Vega w/Torque Drive .....	<b>3993075</b>	1	34.75	
72	Vega (P.G. w/1BC) w/NB-2,				
72	Vega (P.G. w/2BC),				
73	Vega w/1BC .....	<b>6273277</b>	1	40.70	
62-63	Chevy w/P.G.,				
65	Pass. (409) .....	<b>3839771</b>	1	.82	<b>DAMPER ASSY.</b> , pressure regulator .....
62-71	All (exc. Vega),				
71-73	Vega .....	<b>3744352</b>	1	.06	<b>RING</b> , press. reg. valve spring seat .....
65-66	All .....	<b>9411820</b>	1	.24	<b>RING</b> , internal retaining (type T)— (8.934) ..
62-66	All,				
67	All (exc. A.I.R.),				
68-72	All (exc. Vega),				
71-72	Vega w/Torque Drive,				
73	Vega .....	<b>3814086</b>	1	.20	<b>SPRING</b> , pressure regulator .....
62-66	All .....	<b>6257100</b>	2	.12	<b>SPRING</b> , oil pump check valve ( <sup>25</sup> / <sub>32</sub> " O.L.) ..
70-73	All .....	<b>3977616</b>	1	.65	<b>SPRING UNIT</b> , low and drive valve (Note 1)
	<i>NOTE 1 Also listed in torque drive grouping.</i>				
62-73	All (aluminum) .....	<b>6256829</b>	1	.13	<b>STUD</b> , button head groove drive ( <sup>13</sup> / <sub>16</sub> " .....
62-66	All,				
71-73	Vega w/P.G.,				
73	Nova .....	<b>3795898</b>	1	.38	<b>TUBE</b> , servo applicator press .....
62-66	All,				
66-67	Pass. w/A.I.R. (327),				
67-69	All (exc. A.I.R.),				
70-73	All (exc. Vega),				
71-73	Vega w/P.G. .....	<b>3830128</b>	1	1.05	<b>VALVE</b> , clutch low servo .....
62-72	All,				
73	Vega .....	<b>3925674</b>	1	2.01	<b>VALVE</b> , manual .....
64	Chevelle w/P.G. (exc. 327, Taxi, Police),				
64-66	Chevy w/P.G. (exc. 230, 8 cyl.),				
65-66	Chevelle w/P.G. (6 cyl.) (exc. 230, Taxi, Police),				
66-69	Pass. (6 cyl.) (exc. Taxi, Police),				
67-68	Chevy w/P.G. (153, 194, 250),				
67-68	Chevelle, Camaro w/P.G. (250),				
69	Chevy, Chevelle, Camaro (exc. 8 cyl.),				
70-72	All (6 cyl.) (exc. Taxi, Police),				
71-73	Vega w/P.G. .....	<b>3792251</b>	1	1.05	<b>VALVE</b> , hydraulic modulator .....
71-72	Vega w/Torque Drive .....	<b>3946726</b>	1	1.05	<b>VALVE</b> , trans. down shift timing (orange) ..
65	Pass. (327, 409),				
66	Pass. (327, 396),				
66	Chevelle (327) .....	<b>3895744</b>	1	37.60	<b>VALVE ASSY.</b> , press. reg. .....
63	Chevy w/P.G.,				
64	Chevy w/P.G. (230, 283) (exc. Taxi),				

**POWERGLIDE AND TORQUE DRIVE TRANSMISSION**

**4.216 BODY ASSY.— BUSHING UNIT— DAMPER ASSY.— RING— SPRING—  
STUD— TUBE— VALVE, Transmission Main Valve (Con't)**

65	Chevelle w/P.G. (327) (exc. Sp. H/Per.),				
65-69	Pass. (327, 396, 409),				
66-68	Taxi, Police (6 cyl.),				
66	Chevy, Chevelle w/P.G. (exc. 153, 194, 283),				
67-69	Chevy, Chevelle, Camaro w/P.G. (exc. 250, 283, 307),				
69	Pass. (350) (exc. 4BC),				
70	Taxi, Police (6 cyl.),				
70	All (350),				
71-72	Nova, Chevelle, Camaro (8 cyl.) (exc. Monte Carlo),				
72	Pass. (Sta. Wag.)	3900940	1	2.27	VALVE UNIT, hydraulic modulator w/sleeve
64-68	Chevy w/P.G. (153, 194, 250),				
64-66	Chevelle w/P.G. (6 cyl.) (exc. 230, Taxi, Police),				
64	Chevelle w/P.G. (283),				
66-70	Pass. (6 cyl.) (exc. Taxi, Police),				
67-68	Chevelle, Camaro w/P.G. (250),				
69	Chevy, Chevelle, Camaro w/P.G. (exc. 8 cyl.),				
71-72	All (exc. Taxi, Police, Vega),				
73	Nova	6258671	1	2.27	VALVE UNIT, w/sleeve hyd. mod.
64	Chevelle w/P.G. (283),				
64	Chevelle (Police, Taxi) w/P.G. (6 cyl.),				
65-66	All,				
67-68	All (8 cyl.),				
69-72	All (exc. Vega)	3977543	1	.26	VALVE UNIT, oil cooler by-pass.
62	Chevy w/P.G.,				
65-66	Pass. (exc. 327, 396, 409),				
65	Chevy, Chevelle w/P.G. (230, 283),				
65	Chevelle (Taxi, Police) w/P.G. (6 cyl.),				
65	Pass. (exc. 327, 409),				
66-68	All (283, 307),				
69	Chevy, Chevelle, Camaro (8 cyl.) (exc. 350),				
70	All (8 cyl.) (exc. 350),				
71-72	Taxi, Police (6 cyl.),				
71	Pass., Monte Carlo (8 cyl.),				
72	Pass., Monte Carlo (8 cyl.) (exc. Sta. Wag.)	3900938	1	2.06	VALVE UNIT, hydraulic modulator with sleeve

**BODY ASSY.— RING— SPRING— VALVE, Torque Drive**

68-72	All (exc. Vega)	3993075	1	34.75	lower valve
68-72	All (exc. Vega)	3950334	1	26.75	upper valve
68-73	All (exc. Vega)	3744352	1	.06	RING, snap
68-73	All (exc. Vega)	3814086	1	.20	SPRING, pressure regulator
70	Nova	3977616	1	.65	SPRING UNIT, low and drive valve
68-72	All (exc. Vega)	3946726	1	1.05	VALVE, downshift timing (orange)
68-73	All (exc. Vega)	3925674	1	2.01	VALVE, manual
68-72	All (exc. Vega)	3986000	1	2.68	VALVE UNIT, hydraulic modulator w/sleeve
68-72	All (exc. Vega)	3977543	1	.26	VALVE UNIT, oil cooler by-pass

**4.217 GASKET— NUT, Transmission Main Valve Body Accumulator**

62-66	All w/P.G.	3840330	1	.95	transfer plate to upper valve body
62-66	All w/P.G.	3840331	1	.95	transfer plate to lower body
62-73	All w/P.G. (exc. Vega),				
71-73	Vega	3840329	1	.14	upper valve body plate
67-70	All w/P.G.	7420925	2	.90	transfer plate valve upper and lower
68-70	Chevy, Camaro w/Torque Drive	3830195	1		transfer plate valve (cut as reqd.)
65-73	All w/P.G. (exc. Vega),				
71-73	Vega	3767300	1	.20	NUT, throttle valve spring regulator (1/4" x 28)

**4.218 LEVER ASSY.— RETAINER— RING— SPRING— GUIDE, Manual Valve**

62-73	All w/P.G. Torque Drive	3824051	1	4.85	inner range selector and parking lock
65-73	All w/P.G., Torque Drive	3886200	1	1.20	w/roller trans. range selector detent
62-73	All w/P.G., Torque Drive	3789117	1	.13	RETAINER, range selector detent roller spring

**POWERGLIDE AND TORQUE DRIVE TRANSMISSION**

**4.218 LEVER ASSY.— RETAINER— RING— SPRING— GUIDE, Manual Valve (Con't)**

62-64	Chevy, Chevelle w/P.G.,					
62	Chevy w/P.G. ....	9416094	1	.11	RING, throttle valve spring seat retainer, parking lock actuator to inner lever retaining— (8.934) .....	
62-73	All w/P.G., Torque Drive .....	3839320	1	.13	SPRING, trans. range selector detent roller .....	
62-73	All w/P.G., Torque Drive .....	3813591	1	1.20	GUIDE, transmission parking lock and range selector inner lever .....	

**4.220 PAWL— ACTUATOR ASSY.— BRACKET— PIN— SEAL— SHAFT— SPRING— RING, Transmission Parking Lock**

62-73	All w/P.G., Torque Drive .....	3815199	1	3.35		
62-73	All w/P.G., Torque Drive .....	3978780	1	2.68	ACTUATOR ASSY. ....	
62-68	All w/P.G., Torque Drive,					
70-73	All w/A.T. ....	3789127	1	2.83	BRACKET, reaction .....	
62	Chevy w/P.G. ....	455478	1	.04	PIN, pawl shaft retaining (1/16" x 1/2")— (8.939) .....	
73	All .....	8526398	1	.25	SEAL, park. lock and range sel. shaft .....	
62-73	All w/P.G., Torque Drive .....	3789137	1	.54	SEAL ASSY., park lock and range sel. shaft oil .....	
62-73	All w/P.G., Torque Drive .....	3789130	1	.80	SHAFT, pawl .....	
62-73	All w/P.G., Torque Drive .....	3821953	1	.20	SPRING, pawl disengaging .....	
62-73	All w/P.G., Torque Drive .....	3750532	1	.06	RING, pawl shaft retaining .....	

**4.226 SEAL— SCREW, Transmission Front Servo**

62-65	All w/P.G. (1st design) .....	3789024 A.R.		.13	frt. pump, "O" ring (5/16" I.D. x 1/16" thk.) ....	
65-67	Pass. w/A.T. (2nd design),					
65-66	Chevy, Chevelle, w/P.G. (2nd design),					
67-71	All w/A.T.,					
68-69	Pass. w/A.T.,					
71-73	Vega .....	3884683 A.R.		.06	front oil pump to trans. case bolt .....	
69-71	All w/A.T.,					
71-73	Vega .....	8626916	1	3.43	SEAL ASSY., oil pump body inner .....	
62-73	All w/A.T. ....	6261374	1	.20	SCREW ASSY., oil pump lower to case (5/16" — 18 x 17/16") .....	

**4.228 PISTON— ROD— RETAINER— RING— WASHER, Low Servo**

62-73	All w/P.G., Torque Drive .....	3846173	1	4.12		
65-73	All w/P.G. (exc. Vega) .....	3907181	1	2.06	ROD, w/retainer low servo .....	
68-72	All w/Torque Drive,					
71-73	Vega w/P.G. ....	3946728	1	2.27	ROD, piston .....	
62-66	All w/P.G. ....	455564	1	.11	RETAINER, piston rod spring (hair pin type) .....	
67-73	All w/P.G., Torque Drive .....	3905402	1	.20	RETAINER, piston rod spring .....	
62-73	All w/P.G., Torque Drive .....	3789084	1	.87	RING, piston .....	
65-73	All w/P.G., Torque Drive .....	3702807	1	.06	WASHER, piston apply spring (9/16" I.D. x 7/8" O.D. x 5/64") .....	

**4.233 SPRING, Transmission Front Servo**

64-71	All w/P.G.,					
72	Taxi, Police (6 cyl.),					
72	Pass., Monte Carlo (8 cyl.) (exc. Sta. Wag.) .....	3815914	1	.54	piston return .....	
64-66	Chevy, Chevelle w/P.G. (283, 230 w/H/Per.),					
65	Pass. w/P.G. (exc. 327, 409, Taxi, Police),					
66-68	Pass. w/P.G. (250, 283, 307, 327),					
67	Chevy, Chevelle w/P.G. (exc. A.I.R. 396),					
67	Camaro w/P.G. (250, 327 w/4BC) (exc. A.I.R.),					
68	Chevy, Chevelle, Camaro w/P.G. (exc. 350, 396),					
69	Chevy, Chevelle, Camaro w/P.G. (6 cyl.),					
68-72	Chevy, Camaro, Vega w/Torque Drive .....	3946729	1	.54	lower piston .....	
64-73	All w/P.G. ....	3846166	1	.33	piston apply .....	
68-72	Chevy, Camaro, Vega w/Torque Drive (6 cyl.) .....	3946730	1	.71	piston return .....	
70	All w/P.G. (6 cyl.),					
71-72	All w/P.G. (6 cyl.) (exc. Taxi, Police),					

**POWERGLIDE AND TORQUE DRIVE TRANSMISSION**

<b>4.233 SPRING, Transmission Front Servo (Con't)</b>					
71-72	Nova, Chevelle, Camaro w/P.G. (8 cyl.) (exc. Monte Carlo), Pass. (Sta. Wag.) w/P.G.,				
73	All	3830235	1	.54	low servo piston return
71-72	Vega w/P.G.	3815914	1	.54	trans. low servo piston return
<b>4.241 RING, Reverse Servo</b>					
62-68	All w/P.G., Torque Drive	3789084	1	.87	low servo piston— (4.228)
<b>4.248 SCREEN ASSY., Transmission Oil</b>					
63-73	All w/P.G.	3848365	1	.26	governor valve
<b>4.251 BAND ASSY.— STRUT, Transmission Brake</b>					
62-73	All w/P.G., Torque Drive	3883918	1	15.70	low
62-73	All w/P.G., Torque Drive	1362592	1	1.20	STRUT, anchor
62-73	All w/P.G., Torque Drive	3713613	1	1.30	STRUT ASSY., apply (use w/dbl. wrap band) (1 <sup>5</sup> / <sub>8</sub> " long)
<b>4.253 SCREW— NUT, Brake Band Adjusting</b>					
62-73	All w/P.G., Torque Drive	3789089	1	.87	anchor
62-69	All w/P.G.,				
70-73	All	3840137 A.R.		.13	NUT, brake screw (7/16"— 20 x 1/4")
<b>4.256 GOVERNOR ASSY.— BODY ASSY.— BUSHING— GASKET— RING— SCREW— SHAFT— SPRING— VALVE— WASHER— WEIGHT ASSY., Transmission</b>					
62-65	All w/P.G. (exc. 327 H/Per., 409),				
66-68	Pass. w/P.G. (283, 307),				
66-69	Chevy, Chevelle w/P.G. (153, 194, 283, 307),				
70	All w/P.G. (8 cyl.) (exc. 350),				
71	Pass., Monte Carlo w/P.G. (8 cyl.)	3850510	1	24.85	(Note 1)
<i>NOTE 1 Not used on 283, 307 engines when the transmission code ends with the letter L.</i>					
64-66	Chevy, Chevelle w/P.G. (327, 396) (exc. H/Per., Sp. H/Per.),				
65	Police (327) (exc. H/Per.),				
65-68	Pass. w/P.G. (8 cyl.) (exc. 283, 307, low comp.),				
67-68	Chevy, Chevelle w/P.G. (327) (exc. low comp.),				
67-68	Camaro w/P.G. (327, w/4BC),				
69-70	Pass. w/P.G. (327, 350) (exc. 4BC),				
69-70	All w/P.G. (350 w/2BC) (exc. Pass.)	3850511	1	24.85	
66-68	Pass. w/P.G. (250, 283, 307),				
66-69	Chevy, Chevelle w/P.G. (230, 250, 283, 307),				
67-69	Camaro w/P.G. (exc. 327 w/4BC, 350),				
69	Pass. (6 cyl.),				
70	All w/P.G. (6 cyl.)	3882876	1	24.85	(Note 2)
<i>NOTE 2 When using Governor Assy. on the 283, 307 engines the transmission code must end with the letter L.</i>					
67-68	Camaro w/P.G. (350),				
67-68	Chevelle w/P.G. (396) (exc. H/Per.),				
68	Chevy w/P.G. (350),				
69-70	All w/P.G. (350 4BC)	3905414	1	22.65	
71	Nova, Chevelle, Camaro w/P.G. (exc. Monte Carlo),				
71	Pass. w/P.G. (6 cyl.),				
72-73	All w/P.G. (exc. Vega)	3987913	1	25.00	
71-73	Vega (P.G. w/1BC) (exc. NB-2)	3993052	1	22.70	trans.
71-73	Vega w/2BC	6273208	1	22.55	trans.
73	Vega (P.G. w/NB-2) w/1BC	326529	1	22.55	trans.
67-73	All w/P.G.	3996642	1	13.65	BODY ASSY., trans. gov. support (w/gasket and ring)
62-73	All (exc. Vega)	3789877	1	.39	BUSHING, gov. supt. body— (4.203)
62	Chevy w/P.G. (1st design)	3789047	1	.13	GASKET, governor (use w/governor w/casting No. 3789045)
62-73	All w/P.G. (2nd design)	3818935	1	.14	GASKET, governor (use w/governor w/casting No. 3818876)

**POWERGLIDE AND TORQUE DRIVE TRANSMISSION**

**4.256 GOVERNOR ASSY.— BODY ASSY.— BUSHING— GASKET— RING— SCREW— SHAFT— SPRING— VALVE— WASHER— WEIGHT ASSY., Transmission (Con't)**

67-70	All w/P.G. ....	3890524	1	.23	GASKET, trans. to gov. support body .....
71-73	All w/P.G. ....	3987943	1	.26	GASKET, governor support body .....
62-72	Chevy w/P.G. ....	9414875	1	.11	RING, governor inner weight retainer— (8.934) .....
62-73	All w/P.G. ....	3798068	A.R.	.06	RING, inner weight to conn. shaft retainer, governor valve to conn. shaft retainer (3/8" dia.) .....
62-70	All A.T. ....	3689808	2	1.40	RING, hub oil seal— (4.169) .....
71-73	All w/P.G. ....	3987944	1	.23	RING, governor support oil seal (1 3/16" I.D.) .
62-73	All w/P.G. ....	3789048	1	.13	SCREW, hub drive .....
65-72	All w/P.G. ....	3856672	4	.13	SCREW, governor body to trans. governor hub screw and lock washer (1/4"— 20 x 3/4") .....
65-73	All w/P.G. ....	3850517	1	.38	SHAFT, governor connector .....
62-66	All w/P.G. ....	3815089	2	.05	SPRING, governor damping .....
64-73	All w/P.G. (2nd design) .....	3850516	1	.65	VALVE, governor .....
67-73	All w/P.G. ....	3905432	1	.20	WASHER, governor damping .....
64-65	Chevy, Chevelle w/P.G. (exc. 327),				
65	All w/P.G. (exc. 327 H/Per., 409, Police) (2nd design),				
66-68	Pass. w/P.G. (283, 307),				
66-69	Chevy, Chevelle w/P.G. (153, 194, 283, 307),				
70	All w/P.G. (8 cyl.) (exc. 350) ... <i>NOTE 3 Use with small gear set.</i>	3850512	1	2.16	WEIGHT ASSY., governor (Note 3) .....
64-66	Chevy, Chevelle w/P.G. (327, 396) (2nd design) (exc. H/Per., Sp. H/Per.),				
65-68	Pass. w/P.G. (327, 396, 409) (2nd design) (exc. low comp.),				
66-68	Chevy, Chevelle w/P.G. (327, 396) (exc. H/Per., Sp. H/Per., reg. fuel),				
67-68	Camaro w/P.G. (327 w/4BC),				
69-70	Chevy, Chevelle, Camaro (P.G. w/reg. fuel) (350),				
69-70	Pass. (P.G. w/2BC) (8 cyl.) (exc. 350) .....	3850513	1	2.06	WEIGHT ASSY., governor .....
	<i>NOTE 4 Use with large gear set.</i>				
71-73	All w/P.G. (exc. Vega) .....	3987914	1	2.21	WEIGHT ASSY., governor .....
71-73	Vega (P.G. w/1BC) (exc. NB-2) ..	3993053	1	1.96	WEIGHT ASSY., trans. gov. ....
71-73	Vega (P.G. w/2BC) .....	6273206	1	2.11	WEIGHT ASSY., trans. gov. ....
72	Vega (P.G. w/1BC) w/NB-2 ....	326530	1	2.21	WEIGHT ASSY., trans. gov. ....

**4.260 LENS ASSY., Transmission Control Pedal Rod**

Not required in this group. See  
group 10.275 .....

		5939863	1	1.85	cover .....
--	--	---------	---	------	-------------

**4.265 SCREEN ASSY., Transmission Low and Drive Valve**

63-73	All w/P.G. ....	3846834	1	1.25	trans. throttle valve feed .....
-------	-----------------	---------	---	------	----------------------------------

**4.278 LEVER ASSY.— GASKET— WASHER, Transmission Throttle Valve**

62-73	All w/P.G. ....	3789138	1	2.37	inner .....
62-70	All w/P.G. ....	8526398	1	.25	GASKET, lever shaft "O" ring (5/16" I.D.)— (9.211) .....
62-70	All w/P.G. ....	3978774	1	.12	WASHER, throttle valve control shaft— (4.052) .....

**4.317 EXTENSION ASSY.— RING, Transmission Rear Main Bearing**

62-73	All (exc. Vega) .....	3987986	1	17.50	w/bushing .....
71-73	Vega .....	3993064	1	17.80	trans. w/bushing .....
68-71	Chevy, Camaro w/Torque Drive .	3946707	1	2.10	RING, ext. pilot .....

**4.318 SEAL ASSY., Transmission Rear Bearing Retainer**

62-69	All (exc. Pass.),				
65	All w/P.G.,				
66-69	All,				
71	All,				
71-73	Vega,				
73	Nova .....	1243402	1	2.95	extension oil .....
70	All,				
72	All (exc. Vega) .....	3932255	1	4.02	extension oil .....

**POWERGLIDE AND TORQUE DRIVE TRANSMISSION**

**4.319 BUSHING, Transmission Rear Main Bearing**

62-73 All ..... 6260048 1 .74 extension (1½" I.D. x 1⅝" O.D.) .....

**4.329 ADAPTER ASSY.— ADAPTER UNIT, Speedometer**

68 (For application refer to chart in group 4.337) ..... 6451928 1 36.59  
 68 (For application refer to chart in group 4.337) ..... 1585657 1 28.80  
 68 (For application refer to chart in group 4.337) ..... 1565452 1 30.15  
 68 (For application refer to chart in group 4.337) ..... 1583624 1 25.28  
 69 (For application refer to chart in group 4.337) ..... 3950348 1 18.10  
 69 (For application refer to chart in group 4.337) ..... 3950350 1 18.10  
 69 (For application refer to chart in group 4.337) ..... 3950352 1 18.10  
 69 (For application refer to chart in group 4.337) ..... 3950354 1 18.10  
 65-66 (For models and comb. see group 4.337) ..... **ADAPTER UNIT, ratio 17.16 (stamped 1563871),** .....

68 (For application refer to chart in group 4.337) ..... 1565812 A.R. 26.70 (Note 2) .....

65-66 (For models and comb. see group 4.337) ..... **ADAPTER UNIT, ratio 17.15 (stamped 1563872),** .....

68 (For application refer to chart in group 4.337) ..... 1565813 A.R. 26.70 (Note 2) .....

68 (For application refer to chart in group 4.337) ..... 1565814 A.R. 28.80 **ADAPTER UNIT, ratio 16.17 (stamped 1564409) (Note 2)** .....

*NOTE 2 Above adapters used as required in combination with speedometer gears to correct odometer reading for various tire sizes, transmission and rear axle gear ratio combinations— See group 4.337.*

68 (For application refer to chart in group 4.337) ..... 1584275 1 28.80 **ADAPTER UNIT** .....

68 (For application refer to chart in group 4.337) ..... 1584277 1 28.80 **ADAPTER UNIT** .....

69 (For application refer to chart in group 4.337) ..... 3925673 1 18.10 **ADAPTER UNIT** .....

**4.330 KEY— CUP, Speedometer Adapter**

62-69 All ..... 867209 1 1.14 (also included w/adapters 1565811-12-13-14-1580273-3876) .....

62-69 All ..... 860187 1 1.88 **CUP, drive (¼"— 32 x 1⅜" nickel bright)** .....

**4.337 GEAR, Transmission Speedometer Driven Gears (only)**

62 Chevy w/3.55 axle ..... (6.00 x 13), .....

64 Chevelle w/3.70 axle ..... (6.50 x 14), .....

65-66 Chevy, Chevelle w/2.73 axle ..... 3987917 1 1.05 (6.95, 7.35, 7.75 x 14) .....

62-65 Chevy w/3.08 axle ..... (6.00 x 13), .....

62-66 Chevy (Sta. Wag.) w/3.36 axle ..... (6.95 x 14, 7.00 x 13), .....

64 Chevelle (Sta. Wag., El Camino) w/3.36 axle (6 cyl.) ..... (6.50, 7.00 x 14), .....

65-66 Pass. w/3.36, 3.31 axle ..... (7.35 x 14), .....

65-66 Pass. w/3.55 axle ..... (7.75 x 14, 8.25 x 14, 7.75 x 15, 8.15 x 15, 8.55 x 14) (red-21 teeth), .....

65-66 Chevelle w/3.36, 3.31 axle ..... (6.95, 7.35 x 14), .....

66 Chevelle w/3.55 axle ..... (7.75 x 14), .....

66 Chevy w/3.31 axle ..... (6.95 x 14), .....

67 Pass. w/3.55 axle ..... (8.55 x 14, 8.15 x 15, 8.45 x 15, 8.25 x 14), .....

67 Pass. w/3.70 axle ..... (8.45 x 15), .....

67 Chevelle w/3.36 axle ..... (7.00, 7.35, 7.75 x 14), .....

67 Chevelle, Camaro w/3.31 axle ..... 3987921 1 1.15 (7.00, 7.35 x 14) (red— 21 teeth) .....

62-66 Chevy w/3.07, 3.08 axle ..... (6.50, 7.00 x 13, 6.95 x 14), .....

64 Chevelle w/3.08 axle (exc. Sta. Wag., El Camino) ..... (6.50 x 14), .....

64-66 Chevelle (Sta. Wag., El Camino) w/3.36 axle (6 cyl.) ..... (7.50, 7.75 x 14), .....

65-66 Pass. w/3.36, 3.31 axle ..... (7.75 x 14, 8.25 x 14, 7.75 x 15, 8.15 x 15, 8.55 x 14) (blue— 20 teeth), .....

65-66 Chevelle w/3.31 axle ..... (7.75 x 14), .....

65-66 Chevelle w/3.07, 3.08 axle ..... (6.95 x 14), .....

**POWERGLIDE AND TORQUE DRIVE TRANSMISSION**

**4.337 GEAR, Transmission Speedometer Driven Gears (only) (Con't)**

67	Pass. w/3.36 axle				(8.25 x 14, 8.55 x 14, 8.15 x 15, 7.75 x 15, 8.45 x 15),
67	Pass. w/3.31 axle				(8.25 x 14, 8.55 x 14, 8.15 x 15),
67	Chevelle w/3.07, 3.08, 2.73 axle				(7.35 x 14),
67	Chevelle w/3.31 axle				(7.75 x 14),
67	Chevy w/3.07, 3.08 axle				(6.95, 7.35 x 14),
67	Camaro w/2.73, 3.07, 3.08 axle	<b>3987920</b>	<b>1</b>	<b>.98</b>	(7.00, 7.35 x 14)
62-66	Chevy w/3.36 axle				(6.50 x 13),
64	Chevelle w/3.70 axle				(7.50 x 14),
65-66	Pass. w/3.55 axle				(7.35 x 14),
65-66	Pass. w/3.70, 3.73 axle				(7.75 x 14, 8.25 x 14, 7.75 x 15, 8.15 x 15, 8.55 x 14),
65-66	Chevelle w/3.70 axle				(7.75 x 14),
67	Pass. w/3.55 axle				(8.25 x 14, 7.75 x 15),
67	Pass. w/3.70 axle				(8.25 x 14, 8.55 x 14, 7.75 x 15),
67	Pass. w/3.73 axle				(8.55 x 14, 8.15 x 15, 8.45 x 15) (green— 22 teeth),
67	Chevelle w/3.55 axle				(7.00, 7.75, F70 x 14),
67	Chevy w/3.31, 3.36 axle				(6.95 x 14),
67	Camaro w/4.10 axle	<b>3860345</b>	<b>1</b>	<b>1.05</b>	(7.00, 7.35 x 14)
62-65	Chevy w/3.36 axle				(6.00 x 13),
62-66	Chevy w/3.55 axle				(6.50, 7.00 x 13, 6.95 x 14),
64	Chevelle w/3.70 axle				(7.00 x 14),
65-66	Pass. w/3.70 axle				(7.35 x 14),
65-66	Pass. w/3.73 axle				(7.35 x 14, 7.75 x 14),
65-66	Chevelle w/3.70 axle				(7.35 x 14),
65-66	Chevelle w/3.73 axle				(7.35, 7.75 x 14),
67	Pass. w/3.73 axle				(8.25 x 14),
67	Chevelle w/3.70 axle				(7.00, 7.75 x 14),
67	Chevelle w/3.73 axle				(7.00, 7.75 x 14),
67	Chevy w/3.55 axle				(6.95, E70 x 14),
67	Camaro w/3.55 axle	<b>3860346</b>	<b>1</b>	<b>1.10</b>	(7.00, 7.35 x 14) (black— 23 teeth)
63-65	Chevy w/3.55 axle				(6.00 x 13),
67	Pass. w/4.10 axle				(7.75 x 14, 8.25 x 14, 7.75 x 15),
67	Chevelle w/4.10, 4.88 axle				(7.00, 7.75 x 14),
67	Camaro w/4.88 axle	<b>3860348</b>	<b>1</b>	<b>1.05</b>	(7.00, 7.35 x 14) (orange— 25 teeth)
64	Chevelle (Sta. Wag., El Camino) w/3.08 axle (8 cyl.) (exc. S.S.),				
64	Chevelle w/3.08 axle (exc. Sta. Wag., El Camino)				(7.00, 7.50 x 14),
65-66	Pass. w/3.07, 3.08, 3.31 axle				(7.35 x 14, 7.75 x 14, 8.25 x 14, 8.15 x 15, 8.55 x 14),
65	Chevelle w/3.07, 3.08 axle				(7.35, 7.75 x 14),
67	Pass. w/3.07 axle				(8.25 x 14),
67	Pass. w/3.08 axle				(8.25 x 14, 7.75 x 15),
67	Pass. w/3.31 axle				(8.45 x 15),
67	Pass. w/2.73 axle				(8.25 x 14),
67	Chevelle w/3.07, 3.08 axle				(7.00, 7.75 x 14),
67	Chevelle w/2.73 axle	<b>3987919</b>	<b>1</b>	<b>.98</b>	(7.75, 7.35 x 14) (natural— 19 teeth)
65-66	Pass. w/4.89 axle	<b>3860033</b>	<b>1</b>	<b>4.70</b>	(8.25 x 14, 8.15 x 15, 8.55 x 14) (21 teeth)
65	Pass. w/2.73	<b>1359273 A.R.</b>		<b>1.20</b>	(7.75 x 15, 8.25 x 14, 8.15 x 15, 8.55 x 14) (brown— 39 teeth) (Note 1)
65-66	Pass. w/4.10 axle				(8.25 x 14, 7.75 x 15, 8.15 x 15, 8.55 x 14) (yellow— 24 teeth),
65-66	Chevelle w/3.70, 3.73 axle,				
66	Chevy w/3.55 axle				(6.95 x 14),
67	Chevelle w/3.70 axle				(7.35 x 14),
67	Chevelle w/3.73 axle				(7.75 x 14),
67	Chevelle w/4.56 axle				(7.00, 7.75 x 14),
67	Chevy w/3.73 axle				(6.95 x 14),
67	Camaro w/3.73, 4.56 axle				(7.00, 7.35 x 14),
67	Pass. w/4.10 axle	<b>3860347</b>	<b>1</b>	<b>1.10</b>	(8.55 x 14, 8.15 x 15, 8.45 x 15)
65-66	Pass. w/4.56 axle	<b>3860329</b>	<b>1</b>	<b>2.20</b>	(8.25 x 14, 8.15 x 15, 8.55 x 14) (20 teeth— steel)
65-66	Pass. w/3.08 axle				(8.00 x 14, 6.70 x 15, 7.10 x 15, 7.75-15, 8.25-14, 8.55-14),
65-66	Pass. w/3.07 axle				(8.25 x 14, 8.15 x 15, 8.55 x 14),
65	Pass. w/3.08 axle				(7.75 x 15, 8.15 x 15, 8.25 x 15),
67	Pass. w/3.07 axle				(8.55 x 14, 8.15 x 15, 8.45 x 15, 6.70 x 15),
67	Pass. w/3.08 axle				(8.15 x 15, 8.45 x 15, 8.55 x 14),
67	Pass. w/2.73 axle	<b>3987918</b>	<b>1</b>	<b>1.05</b>	(8.55 x 14, 8.15 x 15, 8.45 x 15) (brown— 18 teeth)



**POWERGLIDE AND TORQUE DRIVE TRANSMISSION**

**1968 PASSENGER SPEEDOMETER GEAR CHART**

*NOTE: To order Speedometer Gears or Parts, Transmission Type, Rear Axle Ratio and Tire Size must be known.*

REAR AXLE RATIO	TIRE SIZE .....	4.343 GEAR, SPEEDO. DRIVE	4.337 GEAR, SPEEDO. DRIVEN	4.329 ADAPTER, SPEEDO.
<b>POWERGLIDE</b>				
2.73	8.55 x 14, 8.15 x 15, 8.45 x 15, G70 x 15 ...	3905494	3987918	—
2.73	8.25 x 14 .....	3905494	3987919	—
3.07	8.55 x 14, 8.15 x 15, 8.45 x 15, G70 x 15 ...	6261794	3987918	—
3.07	8.25 x 14, F70 x 15 .....	6261794	3987919	—
3.08	8.55 x 14, 8.15 x 15, 8.45 x 15, G70 x 15 ...	6261794	3987918	—
3.08	8.25 x 14, F70 x 15 .....	6261794	3987919	—
3.31	8.45 x 15 .....	6261794	3987919	—
3.31	8.25 x 14, 8.55 x 14, 8.15 x 15, F70 x 15, G70 x 15 .....	6261794	3987920	—
3.36	8.25 x 14, 8.55 x 14, 8.15 x 15, F70 x 15, G70 x 15 .....	6261794	3987920	—
3.55	8.25 x 14, 8.55 x 14, 8.15 x 15, 8.45 x 15, G70 x 15 .....	6261794	3987921	—
3.55	F70 x 15 .....	3924097	3860345	—
3.70	8.25 x 14, 8.55 x 14, 8.15 x 15, F70 x 15, G70 x 15 .....	3924097	3860345	—
3.70	8.45 x 15 .....	6261794	3987921	—
3.73	8.55 x 14, 8.15 x 15, 8.45 x 15, G70 x 15 ...	3924097	3860345	—
3.73	8.25 x 14, F70 x 15 .....	3924097	3860348	—
4.10	8.55 x 14, 8.15 x 15, 8.45 x 15, G70 x 15 ...	3924097	3860347	—
4.10	8.25 x 14 .....	3924097	3860348	—
4.11	F70 x 15 .....	3924097	3860348	—
4.56	8.55 x 14, 8.45 x 15 ...	3924097	3860345	3890575
4.56	8.25 x 14, 8.15 x 15, G70 x 15 .....	3924097	3860346	3890575
4.56	F70 x 15 .....	3845079	3860033	—
4.89	8.55 x 14, 8.15 x 15, 8.45 x 15, G70 x 15 ...	3924097	3860347	3890575
4.89	8.25 x 14 .....	3924097	3860348	3890575

**POWERGLIDE AND TORQUE DRIVE TRANSMISSION**

**1968 CHEVY, CHEVELLE, CAMARO SPEEDOMETER GEAR CHART**

*NOTE: To order Speedometer Gears or Parts, Transmission Type, Rear Axle Ratio and Tire Size must be known.*

REAR AXLE RATIO	TIRE SIZE	4.343 GEAR, SPEEDO. DRIVE	4.337 GEAR, SPEEDO. DRIVEN	4.329 ADAPTER, SPEEDO.
<b>POWERGLIDE</b>				
2.56	7.35 x 14	3905494	3987918	—
2.56	E70 x 14, F70 x 14	3905494	3987919	—
2.73	7.35 x 14, 7.75 x 14, E70 x 14, F70 x 14	3905494	3987919	—
3.07	7.35 x 14, 7.75 x 14, F70 x 14, G70 x 14, E70 x 15	6261794	3987919	—
3.07	E70 x 14	6261794	3987920	—
3.08	7.75 x 14, F70 x 14, G70 x 14	6261794	3987919	—
3.08	7.35 x 14, E70 x 14	6261794	3987920	—
3.31	7.75 x 14, G70 x 14, E70 x 15	6261794	3987920	—
3.31	7.35 x 14, E70 x 14, F70 x 14	6261794	3987921	—
3.36	7.35 x 14, 7.75 x 14, F70 x 14, G70 x 14	6261794	3987921	—
3.36	E70 x 14	3924097	3860345	—
3.55	7.35 x 14, 7.75 x 14, F70 x 14, G70 x 14, E70 x 15	3924097	3860345	—
3.55	E70 x 14	3924097	3860346	—
3.70	7.35 x 14, 7.75 x 14, F70 x 14, G70 x 14	3924097	3860346	—
3.73	7.75 x 14, F70 x 14, G70 x 14, E70 x 15	3924097	3860346	—
3.73	7.35 x 14, E70 x 14	3924097	3860347	—
4.10	7.35 x 14	3924097	3860345	3890575
4.10	7.75 x 14, F70 x 14, G70 x 14	3924097	3860348	—
4.10	7.35 x 14, F70 x 14	6261794	3987920	6476736
4.10	E70 x 14	3924097	3860345	6476735
4.10	E70 x 15	3924097	3860348	—
4.56	7.75 x 14, G70 x 14	3924097	3860346	3890575
4.56	7.35 x 14, F70 x 14	3924097	3860347	3890575
4.56	7.35 x 14	3924097	3860347	6476735
4.56	F70 x 14, E70 x 15	3924097	3860346	6476735
4.56	E70 x 14	3924097	3860346	6476736
4.89	7.75 x 14, F70 x 14, G70 x 14	3924097	3860348	3890575
4.89	7.35 x 14	3924097	3860348	3905497
4.89	E70 x 14, E70 x 15	3924097	3860346	6476736
4.89	7.35 x 14, F70 x 14	3924097	3860347	6476736

**POWERGLIDE AND TORQUE DRIVE TRANSMISSION**

**1969 PASSENGER SPEEDOMETER GEAR CHART**

*NOTE: To order Speedometer Gears or Parts, Transmission Type, Rear Axle Ratio and Tire Size must be known.*

REAR AXLE RATIO	TIRE SIZE	4.343 GEAR, SPEEDO. DRIVE POWER-GLIDE	4.337 GEAR, SPEEDO. DRIVEN	4.329 ADAPTER, SPEEDO.
<b>POWERGLIDE</b>				
2.56	7.35 x 14, 7.75 x 14, E78 x 14, F70 x 14, F78 x 14, G78 x 14 . . .	3905494	3987918	—
2.56	8.25 x 14, E70 x 14, F70 x 15, G70 x 15, G78 x 15 . . . . .	3905494	3987919	3925673
2.73	8.55 x 14, G70 x 15, G78 x 15, 8.85 x 14, 8.25 x 15, 8.55 x 15 . .	3905494	3987918	—
2.73	7.35 x 14, 7.75 x 14, 8.25 x 14, F70 x 14, F70 x 15, F78 x 14, G78 x 14 . . . . .	3905494	3987919	—
2.73	E70 x 14, E78 x 14 . . . .	3905494	3987920	—
3.07	8.55 x 14, 8.85 x 14, 8.25 x 15, G70 x 15, G78 x 15 . . . . .	6261794	3987918	—
3.07	7.35 x 14, 7.75 x 14, F70 x 14, F78 x 14, G70 x 14 . . . . .	6261794	3987919	—
3.07	8.55 x 15 . . . . .	3905494	3987920	—
3.07	E70 x 14, E78 x 14 . . . .	6261794	3987920	—
3.07	8.25 x 14, E70 x 15, F70 x 15, G78 x 14 . . . . .	3905494	3987921	—
3.08	8.55 x 14, 8.85 x 14, 8.55 x 15, G70 x 15, G78 x 15 . . . . .	6261794	3987918	—
3.08	7.75 x 14, F70 x 14, F78 x 14 . . . . .	6261794	3987919	—
3.08	7.35 x 14, E70 x 14, E78 x 14 . . . . .	6261794	3987920	—
3.08	8.25 x 14, 8.25 x 15, F70 x 15, G78 x 14 . . .	3924099	3987921	—
3.31	8.55 x 15 . . . . .	6261794	3987919	—
3.31	7.75 x 14, 8.25 x 14, 8.55 x 14, 8.85 x 14, 8.25 x 15, E70 x 15, F70 x 15, G70 x 14, G70 x 15, G78 x 14, G78 x 15 . . . . .	6261794	3987920	—
3.31	7.35 x 14, E70 x 14, E78 x 14, F70 x 14, F78 x 14 . . . . .	6261794	3987921	—
3.36	8.25 x 14, 8.55 x 14, 8.85 x 14, 8.25 x 15, 8.55 x 15, F70 x 15, G70 x 15, G78 x 15 . . .	6261794	3987920	—
3.36	7.35 x 14, 7.75 x 14, E78 x 14, F70 x 14, F78 x 14, G78 x 14 . . . . .	6261794	3987921	—
3.36	E70 x 14 . . . . .	3924097	3860345	—
3.55	8.25 x 14, 8.55 x 14, 8.85 x 14, 8.25 x 15, 8.55 x 15, G70 x 15, G78 x 15 . . . . .	6261794	3987921	—
3.55	7.35 x 14, 7.75 x 14, E70 x 15, F70 x 14, F70 x 15, F78 x 14, G70 x 14, G78 x 14 . . .	3924097	3860345	—

**POWERGLIDE AND TORQUE DRIVE TRANSMISSION**

**1969 PASSENGER SPEEDOMETER GEAR CHART (Cont.)**

REAR AXLE RATIO	TIRE SIZE .....	4.343 GEAR, SPEEDO. DRIVE POWER- GLIDE	4.337 GEAR, SPEEDO. DRIVEN	4.329 ADAPTER, SPEEDO.
<b>POWERGLIDE (Cont.)</b>				
3.55	E70 x 14, E78 x 14 .....	3924097	3860346	—
3.70	E70 x 14 .....	3924097	3860347	—
3.73	8.25 x 14, 8.55 x 14, 8.85 x 14, 8.25 x 15, 8.55 x 15, G70 x 15, G78 x 15 .....	3924097	3860345	—
3.73	E70 x 15, F70 x 14, F70 x 15, G70 x 14, G78 x 14 .....	3924097	3860346	—
3.73	E70 x 14 .....	3924097	3860347	—
4.10	F70 x 14 .....	6261794	3987919	3932220
4.10	8.55 x 14, 8.85 x 14, 8.25 x 15, 8.55 x 15, G70 x 15, G78 x 15 ...	3924097	3860347	—
4.10	8.25 x 14, G70 x 14, G78 x 14 .....	3924097	3860348	—
4.56	8.55 x 15 .....	6261794	3987919	3932220
4.56	8.25 x 14, 8.55 x 14, 8.85 x 14, G70 x 15, G78 x 14, G78 x 15 ...	6261794	3987920	3932220
4.56	8.25 x 15 .....	6261794	3987920	3932220
4.56	F70 x 14, G70 x 14 .....	6261794	3987921	3932220
4.88	8.55 x 14, 8.85 x 14, 8.25 x 15, 8.55 x 15, G70 x 15, G78 x 15 ...	6261794	3987921	3932220
4.88	8.25 x 14, F70 x 14, G70 x 14, G78 x 14 .....	3924097	3860345	3932220

**POWERGLIDE AND TORQUE DRIVE TRANSMISSION**

**1969 CHEVY, CHEVELLE, CAMARO SPEEDOMETER GEAR CHART**

*NOTE: To order Speedometer Gears or Parts, Transmission type, Rear Axle Ratio and Tire Size must be known.*

REAR AXLE RATIO	TIRE SIZE	4.343 GEAR, SPEEDO. DRIVE POWER-GLIDE	4.337 GEAR, SPEEDO. DRIVEN	4.329 ADAPTER, SPEEDO.
<b>POWERGLIDE</b>				
2.73	8.25 x 14, 7.75 x 14, F70 x 14, 7.35 x 14, 5.78 x 14	6261794	3987919	—
2.73	E78 x 14, E70 x 14	6261794	3987920	—
3.07	8.25 x 14, E70 x 15	3905494	3987921	—
3.07	7.75 x 14, G70 x 14, F70 x 14, F78 x 14	3905494	3987919	—
3.07	E70 x 14	3905494	3987920	—
3.08	8.25 x 14	3905494	3987921	—
3.08	7.75 x 14, F70 x 14, F78 x 14	3905494	3987919	—
3.08	7.35 x 14, E78 x 14, E70 x 14	3905498	3987920	—
3.31	8.25 x 14, 7.75 x 14, G70 x 14, E90 x 15	3905494	3987920	—
3.31	F70 x 14, F78 x 14, E70 x 14	3905494	3987921	—
3.36	8.25 x 14	3905494	3987920	—
3.36	7.75 x 14, F70 x 14, 7.35 x 14, E78 x 14, F78 x 14	3905494	3987921	—
3.36	E70 x 14	3924097	3860345	—
3.55	8.25 x 14	3905494	3987921	—
3.55	7.75 x 14, G70 x 14, F70 x 14, 7.35 x 14, F78 x 14, E70 x 15	3924097	3860345	—
3.55	E70 x 14	3924097	3860346	—
3.70	E70 x 14	3924097	3860347	—
3.73	8.25 x 14	3924097	3860345	—
3.73	7.75 x 14, G70 x 14, F70 x 14, F78 x 14, E70 x 15	3924097	3860346	—
3.73	E70 x 14	3924097	3860347	—
2.56	8.25 x 14	3905494	3987919	3925673
2.56	G78 x 14, 7.75 x 14, F70 x 14, 7.35 x 14, E78 x 14, F78 x 14	3905494	3987918	—
2.56	E70 x 14	3905494	3987919	—
4.10	8.55 x 14	3924097	3860347	—
4.10	8.25 x 14, G78 x 14, 7.75 x 14, G70 x 14, E78 x 14	3924097	3860348	—
4.10*	F70 x 14	6261794	3987919	3932220
4.10	F70 x 14	6261794	3987920	6476736
4.10	E70 x 14	6261794	3987921	6476736
4.10	E70 x 15	3924097	3860348	6476736
4.55	8.55 x 14, 8.25 x 14, G78 x 14, 7.75 x 14	6261794	3987920	3932220
4.55*	G70 x 14, F70 x 14, F78 x 14	6261794	3987921	3932220
4.55	F70 x 14, E70 x 15	3924097	3860345	6476736
4.55	E70 x 15	3924097	3860346	6476736
4.88	8.55 x 14	6261794	3987921	3932220
4.88*	8.25 x 14, G78 x 14, 7.75 x 14, G70 x 14, F70 x 14, F78 x 14	3924097	3860345	3932220
4.88	F70 x 14, E70 x 14	3924097	3860347	6476736
4.88	E70 x 15	3924097	3860346	6476736

**POWERGLIDE AND TORQUE DRIVE TRANSMISSION**

**1970 PASSENGER, NOVA, CHEVELLE, CAMARO SPEEDOMETER GEAR CHART**

REAR AXLE RATIO	REAR TIRE SIZE	4.337 GEAR, SPEEDO. DRIVEN	4.343 GEAR, SPEEDO. DRIVE	4.329 ADAPTER, SPEEDO.
<b>ALL W/POWERGLIDE, TORQUE DRIVE (EXC. TAXI, POLICE, 350)</b>				
2.73	E70 x 14, F70 x 14, E78 x 14, 7.35 x 14	3987919	3905494	—
3.07	F70 x 14, E78 x 14, F78 x 14, 7.35 x 14, 7.75 x 14	3987919	6261794	—
3.07	G70 x 15, G78 x 15, H78 x 15, 8.25 x 15	3987918	6261794	—
3.07	F78 x 15	3987919	3905494	—
3.08	F70 x 14, F78 x 14, 7.75 x 14	3987919	6261794	—
3.08	E78 x 14, 7.35 x 14	3987920	6261794	—
3.08	G70 x 15, G78 x 15, H78 x 15	3987918	6261794	—
3.08	F78 x 15, 8.25 x 15	3987921	3905494	—
3.31	F70 x 14, F78 x 14, 7.35 x 14	3987921	6261794	—
3.31	G78 x 14, 7.75 x 14, 8.25 x 14	3987920	6261794	—
3.36	F70 x 14, F78 x 14, G78 x 14, 7.35 x 14, 7.75 x 14	3987921	6261794	—
3.36	8.25 x 14	3987920	6261794	—

**ALL W/POWERGLIDE (350)**

2.56	E70 x 14, E78 x 14, 7.35 x 14	3987918	3905494	—
2.73	F70 x 14, E78 x 14, F78 x 14, G78 x 14, F78 x 15, 7.35 x 14, 7.75 x 14	3987919	3905494	—
2.73	G70 x 15, G78 x 15, H78 x 15, 8.25 x 15	3987918	3905494	—
2.73	8.25 x 14	3974422	3905494	3950348
3.07	E70 x 14	3974422	3905494	—
3.07	F70 x 14, 8.25 x 15	3987921	3905494	—
3.07	G70 x 15, G78 x 15, H78 x 15	3987920	3905494	—
3.08	E70 x 14, F70 x 14	3974422	3905494	—
3.08	G70 x 15, H78 x 15	3987920	3905494	—
3.08	G78 x 15, 8.25 x 15	3987921	3905494	—
3.31	H78 x 15	3974422	3905494	—
3.36	H78 x 15	3974422	3905494	—

**POWERGLIDE AND TORQUE DRIVE TRANSMISSION**

REAR AXLE RATIO	REAR TIRE SIZE .....	4.337 GEAR, SPEEDO. DRIVEN	4.343 GEAR, SPEEDO. DRIVE (P.G.) (Exc. 350 w/4/BC)	4.343 GEAR, SPEEDO. DRIVE (P.G.) (350 w/4/BC)	4.329 ADAPTER, SPEEDO.
--------------------	----------------------	-------------------------------------	---	---	------------------------------

**POLICE AND TAXI**

2.73	F78 x 15 .....	3987920	3708144	6261794	3950348
2.73	G78 x 15, G70 x 15, H78 x 15 .....	3987919	3708144	6261794	3950348
3.07	G70 x 15, G78 x 15, H78 x 15 .....	3987918	3708144	6261794	—
3.07	F78 x 15 .....	3987919	3708144	6261794	—
3.31	G70 x 15, F78 x 15, G78 x 15 .....	3987920	3708144	6261794	—
3.31	H78 x 15 .....	3987919	3708144	6261794	—

**POWERGLIDE AND TORQUE DRIVE TRANSMISSION**

**1971 SPEEDOMETER GEAR CHART**

**DRIVE GEARS**

PART NUMBER	COLOR	NUMBER OF TEETH
6261794	Natural	8
6261796	Solid Red	9

**DRIVEN GEARS**

3987918	Brown	18
3987919	Natural	19
3987920	Blue	20
3987921	Red	21
3987922	Silver	22

**POWERGLIDE (Exc. 350, Taxi, Police, Vega)**

REAR AXLE RATIO	REAR TIRE SIZE	4.337 GEAR SPEEDO. DRIVEN	4.343 GEAR SPEEDO. DRIVE
3.083	E78-14, E70-14	3987920	6261794
3.083	G78-15, H78-15	3987918	6261794
3.083	F78-14, F70-14, F78-15	3987919	6261794
3.364	E78-14, G78-14	3987921	6261794

**POWERGLIDE (350), TAXI, POLICE, ALL TORQUE DRIVE**

REAR AXLE RATIO	REAR TIRE SIZE	4.337 GEAR SPEEDO. DRIVEN	4.343 GEAR SPEEDO. DRIVE
2.733	F78-15	3987919	6261796
2.733	G78-15, H78-15	3987918	6261796
3.083	E70-14, F78-14, F70-14	3987922	6261796
3.083	E78-14, G70-15, G78-15, F78-15	3987921	6261796
3.083	H78-15	3987920	6261796

**VEGA**

REAR AXLE RATIO	MODEL USAGE	4.337 GEAR SPEEDO. DRIVEN	4.343 GEAR SPEEDO. DRIVE
2.53	P.G. w/1BC	3987918	6261794
2.92	P.G. w/1BC	3987921	6261794
2.92	Torque Drive	3987918	6261797
3.36	Torque Drive	3987921	6261797
3.36	P.G. w/2BC	3860347	6261795



**POWERGLIDE AND TORQUE DRIVE TRANSMISSION**

**1972 SPEEDOMETER GEAR CHART**

**DRIVE GEARS**

PART NUMBER	COLOR	NUMBER OF TEETH
6261794	Natural	8
6261785	Purple	10

**DRIVEN GEARS**

3987918	Brown	18
3987919	Natural	19
3987920	Blue	20
3987921	Red	21
3987922	Solid Silver	22

*NOTE: To order speedometer gears & parts, transmission type, rear axle ratio, & tire size must be known.*

**POWERGLIDE & TORQUE DRIVE**

**(250, 307)**

REAR AXLE RATIO	REAR TIRE SIZE	GEAR SPEEDO. DRIVEN	GEAR SPEEDO. DRIVE	ADAPTER ASSY.	SLEEVE DRIVEN GEAR
3.083	E78-14, F60-15, E70-14	3987920	6261794		3869914
3.083	F78-14, F70-14, G78-14, F78-15, G70-14	3987919	6261794		3869914
3.083	G70-15, G78-15, H78-15, 8:55-15	3997918	6261794		3869914
3.364	E78-14, F78-14, F70-14, G78-14, F60-15, E70-14, G70-14	3987921	6261794		3869914
3.364	G70-15, G78-15, H78-15, F78-15, 8:55-15	3987920	6261794		3869914
3.364	L78-15	3987919	6261794		3869914

**POWERGLIDE (350)**

2.733	E78-14	3987922	6261785		3869914
2.733	F78-14, F70-14, G78-14, F78-15, G70-14	3987921	6261785		3869914
2.733	G70-15, G78-15	3987920	6261785		3869914
2.733	L78-15	3987919	6261785		3869914
3.083	E78-14, F78-14, F70-14, F60-15, E70-14	3987920	6261785	3950352	3869914
3.083	H78-15, L78-15	3987922	6261785		3869914

**VEGA**

REAR AXLE RATIO	MODEL USAGE	4.337 GEAR SPEEDO DRIVEN	4.343 GEAR SPEEDO DRIVE
2.53	P.G. w/1BC	3987918	6261794
2.92	Torque Drive	3987918	6261797
2.92	P.G. w/1BC	3987921	6261794
3.36	Torque Drive	3987921	6261797
3.36	P.G. w/2BC	3860347	6261795

**POWERGLIDE AND TORQUE DRIVE TRANSMISSION**

**1973 SPEEDOMETER GEAR CHART**

**NOVA (Powerglide)**

CODE	DRIVEN GEAR		SLEEVE ASSY.
A	3987920	20T	3775589
TIRE SIZE		3.08 DRIVE GEAR 6261794	
E78-14 E70-14		Driven A A	

**VEGA**

REAR AXLE RATIO	MODEL USAGE	4.337 GEAR SPEEDO DRIVEN	4.343 GEAR SPEEDO DRIVE
2.92	All	3987918	6261797
3.36	All	3987921	6261797

**4.338 FITTING— GROMMET— RETAINER— SEAL, Speedometer Driven Gear**

62-64	Chevy, Chevelle,			
65-67	Pass. w/P.G.,			
65-66	Chevy,			
65-68	Chevelle,			
67-69	Chevy, Camaro,			
68-69	Pass.,			
69	Chevelle,			
70-72	All	3869914	1	2.75 w/seal
73	Vega w/P.G.	6258100	1	speedo. drive gear
71-73	Vega	3900894	1	.18 GROMMET, speedo. flex. shaft
65-69	Pass.,			
70-73	All	3708148	1	.12 RETAINER, gear fitting (9/16" I.D.)
71-72	Vega	27773	1	SCREW, speedo. driven gear fitting retainer
62-73	All	6264903	1	.20 SEAL, gear fitting "O" ring, hole plug (1 1/16" I.D.)
71-72	Vega,			
73	All	3869910	1	1.05 SEAL, speedo. pinion
71-73	Vega	6264903	1	.20 SEAL "O" RING, speedo. driven gear fitting
71-73	Vega	6478373	1	.70 SPRING, speedo. cable locking

**4.342 SHAFT ASSY.— SHAFT UNIT— CLIP, Speedometer without Casing**

64-65	Chevelle w/P.G.	6478171	1	6.58 (55 1/8")
65-68	Pass.,			
67	Camaro (exc. 350, 396),			
69	Camaro w/floor shift (302, 350, 396) (exc. P/Trac.)	6452474	1	2.08 (62 1/8")
66-67	Chevy, Chevelle,			
68	Chevy (8 cyl.)	1564778	1	2.20 (56 1/8" O.L.)
68	Chevelle w/cruise control	3928703	1	(48" O.L.)
69	Chevy, Camaro (Spt. Cpe.) (exc. floor shift, 302, 350, 396),			
69	Pass.	6477306	1	2.35 (61 7/16")
69	Chevy, Camaro (Spt. Cpe.) w/floor shift (exc. 302, 350, 396)	6477297	1	1.80 upper flex (37 7/16")
69	Camaro (Conv.) (exc. floor shift, 302, 350, 396)	6478073	1	2.40 (67 7/16")
62-75	All	6477499	1	3.70 SHAFT UNIT (consists of shaft, tip) (AC-615) (70" O.L.) (Note 1)
62-75	All	6478825	1	6.70 SHAFT UNIT (171" O.L.) (Note 2)
69	All w/quick release cable	6491006	1	.35 CLIP, instr. cluster cable release

NOTE 1 For models requiring maximum length of 81" cut to required length.

NOTE 2 For models requiring length of 81" to 172" cut to required length.

**POWERGLIDE AND TORQUE DRIVE TRANSMISSION**

**4.342A SHAFT ASSEMBLY with Casing**

*NOTE Shaft length is generally 1 1/8" longer than casing dimension listed.*

62-69	All	6478125	1	7.13	(55" casing)
62-69	All	6478128	1	8.91	(CC-75) (67 1/2" casing)
65-69	Pass.	6478131	1	9.62	(77 1/2" casing O.L.)
65-66	Pass.	6478193	1	11.88	(120" casing)
65-69	All	6478134	1	11.85	(92 1/2" casing)
67	Pass.	6478132	1	10.83	(82" casing)
69-70	All	6478176	1	7.28	(64" O.L.)
69	Taxi	6476587	1		lower

**4.342B SHAFT ASSY., Speed and Cruise Control**

65-69	All	3919007	1	4.95	w/casing (37" O.L.)
65-66	Pass., Chevelle	3852599	1	13.10	w/casing (control regulator to transmission) (72" O.L.)
65-66	Chevelle	6478121	1	6.42	w/casing (regulator to speedometer) (40" O.L.)
67	Pass.	6478132	1	10.83	w/casing (regulator to transmission) (82" O.L.)
68	Chevelle	3928703	1		w/o casing (48" O.L.)
69	Pass.	6477264	1	2.06	w/o casing (to speedometer shaft) (29 7/16" O.L.)
69	Pass., Chevelle	6478168	1	6.87	w/casing (29" O.L.)
69	Chevelle	3943641	1	7.25	w/casing (selector)

**POWERGLIDE AND TORQUE DRIVE TRANSMISSION**

<b>70 PASSENGER</b> . . . . .	<b>WITH CASING</b>	<b>WITHOUT CASING</b>
(exc. Taxi) . . . . .	6478176 (64" O.L.)	6477306 (61 <sup>7</sup> / <sub>16</sub> " O.L.)
Taxi (upper) . . . . .	6477857 (7 <sup>1</sup> / <sub>2</sub> ")	—
Taxi (lower) . . . . .	6476587	—
w/Speed and Cruise Control . . . . .	—	6477264

<b>70 NOVA</b> . . . . .		
w/4/BC . . . . .	*6478176	6451067 (Note 1)
(exc. Floor Shift) . . . . .	*6478176	6451067 (Note 1)
w/A.T. . . . .	*6478176	6451067 (Note 1)

<b>70 CHEVELLE</b> . . . . .		
(exc. 4-Spd.) . . . . .	6478176 (64" O.L.)	6451067 (Note 1)
w/Speed and Cruise Control . . . . .	3943641	—

<b>70 CAMARO</b> . . . . .		
w/A.T. . . . .	6478175 (60")	—

*NOTE 1 Shaft Unit-consists of shaft and tip (81" O.L.-cut to required length).  
NOTE: See Dealer Price Schedule (P&A 26) for Applicable Prices.  
NOTE: For Cables less casing refer to old book for universal cables.*

<b>71 PASSENGER</b> . . . . .	<b>WITH CASING</b>	<b>O.L.</b>
exc. Taxi, Spd. Cruise Control . . . . .	6478514	53"
w/Spd. Cruise Control . . . . .	6478170-A	40"
w/Spd. Cruise Control . . . . .	6478124-B	52"

<b>71 NOVA</b> . . . . .		
	6478176	64"

<b>71 CHEVELLE</b> . . . . .		
exc. Spd. Cruise Control . . . . .	6478175	60"
w/Spd. Cruise Control . . . . .	6478176 (Lower)	60"
w/Spd. Cruise Control . . . . .	6478171 (Upper)	44"

<b>71 VEGA</b>	<b>WITH CASING</b>	<b>O.L.</b>
All	6478175	60"

<b>72 PASSENGER</b>		
exc. Taxi, Spd. Cruise Control . . . . .	6478514	53"
w/Spd. Cruise Control . . . . .	6478170-A	40"
w/Spd. Cruise Control . . . . .	6478124-B	52"

<b>72 NOVA</b>		
	6478176	64"

<b>72 CHEVELLE</b>		
exc. Spd. Cruise Control . . . . .	6478175	60"
w/Spd. Cruise Control . . . . .	6478176 (Lower)	60"
w/Spd. Cruise Control . . . . .	6478171 (Upper)	44"

<b>72-73 VEGA</b>		
All	6478175	60"

*A. Regulator to Speedometer  
B. Regulator to Transmission*

**POWERGLIDE AND TORQUE DRIVE TRANSMISSION**

**4.342B SHAFT ASSY., Speed and Cruise Control (Con't)**

72 All w/quick release cable . . . . . **6491006** 1 .35 **CLIP, spring, inst. cluster speedo. cable release** . . . . .

**4.343 GEAR, Speedometer Drive**

62-65 Chevy w/3.36, 3.55 axle,  
 65 Chevelle w/3.55, 3.70, 3.73 axle (7.00 x 13 tires), . . . . .  
 65 Pass. (P.G.) (3.55 axle) . . . . . (7.00 x 14 tires), . . . . .  
 65 Pass. w/P.G. (3.70 ratio),  
 66-67 Pass. w/3.31, 3.36, 3.55, 3.70, 3.73 axle (exc. T.H.) . . . . . (6.95 x 14 tires), . . . . .  
 66-67 Pass. w/3.55, 3.70, 3.73, 4.10, 4.89 axle (7.35 x 14, 7.75 x 14, 7.75 x 15, 8.25 x 14 tires), . . . . .  
 66-67 Pass. w/3.70, 3.73, 4.10, 4.89 axle (8.15 x 15, 8.55 x 14 tires), . . . . .  
 66-67 Pass. w/3.73, 4.10, 4.89 axle (8.45 x 15 tires), . . . . .  
 66-67 All w/3.31, 3.36, 3.55, 3.70, 3.73 axle (6.95 x 14 tires), . . . . .  
 66-67 All w/3.55, 3.70, 3.73, 4.10, 4.56, 4.89 axle,  
 67 Pass. w/4.56 axle . . . . . **3708145** 1 3.15 8 teeth (1<sup>3</sup>/<sub>4</sub>" O.D. x 1<sup>7</sup>/<sub>32</sub>" thick) (7.35 x 14, 7.75 x 14, 7.75 x 15, 7.35 x 15 tires) . . . . .  
 62-65 Chevy, Chevelle w/3.08 axle,  
 64-65 Chevelle w/3.36 axle,  
 65 Chevy, Chevelle w/2.73, 3.07, 3.31 axle (7.00 x 13 tires), . . . . .  
 65 Pass. w/3.08, 3.36 axle,  
 65 Pass. (3.55 axle) (exc. 7.00-14 tires),  
 66-67 Pass. w/3.07, 3.08, 3.31, 3.36 axle (7.35 x 14, 7.75 x 14, 8.25 x 14), . . . . .  
 66-67 Pass. w/3.07, 3.08 axle (6.95 x 14 tires), . . . . .  
 66-67 Pass. w/3.07, 3.08, 3.31, 3.36, 3.55 axle (8.55 x 14, 8.45 x 15, 15), . . . . .  
 66-67 Pass. w/3.70 axle . . . . . **3708144** 1 2.11 (8.45 x 15) . . . . .  
 65-66 All w/4.56, 4.89 axle . . . . . **3845079** 1 3.14 6 teeth (1<sup>59</sup>/<sub>64</sub>" O.D. x 2<sup>9</sup>/<sub>64</sub>" thick) . . . . .  
 67-68 Pass. w/2.73 axle . . . . . **3905494** 1 2.94 9 teeth (1<sup>27</sup>/<sub>32</sub>" O.D. x 5/<sub>8</sub>" thick) . . . . .

**4.345 CLIP, Speedometer Drive Gear**

71-75 All . . . . . **6261781** 1 .13



**BRAKES**

**4.589 SWITCH—STRIKER—STRAP—LENS—SOCKET ASSY., Parking Brake Alarm**

65-70	Pass.,					
67-69	Camaro,					
68-71	Chevy	3934201	1	.71	SWITCH ASSY., w/bracket	
67-72	Chevelle	6270647	1	.93	SWITCH ASSY.	
70-72	Camaro	3983909	1	.78	SWITCH ASSY., bracket	
71-72	Pass.,					
73	Pass., Chevelle (exc. 4-Spd.),					
74-75	Pass., Chevelle	1241639	1	.64	SWITCH ASSY., w/bracket	
71-72	Vega	6273392	1	1.25	SWITCH ASSY., parking brake w/bracket	
72	Nova	3954295	1	.70	SWITCH ASSY., w/bracket	
73	Nova w/A.T.,					
73	Nova w/3-Spd. (exc. floor shift),					
73-75	Camaro,					
74-75	Nova	331960	1	.78	SWITCH ASSY., w/bracket	
73	Nova w/floor shift (exc. A.T.),					
73	Camaro (exc. A.T.)	331961	1	2.50	SWITCH ASSY., park. brake, and seat belt warning	
73	Chevelle w/4-Spd.	6270696	1	1.50	SWITCH ASSY., park. brake, and seat belt warning	
73	Vega	331962	1	1.65	SWITCH ASSY., parking brake and seat belt warning alarm— (11.950)	
74-75	Vega, Monza	354745	1	1.65	SWITCH ASSY., parking brake and seat belt warning alarm— (11.950)	
67-68	Camaro,					
68	Chevy	3916762	1	.12	STRAP	
69	Camaro, Chevy,					
70-75	Nova	3951279	1	.12	STRAP	
64	Chevy,					
64-65	Chevelle				LENS, w/housing,	
74-75	Nova (4-Dr.)	3843523	1	.98	rear door warning lamp	
66-67	Pass.,					
67	Camaro	3882798	1	.58	SOCKET ASSY., bulb— (2.776)	

**4.591 LEVER ASSY.— GASKET— HOUSING— PEDAL ASSY.— SEAL— STUD, Parking Brake Apply**

*NOTE 1 Handle mounts at side.*

*NOTE 2 Handle mounts at center.*

64-67	Chevelle	3908775	1	10.30	w/pedal	
66-67	Chevy	3877515	1	12.50		
67	Camaro,					
68	Chevy, Camaro	3928357	1	10.05	w/pedal	
68-69	Chevelle	3946779	1	11.45	w/pedal	
70-72	Chevelle	3960783	1	11.45	w/pedal	
70-75	Camaro	344625	1	10.20	w/pedal	
69	Chevy, Camaro,					
70-75	Nova	378121	1		w/pedal (repl. 344626)	
71-75	Vega	329790	1	7.25		
75	Monza	366191	1	10.25	(repl. 356380)	
71	Vega	3988096	1	.13	GASKET, parking brake lever housing	
72-75	Vega, Monza	6264324	1	.15	GASKET, parking brake lever housing	
71	Vega	3983977	1	1.20	HOUSING, parking brake lever	
72-75	Vega, Monza	6264323	1	1.20	HOUSING, parking brake lever	
65-66	Pass.	3903063	1	14.00	PEDAL ASSY., w/release lever	
67	Pass.	3898221	1	10.50	PEDAL ASSY., w/release lever	
68	Pass.	3925075	1	9.75	PEDAL ASSY, w/lever	
69-70	Pass.	3939223	1	11.45	PEDAL ASSY., w/lever	
71-72	Pass.	1239738	1	10.05	PEDAL ASSY.	
71-75	Pass., Chevelle	1239738	1	10.05	PEDAL ASSY., w/rod park. brake release	
73-75	Camaro	3982308	1	.84	STUD, rel. lever to body ( <sup>5</sup> / <sub>16</sub> "— 18 x 3 <sup>1</sup> / <sub>8</sub> ")	

**4.592 HANDLE— BOOT— LEVER, Parking Brake**

62	Chevy,					
63-67	Chevy (exc. C.A.C.)	3877513	1	1.50		
63-67	Chevy w/C.A.C.	3793460	1	2.00		
64-69	Pass., Chevelle, Camaro,					
68-69	Chevy,					
70-71	Nova, Camaro,					
70-72	Chevelle	3960789	1	.64		
71-75	Vega, Monza	3996357	1	.72	parking brake lever	
71	Vega	3978197	1	7.90	BOOT, parking brake lever	
73-75	Nova, Camaro	3893179	1	.64	LEVER	

## BRAKES

### 4.594 ROD— GROMMET— HANDLE ASSY.— NUT— RETAINER, Parking Brake Lever Release

69-70	Pass. ....	3939229	1	.92	release .....
69	Chevy, Camaro,				
70-72	Nova .....	3989413	1	1.10	release .....
70-71	Chevelle .....	3960787	1	1.30	release (4 <sup>5</sup> / <sub>8</sub> " O.L.) .....
70-72	Chevelle .....	3960791	1	2.10	pedal release (6 <sup>1</sup> / <sub>4</sub> " O.L.) .....
70-75	Camaro .....	3982371	1	.92	pedal release .....
73-75	Nova .....	3989413	1	1.10	release .....
67-69	Camaro,				
68-69	Chevy, Chevelle,				
70	Pass., Nova,				
72-75	Nova,				
73-75	Camaro .....	3945592	1	.17	GROMMET, park brake pedal release rod ..
70-71	Chevelle .....	3983382	1	.12	GROMMET, release rod .....
72	Chevelle .....	3972600	1	.18	GROMMET, release rod (nylon) .....
71-75	Pass.,				
73-75	Chevelle .....	357734	1	2.75	HANDLE ASSY., w/cable (repl. 3991164) ..
65-69	Pass., Chevelle,				
70	Pass. ....	3857467	1	.12	NUT, pedal release rod .....
70	Chevelle .....	3949158	1	.17	RETAINER, release rod (hairpin type) .....

### 4.595 RETAINER— CLIP, Parking Brake Lever Release

67-68	All .....	3930834	1	.12	brk. handle return spring .....
72	Chevelle .....	3949158	1	.17	CLIP, park. brake pedal release rod ret. ....

### 4.597 SPRING, Parking Brake Release

64-69	Chevelle,				
65-67	Pass.,				
72	Chevelle .....	3846515	1	.18	pawl .....
67-69	Camaro,				
68-69	Chevy,				
73	Chevelle,				
75	Nova .....	3953286	1	.32	SPRING, pawl rel. lever return .....

### 4.606 SPRING, Parking Brake Lever

65-67	All,				
68-69	Chevelle,				
72	Chevelle .....	3846514	1	.33	release rod pawl return .....
68-70	Pass. ....	3928212	1	.18	pedal release rod pawl return .....
70-73	Camaro .....	3980934	1	.38	pawl release lever return .....

### 4.612 SEAL, Parking Brake Lever Housing

71-75	Vega, Monza .....	3986798	1	.38	SEAL .....
-------	-------------------	---------	---	-----	------------

### 4.615 COVER, Parking Brake Lever

72-73	Vega .....	329772	1	5.20	
74-75	Vega .....	339075	1	5.20	
75	Monza .....	379801	1	5.20	

### 4.625 PEDAL ASSY., Brake

64-66	Chevelle (exc. P.G.) .....	3843931	1	6.40	
65-70	Pass. (exc. A.T.) .....	3926959	1	5.05	
65-68	Pass. w/A.T.,				
67-72	Chevelle w/A.T. ....	3937893	1	5.60	
67-72	Chevelle (exc. A.T.) .....	3937889	1	5.90	
67	Camaro w/A.T.,				
68	Chevy, Camaro w/A.T. ....	3923545	1	6.20	
67	Camaro (exc. A.T.),				
68	Chevy, Camaro (exc. A.T.) .....	3923541	1	5.55	
67	Chevy (exc. P.G.) .....	3908345	1	5.35	
69	Pass. w/P.G.,				
70	Pass. w/A.T. ....	3908767	1	5.35	
69	Chevy, Camaro (exc. A.T.),				
70-74	Nova (exc. A.T.) .....	3953287	1	5.90	
69	Chevy, Camaro w/A.T.,				
70-74	Nova w/A.T. ....	3953291	1	5.60	
70-74	Camaro (exc. A.T.) .....	3965697	1	5.80	
70-74	Camaro w/A.T. ....	3972201	1	5.50	
71-73	Pass. (exc. A.T.) .....	3988256	1	5.60	
71-75	Pass. w/A.T. ....	1238350	1	15.10	
71-75	Vega (exc. A.T.) .....	3978023	1	4.70	
71-75	Vega, Monza w/A.T. ....	3992941	1	4.70	
73-75	Chevelle (exc. A.T., P.B.) .....	1241359	1	8.50	
73-75	Chevelle w/A.T. (exc. P.B.) .....	1241358	1	5.90	
73-75	Chevelle (A.T. w/P.B.) .....	1241360	1	5.90	



**BRAKES**

**4.625 PEDAL ASSY., Brake (Con't)**

73-75	Chevelle w/P.B. (exc. A.T.)	1241361	1	8.50
75	Nova w/P.B. (exc. A.T.)	347420	1	6.75
75	Nova w/P.B., A.T.	347421	1	9.00
75	Nova w/A.T. (exc. P.B.)	347408	1	10.30
75	Nova (exc. A.T., P.B.)	347406	1	10.10
75	Camaro (exc. A.T.)	347401	1	7.10
75	Camaro w/A.T.	347403	1	7.00
75	Monza (exc. A.T.)	358401	1	5.20

**4.626 BUSHING, Brake Pedal**

62-75	All	1247439	2	.11	clutch or brake pedal (nylon)
63-67	Chevy (1st design) (exc. P.B.),				
65-67	Pass. (1st design)	3830966	1	.16	pedal return spring bushing (1 <sup>1</sup> / <sub>16</sub> " I.D.)
64	Chevelle w/C.A.C. (exc. P.B.)	444026	1	.76	comp. gov. hose— (8.963)
67	Chevy, (2nd design) (exc. P.B.),				
67-69	Pass. (2nd design) (exc. P.B.),				
68-70	Pass. w/P.B.,				
69	Pass. w/Speed and Cruise Control	3908768	1	.11	pedal return spring bushing (7/ <sub>8</sub> " I.D.)

**4.630 COVER— PLATE, Brake and Clutch Pedal**

62-67	Chevy (P.G. w/P.B.),				
65-67	Nova (exc. A.T.),				
65-67	Pass. (A.T. w/P.B.) (exc. Caprice, S.S.),				
65-70	Pass. w/A.T. (exc. P.B.),				
65-67	Chevy w/P.G. (exc. P.B.),				
68-70	Pass. (Disc Brakes w/A.T.)	3881784	1	.66	brake
62-67	Chevy w/P.B. (exc. P.G.),				
64-69	Chevelle (exc. A.T., Disc Brake),				
68-71	Chevelle w/Disc Brakes (exc. A.T.),				
70	Chevelle (exc. A.T.),				
72-75	Pass. (exc. A.T.),				
72	Chevelle (exc. A.T., Disc Brakes),				
73-75	Chevelle (exc. A.T.)	3988198	1	.64	(rubber— 3 <sup>5</sup> / <sub>16</sub> " x 2 <sup>5</sup> / <sub>16</sub> " )
64-74	Chevelle,				
67-68	Camaro,				
68	Chevy	3893181	1	.42	parking brake pedal pad
64-72	Chevelle w/A.T. (exc. Disc Brake),				
68-71	Chevelle (Disc Brakes w/A.T.)	3858199	1	.92	brake pedal pad (black) (rubber)
65-70	Pass. (exc. A.T., P.G.),				
68	Impala (S.S.) (Disc Brakes w/A.T.),				
68-70	Impala (Disc Brakes) (exc. A.T.),				
68-70	Caprice w/Disc Brakes (exc. A.T.),				
68-70	Pass. w/Disc Brakes (exc. A.T., Caprice, Impala)	3884850	1	.66	brake and clutch
65-66	Pass. w/P.B. (exc. Caprice, S.S., A.T.)	3746701	1	1.20	brake (Moraine) (Note 1)
65-70	Pass.	3881780	1	.42	parking brake (rubber)
67	Camaro (exc. A.T.),				
68-72	Chevy, Camaro (exc. A.T., Disc Brakes),				
68-69	Chevy, Camaro w/Disc Brake (exc. A.T.),				
70	Chevy w/Disc Brake (exc. A.T.),				
73-75	Nova, Camaro (exc. A.T.)	3921648	1	.80	brake
67-72	Camaro w/A.T. (exc. Disc Brakes),				
68-72	Chevy w/A.T. (exc. Disc Brake),				
73-74	Nova, Camaro w/A.T.,				
75	Camaro w/A.T.	3888682	1	.97	brake pedal pad (rubber)
68-70	Chevy, Camaro (Disc Brake w/A.T.),				
71	Nova (A.T. w/Disc Brakes)	3930091	1		brake
69-75	Camaro, Nova	3945593	1	.47	park brake (rubber)
71-75	Pass. w/A.T.	3988288	1	.92	brake pedal pad (rubber)
71-75	Pass.,				
75	Chevelle	3991165	1	.61	park. brake pedal pad (rubber)
71-75	Pass. (exc. A.T.),				
72-75	Chevelle (exc. A.T.)	3993614	1	.61	brake pedal pad (rubber)
71-75	Vega, Monza w/A.T.	3988198	1	.64	brake pedal pad

## BRAKES

### 4.630 COVER— PLATE, Brake and Clutch Pedal (Con't)

71-75	Vega, Monza (exc. A.T.),				
73-75	Nova, Camaro (exc. A.T.)	332515	1	1.05	clutch pedal pad
73-75	Chevelle w/A.T.,				
75	Nova w/A.T.	3994495	1	.92	brake pedal pad (rubber)
75	HM, HV	349501	1	5.20	park. brake lever
65-70	Pass.	3881781	1	.53	PLATE, parking brake pedal pad cover trim
65-70	Pass. (exc. A.T.)	3881783	1	.67	PLATE, clutch and brake pad trim cover
65-70	Pass. w/A.T.	3881785	1	.84	PLATE, brake pad trim cover
67-69	Camaro w/A.T.,				
68-70	Chevy w/A.T.	3888683	1	.84	PLATE, brake cover trim
67-68	Camaro,				
68	Chevy	3893182	1	.66	PLATE, park pedal pad cover trim
67	Camaro (exc. P.G.),				
68-70	Chevy, Camaro (exc. A.T.)	3923615	1	.77	PLATE, brake and clutch cover trim
69-70	Chevy, Camaro	3945594	1	.71	PLATE, park brk. trim

NOTE 1 Part number appears on these parts.

### 4.634 SHAFT— BRACKET ASSY.— INSULATOR— RETAINER— SPACER— SPRING— WASHER, Brake Pedal

NOTE. Also see groups 0.847 and 4.648 for pedal shaft brackets and master cylinder supports.

62-69	Chevy, Chevelle, Camaro w/A.T.,				
70-72	Nova, Chevelle w/A.T.,				
73-75	Nova w/A.T.	3828427	1	.82	
65-70	Pass. w/A.T.	3854320	1	.87	brake
67-68	Camaro	3918739	1	60.75	BRACKET ASSY., brake pedal (without welded nut)
69-70	Pass.	3972007	1	25.25	BRACKET ASSY., brake pedal
69	Chevy, Camaro,				
70-74	Nova	3999496	1	24.50	BRACKET ASSY., brake pedal
69-72	Chevelle	3969416	1	25.50	BRACKET ASSY., brake pedal
70	Camaro	3965466	1	25.25	BRACKET ASSY., brake pedal
71-74	Pass.	3991741	1	10.55	BRACKET ASSY., brake pedal
71-75	Camaro	3996355	1	23.45	BRACKET ASSY., brake pedal
71-75	Vega	3975893	1	5.90	BRACKET ASSY., brake pedal
73	Chevelle w/P.B.	1243528	1	9.85	BRACKET ASSY., brake pedal
74-75	Chevelle w/P.B.	1245404	1	9.85	BRACKET ASSY., brake pedal
73-75	Chevelle (exc. P.B.)	1245405	1	9.85	BRACKET ASSY., brake pedal
75	Nova	332191	1	11.05	BRACKET ASSY., brake pedal
75	Pass.	1243897	1	10.25	BRACKET ASSY., brake pedal
75	Monza (exc. A.T., Towne Cpe.)	346789	1	12.15	BRACKET ASSY., brake pedal
75	Monza w/A.T. (exc. Towne Cpe.)	346791	1	7.60	BRACKET ASSY., brake pedal
75	Monza (Towne Cpe.)	364657	1	5.90	BRACKET ASSY., brake pedal
75	Chevelle w/P.B.	346765	1		INSULATOR, brake pedal bracket
63-69	All w/A.T.,				
70	Pass., Nova, Chevelle w/A.T.,				
71-72	Nova, Chevelle w/A.T.,				
73-75	Nova	3828428	1	.22	RETAINER, shaft
70	Camaro,				
71	Pass., Camaro (exc. A.T.),				
74	Pass., Chevelle,				
71-74	Vega	9783098	1	.87	SPACER, brake pedal
62	Chevy w/P.G.	148152	1	.06	SPRING, brake pedal shaft retainer— (8.934)
73-75	Chevelle (exc. P.B.)	1193696	1	.14	WASHER, brake pedal push rod (spring type)
73-74	Pass., Chevelle w/P.B.	492346	1	.34	WASHER, brake pedal push rod

### 4.639 SPRING, Brake Pedal Return

62-66	Pass., Chevy (exc. P.B.)	3854322	1	.24	pedal return— (4.760)
75	Vega	3850084	1	.32	
75	Monza (exc. P.B.)	346792	1	.43	

### 4.648 GASKET— SCREW, Brake Cyl. and Pedal Shaft (Also See Group 0.847 for pedal shaft bracket)

62-70	All (exc. P.B.),				
71-72	Nova, Chevelle, Camaro (exc. P.B.),				
71-75	Vega, Monza (exc. P.B.),				
73-75	Nova, Camaro (exc. P.B.)	3792566	1	.13	main cyl. (.18" thk.) (rubber)
62-67	Chevy w/P.B.	3791270	1	.12	mounting (.18" thk. w/three <sup>13</sup> / <sub>32</sub> " holes)
73-75	Chevelle (exc. P.B.)	1242063	1	.12	brake main cyl. mtg.
65-68	Pass., Chevelle,				
68	Camaro	3874876	1	.16	SCREW, w/lock washer ( <sup>3</sup> / <sub>8</sub> "— 16 x 1 <sup>1</sup> / <sub>4</sub> ")— (3.901)

**BRAKES**

**4.649 REPAIR UNIT, Hydraulic Brake Main Cylinder**

*NOTE. Also see group 4.898 for power brakes.*

<b>62-63</b>	All	<b>5463669</b>	1	6.85	(1" dia.) (repair of 5462031-2540) (Moraine) (Note 1)
	<i>NOTE 1 Contains (1) each piston assy., spring assy., cup, check valve assy., washer, retaining ring, boot, reservoir gasket, and filter.</i>				
	<i>NOTE 2 Contains (1) each piston assy., cup w/ring, valve assy., washer, spring assy., reservoir gasket, ring and boot.</i>				
<b>62-63</b>	Chevy (exc. Prod. P.B. Metallic Linings),				
<b>62-66</b>	Chevy, Chevelle w/P.G.,				
<b>65-66</b>	Pass. w/P.B., Brake Booster	<b>3905792</b>	1	5.95	(Bendix 617475) (1" dia.)
<b>64-66</b>	All (exc. metallic linings)	<b>5463669</b>	1	6.85	(repair of 5465094-5489) (1" dia.) (repl. 5464569)
<b>64-66</b>	All (exc. Pass.),				
<b>65-66</b>	Pass. w/Metallic Linings (exc. P.B.)	<b>5465033</b>	1	6.65	(7/8" dia.) (repair of 5464275)
<b>67-69</b>	Pass. (exc. P.B., w/Metallic Lining, Disc Brakes),				
<b>70</b>	Pass. (exc. Disc Brakes)	<b>3912149</b>	1	16.85	(1" dia. cyl.) (Bendix 617525)
<b>67</b>	Chevy (P.B. w/Disc. Brake),				
<b>67-69</b>	Pass. w/Disc Brake (exc. P.B.)	<b>5468452</b>	1	10.90	(1" dia. cyl.)
<b>67</b>	All w/Metallic Brakes (exc. P.B., Chevy)	<b>5468454</b>	1	15.80	(1" dia. cyl.)
<b>67-70</b>	All (exc. Disc Brakes, Metallic Linings),				
<b>67</b>	Camaro w/Disc Brake,				
<b>71-72</b>	Nova, Chevelle (exc. Disc Brakes),				
<b>73-74</b>	Nova (exc. Disc Brakes)	<b>5468453</b>	1	14.10	(1" dia. cyl.)
<b>67</b>	Camaro, Chevelle (P.B. w/Disc Brakes),				
<b>67</b>	Pass. w/Disc Brakes,				
<b>68</b>	All w/Disc Brakes	<b>5468449</b>	1	11.35	(1 1/8" dia. cyl.)
<b>69</b>	All w/Disc Brakes,				
<b>70</b>	Pass. w/Disc Brakes	<b>5469406</b>	1	13.05	(Moraine)
<b>70</b>	Pass. w/Disc Brakes	<b>3995820</b>	1	15.90	(Bendix 2509953)
<b>70</b>	Nova, Chevelle w/Disc Brakes,				
<b>71-74</b>	Nova w/Disc Brakes	<b>5470769</b>	1	13.15	
<b>70-74</b>	Camaro (exc. P.B.)	<b>5471960</b>	1	14.50	
<b>70-72</b>	Camaro w/P.B.,				
<b>71-72</b>	Pass., Chevelle w/Disc Brakes,				
<b>73-74</b>	Pass., Chevelle, Camaro w/P.B.,				
<b>75</b>	Pass., Chevelle, Camaro, Nova	<b>5470766</b>	1	13.35	(Moraine)
<b>71-72</b>	Pass.	<b>6263162</b>	1	11.50	(Bendix 2226306) (Note 4)
	<i>NOTE 4 Contains lip type seals, plus an "O" ring seal.</i>				
<b>71-75</b>	Vega, Monza (exc. Power Disc Brakes)	<b>5471273</b>			
<b>73</b>	Chevelle (exc. P.B.)	<b>335151</b>	1	12.60	(Bendix 2226371)
<b>74-75</b>	Chevelle (exc. P.B.)	<b>346409</b>	1	12.50	(Bendix 3361926)
<b>73-75</b>	Pass., Chevelle, Camaro, Nova w/P.B.	<b>335152</b>	1	18.60	(Bendix 2226372)
<b>75</b>	Camaro, Nova (exc. P.B.)	<b>2623066</b>	1	11.65	
<b>75</b>	Vega, Monza w/Power Disc Brakes	<b>2623074</b>	1	11.80	

**4.650 CYLINDER ASSY.— Hydraulic Brake Main**

*NOTE. Also see group 4.901 for power brakes.*

<b>62-66</b>	All w/Metallic Linings (exc. P.B.)	<b>5464345</b>	1	35.30	(7/8" dia. cyl.) (Moraine)
<b>62-66</b>	All (exc. Pass.),				
<b>65-66</b>	Pass. (exc. P.B., Metallic Linings, Police),				
<b>65-66</b>	Pass. w/P.B. (exc. Metallic Linings)	<b>5465489</b>	1	31.95	(1" dia. cyl.) (Moraine)
<b>64-66</b>	All w/Bendix P.B.	<b>3853776</b>	1	33.75	(Bendix 618105) (1" dia. cyl.)
<b>67-69</b>	Pass. w/P.B. (exc. Disc Brakes Metallic Linings, 396, 427 Hi-Perf., 427 Spec. Hi-Perf.),				
<b>67-70</b>	Pass. (exc. P.B., Metallic Linings)	<b>3912145</b>	1	46.25	(Bendix 2226685) (1" dia. cyl.)
<b>67</b>	Chevelle w/Disc Brakes,				
<b>67-69</b>	Pass., Camaro w/Disc Brakes,				
<b>70</b>	Pass. w/Disc Brakes	<b>5469489</b>	1	53.00	(1 1/8" dia. cyl.) (stamped SA) (Moraine)
<b>67-70</b>	Pass. (exc. Disc Brakes, Metallic Brake)	<b>5463267</b>	1	41.60	(1" dia. cyl.) (stamped AT) (Moraine)
<b>67</b>	Chevy, Camaro w/Disc Brake,				
<b>67-68</b>	Taxi w/Disc Brake (exc. P.B.),				

**BRAKES**

**4.650 CYLINDER ASSY.— Hydraulic Brake Main (Con't)**

68-69	Pass. w/Disc Brake (exc. P.B.)	5468813	1	46.75	(sgl. piston design) (stamped AD) (1" dia. cyl.)
67-70	All (exc. Disc Brake, metallic brake),				
71-72	Nova, Chevelle (exc. Disc Brakes),				
73-75	Nova (exc. Disc Brakes)	5472651	1	43.25	
68	Chevy w/Disc Brakes	5463492	1	48.10	(Moraine) (1 <sup>1</sup> / <sub>8</sub> " dia. cyl.)
68	Chevelle w/Disc Brakes	5468811	1	46.65	(1 <sup>1</sup> / <sub>8</sub> " dia. cyl.)
69	Chevy, Camaro w/Disc Brakes	5463751	1	45.35	(1 <sup>1</sup> / <sub>8</sub> " dia. cyl.) (stamped U.S.)
69	Chevelle, w/Disc Brakes	2622249	1	65.75	(1 <sup>1</sup> / <sub>8</sub> " dia. cyl.)
70	Pass. w/Disc Brakes	3979629	1	46.25	(Bendix 2228285)
70-74	Nova w/Disc Brakes	5470721	1	60.35	(1 <sup>1</sup> / <sub>8</sub> " dia.)
70	Chevelle w/Disc Brakes	5470665	1	56.35	(1 <sup>1</sup> / <sub>8</sub> " dia.)
	<i>NOTE 1 It may be necessary to transfer push rod.</i>				
70-74	Camaro w/P.B.	2622655	1	60.05	
71-74	Pass.,				
71-74	Chevelle w/Disc Brakes,				
75	Pass., Chevelle, Camaro, Nova w/Disc Brakes	5471802	1	50.15	(1 <sup>1</sup> / <sub>8</sub> " dia.) (Moraine)
71-72	Pass.	6263169	1	51.25	(Bendix 2231125) w/lip seals, and an "O" ring seal.
70-74	Camaro (exc. P.B.)	5472652	1	55.40	
71-74	Vega,				
75	Vega, Monza (exc. Power Disc Brakes)	5471274	1	56.20	brake less push rod (Moraine) (.750 dia.)
73-74	Pass., Chevelle w/P.B.	1245729	1	33.75	(Bendix 2231665)
73-74	Chevelle (exc. P.B.)	335163	1	45.75	(Bendix 2231685)
75	Camaro, Nova (exc. Power Disc Brakes)	2623065	1	42.10	(1.00" dia.) (Moraine)
75	Chevelle (exc. P.B.)	1245926	1	33.75	(Bendix 2235550)
75	All w/P.B. (exc. Vega, Monza)	5471802	1	50.15	(Bendix 2235490) (repl. 346405)
75	Vega, Monza w/Power Disc Brakes	2623644	1	53.30	(Moraine) (.750 dia.)

**4.651 CAP— BAIL— COVER— GASKET**

62	Chevy	5460820	1	1.02	(1 <sup>3</sup> / <sub>4</sub> " dia.)
64-66	All	391599	1	1.15	(Bendix 617177)
64-66	All	5462996	1	.70	BAIL, reservoir cover
67-68	Pass. w/Disc Brakes,				
67-68	Camaro (P.B. w/Disc Brakes),				
68	Chevy, Chevelle (P.B. w/Disc Brakes),				
69	Chevy, Camaro w/Disc Brakes	5455518	2	.86	BAIL, reservoir cover
67-69	Pass.,				
67-69	All (exc. Pass., Disc Brakes, Metallic Brakes),				
70	All (exc. Disc Brakes),				
71-72	Nova, Chevelle (exc. Disc Brakes),				
73-75	Nova (exc. Disc Brakes)	5468053	1	1.12	BAIL, reservoir cover (Moraine)
67-68	Pass. (exc. P.B., Metallic Brakes, Disc Brakes, 396, 427),				
69	Pass. (exc. P.B., Disc Brakes, 396, 427),				
70	Pass. (exc. Disc Brakes)	3943690	1	.58	BAIL, reservoir cover (Bendix 2226844)
69	Pass. (P.B. w/Disc Brake),				
70	Pass. w/Disc Brakes,				
70-75	Camaro (exc. P.B.)	5468103	1	1.04	BAIL, reservoir cover (Moraine) (3 <sup>13</sup> / <sub>16</sub> " long)
69	Chevelle w/Disc Brakes	5468305	2	1.07	BAIL, reservoir cover
70	Nova, Chevelle w/Disc Brakes,				
71-72	Pass.,				
71-72	All (P.B. w/Disc Brakes) (exc. Pass., Vega),				
73-75	Pass., Chevelle, Camaro, Nova (P.B. w/Disc Brakes)	5470407	1	1.35	BAIL, cover (Moraine)
71-75	Pass.,				
73-75	Chevelle w/P.B.	409354	1	.63	BAIL, resvr. cup assy. (Bendix 2227166)
71-74	Vega,				
75	Vega, Monza (exc. P.B.)	5470862	2	1.18	BAIL, brake reservoir cover
73-75	Chevelle (exc. P.B.)	335159	1	.63	BAIL, resvr. cup (Bendix 2229846)
75	Vega, Monza w/P.B.	5468053	2	1.12	BAIL, brake reservoir cover
64-66	All	5462994	1	.98	COVER, reservoir
67-69	Pass. (exc. Metallic Linings, Disc Brakes, 396, 427),				

**BRAKES**

**4.651 CAP— BAIL— COVER— GASKET (Con't)**

70	Pass. (exc. Disc Brakes) . . . . .	9787663	1	1.35	COVER, reservoir (Bendix 2225646) . . . . .
67-70	All (exc. Disc Brakes),				
71-72	Nova, Chevelle (exc. Disc Brakes),				
71-75	Vega, Monza,				
73-75	Nova (exc. Disc Brakes) . . . . .	5452320	1	1.37	COVER (Delco) . . . . .
67-69	All w/Disc Brakes,				
70	Pass. w/Disc Brakes,				
71-75	Camaro w/Disc Brakes (exc. P.B.) . . . . .	5455517	1	3.16	COVER (Moraine) . . . . .
70	Pass. w/Disc Brakes . . . . .	9790611	1	1.40	COVER (Bendix 2227024) . . . . .
70	Nova, Chevelle, Camaro w/Disc Brakes,				
71-72	Pass.,				
71-72	All (P.B. w/Disc Brakes) (exc. Pass., Vega),				
73-75	Pass., Chevelle, Camaro, Nova (P.B. w/Disc Brakes) . . . . .	5470405	1	3.57	COVER (Moraine) . . . . .
71-75	Pass. w/P.B.,				
73-75	Chevelle w/P.B. . . . .	6259024	1	2.75	COVER (Bendix 2229022) . . . . .
73-75	Chevelle (exc. P.B.) . . . . .	335157	1	2.75	COVER (Bendix 2229844) . . . . .
62-63	Chevy . . . . .	5460946	1	.90	GASKET, reservoir (3" O.D. w/six 9/32" holes) . . . . .
64-66	All . . . . .	5465725	1	1.80	GASKET, reservoir . . . . .
64-66	All . . . . .	2458524	1	.72	GASKET, filler cap (Bendix 617178) . . . . .
67-69	Pass. (exc. P.B., Metallic Brake, Disc Brakes, 396, 427),				
70	Pass. (exc. Disc Brakes) . . . . .	9787664	1	1.30	GASKET, reservoir (Bendix 2225647) . . . . .
67-69	All w/Disc Brakes,				
70	Pass. w/Disc Brakes,				
71-75	Camaro w/Disc Brakes (exc. P.B.) . . . . .	5455516	1	2.67	GASKET, reservoir . . . . .
67-70	All (exc. Disc Brakes, Metallic Linings),				
71-72	Nova, Chevelle (exc. Disc Brakes),				
71-75	Vega, Monza,				
73-75	Nova (exc. Disc Brakes) . . . . .	5470861	1	3.36	GASKET, reservoir (Moraine) . . . . .
70	Nova, Chevelle, Camaro w/Disc Brakes,				
71-72	Pass.,				
71-72	All (P.B. w/Disc Brakes) (exc. Pass., Vega),				
73-75	Pass., Chevelle, Camaro, Nova (P.B. w/Disc Brakes) . . . . .	5470404	1	3.46	GASKET, reservoir (Moraine) . . . . .
71-75	Pass. w/P.B.,				
73-75	Chevelle w/P.B. . . . .	409353	1	1.10	GASKET, resvr. (Bendix 2227168) . . . . .
73-75	Chevelle (exc. P.B.) . . . . .	335158	1	1.10	GASKET, resvr. (Bendix 2229846) . . . . .

**4.653 PISTON— BOLT— STOP, Brake Main Cylinder**

67-69	Pass. (exc. P.B., Metallic Linings),				
67-68	Pass. w/P.B. (exc. Disc Brakes, Metallic Linings, 396, 427),				
70	Pass. (exc. Disc Brakes) . . . . .	3912147	1	5.95	main cyl. secondary (Bendix 2226789) . . . . .
67	Pass. (exc. Disc Brakes, Metallic Linings),				
70	Pass. (exc. Disc Brakes) . . . . .	5461927	1	2.82	secondary (Moraine) . . . . .
67-69	Camaro w/Disc Brakes,				
68-69	Pass. (P.B. w/Disc Brakes),				
68-74	Nova w/Disc Brakes . . . . .	5460257	1	3.86	secondary (Moraine) . . . . .
67-69	All (exc. Pass. Disc Brakes, Metallic Brakes),				
70-72	Nova, Chevelle (exc. Disc Brakes),				
73-74	Nova (exc. Disc Brakes) . . . . .	5452694	1	2.78	secondary . . . . .
68-69	Chevelle w/Disc Brakes (exc. S.S.),				
68-69	Chevelle (S.S.) (exc. Metallic Linings),				
70	Chevelle, Camaro w/Disc Brakes,				
71-74	Camaro w/P.B. . . . .	5468776	1	2.78	secondary . . . . .
70-74	Camaro (exc. P.B.) . . . . .	5470811	1	4.60	secondary . . . . .
71-75	Pass. w/P.B.,				

**BRAKES**

**4.653 PISTON— BOLT— STOP, Brake Main Cylinder (Con't)**

73-75	Chevelle w/P.B. ....	6263170	1	5.05	secondary (Bendix 2227196) .....
72	Chevelle w/Disc Brakes,				
72-75	Pass. w/P.B.,				
73-75	Chevelle w/P.B. ....	5471610	1	3.15	secondary (Moraine) .....
72	Pass. ....	409348	1	7.05	primary (Bendix 2227034) .....
71-75	Vega, Monza .....	5470850	1	2.72	brake secondary .....
73-74	Chevelle (exc. P.B.) .....	335155	1	7.05	primary (Bendix 2229836) .....
73-75	Chevelle (exc. P.B.) .....	335156	1	5.05	secondary (Bendix 2229856) .....
73-75	Pass., Chevelle w/P.B. ....	335161	1	7.05	primary (Bendix 2229856) .....
75	Chevelle (exc. P.B.) .....	346407	1	7.05	primary (Bendix 2229417) .....
67-68	All (exc. Chevy Metallic Lining, Disc Brakes),				
67-68	Chevy .....	5460877	1	2.00	PISTON ASSY., primary .....
67-69	Pass. (P.B. w/Disc Brakes),				
67	Chevelle w/Disc Brakes,				
70	Pass. w/Disc Brakes .....	5460256	1	4.35	PISTON ASSY., secondary (Moraine) .....
70	Pass. w/Disc Brakes .....	3995813	1	8.60	PISTON ASSY. (primary) (Bendix 2228286)
68-70	Pass. (2nd design) (exc. P.B., Metallic Brake) .....	3943688	1	.24	BOLT, secondary piston stop ( <sup>5</sup> / <sub>16</sub> "— 24) (Bendix 2226859) .....
71-72	Pass. ....	409355	1	.44	BOLT, piston stop (Bendix 2227139) .....
73-75	Pass., Chevelle, Camaro, Nova ..	335153	1	.44	BOLT, piston stop (Bendix 2227564) .....

**4.654 CUP— PROTECTOR— RETAINER— SEAL, Main Cylinder Piston**

62-66	All (exc. metallic linings) .....	5460419	1	1.15	primary .....
67-69	Pass. (P.B. w/Disc Brakes),				
67	Camaro (P.B. w/Disc Brakes),				
68-69	All w/Disc Brakes (exc. Pass.),				
70	Pass., Nova, Chevelle w/Disc Brakes,				
71-72	Pass.,				
71-72	All w/Disc Brakes (exc. Pass., Vega),				
73-75	Pass., Chevelle, Camaro, Nova (P.B. w/Disc Brakes) .....	5455859	2	1.15	primary (Moraine) .....
67	Pass. (exc. Disc. Brake, metallic lining),				
67-69	All w/Disc Brake (exc. P.B.),				
70-75	Camaro (exc. P.B.),				
70	All (exc. Disc Brakes),				
71-72	Nova, Chevelle (exc. Disc Brakes),				
73-75	Nova (exc. Disc Brakes) .....	5453620	2	.98	primary .....
67-69	Chevy, Chevelle, Camaro,				
67-69	Pass. (exc. Metallic Disc Brakes),				
67-69	Pass. w/Disc Brakes (exc. P.B.),				
70-75	Camaro (exc. P.B.),				
70	All (exc. Disc Brakes),				
71-72	Nova, Chevelle (exc. Disc Brakes),				
73-75	Nova (exc. Disc Brakes) .....	5460195	2	.98	secondary .....
67-69	Pass. (exc. P.B., Metallic Brk.),				
70	Pass. (exc. Disc Brakes),				
73-75	Chevelle (exc. P.B.) .....	9787651	2	.73	secondary (inboard) (Bendix 2225454) ....
67-69	Pass. (exc. P.B. w/Metallic Brk.),				
70	Pass. (exc. Disc Brakes),				
73-75	Chevelle (exc. P.B.) .....	9787653	1	.76	secondary (outboard) (Bendix 2225457) ...
67-69	Pass. (P.B. w/Disc Brake),				
67	Camaro (P.B. w/Disc Brakes),				
68-69	All w/Disc Brakes (exc. Pass.),				
70	Pass., Nova, Chevelle w/Disc Brakes,				
71-72	Pass.,				
71-72	All w/Disc Brakes (exc. Pass., Vega),				
73-75	Pass., Chevelle, Nova, Camaro (P.B. w/Disc Brakes) .....	5455858 A.R.		.78	secondary .....
71-75	Pass. w/P.B.,				
73-75	Chevelle w/P.B. ....	3912131	2	.76	secondary inboard (Bendix 2225329) .....
71-75	Pass. w/P.B.,				
73-75	Chevelle w/P.B. ....	3912133	1	.76	secondary outboard (Bendix 2225423) ....
72-75	Pass. w/P.B.,				
73-75	Chevelle w/P.B. ....	409349	1	.76	primary (Bendix 2229179) .....
73-75	Chevelle (exc. P.B.) .....	483092	1	.76	primary (Bendix 2228214) .....
65-66	Taxi,				

**BRAKES**

**4.654 CUP— PROTECTOR— RETAINER— SEAL, Main Cylinder Piston (Con't)**

<b>67-69</b>	Pass. w/Disc Brakes,				
<b>67</b>	All (P.B. w/Metallic Brakes),				
<b>68-69</b>	Camaro, Chevy (exc. Disc Brake),				
<b>68-69</b>	Chevelle w/Disc Brake,				
<b>70-75</b>	All	<b>5462635</b>	<b>2</b>	<b>.15</b>	<b>PROTECTOR, primary cup (Moraine)</b>
<b>67-69</b>	Pass. (exc. P.B., Metallic Brakes),				
<b>70</b>	Pass. (exc. Disc Brakes),				
<b>73-75</b>	Chevelle (exc. P.B.)	<b>9787652</b>	<b>1</b>	<b>.32</b>	<b>PROTECTOR, primary cup (Bendix 225456)</b>
<b>71-75</b>	Pass. w/P.B.,				
<b>73-75</b>	Chevelle w/P.B.	<b>3912132</b>	<b>1</b>	<b>.41</b>	<b>PROTECTOR, cup (Bendix 2225364)</b>
<b>67-69</b>	Pass. (exc. P.B., Metallic Brakes),				
<b>70</b>	Pass. (exc. Disc Brakes),				
<b>73-75</b>	Chevelle (exc. P.B.)	<b>3912109</b>	<b>1</b>	<b>.32</b>	<b>RETAINER, secondary cup (Bendix 2226009)</b>
<b>72-75</b>	Pass. w/P.B.,				
<b>73-75</b>	Chevelle w/P.B.	<b>3912134</b>	<b>1</b>	<b>.31</b>	<b>RETAINER, secondary cup (Bendix 2225434)</b>
<b>71-75</b>	Pass. w/P.B.,				
<b>73-75</b>	Chevelle w/P.B.	<b>6263171</b>	<b>1</b>	<b>.48</b>	<b>SEAL, brake main cyl. secondary (Bendix 2226969)</b>
<b>73-75</b>	Chevelle (exc. P.B.)	<b>1482321</b>	<b>1</b>	<b>.77</b>	<b>SEAL, secondary (Bendix 618027)</b>

**4.655 SPRING— RETAINER, Main Cylinder Return**

<b>67-69</b>	Pass. (P.B. w/Disc Brakes),				
<b>67-72</b>	Camaro (P.B. w/Disc Brakes),				
<b>68-69</b>	Chevy, Chevelle w/Disc Brakes (exc. S.S.),				
<b>68-69</b>	Chevelle (S.S.),				
<b>70-72</b>	All w/Disc Brakes (exc. Camaro, Vega),				
<b>73-75</b>	Pass., Chevelle, Nova, Camaro (P.B. w/Disc Brakes)	<b>5455515</b>	<b>1</b>	<b>.88</b>	<b>secondary piston (Moraine)</b>
<b>67</b>	Chev. (P.B. w/Disc Brakes),				
<b>67-69</b>	Pass. w/Disc Brakes (exc. P.B.),				
<b>70-75</b>	Camaro (exc. P.B.)	<b>5460806</b>	<b>1</b>	<b>.58</b>	<b>secondary piston</b>
<b>67-68</b>	Pass. (exc. P.B., Metallic Brakes)	<b>1489986</b>	<b>1</b>		<b>secondary piston (Bendix 2225869) (repl. 3912148)</b>
<b>67-69</b>	Pass. w/Disc Brakes,				
<b>67-69</b>	All (exc. Pass.),				
<b>70</b>	All (exc. disc brakes)	<b>5462637</b>	<b>2</b>	<b>.28</b>	<b>check valve</b>
<b>67-69</b>	Pass. (exc. P.B., Metallic Brake, Disc Brakes, 396, 427),				
<b>70</b>	Pass. (exc. disc brakes)	<b>1482311</b>	<b>2</b>	<b>.44</b>	<b>check valve (Bendix 618014)</b>
<b>70</b>	Pass. w/Disc Brakes	<b>546502</b>	<b>1</b>	<b>.83</b>	<b>secondary piston (Bendix 2229002)</b>
<b>71-72</b>	Pass.	<b>409351</b>	<b>1</b>	<b>.76</b>	<b>secondary piston (Bendix 2227057)</b>
<b>71-74</b>	Vega	<b>5470857</b>	<b>1</b>	<b>1.44</b>	<b>brake secondary piston w/retainer</b>
<b>73</b>	Chevelle (exc. P.B.)	<b>335154</b>	<b>1</b>	<b>.76</b>	<b>secondary piston (Bendix 2229834)</b>
<b>73-75</b>	Pass., Chevelle w/P.B.	<b>231375</b>	<b>1</b>	<b>.44</b>	<b>secondary piston (Bendix 2227236)</b>
<b>74-75</b>	Chevelle (exc. P.B.)	<b>231639</b>	<b>1</b>	<b>.44</b>	<b>SPRING ASSY., secondary piston (Bendix 2229258)</b>
<b>67-70</b>	All (exc. disc brakes, Metallic Linings),				
<b>67-68</b>	Pass. w/Disc Brake (exc. P.B.),				
<b>70-72</b>	Camaro (exc. P.B.),				
<b>71-72</b>	Nova, Chevelle (exc. Disc Brakes),				
<b>73-75</b>	Camaro w/Disc Brakes (exc. P.B.),				
<b>73-75</b>	Nova (exc. Disc Brakes)	<b>5451070</b>	<b>1</b>	<b>.43</b>	<b>RETAINER, piston spring</b>
<b>67-68</b>	Pass. (P.B. w/Disc Brakes),				
<b>67-69</b>	Camaro (P.B. w/Disc Brakes),				
<b>68-69</b>	Chevy, Chevelle w/Disc Brakes,				
<b>70</b>	All w/Disc Brakes,				
<b>71-72</b>	Nova, Chevelle w/Disc Brakes,				
<b>71-72</b>	Pass.,				
<b>71-72</b>	Camaro (Disc Brakes w/P.B.),				
<b>73-75</b>	Pass., Chevelle, Nova, Camaro (P.B. w/Disc Brakes)	<b>5460627</b>	<b>1</b>	<b>.46</b>	<b>RETAINER, secondary piston spring</b>

**4.656 RING— RETAINER— SCREW— SEAL, Main Cylinder Stop**

<b>62-66</b>	All,				
<b>67-70</b>	All (exc. disc brakes, metallic linings),				
<b>67-69</b>	Pass. w/Disc Brakes (exc. P.B.),				
<b>70-72</b>	Camaro (exc. P.B.),				

## BRAKES

### 4.656 RING— RETAINER— SCREW— SEAL, Main Cylinder Stop (Con't)

71-72	Nova, Chevelle (exc. Disc Brakes),				
73-75	Camaro w/Disc Brakes (exc. P.B.),				
73-75	Nova (exc. Disc Brakes)	5467356	1	.27	lock
71-74	Vega	274978	1	.34	brake main cyl. secondary (type TA) internal ret. (1 <sup>1</sup> / <sub>4</sub> "— (8.934)
73-75	Chevelle, Pass., Camaro, Nova w/P.B.	231495	1	.24	main cyl. lock (Bendix 2229118)
75	Chevelle (exc. P.B.)	346408	1	.55	main cyl. lock (Bendix 2229427)
65-66	Taxi,				
71-75	Pass. w/P.B.,				
73-75	Chevelle w/P.B.	1478135	1	.84	RETAINER, main cyl. lock (Bendix 907681)
67-75	All	5464418	1	.67	SCREW, stop (Moraine)
68-69	Pass. w/P.B. (2nd design) (exc. Disc Brakes, Metallic Linings, 396, 427 H/Per., 427 Spec. H/Per.),				
68-69	Pass. (2nd design) (exc. P.B., Metallic Linings),				
70	Pass. (exc. P.B.)	1482330	1	.42	SEAL, secondary piston stop bolt "O" ring

### 4.657 VALVE, Main Cylinder

62-66	Chevy, Chevelle w/Moraine,				
65-66	Pass. (exc. Bendix Prod. P.B.)	5453711	1	.59	check
62-65	Chevy, Chevelle w/metallic linings,				
63	Chevy w/P.B.,				
65-66	Pass. w/metallic linings,				
66	Chevy, Chevelle	5454145	1	.68	check
64	All (exc. Pass.),				
67-69	Pass. w/Disc Brakes,				
70-72	All w/Disc Brakes	5469230	A.R.	.30	bleeder— (4.666)
67-68	Pass. (exc. P.B., Metallic Brake, Disc Brakes, 396, 427),				
70	Pass. (exc. P.B.)	1482313	2	.76	VALVE ASSY., residual check (Bendix 618017)
67-69	All (exc. Pass.),				
67-69	Pass. w/Disc Brakes,				
70	All (exc. disc brakes)	5462642	A.R.	.67	VALVE ASSY., check

### 4.658 ROD— COVER— NUT— RETAINER— VALVE ASSY., Main Cylinder Push

62-67	Chevy,				
64-66	Chevelle (1st design) (exc. P.B.),				
65-66	Pass. (exc. P.B.),				
68-69	Camaro, Chevy (exc. P.B.),				
70-74	Nova (exc. P.B.)	3790222	1	.78	(5 <sup>1</sup> / <sub>2</sub> " O.L.)
67-70	Pass. (exc. P.B.)	3779974	1	.78	(5 <sup>7</sup> / <sub>8</sub> " O.L.)
68-72	Chevelle (exc. P.B.)	3934004	1	.78	push
71-72	Pass.	409345	1	3.60	vac. power brake cyl. valve operating
71-75	Vega, Monza	5472127	1	6.00	
73-75	Chevelle (exc. P.B.)	1242338	1	4.00	(Bendix 2229849) (repl. 335160)
73-74	Pass. (Sta. Wag.),				
73-74	Pass. (454),				
73-74	Pass. w/H.D. Brake	335078	1	4.35	(Bendix 2510656)
75	Nova (exc. P.B.)	2622209	1	5.35	ROD ASSY., brake pedal push
75	Camaro (exc. P.B.)	2622210	1	5.35	ROD ASSY., push
73-75	Chevelle (exc. P.B.)	1242338	1	4.00	ROD ASSY., w/retainer brake pedal push
70	Camaro (exc. P.B.),				
71-72	Camaro w/Disc Brakes (exc. P.B.)	5472426	1	5.20	COVER, cyl. push rod hole
67-69	Pass. (P.B. w/Disc Brake),				
70	Pass. w/Disc Brakes	5461081	1	6.80	VALVE ASSY., w/push rod vacuum P.B. cylinder air
68-69	Chevelle,				
70	Chevelle w/Disc Brakes,				
71	Chevelle w/P.B. (exc. Disc Brakes),				
72	Chevelle (P.B. w/Disc Brakes)	5470882	1	5.65	VALVE ASSY., w/push rod air w/push rod
69	All w/Disc Brakes,				
70	Nova w/Disc Brakes,				
71-72	Nova,				
73-74	Nova w/Disc Brakes	5463974	1	6.25	VALVE ASSY., w/push rod power brake cylinder (Moraine)
71-72	Pass. (exc. Sta. Wag.),				



**BRAKES**

**4.658 ROD— COVER— NUT— RETAINER— VALVE ASSY., Main Cylinder Push (Con't)**

73-74	Pass. (exc. Sta. Wag., H.D. Brakes, 454) .....	5472429	1	6.55	VALVE ASSY., cyl. air .....
71	Chevelle w/Disc Brakes .....	5472126	1	5.50	VALVE ASSY., w/rod, air (Moraine) .....

**4.659 BOOT— COVER— GUARD— RING— RETAINER— WASHER, Main Cylinder (Rubber)**

63-67	All (exc. Pass., P.B.),				
65-69	Pass. (exc. Disc Brakes, Metallic Linings),				
65-66	Taxi,				
68-69	Chevy, Camaro,				
70	All (exc. P.B.),				
71-72	Nova, Chevelle w/P.B. (exc. Disc Brakes),				
71-75	Vega, Monza,				
73-75	Nova (exc. P.B.) .....	5456779	1	1.03	(rubber) .....
65-66	Chevy w/P.B.,				
65-69	Pass. w/P.B.,				
70	Pass. w/P.B. (exc. Disc Brakes),				
71-72	Pass. (exc. Sta. Wag.),				
73-74	Pass. ....	548179	1	.70	valve body (Bendix 2501643) .....
67-70	Pass. w/P.B.,				
71	Pass. (exc. Sta. Wag.),				
73-74	Pass. (exc. Sta. Wag., H.D. Brakes, 454) .....	5452476	1	1.55	pwr. brk. cyl. (Moraine) .....
67-69	Chevelle, Camaro,				
68-69	Chevy,				
70-72	Nova, Chevelle w/Disc Brakes,				
73-74	Nova w/Disc Brakes .....	5452997	1	1.80	power brake cyl. (Moraine) .....
71-74	Pass. (Sta. Wag.),				
72	Pass.,				
73-74	Pass. (454),				
73-74	Pass. w/H.D. Brakes .....	5466535	1	1.80	power brake cyl. (Moraine) .....
71-74	Camaro w/Disc Brakes (exc. P.B.) .....	5452526	1	1.11	power brake cyl. ....
73-75	Chevelle (exc. P.B.) .....	1242337	1	1.50	main cyl. push rod (Bendix 2225633) .....
71-72	Camaro .....	9788697	1	.29	COVER, cyl. push rod hole .....
73-75	Camaro (exc. P.B.) .....	9788697	1	.29	COVER, cyl. push rod hole .....
75	Nova (exc. P.B.) .....	9788697	1	.29	COVER, cyl. push rod hole .....
67	Camaro w/Bendix, P.B.,				
68-70	Chevy, Camaro w/Bendix P.B.,				
68-69	Chevelle,				
71	Nova, Chevelle w/P.B.,				
72	Nova w/P.B. ....	3918722	1	1.15	GUARD, diaphragm plate (Bendix 2505593) .....
71-74	Vega .....	9431992	1	.40	RING, brake main cyl. rod— (8.934) .....
65-66	Pass. w/P.B. ....	5464392	1	.31	RETAINER, boot .....
64-67	Chevelle, Camaro w/P.B.,				
65-69	Pass. w/P.B.,				
68-69	Chevy, Camaro w/P.B.,				
70	Pass., Nova w/P.B.,				
71-72	Nova w/P.B.,				
73-75	Nova .....	3953987	A.R.	.12	WASHER, pedal and main cyl. push rod to actuating lever (3/8") .....
64-70	All w/P.B.,				
71	Nova, Chevelle, Camaro,				
71	Pass. (exc. Sta. Wag.),				
72	Pass., Nova, Chevelle,				
73-74	Nova, Camaro (P.B. w/Disc Brakes),				
73-74	Pass. (exc. Sta. Wag., H.D. Brakes, 454) .....	5464812	A.R.	.26	WASHER, push rod limiter .....
65-69	Pass. w/P.B.,				
65-66	Chevy, Chevelle w/P.B.,				
67	Camaro w/Bendix P.B.,				
68-70	Chevy, Camaro w/Bendix P.B.,				
68-69	Chevelle,				
70	Pass. w/P.B. (exc. Disc Brakes),				
71	Nova, Chevelle w/P.B.,				
71	Pass. (exc. Sta. Wag.),				
72	Pass.,				
72	Nova w/P.B.,				
73-74	Pass. (exc. Sta. Wag., H.D. Brakes, 454) .....	382445	1	.63	WASHER, valve rod (Bendix 2502153) ....

**BRAKES**

**4.659 BOOT— COVER— GUARD— RING— RETAINER— WASHER, Main Cylinder (Rubber) (Con't)**

71-74	Pass. (Sta. Wag.),				
73-74	Pass. (454),				
73-74	Pass. w/H.D. Brakes	5463881	1	.46	WASHER, push rod limiter

**4.661 SEAT— INSERT, Main Cylinder Outlet Fitting**

67	Chevelle (exc. P.B. Metallic Brake),				
67-69	Pass. (exc. P.G., Metallic Brake),				
70	Pass. (exc. P.B.)	9787648	2	.58	outlet tube (Bendix 618047)
70-72	Pass. w/Disc Brakes	1472931	1	.76	outlet tube (Bendix 39955)
75	A, B, F, X	6273937	2	.91	SEAT, whl. brake pipe fitting
67-69	Pass.				INSERT, main cyl. pipe connector bolt
67	Pass.,				
68	Pass. (exc. Disc Brakes),				
70-75	All	5452322	2	.37	INSERT, main cyl. piston extension (Moraine)

**4.662 CLEVIS— PIN— RETAINER— WASHER, Main Cylinder Adjusting**

67-69	Chevelle,				
70	Pass., Nova, Chevelle,				
73-75	Nova	3953288	1	.39	brake pedal to brake main cyl.— (8.946)
62-70	All,				
71	Nova, Chevelle,				
73-74	Nova	3817879	A.R.	.12	PIN, clevis, brake main cylinder, P.B. push rod to brake pedal end and actuator lever (use w/3817880 ret.)
70	Camaro (exc. P.B.),				
71-75	Vega, Monza (exc. P.B.)	3965696	1	.25	PIN, push rod clevis
70-75	Camaro w/P.B.,				
75	Vega, Monza w/P.B.	3975544	1	.44	PIN, push rod
71-75	Camaro (exc. P.B.)	3992577	1	.23	PIN, push rod
71-75	Camaro w/Disc Brakes (exc. P.B.)	5452525	1	1.09	RETAINER, push rod
62-72	All,				
71-75	Vega, Monza,				
69-70	Camaro	1488371	1	.12	RETAINER, rod to clevis (3/8" — 16)
72	Nova, Chevelle w/P.B.	1488371	1	.12	RETAINER, rod to clevis (3/8" — 16)
73-75	Nova w/P.B.	1488371	1	.12	RETAINER, rod to clevis (3/8" — 16)
73-75	Nova, Camaro	3817880	A.R.	.12	RETAINER, clevis pin, brake main cylinder P.B. push rod to brake pedal end and actuator lever
71	Pass. (Sta. Wag.),				
72	Pass.	5466546	1	1.46	RETAINER, power brake cyl. push rod
72-74	Pass.,				
73-74	Chevelle	1244707	1	.12	RETAINER, brake pedal to vac. pwr. brake main cyl. push rod pin (repl. 1351769)— (4.037)
73-75	Chevelle (exc. P.B.)	6259014	1	.18	RETAINER, push rod (Bendix 2227943)
75	Pass., Chevelle	1244707	1	.12	RETAINER, push rod
71-75	Pass.,				
72-75	Chevelle	492346	1	.34	WASHER, push rod pin (steel)
71-75	Pass.,				
71-75	Camaro w/P.B.,				
72-75	Chevelle w/P.B.	410230	1	.11	WASHER, push rod pin spring (7/16" x 11/16")

**4.665 CYLINDER ASSY.— BOLT— BUSHING— BRACKET— CALIPER ASSY.— HOUSING— PIN— RETAINER— REPAIR UNIT— SCREW ASSY.— SLEEVE, Wheel Brake (Also See Group 4.667)**

62-63	Chevy	5460812	L.H.	14.80	front, left
62-63	Chevy	5460813	R.H.	14.80	front, right
62-63	Chevy	5460808	L.H.	10.65	rear, left
62-63	Chevy	5460809	R.H.	10.65	rear, right
64-67	Chevelle w/P.B. (2nd design) (exc. Disc Brakes),				
64-67	Chevelle (exc. P.B., Disc Brakes),				
67-69	Camaro (exc. Disc Brakes),				
68-74	Nova (exc. Disc Brakes)	5469303	L.H.	13.30	front (1 1/8" dia.) left
64-67	Chevelle w/P.B. (2nd design) (exc. Disc Brakes),				
64-67	Chevelle (exc. P.B., Disc Brakes),				
67-69	Camaro (exc. Disc Brakes),				
68-74	Nova (exc. Disc Brakes)	5469304	R.H.	13.30	front (1 1/8" dia.) right
64	Chevelle (2nd design) (exc. P.B.),				
65	Chevelle (exc. Spl. Spt. Cpe.),				

**BRAKES**

**4.665 CYLINDER ASSY.— BOLT— BUSHING— BRACKET— CALIPER ASSY.— HOUSING— PIN— RETAINER— REPAIR UNIT— SCREW ASSY.— SLEEVE, Wheel Brake (Also See Group 4.667) (Con't)**

66-69	Chevelle	5469321	2	10.05	rear (1 <sup>5</sup> / <sub>16</sub> " dia.)
64	Chevelle w/P.B. (1st design),				
64-67	Chevy (exc. Disc Brakes)	5462963	L.H.	12.15	front (1 <sup>1</sup> / <sub>16</sub> " dia.), left
64	Chevelle w/P.B. (1st design),				
64-67	Chevy (exc. Disc Brakes)	5462964	R.H.	12.15	front (1 <sup>1</sup> / <sub>16</sub> " dia.), right
64-72	Chevy,				
64	Chevelle w/P.B.,				
67-72	Camaro,				
70-72	Chevelle,				
73-75	Chevelle, Nova, Camaro (exc. Sta. Wag.)	5469245	2	11.50	rear (9 <sup>1</sup> / <sub>2</sub> " x 2 brk.)
65-70	Pass. (exc. Disc Brakes)	5465548	L.H.	12.20	front, left
65-70	Pass. (exc. Disc Brakes)	5465549	R.H.	12.20	front, right
65-70	Pass.,				
71-75	Pass. (Sta. Wag.)	5472327	2	12.15	rear (12 x 2 brk.)
67-68	Pass. (P.B. w/Disc Brakes) (exc. Police),				
68-72	Chevelle (exc. Disc Brakes)	5469252	L.H.	12.15	front, left
68-72	Chevelle (exc. Disc Brakes)	5469253	R.H.	12.15	right frt.
71-75	Pass. (exc. Sta. Wag.),				
73-75	Chevelle (Sta. Wag.)	5469302	2	10.70	rear (11 x 2 brk.)
71-75	Vega, Monza	5469256	2	13.15	rear wheel (9 <sup>3</sup> / <sub>4</sub> ")
67-68	Chevy, Chevelle, Camaro w/Disc Brakes,				
69	Camaro w/Disc Brakes (front and rear)	9422268	4	.53	BOLT, front caliper housing— (8.900)
68-69	Camaro w/Disc Brakes-Front and Rear	9422407	4	.87	BOLT, rear caliper housing (7 <sup>7</sup> / <sub>16</sub> "— 20 x 2 <sup>1</sup> / <sub>2</sub> "— (8.900)
68	Pass. (4 piston design)	9427324	4	.65	BOLT, front caliper housing (9 <sup>9</sup> / <sub>16</sub> "— 18 x 2 <sup>3</sup> / <sub>4</sub> ")
68-69	Pass. w/Disc Brakes (Spg. Piston Design) (exc. P.B.),				
70-75	Pass. w/Disc Brakes	5468226	4	4.60	BOLT, frt. calip. housing (3 <sup>31</sup> / <sub>32</sub> " x 3 <sup>3</sup> / <sub>8</sub> ")
71-75	Vega, Monza	355431	2	.68	BOLT, front brake hose
69	Chevy, Chevelle, Camaro w/Disc Brakes (exc. Front and Rear Disc Brake),				
70-72	Nova, Chevelle, Camaro w/Disc Brakes,				
73	Chevelle, Nova, Camaro,				
74-75	Chevelle, Camaro w/P.B.	5463495	A.R.	4.18	BOLT, front caliper (3 <sup>23</sup> / <sub>32</sub> " x 3 <sup>3</sup> / <sub>8</sub> ")
68-70	Pass. w/Disc Brakes (Sgl. piston design),				
69-72	All w/Disc Brakes (exc. Pass., Vega),				
73	All w/Disc Brakes, (exc. Vega),				
74-75	Pass., Chevelle, Camaro w/P.B.,				
75	Nova w/Disc Brakes	5470497	1	.60	BUSHING, frt. brake caliper bolt outer "O" ring
69	Pass. w/Disc Brakes (Sgl. piston design),				
69	Chevy, Chevelle, Camaro w/Disc Brakes (exc. Front and Rear Disc Brakes),				
70-72	All w/Disc Brakes (exc. Vega),				
73	All w/Disc Brakes, (exc. Vega),				
74-75	Pass., Chevelle, Camaro w/P.B.,				
75	Nova w/Disc Brakes	5469178	4	.72	BUSHING, frt. brake caliper piston hsg. inner
71-75	Vega, Monza	3980398	4	.50	BUSHING ASSY., caliper pin, w/sleeve
73-74	Nova w/Disc Brakes	5470660	L.H.	11.10	BRACKET, front caliper adapter— (5.001)
73-74	Nova w/Disc Brakes	5470661	R.H.	10.10	BRACKET, front caliper adapter— (5.001)
68-70	Pass. w/Disc Brakes (Sgl. Piston Design)	5472813	L.H.	80.05	CALIPER ASSY., front left
68-70	Pass. w/Disc. Brakes (Sgl. Piston Design)	5472814	R.H.	80.05	CALIPER ASSY., front, right
69-72	Chevelle w/Disc Brakes	5472161	L.H.	75.75	CALIPER ASSY., front, left
69-72	Chevelle w/Disc Brakes	5472162	R.H.	75.75	CALIPER ASSY., front, right
69	Chevy, Camaro w/Disc Brakes,				
70-74	Nova w/disc brakes	5472433	L.H.	76.65	CALIPER ASSY., front, left
70-75	Camaro,				
73-75	Chevelle	2620585	L.H.	81.95	CALIPER ASSY., left frt.

**BRAKES**

**4.665 CYLINDER ASSY.— BOLT— BUSHING— BRACKET— CALIPER ASSY.— HOUSING— PIN— RETAINER— REPAIR UNIT— SCREW ASSY.— SLEEVE, Wheel Brake (Also See Group 4.667) (Con't)**

70-75 Camaro,				
73-75 Chevelle	2620586 R.H.	81.95		CALIPER ASSY., right frt. ....
69 Chevy, Camaro w/Disc Brakes,				
70-74 Nova w/disc brakes	5472434 R.H.	76.65		CALIPER ASSY., front, right .....
71 Pass. (exc. Taxi, Police),				
72-75 Pass.	5474053 R.H.	88.60		CALIPER ASSY., right, front .....
71 Pass. (exc. Taxi, Police),				
72-75 Pass.	5474052 L.H.	88.60		CALIPER ASSY., left, front .....
72 Camaro	2620856 R.H.			CALIPER ASSY., right front brake (repl. 5474056) .....
71-75 Vega, Monza	3976615 L.H.	70.50		CALIPER ASSY. ....
71-75 Vega, Monza	3976616 R.H.	70.50		CALIPER ASSY. ....
67-68 Pass. (4 piston design)	5456479 2	46.50		HOUSING, front caliper outer .....
67-68 Chevy, Camaro w/Disc Brakes	5455534 2	55.50		HOUSING, front caliper outer .....
67-68 Chevelle w/Disc Brakes	5456076 2	47.75		HOUSING, front caliper outer .....
68-69 Camaro w/Disc Brakes (front & rear)	2621206 2	49.45		HOUSING, front caliper outer .....
67-68 Pass. w/Disc Brakes (4 piston design)	5468554 L.H.	41.25		HOUSING ASSY., front caliper inner, left ..
67-68 Pass. w/Disc Brakes (4 piston design)	5468555 R.H.	41.25		HOUSING ASSY., front caliper inner, right .
67-68 Chevelle w/Disc Brakes	5468363 L.H.	37.25		HOUSING ASSY., front caliper inner, left (Note 1) .....
<i>NOTE 1 On early 1967 models it will be necessary to also use 1382795 pipe assy., 5466977 pin and 5466978 retainer.</i>				
67-68 Chevelle w/Disc Brakes	5468364 R.H.	37.25		HOUSING ASSY., front caliper inner, right (Note 2) .....
<i>NOTE 2 On early 1967 models it will be necessary to also use 1382794 pipe assy., 5466977 pin and 5466978 retainer.</i>				
67-68 Chevy, Camaro w/front Disc Brakes	5468376 L.H.	38.75		HOUSING ASSY., front caliper inner, left (Note 2) .....
67-68 Chevy, Camaro w/Front Disc Brakes	5468377 R.H.	38.75		HOUSING ASSY., front caliper inner, right (Note 2) .....
<i>NOTE 2: When using on models that incorporate housings with smaller fitting sizes, pipes in Group 4.681 are needed.</i>				
68-69 Camaro w/Disc Brakes-Front and Rear	5469486 R.H.	72.20		HOUSING ASSY., front caliper inner, right .
68-69 Camaro w/Disc Brakes-Front and Rear	5469487 L.H.	77.25		HOUSING ASSY., front caliper inner, left ..
68-69 Camaro w/Disc Brakes-Front and Rear	5461992 2	40.75		HOUSING ASSY., rear (inner) R.H. and L.H.
68-69 Camaro w/Disc Brakes-Front and Rear	5462017 2	40.50		HOUSING ASSY., rear (outer) R.H. and L.H.
71-75 Vega, Monza	3976629 2	.20		PIN, caliper front .....
71-75 Vega, Monza	3976631 4	.20		RETAINER, caliper pin .....
62-63 Chevy	5467234 A.R.	3.75		REPAIR UNIT, rear (Note 1) .....
62-63 Chevy	5461649 2	3.65		REPAIR UNIT, front (1" dia.) (Note 1) .....
64-67 Chevy,				
64 Chevelle w/P.B. (1st design)	5465084 A.R.	3.52		REPAIR UNIT, front (1 <sup>1</sup> / <sub>16</sub> " dia.) (Note 1) . . .
64-68 Chevelle (exc. 1st design P.B.),				
65 Chevelle (exc. Spl. Spt. Cpe.),				
66-69 Chevelle,				
71-72 Pass. (exc. Sta. Wag.),				
73-75 Chevelle (Sta. Wag.),				
73-75 Pass.	5464763 A.R.	3.37		REPAIR UNIT, rear (1 <sup>5</sup> / <sub>16</sub> " dia.) (Note 1) . . . .
64 Chevelle w/P.B. (1st design),				
64-69 Chevy,				
67-69 Camaro,				
70-72 Nova, Chevelle, Camaro,				
73-75 Chevelle (exc. Sta. Wag.),				
73-75 Nova, Camaro	5464848 1	3.50		REPAIR UNIT, rear (7/8" dia.) (Note 1) .....
64-67 Chevelle (exc. 1st design P.B.),				
64-69 Camaro (exc. Disc Brakes),				
68-72 Chevy, Chevelle (exc. Disc Brakes),				
73-74 Nova (exc. Disc Brakes)	5465083 A.R.	3.58		REPAIR UNIT, front (1 <sup>1</sup> / <sub>8</sub> " dia.) (Note 1) . . .
65 Chevelle (Spl. Spt. Cpe.),				
65-70 Pass.	5467284 A.R.	3.82		REPAIR UNIT, rear (1" dia. cyl.) (Note 1) . . .
65-70 Pass. (exc. Disc Brakes)	5456566 A.R.	3.66		REPAIR UNIT, front (1 <sup>3</sup> / <sub>16</sub> " dia.) (repl. 5467028) .....
71-72 Pass. (Sta. Wag.)	5472326 1	3.69		REPAIR UNIT, rear .....

**BRAKES**

**4.665 CYLINDER ASSY.— BOLT— BUSHING— BRACKET— CALIPER ASSY.— HOUSING— PIN— RETAINER— REPAIR UNIT— SCREW ASSY.— SLEEVE, Wheel Brake (Also See Group 4.667) (Con't)**

71-75	Vega, Monza	5471272	1	3.05	REPAIR UNIT, wheel cyl. (repair of 5469256) (3/4")
73-75	Chevelle,				
74-75	Vega, Monza	5463185	4	.06	SCREW ASSY., w/lockwasher, rear wheel cyl.
68-72	All w/Disc Brake (single piston design) (exc. Vega),				
73-75	Pass., Chevelle, Camaro, Nova w/P.B.	5474406	4	.73	SLEEVE, front brake retaining bolt housing

*NOTE 1 Contains 2 pistons, 2 piston cups, 2 boots and 1 spring and expander assy.*

**4.666 VALVE— COVER— PLUG— RING, Wheel Cylinder**

62-63	Chevy,				
65-69	Pass.,				
69	Chevy, Camaro w/Disc Brakes,				
70	Pass. (exc. Disc Brakes),				
71-75	Vega, Monza				rear,
68-69	Pass. w/Disc Brake (single piston design),				
71-73	All w/Disc Brakes (exc. Vega),				
71-75	Vega, Monza,				
74-75	Pass., Chevelle, Camaro w/P.B.,				
75	Nova w/Disc Brakes	5455122	A.R.	.33	front
62-63	Chevy,				
65-69	Pass.,				
70	Pass. (exc. disc brakes)				bleeder, front,
65-66	Pass.	5459294	A.R.	.66	bleeder, front and rear (repl. 5459470)
64-75	All (exc. Vega, Monza)	5469230	A.R.	.30	bleeder, front and rear
70-75	All w/Disc Brakes (exc. Vega, Monza)	5469581	2	.17	COVER, frt. brake bleeder screw (plastic)
69	Camaro w/Disc Brakes-Front and Rear	5467211	2	.36	PLUG, rear brk. caliper inlet hose conn. hole
67	All,				
68	All (exc. Pass.),				
68-69	Pass., w/Disc Brakes				RING, front, caliper bleeder valve,
68-69	Camaro w/Disc Brakes-Front and Rear	5465969	2	.37	rear caliper bleeder valve "O"

**4.667 CUP— REPAIR UNIT— SEAL, Wheel Cylinder Piston (Also See Group 4.665)**

64-69	Chevelle,				
71-72	Pass. (exc. Sta. Wag.),				
73-74	Chevelle (Sta. Wag.),				
73-74	Pass.	5455439	4	.72	rear (15/16" dia.)
64-67	Chevy,				
64	Chevelle w/P.B.	5454234	4	.87	front and rear (1 1/16" dia.)
65-69	Pass.	5455855	1	2.78	rear (1" dia. cyl.)
65-72	Chevelle (exc. Disc Brakes),				
67-69	Camaro (exc. Disc Brakes),				
68-74	Nova (exc. Disc Brakes)	5455856	1	2.92	REPAIR UNIT, front (1 1/8" dia.)
67-68	Pass., Chevelle w/Disc Brakes (4 piston design)	5463232	A.R.	2.79	REPAIR UNIT, front
67-68	Chevy w/Disc Brakes,				
67-68	Camaro (H.D. Brakes w/Disc Brakes) (302),				
69	Camaro w/Disc Brakes (front and rear)	5467286	A.R.	3.53	REPAIR UNIT, front (1 7/8" dia.)
68-69	Pass. w/Disc Brakes (single piston design),				
69	Chevy, Chevelle, Camaro w/Disc Brakes (exc. front and rear Disc Brakes),				
70-75	All w/frt. Disc Brakes (exc. Vega, Monza)	5468767	A.R.	5.60	REPAIR UNIT, front (Note 1)

*NOTE 1 Consists of 1 Boot, 1 Seal. For piston see group 4.668, Part Number 5463483.*

68-69	Camaro w/Disc Brakes-Front and Rear	5467288	A.R.	3.39	REPAIR UNIT, rear (1 3/8" dia.)
71-75	Vega, Monza	325158	1	5.05	REPAIR UNIT, caliper piston (Note 2)

*NOTE 2: Consists of 1-3976622 "O" Ring, 1-3976623 Seal Assy., and 1-6264659 Seal Assy.*

67-68	Pass., Chevelle w/Disc Brakes (4 piston design)	5467984	4	1.34	SEAL, front brake caliper piston
-------	---	---------	---	------	----------------------------------

## BRAKES

### 4.667 CUP— REPAIR UNIT— SEAL, Wheel Cylinder Piston (Also See Group 4.665) (Con't)

68-69 Camaro w/Disc Brakes-Front and Rear ..... 5465914 8 1.01 SEAL, piston rear brake caliper .....

### 4.668 PISTON ASSY.— INSULATOR, Brake Caliper

67-68 Pass. (4 piston design),  
67-68 Chevelle w/Disc Brakes ..... 5457273 4 4.73 front .....

67 Chevy, Camaro,  
68-69 Chevy, Camaro w/Disc Brakes (exc. Spl. Strg.) ..... 5457272 4 4.33 front .....

67 Camaro w/H.D. Brakes ..... 5463823 8 17.35 front .....

68-69 Camaro w/Disc Brakes-Front and Rear ..... 5457264 8 4.33 rear .....

68-69 Pass. (single piston design),  
69 Chevy, Chevelle, Camaro w/Disc Brakes (exc. Front and Rear Disc Brakes),  
70-75 All w/Disc Brakes (exc. Vega, Monza) ..... 2622207 2 5.70 front .....

71-74 Vega ..... 5471073 4 .56 wheel cyl., rear .....

71-75 Vega, Monza ..... 3976621 1 4.05 caliper front .....

67-68 Pass.,  
67 Camaro w/H.D. Brakes ..... 5463822 8 9.95 INSULATOR, front .....

67-68 Pass.,  
68 Police ..... 5469593 8 9.95 INSULATOR, rear .....

### 4.669 SPRING, Wheel Cylinder Piston

62-63 Chevy ..... front (1" dia.), .....

65-70 Pass.,  
71-72 Pass. (Sta. Wag.) ..... 5455489 2 .44 rear, w/expander .....

64-69 Chevelle,  
71-72 Pass. (exc. Sta. Wag.),  
73-74 Pass. .... 5455422 2 .45 rear (<sup>15</sup>/<sub>16</sub>" dia.) .....

64-68 Chevelle w/P.B.,  
67-68 Pass. w/Disc Brakes,  
67-69 All w/Disc Brakes (4 piston design) (exc. Pass.) ..... 5466733 8 .47 front brake caliper piston return .....

65-72 Chevelle (exc. Disc Brakes),  
67-69 Camaro (exc. Disc Brakes),  
68-74 Nova (exc. Disc Brakes) ..... 5455487 2 .52 front (1<sup>1</sup>/<sub>8</sub>" dia.) .....

65-69 Pass.,  
70 Pass. (exc. disc brakes) ..... 5456982 2 .68 front .....

68-69 Camaro w/Disc Brakes - Front and Rear ..... 5465915 8 .72 rear piston return .....

69 All w/Disc Brakes (single piston design) 1st design ..... 5469180 4 .61 front brake caliper piston return (hairpin type) (Note 1) .....

69 All w/Disc Brakes (single piston design) (second design),  
70-71 All w/Disc Brakes (exc. Vega),  
72 Nova,  
73 All w/Disc Brakes (exc. Vega),  
74-75 Pass., Chevelle, Camaro w/P.B.,  
75 Nova w/Disc Brakes ..... 5469497 4 .61 front brake caliper piston return (clip-on type) (Note 1) .....

*NOTE 1 Three types of shoes are in service. Part number 5469180 may be used with any type shoe. Part number 5469497 is used only on inboard shoe with flat notch on top.*

### 4.670 BOOT, Wheel Cylinder

62 Chevy ..... front and rear, .....

63 Chevy ..... 5459963 8 .43 rear (<sup>3</sup>/<sub>32</sub>" O.D. x <sup>13</sup>/<sub>32</sub>" thk.) .....

64-70 Chevelle,  
71-72 Pass. (exc. Sta. Wag.),  
73-74 Pass. .... 5462938 4 .60 rear (use w/5462939) .....

64-70 Chevy,  
64 Chevelle w/P.B.,  
67-70 Camaro,  
71-74 Chevelle, Camaro,  
71-74 Vega,  
72-74 Nova ..... 5464011 4 .60 rear (use w/5464077) .....

65-70 Pass. .... 231335 4 .52 rear (1<sup>1</sup>/<sub>2</sub>" O.D.) .....

64 Chevelle,  
65-67 Chevy ..... 5462969 4 .63 BOOT ASSY., front w/ring .....

64-72 Chevelle (exc. Disc Brakes),  
67-69 Camaro (exc. Disc Brakes),

**BRAKES**

**4.670 BOOT, Wheel Cylinder (Con't)**

68-74	Nova (exc. Disc Brakes) . . . . .	5464988	4	.67	BOOT ASSY., front w/ring (1 <sup>1</sup> / <sub>8</sub> " dia.) . . . . .
67-68	Chevy w/Disc Brakes,				
67-68	Camaro (H.D. Brakes w/Disc Brakes) (302),				
69	Camaro w/Disc Brakes (front and rear) . . . . .	5465979	8	1.25	BOOT ASSY., front brake caliper piston . . .
68-69	Camaro w/Disc Brake-Front and Rear . . . . .	5465972	8	1.21	BOOT ASSY., rear brake caliper piston . . . . .

**4.671 INSERT— BOLT— WASHER, Brake Connector**

67-72	All (exc. Vega),				brake main cyl. pipe connector bolt, . . . . .
71-74	Vega . . . . .				
67	Pass.,				
68	Pass. (exc. Disc Brake) . . . . .	5452322	2	.37	brake-main cyl. piston extension (Moraine)— (4.661) . . . . .
72	Chevelle (exc. Disc Brakes) . . . . .				front brake hose conn. hole, . . . . .
71-75	Vega, Monza . . . . .				rear wheel cyl. inlet hose conn. hole insert, .
75	All (exc. Vega, Monza) . . . . .	5453786	2	.43	rear wheel brk. cyl. insert . . . . .
71-72	Pass.,				
72-75	All . . . . .	487293	2	.34	BOLT, front brake hose (1 <sup>3</sup> / <sub>16</sub> " O.L.— <sup>3</sup> / <sub>8</sub> " head) . . . . .
62-66	All . . . . .	231343	A.R.	.33	WASHER (7 <sup>7</sup> / <sub>16</sub> " I.D. x 1 <sup>1</sup> / <sub>16</sub> " O.D. x .032) (copper) . . . . .

**4.675 ROD, Wheel Cyl. to Brake Shoe Thrust**

63	Chevy . . . . .				rear, . . . . .
65-66	Pass.,				
67-70	Pass. (exc. Disc Brakes) . . . . .	509233	8	.39	front and rear (2 <sup>1</sup> / <sub>16</sub> " long w/ <sup>13</sup> / <sub>16</sub> " slot) . . . . .
64-68	All (exc. Pass.),				
71-72	All (exc. Pass., Vega),				
73-75	Nova, Chevelle, Camaro . . . . .				rear, . . . . .
65-70	All (exc. Pass.),				
71-72	Nova, Chevelle (exc. Disc Brakes),				
73	Nova (exc. Disc Brakes) . . . . .	5464748	4	.58	front . . . . .
71-72	Pass. (exc. Sta. Wag.),				
75	Pass., Chevelle . . . . .	5472176	4	.98	ROD, rr. whl. cyl. to brake shoe thrust . . . . .
73-75	Pass.,				
71-75	Vega, Monza . . . . .	5471148	4	.68	rear wheel cyl. . . . .

**4.680 HOSE ASSY.— RETAINER, Hydraulic Brake**

**FRONT**

62-66	Chevy,				
67	Chevy (exc. Disc Brakes) . . . . .	3910723	2	8.35	(7 <sup>7</sup> / <sub>16</sub> "— 20 ext.— <sup>3</sup> / <sub>8</sub> "— 24 int.— 14 <sup>3</sup> / <sub>8</sub> " O.L.)
64	Chevelle (exc. Disc Brakes),				
65-70	Pass. (exc. Disc Brakes) . . . . .	3910724	2	4.05	(7 <sup>7</sup> / <sub>16</sub> "— 20 ext.— <sup>3</sup> / <sub>8</sub> "— 24 int.— 13 <sup>1</sup> / <sub>4</sub> " O.L.)
65-67	Chevelle (exc. Disc Brks.) . . . . .	3898231	2	13.20	(7 <sup>7</sup> / <sub>16</sub> "— 20 ext.— <sup>3</sup> / <sub>8</sub> "— 24 int.— 13 <sup>1</sup> / <sub>4</sub> " O.L.) . .
67-70	Pass. w/Disc Brakes . . . . .	3958982	2	10.15	(7 <sup>7</sup> / <sub>16</sub> "— 20 ext.— <sup>3</sup> / <sub>8</sub> "— 24 int.— 16 <sup>5</sup> / <sub>8</sub> " O.L.)
67	Chevelle w/Disc Brakes . . . . .	3904943	2	8.65	( <sup>3</sup> / <sub>8</sub> "— 24 both ends 11 <sup>3</sup> / <sub>4</sub> " O.L.) . . . . .
67	Chevy w/Disc Brakes . . . . .	3910719	1	12.80	( <sup>3</sup> / <sub>8</sub> "— 24 both ends— 13 O.L.) . . . . .
67	Camaro (exc. Disc Brakes) . . . . .	3910718	2	7.90	(7 <sup>7</sup> / <sub>16</sub> "— 20 ext.— <sup>3</sup> / <sub>8</sub> "— 24 int.— 12 <sup>1</sup> / <sub>4</sub> " O.L. .
67-68	Camaro w/Disc Brakes,				
68	Chevy w/Disc Brakes . . . . .	3910710	2	9.25	( <sup>3</sup> / <sub>8</sub> "— 24 both ends— 9 <sup>3</sup> / <sub>4</sub> " O.L.) . . . . .
68	Chevelle,				
69-72	Chevelle (exc. Disc Brakes) . . . . .	9747245	2	12.25	( <sup>3</sup> / <sub>8</sub> "— 24 both ends— 11 O.L.) . . . . .
68-69	Chevy, Camaro (exc. Disc Brake),				
70-74	Nova (exc. Disc Brakes) . . . . .	9745221	2	7.80	(7 <sup>7</sup> / <sub>16</sub> "— 20 ext.— <sup>3</sup> / <sub>8</sub> "— 24 int.— 11 <sup>1</sup> / <sub>2</sub> " O.L.)
69	Chevy, Camaro w/Disc Brakes (exc. Front and Rear Disc),				
70-72	Nova w/Disc Brakes . . . . .	9753906	2	17.65	(14 <sup>13</sup> / <sub>16</sub> " O.L.) . . . . .
69-72	Chevelle w/Disc Brakes,				
73	Monte Carlo . . . . .	1230992	2	8.75	(11 <sup>3</sup> / <sub>8</sub> " O.L.) . . . . .
69	Camaro w/Disc Brakes-Front and Rear . . . . .	3953247	2	16.10	( <sup>3</sup> / <sub>8</sub> "— 24 both ends— 10 <sup>1</sup> / <sub>4</sub> " O.L.) . . . . .
70-71	Camaro . . . . .	9753907	2	17.00	(14 <sup>1</sup> / <sub>2</sub> " O.L.) (repl. 3984577) . . . . .
71-73	Pass. . . . .	3991232	2	7.25	(14 <sup>1</sup> / <sub>2</sub> " O.L.) (rayon) . . . . .
72-73	Camaro . . . . .	9753907	2	17.00	(14 <sup>3</sup> / <sub>8</sub> " O.L.) . . . . .
71-74	Vega . . . . .	3996332	2	8.30	
73-75	Nova w/Disc Brakes . . . . .	9754997	L.H.	17.65	
73-74	Nova w/Disc Brakes . . . . .	9754998	R.H.	17.65	
73-75	Chevelle (exc. Monte Carlo) . . . . .	9753753	2	15.00	(13 <sup>5</sup> / <sub>8</sub> " O.L.) . . . . .
74-75	Pass., Monte Carlo,				
75	Nova . . . . .	9757654	2	19.55	(repl. 338735) . . . . .

## BRAKES

### 4.680 HOSE ASSY.— RETAINER, Hydraulic Brake (Con't)

74	Camaro	340320	2	12.65	
75	Camaro	352892	2	14.35	
75	Vega, Monza	9758869	2		(repl. 9757630)

### REAR

62-65	Chevy	3910724	2	4.05	( $\frac{7}{16}$ "— 20 ext.— $\frac{3}{8}$ "— 24 int.— $13\frac{7}{16}$ " O.L.) (Note 2)
-------	-------	---------	---	------	---

*NOTE 2 Part appears in both sections of this group.*

64-65	Chevelle	9740566	1	8.90	( $\frac{7}{16}$ "— 20 ext.— $\frac{3}{8}$ "— 24 int.— 12 O.L.)
65	Pass.	3910721	1	3.40	( $\frac{7}{16}$ "— 20 ext.— $\frac{3}{8}$ "— 24 int.— $16\frac{5}{16}$ " O.L.)
66	Pass.	3878050	1	9.55	( $\frac{7}{16}$ "— 20 ext.— $\frac{3}{8}$ "— 24 int.— $15\frac{1}{16}$ " O.L.)
66-67	Chevelle	3877771	1	8.75	( $\frac{7}{16}$ "— 20 ext.— $\frac{3}{8}$ "— 24 int.— 12" O.L.)
66	Chevy,				
67	Chevy, Camaro	3910720	1	4.05	( $\frac{7}{16}$ "— 20 ext.— $\frac{7}{16}$ "— 24 int.— 12 O.L.)
67-68	Pass.	3934010	1	13.00	( $\frac{7}{16}$ "— 20 ext.— $\frac{7}{16}$ "— 24 int.— $14\frac{1}{16}$ " O.L.)
68	Chevy, Camaro	3930039	1	13.20	( $\frac{7}{16}$ "— 20 ext.— $\frac{7}{16}$ "— 24 int.— $12\frac{3}{4}$ " O.L.)
68	Chevelle	9750028	1	4.70	( $\frac{7}{16}$ "— 20 ext.— $\frac{1}{16}$ "— 24 int.— $13\frac{1}{16}$ " O.L.)
69	Camaro		1		( $13\frac{7}{8}$ " O.L.)
69-72	Chevy, Chevelle,				
73	Nova	9753903	1	15.10	(14" O.L.)
69-70	Pass.	3953545	1	11.00	( $\frac{7}{16}$ "— 20 ext.— $\frac{7}{16}$ "— 24 int.— $12\frac{15}{16}$ " O.L.)
69-73	Camaro	9755607	2	16.10	( $13\frac{7}{8}$ " O.L.)
71-73	Pass. (Sta. Wag.)	9750327	1	15.70	( $14\frac{1}{8}$ " O.L.)
71-73	Pass. (exc. Sta. Wag.),				
73	Chevelle	1239721	1	12.05	( $11\frac{1}{4}$ " O.L.)
71-74	Vega (140)	3996333	1	6.80	
74	Chevelle,				
74	Pass. (exc. Sta. Wag.)	1244629	1	8.60	
74	Nova, Camaro,				
74	Pass. (Sta. Wag.)	9756227	1	15.65	
75	Vega (122), Monza,				
75	Nova, Camaro,				
75	Pass. (Sta. Wag.)	9758884	1	8.50	
75	Chevelle,				
75	Pass. (exc. Sta. Wag.)	9757655	1	18.15	
75	Nova	1244627	1	11.70	
75	Vega (140)	9757851	1	7.65	
74-75	Vega, Monza	3817880	1	.12	RETAINER, push rod

### 4.681 BRACKET— CLIP— SPRING, Brake Hose or Pipe

67-68	Camaro (exc. Disc Brakes),				
68	Chevy (exc. Disc Brakes),				
69	Chevy, Camaro (exc. disc brakes),				
70-74	Nova (exc. Disc Brakes)	3953283	L.H.	.54	front, left (steel)
67-69	Camaro (exc. Disc Brakes),				
68-74	Nova (exc. Disc Brakes)	3953284	R.H.	.24	front, right (steel)
68	Chevelle	1383567	2	.23	front to frame
68-69	Camaro w/Disc Brakes-Front and Rear,				
69	Camaro w/Spl. Strg., Hyd. Strg.	3947283	L.H.	4.00	front, connector, left
68-69	Camaro w/Disc Brakes-Front and Rear,				
69	Camaro w/Spl. Strg., Hyd. Strg.	3947284	R.H.	4.00	front, connector, right
69	Chevy, Camaro (exc. S.S., 4-Spd., 302),				
69	Chevy, Camaro (S.S.) w/P.G., T.H. 350,				
70	Nova w/A.T. (350),				
70	Nova (exc. 350, 396),				
71	Nova (exc. 350 w/4BC),				
72-75	Nova	3954381	1	1.90	rear brake hose axle
69	Chevy, Camaro (S.S.) (exc. P.G., T.H. 350),				
69	Chevy, Camaro (302),				
69	Camaro (Disc Brakes-Front and Rear w/reg. fuel) (350),				
70	Nova (350, 396) (exc. A.T.),				
71	Nova w/4BC (350)	3954382	1	1.90	rear brake hose axle
69	Chevelle	3956787	1	.29	rear connector (10 bolt cover)
69-72	Chevelle w/12 bolt cover	3956788	1	.73	rear connector (12 bolt cover) (steel)
69	Chevy, Camaro,				



## BRAKES

### 4.681 BRACKET— CLIP— SPRING, Brake Hose or Pipe (Con't)

70-72	Nova	6264048	1	.52	rear
69	Chevy, Camaro w/Front Disc Brakes,				
70-71	Nova w/Disc Brakes	3958439	L.H.	1.05	front, left
69	Chevy, Camaro w/Front Disc Brakes,				
70-74	Nova w/Disc Brakes	6264046	R.H.	.29	front, right
69-72	Chevlelle (w/Disc Brakes)	1239710	R.H.	.18	front, frame, right
69-72	Chevlelle (w/Disc Brakes)	1239711	L.H.	.18	front, frame, left
69-72	Chevlelle (exc. Disc Brakes)	6270975	L.H.	1.90	front connector, left
69-71	Chevlelle (exc. Disc Brakes)	6270976	R.H.	1.90	front connector, right
69	Chevy, Camaro (exc. Disc Brakes),				
70-74	Nova (exc. Disc Brakes)	3958443	1	.29	front brake pipe (steel)
70	Monte Carlo w/10 bolt cut out cover	1385868	1	.59	rear hose (Note 1)
<i>NOTE 1 See illustration proceeding Grp. 5.398 for identification of axle cover.</i>					
70-74	Camaro	6264041	L.H.	.36	left, front
70-71	Camaro	6264042	R.H.	.52	right, front (repl. 3975500)
70-73	Camaro	6264043	1	.67	rear
71-73	Pass. (Sta. Wag.)	1237552	1	.36	rear brake hose axle
71-73	Pass. (Sta. Wag.)	1239707	1	.52	rear brake hose frame
71-75	Vega, Monza	3978167	1	.34	rear brake hose, body
71-74	Vega	342650	1	1.40	rear brake hose axle
72	Chevlelle (exc. Disc Brakes)	6270976	R.H.	1.90	right front brake hose conn.
72	Nova w/Disc Brakes	6264027	L.H.	1.05	left front brake hose
72-73	Camaro	6264042	R.H.	.52	right front hose
72	Chevlelle (exc. Disc Brks.)	1239715	L.H.	.18	front frame, left
72	Chevlelle (exc. Disc Brks.)	1239714	R.H.	.18	front frame, right
71-73	Pass.,				
73	Monte Carlo	6270701	L.H.	.32	left front brk. hose frame
72-73	Pass.,				
73	Monte Carlo	6270702	R.H.	.32	right front brk. hose frame
73-75	Chevlelle (exc. Monte Carlo)	6271683	L.H.	.18	left front brake hose
73-75	Chevlelle (exc. Monte Carlo)	6271684	R.H.	.18	right front brake hose
73-74	Nova w/Disc Brakes	332619	L.H.	1.05	left front brake hose
73	Nova	330231	1	.23	rear brake hose
74	Vega	3996324	2	.25	front brake pipe
74-75	Pass., Monte Carlo	338737	L.H.	.32	front brake hose, left
74-75	Pass., Monte Carlo	338738	R.H.	.32	front brake hose, right
74-75	Nova, Camaro	340317	1	.29	rear brake hose
74-75	Camaro	340321	L.H.	.38	front brake hose, left
74-75	Camaro	340322	R.H.	.23	front brake hose, right
74-75	Pass. (Sta. Wag.)	1244614	1	.23	rear brake hose frame
74-75	Pass. (Sta. Wag.)	1244615	1	.40	rear brake hose axle
75	Nova	352853	L.H.	.40	left, front hose (steel)
75	Nova	352854	R.H.	.40	right, front hose (steel)
75	Monza, Vega (122)	349522	1	.64	rear brake hose
75	Vega, Monza	360302	2	.25	front brake pipe
75	Vega (140)	356352	1	.64	rear brake hose
75	Monza, Vega (122)	6264044	1	.19	CLIP, rear brake hose
73-75	All (exc. Vega, Monza)	334961	A.R.	.19	SPRING, front and rear brake hose yoke

### 4.683 FLUID— DECLINE, Hydraulic Brake

62-75	All (Heavy Duty)	5464832	A.R.	QT/8.95	supreme No. 11 (1 quart)
62-75	All (Heavy Duty)	5464833	A.R.	GA/32.50	supreme No. 11 (1 gallon)
62-75	All (Heavy Duty)	5464834	A.R.	154.90	supreme No. 11 (5 gallons)

### 4.685 PIPE— CLIP— GROMMET— SHIELD, Hydraulic Brake

67-69	Pass. w/Disc Brake,				
67	Chevy w/Disc Brakes (exc. P.B.),				
67-68	Chevy, Chevlelle, Camaro w/Disc Brakes,				
69	Chevlelle w/Disc Brakes	1384694	1	1.20	brk. main cyl. to metering valve
67	Chevy, Camaro,				
68-69	Chevy, Camaro w/P.B.,				
70	Nova w/P.B.	3909903	1	1.20	rear to pressure switch
67-68	Camaro w/Disc Brakes,				
67-68	Camaro w/Disc Brakes,				
68	Chevy w/Disc Brakes	3696822	1	RL/.17	metering valve to brk. pipe distributor and switch
68	Chevlelle (exc. Disc Brakes)	1385344	R.H.	1.20	front brk. hose to brk., right
68	Chevlelle (exc. Disc Brakes)	1385345	L.H.	1.30	front brk. hose to brk., left
68	Chevlelle w/Disc Brakes	1384694	1	1.20	main cyl. to metering valve
69-72	Chevlelle (exc. Disc Brakes)	3952755	L.H.	1.30	front brake hose to brake, left

## BRAKES

### 4.685 PIPE— CLIP— GROMMET— SHIELD, Hydraulic Brake (Con't)

69-72	Chevelle (exc. Disc Brakes) . . . .	3952756 R.H.	1.30	front brake hose to brake, right . . . . .
69	Chevy, Camaro w/P.B.,			
70	Nova w/P.B.,			
71-72	Nova,			
73-74	Nova w/P.B. (exc. Disc Brakes) . .	3958441 1	1.30	main cyl. to dist. and switch front . . . . .
69	Camaro w/Disc Brakes-Front and Rear . . . . .	3947037 L.H.	8.15	front brake caliper, left . . . . .
69	Camaro w/Disc Brakes-Front and Rear . . . . .	3947038 R.H.	8.15	front brake caliper, right . . . . .
70	Camaro,			
70	Nova w/Disc Brakes . . . . .	3980974 1	1.20	cyl. to dist. switch, rear . . . . .
70	Camaro,			
70	Nova w/Disc Brakes . . . . .	3980977 1	1.25	rear brake pressure reg. valve, inlet . . . . .
70	Camaro,			
70	Nova w/Disc Brakes . . . . .	3980980 1	1.10	rear brake pressure reg. valve, outlet . . . . .
71-73	Camaro (exc. P.B.) . . . . .	3992543 1	1.10	brake comb. valve front . . . . .
71	Nova, Camaro w/Disc Brakes,			
72-74	Nova . . . . .	6264028 1	1.45	rear brake extension . . . . .
75	Pass. (exc. 454) . . . . .	1235482 1	1.45	front, brake man. cyl. to dist. and switch . . .
75	Nova w/P.B. . . . .	352852 1	1.30	rear, brake main cyl. to dist. and switch . . .
69-71	Chevelle,			
72	Chevelle (Sta. Wag.) . . . . .	1231003 1	.16	CLIP, rear brake front pipe, fuel feed pipe— (3.162) . . . . .
72	Nova . . . . .	3993970 4	.09	CLIP, rear brake front pipe— (3.003) . . . . .
70-75	Camaro,			
75	Nova . . . . .	3983038 1	.15	GROMMET, front brake pipe . . . . .
71-75	Vega, Monza . . . . .	3982095 2	.32	GROMMET, front brake pipe . . . . .
74-75	Pass.,			
74-75	Chevelle w/P.B. (exc. 454) . . . . .	342432 1	.27	GROMMET, pwr. brake cyl. pipe . . . . .
62-69	All . . . . .	3886933 A.R.	3.10	SHIELD (1/4" O.D.) pipe . . . . .
62-69	All . . . . .	3792505 A.R.	3.75	SHIELD (5/16" O.D.) pipe— (3.163) (Note 1) . .
	<i>NOTE 1 Cut to required length when necessary.</i>			
64-68	Chevelle w/Air Lift,			
65-69	El Camino,			
70-72	Monte Carlo w/level control,			
70-71	El Camino (exc. 396),			
72	El Camino . . . . .	3952715 L.H.	.82	SHIELD, rear pipe, left . . . . .
64-68	Chevelle w/Air Lift,			
65-69	El Camino,			
70-72	Monte Carlo w/level control,			
70-71	El Camino (exc. 396),			
72	El Camino . . . . .	3859408 R.H.	.76	SHIELD, rear pipe, right . . . . .

**BRAKES**

**4.686 CONNECTOR— BRACKET— CLIP— INSERT— NUT— SWITCH ASSY.— TEE, Hydraulic Brake**

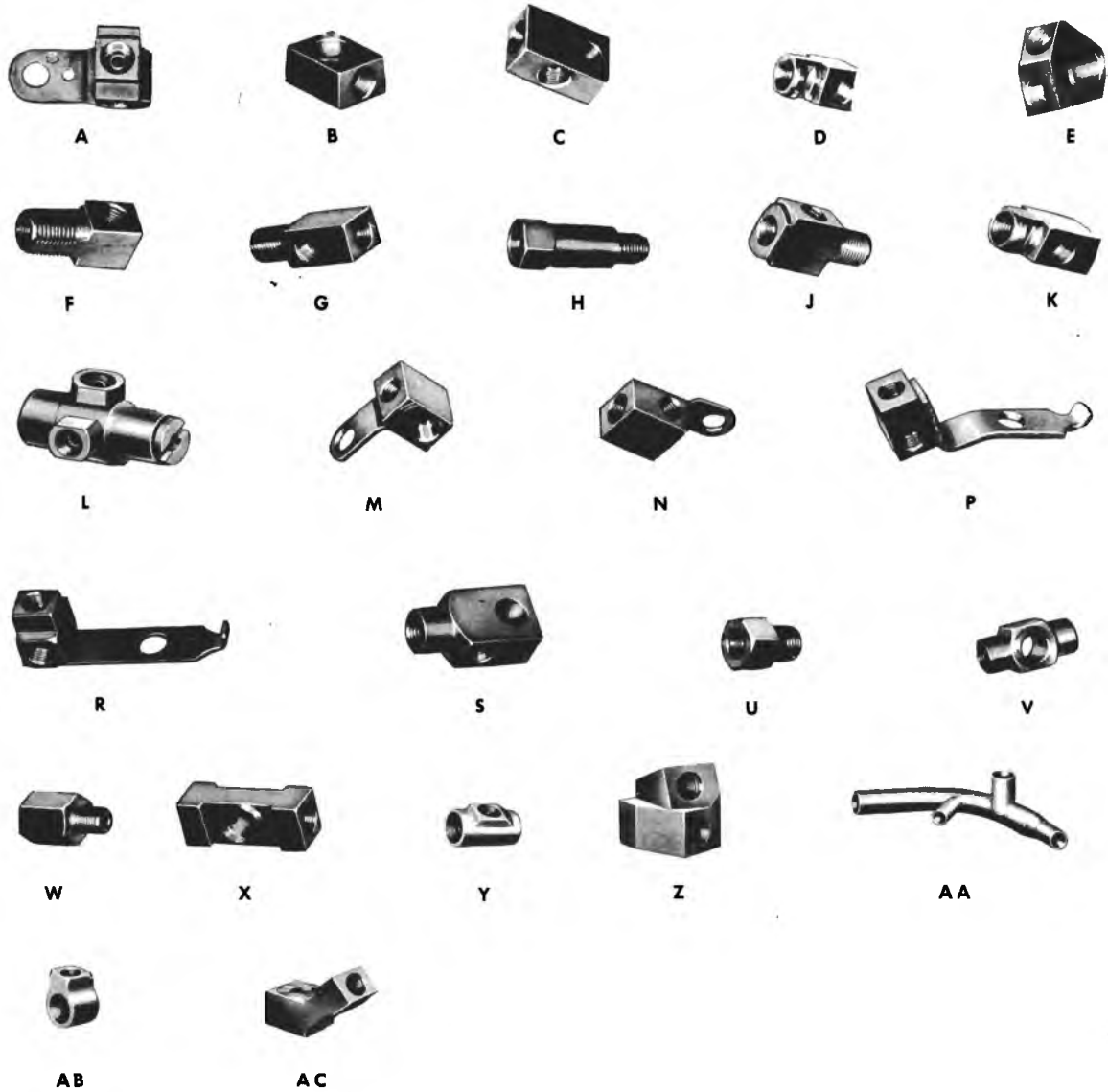

62-66	Chevy,				
65-67	Pass. ....				rear brake hose to axle (Type "D"), .....
67	Camaro .....	<b>3696552</b>	1	.84	rear brake hose to axle (Type "O") .....
66	Chevy .....	<b>3877784</b>	1	.96	front, right, pipe tee .....
65	Pass. ....	<b>3826348</b>	1	.98	<b>CONNECTOR ASSY.</b> , front pipe tee (Type "R") .....
66-68	Chevy,				
69-72	Chevelle (exc. P.B.),				
70	Nova, Camaro w/Disc Brakes ..	<b>3952751</b>	1	.29	<b>BRACKET</b> , brake main cyl. to dist. and switch pipe .....
67-69	Chevy, Camaro (exc. P.G.),				
70	Nova (exc. disc brakes) .....	<b>3909933</b>	1	.40	<b>BRACKET</b> , pipe distributor and switch— (4.874) .....
66-68	Chevy,				
67-68	Camaro .....	<b>3825340</b>	A.R.	.11	<b>CLIP</b> , rear brk. pipe, rear brk. front pipe (repl. 3881339)— (3.162) .....

**BRAKES**

**4.686 CONNECTOR— BRACKET— CLIP— INSERT— NUT— SWITCH ASSY.— TEE, Hydraulic Brake (Con't)**

68	Chevelle,				
68	Pass. (307) (exc. Dual Exhaust)	3927977	A.R.	.26	CLIP, front brake pipe (strap type)
68-69	Chevelle w/P.B.	401429	1	.16	CLIP, main cyl. to dist. and switch, frt. and rear pipe
69	Chevy, Chevelle,				
70	All,				
71-72	Nova, Chevelle, Camaro,				
73-75	Camaro, Nova	342653	1	.18	CLIP, rear brake rear pipe
69-72	Chevelle	1231003	1	.16	CLIP, rear brake front pipe ret.— (3.162)
69-72	All (exc. Vega)	343464	A.R.	.11	CLIP, front brake pipe (dk. green) ( <sup>9</sup> / <sub>16</sub> " x <sup>3</sup> / <sub>4</sub> ") (repl. 3952718)— (3.162)
All	All	1380949	A.R.	.12	CLIP, rear brake pipe ( <sup>3</sup> / <sub>16</sub> " to <sup>3</sup> / <sub>8</sub> " dia. pipe)— (3.162)
70-75	Camaro	3975504	1	.12	CLIP, rear brake hose
70-75	Camaro,				
75	Nova	3982380	L.H.	.12	CLIP, front brake pipe, left
71-72	Pass. (Sta. Wag.)	342676	1	.16	CLIP, rear brake front pipe (repl. 478728)
71-75	Pass. (exc. Sta. Wag.),				
73-75	Chevelle	1235476	1	.11	CLIP, rear brake front pipe
71-75	Pass.	478600	1	.11	CLIP, vac. pwr. brake main cyl. clip to brk. comb. valve
71-74	Vega (140)	343448	2	.28	CLIP, front brake pipe (repl. 3996329)
71-75	Vega, Monza	342653	1	.18	CLIP, rear brake rear pipe
73-75	Pass. (Sta. Wag.)	340814	A.R.	.11	CLIP, rear brake front pipe
75	Chevelle (exc. Monte Carlo)	348071	R.H.	.11	CLIP, right, front brake pipe
75	Vega, Monza	343448	A.R.	.28	CLIP, front brake pipe
75	Monza	348292	1	.18	CLIP, rear brake rear pipe
75	Monza (Notchback)	362256	1	.18	CLIP, fuel feed inter. pipe
67-69	Chevelle,				
67-69	Chevy, Camaro w/Disc Brakes, Spl. Steering,				
70-72	Chevelle (exc. Disc Brakes)	5453786	2	.43	INSERT, front and rear hose connector hole— (4.671)
62-69	All	9424954	A.R.	.22	NUT ( <sup>5</sup> / <sub>16</sub> " x 1 <sup>1</sup> / <sub>2</sub> "— 20)— (8.963)
62-69	All	9424955	A.R.	.18	NUT ( <sup>1</sup> / <sub>4</sub> " x <sup>9</sup> / <sub>16</sub> "— 18)— (8.963)
67-69	Camaro, Chevy	3904270	1	13.05	SWITCH ASSY., w/distributor— (4.874)
67	Chevy	3904303	1	13.70	SWITCH ASSY., w/distributor— (4.874)
67	Chevelle	3921043	1	11.50	SWITCH ASSY., w/distributor ( <sup>19</sup> / <sub>32</sub> " oval hole in bracket— (4.874)
67-68	Pass.	3906933	1	11.45	SWITCH ASSY., w/dist., brk. pipe (Bendix 2226720)— (4.874)
68-69	Chevelle	3934089	1	10.95	SWITCH ASSY., w/distributor— (4.874)
69	Pass.	3953514	1	10.55	SWITCH ASSY., w/dist. brk. pipe— (4.874)
70	Pass.	3980761	1	11.60	SWITCH, w/dist., brake pipe— (4.874)
70	Nova	3980762	1	11.70	SWITCH, w/dist., brake pipe— (4.874)
64-68	Chevelle,				
67	Chevy				TEE, rear brake hose to axle conn.,
67-68	Camaro,				
67-68	Pass.,				
68	Chevy	1364657	1	.64	rear brake hose connector

**4.690 VALVE ASSY.— BRACKET— SPACER— SWITCH ASSY., Rear Brake Pressure Regulator**

67-69	All w/Disc Brakes	3905525	1	18.40	metering
70	All w/Disc Brakes	1233464	1	19.30	front metering
70	Nova w/Disc Brakes,				
70	Camaro	3980978	1	16.10	rear brake pressure reg.
70	Chevelle w/Disc Brakes	3987805	1	15.95	rear brake press. reg. (stamped S) (Note 1)
<i>NOTE 1: Part number 3987805 is 400 P.S.I.</i>					
67-68	All w/Disc Brakes,				
70	Nova, Chevelle, Camaro w/disc brakes	3912539	1	1.90	BRACKET, front brake pressure regulator valve
71-72	Camaro (exc. P.B.)				BRACKET, brake comb. valve,
73-75	Camaro,				
75	Nova (exc. vac. power brakes)	3989486	1	1.25	brake pipe dist. and switch
71-75	Nova w/Disc Brakes,				
71-75	Camaro w/P.B.	3992571	1	1.35	BRACKET, brake comb. valve
73-74	Nova (exc. Disc Brakes)	3909933	1	.40	BRACKET, brake pipe dist. and switch
75	Nova w/P.B.	352857	1	1.35	BRACKET, brake pipe dist. and switch
71-75	Camaro (exc. P.B.)	3989487	1	.19	SPACER, brake comb. valve bracket
71-72	Chevelle w/Disc Brakes (exc. Sta. Wag.)	5472141	1		SWITCH ASSY., w/dist., brake pipe
71-72	Pass. w/Disc Brakes,				

**BRAKES**

**4.690 VALVE ASSY.— BRACKET— SPACER— SWITCH ASSY., Rear Brake Pressure Regulator (Con't)**

71-75	Chevelle (Sta. Wag.) w/Disc Brakes,				
73-75	Pass. (exc. H.D. Brakes)	5472140	1	25.80	SWITCH ASSY., w/dist. brake pipe
71-73	Nova w/Disc Brakes	2620845	1	26.30	SWITCH ASSY., w/dist. brake pipe
71-72	Camaro,				
73-75	Pass. w/H.D. Brakes (exc. Sta. Wag.),				
73	Camaro,				
74-75	Camaro w/P.B.,				
74-75	Nova w/Disc Brakes	5472359	1	28.90	SWITCH ASSY., w/dist. brake pipe
72	Pass. w/H.D. Brakes (exc. Sta. Wag.),				
73	Chevelle (exc. Sta. Wag.),				
74-75	Chevelle w/P.B. (exc. Sta. Wag.)	2620851	1	26.30	SWITCH ASSY., w/dist. brake pipe
72-75	Pass. (Sta. Wag.) w/H.D. Brakes,				
74-75	Camaro (exc. P.B.)	2620849	1	26.30	SWITCH ASSY., w/dist. brake pipe
73-75	Pass. (exc. Sta. Wag., H.D. Brakes)	2620635	1	23.45	SWITCH ASSY., w/dist. brake pipe
75	Pass. (exc. Sta. Wag., H.D. Brakes)	1241933	1	27.50	SWITCH ASSY., w/dist. brake pipe
73-74	Nova (exc. Disc Brakes)	3980762	1	11.70	SWITCH ASSY., w/dist. brake pipe
74-75	Chevelle (exc. P.B., Sta. Wag.)	5470860	1	23.45	SWITCH ASSY., w/dist. brake pipe

**4.760 SPRING— EXTENSION, Brake Pull Back**

62-67	Chevy	3790286	1	.32	parking
62-67	Chevy (exc. P.B.),				
65-66	Pass. (exc. P.B.)	3854322	1	.24	pedal return
64-72	Chevelle, Camaro,				
68-72	Chevy,				
71-75	Vega, Monza,				
73-75	Nova, Camaro (exc. P.B.)	3850084	1	.32	parking— (4.639)
67	Chevy (exc. P.B.),				
67-70	Pass.	3921686	1	.23	pedal return
64-70	Chevelle,				
67-75	Camaro	3996374	1	.55	cable return
68-72	Chevy,				
70-72	Chevelle,				
73-74	Nova (exc. P.B.)	3841645	1	.12	EXTENSION, pedal pull back spring
71	Camaro,				
71-75	Vega, Monza,				
73-75	Nova, Camaro (exc. P.B.)	3991374	1	.21	EXTENSION, pedal pull back spring

**4.765 CLIP— CONNECTOR— EQUALIZER— NUT ASSY.— WASHER, Parking Brake**

62-69	All	3749084 A.R.		.27	idler lever rod & actuator lever rod— (4.037)
70	Pass., Chevelle,				
73-75	Chevelle				CONNECTOR, cable,
71-75	Pass.				intermediate,
70	Nova, Camaro,				
71-72	Nova, Chevelle, Camaro,				
	Nova, Camaro	537485	2	.11	rear cable
62-69	Chevy	3794010	1	.71	EQUALIZER, rear cable
65-66	Pass.,				
70-75	Camaro				EQUALIZER, rear cable,
67-69	Pass.,				
70-72	Pass., Nova, Chevelle,				
73-75	Chevelle, Nova				inter.,
73-75	Pass.	1497525	1	.66	front
71-72	Nova, Chevelle,				
71-75	Vega, Monza	3986799	1	.44	EQUALIZER, parking brake rear cable
71-74	Vega	9422296	1	.06	NUT ASSY., parking brake rear cable equalizer
62-69	All	382105 A.R.		.12	WASHER, park brake lever (2 <sup>5</sup> / <sub>64</sub> " I.D. x 3/4" O.D.)— (4.037)

**4.779 CABLE, Parking Brake**

**FRONT**

62-66	Chevy	3790295	1	6.55	(88 <sup>3</sup> / <sub>4</sub> " O.L.)
64-66	Chevelle,				
67	Chevelle (exc. T.H.)	3904278	1	5.20	(44 <sup>1</sup> / <sub>2</sub> " O.L.)
65-66	Pass. (exc. T.H.)	3870459	1	4.75	(46 <sup>13</sup> / <sub>16</sub> " O.L.)

## BRAKES

### 4.779 CABLE, Parking Brake (Con't)

65-66	Pass. w/T.H.	3869826	1	5.15	(53 <sup>11</sup> / <sub>32</sub> " O.L.)
67	Chevy	3790295	1	6.55	(88 <sup>3</sup> / <sub>4</sub> " O.L.)
67	Pass. (exc. T.H.),				
68-70	Pass. (exc. T.H. 400 4-Spd.)	3900581	1	4.75	(45 <sup>5</sup> / <sub>8</sub> " O.L.)
67-70	Pass. w/T.H. 400,				
68-69	Pass. w/4-Spd.	3900583	1	4.75	(52 <sup>5</sup> / <sub>32</sub> " O.L.)
67-69	Camaro,				
68-74	Nova	338250	1	6.30	(57 <sup>1</sup> / <sub>2</sub> " O.L.)
68-72	Chevelle w/T.H. 400	3983308	1	5.05	(51 <sup>1</sup> / <sub>2</sub> " O.L.)
68-72	Chevelle (exc. T.H. 400)	3987896	1	5.50	(47 <sup>5</sup> / <sub>32</sub> " O.L.)
70-72	Camaro	3975649	1	5.90	(55 <sup>1</sup> / <sub>2</sub> " O.L.)
71-72	Pass. w/T.H. 400	6259781	1	5.15	(53 <sup>3</sup> / <sub>4</sub> " O.L.) (repl. 3991161)
71-72	Pass. (exc. T.H. 400)	6259780	1	6.15	(48 <sup>5</sup> / <sub>8</sub> " O.L.)
73-74	Camaro	3975649	1	5.90	(55 <sup>1</sup> / <sub>2</sub> " O.L.)
73	Pass. w/T.H. 400	1241400	1	5.20	
73-74	Chevelle w/T.H. 400	6259777	1	6.15	
73-74	Chevelle (exc. T.H. 400)	6259776	1	6.20	
75	Camaro	344682	1	6.80	
73-74	Pass. (exc. T.H. 400)	6259778	1	5.20	
74	Pass. w/T.H. 400	6259779	1	5.20	
75	Pass. w/T.H. 400	1250625	1	4.80	
75	Chevelle	1247969	1	4.95	
75	Vega, Monza	356371	1	4.50	
75	Nova	357320	1	6.55	

### INTERMEDIATE

64-67	Chevelle (exc. T.H.)	1383493	1	2.25	(100" O.L.) (Note 2)
<i>NOTE 2 When replacing 1st design cable (103" O.L.) also use 2nd design guide 3854126.</i>					
65-66	Pass. (exc. T.H.)	3870460	1	3.55	(109" O.L.)
65-66	Pass. w/T.H.	3869827	1	3.30	(96 <sup>11</sup> / <sub>32</sub> " O.L.)
67	Camaro (1st design) (exc. 396)	1374758	1	5.95	(82 <sup>1</sup> / <sub>2</sub> " O.L.) (repl. 3892743)
67	Chevelle w/T.H.	3908746	1	2.15	(92 <sup>17</sup> / <sub>32</sub> " O.L.)
67-70	Pass. (exc. T.H. 400),				
68-69	Pass. (exc. 4-Spd.)	3902210	1	4.55	(110" O.L.)
67-70	Pass. w/T.H. 400,				
68-69	Pass. w/4-Spd.	3918718	1	4.55	(97 <sup>19</sup> / <sub>32</sub> " O.L.)
67-69	Camaro (2nd design)	3914813	1	2.25	(79" O.L.)
68-74	Nova	3923531	1	3.20	(83 <sup>27</sup> / <sub>32</sub> " O.L.)
68-69	Chevelle (4-Dr., El Camino) (exc. S.S.),				
68-69	S.S. (El Camino) (exc. T.H.),				
70	Chevelle (4-Dr., El Camino) w/3-4-Spd.,				
71-72	El Camino (exc. T.H. 400),				
71-72	Chevelle (4-Dr.) (exc. Spt. Sed., T.H. 400)	3983328	1	3.45	(97 <sup>1</sup> / <sub>4</sub> " O.L.) (repl. 3934838)
68-69	Chevelle w/H.D. 3-Spd., 4-Spd.,				
70-72	Chevelle (Spt. Cpe. Conv.) (exc. T.H. 400)	3934839	1	3.30	(89 <sup>1</sup> / <sub>2</sub> " O.L.) (stmp. PC)
68-69	El Camino (S.S.) w/T.H. 400,				
70	Chevelle w/T.H. 400,				
71-72	Chevelle (4-Dr.) w/T.H. 400 (exc. Spt. Sed.),				
71-72	El Camino w/T.H. 400	3925053	1	3.25	(87" O.L.)
68-69	Chevelle (S.S.) w/T.H. 400 (exc. El Camino),				
70	Malibu, Monte Carlo w/T.H. 400,				
71-72	Chevelle (Spt. Cpe. Conv.) w/T.H. 400	3925055	1	3.25	(79 <sup>1</sup> / <sub>4</sub> " O.L.)
70-72	Chevelle (Spt. Sed.) (exc. T.H. 400)	3983328		3.45	(96 <sup>1</sup> / <sub>4</sub> " O.L.)
70-72	Chevelle (Spt. Sed.) w/T.H. 400 (8 cyl.)	3983330		3.40	(86" O.L.)
71	Pass. (Sta. Wag.) w/T.H. 400 (1st design),				
71-72	Pass. w/T.H. 400 (exc. Sta. Wag.),				
73-74	Chevelle (Spt. Cpe.) (exc. T.H. 400)	3992383	1	3.25	(106 <sup>5</sup> / <sub>8</sub> " O.L.)
71-72	Pass. (Sta. Wag.) w/T.H. 400 (2nd design)	1238515	1	3.25	(104 <sup>5</sup> / <sub>8</sub> " O.L.)
71-72	Pass. (8 cyl.) (exc. Sta. Wag., T.H. 400),				

## BRAKES

### 4.779 CABLE, Parking Brake (Con't)

71-72	Pass. (Sta. Wag.) (1st design) (exc. T.H. 400),				
71	Pass. (6 cyl.) (1st design),				
71	Pass. (Sta. Wag.) (2nd design) (exc. T.H. 400),				
72	Pass. w/T.H. 350,				
73-74	Pass. (exc. T.H. 400) .....	1235466	1	3.35	(119" O.L.) (coded TB) .....
71-72	Pass. (6 cyl.) (2nd design) .....	3993709	1	2.85	(110 <sup>1</sup> / <sub>2</sub> " O.L.) (rubber coated) .....
73-74	Pass. w/T.H. 400 .....	350052	1	5.70	
73-74	Chevelle (Spt. Cpe.) w/T.H. 400 ..	1238689	1	5.30	
73-74	Pass., Chevelle w/T.H. 400 (exc. Spt. Cpe.) .....	3992383	1	3.25	
73-75	Pass., Chevelle (exc. T.H. 400 Spt. Cpe.) .....	1240298	1	3.05	
75	Chevelle w/T.H. 400 (exc. Spt. Cpe.) .....	1238515	1	3.25	
75	Chevelle (Spt. Cpe.) .....	1240297	1	2.75	
75	Chevelle (Sta. Wag.) .....	1361843	1	2.95	
75	Pass. w/T.H. 400 .....	350052	1	5.70	
75	Nova .....	352806	1	3.20	(approx. 67") .....

### REAR

62-63	Chevy .....	3790280	1	12.20	(103 <sup>9</sup> / <sub>16</sub> " O.L.) .....
64	Chevelle,				
65	Chevelle (exc. 396),				
66-67	Chevelle (exc. Metallic Brakes) ..	3847994	1	5.80	(34" O.L.) .....
64-67	Chevy .....	3849054	1	11.55	(103 <sup>3</sup> / <sub>32</sub> " O.L.) .....
65-70	Pass. (exc. Metallic Brakes) .....	3888735	2	5.35	(38 <sup>3</sup> / <sub>4</sub> " O.L.) .....
67	Camaro (1st design) .....	3892742	1	4.50	
67	Camaro w/Metallic Brakes, H.D. Brake (302) (2nd design),				
68	Camaro (Spt. Cpe.) w/H.D. Brakes (8 cyl.) .....	3934646	2	6.90	(32 <sup>1</sup> / <sub>8</sub> " O.L.) .....
68-72	Chevelle .....	1382429	2	8.65	(36 <sup>23</sup> / <sub>32</sub> " O.L.) .....
68-69	Chevy, Camaro (exc. Disc Brakes-Front and Rear),				
70-75	Nova .....	3988527	2	4.50	(32 <sup>1</sup> / <sub>8</sub> " O.L.) .....
68-69	Camaro w/Disc Brakes - Front and Rear .....	3953379	L.H.	6.40	(44 <sup>1</sup> / <sub>2</sub> " O.L.), left .....
68-69	Camaro w/Disc Brakes - Front and Rear .....	3953380	R.H.	5.05	(36" O.L.), right .....
70	Monte Carlo w/10 bolt cut out cover .....	387621	2	5.60	(35 <sup>5</sup> / <sub>8</sub> " O.L.) (Note 1) .....
	<i>NOTE 1 See illus. preceeding Grp. 5.398 for ident. of axle cover.</i>				
70-74	Camaro .....	3992584	2	5.00	(66 <sup>13</sup> / <sub>16</sub> " O.L.) .....
71-74	Vega .....	3978150	1	4.50	CABLE, rr. ....
71	Pass. (exc. Sta. Wag.),				
72	Pass. w/2.73, 3.08 ratio (exc. Sta. Wg.) .....	1236712	2	5.50	(36 <sup>5</sup> / <sub>16</sub> " O.L.) (type G, K, B, O) .....
72	Police w/3.08 ratio (exc. Sta. Wag., P/Trac.),				
75	Pass. (exc. Sta. Wag.) .....	1235886	2	5.50	(36 <sup>41</sup> / <sub>64</sub> " O.L.) (type P) .....
71	Pass. (Sta. Wag.),				
72	Pass. (Sta. Wag.) w/2.73, 3.08, 3.42 ratio,				
72	Police (3.08 ratio w/P/Trac.) (exc. Sta. Wag.),				
75	Pass. (Sta. Wag.) .....	1236868	2	5.50	(type P) .....
73-75	Pass., Chevelle .....	1238232	2	9.70	
75	Camaro .....	356548	2	5.50	
75	Vega, Monza .....	356371	1	4.50	

### 4.785 RETAINER— BRACKET— CLIP— CONNECTOR— GUIDE— SUPPORT, Parking Brake Cable

All	All .....	516213	A.R.	.05	front and rear .....
71-75	Pass. ....	1385078	1	.36	front cable return spring .....
71-72	Pass.,				
73-75	Chevelle .....	3992379	1	.11	rel. cable and handle .....
72	Pass., Nova, Chevelle .....				front and rear, .....
72	Camaro .....	516213	1	.05	rear (repl. 3875092) .....
73-75	Pass., Chevelle .....	1385078	1	.36	front cable return spring .....
67-69	Camaro,				
68-74	Nova .....	3893123	1	.24	BRACKET, front .....
67-69	Camaro (exc. 350, 396, 4-Spd.),				

**BRAKES**

**4.785 RETAINER— BRACKET— CLIP— CONNECTOR— GUIDE— SUPPORT, Parking Brake Cable (Con't)**

68-69	Chevy (327) (exc. Sp. H/Per., 4-Spd.),				
70-72	Nova (exc. 350, 396),				
73-75	Nova (exc. Special Susp.)	3895206	R.H.	.16	BRACKET, rear, park brake cable, right
67-68	Camaro (exc. 350, 396, 4-Spd.),				
68-69	Chevy (327) (exc. Sp. H/Per., 4-Spd.)	3895205	L.H.	.16	BRACKET, rear, park brake cable, left
68-69	Chevy, Camaro,				
73	Nova				BRACKET, rear, left,
68-69	Chevy, Camaro (302, 327 Sp. H/Per., 350, 396),				
68-69	Chevy, Camaro w/4-Spd. (327) (exc. Sp. H/Per.),				
69	Chevy, Camaro (350 w/reg. fuel),				
69	Camaro w/Disc Brake-Front and Rear (350 w/reg. fuel),				
70-72	Nova (350, 396),				
73	Nova w/Special Susp.)	3923533	1	.36	rear, right
70-75	Camaro	3983021	L.H.	.22	BRACKET, cable rear, left
70-75	Camaro	3983022	R.H.	.22	BRACKET, cable rear, right
74-75	Nova	340323	L.H.	.36	BRACKET, rear cable, left
71-72	Nova, Chevelle, Camaro,				
73-75	Nova, Camaro	3992592	1	.12	CLIP, front
72	Nova, Chevelle, Camaro	537485	2	.11	CONNECTOR, rear cable
64-66	Chevelle,				
65-66	Pass.	3854126	1	.22	GUIDE, intermediate cable, frt. (7" O.L.)
64-70	Chevelle,				
71-72	Chevelle (exc. Spt. Sed.)	1243146	2	.85	GUIDE, inter., rear
67	Chevelle	3900584	1	.29	GUIDE, intermediate cable, front
67-69	Camaro,				
68-72	Chevelle	3925047	1	.32	GUIDE, intermediate front
68-74	Nova	3892744	1	.57	GUIDE, intermediate cable
68-69	Camaro w/Disc Brake-Front and Rear	3947295	2	2.00	GUIDE, rear cable
67	Pass.,				
68-69	Pass. (exc. 4-Spd.),				
70	Pass.	3900580	1	.24	GUIDE, intermediate cable, front
68-69	Pass. w/4-Spd.	3941819	1	.32	GUIDE, intermediate front
70-74	Camaro	3975648	1	.36	GUIDE, cable rear
71-75	Pass. (Sta. Wag.)	1236870	2	.16	GUIDE, rear
71-72	Pass.	1236215	2	.22	GUIDE, inter. (3/16" dia. x 2 1/4" O.L.)
71-72	Pass.,				
73-74	Chevelle w/T.H. 400	3991163	1	.24	GUIDE, inter. frt. (5/16" dia. x 5 19/32" O.L.)
71-72	Pass.,				
73-74	Pass. w/T.H. 400	3993704	1	.18	GUIDE, front
71-72	Chevelle (Spt. Sed.)	1234797	2	.92	GUIDE, inter., rear
73-75	Pass.	1243146	1	.85	intermediate
73-74	Chevelle (exc. T.H. 400)	1361844	1	.22	intermediate front
73-75	Chevelle	1240299	2	.85	intermediate side
75	Chevelle	1250062	1	.85	intermediate side (left) (repl. 1247986)
75	Chevelle w/T.H. 400	1248230	1	.85	intermediate front
75	Chevelle (exc. T.H. 400)	1247985	1	.85	intermediate
75	Nova	352807	1	.67	intermediate
74	Pass.	1241455	1	.34	intermediate
75	Pass. w/T.H. 400	1248458	1	.33	front
75	Pass. w/T.H. 400	1248457	1	.33	intermediate— (4.785)
75	Pass. w/A.T. (exc. Sta. Wag.)	1248452	1	.33	front
74	Pass.	3960314	1	.12	SCREW, guide— (1.276)
70-74	Camaro	9814174	L.H.	1.40	SUPPORT, left cable (on panel)
70-74	Camaro	9814173	R.H.	1.40	SUPPORT, right cable (on panel)

**4.790 SPACER— CLIP— HANGER— PLATE— SPRING, Parking Brake Cable Pulley**

64-65	Chevy w/C.A.C.,				
66-67	Chevy (8 cyl.),				
65	Pass.	3785008	2	.26	pulley (Note 1)
NOTE 1 The following parts must be used in conjunction with each other - 3785008 Spacer, 3780118 Pulley, 3779522 Bracket, and 3779521 Bracket.					
71-75	Vega, Monza	3996335	2	.32	HANGER, parking brake cable
71-75	Vega, Monza	3996336	2	.06	PLATE, parking brake hanger

**4.792 LEVER ASSY., Parking Brake**

62-67	Chevy	3792347	1	3.50	actuating
-------	-------	---------	---	------	-----------



**BRAKES**

**4.874 SWITCH ASSY.— BRACKET— SCREW— VALVE ASSY., Brake Press Ind.**

67-68	Pass. ....	3906933	1	11.45	w/dist. brk. pipe (Bendix 2226720) .....
67-69	Camaro, Chevy .....	3904270	1	13.05	w/distributor .....
67	Chevy .....	3904303	1	13.70	w/distributor .....
67	Chevelle .....	3921043	1	11.50	w/distributor (1 <sup>3</sup> / <sub>32</sub> " oval hole in bracket) .....
68-69	Chevelle .....	3934089	1	10.95	w/distributor .....
69	Pass. ....	3953514	1	10.55	w/dist. brk. pipe .....
70	Pass. ....	3980761	1	11.60	w/dist., brake pipe .....
70	Nova,				
71-72	Nova (exc. Disc Brakes),				
71-75	Vega, Monza .....	3980762	1	11.70	w/dist., brake pipe .....
70	Chevelle,				
71-72	Chevelle (exc. Disc Brakes) .....	3980760	1	11.70	w/dist., brake pipe .....
70	Camaro .....	3983040	1	21.50	w/bracket brake pipe dist. and switch .....
71-72	Camaro w/Disc Brakes .....	5472359	1	28.90	w/dist. brake pipe .....
71-72	Chevelle w/Disc Brakes (exc. Sta. Wag.) .....	5472141	1		w/dist. brake pipe— (4.690) .....
71-72	Chevelle (Sta. Wag.) w/Disc Brakes,				
71-72	Pass. w/Disc Brakes .....	5472140	1	25.80	w/dist. brake pipe— (4.690) .....
67-69	Chevy, Camaro,				
70	Nova,				
71-72	Nova (exc. Disc Brakes) .....	3909933	1	.40	BRACKET, brk. pipe dist. and switch .....
71-74	Vega .....	3986800	1	.35	BRACKET, brake pipe dist. & switch .....
75	Vega, Monza .....	349513	1	.35	BRACKET, brake pipe dist. & switch .....
71-72	Pass., Nova, Chevelle .....	9432192	2	.05	SCREW, valve (5/16"— 18 x 2")— (8.977) ...

**4.898 REPAIR UNIT— BRACE— BRACKET— GASKET, Vacuum Power Brake**

65-66	Pass. w/P.B. (exc. Metallic Brk.) .	5465994	1	14.85	cyl. (1" dia.) (Moraine) .....
65-66	Pass. w/P.B. ....	3872456	1	25.50	cyl. (Bendix) .....
67	Chevelle, Camaro,				
68-69	Chevy, Chevelle, Camaro,				
70-72	Nova, Chevelle,				
73-74	Nova .....	5463228	1	14.55	cylinder repair (Moraine) .....
67-71	Chevelle .....	3928456	1	18.65	cylinder repair (Bendix 2506273) .....
67-70	Pass. ....	3912142	1	17.25	cyl. (Bendix 2506026) .....
67-70	Pass. ....	5463260	1	16.94	cyl. (Moraine) .....
69-70	Nova, Camaro,				
71-72	Nova .....	3974364	1	21.80	cyl. (Bendix 2508823) .....
70-72	Camaro,				
73-74	Camaro w/P.B. ....	5471249	1	17.00	(Moraine) .....
71-72	Pass. (exc. Sta. Wag.) .....	3995838	1	21.10	(Bendix 2509940) .....
72	Pass.,				
73-74	Pass. (exc. Sta. Wag., H.D. Brakes, 454) .....	5472430	1	20.55	(Moraine) .....
71	Pass. (Sta. Wag.),				
72	Pass.,				
73-74	Pass. (Sta. Wag.),				
73-74	Pass. w/H.D. Brakes,				
73-74	Pass. (454) .....	5472146	1	14.90	(Moraine) .....
71	Pass. (Sta. Wag.),				
72	Pass. ....	409347	1	17.10	(Bendix 2509802) .....
73-74	Pass. (exc. Sta. Wag., H.D. Brakes, 454) .....	6259013	1	21.10	(Bendix) .....
73-74	Chevelle (exc. 454) .....	5470060	1	13.75	
75	Chevelle (6 cyl.) w/P.B. ....	2623972	1	21.10	
75	Chevelle (V-8) .....	18000155	1	28.45	
75	Pass. (exc. Sta. Wag., H.D. Brakes, 454) .....	18000156	1	26.25	
75	Camaro w/P.B. ....	2623958	1	21.10	
75	Nova .....	2623959	1	21.10	
75	Vega, Monza .....	2623975	1	18.55	
75	Vega, Monza .....	358494	1	1.45	BRACE, pwr. brk. cyl. ....
67-68	Camaro,				
67-68	Chevelle,				
68	Chevy .....	3917765	L.H.	4.80	BRACKET, left cylinder mounting (Bendix 2505599) .....
67-69	Chevelle, Camaro,				
68-69	Chevy,				
70	Nova, Camaro,				
71	Nova, Chevelle,				
72	Nova .....	3917766	R.H.	4.80	BRACKET, right cylinder mounting (Bendix 2505598) .....
69	Chevy, Chevelle, Camaro,				
70	Nova, Camaro,				
71	Nova, Chevelle,				

**BRAKES**

**4.898 REPAIR UNIT— BRACE— BRACKET— GASKET, Vacuum Power Brake (Con't)**

72 Nova ..... 3974363 L.H. 4.65 BRACKET, left cyl. mounting (Bendix 2508170) .....

**4.901 CYLINDER ASSEMBLY— BRAKE UNIT— GASKET, Vacuum Power Brake**

62-66 Chevy ..... 5467251 1 40.70 (Moraine) .....

64-66 Chevelle ..... 3848934 1 71.00 (Bendix 2502713) .....

65-66 Pass. w/P.B. .... 5465511 1 38.17 (Moraine) .....

67-69 Pass. (396, 427) (exc. Disc Brakes, Metallic Linings),  
70 Pass. w/P.B. (454) (exc. disc brakes) ..... 5460620 1 51.50 (Moraine) .....

67-69 Pass. w/P.B. (exc. 396, 427, Disc Brakes, Metallic Linings),  
70 Pass. w/P.B. (exc. disc brakes, 454) ..... 3958996 1 66.50 (Bendix 2508393) .....

67-70 Pass. w/Disc Brakes ..... 5463968 1 69.08 (Moraine) .....

67-68 Camaro (exc. Disc Brakes, Metallic Linings),  
68 Chevy (exc. Disc Brakes) ..... 5462049 1 62.87 (Moraine) .....

67 Camaro w/Disc Brakes,  
68 Chevy, Camaro w/Disc Brakes .. 5458828 1 65.45 (Moraine) .....

67-71 Chevelle ..... 3979596 1 69.25 (Bendix 2507467) .....

67 Camaro,  
68 Chevy, Camaro ..... 3918715 1 54.50 (Bendix 2505735) .....

69 Chevy, Camaro (exc. Disc Brakes),  
70 Nova w/P.B. (exc. Disc Brakes) . 5469397 1 52.90 (Moraine) .....

69 Chevy, Camaro w/Disc Brakes,  
70 Nova w/Disc Brakes ..... 5469405 1 67.65 (Moraine) .....

69-70 Chevelle w/Disc Brakes ..... 5469400 1 65.89 (Moraine) .....

69-70 Nova, Camaro,  
71-72 Nova ..... 3974365 1 68.25 (Bendix 2508241) .....

70 Pass. w/Disc Brakes ..... 3979624 1 54.50 (Bendix 2508719) .....

70 Camaro ..... 5470735 1 61.75 Moraine .....

71-72 Pass. (exc. Sta. Wag.),  
73-74 Pass. (exc. Sta. Wag., H.D. Brakes, 454) ..... 5472150 1 66.99 (Moraine) (1<sup>1</sup>/<sub>8</sub>" dia.) .....

71 Pass. w/H.D.,  
72-74 Pass. (Sta. Wag.),  
73-74 Pass. w/H.D. Brakes,  
73-74 Pass. (454),  
75 Pass. .... 5472151 1 86.79 (Moraine) (1<sup>1</sup>/<sub>8</sub>" dia.) .....

71 Pass. w/H.D.,  
72 Pass. (Sta. Wag.) ..... 408215 1 92.00 (Bendix 2509458) .....

71 Pass. (exc. H.D. Brakes),  
72 Pass. (exc. Sta. Wag.) ..... 3993706 1 69.00 (Bendix 2509763) .....

71-74 Nova (exc. Disc Brakes) ..... 5472407 1 54.00 (Moraine) .....

71-74 Nova w/Disc Brakes ..... 5472403 1 74.50 (Moraine) (1<sup>1</sup>/<sub>8</sub>" dia.) .....

71-72 Chevelle (exc. Disc Brakes) .... 5472408 1 54.00 (Moraine) .....

71-72 Chevelle w/Disc Brakes ..... 5472405 1 61.25 (Moraine) (1<sup>1</sup>/<sub>8</sub>" dia.) .....

71-74 Camaro ..... 5472354 1 64.52 (Moraine) (1<sup>1</sup>/<sub>8</sub>" dia.) .....

73-74 Pass. (Sta. Wag.),  
73-74 Pass. w/H.D. Brakes,  
73-74 Pass. (454) ..... 1241393 1 99.25 (Bendix 2510577) .....

73-74 Chevelle (exc. 454),  
75 Chevelle (6 cyl.) ..... 2620599 1 70.29 (Moraine) .....

73-74 Chevelle (454),  
75 Chevelle (exc. 6 cyl.) ..... 2620600 1 86.74 (Moraine) .....

73-74 Pass. (exc. H.D. Brakes, Sta. Wag. 454) ..... 338927 1 61.25 (Bendix 2511127) .....

75 Nova w/Disc Brakes ..... 18000018 1 76.15 (Moraine) (1<sup>1</sup>/<sub>8</sub>" dia.) .....

75 Camaro ..... 18000021 1 76.20 (Moraine) (1<sup>1</sup>/<sub>8</sub>" dia.) .....

75 Vega ..... 18000020 1 77.25 .....

75 Monza ..... 18000017 1 72.70 .....

**4.904 DIVIDER, Vacuum Power Brake Cylinder**

71 Pass. (Sta. Wag.),  
72 Pass.,  
73-74 Pass. (Sta. Wag.),  
73-74 Pass. w/H.D. Brakes,  
73-74 Pass. (454) ..... 5469111 1 9.35 cyl. housing .....

**4.906 SHELL ASSY., Vacuum Power Brake Cylinder**

67-70 Pass. w/Disc Brakes,

**BRAKES**

**4.906 SHELL ASSY., Vacuum Power Brake Cylinder (Con't)**

70	Pass. w/P.B. (454),				
71-72	Pass. (exc. Sta. Wag.),				
73-74	Pass. (exc. Sta. Wag., H.D. Brakes, 454) .....	5463500	1	11.60	rear (Moraine) .....
67	Chevelle, Camaro (exc. Disc Brakes),				
68-72	All (exc. Pass., Vega),				
71-72	Pass. (exc. Sta. Wag.),				
73-74	Nova, Camaro (P.B. w/Disc Brakes),				
73-74	Pass. (exc. Sta. Wag., H.D. Brakes, 454) .....	5467850	1	11.45	front (Moraine) .....
69	All (exc. Pass.),				
70-72	Nova, Chevelle w/P.B.,				
73-74	Nova w/Disc Brakes .....	5469351	1	16.90	rear (Moraine) .....
69-70	Nova, Camaro,				
71-72	Nova, Chevelle .....	1382322	1	8.80	w/seal, rear (Bendix 2505431) .....
69-71	Nova, Camaro,				
72	Nova .....	1382323	1	8.80	w/seal, front (Bendix 2505436) .....
70	Pass. w/P.B. (exc. Disc Brakes) .	3974147	1	10.70	w/stud frt. (Bendix 2505854) .....
71-72	Pass. (Sta. Wag.) .....	231266	1	8.85	rear (Bendix 2509924) .....
71-74	Pass. (Sta. Wag.),				
73-74	Pass. w/H.D. Brakes,				
73-74	Pass. (454) .....	231267	1	9.10	w/stud, front (Bendix 2508957) .....
71-74	Pass. (Sta. Wag.),				
73-74	Pass. w/H.D. Brakes,				
73-74	Pass. (454) .....	5465697	1	11.75	cyl. front (Moraine) .....
71-72	Pass. (exc. Sta. Wag.),				
73-74	Pass. (exc. Sta. Wag., H.D. Brakes, 454) .....	3995834	1	7.85	rear (Bendix 2509690) .....
71-72	Pass. (exc. Sta. Wag.),				
73-74	Pass. (exc. Sta. Wag., H.D. Brakes, 454) .....	3995835	1	7.30	w/stud, front (Bendix 2508904) .....
71-74	Pass. (Sta. Wag.),				
73-74	Pass. w/H.D. Brakes,				
73-74	Pass. (454) .....	5469207	1	13.55	cyl. rear (Moraine) .....

**4.910 GASKET— CUP— RETAINER— SEAL, Vacuum Power Brake**

71-75	Pass. ....	9791640	1	.19	cyl. (plastic) .....
73-75	Chevelle w/P.B. ....	1242062	1	.11	cyl. ....
65	Taxi,				
67-69	All (exc. Metallic Disc Brakes),				
67-69	Pass. w/Disc Brakes (exc. P.B.) .	5460195	2	.98	CUP, cyl. secondary— (4.654) .....
62-69	All w/Bendix P.B.,				
68	Chevelle,				
68-70	Pass. w/P.B. ....	9787620	1	.32	RETAINER, main cyl. seal gasket .....
70	Pass., Nova, Camaro w/P.B.,				
71-72	Nova, Chevelle,				
71-72	Pass. (exc. Sta. Wag.) .....	3815837	1	1.60	SEAL, w/plate, pwr. brake cyl. (Bendix 2501198) .....
64-66	Chevy, Chevelle w/Moraine P.B.,				
65-66	Pass. w/Moraine P.B. ....	5464287	1	1.45	SEAL, front shell assy. ....
67-71	All,				
72	All (exc. Camaro, Vega),				
73-74	All (P.B. w/Disc Brakes) (exc. Chevelle, Vega) .....	5452549	1	5.00	SEAL, front shell assy. (Moraine) .....
67	Pass.,				
68	Chevelle,				
68-70	Pass. (exc. 396, 427 H/Per., 454) .....	1490828	1	.36	SEAL, main cyl. to vac. pwr. brk. cyl. ....
71-72	Pass. (Sta. Wag.),				
73-75	Pass. ....	3910048	1	1.40	SEAL ASSY., w/plate (Bendix 2501325) ...
67	Pass. w/P.B. (2nd design),				
68-70	Pass. ....	3913413	1	.28	GASKET, main cyl. mtg. ....

**4.913 RING— BRACE— FILTER— RETAINER— SILENCER, Vacuum Power Brake  
Cylinder Air**

67	Chevelle, Camaro (exc. Disc Brakes, Metallic Linings),
68-71	All (exc. Pass.),
67-70	Pass.,
71	Pass. (exc. Sta. Wag.),
72	All (exc. Vega),
73-74	Nova, Camaro (P.B. w/Disc Brakes),

**BRAKES**

**4.913 RING— BRACE— FILTER— RETAINER— SILENCER, Vacuum Power Brake Cylinder Air (Con't)**

73-74	Pass. (exc. Sta. Wag., H.D. Brakes, 454)	5460612	1	.41	brk. cyl. air clnr. sil. (Moraine)
75	Vega w/P.B.	364629	1	.98	<b>BRACE</b> , cylinder
62-69	All w/Bendix P.B.,				
70	Pass., Nova, Camaro w/P.B.,				
71-72	Pass., Chevelle,				
73-74	Pass. (exc. Sta. Wag., H.D. Brakes, 454)	1478276	1	.24	<b>FILTER</b> , cyl. air cleaner (Bendix 2501060)
64-70	All w/Moraine P.B.,				
71	All (exc. Pass., Sta. Wag.),				
72	All (exc. Camaro, Vega),				
73-74	Nova, Camaro (P.B. w/Disc Brakes),				
73-74	Pass. (exc. Sta. Wag., H.D. Brakes, 454)	5467788	A.R.	.66	<b>FILTER</b> , air cleaner (foam) (Moraine)
68-69	Chevelle,				
71-72	Pass., Nova, Chevelle,				
73-74	Pass. (Sta. Wag.),				
73-74	Pass. w/H.D. Brakes,				
73-74	Pass. (454)	1382321	1	.32	<b>FILTER</b> , cyl. air cleaner (Bendix 2503551)
71	Pass. (Sta. Wag.),				
72	Pass.,				
73-74	Pass. (Sta. Wag.),				
73-74	Pass. w/H.D. Brakes,				
73-74	Pass. (454)	5465064	1	.58	<b>FILTER</b> , cyl. air cleaner power piston (foam)
63-65	Chevy, Chevelle w/P.B.,				
67-70	Camaro, Chevelle, Chevy,				
65-70	Pass. w/P.B.,				
71	All (exc. Vega),				
72	Pass., Chevelle,				
73-74	All (P.B. w/Disc Brakes) (exc. Chevelle, Vega)	5466534	1	.56	<b>FILTER</b> , air cleaner (Moraine) (felt)
62-66	Chevy, Chevelle w/Bendix P.B.,				
65-69	Pass. w/P.B.,				
70	Pass., Nova, Camaro w/P.B.,				
71	Pass., Nova, Chevelle,				
72	Pass. (exc. Sta. Wag.),				
72	Nova, Chevelle,				
73-74	Pass.	9776477	1	.53	<b>RETAINER</b> , cyl. silencer (Bendix 2501644)
68-69	Chevy, Chevelle, Camaro,				
70	Nova, Camaro w/P.B.,				
71-72	Nova, Chevelle	1382320	1	.37	<b>SILENCER</b> , valve (Bendix 2503550)
71-72	Pass. (exc. Sta. Wag.),				
73-74	Pass. (exc. Sta. Wag., H.D. Brakes, 454)	548177	1	.24	<b>SILENCER</b> , cyl. valve (Bendix 2501641)
71	Pass. (Sta. Wag.),				
72	Pass.,				
73-74	Pass. (Sta. Wag.),				
73-74	Pass. w/H.D. Brakes,				
73-74	Pass. (454)	1493038	1	.28	<b>SILENCER</b> , valve (Bendix 2507346)
71	Pass. (Sta. Wag.),				
72	Pass.,				
73-74	Pass. (Sta. Wag.),				
73-74	Pass. w/H.D. Brakes,				
73-74	Pass. (454)	5466560	1	.68	<b>SILENCER</b> , cyl. air cleaner (Moraine) (foam)

**4.918 SEAL— PLUNGER ASSY.— RING— SPRING— KEY— RETAINER, Vacuum Power Brake Cylinder Air Valve (See Group 4.658 for Valve and Push Rod Assy.)**

62-69	All w/Bendix P.B.,				
70	Pass., Nova, Camaro w/P.B.,				
71-72	Pass., Nova, Chevelle	1478290	1	2.20	body (Bendix 2500929)
71	Pass. (exc. Sta. Wag.),				
72	Pass.	3995837	1	8.45	<b>PLUNGER ASM.</b> (Bendix 2509764)
73-74	Pass.	335077	1	3.45	cyl. valve body (Bendix 2510508)
73-74	Pass. (exc. Sta. Wag., H.D. Brakes, 454)	6259003	1	8.45	<b>PLUNGER ASM.</b> , cyl. valve (Bendix)
71	Pass. (Sta. Wag.),				
72	Pass.,				
73-74	Pass. (Sta. Wag.),				
73-74	Pass. w/H.D. Brakes,				
73-74	Pass. (454)	485052	1	3.50	<b>PLUNGER ASSY.</b> (Bendix 2509906)
64-70	All w/Moraine P.B.,				
71	All (exc. Pass., Sta. Wag., Vega),				

**BRAKES**

**4.918 SEAL— PLUNGER ASSY.— RING— SPRING— KEY— RETAINER, Vacuum Power Brake Cylinder Air Valve (See Group 4.658 for Valve and Push Rod Assy.) (Con't)**

72	All (exc. Camaro, Vega),				
73-74	Nova, Camaro (P.B. w/Disc Brakes),				
73-74	Pass. (exc. Sta. Wag., H.D. Brakes, 454) . . . . .	5464317	1	.45	RING, cylinder retaining . . . . .
65-67	Pass.,				
68-70	All w/Moraine P.B.,				
71	All (exc. Pass., Sta. Wag., Vega),				
72	All (exc. Camaro, Vega),				
73-74	Nova, Camaro (P.B. w/Disc Brakes),				
73-74	Pass. (exc. Sta. Wag., H.D. Brakes, 454) . . . . .	5464319	1	.31	RING, cylinder air valve . . . . .
71	Pass. (Sta. Wag.),				
72	Pass.,				
73-74	Pass. (Sta. Wag.),				
73-74	Pass. w/H.D. Brakes,				
73-74	Pass. (454) . . . . .	5463322	1	.53	RING, cyl. air valve (Moraine) . . . . .
64	Chevy, Chevelle,				
65-70	Pass. w/Moraine P.B.,				
71	Pass., Camaro (exc. Sta. Wag.),				
72	Pass.,				
73-74	Camaro w/P.B.,				
73-74	Pass. (exc. Sta. Wag., H.D. Brakes, 454) . . . . .	5464853	1	.53	SPRING, air valve . . . . .
65-70	Chevy, Chevelle, Camaro w/Moraine P.B.,				
71-72	Nova, Chevelle,				
73-74	Nova w/Disc Brakes . . . . .	5465074	1	.66	SPRING (Moraine) . . . . .
71	Pass. (Sta. Wag.),				
72	Pass.,				
73-74	Pass. (Sta. Wag.),				
73-74	Pass. w/H.D. Brakes,				
73-74	Pass. (454) . . . . .	5468950	1	.47	SPRING, cyl. air valve . . . . .
62-69	All w/Bendix P.B.,				
70	Pass., Nova, Camaro w/P.B.,				
71	Pass. (Sta. Wag.),				
72	Pass. (exc. Sta. Wag.),				
72	Nova,				
73-74	Pass. (exc. Sta. Wag., H.D. Brakes, 454) . . . . .	1478501	1	.32	KEY, plunger stop (Bendix 2501186) . . . . .
64-70	All w/Moraine P.B.,				
71	All (exc. Pass., Sta. Wag., Vega),				
72	All (exc. Camaro, Vega) . . . . .	5464316	1	.35	RETAINER, air valve spring . . . . .

**4.922 PISTON— PLATE— RETAINER— RING— SEAL— DIAPHRAGM— GASKET— SUPPORT— BODY— GUARD, Vacuum Power Brake Cylinder**

64-70	All w/Moraine P.B.,				
71-72	All (exc. Vega),				
73-75	Nova, Camaro (P.B. w/Disc Brakes),				
73-75	Pass. (exc. Sta. Wag., H.D. Brakes, 454) . . . . .	5467849	1	7.95	(Moraine) . . . . .
71	Pass. (Sta. Wag.),				
72	Pass.,				
73-74	Pass. (Sta. Wag.),				
73-74	Pass. w/H.D. Brakes,				
73-74	Pass. (454),				
75	Pass., Chevelle . . . . .	5471913	1	17.95	PISTON UNIT . . . . .
67,	Pass. . . . .	9785082	1	5.95	PLATE, diaphragm front (Bendix 2503524)
71	Pass. (Sta. Wag.),				
72	Pass.,				
73-74	Pass. (Sta. Wag.),				
73-74	Pass. w/H.D. Brakes,				
73-74	Pass. (454) . . . . .	9789753	1	6.75	PLATE, cyl. diaph. front (Bendix 2505920)
71	Pass. (Sta. Wag.),				
72	Pass.,				
73-74	Pass. (Sta. Wag.),				
73-74	Pass. w/H.D. Brakes,				
73-74	Pass. (454) . . . . .	9785104	1	4.55	PLATE ASSY., cyl. center (Bendix 2503488) . . . . .
71	Pass. (Sta. Wag.),				
72	Pass.,				

**BRAKES**

**4.922 PISTON— PLATE— RETAINER— RING— SEAL— DIAPHRAGM—  
GASKET— SUPPORT— BODY— GUARD, Vacuum Power Brake Cylinder  
(Con't)**

73-74	Pass. (Sta. Wag.),				
73-74	Pass. w/H.D. Brakes,				
73-74	Pass. (454) . . . . .	5469059	1	.62	PLATE, cyl. retainer (Moraine) . . . . .
71	Pass. (Sta. Wag.),				
72	Pass.,				
73-74	Pass. (Sta. Wag.),				
73-74	Pass. w/H.D. Brakes,				
73-74	Pass. (454) . . . . .	3910042	1	3.15	RETAINER, cyl. diaph. (Bendix 2503490) . . . . .
71	Pass. (Sta. Wag.),				
72	Pass.,				
73-74	Pass. (Sta. Wag.),				
73-74	Pass. w/H.D. Brakes,				
73-74	Pass. (454) . . . . .	5469113	1	2.15	RING, diaph. support (9 <sup>9</sup> / <sub>16</sub> " I.D. x 10 <sup>3</sup> / <sub>8</sub> " O.D., 4 slots) . . . . .
71	Pass. (Sta. Wag.),				
72	Pass.,				
73-74	Pass. (Sta. Wag.),				
73-74	Pass. w/H.D. Brakes,				
73-74	Pass. (454) . . . . .	9785083	1	.29	SEAL, cyl. diaph. plate (Bendix 2503493) . . . . .
62-66	All w/Bendix P.B. . . . .	1478273	1	4.80	DIAPHRAGM, power brake cylinder (Bendix 2501082) . . . . .
64-66	All w/Moraine P.B.,				
67	Chevy w/P.B. . . . .	5464288	1	7.00	DIAPHRAGM, piston . . . . .
67	Chevelle, Camaro w/Moraine P.B.,				
68-69	Chevy, Chevelle, Camaro w/Moraine P.B.,				
67-69	Pass. w/Moraine P.B.,				
70	All w/P.B.,				
71	All (exc. Pass., Sta. Wag.),				
72	Pass. (exc. Sta. Wag.),				
72	Nova, Chevelle, Camaro,				
73-74	Nova, Camaro (P.B. w/Disc Brakes),				
73-74	Pass. (exc. Sta. Wag., H.D. Brakes, 454) . . . . .	5467856	1	7.85	DIAPHRAGM, piston (Moraine) . . . . .
67-68	Chevelle, Camaro,				
67-69	Pass. (exc. 396, 427, Disc Brakes, Metallic Linings),				
69	Chevelle,				
70	Pass. w/P.B. (exc. Disc Brakes),				
71	Nova, Chevelle,				
72	Nova . . . . .	9787626	1	6.70	DIAPHRAGM, cyl. (Bendix 2505109) . . . . .
70	Pass. w/Disc Brakes . . . . .	3995819	1	9.40	DIAPHRAGM, plate and valve body (Bendix 2506777) . . . . .
70	Pass.,				
71-72	Pass. (exc. Sta. Wag.),				
73-74	Pass. (exc. Sta. Wag., H.D. Brakes, 454) . . . . .	3979623	1	5.70	DIAPHRAGM (Bendix 2508888) . . . . .
71	Pass. (Sta. Wag.),				
72	Pass.,				
73-74	Pass. (Sta. Wag.),				
73-74	Pass. w/H.D. Brakes,				
73-74	Pass. (454) . . . . .	485056	1	4.60	DIAPHRAGM, cyl. front (Bendix 2509818) . . . . .
71	Pass. (Sta. Wag.),				
72	Pass.,				
73-74	Pass. (Sta. Wag.),				
73-74	Pass. w/H.D. Brakes,				
73-74	Pass. (454) . . . . .	9785081	1	4.55	DIAPHRAGM, cyl. rear (Bendix 2503491) . . . . .
71	Pass. (Sta. Wag.),				
72	Pass.,				
73-74	Pass. (Sta. Wag.),				
73-74	Pass. w/H.D. Brakes,				
73-74	Pass. (454),				
74	Chevelle . . . . .	5468961	1	7.85	DIAPHRAGM UNIT, primary (Moraine) . . . . .
71	Pass. (Sta. Wag.),				
72	Pass.,				
73-74	Pass. (Sta. Wag.),				
73-74	Pass. w/H.D. Brakes,				
73-74	Pass. (454),				
74	Chevelle . . . . .	5466536	1	8.20	DIAPHRAGM UNIT, secondary (Moraine) . . . . .
70	Pass. . . . .	1490240	1	1.10	GASKET, diaph. cover (Bendix 2225441) . . . . .

**BRAKES**

**4.922 PISTON— PLATE— RETAINER— RING— SEAL— DIAPHRAGM— GASKET— SUPPORT— BODY— GUARD, Vacuum Power Brake Cylinder (Con't)**

67-70	All w/Moraine P.B. (exc. Metallic Linings),				
71	All (exc. Pass., Sta. Wag., Vega),				
72	All (exc. Vega),				
73-74	Nova, Camaro (P.B. w/Disc Brakes),				
73-74	Pass. (exc. Sta. Wag., H.D. Brakes, 454) . . . . .	5467857	1	6.45	SUPPORT, diaphragm . . . . .
71	Pass. (Sta. Wag.),				
72	Pass.,				
73-74	Pass. (Sta. Wag.),				
73-74	Pass. w/H.D. Brakes,				
73-74	Pass. (454) . . . . .	5466372	1	7.00	SUPPORT, diaph. primary . . . . .
71-72	Pass. (Sta. Wag.),				
73-74	Pass. (Sta. Wag.),				
73-74	Pass. w/H.D. Brakes,				
73-74	Pass. (454) . . . . .	5466538	1	6.30	SUPPORT, diaph. secondary . . . . .
70	Pass. w/P.B. (exc. Disc Brakes),				
71	Chevelle . . . . .	3943669	1	7.65	BODY, brk. cyl. vlv. (w/diaphragm) . . . . .
69-70	Nova, Camaro,				
71-72	Nova . . . . .	3974362	1	7.25	BODY, valve (Bendix 2506776) . . . . .
71-72	Pass. (exc. Sta. Wag.),				
73-74	Pass. (exc. Sta. Wag., H.D. Brakes, 454) . . . . .	1492544	1	6.20	BODY, cyl. valve (Bendix 2506780) . . . . .
71-72	Pass. (Sta. Wag.),				
73-74	Pass. (Sta. Wag.),				
73-74	Pass. w/H.D. Brakes,				
73-74	Pass. (454) . . . . .	9785077	1	6.55	BODY, cyl. valve (Bendix 2503485) . . . . .

**4.924 ROD ASSY.— BEARING— RETAINER— RING— SPRING, Vacuum Power Brake Cylinder Piston**

65-69	Pass. w/Moraine P.B.,				
70	All w/P.B.,				
71-72	Nova, Chevelle (exc. Disc Brakes),				
73-74	Nova w/Disc Brakes . . . . .	5464521	1	2.40	main cyl. piston (Moraine) . . . . .
67-69	Chevelle,				
67-68	Camaro,				
68	Chevy,				
67-69	Pass. (exc. 396, 427, Disc Brakes, Metallic Linings),				
70	Pass. w/P.B. (exc. Disc Brakes),				
71-72	Pass. (exc. Sta. Wag.),				
71	Chevelle, Nova,				
72	Nova . . . . .	3918716	1	4.35	w/support ( $\frac{3}{8}$ " x $1\frac{1}{8}$ " O.L.) . . . . .
68-71	Chevelle . . . . .	3957861	1	7.60	w/plunger (Bendix 2507469) . . . . .
69-70	Nova, Camaro,				
72	Nova . . . . .	3974366	1	8.00	w/plunger (Bendix 2508242) . . . . .
70	Camaro w/P.B.,				
71	Pass. w/Disc Brakes (exc. Sta. Wag.),				
71	Chevelle, Camaro w/Disc Brakes,				
72	Pass., Chevelle,				
73-75	Camaro w/P.B.,				
73-75	Pass. (exc. Sta. Wag., H.D. Brakes, 454) . . . . .	5462683	1	3.59	w/support (Moraine) ( $\frac{3}{8}$ " dia. x $11\frac{3}{16}$ " dev. length) . . . . .
71	Pass. (Sta. Wag.),				
72	Pass.,				
73-74	Pass. (Sta. Wag.),				
73-74	Pass. w/H.D. Brakes,				
73-74	Pass. (454),				
75	Pass., Chevelle . . . . .	5469384	1	7.20	cyl. (Moraine) . . . . .
71	Pass. (Sta. Wag.),				
72	Pass. . . . .	3957945	1	3.95	cyl. push (Bendix 2507042) . . . . .
71	Pass. (Sta. Wag.),				
72	Pass.,				
73-74	Pass. (Sta. Wag.),				
73-74	Pass. w/H.D. Brakes,				
73-74	Pass. (454) . . . . .	5472147	1	7.95	air valve push (Moraine) . . . . .
64-70	All w/P.B.,				
71	All (exc. Pass., Sta. Wag., Vega),				

**BRAKES**

**4.924 ROD ASSY.— BEARING— RETAINER— RING— SPRING, Vacuum Power Brake Cylinder Piston (Con't)**

72	All (exc. Camaro, Vega),				
73-74	Nova, Camaro (P.B. w/Disc Brakes),				
73-74	Pass. (exc. Sta. Wag., H.D. Brakes, 454) . . . . .	5465205	1	1.88	BEARING, piston (Moraine) . . . . .
71	Pass. (Sta. Wag.),				
72	Pass.,				
73-74	Pass. (Sta. Wag.),				
73-74	Pass. w/H.D. Brakes,				
73-74	Pass. (454) . . . . .	5465302	1	1.99	BEARING, cyl. piston (primary) . . . . .
71	Pass. (Sta. Wag.),				
72	Pass.,				
73-74	Pass. (Sta. Wag.),				
73-74	Pass. w/H.D. Brakes,				
73-74	Pass. (454) . . . . .	5469112	1	2.28	BEARING, cyl. piston (secondary) . . . . .
64-70	All w/P.B.,				
71	All (exc. Pass., Sta. Wag., Vega),				
72	All (exc. Camaro, Vega),				
73-74	Nova, Camaro (P.B. w/Disc Brakes),				
73-74	Pass. (exc. Sta. Wag., H.D. Brakes, 454) . . . . .	5464332	1	.51	RING, "O" main cyl. piston (Moraine) . . . . .
64-69	All w/Moraine w/P.B.,				
71	All (exc. Pass., Sta. Wag., Vega),				
72	All (exc. Camaro, Vega),				
73-74	Nova, Camaro (P.B. w/Disc Brakes),				
73-74	Pass. (exc. Sta. Wag., H.D. Brakes, 454) . . . . .	5464312	1	1.80	SPRING, power piston . . . . .
69	Nova, Camaro,				
70	Pass., Nova, Camaro w/P.B.,				
71-72	Pass. (exc. Sta. Wag.),				
71	Chevelle, Nova,				
72	Nova,				
74	Pass. (exc. Sta. Wag., H.D. Brakes, 454) . . . . .	1232889	1	1.45	SPRING, diaphragm return (Bendix 2508131) . . . . .
71	Pass. (Sta. Wag.),				
72	Pass.,				
73-74	Pass. (Sta. Wag.),				
73-74	Pass. w/H.D. Brakes,				
73-74	Pass. (454) . . . . .	546329	1	.63	SPRING, cyl. diaph. return (Bendix 2504923) . . . . .
71	Pass. (Sta. Wag.),				
72	Pass. . . . .	9785080	1	.24	SPRING, cyl. valve rod (Bendix 2503486) . . . . .
71	Pass. (Sta. Wag.),				
72	Pass.,				
73-74	Pass. (Sta. Wag.),				
73-74	Pass. w/H.D. Brakes,				
73-74	Pass. (454) . . . . .	5466558	1	1.68	SPRING, power piston (Moraine) . . . . .
73-74	Pass. (Sta. Wag.),				
73-74	Pass. w/H.D. Brakes,				
73-74	Pass. (454) . . . . .	335076	1	.24	SPRING, cyl. valve rod (Bendix 2510568) . . . . .

**4.926 RETAINER, Cyl. Push Rod**

73-74	Pass. (Sta. Wag.) . . . . .	5466546	1	1.46	RETAINER, cyl. push rod (Moraine) . . . . .
73-74	Pass. (454) . . . . .	5466546	1	1.46	RETAINER, cyl. push rod (Moraine) . . . . .
73-74	Pass. w/H.D. Brakes . . . . .	5466546	1	1.46	RETAINER, cyl. push rod (Moraine) . . . . .

**4.930 PIPE ASSY.— CLAMP— CLIP— SUPPORT, Vacuum Power Brake Cylinder**

67	Chevelle, Camaro (396),				
67	Pass. (396, 427) . . . . .	3909606	1	2.40	w/support . . . . .
70	All w/P.B. . . . .	3976001	1	2.45	w/support (3/8" dia. x 11 <sup>3</sup> / <sub>16</sub> " dev. length) . . . . .
71-72	All w/4BC (400, 402, 454),				
73-75	All (454) . . . . .	3989307	1	2.70	w/support (3/8" dia. x 11 <sup>7</sup> / <sub>8</sub> " dev. length) . . . . .
73-74	All (6 cyl.) w/P.B. . . . .	326575	1	1.45	(3/8" dia. x 6 <sup>1</sup> / <sub>4</sub> " dev. length) . . . . .
75	All (6 cyl.) w/P.B. . . . .	6261836	1	1.35	
75	Nova w/1BC (350) . . . . .	352289	1	1.55	
74	All w/2BC (exc. Vega) . . . . .	342433	1	1.45	
75	All w/2BC (exc. Vega) . . . . .	354633	1	1.45	
62-69	All . . . . .	1470029	A.R.	.73	CLAMP, hose— (1.166) . . . . .
68-69	Chevelle . . . . .	3866187	1	.16	CLIP (3/4") . . . . .
72	All (6 cyl.) . . . . .	3977200	1	2.15	(3/8" dia. x 7 <sup>31</sup> / <sub>32</sub> " dev. length) . . . . .



**BRAKES**

**4.931 HOSE— CONNECTOR— TEE ASSY.— FITTING ASSY.— GROMMET, Vacuum Power Brake Cyl.**

62-69	All	9433154 A.R.	RL/.67	(1/2" I.D.— 25 ft. roll) (cyl. pipe and check valve) (cut to length required)— (8,962)
62-69	All	358411 A.R.	RL/.88	(1 1/32" x 10 ft. roll) vacuum main cylinder (repl. 609863)— (8.962)
62	Chevy (4 cyl.),			
62	Chevy w/3-Spd. (6 cyl.),			
63-64	Chevy, Chevelle w/P.B.	3751207	1	1.15 <b>CONNECTOR</b> , main cyl. hose (3/8" I.D.— at hose end— 1 9/16" O.L.)— (3.163)
66-67	All w/A.I.R. (6 cyl.),			
70	Pass., Chevelle w/P.B.	3751206	1	.67 <b>CONNECTOR</b> , manifold vacuum hose— (3.163)
63-64	Chevy, Chevelle w/P.B. (exc. Air Cond.)	3794176	1	3.70 <b>TEE ASSY.</b> , brake hose— (9.198)
64	Chevy w/C.A.C. (283),			
65-66	Chevy,			
67-68	Camaro,			
65-67	Pass.	3891528	1	1.70 <b>TEE ASSY.</b> , inlet manifold, P.B. hose tee assy., P.B. to main cyl. to manifold hose tee assy. (3/8"— 18) (repl. 3891525)— (7.447) (Note 1)
<i>NOTE 1 Hose take off s 3/8" and 1/4".</i>				
65-70	All,			
71	Pass., Nova, Chevelle	3989020	1	.59 <b>FITTING ASSY.</b> , inlet manifold (3/8"— 18) (pipe thd.) one 3/8" hose
68-69	Chevelle, Chevy, Camaro (P.B. w/C.A.C.) (6 cyl.),			
68-69	Pass. w/P.B. (6 cyl.) (exc. Rear Shock Absorber, Level Control w/Vacuum Operated Door Locks, Retractable Headlamp Cover, Traction Compound and Dispenser),			
70-71	Nova w/P.B.,			
72	Nova	3920996	1	<b>FITTING ASSY.</b> , vac. (3/8"— 18 x 1 7/8" O.L.) (3/32" hose conn.) (repl. 3915971)
70	All w/P.B. (6 cyl.),			
71	Chevelle w/Sp. H/Per. (454)	3981049	1	1.75 <b>FITTING ASSY.</b> , in inlet manifold (3/8"— 18 x 1 15/16" O.L.) (1 hose conn.) (repl. 3981046)
70	All w/P.B. (6 cyl.),			
71	Chevelle	3981049	1	1.75 <b>FITTING ASSY.</b> , in inlet manifold (3/8"— 18 x 1 15/16" O.L.) (2 hose conn.) (repl. 3981047)
72-75	All (6 cyl.)	330138	1	2.35 <b>FITTING ASSY.</b> , in inlet manifold (3/8"— 18 x 1 27/32" O.L.) (1 hose conn.)— (3.278)
67-68	Pass. w/Disc Brakes	5461059	1	.92 <b>GROMMET</b> , control tube

**4.934 LEVER— BUMPER— DISC— PLATE— RETAINER— SPRING, Vacuum Power Brake Cyl. Reaction**

64-70	All w/Moraine P.B.,			
71	All (exc. Pass., Sta. Wag., Vega),			
72	All (exc. Camaro, Vega),			
73-74	Nova, Camaro (P.B. w/Disc Brakes),			
73-74	Pass. (exc. Sta. Wag., H.D. Brakes, 454)	5464313	3	.25 piston reaction
64-70	All w/Moraine P.B.,			
71	All (exc. Pass., Sta. Wag., Vega),			
72	All (exc. Camaro, Vega),			
73-74	Nova, Camaro (P.B. w/Disc Brakes),			
73-74	Pass. (exc. Sta. Wag., H.D. Brakes, 454)	5464318	1	.31 <b>BUMPER</b> , cyl. reaction
71	Pass. (Sta. Wag.),			
72	Pass.,			
73-74	Pass. (Sta. Wag.),			
73-74	Pass. w/H.D. Brakes,			
73-74	Pass. (454)	5469016	1	.60 <b>BUMPER</b> , cyl. reaction
62-65	Chevy w/Bendix P.B. (1st design),			
62-66	Chevelle w/Bendix P.B.,			
67-69	Chevelle, Camaro,			
65-69	Pass. w/Bendix P.B.,			
70	Pass., Nova, Chevelle w/P.B.,			

## BRAKES

### 4.934 LEVER— BUMPER— DISC— PLATE— RETAINER— SPRING, Vacuum Power Brake Cyl. Reaction (Con't)

71	Pass. (exc. Sta. Wag.),				
71	Nova, Chevelle,				
72	Nova,				
73-74	Pass. (exc. Sta. Wag., H.D. Brakes, 454) . . . . .	1478287	1	.52	DISC, reaction (Bendix 2501061) (7/32" thk.)
65-66	Chevy w/Bendix P.B. (2nd design),				
71	Pass. (Sta. Wag.),				
72	Pass.,				
73-74	Pass. (Sta. Wag.),				
73-74	Pass. w/H.D. Brakes,				
73-74	Pass. (454) . . . . .	386134	1	1.10	DISC, reaction (Bendix 2503065) (9/16" thk.)
71	Pass. (Sta. Wag.),				
72	Pass.,				
73-74	Pass. (Sta. Wag.),				
73-74	Pass. w/H.D. Brakes,				
73-74	Pass. (454) . . . . .	5463740	1	1.46	DISC (Moraine) . . . . .
65-70	Chevelle (exc. Metallic Linings, Disc Brakes),				
71-72	Chevelle (exc. Disc Brakes) . . . . .	5463433	1	.52	PLATE, piston support (Moraine) . . . . .
67-69	Pass. w/Disc Brakes,				
69-72	Chevelle w/Disc Brakes . . . . .	5463450	1	.57	PLATE, piston reaction support . . . . .
67	Camaro w/P.B.,				
67-69	Pass. w/P.B. (250, 283, 327) (exc. Disc Brakes, Metallic Linings),				
70	Pass., Nova w/P.B. (350) (exc. Disc Brakes) . . . . .	5463452	1	.44	PLATE, piston reaction support . . . . .
67-68	Chevelle w/Metallic Linings,				
67-68	Pass., Camaro w/Disc Brakes,				
69	Chevy, Chevelle, Camaro,				
70-71	Nova, Camaro w/Disc Brakes,				
72	Nova,				
73-74	Nova, Camaro (P.B. w/Disc Brakes) . . . . .	5452963	1	.63	PLATE, cyl. reaction (Moraine) . . . . .
68	Chevy, Camaro, Chevelle w/P.B. (exc. Disc Brakes),				
71-72	Nova (exc. Disc Brakes) . . . . .	5468815	1	.48	PLATE, cylinder piston reaction . . . . .
69-70	Pass. w/Disc Brakes,				
71-72	Pass. w/Disc Brakes (exc. Sta. Wag.),				
73-74	Pass. (exc. Sta. Wag., H.D. Brakes, 454) . . . . .	5462190	1	.68	PLATE, piston reaction main cyl. stamped (TA) (Moraine) . . . . .
64-70	All w/Moraine P.B.,				
71	All (exc. Pass., Sta. Wag.),				
72	Pass. (exc. Sta. Wag.),				
72	Chevelle, Nova, Camaro,				
73-74	Nova, Camaro (P.B. w/Disc Brakes),				
73-74	Pass. (exc. Sta. Wag., H.D. Brakes, 454) . . . . .	5464282	1	2.44	RETAINER, reaction (Moraine) . . . . .

### 4.935 VALVE UNIT— RETAINER— RING, Vacuum Power Brake Cyl. Relay Valve

64-69	All w/Moraine P.B.,				
69	Pass. w/Disc Brakes,				
70-71	Nova, Chevelle w/P.B.,				
72	Nova, Chevelle,				
73-74	Nova w/Disc Brakes . . . . .	5464967	1	1.64	floating control (Moraine) (Note 1) . . . . .
	<i>NOTE 1 This unit consists of a spring seat, spring retainer, control valve spring, floating control valve assy., and floating valve retainer.</i>				
64-70	All w/Moraine P.B.,				
71	All (exc. Pass., Sta. Wag., Vega),				
72	All (exc. Camaro, Vega),				
73-74	Nova, Camaro (P.B. w/Disc Brakes),				
73-74	Pass. (exc. Sta. Wag., H.D. Brakes, 454) . . . . .	5464369	1	.53	RETAINER, floating valve . . . . .
71	Pass. (Sta. Wag.),				
73-74	Pass. (Sta. Wag.),				
73-74	Pass. w/H.D. Brakes,				
73-74	Pass. (454) . . . . .	5466522	1	.43	RETAINER, control valve, floating (Moraine)
64-70	All w/Moraine P.B.,				
71	All (exc. Pass., Sta. Wag., Vega),				

**BRAKES**

**4.935 VALVE UNIT— RETAINER— RING, Vacuum Power Brake Cyl. Relay Valve  
(Con't)**

72	All (exc. Camaro, Vega),				
73-74	Nova, Camaro (P.B. w/Disc Brakes),				
73-74	Pass. (exc. Sta. Wag., H.D. Brakes, 454) . . . . .	5464328	1	.56	RING, reaction retainer lock . . . . .

**4.940 POPPET ASM., Vac. Pwr. Brake Cyl.**

71	Pass. (Sta. Wag.),				
72	Pass.,				
73-74	Pass. (Sta. Wag.),				
73-74	Pass. w/H.D. Brakes,				
73-74	Pass. (454) . . . . .	9785071	1	2.15	POPPET ASM. (Bendix 2501062) . . . . .

**4.942 RETAINER, Cyl. Poppet**

72	Pass. . . . .	3910036	1	.24	RETAINER (Bendix 2501318) . . . . .
73-74	Pass. (Sta. Wag.),				
73-74	Pass. w/H.D. Brakes,				
73-74	Pass. (454) . . . . .	1478268	1	13.10	RETAINER (Bendix 2501094) . . . . .

**4.955 VALVE ASSY.— GROMMET, Vacuum Power Brake Check**

62-64	Chevy, Chevelle w/P.B.,				
65-70	Pass. w/P.B.,				
68-69	Pass. w/Disc Brake . . . . .	5464705	1		check (w/hose connection) . . . . .
64-70	Chevy, Chevelle, Camaro w/Moraine P.B.,				
65	Pass. w/Moraine P.B. (2nd design),				
71-72	All (exc. Vega),				
73-74	All w/P.B. (exc. Vega, Monza) . .	5472419	1	2.90	check (w/2 hose connections) (Moraine) . . .
69	Nova, Camaro w/P.B. . . . .	546326	1	2.20	check (Bendix 2508755) . . . . .
71	Pass. (Sta. Wag.),				
72	Pass.,				
73-74	Pass. (Sta. Wag.),				
73-74	Pass. w/H.D. Brakes,				
73-74	Pass. (454) . . . . .	485055	1	1.95	cyl. check (Bendix 2509424) . . . . .
71-72	Pass. (exc. Sta. Wag.),				
73-74	Pass. (exc. Sta. Wag., H.D. Brakes, 454) . . . . .	3995836	1	1.95	cyl. check (Bendix 2509702) . . . . .
75	All w/P.B. (exc. Vega, Monza) . .	18000139	1	3.19	VALVE UNIT, cyl. check . . . . .
62-63	Chevy w/Bendix P.B.,				
65-69	Pass. w/Bendix P.B.,				
70	Pass. w/P.B. (exc. Disc Brakes) .	3815834	1	.32	GROMMET, check valve (Bendix 2501147)
62-71	All w/Moraine P.B. (exc. Vega),				
72	Pass., Chevelle,				
73-74	All w/P.B. (exc. Vega) . . . . .	5461808	1	.97	GROMMET, check valve (Moraine) . . . . .

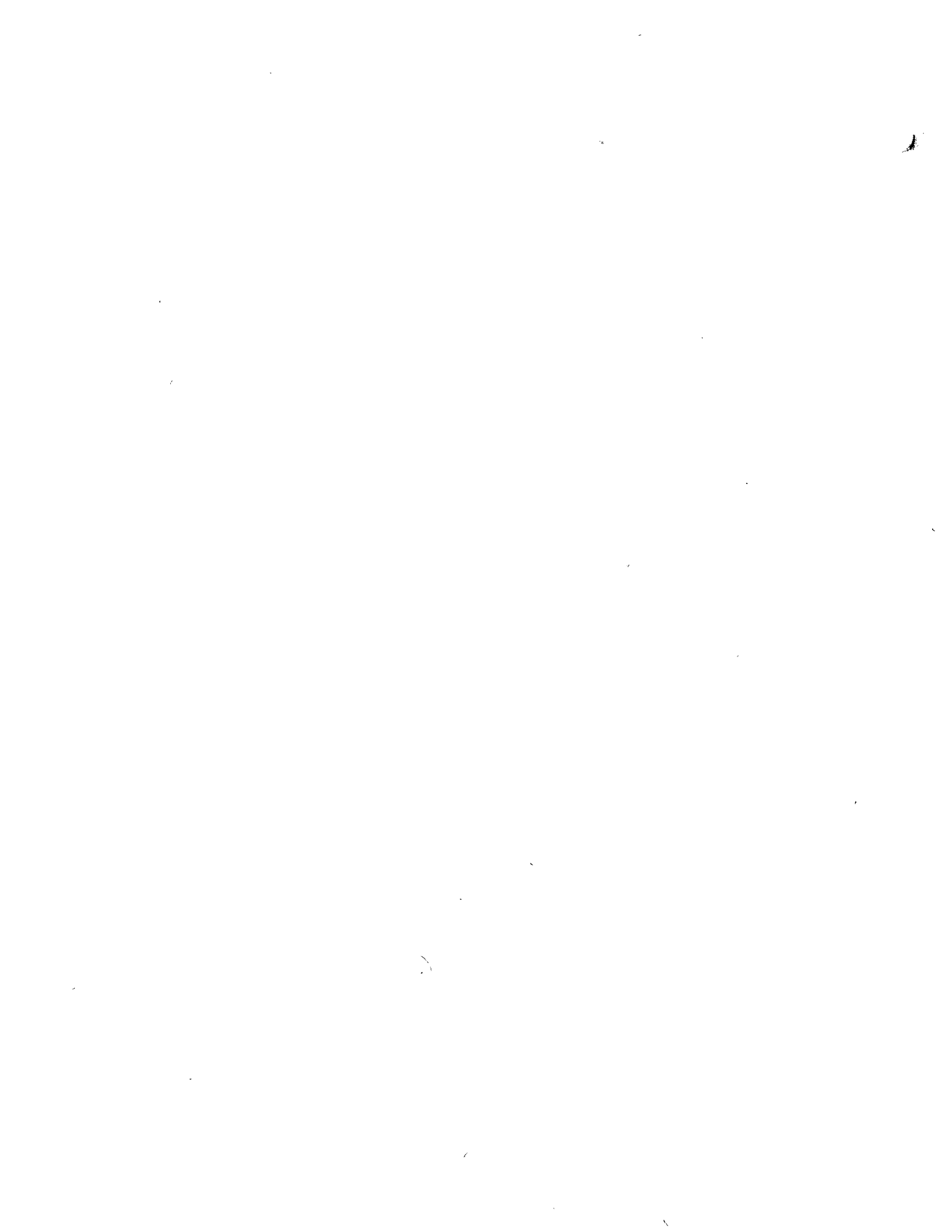



# CHEVROLET CHASSIS GROUP 4.000



## ILLUSTRATION INDEX

TITLE	PAGE	TITLE	PAGE
1955-66 Passenger, Chevy and Chevelle Three Speed Transmission .....	4-1	1973-75 140 C.I.D. 3-Spd. Transmission Mounting .....	4-36
Muncie 3-Spd. Transmission .....	4-2	1971-72 Vega Transmission Floor Shift Lever .....	4-37
1966-72 Saginaw 3-Spd. Transmission—Exploded	4-4	1973-75 Vega 3-Spd. Shift Lever and Lower Boot .....	4-38
1973-75 Saginaw 3-Spd. Transmission .....	4-5	1973-75 Vega 3-Spd. Bezel, Boot & Insulator .....	4-39
1971-72 Vega 3-Speed Transmission .....	4-6	1973-75 Vega 3-Spd. Control Rod Linkage .....	4-40
1973-75 Vega — Monza Saginaw 3-Spd. ....	4-8	1971-75 Vega Speedometer Shaft .....	4-41
1973 Chevelle 3-Spd. Control Linkage .....	4-10	1966-72 Saginaw 4-Spd. Transmission— Exploded .....	4-42
1965 Passenger Three Speed Gear Shift Control .....	4-11	1963-72 Muncie Four Speed Transmission— Exploded .....	4-43
1965 Passenger 3-Spd. Transmission Control Rods .....	4-12	1973-74 Muncie 4-Spd. Trans. ....	4-44
1966 Passenger—3-Spd. Transmission Control Rods .....	4-13	1973 4-Speed Saginaw Transmission .....	4-46
3-Speed Floor Shift Control Assy. ....	4-14	1974 Warner 4-Spd. Transmission — Exploded .....	4-48
1967-70 Passenger 3-Spd. Transmission Control Rods .....	4-15	1971-72 Vega 4-Spd. Transmission .....	4-50
1964-65 Chevelle 3-Speed Transmission Linkage .....	4-16	1973-75 Vega—Monza Saginaw 4-Spd. ....	4-52
1967 Chevelle 3-Spd. Transmission Controls— Floor Shift .....	4-17	1967-68 Passenger Saginaw 4-Spd. Transmission Controls .....	4-54
1966-67 Chevelle 3-Speed Transmission Linkage .....	4-18	1967-68 Passenger Muncie 4-Spd. Transmission Controls .....	4-55
1968 Chevelle 3-Speed Transmission Control Linkage (exc. 396) .....	4-19	1969 Passenger 4-Spd. Transmission Control Rods .....	4-56
1969 Chevelle Column Mounted Control Linkage .....	4-20	1969 Passenger 4-Spd. Transmission Interlock Linkage .....	4-56
1969 Chevelle H.D. 3-Spd. Backdrive Linkage .....	4-21	1969 Passenger 4-Speed Transmission— Lever and Bracket .....	4-57
1970 Chevelle H.D. 3-Spd. Control Rods & Lever .....	4-22	1964-65 Chevelle 4-Spd. Controls .....	4-58
1969-70 Nova H.D. 3-Spd. Transmission Control Rods .....	4-23	1969 Chevelle 4-Spd. Backdrive Linkage .....	4-59
1970 Nova 3-Spd. Transmission Safety Switch .....	4-24	1970-73 Chevelle 4-Spd. Trans. Control Rods .....	4-60
1970-74 Nova 3-Spd. Transmission Control Rod Linkage .....	4-24	1970 Chevelle 4-Spd. Trans. Bracket & T.C.S. Switch .....	4-60
1970-74 Nova 3 Speed Trans-Back Drive Linkage .....	4-25	1967-68 Camaro 4-Spd. Trans. Control Assy. ....	4-61
1967-69 Camaro 3-Spd. Transmission Control Linkage .....	4-26	1973 Chevelle 4-Spd. Trans. Control Rods ....	4-62
1967-69 Camaro 3-Spd. Transmission Linkage Floor Shift .....	4-27	1974 Chevelle Floor Shifter Support and Levers .....	4-62
1974 Chevelle Gearshift Controls Column Shift .....	4-28	1974 Chevelle Control Rod Linkage .....	4-63
1973-74 Nova 3-Speed Trans-Back Drive Linkage .....	4-29	1974 Chevelle Back Drive Linkage .....	4-63
1973-75 Nova 3-Spd. Transmission Control Rod Linkage .....	4-30	1973-74 Nova Control Rod Linkage (M-20) .....	4-64
1974 Nova (3-Spd. w/Floor Controls) Control Rod Linkage .....	4-31	Nova 4-Spd. Transmission T.C.S. Switch and Lever .....	4-65
1973-74 "Camaro" Shifter and Support .....	4-32	1973-75 Nova, Camaro Shifter and Support .....	4-66
1974 Camaro 3-Speed Transmission Mounting .....	4-33	4-Speed Floor Shift Control Assy. (Exc. Camaro) .....	4-67
1974 Camaro w/3-Spd. — Control Rod Linkage .....	4-33	Camaro 4 Speed Shift Control .....	4-68
1971-74 Vega 3-Spd. Clutch Neutral Starting Switch and T.C.S. ....	4-34	1969 Camaro 4-Spd. Interlock Linkage .....	4-69
Switch and Relay .....	4-34	1973-75 Chevelle w/4-Spd. ....	4-70
1971-72 3-Spd. Transmission Mounting .....	4-35	1974 Camaro 4-Speed Transmission Mounting .....	4-70
		1971-73 Vega 4-Spd. Clutch Neutral Starting Switch and T.C.S. Switch and Relay .....	4-71
		1973-75 Vega 4-Spd. TCS Solenoid and Switch .....	4-72
		1971-72 Vega 4-Spd. Transmission Mounting .....	4-73

TITLE	PAGE	TITLE	PAGE
1973-75 Vega—Monza 4-Spd. Transmission Mounting	4-74	1972-75 Detent Control Cable	4-113
1971-72 Vega 4-Spd. Transmission Floor Shift Lever	4-75	1972-75 Modulator Pipe	4-114
1973-75 Vega—Monza 4-Spd. Shift Lever, Boots, Bezel and Insulator	4-76	1972-74 Vega T.C.S. Relay	4-115
1973-75 Vega—Monza 4-Spd. Control Rod Linkage	4-77	1972-75 Vega—Monza Control Lever	4-116
Turbo-Hydra-Matic (250) Case Extension and Planet Carrier Parts	4-78	1962-70 Aluminum Powerglide Transmission Case and Linkage	4-118
Turbo Hydra-Matic 250 Pump, Forward and Direct Clutch and Center Supports	4-80	1962-70 Aluminum Powerglide Transmission—Exploded	4-119
Turbo Hydra-Matic (250) Front & Rear Servos & Control Valve	4-82	1962-70 Aluminum Powerglide Transmission Case—Exploded	4-120
1969-73 Turbo Hydra-Matic 350 Case, Extension & Planet Carrier Parts	4-84	1962-70 Aluminum Powerglide Transmission Valve Body—Exploded	4-121
1969-73 Turbo Hydra-Matic 350 Pump, Forward & Direct Clutch	4-86	1962-70 Aluminum Powerglide Transmission Governor—Exploded	4-122
1969-73 Turbo Hydra-Matic 350 Front & Rear Servos & Control Valve	4-88	1970-73 Powerglide Transmission Assy.	4-124
Turbo Hydra-Matic 375-400 Case, Extension & Planet Carrier Parts	4-90	1970-73 Powerglide Transmission Assy. Torque Drive Transmission (Internal Mechanism)	4-126
Turbo Hydra-Matic 375-400 Pump, Forward & Direct Clutch & Center Support	4-92	1971-73 Torque Transmission Case	4-128
Turbo Hydra-Matic 375-400 Front & Rear Servos & Control Valve	4-94	Torque Planet Carrier	4-130
Turbo Hydra-Matic Parking Lock & Range Selector Parts	4-95	Torque Drive Governor	4-131
1966-67 Turbo-Hydrumatic Trans. Controls—Floor Console	4-96	Torque Drive Valve Body Exploded	4-132
1967-68 Turbo-Hydrumatic Trans. Controls—Column Shift	4-97	1971-73 Torque Drive Linkage	4-133
1969 Passenger T.H. 350 Transmission Control Linkage & Adjustment	4-98	1964-66 Passenger Power Glide Floor Shift Control Lever	4-134
1970 Passenger 3-Spd. Auto. Trans. Adjustment Linkage	4-99	1965-69 Passenger Powerglide Throttle Control & Modulator Pipe	4-135
1969-70 Nova Floor Shift T.H. 350 Transmission Control Linkage	4-100	1965-66 Pass.—P.G. Dial Indicator	4-136
1968-69 Camaro Turbo Hydra-Matic Floor Shift—(Exc. Console)	4-101	1967 Passenger P.G. Trans. Dial Indicator	4-137
1968-69 Camaro Turbo Hydra-Matic Transmission Controls Floor Shift	4-101	1965-66 Passenger Powerglide Transmission Control	4-138
1970 Passenger 3-Spd. Auto. Trans.—Neutral Safety Switch & Wiring	4-102	1965-66 Passenger Powerglide Transmission Control Linkage	4-138
1974 Pass. Gear Shift Controls	4-103	1965-67 Passenger Powerglide Transmission Controls—Exploded	4-139
1974 Passenger w/T.H. 350, 375, 400	4-103	1967-68 Passenger Powerglide Transmission Control Linkage	4-140
1974-75 Chevelle Gear Shift Controls, Column Shift	4-104	1968-69 Passenger Automatic Transmission Shift Lever	4-141
1974-75 Chevelle w/Floor Console Gearshift Control — Console Shifter Cable	4-104	1969 Passenger Powerglide Transmission Control Linkage	4-142
1973-75 Chevelle Camaro Control Linkage Adjustment (M38/40)	4-105	1964-67 Chevelle Powerglide Linkage (Floor Shift)	4-143
1974 Camaro w/Floor Console Gearshift Controls, Console Shifter	4-106	1964-67 Chevelle Powerglide Controls (Floor Shift)	4-144
1974 Camaro Steering Column Lock Controls	4-106	1968-69 Chevelle Powerglide Controls Floor Shift	4-144
1974 Camaro w/Floor Console Gearshift Controls Console Shifter Cable	4-107	1964-69 Chevelle Powerglide Transmission Controls (6 Cyl.)	4-145
1973-74 Nova Control Lever & Rod	4-108	1966-67 Chevy II Auto. Trans. Dial Indicator	4-146
1974 Nova w/TH 350 — Control Rod Linkage	4-109	Chevy II Nova Powerglide Transmission Linkage (Typical)	4-147
1974 Chevelle w/T.H. 400 Trans. Control Switch	4-110	1967 Camaro Powerglide Floorshift Controls	4-148
1972-74 Vega T.H. 350 Mounting and Support	4-111	1967-68 Torque Drive Transmission Shift Controls	4-149
1972-74 Vega Transmission Safety, Back-Up Lamp, and Seat Belt Warning Switch	4-111	1968-69 Camaro Powerglide Control Lever and Cable	4-150
1972-73 Vega Control Linkage	4-112	1967-69 Camaro Automatic Transmission Indicator Tilt Wheel	4-150
		1970-72 Camaro Powerglide Transmission Controls	4-151
		1970 Nova Neutral Starting Switch	4-151
		1970 Passenger Powerglide Trans.—Neutral Safety Switch & Wiring	4-152
		1970 Chevelle Automatic Trans. Neutral Safety Switch	4-152
		1970-73 Camaro Powerglide Transmission Controls	4-153
		1971-73 Vega Powerglide and Torque Transmission Mounting and Support	4-154
		1971-73 Vega Control Linkage	4-155
		1971-73 Vega Control Linkage	4-156

TITLE	PAGE	TITLE	PAGE
1971-73 Vega Modulator Pipe and Oil Filler Gauge .....	4-157	1974 Chevelle Stop Lamp Switch .....	4-172
1971-73 Vega Transmission Safety, Back-up Lamp, and Seat Belt Warning Switch .....	4-158	1974 Camaro Brake Pedal and Bracket .....	4-172
1971-72 Vega Control Lever Unlighted .....	4-159	1970 Passenger Parking Brake .....	4-173
1972-73 Vega Control Lever Lighted .....	4-160	1964-67 Chevelle Parking Brake .....	4-174
<b>BRAKES</b>			
Passenger Self Adjusting Brake (Typical) Caliper Assy.—Exploded .....	4-162	1965-67 Chevy Parking Brake Control Linkage .....	4-175
1970-75 Single Piston Caliper Assy. ....	4-163	1967-69 Camaro Parking Brake .....	4-176
1964-66 Brake Master Cylinder (Exploded) .....	4-164	1974 Passenger Parking Brake Pedal and Front Cable Assy. ....	4-177
1967-74 Brake Master Cylinder (Exploded) .....	4-164	1974-75 Passenger Brake Pedal, Brake Cylinder Bracket .....	4-177
1971-75 Vega—Monza Main Cylinder Assy. ....	4-165	1971-75 Vega—Monza Parking Brake Lever & Equalizer .....	4-178
Rear Wheel Cylinder .....	4-166	1971-75 Vega—Monza Parking Brake Rear Cable Retainers .....	4-178
1967-69 Camaro Brake Pedal Details .....	4-167	Bendix Power Brake Cylinder—Exploded .....	4-179
1970-74 Camaro Brake Pedal .....	4-168	1964-72 Moraine Power Brake Piston—Exploded .....	4-180
1971-75 Vega—Monza Brake Pedal and Bracket .....	4-169	1965-66 Pass.—Power Brake Cylinder & Pipes .....	4-180
1974 Chevelle Parking Brake Control Assy. ....	4-170	1970 Passenger Brake Cylinder, Bracket & Pressure Switch Assy. ....	4-181
1974-75 Chevelle Brake Pedal, Push Rod, and Stop Lamp Switch Bracket .....	4-170	1970 Passenger Brake Pedal .....	4-182
1974 Nova Brake Pedal and Bracket .....	4-171	1970 Passenger Disc Brakes—Front .....	4-182
		1974 Front Disc Brake .....	4-183



# CHEVROLET CHASSIS GROUP 5.000



## BRAKES — REAR AXLE — PROPELLER SHAFT — WHEELS

### ALPHABETICAL INDEX

A	D
ADAPTER, Tire Traction..... 5.885	DAMPER ASSY., Propeller Shaft Damper..... 5.544A
ARM ASSY., Rear Axle Control..... 5.382	DAMPER UNIT, Rear Axle Control Arm..... 5.383
ARM, Rear Axle Control Arm..... 5.380	DAMPER UNIT, Universal Joint..... 5.555
	DEFLECTOR, Propeller Shaft Pinion..... 5.545
	DISC, Front and Rear Wheel Brake..... 5.809
	DISPENSER ASSY., Tire Traction..... 5.885
	DRUM ASSY., Front and Rear Wheel Brake... 5.809
	<b>E</b>
	EMBLEM, Wheel Cover Appearance..... 5.871
	EXTENSION, Tire Valve..... 5.875
	<b>F</b>
	FLANGE, Propeller Shaft Pinion..... 5.545
	<b>G</b>
	GASKET, Axle Filler and Drain..... 5.400
	GASKET, Axle Housing to Differential Carrier (paper)..... 5.508
	GASKET, Axle Housing Cover (Cork)..... 5.399
	GASKET, Axle Housing Flange..... 5.819
	GASKET, Flange Plate..... 5.002
	GEAR ASSEMBLY, Ring and Pinion (not sold separately)..... 5.529
	GEAR, Differential Pinion..... 5.526
	GEAR, Differential Side..... 5.528
	GEAR UNIT, Differential Side with Pinion..... 5.527
	GREASE CAP, Wheel..... 5.858
	GUIDE, Differential Clutch (Positraction)..... 5.511
	<b>H</b>
	HARNES ASSY., Tire Traction..... 5.885
	HOSE, Tire Traction..... 5.885
	HOUSING, Rear Axle..... 5.387
	HUB CAP, Wheel..... 5.858
	HUB, Wheel Cover Appearance..... 5.871
	<b>I</b>
	INFLATER ASSY..... 5.880
	INSERT, Wheel Cover Appearance..... 5.871
	INSULATOR UNIT, Brake Shoe..... 5.018
<b>B</b>	
BALL UNIT, Universal..... 5.548	
BEARING and CUP UNIT, Universal..... 5.548	
BEARING ASSY., Drive Pinion Rear..... 5.484	
BEARING ASSY., Drive Pinion-Front..... 5.447	
BEARING ASSY., Rear Wheel..... 5.855	
BEARING, Differential Side..... 5.536	
BEARING, Rear Axle Shaft Bearing or Hub..... 5.822	
BEARING, Universal Joint Yoke Trunnion..... 5.566	
BOLT, Brake Shoe Anchor Pin..... 5.056	
BOLT, Differential Carrier Cap..... 5.506	
BOLT, Flange Plate..... 5.002	
BOLT, Hub or Drum (Front and Rear Wheel).. 5.812	
BOLT, Propeller Shaft Damper..... 5.544A	
BOLT, Rear Axle U Joint..... 5.428	
BOLT, Rear Axle Control Arm..... 5.383	
BOLT, Rear Axle Tie Rod..... 5.418	
BOLT, Ring Gear..... 5.531	
BOLT, 'U' Joint Trunnion and Yoke..... 5.586	
BRACKET, Brake Flange Front..... 5.001	
BRACKET, Rear Axle Control Arm..... 5.380	
BRACKET, Rear Axle Tie Rod..... 5.418	
BRACKET, Rear Axle..... 5.395	
BUMPER, Rear Axle..... 5.395	
BUSHING ASSY., Rear Axle Control Arm..... 5.381	
BUSHING ASSY., Rear Axle..... 5.417	
BUSHING UNIT, Rear Axle Control Arm..... 5.380	
<b>C</b>	
CABLE ASSY., Rear Axle Lateral Movement-(Stop)..... 5.410	
CAGE, Differential Clutch (Positraction)..... 5.511	
CAP, Tire Valve..... 5.875	
CASE, Differential and Planet..... 5.510	
CLAMP, Rear Axle Control Arm..... 5.383	
CLAMP, Rear Axle..... 5.638	
CLIP, Brake Shoe Anchor Pin..... 5.056	
CLIP, Wheel Cover Appearance..... 5.871	
CLUTCH UNIT, Differential Clutch (Positraction)..... 5.511	
CONTAINER ASSY., Tire Traction..... 5.885	
COVER, Axle Housing with Filler Plug..... 5.398	
COVER, Brake Adjusting Hole..... 5.117	
COVER, Wheel..... 5.858	
CUP, Differential Clutch (Positraction)..... 5.511	
CUSHION, Rear Axle..... 5.395	



## ALPHABETICAL INDEX

INSULATOR, Wheel Cover Appearance..... 5.871

### L

LEVER, Brake Shoe Automatic Adjusting..... 5.103  
 LEVER, Parking Brake Shoe..... 5.149  
 LINING UNIT, Brake Shoe..... 5.018  
 LINK, Brake Shoe Automatic Adjusting Lever..... 5.105  
 LOCK, Axle Shaft..... 5.422  
 LOCK, Brake Shoe Anchor Pin..... 5.056  
 LOCK RING, 'U' Joint Trunnion and Yoke..... 5.586  
 LUBRICANT, Hypoid Gear..... 5.535

### M

MEMBER, Rear Axle Control Arm..... 5.380

### N

NUT ASSY., Wheel Cover Appearance..... 5.871  
 NUT, Brake Shoe Anchor Pin..... 5.056  
 NUT, Brake Shoe Hold Down..... 5.043A  
 NUT, Flange Plate..... 5.002  
 NUT, Hub-Front and Rear..... 5.813  
 NUT, Propeller Shaft Damper..... 5.544A  
 NUT, Propeller Shaft Pinion Flange..... 5.595  
 NUT, Rear Axle Control Arm..... 5.383  
 NUT, Rear Axle Tie Rod..... 5.418  
 NUT, 'U' Joint Trunnion and Yoke..... 5.586

### O

ORNAMENT, Wheel Cover Appearance..... 5.871

### P

PIN, Brake Shoe Anchor..... 5.055  
 PIN, Brake Shoe..... 5.043  
 PIN UNIT, Brake Shoe Hold Down..... 5.043A  
 PIVOT, Brake Shoe Automatic Adjusting..... 5.103  
 PLATE ASSEMBLY, Brake Flange Front..... 5.001  
 PLATE, Brake Shoe Guide..... 5.045  
 PLATE, Differential Clutch (Positraction)..... 5.511  
 PLUG, Axle Filler and Drain..... 5.400

### R

REINFORCEMENT, Rear Axle Control Arm..... 5.380  
 REINFORCEMENT, Rear Axle Control..... 5.382  
 REINFORCEMENT, Wheel Cover Appearance..... 5.871  
 REPAIR KIT, Rear Axle U Joint..... 5.428  
 REPAIR KIT, Universal..... 5.548  
 RETAINER..... 5.880  
 RETAINER, Brake Shoe..... 5.043  
 RETAINER, Rear Axle Bumper..... 5.394  
 RETAINER, Rear Axle Shaft Bearing..... 5.816  
 RETAINER, Wheel Cover Appearance..... 5.871  
 RING ASSY., Wheel Cover Appearance..... 5.871  
 RING, Differential Clutch (Positraction)..... 5.511  
 ROD ASSY., Rear Axle..... 5.415  
 ROLLER, Rear Axle U Joint..... 5.428  
 ROLLER, Universal Joint Yoke Trunnion..... 5.566

### S

SCREW, Axle Filler and Drain..... 5.400  
 SCREW, Axle Housing with Filler Plug..... 5.398  
 SCREW, Brake Shoe Adjusting..... 5.110  
 SCREW, Pinion Shaft Lock..... 5.518  
 SCREW, Wheel Cover Appearance..... 5.871  
 SEAL ASSY., Drive Pinion..... 5.469  
 SEAL, Propeller Shaft Universal Joint Trunnion..... 5.560  
 SEAL, Rear Axle Shaft Bearing or Hub..... 5.822  
 SHAFT, Axle..... 5.420  
 SHAFT, Differential Pinion..... 5.517  
 SHAFT, Rear Propeller (Shaft attaches to rear axle)..... 5.441  
 SHAFT, Rear Propeller (Shaft attaches to rear axle)..... 5.544  
 SHIELD, Flange Plate..... 5.002  
 SHIELD, Pinion Flange..... 5.468  
 SHIM, Differential Clutch (Positraction)..... 5.511  
 SHIM, Pinion Shaft Bearing..... 5.460  
 SHIM, Rear Axle Control Arm..... 5.380  
 SHIM UNIT, Differential Bearing Adjusting..... 5.537  
 SHOE & LINING PACKAGE, Brakes..... 5.017  
 SHOE UNIT, Brake With Facing, Metallic..... 5.017  
 SLEEVE, Wheel Cover Appearance..... 5.871  
 SLINGER, Propeller Shaft Pinion..... 5.545  
 SOCKET, Brake Shoe Adjusting Screw..... 5.111  
 SPACER, Differential Bearing Adjusting..... 5.537  
 SPACER, Differential Clutch (Positraction)..... 5.511  
 SPACER, Flange Plate..... 5.002  
 SPACER, Pinion Shaft Bearing..... 5.453  
 SPACER, Rear Axle Bumper..... 5.394  
 SPACER, Rear Axle Control Arm..... 5.383  
 SPACER, Rear Axle Lateral Movement-(Stop)..... 5.410  
 SPACER, Rear Axle Tie Rod..... 5.418  
 SPACER, Universal Joint Yoke Trunnion..... 5.566  
 SPACER, Wheel Cover Appearance..... 5.871  
 SPOKE ASSY., Wheel Cover Appearance..... 5.871  
 SPRING, Brake Drum..... 5.810  
 SPRING, Brake Shoe Automatic Adjusting Lever..... 5.107  
 SPRING, Brake Shoe Hold Down..... 5.043A  
 SPRING, Brake Shoe..... 5.026  
 SPRING, Differential Clutch (Positraction)..... 5.511  
 SPRING KIT, Brake Shoe Hold Down..... 5.043A  
 SPRING, Parking Brake Shoe Lever..... 5.151  
 STEM ASSY., Tire Valve..... 5.875  
 STOP, Rear Axle..... 5.395  
 STRAP, 'U' Joint Trunnion and Yoke..... 5.586  
 STRUT, Parking Brake Shoe Lever..... 5.150  
 STUD, Hub or Drum (Front and Rear Wheel)..... 5.812  
 STUD, Rear Axle Tie Rod..... 5.418  
 SUPPORT MOUNTING, Rear Axle Control Arm..... 5.380  
 SWITCH ASSY., Tire Traction..... 5.885

### T

TAG, Axle Filler and Drain..... 5.400

### U

UNIT, Brake Shoe Adjusting..... 5.110  
 UNIT, Rear Propeller (Shaft attaches to rear axle)..... 5.544  
 UNIT, Rear Wheel Spacer..... 5.811

### V

VENTILATOR, Rear Axle..... 5.387

# ALPHABETICAL INDEX

## W

WASHER, Brake Shoe Adjusting.....	5.110
WASHER, Brake Shoe Anchor Pin.....	5.056
WASHER, Differential Pinion Thrust.....	5.542
WASHER, Differential Side with Pinion.....	5.527
WASHER, Differential Side Gear Thrust.....	5.543
WASHER, Parking Brake Lever Anchor.....	5.158
WASHER, Pinion Shaft Bearing.....	5.453
WASHER, Pinion Shaft Lock.....	5.518
WASHER, Propeller Shaft Damper.....	5.544A
WASHER, Propeller Shaft Pinion Flange.....	5.595
WASHER, Propeller Shaft Pinion.....	5.545
WASHER, Rear Axle Control Arm.....	5.381
WASHER, Rear Axle Control Arm.....	5.383
WASHER, Rear Axle Tie Rod.....	5.418
WEIGHT, Wheel Balance.....	5.805
WHEEL, Front or Rear.....	5.803

## Y

YOKE, Universal Joint.....	5.555
----------------------------	-------



## BRAKES—REAR AXLE AND DRIVE

The axles for Chevrolet will be built by Chevrolet Buffalo, Chevrolet Gear and Axle, Buick, Oldsmobile and McKinnon. Divisional Manufacturer code letters will be metal stamped on the axle tube adjacent to the carrier for field identification. (See Example). Metal stamp on left rear axle tube on rear side, letters and numerals 3/16" high, 3" outboard of carrier.

### FIELD IDENTIFICATION

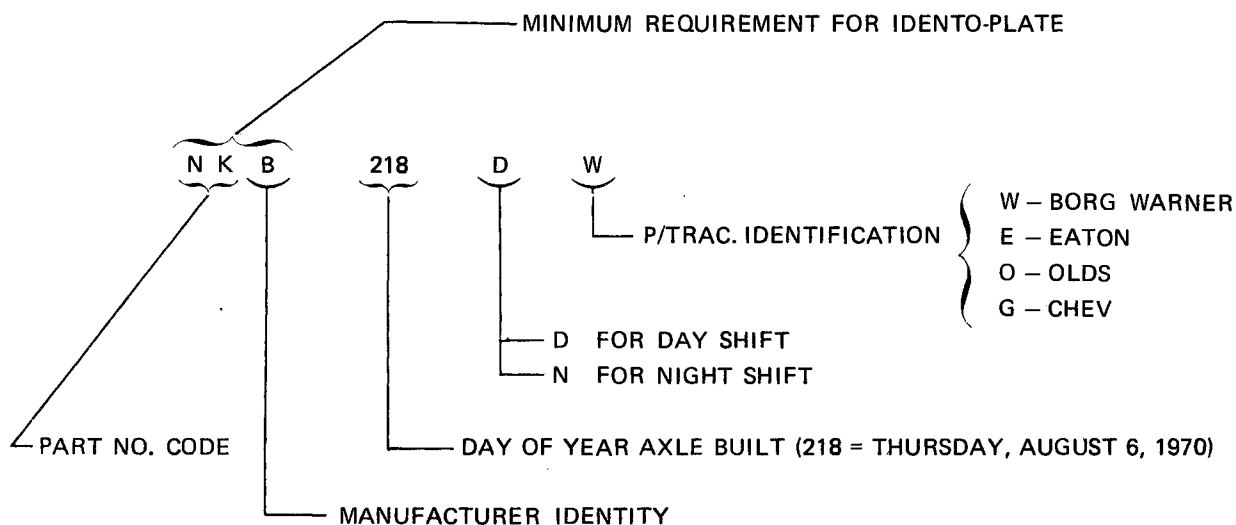

### MANUFACTURER IDENTITY

- B - Buick
- O - OLDSMOBILE
- P - PONTIAC
- G - CHEVROLET GEAR AND AXLE
- C - CHEVROLET BUFFALO
- K - GM OF CANADA, ST. CATHARINES
- M - GM OF CANADA

MANUFACTURERS IDENTIFICATION WILL APPEAR IN THE DESCRIPTION COLUMN.

#### EXAMPLE:

72 PASS. w/2.73, 3.08, 3.42 Ratio ..... 7451409 ..... 2 BEARING ASSY. (TYPE P, B, O).

**BRAKES—REAR AXLE AND DRIVE**

**5.001 PLATE ASSEMBLY— BRACKET, Brake Flange Front**

**FRONT**

<b>65-70</b>	Pass. (exc. Disc Brakes) . . . . .	<b>3980463</b>	L.H.	8.50	L.H. . . . .
<b>65-70</b>	Pass. (exc. Disc Brakes) . . . . .	<b>3980464</b>	R.H.	8.00	R.H. . . . .
<b>67-70</b>	Chevy, Chevelle, Camaro (exc. Disc Brakes),				
<b>71-72</b>	Chevelle, Nova (exc. Disc Brakes),				
<b>73-74</b>	Nova (exc. Disc Brakes) . . . . .	<b>3902949</b>	L.H.	5.85	front . . . . .
<b>67-70</b>	Chevy, Chevelle, Camaro (exc. Disc Brakes),				
<b>71-72</b>	Chevelle, Nova (exc. Disc Brakes),				
<b>73-74</b>	Nova (exc. Disc Brakes) . . . . .	<b>3902950</b>	R.H.	5.10	front . . . . .
<b>68-70</b>	Pass. w/Disc Brake . . . . .	<b>3974858</b>	2	10.00	<b>BRACKET</b> , caliper adapter (Single Piston Design) . . . . .
<b>69-71</b>	Chevy, Chevelle, Camaro w/Disc Brk.,				
<b>72</b>	Chevelle, Nova w/Disc Brake,				
<b>73-74</b>	Nova w/Disc Brakes . . . . .	<b>5470660</b>	L.H.	11.10	<b>BRACKET ASSY.</b> , front caliper adapter (1-piece integral hub and disc assy.) . . . . .
<b>69-71</b>	Chevy, Chevelle, Camaro w/Disc Brk.,				
<b>72</b>	Chevelle, Nova w/Disc Brake,				
<b>73-74</b>	Nova w/Disc Brakes . . . . .	<b>5470661</b>	R.H.	10.10	<b>BRACKET ASSY.</b> , front caliper adapter (1-piece integral hub and disc assy.) . . . . .

**REAR**

<b>64-70</b>	Chevy, Chevelle, Camaro (exc. Disc Brakes),				
<b>71-72</b>	Chevelle, Nova, Camaro,				
<b>73-75</b>	Nova, Camaro . . . . .	<b>3996103</b>	L.H.	6.90	rear (Note 1) . . . . .
<b>64-70</b>	Chevy, Chevelle, Camaro (exc. Disc Brks.),				
<b>71-72</b>	Chevelle, Nova, Camaro,				
<b>73-75</b>	Nova, Camaro . . . . .	<b>3996104</b>	R.H.	10.30	rear (Note 1) . . . . .
<b>65</b>	Chevelle (396),				
<b>65-70</b>	Pass. . . . .	<b>3921171</b>	L.H.	6.75	left . . . . .
<b>65</b>	Chevelle (396),				
<b>65-70</b>	Pass. . . . .	<b>3921172</b>	R.H.	6.75	right . . . . .
<b>70</b>	Monte Carlo w/10 bolt cut out cover,				
<b>73-75</b>	Chevelle (exc. Sta. Wag.) . . . . .	<b>2620563</b>	L.H.	11.35	left (repl. 5469279) (Note 1) . . . . .
<b>70</b>	Monte Carlo w/10 bolt cut out cover,				
<b>73-75</b>	Chevelle (exc. Sta. Wag.) . . . . .	<b>2620564</b>	R.H.	11.35	right (Note 1) . . . . .
<i>NOTE 1: See illustration preceding Group 5.398 for identification of axle cover.</i>					
<b>71-74</b>	Pass. w/2.73, 3.08 ratio (exc. Sta. Wag.) . . . . .				(type G, K, C) . . . . .
<b>71-74</b>	Pass. w/2.73, 3.08, 3.42 ratio (exc. Sta. Wag., Taxi, Police),				
<b>73-74</b>	Chevelle (Sta. Wag.) . . . . .	<b>5472324</b>	L.H.	15.50	(type B, O, P, M) . . . . .
<b>71-74</b>	Pass. w/2.73, 3.08 ratio (exc. Sta. Wag.) . . . . .				(type G, K, C) . . . . .
<b>71-74</b>	Pass. w/2.73, 3.08, 3.42 ratio (exc. Sta. Wag., Taxi, Police),				
<b>73-74</b>	Chevelle (Sta. Wag.) . . . . .	<b>5472325</b>	R.H.	15.50	(type B, O, P, M) . . . . .
<b>71-72</b>	Pass. (Sta. Wag.) w/2.73, 3.08, 3.42 ratio,				
<b>71-72</b>	Police, Taxi w/2.73, 3.08, 3.42 ratio . . . . .	<b>5472318</b>	L.H.	18.80	(type P, M) . . . . .
<b>71-72</b>	Pass. (Sta. Wag.) w/2.73, 3.08, 3.42 ratio,				
<b>71-72</b>	Police, Taxi w/2.73, 3.08, 3.42 ratio . . . . .	<b>5472319</b>	R.H.	18.80	(type P, M) . . . . .
<b>71-75</b>	Vega, Monza . . . . .	<b>3982209</b>	L.H.	5.90	
<b>71-75</b>	Vega, Monza . . . . .	<b>3982210</b>	R.H.	5.90	
<b>73-75</b>	Pass. (Sta. Wag.),				
<b>73-75</b>	Police, Taxi . . . . .	<b>2620575</b>	L.H.	18.80	(type P, M) (12 x 2) . . . . .
<b>73-75</b>	Pass. (Sta. Wag.),				
<b>73-75</b>	Police, Taxi . . . . .	<b>2620576</b>	R.H.	18.80	(type P, M) (12 x 2) . . . . .
<b>75</b>	Chevelle,				
<b>75</b>	Pass. w/2.73, 3.08 ratio (exc. Sta. Wag.) . . . . .				(type G, K, C), . . . . .

**BRAKES—REAR AXLE AND DRIVE**

**5.001 PLATE ASSEMBLY— BRACKET, Brake Flange Front (Con't)**

75	Pass. w/2.56, 2.73, 3.08 ratio (exc. Sta. Wag., Taxi, Police) . . .	<b>2623587</b> L.H.	15.55	(type B, O) (11 x 2) . . . . .
75	Chevelle, Pass. w/2.73, 3.08 ratio (exc. Sta. Wag.) . . . . .			(type G, K, C), . . . . .
75	Pass. w/2.56, 2.73, 3.08 ratio (exc. Sta. Wag., Taxi, Police) . . .	<b>2623588</b> R.H.	15.55	(type B, O) (11 x 2) . . . . .

**PARK BRAKE**

68-69	Camaro w/Disc Brake-Front and Rear . . . . .	<b>5465983</b> 2	7.15	park brake flange right and left . . . . .
-------	---	------------------	------	--

**5.002 BOLT— GASKET— NUT— SHIELD— SPACER, Flange Plate**

62-69	All w/Disc Brake . . . . .	<b>9424069</b> A.R.	.24	front brake caliper ( <sup>7</sup> / <sub>16</sub> "— 14 x 1 <sup>1</sup> / <sub>4</sub> "— (8.900) . . . . .
62-63	Chevy . . . . .	<b>3697704</b> 8	.16	rear flange plate ( <sup>3</sup> / <sub>8</sub> "— 24 x <sup>31</sup> / <sub>32</sub> "— (5.531) . . . . .
64-67	Chevy, Chevelle . . . . .	<b>3815933</b> 2	.63	front flange plate ( <sup>7</sup> / <sub>16</sub> "— 20 x 2 <sup>1</sup> / <sub>8</sub> "— (0.662) . . . . .
64	Chevelle . . . . .	<b>454977</b> 2		front flange, short ( <sup>7</sup> / <sub>16</sub> "— 20 x 1 <sup>31</sup> / <sub>32</sub> " ) . . . . .
65-72	Pass. (exc. Disc Brake), 69 Camaro (exc. Disc Brakes), 69-72 Chevy, Chevelle (exc. Disc Brks.), 73-74 Nova (exc. Disc Brakes) . . . . .	<b>3871512</b> A.R.	.27	front flange plate ( <sup>1</sup> / <sub>2</sub> "— 20 x 2 <sup>21</sup> / <sub>32</sub> " hex. hd.) . . . . .
65-70	Pass. (exc. Disc Brake), 67-68 Chevy, Chevelle, Camaro . . . . .			frt. flange plate ( <sup>1</sup> / <sub>2</sub> "— 20 x 2 <sup>5</sup> / <sub>32</sub> " hex. hd.) (Note 1), . . . . .
67	Chevy, Camaro (Disc Brakes w/Spl. Strg.), 67 Camaro w/H.D. Brakes (302) . . . . .			front flange plate upper, . . . . .
67	Chevy, Chevelle (exc. Disc Brakes), 68 Chevy, Chevelle, Camaro, 69 Chevy, Camaro . . . . .	<b>331421</b> A.R.	.32	front flange plate short . . . . .
65-70	Pass. w/Disc Brake . . . . .	<b>3864119</b> 2	.34	front caliper adapter bracket ( <sup>11</sup> / <sub>16</sub> "— 16 x <sup>7</sup> / <sub>8</sub> " ) . . . . .
67-68	Chevy, Camaro, 67-70 Pass., Chevelle, 70-72 Nova, 71-72 Chevelle . . . . .			front flange plate long ( <sup>1</sup> / <sub>2</sub> "— 20 x 2 <sup>1</sup> / <sub>2</sub> " ), . . . . .
73-74	Nova (exc. Disc Brakes) . . . . .	<b>1385922</b> A.R.	.59	front flange plate short . . . . .
67-72	Nova, Chevelle w/Disc Brakes, 67-69 Camaro w/Disc Brakes, Spl. Strg., Hyd. Strg., H.D. Brakes, Spl. Eng., 73-74 Nova w/Disc Brakes . . . . .	<b>1381744</b> 2	.71	frt. brake caliper adapter bracket ( <sup>5</sup> / <sub>8</sub> "— 18 x <sup>19</sup> / <sub>32</sub> " ) . . . . .
69	Camaro (exc. Disc Brks.), 69-70 Nova (exc. Disc Brakes) . . . . .	<b>3954396</b> 2	.53	frt. brk. ( <sup>1</sup> / <sub>2</sub> "— 20 x 2 <sup>7</sup> / <sub>32</sub> " )— (6.104) . . . . .
71-75	Pass., 73-75 Chevelle (Sta. Wag.) . . . . .	<b>1234817</b> 8	.18	rear flange plate . . . . .
74	Vega (122) . . . . .	<b>345631</b> 8	.27	rear flange plate and brake . . . . .
75	Chevelle . . . . .	<b>1378943</b> 8	.24	brg. retainer & brk. assy. to axle ( <sup>3</sup> / <sub>8</sub> "— 24 x 1) . . . . .
75	Pass. . . . .	<b>409845</b> 8	.27	brg. retainer & brk. assy. to axle ( <sup>7</sup> / <sub>16</sub> "— 14 x <sup>1</sup> / <sub>8</sub> " ) . . . . .
64-72	Chevy, Chevelle w/Disc Brake, 67-69 Camaro w/Disc Brake, 73-74 Nova . . . . .	<b>579092</b> 2	.12	<b>GASKET</b> , flange plate to strg. knuckle, frt. brk. disc splash shield . . . . .
65-68	Pass. . . . .	<b>3828581</b> 2	.16	<b>GASKET</b> , knuckle . . . . .
68	Pass. w/Disc Brake (exc. P.B.), 69-70 Pass. w/Disc Brake . . . . .			<b>GASKET</b> , frt. brake disc splash shield, . . . . .
69-70	Pass. (exc. Disc Brk.) . . . . .	<b>3953431</b> 2	.16	strg. knuckle to front brk. flange plate . . . . .
70-75	Camaro, 71-75 Pass., 73-75 Chevelle, 75 Nova . . . . .	<b>3966202</b> 2	.11	<b>GASKET</b> , frt. brk. disc splash shield to steering knuckle . . . . .
71-75	Vega, Monza . . . . .	<b>326883</b> 2	.13	<b>GASKET</b> , frt. brk. disc splash shield . . . . .
70	Monte Carlo w/10 bolt cut out cover . . . . .	<b>9422298</b> 8	.11	<b>NUT</b> , rear brk. to axle housing (Note 2) . . . . .

*NOTE 2 See illustration preceding Group 5.398 for identification of axle cover.*

**BRAKES—REAR AXLE AND DRIVE**

**5.002 BOLT— GASKET— NUT— SHIELD— SPACER, Flange Plate (Con't)**

74	Vega (122) .....	345633	8	.11	NUT, rear flange plate and brake .....
75	Pass. ....	2482399	8	.38	NUT, rear brk. to axle hsg. (7/16" — 14) .....
67-68	Chevy, Chevelle w/Disc Brake, Special Steering,				
67-68	Camaro w/Disc Brakes, Spl. Strg., Hyd. Strg., Spl. Eng. (exc. Front and rear Disc) .....	1381723	L.H.	4.05	SHIELD, w/deflector, front brake disc splash .....
68-70	Pass. w/Disc Brake .....	3953422	R.H.	3.69	SHIELD, front, right disc splash (Single Piston Design) .....
68-70	Pass. w/Disc Brake .....	3953421	L.H.	3.69	SHIELD, front, left disc splash (Single Piston Design) .....
71-75	Vega, Monza .....	326897	L.H.	3.85	SHIELD, frt. brk. disc splash .....
71-75	Vega, Monza .....	326898	R.H.	3.85	SHIELD, frt. brk. disc splash .....
70-72	Camaro, 71-72 Pass.,				
73-75	Pass., Chevelle, Camaro, 75 Nova .....	344023	L.H.	3.20	SHIELD, front brk. disc splash left .....
70-72	Camaro, 71-72 Pass.,				
73-75	Pass., Chevelle, Camaro, 75 Nova .....	344024	R.H.	3.20	SHIELD, front brk. disc splash right .....
69-72	Chevelle w/Disc Brakes, 69-72 Chevy w/Disc Brakes, 69 Camaro w/Disc Brakes (exc. Front and Rear),				
73-74	Nova w/Disc Brakes .....	5463565	L.H.	6.10	SHIELD ASSY., front left disc splash .....
69-72	Chevelle w/Disc Brakes, 69-72 Chevy w/Disc Brakes, 69 Camaro w/Disc Brakes (exc. Front and Rear),				
73-74	Nova w/Disc Brakes .....	5463566	R.H.	6.10	SHIELD ASSY., front right disc splash .....
71-74	Pass. ....	329317	L.H.	8.75	SHIELD ASSY., frt. brk. disc splash (Note 3)
71-74	Pass. ....	329318	R.H.	8.75	SHIELD ASSY., frt. brk. disc splash (Note 3)
<i>NOTE 3: Used under unusual or heavy duty road conditions.</i>					
68	Camaro w/Disc Brakes-Front and Rear .....	3945189	A.R.	5.05	SPACER, rear brake caliper .....

**5.017 SHOE UNIT, Brake With Facing, Metallic**

*NOTE Metallic linings are double sintered as compared to the single and much larger sintered cerametalix linings.*

64-67	Chevy, Chevelle, Camaro w/Metallic Linings .....	3845291	1	35.25	front (primary and secondary) (bonded) .....
64-67	Chevelle, Camaro, Chevy w/H.D. Brakes .....	3830635	1	35.25	rear (primary and secondary) (bonded) .....
65-67	Pass. ....	3794191	1	72.00	front (primary and secondary) (bonded) (11" x 2 <sup>3</sup> / <sub>4</sub> ") .....
65-67	Pass. ....	3794194	1	72.00	rear (primary and secondary) (11" x 2") (bonded) .....

**5.017 SHOE & LINING PACKAGE, Brakes**

*NOTE: In no case should a brake drum be turned down more than .030/.060 on dia.*

*The GM Merchandising Line of Tune-Up Kits, Shock Absorbers, and Brake Sets are shipped direct to dealers from the source, and are not stocked at GM Parts Division Distribution Centers.*

*There is a required minimum order quantity. Combination Tune-Up Kits, Brake Sets and Shocks orders may qualify based on weight.*

*All orders are shipped freight prepaid.*

*Orders must be written on a special order form which allows scheduling of four dealer shipments. Specific weights and qtys. are specified on order form.*

*All purchases accrue toward Dealer's parts return reserve.*

*Purchases are not eligible for wholesale compensation or stock order allowance.*

*GM Merchandising Line Parts are not returnable to GM Parts Division.*

*Merchandising Line Parts are warranted in accordance with current GM Parts Division parts policy.*

Yr.	Model Application .....	Mdse. No.		O.E.M. No. ....
62-63	Chevy .....	N.A.A.R.		3794193 (rr.) .....
62-63	Chevy .....	N.A.A.R.		3793859 (frt.) .....
64-68	Chevy, Chevelle, Camaro (exc. Disc Brks.),			
71-72	Nova (exc. Disc Brks.) .....	1154119	A.R.	N.L. 3998252 (frt.) (Note 3) .....
64-67	Chevy, Chevelle, Camaro, 68 All w/Finned frt. brk. drums, 69 All (exc. rr. Disc Brk.), 70 Nova, Chevelle, Camaro w/round cvt.,			

**BRAKES—REAR AXLE AND DRIVE**

**5.017 SHOE & LINING PACKAGE, Brakes (Con't)**

71-72	Chevelle, Camaro (exc. Disc Brk.),				
73-74	Camaro, Nova	1154120 A.R.	N.L.	3998250 (rr.) (Note 3)	
65-72	Nova	1154120 A.R.	N.L.	3998251 (rr.) (Note 3)	
65	Chevelle (S.S.) (396)	1154134 A.R.	N.L.	3849026 (frt. & rr.)	
65-70	Pass. (exc. Pol., Taxi, H.D.)	1154134 A.R.	N.L.	3849026 (rr.)	
65-70	Pass.	1154134 A.R.	N.L.	3849062 (rr.) (.030 O.S.)	
65-70	Pass. (exc. Taxi, H.D. Chassis, Disc Brk.)	1154123 A.R.	N.L.	3849027 (frt.) (11" x 2 <sup>3</sup> / <sub>4</sub> ")	
65-70	Pass. (exc. Disc Brk.)	1154123 A.R.	N.L.	3849056 (frt.) (11 x 2 <sup>3</sup> / <sub>4</sub> ") .030 O.S.	
67-68	Pass. w/Disc Brk. (4 piston design),				
67-68	Chevy, Chevelle, Camaro w/frt. Disc Brk. (exc. H.D.)	N.A. A.R.		5470879 (frt.) riveted	
68-72	Pass. w/Disc Brk. (single piston design),				
69-72	Chevy, Chevelle, Camaro w/frt. Disc Brk. (single piston),				
73-75	Pass. w/Disc Brk. (exc. H.D.),				
73	Nova w/Disc Brk.,				
74	Chevelle, Camaro, Nova (Pwr. Disc Brk.)	1154121 A.R.	N.L.	347051 (riveted)	
68-69	Camaro w/Disc Brk.-frt. & rr.	N.A. A.R.		5463579 (park. brk.) riveted	
68-69	All w/Finned frt. brk. drums,				
70-71	Nova, Chevelle w/Finned frt. brk. drums,				
72	Nova (exc. Disc Brks.)	1154119 A.R.	N.L.	2621336 (frt.) (riveted) (Note. 1)	
68-70	Pol. (exc. Disc Brks.)	N.A. A.R.		3851790 (frt.) bonded	
68-69	Pass. (P/Trac. w/3.07, 3.31, 3.55 axles),				
70	Pol., Taxi	N.A. A.R.		3852220 (rr.) bonded	
68-69	Camaro w/Disc Brk. (frt. & rr.)	1154122 A.R.	N.L.	2621609 (frt. & rr.) riveted	
70	Monte Carlo w/10 bolt cut out	1154120 A.R.	N.L.	2621339 (std.) riveted (Note 2)	
<i>NOTE 2: See illustration preceding Grp. 5.398 for identification of axle cvr.</i>					
71-75	Pass. w/2.73, 3.08, 3.42 ratio (exc. Sta. Wgn.),				
73-75	Chevelle (Sta. Wgn.)	1154391 A.R.		5472182 (rr.) riveted (11 x 2)	
71-75	Pass. (Sta. Wgn.)	1154392 A.R.		5472320 (rr) std. (12 x 2) riveted	
71-75	Pass. w/H.D. Disc Brks.	N.A. A.R.		2621607 (frt.)	
71-75	Vega, Monza	1154141 A.R.	N.L.	3987385 (rr.)	
71-75	Vega (Disc)	1154125 A.R.	N.L.	3451116 (frt.) (std. lining)	
71-75	Vega (Premium Lining)	1154398 A.R.		18001521	
72	Chevelle (exc. Disc Brk.)	1154119 A.R.	N.L.		
73-74	Nova (exc. Disc Brks.)	1154119 A.R.	N.L.	338318 (frt.) (riveted) (repl. 5460732)	
73-75	Chevelle	1154393 A.R.		2620554 (rr.) (9 <sup>1</sup> / <sub>2</sub> x 2")	
73-75	Chevelle, Camaro (Man. Disc)	1154395 A.R.		2620560 (frt.)	
74-75	Chevelle, Camaro w/Disc Brks. (exc. P.B.),				
75	Nova w/Disc Brks. (exc. P.B.)	1154395 A.R.		2621606 (frt.)	
75	Monza (Disc)	N.A. A.R.		361094 (frt.)	
75	Camaro, Nova	1154393 A.R.		357397 (rr.) (bonded)	
75	Chevelle, Camaro, Nova (P.B. w/Disc Brk.)	1154121 A.R.	N.L.	2621605 (frt.)	
<i>NOTE 1: Used on Nova w/H.D. Brks. for Year 1970 and 1972.</i>					
<i>NOTE 3: Used on Nova (exc. H.D. Brks.).</i>					

**5.018 LINING UNIT— INSULATOR UNIT, Brake Shoe**

70	Monte Carlo w/10 bolt cover	2621345	1	14.95	standard (riveted) (Note 2)
<i>NOTE 2: See illustration preceding Group 5.398 for identification of axle cover.</i>					
72-74	All w/Disc Brk.	231474	1	.96	<b>INSULATOR UNIT</b> , front (Note 1)
<i>NOTE 1: Unit contains an anti-squeak material which is cemented to the metal back of each brake pad and includes installation instructions.</i>					

**5.026 SPRING, Brake Shoe**

62	Chevy				rear, pull back (primary),
63	Chevy (exc. Metallic Linings, 327)	3790239 A.R.		.44	front and rear pull back (primary) (10 <sup>1</sup> / <sub>2</sub> " coils— 3 <sup>5</sup> / <sub>16</sub> " free length) (yellow)
62	Chevy	3707417 A.R.		.57	front and rear
65-70	Pass. (exc. Disc Brake),				
65	Chevelle (396),				
65	Chevy	3887347 A.R.		.29	adjusting screw, front and rear (2 <sup>3</sup> / <sub>32</sub> " O.L. green)
68-69	Camaro w/Disc Brakes-Front and Rear	5465943	4	.59	retractor, park brake pull back spring



**BRAKES—REAR AXLE AND DRIVE**

**5.026 SPRING, Brake Shoe (Con't)**

68-69	Camaro w/Disc Brakes-Front and Rear	5465944	2	.38	park brake adj. screw spring
71-75	Vega, Monza	3987384	1	.55	rear, pull back (Note 3)
73	Chevelle, Camaro,				frt. adjusting screw,
73	Nova (exc. Disc Brk.)			.88	rear brk. shoe adjusting screw
73-75	Camaro, Chevelle	5464695	2		<b>SPRING UNIT</b> , pull back front and rear (secondary),
63-70	Pass.				
65-67	Pass. w/Metallic Linings,				
65-69	Police, Taxi	3981988	A.R.	2.45	pull back, rear (primary) (red) (Note 3)
63	Chevy	3981991	2	2.35	<b>SPRING UNIT</b> (Note 3)
64-70	Chevy, Chevelle, Camaro,				
71	Chevelle, Nova,				
72	All (exc. Pass.),				
73-75	Chevelle (exc. Sta. Wag.),				
73-75	Nova (exc. Disc Brk.),				
73-75	Camaro	3981987	A.R.	2.35	<b>SPRING UNIT</b> , pull back, front and rear secondary (3 <sup>25</sup> / <sub>32</sub> " O.L.-green) (Note 3)
71-75	Pass. (Sta. Wag.) w/2.73, 3.08, 3.42 ratio,				
71-75	Police, Taxi w/3.08, 3.42 ratio	5472520	1	4.44	<b>SPRING UNIT</b> , rr. brake (12 x 2) (type P, M) (Note 4)
71-75	Pass. (exc. Sta. Wag.)	5472525	1	3.75	<b>SPRING UNIT</b> , rear brake (primary and secondary) (type B, O, C, G, K, W) (Note 4)
73-75	Chevelle (Sta. Wag.),				
73-75	Pass. (exc. Sta. Wag., Taxi, Police)	2620587	1	4.72	<b>SPRING UNIT</b> , rear brake (11 x 2) (primary and secondary) (Note 4)
63-69	Chevy, Chevelle, Camaro (exc. Metallic Brakes, Disc Brakes),				
70	Monte Carlo w/10 bolt cut out cover				secondary pull back (front and rear) (Note 1),
73	Nova, Camaro				frt. pull back (secondary),
75	Chevelle, Nova, Camaro	5472840	1	4.78	<b>SPRING UNIT</b> , rear brk. (9 <sup>1</sup> / <sub>2</sub> " x 2) (repl. 5462958)

*NOTE 1 Consists of 4 each Pull Back Springs, Hold Down Pins, and Springs, Hold Down Spring Cups, 2 Adj. Hole Covers.*

*NOTE 3: Each unit contains material for one wheel.*

*NOTE 4: Each unit contains material for one axle.*

**5.043 PIN— RETAINER, Brake Shoe**

67-68	Pass. w/Disc Brakes (4 piston design)	5456841	1	.71	front brake shoe retainer
67-68	Chevy, Chevelle, Camaro w/Disc Brakes	5456846	1	.86	shoe return
68-69	Camaro w/Disc Brakes (front and rear)	5467815	2	.95	front and rear retaining (5 <sup>5</sup> / <sub>16</sub> " x 3 <sup>27</sup> / <sub>32</sub> ")

**5.043A PIN UNIT— NUT— SPRING KIT— SPRING, Brake Shoe Hold Down**

62	Chevy w/metallic linings,				
65-72	Pass.,				
65-71	Chevelle, Nova,				
67-69	Camaro				front and rear w/spring,
63-64	Chevy (exc. metallic linings)				rear,
72-75	All	325075	1	1.40	w/spring, frt. axle
70	Monte Carlo w/10 bolt cut out cover	3917938	A.R.	1.50	rear (Note 1)
67	Chevelle, Camaro	9424987	2	.11	<b>NUT</b> , anchor pin, rear— (8.915)
75	Chevelle	5472838	1	3.12	<b>SPRING KIT</b> , brake shoe hold down (9 <sup>1</sup> / <sub>2</sub> " x 2)
71-75	Vega, Monza	3982216	4	.92	<b>SPRING</b>

*NOTE 1 See illustration preceding group 5.398 for identification of axle cover.*

**5.045 PLATE, Brake Shoe Guide**

64-65	Chevy, Chevelle,				
66-70	Chevy, Chevelle, Camaro (exc. Disc Brakes),				
71	Nova, Camaro (exc. Disc Brk.),				
72	Nova, Camaro, Chevelle (exc. Disc Brakes)				front, rear,
73-75	Nova, Camaro, Chevelle (exc. Disc Brakes)	5460399	2	.24	rear (2 <sup>15</sup> / <sub>64</sub> " O.L. x 7 <sup>7</sup> / <sub>64</sub> " thick)
65	Chevelle (S.S.) (8 cyl.)				front,
65-71	Pass.,				

**BRAKES—REAR AXLE AND DRIVE**

**5.045 PLATE, Brake Shoe Guide (Con't)**

<b>68-69</b>	Camaro w/Disc Brakes (front and rear) . . . . .	<b>5465949</b>	2	.18	front and rear (type P, B, O, M) . . . . .
<b>71-75</b>	Pass. w/2.73, 3.08, 3.42 ratio,				
<b>73-75</b>	Chevelle (Sta. Wag.) . . . . .	<b>5472139</b>	2	.32	rear (type P, M, G, C, K, B, O) . . . . .

**5.055 PIN, Brake Shoe Anchor**

<b>62-63</b>	Chevy . . . . .	<b>3823360</b>	A.R.	1.90	front (2 <sup>17</sup> / <sub>64</sub> " O.L. w/ <sup>9</sup> / <sub>16</sub> "— 18 x <sup>11</sup> / <sub>16</sub> " thds) . . . . .
<b>64-70</b>	Chevy, Chevelle, Camaro,				
<b>71-75</b>	Camaro,				
<b>73-75</b>	Chevelle,				
<b>75</b>	Nova . . . . .	<b>3841173</b>	2	2.60	rear (2 <sup>23</sup> / <sub>64</sub> " O.L. w/ <sup>9</sup> / <sub>16</sub> "— 18 x <sup>3</sup> / <sub>4</sub> " thds.) . . . . .
<b>64-65</b>	Chevy, Chevelle (1st design) . . . . .	<b>3832869</b>	2	1.85	front (2 <sup>29</sup> / <sub>64</sub> " O.L. w/ <sup>1</sup> / <sub>2</sub> "— 20 thds) . . . . .
<b>65</b>	Chevelle,				
<b>65-70</b>	Pass. (exc. Disc Brake) . . . . .	<b>3820146</b>	2	2.25	rear (2 <sup>29</sup> / <sub>64</sub> " O.L. w/ <sup>5</sup> / <sub>8</sub> "— 18 x <sup>21</sup> / <sub>32</sub> " thds) . . . . .
<b>65-70</b>	Pass. (exc. Disc Brakes) . . . . .	<b>3855003</b>	2	2.25	front . . . . .
<b>65</b>	Chevy, Chevelle (2nd design),				
<b>66-69</b>	Chevy, Chevelle, Camaro (exc. disc brakes),				
<b>70-72</b>	Nova, Chevelle (exc. Disc Brake),				
<b>73-74</b>	Nova (exc. Disc Brake) . . . . .	<b>3885913</b>	2	3.10	front (2 <sup>29</sup> / <sub>64</sub> " O.L. w/ <sup>5</sup> / <sub>8</sub> "— 18 thds.) . . . . .

**5.056 WASHER— BOLT— CLIP— LOCK— NUT, Brake Shoe Anchor Pin**

<b>62-68</b>	Chevy, Chevelle, Camaro . . . . .	<b>3846589</b>	2	.26	front . . . . .
<b>62-63</b>	Chevy . . . . .	<b>6257603</b>	2	.11	front brake (1 <sup>1</sup> / <sub>8</sub> " O.D. w/ <sup>19</sup> / <sub>32</sub> " hole— hook end) . . . . .
<b>65-70</b>	Pass. (exc. Disc Brakes) . . . . .	<b>3867279</b>	2	.11	front . . . . .
<b>68-72</b>	Camaro w/Disc Brks. (frt. and rear) . . . . .	<b>5467056</b>	1	.75	<b>BOLT</b> , parking (1/2"— 20 x 2) . . . . .
<b>68-69</b>	Camaro w/Disc Brakes-Front and Rear . . . . .	<b>5465995</b>	2	.23	<b>CLIP</b> , lever pivot pin . . . . .
<b>64</b>	Chevy, Chevelle,				
<b>65</b>	Chevy, Chevelle (1st design) . . . . .	<b>3832870</b>	2	.11	<b>LOCK</b> , front brake (hole dia. <sup>25</sup> / <sub>32</sub> ") . . . . .
<b>65</b>	Chevy, Chevelle (2nd design),				
<b>66-69</b>	Chevy, Chevelle, Camaro (exc. Disc Brakes),				
<b>70-72</b>	Nova, Chevelle (exc. Disc Brakes),				
<b>73-74</b>	Nova (exc. Disc Brakes) . . . . .	<b>3885914</b>	2	.12	<b>LOCK</b> , front brake (hole dia. <sup>11</sup> / <sub>16</sub> ") . . . . .
<b>62-69</b>	Chevy, Chevelle, Camaro . . . . .	<b>9424987</b>	2	.11	<b>NUT</b> , rear brake pin ( <sup>9</sup> / <sub>16</sub> "— 18 hex.)— (8.915) . . . . .

**5.103 LEVER— PIVOT, Brake Shoe Automatic Adjusting**

<b>63-69</b>	Chevy, Chevelle, Camaro (exc. Spl. Spt. Cpe.),				
<b>72</b>	Chevelle, Nova, Camaro (exc. Disc Brakes),				
<b>73-75</b>	Nova, Camaro . . . . .				left front and rear, . . . . .
<b>70-71</b>	Camaro,				
<b>70-71</b>	Nova, Chevelle (exc. Disc Brks.) . . . . .				left front, . . . . .
<b>70</b>	Nova, Chevelle, Camaro w/round cover . . . . .	<b>3823363</b>	L.H.	.71	rear (Note 1) . . . . .
<b>63-69</b>	Chevy, Chevelle, Camaro (exc. Spl. Spt. Cpe.),				
<b>72</b>	Chevelle, Nova, Camaro (exc. Disc Brakes),				
<b>73-75</b>	Nova, Camaro . . . . .				right front and rear, . . . . .
<b>70-71</b>	Camaro,				
<b>70-71</b>	Nova, Chevelle (exc. Disc Brks.) . . . . .				right front, . . . . .
<b>70</b>	Nova, Chevelle, Camaro w/round cover . . . . .	<b>3823364</b>	R.H.	.67	rear (Note 1) . . . . .
<b>65-66</b>	Pass. . . . .				left, frt. and rear . . . . .
<b>65-70</b>	Pass. . . . .				rear . . . . .
<b>67</b>	Pass. (exc. 6 cyl., Sta. Wag.),				
<b>68-69</b>	Pass. (exc. Disc Brakes) . . . . .	<b>5462098</b>	L.H.	.72	left, front . . . . .
<b>65-66</b>	Pass. (exc. Disc Brakes) . . . . .				right frt. and rear . . . . .
<b>65-70</b>	Pass. . . . .				rear . . . . .
<b>67-69</b>	Pass. (exc. Disc Brakes) . . . . .	<b>5462099</b>	R.H.	.72	right, front . . . . .
<b>68-69</b>	Camaro w/Disc Brakes (front and rear) . . . . .	<b>5468679</b>	R.H.	2.60	park brake . . . . .
<b>70</b>	Monte Carlo w/10 bolt cut out cover,				
<b>73-75</b>	Chevelle . . . . .	<b>5462767</b>	L.H.	2.29	left rear (Note 1) . . . . .
<b>70</b>	Monte Carlo w/10 bolt cut out cover,				
<b>73-75</b>	Chevelle . . . . .	<b>5462768</b>	R.H.	2.29	right rear (Note 1) . . . . .

**BRAKES—REAR AXLE AND DRIVE**

**5.103 LEVER— PIVOT, Brake Shoe Automatic Adjusting (Con't)**

71-75	Pass. w/2.73, 3.08 ratio (exc. Sta. Wag.)				
73-75	Chevelle (Sta. Wag.)	5472527	L.H.	3.91	LEVER UNIT, w/pawl rear (type C, G, K, B, O, P, M) (11 x 2)
71-75	Pass. w/2.73, 3.08 ratio (exc. Sta. Wag.)				
73-75	Chevelle (Sta. Wag.)	5472528	R.H.	3.91	LEVER UNIT, w/pawl rear (type C, G, K, B, O, P, M) (11 x 2)
71-75	Pass. (Sta. Wag.) w/2.73, 3.08, 3.42 ratio,				
71-75	Police, Taxi w/2.73, 3.08, 3.42 ratio	5472521	L.H.	3.99	LEVER UNIT, w/pawl (type P, M) (12 x 2)
71-75	Pass. (Sta. Wag.) w/2.73, 3.08, 3.42 ratio,				
71-75	Police, Taxi w/2.73, 3.08, 3.42 ratio	5472522	R.H.	3.99	LEVER UNIT, w/pawl (type P, M) (12 x 2)
63-75	Chevy, Chevelle, Camaro, Nova (exc. Disc Brakes)	5462769	L.H.	.36	PIVOT, front and rear lever
63-75	Chevy, Chevelle, Camaro, Nova (exc. Disc Brakes)	5462770	R.H.	.36	PIVOT, front and rear lever
65	Pass. (exc. Impala, Sp. H/Per.),				
66-70	Pass. (exc. Disc Brakes)	3856855	L.H.	.21	PIVOT, left, front and rear
65	Pass. (exc. Impala, Sp. H/Per.),				
66-70	Pass. (exc. Disc Brakes)	3856856	R.H.	.21	PIVOT, right, front and rear

*NOTE 1 See illustration preceding group 5.398 for identification of axle cover.*

**5.105 LINK, Brake Shoe Automatic Adjusting Lever**

64-72	Chevy, Chevelle, Camaro,				
73-75	Chevelle, Camaro, Nova (exc. Disc Brakes)	5462526	L.H.	.95	front and rear
64-72	Chevy, Chevelle, Camaro,				
73-75	Chevelle, Camaro, Nova (exc. Disc Brakes)	5462527	R.H.	.92	front and rear
65-69	Pass. (exc. Disc Brake)	5461156	L.H.	1.13	left, front and rear (5 <sup>15</sup> / <sub>16</sub> " O.L.)
65-69	Pass. (exc. Disc Brake)	5461157	R.H.	.94	right, front and rear (5 <sup>15</sup> / <sub>16</sub> " O.L.)

**5.107 SPRING, Brake Shoe Automatic Adjusting Lever**

*Refer to Group 5.026 for Spring Unit.*

63-75	Chevy, Chevelle, Camaro (exc. metallic linings)	5462264	A.R.	.67	front and rear override (24 <sup>1</sup> / <sub>2</sub> " coils— 3 <sup>7</sup> / <sub>8</sub> " free length) (blue)
63-75	All (exc. Disc Brake, Metallic Linings, Taxi, Police)	5461984	A.R.	.27	front and rear return (7 <sup>1</sup> / <sub>2</sub> " coils— 1 <sup>1</sup> / <sub>2</sub> " free length) (red)
65-70	Pass. (exc. metallic linings, Disc Brake, Taxi, H.D. Chassis),				
65-67	Pass. w/Metallic Brakes,				
65-69	Taxi, Police (exc. Metallic Brakes)	5464507	A.R.	.63	front and rear override (2 <sup>21</sup> / <sub>32</sub> " O.L.— green) (18 coils— 2 <sup>5</sup> / <sub>8</sub> " free length)
74-75	Nova (exc. Disc Brk.)				frt. and rear brk. shoe automatic adjusting lever return,
74-75	Chevelle, Camaro	344004	2	.21	rear
75	Pass., Chevelle	5473588	2	.26	pawl return rear brk. (11 x 2)

**5.110 SCREW— UNIT— WASHER, Brake Shoe Adjusting**

62	Chevy	496351	2	1.07	front and rear brake shoe adjusting (2" O.L. w/ <sup>1</sup> / <sub>2</sub> "— 20 x 1 <sup>45</sup> / <sub>64</sub> " thds) (Bendix 29491)
68-69	Camaro w/Disc Brakes-Front and Rear	5467297	2	1.62	SCREW ASSY., w/nut adj. pivot
63	Chevy	3981981	L.H.	1.30	UNIT, left (Note 1)
64-75	Chevy, Chevelle, Nova,				
67-69	Camaro	5472845	L.H.	3.06	UNIT, left (Note 1)
64-75	Chevy, Chevelle, Nova,				
67-69	Camaro	3981986	R.H.	2.20	UNIT, right (Note 1)
65-70	Pass.	3997399	L.H.	1.30	UNIT, left (Note 1)
65-70	Pass.	3997400	R.H.	1.30	UNIT, right (Note 1)
71-75	Pass.,				
73-75	Chevelle (Sta. Wag.)	5472638	L.H.	3.59	UNIT (type C, G, K, B, O, P, M) (Note 1)
71-75	Pass.,				
73-75	Chevelle (Sta. Wag.)	5472639	R.H.	3.59	UNIT (type C, G, K, B, O, P, M) (Note 1)

*NOTE 1 Unit contains screw, nut, socket for one wheel.*

75	Chevelle	5472846	R.H.	3.06	UNIT (9 <sup>1</sup> / <sub>2</sub> " brk.) adj. screw rr.
75	All	5462496	2	.33	WASHER, rear brk. shoe adjusting screw socket

**BRAKES—REAR AXLE AND DRIVE**

<b>5.111 SOCKET, Brake Shoe Adjusting Screw</b>					
68-69	Camaro w/Disc Brakes-Front and Rear	5465948	2	.80	
70	Monte Carlo w/10 bolt cut out cover,				
75	Chevelle, Camaro, Nova	5467204	1	.82	rear (Note 1)
<i>NOTE 1 See illustration preceding group 5.398 for identification of axle cover.</i>					
70	Pass.	3842985	1	.43	
73-74	Nova, Camaro, Chevelle	5462946	2	.61	rear
<b>5.117 COVER, Brake Adjusting Hole</b>					
38-75	All	5464803	2	.20	rear brake adjusting hole cover
<b>5.149 LEVER, Parking Brake Shoe</b>					
65-70	Pass.	338299	1	1.35	left
65-70	Pass.	338300	1	1.35	right
71-75	Vega, Monza	3982227	L.H.	1.05	
71-75	Vega, Monza	3982228	R.H.	1.05	
73-75	Pass. (exc. Sta. Wag.),				
73-75	Chevelle (Sta. Wag.)	2620569	L.H.	4.60	w/strut
73-75	Pass. (exc. Sta. Wag.),				
73-75	Chevelle (Sta. Wag.)	2620570	R.H.	4.60	w/strut
64-72	Chevy, Chevelle,				
67-70	Camaro (exc. Disc Brakes, front and rear),				
71-75	Camaro,				
73-75	Chevelle, Nova (exc. Sta. Wag.)	2620565	L.H.	4.25	LEVER ASSY., w/strut
64-72	Chevy, Chevelle,				
67-70	Camaro (exc. Disc Brakes, front and rear),				
71-75	Camaro,				
73-75	Chevelle, Nova (exc. Sta. Wag.)	2620566	R.H.	4.25	LEVER ASSY., w/strut
71-75	Pass. w/2.73, 3.08 ratio (exc. Sta. Wag.)	5472530	L.H.	3.65	LEVER UNIT, w/strut (type C, G, K)
71-75	Pass. w/2.73, 3.08 ratio (exc. Sta. Wag.)	5472531	R.H.	3.65	LEVER UNIT, w/strut (type C, G, K)
71-75	Pass. (Sta. Wag.) w/2.73, 3.08, 3.42 ratio,				
71-75	Police, Taxi w/2.73, 3.08, 3.42 ratio	5472523	L.H.	6.20	LEVER UNIT, w/strut (type P, M)
71-75	Pass. (Sta. Wag.) w/2.73, 3.08, 3.42 ratio,				
71-75	Police, Taxi w/2.73, 3.08, 3.42 ratio	5472524	R.H.	6.20	LEVER UNIT, w/strut (type P, M)
<b>5.150 STRUT, Parking Brake Shoe Lever</b>					
62-64	Chevy	6256541	2	.53	(5 <sup>15</sup> / <sub>32</sub> " O.L.)
65	Chevelle (Spl. Spt. Cpe.),				
65-70	Pass. (exc. H.D. chassis, Taxi)	3825500	A.R.	.71	
65-70	Taxi, Police	3849768	2	.71	
68-69	Camaro w/Disc Brakes front and rear	5463538	R.H.	.62	
71-75	Vega, Monza	3982229	L.H.	1.75	includes lock & rod
71-75	Vega, Monza	3982230	R.H.	1.75	includes lock & rod
<b>5.151 SPRING, Parking Brake Shoe Lever</b>					
65-75	Pass.	1312281	2	.52	( <sup>27</sup> / <sub>32</sub> " max. I.D. x 1 <sup>1</sup> / <sub>4</sub> " O.L.)
75	Chevelle	5464520	2		SPRING, park. brk. shoe lever strut (9 <sup>1</sup> / <sub>2</sub> " x 2")
<b>5.158 WASHER, Parking Brake Lever Anchor</b>					
62-63	Chevy	5454797	2	.20	spring ( <sup>3</sup> / <sub>8</sub> " I.D. x <sup>3</sup> / <sub>4</sub> " O.D.)
68-69	Camaro w/R.S.	1300540	4	.14	spring steel ( <sup>17</sup> / <sub>32</sub> " hole)
69	Camaro w/Disc Brakes	5465996	2	.32	front and rear
<b>5.380 ARM— BRACKET— BUSHING UNIT— MEMBER— REINFORCEMENT— SUPPORT MOUNTING— SHIM, Rear Axle Control Arm</b>					
75	Monza (262)	353932	1	27.75	rear axle torque— (5.382)
75	Monza (Rotary) (exc. Notchback)	346503	1	27.00	rear axle torque— (5.382)
75	Monza (140) (exc. 5-Spd.)	356318	1	27.75	rear axle torque— (5.382)
75	Monza (140) w/5-Spd. (exc. Notchback)	346501	1	33.50	rear axle torque— (5.382)
75	Vega (122)	360355	1		rear axle torque— (5.382)
68-72	Chevelle	3908717	L.H.	4.35	BRACKET, rear axle lower control arm frame

**BRAKES—REAR AXLE AND DRIVE**

**5.380 ARM— BRACKET— BUSHING UNIT— MEMBER— REINFORCEMENT— SUPPORT MOUNTING— SHIM, Rear Axle Control Arm (Con't)**

68-72	Chevelle	3908718	R.H.	4.35	BRACKET, rear axle lower control arm frame
71-75	Pass. (exc. Sta. Wag.)	3981235	L.H.	6.40	BRACKET, rear axle lower control arm
71-75	Pass. (exc. Sta. Wag.)	3981236	R.H.	6.40	BRACKET, rear axle lower control arm
71-75	Pass. (exc. Sta. Wag.)	3981237	2	3.40	BRACKET, rear axle upper control arm
73	Chevelle (exc. Sta. Wag., El Camino),				
74	Chevelle (exc. Sta. Wag., El Camino, Monte Carlo)	3994355	L.H.	5.85	BRACKET, rear axle lower control arm
73	Chevelle (exc. Sta. Wag., El Camino)				
74	Chevelle (exc. Sta. Wag., El Camino, Monte Carlo)	3994356	R.H.	5.85	BRACKET, rear axle lower control arm
73	Chevelle (Sta. Wag.) El Camino,				
74	Chevelle (Sta. Wag.), El Camino, Monte Carlo	6271613	L.H.	5.85	BRACKET, rear axle lower control arm
73	Chevelle (Sta. Wag.), El Camino,				
74	Chevelle (Sta. Wag.), El Camino, Monte Carlo	6271614	R.H.	5.85	BRACKET, rear axle lower control arm
75	Monza (140) w/4-Spd. (exc. Notchback)	353915	1	7.90	BRACKET, rear axle torque arm
75	Monza (140) w/5-Spd.	346541	1	3.25	BRACKET, rear axle torque arm
75	Monza (140) (262),				
75	Vega (122)	346540	1	4.40	BRACKET, rear axle torque arm
67-68	Pass.	3900542	1	3.75	BRACKET ASSY., upper control arm (3 <sup>33</sup> / <sub>64</sub> " x 3 <sup>1</sup> / <sub>2</sub> ")
69-70	Pass. w/parallel edges	3953581	L.H.	11.05	BRACKET ASSY., left, lower frame
69-70	Pass. w/parallel edges	3953582	R.H.	11.05	BRACKET ASSY., right, lower frame
69-70	Pass. (exc. Sta. Wag.)	3982819	A.R.	3.40	BRACKET ASSY., upper control arm
75	Vega (122),				
75	Monza (exc. Notchback)	358059	1	5.15	BUSHING UNIT, rear axle torque arm
65-66	Pass. w/parallel edges	3881660	1	22.75	MEMBER, upper cross— (7.012)
71-72	Pass. (exc. Sta. Wag.)	325810	1	17.40	MEMBER, rear axle upper control arm cross
67-70	Pass. w/angled edges	3950224	1	21.10	MEMBER ASSY., upper cross
67-70	Pass. w/parallel edges	3950222	1	18.25	MEMBER ASSY., upper (Note 2)
<i>NOTE 2: When used in place of 3901660 on past models rework as follows— and one 1/16" dia. hole and one 1/32" dia. hole on each side of member to attach. muff. tail pipe frt. hanger assy.</i>					
66-69	Pass. w/H.D. Susp. (8 cyl.)	3888726	2	.52	REINFORCEMENT, lower
68-72	Chevelle	3945414	1	.65	REINFORCEMENT, upper control arm
70	Pass. (350) (exc. A.T.)	3964048	1	1.55	REINFORCEMENT (7.039)
75	Vega (122)	1726996	L.H.	13.85	REINFORCEMENT, mounting support left
71-72	Vega	9654012	R.H.	9.60	SUPPORT MOUNTING
71-72	Vega	9654013	L.H.	9.60	SUPPORT MOUNTING
75	Vega (122)	1726995	1	13.85	SUPPORT MOUNTING, reinforcement left
71-72	Malibu, Deluxe	3983393	2	.50	SHIM, rear suspension torq. control arm, rear bumper lower bracket to body

**5.381 BUSHING ASSY.— WASHER, Rear Axle Control Arm**

64	Chevelle	9773067	2	1.90	upper (1 <sup>51</sup> / <sub>64</sub> " dia.)
64	Chevelle				lower,
65-70	Chevelle w/round cover,				
71-72	Chevelle (exc. spec. perf. susp.)	3997973	2	2.60	upper (Note 1)
65-72	Chevelle	3869857	4	2.35	lower
65-70	Pass.	3964043	A.R.	3.85	lower rear, upper rear
68-69	Pass.,				
70	Pass. (6 cyl.)	3953593	1	3.95	lower front (2 <sup>1</sup> / <sub>16</sub> " O.D.— 2 <sup>1</sup> / <sub>2</sub> " long)
69	Pass. (327) (exc. Sta. Wag., H.D. Susp.),				
70	Pass. w/2BC (350) (exc. A.T., Sta. Wag., Taxi, Police)	3953959	2	3.95	rear axle upper
70	Monte Carlo w/10 bolt cut out cover	388265	2	3.55	upper (Note 1)
71	Pass.,				
72-75	Pass. (exc. Sta. Wag.)	480554	1	3.85	rear axle upper and lower control arm to frame bracket assy.
71-75	Pass. w/2.73, 3.08, 3.42 ratio (exc. Sta. Wag.),				
75	Nova	482026	2	3.85	(type P, B, O, M) rr. axle upper control arm
71-75	Pass. (exc. Sta. Wag.)	483102	2	3.85	rr. axle upper control arm (type G, C, K)
71-72	Chevelle w/spec. perf. susp.	1371368	2	3.15	rear axle upper control arm
71-74	Vega	3978060	4	1.65	upper control arm
71-75	Vega, Monza	3997973	2	2.60	upper control arm (rear)
71-75	Vega, Monza	3988064	2	2.10	lower control arm (rear)
73-75	Chevelle				rear axle lower control arm,

**BRAKES—REAR AXLE AND DRIVE**

**5.381 BUSHING ASSY.— WASHER, Rear Axle Control Arm (Con't)**

73-75	Chevelle (exc. Sta. Wag., Monte Carlo) .....	<b>484373</b>	1	3.95	rear axle upper control arm .....
73	Pass.,				
73-75	Chevelle (Sta. Wag.) .....	<b>489092</b>	1	3.25	rear axle upper control arm .....
73	Monte Carlo .....	<b>490531</b>	2	3.90	rear axle upper control arm .....
74	Chevelle (exc. Sta. Wag., S.S., H.D. Susp.) .....	<b>490526</b>	1	4.20	rear axle upper control arm .....
75	Pass. (exc. Sta. Wag.) .....	<b>498827</b>	2	3.90	upper control arm to carrier .....
75	Vega (122),				
75	Monza .....	<b>346562</b>	2	.52	<b>WASHER</b> , rear axle torque arm bushing .....

*NOTE 1 See illustration preceding Group 5.398 for identification of axle cover.*

**5.382 ARM ASSY.— REINFORCEMENT, Rear Axle Control**

64-67	Chevelle .....	<b>3869853</b>	A.R.	8.90	upper, left or right .....
64-68	Chevelle,				
69-71	Chevelle (exc. Spec. Perf. Susp.),				
70-72	Monte Carlo (exc. 454),				
72	Chevelle (exc. Spec. Perf. Susp.)	<b>9791773</b>	2	20.15	lower .....
65	Chevelle (spec. Spt. Coupe) (396) .....	<b>9791102</b>	2	18.70	lower .....
65	Pass.,				
66	Pass. w/4 arm Suspension (exc. Sta. Wag., H.D. Susp.),				
66	Pass. w/H.D. Suspension,				
66	Pass. w/3 arm Suspension .....	<b>3856386</b>	A.R.	9.10	upper .....
66	Sta. Wag.,				
65-68	Pass.,				
69-70	Pass. (6 cyl.) .....	<b>3953592</b>	2	12.75	lower (Note 3) .....
<i>NOTE 3 When using for Special Performance Suspension, drill 3 holes for stabilizer bar attachment.</i>					
67-70	Pass. ....	<b>3900543</b>	A.R.	9.10	upper .....
68-72	Chevelle (exc. Spec. Perf. Susp.)	<b>9790979</b>	A.R.	8.90	upper .....
69-72	Chevelle w/Spec. Perf. Susp.,				
70-72	Monte Carlo (454) .....	<b>3937877</b>	2	20.60	lower .....
69	Pass. (327) (exc. Taxi, Police, Sta. Wag.),				
70	Pass. w/2BC (350) (exc. A.T., Sta. Wag., Taxi, Police) .....	<b>3953957</b>	1	9.25	upper .....
69-70	Pass. (8 cyl.) .....	<b>3953964</b>	2	12.75	lower .....
71-72	Chevelle w/spec. perf. susp. ....	<b>9789332</b>	R.H.	8.30	upper .....
71-72	Chevelle w/spec. perf. susp. ....	<b>9789333</b>	L.H.	8.30	upper .....
71-75	Pass. (exc. Sta. Wag.) .....	<b>494417</b>	2	14.70	lower .....
71-75	Pass. (exc. Sta. Wag.) .....	<b>483106</b>	2	13.90	upper .....
71-75	Vega,				
75	Monza .....	<b>349561</b>	2	12.00	lower control (repl. 3978034) .....
71-75	Vega .....	<b>3978058</b>	2	11.05	upper control .....
73	Monte Carlo,				
74-75	Chevelle (exc. Sta. Wag., S.S., H.D. Susp.) .....	<b>491637</b>	2	6.75	upper .....
73-75	Chevelle .....	<b>494242</b>	2	20.15	lower .....
73	Chevelle (exc. Monte Carlo) ....	<b>491636</b>	2	7.55	upper .....
65-67	Chevelle (396, 327 H/Per., Sp. H/Per.) .....	<b>3909670</b>	R.H.	1.05	<b>REINFORCEMENT</b> , frame .....
68-70	Chevelle (327, 350, 396),				
71-72	Chevelle (8 cyl.) .....	<b>3918061</b>	L.H.	3.20	<b>REINFORCEMENT</b> , frame .....
68-70	Chevelle (327, 350, 396),				
71-72	Chevelle (8 cyl.) .....	<b>3918062</b>	R.H.	3.20	<b>REINFORCEMENT</b> , frame .....
75	Vega (exc. Panel) .....	<b>349563</b>	1	1.05	<b>REINFORCEMENT</b> , rear stabilizer shaft .....

**5.383 BOLT— CLAMP— DAMPER UNIT— NUT— SPACER— WASHER, Rear Axle Control Arm**

65-67	Pass. ....	<b>3982818</b>	A.R.	1.05	upper and lower ( <sup>5</sup> / <sub>8</sub> "— 18 x 4 <sup>1</sup> / <sub>4</sub> ")— (7.529)
67-70	Pass. ....	<b>3904269</b>	A.R.	.71	upper and lower ( <sup>5</sup> / <sub>8</sub> "— 18 x 3 <sup>7</sup> / <sub>8</sub> ") .....
71	Pass. (exc. Sta. Wag.),				
72-75	Pass. ....	<b>479352</b>	A.R.	.46	( <sup>9</sup> / <sub>16</sub> "— 12 x 4") (hex.) .....
71-75	Vega .....	<b>3991352</b>	4	.31	rear suspension upper control arm .....
75	Vega, Monza .....	<b>346559</b>	1	1.15	hex. red body ( <sup>9</sup> / <sub>16</sub> "— 12 x 6 <sup>5</sup> / <sub>8</sub> ") rear axle torque .....
65-70	Pass. ....	<b>3888774</b>	2	.38	<b>CLAMP</b> , rr. axle lower control arm spring ..
73-74	Vega .....	<b>6259392</b>	1	10.30	<b>DAMPER UNIT</b> (rear axle noise) (less yoke) (Note 1) .....

*NOTE 1: Unit contains 2 control arm damper weights, 2 tapping plates 2<sup>5</sup>/<sub>16</sub>" x 1<sup>5</sup>/<sub>8</sub>" bolts, 2<sup>5</sup>/<sub>16</sub>" lock washers, instruction sheet.*

62-67	Chevy .....	<b>3791855</b>	2	.34	<b>NUT</b> ( <sup>1</sup> / <sub>16</sub> " x 18)— (6.172) .....
64	Chevelle .....	<b>3691530</b>	A.R.	.16	<b>NUT</b> , lower end ( <sup>1</sup> / <sub>2</sub> "— 20) .....
65-69	Chevelle, Camaro,				

**BRAKES—REAR AXLE AND DRIVE**

**5.383 BOLT— CLAMP— DAMPER UNIT— NUT— SPACER— WASHER, Rear Axle Control Arm (Con't)**

65-69	Pass. ....	3866766	A.R.	.12	NUT (2/8" — 24) — (0.626) .....
66	Pass. ....	9422304	2	.22	NUT (9/16" — 18) — (8.917) .....
66-69	Pass. w/H.D. Suspension .....	3888727	2	.70	SPACER, lower .....
68	Impala w/H.D. Suspension (exc. Conv., Sta. Wag.) .....	3888725	8	.16	SPACER (7.243) .....
70	Pass. w/3-Spd. (350) .....	3981297	1	.16	WASHER, lower control arm bolt right front 2 1/32" I.D. x 1 1/8" O.D. (.169-.189" thk.) ...

**5.387 HOUSING— VENTILATOR, Rear Axle**

65-70	Pass. w/12 bolt cover .....	3981667	1	159.00	
66-70	Pass. w/10 bolt cover .....	3981666	1	159.00	
67-69	Camaro, 68-69 Chevy, 70-71 Chevy w/single leaf spring .....	3981670	1	127.00	(w/10 bolt cover) .....
67	Camaro .....	3921189	1	124.00	(w/12 bolt cover) .....
68-71	Chevy, 68-69 Camaro (exc. Disc Brks. front and rear) .....	3981672	1	127.00	(w/12 bolt cover) .....
68-72	Chevelle .....	3981669	1	127.00	(w/12 bolt cover) w/spacer .....
68-69	Camaro w/Disc Brks. (front and rear) .....	3961340	1	131.00	(w/12 bolt cover) .....
68-72	Chevelle w/10 bolt round cover .	3981668	1	127.00	w/spacer (Note 1) .....
69	Chevy, Camaro w/multi leaf spring .....	3981900	1	112.00	(w/10 bolt cover) .....
70	Monte Carlo w/10 bolt cut out cover .....	479724	1	122.00	(Note 1) .....
<i>NOTE 1 See illustration preceding group 5.398 for identification of axle cover.</i>					
70-71	Nova w/10 bolt cover .....	3981671	1	127.00	(multi leaf spring) (Note 2) .....
<i>NOTE 2 Used w/H.D. axle w/small ring gear. Also used on 1969 Chevy, Camaro.</i>					
70	Camaro (multi-leaf spring w/10 bolt cover) .....	3981971	1	135.00	
70	Camaro w/12 bolt cover .....	3981972	1	127.00	
71-75	Camaro .....	3997573	1	134.00	w/spacer .....
71-75	Pass. w/2.73, 3.08, 3.42 ratio (exc. Sta. Wag.) .....	1235274	A.R.	217.00	(type B, O) (8 1/2" dia. ring gear) .....
71-75	Pass. w/2.73, 3.08, ratio (exc. Sta. Wag.) .....	3993462	A.R.	165.00	diff. housing and axle tube assy. (type G, C, K) (8 1/2" dia. ring gear) .....
71-75	Pass. w/2.73, 3.08, 3.42 ratio (exc. Sta. Wag.) .....	495904	1	122.00	w/diff. carrier (type P, M) (coil spring) .....
71-75	Pass. (Sta. Wag.) w/2.73, 3.08, 3.42 ratio .....	495905	1	127.00	w/diff. carrier (type P, M) (leaf spring) .....
71-75	Vega (140) .....	6272172	1	155.00	w/spacer (6 1/2" dia. ring gear) .....
72	Nova .....	1238070	1	127.00	w/spacer (mono-leaf spring) .....
72-73	Nova .....	1238071	1	127.00	w/spacer (multi-leaf spring) .....
73-75	Chevelle (Sta. Wag.) .....	495906	1	115.00	diff. housing and axle tube assy. (type P, M)
73-75	Chevelle, Monte Carlo (exc. Sta. Wag.) .....	1238068	1	204.00	diff. housing and axle tube assy. (type C, K, G, W) (round cover) .....
73-75	Chevelle (exc. Sta. Wag.) .....	1238541	1	202.00	diff. housing and axle tube assy. (10 bolt) (type B, O) (cut out cover) .....
74-75	Nova .....	1245260	1	127.00	
74	Vega (122) .....	345606	1	173.00	w/spacer .....
75	Vega (122), Monza .....	231956	1	160.00	(7 1/2" dia. ring gear w/torque arm) w/spacer .....
75	Vega (122), Monza .....	231957	1	156.00	w/spacer (7 1/2" dia. ring gear w/4 link) .....
62-70	All, 71 Chevelle, Nova, 71-75 Vega, Monza, 72-75 Chevelle .....	3820840	1	.36	VENTILATOR (6 1/2", 7 1/2", 8 7/8" ring gear) .
71	Pass., Camaro, 72-75 Pass., Camaro, Nova, Chevelle .	1236317	1	.43	VENTILATOR, diff. carrier (8 1/2" ring gear) .

**5.394 SPACER— RETAINER, Rear Axle Bumper**

64-70	Chevelle (Sta. Wag., El Camino) .	9793637	L.H.	1.50	bumper .....
74	Nova (exc. P/S) .....	344655	2	.87	bumper .....
74-75	Pass. (exc. Sta. Wag.) .....	483432	R.H.	2.65	bumper .....
74-75	Pass. (exc. Sta. Wag.) .....	483433	L.H.	2.65	bumper .....
75	Vega (122) .....	360354	2	2.00	RETAINER, rear axle .....

**5.395 BUMPER— BRACKET— CUSHION— STOP, Rear Axle**

62-67	Chevy .....	3790212	1	.27	(1 5/8" x 1 7/16" x 1 7/16") .....
64	Chevelle (exc. Sta. Wag.), 65-70 Chevelle,				

**BRAKES—REAR AXLE AND DRIVE**

**5.395 BUMPER— BRACKET— CUSHION— STOP, Rear Axle (Con't)**

71	Chevelle (exc. Monte Carlo, Sta. Wag.)	9773073	2	1.00	
65-66	Pass.,				
71	Chevelle (Sta. Wag.)	9770780	1	.57	pinion nose
65-70	Pass.	3869845	2	.98	
67-70	Pass.,				
68-70	Chevelle,				
71	Chevelle (exc. Monte Carlo)	535757	1	1.25	pinion nose (3 <sup>1</sup> / <sub>64</sub> " O.L.)
71-75	Pass. (exc. Sta. Wag.)	482022	2	.92	rear axle
71-75	Pass. (Sta. Wag.)	481860	2	1.95	rear side rail
71	Monte Carlo,				
71	Chevelle (Sta. Wag.),				
72	Chevelle	3987819	2	1.05	
73-75	Pass. (Sta. Wag.),				
73-75	Chevelle	485128	2	.90	rear axle
67-69	Camaro,				
68-69	Chevy,				
70-75	Nova, Camaro,				
74	Vega (122)	481834	1	1.40	BUMPER ASSY., rear axle pinion
67	Camaro w/4-Spd. (327, 350),				
67	Camaro (302, 396) (exc. T.H.)	3920240	1	2.30	BUMPER ASSY., radius rod stop
70-72	Nova				BUMPER ASSY., torque control arm (2 <sup>13</sup> / <sub>32</sub> " high x 1 <sup>51</sup> / <sub>64</sub> " wide),
73-75	Nova	3858017	2	.62	pinion nose
70	Monte Carlo,				
72	Chevelle (exc. Monte Carlo)	9796093	1	1.30	BUMPER ASSY., pinion nose (special)
71	Pass. (Sta. Wag.)	485019	1	1.60	BUMPER ASSY., pinion
71-75	Pass. (exc. Sta. Wag.)	483038	1	1.25	BUMPER ASSY., pinion nose
72-75	Pass. (Sta. Wag.)	487409	1	1.60	BUMPER ASSY., pinion nose
73-75	Chevelle	486136	1	1.35	BUMPER ASSY., pinion nose
73-75	Pass. (Sta. Wag.) w/2.73, 3.08, 3.42 ratio	481362	1	.91	BRACKET, pinion nose bumper support (type P, M)
71-75	Pass. (Sta. Wag.)	483733	1	1.20	CUSHION, under body to frame— (9.023)
67	Camaro w/4-Spd. (327, 350),				
67	Camaro (302, 396) (exc. T.H.)	3920237	1	4.55	STOP, radius rod

**5.398 COVER— SCREW, Axle Housing with Filler Plug**

64-72	All w/10 bolt round cover,				
73-75	Pass., Chevelle, Camaro,				
75	Nova	410917	1	2.85	(type C, G, K, B, O) (Note 1) (8 <sup>1</sup> / <sub>2</sub> " dia. ring gear)
65-70	All w/12 bolt cover,				
71-72	Chevelle, Nova w/12 bolt cover	3976857	1	2.80	
70	Monte Carlo w/cut out cover	9777035	1	3.55	(Note 1)
71-75	Pass. w/2.73, 3.08, 3.42 ratio,				
73-75	Chevelle (Sta. Wag.)	9790538	1	4.85	(type P, M) (8 <sup>7</sup> / <sub>8</sub> " dia. ring gear)
71-74	Vega (140)	3974878	1	2.35	
74	Vega (122)	345638	1	4.90	
75	Monza, Vega (122)	551619	1	4.05	(7 <sup>1</sup> / <sub>2</sub> " dia. ring gear) (repl. 344173)
70	Monte Carlo w/cut out cover,				
71-75	Chevelle, Camaro,				
71-75	Pass. w/2.73, 3.08, 3.42 ratio,				
72-75	Nova,				
75	Vega (122) Monza	384951	10	.11	SCREW (5 <sup>5</sup> / <sub>16</sub> "— 18 x 15 <sup>15</sup> / <sub>16</sub> " (type G, K, B, O) (Note 1) diff. carrier cover (7 <sup>1</sup> / <sub>2</sub> ", 8 <sup>1</sup> / <sub>2</sub> " dia. ring gear)
71-75	Pass. w/2.73, 3.08, 3.42 ratio,				
73-75	Chevelle (Sta. Wag.)	1480294	1	.38	SCREW, diff. carrier cover assy. oil filler (type P, M) (8 <sup>7</sup> / <sub>8</sub> " dia. ring gear)
74	Vega (122)	650516	10	.16	SCREW, diff. carrier cover

NOTE 1 See illustration preceding group 5.398 for identification of axle cover.



**BRAKES—REAR AXLE AND DRIVE**

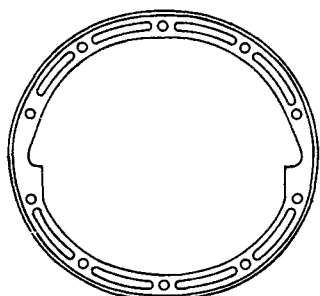

**CHEVROLET  
ROUND COVER**

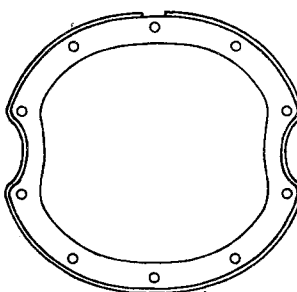

**PONTIAC  
CUT OUT COVER**

**5.399 GASKET, Axle Housing Cover (Cork)**

64-70	All w/10 bolt round cover,				
71-72	Chevelle w/10 bolt round cover,				
71	Nova w/10 bolt round cover . . .	<b>3931151</b>	1	.80	(Note 1) . . . . .
65-70	All w/12 bolt cover,				
71-72	Chevelle w/12 bolt cover,				
71	Nova w/12 bolt cover . . . . .	<b>3931152</b>	1	.80	
70	Monte Carlo w/cut out cover . . .	<b>9775683</b>	1	.97	(Note 1) . . . . .
71-75	Pass. w/2.73, 3.08, 3.42 ratio,				
73-75	Chevelle (Sta. Wag.) . . . . .	<b>9778192</b>	1	1.40	(type P, M) (8 <sup>7</sup> / <sub>8</sub> " dia. ring gear) . . . . .
71-72	Pass. w/2.73, 3.08 ratio . . . . .	<b>1234482</b>	1	1.10	(type B, O) (plain) . . . . .
71	Camaro,				
72-75	Camaro, Nova, Chevelle,				
71-75	Pass. w/2.73, 3.08 ratio . . . . .	<b>3993593</b>	1	1.10	(type G, C, K, B, O) (slotted) (8 <sup>1</sup> / <sub>2</sub> " dia. ring gear) . . . . .
71-75	Vega (140) . . . . .	<b>3974879</b>	1	.70	(6 <sup>1</sup> / <sub>2</sub> " dia. ring gear) . . . . .
74	Vega (122) . . . . .	<b>345632</b>	1	.70	
75	Vega (122), Monza . . . . .	<b>344172</b>	1	.76	(7 <sup>1</sup> / <sub>2</sub> " dia. ring gear) . . . . .

*NOTE 1: See illustration preceding Group 5.398 for identification of axle cover.*

**5.400 PLUG— GASKET— SCREW— TAG, Axle Filler and Drain**

62-63	Chevy . . . . .	<b>344829</b>	1	.27	(1-20 sq. hd.-1 <sup>3</sup> / <sub>8</sub> " dia. flange . . . . .
65-67	All w/P/Trac. . . . .	<b>3866433</b>	1	.60	w/instr. tag (1 <sup>7</sup> / <sub>64</sub> " O.L.) . . . . .
68-70	All w/P/Trac. . . . .	<b>3931171</b>	1	.66	
68	Pass. . . . .	<b>3866776</b>	A.R.	1.35	rear axle drain (magnetic) (1 <sup>1</sup> / <sub>2</sub> "— 20)— (1.453) . . . . .
71	Pass. w/P/Trac. (exc. Sta. Wag.),				
71-72	Chevelle, Nova, Camaro w/P/Trac.,				
72	Pass. w/P/Trac.,				
73-75	All w/P/Trac. . . . .	<b>444667</b>	1	.11	less tag— (8.971) . . . . .
72	All (exc. P/Trac.) . . . . .	<b>444746</b>	1	.11	
74	Vega (122) . . . . .	<b>345634</b>	1	.22	
62-69	All . . . . .	<b>3921989</b>	A.R.	.20	<b>GASKET</b> , drain screw (1 <sup>1</sup> / <sub>2</sub> " I.D. x 1 <sup>5</sup> / <sub>16</sub> " O.D.)— (1.456) . . . . .
62-63	Chevy . . . . .	<b>3714775</b>	1	.11	<b>GASKET</b> , filler (leather) (1" I.D. x 10" O.D.) . . . . .
71-75	Pass. w/2.73, 3.08, 3.42 ratio,				
73-75	Chevelle (Sta. Wag.) . . . . .	<b>483085</b>	1	.17	<b>GASKET</b> (type P, M) . . . . .
68	All . . . . .	<b>3923420</b>	1	.36	<b>SCREW</b> , drain (1 <sup>1</sup> / <sub>2</sub> "— 20 x 1 <sup>3</sup> / <sub>16</sub> ")— (1.453) . . . . .
71-75	All w/P/Trac. . . . .	<b>1363739</b>	1	.22	<b>TAG</b> , axle lub. ident. . . . .

**5.410 CABLE ASSY.— SPACER, Rear Axle Lateral Movement-(Stop)**

74-75	Vega (122) . . . . .	<b>339089</b>	2	4.00	restraint . . . . .
-------	----------------------	---------------	---	------	---------------------

**5.415 ROD ASSY., Rear Axle**

65-70	Pass. . . . .	<b>3856396</b>	1	19.00	tie w/bushings (Note 1) . . . . .
-------	---------------	----------------	---	-------	-----------------------------------

*NOTE 1: It may be necessary to use stud 3901736, located in Group 5.418.*

75	Vega (122), Monza . . . . .	<b>346577</b>	1	20.40	
----	-----------------------------	---------------	---	-------	--

**5.417 BUSHING ASSY., Rear Axle**

65	Caprice (exc. H.D. Susp.),				
66	Pass. (exc. Sta. Wag., H.D. Susp.),				
68	Pass. w/H.D. Susp. . . . .	<b>3866557</b>	A.R.	2.80	tie rod . . . . .
65	Caprice w/H.D. Susp.),				

**BRAKES—REAR AXLE AND DRIVE**

**5.417 BUSHING ASSY., Rear Axle (Con't)**

66	Pass. w/H.D. Susp.,				
67-68	Camaro (8 cyl.) (exc. 327)	1374270	1	3.80	tie rod

**5.418 BRACKET— BOLT— NUT— SPACER— STUD— WASHER, Rear Axle Tie Rod**

65	Pass.,				
66-68	Pass. (exc. Spt. Mdls.),				
66-68	Pass. (Conv.) w/Parallel edges,				
69-70	Pass.	3895856	1	4.05	frame
65-69	Pass.,				
67	Camaro,				
70	Camaro	3917528	1	.28	BOLT, tie rod to frame ( <sup>9</sup> / <sub>16</sub> "— 18 x 3)
67	Camaro (8 cyl.)	3920236	1	.38	BOLT, radius rod to axle ( <sup>5</sup> / <sub>8</sub> "— 18 x 3 <sup>1</sup> / <sub>2</sub> ")
67	Camaro (8 cyl.)	3920238	1	.32	BOLT, radius rod stop bolt (1 <sup>1</sup> / <sub>2</sub> "— 20 x 3 <sup>1</sup> / <sub>2</sub> ")
67	Camaro (8 cyl.)	3914804	1	.98	NUT, radius rod to axle
67	Camaro w/4-Spd. (327, 350),				
67	Camaro (320, 396) (exc. T.H.)	3920241	1	.24	SPACER, radius rod axle bracket
65-66	Pass. (H.D. Suspension w/Sp. H/Per.) (396, 427) (exc. Sta. Wag.),				
65-66	Sta. Wag.,				
67-70	Pass.	3901736	1	.63	STUD, tie rod to axle ( <sup>9</sup> / <sub>16</sub> "— 18 x 4 <sup>3</sup> / <sub>16</sub> ")
65-70	Pass.,				
71-73	Camaro, Nova	3916493	A.R.	.11	WASHER, attaching tie rod ( <sup>9</sup> / <sub>16</sub> ")
65	Caprice (exc. Sp. H/Per. 396),				
66-69	Pass. (exc. Sp. H/Per. 396, 427, H.D. Suspension, Sta. Wag.),				
70	Pass. (exc. Taxi, Police)	3903701	1	.16	WASHER, at axle ( <sup>9</sup> / <sub>16</sub> ")
67-68	Camaro (8 cyl.)	3905569	1	.11	WASHER, radius rod seal— (7.397)

**5.420 SHAFT, Axle**

62-63	Chevy	3790603	L.H.	36.25	(17 splines— 28 <sup>1</sup> / <sub>4</sub> " O.L.)
62-63	Chevy	3790604	R.H.	36.25	(17 splines— 29 O.L.)
64	Chevy	3847922	2	38.25	(28 splines— 28 <sup>23</sup> / <sub>64</sub> " O.L.)
64	Chevelle	3832417	2	36.50	(28 splines— 29— WWH" O.L.)
65-67	Chevelle, Camaro w/10 bolt cover,				
68-69	Chevy, Camaro w/10 bolt cover,				
70-74	Nova w/10 bolt cover	3969348	2	40.75	(28 splines— 29 <sup>33</sup> / <sub>64</sub> " O.L.)
65-67	Chevy w/10 bolt cover	3863726	2	39.25	(28 splines— 28-20/64" O.L.)
65-67	Chevy w/12 bolt cover	3868992	2	35.50	(30 splines— 28 <sup>27</sup> / <sub>64</sub> " O.L.)
65-67	Chevelle w/12 bolt cover,				
67-69	Camaro w/12 bolt cover (exc. Disc Brks. frt. and rear),				
68-71	Chevy w/12 bolt cover	3969349	2	43.00	(30 splines— 30 <sup>1</sup> / <sub>2</sub> " O.L.)
65-70	Pass. w/12 bolt cover	3985720	2	39.50	(30 splines— 31 <sup>17</sup> / <sub>64</sub> " O.L.)
65	Pass. w/10 bolt cover	3914059	2	39.75	(28 splines— 31 <sup>19</sup> / <sub>64</sub> " O.L.)
66-70	Pass. w/10 bolt cover	3985719	2	36.50	(28 splines— 31 <sup>15</sup> / <sub>32</sub> " O.L.)
68-72	Chevelle w/10 bolt round cover,				
70-74	Camaro w/10 bolt cover	3969284	2	39.50	(28 splines— 30 <sup>5</sup> / <sub>32</sub> " O.L.) (Note 1)
68-72	Chevelle w/12 bolt round cover,				
70	Camaro w/12 bolt cover	3969285	2	35.50	(30 splines— 30 <sup>5</sup> / <sub>32</sub> " O.L.) (Note 1)
68-69	Camaro w/Disc Brakes front and rear (12 bolt cover)	3947206	2	53.50	(30 splines— 29 <sup>11</sup> / <sub>16</sub> " O.L.)
70	Monte Carlo w/cut out cover	9799288	2	51.25	w/bearing (Note 1)
71-72	Pass. w/2.73, 3.08, 3.42 ratio	480448	2	56.00	(type P, M)
71-75	Pass. w/2.73, 3.08, 3.42 ratio (exc. Sta. Wag.)	1244399	2	63.50	(type B, O) (8 <sup>1</sup> / <sub>2</sub> " dia. ring gear)
71-75	Pass. w/2.73, 3.08, 3.23 ratio (exc. Sta. Wag.)	1244847	2	42.50	(type G, K, C) (8 <sup>1</sup> / <sub>2</sub> " dia. ring gear)
71-75	Vega (140)	3974979	2	52.50	(6 <sup>1</sup> / <sub>2</sub> " dia. ring gear)
73-75	Pass. w/2.73, 3.08, 3.42 ratio	490300	2	56.00	(type P, M) (8 <sup>7</sup> / <sub>8</sub> " dia. ring gear)
73-75	Chevelle (Sta. Wag.) w/2.73, 3.08, 3.42 ratio	487414	2	63.50	(type P, M) (8 <sup>7</sup> / <sub>8</sub> " dia. ring gear)
73-75	Chevelle w/2.73, 3.08, 3.42 ratio (exc. Sta. Wag.)	1237357	2	63.50	(type B, O) (8 <sup>1</sup> / <sub>2</sub> " dia. ring gear)
73-75	Chevelle	1237144	2	60.75	(type C, K) (8 <sup>1</sup> / <sub>2</sub> " dia. ring gear)
74	Vega (122)	345635	1	45.50	
75	Vega (122), Monza	344170	2	45.50	(7 <sup>1</sup> / <sub>2</sub> " dia. ring gear)
75	Nova w/10 bolt cover	1249145	2	49.00	
75	Camaro w/10 bolt cover	1249142	2	49.50	

NOTE 1: See illustration preceding group 5.398 for identification of axle cover.

**BRAKES—REAR AXLE AND DRIVE**

**5.422 LOCK, Axle Shaft**

64-75	All	3833322	2	.38	(horseshoe) (.150) (use selectively)
70-75	All	3959067	2	2.30	(.155) (use selectively)
70-75	All	3959068	2	2.30	(.160) (use selectively)
71-75	Vega (140)	3974881	2	.36	(6 1/2" dia. ring gear)
75	Vega (122), Monza	344171	2	.38	(7 1/2" dia. ring gear)

**5.428 REPAIR KIT— BOLT— ROLLER, Rear Axle U Joint**

68	Pass.	386451	2	16.70	diff. carrier "U" joint (Note 1)
<i>NOTE 1 Contains trunnion assy., 4 bearing assys., 4 U-joint snap rings, 2 bolts, 4 nuts, 4 washer and 2 seals.</i>					
62-69	All	1358938	4	.55	<b>BOLT</b> , "U" rear axle flange (1 13/32" ctr. to ctr. stud) (5/16"— 18 thd.)— (5.566)
65	Chevy,				
65	Chevelle Deluxe (6 cyl.)	9418456	A.R.	.12	<b>ROLLER</b> , differential carrier (1 3/32" O.L. x 3/32" dia.) (black oxide coated)— (5.566)

**5.441 SHAFT, Rear Propeller (Shaft attaches to rear axle)**

*NOTE All the parts formerly in this group have been relocated and regrouped into 5.544. See Group 5.544 for all the above parts.*

**5.447 BEARING ASSY., Drive Pinion— Front**

62-72	All w/12 bolt cover,				
71-72	Pass.,				
73-75	Pass., Chevelle, Nova, Camaro	7450984	1	7.81	(Hy A-200248-Z)
62-68	Chevy, Chevelle, Camaro w/10 bolt cover,				
65-70	Pass. w/10 bolt cover,				
69-72	Camaro w/10 bolt cover,				
69-72	Chevelle w/10 bolt cover,				
70-72	Nova w/10 bolt cover,				
71-75	Vega, Monza	7451202	A.R.	7.55	w/roller (Hy A-200233-Z)
74	Vega (122)	9436127	1	11.90	drive pinion, front

**5.453 SPACER— WASHER, Pinion Shaft Bearing**

62-65	All (3 arm suspension, w/10 bolt cover)	3849414	A.R.	.40	(1 15/64" I.D. x 1 3/8" O.D.)
65-70	All (4 arm suspension w/12 bolt cover),				
71	Nova w/12 bolt cover,				
71-72	Chevelle w/12 bolt cover	3954480	A.R.	1.05	(2 21/64" O.L.)
66-70	All w/10 bolt round cover,				
71	Nova w/10 bolt cover,				
71-72	Chevelle w/10 bolt cover	3954478	A.R.	.93	(Note 1)
70	Monte Carlo w/cut out cover,				
75	Vega 122, Monza	9785792	1	.63	(Note 1)
<i>NOTE 1 See illustration preceding group 5.398 for identification of axle cover.</i>					
71-75	Camaro,				
71-72	Pass. w/2.73, 3.08 ratio (exc. Sta. Wag.),				
72-75	Nova, Chevelle,				
73-75	Pass. w/2.73, 3.08, 3.23 ratio				(type G, K, B, O),
71-75	Pass. w/2.73, 3.08, 3.42 ratio	1234726	1	.61	(type P, M)
71-75	Vega	3974898	1	.87	(6 1/2" dia. ring gear)
66-70	All w/12 bolt cover,				
71	Nova w/12 bolt cover,				
71-72	Chevelle w/12 bolt cover	3886318	A.R.	.24	<b>WASHER</b> , pinion brg. spacer
66-70	All w/10 bolt cover,				
71	Nova w/10 bolt cover,				
71-72	Chevelle w/10 bolt cover	3886319	A.R.	.32	<b>WASHER</b> , pinion brg. spacer

**5.460 SHIM, Pinion Shaft Bearing**

62-63	Chevy	3790634	A.R.	.18	(.021)
62-63	Chevy	3790635	A.R.	.18	(.024)
62-63	Chevy	3790638	A.R.	.18	(.033)
74	Vega (122)	345615	A.R.	.13	pinion shaft bearing, front (.003)
74	Vega (122)	345616	A.R.	.13	pinion shaft bearing, front (.005)
74	Vega (122)	345617	A.R.	.13	pinion shaft bearing, front (.010)
74	Vega (122)	345618	A.R.	.13	pinion shaft bearing, front (.030)
74	Vega (122)	345612	A.R.	.13	pinion shaft bearing, rear (.003)
74	Vega (122)	345613	A.R.	.13	pinion shaft bearing, rear (.005)
74	Vega (122)	345614	A.R.	.13	pinion shaft bearing, rear (.010)
64-70	All w/10 bolt round cover,				
71	Nova w/10 bolt cover,				
71-72	Chevelle w/10 bolt cover	3893584	A.R.	1.15	<b>SHIM UNIT</b> (.021-.026) (2 9/64" O.D. x 1 29/64" I.D.)

**BRAKES—REAR AXLE AND DRIVE**

**5.460 SHIM, Pinion Shaft Bearing (Con't)**

<b>64-70</b>	All w/10 bolt round cover,				
<b>71</b>	Nova w/10 bolt cover,				
<b>71-72</b>	Chevelle w/10 bolt cover . . . . .	<b>3893585</b>	<b>A.R.</b>	<b>1.70</b>	<b>SHIM UNIT (.027-.032) (2<sup>9</sup>/<sub>64</sub>" O.D. x 1<sup>29</sup>/<sub>64</sub>" I.D.) . . . . .</b>
<b>64-70</b>	All w/10 bolt round cover,				
<b>71</b>	Nova w/10 bolt cover,				
<b>71-72</b>	Chevelle w/10 bolt cover . . . . .	<b>3893583</b>	<b>A.R.</b>	<b>1.35</b>	<b>SHIM UNIT (.033-.037) (2<sup>9</sup>/<sub>64</sub>" O.D. x 1<sup>29</sup>/<sub>64</sub>" I.D.) . . . . .</b>
<b>65-70</b>	All w/12 bolt round cover,				
<b>71</b>	Nova w/12 bolt cover,				
<b>71</b>	Chevelle w/12 bolt cover . . . . .	<b>3893582</b>	<b>A.R.</b>	<b>1.70</b>	<b>SHIM UNIT (.021-.026) (2<sup>24</sup>/<sub>64</sub>" O.D. x 1<sup>41</sup>/<sub>64</sub>" I.D.) . . . . .</b>
<b>65-70</b>	All w/12 bolt round cover,				
<b>71</b>	Nova w/12 bolt cover,				
<b>71-72</b>	Chevelle w/12 bolt cover . . . . .	<b>3893587</b>	<b>A.R.</b>	<b>1.70</b>	<b>SHIM UNIT (.027-.032) (2<sup>24</sup>/<sub>64</sub>" O.D. x 1<sup>41</sup>/<sub>64</sub>" I.D.) . . . . .</b>
<b>65-70</b>	All w/12 bolt round cover,				
<b>71</b>	Nova w/12 bolt cover,				
<b>71-72</b>	Chevelle w/12 bolt cover . . . . .	<b>3893586</b>	<b>A.R.</b>	<b>2.00</b>	<b>SHIM UNIT (.033-.037) (2<sup>24</sup>/<sub>64</sub>" O.D. x 1<sup>41</sup>/<sub>64</sub>" I.D.) . . . . .</b>
<b>70</b>	Monte Carlo w/cut out cover,				
<b>71-75</b>	Camaro,				
<b>71-72</b>	Pass. w/2.73, 3.08, 3.42 ratio (exc. Sta. Wag.),				
<b>72-75</b>	Nova,				
<b>73-75</b>	Chevelle,				
<b>73-75</b>	Pass. w/2.73, 3.08, 3.23, 3.42 ratio . . . . .	<b>1394892</b>	<b>A.R.</b>	<b>.57</b>	<b>SHIM UNIT (.020-.024) (type C, B, O, G, K) .</b>
<b>70</b>	Monte Carlo,				
<b>71-75</b>	Camaro,				
<b>71-72</b>	Pass. w/2.73, 3.08, 3.42 ratio (exc. Sta. Wag.),				
<b>72-75</b>	Nova,				
<b>73-75</b>	Chevelle,				
<b>73-75</b>	Pass. w/2.73, 3.08, 3.23, 3.42 ratio . . . . .	<b>1394893</b>	<b>A.R.</b>	<b>.57</b>	<b>SHIM UNIT (.025-.029) (type C, B, O, G, K) .</b>
<b>70</b>	Monte Carlo,				
<b>71-75</b>	Camaro,				
<b>71-72</b>	Pass. w/2.73, 3.08, 3.42 ratio (exc. Sta. Wag.),				
<b>72-75</b>	Nova,				
<b>73-75</b>	Chevelle,				
<b>73-75</b>	Pass. w/2.73, 3.08, 3.23, 3.42 ratio . . . . .	<b>1394894</b>	<b>A.R.</b>	<b>.84</b>	<b>SHIM UNIT (.030-.034) (type C, B, O, G, K) .</b>
<b>70</b>	Monte Carlo,				
<b>71-75</b>	Camaro,				
<b>71-72</b>	Pass. w/2.73, 3.08, 3.42 ratio (exc. Sta. Wag.),				
<b>72</b>	Nova,				
<b>73-75</b>	Chevelle,				
<b>73-75</b>	Pass. w/2.73, 3.08, 3.23, 3.42 ratio . . . . .	<b>1394895</b>	<b>A.R.</b>	<b>.82</b>	<b>SHIM UNIT (.035-.039) (type B, O, G, K) . . .</b>
<b>71-75</b>	Pass. w/2.73, 3.08, 3.42 ratio,				
<b>73-75</b>	Chevelle (Sta. Wag.) . . . . .	<b>484365</b>	<b>A.R.</b>	<b>.78</b>	<b>SHIM UNIT (.020-.028) (type P, M) . . . . .</b>
<b>71-75</b>	Pass. w/2.73, 3.08, 3.42 ratio,				
<b>73-75</b>	Chevelle (Sta. Wag.) . . . . .	<b>484366</b>	<b>A.R.</b>	<b>1.20</b>	<b>SHIM UNIT (.030-.038) (type P, M) . . . . .</b>
<b>71-75</b>	Vega (140) . . . . .	<b>3987350</b>	<b>A.R.</b>	<b>1.60</b>	<b>SHIM UNIT, pinion shaft bearing (.021-.026) (6<sup>1</sup>/<sub>2</sub>" dia. ring gear) . . . . .</b>
<b>71-75</b>	Vega (140) . . . . .	<b>3987351</b>	<b>A.R.</b>	<b>1.60</b>	<b>SHIM UNIT, pinion shaft bearing (.027-.032) (6<sup>1</sup>/<sub>2</sub>" dia. ring gear) . . . . .</b>
<b>71-75</b>	Vega (140) . . . . .	<b>3987352</b>	<b>A.R.</b>	<b>1.60</b>	<b>SHIM UNIT, pinion shaft bearing (.033-.037) (6<sup>1</sup>/<sub>2</sub>" dia. ring gear) . . . . .</b>
<b>75</b>	Vega (122), Monza . . . . .	<b>358809</b>	<b>A.R.</b>	<b>1.35</b>	<b>SHIM UNIT (.020-.024) (7<sup>1</sup>/<sub>2</sub>" dia. ring gear)</b>
<b>75</b>	Vega (122), Monza . . . . .	<b>358810</b>	<b>A.R.</b>	<b>1.35</b>	<b>SHIM UNIT (.025-.029) (7<sup>1</sup>/<sub>2</sub>" dia. ring gear)</b>
<b>75</b>	Vega (122), Monza . . . . .	<b>358811</b>	<b>A.R.</b>	<b>1.35</b>	<b>SHIM UNIT (.030-.034) (7<sup>1</sup>/<sub>2</sub>" dia. ring gear)</b>
<b>75</b>	Vega (122), Monza . . . . .	<b>358812</b>	<b>A.R.</b>	<b>1.55</b>	<b>SHIM UNIT (.035-.040) (7<sup>1</sup>/<sub>2</sub>" dia. ring gear)</b>
<b>75</b>	Vega (122), Monza . . . . .	<b>358810</b>	<b>A.R.</b>	<b>1.35</b>	<b>SHIM UNIT (.025-.029) (7<sup>1</sup>/<sub>2</sub>" dia. ring gear)</b>

*NOTE: See illustration preceding Group 5.398 for identification of axle cover.*

**5.468 SHIELD, Pinion Flange**

<b>70</b>	Monte Carlo w/cut out cover . . .	<b>543319</b>	<b>1</b>	<b>.27</b>	<b>(Note 1) . . . . .</b>
-----------	-----------------------------------	---------------	----------	------------	---------------------------

*NOTE 1 See illustration preceding group 5.398 for identification of axle cover.*

**5.469 SEAL ASSY., Drive Pinion**

<b>62-64</b>	Chevy . . . . .	<b>3790622</b>	<b>1</b>	<b>2.60</b>	<b>pinion flange oil (1<sup>17</sup>/<sub>32</sub>" I.D. x 2<sup>21</sup>/<sub>32</sub>" O.D.) . .</b>
--------------	-----------------	----------------	----------	-------------	--

**BRAKES—REAR AXLE AND DRIVE**

**5.469 SEAL ASSY., Drive Pinion (Con't)**

64-70	All w/10 bolt round cover,				
71	All w/10 bolt round cover (exc. Pass.),				
71-75	Vega, Monza,				
72	Chevelle w/10 bolt round cover .	<b>3921072</b>	1	3.35	prop. shaft flange oil (Note 1) . . . . .
65-70	All w/12 bolt cover,				
71-72	Chevelle, Nova w/12 bolt cover .	<b>3924031</b>	1	2.45	prop. shaft pinion flange oil . . . . .
70	Monte Carlo w/cut out cover . . .		1		(Note 1), . . . . .
71-75	Camaro,				
71-75	Pass. w/2.73, 3.08 ratio (exc. Sta. Wag.),				
72-75	Nova,				
73-75	Chevelle . . . . .				(type G, K), . . . . .
71-75	Pass. w/2.73, 3.08, 3.42 ratio . .	<b>1242068</b>	1	3.90	(type B, O, P, M) prop. shaft pinion flange oil . . . . .
74	Vega (122) . . . . .	<b>3979616</b>	1	3.20	pinion flange oil (Chicago Rawhide 522433) . . . . .

*NOTE 1 See illustration preceding Group 5.398 for identification of axle cover.*

**5.484 BEARING ASSY., Drive Pinion Rear**

62-63	Chevy . . . . .	<b>7451203</b>	1	10.02	
64-70	All w/10 bolt cover,				
71	Nova w/10 bolt cover,				
71-72	Chevelle w/10 bolt cover . . . . .	<b>7450371</b>	1	11.56	
64-71	All w/12 bolt cover,				
71	Pass., Camaro (exc. Sta. Wag.),				
72	Pass. (exc. Sta. Wag.),				
72	Nova, Camaro,				
72	Chevelle w/12 bolt cover,				
73-75	Pass.,				
73-75	Nova, Camaro,				
73-75	Chevelle (exc. Sta. Wag.) . . . . .	<b>7451155</b>	1	11.20	(type G, C, K, B, O) (8 <sup>1</sup> / <sub>2</sub> " dia. ring gear) . . .
71-75	Pass.,				
73-75	Chevelle (Sta. Wag.) . . . . .	<b>7451409</b>	1	20.44	(type P, M) (8 <sup>7</sup> / <sub>8</sub> " dia. ring gear) . . . . .
71-75	Vega (140) . . . . .	<b>7450984</b>	1	7.81	pinion gear (6 <sup>1</sup> / <sub>2</sub> " dia. ring gear) . . . . .
74	Vega (122) . . . . .	<b>9417781</b>	1	15.00	pinion gear . . . . .
75	Vega (122), Monza . . . . .	<b>7451973</b>	1	9.90	pinion gear (7 <sup>1</sup> / <sub>2</sub> " dia. ring gear) . . . . .

**5.506 BOLT, Differential Carrier Cap**

64-72	All w/round cover,				
73-75	All . . . . .	<b>3818764</b>	4	.27	(bearing cap to carrier) (Note 1) . . . . .
70	Monte Carlo w/cut out cover . . .	<b>9783197</b>	4	.32	(Note 1) . . . . .
74	Vega (122) . . . . .	<b>345636</b>	2	.26	

*NOTE 1 See illustration preceding group 5.398 for identification of axle cover.*

**5.508 GASKET, Axle Housing to Differential Carrier (paper)**

62-63	Chevy . . . . .	<b>3769870</b>	1	.66	(9 <sup>13</sup> / <sub>16</sub> " x 11 <sup>3</sup> / <sub>8</sub> ") . . . . .
-------	-----------------	----------------	---	-----	--

**5.510 CASE, Differential and Planet**

*NOTE Differential case halves are not sold separately.*

**Differential Assy. (Case with internal gears)**

64	Chevy, Chevelle w/P/Trac. 3.08, 3.36 ratio,				
65	Chevy (P/Trac., w/3.08, 3.36, 3.55 ratio),				
65	Pass., Chevelle (P/Trac., w/3.08, 3.36, 3.55, 3.70 ratio) (1st design) . . . . .	<b>3863433</b>	1	163.00	w/internal gears (Dana 25548X) . . . . .
65-70	All w/P/Trac. w/round cover . . .				w/3.08, 3.36, 3.55, 3.70 ratio (Note 1-3), . .
71	Nova w/P/Trac.,				
71-72	Chevelle w/P/Trac. . . . .	<b>3993502</b>	1	145.00	w/3.08, 3.36 ratio (Eaton ED-11171-4) use w/10 bolt cover . . . . .
65-69	Pass.,				
70	Chevelle, Camaro (P/Trac. w/4.10 ratio),				
71	El Camino (Custom) Malibu (Spt. Cpe., Conv.) w/P/Trac.,				
72	Chevelle w/P/Trac. . . . .	<b>3993517</b>	1	145.00	w/4.10, 4.56, 4.88 ratio (Eaton ED-12666-8) use w/12 bolt cover . . . . .
66-68	Chevy (P/Trac. w/3.08, 3.36, 3.55 ratio),				
66-68	Chevelle (P/Trac. w/3.08, 3.36, 3.355, 3.70 ratio),				

**BRAKES—REAR AXLE AND DRIVE**

**5.510 CASE, Differential and Planet (Con't)**

67-68	Camaro (P/Trac. w/3.08, 3.36, 3.55 ratio),				
69	Chevy, Camaro (P/Trac. w/3.08, 3.36 ratio),				
69	Chevelle (P/Trac. w/3.08, 3.36, 3.55 ratio),				
65-70	All w/P/Trac.,				
71-72	Chevelle, Nova w/P/Trac. ....	3993516	1	145.00	w/3.07, 3.31, 3.55, 3.73 ratio (Eaton 12666-7) use w/12 bolt cover (Note 2) ...
66-69	Chevelle, Camaro w/P/Trac. (8 cyl.),				
67	Chevelle (P/Trac. w/2.73 ratio) (6 cyl.) (exc. Sta. Wag., El Camino),				
67-69	Chevy, Camaro (P/Trac. w/2.73, 2.56 ratio),				
68	Chevelle (P/Trac. w/2.73 ratio) (exc. S.S.),				
69	Chevelle w/P/Trac. (2.56, 2.73 ratio),				
68-69	Pass.,				
69	Chevelle w/P/Trac. (3.07, 3.31, 3.55, 3.73 ratio),				
70	Pass., Chevelle, Nova (P/Trac. w/2.29, 2.56, 2.73 ratio) ....	3936444	1	137.00	w/2.29, 2.56, 2.73 ratio (Eaton 12666-9) (Note 2) .....
67	Chevelle (P/Trac. w/2.73 ratio) (6 cyl.) (exc. Sta. Wag., El Camino),				
67-69	Chevy, Camaro (P/Trac. w/2.73, 2.56 ratio),				
68	Chevelle (P/Trac. w/2.73 ratio) (exc. S.S.),				
69	Chevelle w/P/Trac. (2.56, 2.73 ratio),				
68-69	Pass. w/2.56, 2.73 ratio,				
70	All P/Trac. w/2.56, 2.73 ratio,				
71	Chevelle, Nova (P/Trac. w/2.56, 2.73 ratio),				
72	Chevelle (P/Trac. w/2.73 ratio) .	3993504	1	145.00	(Eaton ED-11171-5) use w/10 bolt cover (Note 1) .....
68-69	Camaro w/disc brks. (front and rear) (3.07, 3.31, 3.55, 3.73 ratio) .....	3947280	1	130.00	w/12 bolt cover (Eaton 11523-1) .....
71-72	Chevelle w/P/Trac. ....	3993518	1	145.00	w/2.73 ratio (Eaton 12666-9) use w/12 bolt cover .....
71-72	Pass. (P/Trac. w/2.73, 3.08 ratio),				
71-72	Police, Taxi (P/Trac. w/3.08 ratio) .....	488373	1	170.00	(type P, M) .....
71	Pass. (P/Trac. w/3.42 ratio),				
71	Police, Taxi (P/Trac. w/3.42 ratio) .....	482156	1	170.00	(type P, M) .....
71-75	Vega (140) w/P/Trac. ....	3997990	1	127.00	diff. and planet, w/internal gears (Warner 8420-001) (6 1/2" dia. ring gear) (Note 1) ..
71-72	Pass., Camaro w/P/Trac. (exc. Sta. Wag.),				
71-75	Camaro w/P/Trac.,				
72-75	Nova w/P/Trac.,				
73-75	Chevelle w/P/Trac.,				
73-75	Pass. w/P/Trac. ....	407891	1	181.00	(w/2.73, 3.08, 3.23, 3.42, 3.73, 4.10) (type G, C, K, B, O, W) (8 1/2" dia. ring gear) ..
72	Pass. (P/Trac. w/3.42 ratio),				
72	Police, Taxi (P/Trac. w/3.42 ratio) .....	488374	1	170.00	(type P, M) .....
73-75	Chevelle (Sta. Wag.) w/P/Trac. .	490776	1	170.00	w/2.73, 3.08 ratio (type P, M), .....
73-75	Pass. w/P/Trac. ....	490777	1	170.00	w/2.73, 3.08 ratio (type P, M) (8 7/8" dia. ring gear) .....
73-75	Chevelle (Sta. Wag.) w/P/Trac. .	490777	1	170.00	w/3.42 ratio (type P, M), .....
73-75	Pass. w/P/Trac. ....	490777	1	170.00	w/3.42 ratio (type P, M) (8 7/8" dia. ring gear) .....
74	Vega (122) w/P/Trac. ....	345604	1	151.00	diff. and planet, w/internal gears (Note 1) ..
75	Vega (122), Monza (P/Trac. w/3.42, 3.73 ratio) .....	345938	1	126.00	diff. and planet, w/internal gears (7 1/2" dia. ring gear) (Note 1) .....

**BRAKES—REAR AXLE AND DRIVE**

**5.510 CASE, Differential and Planet (Con't)**

75	Vega (122), Monza (P/Trac. w/2.29, 2.56, 2.93 ratio) . . . . .	<b>352952</b>	1	126.00	diff. and planet, w/internal gears (7 <sup>1</sup> / <sub>2</sub> " dia. ring gear) (Note 1) . . . . .
75	Pass. w/P/Trac.,				
75	Chevelle (Sta. Wag.) w/P/Trac. . . . .	<b>496940</b>	1	141.00	w/2.56 ratio (type P, M) (8 <sup>7</sup> / <sub>8</sub> " dia. ring gear) . . . . .
75	All w/P/Trac. . . . .	<b>407890</b>	1	172.00	w/2.56 ratio (type C, G, K, W, B, O) (8 <sup>1</sup> / <sub>2</sub> " dia. ring gear) . . . . .

*NOTE 1: Internal positraction parts not serviced separately.  
 NOTE 1 Use with 10 bolt cover.  
 NOTE 2 Use with 12 bolt cover.  
 NOTE 3 See illustration preceding group 5.398 for identification of axle cover.*

**Differential Case (Case less internal gears)**

64-70	All (3.08, 3.36, 3.55, 3.70 ratio) (exc. P/Trac.),				
71	All w/3.08, 3.36 ratio (exc. Pass., P/Trac.),				
72	Chevelle w/3.36 ratio (exc. P/Trac.) . . . . .	<b>3958109</b>	1	33.50	w/10 bolt round cover (8 <sup>1</sup> / <sub>8</sub> " dia. ring gear) (Note 1) . . . . .
65-69	Pass. w/T.H. (2.73, 2.29, 2.56 ratio) (exc. P/Trac.),				
65	Chevy, Chevelle w/P.G. (2.73 ratio),				
67	Chevelle, Camaro w/A.T. (2.73 ratio) (exc. P/Trac.),				
68-69	Chevy, Camaro, Chevelle w/2.56, 2.73 ratio (exc. P/Trac.),				
70	Pass., Nova, Chevelle w/2.56, 2.73 ratio (exc. P/Trac.),				
71-72	Chevelle w/2.56, 2.73 ratio (exc. P/Trac.) . . . . .	<b>3869789</b>	1	31.50	w/12 bolt cover . . . . .
65-69	Pass. (3.07, 3.31, 3.55, 3.73 ratio) (exc. P/Trac.),				
65-66	Sta. Wag. (exc. P/Trac.),				
65-69	Chevy w/3.07, 3.31, 3.55, 3.73 ratio (exc. P/Trac.),				
65	Chevelle (327) (exc. P/Trac.),				
65	El Camino w/3.73 ratio (exc. P/Trac.),				
66-68	Chevelle (S.S.) (exc. P/Trac.),				
66-67	El Camino w/3.07, 3.31, 3.73 ratio (396) (exc. P/Trac.),				
67-69	Camaro w/3.07, 3.31, 3.55, 3.73 ratio (exc. P.G., P/Trac.),				
69	Chevelle w/3.07, 3.31, 3.55 ratio (exc. P/Trac.),				
70	Camaro w/3.07, 3.31 ratio (exc. P/Trac.),				
70	All w/3.07, 3.31, 3.55 ratio (exc. P/Trac.),				
71	Chevelle, Nova w/3.07, 3.31, 3.55 ratio (exc. P/Trac.),				
72	Chevelle w/3.31 ratio (exc. P/Trac.) . . . . .	<b>3852989</b>	1	31.50	w/12 bolt cover . . . . .
65-70	Pass. w/P/Trac. (3.08, 3.36, 3.55, 3.70 ratio),				
65-70	Chevy (P/Trac., w/3.08, 3.36, 3.55, 3.70 ratio),				
67-70	Chevelle (P/Trac. w/3.08, 3.36, 3.70 ratio),				
67-69	Camaro (P/Trac. w/3.08, 3.55 ratio),				
71	All (P/Trac. w/3.08, 3.36 ratio) (exc. Pass.),				
72	Chevelle (P/Trac. w/3.08, 3.36 ratio) . . . . .	<b>3869342</b>	1	68.75	(Eaton ED 30116) w/10 bolt round cover (Note 1) . . . . .
65-70	Pass. w/P/Trac. (3.07, 3.31, 3.55, 3.73 ratio),				
65-70	Chevelle (P/Trac. w/3.07, 3.31, 3.55, 3.73 ratio),				

**BRAKES—REAR AXLE AND DRIVE**

**5.510 CASE, Differential and Planet (Con't)**

65-67	El Camino (P/Trac. w/3.73 ratio) (8 cyl.),				
66-70	Chevy (P/Trac. w/3.07, 3.31, 3.55, 3.73 ratio),				
67-69	Camaro P/Trac. (3.07, 3.31 ratio),				
71	Chevelle, Nova (P/Trac. w/3.07, 3.31, 3.55 ratio),				
72	Chevelle (P/Trac. w/3.31 ratio) .	<b>3869315</b>	1	68.75	(Eaton ED 30140) w/12 bolt cover . . . . .
66-69	All w/P/Trac. (4.10, 4.56, 4.88 ratio) (8 cyl.),				
70	Chevelle w/P/Trac. (4.10, 4.56, 4.88 ratio),				
72	Chevelle (P.T. w/4.10 ratio) . . . .	<b>3869316</b>	1	68.75	(Eaton ED-30174) use w/12 bolt cover . . . . .
66-69	All w/P/Trac. (2.56, 2.73 ratio),				
70	Pass., Nova, Chevelle (2.29, 2.56, 2.73 ratio w/P/Trac.),				
71	Chevelle (P/Trac. w/2.29, 2.56, 2.73 ratio),				
72	Chevelle (P/Trac. w/2.73 ratio) .	<b>3890129</b>	1	67.75	w/12 bolt cover (Eaton 32088) . . . . .
67-68	Chevelle (P/Trac. w/2.56, 2.73 ratio) (6 cyl.) (exc. Sta. Wag., El Camino),				
67-69	Chevy, Camaro (P/Trac. w/2.56, 2.73 ratio),				
68-70	Pass. (P/Trac. w/2.56, 2.73 ratio),				
68-71	Chevelle (P/Trac. w/2.56, 2.73 ratio) (exc. S.S.),				
71	Nova (P/Trac. w/2.56, 2.73 ratio),				
72	Chevelle (P/Trac. w/2.73 ratio) .	<b>3918830</b>	1	67.75	w/10 bolt cover (Eaton 32118) . . . . .
67	Chevelle (P.G. w/A.I.R.) (exc. P/Trac., 3.08, 3.36, 3.55, 3.70 ratio),				
67-68	Camaro, Chevy w/2.56, 2.73 ratio (exc. P/Trac.),				
68-69	Pass. w/T.H. (2.56, 2.73 ratio) (exc. P/Trac.),				
68	Chevelle w/2.73 ratio (exc. P/Trac.),				
69	Chevy, Chevelle, Camaro w/2.56, 2.73 ratio (exc. P/Trac.),				
70	All w/2.56, 2.73 ratio (exc. P/Trac.),				
71	Chevelle, Nova w/2.56, 2.73 (exc. P/Trac.),				
72	Chevelle w/2.73 ratio (exc. P/Trac.) . . . . .	<b>3958110</b>	1	33.50	w/10 bolt cover . . . . .
68-69	Camaro w/disc brakes front and rear (4.10, 4.56, 4.88 ratio) . . .	<b>3947281</b>	1	126.00	w/12 bolt cover (Eaton 1523-2) . . . . .
70	Monte Carlo w/2.78 ratio (exc. P/Trac.) . . . . .	<b>9794845</b>	1	39.50	w/10 bolt cut out cover (Note 1) . . . . .
70	Monte Carlo w/3.08, 3.23 ratio (exc. P/Trac.) . . . . .	<b>9794846</b>	1	42.75	w/10 bolt cut out cover (Note 1) . . . . .
70	Monte Carlo w/P/Trac. (2.78 ratio) . . . . .	<b>479726</b>	1	195.00	w/10 bolt cut out cover (Note 1) . . . . .
70	Monte Carlo w/P/Trac. (3.08, 3.28) . . . . .	<b>479727</b>	1	195.00	w/10 bolt cut out cover (Note 1) . . . . .
71-75	Vega (140) (exc. P/Trac.) . . . . .	<b>3974927</b>	1	33.00	less internal gears (6½" dia. ring gear) . . . . .
71-73	Pass. w/2.73, 3.08 ratio (exc. P/Trac.),				
73	Chevelle (Sta. Wag.) w/2.73, 3.08 ratio (exc. P/Trac.) . . . . .	<b>484361</b>	1	73.50	(type P, M) (8⅞" dia. ring gear) . . . . .
71-73	Pass. w/3.42 ratio (exc. P/Trac.),				
73	Chevelle (Sta. Wag.) w/3.42 ratio (exc. P/Trac.) . . . . .	<b>484360</b>	1	73.50	(type P, M) (8⅞" dia. ring gear) . . . . .
71	Pass., Nova, Camaro w/P/Trac. (exc. Sta. Wag.),				
72	Camaro w/P/Trac.,				
73-75	All w/P/Trac. . . . .	<b>3995893</b>	1	67.50	(Eaton type) (type C, G, K, W) (8½" dia. ring gear) . . . . .
71-72	Camaro (exc. P/Trac.),				
72	Nova (exc. P/Trac.) . . . . .				2.73, 3.08, 3.42 ratio, . . . . .



**BRAKES—REAR AXLE AND DRIVE**

**5.510 CASE, Differential and Planet (Con't)**

71-72	Pass. w/2.73, 3.08, 3.42 ratio (exc. Sta. Wag. P/Trac.),				
73-75	All w/2.73, 3.08, 3.42 ratio (exc. P/Trac.) . . . . .	1234495	1	54.75	(type G, C, K, B, O, W) (8 <sup>1</sup> / <sub>2</sub> " dia. ring gear) .
72-74	Pass. (2.73, 3.08 ratio w/P/Trac.),				
73-74	Chevelle (Sta. Wag.) (2.73, 3.08 ratio w/P/Trac.) . . . . .	9792713	1	64.75	(type P, M) (8 <sup>7</sup> / <sub>8</sub> " dia. ring gear) . . . . .
72-74	Pass. (3.42 ratio w/P/Trac.),				
73-74	Chevelle (Sta. Wag.) (3.42 ratio w/P/Trac.) . . . . .	9792714	1	64.75	(type P, M) (8 <sup>7</sup> / <sub>8</sub> " dia. ring gear) . . . . .
72-75	All w/P/Trac. . . . .	407725	1	69.00	(Olds. type) (type B, O) (8 <sup>1</sup> / <sub>2</sub> " dia. ring gear) (exc. 2.56 ratio) . . . . .
74	Vega (122) (exc. P/Trac.) . . . . .	345620	1	44.25	less internal gears . . . . .
74	Chevelle (Sta. Wag.) (exc. P/Trac.),				
74	Pass. (exc. P/Trac.) . . . . .	491087	1	73.50	w/2.73, 3.08 ratio (type P, M) (8 <sup>7</sup> / <sub>8</sub> " dia. ring gear) . . . . .
74	Chevelle (Sta. Wag.) (exc. P/Trac.),				
74	Pass. (exc. P/Trac.) . . . . .	491088	1	73.50	w/3.42 ratio (type P, M) (8 <sup>7</sup> / <sub>8</sub> " dia. ring gear) . . . . .
75	Pass. (2.56 ratio w/P/Trac.),				
75	Chevelle (Sta. Wag.) (2.56 ratio w/P/Trac.) . . . . .	9792712	1	101.00	(type P, M) (8 <sup>7</sup> / <sub>8</sub> " dia. ring gear) . . . . .
75	All w/P/Trac. (exc. Pass.) . . . . .	231262	1	152.00	w/2.56 ratio (type B, O, C, G, K, W) (8 <sup>1</sup> / <sub>2</sub> " dia. ring gear) . . . . .
75	All (exc. P/Trac.) . . . . .	1234494	1	52.00	w/2.56 ratio) (type B, O, C, G, K, W) (8 <sup>1</sup> / <sub>2</sub> " dia. ring gear) . . . . .
75	Chevelle (Sta. Wag.) (exc. P/Trac.),				
75	Pass. (exc. P/Trac.) . . . . .	488793	1	61.25	w/3.42 ratio (type P, M) (8 <sup>7</sup> / <sub>8</sub> " dia. ring gear) . . . . .
75	Chevelle (Sta. Wag.) (exc. P/Trac.),				
75	Pass. (exc. P/Trac.) . . . . .	488792	1	61.25	w/2.73, 3.08 ratio (type P, M) (8 <sup>7</sup> / <sub>8</sub> " dia. ring gear) . . . . .
75	Pass. (2.73, 3.08 ratio w/P/Trac.),				
75	Chevelle (Sta. Wag.) (2.73, 3.08 ratio w/P/Trac.) . . . . .	488373	1	170.00	(type P, M) (8 <sup>7</sup> / <sub>8</sub> " dia. ring gear) . . . . .
75	Pass. (3.42 ratio w/P/Trac.),				
75	Chevelle (Sta. Wag.) (3.42 ratio w/P/Trac.) . . . . .	488374	1	170.00	(type P, M) (8 <sup>7</sup> / <sub>8</sub> " dia. ring gear) . . . . .
75	Vega (122) Monza w/3.42, 3.73 ratio (exc. P/Trac.) . . . . .	344163	1	40.00	less internal gears (7 <sup>1</sup> / <sub>2</sub> " dia. ring gear) . . . .
75	Vega (122) Monza w/2.29, 2.56, 2.93 ratio (exc. P/Trac.) . . . . .	352951	1	40.00	less internal gears (7 <sup>1</sup> / <sub>2</sub> " dia. ring gear) . . . .

*NOTE 1 See illustration preceding Group 5.398 for identification of axle cover.*

**5.511 PLATE— CAGE— CLUTCH UNIT— CUP— GUIDE— RING— SHIM—  
SPACER— SPRING, Differential Clutch (Positraction)**

62-63	Chevy . . . . .	3777268	2	2.70	(Belleville type) (dished— ink stamped .095)
62-63	Chevy . . . . .	534935	2	1.90	std. (.095 thick) . . . . .
64-65	Chevy, Chevelle,				
65	Pass. w/3.08, 3.36, 3.55, 3.70 ratio . . . . .	3830747	2	2.70	(Dana 32328) (spring seat plate) (No tangs on plates) . . . . .
65	Chevelle w/4.10, 4.56, 4.88 ratio . . . . .	3884025	2	2.45	pressure (w/12 bolt cover) (Dana 34002) . .
65-69	All,				
70	Pass., Nova, Chevelle,				
71-72	All (exc. Pass.),				
73-75	All w/Eaton type diff. . . . .	3869320	2	2.30	pressure (Eaton ED 94153) (spring seat plate) (type G, C, K) . . . . .
65-68	Pass. w/3.08, 3.36, 3.55, 3.70 ratio (10 bolt cover),				
65-68	Chevelle, Camaro w/3.08, 3.36, 3.70 ratio . . . . .	2494749	A.R.	.82	(Dana 34001) (4 tangs on each plate) . . . .
73-75	Pass. w/Eaton type diff.,				
73-75	Chevelle (Sta. Wag.) w/Eaton type diff. . . . .	488333	2	1.60	(pre-load) (type P, M) . . . . .
62-63	Chevy . . . . .	3865208	1	23.50	PLATE UNIT, w/discs (Note 1) . . . . .

*NOTE 1 Consists of 6 plates and 4 discs.*

65-69 All,

**BRAKES—REAR AXLE AND DRIVE**

**5.511 PLATE—CAGE—CLUTCH UNIT—CUP—GUIDE—RING—SHIM—  
SPACER—SPRING, Differential Clutch (Positraction) (Con't)**

70	Pass., Nova, Chevelle,					
71-72	All (exc. Pass.),					
71-72	Pass. (exc. Sta. Wag.),					
73-75	All w/Eaton type diff. ....	483722	1	26.75	PLATE UNIT, w/discs (Eaton type diff.) (type C, G, K, P, M) (Note 2) .....	
	<i>NOTE 2: Consists of 10 eared discs and 8 splined discs and 4 guides.</i>					
65-68	Pass. w/3.08, 3.36, 3.55, 3.70 (2nd design),					
65-68	Chevy, Camaro w/3.08, 3.36, 3.55 ratio (3rd design),					
65-68	Chevelle w/3.08, 3.36, 3.70 ratio (3rd design) .....	3888070	1	39.75	PLATE UNIT, (Dana 24652X) (4 tangs on plate) .....	
74	Vega (122) w/P/Trac. ....	345602	1	27.00		
64-65	Chevy, Chevelle,					
65-66	Pass. w/3.08, 3.36, 3.55, 3.70 ratio .....	3830746	2	2.90	CAGE, clutch friction plate (Dana 32327) ..	
64	Chevy, Chevelle .....	3830740	1	21.60	CLUTCH UNIT (Dana 23230X) .....	
72	Pass. w/2.73, 3.08 ratio,					
73-75	All w/Olds type diff. ....	231127	1	26.50	CLUTCH UNIT (Olds. type diff.) w/disc diff. (type G, K, C, B, O) (Note 3) .....	
	<i>NOTE 3: Consists of 8 Fixed Discs and 6 Splined Discs.</i>					
65	All w/3.08, 3.36, 3.55, 3.70 ratio .....	3867896	8	.53	CUP, press. plate spring (Dana 33230) ....	
64-68	Chevy, Chevelle, Camaro w/3.08, 3.36, 3.55, 3.70 ratio,					
65-68	Pass. ....	3872495	4	.58	GUIDE, w/3871310, 3883763, w/3883763 (Dana 33295) .....	
65-69	All,					
70	Pass., Chevelle, Nova,					
71-72	All (exc. Pass.),					
71-72	Pass. (P/Trac. w/2.73, 3.08, 3.42 ratio),					
73-75	All w/Eaton type diff. ....	9778355	4	.59	GUIDE, plate (Eaton ED 94228) (type P, M, G, C, K) .....	
62	Chevy .....	3745318	2	20.15	RING, side gear (3 <sup>3</sup> / <sub>4</sub> " O.D.) .....	
74	Vega (122) w/P/Trac. ....	345626	2	20.80	RING, side gear .....	
65-69	All,					
70	Pass., Chevelle, Nova,					
71	All (exc. Pass.),					
72	Chevelle .....	9778347	A.R.	1.05	SHIM (.005) (Eaton 94128-5) .....	
65-69	All,					
70	Pass., Chevelle, Nova,					
71	All (exc. Pass.),					
72	Chevelle .....	9778348	A.R.	1.05	SHIM (.007) (Eaton 94128-7) .....	
65-69	All,					
70	Pass., Chevelle, Nova,					
71-72	All (exc. Pass.),					
71-72	Pass. (P/Trac. w/2.73, 3.08, 3.42 ratio),					
73-75	All w/Eaton type diff. ....	9778349	A.R.	1.05	SHIM (.010) (Eaton ED 94128-10) (type P, M, G, C, K) .....	
65	Pass. w/10 bolt cover,					
66-69	All,					
70	Pass., Chevelle, Nova,					
71-72	All (exc. Pass.),					
71-72	Pass. (P/Trac. w/2.73, 3.08, 3.42 ratio),					
73-75	All w/Eaton type diff. ....	2472358	A.R.	1.00	SHIM (.012 thick) (Eaton ED 94128-12) (type P, M, G, C, K) .....	
65	Pass. w/10 bolt cover,					
66-69	All,					
70	Pass., Chevelle, Nova,					
71-72	All (exc. Pass.),					
71-72	Pass. (P/Trac. w/2.73, 3.08, 3.42 ratio),					
73-75	All w/Eaton type diff. ....	2472359	A.R.	1.00	SHIM (.015) (Eaton ED 94128-15) (type P, M, G, C, K) .....	
65-69	Pass.,					
66-69	Chevy, Chevelle, Camaro,					
70	Pass., Chevelle, Nova,					
71-72	All (exc. Pass.),					
71-72	Pass. (P/Trac. w/2.73, 3.08, 3.42 ratio),					

**BRAKES—REAR AXLE AND DRIVE**

**5.511 PLATE— CAGE— CLUTCH UNIT— CUP— GUIDE— RING— SHIM—  
SPACER— SPRING, Differential Clutch (Positraction) (Con't)**

73-75	All w/Eaton type diff. . . . .	9777600 A.R.	1.50	SHIM (.020) (Eaton ED 94128-20) (type P, G, C, K, M) . . . . .
65-69	Pass.,			
66-69	Chevy, Chevelle, Camaro,			
70	Pass., Chevelle, Nova,			
71-72	All (exc. Pass.),			
71-72	Pass. (P/Trac. w/2.73, 3.08, 3.42 ratio),			
73-75	All w/Eaton type diff. . . . .	9777601 A.R.	1.50	SHIM (.025) (Eaton ED 94128-25) (type P, G, C, K, M) . . . . .
65-69	Pass.,			
66-69	Chevy, Chevelle, Camaro,			
70	Pass., Chevelle, Nova,			
71-72	All (exc. Pass.),			
71-72	Pass. (P/Trac. w/2.73, 3.08, 3.42 ratio),			
73-75	All w/Eaton type diff. . . . .	9777602 A.R.	1.50	SHIM (.030) (Eaton ED 94128-30) (type P, M, G, C, K) . . . . .
68-69	Camaro w/Disc Brakes (front and rear),			
71-72	Pass. (P/Trac. w/2.73, 3.08, 3.42 ratio),			
72	Nova, Camaro,			
73-75	All w/Eaton type axle . . . . .	9789247 A.R.	1.05	SHIM (.017) (Eaton 94128-17) (type P, M, G, C, K) . . . . .
72-75	All w/Olds. type diff. . . . .	410864	1	1.45 SHIM (.070) (type C, G, K, B, O) . . . . .
72-75	All w/Olds. type diff. . . . .	410865	1	1.45 SHIM (.074) (type C, G, K, B, O) . . . . .
72-75	All w/Olds. type diff. . . . .	410866	1	1.45 SHIM (.078) (type C, G, K, B, O) . . . . .
72-75	All w/Olds. type diff. . . . .	410867	1	1.45 SHIM (.082) (type C, G, K, B, O) . . . . .
72-75	All w/Olds. type diff. . . . .	410868	1	1.45 SHIM (.086) (type C, G, K, B, O) . . . . .
72-75	All w/Olds. type diff. . . . .	410869	1	1.45 SHIM (.090) (type C, G, K, B, O) . . . . .
72-75	All w/Olds. type diff. . . . .	410870	1	1.45 SHIM (.094) (type C, G, K, B, O) . . . . .
72-75	All w/Olds. type diff. . . . .	410871	1	1.45 SHIM (.098) (type C, G, K, B, O) . . . . .
72-75	All w/Olds. type diff. . . . .	410872	1	1.45 SHIM (.102) (type C, G, K, B, O) . . . . .
72-75	All w/Olds. type diff. . . . .	410873	1	1.45 SHIM (.106) (type C, G, K, B, O) . . . . .
72-75	All w/Olds. type diff. . . . .	410874	1	1.45 SHIM (.110) (type C, G, K, B, O) . . . . .
72-75	All w/Olds. type diff. . . . .	410875	1	1.45 SHIM (.114) (type C, G, K, B, O) . . . . .
72-75	All w/Olds. type diff. . . . .	410876	1	1.45 SHIM (.118) (type C, G, K, B, O) . . . . .
72-75	All w/Olds. type diff. . . . .	410877	1	1.45 SHIM (.122) (type C, G, K, B, O) . . . . .
65-68	All w/3.08, 3.36, 3.55, 3.70 ratio . . . . .	2489185	1	.25 SPACER (.024) . . . . .
64	Chevy, Chevelle . . . . .	3854101	4	3.75 SPRING, clutch (Dana 32823) . . . . .
65-69	Chevy, Chevelle, Camaro,			
66-69	Pass.,			
70	Pass., Chevelle, Nova,			
71-75	All w/Eaton type diff. . . . .	3890899	4	.59 SPRING, pressure plate (Eaton ED-7976) (50 lb.) (type G, C, K) . . . . .
65	Pass. w/3.07, 3.31, 3.55, 3.73 ratio (Metallic Brk.) . . . . .			SPRING, clutch press plate, . . . . .
65	Pass. w/4.10, 4.56, 4.88 (8 cyl.) w/Metallic Brks. . . . .	3869311	4	1.20 w/12 bolt cover (Dana 33275) . . . . .
65-68	Pass. w/3.08, 3.36, 3.55, 3.70 ratio (2nd design),			
65-68	Chevy w/3.08, 3.36, 3.55 ratio (3rd design),			
65-68	Chevelle w/3.08, 3.36, 3.70 ratio (3rd design),			
67-68	Camaro w/3.08, 3.55 ratio . . . . .	3888078	2	1.15 SPRING, clutch pressure plate (Dana 33824) (free length of 1 <sup>11</sup> / <sub>32</sub> " ) . . . . .
65-68	Pass.,			
66-68	Chevy, Chevelle, Camaro (2nd design) . . . . .	3890860	4	.59 SPRING, pressure plate (Eaton ED 72043) (75 lb.) (yellow) . . . . .
72-75	All w/Olds. type diff. . . . .	231260	1	.88 SPRING, diff. preload (type G, K, C, B, O) ("S" shaped) . . . . .
73-75	Pass. w/Eaton type diff.,			
73-75	Chevelle (Sta. Wag.) w/Eaton type diff. . . . .	488332	4	2.00 SPRING, diff. pre-load (type P, M) . . . . .
<b>5.517 SHAFT, Differential Pinion</b>				
62-63	Chevy w/P/Trac. . . . .	531312	2	10.70 (9/4" x 4 <sup>25</sup> / <sub>32</sub> "— "V" cut) (Spicer 30931) . . . . .
62-64	Chevy, Chevelle (exc. P/Trac.),			

**BRAKES—REAR AXLE AND DRIVE**

**5.517 SHAFT, Differential Pinion (Con't)**

65-69	Chevy, Chevelle, Camaro w/2.56, 2.73, 3.08, 3.36, 3.55, 3.70 ratio,				
65-69	Pass. w/10 bolt cover (exc. P/Trac.),				
70	All (exc. P/Trac.),				
71	All (exc. Pass., P/Trac.),				
72	Chevelle . . . . .	<b>3935181</b>	1	3.15	(w/10 bolt cover) . . . . .
64-68	Chevy, Chevelle, Camaro w/P/Trac. (exc. 396),				
65-68	Pass. w/P/Trac. (3.08, 3.36, 3.55, 3.70 ratio) . . . . .	<b>3830742</b>	1	2.40	(Dana 32266) . . . . .
All	Pass. w/12 bolt cover,				
65-67	Chevelle w/3.07, 3.31 ratio (8 cyl.),				
65-67	Chevy (C.A.C. w/P/Trac.) (3.07, 3.31 ratio) (327),				
65-66	El Camino w/3.37 ratio (8 cyl.),				
67	Camaro (exc. P/Trac. 3.08, 3.55 ratio),				
68-69	Chevy, Chevelle, Camaro w/2.56, 2.73, 3.07, 3.31, 3.55, 3.73 ratio (exc. P/Trac.),				
70	All (exc. P/Trac.),				
71	All (exc. Pass., P/Trac.),				
72	Chevelle w/2.73, 3.08, 3.31, 3.36 ratio (exc. P/T) . . . . .	<b>3931175</b>	1	2.80	(w/12 bolt cover) . . . . .
65-69	Pass. w/P/Trac. (3.08, 3.36, 3.55, 3.70 ratio),				
65-69	Chevy, Chevelle, Camaro (P/Trac. w/2.73, 3.08, 3.26, 3.55, 3.70 ratio),				
70	Nova w/P/Trac. (3.08, 3.36 ratio),				
70	Pass., Chevelle w/P/Trac. (2.56, 2.73, 3.08, 3.36 ratio),				
71	Chevelle, Nova w/P/Trac.,				
72	Chevelle 2.73, 3.08, 3.36 ratio w/P/Trac. . . . .	<b>9776894</b>	1	4.15	( <sup>3</sup> / <sub>4</sub> " O.D. x 4 <sup>51</sup> / <sub>64</sub> " O.L.) (Eaton ED 6960) (w/10 bolt cover) . . . . .
65	Chevy, Chevelle w/P/Trac.,				
65	Pass. w/P/Trac. (3.07, 3.31, 3.55, 3.73 ratio),				
65	Pass. w/P/Trac. (4.11, 4.56, 4.88 ratio) (8 cyl.),				
67	Pass. (8 cyl.) (2.73 ratio) . . . . .	<b>3869308</b>	A.R.	3.50	( <sup>51</sup> / <sub>64</sub> " O.D. x 5 <sup>5</sup> / <sub>16</sub> " ) (Dana 33270) . . . . .
68-69	Camaro w/disc brakes (front and rear) . . . . .	<b>3960349</b>	1	9.20	(Eaton ED-62145) . . . . .
71	Pass., Camaro (exc. Sta. Wag.),				
72	Pass. (2.73, 3.08 ratio w/P.T.) (exc. Sta. Wag.),				
72	Nova, Camaro w/P.T.,				
73-75	All (2.73, 3.08 ratio w/P.T.) . . . . .	<b>3995896</b>	1	2.95	(type G, C, K) (Eaton type) (8 <sup>1</sup> / <sub>2</sub> " dia. ring gear) . . . . .
72	Nova, Camaro,				
71-72	Pass. w/2.73, 3.08 ratio (exc. Sta. Wag.),				
73-75	All w/2.73, 3.08, 3.23 ratio (exc. Sta. Wag.) . . . . .	<b>1234376</b>	1	5.60	(type B, O, C, G, K) (Olds. type) (8 <sup>1</sup> / <sub>2</sub> " dia. ring gear) . . . . .
71-75	Pass. (exc. P/Trac.),				
73-75	Chevelle (Sta. Wag.) (exc. P/Trac.) . . . . .	<b>9778184</b>	1	4.35	(type P, M) (Olds. type) (8 <sup>7</sup> / <sub>8</sub> " dia. ring gear)
71-75	Pass. w/P/Trac.,				
73-75	Chevelle (Sta. Wag.) w/P/Trac. . . . .	<b>9792718</b>	1	5.30	(type P, M) (8 <sup>7</sup> / <sub>8</sub> " dia. ring gear) . . . . .
71-75	Vega (140) (exc. P/Trac.) . . . . .	<b>3855511</b>	1	2.00	(6 <sup>1</sup> / <sub>2</sub> " dia. ring gear) . . . . .
74	Vega (122) (exc. P/Trac.) . . . . .	<b>345621</b>	1	2.10	
74	Vega (122) w/P/Trac. . . . .	<b>345630</b>	1	11.35	
75	Vega (122) Monza (exc. P/Trac.) . . . . .	<b>344168</b>	1	4.35	(7 <sup>1</sup> / <sub>2</sub> " dia. ring gear) . . . . .

**5.518 SCREW— WASHER, Pinion Shaft Lock**

62-70	All (exc. P/Trac.),				
70	Monte Carlo w/cut out cover,				
71	Chevelle, Nova (exc. P/Trac.),				
72	Chevelle (exc. P/Trac.) . . . . .	<b>472546</b>	1	.32	( <sup>5</sup> / <sub>16</sub> "— 18— 2) (round cover) (Note 1) . . . . .

**BRAKES—REAR AXLE AND DRIVE**

**5.518 SCREW— WASHER, Pinion Shaft Lock (Con't)**

64	Chevy, Chevelle w/P/Trac. (1st design) .....	3830743	1	1.45	(Dana 32267) .....
64	Chevy, Chevelle w/P/Trac. (2nd design),				
65-68	Chevy w/P/Trac., 3.08, 3.36, 3.55 ratio,				
65-68	Chevelle, Camaro (P/Trac. w/3.08, 3.36, 3.70 ratio),				
65-68	Pass. w/P/Trac. ....	2462906	1	.48	(Dana 32845) .....
65-69	Pass. w/P/Trac. (12 bolt ring gear),				
65-69	Chevelle w/3.07, 3.31 ratio (8 cyl.),				
65-69	El Camino w/3.07, 3.31, 3.73 ratio (8 cyl.),				
66-69	Camaro, Chevy (P/Trac. w/3.07, 3.31, 3.55, 3.73 ratio),				
70	All (exc. P/Trac.),				
70	Pass., Chevelle w/P/Trac. (12 bolt cover),				
70	Nova (P/Trac. w/2.73, 3.07, 3.31, 3.55 ratio),				
71	Pass. w/2.73, 3.08, 3.42 ratio,				
71	Chevelle, Nova w/P/Trac.,				
72	Pass. (2.73, 3.08, 3.42 ratio w/P.T.),				
72	Chevelle w/P/Trac. ....	3830672	1	.38	(Eaton ED 92994) (type P, M) (w/12 bolt cover) .....
65-69	Pass. w/P/Trac. (3.08, 3.36, 3.55, 3.70 ratio),				
65-68	Chevy, Chevelle, Camaro (P/Trac. w/2.73, 3.08, 3.36, 3.55, 3.70 ratio) .....	3869319	1	.38	(Eaton 93465) .....
66-67	Pass. w/P/Trac. (273 ratio) (8 cyl.) .....	3849912	1	2.10	(Dana 32283) .....
71	Camaro (exc. P/Trac.),				
71-72	Pass. w/2.73, 3.08 ratio (exc. Sta. Wag., P/Trac.) .....				(type G, K), .....
71-72	Pass. w/2.73, 3.08, 3.42 ratio (exc. P/Trac.) .....				(type P, M), .....
71-72	Pass. w/2.73, 3.08 ratio .....				(type B, O), .....
72	Camaro, Nova,				
73-75	All .....	393132	1	.22	(type G, K, B, O) (5/16" — 18 x 1 13/16") .....
71-75	Vega (140) .....	3974957	1	.24	(6 1/2" dia. ring gear) (hex. head) .....
71-73	Vega w/P/Trac. ....	6260534	1	.53	(Allen Head) .....
74	Vega (122) (exc. P/Trac.) .....	2402527	1	.10	
74	Vega (122) w/P/Trac. ....	345611	1	.56	
75	Vega (122) Monza (exc. P/Trac.)	393132	1	.22	(7 1/2" dia. ring gear) .....
71-72	Pass. (P/Trac. w/2.73, 3.08, 3.42 ratio) .....	9778346 A.R.		.24	WASHER, diff. case lock (type P, M) .....

NOTE 1 See illustration preceding group 5.398 for identification of axle cover.

**5.526 GEAR, Differential Pinion**

62-68	Chevy, Chevelle, Camaro (exc. P/Trac.),				
65-68	Pass. (exc. P/Trac.),				
69-70	All w/10 bolt round cover (exc. P/Trac.),				
71	Chevelle, Nova (exc. P/Trac.),				
72	Chevelle (exc. P/Trac.) .....	3958108	2	7.55	(10 teeth) (3.36, 3.70 ratio) (Note 1) .....
62-63	Chevy, Chevelle w/P/Trac. ....	2370715	4	4.30	(10 teeth) (daub of orange paint) .....
64	Chevy, Chevelle w/P/Trac.,				
65-68	Chevy (P/Trac. w/3.08, 3.36, 3.55 ratio),				
65-68	Chevelle (P/Trac. w/3.08, 3.36, 3.70 ratio),				
67-68	Camaro (P/Trac. w/3.08, 3.55 ratio),				
65-68	Pass. w/P/Trac. (3.08, 3.36, 3.55, 3.70 ratio) .....	3854260	2	5.50	(10 teeth) (Dana 32808) w/10 bolt cover ..
65-69	All (P/Trac. w/12 bolt cover),				
70	Pass., Chevelle, Nova (P/Trac. w/12 bolt cover),				
71	Chevelle, Nova (P/Trac. w/12 bolt cover) .....	3830670	2	9.75	(Eaton 40343) (18 teeth) .....

**BRAKES—REAR AXLE AND DRIVE**

**5.526 GEAR, Differential Pinion (Con't)**

65	Chevelle (P/Trac. w/3.07, 3.31 ratio) (8 cyl.),				
65	Chevy (C.A.C. w/3.07, 3.31 ratio) (327),				
65	El Camino, w/3.73 ratio (8 cyl.),				
65	Chevelle, C.A.C., P.G. w/2.73 ratio (327) (exc. Sp. H/Per.),				
66-69	Chevy, Chevelle (exc. P/Trac.),				
67-69	Camaro w/3.07, 3.31, 3.55, 3.73 ratio (exc. P/Trac.),				
67-69	Camaro w/H.D. Brake (exc. P/Trac.),				
65-69	Pass. w/12 bolt cover (exc. P/Trac.),				
70	All (exc. P/Trac.),				
71	Chevelle, Nova (exc. P/Trac.),				
72	Chevelle (exc. P/Trac.)	3880140	2	6.05	(10 teeth) 12 bolt cover
65-69	Chevy, Chevelle, Camaro w/P/Trac.,				
65-69	Pass. w/P/Trac. (3.08, 3.36, 3.55, 3.70 ratio),				
70	Pass., Chevelle w/P/Trac. (2.56, 2.73, 3.08, 3.36 ratio),				
71-72	Chevelle, Nova, Camaro w/P/Trac. (1st design)	9778343	2	9.95	(Eaton ED 40335) 10 bolt round cover 18 teeth on side gear (Note 1)
70	Monte Carlo w/cut out cover (exc. P/Trac.)	9783005	1	6.25	(Note 1)
71	Chevelle, Nova w/P/Trac. (2nd design),				
72	Chevelle w/P/Trac. (2nd design)	3995842	2	10.70	(17 teeth on side gear)
71-72	Pass., Camaro w/P/Trac. (exc. Sta. Wag.),				
72	Nova w/P/Trac.,				
73-75	All w/P/Trac. (exc. Sta. Wag.)	3995895	2	10.70	(Eaton type) (type C, G, K) (8½" dia. ring gear)
71-75	Vega (140) (exc. P/Trac.)	3974949	2	6.05	(6½" dia. ring gear)
72	Chevelle w/P/Trac.	3995843	2	10.70	w/12 bolt cover (Eaton ED-40343) (17 teeth)
74	Vega (122) (exc. P/Trac.)	345622	1	4.95	
74	Vega (122) w/P/Trac.	345627	1	6.20	
75	All w/P/Trac.	6270977	1	7.60	(8½" dia. ring gear) (B-O type)
75	Vega (122) Monza (exc. P/Trac.)	344166	2	6.55	(7½" dia. ring gear)

*NOTE 1 See illustration preceding Group 5.398 for identification of axle cover.*

**5.527 GEAR UNIT— WASHER, Differential Side with Pinion**

*NOTE: Unit contains 2-side gears-2 pinion gears-thrust washers-pinion shaft.*

71-72	Pass. w/2.73, 3.08, 3.42 ratio (exc. P/Trac., Sta. Wag.),				
71-72	Pass. (Sta. Wag.) w/2.73, 3.08 ratio (exc. P/Trac.)	483721	1	48.00	diff. side gear, pinion & pinion shaft (type P, M)
71-72	Pass. (2.73, 3.08, 3.42 ratio w/P/Trac.) (exc. Sta. Wag.),				
71-72	Pass. (Sta. Wag.) (2.73, 3.08 ratio w/P/Trac.)	484666	1	89.75	diff. side gear, pinion & pinion shaft (type P, M)
71-72	Camaro w/2.73, 3.08, 3.42 ratio (exc. P/Trac.),				
71-72	Pass. w/2.73, 3.08 ratio (exc. Sta. Wag., P/Trac.),				
72	Nova w/2.73, 3.08, 3.42 ratio (exc. P/Trac.),				
73-75	All (exc. P/Trac.)	1397647	1	59.75	(type G, C, K, B, O)
73-75	Pass. w/P/Trac.,				
73-75	Chevelle (Sta. Wag.) w/P/Trac.	490778	1	79.50	pinion & side gear (type P, M) (8 <sup>7</sup> / <sub>8</sub> " dia. ring gear)
73	Pass. (exc. P/Trac.),				
73	Chevelle (Sta. Wag.) (exc. P/Trac.)	491941	1	48.00	side gear pinion & pinion shaft (type P, M) (8 <sup>7</sup> / <sub>8</sub> " dia. ring gear)
74-75	Pass. (exc. P/Trac.),				
74-75	Chevelle (Sta. Wag.) (exc. P/Trac.)	491237	1	48.00	side gear pinion & pinion shaft (type P, M) (8 <sup>7</sup> / <sub>8</sub> " dia. ring gear)

**BRAKES—REAR AXLE AND DRIVE**

**5.527 GEAR UNIT— WASHER, Differential Side with Pinion (Con't)**

<b>73-75</b>	Chevelle (exc. Sta. Wag., P/Trac.),				
<b>73-75</b>	Pass. w/2.73, 3.08 ratio (exc. Sta. Wag., P/Trac.) . . . . .	<b>393140</b>	<b>2</b>	<b>.16</b>	<b>WASHER, diff. pinion thrust (type B, O) (8½" dia. ring gear) . . . . .</b>

**5.528 GEAR, Differential Side**

*NOTE: Differential Side Gear for "P" type axle see Unit in Group 5.527.*

<b>62-63</b>	Chevy w/P/Trac. . . . .	<b>3744618</b>	<b>2</b>	<b>9.65</b>	right or left (daub of orange paint) . . . . .
<b>62-63</b>	Chevy (exc. P/Trac.) . . . . .	<b>3820638</b>	<b>2</b>	<b>13.30</b>	right or left (16 teeth) . . . . .
<b>64</b>	Chevy, Chevelle (exc. P/Trac.) . . .	<b>3832415</b>	<b>2</b>	<b>12.70</b>	
<b>64</b>	Chevy, Chevelle w/P/Trac., 3.08, 3.36 ratio . . . . .	<b>3848014</b>	<b>2</b>	<b>17.50</b>	(Dana 32630) . . . . .
<b>65-66</b>	Sta. Wag. (exc. P/Trac.),				
<b>65-69</b>	Pass. w/12 bolt cover (exc. P/Trac.),				
<b>65-67</b>	Chevy w/3.07, 3.31, 3.55 ratio (327),				
<b>65</b>	Chevelle w/2.73, 3.07, 3.31 ratio (327) (exc. Sp. H/Per.),				
<b>65</b>	El Camino w/3.73 ratio (8 cyl.),				
<b>66-69</b>	Chevelle, Camaro (exc. P/Trac.),				
<b>67-69</b>	Chevy (exc. P/Trac.),				
<b>70</b>	All w/12 bolt cover (exc. P/Trac.),				
<b>71</b>	Chevelle, Nova (exc. P/Trac.),				
<b>72</b>	Chevelle (exc. P/Trac.) . . . . .	<b>3846078</b>	<b>2</b>	<b>13.30</b>	(30 splines— 16 teeth) w/12 bolt cover . . .
<b>65-68</b>	Pass. w/P/Trac. (3.08, 3.36, 3.55, 3.70 ratio),				
<b>65-68</b>	Chevy, Camaro (P/Trac., w/3.08, 3.36, 3.55 ratio),				
<b>65-68</b>	Chevelle (P/Trac., w/3.08, 3.36, 3.70 ratio) . . . . .	<b>2472350</b>	<b>2</b>	<b>12.05</b>	(Dana 33243) (28 splines— 16 teeth) . . . . .
<b>65-69</b>	Pass. w/10 bolt cover (exc. P/Trac.),				
<b>65-69</b>	Chevelle (exc. P/Trac.),				
<b>65-67</b>	Chevy (exc. P/Trac.),				
<b>67-68</b>	Camaro w/2.56, 2.73, 3.08, 3.55, 3.36 ratio (exc. P/Trac.),				
<b>68-69</b>	Chevy w/2.56, 2.73, 3.08, 3.55, 3.66 ratio,				
<b>70</b>	All w/10 bolt round cover (exc. P/Trac.),				
<b>71</b>	Chevelle, Nova (exc. P/Trac.),				
<b>72</b>	Chevelle (exc. P/Trac.) . . . . .	<b>3863725</b>	<b>2</b>	<b>12.00</b>	(28 splines— 16 teeth) w/10 bolt cover (Note 1) . . . . .
<b>65-69</b>	Pass. w/3.07, 3.31, 3.55, 3.73 ratio,				
<b>65-69</b>	Pass. w/3.73, 4.56, 4.88 ratio, (8 cyl.),				
<b>65-69</b>	Chevy, Chevelle, Camaro w/P/Trac. (exc. 3.08, 3.36, 3.70 ratio),				
<b>65-69</b>	El Camino w/3.73 ratio (8 cyl.),				
<b>70</b>	Pass., Nova, Chevelle w/P/Trac. (2.29, 2.56, 2.73, 3.07, 3.31, 3.55, 3.73 ratio),				
<b>71</b>	Chevelle, Nova w/P/Trac. . . . .	<b>2472352</b>	<b>2</b>	<b>12.00</b>	(23— 18 teeth) (Eaton ED 40334-7) (w/12 bolt cover) . . . . .
<b>65</b>	Chevy, Chevelle w/P/Trac.,				
<b>65</b>	Pass. w/P/Trac., (3.07, 3.31, 3.55, 3.73, 4.10, 4.56, 4.88 ratio),				
<b>66-67</b>	Pass. w/P/Trac. (2.73 ratio) (8 cyl.) . . . . .	<b>3869305</b>	<b>2</b>	<b>26.50</b>	(30 splines— 16 teeth) (Dana 33267) . . . . .
<b>65-70</b>	Pass. w/P/Trac. (3.08, 3.36, 3.55, 3.70 ratio) (10 bolt cover),				
<b>65-68</b>	Chevy, Chevelle, Camaro (P/Trac. w/2.73, 3.08, 3.36, 3.55, 3.70 ratio),				
<b>70</b>	Nova, Chevelle w/P/Trac. (3.08, 3.36, 3.55, 3.70 ratio w/10 bolt round cover),				

**BRAKES—REAR AXLE AND DRIVE**

**5.528 GEAR, Differential Side (Con't)**

71	All w/P/Trac. (exc. Pass.)	3869344	2	15.45	(interior spline 28— exterior spline 23— 18 teeth) (ED 40334-5) (w/10 bolt cover) (Note 1)
70	Monte Carlo (2.78, 3.08, 3.28 ratio w/10 bolt cut out cover)	9773210	1	7.10	(Note 1)
71	Pass., Camaro w/P/Trac. (exc. Sta. Wag.),				
73-75	All w/P/Trac.	3995894	2		(Eaton type) (type C, G, K) (8 <sup>1</sup> / <sub>2</sub> " dia. ring gear)
71-75	Vega (140) (exc. P/Trac.)	3974947	2	8.15	(6 <sup>1</sup> / <sub>2</sub> " dia. ring gear)
72	Chevelle w/P/Trac.	3995839	2	19.45	w/12 bolt cover (17 teeth)
72	Chevelle w/P/Trac.	3995840	2	16.70	w/10 bolt cover
72	Pass., Camaro, Nova w/P/Trac. (exc. Sta. Wag.),				
73-75	All w/P/Trac.	231075	2	22.60	(Olds. type) (type C, G, K, B, O) (8 <sup>1</sup> / <sub>2</sub> " dia. ring gear)
74	Vega (122) (exc. P/Trac.)	345623	1	12.95	
74	Vega (122) w/P/Trac.	345625	1	22.30	
75	Vega (122) Monza (exc. P/Trac.)	344164	2	8.70	(7 <sup>1</sup> / <sub>2</sub> " dia. ring gear)

NOTE 1 See illustration preceding Group 5.398 for identification of axle cover.

**5.529 GEAR ASSEMBLY, Ring and Pinion (not sold separately)**

NOTE: Axle ratio is equal to ring gear divided by pinion, 37 divided by 10 is equal to 3.70 to 1.

NOTE Part numbers in parentheses are stamped on ring gear and pinion respectively.

62-63	Chevy	3790900	1	90.25	(3.36 to 1 ratio)
62-63	Chevy	3790901	1	84.75	(3.08 to 1 ratio)
64-68	Chevy, Chevelle, (3.36 ratio),				
65-68	Pass. (3.36 ratio w/10 bolt cover),				
69-70	All (3.36 ratio w/10 bolt cover),				
71-72	Chevelle, Nova (3.36 w/10 bolt cover)	3961412	1	94.75	(37-11T) (3880044-3790628)
64-68	Chevelle (3.70 ratio),				
65-68	Pass. (3.70 ratio w/10 bolt cover)	3961414	1	94.75	(37-10T) (3880048-3849722)
64-70	All (3.08 ratio w/10 bolt round cover),				
71	All (3.08 ratio w/10 bolt cover) (exc. Pass.),				
72	Chevelle (3.08 ratio w/10 bolt cover)	3961413	1	94.75	(37-12T) (3880042-3790629) (Note 1)
64-69	All (3.55 ratio w/10 bolt cover)	3961411	1	94.75	(39-11T) (3880046-3790627)
65-69	All (4.88 ratio w/12 bolt cover)	3961404	1	107.00	(39-8T) (3862528-3862516)
65-70	All (3.31 ratio w/12 bolt cover),				
71	Chevelle, Nova (3.31 w/12 bolt cover),				
72	Chevelle (3.31 ratio w/12 bolt cover)	3961405	1	102.00	(43-13T) (3862689-3862693)
65-69	Pass. (3.55 ratio w/12 bolt cover),				
66-68	Chevy, Chevelle, Camaro (3.55 ratio),				
69	Chevelle,				
70	All (3.55 ratio w/12 bolt cover)	3961406	1	111.00	(39-11T) (3853010-3853008)
65-70	All (3.07 ratio w/12 bolt cover),				
71	Nova (3.07 w/12 bolt cover)	3961407	1	111.00	(43-14T) (3863691-3853003)
65-69	All (3.73 ratio w/12 bolt cover),				
70	Camaro	3961408	1	102.00	(41-11T) (3862525-3862513)
65-69	All (4.10 ratio w/12 bolt cover),				
70	Chevelle, Camaro (4.10 ratio w/12 bolt cover),				
71-72	Malibu (Spt. Cpe., Conv.) El Camino (Custom) (8 cyl.) (4.10 ratio w/12 bolt cover)	3961409	1	111.00	(41-10T) (3862526-382514)
65-69	All (4.56 ratio w/12 bolt cover)	3961410	1	107.00	(41-9T) (3862527-3862515)
65-70	All (2.73 ratio w/12 bolt cover),				
71-72	Chevelle (2.73 ratio w/12 bolt cover)	3961435	1	96.50	(41-15T) (3869788-3869785)
67-70	Chevy, Chevelle, Camaro (2.73 ratio),				
68-70	Pass. (2.73 ratio w/10 bolt cover),				
71	Chevelle, Nova (2.73 w/10 bolt cover),				



**BRAKES—REAR AXLE AND DRIVE**

**5.529 GEAR ASSEMBLY, Ring and Pinion (not sold separately) (Con't)**

72	Chevelle (2.73 ratio w/10 bolt cover) .....	<b>3961425</b>	1	91.25	(41-15T) (3910818-3910823) .....
67	Chevelle w/A.I.R.,				
68-70	Chevelle, Camaro,				
69	Chevy (2.56 ratio),				
68-70	Pass. (2.56 ratio w/12 bolt cover) .....	<b>3961434</b>	1	96.50	(41-16T) (3871038-3871041) .....
68-70	Chevy, Camaro,				
69-71	Chevelle (2.56 ratio),				
68-70	Pass. (2.56 ratio w/10 bolt cover),				
71	Nova (2.56 ratio w/10 bolt cover) .....	<b>3961426</b>	1	91.25	(41-16T) (3917184-3917185) .....
68-69	Pass. (2.29 ratio w/12 bolt cover) .....	<b>3961433</b>	1	97.75	(3931114-3931124) .....
70	Monte Carlo (2.78 ratio w/cut out cover) .....	<b>479254</b>	1	131.00	(Note 1) .....
70	Monte Carlo (3.08 ratio w/cut out cover) .....	<b>479256</b>	1	131.00	(Note 1) .....
70	Monte Carlo (3.23 ratio w/cut out cover) .....	<b>479257</b>	1	131.00	(Note 1) .....
71-75	Camaro (3.73 ratio w/10 bolt cover) .....	<b>1394823</b>	1	140.00	(8 <sup>1</sup> / <sub>2</sub> " dia. ring gear) .....
71-75	Camaro (3.42 ratio w/10 bolt cover),				
72-75	Nova (3.42 ratio w/10 bolt cover),				
73-75	Chevelle (3.42 ratio w/10 bolt cover) .....	<b>1394768</b>	1	140.00	(type G, K, B, O, C) (8 <sup>1</sup> / <sub>2</sub> " dia. ring gear) ...
71-72	Camaro (4.10 ratio w/10 bolt cover) .....	<b>1394824</b>	1	140.00	
71-75	Pass. w/2.73 ratio,				
73-75	Chevelle (Sta. Wag.) w/2.73 ratio .....	<b>483726</b>	1	130.00	(type P, M) (8 <sup>7</sup> / <sub>8</sub> " dia. ring gear) .....
71-75	Pass. w/3.08 ratio,				
73-75	Chevelle (Sta. Wag.) w/3.08 ratio .....	<b>483728</b>	1	130.00	(type P, M) (8 <sup>7</sup> / <sub>8</sub> " dia. ring gear) .....
71-75	Pass. w/3.42 ratio,				
73-75	Chevelle (Sta. Wag.) w/3.42 ratio .....	<b>483730</b>	1	130.00	(type P, M) (8 <sup>7</sup> / <sub>8</sub> " dia. ring gear) .....
71-75	Pass. w/2.73 ratio (exc. Sta. Wag.) .....	<b>1394767</b>	1	140.00	(type C, G, K, B, O) (8 <sup>1</sup> / <sub>2</sub> " dia. ring gear) ...
71-74	Vega (140) w/2.53 ratio .....	<b>3987348</b>	1	93.50	(6 <sup>1</sup> / <sub>2</sub> " dia. ring gear) .....
71-75	Vega (140) w/2.92 ratio .....	<b>3987347</b>	1	93.50	(6 <sup>1</sup> / <sub>2</sub> " dia. ring gear) .....
71-74	Vega (140) w/3.36 ratio .....	<b>3987349</b>	1	93.50	(6 <sup>1</sup> / <sub>2</sub> " dia. ring gear) .....
71-75	Camaro, Pass. w/3.08 ratio (exc. Sta. Wag.),				
72-75	Nova w/3.08 ratio,				
73-75	Chevelle w/3.08 ratio .....	<b>1394776</b>	1	140.00	(type C, G, K, B, O) (8 <sup>1</sup> / <sub>2</sub> " dia. ring gear) ...
72-75	Nova w/2.73 ratio,				
73-75	Chevelle, Camaro w/2.73 ratio,				
74	Nova, Camaro w/2.56 ratio,				
75	All w/2.56 ratio .....	<b>1394766</b>	1	140.00	(type G, K, C, W, B, O) (8 <sup>1</sup> / <sub>2</sub> " dia. ring gear) (repl. 359030) .....
74	Vega (122) w/3.73 ratio .....	<b>345605</b>	1	102.00	
75	Monza w/2.29 ratio (exc. Notchback) .....	<b>231958</b>	1	103.00	(7 <sup>1</sup> / <sub>2</sub> " dia. ring gear) .....
75	Vega (122) Monza w/3.42 ratio .....	<b>553727</b>	1	108.00	(7 <sup>1</sup> / <sub>2</sub> " dia. ring gear) (repl. 359978) .....
75	Vega (122) w/3.73 ratio,				
75	Monza w/3.73 ratio (exc. Notchback) .....	<b>553728</b>	1	108.00	(7 <sup>1</sup> / <sub>2</sub> " dia. ring gear) (repl. 359979) .....
75	Vega (122) Monza w/2.56 ratio .....	<b>553725</b>	1	103.00	(7 <sup>1</sup> / <sub>2</sub> " dia. ring gear) (repl. 359977) .....
75	Vega (122) Monza w/2.93 ratio .....	<b>553726</b>	1	108.00	(7 <sup>1</sup> / <sub>2</sub> " dia. ring gear) (repl. 231959) .....

*NOTE 1 See illustration preceding group 5.398 for identification of axle cover.*

**5.531 BOLT, Ring Gear**

62-70	Pass., Camaro,				
70-71	Chevelle, Nova w/round cover,				
71-75	Vega (140) w/6 <sup>1</sup> / <sub>2</sub> " dia. ring gear,				
72	Chevelle .....	<b>3884942</b>	A.R.	.18	( <sup>9</sup> / <sub>8</sub> "— 24 x <sup>25</sup> / <sub>32</sub> " ) (used with lockwasher) ...
70	Monte Carlo w/cut out cover ...	<b>9794835</b>	10	.22	(Note 1) .....
71-75	Camaro, Pass.,				
72-75	Nova,				
73-75	Chevelle,				

## BRAKES—REAR AXLE AND DRIVE

### 5.531 BOLT, Ring Gear (Con't)

75	Vega (122), Monza w/7 <sup>1</sup> / <sub>2</sub> " dia. ring gear	1235420	10	.16	hypoid drive gear (type G, C, K, B, O) (8 <sup>1</sup> / <sub>2</sub> " dia. ring gear)
71-72	Pass. w/2.73, 3.08, 3.42				(type P, M) (7 <sup>1</sup> / <sub>16</sub> "— 20 x 7 <sup>7</sup> / <sub>8</sub> ")
71-72	Pass. w/2.73, 3.08 ratio (exc. Sta. Wag.)	1234817	8	.18	rear flange plate and brake (type G, K, B, O) (7 <sup>7</sup> / <sub>16</sub> "— 14 x 1 <sup>7</sup> / <sub>16</sub> ")
71-75	Pass. w/2.73, 3.08, 3.42 ratio,				
73-75	Chevelle (Sta. Wag.) w/2.73, 3.08, 3.42 ratio	9778193	12	.22	rear axle ring gear to case bolt (type P, M) (8 <sup>7</sup> / <sub>8</sub> " dia. ring gear)
74	Vega (122)	2402525	10	.15	

NOTE 1 See Illustration preceding group 5.398 for identification of axle cover.

### 5.535 LUBRICANT, Hypoid Gear

62-75	All	1050081	1	1.25	special hypoid (1 quart container)— (8.800)
65-75	All	1050527	1	DR/.52	special hypoid (15 gal.)— (8.800)

### 5.536 BEARING, Differential Side

62-63	Chevy, Chevelle	7451226	2	7.37	
64-72	All w/10 bolt cover,				
72	Pass. (exc. Sta. Wag.),				
73-75	All	7451281		7.73	(1 <sup>5</sup> / <sub>8</sub> " x 2 <sup>57</sup> / <sub>64</sub> " O.D.) (type G, C, K, B, O, W) (w/7 <sup>1</sup> / <sub>2</sub> ", 8 <sup>1</sup> / <sub>2</sub> " dia. ring gear)
65-69	All w/12 bolt cover,				
70	Pass., Nova, Chevelle w/12 bolt cover,				
71	Nova w/12 bolt cover,				
71-72	Chevelle w/12 bolt cover,				
71	Pass. w/2.73, 3.08 ratio,				
71-72	Pass. w/2.73, 3.08, 3.42 ratio,				
73-75	All	7451140	2	9.30	(type P, M) (w/8 <sup>7</sup> / <sub>8</sub> " dia. ring gear)
71-75	Vega (140)	7451897	2	8.04	(6 <sup>1</sup> / <sub>2</sub> " dia. ring gear)

### 5.537 SHIM UNIT— SPACER, Differential Bearing Adjusting

64-70	All w/10 bolt cover,				
71-75	Pass. w/2.73, 3.08 ratio (exc. Sta. Wag.)				(type G, C, K, B, O),
71-75	All w/10 bolt cover (exc. Pass.)	3853759	A.R.	1.70	(.064, .066, .068, .070)
64-70	All w/10 bolt cover,				
71-75	Pass. w/2.73, 3.08 ratio (exc. Sta. Wag.)				(type G, C, K, B, O),
71-75	All w/10 bolt cover (exc. Pass.)	3853760	A.R.	1.70	(.072, .074, .076, .078)
64-70	All w/10 bolt cover,				
71-75	Pass. w/2.73, 3.08 ratio (exc. Sta. Wag.)				(type G, C, K, B, O),
71-75	All w/10 bolt cover (exc. Pass.)	3853761	A.R.	1.55	(.080, .082, .084, .086) (Note 1),
64-70	All w/10 bolt round cover				
71-75	Pass. w/2.73, 3.08 ratio (exc. Sta. Wag.)				(type G, C, K, B, O),
71-75	All w/10 bolt cover (exc. Pass.)	3853762	A.R.	1.65	(.088, .090, .092, .094)
64-67	All w/10 bolt cover,				
71-75	Camaro,				
71-72	Pass. w/2.73, 3.08 ratio (exc. Sta. Wag.),				
72-75	Nova,				
73-75	Chevelle,				
73-75	Pass.,				
75	Vega (122) Monza	3853912	A.R.	1.40	(.096, .098, .100) (type C, G, K, B, O)
65-70	All w/12 bolt cover,				(type P, M),
71-75	Pass. w/2.73, 3.08, 3.42 ratio				
71	Chevelle, Nova w/12 bolt cover,				
72	Chevelle w/12 bolt cover,				
73-75	Chevelle	3851480	A.R.	1.70	(.064, .066, .068)
65-70	All w/12 bolt cover,				(type P, M),
71-75	Pass. w/2.73, 3.08, 3.42 ratio				
71	Chevelle, Nova w/12 bolt cover,				
72	Chevelle w/12 bolt cover,				
73-75	Chevelle	3851481	A.R.	1.55	(.070, .072, .074)
65-70	All w/12 bolt cover,				(type P, M),
71-75	Pass. w/2.73, 3.08, 3.42 ratio				
71	Chevelle, Nova w/12 bolt cover,				
72	Chevelle w/12 bolt cover,				
73-75	Chevelle	3851482	A.R.	1.85	(.076, .078, .080)
65-70	All w/12 bolt cover,				

**BRAKES—REAR AXLE AND DRIVE**

**5.537 SHIM UNIT— SPACER, Differential Bearing Adjusting (Con't)**

71-75	Pass. w/2.73, 3.08, 3.42 ratio . . .			(type P, M), . . . . .
71	Chevelle, Nova w/12 bolt cover,			
72	Chevelle w/12 bolt cover,			
73-75	Chevelle . . . . .	<b>3851483</b> A.R.	1.70	(.082, .084, .086) . . . . .
65-70	All w/12 bolt cover,			
71-75	Pass. w/2.73, 3.08, 3.42 ratio . . .			(type P, M), . . . . .
71	Chevelle, Nova w/12 bolt cover,			
72	Chevelle w/12 bolt cover,			
73-75	Chevelle . . . . .	<b>3851484</b> A.R.	1.85	(.088, .090, .092, .094) . . . . .
65-69	All w/12 bolt cover,			
70	Pass., Nova, Chevelle w/12 bolt cover,			
71-75	Pass. w/2.73, 3.08, 3.42 ratio . . .			(type P, M), . . . . .
71	Chevelle, Nova w/12 bolt cover,			
73-75	Chevelle (Sta. Wag.) w/2.73, 3.08, 3.42 ratio . . . . .	<b>3876174</b> A.R.	1.70	(.096, .098, .100) . . . . .
67-70	All w/10 bolt cover,			
71-75	Pass. w/2.73, 3.08 ratio (exc. Sta. Wag.) . . . . .			(type G, C, K, B, O), . . . . .
71-75	All w/10 bolt cover (exc. Pass.) . . . . .	<b>3907088</b> A.R.	1.85	(.052, .054, .056) . . . . .
67-69	All w/10 bolt cover,			
72-75	Pass. w/2.73, 3.08 ratio,			
72-75	Chevelle, Nova, Camaro w/10 bolt cover . . . . .	<b>3907089</b> A.R.	1.85	(.058, .060, .062) (type G, C, K, B, O) . . . . .
70	Monte Carlo w/cut out cover,			
71-75	Camaro,			
71-75	Pass. w/2.73, 3.08 ratio,			
72-75	Nova,			
73-75	Chevelle,			
75	Vega (122) Monza . . . . .	<b>3995792</b> A.R.	2.15	(.046, .048, .050) (type C, G, K, B, O) (Note 1) . . . . .
71-75	Camaro,			
71-75	Pass. w/2.73, 3.08 ratio,			
72-75	Nova,			
73-75	Chevelle,			
75	Vega (122) Monza . . . . .	<b>3995791</b> A.R.	2.15	(.040, .042, .044) (type C, G, K, B, O) . . . . .
71-75	Pass. w/2.73, 3.08, 3.42 ratio,			
73-75	Chevelle . . . . .	<b>3996610</b> A.R.	2.15	(.040, .042, .044, .046) (type P, M) . . . . .
71-75	Pass. w/2.73, 3.08, 3.42 ratio,			
72	Chevelle w/12 bolt cover,			
73-75	Chevelle . . . . .	<b>3996611</b> A.R.	2.15	(.048, .050, .052, .054) (type P, M) . . . . .
71-75	Pass. w/2.73, 3.08, 3.42 ratio,			
72	Chevelle w/12 bolt cover,			
73-75	Chevelle . . . . .	<b>3996612</b> A.R.	2.15	(.056, .058, .060, .062) (type P, M) . . . . .
71-75	Vega (140) . . . . .	<b>3988980</b> A.R.	4.05	(.064-.068) (6 <sup>1</sup> / <sub>2</sub> " dia. ring gear) . . . . .
71-75	Vega (140) . . . . .	<b>3988981</b> A.R.	1.95	(.070-.074) (6 <sup>1</sup> / <sub>2</sub> " dia. ring gear) . . . . .
71-75	Vega (140) . . . . .	<b>3988982</b> A.R.	1.95	(.076-.080) (6 <sup>1</sup> / <sub>2</sub> " dia. ring gear) . . . . .
71-75	Vega (140) . . . . .	<b>3988983</b> A.R.	1.95	(.082-.086) (6 <sup>1</sup> / <sub>2</sub> " dia. ring gear) . . . . .
71-74	Vega (140) . . . . .	<b>3988984</b> A.R.	1.95	(.088-.094) (6 <sup>1</sup> / <sub>2</sub> " dia. ring gear) . . . . .
71-74	Vega (140) . . . . .	<b>3988985</b> A.R.	1.95	(.096-.100) (6 <sup>1</sup> / <sub>2</sub> " dia. ring gear) . . . . .
74	Vega (122) . . . . .	<b>345607</b> A.R.	.15	<b>SHIM</b> (.003) . . . . .
74	Vega (122) . . . . .	<b>345608</b> A.R.	.15	<b>SHIM</b> (.005) . . . . .
74	Vega (122) . . . . .	<b>345609</b> A.R.	.15	<b>SHIM</b> (.010) . . . . .
74	Vega (122) . . . . .	<b>345610</b> A.R.	.15	<b>SHIM</b> (.030) . . . . .
67-69	Chevy, Chevelle, Camaro w/10 bolt cover,			
70-71	All w/10 bolt cover,			
72-75	Pass. w/2.73, 3.08 ratio,			
72-75	Chevelle, Nova, Camaro w/10 bolt cover,			
75	Vega (122), Monza . . . . .	<b>9775809</b> A.R.	.92	<b>SPACER</b> , diff. bearing (.170 x 2 <sup>27</sup> / <sub>32</sub> " O.D.) (type G, C, K, B, O) (Note 2) . . . . .
67-70	All w/12 bolt cover,			
71-73	Pass. w/2.73, 3.08, 3.42 ratio . . .			<b>SPACER</b> (type P, M) . . . . .
71	Chevelle, Nova w/12 bolt cover,			
72	Chevelle w/12 bolt cover,			
73	Chevelle,			
75	Pass. w/2.73, 3.08, 3.42 ratio,			
75	Chevelle . . . . .	<b>9780883</b> A.R.	1.25	(.170" thk.) (type G, C, K, B, O) (Note 1, 2) . . . . .
71-75	Vega . . . . .	<b>3988534</b> A.R.	1.25	<b>SPACER</b> , diff. brg. (6 <sup>1</sup> / <sub>2</sub> " dia. ring gear) . . . . .

NOTE 1 See illustration preceding group 5.398 for identification of axle cover.

NOTE 2 Used with matching shim units, to replace prod. cast iron type adjustment.

**BRAKES—REAR AXLE AND DRIVE**

**5.542 WASHER, Differential Pinion Thrust**

64	Chevy, Chevelle w/P/Trac., (2nd design),				
65-68	Chevy (P/Trac., w/3.08, 3.36, 3.55 ratio) (1st design),				
65-68	Chevelle, Camaro (P/Trac., w/3.08, 3.36, 3.55, 3.70 ratio) (1st design),				
65-68	Pass. w/P/Trac., 3.08, 3.36, 3.55, 3.70 ratio	<b>2346848</b>	2	.69	( <sup>49</sup> / <sub>64</sub> " I.D. x 1 <sup>21</sup> / <sub>32</sub> " O.D.) (Dana 13338-3) . . .
64-65	Chevy, Chevelle (exc. P/Trac.),				
65	Pass. (exc. P/Trac.)	<b>3843266</b>	2	.62	(1 <sup>45</sup> / <sub>64</sub> " O.D. x <sup>3</sup> / <sub>4</sub> " I.D.) (10 bolt cover) . . . .
65-70	Pass. w/3.07, 3.31, 3.55, 3.73, 4.10, 4.56, 4.88,				
65-70	Chevelle (P/Trac., w/3.07, 3.31 ratio) (8 cyl.),				
65-70	El Camino (P/Trac., w/3.73 ratio) (8 cyl.),				
66-70	Chevy (P/Trac., w/3.07, 3.31, 3.35, 3, 73 ratio),				
67-69	Camaro w/P/Trac. (exc. 3.08, 3.36, 3.70 ratio),				
71	Nova (P/Trac. w/12 bolt cover),				
71-72	Chevelle (P/Trac. w/12 bolt cover)	<b>3957940</b>	2	.64	(1 <sup>11</sup> / <sub>16</sub> " O.D. x <sup>13</sup> / <sub>16</sub> " I.D.) (Eaton 93691) . . . .
65	Chevy, C.A.C., 3.07, 3:31 ratio (327),				
65	Chevelle w/P/Trac. (2.73, 3.07, 3.31 ratio, w/P.G.) (327),				
65	El Camino w/3.73 ratio,				
65	Pass. (exc. P/Trac.)	<b>3852991</b>	2	.40	( <sup>13</sup> / <sub>64</sub> " I.D. x 1 <sup>55</sup> / <sub>64</sub> " O.D.) (12 bolt cover) . . . .
65-69	Pass. w/P/Trac., 3.08, 3.36, 3.55, 3.70 ratio,				
65-69	Chevy, Chevelle, Camaro (P/Trac. w/2.73, 3.08, 3.36, 3.55, 3.70 ratio),				
70	Pass., Chevelle w/P/Trac. (2.56, 2.73, 3.08, 3.36 ratio),				
71	All (P/Trac. w/10 bolt cover),				
72	Chevelle (P/Trac. w/10 bolt cover)	<b>1385734</b>	2	1.05	(Eaton ED-93690) w/10 bolt round cover (Note 1) . . . . .
65	Chevy, Chevelle w/P/Trac.,				
65-66	Pass. w/P/Trac., 3.07, 3.31, 3.55, 3.73 ratio,				
65-67	Pass. (P/Trac., w/2.73, 4.10, 4.56, 4.88 ratio) (8 cyl.)	<b>2236256</b>	2	.20	(1 <sup>27</sup> / <sub>32</sub> " O.D. x <sup>53</sup> / <sub>64</sub> " I.D.) (Dana 34730) . . . . .
66-69	Chevy w/3.07, 3.31, 3.55, 3.73 ratio (exc. P/Trac.),				
66-69	Chevelle, Camaro w/2.56, 2.73, 3.07, 3.31, 3.55, 3.73 ratio (exc. P/Trac.),				
66-69	Pass. (exc. P/Trac.),				
70	Pass., Nova, Chevelle (exc. P/Trac.),				
71	Nova w/12 bolt cover (exc. P/Trac.),				
71-72	Chevelle w/12 bolt cover (exc. P/Trac.)	<b>3880141</b>	2	.40	(w/12 bolt cover) . . . . .
66-69	Pass. (exc. P/Trac.),				
66-69	Chevy, Chevelle, Camaro (exc. P/Trac., 327 Sp. H/Per., 350, 396),				
70	All (exc. P/Trac.),				
71	Nova w/10 bolt cover (exc. P/Trac.),				
71-72	Chevelle w/10 bolt cover (exc. P/Trac.)	<b>3880143</b>	2	.40	(w/10 bolt round cover) (Note 1) . . . . .
70	Monte Carlo w/cut out cover	<b>9783007</b>	2	.14	( <sup>3</sup> / <sub>4</sub> "— 1 <sup>23</sup> / <sub>32</sub> " x 1 <sup>1</sup> / <sub>32</sub> ") (Note 1) . . . . .
71	Pass. w/2.73, 3.08, 3.42 ratio (exc. Sta. Wag., P/Trac.),				
71	Pass. (Sta. Wag.) w/2.73, 3.08 ratio (exc. P/Trac.),				
72	Pass. w/2.73, 3.42, 3.08 ratio,				
73-75	Pass. (exc. P/Trac.),				

## BRAKES—REAR AXLE AND DRIVE

### 5.542 WASHER, Differential Pinion Thrust (Con't)

73-75	Chevelle (Sta. Wag.) (exc. P/Trac.)	481510	2	.34	(type P, M)
71-72	Camaro (exc. P/Trac.),				(2.73, 3.08, 3.42 ratio) (C, G, K),
72	Nova (exc. P/Trac.)				
71	Pass. (exc. Sta. Wag., P/Trac.),				(2.73, 3.08 ratio) (type B, O, G, K),
72	Pass.				(2.73, 3.08, 3.42 ratio),
73-75	Camaro, Nova, Chevelle				(2.73, 3.08 ratio) (type B, O),
73-75	All w/P/Trac.				(2.73, 3.08 ratio) (type B, O),
73-75	All (exc. P/Trac.)	3984818	2	.36	(2.73, 3.08, 3.23 ratio) (type G, C, K)
71-72	Camaro w/P/Trac.,				
72	Nova w/P/Trac.,				
71-72	Pass. w/P/Trac. (exc. Sta. Wag.),				
73-74	All w/P/Trac.	3995997	2	.98	(type G, C, K) (Eaton type)
71-75	Vega (140) (exc. P/Trac.)	3974899	2	.12	(6 1/2" dia. ring gear)
73-75	All (exc. P/Trac.)				(type B, O),
73-75	All w/P/Trac.	393140	2	.16	(type O)
73-74	Pass. w/P/Trac.,				
73-74	Chevelle (Sta. Wag.) w/P/Trac.	9792620	2	.98	(type P, M)
73-75	All (exc. P/Trac.)				(type B, O),
74	Vega (122) (exc. P/Trac.)	345629	2	.39	
75	Vega (122) Monza (exc. P/Trac.)	344167	2	.22	(7 1/2" dia. ring gear)

NOTE 1 See illustration preceding group 5.398 for identification of axle cover.

### 5.543 WASHER, Differential Side Gear Thrust

62-70	All,				
71	Chevelle, Nova w/10 bolt cover,				
72	Chevelle w/10 bolt cover (exc. P/Trac.)	9789002	2	.34	(w/10 bolt cover)
65-70	All,				
71	Chevelle, Nova,				
72	Chevelle w/12 bolt cover (exc. P/Trac.),				
71-72	Camaro (exc. P/Trac.),				
71-72	Pass. w/2.73, 3.08 ratio (exc. Sta. Wag.),				
72	Nova (exc. P/Trac.),				
73-75	All (exc. P/Trac.)				(w/12 bolt cover) (type G, K, B, O),
71-75	Pass. w/2.73, 3.08, 3.42 ratio (exc. P/Trac.),				
73-75	Chevelle (Sta. Wag.) (exc. P/Trac.)	393578	2	.46	(type P, M)
71-75	Vega (140) (exc. P/Trac.)	6257691	2	.31	(6 1/2" dia. ring gear)
74	Vega (122) (exc. P/Trac.)	345628	2	.56	
75	Vega (122) Monza (exc. P/Trac.)	344165	2	.33	(7 1/2" dia. ring gear)

### 5.544 SHAFT— UNIT, Rear Propeller (Shaft attaches to rear axle)

NOTE: The 1971 passenger car constant velocity design production propshafts for all models (except Police) are not serviced. The service replacement propshaft is identical to the production version with the exception that the slip yoke has been removed. The two U-joint bearing assemblies at this location are then held together using two clips with a special retaining strap. These parts are to be discarded when assembling the new propshaft for installation. Two snap rings part number 1456507 must be used to retain the bearing assemblies in the slip yoke.

Do not use the parts shipped with the service propshaft.

NOTE: See Dealer Price Schedule for applicable prices.

### PASSENGER

	O.L.	Splines	Part No.	Qty.
65-68	Police	62 <sup>5</sup> / <sub>32</sub> ( <sup>1</sup> )	3879720	1
65-66	Pass. (8 cyl.) (exc. T.H.),			
67-68	Pass. (exc. Caprice, T.H.),			
67-68	Caprice (exc. A.T.)	62 <sup>5</sup> / <sub>32</sub> ( <sup>2</sup> )	3878340	1
65	Pass. w/T.H.	61 <sup>7</sup> / <sub>16</sub> ( <sup>2</sup> )	3871141	1
66	Pass. w/T.H.,			
68	Pass. (6 cyl.)	60 <sup>15</sup> / <sub>16</sub> ( <sup>2</sup> , <sup>3</sup> )	5697871	1
67-68	Caprice w/P.G.	67 <sup>3</sup> / <sub>32</sub>	3939255	1
67	Caprice w/T.H.,			
68	Caprice (396, 427),			
68	Caprice w/T.H. (327) (1st design),			
70	Caprice w/T.H. 400 (454)	67 <sup>51</sup> / <sub>64</sub> ( <sup>2</sup> , <sup>4</sup> )	5699400	1

(<sup>1</sup>) With damper. Plastic injection or inner position U-Joint lock rings.

**BRAKES—REAR AXLE AND DRIVE**

**5.544 SHAFT— UNIT, Rear Propeller (Shaft attaches to rear axle) (Con't)**

67	Pass. w/T.H. (8 cyl.) (exc. Caprice),				
68	Pass. w/T.H. (396, 427) (exc. Caprice),				
68	Pass. w/T.H. (327) (1st design) (exc. Caprice) . . . . .	67 <sup>51</sup> / <sub>64</sub> ( <sup>2</sup> , <sup>5</sup> )	—	7801540	1
	<i>(<sup>5</sup>) Less damper.</i>				
68	Pass. w/T.H. (307),				
68	Pass. w/T.H. (327) (2nd design) . . . . .	68 <sup>13</sup> / <sub>64</sub> ( <sup>2</sup> , <sup>6</sup> )	—	3954690	1
	<i>(<sup>6</sup>) With damper. "U" Joints have brg. retainer rings.</i>				
68	Police w/T.H. (8 cyl.),				
70	Pass. w/T.H. 400 (454) (exc. Caprice) . . . . .	67 <sup>25</sup> / <sub>32</sub> ( <sup>2</sup> )	—	5699401	1
68	Pass. w/T.H. 350,				
69	Pass. (exc. T.H. 400, Police, 327, 350 2BC),				
69-70	Police, Taxi,				
70	Pass. w/T.H. 350 (400),				
70	Pass. (T.H. 350 w/4BC) (350) . . . . .	( <sup>7</sup> )	—	3961477	1
	<i>(<sup>7</sup>) Length 61 1/2" center line to center line of brgs. use w/strap retained rear trunnion.</i>				
69	Pass. (T.H. 400 w/H.D. Susp.) (exc. 327, 350 2BC),				
69	Police (T.H. 400 w/H.D. Susp.) (8 cyl.),				
70	Pass. w/T.H. 400 (exc. 454) . . . . .	( <sup>8</sup> )	—	3950261	1
	<i>(<sup>8</sup>) Length 60 1/8" centerline of brgs. use w/strap retained rear trunnion.</i>				
69-70	Pass. w/T.H. 350 (exc. 4BC) (exc. Police, Taxi),				
69-70	Pass. w/P.G., 3-Spd. (exc. Police, Taxi) . . . . .	( <sup>11</sup> )	—	3955596	1
	<i>(<sup>11</sup>) Length 61 1/2" centerline to centerline of brgs. use w/"U" bolt retained rear trunnion.</i>				
69	Pass. (T.H. 400 w/2BC 327, 350) (exc. Police, H.D. Susp.) . . . . .	( <sup>12</sup> )	—	3961478	1
	<i>(<sup>12</sup>) Length 60 1/8" centerline to centerline of brgs.</i>				
	<i>(<sup>1</sup>) Tube length.</i>				
	<i>(<sup>2</sup>) Complete shaft assy. including front and rear U-Joints and trans. sleeve yoke.</i>				
	<i>(<sup>3</sup>) For U-Joint repair kits use 1-5677659 (frt.) and 1-5698221 (rear).</i>				
71	Pass. w/P.G., 3-Spd. (exc. Sta. Wag.),				
72	Pass. w/3-Spd., P.G.,				
73-75	Pass. w/3-Spd. (exc. Sta. Wag.) . . . . .	7816189	1	147.00	w/slip yoke . . . . .
71	Pass. w/T.H. 350,				
72	Pass. w/T.H. 350 (exc. Sta. Wag.),				
73-74	Pass. w/T.H. 350 (exc. Sta. Wag., Police) . . . . .	7816192	1	147.00	(Note 3) . . . . .
71-72	Police w/T.H. 400 (exc. Sta. Wag.) . . . . .	7812742	1	178.00	(Note 3) . . . . .
71	Pass. w/T.H. 400 (exc. Police),				
72-73	Pass. w/T.H. 400 (exc. Sta. Wag., Police),				
74-75	Pass. w/T.H. 400 (350, 454) (exc. Sta. Wag., Police) . . . . .	7816190	1	147.00	(Note 3) . . . . .
71	Pass. (Sta. Wag.) w/T.H. 350, 3-Spd. (exc. Estate Wag.),				
71	Kingswood (Estate) w/3-Spd.,				
72	Pass. (Sta. Wag.) w/T.H. 350, 3-Spd.,				
73-75	Pass. (Sta. Wag.) (350, 400) (exc. Police) . . . . .	7810442	1	116.00	(Note 3) . . . . .
71	Kingswood Estate (exc. T.H. 400) . . . . .	7810446	1	119.00	(Note 3) . . . . .
71	Pass. (Sta. Wag.) w/T.H. 400 (exc. Police) . . . . .	7810447	1	119.00	(Note 3) . . . . .
72	Pass. (Sta. Wag.) w/T.H. 400 (exc. Police),				
73-75	Pass. (Sta. Wag.) w/T.H. 400 (454) (exc. Police) . . . . .	7813402	1	147.00	

*NOTE 3 It will be necessary to purchase two (2) 1456507 snap rings and install to retain slip yoke.*

**BRAKES—REAR AXLE AND DRIVE**

**5.544 SHAFT— UNIT, Rear Propeller (Shaft attaches to rear axle) (Con't)**

73	Police w/T.H. 400 (exc. Sta. Wag.)	7816531	1	164.00	
73	Pass. w/T.H. 375 (exc. Sta. Wag., Police)	7815857	1	147.00	
73-75	Police (Sta. Wag.) (350, 400)	7815567	1	116.00	
73	Police w/T.H. 350 (exc. Sta. Wag.)	7816532	1	147.00	
74-75	Pass. w/T.H. 375 (400 w/2BC) (exc. Sta. Wag., Police)	7816193	1	147.00	
74-75	Police w/T.H. 400 (454) (exc. Sta. Wag.)	7816543	1	164.00	
74-75	Police w/T.H. 350 (exc. Sta. Wag.)	7816544	1	147.00	
74-75	Police w/T.H. 375 (400 w/2BC)	7816726	1	147.00	
75	Pass. w/T.H. 350 (exc. Sta. Wag., Police)	7816185	1	147.00	
71-72	Pass. (exc. Sta. Wag.),				
73-75	Pass.	6263010	1	3.80	UNIT, prop. shaft compensation weight . . . .

**CHEVELLE**

64-67	Chevelle,				
68	Chevelle (4-Dr.) El Camino	3898244	1	82.00	
67	Chevelle w/T.H.	7801541	1	105.00	
67	Malibu, Concours (P.G. w/327, 4BC),				
67	Chevelle w/P.G.,				
68	Chevelle (4-Dr., El Camino) w/P.G.	3895845	1	94.00	(w/damper) . . . . .
68	Chevelle (2-Dr.) (exc. T.H.)	3924126	1	54.25	
68	Chevelle w/T.H. (exc. El Camino),				
71	Malibu w/T.H. 400 (454),				
72	Monte Carlo, Malibu (Spt. Cpe., Conv.) w/T.H. 400 (454)	7801646	1	97.50	
68	El Camino w/T.H.,				
70-72	El Camino (Custom) (T.H. 400 w/454)	7802607	1	96.00	
68	All w/T.H. 350,				
69-70	Chevelle (exc. Spt. Cpe., Conv., 396),				
71	Chevelle (6 cyl.) (exc. Spt. Cpe., Conv.),				
71	Chevelle (4-Dr.) El Camino w/2BC (307, 350) (exc. Concours Estate),				
71	Concours Estate w/2BC (307, 350),				
72	Chevelle (4-Dr.) El Camino w/3-Spd. Col. Shift, P.G.,				
72	Chevelle (Sta. Wag.) w/T.H. 350 (exc. 350)	3955597	1	69.50	
68	Chevelle w/T.H. 350,				
69	Chevelle (2-Dr.) (exc. El Camino, 396),				
70	Chevelle (2-Dr.) (250, 350) (exc. A.T., El Camino),				
70	Monte Carlo w/P.G.,				
71	Chevelle (Spt. Cpe., Conv.) (6 cyl.),				
71	Chevelle (Spt. Cpe., Conv.) w/2BC (307, 350) (exc. Monte Carlo),				
71	Monte Carlo w/2BC (350) (exc. T.H. 350),				
72	Chevelle (Spt. Cpe., Conv.) w/P.G., 3-Spd. Col. Shift	3955598	1	69.50	
69-70	El Camino (Custom) (396) (exc. T.H. 400, P/Trac.),				
71	Chevelle (4-Dr.) El Camino w/4BC (350) (exc. 4-Spd., Concours Estate),				
71	Concours Estate w/4BC (350),				
71	Chevelle (4-Dr.) El Camino w/4-Spd. (400 w/4BC),				

**BRAKES—REAR AXLE AND DRIVE**

**5.544 SHAFT— UNIT, Rear Propeller (Shaft attaches to rear axle) (Con't)**

72	Concours Estate w/T.H. 350 (350),			
72	El Camino w/H.D. 3-Spd., T.H. 350,			
72	Chevelle (4-Dr.) w/H.D. 3-Spd.,			
72	Chevelle (4-Dr.) (T.H. 350 w/4BC) (350) (exc. Concours Estate) . . . . .	<b>3970518</b>	1	74.25
69	Chevelle (396) (exc. El Camino, T.H. 400),			
70	Monte Carlo (400) w/4-Spd.,			
70	Chevelle (2-Dr.) (8 cyl.) (exc. El Camino, 350 w/4BC, T.H. 400),			
71	Chevelle (Spt. Cpe., Conv.) (T.H. 350 w/2BC) (350) (exc. Monte Carlo),			
71	Monte Carlo w/T.H. 350,			
72	Chevelle (Spt. Cpe., Conv.) w/H.D. 3-Spd. (exc. Monte Carlo),			
72	Chevelle (Spt. Cpe., Conv.) w/T.H. 350 . . . . .	<b>3949161</b>	1	69.50
69	El Camino (8 cyl.) w/T.H. 400 (exc. Deluxe, P/Trac.),			
70	El Camino (Custom) w/T.H. 400 (exc. 454),			
71	Chevelle (4-Dr.) El Camino (T.H. 400 w/4BC) (400),			
72	El Camino w/T.H. 400 (402),			
72	Chevelle (4-Dr.) w/T.H. 400 (402) . . . . .	<b>3970519</b>	1	74.25
69	Malibu (Spt. Cpe., Conv.) w/T.H. 400 (8 cyl.),			
70	Monte Carlo (T.H. 400 w/400),			
70	Chevelle T.H. 400 w/396, 400 (exc. El Camino),			
71	Chevelle (Spt. Cpe., Conv.) (T.H. 400 w/4BC) (400),			
72	Chevelle, Monte Carlo, (Spt. Cpe., Conv.) w/T.H. 400 (402) .	<b>3949163</b>	1	69.50
70	Monte Carlo w/cut away cover .	<b>7804819</b>	1	86.75
70	Malibu (Spt. Cpe., Conv.) (454) (exc. T.H. 400),			
71	Chevelle w/H.D., 4-Spd. (exc. El Camino),			
72	Chevelle w/H.D. 4-Spd. (454) (exc. El Camino) . . . . .	<b>7809871</b>	1	130.00
71	El Camino (Custom) w/H.D. 4-Spd.,			
72	El Camino (Custom) w/H.D. 4-Spd. (454) . . . . .	<b>7809870</b>	1	130.00
71	Chevelle (4-Dr., El Camino) (4-Spd. w/4BC) (350),			
72	El Camino w/4-Spd. (402),			
72	Chevelle (4-Dr.) w/4-Spd. (402) .	<b>3997574</b>	1	69.50
71	Chevelle (Spt. Cpe., Conv.) (4-Spd. w/4BC) (400),			
72	Chevelle (Spt. Cpe., Conv.) w/4-Spd. (350, 402) . . . . .	<b>3997575</b>	1	69.25
73-75	Chevelle (4-Dr., El Camino) (exc. T.H. 400) . . . . .	<b>7818793</b>	1	91.00
73-74	Chevelle (Spt. Cpe.) (exc. T.H. 400, close ratio 4-Spd.) . . . . .	<b>7812622</b>	1	97.75
73-74	Chevelle (Spt. Cpe.) w/close ratio 4-Spd. . . . .	<b>7812623</b>	1	97.75
73-74	El Camino w/close ratio 4-Spd. .	<b>7812626</b>	1	130.00
73-74	Chevelle w/T.H. 400 (exc. Monte Carlo, Spt. Cpe.) . . . . .	<b>7812627</b>	1	107.00
73-74	Chevelle (Spt. Cpe.) Monte Carlo w/T.H. 400 . . . . .	<b>7812628</b>	1	121.00
75	Chevelle (Spt. Cpe.) Monte Carlo w/T.H. 400 . . . . .	<b>7818798</b>	1	121.00
75	Chevelle w/T.H. 400 (exc. Monte Carlo, Spt. Cpe.) . . . . .	<b>7818797</b>	1	112.00



**BRAKES—REAR AXLE AND DRIVE**

**5.544 SHAFT— UNIT, Rear Propeller (Shaft attaches to rear axle) (Con't)**

75 Chevelle (2-Dr.) (exc. T.H. 400) . . . **7818794** 1 110.00

**CHEVY— NOVA**

62-67 Chevy (6, 8 cyl.) . . . . . **3938535** 1 66.25  
 68 Chevy (exc. T.H.),  
 68 Chevy Spec. H/Per. 396 . . . . . **3958072** 1 59.50  
 68 Chevy w/T.H. . . . . **3958076** 1 73.50  
 69-70 Chevy w/T.H. 400 . . . . . **3950142** 1 67.00  
 69-70 Chevy (exc. T.H. 400),  
 69 Nova w/T.H. 350,  
 71 Nova (exc. H/Per. 350) . . . . . **3950198** 1 65.25  
 70 Nova w/4-Spd. (350, 396) . . . . . **3977620** 1 66.50  
 70-71 Nova 2-Dr. (T.H. 350) w/4BC  
 (350) . . . . . **3981933** 1 66.50  
 72-75 Nova (exc. T.H. 350),  
 72-75 Nova w/T.H. 350 (307),  
 72-75 Nova (6 cyl.) w/T.H. 350 . . . . . **7812640** 1 65.25  
 72 Nova w/T.H. 350 (350) . . . . . **7812641** 1 66.50

**CAMARO**

67-68 Camaro (exc. 396) . . . . . **3910061** 1 46.50  
 67-68 Camaro w/T.H. (1st design) . . . . . **7801406** 1 95.00 (Note 1) . . . . .  
*NOTE 1: Can be identified by a trunion brg. retaining strap which contacts a step on the brg. hsg. O.D. (outboard end).*  
 67-68 Camaro (396) (exc. T.H.) . . . . . **3914190** 1 48.50  
 68 Camaro w/P.G. . . . . **3917578** 1 94.00 (w/damper) . . . . .  
 68-69 Camaro w/T.H. 350,  
 69 Camaro (exc. T.H. 400) . . . . . **3950194** 1 65.25  
 69 Camaro w/Muncie 4-Spd. . . . . **3970521** 1 66.50  
 69 Camaro w/T.H. 350 (350  
 w/4BC) . . . . . **3981931** 1 66.50  
 69 Camaro w/T.H. 400 . . . . . **3950196** 1 67.00  
 70 Camaro w/3-Spd., P.G. . . . . **3981929** 1 61.50  
 70 Camaro w/T.H. 400,  
 71 Camaro w/Sp. H/Per. (350),  
 72-74 Camaro w/Sp. H/Per. 350, 402 . . . . . **3981930** 1 66.50  
 70 Camaro (T.H. 350) (350),  
 70 Camaro w/4-Spd. (350, 396) . . . . . **3981932** 1 66.50  
 71 Camaro (T.H. 350 w/2BC) (307,  
 350) . . . . . **7811094** 1 97.00 (3.42 ratio) . . . . .  
 71 Camaro (4-Spd. w/4BC) (350),  
 71 Camaro w/4BC (400) . . . . . **7811095** 1 97.00  
 71 Camaro (exc. 3.42 ratio, 4-Spd.,  
 400),  
 72-74 Camaro (exc. Sp. H/Per. 350,  
 402) . . . . . **3997539** 1 66.00  
 75 Camaro (exc. Close Ratio 4-Spd.) . . . . . **7819344** 1 84.00  
 75 Camaro w/Close Ratio 4-Spd. . . . . **7819345** 1 90.25

**VEGA— MONZA**

71-72 Vega w/A.T. . . . . **3987346** 1 43.00 propeller, tube and trunion . . . . .  
 71-72 Vega w/3-Spd. . . . . **3991008** 1 51.50 propeller, tube and trunion . . . . .  
 71-72 Vega w/4-Spd. . . . . **3991010** 1 51.50 propeller, tube and trunion . . . . .  
 73-75 Vega (140) . . . . . **7814793** 1 69.75 propeller, tube and trunion w/2.92 ratio . . . . .  
 74-75 Vega (122) . . . . . **7816933** 1 63.75 propeller, tube and trunion . . . . .  
 75 Monza (Rotary) (exc. 5-Spd.) . . . . . **7817613** 1 83.50 propeller, tube and trunion . . . . .  
 75 Monza (262) . . . . . **7818594** 1 83.50 propeller, tube and trunion . . . . .  
 75 Monza (140) (exc. 5-Spd.),  
 75 Vega (122) . . . . . **7818681** 1 60.75 propeller, tube and trunion (7½" dia. ring  
 gear) . . . . .  
 75 Monza (140) w/5-Spd. . . . . **7819403** 1 68.00 propeller, tube and trunion (7½" dia. ring  
 gear) . . . . .

**5.544A DAMPER ASSY.— BOLT— NUT— WASHER, Propeller Shaft Damper**

71-72 Vega (exc. A.T.) . . . . . **3993012** 1 11.85  
 71-73 Vega w/P.G. (exc. C.A.C.) . . . . . **3987989** 1 11.85  
 71-73 Vega (P.G. w/C.A.C.) . . . . . **3993006** 1 11.85  
 72-75 Vega (140) w/A.T. (exc. C.A.C.) . . . . . **330116** 1 18.50  
 72-75 Vega (140) (A.T. w/C.A.C.) . . . . . **330118** 1 17.00  
 73-75 Vega (exc. A.T.) . . . . . **335321** 1 17.00  
 75 Monza (140) w/A.T. . . . . **347417** 1 13.75  
 75 Monza (140) (exc. A.T.),  
 75 Vega (122) . . . . . **347415** 1 12.50  
 71-72 Vega . . . . . **329793** 1 48.50 **DAMPER UNIT, w/yoke (rear axle noise)**  
 (Note 1) . . . . .

**BRAKES—REAR AXLE AND DRIVE**

**5.544A DAMPER ASSY.— BOLT— NUT— WASHER, Propeller Shaft Damper (Con't)**

*NOTE 1: Unit contains 1 damper yoke-2 control arm damper weights-2 tapping plates-2<sup>5</sup>/<sub>16</sub>" x 1<sup>5</sup>/<sub>8</sub>" bolts-2<sup>5</sup>/<sub>16</sub>" lock washers, instruction sheet.*

71-72 Vega	3993015	1	1.55	BOLT, prop. shaft damper ("U")— (5.586) ..
73-74 Vega (140) (exc. A.T.)	3733130	3	.24	BOLT, prop. shaft damper ( <sup>3</sup> / <sub>8</sub> "— 16 x 2 <sup>1</sup> / <sub>4</sub> ")— (3.275) ..
71-72 Vega	3993018	2	.84	NUT, prop. shaft damper— (5.586) ..
71-72 Vega	382105	4	.12	WASHER, prop. shaft damper— (4.037) ..
71-72 Vega	2436162	2	.35	WASHER, prop. shaft damper "U" bolt ..

**5.545 FLANGE— DEFLECTOR— SLINGER— WASHER, Propeller Shaft Pinion**

64-70 All w/10 bolt round cover,				
71 Chevelle, Nova w/10 bolt cover,				
71-74 Vega (140),				
72 Chevelle w/10 bolt cover	3997957	1	14.95	w/deflector (Note 1-2-3) ..

*NOTE 1: See illustration preceding Group 5.398 for identification of axle cover.*

*NOTE 2: It will be necessary to use (2) 3882979 strap (4) 3887348 bolts on rear axle.*

*NOTE 3: Strap type attaching.*

64-70 All w/10 bolt round cover,				
71 Chevelle, Nova w/10 bolt cover,				
71-75 Vega, Monza,				
72 Chevelle w/10 bolt cover	3878968	1	10.80	w/deflector (Note 4) ..

*NOTE 4: "U" bolt attaching.*

65-68 All w/12 bolt cover (exc. 1330 U-Joint)	3878972	1	12.30	w/deflector (3 <sup>7</sup> / <sub>32</sub> " dia.) ..
66-68 Pass. (T.H.) w/1330 U-Joint,				
70 Pass. w/1330 U-joint,				
67-68 Chevelle, w/T.H.,				
67 Camaro,				
70-72 Chevelle (12 bolt cover w/1330 U-joint)	3879208	1	13.30	w/deflector (4 <sup>5</sup> / <sub>16</sub> " dia.) (12 bolt cover) (H.D. u-joint) ..

69-70 All w/12 bolt cover,				
71 Nova w/12 bolt cover,				
71-72 Chevelle (12 bolt cover w/1280, 1310 U-joint)	3996118	1	14.95	w/deflector (standard u-joint) ..
70 Monte Carlo w/cut out cover	9783530	2	12.95	(Note 1) ..
71-74 Camaro w/10 bolt cover,				
72-75 Nova	3988524	1	13.90	w/deflector, strap-type spring attaching ..
71 Camaro,				
71-75 Pass. (Sta. Wag.) w/2.73, 3.08, 3.42 ratio,				
73-75 Chevelle,				
75 Camaro	7812565	1	14.95	(type P, M) ..
71-75 Pass. w/2.73, 3.08, 3.23, 3.42 ratio (exc. Sta. Wag.)	7808671	1	15.75	(type B, O, P, G, C, K) ..
74 Vega (122)	2403641	1	13.25	w/deflector ..

64-70 All w/10 bolt cover,				
71 Chevelle, Nova w/10 bolt cover,				
71-75 Camaro,				
72-75 Nova,				
73-75 Chevelle,				
71-75 Vega, Monza,				
72 Chevelle w/10 bolt cover	3832398	1	.65	DEFLECTOR, flange (3 <sup>5</sup> / <sub>32</sub> " O.D. x 1 <sup>41</sup> / <sub>64</sub> " I.D.) ..

65-70 All w/12 bolt cover,				
71 Chevelle, Nova w/12 bolt cover,				
72 Chevelle w/12 bolt cover	3819415	1	.43	DEFLECTOR, pinion flange ..
74 Vega (122)	1784583	1	.31	SLINGER, pinion frt. brg. (type G, K) ..
71-75 Pass. w/2.73, 3.08, 3.23 ratio				(type P, M) ..
71-75 Pass. w/2.73, 3.08, 3.42 ratio	543319	1	.27	(type P, M) ..
62-70 All,				
71 Chevelle, Nova				WASHER, flange ( <sup>67</sup> / <sub>64</sub> " I.D. x 1 <sup>7</sup> / <sub>16</sub> " x 1/4" thk.) ..
71-72 Camaro,				
72 Nova,				
71-72 Pass. w/2.78, 3.08 ratio				(type B, O) ..
71-72 Pass. w/2.78, 3.08, 3.42 ratio				(type P, M) ..
71-72 Pass. w/2.78, 3.08 ratio	3714792	1	.90	(type G, K) ..
74 Vega (122)	345619	1	.44	WASHER, pinion rear brg. spacer ..

**5.548 REPAIR KIT— BALL UNIT— BEARING and CUP UNIT, Universal**

*NOTE: Numbers following model usages are forged on the frt. and rear yokes respectively. All see Groups 4.404 and 4.405 for Universal Joint attaching parts.*

65-69 Pass.,				
--------------	--	--	--	--

**BRAKES—REAR AXLE AND DRIVE**

**5.548 REPAIR KIT— BALL UNIT— BEARING and CUP UNIT, Universal (Con't)**

66	Pass. (exc. T.H.)				front and inter.,
62-68	Chevy,				
64-68	Chevelle, Camaro,				
72	Chevelle (250, 307),				
72	Camaro (exc. 350, 402),				
72	Camaro w/2BC (350) (exc. T.H. 350),				
72	Nova (exc. T.H. 350)				frt. and rear,
69	Nova, Camaro (exc. T.H. 400, 4-Spd.),				
69	Chevelle, Pass. (exc. 4BC, T.H. 400, 4-Spd.),				
70	Nova, Camaro (exc. 4BC),				
70	Pass., Chevelle (exc. 4BC, 4-Spd., T.H. 400),				
70	Monte Carlo, Caprice, Kingswood (Estate) w/P.G. (350),				
71	Chevelle (6 cyl.) (exc. 4-Dr.),				
71	Chevelle w/2BC (307, 350) (exc. Monte Carlo),				
71	Monte Carlo w/2BC (350) (exc. T.H. 350),				
71	Nova (exc. T.H. 350, H/Per. 350),				
71	Camaro (exc. 4BC, T.H. 350, 3.42 ratio)				U-joint (strap or "U" bolt) (24 brg. rollers) (Note 1),
69	Nova, Camaro w/T.H. 400, 4-Spd.,				
66-68	Pass. w/T.H.,				
67-68	Chevelle, Camaro w/T.H.,				
70	Caprice, Kingswood (Estate Wag.) w/T.H. 400 (454),				
70	Monte Carlo (T.H. 400 w/454),				
71-72	Chevelle (454),				
71	Camaro (T.H. 350 w/2BC) (307, 350),				
71	Camaro (4-Spd. w/4BC) (350),				
71	Camaro w/4BC (400),				
71-75	Pass.,				
73-75	Chevelle,				
75	Camaro	7806140	1	18.35	front U-joint (Note 4-5)
66-68	Pass. w/T.H.,				
67-68	Chevelle, Camaro w/T.H.,				
70	Caprice, Kingswood (Estate Wag.) w/T.H. 400 (454),				
70	Monte Carlo (T.H. 400 w/454),				
71-72	Chevelle (454)	5698221	1	15.45	rear U-joint (Note 2, 4 and 5)
<i>NOTE 2: Consists of 1 trunnion, 4 brgs., 4 snap rings, 2 "U" bolts, 4 washers and 4 nuts.</i>					
69-70	Chevelle, Pass.,				
70	Nova, Camaro w/4BC,				
71	Chevelle w/4BC (exc. 454),				
71	Nova (350),				
71	Camaro w/T.H. 350 (350) (exc. Sp. H/Per., 3.42 ratio),				
71	Camaro w/Sp. H/Per. 350,				
71-75	Vega, Monza,				
72	Chevelle (350, 402),				
72	Camaro w/4BC,				
72-74	Camaro (2BC w/T.H. 350) (350),				
72	Nova w/T.H. 350 (350),				
73	Camaro (exc. 350),				
73	Camaro w/2BC (350) (exc. T.H. 350),				
73	Nova (exc. T.H. 350),				
73-74	Camaro w/4BC,				
73-75	Nova	386451 A.R.		16.70	"U"-joint (Note 6)
73-75	Pass. (exc. Sta. Wag.)	7815848	1	11.30	BALL UNIT, prop. shaft replacement
73-75	Pass. (exc. Sta. Wag.)	7815851	1	10.50	BEARING AND CUP UNIT, prop. shaft trunnion

*NOTE 1: Consists of 1 trunnion, 2 snap rings, 2 "U" bolts, 4 nuts, 4 washers, 4 seals, and 4 bearings.*

*NOTE 4: Use only with prop shaft assy. 567871 for 1966.*

*NOTE 5: Used on "U" joints which have plastic injected or inner position "U" joint bearing lock rings.*

*NOTE 6: Do not use on "U" bolt type.*

**BRAKES—REAR AXLE AND DRIVE**

**5.555 YOKE— DAMPER UNIT, Universal Joint**

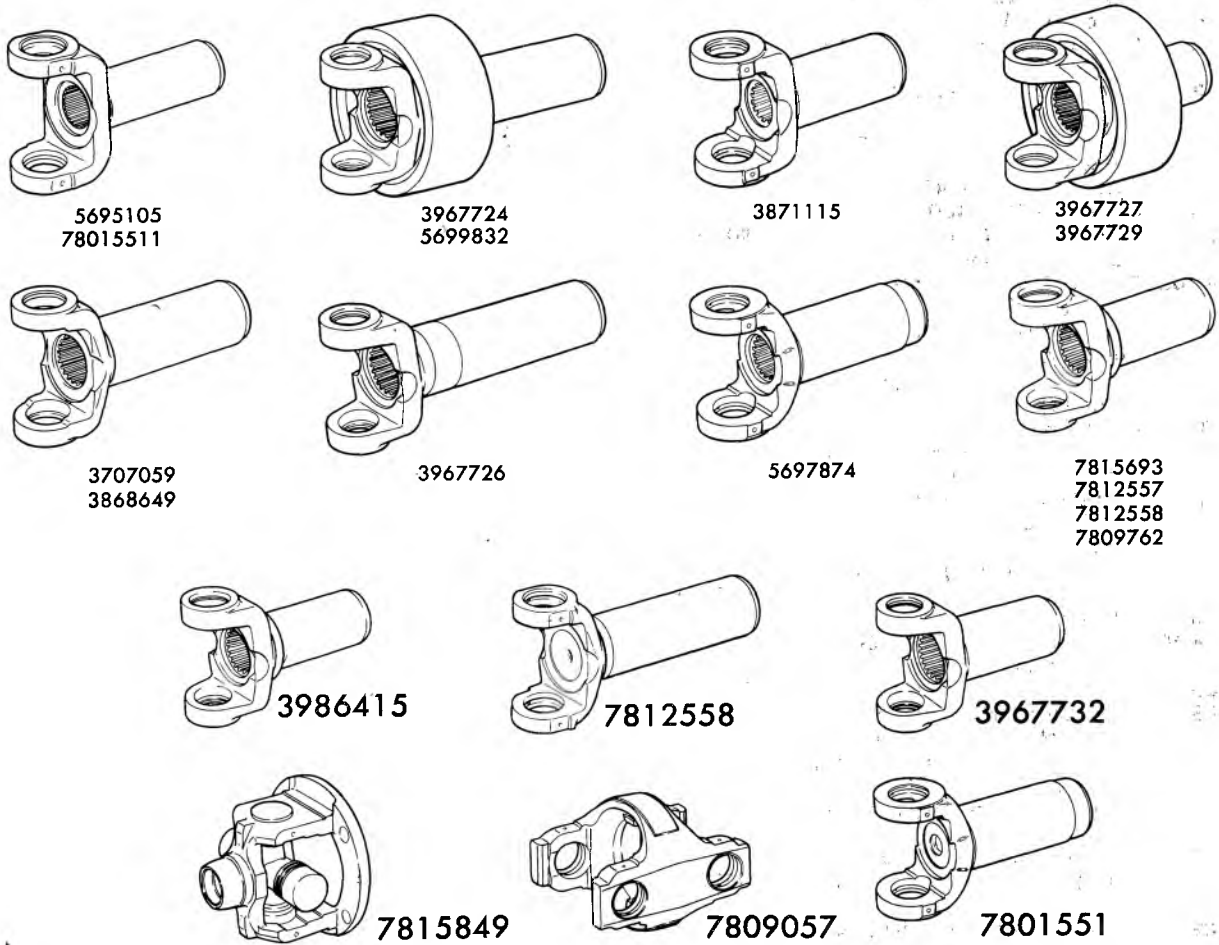

5-65

62-63	Chevy (exc. 4-Spd.)	3707059 A.R.	11.90	(16 splines)
71-75	Pass. (exc. Sta. Wag.)	7809057 1	44.25	link (use w/constant velocity shaft)
63	Chevy w/Muncie 4-Spd.,			
64-68	Chevy, Chevelle, Camaro,			
65-66	Pass. (exc. T.H.),			
67-69	Pass. (exc. Caprice, T.H.),			
67-69	Caprice (exc. A.T.),			
71-72	Vega	3868649 1	18.60	YOKE ASSY., U-joint sleeve yoke (27 splines)
65-66	Pass. w/T.H.	3871115 1	39.00	YOKE ASSY., U-joint 22.75 sleeve yoke (splines)
66	Pass. w/T.H.	5697874 1	19.30	YOKE ASSY., prop. shaft
67-68	Chevelle w/P.G. (exc. Std., Deluxe),			
67-68	Caprice w/P.G.,			
69	Caprice, Sta. Wag. w/P.G.,			
69	Estate Wag. w/P.G.,			
70	(Concours Estate Wagon) w/P.G.,			
70	Caprice, Monte Carlo w/P.G.,			
71-72	Monte Carlo, Concours Estate w/A.T. (exc. T.H. 400)	3967727 1	19.65	YOKE ASSY., w/dampener front U-joint
67-68	Chevelle, Camaro w/T.H.,			
67	Pass. w/T.H. (exc. Caprice),			
68	Pass. w/T.H. (396, 427) (exc. Caprice),			
68	Pass. w/T.H. (327) (1st Design) (exc. Caprice),			

**BRAKES—REAR AXLE AND DRIVE**

**5.555 YOKE— DAMPER UNIT, Universal Joint (Con't)**

70-71	El Camino (Custom), Malibu w/T.H. 400 (454),				
71	Pass. (Sta. Wag.) w/T.H. 400 (exc. Police),				
72	Malibu (Spt. Cpe., Conv.) w/T.H. 400 (454),				
72	El Camino (Custom) w/T.H. 400 (454),				
73-75	Police w/T.H. 350 (exc. Sta. Wag.),				
73-75	Pass. w/T.H. 400 (454),				
73-75	Chevelle w/T.H. 400,				
75	Pass. w/T.H. 400 (350) . . . . .	7801551	1	36.50	YOKE ASSY., front U-joint sleeve (Note 3)
	<i>NOTE 3 Less damper.</i>				
67-68	Pass. w/T.H. (396, 427) (exc. Caprice),				
68	Pass. w/T.H. (327) (1st design) (exc. Caprice),				
69	All w/T.H. 400 (8 cyl.) (exc. Caprice),				
70	All w/T.H. 400,				
71	Chevelle (T.H. 400 w/4BC) (400) (exc. Monte Carlo),				
72	Chevelle (4-Dr.) El Camino w/T.H. 400 (402),				
72	Chevelle (Spt. Cpe., Conv.) w/T.H. 400 (402) (exc. Monte Carlo) . . . . .	3967726	1	14.50	YOKE ASSY., U-joint . . . . .
68	All w/T.H. 350,				
69-70	Chevy, Chevelle w/T.H. 350 (exc. Estate Wag.),				
69	Pass. w/T.H. 350 (exc. Caprice) .	7815693	1	32.75	YOKE ASSY., front U-joint . . . . .
68	Pass., Chevelle w/T.H. 350,				
69	(Estate Wag.) w/T.H. 350,				
69	Caprice, Sta. Wag. w/T.H. 350,				
70	Monte Carlo w/T.H. 350,				
70	(Concours Estate Wag.) w/T.H. 350,				
70	Caprice (Kingswood Estate Wag.) w/T.H. 350 . . . . .	3967729	1	18.80	YOKE ASSY., front U-joint . . . . .
69-70	Pass.,				
69-70	Chevy, Camaro, Chevelle (exc. T.H.),				
70	Camaro w/T.H. 350 (350),				
71	Chevelle (6 cyl.),				
71	Chevelle w/2BC (307, 350) (exc. Monte Carlo, Concours Estate),				
71	Chevelle (4-Spd., w/4BC) (400) (exc. Monte Carlo),				
71	Chevelle (4-Dr.) El Camino w/4BC (350) (exc. 4-Spd., Concours Estate),				
71	Chevelle (Spt. Cpe., Conv.) (T.H. 350 w/4BC) (350) (exc. Monte Carlo),				
71	Concours Estate, Monte Carlo w/2BC (307, 350) (exc. A.T.),				
71	Concours Estate (3-Spd. w/4BC) (350),				
71	Monte Carlo w/4BC (350) (exc. 4-Spd., T.H. 350),				
71	Nova (exc. T.H. 350, H/Per. 350),				
71	Nova w/T.H. 350 (350),				
71	Camaro (exc. 4BC, T.H. 350, 3.42 ratio),				
71	Camaro w/T.H. 350 (350) (exc. Sp. H/Per., 3.42, ratio),				
72	Camaro (exc. 350, 402),				
72	Camaro w/2BC (350) (exc. T.H. 350),				
72	Nova,				
72	Chevelle w/3-Spd. col. shift, P.G.,				

**BRAKES—REAR AXLE AND DRIVE**

**5.555 YOKE— DAMPER UNIT, Universal Joint (Con't)**

72	Chevelle w/H.D. 3-Spd. (exc. Monte Carlo),				
72	Chevelle (4-Dr.) (T.H. 350 w/4BC) (350) (exc. Concours Estate),				
72	Chevelle (2-Dr.) w/T.H. 350 (exc. Monte Carlo),				
73-74	Camaro (exc. Sp. H/Per.),				
73-75	Nova,				
73-75	Vega, Monza (exc. damper) . . . . .	3967732	1	18.85	YOKE ASSY., front U-joint . . . . .
68	Pass. w/T.H. (307),				
68	Pass. w/T.H. (327) (2nd design),				
68	Camaro w/T.H. (396),				
69	Caprice, Sta. Wag. w/T.H. 400,				
70	Caprice, Monte Carlo w/T.H. 400 (400),				
70-72	(Concours Estate Wag.) w/T.H. 400,				
71	Monte Carlo w/T.H. 400 (400, 4BC),				
72	Monte Carlo w/T.H. 400 (402) . . . . .	3967724	1	16.20	YOKE ASSY., front U-joint . . . . .
69	Caprice w/T.H. 400,				
68	Caprice w/T.H. (327) (1st Design),				
70	Caprice, Kingswood (Estate Wag.) w/T.H. 400 (454),				
70	Monte Carlo (T.H. 400 w/454),				
72	Monte Carlo w/T.H. 400 (454) . . . . .	5699832	1	51.00	YOKE ASSY., front "U" joint sleeve (Note 2)
	<i>NOTE 2: With damper. Plastic injection or inner position U-joint lock rings.</i>				
71	Pass. w/T.H. 350,				
71	Pass. (Sta. Wag.) w/3-Spd.,				
71	Pass. w/P.G., 3-Spd. (exc. Sta. Wag.),				
72-75	Pass. (exc. T.H. 400),				
73-75	Chevelle (exc. 4-Spd., T.H. 400),				
75	Camaro (exc. close ratio 4-Spd.)	7812557	1	40.00	YOKE ASSY., front . . . . .
71	Pass. w/T.H. 400 (exc. Police, Sta. Wag.),				
71	Police w/T.H. 400,				
72-74	Pass. w/T.H. 400 . . . . .	7812558	1	40.00	YOKE ASSY., front . . . . .
71-74	Chevelle w/4-Spd. (exc. H.D.),				
71	Camaro w/Sp. H/Per. 350,				
71	Nova w/4BC (350) (exc. T.H. 350),				
72	Camaro w/4BC,				
72	Camaro (2BC w/T.H. 350) (350),				
73-74	Camaro w/Sp. H/Per. (350) . . . . .	3986415	1	36.00	YOKE ASSY., sleeve front . . . . .
71-72	Chevelle w/H.D. 4-Spd.,				
71	Camaro (4-Spd. w/4BC) (350),				
71	Camaro w/4BC (400),				
73-74	Chevelle w/H.D. 4-Spd. (454),				
75	Chevelle (4-Dr.-El Camino) (exc. T.H. 400),				
75	Camaro w/close ratio 4-Spd. . . . .	7809762	1	36.00	YOKE ASSY., sleeve front . . . . .
71	Kingswood Estate (exc. T.H. 400),				
71	Camaro (T.H. 350 w/2BC) (307, 350) . . . . .	5695105	1	31.00	YOKE ASSY., sleeve front . . . . .
71-72	Vega . . . . .	6264300	1	35.00	YOKE ASSY., front w/damper (rear axle noise) . . . . .
73-74	Vega . . . . .	7815325	1	39.25	YOKE ASSY., front w/damper (rear axle noise) . . . . .
73-75	Pass. (exc. Sta. Wag.) . . . . .	7815849	1	63.25	YOKE ASSY., prop. shaft support . . . . .
73-74	Vega . . . . .	6259392	1	10.30	DAMPER UNIT (rear axle noise) less yoke—(5.383) (Note 4) . . . . .

*NOTE 4: Unit contains 2 control arm damper weights, 2 tapping plates, 2<sup>5/16</sup>" x 1<sup>5/8</sup>" bolts, 2<sup>5/16</sup>" lock washers, instruction sheet.*

**5.560 SEAL, Propeller Shaft Universal Joint Trunnion**

63	Chevy,				
65	Chevy, Chevelle . . . . .	3821777 A.R.		.55	yoke brg. (3/32" O.D. x 1/4" thk.) (w/oblong identification mark) . . . . .
65-70	All,				
71	All (exc. Pass., Camaro) (454),				

**BRAKES—REAR AXLE AND DRIVE**

**5.560 SEAL, Propeller Shaft Universal Joint Trunnion (Con't)**

71	Camaro (T.H. 350 w/2BC) (307, 350),			
71	Camaro (exc. 3.42 ratio, 4-Spd., 400),			
71-73	Vega,			
72	Camaro,			
72	Chevelle (exc. 454),			
73-74	Camaro .....	3841923 A.R.	.20	yoke brg. (1 1/2" O.D. x 2 1/32" I.D.) .....

**5.566 BEARING— ROLLER— SPACER, Universal Joint Yoke Trunnion**

63	Chevy,			
65	Chevy .....			(1 1/16" O.D. x 9/16" thick), .....
65	Chevelle (Deluxe) (6 cyl.) .....	3828467 A.R.	2.20	(black oxide on rollers) .....
64-70	All (exc. T.H.),			
71	Chevelle (6 cyl.),			
71	Chevelle w/2BC,			
71	Monte Carlo w/T.H. 350,			
71	Nova (exc. T.H. 350, H/Per. 350),			
71	Camaro (exc. 4BC, T.H. 350, 3.42 ratio),			
71-73	Vega .....	9419578 A.R. *	.12	ROLLER, U-joint yoke trunnion brg. ....
69	Pass.,			
69-70	Chevy, Camaro w/T.H. 400,			
69	Malibu (Spt. Cpe.), El Camino (Custom),			
70	Pass., Camaro,			
71-72	Chevelle w/4BC (exc. 454),			
71-72	Nova (350),			
71-74	Camaro w/Sp. H/Per. 350,			
71-74	Camaro w/T.H. 350 (350) (exc. Sp. H/Per., 3.42 ratio) .....	3856809 A.R.	.12	SPACER, trunnion brg. (Dana 2300727-1) .

**5.586 LOCK RING— BOLT— NUT— STRAP, "U" Joint Trunnion and Yoke**

62-66	Chevy,			
63-68	Chevelle (exc. T.H.),			
67-68	Camaro,			
65-69	Pass.,			
69	El Camino (Custom) (P/Trac. w/396) (4.10 ratio) (exc. T.H. 400),			
70	All,			
71	All (exc. Pass.),			
71-74	Vega (140),			
72-74	Camaro,			
72	Chevelle (exc. 454),			
73-75	Nova,			
75	Vega, Monza .....	3721887 A.R.	.21	all locations (finger dia. 596) .....
66	Pass. (8 cyl.) w/T.H.,			
67	Chevelle w/T.H.,			
67	Sta. Wag. (8 cyl.) w/T.H.,			
67	Impala, Caprice (8 cyl. w/T.H.) (exc. Sta. Wag.),			
71	Pass. (exc. Police),			
72	Pass. w/T.H. 350,			
72	Pass. (Sta. Wag.) w/3-Spd.,			
73-74	Chevelle,			
73-75	Pass. (Sta. Wag.) (400, 454) ...	1456507 A.R.	.24	U-joint yoke trunnion bearing snap .....
66-69	Pass. w/T.H. (8 cyl.),			
67-69	Chevelle, Camaro w/T.H.,			
69	Chevy (8 cyl.),			
70-75	All .....	3887348	4	.16 BOLT, shaft and U-joint assy. strap (5/16"— 24 x 1 7/16") .....
69	Chevy, Camaro,			
70	All,			
71	Nova .....	3877199	16	.16 BOLT, rr. wheel drive shaft strip (1 7/64" head thickness) (1/4"— 20 x 3/4") .....
70	Monte Carlo w/2.73, 3.08, 3.23 ratio .....	1357255	2	.66 BOLT, U-joint (5/16"— 18 x 1 3/8") .....
All	All .....	1358938 A.R.		.55 BOLT, U-joint trunnion brg. (5/16"— 18 x 1 3/16") .....
71-74	Pass. ....	1240073	4	.18 BOLT, prop. shaft and "U" joint (hex. (7/16" x 1 1/16") .....
71-72	Vega .....	3993015	1	1.55 BOLT, prop. shaft damper ("U") .....
75	Pass. ....	1245509	4	.18 BOLT, prop. shaft and "U" joint .....

## BRAKES—REAR AXLE AND DRIVE

### 5.586 LOCK RING— BOLT— NUT— STRAP, "U" Joint Trunnion and Yoke (Con't)

71-72 Vega	3993018	2	.84	NUT, prop. shaft damper
66 Pass. w/T.H.,				
67-70 All,				
73-75 Nova, Camaro	3882979	2	.12	STRAP, prop. shaft
71-75 Pass. (Sta. Wag.),				
73-75 Chevelle	7810416	2	.24	STRAP, prop. shaft

### 5.595 NUT— WASHER, Propeller Shaft Pinion Flange

64-70 All w/round cover,				
71 Chevelle, Nova w/round cover,				
71-75 Vega, Monza,				
72 Chevelle	3736464	A.R.	.81	(7/8" — 16) (Note 1)
71-72 Camaro,				
71-73 Pass. w/2.73, 3.08, 3.42 ratio,				
72 Nova,				
73-75 All	9783762	1	.76	(type C, G, B, O, K, P, M) (7/8" — 14 I.D. x 17/16" O.D. x 3/16") (plain)
74 Vega (122)	2346852	1	.57	
65-75 All	3714792	1	.90	WASHER (57/64" — 17/16" x 11/64") (type B, G, C, K, O, P, M) (Note 1) (12 bolt cover) (plain)
70-75 All	517900	1	.40	WASHER (1 5/8" O.D.) (10 bolt cover)

*NOTE 1 See illustration preceding group 5.398 for identification of axle cover.*

### 5.638 CLAMP, Rear Axle

62-69 All	2494772	A.R.	.65	(1/4" — 5/8" diameters)— (1.166)
-----------	---------	------	-----	----------------------------------

### 5.803 WHEEL, Front or Rear

*This section contains Model Usage and Prices for Passenger, Chevy II, Chevelle and Camaro wheels for Wheel size. Tire size and other added description, see the following charts.*

*These two sections should be used in conjunction with one another to determine the correct wheel.*

#### WHEEL RIMS

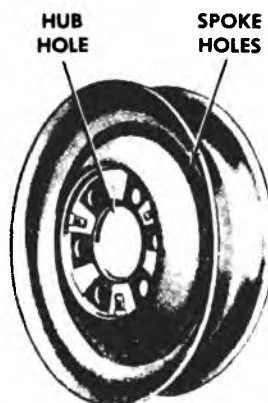

**6 STUD  
STAMPED DISC WHEEL**

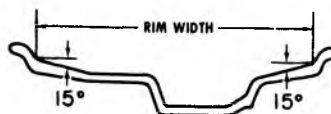

#### ONE PIECE

One-piece rims: 5.25" or larger rims have a 15° taper bead seat, and are used for tubeless tires. Smaller rims have a 5° taper bead seat, and are used for both tubeless and tube tires.

**NOTE:** Offset is determined by measuring the distance from the centerline of the rim to the inner side of the wheel disc.

62-63 Chevy w/6.50 x 14 tires	3793396	A.R.	19.85	(14 x 5 J)
62-63 Chevy w/6.00 x 13 tires	3790690	A.R.	15.90	(13 x 4J)
62-63 Chevy w/6.50, 7.00 x 13 tires	3790693	A.R.	16.95	(13 x 5 1/2")



**BRAKES—REAR AXLE AND DRIVE**

**5.803 WHEEL, Front or Rear (Con't)**

64-68	Chevy, Chevelle (exc. S.S. disc brakes),			
69	Chevelle	3872276 A.R.	17.70	(14 x 5J)
64	Chevy Std. (Sta. Wag.),			
64	Nova	3860957 A.R.	18.10	(13 x 5.5J)
64-66	Chevy Std. (Sedan) (exc. 8 cyl.)	3852832 A.R.	15.85	(13 x 4J)
65	Chevelle (Spec. Spt. Coupe) (396),			
68-69	Chevelle	3928297 A.R.	21.35	(14 x 6)
65-67	Pass. (exc. Police)	3834956 A.R.	27.50	(15 x 5K)
65-69	Pass. (exc. Sta. Wag.),			
67	Camaro,			
68-69	Chevy,			
70	El Camino, Nova (exc. Custom, Sta. Wag.),			
71-72	Nova,			
71-72	Chevelle (exc. Monte Carlo, Sta. Wag.)	736365 A.R.	18.45	(14 x 5JJ)
65-66	Police	3838080 A.R.	25.25	(15 x 5.5K)
65-69	Pass. (exc. disc brakes)	3960347 A.R.	21.40	(14 x 6JK)
66-69	Chevelle (S.S.),			
68-69	Chevelle w/F 70 x 14 tires (exc. Sta. Wag. disc brk., rally wheel)	3871919 A.R.	20.55	(14 x 6JK)
67-68	Chevy, Chevelle, Camaro w/disc brakes (exc. 396, 350)	3918077 A.R.	24.15	(14 x 5.00J) (1/2" offset) (stamped XA)
67-68	Camaro w/disc brakes,			
67	Chevelle (S.S.),			
68-69	Chevelle w/Spec. F70 x 14 tire,			
70	Chevelle w/rally wheel (exc. Sta. Wag.)	3918078 A.R.	36.00	(14 x 6.00JJ) (stamped XB)
67-69	Camaro (exc. disc brakes, spec. wheel)	3970535 A.R.	18.45	(14 x 6.00JK)
67-68	Camaro (302) w/disc brakes	3914894 A.R.	29.50	(15 x 6.00JK)
67	Chevy, Camaro w/disc brakes,			
67	Chevelle w/disc brakes (exc. S.S.),			
68-69	Camaro w/space saver wheel	9792737 A.R.	24.15	(14 x 5)
67	Pass. w/disc brakes,			
68	Pass. w/disc brakes (1st design),			
68-70	Pass. w/rally wheel,			
68-69	Camaro w/15" wheel and tire (exc. Disc Brk.)	3968773 A.R.	36.25	(15 x 6JK) (5 slotted rim holes) (stamped FI)
68	Pass. (exc. Sta. Wag.)	3928262 A.R.	23.50	(15 x 5JJ) (stamped XH)
68	Chevelle w/disc brakes (exc. S.S. rally wheel),			
68	Chevy w/disc brakes (exc. rally wheels, 350)	3928294 A.R.	18.45	(14 x 5.00J)
68-69	Camaro (rally wheel w/Disc Brks.) (exc. space saver wheel),			
68-69	Chevy (rally wheel, w/Disc Brks.) (350),			
68-69	El Camino (S.S.) w/rally wheel (exc. Disc Brake),			
70	Nova w/rally wheel (exc. S.S.)	3938984 A.R.	23.50	(1/2" offset) (14 x 6.00JJ) (stamped XG)
68-69	Camaro w/Disc Brakes (exc. rally wheel, space saver wheel 302),			
68	Chevy w/Disc Brakes,			
69	Chevy,			
70	Nova (exc. S.S. rally wheel)	3938983 A.R.	21.35	(14 x 6.00JJ)
68-69	Camaro w/rally wheel (exc. Disc Brakes)	3940185 A.R.	25.25	(14 x 6.00JK) (1/4" offset) (stamped XN)
68-69	Pass. (exc. Disc Brk., rally wheel),			
68-69	Pass. w/Disc Brk. (2nd Design),			
70	Pass.	3984792 A.R.	28.00	(15 x 6JK)
69	Camaro w/Disc Brakes (front and rear),			
69	Camaro (302),			
70-75	Monte Carlo w/rally wheel,			
74-75	Chevelle w/rally wheels (exc. Sta. Wag.)	3997899 A.R.	34.50	(15 x 7JJ) (stamped FW)
69	Chevy, Camaro (S.S.) (exc. mag. type wheel rally wheel),			

**BRAKES—REAR AXLE AND DRIVE**

**5.803 WHEEL, Front or Rear (Con't)**

70	Nova (S.S.) (exc. mag. type wheel, rally wheel),				
70	Camaro (350, 396 4BC) (exc. rally wheel),				
71-74	Camaro (exc. rally wheel),				
71-72	Nova (Spt. Cpe.) (exc. rally wheel),				
73-74	Nova (exc. rally wheel) . . . . .	334397 A.R.	24.45	(14 x 7.00JJ) ( <sup>13</sup> / <sub>32</sub> " offset) (stamped XG) . .	
69	Chevy, Chevelle, Camaro (S.S.) w/mag. style wheels,				
70	Nova, Chevelle (S.S.) w/mag. type wheel . . . . .	3975671 A.R.	30.75	(14 x 7.00JJ) ( <sup>13</sup> / <sub>32</sub> " offset) (painted gray and silver) (stamped AO) . . . . .	
69	Chevy w/rally wheel (4BC 350, 396) (exc. reg. fuel),				
69	Camaro (Disc Brks. w/rally wheel) (4BC 350, 396) (exc. reg. fuel),				
70	Nova (S.S.) w/rally wheel . . . . .	3970530 A.R.	38.25	(14 x 7.00JJ) (stamped YJ) . . . . .	
69-70	Pass. (exc. Sta. Wag.) . . . . .	3964071 A.R.	27.75	(15 x 5JJ) . . . . .	
70-72	Chevelle . . . . .	409879 A.R.	26.25	(14 x 6JJ) (stamped MH) . . . . .	
70-72	Monte Carlo . . . . .	3990502 A.R.	24.35	(15 x 6JK) (stamped XX) . . . . .	
70	Monte Carlo . . . . .	3977968 A.R.	31.50	(15 x 7JJ) (stamped AF) . . . . .	
70	Chevelle (Sta. Wag.) w/rally wheel . . . . .	3972635 A.R.	26.25	(14 x 6JJ) (stamped AE) . . . . .	
70	Camaro (exc. 4BC, rally wheel),				
70-75	Camaro w/Sp. H/Per. (350),				
71-72	Chevelle w/Disc Brake (454) (exc. Monte Carlo) . . . . .	3998532 A.R.	53.50	(15 x 7JJ) (stamped AU) (Note 1) . . . . .	
	<i>NOTE 1: Used with options Z-28 or Z-86.</i>				
70-75	Camaro w/rally wheel,				
71-75	Nova (Spt. Cpe.) w/rally wheel,				
73-74	Chevelle w/rally wheels . . . . .	362055 A.R.	25.75	(14 x 7JJ) (stamped UD) (Note 2) . . . . .	
	<i>NOTE 2: Part #362055 is also used for the "Spirit of America". Paint as reqd.</i>				
71-74	Nova w/rally wheel,				
71-72	Chevelle w/rally wheel (exc. Deluxe),				
73-74	Camaro w/rally wheel (250) . . .	334329 A.R.	24.45	(14 x 6JJ) (stamped DE) . . . . .	
71-72	Monte Carlo,				
73	Monte Carlo (exc. rally wheel, Custom wheels),				
74-75	Chevelle, Monte Carlo (exc. Sta. Wag., rally wheels, Custom wheels) . . . . .	326875	26.50	(15 x 7) (stamped AE) . . . . .	
71-75	Pass. . . . .	3997997 A.R.	28.00	(15 x 6JJ) (stamped AK) . . . . .	
71-75	Vega, Monza (exc. GT) . . . . .	3978077 A.R.	16.60	(13 x 5) primed <sup>3</sup> / <sub>16</sub> " offset (stamped AS) (Note 1) . . . . .	
71-75	Vega, Monza (exc. GT) . . . . .	3978080 A.R.	16.60	(13 x 6) primed (stamped AT) (Note 1) . . . .	
71-75	Vega (G.T.) . . . . .	3978191 A.R.	38.25	(13 x 6) (stamped FF) (Note 1) (Note 2) . . . .	
73-75	Camaro w/space saver tire,				
73-75	Nova (exc. S.S., rally wheel) . . . .	326843 A.R.	18.45	(14 x 5) (stamped XA) . . . . .	
73-75	Camaro, Nova (exc. Sp. H/Per. 350, rally wheel, G.T. wheel),				
73-75	Chevelle (exc. Monte Carlo, rally wheel, G.T. wheel) . . . . .	333274 A.R.	25.50	(14 x 6JJ) (stamped XJ or UA) . . . . .	
73-74	Chevelle, Camaro w/G.T. wheel (RPO PE1) . . . . .	326887 A.R.	52.75	(14 x 7) (ident. blue strip) (stamped AN) (urethane) . . . . .	
73	Monte Carlo w/Custom wheel (RPO PE2) . . . . .	326891 A.R.	53.50	(15 x 7) (stamped AG) (urethane) . . . . .	
74-75	Chevelle (exc. Monte Carlo, Laguna, rally wheels, Custom wheels) . . . . .	344003 A.R.	26.50	(15 x 7) (stamped FN) . . . . .	
74-75	Monte Carlo w/Custom Wheel (RPO PE2) . . . . .	345940 A.R.	53.50	(15 x 7) (urethane) (stamped CB) . . . . .	
74-75	Chevelle, Monte Carlo (exc. Sta. Wag.) . . . . .	331427 A.R.	26.50	(15 x 6) (primed) . . . . .	
74	Pass. w/spirit of America . . . . .	352911 A.R.	44.50	(15 x 6) . . . . .	
74-75	Cosworth (122) . . . . .	339619 A.R.	85.25	(alum. wheel) (13 x 6) . . . . .	
75	Chevelle, Camaro, Nova w/G.T. wheel (RPO PE1) . . . . .	362056 A.R.	52.75	(14 x 7) (urethane) (stamped UF) . . . . .	
75	Nova, Camaro (exc. rally wheel) . .	362052 A.R.	25.00	(14 x 7) (stamped UC) . . . . .	
75	Camaro w/rally wheel (250),				
75	Nova w/rally wheel . . . . .	362059 A.R.	25.00	(14 x 6) (stamped UB) . . . . .	
75	Monza w/RPO N77 . . . . .	355820 A.R.	108.00	(alum. wheel) (13 x 6) . . . . .	

## BRAKES—REAR AXLE AND DRIVE

### 5.803 WHEEL, Front or Rear (Con't)

NOTE 1: Letters stamped on rim approx. 2" clockwise from valve hole.

NOTE 2: Part #3978191 is also used for the "Spirit of America." Paint as required.

Construction	Wheel Size	Offset	Tire Size	No. Hub Cap Attach. Clips or Proj.	Tire Type	No. Lug Holes	Wheel	Clamp Ring	Side Ring	No. Spoke or Hand Holes
1 Piece (Welded)	14 x 6.00JK	1	7.00 x 14	0	Tubeless	5	3871919			
1 Piece (Welded)	14 x 6JK	1/16	8.25 x 14, 8.55 x 14	9	Both	5	3960347			
1 Piece (Riveted)	15 x 15K	9/16	6.70 x 15, 7.10 x 15	0	Both	5	3834956			4
1 Piece (Welded)	14 x 5JJ	19/32	7.00 x 14, 7.50 x 14, 7.75 x 14, 8.25 x 14	4	Tubeless	5	736365			4
1 Piece (Welded)	14 x 6JJ	1	7.00 x 14	0	Tubeless	5	409879			5
1 Piece (Welded)	14 x 6JJ	1/2	E78 x 14, F78 x 14	4	Tubeless	5	333274			4
1 Piece (Welded)	14 x 7JJ	11/32	E78 x 14, F78 x 14	4	Tubeless	5	3975667			4
1 Piece (Welded)	15 x 6JK	27/32	F70 x 15	4	Tubeless	5	3990502			4
1 Piece (Welded)	15 x 7JJ	9/32	F60 x 15	4	Tubeless	5	3998532			4
1 Piece (Welded)	14 x 6JJ	1/2	F78 x 14	5	Tubeless	5	334329			6
1 Piece (Welded)	15 x 7	5/16	G78 x 15	4	Tubeless	5	326875			4
1 Piece (Welded)	15 x 6JJ	11/32	G78 x 15	4	Tubeless	5	3997997			4
1 Piece (Welded)	15 x 7	19/32	G78 x 15	4	Tubeless	5	3997899			5
1 Piece (Welded)	15 x 5JJ	1/4	7.75 x 15, 8.15 x 15	5	Both	5	3901696			5
1 Piece (Riveted)	15 x 5.5K	7/16	6.70 x 15, 7.10 x 15	0	Tube	5	3838080			4
1 Piece (Welded)	15 x 5JJ		8.00 x 15	3	Both	5	3928262			4
1 Piece (Welded)	15 x 5JJ	2-29/32	8.25 x 14	0	Tubeless	5	3964071			4
1 Piece (Welded)	15 x 6JK	1/16	7.75 x 15, 8.15 x 15 (INT.)	3	Both	5	3968773			5
1 Piece (Welded)	15 x 6JK	1/16	8.15 x 15 (EXT.)	3	Tubeless	5	3984792			4
1 Piece (Welded)	14 x 5	13/64	E78 x 14, F78 x 14	4	Tubeless	5	326843			4
1 Piece (Welded)	14 x 7JJ	11/32	E78 x 14, F78 x 14	4	Tubeless	5	334397			4
1 Piece (Welded)	14 x 7	11/32	F70 x 14	5	Tubeless	5	362055			5
1 Piece (Welded)	14 x 7	11/32	E78 x 14, F78 x 14	4	Tubeless	5	362052			4
1 Piece (Welded)	14 x 6	1/2	E78 x 14, F78 x 14	4	Tubeless	5	362059			4
1 Piece (Welded)	15 x 7	9/32	G78 x 15	4	Tubeless	5	344003			4

### 5.805 WEIGHT, Wheel Balance

62-75	All (exc. Vega, Monza, 122)	9421502	50	.24	(1 1/2 oz.) (size cast on weight)
62-75	All (exc. Vega, Monza, 122)	9421504	5	.24	(1 oz.) (size cast on weight)
62-75	All (exc. Vega, Monza, 122)	9421506	5	.24	(1 1/2 oz.) (size cast on weight)
62-75	All (exc. Vega, Monza, 122)	9421508	5	.31	(2 oz.) (size cast on weight)
62-75	All (exc. Vega, Monza, 122)	9421510	5	.31	(2 1/2 oz.) (size cast on weight)
70-75	All (exc. Vega, Monza, 122)	9772182	A.R.	.18	(1/4 oz.) (size cast on weight)
72-75	All (exc. Vega, Monza, 122)	9421512	A.R.	.42	(3 oz.) (size cast on weight)
74-75	Vega, Monza (122)	331451	A.R.	.24	(5 oz.) (size cast on weight)
74-75	Vega, Monza (122)	331452	A.R.	.24	(1 oz.) (size cast on weight)
74-75	Vega, Monza (122)	331453	A.R.	.24	(1 1/2 oz.) (size cast on weight)
74-75	Vega, Monza (122)	331454	A.R.	.31	(2 oz.) (size cast on weight)
74-75	Vega, Monza (122)	331455	A.R.	.31	(2 1/2 oz.) (size cast on weight)
74-75	Vega, Monza (122)	331456	A.R.	.41	(3 oz.) (size cast on weight)

### 5.809 DRUM ASSY.—DISC, Front and Rear Wheel Brake

62-63	Chevy (exc. metallic linings)	3850107	2	30.60	rear
62-63	Chevy (exc. metallic linings)	3830169	2	27.20	front
64-67	Chevy, Chevelle, Camaro (exc. metallic linings),				
68-69	Chevy, Chevelle,				
68-70	Camaro (exc. Disc Brakes, front and rear),				
70-73	Nova,				
71-74	Camaro	3996135	2	32.85	rear
64-67	Chevy, Chevelle, Camaro w/metallic linings	3998266	2	31.75	rear
64-67	Chevy, Chevelle, Camaro (exc. Spl. Spt. Cpe., Disc Brakes),				
68	Chevy, Chevelle, Camaro (exc. finned front brk. drums)	3845258	2	41.95	front

**BRAKES—REAR AXLE AND DRIVE**

**5.809 DRUM ASSY.— DISC, Front and Rear Wheel Brake (Con't)**

64-67	Chevy, Chevelle, Camaro w/metallic linings	3845282	2	34.50	front
65-70	Pass. (exc. metallic linings)	3985944	2	31.75	rear
65-70	Pass. (exc. metallic brakes)	3872326	2	33.35	front
65-67	Pass. w/metallic brakes	3872384	2	34.50	front
67	Pass. w/metallic linings				front and rear,
65-66	Pass. w/metallic linings (exc. Sp./H/Per.),				
67	Pass. w/metallic linings	3869537	A.R.	32.75	rear
68-70	Chevy, Chevelle, Camaro w/finned front brk. drums,				
71	Chevelle, Nova (exc. Monte Carlo),				
72	Nova, Chevelle (exc. Frt. Disc Brk.),				
73-74	Nova (exc. Frt. Disc Brk.)	3996670	2	33.65	front
70-72	Chevelle w/finned brk. drum,				
74	Nova	3987445	2	32.85	rear (round axle cover) (Note 1)
70	Monte Carlo w/cut out cover,				
73-75	Chevelle (exc. Sta. Wag.)	1240212	2	34.00	rear (9 <sup>1</sup> / <sub>2</sub> " brk.) (Note 1)
71-72	Pass. w/2.73, 3.08 ratio,				
73-75	Pass. w/2.73, 3.08, 3.23 ratio (exc. Sta. Wag.)	1235496	2	36.25	rear (fin. type) (type G, C, K, B, O, P, M) (11" brk.)
71-72	Pass. (Sta. Wag., Police, Taxi)	1235200	2	43.10	rear
71-75	Vega, Monza	3982204	2	28.35	rear brake
73-75	Pass. (Sta. Wag.)	1244544	2	40.75	rear (type P, M) (12" brk.)
73-75	Chevelle (Sta. Wag.)	1241758	2	34.00	rear (11" brk.)
75	Camaro, Nova	1249146	2	30.75	rear
<i>NOTE 1 See illustration preceding group 5.398 for identification of axle cover.</i>					
67	Pass. w/Disc Brakes,				
68	Pass. w/Disc Brakes (four piston design)	3933936	2	58.95	DISC, front w/hub (9 <sup>1</sup> / <sub>2</sub> " groove)
67-70	Chevy, Chevelle w/Disc Brake (exc. front and rear Disc Brakes),				
67-69	Camaro w/Disc Brks. (exc. frt. and rear Disc Brks.),				
71-72	Chevelle, Nova w/Disc Brks.,				
73-74	Nova w/Disc Brk.	3901098	2	63.00	DISC, w/hub frt.
68	Camaro w/Disc Brks. (front and rear)	3991041	2	63.00	DISC, w/hub front
68-70	Camaro w/Disc Brks. (front and rear)	3996663	2	77.60	DISC
68-70	Pass. w/Disc Brks. (single piston design)	3986083	2	58.95	DISC, front w/hub
70-75	Camaro,				
73-75	Chevelle,				
75	Nova	334348	2	54.40	DISC, front w/hub
71-75	Pass.	6274216	2	60.55	DISC, front w/hub
71-75	Vega, Monza	3976609	2	56.70	DISC, frt. wheel w/hub

**5.810 SPRING, Brake Drum**

65-68	Pass. (exc. Sp. H/Per.),				
69-70	Pass. (exc. Disc Brk. Sp./Per.)	3694290	A.R.	1.50	(32 <sup>3</sup> / <sub>4</sub> " free length)

**5.811 UNIT, Rear Wheel Spacer**

71-75	H	369011	1	15.40	(Note 1)
<i>NOTE 1: Consists of 1 spacer-4 studs and instruction sheet, used for field fix only.</i>					

**5.812 BOLT— STUD, Hub or Drum (Front and Rear Wheel)**

62-70	All,				
71-75	Vega, Monza,				
71-72	Camaro, Nova, Chevelle,				
73-75	Nova, Camaro				rear,
65-70	Pass.,				
69	Nova, Camaro (exc. Disc Brake),				
69	Chevelle w/Disc Brake,				
70	Pass., Nova, Chevelle,				
71	Chevelle, Nova (exc. Disc Brk.),				
72	Chevelle, Nova, Camaro,				
73-75	Nova (exc. Disc Brk.)	3980406	A.R.	.73	front wheel (7 <sup>7</sup> / <sub>16</sub> "— 20 x 1 <sup>3</sup> / <sub>8</sub> ")
67-70	Pass. w/Disc Brakes	3961225	A.R.	.16	(front and rear)
69	Camaro (Disc Brake w/P.S.)	3910340	10	.24	(7 <sup>7</sup> / <sub>16</sub> "— 20 x 1 <sup>3</sup> / <sub>4</sub> ") (frt. and rear)
70	Camaro,				

## BRAKES—REAR AXLE AND DRIVE

### 5.812 BOLT—STUD, Hub or Drum (Front and Rear Wheel) (Con't)

71-75	Vega, Monza,					
71	Chevelle, Nova, Camaro w/disc brakes,					
73-75	Chevelle, Nova, Camaro w/Disc Brk. ....	3961272 A.R.	.73	front		
71-75	Pass. w/Disc Brakes	3961258 A.R.	.64	front		
71-75	Pass. w/2.73, 3.08, 3.42, 3.23 ratio	1235137 10	.34	(type B, O, P, G, K, M) rear		
73-75	Chevelle	1235136 A.R.	.22	rear		
71-75	Vega, Monza	369095 A.R.	.71	STUD, rr. wheel (used for field fix only)		

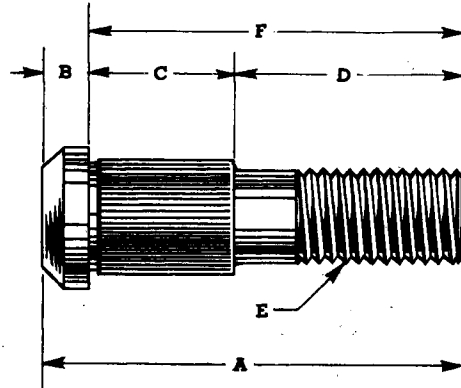

**HUB BOLT CHART**

PART NO.	A	B	C	D	E	F
3980406	1 <sup>5</sup> / <sub>8</sub>	1/4	5/16	1 <sup>5</sup> / <sub>64</sub>	7/16—20	1 <sup>3</sup> / <sub>8</sub>
3961225	2	1/4	27/32	29/32	7/16—20	1 <sup>3</sup> / <sub>4</sub>
3910340	2	1/4	1/8	15/32	7/16—20	1 <sup>3</sup> / <sub>4</sub>
3961272	1 <sup>1</sup> / <sub>2</sub>	1/4	1/2	29/32	7/16—20	1 <sup>5</sup> / <sub>16</sub>
3961258	1 <sup>31</sup> / <sub>32</sub>	9/32	9/16	1 <sup>1</sup> / <sub>8</sub>	5/8—18	2 <sup>27</sup> / <sub>32</sub>

### 5.813 NUT, Hub— Front and Rear

62-70	All,					
71-75	Vega, Monza (exc. G.T.),					
71-75	Chevelle, Nova, Camaro	358501 A.R.	.27	wheel hub bolt (7/16" — 20)		
69-70	Chevy, Chevelle, Camaro (S.S.),					
71-75	Vega, Monza (G.T.),					
71-75	Chevelle, Nova, Camaro w/mag. type wheel	414188 A.R.	1.15	NUT ASSY. (7/16" — 20) (hex. capped)		
71-75	Pass.	516637 A.R.	.53	NUT ASSY. (1/2" — 20) (hex.)		
74-75	Cosworth (122),					
75	Monza w/RPO N77	329383 A.R.	2.35	NUT ASSY. (alum. wheel)		
74	Pass. w/Spirit of America	414187 20	1.10	NUT ASSY. (1/2" — 20)		

### 5.816 RETAINER, Rear Axle Shaft Bearing

62-63	Chevy	3790605	2	.71	bearing (1 <sup>11</sup> / <sub>16</sub> " dia. ctr. hole w/four .3/8" holes)
70	Monte Carlo w/cut out cover	9799290	2	.84	outer (Note 1)
70	Monte Carlo w/cut out cover	9776340	2	1.20	inner (Note 1)
71-72	Pass. w/2.73, 3.08 ratio	1385730 A.R.		2.00	bearing inner (type B, O)
71-73	Pass. w/2.73, 3.08 ratio	406705	2	.94	bearing outer (type B, O)
73-74	Pass. w/2.73, 3.08 ratio	7451961 A.R.		5.40	bearing inner (type B, O)
73-75	Chevelle (exc. Sta. Wag.)	1235431	2	1.60	outer
73-74	Chevelle (exc. Sta. Wag.)	1239916	2	1.80	bearing inner
74-75	Pass. w/2.73, 3.08 ratio	1235432	2	.94	bearing outer (type B, O)

NOTE 1 See illustration preceding group 5.398 for identification of axle cover.

### 5.819 GASKET, Axle Housing Flange

62-63	Chevy	3792761	4	.17	(.035" thick)
-------	-------	---------	---	-----	---------------

### 5.822 SEAL—BEARING, Rear Axle Shaft Bearing or Hub

62-63	Chevy	3792806	2	1.70	(stamped 3792806)
-------	-------	---------	---	------	-------------------

**BRAKES—REAR AXLE AND DRIVE**

**5.822 SEAL— BEARING, Rear Axle Shaft Bearing or Hub (Con't)**

64-69	Chevy, Chevelle, Camaro,				
65	Pass. w/10 bolt cover (exc. Sta. Wag.),				
70-72	Chevelle, Camaro, Nova w/round cover,				
71-75	Vega, Monza,				
73-75	Chevelle, Nova, Camaro (exc. Sta. Wag.)	1241991	2	1.70	rear wheel (Note 1)
65	Chevelle (Spec. Spt. Cpe.) (396),				
65	Pass. w/12 bolt cover,				
66-75	Pass.,				
73-75	Chevelle (Sta. Wag.) w/2.73, 3.08, 3.42 ratio	3958078	2	2.05	rear wheel (type G, C, K, P, M)
70	Monte Carlo w/cut out cover	9799291	2	2.70	rear (Note 1)
71-75	Pass. w/2.73, 3.08 ratio	1236163	2	2.75	rear shaft oil (type B, O)
73-75	Chevelle (exc. Sta. Wag.)	1234498	2	2.35	SEAL ASSY., rear axle shaft oil (B, O type)
74	Vega (122)	345624	2	3.60	SEAL ASSY., rear axle tube oil
74	Vega (122)	345637	2	22.15	BEARING, w/seal unit rear axle shaft

NOTE 1 See illustration preceding group 5.398 for identification of axle cover.

**5.855 BEARING ASSY., Rear Wheel**

62-63	Chevy	907370	2	16.00	w/seal and retaining ring (ND 9077279)
64-72	Chevy, Chevelle, Camaro w/10 and 12 bolt round cover,				
65	Pass. w/10 bolt cover,				
73-75	Chevelle, Camaro, Nova (exc. Sta. Wag.),				
71-75	Vega, Monza	7451785	2	7.00	(type G, C, K, W) (Note 1)
65-70	Pass. w/10, 12 bolt cover,				
65	Chevelle (Spec. Spt. Cpe.) (396),				
65	Pass. w/12 bolt,				
71-75	Pass. w/2.73, 3.08, 3.42 ratio,				
73-75	Chevelle (Sta. Wag.)	7451809	2	8.06	rear wheel (HY-1559TS) (type C, P, K, G, M)
70	Monte Carlo w/cut out cover,				
73-75	Chevelle	7451959	2	12.78	(type B, O) (Note 1)
71	Pass. w/2.73, 3.08 ratio	7451868	2	11.58	less retainer (type B, O)
71-75	Pass. w/2.73, 3.08 ratio	7451960	2	13.72	w/retainer asm.-axle shaft (type B, O)

NOTE 1 See illustration preceding group 5.398 for identification of axle cover.

**5.858 GREASE CAP— HUB CAP— COVER, Wheel**

NOTE For Grease Caps see Group 6.330.

**PASSENGER**

**HUB CAP**

65	Pass.	3871108	A.R.	7.85	w/painted emblem
66	Pass.	3875027	4	8.70	
67	Pass. w/Disc Brakes (exc. Police)	3901712	4	7.15	(2-piece)
67	Pass. (exc. S.S., Caprice, Disc Brakes)	3893336	4	8.75	(14" wheel)
67	Police w/15" wheel,				
68	Biscayne, Bel Air, Police (15" wheel w/Disc Brakes)	3908672	A.R.	9.15	(bow tie 8 <sup>1</sup> / <sub>4</sub> ")
68	Pass. (exc. Caprice, Disc Brakes, sim. wire wheel, sim. mag. wheel trim cover),				
68	Pass. (exc. Caprice, Sta. Wag. rally wheel),				
69-73	Pass. (exc. Caprice, Estate Wag., sim. wire wheel, sim. mag. wheel, wheel trim cover, rally wheel, mag. wheel)	3916402	4	8.75	(bow tie 10 <sup>3</sup> / <sub>4</sub> ")
68	Pass. w/Disc Brk., rally wheel,				
69-70	Pass. w/rally wheel	3925801	4	17.75	(15" wheel)
74-75	Pass.	337281	1	8.95	(bow tie design)
74	Pass. w/Spirit of America	349072	1	14.25	

**WHEEL COVER— COVER UNIT (Full Wheel)**

65	Pass. (exc. S.S., Caprice, wire, mag. wheels)	3860204	4	18.50	
65-66	Pass. w/14" mag. wheels	3872861	4	41.75	
65-66	Pass. w/wire wheels	3834904	4	48.75	w/ornament

**BRAKES—REAR AXLE AND DRIVE**

**WHEEL COVER—COVER UNIT (Full Wheel) (Con't)**

65	S.S., Caprice (exc. wire, mag. wheels),				
66	S.S. (exc. wire, mag. wheels) . . .	3964523	4	27.25	
66	Pass. (exc. S.S., Caprice, wire, mag. wheels) . . . . .	3875029	4	18.50	
66	Caprice (exc. wire, mag. wheels)	3875033	4	21.65	
67	Caprice (exc. Disc Brakes, mag. wire wheels) . . . . .	3893350	4	16.70	
67-68	Pass. w/14" wire wheels . . . . .	3903059	4	48.75	
67	Pass. w/14" wheels (exc. S.S., Caprice) . . . . .	3893361	4	16.60	
67-69	Pass. w/14" mag. wheels (1st design) . . . . .	3903086	4	41.75	(matt finish) . . . . .
68	Pass. w/14" wheel (exc. Caprice, S.S.) . . . . .	3916408	4	15.45	
68-69	Pass. w/14" sim. mag. wheels (1st design) . . . . .	3918080	4	42.75	(charcoal) (6 ornament lugs) . . . . .
68-69	Caprice, S.S. w/Disc Brks. (exc. 427),				
68-69	Pass. . . . .	3930774	4	17.80	(15" wheel) (1 piece cover) (bow tie design)
68	Caprice (exc. sim. wire, mag., Disc Brake, rally wheel),				
69	Caprice (exc. rally, sim. mag. wire wheel, wheel trim cover) . .	3941813	4	16.35	
69	Pass. (exc. Caprice, Estate Wag.)	3939273	4	16.15	(14" wheel) (Chevrolet Motor Division) . . . .
69	Pass. (1st design) . . . . .	3923630	4	46.50	(15" wheel) (convex ornament) (use w/hub 3923631) (plastic emblem) . . . . .
69-70	Pass. w/sim. 15" wire wheel (1st design) . . . . .	3957059	4	52.50	
69-72	Pass. w/sim. 15" mag. wheel (3rd design) . . . . .	3968716	A.R.	44.00	(Note 4) . . . . .
	<i>NOTE 4 Part No. 3968716 is identified by a 15" dia. flange entering wheel.</i>				
69	Pass. . . . .	3968708	4	17.55	(15" wheel) (Chevrolet Motor Division) . . . .
69	Pass. w/14" sim. mag. wheels (2nd design) . . . . .	3963436	4	44.00	(dark argent) . . . . .
69	Pass. w/14" wire wheels . . . . .	3957061	4	52.50	
69	Pass. w/sim. 14" mag. wheel (2nd design) . . . . .	3963434	4	44.00	(flat black finish) . . . . .
69-71	Pass. (2nd design),				
72-73	Pass. w/deluxe wheel trim cover	3963405	4	46.50	(15" wheel) (flat ornament only) (use w/6" rim) (use with hub 3972794) . . . . .
70	Caprice . . . . .	3972748	4	20.35	(15" wheel) (Note 6) . . . . .
	<i>NOTE 6: Color coordinated with body color.</i>				
70-75	Pass. w/PO-1 (exc. Caprice) . . . .	3968761	4	21.50	(15" wheel) (bow tie design) . . . . .
71	Pass. w/sim. 15" wire wheel (2nd design) . . . . .	3982876	4	52.75	
71-72	Caprice (exc. deluxe wheel trim cover) . . . . .	3988171	4	17.35	(15" wheel) (bow tie design) . . . . .
71-72	Pass. (RPO PO1) . . . . .	6264291	4	17.55	(15" wheel) . . . . .
71-75	Pass. w/15" sim. wire wheel . . . .	341332	4	49.00	
73	Caprice (exc. sim. wire wheel) . . .	327767	4	17.10	use w/insert 327759 . . . . .
73	Pass. . . . .	327764	4	17.55	(15" wheel) (bow tie design) . . . . .
73-74	Pass. w/Sim. 15" mag wheel (exc. fender skirts) . . . . .	3968716	4	44.00	(Note 2) . . . . .
	<i>NOTE 2: Part #3968716 is identified by 2 15" dia. flange entering wheel.</i>				
74	Caprice (exc. sim. wire wheel) . . .	339609	4	18.35	(Caprice emblem) . . . . .
75	Caprice (exc. sim. wire wheel) . . .	348158	4	20.10	use w/insert 327759 . . . . .
75	Pass. w/PO-1 (exc. Caprice) . . . .	345978	4	19.80	(15" wheel) (bow tie design) use w/insert 345976 . . . . .
75	Impala, Caprice w/Z03 . . . . .	363753	4	22.30	(Landau equip.) use w/insert 366371 . . . .
71	Pass. w/15" sim. wire wheel (exc. rear wheel skirts),				
72-75	Pass. w/15" sim. wire wheel . . . .	994557	1	N.L.	COVER UNIT (Note 5) . . . . .
	<i>NOTE 5: Consists of four covers (full wheel).</i>				

**CHEVELLE**

**HUB CAP**

64	Chevelle (Std.) w/13" wheels . . .	3840898	4	8.15	
64	Malibu (S.S.) w/chrome wheels,				
64-65	Chevelle . . . . .	3840899	4	9.15	
66	Chevelle (exc. wire, mag. wheels)	3875039	4	8.30	
67	Chevelle w/14" wheels (exc. Disc Brakes) . . . . .	3890679	4	8.30	

**BRAKES—REAR AXLE AND DRIVE**

**WHEEL COVER— COVER UNIT (Full Wheel) (Con't)**

<b>67</b>	Chevelle w/Disc Brakes . . . . .	<b>3901712</b>	4	7.15	
<b>68-69</b>	Chevelle (exc. sim. wire mag. wheels, rally wheel),				
<b>70</b>	Chevelle (exc. Disc Brks., rally wheel, wheel trim cover, Monte Carlo) . . . . .	<b>3916434</b>	4	8.15	
<b>68-70</b>	Chevelle w/rally wheel,				
<b>72-73</b>	Monte Carlo w/rally wheel,				
<b>74-75</b>	Chevelle w/rally wheels (exc. Sta. Wag.) . . . . .	<b>3925801</b>	4	17.75	(15" wheel) . . . . .
<b>69</b>	Chevelle,				
<b>70</b>	Chevelle (exc. Monte Carlo) . . . . .	<b>3963444</b>	4	15.55	
<b>71-73</b>	Chevelle (exc. Monte Carlo, Rally Wheel, Disc Brake, Wheel Trim Cover) . . . . .	<b>6274292</b>	4	9.30	(bow tie design) . . . . .
<b>71-72</b>	Chevelle (S.S.) . . . . .	<b>3989479</b>	4	5.60	
<b>71-72</b>	Chevelle w/rally wheel (exc. Monte Carlo) . . . . .	<b>352933</b>	4	10.30	(bow tie design) . . . . .
<b>73-74</b>	Malibu (S.S.) w/Rally Wheel . . . . .	<b>329366</b>	4	15.70	use w/comb. 919-926-929-942-946-948-966-968-974 (light silver) . . . . .
<b>73-74</b>	Malibu (Spt. Cpe.) w/Rally Wheel . . . . .	<b>329368</b>	4	15.70	use w/comb. 911-924-944-956-960-964-981 (dark silver) . . . . .
<b>73-75</b>	Monte Carlo w/Custom Wheels RPO PE2 . . . . .	<b>329392</b>	4	8.25	(15" wheel) (turbine wheel) w/insert . . . . .
<b>73-75</b>	Chevelle w/G.T. wheels (RPO PE1) (exc. Monte Carlo) . . . . .	<b>329389</b>	4	5.45	(14" wheel) (turbine wheel) . . . . .
<b>74-75</b>	Chevelle . . . . .	<b>337283</b>	4	9.30	

**WHEEL COVER— COVER UNIT (FULL WHEEL)**

<b>64</b>	Malibu (S.S.) (exc. wire, chrome wheels) . . . . .	<b>3849435</b>	4	29.50	
<b>64</b>	Chevelle w/14" wheels (exc. S.S., wire wheels) . . . . .	<b>3840900</b>	4	18.05	
<b>64-66</b>	Chevelle w/14" wire wheels . . . . .	<b>3834904</b>	4	48.75	
<b>65</b>	Malibu (S.S.) (exc. wire, mag. wheels) . . . . .	<b>3867968</b>	4	17.80	
<b>65</b>	Chevelle (exc. S.S., wire, mag. wheels) . . . . .	<b>3860209</b>	4	18.40	
<b>65-66</b>	Chevelle w/14" mag. wheels . . . . .	<b>3872861</b>	4	41.75	
<b>66</b>	Chevelle w/14" wheels (exc. wire, mag. wheels) . . . . .	<b>3875041</b>	4	18.05	
<b>67</b>	Chevelle (exc. S.S., Concours) . . . . .	<b>3890691</b>	4	15.20	
<b>67</b>	Concours . . . . .	<b>3895852</b>	4	15.20	
<b>67</b>	Chevelle (S.S.) . . . . .	<b>3893342</b>	4	15.45	
<b>67-68</b>	Chevelle w/14" wire wheels . . . . .	<b>3908761</b>	4	50.00	
<b>67-72</b>	Chevelle w/14" mag. wheels (1st design) . . . . .	<b>3903086</b>	4	41.75	(matt. finish) . . . . .
<b>68</b>	Chevelle . . . . .	<b>3918054</b>	4	14.85	(w/insert) (Note 2) . . . . .
<b>68-69</b>	Chevelle . . . . .	<b>3918080</b>	4	42.75	(sim. mag. wheel) (14" wheel) . . . . .
<i>NOTE 2 On S.S. models it will be necessary to order Insert 3920604. On Concours models order Insert 3898242.</i>					
<b>69</b>	Chevelle . . . . .	<b>3937879</b>	4	16.15	
<b>69</b>	Chevelle w/14" wire wheels . . . . .	<b>3957061</b>	4	52.50	
<b>69-71</b>	Chevelle w/sim. 14" mag. wheel (2nd design) (exc. Monte Carlo),				
<b>73-74</b>	Chevelle w/sim. 14" mag. wheel (exc. Monte Carlo) . . . . .	<b>3963434</b>	4	44.00	(flat black finish) . . . . .
<b>70-72</b>	Monte Carlo (exc. Special Wheel Trim Cover, rally wheel),				
<b>72</b>	Chevelle (Sed.) (exc. Spt. Sed., rally wheel) . . . . .	<b>3972645</b>	4	16.35	(chrome) (15" wheel) . . . . .
<b>70</b>	Monte Carlo . . . . .	<b>3972748</b>	4	20.35	(15" wheel) . . . . .
<b>70-72</b>	Chevelle (exc. Monte Carlo) . . . . .	<b>3972260</b>	4	47.75	w/insert (crossed flag type) (14" wheel) . . . . .
<b>70</b>	Chevelle (exc. Monte Carlo) . . . . .	<b>3983390</b>	4	16.45	(bow tie) . . . . .
<b>70</b>	Monte Carlo w/sim. wire wheel (1st design) . . . . .	<b>3957059</b>	4	52.50	(15" wheel) . . . . .
<b>70-72</b>	Monte Carlo,				
<b>73-74</b>	Monte Carlo w/sim. 15" mag. wheel (exc. fender skirts) . . . . .	<b>3968716</b>	4	44.00	(15" wheel) (mag. type) (flat black paint) . . . . .
<b>70-72</b>	Monte Carlo w/deluxe wheel trim cover . . . . .	<b>3963405</b>	4	46.50	(15" wheel) (use w/6" rim) (use w/hub 3972794) (flat ornament) . . . . .



**BRAKES—REAR AXLE AND DRIVE**

**WHEEL COVER— COVER UNIT (Full Wheel) (Con't)**

<b>71-72</b>	Monte Carlo (exc. deluxe wheel trim cover) . . . . .	<b>3988171</b>	4	17.35	(15" wheel) (bow tie design) . . . . .
<b>71-75</b>	Monte Carlo w/15" sim. wire wheel . . . . .	<b>341332</b>	4	49.00	
<b>71-72</b>	Chevell (exc. Monte Carlo) . . . . .	<b>3990555</b>	4	17.55	(14" wheel) (Chevrolet Motor Div.) . . . . .
<b>71-75</b>	Chevell w/14" sim. wire wheel . . . . .	<b>3998506</b>	4	53.00	
<b>73-75</b>	Monte Carlo (exc. Deluxe Wheel trim cover, Rally Wheel, Custom Wheel) . . . . .	<b>327761</b>	4	20.50	(chrome) (15" wheel) . . . . .
<b>71</b>	Monte Carlo w/15" sim. wire wheel (2nd design) . . . . .	<b>3982876</b>	4	52.75	
<b>73</b>	Monte Carlo w/Deluxe Wheel trim cover (RPO PA3) . . . . .	<b>327770</b>	4	17.10	(15" wheel) . . . . .
<b>73-74</b>	Chevell w/PO-1 (exc. Monte Carlo) . . . . .	<b>3968761</b>	4	21.50	(15" wheel) (bow tie design) . . . . .
<b>73-74</b>	Chevell . . . . .	<b>3997992</b>	4	16.15	(14" wheel) (bow tie design) . . . . .
<b>74</b>	Malibu Classic (Spt. Cpe.) (RPO PO1 & RPO Z03) . . . . .	<b>345917</b>	4	20.35	(less insert) (use insert 345915) (15" wheel)
<b>74</b>	Monte Carlo w/Deluxe wheel trim cover (RPO PA3) . . . . .	<b>339658</b>	4	17.80	(15" wheel) . . . . .
<b>74-75</b>	Malibu Classic (Spt. Cpe.) (RPO PO1 & RPO Z03) . . . . .	<b>345914</b>	4	17.55	(less insert) (use insert 345915) (14" wheel)
<b>75</b>	Chevell . . . . .	<b>349032</b>	4	17.55	(14" wheel) (bow tie design) . . . . .
<b>75</b>	Chevell w/PO-1 (exc. Monte Carlo) . . . . .	<b>345978</b>	4	19.80	(15" wheel) (bow tie design) use w/insert 345976 . . . . .
<b>75</b>	Monte Carlo w/Deluxe wheel trim cover (RPO PA3) . . . . .	<b>348161</b>	4	20.10	(15" wheel) . . . . .
<b>75</b>	Malibu Classic (Spt. Cpe.) (RPO PO1 & RPO Z03) . . . . .	<b>359343</b>	4	21.30	w/insert (15" wheel) . . . . .
<b>71</b>	Monte Carlo w/15" sim. wire wheel (exc. rear wheel skirts),				
<b>72-75</b>	Monte Carlo w/15" sim. wire wheel . . . . .	<b>994557</b>	1	N.L.	<b>COVER UNIT (Note 5)</b> . . . . .
<b>75</b>	Chevell (exc. Monte Carlo, Laguna, El Camino) . . . . .	<b>994689</b>	1		<b>COVER UNIT (15" wheel) (bow tie design) (Note 5)</b> . . . . .
<b>75</b>	Chevell . . . . .	<b>994688</b>	1	N.L.	<b>COVER UNIT (14" wheel) (bow tie design) (Note 5)</b> . . . . .

NOTE 5 Consists of four covers (full wheel).

**CHEVY—NOVA**

**HUB CAP**

<b>63-65</b>	Chev w/14" wheels,				
<b>64-65</b>	Chev (Taxi) . . . . .	<b>3821120</b>	4	8.70	
<b>64-67</b>	Chev w/13" wheels . . . . .	<b>3840898</b>	4	8.15	
<b>66</b>	Chev w/14" wheels . . . . .	<b>3876915</b>	4	9.65	
<b>67</b>	Chev w/14" wheels (exc. S.S., Disc Brakes) . . . . .	<b>3890679</b>	4	8.30	
<b>67</b>	Chev w/Rally Wheels . . . . .	<b>3901712</b>	4	7.15	
<b>68-69</b>	Chev (exc. sim. wire mag. wheels, rally wheel),				
<b>68-70</b>	Nova w/rally wheel . . . . .	<b>3925801</b>	4	17.75	(15" wheel) . . . . .
<b>68-70</b>	Nova (exc. rally wheel, wheel trim cover) . . . . .	<b>3916434</b>	4	8.15	
<b>69-70</b>	Nova . . . . .	<b>3963444</b>	4	15.55	
<b>71-73</b>	Nova (exc. rally wheel, wheel trim cover) . . . . .	<b>6274292</b>	4	9.30	
<b>71-74</b>	Nova w/rally wheel (RPO ZJ7) . . . . .	<b>352933</b>	4	10.30	(bow tie design) . . . . .
<b>73-75</b>	Nova (S.S.) (RPO Z26) . . . . .	<b>329362</b>	4	15.70	(Chevrolet) . . . . .
<b>74-75</b>	Nova . . . . .	<b>337283</b>	4	9.30	
<b>74</b>	Nova (RPO Z51) . . . . .	<b>348191</b>	A.R.	12.70	w/insert (Spirit of America) . . . . .
<b>75</b>	Nova w/G.T. wheels . . . . .	<b>329389</b>	4	5.45	(14" wheel) (turbine wheel) . . . . .

**WHEEL COVER— COVER UNIT (FULL WHEEL)**

<b>62</b>	Chev w/13" wheels (exc. wire wheels) . . . . .	<b>3793136</b>	4	13.50	
<b>62</b>	Chev F.C. w/14" wheels (exc. wire wheels) . . . . .	<b>3819934</b>	4	16.35	
<b>62-63</b>	Chev w/13" wire wheels . . . . .	<b>3820245</b>	4	25.00	less ornament . . . . .
<b>62-63</b>	Chev w/14" wire wheels . . . . .	<b>3826516</b>	4	28.50	less ornament . . . . .
<b>63</b>	Chev w/13" wheels (exc. wire wheels) . . . . .	<b>3793360</b>	4	14.65	

**BRAKES—REAR AXLE AND DRIVE**

**WHEEL COVER— COVER UNIT (Full Wheel) (Con't)**

63-64	Chevy w/14" wheels (exc. S.S., wire wheels) . . . . .	3821121	4	18.25	
64	Chevy w/13" wheels (exc. wire wheels) . . . . .	3849126	4	13.50	
64-66	Chevy w/13" wire wheels . . . . .	3855383	4	47.75	w/ornament . . . . .
64-66	Chevy w/14" wire wheels . . . . .	3834904	4	48.75	w/ornament . . . . .
65	Chevy w/13" wheels (exc. wire, mag. wheels) . . . . .	3840301	4	18.25	(Note 6) . . . . .
<i>NOTE 6: To utilize production surplus some wheel covers include emblems. When using on 1965 models discard this emblem.</i>					
65	Nova (S.S.) (exc. wire, mag. wheels) . . . . .	3871174	4	27.75	
65	Chevy w/14" wheels (exc. S.S., wire, mag. wheels) . . . . .	3866210	4	16.10	
65-66	Chevy w/14" mag. wheels . . . . .	3872861	4	41.75	
65-69	Chevy w/13" mag. wheels . . . . .	3874648	4	32.75	
66	Chevy w/13" wheel (exc. S.S.) . . . . .	3861087	4	14.10	less emblem . . . . .
66	Chevy w/14" wheels (exc. S.S.) . . . . .	3876956	4	15.70	
66	Nova (S.S.) (exc. wire, mag. wheels) . . . . .	3890162	4	22.50	w/ornament . . . . .
67	Chevy (S.S.) (exc. wire, mag. wheels) . . . . .	3964523	4	27.25	w/ornament . . . . .
67	Chevy (exc. S.S.) w/14" wheels . . . . .	3895218	4	14.85	
67-68	Chevy w/14" wire wheels . . . . .	3908761	4	50.00	
67-72	Nova w/14" mag. wheels (1st design) . . . . .	3903086	4	41.75	(matt finish) . . . . .
68	Chevy w/14" wheels . . . . .	3893361	4	16.60	
68	Chevy . . . . .	3923556	4	15.40	(Note 3) . . . . .
<i>NOTE 3: On S.S. models it will be necessary to order emblem 3925880.</i>					
68-69	Nova w/14" sim. mag. wheels (1st design) . . . . .	3918080	4	42.75	(charcoal) (6 ornament lugs) . . . . .
69-70	Nova w/14" wire wheels . . . . .	3957061	4	52.50	
69-74	Nova w/sim. 14" mag. wheel (2nd design) . . . . .	3963434	4	44.00	(flat black finish) . . . . .
69	Nova w/14" sim. mag. wheels (2nd design) . . . . .	3963436	4	44.00	(dark argent) . . . . .
69-70	Chevy w/14" wheels . . . . .	3962724	4	16.15	
70-72	Nova . . . . .	3972260	4	47.75	w/insert (crossed flag type) (14" wheel) . . . . .
71-73	Nova . . . . .	3990555	4	17.55	(14" wheel) (Chevrolet Motor Div.) w/insert . . . . .
71-75	Nova w/14" sim. wire wheel . . . . .	3998506	4	53.00	
73-75	Nova w/14" sim. wire wheel . . . . .	3998506	4	53.00	
73-74	Nova . . . . .	3997992	4	16.15	(14" wheel) (bow tie design) . . . . .
75	Nova . . . . .	349032	4	17.55	(14" wheel) (bow tie design) . . . . .
75	Nova Custom w/LN pkg. . . . .	361026	4	23.75	(white) . . . . .
75	Nova Custom w/LN pkg. . . . .	361027	4	23.75	(silver met.) . . . . .
75	Nova Custom w/LN pkg. . . . .	361028	4	23.75	(lt. graystone) . . . . .
75	Nova Custom w/LN pkg. . . . .	361029	4	23.75	(med. blue met.) . . . . .
75	Nova Custom w/LN pkg. . . . .	361030	4	23.75	(dk. blue met.) . . . . .
75	Nova Custom w/LN pkg. . . . .	361031	4	23.75	(dk. green met.) . . . . .
75	Nova Custom w/LN pkg. . . . .	361032	4	23.75	(cream beige) . . . . .
75	Nova Custom w/LN pkg. . . . .	361033	4	23.75	(sandstone) . . . . .
75	Nova Custom w/LN pkg. . . . .	361034	4	23.75	(dk. sandstone) . . . . .
75	Nova Custom w/LN pkg. . . . .	361035	4	23.75	(red met.) . . . . .
75	Nova . . . . .	994688	1	N.L.	<b>COVER UNIT (14" wheel) (bow tie design) (Note 5) . . . . .</b>

*NOTE 5 Consists of four covers (full wheel).*

**CAMARO**

**HUB CAP**

67	Camaro w/14" wheels (exc. Disc Brakes, wire, mag. wheels, 350) . . . . .	3890679	4	8.30	
67	Camaro w/rally wheel . . . . .	3901712	4	7.15	
68-69	Camaro w/rally wheels . . . . .	3925801	4	17.75	
68-69	Camaro (exc. sim. wire mag. wheels, rally wheel) . . . . .	3916434	4	8.15	
69	Camaro . . . . .	3963444	4	15.55	
70-73	Camaro (exc. Rally Wheel, Wheel Trim Cover, 350 Sp. H/Per.) . . . . .	6274292	4	9.30	(bow tie design) . . . . .
70-75	Camaro w/rally wheel (RPO ZJ7) . . . . .	352933	4	10.30	(bow tie design) . . . . .
70-75	Camaro w/Sp. H/Per. (350) . . . . .	3989479	4	5.60	(bow tie design) (use w/wheel 3998532) (Note 6) . . . . .

**BRAKES—REAR AXLE AND DRIVE**

**WHEEL COVER— COVER UNIT (Full Wheel) (Con't)**

*NOTE 6: Used with RPO Z-28 or Z86.*

<b>74-75</b>	Camaro .....	<b>337283</b>	4	9.30	
<b>73-75</b>	Camaro w/G.T. Wheels .....	<b>329389</b>	4	5.45	(14" wheel) (turbine wheel) .....

**COVER— COVER UNIT (FULL WHEEL)**

<b>67</b>	Camaro w/14" mag. wheels ....	<b>3872861</b>	4	41.75	
<b>67</b>	Camaro w/14" wheels (exc. wire mag. wheels) .....	<b>3888699</b>	4	15.20	
<b>67-68</b>	Camaro w/trim cover (350, 396)	<b>3871174</b>	4	27.75	
<b>67-68</b>	Camaro w/14" wire wheels ....	<b>3908761</b>	4	50.00	
<b>67-72</b>	Camaro w/14" mag. wheels ....	<b>3903086</b>	4	41.75	matt finish .....
<b>68-69</b>	Camaro w/14" sim. mag. wheels	<b>3918080</b>	4	42.75	(charcoal) (6 ornament lugs) .....
<b>68-70</b>	Camaro w/14" wheel .....	<b>3925886</b>	4	14.85	w/insert .....
<b>69</b>	Camaro w/14" sim. mag. wheels	<b>3963436</b>	4	44.00	(dark argent) .....
<b>69-70</b>	Camaro w/14" wire wheels ....	<b>3957061</b>	4	52.50	
<b>69-74</b>	Camaro w/sim. 14" mag. wheel .	<b>3963434</b>	4	44.00	(flat black finish) .....
<b>70</b>	Camaro w/14" wheels .....	<b>3980992</b>	4	15.25	
<b>70-72</b>	Camaro .....	<b>3972260</b>	4	47.75	(14" wheel) (crossed flag type) .....
<b>71-73</b>	Camaro .....	<b>3990555</b>	4	17.55	(14" wheel) (Chevrolet Motor Div.) w/insert .
<b>71-75</b>	Camaro w/14" sim. wire wheel .	<b>3998506</b>	4	53.00	
<b>73-74</b>	Camaro .....	<b>3997992</b>	4	16.15	(14" wheel) (bow tie design) .....
<b>75</b>	Camaro .....	<b>349032</b>	4	17.55	(14" wheel) (bow tie design) .....
<b>75</b>	Camaro .....	<b>994688</b>	1	N.L.	<b>COVER UNIT (14" wheel) (bow tie design) (Note 5) .....</b>

**VEGA— MONZA— COVER UNIT— COVER— HUB CAP, Wheel**

<b>71-75</b>	Vega, Monza .....	<b>994205</b>	1		(13" wheel) (simulated wire wheel) (Note 5)
<b>71-75</b>	Vega, Monza .....	<b>3998508</b>	4	53.00	<b>COVER (13" wheel) (simulated wire wheel) (w/ornament) .....</b>
<b>73-75</b>	Vega, Monza (Notchback) w/PO2 .....	<b>3840301</b>	A.R.	18.25	<b>COVER (less emblem) use w/emblem 3840306 .....</b>
<b>75</b>	Monza (exc. Alum. Notchback) ..	<b>367532</b>	4	32.75	<b>COVER, wheel trim use clip 367575 .....</b>
<b>71-75</b>	Vega (exc. G.T.) .....	<b>3978123</b>	4	8.10	<b>HUB CAP .....</b>
<b>71-75</b>	Vega (G.T.) .....	<b>6274214</b>	4	8.80	<b>HUB CAP, wheel w/retainer (use w/wheel 3978191) .....</b>
<b>75</b>	Monza w/RPO N77 .....	<b>349091</b>	4	8.10	<b>HUB CAP (alum.) (13 x 6) .....</b>

*NOTE 5: Consists of four covers (full wheel).*

**5.871 RING ASSY.— CLIP— EMBLEM— HUB— INSERT— INSULATOR— NUT ASSY.— ORNAMENT— REINFORCEMENT— RETAINER— SCREW— SPOKE ASSY.— SLEEVE— SPACER, Wheel Cover Appearance**

<b>67</b>	Pass. (w/Disc Brakes, 15 x 5J),				
<b>67-68</b>	Camaro (302) (15" wheel w/Disc Brake),				
<b>69</b>	Pass. (exc. 15 x 6JK wheel),				
<b>70</b>	Monte Carlo w/Rally wheel (15 x 6),				
<b>74</b>	Pass. w/Spirit of America .....	<b>3901704</b>	4	14.95	wheel trim (1 <sup>3</sup> / <sub>4</sub> " wide) (DF) .....
<b>67</b>	Pass. (Sta. Wag.) w/disc brakes,				
<b>67</b>	Pass., w/15 x 6J wheel (exc. Sta. Wag., Caprice),				
<b>68</b>	Camaro w/15" wheel,				
<b>69</b>	Camaro w/Disc Brk.,				
<b>68-69</b>	Pass.,				
<b>70</b>	Pass., Monte Carlo w/Rally Wheel,				
<b>71-74</b>	Monte Carlo w/Rally wheel,				
<b>75</b>	Chevelle w/Rally wheel .....	<b>9796696</b>	4	16.20	wheel trim (16 <sup>5</sup> / <sub>8</sub> " O.D.) (15 x 7) (2 <sup>3</sup> / <sub>8</sub> " wide)
<b>67</b>	Chevy, Camaro, Chevelle w/Disc Brakes (exc. 302),				
<b>68</b>	Chevy w/Disc Brakes,				
<b>68-69</b>	Chevelle w/rally wheels,				
<b>68-69</b>	Chevy w/rally wheel (1st design) (exc. 350),				
<b>68</b>	Camaro w/rally wheel (1st design),				
<b>68</b>	Pass. w/spec. wheel (exc. Sta. Wag.),				
<b>69</b>	Pass. w/14" wheels (exc. Caprice, Sta. Wag.),				
<b>70</b>	Nova, Chevelle w/rally wheel,				
<b>71-72</b>	Chevelle, Nova w/Rally wheel (exc. Sta. Wag., Monte Carlo),				

**BRAKES—REAR AXLE AND DRIVE**

**5.871 RING ASSY.— CLIP— EMBLEM— HUB— INSERT— INSULATOR— NUT  
ASSY.— ORNAMENT— REINFORCEMENT— RETAINER— SCREW—  
SPOKE ASSY.— SLEEVE— SPACER, Wheel Cover Appearance (Con't)**

73-75	Camaro, Nova w/Rally wheel . . .	3923522	4	13.40	wheel trim (15 <sup>5</sup> / <sub>8</sub> " O.D.) (1.86" offset) 4 clip attachment (14 x 6) . . . . .
68-69	Nova (Spt. Cpe.) w/rally wheel (350),				
68-71	Chevy, Camaro w/rally wheel (2nd design),				
69	Pass. w/14" wheels (exc. Caprice, Sta. Wag.),				
72-75	Nova (4BC) (350) w/rally wheel,				
72-75	Camaro w/Rally wheel,				
73-74	Malibu (S.S.) w/Rally wheel . . . .	3934892	4	13.65	wheel trim (2.24" offset) (14 x 7) . . . . .
69-70	Chevy, Chevelle, Camaro (S.S.) . .	9796919	A.R.	15.15	wheel trim . . . . .
70-75	Camaro w/Sp. H/Per. (350),				
71-74	Chevelle (S.S.) . . . . .	3984524	4	14.20	wheel trim (15 x 7) (use w/Z28 or Z86 option for Camaro only) . . . . .
71-75	Vega, Monza . . . . .	3978110	4	13.30	
73	Monte Carlo w/Custom wheels . . .	337262	1	13.60	(15 x 7) (turbine wheel) (Note 3) . . . . .
	<i>NOTE 3: Retainer clips attaches into wheel slots.</i>				
73-75	Chevelle, Camaro, Nova w/G.T. wheels . . . . .	483250	1	17.40	(14 x 7) (turbine wheel) . . . . .
73	Monte Carlo w/custom wheels,				
75	Monte Carlo w/Custom wheels . . .	348188	1	13.20	(15 x 7) (turbine wheel) (Note 4) . . . . .
	<i>NOTE 4: Retainer clips attaches to outer edge of wheel rim.</i>				
74	Monte Carlo w/custom wheels . . .	490771	4	16.20	(15 x 7) turbine whl. . . . .
75	Monza (exc. Alumn., Notchback) . .	367575	6	.38	CLIP, wheel trim cover . . . . .
63-64	Chevy w/14" wheels (exc. S.S.) . . .	3821123	4	1.50	EMBLEM, wheel cover . . . . .
65	Chevy w/13" wheels . . . . .	3863511	4	3.45	EMBLEM, wheel cover . . . . .
65	Chevy w/14" wheels (exc. S.S.) . . .	3866212	4	3.20	EMBLEM, wheel cover . . . . .
65-66	S.S. . . . . .	3860217	4	1.05	EMBLEM (S.S.) . . . . .
65	Pass. (exc. S.S.) . . . . .	3860206	4	3.45	EMBLEM . . . . .
66	Pass. (exc. S.S., Caprice) . . . . .	3875031	A.R.	3.45	EMBLEM . . . . .
66	Chevy w/13" wheels . . . . .	3876954	4	3.45	EMBLEM, wheel cover . . . . .
66	Chevy w/14" wheels (exc. S.S.) . . .	3876957	4	3.05	EMBLEM, wheel cover . . . . .
66	Chevelle . . . . .	3875043	4	2.75	EMBLEM, wheel cover . . . . .
67	Chevy (exc. S.S.) (w/14 x 6.95) . . .	3895220	4	3.20	EMBLEM, wheel cover . . . . .
68-69	Chevy (exc. 350, 396) . . . . .	3923558	A.R.	3.80	EMBLEM, trim cover . . . . .
73-75	Vega, Monza (Notchback) w/PO2 . . . . .	3840306	A.R.	3.00	EMBLEM, wheel trim cover (use w/Cover Assy. 3840301) . . . . .
69	Pass. (1st design) . . . . .	3923631	4	14.90	HUB, wheel cover (convex emblem) (use w/wheel cover 3923630) . . . . .
70	Monte Carlo,				
69-70	Pass. (2nd design),				
71-72	Pass., Monte Carlo,				
73	Pass.,				
73-74	Nova, Camaro . . . . .	3972794	4	6.30	HUB, wheel cover (flat emblem) (cross flag type) (use w/wheel cover 3963405) . . . . .
64	Malibu (exc. wire wheel),				
65	Nova (S.S.) . . . . .	3841192	4	5.80	HUB ASSY., wheel cover . . . . .
67	Pass. (exc. S.S., Caprice) . . . . .	3893362	4	3.05	INSERT, trim cover . . . . .
67	S.S. (exc. wire, mag., disc brakes) . . . . .	3893359	4	3.05	INSERT, wheel cover . . . . .
67	Chevelle (exc. S.S.),				
67-68	Chevelle w/wheel trim cover (exc. Concours, S.S.),				
68	Concours (2nd design) . . . . .	3890693	4	.93	INSERT (bow tie design) . . . . .
67	Concours,				
68	Concours (1st design) . . . . .	3898242	4	2.65	INSERT, wheel trim cover rectangular design . . . . .
68	Chevelle (S.S.) . . . . .	3920604	4	1.95	INSERT, wheel trim cover SS-396 . . . . .
68-69	Caprice . . . . .	3916417	4	3.10	INSERT (Caprice) (3 <sup>1</sup> / <sub>2</sub> " dia.) (flat black) . . . . .
68	Impala, Caprice (Spt. Cpe.),				
69-70	Pass.,				
71-72	Caprice, Kingswood Estate, Monte Carlo (exc. Deluxe wheel trim cover),				
73-74	Chevelle w/simulated wire wheel,				
73-74	Camaro, Nova,				
73-75	Pass.,				
74-75	Chevelle w/sim. wire wheel . . . .	3992353	4	2.65	INSERT (bow tie design) (2 <sup>15</sup> / <sub>16</sub> " dia.) (Note 6) . . . . .

*NOTE 6: Use w/cover assy. 3968761.*

**BRAKES—REAR AXLE AND DRIVE**

**5.871 RING ASSY.— CLIP— EMBLEM— HUB— INSERT— INSULATOR— NUT ASSY.— ORNAMENT— REINFORCEMENT— RETAINER— SCREW— SPOKE ASSY.— SLEEVE— SPACER, Wheel Cover Appearance (Con't)**

68-69	Camaro	3925887	4	2.95	INSERT (bow tie design w/vert. bar)
69	Pass. (exc. Caprice, Estate Wag.)	3939275	4	3.45	INSERT, trim cover
69	All w/sim. mag. wheel	3924478	A.R.	12.40	INSERT, outer cover (Note 1)
<i>NOTE 1: It will be necessary to use Retainer Part No. 3931884.</i>					
69	Chevelle, Nova, Camaro,				
71	Chevelle (S.S.) w/disc brake	3956772	4	1.20	INSERT (S.S.)
71-72	Pass. (exc. deluxe wheel trim cover)	3992354	4	2.90	INSERT (bow tie design) (3 <sup>5</sup> / <sub>16</sub> " dia.) use w/6264291, 3968761 cover assy.
73	Caprice (exc. sim. wire wheel),				
75	Caprice (exc. sim. wire wheel)	327759	A.R.	3.00	INSERT (Note 5)
<i>NOTE 5: Use w/cover assy. 327767 for year 1973. Use w/cover assy. 348158 for year 1975.</i>					
74	Nova (RPO Z51)	348192	A.R.	2.95	INSERT, hub-cap (use w/cap 348191)
74-75	Malibu Classic (Spt. Cpe.) (RPO PO1)	345915	4	2.65	INSERT, use w/cover assy. 345914, 345917
75	Nova, Custom w/RPOZ11	349069	4	2.75	INSERT, w/LN pkg.
75	Pass., Chevelle w/RPO PO-1 (exc. Caprice, Monte Carlo)	345976	4	2.75	INSERT, wheel trim cover (bow tie design) use w/wheel cover 345978
75	Impala, Caprice w/ZO3	366371	4	2.65	INSERT, use w/cover assy. 363753 (Landau equip.)
75	Chevelle w/PE2	3997994	4	2.85	INSERT, turbine wheel
65-68	Pass. w/simulated wire wheels	3782302	A.R.	.16	INSULATOR (1 <sup>3</sup> / <sub>4</sub> " x 3 <sup>3</sup> / <sub>8</sub> "— <sup>9</sup> / <sub>32</sub> " thk.)— (3.704)
69	Chevy, Chevelle, Camaro,				
70	Nova, Camaro	3963445	A.R.	1.50	NUT ASSY. (14 x 6 wheel)
69	Chevy, Chevelle, Camaro (exc. Sta. Wag.),				
70	Nova,				
70	Chevelle (exc. Sta. Wag., Monte Carlo)	3963449	A.R.	1.50	NUT ASSY. (14 x 5 wheel)
62-63	Chevy	3964514	4		ORNAMENT, wire wheel cover (spinner)
63	Nova (Super Sport),				
65	Nova (Super Sport),				
67-68	Camaro (350, 396)	3827394	4	3.40	ORNAMENT, wheel cover
64	Malibu,				
64	Nova (S.S.)	3840974	4	6.15	ORNAMENT, wheel cover
64-68	All w/wire wheels,				
65-69	Pass. w/wire wheels	3908762	4	3.80	ORNAMENT (Note 2)
<i>NOTE 2: Due to motor vehicle safety standards it is necessary to replace open end winged spinner on 1964-1966 models.</i>					
65-66	Caprice, S.S. (exc. wire whl. cvr.),				
66	Chevelle,				
67	Nova (S.S.) (exc. mag. wheels, disc brakes)	3964522	4	5.20	ORNAMENT
67	All w/Disc Brakes (exc. aluminum, Sta. Wag.)	3901715	4	3.55	ORNAMENT, hub cap
67-69	Chevy, Chevelle, Camaro w/wire wheels,				
65	El Camino Custom,				
65	Malibu (S.S.) (exc. wire wheels)	3860243	4	5.80	ORNAMENT, wheel cover
68	Chevy, Chevelle, Camaro (S.S.),				
70	Nova, Chevelle (S.S.) (1st design)	3956770	4	3.85	ORNAMENT (2 <sup>3</sup> / <sub>4</sub> " dia. with S.S. emblem)
70	Nova, Chevelle w/wheel trim cover,				
71-72	Chevelle, Nova, Camaro w/deluxe wheel trim cover (exc. Monte Carlo)	3980984	4	24.10	ORNAMENT (cross flag type)
70	Nova, Chevelle (S.S.) (2nd design)	3983323	A.R.	4.85	ORNAMENT (2 <sup>3</sup> / <sub>4</sub> " dia. with S.S. emblem) (3 attaching holes)
65	Nova (Super Sport),				
67-68	Camaro (350, 396)	3827393	4	10.60	ORNAMENT ASSY., w/hub wheel cover
68-69	Pass. w/mag. wheel (exc. fender skirt)	3913125	A.R.	.73	ORNAMENT ASSY.
68-69	All w/Disc Brake, spec. wheel,				
70	All w/Rally Wheel (exc. Camaro),				
71-75	Chevelle w/rally wheel	3925805	4	4.90	ORNAMENT ASSY., hub type ornament marked (Chev. Motor Div.)
64	Malibu (exc. wire wheel),				

**BRAKES—REAR AXLE AND DRIVE**

**5.871 RING ASSY.— CLIP— EMBLEM— HUB— INSERT— INSULATOR— NUT ASSY.— ORNAMENT— REINFORCEMENT— RETAINER— SCREW— SPOKE ASSY.— SLEEVE— SPACER, Wheel Cover Appearance (Con't)**

65	Nova (S.S.) wire wheel . . . . .	3840976	4	.24	REINFORCEMENT, wheel cover . . . . .
65-66	Caprice, S.S. (exc. wire wheel cover),				
66	Malibu (El Camino) (S.S.) (exc. wire wheels) . . . . .	3860216	4	.24	REINFORCEMENT . . . . .
68-69	All w/sim. mag. wheels . . . . .	3931884	1	1.50	RETAINER, outer cover insert . . . . .
69	Pass. w/wheel trim cover . . . . .	3954630	4	.24	RETAINER, spring . . . . .
69	Chevy, Chevelle (S.S.),				
70	Nova, Chevelle, Camaro (S.S.) . .	393799	4	1.10	RETAINER . . . . .
64-66	Malibu (S.S.) El Camino Deluxe (exc. wire wheel cover) . . . . .	9422207	12	.13	SCREW, wheel trim cover hub (8— 18 x 5/8")— (8.977) . . . . .
65-66	Pass.,				
67-69	Chevy, Camaro, Chevelle w/Disc Brakes, wire wheels,				
67-69	Pass. w/Disc Brakes,				
68-69	Pass. w/mag. wheel,				
70	All w/Rally Wheel (exc. Camaro),				
71-75	Chevelle w/rally wheel . . . . .	3824195	16	.11	SCREW, wire wheel cover ornament (8-18 x 9/16") (hex. hd.-spherical face) . . . . .
65-68	All w/simulated wire wheel . . . .	385958	16	.13	SCREW, trim spinner ornament (8-18 x 7/8") . . . . .
65-68	Chevy, Camaro, Chevelle w/14" wire wheels,				
65-66	Pass. w/14" wire wheels . . . . .	3874686	A.R.	.80	SPOKE ASSY., outer . . . . .
65-66	Chevy w/13" wire wheels . . . . .	3888830	A.R.	.80	SPOKE ASSY., inner . . . . .
65-66	Chevy w/13" wire wheels . . . . .	3888831	A.R.	.80	SPOKE ASSY., outer . . . . .
69	Chevy, Chevelle, Camaro,				
70	Nova, Chevelle (exc. Monte Carlo) . . . . .	3963446	A.R.	.39	SLEEVE, hub cap nut . . . . .
69	Chevy, Chevelle, Camaro,				
70	Nova, Chevelle . . . . .	3963447	A.R.	.54	SPACER, hub cap nut (14 x 6 wheel) . . . . .
69	Chevy, Chevelle, Camaro (exc. Sta. Wag.),				
70	Nova,				
70	Chevelle (exc. Sta. Wag., Monte Carlo) . . . . .	3963450	A.R.	.54	SPACER, hub cap nut (14 x 5 wheel) . . . . .

**5.875 STEM ASSY.— CAP— EXTENSION, Tire Valve**

62-74	All . . . . .	274083	5	1.10	tubeless tire, snap in type w/cap (1 1/4" O.L.)
62	All . . . . .	274288	5	1.20	(1 1/2 in. snap in type) w/cap . . . . .
62-70	Pass.,				
65-70	Chevelle,				
71-73	El Camino, Monte Carlo . . . . .	3171598	5	.18	CAP (type "F"— 3/8" O.D. x 37/64" long) . . . . .
62	Chevy w/14" wheels,				
63-69	Chevy,				
64-69	Chevelle,				
65	S.S.,				
65-69	Pass. (exc. wire wheel covers),				
69	Camaro,				
70	Pass., Nova, Chevelle,				
71-74	Chevelle,				
72-74	Nova . . . . .	9417745	4	.63	EXTENSION, tubeless tire valve stem (7/8" O.L.) . . . . .
63	Chevy w/14" wheels,				
64	Chevelle,				
68-72	All,				
73-74	All w/RPO Pol. . . . .	9422872	A.R.	.58	EXTENSION, tubeless tire valve stem (1 27/32") . . . . .
64-69	All,				
70	Pass., Nova, Chevelle,				
71-75	All . . . . .	9422212	4	.58	EXTENSION, valve stem (1 11/32" O.L.) . . . . .

**5.880 INFLATER ASSY.— RETAINER**

62-74	All . . . . .	3891441	1	7.25	tire w/sealer . . . . .
67-69	Camaro w/space saver wheel,				
73-75	All w/space saver wheel . . . . .	486508	1	8.45	tire (16.9 oz.) (2.96 dia. can) (8.06 height) (use w/E78-14, F78-14 w/6" rim) (F78-14 w/5" rim, w/G78-14 w/6" rim) (repl. 494607) . . . . .
75	Vega, Monza w/space saver tire	486506	1	7.00	(13.60Z) . . . . .
67-69	Camaro w/space saver wheel . .	3934184	1	.70	RETAINER, inflator . . . . .

**BRAKES—REAR AXLE AND DRIVE**

**5.885 DISPENSER ASSY.— CONTAINER ASSY.— ADAPTER— SWITCH ASSY.—  
HARNES ASSY.— HOSE, Tire Traction**

<b>69-70</b>	All (exc. Sta. Wag.) . . . . .	<b>1550521</b>	<b>2</b>	<b>1.23</b>	<b>CONTAINER ASSY.</b> , compound aerosol (24 per case) . . . . .
<b>70</b>	All (exc. Sta. Wag.) . . . . .	<b>3963229</b>	<b>1</b>	<b>.88</b>	<b>ADAPTER</b> , tire traction . . . . .
<b>69-70</b>	All (exc. Sta. Wag.) . . . . .	<b>1378545</b>	<b>1</b>	<b>8.35</b>	<b>SWITCH ASSY.</b> , compound dispenser . . . . .
<b>69-70</b>	All (exc. Sta. Wag.) . . . . .	<b>9433153</b>	<b>1</b>	<b>RL/.19</b>	<b>HOSE</b> (30 ft. coil) (.150" I.D.)— (8.962) . . . . .



# CHEVROLET CHASSIS GROUP 6.000



## FRONT SUSPENSION — STEERING

### ALPHABETICAL INDEX

<b>A</b>			
ABSORBER ASSY., Steering Relay and Tie Rod Shock.....	6.865	BRACKET, Steering Knuckle Upper and Lower Control Arm.....	6.177
ADAPTER ASSY., Steering Gear Hydraulic.....	6.550	BUMPER, Steering Knuckle Upper and Lower Control Arm.....	6.176
ADAPTER, Mast Jacket.....	6.521	BUMPER, Tilt or Tel. Steering Column.....	6.514
ADAPTER, Steering.....	6.508	BUSHING ASSY., Steering Idler.....	6.897
ADAPTER UNIT, Steering.....	6.508	BUSHING, Mast (Also see Group 6.803).....	6.518
ADJUSTER ASSY., Steering Gear Housing End Cover Worm Bearing.....	6.830	BUSHING, Pitman Shaft.....	6.786
ADJUSTER, Pitman Shaft.....	6.822	BUSHING, Steering Knuckle Lower Control Arm Shaft.....	6.170
ARM ASSY., Steering Knuckle Upper and Lower Control Arm Assy.....	6.168	BUSHING, Steering Knuckle Upper Control Arm.....	6.164
ARM, Pitman.....	6.859		
ARM, Steering Knuckle.....	6.103	<b>C</b>	
<b>B</b>		CAM, Steering Knuckle Lower Control Arm Attaching.....	6.172
BALL, Steering Gear.....	6.844	CAP ASSY., Steering Gear Hydraulic Pump.....	6.635
BEARING ASSY., Front Wheel Inner.....	6.311	CAP, Steering Knuckle Lower Control Arm Shaft.....	6.170
BEARING ASSY., Front Wheel Outer.....	6.313	CLAMP, Hydraulic Steering Pump Hose.....	6.672
BEARING ASSY., Mast Jacket.....	6.521	CLAMP, Mast Jacket.....	6.521
BEARING, Pitman Shaft.....	6.786	CLAMP, Steering Column.....	6.760
BEARING, Steering Gear Worm Lower.....	6.826	CLAMP, Steering Gear Ball Return Guide.....	6.843
BEARING, Steering Shaft U-Joint.....	6.525	CLAMP, Steering Shaft U-Joint.....	6.525
BEARING, Steering Worm Thrust.....	6.835	CLAMP, Tie Rod End.....	6.234
BELT, Steering Gear Hydraulic Pump Drive.....	6.660	CLIP, Hydraulic Steering Pump Hose.....	6.672
BOLT, Steering Column Lock Bolt.....	6.500	CLIP, Steering Shaft U-Joint.....	6.525
BOLT, Steering Column.....	6.760	COLLAR, Steering Column.....	6.758
BOLT, Steering Gear to Frame.....	6.509	COLUMN ASSY., Mast (Also see Group 6.803).....	6.518
BOLT, Steering Gear Ball Return Guide.....	6.843	COUPLING ASSY., Steering Shaft U-Joint.....	6.525
BOLT, Steering Gear Housing Side Cover.....	6.809	COVER ASSEMBLY, Steering Gear Housing (also see group 6.518).....	6.807
BOLT, Steering Gear Hydraulic Pump Mounting.....	6.606	COVER KIT, Hydraulic Steering Valve.....	6.554
BOLT, Steering Gear Hydraulic Pump.....	6.635	COVER, Mast (Also see Group 6.803).....	6.518
BOLT, Steering Idler.....	6.897	COVER, Steering Column Lock Bolt.....	6.500
BOLT, Steering Knuckle Lower Control Arm Attaching.....	6.172	COVER, Steering Column.....	6.758
BOLT, Steering Knuckle Lower Control Arm Pivot.....	6.174	CUP, Steering Worm Thrust.....	6.835
BOLT, Steering Knuckle Upper and Lower Control Arm Assy.....	6.168	CYLINDER ASSY., Steering Gear Hydraulic.....	6.576
BOLT, Steering Knuckle Upper Control Arm.....	6.164		
BOLT, Steering Knuckle Upper Control Arm.....	6.178	<b>D</b>	
BOLT, Steering Knuckle.....	6.104	DAMPER, Steering Knuckle Upper Control Arm.....	6.178
BOLT, Steering Shaft U-Joint.....	6.525		
BOWL, Mast (Also see Group 6.803).....	6.518	<b>E</b>	
BRACE, Steering Gear Hydraulic Pump Mounting.....	6.606	ELEMENT, Hydraulic Steering Pump Inlet.....	6.630
BRACE, Steering Knuckle Lower Control Arm Shaft.....	6.170	END ASSY., Tie Rod.....	6.233
BRACKET ASSY., Mast (Also see Group 6.803).....	6.518	EXTENSION, Mast (Also see Group 6.803).....	6.518
BRACKET ASSY., Steering Column.....	6.760		
BRACKET ASSY., Tilt or Tel. Steering Column.....	6.514		
BRACKET, Hydraulic Steering Pump Hose.....	6.672		
BRACKET, Steering Gear Hydraulic Pump Mounting.....	6.606		



## ALPHABETICAL INDEX

<b>F</b>	
FASTENER, Steering Column .....	6.758
FILTER, Hydraulic Steering Pump Inlet.....	6.630
FITTING ASSY., Steering Gear Hydraulic Valve Hose .....	6.673
FITTING, Steering Knuckle, Upper and Lower Control Arm .....	6.166
FLANGE, Steering Shaft U-Joint.....	6.525

<b>G</b>	
GASKET, Hydraulic Steering Valve.....	6.554
GASKET, Steering Gear Housing Side Cover .....	6.809
GASKET, Steering Gear Hydraulic Pump.....	6.609
GATE, Tilt or Tel. Steering Column .....	6.514
GEAR ASSY., Steering .....	6.508
GEAR, Steering Gear Pitman .....	6.850
GEAR UNIT, Steering .....	6.508
GREASE CAP, wheel bearing.....	6.330
GROMMET, Hydraulic Steering Cylinder Piston Rod .....	6.581
GUARD, Steering Gear Hydraulic Pump.....	6.655
GUIDE, Steering Gear Ball Return.....	6.842
GUIDE, Tilt or Tel. Steering Column.....	6.514

<b>H</b>	
HOSE, Steering Gear Pressure .....	6.670
HOSE, Steering Gear Return .....	6.671
HOUSING ASSY., Steering Gear Hydraulic Pump .....	6.608
HOUSING ASSY., Tilt or Tel. Steering Column .....	6.514
HOUSING, Mast (Also see Group 6.803).....	6.518
HOUSING, Steering Gear .....	6.803
HUB ASSY., Steering Wheel Hub .....	6.512
HUB, Front Wheel.....	6.307

<b>I</b>	
INSULATOR, Steering Wheel Hub.....	6.512

<b>J</b>	
JACKET ASSY., Mast (Also see Group 6.803) .....	6.518

<b>K</b>	
KEY, Hydraulic Steering Adapter .....	6.560
KIT, Hydraulic Steering (Small Parts) (see Groups 6.551 for adapter kits and 6.609, 6.610, 6.612, 6.614, 6.615 for pump kits).....	6.507
KIT, Steering Gear Hydraulic Valve.....	6.551
KNOB, Tilt or Tel. Steering Column.....	6.514
KNUCKLE ASSY., Steering .....	6.020

<b>L</b>	
LEVER ASSY., Steering Idler .....	6.895
LEVER, Steering Idler.....	6.895
LEVER, Tilt or Tel. Steering Column.....	6.514
LOCK LEVER, Steering Column Lock Bolt.....	6.500

LOCK NUT, Steering Gear Housing End Cover Worm Bearing .....	6.830
LOCK, Tilt or Tel. Steering Column .....	6.514

<b>N</b>	
NUT, Hydraulic Steering Cylinder.....	6.575
NUT, Mast Jacket.....	6.521
NUT, Pitman Arm .....	6.861
NUT, Pitman Shaft .....	6.822
NUT, Steering Column .....	6.760
NUT, Steering Connecting (With Internal Parts).....	6.870
NUT, Steering Gear Ball.....	6.841
NUT, Steering Gear Hydraulic Pump.....	6.655
NUT, Steering Gear Worm Bearing.....	6.832
NUT, Steering Idler.....	6.896
NUT, Steering Idler.....	6.897
NUT, Steering Knuckle Lower Control Arm Attaching .....	6.172
NUT, Steering Knuckle Spindle .....	6.022
NUT, Steering Knuckle Upper Control Arm .....	6.164
NUT, Steering Knuckle Upper Control Arm .....	6.178
NUT, Steering Knuckle .....	6.104
NUT, Steering Wheel .....	6.515

<b>O</b>	
OIL, Steering Gear Hydraulic.....	6.605

<b>P</b>	
PAD, Steering Wheel Hub.....	6.512
PIN, Steering Gear Hydraulic Pump .....	6.608
PIN, Tilt or Tel. Steering Column .....	6.514
PIPE ASSY., Hydraulic Steering.....	6.677
PLATE, Steering Column Lock Bolt.....	6.500
PLATE, Steering Column.....	6.760
PLATE, Steering Gear Hydraulic Pump .....	6.609
PLATE, Steering Gear Hydraulic Pump .....	6.612
PLATE, Steering Knuckle Upper Control Arm .....	6.178
PLATE, Steering Wheel Hub.....	6.512
PLATE, Tilt or Tel. Steering Column.....	6.514
PLUG ASSY., Steering Gear Housing End Cover Worm Bearing .....	6.830
PLUG, Hydraulic Steering Adapter .....	6.560
PLUG, Hydraulic Steering Cylinder Piston Rod .....	6.581
PLUG, Steering Connecting Rod End.....	6.881
PLUG, Steering Gear Housing End .....	6.824
PLUG, Steering Gear .....	6.586
PULLEY, Steering Gear Hydraulic Pump.....	6.655
PUMP ASSY., Steering Gear Hydraulic .....	6.605

<b>R</b>	
RACE, Mast Jacket .....	6.521
RACE, Steering Worm Thrust.....	6.835
RACK, Mast (Also see Group 6.803).....	6.518
RACK, Steering Column Lock Bolt.....	6.500
RACK, Steering Gear.....	6.586
REINFORCEMENT, Mast (Also see Group 6.803).....	6.518
REINFORCEMENT, Mast Jacket .....	6.521
REINFORCEMENT, Steering Shaft U-Joint.....	6.525
REPAIR KIT, Steering Gear, with Worm.....	6.524
RESERVOIR ASSY., Steering Gear Hydraulic Pump.....	6.635
RETAINER, Mast Jacket .....	6.521
RETAINER, Steering Gear Hydraulic Valve .....	6.552
RETAINER, Steering Knuckle Lower Control Arm Shaft .....	6.170

## ALPHABETICAL INDEX

RETAINER, Steering Knuckle Upper Control Arm .....	6.163	SHIM, Steering Knuckle Upper Control Arm ..	6.178
RETAINER, Steering Shaft U-Joint.....	6.525	SHIM UNIT, Steering Gear Lash Adjuster.....	6.828
RETAINER, Steering Wheel Hub.....	6.512	SHOE, Tilt or Tel. Steering Column .....	6.514
RETAINER, Steering Wheel.....	6.515	SHROUD ASSY., Steering Wheel Hub.....	6.512
RETAINER, Steering Worm Thrust.....	6.835	SHROUD, Mast (Also see Group 6.803).....	6.518
RETAINER, Tilt or Tel. Steering Column .....	6.514	SHROUD, Steering Wheel Hub .....	6.512
RING, Hydraulic Pump Drive Shaft Outer Bearing Retaining .....	6.616	SLEEVE, Front Axle Tie Rod .....	6.232
RING, Hydraulic Steering Cylinder Piston Rod .....	6.581	SLEEVE, Hydraulic Steering Adapter.....	6.560
RING, Mast Jacket .....	6.521	SLEEVE, Hydraulic Steering Pump Hose .....	6.672
RING, Pitman Shaft Packing .....	6.856	SLEEVE, Mast Jacket.....	6.521
RING, Steering Gear Housing End .....	6.824	SLEEVE, Steering Knuckle Lower Control Arm Shaft .....	6.170
RING, Steering Gear Hydraulic Cylinder Piston.....	6.579	SOCKET ASSY., Tie Rod .....	6.233
RING, Steering Gear Hydraulic Pump .....	6.609	SPACER, Hydraulic Steering Cylinder Piston Rod .....	6.581
RING, Steering Gear Hydraulic Pump .....	6.610	SPACER, Hydraulic Steering Valve.....	6.554
ROD ASSY., Steering Connecting (With Internal Parts).....	6.870	SPACER, Mast Jacket.....	6.521
ROD, Steering Column Lock Bolt .....	6.500	SPACER, Steering Gear Hydraulic Pump Mounting.....	6.606
ROD, Steering Connecting (With Internal Parts).....	6.870	SPACER, Steering Gear Thrust .....	6.840
ROTOR KIT, Steering Gear Hydraulic Pump...	6.610	SPACER, Steering Knuckle Upper and Lower Control Arm .....	6.176
<b>S</b>		SPACER, Steering Shaft U-Joint.....	6.525
SCREW ASSY., Steering Gear Ball Return Guide.....	6.843	SPACER, Tilt or Tel. Steering Column .....	6.514
SCREW, Mast (Also see Group 6.803).....	6.518	SPHERE, Tilt or Tel. Steering Column.....	6.514
SCREW, Steering Column Lock Bolt.....	6.500	SPRING, Hydraulic Steering Adapter.....	6.560
SCREW, Steering Column.....	6.760	SPRING, Hydraulic Steering Cylinder Piston Rod .....	6.581
SCREW, Steering Gear .....	6.586	SPRING, Mast Jacket .....	6.521
SCREW, Steering Shaft U-Joint.....	6.525	SPRING, Steering Column Lock Bolt.....	6.500
SCREW, Tilt or Tel. Steering Column .....	6.514	SPRING, Steering Connecting Rod .....	6.876
SEAL ASSY., Front Wheel Bearing .....	6.326	SPRING, Steering Gear Hydraulic Pump .....	6.612
SEAL ASSY., Pitman Shaft.....	6.855	SPRING, Steering Gear Hydraulic Valve .....	6.552
SEAL, Gear Shaft.....	6.519	SPRING, Steering Shaft U-Joint.....	6.525
SEAL, Hydraulic Steering Cylinder Piston Rod .....	6.581	SPRING, Tilt or Tel. Steering Column .....	6.514
SEAL KIT, Steering Gear Hydraulic Pump.....	6.609	STOP, Tilt or Tel. Steering Column.....	6.514
SEAL KIT, Steering Gear Thrust.....	6.840	STRAP, Steering Gear Pressure.....	6.670
SEAL, Pitman Arm.....	6.861	STRAP, Steering Shaft U-Joint.....	6.525
SEAL, Steering Column .....	6.758	STRUT, Steering Knuckle Upper and Lower Control Arm Assy. ....	6.168
SEAL, Steering Column .....	6.760	STUD, Hydraulic Steering Cylinder Piston Rod .....	6.581
SEAL, Steering Connecting or Relay Rod.....	6.886	STUD, Steering Connecting Rod .....	6.874
SEAL, Steering Gear End Cover.....	6.825	STUD, Steering Gear Housing Side Cover .....	6.809
SEAL, Steering Gear Housing Side Cover .....	6.809	STUD, Steering Gear Hydraulic Pump Mounting.....	6.606
SEAL, Steering Gear Hydraulic Cylinder Piston .....	6.579	STUD UNIT, Steering Knuckle Lower Control Arm Pivot.....	6.174
SEAL, Steering Gear Hydraulic Pump Drive Shaft.....	6.617	STUD UNIT, Steering Knuckle Upper Control Arm.....	6.164
SEAL, Steering Gear Hydraulic Pump .....	6.609	SUPPORT ASSY., Tilt or Tel. Steering Column .....	6.514
SEAL, Steering Gear Hydraulic Pump .....	6.635	SUPPORT, Steering Column .....	6.760
SEAL, Steering Gear Hydraulic Valve Hose and Fitting 'O' Ring .....	6.674	SUPPORT, Steering Gear Hydraulic Pump Mounting.....	6.606
SEAL, Steering Gear Hydraulic Valve .....	6.552	SUPPORT, Steering Idler .....	6.896
SEAL, Steering Gear Thrust.....	6.840	<b>T</b>	
SEAL, Steering Gear .....	6.806	TIE ROD ASSY., Tie Rod .....	6.230
SEAL, Steering Idler .....	6.898	TIE ROD ASSY., Tie Rod .....	6.233
SEAL, Steering Knuckle, Upper and Lower Control Arm .....	6.166	TUBE, Mast (Also see Group 6.803).....	6.518
SEAL, Steering Shaft U-Joint.....	6.525	<b>U</b>	
SEAL, Tie Rod Dust .....	6.242	UNIT, Front Axle Tie Rod.....	6.232
SEAL UNIT, Steering Gear .....	6.586	<b>V</b>	
SEAT, Hydraulic Steering Adapter.....	6.560	VALVE ASSY., Steering Gear Hydraulic Pump Control.....	6.624
SEAT, Hydraulic Steering Cylinder Piston Rod .....	6.581	VALVE ASSY., Steering Gear Hydraulic.....	6.550
SEAT, Mast Jacket.....	6.521	VALVE KIT, Steering Gear Hydraulic Valve Hose .....	6.673
SEAT, Steering Connecting Rod.....	6.874	VANE KIT, Steering Gear Hydraulic Pump.....	6.610
SEAT, Steering Gear Hydraulic Valve Hose .....	6.673		
SHAFT ASSY., Steering Gear, with Worm.....	6.524		
SHAFT, Steering Gear Hydraulic Pump Drive .....	6.614		
SHAFT UNIT, Steering Gear, with Worm.....	6.524		
SHAFT UNIT, Steering Knuckle Upper Control Arm .....	6.164		
SHIELD, Hydraulic Steering Adapter.....	6.560		
SHIELD, Hydraulic Steering Pump Hose .....	6.672		
SHIELD, Steering Connecting Rod End .....	6.881		
SHIELD, Tilt or Tel. Steering Column .....	6.514		
SHIELD UNIT, Steering Shaft U-Joint.....	6.525		

# ALPHABETICAL INDEX

## W

WASHER, Hydraulic Steering Cylinder Piston Rod .....	6.581
WASHER, Hydraulic Steering Valve .....	6.554
WASHER, Mast (Also see Group 6.803) .....	6.518
WASHER, Pitman Arm .....	6.861
WASHER, Pitman Shaft .....	6.822
WASHER, Pitman Shaft .....	6.855
WASHER, Steering Column Lock Bolt .....	6.500
WASHER, Steering Column .....	6.760
WASHER, Steering Gear to Frame .....	6.509
WASHER, Steering Gear Hydraulic Pump Mounting .....	6.606
WASHER, Steering Gear Hydraulic Pump .....	6.655
WASHER, Steering Gear Hydraulic Valve .....	6.552
WASHER, Steering Idler .....	6.897
WASHER, Steering Knuckle Spindle .....	6.321
WASHER, Steering Knuckle Upper Control Arm .....	6.164
WASHER, Steering Shaft U-Joint .....	6.525
WASHER, Steering Wheel .....	6.515
WASHER, Tilt or Tel. Steering Column .....	6.514
WEDGE, Mast (Also see Group 6.803) .....	6.518
WEDGE, Tilt or Tel. Steering Column .....	6.514
WHEEL ASSY., Steering .....	6.513

## Y

YOKE ASSY., Steering Shaft U-Joint .....	6.525
--	-------

**FRONT AXLE—STEERING**

**6.020 KNUCKLE ASSY., Steering**

62-63	Chevy	3790426	2	31.25	
65-66	Pass.	3855004	2	35.50	
67-68	Pass. (exc. disc. brakes)	3924383	2	34.00	
67-68	Pass. w/Disc Brakes, pwr. brakes	3924384	2	36.00	
67	Chevy w/Disc Brake	3901211	2	34.75	
67	Chevy (exc. Disc Brakes)	3902968	2	23.80	
67-68	Chevelle, Camaro (w/Disc Brake, Special Steering) (exc. Metallic Brakes),				
68	Chevy w/Disc Brake,				
69	Chevy w/P/S (350, 396) (exc. Spec. Strg.),				
69	Camaro w/P/S (exc. 302, Spec. Strg.),				
69	Chevy, Chevelle, Camaro w/Disc Brakes,				
70-72	Chevelle w/Disc Brakes,				
70-74	Nova w/Disc Brakes	3966151	2	32.00	
67-68	Camaro, Chevelle (exc. Disc Brakes),				
68	Chevy (exc. Disc Brake),				
69	Chevy, Chevelle, Camaro (exc. Disc Brakes),				
70-72	Chevelle (exc. Disc Brakes),				
70-74	Nova (exc. Disc Brakes)	3966159	2	38.75	
68	Pass. w/Disc Brakes (exc. P.B.),				
69-70	Pass. w/Disc Brakes	3953416	2	39.00	
69-70	Pass. (exc. Disc Brakes)	3953415	2	32.00	
70-75	Camaro,				
73-75	Chevelle,				
75	Nova	329350	R.H.	45.00	
70-75	Camaro,				
73-75	Chevelle,				
75	Nova	329349	L.H.	45.00	
71-75	Pass. w/Disc Brakes	3961261	L.H.	50.00	
71-75	Pass. w/Disc Brakes	3961262	R.H.	50.00	
71-74	Vega	3976601	L.H.	55.25	
71-74	Vega	3976602	R.H.	55.25	
75	Vega, Monza	348173	L.H.	48.25	
75	Vega, Monza	348174	R.H.	48.25	
64-66	Chevelle	3881524	2	24.70	KNUCKLE UNIT ( <sup>5</sup> / <sub>8</sub> "— 18 anchor hole on knuckle) (Note 1)
64-66	Chevy	3890126	2	23.80	KNUCKLE UNIT ( <sup>5</sup> / <sub>8</sub> "— 18 anchor hole on knuckle) (Note 1)

NOTE 1 Includes strg. knuckle, brake shoe anchor pin and anchor pin lock.

**6.022 NUT, Steering Knuckle Spindle**

62-63	Chevy,				
71-75	Vega, Monza	6255553	2	.47	( <sup>11</sup> / <sub>64</sub> "— 24 hex. hd.)
64-69	All,				
70-72	Nova, Chevelle, Camaro,				
71-72	Pass., Camaro w/Disc Brakes,				
73-75	All (exc. Vega, Monza)	378137	2	.40	( <sup>3</sup> / <sub>4</sub> "— 20 hex.)
68-69	Pass. w/Disc Brakes (exc. pwr. brakes),				
70	Pass.	3953436	2	.53	strg. knuckle spindle

**6.103 ARM, Steering Knuckle**

64-66	Chevy	3847925	L.H.	6.65	left (forged 3847925)
64-66	Chevy	3847926	R.H.	6.55	right (forged 3847926)
64-66	Chevelle	3852253	L.H.	5.35	left
64-66	Chevelle	3852254	R.H.	5.35	right
65-66	Pass.	3855005	L.H.	7.60	left (forged 3855005)
65-66	Pass.	3855006	R.H.	7.60	right (forged 3855006)
67	Pass.,				
68-69	Pass. (exc. Sgl. Piston Disc Brake)	3909786	R.H.	8.55	right (forged 3909786)
67	Pass.,				
68-69	Pass. (exc. Sgl. Piston Disc Brake)	3909785	L.H.	8.55	left (forged 3909785)
67	Camaro w/Spl. Strg. H.D. Brake,				
68	Camaro w/P/S (exc. Spec. Strg.),				
68	Camaro (302) (exc. H.D. Brake)	3902519	L.H.	12.60	left
67	Camaro w/Spl. Strg., H.D. Brake,				

**FRONT AXLE—STEERING**

**6.103 ARM, Steering Knuckle (Con't)**

68	Camaro w/P/S (exc. Spec. Strg.),				
68	Camaro (302) (exc. H.D. Brake)	3902520	R.H.	12.60	right
67	Camaro (exc. Spl. Strg.)	9792464	L.H.	7.85	left (forged 3916265)
67	Camaro (exc. Spl. Strg.)	3916266	R.H.	8.45	right (forged 3916266)
67-68	Chevelle	3894487	L.H.	5.75	left
67-68	Chevelle	3894488	R.H.	5.75	right
67	Chevy	3902970	R.H.	6.65	right
67	Chevy	3902969	L.H.	6.65	left
68	Chevy, Camaro (exc. Spl. Strg., P/S)	3917193	L.H.	8.90	left
68	Chevy, Camaro (exc. Spl. Strg., P/S)	3917194	R.H.	8.90	right
68-69	Pass. w/Disc Brake (Sgl. Piston design)	3928625	L.H.	8.70	left
68-69	Pass. w/Disc Brake (Sgl. Piston design)	3928626	R.H.	8.70	right
69	Chevy (exc. 350, 396),				
69	Camaro (exc. P/S, Spec. Strg., 302),				
70	Nova (exc. P/S, 350, 396, Disc Brakes),				
71-74	Nova (exc. P/S),				
71-74	Nova w/P/S (exc. 4BC)	3954873	L.H.	10.15	left
69	Chevy (exc. 350, 396),				
69	Camaro (exc. P/S, Spec. Strg., 302),				
70	Nova (exc. P/S, 350, 396, Disc Brakes),				
71-74	Nova (exc. P/S),				
71-74	Nova w/P/S (exc. 4BC)	3954874	R.H.	10.15	right
69	Camaro w/P/S (exc. Spec. Strg.),				
69-70	Chevy (P/S, w/frt. Disc Brakes) (350, 396),				
69	Camaro w/Disc Brakes (302),				
71-74	Nova (P/S w/4BC) (350)	3954875	L.H.	13.20	left
69	Camaro w/P/S (exc. Spec. Strg.),				
69-70	Chevy (P/S, w/frt. Disc Brakes) (350, 396),				
69	Camaro w/Disc Brakes (302),				
71-74	Nova (P/S w/4BC) (350)	3954876	R.H.	13.20	right
69-72	Chevelle	3954877	L.H.	6.55	left
69-72	Chevelle	3954878	R.H.	6.55	right
70	Pass. (exc. Disc Brakes)	3966185	L.H.	8.65	left
70	Pass. (exc. Disc Brakes)	3966186	R.H.	8.65	right
70	Pass. w/Disc Brakes	3966187	L.H.	12.10	left
70	Pass. w/Disc Brakes	3966188	R.H.	12.10	right

**6.104 NUT— BOLT, Steering Knuckle**

63-67	Chevy	9422300	2	.12	attach. ( $\frac{7}{16}$ "— 20)— (8.917)
70-75	Camaro,				
71-75	Vega, Monza,				
75	Nova	3983076	2	.18	tie rod to knuckle— (6.870)
62-69	All,				
70-71	Pass., Chevelle,				
72	Chevelle, Nova (exc. Disc Brk.)	1385922	A.R.	.59	<b>BOLT</b> , strg. knuckle arm short ( $\frac{1}{2}$ "— 20 x $2\frac{1}{4}$ ")— (5.002)
67	Chevelle	454915	1	.12	<b>BOLT</b> ( $\frac{3}{4}$ "— 24 x $\frac{5}{8}$ ")— (8.900)
68	Chevy, Camaro,				
68	Chevelle (Spt. Cpe., Conv., El Camino),				
69	Chevelle,				
68-69	Pass. w/Disc Brakes,				
70	Chevelle w/frt. Disc Brakes	3871512	A.R.	.27	<b>BOLT</b> ( $\frac{1}{2}$ "— 20 x $2\frac{3}{4}$ ")— (5.002)
69	Chevy, Camaro (Disc Brakes, w/P/S, Spec. Strg.) (exc. 302),				
70	Nova (P/S w/Disc Brakes) (350, 396),				
71-75	Nova (Disc Brakes w/P/S)	3916286	A.R.	.28	<b>BOLT</b> , long ( $\frac{1}{2}$ "— 20 x $2\frac{3}{32}$ ")
69	Chevy, Camaro (P/S w/Spec. Strg., Disc Brakes),				
70	Nova	3954396	2	.53	<b>BOLT</b> , short ( $\frac{1}{2}$ "— 20 x $2\frac{7}{32}$ ")
67	Chevy, Camaro (w/Disc Brakes, Spec. Strg.)	331421	2	.32	<b>BOLT</b> ( $\frac{1}{2}$ "— 20 x $2\frac{5}{32}$ " hex. head) (repl. 3909795)— (5.002)

**FRONT AXLE—STEERING**

**6.163 RETAINER, Steering Knuckle Upper Control Arm**

62-67	Chevy	3790498	2	.31	bushing (17/32" I.D. x 2 1/16" O.D.)
64-69	All (exc. Chevy),				
68-69	Chevy,				
70	All (exc. Camaro),				
71-72	Chevelle, Nova	3710586	4	.17	bushing (small hole 3/8" I.D.)
72	Pass., Camaro,				
73	Chevelle	9787797	4	.25	bushing (small hole 5/8" I.D.)
73-74	Nova	9785742	2	.28	bushing (small hole 3/8" I.D.)
74	Chevelle, Camaro	335888	A.R.	.19	bushing
75	Pass., Chevelle, Nova, Camaro	351212	4	.19	bushing

**6.164 SHAFT UNIT— BOLT— BUSHING— NUT— STUD UNIT— WASHER, Steering Knuckle Upper Control Arm**

*NOTE: On late production assys. with untapped lubrication fitting holes, it is necessary to use self-tapping lube fittings or tap new threads for standard type lube fittings.*

62-67	Chevy	3845270	1	8.35	(Note 1)
64-67	Chevelle, Camaro,				
68-69	Chevelle, Chevy, Camaro,				
70-72	Chevelle,				
70-74	Nova	3849412	1	10.70	(Note 2)
65-70	Pass.	3845244	2	13.00	(Note 2)
70-73	Camaro,				
71-73	Pass.	6259679	2	14.75	(Note 8)
73	Chevelle	6258153	1	14.75	(Note 9)
74-75	Pass., Camaro,				
75	Nova	338387	1	14.75	(Note 10)
74-75	Chevelle	6260594	1	14.75	(Note 11)
64	Chevy	3862152	3	.11	<b>BOLT</b> (5/16"— 24 x 7/8")
65-69	Pass. (exc. Police, 427),				
64-67	Chevelle, Camaro,				
68-70	Chevelle, Chevy, Camaro,				
71	Chevelle, Nova,				
68-69	Police,				
70	Pass.,				
72-74	Nova,				
72	Chevelle	401267	4	1.45	<b>BUSHING</b> (1 1/2" O.D. x 1 1/2" O.L.)
70	Camaro,				
71-73	Pass., Camaro,				
73	Chevelle	3975588	4	1.65	<b>BUSHING</b> , frt. and rear (Note 3)
62-67	Chevy	3790199	4	1.60	<b>BUSHING ASSY.</b> (1 1/16" I.D. x 1 5/8" O.D. x 1 3/4" O.L.)
74-75	Pass., Chevelle, Camaro,				
75	Nova	335897	1	1.65	<b>BUSHING</b> , front
74-75	Pass., Chevelle, Camaro,				
75	Nova	335898	1	1.80	<b>BUSHING</b> , rear
70-75	Camaro,				
72-75	Pass.,				
73-75	Chevelle,				
75	Nova	3983036	2	.16	<b>NUT</b> , upper ball stud (1/2"— 20 x 7/16" thick)
73-74	All (exc. Nova, Vega)	335874	2	.24	<b>NUT</b> , strg. knuckle upper control arm rear (5/8"— 18)
75	All (exc. Vega, Monza)	351249	2	.34	<b>NUT</b> , strg. knuckle upper control arm shaft
75	Vega, Monza	3983036	2	.16	<b>NUT</b> , frt. wheel hub at upper and lower end (1/2"— 20 x 7/16")
70-72	Camaro	3983037	2	.18	<b>NUT</b> , lower ball stud (9/16"— 18 x 15/32")
62-67	Chevy	3862153	2	15.50	<b>STUD UNIT</b> , ball replacement (Note 4)
64-72	Chevelle,				
67-69	Camaro,				
68-72	Nova	3963842	2		<b>STUD UNIT</b> , ball replacement
65-70	Taxi, Police	3912097	2	20.40	<b>STUD UNIT</b> , ball replacement
65-70	Pass. (exc. Police, Taxi)	3865827	2	16.35	<b>STUD UNIT</b> , ball replacement
70	Camaro,				
71-72	Pass., Camaro,				
73	Pass., Camaro, Chevelle	6258152	1	15.50	<b>STUD UNIT</b> (Note 5, 6)
71-75	Vega, Monza	3987375	2	14.65	<b>STUD UNIT</b>
74	Nova	3963842	2		<b>STUD UNIT</b> , ball replacement
74-75	Pass., Chevelle, Camaro,				
75	Nova	338388	1	14.65	<b>STUD UNIT</b>

*NOTE 1: Consists of 1 shaft, 2 bushings, 2 retainers, 2 washers, and 4 nuts.*

*NOTE 2: Consists of 1 shaft, 2 bushings, 2 retainers, 4 bolts, and 4 washers.*

*NOTE 3: 2 used front-2 used rear.*

*NOTE 4: Consists of 3 bolts, 6 washers, and 6 nuts.*

*NOTE 5: CAUTION this part is not to be used on 1969 or earlier models due to taper differences.*

*NOTE 6: It may be necessary to drill the new stud assembly and the control arm attaching holes to 21/64" diameter.*

**FRONT AXLE—STEERING**

**6.164 SHAFT UNIT— BOLT— BUSHING— NUT— STUD UNIT— WASHER,  
Steering Knuckle Upper Control Arm (Con't)**

*NOTE 7: Stud unit should not be drilled, and to proper utilize dealer stock of 6258152 the proper 1/4" nuts, bolts, and washers must be used.*

*NOTE 8: Consists of 1 shaft, 2 bushings rear, 2 retainers, 2 nuts, and 1 washer.*

*NOTE 9: Consists of 1 shaft, 2 bushings, 2 retainers, and 2 nuts.*

*NOTE 10: Consists of 1 shaft, 2 bushings (1) front and (1) rear, 2 retainers, 2 nuts, 1 washer.*

*NOTE 11: Consists of 1 shaft, 2 bushings (1) front and (1) rear, 2 retainers, 2 nuts.*

**6.166 SEAL— FITTING, Steering Knuckle, Upper and Lower Control Arm**

65-70	Police, Taxi	3861869	2	.36	lower ball stud, inner
65-70	Police, Taxi	762599	2	.33	lower ball stud, outer
65-70	Police, Taxi	770982	2	.66	upr. ball stud
62-67	Chevy	3789204	2	.22	FITTING, upper arm lub. (straight)

**6.168 ARM ASSY.— STRUT— BOLT, Steering Knuckle Upper and Lower Control Arm Assy.**

**PASSENGER**

65-70	Pass. (exc. Police, Taxi)	3966931	L.H.	36.75	upper
65-70	Pass. (exc. Police, Taxi, 427, 454)	3865822	R.H.	36.75	upper
65-70	Pass. (427, 454) (exc. Police, Taxi),				
65-70	Police, Taxi	3912096	R.H.	36.75	upper
65-70	Pass. (427, 454) (exc. Police, Taxi),				
65-70	Police, Taxi	3966935	L.H.	36.75	upper
71-74	Pass.	335893	L.H.	40.25	upper
71-74	Pass.	335894	R.H.	40.25	upper
65-70	Pass. (exc. Police, Taxi, H.D. Susp.)	3881577	L.H.	40.25	lower
65-70	Pass. w/H.D. Susp. (exc. Police, Taxi),				
65-70	Police, Taxi w/H.D. Susp.	3918839	L.H.	40.25	lower
65-70	Pass. (exc. Police, Taxi, H.D. Susp.)	3881578	R.H.	40.25	lower
65-70	Pass. w/H.D. Susp. (exc. Police, Taxi),				
65-70	Police, Taxi w/H.D. Susp.	3918840	R.H.	40.25	lower
71	Police (exc. 454),				
71-72	Pass. (exc. Police),				
73-74	Pass.	335895	L.H.	40.25	lower
71	Police (exc. 454),				
71-72	Pass. (exc. Police),				
73-74	Pass.	335896	R.H.	40.25	lower
75	Pass.	351217	L.H.	40.00	upper
75	Pass.	351218	R.H.	40.00	upper
75	Pass.	343539	L.H.	40.00	lower
75	Pass.	343540	R.H.	40.00	lower
65-70	Pass.	3925172	R.H.	6.70	STRUT, lwr. right
65-70	Pass.	3925171	L.H.	6.70	STRUT, lwr. left
73-74	Pass.	336185	4	.71	BOLT, lwr.

**CHEVELLE**

64-72	Chevelle	3974217	L.H.	36.75	upper
64-72	Chevelle	3877062	R.H.	34.00	upper
64-70	Chevelle,				
71-72	Chevelle (Sta. Wag.),				
71-72	Chevelle (400 w/4BC, 454)	3990509	L.H.	40.00	lower
64-70	Chevelle,				
71-72	Chevelle (Sta. Wag.),				
71-72	Chevelle (400 w/4BC, 454)	3990510	R.H.	40.00	lower
70-71	Chevelle (exc. 396, 400 w/4BC, 454)	3967769	L.H.	40.00	lower
70-71	Chevelle (exc. 396, 400 w/4BC, 454)	6263618	R.H.	36.75	lower
72	Chevelle (exc. 400 w/4BC, 454 Sta. Wag.)	6263617	L.H.	36.75	lower
72	Chevelle (exc. 400 w/4BC, 454, Sta. Wag.)	6263618	R.H.	36.75	lower
73-74	Chevelle	335894	R.H.	40.25	upper
73-74	Chevelle	339781	L.H.	37.50	upper
75	Chevelle	348379	L.H.	37.25	upper
75	Chevelle	351218	R.H.	40.00	upper

**FRONT AXLE—STEERING**

**6.168 ARM ASSY.— STRUT— BOLT, Steering Knuckle Upper and Lower Control Arm Assy. (Con't)**

73-75	Chevelle	6260591 L.H.	40.50	lower
73-75	Chevelle	6260592 R.H.	40.50	lower
73-74	Chevelle	336185 4	.71	BOLT, lwr.
73-74	Chevelle	338233 2	2.65	BOLT UNIT, lwr.

**CHEVY— NOVA**

62-67	Nova	3849392 2	28.25	upper
68-74	Nova	3963843 L.H.	31.75	upper w/ball stud
68-74	Nova	3963844 R.H.	31.75	upper w/ball stud
62-63	Nova	3832055 L.H.	34.00	lower
62-63	Nova	3832056 R.H.	34.00	lower
64-67	Nova	3849785 L.H.	34.00	lower
64-67	Nova	3849786 R.H.	34.00	lower
68-74	Nova	6258451 L.H.	36.75	lower
68-74	Nova	6258452 R.H.	36.75	lower
75	Nova	6260591 L.H.	40.50	lower
75	Nova	6260592 R.H.	40.50	lower
75	Nova	351217 L.H.	40.00	upper
75	Nova	351218 R.H.	40.00	upper
62-67	Chevy	3848058 2	7.50	STRUT, lower-right or left

**CAMARO**

67-69	Camaro	3963843 L.H.	31.75	upper
67-69	Camaro	3963844 R.H.	31.75	upper
70-74	Camaro	335893 L.H.	40.25	upper
70-74	Camaro	335894 R.H.	40.25	upper
67-69	Camaro	6258451 L.H.	36.75	lower
67-69	Camaro	6258452 R.H.	36.75	lower
70-75	Camaro	6260591 L.H.	40.50	lower (Note 1)
70-75	Camaro	6260592 R.H.	40.50	lower (Note 1)

*NOTE 1: When using on 1970-1972 Camaro it will be necessary to drill frame mounting holes to .573-.578 dia.*

75	Camaro	351217 L.H.	40.00	upper
75	Camaro	351218 R.H.	40.00	upper
73-74	Camaro	336185 4	.71	BOLT, lwr.
73-74	Camaro	338233 2	2.65	BOLT UNIT, lwr.

**VEGA— MONZA**

71-74	Vega	3978011 L.H.	31.75	lower
71-74	Vega	3978012 R.H.	31.75	lower
71-75	Vega, Monza	6264317 L.H.	24.75	upper
71-75	Vega, Monza	6264318 R.H.	24.75	upper
75	Vega, Monza	378115 L.H.		lower (repl. 349583)
75	Vega, Monza	378116 R.H.		lower (repl. 349584)

**6.170 BUSHING— BRACE— CAP— RETAINER— SLEEVE, Steering Knuckle Lower Control Arm Shaft**

62-67	Chevy	3790207 2	2.10	(1 <sup>31</sup> / <sub>32</sub> " O.L. x 1 <sup>5</sup> / <sub>8</sub> " O.D.) (Note 1)
-------	-------	-----------	------	--

*NOTE 1: If caps are necessary for the bushing ends use 348390.*

64-66	Chevelle (1st design)	382740 2	2.15	front (1 <sup>1</sup> / <sub>2</sub> " I.D. x 1 <sup>5</sup> / <sub>8</sub> " O.D. x 2 <sup>13</sup> / <sub>32</sub> " O.L.)
64-66	Chevelle (1st design)	382741 2	2.30	rear (1 <sup>1</sup> / <sub>2</sub> " I.D. x 1 <sup>13</sup> / <sub>16</sub> " O.D. x 2 <sup>13</sup> / <sub>32</sub> " O.L.)
65-68	Pass.,			
70	Pass. (exc. Police)	3913462 2	2.15	
66-70	Chevelle (2nd design)			front,
67-69	Camaro,			
68-70	Nova	391016 2	2.10	rear (3 <sup>3</sup> / <sub>64</sub> " I.D. x 2 <sup>13</sup> / <sub>32</sub> " x 1 <sup>37</sup> / <sub>64</sub> " O.D.)
66-69	Chevelle (2nd design),			
67-72	Camaro,			
70-72	Chevelle			rear,
68	Camaro,			
68-74	Nova	392826 2	2.35	front and rear (2 <sup>13</sup> / <sub>32</sub> " O.L. x 3 <sup>3</sup> / <sub>64</sub> " I.D. x 2 <sup>3</sup> / <sub>64</sub> " O.D.)
71-72	Nova			rear,
71-72	Chevelle	3984541 2	2.35	front (2 <sup>13</sup> / <sub>32</sub> " O.L. x 3 <sup>3</sup> / <sub>64</sub> " I.D. x 2 <sup>3</sup> / <sub>64</sub> " O.D.)
67-70	Police	3913471 2	2.45	
70-74	Camaro,			
73-74	Pass., Chevelle	3984541 2	2.35	front
70	Chevelle (exc. 396, 454),			
71	Chevelle (exc. 400 w/4BC, 454, Sta. Wag., Deluxe),			
72	Chevelle (exc. 402, 454, Sta. Wag., El Camino)	9792687 2	3.25	
71	Pass.,			
72	Police (exc. 454),			



**FRONT AXLE—STEERING**

**6.170 BUSHING— BRACE— CAP— RETAINER— SLEEVE, Steering Knuckle Lower Control Arm Shaft (Con't)**

72	Pass. (exc. Police),				
73-75	Pass., Chevelle, Camaro,				
75	Nova	331283	1	3.15	front
71	Pass.,				
72	Police (exc. 454),				
72	Pass. (exc. Police),				
73-75	All (exc. Nova, Vega, Monza)	335899	2	3.40	rear
62-67	Chevy	3793684	1	2.60	BUSHING UNIT, lower arm strut
65-70	Pass.	3869193	2	1.20	BUSHING UNIT, strut
67-70	Police	3916068	2	8.80	BUSHING UNIT, strut
71-75	Vega, Monza	3978006	4	2.00	BUSHING UNIT, upper control arm
71-75	Vega, Monza	3988062	2	2.20	BUSHING UNIT, lower control arm rear
71-75	Vega, Monza	3978003	2	2.00	BUSHING UNIT, lower control arm front
62-67	Chevy	3790479	L.H.	20.60	BRACE, lower arm strut bracket
62-67	Chevy	3790480	R.H.	5.90	BRACE, right lower arm strut bracket
62-67	Chevy	348390	4	.18	CAP, bushing
65-70	Pass.	3913461	A.R.	.22	CAP, bushing
71-75	Vega, Monza	3978005	8	.12	CAP, lwr. control arm
62-67	Chevy	3790250	4	.46	RETAINER, strut bushing (1 <sup>1</sup> / <sub>16</sub> " I.D. x 2 <sup>1</sup> / <sub>4</sub> " O.D.)
65-70	Pass.	3857443	4	.22	RETAINER, lower arm strut (2 <sup>3</sup> / <sub>4</sub> " I.D. x 2 <sup>39</sup> / <sub>64</sub> " O.D.)
62-67	Chevy	3792486	2	.22	SLEEVE, strut bushing (7 <sup>7</sup> / <sub>8</sub> " O.D. x 1 <sup>5</sup> / <sub>16</sub> " O.L.)
65-67	Pass.,				
68-69	Pass. (exc. Taxi),				
70	Pass. (exc. Police)	3857444	2	.25	SLEEVE, strut, bshg. (2 <sup>9</sup> / <sub>32</sub> " I.D. x 1 <sup>21</sup> / <sub>32</sub> " O.D.)

**6.172 BOLT— CAM— NUT— BOLT, Steering Knuckle Lower Control Arm Attaching**

65-70	Pass.	3859094	2	.18	lower (7 <sup>7</sup> / <sub>16</sub> " x 20 x 1 <sup>7</sup> / <sub>16</sub> " x 20 x 1 <sup>9</sup> / <sub>16</sub> "
65-70	Pass.	3859095	2	.38	lower (7 <sup>7</sup> / <sub>16</sub> " x 20 x 1 <sup>3</sup> / <sub>4</sub> "
70	Camaro,				
72	Chevelle	3816560	4	.95	(1 <sup>1</sup> / <sub>2</sub> "— 13 x 3 <sup>7</sup> / <sub>8</sub> " (hex.)— (9.008)
71-72	Pass.	479352	4	.46	hex. (9 <sup>9</sup> / <sub>16</sub> "— 12 x 4)— (5.383)
73-75	Pass., Chevelle, Camaro, Nova	336185	4	.71	BOLT, strg. knuckle lower control arm
62-67	Chevy	3790331	2	.22	CAM (1 <sup>3</sup> / <sub>4</sub> " O.D.)
65-70	Pass.	3913474	2	.28	CAM, outer adjusting (Note 1)
<i>NOTE 1 1/2 dia. "O" stamped on face.</i>					
65-70	Pass.	3913473	2	4.10	CAM, lower adjusting
71-75	Vega, Monza	3978021	4	.24	CAM
62-67	Chevy	3793012	2	1.05	CAM ASSY. (welded 1 <sup>1</sup> / <sub>2</sub> "— 20 x 4 <sup>1</sup> / <sub>2</sub> " bolt)
71-75	Vega, Monza	3978020	4	1.60	CAM ASSY., steering knuckle lower control arm adj.
62-67	Chevy	3791855	4	.34	NUT, strut bushing (1 <sup>1</sup> / <sub>16</sub> "— 18) (268-M steel)
62-64	Chevy, Chevelle	3691530	2	.16	NUT, adj. cam (1 <sup>1</sup> / <sub>2</sub> "— 20 x 1 <sup>1</sup> / <sub>16</sub> "— (7.395)
62-70	All	3866766	A.R.	.12	NUT (2 <sup>3</sup> / <sub>8</sub> "— 24)— (0.626)
62-70	All	9424987	2	.11	NUT (2 <sup>9</sup> / <sub>16</sub> "— 18) (301-M steel)
62-70	All	9422301	A.R.	.11	NUT (1 <sup>1</sup> / <sub>2</sub> "— 13)— (8.917)
65-70	Pass.	3857205	2	.52	NUT, adjusting cam
66	Pass.	9422304	A.R.	.22	NUT, strg. knuckle lower control arm rr. (9 <sup>9</sup> / <sub>16</sub> "— 18)— (8.917)
66	Pass.	9422306	A.R.	.22	NUT, rr. susp. lower control arm (5 <sup>5</sup> / <sub>8</sub> "— 18) (301M)— (8.917)
71-75	Pass.	3983808	2	.34	NUT, steering knuckle and front wheel hub at lower end
71-75	Vega, Monza	3978082	4	.31	NUT, steering knuckle lower control arm

**6.174 BOLT— STUD UNIT, Steering Knuckle Lower Control Arm Pivot**

65-67	Pass.,				
70	Pass.	3882954	2	.40	(5 <sup>5</sup> / <sub>16</sub> " x 24 x 1 <sup>1</sup> / <sub>8</sub> "
<i>NOTE 1 Consists of 4 bolts, 4 nuts and 4 washers.</i>					
62-67	Chevy	3832051	2	15.50	STUD UNIT, ball replacement
64-72	Chevelle,				
67-69	Camaro,				
68-74	Nova	3875067	2	15.50	STUD UNIT, ball replacement w/seal assy.
65-70	Pass. (exc. Police, Taxi)	3886422	2	17.10	STUD UNIT, lower ball replacement
65-70	Taxi, Police	3917822	2	20.40	STUD UNIT, lower ball replacement
70-75	Camaro,				
73-75	Chevelle,				
75	Nova	9756251	2	14.65	STUD UNIT, w/seal, control arm ball
71-72	Pass.	7808865	2	15.50	STUD UNIT, w/seal, control arm ball

**FRONT AXLE—STEERING**

**6.174 BOLT— STUD UNIT, Steering Knuckle Lower Control Arm Pivot (Con't)**

73-74	Pass. ....	7814131	1	14.65	STUD UNIT, w/seal, control arm ball
75	Pass. ....	9754378	2	14.65	STUD UNIT, w/seal, control arm ball
71-74	Vega	9751703	2	14.65	STUD UNIT, w/seal, control arm ball
75	Vega, Monza	9757312	2	14.65	STUD UNIT, w/seal, control arm ball

*NOTE On late production assy. with untapped lubrication fitting holes. It is necessary to use self tapping lub. fittings or tap new threads for standard type lube fittings.*

**6.176 BUMPER— SPACER, Steering Knuckle Upper and Lower Control Arm**

64-67	Chevelle (exc. S.S., 396),				
67-69	Camaro,				
65-70	Pass.,				
68-72	Chevelle,				
68-74	Nova,				
71	Vega	384220	2	.34	upper arm (1 1/2" dia. x 2 3/4" high)
65	Pass.	3852039	2	.38	lower
66-68	Chevelle (396),				
69-70	Chevelle	9770780	2	.57	upper arm— (5.385)
70-75	Camaro,				
73-75	Chevelle,				
75	Nova	1362014	2	.28	upper
71-75	Pass.	3993607	2	.40	upper
71-74	Pass.,				
73-74	Chevelle	334931	2	.93	lower
71-74	Vega	3988063	2	.80	lower
72-75	Vega, Monza	6264319	2	.31	upper
75	Vega, Monza	360301	2	1.10	lower
75	Chevelle,				
75	Pass.	357733	1	.98	lower
75	Nova,				
75	Camaro w/Sp. H/Per. 350	352888	2	.95	lower
62-67	Chevy,				
67	Camaro,				
67-70	Pass.	3939198	2	.93	BUMPER ASSY., lower (1 x 1 7/8" x 2 19/64")
64-72	Chevelle	402410	2	.93	BUMPER ASSY., lower arm (1 x 1 5/32" x 2 5/16")
68-69	Chevy, Camaro,				
70-72	Nova	3928362	2	1.80	BUMPER ASSY., lower
68-69	Chevy	3858017	2	.62	BUMPER ASSY., upper arm— (5.395)
73-74	Nova,				
70-75	Camaro (exc. Sp. H/Per. 350)	3973052	2	.87	BUMPER ASSY., lower
70-74	Camaro (Sp. H/Per. 350)	3983017	2	1.10	BUMPER ASSY., lower
70-74	Camaro w/Spec. H/Per. 350	3983019	2	1.70	SPACER, arm bumper

**6.177 BRACKET, Steering Knuckle Upper and Lower Control Arm**

64-72	Chevelle	3837589	L.H.	3.20	left lower arm
64-72	Chevelle	3837590	R.H.	8.25	right lower arm
65-70	Pass.	3953980	1	4.25	right upper
68-72	Chevelle	3937855	L.H.	3.85	left upper arm
68-72	Chevelle	3937856	R.H.	3.85	right upper arm
71-72	Pass.	325843	L.H.	4.25	lower
71-72	Pass.	325844	R.H.	4.25	lower
71-75	Pass.	3981225	L.H.	6.55	upper
71-75	Pass.	3981226	R.H.	6.55	upper
73-74	Chevelle (exc. Monte Carlo)	3994351	L.H.	9.25	upper
73-74	Chevelle (exc. Monte Carlo)	3994352	R.H.	9.25	upper
73-74	Monte Carlo	3994481	L.H.	9.25	upper
73-74	Monte Carlo	3994482	R.H.	9.25	upper
73-74	Chevelle	3994350	R.H.	4.00	lower
73-74	Chevelle	3994349	L.H.	4.00	lower
73-75	Pass.	325843	L.H.	4.25	lower
73-75	Pass.	325844	R.H.	4.25	lower

**6.178 BOLT— NUT— SHIM— DAMPER— PLATE, Steering Knuckle Upper Control Arm**

62-69	Chevy	3886595	4	.26	(7/16"— 20 x 1 7/8") (300-M steel)
64-69	Chevelle, Camaro,				
70-72	Chevelle,				
70-75	Nova	381909	A.R.	.35	(7/16"— 14 x 2 1/4") (300-M steel)
70-75	Camaro	3964832	4	.37	
71-73	Pass.,				
73	Chevelle	3994402	4	.37	(1/2"— 13 x 2 5/8") (300-M)
74-75	Pass., Chevelle	340808	4	.58	(1/2"— 13 x 2 5/8") (300M)
71-75	Vega, Monza	3978091	2	.21	steering knuckle and frt. wheel hub at upper end
71-75	Vega, Monza	9432433	4	.23	(1/2"— 13 x 3 1/8")— (8.900)

**FRONT AXLE—STEERING**

**6.178 BOLT— NUT— SHIM— DAMPER— PLATE, Steering Knuckle Upper Control Arm (Con't)**

62-69	Chevy, Chevelle, Camaro	3866766	A.R.	.12	NUT ( <sup>9</sup> / <sub>8</sub> "— 24) (301-M steel) use with bolts not requiring cotter pins— (0.626)
62-69	Chevy, Chevelle, Camaro	9422302	A.R.	.16	NUT ( <sup>1</sup> / <sub>2</sub> "— 20) (301-M Cad.)— (8.917)
62-69	All	9424985	A.R.	.16	NUT ( <sup>7</sup> / <sub>16</sub> "— 14) (301-M steel)
66	Chevy	9422300	A.R.	.12	NUT, strg. knuckle upper control arm assy. ( <sup>7</sup> / <sub>16</sub> "— 20)— (8.917)
66	Pass.	9422306	A.R.	.22	NUT, rr. susp. upper control arm to axle hsg. and frame bracket ( <sup>5</sup> / <sub>8</sub> "— 18) (301-M)— (8.917)
66	Pass.	9422299	A.R.	.16	NUT, strg. upper control arm to front cross member ( <sup>7</sup> / <sub>16</sub> "— 14)— (8.917)
70-75	Camaro,				
73-75	Chevelle,				
75	Nova	3983037	2	.18	NUT (at lwr. end) ( <sup>9</sup> / <sub>16</sub> " )
64-69	Chevelle, Camaro,				
68-69	Chevy,				
70	Nova, Chevelle	3751282	A.R.	.13	SHIM ( <sup>7</sup> / <sub>16</sub> " )
70-74	Camaro	1374984	A.R.	.18	SHIM (.100)
71-72	Pass., Camaro,				
73-74	All (exc. Vega, Monza)	6270717	A.R.	.12	SHIM (.030)
71-75	Vega	342664	1	2.80	DAMPER, rr. susp. upper control arm
71-75	Vega	329797	2	1.90	PLATE, rr. susp. upper control arm damper

**6.230 TIE ROD ASSY., Tie Rod**

71-72	Pass.	7816949	2	20.45	inner
-------	-------	---------	---	-------	-------

**6.232 SLEEVE— UNIT, Front Axle Tie Rod**

62	Chevy w/straight tie rods (1st design)	3854805	2	3.95	adjusting ( <sup>9</sup> / <sub>16</sub> " I.D. x <sup>13</sup> / <sub>16</sub> " O.D. x 8 <sup>3</sup> / <sub>4</sub> " O.L.)
62-68	Chevy w/offset tie rods (2nd design)	3793314	2	2.60	adjusting ( <sup>9</sup> / <sub>16</sub> " I.D. x <sup>13</sup> / <sub>16</sub> " O.D. x 4 <sup>1</sup> / <sub>2</sub> " O.L.)
64-70	Chevelle	5678367	2	2.10	adjusting
65-70	Pass.,				
67-69	Camaro,				
68-72	Chevy,				
73-74	Nova	3855946	2	2.75	w/integral pwr. strg., tie rod sleeve
71-75	Vega, Monza	5678367	2	2.10	
71-72	Pass., Chevelle, Camaro,				
73-75	All (exc. Vega, Monza)	7812118	1	6.70	UNIT, adj. tube

**6.233 END ASSY.— TIE ROD ASSY.— SOCKET ASSY., Tie Rod**

*NOTE. On End Assy'S. requiring a dust seal. See group 6.111.*

*NOTE Some end assy. have untapped lubrication fitting holes, on these it is necessary to use a self-tapping lub. fittings or tap new threads for standard type lub. fittings.*

62	Chevy w/straight tie rods (1st design)	3791292	2	12.10	long (6 <sup>3</sup> / <sub>4</sub> " center of socket to end)
62	Chevy w/offset tie rods (2nd design)	3793844	2	12.10	long (10 <sup>15</sup> / <sub>16</sub> " dev. length center of socket to end)
62	Chevy	3790672	2	8.80	short (3 <sup>7</sup> / <sub>16</sub> " center of socket to end) (w/o seal)
63-67	Chevy	3793583	2	12.10	long
63-67	Chevy	3826596	2	8.80	short
64-70	Chevelle	3956705	2	12.10	outer
64-70	Chevelle	3956702	2	13.90	inner
65-66	Pass.	3855947	2	12.10	right thread (inner)
65-68	Pass.	3909642	2	12.10	left thread use w/integral P/S (outer)
67-68	Pass.	3909641	2	12.10	right thread (outer)
67-69	Chevy, Camaro,				
70-74	Nova	3986489	2	13.90	inner
69-70	Pass.	3953516	2	12.10	right thread (inner)
69-70	Pass.	3953517	2	12.10	left thread (outer)
70-74	Camaro	3964865	2	10.10	outer
70-74	Camaro	3964869	L.H.	13.90	left, inner
70-74	Camaro	3964870	R.H.	13.90	right, inner
71-75	Pass.	7816950	2	18.05	outer
71-72	Chevelle	3987857	2	13.90	inner
71-72	Chevelle	3987858	2	13.90	outer
67-69	Camaro,				
68-74	Nova	3986491	2	10.10	outer
73	Chevelle	7814682	2	15.75	inner
73-75	Chevelle	7816952	2	12.10	outer
74-75	Chevelle	7816951	2	15.75	inner
75	Camaro, Nova	344667	L.H.	12.10	inner

**FRONT AXLE—STEERING**

**6.233 END ASSY.— TIE ROD ASSY.— SOCKET ASSY., Tie Rod (Con't)**

75	Camaro, Nova	344668	R.H.	12.10	inner
75	Camaro, Nova	344665	2	8.80	outer
71-75	Pass.	7816949	2	20.45	TIE ROD, inner (Note 1)— (6.230)
<i>NOTE 1: Used as a socket assy.</i>					
71-75	Vega, Monza	3978046	2	12.10	SOCKET ASSY., outer w/seal and fitting
71-75	Vega, Monza	3978049	2	12.10	SOCKET ASSY., inner w/seal and fitting

**6.234 CLAMP, Tie Rod End**

62-68	Nova	3954397	2	.63	( <sup>13</sup> / <sub>16</sub> " I.D. x <sup>3</sup> / <sub>4</sub> " wide)
64-69	Chevelle,				
67-69	Camaro, Chevy,				
65-69	Pass.,				
70	All (exc. Camaro),				
71-75	Nova, Vega, Monza	3886435	4	.27	adjust. sleeve
70	Camaro	5668675	2	.84	adj.
71-75	Pass., Chevelle, Camaro	7807288	4	.28	adjust sleeve

**6.242 SEAL, Tie Rod Dust**

62	Chevy	3687643	A.R.	.17	socket (1 <sup>1</sup> / <sub>2</sub> " O.D.)
63-67	Chevy,				
65-69	Pass.,				
69	Chevelle,				
71	Chevelle, Nova, Camaro,				
72	Chevelle, Camaro	3826598	A.R.	.17	socket (1 <sup>1</sup> / <sub>2</sub> " I.D. x 1 <sup>35</sup> / <sub>64</sub> " O.D.)
64-67	Camaro, Chevelle,				
68-69	Nova, Chevelle, Camaro,				
70-75	Nova,				
71-75	Vega, Monza,				
73-75	Chevelle	3989415	4	.22	tie rod socket
73-75	Camaro	3826598	4	.17	socket (1 <sup>1</sup> / <sub>2</sub> " I.D. x 1 <sup>35</sup> / <sub>64</sub> " O.D.)

**6.307 HUB, Front Wheel**

62-64	Chevy	3790279	2	14.70	(8 holes— 5 <sup>7</sup> / <sub>8</sub> " O.D.)
64-69	Chevy, Chevelle, Camaro (exc. Disc Brakes),				
70-72	Chevelle (exc. Disc Brakes),				
70-74	Nova (exc. Disc Brakes)	3887867	2	13.65	(5 holes) w/bolt assy. (Note 1)
<i>NOTE 1 Does not include 65 Chevelle (396).</i>					
69-70	Pass. (exc. Disc Brake)	3988886	2	13.60	w/bolt
68-70	Pass. w/Disc Brake	3986083	2	58.95	w/disc— (5.809)
70-75	Camaro,				
73-75	Chevelle,				
75	Nova	334348	2	54.40	w/disc— (5.809)
73-75	Pass.	6274216	1	60.55	w/bolts— (5.809)
71-75	Vega, Monza	3976609	1	56.70	w/bolts— (5.809)
65-68	Pass. (exc. Disc Brakes)	3812712	2	15.00	HUB ASSY., w/bolts (5 holes— 60.D.)
67-68	Pass. w/Disc Brakes (4 piston design)	3933936	2	58.95	HUB ASSY. (w/disc) (9 <sup>1</sup> / <sub>2</sub> " groove)— (5.809)
67-69	Camaro w/Disc Brakes, Spl. Strg.,				
67-72	Chevelle,				
67-74	Nova w/Disc Brakes	3901098	2	63.00	HUB ASSY., w/disc— (5.809)

**6.311 BEARING ASSY., Front Wheel Inner**

62-63	Chevy	7451080	2	5.27	(HY L-44649-L-44610)
64-68	All,				
69-75	Chevy, Chevelle, Camaro,				
71-75	Vega, Monza	7450630	2	5.37	(HY-LM-67048-LM-67010)
69-75	Pass.	7450700	2	6.58	(HY-LM-48548-LM-48510)

**6.313 BEARING ASSY., Front Wheel Outer**

62-63	Chevy,				
71-75	Vega, Monza	7451077	2	4.70	(HY-LM-11749-LM-11710)
64-68	All,				
69-75	Nova, Chevelle, Camaro	7450627	2	4.28	(HY-LM-11949-11910)
69-75	Pass.	7450697	2	5.78	(HY-M-12649-M-12610)

**6.321 WASHER, Steering Knuckle Spindle**

62-63	Chevy,				
71-75	Vega, Monza	6255552	2	.18	( <sup>11</sup> / <sub>16</sub> " I.D. x 1 <sup>7</sup> / <sub>16</sub> " O.D.)
69-70	Pass.	379657	2	.26	
64-69	Chevy, Chevelle, Camaro,				
65-68	Pass.,				
70	Nova, Chevelle,				

**FRONT AXLE—STEERING**

**6.321 WASHER, Steering Knuckle Spindle (Con't)**

70	Camaro,				
71-75	All (exc. Vega, Monza) . . . . .	3985839	1	.18	
68	Pass. w/Disc Brakes (exc. pwr. brakes),				
69-70	Pass. . . . .	568860	2	.28	(w/knuckle having inner cone seat 1.40" O.D.) . . . . .

**6.326 SEAL ASSY., Front Wheel Bearing**

62-63	Chevy . . . . .	3814160	2	1.10	inner (w/four tabs) . . . . .
65-68	Pass. . . . .	3876192	2	1.80	inner brg. . . . .
64-69	Chevy, Chevelle, Camaro,				
67	Pass. w/Disc Brakes,				
70-72	Chevelle,				
70-74	Nova,				
71-75	Vega, Monza . . . . .	3876191	2	1.80	inner bearing . . . . .
68	Pass. w/Disc Brakes (exc. pwr. brakes),				
69-70	Pass. . . . .	3953412	2	1.65	inner brg. . . . .
70-72	Camaro,				
71-75	Pass.,				
73-75	Camaro, Chevelle,				
75	Nova . . . . .	3965092	1	2.60	inner . . . . .

**6.330 GREASE CAP, wheel bearing**

62-63	Chevy,				
71-75	Vega, Monza . . . . .	6255554	2	.74	front wheel (1 <sup>7</sup> / <sub>32</sub> " x 1 <sup>9</sup> / <sub>16</sub> ") . . . . .
64-69	Chevy, Chevelle, Camaro,				
65-68	Pass.,				
70-72	Nova, Chevelle,				
73-74	Nova . . . . .	539153	2	.32	front wheel (1 <sup>1</sup> / <sub>4</sub> " x 2 <sup>1</sup> / <sub>2</sub> ") . . . . .
69-75	Pass.,				
70-75	Camaro,				
73-75	Chevelle,				
75	Nova . . . . .	6274217	2	.98	grease . . . . .

**6.500 SPRING— BOLT— COVER— ROD— PLATE— RACK— SCREW— WASHER— LOCK LEVER, Steering Column Lock Bolt**

69	Camaro w/T.W.,				
69	Chevelle (floor shift w/T.W.) (396) (exc. A.T.),				
69	Pass. w/T.W.,				
71-75	All w/T.W. . . . .	7805827	1	2.00	strg. shaft lock bolt . . . . .
71-74	Vega . . . . .	7810516	1	.57	stg. column lock lever . . . . .
69	All w/T.W.,				
70	All w/T.W. (exc. Camaro),				
71-75	Pass., Chevelle, Camaro, Vega, Monza w/T.W. . . . .	7808613	1	1.35	<b>BOLT</b> , shaft lock . . . . .
69-75	All (exc. T.W.) . . . . .	7806185	1	2.10	<b>BOLT</b> , w/spring . . . . .
71-74	Camaro w/A.T. (exc. floor console, T.W.) . . . . .	7808614	1	1.35	<b>BOLT</b> , column shaft lock . . . . .
69-75	All (exc. T.W.) . . . . .	7806232	1	2.40	<b>COVER</b> , shaft lock plate . . . . .
69	All w/T.W.,				
70-72	Pass., Chevelle, Camaro, Vega, Monza w/T.W.,				
73-75	All w/T.W. . . . .	7806159	1	2.40	<b>COVER</b> , shaft lock plate . . . . .
71-73	Pass. (exc. T.W.) . . . . .	7806117	1	6.75	<b>ROD</b> , w/rack, strg. column— (2.195) . . . . .
71-74	Vega . . . . .	7810387	1	3.10	<b>ROD</b> , stg. col. lk. switch actuator . . . . .
71-74	Pass. w/T.W. . . . .	7805376	1	3.80	<b>ROD ASSY.</b> , strg. column— (2.195) . . . . .
69-70	Pass. (exc. T.W.) . . . . .	7806115	1	4.95	<b>ROD ASSY.</b> , w/rack, ign. switch actuator— (2.195) . . . . .
69-70	Nova, Chevelle, Camaro (exc. T.W.) . . . . .	7806114	1	5.20	<b>ROD ASSY.</b> , ign. switch actuator w/rack— (2.195) . . . . .
72-75	All w/floor controls (exc. T.W., Vega, Monza) . . . . .	7807282	1	6.05	<b>ROD ASSY.</b> , w/rack— (2.195) . . . . .
69-70	All (exc. T.W.),				
71	Pass. (exc. A.T.),				
71	Chevelle w/floor console (exc. T.W.),				
71	Camaro (exc. T.W.),				
72-75	All (exc. T.W., Vega, Monza),				
71-75	Vega, Monza (exc. T.W., P/S) . . . . .	7804766 A.R.		4.25	<b>PLATE</b> , shaft lock plate . . . . .
69	All w/T.W.,				
70	All w/T.W. (exc. Camaro),				
71	Pass., Chevelle, Camaro w/T.W.,				

**FRONT AXLE—STEERING**

**6.500 SPRING— BOLT— COVER— ROD— PLATE— RACK— SCREW—  
WASHER— LOCK LEVER, Steering Column Lock Bolt (Con't)**

72-75	All w/T.W. ....	7805227	1	3.70	PLATE, shaft lock plate .....
71	Chevelle, Camaro w/T.W.,				
74-75	Pass. (exc. T.W.) .....	7807284	1	5.70	RACK ASSY., ign. switch actuator— (2.195)
69-71	All,				
73-74	All (exc. T.W., Vega, Monza) ...	7804772	3	.32	SCREW, lock plate cover .....
69	All w/T.W. ....	7803623	1	.53	SCREW, shaft lock bolt spring .....
69-70	All (exc. T.W.),				
72	Nova,				
73-75	All (exc. T.W.),				
73-75	Vega, Monza .....	7805950	1	.47	WASHER, spring thrust .....
71-74	All (exc. T.W., Vega) .....	7811794	1	.44	WASHER, strg. column lock bolt spring retainer .....
71-74	Vega .....	7810253	1	1.40	LOCK LEVER, strg. column .....

**6.507 KIT, Hydraulic Steering (Small Parts) (see Groups 6.551 for adapter kits  
and 6.609, 6.610, 6.612, 6.614, 6.615 for pump kits)**

62-67	Chevy .....	5688501	1	47.75	control valve (Note 1) .....
	<i>NOTE 1 Complete valve service kit.</i>				
62-67	Chevy .....	5686382	1	2.75	cylinder, piston rod seal (Note 2) .....
	<i>NOTE 2 Consists of 1 each seal, ring, washer, scraper, and element.</i>				
62-67	Chevy .....	5687997	1	2.20	control adapter valve seal and washer (Note 4) .....
	<i>NOTE 4 Consists of 2 seals, 1 "O" ring, 1 nut.</i>				
63-67	Chevy .....	5691207	1	1.35	ball stud (Note 5) .....
	<i>NOTE 5 Consists of 2 seats, 2 plugs, 1 spring, 1 grease fitting, 1 seal, 1 ring.</i>				
64-68	Chevelle,				
65-69	Pass.,				
67-68	Camaro,				
68	Chevy,				
70-75	All .....	7811277	1	18.85	master seal (major repair) .....
64-72	Pass., Chevelle,				
67-72	Camaro,				
68-72	Chevy,				
73-75	All .....	7811276	1	5.45	"O" ring seal (minor repair) .....

**6.508 GEAR ASSY.— GEAR UNIT— ADAPTER UNIT— ADAPTER, Steering**

64-66	Pass., Chevelle w/P/S (exc. T.W., Tel. W.) .....	5696113	1	117.00	
64-66	Chevelle w/P/S,				
65	Pass. (exc. P/S) .....	5679270	1	77.50	
67	Chevy .....	5699256	1	85.25	
67-69	Camaro w/spec. strg. (302) .....	7806396	1	80.25	
67-69	Chevelle (exc. P/S),				
67-70	Pass., Nova (exc. P.S.) .....	7808549	1	91.50	
70	Camaro (6 cyl.) (exc. P/S),				
70-72	Camaro w/Sp. H/Per. 350 (exc. P/S),				
70	Chevelle (exc. P/S) .....	7812897	1	82.50	
70	Camaro (exc. P/S, Spec. H/Per. 350) .....	7809504	1	78.25	
71	Pass. w/P/S .....	7813599	1	197.00	
71-74	Vega w/P/S .....	7816444	1	157.00	
71-75	Vega, Monza (exc. P/S, 8 cyl.) ..	7815599	1	88.25	
72	Pass. (exc. Police) .....	7814224	1	197.00	
72	Chevelle (exc. P/S),				
72	Camaro (exc. P/S, Sp. H/Per. 350) .....	7813496	1	90.75	
72	Nova (exc. P/S) .....	7813497	1	90.75	
73	Nova w/P/S .....	7814627	1	173.00	
73	Chevelle w/P/S (exc. Monte Carlo, S.S., Sta. Wag.) .....	7816432	1		
73	Camaro (exc. P.S. 8 cyl.),				
73	Pass. (exc. Police) .....	7814919	1	173.00	
73-75	Camaro w/P/S (exc. R.T.S., Sport Susp.) .....	7818138	1	173.00	
73-74	Nova (exc. P/S),				
73-75	Chevelle (exc. P/S) .....	7815770	1	90.75	
74	Pass. (exc. Police) .....	7818145	1	197.00	
74	Police .....	7825371	1	199.00	
74	Vega (122) w/Fast Steering .....	7817535	1	80.50	
74	Vega (122) (exc. Fast Steering) .	7817538	1	80.50	
75	Chevelle (exc. Sta. Wag., Monte Carlo, S.S., Sp./Per./Susp.) ...	7818886	1	173.00	
75	Pass. (exc. 454) .....	7818145	1	197.00	

**FRONT AXLE—STEERING**

**6.508 GEAR ASSY.— GEAR UNIT— ADAPTER UNIT— ADAPTER, Steering  
(Con't)**

75	Chevelle (Sta. Wag.) w/P/S . . . .	7819389	1	173.00	
75	Chevelle (P/S w/Sport/Susp.) (exc. Sta. Wag.) . . . . .	7818127	1	173.00	
75	Chevelle w/P/S (exc. Sta. Wag., Sport/Susp.) . . . . .	7818886	1	173.00	
75	Nova (exc. P/S) . . . . .	7818085	1	92.50	
75	Camaro (P/S w/R.T.S.), Nova (P/S w/Sport/Susp.) . . . .	7818139	1	173.00	
75	Nova w/P/S (exc. Sport Susp.), Pass. (454) . . . . .	7825371	1	199.00	
75	Vega (122) . . . . .	7819934	1	81.75	
75	Vega, Monza w/P/S . . . . .	7818137	1	157.00	
75	Monza (8 cyl.) (exc. P/S, Notchback) . . . . .	7819933	1	80.75	
67	Pass., Chevelle, Camaro,				
68	All . . . . .	3930709	1	81.05	GEAR UNIT, basic (P/S Installation) (Note 1, 2) . . . . .
<i>NOTE 1: When using 3912120 on Camaro w/396, it will be necessary to use clip 7802624 in place of 3692525.</i>					
<i>NOTE 2 Used with 1968 Camaro using strg. arms 3917193-94.</i>					
69	Biscayne, Bel Air,				
69	Chevy, Chevelle, Pass. (Sta. Wag.) . . . . .	3960244	1	83.35	GEAR UNIT, power/basic . . . . .
69	Impala, Caprice (exc. Sta. Wag.)	3960245	1	90.00	GEAR UNIT, pwr./basic . . . . .
69	Camaro . . . . .	3960246	1	90.00	GEAR UNIT, power/basic . . . . .
70	Camaro (350 4BC, 396) . . . . .	3986004	1	85.00	GEAR UNIT, power basic (variable ratio) (repl. 3974376) . . . . .
69	Chevelle w/P/S (396), 70 Nova (8 cyl.), 70 Pass., Chevelle (exc. Sta. Wag.) .	3974375	1	86.75	GEAR UNIT, pwr./basic/var. ratio . . . . .
70	Nova (6 cyl.), 70 Pass., Chevelle (Sta. Wag.) . . . .	3974377	1	78.00	GEAR UNIT, pwr./basic/stgth. ratio . . . . .
71-72	Nova . . . . .	3996779	1	89.50	GEAR UNIT, power basic (variable ratio) . . .
71	Chevelle . . . . .	3996781	1	85.90	GEAR UNIT, power basic (variable ratio) . . .
71-72	Camaro . . . . .	3996780	1	110.00	GEAR UNIT, power basic (variable ratio) . . .
72	Chevelle . . . . .	6272004	1	102.00	GEAR UNIT, power basic (variable ratio) . . .
73	Nova . . . . .	6258457	1	146.00	GEAR UNIT, power basic (variable ratio) . . .
73	Chevelle (Sta. Wag.) . . . . .	6258458	1	110.00	GEAR UNIT, power basic (variable ratio) . . .
73	Chevelle (S.S.) Monte Carlo . . . .	6258459	1	110.00	GEAR UNIT, power basic (variable ratio) . . .
73	Chevelle (exc. S.S., Sta. Wag., Monte Carlo) . . . . .	6258460	1	110.00	GEAR UNIT, power basic (variable ratio) . . .
73-75	Camaro w/P.S., 75 Nova (exc. Sp./Perf. Susp.) . . . .	358938	1	159.00	GEAR UNIT, power basic (variable ratio) . . .
74	Chevelle (exc. Sta. Wag., Monte Carlo, S.S.) . . . . .	6260560	1	146.00	GEAR UNIT, power basic (variable ratio) . . .
74	Chevelle (Sta. Wag.) . . . . .	6260558	1	146.00	GEAR UNIT, power basic (variable ratio) . . .
74	Monte Carlo, Chevelle (S.S.) . . . .	6260559	1	146.00	GEAR UNIT, power basic (variable ratio) . . .
74	Nova . . . . .	6260557	1	146.00	GEAR UNIT, power basic (variable ratio) . . .
74	Camaro (250) . . . . .	6260556	1	146.00	GEAR UNIT, power basic (variable ratio) . . .
75	Malibu (250 Eng.) (exc. C.A.C.) . . .	369127	1	173.00	GEAR UNIT . . . . .
65-67	Pass. (283, 327) . . . . .	3912339	1	48.60	ADAPTER UNIT (Note 3) . . . . .
<i>NOTE 3 When using with Sp. H/Per. engine order (1) 3873847 pulley and discard (1) 3874416 and (1) 3860457 pulley.</i>					
66-67	Chevelle (283, 327) . . . . .	3912203	1	48.60	ADAPTER UNIT . . . . .
67	Chevelle, Chevy (6 cyl.) . . . . .	3912239	1	10.50	ADAPTER UNIT, supplementary . . . . .
66-67	Chevy (exc. 8 cyl.) . . . . .	3912349	1	14.80	ADAPTER UNIT (Note 5) . . . . .
<i>NOTE 5 When used on L4 engine also order 1/3793680 Brace, also order unit 3912239 for installation on vehicles with A.I.R.</i>					
66-67	Chevy (8 cyl.) . . . . .	3912351	1	14.80	ADAPTER UNIT . . . . .
67	Camaro (327, 350) . . . . .	3912347	1	49.60	ADAPTER UNIT (Note 6) . . . . .
<i>NOTE 6 When using this unit on 302 engine models it will be necessary to order 1/3916385 crankshaft pulley and 1/3871258 hyd. steering pump belt.</i>					
<i>NOTE 7 Also order unit 3912345 for installation on vehicles with A.I.R.</i>					
68	Pass. w/P.G. (6 cyl.) (exc. C.A.C.) . .	3930722	1	51.95	ADAPTER UNIT . . . . .
68	Pass. (396, 427) . . . . .	3930724	1	51.95	ADAPTER UNIT . . . . .
68	Chevelle w/P.G. (6 cyl.) (exc. C.A.C.) . . . . .	3930718	1	49.60	ADAPTER UNIT . . . . .
68	Chevelle (396) (exc. C.A.C.) . . . .	3930720	1	49.60	ADAPTER UNIT (Note 8) . . . . .
<i>NOTE 8 When used on 396 Spec. Hi Perf. order pulleys 3873847 and 3869978.</i>					
68	Chevy, Camaro (exc. 8 cyl. C.A.C., P.G.) . . . . .	3930725	1	49.60	ADAPTER UNIT (Note 9) . . . . .
68	Chevy, Camaro w/P.G. (exc. 8 cyl.) . . . . .	3930726	1	49.60	ADAPTER UNIT (Note 9) . . . . .

**FRONT AXLE—STEERING**

**6.508 GEAR ASSY.— GEAR UNIT— ADAPTER UNIT— ADAPTER, Steering  
(Con't)**

68	Chevy, Camaro (8 cyl.) (exc. 396)	3930727	1	49.60	ADAPTER UNIT (Note 9)
69	Chevelle w/A.T. (6 cyl.)	3960248	1	50.75	ADAPTER UNIT
69	Chevelle (8 cyl.) (exc. 396)	3960249	1	50.75	ADAPTER UNIT
69	Chevy (6 cyl.) (exc. Torque Drive, P.G.)	3960255	1	35.75	ADAPTER UNIT
69	Chevy (8 cyl.) (exc. 396)	3960257	1	35.75	ADAPTER UNIT
69	Camaro (6 cyl.) (exc. A.T.)	3960263	1	35.75	ADAPTER UNIT
69	Camaro (8 cyl.) (exc. 396)	3960265	1	35.75	ADAPTER UNIT
69	Biscayne, Bel Air (396, 427), Sta. Wag. (396, 427)	3960254	1	50.75	ADAPTER UNIT
69	Impala w/P.G. (6 cyl.) (exc. Sta. Wag.)	3960260	1	50.75	ADAPTER UNIT
69	Impala, Caprice (307, 327, 350) (exc. Sta. Wag.)	3960261	1	50.75	ADAPTER UNIT
69	Impala, Caprice (396, 427) (exc. Sta. Wag.)	3960262	1	50.75	ADAPTER UNIT
69	Pass. w/A.T. (250)	3960252	1	50.75	ADAPTER UNIT
70	Pass. (6 cyl.) (exc. Sta. Wag.)	3974379	1	66.75	ADAPTER UNIT (Note 10)
70	Pass. (307, 350) (exc. Sta. Wag.)				
70	Pass. (400 2BC) (exc. Sta. Wag.)	3974380	1	65.00	ADAPTER UNIT (Note 11)
70	Pass. (396, 400 w/4BC, 454) (exc. Sta. Wag.)	3974381	1	66.00	ADAPTER UNIT (Note 11)
70	Pass. (Sta. Wag.) (307, 350), Pass. (Sta. Wag.) (400 2BC)	3977500	1	66.75	ADAPTER UNIT (Note 11)
70	Nova (396)	3974393	1	52.50	ADAPTER UNIT (Note 11)
70	Chevelle (6 cyl.) (exc. Sta. Wag.)	3974387	1	66.75	ADAPTER UNIT (Note 10)
70	Chevelle (Sta. Wag.) (6 cyl.)	3974395	1	66.75	ADAPTER UNIT (Note 10)
70	Chevelle (Sta. Wag.) (8 cyl.) (exc. 400, 454)	3974396	1	66.75	ADAPTER UNIT (Note 11)
70	Camaro (6 cyl.)	3974383	1	52.50	ADAPTER UNIT (Note 12)
70	Camaro (307, 350)	3974384	1	52.50	ADAPTER UNIT (Note 11)
71	Chevelle (6 cyl.)	3996788	1	66.00	ADAPTER UNIT (Note 12)
71	Chevelle w/2BC, Chevelle w/4BC (350)	3996789	1	66.00	ADAPTER UNIT (Note 11)
71	Chevelle w/4BC (400, 454)	3996790	1	66.00	ADAPTER UNIT (Note 11)
71	Nova (6 cyl.)	3996791	1	53.00	ADAPTER UNIT (Note 12)
71	Nova (8 cyl.)	3996792	1	53.00	ADAPTER UNIT (Note 11)
71	Camaro w/2BC, Camaro w/4BC (350)	6263193	1	59.00	ADAPTER UNIT (Note 11)
72	Chevelle (6 cyl.)	6272005	1	75.25	ADAPTER UNIT (Note 12)
72	Chevelle (307, 350)	6272006	1	82.25	ADAPTER UNIT (Note 11)
72	Chevelle w/4BC (400, 454)	6272007	1	82.25	ADAPTER UNIT (Note 11)
72	Nova (6 cyl.)	6272008	1	59.75	ADAPTER UNIT (Note 12)
72	Nova (8 cyl.)	6272009	1	66.00	ADAPTER UNIT (Note 11)
72	Camaro (6 cyl.)	6272001	1	60.00	ADAPTER UNIT (Note 12)
72	Camaro (307, 350)	6272002	1	66.00	ADAPTER UNIT (Note 11)
72	Camaro w/4BC (400)	6272003	1	66.00	ADAPTER UNIT (Note 11)
73	Nova (6 cyl.)	6258466	1	77.75	ADAPTER UNIT (Note 12)
73	Nova (8 cyl.)	6258467	1	66.00	ADAPTER UNIT (Note 11)
73	Chevelle (Sta. Wag.) (8 cyl.)	6258469	1	82.25	ADAPTER UNIT (Note 11)
73	Chevelle (8 cyl.) (exc. Sta. Wag.)	6258470	1	82.25	ADAPTER UNIT (Note 11)
73	Chevelle (6 cyl.) (exc. Sta. Wag.)	6258471	1	82.25	ADAPTER UNIT (Note 12)
74	Chevelle (Sta. Wag.)	6260567	1	82.25	ADAPTER UNIT (Note 11)
74	Chevelle (8 cyl.) (exc. Sta. Wag.)	6260568	1	82.25	ADAPTER UNIT (Note 11)
74	Camaro (6 cyl.)	6260561	1	82.25	ADAPTER UNIT (Note 12)
74	Nova (6 cyl.)	6260564	1	77.75	ADAPTER UNIT (Note 12)
74	Nova (8 cyl.)	6260565	1	77.75	ADAPTER UNIT (Note 11)
75	Nova (8 cyl.)	358990	1	97.00	ADAPTER UNIT (Note 11)
75	Nova (6 cyl.) (exc. Calif.)	358942	1	97.00	ADAPTER UNIT (Note 12, 13)
75	Malibu (250 Eng.) (exc. C.A.C. & Calif.)	369128	1	97.00	ADAPTER UNIT
69	Pass. (8 cyl.) (exc. 396, 427)	3960253	1	50.75	ADAPTER

*NOTE 9: When used with spec. steering on Camaro order Pitman arm 3908379.*

*NOTE 10 When U/W 6 cyl. eng. and A/C it will be necessary to order (1) crankshaft pulley 3876821 (1) generator pulley 800260 and (1) fan and generator belt 3953733 and 3 crankshaft front pulley.*

*NOTE 11 When used with 8 cyl. engines and A/C it will be necessary to order (1) power steering pump pulley 3941107. Except use 354325 for year 1975.*

*NOTE 12 When U/W 6 cyl. and A/C, it will be necessary to order (1) crankshaft pulley (0.659), (1) gen. pulley (2.274), (1) fan and gen. belt (1.066), and (3) crankshaft front pulley bolt (9423959).*

*NOTE 13: When used on 6 cyl. engines which do not have integrated cylinder head discard hyd. strg. pump frt. support from unit and order support 360138.*



**FRONT AXLE—STEERING**

**6.509 BOLT— WASHER, Steering Gear to Frame**

64-72	Chevelle,				
64-75	Pass.,				
71-75	Vega	399803	1	.42	( <sup>7</sup> / <sub>16</sub> "— 14 x 4 <sup>7</sup> / <sub>16</sub> ")
73-75	Chevelle	9433287	3	.40	( <sup>7</sup> / <sub>16</sub> "— 14 x 5 <sup>3</sup> / <sub>4</sub> ")— (8.900)
73-75	Camaro,				
75	Nova	3972245	3	.63	( <sup>7</sup> / <sub>16</sub> "— 14 x 4 <sup>5</sup> / <sub>8</sub> ")— (6.525)
73-75	Nova	9419713	3	.34	( <sup>7</sup> / <sub>16</sub> "— 14 x 3 <sup>3</sup> / <sub>4</sub> ")— (8.900)
75	Nova	344659	1	.65	red body hex. ( <sup>7</sup> / <sub>16</sub> "— 14 x 6 <sup>1</sup> / <sub>2</sub> ")
75	Nova	344662	1	.65	red body hex. ( <sup>7</sup> / <sub>16</sub> "— 14 x 5 <sup>3</sup> / <sub>8</sub> ")
75	Monza	356369	3	.61	red body hex. ( <sup>7</sup> / <sub>16</sub> "— 14 x 4 <sup>3</sup> / <sub>16</sub> ")
62-63	Chevy	3754153	6	.21	WASHER ( <sup>13</sup> / <sub>32</sub> ")— (5.383)
69	Pass., Chevelle,				
70	Pass., Chevelle, Nova,				
71-75	All	479684 A.R.		.18	WASHER, flat ( <sup>15</sup> / <sub>32</sub> " I.D. x 1 <sup>1</sup> / <sub>8</sub> " O.D. x <sup>3</sup> / <sub>16</sub> " thk.)

**6.512 HUB ASSY.— SHROUD— SHROUD ASSY.— INSULATOR— PAD— PLATE— RETAINER, Steering Wheel Hub**

NOTE For Emblem see Group 2.820.

NOTE. Direction signal housings are in 2.906 group.

67-68	Pass., Camaro w/wood grained plastic,				
68	Chevy w/wood grained wheel	3930062	1	22.15	
69	All w/wood grain wheel	3937896	1	13.90	
67	Chevelle, Chevy w/wood grain wheel,				
68	Chevelle w/wood grain wheel	3923697	1	22.15	
68	Nova,				
67-68	Camaro (Deluxe) (exc. deluxe wheel)	9750089	1	21.65	SHROUD (chrome)
68	All w/del. wheel	9748925	1	17.65	SHROUD (black)
68	All w/del. wheel (exc. Camaro, 396)	9748926	1	17.65	SHROUD (blue)
69	Brookwood, Townsman, Biscayne, Bel Air,				
69	Chevy, Camaro (exc. 350, 396, R.S., int. decr. pkg.),				
69	Chevelle (exc. 350, 396, wood grain wheel)	3961774	1	13.90	SHROUD (med. blue)
69	Biscayne,				
69	Bel Air, Townsman (exc. wood grain wheel),				
69	Camaro,				
69	Chevy (exc. 350, 396),				
69	Chevelle (Spt. Cpe., Sed.) (exc. 350, 396, wood grain wheel),				
69	Impala, Caprice (exc. wood grain wheel, S.S. 427)	3961796	1	7.75	SHROUD (med. green)
69	Bel Air (exc. wood grain wheel),				
69	Impala, Caprice (exc. S.S.),				
69	Kingswood,				
69	Chevy (exc. 350, 396),				
69	Camaro (exc. R.S., int. dec. pkg., 350, 396, wood grain wheel),				
69	Malibu, Concours (exc. El Camino, 6 pass., 396, wood grain wheel),				
69	Malibu (Spt. Sed.) Camaro (exc. wood grain wheel)	3972738	1	13.90	SHROUD (mid. green)
69	Brookwood, Townsman,				
69	Chevelle (Sta. Wag., El Camino) (exc. 396)	3961779	1	10.80	SHROUD (med. saddle)
69	Impala (exc. T.W., S.S. 427)	3972735	1	13.90	SHROUD (med. turq.)
69	Impala (2 Dr.) (exc. S.S. 427),				
69	Kingswood (exc. Estate Wag.),				
69	Chevy (Spt. Cpe.) (exc. 396),				
69	Camaro (exc. 350, 396, R.S., int. decr. pkg., wood grain wheel),				
69	Chevelle (Spt. Cpe., Conv.) (exc. 396, wood grain wheel)	3961795	1	24.20	SHROUD (med. red)
69	Pass. (exc. S.S., 427, wood grain wheel),				
69	Estate Wag.,				
69	Malibu (Spt. Sed.) w/Spec. Spt. Sed.,				

**FRONT AXLE—STEERING**

**6.512 HUB ASSY.—SHROUD—SHROUD ASSY.—INSULATOR—PAD—  
PLATE—RETAINER, Steering Wheel Hub (Con't)**

69	Camaro w/deluxe equip.,						
70	All (exc. Monte Carlo, Camaro)	3972735	1	13.90		SHROUD ASSY. (black) (rosewood insert) (Note 1)	
70	Monte Carlo	3972691	1	15.70		SHROUD ASSY. (comb. 758, 767) (dk. blue) (burl insert)	
69	Impala, Kingswood (exc. wood grain wheel, S.S., Estate Wag.),						
69	Malibu (Spt. Sed.) Camaro (exc. wood grain wheel),						
70	All (exc. Monte Carlo, Nova)	3972736	1	15.70		SHROUD ASSY. (dk. blue) (rosewood insert) (Note 1)	
70	Monte Carlo	3972692	1	15.70		SHROUD ASSY. (comb. 769, 778) (dk. saddle) (burl insert)	
70	Monte Carlo	3972695	1	24.20		SHROUD ASSY. (comb. 792) (dk. sandalwood) (burl insert)	
70	Nova					SHROUD ASSY. (comb. 746, 747),	
70	Pass. (Spt. Cpe., Spt. Sed.)	3972742	1	15.70		SHROUD ASSY. (comb. 828, 870) (dk. sandalwood) (rosewood insert) (Note 1)	
70	Monte Carlo	3972690	1	15.70		SHROUD ASSY. (black) (burl insert)	
70	Pass., Chevelle, Nova (exc. Monte Carlo)	3972737	1	13.90		SHROUD ASSY. (comb. 770, 771, 772, 773, 830, 831, 838) (dk. saddle) (rosewood insert) (Note 1)	
70	Monte Carlo	3972694	1	15.70		SHROUD ASSY. (comb. 774) (dk. gold) (burl insert)	
69	Impala, Caprice (exc. Conv., wood grain wheel, S.S., 427),						
69-70	All (exc. Monte Carlo, Camaro)	3972741	1	15.70		SHROUD ASSY. (comb. 775, 776, 777, 836, 839, 843, 740, 741, 742, 836, 839, 843, 837, 840, 841) (dk. gold) (rosewood insert) (Note 1)	
70	Monte Carlo	3972693	1	15.70		SHROUD ASSY. (comb. 780, 784, 785) (dk. green) (burl insert)	
70	All (exc. Monte Carlo, Camaro)	3972738	1	13.90		SHROUD ASSY. (comb. 782 786, 795, 796, 848, 744, 745, 855, 860, 861) (dk. green) (rosewood insert) (Note 1)	
70	Nova,					(comb. 844, 845),	
70	Impala, Caprice (Spt. Cpe., Sed.)					SHROUD ASSY. (comb 779) (k. turq.) (rosewood insert) (Note 1)	
70	Malibu (Sed.)	3972739	1	13.90		(comb. 787, 788),	
70	Malibu (Spt. Cpe.)						
70	Impala (Spt. Cpe.) (exc. Custom),						
70	Nova	3972740	1	15.70		SHROUD ASSY. (comb. 866) (dk. red) (rosewood insert) (Note 1)	
70	Camaro w/deluxe int.	3982326	1	13.90		SHROUD ASSY. (black) (woodgrain insert) (Paint as reqd.) (Note 1)	
71-72	All w/deluxe vinyl steering wheel	3992587	1	25.75		SHROUD ASSY.	
71-72	Pass., Camaro (exc. Impala, Caprice, Kingswood),						
71-72	Chevelle (exc. Monte Carlo)	9752599	1	15.70		SHROUD ASSY. (Chevrolet) (black)	
71-72	Impala (exc. deluxe vinyl steering wheel)	9752682	1	15.70		SHROUD ASSY. (Impala) (black)	
71-72	Caprice (exc. deluxe vinyl steering wheel)	9752683	1	15.70		SHROUD ASSY. (Caprice) (elm burl)	
71-72	Monte Carlo (exc. deluxe vinyl steering wheel)	9752684	1	15.70		SHROUD ASSY. (Monte Carlo) (elm burl)	
71	Kingswood (exc. deluxe vinyl steering wheel)	9752899	1	15.70		SHROUD ASSY. (Kingswood) (elm burl)	
71-72	Camaro (exc. deluxe vinyl steering wheel)	9752900	1	15.70		SHROUD ASSY. (Camaro) (elm burl)	
71	Camaro (exc. deluxe vinyl steering wheel)	9752901	1	15.70		SHROUD ASSY. (RS) (black)	
71	Chevelle, Camaro, Nova (exc. deluxe vinyl steering wheel)	9752902	1	15.70		SHROUD ASSY. (SS) (black)	
71-72	Nova (exc. deluxe vinyl steering wheel)	9752903	1	15.70		SHROUD ASSY. (Nova) (black)	
71-72	Chevelle (exc. Monte Carlo, deluxe vinyl steering wheel)	9752904	1	15.70		SHROUD ASSY. (Chevrolet) (dk. blue)	
71	Chevelle (exc. Monte Carlo, deluxe vinyl steering wheel)	9752905	1	15.70		SHROUD ASSY. (Chevrolet) (dk. beige)	
71	Chevelle (exc. Monte Carlo, deluxe vinyl steering wheel)	9752906	1	15.70		SHROUD ASSY. (Chevrolet) (dk. saddle)	

**FRONT AXLE—STEERING**

**6.512 HUB ASSY.— SHROUD— SHROUD ASSY.— INSULATOR— PAD—  
PLATE— RETAINER, Steering Wheel Hub (Con't)**

71	Chevelle (exc. Monte Carlo, deluxe vinyl steering wheel) . . .	9752907	1	15.70	SHROUD ASSY. (Chevrolet) (dk. jade) . . . . .
71-73	Vega . . . . .	329735	1	14.40	SHROUD ASSY. . . . .
73-75	Nova (exc. S.S.),				
73-75	Bel Air, Impala . . . . .	9754753	1	15.70	SHROUD ASSY. (Chevrolet) (black) . . . . .
73-75	Caprice Estate, Conv. . . . .	9754754	1	15.70	SHROUD ASSY. (black) . . . . .
73-74	Nova (S.S.) . . . . .	9754755	1	15.70	SHROUD ASSY. (black) . . . . .
73-74	Caprice . . . . .	9754757	1	15.70	SHROUD ASSY. (black) . . . . .
73	Monte Carlo . . . . .	9754758	1	15.70	SHROUD ASSY. (black) . . . . .
73	Chevelle (Deluxe) . . . . .	9754759	1	15.70	SHROUD ASSY. (black) . . . . .
73	Chevelle (S.S.) . . . . .	9754762	1	15.70	SHROUD ASSY. (black) . . . . .
73-74	Caprice (Conv.) . . . . .	9755380	1	15.70	SHROUD ASSY. (neutral) . . . . .
73	Caprice Estate, Conv. . . . .	9755382	1	15.70	SHROUD ASSY. (dk. green) . . . . .
73	Caprice Estate . . . . .	9755383	1	15.70	SHROUD ASSY. (dk. saddle) . . . . .
73-74	Caprice Estate . . . . .	9755379	1	15.70	SHROUD ASSY. (blue) . . . . .
73-74	Caprice . . . . .	9755384	1	15.70	SHROUD ASSY. (midnight blue) . . . . .
73-74	Caprice . . . . .	9755385	1	15.70	SHROUD ASSY. (neutral) . . . . .
73	Caprice . . . . .	9755386	1	15.70	SHROUD ASSY. (dk. green) . . . . .
73-74	Caprice . . . . .	9755387	1	15.70	SHROUD ASSY. (dk. oxblood) . . . . .
73-75	Chevelle (exc. Monte Carlo) . . . . .	9754756	1	15.70	SHROUD ASSY. (black) (comb. 702, 707, 747) . . . . .
73	Monte Carlo . . . . .	9755096	1	15.70	SHROUD ASSY. (midnight blue) . . . . .
73	Monte Carlo . . . . .	9755097	1	15.70	SHROUD ASSY. (midnight neutral) . . . . .
73	Monte Carlo . . . . .	9755098	1	15.70	SHROUD ASSY. (dk. green) . . . . .
73	Monte Carlo . . . . .	9755099	1	15.70	SHROUD ASSY. (dk. oxblood) . . . . .
73	Laguna . . . . .	9755100	1	15.70	SHROUD ASSY. (black) . . . . .
73	Laguna . . . . .	9755101	1	15.70	SHROUD ASSY. (dk. blue) . . . . .
73	Laguna . . . . .	9755103	1	15.70	SHROUD ASSY. (dk. green) . . . . .
73	Laguna (2-dr.) . . . . .	9755104	1	15.70	SHROUD ASSY. (dk. oxblood) . . . . .
73	Laguna (2-Dr. Sta. Wag.) . . . . .	9755105	1	15.70	SHROUD ASSY. (dk. saddle) . . . . .
73	Laguna . . . . .	9755102	1	15.70	SHROUD ASSY. (midnight neutral) . . . . .
74-75	Laguna, Monte Carlo . . . . .	9756210	1	15.70	SHROUD ASSY. (black) (comb. 703, 705, 708, 709) . . . . .
74	Laguna, Monte Carlo . . . . .	9756211	1	15.70	SHROUD ASSY. (mid. blue) (comb. 733, 734, 736, 737) . . . . .
74	Laguna, Monte Carlo . . . . .	9756213	1	15.70	SHROUD ASSY. (neutral) (comb. 711, 715, 716) . . . . .
74-75	Laguna, Monte Carlo . . . . .	9756214	1	15.70	SHROUD ASSY. (med. green) (comb. 725, 726, 729, 730) . . . . .
74-75	Laguna, Monte Carlo (exc. Sta. Wag., El Camino) . . . . .	9756215	1	15.70	SHROUD ASSY. (oxblood) (comb. 743, 744) . . . . .
74	Laguna (Sta. Wag.), Monte Carlo . . . . .	9756216	1	15.70	SHROUD ASSY. (saddle) (comb. 741, 742) . . . . .
74-75	Malibu, El Camino (Custom) . . . . .	9756283	1	15.70	SHROUD ASSY. (mid. blue) (comb. 732, 735) . . . . .
74	Malibu, El Camino (Custom) . . . . .	9756284	1	15.70	SHROUD ASSY. (neutral) (comb. 714, 722) . . . . .
74-75	Malibu, El Camino (Custom) . . . . .	9756285	1	15.70	SHROUD ASSY. (mid. green) (comb. 724, 728) . . . . .
74-75	Malibu . . . . .	9756286	1	15.70	SHROUD ASSY. (saddle) (comb. 740) . . . . .
74-75	Malibu Classic, Laguna, El Camino (Custom) (exc. Sta. Wag.) . . . . .	9756287	1	15.70	SHROUD ASSY. (oxblood) (comb. 743) . . . . .
74	Caprice (exc. Sta. Wag.) . . . . .	9756292	1	15.70	SHROUD ASSY. (med. green) (comb. 850, 855) . . . . .
74	Caprice (exc. Sta. Wag., Conv.) . . . . .	9756293	1	15.70	SHROUD ASSY. (taupe) (comb. 896) . . . . .
74	Impala . . . . .	9756294	1	15.70	SHROUD ASSY. (saddle) (comb. 849, 858) . . . . .
74	Bel Air, Impala . . . . .	9756296	1	15.70	SHROUD ASSY. (neutral) (comb. 815, 817, 819, 821) . . . . .
74	Bel Air, Impala . . . . .	9756297	1	15.70	SHROUD ASSY. (med. green) (comb. 851, 852, 853, 855) . . . . .
74	Impala . . . . .	9756298	1	15.70	SHROUD ASSY. (med. blue) (comb. 813, 847) . . . . .
74	Caprice Estate . . . . .	9756299	1	15.70	SHROUD ASSY. (saddle) (comb. 849) . . . . .
74	Caprice Estate . . . . .	9756301	1	15.70	SHROUD ASSY. (med. green) (comb. 855) . . . . .
74	Nova w/RPO Z51 . . . . .	9754399	1	15.70	SHROUD ASSY. ("Spirit of America") . . . . .
74	Impala (Spt. Cpe.) w/RPO Z-10 . . . . .	9754400	1	15.70	SHROUD ASSY. (midnight blue) (comb. 804) ("Spirit of America") . . . . .
74-75	Vega, Monza . . . . .	339016	1	12.35	SHROUD ASSY. . . . .
74	Impala (Spt. Cpe.) w/RPO Z-10 . . . . .	9754403	1	15.70	SHROUD ASSY. (oxblood) (comb. 809) ("Spirit of America") . . . . .
75	Bel Air . . . . .	9754425	1	15.70	SHROUD ASSY. (dk. blue) . . . . .
75	Bel Air . . . . .	9754426	1	15.70	SHROUD ASSY. (dk. sandstone) . . . . .
75	Impala . . . . .	9754427	1	15.70	SHROUD ASSY. (black) . . . . .
75	Impala . . . . .	9754428	1	15.70	SHROUD ASSY. (dk. blue) . . . . .

**FRONT AXLE—STEERING**

**6.512 HUB ASSY.— SHROUD— SHROUD ASSY.— INSULATOR— PAD—  
PLATE— RETAINER, Steering Wheel Hub (Con't)**

75	Impala	9754429	1	15.70	SHROUD ASSY. (dk. green)
75	Impala	9754430	1	15.70	SHROUD ASSY. (dk. sandstone)
75	Impala	9754431	1	15.70	SHROUD ASSY. (dk. saddle)
75	Impala (Spt. Cpe.)	9754432	1	15.70	SHROUD ASSY. (dk. oxblood)
75	Nova (exc. Sport Wheel)	9754433	1	15.70	SHROUD ASSY. (black)
75	Nova (exc. Sport Wheel)	9754434	1	15.70	SHROUD ASSY. (dk. graystone) ("LN" pkg.)
75	Nova (exc. Sport Wheel)	9754435	1	15.70	SHROUD ASSY. (dk. blue) ("LN" pkg.)
75	Nova (exc. Sport Wheel)	9754436	1	15.70	SHROUD ASSY. (dk. sandstone) ("LN" pkg.)
75	Nova (exc. Sport Wheel)	9754437	1	15.70	SHROUD ASSY. (dk. oxblood) ("LN" pkg.)
75	Malibu Classic, El Camino (exc. Sta. Wag.)	9754438	1	15.70	SHROUD ASSY. (dk. graystone)
75	Malibu Classic	9754439	1	15.70	SHROUD ASSY. (dk. blue)
75	Malibu Classic	9754440	1	15.70	SHROUD ASSY. (dk. sandstone)
75	Malibu Classic (exc. Sed.)				
75	Laguna, El Camino (Custom)	9754441	1	15.70	SHROUD ASSY. (dk. saddle)
75	Monte Carlo	9754446	1	15.70	SHROUD ASSY. (dk. blue)
75	Monte Carlo	9754447	1	15.70	SHROUD ASSY. (dk. sandstone)
75	Caprice Classic	9754448	1	15.70	SHROUD ASSY. (black)
75	Caprice Classic (exc. Conv.)	9754449	1	15.70	SHROUD ASSY. (dk. gray)
75	Caprice Classic (exc. Conv.)	9754450	1	15.70	SHROUD ASSY. (dk. blue)
75	Caprice Classic	9754451	1	15.70	SHROUD ASSY. (dk. green)
75	Caprice Classic	9754452	1	15.70	SHROUD ASSY. (dk. sandstone)
75	Caprice (Conv.)	9754453	1	15.70	SHROUD ASSY. (dk. saddle)
75	Caprice Classic (exc. Conv.)	9754454	1	15.70	SHROUD ASSY. (dk. oxblood)
75	Caprice Estate	9754455	1	15.70	SHROUD ASSY. (black)
75	Caprice Estate	9754456	1	15.70	SHROUD ASSY. (dk. blue)
75	Caprice Estate	9754457	1	15.70	SHROUD ASSY. (dk. green)
75	Caprice Estate	9754458	1	15.70	SHROUD ASSY. (dk. sandstone)
75	Caprice Estate	9754459	1	15.70	SHROUD ASSY. (dk. saddle)
75	Malibu Classic, El Camino w/Sport Wheel	356936	1	57.75	SHROUD ASSY. (dk. green)
75	Monza	9758853	1	14.35	SHROUD ASSY. (oxblood)
73	Caprice, Chevelle, Nova, Pass., Chevelle, Nova	9752567	1	3.15	INSULATOR, strg. wheel
73-74	All (exc. Vega)	9755107	1	8.25	PAD (mid. blue) (725, 733, 734, 737, 843)
73-74	All (exc. Vega)	9755108	1	8.25	PAD (mid. neutral) (711, 715, 716, 731, 734, 735, 819, 841)
73	All (exc. Vega)	9755109	1	8.25	PAD (dk. green) (715, 726, 727, 728)
73-74	All (exc. Vega)	9755110	1	8.25	PAD (dk. oxblood) (709, 714, 740, 743, 744, 857)
73	All (exc. Vega)	9755111	1	8.25	PAD (dk. blue) (719, 723)
73	All (exc. Vega)	9755112	1	8.25	PAD (dk. saddle) (717)
73	Caprice, Chevelle, Nova, Pass., Chevelle, Nova	9752568	1	5.60	PLATE, strg. wheel trim
73	Caprice, Chevelle, Nova, Pass., Chevelle, Nova	9752566	1	4.25	RETAINER, strg. wheel shroud assy.

NOTE 1 May be used without insert.

**6.513 WHEEL ASSY., Steering**

NOTE For Horn Ring see group 2.830, for Horn Cap see group 2.820.

NOTE See Dealer Price Schedule (P&A 26) for Applicable Prices.

64-66	Chevelle w/wood grain wheel,				
65-66	Pass. w/wood grain wheel	9741033	1	65.50	plastic (walnut) (16 <sup>1</sup> / <sub>2</sub> " O.D.)
71-72	Vega (exc. G.T.),				
73	Vega (exc. G.T., Spt. Wheel)	329733	1	40.25	
71-72	Vega (G.T.)	3978125	1	60.75	
73-75	Camaro,				
74	Laguna w/Sport Wheel,				
73-75	Monza, Vega w/G.T., Spt. Wheel,				
75	Chevelle, Nova w/Sport Wheel	329734	1	60.75	(black)
73-75	All (exc. Sport Wheel, Monza) (Towne Cpe.)	9757008	1	37.75	(dk. oxblood) (709, 714, 719, 720, 731, 740, 743, 744, 809, 845, 846, 856, 857)
73-74	Pass., Chevelle, Nova,				
74	Vega (exc. G.T., Spt. Wheel)	9754752	1	40.25	(black)
73-74	Pass., Chevelle	9757004	1	37.75	(midnight blue)
73	Laguna (exc. Estate)	9755091	1	37.75	(dk. blue)
73-74	Chevelle,				
73-74	Caprice (exc. Estate)	9757006	1	37.75	(midnight neutral)
73	Caprice, Laguna, Monte Carlo	9755093	1	37.75	(dk. green)
73	Bel Air (Sta. Wag.),				
73	Laguna (exc. Sed.)	9755095	1	37.75	(dk. saddle)
74	Impala, Caprice				(comb. 849, 858)

**FRONT AXLE—STEERING**

<b>6.513 WHEEL ASSY., Steering (Con't)</b>					
74	Chevelle	9757010	1	37.75	(saddle) (comb. 631, 740, 741, 742)
75	Monza (Towne Cpe.) (exc. Sport Wheel),				
74-75	Pass., Chevelle, Nova	9757011	1	37.75	(comb. 724, 725, 726, 728, 729, 730, 850, 851, 852, 853, 855) (drk. green)
74	Caprice (exc. Sta. Wag.)	9757013	1	37.75	(taupe) (comb. 896)
74	Camaro	340375	1	57.75	(neutral) (comb. 780)
74	Camaro, Laguna w/Sport Wheel,				
75	Monza (Towne Cpe.) w/Sport Wheel	340376	1	57.75	(saddle) (comb. 718, 731, 797, 799)
74	Camaro	340377	1	57.75	(taupe) (comb. 783, 784)
74-75	Laguna w/Sport Wheel,				
75	Malibu Classic, El Camino (Custom) w/Sport Wheel (exc. Sta. Wag.)	356936	1	57.75	(dk. green) (trim 441)
75	Malibu Classic, El Camino (Custom) w/Sport Wheel (exc. Sta. Wag.),				
75	Camaro, Nova w/Sport Wheel,				
75	Vega w/Sport Wheel	339752	1	57.75	(oxblood)
75	Camaro (L.T.),				
75	Nova, Custom w/Sport Wheel,				
75	Malibu Classic, El Camino, Laguna,				
75	Monza w/Sport Wheel	352816	1	57.75	(dk. graystone) (trim 161)
75	Nova Custom w/Sport Wheel,				
75	Malibu Classic, El Camino w/Sport Wheel,				
75	Camaro (L.T.),				
75	Monza w/Sport Wheel	352817	1	57.75	(dk. sandstone) (trim 551)
75	Pass., Chevelle, Monza	9757009	1	38.75	(saddle)
75	Camaro (L.T.),				
75	Malibu Classic, El Camino Custom w/Sport Wheel,				
75	Monza w/Sport Wheel	352818	1	57.75	(dk. saddle) (trim 631)
75	Pass., Chevelle,				
75	Nova (exc. Sport Wheel),				
75	Vega, Monza (exc. Sport Wheel)	9754423	1	34.50	(dk. sandstone)
75	Pass., Chevelle,				
75	Nova (exc. Sport Wheel)	9754421	1	34.50	(dk. graystone)
75	Pass., Chevelle, Nova, Vega,				
75	Monza (exc. Sport Wheel)	9757003	1	37.75	(black)
75	Pass., Malibu Classic, Monte Carlo (exc. Sport Wheel),				
75	Nova (exc. Sport Wheel),				
75	Vega, Monza (exc. Sport Wheel)	9754422	1	34.50	(blue)
75	Malibu Classic w/Sport Wheel,				
75	Vega, Monza w/Sport Wheel	352894	1	57.75	(dk. blue) (trim 261)
75	Laguna	348030	1	57.75	(dk. gray)
75	H (exc. Sport Whl.)	9758584	1	38.25	(firethorn) (trim 711)

**FRONT AXLE—STEERING**

**1965**

	BLACK	RED	AQUA	GREEN	SADDLE	FAWN	BLUE	AQUA & WHITE	TWO TONE GRAY
IMPALA . . . . .	9742438								9742438

**1966**

	BLACK	RED	TURQ.	GREEN	BRONZE	LT. FAWN	MED. FAWN	BRT. BLUE	MED. BLUE
BISCAYNE, BEL AIR . . . . .									3881726
IMPALA, CAPRICE . . . . .	9742438								

**1967**

	BLACK	BLUE	TURQ.	FAWN	MAROON	RED	PLUM	BRT. BLUE	GOLD
PASS. (exc. DELUXE Whl.) . . . . .									9747568
PASS. (w/DELUXE Whl.) . . . . .	9746436								

**1968**

	BLACK	BLUE	GOLD	TEAL	RED	SADDLE	GRAY GREEN	TURQ.	ROSE- WOOD
PASS. (exc. DELUXE Whl.) . . . . .	9747568								
PASS. w/DELUXE Whl.) . . . . .	9747536	9747537	9747538						9747542

**NOVA—CHEVELLE—CAMARO**

	BLUE	RED	FAWN	SADDLE	BLACK	AQUA	BRT. BLUE	GOLD	OTHERS
62-64 CHEVY . . . . .	3883633				770631				
64 CHEVELLE . . . . .	3883633				3883633				
64 CHEVELLE . . . . .									
65 CHEVY . . . . .					770631				
65 CHEVELLE . . . . .	3883633								
65 CHEVELLE (STD.) . . . . .									
65 CHEVELLE (DEL.) . . . . .	3863621					3883633			
66 CHEVY (STD.) . . . . .	3873628		3873621						
66 CHEVY (DEL.) . . . . .							3879712		
66 CHEVELLE (STD.) . . . . .									
66 CHEVELLE (DEL.) . . . . .		3883633			3883633				
67 CHEVY, CHEVELLE (STD.) . . . . .	9745997				9747748				
67 CHEVY, CHEVELLE (DEL.) . . . . .						9746503			
67 CAMARO (STD.) . . . . .					9745977				
67 CAMARO, w/DEL. WHEEL . . . . .					9746436				

## FRONT AXLE—STEERING

	BLACK	GOLD	RED	TURQ.	BLUE	SADDLE	GRAY GREEN	TEAL
68 CAMARO (exc. Del. Wheel) . . . . .	9747926							
68 CAMARO w/Del. Wheel . . . . .	9747536♣							
68 CAMARO w/Del. Interior . . . . .	9747536	9747538			9747537			
68 CHEVY (exc. Int. Conv. Pkg., Del. Wheel) . . . . .								
68 CHEVY w/Int. Conv. Pkg., tel. w. (exc. Del., Wood Grain Wheel) . . . . .	9747926							
68 CHEVY w/Del. Wheel . . . . .	9747536	9747538			9747537			
68 CHEVELLE (STD.) (exc. Deluxe Wheel), . . . . .								
68 NOMAD (exc. Deluxe Wheel) . . . . .								
68 CHEVELLE w/Del. Wheel . . . . .	9747536	9747538			9747537		9747542	

+NOTE: For service use two-tone in place of single-tone.  
Two-Tone w/White

‡Bronze  
♣May be necessary to paint as req'd.

### 1969

	BLACK	RED	SADDLE	MIDNIGHT GREEN	MED. GREEN	BLUE	TURQ.	GOLD	ROSE- WOOD
ALL. . . . .	3997584	3997589	3997586	3997593	3997592	3997585	3997594	3997590	
ALL. w/Wood Grain Wheel . . . . .									

### 1970

BLACK	BLUE	SADDLE	GREEN	TURQ.	RED	GOLD	SANDAL- WOOD
3997584	3997585	3997586	3997587	3997588	3997589	3997590	3997591
333590							
3989115(1)							
9752131(3)							

- (1) Camaro
- (2) Madrid Grain Finish
- (3) Fits all w/Deluxe Vinyl Steering Wheel.

### 1971

BLACK	DK. BEIGE	DK. SADDLE	DK. BLUE	DK. JADE
3989115	3992316(3)	3992317(3)	3992318(3)	3992319(3)
9752131(1)				
3978125(2)				

- (1) Fits Pass., Chevelle, Nova, Camaro w/Deluxe Vinyl Steering Wheel.
- (2) Fits Chevelle, Nova, Camaro w/Sport Steering Wheel (4 Spokes) (Simulated Stitch)
- (3) Fits Chevelle, only (exc. Monte Carlo, S.S.)

### 1972

#### BLACK

3989115 (3)  
9752131 (1)  
3978125 (2)

- (1) Fits All w/Deluxe Vinyl Steering Wheel.
- (2) Fits Chevelle, Camaro, Nova w/Sports Steering Wheel (4 Spokes) (Simulated Stitch).
- (3) Standard

**FRONT AXLE—STEERING**

**6.514 SHOE— BUMPER— GATE— GUIDE— HOUSING ASSY.— KNOB— LEVER— PIN— PLATE— RETAINER— SCREW— SPACER— SPHERE— SHIELD— SPRING— STOP— SUPPORT ASSY.— LOCK— BRACKET ASSY.— WASHER— WEDGE, Tilt or Tel. Steering Column**

67-68	Pass., Chevelle, Camaro	5698425	1		column lock, (3 position)
67-68	Pass., Chevelle, Camaro	7815595	1	15.45	column lock (4 position)
69-72	All w/T.W.,				
72-75	Camaro w/A.T. (exc. floor console),				
73-75	All w/T.W.	7804925	1	5.00	lock (3 position)
69-72	All w/T.W.,				
72-75	Camaro w/A.T. (exc. floor console),				
73-75	All w/T.W.	7813068	1	5.00	lock (4 position)
71	Monte Carlo w/T.W., 4BC (400) w/4-Spd.,				
72-75	All w/T.W.	7813069	1	.78	BUMPER, strg. col. down
71	Pass., Chevelle, Camaro w/T.W. (exc. floor console)	7811691	1	2.70	GATE, strg. column gear shift lever
69	Pass., Chevelle, Camaro w/T.W.,				
70	All w/T.W. (exc. Camaro),				
71-75	All w/T.W.,				
72	Camaro w/A.T. (exc. floor console, T.W.)	7800176	1	1.05	GUIDE, strg. col. tilt spring
66	Pass. (T.W. w/Tel. W.)	5694942	1	45.50	HOUSING ASSY., w/actuator, turn signal
69-70	All Tilt Whl.	7819860	1	71.75	HOUSING KIT, strg. col. brg.
71-74	Chevelle, Camaro, Nova	7819856	1	69.00	HOUSING KIT, strg. col.
71-74	Pass.	7819861	1	69.50	HOUSING KIT, strg. col.
75	Vega, Monza w/T.W.	7818951	1	64.75	HOUSING ASSY., column
65	Pass. w/T.W.	3782965	1	.46	KNOB, release lever— (2.897)
65-66	Caprice w/T.W.	3973060	1	.24	KNOB, release lever— (2.897)
64-69	Pass., Chevelle w/Tel. W.,				
67-69	Camaro,				
70	All w/T.W.	3832567	1	1.45	LEVER, wheel release
67-68	Pass.,				
67	Chevelle, Camaro,				
69	Chevelle, Camaro w/T.W.,				
69	Pass. w/T.W., Tel. W.,				
70	All w/T.W. (exc. Camaro),				
71-75	All w/T.W.	7800154	1	6.25	LEVER, shoe release
71	All w/T.W.,				
72	All w/T.W. (exc. Nova),				
73-75	All w/T.W.	3990859	1	1.50	LEVER, wheel release (black)
66-68	Pass.,				
67-68	Chevelle, Camaro	5693411	1	.78	PIN, pivot
67-68	Pass., Chevelle, Camaro	5698688	1	.78	PIN, shoe rel.
67-68	Pass., Chevelle, Camaro,				
69	Pass., Chevelle, Camaro w/T.W., Tel. W.,				
70	All w/T.W. (exc. Camaro),				
71-75	All w/T.W.	5698406	1	.38	PIN, shoe rel. lever
68-69	Chevelle,				
69	Malibu, El Camino (Custom) (2-Dr.),				
70	Chevelle (exc. T.W.)	5690977	1	.32	PIN, strg. column shaft
69	Pass., Chevelle, Camaro w/T.W.,				
70	All w/T.W. (exc. Camaro),				
71-75	Camaro w/A.T. (exc. floor console),				
71-75	All w/T.W.	7810363	2	1.10	PIN, pivot
69	Pass., Chevelle, Camaro w/T.W.,				
70	All w/T.W. (exc. Camaro),				
71-72	Camaro w/A.T. (exc. floor console, T.W.),				
71	All w/T.W.,				
72-75	Pass., Chevelle, Camaro w/T.W.	7806567	1	.38	PIN, lock shoe retainer
67-68	Pass., Chevelle, Camaro	5698395	1	1.95	PLATE, strg. col. supt. lock
67-68	Chevy, Chevelle, Camaro w/col. shift (exc. T.W.),				
69	Pass., Chevelle, Camaro w/T.W.,				
70	All w/T.W. (exc. Camaro),				
71-75	All w/T.W.	7804915	1	2.15	PLATE, lock
70	All w/T.W. (exc. Camaro)	7804916	1	2.10	PLATE, gear shaft lever detent
67-69	Pass., Chevelle, Camaro w/T.W.,				
70	All w/T.W. (exc. Camaro),				
71-75	All w/T.W.,				



**FRONT AXLE—STEERING**

**6.514 SHOE— BUMPER— GATE— GUIDE— HOUSING ASSY.— KNOB— LEVER— PIN— PLATE— RETAINER— SCREW— SPACER— SPHERE— SHIELD— SPRING— STOP— SUPPORT ASSY.— LOCK— BRACKET ASSY.— WASHER— WEDGE, Tilt or Tel. Steering Column (Con't)**

72-75	Camaro w/A.T. (exc. floor console, T.W.)	7800177	1	.53	RETAINER, spring
67-68	Pass., Chevelle, Camaro	5698404	4	.38	SCREW, column supt. asm. (1/2" — 28 x 1 13/32")
69	Pass., Chevelle, Camaro w/T.W., Tel. W.,				
70	All w/T.W. (exc. Camaro),				
71-75	Camaro w/A.T. (exc. floor console, T.W.),				
71-75	All w/T.W.	7807274	4	.32	SCREW, strg. column support
67-68	Pass., Chevelle, Camaro	7801021	2	1.05	SPHERE, shaft centering
64-66	Pass., Chevelle w/T.W.,				
65-70	Pass.,				
63-70	Chevy, Chevelle, Camaro,				
71-75	Camaro w/A.T. (exc. floor console, T.W.),				
71-75	All w/T.W.	7808505 A.R.		3.40	SPHERE UNIT, shaft centering (Note 1)
	<i>NOTE 1 Unit consists of (2) Sphere column shaft centering, (2) Spheres, center, (1) Spring (1) Instruction sheet.</i>				
69	Pass., Chevelle, Camaro w/T.W.,				
70	All w/T.W. (exc. Camaro),				
71-75	Camaro w/A.T. (exc. floor console, T.W.),				
71-75	All w/T.W.	7805608	1	.53	SHIELD, strg. column tilt lever opening
75	Vega, Monza w/P/S	360327	1	3.00	SHIELD, strg. shaft coupling
64-66	Chevelle,				
65-66	Pass.	5676787	2	1.20	SPRING, steering column tilt
64-68	Pass., Chevelle, Camaro w/T.W.	5679311	1	.71	SPRING, strg. shaft yoke
67-68	Chevelle, Camaro,				
67	Pass.	5698998	2	1.45	SPRING, shoe rtn.
67-68	Pass., Chevelle, Camaro,				
69	Pass., Chevelle, Camaro w/T.W., Tel. W.,				
70	All w/T.W. (exc. Camaro),				
71	All w/T.W.,				
72	Camaro w/T.W.,				
72	Monte Carlo,				
72	Camaro w/A.T. (exc. floor console, T.W.),				
73-75	All w/T.W.	5698410	1	.78	SPRING, shoe rel.
67-68	Pass., Chevelle, Camaro	5698415	1	1.20	SPRING, tilt
67-69	Pass., Chevelle, Camaro w/T.W. (exc. 3-Spd.),				
70	All w/T.W. (exc. Camaro),				
71-75	All w/T.W.,				
72-75	Camaro w/A.T. (exc. floor console, T.W.)	7804912	2	.53	SPRING, lock shoe return
69	Pass., Chevelle, Camaro w/T.W.,				
70	All w/T.W. (exc. Camaro),				
71	All w/T.W.	7812854	1	1.25	SPRING, tilt
72-75	All w/T.W.	7812854	1	1.25	SPRING, steering column wheel tilt
75	Vega, Monza w/T.W.	7816826	1	.60	SPRING, inhibitor return
67-68	Pass., Chevelle, Camaro (column shift) w/T.W.	5698649		14.85	SUPPORT ASSY., strg. col.
67-68	Chevelle, Camaro (floor shift w/T.W.),				
67	Pass. (Floor Shift)	5698847	1	12.50	SUPPORT ASSY., strg. col.
69	Pass., Chevelle, Camaro (T.W., w/A.T.) (exc. bucket seats, floor controls),				
69	Pass., Chevelle, Camaro (T.W. w/floor shift),				
70	All w/T.W. (exc. Camaro),				
71-72	Pass. w/A.T. (exc. T.W.),				
71	All w/T.W.,				
72	Camaro w/T.W. (exc. A.T.),				
72-75	Chevelle w/T.W. (exc. Monte Carlo),				
73-75	Pass. w/A.T. (exc. T.W.),				
73-75	Camaro w/T.W. (exc. A.T.)	7807635	1	17.20	SUPPORT ASSY., turn signal housing
71	All w/T.W. (exc. floor console),				
72-75	Pass. w/T.W.,				

**FRONT AXLE—STEERING**

**6.514 SHOE— BUMPER— GATE— GUIDE— HOUSING ASSY.— KNOB— LEVER— PIN— PLATE— RETAINER— SCREW— SPACER— SPHERE— SHIELD— SPRING— STOP— SUPPORT ASSY.— LOCK— BRACKET ASSY.— WASHER— WEDGE, Tilt or Tel. Steering Column (Con't)**

72-75	Chevelle w/T.W., A.T. (exc. floor console),				
72	Camaro (A.T. w/T.W.),				
73-75	Camaro (A.T. w/T.W.) (exc. floor console)	7811692	1	18.05	SUPPORT ASSY., strg. column housing
75	Vega, Monza w/T.W.	7819197	1	18.20	SUPPORT ASSY., housing
75	Vega, Monza w/T.W.	7815896	1	3.80	LOCK, inhibitor
75	Vega, Monza w/T.W.	7818512	1	15.75	BRACKET ASSY., col. support
67-68	Pass., Chevelle, Camaro	5699618	1	.53	WASHER, strg. column supt. asm. wave— (4.012)
67	Chevelle, Camaro,				
67-68	Pass.	5698413	1	.53	WASHER, column supt. thrust— (4.012)
67-68	Chevelle, Camaro,				
67	Pass.	7808505	1	3.40	WASHER, shaft centering sphere
66	Pass. w/T.W.	7809977	1	2.00	WEDGE, column locking

**6.515 WASHER— NUT— RETAINER, Steering Wheel**

62-71	All	3954735	A.R.	.13	( <sup>17</sup> / <sub>32</sub> " I.D. x <sup>15</sup> / <sub>16</sub> " O.D. x <sup>3</sup> / <sub>32</sub> " thick)
62-71	All	124934	1		NUT, hub ( <sup>1</sup> / <sub>2</sub> "— 20)— (8.916)
75	All	419454	1	.12	RETAINER, nut

**6.518 COLUMN ASSY.— BRACKET ASSY.— COVER— EXTENSION— HOUSING— JACKET ASSY.— REINFORCEMENT— SCREW— SHROUD— TUBE— WEDGE— WASHER— BUSHING— RACK— BOWL, Mast (Also see Group 6.803)**

67	Chevelle (column shift) w/3-Spd.	7802717	1	83.75	
67	Chevy w/3-Spd. (column shift)	7803533	1	91.25	
67-68	Camaro w/P.G. column shift (exc. T.W.)	7803775	1	78.00	(Note 1)
67-68	Camaro w/floor shift (exc. T.W.)	7803777	1	78.00	(Note 1)
67-68	Pass. w/T.W. column shift	7803774	1	141.00	
67-68	Pass. w/A.T. column shift (exc. T.W.)	7803773	1	78.00	
67	Pass. w/3-Spd. column shift (2nd design),				
68	Pass. w/3-Spd. column shift (exc. Police)	7803567	1	78.00	
68	Chevy (column shift w/A.T.) (exc. Torque Drive),				
68	Camaro w/T.H. 350	7803781	1	74.50	
68	Chevy column shift (exc. A.T.)	7803783	1	80.75	
68	Chevelle (column shift) w/3-Spd. (exc. 396)	7802411	1	83.75	
69	Chevy, Camaro (floor shift) (exc. T.W.)	7804300	1	84.00	
69	Camaro, Chevy w/Torque Drive (exc. T.W.),				
70-71	Nova w/Torque Drive	7812232	1	88.25	
69	Chevelle (floor shift) w/A.T. (exc. 396, T.W.),				
70	Monte Carlo (Console w/A.T.) (exc. T.W. 396, T.H. 400),				
71-72	Chevelle w/Console (exc. T.W.)	7812236	1	75.50	
69	Pass. w/A.T. column shift (exc. T.W.)	7804295	1	87.50	
69	Pass. w/3-Spd. (column shift)	7804296	1	87.50	
69	Pass. (floor shift) (exc. T.W.)	7804297	1	87.50	
69	Pass. column shift (w/T.W.)	7810030	1	181.00	
69-70	Chevelle (column shift) (T.W. w/A.T.) (exc. 396),				
70-71	Chevelle (T.W. w/T.H. 400) (exc. Monte Carlo)				column shift,
72	Chevelle w/T.W., A.T. (exc. Console)	7812207	1	165.00	steering
70	Pass. w/T.W.	7810030	1	181.00	
70	Pass. w/A.T. (exc. T.W.)	7804295	1	87.50	column shift
70	Pass. (exc. A.T., T.W.)	7804296	1	87.50	column shift
71-74	Pass. w/A.T. (exc. T.W.)	7811782	1	87.50	steering
71-74	Pass. w/T.W.	7813073	1	191.00	steering
71-72	Pass. (exc. A.T., T.W.)	7810198	1	75.50	steering
70	Monte Carlo (T.W. w/T.H. 400, Console),				

**FRONT AXLE—STEERING**

**6.518 COLUMN ASSY.— BRACKET ASSY.— COVER— EXTENSION— HOUSING— JACKET ASSY.— REINFORCEMENT— SCREW— SHROUD— TUBE— WEDGE— WASHER— BUSHING— RACK— BOWL, Mast (Also see Group 6.803) (Con't)**

70	Chevelle (T.W. w/A.T.) (exc. Monte Carlo),				
71-72	Chevelle (Console w/A.T., T.W.)	7812208	1	165.00	floor shift
69	Chevelle (column shift) w/A.T. (exc. T.W. 396),				
70	Monte Carlo w/A.T. (exc. T.W., Console, T.H. 400)				column shift,
70-72	Chevelle w/A.T. (exc. Console, T.W.)	7812230	1	75.50	steering
69	Chevelle (floor shift) (396) (exc. T.W., A.T.),				
70	Chevelle (exc. T.W., A.T.),				
70	Monte Carlo w/4-Spd.,				
71	Chevelle (3, 4-Spd.) (exc. Column Shift),				
72	Chevelle (4-Spd.) (exc. T.W.)	7812237	1	75.50	steering
71-72	Chevelle (4-Spd. w/T.W.)	7812209	1	165.00	steering
69	Chevelle (column shift) w/3-Spd.,				
70	Monte Carlo w/3-Spd. (exc. T.W.)				floor shift,
70-72	Chevelle w/3-Spd. column shift	7812234	1	75.50	steering
70	Nova w/Console (exc. A.T.)	7804300	1	84.00	floor shift
69	Nova, Camaro (column shift) w/A.T. (exc. T.W.),				
70	Nova w/A.T. (exc. T.W.)				column shift,
71	Nova w/A.T. (exc. floor console)	7812231	1	88.25	steering
69	Nova, Camaro (column shift) w/3-Spd.,				
70	Nova w/3-Spd. (exc. T.W.)				column shift,
71-72	Nova w/3-Spd.,				
73-74	Nova w/3-Spd. (exc. floor console)	7812235	1	88.25	steering
71	Nova w/floor console	7812238	1	100.00	steering
70	Camaro (w/T.W., 4-Spd.),				
70	Camaro (w/T.W., A.T.) w/floor console,				
71-72	Camaro w/T.W. (exc. A.T.),				
73-74	Camaro T.W. w/floor console	7812204	1	165.00	steering
70	Camaro (w/T.W., A.T.) (exc. floor console)	7808582	1	186.00	
70-71	Camaro (exc. T.W.),				
72-75	Camaro A.T., w/floor console (exc. T.W.),				
72	Camaro w/3, 4-Spd. (exc. floor console, T.W.)	7812229	1	75.50	steering
71	Camaro w/A.T., T.W. (exc. floor console),				
72	Camaro w/A.T., T.W.,				
73-74	Camaro w/A.T., T.W. (exc. floor console)	7812203	1	165.00	steering
71-75	Camaro w/A.T. (exc. Console, T.W.)	7812224	1	75.50	steering
72	Nova w/A.T. (exc. floor console),				
73-74	Nova (2-Dr.) w/P.G., T.H. 350 (exc. T.W. console),				
73-74	Nova (4-Dr.) w/P.G., T.H. 350 (exc. T.W.)	7813671	1	88.25	steering
72	Nova w/Torque Drive	7813672	1	88.25	steering
72	Nova w/floor console,				
73-74	Nova w/floor console (exc. A.T., T.W.),				
73-74	Nova (T.H. 350 w/floor console) (exc. T.W.)	7813673	1	100.00	steering
71-73	Vega (exc. P/S)	7811979	1	85.25	steering
71-73	Vega w/P/S	7810705	1	75.25	steering
73-74	Chevelle (T.H. 350) (exc. floor console, T.W.)	7812366	1	75.50	steering
73-74	Chevelle w/3-Spd.	7812378	1	88.25	steering
73-74	Chevelle (T.H. 350 w/floor console) (exc. T.W. close ratio)	7812389	1	75.50	steering

**FRONT AXLE—STEERING**

**6.518 COLUMN ASSY.— BRACKET ASSY.— COVER— EXTENSION— HOUSING— JACKET ASSY.— REINFORCEMENT— SCREW— SHROUD— TUBE— WEDGE— WASHER— BUSHING— RACK— BOWL, Mast (Also see Group 6.803) (Con't)**

73-74	Chevelle (A.T. w/T.W.) (exc. Deluxe floor console) . . . . .	7812582	1	165.00	steering . . . . .
73-74	Chevelle (2-Dr.) w/4-Spd., T.W.,				
73-74	Chevelle (2-Dr.) (T.H. 350 w/floor console) w/T.W. . . . .	7812583	1	165.00	steering . . . . .
73-74	Nova (A.T. w/T.W.) (exc. floor console) . . . . .	7815159	1	165.00	steering . . . . .
73-74	Nova (T.H. 350, w/floor console) w/T.W.,				
73-74	Nova (floor console w/T.W.) (exc. A.T.) . . . . .	7815160	1	165.00	steering . . . . .
74	Vega (140) (exc. P/S) . . . . .	7816850	1	85.25	
74	Vega w/P/S . . . . .	7816852	1	85.25	steering . . . . .
74-75	Vega (122) . . . . .	7817606	1	85.25	steering . . . . .
75	Nova w/3-Spd. (exc. floor shift) . . . . .	7818760	1	82.25	steering . . . . .
75	Nova (T.W. w/T.H. 350) (exc. floor console) . . . . .	7818762	1	150.00	steering . . . . .
75	Nova w/T.H. 350 (exc. floor console, T.W.) . . . . .	7818758	1	82.25	steering . . . . .
75	Camaro (A.T. w/T.W.) (exc. floor console) . . . . .	7818756	1	165.00	steering . . . . .
75	Camaro (T.W. w/floor console) . . . . .	7818757	1	165.00	steering . . . . .
75	Nova w/floor console (exc. A.T., T.W.),				
75	Nova (T.H. 350 w/floor console) (exc. T.W.) . . . . .	7818759	1	100.00	steering . . . . .
75	Nova w/T.W. (T.H. 350, w/floor console),				
75	Nova (floor console w/T.W.) . . . . .	7818761	1	165.00	steering . . . . .
75	Chevelle w/3-Spd. . . . .	7818906	1	82.25	steering . . . . .
75	Chevelle (A.T. w/floor console) (exc. T.W.) . . . . .	7818898	1	82.25	steering . . . . .
75	Chevelle w/A.T. (exc. floor console, T.W.) . . . . .	7818896	1	82.25	steering . . . . .
75	Chevelle w/T.W. (A.T. w/floor console) . . . . .	7818832	1	151.00	steering . . . . .
75	Chevelle (A.T. w/T.W.) (exc. floor console) . . . . .	7818830	1	151.00	steering . . . . .
75	Pass. w/T.W. . . . .	7818859	1	188.00	steering . . . . .
75	Pass. (exc. T.W.) . . . . .	7818915	1	87.50	steering . . . . .
75	Vega, Monza (140) (exc. T.W., P.S.),				
75	Vega, Monza (H.B.) (exc. P/S, T.W.) . . . . .	7818994	1	76.00	steering . . . . .
75	Vega, Monza w/P/S (exc. T.W.) . . . . .	7818996	1	76.00	steering . . . . .
75	Vega, Monza w/T.W. . . . .	7816818	1	141.00	steering . . . . .
75	Monza (H.B.) (8 cyl.) (exc. P/S) . . . . .	7819923	1	77.75	steering . . . . .
70-75	Camaro . . . . .	7808639	1	5.45	BRACKET ASSY., column support . . . . .
67-68	Camaro . . . . .	3899895	1	.70	COVER, steering gear jacket inner . . . . .
67	Camaro . . . . .	3899897	1	.71	COVER, steering gear jacket outer . . . . .
67	Pass. w/A.T. (exc. Strato Seats) . . . . .	3913689	1	1.90	COVER, strg. gear jacket upper . . . . .
68	All . . . . .	5699613	1	1.50	COVER, strg. col. mesh . . . . .
68	Impala, Caprice . . . . .	3920373	1	1.25	COVER, inst. panel strg. gear jacket lower . . . . .
68	Chevy . . . . .	3919062	1	1.35	COVER, strg. column . . . . .
68	Chevelle . . . . .	3919937	1	1.10	COVER, inst. panel strg. col. hole . . . . .
69-72	Chevy . . . . .	3935940	1	1.10	COVER, strg. column . . . . .
69	Camaro . . . . .	3935995	1	1.10	COVER, strg. column . . . . .
69	Chevelle . . . . .	3939627	1	1.10	COVER, inst. panel strg. column hole . . . . .
69-70	Pass. . . . .	3950015	1	1.10	COVER, inst. panel strg. gear jacket . . . . .
70-72	Monte Carlo,				
71	Chevelle (454 w/inst. panel gauges),				
72	Chevelle (S.S. w/inst. panel gauges) . . . . .	3965451	1	1.20	COVER, inst. panel strg. column hole . . . . .
70	Chevelle (exc. Monte Carlo),				
71-72	Chevelle (exc. 454, inst. panel gauges),				
72	Chevelle (S.S. w/inst. panel gauges) . . . . .	3965459	1	1.20	COVER, inst. panel strg. column hole (Note 4) . . . . .
70-75	Camaro . . . . .	6264759	1	6.80	COVER, inst. panel strg. column hole (Note 4) . . . . .

**FRONT AXLE—STEERING**

**6.518 COLUMN ASSY.— BRACKET ASSY.— COVER— EXTENSION— HOUSING— JACKET ASSY.— REINFORCEMENT— SCREW— SHROUD— TUBE— WEDGE— WASHER— BUSHING— RACK— BOWL, Mast (Also see Group 6.803) (Con't)**

71-75	Pass. ....	6264796	1	1.55	COVER, strg. gear jacket .....
71-74	Camaro w/A.T. (exc. floor console, T.W.) .....	7808410	1	8.15	COVER, trans. control lock tube shroud ...
74-75	Nova .....	6264714	1	.76	COVER, strg. column to dash lower .....
75	Nova .....	347579	1	2.80	COVER, steering gear jacket to dash trim ...
75	Monza (Towne Cpe.) .....	346764	1	3.20	COVER, instr. pnl. strg. column (black) paint as req. ....
67-68	Camaro (w/T.W., floor console) ..	7800262	1	16.45	EXTENSION, strg. jacket .....
67-68	All w/3-Spd. (exc. H.D.) .....	7800586	1	7.15	HOUSING, shaft upper bearing .....
67-68	Camaro w/floor shift (exc. T.W.) ..	5699057	1	23.10	HOUSING, w/shroud assy. less gear shift lever .....
69-70	Chevelle, Pass., Camaro .....	7819857	1	60.50	HOUSING, w/strg. col. brg. ....
71	Pass., Chevelle, Camaro w/T.W.,				
72-74	All w/T.W. ....	7819856	1	69.00	HOUSING ASSY., steering column steering shaft bearing .....
71-74	Camaro w/A.T. (exc. floor console, T.W.) .....	7813095	1	65.00	HOUSING ASSY., steering column steering shaft .....
73	Pass., Camaro w/T.W. ....	7809362	1	56.25	HOUSING ASSY., strg. column ign. switch selector .....
75	All w/T.W. (exc. Vega, Monza) ..	7818781	1	65.00	HOUSING ASSY., strg. column steering shaft bearing .....
62	Chevy (exc. P.G.) .....	3792717	1	9.30	JACKET ASSY. (29 <sup>5</sup> / <sub>32</sub> " O.L.) .....
65	Pass. w/3-Spd. ....	3872055	1	9.25	JACKET ASSY. (28 <sup>33</sup> / <sub>64</sub> " O.L.) .....
66	Chevy w/3-Spd. ....	3886537	1	7.85	JACKET ASSY. (Note 3) .....
67	Chevelle (exc. T.W.) .....	5699816	1	13.85	JACKET ASSY. ....
67-68	Camaro w/T.W.,				
68	Chevelle w/T.W. ....	5699944	1	15.45	JACKET ASSY. (25 <sup>1</sup> / <sub>2</sub> " ) .....
67-68	Camaro,				
68	Chevelle .....	5699820	1	13.85	JACKET ASSY. (28" ) .....
67-68	Pass. (exc. T.W.) .....	7803008	1	14.65	JACKET ASSY. ....
68	Chevy .....	7801442	1	36.25	JACKET ASSY., includes break away bracket .....
69	Chevelle, Camaro w/T.W.,				
70	Chevelle w/T.W.,				
71	All w/T.W. ....	7805254	1	28.75	JACKET ASSY. ....
69-70	Pass. (exc. T.W.) .....	7807539	1	25.75	JACKET ASSY. ....
70	Nova, Chevelle,				
71	Camaro (exc. T.W.),				
72	Camaro (exc. floor console),				
72-75	Camaro (exc. T.W.) .....	7809701	1	27.50	JACKET ASSY. ....
70-75	Camaro w/T.W. ....	7809702	1	27.50	JACKET ASSY. ....
71-72	Chevelle w/floor console,				
71-72	Camaro w/A.T. (exc. T.W.) .....	7805697	1	58.25	JACKET ASSY., steering column .....
71	Nova w/floor console .....	7805743	1	50.25	JACKET ASSY., steering column .....
71-72	Pass. (exc. T.W.) .....	7808885	1	29.50	JACKET ASSY. ....
72	All w/T.W.,				
73-74	Nova w/T.W. ....	7814019	1	28.25	JACKET ASSY., steering column .....
69-70	Chevy, Chevelle, Camaro (exc. T.W.),				
71	Nova (exc. floor console),				
71	Chevelle (exc. T.W.),				
72	Chevelle (exc. T.W.),				
72-74	Nova (exc. T.W.) .....	7813871	1	27.50	JACKET ASSY., steering column .....
71-75	Vega, Monza w/P/S (exc. T.W.) ..	7811012	1	25.00	JACKET ASSY., hyd. steering column .....
71-75	Vega, Monza (exc. P/S) .....	7810307	1	25.00	JACKET ASSY., steering column .....
73	Chevelle w/floor console,				
73	Camaro w/A.T. (exc. T.W.) .....	7805697	1	58.25	JACKET ASSY., steering column .....
73-75	Chevelle (exc. T.W.) .....	7812499	1	27.50	JACKET ASSY., strg. column .....
73-75	Pass. (exc. T.W.) .....	7808885	1	29.50	JACKET ASSY. ....
73-75	Pass. w/T.W. ....	7805257	1	28.75	JACKET ASSY. ....
73-75	Chevelle w/T.W. ....	7812645	1	31.25	JACKET ASSY. ....
75	Nova (exc. T.W.) .....	7817843	1	28.25	JACKET ASSY., strg. column .....
75	Nova w/T.W. ....	7818253	1	28.25	JACKET ASSY., steering column .....
75	Vega, Monza w/T.W. ....	7816777	1	28.25	JACKET ASSY., strg. column .....
70-75	Camaro .....	3999497	1	1.55	REINFORCEMENT, column to pillar .....
69	Pass., Chevelle, Camaro w/T.W.,				
70	All w/T.W. (exc. Camaro) .....	9419728	3	.16	SCREW, strg. column housing (repl. 9420804) .....
71-75	Camaro w/A.T. (exc. floor console, T.W.) .....	7808784	3	.38	SCREW, strg. column cover (to shroud) .....

**FRONT AXLE—STEERING**

**6.518 COLUMN ASSY.— BRACKET ASSY.— COVER— EXTENSION— HOUSING— JACKET ASSY.— REINFORCEMENT— SCREW— SHROUD— TUBE— WEDGE— WASHER— BUSHING— RACK— BOWL, Mast (Also see Group 6.803) (Con't)**

69	Pass., Chevelle (floor shift w/T.W.),					
70	Chevelle (A.T. w/T.W.) (exc. column shift),					
71	Chevelle (T.W. w/floor console)	7806003	1	28.25	SHROUD, strg. column trans. cont. link tube	
71-72	Camaro w/A.T. (exc. floor console, T.W.)	7808408	1	19.85	SHROUD, steering column trans. control lock tube	
71-72	Camaro w/T.W. (exc. A.T.)	7809375	1	26.50	SHROUD, steering column trans. control lock tube	
71-72	Pass. (exc. A.T., T.W.),					
71	Monte Carlo w/4-Spd. (exc. T.W.),					
71	Nova, Camaro (exc. T.W.),					
72	Camaro (exc. floor console, T.W.),					
72	Monte Carlo w/4-Spd. (350 4BC) (exc. T.W.)	7811350	1	7.90	SHROUD, steering column gear shift housing (bowl)— (4.010)	
71-72	Pass. w/A.T. (exc. T.W.),					
71	Chevelle (exc. T.W.),					
72	Chevelle (exc. T.W., Monte Carlo),					
72	Monte Carlo (exc. 4-Spd. 350 4BC, T.W.),					
73-75	Pass. (exc. T.W.),					
73-75	Monte Carlo (T.H. 400 w/floor console) (exc. T.W.)	7811352	1	7.75	SHROUD, steering column gear shift housing (bowl)— (4.010)	
73-75	Camaro w/A.T. (exc. floor console, T.W.)	7808408	1	19.85	SHROUD, steering column trans. control lock tube	
73-75	All w/T.W. (exc. Pass., Vega, Monza)	7809375	1	26.50	SHROUD, steering column trans. control lock tube	
71-75	Vega, Monza	7810336	1	7.15	SHROUD, steering column— (4.010)	
67-69	All	1374446	1	.28	WEDGE, strg. col. supt.	
74	Camaro	341092	4	.14	WASHER, rear bumper face bar spring	
71-75	Vega, Monza	7800580	1	.34	WASHER, steering column shaft upper retaining rim	
71-75	Vega, Monza (exc. P/S)	7810517	1	1.30	BUSHING, steering column jacket	
71-75	Vega, Monza (exc. T.W.)	7810020	1	1.30	RACK, switch actuator strg. column	
73-75	Chevelle, Nova, Camaro (exc. T.W.)	7810762	1	15.45	BOWL, strg. column	

NOTE 1 Order 1 dash seal 7800497 when used on 1967.

NOTE 2 Used with Boyne switch.

NOTE 3 Used with Delco switch.

NOTE 4 Paint as required.

**6.519 SEAL, Gear Shaft**

63	Chevy	6264903	1	.20	"O" ring, upper bearing (1 <sup>1</sup> / <sub>16</sub> " I.D.)
----	-------	---------	---	-----	---

**6.521 BEARING ASSY.— ADAPTER— CLAMP— NUT— RACE— REINFORCEMENT— RETAINER— RING— SEAT— SLEEVE— SPACER— SPRING, Mast Jacket**

63	Chevy	5672508	1	3.55	upper (w/horn wire) (1 <sup>5</sup> / <sub>8</sub> " O.D.) (Note 1)
					NOTE 1 Consists of bearing and cable assy., spring and "O" ring seal.
63	All	5691182	1	1.50	dir. signal switch— (2.895)
64-66	Chevelle (exc. T.W.),				
66	Chevy	383871	1	1.75	control switch
64-66	Chevelle,				
65-66	Pass. (exc. 4-Spd.),				
65-66	Pass. w/4-Spd. (exc. T.W.)				strg. shaft lower,
64-66	Chevelle,				
65-66	Pass. w/4-Spd. (exc. T.W.)	7802845	1	2.60	intermediate shaft and yoke
64-66	Pass., Chevelle w/T.W.	7451325	2	2.00	upper
64-66	Pass., Chevy (exc. T.W.)	5679205	1	2.70	upper— (2.895)
67-68	Pass. w/T.W.,				
67-69	Chevelle, Camaro w/T.W.	5698407	1	3.76	upper strg. shaft upper
67-69	All w/T.W.,				
70	All w/T.W. (exc. Camaro),				
71-75	All w/T.W.,				

**FRONT AXLE—STEERING**

**6.521 ■ BEARING ASSY.— ADAPTER— CLAMP— NUT— RACE—  
REINFORCEMENT— RETAINER— RING— SEAT— SLEEVE— SPACER—  
SPRING, Mast Jacket (Con't)**

72	Camaro w/3, 4- Spd. (exc. floor console, T.W.),				
73-75	Camaro w/A.T. (exc. floor console, T.W.)	5696210	1	2.62	upper strg. shaft lower
67-68	All	7806142	1	1.70	strg. shaft lower
67-68	All	7800528	1	1.25	strg. col. jacket asm. bowl lower
69	Chevy, Camaro, Chevelle (exc. T.W.),				
70	Nova w/A.T. (column shift),				
71-75	All (exc. T.W., Vega, Monza)	7805365	1	1.10	strg. col. jacket assy. bowl lever bearing
69	Chevy, Camaro w/Torque Drive,				
69-71	All,				
72	Malibu, El Camino (Custom) (floor console w/T.H. 400) (exc. T.W.),				
72	Monte Carlo (floor console w/A.T.) (exc. T.W.),				
73-75	All (exc. T.W., Vega, Monza),				
71-75	Vega, Monza w/P/S	7805700	1	4.10	lower shift tube
67-70	All	7800269	1	1.90	strg. column shaft upper
71-75	Vega, Monza w/P/S	7811024	1	4.50	hyd. steering column lower jacket
64-66	Chevelle (exc. T.W.)	383873	1	.59	ADAPTER, str. shaft (plastic)
65-66	Pass. w/A.T. (exc. B.S., T.W.)	3857435	1	.64	ADAPTER, steering shaft
67-68	Chevelle w/T.W.	5698423	1	2.75	ADAPTER, lower brg.
67-68	Chevelle, Camaro w/T.W., floor shift,				
67-68	Pass. w/T.W.	5699296	1	1.95	ADAPTER, lower bearing
67-68	All (exc. T.W.)	5698365	1	1.20	ADAPTER, lower, brg.
69-75	All (exc. Vega, Monza)	7805822	1	1.10	ADAPTER, strg. column strg. shaft lower bearing
67-68	All w/3-Spd. (exc. Pass.)	7804031	1	5.35	ADAPTER ASSY., lower brg.
71-75	Vega, Monza w/P/S	7811013	1	2.00	ADAPTER, hyd. steering column lower shaft tube
67	Chevelle	7802662	1	1.20	CLAMP, lower
71-75	Vega, Monza (exc. P/S)	7809820	1	.98	CLAMP, steering column lower coupling
65-68	All w/T.W.	5698741	1	4.00	NUT, upper brg. race seat
69	All w/T.W.,				
70	All w/T.W. (exc. Camaro)	7805154	1	3.55	NUT, upper bearing race seat
66-69	Pass. w/T.W.				RACE, upper shaft upper bearing,
67-69	All w/T.W.,				
70	All w/T.W. (exc. Camaro)				upper shaft lower bearing,
71-72	Camaro w/A.T. (exc. floor console, T.W.),				
71	All w/T.W.,				
72	Pass., Chevelle w/T.W.,				
73-75	All w/T.W.	5693941	1	2.10	strg. column upper shaft upper bearing
67-68	All w/T.W.	5698422	1	2.70	RACE, upper strg. upper inr. brg.
69	All,				
70	All (exc. Chevelle),				
71-75	All (exc. Vega, Monza)	7804440	1	.71	REINFORCEMENT, lower bearing adapter
67-68	All (exc. T.W.)	5699583	1	.59	RETAINER, lower brg. adapter
68-70	Chevelle,				
70	Pass.,				
73-74	Camaro w/A.T. (exc. T.W.),				
74	Nova (A.T. w/T.W.),				
75	Chevelle w/T.H. 400,				
73-75	Vega, Monza (exc. P/S)	7803432	1	.40	RETAINER, inter. strg. shaft coupling seal
69-75	All (exc. Vega, Monza)	7804439	1	.44	RETAINER, lower bearing adapter
67-69	Chevy, Chevelle, Camaro,				
67-68	Pass. (exc. T.W.),				
69	Pass.,				
71-75	All	580074	2	.12	RETAINER, strg. upper shaft assy.
73-75	Pass., Chevelle w/T.H.	7809408	1	.32	RETAINER, strg. column intermediate strg. shaft coupling seal
62-66	All	3760579	1	.22	RING, control shifter tube clamping
67-68	Pass. (3-Spd. w/O.D.) (exc. H.D.),				
67-68	Chevy, Chevelle, Camaro w/3-Spd. (exc. H.D., floor controls)	7801280	1	1.20	RING, trans. cont. shift tube lwr. brg. clamp
67-69	All (exc. T.W.)	5699603	1	.44	RING, upper retaining
66	Pass. w/T.W.,				
67-69	All w/T.W.,				
70	All w/T.W. (exc. Camaro),				

**FRONT AXLE—STEERING**

**6.521 BEARING ASSY.— ADAPTER— CLAMP— NUT— RACE—  
REINFORCEMENT— RETAINER— RING— SEAT— SLEEVE— SPACER—  
SPRING, Mast Jacket (Con't)**

71-75	Camaro w/A.T. (exc. floor console, T.W.)	7804909	1	1.35	SEAT, shaft upper bearing
71-75	All w/T.W.	7815184	1	1.45	SEAT, strg. column upper shaft upper bearing inner
67	All	7803370	1	.59	SLEEVE, strg. shaft centering
69	Pass., Camaro w/T.W.,				
70	Monte Carlo,				
71	Nova,				
71-75	Camaro w/A.T. (exc. floor console, T.W.),				
72	Nova w/3-Spd.	7806405	1	.71	SLEEVE, strg. shaft centering
67	All,				
68	Pass., Chevy, Camaro	7801219	1	2.00	SLEEVE UNIT, w/adjuster, lwr. strg. shaft
67-68	Camaro (exc. T.W.),				
68	Chevy, Pass. (exc. T.W.)	5698570	1	.78	SPACER, lower brg.
69	Chevy, Camaro	7804541	1	.84	SPACER, lower bearing
69	Pass.	7804812	1	.38	SPACER, strg. shaft lower bearing
64-67	Chevelle (exc. T.W.),				
67	Chevy, Camaro (exc. T.W.)	386789	1	.22	SPRING, upper (1 <sup>3</sup> / <sub>32</sub> " length)
65-66	Pass. (exc. T.W.)	3866591	1	.12	SPRING, lower brg. asm.
66	Pass. w/T.W.,				
71-74	Camaro w/A.T. (exc. floor console, T.W.)	5695946	1	.78	SPRING, upper strg. shaft bearing
68	Chevelle	7801197	1	.71	SPRING, strg. col. lower brg. thrust
69-70	All,				
71-75	All (exc. T.W.)	7804771	1	.40	SPRING, strg. col. shaft upper
69	All w/T.W.	7808505	1	3.40	SPRING, center sphere
70	All w/T.W. (exc. Camaro)	7805827	1	2.00	SPRING, shaft lock bolt
71	All w/T.W.,				
72	Pass., Camaro, Monte Carlo w/T.W.	7811800	1	1.45	SPRING, strg. col. upper bearing
71-74	Camaro w/A.T. (exc. floor console, T.W.)	7801309	1	1.90	SPRING, wheel tilt
73-75	All (exc. Vega, Monza),				
75	Vega, Monza w/T.W.	7815185	1	1.45	SPRING, strg. column strg. shaft upper bearing

**6.524 SHAFT ASSY.— SHAFT UNIT— REPAIR KIT, Steering Gear, with Worm**

62-66	Chevy	5675929	1	36.75	w/ball nut (38 <sup>3</sup> / <sub>4</sub> " O.L.)
64-66	Chevelle (exc. T.W.)	5691416	1	9.55	upper (50 <sup>1</sup> / <sub>4</sub> " O.L.)
64-68	Chevelle,				
65-69	Pass.,				
67-68	Camaro (exc. P/S),				
68	Chevy (exc. P/S)	5678409	1	29.50	w/ball nut assy.
64-68	Chevelle,				
65-69	Pass.,				
67-68	Camaro (exc. P/S)	5678410	1	11.05	w/worm
65-66	Pass. (exc. T.W.)	5693115	1	7.65	upper
67	Chevy	5699158	1	15.65	w/worm
67-68	Camaro (exc. T.W.),				
68	Chevy (exc. T.W.)	5699858	1	24.70	(33 <sup>15</sup> / <sub>32</sub> " type B)
67	Chevelle (396) (exc. T.W.)	7802787	1	32.75	(49 <sup>31</sup> / <sub>32</sub> " type C)
67	Chevy	5699850	1	27.75	(32 <sup>15</sup> / <sub>32</sub> " type B)
67	Chevy	5699109	1	37.00	w/ball nut
67	Camaro (Spt. Cpe.),				
68-69	Camaro w/spl. strg. (302) (exc. P/S)	5678504	1	37.50	w/ball nut
67	Camaro (Spt. Cpe.),				
68-69	Camaro (Spt. Cpe.) (8 cyl.)	5678505	1	12.20	
67-68	Pass. (exc. T.W.)	5699849	1	24.70	upper (33 <sup>23</sup> / <sub>32</sub> " type B)
68-69	Chevelle (396),				
70	Chevelle (exc. Monte Carlo)	7813723	1	21.95	w/pin intermediate (Note 1)
	<i>NOTE 1 It may be necessary to use (1) 7807271 Bolt and (1) 7807052 Flange.</i>				
68	Chevelle (exc. T.W.)	7802936	1	22.10	upper (32 <sup>31</sup> / <sub>32</sub> " type A)
69-72	Chevelle (exc. T.W.)				upper,
70-74	Camaro (exc. T.W.)	7804469	1	23.90	upper and lower (34 <sup>7</sup> / <sub>32</sub> " type A)
69	Chevy, Camaro (exc. T.W.),				
70-74	Nova	7804463	1	23.90	steering w/flange (34 <sup>29</sup> / <sub>32</sub> " type B)
69	Chevelle w/T.W.,				
70	Chevelle, Camaro w/T.W.	7805272	1	60.75	upper and lower (29 <sup>1</sup> / <sub>8</sub> " type E)
69-70	Pass., Chevelle, Camaro w/T.W.	7806288	1	26.75	race and upper
69	Chevelle w/T.W.,				
70-71	Chevelle, w/T.W.,				



**FRONT AXLE—STEERING**

**6.524 SHAFT ASSY.— SHAFT UNIT— REPAIR KIT, Steering Gear, with Worm  
(Con't)**

72	All w/T.W. (exc. Vega, Monza),				
70-74	Camaro w/T.W. ....	7806309	1	31.50	lower (29 <sup>1</sup> / <sub>8</sub> " type E) .....
69-70	Pass. (exc. T.W.) .....	7804462	1	23.90	steering w/flange (35 <sup>3</sup> / <sub>8</sub> " type B) .....
69-70	Pass. w/T.W. ....	7805261	1	54.75	upper and lower (30 <sup>1</sup> / <sub>32</sub> " type E) .....
70	All Pass., Chevelle, Nova (exc. P.S.),				
70	All Camaro 6 cyl. less Z-28 (exc. P.S.) .....	7808314	1	34.50	lower, w/worm and nut .....
71-74	Chevelle, Camaro (exc. P/S),				
73-74	Nova (exc. P.S.),				
75	Chevelle (exc. P.S.) .....	7811333	1	34.50	lower, w/worm .....
70	Camaro .....	7808565	1	42.75	intermediate, w/coupling .....
70	Monte Carlo (exc. 400, 454, T.W.),				
70	Monte Carlo w/2BC (400) (exc. T.W.),				
70	Monte Carlo T.W. w/A.T. (exc. T.H. 400),				
70	Monte Carlo T.W. w/4-Spd. (exc. 400 w/4BC),				
70	Monte Carlo T.W. w/T.H. 400 (exc. floor console),				
71-72	Monte Carlo (exc. T.H. 400) ....	7810376	1	25.75	intermediate, w/coupling .....
70	Monte Carlo (T.W. w/T.H. 400) w/floor console,				
70	Monte Carlo (T.W. w/4BC) (400),				
70	Monte Carlo (400, 454) (exc. 2BC, T.W.) .....	7811132	1	25.75	intermediate, w/coupling .....
71-75	Pass. ....	7817475	1	25.75	intermediate .....
71-74	Pass. (exc. T.W.) .....	7809416	1	33.25	strg. column strg. (standard) (36 <sup>15</sup> / <sub>32</sub> " type A) .....
71-75	Pass. w/T.W. ....	7809745	1	33.00	strg. column strg. (lower) (31 <sup>3</sup> / <sub>8</sub> " type E) ...
71-74	Pass. w/T.W.,				
72	Chevelle w/T.W. ....	7809755	1	56.75	strg. shaft strg. (upper and lower) (31 <sup>3</sup> / <sub>8</sub> " type E) .....
71	Chevelle w/T.W.,				
72	All w/T.W. (exc. Vega),				
71-74	Camaro w/T.W. ....	7809756	1	56.75	strg. shaft strg. (upper) (29 <sup>1</sup> / <sub>8</sub> " type E) .....
71	Chevelle w/A.T., T.W. (exc. Monte Carlo, floor console, T.H. 400),				
71	Monte Carlo (floor console w/T.W., T.H. 400),				
72-74	All w/T.W. (exc. Vega) .....	7810569	1	28.25	strg. column strg. (upper) w/race .....
68-72	Chevelle (exc. T.H. 400, 400, 454) .....	7810369	1	25.75	intermediate (coupling w/flange) .....
68-69	Chevelle,				
70	Chevelle (exc. Monte Carlo),				
71-72	Chevelle w/T.H. 400 (400, 454)	7810374	1	25.75	intermediate w/coupling (less flange) .....
71-72	Monte Carlo w/T.H. 400 .....	7810383	1	25.75	intermediate w/coupling .....
71-74	Camaro w/A.T. (exc. floor console, T.W.) .....	7806314	1	33.00	lower w/o steering wheel shaft (31 <sup>17</sup> / <sub>32</sub> " type E) .....
71-74	Camaro w/A.T. (exc. floor console, T.W.) .....	7809174	1	89.25	upper w/steering wheel shaft (31 <sup>17</sup> / <sub>32</sub> " type E) .....
71-75	Camaro w/T.W. ....	7810380	1	25.75	intermediate .....
71-75	Vega, Monza w/P/S .....	7811016	1	22.70	hyd. steering column intermediate w/pin and seal .....
71-75	Vega, Monza (exc. P/S & 122) ..	7809767	1	48.75	steering gear w/worm and ball nut .....
71-74	Vega (exc. P/S) .....	7810298	1	48.75	intermediate steering (48 <sup>3</sup> / <sub>4</sub> " type G) .....
71-74	Vega w/P/S .....	7811011	1	22.70	intermediate (31 <sup>3</sup> / <sub>32</sub> " type A) .....
71-75	Vega, Monza w/P/S .....	7810715	1	34.00	intermediate strg. ....
73-74	Nova w/T.W. ....	7815207	1	56.75	strg. column upper and lower (29 <sup>7</sup> / <sub>16</sub> " type E) .....
73-75	Chevelle w/T.H. 350 (exc. Monte Carlo) .....	7817478	1	25.75	strg. column intermediate (incl. seal) .....
73-75	Monte Carlo w/T.H. 350 .....	7817479	1	25.75	strg. column intermediate .....
73-75	Chevelle w/T.H. 400 (exc. Monte Carlo) .....	7815163	1	25.75	strg. col. intermediate .....
73-75	Monte Carlo w/T.H. 400 .....	7815164	1	25.75	strg. col. intermediate .....
73-74	Nova w/T.W. ....	7815214	1	26.25	strg. col. shaft .....
73-74	Chevelle (exc. T.W.) .....	7813687	1	23.90	strg. column (34 <sup>9</sup> / <sub>16</sub> " type A) .....

**FRONT AXLE—STEERING**

**6.524 SHAFT ASSY.— SHAFT UNIT— REPAIR KIT, Steering Gear, with Worm (Con't)**

73-74	Nova w/T.W. . . . .	7815206	1	31.50	strg. column lower strg. (29 <sup>7</sup> / <sub>16</sub> " type E) . . . .
73-74	Chevelle w/T.W. . . . .	7812647	1	31.50	strg. column upper and lower (29 <sup>15</sup> / <sub>32</sub> " type E) . . . . .
73-75	Chevelle w/T.W. . . . .	7812648	1	31.50	strg. column lower (29 <sup>15</sup> / <sub>32</sub> " type E) . . . . .
73-74	Vega . . . . .	7810022	1	28.25	steering column upper . . . . .
74	Vega (exc. P/S) . . . . .	7810518	1	44.75	steering column (48 <sup>3</sup> / <sub>4</sub> " type G) . . . . .
75	Nova (exc. P/S) . . . . .	7816558	1	34.50	strg. gear w/worm . . . . .
75	Camaro, Nova . . . . .	7818763	1	26.25	intermediate . . . . .
75	Nova, Camaro (exc. T.W.) . . . . .	7818735	1	26.50	strg. (standard) (34 <sup>1</sup> / <sub>2</sub> " type A) . . . . .
75	All w/T.W. . . . .	7818890	1	33.25	strg. upper w/race . . . . .
75	Chevelle w/T.W. (29 <sup>15</sup> / <sub>32</sub> " type E) . . . . .	7818891	1	59.75	strg. column upper and lower (complete) . . . . .
75	Pass. w/T.W. (31 <sup>3</sup> / <sub>8</sub> " type E) . . . . .	7818892	1	59.75	strg. column upper and lower (complete) . . . . .
75	Nova, Camaro w/T.W. (29 <sup>15</sup> / <sub>32</sub> " type A) . . . . .	7819039	1	58.75	strg. column upper and lower (complete) . . . . .
75	Nova, Camaro w/T.W. . . . .	7819040	1	32.75	strg. column (lower) (29 <sup>15</sup> / <sub>32</sub> " type A) . . . . .
75	Chevelle (exc. T.W.) . . . . .	7819297	1	25.50	strg. column (36 <sup>15</sup> / <sub>32</sub> " type A) . . . . .
75	Pass. (exc. T.W.) . . . . .	7819298	1	33.25	strg. column (36 <sup>15</sup> / <sub>32</sub> " type A) . . . . .
75	Camaro, Nova (exc. P/S) . . . . .	7812945	1	35.25	w/worm . . . . .
75	Vega, Monza w/T.W. (exc. P/S, 8 cyl.) . . . . .	7816776	1	31.00	steering column intermediate . . . . .
75	Vega, Monza w/T.W. (exc. P/S) . . . . .	7816834	1	20.90	steering column w/pin and seal . . . . .
75	Vega, Monza w/T.W. . . . .	7816774	1	31.50	lower strg. (26 <sup>9</sup> / <sub>32</sub> " type E) . . . . .
75	Vega, Monza w/T.W. . . . .	7816775	1	52.75	lower strg. (26 <sup>9</sup> / <sub>32</sub> " type E) . . . . .
75	Vega (122) . . . . .	7819943	1	39.75	strg. gear w/worm . . . . .
75	Monza 8 cyl. (exc. Towne Coupe, T.W. & P.S.) . . . . .	7819948	1	42.50	strg. column . . . . .
75	Vega, Monza (Towne Coupe) (exc. T.W. & P.S.) . . . . .	7819305	1	44.75	strg. column— (48.92") . . . . .
75	Vega, Monza w/P/S (exc. T.W.) . . . . .	7819308	1	22.70	strg. column (31 <sup>1</sup> / <sub>4</sub> " type A) . . . . .
75	Vega, Monza (4 cyl.) (exc. T.W., P/S) . . . . .	7819304	1	48.75	w/coupling . . . . .
67-72	All, . . . . .				
71-73	Vega . . . . .	7810077	1	11.50	REPAIR KIT, injected steering repair (Note 2) . . . . .

*NOTE 2: To be used on upper steering shaft only, not to be used on lower intermediate shaft.*

**6.525 COUPLING ASSY.— BOLT— BEARING— FLANGE— REINFORCEMENT— RETAINER— SHIELD UNIT— SPRING— SCREW— SEAL— CLAMP— WASHER— YOKE ASSY.— STRAP— SPACER— CLIP, Steering Shaft U-Joint**

64-66	Chevelle (exc. P/S), . . . . .				
65-67	Pass., P/S . . . . .	5692007	1	11.95	w/lower flange asm.-strg. shaft . . . . .
67-69	All (exc. P/S) . . . . .	7806391	1	12.20	w/lower flange-strg. shaft . . . . .
68-69	Chevelle (exc. P/S), . . . . .				
70	Monte Carlo (exc. P/S), . . . . .				
71	Chevelle, Camaro (exc. P/S), . . . . .				
72	Chevelle, Camaro, . . . . .				
73-75	Chevelle, Camaro (exc. T.W.) . . . . .	7808090	1	8.75	w/clamp assy.-inter. strg. . . . .
70	All (exc. P/S), . . . . .				
71	All (exc. P/S, Nova), . . . . .				
72	Chevelle, Camaro, . . . . .				
73-74	Chevelle, Nova, Camaro (exc. P.S.) . . . . .	7818568	1	14.95	w/lower flange assy. . . . .
70-72	All w/P/S . . . . .	7818514	1	17.90	w/coupling asm.-hyd. strg. (repl. 7813349) . . . . .
71-72	Pass., . . . . .				
73-75	All (exc. Vega, Monza), . . . . .				
75	Vega, Monza (exc. T.W., P/S) . . . . .	7817473	1	8.05	w/clamp assy.-inter. strg. shaft . . . . .
72	Pass. (402, 454) (exc. Police), . . . . .				
72	Pass. (exc. 402, 454), . . . . .				
72	Police (Sta. Wag.), . . . . .				
73-74	All w/P.S. (exc. Nova, Vega), . . . . .				
75	All w/P.S. (exc. Vega, Monza) . . . . .	7813348	1	13.20	w/lower flange . . . . .
71-75	Vega, Monza w/P/S . . . . .	7811023	1	10.95	hyd. steering column lower . . . . .
71-75	Vega, Monza (exc. P/S, T.W.) . . . . .	7810299	1	11.75	intermediate steering shaft . . . . .
71-75	Vega, Monza w/P/S . . . . .	7811014	1	13.40	w/upper flange assy. . . . .
73-74	Nova w/P/S . . . . .	7818514	1	17.90	w/lower flange . . . . .
75	Camaro . . . . .	7818723	1	20.40	strg. shaft . . . . .
75	Nova, Camaro (exc. P/S) . . . . .	7818568	1	14.95	w/lower flange . . . . .
75	Vega, Monza w/T.W. (exc. P/S) . . . . .	7819175	1	13.00	w/flange intermediate steering shaft . . . . .
65-75	All . . . . .	7807271	1	1.05	BOLT ( <sup>5</sup> / <sub>8</sub> "— 24 x 1 <sup>7</sup> / <sub>32</sub> ") . . . . .
70	Pass., Nova (exc. P/S), . . . . .				
71-74	Nova . . . . .	7806388	1	.98	BOLT, coupling ( <sup>5</sup> / <sub>16</sub> "— 24 x 1 <sup>9</sup> / <sub>16</sub> ") . . . . .
70	Pass., Nova (exc. P/S), . . . . .				
71-74	Nova . . . . .	7806389	1	.98	BOLT, coupling ( <sup>3</sup> / <sub>8</sub> "— 24 x 1 <sup>9</sup> / <sub>16</sub> ") . . . . .

**FRONT AXLE—STEERING**

**6.525 COUPLING ASSY.— BOLT— BEARING— FLANGE— REINFORCEMENT—  
RETAINER— SHIELD UNIT— SPRING— SCREW— SEAL— CLAMP—  
WASHER— YOKE ASSY.— STRAP— SPACER— CLIP, Steering Shaft U-  
Joint (Con't)**

70-75	Camaro,						
75	Nova	3972245	3	.63	BOLT, steering gear (7/16" — 24 x 4 5/8")		
65	Pass.,						
65-67	Chevelle,						
67-68	Pass.,						
69	All (exc. P/S),						
70	Chevelle, Camaro (exc. P/S, 302),						
71-74	All (exc. Nova, Vega),						
71-75	Vega, Monza w/P.S.	7806747	1	2.25	BOLT UNIT, strg. shaft		
68-69	Chevelle,						
71-73	Vega (exc. P/S, T.W.)	7809819	1	.24	BOLT, steering column lower coupling clamp		
71-75	Vega, Monza (exc. P/S)	7810304	1	.98	BOLT, steering column shaft upper clamp		
71-75	Vega, Monza w/P/S	7809553	1	.12	BOLT, hyd. steering column lower coupling clamp		
71-75	All (exc. Nova)	5671921	1	.73	BEARING, upper shaft		
75	Camaro	7818729	2	.76	BEARING, inter. strg. shaft "U" joint coupling		
67-69	Pass. w/T.W. (8 cyl.),						
67-68	Chevelle, Camaro w/T.W.,						
69	Camaro w/T.W.	5699294	1	8.30	FLANGE, strg. shaft		
67	Chevelle (396)	5699177	1	8.95	FLANGE, upper shaft		
64-66	Pass., Chevelle w/P/S	5691698	1	14.55	FLANGE ASSY., lower		
68-69	Chevelle,						
70	Chevelle (396, 400 w/4BC),						
71-72	Chevelle w/T.H. 400, 4-Spd., H.D., 3-Spd.	7807052	1	9.65	FLANGE ASSY., strg. gear shaft upper		
73-74	Camaro w/A.T. (exc. floor console, T.W.),						
74	Nova w/T.W.	7807048	1	8.80	FLANGE, strg. shaft		
67	Pass.,						
67-69	Chevelle, Camaro (exc. P/S),						
68-69	Chevy, Camaro (exc. Spec. Steering, P/S),						
69	Pass. (exc. P/S),						
70	All	5682486	4	.24	REINFORCEMENT, intermediate shaft coupling		
71-72	Pass.	7809408	1	.32	RETAINER, inter. steering shaft coupling seal		
71	Pass. (exc. A.T., T.W.),						
71-72	Chevelle, Camaro,						
72	Pass. w/T.W.,						
71-75	Vega, Monza (exc. P/S)	7803432	1	.40	RETAINER, inter. steering shaft coupling seal		
71	Pass.,						
73-74	Pass.	231480	1	1.10	SHIELD UNIT, strg. gear coupling		
74-75	Pass., Chevelle w/P/S,						
75	Nova w/P/S	231780	1	3.75	SHIELD UNIT, strg. gear coupling upper and lower (repl. 417759)		
73	Monte Carlo	334969	1	1.50	SHIELD, strg. shaft coupling		
73-74	Chevelle (exc. P/S, Monte Carlo)	414017	1	1.00	SHIELD, strg. coupling		
73-75	Camaro (exc. P/S)	332638	1	1.50	SHIELD, strg. coupling		
73-75	Camaro w/P/S	332639	1	1.50	SHIELD, strg. coupling		
73-74	Chevelle w/P/S (exc. Monte Carlo)	415863	1	3.30	SHIELD, strg. coupling		
74-75	Chevelle (exc. P/S),						
75	Nova (exc. P/S)	417196	1	1.50	SHIELD, strg. gear coupling upper		
74-75	Chevelle (exc. P/S),						
75	Nova (exc. P/S)	417197	1	1.50	SHIELD, strg. gear coupling lower		
74-75	Camaro	352811	1	1.05	SHIELD, strg. shaft stone		
68-69	Chevelle,						
71-72	Chevelle,						
72-74	Pass. w/T.W.,						
71-74	Camaro,						
73-75	Chevelle w/T.H. 400, close ratio,						
71-75	Vega, Monza (exc. P/S)	5675186	1	.27	SPRING, upper & lower coupling		
71-72	All w/T.W.,						
71-75	Vega, Monza (exc. P/S)	7810520	1	.62	SPRING, steering column shaft lower coupling load		
73-74	Chevelle (exc. T.H. 400, close ratio),						

**FRONT AXLE—STEERING**

**6.525 COUPLING ASSY.— BOLT— BEARING— FLANGE— REINFORCEMENT—  
RETAINER— SHIELD UNIT— SPRING— SCREW— SEAL— CLAMP—  
WASHER— YOKE ASSY.— STRAP— SPACER— CLIP, Steering Shaft U-  
Joint (Con't)**

74-75	Pass. ....	7809409	1	.18	SPRING, shaft coupling upper strg. column assy. ....
75	Camaro .....	7818730	1	.33	SPRING, strg. shaft coupling .....
72	Camaro w/A.T. (exc. floor console, T.W.),				
73-75	All w/T.W. ....	7803623	1	.53	SCREW, strg. col. strg. shaft lock bolt spring .....
67-68	All .....	7806610	1	.61	SEAL, shift tube strg. shaft .....
68-69	Chevelle .....	7802919	1	1.50	SEAL, inter. strg. shaft coupling .....
68-74	Chevelle .....	7802916	1	.38	CLAMP, inter. shaft seal .....
68-69	Chevelle,				
71-75	All (exc. Nova) .....	7804801	1	3.60	CLAMP UNIT, w/bolt .....
71-75	Vega, Monza (exc. P/S) .....	7810277	1	1.55	CLAMP, steering column shaft upper .....
71-75	Vega, Monza w/P/S .....	7809381	1	.98	CLAMP, hyd. steering column lower coupling .....
74	Vega (122) .....	7809433	1	1.05	CLAMP, intake steering shaft coupling .....
68	Pass. w/T.H. 350 (exc. Air Cond.) .....	3954735	2	.13	WASHER, inter. shaft— (11.714) .....
67-69	All (exc. T.W.) .....	7800580	1	.34	WASHER, upper retaining ring thrust— (4.012) .....
67	All (exc. T.W.) .....	7800581	1	.38	WASHER, upper retaining ring wave— (4.012) .....
75	Pass., Chevelle,				
75	Vega, Monza (exc. T.W., P/S) ...	7817454	1	.58	WASHER, coupling & clamp intermediate strg. shaft .....
71-73	Camaro w/A.T. (exc. floor console, T.W.) .....	7809169	1	35.75	YOKE ASSY., strg. column shaft upper .....
73	Pass. ....	409797	1	.32	STRAP, strg. coupling shield— (3.417) .....
71-75	Vega, Monza w/P/S .....	7811025	1	.47	SPACER, hyd. steering column jacket to strg. shaft .....
74-75	Chevelle (exc. P/S) .....				CLIP, strg. shaft coupling shield, .....
74-75	Pass., Chevelle w/P/S,				
75	Nova w/P/S .....	417567 A.R.		.39	strg. shaft coupling shield upper .....
74-75	Pass., Chevelle w/P/S,				
75	Nova w/P/S .....	417566	1	.57	CLIP, strg. shaft coupling shield lower .....

**6.550 VALVE ASSY.— ADAPTER ASSY., Steering Gear Hydraulic**

*NOTE: For Seal and Gasket Kits see group 6.507.*

62-67	Chevy .....	5691108	1	59.00	w/adaptor .....
64-70	Chevelle, Camaro,				
65-69	Pass.,				
68-69	Chevy,				
70	Pass. (Sta. Wag.),				
70	Nova (8 cyl.) .....	7811734	1	52.50	
70	Pass. (exc. Sta. Wag.),				
70	Nova (6 cyl.),				
71	Pass., Chevelle, Nova w/P/S,				
72	Chevelle, Pass. (exc. Police),				
72	Police (exc. 454),				
72	Nova (exc. 4BC),				
71-74	Vega .....	7810897	1	60.75	
70	Camaro (4BC),				
71-74	Nova w/4BC,				
71-72	Camaro,				
72-73	Police (454),				
73-75	Camaro (exc. Sp. H/Per. 350) ..	7808369	1	86.00	
73	Pass. (exc. Police),				
73-75	Chevelle (exc. S.S., Monte Carlo),				
74-75	Pass. (exc. Police, Sp./Per./Susp.) .....	7807837	1	86.00	
73-74	Camaro w/Sp. H/Per. 350,				
75	Camaro w/R.T.S.,				
75	Nova w/Sport Susp. ....	7814326	1	86.00	
73-74	Chevelle (S.S.) Monte Carlo,				
74	Pass., Police w/Sp./Per./Susp.,				
75	Chevelle,				
75	Camaro (exc. R.T.S.),				
75	Nova (exc. Sport Susp.),				
75	Pass. (454) .....	7814930	1	86.00	
75	Vega, Monza .....	7819411	1	56.25	
62-67	Chevy .....	5691130	1	29.75	ADAPTER ASSY. ....

**FRONT AXLE—STEERING**

<b>6.551 KIT, Steering Gear Hydraulic Valve</b>					
62-67	Chevy	5687998	1	2.60	w/valve shaft and ball seat spring
62	Chevy	5686260	1	3.40	w/spring, stud, 2 seats
63-67	Chevy	5691150	1	6.30	adapter
63-67	Chevy	5691151	1	13.60	adapter and sleeve
63-67	Chevy	5691690	1	1.75	ball stud seal and clamp
<b>6.552 SPRING— RETAINER— SEAL— WASHER, Steering Gear Hydraulic Valve</b>					
62-67	Chevy	5688441	1	.28	(2.9 coils— <sup>35</sup> / <sub>64</sub> " free length)
62-67	Chevy	5687990	1	.18	adjustment (6 coils— <sup>25</sup> / <sub>32</sub> " free length)
64-67	Chevelle, Camaro,				
65-66	Pass.,				
68	Chevy,				
69	Pass.,				
69	Chevelle	5687252	1	.18	valve spool
62-67	Chevy	5687006	1	.32	RETAINER, spring
63	Chevy	5691199	1	.23	SEAL, end plug, valve housing— (6.581)
64-66	Chevelle (396),				
65-69	Pass.,				
67-69	Chevelle,				
68-69	Chevy, Camaro,				
70	All (exc. Camaro)	5695061	1	.74	SEAL, "O" ring ( <sup>15</sup> / <sub>64</sub> " x 1 <sup>1</sup> / <sub>4</sub> ")
64-69	Pass., Chevelle,				
68-69	Chevy, Camaro,				
71-75	All	5687182	1	5.25	SEAL KIT, valve ring and back-up
62-67	Chevy	5687991	1	.18	WASHER, spring thrust ( <sup>7</sup> / <sub>8</sub> " O.D.)
<b>6.554 COVER KIT— GASKET— SPACER— WASHER, Hydraulic Steering Valve</b>					
62-67	Chevy	5687996	1	.64	dust, w/lock nut
63-67	Chevy	5691581	1	.33	GASKET, adapter annulus spacer
62-67	Chevy	5685469	1	.28	SPACER, adapter annulus
62-67	Chevy	5687011	1	.18	WASHER, adapter shaft
<b>6.560 SLEEVE— KEY— PLUG— SPRING— SEAT— SHIELD, Hydraulic Steering Adapter</b>					
62-64	Chevy	5687704	1	3.75	bearing (1 <sup>7</sup> / <sub>32</sub> " O.D. x 1 <sup>13</sup> / <sub>16</sub> " O.L.)
62-67	Chevy	5686218	1	.12	KEY ( <sup>9</sup> / <sub>16</sub> " dia. hole)
62-66	Chevy	5691747	1	2.45	PLUG, adjuster ball
62-67	Chevy	5687733	1	.18	SPRING, ball seat ( <sup>9</sup> / <sub>32</sub> " free hgt.— spiral shape)
62-64	Chevy	264946	2	.71	SEAT, ball (1 O.D.)— (6.874)
<b>6.575 NUT, Hydraulic Steering Cylinder</b>					
63-66	Chevy	3829413	1	.14	hyd. steering cyl. and steering idler lever support
<b>6.576 CYLINDER ASSY., Steering Gear Hydraulic</b>					
62-67	Chevy	5691110	1	41.50	(2 <sup>35</sup> / <sub>64</sub> " O.L.)
<b>6.579 RING— SEAL, Steering Gear Hydraulic Cylinder Piston</b>					
64-69	Pass., Chevelle, Camaro,				
68-69	Chevy,				
70	Pass. (Sta. Wag.),				
70	Chevelle,				
70	Nova (8 cyl.),				
71-74	All	5689008	1	2.40	
65	Chevelle (396),				
70	Pass. (exc. Sta. Wag.),				
70	Nova (6 cyl.)	5687958	1	2.45	
64-69	Pass., Chevelle, Camaro,				
68-69	Chevy,				
70	Pass. (Sta. Wag.),				
70	Chevelle,				
70	Nova (8 cyl.),				
71-74	All	5689009	1	.78	SEAL, back-up "O" ring
<b>6.581 WASHER— GROMMET— RING— SPACER— STUD— SEAT— SPRING— PLUG— SEAL, Hydraulic Steering Cylinder Piston Rod</b>					
62-67	Chevy	3938729	2	.84	cyl. to cyl. and idler lever support grommet retainer ( <sup>13</sup> / <sub>32</sub> " I.D. x 1 <sup>3</sup> / <sub>8</sub> " O.D.)
62-67	Chevy	3709452	2	.11	GROMMET, cyl. to cyl. and idler lever support
63-67	Chevy	5691200	1	.18	RING, ball stud plug retainer
62-67	Chevy	3709917	1	.11	SPACER, cyl. to cyl. and idler lever support
62-67	Chevy	5685382	1	1.50	STUD, mounting ball
62-67	Chevy	264936	1	.53	SEAT, ball stud

**FRONT AXLE—STEERING**

**6.581 WASHER— GROMMET— RING— SPACER— STUD— SEAT— SPRING— PLUG— SEAL, Hydraulic Steering Cylinder Piston Rod (Con't)**

62-67	Chevy	264937	1	.18	SEAT, ball stud spring
62-67	Chevy	5684403	1	.12	SPRING, ball stud seat
63-67	Chevy	5691201	1	.64	PLUG, ball stud end (1 <sup>3</sup> / <sub>16</sub> " O.D.)
63-67	Chevy	5691199	1	.23	SEAL, end plug, valve housing
63-64	Chevy	3687643	1	.17	SEAL, ball stud— (6.111)
64-67	Chevelle, Camaro	3989415	1	.22	SEAL, ball stud

**6.586 RACK— PLUG— SEAL UNIT— SCREW, Steering Gear**

64-69	Chevelle, Camaro,				
71-74	Vega,				
69	Impala, Caprice, Camaro w/P/S,				
70	Monte Carlo,				
70	Pass. w/P/S (exc. Sta. Wag.),				
70	Nova w/P/S,				
71-73	All w/P/S,				
74	All w/P/S (exc. Pass., w/Sp./Per./Susp.)	7804838	1	70.00	piston and ball nut
65-68	Pass.,				
68-69	Chevy,				
69	Sta. Wag.,				
70	Pass. (Sta. Wag.),				
70	Chevelle (6 cyl.) w/P/S,				
70	Chevelle (Sta. Wag.) w/P/S	5692432	1	63.00	piston and ball nut
70	Camaro (8 cyl.) (exc. 4BC)	7804937	1	63.75	piston and ball nut
74	Pass. w/Sp./Per./Susp.	7817529	1	64.00	piston and ball nut
75	Pass. (exc. 454),				
75	Chevelle, Nova, Camaro w/P/S,				
75	Vega, Monza w/P/S	7817528	1	63.50	piston and ball nut
64-69	Pass., Chevelle, Camaro,				
68-69	Chevy,				
70	All (exc. Camaro),				
71-75	All w/P/S	5689695	1	1.65	PLUG, rack piston end
75	All w/P/S	7817487	1	4.95	SEAL UNIT, w/rack and piston
73-75	All w/P/S	5696151	1	1.05	SCREW, strg. gear worm bearing

**6.605 PUMP ASSY.— OIL, Steering Gear Hydraulic**

62-64	Chevy (6 cyl.)	5692840	1	77.75	
65-66	Chevy	5693129	1	67.00	
64	Chevelle (8 cyl.),				
65	Chevelle, Sp. H/Per. w/Hyd. lifters,				
65-66	Chevelle (8 cyl.) (exc. Sp. H/Per., 396),				
67-68	Chevelle (8 cyl.) (exc. 396)	5698076	1	74.50	(Note 3)
<i>NOTE 3: When using 5698076 on 1964 models also order 1-3860458 guard, 2-180116 bolts, 2-3860454 Spl. L/Wa.</i>					
65-68	Pass. (396, 427)	5698075	1	74.50	
66-67	Chevelle (396)	5698077	1	76.00	
67-68	Chevy	5698079	1	74.50	(Note 1)
<i>NOTE 1 When 5698079 is used in place of 5693129 on L-6 engines also order 3904180 stud.</i>					
67-68	Chevelle, Camaro (6 cyl.),				
69	Chevy (6 cyl.)	7800514	1	77.75	(Note 2)
<i>NOTE 2 When using 7800514 in place of 5693287 on L-6 engines also order 3904180 stud.</i>					
67-68	Camaro (8 cyl.)	7800515	1	81.00	
65	Pass. (8 cyl.) (exc. 409),				
66	Pass. (283, 327),				
66	Pass. w/A.I.R. (6 cyl.),				
67	Pass. (283)	5698072	1	74.50	
65-66	Pass. (6 cyl.) (exc. A.I.R.),				
67-68	Pass. (6 cyl.),				
69	Pass. (6 cyl.) (exc. Impala)	5698074	1	68.00	
67	Pass. (327)	5698073	1	74.50	
68	Pass. (8 cyl.) (exc. 396, 427)	7803747	1	71.25	
68	Chevelle (396)	7803404	1	81.00	
69	Camaro (6 cyl.) w/P/S	7805653	1	76.00	
69	Camaro (8 cyl.) w/P/S (exc. 396)	7805656	1	76.00	
69	Chevy, Chevelle w/P/S (396)	7806372	1	77.75	(exc. variable P/S)
69	Chevy, Chevelle w/P/S (8 cyl.) (exc. 396)	7806371	1	76.00	
69	Camaro, Chevelle (396),				
69	Chevelle (Deluxe) (Spt. Cpe., 2- Dr. Sed.)	7806370	1	77.75	w/variable P/S
69	Impala, Caprice (8 cyl.) w/P/S (exc. 396, 427)	7804687	1	73.25	

**FRONT AXLE—STEERING**

**6.605 PUMP ASSY.— OIL, Steering Gear Hydraulic (Con't)**

69	Impala (6 cyl.) w/P/S	7804689	1	75.25	
69	Impala, Caprice w/P.S. (396, 427)	7804690	1	75.25	
69	Biscayne, Bel Air w/P/S (8 cyl.) (exc. 396, 427),				
69	Pass. (Sta. Wag.) w/P/S (8 cyl.) (exc. 396, 427)	7806367	1	73.25	
70	Pass. (6 cyl.) (exc. Sta. Wag.)	7808275	1	78.00	
70	Pass. (8 cyl.) (exc. Sta. Wag., 454)	7808276	1	78.00	
70	Pass. (Sta. Wag.) (8 cyl.) (exc. 454)	7808277	1	78.00	
70	Pass. (454) (exc. Sta. Wag.)	7808278	1	78.00	
70	Nova, Camaro, Chevelle (6 cyl.) (exc. Sta. Wag.),				
71-72	All (6 cyl.)	7813398	1	78.00	
70	Nova,				
70	Chevelle (Sta. Wag.) (6 cyl.)	7808280	1	78.00	
70	Chevelle (Sta. Wag.) (8 cyl.)	7808282	1	78.75	
70	Nova, Camaro, Chevelle (8 cyl.) (exc. Sta. Wag.),				
71-72	All (8 cyl.),				
73	All (8 cyl.) (exc. 454),				
74	All (8 cyl.) (exc. 454, Sp./Per./Susp.)	7813397	1	78.00	
73-74	All (6 cyl.)	7815450	1	78.00	
73	Pass., Chevelle (454),				
74	Pass., Chevelle (454) (exc. Sp./Per./Susp.)	7814303	1	78.00	
74	Pass. (454) w/Sp./Per./Susp.	7817558	1	78.00	
74	Pass. (8 cyl.) w/Sp./Per./Susp. (exc. 454)	7817559	1	78.00	
71-74	Vega (140)	7813544	1	85.25	
75	Vega, Monza (140) P/S	7818025	1	79.50	
75	Monza (8 cyl.) P/S	7819292	1	79.50	
75	All (6 cyl.) w/P/S less Calif.	7818036	1	79.50	
75	All (8 cyl.) (exc. 454, Sport Susp.)	7818022	1	79.50	
75	All (6 cyl.) w/C.A.C., P/S Calif.	7826013	1	75.50	
75	Pass. (454) (w/Sport Susp.)	7818052	1	79.50	
75	Pass., Chevelle (454) (exc. Sport Susp.)	7818030	1	79.50	
62-72	All	1050017 A.R.		1.10	OIL (1 qt. can)— (8.800)

**6.606 BRACKET— BRACE— BOLT— SPACER— SUPPORT— STUD— WASHER, Steering Gear Hydraulic Pump Mounting**

64-67	Chevy (8 cyl.)	3786870	1	2.65	
64-68	Chevelle (8 cyl.) (exc. 396)	3858872	1	4.80	
65-67	Chevelle (396)	3873845	1	6.35	
65	Pass. (409)	3786872	1	2.25	used w/pump w/rear mtg. studs
65-68	Pass., Chevy, Camaro (283, 307, 327, 350)	3941114	1	2.35	used w/stamped bracket
65-68	Pass. w/P/S (396, 427),				
67-68	Camaro (396)	3863146	1	3.15	
63-69	All (6 cyl.) (exc. Pass.),				
65-67	Pass. (6 cyl.),				
70	All	3877430	1	.96	
66	Chevelle (8 cyl.)	3888740	1	.79	pump reservoir
67-68	Camaro (350, 302),				
68	Chevy (327, 350)	3892698	1	3.40	
67	Chevelle (396)	3893373	1	1.25	pump reservoir
67-68	Pass. (396, 427)	3906962	1	.79	pump to strg. gear inlet and outlet hose
68	Chevelle (396)	3925527	1	7.25	
69	Chevelle (8 cyl.) (exc. 396),				
69	Camaro (8 cyl.),				
69	Chevy (8 cyl.) w/P/S (exc. 396),				
69	Pass. w/P/S (8 cyl.) (exc. 396, 427, 454),				
71-75	All (8 cyl.) (exc. Monza)	3941102	1	2.70	pivot
69	All (8 cyl.) (exc. 396, 427, 454),				
71-75	All (8 cyl.) (exc. Monza)	3941103	1	.88	adjuster
69	All w/P/S (396, 427)	3946018	1	1.80	
70	All (396, 400, 454) (exc. Impala, Caprice),				

**FRONT AXLE—STEERING**

**6.606 BRACKET— BRACE— BOLT— SPACER— SUPPORT— STUD— WASHER,  
Steering Gear Hydraulic Pump Mounting (Con't)**

70	Impala, Caprice w/T.H. 400 (454),				
71	All (8 cyl.),				
72	All (8 cyl.) (exc. Nova) . . . . .	3967422	1	3.40	
70	Camaro (6 cyl.),				
71-74	All (6 cyl.) . . . . .	3973155	1	7.80	
71-75	Vega, Monza (140) (exc. A.I.R.) . . . . .	3994232	1	2.30	
73-75	Pass., Chevelle (454) . . . . .	329237	1	2.65	hyd. strg. pump . . . . .
74	Nova (6 cyl.) w/C.A.C. . . . .	3877430	1	.96	
75	All (6 cyl.) . . . . .	354528	1	13.55	hyd. strg. pump . . . . .
75	Monza (8 cyl.) P/S . . . . .	354355	1	3.40	hyd. steering pump . . . . .
75	Vega, Monza (140) (P/S w/A.I.R.) (exc. C.A.C.) . . . . .	357698	1	12.15	hyd. steering pump . . . . .
64-66	Chevelle (8 cyl.) . . . . .	3857355	1	1.25	<b>BRACE</b> . . . . .
65	Chevy (8 cyl.),				
65-68	Pass. (283, 307, 327),				
67-68	Camaro (307, 327),				
68	Chevy (327) . . . . .	3905366	1	1.90	<b>BRACE</b> . . . . .
65	Chevy (8 cyl.),				
65-68	Pass. (283, 307, 327),				
67-68	Camaro (307, 327),				
68	Chevy (327) . . . . .	3988971	1	3.20	<b>BRACE</b> (Note 1) . . . . .
	<i>NOTE 1 Use Brace 3988971 in place of Brace 3905366 for the above usage. Mount the Brace underneath engine mount and use bolts 186678 and lock washer 120382.</i>				
64-70	All (6 cyl.) (exc. 62 amp. AC gen.),				
71-72	Chevelle (6 cyl.) . . . . .	3838446	1	.56	<b>BRACE</b> . . . . .
65-68	Pass. (396),				
67-68	Camaro (396, 350),				
68	Chevy (396) . . . . .	3876788	1	1.90	<b>BRACE</b> . . . . .
66-67	Chevelle w/A.I.R. (396) (exc. Sp. H/Per.) . . . . .	3881517	1	3.10	<b>BRACE</b> . . . . .
66-68	Chevelle (8 cyl.) (exc. 396) . . . . .	3878257	1	1.65	<b>BRACE</b> . . . . .
66	Chevy w/62 amp. AC gen. (6 cyl.),				
66-67	Pass. w/62 amp. AC gen. (6 cyl.) (2nd design) . . . . .	3998339	1	5.25	<b>BRACE</b> . . . . .
67-68	Camaro (302, 350),				
68	Chevy (327, 350) . . . . .	3896900	1	1.70	<b>BRACE</b> . . . . .
66-67	All (6 cyl.) w/A.I.R.,				
68-69	Chevelle, Chevy (6 cyl.),				
68-69	Pass. w/A.I.R. (6 cyl.),				
74	Nova (6 cyl.) w/C.A.C. . . . .	3901807	1	.98	<b>BRACE</b> . . . . .
68	Chevelle (396) . . . . .	3925528	1	1.70	<b>BRACE</b> . . . . .
68-70	Nova (6 cyl.) (exc. P.G.),				
74	Nova (6 cyl.) w/C.A.C. . . . .	3924564	1	1.55	<b>BRACE</b> , air inj. pump adj. ext. . . . .
69	All (396, 427) . . . . .	3946016	1	1.35	<b>BRACE</b> . . . . .
70	All (396, 400 w/4BC 454),				
71-72	Camaro (8 cyl.),				
73	Pass., Chevelle (8 cyl.) . . . . .	3967420	1	1.45	<b>BRACE</b> . . . . .
71-75	Vega, Monza (140) . . . . .	3992227	1	.54	<b>BRACE</b> , hyd. steering pump front . . . . .
71-75	Vega, Monza (140) . . . . .	3988757	1	1.35	<b>BRACE</b> , hyd. steering pump rear . . . . .
73-74	Camaro, Nova (6 cyl.) w/P/S,				
73-74	Deluxe (6 cyl.) w/P/S,				
73-74	Malibu (6 cyl.) w/P/S (exc. Sta. Wag.),				
73-74	Bel Air (6 cyl.) . . . . .				<b>BRACE</b> , hyd. strg. pump, . . . . .
75	Camaro, Nova (6 cyl.) w/P/S,				
75	Malibu, El Camino (6 cyl.) w/P/S (exc. Sta. Wag.) . . . . .	333999	1	1.55	rear . . . . .
74-75	Pass., Chevelle (8 cyl.) . . . . .	336056	1	1.90	<b>BRACE</b> , hyd. strg. pump . . . . .
75	Monza (8 cyl.) P/S . . . . .	354356	1	2.40	<b>BRACE</b> , hyd. steering pump . . . . .
75	Malibu, El Camino (6 cyl. w/C.A.C.),				
75	Nova, Camaro (6 cyl. w/C.A.C.) Calif. . . . .	355731	1	4.00	<b>BRACE</b> , hyd. strg. pump front . . . . .
63-70	All (6 cyl.),				
71-72	Pass., Nova, Camaro . . . . .	3826039	1	.14	<b>BOLT</b> , pump brace to gen. ( <sup>5</sup> / <sub>16</sub> "— 18 x 1 <sup>3</sup> / <sub>4</sub> ") . . . . .
62-69	All,				
70	Chevelle,				
71-72	Pass., Chevelle . . . . .	3792380	1	.31	<b>BOLT</b> , pump mounting brkt. to support ( <sup>3</sup> / <sub>8</sub> "— 16 x 3 <sup>3</sup> / <sub>4</sub> ") . . . . .
69	Chevelle,				



**FRONT AXLE—STEERING**

**6.606 BRACKET— BRACE— BOLT— SPACER— SUPPORT— STUD— WASHER,  
Steering Gear Hydraulic Pump Mounting (Con't)**

69	Pass., Chevy, Camaro (8 cyl.) . . .	5696245	1	.64	BOLT, pump reservoir . . . . .
66-68	Chevelle w/P/S (exc. 396) . . . . .	3718608	1	.41	SPACER, pump bracket to generator . . . . .
70	All (396, 400 4BC 454),				
71-72	Pass. (454),				
71-72	Chevelle, Camaro (400, 4BC, 454),				
73-75	Camaro, Nova, Pass. (250),				
73-75	Pass.,				
73-75	Chevelle (454) (exc. Malibu Estate, El Camino),				
73-75	Deluxe (250) w/P/S,				
73-75	Malibu (exc. Sta. Wag.) (250) w/P/S . . . . .	3967424	1	.21	SPACER, hyd. strg. pump . . . . .
70	Camaro (6 cyl.),				
71-72	All (6 cyl.),				
74	Nova (6 cyl.) w/C.A.C. . . . .	3973158	2	.31	SPACER, support spacer to front support . .
71-75	Vega, Monza P/S . . . . .	3997292	1	1.15	SPACER, strg. gear . . . . .
65-67	Chevy (8 cyl.) (exc. H/Per.) . . . . .	3858138	1	1.65	SUPPORT . . . . .
63-65	Chevy, Chevelle (6 cyl.),				
65	Pass. (6 cyl.),				
66-70	All (6 cyl.) . . . . .	3891598	1	1.75	SUPPORT . . . . .
69-70	Pass., Chevelle (8 cyl.) (exc. 396, 427, 454),				
69-70	Chevy, Camaro (8 cyl.),				
71	All (8 cyl.),				
72	All (8 cyl.) (exc. C.A.C.) . . . . .	3959558	1	1.60	SUPPORT . . . . .
72-73	All (8 cyl.) w/C.A.C. . . . .	6262940	1	1.70	SUPPORT, hyd. strg. pump adj. . . . .
70	Camaro (6 cyl.),				
71-72	All (6 cyl.),				
74	Nova (6 cyl.) w/C.A.C. . . . .	3973157	1	.57	SUPPORT, rear . . . . .
70	Camaro (6 cyl.),				
71-72	All (6 cyl.),				
74	Nova (6 cyl.) w/C.A.C. . . . .	3973156	1	1.85	SUPPORT, front . . . . .
69	All (396, 427) . . . . .	3946017	1	1.35	SUPPORT ASSY. . . . .
66-67	Chevy, w/Sp. H/Per. (327) . . . . .	3928493	1	4.60	SUPPORT UNIT . . . . .
73	Camaro, Nova (6 cyl.) w/P/S,				
73	Deluxe (6 cyl.) w/P/S,				
73	Malibu (6 cyl.) w/P/S (exc. Sta. Wag.),				
73	Impala, Bel Air (6 cyl.) (Sed.) . . .	329657	1	2.10	SUPPORT, hyd. strg. pump frt. . . . .
73-74	Camaro, Nova (6 cyl.) w/P/S,				
73-74	Malibu (6 cyl.) w/P/S (exc. Sta. Wag.),				
73	Impala, Bel Air (6 cyl.) (Sed.) . . .	329658	1	1.85	SUPPORT, hyd. strg. pump lwr. . . . .
73-75	All (8 cyl.) (exc. C.A.C., Monza) . .	6262943	1	1.55	SUPPORT, hyd. strg. pump adj. bracket . . .
74	Nova, Camaro (6 cyl.) w/P/S,				
74	Malibu (6 cyl.) w/P/S (exc. Sta. Wag.) . . . . .	343301	1	1.90	SUPPORT, hyd. strg. pump front . . . . .
74-75	All (8 cyl.) w/C.A.C. (exc. Monza)	354331	1	2.10	SUPPORT, hyd. strg. pump adj. . . . .
75	Nova, Camaro (6 cyl.) (P/S w/C.A.C.) (exc. Calif.),				
75	Malibu, El Camino (6 cyl.) (P/S w/C.A.C.) (exc. Sta. Wag.) . . . . .	354526	1	3.05	SUPPORT, hyd. strg. pump front . . . . .
75	Nova (6 cyl.) (exc. integrated cylinder head) . . . . .	360138	1	2.40	SUPPORT, hyd. strg. pump frt. . . . .
75	Camaro, Nova (6 cyl.) (P/S w/C.A.C.),				
75	Malibu, El Camino (6 cyl.) (P/S w/C.A.C.) (exc. Sta. Wag.) . . . . .	354527	1	3.05	SUPPORT, hyd. strg. pump lwr. . . . .
75	Camaro, Nova (6 cyl.) w/P/S (exc. C.A.C.),				
75	Malibu, El Camino (6 cyl.) w/P/S (exc. C.A.C., Sta. Wag.) . . . . .	355749	1	1.90	SUPPORT, hyd. strg. pump front . . . . .
75	Camaro, Nova (6 cyl.) w/P/S (exc. C.A.C.),				
75	Malibu, El Camino (6 cyl.) w/P/S (exc. C.A.C., Sta. Wag.) . . . . .	355750	1	3.30	SUPPORT, hyd. strg. pump lwr. . . . .
75	Malibu, El Camino (6 cyl.) w/C.A.C. (exc. Sta. Wag.),				
75	Camaro, Nova (6 cyl.) (P/S w/C.A.C.) Calif. . . . .	355730	1	4.80	SUPPORT ASSY., hyd. strg. pump . . . . .
75	Monza (8 cyl.) P/S . . . . .	354354	1	12.15	SUPPORT ASSY., hyd. steering pump adjusting bracket . . . . .

**FRONT AXLE—STEERING**

<b>6.606 BRACKET— BRACE— BOLT— SPACER— SUPPORT— STUD— WASHER, Steering Gear Hydraulic Pump Mounting (Con't)</b>					
64-66	All (6 cyl.)	3841932	1	.39	STUD, pump brace to pump (3/8" — 16 x 2 13/32")
67-70	All (6 cyl.),				
74	Nova (6 cyl.) w/C.A.C.	3904180	1	.71	STUD
62-72	All,				
73-75	All (exc. 454),				
71-75	Vega, Monza	5689546	A.R.	.50	STUD, pump mounting
73-75	All w/454	7815239	1	.94	STUD, pump mounting
62-75	All	3765135	A.R.	.14	WASHER (1 1/16" x 13/32" x 3/32")
62-75	All (exc. Vega, Monza)	3792381	A.R.	.14	WASHER (3/4" x 3/8" x 1/4")
<b>6.608 HOUSING ASSY.— PIN, Steering Gear Hydraulic Pump</b>					
65-66	All	5692883	1	28.75	
67-75	All	7807934	1	36.50	
62-75	All	5689357	2	.27	PIN, dowel (3/16" x 1 13/16") (Note 1)
<i>NOTE 1 Used with pumps with date stamped on reservoir 356xx7 or higher.</i>					
65	Chevelle (396)	5691490	2	.38	PIN, dowel
<b>6.609 SEAL— PLATE— RING— SEAL KIT— GASKET, Steering Gear Hydraulic Pump</b>					
62-75	All	5688034	2	.78	(2 51/64" I.D.)
65	Chevelle (396)	5691489	1	1.55	PLATE, pump end
62-69	Chevy, Chevelle, Camaro,				
65-68	Pass.,				
70-75	All	5689358	1	1.30	PLATE, pump end (2 25/64" dia.)
62-75	All	5688014	1	.21	RING, end plate retaining (3 O.D.)
62-75	All	5688044	1	4.50	SEAL KIT
71-73	Vega	7809204	1	.42	GASKET, steering gear housing side cover
<b>6.610 VANE KIT— ROTOR KIT— RING, Steering Gear Hydraulic Pump</b>					
62-74	All	5688047	1	12.10	(consists of 10 vanes) (Note 1)
<i>NOTE 1 Used with pumps with date stamped on reservoir 356xx7 or higher.</i>					
62-75	All	5690858	1	38.25	ROTOR KIT, w/ring
65	Chevelle (396)	5688890	1	39.00	RING
<b>6.612 PLATE— SPRING, Steering Gear Hydraulic Pump</b>					
62-66	Chevy, Chevelle,				
65-67	Pass.,				
67-68	All,				
69	Pass.,				
69	Chevy, Chevelle (6 cyl.),				
70-75	All	7813462	1	6.05	thrust
62-68	All,				
69	Pass.,				
70-75	All	5688043	1	6.05	pressure (1 7/32" thk.)
65	Chevelle (396)	5688879	1	4.25	pressure
71-73	Vega	5689358	1	1.30	PLATE, strg. pump end
62-75	All	5688037	1	.47	SPRING, flow control (1 31/32" free length)
62-75	All	5689359	1	.21	SPRING, pressure plate
65	Chevelle (396)	5688877	1	.58	SPRING, pressure plate
<b>6.614 SHAFT, Steering Gear Hydraulic Pump Drive</b>					
62-66	All	7807816	1	9.85	(4 9/16" O.L.)
65	Chevelle (396)	7807818	1	9.95	
67-74	All	7810333	1	12.50	(Note 1)
75	All	7818175	1	16.70	
<i>NOTE 1 Used with pumps with date stamped on reservoir 356xx7 or higher.</i>					
<b>6.616 RING, Hydraulic Pump Drive Shaft Outer Bearing Retaining</b>					
62-68	All (exc. Pass.),				
69-75	All	5689388	1	.27	
<b>6.617 SEAL, Steering Gear Hydraulic Pump Drive Shaft</b>					
62-66	All	5688020	1	1.75	(stamped 5688020)
67-75	All	7808195	1	1.90	
<b>6.624 VALVE ASSY., Steering Gear Hydraulic Pump Control</b>					
62	Chevy,				
63	Chevy (6 cyl.),				
64-67	All (exc. Pass.),				
68	Chevelle, Camaro,				
69	Chevy, Chevelle (8 cyl.)	5692407	1	7.45	
65-68	Pass.	5693276	1	7.00	(includes plunger, guide, ball spring, screw, shim, filter and screw assy.)

**FRONT AXLE—STEERING**

**6.624 VALVE ASSY., Steering Gear Hydraulic Pump Control (Con't)**

67-68	Pass. (8 cyl.)	5691948	1	8.60	(includes plunger, guide, ball, spring, screw, shim, filter and screw assy.)
69	Camaro (6 cyl.)	7803767	1	5.20	
69	Impala, Caprice (exc. 396)	7805647	1	4.20	
69	Camaro (8 cyl.) (exc. 396),				
69	Impala, Caprice (396)	5697028	1	8.55	
70	Chevelle (Sta. Wag.)	7809226	1	4.50	
70	Pass. (Sta. Wag.) (exc. 454)	7809228	1	4.50	
70	Pass. (exc. Sta. Wag.),				
70	Nova, Chevelle, Camaro (8 cyl.) (exc. Sta. Wag.),				
71	All (8 cyl.),				
72-75	All (exc. Vega, Monza)	7809232	1	4.50	
70	Nova, Chevelle, Camaro (6 cyl.) (exc. Sta. Wag.),				
71	All (6 cyl.) (exc. Vega, Monza)	7809230	1	4.50	
71-75	Vega,				
75	Monza (H.B.) (8 cyl.)	7809224	1	4.75	

**6.630 FILTER— ELEMENT, Hydraulic Steering Pump Inlet**

65-67	Chevy,				
69	Chevy, Chevelle (396)	5689351	1	3.70	oil
62-64	Chevy, Chevelle,				
65-67	Chevy,				
69	Chevy, Chevelle (396)	5689352	1	2.10	ELEMENT, filter

**6.635 RESERVOIR ASSY.— BOLT— CAP ASSY.— SEAL, Steering Gear Hydraulic Pump**

64-68	Chevelle (283, 307, 327)	5692839	1	11.80	cover (5696221)
65-66	Chevelle	3823695	1	9.65	auxiliary mtd. to side fender
65	Pass. (8 cyl.)	5692848	1	12.75	
64-66	Chevy, Chevelle (6 cyl.),				
65-67	Chevy,				
66	Pass. (8 cyl.) (exc. 409, 396),				
67	Pass.	7804118	1	12.75	
65-68	Pass. (6 cyl.),				
67-69	Chevelle, Camaro (6 cyl.),				
69	Biscayne, Bel Air (6 cyl.),				
70-71	All (6 cyl.)	5694612	1	11.55	
65-67	Chevelle (396)	5696653	1	19.65	cover (5696636)
67-68	Camaro (8 cyl.),				
68	Chevy (8 cyl.)	5692845	1	11.80	
67	Chevelle (396)	3900185	1	9.65	
68	Chevelle (396)	7803552	1	20.15	
68	Chevelle (S.S.) (396),				
69	Malibu, El Camino (396)	3928205	1	10.05	w/bracket
68	Pass. (exc. 396, 427)	7803755	1	12.65	
69	Chevy, Chevelle (396),				
69	Biscayne, Bel Air (396, 427)	7806439	1	13.60	
69	Chevy, Camaro (8 cyl.) (exc. 396),				
69	Malibu (Spt. Mdls.) El Camino (exc. 396)	7806532	1	13.20	
69-70	Pass. (8 cyl.) (exc. 396, 427, 454)	7806543	1	13.20	
70	Chevelle, Nova, Camaro (8 cyl.),				
71-72	All (8 cyl.),				
73-75	All (8 cyl.) w/454	7808859	1	14.00	
72	All (6 cyl.)	7813893	1	11.55	
73-75	All (6 cyl.)	7815452	1	20.65	
73-75	All (8 cyl.) (exc. 454)	7813894	1	20.65	
75	All (6 cyl.)	7819291	1	29.75	
71-75	Vega (exc. 8 cyl.)	7810691	1	12.55	
75	Monza (H.B.) (8 cyl.)	7819294	1	16.80	
69-70	All (8 cyl.),				
72-75	All (8 cyl.) (exc. Monza)	5696245	1	.64	BOLT, strg. pump reservoir
66	El Camino (396)	2496052	1	20.75	CAP ASSY., reservoir— (3.028)
67-68	Chevelle (396)	3908539	1	2.15	CAP ASSY., reservoir
62-69	All,				
70	All (exc. Sta. Wag.),				
71-75	All	7803820	1	3.60	CAP ASSY., filler
62-75	All	5688015	1	1.35	SEAL, "O" ring, reservoir (4 1/2" I.D.)
62-75	All	5688109	2	.28	SEAL, reservoir bolt (29/64" O.D.)

**FRONT AXLE—STEERING**

**6.655 PULLEY— GUARD— NUT— WASHER, Steering Gear Hydraulic Pump**

64-68	All (8 cyl.) (exc. 396, Pass.),				
65	Pass. w/Air Cond. (409),				
68-69	Police (8 cyl.),				
69	All (8 cyl.) (exc. Pass., C.A.C.,				
	302, Sp. H/Per.),				
69	Pass. (8 cyl.) (exc. C.A.C., 427),				
70-71	All (8 cyl.) (exc. 350, 396,				
	C.A.C.),				
72-74	All (8 cyl.) (exc. C.A.C., Sp.				
	H/Per. 350, Monte Carlo) . . . . .	<b>3770509</b>	1	6.80	(5 <sup>47</sup> / <sub>64</sub> " O.D.) . . . . .
65	Pass. w/Sp. H/Per. (409) . . . . .	<b>3878245</b>	1	21.15	(6 <sup>1</sup> / <sub>8</sub> " O.D.) . . . . .
62-69	All (6 cyl.),				
70	All (6 cyl.) (exc. Camaro),				
73-74	All (6 cyl.),				
71-74	Vega . . . . .	<b>3791943</b>	1	6.80	(5 <sup>3</sup> / <sub>4</sub> " O.D.) . . . . .
65	Chevy (4 cyl.),				
65-66	Chevy (8 cyl.),				
65-68	Pass. (8 cyl.) (exc. 396, 409,				
	427),				
66-67	Chevelle, Camaro (302, 396)				
	(exc. Sp. H/Per.),				
68	Chevy, Camaro (307, 327) (exc.				
	H/Per.),				
70	Camaro (6 cyl.),				
71-72	All (6 cyl.) . . . . .	<b>3860457</b>	1	6.80	(5 <sup>47</sup> / <sub>64</sub> " O.D.) . . . . .
66-69	All w/A.I.R. (6 cyl.),				
70	Camaro (6 cyl.) . . . . .	<b>3880866</b>	1	7.30	(5 <sup>23</sup> / <sub>64</sub> " O.D.) . . . . .
65-68	Chevelle (396),				
66-67	Pass. (396, 427),				
67-68	Camaro w/A.I.R. (302, 396),				
68	Chevy (396),				
68	Biscayne, Bel Air (427) . . . . .	<b>3873847</b>	1	10.30	
68	Pass., Chevelle, Camaro (396)				
	(exc. Spec. H/Per.) . . . . .	<b>3925537</b>	1	6.80	
69	All w/Sp. H/Per. (302, 396,				
	427),				
70	Nova, Chevelle, Camaro w/Sp.				
	H/Per. (350, 396, 454),				
71-72	Camaro w/Sp. H/Per. (350),				
71	Monte Carlo, Malibu w/Sp.				
	H/Per. (454),				
72	Monte Carlo, Malibu, El Camino				
	(Custom) w/Sp. H/Per. 454,				
73-74	Camaro w/Sp. H/Per. 350 (exc.				
	C.A.C.) . . . . .	<b>3941105</b>	1	6.80	
69	All w/Air Cond.,				
71-74	All w/C.A.C. (8 cyl.) . . . . .	<b>3941107</b>	1	6.80	(9.169) . . . . .
73-74	Pass., Nova, Camaro (250),				
73-74	Chevelle (Deluxe, Malibu) (exc.				
	Malibu Wag., Estate) . . . . .	<b>329671</b>	1	6.95	w/pump and fan front— (1.062) . . . . .
74	Nova (6 cyl.) (C.A.C. w/T.H. 350)	<b>3860457</b>	1	6.80	(5 <sup>47</sup> / <sub>64</sub> " O.D.) . . . . .
74	Nova (6 cyl.) (C.A.C. w/3-Spd.) . .	<b>3880866</b>	1	7.30	(5 <sup>23</sup> / <sub>64</sub> " O.D.) . . . . .
75	Camaro w/Sp. H/Per. 350 (exc.				
	C.A.C.) . . . . .	<b>354326</b>	1	6.80	hyd. strg. pump . . . . .
75	All (6 cyl.),				
75	Vega, Monza (140) w/P/S (exc.				
	A.I.R.) . . . . .	<b>354539</b>	1	4.00	hyd. strg. pump . . . . .
75	All (8 cyl.) w/C.A.C. (exc. Monza)	<b>354325</b>	1	4.35	hyd. strg. pump . . . . .
75	All (8 cyl.) (exc. C.A.C., Sp.				
	H/Per. 350, Monza),				
75	Vega, Monza (140) (P/S				
	w/A.I.R.) (exc. C.A.C.) . . . . .	<b>354324</b>	1	6.80	hyd. strg. pump . . . . .
75	Monza (262) (exc. C.A.C.) . . . . .	<b>354357</b>	1	6.80	
75	Monza (262) w/C.A.C. . . . .	<b>360413</b>	1	7.05	
64-67	Chevy (8 cyl.) (exc. Sp. H/Per.),				
66-67	Chevelle (8 cyl.) (exc. 396) . . . . .	<b>3890478</b>	1	2.00	<b>GUARD, belt</b> . . . . .
62-66	All,				
70-75	All . . . . .	<b>3824475</b>	1	.24	<b>NUT, pulley (9<sup>1</sup>/<sub>16</sub>"— 18)</b> . . . . .
65-66	Chevelle (8 cyl.),				
65	Pass. w/Air Cond. (409) . . . . .	<b>3860454</b>	2	.11	<b>WASHER, belt guard (3<sup>1</sup>/<sub>8</sub>" I.D. x 17<sup>1</sup>/<sub>32</sub>" O.D.)</b> . . . . .

**6.660 BELT, Steering Gear Hydraulic Pump Drive**

62	Chevy (exc. 42 amp. A.C. gen.),
64	Chevelle (Access. Air Cond.) (6 cyl.),

**FRONT AXLE—STEERING**

**6.660 BELT, Steering Gear Hydraulic Pump Drive (Con't)**

65-66	Chevelle (6 cyl.),				
65-66	Pass. (w/Acc. Air Cond.) (6 cyl.) .	<b>3887104</b>	1	4.75	(48½" long)—(1.066) . . . . .
64-67	Chevy (8 cyl.) (exc. Sp. H/Per.),				
65	Pass. (8 cyl.) (exc. 409, 396),				
66-68	Pass. (8 cyl.) (exc. 396, 427),				
67	Camaro (327) . . . . .	<b>9433722</b>	1	4.15	(35 long)—(1.066) (Note 1) . . . . .
<i>NOTE 1: The difference in design is the position of the power steering pump. You must use support, which is 3858138 and 3786870 bracket found in Group 6.606.</i>					
64-68	Chevelle (8 cyl.) (exc. 396),				
69	Camaro, Chevelle (396) . . . . .	<b>9433735</b>	1	4.75	(41½" long)—(1.066) . . . . .
65	Pass. w/Air Cond. (409) . . . . .	<b>9433742</b>	1	5.15	(44½" long)—(1.066) . . . . .
65	Pass. (409) (exc. Air Cond.) . . . . .	<b>3953786</b>	1	4.75	(44 long)—(1.066) . . . . .
65-67	Pass. (396, 427) . . . . .	<b>9433728</b>	1	4.95	(37 <sup>19</sup> / <sub>64</sub> " long)—(1.066) . . . . .
65-69	Pass. (6 cyl.) (exc. C.A.C., Cool Pack, AC gen.),				
66-68	All w/A.I.R. (6 cyl.) (exc. Pass.) . .	<b>9433753</b>	1	6.05	(50" long)—(1.066) . . . . .
66-69	Chevy w/Sp. H/Per. (327),				
67-69	Camaro (350),				
69	Pass. (exc. 396) . . . . .	<b>9433725</b>	1	4.95	(36¼" long)—(1.066) . . . . .
69	Pass., Chevelle (8 cyl.) . . . . .	<b>9433737</b>	1	5.15	(42 long)—(1.066) . . . . .

**6.670 HOSE—STRAP, Steering Gear Pressure**

62-67	Chevy (exc. 8 cyl.) . . . . .	<b>3793335</b>	1	11.00	pump to control valve inlet (35 <sup>5</sup> / <sub>8</sub> " dev. length) . . . . .
64-67	Chevy (8 cyl.) . . . . .	<b>3793337</b>	1	7.20	pump to control valve inlet . . . . .
64-67	Chevelle (6 cyl.) . . . . .	<b>5698217</b>	1	9.85	pump to strg. gear inlet (21 dev. length) . . . . .
64-68	Chevelle (8 cyl.) (exc. 396) . . . . .	<b>3928214</b>	1	11.55	pump to strg. gear inlet (23 dev. length) . . . . .
65-67	Chevelle (396) . . . . .	<b>3880584</b>	1	11.50	pump to strg. gear inlet (24 dev. length) . . . . .
65-67	Pass. (6 cyl.),				
67-69	Camaro (6 cyl.),				
68	Chevy, Biscayne, Bel Air (6 cyl.),				
69	Pass., Chevy (6 cyl.) . . . . .	<b>3964566</b>	1	10.10	pump to inlet . . . . .
65-67	Pass. (283, 327) . . . . .	<b>3874694</b>	1	11.10	pump to inlet . . . . .
65-66	Pass. (396, 427) . . . . .	<b>3875021</b>	1	11.10	pump to inlet . . . . .
67-68	Pass. (396, 427) . . . . .	<b>3906961</b>	1	12.55	pump to inlet . . . . .
67-68	Camaro (8 cyl.),				
68	Chevy (8 cyl.) . . . . .	<b>3912551</b>	1	12.55	pump to strg. gear inlet . . . . .
68	Chevelle (396) . . . . .	<b>3928204</b>	1	11.50	pump to strg. gear inlet . . . . .
68-70	Chevelle (6 cyl.),				
71-72	Pass., Chevelle (6 cyl.),				
73-75	Impala, Bel Air, Chevelle (6 cyl.)	<b>3972671</b>	1	11.05	pump to strg. gear inlet . . . . .
68	Pass. (307, 327) . . . . .	<b>3931411</b>	1	9.95	pump to inlet . . . . .
69	Chevelle (8 cyl.) (exc. 396) . . . . .	<b>3949136</b>	1	11.60	pump to strg. gear inlet . . . . .
69	Chevelle (396) . . . . .	<b>3964567</b>	1	12.40	pump to strg. gear inlet . . . . .
69	Pass. (8 cyl.) . . . . .	<b>3964563</b>	1	12.55	pump to strg. gear inlet . . . . .
70	Pass. (8 cyl.) . . . . .	<b>3968769</b>	1	11.20	pump to strg. gear inlet . . . . .
70	Pass., Nova (6 cyl.),				
71-74	Nova (6 cyl.) . . . . .	<b>3972200</b>	1	10.10	pump to strg. gear inlet . . . . .
69	Camaro (307, 350),				
69-72	Nova (8 cyl.) . . . . .	<b>7811627</b>	1	13.15	pump to strg. gear inlet . . . . .
69	Nova, Camaro (396, 427, 454),				
70	Nova (396) . . . . .	<b>7811628</b>	1	13.15	pump to strg. gear inlet . . . . .
70	Chevelle (8 cyl.) (exc. 396, Monte Carlo) . . . . .	<b>3974649</b>	1	11.05	pump to strg. gear inlet . . . . .
70	Chevelle (396, 454) (exc. Monte Carlo),				
71	Chevelle (400, 4BC, 454),				
70	Monte Carlo (400 4BC),				
71-72	Monte Carlo (454) . . . . .	<b>7813758</b>	1	11.05	pump to strg. gear inlet . . . . .
70	Monte Carlo (exc. 400, 4BC),				
71-72	Monte Carlo, Concours (Estate) (exc. 454) . . . . .	<b>7813596</b>	1	11.05	pump to strg. gear inlet . . . . .
70-72	Camaro (396, 400, 402) . . . . .	<b>3973078</b>	1	10.45	pump to strg. gear inlet . . . . .
70-72	Camaro (8 cyl.) (exc. 396, 400, 402) . . . . .	<b>3973077</b>	1	10.45	pump to strg. gear inlet . . . . .
70-75	Camaro (6 cyl.),				
75	Nova (6 cyl.) . . . . .	<b>3983093</b>	1	10.55	pump to steering gear inlet . . . . .
71-72	Pass. w/4BC (400, 402, 454) . .	<b>7811644</b>	1	14.40	hyd. strg. pump to strg. gear inlet . . . . .
71-72	Chevelle (exc. 400, 4BC, 454),				
73-75	Chevelle (8 cyl.) (exc. 454, Monte Carlo) . . . . .	<b>7811621</b>	1	12.20	hyd. strg. pump to strg. gear inlet . . . . .
71-72	Pass. w/2BC,				
71-72	Pass. w/4BC (350),				
73-75	Pass. (8 cyl.) (exc. 454),				
73-75	Camaro (8 cyl.),				

**FRONT AXLE—STEERING**

**6.670 HOSE— STRAP, Steering Gear Pressure (Con't)**

75	Nova (8 cyl.)	7813759	1	10.45	hyd. strg. pump to strg. gear inlet (Note 2)
<i>NOTE 2: When used on 1971 "B" body route same as when installing on 1972 "B" body.</i>					
72	Chevelle w/402, 4BC, 454	7812994	1	10.50	hyd. strg. pump to strg. gear inlet
73-75	Monte Carlo (350)	7815390	1	12.20	hyd. strg. pump to strg. gear inlet
73-75	Monte Carlo (454)	7815391	1	11.05	hyd. strg. pump to strg. gear inlet
73-75	Chevelle (454) (exc. Monte Carlo)	7815392	1	11.05	hyd. strg. pump to strg. gear inlet
73-74	Nova (8 cyl.)	7815460	1	13.15	hyd. strg. pump to strg. gear inlet
73-75	Pass. (454)	7813680	1	15.20	hyd. strg. pump to strg. gear inlet
71-75	Vega, Monza (140) P/S	7811007	1	9.55	hyd. steering pump to steering gear inlet
75	Monza (8 cyl.) P/S	7819113	1	12.50	hyd. steering pump to steering gear inlet
71-74	Vega	1361756	1	.57	STRAP, engine & gen. wiring harness (to hyd. strg. hose)— (3.162)

**6.671 HOSE, Steering Gear Return**

62	Chevy w/offset tie rods (2nd design),				
63-67	Chevy	3793341	1	6.70	pump to control valve outlet (33 dev. length)
65-75	All w <sup>3/8</sup> " hose	9432963	1	RL/.55	pump to gear (3/8" I.D.)— (8.962)

**6.672 CLAMP— CLIP— BRACKET— SHIELD— SLEEVE, Hydraulic Steering Pump Hose**

65-67	Pass. w/P/S (exc. 409, A.I.R.)				clip hyd. strg. pump to control valve outlet and inlet hose assys.,
66	Chevelle (6 cyl.) (exc. Std.),				
67-69	Camaro,				
68-69	Chevy (Nova),				
68	Pass. w/P/S. (327),				
69	Pass. (6 cyl.),				
69	Chevelle,				
70	All,				
71-72	Nova,				
71-72	Chevelle (8 cyl.),				
72-75	Camaro (8 cyl.),				
73-75	Nova (6 cyl.)	3874661	1	.11	strg. to gear, inlet and outlet
64-69	Chevelle, Camaro (8 cyl.)	5187661	1	.63	pump reservoir to pump hose
75	Vega (122)	3892948	1	.12	clip support
68-69	Chevy (8 cyl.),				
70	Chevelle,				
71	Camaro,				
71	Chevelle, Nova (8 cyl.),				
71	Pass. (400, 4BC, 454)	7802624	1	.53	CLIP, gear hose retaining
70-72	Nova (8 cyl.)	3972205	1	.16	CLIP, pump to strg. gear inlet and outlet hose
70	Camaro (8 cyl.),				
69-70	Pass. (8 cyl.)	3947540	1	.22	BRACKET, pump to inlet and outlet hose
75	F, X w/P/S	3791812	1	1.40	SLEEVE, pump to gr. outlet hose

**6.673 FITTING ASSY.— SEAT— VALVE KIT, Steering Gear Hydraulic Valve Hose**

64-67	Chevy,				
69	Chevy, Chevelle (396),				
69	Pass. (6 cyl.)	5692841	1	3.45	w/filter pump outlet
64-68	Chevelle (6 cyl.),				
65-66	Pass.,				
67-68	Camaro,				
68-69	Nova,				
69	Chevelle	5692823	1	3.45	w/orifice
64-68	Chevelle (8 cyl.)	5692836	1	3.45	w/filter, pump outlet
67-69	Pass.	7803763	1	3.70	
69	Impala, Caprice, Kingswood, Camaro	5699529	1	3.45	w/orifice, pump outlet
70	Chevelle (Sta. Wag.)	7811617	1	13.15	w/orifice, pump outlet
70-71	All (exc. Sta. Wag.),				
70-71	Pass. (Sta. Wag.),				
72-75	All	7811616	1	2.05	w/orifice, pump outlet
62-67	Chevy	5681757	A.R.	.24	SEAT, pressure port (3/4" I.D. x 3/4" O.D.)
62-66	Chevy, Chevelle,				
65-69	Pass.,				
67-69	Chevelle, Camaro,				
68-69	Chevy,				
71-74	All	5682044	A.R.	.27	SEAT, pump body connector return port (1/4" I.D. x 11/32" O.D.)
64-72	Chevelle, Camaro,				
65-72	Pass.,				

**FRONT AXLE—STEERING**

**6.673 FITTING ASSY.— SEAT— VALVE KIT, Steering Gear Hydraulic Valve Hose (Con't)**

68-72	Chevy,				
71-74	Vega, Monza,				
73-74	All	5687538 A.R.	.34	SEAT (integral pwr. strg.) inverted flared tube	
64-69	Chevelle,				
65-66	Pass.,				
68-69	Pass.,				
69	Camaro, Chevy (exc. 4 cyl.),				
70-73	All,				
71-74	Vega,				
74	Camaro,				
75	Pass. (454)	5687624 1	.91	VALVE KIT, strg. gear check valve	

**6.674 SEAL, Steering Gear Hydraulic Valve Hose and Fitting "O" Ring**

62-67	Chevy	5681740 1	.31	"O" ring valve reaction spool ( <sup>27</sup> / <sub>64</sub> " I.D.)
62-75	All	5688049 1	.28	pump outlet fitting ( <sup>37</sup> / <sub>64</sub> " I.D.)
62-75	All	5688035 1	.28	"O" ring pump outlet fitting ( <sup>15</sup> / <sub>16</sub> " O.D.)

**6.677 PIPE ASSY., Hydraulic Steering**

62-67	Chevy	3790857 1	7.05	control valve to extend cyl.
62-67	Chevy	3790859 1	7.05	control valve to retract cyl. (Note 1)
<i>NOTE 1 3780859 must not be used in place of 3790857.</i>				
64-67	Chevelle (6 cyl.)	5691999 1	.38	pump to strg. gear outlet (formed)
64-67	Chevelle (8 cyl.) (exc. 396)	5692268 1	.53	pump to strg. gear outlet (formed)

**6.758 COLLAR— COVER— SEAL— FASTENER, Steering Column**

67-68	Camaro,				
68	Police w/H.D. Trans.,				
68	Chevy	7800937 1	1.25	strg. column	
69	Chevy, Camaro,				
70	Nova (exc. T.W.),				
71-73	Nova,				
71-72	Chevelle (floor console w/A.T., T.W.),				
71-73	Camaro w/A.T., T.W. (exc. floor console)	7805550 1	1.35	strg. column	
67-68	Camaro	3914799 1	.58	COVER, col. to dash lower	
67-68	Camaro	3899848 1	1.90	COVER, col. to dash upper	
67-68	Camaro,				
68	Chevy,				
69	Chevy, Camaro,				
70-74	Nova	333708 1	1.50	COVER, strg. gear jkt., to dash trim	
69-70	Pass.	3950067 1	.84	COVER, strg. column to dash trim	
69	Chevy, Camaro,				
70-72	Nova	3949736 1	.76	COVER, strg. column to dash lower	
69-72	Chevelle	3947979 1	1.70	COVER, strg. gear jkt. to dash trim	
70-75	Camaro	333707 1	1.80	COVER, jacket to dash trim	
71-75	Pass.	410055 1	1.95	COVER, trim column to dash upper	
71-75	Pass.	406230 1	1.20	COVER, strg. column to dash lower	
71-75	Pass.	1235625 1	1.10	COVER, strg. column to dash panel trim	
69-72	Chevelle	401946 1	1.10	COVER ASSY., strg. column inner	
69-72	Chevelle	401949 1	1.25	COVER ASSY., strg. column outer	
69	Chevy, Camaro,				
70-72	Nova	3949735 1	1.45	COVER ASSY., strg. column to dash upper	
73-75	Chevelle	413545 1	1.30	COVER, strg. column dash upper	
73-75	Chevelle	413546 1	1.25	COVER, strg. column dash lower	
73-74	Nova	6264714 1	.76	COVER, strg. column to dash lower	
73-75	Chevelle	1238055 1	1.70	COVER, strg. column to dash panel trim	
73-74	Nova			COVER, strg. gear jkt. to dash trim,	
73-75	Nova	6264713 1	.98	COVER, strg. column to dash upper	
73-75	Chevelle (exc. C.A.C.)	3994499 1	1.20	COVER, inst. panel strg. col.	
73-75	Vega, Monza	326201 1	.46	COVER, dash mat. trim at strg. col.	
62-66	Chevy (exc. P.G.)	3793307 1	.19	SEAL	
64-65	Chevy w/4-Spd.,				
64-65	Nova (S.S.) (exc. 3-Spd.)	3756862 1	.17	SEAL	
67	Chevelle,				
67	Camaro w/T.W.				
67-68	Pass. (T.W. w/A.T.)	7800467 1	1.35	SEAL, dash	
68	Chevy, Camaro	7802595 1	.96	SEAL, dash	
69-70	Chevy, Camaro,				
71-74	Nova	7807361 1	1.45	SEAL, strg. column to dash cover	
69-70	Pass.	7805572 1	2.25	SEAL, strg. column to dash cover	
68-69	Chevelle w/floor shift,				
70	Monte Carlo,				

**FRONT AXLE—STEERING**

**6.758 COLLAR— COVER— SEAL— FASTENER, Steering Column (Con't)**

71-72	Chevelle,				
73	Nova w/T.W.	7807812	1	1.90	SEAL, dash
71-73	Camaro w/A.T. (exc. floor console, T.W.)	7806815	1	2.00	SEAL, strg. column dash
71-75	Pass.	7809661	1	3.60	SEAL, dash (toe plate)
71-73	Camaro w/T.W.	7809696	1	1.55	SEAL, dash (toe plate)
73-75	Chevelle (exc. T.H. 400, close ratio)	7814386	1	3.60	SEAL, strg. column dash
71-75	Vega, Monza (exc. P/S)	7811191	1	1.35	SEAL, steering column dash bracket
62-69	All	3764424	A.R.	.18	FASTENER, strg. column jacket

**6.760 CLAMP— BOLT— BRACKET ASSY.— NUT— PLATE— SCREW— SEAL— SUPPORT— WASHER, Steering Column**

62-64	Chevy w/P.G. (exc. S.S.)	3938986	1	.43	strg. gear jacket lower, w/screw
67	Chevy	454467	1	.22	BOLT (3/8"— 16 x 1 3/4") strg. col. clamp
67	All	9419029	4	.11	BOLT (5/16"— 18 x 7/16") support to column— (8.900)
67-68	Camaro	3898183	1	4.45	BRACKET ASSY., strg. col. supt.
67	Chevy	3909157	1	6.65	BRACKET ASSY., strg. col. supt.
69-72	Chevelle	7804091	1	6.65	BRACKET ASSY., strg. column supt.
69-72	Chevy	7804096	1	7.60	BRACKET ASSY., strg. column supt.
69-70	Pass.	7804094	1	13.00	BRACKET ASSY., strg. col. supt.
71-75	Pass.,				
73-75	Chevelle	7809925	1	5.75	BRACKET ASSY., strg. col. support
71-75	Pass.	407976	1	5.95	BRACKET, strg. col. guide
71-75	Vega, Monza (exc. P/S)	7810273	1	4.80	BRACKET, steering column to dash
71-75	Vega, Monza w/P/S	7811289	1	5.30	BRACKET, hyd. steering column to dash
71-75	Vega, Monza	7804091	1	6.65	BRACKET, strg. column support
73-74	Nova	7815150	1	5.05	BRACKET, strg. column support
73-75	Chevelle	410900	1	4.80	BRACKET, strg. column guide
75	Monza (H.B.)	7817958	1	4.90	BRACKET, strg. column support
75	Monza (H.B.)	346793	1	5.15	BRACKET, strg. column guide
62-69	All,				
72-75	All	1378333	A.R.	.12	NUT (3/8"— 16, support)
70-74	Camaro	9812716	1	4.70	PLATE, support anchor lower
62-67	Chevy w/P.G., P/S				SCREW (1/16"— 12 x 1 1/8"), strg. gear jacket clamp, strg. control valve to cyl. pipe clamp,
68	Chevelle (exc. 4-Dr. Sed., Conv.)	3826260	1	.12	frt. brk. right pipe clip
69	Camaro, Chevy,				
70-75	Nova	3948595	R.H.	.70	SUPPORT, side
69	Camaro, Chevy,				
70-75	Nova	3948597	L.H.	.70	SUPPORT, side
71-72	Vega	8802009	1	9.80	SUPPORT, at reinforcement, lower
73-75	Vega, Monza	9727456	1	9.80	SUPPORT, at reinforcement, lower
65	Pass.,				
64-66	Chevelle	3704579	A.R.	.13	WASHER, strg. column to dash cover (1 O.D. x 7/32" I.D. x 1/16" thk.)— (8.143)

**6.765 "U" BOLT, Steering Column**

*NOTE. For Steering Column "U" Bolt, see group 6.760.*

**6.786 BUSHING— BEARING, Pitman Shaft**

62-69	Pass., Chevy, Chevelle,				
67-69	Camaro (exc. P/S),				
70-75	All (exc. P/S, Vega, Monza),				
75	Monza (H.B.) (exc. P/S)	266316	A.R.	2.10	(1 1/8" I.D. x 1 3/8")
73-75	Vega, Monza (140) (exc. P/S)	7809250	1	2.20	
64-69	Pass., Chevelle, Camaro,				
68-69	Chevy	5687757	1	6.55	BEARING (1 1/4" I.D. x 1 5/8" O.D. x 1 1/4" long)
71-72	Vega (exc. P/S)	7813619	1	5.20	BEARING, Pitman shaft needle
69	Impala, Caprice, Camaro w/P/S,				
70	Camaro w/P/S,				
71-75	All w/P/S	5697804	1	6.50	BEARING ASSY., strg. gear hsg.

**6.803 HOUSING, Steering Gear**

*NOTE. For Steering Gear Housings not listed see Group No. 6.508.*

64-69	Chevelle, Camaro w/Spl. Strg. (exc. P/S),				
65-69	Pass. (exc. P/S),				
68-69	Chevy w/Spl. Strg.,				
68-69	Camaro (Spt. Cpe.) w/Sp. Strg. (8 cyl.),				
70	All (exc. P/S),				



**FRONT AXLE—STEERING**

**6.803 HOUSING, Steering Gear (Con't)**

72	Camaro w/Sp. H/Per. 350 (exc. P/S),				
74	Pass., Police w/Sp./Per/Susp.,				
75	Vega (122) (exc. P/S),				
75	Nova, Camaro (exc. P/S),				
75	Monza (Notchback) (8 cyl.) (exc. P/S) .....	5679271	1	38.00	
64-67	Chevelle, Camaro w/P/S,				
65-69	Pass. w/P/S,				
68-69	Chevy, Chevelle w/P/S,				
70	Nova w/P/S (8 cyl.),				
70	Chevelle w/P/S,				
70	Pass. (Sta. Wag.),				
71-72	Chevelle w/P/S (8 cyl.) .....	5693456	1	63.75	
68-69	Camaro w/P/S .....	7805160	1	58.25	w/ring .....
71-72	Nova w/P/S, 4BC .....	7811460	1	47.00	w/ring .....
71-74	Nova w/P/S (6 cyl.),				
71	Pass. w/P/S,				
72	Nova (8 cyl.) (exc. 4BC),				
72	Pass. w/P/S (exc. Police),				
72	Police w/P/S (exc. 454) .....	7811211	1	62.25	w/ring .....
70-74	Camaro w/P/S .....	7805232	1	56.25	w/ring .....
69-70	Pass. w/P/S (exc. Sta. Wag.),				
70	Nova w/P/S (6 cyl.),				
75	Camaro, Nova w/P/S,				
70-71	Chevelle w/P/S (8 cyl.) (exc. Sta. Wag.),				
72	Chevelle w/P/S (6 cyl.),				
72	Police w/P/S (454),				
73	Police,				
74	Pass. w/P/S (exc. Police, Sp./Per./Susp.),				
73-74	Chevelle w/P/S (exc. Sta. Wag., S.S., Monte Carlo),				
75	Chevelle (P/S w/sport/susp.) (exc. Sta. Wag.),				
75	Pass. w/P/S (exc. 454),				
75	Vega, Monza w/P/S .....	7806752	1	39.50	(repl. 7805541) .....
71	All (exc. P/S),				
72	All (exc. P/S, Camaro),				
72	Camaro (exc. P/S, Sp. H/Per. 350),				
73-75	Chevelle, Nova (exc. Monte Carlo, P/S),				
74-75	Camaro (exc. P/S) .....	7809664	1	33.00	
71-75	Vega, Monza (140) (exc. P/S) ..	7815600	1	24.00	
71-72	Vega w/P/S .....	5693456	1	63.75	
73-74	Vega w/P/S,				
73-74	Monte Carlo w/P/S,				
73-74	Chevelle (S.S.) w/P/S .....	7815069	1	63.75	w/ring .....
73-74	Chevelle (Sta. Wag.) w/P/S,				
73	Pass. (exc. Police) .....	7805230	1	59.25	
75	Chevelle w/P/S (exc. Monte Carlo, Laguna) .....	7817518	1	63.75	
74	Pass., Police w/Sp./Per./Susp.,				
75	Pass. w/P/S (454) .....	7803764	1		

**6.806 SEAL, Steering Gear**

62-67	Chevy,				
68	Chevelle, Camaro (exc. P/S) ....	5674114	1	.91	shaft (1 <sup>1</sup> / <sub>16</sub> " I.D. x 1 <sup>1</sup> / <sub>8</sub> " O.D.) .....
64-67	Chevelle,				
65-69	Pass. (exc. P/S),				
67	Camaro (exc. P/S),				
68	Camaro (Spt. Cpe.) (8 cyl.) w/Spl. Strg.,				
69	Chevy, Chevelle, Camaro (exc. P/S, w/Spl. Strg.),				
70-72	All (exc. P/S),				
73-75	Chevelle, Nova, Camaro (exc. P/S),				
74	Vega (122) (exc. P/S),				
75	Monza (H.B.) (8 cyl.) (exc. P/S) ..	7802160	1	1.35	shaft dust .....
71-75	Vega, Monza (140) (exc. P/S) ..	5696537	1	1.10	worm dust .....

**FRONT AXLE—STEERING**

**6.807 COVER ASSEMBLY, Steering Gear Housing (also see group 6.518)**

62-67	Chevy	5675992	1	1.10	side ( $\frac{7}{16}$ "— 20 center hole)
64-69	All w/P/S,				
70	Pass. w/P/S (exc. Sta. Wag.),				
70	Nova (6 cyl.),				
71-74	All w/P/S	7815398	1	10.05	side
69	Camaro,				
69	All (exc. P/S, Camaro),				
70	All (exc. P/S),				
71-72	Camaro w/Sp. H/Per. (350) (exc. P/S),				
75	Camaro, Nova (exc. P/S),				
74	Vega (122) (exc. P/S),				
75	Monza (H.B.) (8 cyl.) (exc. P/S) ..	7806748	1	10.05	w/adjuster
71-72	All (exc. P/S, Sp. H/Per. 350),				
73-75	All (exc. P/S) (Vega, Monza) . . . .	7801619	1	9.25	side
71-75	Vega, Monza (140) (exc. P/S) . . . .	7809201	1	10.05	side
75	All w/P/S	7817484	1	10.05	side

**6.809 GASKET— BOLT— SEAL— STUD, Steering Gear Housing Side Cover**

62-69	Camaro, Chevy, Chevelle (exc. P/S),				
65-69	Pass.,				
70	All (exc. P/S),				
71-72	Camaro w/Sp. H/Per. (350) (exc. P/S),				
74	Vega (122),				
75	Camaro, Nova (exc. P/S),				
75	Monza (H.B.) (8 cyl.) (exc. P/S) . . . .	5666734	1	.22	(3 holes $\frac{13}{32}$ " I.D.)
71-72	All (exc. P/S, Sp. H/Per. 350),				
73-75	Chevelle, Nova, Camaro (exc. P/S)	7810041	1	.19	GASKET
71-75	Vega, Monza (140) (exc. P/S) . . . .	7809204	1	.42	GASKET
69	All w/P/S (exc. Sta. Wag.),				
69	Estate Wag. w/P/S,				
70	Camaro,				
71-73	All w/P/S	7806685	4	.74	BOLT, side cover ( $\frac{3}{8}$ "— 16)
70	All (exc. P/S),				
71-72	Camaro w/Sp. H/Per. (350) (exc. P/S),				
73-75	Camaro, Chevelle, Nova (exc. P/S),				
74	Vega (122) (exc. P/S),				
75	Monza (H.B.) (8 cyl.) (exc. P/S) . . . .	180120	3	.12	BOLT, strg. gear cover ( $\frac{7}{8}$ "— 16 x $\frac{3}{4}$ " repl. 7807009)
74-75	All w/P/S	7816516	1	1.05	BOLT ( $\frac{3}{8}$ "— 16)
71-75	Vega, Monza (140) (exc. P/S) . . . .	7809206	1	.34	BOLT
64-69	Pass., Chevelle, Camaro,				
68-69	Chevy,				
70-75	All w/P/S (exc. Vega, Monza),				
71-73	Vega w/P/S	5686570	1	.84	SEAL, "O" ring
74	All w/P/S (exc. Camaro, Vega) . . . .	7816227	1	1.85	SEAL, strg. valve gasket
75	All w/P/S	7817486	1	3.60	SEAL UNIT, housing side cover
75	Monza (H.B.) (8 cyl.) (exc. P/S) . . . .	7819947	1	.98	STUD, side cover

**6.822 ADJUSTER— NUT— WASHER, Pitman Shaft**

62-72	All (exc. P/S),				
73-75	Chevelle, Nova, Camaro (exc. P/S),				
74	Vega (122) (exc. P/S),				
75	Monza (H.B.) (8 cyl.) (exc. P/S) . . . .	7802482	1	.60	lash
64-69	Pass., Chevelle, Camaro w/P/S,				
68-69	Chevy w/P/S,				
70	All w/P/S (exc. Chevelle),				
71-72	All w/P/S	5685372	1	.62	NUT ( $\frac{7}{16}$ "— 20)
73-74	All w/P/S,				
73-75	Vega, Monza w/P/S,				
75	Pass. (454) w/P/S	5687973	1	.74	NUT, hyd. steering gear lash adjusting
73-74	Chevelle, Nova, Camaro (exc. P/S),				
74	Vega (122) (exc. P/S)	5697702	1	.21	WASHER, strg. gear Pitman shaft lock

**6.824 PLUG— RING, Steering Gear Housing End**

64-67	Chevelle, Camaro w/P/S,
65-68	Pass. w/P/S,
68-69	Chevelle w/P/S,

**FRONT AXLE—STEERING**

**6.824 PLUG— RING, Steering Gear Housing End (Con't)**

70	Pass. w/P/S (exc. Sta. Wag.),				
70	Nova w/P/S (6 cyl.),				
71-72	Chevelle w/P/S (8 cyl.),				
73	Chevelle (Sta. Wag.) w/P/S . . . . .	5689010	1	3.80	
65	Chevelle (396),				
70	Chevelle (Sta. Wag.) w/P/S (6 cyl.) . . . . .	5686815	1	4.00	
69	Impala, Caprice w/P/S,				
70	Nova w/P/S (8 cyl.),				
71	Nova w/P/S, 2BC,				
71	Pass.,				
73-74	Pass.,				
73	Chevelle w/P/S (exc. Sta. Wag.),				
73-75	Nova w/P/S,				
75	Camaro w/P/S . . . . .	7809512	1	2.40	
68-69	Chevy w/P/S,				
69	Biscayne, Bel Air w/P/S,				
69	Brookwood, Townsman w/P/S,				
70	Pass. (Sta. Wag.) w/P/S,				
70	Chevelle w/P/S (8 cyl.) (exc. Sta. Wag.),				
71-72	Chevelle w/P/S (6 cyl.),				
72	Nova w/P/S, 2BC,				
72	Pass.,				
71-75	Vega, Monza w/P/S,				
74-75	Chevelle w/P/S,				
75	Pass. w/P/S (exc. 454) . . . . .	7806688	1	3.90	
64-69	Pass., Chevelle, Camaro w/P/S,				
70	Camaro (6 cyl.),				
71-74	Camaro w/P/S . . . . .	7800715	1	4.00	
71-72	Nova w/P/S, 4BC . . . . .	7811459	1	3.50	
75	Pass. (454) w/P/S . . . . .	7810890	1	4.20	
68-69	Chevy w/P/S,				
70	Pass. (Sta. Wag.) w/P/S,				
70	Chevelle,				
70	Nova (8 cyl.),				
71-73	Vega w/P/S . . . . .	5689012	1	.40	RING, plug retaining . . . . .
65	Chevelle (396),				
70	Pass. w/P/S (exc. Sta. Wag.),				
70	Nova (6 cyl.) . . . . .	5686814	1	.32	RING, plug retaining . . . . .

**6.825 SEAL, Steering Gear End Cover**

64-69	Pass., Chevelle, Camaro w/P/S,				
68-69	Chevy w/P/S,				
70	Pass. (Sta. Wag.) w/P/S,				
70	Chevelle,				
70	Nova (8 cyl.) . . . . .	7812123	1	1.35	end plug "O" ring . . . . .
65	Chevelle (8 cyl.),				
70	Pass. w/P/S (exc. Sta. Wag.),				
70	Nova w/P/S (6 cyl.) . . . . .	7812122	1	.81	"O" ring (3 <sup>7</sup> / <sub>32</sub> " I.D.) . . . . .
75	All w/P/S . . . . .	7817485	1	2.60	end plug . . . . .

**6.826 BEARING, Steering Gear Worm Lower**

65-69	Pass., Chevelle, Camaro w/P/S,				
68-69	Chevy w/P/S,				
70	All w/P/S (exc. Camaro),				
71-75	All w/P/S . . . . .	5683229	1	3.30	gear adj. plug . . . . .

**6.828 SHIM UNIT, Steering Gear Lash Adjuster**

62-69	All,				
73-75	Chevelle, Camaro, Nova,				
74	Vega (122) (exc. P/S),				
75	Monza (H.B.) (8 cyl.) (exc. P/S) . . . . .	605142	1	.91	contains (1) each .063, .065, .067, .069 (Note 1) . . . . .

NOTE 1. Not used w/P/S on 1965 Pass. models.

**6.830 ADJUSTER ASSY.— LOCK NUT— PLUG ASSY., Steering Gear Housing End Cover Worm Bearing**

64-69	Pass., Chevelle,				
67-69	Camaro (exc. P/S),				
68-69	Chevy w/P/S,				
70	All (exc. P/S),				
71-72	Camaro w/Sp. H/Per. (350) (exc. P/S),				
74	Vega (122) (exc. P/S),				

**FRONT AXLE—STEERING**

**6.830 ADJUSTER ASSY.— LOCK NUT— PLUG ASSY., Steering Gear Housing End Cover Worm Bearing (Con't)**

74-75	Chevelle, Nova, Camaro (exc. P/S),				
75	Monza (H.B.) (8 cyl.) (exc. P/S) ..	5666681	1	5.95	
71-72	All (exc. P/S, Sp. H/Per. 350),				
73-75	Chevelle, Nova, Camaro (exc. P/S),				
75	Monza (H.B.) (8 cyl.) (exc. P/S) ..	7809662	1	5.75	
71-75	Vega, Monza (140) (exc. P/S) ..	7808986	1	7.20	
71-72	All (exc. P/S, Sp. H/Per. 350),				
74	Vega (122) (exc. P/S),				
73-75	Chevelle, Nova, Camaro (exc. P/S) ..	5676217	1	.82	LOCK NUT, adj. ....
71-75	Vega, Monza (140) (exc. P/S) ..	7809207	1	1.25	NUT, steering gear worm assy. lock .....
64-70	Pass., Chevelle, Camaro w/P/S,				
68-70	Chevy w/P/S,				
71-75	All w/P/S .....	7817725	1	22.75	PLUG ASSY., adjuster valve .....

**6.832 NUT, Steering Gear Worm Bearing**

62-67	All,				
75	All (6 cyl.) (exc. P/S),				
75	Monza (H.B.) (8 cyl.) (exc. P/S) ..	5676217	1	.82	adjuster lock (2 <sup>3</sup> / <sub>4</sub> "— 16 thread) .....
64-67	Chevelle w/P/S,				
65-66	Pass.,				
71-75	All w/P/S .....	5690698	1	.82	adjuster plug lock (2 <sup>1</sup> / <sub>4</sub> "— 20 x 2 <sup>3</sup> / <sub>4</sub> ") .....
67	Camaro (exc. P/S, Spl. Strg.) ...	267387	1	4.55	side .....
70	All w/P/S .....	5687383	1	.53	housing .....

**6.835 BEARING— CUP— RACE— RETAINER, Steering Worm Thrust**

62-69	Chevy, Chevelle, Camaro (exc. P/S),				
65-69	Pass.,				
70-72	All (exc. P/S),				
73-75	Chevelle, Nova, Camaro (exc. P/S),				
74	Vega (122) (exc. P/S),				
75	Vega, Monza (exc. P/S, Rotary) .	5666693	2	1.08	(1 <sup>5</sup> / <sub>16</sub> " O.D. x 1 <sup>1</sup> / <sub>64</sub> ") .....
64-67	Chevelle, Camaro w/P/S,				
65	Pass. w/P/S,				
68-69	All w/P/S,				
70	All w/P/S (exc. Camaro) .....	5686837	1	1.70	adj. plug upper .....
64-69	Pass., Chevelle, Camaro w/P/S,				
68-69	Chevy w/P/S,				
70	All w/P/S (exc. Camaro),				
71-75	All w/P/S (exc. Vega, Monza),				
71-74	Vega w/P/S .....	5687185	1	5.50	upper thrust .....
64-69	Pass., Chevelle, Camaro w/P/S,				
68-69	Chevy w/P/S,				
70	All w/P/S (exc. Camaro),				
71-73	All w/P/S,				
74	Vega, Camaro w/P/S .....	5687186	1	4.70	lower thrust .....
71-75	Vega, Monza (140) (exc. P/S) ..	5673113	2	1.30	steering gear housing thrust .....
71-72	Vega (exc. P/S) .....	605810	1	3.95	steering gear housing thrust .....
74	All w/P/S (exc. Camaro, Vega),				
75	All w/P/S .....	7816645	1	4.45	lower thrust .....
62-69	All (exc. Camaro),				
67-69	Camaro (exc. P/S),				
70-72	All (exc. P/S),				
73-75	Chevelle, Nova, Camaro (exc. P/S),				
74	Vega (122) (exc. P/S),				
75	Monza (H.B.) (8 cyl.) (exc. P/S) ..	5666683	2	2.02	CUP (1 <sup>1</sup> / <sub>2</sub> " O.D. x 5 <sup>5</sup> / <sub>16</sub> " thk.) .....
71-73	Vega (exc. P/S) .....	7812964	1	1.68	CUP, steering gear worm thrust bearing ...
64-69	Pass., Chevelle w/P/S,				
67-69	Camaro,				
68-69	Chevy w/P/S,				
70	All w/P/S (exc. Camaro) .....	5686836	1	.38	RACE, upper thrust brg. (1 <sup>15</sup> / <sub>16</sub> " O.D.) .....
64-69	Pass., Chevelle, Camaro w/P/S,				
68-69	Chevy w/P/S,				
70	All w/P/S (exc. Camaro) .....	5687209	1	.53	RACE, upper thrust brg. (1 <sup>63</sup> / <sub>64</sub> " O.D.) .....
64-70	Pass., Chevelle, Camaro (exc. P/S),				
68-70	Chevy (exc. P/S),				
71-72	Camaro w/Sp. H/Per. (350) (exc. P/S),				

**FRONT AXLE—STEERING**

**6.835 BEARING— CUP— RACE— RETAINER, Steering Worm Thrust (Con't)**

74	Vega (122) (exc. P/S),				
75	All (exc. P/S, Vega, Monza) . . . . .	<b>5668489</b>	1	.20	<b>RETAINER</b> , lwr. brg. ( $1\frac{13}{64}$ " I.D. x $1\frac{1}{2}$ " O.D.) . . . . .
64-69	Pass., Chevelle, Camaro w/P/S,				
68-69	Chevy w/P/S,				
70	All w/P/S (exc. Camaro) . . . . .	<b>5686872</b>	1	.15	<b>RETAINER</b> , adj. plug bearing . . . . .

**6.840 SEAL— SEAL KIT— SPACER, Steering Gear Thrust**

64-69	Pass., Chevelle, Camaro w/P/S,				
68-69	Chevy w/P/S,				
70	All w/P/S (exc. Camaro) . . . . .	<b>5686527</b>	1	.61	"O" ring, adj. plug ( $1\frac{25}{32}$ " x $1\frac{13}{16}$ ") . . . . .
65	Chevelle (396),				
70	Pass. w/P/S (exc. Sta. Wag.),				
70	Nova w/P/S (6 cyl.) . . . . .	<b>7812122</b>	1	.81	"O" ring ( $3\frac{7}{32}$ " I.D.)— (6.825) . . . . .
64-69	Pass., Chevelle, Camaro w/P/S,				
68-69	Chevy w/P/S,				
70	All w/P/S (exc. Camaro),				
71-75	All w/P/S . . . . .	<b>5687183</b>	1	3.35	<b>SEAL KIT</b> , adj. plug seal . . . . .
64-69	Pass., Camaro w/P/S,				
68-69	Chevy w/P/S,				
70	All w/P/S (exc. Camaro) . . . . .	<b>5687435</b>	1	2.40	<b>SPACER</b> , adj. plug thrust brg. ( $1\frac{57}{64}$ " O.D.) . . . . .

**6.841 NUT, Steering Gear Ball**

64-66	Chevy (exc. P/S) . . . . .	<b>5666886</b>	1	11.65	$1\frac{21}{32}$ " x $2\frac{1}{2}$ " x $1\frac{15}{16}$ " . . . . .
67-69	Camaro (Spt. Cpe.) w/Spec. Steering . . . . .	<b>5666690</b>	1	12.50	( $2\frac{1}{2}$ " O.L.) . . . . .
64-68	Pass., Chevelle, Camaro (exc. P/S),				
68	Chevy (exc. P/S) . . . . .	<b>5675672</b>	1	15.25	<b>NUT UNIT</b> , w/guide and clamp . . . . .

**6.842 GUIDE, Steering Gear Ball Return**

65-69	Pass., Chevelle, Camaro w/P/S,				
68-69	Chevy w/P/S,				
70	Chevelle (Sta. Wag.) w/P/S . . . . .	<b>5686540</b>	2	.53	
69	Camaro w/P/S,				
69	Impala, Caprice w/P/S,				
69	Kingswood w/P/S,				
71-75	All w/P/S . . . . .	<b>5695774</b>	2	.57	
70	Camaro (8 cyl.) . . . . .	<b>7804938</b>	1	.24	
71-74	Vega (exc. P/S) . . . . .	<b>7809770</b>	4	.57	<b>GUIDE</b> . . . . .
62-67	Chevy,				
68-69	Camaro w/P/S,				
70	Camaro w/Spec. Strg. (302) . . . . .	<b>5676231</b>	1	1.45	<b>GUIDE UNIT</b> , w/clamp (Note 1) . . . . .
	<i>NOTE 1 Consists of 1 bolt and washer assy., 1 clamp, 1 guide, ball return.</i>				
64-65	Pass., Chevelle (exc. P/S),				
67-69	Pass., Chevelle, Camaro (exc. P/S),				
68-69	Chevy (exc. P/S),				
70	All (exc. 302, P/S),				
71-72	All (exc. P/S),				
73-75	Chevelle, Nova, Camaro (exc. P/S) . . . . .	<b>5676222</b>	1	1.95	<b>GUIDE UNIT</b> , w/clamp (R.H. thread) . . . . .

**6.843 CLAMP— BOLT— SCREW ASSY., Steering Gear Ball Return Guide**

64-69	Pass., Chevelle, Camaro w/P/S,				
68-69	Chevy w/P/S,				
70	All w/P/S (exc. Camaro),				
71-75	All w/P/S . . . . .	<b>5686539</b>	1	.13	
71-74	Vega (exc. P/S) . . . . .	<b>7809771</b>	1	.21	
74	Vega (122) (exc. P/S),				
75	Monza (H.B.) (8 cyl.) (exc. P/S) . . . . .	<b>5676222</b>	1	1.95	<b>CLAMP UNIT</b> , ball return guide . . . . .
71-73	Vega (exc. P/S) . . . . .	<b>5674951</b>	2	.21	<b>BOLT</b> , steering gear worm ball return guide clamp (10— 32) w/lock washer . . . . .
64-69	Pass., Chevelle, Camaro (exc. P/S),				
68-69	Chevy (exc. P/S) . . . . .	<b>5674113</b>	3	.18	<b>SCREW ASSY.</b> , w/lockwasher ( $12— 28$ x $\frac{5}{16}$ ") . . . . .

**6.844 BALL, Steering Gear**

62-69	Chevy, Chevelle,				
65-66	Pass.,				
67-69	Camaro,				
68-69	Chevy (Spt. Cpe.) (8 cyl.) (exc. P/S),				
70	All,				

**FRONT AXLE—STEERING**

**6.844 BALL, Steering Gear (Con't)**

71-72	Camaro w/Sp. H/Per. (350) . . . .	7808541	A.R.	.12	( <sup>9</sup> / <sub>32</sub> " dia.) . . . . .
64-71	Pass., Chevelle, Camaro w/P/S,				
68-71	Chevy w/P/S . . . . .				<b>BALL KIT (code No. 6) (1-size under), . . . .</b>
64-72	Pass., Chevelle, Camaro w/P/S,				
68-72	Chevy w/P/S,				
71-75	Vega, Monza w/P/S,				
73-75	All w/P/S . . . . .	5695513	1	3.30	(Code No. 7, 8, 9, 10) (standard 1-size over)
64-71	Pass., Chevelle, Camaro w/P/S,				
68-71	Chevy w/P/S,				
71-74	Vega w/P/S . . . . .	5695517	1	2.90	<b>BALL KIT (Code No. 11) (4-sizes over) . . . .</b>

**6.850 GEAR, Steering Gear Pitman**

64-68	Pass., Chevelle, Camaro w/P/S,				
68-70	Chevy w/P/S,				
69-70	Chevelle w/P/S,				
69-70	Biscayne, Bel Air, Brookwood, Townsmen w/P/S . . . . .	7815885	1	25.50	w/gear (repl. 5692950) (Note 1) . . . . .
<i>NOTE 1 When using on 6 cyl. models use (1) nut 5692775 in group 6.832.</i>					
67	Camaro (exc. P/S, Spl. Strg.),				
70	Camaro (8 cyl.) (exc. P/S, Sp. H/Per. 350),				
71-72	All (exc. P/S, Sp. H/Per. 350),				
73-75	Nova (exc. P/S),				
73-75	Chevelle (exc. P/S) . . . . .	7815872	1	17.75	
69	Impala, Caprice, Camaro w/P/S .	7803089	1	32.00	
62-68	Chevelle, Camaro w/Spl. Strg. (exc. P/S),				
65-67	Pass. (exc. P/S),				
69	Camaro w/Spl. Strg. (302),				
69	Pass., Nova (exc. P.S.),				
70	All (exc. P/S),				
71-72	Camaro w/Sp. H/Per. (350) (exc. P/S),				
74	Vega (122) (exc. P/S),				
75	Monza (H.B.) (8 cyl.) (exc. P/S) . .	7815992	1	16.15	shaft . . . . .
69	Impala, Caprice w/P/S,				
69	Malibu (Spt. Cpe., Conv.) El Camino (Custom) w/P/S,				
69-72	Camaro w/P/S,				
70-71	Chevelle, Nova w/P.S.,				
70	Pass. w/P/S (exc. Sta. Wag.),				
71	Pass. w/P/S,				
72	Nova w/P/S (6 cyl.),				
72	Nova w/P/S 4BC,				
72	Pass., Chevelle w/P/S,				
72	Pass. (402, 454) (exc. Police),				
72	Pass. (exc. 402, 454),				
72	Police (Sta. Wag.),				
73-75	All w/P/S (exc. Vega, Monza),				
71-72	Vega w/P/S,				
75	Vega, Monza w/P/S . . . . .	7813631	1	36.50	shaft . . . . .
71-75	Vega, Monza (140) (exc. P/S) . .	7815602	1	15.75	
73-74	Vega w/P/S . . . . .	7815541	1	36.50	
75	Vega (122) (exc. P/S) . . . . .	7819934	1	81.75	
75	Nova, Camaro (exc. P/S) . . . . .	7818463	1	25.25	shaft . . . . .

**6.855 SEAL ASSY.— WASHER, Pitman Shaft**

62-68	All (exc. P/S),				
69	Pass., Chevy, Chevelle (exc. P/S),				
70-72	All (exc. P/S),				
73-75	Chevelle, Nova, Camaro (exc. P/S),				
74	Vega (122) (exc. P/S),				
75	Monza (H.B.) (8 cyl.) (exc. P/S) . .	7801626	1	1.60	
64-69	Pass., Chevelle w/P/S,				
67-68	Camaro,				
68-69	Chevy w/P/S,				
70	All w/P/S,				
71-75	All w/P/S . . . . .	5685355	1	6.10	
71-75	Vega, Monza (140) (exc. P/S) . .	7809243	1	1.30	<b>SEAL, steering gear Pitman shaft grease . .</b>
64-69	Pass., Chevelle w/P/S,				
67-69	Camaro,				
68-69	Chevy w/P/S,				
70	All w/P/S (exc. Camaro) . . . . .	5684477	2	.38	<b>WASHER, back-up seal . . . . .</b>

## FRONT AXLE—STEERING

### 6.856 RING, Pitman Shaft Packing

64-71	Pass., Chevelle, Camaro w/P/S,				
68-71	Chevy w/P/S	5682898	1	.32	seal retaining

### 6.859 ARM, Pitman

62	Chevy,				
63-67	Chevy w/P/S	3790253	1	12.50	(cast 3790253)
64-67	Chevelle (2nd design) (exc. P/S)	5693762	1	12.50	(cast 5693761)
64-67	Chevelle w/P/S (2nd design)	5693764	1	21.10	(cast 5693763)
64	Chevelle w/P/S (1st design),				
68-72	Chevelle w/P/S	5679209	1	12.50	(cast 5679208)
65-66	Pass. (exc. P/S)	3864703	1	12.50	(forged 3855955)
65-66	Pass. w/P/S	3864707	1	12.50	(forged 3855956)
67-68	Pass. w/P/S	3900559	1	12.50	(forged 3900559)
67-68	Pass. (exc. P/S)	3900557	1	12.50	(forged 3900557)
69-70	Pass. (exc. P/S)	3953521	1	12.50	
69-70	Pass. w/P/S	3953523	1	12.50	
70-75	Camaro w/P/S,				
75	Nova w/P/S	3964881	1	12.50	
70-72	Camaro w/Sp. H/Per. (350) (exc. P/S),				
73-74	Camaro (exc. C.A.C., P/S)	3964877	1	13.30	
70-72	Camaro (exc. Sp. H/Per. 350, P/S),				
73-74	Camaro w/C.A.C. (exc. P/S)	3964851	1	12.50	
71	Pass. w/P/S,				
73-75	Chevelle w/P/S (exc. Sta. Wag.),				
75	Pass. (454)	7816344	1	12.50	
64	Chevelle (exc. P/S),				
68-72	Chevelle (exc. P/S)	7811779	1	17.10	
72	Pass. w/P/S	7814220	1	12.50	
71-72	Nova w/P/S (exc. H/Per. 350),				
73-74	Nova w/P/S	3989443	1	18.60	ARM ASSY.
63-67	Chevy (exc. P/S)	3909951	1	17.45	ARM ASSY.
68-69	Chevy, Camaro (exc. 302, P/S, Spec. Strg.),				
70	Nova (exc. P/S)	3953217	1	17.45	ARM ASSY. (forged 3953219) (Note 2)
<i>NOTE 2 To be used to replace the curved arm forged 9791825.</i>					
67	Camaro w/Spec. Strg.				
68-69	Camaro w/Spec. Strg. (302)	3953225	1	17.45	ARM ASSY.
68-69	Chevy w/P/S,				
68-69	Camaro w/P/S (327) (exc. Spec. Strg.),				
67	Camaro w/P/S,				
68	Camaro w/P/S, Spec. Steering (exc. 302),				
68	Camaro w/P/S (302) (exc. Spec. Steering),				
69	Camaro w/Spec. Strg. (exc. 327),				
70	Nova w/P/S,				
71-72	Nova (P/S w/H/Per. 350)	3989445	1	18.60	ARM ASSY.
71-74	Nova (exc. P/S)	3989441	1	18.60	ARM ASSY.
71-75	Vega, Monza (exc. P/S)	3978040	1	12.50	ARM
71-75	Vega, Monza w/P/S	3978101	1	12.50	ARM
73-75	Chevelle (Sta. Wag.) w/P/S,				
73-75	Pass. w/P/S (exc. 454)	7814220	1	12.50	ARM
74-75	Vega (122)	336586	1	12.50	ARM
73-74	Chevelle (exc. P/S)	7815866	1	24.15	ARM ASSY.
75	Nova,				
75	Camaro (6 cyl.) (exc. P/S)	344675	1	17.45	ARM ASSY.

### 6.861 NUT—SEAL—WASHER, Pitman Arm

62	Chevy	254291	1	.36	( <sup>3</sup> / <sub>4</sub> "— 16 x <sup>3</sup> / <sub>8</sub> " thk.) (1 <sup>1</sup> / <sub>4</sub> " hex.)
62-69	All,				
70	All (exc. P/S, 302),				
71-75	All (exc. Vega, Monza),				
74	Vega (122) (exc. P/S),				
75	Monza (H.B.) (8 cyl.) (exc. P/S)	5667628	1	.84	w/integral pwr. strg. ( <sup>7</sup> / <sub>8</sub> "— 14 x 1 <sup>1</sup> / <sub>2</sub> " hex.)
71-75	Vega, Monza (140) (exc. P/S)	7809779	1	.62	
63	Chevy (exc. P/S)	3744796	1	.16	SEAL, arm ball stud— (6.898)
64-65	Chevelle (2nd design),				
65-66	Pass.,				
65-66	Taxi w/P/S,				
70-72	Pass., Camaro, Nova,				

**FRONT AXLE—STEERING**

<b>6.861 NUT— SEAL— WASHER, Pitman Arm (Con't)</b>					
73-75	All (exc. Vega, Monza)	5693027	2	.97	SEAL, relay rod stud ( <sup>19</sup> / <sub>32</sub> " I.D. x <sup>1</sup> / <sub>32</sub> " O.D.)— (6.898)
68	Chevelle,				
73	Pass.	5693125	2	1.05	SEAL, arm ball stud— (6.898)
63-67	Chevy (exc. P/S)	3793578	1	.11	WASHER, pitman arm to relay rod, pitman arm ball stud ( <sup>5</sup> / <sub>8</sub> "— (6.897)
71-75	Vega, Monza (140) (exc. P/S)	7809776	1	.40	WASHER, Pitman shift gear assy. lock
73-74	All w/P/S (exc. Vega)	5697702	1	.21	WASHER, strg. gear Pitman shaft lock
<b>6.865 ABSORBER ASSY., Steering Relay and Tie Rod Shock</b>					
73-75	Monte Carlo	4975474	1	16.00	
73-74	Chevelle (exc. P/S, Monte Carlo)	4975472	1	16.00	
<b>6.870 ROD ASSY.— ROD— NUT, Steering Connecting (With Internal Parts)</b>					
62	Chevy (exc. P/S)	3791295	1	29.00	relay ( <sup>29</sup> / <sub>32</sub> " ctr. of socket to end)
64	Chevelle (1st design)	5695201	1	29.00	relay
64-67	Chevelle (2nd design)	5698848	1	31.50	relay
65-66	Pass.	3893383	1	29.00	(Note 2)
<i>NOTE 2. When using in place 3872045 use (2) 5693027 seals.</i>					
67	Pass.,				
68	Pass. (exc. Sta. Wag.)	3900553	1	29.00	
68	Sta. Wag.	3931493	1	17.50	relay
68-72	Chevelle	7800896	1	29.00	relay (u/w P/S gear with AA or AH on side)
69-70	Pass. (exc. Sta. Wag.)	3953509	1	29.00	relay
69-70	Sta. Wag.	3953513	1	31.50	relay
70-71	Camaro (Sp. H/Per. 350),				
70-72	Camaro w/P/S,				
73	Camaro (exc. C.A.C.),				
74-75	Camaro,				
75	Nova	3964873	1	29.00	
70-71	Camaro (exc. P/S, Sp. H/Per. 350),				
72	Camaro (exc. P/S)	3964883	1	28.00	
71-72	Pass.	7811835	1	31.50	
62	Chevy w/P/S	3790769	1	17.50	ROD, relay
63-67	Chevy w/P/S	3793653	1	17.50	ROD, relay
63-67	Chevy (exc. P/S)	3793661	1	17.50	ROD, relay
67-69	Camaro,				
68-72	Chevy	3953221	1	17.50	ROD, relay
68	Camaro (302)	3958493	1	18.25	ROD, relay
71-75	Vega, Monza (exc. P/S)	3978041	1	17.50	ROD ASSY.
71-75	Vega, Monza w/P/S	3978102	1	17.50	ROD ASSY.
73-74	Nova	3953221	1	17.50	ROD, relay
73-75	Pass.	7814340	1	29.00	ROD ASSY.
73	Camaro w/C.A.C. (exc. P/S)	3964883	1	28.00	ROD ASSY.
73-75	Chevelle (exc. P/S)	7815408	1	32.75	ROD ASSY.
73-75	Chevelle w/P/S (exc. Monte Carlo)	7816374	1	29.00	ROD ASSY.
73-75	Monte Carlo	3994472	1	21.60	ROD ASSY.
70-72	Camaro	3983076	2	.18	NUT (6.104)
<b>6.874 SEAT— STUD, Steering Connecting Rod</b>					
62	Chevy (exc. P/S)	3741378	2	.62	ball stud
62-67	Chevy w/P/S	264946	2	.71	adapter ball
62	Chevy w/P/S	5685461	1	2.10	STUD, adapter ball ( <sup>2</sup> / <sub>2</sub> " O.L.)
62	Chevy (exc. P/S)	3741384	1	1.05	STUD, ball ( <sup>2</sup> / <sub>16</sub> " O.L.)
<b>6.876 SPRING, Steering Connecting Rod</b>					
62	Chevy (exc. P/S)	3741385	2	.63	ball stud ( <sup>4</sup> / <sub>4</sub> " coil)
<b>6.881 PLUG— SHIELD, Steering Connecting Rod End</b>					
62	Chevy (exc. P/S)	335977	1	.98	relay rod ( <sup>1</sup> / <sub>16</sub> "— 18 x <sup>1</sup> / <sub>2</sub> " O.L.)
<b>6.886 SEAL, Steering Connecting or Relay Rod</b>					
71-74	Chevelle, Camaro	3826598	4	.17	tie rod socket— (6.111)
<b>6.895 LEVER ASSY.— LEVER, Steering Idler</b>					
63-67	Chevy w/P/S	3793655	1	13.65	(forged 3793657)
63-67	Chevy (exc. P/S)	3793659	1	13.70	(forged 3793587)
64	Chevelle (1st design),				
68-72	Chevelle	7801909	1	17.65	( <sup>43</sup> / <sub>64</sub> " thk. at ball stud end)
64	Chevelle (2nd design),				
65-67	Chevelle	5699538	1	17.65	( <sup>45</sup> / <sub>64</sub> " thk. at ball stud end)
65-66	Pass.	3896518	1	17.65	w/fitting
67-70	Pass.	3900562	1	17.65	



**FRONT AXLE—STEERING**

<b>6.895 LEVER ASSY.— LEVER, Steering Idler</b>				<b>(Con't)</b>
67	Camaro	3908383	1	17.65 (forged 3908385)
68-69	Chevy, Camaro,			
70-74	Nova	3989447	1	20.35
70-75	Camaro,			
75	Nova	328741	1	19.95
71-72	Pass.	7811071	1	17.65
71-75	Vega, Monza	3978043	1	17.65 w/seal assy.
73-75	Pass.	7818386	1	17.65
73-74	Chevelle	7817317	1	17.65
75	Chevelle	7818244	1	21.30
62	Chevy w/P/S	3790771	1	3.80 LEVER (forged 3790771)
62	Chevy (exc. P/S)	3790265	1	5.70 LEVER (forged 3790265)
<b>6.896 SUPPORT— NUT, Steering Idler</b>				
62	Chevy w/P/S	3792968	1	5.50 lever w/o bushing
62	Chevy (exc. P/S)	3790203	1	1.35 lever w/o bushing
63-67	Chevy (exc. P/S)	3793590	1	4.55 lever
63-67	Chevy w/P/S	3793663	1	5.40 lever and strg. cyl.
74-75	All (exc. Vega, Monza)	3979999	2	.11 NUT (.375-16) hex. head
<b>6.897 BUSHING ASSY.— BOLT— NUT— WASHER, Steering Idler</b>				
62	Chevy	3790201	2	5.95 lever ( <sup>3</sup> / <sub>4</sub> " I.D. x <sup>7</sup> / <sub>8</sub> " O.D. x 2" O.L.)
63-67	Chevy	3793589	1	1.55 idler lever long
63-67	Chevy	3793593	1	1.45 idler lever short
63-67	Chevy	3793591	1	.93 BOLT, idler lever to support ( <sup>1</sup> / <sub>2</sub> "— 20)
66	Pass., Chevy	9422293	1	.05 NUT, strg. idler to frame ( <sup>1</sup> / <sub>4</sub> "— 20)— (8.917)
62-69	All,			
71-72	All	3914674	2	.11 WASHER ( <sup>25</sup> / <sub>32</sub> " strg. relay and tie rod asm.
63-67	Chevy	3793592	1	.11 WASHER, lever to relay rod ( <sup>33</sup> / <sub>64</sub> "
63-68	Chevy	3793594	1	.11 WASHER, lever to support ( <sup>1</sup> / <sub>2</sub> "
65-68	Chevy	3793578	1	.11 WASHER, lever to relay rod ( <sup>5</sup> / <sub>8</sub> " pitman arm ball stud
<b>6.898 SEAL, Steering Idler</b>				
62	Chevy	3790204	2	.16 lever bushing ( <sup>5</sup> / <sub>8</sub> " I.D. x <sup>7</sup> / <sub>8</sub> " O.D. x <sup>1</sup> / <sub>2</sub> " thk.)
63-67	Chevy	3744796 A.R.		.16 arm ball stud ( <sup>1</sup> / <sub>2</sub> " I.D. x 1 <sup>1</sup> / <sub>4</sub> " O.D. x <sup>1</sup> / <sub>4</sub> " thk.)
64-69	Chevelle, Camaro,			
68-69	Chevy,			
70-71	Nova, Chevelle,			
73-74	Nova	5678350	1	.13 lever support
64-67	Chevelle,			
65-69	Pass.,			
65-66	Taxi w/P/S,			
67-69	Chevy,			
68-69	Camaro,			
70-71	Pass., Camaro,			
71	Nova,			
75	Camaro, Nova	5693027	1	.97 relay rod stud ( <sup>19</sup> / <sub>32</sub> " I.D. x 1 <sup>1</sup> / <sub>2</sub> " O.D.)
68-71	Chevelle,			
75	Pass., Chevelle,			
71-75	Vega, Monza	5693125	2	1.05 idler lever
70	Camaro,			
71	Pass.	3779196	1	.19 lever support
71	Pass., Camaro,			
73-75	Pass., Chevelle, Camaro,			
71-75	Vega, Monza,			
75	Nova	3989414	1	.22 strg. idler lever support



# CHEVROLET CHASSIS GROUP 7.000



## FRAME — SPRINGS — SHOCKS — BUMPERS

### ALPHABETICAL INDEX

<b>A</b>	
ABSORBER ASSY., Front and Rear Bumper Shock.....	7.840
ADAPTER, Air Suspension or Level Control Air Compressor.....	7.452
ADAPTER, Air Suspension Level Control.....	7.447
ADAPTER ASSY., Air Suspension Pressure, or Level Control.....	7.465
ARM UNIT, Air Suspension, Air Compressor..	7.460
ATTACHMENT UNIT, Bumper Valance Panel	7.833

<b>B</b>	
BALL, Trailer.....	7.068
BAR.....	7.836A
BAR, Bumper Face.....	7.831
BAR, Frame to Bumper Attaching (Also See Group 7.869).....	7.836
BOLT.....	7.831A
BOLT.....	7.836A
BOLT, Air Suspension or Level Control Air Compressor.....	7.452
BOLT, Frame to Bumper Attaching (Also See Group 7.869).....	7.836
BOLT, Front and Rear Bumper Shock.....	7.840
BOLT, Front or Rear Bumper Bar Mounting and Attaching.....	7.874
BOLT, Front Spring.....	7.418
BOLT, License Plate.....	7.800
BOLT, Rear Spring and Shock Absorber.....	7.516
BOLT, Rear Spring.....	7.529
BOLT, Shock Absorber Frame.....	7.395
BOLT, Shock Absorber.....	7.347
BOLT, Spring Center (Front and Rear).....	7.506
BOLT, Stabilizer Shaft.....	7.242
BOLT, Stabilizer.....	7.240
BOLT, Trailer.....	7.068
BOLT, Wheel Carrier.....	7.632
BRACE, Bumper Valance Panel.....	7.833
BRACE, Cross Member.....	7.039
BRACE, Frame to Bumper Attaching (Also See Group 7.869).....	7.836
BRACKET.....	7.836A
BRACKET ASSY., Air Suspension or Level Control Air Compressor.....	7.452
BRACKET, Auxiliary Spring.....	7.526
BRACKET, Body.....	7.330
BRACKET, Bumper Guard Mounting.....	7.829
BRACKET, Bumper Valance Panel.....	7.833
BRACKET, Bumper.....	7.865
BRACKET, Frame to Bumper Attaching (Also See Group 7.869).....	7.836
BRACKET, Front and Rear Bumper Shock.....	7.840
BRACKET, Front and Rear Bumper.....	7.869
BRACKET, License Plate.....	7.800
BRACKET, Rear Bumper Upper Face Bar.....	7.832
BRACKET, Rear Spring.....	7.535
BRACKET, Shock Absorber Frame.....	7.395
BRACKET, Shock Absorber, Air Lift.....	7.346

BRACKET, Shock Absorber.....	7.380
BRACKET, Stabilizer Shaft.....	7.242
BUMPER ASSY.....	7.831A
BUMPER, Bumper Valance Panel.....	7.833
BUMPER, License Plate.....	7.800
BUMPER, Rear Spring.....	7.535
BUSHING, Rear Spring Eye.....	7.504
BUSHING, Rear Spring Shackles.....	7.524
BUSHING, Shock Absorber Link.....	7.388
BUSHING, Stabilizer Shaft.....	7.243

<b>C</b>	
CAP, Shock Absorber, Air Lift.....	7.346
CASE ASSY., Wheel Carrier.....	7.675
CASE, Wheel Carrier Lock.....	7.679
CLAMP.....	7.836A
CLAMP, Bumper Guard Mounting.....	7.829
CLAMP, Frame to Bumper Attaching (Also See Group 7.869).....	7.836
CLAMP, Rear Spring 'U' Bolt (See Group 5.403).....	7.518
CLAMP, Stabilizer Shaft.....	7.242
CLAMP, Stabilizer Shaft.....	7.243
CLEANER, Air Suspension Level Control.....	7.447
CLIP ASSY., Front or Rear Bumper Bar Mounting and Attaching.....	7.874
CLIP, Bumper Valance Panel.....	7.833
CLIP, Shock Absorber, Air Lift.....	7.346
CLIP, Shock Absorber.....	7.380
COMPRESSOR ASSY., Air Suspension Air Compressor.....	7.455
CONNECTOR, Shock Absorber, Air Lift.....	7.346
COVER, License Plate.....	7.800
COVER, Rear Bumper Upper Face Bar.....	7.832
CROSSMEMBER, Front and Rear Bumper Shock.....	7.840
CUSHION.....	7.831A
CUSHION ASSY., Bumper and Grille.....	7.828
CUSHION, Bumper.....	7.865
CUSHION, Spring.....	7.545
CYLINDER ASSY., Wheel Carrier Lock.....	7.680

<b>D</b>	
DAMPENER UNIT, Spring.....	7.545
DAM UNIT, Bumper Valance Panel.....	7.833
DEFLECTOR, Bumper Valance Panel.....	7.833
DIAPHRAGM UNIT, Air Suspension, Air Compressor.....	7.460

<b>E</b>	
EMBLEM UNIT, Rear Bumper Upper Face Bar.....	7.832

# ALPHABETICAL INDEX

EXTENSION ASSY., Front and Rear Bumper..	7.869
EXTENSION ASSY.....	7.831A
EXTENSION UNIT, Frame.....	7.009
EXTENSION, Bumper Valance Panel.....	7.833
EXTENSION, Frame to Bumper Attaching (Also See Group 7.869).....	7.836
EXTENSION, Frame Cross, Front.....	7.010
EXTENSION.....	7.836A
EXTRACTOR, Wheel Carrier.....	7.632

## F

FILLER, Bumper Valance Panel.....	7.833
FITTING ASSY., Air Suspension Level Control.....	7.447
FITTING ASSY., Shock Absorber, Air Lift.....	7.346
FRAME ASSEMBLY.....	7.003
FRAME ASSY., License Plate.....	7.800

## G

GASKET, Air Suspension Air Compressor Level Control.....	7.457
GRILLE, Bumper Valance Panel.....	7.833
GROMMET, Shock Absorber Link.....	7.388
GROMMET, Shock Absorber, Air Lift.....	7.346
GROMMET, Stabilizer Link.....	7.244
GUARD, Bumper and Grille.....	7.828
GUIDE ASSY., Front and Rear Bumper Shock.....	7.840
GUSSET, Front and Rear Bumper.....	7.869

## H

HANGER, Rear Spring Front and Rear.....	7.112
HARNESS ASSY., Trailer.....	7.068
HARNESS UNIT, Trailer.....	7.068
HITCH UNIT, Trailer.....	7.068
HOSE ASSY., Air Suspension Pressure, or Level Control.....	7.465
HOSE ASSY., Shock Absorber, Air Lift.....	7.346
HOUSING, Air Suspension Air Compressor....	7.455

## I

INSERT, Shock Absorber, Air Lift.....	7.346
INSERT, Spring Leaf.....	7.495
INSULATOR, Bumper Valance Panel.....	7.833
INSULATOR, Engine Rear Cross Member.....	7.011
INSULATOR, Spring.....	7.545

## L

LINER, Rear Spring and Shock Absorber.....	7.516
LINK, Stabilizer.....	7.240

## M

MEMBER ASSY., Frame Cross, Front.....	7.010
MEMBER, Frame Cross, Intermediate.....	7.012
MEMBER, Frame Cross, Rear.....	7.014
MEMBER, Frame Side.....	7.006
MEMBER, Shock Absorber Frame.....	7.395
MOULDING ASSY., Rear Bumper Upper Face Bar.....	7.832
MOULDING UNIT, Bumper Valance Panel.....	7.833

MOUNT, Air Suspension or Level Control Air Compressor.....	7.452
---	-------

## N

NIPPLE, Shock Absorber, Air Lift.....	7.346
NUT, Bumper Guard Mounting.....	7.829
NUT, Bumper Valance Panel.....	7.833
NUT, Bumper.....	7.865
NUT, Front or Rear Bumper Bar Mounting and Attaching.....	7.874
NUT, License Plate.....	7.800
NUT, Rear Spring and Shock Absorber.....	7.516
NUT, Rear Spring Eye.....	7.530
NUT, Shock Absorber Frame.....	7.395
NUT, Shock Absorber, Air Lift.....	7.346
NUT, Shock Absorber.....	7.347
NUT, Stabilizer Link.....	7.238
NUT, Stabilizer Link.....	7.245
NUT, Wheel Carrier.....	7.633

## O

O RING, Air Suspension Air Compressor Level Control.....	7.457
O RING, Air Suspension Leveling Valve.....	7.476

## P

PAD.....	7.836A
PAD ASSY.....	7.831A
PAD ASSY., Bumper.....	7.865
PAD ASSY., Rear Bumper.....	7.875
PAD, Frame to Bumper Attaching (Also See Group 7.869).....	7.836
PANEL, Bumper Valance Panel.....	7.833
PISTON ASSY., Air Suspension Air Compressor.....	7.455
PLATE ASSY., Frame to Bumper Attaching (Also See Group 7.869).....	7.836
PLATE ASSY.....	7.836A
PLATE, Bumper Valance Panel.....	7.833
PLATE, Front and Rear Bumper Shock.....	7.840
PLATE, Front or Rear Bumper Bar Mounting and Attaching.....	7.874
PLATE, Rear Spring 'U' Bolt (See Group 5.403).....	7.518
PLUG, Shock Absorber.....	7.347
POCKET, License Plate.....	7.800

## R

RAIL, Frame Side.....	7.006
REFLECTOR ASSY., Bumper Valance Panel... Compressor.....	7.833
REGULATOR UNIT, Air Suspension, Air Compressor.....	7.460
REINFORCEMENT.....	7.836A
REINFORCEMENT, Bumper Guard Mounting....	7.829
REINFORCEMENT, Bumper Valance Panel.....	7.833
REINFORCEMENT, Cross Member.....	7.039
REINFORCEMENT, Frame to Bumper Attaching (Also See Group 7.869).....	7.836
REINFORCEMENT, Frame Cross, Front.....	7.010
REINFORCEMENT, Front and Rear Bumper Shock.....	7.840
REINFORCEMENT, Stabilizer Shaft.....	7.242
REINFORCEMENT.....	7.831A
REPAIR KIT, Rear Spring Shackle.....	7.523
REPAIR KIT, Rear Spring.....	7.529
REPAIR UNIT, Air Suspension Air Compressor Level Control.....	7.457
REPAIR UNIT, Stabilizer.....	7.240

## ALPHABETICAL INDEX

RETAINER ASSY., Bumper .....	7.865
RETAINER, Bumper Guard Mounting.....	7.829
RETAINER, Bumper Valance Panel.....	7.833
RETAINER, Engine Rear Cross Member.....	7.011
RETAINER, Rear Bumper Upper Face Bar.....	7.832
RETAINER, Rear Spring Eye .....	7.530
RETAINER, Shock Absorber Bushing (Double Acting) .....	7.389
RETAINER, Spring.....	7.545
RETAINER, Stabilizer Link.....	7.245
RETAINER, Wheel Carrier.....	7.633
ROCKER ARM, Air Suspension, Air Compressor.....	7.460
ROD .....	7.836A
ROD ASSY., Shock Absorber, Air Lift.....	7.346
ROD, Bumper Valance Panel.....	7.833
ROD, Frame to Bumper Attaching (Also See Group 7.869).....	7.836
<b>S</b>	
SCREW, Air Suspension Air Compressor .....	7.455
SCREW ASSY., Front or Rear Bumper Bar Mounting and Attaching.....	7.874
SCREW, Bumper Guard Mounting.....	7.829
SCREW, Bumper Valance Panel.....	7.833
SCREW, Rear Bumper.....	7.875
SCREW, Shock Absorber Bushing (Double Acting) .....	7.389
SCREW, Shock Absorber Frame.....	7.395
SCREW, Stabilizer Shaft.....	7.243
SEAL, Air Suspension Leveling Valve Junction .....	7.482
SEAL, Bumper Valance Panel.....	7.833
SEAL, Front Spring.....	7.418
SEAL & GASKET UNIT, Air Suspension, Air Compressor.....	7.460
SEAL, Shock Absorber, Air Lift.....	7.346
SEAL UNIT, Air Suspension Air Compressor Level Control.....	7.457
SEAT, Front Spring.....	7.418
SEAT, Spring.....	7.545
SHACKLE, Rear Spring Shackle.....	7.523
SHAFT, Stabilizer.....	7.241
SHIELD, Shock Absorber.....	7.371
SHIM, Bumper.....	7.865
SHIM, Front and Rear Bumper Shock.....	7.840
SHIM, Stabilizer Shaft.....	7.243
SHIM UNIT, Rear Spring 'U' Bolt (See Group 5.403).....	7.518
SHOCK ABSORBERS .....	7.345
SLEEVE, Front and Rear Bumper Shock.....	7.840
SLEEVE, Stabilizer Shaft.....	7.243
SPACER, Bumper and Grille .....	7.828
SPACER, Bumper Guard Mounting.....	7.829
SPACER, Bumper Valance Panel.....	7.833
SPACER, Bumper.....	7.865
SPACER, Front and Rear Bumper Shock.....	7.840
SPACER, Front Spring.....	7.425
SPACER, License Plate.....	7.800
SPACER, Rear Spring.....	7.535
SPACER, Stabilizer Shaft.....	7.242
SPACER, Stabilizer Shaft.....	7.243
SPACER, Stabilizer.....	7.240
SPOILER, Bumper Valance Panel.....	7.833
SPRING ASSEMBLY, Rear.....	7.503
SPRING ASSY., Front and Rear Bumper Shock.....	7.840
SPRING ASSY., Front and Rear.....	7.503
SPRING, Front (coil) (CHEVY, CHEVELLE, CAMARO).....	7.412
STOP, Bumper Valance Panel.....	7.833
STRIP ASSY.....	7.831A
STRUT, Frame Cross, Front.....	7.010
STUD, Rear Bumper Upper Face Bar.....	7.832
SUPPORT.....	7.831A
SUPPORT.....	7.836A
SUPPORT ASSY., Bumper Valance Panel.....	7.833
SUPPORT ASSY., Engine Rear Cross Member.....	7.011

SUPPORT ASSY., Rear Spring Front and Rear.....	7.112
SUPPORT, Frame to Bumper Attaching (Also See Group 7.869).....	7.836
SUPPORT, Frame Side.....	7.006
SUPPORT, License Plate.....	7.800
SUPPORT, Rear Bumper.....	7.875
SUPPORT, Stabilizer Shaft.....	7.242

### T

TAPE, Rear Bumper Upper Face Bar.....	7.832
TEE AND TUBE ASSY., Air Suspension Level Control.....	7.447
TEE ASSY., Air Suspension Level Control.....	7.447
TOWER ASSY., Shock Absorber Frame.....	7.395
TUBE ASSY., Air Suspension Level Control....	7.447
TUBE ASSY., Front and Rear Bumper Shock.	7.840
TUBE, Shock Absorber, Air Lift.....	7.346

### V

VALVE ASSY., Air Suspension Leveling or Level Control.....	7.475
VALVE, Shock Absorber, Air Lift.....	7.346
VALVE UNIT, Air Suspension, Air Compressor.....	7.460

### W

WASHER, Air Suspension Level Control.....	7.447
WASHER, Bumper.....	7.865
WASHER, Cross Member.....	7.039
WASHER, Frame Cross, Front.....	7.010
WASHER, Front or Rear Bumper Bar Mounting and Attaching.....	7.874
WASHER, Rear Spring 'U' Bolt (See Group 5.403).....	7.518
WASHER, Shock Absorber Bushing (Double Acting).....	7.389
WASHER, Shock Absorber, Air Lift.....	7.346
WASHER, Shock Absorber.....	7.347
WASHER, Shock Absorber.....	7.371
WASHER, Shock Absorber.....	7.397
WASHER, Trailer.....	7.068



**FRAME—SPRINGS—BUMPER**

**7.003 FRAME ASSEMBLY**

*The left hand side outer member will bear the frame identification with characters stamped ahead of the rear bumper bracket attaching slot.*

*The top line of the identification will provide the part number of the frame assembly, the name of the manufacturer (abbreviated, ie., Pontiac— Pon., A.O. Smith— S, Parish Pressed Steel— P.P.S.).*

*The bottom line will provide the month, day, year and shift number.*

67	Chevelle (Conv.)	3893333	1	314.00	(Note 1)
67	Sta. Wag., El Camino	3893335	1	314.00	(Note 1)
67-72	Chevelle (4-Dr.) (exc. Sta. Wag.)	6263666	1	314.00	

*NOTE 1 When using these frames on Spt. Cpe., Sta. Wag., and 1964-66 Sedans transmission support 3931446 must be used.*

*NOTE 2 When using on 4 Door Sport Sedan models it will be necessary to rework the inner portion of the Side Members to provide clearance with the longitudinal Reinforcement, welded to the underbody.*

*NOTE 3 When 6263668 is used in place of 6263667 it will be necessary to use Conv. trans. supt. asm.*

*NOTE 4 When using these frames on Spt. Cpe., and Sta. Wag., transmission support 3949152 must be used.*

70-72	Monte Carlo	6263664	1	314.00	
73	Monte Carlo	3994306	1	314.00	
73	Chevelle (Sed.)	3994301	1	314.00	
73	Chevelle (Spt. Cpe.) (exc. Monte Carlo)	3994302	1	314.00	
73	Chevelle (Sta. Wag.) El Camino	338005	1	314.00	(repl. 3994304)
74-75	El Camino	348334	1	314.00	
74-75	Chevelle (Sta. Wag.)	348010	1	314.00	(repl. 340844)
74-75	Chevelle (Sed.)	367997	1	314.00	(repl. 338032, 348009)
74-75	Chevelle (Spt. Cpe.) (exc. Monte Carlo)	348331	1	314.00	
74-75	Monte Carlo	348335	1	314.00	(repl. 338033)

**PASSENGER**

65-66	Pass. (exc. Conv.)	3881649	1	324.00	
67-68	Pass. (exc. Conv.)	3916431	1	324.00	
67	Conv.,				
68	Pass. (Conv.)	3916429	1	324.00	
69-70	Pass. (Conv.)	3972707	1	324.00	
70	Taxi	3972708	1	324.00	(Budd)
70	Pass. (exc. Taxi, Conv.)	3982879	1	324.00	
71-72	Pass. (Sta. Wag.)	3977292	1	371.00	
73	Pass. (Sta. Wag.)	6270722	1	371.00	
73	Pass. (exc. Sta. Wag.)	6270721	1	337.00	
74	Pass. (exc. Sta. Wag.)	344948	1	337.00	
74-75	Pass. (Sta. Wag.)	344910	1	337.00	
75	Pass. (exc. Sta. Wag.)	367949	1	337.00	(repl. 344909)

**7.006 MEMBER— RAIL— SUPPORT, Frame Side**

69	Pass. (4-Dr.) (exc. Spt. Sed.),				
69	Biscayne, Bel Air (2-Dr.),				
70	Pass. (exc. Conv.)	3984724	R.H.	15.95	frame side, outer rear (Budd)
70	Pass. (Conv.)	3972711	L.H.	11.60	frame side, outer rear (Budd)
74	Camaro	350021	L.H.	94.00	
74	Camaro	350022	R.H.		
67-68	Camaro,				
68	Chevy	3935797	L.H.	49.25	MEMBER ASSY., side
71-72	Vega	9605523	L.H.	147.00	RAIL, motor compt. side
71-74	Vega	9739752	R.H.	147.00	RAIL, motor compt. side
73-74	Vega	9739753	L.H.	147.00	RAIL, motor compt. side
75	Monza (262)	1721703	R.H.		RAIL, motor compt. side (repl. 1708231)
75	Monza (262)	1708236	L.H.		RAIL, motor compt. side
75	Monza (140)	1721701	R.H.	147.00	RAIL ASSY., motor compt. side
75	Monza (140)	1746135	L.H.	153.00	RAIL ASSY., motor compt. side T/W 1706679 (repl. 1721702, 1708235)
75	Vega	1665992	R.H.	139.00	RAIL ASSY., motor compt. side
75	Vega	1665993	L.H.	139.00	RAIL ASSY., motor compt. side
75	Monza	1706678	R.H.	20.55	SUPPORT ASSY., frt. susp. coil spring
75	Monza	1706679	L.H.	20.55	SUPPORT ASSY., frt. susp. coil spring

**7.009 EXTENSION UNIT, Frame**

68-72	Chevelle (exc. Monte Carlo)	3977555	L.H.	59.00	frame, front side member
68-72	Chevelle (exc. Monte Carlo)	3960284	R.H.	58.00	frame, front side member
69-70	Pass.	3955536	R.H.	39.50	frame, side member
69-70	Pass.	3955535	L.H.	39.50	frame, side member
70-72	Monte Carlo	3988933	L.H.	59.00	frame, front side member
70-72	Monte Carlo	3988934	R.H.	59.00	frame, front side member
71	Pass.	3991086	R.H.	84.50	frame, side member front
71-72	Pass.	325003	L.H.	84.50	frame, side member front
72	Pass.	325004	R.H.	84.50	frame, side member front

**FRAME—SPRINGS—BUMPER**

**7.009 EXTENSION UNIT, Frame (Con't)**

73	Chevelle (exc. Monte Carlo)	6258538	R.H.	58.00	front side
73	Chevelle (exc. Monte Carlo)	6258537	L.H.	58.00	front side
73	Monte Carlo	6258539	L.H.	59.00	front side
73	Monte Carlo	6258540	R.H.	59.00	front side
73	Pass.	6259687	L.H.	84.50	front side
73	Pass.	6259688	R.H.	84.50	front side
74	Pass.	345095	L.H.	99.25	frt. side
74-75	Pass.	345096	R.H.	114.00	frt. side
74	Monte Carlo	6260928	R.H.	83.50	frt. side
74-75	Monte Carlo	6260933	L.H.	83.50	frt. side
74	Chevelle (exc. Estate Wag., Monte Carlo)	359983	L.H.	81.75	frt. side
74	Chevelle (exc. Estate Wag., Monte Carlo)				
75	Chevelle (exc. Monte Carlo)	359984	R.H.	81.75	frt. side
75	Chevelle (exc. Monte Carlo)	359983	L.H.	81.75	front side
75	Monte Carlo	360936	R.H.	83.50	front side

**7.010 MEMBER ASSY.— EXTENSION— REINFORCEMENT— STRUT— WASHER, Frame Cross, Front**

65-67	Nova	3875057	1	13.50	front cross
67-69	Camaro,				
68-72	Nova	6264000	1	208.00	frame, side and cross
70-75	Camaro	358740	1	202.00	frame, side and cross (repl. 344700)
71-74	Vega	3986597	1	17.00	frame cross
73	Nova	330201	1	208.00	side and cross
73	Pass.	6259681	1	262.00	front side and cross
74	Nova	6260965	1	204.00	side and cross
75	Nova	357732	1	222.00	side and cross
75	Vega	360323	1	33.75	front
73	Chevelle (exc. Monte Carlo)	6258536	1	241.00	MEMBER UNIT, side and cross
73	Chevelle (exc. Monte Carlo)	6258537	L.H.	58.00	MEMBER UNIT, frt. side
73	Chevelle (exc. Monte Carlo)	6258538	R.H.	58.00	MEMBER UNIT, frt. side
73	Monte Carlo	6258539	L.H.	59.00	MEMBER UNIT, frt. side
73	Monte Carlo	6258540	R.H.	59.00	MEMBER UNIT, frt. side
73	Monte Carlo	6258541	1	241.00	MEMBER UNIT, frt. side and cross
74-75	Pass.	352672	1	266.00	MEMBER UNIT, frt. side and cross
74	Monte Carlo	6260934	1	179.00	MEMBER UNIT, frt. side and cross
74	Chevelle (exc. Estate Wag., Monte Carlo)	359985	1	241.00	MEMBER UNIT, frt. side and cross
74-75	Chevelle (exc. Monte Carlo)	359983	L.H.	81.75	MEMBER UNIT, frt. side and cross
74-75	Chevelle (exc. Monte Carlo)	359984	R.H.	81.75	MEMBER UNIT, frt. side and cross
75	Chevelle (exc. Monte Carlo)	359985	1	241.00	MEMBER UNIT, frt. side and cross
75	Monte Carlo	360843	1	221.00	MEMBER UNIT, frt. side and cross
64-66	Chevelle w/A.O. Smith, Parrish Frame,				
67	Chevelle (exc. Taxi)	3876916	1	130.00	EXTENSION UNIT, front w/X member
68-72	Chevelle (exc. Monte Carlo)	3997410	1	156.00	EXTENSION UNIT, side and cross
69-70	Pass. (exc. Taxi)	3955531	1	141.00	EXTENSION UNIT, frame front
70-72	Monte Carlo	3997398	1	220.00	EXTENSION UNIT, side and cross
71-72	Pass.	6272198	1	201.00	EXTENSION UNIT, frame front
67-69	Camaro,				
68-72	Nova	3917571	1	1.80	REINFORCEMENT, front to rear
75	Monza	360315	L.H.	1.40	STRUT, front cross member
75	Monza (262-350 Eng.)	360316	R.H.	1.35	STRUT, frt. cross member
75	Monza (140 Eng.)	360336	R.H.	2.10	STRUT, frt. cross member

**7.011 INSULATOR— RETAINER— SUPPORT ASSY., Engine Rear Cross Member**

70	Pass. w/T.H. 400, C.A.C.	9780423	2	1.15	trans. support
70	Monte Carlo w/A.T.,				
70	Chevelle w/T.H. 400,				
71-72	Monte Carlo w/A.T.	9774451	2	.73	trans. support
71-72	Caprice w/A.T.	3988187	2	1.25	trans. support
75	Malibu (exc. Estate),				
75	Malibu (Estate) (350, 400)	356983	1	34.00	engine rear support (repl. 348371)— (4.081)
75	Malibu (exc. Estate),				
75	Monte Carlo, Malibu (Estate) (454)	348393	1	37.25	trans.— (4.081)
70	Pass. w/T.H. 400	9780020	2	.74	RETAINER, trans. support
70	Monte Carlo w/A.T.,				
70	Chevelle w/T.H. 400,				
71-72	Monte Carlo w/A.T.	9785627	2	1.25	RETAINER, trans. support
71-72	Caprice w/A.T.	3988188	2	.66	RETAINER, trans. support to frame insul.

**FRAME—SPRINGS—BUMPER**

**7.012 MEMBER, Frame Cross, Intermediate**

65-66	Pass. w/parallel edges	3881660	1	22.75	MEMBER, upper cross
71-74	Pass. (Sta. Wag.)	3981281	1	17.00	center cross

**7.014 MEMBER, Frame Cross, Rear**

68-72	Chevelle (Sta. Wag., El Camino)	3952775	1	10.30	
69-70	Pass.	3939108	1	10.45	
72	Monte Carlo,				
68-72	Chevelle (exc. Sta. Wag., El Camino)	3992321	1	9.75	
71-73	Pass. (Sta. Wag.)	3981286	1	14.80	
71	Pass. (6 cyl.),				
71-72	Pass. (exc. Sta. Wag.)	6270707	1	10.20	
	<i>NOTE 1 See group 7.003 for frame identification.</i>				
73-74	Pass. (Sta. Wag.)	6270762	1	14.80	center cross
73	Pass. (Sta. Wag.)		1		rear cross
73	Chevelle (Sta. Wag., El Camino)	3994383	1	10.30	rear cross
73	Chevelle (exc. Sta. Wag., El Camino)	3994366	1	10.10	rear cross
74	Chevelle (Sed.)	338061	1	10.10	rear center
74	Chevelle (Sta. Wag.)	338067	1	10.30	rear center

**7.039 BRACE— REINFORCEMENT— WASHER, Cross Member**

71-75	Pass.	3993635	L.H.	2.00	front cross
71-75	Pass.	3993636	R.H.	2.00	front cross
71-75	Vega	3986810	R.H.	3.80	frt. cross
71-75	Vega	3986809	L.H.	3.80	frt. cross
73-75	Pass. (Sta. Wag.)	325890	2	2.00	front c/member front
73-75	Pass.				left, front cross rear
73-75	Pass.				right, front cross rear
73	Chevelle (exc. Monte Carlo),				
74-75	Chevelle (exc. Monte Carlo, Laguna)	6271663	L.H.	3.40	front c/member
73	Chevelle (exc. Monte Carlo),				
74-75	Chevelle (exc. Monte Carlo, Laguna)	6271664	R.H.	3.40	front c/member
73-75	Monte Carlo	6271665	L.H.	2.00	front c/member
73-75	Monte Carlo	6271666	R.H.	2.00	front c/member
75	Monza (exc. Rotary)	353984	R.H.	4.65	frt. cross
75	Monza (exc. Rotary)	353983	L.H.	3.80	frt. cross
70	Pass. (8 cyl.) (exc. Taxi, Police, A.T. 454)	3964048	1	1.55	REINFORCEMENT, rear susp. frame
73-74	Nova	3917571	1	1.80	REINFORCEMENT, front to rear
65-68	Chevelle (327),				
66-67	El Camino (396),				
69-71	Chevelle	120390	2		WASHER (17/32" I.D. x 1 1/16" O.D. x 5/64" thk.)
72	Chevelle	1370177	2	.22	WASHER (17/32" I.D. x 1" O.D. x 5/32" thk.)

**7.068 HITCH UNIT— BALL— BOLT— HARNESS ASSY.— HARNESS UNIT— WASHER, Trailer**

73-75	El Camino	994482	1	31.50	deadweight trailer hitch
74-75	Vega	994613	1	31.50	
74-75	Chevelle (exc. Sta. Wag., El Camino)	994638	1	31.50	deadweight trailer hitch
74-75	Chevelle (Sta. Wag.)	994639	1	31.50	deadweight trailer hitch
74-75	Pass. (Sta. Wag.)	994635	1	31.50	deadweight trailer hitch
74-75	Pass. (exc. Sta. Wag.)	994634	1	31.50	deadweight trailer hitch
74-75	Camaro	994644	1	31.50	deadweight trailer hitch
73	Chevelle (Sta. Wag., El Camino),				
74-75	El Camino	994503	1	110.00	trailer weight distributing hitch platform
74-75	Pass. (exc. Sta. Wag.)	994636	1	110.00	trailer weight distribution hitch platform
74-75	Pass. (Sta. Wag.)	994637	1	110.00	trailer weight distribution hitch platform
74-75	Chevelle (exc. Sta. Wag., El Camino)	994640	1	110.00	trailer weight distribution hitch platform
74-75	Chevelle (Sta. Wag.)	994641	1	110.00	trailer weight distribution hitch platform
74-75	Nova	994643	1	110.00	trailer weight distribution hitch platform
75	Nova	994775	1	31.50	deadweight trailer hitch
75	Monza (exc. Towne Cpe.)	994799	1	31.50	
65-70	Pass.,				
64-69	Chevy,				
70	Chevelle,				
71	Nova,				
71	Pass. (Sta. Wag.),				
71-72	Chevelle,				
72	Pass. (Sta. Wag.),				



**FRAME—SPRINGS—BUMPER**

**7.068 HITCH UNIT— BALL— BOLT— HARNESS ASSY.— HARNESS UNIT— WASHER, Trailer (Con't)**

72	Chevelle (exc. Sta. Wag., El Camino),				
72	Camaro, Nova,				
72-75	All .....	981148	1	3.25	BALL, coupling (17/8" dia. ball) .....
73-75	All .....	980670	1	3.25	BALL, coupling (2" dia. ball) .....
65-69	All,				
71	All (exc. Pass.),				
72	All,				
73-75	Vega .....	2988876	1	8.80	HARNESS ASSY., wiring rear .....
69-70	Pass., Chevelle,				
71	All,				
72	All (exc. Sta. Wag.),				
73	All,				
74-75	All (exc. Camaro) .....	994532	1	21.50	HARNESS UNIT, trailer wiring (Note 1) .....
	<i>NOTE 1: Unit consists of 1 harness assy., front and rear, 3 connectors, 1 screw, 1 lockwasher.</i>				
74-75	Camaro, Vega, Monza .....	994622	1	23.50	HARNESS UNIT, trailer wiring .....
73-75	All .....	2988876	1	8.80	HARNESS ASSY., trailer wiring rear .....
74-75	All .....	8908437	1	27.50	HARNESS ASSY., trailer wiring frt. ....
65-69	Chevelle,				
70	Pass., Chevelle (Sta. Wag., El Camino),				
71-72	Chevelle (Sta. Wag., El Camino) .	3846174	1	.52	WASHER, 1/lock-tooth .....

**7.112 HANGER— SUPPORT ASSY., Rear Spring Front and Rear**

62-63	Chevy (exc. Conv.),				
64-67	Chevy .....	4866722 R.H.		11.50	SUPPORT ASSY., right front .....

**7.238 NUT, Stabilizer Link**

62-67	Chevy (Sta. Wag., Police),				
67-69	Camaro,				
68-69	Chevy, Camaro, Chevelle,				
65	Pass., Police,				
70	Nova,				
71	All,				
71-74	Vega,				
72	Nova .....	3654642	2	.11	(5/16"— 24) .....
65-69	Pass.,				
70-72	All (exc. Nova) .....	1365065	2	.11	(5/16"— 18) front bolt .....

**7.240 LINK— BOLT— REPAIR UNIT— SPACER, Stabilizer**

65-69	Pass., Police .....	3862406	2	.16	bolt type .....
62-63	Chevy (Police),				
62-67	Chevy (Sta. Wag.) (6 cyl.),				
62-63	Nova (283, 327),				
64	Chevy (283),				
65-71	Chevy (8 cyl.),				
68-72	Nova w/H.D. Susp. (6 cyl.),				
67-72	Camaro,				
71-72	Pass.,				
73-75	All .....	487129	1	1.70	(Note 1) .....
	<i>NOTE 1: 487129 Link Unit Contains 1 bolt, 4 grommets, 1 nut, 4 retainers, 1 spacer.</i>				
65-70	Pass. ....	3879829	1	1.35	LINK UNIT .....
64-72	Chevelle .....	381954	2	.58	BOLT, bolt type .....
70	Pass. ....	3862406	2	.16	BOLT, link .....
64-72	Chevelle .....	231319	2	2.45	REPAIR UNIT, link bolt repair .....
64-72	Chevelle .....	381955	1	.11	SPACER, link bolt grommet .....
65-70	Pass., Police .....	3862407	2	.11	SPACER, bolt grommet .....
72	Pass.,				
73-75	Pass., Chevelle .....	3993730	2	.16	SPACER, frt. stab. link bolt grommet .....

**7.241 SHAFT, Stabilizer**

64-66	Nova (Spt. Cpe.) (8 cyl.) .....	3790740	1	8.10	front .....
64-65	Chevelle,				
66-67	Chevelle (exc. 396) .....	397703	1	13.30	front .....
65-70	Pass. ....	3868640	1	8.00	front .....
65	Chevelle (396),				
66	Pass. w/Sp. Perf. Susp.,				
67-69	Pass. w/Sp. Perf. Susp. (exc. Sta. Wag.),				
69	Chevelle (2-Dr.) (8 cyl.) (exc. El Camino),				
70-72	Monte Carlo (454),				
70-72	Chevelle w/Spec. Per. Susp. ....	394926	1	16.05	rear .....
66-67	Chevelle (396) .....	397705	1	16.05	front .....

**FRAME—SPRINGS—BUMPER**

**7.241 SHAFT, Stabilizer (Con't)**

67-68	Camaro,					
68	Chevy (8 cyl.) (exc. spec. perf. susp.),					
68	Chevy w/H.D. sups. (6 cyl.) . . . . .	3908373	1	9.15	front . . . . .	
68	Chevelle,					
69-71	Chevelle (exc. Spec. Perf. Susp.),					
72	Malibu w/Sp. Perf. Susp.,					
72	Monte Carlo (exc. 454) . . . . .	401194	1	17.05	front . . . . .	
68	Chevy (Spt. Cpe.) w/spec. perf. susp. (8 cyl.),					
69	Chevy, Camaro,					
70-74	Nova w/Spec. Perf. Susp. . . . .	3955782	1	15.70	front . . . . .	
69	Chevelle w/spec. perf. susp.,					
70-72	Monte Carlo (454),					
70-72	Chevelle w/spec. per. susp. . . . .	402544	1	17.20	front . . . . .	
70	Nova (2-Dr.) w/Spec. Perf. Susp. . . . .	3980997	1	15.85	rear . . . . .	
70	Camaro (exc. Spec. Perf. Susp.) . . . . .	3965651	1	8.95	front . . . . .	
71-75	Vega . . . . .	353920	1	13.10	front stabilizer . . . . .	
70	Camaro (8 cyl.) w/Spec. Perf. Susp.,					
71-72	Camaro,					
73-74	Camaro w/Sp. Perf. Susp. . . . .	3984557	1	10.30	front (1" dia.) . . . . .	
71	Nova (2-Dr.) w/Spec. Perf. Susp. . . . .	6264014	1	17.85	rear . . . . .	
71-73	Police w/454, H/Per. Susp.,					
74-75	Pass. w/Spec. Susp. . . . .	491329	1	23.35	rear (15/16" dia.) . . . . .	
71-75	Pass. (exc. Sta. Wag.) . . . . .	3964067	1	19.45	front . . . . .	
71-75	Pass. (Sta. Wag.) . . . . .	3993657	1	19.85	front (1 1/8" dia.) . . . . .	
71-75	Vega, Monza . . . . .	356302	1	10.15	rear stabilizer . . . . .	
72-73	Nova (2-Dr.) w/Spec. Perf. Susp. . . . .	6264014	1	17.85	rear . . . . .	
73-75	Camaro (exc. Sp. H/Per. 350) . . . . .	481471	1	8.95	rear (9/16" dia.) . . . . .	
73-74	Chevelle,					
75	Chevelle (exc. 3-seat Sta. Wag.) (R.T.S. & Sport Susp.) . . . . .	488336	1	17.05	rear (7/8" dia.) . . . . .	
73	Chevelle (exc. Malibu S.S., Monte Carlo, Sta. Wag.),					
74-75	Malibu (exc. Sta. Wag., Spec. Susp.),					
74-75	El Camino . . . . .	6262298	1	17.20	front (7/8" dia.) . . . . .	
73	Malibu (Spt. Cpe.) (S.S.), Monte Carlo,					
73	Chevelle (Sta. Wag.),					
74-75	Malibu w/Spec. Susp. (exc. Sta. Wag.),					
74-75	Malibu (Sta. Wag.) (exc. Spec. Susp.),					
74-75	Laguna, Monte Carlo . . . . .	6262203	1	16.90	front (1" dia.) . . . . .	
73-74	Camaro w/Sp. H/Per. 350, Sp. Perf. Susp. (RPO 228),					
75	Camaro w/Sp. Perf. Susp. . . . .	3983085	1	18.35	rear . . . . .	
73	Malibu (Sta. Wag.) (S.S.),					
74	Malibu (Sta. Wag.) w/Spec. Susp.,					
75	Malibu w/Spec. Susp. . . . .	3994329	1	26.00	front (1 1/8" dia.) . . . . .	
74	Vega . . . . .	339087	1	11.70	rear stabilizer . . . . .	
74-75	Nova w/Spec. Per Susp. . . . .	340399	1	17.85	rear (9/16" dia.) . . . . .	
75	Malibu (exc. Sta. Wag.) (Sport Susp.) . . . . .	488338	1	22.70	rear (1" dia.) . . . . .	
75	Malibu (exc. R.T.S. & Sport Susp.) . . . . .	351540	1	21.15	front (7/8" dia.) . . . . .	
75	Nova w/Spec. Perf. Susp. . . . .	356529	1	22.70	front (1 1/8" dia.) . . . . .	
75	Camaro w/Spec. Perf. Susp.,					
75	Nova (exc. Spec. Perf. Susp.) . . . . .	356530	1	10.30	front (1" dia.) . . . . .	
75	Vega w/Spt. Susp. . . . .	348206	1	13.10	front stabilizer . . . . .	
75	Monza . . . . .	356399	1	22.70	front stabilizer . . . . .	

**7.242 BRACKET— BOLT— CLAMP— REINFORCEMENT— SPACER— SUPPORT, Stabilizer Shaft**

62-67	Chevy (Sta. Wag., Police),					
64-67	Chevy (8 cyl.) . . . . .	3790660	2	.65	front . . . . .	
64-67	Chevelle,					
67-69	Camaro,					
68-69	Chevy (8 cyl.),					
68-69	Nova (6 cyl.) w/H.D. susp. . . . .	383493	2	.47	front . . . . .	
65-70	Pass., Police . . . . .	3884877	L.H.	.56	left front . . . . .	
65-70	Pass., Police . . . . .	3884878	R.H.	.56	right front . . . . .	

**FRAME—SPRINGS—BUMPER**

**7.242 BRACKET— BOLT— CLAMP— REINFORCEMENT— SPACER— SUPPORT, Stabilizer Shaft (Con't)**

68-69	Chevelle,						
69	Camaro	394130	2	.74	front shaft		
70-71	Nova,						
70-71	Chevelle, Camaro,						
71	Pass.,						
72-75	All	406887	2	.74	front shaft		
70-73	Nova w/Spec. Perf. Susp.	3983075	2	1.85	rear, shaft		
70-75	Camaro w/Spec. Perf. Susp.,						
74-75	Nova w/Spec. Perf. Susp.	3982300	2	.79	rear, shaft		
71-73	Police w/H/Per. (454)	481649	2	3.85	rear shaft		
71-75	Vega, Monza	3978018	2	.44	front stabilizer shaft		
73-75	Chevelle w/Spec. Susp.,						
74-75	Pass. w/Spec. Susp.	488922	2	1.25	rear		
74-75	Camaro w/Spec. Perf. Susp.	485336	1	2.30	rr. stabilizer link attaching		
68-70	Chevy, Camaro (8 cyl.) (exc. 307, 327),						
71	Nova (4-Dr.) (6 cyl.),						
71-72	Camaro (exc. Sp. Perf. Susp.),						
72	Nova (350),						
73	Nova,						
73	Camaro (exc. Sp. Perf. Susp.)	332671	4	.31	BOLT (7/16"— 20 x 1 <sup>5</sup> / <sub>16</sub> ") (300M)		
71-75	Vega, Monza	3997232	4	.15	BOLT, frt. stabilizer shaft bracket		
71-75	Camaro w/Sp. Perf. Susp.,						
75	Nova w/Spec. Perf. Susp.	481949	4	.47	BOLT (7/16"— 20 x 1 <sup>5</sup> / <sub>16</sub> ")		
75	Camaro exc. Sp. Perf. Susp.	9792949	4	.31	BOLT (7/16"— 20 x 1 <sup>5</sup> / <sub>16</sub> ")		
69	Camaro,						
70-72	Nova (8 cyl.),						
70-72	Nova (6 cyl.) w/H.D. Susp.	9786588	2	.21	CLAMP, frt. stab. shaft		
73-74	Nova	9786588	2	.21	CLAMP, frt. shaft		
73-75	Camaro w/Sp. Perf. Susp.	481151	2	.13	CLAMP, rear		
66-69	Pass. w/spec. perf. susp.	3888726	2	.52	REINFORCEMENT, lower— (5.380)		
66-67	Pass. w/spec. perf. susp.	3888727	2	.70	SPACER, rr. bumper to face bar to frame— (5.383)		
70	Nova (4BC),						
71-72	Nova,						
73-75	Nova w/Spec. Perf. Susp.	9815898	R.H.	4.20	SUPPORT, stab. bar end		
70	Nova (4BC),						
71-72	Nova,						
73-75	Nova w/Spec. Perf. Susp.	9815899	L.H.	4.20	SUPPORT, stab. bar end		
70-72	Camaro (8 cyl.) w/Spec. Perf. Susp.,						
73	Camaro w/Spec. Perf. Susp.	3982298	2	4.95	SUPPORT ASSY., rear		
70-71	Nova (8 cyl.) w/Spec. Perf. Susp.	3986422	2	9.70	SUPPORT ASSY., rear		
72-75	Nova (8 cyl.) w/Spec. Perf. Susp.	3998667	L.H.	9.70	SUPPORT ASSY., rear		
72-75	Nova (8 cyl.) w/Sp. Perf. Susp.	3998668	R.H.	9.70	SUPPORT ASSY., rear		
74	Camaro w/Spec. Perf. Susp.	486066	2	4.95	SUPPORT ASSY., rear		
75	Camaro w/Spec. Perf. Susp.	486050	R.H.	5.15	SUPPORT ASSY., rear		
75	Camaro w/Spec. Perf. Susp.	486051	L.H.	5.15	SUPPORT ASSY., rear		

**7.243 BUSHING— CLAMP— SCREW— SHIM— SLEEVE— SPACER, Stabilizer Shaft**

62-69	Chevy, Camaro	3760439	2	.76	front		
64-67	Chevelle,						
65-66	Biscayne, Bel Air (6 cyl.) w/H.D. Susp.,						
65-67	Pass. (exc. H.D. Susp., S.S. 427),						
68-69	Pass. (exc. Police H.D. Susp., S.S. 427),						
70	Pass. (8 cyl.) (exc. Police)	3903083	2	.63	front shaft		
66-67	Pass. (Sta. Wag.),						
66-67	Chevelle (396),						
67-69	Pass. w/H.D. Susp.,						
68-70	Police	3903084	2	.63	front shaft		
68-72	Chevelle (exc. spec. perf. susp.),						
70-72	Camaro,						
71-72	Pass. (8 cyl.) (exc. H.D. Susp., Sta. Wag.),						
72	Monte Carlo (exc. 454),						
73-75	Pass., Camaro,						
73	Chevelle (Sta. Wag., Monte Carlo) (exc. Malibu S.S.),						
74-75	Chevelle (Sta. Wag., Monte Carlo) (exc. Spec. Susp.)	388294	2	.38	front		
69	Chevelle w/Spec. Perf. Susp.,						

**FRAME—SPRINGS—BUMPER**

**7.243 BUSHING— CLAMP— SCREW— SHIM— SLEEVE— SPACER, Stabilizer Shaft (Con't)**

71	Monte Carlo,				
71	Chevelle (8 cyl.) w/Sp. H/Per. Susp.,				
72	Pass. w/H.D. Susp. (exc. Sta. Wag.)	396420	2	.53	front
70-72	Nova (8 cyl.),				
70-72	Nova (6 cyl.) w/H.D. Susp.,				
73-74	Nova,				
74	Chevelle (exc. Sta. Wag., Monte Carlo)	392592	2	.38	front
70	Camaro (8 cyl.) w/Spec. Perf. Susp. (exc. 396),				
70	Nova (396),				
70-74	Camaro w/Spec. Perf. Susp.,				
70-72	Camaro (exc. Spec. H/Per. 350)	480912	2	.76	rear
70-74	Camaro (Spec. Perf. Susp. Sp. H/Per.) (350)	3983072	2	.34	rear support clamp
70-71	Nova (350) w/Sp. Perf. Susp.,				
70	Camaro w/Sp. Perf. Susp. (exc. Sp. H/Per. 350),				
72-74	Nova w/Sp. Perf. Susp.,				
71-72	Camaro w/Sp. Perf. Susp. (exc. Sp. H/Per. 350),				
73-74	Camaro (exc. Spec. H/Per. 350)	344697	2	.71	rear support clamp
70-74	Camaro w/Spec. H/Per. 350, Spec. Perf. Susp.	480913	2	.87	rear
71-75	Pass. (Sta. Wag.),				
72	Monte Carlo (454),				
72	Chevelle (8 cyl.) w/Sp. Perf. Susp.,				
73	Malibu (S.S.),				
74-75	Chevelle (Sta. Wag.) w/Spec. Susp.,				
75	Chevelle, Nova w/Spec. Perf. Susp.	3994335	2	.34	front
71-75	Vega, Monza	388292	2	.42	front stabilizer shaft
73-75	Chevelle (exc. Sta. Wag., Malibu S.S.)	392592	2	.38	front
75	Nova w/Spec. Perf. Susp.	344697	2	.71	rear support clamp
75	Camaro	498581	2	.34	rear support clamp
75	Camaro w/Sport Susp.	486960	2	.48	rear support clamp
70-72	Camaro w/Spec. Perf. Susp.,				
71-72	Nova w/Spec. Perf. Susp.	481151	2	.13	CLAMP, rr. support
71-72	All w/Spec. Susp.	9431970	4	.11	SCREW, front shaft brkt. (3/8"— 16 x 1 1/8")— (8.977)
65	Chevelle (396),				
70-72	Monte Carlo (454),				
70-72	Chevelle w/Spec. Perf. Susp.	385967	A.R.	.27	SHIM, lower control arm to stab.
71-75	Vega, Monza	3978064	A.R.	.18	SHIM, rear stabilizer shaft
70-72	Nova (8 cyl.),				
70-72	Nova (6 cyl.) w/H.D. front and rear susp.,				
73-74	Nova	9786584	2	.16	SLEEVE, front
66-68	Pass. w/Sp. Perf. Susp.,				
69	Pass. w/Sp. Perf. Susp. (exc. Sta. Wag.)	3888725	1	.16	SPACER, rear stab. shaft

**7.244 GROMMET, Stabilizer Link**

62-64	Chevy, Chevelle,				
65-69	Pass.				front bolt,
71-74	Vega				front stabilizer link bolt, shock absorber frt. upper end
73-75	All (exc. Police, Taxi)	6264018	A.R.	.22	front shock abs. upper end
73-75	Police, Taxi	6270710	4	.11	front shock abs. upper end
73-75	Pass. w/H.D. Susp. (exc. Sta. Wag.),				
73-75	Pass. (Sta. Wag.),				
75	Chevelle w/Spec. Perf. Susp.	325897	A.R.	.16	front stab. link bolt

**7.245 RETAINER— NUT, Stabilizer Link**

64-74	All	4941130	A.R.	.09	grommet (25/64" I.D. x 1 1/4" O.D.)
72	All	3993729	A.R.	.16	front bolt grommet
74-75	Pass. w/H.D. Susp.,				
74-75	Pass. (Sta. Wag.),				

**FRAME—SPRINGS—BUMPER**

**7.245 RETAINER— NUT, Stabilizer Link (Con't)**

<b>74-75</b>	Chevelle (Sta. Wag.) w/Spec. Susp. ....	<b>3849098</b>	<b>8</b>	<b>1.80</b>	frt. bolt grommet (1 <sup>1</sup> / <sub>32</sub> " dia.) .....
<b>73-74</b>	All (exc. Nova) .....	<b>1365065</b>	<b>2</b>	<b>.11</b>	<b>NUT, hex. (5/16"— 18) front stabilizer shaft link bolt</b> .....
<b>75</b>	All .....	<b>3654642</b>	<b>A.R.</b>	<b>.11</b>	<b>NUT, hex. (5/16"— 18) front stabilizer shaft link bolt</b> .....

**7.330 BRACKET, Body**

*NOTE Nos. following description are model and valve No. which are stamped on cover or valve nut.*

<b>68-70</b>	Pass. w/parallel edges .....	<b>3926941</b>	<b>L.H.</b>	<b>2.20</b>	left No. 4 .....
<b>68-70</b>	Pass. w/parallel edges .....	<b>3926942</b>	<b>R.H.</b>	<b>3.35</b>	right No. 4 .....

**7.345 SHOCK ABSORBERS**

*The GM Merchandising Line of Tune-Up Kits, Shock Absorbers, and Brake Sets are shipped direct to dealers from the source, and are not stocked at GM Parts Division Distribution Centers.*

*There is a required minimum order quantity. Combination Tune-Up Kits, Brake Sets and Shocks orders may qualify based on weight.*

*All orders are shipped freight prepaid.*

*Orders must be written on a special order form which allows scheduling of four dealer shipments. Specific weights and qtys. are specified on order forms.*

*All purchases accrue toward Dealer's parts return reserve.*

*Purchases are not eligible for wholesale compensation or stock order allowance.*

*GM Merchandising Line Parts are not returnable to GM Parts Division.*

*Merchandising Line Parts are warranted in accordance with current GM Parts Division parts policy.*

**FRONT**

<b>Yr.</b>	<b>Model Application</b> .....	<b>Mdse. No.</b>		<b>O.E.M. No.</b> .....
<b>62-67</b>	Chevy .....	<b>1154078</b>	<b>A.R.</b>	<b>N.L. 3192090</b> .....
<b>64-67</b>	Chevelle .....	<b>N.A.</b>	<b>A.R.</b>	<b>3192955</b> .....
<b>65</b>	Caprice (exc. 396 Spec. H/Per., H.D. Susp.),			
<b>65-67</b>	Pass. (exc. Sta. Wag., Pol., Taxi, H.D. Susp., Spec. Perf. Susp., Sp. H/Per. 427, 409 H.D. Chassis),			
<b>65-67</b>	Police,			
<b>65-67</b>	Pass. w/H.D. Susp., H.D. Chassis,			
<b>65-67</b>	Pass. (Sta. Wag.), Taxi (exc. Spec. Perf. Susp.),			
<b>65-67</b>	Pass. (Sp. H/Per., w/Spec. Perf. Susp.),			
<b>68-70</b>	Pass. (exc. Taxi, Sta. Wag., H.D. Susp., S.S. 427),			
<b>68-70</b>	Pass., Pol. w/Spec. Perf. Susp. . .	<b>1154078</b>	<b>A.R.</b>	<b>N.L. 3192971</b> .....
<b>65-66</b>	Pass. w/Spec. Perf. Susp. (396-427) (exc. Air Booster),			
<b>68</b>	Chevelle (Sta. Wag., El Camino),			
<b>68-69</b>	Chevelle (exc. 396, H.D. Susp., Sta. Wag., El Camino),			
<b>70</b>	Malibu (Spt. Cpe., Conv.) (396, 454),			
<b>70</b>	Chevelle w/H.D. Susp. (exc. El Camino, Monte Carlo),			
<b>71</b>	Chevelle (454) (exc. Monte Carlo),			
<b>71</b>	Chevelle w/H.D. Susp. ....	<b>1154077</b>	<b>A.R.</b>	<b>N.L. 3188931</b> .....
<b>67-69</b>	Camaro,			
<b>68-74</b>	Chevy, Nova .....	<b>1154077</b>	<b>A.R.</b>	<b>N.L. 3192977</b> .....
<b>68-69</b>	Chevelle w/H.D. Susp. (exc. Sta. Wag., El Camino),			
<b>69-70</b>	Chevelle (exc. 396, 454, Monte Carlo),			
<b>70-71</b>	Monte Carlo,			
<b>71</b>	Chevelle (exc. H.D. Susp., Spec. Perf. Susp., Sta. Wag.),			
<b>72</b>	Chevelle .....	<b>1154077</b>	<b>A.R.</b>	<b>N.L. 3192974</b> .....
<b>70-75</b>	Camaro .....	<b>1154078</b>	<b>A.R.</b>	<b>N.L. 5535623</b> .....
<b>71-74</b>	Vega .....	<b>1154079</b>	<b>A.R.</b>	<b>N.L. 3188935</b> .....
<b>71-75</b>	Pass. (exc. H.D. Susp., Police, Taxi) .....	<b>1154078</b>	<b>A.R.</b>	<b>N.L. 3188933</b> .....
<b>71-72</b>	Pass. w/H.D. Susp., Police, Taxi,			
<b>72</b>	Pass. (Sta. Wag.),			
<b>73-75</b>	Pass. w/H.D. Susp. ....	<b>1154078</b>	<b>A.R.</b>	<b>N.L. 3188934</b> .....

**FRAME—SPRINGS—BUMPER**

**7.345 SHOCK ABSORBERS (Con't)**

<b>73</b>	Chevelle (exc. H.D. Susp., Sta. Wag.),			
<b>74-75</b>	Malibu (exc. Sta. Wag., H.D. Susp. Perf. Susp.),			
<b>74-75</b>	El Camino (exc. S.S., H.D. Susp., Perf. Susp.)	<b>1154101</b>	<b>A.R.</b>	<b>N.L. 4975449</b>
<b>73-75</b>	Chevelle w/Spec. Perf. Susp.,			
<b>73-75</b>	Chevelle (Sta. Wag.),			
<b>74-75</b>	Chevelle w/H.D. Susp.,			
<b>74-75</b>	Monte Carlo, Laguna,			
<b>74-75</b>	El Camino (S.S.)	<b>1154101</b>	<b>A.R.</b>	<b>N.L. 4975452</b>
<b>75</b>	Nova	<b>1154078</b>	<b>A.R.</b>	<b>N.L. 5535623</b>
<b>75</b>	Vega, Monza	<b>1154159</b>	<b>A.R.</b>	<b>N.L. 3188972</b>

**REAR**

<b>62-63</b>	Chevy w/H.D. (exc. Sta. Wag., Taxi)	<b>N.A.</b>	<b>A.R.</b>	<b>3192093</b>
<b>62-67</b>	Chevy	<b>1154089</b>	<b>A.R.</b>	<b>N.L. 3192091</b>
<b>65</b>	Pass. w/Air Booster (exc. 396, 409),			
<b>66-69</b>	Pass. w/Air Booster (exc. 427),			
<b>70</b>	Pass. (Air Lift)	<b>1</b>		<b>3196954</b>
<b>67</b>	Camaro	<b>N.A.</b>	<b>A.R.</b>	<b>3192976</b>
<b>68</b>	Camaro (exc. 350, 327, 396),			
<b>68</b>	Camaro (327) (exc. 4-Spd.),			
<b>69</b>	Camaro (exc. Disc Brks., 302, 350, 396, 4-Spd., Spec. Perf. Susp.)	<b>N.A.</b>	<b>A.R.</b>	<b>3182020</b>
<b>68</b>	Camaro w/4-Spd. (8 cyl.) (exc. Spec. Perf. Susp.),			
<b>69</b>	Camaro w/P.G. (exc. Spec. Perf. Susp.),			
<b>69</b>	Camaro w/T.H. 400 (exc. Spec. Perf. Susp.)	<b>N.A.</b>	<b>A.R.</b>	<b>3182021</b>
<b>68</b>	Camaro w/Spec. Perf. Susp. (307, 327) (exc. 4-Spd.),			
<b>68-69</b>	Camaro w/H.D. Susp. (6 cyl.),			
<b>69</b>	Camaro w/Spec. Perf. Susp. (exc. 4-Spd., 327, 350, 396)	<b>N.A.</b>	<b>A.R.</b>	<b>3182032</b>
<b>68</b>	Camaro w/Spec. Perf. Susp. 4-Spd. (exc. 327 2BC),			
<b>69</b>	Camaro w/Spec. Perf. Susp. (8 cyl.) (exc. 3-Spd.)	<b>N.A.</b>	<b>A.R.</b>	<b>3182033</b>
<b>70-75</b>	Camaro	<b>1154076</b>	<b>A.R.</b>	<b>N.L. 3188143</b>
<b>64-66</b>	Chevelle (S.S.) w/Air Booster (1st design),			
<b>64-66</b>	El Camino,			
<b>64-67</b>	Chevelle w/Air Booster (exc. S.S.)	<b>N.A.</b>	<b>1</b>	<b>3186547 (L.H.)</b>
<b>64-66</b>	El Camino,			
<b>64-66</b>	Chevelle (S.S. w/Air Booster),			
<b>64-67</b>	Chevelle w/Air Booster (exc. S.S.)	<b>N.A.</b>	<b>1</b>	<b>4975437 (R.H.)</b>
<b>64-67</b>	Chevelle w/H.D. Susp. (exc. Air Booster, Sta. Wag., El Camino, S.S.),			
<b>64-65</b>	Chevelle (Taxi, Pol.) (exc. Air Booster),			
<b>64-67</b>	Chevelle (Sta. Wag.) (exc. Air Booster),			
<b>64-67</b>	Chevelle (S.S.) (exc. Air Booster),			
<b>65</b>	Pass. w/H/Per. (409) (exc. Sta. Wag., Air Booster),			
<b>65</b>	S.S. w/Spec. Frt. & Rr. Susp. (exc. Air Booster),			
<b>65</b>	Impala (S.S.) w/409 (exc. H.D. Susp., Air Booster),			
<b>67</b>	Pass. (Sta. Wag.) Taxi (exc. Air Booster),			
<b>68</b>	Pass. (exc. H.D. Susp., Spec. Perf. Susp., Air Booster),			
<b>67-70</b>	Pass. w/H.D. Chassis, H.D. Susp. (exc. Air Booster),			

**FRAME—SPRINGS—BUMPER**

**7.345 SHOCK ABSORBERS (Con't)**

67-70	Pass. (exc. 427, Sta. Wag., Taxi, H.D. Chassis, H.D. Susp., Air Booster, S.S.),			
68-69	Pass. w/Spec. Perf. Susp.,			
68-70	Police (exc. Air Booster) . . . . .	1154089 A.R.	N.L.	3197636 . . . . .
65	Biscayne w/H.D. Chassis (exc. Air Booster),			
65	Pass. w/Spec. Frt. & Rr. Susp. (exc. S.S. Air Booster),			
65	Pass. (Sta. Wag.) Taxi (exc. Air Booster),			
65	Caprice w/Sp. H/Perf. (396) (exc. Air Booster),			
65-66	Pass. w/H.D. Susp., H.D. Chassis (exc. Air Booster),			
66	Pass. (Sta. Wag.) Taxi (exc. Air Booster) . . . . .	1154092 A.R.	N.L.	3197660 . . . . .
65-66	Pass. w/Air Booster (exc. 396, 409, 427 Spec. Perf. Susp.) . . . . .	N.A.	1	3186453 (L.H.) . . . . .
65-66	Pass. w/Air Booster (exc. 396, 409, 427 Spec. Perf. Susp.) . . . . .	N.A.	1	3186452 (R.H.) . . . . .
66-68	Chevelle w/Air Booster,			
70	El Camino, Monte Carlo w/Lever Control,			
71-72	Chevelle w/Air Booster,			
72	El Camino . . . . .	N.A.	1	3197337 (L.H.) . . . . .
66-67	Chevelle (S.S.) w/Air Booster (2nd design),			
68	Chevelle w/Air Booster,			
70	El Camino, Monte Carlo w/Lever Control,			
71-72	Chevelle w/Air Booster,			
72	El Camino . . . . .	N.A.	1	3197338 (R.H.) . . . . .
67-70	Pass. w/Air Booster . . . . .	N.A.	1	3197582 (L.H.) . . . . .
67-70	Pass. w/Air Booster . . . . .	N.A.	1	3197581 (R.H.) . . . . .
67	Pass. w/Spec. Perf. Susp. (exc. Sta. Wag.),			
68	Chevelle (Sta. Wag., S.S.) (exc. Air Booster),			
68	Chevelle w/H.D. Susp. (exc. Sta. Wag., S.S. Air Booster),			
69-70	Chevelle (Sta. Wag.) . . . . .	1154094 A.R.	N.L.	3197672 . . . . .
69-70	Chevelle w/H.D. Susp. (exc. Monte Carlo, Sta. Wag., El Camino),			
69	Chevelle (396) (exc. Spec. Perf. Susp.),			
69-70	Chevelle (4-Dr. Sed.),			
68	Chevy w/Spec. Perf. Susp.,			
69-70	Chevelle (2-Dr.) (exc. 396, El Camino),			
71-72	Chevelle (Sta. wag., Conv.),			
71-72	Chevelle w/H.D. Susp.,			
71-72	Chevelle (400 4BC) (exc. Spec. Perf. Susp.),			
72-73	Nova w/H.D. Spec. Perf. Susp. . . . .	1154094 A.R.	N.L.	3197672 . . . . .
68	Chevelle (exc. Sta. wag., S.S., H.D. Susp., Air Booster) . . . . .	N.A. A.R.		3192823 . . . . .
68-70	Chev. (exc. 327, 350, 396 Spec. H/Perf., H.D. Susp., 4-Spd.),			
69	Chevy (exc. 350, 396),			
68	Chevy w/H.D. Susp. (exc. 327 Spec. H/Perf., 4-Spd.),			
69-71	Chevy w/H.D. Susp.,			
71	Nova (exc. 350, 396, H.D. Susp.),			
72-73	Nova (exc. H.D., Spec. Perf. Susp.) . . . . .	1154095 A.R.	N.L.	3197671 . . . . .
69-72	Chevelle w/Spec. Perf. Susp. . . . .	1154096 A.R.	N.L.	3197677 . . . . .
71	Vega . . . . .	1154080 A.R.	N.L.	3188938 . . . . .
71-75	Pass. w/Air Booster (exc. Sta. Wag.) . . . . .	1154102	1	N.L. 3188936 (complete) . . . . .
71-75	Pass. (Sta. wag.) w/Air Booster . . . . .	1154103	1	N.L. 3188937 (complete) . . . . .
71-75	Pass. (Sta. Wag.) w/Air Booster . . . . .	N.A.	1	3197687 (L.H.) . . . . .
71-75	Pass. (Sta. Wag.) w/Air Booster . . . . .	N.A.	1	3197688 (R.H.) . . . . .

**FRAME—SPRINGS—BUMPER**

**7.345 SHOCK ABSORBERS (Con't)**

71-75	Pass. w/Air Booster (exc. Sta. Wag.)	N.A.	1	3197689 (L.H.)
71-75	Pass. w/Air Booster (exc. Sta. Wag.)	N.A.	1	3197690 (R.H.)
71-75	Pass. (Sta. Wag.) (exc. Air Booster)	1154096	A.R.	N.L. 3197683
71-75	Pass. (exc. Sta. Wag., Pol., Air Booster, axi, H.D. Susp.)	1154096	A.R.	N.L. 3197682
71	Pol., Taxi,			
71-75	Pass. w/H.D. Susp. (exc. Air Booster, Sta. Wag.)	1154089	A.R.	N.L. 3197684
72-73	Vega	1154100	A.R.	N.L. 4949842
73	Chevelle (exc. Sta. Wag.),			
74	Chevelle (exc. Sta. Wag.), El Camino w/Air Booster	N.A.	1	4975455 (L.H.)
73	Chevelle (exc. Sta. Wag.),			
74	Chevelle (exc. Sta. Wag.), El Camino w/Air Booster	N.A.	1	4975456 (R.H.)
73	El Camino w/Air Booster	1154105	1	N.L. 4975458 (complete)
73	Chevelle w/Air Booster (exc. Sta. Wag.)	1154104	1	N.L. 4975457 (complete)
73-75	Chevelle (exc. H.D. Susp., Perf. Susp., Sta. Wag., I Camino)	1154095	A.R.	N.L. 4975450
73-75	Chevelle w/H.D. Susp. (exc. El Camino),			
74-75	Chevelle w/Spec. Perf. Susp. (exc. Sta. Wag., El Camino)	1154096	A.R.	N.L. 4975453
73-75	Chevelle (Sta. Wag.)	1154096	A.R.	N.L. 4975454
74-75	El Camino w/Air Booster	N.A.	1	4975459 (L.H.)
74-75	El Camino w/Air Booster	N.A.	1	4975460 (R.H.)
74-75	Nova	1154149	A.R.	N.L. 4975499
74-75	Vega	N.A.	A.R.	4949842 (repl. 4975324)
75	Monza (exc. Towne Cpe.)	1154160	A.R.	N.L. 3188973
75	Monza (Towne Cpe.)	N.A.	A.R.	3192796 (repl. 4984864)

**7.346 TUBE— BRACKET— CAP— CLIP— CONNECTOR— FITTING ASSY.— GROMMET— HOSE ASSY.— INSERT— NIPPLE— NUT— ROD ASSY.— SEAL— VALVE— WASHER, Shock Absorber, Air Lift**

65-66	Chevelle,			
65-66	Pass.,			
70	Pass., Chevelle,			
71	Chevelle,			
72	Monte Carlo	3977228	1	2.50 rear, air inlet
71-73	Pass. (Sta. Wag.) w/air booster	488188	L.H.	3.05 TUBE ASSY.
71-72	Pass. (Sta. Wag.) w/air booster	484279	R.H.	1.45 TUBE ASSY.
71-74	Pass. (exc. Sta. Wag.),			
73-74	El Camino	485517	1	1.75 TEE & TUBE ASM., rear shk. abs. air inlet
68-72	El Camino	3934095	1	.11 BRACKET, rear inlet valve to tee pipe
65-66	Pass., Chevelle w/Air Booster,			
72	Monte Carlo, El Camino	3171598	1	.18 CAP, rear, air inlet valve
	<i>NOTE 1 Holds two (2) 3/16" pipes together.</i>			
65-66	Chevelle,			
65-67	Pass.	3884821	8	.46 CLIP, air lift tube
65	Pass., Chevelle	3182801	3	.16 CLIP, air inlet tube
69-70	Pass. w/Level Control,			
70-71	Monte Carlo	343438	A.R.	.16 CLIP, air inlet frt. pipe
71-72	Pass. (Sta. Wag.)	1457094	4	.13 CLIP, rear shock absorber air inlet tube and tee— (7.380)
65-70	Pass. w/level control	3863527	1	.94 CONNECTOR, rear inlet tube
65-67	Pass., Chevelle w/Air Lift,			
71-72	Pass. (Sta. Wag.) w/air booster	9781790	1	9.30 FITTING ASSY.
65-67	Pass., Chevelle w/Air Booster (exc. El Camino),			
70-72	Monte Carlo w/level control	3176207	2	.65 FITTING ASSY.
65	Chevelle,			
65-66	Pass.	6264018	4	.22 GROMMET (7.244)
65-67	El Camino	3863549	2	2.40 HOSE ASSY., rear air inlet
65-70	Pass. w/Air Booster	3863525	2	2.05 HOSE ASSY., rear air inlet
65-68	Chevelle (Sta. Wag.) (exc. level control),			
65-68	Chevelle w/Air Booster (exc. El Camino, level control),			
63-72	El Camino	3920631	2	3.30 HOSE ASSY., rear air inlet
65	Pass.	3749168	1	.22 NIPPLE, air compressor vacuum hose— (2.420)



**FRAME—SPRINGS—BUMPER**

**7.346 TUBE— BRACKET— CAP— CLIP— CONNECTOR— FITTING ASSY.— GROMMET— HOSE ASSY.— INSERT— NIPPLE— NUT— ROD ASSY.— SEAL— VALVE— WASHER, Shock Absorber, Air Lift (Con't)**

65	Pass., Chevelle	3176207 A.R.		.65	NUT, air inlet tube
72	Pass. w/Air Booster (exc. Sta. Wag.),				
74-75	El Camino,				
73-75	Pass. w/Air Booster	3171533 A.R.		.10	NUT, air inlet valve
68-69	Pass. w/Level Control	3976417	1	1.20	ROD ASSY., rear level control
70-72	Monte Carlo w/level control	3982138	1	1.50	ROD ASSY., level control valve
65-66	Pass.	3750232	5	.11	SEAL, air inlet hose pipe
64	Chevy,				
65-68	Chevelle, El Camino w/Air Booster,				
65	Chevy,				
69-72	El Camino,				
65-70	Pass. w/Air Booster (exc. Air Lift)	3868676	1	.46	VALVE, rear air intake
70-72	Monte Carlo w/level control	4950745	1	53.00	VALVE ASSY., rear, air intake (repl. 4949863)
65-68	Chevelle (exc. El Camino),				
65-67	Pass.,				
71-72	Pass. (exc. Sta. Wag.),				
73	Pass., El Camino w/Air Booster,				
74	Pass., El Camino w/Air Booster (exc. Sta. Wag.)	3178498	1	1.81	VALVE UNIT
74-75	Pass. (Sta. Wag.) w/Air Booster	494705	1	6.25	VALVE UNIT
64-66	Chevy, Chevelle w/Air Booster,				
65-70	Pass. w/Air Booster,				
67-68	Chevelle w/Air Booster,				
68-72	El Camino	3827499	1	.11	WASHER, rear air intake valve (5/16" x 1 1/2" x 1/16")

**7.347 NUT— BOLT— PLUG— WASHER, Shock Absorber**

62-75	All	3866766 A.R.		.12	front & rear, to cross member (3/8" — 24) (3/8" thick)— (0.626)
64-66	Pass., Chevelle	9421085	2	.16	rear shock absorber assy. nut, 1/2" — 29, lower end— (8.915)
65-67	El Camino (exc. air lift)	3863555	1	.11	(3/4" — 24) (1/2" thick)
72	All,				
75	All (exc. Pass.)	339715	4	.11	front, J shape (5/16" — 18)
72	Monte Carlo w/level control	3162743	3	.34	BOLT, rr. shk. abs. comp. resvr. ret. thru
71-75	Vega, Monza	3978092	2	.06	PLUG, frt. shock absorber access hole
65-67	Chevy	3790342	2	.11	WASHER, front upper (1 3/32" I.D. x 1 7/8" O.D.)

**7.371 WASHER— SHIELD, Shock Absorber**

64-67	Chevelle	3861040 A.R.		.81	SHIELD
-------	----------	--------------	--	-----	--------

**7.380 BRACKET— CLIP, Shock Absorber**

71-72	Pass. w/Air Booster (exc. Sta. Wag.)	3993637	1	1.15	rear, air inlet valve
73	Pass. w/Air Booster (exc. Sta. Wag.)	325841	1	1.00	rear, air inlet valve
74-75	Pass. w/Super lift rear shock absorbers (exc. Sta. Wag.)	335870	1	1.00	rear air inlet valve
71	Pass. w/Air Booster (exc. Sta. Wag.)				CLIP, rr. air int. valve tube,
71-72	Pass. (Sta. Wag.) w/Air Booster,				
73-74	Pass., El Camino w/Air Booster	1457094 A.R.		.13	rr. air int. tube
75	El Camino, w/air shocks,				
75	Pass. (Sta. Wag.) w/air shocks	4553268 A.R.		.14	CLIP, rr. shock air inlet tube and tee— (2.698)

**7.388 BUSHING— GROMMET, Shock Absorber Link**

68-69	Pass.	3654642	4	.11	steering col. to steering gear— (7.238)
62-67	Chevy	3852230	8	.11	GROMMET, lower spring seat (7/16" I.D. x 15/16" O.D.)
62-67	Chevy	3790341	2	.16	GROMMET, front, upper (1 5/16" O.D. x 1 1/16" thk.)
62-67	Chevy	3792289	2	.16	GROMMET, front, lower (1" O.D. x 3/4" thk.)
67-69	Camaro w/floor console (exc. P.G.),				
68-69	Chevy w/4-Spd. Close Ratio,				
71	Vega,				

**FRAME—SPRINGS—BUMPER**

**7.388 BUSHING— GROMMET, Shock Absorber Link (Con't)**

72	Biscayne, Bel Air, Police w/H/Per. 454,						
72	Pass. (Sta. Wag.),						
72	Chevelle, Camaro, Nova					<b>GROMMET, rear, front strut (17/32" O.D. x 1/8" thk.),</b>	
73-74	Chevelle (Sta. Wag., S.S.),					front stab. link bolt	
73-75	Camaro					rear shock, lower end	
75	Camaro	6270704	2	.24			
67	Camaro,						
65-69	Pass.	6264018	4	.22		<b>GROMMET, rear— (7.244)</b>	

**7.389 RETAINER— SCREW— WASHER, Shock Absorber Bushing (Double Acting)**

62-74	All	4941130	A.R.	.09		front and rear (25/64" I.D. x 1 1/4" O.D.)— (7.245)	
71-73	Vega	3968522	4	.15		<b>SCREW, shock absorber frt. lower end (5/16"— 18)</b>	
70-75	Camaro,						
71	Vega	3798007	4	.11		<b>WASHER, rear lower</b>	

**7.395 BRACKET— BOLT— MEMBER— NUT— SCREW— TOWER ASSY., Shock Absorber Frame**

62-67	Chevy	3792171	2	1.65		rear	
67-69	Camaro	3892761	2	1.80		rear	
71-74	Pass. (exc. Sta. Wag.)	3981239	L.H.	2.40		left, rear spring and shock	
71-74	Pass. (exc. Sta. Wag.)	3981240	R.H.	2.40		right, rear spring and shock	
71-74	Pass. (Sta. Wag.)	3982839	L.H.	3.05		left, rear shock	
71-74	Pass. (Sta. Wag.)	3982840	R.H.	2.15		right, rear shock	
71-75	Vega, Monza	1728943	R.H.	10.60		(repl. 1706690)	
71-75	Vega, Monza	9862823	L.H.				
73	Monte Carlo	3994480	1	2.50			
62-67	Chevy	3790680	8	.15		<b>BOLT, front shock absorber lower assy. (5/16"— 18 x 5/8")</b>	
65-70	Pass.	3953988	1	19.35		<b>MEMBER, cross, rear (O.A. Smith)</b>	
64	Chevelle	3691530	A.R.	.16		<b>NUT, lower end (1/2"— 20)</b>	
71-75	Vega, Monza	3986564	4	.26		<b>NUT ASSY., cross member (3/8"— 16)</b>	
70-71	All	3968522	4	.15		<b>SCREW, w/washer, front lower end (5/8"— 18)— (5.383)</b>	
62-67	Chevy	3790339	2	1.10		<b>TOWER ASSY., front shock absorber</b>	

**7.397 WASHER, Shock Absorber**

67-69	Camaro	3905569	4	.11		rear, bracket screw (9/32" I.D. x 1 9/16" O.D. x 3/32" thk.)	
-------	--------	---------	---	-----	--	--	--

**7.412 SPRING, Front (coil) (CHEVY, CHEVELLE, CAMARO)**

*NOTE: All 1969-72 Springs (front and rear) are located in Group 7.503.  
NOTE Springs may be identified from the years 1963 thru 1965 by a piece of tape attached to the spring listing the part number.  
NOTE: Spring charts found at the end of this group include 1967-68 Chevelle, 1967 Camaro, 1965-68 Pass.  
NOTE Maximum Load Capacity should be used for comparison purposes only.*

62	Chevy (Sta. Wag.) (4 cyl.),						
62-63	Chevy (Sta. Wag.) (6 cyl.),						
62	Chevy (Sedan) w/C.A.C. (4 cyl.),						
62-66	Nova (Sedan, Spt. Cpe.) w/C.A.C.,						
62-65	Chevy (Sedan) (6 cyl.) (exc. C.A.C.),						
62-65	Chevy (exc. C.A.C., H.D.),						
63	Nova (Conv.),						
64-66	Chevy (Sed.) (6 cyl.) (exc. Taxi, H.D., Air Cond.),						
64-67	Chevy (Sed., Sta. Wag.) (6 cyl.) (exc. Taxi, H.D., Air Cond.),						
66-67	Nova (Spt. Cpe.) (283) (exc. S.S.),						
65-67	Nova (S.S.) (8 cyl.) (exc. H.D., C.A.C.),						
67	Chevy (4 cyl.),						
67	Nova, Spt. Cpe. (exc. C.A.C., H.D. Susp.),						
67	Nova w/C.A.C. (6 cyl.)	3792773	2	10.85		(1/2" light green, 1/2" light green full length of spring)	
62	Chevy (Sedan) w/C.A.C. (6 cyl.) (exc. Nova),						
62	Nova (Conv.),						

**FRAME—SPRINGS—BUMPER**

**7.412 SPRING, Front (coil) (CHEVY, CHEVELLE, CAMARO) (Con't)**

64-67	Chevy w/H. Perf. 327 (exc. Spt. Cpe., S.S.),				
64-67	Chevy (S.S.) w/C.A.C., (327),				
65-67	Chevy (6 cyl.) w/C.A.C. (exc. S.S.),				
66-67	Chevy w/H.D. Susp. (4 cyl.),				
66-67	Chevy w/H. Perf. (327) . . . . .	<b>3792041</b>	<b>2</b>	10.85	(1/2" lt. blue, 1/2" dark blue full length of spring) (max. load 1265 lbs.) . . . . .
62-65	Chevy, Taxi w/H.D. (4 cyl.),				
64-65	Chevy (Sta. Wag.) w/C.A.C. (exc. H.D., 8 cyl.),				
65	Chevy w/H.D. susp. (4 cyl.),				
65	Chevy (Spt. Cpe.) (327) . . . . .	<b>3792044</b>	<b>2</b>	10.40	(1/2" yellow, 1/2" grey full length of spring) (max. load 1200 lbs.) . . . . .
62-66	Chevy w/H.D. (exc. Conv., Spt. Cpe.),				
62-65	Chevy (Taxi, Police),				
67	Chevy w/H.D. Susp. (6 cyl.) (exc. Spt. Cpe.),				
67	Chevy (S.S.) w/H.D. Susp. (8 cyl.) (exc. C.A.C.),				
67	Chevy w/C.A.C., H.D. Susp. (8 cyl.) (exc. 327, Spt. Cpe., S.S.),				
67	Chevy (Spt. Cpe.) w/C.A.C. (327) (exc. S.S.),				
67	Chevy (S.S.) w/C.A.C. (327) . . . .	<b>3792045</b>	<b>2</b>	10.85	(1/2" lt. brown, 1/2" grey full length of spring) (max. load 1280 lbs.) . . . . .
64	El Camino (6 cyl.) (exc. H.D. susp.),				
64-66	Chevy w/C.A.C. (8 cyl.) (exc. S.S.),				
64	Chevelle (Sta. Wag.) w/C.A.C. (6 cyl.) (exc. 3-Seat),				
64	Malibu (Spt. Cpe.) w/C.A.C. (6 cyl.),				
64	Chevelle (2-Dr. Sta. Wag.) w/C.A.C. (6 cyl.),				
64	Malibu (Spt. Cpe.) (8 cyl.),				
64	Chevelle (2-Dr. Sed.) (6 cyl.),				
64	Malibu (6 cyl.),				
64	Chevelle (2-Dr. Sta. Wag.) (8 cyl.),				
64	Chevelle (4-Dr., Sta. Wag.) (6 cyl.),				
64	Chevelle (Sta. Wag.) (8 cyl.) (exc. 327, 3-Seat),				
64-65	Chevelle (2-Dr. Sta. Wag.) (327),				
64-65	Malibu (Spt. Cpe.) (327) (exc. S.S.),				
65	Chevelle (2-Dr. Sta. Wag.) w/H.D. Susp. (6 cyl.),				
65	Chevelle Deluxe (4-Dr. Sta. Wag.) w/H.D. Susp. . . . .	<b>3955712</b>	<b>2</b>	15.05	(max. load 2262 lbs.) . . . . .
64	Malibu (Sta. Wag.) (327),				
64	Chevelle (2-Dr. Sta. Wag.) w/C.A.C. (8 cyl.),				
64	Malibu (Conv.) w/C.A.C. (6 cyl.),				
64	Malibu (Conv.) (8 cyl.),				
64	Malibu (Conv.) w/C.A.C. (8 cyl.),				
64	Chevelle (2-Dr. Sed.) (8 cyl.),				
64	Chevelle (2-Dr. Sed.) w/Air Cond. (6 cyl.),				
64	Malibu (Spt. Cpe.) w/C.A.C. (8 cyl.),				
64	Malibu (Conv.) (327) (exc. S.S.),				
64	Chevelle (Sta. Wag.) w/C.A.C. (8 cyl.) (exc. 3-Seat),				
64	Chevelle (Sed.) (8 cyl.),				
64	Chevelle (2-Dr. Sed.) (327),				
64	Chevelle (2-Dr. Sta. Wag.) w/C.A.C. (327),				
64	Malibu (Spt. Cpe.) w/C.A.C. (327) (exc. S.S.),				
64	El Camino w/C.A.C. (6 cyl.),				
64	El Camino (8 cyl.),				

**FRAME—SPRINGS—BUMPER**

**7.412 SPRING, Front (coil) (CHEVY, CHEVELLE, CAMARO) (Con't)**

- 64-65 Chevelle (4-Dr. Sed.) w/C.A.C. (6 cyl.),
- 64-65 Malibu (S.S. Conv.) (327),
- 65 Chevelle (4-Dr. Sta. Wag.) w/H.D. Susp.,
- 65 Chevelle (2-Dr. Sta. Wag.) w/H.D. Susp.,
- 65 Chevelle (Deluxe) (2-Dr. Sed.) (327),
- 65 Chevelle (2-Dr. Sta. Wag.) w/H.D. Susp. (327),
- 65 Malibu (Sta. Wag.) w/H.D. susp. (6 cyl.) (exc. C.A.C.),
- 65 Malibu (Sta. Wag.) w/H.D. susp. (8 cyl.),
- 65 Chevelle (2-Dr. Sed.) w/C.A.C. (6 cyl.),
- 65 Chevelle (4-Dr. Sta. Wag.) (327) (exc. Malibu),
- 65-66 Chevelle (2-Dr. Sed.) (8 cyl.),
- 65 Chevelle (4-Dr. Sed.) w/C.A.C. (6 cyl.),
- 65 Chevelle (2-Dr. Sta. Wag.) w/C.A.C. (8 cyl.),
- 65 Malibu (S.S. Conv.) (8 cyl.),
- 65 Malibu (Spt. Cpe.) (327),
- 65 Malibu (Conv.) (327) (exc. S.S.),
- 65 Malibu (Sta. Wag.) (327),
- 65-66 El Camino (8 cyl.),
- 65-66 Malibu (Conv.) (8 cyl.),
- 66 Malibu (Spt. Cpe.) (8 cyl.),
- 65-66 El Camino w/C.A.C. (6 cyl.),
- 65-66 Chevelle (2-Dr. Sed.) w/C.A.C. (6 cyl.),
- 65-66 Malibu w/C.A.C. (6 cyl.) (exc. Sed.),
- 68 Chevy (Sed.) w/C.A.C. (6 cyl.),
- 68 Chevy (Spt. Cpe.) w/H.D. Susp., Spec. perf. susp. (8 cyl.) (exc. C.A.C.),
- 68 Camaro (Spt. Cpe.) w/C.A.C., (6 cyl.),
- 68 Camaro (Conv.) w/C.A.C., 4-Spd. (327, 350),
- 68 Camaro (Conv.) (6 cyl.) (exc. C.A.C.),
- 68 Chevy (Sed.) (8 cyl.) . . . . . **3955714 2 15.05** (max. load 2373 lbs.) . . . . .
- 64 Chevelle (C.A.C.),
- 64 Malibu (3-Seat Sta. Wag.) (H.D. Susp. w/C.A.C.) (327),
- 64-66 El Camino (H.D. Susp. w/C.A.C.) (283, 327),
- 65 Chevelle (H.D. Susp. w/C.A.C.) (8 cyl.) (exc. Sed., El Camino),
- 65 Chevelle (H.D. Susp. w/C.A.C.) (327) (exc. Malibu),
- 65-66 Malibu w/H.D. Susp.,
- 66 Chevelle (H.D. Susp. w/C.A.C.) (exc. Conv., El Camino),
- 66 Chevelle (Conv., El Camino) w/H.D. Susp. (327),
- 64-65 Taxi (6 cyl.),
- 64 Chevelle (4-Dr. Sed.) w/H.D. Susp. (8 cyl.),
- 64-65 Malibu (Conv.) w/H.D. Susp., C.A.C. (327),
- 64-65 El Camino w/H.D. Susp. (8 cyl.),
- 64-65 Chevelle (Sta. Wag.) w/H.D. Susp., C.A.C. (8 cyl.),
- 64-65 Chevelle (2-Dr. Sed.) w/H.D. Susp. (327),
- 65 Chevelle (4-Dr. Sed.) w/H.D. Susp., C.A.C.,
- 65 Chevelle (Std.) w/H.D. Susp. (8 cyl.) (exc. Sta. Wag.),

**FRAME—SPRINGS—BUMPER**

**7.412 SPRING, Front (coil) (CHEVY, CHEVELLE, CAMARO) (Con't)**

65	S.S. w/H.D. Susp. (327),				
65	Chevelle (2-Dr. Sed.) (H.D. Susp. w/C.A.C.) (8 cyl.),				
65	Chevelle (4-Dr. Sed.) w/H.D. Susp. (327) (exc. Malibu),				
65	Malibu (4-Dr. Sed.) (H.D. Susp. w/C.A.C.) (8 cyl.),				
65	El Camino (Custom) (H.D. Susp. w/C.A.C.) (327),				
66	Chevelle (C.A.C. w/H.D. Susp.) (8 cyl.) (exc. Malibu, Sta. Wag., S.S.),				
66	El Camino (H.D. Susp. w/C.A.C.) (327),				
66	Chevelle (H.D. Susp., w/C.A.C.) (6 cyl.) (exc. Sed.),				
66	Chevelle w/H.D. Susp. (8 cyl.) (exc. Sed., S.S.),				
66	Malibu (Sed.) w/H.D. Susp. . . . .	<b>3850967</b>	2	16.70	(max. load 2577 lbs.) . . . . .
64	Chevelle (4-Dr. Sta. Wag.) (327) (exc. Malibu),				
64	Malibu (S.S. Spt. Cpe.) (327),				
65	El Camino w/level control, C.A.C. (8 cyl.) . . . . .	<b>3895812</b>	2	15.35	(max. load 2259 lbs.) . . . . .
64	Chevelle (Sta. Wag.) w/H.D. Susp., C.A.C. (8 cyl.) (exc. 3-Seat),				
64	Malibu (3-Seat Sta. Wag.) (8 cyl.) (exc. C.A.C., H.D. Susp.),				
64	S.S. (Spt. Cpe.) w/H.D. Susp., C.A.C. (327),				
64	S.S. (Conv.) w/H.D. Susp. (327),				
64	El Camino w/H.D., Susp., C.A.C. (6 cyl.),				
64	El Camino w/H.D., Susp. (8 cyl.),				
64-65	Chevelle (4-Dr. Sed.) w/H.D. Susp. (6 cyl.),				
64-66	Malibu (Conv.) w/H.D. Susp.,				
64-66	Malibu (Spt. Cpe.) (H.D. Susp.),				
64-66	Police (6 cyl.),				
65	Police (exc. C.A.C.),				
65	Chevelle (Sed., El Camino) w/H.D. Susp.,				
66	Chevelle (S.S.) w/C.A.C.,				
66	Chevelle w/H.D. Susp. (6 cyl.) (exc. Malibu, Sta. Wag.),				
66	El Camino w/H.D. Susp.,				
66	2-Dr. Sed. w/H.D. Susp. (327),				
66	Spt. Cpe. w/C.A.C.,				
68	Camaro (Conv.) (396) (exc. C.A.C., Sp. H/Per.) . . . . .	<b>3955725</b>	2	15.05	(max. load 2451 lbs.) . . . . .
64	Malibu (Spt. Cpe.) w/H.D. Susp. (6 cyl.),				
66	Malibu (Conv.) w/H.D. Susp. (6 cyl.),				
68	Camaro (Conv.) (327 w/2BC) (exc. C.A.C., Spec. Perf. Susp.),				
68	Camaro (Spt. Cpe.) w/C.A.C., Sp. H/Per. (327, 396) (exc. 4-Spd., Spec. Perf. Susp.),				
68	Camaro (Spt. Cpe.) w/C.A.C., Spec. Perf. Susp. (exc. 396),				
68	Camaro (Conv.) w/Spec. Perf. Susp., 2BC (327) (exc. C.A.C.),				
68	Camaro (Conv.) w/4BC (327) (exc. C.A.C., 4-Spd.),				
68	Camaro (Conv.) w/C.A.C. (350) (exc. Spec. Perf. Susp.),				
68-69	Camaro (Spt. Cpe.) w/Spec. Perf. Susp. (302, 350),				
68	Camaro (Conv.) (C.A.C., w/H.D. Susp.) (6 cyl.),				
68	Chevy (Sed.) w/H.D. Susp., C.A.C. (exc. 327, Sp. H/Per., 4-Spd.),				

**FRAME—SPRINGS—BUMPER**

**7.412 SPRING, Front (coil) (CHEVY, CHEVELLE, CAMARO) (Con't)**

68	Chevy (Spt. Cpe.) (396) (exc. Sp. Perf. Susp.),				
68	Chevy (Sed.) (8 cyl.),				
68	Camaro (Spt. Cpe.) w/Spec. H/Per. (396) (exc. Spec. Perf. Susp.),				
68	Chevy (Sed.) w/H.D. Susp., C.A.C. (exc. 327 Sp. H/Per., 4-Spd.),				
68	Chevy (Spt. Cpe.) (396) (exc. Spec. Perf. Susp.)	<b>3955722</b>	2	15.05	(max. load 2388 lbs.)
65	Chevelle (6 cyl.)	<b>3895809</b>	2	14.95	(max. load 2041 lbs.)
65	Malibu (Conv.) (6 cyl.) (exc. S.S.),				
65	Malibu (S.S. Spt. Cpe.) (6 cyl.)	<b>3895811</b>	2	15.35	(max. load 2053 lbs.)
65	Chevelle (2-Dr. Sed.) (327),				
65	Chevelle (4-Dr. Sed.) (283, 327) (exc. C.A.C.),				
65	Chevelle (Sta. Wag.) w/C.A.C. (8 cyl.),				
65-66	Chevelle (2-Dr. Sed.) (327),				
65-66	Chevelle (S.S., Conv.) (327),				
65-66	El Camino (327),				
66	Chevelle (4-Dr. Sed.) w/C.A.C. (6 cyl.),				
66	Chevelle (4-Dr. Sed.) (8 cyl.),				
66	Chevelle (Deluxe) (2-Dr. Sed.) (8 cyl.),				
66	Malibu (Sedan) (8 cyl.)	<b>3866288</b>	2	16.35	(max. load 2361 lbs.)
65	El Camino w/Level Control (8 cyl.),				
65	El Camino, Sta. Wag. (6 cyl.)	<b>3895810</b>	2	14.20	(max. load 2091 lbs.)
65	Chevelle w/C.A.C. (6 cyl.) (exc. Sta. Wag., El Camino),				
65	Chevelle (8 cyl.) (exc. Sta. Wag., El Camino, S.S.),				
65	Malibu (Sta. Wag.) w/C.A.C. (8 cyl.),				
65	Malibu (S.S., Spt. Cpe.),				
66	Chevelle (6 cyl.),				
68	Chevy (Spt. Cpe.) w/C.A.C., spec. perf. susp. (327, 350) (exc. H.D. Susp.),				
68	Chevy (Sed.) w/4-Spd. (327) (exc. H.D. Susp.),				
68-69	Camaro (Spt. Cpe.) w/C.A.C., 4-Spd. (327, 350) (exc. spec. perf. susp.),				
68-69	Camaro (Conv.) (350) (exc. C.A.C.),				
68-69	Camaro (Conv.) w/4-Spd. (327) (exc. C.A.C.)	<b>3955712</b>	2	15.05	(max. load 2270 lbs.)
66	El Camino w/H.D. Susp. (396)	<b>3870479</b>	2	15.80	(max. load 3208 lbs.)
66	Malibu (Sed.) (H.D. Susp. w/C.A.C.) (8 cyl.),				
66	El Camino (396)	<b>3881627</b>	2	15.80	(max. load 2859 lbs.)
66	Chevelle (S.S.) w/H.D. Susp. (1st design)	<b>3890620</b>	2	15.80	(max. load 2818 lbs.)
66	Chevelle (S.S.) w/H.D. Susp. (2nd design)	<b>3955707</b>	2	15.05	(max. load 2718 lbs.)
68	Chevy (Spt. Cpe.) w/C.A.C., 4-Spd. (327, 350) (exc. H.D. Spec. Perf. Susp.),				
68	Chevy (Sed.) (327 Sp. H/Per.) (exc. C.A.C., H.D. Susp.),				
68	Chevy (Sed.) w/4-Spd. (327) (exc. C.A.C., H.D. Susp.),				
68-69	Camaro (6 cyl.),				
68-69	Camaro (Spt. Cpe.) (327, 350) (exc. Spec. Perf. Susp.),				
68-69	Camaro (Spt. Cpe.) w/4-Spd. (327) (exc. Spec. Perf. Susp.)	<b>3955709</b>	2	15.05	(max. load 2278 lbs.)
68	Camaro (Spt. Cpe.) w/2BC (327) (exc. 4-Spd., C.A.C., spec. perf. susp.)	<b>3928304</b>	2	15.90	(max. load 2246 lbs.)

**FRAME—SPRINGS—BUMPER**

**7.412 SPRING, Front (coil) (CHEVY, CHEVELLE, CAMARO) (Con't)**

68	Camaro (Spt. Cpe.) (C.A.C. w/Sp. H/Per.) (327) (exc. 4-Spd.),						
68	Camaro (Spt. Cpe.) (396) (exc. Spec. Perf. Susp., Sp. H/Per.),						
68	Camaro (Conv.) (396) .....	<b>3955725</b>	2	15.05	(max. load 2726 lbs.)		
68	Camaro (Spt. Cpe.) (396) (exc. C.A.C.) .....	<b>3928310</b>	2	15.65	(max. load 2608 lbs.)		
68	Camaro (Spt. Cpe.) w/C.A.C., spec. perf. susp. (396) .....	<b>3955707</b>	2	15.05	(max. load 2698 lbs.)		
68	Chevy, Camaro w/Spec. Perf. Susp. (396) .....	<b>3955727</b>	2	15.05	(max. load 2548 lbs.)		
68	Chevy (Sed.) (6 cyl.) (exc. C.A.C., H.D. Susp.),						
68	Chevy (Spt. Cpe.) (6 cyl.) (exc. H.D. Susp.),						
68	Camaro (302),						
68	Camaro (Spt. Cpe.) w/H.D. Susp. (6 cyl.) .....	<b>3955720</b>	2	15.05	(max. load 2127 lbs.)		
68	Nova (Sed.) (8 cyl.) (exc. H.D. susp., 4-Spd.),						
68	Nova (Spt. Cpe.) (exc. 4-Spd., H.D. susp.),						
68	Chevy (Sed.) w/C.A.C. (8 cyl.) (exc. 327 H.D. susp., 4-Spd.),						
68	Nova (Sed.) w/C.A.C. (307) (exc. H.D. susp.),						
68	Nova (Sed.) w/C.A.C. (1st design) (exc. 327, H.D. susp., 4-Spd.) .....	<b>3935702</b>	2	15.65	(max. load 2276 lbs.)		
68	Chevy (Spt. Cpe.) (4 cyl.),						
69	Chevy .....	<b>3932767</b>	2	14.95	(max. load 1876 lbs.)		
68	Chevy (Sed.) (4 cyl.) .....	<b>3932768</b>	2	14.95	(max. load 1936 lbs.)		
68	Chevy (Spt. Cpe.) w/Sp. H/Per. (327, 350) (exc. C.A.C., H.D., spec. perf. susp.),						
68	Chevy (Spt. Cpe.) w/4-Spd. (327) .....	<b>3955709</b>	2	15.05	(max. load 2070 lbs.)		
68	Chevy (Sed.) w/C.A.C. (327) (exc. 4-Spd.),						
68	Chevy w/H.D. susp., C.A.C. (327)	<b>3955715</b>	2	15.05	(max. load 2382 lbs.)		

## 1967 CHEVELLE FRONT SPRINGS

To select the required spring, it will be necessary to know the vehicle model, body style and options. After determining the required spring code, refer to the code chart for applicable spring.

### 1967 FRONT SPRING CODE CHART

NOTE: See Dealer Price Schedule (P&A 26) for Applicable Prices.

Code Letters	Part Number	Max. Load Lbs.	Code Letters	Part Number	Max. Load Lbs.
AB-AC	3890620	2,918	GD	3895811	2,131
			GE	3895812	2,259
AI	3955722	2,231	GH-GU-GF-AH	3955714	2,309
AQ-GJ	3850967	2,577	GG	3955712	2,181
AR	3851065	2,311	GI	3866290	2,459
AZ	3850967	2,729	GM	3881627	2,859
GA	3955709	1,991	AA-GR-AJ-AW	3955725	2,501
GB	3895809	2,041	GS		3,017
GC	3895810	2,091	GT	3870479	3,117

Model	13100		13200		13300			13400				13500					13600					13800						
	11	69	11	69	11	35	69	80	11	35	69	80	17	35	39	67	69	80	17	35	39	67	69	80	17	67	35	
3 Spd., 4 Spd., or A.T.	GA	GA	GD	GD	GA	GA	GA	GC	GD	GD	GG	AH	GB	GA	GB	GA	GB	GC	GG	GG	GD	GD	GG	AH	AA	AQ		
327			GC	GD					GC	GG	GD	AH							GD	GG	GG	GG	GD	AH				
C.A.C.	GC	GC	GE	GE	GC	GD	GD	GG	GE	GH	GE	GI	GD	GD	GC	GC	GD	GG	GE	GH	GF	GF	GE	GI	GJ	GJ		
With 283																												GU
With 327			GE	GF					GE	GH	GF	GI							GF	GH	GH	GH	GF	GI				
H.D. Front & RR. Susp.	AW	AW	AA	AQ	AW	AR	AJ	AW	AA	AJ	AQ	AA	AR	AR	AJ	AI	AJ	AW	AJ	AJ	AA	AW	AQ	AA	AB	AB		
With 327			GR	AA					GR	AJ	AA	AQ							AW	AJ	AQ	AJ	AA	AQ				
With C.A.C.	AA	AA	AQ	AQ	AA	AW	AA	GR	AQ	AA	AQ	GJ	AJ	AW	GR	AW	AA	GR	GR	AA	GJ	AA	AQ	GJ	AC	AC		
With C.A.C. & 327			AQ	GJ					AQ	AQ	GJ	GJ							AA	AQ	GJ	AA	GJ	GJ				
With 396																									GS	AB	AB	
With C.A.C. & 396																									GT	AC	AC	
396																									AZ	AA	AQ	
With C.A.C.																									GM	GJ	GJ	



**FRAME—SPRINGS—BUMPER**

**1968 CHEVELLE FRONT SPRINGS**

To select the required spring, it will be necessary to know the vehicle model, body style and options.  
After determining the required spring code, refer to the code chart for applicable spring.

**1968 FRONT SPRING CODE CHART**

NOTE: See Dealer Price Schedule (P&A 26) for Applicable Prices.

CODE LETTERS	PART NUMBER	MAX. LOAD LBS.	CODE LETTERS	PART NUMBER	MAX. LOAD LBS.
CA-CI-CF	3952808	2109	CM	3923383	2553
CB	3937829	2055	CN-CS	3952820	2613
CD-CE-CH	3952811	2319	CO-CK	3952815	2283
CC	3923377	2219	CP	3926992	2383
CJ	3952813	2379	CQ-CR	3952824	2761
CL	3923382	2448	CC	3937823	2135

MODEL	13100		13200		13300				13400				13500				13600				13700 13800		13800								
	Standard		Deluxe				Deluxe				Malibu				Malibu				Concours Super Sport												
	2 Dr. Sed.	Sta. Wag.	2 Dr. Sed.	Sta. Wag.	2 Dr. Sed.	Sta. Wag.	Spt. Cpe.	4 Dr. Sed.	El Camino	2 Dr. Sed.	Sta. Wag.	Spt. Cpe.	4 Dr. Sed.	El Camino	35-45	Spt. Cpe.	Spt. Sed.	Conv.	Sed.	El Camino	35-45	Sta. Wag.	Sta. Wag.	Spt. Cpe.	Conv.	El Camino					
27	35	27	35	27	35	37	69	80	27	35	37	69	80	35-45	37	39	67	69	80	35-45	35-45	37	67	67	80						
3 Spd., 4 Spd., or A.T.	CA	CF	CB	CG	CA	CF	CA	CA	CF	CB	CH	CC	CB	CH	CF	CA	CA	CB	CA	CF	CH	CC	CC	CD	CB	CH	CF	CH	CM	CM	CN
327			CC	CH						CC	CH	CC	CC	CH							CH	CC	CC	CD	CC	CH		CH			
327 H/Per.			CF	CH						CF	CH	CG	CF	CH							CH	CG	CF	CH	CF	CH		CH			
396																													CM	CM	CN
396 Spec. H/Per.																													CM	CM	CN
C.A.C.	CB	CG	CD	CI	CB	CG	CC	CB	CH	CD	CI	CD	CJ	CH	CC	CC	CC	CB	CH	CI	CD	CD	CE	CD	CJ	CH	CI	CN	CN	CS	
With 327			CD	CJ						CD	CJ	CE	CD	CJ							CJ	CE	CE	CE	CD	CJ		CJ			
With 327 H/Per.			CH	CJ						CH	CJ	CH	CH	CJ							CJ	CH	CH	CI	CH	CJ		CJ			
With 396																													CN	CN	CS
H.D. Front & Rear Susp.	CO	CO	CK	CK	CO	CO	CO	CO	CO	CK	CK	CK	CK	CK	CO	CO	CO	CO	CO	CO	CK	CK	CK	CK	CK	CK	CO	CK	CQ	CQ	CO
With C.A.C.	CK	CK	CP	CP	CK	CK	CK	CK	CP	CP	CP	CP	CL	CL	CK	CK	CK	CK	CK	CP	CP	CP	CL	CL	CL	CL	CK	CP	CR	CR	CR
With 327			CK	CK						CK	CK	CK	CK	CP							CK	CK	CP	CP	CK	CP		CK			
With 327 & C.A.C.			CP	CL						CP	CL	CL	CL	CL							CL	CL	CM	CL	CL	CL		CL			
With 327 H/Per.			CK	CK						CK	CK	CK	CK	CK							CK	CK	CK	CK	CK	CK		CK			
With 327 H/Per. & C.A.C.			CP	CL						CP	CL	CL	CL	CL							CL	CL	CL	CL	CL	CL		CL			
With 396																													CQ	CQ	CQ
With 396 & C.A.C.																													CR	CR	CR
With 396 Spec. H/Per.																													CQ	CQ	CQ

## 1967 CAMARO—FRONT SPRINGS

To select the required spring, it will be necessary to know the vehicle model, body style and options. After determining the required spring code, refer to the code chart for applicable spring.

### 1967 FRONT SPRING CODE CHART

NOTE: See Dealer Price Schedule (P&A 26) for Applicable Prices.

Code	Part Number	Max. Load Lbs.	Code	Part Number	Max. Load Lbs.
YJ-YK	3955707	2,805	YU	3955715	2,382
YN-YR	3955709	2,243	YV	3909946	2,379
YQ	3955725	2,629	YT-YY-YX-YW	3955722	2,457
YS	3909947	2,589	YZ	3955720	2,309

Model	L-6 Engine				V-8 Engine			
	12300		12500		12400		12600	
	37	67	37	67	37	67	37	67
Body Style	37	67	37	67	37	67	37	67
Production	YZ	YN	YZ	YN	YU	YY	YU	YY
C.A.C.	YV	YY	YV	YY	YT	YT	YT	YT
With Spec. Front & RR. Susp.					YX	YQ	YX	YQ
250	YZ	YR	YZ	YR				
With C.A.C.	YN	YS	YN	YS				
Spec. Front & RR. Susp.					YW	YS	YW	YS
327					YU	YS	YU	YS
With C.A.C.					YY	YQ	YY	YQ
With PG.					YU	YU	YU	YU
With Spec. Front & RR. Susp.					YW	YW	YW	YW
With C.A.C. & Spec. Front & RR. Susp.					YX	YX	YX	YX
With PG. & Spec. Front & RR. Susp.					YW	YW	YW	YW
With PG. & C.A.C.					YY	YY	YY	YY
With PG., C.A.C. & Spec. Front & R.R. Susp.					YX	YX	YX	YX
350					YW	YS	YW	YS
With C.A.C.					YX	YQ	YX	YQ
With PG.					YU	YU	YU	YU
With Spec. Front & RR. Susp.					YW	YW	YW	YW
With C.A.C. & Spec. Front & RR. Susp.					YX	YX	YX	YX
With PG. & Spec. Front & RR. Susp.					YW	YW	YW	YW
With PG., C.A.C.					YY	YY	YY	YY
With PG., C.A.C. & Spec. Front & RR. Susp.					YX	YX	YX	YX
396					YJ	YK	YJ	YK
396 Spec. H/Per.					YJ	YK	YJ	YK

1965 PASSENGER—FRONT SPRINGS

Model	8 Cylinder Engine (Prod. - Except as Shown)															
	15400			15600				16400					16600			
Body Style	11	69	35	11	69	35	45	69	39*	37	67	35	45	37	39*	67
3 Spd., 4 Spd., or P.G.	CC	CC	CA	CC	CC	CA	CN	CC	CD	CD	CD	CA	CN	CD	CG	CC
Air Cond. (C.A.C.)	CE	CE	CD	CE	CE	CD	CP	CE	CE	CE	CG	CD	CP	CC	CJ	CF
With 327	CF	CF	CE	CF	CF	CE	CQ	CF	CF	CF	CH	CE	CQ	CD		CG
With 396	CL	CL	FA	CL	CL	FA	FA	CL	CL	CX	CX	CT	FA	FA	CY	CT
With 409	CK	CK	CS	CK	CK	CS	CS	CK	CK	CL	CL	CS	CS	FA		CS
Taxi		CK														
409 H/Per.	CQ	CQ	CR	CQ	CQ	CR	CQ	CQ	CR	CR	CR	CZ	CQ	CR		CR
396 Sp./H/Per.	CR	CR	CR	CR	CR	CR	CR	CZ	CZ	CZ	CS	CZ	CR	CR	CT	CZ
327	CC	CC	CB	CC	CC	CB	CP	CC	CC	CC	CF	CB	CP	CB		CD
396	CJ	CJ	CZ	CJ	CJ	CZ	CZ	CV	CV	CV	CV	CZ	CZ	CZ	CV	CZ
With T.H.			CS			CS						CS	CS			CS
With T.H. & C.A.C.			CT			CT						CT	CT			
409	CG	CG	CZ	CG	CG	CZ	CR	CG	CG	CG	CJ	CZ	CR	CR		CR
T.H.															CW	
Spec. Frnt. & RR. Susp.	CQ	CQ	CP	CQ	CQ	CP		CQ	CQ	CR	CQ	CP		CQ	CR	CP
With C.A.C.	CQ	CQ	CQ	CQ	CQ	CQ		CQ	CR	CS	CS	CQ		CQ	CS	CQ
With 327	CP	CP	CP	CP	CP	CP		CP	CQ	CQ	CR	CP		CP		CP
With 327 & C.A.C.	CR	CR	CR	CR	CR	CR		CS	CS	CS	CS	CR		CR		CR
With 396	CS	CS	FA	CS	CS	FA		FA	FA	FA	CT	FA			CT	
With 396 & C.A.C.	CT	CT	FB	CT	CT	FB		FB	FB	FB	FB	FB			FB	
With 396 & T.H.			CT			CT						CT				
With 409	CS	CS	CS	CS	CS	CS		CS	CS	CS	CS	CS				
With 409 & C.A.C.	CS	CS	CT	CS	CS	CT		CS	CS	CT	CT	CT				
Heavy Front Spring							CP						CP			
With C.A.C.							CR						CR			
With 327							CR						CR			
With 327 & C.A.C.							CS						CS			
With 396							FA						FA			
With 396 & C.A.C.							FB						FB			
With 396 & T.H.													CT			
With 409							CS						CS			
With 340 H.P. & C.A.C.							CT						CT			

\*NOTE: 16639 Springs represent Caprice Option on 16439 Impala Models.

## 1965 PASSENGER FRONT SPRINGS

To select the required spring, it will be necessary to know the vehicle model, body style and options. After determining the required spring code, refer to the code chart for applicable spring.

### 1965 FRONT SPRING CODE CHART

NOTE: See Dealer Price Schedule (P&A 26) for Applicable Prices.

Code	Part Number	Max. Load Lbs.	Code	Part Number	Max. Load Lbs.
CA-CB	3953902	2,459	CP-CQ-CR-CZ	3953915	2,872
CD	3864717	2,539	CS	3864722	3,022
CC-CE-CF-CG-CH	3953906	2,649	CJ-CW-CV	3954605	2,839
CK	3862973	2,870	CX-CY	3869402	2,990
CL	3972765	2,935	FA-FB-CT	3953920	3,202
CM-CN	3953911	2,622			

Model	6 Cylinder Engine														
	15300			15500				16300					16500		
	11	69	35	11	69	35	45	69	39	37	67	35	45	37	67
3 Spd., 4 Spd., or PG	CN	CN	CA	CN	CN	CA	CM	CA	CA	CB	CA	CA	CM	CA	CA
Air Cond. (C.A.C.)	CN	CN	CA	CN	CN	CA	CN	CA	CB	CB	CE	CA	CN	CA	CC
Taxi		CR													
Spec. Front & RR. Susp.	CP	CP	CN	CP	CP	CN		CP	CP	CP	CP	CN		CN	CN
with C.A.C.	CP	CP	CP	CP	CP	CP		CP	CP	CQ	CQ	CP		CP	CP
Heavy Front Spring							CN						CN		
with C.A.C.							CP						CP		

## FRAME—SPRINGS—BUMPER

### 1966 PASSENGER FRONT SPRINGS

To select the required spring, it will be necessary to know the vehicle model, body style and options. After determining the required spring code, refer to the code, chart for the applicable spring.

#### 1966 FRONT SPRING CODE CHART

NOTE: See Dealer Price Schedule (P&A 26) for Applicable Prices.

CODE COLORS BLACK PRINT ON GREEN TAPE					
CODE LETTERS	PART NUMBERS	MAX. LOAD LBS.	CODE LETTERS	PART NUMBERS	MAX. LOAD LBS.
CA-CB-FJ	3953902	2,459	CS	3864722	3,022
CC-CF-CG-CE-CH	3953906	2,649	CX-CY	3869402	2,990
CJ-CV	3954605	2,729	CQ-CZ	3953915	2,982
CL	3972765	2,935	CT-FA-FB	3953920	3,202
CM-CN	3953911	2,702	CU-FC	3953924	3,165
CP-CR	3953915	2,802	FD	3953927	3,345

6-Cylinder Engine															
Model	15300			15500				16300					16700		
Body Style	11	69	35	11	69	35	45	69	39	37	67	35	45	37	67
3-Spd., 4-Spd., or P.G. C.A.C.	CM	CM	CA	CM	CM	CA	CN	CA	CA	FH	FH	CA	CN	FH	FH
Taxi	—	CR	—	—	—	—	—	—	—	—	—	—	—	—	—
Police (H.D. Chassis)	CN	CN	CN	—	—	—	—	—	—	—	—	—	—	—	—
H.D. Suspension or H.D. Spring	CN	CN	CN	CN	CN	CN	CN	CN	CN	CN	CN	CN	CN	—	—
With C.A.C.	CP	CP	CP	CP	CP	CP	CP	CP	CQ	CP	CP	CP	CP	—	—

1966 PASSENGER—FRONT SPRINGS

Model	8 Cylinder Engine																		
	15400			15600				16400						16600				16800	
	11	35	69	11	35	45	69	35	37	39	45	67	69	35	39	45	47	37	67
Production 3 Speed, 4 Speed, or P.G.	CB	CA	CB	CB	CA	CN	CB	CA	FJ	CC	CN	FJ	CC	CA	CC	CN	FJ	FJ	FJ
Air Conditioning (C.A.C.)	CC	CC	CE	CC	CC	CP	CE	CC	CB	CF	CP	CB	CF	CC	CG	CP	CB	CB	CB
With 327	CE	CE	CF	CE	CE	CQ	CE	CE	CB	CG	CQ	CB	CF	CE	CG	CQ	CB	CB	CB
With 396	CJ	FA	CV	CJ	FA	FA	CV	CT	CF	CL	FA	CG	CL	CT	CX	FA	CG	CF	CG
With 396 and T.H.	CJ	-	CL	CJ	-	FA	CV	-	CG	CX	-	CG	CL	-	CX	-	CG	CG	CG
With 427 H/Per	CJ	FA	CJ	CJ	FA	FA	CV	-	CF	CL	FA	CG	CV	-	CL	FA	CG	CF	CG
With 427 H/Per and T.H.	CV	-	CL	CV	-	FA	CL	-	CG	CX	-	CH	CL	-	CX	-	CH	CG	CH
With T.H.	FG	CT	CX	FG	CT	FA	CX	CT	CY	CY	CT	CY	CX	CT	CY	CT	CY	-	-
Taxi	-	-	FA	-	-	-	-	-	-	-	-	-	-	-	-	-	-	-	-
Police (H.D. Chassis)	CP	CP	CQ	-	-	-	-	-	-	-	-	-	-	-	-	-	-	-	-
With 327	CP	CP	CQ	-	-	-	-	-	-	-	-	-	-	-	-	-	-	-	-
327	CB	CB	CC	CB	CB	CP	CC	CB	CA	CE	CP	CA	CC	CB	CE	CP	CA	CA	CA
396	CF	CZ	CG	CF	CZ	CZ	CG	CZ	CE	CJ	CZ	CE	CG	CZ	CJ	CZ	CE	CE	CE
427 H/Per	CG	CZ	CG	CG	CZ	CZ	CG	CZ	CC	CH	CZ	CC	CH	CZ	CJ	CZ	CC	CC	CC
427 Sp. H/Per	CN	CZ	CP	CN	CZ	CZ	CP	CZ	CP	CP	CZ	CP	CP	CZ	CP	CZ	CP	CP	CP
T.H.	CJ	CS	CJ	CJ	CS	CZ	CJ	CS	CG	CV	CS	FC	CV	CS	CG	CS	CG	-	-
With 396	CG	CS	CH	CG	CS	CZ	CH	CS	CE	CV	CS	CF	CH	CS	CJ	CS	CF	CE	CF
With 427 H/Per	CG	CS	CH	CG	CS	CZ	CJ	CS	CE	CV	CS	CE	CH	CS	CJ	CS	CE	CE	CE
H.D. Susp or H.D. Springs	CP	CP	CP	CP	CP	CP	CQ	CP	CQ	CQ	CP	CQ	CQ	-	-	-	-	-	-
With C.A.C.	CQ	CQ	CR	CQ	CQ	CR	CR	CQ	CR	CZ	CR	CZ	CZ	-	-	-	-	-	-
With 327	CP	CP	CQ	CP	CP	CR	CQ	CP	CQ	CR	CR	CQ	CQ	-	-	-	-	-	-
With 327 and C.A.C.	CR	CR	CZ	CR	CR	CS	CZ	CR	CZ	CS	CS	CZ	CZ	-	-	-	-	-	-
With 396 or 427 H/Per	CZ	FA	CS	CZ	FA	FA	CS	FA	CS	FA	FA	FA	FA	-	-	-	-	-	-
With 396 or 427 H/Per & C.A.C.	FA	FB	CT	FA	FB	FB	CT	FB	CT	FB	FB	FB	FB	-	-	-	-	-	-
With T.H.	CS	CT	FA	CS	CT	FA	FA	CT	FA	CT	CT	CT	FA	-	-	-	-	-	-
With T.H. and C.A.C.	CT	FB	FB	CT	FB	FB	FB	FB	FB	FB	FB	FB	FB	-	-	-	-	-	-
Spec. Perf. Susp. and 396	CU	FC	CU	CU	FC	FC	CU	FC	CU	CU	FC	CU	CU	FC	CU	FC	CU	CU	CU
With T.H.	CU	FC	CU	CU	FC	FD	CU	FC	CU	CU	FD	FC	CU	FC	CU	FD	FC	CU	CU
With C.A.C.	FC	FD	FC	FC	FD	FD	FC	FD	FC	FC	FD	FC	FC	FD	FC	FD	FC	FC	FC
With T.H. and C.A.C.	FC	FD	FC	FC	FD	FD	FC	FD	FC	FC	FD	FC	FC	FD	FC	FD	FC	FC	FC
Spec. Perf. Susp. and 427	CU	FC	CU	CU	FC	FC	CU	FC	CU	CU	FC	CU	CU	FC	CU	FC	CU	CU	CU
With T.H.	CU	FC	CU	CU	FC	FD	CU	FC	CU	CU	FD	FC	CU	FC	CU	FD	FC	CU	CU
With C.A.C.	FC	FD	FC	FC	FD	FD	FC	FD	FC	FC	FD	FC	FC	FD	FC	FD	FC	FC	FC
With T.H. and C.A.C.	FC	FD	FC	FC	FD	FD	FC	FD	FC	FC	FD	FC	FC	FD	FC	FD	FC	FC	FC

## 1967 PASSENGER—FRONT SPRINGS

To select the required spring, it will be necessary to know the vehicle model, body style and options. After determining the required spring code, refer to the code chart for applicable spring.

### 1967 FRONT SPRING CODE CHART

NOTE: See Dealer Price Schedule (P&A 26) for Applicable Prices.

Code Letters	Part Numbers	Max. Load Lbs.
CA-CB-FJ	3953902	2,459
CC-CF-CG-CH-CE	3953906	2,689
CJ	3954605	2,729
CL	3972765	2,935
CM-CN	3953911	2,622
CS	3864722	3,022
CV	3954605	2,789
CX	3869402	2,990
CP-CQ-CZ-CR	3953915	2,982
CT-FA	3953920	3,082
CU-FC	3953924	3,165
FD	3953927	3,345

Model	L-6 ENGINE														
	15300			15500				16300					16700		
Body Style	11	35	69	11	35	45	69	35	39	45	67	69	87	67	87
Prod. 3-Spd., 4-Spd. P.G.	CM	CA	CM	CM	CA	CM	CM	CA	CB	CM	FJ	CA	FJ	FJ	FJ
C.A.C.	CN	CB	CN	CN	CB	CN	CN	CB	CE	CN	CA	CC	CA	CA	CA
H.D. Frnt. 6 R.R. Susp.	CM	CM	CM	CM	CM	—	CM	CM	CN	CN	CM	CM	CM	CM	CM
With C.A.C.	CN	CN	CN	CN	CN	—	CN	CN	CP	—	CN	CN	CN	CN	CN
With H.D. Chassis	CM	CM	CM	—	—	—	—	—	—	—	—	—	—	—	—
With Taxi	—	—	CN	—	—	—	—	—	—	—	—	—	—	—	—

1967 PASSENGER—FRONT SPRINGS

Model	8 Cylinder Engine																		
	15400			15600				16400					16600				16800		
	11	35	69	11	35	45	69	35	39	45	67	69	87	35	39	45	47	67	87
Prod. 3-Spd., 4-Spd. & P.G.	CA	CN	CB	CA	CN	CN	CB	CN	CC	CN	CA	CC	CA	CN	CC	CN	CA	CA	CA
C.A.C.	CC	CP	CE	CC	CP	CP	CE	CP	CG	CP	CB	CF	CB	CP	CG	CP	CB	CB	CB
With 327	CC	CP	CF	CC	CP	CQ	CF	CP	CG	CQ	CB	CF	CB	CP	CG	CQ	CB	CB	CB
With 396	CJ	FA	CV	CJ	FA	CS	CV	CT	CX	CS	CH	CX	CH	CT	CX	CS	CH	CH	CH
With 396 & T.H.	CJ	CT	CL	CJ	CT	FA	CL	CT	CX	FA	CJ	CX	CH	CT	CX	FA	CH	CJ	CH
With 427	CJ	FA	CV	CJ	FA	CS	CL	FA	CL	CS	CH	CL	CH	FA	CL	CS	CH	CH	CH
With 427 & T.H.	CV	CT	CL	CV	CT	FA	CL	CT	CX	FA	CJ	CL	CJ	CT	CX	FA	CJ	CJ	CJ
327	CB	CB	CC	CB	CB	CN	CC	CB	CE	CN	CA	CC	CA	CB	CE	CN	CA	CA	CA
With T.H.	-	-	-	-	-	-	-	-	-	-	-	-	-	CP	CG	CP	CB	CB	CB
With T.H. & C.A.C.	-	-	-	-	-	-	-	-	-	-	-	-	-	CP	CJ	CQ	CE	CE	CE
396	CF	CZ	CH	CF	CZ	CR	CH	CZ	CV	CR	CE	CH	CE	CZ	CV	CR	CE	CE	CE
With T.H.	CG	CS	CJ	CG	CS	CZ	CJ	CS	CV	CZ	CF	CJ	CF	CS	CV	CZ	CF	CF	CF
427	CG	CZ	CG	CG	CZ	CR	CG	CZ	CJ	CR	CF	CJ	CE	CZ	CJ	CR	CE	CF	CE
With T.H.	CH	CZ	CH	CH	CZ	CR	CJ	CZ	CJ	CR	CF	CJ	CF	CZ	CJ	CR	CF	CF	CF
With S.S. 427	-	-	-	-	-	-	-	-	-	-	-	-	-	-	-	-	-	CQ	CQ
With S.S. 427 & T.H.	-	-	-	-	-	-	-	-	-	-	-	-	-	-	-	-	-	CR	CR
With S.S. 427 & C.A.C.	-	-	-	-	-	-	-	-	-	-	-	-	-	-	-	-	-	CZ	CZ
With S.S. 427, T.H. & C.A.C.	-	-	-	-	-	-	-	-	-	-	-	-	-	-	-	-	-	CS	CS
H.D. Frnt. & Rr. Susp.	CN	-	CN	CN	-	-	CP	-	CP	-	CP	CP	CP	-	-	-	-	CP	CP
With C.A.C.	CP	-	CQ	CP	-	-	CQ	-	CR	-	CR	CR	CR	-	-	-	-	CR	CR
With 327	CN	-	CP	CN	-	-	CP	-	CP	-	CP	CP	CP	-	-	-	-	CP	CP
With 327 & C.A.C.	CP	-	CR	CP	-	-	CR	-	CR	-	CR	CR	CR	-	-	-	-	CR	CR
With 327 & T.H.	-	-	-	-	-	-	-	-	-	-	-	-	-	-	-	-	-	CQ	CP
With 327, T.H. & C.A.C.	-	-	-	-	-	-	-	-	-	-	-	-	-	-	-	-	-	CZ	CR
With 396	CR	-	CZ	CR	-	-	CZ	-	CS	-	CS	CS	CS	-	-	-	-	CS	CS
With 396 & C.A.C.	CS	-	CT	CS	-	-	CT	-	CT	-	CT	CT	CT	-	-	-	-	CT	CT
With 396 & T.H.	CR	-	CS	CR	-	-	CS	-	FA	-	FA	CS	FA	-	-	-	-	FA	FA
With 396, T.H. & C.A.C.	FA	-	CT	FA	-	-	CT	-	CT	-	CT	CT	CT	-	-	-	-	CT	CT
With 427	CR	-	CZ	CR	-	-	CZ	-	CS	-	CS	CS	CS	-	-	-	-	CS	CS
With 427 & C.A.C.	CS	-	FA	CS	-	-	FA	-	CT	-	CT	CT	CT	-	-	-	-	CT	CT
With 427 & T.H.	CR	-	CS	CR	-	-	CS	-	FA	-	CS	CS	CS	-	-	-	-	CS	CS
With 427, T.H. & C.A.C.	FA	-	CT	FA	-	-	CT	-	CT	-	CT	CT	CT	-	-	-	-	CT	CT
With H.D. Chassis	CN	-	CN	-	-	-	-	-	-	-	-	-	-	-	-	-	-	-	-
With H.D. Chassis & 327	CN	-	CP	-	-	-	-	-	-	-	-	-	-	-	-	-	-	-	-
With Taxi	-	-	CP	-	-	-	-	-	-	-	-	-	-	-	-	-	-	-	-
Spec. Frnt. & Rr. Susp., 396, 427	CU	FC	CU	CU	FC	FC	CU	FC	CU	CU	FC	CU	CU	FC	CU	FC	CU	CU	CU
With T.H.	CU	FC	CU	CU	FC	FD	CU	FC	FC	CU	FD	FC	CU	FC	FC	FD	FC	CU	CU
With C.A.C.	FC	FD	FC	FC	FD	FD	FC	FD	FC	FC	FD	FC	FC	FD	FC	FD	FC	FC	FC
With T.H., C.A.C.	FC	FD	FC	FC	FD	FD	FC	FD	FC	FC	FD	FC	FC	FD	FC	FD	FC	FC	FC
With S.S. 427	-	-	-	-	-	-	-	-	-	-	-	-	-	-	-	-	-	CU	CU
With T.H. & S.S. 427	-	-	-	-	-	-	-	-	-	-	-	-	-	-	-	-	-	CU	CU
With C.A.C. & S.S. 427	-	-	-	-	-	-	-	-	-	-	-	-	-	-	-	-	-	FC	FC
With T.H., C.A.C. & S.S. 427	-	-	-	-	-	-	-	-	-	-	-	-	-	-	-	-	-	FC	FC



**FRAME—SPRINGS—BUMPER**

**1968 PASSENGER FRONT SPRINGS**

To select the required spring, it will be necessary to know the vehicle model, body style and options. After determining the required spring code, refer to the code chart for the applicable spring.

**1968 FRONT SPRING CODE CHART**

NOTE: See Dealer Price Schedule (P&A 26) for Applicable Prices.

CODE LETTERS	PART NUMBERS	MAX. LOAD LBS.	CODE LETTERS	PART NUMBERS	MAX. LOAD LBS.
CA-CB-FJ	3953902	2,459	CS	3864722	3,022
CC-CF-CG-CH-CE	3953906	2,689	CX	3869402	2,990
CJ-CV	3954605	2,729	CT-FA	3953920	3,082
CL	3972765	2,935	CU-FC	3953924	3,165
CM-CN	3953911	2,622	FD	3953927	3,345
CP-CQ-CR-CZ	3953915	2,872			

Model	L-6 ENGINE										
	15300			15500				16300			
	11	35	69	11	35	45	69	39	47	69	87
Body Style											
Prod. 3-Spd., 4-Spd. P.G.	CM	CM	CM	CM	CM	CM	CM	CB	FJ	CA	FJ
C.A.C.	CN	CN	CN	CN	CN	CN	CN	CE	CA	CC	CA
H.D. Front & R.R. Susp.	CM	-	CM	CM	-	-	CM	CN	CM	CM	CM
With C.A.C.	CM	-	CM	CM	-	-	CM	CP	CN	CN	CN
With H.D. Chassis	FC	FC	FC	FC	FC	-	FC	-	-	-	-
With Taxi	-	-	CN	-	-	-	-	-	-	-	-

**FRAME—SPRINGS—BUMPER**

**1968 PASSENGER—FRONT SPRINGS**

Model	8 Cylinder Engine																	
	15400			15600				16400					16600					
	11	35	69	11	35	45	69	35	39	45	47	67	69	87	35	39	45	47
Prod. 3-Spd., 4-Spd. & P.G. C.A.C.	CA	CN	CB	CA	CN	CN	CB	CN	CC	CN	CA	CA	CC	CA	CN	CC	CN	CA
With 327	CC	CP	CE	CC	CP	CP	CE	CP	CG	CP	CB	CB	CF	CB	CP	CG	CP	CB
With 396	CC	CP	CF	CC	CP	CQ	CF	CP	CG	CQ	CB	CB	CF	CB	CP	CG	CQ	CB
With 396 & T.H.	CJ	FA	CV	CJ	FA	CS	CV	CT	CX	CS	CJ	CJ	CX	CJ	CT	CX	FA	CJ
With 427	CJ	CT	CL	CJ	CT	FA	CL	CT	CX	FA	CJ	CJ	CX	CJ	CT	CX	FA	CJ
With 427 & T.H.	CJ	FA	CV	CJ	FA	CS	CL	FA	CL	CS	CJ	CJ	CL	CJ	FA	CL	CS	CJ
327	CV	CT	CL	CV	CT	FA	CL	CT	CX	FA	CJ	CJ	CL	CJ	CT	CX	FA	CJ
With T.H.	CA	CN	CC	CA	CN	CN	CC	CN	CE	CN	CB	CB	CE	CB	CN	CE	CN	CB
With T.H. & C.A.C.	CC	CP	CE	CC	CP	CP	CE	CP	CE	CP	CC	CC	CE	CC	CP	CE	CP	CC
396	CF	CR	CG	CF	CR	CQ	CG	CR	CG	CQ	CF	CF	CG	CF	CR	CG	CQ	CF
With T.H.	CF	CZ	CH	CF	CZ	CR	CH	CZ	CV	CR	CG	CG	CH	CG	CZ	CV	CR	CE
427	CG	CS	CJ	CG	CS	CZ	CJ	CS	CV	CZ	CF	CF	CS	CF	CS	CV	CZ	CF
With T.H.	CG	CZ	CG	CG	CZ	CR	CG	CZ	CJ	CR	CF	CG	CJ	CF	CZ	CJ	CR	CE
With S.S. 427	CH	CZ	CH	CH	CZ	CR	CJ	CZ	CJ	CR	CG	CG	CJ	CG	CZ	CJ	CR	CF
With S.S. 427 & T.H.	-	-	-	-	-	-	-	-	-	-	CQ	CR	-	CQ	-	-	-	-
With S.S. 427 & C.A.C.	-	-	-	-	-	-	-	-	-	-	CR	CR	-	CR	-	-	-	-
With S.S. 427, T.H. & C.A.C.	-	-	-	-	-	-	-	-	-	-	CS	CS	-	CS	-	-	-	-
H.D. Frnt. & Rr. Susp.	CN	-	CN	CN	-	-	CP	-	CP	-	CP	CP	CP	CP	-	CP	-	CP
With C.A.C.	CP	-	CQ	CP	-	-	CQ	-	CR	-	CR	CR	CR	CR	-	CR	-	CR
With 327	CN	-	CP	CN	-	-	CP	-	CP	-	CP	CP	CP	CP	-	CP	-	CP
With 327 & C.A.C.	CP	-	CR	CP	-	-	CR	-	CR	-	CR	CR	CR	CR	-	CR	-	CR
With 327 & T.H.	CN	-	CP	CN	-	-	CP	-	CQ	-	CP	CQ	CP	CP	-	CQ	-	CQ
With 327, T.H. & C.A.C.	CP	-	CR	CP	-	-	CR	-	CZ	-	CR	CZ	CR	CR	-	CZ	-	CZ
With 396	CR	-	CZ	CR	-	-	CZ	-	CS	-	CS	CS	CS	CS	-	FA	-	CS
With 396 & C.A.C.	CS	-	CT	CS	-	-	CT	-	CT	-	CT	CT	CT	CT	-	CT	-	CT
With 396 & T.H.	CR	-	CS	CR	-	-	CS	-	FA	-	CS	CS	CS	CS	-	FA	-	CS
With 396, T.H. & C.A.C.	FA	-	CT	FA	-	-	CT	-	CT	-	CT	CT	CT	CT	-	CT	-	CT
With 427	CR	-	CZ	CR	-	-	CZ	-	CS	-	CS	CS	CS	CS	-	FA	-	CS
With 427 & C.A.C.	CS	-	FA	CS	-	-	FA	-	CT	-	CT	CT	CT	CT	-	CT	-	CT
With 427 & T.H.	CR	-	CS	CR	-	-	CS	-	FA	-	CS	CS	CS	CS	-	FA	-	CS
With 427, T.H. & C.A.C.	FA	-	CT	FA	-	-	CT	-	CT	-	CT	CT	CT	CT	-	CT	-	CT
With H.D. Chassis	CN	CN	CN	-	-	-	-	-	-	-	-	-	-	-	-	-	-	-
With H.D. Chassis & 327	CP	CP	CP	-	-	-	-	-	-	-	-	-	-	-	-	-	-	-
With Taxi	-	-	CP	-	-	-	-	-	-	-	-	-	-	-	-	-	-	-
Police	CU	CU	CU	CU	CU	CU	FC	-	-	-	-	-	-	-	-	-	-	-
Spec. Frnt. & Rr. Susp., 396, 427	CU	FC	CU	CU	FC	FC	CU	FC	CU	FC	CU	CU	CU	CU	FC	CU	FC	CU
With T.H.	CU	FC	CU	CU	FC	FD	CU	FC	CU	FD	CU	CU	CU	CU	FC	CU	FD	CU
With C.A.C.	FC	FD	FC	FC	FD	FC	FD	FD	FC	FD	FC	FC	FC	FC	FD	FC	FD	FC
With T.H., C.A.C.	FC	FD	FC	FC	FD	FD	FC	FD	FC	FD	FC	FC	FC	FC	FD	FC	FD	FC
With S.S. 427	-	-	-	-	-	-	-	-	-	-	CQ	CR	-	CQ	-	-	-	-
With T.H. & S.S. 427	-	-	-	-	-	-	-	-	-	-	CR	CR	-	CR	-	-	-	-
With C.A.C. & S.S. 427	-	-	-	-	-	-	-	-	-	-	CZ	CZ	-	CZ	-	-	-	-
With T.H., C.A.C. & S.S. 427	-	-	-	-	-	-	-	-	-	-	CS	CS	-	CS	-	-	-	-

**1969 FRONT SPRINGS**

NOTE: All 1969 Coil Spring usage can be found in Group 7.503.

SEE DEALER PRICE SCHEDULE (P&A 26) FOR APPLICABLE PRICES.

**FRAME—SPRINGS—BUMPER**

**7.418 SEAT— BOLT— SEAL, Front Spring**

62-67	Chevy	3790573	2	1.10	upper
62-67	Chevy	3892794	2	9.10	SEAT ASSY., lower
62-67	Chevy	3790739	4	.15	BOLT, seat assy. (3/8" — 24 x 1 1/8")
62-66	Chevy	767726	4	.15	SEAL, seat pivot (1 11/32" O.D. x 11/32" thk.)

**7.425 SPACER, Front Spring**

65-68	Pass.	3789664	A.R.	2.80	to correct trim front and rear (3/8" thk.) (plastic)
70	Monte Carlo	400360	A.R.	1.30	

**7.447 CLEANER— ADAPTER— FITTING ASSY.— TEE ASSY.— TUBE ASSY.—  
TEE AND TUBE ASSY.— WASHER, Air Suspension Level Control**

67-70	Pass.,				
70-72	Monte Carlo	5353826	1	1.50	rr. shock absorber air comp.
65-66	Pass. (level control, w/C.A.C.),				
65	Chevelle w/level control,				
67	Pass. (6 cyl.) (vacuum door locks, w/level control) (exc. C.A.C., P.B.)	3871227	1	2.10	ADAPTER, inlet manifold to air compressor— (3.778)
67-69	Chevelle w/vac. P.B. (exc. cruise cont.),				
68-70	Pass.,				
71	All (P.B. w/A.T.) (8 cyl.),				
72	Camaro (Sp. H/Per. 350 w/T.H. 400)	3905378	1	1.35	FITTING ASSY., vacuum inlet manifold— (3.278)
67-70	Pass. (8 cyl.) (P.B., w/C.A.C. Cruise cont.) (exc. vacuum door locks),				
67-70	Pass. (8 cyl.) (vacuum door locks, w/P.B., A.T., C.A.C.) (exc. cruise cont.),				
68-70	Chevelle w/P.B., C.A.C.,				
68-70	Camaro w/P.G., C.A.C., P.B.,				
68-70	Pass. (8 cyl.) (retr. hdlp. cvrs. w/cruise cont.)	3905376	1	1.75	FITTING ASSY., vacuum inlet manifold
70-71	Camaro (R.S.)	3952329	1	1.65	FITTING ASSY., inl. manifold vac.— (3.278)
72	Pass., Chevelle (8 cyl.)	336016	1	1.30	FITTING ASSY., vac. inlet
67-69	Chevy, Camaro,				
65	Pass. (level control, w/Air Cond.) (exc. P.G., P.B.),				
65-67	Pass. (level control w/P.G.) (exc. Air Cond., P.B.)				TEE ASSY., inlet manifold,
65-66	Chevelle w/Air Cond. (exc. P.G., P.B.),				
65-66	Chevelle w/P.G. (exc. Air Cond. P.B.),				
64-72	All	336015	1	.80	special (1/8" — 18) two— (3.278)
65-67	Pass. w/level control (Air Cond. w/A.T.) (exc. P.B.),				
65	Chevelle (Air Cond. w/P.G.) (exc. P.B.),				
67-69	Pass. (vac. dr. lok w/Cruise Control, C.A.C.) (8 cyl.) (exc. P.B.),				
69	Camaro (R.S.) (C.A.C., w/P.G., T.H. 400) (exc. P.B.),				
68-70	Pass. w/C.A.C., Cruise Control (exc. P.B.)	3894339	1	3.85	TEE ASSY., inlet manifold (3/8" — 18)
65-72	All	336013	1	1.05	TEE ASSY (3/8" — 18 pipe thd. 1 1/4" hose take off)— (3.278)
71	Pass. (Sta. Wag.)	488188	L.H.	3.05	TUBE ASSY.
65-66	El Camino	3827499	A.R.	.11	WASHER (13.346)

**7.452 BRACKET ASSY.— ADAPTER— BOLT— MOUNT, Air Suspension or Level  
Control Air Compressor**

70-72	Monte Carlo w/level control	3982134	1	1.95	rear shock compressor rear
70-72	Monte Carlo w/level control	3982132	1	1.75	rear shock compressor front
67-70	Pass. w/level control,				
70-72	Monte Carlo	5345623	1	.58	ADAPTER, air compressor mounting
65-70	Pass., Chevelle,				
71-72	Monte Carlo	3162743	3	.34	BOLT, rear shock compressor reserv. retainer
65-70	Pass., Chevelle w/level control,				

**FRAME—SPRINGS—BUMPER**

**7.452 BRACKET ASSY.— ADAPTER— BOLT— MOUNT, Air Suspension or Level Control Air Compressor (Con't)**

71-72 Monte Carlo ..... 5345624 3 1.40 MOUNT, flexible (air compressor) .....

**7.455 COMPRESSOR ASSY.— HOUSING— PISTON ASSY.— SCREW, Air Suspension Air Compressor**

65 Chevelle,  
 65-70 Pass. w/level control ..... 5357969 1 73.50 w/air booster .....

70-72 Monte Carlo w/level control .... 4950174 1 70.50 rear air shock .....

67-70 Pass. w/level control,  
 70-72 Monte Carlo ..... 5345808 1 26.75 HOUSING, rr. shock abs. air compr. (1st Stage) .....

67-70 Pass. w/level control,  
 70-72 Monte Carlo ..... 5345809 1 29.75 HOUSING, rr. shock abs. air compr. (2nd Stage) .....

67-70 Pass. w/level control,  
 70-72 Monte Carlo ..... 5345886 1 40.25 PISTON ASSY., rr. shock abs. air compr. ...

69 Pass. .... 3166753 3 .22 SCREW (10-32 x 1½") compressor ventilator .....

**7.457 GASKET— O RING— REPAIR UNIT— SEAL UNIT, Air Suspension Air Compressor Level Control**

65 Chevelle,  
 65-70 Pass. w/level control,  
 70-72 Monte Carlo ..... 5345989 1 .80 (air compressor cover) .....

65 Chevelle,  
 65-70 Pass. w/level control ..... 5549030 2 .29 "O" RING, adapter assy. (air compressor)— (7.476) .....

65 Chevelle,  
 65-70 Pass.,  
 70-72 Monte Carlo ..... 3166752 1 .22 "O" RING, regulator to compressor .....

67-70 Pass. w/level control,  
 70-72 Monte Carlo ..... 5345759 1 3.20 "O" RING, rr. shock abs. resvr. to compressor .....

65 Chevelle,  
 65-70 Pass.,  
 70-72 Monte Carlo ..... 5354587 1 10.90 REPAIR UNIT, air compressor .....

65 Chevelle,  
 65-70 Pass.,  
 70-72 Monte Carlo ..... 3188819 1 5.35 SEAL UNIT (air compressor) .....

67-70 Pass. w/level control,  
 70-71 Monte Carlo ..... 5353828 1 5.05 SEAL UNIT, w/gasket (air compr.) .....

**7.460 ARM UNIT— DIAPHRAGM UNIT— REGULATOR UNIT— ROCKER ARM— SEAL & GASKET UNIT— VALVE UNIT, Air Suspension, Air Compressor**

65 Chevelle,  
 65-70 Pass. w/Level Control,  
 70-72 Monte Carlo ..... 5355549 1 13.90 distributor .....

65 Chevelle,  
 65-70 Pass. w/Level Control,  
 70-72 Monte Carlo ..... 3188818 1 7.20 DIAPHRAGM UNIT (use w/5357969) ....

65 Chevelle,  
 65-70 Pass. w/Level Control,  
 70-72 Monte Carlo ..... 3188822 1 24.80 REGULATOR UNIT .....

65 Chevelle,  
 65-70 Pass. w/Level Control,  
 70-72 Monte Carlo ..... 3188816 1 5.15 ROCKER ARM, w/swivel (use 5357969) ..

72 Monte Carlo ..... 5353828 1 5.05 SEAL & GASKET UNIT .....

65 Chevelle,  
 65-70 Pass. w/Level Control,  
 70-72 Monte Carlo ..... 3188817 1 10.05 VALVE UNIT (air compressor distributor) ..

65 Chevelle,  
 65-70 Pass. w/Level Control,  
 70-72 Monte Carlo ..... 5355548 1 6.95 VALVE UNIT, distributor .....

**7.465 ADAPTER ASSY.— HOSE ASSY., Air Suspension Pressure, or Level Control**

65 Chevelle,  
 65-70 Pass. w/Level Control,  
 70-72 Monte Carlo ..... 3187089 1 1.85 reservoir fill valve .....

65 Chevelle,  
 65-70 Pass. w/Level Control,  
 70-72 Monte Carlo ..... 3178898 1 1.20 outlet .....

69-70 Pass. w/Level Control ..... 3954618 1 4.65 HOSE ASSY., air inlet .....

**FRAME—SPRINGS—BUMPER**

**7.475 VALVE ASSY., Air Suspension Leveling or Level Control**

67-70 Pass. w/Level Control ..... 5549219 1 52.00 level control .....

**7.476 O RING, Air Suspension Leveling Valve**

65 Chevelle w/level control,

65-70 Pass. w/level control,

70-72 Monte Carlo ..... 5549030 1 .29 adapter assy. (air compressor) .....

**7.482 SEAL, Air Suspension Leveling Valve Junction**

65-70 Pass., Chevelle,

71 El Camino, Pass.,

72 El Camino ..... 3750232 A.R. .11 block to frt. and rear leveling valve exhaust pipe, to frt. and rear valve inlet pipe and rear crossover pipe ring (<sup>15</sup>/<sub>64</sub>" I.D. x <sup>21</sup>/<sub>64</sub>" O.D. x <sup>3</sup>/<sub>64</sub>" thk.) .....

**7.495 INSERT, Spring Leaf**

68 Chevy w/4-Spd. (327, 350) (exc. close ratio),

68 Camaro w/4/BC, 4-Spd. (exc.

H.D. susp., close ratio) ..... 3935737 A.R. .16 spring leaf .....

**7.503 SPRING ASSEMBLY, Rear**

*NOTE: This group includes Spring Charts (front and rear) for years 1969-72.*

**COIL TYPE**

67-68 Police ..... 3913410 2 17.60 (1415 lbs.) (Note 1, 2) .....

73-74 Nova ..... 332720 .24 rear susp. spring tip .....

*NOTE 1 Springs may be identified by the color of paint noted in the description or by a piece of tape attached to the spring listing the part number.*

*NOTE 2 Part number taped on spring.*

## 1965 PASSENGER—REAR SPRINGS

To select the required spring, it will be necessary to know the vehicle model, body style and options. After determining the required spring code, refer to the code chart for applicable spring.  
1965 REAR SPRING CODE CHART

Code	Part Number	Max. Load Lbs.	Code	Part Number	Max. Load Lbs.
DC-DE-DD	3862984	2,097	DN	3882968	2,683
DG-DH	3862987	2,103	DO	3879408	2,242
DJ-DZ	3876950	2,263	DV	3882961	2,313
DL-DM	3884498	2,503	DX	3864732	3,043
			DS-DY	3864733	3,635

6 Cylinder Engine															
Model	15300			15500				16300					16500		
Body Style	11	69	35	11	69	35	45	69	39	37	67	35	45	37	67
3 Spd., 4 Spd., or P.G. Air Condition (C.A.C.)	DH	DH	DX	DH	DH	DX	DY	DD	DE	DD	DD	DX	DY	DD	DD
Taxi	DG	DG	DX	DG	DG	DX	DY	DD	DD	DD	DD	DX	DY	DD	DD
Spec. Front & RR. Susp with C.A.C.	DL	DM	DS	DL	DM	DS		DM	DN	DL	DL	DS		DZ	DZ
	DL	DL	DS	DL	DL	DS		DM	DM	DL	DL	DS		DZ	DZ

8 Cylinder Engine (Prod. - Except as Shown)																
Model	15400			15600				16400					16600			
Body Style	11	69	35	11	69	35	45	69	39*	37	67	35	45	37	39*	67
3 Spd., 4 Spd., or P.G. Air Condition (C.A.C.)	DD	DV	DX	DD	DV	DX	DY	DV	DV	DE	DD	DX	DY	DV	DD	DE
Taxi	DC	DE	DX	DC	DE	DX	DY	DE	DE	DD	DD	DX	DY	DE		DE
327	DC	DV	DX	DC	DV	DX	DY	DV	DV	DD	DD	DX	DY	DE		DE
409 H/Per or 396 Sp/H/Per	DZ	DJ	DS	DZ	DJ	DS	DY	DJ	DJ	DZ	DJ	DS	DY	DZ	DM	DZ
396	DD	DE	DX	DD	DE	DX	DY	DV	DV	DE	DE	DX	DY	DZ		DZ
With C.A.C.	DE	DE	DX	DE	DE	DX	DY	DV	DV	DE	DE		DY	DZ		DZ
409	DC	DE	DX	DC	DE	DX	DY	DE	DV	DE	DE	DX	DY	DZ		DZ
With C.A.C.	DC	DE	DX	DC	DE	DX	DY	DE	DV	DE	DE		DY	DZ		DZ
Spec. Front & RR. Susp.	DM	DN	DS	DM	DN	DS		DN	DN	DM	DM	DS		DZ	DN	DZ
With C.A.C.	DL	DM	DS	DL	DM	DS		DM	DM	DL	DM	DS		DZ		DZ
With 327	DL	DM	DS	DL	DM	DS		DM	DM	DL	DM	DS		DZ		DZ
With 396	DN	DN	DY	DN	DN	DY		DN	DN	DN	DN	DY				
With 409	DL	DM	DS	DL	DM	DS		DM	DN	DL	DM	DS				

\*NOTE: 16639 Springs represent Caprice Option on 16439 Impala models.

## 1966 PASSENGER—REAR SPRINGS

To select the required spring, it will be necessary to know the vehicle model, body style and options. After determining the required spring code, refer to the code chart for the applicable spring.

1966 REAR SPRING CODE CHART

Code Colors		
Black Print On Orange Tape		
Code Letters	Part Numbers	Max. Load Lbs.
DL	3884498	2,503
DX	3864732	3,043
DS-DY	3864733	3,635
JB	3886431	2,243
JC	3882961	2,162
DA-DB-JE	3862984	2,032
JF	3879408	2,242
JK	3882968	2,723
JP	3879784	2,604

Model	6-Cylinder Engine														
	15300			15500				16300				16700			
Body Style	11	69	35	11	69	35	45	69	39	37	67	35	45	37	67
3-Spd., 4-Spd., or P.G.	JB	JB	DX	JB	JB	DX	DY	JF	JF	DA	DA	DX	DY	DA	DA
Taxi	—	JK	—	—	—	—	—	—	—	—	—	—	—	—	—
Police (H.D. Chassis)	DL	DL	DS	—	—	—	—	—	—	—	—	—	—	—	—
H.D. Suspension	DL	DL	DS	DL	JK	DS	—	JK	JK	JK	JK	DS	—	—	—
With C.A.C.	DL	DL	DS	DL	JK	DS	—	JK	JK	DL	JK	DS	—	—	—
C.A.C.	JB	JB	DX	JB	JB	DX	DY	JF	JF	DA	DB	DX	DY	DA	DB

1966 PASSENGER—REAR SPRINGS

Model	8 Cylinder Engine																		
	15400			15600				16400						16600				16800	
Body Style	11	35	69	11	35	45	69	35	37	39	45	67	69	35	39	45	47	37	67
3-Spd., 4-Spd., or P.G.	JE	DX	JC	JE	DX	DY	JC	DX	DA	JE	DY	DB	JF	DX	JF	DY	DB	DA	DB
Taxi	-	-	JK	-	-	-	-	-	-	-	-	-	-	-	-	-	-	-	-
Police (H.D. Chassis) With 327	DL	DS	DL	-	-	-	-	-	-	-	-	-	-	-	-	-	-	-	-
327	JE	DX	JC	JE	DX	DY	JC	DX	DB	JF	DY	DB	JC	DX	JF	DY	DB	DB	DB
396 With C.A.C. With T.H.	JE	DX	JC	JE	DX	DY	JC	DX	DB	JF	DY	DB	JC	DX	JF	DY	DB	DB	DB
427 H/Per. With C.A.C. With T.H.	JC	DX	JC	JC	DX	DY	JC	DX	DB	JF	DY	DB	JF	DX	JF	DY	DB	DB	DB
427 Sp./H/Per	DL	DS	DL	DL	DS	DY	DL	DS	DL	DL	DY	DL	DL	DS	DL	DY	DL	-	-
H.D. Suspension With C.A.C. With 327 With 396 With 427 H/Per With T.H. and 396 With T.H. and 427 H/Per With C.A.C. and 427 H/Per With C.A.C., T.H., & 427 H/Per With C.A.C. and 396 With C.A.C. and 327 With C.A.C., T.H. and 396	DL	DS	DL	DL	DS	-	JK	DS	JK	JK	-	JK	JK	-	-	-	-	-	-
C.A.C. With 327 With T.H. and 396 With T.H. and 427 H/Per	JE	DX	JC	JE	DX	DY	JC	DX	DB	JF	DY	DB	JF	DX	JF	DY	DB	DB	DB
Spec. Perf. Susp. and 396, 427 With T.H. With C.A.C. With T.H. and C.A.C.	JP	DS	JP	JP	DS	DY	JP	DS	JP	JP	DY	JP	JP	DS	JP	DY	JP	-	-



## 1967 PASSENGER—REAR SPRINGS

To select the required spring, it will be necessary to know the vehicle model, body style and options. After determining the required spring code, refer to the code chart for applicable spring.

1967 REAR SPRING CODE CHART

Code Letters	Part Numbers	Max. Load Lbs.
DA-DB-JE	3862984	2,032
DY	3864733	3,635
JC	3882961	2,162
DL-JM-JO	3884498	2,503
JP	3879784	2,604
JK-JL	3882968	2,723
JF-JD	3879408	2,242
JB	3886431	2,243

Model	L-6 ENGINE														
	15300			15500				16300				16700			
Body Style	11	35	69	11	35	45	69	35	39	45	67	69	87	67	87
Prod. 3-Spd., 4-Spd. P.G.	JB	DY	JB	JB	DY	DY	JB	DY	JD	DY	JE	JF	JE	JE	JE
C.A.C.	JB	DY	JB	JB	DY	DY	JB	DY	JD	DY	JE	JF	JE	JE	JE
H.D. Frnt. & Rr. Susp.	JK	—	JK	JK	—	—	JK	—	JL	—	JM	JK	JM	JM	JM
With C.A.C.	JK	—	JK	JK	—	—	JK	—	JL	—	JM	JK	JM	JM	JM
With H.D. Chassis	JK	DY	JK	—	—	—	—	—	—	—	—	—	—	—	—
With Taxi	—	—	JL	—	—	—	—	—	—	—	—	—	—	—	—

1967 PASSENGER—REAR SPRINGS

Model	8 Cylinder Engine.																		
	15400			15600				16400					16600				16800		
Body Style	11	35	69	11	35	45	69	35	39	45	67	69	87	35	39	45	47	67	87
Prod. 3-Spd. & P.G.	JC	DY	JF	JC	DY	DY	JF	DY	JD	DY	JE	JF	JE	DY	JD	DY	JE	JE	JE
C.A.C.	JC	DY	JF	JC	DY	DY	JF	DY	JD	DY	JE	JF	JE	DY	JD	DY	JE	JE	JE
4-Spd. With C.A.C.	JC	-	JF	JC	-	-	JF	-	JD	-	JE	JF	JE	-	JD	-	JE	JE	JE
	JC	-	JF	JC	-	-	JF	-	JD	-	JE	JF	JE	-	JD	-	JE	JE	JE
327	JC	DY	JF	JC	DY	DY	JF	DY	JD	DY	JE	JF	JE	DY	JD	DY	JE	JE	JE
With C.A.C.	JC	DY	JF	JC	DY	DY	JF	DY	JD	DY	JE	JF	JE	DY	JD	DY	JE	JE	JE
With T.H.	JF	DY	JD	JF	DY	DY	JD	DY	JD	DY	JC	JD	JC	DY	JD	DY	JC	JC	JC
With T.H. & C.A.C.	JF	DY	JD	JF	DY	DY	JD	DY	JD	DY	JC	JD	JC	DY	JD	DY	JC	JC	JC
396	DB	DY	JE	DB	DY	DY	JE	DY	JC	DY	DA	JE	DA	DY	JC	DY	DA	DA	DA
With T.H.	DB	DY	JE	DB	DY	DY	JE	DY	JC	DY	DA	JE	DA	DY	JC	DY	DA	DA	DA
With C.A.C.	DB	DY	JE	DB	DY	DY	JE	DY	JC	DY	DA	JC	DA	DY	JC	DY	DA	DA	DA
With T.H. & C.A.C.	DB	DY	JE	DB	DY	DY	JE	DY	JC	DY	DA	JC	DA	DY	JC	DY	DA	DA	DA
427	JE	DY	JE	JE	DY	DY	JE	DY	JC	DY	DB	JC	DB	DY	JC	DY	DB	DB	DB
With T.H.	JE	DY	JE	JE	DY	DY	JC	DY	JC	DY	DB	JC	DB	DY	JC	DY	DB	DB	DB
With C.A.C.	JE	DY	JE	JE	DY	DY	JC	DY	JC	DY	DB	JC	DB	DY	JC	DY	DB	DB	DB
With T.H. & C.A.C.	JE	DY	JC	JE	DY	DY	JC	DY	JC	DY	DB	JC	DB	DY	JC	DY	DB	DB	DB
With S.S. 427	-	-	-	-	-	-	-	-	-	-	-	-	-	-	-	-	-	DL	DL
With T.H. & S.S. 427	-	-	-	-	-	-	-	-	-	-	-	-	-	-	-	-	-	DL	DL
With C.A.C. & S.S. 427	-	-	-	-	-	-	-	-	-	-	-	-	-	-	-	-	-	DL	DL
With T.H., C.A.C. & S.S. 427	-	-	-	-	-	-	-	-	-	-	-	-	-	-	-	-	-	DL	DL
H.D. Suspension	JK	-	JK	JK	-	-	JL	-	JL	-	JL	JL	JL	-	-	-	-	JL	JL
With C.A.C.	JK	-	JL	JK	-	-	JL	-	JL	-	JL	JL	JL	-	-	-	-	JL	JL
With 327	JK	-	JL	JK	-	-	JL	-	JL	-	JK	JL	JL	-	-	-	-	JK	JL
With 396	JO	-	JM	JO	-	-	JM	-	JM	-	JM	JM	JM	-	-	-	-	JM	JM
With 427	JO	-	JM	JO	-	-	JM	-	JM	-	JM	JM	JM	-	-	-	-	JM	JM
With 327 & C.A.C.	JK	-	JL	JK	-	-	JL	-	JL	-	JK	JL	JL	-	-	-	-	JK	JL
With 327 & T.H.	JM	-	JK	JM	-	-	JK	-	JL	-	JL	JK	JK	-	-	-	-	JL	JK
With 327, C.A.C. & T.H.	JM	-	JK	JM	-	-	JK	-	JL	-	JL	JM	JK	-	-	-	-	JL	JK
With 396 & T.H.	JO	-	JM	JO	-	-	JM	-	JM	-	JM	JM	JM	-	-	-	-	JM	JM
With 396 & C.A.C.	JO	-	JM	JO	-	-	JM	-	JM	-	JM	JM	JM	-	-	-	-	JM	JM
With 396, T.H. & C.A.C.	JO	-	JM	JO	-	-	JM	-	JM	-	JM	JM	JM	-	-	-	-	JM	JM
With 427 & T.H.	JO	-	JM	JO	-	-	JM	-	JM	-	JM	JM	JM	-	-	-	-	JM	JM
With 427 & C.A.C.	JO	-	JM	JO	-	-	JM	-	JM	-	JM	JM	JM	-	-	-	-	JM	JM
With 427, T.H. & C.A.C.	JM	-	JM	JM	-	-	JM	-	JM	-	JM	JM	JM	-	-	-	-	JM	JM
With Taxi Cab	-	-	-	-	-	-	-	-	-	-	-	-	-	-	-	-	-	-	-
With H.D. Chassis	JK	-	JK	-	-	-	-	-	-	-	-	-	-	-	-	-	-	-	-
With H.D. Chassis & 327	JK	-	JL	-	-	-	-	-	-	-	-	-	-	-	-	-	-	-	-

## 1968 PASSENGER—REAR SPRINGS

To select the required spring, it will be necessary to know the vehicle model, body style and options. After determining the required spring code, refer to the code chart for applicable spring.

1968 REAR SPRING CODE CHART

Code Letters	Part Numbers	Max. Load Lbs.
AA	3882961	2,162
AB	3886431	2,243
AC	3864733	3,635
AD	3879408	2,242
AE	3862984	2,032
AF-AK	3884498	2,503
AG	3882968	2,723
AH	3879784	2,604
AJ	3913410	3,410

Model	6-CYLINDER ENGINE										
	15300			15500				16300			
	11	35	69	11	35	45	69	39	47	69	87
Prod. 3-Spd., 4-Spd. or P.G. C.A.C.	AB	AC	AB	AB	AC	AC	AB	AD	AA	AD	AA
H.D. Front & Rear. Susp. With C.A.C.	AG		AG	AG			AG	AG	AF	AG	AF
With H.D. Chassis	AG	AC	AG								
Taxi			AG								
Police	AJ	AC	AJ	AJ	AC	AC	AJ				

1968 PASSENGER—REAR SPRINGS

Model	8 Cylinder Engine																	
	15400			15600				16400					16600					
	BISCAYNE			BEL AIR				IMPALA					CAPRICE					
Body Style	2-DR.	STA. WAG.	4-DR.	2-DR.	6-PASS. STA. WAG.	9-PASS. STA. WAG.	4-DR.	6-PASS. STA. WAG.	SPT. SED.	9-PASS. STA. WAG.	CUSTOM SPT. CPE.	CONV.	SEDAN	SPT. CPE.	6-PASS. STA. WAG.	SPT. SED.	9-PASS. STA. WAG.	SPT. CPE.
	11	35	69	11	35	45	69	35	39	45	47	67	69	87	35	39	45	47
Prod. 3-Spd., 4-Spd. & P.G. C.A.C.	AA	AC	AD	AA	AC	AC	AD	AC	AD	AC	AA	AA	AD	AA	AC	AD	AC	AA
With 327	AA	AC	AD	AA	AC	AC	AD	AC	AD	AC	AA	AA	AD	AA	AC	AD	AC	AA
With 396	AA	AC	AD	AA	AC	AC	AD	AC	AD	AC	AA	AA	AD	AA	AC	AD	AC	AA
With 396 & T.H.	AA	AC	AD	AA	AC	AC	AD	AC	AD	AC	AA	AA	AD	AA	AC	AD	AC	AA
With 427	AA	AC	AD	AA	AC	AC	AA	AC	AD	AC	AA	AA	AD	AA	AC	AD	AC	AA
With 427 & T.H.	AA	AC	AA	AA	AC	AC	AA	AC	AD	AC	AA	AA	AD	AA	AC	AD	AC	AA
327	AA	AC	AD	AA	AC	AC	AD	AC	AD	AC	AA	AA	AD	AA	AC	AD	AC	AA
With T.H.	AD	AC	AD	AD	AC	AC	AD	AC	AD	AC	AA	AA	AD	AA	AC	AD	AC	AA
With T.H. & C.A.C.	AA	AC	AD	AA	AC	AC	AD	AC	AD	AC	AA	AA	AD	AA	AC	AD	AC	AA
396	AE	AC	AE	AE	AC	AC	AE	AC	AA	AC	AE	AE	AE	AE	AC	AA	AC	AE
With T.H.	AA	AC	AD	AA	AC	AC	AD	AC	AD	AC	AA	AA	AD	AA	AC	AD	AC	AA
427	AE	AC	AE	AE	AC	AC	AE	AC	AA	AC	AE	AA	AA	AE	AC	AA	AC	AE
With T.H.	AA	AC	AD	AA	AC	AC	AA	AC	AD	AC	AA	AA	AD	AA	AC	AD	AC	AA
With S.S. 427	-	-	-	-	-	-	-	-	-	-	AK	AK	-	AK	-	-	-	-
With S.S. 427 & T.H.	AA	AC	AD	AA	AC	AC	AA	AC	AD	AC	AA	AA	AD	AA	AC	AD	AC	AA
With S.S. 427 & C.A.C.	-	-	-	-	-	-	-	-	-	-	-	-	-	-	-	-	-	-
With S.S. 427, T.H. & C.A.C.	-	-	-	-	-	-	-	-	-	-	-	-	-	-	-	-	-	-
H.D. Frnt. & Rr. Susp.	AG	-	AG	AG	-	-	AG	-	AG	-	AG	AG	AG	AG	-	AG	-	AG
With C.A.C.	AG	-	AG	AG	-	-	AG	-	AG	-	AG	AG	AG	AG	-	AG	-	AG
With 327	AG	-	AG	AG	-	-	AG	-	AG	-	AG	AG	AG	AG	-	AG	-	AG
With 327 & C.A.C.	AG	-	AG	AB	-	-	AG	-	AG	-	AG	AG	AG	AG	-	AG	-	AG
With 327 & T.H.	AF	-	AG	AF	-	-	AG	-	AG	-	AG	AG	AG	AG	-	AG	-	AG
With 327, T.H. & C.A.C.	AF	-	AG	AF	-	-	AG	-	AG	-	AG	AG	AG	AG	-	AG	-	AG
With 396	AF	-	AF	AF	-	-	AF	-	AF	-	AF	AF	AF	AF	-	AF	-	AF
With 396 & C.A.C.	AF	-	AF	AF	-	-	AF	-	AF	-	AF	AF	AF	AF	-	AF	-	AF
With 396 & T.H.	AF	-	AF	AF	-	-	AF	-	AF	-	AF	AF	AF	AF	-	AF	-	AF
With 396, T.H. & C.A.C.	AF	-	AF	AF	-	-	AF	-	AF	-	AF	AF	AF	AF	-	AF	-	AF
With 427	AF	-	AF	-	-	-	AF	-	AF	-	AF	AF	AF	AF	-	AG	-	AF
With 427 & C.A.C.	AF	-	AF	-	-	-	AF	-	AF	-	AF	AF	AF	AF	-	AF	-	AF
With 427 & T.H.	AF	-	AF	-	-	-	AF	-	AF	-	AF	AF	AF	AF	-	AG	-	AF
With 427, T.H. & C.A.C.	AF	-	AF	-	-	-	AF	-	AF	-	AF	AF	AF	AF	-	AF	-	AF
With H.D. Chassis	AG	AC	AG	-	-	-	-	-	-	-	-	-	-	-	-	-	-	-
With H.D. Chassis & 327	AG	AC	AG	-	-	-	-	-	-	-	-	-	-	-	-	-	-	-
With Taxi	-	-	AG	-	-	-	-	-	-	-	-	-	-	-	-	-	-	-
Police	AJ	AC	AJ	AJ	AC	AC	AJ	-	-	-	-	-	-	-	-	-	-	-
Spec. Frnt. & Rr. Susp., 396, 427	AH	AC	AH	AH	AC	AC	AH	AC	AH	AC	AH	AH	AH	AH	AC	AH	AC	AH
With T.H.	-	-	-	-	-	-	-	-	-	-	-	-	-	-	-	-	-	-
With C.A.C.	-	-	-	-	-	-	-	-	-	-	-	-	-	-	-	-	-	-
With T.H., C.A.C.	-	-	-	-	-	-	-	-	-	-	-	-	-	-	-	-	-	-
With S.S. 427	-	-	-	-	-	-	-	-	-	-	-	-	-	-	-	-	-	-
With T.H. & S.S. 427	-	-	-	-	-	-	-	-	-	-	-	-	-	-	-	-	-	-
With C.A.C. & S.S. 427	-	-	-	-	-	-	-	-	-	-	-	-	-	-	-	-	-	-
With T.H., C.A.C. & S.S. 427	-	-	-	-	-	-	-	-	-	-	-	-	-	-	-	-	-	-

## 1969 COIL SPRINGS

A new system for release of front and rear coil springs will be used for the 1969 A, B, F and X cars. The assembly plants will use a computer to determine the correct spring based on the RPO equipment on the dealer order. It will also be put on an engineering drawing to Maintain engineering records.

Determination of the correct spring by dealer personnel will be as follows:

1. If the identification tag is still on the spring, Table A will give the part number.
2. If the identification tag is not available, it will be necessary to add the weight for all the RPO equipment on the vehicle. This is shown on Table A. (Only RPO's with 5 lbs. or more are given.)
3. After the extra weight of the vehicle is determined, Table C shows the identification letters of the required spring. These letters are used with Table B to determine the part number.

Example:

A 13646 Concours 4 Door Station Wagon with dual action tail gate is equipped with the following:

Weight to add

<u>Front</u>	<u>Rear</u>	<u>RPO</u>	
196	46	L35	V8 Engine - 396 Cu. In. - 325 HP
23	9	M40	3-Speed Automatic Transmission
* -2	7	A33	Electric Tail Gate Window
30	0	N40	Power Steering
2	14	V55	Luggage Carrier
<u>Total</u> 249	<u>76</u>		

\*NOTE: Some options have negative value and must be subtracted instead of added.

1. The weights were obtained from Table B.
2. Table C for this model shows the spring requirement.  
 Standard Springs - front - 249 # requires spring "GO"  
   rear - All use spring "BB"  
 Heavy Duty Springs - front - 249 # requires spring "GW"  
   rear - All use spring "BG"
3. Table A would then be used to convert to part numbers and the customers requirements would be as follows:

	<u>Front</u>	<u>Rear</u>
Standard Springs	(GO)3952812	(BB)3949015
Heavy Duty Springs	(GW)3952818	(BG)3949006

The use of this system will present two additional advantages. Customer request of upgrading springs due to trunk loads, etc. can be easily accomplished. If there is a question of improper springs installed on the car, it can be easily checked.

**TABLE A  
1969 PASSENGER  
SPRING IDENTIFICATION**

NOTE: See Dealer Price Schedule (P & A 26) for Applicable Prices.

Ident.	Front Part No.	Rate
CC-CD-CB	3953927	500
CE-CF	3953929	500
CL-CJ-CK-CH	3954605	290
QA-QB-QD	3953902	290
CG-QF-QG-QC-QE	3953906	290
QK	3972765	330
QN-QL-QM-QO	3953911	390
QP	3953914	390
QQ-QR-QS	3953915	390
QT-QU-QV-QW-QX	3953920	390
CA-QY-QZ	3953924	500
DX-DZ	3953952	340
JA-JB-JZ	3953937	230
JH-JI-JM	3953952	385
JJ-JK	3953955	450
JL	3953956	450
DI-JO-JP-DW	3953951	385
JC-JD-JV-JW-JX-JY	3953940	230

Weight to Add		RPO	Item
Front	Rear		
19	6	M38	3-Speed Automatic Transmission V8
32	10	M40	3-Speed Automatic Transmission
32	3	MC1	H.D. 3-Speed Transmission
12	10	A31	Power Windows
-3	10	A33	Power Tailgate
11	10	A42	Power Seats
10	10	A51	Astro Seat
11	11	A53	Astro Bench Seat
6	4	A93	Vacuum Operated Door Locks
33	39	B02	Taxi Cab L6 3-Speed
48	39	B02	Taxi Cab L6 Powerglide
35	39	B02	Taxi Cab V8
12	11	B07	Police Car L6 2 & 4 Door
7	2	B07	Police Car L6 Station Wagon
6	3	B07	Police Car 307 Engine
10	6	B34	H.D. Front Floor Mat
4	8	B35	H.D. Rear Floor Mat
6	6	B37	Floor Mats Front & Rear
-3	16	B39	Load Floor Carpet
3	8	C08	Vinyl Roof
-1	5	C50	Rear Window Defroster
-1	5	C51	Rear Window Air Deflector - Wagon
97	5	C60	Air Conditioning
102	6	C75	Air Conditioning
12	8	F40	H.D. Front & Rear Suspension L6 Exc. Impala
2	9	F40	H.D. Front & Rear Suspension L6 Impala & Base V8
1	12	F41	Spec. Perf. Susp. - Exc. Wagon
7	6	G67	Shock Abs Level Control
8	1	J50	Power Brakes
5	0	K30	Cruise Control
4	39	N10	Dual Exhaust
27	1	N40	Power Steering
0	8	T58	Rear Wheel Opening Cover
17	-2	T60	H.D. Battery L6 Base V8
6	-1	T60	H.D. Battery RPO V8
26	-4	T83	Retractable Headlamp Cover (Exc. Z24)
14	4	U57	Tape Player
7	2	U63	Radio-Push Button
8	2	U69	Radio-Am-FM Push Button
8	4	U79	Radio Stereo Equip.
12	-2	V01	H.D. Radiator L6
6	-1	V01	H.D. Radiator V8
12	11	Z24	SS 427
13	8	ZK1	Body Insulation Pkg.

**TABLE B  
1969 PASSENGER RPO WEIGHTS**

Weight to Add		RPO	Item
Front	Rear		
211	52	L36	V8 Engine 427 Cu. In. 385 HP
21	10	L48	V8 Engine 350 Cu. In. 300 HP
12	2	L65	V8 Engine 350 Cu. In. 250 HP
205	14	L66	V8 Engine 396 Cu. In. 265 HP
163	44	L72	V8 Engine 427 Cu. In. 425 HP
190	24	LS1	V8 Engine 427 Cu. In. 335 HP
12	7	M20	4-Speed Transmission
4	1	M21	4-Speed Transmission - Close Ratio
2	1	M22	H.D. 4-Speed Transmission
-9	-2	M35	Powerglide Transmission L6
8	4	M38	3-Speed Automatic Transmission L6

**TABLE C**  
**1969 PASSENGER (Continued)**

Model	RPO	Front		Rear	
		Weight	Spring	Weight	Spring
15469 15669	Base	0-22	QD	0-30	JW
		23-72	QE	31-100	JX
		73-112	QF	101-160	JY
		113-162	QG	Over 160	JZ
		163-212	CG		
		213-252	CH		
		253-302	CJ		
		303-342	CK		
		343-412	CL		
		SEE NOTE	Over 472	QK	
Base	0-64	QE			
	65-132	QF			
	133-198	QG			
	199-264	CG			
	265-332	CH			
	333-398	CJ			
	399-464	CK			
	Over 464	CL			
B02 (15469 Only) SEE NOTE	0-52	QO	All	DZ	
	53-112	QP			
	Over 112	QQ			
(15469 Only) B02 Z89 ZM8	0-52	QO	0-68	DZ	
	53-112	QP	Over 68	D1	
	113-172	QQ			
	173-232	QR			
	233-292	QS			
	Over 292	QT			
B07	0-72	QZ	0-30	JP	
	73-162	CA	31-120	JH	
	163-252	CB	Over 120	JI	
	253-332	CC			
	333-422	CD			
	423-512	CE			
	Over 512	CF			
F40	0-72	QP	0-30	DX	
	73-116	QQ	31-110	DZ	
	117-178	QR	Over 110	D1	
	179-232	QS			
	233-292	QT			
	293-352	QU			
	353-412	QV			
	Over 412	QW			
F41	0-232	CB	0-50	JO	
	233-312	CC	Over 50	JP	
	313-402	CD			
	403-492	CE			
	Over 492	CF			

**TABLE C**  
**1969 PASSENGER**

Model	RPO	Front		Rear	
		Weight	Spring	Weight	Spring
15311 15511	Base	0-80	QO	0-72	JC
		81-140	QP	73-132	JD
		141-196	QQ	Over 132	JE
		197-256	QR		
		257-316	QS		
		Over 316	QT		
	B07	0-106	QY	0-126	JP
		107-196	QZ	127-212	JH
		197-286	CA	Over 212	JI
		287-376	CB		
		377-456	CC		
		Over 456	CD		
F40	0-72	QN	0-122	DX	
	73-126	QO	Over 122	DZ	
	127-186	QP			
	187-246	QQ			
	247-306	QR			
	Over 306	QS			
15369 15569	Base	0-60	QO	0-16	JC
		61-120	QP	17-76	JD
		121-176	QQ	Over 76	JE
		177-236	QR		
		237-296	QS		
		Over 296	QT		
	B02 (15369 Only) SEE NOTE	0-96	QN	All	DX
		97-150	QO		
		Over 150	QP		
	B02 or Z89 (15369 Only)	0-96	QN	0-72	DX
		97-150	QO	Over 72	DZ
		151-210	QP		
		211-270	QQ		
		271-330	QR		
		Over 330	QS		
	B07	0-86	QY	0-70	JP
		87-176	QZ	71-156	JH
		177-266	CA	Over 156	JI
267-356		CB			
357-436		CC			
Over 436		CD			
F40	0-52	QN	0-66	DX	
	53-106	QO	Over 66	DZ	
	107-166	QP			
	167-226	QQ			
	227-286	QR			
	Over 286	QS			



**TABLE C**  
**1969 PASSENGER (Continued)**

Model	RPO	Front		Rear				
		Weight	Spring	Weight	Spring			
15411	Base	0-38	QD	0-43 44-78 79-108 Over 108	JW			
		39-88	QE		JX			
		89-128	QF		JY			
		129-178	QG		JZ			
		179-228	CG					
		229-268	CH					
		269-318	CJ					
		319-358	CK					
		359-428	CL					
		429-488	QJ					
		SEE NOTE	Over 488		QK			
		15611	Base		0-14	QD		
					15-80	QE		
81-148	QF							
149-214	QG							
215-280	CG							
281-348	CH							
349-414	CJ							
415-480	CK							
Over 480	CL							
B07	0-88		QZ	0-86 87-176 Over 176	JP JH JI			
	89-178		CA					
	179-268		CB					
	269-348		CC					
	349-438		CD					
	439-528		CE					
Over 528	CF							
F40	0-18		QO	0-86 87-166 Over 166	DX DZ DI			
	19-88		QP					
	89-132		QQ					
	133-194		QR					
	195-248		QS					
	249-308		QT					
	309-368		QU					
	369-428		QV					
	Over 428		QW					
	F41		0-248			CB	0-106 Over 106	JO JP
			249-328			CC		
329-418		CD						
419-508		CE						
Over 508		CF						
L72	0-172	QR	0-106 107-186 Over 186	DW DX DZ				
	173-232	QS						
	233-292	QT						
	293-348	QU						
	Over 348	QV						

**TABLE C**  
**1969 PASSENGER (Continued)**

Model	RPO	Front		Rear			
		Weight	Spring	Weight	Spring		
15469 15669	L72	0-156	QR	0-50	DW		
		157-216	QS	51-130	DX		
		217-276	QT	Over 130	DZ		
		277-332	QU				
		Over 332	QV				
16337	Base	0-72	QA	0-96	JV		
		73-118	QB	Over 96	JW		
		119-168	QC				
		169-218	QD				
		219-258	QE				
		259-308	QF				
		Over 308	QG				
	F40	0-84	QM		0-106	DW	
		85-144	QN	Over 106	DX		
		145-198	QO				
199-258	QP						
16339	Base	0-32	QC	0-116	JX		
		33-72	QD	117-176	JY		
		73-122	QE	Over 176	JZ		
		123-162	QF				
		163-212	QG				
		213-262	CG				
		263-302	CH				
		Over 302	CJ				
	SEE NOTE	Base	0-48		QD		
			49-114		QE		
			115-182	QF			
			183-248	QG			
			249-314	CG			
			Over 314	CH			
	F40	Base	0-52	QO	0-126	DZ	
			53-112	QP	Over 126	DI	
			113-172	QQ			
173-232			QR				
233-292			QS				
293-352			QT				
Over 352			QU				
ZM9	Base	0-32	QY	0-70		JH	
		33-122	QZ	Over 70	JI		
		123-212	CA				
		213-302	CB				
		303-382	CC				
		Over 382	CD				

**TABLE C**  
**1969 PASSENGER (Continued)**

Model	RPO	Front		Rear	
		Weight	Spring	Weight	Spring
16369	Base	0-62	QC	0-114	JX
		63-102	QD	115-174	JY
		103-152	QE	Over 174	JZ
		153-192	QF		
		193-242	QG		
		243-292	CG		
		293-332	CH		
		Over 332	CJ		
	SEE NOTE				
	Base	0-78	QD		
		79-144	QE		
		145-212	QF		
213-278		QG			
279-344		CG			
Over 344		CH			
F40	0-82	QO	0-124	DZ	
	83-142	QP	Over 124	DI	
	143-202	QQ			
	203-262	QR			
	263-322	QS			
	323-382	QT			
	Over 382	QU			
ZM9	0-62	QY	0-46	JP	
	63-152	QZ	47-132	JH	
	153-242	CA	Over 132	JI	
	243-332	CB			
	333-412	CC			
	Over 412	CD			
16469	Base	0-42	QE	0-82	JX
		43-82	QF	83-142	JY
		83-132	QG	143-212	JZ
		133-182	CG	213-282	JA
		183-222	CH	Over 282	JB
		223-252	CJ		
		253-312	CK		
		313-382	CL		
		383-442	QJ		
		Over 442	QK		
		SEE NOTE			
	Base	0-34	QE		
		35-102	QF		
		103-168	QG		
		169-234	CG		
		235-302	CH		
		303-368	CJ		
		369-434	CK		
Over 434		CL			

**TABLE C**  
**1969 PASSENGER (Continued)**

Model	RPO	Front		Rear			
		Weight	Spring	Weight	Spring		
16469	F40	0-42	QP	0-92 93-182 Over 182	DZ DI JM		
		43-86	QQ				
		87-148	QR				
		149-202	QS				
		203-262	QT				
		263-322	QU				
		323-382	QV				
		383-432	QW				
		Over 432	QX				
		0-282	CC			0-122 123-206 Over 206	JP JH JI
		283-372	CD				
		373-462	CE				
0-186	QS	0-112 113-192 Over 192	DX DZ DI				
187-246	QT						
247-302	QU						
303-362	QV						
		363-422	QW				
		Over 422	QX				
		0-42	QZ			0-12 13-102 Over 102	JP JH JI
		43-132	CA				
133-222	CB						
223-302	CC						
		303-392	CD				
		393-482	CE				
		Over 482	CF				
		0-12	QE			0-8 9-68 69-138 139-208 Over 208	JX JY JZ JA JB
13-52	QF						
53-102	QG						
103-152	CG						
		153-192	CH				
		193-242	CJ				
		243-282	CK				
		283-352	CL				
	SEE NOTE	353-412	QJ				
		Over 412	QK				
		0-72	QF				
		73-138	QG				
139-204	CG						
205-272	CH						
		273-338	CJ				
		339-404	CK				
		Over 404	CL				
		0-12	QP			0-18 19-108 Over 108	DZ DI JM
13-56	QQ						
57-118	QR						
119-172	QS						
		173-232	QT				
		233-292	QU				
		293-352	QV				
		353-402	QW				
		Over 402	QX				

**TABLE C**  
**1969 PASSENGER (Continued)**

Model	RPO	Front		Rear	
		Weight	Spring	Weight	Spring
16439 16639	F41	0-252	CC	0-48	JP
		253-342	CD	49-132	JH
		343-432	CE	Over 132	JI
		Over 432	CF		
	L72	0-156	QS	0-38	DX
		157-216	QT	39-118	DZ
		217-272	QU	Over 118	DJ
		273-332	QV		
		333-392	QW		
	ZM9 (16439 Only)	Over 392	QX		
		0-22	QZ	0-38	JH
		23-112	CA	Over 38	JI
113-202		CB			
203-282		CC			
283-372		CD			
16437 16447 16467 16647	Base	373-462	CE		
		Over 462	CF		
		0-8	QB	0-52	JV
		9-58	QC	53-112	JW
		59-108	QD	113-172	JX
		109-148	QE	Over 172	JY
		149-198	QF		
		199-248	QG		
		249-288	CG		
		289-338	CH		
		339-388	CJ		
		389-428	CK		
		429-488	CL		
	Over 488	QJ			
	F40	0-34	QN	0-72	DW
		35-88	QO	73-152	DX
		89-148	QP	Over 152	DZ
		149-208	QQ		
		209-268	QR		
		269-318	QS		
319-378		QT			
379-438		QU			
439-498		QV			
Over 498		QW			
F41 ZM9 on 16447 Only	0-268	CA	0-198	JO	
	269-348	CB	Over 198	JP	
	349-438	CC			
	439-518	CD			
L72	Over 518	CE			
	0-198	QQ	0-101	DW	
	199-258	QR	Over 101	DX	
	259-318	QS			
	319-368	QT			
Over 368	QU				

**TABLE C**  
**1969 PASSENGER (Continued)**

Model	RPO	Front		Rear	
		Weight	Spring	Weight	Spring
16437 16447 16467 16647	Z24 (16437 16447 16467)	0-198 199-258 259-318 319-368 369-438 439-498 Over 498	QQ QR QS QT QU QV QW	0-101 Over 101	DW DX
15336 15536	Base	0-94 95-164 165-224 225-284 285-344 345-404 405-464 465-524 525-584 Over 584	QL QM QN QO QP QQ QR QS QT QU	0-172 173-262 Over 262	JJ JK JL
	B07	0-284 285-364 365-444 445-534 Over 534	QY QZ CA CB CC	0-172 Over 172	JJ JK
15436 15636 16436 16636	Base	0-54 55-114 115-174 175-234 235-294 295-354 355-414 415-474 Over 474	QM QN QO QP QQ QR QS QT QU	0-116 117-206 Over 206	JJ JK JL
	B07 (15436 15636)	0-174 175-254 255-334 335-424 Over 424	QY QZ CA CB CC	0-116 Over 116	JJ JK
	F41	0-254 255-334 335-424 425-514 Over 514	QZ CA CB CC CD	0-116 117-206 Over 206	JJ JK JL
15546	Base	0-106 107-176 177-236 237-296 297-356 357-416 417-476 477-536 537-596 Over 596	QL QM QN QO QP QQ QR QS QT QU	0-104 105-194 Over 194	JJ JK JL

**TABLE C  
1969 PASSENGER (Continued)**

Model	RPO	Front		Rear	
		Weight	Spring	Weight	Spring
15546	B07	0-296	QY	0-104	JJ
		297-376	QZ	105-194	JK
		377-456	CA	Over 194	JL
		457-546	CB		
		Over 546	CC		
15646 16446 16646	Base	0-66	QM	0-46	JJ
		67-126	QN	47-136	JK
		127-186	QO	Over 136	JL
		187-246	QP		
		247-306	QQ		
		307-366	QR		
		367-426	QS		
		427-486	QT		
		Over 486	QU		
	B07 (15646)	0-204	QY	0-68	JJ
		205-284	QZ	69-158	JK
		285-364	CA	Over 158	JL
		365-454	CB		
F41	Over 454	CC			
	0-266	QZ	0-136	JK	
	267-346	CA	Over 136	JL	
	347-436	CB			
	Over 436	CC			

NOTE: Spring usage in this section has been revised. Check the following section for later production vehicles.

1970 PASSENGER SPRING CHART SERVICE

	MODEL	STD. SUSPENSION		H.D. SUSPENSION	
		FRONT	REAR	FRONT	REAR
70	Police (400) (exc. Sta. Wag.) . . . . .	3953924	3953951	—	—
70	Police (454) (exc. Sta. Wag.) . . . . .	3953927	3953951	—	—
70	Police (6 cyl.) (exc. Sta. Wag.) . . . . .	3953924	3953951	—	—
70	Taxi (6 cyl.) . . . . .	3953915	3953952	—	—
70	Taxi (350) (exc. CAC) . . . . .	3953915	3953952	—	—
70	Taxi (350) (w/CAC) . . . . .	3953920	3953952	—	—
70	Police (Sta. Wag.) (350) . . . . .	3953924	3953955	—	—
70	Police (Sta. Wag.) (400) . . . . .	3953924	3953955	—	—
70	Police (Sta. Wag.) (454) . . . . .	3953924	3953955	—	—
70	Police (350) (exc. Sta. Wag.) . . . . .	3953927	3953951	—	—
70	Biscayne, Bel Air (6 cyl.) (exc. CAC) . . . . .	3953914	3953940	3953914	3953952
70	Biscayne, Bel Air (6 cyl.) (w/CAC) . . . . .	3953915	3953940	3953915	3953952
70	Impala (Spt. Cpe.) (6 cyl.) (exc. CAC) . . . . .	3953902	3953940	3953914	3953951
70	Impala (Spt. Cpe.) (6 cyl.) (w/CAC) . . . . .	3953902	3953940	3953914	3953951
70	Impala (Sed.) (6 cyl.) (exc. CAC) . . . . .	3953902	3953940	3953915	3953952
70	Impala (Sed.) (6 cyl.) (w/CAC) . . . . .	3953906	3953940	3953915	3953952
70	Biscayne, Bel Air (350) (exc. CAC) . . . . .	3953906	3953940	3953915	3953952
70	Biscayne, Bel Air (350) (w/CAC) . . . . .	3953906	3953940	3953915	3953952
70	Impala, Caprice (Spt. Cpe., Conv.) (350) (exc. CAC) . . . . .	3953902	3953940	3953915	3953951
70	Impala, Caprice (Spt. Cpe., Conv.) (350, CAC) . . . . .	3953906	3953940	3953915	3953951
70	Impala, Caprice (Sed.) (350) (exc. CAC) . . . . .	3953906	3953940	3953915	3953952
70	Impala, Caprice (Sed.) (350) (w/CAC) . . . . .	3953906	3953940	3953920	3953952
70	Pass. (Sta. Wag.) (350) (exc. CAC) . . . . .	3953911	3953955	—	—
70	Pass. (Sta. Wag.) (350) (w/CAC) . . . . .	3953915	3953955	—	—
70	Pass. (Sta. Wag.) (454) (exc. CAC) . . . . .	3953914	3953955	—	—
70	Pass. (Sta. Wag.) (454) (w/CAC) . . . . .	3953915	3953955	—	—
70	Pass. (Sta. Wag.) (400) (exc. CAC) . . . . .	3953911	3953955	—	—
70	Pass. (Sta. Wag.) (400) (w/CAC) . . . . .	3953915	3953955	—	—
70	Biscayne, Bel Air (454) (exc. CAC) . . . . .	3953906	3953951	3953915	3953952
70	Biscayne, Bel Air (454) (w/CAC) . . . . .	3954605	3953951	3953920	3953952
70	Biscayne, Bel Air (400) (exc. CAC) . . . . .	3953902	3953940	3953914	3953952
70	Biscayne, Bel Air (400) (w/CAC) . . . . .	3953906	3953940	3953915	3953952
70	Impala, Caprice (Spt. Cpe.) (454) (exc. CAC) . . . . .	3953906	3953940	3953915	3953952
70	Impala, Caprice (Spt. Cpe.) (454 w/CAC) . . . . .	3953906	3953940	3953915	3953952
70	Impala, Caprice (Spt. Cpe.) (400) (exc. CAC) . . . . .	3953902	3953940	3953915	3953951
70	Impala, Caprice (Spt. Cpe.) (400 w/CAC) . . . . .	3953906	3953940	3953915	3953951
70	Impala, Caprice (Sed.) (454) (exc. CAC) . . . . .	3953906	3953940	3953915	3953952
70	Impala, Caprice (Sed.) (454 w/CAC) . . . . .	3954605	3953940	3953920	3953952
70	Impala, Caprice (Sed.) (454) (exc. CAC) . . . . .	3953902	3953940	3953915	3953952
70	Impala, Caprice (Sed.) (400 w/CAC) . . . . .	3953906	3953940	3953915	3953952



FRAME—SPRINGS—BUMPER

1971 PASSENGER

MODEL	FRONT	REAR	H.D.	
			FRONT	REAR
Police (4-Dr.) (exc. Sta. Wag.) w/CAC				
6 Cyl. . . . .	3991250	482090	—	—
350, 400 2/BC . . . . .	3991253	482152	—	—
400 4/BC, 454 . . . . .	3991254	482152	—	—
exc. CAC				
6 Cyl. . . . .	3991250	482090	—	—
350 2/BC . . . . .	3991252	482152	—	—
350 4/BC, 400 2/BC . . . . .	3991251	482152	—	—
400 4/BC, 454 . . . . .	3991253	482152	—	—
Police (Sta. Wag.)				
w/CAC				
350 2/BC . . . . .	3991253	482582	—	—
350 4/BC, 400 2/BC . . . . .	3991252	482582	—	—
400 4/BC, 454 . . . . .	3991254	482582	—	—
exc. CAC				
350, 400 2/BC . . . . .	3991251	482582	—	—
400 4/BC, 454 . . . . .	3991252	482582	—	—
Taxi				
6 Cyl. . . . .	3991250	482582	—	—
8 Cyl. . . . .	3991252	482152	—	—
Sta. Wag. (exc. Estate Wag.)				
w/CAC				
350, 400 2/BC . . . . .	3991253	482582	—	—
400 4/BC, 454 . . . . .	3991255	482582	—	—
exc. CAC				
350, 400 2/BC . . . . .	3991251	482582	—	—
400 4/BC, 454 . . . . .	3991253	482582	—	—
Estate Wag.				
w/CAC				
400 2/BC . . . . .	3991253	482702	—	—
400 4/BC, 454 . . . . .	3991254	482702	—	—
exc. CAC				
400 2/BC . . . . .	3991251	482702	—	—
400 4/BC, 454 . . . . .	3991252	482702	—	—
Biscayne, Bel Air				
6 Cyl. . . . .	3991250	482090	—	—
Impala				
6 Cyl. . . . .	3991239	482065	3991250	482090
Pass. (exc. Caprice, Stat Wag., Spt. Sed.)				
w/CAC				
350, 400 2/BC . . . . .	3991243	482067	3991253	482152
400 4/BC, 454 . . . . .	3991244	482067	3991255	482152
exc. CAC				
350, 400 2/BC . . . . .	3991241	482065	3991252	482152
400 4/BC, 454 . . . . .	3991243	482067	3991253	482152
Spt. Sed. (exc. Caprice)				
w/CAC				
350, 400 2/BC . . . . .	3991243	482065	3991251	482090
400 4/BC, 454 . . . . .	3991244	482065	3991254	482090
exc. CAC				
350, 400 2/BC . . . . .	3991241	482065	3991252	482090
400 4/BC, 454 . . . . .	3991242	482065	3991252	482090
Caprice				
w/CAC				
400, 454 . . . . .	3991244	482067	3991254	482152
exc. CAC				
400, 454 . . . . .	3991242	482065	3991252	482152

## FRAME—SPRINGS—BUMPER

Follow the three steps below to utilize the 1972 spring charts.

1. Select the model desired with the base spring weight on Chart "A".
2. Then select options accordingly shown on Chart "B" and add that weight to the base spring weight.
3. Once accumulated weight has been determined refer to chart "C" and select correct spring.

### CHART "A" 1972 PASSENGER

MODEL	BASE SPRING WEIGHT		
	FRONT	REAR	
15369	Biscayne (6 Cyl.)	912.5	762.0
15469	Biscayne (8 Cyl.)	984.5	784.5
15569	Bel Air (6 Cyl.)	911.5	762.0
15669	Bel Air (8 Cyl.)	983.5	783.5
16369	Impala (Sed.) (exc. Spt. Sed.) (6 Cyl.)	922.5	788.5
16469	Impala (Sed.) (exc. Spt. Sed.) (8 Cyl.)	995.5	803.5
16439	Impala (Spt. Sed.)	999.5	818.5
16639	Caprice (Spt. Sed.)	1011.5	823.0
16357	Impala (Spt. Cpe.) (exc. Custom) (6 Cyl.)	914.5	764.5
16457	Impala (Spt. Cpe.) (exc. Custom) (8 Cyl.)	985.5	782.5
16447	Impala (Custom)	981.5	788.5
16647	Caprice (Spt. Cpe.)	1000.5	783.0
16467	Impala (Conv.)	1001.5	807.5
15435	Brookwood	952.5	1069.0
15635	Townsmen (6 Pass.)	951.5	1069.0
15645	Townsmen (9 Pass.)	948.5	1116.0
16435	Kingswood (exc. Estate) (6 Pass.)	963.5	1082.0
16445	Kingswood (exc. Estate) (9 Pass.)	959.5	1130.0
16635	Kingswood (Estate) (6 Pass.)	972.0	1093.5
16645	Kingswood (Estate) (9 Pass.)	968.0	1138.5

### CHART "B" 1972 PASSENGER

RPO OPTIONS	FRONT	REAR	
A31	Electric Window	6.5	5.5
A42	6-Way Seat	5.5	5.0
B02	Taxi	14.0	13.0
B07	Police	13.5	6.0
C60	Air Conditioning	51.5	2.5
F40	Heavy Duty Susp.	8.5	0
LS3	(402)	90.5	8.5
LS5	(454)	92.5	27.5
M40	TH-400	14.5	2.0
N10	Dual Exhaust	0	20.0
V55	Roof Luggage Carrier	0	12

**FRAME—SPRINGS—BUMPER**

**CHART "C"**

**1972 PASSENGER**

**6 CYLINDER (EXC. H.D. SUSP.) 15300-15500**

FRONT			REAR		
CODE	SPRUNG WEIGHT	PART NUMBER	CODE	SPRUNG WEIGHT	PART NUMBER
FK	0-895	3991250	YK	ALL	482090
FL	896-939	2991251			
FP	940-Over	3991252			

**8 CYLINDER (EXC. H.D. SUSP.) 15469-669-16300-16439-47-16457-67-69-16639-47**

FRONT			REAR		
CODE	SPRUNG WEIGHT	PART NUMBER	CODE	SPRUNG WEIGHT	PART NUMBER
CT	0-949	3991239	XK,XL	0-850	482065
CY,CW	950-1009	3991241	XM,XN	851-Over	482067
CZ	1010-1039	3991242			
FA	1040-1073	3991243			
FJ,FH,FB,FC,FD,FG	1074-Over	3991244			

**POLICE—TAXI—HEAVY DUTY 15300-15469-15500-15669-16300-439-47-67-16639-47-16457-69**

FRONT			REAR		
CODE	SPRUNG WEIGHT	PART NUMBER	CODE	SPRUNG WEIGHT	PART NUMBER
FK	0-913	3991250	YM	0-799	482090
FL	914-958	3991251	ZA,ZH	800-Over	482152
FP	959-1002	3991252			
FR	1003-1043	3991253			
FS	1044-1083	3991254			
FT,FW,FX	1084-Over	3991255			

**ALL STA. WAG. 15435-15635-45-16435-45-16635-45**

FRONT			REAR		
CODE	SPRUNG WEIGHT	PART NUMBER	CODE	SPRUNG WEIGHT	PART NUMBER
FK	0-923	3991250	VA,VU	0-1165	486382
FL	924-965	3991251	VL,VM	1166-Over	486260
FP	966-1008	3991252			
FR	1009-1052	3991253			
FS	1053-1093	3991254			
FT,FW,FX	1094-Over	3991255			

**FRAME—SPRINGS—BUMPER**

**SPRING, Rear, Chevy, Chevelle, Camaro**

*NOTE Springs may be identified from the years 1963 thru 1965 by a piece of tape attached to the spring listing the part number.  
NOTE Maximum Load Capacity should be used for Comparison purposes only.*

**LEAF TYPE**

62-67	Chevy (Sta. Wag.) (exc. H.D.),					
62-67	Chevy w/H.D. (exc. Sta. Wag., Spt. Cpe., 327),					
64-67	Chevy (Taxi) . . . . .	<b>3792597</b>	2	65.75	(stripe of lt. green paint) (max. load 855 lbs.) . . . . .	
62-63	Chevy (3 Seat Sta. Wag.),					
62-67	Chevy (2 Seat Sta. Wag.) w/H.D.	<b>3792598</b>	2	65.75	(stripe of white paint) (max. load 955 lbs.)	
62-67	Chevy (exc. H.D. susp., 327, Sta. Wag.) . . . . .	<b>3892730</b>	2	69.00	(stripe of dk. green) (max. load 620)	
65-67	Chevy w/H.D. susp. (327),					
65-67	Nova (Spt. Mdls.) w/H.D. susp. . .	<b>3872051</b>	2	52.25	(max. load 799 lbs.) (stripe orange paint)	
67-69	Camaro (Conv.) w/2/BC (exc. spec. perf. susp. 3.55 ratio),					
67-68	Camaro (Spt. Cpe.) (396),					
68-69	Camaro (Spt. Cpe.) w/spec. rr. spring, (6 cyl.),					
68	Chevy (Spt. Cpe.) (exc. H.D. susp 327 spec. H/Per., 350) . . . . .	<b>3909940</b>	2	52.25	(stripe of yellow paint) (max. load 1, 310 lbs.) . . . . .	
67	Camaro (Conv.) (2/BC w/spec. perf. susp.),					
67	Camaro (Conv.) (exc. 2/BC),					
68	Chevy (Sed.) w/H.D. susp. (327) (exc. 4-Spd., 3.55 axle),					
68	Chevy (Sed.) w/H.D. susp. (6 cyl.),					
68	Chevy (Sed.) w/3.55 rr. axle (8 cyl.) (exc. 4-Spd.) . . . . .	<b>3909941</b>	2	52.25	(stripe of dk. blue paint) (max. load 1, 370 lbs.) . . . . .	
67	Camaro (Conv.) (6 cyl.) . . . . .	<b>3909942</b>	2	52.25	(stripe of dk. green paint) (max. load 1, 220 lbs.) . . . . .	
67	Camaro (Spt. Cpe.) (250) (exc. Spec. Rr. Spring),					
68	Camaro (Conv.) (6 cyl.) (exc. Spec. Rr. Spring) . . . . .	<b>3925815</b>	2	52.25	(stripe of white paint) (max. load 1, 220 lbs.) . . . . .	
67	Camaro (Spt. Cpe.) (230),					
67	Camaro (Spt. Cpe.) (327) (exc. spec. perf. susp.) . . . . .	<b>3901395</b>	2	52.25	(stripe of coral paint) (max. load 1, 310 lbs.)	
67	Camaro (Conv.) w/spec. rr. spring (8 cyl.),					
68	Camaro (Conv.) (4BC w/spec. rr. spring) (327) (exc. 4-Spd.),					
68	Camaro (Conv.) (2BC w/spec. rr. spring) (327) . . . . .	<b>3920220</b>	2	52.25	(max. load 1, 490 lbs.) . . . . .	
67	Camaro (Spt. Cpe.) w/spec. perf. susp. (exc. 350),					
67	Camaro (Spt. Cpe.) (302, 350, 396) . . . . .	<b>3901397</b>	2	52.25	(stripe of purple paint) (max. load 1, 370 lbs.) . . . . .	
67-68	Camaro (Spt. Cpe.) (6 cyl.) (exc. spec. rr. spring) . . . . .	<b>3932727</b>	2	52.25	(max. load 1, 220 lbs.) (mono leaf) . . . . .	
68	Camaro (Spt. Cpe.) (327) (exc. spec. perf. susp. 4/Spd.),					
69	Camaro . . . . .	<b>3962776</b>	2	52.25	(max. load 1, 310 lbs.) (mono leaf) . . . . .	
68	Camaro (Conv.) w/4-Spd. (exc. 327, spec. rr. spring),					
68	Camaro (Spt. Cpe.) (350) (exc. P.G., P/Trac., spec. perf. susp., 3.55, 3.73 rr. axle),					
68	Camaro (Spt. Cpe.) w/4-Spd. (327) (exc. spec. perf. susp., spec. rr. spring),					
68	Camaro (Conv.) w/3.55 axle (350) (exc. P.G., spec. rr. spring),					
68	Camaro (Conv.) (396) (exc. spec. rr. spring),					
68	Camaro w/P.G. (350) (exc. spec. rr. spring),					

**FRAME—SPRINGS—BUMPER**

**7.503 SPRING ASSEMBLY, Rear (Con't)**

68	Chevy (Sed.) w/H/Per. (327) (exc. H.D. susp.),				
68	Chevy (Sed.) w/4-Spd. (327) (exc. H.D. susp.)	3930096	2	58.50	5 leaves
68	Camaro (302),				
68	Camaro (Spt. Cpe.) w/spec. perf. susp., 4-Spd. (327) (exc. spec. rear spring)	3930080	2	56.75	4 leaves
68	Camaro (Spt. Cpe.) w/spec. perf. susp. (350, 396) (exc. spec. rear spring),				
67-68	Camaro (Conv.) w/spec. rr. spring (6 cyl.)	3932719	2	56.75	4 leaves
68	Camaro (Spt. Cpe.) w/spec. rr. spring (327) (exc. 4-Spd.),				
68	Camaro (Spt. Cpe.) w/spec. rr. spring (302, 327-2BC),				
68	Camaro (Conv.) (6 cyl.) w/spec. rr. spring	3912554	2	52.25	(max. load 1, 490 lbs.) (mono leaf)
68	Nova (Spt. Cpe.) (350),				
68	Nova (Spt. Cpe.) w/H/Per. (327) (exc. H.D. susp., spec. perf. susp.),				
68	Nova (Spt. Cpe.) (327) w/4-Spd. (exc. H.D. susp.)	3955740	2	58.75	5 leaves
68	Camaro (Spt. Cpe.) (350, 396) (exc. spec. perf. susp., spec. rear spring),				
68	Camaro (Spt. Cpe.) w/positraction (350) (exc. spec. rr. spring spec. perf. susp.),				
68	Camaro (Spt. Cpe.) w/3.73 rr. axle, 4-Spd. (350) (exc. spec. rr. spring, spec. perf. susp.),				
68	Nova (Spt. Cpe.) (exc. 350, 327 H/Per., 4-Spd., H.D. susp. 3.55 rr. axle)	3934897	2	52.25	(max. load 1310)
68	Nova (Sed.) (exc. 350, 327 H/Per., 4-Spd., H.D. susp., 3.55 rr. axle)	3934898	2	52.25	(max. load 1310)
68	Camaro w/spec. rr. spring, 4- Spd. (327),				
68	Camaro w/spec. rr. spring (350, 396)	3932720	2	56.75	4 leaves
68	Chevy (Spt. Cpe.) w/H.D. susp. 4-Spd. (327)	3955742	2	56.75	4 leaves

**COIL TYPE**

64	Chevelle Sta. Wag. (2-Dr.) (8 cyl.),				
64	Chevelle Sta. Wag. (6 cyl.) (exc. 3-Seat),				
64	Chevelle (Sta. Wag.) (4-Dr.) (8 cyl.) (exc. 3-Seat),				
65	Chevelle Deluxe (Sta. Wag.) (4- Dr.),				
65	Malibu (Sta. Wag.) (4-Dr.) (6 cyl.),				
65-66	Chevelle (Sta. Wag.) (327) (exc. H.D. susp.)	3843675	2	14.25	(max. load 1489 lbs.)
64	El Camino w/H.D.,				
65	Chevelle (Taxi) (6 cyl.),				
65	El Camino,				
66	El Camino w/H.D. Susp.	3851066	2	14.50	(max. load 1519 lbs.)
64	El Camino,				
64	Chevelle (Taxi) (6 cyl.),				
64-65	Chevelle (Sed.) w/H.D. susp. (8 cyl.) (exc. Malibu),				
64-65	Malibu (4-Dr. Sed.) w/H.D. susp.,				
66	Malibu w/H.D. susp. (exc. Cpe., Conv.),				
66	Chevelle (S.S., Conv.) w/H.D. Susp.,				
64-65	Chevelle w/H.D.,				

**FRAME—SPRINGS—BUMPER**

**7.503 SPRING ASSEMBLY, Rear (Con't)**

64-65	Police (6 cyl.),				
65	Malibu (Conv.) w/H.D.,				
66	Chevelle (Sed.) (396) (exc. Malibu, H/Per.),				
66	Chevelle (Sed., Conv.) w/H.D. susp.,				
66	Malibu (Conv.) (396),				
67	S.S. (Conv.) (396) . . . . .	<b>3890626</b>	2	13.70	(max. load 1291 lbs.) . . . . .
64	Malibu (Conv., Spt. Cpe.),				
64	Chevelle (2-Dr. Sed.) (8 cyl.),				
64	Chevelle (4-Dr. Sed.),				
64	Chevelle (Std. Sed.) (6 cyl.),				
64	Malibu (Spt. Cpe.) (327),				
65	Chevelle (Sed.) (6 cyl.) (exc. Malibu, C.A.C.),				
65	Malibu (Conv.) (6 cyl.),				
65	Malibu (Spt. Cpe.) w/C.A.C. (8 cyl.),				
65	Malibu (S.S.) (Conv.) (327) . . . . .	<b>3856590</b>	2	14.00	(max. load 1, 158 lbs.) . . . . .
64-66	Chevelle (4-Dr. Sta. Wag.) w/H.D. Susp., 396 H/Perf.,				
65	Chevelle (S.S.) (Conv.) (327),				
65	Malibu (4-Dr. Sed.) (8 cyl.),				
65	Malibu (Spt. Cpe.) (6 cyl.) . . . . .	<b>3848304</b>	2	14.25	(max. load 1340 lbs.) . . . . .
64	Chevelle (Sed.) (327),				
64	Malibu (Conv.) (327),				
65	Chevelle (Sed.) (8 cyl.) (exc. Malibu),				
65	Chevelle (4-Dr. Sed.) w/C.A.C. (6 cyl.) (exc. Malibu),				
65	Malibu (Sed.),				
65-66	Chevelle (Sed.) w/C.A.C. (327),				
65	Malibu (Conv.),				
66	Chevelle (Sed., Conv.) (6 cyl.),				
66	Chevelle (2-Dr. Sed.) (exc. Deluxe),				
66	Chevelle (Spt. Cpe.) (exc. S.S.),				
66	Chevelle (4-Dr., Spt. Sed., Conv.) (8 cyl.),				
66	Chevelle (Deluxe) (2-Dr. Sed.) (8 cyl.),				
66	Chevelle (Std. Sed.) (327) . . . . .	<b>3895818</b>	2	12.55	(max. load 1114 lbs.) . . . . .
65	Chevelle H/Per., Sp. H/Per., (396) w/Level Control (exc. Sta. Wag., Malibu),				
65	Malibu (Conv., El Camino) H/Per., Sp. H/Per., (396) w/Level Control,				
65	Chevelle (Sta. Wag.) w/Level Control (exc. Malibu),				
65	Malibu (Sta. Wag.) (6 cyl.) w/Level Control,				
65-66	El Camino . . . . .	<b>3895820</b>	2	13.25	(max. load 1182 lbs.) . . . . .
65	Chevelle (Sta. Wag.) w/H.D. susp.,				
66	Chevelle (Sta. Wag.) . . . . .	<b>3895827</b>	2	14.25	(max. load 1564 lbs.) . . . . .
66	Chevelle (S.S., Spt. Cpe.) (1st design),				
66	Malibu (8 cyl.) (Spt. Cpe.) w/H.D. susp.,				
66	Malibu (6 cyl.) (Conv.) w/H.D. susp. . . . .	<b>3856269</b>	2	14.00	(max. load 1281 lbs.) . . . . .
66	Chevelle (S.S.) (Conv., Spt. Cpe.) w/H.D. (2nd design) . . . . .	<b>3895825</b>	1	13.30	(max. load 1389 lbs. lbs.) . . . . .

**FRAME—SPRINGS—BUMPER**

**1967-68 CHEVELLE REAR SPRING CODE CHART**

NOTE: See Dealer Price Schedule (P&A 26) for Applicable Prices.

Code Letters	Part Number	Max. Load Lbs.
CB-BC-BH-BT	3908799	1,256
BE-BJ	3952828	1,128
BF-BW	3952831	1,185
BA-BL-CE	3924406	1,741
BK-BO-BP-BZ-CA	3893397	1,469
CC-BB-BS	3893398	1,601
CD	3924405	1,504
CF	3931472	1,342
CG-CH	3937874	1,775

**1967 MODELS**

MODEL	13100		13200		13300				13400				13500				13600				13800					
	11	69	11	69	11	69	35	80	11	69	35	80	69	39	17	67	35	80	69	39	17	67	35	80	17	67
3-Spd., 4-Spd., or A.T.	BE	BE	BF	BF	BE	BE	BA	BW	BF	BF	BA	BW	BF	BF	BE	BE	BA	BW	BF	BE	BE	BE	BA	BW	BH	
327			BE	BE					BE	BE	BA	BW							BE	BF	BJ	BF	BA	BW		
C.A.C.	BE	BE	BE	BE	BE	BE	BA	BW	BE	BE	BA	BW	BF	BE	BE	BE	BA	BW	BE	BF	BJ	BE	BA	BW	BH	
with 327			BE	BE					BE	BE	BA	BW							BE	BF	BJ	BF	BA	BW		
with 396												BB												BB	BH	BC
396												BB												BB	BH	BC
H.D. Front & RR. Susp.	BK	BK	BK	BK	BK	BK	BL	BB	BK	BK	BL	BB	BK	BK	BO	BT	BL	BB	BK	BK	BO	BO	BL	BB	BZ	BP
with C.A.C.	BK	BK	BO	BO	BK	BK	BL	BB	BO	BO	BL	BB	BK	BO	BO	BT	BK	BB	BK	BK	BT	BO	BL	BB	BZ	BP
with 327			BO	BO					BO	BO	BL	BB							BK	BK	BT	BO	BL	BB		
with C.A.C. & 327			BO	BO					BO	BO	BL	BB							BK	BK	BT	BO	BL	BB		
with 396												BS												BS	BZ	BP
with C.A.C. & 396												BS												BZ	BZ	BP

1968 MODELS

MODEL	13100		13200		13300					13400					13500					13600					13700		13800										
	27	35	27	35	27	35	37	69	80	45	27	35	37	69	80	45	35	37	39	67	69	80	45	35	37	39	67	69	80	35	45	35	37	67	80	45	
3 Spd., 4 Spd., or A.T.	CB	CC	BJ	CC	CB	CC	CB	BE	BW	CH	BJ	CC	BJ	BE	BW	CH	CC	CB	BE	BJ	BE	BW	CH	CC	BJ	BF	BE	BE	BW	CC	CH	CC	BH	BH	BB	CH	
327					BJ	CC					BJ	CC	BJ	BE	BW																						
327 H/Per.					BC	CC					BC	CC	BO	BO	CF																						
396																																					
396 Spec. H/Per.																																					
C.A.C.	CB	CC	BJ	CC	CB	CC	BJ	BE	BW		BJ	CC	BJ	BE	BW		CC	BJ	BE	BJ	BE	BW		CC	BJ	BF	BE	BE	BW	CC		CC	BH	BH	BB		
327			BJ	CC							BJ	CC	BJ	BE	BW																						
327 H/Per.			BJ	CC							BJ	CC	BJ	BE	BW																						
396																																					
H.D. Front & Rear Susp.	BC	CE	BC	CE	BC	CE	BC	BO	CF	CG	BC	CE	BC	BO	CF	CG	CE	BC	BO	BC	BO	CF	CG	CE	BC	BK	BT	BO	CF	CE	CG	CE	CA	CA	CD	CG	
With C.A.C.	BC	CE	BC	CE	BC	CE	BC	BO	CF		BC	CE	BC	BK	CF		CE	BC	BO	BT	BO	CF		CE	BC	BK	BT	BK	CF	CE		CE	CA	CA	CD		
With 327			BC	CE							BC	CE	BC	BO	CF																						
With 327 & C.A.C.			BC	CE							BC	CE	BT	BK	CF																						
With 327 H/Per.			BC	CE							BC	CE	BT	BK	CD																						
With 327 H/Per. & C.A.C.			BC	CE							BC	CE	BT	BK	CD																						
With 396																																					
With 396 & C.A.C.																																					
With 396 Spec. H/Per.																																					

FRAME—SPRINGS—BUMPER



## 1969 SPRING CHART

A new system for release of front and rear coil springs will be used for the 1969 A, B, F and X cars. The assembly plants will use a computer to determine the correct spring based on the RPO equipment on the dealer order.

Determination of the correct spring by dealer personnel will be as follows:

1. If the identification tag is still on the spring, Table B will give the part number.
2. If the identification tag is not available, it will be necessary to add the weight for all the RPO equipment on the vehicle. This is shown on Table A. (Only RPO's with 5 lbs. or more are given.)
3. After the extra weight of the vehicle is determined, Table C shows the identification letters of the required spring. These letters are used with Table A to determine the part number.

Example:

A 13646 Concours 4 Door Station Wagon with dual action tail gate is equipped with the following:

Weight to add

<u>Front</u>	<u>Rear</u>	<u>RPO</u>	
196	46	L35	V8 Engine - 396 Cu. In. - 325 H.P.
23	9	M40	3-Speed Automatic Transmission
* -2	7	A33	Electric Tail Gate Window
30	0	N40	Power Steering
<u>2</u>	<u>14</u>	V55	Luggage Carrier
Total 249	76		

\*NOTE: Some options have negative value and must be subtracted instead of added.

1. The weights were obtained from Table B.
2. Table C for this model shows the spring requirement.  
 Standard Springs - front - 249 # requires spring "GO"  
                           rear - All use spring "BB"  
 Heavy Duty Springs - front - 249 # requires spring "GW"  
                           rear - All use spring
3. Table A would then be used to convert to part numbers and the customers requirements would be as follows:

	Front	Rear
Standard Springs	(GO)3952812	(BB)3949015
Heavy Duty Springs	(GW)3952818	(BB)3949006

The use of this system will present two additional advantages. Customer request of upgrading springs due to trunk loads, etc. can be easily accomplished. If there is a question of improper springs installed on the car, it can be easily checked.

1969 FRONT AND REAR COIL SPRING WEIGHT VARIATIONS

RPO	Equipment	Chevelle		Chevy		Camaro	
		Front	Rear	Front	Rear	Front	Rear
L22	L-6 Eng. 250 Cu. In. - 155 H.P.	16	-	16	1	17	-
L34	V-8 Eng. 396 Cu. In. - 350 H.P.	194	46	228	31	209	46
L35	V-8 Eng. 396 Cu. In. - 325 H.P.	196	46	-	-	211	46
L48	V-8 Eng. 350 Cu. In. - 300 H.P.	27	44	48	56	27	44
L65	V-8 Eng. 350 Cu. In. - 250 H.P.	24	44	24	44	24	44
L78	V-8 Eng. 396 Cu. In. - 375 H.P.	179	44	200	31	188	36
L78	V-8 Eng. 396 Cu. In. 375 H.P. (w/L89 Al. Head)	-	-	-	-	133	36
M20	4-Speed Trans.	13	5	-	-	11	5
M35	Powerglide Trans. (L6)	-14	2	12	0	-12	2
M35	Powerglide Trans. (V8)	- 6	2	- 8	1	-	-
M38	3-Speed Auto. Trans.	-	-	-	-	21	6
M38	3-Speed Auto. Trans.	18	6	18	6	-	-
M40	3-Speed Auto. Trans.	23	9	41	12	44	12
MB1	2-Speed Trans.	-	-	-13	-1	-13	1
MC1	HD 3-Speed Trans.	16	3	12	7	17	6
A31	Elect. Windows (exc. Pick-up)	11	13	-	-	8	10
A31	Elect. Windows (Pick-up)	6	4	-	-	-	-
A33	Elect. Tailgate Window	- 2	7	-	-	-	-
A51	Astro Bucket Seats	11	10	8	7	-	-
A67	Folding Rear Seat	-	-	-	-	5	29
A81	Head Rest (Spec. Contour)	-	-	5	6	-	-
A93	Vacuum Door Locks (2 Dr.)	5	3	-	-	-	-
A93	Vacuum Door Locks (4 Dr.)	7	4	-	-	-	-
B37	Floor Mats (Front & Rear)	7	5	4	5	4	5
B37	Floor Mats (Front)	5	2	-	-	-	-
C06	Elect. Folding Top	-	-	-	-	1	5
C-8	Vinyl Top (exc. Pick-up)	2	5	-	-	7	5
C60	Air Conditioning	101	7	91	7	89	8
D55	Console (exc. M40)	7	4	-	-	8	4
D55	Console (w/M40)	12	4	-	-	-	-
D80	Aux. Panel & Valance	-	-	-	-	-1	6
F40	HD Suspension	-	-	8	1	-	-
G31	Spl. Rear Spring	-	-	-	-	-2	8
J50	Power Brakes	10	2	9	2	9	2
J52	Disc Brakes	-	-	7	9	-	-
N10	Dual Exhaust (exc. Sta. Wag., Pick-up, L78)	4	37	1	27	3	26
N10	Dual Exhaust (Sta. Wag., Pick-up, L78)	3	29	0	10	1	9
N40	Power Steering	30	0	30	1	30	0
N65	Space Saver Spare	-	-	-	-	3	-11
T60	HD Battery	18	-3	-	-	-	-
T60	HD Battery (Base Eng.)	-	-	17	-2	-	-
T60	HD Battery (RPO Eng.)	-	-	6	-1	-	-
T60	HD Battery (L6 & Z28)	-	-	-	-	18	-3
T60	HD Battery (307, 350, 396)	-	-	-	-	6	-1
U57	Tape Player (w/U79)	12	4	-	-	-	-
U57	Tape Player (exc. U79)	9	3	-	-	-	-
U57	Tape Player	-	-	13	5	14	5
U63	Radio (Pushbutton)	6	2	6	2	6	3
U69	Radio (AM-FM)	6	3	7	2	7	3
U79	Stereo	7	2	5	2	5	2
V01	HD Radiator (L6)	8	-1	-	-	-	-
V01	HD Radiator (V-8)	7	-1	6	-1	7	-1
V31	Front Bumper Guard	-	-	-	-	5	-1
V32	Rear Bumper Guard	-	-	-	-	-1	5
V55	Luggage Carrier (Sta. Wag.)	2	14	-	-	-	-
VE3	Spec. Front Bumper	-	-	-	-	-6	1
Z22	R.S. Package	-	-	-	-	23	-2
Z28	Spec. Eng. (exc. Spec. Exh.)	-	-	-	-	3	33
Z28	Spec. Eng. (w/Plenum Air Panel)	-	-	-	-	1	45
Z28	Spec. Eng. (w/Spec. Exh.)	-	-	-	-	0	49
Z28	Spec. Eng. (w/Air Pol., Spec. Exh.)	-	-	-	-	1	61
ZJ1	Custom Interior	-	-	5	6	-	-
ZJ2	Custom Interior	-	-	6	7	-	-

1969 CHEVELLE—SPRINGS—REQUIREMENTS

Model	Susp.	6 Cylinder				8 Cylinder			
		Front		Rear		Front		Rear	
		Weight	Spring	Weight	Spring	Weight	Spring	Weight	Spring
Sedan 13369 13469 13539 13639 13569 13669	Std.	0-54 55-134 135-208 209-284 285-358 Over 358	AF AH AI AJ AO AQ	0-50 51-106 Over 106	BE BF BI	0-20 21-94 95-170 171-244 Over 244	AH AI AJ AO AQ	0-24 25-80 Over 80	BE BF BI
	HD	0-110 111-186 187-262 263-338 Over 338	GS GT GU GV GW	0-60 Over 60	BQ BR	0-72 73-148 149-224 Over 224	GT GU GV GW	0-34 Over 34	BQ BR
Coupe 13327-37 13427137 13537 & 13637 Ex. L34, L35 & L78	Std.	0-62 63-142 143-222 223-292 293-372 Over 372	AF AH AI AJ AO AQ	0-96 97-156 Over 156	BU BE BF	0-28 29-108 109-178 179-258 Over 258	AH AI AJ AO AQ	0-70 71-128 Over 128	BU BE BF
	HD	0-102 103-182 183-258 259-336 337-412 Over 412	GS GT GU GV GW GX	0-96 97-192 Over 192	BF BQ BR	0-68 69-144 145-222 223-298 Over 298	GT GU GV GW GX	0-70 71-166 Over 166	BP BQ BR
Coupe 13637 With L34, L35 & L78	Std.					* 0-264 265-326 327-372 373-456 Over 456	GW GX GY GZ AA	0-130 Over 130	BL BM
	HD					0-304 305-422 Over 422	AB AC AD	All	BT
Conv. 13567 & 13667 Ex. L34, L35 L78	Std.	0-18 19-98 99-178 179-248 249-328 Over 328	AF AH AI AJ AO AQ	0-42 43-100 Over 100	BU BE BF	0-66 67-136 137-216 Over 216	AI AJ AO AQ	0-18 19-76 Over 76	BU BE BF

1969 CHEVELLE—SPRINGS—REQUIREMENTS (CONT'D.)

Model	Susp.	6 Cylinder				8 Cylinder			
		Front		Rear		Front		Rear	
		Weight	Spring	Weight	Spring	Weight	Spring	Weight	Spring
Conv. 13567 & 13667 Ex. L34, L35 L78	HD	0-58 59-138 139-214 215-292 293-368 Over 368	GS GT GU GV GW GX	0-42 43-138 Over 138	BP BQ BR	0-26 27-102 103-180 181-256 Over 256	GT GU GV GW GX	0-18 19-114 Over 114	BP BQ BQ
Conv. 13667 With L34, L35 & L78	Std.					0-230 231-292 293-358 359-422 Over 422	GW GX GY GZ AA	0-88 Over 88	BL BM
	HD					0-270 271-388 Over 388	AB AC AD	All	BT
Pick Up 13380 13480 13580 & 13680 Ex. L34 L35 & L78	Std.	0-26 27-102 103-176 177-252 253-328 Over 328	AR AW AZ GI GO GQ	All	BW	0-58 59-134 135-210 Over 210	AZ GI GO GQ	All	BW
	HD	0-12 13-88 89-162 163-238 239-314 Over 314	GS GT GU GV GW GX	All	BS	0-44 45-120 121-196 Over 196	GU GV GW GX	All	BS
13680 With L34, L35 & L78	Std.					0-270 271-334 335-400 401-464 Over 464	GW GX GY GZ AA	All	BR
	HD					0-310 311-428 Over 428	AB AC AD	All	BX

1969 CHEVELLE—SPRINGS—REQUIREMENTS (CONT'D.)

Model	Susp.	6 Cylinder				8 Cylinder			
		Front		Rear		Front		Rear	
		Weight	Spring	Weight	Spring	Weight	Spring	Weight	Spring
2 Seat Wagon Std. Gate 13135 13235 13335 13435	Std.	0-82 83-156 157-232 233-306 307-380 Over 380	AR AW AZ GI GO GQ	0-120 121-250 Over 250	BY BA BB	0-56 57-132 133-206 207-280 Over 280	AW AZ GI GO GQ	0-92 93-222 Over 222	BY BA BB
	HD	0-72 73-152 153-232 233-298 299-374 Over 374	GS GT GU GV GW GX	0-80 81-170 Over 170	BC BD BG	0-48 49-124 125-198 199-274 Over 274	GT GU GV GW GX	0-52 53-142 Over 142	BC BD BG
2 Seat Wagon Dual Gate 13136-236 13336-436 13536-636 13836	Std.	0-114 115-188 189-264 265-338 339-412 Over 412	AR AW AZ GI GO GQ	0-136 Over 136	BA BB	0-78 79-154 155-228 229-302 Over 302	AW AZ GI GO GQ	0-98 Over 98	BA BB
	HD	0-104 105-180 181-256 257-330 331-406 Over 406	GS GT GU GV GW GX	0-56 Over 56	BD BG	0-70 71-146 147-220 221-396 Over 396	GT GU GV GW GX	0-18 Over 18	BD BG
3 Seat Wagon Dual Gate 13346-446 13546-646 13846	Std.	0-108 109-182 183-258 259-332 333-406 Over 406	AR AW AZ GI GO GQ	All	BB	0-74 75-150 151-224 225-298 Over 298	AW AZ GI GO GQ	All	BB
	HD	0-98 99-174 175-250 251-324 325-400 Over 400	GS GT GU GV GW GX	All	BG	0-66 67-142 143-216 217-292 Over 292	GT GU GV GW GX	All	BG

**FRAME—SPRINGS—BUMPER**

**"A"**  
**1969 CHEVELLE SPRINGS—IDENTIFICATION**

FRONT			REAR		
IDENTIFICATION	PART NO.	RATE	IDENTIFICATION	PART NO.	RATE
AA	3983304	320	GX-GV-GW	3952818	320
AB	3960665	390	GZ-GY	3952820	320
AC-AD	3952824	390	BD-BA-BC-BY	3949002	200
AF	3952808	250	BG-BB	3949006	200
AW-AI-AH-AR	3952808	275	BU-BP-BE-BL-BM	3952828	130
AO-AZ-AJ-GI-GO	3952811	275	BW-BS-BR-BF-BQ-BI	3952831	130
GQ-AQ	3952813	275	BT	3960652	160
GU-GS-GT	3952815	320	BX	3952834	160

**FRAME—SPRINGS—BUMPER**

**1970-71 CHEVELLE**

MODEL	STD. SUSPENSION		H.D. SUSPENSION	
	FRONT	REAR	FRONT	REAR
Chevelle (Sed.) (6 cyl.) (exc. CAC) . . . . .	3952808	3952831	3952815	3952831
Chevelle (Sed.) (6 cyl.) (w/CAC) . . . . .	3952811	3952831	3952815	3952831
Chevelle (Sta. Wag.) (6 cyl.) (exc. CAC) . . . . .	3952815	3949002	—	—
Chevelle (Sta. Wag.) (6 cyl. w/CAC) . . . . .	3952818	3949002	—	—
Chevelle (2-Dr.) (6 cyl.) (exc. El Camino CAC).	3952808	3952828	3952815	3952831
Chevelle (2-Dr.) (6 cyl.) (w/CAC) (exc. El Camino) . . . . .	3952808	3952828	3952815	2952831
El Camino (307,350) (exc. CAC) . . . . .	3952811	3952828	3952818	3952831
El Camino (307,350) (w/CAC) . . . . .	3952813	3952828	3952818	3952831
Monte Carlo (307,350) (exc. CAC) . . . . .	3952808	3952828	—	—
Monte Carlo (307,350) (w/CAC) . . . . .	3952811	3952828	—	—
Concours (307,350) (exc. CAC) . . . . .	3952818	3949006	—	—
Concours (307,350) (w/CAC) . . . . .	3952820	3949006	—	—
Chevelle (Sta. Wag.) (307,350) (exc. CAC) . . . . .	3952815	3949006	—	—
Chevelle (Sta. Wag.) (307,350) (w/CAC) . . . . .	3952818	3949006	—	—
Chevelle (307,350) (exc. Sta. Wag., El Camino, CAC) . . . . .	3952808	3952828	3952815	3952831
Chevelle (307,350) (w/CAC) (exc. Sta. Wag., El Camino) . . . . .	3952811	3952828	3952818	3952831
El Camino (Custom) (400, 454) (exc. CAC) . . . . .	3952818	3952831	—	3952834
El Camino (Custom) (400, 454) w/CAC . . . . .	3952820	3952831	—	3952834
Malibu (Spt. Cpe., Conv.) (400, 454) (exc. CAC) . . . . .	—	—	3960665	3960652
Malibu (Spt. Cpe., Conv.) (400, 454) w/CAC . . . . .	—	—	3960665	3987800
Monte Carlo (400, 454) (exc. CAC) . . . . .	3952811	3952828	—	—
Monte Carlo (400, 454) w/CAC . . . . .	3952811	3952828	—	—

**CHART "A"  
1972 CHEVELLE**

MODEL	BASE SPRING WEIGHT	
	FRONT	REAR
13369 Chevelle (Sed.) (Standard) (6 Cyl.)	784.0	607.5
13469 Chevelle (Sed.) (Standard) (8 Cyl.)	835.0	618.0
13569 Malibu (Sed.) (exc. Spt. Sed.) (6 Cyl.)	794.0	615.5
13669 Malibu (Sed.) (exc. Spt. Sed.) (8 Cyl.)	845.0	629.0
13639 Malibu (Spt. Sed.)	853.0	654.0
13337 Chevelle (Spt. Cpe.) (Standard) (6 Cyl.)	774.0	598.5
13437 Chevelle (Spt. Cpe.) (Standard) (8 Cyl.)	827.0	608.0
13537 Malibu (Spt. Cpe.) (6 Cyl.)	780.0	604.5
13637 Malibu (Spt. Cpe.) (8 Cyl.)	834.0	615.0
13667 Malibu (Conv.)	829.0	647.0
13857 Monte Carlo	874.5	642.0
13380 El Camino (exc. Custom) (6 Cyl.)	782.5	609.0
13480 El Camino (exc. Custom) (8 Cyl.)	833.5	620.0
13680 El Camino (Custom)	836.5	622.0
13136 Nomad (6 Cyl.)	719.0	859.5
13236 Nomad (8 Cyl.)	775.0	863.5
13436 Greenbrier (6 Pass.)	781.0	890.5
13446 Greenbrier (9 Pass.)	778.0	922.0
13636 Concours (exc. Estate) (6 Pass.)	773.0	920.5
13646 Concours (exc. Estate) (9 Pass.)	785.0	935.5
13836 Concour (Estate) (6 Pass.)	799.0	910.5
13846 Concour (Estate) (9 Pass.)	792.0	944.5

**FRAME—SPRINGS—BUMPER**

**CHART "B"  
1972 CHEVELLE**

RPO OPTIONS		FRONT	REAR
A-31	Electric Window	5.5	6.0
A-46	Electric 4-Way Seat	7.5	4.5
A-51	Bucket Seat	10.0	8.0
C-60	Air Conditioning	48.0	3.0
D-55	Floor Console	6.5	6.5
G-67	Level Control	4.0	1.5
K-30	Speed and Cruise Control	7.5	0
LS3	(402)	106.5	25.0
LS5	(454)	104.5	24.5
L48	(350) 4 BC	11.5	1.5
L65	(350) 2 BC	8.5	1.5
MC1	Heavy Duty 3-Spd.	12.0	3.0
M20	4-Spd.	6.0	2.5
M38	TH-350	14.0	3.0
M40	TH-400	30.0	9.5
N40	Power Steering	13.5	0.5
YF3	Heavy Chevy Exterior	7.0	0.5

**CHART "C"  
CHEVELLE**

STANDARD (EXC. H.D. SUSP.)

1972 CHEVELLE SED. 13369-469-569-639-69

FRONT			REAR		
CODE	SPRUNG WEIGHT	PART NUMBER	CODE	SPRUNG WEIGHT	PART NUMBER
AR,AH,AI	0-863	3952808	BM,BU,BE	0-665	3952828
GI,AJ,AO	864-943	3952811	BW,BR,BF,BI	665-Over	3952831
AK,GQ,AQ,GD	944-1046	3952813			
AP,AL	1046-Over	3983304			

CHEVELLE (SPT. CPE., CONV.) (350) (EXC. MONTE CARLO) 13337-437-537-13637-67

FRONT			REAR		
CODE	SPRUNG WEIGHT	PART NUMBER	CODE	SPRUNG WEIGHT	PART NUMBER
AR,AF,AH,AI	0-822	3952808	BM,BU,BE	0-665	3952828
GI,AJ,AO	823-902	3952811	BW,BR,BF,BI	666-Over	3952831
AK,GQ,AQ,GD	903-1048	3952813			
AP,AL	1049-Over	3983304			

EL CAMINO (EXC. 454) 13380-480-680

FRONT			REAR		
CODE	SPRUNG WEIGHT	PART NUMBER	CODE	SPRUNG WEIGHT	PART NUMBER
GO,GI,AZ,GI	0-914	3952811	BR,BW	ALL	3952831
GQ,AK	915-990	3952813			
AP,AL	991-Over	3983304			

EL CAMINO (CUSTOM) (454) 13680

FRONT			REAR		
CODE	SPRUNG WEIGHT	PART NUMBER	CODE	SPRUNG WEIGHT	PART NUMBER
GW,GX	0-972	3952818	BR	ALL	3952831
GY,GZ	973-1036	3952820			
AP,AA	1037-Over	3983304			

MONTE CARLO 13857

FRONT			REAR		
CODE	SPRUNG WEIGHT	PART NUMBER	CODE	SPRUNG WEIGHT	PART NUMBER
AI,GI,AJ,AO,GO	0-1005	3952811	BM,BP	0-725	3952828
GQ,AK	1006-1087	3952813	BR,BQ	725-Over	3952831
AP,AL	1087-Over	3983304			



**FRAME—SPRINGS—BUMPER**

**HEAVY DUTY**

**1972 CHEVELLE (SED.) 13369-569-13469-639-69**

FRONT			REAR		
CODE	SPRUNG WEIGHT	PART NUMBER	CODE	SPRUNG WEIGHT	PART NUMBER
GA,GB,GC GP	0-1025 1025-Over	3960665 3987798	OQ OJ,OH,OG	0-640 641-Over	3960652 3987800

**CHEVELLE (SPT. CPE., CONV.) (EXC. 454, MONTE CARLO)**

FRONT			REAR		
CODE	SPRUNG WEIGHT	PART NUMBER	CODE	SPRUNG WEIGHT	PART NUMBER
GA,GB,GC GP	0-1045 1046-Over	3960665 3987798	OQ OH,OG	0-630 631-Over	3960652 3987800

**MALIBU (SPT. CPE., CONV.) (454) 13637-67**

FRONT			REAR		
CODE	SPRUNG WEIGHT	PART NUMBER	CODE	SPRUNG WEIGHT	PART NUMBER
GB,GC GP	0-1040 1041-Over	3960665 3987798	OQ OJ,OH,OG	0-620 621-Over	3960652 3987800

**CHEVELLE (SPT. CPE., CONV.) (402) (EXC. MONTE CARLO) 13437-637-667**

FRONT			REAR		
CODE	SPRUNG WEIGHT	PART NUMBER	CODE	SPRUNG WEIGHT	PART NUMBER
GA,GB,GC GP	0-1028 1029-Over	3960665 3987798	OQ OH,OG	0-630 631-Over	3960652 3987800

**EL CAMINO (EXC. 454) 13380-480-680**

FRONT			REAR		
CODE	SPRUNG WEIGHT	PART NUMBER	CODE	SPRUNG WEIGHT	PART NUMBER
GT,GU GW,GV,GX GY,GZ AP,AA	0-846 847-950 951-1015 1016-Over	3952815 3952818 3952820 3983304	BR	ALL	3952831

**EL CAMINO (CUSTOM) (454) 13680**

FRONT			REAR		
CODE	SPRUNG WEIGHT	PART NUMBER	CODE	SPRUNG WEIGHT	PART NUMBER
GB,AB AC,AD	0-980 981-Over	3960665 3952824	BX,OZ	ALL	3952834

**ALL STA. WAG.**

FRONT			REAR		
CODE	SPRUNG WEIGHT	PART NUMBER	CODE	SPRUNG WEIGHT	PART NUMBER
GT,GU GW,GV,GX GY,GZ AP,AA	0-832 833-938 939-1002 1003-Over	3952815 3952818 3952820 3983304	BC,BD BG,OY	0-922 923-Over	3949002 3949006

**1969 CHEVY II SPRING IDENTIFICATION**

FRONT			REAR		
Identification	Part No.	Rate	Identification	Part No.	Rate
EK-EB-ED	3955709*	280	BG	3955742*	100
EL	3955712*	280	BK	3955740*	115
ES	3932767*	320	BQ	3955730*	115
EZ	3955715*	320	BR	3955731*	115
HJ-HH	3955727	400	BU	3955734*	125
HK-EY-HL-			BV	3955735*	125
HM-YF	3955720*	345			
YA-YP-YM-					
YH	3955722*	345			

\*NOTE: Prices for these parts can be found in group 7.412

**1969 CHEVY II SPRING REQUIREMENTS**

Model	Standard Suspension				Heavy Duty Suspension			
	Front		Rear		Front		Rear	
	Weight	Spring	Weight	Spring	Weight	Spring	Weight	Spring
All 4 Cylinder 11127 11169	0-122 123-240 241-308 309-378 Over 378	ES HK HL EZ YA	0-80 Over 80	BQ BR	Not Available			
All 6 Cylinder 11327 11369	0-66 67-148 149-230 231-312 313-394 Over 394	HM YF EY YH YM YP	0-78 Over 78	BQ BR	Same As Prod.		0-86 Over 86	BU BV
8 Cylinder 11400 With 307	0-36 37-104 105-174 Over 174	HK HL EZ YA	0-50 Over 50	BQ BR	0-50 51-132 133-214 215-296 Over 296	YF EY VH VM YP	0-58 Over 58	BU BV
11427 With L48, L65 11469 With L65	0-62 63-128 129-194 Over 194	EB ED EK EL	All	BK	0-50 51-132 133-214 215-296 Over 296	YF EY YH YM YP	All	BG
11427 With L34, L78	0-50 51-132 133-214 215-296 Over 296	YF EY YH YM YP	All	BK	0-294 Over 294	HH HJ	All	BG

**FRAME—SPRINGS—BUMPER**

**1970 NOVA SPRING CHART SERVICE**

	MODEL	STD. SUSPENSION		H.D. SUSPENSION	
		FRONT	REAR	FRONT	REAR
70	Nova (4 cyl.) . . . . .	3955720	3962778	—	—
70	Nova (6 cyl.) (exc. CAC) . . . . .	3955720	3962778	—	—
70	Nova (6 cyl. w/CAC) . . . . .	3955720	3962778	—	—
70	Nova (2-Dr.) (307) (exc. CAC) . . . . .	3955720	3962778	3955720	3962778
70	Nova (4-Dr.) (307) (w/CAC) . . . . .	3955722	3962778	3955722	3962778
70	Nova (4-Dr.) (307) (w/CAC T.H.) . . . . .	—	—	3955722	3962778
70	Nova (2-Dr.) (350) . . . . .	3955709	3955742	3955722	3955742
70	Nova (4-Dr.) (350) . . . . .	3955712	3955742	3955722	3955742
70	Nova (2-Dr.) (396) . . . . .	3955712	3955742	3955727	3955742
70	Nova (4-Dr.) (396) . . . . .	3955712	3955742	3955727	3955742

**1971 NOVA SPRING CHART SERVICE**

	MODEL	STD. SUSPENSION		H.D. SUSPENSION	
		FRONT	REAR	FRONT	REAR
71	Nova (4 cyl.) . . . . .	3955720	3962778	—	—
71	Nova (6 cyl.) (exc. CAC) . . . . .	3955720	3962778	—	—
71	Nova (6 cyl. w/CAC) . . . . .	3955720	3962778	—	—
71	Nova (2-Dr.) (307) (exc. CAC) . . . . .	3955720	3962778	3955720	3962778
71	Nova (4-Dr.) (307) (w/CAC) . . . . .	3955722	3962778	3955722	3962778
71	Nova (4-Dr.) (307) (w/CAC T.H.) . . . . .	—	—	3955722	3962778
71	Nova (2-Dr.) (350) . . . . .	3955709	3955742	3955722	3955742
71	Nova (4-Dr.) (350) . . . . .	3955712	3955742	3955722	3955742

**CHART "A"**

**1972 NOVA**

MODEL	BASE SPRING WEIGHT	
	FRONT	REAR
11327 Nova (2-Dr.) (6 Cyl.)	708.5	557.5
11427 Nova (2-Dr.) (8 Cyl.)	764.5	568.5
11369 Nova (4-Dr.) (6 Cyl.)	710.5	572.5
11469 Nova (4-Dr.) (8 Cyl.)	765.5	584.5

**CHART "B"**

**1972 NOVA**

RPO OPTIONS	FRONT	REAR
A-51 Bucket Seats	6.0	5.5
C-60 Air Conditioning	47.0	3.5
D-55 Floor Console	4.5	2.0
L-65 (350) (2 BC)	4.0	5.0
L-48 (350) (4 BC)	11.0	22.0
M-20 (4-Spd.)	1.5	.5
M-38 TH-350	13.0	3.0
N-40 Power Steering	19.5	.0
T-60 Heavy Duty Battery	6.5	0
ZJ1 Custom Interior	7.0	9.5

**FRAME—SPRINGS—BUMPER**

**CHART "C"**

**1972 NOVA**

**NOVA (6 CYL.) W/P.S. (EXC. H.D. SUSP.) NOVA (350)**

FRONT		
CODE	SPRUNG WEIGHT	PART NUMBER
EB,ED,EK EM,EL	0-805 806-Over	3955709 3955712

**NOVA (307) (EXC. H.D. SUSP.)**

FRONT		
CODE	SPRUNG WEIGHT	PART NUMBER
ES YF,HN,HO EZ YA,YB,YM,YC	0-662 663-753 754-788 789-Over	3932767 3955720 3955715 3955722

**NOVA (6 CYL.) (EXC. P/S H.D. SUSP.) NOVA W/H.D. SUSP.**

FRONT		
CODE	SPRUNG WEIGHT	PART NUMBER
HP,YF,EY YH,YM,YP	0-766 767-Over	3955720 3955722

**NOVA (6 CYL. 307) (EXC. H.D. SUSP.)**

REAR		
CODE	SPRUNG WEIGHT	PART NUMBER
DF DG	0-609 610-Over	3962776 3962777

**NOVA (6 CYL., 307) (H.D. SUSP.)**

REAR		
CODE	SPRUNG WEIGHT	PART NUMBER
DH-DI	ALL	3962778

**NOVA (350) (EXC. H.D. SUSP.)**

REAR		
CODE	SPRUNG WEIGHT	PART NUMBER
BK	ALL	3955740

**NOVA (350) (H.D. SUSP.)**

REAR		
CODE	SPRUNG WEIGHT	PART NUMBER
BK	ALL	3955742

**TABLE B**  
**1969 CAMARO SPRING IDENTIFICATION**

FRONT		REAR	
Identification	Part No.	Identification	Part No.
EA	3955707	BA	3920220
EB-EK-ED	3955709	BF	3955741
EL	3955712	GB-BM	3955742
EM	3955712	BK-BY	3955740
EQ	3955712	BL	3955743
ER	3955714	BN	3955744
EZ	3955715	BP	3955729
HA-HB-HG	3955725	BQ	3955730
HH-HJ	3955727	BR	3955731
YD	3955725	BS	3955732
EY-YF	3955720	BT	3955733
YA-YB-YM-YC-YP-YH	3955722	BU	3955734
		BV	3955735
		BW	3955736
		BX	3955737

NOTE: See Dealer Price Schedule (P&A 26) for Applicable Prices.

**TABLE C**  
**1969 CAMARO SPRING DETERMINATION**

Model	Standard				Heavy Duty			
	Front		Rear		Front		Rear	
	Weight	Ident.	Weight	Ident.	Weight	Ident.	Weight	Ident.
12337	0-68	EB	0-66	BP	0-162	YF	F40	
	69-136	ED	67-140	BQ	163-242	EY	0-76	BT
	137-204	EK	141-222	BR	Over 242	YH	77-150	BU
	205-272	EL	Over 222	BS			151-234	BV
	273-340	EM					Over 234	BW
	341-408	EQ					G31	
	Over 408						0-42	BV
							Over 42	BW
							JL8	
							0-116	BY
12367 (Base Eng. Ex. JL8)	0-56	ED	0-48	BR	0-30	EY	F40	
	57-124	EK	Over 48	BS	31-112	YH	0-60	BV
	125-192	EL			113-194	YM	Over 60	BW
	193-260	EM			195-276	YP	G31	
	261-328	EQ			277-358	HA	All	BA
	Over 328	ER			359-440	HB	JL8	
					Over 440	HG	0-48	BK
							Over 48	BF
							G31 & JL8	
							0-40	BL
12437 (Base Eng. with JL8)	0-66	EZ	0-38	BP	0-16	EY	F41	
	67-140	YA	39-112	BQ	17-98	YH	0-48	BT
	141-214	YB	113-194	BR	99-180	YM	49-122	BU
	215-288	YO	Over 194	BS	181-262	YP	123-206	BV
	Over 288	YD			263-344	HA	Over 206	BW
					345-426	HB	G31	
					Over 426	HG	0-132	BX
							Over 132	BA
12437 (Base Eng. with JL8)	0-42	ED	0-88	BY	0-66	EZ	F41	
	43-110	EK	89-194	BK	67-140	YA	0-96	BM
	111-178	EL	Over 194	BF	141-214	YB	97-214	BG
	179-246	EM			215-288	YO	Over 214	BL
	247-314	EQ			Over 288	YD	G31	
	Over 314	ER					0-16	BG
							17-186	BL
						Over 186	BN	

**TABLE C**  
**1969 CAMARO SPRING DETERMINATION (CONT'D.)**

Model	Standard				Heavy Duty			
	Front		Rear		Front		Rear	
	Weight	Ident.	Weight	Ident.	Weight	Ident.	Weight	Ident.
12437 (L48, L65)	0-42 43-110 111-178 179-246 247-314 Over 314	ED EK EL EM EQ ER	0-88 89-194 Over 194	BY BK BF	0-16 17-98 99-180 181-262 263-344 345-426 Over 426	EY YH YM YP HA HB HG	F41 0-96 97-214 Over 214 G31 0-16 17-186 Over 186	BM BG BL BG BL BN
12437 (L34, L35 & L78)	0-16 17-98 99-180 181-262 263-344 345-426 Over 426	EY YH YM YP HA HB HG	0-166 Over 166	BK BF	0-182 183-304 Over 304	HH HJ EA	F41 0-96 97-214 Over 214 G31 0-16 17-186 Over 186	BM BG BL BG BL BN
12437 (Z28)	0-68 69-148 Over 148	YF EY YH	All	BM				
12467 (Base Eng. Ex. JL8)	0-58 59-132 123-206 Over 206	YA YB YC YD	0-16 Over 16	BR BS	0-16 17-98 99-180 181-262 263-344 Over 344	YH YM YP HA HB HG	F41 0-28 Over 28 G31 All	BV BW BA
12467 (Base Eng. with JL8)	0-28 29-96 97-164 165-232 Over 232	EK EL EM EQ ER	0-16 Over 16	BK BF	0-58 59-132 133-206 Over 206	YA YB YC YD	F41 0-36 Over 36 G31 0-8 Over 8	BG BL BL BN
12467 (L48, L65)	0-28 29-96 97-164 165-232 Over 232	EK EL EM EQ ER	0-16 Over 16	BK BF			G31 0-8 Over 8	BL BN
12467 (L34, L35 & L78)	0-16 17-98 99-180 181-262 263-344 Over 344	YH YM YP HA HB HG	All	BF			G31 0-8 Over 8	BL BN

**FRAME—SPRINGS—BUMPER**

**1970 CAMARO SPRING CHART SERVICE**

	MODEL	STD. SUSPENSION		H.D. SUSPENSION	
		FRONT	REAR	FRONT	REAR
70	Camaro (6 cyl.) (exc. P/S, A.T.) . . . . .	3982342	480878	—	—
70	Camaro (6 cyl.) w/P/S, A.T. . . . .	3982342	480878	—	—
70	Camaro (307) (exc. CAC) . . . . .	3982342	480878	—	—
70	Camaro (307) w/CAC . . . . .	3996365	480878	—	—
70	Camaro (350) (exc. CAC) . . . . .	3982342	480878	—	—
70	Camaro (350) w/CAC . . . . .	3996365	494776	—	—
70	Camaro (396) (exc. CAC) . . . . .	3982342	480878	—	—
70	Camaro (396) w/CAC . . . . .	3988104	494776	—	—
70	Camaro (w/Sp H/Per 350) (exc. CAC) . . . . .	3982342	480881	—	—
70	Camaro (CAC w/Sp H/Per 350) w/CAC . . . . .	3982344	480881	—	—

**1971 CAMARO SPRING CHART SERVICE**

	MODEL	STD. SUSPENSION		H.D. SUSPENSION	
		FRONT	REAR	FRONT	REAR
71	Camaro (6 cyl.) w/P/S, A.T. . . . .	3982342	480878	—	—
71	Camaro (307) (exc. CAC) . . . . .	3982342	480878	—	—
71	Camaro (307) w/CAC . . . . .	3996365	480878	—	—
71	Camaro (350) (exc. CAC) . . . . .	3982342	480878	—	—
71	Camaro (350) w/CAC . . . . .	3982354	494776	—	—
71	Camaro (w/SP, H/Per. 350) (exc. CAC) . . . . .	3982347	480881	—	—
71	Camaro (CAC w/SP, H/Per. 350) w/CAC . . . . .	3996365	480881	—	—



**CHART "A"**  
**1972 CAMARO**

MODEL	BASE SPRING WEIGHT	
	FRONT	REAR
12387 Camaro (6 Cyl.)	765.0	548.0
12487 Camaro (8 Cyl.)	817.0	558.0

**CHART "B"**  
**1972 CAMARO**

RPO OPTIONS	FRONT	REAR
A-51 Bucket Seats	5.5	4.5
C-60 Air Conditioning	50.0	8.0
D-55 Floor Console	7.0	2.0
D-80 Spoilers	0	10.5
LS3 (402)	102.5	14.0
L48 (350) 2/BC	9.5	14.0
L65 (350) 2 BC	5.0	0
M-38 TH-350	7.5	4.5
M-40 TH-400	13.0	7.0
N-40 Power Steering	14.5	0
T-60 Heavy Duty Battery	7.0	0
Z-22 Rally Sport Package	11.0	0
Z-28 Sp. H/Per. 350	21.5	21.5
Z-87 Deluxe Int.	4.5	7.5

**FRAME—SPRINGS—BUMPER**

**1972 CAMARO**

**CAMARO (EXC. SP. H/PER 350)**

**CHART "C"**

**FRONT**

CODE	SPRUNG WEIGHT	PART NUMBER
EF, EG, EH	0-858	3996362
EI	859-888	3996364
EJ	889-905	3996365
YR, GL, GM	957-Over	3988104

**CAMARO W/SP. H/PER 350**

**FRONT**

CODE	SPRUNG WEIGHT	PART NUMBER
EJ	0-847	3996365
EI, EN	848-877	3996364
EO	878-Over	3996367

**CAMARO (EXC. SP. H/PER 350)**

**REAR**

CODE	SPRUNG WEIGHT	PART NUMBER
PA	0-580	480878
PB	581-Over	494776

**CAMARO W/SP. H/PER 350**

**REAR**

CODE	SPRUNG WEIGHT	PART NUMBER
DY	ALL	480881

**FRAME—SPRINGS—BUMPER**

**7.503 SPRING ASSY., Front and Rear**

*Follow the three steps below to utilize the 1973 spring charts.*

1. Select the model desired with the base spring weight on Chart "A".
2. Then select options accordingly shown on Chart "B" and add that weight to the base spring weight.
3. When accumulated weight has been determined refer to chart "C" and select correct spring.

**1973 PASS.**

**CHART "A"**

	<b>MODEL</b>	<b>FRONT</b>	<b>REAR</b>
BK-35	Bel Air (Sta. Wag.) (6-Pass.)	998.0	1040.5
BK-45	Bel Air (Sta. Wag.) (9-Pass.)	995.5	1069.5
BK-69	Bel Air (Sed.)	924.5	768.5
BL-35	Impala (Sta. Wag.) (6-Pass.)	1005.0	1046.0
BL-39	Impala (Spt. Sed.)	1005.0	821.0
BL-45	Impala (Sta. Wag.) (9-Pass.)	1004.5	1079.0
BL-47	Impala (Custom)	1000.0	800.5
BL-57	Impala (Spt. Cpe.) (exc. Custom)	999.5	794.0
BL-69	Impala (Sed.)	1013.0	801.5
BN-35	Caprice (Estate) (6-Pass.)	1019.5	1058.5
BN-39	Caprice (Spt. Sed.)	1022.0	826.0
BN-45	Caprice (Estate) (9-Pass.)	1017.0	1091.0
BN-47	Caprice (Spt. Cpe.)	1014.5	801.0
BN-67	Caprice (Conv.)	1022.0	817.5
BN-69	Caprice (Sed.)	1027.0	805.0

**CHART "B"**

	<b>RPO OPTIONS</b>	<b>FRONT</b>	<b>REAR</b>
AT-8	Frnt. Seat 50/50 Bench	10.5	9.0
AU-3	Electric Door Lock	4.5	2.0
A-31	Power Window	6.5	5.5
A-42	Power Seats	5.5	4.5
BY-2	Body-Police Car	12.5	8.0
BO-2	Taxi Cab	26.5	13.5
C-60	Air Conditioning	53.5	3.0
F-40	H/D Frnt. & Rear Suspension	7.0	0.0
LF-6	(400)	58.5	7.5
LS-4	(454)	131.0	40.5
L-48	(350)	53.0	27.0
M-38	3-Spd. Trans. CBC	34.0	11.0
M-40	3-Spd. Trans.-Hyd.	44.5	16.0
NB-2	Exhaust Emission Control	9.0	0.0
T-60	H/D Battery	8.0	1.0
UM-1	Radio	8.5	2.5

**FRAME—SPRINGS—BUMPER**

**1973 PASSENGER**

**CHART "C"**

*Pass. (350, 400) (exc. Sta. Wag., Police, Taxi) BL39-BL47-BL57-BL69-BN39-BN47-BN67-BN69*

CODE	FRONT SPRUNG WEIGHT	PART NUMBER	CODE	REAR SPRUNG WEIGHT	PART NUMBER
BH, BJ, BK BL	0— 1122 1123— Over	3988118 3988126	XK, XL XM	0— 866 867— Over	482065 482067

*Pass. (454) (exc. Sta. Wag., Police, Taxi) BL39-BL47-BL57-BL69-BN39-BN47-BN67-BN69*

BW BX BY	0— 1147 1148— 1188 1189— Over	3988126 3988138 3988139	YK, XL XM	0— 866 867— Over	482065 482067
----------------	-------------------------------------	-------------------------------	--------------	---------------------	------------------

*Bel Air (Sed.) (6 Cyl.) BK69*

BZ JW	0— 983 984— Over	3988134 3988135	YJ YK	0— 800 801— Over	482089 482090
----------	---------------------	--------------------	----------	---------------------	------------------

*Pass., Police (Sta. Wag.) (exc. H.D. Suspension) BK35-BK45-BL35-BL45-BN35-BN45*

BZ JW JA JX, JY JZ	0— 1006 1007— 1054 1055— 1102 1103— 1198 1199— Over	3988134 3988135 3988136 3988138 3988139	WA, WB ZP	0— 1157 1158— Over	486382 486387
--------------------------------	---	---	--------------	-----------------------	------------------

*Pass., Police (Sta. Wag.) (w/H.D. Suspension) BK35-BK45-BL35-BL45-BN35-BN45*

BZ JW JA JX, JY JZ	0— 1006 1007— 1054 1055— 1101 1103— 1198 1199— Over	3988134 3988135 3988136 3988138 3988139	UY, WC UZ	0— 1144 1145— Over	486383 487999
--------------------------------	---	---	--------------	-----------------------	------------------

*Police, Taxi (w/H.D. Suspension) (exc. Sta. Wag.) BK69-BL69*

JA JX, JY JZ, JV	0— 1028 1029— 1124 1125— Over	3988136 3988138 3988139	YL YM ZA	0— 829 830— 879 880— Over	482089 482090 482152
------------------------	-------------------------------------	-------------------------------	----------------	---------------------------------	----------------------------

**FRAME—SPRINGS—BUMPER**

**1971-72 VEGA**

BASE & RPO COMBINATIONS	Pounds	MODELS							
		PANEL		SEDAN		STA. WAG.		COUPE	
		Sprung Weight	Code Ltr.	Sprung Weight	Code Ltr.	Sprung Weight	Code Ltr.	Sprung Weight	Code Ltr.
Front Springs									
Base Only	0	510.5	HC	522.5	HC	531.5	HC	525.0	HC
C.A.C. Only	39	549.5	HD	561.5	HD	570.5	HD	564.0	HD
P.G. Only	22	532.5	HC	544.0	HD	553.5	HD	547.0	HD
Torque Drive Only	18.5	528.5	HC	541.0	HD	550.0	HD	543.5	HD
P/S Only	15.5	526.0	HC	538.0	HC	547.0	HD	540.5	HD
C.A.C. w/P.G.	61	571.5	HD	583.5	HG	592.5	HG	586.0	HG
C.A.C. w/Torque Drive	57.5	567.5	HD	580.0	HD	589.0	HG	582.5	HD
C.A.C. w/P/S	54.5	564.5	HD	577.0	HD	586.0	HG	579.5	HD
C.A.C. w/P.G. and P/S	76.5	586.5	HG	599.0	HG	608.0	HG	601.5	HG
C.A.C. w/Torque Drive and P/S	72.5	582.5	HD	595.0	HG	604.0	HG	597.5	HG
P.G. w/P/S	37.5	547.5	HD	560.0	HD	569.0	HD	562.5	HD
Torque Drive w/P/S	33.5	543.5	HD	555.0	HD	565.0	HD	558.5	HD

BASE & RPO COMBINATIONS	Pounds	MODELS							
		PANEL		SEDAN		STA. WAG.		COUPE	
		Sprung Weight	Code Ltr.	Sprung Weight	Code Ltr.	Sprung Weight	Code Ltr.	Sprung Weight	Code Ltr.
Rear Springs									
All Usages (Regardless of Options)	0	414.0	HT	408.0	HT	461.0	HW	447.0	HW

Code Ltr.	Spring No. Frt. L.H. & R.H.	Spring Weight
HC	3988073	0-539
HD	3988074	540-583
HG	3988075	584-Over

Code Ltr.	Spring No. Rr. L.H. & R.H.	Spring Weight
HT	3988081	0-446
HW	3988082	447-Over

**FRAME—SPRINGS—BUMPER**

**1973 CHEVELLE**

**CHART "C" (Cont.)**

CODE	FRONT SPRUNG WEIGHT	PART NUMBER	CODE	REAR SPRUNG WEIGHT	PART NUMBER
KT	0— 937	334447	SB, SC	All	485706
KU, DJ	938— 975	6262426			
KV	976— 1013	334451			
KW, DL	1014— 1051	6262428			
KX	1052— Over	334453			

*El Camino (454) (exc. S.S., H.D. Susp.) AC80-AD80*

DL	0— 1041	6262428	SB, SC	All	485706
DM, DN	1042— 1121	6262430			
HE, BT	1122— Over	3988125			

*El Camino (S.S.) (exc. H.D. Susp., 454) AD80*

K	0— 937	334447	SB, SC	All	485706
KU, DJ	938— 975	6262426			
KV	976— 1013	334451			
KW, DL	1014— 1051	6262428			
KX	1052— Over	334453			

*El Camino (S.S.) (454) (exc. H.D. Susp.) AD80*

BV, BZ	0— 1098	3988134	SC	All	485706
JW	1099— 1143	3988135			
JA	1144— Over	3988136			

*El Camino (w/H.D. Susp.) AC80-AD80*

DT	0— 916	3988130	TR, WW, TA	All	485736
DU, DW	917— 1006	3988132			
BV, BZ	1007— 1096	3988134			
JW	1097— 1141	3988135			
JA	1141— Over	3988136			

*Chevelle (Spt. Cpe., Sed.) (w/H.D. Susp.) (6 Cyl.) AC29-AC37-AD29-AD37*

DT, BU	0— 878	3988130	TA	0— 646	485736
DU, DW	879— Over	3988132	ZZ	647— Over	483737

*Chevelle (Spt. Cpe., Sed.) (w/H.D. Susp.) (8 Cyl.) AC29-AD29-AE29-AC37-AD37-AE37*

DT	0— 919	3988130	TA	0— 646	485736
DU, DW	920— 1009	3988132	ZZ	647— Over	485737
BV, BZ	1010— 1100	3988134			
JW	1101— 1144	3988135			
JA	1145— Over	3988136			

*Monte Carlo (exc. H.D. Susp., 454) AH57*

DH, DT	0— 954	3988130	TA, TF	0— 754	485736
DJ	955— 994	6262426	ZX	755— Over	485722
DK, KV	995— 1034	334451			
DL	1035— Over	6262428			

*Monte Carlo (454) (exc. H.D. Susp.) AH57*

DW	0— 1044	3988132	TA, TF	0— 754	485736
BV, BZ	1045— Over	3988134	ZX	755— Over	485722

**FRAME—SPRINGS—BUMPER**

**1973 CHEVELLE**

**CHART "C" (Cont.)**

*Monte Carlo (w/H.D. Susp.) AH57*

CODE	FRONT SPRUNG WEIGHT	PART NUMBER	CODE	REAR SPRUNG WEIGHT	PART NUMBER
DT	0— 954	3988130	ZZ	0— 749	485737
DJ, DW	955— 1044	3988132	WU	750— Over	485738
BV, BZ	1045— Over	3988134			

*Chevelle (Spt. Cpe., Sed.) (6 Cyl.) (exc. H.D. Susp.) AC29-AC37-AD29-AD37*

KJ, KT DJ, KU	0— 906 907— Over	334447 6262426	TE, TF	All	485736
------------------	---------------------	-------------------	--------	-----	--------

*Chevelle (Spt. Cpe., Sed.) (307, 350) (exc. H.D. Susp.) AC29, 37-AD29-AE29, 37*

KJ, KT	0— 939	334447	TE, TF	All	485736
KU	940— 976	6262426			
KV	977— 1014	334451			
KW	1015— 1051	6262428			
KX	1051— Over	334453			

*Chevelle (Spt. Cpe., Sed.) (454) (exc. S.S., H.D. Susp.) AC29, 37-AD29-AE29, 37*

DL	0— 1042	6262428	TE, TF	All	485736
DM, DN	1043— 1123	6262430			
HE, BT	1124— Over	3988125			

*Malibu (S.S.) (454) (exc. H.D. Susp.) AD37*

BV, BZ JW	0— 1101 1102— Over	3988134 3988135	TN	All	485737
--------------	-----------------------	--------------------	----	-----	--------

**FRAME—SPRINGS—BUMPER**

**1973 NOVA**

**CHART "A"**

	<b>MODEL</b>	<b>FRONT</b>	<b>REAR</b>
XX-17	Nova (Hatchback Cpe.) (exc. Custom)	742.5	621.0
XX-27	Nova (Cpe.) (exc. Custom)	731.0	576.5
XX-69	Nova (Sed.) (exc. Custom)	736.5	587.0
XY-17	Nova (Custom) (Hatchback Cpe.)	749.0	618.0
XY-27	Nova (Custom) (Cpe.) (exc. Hatchback)	738.5	589.0
XY-69	Nova (Custom) (Sed.)	743.0	600.0

**CHART "B"**

	<b>RPO OPTIONS</b>	<b>FRONT</b>	<b>REAR</b>
A-51	Bucket Seat	6.0	5.5
C-60	Air Conditioning	44.0	3.5
D-55	Floor Console	45	2.0
F-40	H.D. Susp.	4.0	0.5
L-14	(307)	54.0	10.5
L-48	(350)	68.0	23.5
M-20	4-Spd.	5.0	2.5
M-38	TH-350	11.0	2.5
N-40	Power Steering	16.0	0.0
T-60	H.D. Battery	6.0	0.0
UMI	Radio	3.5	0.5

**CHART "C"**

*Nova (exc. S.S., H.D. Susp.) (w/Sp. Perf. Susp.)*

<b>CODE</b>	<b>FRONT SPRUNG WEIGHT</b>	<b>PART NUMBER</b>	<b>CODE</b>	<b>REAR SPRUNG WEIGHT</b>	<b>PART NUMBER</b>
FM	0— 760	334430	RA	0— 557	6272839
KA, KD, KE	761— 858	6272865	RB	558— 612	6272840
KG	859— 887	6272872	RC	613— 659	6272841
KH, KK	888— Over	6272874	RT	660— Over	337230

*Nova (w/H.D. Susp.) (exc. S.S.)*

KL, KM	0— 837	6272871	RD	0— 588	6272842
KN	838— 880	6272872	RE	589— 642	6272843
KR, KS	881— Over	6272874			



**FRAME—SPRINGS—BUMPER**

**1973 CAMARO**

**CHART "A"**

	MODEL	FRONT	REAR
FQ-87	Camaro (exc. L.T.)	779.0	536.5
FS-87	Camaro (L.T.)	862.5	563.0

**CHART "B"**

	RPO OPTIONS	FRONT	REAR
C-60	Air Conditioning	46.5	7.5
D-55	Floor Console	7.0	2.0
F-41	Spec. Perf. Susp.	1.0	2.5
L-14	(307)	52.5	7.0
L-48	(350) (4BC)	61.0	20.0
L-65	(350) (2BC)	57.5	7.0
M-20	4-Spd.	2.0	1.0
M-38	TH-350	7.5	4.0
M-40	TH-400	14.5	8.0
N-40	Power Steering	15.5	0.0
T-60	H.D. Battery	7.0	0.0
UMI Radio		3.0	1.0
Z-22	Rally Sport Package	8.5	1.0
Z-28	Special 350 Engine	18.0	14.0

**CHART "C"**

*Camaro (exc. Z-28)*

CODE	FRONT WEIGHT	NUMBER	CODE	REAR WEIGHT	NUMBER
AE, AF	0— 820	3996362	PA	0— 580	480878
AM, AP	821— 883	3996364	PB	581— Over	494776
AU	884— 915	3996365			
AV, AW	916— Over	3996367			

*Camaro (Z-28)*

AV, AW CR, CS, CU	0— 918 919— Over	3996367 3998629	DY	All	477572
----------------------	---------------------	--------------------	----	-----	--------

**FRAME—SPRINGS—BUMPER**

**1973 VEGA**

*Follow the three steps below to utilize the 1973 spring charts.*

*1. Select the model desired with the base spring weight on Chart "A".*

*2. Then select options accordingly shown on Chart "B" and add that weight to the base spring weight.*

*3. When accumulated weight has been determined refer to Chart "C" and select correct spring.*

**CHART "A"**

MODEL		BASE SPRING WEIGHT	
		FRONT	REAR
14005	2 Dr. Panel	540.0	405.0
14011	2 Dr. Sedan	550.5	406.5
14015	2 Dr. Sta. Wag.	553.0	452.5
14077	2 Dr. Coupe	557.5	441.0

**1973 VEGA**

**CHART "B"**

	RPO OPTIONS	FRONT	REAR
A-61	Aux. Seat	4.0	6.0
B-37	Floor Mats	3.5	1.5
C-60	Air Conditioning	40.0	3.5
F-41	Spec. Perf. Susp.	4.0	2.0
M-20	4-Spd.	3.0	2.0
M-35	Powerglide	3.0	1.0
M-38	TH-350	19.0	8.0
N-40	Power Steering	18.0	0.5
T-60	H.D. Battery	6.0	0
Radio		3.0	1.0
VO1	H.D. Radiator	3.0	0
YG5	Acoustics & Appearances	7.5	11.0
ZJ1	Custom Interior	2.0	2.5

**CHART "C"**

**1973 VEGA**

FRONT			REAR		
CODE	SPRUNG WEIGHT	PART NUMBER	CODE	SPRUNG WEIGHT	PART NUMBER
HC	0— 539	3988073	HT	0— 446	3988081
HD	540— 583	3988074	HW	446— Over	3988082
HG	583— Over	3988075			

**FRAME—SPRINGS—BUMPER**

**1974 PASSENGER**

*Follow the three steps below to utilize the 1974 spring charts.*

- 1. Select the model desired with the base spring weight on Chart "A".*
- 2. Then select options accordingly shown on Chart "B" and add that weights to the base spring weight.*
- 3. When accumulated weight has been determined refer to Chart "C" and select correct spring.*

**CHART "A"**

MODEL		FRONT	REAR
		L.H.— R.H.	L.H.— R.H.
BK-35	Bel Air (Sta. Wag.) (6-Pass.)	1016.5— 1016.5	1099.0— 1049.0
BK-45	Bel Air (Sta. Wag.) (9-Pass.)	1010.5— 1010.5	1132.5— 1082.5
BK-69	Bel Air (Sed.)	1012.0— 992.0	817.5— 817.5
BL-35	Impala (Sta. Wag.) (6-Pass.)	1031.5— 1031.5	1115.0— 1065.0
BL-39	Impala (Spt. Sed.)	1038.5— 1038.5	847.0— 823.0
BL-45	Impala (Sta. Wag.) (9-Pass.)	1023.0— 1023.0	1146.0— 1096.0
BL-47	Impala (Custom)	1029.0— 1029.0	813.0— 789.0
BL-57	Impala (Spt. Cpe.) (exc. Custom)	1031.0— 1011.0	808.0— 808.0
BL-69	Impala (Sed.) (exc. Spt. Sed.)	1034.5— 1014.5	835.5— 811.5
BN-35	Caprice (Estate) (6-Pass.)	1049.0— 1049.0	1131.0— 1081.0
BN-39	Caprice (Spt. Sed.)	1073.0— 1053.0	851.0— 851.0
BN-45	Caprice (Estate) (9-Pass.)	1039.5— 1039.5	1162.5— 1112.5
BN-47	Caprice (Spt. Cpe.)	1051.0— 1051.0	825.5— 801.5
BN-67	Caprice (Conv.)	1071.0— 1051.0	835.0— 835.0
BN-69	Caprice (Sed.) (exc. Spt. Sed.)	1059.5— 1039.5	839.5— 839.5

**CHART "B"**

	RPO OPTIONS	FRONT	REAR
AG-7	Power Seats	5.0	4.5
AT-8	Frnt. Seat 50/50 Bench	8.0	7.0
AU-3	Electric Door Lock	3.0	2.0
A-31	Power Window	4.5	4.0
A-42	Power Seats	5.5	4.5
C-60	Air Conditioning	43.0	3.0
LF-6	(400)	6.0	1.0
LS-4	(454)	90.0	27.0
M-40	3-Spd. Trans.-Hyd.	8.5	4.0
	Radio	4.0	2.5
V-01	H.D. Radiator	3.5	0.0
U-55	Roof Luggage Carrier	0.0	7.5

**FRAME—SPRINGS—BUMPER**

**1974 PASSENGER**

**CHART "C"**

*Pass. (350, 400) (exc. Sta. Wag., H.D. Susp., Air Booster Shock, Taxi, Police)*

Tire	Code	Front Weight	Part Number	Code	Rear Weight	Part Number
G78	BG	0— 991	334453	XJ-XK-XL	0— 858	482065
	BH	992— 1031	3988116	XM-XN	Over— 859	482067
	BJ-BK	1032— 1111	3988118			
	BL	1112— 1151	3988126			
	LW	Over— 1151	3988118			
H78	BG	0— 1018	334453	XJ-XK-KL	0— 887	482065
	BH	1019— 1058	3988116	XM	887— Over	482067
	BJ-BK	1059— 1138	3988118			
	BL	1138— Over	3988126			
HR78	BG	0— 980	334453	XK-XL	0— 844	482065
	BH	981— 1020	3988116	XM-XN	845— Over	482067
	BJ-BK	1021— 1100	3988118			
	BL	1101— 1140	3988126			
	LW	1140— Over	3988118			

*Pass. (454) (exc. Sta. Wag., H.D. Susp., Air Booster Shock, Taxi, Police)*

H78	JA	0— 1086	3988136	XK-XL	0— 883	482065
	JX-JY	1087— 1182	3988138	XM-XN	884— Over	482067
	JZ	1183— 1230	3988139			
	LY	1230— Over	344517			
HR78	JX-JY	0— 1135	3988138	XL-XK	0— 839	482065
	JZ	1136— 1183	3988139	XM-XN	840— Over	482067
	LY	1183— Over	344517			

*Taxi, Police (exc. Sta. Wag., Air Booster Shock)*

*Pass. w/H.D. Susp. (exc. Sta. Wag., Air Booster Shock)*

G78	BZ	0— 969	3988134	YJ-YK-YL	0— 892	482089
	JW	970— 1017	3988135	YM	892— Over	482090
	JA	1018— 1065	3988136			
	JX-JT	1066— 1161	3988138			
	JZ	1161— Over	3988139			
H78	BZ	0— 996	3988134	YH	0— 778	482086
	JW	997— 1044	3988135	YJ-YK-YL	779— 928	482089
	JA	1045— 1092	3988136			
	JX-JY	1093— 1189	3988138	YM	928— Over	482090
	JZ	1189— 1236	3988139			
	LY	1236— Over	344517			
HR78	JW	0— 1000	3988135	YJ-YK-YL	0— 870	482089
	JA	1001— 1048	3988136	YM	871— 920	482090
	JX-JY	1049— 1144	3988138			
	JZ	1145— 1192	3988139			
	LY	1192— Over	344517	ZA	920— Over	482152

**FRAME—SPRINGS—BUMPER**

**1974 PASSENGER**

**CHART "C" (Cont.)**

*Pass. (Sta. Wag.) (exc. H.D. Susp., Air Booster Shock, Taxi, Police)*

Tire	Code	Front Weight	Part Number	Code	Rear Weight	Part Number
L78B or L780	BZ	0— 1025	3988134	TP	0— 1094	490486
	JW	1026— 1073	3988135	WA-WB	1095— 1194	486382
	JA	1074— 1121	3988136	ZP-ZR	1195— Over	486387
	JX-JY	1122— 1217	3988138			
	JZ	1217— Over	3988139			
LR78	JW	0— 1023	3988135	WB	0— 1118	486377
	JA	1024— 1071	3988136	ZP-ZR KV	1119— 1218 1218— Over	486387 494898
	JX-JY	1072— 1167	3988138			
	JZ	1167— Over	3988139			

*Police (Sta. Wag.) (exc. Air Booster Shock)*

*Pass. (Sta. Wag.) w/H.D. Susp. (exc. Air Booster Shock)*

L78B or L78D	BZ	0— 1025	3988134	KW	0— 1094	494918
	JW	1026— 1073	3988135	UY-WC	1095— 1194	486383
	JA	1074— 1121	3988136	UZ-ZS	1195— Over	487999
	JX-JY	1122— Over	3988138			
LR78	JW	0— 1023	3988135	WC	0— 1088	486383
	JA	1024— 1071	3988136	UZ-ZS	1089— 1188	487999
	JX-JY	1072— 1167	3988138	ZT	1188— Over	486390
	JZ	1167— Over	3988139			

*Pass. (350, 400) w/Air Booster Shock (exc. Sta. Wag., H.D. Susp., Taxi, Police)*

G-78	BG	0— 991	334453	XJ-XK-XL	0— 908	482065
	BH	992— 1031	3988116	XM	908— Over	482067
	BJ-BK	1032— 1111	3988118			
	BL	1112— 1151	3988126			
	LW	1151— Over	3988118			
H-78	BG	0— 1018	334453	XJ-XK-XL	0— 887	482065
	BH	1019— 1058	3988116	887— Over		
	BJ-BK	1059— 1138	3988118			
	BL	1138— Over	3988126			
HR78	BG	0— 980	334453	XJ-XK-XL	0— 894	482065
	BH	981— 1020	3988116	XM	894— Over	482067
	BJ-BK	1021— 1100	3988118			
	BL	1101— 1140	3988126			
	LW	1140— Over	3988118			

*Pass. (454) w/Air Booster Shock (exc. Sta. Wag., H.D. Susp., Taxi, Police)*

H78	JA	0— 1086	3988136	XJ-XK-XL	0— 933	482065
	JX-JY	1087— 1182	3988138	XM	933— Over	482067
	JZ	1183— 1230	3988139			
	LY	1230— Over	344517			
HR78	JX-JY	0— 1135	3988138	XK-XL	0— 889	482065
	JZ	1136— 1183	3988139	XM-XN	889— Over	482067
	LY	1183— Over	344517			

**FRAME—SPRINGS—BUMPER**

**1974 PASSENGER**

**CHART "C" (Cont.)**

*Taxi, Police w/Air Booster Shock (exc. Sta. Wag.)  
Pass. w/H.D. Susp., Air Booster Shock (exc. Sta. Wag.)*

Tire	Code	Front Weight	Part Number	Code	Rear Weight	Part Number
G-78	BZ	0— 969	3988134	YH	0— 792	482086
	JW	970— 1017	3988135	YJ-YK-YL	792— Over	482089
	JA	1018— 1065	3988136			
	JX-JY	1066— 1161	3988138			
	JZ	1161— Over	3988139			
H-78	BZ	0— 996	3988134	YH	0— 828	482086
	JW	997— 1044	3988135	YJ-YK-YL	828— Over	482089
	JA	1045— 1092	3988136			
	JX-JY	1093— 1188	3988138			
	JZ	1189— 1236	3988139			
	LY	1236— Over	344517			
HR-78	JW	0— 1000	3988135	YJ-YK-YL	0— 920	482089
	JA	1001— 1048	3988136	YM	920— Over	482090
	JX-JY	1049— 1144	3988138			
	JZ	1145— 1192	3988139			
	LY	1192— Over	344517			

*Pass. (Sta. Wag.) w/Air Booster Shock (exc. H.D. Susp. Taxi, Police)*

L78D or L78B	BZ	0— 1025	3988134	TP	0— 1144	490486
	JW	1026— 1073	3988135	WA-WB	1145— 1244	486382
	JA	1074— 1121	3988136			
	JX-JY	1122— 1217	3988138	ZP	1244— Over	486387
	JZ	1217— Over	3988139			
LR78	JW	0— 1023	3988135	WA-WB	0— 1168	486382
	JA	1024— 1071	3988136	ZP-ZR	1169— Over	486387
	JX-JY	1072— 1167	3988138			
	JZ	1167— Over	3988139			

*Police (Sta. Wag.) w/Air Booster Shock  
Pass. (Sta. Wag.) w/H.D. Susp., Air Booster Shock*

L78B or L78D	BZ	0— 1025	3988134	KW	0— 1144	494918
	JW	1026— 1073	3988135	UY-WC	1145— 1244	486383
	JA	1074— 1121	3988136	UZ	1244— Over	487999
	JX-JY	1122— Over	3988138			
LR78	JW	0— 1023	3988135	WC	0— 1138	486383
	JA	1024— 1071	3988136	UZ-ZS	1139— 1238	487999
	JX-JY	1072— 1167	3988138	ZT	1238— Over	494897
	JZ	1167— Over	3988139			

**FRAME—SPRINGS—BUMPER**

**1974 CHEVELLE**

*Follow the three steps below to utilize the 1974 spring charts.*

- 1. Select the model desired with the base spring weight on Chart "A".*
- 2. Then select options accordingly shown on Chart "B" and add that weight to the base spring weight.*
- 3. When accumulated weight has been determined refer to chart "C" and select correct spring.*

**CHART "A"**

Model	Front	Rear
AC-29 Malibu (Sed.) (exc. Classic)	905.0	683.5
AC-35 Malibu (Sta. Wag.) (exc. Classic)	934.5	893.5
AC-37 Malibu (Spt. Cpe.) (exc. Classic)	896.5	660.0
AC-80 El Camino (exc. Classic)	965.5	701.0
AD-29 Malibu Classic (Spt. Sedan)	918.5	698.5
AD-35 Malibu Classic (Sta. Wag.)	960.5	913.5
AD-37 Malibu Classic (Spt. Cpe.)	904.0	670.5
AD-80 El Camino Classic	974.0	700.0
AE-37 Laguna	1011.5	706.5
AG-35 Malibu Estate	964.0	921.5
AH-57 Monte Carlo	976.5	728.0

**CHART "B"**

RPO Options	Front	Rear
AN-7 Bucket Seat-Swivel	3.0	3.0
AU-3 Electric Door Lock	3.0	2.0
A-31 Electric Window	3.5	3.0
A-42 6-Way Seat	6.5	5.5
CA-1 Electric Sun Roof	9.0	14.0
C-60 Air Conditioning	44.0	2.0
D-55 Floor Console	3.0	2.0
J-50 Power Brakes	5.0	0.0
Radio	7.5	2.5
LF-6 (400) 2BC Malibu (exc. Sta. Wag.)	70.5	4.5
LM-1 (350) 4BC Malibu (exc. Sta. Wag.)	72.5	4.5
LS-4 (454) Malibu (exc. Sta. Wag.)	135.0	29.0
LS-4 (454) El Camino	89.0	20.0
LS-4 (454) (Sta. Wag.)	70.0	16.0
LS-4 (454) Monte Carlo, Laguna	85.0	22.5
LT-4 (400) 4BC Malibu (exc. Sta. Wag.)	78.0	4.5
L-65 (350) 2BC Malibu (exc. Sta. Wag.)	70.5	4.5
M-38 T.H. 350	20.0	5.0
M-40 T.H. 400	25.0	10.0
N-41 Power Steering	12.0	0.0

**FRAME—SPRINGS—BUMPER**

**1974 CHEVELLE**

**CHART "C"**

*Malibu (6 Cyl.) (exc. H.D. Susp.)*

Tire	Code	Front Weight	Part Number	Code	Rear Weight	Part Number
E78-14	KJ-KT	0— 904	334447	TE-TF	0— 703	485721
	KU-KV	904— Over	334451	ZX-ZY	703— Over	485722
G78-14	KJ-KT	0— 938	334447	TU	0— 645	485719
	KU-KV	938— Over	334451	TE-TF	646— 745	485721
					ZX-ZY	745— Over

*Malibu (350, 400) (exc. Sta. Wag., H.D. Susp., Spec. Perf. Susp.)*

G78-14	KU-KV	935— 1010	334451	TU	0— 649	485719
	KW-KX	1011— 1086	334453	TE-TF	650— 749	485721
	BH	1087— 1124	3988116	ZX-ZY	749— Over	485722
	BJ	1124— Over	3988118			
G70-14	KT	0— 928	334447	TU	0— 639	485719
	KU-KV	929— 1004	334451	TE-TF	639— 739	485721
	KW-KX	1005— 1080	334453	ZX-ZY	739— Over	485722
	BH	1081— 1118	3988116			
BJ	1118— Over	3988118				
H78-14	KJ-KT	0— 958	334447	TU	0— 679	485719
	KU-KV	959— 1034	334451	TE-TF	680— 779	485721
	KW-KX	1035— 1111	334453	ZX	779— Over	485722
	BH	1112— 1148	3988116			
BJ	1148— Over	3988118				
GR78-15	KT	0— 920	334447	TU	0— 639	485719
	KU-KV	921— 996	334451	TE-TF	640— 739	485721
	KW-KX	997— 1072	334453	ZX-ZY	739— Over	485722
	BH	1073— 1110	3988116			
BJ	1110— Over	3988118				

*Malibu (350, 400) w/Spec. Perf. Susp. (exc. Sta. Wag., H.D. Susp.)*

GR70-15	KT	0— 920	334447	TU	0— 639	485719
	KU-KV	921— 996	334451	TE-TF	640— 739	485721
	KW-KX	997— 1072	334453	ZX-ZY	739— Over	485722
	BH	1073— 1110	3988116			
BJ	1110— Over	3988118				
HR70-15	KJ-KT	0— 943	334447	TU	0— 672	485719
	KU-KV	944— 1019	334451	TE-TF	673— 762	485721
	KW-KX	1020— 1095	334453	ZX-ZY	762— Over	485722
	BH	1096— 1133	3988116			
BJ	1133— Over	3988118				



**FRAME—SPRINGS—BUMPER**

**1974 CHEVELLE**

**CHART "C" (Cont.)**

*Malibu (454) (exc. Sta. Wag., Spec. Perf. Susp., H.D. Susp.)*

Tire	Code	Front Weight	Part Number	Code	Rear Weight	Part Number
G78-14	DL	0— 1040	6262428	TU	0— 649	485719
	DM	1041— 1080	6262429	TE-TF	650— 749	485721
	DN	1081— 1120	6262430	ZX-ZY	749— Over	485722
	HE-BT	1121— 1200	3988125			
	BW	1201— 1240	3988126			
	BX	1240— Over	3988138			
G70-14	DL	0— 1032	6262428	TU	0— 639	485719
	DM	1033— 1072	6262429	TE-TF	640— 739	485721
	DN	1073— 1112	6262430			
	HE-BT	1113— 1192	3988125	ZX-ZY	739— Over	485722
	BW	1193— 1232	3988126			
	BX	1232— Over	3988138			
H78-14	DK-DL	0— 1068	6262428			
	DM	1069— 1108	6262429	TE-TF	680— 779	485721
	DN	1109— 1148	6262430	ZX	779— Over	485722
	HE-BT	1149— 1228	3988125			
	BW	1228— Over	3988126			
	GR78-15	DK	0— 1024			
DM		1025— 1064	6262429	TE-TF	640— 739	485721
DN		1065— 1104	6262430			
HE-BT		1105— 1184	3988125	ZX-ZY	739— Over	485722
BW		1185— 1224	3988126			
BX		1224— Over	3988138			

*Malibu (454) w/Spec. Perf. Susp. (exc. Sta. Wag., H.D. Susp.)*

GR70-15	DT	0— 898	3988130	TS-TA	0— 679	485736
	DU-DW	899— 988	3988132	ZZ	680— 729	485737
	BU-BZ	989— 1078	3988134	WU WV	730— 779 779— Over	485738 485739
	JW	1079— 1123	3988135			
	JA	1124— 1168	3988136			
	JX	1168— Over	3988138			
HR70-15	BU	0— 1097	3988134	TS-TA	0— 717	485736
	JW	1098— 1142	3988135	ZZ	718— 767	485737
	JA	1143— 1187	3988136	WU	767— Over	485738
	JX	1187— Over	3988138			

*Laguna (350, 400) (exc. H.D. Susp.)*

GR70-15	KT	0— 920	334447	TU	0— 639	485719
	KU-KV	921— 996	334451	TE-TF	640— 739	485721
	KW-KX	997— 1072	334453			
	BH	1073— 1110	3988116	ZX	739— Over	485722
	BJ	1110— Over	3988118			
HR70-15	KJ-KT	0— 943	334447	TU	0— 672	485719
	KU-KV	944— 1019	334451	TE-TF	673— 762	485721
	KW-KX	1020— 1095	334453	ZX-ZY	762— Over	485722
	BH	1096— 1133	3988116			
	BJ	1133— Over	3988118			

**FRAME—SPRINGS—BUMPER**

**1974 CHEVELLE**

**CHART "C" (Cont.)**

*Malibu (6 Cyl.) w/H.D. Susp.*

Tire	Code	Front Weight	Part Number	Code	Rear Weight	Part Number
E78-14	DT	0— 875	3988130	TA	0— 648	485736
	DU-DW	876— 965	3988132	ZZ	649— 688	485737
	BV-BZ	965— Over	3988134	WU	689— 728	485738
				WV	728— Over	485739
G78-14	BU-DT	0— 916	3988130	TA	0— 648	485736
	DU-DW	962— 1006	3988132	ZZ	649— 688	485737
	BU-BZ	1006— Over	3988134	WU	689— 728	485738
				WV	728— Over	485739

*Malibu (8 Cyl.) w/H.D. Susp. (exc. Sta. Wag.)*

G78-14	DT	0— 913	3988130	TS-TA	0— 694	485736
	DU-DW	914— 1003	3988132	ZZ	695— 744	485737
	BU-BZ	1004— 1093	3988134	WU	745— 794	485738
	JW	1094— 1138	3988135	WV	794— Over	485739
	JA	1138— Over	3988136			
H78-14	DT	0— 945	3988130	TS-TA	0— 728	485736
	DU-DW	946— 1035	3988132	ZZ	729— 778	485737
	BV-BZ	1036— 1125	3988134	WU	778— Over	485738
	JW	1126— 1170	3988135			
	JA	1170— Over	3988136			
G70-14	DT	0— 906	3988130	TS-TA	0— 682	485736
	DU-DW	907— 996	3988132	ZZ	683— 732	485737
	BV-BZ	997— 1086	3988134			
	JW	1087— 1131	3988135			
	JA	1132— 1176	3988136			
	JX	1176— Over	3988138	WU	733— 782	485738
WV	782— Over		WV	782— Over	485739	
GR78-15	DT	0— 898	3988130	TS-TA	0— 679	485736
	DU-DW	899— 988	3988132	ZZ	680— 729	485737
	BV-BZ	989— 1078	3988134	WU	730— 779	485738
	JW	1079— 1123	3988135			
	JA	1124— 1168	3988136			
	JX	1168— Over	3988138	WV	779— Over	485739

*Laguna (350, 400) w/H.D. Susp.*

*Malibu (350, 400) (H.D. Susp., w/Spec. Perf. Susp.) (exc. Sta. Wag.)*

GR70-15	DT	0— 898	3988130	TS-TA	0— 679	485736
	DU-DW	899— 988	3988132	ZZ	680— 729	485737
	BU-BZ	989— 1078	3988134	WU	730— 779	485738
	JW	1079— 1123	3988135	WV	779— Over	485739
	JA	1124— 1168	3988136			
	JX	1168— Over	3988138			
HR70-15	BV-BZ	0— 1097	3988134	TS-TA	0— 717	485736
	JW	1098— 1142	3988135	ZZ	718— 767	485737
	JA	1143— 1187	3988136	WU	767— Over	485738
	JX	1187— Over	3988138			

*Laguna (454).*

*Laguna (454) w/C.A.C.*

HR70-15	BV-BZ	0— 1097	3988134	TS-TA	0— 717	485736
	JW	1098— 1142	3988135	ZZ	718— 767	485737
	JA	1143— 1187	3988136	WU	767— Over	485738
	JX	1187— Over	3988138			

**FRAME—SPRINGS—BUMPER**

**1974 CHEVELLE**

**CHART "C" (Cont.)**

*Monte Carlo (350, 400) (exc. H.D. Susp.)*

Tire	Code	Front Weight	Part Number	Code	Rear Weight	Part Number
GR70-15	DH	0— 943	6262425	TE-TF ZX-ZY	0— 760 760— Over	485721 485722
	DJ	944— 983	6262426			
	DK-DL	984— 1063	6262428			
	DM-DN	1064— 1143	6262430			
	HE-BT	1144— 1223	3988125			
	BW	1223— Over	3988126			

*Monte Carlo (454) (exc. H.D. Susp.)*

GR70-15	BV-BZ	0— 1122	3988134	TF ZX-ZY	0— 760 760— Over	485721 485722
	JW	1123— 1167	3988135			
	JA	1168— 1212	3988136			
	JX	1212— Over	3988138			
HR70-15	DW-BV	0— 1062	3988132	TE-TF ZX-ZY	0— 793 793— Over	485721 485722
	BZ	1063— 1152	3988134			
	JW	1153— 1117	3988135			
	JA	1198— 1242	3988136			
	JX	1242— Over	3988138			

*Monte Carlo w/H.D. Susp.*

GR70-15	DT	0— 943	3988130	TA ZZ WU WV	0— 707 708— 757 758— 807 807— Over	485736 485737 485738 485739
	DU-DW	944— 1033	3988132			
	BV-BZ	1034— 1123	3988134			
	JW	1124— 1168	3988135			
	JA	1169— 1213	3988136			
	JX	1213— Over	3988138			
HR70-15	DW	0— 1062	3988132	TA ZZ WU WV	0— 743 744— 793 794— 843 843— Over	485736 485737 485738 485739
	BV-BZ	1063— 1152	3988134			
	JW	1153— 1197	3988135			
	JA	1198— 1242	3988136			
	JX	1242— Over	3988138			

*Malibu (Sta. Wag.) (exc. Spec. Perf. Susp.)*

H78-14	HW	0— 848	6272862	TV TW-TG TH WL	0— 880 881— 980 981— 1030 1030— Over	485685 485687 485688 485689
	DH	848— 888	6262425			
	DJ	889— 928	6262426			
	DK-DL	929— 1008	6262428			
	DM-DN	1009— 1088	6262430			
	HE-BT	1089— 1168	3988125			
	BW	1169— 1208	3988126			
	BX	1208— Over	3988138			
HR78-15	DH	0— 870	6262425	TV TW-TG TH WL	0— 870 871— 970 971— 1020 1020— Over	485685 485687 485688 485689
	DJ	871— 910	6262426			
	DK-DL	911— 990	6262428			
	DM-DN	991— 1070	6262430			
	HE-BT	1071— 1150	3988125			
	BW	1151— 1190	3988126			
	BX	1190— Over	3988138			

**FRAME—SPRINGS—BUMPER**

**1974 CHEVELLE**

**CHART "C" (Cont.)**

*Malibu (Sta. Wag.) w/Spec. Perf. Susp.*

Tire	Code	Front Weight	Part Number	Code	Rear Weight	Part Number
HR70-15	DH	0— 870	6262425	TV	0— 870	485685
	DJ	871— 910	6262426			
	DK-DL	911— 990	6262428	TW-TG	871— 970	485687
	DM-DN	991— 1070	6262430			
	HE-BT	1071— 1150	3988125			
	BW	1151— 1190	3988126	TH	971— 1020	485688
	BX	1190— Over	3988138	WL	1020— Over	485689

*El Camino (350, 400) (exc. H.D. Susp., Spec. Perf. Susp., S.S.)*

G78-14	KT	0— 928	334447	SC	0— 740	485706
H78-14	KU-KV	929— 1004	334451	KJ	740— Over	485707
G70-14	KW-KX	1005— 1080	334453			
G78-15	BH	1081— 1118	3988116			
	BJ	1118— Over	3988118			

*El Camino (350, 400) w/Spec. Perf. Susp. (exc. H.D. Susp., S.S.)*

GR70-15	KT	0— 928	334447	SC	0— 740	485706
HR70-15	KU-KV	929— 1004	334451	KJ	740— Over	485707
	KW-KX	1005— 1080	334453			
	BH	1081— 1118	3988116			
	BJ	1118— Over	3988118			

*El Camino (454) (exc. H.D. Susp., Spec. Perf. Susp., S.S.)*

G78-14	DL	0— 1032	6262428	SC	0— 740	485706			
H78-14,	DM-DN	1033— 1112	6262430	KJ	740— Over	485707			
G70-14									
GR78-15							HE-BT	1113— 1192	3988125
							BW	1193— 1232	3988126
	BX	1232— Over	3988138						

*El Camino (454) w/Spec. Perf. Susp. (exc. H.D. Susp., S.S.)*

GR70-15	DU-DW	0— 995	3988132	WW-TA	0— 753	485736
HR70-15	BV-BZ	996— 1085	3988134	KK	753— Over	487391
	JW	1086— 1130	3988135			
	JA	1131— 1175	3988136			
	JX	1175— Over	3988138			

*El Camino w/H.D. Susp. (exc. S.S.)*

G78-14	DU-DW	0— 995	3988132	WW-TA	0— 753	485736
H78-14	BV-BZ	996— 1085	3988134	KK	753— Over	487391
G70-14	JW	1086— 1130	3988135			
GR78-15	JA	1131— 1175	3988136			
	JX	1175— Over	3988138			

*El Camino (S.S.) (350, 400) (exc. H.D. Susp., Spec. Perf. Susp.)*

G70-14	KT	0— 928	334447	SC	0— 740	485706
GR70-15	KU-KV	929— 1004	334451	KJ	740— Over	485707
HR70-15	KW-KX	1005— 1080	334453			
	BH	1081— 1118	3988116			
	BJ	1118— Over	3988118			

**FRAME—SPRINGS—BUMPER**

**1974 CHEVELLE**

**CHART "C" (Cont.)**

*El Camino (S.S.) (350, 400) w/Spec. Perf. Susp. (exc. H.D. Susp.)*

Tire	Code	Front Weight	Part Number	Code	Rear Weight	Part Number
GR70-15	KT	0— 928	334447	SC	0— 740	485706
HR70-15	KU-KV	929— 1004	334451	KJ	740— Over	485707
	KW-KX	1005— 1080	334453			
	BH	1081— 1118	3988116			
	BJ	1118— Over	3988118			

*El Camino (S.S.) (454) (exc. H.D. Susp., Spec. Perf. Susp.)*

G70-14	DL	0— 1032	6262428	SC	0— 740	485706
GR70-15,	DM-DN	1033— 1112	6262430	KJ	740— Over	485707
HR70-15	HE-BT	1113— 1192	3988125			
	BW	1193— 1232	3988126			
	BX	1232— Over	3988138			

*El Camino (S.S.) (454) w/Spec. Perf. Susp. (exc. H.D. Susp.)*

GR70-15	DU-DW	0— 995	3988132	WW	0— 753	485736
HR70-15	BV-BZ	996— 1085	3988134	KK	753— Over	487391
	JW	1086— 1130	3988135			
	JA	1131— 1175	3988136			
	JX	1175— Over	3988138			

*El Camino (S.S.) w/H.D. Susp.*

G70-14	DU-DW	0— 995	3988132	WW	0— 753	485736
GR70-15	BU-BZ	996— 1085	3988134	KK	753— Over	487391
HR70-15	JW	1086— 1130	3988135			
	JA	1131— 1175	3988136			
	JX	1175— Over	3988138			

**1974 NOVA**

**CHART "A"**

Model	Front	Rear
Nova (Hatchback Cpe.) (exc. Custom)	758.5	655.5
Nova (Coupe) (exc. Custom)	763.5	595.5
Nova (Sedan) (exc. Custom)	766.0	614.0
Nova (Custom) (Hatchback Cpe.)	766.5	667.0
Nova (Custom) (Coupe)	774.5	617.5
Nova (Custom) (Sedan)	778.5	622.0

**FRAME—SPRINGS—BUMPER**

**1974 NOVA**

**CHART "B"**

RPO Options	Front	Rear
BSI Insulation Package	4.0	5.5
C-60 Air Conditioning	44.0	3.5
D-55 Floor Console	3.0	1.5
F-41 Spec. Perf. Susp.	1.0	5.0
J-50 Power Brakes	4.0	0.5
LM1 (350) (4BC) (Single Exhaust)	63.0	12.0
L-48 (350) (4BC) (Dual Exhaust)	68.0	22.0
L-65 (350) (2BC)	61.0	8.0
M-20 4-Spd.	4.0	2.0
M-38 T.H. 350	9.5	4.0
N-41 Power Steering	15.0	0.0
UA1 H.D. Battery	6.5	0.0
Radio	3.0	0.5
VO1/H.D. Radiator	2.5	0.0

**CHART "C"**

*Nova (exc. S.S., Spec. Perf. Susp.),  
Nova w/Spec. Perf. Susp.*

Tire	Code	Front Weight	Part Number	Code	Rear Weight	Part Number
E78-14	FM	0— 756	334430	NF	0— 638	340509
	KA-KD-KE	757— 854	6272865	NH	639— 690	362105
	KG	855— 884	6272872	NC	691— 752	340508
	KH-KK-ML	885— 952	6272874	RZ	752— Over	362102
E70-14	FM	0— 753	334430	NF	0— 632	340509
	KA-KD-KE	754— 851	6272865	NH	633— 684	362105
	KG	852— 881	6272872	NC	685— 746	340508
	KH-KK-ML	882— 949	6272874	RZ	746— Over	362102
FR78-14	KA-KD-KE	0— 834	6272865	NF	0— 608	340509
	KG	835— 864	6272872	NH	609— 657	362105
	KH-KK-ML	865— 964	6272874	NC	658— 716	340508
	MM	964— Over	334457	RZ	716— Over	362102

*Nova w/H.D. Susp. (exc. S.S.)  
Nova (S.S.)*

E78-14	HF	0— 758	340513	NJ	0— 622	340511
	KL-KM	759— 834	6272871	UB	623— 687	340512
	KN	835— 872	6272872	NC	688— 746	340508
	KR-KS	873— 948	6272874	RZ	746— Over	362102
	KZ	948— Over	334459			
E70-14	HF	0— 754	340513	NJ	0— 615	340511
	KL-KM	755— 830	6272871	UB	616— 681	340512
	KN	831— 868	6272872	NC	682— 746	340508
	KR-KS	869— 944	6272874	RZ	746— Over	362102
	KZ	944— Over	334459			
FR78-14	KL-KM	0— 805	6272871	NJ	0— 597	340511
	KN	806— 843	6272872	UB	598— 651	340512
	KR-KS	844— 919	6272874	NC	652— 716	340508
	KZ	920— 957	334459	RZ	716— Over	362102
	MR	957— Over	334460			

**FRAME—SPRINGS—BUMPER**

**1974 CAMARO**

**CHART "A"**

Model	Front	Rear
IFQ87 Camaro (exc. LT)	811.0	603.5
IFS87 Camaro (LT)	896.5	633.5

**CHART "B"**

RPO Options	Front	Rear
A-31 Power Windows	2.5	2.0
C-60 Air Conditioning	40.0	5.0
D-55 Floor Console	3.0	1.0
F-41 Spec. Perf. Susp.	1.0	2.5
J-50 Power Brakes	5.5	0.5
LM-1 (350) (4BC) (Single Exhaust) (IFQ87)	69.5	3.0
LM-1 (350) (4BC) (Single Exhaust) (IFS87)	2.0	0.0
L-48 (350) (4BC) (Dual Exh.) (exc. Sp. H/Per.) (IFQ87)	71.5	12.0
L-48 (350) (4BC) (Dual Exh.) (exc. Sp. H/Per.) (IFS87)	5.0	8.5
L-65 (350) (2BC) (IFQ87)	67.5	3.0
L-65 (350) (2BC) (IFS87)	0.0	0.0
M-38 T.H. 350	7.5	4.0
M-40 T.H. 400	14.5	8.0
N-41 Power Steering	13.0	0.0
UA-1 H.D. Battery	4.0	0.0
Radio	3.0	1.0
Z-28 (350) (Sp. H/Per.) (IFQ87)	80.5	20.0
Z-28 (350) (Sp. H/Per.) (IFS87)	12.5	12.5
Z-54 Interior Decor. and Sound	2.0	3.0

**CHART "C"**

*Camaro (exc. Z-28)*

Tire	Code	Front Weight	Part Number	Code	Rear Weight	Part Number
E78-14	AF	0— 799	3996362	PB	0— 627	494776
	AM-AR	800— 861	3996364	PD	669— Over	480881
	AU	862— 892	3996365			
	MF	893— 954	344537			
	CR-CS	954— Over	3998629			
F70-14	AF	0— 815	3996362	PB	0— 642	494776
	AM-AR	816— 877	3996364	PD	683— Over	480881
	AU	878— 908	3996365			
	MF	909— 970	344537			
	CR-CS	970— Over	3998629			
FR78-14	AR-AM	0— 842	3996364	PD	642— 674	480881
	AU	843— 873	3996365			
	MF	874— 935	344537	PE	674— Over	480881
	CR-CS	936— Over	3998629			

*Camaro (Z-28)*

F60-15	MB-MF CR-CS-CU	0— 910	344537	TK SZ	0— 644	480881
		911— 972	3998629		644— Over	493689
		972— Over	3998629			

**FRAME—SPRINGS—BUMPER**

**1974 VEGA**

*Follow the three steps below to utilize the 1974 spring charts.*

- 1. Select the model desired with the base spring weight on Chart "A".*
- 2. Then select options accordingly shown on Chart "B" and add that weight to the base spring weight.*
- 3. When accumulated weight has been determined refer to chart "C" and select correct spring.*

**CHART "A"**

Model	Base Spring	
	Front	Rear
IHV05 2-Dr. Panel	578.5	462.0
IHV11 2-Dr. Sedan	579.0	450.0
IHV15 2-Dr. Sta. Wag.	588.0	508.5
IHV77 2-Dr. Coupe	582.5	477.0

**CHART "B"**

RPO	Options	Front	Rear
A-57	Aux. Seat	5.5	8.0
B-37	Floor Mats	2.0	2.5
F-41	Spec. Perf. Susp.	4.0	2.0
M-20	4-Spd.	3.0	2.0
C-60	Air Conditioning	38.5	4.0
M-38	T.H. 350	9.0	4.0
N-40	Power Steering	18.0	0.5
	Radio	3.0	1.0
V01	H.D. Radiator	2.5	0
V55	Luggage Carrier	0.5	5.5
YF9	Spec. Deluxe Equipt.	4.0	2.5
YG5	Acoustics and Appearances	4.5	7.5
YO5	Floor Deadeeper	4.0	4.0

**CHART "C"**

Tire Size	Code	Front Sprung Weight	Part Number	Code	Rear Sprung Weight	Part Number
6.00-13 A78-13 A70-13	HC	0— 525	3988073	HT	0— 453	3988081
	HD	526— 575	3988074	HW	454— 500	3988082
	HG	576— 625	3988075	RW	501— 542	336877
	DF	626— 680	336884	NA	542— Over	344539
	AC	680— Over	344538			
BR70-13	HC	0— 505	3988073	HT	0— 421	3988081
	HD	506— 555	3988074	HW	422— 468	3988082
	HG	556— 603	3988075	RW	469— 508	336877
	DF	604— 656	336884	NA	508— Over	344539
	AC	656— Over	344538			



**FRAME—SPRINGS—BUMPER**

**1975 PASSENGER**

Follow the three steps below to utilize the 1975 spring charts.

1. Select the model desired with the base spring weight on Chart "A".
2. Then select options accordingly shown on Chart "B" and add that weight to the base spring weight.
3. When accumulated weight has been determined refer to Chart "C" and select correct spring.

**CHART "A"**

		<b>BASE SPRUNG WEIGHT</b>	
	<b>MODELS</b>	<b>FRONT</b>	<b>REAR</b>
IBK35	Bel Air 4 Dr. Sta. Wag. (2 Seat)	1027	1066
IBK45	Bel Air 4 Dr. Sta. Wag. (3 Seat)	1026.5	1095
IBK69	Bel Air 4 Dr. Sed.	1010	813
IBL35	Impala 4 Dr. Sta. Wag. (2 Seat)	1040.5	1079.5
IBL39	Impala 4 Dr. Sport Sed.	1032	834
IBL45	Impala 4 Dr. Sta. Wag. (3 Seat)	1037.5	1107
IBL47	Impala 2 Dr. Custom Cpe.	1026	802.5
IBL57	Impala 2 Dr. Sport Cpe.	1022	815
IBL69	Impala 4 Dr. Sed.	1021	821.5
IBN35	Caprice 4 Dr. Sta. Wag. (2 Seat)	1056	1096
IBN39	Caprice 4 Dr. Sport Sed.	1057.5	854
IBN45	Caprice 4 Dr. Sta. Wag. (3 Seat)	1055	1121
IBN47	Caprice 2 Dr. Sport Cpe.	1049	820
IBN67	Caprice Convertible	1065.5	837
IBN69	Caprice 4 Dr. Sed.	1046	841

**CHART "B"**

	<b>RPO OPTION WEIGHTS</b>	<b>FRONT</b>	<b>REAR</b>
AG7	Power Driver Seat	5.0	4.5
AT8	Frt. Seat 50/50 Bench	8.5	7.5
AU3	Electric Door Lock (2 Dr.)	2.0	1.5
	Electric Door Lock (4 Dr.)	4.0	2.0
A31	Power Window (2 Dr.)	6.0	5.0
	Power Window (4 Dr.)	5.0	4.5
A42	Power Seats (exc. Bk.)	5.5	4.5
C60	Air Conditioning (454)	46.0	3.0
	Air Conditioning (350-400)	42.5	3.0
C61	Auto. Temp. Air Conditioning	2.5	0
K30	Cruise Control	3.0	0
LM1	350 4 BC Engine	2.0	1.0
LS4	454 4 BC Engine	93.5	28.5
LT4	400 4 BC Engine	8.0	1.0
M40	Hydramatic Transmission	8.5	4.0
UM1	Radio & Tape Player	7.5	2.5
U58	AM-FM Radio	6.0	1.5
VE5	Bumper Bar Pad	4.0	2.0
VO1	H.D. Radiator	4.5	0
V30	Bumper Guard	4.0	2.0

**FRAME—SPRINGS—BUMPER**

**1975 PASSENGER**

**CHART "C"**

**FRONT SPRINGS— GROUP 7.412**

<b>MODELS</b>	<b>TIRES</b>	<b>SPRUNG WEIGHT</b>	<b>PART NO.</b>
All B exc. 454 or Sta. Wag. (w/Std. Susp.)	G78-15	0— 1011 1012— 1091 1092— 1131 1132— 1171 1172— Over	3988116 3988118 3988126 344516 344504
	HR78-15	0— 995 996— 1073 1074— 1113 1114— 1193 1194— Over	3988116 3988118 3988126 344516 344504
All B/454 exc. Sta. Wag. (w/Std. Susp.)	HR78-15	0— 1170 1171— 1220 1221— Over	3988139 344504 344505
All B exc. Sta. Wag. or Police w/454 (w/H.D. Susp.)	G78-15	0— 993 994— 1093 1094— 1193 1194— 1243 1244— Over	3988135 3988137 3988139 344504 344505
	HR78-15	0— 970 971— 1070 1071— 1170 1171— 1220 1221— Over	3988135 3988137 3988139 344504 344505
All B/Police w/454 exc. Sta. Wag. (w/H.D. Susp.)	H78-15	0— 993 994— 1093 1094— 1193 1194— 1243 1244— Over	3988135 3988137 3988139 3988139 344504
All B/Sta. Wag.	L78-15	0— 1045 1046— 1145 1146— 1245 1246— 1295 1296— Over	3988135 3988137 3988139 344504 344505
	LR78-15	0— 980 981— 1080 1081— 1180 1181— 1230 1231— Over	3988135 3988137 3988139 344504 344505

**FRAME—SPRINGS—BUMPER**

**1975 PASSENGER**

**CHART "C"**

**REAR SPRINGS— GROUP 7.503**

MODELS	TIRES	SPRUNG WEIGHT	PART NO.
All B exc. Sta. Wag. (w/Std. Susp. exc. Superlift Shock Abs.)	G78-15	0— 785	482066
		786— 935	482068
	HR78-15	0— 775	482066
		776— 925	482068
All B exc. Sta. Wag. (w/Std. Susp. & Superlift Shock Abs.)	G78-15	0— 785	482064
		786— 885	482066
		886— Over	482068
	HR78-15	0— 775	482064
		776— 875	482066
		886— Over	482068
All B exc. Sta. Wag. or Police w/454 (w/H.D. Susp. exc. Superlift Shock Abs.)	G78-15	811— 910	482090
		911— Over	483671
	HR78-15	851— 900	482090
		901— Over	483671
All B/Police w/454 exc. Sta. Wag. (w/H.D. Susp. exc. Superlift Shock Abs.)	H78-15	861— 960	482090
		961— Over	483671
	HR78-15	0— 900	482090
		901— Over	483671
All B exc. Sta. Wag. (w/H.D. Susp. & Superlift Shock Abs.)	G78-15	0— 760	482086
		861— 960	482090
		961— Over	483671
	HR78-15	851— 950	482090
		951— Over	483671
All B/Sta. Wag. (w/Std. Susp. exc. Superlift Shock Abs.)	L78-15	1101— 1240	486387
		1241— 1305	494930
		1306— Over	494688
	LR78-15	1001— 1130	486387
		1131— 1200	494930
		1201— Over	494688
All B/Sta. Wag. (w/Std. Susp. & Superlift Shock Abs.)	L78-15	1151— 1287	486387
		1288— 1353	494930
		1354— Over	494688
	LR78-15	1051— 1179	486387
		1180— 1250	494930
		1251— Over	494688
All B/Sta. Wag. (w/H.D. Susp. exc. Superlift Shock Abs.)	L78-15	0— 1190	486383
		1191— 1280	494897
		1281— Over	494688
	LR78-15	0— 1070	486383
		1071— 1155	494897
		1156— Over	494688
All B/Sta. Wag. (w/H.D. Susp. & Superlift Shock Abs.)	L78-15	0— 1240	486383
		1241— 1330	494897
		1331— Over	494688

**FRAME—SPRINGS—BUMPER**

7.503	SPRING ASSY., Front and Rear	(Con't)	
	LR78-15	0— 1120	486383
		1121— 1205	494897
		1206— Over	494688

**FRAME—SPRINGS—BUMPER**

**1975 CHEVELLE**

Follow the three steps below to utilize the 1975 spring charts.

1. Select the model desired with the base spring weight on Chart "A".
2. Then select options accordingly shown on Chart "B" and add that weight to the base spring weight.
3. When accumulated weight has been determined refer to Chart "C" and select correct spring.

**CHART "A"**

		<b>BASE SPRUNG WEIGHT</b>	
	<b>MODELS</b>	<b>FRONT</b>	<b>REAR</b>
1AC29	Malibu 4 Dr. Sport Sed.	900.5	713
1AC35	Malibu 4 Dr. Sta. Wag.	941	894
1AC37	Malibu 2 Dr. Sport Cpe.	877	701
1AC80	El Camino Pick-Up	894	690
1AD29	Malibu Classic 4 Dr. Sport Sed.	919	727
1AD35	Malibu Classic 4 Dr. Sta. Wag.	958.5	910.5
1AD37	Malibu Classic 2 Dr. Sport Cpe.	888	709.5
1AD80	El Camino Classic Pick-Up	903	697
1AG35	Malibu Estate 4 Dr. Sta. Wag.	965	917
1AH37	Monte Carlo 2 Dr. Sport Cpe.	972.5	737

**CHART "B"**

	<b>RPO OPTION WEIGHTS</b>	<b>FRONT</b>	<b>REAR</b>
AG7	6-Way Power Seat	5.0	4.5
AN7	Swivel Bkt. Seat	3.5	4.0
AT8	Pass. & Driver Adj. Seat	12.0	12.5
AU3	Electric Door Lock	3.5	4.0
A31	Electric Window	4.5	5.5
A42	6-Way Power Seat	6.5	5.5
CA1	Electric Sun Roof	9.0	14.0
C60	Air Conditioning (454 4 BC)	44.5	2.0
	(350-400)	43.0	2.0
	(250)	35.5	2.0
D55	Frnt. Floor Console	5.0	2.5
J50	Power Brake	5.0	0
LM1	350 4 BC Engine	58.0	4.0
LS4	454 4 BC Engine	114.0	27.5
LT4	400 4 BC Engine	34.0	5.0
L65	350 2 BC Engine	56.0	4.0
M38	Hydramatic Transmission		
	(250)	10.5	3.0
	(350)	11.0	4.0
	(400)	35.5	9.5
M-40	Hydramatic Transmission		
	(400-454)	41.5	13.5
	(350)	19.0	7.0
NB2	Exc. Emission Control	6.5	0
N41	Power Steering	13.5	0
UM1	Radio & Tape Player	7.5	2.5
U58	Stereo Radio	5.5	2.0
VO1	H.D. Radiator	4.0	0
V30	Frnt. & Rear Bumper Guards	5.0	2.0

**FRAME—SPRINGS—BUMPER**

**1975 CHEVELLE**

**CHART "C"**

**FRONT SPRINGS— GROUP 7.412**

MODELS	TIRE	SPRUNG WEIGHT	PART NO.
AC29-37, AD29-37 (exc. 454)	F78-14	915— 990 991— Over	3988113 3988116
	G78-14	926— 1001 1002— Over	3988113 3988116
	FR78-15	0— 976 977— 1052 1053— Over	3988113 3988116 3988116
	GR78-15	0— 992 992— 1068 1069— 1106 1107— Over	3988113 3988116 3988116 3988118
	HR78-15	0— 1010 1011— 1086 1087— 1124 1124— Over	3988113 3988116 3988116 3988118
	GR70-15	0— 992 993— 1068 1068— 1106 1107— Over	3988113 3988116 3988116 3988118
	HR70-15	0— 942 943— 1018 1019— 1094 1095— 1132 1133— Over	3988113 3988116 3988116 3988116 3988118
AC29-37, AD29-37 (w/454)	G78-14	0— 1104 1105— 1224 1225— Over	6262430 3988126 3988139
	H78-14	0— 1091 1092— 1131 1132— 1251 1252— Over	6262430 6262430 3988126 3988139
	GR78-15	0— 1092 1093— 1212 1213— Over	6262430 3988126 3988139
	HR78-15	0— 1110 1111— 1230 1231— Over	6262430 3988126 3988139
	GR70-15	0— 1095 1096— 1215 1216— Over	6262430 3988126 3988139
	HR70-15	0— 1120 1121— 1240 1241— Over	6262430 3988126 3988139

**FRAME—SPRINGS—BUMPER**

**1975 CHEVELLE**

**CHART "C" (Con't)**

**FRONT SPRINGS— GROUP 7.412 (Con't)**

<b>MODELS</b>	<b>TIRE</b>	<b>SPRUNG WEIGHT</b>	<b>PART NO.</b>
AC35, AD35, AG35	H78-14	0— 922 923— 1002 1003— 1042 1043— 1082 1083— 1202 1203— Over	6262426 6262428 6262430 6262430 3988126 3988139
	HR78-15	0— 968 969— 1008 1009— 1048 1049— Over	6262428 6262430 6262430 3988126
	HR70-15	0— 989 990— 1029 1030— 1069 1070— Over	6262428 6262430 6262430 3988126
AH57 (exc. 454)	GR70-15	0— 983 984— 1063 1064— 1103 1104— Over	6262426 6262428 6262430 6262430
AC80, AD80 (exc. 454)	G78-14	922— 997 998— 1073 1074— Over	3988113 3988116 3988116
AC80, AD80 (w/454)	G78-14	0— 1024 1025— 1064 1065— 1104 1105— Over	6262428 6262430 6262430 3988126
AC80, AD80 (Std. Susp.)	15"	0— 997 998— Over	3188113 3188116
AC80, AD80 (H.D. Susp.)	15"	0— 955 1056— 1155 1156— Over	3988142 3988146 3988148

**FRAME—SPRINGS—BUMPER**

**1975 CHEVELLE**

**CHART "C"**

**REAR SPRINGS— GROUP 7.503**

<b>MODELS</b>	<b>TIRE</b>	<b>SPRUNG WEIGHT</b>	<b>PART NO.</b>
AC29-37, AD29-37 (w/Std. Susp.)	F78-14	0— 713 714— Over	482064 485722
	G78-14	0— 735 736— Over	482064 485722
	H78-14	0— 670 671— 770 771— Over	485719 482064 485722
	FR78-15	0— 748 748— Over	485722 482064
	GR78-15	0— 775 776— Over	485722 482064
	HR78-15	0— 803 804— Over	485722 482064
	GR70-15	0— 787 788— Over	485722 482064
	HR70-15	0— 814 815— Over	485722 482064
AC29-37, AD29-37 (w/H.D. Susp.)	F78-14	0— 650 651— 700 701— 750 751— Over	485736 485738 485738 484799
	G78-14	0— 675 676— 725 726— 775 776— Over	485736 485738 485738 484799
	H78-14	0— 715 716— 765 766— 815 816— Over	485736 485738 485738 484799
	FR78-15	0— 682 683— 732 733— Over	485738 485738 484799
	GR78-15	0— 712 713— 762 763— Over	485738 485738 484799
	HR78-15	0— 697 698— 747 748— 797 798— Over	485736 485738 485738 484799
	GR70-15	0— 667 668— 717 718— 767 768— Over	485736 485738 485738 484799
	HR70-15	0— 708 709— 758 759— 808 809— Over	485736 485738 485738 484799



**FRAME—SPRINGS—BUMPER**

**1975 CHEVELLE**

**CHART "C" (Con't)**

**REAR SPRINGS— GROUP 7.503 (Con't)**

MODELS	TIRE	SPRUNG WEIGHT	PART NO.
AC35, AD35, AG35	H78-14	0— 863 864— 963 964— 1013 1014— Over	485687 485687 485689 485689
	HR78-15	0— 833 834— 933 934— 983 984— Over	485687 485687 485689 485689
	HR70-15	0— 850 851— 950 951— 1000 1001— Over	485687 485687 485689 485689
AH57 (All 8 Cyl. w/Std. Susp.)	GR70-15	0— 799 800— Over	485722 482064
AH57 (454 w/A.C. & Std. Susp.)	HR70-15	0— 828 829— Over	485722 482064
AH57 (All 8 Cyl. w/H.D. Susp.)	GR70-15	0— 745 746— 795 796— Over	485738 485738 484799
AH57 (454 w/A.C. & H.D. Susp.)	HR70-15	0— 778 779— 828 829— Over	485738 485738 484799
AC80, AD80 (w/Std. Susp.)	All	0— 740 741— Over	485707 485707
AC80, AD80 (w/H.D. Susp.)	All	0— 775	487391

**FRAME—SPRINGS—BUMPER**

**1975 NOVA**

*Follow the three steps below to utilize the 1975 spring charts.*

*1. Select the model desired with the base spring weight on Chart "A".*

*2. Then select options accordingly shown on Chart "B" and add that weight to the base spring weight.*

*3. When accumulated weight has been determined refer to chart "C" and select correct spring.*

**CHART "A"**

	MODELS	BASE SPRUNG WEIGHT	
		FRONT	REAR
1XX17	Nova 2 Dr. Hatchback Cpe.	774	669.5
1XX27	Nova 2 Dr. Cpe.	777.5	608.5
1XX69	Nova 4 Dr. Sed.	779	622
1XY17	Nova Custom 2 Dr. Hatchback Cpe.	777	681.5
1XY27	Nova Custom 2 Dr. Cpe.	794	621.5
1XY69	Nova Custom 4 Dr. Sed.	796	635.5

**CHART "B"**

	RPO OPTION WEIGHTS	FRONT	REAR
AR9	European Bkt. Seat (XY27) (XY69)	6.0 8.5	6.0 8.5
AV3	Side Door Locks (2 Dr.) (4 Dr.)	2.0 3.5	1.5 4.0
BS1	Insulation Pkg.	9.0	6.0
C60	Air Conditioning (6 Cyl.) (8 Cyl.)	36.5 44.0	3.5 3.5
D55	Frnt. Floor Console	4.0	1.0
J50	Power Brake	4.0	0
LM1	350 4 BC Engine	48.0	12.0
LV1	262.5 2 BC Engine	41.0	10.0
L65	350 2 BC Engine	46.0	10.0
M20	Four Spd. Transmission	4.0	2.0
M38	Hydramatic Transmission	9.5	4.0
NB2	Exh. Emission Control	6.0	0
N41	Power Steering	16.0	0
UA1	H.D. Battery	6.5	0
UM1	Radio & Tape Player	7.5	3.0
U63	Radio	3.5	0
VO1	H.D. Radiator	3.0	0

**FRAME—SPRINGS—BUMPER**

**1975 NOVA**

**CHART "C"**

**FRONT SPRINGS— GROUP 7.412**

<b>MODELS</b>	<b>WEIGHT SPRUNG</b>	<b>PART NO.</b>
All w/FR78-14 tires (exc. H.D. Suspension)	0— 784 785— 857 858— 885 916— 985 986— 1017 1018— Over	346996 3982352 3982352 3988113 6262428 6262430
All w/FR78-14 tires (w/H.D. Suspension)	0— 812 813— 853 854— 894 895— 935 936— Over	334445 6262425 6262425 6262426 6262428
All w/78-14 tires (exc. H.D. Suspension)	0— 806 807— 883 884— 911 946— 1015 1016— Over	346996 3982352 3982352 3988113 6262428
All w/78-14 tires (w/H.D. Suspension)	0— 843 844— 884 885— 925 926— 966 967— Over	334445 6262425 6262425 6262426 6262428

**CHART "C"**

**REAR SPRINGS— GROUP 7.503**

<b>MODELS</b>	<b>SPRUNG WEIGHT</b>	<b>PART NO.</b>
All w/FR78-14 tires (exc. H.D. Suspension)	0— 643 644— Over	362105 362102
All w/FR78-14 tires (w/H.D. Suspension)	0— 635 636— Over	340512 362102
All w/78-14 tires (exc. H.D. Suspension)	0— 672 673— Over	362105 362102
All w/78-14 tires (w/H.D. Suspension)	0— 666 667— Over	340512 362102

## FRAME—SPRINGS—BUMPER

### 1975 CAMARO

*Follow the three steps below to utilize the 1975 spring charts.*

*1. Select the model desired with the base spring weight on Chart "A".*

*2. Then select options accordingly shown on Chart "B" and add that weight to the base spring weight.*

*3. When accumulated weight has been determined refer to Chart "C" and select correct spring.*

#### CHART "A"

	MODELS	BASE SPRUNG WEIGHT	
		FRONT	REAR
1FQ87	Camaro Hdtp. Cpe.	821	645.5
1FS87	Camaro Hdtp. Cpe.	887.5	664.5

#### CHART "B"

	RPO OPTION WEIGHTS	FRONT	REAR
A31	Power Windows	2.5	2.0
BS1	Body Insulation Pkg. (FQ)	4.5	5.0
C60	Air Conditioning (6 Cyl.)	34.0	5.0
	(8 Cyl. exc. Z-28)	41.5	5.0
	(8 Cyl. w/Z-28)	40.0	5.0
D55	Frnt. Floor Console	4.0	1.5
J50	Power Brake	5.5	0
LM1	350 4 BC Engine (FQ87)	54.5	3.0
	(FS87)	2.0	0
L65	350 2 BC Engine (FQ87)	52.5	3.0
M38	Hydramatic Transmission		
	(exc. Z-28)	7.5	4.0
	(w/Z-28)	4.0	2.5
M40	Hydramatic Transmission	14.5	8.0
N41	Power Steering	16.0	0
VA1	H.D. Battery	7.0	0
U58	Stereo Radio	5.5	2.0
U63	Radio	3.0	0
Z28	350 4 BC Engine (FQ87)	81.5	27.5
	(FS87)	12.5	12.5
Z54	Int. Decor & Sound (FQ87)	3.5	5.5

**FRAME—SPRINGS—BUMPER****1975 CAMARO****CHART "C"****FRONT SPRINGS— GROUP 7.412**

<b>MODELS</b>	<b>SPRUNG WEIGHT</b>	<b>PART NO.</b>
All w/E78-14 tires	0— 808	3996362
	809— 871	3996364
	872— 903	3996365
	904— 966	344537
	967— Over	3998629
All w/FR78-14 tires	0— 785	3996362
	786— 848	3996364
	849— 880	3996365
	881— 944	344537
	945— Over	3998629
All w/E60-15 tires	0— 790	3996362
	791— 853	3996364
	854— 885	3996365
	886— 949	344537
	950— Over	3998629

**CHART "C"****REAR SPRINGS— GROUP 7.503**

<b>MODELS</b>	<b>SPRUNG WEIGHT</b>	<b>PART NO.</b>
All w/E78-14 tires	0— 631	494776
	632— 707	480882
	708— Over	480881
All w/FR78-14 tires	0— 603	494776
	604— 677	480882
	678— Over	480881
All w/E60-15 tires	0— 711	480881
	712— Over	493689

**FRAME—SPRINGS—BUMPER**

**1975 VEGA— MONZA**

*Follow the three steps below to utilize the 1975 spring charts.*

- 1. Select the model desired with the base spring weight on Chart "A".*
- 2. Then select options accordingly shown on Chart "B" and add that weight to the base spring weight.*
- 3. When accumulated weight has been determined refer to chart "C" and select correct spring.*

**CHART "A"**

		BASE SPRUNG WEIGHT	
	MODEL	FRONT	REAR
1HV05	Vega 2 Dr. Panel	572	459.5
1HV11	Vega 2 Dr. Notchback Cpe.	583	455.5
1HV15	Vega 2 Dr. Sta. Wag.	583	513.5
1HV77	Vega 2 Dr. Hatchback Cpe.	589.5	480.5
1HR07	Monza 2 Dr. (exc. Towne Cpe.)	644.5	523.0
1HM27	Monza 2 Dr. (Towne Cpe.)	626.5	519.5

**CHART "B"**

	RPO OPTION WEIGHTS	FRONT	REAR
A57	Auxiliary Seat	5.5	8.0
C60	Air Conditioning	38.5	4.0
F41	Spec. Perf. Suspension	4.0	2.0
J50	Power Brake	4.0	0
LV1	262.5 2 BC Engine	133.0	7.0
M38	Hydramatic Transmission		
	(HV)	8.0	3.0
	(HR)	6.0	2.5
N41	Power Steering	18.0	0
U63	Radio	3.0	1.0
VO1	H.D. Radiator	2.5	0
V31	Frnt. Bumper Guards	2.5	0

**FRAME—SPRINGS—BUMPER**

**CHART "C"**

**FRONT SPRINGS— GROUP 7.412**

MODELS	SPRUNG WEIGHT	PART NO.
H140 w/BR78-13 tires	0— 620 621— 690 691— Over	354136 346952 346954
H140 w/A78-13 or A70-13 tires	0— 640 641— 710 711— Over	354136 346952 346954
H262 w/BR78-13 tires	0— 695 696— 775 776— Over	354139 346959 354147
H262 w/A70-13 tires	0— 715 716— 785 786— Over	354139 346959 354147

**REAR SPRINGS— GROUP 7.503**

MODELS	SPRUNG WEIGHT	PART NO.
H140 w/BR78-13 tires	0— 485 486— 535 536— Over	398808-1 3988082 336877
H140 w/A78-13 or A70-13 tires	0— 510 511— 560 561— Over	3988081 3988082 336877
H262 w/BR78-13 tires	0— 510 511— 560 561— Over	3988081 3988082 336877
H262 w/A70-13 tires	0— 550 551— 600 601— Over	3988081 3988082 336877
H122 w/BR70-13 tires	0— Over	344539

**7.504 BUSHING, Rear Spring Eye**

62-67 Chevy	3792614	4	1.30	front eye
67-72 Camaro,				
68 Chevy,				
73-74 Nova	483275	2	4.50	
73-74 Camaro	3992579	2	3.30	

**7.506 BOLT, Spring Center (Front and Rear)**

68 Chevy, Camaro	3932718	2	.22	rear
ALL Pass.	3723009	A.R.	2.40	fill. plain hd.— (3/8" — 24 x 5 <sup>9</sup> / <sub>16</sub> " )
ALL Pass.	3723010	2	.76	fill. plain hd.— (5/16" — 24 x 3 <sup>5</sup> / <sub>8</sub> " )

**7.516 NUT— BOLT— LINER, Rear Spring and Shock Absorber**

64 Chevelle	3691530	A.R.	.16	"U" bolt (1/2" — 20 x 1 <sup>1</sup> / <sub>16</sub> " thk.)— (7.395) ...
68 Chevy (327, 350),				
68 Camaro (exc. spec. perf. susp.),				
73-74 Nova	3925834	2	.15	rr. spring leaf bolt (5/16 x 24)
73-75 Pass. (Sta. Wag.),				
73-75 Nova, Camaro	487182	8	.36	rr. spring and shock abs. anc.
68-70 Chevy w/4-Spd. (327, 350, 396),				
71-72 Nova (350),				
69-75 Camaro,				
71-75 Pass. (Sta. Wag.),				

**FRAME—SPRINGS—BUMPER**

**7.516 NUT— BOLT— LINER, Rear Spring and Shock Absorber (Con't)**

73-75	Nova	482970	2	2.30	BOLT, "U" (7/16"— 20 x 6 1/16)
73-74	Nova	9793217	A.R.	.21	LINER, rr. spring front eye

**7.518 PLATE— CLAMP— SHIM UNIT— WASHER, Rear Spring "U" Bolt (See Group 5.403)**

62-67	Chevy (exc. Air Lift)	3792583	L.H.	2.85	left anchor
62-67	Chevy (exc. Air Lift)	3792584	R.H.	2.95	right anchor
67	Camaro	3901315	L.H.	3.40	left anchor
67	Camaro	3901316	R.H.	3.40	right anchor
68	Camaro, Chevy,				
69	Chevy, Camaro (exc. 302, 350, 396, disc brakes),				
70-72	Nova (exc. 350, 396)	3923570	2	3.60	rear anchor
68-69	Chevy, Camaro (302, 350, 396),				
70	Nova (350, 396),				
71	Nova,				
72-73	Nova w/Spec. Perf. Susp.	330263	L.H.	9.80	left anchor
68-69	Chevy, Camaro (302, 350, 396),				
70	Nova (350, 396),				
71-73	Nova w/Spec. Perf. Susp.,				
71	Nova (350) (exc. Sp. Perf. Susp.)	330264	R.H.	9.80	right anchor
70-75	Camaro	480909	2	5.05	anchor
71-75	Pass. (Sta. Wag.)	480139	R.H.	5.95	right
71-75	Pass. (Sta. Wag.)	480140	L.H.	5.95	left
73	Nova (exc. Sp. Perf. Susp.)	330259	L.H.	5.65	
73	Nova (exc. Sp. Perf. Susp.)	330260	R.H.	6.15	
73-75	Camaro,				
74-75	Nova	340325	2	3.20	
64-66	Chevelle	537047	2	.65	<b>CLAMP</b>
73-74	Pass. (Sta. Wag.)	488368	1	4.70	<b>SHIM UNIT, leaf spring (2 degrees)</b>
73-74	Pass. (Sta. Wag.)	488369	1	5.10	<b>SHIM UNIT, leaf spring (3 degrees)</b>
64-67	Chevelle				<b>WASHER, clamp (3 3/8" I.D. x 1 1/2" O.D. x 3/16" thk.)</b>
67-70	Camaro,				
68-72	Chevy,				
72	Camaro,				
73	Pass. (Sta. Wag.),				
73	Nova	1305797	2	.14	<b>WASHER, No. 1 bolt (1/2" I.D. x 1 1/2" O.D. x 3/16" thick)</b>

**7.523 REPAIR KIT— SHACKLE, Rear Spring Shackle**

62-70	Chevy, Camaro,				
72	Camaro, Nova	3849248	1	7.95	shackle (4 5/8" shackle pin and 2" bushing)
71-74	Pass. (Sta. Wag.)	485872	1	9.10	shackle
70	Nova,				
71-74	Nova, Camaro	3981813	1	6.15	<b>REPAIR UNIT, shackle (5 5/16" shackle pin and 2 15/32" bushing)</b>

**7.524 BUSHING, Rear Spring Shackle**

62-69	Chevy, Camaro,				
62-71	Pass. (Sta. Wag.)	3908370	8	.64	shackle
70-75	Nova, Camaro	480902	8	.98	shackle

**7.526 BRACKET, Auxiliary Spring**

67-69	Camaro	3892751	L.H.	2.50	left, front, eye
67-69	Camaro	3892752	R.H.	2.50	right, front, eye
68-75	Chevy, Nova	3923591	L.H.	2.35	left, front, eye
68-75	Chevy, Nova	3923592	R.H.	2.35	right, front, eye
70-75	Camaro	3980956	R.H.	2.70	right, front eye
70-75	Camaro	3980955	L.H.	2.70	left, front eye

**7.529 BOLT— REPAIR KIT, Rear Spring**

62-68	Chevy, Camaro,				
69	Chevy, Camaro (exc. Disc Brakes),				
70-72	Nova w/mono leaf spring	3791510	8	.65	bracket (7/16"— 20 x 1 1/4")
62-67	Chevy	3792615	2	1.05	front eye (7/16"— 20 x 5 1/2")
70-71	Pass. (exc. Sta. Wag.)	3982818	1	1.05	hex. (280M)
71	Pass. (Sta. Wag.)	9432580	2	.22	hex. (300M) (1/2"— 13 x 4 3/4")— (8.900)
71-74	Pass. (Sta. Wag.)	9430838	4	.63	shackle (9/16"— 12 x 4 5/8") (repl. 9432568)— (8.900)
72-73	Nova (350)	332671	4	.31	(7/16"— 20 x 1 5/16") (300M)
73-74	Camaro	481949	4	.47	
63	Chevy	3849248	1	7.95	<b>REPAIR KIT, shackle— (7.523)</b>



**FRAME—SPRINGS—BUMPER**

**7.530 RETAINER— NUT, Rear Spring Eye**

62-67	Chevy	3792613	2	.72	bushing
67-69	Camaro,				
68-75	Chevy, Nova,				
69-72	Chevelle (Sta. Wag.),				
70-75	Camaro	3892755	6	.11	NUT, front eye ( <sup>5</sup> / <sub>8</sub> "— 16)

**7.535 BUMPER— BRACKET— SPACER, Rear Spring**

62-67	Chevy	3852039	2	.38	
67	Camaro	3892756	2	.34	
68-69	Camaro	3932735	2	.78	
69-72	Chevy	3972299	2	.93	
70	Camaro	480717	1	.93	
71-75	Camaro,				
71	Vega,				
75	Vega, Monza (exc. Vega Notchback)	3996323	2	1.15	
72-75	Vega, Monza	6264329	2	1.15	
73-75	Nova	483746	2	.87	rear axle compression
74-75	Nova (exc. Spec. Perf. Susp.)	344656	2	1.75	
70-72	Nova	3972299	1	.93	BUMPER ASSY.
70-72	Camaro	340324	1	1.75	BRACKET
73-75	Nova, Camaro	340324	2	1.75	BRACKET, bumper
75	Pass. (Sta. Wag.)	494782	2	1.75	BRACKET, bumper
74-75	Nova (exc. Spec. Perf. Susp.)	344655	2	.87	SPACER, rear axle bumper

**7.545 CUSHION— DAMPENER UNIT— INSULATOR— RETAINER— SEAT, Spring**

62-67	Chevy, Camaro,				
68-69	Camaro (327)	3791381	2	.53	upper
62-65	Chevy (exc. Sta. Wag., H.D., 327),				
66-68	Chevy (exc. Sta. Wag., H.D.),				
67	Camaro,				
68	Camaro (327),				
69	Camaro (exc. 302, 350, 396)	3792585	2	.65	lower
68	Chevy (327),				
69-73	Chevy (exc. 350, 396)	3947036	2	3.35	upper and lower
68-69	Camaro (exc. 327),				
68-69	Camaro w/4-Spd. (327) (exc. H/Per.),				
68	Chevy w/4-Spd. (327 H/Per., 350) (exc. Close Ratio),				
74-75	Nova	3930052	4	.98	
69-73	Chevy (350, 396)	3934860	4	1.10	
69-72	Chevy	3950191	2	.22	dampener
70-72	Camaro,				
72	Pass. (Sta. Wag.)	477818	2	.93	upper
70-72	Camaro	480566	2	1.20	lower
71-72	Pass. (Sta. Wag.)	483732	2	.63	lower
73-75	Camaro,				
73-75	Pass. (Sta. Wag.)	477818	2	.93	upper
73-75	Camaro	480566	2	1.20	lower
73-75	Pass. (Sta. Wag.)	483732	2	.63	lower
75	Pass. (Sta. Wag.)	497587	2	1.50	lower
75	Monza	346557	2	1.20	rear axle bumper ret.
67-69	Camaro	3921060	1	2.85	CUSHION UNIT
69-71	Chevy	3981802	2	2.75	DAMPENER UNIT
64-67	Chevelle	9775680	2	.64	INSULATOR
71-75	Vega, Monza		2		INSULATOR, upper
67-75	Chevelle,				
71-75	Pass. (exc. Sta. Wag.)	1366500	2	.42	
67-70	Pass.	3918708	2	.58	INSULATOR
71-75	Vega, Monza	3997223	2	.50	INSULATOR, lower
69-72	Chevy	3950190	1	.24	RETAINER, dampener lower & upper
75	Monza	346558	2	.71	RETAINER, rear axle bumper
65-70	Pass.	3856395	2	.38	SEAT, rear lower spring
73-74	Camaro	3976852	2	4.00	SEAT

**7.632 BOLT— EXTRACTOR, Wheel Carrier**

62-67	Chevy (Sta. Wag.)	3792658	1	.82	clamp ( <sup>5</sup> / <sub>16</sub> "— 18 x 6 <sup>3</sup> / <sub>4</sub> " O.L.)
65-67	Chevelle (Sta. Wag., El Camino),				
65-70	Pass. (Sta. Wag.),				
68-71	Chevelle (Sta. Wag.),				
73-75	Pass. (Sta. Wag.)	3991124	1	1.15	clamp ( <sup>5</sup> / <sub>16</sub> "— 18 x 9 <sup>13</sup> / <sub>16</sub> " O.L.)
67	Chevy, Chevelle (exc. Sta. Wag.),				
67	Chevelle (Concours),				

**FRAME—SPRINGS—BUMPER**

**7.632 BOLT— EXTRACTOR, Wheel Carrier (Con't)**

69	Chevelle (396) (exc. El Camino),				
70-71	Malibu (2-Dr.) w/frt. Disc Brakes (396, 454),				
70-71	Monte Carlo (400),				
67-69	Pass. (Conv.),				
73-74	Nova w/space saver tire . . . . .	9792305	1	.64	
67	Chevelle (Sta. Wag.) . . . . .	3899525	1	.70	clamp . . . . .
69	Camaro (Spt. Cpe.) (exc. space saver wheel) . . . . .	1235009	1	.70	clamp (repl. 3949607) . . . . .
69-70	El Camino w/Disc Brake (396, 454),				
71-72	El Camino,				
72	Chevelle (Sta. Wag.) . . . . .	9793438	1	1.05	clamp . . . . .
69-71	Chevy (350, 396),				
70	Pass. (exc. Sta. Wag., Conv.),				
67-68	Camaro (Spt. Cpe.),				
68-69	Camaro (Conv.),				
70-72	Chevelle (Spt. Cpe., Sed.) (exc. Malibu),				
70-71	Malibu (4-Dr.),				
70-71	Malibu (2-Dr.) (exc. Frt. Disc Brake),				
70-71	Monte Carlo,				
70-71	Nova (exc. 4BC),				
71-73	Vega,				
72	Malibu (2-Dr.) w/frt. Disc Brakes (454),				
72	Monte Carlo (400) w/15 x 7 wheel . . . . .	488243	1	.96	clamp (5/16"— 18 x 6" O.L.) . . . . .
70-72	Camaro . . . . .	482942	1	.87	clamp . . . . .
71-72	Pass. (exc. Sta. Wag.) . . . . .	3986982	A.R.	.87	clamp (5/16"— 18 x 8 1/2" O.L.) . . . . .
71-72	Pass. (Sta. Wag.) . . . . .	3991124	1	1.15	clamp (5/16"— 18 x 9 13/16" O.L.) . . . . .
73-75	Pass. (exc. Sta. Wag.),				
73-74	Nova (2-Dr.) (exc. Hatchback),				
73-75	Chevelle (exc. El Camino),				
75	Camaro (exc. Space Saver) . . . . .	488243	1	.96	(5/16"— 18 x 7" O.L.) . . . . .
73-75	Nova (exc. Spare Saver Tire) . . . . .	3986982	1	.87	clamp (5/16"— 18 x 8 1/2" O.L.) . . . . .
73	Camaro (exc. Space Saver Tire) . . . . .	482942	1	.87	clamp . . . . .
73	Camaro w/Space Saver Tire . . . . .	483966	1	1.25	clamp . . . . .
74	Camaro (exc. Space Saver Tire) . . . . .	488243	1	.96	
75	Pass. (Sta. Wag.) . . . . .	344981	1	.96	spare tire hold down . . . . .
75	Pass. (Sta. Wag.) . . . . .	344978	1	3.65	EXTRACTOR, spare tire . . . . .

**7.633 NUT— RETAINER, Wheel Carrier**

62-75	All . . . . .	9785616	A.R.	.68	wing (5/16"— 18) . . . . .
63-70	Sta. Wag., El Camino,				
71-72	Chevelle (Sta. Wag.) El Camino . . . . .	3818748	1	.13	clamp bolt (39/64" O.D.) . . . . .
65-66	Chevy, Chevelle w/lock, (exc. Sta. Wag.),				
67-68	Chevy, Chevelle, Camaro,				
65-69	Pass. (exc. Sta. Wag.),				
70	All (exc. Camaro) . . . . .	3869763	1	.87	lock . . . . .
65-67	Chevy, Chevelle (Sta. Wag.) w/lock,				
67-68	Chevy, Camaro, Chevelle,				
65-69	Sta. Wag.,				
70	All (exc. Camaro) . . . . .	3869764	1	.87	lock . . . . .
65-67	Pass.,				
68-71	All . . . . .	358501	A.R.	.27	(7/16"— 20) (wheel assembly to rear wheel carrier)— (5.813) . . . . .
65-70	All . . . . .	3869761	1	1.55	RETAINER, lock nut . . . . .

**7.675 CASE ASSY., Wheel Carrier**

62-70	Chevelle, Nova, Camaro,				
65-70	Pass. . . . .	3912416	A.R.	7.55	w/cyl. asm. . . . .

**7.679 CASE, Wheel Carrier Lock**

62-70	All . . . . .	3912416	A.R.	7.55	
-------	---------------	---------	------	------	--

**7.680 CYLINDER ASSY., Wheel Carrier Lock**

NOTE: See group 10.553 for tumbler unit, spring unit, and retainer used with lock cylinders.

**7.800 BRACKET— BOLT— BUMPER— COVER— FRAME ASSY.— NUT—  
POCKET— SPACER— SUPPORT, License Plate**

67-68	Camaro . . . . .	3893807	1	1.20	front . . . . .
-------	------------------	---------	---	------	-----------------

**FRAME—SPRINGS—BUMPER**

<b>7.800</b>		<b>BRACKET— BOLT— BUMPER— COVER— FRAME ASSY.— NUT—</b>		<b>POCKET— SPACER— SUPPORT, License Plate (Con't)</b>	
68	Chevelle	3910699	1	1.10	front
69	Camaro	3945756	1	1.35	front
69	Pass.	3938057	1	1.55	front
70	Pass.	3950753	1	1.55	front
70-72	Chevelle	3982425	1	1.80	front
70-73	Camaro (exc. R.S.)	3966839	1	1.20	front
70-73	Camaro (R.S.)	3973960	1	1.20	front
71	Pass.	3985697	1	1.65	front
71-72	Vega	3974557	1	.93	frt. license plate
72	Pass.	3997386	1	1.65	front
73	Monte Carlo	328935	1	1.70	frt. (attaches to lower bumper)
74	Nova	494358	1	2.00	frt. (license plate mounting)
73	Pass.	6273767	1	1.60	frt.
73	Vega	325724	1	.73	frt. lic. plate
74-75	Vega	336575	1	1.65	frt. license plate
74	Pass.,				
75	Impala, Bel Air	354025	1	4.10	front
74-75	Camaro	341037	1		front
74-75	Monte Carlo	342106	1	3.70	front
74	Nova	341087	1	1.20	front
74-75	Malibu, El Camino	342107	1	3.65	front
74	Laguna	342197	1	5.50	front
75	Caprice	343538	1	3.50	front
75	Camaro, Nova	352576	1	3.65	front
75	Monza (exc. Towne Cpe.)	339142	1	.66	front lic. plate
75	Monza (exc. Towne Cpe.)	346531	1	2.40	rear license plate
75	Laguna	347348	1	4.65	front
75	Monza (Towne Cpe.)	365221	1	2.40	front
65-69	Pass.	273450	A.R.		<b>BOLT</b> (1/4"— 14 x 1) (repl. 9414403)— (8.977)
64-70	All				rear,
71-72	El Camino				rear (1/2" dia. x 2 1/32" O.L.),
71-72	Chevelle, Camaro,				
73	Camaro (R.S.)	3841098	A.R.	.11	<b>BUMPER, front</b>
65	Pass.	3762180	A.R.	.22	<b>BUMPER, front and rear rubber</b> (9/16" dia. x 1/2")— (8.024)
66-68	Pass.	3876566	2	.11	<b>BUMPER, front</b>
66-70	All,				
71-72	All (exc. Camaro)				<b>BUMPER, frt. and rear lic. plate,</b>
73	All,				
74	Pass. (Sta. Wag.)				rear,
74-75	Chevelle (exc. Sta. Wag., El Camino)	3938600	2	.11	front and rear (1/4" dia. 1 1/8")
67	Chevelle (exc. Sta. Wag., El Camino)	1370909	2	.11	<b>BUMPER, backing lamp bumper</b>
69-71	Pass.	3938058	1	.11	<b>BUMPER, front</b>
69	Camaro (6 cyl.)	3745361	2		<b>BUMPER, rear (rubber)</b> (1/2" dia. x 7/16")
70-73	Camaro	3966840	1	.11	<b>BUMPER, front</b>
70-73	Monte Carlo	3973636	2	.11	<b>BUMPER, backing lamp bumper</b>
71-72	Vega	3982096	1	.13	<b>BUMPER, front license plate</b>
73	Pass.	6273792	1	.11	<b>BUMPER, front</b>
74-75	Nova	341089	2	.11	<b>BUMPER, front (license plate mounting)</b>
75	Vega	4691643	2	.39	<b>BUMPER, rear license plate</b>
74-75	Vega (Sta. Wag., Panel)	9699384	1	.99	<b>COVER, back door inner at lic. plate</b>
64-66	All	3797485	1	5.00	<b>FRAME ASSY., front and rear</b>
66-69	All,				
70-72	Nova,				
70-71	Chevelle, Pass.,				
73-74	All,				
75	Vega, Monza	3877254	1	.21	<b>NUT</b> (special spring 1/4"— 14) (Note 1)
	<i>NOTE 1 For flush mtd. plates cut off ext. above flange.</i>				
73	Vega	3844999	2	.21	<b>NUT, frt. lic. plate bracket—</b> (1.303)
75	All	4755299	A.R.	.11	<b>NUT, front</b>
74	Vega (Sta. Wag., Panel)	9638277	1	15.15	<b>POCKET, rr. license plate</b>
75	Vega (Sta. Wag., Panel)	1669559	1	7.75	<b>POCKET, rear lic. plate to panel</b>
65-66	All	3885920	4	.11	<b>SPACER, front or rear</b> (1/4"— 14)
68-69	Chevelle (2nd design),				
70-72	Chevelle	3929857	1	.18	<b>SPACER, front (strip type)</b>
68	Pass.	3920162	2	.18	<b>SPACER, front</b>
71-73	Vega	3984089	4	.11	<b>SPACER, radiator grille mldg.</b>
75	Vega (Sta. Wag., Panel)	1667751	2	1.00	<b>SUPPORT, back door otr. panel to inner lower</b>

**FRAME—SPRINGS—BUMPER**

**7.828 GUARD— CUSHION ASSY.— SPACER, Bumper and Grille**

65	Pass.	3856531	L.H.	12.25	left, front valance panel, center
65	Pass.	3856532	R.H.	12.25	right, front valance panel, center
64	Chevelle	3841243	2	14.40	GUARD ASSY., front
66	Pass.	3872141	L.H.	12.25	GUARD ASSY., left front valance panel
66	Pass.	3872142	R.H.	12.25	GUARD ASSY., right front valance panel
66	Pass. (exc. Sta. Wag.)	3874565	L.H.	14.80	GUARD ASSY., left rear
66	Pass. (exc. Sta. Wag.)	3874566	R.H.	14.80	GUARD ASSY., right rear
66	Pass.	3879591	L.H.	14.80	GUARD ASSY., left front
66	Pass.	3879592	R.H.	14.80	GUARD ASSY., right front
66-67	Chevy	3870443	L.H.	12.20	GUARD ASSY., left front
66-67	Chevy	3870444	R.H.	12.20	GUARD ASSY., right front
66-67	Chevy (exc. Sta. Wag.)	3870454	2	13.05	GUARD ASSY., rear
66	Chevelle	3874593	L.H.	14.80	GUARD ASSY., left front
66	Chevelle	3874594	R.H.	14.80	GUARD ASSY., right front
66	Chevelle	3874595	L.H.	14.80	GUARD ASSY., left rear
66	Chevelle	3874596	R.H.	14.80	GUARD ASSY., right rear
67	Chevelle	3895109	L.H.	14.80	GUARD ASSY., left front
67	Chevelle	3895110	R.H.	14.80	GUARD ASSY., right front
67	Chevelle (exc. Sta. Wag., El Camino)	3895111	L.H.	14.80	GUARD ASSY., left rear
67	Chevelle (exc. Sta. Wag., El Camino)	3895112	R.H.	14.80	GUARD ASSY., right rear
67-68	Camaro	3893801	L.H.	12.20	GUARD ASSY., left front
67-68	Camaro	3893802	R.H.	12.20	GUARD ASSY., right front
67	Camaro (exc. rr. bumper guard)	3916609	2	11.85	GUARD ASSY., rear (Note 1)
<i>NOTE 1 All w/o rubber insert - If the bracket is welded to the guard, replace individually - If the bracket is bolted to the guard, replace in pairs.</i>					
67-68	Camaro	3891694	2	15.70	GUARD ASSY., rear
67	Pass.	3895105	L.H.	14.80	GUARD ASSY., left front
67	Pass.	3895106	R.H.	14.80	GUARD ASSY., right front
67	Pass. (exc. Sta. Wag.)	3895107	L.H.	14.80	GUARD ASSY., left rear
67	Pass. (exc. Sta. Wag.)	3895108	R.H.	14.80	GUARD ASSY., right rear
68	Pass. (exc. Sta. Wag.)	3922857	2	14.80	GUARD ASSY., rear
68	Pass.	3917401	L.H.	14.80	GUARD ASSY., left front (deluxe)
68	Pass.	3917402	R.H.	14.80	GUARD ASSY., right front (deluxe)
68	Pass.	3920151	L.H.	12.80	GUARD ASSY., left front (standard)
68	Pass.	3920152	R.H.	14.40	GUARD ASSY., right front (standard)
68	Chevelle	3916527	L.H.	14.80	GUARD ASSY., left rear
68	Chevelle	3916528	R.H.	14.80	GUARD ASSY., right rear
68	Chevelle	3917415	L.H.	14.80	GUARD ASSY., left front
68	Chevelle	3917416	R.H.	14.80	GUARD ASSY., right front
68-72	Chevy (exc. Hi Rise Guards)	3916635	L.H.	12.20	GUARD ASSY., left rear
68-72	Chevy (exc. Hi Rise Guards)	3916636	R.H.	12.20	GUARD ASSY., right rear
68	Chevy	3916645	L.H.	12.20	GUARD ASSY., left front
68	Chevy	3916646	R.H.	12.20	GUARD ASSY., right front
69-72	Chevy (exc. Hi Rise Guards)	3943221	L.H.	12.20	GUARD ASSY., left front
69-72	Chevy (exc. Hi Rise Guards)	3943222	R.H.	12.20	GUARD ASSY., right front
69	Camaro (exc. rr. bumper guard, Spec. rr. spring)	3938633	2	12.20	GUARD ASSY., right rear
69	Camaro	3938681	L.H.	12.20	GUARD ASSY., left front
69	Camaro	3938682	R.H.	12.20	GUARD ASSY., right front
69	Camaro	3938607	2	13.60	GUARD ASSY., rear
69	Chevelle (exc. El Camino, Sta. Wag.)	3942785	L.H.	14.80	GUARD ASSY., left rear
69	Chevelle (exc. El Camino, Sta. Wag.)	3942786	R.H.	14.80	GUARD ASSY., right rear
69	Chevelle	3947937	L.H.	14.80	GUARD ASSY., left front
69	Chevelle	3947938	R.H.	14.80	GUARD ASSY., right front
69	Pass. (exc. Sta. Wag.)	3942181	L.H.	14.80	GUARD ASSY., left rear
69	Pass. (exc. Sta. Wag.)	3942182	R.H.	14.80	GUARD ASSY., right rear
69	Pass. (exc. frt. bumper guard)	3945683	L.H.	7.90	GUARD ASSY., left front
69	Pass. (exc. frt. bumper guard)	3945684	R.H.	7.90	GUARD ASSY., right front
69	Pass.	3957283	L.H.	14.80	GUARD ASSY., left front
69	Pass.	3957284	R.H.	14.80	GUARD ASSY., right front
70	Chevelle,				
71-72	Monte Carlo (exc. Hi Rise Guards)	3968503	L.H.	14.80	GUARD ASSY., left, front
70	Chevelle,				
71-72	Monte Carlo (exc. Hi Rise Guards)	3968504	R.H.	14.80	GUARD ASSY., right, front
70	Malibu	3972331	L.H.	14.80	GUARD ASSY., left, rear
70	Malibu	3972332	R.H.	14.80	GUARD ASSY., right, rear
70-72	Monte Carlo (exc. Hi Rise Guards)	3974019	L.H.	14.80	GUARD ASSY., left, rear

**FRAME—SPRINGS—BUMPER**

**7.828 GUARD—CUSHION ASSY.—SPACER, Bumper and Grille (Con't)**

70-72	Monte Carlo (exc. Hi Rise Guards)	3974020 R.H.	14.80	GUARD ASSY., right, rear
70	Pass.	3962343 L.H.	14.80	GUARD ASSY., left, front
70	Pass.	3962344 R.H.	14.80	GUARD ASSY., right, front
70	Pass. (exc. Sta. Wag.)	3962367 L.H.	14.80	GUARD ASSY., left, rear
70	Pass. (exc. Sta. Wag.)	3962368 R.H.	14.80	GUARD ASSY., right, rear
70-72	Camaro (w/Sp. H/Per. 350),			
70-72	Camaro (w/Spec. Bumper)	3982033 2	12.20	GUARD ASSY., rear
70-72	Camaro (exc. R.S.)	3974540 R.H.	11.70	GUARD ASSY., right, front
70-72	Camaro (exc. R.S.)	3974539 L.H.	11.70	GUARD ASSY., left, front
71-72	Chevelle (exc. Hi Rise Guards, Monte Carlo)	3975475 L.H.	14.80	GUARD ASSY., left, front
71-72	Chevelle (exc. Hi Rise Guards, Monte Carlo)	3975476 R.H.	14.80	GUARD ASSY., right, front
71-72	Chevelle w/Hi Rise Guards (exc. Monte Carlo)	6264813 L.H.	19.10	GUARD ASSY., left, front
71-72	Chevelle w/Hi Rise Guards (exc. Monte Carlo)	6264814 R.H.	19.10	GUARD ASSY., right, front
71-72	Chevelle w/Hi Rise Guards (exc. Sta. Wag., El Camino, Monte Carlo)	6264815 L.H.	12.80	GUARD ASSY., left, rear
71-72	Chevelle w/Hi Rise Guards (exc. Sta. Wag., El Camino, Monte Carlo)	6264816 R.H.	19.10	GUARD ASSY., right, rear
71-72	Monte Carlo w/Hi Rise Guards	6264817 L.H.	12.80	GUARD ASSY., left front
71-72	Monte Carlo w/Hi Rise Guards	6264818 R.H.	12.80	GUARD ASSY., right, front
71-72	Monte Carlo w/Hi Rise Guards	6264820 2	12.80	GUARD ASSY., rear
71-72	Nova w/Hi Rise Guards	6264822 2	10.60	GUARD ASSY., front
71-72	Nova w/Hi Rise Guards	6264824 2	12.80	GUARD ASSY., rear
71-72	Chevelle (exc. Hi Rise Guards, Monte Carlo, Sta. Wag., El Camino)	3992601 L.H.	14.80	GUARD ASSY., left, rear
71-72	Chevelle (exc. Hi Rise Guards, Monte Carlo, Sta. Wag., El Camino)	3992602 R.H.	14.80	GUARD ASSY., right, rear
71	Pass.	3995107 L.H.	13.90	GUARD ASSY., left, front
71	Pass.	3995108 R.H.	13.90	GUARD ASSY., right, front
71-73	Pass. (Sta. Wag.)	3995099 2	14.80	GUARD ASSY., rear
71	Pass. (exc. Sta. Wag.)	3995113 1	27.75	GUARD ASSY., rear
71-72	Vega	3978151 L.H.	11.80	GUARD ASSY., front bumper
71-72	Vega	3978152 R.H.	11.80	GUARD ASSY., front bumper
71-73	Vega	3984093 2	11.20	GUARD ASSY., rear bumper
72	Pass.	3997383 L.H.	12.10	GUARD ASSY., left front
72	Pass.	3997384 R.H.	12.10	GUARD ASSY., right front
72	Pass. (exc. Sta. Wag., front and rear impact strip)	6270185 L.H.	17.80	GUARD ASSY., left rear
72	Pass. (exc. Sta. Wag., front and rear impact strip)	6270186 R.H.	17.80	GUARD ASSY., right rear
72	Caprice w/front and rear impact strip	6270189 L.H.	17.80	GUARD ASSY., left rear
72	Caprice w/front and rear impact strip	6270190 R.H.	17.80	GUARD ASSY., right rear
73	Vega	329745 L.H.	11.55	GUARD ASSY., frt. bumper
73	Vega	329746 R.H.	11.55	GUARD ASSY., frt. bumper
73	Chevelle (Spt. Cpe., Sed.) (exc. Laguna, Monte Carlo)	328970 R.H.	12.20	GUARD ASSY., rear
73	Chevelle (Spt. Cpe., Sed.) (exc. Laguna, Monte Carlo)	328969 L.H.	12.20	GUARD ASSY., rear
73	Pass. (exc. Sta. Wag.)	327122 2	12.20	GUARD ASSY., rear
73	Monte Carlo	328979 L.H.	12.20	GUARD ASSY., rear
73	Monte Carlo	328980 R.H.	12.20	GUARD ASSY., rear
73	Chevelle (exc. Laguna, Monte Carlo)	328965 L.H.	14.80	GUARD ASSY., front
73	Chevelle (exc. Laguna, Monte Carlo)	328966 R.H.	14.80	GUARD ASSY., front
73	Monte Carlo	328977 L.H.	14.80	GUARD ASSY., front
73	Monte Carlo	328978 R.H.	14.80	GUARD ASSY., front
73	Pass.	6273795 L.H.	12.10	GUARD ASSY., front
73	Pass.	6273796 R.H.	12.10	GUARD ASSY., front
73	Camaro (exc. R.S.)	327521 L.H.	12.10	GUARD ASSY., front
73	Camaro (exc. R.S.)	327522 R.H.	12.10	GUARD ASSY., front
74	Pass.	339227 L.H.	16.60	GUARD ASSY., front
74	Pass.	339228 R.H.	16.60	GUARD ASSY., front
74	Malibu, El Camino	342123 L.H.	21.95	GUARD ASSY., front
74	Malibu, El Camino	342124 R.H.	21.95	GUARD ASSY., front

**FRAME—SPRINGS—BUMPER**

**7.828 GUARD— CUSHION ASSY.— SPACER, Bumper and Grille (Con't)**

74	Monte Carlo	342149	L.H.	20.60	GUARD ASSY., front
74	Monte Carlo	342150	R.H.	20.60	GUARD ASSY., front
74	Laguna	342153	L.H.	17.80	GUARD ASSY., front
74	Laguna	342154	R.H.	17.80	GUARD ASSY., front
74	Nova	341085	L.H.	10.60	GUARD ASSY., front
74	Nova	341086	R.H.	10.60	GUARD ASSY., front
74	Nova	341076	2	5.75	GUARD ASSY., rear
74-75	Pass. (Sta. Wag.)	337690	2	6.15	GUARD ASSY., rear
74-75	Pass. (exc. Sta. Wag.)	339251	2	16.60	GUARD ASSY., rear
74	Monte Carlo	340165	L.H.	19.05	GUARD ASSY., rear
74	Monte Carlo	340166	R.H.	19.05	GUARD ASSY., rear
74-75	Camaro	341074	2	5.75	GUARD ASSY., rear
74	Laguna,				
74	Malibu (exc. Sta. Wag., El Camino)	342119	L.H.	19.05	GUARD ASSY., rear
74	Laguna,				
74	Malibu (exc. Sta. Wag., El Camino)	342120	R.H.	19.05	GUARD ASSY., rear
74-75	Camaro	341079	L.H.	15.10	GUARD ASSY., front
74-75	Camaro	341080	R.H.	15.10	GUARD ASSY., front
74-75	Vega (exc. Impact Strip)	339065	L.H.	6.30	GUARD ASSY., frt. bumper
74-75	Vega (exc. Impact Strip)	339066	R.H.	6.30	GUARD ASSY., frt. bumper
74-75	Vega w/Impact Strip	339067	L.H.	6.30	GUARD ASSY., frt. bumper
74-75	Vega w/Impact Strip	339068	R.H.	6.30	GUARD ASSY., frt. bumper
75	Chevelle (exc. Monte Carlo)	352025	L.H.	19.85	GUARD ASSY., front
75	Chevelle (exc. Monte Carlo)	352026	R.H.	19.85	GUARD ASSY., front
75	Monte Carlo	352027	L.H.	21.50	GUARD ASSY., front
75	Monte Carlo	352028	R.H.	21.50	GUARD ASSY., front
75	Monte Carlo	352031	L.H.	19.80	GUARD ASSY., rear
75	Monte Carlo	352032	R.H.	19.80	GUARD ASSY., rear
75	Malibu (exc. Sta. Wag.)	352034	R.H.	19.80	GUARD ASSY., rear
75	Malibu (exc. Sta. Wag.)	352033	L.H.	19.80	GUARD ASSY., rear
75	Caprice	343515	L.H.	12.60	GUARD ASSY., front
75	Caprice	343516	R.H.	12.60	GUARD ASSY., front
75	Nova	347564	2	5.95	GUARD ASSY., rear
75	Nova	360614	1	5.70	GUARD ASSY., r.r. bpr. edge
75	Nova	347565	L.H.	11.05	GUARD ASSY., front
75	Nova	347566	R.H.	11.05	GUARD ASSY., front
75	Pass. (exc. Caprice)	339227	L.H.	16.60	GUARD ASSY., front
75	Pass. (exc. Caprice)	339228	R.H.	16.60	GUARD ASSY., front
75	Monza (Towne Cpe.) w/Impact Strip	356633	L.H.	10.20	GUARD ASSY., rear bumper
75	Monza (Towne Cpe.) w/Impact Strip	356634	R.H.	10.20	GUARD ASSY., rear bumper
75	Monza (Towne Cpe.) (exc. Impact Strip)	356635	L.H.	10.20	GUARD ASSY., rear bumper
75	Monza (Towne Cpe.) (exc. Impact Strip)	356636	R.H.	10.20	GUARD ASSY., rear bumper
75	Monza (Towne Cpe.) (exc. Impact Strip)	356647	L.H.	10.20	GUARD ASSY., frt. bumper
75	Monza (Towne Cpe.) (exc. Impact Strip)	356648	R.H.	10.20	GUARD ASSY., frt. bumper
75	Monza (Towne Cpe.) w/Impact Strip	356651	L.H.	10.20	GUARD ASSY., frt. bumper
75	Monza (Towne Cpe.) w/Impact Strip	356652	R.H.	10.20	GUARD ASSY., frt. bumper
75	Monza (exc. Towne Cpe.)	353923	L.H.	10.70	GUARD ASSY., rear bumper
75	Monza (exc. Towne Cpe.)	353924	R.H.	10.70	GUARD ASSY., rear bumper
74-75	Pass. (Sta. Wag.)	994522	1	6.30	GUARD UNIT, rear
74-75	Pass. (exc. Sta. Wag.)	994574	1	20.00	GUARD UNIT, rear
74	Pass.,				
75	Pass. (exc. Caprice)	994573	1	22.60	GUARD UNIT, front
75	Monte Carlo	994759	1		GUARD UNIT, front
75	Malibu	994758	1	N.L.	GUARD UNIT, front
75	Malibu (exc. Sta. Wag.)	994760		N.L.	GUARD UNIT, rear
75	Caprice	994675	1	N.L.	GUARD UNIT, front
67	Pass. (exc. Sta. Wag.)	3897510	2	3.25	CUSHION ASSY., rear bumper guard
67	Pass.	3897519	1	3.25	CUSHION ASSY., front bumper guard
67	Chevelle (exc. Sta. Wag., El Camino)	3895190	2	4.40	CUSHION ASSY., rear
67	Chevelle	3895168	2	1.80	CUSHION ASSY., front
67-68	Camaro	3891697	2	3.60	CUSHION ASSY., rear
67-69	Camaro	3893800	2	4.40	CUSHION ASSY., front
68-72	Chevy	3916640	2	1.90	CUSHION ASSY., rear
68-72	Chevy	3916650	2	1.90	CUSHION ASSY., front

**FRAME—SPRINGS—BUMPER**

**7.828 GUARD— CUSHION ASSY.— SPACER, Bumper and Grille (Con't)**

68	Chevelle (exc. Sta. Wag., El Camino)	3916530	2	1.95	CUSHION ASSY., rear
68	Chevelle	3917419	2	1.95	CUSHION ASSY., front
68	Pass.	3917403	2	1.95	CUSHION ASSY., front bumper guards
68	Pass. (exc. Sta. Wag.)	3922854	2	1.60	CUSHION ASSY., rear bumper guard
69	Camaro	3938611	2	2.10	CUSHION ASSY., rr.
69	Chevelle (exc. El Camino, Sta. Wag.)	3942782	2	2.70	CUSHION ASSY., rear
69	Chevelle	3947936	2	1.90	CUSHION ASSY., front
69	Pass. (exc. Sta. Wag.)	3941222	2	1.90	CUSHION ASSY., rear, bumper guard
69	Pass.	3949219	2	1.90	CUSHION ASSY., front, bumper guard
69	Pass.	3950611	LH	2.50	CUSHION ASSY., left front
69	Pass.	3950612	RH	2.50	CUSHION ASSY., right front
70-72	Chevelle	3968507	2	1.75	CUSHION ASSY., front
70	Malibu,				
71-72	Chevelle (exc. Sta. Wag., El Camino, Monte Carlo)	3972335	2	1.90	CUSHION ASSY., rear
70-72	Monte Carlo	3974018	2	2.85	CUSHION ASSY., rear
70	Pass.	3962342	2	1.90	CUSHION ASSY., front
70	Pass. (exc. Sta. Wag.)	3962371	2	1.90	CUSHION ASSY., rear
71	Pass. (exc. Sta. Wag.)	3995114	1	8.45	CUSHION ASSY., rear
71-73	Pass. (Sta. Wag.)	3995101	2	1.90	CUSHION ASSY., rear
71	Pass.	3995109	2	2.65	CUSHION ASSY., front
72	Pass. (exc. Sta. Wag.)	6270182	2	2.75	CUSHION ASSY., rear
72	Pass.	3997381	2	3.05	CUSHION ASSY., front
73	Chevelle (exc. Laguna, Monte Carlo)	328964	2	1.75	CUSHION ASSY., front
73	Monte Carlo	328976	2	3.05	CUSHION ASSY., front
73	Pass.	6273797	2	3.05	CUSHION ASSY., front
73	Camaro (exc. R.S.)	327527	2	3.05	CUSHION ASSY., front
73	Malibu, Deluxe (Spt. Cpe., Sed.)	328972	2	1.80	CUSHION ASSY., rear
73	Monte Carlo	328981	2	1.80	CUSHION ASSY., rear
73	Pass. (exc. Sta. Wag.)	327123	2	1.60	CUSHION ASSY., rear
74	Pass.	339229	2	3.35	CUSHION ASSY., front
74	Laguna	345318	2	5.00	CUSHION ASSY., front (Note 1)
74-75	Malibu, Laguna (exc. Sta. Wag.)	342121	2	3.60	CUSHION ASSY., rear (Note 1)
<i>NOTE 1: Paint as reqd. with urethane bumper paint.</i>					
74	Malibu, El Camino	342125	2	2.30	CUSHION ASSY., front
74	Monte Carlo	342136	2	2.30	CUSHION ASSY., front
74-75	Monte Carlo	342156	2	2.40	CUSHION ASSY., rear
74-75	Pass. (exc. Sta. Wag.)	339252	2	1.75	CUSHION ASSY., rear
75	Caprice	343517	2	3.15	CUSHION ASSY., front guard
75	Pass. (exc. Caprice)	339229	2	3.35	CUSHION ASSY., front guard
75	Chevelle (exc. Monte Carlo)	352029	2	2.30	CUSHION, front
75	Monte Carlo	352030	2	3.15	CUSHION, front
75	Malibu (exc. Sta. Wag.)	352035	2	1.60	CUSHION, rear
75	Monte Carlo	352037	2	1.65	CUSHION, rear
72	Pass. (exc. Sta. Wag.)	6270195	2	.29	SPACER, rear bumper guard

**7.829 BRACKET— CLAMP— NUT— RETAINER— REINFORCEMENT— SCREW— SPACER, Bumper Guard Mounting**

*NOTE 1 All w/guard w/o rubber insert - First jobs with bracket bolted to guard - similar part on after jobs is welded to guard and not serviced separately.*

69	Pass.	3957285	2	.31	front bumper guard
70	Chevelle,				
71-72	Monte Carlo	3968510	1	.82	front
62-66	Chevy (exc. Sta. Wag.)	3791871	2	.39	CLAMP
66	Pass., Chevelle (exc. Sta. Wag., El Camino)	3877824	2	.59	CLAMP, rear
66-67	Chevy	3870445	L.H.	.72	CLAMP, left
66-67	Chevy	3870446	R.H.	.72	CLAMP, right
67	Chevelle (exc. Sta. Wag., El Camino)	3895184	2	.21	CLAMP, rear
67-68	Camaro	3891698	2	.36	CLAMP, rear bumper guard
67-68	Camaro	3893803	L.H.	.72	CLAMP, left front
67-68	Camaro	3893804	R.H.	.72	CLAMP, right front
67	Chevelle	3895191	L.H.	.55	CLAMP, left front
67	Chevelle	3895192	R.H.	.55	CLAMP, right front
68	Pass.	3917404	2	.31	CLAMP, front
68	Chevelle	3917417	2	.36	CLAMP, front
68-72	Chevy	3916641	2	.42	CLAMP, rear
68	Chevy	3916652	R.H.	.52	CLAMP, right front
69	Camaro	3938609	2	.77	CLAMP, rear
69	Camaro	3938683	L.H.	.98	CLAMP, left front
69	Camaro	3938684	R.H.	.98	CLAMP, right front

**FRAME—SPRINGS—BUMPER**

**7.829 BRACKET— CLAMP— NUT— RETAINER— REINFORCEMENT— SCREW— SPACER, Bumper Guard Mounting (Con't)**

69-72	Chevy	3943223	L.H.	.27	CLAMP, left front
69-72	Chevy	3943224	R.H.	.33	CLAMP, right front
69	Chevelle	3957394	R.H.	.21	CLAMP, right front
69	Chevelle	3957393	L.H.	.21	CLAMP, left front
73	Chevelle (exc. Laguna)	328967	L.H.	.36	CLAMP, front
73	Chevelle (exc. Laguna)	328968	R.H.	.36	CLAMP, front
70	Camaro,				
71	Camaro w/Sp. H/Per. (350)	3903539	2	.22	NUT, spec. self sealing
69	Pass. (exc. frt. bumper guard),				
72	Camaro	3945685	2	.31	RETAINER, front
71-73	Vega	3978153	2	.27	REINFORCEMENT
75	Monza (exc. Towne Cpe.)	346640	1	4.15	REINFORCEMENT, front bumper impact bar
70-72	Camaro	3986524	2	.26	SCREW, front, to lower bumper (3/8"— 16 x 1)
72	Camaro	3903536	2	.11	SCREW, rr. bumper guard lower
74	Vega	3842804	2	.55	SPACER, frt. guard— (0.832)
75	Monza (Towne Cpe.) w/Impact Strip	356632	2	1.70	SPACER, rr. bumper guard
75	Monza (Towne Cpe.)	356645	2	2.05	SPACER, frt. bumper guards

**7.831 BAR, Bumper Face**

**PASSENGER (FRONT)**

65	Pass.	3850205	L.H.	24.45	left outer face
65	Pass.	3850206	R.H.	24.45	right outer face
65	Pass.	3852971	1	43.00	center
66	Pass.	3869710	1	40.00	center
66	Pass.	3869711	L.H.	25.75	left
66	Pass.	3869712	R.H.	25.75	right
67	Pass.	3885929	L.H.	25.50	left outer face
67	Pass.	3885930	R.H.	25.50	right outer face
67	Pass.	3885931	1	60.50	center
68	Pass.	3907637	L.H.	33.00	left outer face
68	Pass.	3907638	R.H.	33.00	right outer face
68	Pass.	3907639	1	43.00	outer face upper
68	Pass.	3907656	1	26.25	lower, center face
69	Pass.	3926848	1	104.00	front outer face
70	Pass.	3950746	1	72.50	front
71	Pass.	3975331	1	91.00	front
72	Pass.	3997318	1	91.00	front (Note 2)
72	Pass.	3997378	1	91.00	front (w/holes)
73	Pass. w/Impact Strip and Guards	327139	1	91.00	
73	Pass. (exc. Impact Strips and Guards)	6270196	1	91.00	
74-75	Pass. (exc. Impact Strips and Guards)	335926	1	91.00	
74	Pass. w/Guards (exc. Impact Strips),				
75	Bel Air, Impala	339234	1	91.00	
74-75	Pass. w/Impact Strips (exc. Guards)	339235	1	105.00	bumper face (includes impact strip)
74-75	Pass. w/Impact Strips and Guards	339236	1	105.00	bumper face (includes impact strips)
75	Caprice (exc. Impact Strips and Guards)	342374	1	105.00	
75	Caprice w/Impact Strips & Guards	343575	1	122.00	bumper face (Note 1)

*NOTE 1: When used on bumpers with Guards, notch out Impact Strip and drill holes for attaching bumper guards.*

*NOTE 2: It may be necessary to add (8) 5/16" holes for attaching bumper pads.*

**CHEVELLE (Front)**

64	Chevelle	3830727	1	78.25	front
65	Chevelle	3856906	1	78.25	front
66	Chevelle	3869723	1	78.25	front
67	Chevelle	3884920	1	78.25	front
68	Chevelle	3907620	1	78.25	front
69	Chevelle	3926850	1	78.25	front
70	Chevelle (exc. Monte Carlo, El Camino)	3954592	1	78.25	front
70	El Camino,				



**FRAME—SPRINGS—BUMPER**

**7.831 BAR, Bumper Face (Con't)**

70	Monte Carlo	3965900	1	85.50	front
71-72	Chevelle (exc. Monte Carlo)	3982398	1	78.25	front
71	Monte Carlo	3982399	1	85.50	front (Note 1)
72	Monte Carlo	6264800	1	85.50	front
73	Monte Carlo w/Impact Strip and Guards	331790	1	82.50	
73	Monte Carlo (exc. Impact Strip and Guards)	3987085	1	82.50	
73	Chevelle (exc. Impact Strips and Guards, Laguna, Monte Carlo)	3992686	1	89.25	
73	Laguna	325285	1	394.00	
73	Chevelle w/Impact Strip and Guards (exc. Laguna, El Camino, Monte Carlo)	331791	1	89.25	
74-75	Malibu, El Camino (exc. Impact Strips)	338512	1	89.25	
74-75	Monte Carlo (exc. Impact Strip)	338514	1	82.50	
74-75	Malibu, El Camino w/Impact Strip	340187	1	89.25	
74-75	Monte Carlo w/Impact Strip	340191	1	82.50	
74	Laguna	338582	1	394.00	
75	Laguna	356438	1	394.00	bumper face

*NOTE 1 When using 3982399 it may be necessary to cut holes for bumper guards.*

**CHEVY (Front)**

62-64	Chevy	3848995	1	61.50	front
65	Chevy	3857942	1	61.50	front
66-67	Chevy	3866471	1	65.25	front
68-72	Nova	3949785	1	65.25	front
73	Nova (exc. Custom, Impact Strip and Guards)	6274307	1	91.00	
73	Nova (Custom),				
73	Nova w/Impact Strip and Guards (exc. Custom)	6274321	1	91.00	
74	Nova (exc. Impact Strip)	337457	1	91.00	
74	Nova w/Impact Strips	339421	1	91.00	
75	Nova (exc. Impact Strips)	344334	1	91.00	
75	Nova w/Impact Strips	347501	1	91.25	bumper face

**CAMARO (Front)**

67-68	Camaro	3929954	1	54.75	front
69	Camaro	3927422	1	54.75	front
70-72	Camaro (R.S.) (exc. spec. bumper)	3986578	R.H.	54.75	right, front, outer
70-72	Camaro (R.S.) (exc. spec. bumper)	3986577	L.H.	54.75	left, front, outer
70-72	Camaro (exc. R.S. spec. bumper)	3986576	1	54.75	front
70-72	Camaro (R.S.)	333749	1	137.00	front, ctr.
70-72	Camaro (spec. bumper) (exc. R.S.)	3986581	1	54.75	front
70-72	Camaro (R.S. spec. bumper)	3986580	R.H.	54.75	right, front, outer
70-72	Camaro (R.S. spec. bumper)	3986579	L.H.	54.75	left, front, outer
73	Camaro (R.S.)	333749	1	137.00	bumper face, center
73	Camaro (R.S.) (exc. spec. bumper)	3986578	R.H.	54.75	bumper face, outer
73	Camaro (R.S.) (exc. spec. bumper)	3986577	L.H.	54.75	bumper face, outer
73	Camaro (exc. R.S.)	6274397	1	54.75	
74-75	Camaro	339431	1	114.00	

**VEGA (Front)**

71-72	Vega	3982052	1	36.50	frt. bumper face (Note 3)
73	Vega	325721	1	36.50	frt. bumper face (Note 3)
74-75	Vega (exc. Impact Strip)	336503	1	88.25	frt. bumper face (Note 3)
74-75	Vega w/Impact Strip	336599	1	88.25	frt. bumper face (Note 3)
75	Monza (Towne Cpe.)	358334	1	88.25	frt. bumper face
75	Monza (exc. Towne Cpe.)	346511		86.25	front bumper impact

*NOTE 3: Drill holes for bumper guards if required.*

**PASSENGER (Rear)**

*NOTE. (front) shown in description indicates part is also used as Front Bumper Face Bar.*

65	Pass.	3850207	L.H.	23.95	left outer face
65	Pass.	3850208	R.H.	23.95	right outer face
65	Pass. (exc. Sta. Wag.)	3850209	1	53.50	center
66	Pass.	3869713	L.H.	23.95	left outer

**FRAME—SPRINGS—BUMPER**

**7.831 BAR, Bumper Face (Con't)**

66	Pass. ....	3869714 R.H.	23.95	right outer .....
66	Biscayne, Bel Air (exc. Sta. Wag.) .....	3869715 1	53.50	center .....
66	Biscayne, Bel Air (Sta. Wag.) .....	3869732 1	40.50	center .....
66	Caprice, Impala (exc. Sta. Wag.) .....	3874740 1	53.50	center .....
66	Impala, Caprice (Sta. Wag.) .....	3874742 1	40.50	center .....
67	Pass. (exc. Sta. Wag.) .....	3885921 1	53.50	center .....
67	Pass. (exc. Caprice) .....	3885925 L.H.	23.95	left outer .....
67	Pass. (exc. Caprice) .....	3885926 R.H.	23.95	right outer .....
67	Sta. Wag. (exc. Caprice), .....			
68	Sta. Wag. ....	3887541 L.H.	23.95	left outer .....
67	Sta. Wag. (exc. Caprice), .....			
68	Sta. Wag. ....	3887542 R.H.	23.95	right outer .....
67	Caprice (exc. Sta. Wag.) .....	3887545 L.H.	23.95	left outer .....
67	Caprice (exc. Sta. Wag.) .....	3887546 R.H.	23.95	right outer .....
67	Caprice, (Sta. Wag.) .....	3887549 L.H.	24.25	left outer .....
67	Caprice (Sta. Wag.) .....	3887550 R.H.	24.25	right outer .....
67-68	Sta. Wag. ....	3918240 1	40.50	center .....
68	Biscayne, Bel Air (exc. Sta. Wag.) .....	3907641 L.H.	50.50	left .....
68	Biscayne, Bel Air (exc. Sta. Wag.) .....	3907642 R.H.	50.50	right .....
68	Impala, Caprice (exc. Sta. Wag.) .....	3907667 L.H.	50.50	left .....
68	Impala, Caprice (exc. Sta. Wag.) .....	3907668 R.H.	50.50	right .....
69	Biscayne, Bel Air (Sed.) (exc. rr. bumper guard) .....	3927691 L.H.	50.50	left .....
69	Biscayne, Bel Air (Sed.) (exc. rr. bumper guard) .....	3927692 R.H.	50.50	right .....
69	Impala, Caprice (exc. rr. bumper guard) .....	3927693 L.H.	50.50	left .....
69	Impala, Caprice (exc. rr. bumper guard) .....	3927694 R.H.	50.50	right .....
69-70	Pass. (Sta. Wag.) .....	3963220 1	88.50	rear .....
70	Biscayne, Bel Air .....	3942135 1	101.00	rear .....
70	Impala, Caprice (exc. bumper guards) .....	3942136 1	101.00	rear .....
71	Pass. (exc. Sta. Wag.) .....	3975332 1	101.00	rear .....
71-72	Pass. (Sta. Wag.) .....	3975333 1	88.50	rear .....
72	Pass. (exc. Sta. Wag.) .....	3995188 1	101.00	rear (Note 1, 2) .....
72	Pass. (exc. Sta. Wag.) .....	6262311 1	101.00	rear (w/holes) .....
72-73	Pass. (Sta. Wag.) .....	339266 1	100.00	rear (w/pad) .....
73	Pass. (Sta. Wag.) w/Impact Strips and Guards .....	332363 1	100.00	bumper face (includes impact strip) .....
73	Bel Air (Sed.) (exc. Impact Strips and Guards) .....	327154 1	101.00	
73	Bel Air (Sed.) w/Impact Strip (exc. Bumper Guards) .....	339268 1	101.00	
73	Impala, Caprice w/Impact Strip (exc. Sta. Wag., Bumper Guards) .....	339269 1	113.00	
73	Bel Air (Sed.) w/Impact Strip and Guards .....	332307 1	101.00	
73	Pass. w/Impact Strip and Guards (exc. Sta. Wag., Bel Air Sedan) .....	332309 1	101.00	
73	Pass. (Sta. Wag.) (exc. Impact Strip and Guards) .....	332361 1	88.50	
73	Pass. (exc. Sta. Wag., Bel Air, Impact Strip and Guards) .....	6270192 1	101.00	
74-75	Pass. (exc. Sta. Wag., Impact Strip) .....	335927 1	101.00	
74-75	Pass. (Sta. Wag.) (exc. Impact Strip) .....	335928 1	88.50	
74-75	Pass. w/Impact Strips (exc. Sta. Wag., Bumper Guards) .....	339259 1	113.00	bumper face (includes impact strip) .....
74-75	Pass. w/Impact Strips, Bumper Guards (exc. Sta. Wag.) .....	339260 1	113.00	bumper face (includes impact strip) .....
74-75	Pass. (Sta. Wag.) w/Impact Strips .....	339263 1	100.00	bumper face (includes impact strip) .....

NOTE 1: It may be necessary to add (8) 1/16" dia. holes for attaching bumper pads.

NOTE 2: It may be necessary to add (2) 1/16" dia. holes for attaching bumper guards.

**CHEVELLE (Rear)**

64	Chevelle .....	3837999 1	76.00	rear .....
65	Chevelle .....	3858438 1	76.00	rear .....

**FRAME—SPRINGS—BUMPER**

**7.831 BAR, Bumper Face (Con't)**

66	Chevelle (exc. Sta. Wag., El Camino) .....	<b>3869756</b>	1	76.00	rear .....	
67	Chevelle (exc. Sta. Wag., El Camino) .....	<b>3895146</b>	1	76.00	rear .....	
67	Chevelle (Sta. Wag., El Camino) .....	<b>3895162</b>	1	77.75	rear .....	
68	Chevelle (Deluxe) (exc. El Camino),					
68	Chevelle (Std.) .....	<b>3907622</b>	1	76.00	rear .....	
68	Chevelle (Sta. Wag.),					
72	El Camino .....	<b>3935692</b>	1	77.75	rear (Note 1) .....	
	<i>NOTE 1 If interference from t/gate hinges is encountered it will be necessary to notch new part using old part as guide.</i>					
68	Malibu, S.S. (exc. Sta. Wag.) ...	<b>3907669</b>	1	76.00	rear .....	
69	Chevelle (exc. Sta. Wag., El Camino) .....	<b>3927689</b>	1	76.00	rear .....	
68-71	El Camino,					
69	Chevelle (Sta. Wag.) (exc. dual t/gate) .....	<b>3954593</b>	1	77.75	rear .....	
69-72	Chevelle (Sta. Wag.) .....	<b>3953042</b>	1	77.75	rear .....	
70	Chevelle (exc. Sta. Wag., Monte Carlo, El Camino) .....	<b>3975450</b>	1	76.00	rear .....	
70-72	Monte Carlo .....	<b>3962323</b>	1	88.25	rear (Note 1) .....	
	<i>NOTE 1: It will be necessary to drill holes for attaching bumper pads or bumper guards.</i>					
71-72	Chevelle (exc. Sta. Wag., El Camino, Monte Carlo) .....	<b>3982400</b>	1	67.75	rear, upper .....	
73	Laguna (exc. Sta. Wag.) .....	<b>328947</b>	1	89.25		
73	Chevelle (Spt. Cpe., Sed.) w/Impact Strip and Guards (exc. Laguna, Monte Carlo) ...	<b>331786</b>	1	83.25		
73	Chevelle (Sta. Wag.) El Camino w/Impact Strip and Guards,					
74	El Camino w/Impact Strip .....	<b>331789</b>	1	80.75		
73	Monte Carlo w/Impact Strip and Guard .....	<b>331797</b>	1	88.25		
73	Monte Carlo (exc. Impact Strip and Guards) .....	<b>3987086</b>	1	88.25		
73	Chevelle (Spt. Cpe., Sed.) (exc. Monte Carlo, Laguna, Impact Strip & Guards) .....	<b>3992687</b>	1	83.25		
73	Chevelle (Sta. Wag., El Camino) (exc. Impact Strip and Guard),					
74	El Camino (exc. Impact Strip) ...	<b>3999709</b>	1	80.75		
74-75	Malibu (Sta. Wag.) (exc. Impact Strips) .....	<b>477589</b>	1	88.50		
74-75	Malibu (Sta. Wag.) w/Impact Strips .....	<b>492609</b>	1	88.50		
74-75	Monte Carlo (exc. Impact Strip) ..	<b>336352</b>	1	88.25		
74-75	Malibu (Spt. Cpe., Sed.) (exc. Impact Strip) .....	<b>338513</b>	1	83.25		
74-75	Malibu, Laguna (Spt. Cpe., Sed.) w/Impact Strip .....	<b>340164</b>	1	83.25		
74-75	Monte Carlo w/Impact Strip .....	<b>342163</b>	1	88.25		
75	El Camino (exc. Impact Strip) ...	<b>356408</b>	1	88.50		
75	El Camino w/Impact Strip .....	<b>356409</b>	1	88.50		

**CHEVY (Rear)**

62-65	Chevy .....	<b>3848996</b>	1	56.75	rear .....
66-67	Chevy .....	<b>3866564</b>	1	56.75	rear .....
68-72	Chevy .....	<b>3903515</b>	1	56.75	rear .....
73	Nova (exc. Impact Strip) .....	<b>337484</b>	1	91.00	
73	Nova w/Impact Strip .....	<b>337485</b>	1	91.00	
74	Nova (exc. Impact Strip) .....	<b>337460</b>	1	91.00	
74	Nova w/Impact Strip (exc. Guards) .....	<b>339468</b>	1	91.00	
74	Nova w/Guards .....	<b>341088</b>	1	91.00	
75	Nova (exc. Impact Strips) .....	<b>344337</b>	1	91.00	
75	Nova w/Impact Strips .....	<b>347516</b>	1	91.00	

**CAMARO (Rear)**

67-68	Camaro .....	<b>3886603</b>	1	55.75	rear .....
69	Camaro .....	<b>3927424</b>	1	55.75	rear .....
70-73	Camaro (exc. spec. bumper, Spec. H/Per. 350) .....	<b>3949772</b>	1	55.75	rear .....
70-72	Camaro w/spec. bumper .....	<b>3982006</b>	1	69.75	rear .....
74-75	Camaro .....	<b>339432</b>	1	112.00	

**FRAME—SPRINGS—BUMPER**

**7.831 BAR, Bumper Face (Con't)**

**VEGA (REAR)**

71-73	Vega	358901	1	36.50	rear bumper face (Note 3)
74-75	Vega (exc. Impact Strip)	336504	1	88.25	rear bumper face (Note 3)
74-75	Vega w/Impact Strip	339002	1	88.25	rear bumper face (Note 3)
75	Monza (Towne Cpe.)	358333	1	88.25	rear, bumper face
75	Monza (exc. Towne Cpe.)	346519		86.25	rear bumper impact

*NOTE 3: Drill holes for bumper guard if required.*

**7.831A BUMPER ASSY.— CUSHION— EXTENSION ASSY.— BOLT— PAD ASSY.— REINFORCEMENT— SUPPORT— STRIP ASSY.**

74-75	Vega	339009	L.H.	4.65	BUMPER ASSY., frt. bumper face bar
74-75	Vega	339010	R.H.	4.65	BUMPER ASSY., frt. bumper face bar
74-75	Vega	342645	2	4.75	BUMPER ASSY., rear bumper face bar
70-72	Camaro (R.S.)	3994723	L.H.	5.75	CUSHION, left, front, outer face bar inner
70-72	Camaro (R.S.)	3994724	R.H.	5.75	CUSHION, right, front, outer face bar inner
70-72	Camaro (exc. R.S.)	3994722	R.H.	11.30	CUSHION, right, front face bar outer
70-72	Camaro	3994716	1	5.10	CUSHION, rear, face bar center
70	Camaro (R.S., spec. bumper),				
71-72	Camaro	3994719	L.H.	5.10	CUSHION, left, rear, face bar outer
70	Camaro (R.S., spec. bumper),				
71-72	Camaro	3994720	R.H.	5.10	CUSHION, right, rear, face bar outer
70-71	Camaro (R.S., spec. bumper)	3994725	L.H.	5.75	CUSHION ASSY., left, front bumper outer face bar outer
70-72	Camaro (R.S., spec. bumper)	3994726	R.H.	5.75	CUSHION ASSY., right, front bumper outer face bar outer
70-71	Camaro w/spec. bumper (exc. R.S.),				
72	Camaro (exc. R.S.)	3994717	1	5.75	CUSHION ASSY., front, face bar center
70-71	Camaro w/spec. bumper (exc. R.S.),				
72	Camaro (exc. R.S.)	3994721	L.H.	5.75	CUSHION ASSY., left, front, face bar outer
69-72	Chevelle (Sta. Wag.) w/dual t/gate	3958360	1	14.45	EXTENSION, rear
69-70	Pass. (Sta. Wag.)	3957280	1	14.45	EXTENSION ASSY., rear bumper filler, tailgate (chrome)
69	Pass.	9425343	2	.16	BOLT, bar to bracket upper— (8.903)
72	Pass.	3997375	L.H.	11.20	PAD ASSY., front bumper
72	Pass.	3997376	R.H.	11.20	PAD ASSY., front bumper
72	Pass.	3997377	1	7.50	PAD ASSY., front bumper center
72	Pass. (exc. Sta. Wag.)	6262309	1	27.00	PAD ASSY., rear bumper
72	Pass.	3997349	1	19.35	REINFORCEMENT, front bumper
72	Pass. (exc. Sta. Wag.)	3995189	1	31.00	REINFORCEMENT, rr. bumper face bar
73	Camaro (exc. R.S.)	6274398	1	11.85	REINFORCEMENT, front bumper face bar
73	Pass.	6273759	1	29.00	REINFORCEMENT, front bumper face bar
73	Chevelle (exc. Laguna, Monte Carlo)	3996994	1	28.75	REINFORCEMENT, front bumper face bar
73	Laguna	331777	1	33.50	REINFORCEMENT, front bumper face bar
73	Monte Carlo	325260	1	26.00	REINFORCEMENT, front bumper face bar
73	Pass.	6273762	1	2.85	REINFORCEMENT, front-bumper face bar center
73	Chevelle (Spt. Cpe., Sed.) (exc. Monte Carlo)	325276	1	20.20	REINFORCEMENT, rr. bpr. face bar
73	Pass. (exc. Sta. Wag.)	6273787	1	41.25	REINFORCEMENT ASSY., rr. bpr. face bar
73	Chevelle (Sta. Wag.) El Camino,				
74	El Camino	325264	1	22.05	REINFORCEMENT, rr. bpr. face bar
73	Monte Carlo	3996983	1	25.25	REINFORCEMENT, rr. bpr. face bar
74	Nova	337470	1	57.25	REINFORCEMENT, frt. bumper face bar
74-75	Monte Carlo	338560	1	98.50	REINFORCEMENT, frt. bumper face bar
74	Laguna	340188	1	36.00	REINFORCEMENT, frt. bumper face bar outer
74	Pass.,				
75	Bel Air, Impala	337611	1	44.00	REINFORCEMENT, frt. bumper face bar
74-75	Chevelle (Sta. Wag.)	496376	1	65.50	REINFORCEMENT, rr. bumper impact bar
74-75	Pass. (exc. Sta. Wag.)	335996	1	44.00	REINFORCEMENT, rear bumper face bar
74-75	Pass. (Sta. Wag.)	337673	1	90.25	REINFORCEMENT ASSY., rr. bumper face bar
74-75	Monte Carlo	338519	1	101.00	REINFORCEMENT, rr. bumper face bar
74	Malibu (exc. Sta. Wag., El Camino),				
74	Laguna	338529	1	102.00	REINFORCEMENT, rr. bumper face bar
74	Nova	341090	1	49.00	REINFORCEMENT, rr. bumper face bar
75	El Camino	356413	L.H.	8.50	REINFORCEMENT, front bumper face bar

**FRAME—SPRINGS—BUMPER**

**7.831A BUMPER ASSY.— CUSHION— EXTENSION ASSY.— BOLT— PAD ASSY.— REINFORCEMENT— SUPPORT— STRIP ASSY. (Con't)**

74	Laguna	338583	1	41.50	REINFORCEMENT ASSY., frt. bumper face bar inner
74	Malibu, El Camino,				
75	Malibu	356432	1	101.00	REINFORCEMENT ASSY., frt. bumper face bar
75	El Camino	356414	R.H.	8.50	REINFORCEMENT, front bumper face bar
75	Caprice	347503	1	34.75	REINFORCEMENT, frt. bumper face bar
75	Malibu, Laguna (exc. Sta. Wag., El Camino)	356431	1	101.00	REINFORCEMENT, rear bumper face bar
75	Laguna	347373	1	79.25	REINFORCEMENT, front bumper face bar
75	Monza (Towne Cpe.)	358355	1	17.95	REINFORCEMENT, frt. bpr. face bar
75	Nova	345520	1	47.50	REINFORCEMENT, rr. bumper face bar
75	Nova	345529	1	57.25	REINFORCEMENT, frt. bumper face bar
73	Laguna (exc. Sta. Wag.)	360909	1	24.45	STRIP ASSY., rear bumper protective center
73	Laguna	328984	1	18.70	STRIP ASSY., frt. bpr. protv.
73	Pass. w/Impact Strip and Guards	327105	1	8.95	STRIP ASSY., frt. bpr. protv. center
73-74	Nova	327572	1	24.45	STRIP ASSY., frt. bpr. protv.
73	Nova	327573	1	24.45	STRIP ASSY., rear bpr. protv.
73	Chevelle (exc. Laguna, Monte Carlo)	328963	1	7.90	STRIP ASSY., frt. bpr. protv. center
73	Monte Carlo	328975	1	24.45	STRIP ASSY., frt. bpr. protv. center
73	Pass. w/Impact Strip and Guards	327103	L.H.	9.90	STRIP ASSY., frt. bpr. protv. side
73	Pass. w/Impact Strip and Guards	327104	R.H.	9.90	STRIP ASSY., frt. bpr. protv. side
73	Pass. w/Impact Strip (exc. Guards)	339265	1	24.45	STRIP ASSY., frt. bumper protv.
73	Monte Carlo	328973	2	24.45	STRIP ASSY., frt. bpr. protv. side
73	Chevelle (exc. Laguna, Monte Carlo)	331792	2	13.85	STRIP ASSY., frt. bpr. protv. side
73	Pass. (exc. Sta. Wag.)	327119	1	24.45	STRIP ASSY., rear bpr. protv.
73	Chevelle (Spt. Cpe., Sed.) (exc. Monte Carlo)	331785	2	5.15	STRIP ASSY., rear bpr. protv. side
73	Chevelle (Sta. Wag.) El Camino (exc. Laguna),				
74-75	El Camino	331787	L.H.	5.15	STRIP ASSY., rear bpr. protv. side
73	Chevelle (Sta. Wag.) El Camino (exc. Laguna),				
74-75	El Camino	331788	R.H.	5.15	STRIP ASSY., rear bpr. protv. side
73	Chevelle (Spt. Cpe., Sed.) (exc. Monte Carlo, Laguna)	328971	1	17.65	STRIP ASSY., rear bpr. protv. center
73	Chevelle (Sta. Wag.) El Camino,				
74	El Camino	328983	1	22.05	STRIP ASSY., rear bpr. protv. center
73	Monte Carlo	328982	1	28.75	STRIP ASSY., rear bpr. protv. center
73	Laguna (Sta. Wag.)	336315	L.H.	5.95	STRIP ASSY., rear bpr. protv. side
73	Laguna (Sta. Wag.)	336316	R.H.	5.95	STRIP ASSY., rear bpr. protv. side
73	Laguna (exc. Sta. Wag.)	336318	2	5.95	STRIP ASSY., rear bpr. protv. side
73	Laguna (Sta. Wag.)	336317	1	20.10	STRIP ASSY., rear bpr. protv. center
74-75	Vega w/Impact Strips (exc. Guards)	348260	1	28.75	STRIP ASSY., frt. bumper protective
74-75	Vega w/Impact Strips	339001	1	28.75	STRIP ASSY., rear bumper protective
74	Pass.,				
75	Pass. (exc. Caprice)	339237	1	19.40	STRIP ASSY., frt. bumper protective (cut as reqd.)
74	Nova	339474	1	28.75	STRIP ASSY., rr. bpr. protv.
74-75	Camaro	341095	1	24.45	STRIP ASSY., frt. bpr. protective
74-75	Camaro	341096	1	24.45	STRIP ASSY., rear bpr. protv.
74	Malibu w/Guards	336369	1	28.75	STRIP ASSY., frt. bpr. protv.
74-75	Malibu (exc. Guards)	340170	1	28.75	STRIP ASSY., frt. bpr. protv.
74-75	Monte Carlo (exc. Guards)	340195	1	33.25	STRIP ASSY., frt. bpr. protv.
74-75	Monte Carlo w/Guards	340198	1	33.25	STRIP ASSY., frt. bpr. protv.
74	Malibu (Spt. Cpe., Sed.) (exc. Guards),				
75	Chevelle (exc. Sta. Wag., guards)	340178	1	28.75	STRIP ASSY., rr. bpr. protv. (paint as reqd.)
74-75	Monte Carlo w/Guards	340185	1	33.25	STRIP ASSY., rr. bpr. protv.
74-75	Monte Carlo (exc. Guards)	340186	1	33.25	STRIP ASSY., rr. bpr. protv.
74-75	Malibu w/Impact Strip and Guards (exc. Sta. Wag.)	342122	1	28.75	STRIP ASSY., rr. bpr. protv.
74-75	Chevelle (Sta. Wag.)	340161	L.H.	6.50	STRIP ASSY., rr. bpr. protv. side
74-75	Chevelle (Sta. Wag.)	340162	R.H.	6.50	STRIP ASSY., rr. bpr. protv. side
74-75	Chevelle (Sta. Wag.)	340163	1	13.60	STRIP ASSY., rr. bpr. protv. center

**FRAME—SPRINGS—BUMPER**

**7.831A BUMPER ASSY.— CUSHION— EXTENSION ASSY.— BOLT— PAD ASSY.— REINFORCEMENT— SUPPORT— STRIP ASSY. (Con't)**

74-75	Pass. (exc. Sta. Wag.)	339253	1	28.75	STRIP ASSY., rr. bpr. protective (cut as reqd.)
74-75	Pass. (Sta. Wag.)	339261	1	26.50	STRIP ASSY., rr. bpr. protective
74	Laguna	345329	1	44.00	STRIP ASSY., frt. bpr. protective (black) (paint to match)
74	Laguna	345330	1	44.00	STRIP ASSY., frt. bpr. protective (silver)
74	Laguna	345331	1	44.00	STRIP ASSY., frt. bpr. protective (orange)
74	Laguna	345332	1	44.00	STRIP ASSY., frt. bpr. protective (dark taupe)
74-75	Laguna	345336	1	44.00	STRIP ASSY., rr. bpr. protective (black)
74	Laguna	345337	1	44.00	STRIP ASSY., rr. bpr. protective (silver)
74	Laguna	345338	1	44.00	STRIP ASSY., rr. bpr. protective (orange)
74	Laguna	345339	1	44.00	STRIP ASSY., rr. bpr. protective (dark taupe)
74	Laguna	345340	1	44.00	STRIP ASSY., rr. bpr. protective (red met.)
75	Laguna	347357	1	44.00	STRIP ASSY., frt. bpr. protective (black) paint to match
75	Caprice	343579	1	25.25	STRIP ASSY., front protective
75	Nova w/Impact Strips	347517	1	36.00	STRIP ASSY., front protective
75	Nova w/Impact Strips	347518	1	36.00	STRIP ASSY., rear protective
75	El Camino	356410	1	17.65	STRIP ASSY., rear bumper protective ctr.
75	Monza (Towne Cpe.)	365264	1	20.55	STRIP ASSY., rear bumper protective

**7.832 EMBLEM UNIT— COVER— BRACKET— MOULDING ASSY.— RETAINER— STUD— TAPE, Rear Bumper Upper Face Bar**

71-72	Chevelle (S.S.)	3995774	1	8.95	rear bumper
75	Monza (exc. Towne Cpe.)	342682	1	111.00	COVER, front lower
75	Monza (exc. Towne Cpe.)	342683	1	111.00	COVER, front upper
75	Monza (exc. Towne Cpe.)	336584	1	53.75	COVER, rear lower
75	Monza (exc. Towne Cpe.)	342699	1	59.00	COVER, rear upper
75	Monza (exc. Towne Cpe.)	346548	2	.22	BRACKET, front bumper upper cvr. ret.
75	Laguna	347349	1	16.75	MOULDING, front bumper prot. strip ctr.
75	Laguna	347351	L.H.	4.25	MOULDING, frt. bumper protv. strip, outer
75	Laguna	347352	R.H.	4.25	MOULDING, frt. bumper protv. strip, outer
75	Monza (exc. Towne Cpe.)	346520	1	6.75	MOULDING ASSY., rear lower center
75	Monza (exc. Towne Cpe.)	346521	L.H.	2.05	MOULDING ASSY., rear lower
75	Monza (exc. Towne Cpe.)	346522	R.H.	2.05	MOULDING ASSY., rear lower
75	Monza (exc. Towne Cpe.)	346579	L.H.	2.05	MOULDING ASSY., frt. lower
75	Monza (exc. Towne Cpe.)	346580	R.H.	2.05	MOULDING ASSY., frt. lower
75	Monza (exc. Towne Cpe.)	346581	1	13.05	MOULDING ASSY., frt. center
75	Monza (exc. Towne Cpe.)	346551	1	26.00	RETAINER, front upper cover
75	Monza (exc. Towne Cpe.)	346518	1	.53	RETAINER, rear lower cover
75	Monza (exc. Towne Cpe.)	346513	1	1.85	RETAINER, rear center
75	Monza (exc. Towne Cpe.)	346514	2	.68	RETAINER, rear upper outer
75	Monza (exc. Towne Cpe.)	346515	L.H.	1.55	RETAINER, rear upper
75	Monza (exc. Towne Cpe.)	346516	R.H.	1.55	RETAINER, rear upper
75	Monza (exc. Towne Cpe.)	346517	2	.68	RETAINER, rear lower outer
75	Monza (exc. Towne Cpe.)	410707	6	.12	STUD, frt. upper cover ret.
75	Camaro w/Sport Decor Pkg.	347521	1	10.00	TAPE, front (white vinyl)
75	Camaro w/Sport Decor Pkg.	347531	1	10.00	TAPE, rear (white vinyl)

**7.833 ATTACHMENT UNIT— BRACE— BRACKET— BUMPER— CLIP— DAM UNIT— DEFLECTOR— EXTENSION— FILLER— GRILLE— INSULATOR— MOULDING UNIT— NUT— PANEL— PLATE— REFLECTOR ASSY.— RETAINER— REINFORCEMENT— ROD— SCREW— SEAL— SPACER— SPOILER— STOP— SUPPORT ASSY., Bumper Valance Panel**

74-75	Camaro w/Spoilers	339495	1	4.15	ATTACHMENT UNIT, frt. bumper valance panel extension
68	Camaro w/aux. panel, valance	3943251	2	4.35	BRACE, outer, frt. bumper valance pnl. ext.
68	Camaro w/aux. panel, valance	3943253	1	5.20	BRACE, center, frt. bumper valance pnl. ext.
69	Camaro w/aux. val. and panel	3938690	1	2.45	BRACE, center, front extension
69	Camaro w/aux. val. and panel	3938691	2	2.75	BRACE, outer, front extension
70-73	Camaro w/Spoiler	3990477	2	1.25	BRACE, front lower bumper to extension
74-75	Camaro w/Spoilers	339497	2	1.10	BRACE, frt. bumper valance panel extension
73	Vega	329707	1	.48	BRACKET, frt. bumper filler panel
70	All (exc. Sta. Wag.)				
71-72	Chevelle (exc. Sta. Wag.)	3945692	A.R.	.11	BUMPER, rear bumper valance panel (insulator)
73	Camaro (exc. R.S.)	327536	1	36.50	BUMPER, front lower valance
65-69	Pass.	3795344	9	.11	CLIP, rear bumper center face bar panel
73-74	Nova				CLIP, rr. bumper to body filler
74-75	Vega (Coupe, Sedan)	333711	6	.27	rr. bumper filler panel
74-75	Vega (Sta. Wag., Panel)	342697		.11	CLIP, rr. bumper filler panel

**FRAME—SPRINGS—BUMPER**

**7.833 ATTACHMENT UNIT— BRACE— BRACKET— BUMPER— CLIP— DAM UNIT— DEFLECTOR— EXTENSION— FILLER— GRILLE— INSULATOR— MOULDING UNIT— NUT— PANEL— PLATE— REFLECTOR ASSY.— RETAINER— REINFORCEMENT— ROD— SCREW— SEAL— SPACER— SPOILER— STOP— SUPPORT ASSY., Bumper Valance Panel (Con't)**

75	Monza (exc. Towne Cpe.) HR (Hvy. Duty Service) . . . . .	3965776	1	43.25	DAM UNIT, front air . . . . .
74-75	Vega . . . . .	339027	1	6.65	DEFLECTOR, front valance panel air . . . . .
75	Monza (Towne Cpe.) . . . . .	365263	1	4.90	DEFLECTOR, frt. valance panel air . . . . .
67-68	Camaro w/aux. pnl. valance . . . . .	3943249	1	22.60	EXTENSION, frt. bumper valance panel . . . . .
69	Camaro w/aux. pnl. valance . . . . .	3938689	1	20.80	EXTENSION, front bumper valance panel . . . . .
70-73	Camaro w/Spoiler (exc. R.S.) . . . . .	3990469	1	17.25	EXTENSION, front lower bumper . . . . .
70-73	Camaro (R.S.) w/Spoiler . . . . .	3990470	1	18.50	EXTENSION, front lower bumper . . . . .
75	Monza (exc. Towne Cpe.) . . . . .	358377	L.H.	2.30	EXTENSION, frt. bpr. valance panel . . . . .
75	Monza (exc. Towne Cpe.) . . . . .	358378	R.H.	2.30	EXTENSION, frt. bpr. valance panel . . . . .
74-75	Camaro w/Spoilers . . . . .	339496	1	5.80	EXTENSION UNIT, frt. bumper valance panel . . . . .
65-67	Pass.,				
71	Pass. (6 cyl.) . . . . .	3892291	1	2.00	FILLER, rear bumper to body ( <sup>3</sup> / <sub>8</sub> " x <sup>1</sup> / <sub>2</sub> " slot, 8 places) . . . . .
67	Pass. (exc. Sta. Wag.) . . . . .	3918253	L.H.	.18	FILLER, left rear bumper outer face . . . . .
67-68	Pass. (Sta. Wag.) . . . . .	3918252	R.H.	.34	FILLER, right rear bumper outer face . . . . .
67-68	Pass. (Sta. Wag.) . . . . .	3918251	L.H.	.34	FILLER, left rear bumper outer face . . . . .
69	Pass. . . . .	3945661	L.H.	.68	FILLER, left fender to front bumper— (8.153) . . . . .
69	Pass. . . . .	3945662	R.H.	.64	FILLER, right fender to front bumper— (8.153) . . . . .
70-72	Camaro w/ext. mldg. . . . .	3984040	R.H.	.42	FILLER, right, face bar to body . . . . .
70-72	Camaro w/ext. mldg. . . . .	3984039	L.H.	.42	FILLER, left, face bar to body . . . . .
73	El Camino . . . . .	331717	L.H.	13.40	FILLER, rr. bpr. face bar to body (paint as reqd.) . . . . .
73	El Camino . . . . .	331718	R.H.	13.40	FILLER, rr. bpr. face bar to body (paint as reqd.) . . . . .
73	El Camino . . . . .	331738	1	10.75	FILLER, rr. bpr. face bar to body, center (paint as reqd.) . . . . .
73	Chevelle (Sta. Wag.) . . . . .	491900	1	12.70	FILLER, rr. bpr. face bar to body . . . . .
73	Laguna (exc. Sta. Wag.) . . . . .	331721	1	10.75	FILLER, rr. bumper face bar to body . . . . .
73	Nova . . . . .	337417	1	14.75	FILLER, rr. bpr. face bar to body (black) . . . . .
73	Camaro . . . . .	6274389	L.H.	1.50	FILLER, rear bumper face bar to body . . . . .
73	Camaro . . . . .	6274390	R.H.	1.50	FILLER, rear bumper face bar to body . . . . .
73	Chevelle (Sta. Wag.) (exc. Estate) . . . . .	491902	L.H.	5.65	FILLER, rr. bpr. face bar to body . . . . .
73	Chevelle (Sta. Wag.) (exc. Estate) . . . . .	491901	R.H.	5.65	FILLER, rear bumper face bar to body . . . . .
74-75	Monte Carlo . . . . .	338597	L.H.	20.60	FILLER, rr. bpr. face bar to body . . . . .
74-75	Monte Carlo . . . . .	338598	R.H.	20.60	FILLER, rr. bpr. face bar to body . . . . .
74-75	Camaro . . . . .	339447	L.H.	8.70	FILLER, rr. bpr. face bar to body . . . . .
74-75	Camaro . . . . .	339448	R.H.	8.70	FILLER, rr. bpr. face bar to body . . . . .
74-75	El Camino . . . . .	342101	L.H.	8.25	FILLER, rear bumper face bar to body (paint as reqd.) . . . . .
74-75	El Camino . . . . .	342102	R.H.	8.25	FILLER, rr. bpr. face bar to body (paint as reqd.) . . . . .
74-75	Pass. (exc. Sta. Wag.) . . . . .	337649	L.H.	8.85	FILLER, rear quarter to bumper (paint as reqd.) . . . . .
74-75	Pass. (exc. Sta. Wag.) . . . . .	337650	R.H.	8.85	FILLER, rear quarter to bumper (paint as reqd.) . . . . .
74-75	Chevelle (Sedan, Spt. Cpe.) (exc. Monte Carlo) . . . . .	338591	L.H.	20.60	FILLER, rear bumper face bar to body . . . . .
74-75	Chevelle (Sed., Spt. Cpe.) (exc. Monte Carlo) . . . . .	338592	R.H.	20.60	FILLER, rear bumper face bar to body . . . . .
74-75	Camaro . . . . .	339449	1	6.65	FILLER, rr. bumper face bar to body (center)
74	Nova . . . . .	339486	1	14.75	FILLER, rear bumper face bar to body (cream beige) (Note 1) . . . . .
74	Nova . . . . .	361187	L.H.	6.85	FILLER, frt. fdr. to bumper (paint to match) .
74	Nova . . . . .	361188	R.H.	6.85	FILLER, frt. fdr. to bumper (paint to match) .
	<i>NOTE 1: Paint with urethane bumper as required.</i>				
	<i>NOTE 2: Includes L.H. &amp; R.H.</i>				
74-75	Chevelle (Sta. Wag.) . . . . .	9730826	R.H.	9.30	FILLER, rear quarter panel to bumper (primed) . . . . .
74-75	Chevelle (Sta. Wag.) . . . . .	9730827	L.H.	9.30	FILLER, rear quarter panel to bumper (primed) . . . . .
74-75	Chevelle (Sta. Wag.) . . . . .	9730828	1	26.75	FILLER, cross bar to rear bumper (primed) .
75	Nova . . . . .	347552	1	26.25	FILLER, rr. bpr. to body filler center (paint as reqd.) . . . . .
75	Nova . . . . .	347551	1		FILLER, rr. bpr. to body filler outer (Includes L.H. & R.H.) (paint as reqd.) . . . . .
75	Caprice (exc. Sta. Wag.) . . . . .	343577	L.H.	8.85	FILLER, rear quarter to bpr. (black) . . . . .
75	Caprice (exc. Sta. Wag.) . . . . .	343578	R.H.	8.85	FILLER, rear quarter to bpr. (black) . . . . .

**FRAME—SPRINGS—BUMPER**

**7.833 ATTACHMENT UNIT— BRACE— BRACKET— BUMPER— CLIP— DAM UNIT— DEFLECTOR— EXTENSION— FILLER— GRILLE— INSULATOR— MOULDING UNIT— NUT— PANEL— PLATE— REFLECTOR ASSY.— RETAINER— REINFORCEMENT— ROD— SCREW— SEAL— SPACER— SPOILER— STOP— SUPPORT ASSY., Bumper Valance Panel (Con't)**

75	Nova	345589	1	6.85	FILLER, frt. fdr. to bpr. (paint as required) (vinyl) (includes L.H. & R.H.)
69-70	Pass. (Sta. Wag.)	3950735	1	7.75	FILLER ASSY., rear bumper to body
74	Pass. (Sta. Wag.)	9730820	1	28.75	FILLER ASSY., body to rear bumper center (primed)
74	Pass. (Sta. Wag.)	337663	L.H.	8.25	FILLER ASSY., rear quarter to bumper (paint as reqd.)
74	Pass. (Sta. Wag.)	337664	R.H.	8.25	FILLER ASSY., rear quarter to bumper (paint as reqd.)
74	Pass. (exc. Sta. Wag.)	339211	1	23.70	FILLER ASSY., rr. bpr. face bar to body (black) (urethane)
75	Pass. (exc. Sta. Wag.)	349115	1	32.50	FILLER ASSY., rr. bpr. face bar to body (black)
75	Pass. (Sta. Wag.)	9730820	1	28.75	FILLER ASSY., body to bpr. ctr.
75	Monza (exc. Towne Cpe.) (Hvy. Duty Service)	3965793	1	247.00	GRILLE, frt. air dam
73	Vega	336525	2	1.35	INSULATOR, frt. bumper filler panel
65	Pass.	3867381	L.H.	4.25	MOULDING UNIT, front bumper valance panel (Note 2)
65	Pass.	3867382	R.H.	4.70	MOULDING UNIT, front bumper valance panel (Note 2)
66	Pass.	3890157	L.H.	3.80	MOULDING UNIT, front bumper valance panel (Note 3)
66	Pass.	3890158	R.H.	3.80	MOULDING UNIT, front bumper valance panel (Note 3)
<i>NOTE 2 Consists of 1— Mouldings, 4— Nuts and 4— Retainers.</i>					
<i>NOTE 3 Consists of 1— Moulding, 3— Nuts and 1— Screw.</i>					
69	Impala, Caprice, Estate Wag.	3952493	L.H.	7.20	MOULDING UNIT, frt. bumper valance panel (Note 4)
69	Impala, Caprice, Estate Wag.	3952494	R.H.	8.65	MOULDING UNIT, frt. bumper valance panel (Note 4)
<i>NOTE 4 Consists of (1)-394 1249 (L.H.-394 1250) (R.H.) Mldg. Assy., and (5)-9427101-Nut.</i>					
73	Chevelle (Sta. Wag.)	336341	1	2.65	MOULDING, rear bumper face bar to body filler
74	Chevelle (Sta. Wag.)	9685145	1	6.15	MOULDING, body to rear bumper filler
74-75	Camaro (L.T.)	6260915	1	6.10	MOULDING UNIT, valance panel
65-67	Sta. Wag. (exc. Caprice),				
66	Pass.	3877248	1	.11	NUT, moulding unit— (2.729)
69-70	Pass. (exc. Sta. Wag.),				
71-72	Chevelle (exc. Sta. Wag.)	3945694	2	.66	NUT, rear bumper valance panel
69-70	Pass. (Sta. Wag.),				
71-73	Police (Sed.)	3953056	A.R.	.24	NUT ASSY., rear bumper filler panel
74	Vega	3907444	4	.11	NUT, rr. bumper valance panel to qtr. panel
65	Pass.	3852970	1	21.40	PANEL, valance
66	Pass.	3887502	1	22.90	PANEL, valance
67-68	Camaro (exc. R.S.)	3925467	1	26.00	PANEL, front valance
67	Camaro (R.S.)	3898143	1	30.50	PANEL, front valance
68	Camaro (R.S.)	3938601	1	30.50	PANEL, front valance
69	Pass.	3934516	1	13.30	PANEL, valance (Note 5)
<i>NOTE 5 When using on Caprice or Estate Wag. add 8 slots and 2 holes for mldg., using old part as guide.</i>					
69	Camaro	3929978	1	26.00	PANEL, front valance
68	Pass. (exc. Sta. Wag.)	3916576	1	24.95	PANEL, rear bumper valance
69	Pass. (exc. Sta. Wag.)	3927687	1	13.05	PANEL, rear bumper valance
69-70	Pass. (Sta. Wag.)	3950704	L.H.	10.70	PANEL, left rear bumper filler
69-70	Pass. (Sta. Wag.)	3950708	R.H.	3.65	PANEL, right rear bumper filler
69	Pass.	3934575	L.H.	3.95	PANEL, left front filler— (1.287)
69	Pass.	3934576	R.H.	3.95	PANEL, right front filler— (1.287)
70	Malibu,				
70	Biscayne, Bel Air	3962322	1	12.30	PANEL, rear valance
70	Brookwood, Townsman	3950747	1	20.35	PANEL, front valance painted
70	Impala, Caprice,				
70	Kingswood	3979914	1	37.00	PANEL, front valance (chrome plated)
70	Pass. (exc. Sta. Wag.)	3945691	1	13.30	PANEL, rear bumper valance
70-73	Camaro	3966861	L.H.	3.95	PANEL, frt. bpr. filler left— (1.287)
70-73	Camaro	3966862	R.H.	3.95	PANEL, frt. bpr. filler right— (1.287)
70-73	Camaro (R.S.)	3990473	1	48.25	PANEL, front lower
70-72	Camaro (exc. R.S.)	327536	1	36.50	PANEL, front lower valance
71-72	Chevelle (exc. Sta. Wag., El Camino, Monte Carlo)	3982401	1	13.10	PANEL, rr. lower
71-73	Pass. (Sta. Wag.)	408865	L.H.	1.95	PANEL, left rear bumper valance
71-73	Pass. (Sta. Wag.)	408864	R.H.	1.95	PANEL, right rear bumper valance



**FRAME—SPRINGS—BUMPER**

**7.833 ATTACHMENT UNIT— BRACE— BRACKET— BUMPER— CLIP— DAM UNIT— DEFLECTOR— EXTENSION— FILLER— GRILLE— INSULATOR— MOULDING UNIT— NUT— PANEL— PLATE— REFLECTOR ASSY.— RETAINER— REINFORCEMENT— ROD— SCREW— SEAL— SPACER— SPOILER— STOP— SUPPORT ASSY., Bumper Valance Panel (Con't)**

71-73	Vega (Cpe., Sed.)	3986811	L.H.	10.80	PANEL, rear bumper valance
71-73	Vega (Cpe., Sed.)	3986812	R.H.	10.80	PANEL, rear bumper valance
71-73	Vega (Sta. Wag., Panel)	3986813	L.H.	10.80	PANEL, rear bumper valance
71-73	Vega (Sta. Wag., Panel)	3986814	R.H.	10.80	PANEL, rear bumper valance
71-72	Vega	3982072	1	22.10	PANEL, front bumper valance
72	Pass. (exc. Sta. Wag.)	6270147	1	.68	PANEL, rr. bumper center filler
73	Pass.	335952	1	16.40	PANEL, front bumper filler (paint as reqd.)
73	Pass. (exc. Sta. Wag.)	325824	1	3.55	PANEL, rr. bumper center filler
73	Chevelle (exc. Sta. Wag., Monte Carlo, El Camino)	331721	1	10.75	PANEL, rr. bpr. to body filler
73	Monte Carlo	331761	1	9.55	PANEL, rr. bpr. to body filler
73	Vega	325730	1	22.10	PANEL, frt. bumper valance
73	Vega	329706	1	14.25	PANEL, frt. bumper filler— (1.263)
74-75	Camaro	333795	1	51.50	PANEL, frt. bumper valance (polyester plastic material) (paint as reqd.)
74-75	Camaro	339425	L.H.	3.70	PANEL, frt. bumper filler— (1.263)
74-75	Camaro	339426	R.H.	3.70	PANEL, frt. bumper filler— (1.263)
74	Nova	341004	1	17.10	PANEL, frt. bumper filler (steel) (paint as reqd.)— (1.263)
74	El Camino	342105	1	12.05	PANEL, rear bumper to body filler
74-75	Vega	342613	1	20.55	PANEL, front bumper valance (white)
74-75	Vega	342614	1	20.55	PANEL, front bumper valance (french blue)
74	Vega	342615	1	20.55	PANEL, front bumper valance (dark blue met.)
74-75	Vega	342616	1	20.55	PANEL, front bumper valance (med. dark green met.)
74	Vega	342617	1	20.55	PANEL, front bumper valance (dark green met.)
74-75	Vega	342618	1	20.55	PANEL, front bumper valance (cream-beige)
74-75	Vega	342619	1	20.55	PANEL, front bumper valance (bright yellow)
74-75	Vega	342621	1	20.55	PANEL, front bumper valance (bright gold met.)
74-75	Vega	342622	1	20.55	PANEL, front bumper valance (silver taupe met.)
74-75	Vega	342623	1	20.55	PANEL, front bumper valance (russet orange met.)
74	Vega	342624	1	20.55	PANEL, front bumper valance (bright orange)
74-75	Vega	342625	1	20.55	PANEL, front bumper valance (dark taupe met.)
74-75	Vega	342626	1	20.55	PANEL, front bumper valance (red met.)
74-75	Vega	342627	1	20.55	PANEL, front bumper valance (red)
74-75	Vega	342628	1	11.40	PANEL, rear bumper valance (white)
74-75	Vega	342629	1	11.40	PANEL, rear bumper valance (french blue)
74	Vega	342630	1	11.40	PANEL, rear bumper valance (dark blue met.)
74-75	Vega	342631	1	11.40	PANEL, rear bumper valance (med. dark green met.)
74	Vega	342632	1	11.40	PANEL, rear bumper valance (dark green met.)
74-75	Vega	342633	1	11.40	PANEL, rear bumper valance (cream beige)
74-75	Vega	342634	1	11.40	PANEL, rear bumper valance (bright yellow)
74-75	Vega	342636	1	11.40	PANEL, rear bumper valance (bright gold met.)
74-75	Vega	342637	1	11.40	PANEL, rear bumper valance (silver taupe met.)
74-75	Vega	342638	1	11.40	PANEL, rear bumper valance (russet orange met.)
74-75	Vega	342640	1	11.40	PANEL, rear bumper valance (dark taupe met.)
74-75	Vega	342641	1	11.40	PANEL, rear bumper valance (red met.)
74-75	Vega	342642	1	11.40	PANEL, rear bumper valance (red)
74	Vega	342643	1	10.25	PANEL, rear bumper valance (bright orange)
74-75	Vega (Coupe, Sedan)	342695	1	8.10	PANEL, rear bumper filler
74-75	Vega (Sta. Wag., Panel)	342696	1	5.60	PANEL, rear bumper filler
75	Nova	345505	1	15.85	PANEL, front bpr. filler— (1.263)
75	El Camino	356423	1	12.05	PANEL, rear bumper to body filler
75	Vega (122)	342635	1	11.40	PANEL, rear bumper valance (neutral silver)

**FRAME—SPRINGS—BUMPER**

**7.833 ATTACHMENT UNIT— BRACE— BRACKET— BUMPER— CLIP— DAM UNIT— DEFLECTOR— EXTENSION— FILLER— GRILLE— INSULATOR— MOULDING UNIT— NUT— PANEL— PLATE— REFLECTOR ASSY.— RETAINER— REINFORCEMENT— ROD— SCREW— SEAL— SPACER— SPOILER— STOP— SUPPORT ASSY., Bumper Valance Panel (Con't)**

75	Vega	353904	1	10.50	PANEL, rear bumper valance (bright blue met.)
75	Vega	353905	1	10.50	PANEL, rear bumper valance (bright green met.)
75	Vega	353906	1	10.50	PANEL, rear bumper valance (dark green met.)
75	Vega	353909	1	10.50	PANEL, rear bumper valance (sandstone)
75	Vega	353913	1	10.50	PANEL, rear bumper valance (bright orange met.)
75	Vega	349567	1	10.50	PANEL, front bumper valance (bright blue met.)
75	Vega	349568	1	11.40	PANEL, front bumper valance (bright green)
75	Vega	349569	1	10.50	PANEL, front bumper valance (dark green met.)
75	Vega	349572	1	10.50	PANEL, front bumper valance (sandstone)
75	Vega	349576	1	10.50	PANEL, front bumper valance (orange)
75	Vega	368870	1	8.00	PANEL, rr. bpr. valance (silver met.)
75	Vega	369821	1	7.50	PANEL, rr. bpr. valance (dk. yellow)
75	Vega	369822	1	7.50	PANEL, rr. bpr. valance (lt. blue)
75	Vega	369823	1	7.50	PANEL, rr. bpr. valance (lime green)
75	Vega	369824	1	20.55	PANEL, frt. bpr. valance (dk. yellow)
75	Vega	369825	1	20.55	PANEL, frt. bpr. valance (lt. blue)
75	Vega	369826	1	20.55	PANEL, frt. bpr. valance (lime green)
75	Monza (Towne Cpe.)	365235	1	21.70	PANEL, front bumper valance (bright blue met.)
75	Monza (Towne Cpe.)	365236	1	21.70	PANEL, front bumper valance (dark blue met.)
75	Monza (Towne Cpe.)	365245	1	21.70	PANEL, front bumper valance (orange met.)
75	Monza (Towne Cpe.)	365232	1	21.70	PANEL, front bumper valance (silver)
75	Monza (Towne Cpe.)	365231	1	21.70	PANEL, front bumper valance (white)
75	Monza (Towne Cpe.)	365237	1	21.70	PANEL, front bumper valance (firethorn met.)
75	Monza (Towne Cpe.)	365238	1	21.70	PANEL, front bumper valance (bright green met.)
75	Monza (Towne Cpe.)	365239	1	21.70	PANEL, front bumper valance (dk. green met.)
75	Monza (Towne Cpe.)	365240	1	21.70	PANEL, front bumper valance (cream beige)
75	Monza (Towne Cpe.)	365241	1	21.70	PANEL, front bumper valance (bright yellow)
75	Monza (Towne Cpe.)	365242	1	21.70	PANEL, front bumper valance (russet orange met.)
75	Monza (Towne Cpe.)	365243	1	21.70	PANEL, front bumper valance (red)
75	Monza (Towne Cpe.)	365244	1	21.70	PANEL, front bumper valance (mahogany met.)
75	Monza (Towne Cpe.)	365250	1	19.00	PANEL, rear bumper valance (bright blue met.)
75	Monza (Towne Cpe.)	365251	1	19.00	PANEL, rear bumper valance (dk. blue met.)
75	Monza (Towne Cpe.)	365260	1	19.00	PANEL, rear bumper valance (orange)
75	Monza (Towne Cpe.)	365247	1	19.00	PANEL, rear bumper valance (silver)
75	Vega (122)	342620	1	20.55	PANEL, front bumper valance (black)
75	Monza (Towne Cpe.)	365246	1	19.00	PANEL, rear bumper valance (white)
75	Monza (Towne Cpe.)	365252	1	19.00	PANEL, rear bumper valance (firethorn met.)
75	Monza (Towne Cpe.)	365253	1	19.00	PANEL, rear bumper valance (bright green met.)
75	Monza (Towne Cpe.)	365254	1	19.00	PANEL, rear bumper valance (dk. green met.)
75	Monza (Towne Cpe.)	365255	1	19.00	PANEL, rear bumper valance (cream beige)
75	Monza (Towne Cpe.)	365256	1	19.00	PANEL, rear bumper valance (bright yellow)
75	Monza (Towne Cpe.)	365257	1	19.00	PANEL, rear bumper valance (orange)
75	Monza (Towne Cpe.)	365258	1	19.00	PANEL, rear bumper valance (red)
75	Monza (Towne Cpe.)	365259	1	19.00	PANEL, rear bumper valance (mahogany met.)
75	Monza (Towne Cpe.)	365226 R.H.		5.70	PANEL, rear bumper filler (black)
75	Monza (Towne Cpe.)	365225 L.H.		5.70	PANEL, rear bumper filler (black)
75	Nova	361185 L.H.		13.70	PANEL, rr. bumper to body filler outer
75	Nova	361186 R.H.		13.70	PANEL, rr. bumper to body filler outer (paint to match)
75	Nova	347552	1	26.25	PANEL, rr. bumper to body fil. ctr.
71-74	Vega	9820850	4	.21	PLATE, rr. bumper valance panel anchor lower

**FRAME—SPRINGS—BUMPER**

**7.833 ATTACHMENT UNIT— BRACE— BRACKET— BUMPER— CLIP— DAM UNIT— DEFLECTOR— EXTENSION— FILLER— GRILLE— INSULATOR— MOULDING UNIT— NUT— PANEL— PLATE— REFLECTOR ASSY.— RETAINER— REINFORCEMENT— ROD— SCREW— SEAL— SPACER— SPOILER— STOP— SUPPORT ASSY., Bumper Valance Panel (Con't)**

74	Vega	9689972	2	.21	PLATE, rr. bumper valance panel anchor upper
75	Monza (exc. Towne Cpe., 4 cyl.)	1705939	R.H.	5.00	PLATE, anchor bumper moulding
69-70	El Camino,				
72	El Camino	910883	2	5.00	REFLECTOR ASSY., rr. bumper
70	Pass. (Sta. Wag.)	3986827	L.H.	2.40	REFLECTOR ASSY., left rear bumper
70	Pass. (Sta. Wag.)	3986828	R.H.	2.40	REFLECTOR ASSY., right rear bumper
65	Pass.	3872100	1	.11	RETAINER, front bumper valance panel moulding
70-73	Camaro	3982097	2	.88	RETAINER, rear bumper seal
70-72	El Camino	3795485	6	.16	RETAINER, rr. bumper to body seal— (8.010)
74-75	Camaro	339450	1	1.75	RETAINER, rr. bumper face bar to body filler
74-75	Camaro	339451	L.H.	1.75	RETAINER, rr. bumper face bar to body filler
74-75	Camaro	339452	R.H.	1.75	RETAINER, rr. bumper face bar to body filler
74-75	Chevelle (Spt. Cpe., Sed.) (1st design) (exc. Monte Carlo)	338593	1	.40	RETAINER ASSY., rear bumper to body filler side (Note 1)
74-75	Monte Carlo	340157	L.H.		RETAINER ASSY., rear bumper to body filler side
74-75	Monte Carlo	362362	R.H.	1.10	RETAINER ASSY., rear bumper to body filler side (repl. 340158)
74-75	Chevelle (Spt. Cpe., Sed.) (1st design) (exc. Monte Carlo)	338595	L.H.	1.75	RETAINER ASSY., rear bumper to body filler center (Note 1)
74-75	Chevelle (Spt. Cpe., Sed.) (1st design) (exc. Monte Carlo)	338596	R.H.	1.75	RETAINER ASSY., rear bumper to body filler center (Note 1)
74	Monte Carlo	340159	L.H.	1.10	RETAINER ASSY., rear bumper to body filler center
74	Monte Carlo	340160	R.H.	1.10	RETAINER ASSY., rear bumper to body filler center
75	Monte Carlo (1st design)	345375	L.H.	1.10	RETAINER ASSY., rear bumper to body filler center (Note 1)
75	Monte Carlo (1st design)	345376	R.H.	1.10	RETAINER ASSY., rear bumper to body filler center (Note 1)
75	Chevelle (Spt. Cpe., Sed.) (2nd design) (exc. Monte Carlo)	362364	R.H.	1.75	RETAINER ASSY., rear bumper to body filler center (Note 1)
75	Chevelle (Spt. Cpe., Sed.) (2nd design) (exc. Monte Carlo)	362363	L.H.	1.75	RETAINER ASSY., bumper to body filler center (Note 1)
75	Chevelle (Spt. Cpe., Sed.) (2nd design) (exc. Monte Carlo)	362360	1	.40	RETAINER ASSY., rear bumper to body filler side (Note 1)
75	Monte Carlo (2nd design)	362366	R.H.	1.75	RETAINER ASSY., rear bumper to body filler center (Note 1)
75	Monte Carlo (2nd design)	362365	L.H.	1.75	RETAINER ASSY., rear bumper to body filler center (Note 1)
<i>NOTE 1: 1st design parts have a threaded stud and requires 4801719 nut. 2nd design parts have an unthreaded stud and requires 9436884 nut when used.</i>					
74-75	Pass. (exc. Sta. Wag.)	337651	L.H.	.44	REINFORCEMENT, rear quarter to bpr. filler
74-75	Pass. (exc. Sta. Wag.)	337652	R.H.	.44	REINFORCEMENT, rear quarter to bpr. filler
75	Monza (Towne Cpe.)	356695	1	1.35	REINFORCEMENT, rr. bumper ctr. filler panel
75	Monza (Towne Cpe.)	365227	1	.45	REINFORCEMENT, rr. valance panel
75	Monza (Towne Cpe.)	365228	1	.45	REINFORCEMENT, rr. bpr. valance panel
69-70	Pass. (exc. Sta. Wag.)	3945693	1	.59	ROD, rear bumper valance panel brace
69-70	Sta. Wag.	3953057	2	.16	SCREW, rear bumper filler panel
62-65	Chevy (exc. Sta. Wag.)	3792277	1	5.15	SEAL, rear bumper to body
64-66	Chevelle (Sta. Wag., El Camino),				
67	Chevelle	3892291	1	2.00	SEAL, rear bumper to body
68-72	Chevy	3938680	1	2.05	SEAL, rear bumper to body
68	Chevelle (Sta. Wag., El Camino) (2nd design),				
69-72	El Camino				
69	Concours	3934157	1	1.05	SEAL, right and left rr. bumper to body (57 <sup>7</sup> / <sub>8</sub> " O.L.)

**FRAME—SPRINGS—BUMPER**

**7.833 ATTACHMENT UNIT— BRACE— BRACKET— BUMPER— CLIP— DAM UNIT— DEFLECTOR— EXTENSION— FILLER— GRILLE— INSULATOR— MOULDING UNIT— NUT— PANEL— PLATE— REFLECTOR ASSY.— RETAINER— REINFORCEMENT— ROD— SCREW— SEAL— SPACER— SPOILER— STOP— SUPPORT ASSY., Bumper Valance Panel (Con't)**

69-70	Pass. (exc. Sta. Wag.)	3941291	1	1.95	SEAL, rear bumper to body
70-72	Monte Carlo	3987089	2	.61	SEAL, rear bumper to body outer
71	Impala, Caprice	3983996	1	2.25	SEAL, rear bumper to body
72	Pass. (exc. Sta. Wag.)	6273700	2	2.25	SEAL, rr. bumper to body outer
72-73	Pass. (exc. Sta. Wag.)	325825	1	2.25	SEAL, rear bumper to body
73	Pass. (exc. Sta. Wag.)	327117	L.H.	4.70	SEAL, rear bumper to body outer
73	Pass. (exc. Sta. Wag.)	327118	R.H.	4.70	SEAL, rear bumper to body outer
69-72	Chevelle (Sta. Wag.)	3954597	2	.16	SPACER, rear bumper face bar
74-75	Camaro	337495	2	9.15	SPACER, rr. bpr. face bar spring
75	Monza (exc. Towne Cpe.) (Hvy. Duty Service)	3965794	R.H.	56.25	SPOILER, end cap
75	Monza (exc. Towne Cpe.) (Hvy. Duty Service)	3965795	L.H.	56.25	SPOILER, end cap
75	Monza (exc. Towne Cpe.) (Hvy. Duty Service)	3965796	1	77.75	SPOILER, center section
69-72	Chevelle (Sta. Wag.)	3954598	1	.98	STOP, rear bumper face bar supt.
74	Nova	347511	L.H.	2.00	SUPPORT, rr. bumper face bar filler
74	Nova	347512	R.H.	1.40	SUPPORT, rr. bumper face bar filler
69-70	Pass. (Sta. Wag.)	3950709	1	3.05	SUPPORT ASSY., rear bumper filler panel

**7.836 BRACE— REINFORCEMENT— ROD— EXTENSION— SUPPORT— BRACKET— BAR— PAD— BOLT— PLATE ASSY.— CLAMP, Frame to Bumper Attaching (Also See Group 7.869)**

**PASS. (Front)**

65	Pass.	3856232	R.H.	5.45	frame to bumper, right
66	Pass.	3872145	L.H.	5.75	frame to bumper, left
66	Pass.	3872146	R.H.	5.75	frame to bumper, right
67	Pass.	3895177	L.H.	5.75	frame to bumper, left
67	Pass.	3895178	R.H.	5.75	frame to bumper, right
68	Pass.	3915487	L.H.	6.50	frame to bumper, left
68	Pass.	3915488	R.H.	6.50	frame to bumper, right
69	Pass.	3942127	L.H.	6.65	frame to bumper, left
69	Pass.	3942128	R.H.	6.65	frame to bumper, right
70	Pass.	3957301	L.H.	6.65	frame to bumper, left, front
70	Pass.	3957302	R.H.	6.65	frame to bumper, right, front
71	Pass.	3979993	L.H.	6.60	frame to bumper, left, front
71	Pass.	3979994	R.H.	6.60	frame to bumper, right, front
72	Pass.	6270177	L.H.	15.90	frame to bumper, left, front
72	Pass.	6270178	R.H.	15.90	frame to bumper, right, front

**CHEVELLE (Front)**

64	Chevelle	3834247	L.H.	4.60	frame to bumper, left
64	Chevelle	3834248	R.H.	4.60	frame to bumper, right
65	Chevelle	3857211	L.H.	5.00	frame to bumper, left
65	Chevelle	3857212	R.H.	5.00	frame to bumper, right
66	Chevelle	3872903	L.H.	3.40	frame to bumper, left
66	Chevelle	3872904	R.H.	3.40	frame to bumper, right
67	Chevelle	3892109	L.H.	3.50	frame to bumper, left
67	Chevelle	3892110	R.H.	3.50	frame to bumper, right
68	Chevelle	3917451	L.H.	2.90	frame to bumper, left
68	Chevelle	3917452	R.H.	2.90	frame to bumper, right
69	Chevelle	3938087	L.H.	3.05	frame to bumper, left
69	Chevelle	3938088	R.H.	3.05	frame to bumper, right
70	Chevelle	3975431	L.H.	2.20	frame to bumper, left, front face bar
70	Chevelle	3975432	R.H.	3.30	frame to bumper, right, front face bar
71-72	Chevelle (exc. Monte Carlo)	3982441	L.H.	3.25	frame to bumper, left, front face bar
71-72	Chevelle (exc. Monte Carlo)	3982442	R.H.	3.25	frame to bumper, right, front face bar
71-72	Monte Carlo	3982483	L.H.	3.25	frame to bumper, left, face bar
71-72	Monte Carlo	3982484	R.H.	3.25	frame to bumper, right, face bar

**CHEVY (Front)**

62-65	Chevy	3792363	L.H.	3.35	frame to bumper, left
62-65	Chevy	3792364	R.H.	3.35	frame to bumper, right
66-67	Chevy	3874753	L.H.	2.05	frame to bumper, left
66-67	Chevy	3874754	R.H.	2.05	frame to bumper, right
68-72	Nova	3998881	L.H.	4.15	frame to bumper, left
68-72	Nova	3998882	R.H.	4.15	frame to bumper, right
73	Nova	327507	L.H.	10.55	front
73	Nova	327508	R.H.	10.55	front

**FRAME—SPRINGS—BUMPER**

**7.836 BRACE— REINFORCEMENT— ROD— EXTENSION— SUPPORT—  
BRACKET— BAR— PAD— BOLT— PLATE ASSY.— CLAMP, Frame to  
Bumper Attaching (Also See Group 7.869) (Con't)**

**CAMARO (FRONT)**

70	Camaro (R.S.)	3974549	1	20.45	frame to bumper, vertical
73	Camaro (exc. R.S.)	327523	L.H.	1.90	BRACE ASSY., front bumper bracket to rad. support
73	Camaro (exc. R.S.)	327524	R.H.	1.90	BRACE ASSY., front bumper bracket to rad. support
73	Camaro (R.S.)	333759	L.H.	1.90	BRACE ASSY., frt. bumper reinforcement to rad. supt. upper
73	Camaro (R.S.)	333760	R.H.	1.90	BRACE ASSY., frt. bumper reinforcement to rad. supt. upper
73	Camaro (R.S.)	333761	L.H.	1.90	BRACE ASSY., frt. bumper reinforcement to rad. supt. lower
73	Camaro (R.S.)	333762	R.H.	1.90	BRACE ASSY., frt. bumper reinforcement to rad. supt. lower
74-75	Camaro	339417	L.H.	3.05	front
74-75	Camaro	339418	R.H.	3.05	front

**PASS. (Rear)**

66	Pass. (exc. Sta. Wag.)	3871335	L.H.	5.10	frame to bumper, left
66	Pass. (exc. Sta. Wag.)	3871336	R.H.	5.10	frame to bumper, right
68	Pass. (exc. Sta. Wag.)	3907687	L.H.	3.20	frame to bumper, left
68	Pass. (exc. Sta. Wag.)	3907688	R.H.	3.20	frame to bumper, right
70	Pass. (exc. Sta. Wag.)	3955091	L.H.	10.75	frame to bumper, left, rear
70	Pass. (exc. Sta. Wag.)	3955092	R.H.	10.75	frame to bumper, right, rear
71	Pass. (exc. Sta. Wag.)	3985643	L.H.	4.30	frame to bumper, left, rear
71	Pass. (exc. Sta. Wag.)	3985644	R.H.	4.30	frame to bumper, right, rear
71-73	Pass. (Sta. Wag.)	3979955	L.H.	3.75	frame to bumper, left, rear
71-73	Pass. (Sta. Wag.)	3979956	R.H.	3.75	frame to bumper, right, rear
69	Pass. (exc. Sta. Wag.)	3938021	L.H.	3.40	BRACE ASSY., left rr. bumper
69	Pass. (exc. Sta. Wag.)	3938022	R.H.	3.40	BRACE ASSY., right rr. bumper
69-70	Pass. (Sta. Wag.)	3950711	1	2.35	BRACE ASSY., rear bumper

**CHEVELLE (Rear)**

64-65	Chevelle (Sta. Wag., El Camino)	3834707	L.H.	4.15	frame to bumper, left
64-65	Chevelle (Sta. Wag., El Camino)	3834708	R.H.	4.15	frame to bumper, right
64-65	Chevelle (exc. Sta. Wag., El Camino)	3834137	L.H.	3.80	frame to bumper, left
64-65	Chevelle (exc. Sta. Wag., El Camino)	3834138	R.H.	3.55	frame to bumper, right
66-67	Chevelle (exc. Sta. Wag., El Camino)	3872195	L.H.	1.40	frame to bumper, left
66-67	Chevelle (exc. Sta. Wag., El Camino)	3872196	R.H.	1.40	frame to bumper, right
66-67	Chevelle (Sta. Wag., El Camino)	3872198	R.H.	1.40	frame to bumper, right
68-69	Chevelle (Sta. Wag., El Camino) (exc. dual t/gate),				
70-72	El Camino	3922837	L.H.	2.05	frame to bumper, left lower
68-69	Chevelle (Sta. Wag., El Camino) (exc. dual t/gate),				
70-72	El Camino	3922838	R.H.	2.05	frame to bumper, right lower
68	Chevelle (exc. Sta. Wag., El Camino)	3920093	L.H.	3.65	frame to bumper, left
68	Chevelle (exc. Sta. Wag., El Camino)	3920094	R.H.	3.65	frame to bumper, right
68-69	Chevelle (Sta. Wag., El Camino) (exc. dual t/gate),				
70-72	El Camino	3922839	L.H.	1.30	frame to bumper, left upper
68-69	Chevelle (Sta. Wag., El Camino) (exc. dual t/gate),				
70-72	El Camino	3922840	R.H.	1.30	frame to bumper, right upper
69-72	Chevelle (Sta. Wag.)	3953047	L.H.	4.15	frame to bumper, left face bar
69	Chevelle (exc. Sta. Wag., El Camino)	3938147	L.H.	5.95	frame to bumper, left
69	Chevelle (exc. Sta. Wag., El Camino)	3938148	R.H.	5.95	frame to bumper, right
70	Chevelle (exc. Sta. Wag., El Camino, Monte Carlo)	3968525	L.H.	1.75	frame to bumper, left, rear lower
70	Chevelle (exc. Sta. Wag., El Camino, Monte Carlo)	3968526	R.H.	1.75	frame to bumper, right, rear lower
70	Chevelle (exc. Sta. Wag., El Camino, Monte Carlo)	3968527	L.H.	3.60	frame to bumper, left, rear upper

**FRAME—SPRINGS—BUMPER**

**7.836 BRACE— REINFORCEMENT— ROD— EXTENSION— SUPPORT—  
BRACKET— BAR— PAD— BOLT— PLATE ASSY.— CLAMP, Frame to  
Bumper Attaching (Also See Group 7.869) (Con't)**

70	Chevelle (exc. Sta. Wag., El Camino, Monte Carlo)	3968528 R.H.	4.60	frame to bumper, right, rear upper
70	Monte Carlo	3968581 L.H.	6.10	frame to bumper, left, rear face bar
70	Monte Carlo	3968582 R.H.	4.10	frame to bumper, right, rear face bar
70	Monte Carlo	3975441 L.H.	1.75	frame to bumper, left, rear
70	Monte Carlo	3975442 R.H.	1.75	frame to bumper, right, rear
71-72	Monte Carlo	3987095 L.H.	1.75	frame to bumper, left, rear
71-72	Monte Carlo	3987096 R.H.	1.75	frame to bumper, right, rear

**7.836A REINFORCEMENT— ROD— EXTENSION— SUPPORT— BRACKET— BAR—  
PAD— BOLT— PLATE ASSY.— CLAMP**

66-67	Chevelle (exc. Sta. Wag., El Camino)	3872190	1	3.70	rear
68	Pass.	3915491	2	.53	front outer face bar
68	Pass. (exc. Sta. Wag.)	3913606 R.H.		.32	upper right
68	Chevelle (exc. Sta. Wag., El Camino)	3913676	1	4.15	rear
68-70	Chevelle (Sta. Wag., El Camino) (exc. dual t/gate)				
71-72	Chevelle (El Camino, Sta. Wag.)	3922834	1	2.60	rear
69	Pass. (exc. Sta. Wag.)	3938025 L.H.		.44	left rear bumper upper
69	Pass. (exc. Sta. Wag.)	3938026 R.H.		.44	right rear bumper upper
69	Chevelle (exc. Sta. Wag., El Camino)	3940607	1	2.75	rr. bumper
70-72	Monte Carlo	3987097	1	2.85	rear
73	Camaro (R.S.)	3998890	1	3.35	frt. bpr. ctr., face bar lower
73	Pass.	327157 L.H.		.44	front fender to bumper filler panel
73	Pass.	327158 R.H.		.44	front fender to bumper filler panel
73	Monte Carlo	3996957	1	4.10	frt. bumper face bar center
73	Laguna	325246	1	2.85	front bumper face bar center
73	Monte Carlo	325236	1	7.15	rr. bpr. face bar center
73	Chevelle (Sta. Wag.) El Camino, El Camino	328991	1	2.80	rr. bpr. face bar center
73	Chevelle (Spt. Cpe., Sed.) (exc. Monte Carlo)	3999767	1	7.15	rr. bpr. face bar center
74-75	Camaro	341099	1	.74	frt. bumper face bar center bracket
75	Monza (Towne Cpe.)	365285	2	2.80	rr. bpr. shock/abs. mtg. plate
69	Pass.	3945636	1	1.70	ROD, front bumper brace
74-75	Vega, Monza	336567	1	4.50	ROD, frame bracket
69-72	Chevelle (Sta. Wag.)	3953043 L.H.		3.25	EXTENSION, left rear bumper to frame
69-72	Chevelle (Sta. Wag.)	3953044 R.H.		3.25	EXTENSION, right rear bumper to frame
62-67	Chevy (Sta. Wag.)	4839196	2	1.95	SUPPORT, rear bumper rear
67-68	Camaro	7635816	2	2.05	SUPPORT, rear bumper inner
67-68	Camaro	7674718	2	.69	SUPPORT, rear bumper
69	Camaro	8714596 L.H.		2.50	SUPPORT, left rear bumper outer
69	Camaro	8714595 R.H.		2.50	SUPPORT, right rear bumper outer
69	Camaro	8748971 L.H.		2.10	SUPPORT, left rear bumper qtr. panel
69	Camaro	8748970 R.H.		2.10	SUPPORT, right rear bumper qtr. panel
69-72	Chevelle (Sta. Wag.)	8732952	1	7.15	SUPPORT, rear bumper fil. cap on gate
69-70	Pass. (Sta. Wag.)	8732953	1	5.70	SUPPORT, rear bumper filler cap on gate
70-73	Camaro	8763562	2	2.45	SUPPORT, right, rear bumper outer mtg.
73	Chevelle (exc. Laguna, Monte Carlo)	325293 L.H.		4.75	SUPPORT, front bpr. face bar inner
73	Chevelle (exc. Laguna, Monte Carlo)	325294 R.H.		4.75	SUPPORT, front bpr. face bar inner
73	Laguna	331757 L.H.		6.60	SUPPORT, front bpr. face bar inner
73	Laguna	331758 R.H.		6.60	SUPPORT, front bpr. face bar inner
73	Chevelle (exc. Laguna, Monte Carlo)	325243 L.H.		4.15	SUPPORT, front bumper face bar outer
73	Chevelle (exc. Laguna, Monte Carlo)	325244 R.H.		4.15	SUPPORT, front bumper face bar outer
73	Monte Carlo	325253 L.H.		3.85	SUPPORT, frt. bpr. face bar outer
73	Monte Carlo	325254 R.H.		3.85	SUPPORT, frt. bpr. face bar outer
73	Laguna	331759 L.H.		3.25	SUPPORT, frt. bpr. face bar outer
73	Laguna	331760 R.H.		3.25	SUPPORT, frt. bpr. face bar outer
74	Camaro	9665916 R.H.		5.30	SUPPORT, compartment pan at bumper
74	Camaro	9665917 L.H.		5.30	SUPPORT, compartment pan at bumper
75	Caprice	343557 L.H.		6.75	SUPPORT, front bumper face bar
75	Caprice	343558 R.H.		6.75	SUPPORT, front bumper face bar
73	Laguna (Sta. Wag.)				
74-75	Laguna	328925 L.H.		4.75	SUPPORT ASSY., front bpr. face bar to fender
73	Laguna (Sta. Wag.)				

**FRAME—SPRINGS—BUMPER**

**7.836A REINFORCEMENT— ROD— EXTENSION— SUPPORT— BRACKET— BAR— PAD— BOLT— PLATE ASSY.— CLAMP (Con't)**

74-75	Laguna	328926	R.H.	4.75	SUPPORT ASSY., front bpr. face bar to fender
73	Pass.	327141	L.H.	4.70	SUPPORT ASSY., frt. bpr. face bar
73	Pass.	327142	R.H.	4.70	SUPPORT ASSY., frt. bpr. face bar
73	Monte Carlo	325257	L.H.	4.45	SUPPORT ASSY., frt. bpr. face bar inner
73	Monte Carlo	325258	R.H.	4.45	SUPPORT ASSY., frt. bpr. face bar inner
74-75	Pass.	337613	L.H.	4.35	SUPPORT ASSY., frt. bumper face bar
74-75	Pass.	337614	R.H.	4.35	SUPPORT ASSY., frt. bumper face bar
75	Laguna	347369	L.H.	15.40	SUPPORT ASSY., front bumper face bar
75	Laguna	347370	R.H.	15.40	SUPPORT ASSY., front bumper face bar
69-72	Chevelle (Sta. Wag.)	3953045	L.H.	4.85	BRACKET, left rear bumper face bar
69-72	Chevelle (Sta. Wag.)	3953046	R.H.	4.50	BRACKET, right rear bumper face bar
70	Pass. (exc. Sta. Wag.)	3957307	1	2.10	BRACKET, rear center
71-72	Monte Carlo	3987091	L.H.	6.40	BRACKET, left, rear bpr. face bar
71-72	Monte Carlo	3987092	R.H.	4.35	BRACKET, right, rear bpr. face bar
71-73	Pass. (Sta. Wag.)	3985641	L.H.	4.60	BRACKET, left, rear bumper
71-73	Pass. (Sta. Wag.)	3985642	R.H.	4.60	BRACKET, right, rear bumper
71	Pass. (exc. Sta. Wag.)	3985651	1	2.25	BRACKET, rear bumper center
71-72	Chevelle (exc. Sta. Wag., Monte Carlo)	3992653	L.H.	3.60	BRACKET, left, rear bumper upper
71-72	Chevelle (exc. Sta. Wag., Monte Carlo)	3992654	R.H.	3.60	BRACKET, right, rear bumper upper
71-72	Chevelle (exc. Sta. Wag., Monte Carlo)	3982417	L.H.	5.90	BRACKET, left, rear bumper lower
71-72	Chevelle (exc. Sta. Wag., Monte Carlo)	3982418	R.H.	5.90	BRACKET, right, rear bumper lower
72	Pass. (exc. Sta. Wag.)	3995193	L.H.	7.10	BRACKET, left front bumper
72	Pass. (exc. Sta. Wag.)	3995194	R.H.	7.10	BRACKET, right front bumper
73	Monte Carlo	325237	L.H.	7.15	BRACKET, rear
73	Monte Carlo	325238	R.H.	7.15	BRACKET, rear
73	Chevelle (exc. Sta. Wag., El Camino, Monte Carlo)	3996981	L.H.	12.55	BRACKET, rear bumper lower
73	Chevelle (exc. Sta. Wag., El Camino, Monte Carlo)	3996982	R.H.	12.55	BRACKET, rear bumper lower
70-73	Camaro (R.S.)	3974549	1	20.45	BAR, front bumper vertical, behind grill
68-69	Chevelle (Sta. Wag., El Camino), El Camino	3922841	2	.27	PAD, left rear upper bracket
73	Chevelle (Sta. Wag.) El Camino, Pass. (exc. Sta. Wag.)	488929	2	.62	BOLT, rr. bumper brkt. to frame
73	Pass.	332381	L.H.	2.50	PLATE ASSY., front bumper stud
73	Pass.	332382	R.H.	2.50	PLATE ASSY., front bumper stud
74	Pass., Chevelle	340189	2	2.25	PLATE ASSY., frt. and rear bumper stud
74	Nova	344345	2	3.15	PLATE ASSY., frt. bpr. stud
74	Chevelle, Pass.	340189	2	2.25	PLATE ASSY., rear bumper stud
74	Nova	1244528	2		PLATE ASSY., rr. bumper stud
74-75	Vega	336572	2	1.00	PLATE ASSY., rr. bumper stud
75	Nova	345573	2	3.75	PLATE ASSY., frt. bpr. face bar
67	Chevelle	3895192	1	.55	CLAMP, front, right
68	Chevelle	3917417	2	.36	CLAMP, front
68	Chevy	3916641	1	.42	CLAMP, rear
68	Chevy	3916652	1	.52	CLAMP, front, right

**7.840 ABSORBER ASSY.— BRACKET— BOLT— CROSSMEMBER— GUIDE ASSY.— PLATE— REINFORCEMENT— SLEEVE— SHIM— SPACER— SPRING ASSY.— TUBE ASSY., Front and Rear Bumper Shock**

73	Pass.	4975706	2	21.20	front bumper shock
73	Chevelle	4975705	2	21.20	front bumper shock
74-75	Nova	4975618	4	21.20	frt. and rear
74	Chevelle (exc. Monte Carlo)	4975613	2	21.20	frt.
75	Chevelle Wgn.	4975617	2	21.20	rear
74	Chevelle				rear,
74-75	Pass.				frt.,
74-75	Pass. (exc. Sta. Wag.)	4975636	2	21.20	rear
74-75	Pass. (Sta. Wag.)	4975619	2	21.20	rear
75	Monte Carlo	4975631	2	21.20	front
75	Caprice	4975632	2	21.20	front
75	Chevelle (exc. Monte Carlo)	4975633	2	21.20	front
75	Chevelle (exc. Sta. Wag., El Camino)	4975634	2	21.20	rear
75	Monza (exc. Towne Cpe.)	4975616	4	21.20	front and rear bumper
75	Monza (Towne Cpe.)	4992971	4	21.20	frt. & rear bumper
73	Chevelle (exc. Laguna)	328941	L.H.	5.20	BRACKET, frt. bumper face bar shock absorber

**FRAME—SPRINGS—BUMPER**

**7.840 ABSORBER ASSY.— BRACKET— BOLT— CROSSMEMBER— GUIDE ASSY.— PLATE— REINFORCEMENT— SLEEVE— SHIM— SPACER— SPRING ASSY.— TUBE ASSY., Front and Rear Bumper Shock (Con't)**

73	Chevelle (exc. Laguna)	328942 R.H.	5.20	BRACKET, frt. bumper face bar shock absorber
73	Pass.	345085 L.H.	21.40	BRACKET, energy absorbing shock
73	Pass.	345086 R.H.	21.40	BRACKET, energy absorbing shock
73	Pass.	6273765 L.H.	4.45	BRACKET, frt. bumper face bar shock absorber
73	Pass.	6273766 R.H.	4.45	BRACKET, frt. bumper face bar shock absorber
74-75	Pass. (exc. Sta. Wag.)	337695 L.H.	10.00	BRACKET, rear bumper shock absorber
74-75	Pass. (exc. Sta. Wag.)	337696 R.H.	10.00	BRACKET, rear bumper shock absorber
74	Pass.	335813 L.H.	21.40	BRACKET, frt. energy absorbing shock
74	Pass.	335814 R.H.	21.40	BRACKET, frt. energy absorbing shock
75	Monza (Towne Cpe.)	358382 R.H.	11.90	BRACKET, frt. bpr. shock abs.
75	Monza (Towne Cpe.)	358381 L.H.	11.90	BRACKET, frt. bpr. shock abs.
73	Chevelle	325292 2	.85	BRACKET ASSY., front bumper shock absorber
74-75	Nova	337473 2	.63	BRACKET ASSY., rr. bumper shock absorber
74-75	Chevelle (exc. El Camino)			BRACKET ASSY., rr. bumper shock, frt. bumper shock
74-75	Monte Carlo	492976 2	.85	BRACKET ASSY., frt. bumper shock absorber
74	Nova	339423 L.H.	11.00	BRACKET ASSY., frt. bumper shock absorber
74	Nova	339424 R.H.	11.00	BRACKET ASSY., frt. bumper shock absorber
74-75	Chevelle (exc. Monte Carlo)	342184 2	.85	BRACKET ASSY., frt. bumper shock absorber
74-75	Camaro	337489 1	8.75	BRACKET ASSY., rr. bumper face bar center
75	Nova	345600 2	.79	BRACKET ASSY., frt. bumper shock absorber
75	Monza (exc. Towne Cpe.)	346509 L.H.	8.15	BRACKET ASSY., front bumper shock abs.
75	Monza (exc. Towne Cpe.)	346510 R.H.	6.90	BRACKET ASSY., front bumper shock abs.
75	Monza	346530 2	1.95	BRACKET ASSY., rear bumper shock abs.
73	Pass., Chevelle	6273769 2	.84	BOLT, front bumper shock absorber
74	Chevelle (Sta. Wag.)	490067 4	.24	BOLT, rr. bumper shock absorber— (7.874)
74-75	Vega	9434169 4	.48	BOLT, frt. bumper spring
74-75	Camaro	339402 1	6.25	CROSSMEMBER, front bumper spring bracket
74-75	Camaro	339439 L.H.	4.50	GUIDE ASSY., front bumper face bar
74-75	Camaro	339440 R.H.	4.50	GUIDE ASSY., front bumper face bar
74-75	Chevelle (Sta. Wag.)	494251 2	.34	PLATE, rr. frame doubler
74	Chevelle (Sta. Wag.)	496196 L.H.	5.00	PLATE, E/A unit reinforcement doubler rear
74	Chevelle (Sta. Wag.)	496195 R.H.	5.00	PLATE, E/A unit reinforcement doubler rear
74-75	Vega	336574 2	.41	PLATE, inter.
74-75	Vega	336550 1	.91	PLATE, center spring
74-75	Vega	336556 2	.91	PLATE, outer spring
74-75	Vega	342681 2	.55	PLATE, rr. bpr. face bar spring outer
74-75	Vega	342680 1	.96	PLATE, rr. bpr. face bar spring center
75	Monza	346532 4	.94	PLATE, front bumper shock abs.
75	Monza (exc. Towne Cpe.)	346526 2	2.50	PLATE, rear bumper shock abs.
74-75	Pass., Chevelle	340189 2	2.25	PLATE ASSY., front bumper stud
74-75	Chevelle (Sta. Wag.)	494250 2	2.85	PLATE ASSY., rr. bpr. absorbing unit mounting
75	Nova	345530 2	3.75	PLATE ASSY., rr. bpr. face bar stud
74-75	Chevelle w/impact strips (exc. Laguna)	342196 2	2.30	REINFORCEMENT, frt. bumper shock absorber
73	Pass., Chevelle	3865601 2	.25	SLEEVE, frt. bumper shock absorber— (7.425)
74	Nova	493267 A.R.	2.35	SHIM, frt. bumper shock absorber— (7.865)
74-75	Nova	341073 4	.28	SPACER, frt. & rr. bumper spring bracket
74	Camaro	337495 2	9.15	SPACER ASSY., rr. bpr. face bar spring
74-75	Camaro	339410 2	34.00	SPRING ASSY., frt. bumper face bar
74-75	Camaro	337444 2	31.75	SPRING ASSY., rr. bpr. face bar
74-75	Vega	336568 1	17.90	SPRING ASSY., frt. center
74-75	Vega	336571 2	7.10	SPRING ASSY., frt. outer
74-75	Vega	336583 2	16.70	SPRING ASSY., rear face bar
74-75	Camaro	339438 2	3.35	TUBE ASSY., frt. bumper face bar

**7.865 SPACER— BRACKET— CUSHION— NUT— PAD ASSY.— RETAINER ASSY.— SHIM— WASHER, Bumper**

67-69	Pass.			front bumper to filler, rr. bumper to underbody,
-------	-------	--	--	--



**FRAME—SPRINGS—BUMPER**

**7.865 SPACER— BRACKET— CUSHION— NUT— PAD ASSY.— RETAINER ASSY.— SHIM— WASHER, Bumper (Con't)**

68-70	Chevelle (exc. Sta. Wag.),					
69-70	Chevelle (Sta. Wag.) (exc. dual tail gate)					rear face bar reinf.,
68-70	Pass. (Sta. Wag.)					rear bracket to underbody,
71-72	Pass.					front bumper brace, rear bumper center upper bracket,
71	Chevelle,					
72	Chevelle (exc. Spt. Cpe., Conv. Sed.)	3895100 A.R.	.14			rear bumper, face bar reinf., reinf. to rear center bar bracket, upper bracket to body
68	Camaro					front bumper jack bracket,
68	Pass., Chevelle	3930189	2	.15		rear bumper bracket
70-71	Chevelle (exc. Sta. Wag., El Camino),					
72	Chevelle (exc. Sta. Wag., El Camino, Monte Carlo)	3968533	4	.14		rear upper to lower face bar
70-73	Camaro	3974546	2	.21		front bumper bracket
71	Pass. (exc. Sta. Wag.)	3986909	L.H.	.39		left, rear bumper brace
71	Pass. (exc. Sta. Wag.)	3986910	R.H.	.39		right, rear bumper brace
72-75	Pass. (exc. Sta. Wag.)	3995186	2	.36		rear bumper brk.
69	Camaro	3943275	2	.56		CUSHION, frt. bumper
69-70	Pass. (Sta. Wag.)	3963221	L.H.	2.40		CUSHION, left, rear
69-70	Pass. (Sta. Wag.)	3963222	R.H.	2.40		CUSHION, right, rear
68	Camaro	3929906	2	.47		CUSHION ASSY., front inner w/shaft insert
68	Camaro	3929907	2	.31		CUSHION ASSY., front outer
69	Camaro w/Spec. frt. bumper	3943272	2	2.65		CUSHION ASSY., frt. bumper
69	Camaro (exc. Spec. frt. bumper)	3945760	1	.56		CUSHION ASSY., frt. bumper
70-71	Monte Carlo	3975425	L.H.	2.40		CUSHION ASSY., rear bumper to body
70-71	Monte Carlo	3975426	R.H.	2.40		CUSHION ASSY., rear bumper to body
70-73	Camaro (R.S.)	3974551	1	2.30		CUSHION ASSY., front bumper vertical bar
69-70	Pass. (Sta. Wag.)	3953055	2	.42		NUT, rear bumper face bar
71	Monte Carlo (S.S.)	3982493	1	13.25		PAD ASSY., rear face bar
75	Monza (exc. Towne Cpe.)	358353	L.H.	2.80		RETAINER ASSY., frt. bumper impact bar upper cover lower
75	Monza (exc. Towne Cpe.)	358354	R.H.	2.80		RETAINER ASSY., frt. bumper impact bar upper cover lower
69-70	Pass. (exc. Sta. Wag.),					
71	Chevelle (exc. Sta. Wag., El Camino),					
72	Chevelle (exc. Sta. Wag., El Camino, Monte Carlo)	3957279	A.R.	.27		SHIM, rear bumper upper bracket to body
69-70	Pass. (exc. Sta. Wag.)	3983393	A.R.	.50		SHIM, rear bumper brk. to underbody— (5.380)
74	Laguna	493267	A.R.	2.35		SHIM, frt. bumper
74	Vega	346506	A.R.	.50		SHIM, front bumper frame bracket
75	Monza (exc. Towne Cpe.)	346528	A.R.	.46		SHIM, rr. bpr. impact bar brkt., frt. bpr. shk. abs. brkt. (.06 + .012 thk.)
75	Monza (exc. Towne Cpe.)	346537	A.R.	1.35		SHIM, rr. bpr. impact bar brkt., frt. bpr. shk. abs. brkt. (.06 + .014 thk.)
67-70	Pass.,					
71-72	All	1362249	A.R.	.21		WASHER, front and rear (1/2" I.D. x 1 1/4" O.D. x 1/8")
69-70	Pass. (exc. Sta. Wag.),					
71	Chevelle,					
72	Pass.	1347774	4	.13		WASHER, rr. face bar reinf., to bumper serr. tooth
69	Chevelle (exc. Sta. Wag., El Camino),					
70-72	Monte Carlo	3948039	A.R.	.27		WASHER, rear bumper brace
73-75	All	492370	A.R.	.16		WASHER, front and rear (1/2" I.D. x 1 1/4" O.D. x 1/8")
74-75	Camaro	341092	4	.14		WASHER, rear bumper face bar spring
74-75	Camaro	1362249	2	.21		WASHER, front bumper spring bracket
<b>7.869 BRACKET— EXTENSION ASSY.— GUSSET, Front and Rear Bumper</b>						
65	Pass.	3856229	L.H.	2.90		left front bumper front
65	Pass.	3856535	L.H.	2.40		left front bumper rear
65	Pass.	3856536	R.H.	2.40		right front bumper rear
66*	Chevelle	3872901	L.H.	2.50		front bumper
66*	Chevelle	3872902	R.H.	2.50		front bumper
66	Pass. (exc. Sta. Wag.)	3871331	L.H.	2.70		left rear
66	Pass. (exc. Sta. Wag.)	3871332	R.H.	2.70		right rear
66	Pass.	3872143	L.H.	2.90		left front
66	Pass.	3872144	R.H.	2.90		right front

**FRAME—SPRINGS—BUMPER**

**7.869 BRACKET— EXTENSION ASSY.— GUSSET, Front and Rear Bumper  
(Con't)**

67	Pass. ....	3893935 L.H.	2.90	left front bumper .....
67	Pass. ....	3893936 R.H.	2.90	right front bumper .....
67	Pass. (Sta. Wag.) .....	3893937 L.H.	4.90	left rear bumper .....
67	Pass. (exc. Sta. Wag.) .....	3893973 L.H.	4.50	left rear bumper .....
67	Pass. (exc. Sta. Wag.) .....	3893974 R.H.	4.85	right rear bumper .....
67	Pass. (exc. Sta. Wag.) .....	3903198 1	1.35	rear bumper center face bar .....
68	Pass. (Sta. Wag.) .....	3918237 L.H.	7.00	left rear .....
68	Pass. (Sta. Wag.) .....	3918238 R.H.	6.45	right rear .....
68	Sta. Wag. ....	3916556 1	.95	rear, center .....
68	Pass. (exc. Sta. Wag.) .....	3938003 L.H.	2.90	left rear .....
68	Pass. (exc. Sta. Wag.) .....	3938004 R.H.	2.70	bumper, right rear .....
68	Pass. ....	3915443 L.H.	2.90	bumper, left front .....
68	Pass. ....	3915444 R.H.	2.90	bumper, right front .....
69	Pass. (exc. Sta. Wag.) .....	3955098 2	1.10	bumper, rear, center .....
70	Pass. ....	3957303 L.H.	7.80	bumper, left, front .....
70	Pass. ....	3957304 R.H.	7.80	bumper, right, front .....
70	Pass. (exc. Sta. Wag.) .....	3972805 L.H.	1.10	bumper, left, rear outer .....
70	Pass. (exc. Sta. Wag.) .....	3972806 R.H.	1.10	bumper, right, rear outer .....
70	Chevelle, .....			
71-72	Monte Carlo .....	3987057 L.H.	2.55	bumper, left, front face bar (Note 1) .....
70	Chevelle, .....			
71-72	Monte Carlo .....	3987058 R.H.	2.55	bumper, right, front face bar (Note 1) .....
	<i>NOTE 1 It may be necessary to widen .562 slots and rework tab as reqd.</i>			
70-72	Camaro (R.S.) .....	3998892 R.H.	5.35	bumper, right, front, center face bar to rad. support .....
70-73	Camaro (R.S.) .....	3998891 L.H.	5.35	bumper, left, front, center face bar to rad. support .....
70-72	Camaro .....	3967133 L.H.	.91	bumper, left, rear inner .....
70-72	Camaro .....	3967134 R.H.	.91	bumper, right, rear inner .....
70-72	Camaro .....	3967141 1	2.30	bumper, rear, center .....
70-72	Camaro .....	3967137 L.H.	1.10	bumper, left, rear outer .....
70-72	Camaro .....	3967138 R.H.	1.10	bumper, right, rear outer .....
70-73	Camaro .....	3994713 L.H.	1.25	bumper, left, front, face bar inner .....
70-73	Camaro .....	3994714 R.H.	1.25	bumper, right, front, face bar inner .....
71	Pass. ....	3979995 L.H.	7.65	bumper, left, front .....
71	Pass. ....	3979996 R.H.	7.65	bumper, right, front .....
71	Pass. (exc. Sta. Wag.) .....	3985639 L.H.	3.00	bumper, left, rear outer .....
71	Pass. (exc. Sta. Wag.) .....	3985640 R.H.	3.00	bumper, right, rear outer .....
71-72	Chevelle (exc. Monte Carlo) .....	3982423 L.H.	2.55	bumper, left, front face bar .....
71-72	Chevelle (exc. Monte Carlo) .....	3982424 R.H.	2.55	bumper, right, front face bar .....
71-73	Camaro .....	3986565 L.H.	2.10	bumper, left, front face bar outer .....
71-73	Camaro .....	3986566 R.H.	2.10	bumper, right, front face bar outer .....
71-72	Vega .....	6264341 L.H.	2.10	front bumper face bar inner .....
71-72	Vega .....	6264342 R.H.	2.10	front bumper face bar inner .....
71-72	Vega .....	3982094 2	2.10	front bumper face bar outer .....
72	Pass. ....	3997345 L.H.	7.65	bumper, left, front .....
72	Pass. ....	3997346 R.H.	7.65	bumper, right, front .....
72	Pass. (exc. Sta. Wag.) .....	3995193 L.H.	7.10	bumper, left, rear face bar outer .....
72	Pass. (exc. Sta. Wag.) .....	3995194 R.H.	7.10	bumper, right, rear face bar outer .....
72	Pass. (exc. Sta. Wag.) .....	6270198 L.H.	4.30	bumper, left, rear bumper to body outer seal .....
72	Pass. (exc. Sta. Wag.) .....	6270199 R.H.	4.30	bumper, right, rear bumper to body outer seal .....
73	Vega .....	325727 L.H.	1.80	frt. bumper outer .....
73	Vega .....	325728 R.H.	1.80	frt. bumper outer .....
73	Vega .....	325743 L.H.	5.25	front bumper interm. ....
73	Vega .....	325744 R.H.	5.25	front bumper interm. ....
73	Pass. (exc. Sta. Wag.) .....	6273785 L.H.	7.95	rear face bar outer .....
73	Pass. (exc. Sta. Wag.) .....	6273786 R.H.	7.95	rear face bar outer .....
73	Nova .....	327509 L.H.	7.65	front .....
73	Nova .....	327510 R.H.	7.65	front .....
73	El Camino, .....			
73	Chevelle (Sta. Wag.) .....	6261907 L.H.	12.55	rear face bar .....
73-74	El Camino, .....			
73	Chevelle (Sta. Wag.) .....	6261908 R.H.	12.55	rear face bar .....
73	Laguna .....	331771 L.H.	9.45	front face bar .....
73	Laguna .....	331772 R.H.	9.45	front face bar .....
73	Camaro (R.S.) .....	3998892 R.H.	5.35	front, center face bar to rad. support .....
73	Camaro .....	6274377 L.H.	2.90	rear inner .....
73	Camaro .....	6274378 R.H.	2.90	rear inner .....
73	Camaro .....	6274376 1	2.30	rear, center .....
73	Camaro .....	6274385 L.H.	2.55	rear outer .....
73	Camaro .....	6274386 R.H.	2.55	rear outer .....
73	Camaro (exc. R.S.) .....	6274395 L.H.	8.65	frt. bumper face bar .....
73	Camaro (exc. R.S.) .....	6274396 R.H.	8.65	frt. bumper face bar .....

**FRAME—SPRINGS—BUMPER**

**7.869 BRACKET— EXTENSION ASSY.— GUSSET, Front and Rear Bumper  
(Con't)**

74-75	Camaro	341027 L.H.	6.05	rr. bumper face bar guide
74-75	Camaro	341028 R.H.	6.05	rr. bumper face bar guide
75	El Camino	364419 L.H.	25.75	rear face bar
75	El Camino	364420 R.H.	25.75	rear face bar
62-65	Chevy	3790437 L.H.	2.05	BRACKET ASSY., left front
62-65	Chevy	3790438 R.H.	2.05	BRACKET ASSY., right front
62-65	Chevy	3791025 L.H.	3.80	BRACKET ASSY., left rear
62-65	Chevy	3791026 R.H.	3.80	BRACKET ASSY., right rear
64	Chevelle	3834245 L.H.	1.95	BRACKET ASSY., left front
64	Chevelle	3834246 R.H.	1.95	BRACKET ASSY., right front
64-65	Chevelle (exc. Sta. Wag., El Camino)	3834133 L.H.	2.20	BRACKET ASSY., left rear
64-65	Chevelle (Sta. Wag., El Camino)	3834709 L.H.	2.25	BRACKET ASSY., left rear
64-65	Chevelle (Sta. Wag., El Camino)	3834710 R.H.	2.25	BRACKET ASSY., right rear
65	Chevelle	3857209 L.H.	2.50	BRACKET ASSY., left front bumper
65	Chevelle	3857210 R.H.	2.50	BRACKET ASSY., right front bumper
66-67	Chevy	3871355 L.H.	1.95	BRACKET ASSY., left front
66-67	Chevy	3871356 R.H.	1.95	BRACKET ASSY., right front
66-67	Chevelle (exc. Sta. Wag.)	3872191 L.H.	2.50	BRACKET ASSY., left rear
66-67	Chevelle (exc. Sta. Wag.)	3872192 R.H.	2.30	BRACKET ASSY., right rear
66-67	Chevelle (Sta. Wag., El Camino)	3872193 L.H.	2.25	BRACKET ASSY., left rear
66-67	Chevelle (Sta. Wag., El Camino)	3872194 R.H.	2.25	BRACKET ASSY., right rear
66	Chevelle	3872901 L.H.	2.50	BRACKET ASSY., left front
66	Chevelle	3872902 R.H.	2.50	BRACKET ASSY., right front
66-67	Chevy (exc. Sta. Wag.)	3872265 L.H.	4.25	BRACKET ASSY., left rear
66-67	Chevy (exc. Sta. Wag.)	3872266 R.H.	4.25	BRACKET ASSY., right rear
66-67	Chevy (Sta. Wag.)	3872269 L.H.	3.80	BRACKET ASSY., left rear
66-67	Chevy (Sta. Wag.)	3872270 R.H.	3.85	BRACKET ASSY., right rear
67-68	Camaro	3886657 L.H.	.69	BRACKET ASSY., left rear outer
67-68	Camaro	3886658 R.H.	.69	BRACKET ASSY., right rear outer
67-68	Camaro	3886661 L.H.	1.80	BRACKET ASSY., left rear inner
67-68	Camaro	3886662 R.H.	1.80	BRACKET ASSY., right rear inner
67-68	Camaro	3886691 L.H.	2.45	BRACKET ASSY., left front inner
67-68	Camaro	3886692 R.H.	2.45	BRACKET ASSY., right front inner
67	Camaro	3886697 L.H.	1.80	BRACKET ASSY., left front outer
67	Camaro	3886698 R.H.	1.80	BRACKET ASSY., right front outer
67	Chevelle	3892107 L.H.	2.90	BRACKET ASSY., left front
67	Chevelle	3892108 R.H.	2.90	BRACKET ASSY., right front
67-68	Camaro	3927473 1	1.15	BRACKET ASSY., rear, center
68	Chevelle (exc. Std., Sta. Wag., El Camino)	3907681 L.H.	2.70	BRACKET ASSY., left rear
68	Chevelle (exc. Std., Sta. Wag., El Camino)	3907682 R.H.	2.70	BRACKET ASSY., right rear
68-72	Chevy	3916601 L.H.	6.10	BRACKET ASSY., left rear
68-72	Chevy	3916602 R.H.	6.10	BRACKET ASSY., right rear
68-69	Chevelle (Sta. Wag., El Camino) (exc. dual t/gate),			
70-72	El Camino	3922835 L.H.	2.20	BRACKET ASSY., left rear
68-69	Chevelle (Sta. Wag., El Camino) (exc. dual t/gate),			
70-72	El Camino	3922836 R.H.	2.20	BRACKET ASSY., right rear
68	Chevelle	3917449 L.H.	2.40	BRACKET ASSY., left front
68	Chevelle	3917450 R.H.	2.40	BRACKET ASSY., right front
68-72	Chevy	3909193 L.H.	2.05	BRACKET ASSY., left front
68-72	Chevy	3909194 R.H.	2.05	BRACKET ASSY., right front
68	Camaro	3929903 L.H.	1.35	BRACKET ASSY., left front outer
68	Camaro	3929904 R.H.	1.35	BRACKET ASSY., right front outer
68	Camaro	3929955 1	.23	BRACKET ASSY., front bumper jack
69	Camaro	3937560 1	2.20	BRACKET ASSY., rear bumper center
69	Camaro	3937561 L.H.	.85	BRACKET ASSY., left rear bumper inner
69	Camaro	3937562 R.H.	.85	BRACKET ASSY., right rear bumper inner
69	Camaro (exc. spec. frt. bumper)	3945769 L.H.	1.30	BRACKET ASSY., left frt. bumper outer
69	Camaro (exc. spec. frt. bumper)	3945770 R.H.	1.30	BRACKET ASSY., right frt. bumper outer
69	Camaro w/spec. frt. bumper	3943273 1	.91	BRACKET ASSY., frt. bumper outer
69	Chevelle	3938085 L.H.	2.35	BRACKET ASSY., left frt. bumper
69	Chevelle	3938086 R.H.	2.35	BRACKET ASSY., right frt. bumper
69	Camaro	3945767 L.H.	3.20	BRACKET ASSY., left front bumper inner
69	Camaro	3945768 R.H.	3.20	BRACKET ASSY., right front bumper inner
69	Camaro	3937565 L.H.	1.10	BRACKET ASSY., left rear bumper outer
69	Camaro	3937566 R.H.	1.10	BRACKET ASSY., right rear bumper outer
69	Pass.	3942121 L.H.	8.05	BRACKET ASSY., left front bumper
69	Pass.	3942122 R.H.	8.05	BRACKET ASSY., right front bumper
71-73	Vega (Sed., Cpe.)	3982077 L.H.	5.15	BRACKET ASSY., rear bumper face bar outer

**FRAME—SPRINGS—BUMPER**

**7.869 BRACKET— EXTENSION ASSY.— GUSSET, Front and Rear Bumper  
(Con't)**

71-73	Vega (Sta. Wag., Panel)	3984043	L.H.	3.75	BRACKET ASSY., rear bumper face bar outer
71-73	Vega (Sed., Cpe.)	3982076	1	2.30	BRACKET ASSY., rear bumper face bar center
71-73	Vega (Sta. Wag., Panel)	3984041	1	5.25	BRACKET ASSY., rear bumper face bar center
71-73	Vega (Sed., Cpe.)	3982078	R.H.	5.15	BRACKET ASSY., rear bumper face bar outer
71-73	Vega (Sta. Wag., Panel)	3984044	R.H.	3.75	BRACKET ASSY., rear bumper face bar outer
73	Nova	345503	L.H.	19.65	BRACKET ASSY., rear
73	Nova	345504	R.H.	19.60	BRACKET ASSY., rear
74-75	Camaro	339405	L.H.	2.75	BRACKET ASSY., frt. face bar outer
74-75	Camaro	339406	R.H.	2.75	BRACKET ASSY., frt. face bar outer
74-75	Camaro	337449	1	4.20	BRACKET ASSY., frt. face bar center
74-75	Camaro	339411	L.H.	12.05	BRACKET ASSY., frt. spring
74-75	Camaro	339412	R.H.	12.05	BRACKET ASSY., frt. spring
74-75	Camaro	337491	L.H.	4.20	BRACKET ASSY., rr. face bar outer
74-75	Camaro	337492	R.H.	4.20	BRACKET ASSY., rr. face bar outer
74-75	Pass. (exc. Sta. Wag.)	335997	L.H.	7.65	BRACKET ASSY., rr. face bar reinf.
74-75	Pass. (exc. Sta. Wag.)	335998	R.H.	7.65	BRACKET ASSY., rr. face bar reinf.
74-75	Pass. (exc. Sta. Wag.)	342340	1	1.10	BRACKET ASSY., rr. bumper face bar reinforcement center
74-75	Vega	336551	L.H.	3.90	BRACKET ASSY., front bumper outer
74-75	Vega	336552	R.H.	3.90	BRACKET ASSY., frt. bumper outer
74-75	Vega	336588	2	3.05	BRACKET ASSY., rear bumper face bar
74-75	Vega	336546	1	4.50	BRACKET ASSY., frt. bumper center
74-75	Vega	336557	L.H.	6.35	BRACKET ASSY., frt. bumper frame
74-75	Vega	336558	R.H.	6.35	BRACKET ASSY., frt. bumper frame
75	Monza (exc. Towne Cpe.)	346509	L.H.	8.15	BRACKET ASSY., front bumper shk. abs.
75	Monza (exc. Towne Cpe.)	346510	R.H.	6.90	BRACKET ASSY., front bumper shk. abs.
75	Monza (exc. Towne Cpe.)	346507	L.H.	14.40	BRACKET ASSY., frt. bumper impact bar
75	Monza (exc. Towne Cpe.)	346508	R.H.	14.40	BRACKET ASSY., frt. bumper impact bar
75	Monza (exc. Towne Cpe.)	346523	L.H.	4.70	BRACKET ASSY., rr. bumper impact bar
75	Monza (exc. Towne Cpe.)	346524	R.H.	4.70	BRACKET ASSY., rr. bumper impact bar
75	Monza (Towne Cpe.)	365210	R.H.	4.70	BRACKET, rr. bpr. face bar
75	Monza (Towne Cpe.)	365209	L.H.	4.70	BRACKET, rr. bpr. face bar
69	Camaro (exc. spec. frt. bumper)	3949621	L.H.	2.50	EXTENSION ASSY., left frt. inner bracket
69	Camaro (exc. spec. frt. bumper)	3949622	R.H.	2.50	EXTENSION ASSY., right frt. inner bracket
69	Camaro w/spec. frt. bumper	3949671	L.H.	3.95	EXTENSION ASSY., left frt. inner bracket
69	Camaro w/spec. frt. bumper	3949672	R.H.	3.95	EXTENSION ASSY., right frt. inner bracket
74-75	Nova	337474	1	1.85	GUSSET, frt. face bar (center)
74	Nova	337475	L.H.	1.85	GUSSET, frt. face bar
74	Nova	337476	R.H.	1.85	GUSSET, frt. face bar

**7.874 BOLT— CLIP ASSY.— NUT— PLATE— SCREW ASSY.— WASHER, Front or Rear Bumper Bar Mounting and Attaching**

62-66	All	3716509	A.R.	.43	front and rear, rad. grill and bpr. guard assy., rr. bumper and center face bar, rr. bumper outer face, front bumper outer face bar to bracket (st. steel $\frac{7}{16}$ "— 14 x $1\frac{1}{4}$ ")
65-71	Pass., Chevy, Chevelle,				
72	Pass.	9425343	A.R.	.16	front bumper center and outer face
65-68	Chevelle, Camaro (8 cyl.),				
67-68	Chevy	3779940	1	.21	rear bumper outer brace, R.H. ( $\frac{3}{8}$ "— 16 x $3\frac{3}{8}$ ") (hex. hd. cad.)
67-69	Camaro, bar ( $\frac{7}{16}$ "— 14 x 1)— (8.903)				
68-69	Pass.,				
70	Pass. (Sta. Wag.),				
71-72	Camaro				front bumper outer face, to center face,
71-75	Vega, Monza				bumper face bar,
74	Chevelle,				
73-75	Pass., Camaro, Nova	3774573	A.R.	.39	( $\frac{3}{8}$ "— 16 x $1\frac{13}{16}$ ") front and rear face bar
66	Pass.	3779976	A.R.	.24	rear bumper support "U" shape ( $\frac{7}{16}$ "— 14) valance panel to bracket
68	Camaro	3929905	2	.24	front bumper face bar, to outer bracket
69-70	Chevelle (exc. Sta. Wag., El Camino),				
70	Pass.,				
71-72	Pass. (Sta. Wag.),				
71	Chevelle,				

**FRAME—SPRINGS—BUMPER**

**7.874 BOLT— CLIP ASSY.— NUT— PLATE— SCREW ASSY.— WASHER, Front or Rear Bumper Bar Mounting and Attaching (Con't)**

72	Chevelle (exc. Sta. Wag., El Camino),					
73	Chevelle (S.S.),					
73	Monte Carlo w/Touring Option	9425080	2	.38	rear bumper brace (7/16"— 14 x 1 1/2")	.....
69-70	Pass. (exc. Sta. Wag.),					
70-71	Chevelle (exc. Sta. Wag., El Camino)	3957278	1	.36	hex. cone pointed (7/16" 14 x 2 1/4") (280-M PC)	.....
70-72	Chevelle (Sta. Wag.)	3926435	2	.18	front bumper to frame (1/2"— 13 x 1)	.....
74-75	Chevelle (Sta. Wag.)	492746	6	.36	rear bumper impact bar inner and center	.....
74	Chevelle				frt. & rr. bumper shock absorber bracket,	.....
74-75	Camaro	493001	4	.31	frt. bumper outer bracket	.....
74-75	Camaro	492975	4	.57	frt. bumper spring bracket	.....
74-75	Camaro	9414511	2	.21	CLIP ASSY., frt. bumper spring bracket	.....
64-67	Chevelle,					
65-66	Pass.	3841008	2	.46	NUT, frt. bumper rr. brkt. to frame	.....
72	Malibu (S.S.)				rr. bumper upper face bar emblem,	.....
72	Pass.	3866846	1	.12	NUT, w/washer, front and rear bumper pad	.....
73-75	All	1494254	2	.39	NUT, frt. fender to rocker panel (3/8"— 16 x 2 1/32")	.....
74-75	Pass., Chevelle				NUT, bumper face bar,	.....
68-72	Chevelle (Sta. Wag.) (El Camino),					
74	Vega	3930109	1	.12	rear bumper reinf. (7/16"— 14 x 7/8")	.....
73	Laguna	331769	2	.88	PLATE, left, frt. bumper face bar supt. anc.	.....
73	Laguna	331770	2	.88	PLATE, right frt. bumper face bar supt. anc.	.....
73	Camaro	327580	1	.16	SCREW ASSY., rr. bumper inr. bracket to body	.....
72	Chevelle (exc. Sta. Wag., El Camino)	3954735	A.R.	.13	WASHER (15/32" I.D. x 7/8" O.D. x 1/16" thk.)	.....
74	Vega	3894057	8	.18	WASHER, rr. bumper face bar spring	.....
75	Camaro	492370	4	.16	WASHER, frt. bpr. spring brkt. (1/2" I.D. x 1 1/4" O.D. x 1/8")	.....

**7.875 PAD ASSY.— SUPPORT— SCREW, Rear Bumper**

66	Pass. (Sta. Wag.) (9 Pass.)	3874569	2	2.05	rear bumper	.....
67-68	Pass. (Sta. Wag.) (9 Pass.)	3899524	2	.79	rear bumper	.....
69-70	Pass. (Sta. Wag.)	3950730	1	17.40	rear bumper, center, step	.....
69-70	Pass. (Sta. Wag.)	3950731	L.H.	27.75	rear bumper, left step	.....
69-70	Pass. (Sta. Wag.)	3950732	R.H.	8.15	rear bumper, right step	.....
69-72	Chevelle (Sta. Wag.)	8758326	1	10.75	rear bumper, rear c/bar to bumper step	.....
69-72	Chevelle (Sta. Wag.)	8758327	R.H.	4.40	rear bumper, right c/bar to bumper step filler	.....
69-72	Chevelle (Sta. Wag.)	8758328	L.H.	10.50	rear bumper, left c/bar to bumper step filler	.....
67-68	Pass. (Sta. Wag.) (9 Pass.)	3938981	2	5.15	SUPPORT, step pad (Note 1)	.....
<i>NOTE 1 Consists of 1-pad, 1-support assy., 2-bolts, and 2-lockwashers.</i>						
69	Sta. Wag. w/dual t/gate,					
70	Pass. (Sta. Wag.)	9431918	A.R.	.11	SCREW, bumper step pad (8— 18 x 1/2")	.....
69-72	Chevelle (Sta. Wag.)	8761885	2	.14	SCREW, c/bar to bumper step pad (8-18 x 1 1/4")	.....



# CHEVROLET CHASSIS GROUP 8.000



## FRONT END SHEET METAL — HEATER

### ALPHABETICAL INDEX

<b>A</b>			
ACTUATOR ASSY., Heater Vacuum			
Actuating .....	8.850	CLAMP, Hood Lock Release .....	8.075
ADHESIVE .....	8.800	CLAMP, Hood Upper Lock Plate .....	8.085
ANTI, Front Fender and Skirt .....	8.154	CLIP, Auto .....	8.820
ANTI, Universal .....	8.205	CLIP, Body Sill Moulding .....	8.309
ARM, Heater .....	8.852	CLIP, Ducted Hood .....	8.036
		CLIP, Front Fender and Skirt .....	8.143
		CLIP, Front Fender and Skirt .....	8.154
		CLIP, Front Fender Moulding .....	8.133
		CLIP, Front Fender .....	8.147
		CLIP, Heater (See Group 1.166 for Clamps) .....	8.846
		CLIP, Heater .....	8.852
		CLIP, Hood Lock Release .....	8.075
		CLIP, Hood Lock-Lower .....	8.080
		CLIP, Hood Panel .....	8.010
		CLIP, Hood Panel .....	8.021
		CLIP, Hood Upper Lock Plate .....	8.085
		CLIP, Wheel Cover Panel Rubber .....	8.177
		COMPASS UNIT, Auto .....	8.873
		CONTAINER, Litter, Tissue .....	8.891
		CONTROL ASSY., Heater .....	8.849
		CONTROL ASSY., Hood Lock Release .....	8.075
		CORE, Heater .....	8.854
		COVER, Auto .....	8.820
		COVER, Heater .....	8.852
		COVER, Hood Lock-Lower .....	8.080
		COVER, Hot Water .....	8.845
		COVER UNIT, Rear Wheel (Wheel Shield) .....	8.175
		<b>D</b>	
		DECAL, Front Fender (See Group 8.147 for Front Fender Mouldings which include Series Designations) .....	8.132
		DECAL, Front Fender .....	8.147
		DECAL, Hood (Also See Group 1.303) .....	8.055
		DIAL, Heater .....	8.852
		DISPENSER UNIT, Litter, Tissue .....	8.891
		<b>E</b>	
		EMBLEM, Front Fender .....	8.147
		EMBLEM, Hood (Also See Group 1.303) .....	8.055
		ESCUTCHEON, Heater .....	8.852
		EXTENSION, Front Fender .....	8.131
		EXTENSION, Front Fender .....	8.153
		EXTENSION, Front .....	8.130
		EXTENSION, Hood Lock Release .....	8.075
		EXTENSION, Rear Fender and Door .....	8.203
		<b>F</b>	
		FAN ASSY., Heater .....	8.857
		FASTENER, Front Fender and Skirt .....	8.154
		FASTENER, Wheel Opening Cover .....	8.179
		FENDER, Front .....	8.130
<b>B</b>			
BAFFLE, Heater .....	8.854		
BASE ASSY., Auto .....	8.820		
BEZEL, Front Fender .....	8.147		
BEZEL, Heater .....	8.852		
BEZEL, Hood (Also See Group 1.303) .....	8.055		
BLOWER ASSY., Heater .....	8.857		
BOARD UNIT, Heater .....	8.852		
BOLT ASSY., Heater and Defroster Motor .....	8.856		
BOLT, Auto .....	8.820		
BOLT, Front Fender and Skirt .....	8.143		
BOLT, Hood Lock-Lower .....	8.080		
BOLT, Hood Moulding and Hinge Attaching ..	8.016		
BOLT, Hood Panel .....	8.015		
BOLT, Hood Upper Lock Plate .....	8.085		
BRACE ASSY., Front Fender Skirt .....	8.155		
BRACE ASSY., Hood Panel .....	8.015		
BRACE, Front Fender .....	8.141		
BRACE, Front Fender .....	8.153		
BRACKET ASSY., Wheel Cover Panel .....	8.176		
BRACKET, Auto .....	8.820		
BRACKET, Front Fender .....	8.141		
BRACKET, Front Fender .....	8.153		
BRACKET, Heater .....	8.852		
BRACKET, Hot Water .....	8.845		
BRACKET, Wheel Opening Cover .....	8.179		
BUMPER, Auto .....	8.820		
BUMPER, Hood .....	8.024		
BUMPER, Wheel Cover Panel .....	8.176		
BUSHING, Heater .....	8.852		
<b>C</b>			
CABLE ASSY., Ducted Hood .....	8.036		
CABLE ASSY., Hood Lock Release .....	8.075		
CAP, Heater .....	8.852		
CAP, Heater .....	8.866		
CAP UNIT, Body Sill .....	8.304		
CAP UNIT, Front Fender (See Group 8.147 for Front Fender Mouldings which include Series Designations) .....	8.132		
CASE ASSY., Heater .....	8.857		
CASE, Heater .....	8.854		
CATCH, Hood Lock-Lower .....	8.080		
CATCH, Hood Lock-Upper .....	8.083		
CLAMP, Auto .....	8.820		
CLAMP, Heater .....	8.854		

## ALPHABETICAL INDEX

FILLER, Front Fender..... 8.131  
 FILLER, Front Fender..... 8.153  
 FILTER, Heater..... 8.852  
 FITTING ASSY., Heater..... 8.866  
 FLAG, Wheel and Tire..... 8.821  
 FLARE ASSY., Wheel and Tire..... 8.821

### G

GASKET, Ducted Hood..... 8.036  
 GASKET, Heater..... 8.854  
 GASKET, Hot Water..... 8.845  
 GRILLE, Hood (Also See Group 1.303)..... 8.055  
 GROMMET, Hood Lock Release..... 8.075  
 GUIDE, Heater..... 8.852

### H

HARNESS ASSY., Heater..... 8.852  
 HEATER ASSY., Hot Water..... 8.845  
 HINGE, Hood Panel..... 8.015  
 HOSE, Heater (See Group 1.166 for Clamps)..... 8.846

### I

INSERT, Front Fender..... 8.147  
 INSERT, Heater..... 8.852  
 INSERT UNIT, Hood (Also See Group 1.303)..... 8.055  
 INSULATOR, Hood Panel..... 8.021

### J

JACK, Auto..... 8.820

### K

KNOB, Heater..... 8.852

### L

LAMP, Underhood..... 8.890  
 LATCH ASSY., Hood Lock-Lower..... 8.080  
 LATCH ASSY., Hood Lock-Upper..... 8.083  
 LENS, Heater..... 8.852  
 LETTER UNIT, Front Fender..... 8.147  
 LETTER UNIT, Hood (Also See Group 1.303)..... 8.055  
 LEVER, Heater..... 8.852  
 LEVER, Wheel Opening Cover..... 8.179  
 LINK, Hood Lock-Lower..... 8.080

### M

MOTOR, Heater and Evaporator..... 8.855  
 MOULDING, Front Fender (See Group 8.147  
 for Front Fender Mouldings which  
 include Series Designations)..... 8.132  
 MOULDING UNIT, Body Sill..... 8.304  
 MOULDING UNIT, Wheel Cover Panel..... 8.176

### N

NIPPLE, Heater..... 8.866  
 NUT ASSY., Hood Lock-Upper..... 8.083  
 NUT, Auto..... 8.820  
 NUT, Body Sill Moulding..... 8.309  
 NUT, Front Fender and Skirt..... 8.143  
 NUT, Front Fender Moulding..... 8.133  
 NUT, Front Fender..... 8.147  
 NUT, Heater..... 8.852  
 NUT, Heater..... 8.857  
 NUT, Hood..... 8.024  
 NUT, Hood Moulding and Hinge Attaching... 8.016  
 NUT, Hood Panel..... 8.015  
 NUT, Hood (Top) Moulding and Ornament.... 8.056  
 NUT, Hot Water..... 8.845

### O

ORNAMENT, Front Fender..... 8.147  
 ORNAMENT, Hood (Also See Group 1.303)... 8.055

### P

PAD, Auto..... 8.820  
 PANEL ASSY., Front..... 8.130  
 PANEL, Front Fender (See Group 8.147 for  
 Front Fender Mouldings which include  
 Series Designations)..... 8.132  
 PANEL, Front Fender..... 8.131  
 PANEL, Front Fender..... 8.153  
 PANEL, Hood Top..... 8.000  
 PIN, Ducted Hood..... 8.036  
 PIN, Heater..... 8.852  
 PIN, Hood Lock-Lower..... 8.080  
 PIN, Hood Moulding and Hinge Attaching..... 8.016  
 PIPE ASSY., Heater (See Group 1.166 for  
 Clamps)..... 8.846  
 PLATE ASSY., Hood Lock-Upper..... 8.083  
 PLATE, Ducted Hood..... 8.036  
 PLATE, Front Fender (See Group 8.147 for  
 Front Fender Mouldings which include  
 Series Designations)..... 8.132  
 PLATE, Front Fender..... 8.147  
 PLATE, Front Fender..... 8.153  
 PLATE, Heater..... 8.849  
 PLATE, Heater..... 8.852  
 PLATE, Hood (Also See Group 1.303)..... 8.055  
 PLATE, Hood Lock-Lower..... 8.080  
 PLATE, Hood Panel..... 8.015

### R

RAIL, Front Fender..... 8.153  
 REINFORCEMENT, Front Fender Skirt..... 8.155  
 REINFORCEMENT, Front Fender..... 8.141  
 REINFORCEMENT, Front Fender..... 8.153  
 REINFORCEMENT, Hood Lock-Lower..... 8.080  
 REINFORCEMENT, Hood Panel..... 8.015  
 REPAIR UNIT..... 8.800  
 RESISTOR ASSY., Heater and Evaporator..... 8.855  
 RETAINER, Auto..... 8.820  
 RETAINER, Body Sill Moulding..... 8.309  
 RETAINER, Front Fender and Skirt..... 8.154  
 RETAINER, Front Fender Moulding..... 8.133  
 RETAINER, Front Fender..... 8.153  
 RETAINER, Heater (See Group 1.166 for  
 Clamps)..... 8.846  
 RETAINER, Heater..... 8.852  
 RETAINER, Heater..... 8.857  
 RETAINER, Heater..... 8.866  
 RETAINER, Hood (Also See Group 1.303)..... 8.055  
 RETAINER, Hood Lock-Lower..... 8.080  
 RETAINER, Hood Panel..... 8.021

## ALPHABETICAL INDEX

RETAINER, Hood Upper Lock Plate..... 8.085  
 RETAINER, Wheel Cover Panel Rubber..... 8.177  
 RETAINER, Wheel Cover Panel..... 8.176  
 RIVET, Litter, Tissue..... 8.891  
 ROD, Hood Panel..... 8.015  
 ROLLER, Heater..... 8.852

### S

SCOOP, Hood Top..... 8.000  
 SCREEN, Hood (Also See Group 1.303)..... 8.055  
 SCREW, Body Sill Moulding..... 8.309  
 SCREW, Front Fender and Skirt..... 8.143  
 SCREW, Hood Lock-Lower..... 8.080  
 SCREW, Hood Moulding and Hinge  
     Attaching..... 8.016  
 SCREW, Hood..... 8.024  
 SCREW, Wheel Cover Panel Rubber..... 8.177  
 SCREW, Wheel Cover Panel..... 8.176  
 SEAL, Front Fender and Skirt..... 8.154  
 SEAL, Heater..... 8.854  
 SEAL, Heater..... 8.857  
 SEAL, Hood (Also See Group 1.303)..... 8.055  
 SEAL, Hood Panel..... 8.010  
 SEAL, Wheel Cover Panel Rubber..... 8.177  
 SEAT ASSY., Hood Upper Lock Plate..... 8.085  
 SHAFT AND LEVER ASSY., Heater..... 8.854  
 SHAFT, Heater Air Deflector..... 8.858  
 SHAFT, Heater..... 8.852  
 SHAFT, Hot Water..... 8.845  
 SHIELD, Front Fender and Skirt..... 8.154  
 SHIELD, Front Fender..... 8.153  
 SHIM, Front Fender..... 8.153  
 SHIM, Hood Moulding and Hinge Attaching.. 8.016  
 SHROUD AND BAFFLE ASSY., Heater..... 8.854  
 SKIRT, Front Fender..... 8.153  
 SLEEVE, Auto..... 8.820  
 SPACER, Front Fender and Skirt..... 8.154  
 SPACER, Wheel Cover Panel..... 8.176  
 SPRING, Heater..... 8.852  
 SPRING, Hood (Also See Group 1.303)..... 8.055  
 SPRING, Hood Hinge..... 8.013  
 SPRING, Hood Lock-Upper..... 8.083  
 SPRING, Hood Upper Lock Plate..... 8.085  
 SQUEAK, Front Fender and Skirt..... 8.154  
 SQUEAK, Universal..... 8.205  
 STOP ASSY., Auto..... 8.820  
 STRIKER, Hood Lock-Lower..... 8.080  
 STRIPE, Front Fender (See Group 8.147 for  
     Front Fender Mouldings which include  
     Series Designations)..... 8.132  
 STRIPE, Hood (Also See Group 1.303)..... 8.055  
 STRIP, Hood Panel..... 8.021  
 STUD, Ducted Hood..... 8.036  
 STUD, Front Fender Moulding..... 8.133  
 SUPPORT, Auto..... 8.820  
 SUPPORT, Front Fender..... 8.141  
 SUPPORT, Front Fender..... 8.153  
 SUPPORT, Heater..... 8.852  
 SUPPORT, Hood Lock-Lower..... 8.080  
 SWITCH ASSY., Heater Vacuum Actuating... 8.850  
 SWITCH ASSY., Heater..... 8.852

### T

TAPE, Front Fender (See Group 8.147 for  
     Front Fender Mouldings which include  
     Series Designations)..... 8.132  
 TAPE, Hood (Also See Group 1.303)..... 8.055  
 TRANSDUCER, Heater..... 8.852  
 TRANSFER, Front Fender (See Group 8.147  
     for Front Fender Mouldings which  
     include Series Designations)..... 8.132  
 TRANSFER, Hood (Also See Group 1.303).... 8.055  
 TUBE, Hood (Also See Group 1.303)..... 8.055

### V

VALVE ASSY., Heater Vacuum Actuating..... 8.850  
 VALVE ASSY., Heater..... 8.866  
 VALVE ASSY., Hot Water..... 8.845  
 VALVE, Heater Air Deflector..... 8.858

### W

WARMER UNIT, Hot Water..... 8.845  
 WASHER, Front Fender and Skirt..... 8.143  
 WASHER, Front Fender and Skirt..... 8.154  
 WASHER, Heater..... 8.852  
 WASHER, Hood Moulding and Hinge  
     Attaching..... 8.016  
 WASHER, Rear Fender Attaching..... 8.206  
 WIRE, Hot Water..... 8.845  
 WRENCH, Wheel and Tire..... 8.821

### Y

YOKE, Heater..... 8.854





**SHEET METAL—HEATER**

**8.000 PANEL—SCOOP, Hood Top**

**PASSENGER**

65-66	Pass. ....	3876590	1	126.00	
67	Pass. (exc. 427) .....	3885974	1	126.00	
68	Pass. (exc. S.S. 427) .....	3907647	1	126.00	
69	Pass. ....	3926836	1	126.00	(Note 1) .....
<i>NOTE 1: When 3926836 is used on Biscayne or Bel Air models it will be necessary to add 3953674 hood pnl. letter unit.</i>					
70	Pass. ....	3945690	1	126.00	
71-72	Pass. ....	6270168	1	126.00	(Note 2) .....
73-74	Pass. ....	6273735	1	126.00	
75	Bel Air, Impala .....	343525	1	126.00	
75	Caprice .....	342321	1	126.00	
<i>NOTE 2: Also use (1) 3738054 clevis pin &amp; (1) 1351769 retainer to attach hood lock safety catch.</i>					

**CHEVELLE**

64	Chevelle .....	3854140	1	122.00	
65	Chevelle .....	3856895	1	122.00	
66	Chevelle (exc. S.S.) .....	3896557	1	122.00	
66	Chevelle (S.S.) .....	3896559	1	122.00	
67	Chevelle (exc. S.S.) .....	3885987	1	122.00	
67	Chevelle (S.S.) .....	3897504	1	122.00	
68	Chevelle (exc. S.S.) .....	3940657	1	122.00	
68	Chevelle (S.S.) .....	3940660	1	122.00	(Note 2) .....
<i>NOTE 2 When used in place of 3915452 Hinge Assys. 3926829-30 to Hood Hinge Springs 3864680 must be used.</i>					
69	Chevelle (exc. 396) .....	3940631	1	122.00	
69	Chevelle (396) .....	3940632	1	122.00	
70-72	Chevelle (exc. Monte Carlo, S.S.) .....	3977767	1	122.00	
70-72	Monte Carlo .....	3977768	1	126.00	
70-72	Chevelle (S.S.) .....	3987022	1	122.00	
71-72	Chevelle w/Ducted Hood Air System .....	3987028	1	213.00	
73-75	Chevelle (exc. Monte Carlo) .....	3992665	1	126.00	
73-75	Monte Carlo .....	3987065	1	126.00	

**CAMARO**

67-69	Camaro (exc. 350, 396, spec. duct hood) .....	3938617	1	124.00	(Note 3) .....
<i>NOTE 3 When used in place of 3886617 rework to relocate hood insl. hole located near hood hge.</i>					
67	Camaro (350, 396), .....				
68-69	Camaro (350, 396) (exc. spec. duct hood) .....	3938619	1	124.00	
69	Camaro w/spec. ducted hood ..	3949708	1	144.00	
70-75	Camaro .....	3962967	1	124.00	

**CHEVY—NOVA**

62-65	Chevy .....	3872697	1	113.00	
66-67	Chevy .....	3872998	1	113.00	
68-72	Chevy (350, 396, 4BC) .....	3974591	1	113.00	
68-69	Chevy (exc. 350, 396 4BC), .....				
70-72	Nova (exc. 4BC) .....	3974588	1	113.00	
73-74	Nova .....	341058	1	113.00	
75	Nova .....	344301	1	113.00	

**VEGA—MONZA**

71-75	Vega (exc. Towne Cpe.) .....	9699499	1	81.75	
75	Monza (exc. Towne Cpe.) (140) ..	1744017	1	86.75	
75	Monza (exc. Towne Cpe.) (262) ..	1665811	1	85.50	
75	Monza (Towne Cpe.) .....	1690660	1	85.50	
75	Monza (Hvy. Duty Service) .....	3965797	1	162.00	<b>PANEL ASSY., hood (includes hinges) .....</b>
75	Monza (exc. Towne Cpe.) (Hvy. Duty Service) .....	3965799	1	65.75	<b>SCOOP, hood .....</b>

**8.010 CLIP—SEAL, Hood Panel**

70	Chevelle (396, 454) (exc. Monte Carlo) .....	3950610	6	.11	panel weather strip— (8.154) .....
70-75	Camaro .....	3974561	L.H.	.73	<b>SEAL, hood shroud upper to fender lower shroud, left .....</b>
70-75	Camaro .....	3974562	R.H.	.73	<b>SEAL, hood shroud upper to fender lower shroud, right .....</b>

**8.013 SPRING, Hood Hinge**

63-64	Chevy, Chevelle,				
-------	------------------	--	--	--	--

**SHEET METAL—HEATER-**

**8.013 SPRING, Hood Hinge (Con't)**

65	Chevelle,				
65-66	Pass.,				
66-67	Chevelle (S.S.),				
67-69	Camaro (350, 396),				
70	Pass.,				
71	Chevelle (454),				
71	Monte Carlo,				
72	Chevelle (S.S., Hvy. Chevy),				
72	Monte Carlo, El Camino				
	(Custom) . . . . .	<b>3848272</b>	2	2.20	(8 <sup>25</sup> / <sub>64</sub> " free length— 27 <sup>3</sup> / <sub>4</sub> " coils) . . . . .
67	Pass.,				
69	Pass.,				
70	Monte Carlo,				
70-75	Camaro . . . . .	<b>3907626</b>	2	2.30	
65	Chevy,				
66-67	Chevelle (exc. S.S.),				
68	Chevelle (2nd design),				
68	Pass.,				
69-72	Chevelle (exc. Monte Carlo, S.S.				
	Hvy. Chevy) . . . . .	<b>3864680</b>	2	1.85	(8 <sup>13</sup> / <sub>32</sub> " . . . . .
66-67	Chevy,				
67-69	Camaro (exc. 350, 396),				
71-74	Nova,				
73-75	Pass., Chevelle . . . . .	<b>409025</b>	2	2.15	

**8.015 HINGE— BOLT— BRACE ASSY.— PLATE— REINFORCEMENT— ROD— NUT, Hood Panel**

66-67	Chevy,				
67-69	Camaro,				
65-67	Pass., Chevelle . . . . .	<b>3910667</b>	L.H.	8.65	hood panel . . . . .
66-67	Chevy,				
67-69	Camaro,				
65-67	Pass., Chevelle . . . . .	<b>3910668</b>	R.H.	8.65	hood panel . . . . .
71-75	Vega . . . . .	<b>9687774</b>	L.H.	3.05	hood side . . . . .
71-75	Vega . . . . .	<b>9687773</b>	R.H.	3.05	hood side . . . . .
71-75	Vega . . . . .	<b>9866269</b>	L.H.	2.75	body side . . . . .
71-75	Vega . . . . .	<b>9866268</b>	R.H.	2.75	body side . . . . .
68	Pass., Chevelle,				
68-70	Chevy . . . . .	<b>3926829</b>	L.H.	10.80	HINGE ASSY., hood (Note 1) . . . . .
68-70	Chevy,				
68	Pass., Chevelle . . . . .	<b>3926830</b>	R.H.	10.80	HINGE ASSY., hood (Note 1) . . . . .
	<i>NOTE 1: It may be necessary to rework by elongating rear slot - 1/2" rearward.</i>				
69	Pass., Chevelle . . . . .	<b>3949201</b>	L.H.	10.80	HINGE ASSY., hood . . . . .
69	Pass., Chevelle . . . . .	<b>3949202</b>	R.H.	10.80	HINGE ASSY., hood . . . . .
62	Chevy . . . . .	<b>3793527</b>	L.H.	10.80	HINGE ASSY., hood . . . . .
62	Chevy . . . . .	<b>3793528</b>	R.H.	10.80	HINGE ASSY., hood . . . . .
63-65	Chevy,				
64	Chevelle . . . . .	<b>3864681</b>	L.H.	10.80	HINGE ASSY., hood . . . . .
63-65	Chevy,				
64	Chevelle . . . . .	<b>3864682</b>	R.H.	10.80	HINGE ASSY., hood . . . . .
70	Pass.,				
70-72	Chevelle . . . . .	<b>3976675</b>	L.H.	10.80	HINGE ASSY. . . . .
70	Pass.,				
70-72	Chevelle . . . . .	<b>3976676</b>	R.H.	10.80	HINGE ASSY. . . . .
73-75	Chevelle . . . . .	<b>325213</b>	L.H.	13.45	HINGE ASSY., left . . . . .
73-75	Chevelle . . . . .	<b>325214</b>	R.H.	13.45	HINGE ASSY., right . . . . .
70-75	Camaro . . . . .	<b>3990431</b>	L.H.	10.80	HINGE ASSY. . . . .
70-75	Camaro . . . . .	<b>3990432</b>	R.H.	10.80	HINGE ASSY. . . . .
71-75	Pass. . . . .	<b>339275</b>	L.H.	11.20	HINGE ASSY. . . . .
71-75	Pass. . . . .	<b>339276</b>	R.H.	11.20	HINGE ASSY. . . . .
71-75	Nova . . . . .	<b>3926829</b>	L.H.	10.80	HINGE ASSY. . . . .
71-75	Nova . . . . .	<b>3926830</b>	R.H.	10.80	HINGE ASSY. . . . .
75	Vega (Hatchback) . . . . .	<b>1651776</b>	R.H.	4.05	HINGE ASSY., hood . . . . .
75	Vega (Hatchback) . . . . .	<b>1651777</b>	L.H.	4.05	HINGE ASSY., hood . . . . .
70	Pass.,				
70-72	Chevelle . . . . .	<b>328946</b>	2	.33	BOLT (7/16"— 14 x 2 <sup>3</sup> / <sub>4</sub> ") (280M) . . . . .
71-75	Pass. . . . .	<b>3995195</b>	2	.27	BOLT . . . . .
73-75	All . . . . .	<b>3975417</b>	4	.27	PLATE, hood hinge reinforcement anchor . . . . .
73	Camaro (R.S.) . . . . .	<b>333765</b>	L.H.	1.35	BRACE ASSY., hood latch support . . . . .
					reinforcement to radiator, diagonal . . . . .
73	Camaro (R.S.) . . . . .	<b>333766</b>	R.H.	1.35	BRACE ASSY., hood latch support . . . . .
					reinforcement to radiator, diagonal . . . . .
73-75	Chevelle . . . . .	<b>328946</b>	2	.33	(7/16"— 14 x 2 <sup>3</sup> / <sub>4</sub> ")— (280M) . . . . .
70-75	Camaro . . . . .	<b>3973956</b>	1	.13	REINFORCEMENT, rear center bumper . . . . .
71-72	Pass. . . . .	<b>335970</b>	1	10.90	REINFORCEMENT UNIT, hood inner panel . . . . .

**SHEET METAL—HEATER**

**8.015 HINGE— BOLT— BRACE ASSY.— PLATE— REINFORCEMENT— ROD— NUT, Hood Panel (Con't)**

75	Vega (Notchback) . . . . .	1701991	1	3.80	ROD, hood hold open . . . . .
73-75	Vega . . . . .	9623098	1	3.80	ROD ASSY., hood hold open . . . . .
75	Vega (Hatchback) . . . . .	1653750	1	2.80	ROD ASSY., hood hold open . . . . .
71-72	Pass. . . . .	125258	2	.16	NUT, hex. jam (7/16" — 18) . . . . .

**8.016 BOLT— NUT— PIN— SCREW— SHIM— WASHER, Hood Moulding and Hinge Attaching**

64-65	Chevy . . . . .	3851272	7	.12	NUT, mold. nut "U" shape No. 10-24 . . . . .
71-75	Vega . . . . .	9847536	2	.18	NUT, hood hinge strap . . . . .
71-73	Vega, Monza . . . . .	9421540	2	.18	PIN, hood hinge— (8.934) . . . . .
71-75	All . . . . .	3986997	8	.22	SCREW (3/8" — 16 x 1") . . . . .
74-75	Nova . . . . .	3745380	A.R.	.22	SHIM, hood latch catch support . . . . .
71-73	Vega, Monza . . . . .	9865624	2	.21	WASHER, hood hinge . . . . .

**8.021 INSULATOR— CLIP— RETAINER— STRIP, Hood Panel**

62-65	Nova . . . . .	1477269	A.R.	8.10	hood panel, side and center (Note 1) . . . . .
	<i>NOTE 1 Cut to required shape.</i>				
64-65	Malibu . . . . .	3917412	A.R.	1.30	hood panel, front (repl. 3839680) . . . . .
64-65	Malibu . . . . .	3877234	1	1.45	hood panel, rear . . . . .
65-66	Impala . . . . .	3861564	1	6.50	
66-68	Chevy, Chevelle (exc. Concours),				
69	Chevy w/Custom interior,				
69	Malibu (exc. Spec. Spt. Sed.),				
70-74	Nova,				
70	Malibu, El Camino, Cust. (exc. 454) . . . . .	3917412	1	1.30	hood panel (Note 2) . . . . .
	<i>NOTE 2: Cut as required.</i>				
66-67	Chevy . . . . .	3917412	1	1.30	hood panel, rear . . . . .
67	Impala, Caprice,				
68	Concours,				
69	Concours, Estate Wag. . . . .	3897522		6.70	hood panel . . . . .
66-67	Chevelle (exc. Std., Deluxe) . . . . .	3877234	A.R.	1.45	hood panel . . . . .
68	Impala, Caprice . . . . .	3917442	1	6.25	hood panel . . . . .
67-69	Camaro (exc. 350, 396),				
69	Camaro w/spec. ducted hood . . . . .	3938631	1	6.30	hood panel . . . . .
69	Caprice,				
69	Impala (2-Dr.) w/spec. insulation (exc. Custom) . . . . .	3955080	1	6.30	hood panel . . . . .
70-72	Monte Carlo . . . . .	3968502	1	6.70	hood panel . . . . .
70	Pass. . . . .	3957268	1	6.70	hood panel . . . . .
70-72	Concours Estate Wagon . . . . .	3972913	1	6.70	hood panel . . . . .
70-75	Camaro . . . . .	3982036	1	6.30	hood panel . . . . .
71-73	Caprice, Kingswood (Estate Wag.) . . . . .	3986911	1	6.75	hood panel . . . . .
71-75	Vega . . . . .	3992923	1	5.80	
74	Pass. . . . .	342356	1	10.15	
73	Laguna Estate,				
74	Chevelle (exc. Monte Carlo) . . . . .	3999786	1	6.70	
73-75	Monte Carlo . . . . .	356479	1	5.55	
75	Pass. . . . .	343531	1	8.50	
75	Nova . . . . .	344597	1	7.55	
75	Chevelle (exc. Monte Carlo) . . . . .	356478	1	11.45	
75	HR (exc. 8 cyl.) . . . . .	349518	1	11.45	
75	HR (8 cyl.) . . . . .	358317	1	11.45	
71-72	Chevelle (S.S.) . . . . .	3950610	6	.11	CLIP, w/strip clip— (8.143) . . . . .
65-75	All . . . . .	3977775	A.R.	.14	RETAINER, insulator pad . . . . .
71-75	Vega, Monza . . . . .	9829415	1	2.70	STRIP, hood panel sealing— (12.801) . . . . .

**8.024 BUMPER— NUT— SCREW, Hood**

62-65	Chevy . . . . .	3790654	4	.22	hood panel, side . . . . .
64	Chevelle . . . . .	3837849	4	.22	hood panel side . . . . .
65-66	All . . . . .				hood lamp to hood, . . . . .
68	Camaro w/R.S. . . . .	3762180	A.R.	.22	hdlp. retainer cover stop . . . . .
63-73	All (exc. Vega, Monza),				
73-75	Camaro . . . . .	3792828	A.R.	.22	hood panel frt. (7/8" O.D. x 7/16") . . . . .
65	Chevelle,				
65-66	Pass. . . . .	3858702	4	.52	side . . . . .
67	Chevy . . . . .	3888234	2	.24	hood panel side . . . . .
67	Chevelle . . . . .	3897514	2	.24	hood panel side (1 1/8" high) . . . . .
67	Chevelle, Chevy, Camaro (exc. Sta. Wag.) . . . . .	4721222	2	.12	on lid (snap-on type)— (12.212) . . . . .
67	Chevelle, Camaro,				
67-69	Pass.,				
68-69	Chevy, Chevelle, Camaro,				

**SHEET METAL—HEATER**

**8.024 BUMPER— NUT— SCREW, Hood (Con't)**

70-75	All (exc. Camaro, Vega, Monza)	3919126 A.R.	.11	hood panel side
70-75	Camaro	3986595 4	.22	hood panel side
68	Pass.,			
68-69	Chevelle	3915418 2	.16	hood panel rear
68-69	Nomad, Greenbrier	4565671 2	.18	cover panel— (12.941)
71	Pass.	6270167 2	.52	hood panel rear
69-70	Pass.,			
70	Chevelle,			
71-72	Monte Carlo	3962891 2	.24	hood panel rear
72	Chevelle	6270167 1	.52	hood panel rear
72-74	Pass.,			
73-74	Chevelle (exc. Monte Carlo)	545998 2	.28	hood panel rear
71-72	Pass.	3995160 1	.18	hood panel front center
72	Chevelle (exc. Monte Carlo)	3915418 2	.16	hood panel rear
70-75	Camaro	3984072 2	.22	hood panel rear
70-75	Camaro	3973952 2	.22	hood panel rear outer
71-75	Vega	9834100 4	.23	
74-75	All (exc. Vega, Monza)	400765 2	.53	hood panel front
73-75	Chevelle	336310 A.R.	.16	hood panel rear
75	Monza (exc. Towne Cpe.)	1650950 4	.22	hood side
75	Vega, Monza	1671321 2		roof otr. pnl. to hood inr. pnl.— (10.716)
75	Vega (Notchback)	7724826 2	.24	hood frt.-emer.— (12.212)
75	Vega (Notchback)	4767559 2	.21	hood frt.— (12.212)
73-75	Pass., Chevelle	1376442 2	.28	NUT, hood panel front bumper
64-73	All (exc. Vega, Monza)	3996899 A.R.	.11	SCREW, hood front bumper ( <sup>5</sup> / <sub>16</sub> "— 18 x 1 <sup>3</sup> / <sub>8</sub> ") (Note 1)

*NOTE 1 Not to be substituted because of possible interference with voltage regulator.*

65-67	Pass. (8 cyl.)	133063 2		SCREW, head bumper ( <sup>1</sup> / <sub>4</sub> "— 20 x 2)— (8.906)
72-75	Camaro			SCREW, hood panel rear,
70	Monte Carlo,			
72-73	Nova	3963260 A.R.	.12	hood panel front ( <sup>5</sup> / <sub>16</sub> "— 18 x 1 <sup>3</sup> / <sub>4</sub> ")
70-75	Camaro	3973972 2	.11	SCREW, hood rear outer bumper ( <sup>7</sup> / <sub>16</sub> " x 14 x 1 <sup>1</sup> / <sub>2</sub> ")
71	Chevelle (exc. Monte Carlo)	3915418 2	.16	SCREW, hood panel rear

**8.036 CABLE ASSY.— CLIP— GASKET— PIN— PLATE— STUD, Ducted Hood**

70-72	Chevelle	3975342 2	4.65	hood hold down
70-72	Chevelle	3975343 2	.14	CLIP, cable
70-72	Chevelle	3975340 2	.22	GASKET, plate
70-72	Chevelle	3975341 2	1.75	PIN
70-72	Chevelle	3975339 2	3.25	PLATE
70-72	Chevelle	3975338 2	3.60	STUD

**8.055 EMBLEM— BEZEL— DECAL— GRILLE— INSERT UNIT— LETTER UNIT— ORNAMENT— PLATE— RETAINER— SCREEN— SEAL— SPRING— STRIPE— TAPE— TRANSFER— TUBE, Hood (Also See Group 1.303)**

68	Chevy	3919092 1	3.20	hood panel mldg. (Note 1)
<i>NOTE 1 Requires 2-9419764 nuts for installation.</i>				
62	Chevy	3792812 1	4.55	EMBLEM ASSY., hood
66	Nova	3878611 1	10.70	EMBLEM UNIT, hood panel
67	Chevy	3904655 1	2.85	EMBLEM UNIT, hood panel
69-72	Chevy	3953840 1	4.75	EMBLEM UNIT, hood panel mldg.
69	Camaro w/Spec. ducted hood	3961496 2	4.75	EMBLEM UNIT (302)
75	Nova (L.N.)	361006 1	3.55	EMBLEM UNIT, hood
68-72	Chevy (350, 396)	3927443 1	12.60	BEZEL, hood ornament
71-72	Nova (Rally Nova)	3998848 1	2.75	DECAL, hood panel (white)
71-72	Nova (Rally Nova)	3998846 1	2.75	DECAL, hood panel (black)
71-72	Chevelle (Hvy. Chevy)	6261943 1	5.25	DECAL, hood panel (white)
71-72	Chevelle (Hvy. Chevy)	6261944 1	5.25	DECAL, hood panel (black)
74	Nova w/Spirit of America	347532 1	6.60	DECAL, panel
68-69	Chevelle (S.S.)	3927551 L.H.	16.10	GRILLE, hood (Note 2)
68-69	Chevelle (S.S.)	3927552 R.H.	16.10	GRILLE, hood (Note 2)
<i>NOTE 2 Requires 5-9419764 nuts for installation.</i>				
66	Chevelle (S.S.)	3890969 2	8.35	INSERT UNIT, hood
64	Chevelle	3844091 1	3.80	LETTER UNIT, name (includes letters C-H-E-V-R-O-L-E-T and mtg. nuts)
65	Chevelle	3862174 1	6.95	LETTER UNIT, name (includes letters C-H-E-V-R-O-L-E-T, and mtg. nuts)
69	Impala, Caprice,			
69	Kingswood, Estate Wagon	3953674 1	4.85	LETTER UNIT, name, letters C-H-E-V-R-O-L-E-T, and nuts
71	Pass.	3988389 1	5.95	LETTER UNIT, rad. grille header panel (Chevrolet)
66	Chevelle (S.S.)	3890967 L.H.	15.25	ORNAMENT, hood

**SHEET METAL—HEATER**

**8.055 EMBLEM— BEZEL— DECAL— GRILLE— INSERT UNIT— LETTER UNIT— ORNAMENT— PLATE— RETAINER— SCREEN— SEAL— SPRING— STRIPE— TAPE— TRANSFER— TUBE, Hood (Also See Group 1.303)  
(Con't)**

66	Chevelle (S.S.)	3890968	R.H.	15.25	ORNAMENT, hood
67-72	Chevy	3927442	2	14.50	ORNAMENT, hood (350)
67	Chevelle (S.S.)	3904582	2	17.90	ORNAMENT UNIT, hood
68-69	Camaro (350, 396)	3930909	2	21.85	ORNAMENT UNIT, hood (Note 3)
<i>NOTE 3: Dealer will be required to drill 2 holes .3125 when using in place of 3930910.</i>					
71	Monte Carlo	6263030	1	14.55	ORNAMENT UNIT, hood (comp.)
71	Monte Carlo	3987001	1	5.70	ORNAMENT ASSY., hood
72	Monte Carlo	6263114	1	7.20	ORNAMENT UNIT, hood (complete)
68-69	Camaro (350, 396)	3927471	L.H.	3.35	PLATE, hood ornam. trim
68-69	Camaro (350, 396)	3927472	R.H.	3.35	PLATE, hood ornam. trim
70-72	Chevelle w/Ducted Hood	3968567	1	1.50	PLATE (cowl)
70-72	Chevelle w/Ducted Hood	3968568	1	1.50	PLATE (induction)
67	El Camino	3904588	1	3.25	PLATE UNIT, hood panel name
67	Chevelle (exc. El Camino)	3904589	1	2.65	PLATE UNIT, hood panel name
69	Biscayne, Bel Air,				
69	Brookwood, Townsman	3953689	1	3.50	PLATE UNIT, hood panel name
73	Nova	328740	1	2.85	PLATE UNIT, panel name (Nova)
74	Nova	6260837	1	2.85	PLATE UNIT, panel name (Nova)
69	Impala, Caprice,				
69	Kingswood, Estate Wag.	3941270	1	.26	RETAINER, hood panel letter
71	Pass.	3986948	1	.11	RETAINER, rad. grille header panel letter
68-69	Camaro (350, 396)	3927468	2	3.20	SCREEN, hood ornament
66	Chevelle (S.S.)	3907602	2	.55	SEAL, hood ornament
67-68	Chevy, Camaro (350, 396),				
69	Chevy, Camaro,				
70-72	Nova (350, 396)	3949698	2	.48	SEAL, hood ornament
71	Monte Carlo	3999797	1	.24	SPRING, ornament
74	Camaro w/Sport Striping	341057	1	63.75	STRIPE, hood panel (Z-28)
74	Camaro w/Spoilers, Sport				
	Striping	341091	1	12.90	STRIPE, rr. deck lid ext. (Z-28)— (12.182)
74	Camaro w/Sport Striping	341064	1	27.75	STRIPE, rr. deck lid (Z-28)— (12.182)
74-75	Nova w/Sport Striping	344375	L.H.	13.65	STRIPE, hood panel (black & gold) (Note 1)
74-75	Nova w/Sport Striping	344376	R.H.	13.65	STRIPE, hood panel (black & gold) (Note 1)
74-75	Nova w/Sport Striping	344377	L.H.	14.75	STRIPE, hood panel (gold & red) (Note 1)
74-75	Nova w/Sport Striping	344378	R.H.	14.75	STRIPE, hood panel (gold & red) (Note 1)
74	Pass. w/Spirit of America	349109	1	2.15	STRIPE, header panel accent
74	Nova w/Spirit of America	347523	L.H.	11.90	TAPE ASSY., hood (vinyl)
74	Nova w/Spirit of America	347524	R.H.	11.90	TAPE ASSY., hood (vinyl)
<i>NOTE 1: For rear deck lid stripe see Group 12.182</i>					
75	Vega (Cosworth)	1657536	1	13.60	TRANSFER, hood panel outer (gold met.)
74	Vega (Coupe)	1676744	1	24.65	TRANSFER, hood panel outer (Spirit of America)
67	Impala (S.S.) (427),				
68-69	Camaro (350, 396)	3903974	1	.16	TUBE, hood ornam. drain

**MOULDING, Hood Top-Side, Front, Rear**

63	Chevy	3793377	1	13.50	hood panel
64	Chevy	3848119	1	14.10	hood panel
64	Chevelle	3838493	1	9.60	hood panel
64	Chevelle (exc. 2-Dr. Std. Sta. Wag., El Camino)	3845890	1	9.50	hood panel crown
65	Chevy	3859175	1	14.65	hood panel
65	Chevelle	3859710	1	11.25	hood panel
68-72	Chevelle (exc. S.S.)	3936293	1	5.95	hood panel rear edge
68-69	Pass.	3936294	1	5.95	hood panel rear edge
70	Pass.	3955030	1	5.55	rear edge
71-74	Pass.	3986952	1	4.00	rear edge
70-72	Chevelle (S.S.)	3968501	1	5.35	rear edge
62-65	Chevy Deluxe	3792123	1	4.25	MOULDING UNIT, hood crown (Note 1)
70-75	Camaro	3998834	1	4.65	
73-75	Chevelle	3996996	1	5.20	rear edge
75	Pass.	343550	1	4.15	hood panel, rear edge
<i>NOTE 1 Consists of 1 moulding and 6 nuts.</i>					
65	Malibu	3865232	1	10.70	MOULDING UNIT, hood crown
66	Chevelle	3878608	1	3.05	MOULDING UNIT, hood crown
66	Chevy	3881472	1	8.30	MOULDING UNIT, hood panel
66	Chevelle	3886220	1	12.15	MOULDING UNIT, hood panel
65-66	Pass.	3871311	1	9.85	MOULDING UNIT, hood crown
67	Pass.	3904632	1	11.20	MOULDING UNIT, hood panel
67	Chevy	3904654	1	8.30	MOULDING UNIT, hood panel
67	Chevelle	3904587	1	8.30	MOULDING UNIT, hood panel
68-72	Nova	6263110	1	9.40	MOULDING UNIT

**SHEET METAL—HEATER**

**8.055 EMBLEM— BEZEL— DECAL— GRILLE— INSERT UNIT— LETTER UNIT—  
ORNAMENT— PLATE— RETAINER— SCREEN— SEAL— SPRING—  
STRIPE— TAPE— TRANSFER— TUBE, Hood (Also See Group 1.303)  
(Con't)**

70	Pass.	3970517	1	15.65	MOULDING UNIT
70	Monte Carlo	3974221	1	5.20	MOULDING UNIT, center
73-75	Nova	6258149	1	6.80	MOULDING UNIT, hood panel front
75	Nova (LN)	358193	1	5.60	MOULDING UNIT, hood panel front

**8.056 NUT, Hood (Top) Moulding and Ornament**

62-69	All	9419761 A.R.		.11	hood name and emblem— (8.921)
62-64	Chevy, Chevelle	9419763 A.R.		.11	front emblem (3/16")— (8.147)

**8.075 EXTENSION— CABLE ASSY.— CLAMP— CLIP— CONTROL ASSY.—  
GROMMET, Hood Lock Release**

70-72	Chevelle	3987017	1	.84	hood lock rel. lever
73-74	Chevelle	328919	1	2.90	CABLE ASSY., hood latch rel.
71-72	Pass.	9878996	1	.16	CLAMP, hood rel. cont.
71-72	Pass.	9878333	1	.11	CLAMP, hood rel. cont. conn.
71-74	Vega	9847535	2	.18	CLIP, hood latch rel. cont. cable frt.-cable to shroud
71-73	Vega	7783546	1	.14	CLIP, cable to handle
73-75	Chevelle	9654003 L.H.		.16	CLIP, hood latch release control
71-75	Pass.,				
73-74	Chevelle	9611970	1	5.50	CONTROL ASSY., hood latch rel. rear (w/white connector)
71-72	Pass.	6262344	1	2.90	CONTROL ASSY., hood latch rel., front
71-75	Vega	9840654	1	2.05	CONTROL ASSY.
73-75	Pass.	327116	1	3.25	CONTROL ASSY., hood latch rel. front
75	Chevelle	1695072	1	7.05	CONTROL ASSY., hood latch rel.
71-74	Pass.,				
73-74	Chevelle	9870128	1	.46	GROMMET, latch rel. cont. cable
71-75	Vega	9820314	1	.12	GROMMET, hood latch cont. cable
71-75	Vega	9840651	1	3.35	HANDLE ASSY., hood latch rel.

**8.080 CATCH— BOLT— CLIP— COVER— LATCH ASSY.— LINK— PIN— PLATE—  
REINFORCEMENT— RETAINER— SCREW— STRIKER— SUPPORT, Hood  
Lock— Lower**

63-64	Chevy	3792982	1	9.55	hood lock
64	Chevelle	3839264	1	9.55	hood lock
65	Chevy	3863300	1	9.55	hood lock
65	Chevelle	3863280	1	10.70	hood lock
66	Chevy	3874583	1	8.30	hood lock
66	Chevelle	3874579	1	9.55	hood lock
67	Chevy	3892280	1	8.30	hood lock
67	Chevelle	3887540	1	9.55	hood lock
67-68	Camaro (exc. R.S.)	3919087	1	16.45	hood lock
68-72	Chevy, Nova	3916616	1	9.55	hood lock
68	Chevelle	3910669	1	9.55	hood lock
67-68	Camaro (R.S.)	3921811	1	10.70	hood lock
69	Camaro	3947609	1	11.90	hood lock
69	Chevelle	3945657	1	9.55	hood lock
71-72	Pass.	3985633	1	.91	hood lock safety
73-74	Pass.	342318	1	8.95	latch catch mtg.
75	Caprice	342377	1	8.95	hood latch catch mtg.
75	Pass. (exc. Caprice)	354072	1	8.95	hood latch catch mtg.
73-75	Pass.	6273779	1	1.00	hood lock safety
65	Pass.	3863285	1	8.55	CATCH ASSY., hood lock
66	Pass.	3874716	1	7.65	CATCH ASSY., hood lock
67	Pass.	3893934	1	9.55	CATCH ASSY., hood lock
68	Pass.	3929814	1	9.55	CATCH ASSY., hood lock
69	Pass.	3942160	1	8.30	CATCH ASSY., hood lock
70-72	Chevelle	3975406	1	10.70	CATCH ASSY., hood lock
70	Pass.	3957248	1	8.30	CATCH ASSY., hood lock
70-71	Camaro (exc. R.S.)	3973918	1	13.10	CATCH ASSY., hood lock
72	Camaro (exc. R.S.)	3994760	1	10.70	CATCH ASSY., hood lock
70-73	Camaro (R.S.)	3974516	1	10.05	CATCH ASSY., hood lock
71-72	Pass.	9827558	1	11.90	CATCH ASSY., hood lock
73-75	Chevelle	3999785	1	2.75	CATCH ASSY., hood lock
73-74	Nova	6274330	1	7.55	CATCH ASSY., hood lock
73	Camaro (exc. R.S.)	3973918	1	13.10	CATCH ASSY., hood lock
74-75	Camaro	339462	1	11.80	CATCH ASSY., hood latch
75	Nova	345535	1	8.70	CATCH ASSY., hood latch
71	Pass.	3985634	1	.71	BOLT, hood lock safety catch
71-75	Pass., Nova	3979975	1	.12	CLIP, lock rel. cable
71-72	Pass.	3995125	1	1.20	COVER, hood lock catch

**SHEET METAL—HEATER**

**8.080 CATCH— BOLT— CLIP— COVER— LATCH ASSY.— LINK— PIN— PLATE—  
REINFORCEMENT— RETAINER— SCREW— STRIKER— SUPPORT, Hood  
Lock— Lower (Con't)**

73-75	Pass.	332330	1	6.10	LATCH ASSY.
71-75	Vega	9666194	1	10.30	LATCH ASSY. (Note 2)
75	Monza	1653556	1	10.30	LATCH ASSY.
71-72	Vega	9828742	2	7.15	LINK ASSY., hood hold open
<i>NOTE 2: When using on 1971-73 models also use 9666197 spring.</i>					
72-74	Pass.	3738054	1	.16	PIN, hood lock safety catch
66-67	Chevy	3874532	1	.96	PLATE, hood lock mounting
70-71	Nova	3949675	1	1.25	PLATE ASSY., hood lock mtg.
69-70	Pass.	3942194	1	2.00	PLATE ASSY., hood lock mounting
71-72	Pass.	3985598	1	8.25	PLATE ASSY., hood lock mtg.
73	Camaro (R.S.)	333747	L.H.	2.60	REINFORCEMENT ASSY., hood latch support
73	Camaro (R.S.)	333748	R.H.	2.60	REINFORCEMENT ASSY., hood latch support
73-75	Pass., Chevelle	6264834	1	.18	RETAINER, hood release cable
71-72	Pass.	3979974	1	.18	RETAINER, hood rel. cable
69	Pass.	3942132	1	.11	SCREW, rad. grille to hood lock catch supt.— (1.267)
71-73	Vega	4539511	2	.32	SCREW (12.184)
73-75	Nova, Camaro	3979949	1	.18	SCREW, hood lock bolt
71-73	Vega	9611418	1	3.05	STRIKER, hood latch
73-75	Pass.	327137	1	.92	STRIKER, hood latch
73-75	Chevelle	3999740	1	.81	STRIKER, hood latch
74-75	Vega	9666198	1	3.05	STRIKER, hood latch
63-64	Chevy	3792989	1	2.15	SUPPORT, hood lock catch
<i>NOTE 1 It may be necessary to remove extension at lower end.</i>					
65	Chevy	3858337	1	2.40	SUPPORT, hood lock catch
65	Chevelle	3858089	1	4.55	SUPPORT, hood lock catch
65	Pass.	3854087	1	3.70	SUPPORT, hood lock catch
66	Pass.	3874734	1	3.70	SUPPORT, hood lock
66	Chevy	3872940	1	2.30	SUPPORT, hood lock catch
66	Chevelle	3874572	1	2.95	SUPPORT, hood lock catch
67	Chevy	3892284	1	2.35	SUPPORT, hood lock catch
67	Chevelle	3891445	1	2.20	SUPPORT, hood lock catch
67-68	Camaro	3938693	1	2.70	SUPPORT, hood lock catch
67	Pass.	3893930	1	3.50	SUPPORT, hood lock catch
68	Pass.	3915465	1	2.95	SUPPORT, hood lock catch
68	Chevy	3914767	1	1.80	SUPPORT, hood lock catch
68	Chevelle	3910674	1	2.40	SUPPORT, hood lock catch
69	Pass.	3934557	1	3.35	SUPPORT ASSY., hood lock catch
69-72	Chevy	3938635	1	2.30	SUPPORT ASSY., hood lock catch
69	Camaro	3937531	1	2.75	SUPPORT ASSY., hood lock catch
69	Chevelle	3938181	1	2.30	SUPPORT ASSY., hood lock catch
70	Pass.	3957231	1	2.70	SUPPORT ASSY., hood lock catch
70	Chevelle,				
71-72	Monte Carlo	3962333	1	2.70	SUPPORT ASSY., hood lock catch
70-73	Camaro	3962995	1	2.90	SUPPORT ASSY., hood lock catch
71-72	Chevelle (exc. Monte Carlo)	6261967	1	3.20	SUPPORT ASSY., hood lock catch
71	Pass.	3991098	1	6.95	SUPPORT ASSY., hood lock catch w/extension
72	Pass.	3995171	1	6.95	SUPPORT ASSY., hood lock catch w/extension
73	Pass.	6273775	1	7.80	SUPPORT ASSY., hood lock catch
73	Monte Carlo	3999735	1	2.35	SUPPORT ASSY., hood lock catch
73-74	Nova	339409	1	2.70	SUPPORT ASSY., hood lock catch
74	Bel Air, Impala	335949	1	7.80	SUPPORT ASSY., hood latch catch
74	Caprice	335968	1	7.80	SUPPORT ASSY., hood latch catch
73-75	Chevelle (exc. Monte Carlo)	3999753	1	7.80	SUPPORT ASSY., hood lock catch
74-75	Monte Carlo	338515	1	2.35	SUPPORT ASSY., hood latch
74-75	Camaro	337477	1	2.60	SUPPORT ASSY., hood latch catch
75	Bel Air, Impala	342372	1	8.75	SUPPORT ASSY., hood lock catch
75	Caprice	342357	1	8.75	SUPPORT ASSY., hood lock catch
75	Nova	344391	1	3.90	SUPPORT ASSY., hood lock catch

**8.083 PLATE ASSY.— CATCH— LATCH ASSY.— NUT ASSY.— SPRING, Hood  
Lock— Upper**

67	Chevelle	3891447	1	1.20	lock mounting
67-75	Camaro	3891682	1	1.25	lock mounting
68	Pass., Chevelle	3942129	1	1.35	lock mounting
68-74	Nova	3949675	1	1.25	lock mounting
69	Chevelle	3947953	1	1.25	lock mounting
70-72	Chevelle	3963342	1	1.45	hood lock mtg.
73	Monte Carlo	3999781	1	6.15	hook lock mtg.



**SHEET METAL—HEATER**

**8.083 PLATE ASSY.— CATCH— LATCH ASSY.— NUT ASSY.— SPRING, Hood  
Lock— Upper (Con't)**

74-75	Monte Carlo	338517	1	6.15	hood latch mounting
75	Nova	345551	1	1.25	hood lock mtg.
75	Monte Carlo	345353	1	7.50	hood latch mtg.
75	Monza (exc. Towne Cpe.)	1656698	1	9.40	<b>CATCH ASSY.</b> , striker bolt
73-75	Chevelle	325300	1	6.80	<b>LATCH ASSY.</b> , hood
74-75	Pass.	332330	1	6.10	<b>LATCH ASSY.</b> , hood
73-74	Nova	6274399	2	.24	<b>NUT ASSY.</b> , hood lock catch to rad. supt. (U-shape $\frac{5}{16}$ "— 18 x $\frac{17}{32}$ ")
73-75	Pass.	325271	1	.40	<b>SPRING</b> , hood pop-up
73-75	Chevelle	331762	1	.53	<b>SPRING</b> , hood pop-up
74	Nova	408576	1		<b>SPRING</b> , hood pop-up
73-75	Vega	336510	1	.66	<b>SPRING ASSY.</b> , hood pop-up
74-75	Vega	9666197	1	.42	<b>SPRING ASSY.</b> , hood latch (Also use on 1971-73 models when installing 9666194)
75	Monza (Hatchback)	1666759	1	.87	<b>SPRING ASSY.</b> , hood pop-up

**8.085 SPRING— BOLT— CLAMP— CLIP— RETAINER— SEAT ASSY., Hood  
Upper Lock Plate**

62-70	All (exc. R.S.),				
72	All (exc. Pass.),				
71	Chevelle, Camaro,				
73-75	Camaro,				
75	Nova	3782562	1	.36	hood lock safety lever
65-66	Pass.,				
67-70	Camaro,				
68	Chevelle	3857882	1	.50	lock bolt (11 coil— 5— PS" lg.)
68	Pass.,				
70-71	Monte Carlo, Camaro,				
72	Monte Carlo, Nova,				
73-75	Camaro	3938019	1	.42	hood lock ( $\frac{1}{4}$ " min. lift)
69	Pass., Camaro	3942166	1	.67	lock rel. lever
70-72	Chevelle	3963341	1	.21	hood lock release lever
71	Pass.,				
72	Pass., Chevelle	3986949	1	.50	hood release
71-72	Pass.	3985635	1	.36	hood lock safety catch
71-73	Vega	9820315	1	.70	hood latch
73-75	Pass.	327149	1	.14	hood lock safety catch
75	Monza	1653564	1	.72	hood latch
62-65	Chevy, Chevelle	3782560	1	.71	<b>BOLT</b> ( $\frac{1}{2}$ "— 20 x $3\frac{3}{4}$ " O.L. w/cone point) (Note 1)
<i>NOTE 1 Cut to req. length.</i>					
69-70	Pass. (1st design)	3942197	1	.65	<b>BOLT</b> ( $\frac{7}{8}$ " sphere length x $3\frac{31}{32}$ " O.L.)
65-75	All	3857883	1	.65	<b>BOLT</b> ( $\frac{29}{32}$ " sphere length x 4" O.L.)
65-67	Chevy, Chevelle,				
65-74	Chevy,				
67	Pass.	3863466	1	.65	<b>BOLT</b> ( $\frac{1}{4}$ "— 20 x 2 O.L. w/cone point)
69	Chevelle	3947952	2	.72	<b>BOLT</b> , hood lock
70-72	Chevelle	3963344	1	.80	<b>BOLT</b> , hood lock
71	Pass.,				
72	Pass., Chevelle	3986957	1	.72	<b>BOLT</b> , hood rel. spring
71-72	Pass.,				
73-74	Chevelle	2459769		.35	<b>CLIP</b> , hood lock rel. cable,
74-75	Chevelle	2459769	A.R.	.35	hood latch release cable— (3.120)
65-68	Pass.,				
67-69	Camaro,				
68	Chevelle,				
71-75	Camaro,				
72	Nova	3857884	1	.50	<b>RETAINER</b> , lock bolt spring
69	Chevelle,				
70	Camaro,				
70-72	Monte Carlo	3947931	1	.27	<b>RETAINER</b> , lock bolt spring
71-72	Pass.	3986950	1	.27	<b>RETAINER</b> , hood rel. spring
70-72	Monte Carlo	3767846	1	.42	<b>SEAT ASSY.</b> , hood lock spring

**8.130 FENDER— EXTENSION— PANEL ASSY., Front**

*May be necessary to drill holes for mldgs. and emblems.*

62-65	Chevy	3859178	R.H.	87.25
62-65	Chevy	3859177	L.H.	87.25
64	Chevelle	3858943	L.H.	92.50
64	Chevelle	3858944	R.H.	92.50
65	Chevelle	3873789	L.H.	92.50
65	Chevelle	3873790	R.H.	92.50
65	Pass.	3865815	L.H.	97.75

**SHEET METAL—HEATER**

**8.130 FENDER— EXTENSION— PANEL ASSY., Front (Con't)**

65	Pass. ....	3865816 R.H.	97.75	
66	Pass. ....	3886309 L.H.	97.75	
66	Pass. ....	3886310 R.H.	97.75	
66	Chevelle .....	3886307 L.H.	92.50	
66	Chevelle .....	3886308 R.H.	92.50	
66	Chevy .....	3888236 R.H.	87.25	
66	Chevy .....	3888235 L.H.	87.25	
67	Chevy .....	3892221 L.H.	87.25	
67	Chevy .....	3892222 R.H.	87.25	
67	Chevelle .....	3904679 L.H.	92.50	
67	Chevelle .....	3904680 R.H.	92.50	
67	Pass. ....	3904677 L.H.	97.75	
67	Pass. ....	3904678 R.H.	97.75	
68	Pass. ....	3924115 L.H.	97.75	
68	Pass. ....	3924116 R.H.	97.75	
68	Chevelle .....	3924117 L.H.	92.50	
68	Chevelle .....	3924118 R.H.	92.50	
68-69	Chevy .....	3953851 L.H.	87.25	(Note 1) .....
68-69	Chevy .....	3953852 R.H.	87.25	(Note 1) .....
	<i>NOTE 1 When used as a replacement add holes for mldg. and emb.</i>			
69	Chevelle .....	3953853 L.H.	92.50	
69	Chevelle .....	3953854 R.H.	92.50	
69	Pass. ....	3953693 L.H.	97.75	
69	Pass. ....	3953694 R.H.	97.75	
73	Pass. ....	328805 L.H.	97.75	
73	Pass. ....	328806 R.H.	97.75	
74	Pass. ....	359091 L.H.	97.75	
74	Pass. ....	359092 R.H.	97.75	
73-75	Monte Carlo .....	359964 R.H.	97.75	
73-75	Monte Carlo .....	359963 L.H.	97.75	
73-74	Chevelle (exc. Monte Carlo) .....	359901 L.H.	97.75	(when using on 1973 also order 1973 skirt assy.) .....
73-74	Chevelle (exc. Monte Carlo) .....	347108 R.H.	97.75	(when using on 1973 also order 1973 skirt assy.) .....
73-74	Nova .....	6258337 L.H.	87.25	
73-74	Nova .....	6258338 R.H.	87.25	
73-75	Camaro .....	3981841 L.H.	92.50	
73-75	Camaro .....	359969 R.H.	92.50	
75	Nova .....	356813 L.H.	95.50	
75	Nova .....	356814 R.H.	95.50	
75	Chevelle (exc. Monte Carlo) .....	359901 L.H.	97.75	
75	Chevelle (exc. Monte Carlo) .....	359902 R.H.	97.75	
75	Pass. (exc. Caprice) .....	359091 L.H.	97.75	
75	Pass. (exc. Caprice) .....	359092 R.H.	97.75	
75	Caprice .....	359075 L.H.	97.75	
75	Caprice .....	359076 R.H.	97.75	
67	Camaro (exc. R.S.) .....	3904685 L.H.	92.50	FENDER UNIT .....
67	Camaro (exc. R.S.) .....	3904686 R.H.	92.50	FENDER UNIT .....
67	Camaro w/R.S. ....	3904687 L.H.	92.50	FENDER UNIT .....
67	Camaro w/R.S. ....	3904688 R.H.	92.50	FENDER UNIT .....
68	Camaro (exc. R.S.) .....	3941965 L.H.	92.50	FENDER UNIT .....
68	Camaro (exc. R.S.) .....	3941966 R.H.	92.50	FENDER UNIT .....
68	Camaro w/R.S. ....	3941967 L.H.	92.50	FENDER UNIT .....
68	Camaro w/R.S. ....	3941968 R.H.	92.50	FENDER UNIT .....
69	Camaro (exc. R.S.) .....	3953855 L.H.	92.50	FENDER UNIT .....
69	Camaro (exc. R.S.) .....	3953856 R.H.	92.50	FENDER UNIT .....
69	Camaro w/R.S. ....	3953857 L.H.	92.50	FENDER UNIT .....
69	Camaro w/R.S. ....	3953858 R.H.	92.50	FENDER UNIT .....
70	Monte Carlo .....	3970613 L.H.	95.00	FENDER ASSY. ....
70	Monte Carlo .....	3970614 R.H.	95.00	FENDER ASSY. ....
70	Chevelle (Sta. Wag., El Camino) .....	3970611 L.H.	92.50	FENDER ASSY. ....
70	Chevelle (Sta. Wag., El Camino) .....	3970612 R.H.	92.50	FENDER ASSY. ....
70	Pass. ....	3970607 L.H.	97.75	FENDER ASSY. (Note 1) .....
	<i>NOTE 1 When used as a replacement, add holes for moulding and emblems.</i>			
70	Pass. ....	3970608 R.H.	97.75	FENDER ASSY. ....
70	Chevelle (exc. Sta. Wag., El Camino, Monte Carlo) .....	3970609 L.H.	92.50	FENDER ASSY. ....
70	Chevelle (exc. Sta. Wag., El Camino, Monte Carlo) .....	3970610 R.H.	92.50	FENDER ASSY. ....
70-72	Nova .....	6258337 L.H.	87.25	FENDER ASSY. ....
70-72	Nova .....	6258338 R.H.	87.25	FENDER ASSY. ....
70-72	Camaro .....	3981841 L.H.	92.50	FENDER ASSY. ....
70-72	Camaro .....	359969 R.H.	92.50	FENDER ASSY. ....
71-72	Monte Carlo .....	3990957 L.H.	95.00	FENDER ASSY. ....
71-72	Monte Carlo .....	3990958 R.H.	95.00	FENDER ASSY. ....

**SHEET METAL—HEATER**

**8.130 FENDER— EXTENSION— PANEL ASSY., Front (Con't)**

71-72	Chevelle (Sta. Wag., El Camino)	325039	L.H.	92.50	FENDER ASSY.
71-72	Chevelle (Sta. Wag., El Camino)	325040	R.H.	92.50	FENDER ASSY.
71	Pass.	3990929	L.H.	97.75	FENDER ASSY.
71	Pass.	3990930	R.H.	97.75	FENDER ASSY.
72	Pass.	6263115	L.H.	97.75	FENDER ASSY.
72	Pass.	6263116	R.H.	97.75	FENDER ASSY.
71-72	Chevelle (exc. Sta. Wag., El Camino, Monte Carlo)	325037	L.H.	92.50	FENDER ASSY., left
71-72	Chevelle (exc. Sta. Wag., El Camino, Monte Carlo)	325038	R.H.	92.50	FENDER ASSY., right
75	Monza (Hvy. Duty Service)	3965779	R.H.	126.00	EXTENSION, frt. fender
75	Monza (Hvy. Duty Service)	3965780	L.H.	126.00	EXTENSION, frt. fender
71-73	Vega	356829	L.H.	68.50	PANEL ASSY.
71-73	Vega	356830	R.H.	68.50	PANEL ASSY.
74-75	Vega	9662594	R.H.	62.50	PANEL ASSY.
74-75	Vega	9739739	L.H.	68.50	PANEL ASSY.
75	Vega	9739738	R.H.	68.50	PANEL ASSY.
75	Monza	1700865	L.H.	82.25	PANEL ASSY.
75	Monza	1700864	R.H.	82.25	PANEL ASSY.

**8.131 EXTENSION— FILLER— PANEL, Front Fender**

64	Chevelle	3837631	L.H.	3.25	
64	Chevelle	3837632	R.H.	3.25	
65	Pass.	3853745	L.H.	3.50	
65	Pass.	3853746	R.H.	3.25	
67-68	Camaro	3891627	L.H.	5.95	
67-68	Camaro	3891628	R.H.	5.95	
69	Camaro	3934171	L.H.	12.05	
69	Camaro	3934172	R.H.	12.05	
69	Pass.	3950795	L.H.	.59	front bumper filler
69	Pass.	3950796	R.H.	.62	front bumper filler
70	Monte Carlo	3975455	L.H.	13.45	
70	Monte Carlo	3975456	R.H.	13.45	
70	Chevelle (Sta. Wag., El Camino)	3958391	L.H.	9.95	
70	Chevelle (Sta. Wag., El Camino)	3958392	R.H.	9.95	
70	Chevelle (exc. Sta. Wag., El Camino, Monte Carlo)	3962327	L.H.	9.95	
70	Chevelle (exc. Sta. Wag., El Camino, Monte Carlo)	3962328	R.H.	9.95	
71	Monte Carlo	3982407	L.H.	9.95	
71	Monte Carlo	3982408	R.H.	9.95	
72	Monte Carlo	6261987	L.H.	9.95	
72	Monte Carlo	6261988	R.H.	9.95	
71-72	Chevelle (Sta. Wag., El Camino)	3982405	L.H.	12.95	
71-72	Chevelle (Sta. Wag., El Camino)	3982406	R.H.	12.95	
71-72	Chevelle (exc. Sta. Wag., El Camino, Monte Carlo)	3982403	L.H.	12.95	
71-72	Chevelle (exc. Sta. Wag., El Camino, Monte Carlo)	3982404	R.H.	12.95	
71	Pass.	3983979	L.H.	10.10	
71	Pass.	3983980	R.H.	10.10	
72	Pass.	6262367	L.H.	10.10	
72	Pass.	6262368	R.H.	10.10	
73	Pass.	327175	L.H.	10.10	
73	Pass.	327176	R.H.	10.10	
74	Caprice	335913	L.H.	10.10	
74	Caprice,				
75	Pass. (exc. Caprice)	343560			
74	Bel Air, Impala	335921	L.H.	7.30	
74	Bel Air, Impala	335922	R.H.	7.30	
73-74	Nova	6274311	L.H.	4.05	
73-74	Nova	6274312	R.H.	4.05	
75	Nova	347513	L.H.	8.10	
75	Nova	347514	R.H.	8.10	
75	Caprice	342331	L.H.	9.40	
75	Caprice	342332	R.H.	9.40	
75	Pass. (exc. Caprice)	343559	L.H.	9.70	
68-72	Chevelle	3926855	L.H.	.62	FILLER, upper rear
68-72	Chevelle	3926856	R.H.	.62	FILLER, upper rear
69	Pass.	3945661	L.H.	.68	FILLER, bumper
69	Pass.	3945662	R.H.	.64	FILLER, bumper
69	Pass.	3942133	L.H.	.28	FILLER, upper rear mldg.
69	Pass.	3942134	R.H.	.28	FILLER, upper rear mldg.
70	Pass.	3950777	L.H.	.28	FILLER, upper rear
70	Pass.	3950778	R.H.	.28	FILLER, upper rear

**SHEET METAL—HEATER**

**8.131 EXTENSION— FILLER— PANEL, Front Fender (Con't)**

65-66	Pass. ....	3766087 L.H.	4.25	PANEL, closing .....
65-66	Pass. ....	3766088 R.H.	4.25	PANEL, closing .....

*NOTE 1: Paint as reqd.*

**8.132 MOULDING— CAP UNIT— PANEL— PLATE— STRIPE— DECAL— TAPE— TRANSFER, Front Fender (See Group 8.147 for Front Fender Mouldings which include Series Designations)**

**PASSENGER**

68	Pass. w/body side mldg. ....	3941205 L.H.	6.95	side— (12.114) (Note 1) .....
68	Pass. w/body side mldg. ....	3941206 R.H.	6.35	side— (12.114) (Note 1) .....
69	Pass. w/body side mldg. ....	3955012 R.H.	6.95	side— (12.114) (Note 1) .....
69	Pass. w/body side mldg. ....	3955011 L.H.	8.70	side— (12.114) (Note 1) .....
69	Pass. ....	3945625 L.H.	2.25	upper rear .....
69	Pass. ....	3945626 R.H.	2.10	upper rear .....
70	Pass. ....	3962365 L.H.	3.05	upper rear .....
70	Pass. ....	3962366 R.H.	3.05	upper rear .....
71-72	Kingswood Estate Wag. ....	3991107 2	4.15	side lower front .....
71-72	Pass. ....	3986953 L.H.	1.40	left, upper rear .....
71-72	Pass. ....	3986954 R.H.	1.40	right, upper rear .....
73-74	Caprice (Estate) ....	3991107 2	4.15	side lower front .....
73-74	Pass. ....	3986953 L.H.	1.40	left, upper rear .....
73-74	Pass. ....	3986954 R.H.	1.40	right, upper rear .....
74-75	Pass. ....	342654 1	RL/1.25	body side (green) (Note 5) .....
74	Pass. ....	342659 1	RL/1.25	body side (red) (Note 5) .....
74-75	Pass. ....	342660 1	RL/1.25	body side (beige) (Note 5) .....
74	Bel Air ....	333719 2	RL/1.25	body side (black) .....
75	Pass. ....	343561 L.H.	1.40	left, upper rear .....
75	Pass. ....	343562 R.H.	1.40	right, upper rear .....
75	Caprice Estate ....	354017 2	3.85	side lower front .....
75	Bel Air, Impala (exc. Opt. mldg.) .....	360000 A.R.	RL/2.20	fender side cut as req. (Note 3) .....
<i>NOTE 3: Black PVC with bright mylar insert (1<sup>3</sup>/<sub>16</sub>" wide) 17-ft. roll.</i>				
75	Impala w/Opt. mldg. ....	360001 A.R.	RL/3.15	fender side cut as req. (repl. 343600) (Note 4) .....
<i>NOTE 4: Argent PVC with bright mylar borders (1<sup>1</sup>/<sub>32</sub>" wide) 17 ft. roll.</i>				
73	Pass. ....	347057 1	13.55	MOULDING ASSY., side upper (black) (Note 2) .....
74	Pass. ....	347058 1	13.55	MOULDING ASSY., side upper (black) (Note 2) .....
<i>NOTE 2: Includes one 10 ft. vinyl mldg. speared at one end.</i>				
65	Bel Air ....	3862223 L.H.	9.55	MOULDING UNIT, side .....
65	Bel Air ....	3862224 R.H.	9.55	MOULDING UNIT, side .....
65	Pass. ....	3865253 L.H.	5.70	MOULDING UNIT, headlamp opening .....
65	Pass. ....	3865254 R.H.	5.70	MOULDING UNIT, headlamp opening .....
65	Pass. ....	3865325 L.H.	15.85	MOULDING UNIT, frt. wheelhouse opening .....
65	Pass. ....	3865326 R.H.	15.85	MOULDING UNIT, frt. wheelhouse opening .....
66	Pass. ....	3886221 L.H.	4.15	MOULDING UNIT, headlamp opening .....
66	Pass. ....	3886222 R.H.	4.15	MOULDING UNIT, headlamp opening .....
66	Pass. ....	3886223 L.H.	2.25	MOULDING UNIT, extension, headlamp opening .....
66	Pass. ....	3886224 R.H.	2.25	MOULDING UNIT, extension, headlamp opening .....
66	Bel Air ....	3886233 L.H.	9.55	MOULDING UNIT, fender side .....
66	Bel Air ....	3886234 R.H.	9.55	MOULDING UNIT, fender side .....
66	Pass. (exc. Caprice), Caprice (exc. Sta. Wag.) .....	3884061 L.H.	15.85	MOULDING UNIT, wheelhouse opening .....
66	Pass. (exc. Caprice), Caprice (exc. Sta. Wag.) .....	3884062 R.H.	15.85	MOULDING UNIT, wheelhouse opening .....
66	Impala ....	3886374 2	10.15	MOULDING UNIT, fender side .....
66	Caprice (Sta. Wag.) ....	3890165 L.H.	8.40	MOULDING UNIT, side upper .....
66	Caprice (Sta. Wag.) ....	3890168 R.H.	9.05	MOULDING UNIT, side intermediate .....
67	Pass. ....	3904633 L.H.	5.60	MOULDING UNIT, headlamp opening, upper .....
67	Pass. ....	3904634 R.H.	5.60	MOULDING UNIT, headlamp opening, upper .....
67	Pass. ....	3904643 L.H.	3.05	MOULDING UNIT, headlamp opening, lower .....
67	Pass. ....	3904644 R.H.	3.05	MOULDING UNIT, headlamp opening, lower .....
67	Bel Air, Biscayne ....	3904666 2	9.55	MOULDING UNIT, side .....
67	Caprice (w/rr. wheel opening cover) .....	3904647 L.H.	14.35	MOULDING UNIT, wheelhouse opening .....

**SHEET METAL—HEATER**

**8.132 MOULDING— CAP UNIT— PANEL— PLATE— STRIPE— DECAL— TAPE— TRANSFER, Front Fender (See Group 8.147 for Front Fender Mouldings which include Series Designations) (Con't)**

67	Caprice (w/rr. wheel opening cover) . . . . .	3904648 R.H.	14.35	MOULDING UNIT, wheelhouse opening . . .
67	Caprice (exc. Sta. Wag.) . . . . .	3904651 L.H.	4.15	MOULDING UNIT, side . . . . .
67	Caprice (exc. Sta. Wag.) . . . . .	3904652 R.H.	4.15	MOULDING UNIT, side . . . . .
67	Caprice (Sta. Wag.) . . . . .	3904635 L.H.	7.55	MOULDING UNIT, side front . . . . .
67	Caprice (Sta. Wag.) . . . . .	3904636 R.H.	7.55	MOULDING UNIT, side front . . . . .
67	Caprice (Sta. Wag.) . . . . .	3904637 L.	8.40	MOULDING UNIT, side, upper . . . . .
67	Caprice (Sta. Wag.) . . . . .	3904639 R.H.	5.30	MOULDING UNIT, side, lower . . . . .
67	Caprice (Sta. Wag.) . . . . .	3904640 R.H.	5.30	MOULDING UNIT, side, lower . . . . .
67	Impala (exc. S.S.) . . . . .	3904641 L.H.	4.15	MOULDING UNIT, side . . . . .
67	Impala (exc. S.S.) . . . . .	3904642 R.H.	4.15	MOULDING UNIT, side . . . . .
67	Impala (S.S.),			
67	Caprice (exc. Rr. wheel opening cover) . . . . .	3904645 L.H.	14.35	MOULDING UNIT, wheelhouse opening . . .
67	Impala (S.S.),			
67	Caprice (exc. Rr. wheel opening cover) . . . . .	3904646 R.H.	14.35	MOULDING UNIT, wheelhouse opening . . .
68	Biscayne, Bel Air . . . . .	3929564 2	9.05	MOULDING UNIT, side . . . . .
68	Impala . . . . .	3931641 L.H.	11.80	MOULDING UNIT, side (vinyl insert, stippled finish) . . . . .
68	Impala . . . . .	3931642 R.H.	11.80	MOULDING UNIT, side (vinyl insert, stippled finish) . . . . .
68	Impala (Sed.) . . . . .	3936269 L.H.	11.80	MOULDING UNIT, side (black paint) . . . . .
68	Impala (Sed.) . . . . .	3936270 R.H.	11.80	MOULDING UNIT, side (black paint) . . . . .
68	Impala (Sed.) . . . . .	8700051 L.H.	17.15	MOULDING UNIT, side (vinyl insert, smooth finish) . . . . .
68	Impala (Sed.) . . . . .	8700050 R.H.	17.15	MOULDING UNIT, side (vinyl insert, smooth finish)— (12.116) . . . . .
68	Pass. (exc. retract. headlamp cover) . . . . .	3928433 L.H.	2.05	MOULDING UNIT, upper front . . . . .
68	Pass. (exc. retract. headlamp cover) . . . . .	3928434 R.H.	2.05	MOULDING UNIT, upper front . . . . .
68	Impala,			
68	Caprice (exc. Rr. wheel skirt) . . . . .	3927923 L.H.	15.85	MOULDING UNIT, wheelhouse opening . . .
68	Impala,			
68	Caprice (exc. Rr. wheel skirt) . . . . .	3927924 R.H.	15.85	MOULDING UNIT, wheelhouse opening . . .
68	Caprice w/Rr. wheel skirt . . . . .	3927925 L.H.	15.85	MOULDING UNIT, wheelhouse opening . . .
68	Caprice w/Rr. wheel skirt . . . . .	3927926 R.H.	15.85	MOULDING UNIT, wheelhouse opening . . .
68	Pass. . . . .	3936291 L.H.	2.85	MOULDING UNIT, upper rear . . . . .
68	Pass. . . . .	3936292 R.H.	2.85	MOULDING UNIT, upper rear . . . . .
68	Caprice (Sta. Wag.) . . . . .	3928460 2	4.50	MOULDING UNIT, side, lower . . . . .
68	Caprice (Sta. Wag.) . . . . .	3928461 L.H.	10.15	MOULDING UNIT, side upper . . . . .
68	Caprice (Sta. Wag.) . . . . .	3928462 R.H.	10.15	MOULDING UNIT, side upper . . . . .
68	Caprice (Sta. Wag.) . . . . .	3928463 L.H.	9.05	MOULDING UNIT, side front . . . . .
68	Caprice (Sta. Wag.) . . . . .	3928464 R.H.	9.05	MOULDING UNIT, side front . . . . .
68	Caprice . . . . .	3928465 L.H.	5.55	MOULDING UNIT, side . . . . .
68	Caprice . . . . .	3928466 R.H.	5.55	MOULDING UNIT, side . . . . .
69	Biscayne (2-Dr. Sed.) w/body side mldg. . . . .	3957930 1	36.25	MOULDING UNIT, side— (12.114) . . . . .
69	Impala, Caprice . . . . .	3953639 L.H.	14.35	MOULDING UNIT, wheelhouse opening . . .
69	Impala, Caprice . . . . .	3953640 R.H.	14.35	MOULDING UNIT, wheelhouse opening . . .
69-70	Bel Air . . . . .	3953646 2	15.10	MOULDING UNIT, side . . . . .
69	Impala . . . . .	3953647 L.H.	15.10	MOULDING UNIT, side (black) . . . . .
69	Impala . . . . .	3953648 R.H.	15.10	MOULDING UNIT, side (black) . . . . .
69	Impala . . . . .	3953649 L.H.	15.10	MOULDING UNIT, side (dark red) . . . . .
69	Impala . . . . .	3953650 R.H.	15.10	MOULDING UNIT, side (dark red) . . . . .
69	Impala (exc. Conv.) . . . . .	3953651 L.H.	15.10	MOULDING UNIT, side (dark blue) . . . . .
69	Impala (exc. Conv.) . . . . .	3953652 R.H.	15.10	MOULDING UNIT, side (dark blue) . . . . .
69	Impala . . . . .	3953653 L.H.	15.10	MOULDING UNIT, side (dk. green) . . . . .
69	Impala . . . . .	3953654 R.H.	15.10	MOULDING UNIT, side (dk. green) . . . . .
69	Impala (exc. Conv.) . . . . .	3953655 L.H.	15.10	MOULDING UNIT, side (dk. brown) . . . . .
69	Impala (exc. Conv.) . . . . .	3953656 R.H.	15.10	MOULDING UNIT, side (dk. brown) . . . . .
69	Pass. (Estate Wag.) . . . . .	3953680 2	4.15	MOULDING UNIT, lower side . . . . .
69	Pass. (Estate Wag.) . . . . .	3953681 L.H.	9.80	MOULDING UNIT, upper side . . . . .
69	Pass. (Estate Wag.) . . . . .	3953682 R.H.	9.80	MOULDING UNIT, upper side . . . . .
69	Pass. (Estate Wag.) . . . . .	3953683 L.H.	6.05	MOULDING UNIT, upper side, frt. . . . .
69	Pass. (Estate Wag.) . . . . .	3953684 R.H.	6.05	MOULDING UNIT, upper side, frt. . . . .
69	Pass. (Estate Wag.) . . . . .	3953685 L.H.	6.45	MOULDING UNIT, lower side, frt. . . . .
69	Pass. (Estate Wag.) . . . . .	3953686 R.H.	6.45	MOULDING UNIT, lower side, frt. . . . .
69	Caprice . . . . .	3961315 L.H.	12.85	MOULDING UNIT, side . . . . .
69	Caprice . . . . .	3961316 R.H.	12.85	MOULDING UNIT, side . . . . .
70	Pass. . . . .	3970549 L.H.	9.80	MOULDING UNIT, headlamp opening, left . . . . .
70	Pass. . . . .	3970550 R.H.	9.80	MOULDING UNIT, headlamp opening, right . . . . .

**SHEET METAL—HEATER**

**8.132 MOULDING— CAP UNIT— PANEL— PLATE— STRIPE— DECAL— TAPE— TRANSFER, Front Fender (See Group 8.147 for Front Fender Mouldings which include Series Designations) (Con't)**

70	Pass. ....	3970547 L.H.	14.35	MOULDING UNIT, wheelhouse opening, left
70	Pass. ....	3970548 R.H.	14.35	MOULDING UNIT, wheelhouse opening, right
70	Caprice .....	3980831 L.H.	12.85	MOULDING UNIT, side, left
70	Caprice .....	3980832 R.H.	12.85	MOULDING UNIT, side, right
70	Kingswood Estate Wag. ....	3980827 L.H.	5.30	MOULDING UNIT, side lower frt., left
70	Kingswood Estate Wag. ....	3980828 R.H.	5.30	MOULDING UNIT, side lower frt., right
70	Kingswood Estate Wag. ....	3980814 2	6.75	MOULDING UNIT, side lower rear, left and right
70	Kingswood Estate Wag. ....	3974233 L.H.	3.75	MOULDING UNIT, frt., left, bumper indentation
70	Kingswood Estate Wag. ....	3974234 R.H.	3.75	MOULDING UNIT, frt., right, bumper indentation
70	Kingswood Estate Wag. ....	3980829 L.H.	13.55	MOULDING UNIT, side upper, left
70	Kingswood Estate Wag. ....	3980830 R.H.	13.55	MOULDING UNIT, side upper, right
70	Impala, Kingswood (exc. Estate Wag.) .....	3974239 L.H.	15.10	MOULDING UNIT, side, left (black)
70	Impala, Kingswood (exc. Estate Wag.) .....	3974240 R.H.	15.10	MOULDING UNIT, side, right (black)
70	Impala, Kingswood (exc. Estate Wag.) .....	3974241 L.H.	15.10	MOULDING UNIT, side, left (saddle)
70	Impala, Kingswood (exc. Estate Wag.) .....	3974242 R.H.	15.10	MOULDING UNIT, side, right (saddle)
70	Impala, Kingswood (exc. Estate Wag.) .....	3974243 L.H.	15.10	MOULDING UNIT, side, left (gold)
70	Impala, Kingswood (exc. Estate Wag.) .....	3974244 R.H.	15.10	MOULDING UNIT, side, right (gold)
70	Impala, Kingswood (exc. Estate Wag.) .....	3974245 L.H.	15.10	MOULDING UNIT, side, left (green)
70	Impala, Kingswood (exc. Estate Wag.) .....	3974246 R.H.	15.10	MOULDING UNIT, side, right (green)
70	Impala, Kingswood (exc. Estate Wag.) .....	3974247 L.H.	15.10	MOULDING UNIT, side, left (blue)
70	Impala, Kingswood (exc. Estate Wag.) .....	3974248 R.H.	15.10	MOULDING UNIT, side, right (blue)
71	Impala, Caprice, Kingswood (exc. Estate Wag.) .....	3991027 L.H.	5.70	MOULDING UNIT, left, side front
71	Impala, Caprice, Kingswood (exc. Estate Wag.) .....	3991028 R.H.	5.70	MOULDING UNIT, right, side front
71	Impala, Caprice, Kingswood (exc. Estate Wag.) .....	3991029 L.H.	6.75	MOULDING UNIT, left, side rear
71	Impala, Caprice, Kingswood (exc. Estate Wag.) .....	3991030 R.H.	6.75	MOULDING UNIT, right, side rear
72	Caprice .....	6263157 L.H.	5.70	MOULDING UNIT, side lwr. frt.
72	Caprice .....	6263158 R.H.	5.70	MOULDING UNIT, side lwr. frt.
72	Caprice .....	6263159 L.H.	6.75	MOULDING UNIT, side lwr. rear
72	Caprice .....	6263160 R.H.	6.75	MOULDING UNIT, side lwr. rear
71-72	Kingswood Estate Wag. ....	3991067 L.H.	13.55	MOULDING UNIT, left, w/house opening
71-72	Kingswood Estate Wag. ....	3991068 R.H.	13.55	MOULDING UNIT, right, w/house opening
71	Impala, Caprice, Kingswood (exc. Estate Wag.) .....	3991013 L.H.	14.35	MOULDING UNIT, left, w/house opening
71	Impala, Caprice, Kingswood (exc. Estate Wag.) .....	3991014 R.H.	14.35	MOULDING UNIT, right, w/house opening
72	Impala, Caprice, Kingswood (exc. Estate Wag.) .....	6263053 L.H.	14.35	MOULDING UNIT, left, w/house opening
72	Impala, Caprice, Kingswood (exc. Estate Wag.) .....	6263054 R.H.	14.35	MOULDING UNIT, right, w/house opening
71-72	Kingswood Estate Wag. ....	3991069 L.H.	6.75	MOULDING UNIT, left, side lower rear
71-72	Kingswood Estate Wag. ....	3991070 R.H.	6.75	MOULDING UNIT, right, side lower rear
71-72	Kingswood Estate Wag. ....	3991071 L.H.	13.25	MOULDING UNIT, left, side upper
71-72	Kingswood Estate Wag. ....	3991072 R.H.	13.25	MOULDING UNIT, right, side upper
71-72	Kingswood Estate Wag. ....	3991073 L.H.	6.75	MOULDING UNIT, left, side front
71-72	Kingswood Estate Wag. ....	3991074 R.H.	6.75	MOULDING UNIT, right, side front
71	Pass. w/exterior mldg. ....	3996796 2	4.85	MOULDING UNIT, front side
72	Impala, Kingswood (exc. Estate) .....	6272122 2	4.85	MOULDING UNIT, side (chrome)
72	Pass. (exc. Estate) .....	6263176 2	6.45	MOULDING UNIT, front fender side upper (black insert)
73-74	Caprice Estate .....	3991067 L.H.	13.55	MOULDING UNIT, left, w/house opening
73-74	Caprice Estate .....	3991068 R.H.	13.55	MOULDING UNIT, right, w/house opening
74	Caprice (exc. Sta. Wag.) .....	6260813 L.H.	14.35	MOULDING UNIT, left, w/house opening
74	Caprice (exc. Sta. Wag.) .....	6260814 R.H.	14.35	MOULDING UNIT, right, w/house opening
73	Pass. (exc. Caprice Estate),			
74-75	Impala, Bel Air (exc. Spt. Cpe.),			

**SHEET METAL—HEATER**

**8.132 MOULDING— CAP UNIT— PANEL— PLATE— STRIPE— DECAL— TAPE— TRANSFER, Front Fender (See Group 8.147 for Front Fender Mouldings which include Series Designations) (Con't)**

74-75	Impala (Spt. Cpe.) (exc. wide lower mldgs.)	6263053 L.H.	14.35	MOULDING UNIT, left, w/house opening
73	Pass. (exc. Caprice Estate),			
74-75	Impala, Bel Air (exc. Spt. Cpe.),			
74-75	Impala (Spt. Cpe.) (exc. wide lower mldgs.)	6263054 R.H.	14.35	MOULDING UNIT, right, w/house opening
73-75	Caprice Estate	3991069 L.H.	6.75	MOULDING UNIT, left, side lower rear
73-75	Caprice Estate	3991070 R.H.	6.75	MOULDING UNIT, right, side lower rear
73-75	Caprice Estate	3991071 L.H.	13.25	MOULDING UNIT, left, side upper
73-75	Caprice Estate	3991072 R.H.	13.25	MOULDING UNIT, right, side upper
73-75	Caprice Estate	3991073 L.H.	6.75	MOULDING UNIT, left, side front
73-75	Caprice Estate	3991074 R.H.	6.75	MOULDING UNIT, right, side front
73	Caprice (exc. Wag.)	6258137 L.H.	6.75	MOULDING UNIT, side lwr., left
73	Caprice (exc. Wag.)	6258138 R.H.	6.75	MOULDING UNIT, side lwr., right
74	Caprice (exc. Sta. Wag.)	6260815 L.H.	5.00	MOULDING UNIT, side lower front
74	Caprice (exc. Sta. Wag.)	6260816 R.H.	5.00	MOULDING UNIT, side lower front
74	Caprice (exc. Sta. Wag.)	6260817 L.H.	5.35	MOULDING UNIT, side lower rear
74	Caprice (exc. Sta. Wag.)	6260818 R.H.	5.35	MOULDING UNIT, side lower rear
73	Pass. (exc. Estate)	6258480 2	15.10	MOULDING UNIT, front fender side upper (vinyl insert) (clip on mldg.)
73	Impala, Caprice (exc. Estate Wag.),			
74	Impala (exc. Custom Coupe)	6258812 2	12.35	MOULDING UNIT, side upper (chrome)
73	Pass.	6258025 L.H.	5.55	MOULDING UNIT, extension, left
73	Pass.	6258026 R.H.	5.55	MOULDING UNIT, extension, right
74	Bel Air, Impala	6260487 L.H.	5.55	MOULDING UNIT, extension, left
74	Bel Air, Impala	6260488 R.H.	5.55	MOULDING UNIT, extension, right
74	Caprice,			
75	Bel Air, Impala	6260493 L.H.	5.55	MOULDING UNIT, ext. left
74	Caprice,			
75	Bel Air, Impala	6260494 R.H.	5.55	MOULDING UNIT, ext. right
74-75	Bel Air, Impala	6260489 L.H.	3.80	MOULDING UNIT, fdr. to park. and sig. lamp
74-75	Bel Air, Impala	6260490 R.H.	3.80	MOULDING UNIT, fdr. to park. and sig. lamp
74	Caprice	6260492 2	3.00	MOULDING UNIT, headlamp housing
73-74	Pass.	981817 1		MOULDING UNIT, body side (black) (Note 1)
75	Caprice (exc. Sta. Wag.)	358719 L.H.	6.20	MOULDING UNIT, side (black)
75	Caprice (exc. Sta. Wag.)	358720 R.H.	6.20	MOULDING UNIT, side (black)
75	Caprice (exc. Sta. Wag.)	358721 L.H.	6.20	MOULDING UNIT, side (white)
75	Caprice (exc. Sta. Wag.)	358722 R.H.	6.20	MOULDING UNIT, side (white)
75	Caprice (exc. Sta. Wag.)	358723 L.H.	6.20	MOULDING UNIT, side (silver met.)
75	Caprice (exc. Sta. Wag.)	358724 R.H.	6.20	MOULDING UNIT, side (silver met.)
75	Caprice (exc. Sta. Wag.)	358725 L.H.	6.20	MOULDING UNIT, side (dk. blue met.)
75	Caprice (exc. Sta. Wag.)	358726 R.H.	6.20	MOULDING UNIT, side (dk. blue met.)
75	Caprice (exc. Sta. Wag.)	358727 L.H.	6.20	MOULDING UNIT, side (med. green)
75	Caprice (exc. Sta. Wag.)	358728 R.H.	6.20	MOULDING UNIT, side (med. green)
75	Caprice (exc. Sta. Wag.)	358729 L.H.	6.20	MOULDING UNIT, side (lt. beige)
75	Caprice (exc. Sta. Wag.)	358730 R.H.	6.20	MOULDING UNIT, side (lt. beige)
75	Caprice (exc. Sta. Wag.)	358733 L.H.	6.20	MOULDING UNIT, side (maroon)
75	Caprice (exc. Sta. Wag.)	358734 R.H.	6.20	MOULDING UNIT, side (maroon)
75	Caprice (exc. Sta. Wag.)	358788 L.H.	14.35	MOULDING UNIT, w/h opening
75	Caprice (exc. Sta. Wag.)	358789 R.H.	14.35	MOULDING UNIT, w/h opening
75	Caprice Estate	358792 L.H.	12.25	MOULDING UNIT, side upper
75	Caprice Estate	358793 R.H.	12.25	MOULDING UNIT, side upper
75	Caprice Estate	358794 L.H.	6.20	MOULDING UNIT, side front
75	Caprice Estate	358795 R.H.	6.20	MOULDING UNIT, side front
75	Caprice Estate	358790 L.H.	12.55	MOULDING UNIT, w/h opening
75	Caprice Estate	358791 R.H.	12.55	MOULDING UNIT, w/h opening

NOTE 1: Includes two 17 ft. vinyl mldgs. w/spared ends.

NOTE 5: Includes one 17 ft. vinyl mldg. w/spared ends.

**CHEVELLE**

68-72	Chevelle	3936289 L.H.	2.25	upper rear
68-72	Chevelle	3936290 R.H.	2.25	upper rear
68	Malibu	3937273 L.H.	12.95	wheel opening (41") (Note 2)
68	Malibu	3937274 R.H.	12.95	wheel opening (41") (Note 2)
68	S.S., w/body side mldg.,			
68	Chevelle (4-Dr.) w/body side mldg.	3941205 L.H.	6.95	side— (12.114) (Note 3)
68	S.S., w/body side mldg.,			

**SHEET METAL—HEATER**

**8.132 MOULDING— CAP UNIT— PANEL— PLATE— STRIPE— DECAL— TAPE— TRANSFER, Front Fender (See Group 8.147 for Front Fender Mouldings which include Series Designations) (Con't)**

68	Chevelle (4-Dr.) w/body side mldg. ....	3941206 R.H.	6.35	side— (12.114) (Note 3) .....
69	Chevelle w/body side mldg. ....	3955011 L.H.	8.70	side— (12.114) (Note 3) .....
69	Chevelle w/body side mldg. ....	3955012 R.H.	6.95	side— (12.114) (Note 3) .....
74-75	Chevelle .....	342654 1	RL/1.25	body side (green) (Note 5) .....
74	Chevelle .....	342659 1	RL/1.25	body side (red) (Note 5) .....
74-75	Chevelle .....	342660 1	RL/1.25	body side (beige) (Note 5) .....
74	Chevelle w/wood grain (exc. El Camino) .....	333719 2	RL/1.25	body side (black) .....
64	Malibu (S.S.) .....	3844285 L.H.	8.70	MOULDING UNIT, front peak .....
64	Malibu (S.S.) .....	3844286 R.H.	8.70	MOULDING UNIT, front peak .....
64	Chevelle (exc. S.S., El Camino) ..	3844321 L.H.	8.70	MOULDING UNIT, fender side .....
64	Chevelle (exc. S.S., El Camino) ..	3844322 R.H.	8.70	MOULDING UNIT, fender side .....
64	Chevelle .....	3844491 L.H.	4.15	MOULDING UNIT, headlamp opening .....
64	Chevelle .....	3844492 R.H.	4.15	MOULDING UNIT, headlamp opening .....
64	Malibu (S.S.) El Camino .....	3845627 L.H.	14.35	MOULDING UNIT, wheelhouse opening .....
64	Malibu (S.S.) El Camino .....	3845628 R.H.	14.35	MOULDING UNIT, wheelhouse opening .....
65	Chevelle .....	3865239 L.H.	6.65	MOULDING UNIT, headlamp opening upper .....
65	Chevelle .....	3865247 L.H.	2.60	MOULDING UNIT, headlamp opening lower .....
65	Chevelle .....	3865248 R.H.	2.60	MOULDING UNIT, headlamp opening lower .....
65	Chevelle (exc. Malibu) .....	3865393 L.H.	4.15	MOULDING UNIT, side .....
65	Chevelle (exc. Malibu) .....	3865394 R.H.	4.15	MOULDING UNIT, side .....
65	Malibu (exc. S.S.) .....	3865863 L.H.	4.85	MOULDING UNIT, side .....
65	Malibu (exc. S.S.) .....	3865864 R.H.	4.85	MOULDING UNIT, side .....
65	Malibu .....	3865323 L.H.	14.35	MOULDING UNIT, front wheelhouse opening .....
65	Malibu .....	3865324 R.H.	14.35	MOULDING UNIT, front wheelhouse opening .....
66	Chevelle (Deluxe) .....	3886373 1	8.70	MOULDING UNIT, fender side .....
66	Chevelle .....	3884031 L.H.	14.35	MOULDING UNIT, wheelhouse opening .....
66	Chevelle .....	3884032 R.H.	14.35	MOULDING UNIT, wheelhouse opening .....
66	Chevelle .....	3886261 L.H.	4.15	MOULDING UNIT, headlamp opening .....
66	Chevelle .....	3886262 R.H.	4.15	MOULDING UNIT, headlamp opening .....
67	Chevelle (exc. Concours, S.S.) ..	3904593 L.H.	4.15	MOULDING UNIT, side .....
67	Chevelle (exc. Concours, S.S.) ..	3904594 R.H.	4.15	MOULDING UNIT, side .....
67	Chevelle (S.S.) Concours .....	3904591 L.H.	14.35	MOULDING UNIT, wheelhouse opening .....
67	Chevelle (S.S.) Concours .....	3904592 R.H.	14.35	MOULDING UNIT, wheelhouse opening .....
67	Concours .....	3914132 R.H.	8.70	MOULDING UNIT, side upper (52 <sup>3</sup> / <sub>4</sub> " O.L.) ..
68	Chevelle (Malibu, S.S.) .....	3928437 L.H.	6.65	MOULDING UNIT, side .....
68	Chevelle (Malibu, S.S.) .....	3928438 R.H.	6.65	MOULDING UNIT, side .....
68	Chevelle .....	3928471 L.H.	5.75	MOULDING UNIT, rad. grille ext.— (1.268) ..
68	Chevelle .....	3928472 R.H.	5.75	MOULDING UNIT, rad. grille ext.— (1.268) ..
68	Concours, .....			
69	Estate Wag. ....	3928483 L.H.	2.25	MOULDING UNIT, side mldg. cap .....
68	Concours, .....			
69	Estate Wag. ....	3928484 R.H.	2.25	MOULDING UNIT, side mldg. cap .....
68	Concours, .....			
69	Estate Wag. ....	3928479 L.H.	5.55	MOULDING UNIT, side front .....
68	Concours, .....			
69	Estate Wag. ....	3928480 R.H.	5.55	MOULDING UNIT, side front .....
68	Concours, .....			
69	Estate Wag. ....	3928481 L.H.	8.70	MOULDING UNIT, side upper .....
68	Concours, .....			
69	Estate Wag. ....	3928482 R.H.	8.70	MOULDING UNIT, side upper .....
68	Concours, .....			
69	Estate Wag. ....	3930905 L.H.	4.15	MOULDING UNIT, side rear .....
68	Concours, .....			
69	Estate Wag. ....	3930906 R.H.	4.15	MOULDING UNIT, side rear .....
68	Concours .....	3928435 L.H.	12.85	MOULDING UNIT, wheelhouse opening .....
68	Concours .....	3928436 R.H.	12.85	MOULDING UNIT, wheelhouse opening .....
68	Malibu .....	3955683 L.H.	12.95	MOULDING UNIT, wheel opening (38") .....
68	Malibu .....	3955684 R.H.	12.95	MOULDING UNIT, wheel opening (38") .....
68-69	Malibu (spec. Spt. Sed.) .....	3937275 L.H.	4.25	MOULDING UNIT, side .....
68-69	Malibu (spec. Spt. Sed.) .....	3937276 R.H.	4.25	MOULDING UNIT, side .....
69	Chevelle (2-Dr.) w/body side mldg. ....	3960124 1	33.75	MOULDING UNIT, side .....
69	Chevelle .....	3952497 L.H.	12.85	MOULDING UNIT, wheelhouse opening .....
69	Chevelle .....	3952498 R.H.	12.85	MOULDING UNIT, wheelhouse opening .....
69	Chevelle (exc. Malibu), .....			
69	Malibu w/396 .....	3953621 L.H.	4.15	MOULDING UNIT, rad. grille ext. otr. ....
69	Chevelle (exc. Malibu), .....			
69	Malibu w/396 .....	3953622 R.H.	4.15	MOULDING UNIT, rad. grille ext. otr. ....



**SHEET METAL—HEATER**

**8.132 MOULDING— CAP UNIT— PANEL— PLATE— STRIPE— DECAL— TAPE— TRANSFER, Front Fender (See Group 8.147 for Front Fender Mouldings which include Series Designations) (Con't)**

69	Malibu, Concours (exc. Estate Wag., 396) . . . . .	3953623 L.H.	5.15	MOULDING UNIT, rad. grille ext. otr. . . . .
69	Malibu, Concours (exc. Estate Wag., 396) . . . . .	3953624 R.H.	5.15	MOULDING UNIT, rad. grille ext. otr. . . . .
69	Malibu, Concours (exc. Estate Wag., 396) . . . . .	3953677 L.H.	4.85	MOULDING UNIT, side rear . . . . .
69	Malibu, Concours (exc. Estate Wag., 396) . . . . .	3953678 R.H.	4.85	MOULDING UNIT, rear side . . . . .
70-72	Malibu . . . . .	3970591 L.H.	12.85	MOULDING UNIT, wheelhouse opening, left . . . . .
70-72	Malibu . . . . .	3970592 R.H.	12.85	MOULDING UNIT, wheelhouse opening, right . . . . .
70	Chevelle (exc. Monte Carlo) . . . . .	3970615 L.H.	4.15	MOULDING UNIT, extension, left . . . . .
70	Chevelle (exc. Monte Carlo) . . . . .	3970616 R.H.	4.15	MOULDING UNIT, extension, right . . . . .
70-72	Concours, El Camino . . . . .	3970589 L.H.	12.85	MOULDING UNIT, wheelhouse opening, left . . . . .
70-72	Concours, El Camino . . . . .	3970590 R.H.	12.85	MOULDING UNIT, wheelhouse opening, right . . . . .
70-72	Concours Estate Wag. . . . .	3980801 L.H.	7.25	MOULDING UNIT, side, rear, left . . . . .
70-72	Concours Estate Wag. . . . .	3980802 R.H.	7.25	MOULDING UNIT, side, rear, right . . . . .
70-72	Concours Estate Wag. . . . .	3980798 2	6.75	MOULDING UNIT, side frt. lower, left and right . . . . .
70-72	Concours Estate Wag. . . . .	3980803 L.H.	11.30	MOULDING UNIT, side upper, left . . . . .
70-72	Concours Estate Wag. . . . .	3980804 R.H.	11.30	MOULDING UNIT, side upper, right . . . . .
70-72	Concours Estate Wag. . . . .	3980805 L.H.	11.30	MOULDING UNIT, side, left (curved from upper mldg. down) . . . . .
70-72	Concours Estate Wag. . . . .	3980806 R.H.	11.30	MOULDING UNIT, side, right (curved from upper mldg. down) . . . . .
70-72	Concours Estate Wag. . . . .	3977565 L.H.	7.95	MOULDING UNIT, side, frt., left (bumper indentation) . . . . .
70-72	Concours Estate Wag. . . . .	3977566 R.H.	7.95	MOULDING UNIT, side, frt., right (bumper indentation) . . . . .
70-71	Malibu (exc. 396, 454) . . . . .	3977511 L.H.	9.80	MOULDING UNIT, side upper, left . . . . .
70-71	Malibu (exc. 396, 454) . . . . .	3977512 R.H.	9.80	MOULDING UNIT, side upper, right . . . . .
70-72	El Camino (Custom) (exc. 396, 454) . . . . .	3977515 L.H.	5.20	MOULDING UNIT, side rear, left . . . . .
70-72	El Camino (Custom) (exc. 396, 454) . . . . .	3977516 R.H.	5.20	MOULDING UNIT, side rear, right . . . . .
70-72	El Camino (Custom) (exc. 396, 454) . . . . .	3977513 2	4.50	MOULDING UNIT, side frt., left and right . . . . .
70-72	Monte Carlo . . . . .	3970593 L.H.	12.85	MOULDING UNIT, wheelhouse opening, left . . . . .
70-72	Monte Carlo . . . . .	3970594 R.H.	12.85	MOULDING UNIT, wheelhouse opening, right . . . . .
70	Monte Carlo . . . . .	3970575 L.H.	5.60	MOULDING UNIT, fender extension, left . . . . .
70	Monte Carlo . . . . .	3970576 R.H.	5.60	MOULDING UNIT, fender extension, right . . . . .
70-72	Monte Carlo . . . . .	3974291 L.H.	7.25	MOULDING UNIT, side frt., lower, left . . . . .
70-72	Monte Carlo . . . . .	3974292 R.H.	7.25	MOULDING UNIT, side frt., lower, right . . . . .
70-71	Monte Carlo (454),			
72	Monte Carlo (S.S.) . . . . .	3977596 R.H.	5.70	MOULDING UNIT, side, lower rear, right . . . . .
70-72	Monte Carlo . . . . .	3997567 L.H.	6.75	MOULDING UNIT, side lower rear, left (Note 14) . . . . .
70-71	Monte Carlo (exc. 454),			
72	Monte Carlo (exc. S.S.) . . . . .	3997568 R.H.	6.75	MOULDING UNIT, side lower rear, right (Note 14) . . . . .
<i>NOTE 14: These mouldings do not include plate (SS 454). If this plate is required order part 3975418.</i>				
72	Chevelle w/body side moulding . . . . .	6263176 2	6.45	MOULDING UNIT, side upper (black insert) . . . . .
73	Laguna Estate . . . . .	6259491 L.H.	1.30	MOULDING UNIT, side, lower front, left . . . . .
73	Laguna Estate . . . . .	6259492 R.H.	1.30	MOULDING UNIT, side, lower front, right . . . . .
73	Laguna Estate . . . . .	6259489 L.H.	6.75	MOULDING UNIT, side, front, left . . . . .
73	Laguna Estate . . . . .	6259490 R.H.	6.75	MOULDING UNIT, side front, right . . . . .
73	Chevelle (exc. Deluxe, Monte Carlo),			
74-75	Chevelle Estate,			
74-75	Malibu Classic,			
74-75	El Camino Classic (exc. S.S.) . . . . .	6258029 L.H.	4.85	MOULDING UNIT, side, rear, left . . . . .
73	Chevelle (exc. Deluxe, Monte Carlo),			
74-75	Chevelle Estate,			
74-75	Malibu Classic,			
74-75	El Camino Classic (exc. S.S.) . . . . .	6258030 R.H.	4.85	MOULDING UNIT, side, rear, right . . . . .
73-75	Malibu Estate,			
73-75	El Camino w/wood grain ext., two-tone paint . . . . .	6258111 L.H.	1.30	MOULDING UNIT, side front lower, left . . . . .
73-75	Malibu Estate,			

**SHEET METAL—HEATER**

**8.132 MOULDING— CAP UNIT— PANEL— PLATE— STRIPE— DECAL— TAPE— TRANSFER, Front Fender (See Group 8.147 for Front Fender Mouldings which include Series Designations) (Con't)**

73-75	El Camino w/wood grain ext., two-tone paint	6258112 R.H.	1.30	MOULDING UNIT, side front lower, right
73	Monte Carlo	6258037 L.H.	7.25	MOULDING UNIT, side frt., left
73	Monte Carlo	6258038 R.H.	7.25	MOULDING UNIT, side frt., right
74	Monte Carlo	6260523 L.H.	7.25	MOULDING UNIT, side front, left
74	Monte Carlo	360950 R.H.	7.25	MOULDING UNIT, side front, right
73-74	Monte Carlo	6258035 L.H.	6.75	MOULDING UNIT, side rear, left
73-74	Monte Carlo	6258036 R.H.	6.75	MOULDING UNIT, side rear, right
73-75	Malibu Estate, El Camino w/wood grain ext., two-tone paint	6258109 L.H.	6.75	MOULDING UNIT, side front upper, left
73-75	Malibu Estate, El Camino w/wood grain ext., two-tone paint	6258110 R.H.	6.75	MOULDING UNIT, side front upper, right
73-75	El Camino w/wood grain ext., two-tone paint, Chevelle Estate	6258107 L.H.	11.30	MOULDING UNIT, side upper, left
73-75	El Camino w/wood grain ext., two-tone paint, Chevelle Estate	6258108 R.H.	11.30	MOULDING UNIT, side upper, right
73-75	Chevelle w/body side mldg.	6258054 2	4.70	MOULDING UNIT, side upper (vinyl insert)
73	Chevelle (exc. El Camino, Monte Carlo, Deluxe), El Camino Custom (exc. S.S.), Chevelle Estate, Malibu Classic, El Camino Classic (exc. S.S.)	6258141 L.H.	12.85	MOULDING UNIT, wheel housing opening, left
73	Chevelle (exc. El Camino, Monte Carlo, Deluxe), El Camino, Custom (exc. S.S.), Chevelle Estate, Malibu Classic, El Camino Classic (exc. S.S.)	6258142 R.H.	12.85	MOULDING UNIT, wheel house opening, right
73-75	Chevelle (Deluxe), El Camino (exc. Custom), El Camino, Custom (S.S.)	6258031 L.H.	12.85	MOULDING UNIT, wheelhouse opening, left
73-75	Chevelle (Deluxe), El Camino (exc. Custom), El Camino, Custom (S.S.)	6258032 R.H.	12.85	MOULDING UNIT, wheelhouse opening, right
73-75	Monte Carlo	6258033 L.H.	12.85	MOULDING UNIT, wheelhouse opening, left
73-75	Monte Carlo	6258034 R.H.	12.85	MOULDING UNIT, wheelhouse opening, right
73-75	Monte Carlo	360951 L.H.	6.75	MOULDING UNIT, frt. fender side, rear, lwr.
73-75	Monte Carlo	360952 R.H.	6.75	MOULDING UNIT, frt. fender side, rear, lwr.
74-75	Monte Carlo	360949 L.H.	7.25	MOULDING UNIT, frt. fender side, front, lwr.
74-75	Monte Carlo	360950 R.H.	7.25	MOULDING UNIT, frt. fender side, front, lwr.
75	Monte Carlo	358957 L.H.	4.70	MOULDING UNIT, side upper rear (black)
75	Monte Carlo	358958 R.H.	4.70	MOULDING UNIT, side upper rear (black)
75	Monte Carlo	358959 L.H.	4.70	MOULDING UNIT, side upper rear (white)
75	Monte Carlo	358960 R.H.	4.70	MOULDING UNIT, side upper rear (white)
75	Monte Carlo	358961 L.H.	4.70	MOULDING UNIT, side upper rear (silver met.)
75	Monte Carlo	358962 R.H.	4.70	MOULDING UNIT, side upper rear (silver met.)
75	Monte Carlo	358963 L.H.	4.70	MOULDING UNIT, side upper rear (dk. blue met.)
75	Monte Carlo	358964 R.H.	4.70	MOULDING UNIT, side upper rear (dk. blue met.)
75	Monte Carlo	358965 L.H.	4.70	MOULDING UNIT, side upper rear (med. green)
75	Monte Carlo	358966 R.H.	4.70	MOULDING UNIT, side upper rear (med. green)
75	Monte Carlo	358967 L.H.	4.70	MOULDING UNIT, side upper rear (sandstone)
75	Monte Carlo	358968 R.H.	4.70	MOULDING UNIT, side upper rear (sandstone)
75	Monte Carlo	358969 L.H.	4.70	MOULDING UNIT, side upper rear (red met.)

**SHEET METAL—HEATER**

**8.132 MOULDING— CAP UNIT— PANEL— PLATE— STRIPE— DECAL— TAPE— TRANSFER, Front Fender (See Group 8.147 for Front Fender Mouldings which include Series Designations) (Con't)**

75	Monte Carlo	358970 R.H.	4.70	MOULDING UNIT, side upper rear (red met.)
----	-------------	-------------	------	---

NOTE 1: Includes two 17 ft. vinyl mldgs. w/speared ends.  
NOTE 5: Includes one 17 ft. vinyl mldg. w/speared ends.

**CAMARO**

67	Camaro w/R.S.	3912087 L.H.	5.60	MOULDING UNIT, side
67	Camaro w/R.S.	3912088 R.H.	5.60	MOULDING UNIT, side
67-68	Camaro w/ext. trim, R.S.	9785881 L.H.	14.35	MOULDING UNIT, wheel opening (Note 9)
67-68	Camaro w/ext. trim, R.S.	9785880 R.H.	14.35	MOULDING UNIT, wheel opening (Note 9)
68	Camaro	3928527 L.H.	5.55	MOULDING UNIT, side
68	Camaro	3928528 R.H.	5.55	MOULDING UNIT, side
69	Camaro (R.S. w/exterior moulding)	3953635 L.H.	14.35	MOULDING UNIT, wheelhouse opening (Note 4)
69	Camaro (R.S. w/exterior moulding)	3953636 R.H.	14.35	MOULDING UNIT, wheelhouse opening (Note 4)
70-75	Camaro	3986059 L.H.	3.40	MOULDING UNIT, left upper
70-75	Camaro	3986060 R.H.	3.40	MOULDING UNIT, right upper
73-75	Camaro (L.T.)	6259429 L.H.	5.70	MOULDING UNIT, side lower, left
73-75	Camaro (L.T.)	6259430 R.H.	5.70	MOULDING UNIT, side lower, right
73-74	Camaro w/body side mldgs. (1st design)	488141	2 5.70	MOULDING UNIT, front fender side
74-75	Camaro w/body side mldgs. (2nd design)	493383	2	MOULDING UNIT, front fender side
74-75	Camaro	488141	2 5.70	MOULDING UNIT, front fender side

**CHEVY— NOVA**

74-75	Nova	342654	1 RL/1.25	body side (green) (Note 5)
74	Nova	342659	1 RL/1.25	body side (red) (Note 5)
74-75	Nova	342660	1 RL/1.25	body side (beige) (Note 5)
75	Nova	231805	L.H. 10.75	wheel opening
75	Nova	231804	R.H. 10.75	wheel opening
75	Nova w/spec. side mldg.	359999	2 RL/3.00	fender side
62	Chevy Deluxe (exc. Nova)	3814939	1 7.85	MOULDING UNIT, left and right side
62	Nova	3824309	L.H. 6.65	MOULDING UNIT, front cove (Note 5)
62	Nova	3824310	R.H. 6.65	MOULDING UNIT, front cove (Note 5)
62	Nova	3814935	L.H. 2.00	MOULDING UNIT, side front
62	Nova	3814936	R.H. 2.00	MOULDING UNIT, side front
62	Nova	3814937	L.H. 7.25	MOULDING UNIT, side rear
62	Nova	3814938	R.H. 7.25	MOULDING UNIT, side rear
63	Chevy Deluxe	3793941	L.H. 9.80	MOULDING UNIT
63	Chevy Deluxe	3793942	R.H. 9.80	MOULDING UNIT
63-64	Nova (Super Sport)	3793681	L.H. 7.85	MOULDING UNIT, front peak
63-64	Nova (Super Sport)	3793682	R.H. 7.85	MOULDING UNIT, front peak
64	Nova	3850219	L.H. 7.85	MOULDING UNIT, front side
64	Nova	3850220	R.H. 7.85	MOULDING UNIT, front side
65	Chevy	3865309	L.H. 13.30	MOULDING UNIT, front
65	Chevy	3865310	R.H. 13.30	MOULDING UNIT, front
65	Nova (exc. S.S.)	3862225	L.H. 10.45	MOULDING UNIT
65	Nova (exc. S.S.)	3862226	R.H. 10.45	MOULDING UNIT
65	Nova (S.S.)	3867370	R.H. 5.25	MOULDING UNIT, lower rear
65	Nova (S.S.)	3865321	L.H. 14.35	MOULDING UNIT, frt. wheelhouse opening
65	Nova (S.S.)	3865322	R.H. 14.35	MOULDING UNIT, frt. wheelhouse opening
66	Nova (exc. S.S.)	3885398	2 7.85	MOULDING UNIT, fender side
66	Nova (S.S.)	3886269	L.H. 3.20	MOULDING UNIT, fender side lower
66	Nova (S.S.)	3886270	R.H. 3.20	MOULDING UNIT, fender side lower
66-67	Nova (S.S.)	3886271	L.H. 14.35	MOULDING UNIT, wheelhouse opening
66-67	Nova (S.S.)	3886272	R.H. 14.35	MOULDING UNIT, wheelhouse opening
67	Nova (exc. S.S.)	3904656	2 8.70	MOULDING UNIT, side
67	Nova (S.S.)	3904657	L.H. 3.20	MOULDING UNIT, lower front
67	Nova (S.S.)	3904658	R.H. 3.20	MOULDING UNIT, lower front
67	Nova (S.S.)	3904659	L.H. 5.60	MOULDING UNIT, lower rear
67	Nova (S.S.)	3904660	R.H. 5.60	MOULDING UNIT, lower rear
68	Chevy	3929261	2 10.15	MOULDING UNIT, side
68-70	Chevy	3927549	L.H. 5.85	MOULDING UNIT, hdlp. opening
68-70	Nova w/custom exterior	3929263	L.H. 5.70	MOULDING UNIT, side lower
68-70	Nova w/custom exterior	3929264	R.H. 5.70	MOULDING UNIT, side lower
69-72	Chevy w/spec. side moulding	3998389	L.H. 15.85	MOULDING UNIT, side, left
69-72	Chevy w/spec. side moulding	3998390	R.H. 15.85	MOULDING UNIT, side, right
68-72	Nova	3997569	L.H. 5.50	MOULDING UNIT, headlamp opening
68-72	Nova	3997570	R.H. 5.50	MOULDING UNIT, headlamp opening

**SHEET METAL—HEATER**

**8.132 MOULDING— CAP UNIT— PANEL— PLATE— STRIPE— DECAL— TAPE— TRANSFER, Front Fender (See Group 8.147 for Front Fender Mouldings which include Series Designations) (Con't)**

73-74	Nova w/spec. side mldg. ....	3998389	L.H.	15.85	MOULDING UNIT, left side .....
73-74	Nova w/spec. side mldg. ....	3998390	R.H.	15.85	MOULDING UNIT, right side .....
73-75	Nova .....	6258147	L.H.	9.80	MOULDING UNIT, extension, left front .....
73-75	Nova .....	6258148	R.H.	9.80	MOULDING UNIT, extension, right front .....
<i>NOTE 5: Includes one 17 ft. vinyl mldg. w/speared ends.</i>					
<b>VEGA— MONZA</b>					
73-75	Vega, Monza .....	347058	2	13.55	(black) (adhesive type) (Note 3) .....
<i>NOTE 3: Includes one 10 ft. vinyl mldg. speared at one end.</i>					
73-74	Vega (Coupe) w/body stripe and mldg. ....	9692389	2	8.10	(blue) (adhesive type) .....
73-74	Vega (Coupe) w/body stripe and mldg. ....	9692390	2	8.10	(green) (adhesive type) .....
73-74	Vega (Coupe) w/body stripe and mldg. ....	9692391	2	8.10	(orange) (adhesive type) .....
73-74	Vega (Coupe) w/body stripe and mldg. ....	9692392	2	8.10	(white) (adhesive type) .....
74-75	Vega, Monza .....	342654	1	RL/1.25	body side (green) (Note 4) .....
74-75	Vega, Monza .....	342659	1	RL/1.25	body side (red) (Note 4) .....
74-75	Vega, Monza .....	342660	1	RL/1.25	body side (beige) (Note 4) .....
<i>NOTE 4: Includes one 17 ft. vinyl mldg. w/speared ends.</i>					
74	Vega w/body side mldg. ....	9734122	2	8.10	MOULDING ASSY., qtr. panel front fender upper (black) .....
75	Vega w/body side mldg. ....	8704082	R.H.	4.25	MOULDING KIT, frt. fdr., lower .....
75	Vega w/body side mldg. ....	8704083	L.H.	4.25	MOULDING KIT, frt. fdr., lower .....
75	Vega .....	9631834	R.H.	5.30	MOULDING KIT, frt. fdr. wheel opening .....
75	Vega .....	9631835	L.H.	5.30	MOULDING KIT, frt. fdr. wheel opening .....
71-72	Vega .....	8704090	2	9.15	MOULDING UNIT, outer panel front fender upper .....
71-75	Vega, Monza .....	995016	1	28.00	MOULDING UNIT (vinyl stick-on) (black) (Note 1) .....
71-74	Vega (exc. wood grain) .....	8704082	R.H.	4.25	MOULDING UNIT, frt. fender lower .....
71-74	Vega (exc. wood grain) .....	8704083	L.H.	4.25	MOULDING UNIT, frt. fender lower .....
71-73	Vega .....	8704088	R.H.	5.85	MOULDING UNIT, frt. wheel opg. ....
71-73	Vega .....	9631835	L.H.	5.30	MOULDING UNIT, frt. wheel opg. ....
74-75	Vega (exc. wood grain) .....	9631834	R.H.	5.30	MOULDING UNIT, frt. wheel opng. ....
74-75	Vega (exc. wood grain) .....	9631835	L.H.	5.30	MOULDING UNIT, frt. wheel opng. ....
73	Vega (exc. wood grain) .....	8707807	2	9.15	MOULDING UNIT, outer panel front fender upper .....
73	Vega w/wood grain .....	9630092	R.H.	9.25	MOULDING UNIT, front fender upper .....
73	Vega w/wood grain .....	9630093	L.H.	9.25	MOULDING UNIT, front fender upper .....
73	Vega w/wood grain .....	9631023	R.H.	8.60	MOULDING UNIT, front fender opening vert. upper & lower .....
73	Vega w/wood grain .....	9631024	L.H.	8.60	MOULDING UNIT, front fender opening vert. upper & lower .....
73	Vega w/wood grain .....	9631015	R.H.	4.60	MOULDING UNIT, front of front w/opening .....
73	Vega w/wood grain .....	9631016	L.H.	4.60	MOULDING UNIT, front of front w/opening .....
73	Vega w/wood grain .....	9631013	R.H.	5.05	MOULDING UNIT, rear of front w/opening .....
73	Vega w/wood grain .....	9631014	L.H.	5.05	MOULDING UNIT, rear of front w/opening .....
74-75	Vega w/wood grain .....	9631715	R.H.	5.05	MOULDING UNIT, rear of front w/opening .....
74-75	Vega w/wood grain .....	9631716	L.H.	5.05	MOULDING UNIT, rear of front w/opening .....
74-75	Vega w/wood grain .....	9631710	L.H.	9.25	MOULDING UNIT, front fender upper .....
74-75	Vega w/wood grain .....	9631709	R.H.	9.25	MOULDING UNIT, front fender upper .....
74-75	Vega w/wood grain .....	9631712	L.H.	8.60	MOULDING UNIT, fdr. opening vertical transfer .....
74-75	Vega w/wood grain .....	9631711	R.H.	8.60	MOULDING UNIT, fdr. opening vertical transfer .....
74-75	Vega w/wood grain .....	9631841	L.H.	15.00	MOULDING UNIT, fdr. wheel opening transfer .....
74-75	Vega w/wood grain .....	9631840	R.H.	15.00	MOULDING UNIT, fdr. wheel opening transfer .....
75	Monza .....	9631898	R.H.	4.70	MOULDING UNIT, frt. wheel opg. ....
75	Monza .....	9631899	L.H.	4.70	MOULDING UNIT, frt. wheel opg. ....
64	Malibu (S.S.), El Camino .....	3845629	L.H.	1.95	CAP UNIT, wheelhouse mldg. ....
64	Malibu (S.S.), El Camino .....	3845630	R.H.	1.95	CAP UNIT, wheelhouse mldg. ....
71-72	Chevelle (Hvy. Chevy) .....	6261947	2	5.25	DECAL (black) (Heavy Chevy)— (12.132) ..
71-72	Chevelle (Hvy. Chevy) .....	6261946	2	5.25	DECAL (white) (Heavy Chevy)— (12.132) ..
73	Vega (Sedan) .....	9693549	2	2.20	DECAL (LX) (black-silver-red) .....
74	Nova (S.S.) .....	341069	2	2.85	DECAL (black and gold) .....
74-75	Nova (S.S.) .....	344374	2	4.60	DECAL (gold and red) .....
75	Camaro .....	360658	R.H.	5.90	DECAL, lower (blue) 3 stripe .....
75	Camaro .....	360657	L.H.	5.90	DECAL, lower (blue) 3 stripe .....
75	Camaro .....	360660	R.H.	5.90	DECAL, lower (red-orange-yellow) .....

**SHEET METAL—HEATER**

**8.132 MOULDING— CAP UNIT— PANEL— PLATE— STRIPE— DECAL— TAPE— TRANSFER, Front Fender (See Group 8.147 for Front Fender Mouldings which include Series Designations) (Con't)**

75	Camaro	360659	L.H.	5.90	DECAL, lower (red-orange-yellow)
75	Camaro	360662	R.H.	5.90	DECAL, lower (silver) 3 stripe
75	Camaro	360661	L.H.	5.90	DECAL, lower (silver) 3 stripe
75	Camaro	360664	R.H.	5.90	DECAL, lower (red) 3 stripe
75	Camaro	360663	L.H.	5.90	DECAL, lower (red) 3 stripe
75	Camaro	360666	R.H.	5.90	DECAL, lower (orange yellow-orange)
75	Camaro	360665	L.H.	5.90	DECAL, lower (orange yellow-orange)
66	Caprice (Sta. Wag.)	3884909	L.H.	43.00	PANEL, simulated wood
66	Caprice (Sta. Wag.)	3884910	R.H.	43.00	PANEL, simulated wood
68	Pass. (exc. Caprice)	3920823	L.H.	7.35	PLATE, fender trim (Note 6)
68	Pass. (exc. Caprice)	3920824	R.H.	7.35	PLATE, fender trim (Note 6)
67	Pass. (exc. Caprice)	3905727	L.H.	7.65	PLATE UNIT, frt. fender trim
67	Pass. (exc. Caprice)	3905728	R.H.	7.65	PLATE UNIT, frt. fender trim
68	Chevelle (S.S.)	3934105	L.H.	4.90	STRIPE, front black
68	Chevelle (S.S.)	3934106	R.H.	4.65	STRIPE, front black
68	Chevelle (S.S.)	3934107	L.H.	4.65	STRIPE, front, white
68	Chevelle (S.S.)	3934108	R.H.	4.65	STRIPE, front, white
68	Chevelle (S.S.)	3934104	1	3.70	STRIPE, rear left and right black (Note 7)
68	Chevelle (S.S.)	3934117	1	4.65	STRIPE, rear left and right white (Note 7)
68	Chevelle (S.S.)	3934118	1	3.35	STRIPE, rear left and right red (Note 7)
68	Camaro (350, 396)	3940135	L.H.	3.60	STRIPE, front, black
68	Camaro (350, 396)	3940136	R.H.	3.00	STRIPE, front, black
68	Camaro (350, 396)	3940137	L.H.	3.60	STRIPE, front, white
68	Camaro (350, 396)	3940138	R.H.	3.60	STRIPE, front, white
69	Chevelle w/body accent stripe	3950069	2	4.75	STRIPE (black)
69	Chevelle w/body accent stripe	3950075	2	4.75	STRIPE (white)
69	Chevelle w/body accent stripe	3950081	2	4.80	STRIPE (red)
69	Chevelle w/body accent stripe	3957001	2	4.55	STRIPE (blue)
71-72	Nova w/Rally Package	6259355	L.H.	15.60	STRIPE, side (white)
71-72	Nova w/Rally Package	6259356	R.H.	15.60	STRIPE, side (white)
71-72	Nova w/Rally Package	6259357	L.H.	15.60	STRIPE, side (black)
71-72	Nova w/Rally Package	6259358	R.H.	15.60	STRIPE, side (black)
71-72	Chevelle (Hvy. Chevy)	6259365	L.H.	13.40	STRIPE, accent (black)
71-72	Chevelle (Hvy. Chevy)	6259366	R.H.	13.40	STRIPE, accent (black)
71-72	Chevelle (Hvy. Chevy)	6259363	L.H.	13.40	STRIPE, accent (white)
71-72	Chevelle (Hvy. Chevy)	6259364	R.H.	13.40	STRIPE, accent (white)
74	Impala w/Spirit of America	349103	L.H.	5.90	STRIPE, accent
74	Impala w/Spirit of America	349104	R.H.	5.90	STRIPE, accent
74-75	Nova w/Sport Striping	344375	L.H.	13.65	STRIPE, hood panel (black)— (8.055)
74-75	Nova w/Sport Striping	344376	R.H.	13.65	STRIPE, hood panel (black)— (8.055)
74-75	Nova w/Sport Striping	344377	L.H.	14.75	STRIPE, hood panel (gold)— (8.055)
74-75	Nova w/Sport Striping	344378	R.H.	14.75	STRIPE, hood panel (gold)— (8.055)
73-75	El Camino	6259367	L.H.	12.20	STRIPE UNIT, white (Note 3)
73-75	El Camino	6259368	R.H.	12.20	STRIPE UNIT, white (Note 3)
73-75	El Camino	6259369	L.H.	12.20	STRIPE UNIT, black (Note 3)
73-75	El Camino	6259370	R.H.	12.20	STRIPE UNIT, black (Note 3)
73-74	Nova	6259359	L.H.	20.50	STRIPE UNIT, white (Note 3)
73-74	Nova	6259360	R.H.	20.50	STRIPE UNIT, white (Note 3)
73-74	Nova	6259361	L.H.	20.50	STRIPE UNIT, black (Note 3)
73-74	Nova	6259362	R.H.	20.50	STRIPE UNIT, black (Note 3)
<i>NOTE 3: Consists of all striping for one complete side.</i>					
69	Caprice	3981905	1	RL/.32	TAPE, mldg. (vinyl) (black) 50 ft. length (Note 8)
69	Caprice	3981906	1	RL/.32	TAPE, mldg. (vinyl) (white) 50 ft. length (Note 8)
69	Caprice	3981907	1	RL/.32	TAPE, mldg. (vinyl) (maroon) 50 ft. length (Note 8)
69	Caprice	3981908	1	RL/.32	TAPE, mldg. (vinyl) (yellow) 50 ft. length (Note 8)
69	Caprice	3981909	1	RL/.32	TAPE, mldg. (vinyl) (champagne) 50 ft. length (Note 8)
69	Caprice	3981910	1	RL/.32	TAPE, mldg. (vinyl) (bright blue) 50 ft. length (Note 8)
69	Caprice	3981911	1	RL/.32	TAPE, mldg. (vinyl) (silver) 50 ft. length (Note 8)
69	Caprice	3981912	1	RL/.32	TAPE, mldg. (vinyl) (med. blue) 50 ft. length (Note 8)
69	Caprice	3981913	1	RL/.32	TAPE, mldg. (vinyl) (turq.) 50 ft. length (Note 8)
69	Caprice	3981914	1	RL/.32	TAPE, mldg. (vinyl) (dark blue) 50 ft. length (Note 8)
69	Caprice	3981915	1	RL/.32	TAPE, mldg. (vinyl) (lime) 50 ft. length (Note 8)

**SHEET METAL—HEATER**

**8.132 MOULDING— CAP UNIT— PANEL— PLATE— STRIPE— DECAL— TAPE— TRANSFER, Front Fender (See Group 8.147 for Front Fender Mouldings which include Series Designations) (Con't)**

69	Caprice	3981916	1	RL/32	TAPE, mldg. (vinyl) (green) 50 ft. length (Note 8)
69	Caprice	3981917	1	RL/32	TAPE, mldg. (vinyl) (red) 50 ft. length (Note 8)
69	Caprice	3981918	1	RL/32	TAPE, mldg. (vinyl) (gold) 50 ft. length (Note 8)
69	Caprice	3981919	1	RL/32	TAPE, mldg. (vinyl) (brown) 50 ft. length (Note 8)
70	Caprice	3980833	1	RL/32	TAPE, mldg. (vinyl) (black) 50 ft. length (Note 8)
70	Caprice	3980834	1	RL/32	TAPE, mldg. (vinyl) (maroon) 50 ft. length (Note 8)
70	Caprice	3980835	1	RL/32	TAPE, mldg. (vinyl) (white) 50 ft. length (Note 8)
70	Caprice	3980836	1	RL/32	TAPE, mldg. (vinyl) (dk. taupe) 50 ft. length (Note 8)
70	Caprice	3980837	1	RL/32	TAPE, mldg. (vinyl) (silver) 50 ft. length (Note 8)
70	Caprice	3980838	1	RL/32	TAPE, mldg. (vinyl) (dk. green) 50 ft. length (Note 8)
70	Caprice	3980839	1	RL/32	TAPE, mldg. (vinyl) (dk. gold) 50 ft. length (Note 8)
70	Caprice	3980840	1	RL/32	TAPE, mldg. (vinyl) (red) 50 ft. length (Note 8)
70	Caprice	3980841	1	RL/32	TAPE, mldg. (vinyl) (med. turq.) 50 ft. length (Note 8)
70	Caprice	3980842	1	RL/32	TAPE, mldg. (vinyl) (med. gold) 50 ft. length (Note 8)
70	Caprice	3980843	1	RL/32	TAPE, mldg. (vinyl) (yellow) 50 ft. length (Note 8)
70	Caprice	3980844	1	RL/32	TAPE, mldg. (vinyl) (med. green) 50 ft. length (Note 8)
70	Caprice	3980845	1	RL/32	TAPE, mldg. (vinyl) (med. blue) 50 ft. length (Note 8)
70	Caprice	3980846	1	RL/32	TAPE, mldg. (vinyl) (dk. blue) 50 ft. length (Note 8)
70	Caprice	3980847	1	RL/32	TAPE, mldg. (vinyl) (saddle) 50 ft. length (Note 8)
74	Nova (H.B.) w/Spirit of America	347525	L.H.	5.90	TAPE ASSY., front fender (vinyl)
74	Nova (H.B.) w/Spirit of America	347526	R.H.	5.90	TAPE ASSY., front fender (vinyl)
66	Caprice (Sta. Wag.)	3995735	1	RL/3.20	TRANSFER, wood grain (19" wide) (25 ft. roll)
66	Caprice (Sta. Wag.)	6259398	1	RL/4.10	TRANSFER, wood grain 19" wide (Note 12)
67-68	Caprice, Concours (Sta. Wag.)	6259399	1	RL/4.75	TRANSFER, wood grain 24" wide (Note 12)
67	Concours	3910610	R.H.	16.80	TRANSFER, simulated wood
69	Pass., Chevelle (Estate Wag.)	6259400	1	RL/4.75	TRANSFER, wood grain 21" wide (Note 12)
70-71	Kingswood, Concours (Estate Wag.)	6259401	1	RL/4.75	TRANSFER, wood grain 24" wide (Note 12)
72	Kingswood, Concours (Estate)	231619	1	RL/4.27	TRANSFER (Note 11)
73-74	All w/wood grain	6258806	1	RL/4.75	TRANSFER (Note 14)
75	All w/wood grain	1154151	1	RL/7.35	TRANSFER
73-74	Vega w/wood grain	6258806	1	RL/4.75	TRANSFER, serviced in 90 inch roll
73-74	Vega (Coupe)	9692326	R.H.	7.60	TRANSFER (silver-black-silver) (Note 15)
73-74	Vega (Coupe)	9692327	L.H.	7.60	TRANSFER (silver-black-silver) (Note 15)
73-74	Vega (Coupe)	9692328	R.H.	7.60	TRANSFER (black-white-black) (Note 15)
73-74	Vega (Coupe)	9692329	L.H.	7.60	TRANSFER (black-white-black) (Note 15)
73-74	Vega (Coupe)	9692330	R.H.	8.75	TRANSFER (red-white-blue) (Note 15)
73-74	Vega (Coupe)	9692331	L.H.	8.75	TRANSFER (red-white-blue) (Note 15)
73-74	Vega (Coupe)	9692332	R.H.	8.75	TRANSFER (red-white-green) (Note 15)
73-74	Vega (Coupe)	9692333	L.H.	8.75	TRANSFER (red-white-green) (Note 15)
73-74	Vega (Coupe)	9692334	R.H.	8.75	TRANSFER (red-yellow-orange) (Note 15)
73-74	Vega (Coupe)	9692335	L.H.	8.75	TRANSFER (red-yellow-orange) (Note 15)
73-74	Vega (Coupe)	9692336	R.H.	7.60	TRANSFER (white-black-white) (Note 15)
73-74	Vega (Coupe)	9692337	L.H.	7.60	TRANSFER (white-black-white) (Note 15)
74-75	Vega (Cpe., Sta. Wag.) w/Sport Stripe	9734700	R.H.	13.80	TRANSFER (black) (Note 15)
74-75	Vega (Cpe., Sta. Wag.) w/Sport Stripe	9734701	L.H.	13.80	TRANSFER (black) (Note 15)
74-75	Vega (Cpe., Sta. Wag.) w/Sport Stripe	9734702	R.H.	13.80	TRANSFER (white) (Note 15)
74-75	Vega (Cpe., Sta. Wag.) w/Sport Stripe	9734703	L.H.	13.80	TRANSFER (white) (Note 15)

**SHEET METAL—HEATER**

**8.132 MOULDING— CAP UNIT— PANEL— PLATE— STRIPE— DECAL— TAPE— TRANSFER, Front Fender (See Group 8.147 for Front Fender Mouldings which include Series Designations) (Con't)**

75	Vega (Coupe) H77 w/frt. and body side paint stripe (Cosworth Twin Cam) . . . . .	1657533 L.H.	6.50	TRANSFER, front fender (gold) . . . . .
75	Vega (Coupe) H77 w/frt. and body side paint stripe (Cosworth Twin Cam) . . . . .	1657532 R.H.	6.50	TRANSFER, front fender (gold) . . . . .
75	Vega (Coupe) H77 w/frt. and body side paint stripe (Cosworth Twin Cam) . . . . .	1657535 L.H.	9.95	TRANSFER, wheel opening (gold) . . . . .
75	Vega (Coupe) H77 w/frt. and body side paint stripe (Cosworth Twin Cam) . . . . .	1657534 R.H.	9.95	TRANSFER, wheel opening (gold) . . . . .
75	Vega (Coupe) H77 . . . . .	1676742 R.H.	5.25	TRANSFER, frt. fender (Spirit of American) . . . . .
75	Vega (Coupe) H77 . . . . .	1676743 L.H.	5.25	TRANSFER, frt. fender (Spirit of American) . . . . .
75	Vega (Coupe) H77 . . . . .	1676745 2	4.90	TRANSFER, frt. fender emblem (Spirit of America) . . . . .
75	Vega w/wood grain . . . . .	1154151	RL/7.35	TRANSFER, wood grain applique . . . . .

- NOTE 1: Also appears in Chevelle Section.*  
*NOTE 2: Requires 7-4446130 screws for installation.*  
*NOTE 3: Also appears in Passenger Section.*  
*NOTE 4: When used as a replacement, use fender & fender skirt attaching screws for balance of attaching parts.*  
*NOTE 5: Consists of upper & lower cove moulding.*  
*NOTE 6: Requires 2-120376 Nuts & 2-138485 Washers for installation.*  
*NOTE 7: It may be necessary to cut to required size.*  
*NOTE 8: Quantity of one when ordering denotes one 50 ft. roll.*  
*NOTE 9: It may be necessary to rework as required using old parts as a guide.*  
*NOTE 11: Serviced in 82" roll.*  
*NOTE 12: Serviced in 90" roll.*  
*NOTE 14: Serviced in 90 inch roll.*  
*NOTE 15: For front door and rear fender transfers see Group 10.354. For rear deck lid transfers see Group 12.182.*

**8.133 NUT— CLIP— RETAINER— STUD, Front Fender Moulding**

62-64	Chevy Deluxe . . . . .	3780673 A.R.	.12	moulding (No. 10-24) . . . . .
62-69	All . . . . .	9427101 A.R.	.16	side, peak, headlamp (No. 10-24)— (8.921) . . . . .
64-65	Chevelle (exc. El Camino Std.) . . . . .			peak, hood panel crown mldg. (No. 8-32), . . . . .
66-67	Nova (exc. S.S.),			
67	Impala (S.S.),			
68	Camaro w/R.S. . . . .	3844130 A.R.	.11	front side mldg. . . . .
67	Pass. . . . .			frt. fender trim plate plastic ( <sup>9</sup> / <sub>16</sub> " x <sup>9</sup> / <sub>8</sub> " ) . . . . .
68	Chevelle . . . . .	3937957 6	.16	rad. grille ext.— (2.729) . . . . .
73	Malibu, Deluxe, Vega, Monza . . . . .	3919773 2	.12	NUT, headlamp housing side mldg. . . . .
71-72	Vega . . . . .	9838109 A.R.	.12	CLIP, upper . . . . .
71-73	Vega . . . . .	7737942 A.R.	.18	CLIP, lower . . . . .
63-64	Nova (S.S.),			
66	Nova (exc. S.S.) . . . . .	3874548 A.R.	.11	RETAINER, fender peak moulding . . . . .
63	Chevy Deluxe . . . . .	3855893 A.R.	.11	RETAINER, fender side . . . . .
64	Chevelle . . . . .	3850257 2	.16	RETAINER, head lamp opening . . . . .
64	Nova,			
67	Biscayne, Bel Air,			
69	Pass. (Estate Wag.),			
70	Nova (Spt. Cpe.) w/Spec. mldg.,			
70	Concours,			
71-72	Concours Estate,			
71-74	Caprice Estate . . . . .	3842013 A.R.	.11	RETAINER, front fender side upper . . . . .
65-66	Bel Air,			
66	Chevelle (Deluxe),			
66	Impala,			
67-68	Concours,			
68	Biscayne, Bel Air,			
68	Chevy,			
69	Bel Air,			
69	Chevelle (Estate Wag.),			
67	Caprice (Sta. Wag.),			
70	Pass. (exc. Estate Wag.),			
70-71	Malibu (exc. 396, 454) . . . . .	3893998 A.R.	.11	RETAINER, front fender side, side upper, lower and frt. mldgs. . . . .
67	Nova (exc. S.S.) . . . . .	3899216 10	.12	RETAINER, frt. fender side . . . . .
67	Nova (exc. S.S.) . . . . .	3899217 4	.12	RETAINER, frt. fender side . . . . .
67	Impala (exc. S.S.),			
70-72	Monte Carlo . . . . .			RETAINER, side lower rear, . . . . .
66	Nova (S.S.),			
68-69	Malibu (4-Dr. Spt. Sed.),			

**SHEET METAL—HEATER**

**8.133 NUT— CLIP— RETAINER— STUD, Front Fender Moulding (Con't)**

69	Caprice,					
70	Kingswood Estate Wag. ....	3899536	6	.12	side, upper and side lower, rear .....	
67	Caprice (exc. Sta. Wag.) .....	3901931	6	.12	RETAINER, side moulding .....	
68	Caprice (exc. Sta. Wag.) .....	3920821	4	.12	RETAINER, side mldg. ....	
66	Chevelle (Deluxe) .....	3877242	2	.12	RETAINER ASSY., front fender side mldg. (ends) .....	
68	Malibu,					
68	S.S. (exc. El Camino),					
69	Malibu, Concours (exc. 396),					
71	El Camino (exc. S.S.) .....	3874551	2	.12	RETAINER ASSY., front fender side mldg.— (1.303) .....	
70	Monte Carlo .....	3968529	L.H.	2.65	RETAINER ASSY., fender extension, left ..	
70	Monte Carlo .....	3968530	R.H.	2.65	RETAINER ASSY., fender extension, right ..	
70	Caprice .....	3979911	A.R.	.18	RETAINER ASSY., front fender side moulding clip retainer .....	
71-74	Caprice Estate .....	3991196	8	.16	RETAINER ASSY., wheelhouse opening ..	
71-74	Nova (Sed.) w/Spec. Mldg. ....	3994733	14	.18	RETAINER ASSY., side .....	
62	Chevy Deluxe,					
64	Chevelle (exc. S.S., El Camino),					
65	Nova (exc. S.S.),					
68	Impala,					
72-74	Pass., Chevelle, Camaro .....	1385099	A.R.	.12	RETAINER ASSY., side .....	
73-74	El Camino w/wood grain trim,					
73-74	Chevelle Estate .....				side upper, side front, .....	
73-74	Camaro (LT) .....	9890529	A.R.	.32	RETAINER ASSY., side lower mldg. ....	
75	Caprice Estate .....	354018	8	.12	RETAINER ASSY., wheel house opening ..	
68	Caprice (Sta. Wag.) .....	3920816	8	.44	STUD, side upper mldg. ....	

**8.141 REINFORCEMENT— BRACE— BRACKET— SUPPORT, Front Fender**

67-69	Camaro .....	3919132	R.H.	11.35	flange center .....	
68	Chevy .....	3938658	R.H.	27.75	flange center .....	
75	Monte Carlo .....	370399	L.H.	97.75	frt. fdr. flange, center .....	
75	Monte Carlo .....	370400	R.H.	97.75	frt. fdr. flange, center .....	
73-74	Nova .....	3938658	R.H.	27.75	REINFORCEMENT ASSY., frt. fdr. flg. ctr. ...	
73-74	Pass.,					
75	Nova .....	344341	L.H.	17.05	REINFORCEMENT ASSY., front fdr. flg. center .....	
75	Nova .....	344342	R.H.	17.05	REINFORCEMENT ASSY., front fdr. flg. center .....	
75	Pass. ....	3795490	2		REINFORCEMENT ASSY., front fdr. skirt to brkt. ....	
66-67	Chevy .....	3886867	2	.67	BRACE .....	
67-69	Camaro .....	3903479	L.H.	1.30	BRACE, fender to rad. supt. ....	
67-69	Camaro .....	3903480	R.H.	1.30	BRACE, fender to rad. supt. ....	
70-72	Camaro .....	3986584	R.H.	1.95	BRACE ASM., face bar to rad. support .....	
70-72	Camaro .....	3986583	L.H.	1.95	BRACE ASM., face bar to rad. support .....	
68	Pass. ....	3917400	2	.45	BRACE, front fender .....	
68-72	Chevy .....	3916672	2	.45	BRACE .....	
68-69	Chevelle .....	3917410	2	.63	BRACE .....	
69	Camaro w/R.S. ....	3949627	L.H.	.45	BRACE, ext. to valance panel .....	
69	Camaro w/R.S. ....	3949628	R.H.	.45	BRACE, ext. to valance panel .....	
69	Pass. ....	3942179	2	.45	BRACE, front fender .....	
70-72	Monte Carlo .....	3965963	L.H.	1.30	BRACE, fdr. to dash, left .....	
70-72	Monte Carlo .....	3965964	R.H.	1.30	BRACE, fdr. to dash, right .....	
70	Pass. ....	3957357	2	.45	BRACE .....	
70-72	Chevelle .....	3958351	2	.45	BRACE .....	
70-72	Camaro .....	3966857	L.H.	1.65	BRACE, fdr. to rad. supt., left .....	
70-72	Camaro .....	3966858	R.H.	1.65	BRACE, fdr. to rad. supt., right .....	
71-72	Pass. ....	3983978	2	.54	BRACE .....	
71	Pass. (1st design) .....	3995103	L.H.	.71	BRACE, front fender to skirt (less weld bolt) ..	
71-72	Pass. (2nd design) .....	3997350	L.H.	.79	BRACE, front fender to skirt (w/weld bolt) ..	
71	Vega .....	9886518	2	.97		
72	Vega .....	6264332	2	.60		
73	Chevelle (exc. Monte Carlo) .....	331793	L.H.	27.75	flange front, left .....	
73	Chevelle (exc. Monte Carlo) .....	331794	R.H.	27.75	flange front, right .....	
73	Nova .....	3916672	2	.45	frt. fdr. ....	
73-75	Pass. ....	6273714	2	.54		
73-75	Chevelle (exc. Monte Carlo) .....	325277	2	.45		
73-75	Monte Carlo .....	3996916	2	.54	frt. fdr. ....	
73	Camaro (R.S.) .....	333763	L.H.	3.40	fdr. to rad. supt., left .....	
73	Camaro (R.S.) .....	333764	R.H.	3.40	fdr. to rad. supt., right .....	
73	Camaro (exc. R.S.),					
73	Vega .....	325729	2	.67		
74-75	Vega .....	336576	2	.60		
74-75	Camaro .....	3966857	L.H.	1.65	rad. support to fender reinf. ....	



**SHEET METAL—HEATER**

**8.141 REINFORCEMENT— BRACE— BRACKET— SUPPORT, Front Fender  
(Con't)**

73	Camaro (exc. R.S.)				
74-75	Camaro	3966858	R.H.	1.65	rad. support to fender reinf.
75	Caprice	343545	2	.50	
75	Monza (exc. Towne Cpe.)	358307	R.H.	1.60	
75	Monza (exc. Towne Cpe.)	358308	L.H.	1.60	
73-75	Chevelle (exc. Monte Carlo)	336334	2	2.95	BRACE ASSY., front fender to cowl
73	Monte Carlo	336373	2	3.40	BRACE ASSY., frt. fender to cowl
74	Nova (Coupe) (8 cyl.)	344399	L.H.	3.40	BRACE ASSY., frt. fdr. to cowl
74-75	Nova (hatchback) (8 cyl.)	344400	R.H.	2.95	BRACE ASSY., frt. fdr. to cowl
74	Nova (hatchback) (6 cyl.)	344397	L.H.	2.95	BRACE ASSY., frt. fdr. to cowl
74	Nova (hatchback) (6 cyl.)	344398	R.H.	3.40	BRACE ASSY., frt. fdr. to cowl
69	Pass.	3938047	L.H.	.76	BRACKET, front fender
69	Pass.	3938048	R.H.	.84	BRACKET, front fender
68-69	Chevelle,				
70-72	Chevelle, Camaro,				
73-74	Camaro	7715377	L.H.	1.75	SUPPORT, on dash
68-69	Chevelle,				
70-72	Chevelle, Camaro,				
73-74	Camaro	9806847	R.H.	1.70	SUPPORT ASSY., on dash, right

**8.143 CLIP— BOLT— NUT— SCREW— WASHER, Front Fender and Skirt**

65-69	Pass.	3795344	A.R.	.11	closing panel to frt. fender, flange reinf. to cowl side seal— (7.833)
73	Chevelle	336336	2	.36	BOLT, frt. fender ( $\frac{5}{16}$ "— 18 x $\frac{3}{4}$ ")
65-69	Pass.	3713542	A.R.	.12	NUT, skirt assy. to fender (14-10) "J" shape— (1.269)
65-69	Pass.	3958324	A.R.	.22	NUT ASSY., skirt assy. to rad. grill header panel supt. head lamp filler panel to frt. fender skirt, tie bar ("J"— $\frac{5}{16}$ "— 18)
62-73	All	1494254	2	.39	NUT ASSY., to rocker panel extn. ( $\frac{2}{8}$ "— 16) (U-shape)
64-66	Pass., Chevelle	3852234	2	.16	NUT ASSY., frt. fender skirt (to rad. supt.) ( $\frac{5}{16}$ "— 18)
70-72	Chevelle (exc. Monte Carlo),				
71	Monte Carlo	3996967	A.R.	.22	NUT ASSY., frt. fender brace to frt. fender skirt, rad. support to frt. fender skirt
65-69	Pass.	3650059	20	.11	SCREW (No. 14— 10 x $\frac{3}{4}$ ")
67-73	All	3960314	A.R.	.12	SCREW, front fender skirt ( $\frac{5}{16}$ "— 18 x $\frac{3}{4}$ ")— (1.276)
69	Chevelle (exc. Sta. Wag., El Camino),				
70-71	Chevelle	3968523	A.R.	.18	SCREW, fender and skirt ( $\frac{5}{16}$ "— 18 x $1\frac{1}{2}$ ")— (1.276)
69	Pass.	3945712	2	.16	SCREW ASSY., fender to battery tray $\frac{5}{16}$ "— 18 x $\frac{5}{8}$ "
74-75	Pass.	3968522	A.R.	.15	SCREW, front fender skirt/to rad. supt./front fender skirt brkt. ( $\frac{5}{16}$ "— 18 x $1\frac{1}{8}$ ")
65-69	Pass.	3710405	A.R.	.11	WASHER ( $\frac{13}{32}$ " I.D. x $\frac{15}{16}$ " O.D. x $\frac{5}{64}$ " thick)
71-72	Vega	3704579	1	.13	WASHER, a/cl. and silencer bolt ( $\frac{9}{32}$ ")

**8.147 PLATE— BEZEL— CLIP— DECAL— EMBLEM— INSERT— LETTER UNIT— NUT— ORNAMENT, Front Fender**

64	Chevelle	3849498	2	1.60	"Chevelle"
64-65	Nova	3832827	2	3.55	"Nova Chevy II"— (12.116)
64-65	Nova (S.S.)	3832828	2	4.10	"Nova S.S."— (12.116)
68	Chevy (350)	3927458	2	3.80	"Super Sport" (Note 1)
68	Chevelle	3920825	2	3.00	"Chevelle" (Note 2)
68	Nomad	3920865	2	2.60	"Nomad" (Note 3)
68	Nomad Custom	3920866	2	2.50	"Custom" (Note 4)
68	Malibu	3920864	2	2.85	"Malibu" (Note 5)
68	Concours	3917461	2	2.75	"Concours" (Note 6)
68	Concours, Caprice	3920806	2	1.90	"Estate Wagon" (Note 7)
68	Camaro (exc. R.S.)	3916660	2	2.95	"CAMARO" (Note 8)
68	Camaro w/R.S. (exc. 350, 396)	3916692	2	2.60	"Rally Sport" (Note 8)

*NOTE 1 Requires 3-3844131 nuts for installation.*  
*NOTE 2 Requires 4-3752642 nuts for installation.*  
*NOTE 3 Requires 4-3752642 nuts for installation.*  
*NOTE 4 Requires 2-3752642 nuts for installation.*  
*NOTE 5 Requires 5-3752642 nuts for installation.*  
*NOTE 6 Requires 3-9419761 nuts for installation.*  
*NOTE 7 Requires 2-9419761 nuts for installation.*  
*NOTE 8 Requires 4-9419761 nuts for installation.*

**SHEET METAL—HEATER**

**8.147 PLATE— BEZEL— CLIP— DECAL— EMBLEM— INSERT— LETTER UNIT—  
NUT— ORNAMENT, Front Fender (Con't)**

68	Biscayne	3928469	2	3.10	(Biscayne) (Note 9)
	<i>NOTE 9 Requires 4-3752642 nuts for installation.</i>				
68	Impala	3917489	2	3.30	(Impala) (Note 10)
	<i>NOTE 10 Requires 4-9419761 nuts for installation.</i>				
68	Impala (Custom)	3920888	2	2.10	(Custom) (Note 12)
	<i>NOTE 12 Requires 2-9419761 nuts for installation.</i>				
68	Impala (SS)	3917490	2	2.15	(Super Sport) (Note 13)
	<i>NOTE 13 Requires 2-9419761 nuts for installation.</i>				
70-72	Monte Carlo	3975418	2		(SS 454) (Note 17)
	<i>NOTE 17: This plate is used with mldg. unit 3997567-8 when needed.</i>				
65-66	Impala (S.S.)	3867735	2	2.65	PLATE UNIT (Impala, Super Sport)
66	Caprice,				
67-68	Caprice (Sta. Wag.)	3876000	2	3.50	PLATE UNIT (Caprice)
67	Impala (S.S.)	3904653	A.R.	3.90	PLATE UNIT, fender and rad. grille (Impala, Super Sport)
67	Camaro	3907901	1	3.45	PLATE UNIT, "Camaro"
68-69	Bel Air	3928485	2	3.00	PLATE UNIT (Bel Air)
69	Impala	3953657	2	3.35	PLATE UNIT, side (Impala)
69-72	Chevelle (396, 454),				
69	Impala (427)	3953658	2	2.85	PLATE UNIT, side (S)
69-70	Nova	3953676	2	2.85	PLATE UNIT, (Nova)
69	Camaro (exc. 302, 350 w/4BC, 396)	3953633	2	4.25	PLATE UNIT, (Rally Sport)
69-72	Camaro (S.S.)	3987377	4	1.90	PLATE UNIT (S.S.)
69	Chevelle (Deluxe) (exc. El Camino)	3952499	2	3.50	PLATE UNIT, (300)
70	Pass.	3974230	2	3.90	PLATE UNIT (Biscayne)
70	Pass.	3974249	2	3.90	PLATE UNIT (Bel Air)
70	Pass.	3974250	2	3.90	PLATE UNIT (Impala)
71-72	Pass.	3995701	2	3.90	PLATE UNIT (Biscayne)
71-72	Pass.	3995702	2	3.90	PLATE UNIT (Bel Air)
70	Malibu (exc. 396, 454)	3974320	2	5.05	PLATE UNIT (Malibu)
71-72	Malibu (exc. S.S.)	3990939	2	2.75	PLATE UNIT (Malibu)
70-72	El Camino	3974322	2	5.05	PLATE UNIT (El Camino)
70-72	Nova	3953676	2	2.85	PLATE UNIT (Nova)
70-72	Camaro (exc. R.S.)	3981851	2	3.25	PLATE UNIT (Camaro)
70-72	Camaro (R.S.)	3981852	2	4.25	PLATE UNIT (Rally Sport)
73-75	Pass.	3995702	2	3.90	PLATE UNIT (Bel Air)
74-75	Impala (exc. Custom Cpe.)	6260499	2	3.90	PLATE UNIT (Impala)
73	Malibu (exc. S.S.)	3990939	2	2.75	PLATE UNIT (Malibu)
73-75	Monte Carlo	6258310	2	2.75	PLATE UNIT (Monte Carlo)
73-75	El Camino	6258311	2	5.05	PLATE UNIT (El Camino)
73	El Camino Custom, Malibu Estate,				
74	El Camino Classic	6258312	2	2.75	PLATE UNIT (Estate)
73-74	Chevelle (Deluxe)	6259420	2	3.55	PLATE UNIT (Deluxe)
73	Laguna	6259487	2	3.90	PLATE UNIT (Laguna by Chevrolet)
73	Laguna Estate	6259488	2	3.90	PLATE UNIT (Laguna Estate)
73-74	Nova	6258151	2	2.05	PLATE UNIT (Custom)
73-74	Nova	6258150	2	2.85	PLATE UNIT (Nova)
73-74	Camaro (exc. R.S.)	3981851	2	3.25	PLATE UNIT (Camaro)
73	Camaro (R.S.)	3981852	2	4.25	PLATE UNIT (Rally Sport)
74-75	Malibu Classic	345118	2	2.75	PLATE UNIT (Malibu Classic)
74-75	El Camino Classic	345189	2	2.75	PLATE UNIT (Classic)
74-75	Malibu	345210	2	3.90	PLATE UNIT (Malibu)
74	Laguna	345213	2	3.90	PLATE UNIT (Laguna S-3)
75	Camaro	358798	2	2.95	PLATE UNIT, name
75	Monza (exc. Towne Cpe.)	1693836	2	2.80	PLATE ASSY. (Monza)
75	Monza (exc. Towne Cpe.) (8 cyl.)	1694475	2	2.80	PLATE ASSY. (V8 4.3 litre)
75	Monza (8 cyl.)	1707615	2	2.65	PLATE ASSY. (V8 5.7 litre)
75	Monza (exc. Towne Cpe.)	1704751	2	2.35	PLATE ASSY. (2 plus)
75	Monza	1693836	2	2.80	PLATE ASSY. (Monza)
75	Monza (8 cyl.)	1694475	2	2.80	PLATE ASSY. (V8 4.3 litre)
74-75	Vega	9823096	A.R.	.07	CLIP, back door name
71-73	Vega	9875547	A.R.	.12	CLIP ASSY., emblem attach.— (12.183)
68	Pass., Chevelle (396)	3935901	L.H.	3.75	BEZEL, fender marker lamp— (2.575)
68	Pass., Chevelle (396)	3935902	R.H.	3.75	BEZEL, fender marker lamp— (2.575)
68	Pass., Chevelle (307)	3935903	L.H.	3.90	BEZEL, fender marker lamp— (2.575)
68	Pass., Chevelle (307)	3935904	R.H.	3.90	BEZEL, fender marker lamp— (2.575)
68	Pass., Chevelle (327)	3935907	L.H.	3.75	BEZEL, fender marker lamp— (2.575)
68	Pass., Chevelle (327)	3935908	R.H.	3.75	BEZEL, fender marker lamp— (2.575)
68	Pass. (427)	3935909	L.H.	3.75	BEZEL, fender marker lamp— (2.575)
68	Pass. (427)	3935910	R.H.	3.90	BEZEL, fender marker lamp— (2.575)
68-69	Chevy (307)	3929993	L.H.	4.45	BEZEL, fender marker lamp— (2.575)

**SHEET METAL—HEATER**

**8.147 PLATE— BEZEL— CLIP— DECAL— EMBLEM— INSERT— LETTER UNIT—  
NUT— ORNAMENT, Front Fender (Con't)**

68-69	Chevy (307)	3929994	R.H.	4.45	BEZEL, fender marker lamp— (2.575)
68	Chevy (327)	3929995	L.H.	4.25	BEZEL, fender marker lamp— (2.575)
68	Chevy (327)	3929996	R.H.	4.25	BEZEL, fender marker lamp— (2.575)
68	Chevy (350)	3929997	L.H.	3.80	BEZEL, fender marker lamp— (2.575)
68	Chevy (350)	3929998	R.H.	3.80	BEZEL, fender marker lamp— (2.575)
68-69	Chevy (396)	3937593	L.H.	3.95	BEZEL, front fender marker lamp— (2.575)
68-69	Chevy (396)	3937594	R.H.	3.95	BEZEL, front fender marker lamp— (2.575)
69	Camaro	3943269	2	.94	BEZEL, side marker lamp— (2.575)
69	Chevelle (307)	3945291	L.H.	1.90	BEZEL, marker lamp— (2.575)
69	Chevelle (307)	3945292	R.H.	1.90	BEZEL, marker lamp— (2.575)
69	Chevelle (350)	3945293	L.H.	1.90	BEZEL, marker lamp— (2.575)
69	Chevelle (350)	3945294	R.H.	1.90	BEZEL, marker lamp— (2.575)
69	Chevelle (250)	3954541	L.H.	2.05	BEZEL, marker lamp— (2.575)
69	Chevelle (250)	3954542	R.H.	2.05	BEZEL, marker lamp— (2.575)
69	Pass. (Estate Wag.)	3950720	2	2.80	BEZEL, fender marker lamp— (2.575)
69	Pass. (327) (exc. Estate Wag.)	3950773	2	2.05	BEZEL, fender marker lamp— (2.575)
69	Pass. (396) (exc. Estate Wag.)	3950774	2	2.05	BEZEL, fender marker lamp— (2.575)
69	Pass. (350) (exc. Estate Wag.)	3949287	2	2.05	BEZEL, fender marker lamp— (2.575)
69	Pass. (427) (exc. Estate Wag.)	3949288	2	2.05	BEZEL, fender marker lamp— (2.575)
75	Nova (LN) (5.7 Litre)	356603	2	4.35	DECAL, eng. ident.
75	Nova (LN) (4.3 Litre)	356604	2	4.35	DECAL, eng. ident.
75	Nova (LN) (4.1 Litre)	356605	2	4.35	DECAL, eng. ident.
75	Camaro	364903	2	3.00	DECAL, "Rally Sport" (blue) 3 stripe
75	Camaro	364904	2	3.00	DECAL, "Rally Sport" (red/orange-red)
75	Camaro	364905	2	3.00	DECAL, "Rally Sport" (black-gray/black)
75	Camaro	364906	2	3.00	DECAL, "Rally Sport" (red) 3 stripe
75	Camaro	364907	2	3.00	DECAL, "Rally Sport" (orange/yellow-orange/orange)
75	Nova S.S.	347597	2	2.15	DECAL (white)— (12.182)
75	Nova S.S.	347598	2	2.15	DECAL (silver)— (12.182)
75	Nova S.S.	347599	2	2.15	DECAL (red)— (12.182)
75	Nova S.S.	360644	2	1.90	DECAL (black)— (12.182)
75	Nova S.S.	360645	2	2.15	DECAL (gold)— (12.182)
62-64	Chevy (283)	3791999	2	1.70	EMBLEM "V"
64	Chevelle (283)	3840317	2	1.35	EMBLEM "V"
64	Chevelle (327),				
65-67	All (8 cyl.)	3840318	2	2.10	EMBLEM (V-crossed flags)
66-67	Pass. (427)	3878607	2	3.10	EMBLEM (427)
68	Camaro (250)	3927480	R.H.	2.40	EMBLEM (250) (Note 14)
68	Camaro (302)	3927481	L.H.	2.15	EMBLEM (302) (Note 14)
68	Camaro (302)	3927482	R.H.	2.15	EMBLEM, (302) (Note 14)
68	Camaro (327)	3927483	L.H.	2.40	EMBLEM, (327) (Note 14)
68	Camaro (327)	3927484	R.H.	2.40	EMBLEM (327) (Note 14)
68	Camaro (350)	3927485	L.H.	2.40	EMBLEM (350) (Note 14)
68	Camaro (350)	3927486	R.H.	2.40	EMBLEM (350) (Note 14)
68	Camaro (396)	3927487	L.H.	2.40	EMBLEM (396) (Note 14)
68	Camaro (396)	3927488	R.H.	2.40	EMBLEM (396) (Note 14)
<i>NOTE 14 Requires 2-9419761 nuts for installation.</i>					
65	Chevy, Chevelle (283),				
65-66	Pass. (283)	3865833	2	1.65	EMBLEM UNIT (283)
65-67	All (327)	3865834	2	1.65	EMBLEM UNIT (327)
65-67	All (396)	3867312	2	3.45	EMBLEM UNIT (396) (Turbo-Jet)
65-66	Impala (exc. S.S., Caprice)	3862208	2	1.90	EMBLEM UNIT, fender (circular insignia)
65-67	Chevy, Chevelle (230)	3865890	2	2.45	EMBLEM UNIT, "230"
67	Impala (S.S.) (427)	3904696	2	6.50	EMBLEM UNIT (427)
67	Chevelle, Chevy, Camaro (250)	3904567	2	3.10	EMBLEM UNIT, "250"
67	Camaro	3905718	1	2.20	EMBLEM UNIT, "350"
68	Camaro (Spt. Cpe.)	3947011	L.H.	5.65	EMBLEM UNIT (Z-28)
68	Camaro (Spt. Cpe.)	3947012	R.H.	5.65	EMBLEM UNIT (Z-28)
69	Camaro (327)	3953625	A.R.	2.75	EMBLEM UNIT (327)
69	Camaro (350)	3953627	2	3.00	EMBLEM UNIT (350)
69	Camaro (396)	3953629	A.R.	3.00	EMBLEM UNIT (396)
69	Camaro (302)	3957935	L.H.	5.85	EMBLEM UNIT (Z/28)
69	Camaro (302)	3957936	R.H.	5.85	EMBLEM UNIT (Z/28)
69	Camaro (307)	3957933	2	3.50	EMBLEM UNIT, "307"
69-70	Chevelle (396)	3953679	2	3.50	EMBLEM UNIT (396)
70-72	El Camino	3981834	2	5.05	EMBLEM UNIT (400)
70	Chevelle (exc. El Camino)	3970625	L.H.	3.90	EMBLEM UNIT (307)
70	Chevelle (exc. El Camino)	3970626	R.H.	3.90	EMBLEM UNIT (307)
70-71	El Camino	3974350	2	5.05	EMBLEM UNIT (307)
70-72	El Camino	3974354	2	5.05	EMBLEM UNIT (350)
68-70	Nova,				
69	Camaro (250)	3970510	2	3.00	EMBLEM UNIT (250)
70	Nova	3970553	2	3.90	EMBLEM UNIT (396)

**SHEET METAL—HEATER**

**8.147 PLATE— BEZEL— CLIP— DECAL— EMBLEM— INSERT— LETTER UNIT—  
NUT— ORNAMENT, Front Fender (Con't)**

70	Nova	3970536	2	3.90	EMBLEM UNIT (307)
70-72	Nova	3970546	2	3.90	EMBLEM UNIT (350)
69-70	Pass., Chevelle (exc. El Camino),				
71-72	Chevelle (exc. El Camino)	3974223	L.H.	3.65	EMBLEM UNIT (350)
69-70	Pass., Chevelle (exc. El Camino)	3974224	R.H.	3.65	EMBLEM UNIT (350)
71-72	Chevelle (exc. El Camino)	3991012	R.H.	4.10	EMBLEM UNIT (350)
70	Pass.,				
72	Pass. (Sta. Wag.)	3970619	L.H.	3.65	EMBLEM UNIT (454)
70	Pass.,				
72	Pass. (Sta. Wag.)	3970620	R.H.	3.65	EMBLEM UNIT (454)
70-71	Pass., Chevelle (exc. El Camino),				
72	Pass. (exc. Caprice),				
72	Kingswood Estate	3974225	L.H.	3.65	EMBLEM UNIT (400)
70	Pass., Chevelle (exc. El Camino),				
72	Pass. (exc. Caprice),				
72	Kingswood Estate	3974226	R.H.	3.65	EMBLEM UNIT (400)
70-72	Chevelle (exc. Monte Carlo)	3981833	2	3.90	EMBLEM UNIT (454)
72	Caprice (exc. Kingswood Estate)	6263018	2	5.05	EMBLEM UNIT (400)
70-72	Camaro (396)	3988829	2	3.00	EMBLEM UNIT (396)
70-72	Camaro (Spec. H/Per. 350)	3981956	2	5.85	EMBLEM UNIT (Z-28)
70-72	Camaro (350) (exc. Spec. H/Per. 350)				
		3988830	2	3.65	EMBLEM UNIT (350)
71	Pass. (454)	3991019	2	5.05	EMBLEM UNIT (454)
72	Caprice	6263021	2	5.05	EMBLEM UNIT (454)
71	Pass. (400 2/BC)	3991009	2	5.05	EMBLEM UNIT (400)
71-72	Pass. (350)	3996797	2	3.65	EMBLEM UNIT (350)
71	Chevelle (exc. El Camino)	3991016	R.H.	4.10	EMBLEM UNIT (400)
73-74	Nova	3970546	2	3.90	EMBLEM UNIT (350)
73-75	Camaro (350) (exc. Spec. H/Per.)	3988830	2	3.65	EMBLEM UNIT (350)
73	Pass.	3970619	L.H.	3.65	EMBLEM UNIT (454)
73	Pass.	3970620	R.H.	3.65	EMBLEM UNIT (454)
74-75	Pass.	6260498	2	3.65	EMBLEM UNIT (454)
73-75	Chevelle	6258039	2	3.90	EMBLEM UNIT (350)
73	Pass.	3974225	L.H.	3.65	EMBLEM UNIT (400)
73	Pass.	3974226	R.H.	3.65	EMBLEM UNIT (400)
74-75	Chevelle	6260916	2	3.90	EMBLEM UNIT (400)
74	Pass.	6260497	2	3.65	EMBLEM UNIT (400)
73-74	Chevelle (exc. Monte Carlo)	3981833	2	3.90	EMBLEM UNIT (454)
73-74	Camaro (Spec. H/Per. 350)	3981956	2	5.85	EMBLEM UNIT (Z-28)
73-74	Nova, Chevelle (S.S.)	6259618	1	3.00	EMBLEM UNIT (S.S.)
75	Caprice	358797	2	3.00	EMBLEM UNIT
75	Nova (Custom) (exc. S.S., LN)	358755	2	2.80	EMBLEM UNIT (Nova Custom)
75	Nova (LN)	358757	2	3.00	EMBLEM UNIT
75	Nova (exc. Custom, S.S.)	358756	2	2.80	EMBLEM UNIT (Nova)
71-75	Vega (G.T.)	9865874	2	2.70	EMBLEM ASSY.
74-75	Vega (L.X.)	9727707	2	2.35	EMBLEM ASSY.
75	HR (4 cyl.)	360813	2	4.20	EMBLEM ASSY.
68	All (307)	3933019	1	.64	INSERT, marker lamp (307)
68	Chevy (350)	3933016	1	.78	INSERT, marker lamp (350)
68	Pass., Chevy, Chevelle (327)	3933017	1	.64	INSERT, marker lamp (327)
68	Pass., Chevelle (396)	3933021	2	.64	INSERT, marker lamp (396)
68	Chevelle (S.S. 396)	3933020	1	.71	INSERT, marker lamp (S.S. 396)
68	Pass. (427)	3933018	1	.64	INSERT, marker lamp (427)
65-66	Impala (exc. S.S., Caprice)	3862173	2	3.45	LETTER UNIT (I-M-P-A-L-A)
67	Camaro (R.S.)	3904573	A.R.	2.60	LETTER UNIT, "RS"
67	Camaro (S.S.)	3917718	2	2.60	LETTER UNIT, "SS"
68-69	Camaro (350, 396)	3987377	2	1.90	LETTER UNIT (S.S.)
62-69	All	9419763	A.R.	.11	NUT, emblem (2/16"-stamped)
65-69	Pass.	9419761	A.R.	.11	NUT, frt. fender name plate frt. fender ornament (type M— 1/4" hole)— (8.921)
65-69	Pass.	9427101	A.R.	.16	NUT, emblem (No. 10-24)— (8.921)
68	Impala (SS 427)	3917453	L.H.	4.75	ORNAMENT, side louver (Note 15)
68	Impala (SS 427)	3917454	R.H.	4.75	ORNAMENT, side louver (Note 15)
<i>NOTE 15 Requires 3-94 19764 nuts for installation.</i>					
69-71	Chevy w/spec. moulding	3953843	2	5.85	ORNAMENT UNIT

**8.153 SKIRT— BRACE— BRACKET— EXTENSION— FILLER— PANEL— PLATE—  
RAIL— REINFORCEMENT— RETAINER— SHIELD— SHIM— SUPPORT,  
Front Fender**

64	Chevelle	3853635	L.H.	33.75	front fender
64	Chevelle	3864322	R.H.	33.75	front fender
65	Chevelle	3856893	L.H.	33.75	front fender
65	Chevelle	3864324	R.H.	33.75	front fender
65-66	Pass.	3887511	L.H.	34.75	front fender

**SHEET METAL—HEATER**

**8.153 SKIRT— BRACE— BRACKET— EXTENSION— FILLER— PANEL— PLATE— RAIL— REINFORCEMENT— RETAINER— SHIELD— SHIM— SUPPORT, Front Fender (Con't)**

65-66	Pass. ....	3887512 R.H.	34.75	front fender (Note 1) .....
<i>NOTE 1 When using 3887512 in place of 3871350 add holes at batt. tray-use old part as guide.</i>				
66	Chevelle .....	3872137 L.H.	33.75	front fender .....
66	Chevelle .....	3872138 R.H.	33.75	front fender .....
67	Chevelle .....	3885985 L.H.	33.75	front fender .....
67	Chevelle .....	3885986 R.H.	33.75	front fender .....
67-68	Pass. ....	3907653 L.H.	34.75	front fender .....
67-68	Pass. ....	3907654 R.H.	34.75	front fender (Note 5) .....
<i>NOTE 5 It may be necessary to rework front outer edge of flange.</i>				
69	Pass. ....	3926839 L.H.	34.75	front fender .....
69	Pass. ....	3926840 R.H.	34.75	front fender .....
71-72	Pass. ....	6262363 L.H.	34.75	front fender .....
71-72	Pass. ....	3972892 R.H.	34.75	front fender .....
68-74	Nova .....	333741 L.H.	31.25	front fender .....
68-74	Nova .....	333742 R.H.	31.25	front fender .....
70	Pass. ....	3957217 L.H.	34.75	front fender .....
70	Pass. ....	3957218 R.H.	34.75	front fender .....
70-72	Monte Carlo .....	6264849 L.H.	33.75	front fender .....
70-72	Monte Carlo .....	3963318 R.H.	33.75	front fender .....
73-74	Pass. ....	342315 L.H.	34.75	front fender .....
73-74	Pass. ....	342316 R.H.	34.75	front fender .....
73-75	Monte Carlo .....	352081 L.H.	33.75	(repl. 347321) .....
73-75	Monte Carlo .....	352082 R.H.	33.75	(repl. 347322) .....
74	Chevelle (exc. Monte Carlo) .....	336371 L.H.	33.75	
74	Chevelle (exc. Monte Carlo) .....	336372 R.H.	33.75	
75	Pass. ....	343505 L.H.	34.75	
75	Pass. ....	343506 R.H.	34.75	
75	Chevelle (exc. Monte Carlo) .....	347379 L.H.	33.75	
75	Chevelle (exc. Monte Carlo) .....	347350 R.H.	33.75	
75	Nova .....	344353 L.H.	31.25	
75	Nova .....	344354 R.H.	31.25	
66-67	Chevy .....	3869771 L.H.	25.00	SKIRT ASSY., upper .....
66-67	Chevy .....	3871378 R.H.	85.00	SKIRT ASSY. (Note 4) .....
<i>NOTE 4 It may be necessary to enlarge hole at brake pipe conn. to 1" dia.</i>				
66-67	Chevy .....	3894513 L.H.	85.00	SKIRT ASSY. ....
67-68	Camaro .....	3927425 L.H.	31.25	SKIRT ASSY. ....
67-68	Camaro .....	3927426 R.H.	31.25	SKIRT ASSY. ....
68	Camaro w/R.S. ....	3925493 L.H.	42.00	SKIRT ASSY. ....
68	Camaro w/R.S. ....	3925494 R.H.	42.00	SKIRT ASSY. ....
68-72	Chevelle (exc. Monte Carlo) .....	6264843 L.H.	33.75	SKIRT ASSY., steel, left .....
68-72	Chevelle (exc. Monte Carlo) .....	3992604 R.H.	33.75	SKIRT ASSY., steel, right .....
69	Camaro w/R.S. ....	3945791 L.H.	42.00	SKIRT ASSY. ....
69	Camaro w/R.S. ....	3945792 R.H.	42.00	SKIRT ASSY. ....
69	Camaro (exc. R.S.) .....	3935917 L.H.	31.25	SKIRT ASSY., complete .....
69	Camaro (exc. R.S.) .....	3935918 R.H.	31.25	SKIRT ASSY., complete .....
70-74	Camaro .....	339443 L.H.	31.25	SKIRT ASSY. ....
70-75	Camaro .....	337462 R.H.	31.25	SKIRT ASSY. ....
73	Chevelle (exc. Monte Carlo) .....	336331 L.H.	33.75	SKIRT ASSY., front fender (use only with original production fdr.) .....
73	Chevelle (exc. Monte Carlo) .....	3992682 R.H.	33.75	SKIRT ASSY., front fender (use only with original production fdr.) .....
73-74	Camaro .....			SKIRT ASSY., front fender .....
73-75	Camaro .....			SKIRT ASSY., front fender .....
75	Camaro .....	356609 L.H.	31.25	SKIRT ASSY., front fender .....
70-72	Monte Carlo .....	3963345 2	1.20	BRACKET, skirt .....
70	Chevelle (exc. Monte Carlo) .....	3963307 L.H.	.13	BRACKET, extension .....
70	Chevelle (exc. Monte Carlo) .....	3963308 R.H.	.36	BRACKET, extension .....
71-72	Monte Carlo .....	3982479 L.H.	.25	BRACKET, left, extension .....
71-72	Monte Carlo .....	3982480 R.H.	.25	BRACKET, right, extension .....
71-72	Chevelle (exc. Monte Carlo) .....	3987012 2	.25	BRACKET, extension .....
68	Pass. ....	3910697 L.H.	1.45	EXTENSION .....
68	Pass. ....	3910698 R.H.	1.45	EXTENSION .....
70	Pass. ....	3963211 L.H.	2.75	EXTENSION, skirt .....
70	Pass. ....	3963212 R.H.	2.75	EXTENSION, skirt .....
70-72	Monte Carlo .....	3992609 L.H.	.93	EXTENSION, skirt (Note 2) .....
70-72	Monte Carlo .....	3992610 R.H.	.93	EXTENSION, skirt (Note 2) .....
<i>NOTE 2: It may be reqd. to add holes for park. and marker lamp wiring harness.</i>				
71-73	Vega .....	9664856 R.H.	12.10	EXTENSION, mtr. compt. side w/h panel front .....
71-73	Vega .....	9664857 L.H.	12.90	EXTENSION, mtr. compt. side w/h panel front .....
74-75	Vega .....	1689166 L.H.	12.90	EXTENSION, mtr. compt. side w/h panel .....
74-75	Vega .....	9629750 R.H.	12.90	EXTENSION, mtr. compt. side w/h panel .....

**SHEET METAL—HEATER**

**8.153 SKIRT— BRACE— BRACKET— EXTENSION— FILLER— PANEL— PLATE— RAIL— REINFORCEMENT— RETAINER— SHIELD— SHIM— SUPPORT, Front Fender (Con't)**

75	Monza	1705942 R.H.	12.90	EXTENSION, mtr. compt. side and w/h
75	Monza	1705943 L.H.	12.90	EXTENSION, mtr. compt. side and w/h
68	Pass.	3934531 L.H.	.93	FILLER, upper rear
69	Pass.	3941237 L.H.	1.60	PANEL, skirt filler
69	Pass.	3941238 R.H.	1.60	PANEL, skirt filler
71-74	Vega (1st design)	9819776 R.H.	1.70	PANEL, mtr. compt. to frt. fdr. filler (plastic)
71-74	Vega (1st design)	9819777 L.H.	1.70	PANEL, mtr. compt. to frt. fdr. filler (plastic)
74	Vega (2nd design),			
75	Vega	9739736 R.H.	4.35	PANEL, frt. w/h outer (plastic)
74	Vega (2nd design),			
75	Vega	9739737 L.H.	4.35	PANEL, frt. w/h outer (plastic)
<i>For 1974 Vega Panels 1st design cars built before January 21, 1974, 2nd design cars built after January 21, 1974.</i>				
75	Monza	9739654 R.H.	5.55	PANEL, frt. w/h outer
75	Monza	9739655 L.H.	5.55	PANEL, frt. w/h outer
70	Pass.	3962336 R.H.	3.00	PANEL ASSY., frt. fender to frt. fender skirt filler
70	Pass.	3962335 L.H.	3.00	PANEL ASSY., frt. fender to frt. fender skirt filler
71-72	Vega	9862807 L.H.	53.50	PANEL ASSY., mtr. compt. side and wheelhouse
71-72	Vega	9890215 R.H.	53.50	PANEL ASSY., mtr. compt. side and wheelhouse
73	Vega	9664314 L.H.	53.50	PANEL ASSY., mtr. compt. side and w/h
73	Vega	9673851 R.H.	53.50	PANEL ASSY., mtr. compt. side and w/h
74	Vega	1650797 L.H.	53.50	PANEL ASSY., mtr. compt. side w/h
74	Vega	1665978 R.H.		PANEL ASSY., mtr. compt. side w/h (repl. 9739750)
75	Vega	1740398 R.H.	54.50	PANEL ASSY., mtr. compt. side and w/h
75	Vega	1665979 L.H.	53.50	PANEL ASSY., mtr. compt. side and w/h
75	Monza (exc. Towne Cpe.)	1740392 R.H.	54.50	PANEL ASSY., mtr. compt. side and w/h (repl. 1705960)
75	Monza (exc. Towne Cpe.)	1705961 L.H.	53.50	PANEL ASSY., mtr. compt. side and w/h
75	Monza	9733898 R.H.	6.70	PLATE, baffle shroud lwr. to comp. rail
75	Monza	9733899 L.H.	7.75	PLATE, baffle shroud lwr. to comp. rail
75	Vega	1665992 R.H.	139.00	RAIL ASSY., mtr. compt. side
75	Vega	1665993 L.H.	139.00	RAIL ASSY., mtr. compt. side
75	Monza (exc. Towne Cpe.)	1705928 L.H.		REINFORCEMENT, mtr. compt. side and w/h panel extension
75	Monza (exc. Towne Cpe.)	1705927 R.H.		REINFORCEMENT, mtr. compt. side and w/h panel extension
71-74	Vega	9739762 R.H.	17.80	REINFORCEMENT ASSY., mtr. compt. side and w/h pnl.
71-73	Vega	9739763 L.H.	17.80	REINFORCEMENT ASSY., mtr. compt. side and w/h panel
74	Vega	9739761 L.H.		REINFORCEMENT ASSY., mtr. compt. side w/h panel
75	Vega	1654478 R.H.	16.20	REINFORCEMENT ASSY., mtr. compt. side and w/h
75	Vega	1654479 L.H.	16.20	REINFORCEMENT ASSY., mtr. compt. side and w/h
75	Monza (exc. Towne Cpe.)	1714121 R.H.	14.95	REINFORCEMENT ASSY., mtr. compt. side and w/h (repl. 1654476)
75	Monza (exc. Towne Cpe.)	1729476 L.H.		REINFORCEMENT ASSY., mtr. compt. side and w/h (repl. 1705958)
74-75	Chevelle (exc. Laguna, Monte Carlo)	340171 L.H.	1.75	RETAINER, fdr. to bumper filler inner
74-75	Chevelle (exc. Laguna, Monte Carlo)	340172 R.H.	1.75	RETAINER, fdr. to bumper filler inner
74-75	Chevelle (exc. Laguna, Monte Carlo)	340173 L.H.	1.40	RETAINER ASSY., fdr. to bumper filler outer
74-75	Chevelle (exc. Laguna, Monte Carlo)	340174 R.H.	1.40	RETAINER ASSY., fdr. to bumper filler outer
73	Chevelle (exc. Laguna, Monte Carlo)	331719 L.H.	1.55	RETAINER ASSY., fdr. to bumper filler
73	Chevelle (exc. Laguna, Monte Carlo)	331720 R.H.	1.55	RETAINER ASSY., fdr. to bumper filler, right
73	Pass.	332311 L.H.	2.00	SHIELD
73	Pass.	332312 R.H.	2.00	SHIELD
62-69	All	3745380 A.R.	.22	SHIM, extension assy.— (8.016)

**SHEET METAL—HEATER**

**8.153 SKIRT— BRACE— BRACKET— EXTENSION— FILLER— PANEL— PLATE— RAIL— REINFORCEMENT— RETAINER— SHIELD— SHIM— SUPPORT, Front Fender (Con't)**

68-72	Chevelle (exc. Conv., Monte Carlo)	7779719	L.H.	2.50	SUPPORT, skirt on brace
68-72	Chevelle (exc. Conv., Monte Carlo)	7779718	R.H.	2.50	SUPPORT, skirt on brace
68-72	Chevelle (Conv., Monte Carlo)	7779723	L.H.	1.85	SUPPORT, skirt on brace
68-72	Chevelle (Conv., Monte Carlo)	7779722	R.H.	2.00	SUPPORT, skirt on brace

**8.154 SEAL— ANTI-SQUEAK— CLIP— FASTENER— RETAINER— SHIELD— SPACER— WASHER, Front Fender and Skirt**

62-72	All	3996620	A.R.	RL/28	( <sup>9</sup> / <sub>16</sub> " edge grip— <sup>3</sup> / <sub>4</sub> " seal reach) (Note 1)
<i>NOTE 1 Use for all fender skirt and other chassis sheet metal sealing applications requiring an edge type seal.</i>					
67-68	Camaro	3909121	2	.36	left or right, skirt to frame upper
67-68	Camaro	3899873	R.H.	.36	skirt to frame lower
67-68	Camaro				L.H., skirt to frame lower,
69	Camaro	3909123	1	.48	right and left skirt to frame lower
68	Concours,				
69	Estate Wag.,				
69	Chevelle (Spec. Spt. Sed.)	3922801	2	3.75	frt. fender to body
68-75	Nova	345516	2	1.45	skirt to frame (Note 2)
<i>NOTE 2 This part has been cut out to provide clearance to front brake system (Disc).</i>					
69	Camaro	3949781	2	1.05	skirt to frame upper
69	Caprice,				
69	Impala w/body insulation package	3972821	2	4.60	front fender to body
70-72	Chevelle	3968599	2	.53	dust (w/plastic skirts)
70	Pass. w/body insulation package				
70-75	Camaro	3967116	2	1.30	body to frt. fender
71-72	Caprice, Kingswood	3986979	L.H.	4.00	lwr. shrd. to fender
71-72	Caprice, Kingswood	3986980	R.H.	4.00	body to fender
73-75	Pass.	6270101	L.H.	4.00	body to fender
73-75	Pass.	6270102	R.H.	4.00	body to fender
75	Nova	347586	2	1.40	body to fender
65-72	Pass.	3997555	A.R.	RL/27	skirt to frame
<i>NOTE 1: Quantity of one when ordering denotes one 50 ft. roll.</i>					
70-72	Monte Carlo	3975835	L.H.	3.75	ANTI-SQUEAK, universal (1 <sup>3</sup> / <sub>4</sub> " wide x 50 ft. roll-one bead) (Note 1)
70-72	Monte Carlo	3975836	R.H.	3.75	SEAL ASSY., fender to hood panel upper shroud, left
70-72	Monte Carlo	3975836	R.H.	3.75	SEAL ASSY., body fender to hood panel upper shroud, right
65-67	Caprice,				
72	Nova	3879573	10	.11	CLIP, body to front fender
67-69	Camaro,				
68-69	Chevy	3921872	1	.11	CLIP, seal, fender to dash
65-75	All	9792217	A.R.	.13	CLIP
72	Caprice, Kingswood Estate,				
73-75	Pass.	1498488	18	.11	CLIP, body to frt. fender seal
Not required in this group. See group 3.015					
74-75	Pass.	540160	1	.12	CLIP
73-74	Camaro	4841199	2		FASTENER, rear wheel opening cover seal
73-75	Pass.	480534	A.R.	.11	RETAINER, hood panel shd.
68-72	Chevelle (exc. Monte Carlo)	3910644	2	1.10	fdr. shield— (12.801)
69	Chevelle (exc. Sta. Wag., El Camino)	3952913	2	.53	SHIELD, dust
70-71	Chevelle	3968599	2	.53	SHIELD, dust (used w/plastic fdr. skirts)
69-75	Nova	3966803	L.H.	.46	SHIELD, skirt splash, left side
67-68	Pass.	3899589	2	1.25	SHIELD, skirt dust
69-70	Pass.	3950725	2	1.20	SHIELD, front, skirt, dust
71-73	Pass.	3991176	2	.58	SHIELD, dust (frt.)
69-70	Pass.	3950727	1	.63	SHIELD, rear, skirt dust
70-72	Monte Carlo	3975401	L.H.	1.30	SHIELD, skirt splash, left
70-72	Monte Carlo	3975402	R.H.	1.30	SHIELD, skirt splash, right
73	Chevelle,				
74-75	Monte Carlo	3999737	2	.53	SHIELD, dust (frt.)
74-75	Chevelle (exc. Monte Carlo)	338537	2	.53	SHIELD, dust (frt.)
75	Caprice	343569	L.H.	2.10	SHIELD, dust
75	Caprice	343570	R.H.	2.10	SHIELD, dust
68-72	Chevy (2nd design),				
73-75	Nova	3929927	2	.12	SPACER, skirt to frame (rectangular) (4 <sup>5</sup> / <sub>16</sub> " long)
62-73	All	3790768	A.R.	.12	WASHER (1 <sup>9</sup> / <sub>32</sub> " I.D. x 1 <sup>1</sup> / <sub>8</sub> " O.D. x 1 <sup>1</sup> / <sub>8</sub> ")

**SHEET METAL—HEATER**

**8.154 SEAL— ANTI-SQUEAK— CLIP— FASTENER— RETAINER— SHIELD— SPACER— WASHER, Front Fender and Skirt (Con't)**

66	Pass. ....	3694533 A.R.	.16	WASHER, skirt to dash panel ( <sup>21</sup> / <sub>64</sub> " I.D. x 1 1/2" O.D. x 1/8" thick) .....
----	------------	--------------	-----	--

**8.155 BRACE ASSY.— REINFORCEMENT, Front Fender Skirt**

67-70	Pass. ....	3920840 R.H.	5.40	front fender skirt, skirt to dash .....
67-68	Camaro, Chevy,			
69	Camaro .....	3919135 L.H.	4.45	front fender skirt .....
67-68	Camaro, Chevy,			
69	Camaro .....	3919136 R.H.	1.80	front fender skirt .....
69-70	Pass. ....	3949237 L.H.	5.10	front fender skirt, skirt to dash panel .....
71-75	Pass. ....	3986901 L.H.	2.95	front fender skirt, skirt to dash .....
71-72	Pass. ....	3986902 R.H.	3.10	front fender skirt, skirt to dash .....
70-72	Camaro .....	3973981 L.H.	2.10	front fender skirt, fdr. skirt .....
70-72	Camaro .....	3973982 R.H.	2.10	front fender skirt, fdr. skirt .....
73	Pass. (Sta. Wag.) .....	327120 1	.72	fdr. skirt .....
74-75	Pass. ....	339206 1	.62	fdr. skirt .....
73-75	Pass. ....	3986902 R.H.	3.10	skirt to dash, right .....
73-75	Camaro .....	3973981 L.H.	2.10	fdr. skirt, left .....
73-75	Camaro .....	3973982 R.H.	2.10	fdr. skirt, right .....
69-72	Chevelle .....	3958325 A.R.	.26	REINFORCEMENT, upper, lower skirt to dash .....

**8.175 COVER UNIT, Rear Wheel (Wheel Shield)**

67-68	Pass. (exc. Sta. Wag.) .....	3930885 L.H.	23.45	rear wheel opening (Note 1) .....
67-68	Pass. (exc. Sta. Wag.) .....	3930886 R.H.	23.45	rear wheel opening (Note 1) .....
<i>NOTE On past models it may be necessary to rework by adding 4 holes— 7/32" dia. to mount rear wheel opening moulding. Use moulding as a template for hole location.</i>				
69-70	Pass. (exc. Sta. Wag.) .....	3955509 L.H.	20.95	rear wheel opening .....
69-70	Pass. (exc. Sta. Wag.) .....	3955510 R.H.	21.85	rear wheel opening .....
70-72	Monte Carlo .....	3981840 R.H.	22.05	rear wheel opening .....
70-72	Monte Carlo .....	3981839 L.H.	22.05	rear wheel opening .....
71-73	Pass.,			
74	Pass. (exc. Caprice),			
75	Pass. ....	6272077 L.H.	24.25	rear wheel opening .....
71-73	Pass.,			
74	Pass. (exc. Caprice),			
75	Pass. ....	6272078 R.H.	24.25	rear wheel opening .....
74	Caprice (exc. Estate) .....	6260969 L.H.	26.00	rear opening, left .....
74	Caprice (exc. Estate) .....	6260970 R.H.	26.00	rear opening, right .....
74	Caprice (exc. Estate) .....	337697 L.H.	20.20	COVER ASSY., rear wheel opening (part of assy. 6260969) .....
74	Caprice (exc. Estate) .....	337698 R.H.	20.20	COVER ASSY., rear wheel opening (part of assy. 6260970) .....

**8.176 RETAINER— BRACKET ASSY.— BUMPER— MOULDING UNIT— SPACER— SCREW, Wheel Cover Panel**

67-70	Pass. (exc. Sta. Wag.) .....	3907402 4	.16	rear wheel cover .....
68	Caprice .....	3918281 L.H.	1.35	cover moulding .....
68	Caprice .....	3918282 R.H.	1.35	cover moulding .....
70-72	Monte Carlo .....	3963391 L.H.	.25	front .....
70-72	Monte Carlo .....	3963392 R.H.	.16	front .....
70-72	Monte Carlo .....	3963395 L.H.	.16	rear .....
70-72	Monte Carlo .....	3963396 R.H.	.16	rear .....
71-72	Pass. ....	3997341 L.H.	.22	front .....
71-72	Pass. ....	3997342 R.H.	.22	front .....
71-72	Pass. ....	3997343 L.H.	.24	rear .....
71-72	Pass. ....	3997344 R.H.	.24	rear .....
72	Caprice .....	6262360 4	.24	RETAINER ASSY., rear mldg. ....
71-72	Pass.,			
70	Monte Carlo w/Wheel Opening Cover .....	3965939 2	.11	BRACKET ASSY., frt., upper .....
70	Monte Carlo w/Wheel Opening Cover,			
71-72	Pass. ....	3965953 4	.12	BUMPER, upper bracket .....
71	Pass. w/Wheel Opening Cover,			
72	Pass. (exc. Caprice) .....	3997421 L.H.	9.10	MOULDING UNIT, left rear wheel .....
71	Pass. w/Wheel Opening Cover,			
72	Pass. (exc. Caprice) .....	6259428 R.H.	8.55	MOULDING UNIT, right rear wheel .....
67	Impala (exc. Sta. Wag.) .....	3905704 R.H.	6.40	MOULDING UNIT, rr. wheel opening cvr. ...
67	Impala (exc. Sta. Wag.) .....	3905703 L.H.	6.40	MOULDING UNIT, rr. wheel opening cvr. ...
67	Caprice (exc. Sta. Wag.) .....	3905701 L.H.	6.35	MOULDING UNIT, rr. wheel opening cvr. ...
67	Caprice (exc. Sta. Wag.) .....	3905702 R.H.	7.05	MOULDING UNIT, rr. wheel opening cvr. ...
68	Caprice .....	3941821 L.H.	10.15	MOULDING UNIT, rr. wheel opening cover ...
68	Caprice .....	3941822 R.H.	10.15	MOULDING UNIT, rr. wheel opening cover ...



**SHEET METAL—HEATER**

**8.176 RETAINER— BRACKET ASSY.— BUMPER— MOULDING UNIT—  
SPACER— SCREW, Wheel Cover Panel (Con't)**

68	Impala	3928487	L.H.	5.50	MOULDING UNIT, rr. wheel opening cover— (12.116)
68	Impala	3928488	R.H.	5.50	MOULDING UNIT, rr. wheel opening cover— (12.116)
69	Impala, Caprice (exc. Sta. Wag.), Pass. w/Wheel Opening Cover	3966953	L.H.	7.00	MOULDING UNIT, rear wheel
70-72	Monte Carlo w/Wheel Opening Cover	3974219	L.H.	8.55	MOULDING UNIT
70-72	Monte Carlo w/Wheel Opening Cover	3974220	R.H.	8.55	MOULDING UNIT
69	Impala, Caprice (exc. Sta. Wag.), Pass. w/Wheel Opening Cover	3966954	R.H.	7.00	MOULDING UNIT, rear wheel
72	Caprice	6263043	L.H.	9.55	MOULDING UNIT, left
72	Caprice	6263044	R.H.	9.55	MOULDING UNIT, right
73	Pass.,				
74	Pass. (exc. Caprice),				
75	Pass.	6259427	L.H.	8.55	MOULDING UNIT, left, rear wheel
73	Pass.,				
74	Pass. (exc. Caprice),				
75	Pass.	6259428	R.H.	8.55	MOULDING UNIT, right, rear wheel
74	Caprice (exc. Estate)	345105	L.H.	9.55	MOULDING UNIT, rear wheel cover
74	Caprice (exc. Estate)	345106	R.H.	9.55	MOULDING UNIT, rear wheel cover
68	Caprice	3938033	4	.12	SPACER, rear wheel opening cvr. mldg.
71-72	Pass.	3995172	2	.11	SCREW, cover lever

**8.177 SEAL— CLIP— RETAINER— SCREW, Wheel Cover Panel Rubber**

67-68	Pass. (exc. Sta. Wag.)	3907670	2	.66	opening cover (rubber)
69-70	Pass. w/skirt (exc. Sta. Wag.)	3939320	2	.66	opening cover (rubber)
70-72	Monte Carlo w/Wheel Opening Cover	3963387	L.H.	.73	opening cover (rubber)
70-72	Monte Carlo w/Wheel Opening Cover	3963388	R.H.	.73	opening cover (rubber)
71-75	Pass.	3985695	2	1.05	
70-72	Monte Carlo	9792217	A.R.	.13	CLIP, cover seal fstn.— (8.154)
67-69	Pass. (exc. Sta. Wag.)	3907675	2	.16	RETAINER, rr. wheel seal front
67-69	Pass. (exc. Sta. Wag.)	3907676	2	.18	RETAINER, rr. wheel seal rear
73-75	Pass.	3997341	L.H.	.22	RETAINER, front
73-75	Pass.	3997342	R.H.	.22	RETAINER, front
73-75	Pass.	3997343	L.H.	.24	RETAINER, rear
73-75	Pass.	3997344	R.H.	.24	RETAINER, rear
73-75	Pass.	3995172	2	.11	SCREW, cover lever

**8.179 BRACKET— FASTENER— LEVER, Wheel Opening Cover**

67-68	Pass. (exc. Sta. Wag.)	3901879	L.H.	.28	rear wheel cover body frt.
67-68	Pass. (exc. Sta. Wag.)	3901880	R.H.	.28	rear wheel cover body frt.
67-70	Pass. (exc. Sta. Wag.)	3901881	L.H.	.28	rear wheel cover body rear
67-70	Pass. (exc. Sta. Wag.)	3901882	R.H.	.28	rear wheel cover body rear
67-70	Pass. (exc. Sta. Wag.)	3901883	2	.32	center, rear wheel cover body center
69-70	Pass. (exc. Sta. Wag.)	3938067	L.H.	.28	rear wheel cover body frt.
69-70	Pass. (exc. Sta. Wag.)	3938068	1	.28	right, rear wheel cover body frt.
69-70	Pass. (exc. Sta. Wag.)	3938072	4	.16	rear wheel body inter.
69-70	Pass. (exc. Sta. Wag.)	3950791	1	.22	left, rear wheel cover body inter.
69-70	Pass. (exc. Sta. Wag.)	3950792	1	.22	right, rear wheel cover body inter.
70-72	Monte Carlo w/Wheel Opening Cover	3963393	2	.22	center
71-75	Pass.	3986993	2	.28	center
71-75	Pass.	3986995	2	.11	lever
74	Pass.	4841194	2	.11	FASTENER, cover seal
71-75	Pass.	3985683	2	1.95	LEVER, cover

**8.203 EXTENSION, Rear Fender and Door**

75	Monza (Hvy. Duty Service)	3965791	R.H.	150.00	EXTENSION
75	Monza (Hvy. Duty Service)	3965792	L.H.	150.00	EXTENSION

**8.205 ANTI-SQUEAK, Universal**

73-74	All	3997555	A.R.	RL/.27	(1 <sup>3</sup> / <sub>4</sub> " wide x 50 ft. roll-one bead) (Note 1)
-------	-----	---------	------	--------	--

*NOTE 1: Quantity of one when ordering denotes one 50 ft. roll.*

**8.206 WASHER, Rear Fender Attaching**

65-69	Pass.	3688003	A.R.	.11	fender attch. (1 <sup>1</sup> / <sub>4</sub> " O.D.— <sup>11</sup> / <sub>32</sub> " I.D. x 1 <sup>1</sup> / <sub>16</sub> ")— (8.143)
-------	-------	---------	------	-----	--

**8.304 MOULDING UNIT— CAP UNIT, Body Sill**

62-63	Chevy	3792280	R.H.	14.35	body sill
-------	-------	---------	------	-------	-----------

**SHEET METAL—HEATER**

**8.304 MOULDING UNIT— CAP UNIT, Body Sill (Con't)**

64	Bel Air	3844288	2	14.35	body sill, left or right
64	Malibu, El Camino Std. (exc. S.S.)	3843903	L.H.	14.35	body sill
64	Malibu, El Camino Std. (exc. S.S.)	3843904	R.H.	14.35	body sill
64	Malibu S.S., El Camino Custom	3846277	L.H.	14.35	body sill
64	Malibu S.S., El Camino Custom	3846278	R.H.	14.35	body sill
64	Chevy (exc. Nova)	3850818	2	11.30	body sill, left or right
64	Nova	3850881	L.H.	15.85	body sill
64	Nova	3850882	R.H.	15.85	body sill
65	Chevelle (Std.), Malibu S.S., El Camino Custom	3865361	L.H.	15.85	body sill
65	Chevelle (Std.), Malibu S.S., El Camino Custom	3865362	R.H.	15.85	body sill
65	Pass. (exc. Impala), Impala (exc. S.S.)	3865331	L.H.	17.40	body sill
65	Impala (exc. S.S.)	3865332	R.H.	17.40	body sill
65	Pass. (exc. Impala), Impala	3862227	2	12.85	body sill, left or right
66	Caprice	3886227	L.H.	15.85	body sill
66	Caprice	3886228	R.H.	15.85	body sill
66-67	Nova (exc. S.S.)	3885381	L.H.	14.35	body sill
66-67	Nova (exc. S.S.)	3885382	R.H.	14.35	body sill
66	Nova (S.S.)	3885383	L.H.	9.75	body sill, upper
66	Nova (S.S.)	3885384	R.H.	9.75	body sill, upper
66	Nova (S.S.)	3885385	L.H.	32.50	body sill, lower
66	Nova (S.S.)	3885386	R.H.	32.50	body sill, lower
66	Chevelle (S.S.), Malibu (El Camino)	3886231	L.H.	15.85	body sill
66	Chevelle (S.S.), Malibu (El Camino)	3886232	R.H.	15.85	body sill
66	Malibu (exc. El Camino)	3886237	L.H.	12.65	body sill
66	Malibu (exc. El Camino)	3886238	R.H.	12.65	body sill
67	Chevelle (S.S. Concours)	3904583	L.H.	15.85	body sill
67	Chevelle (S.S. Concours)	3904584	R.H.	15.85	body sill
67	Chevelle (Deluxe)	3904585	L.H.	14.35	body sill
67	Chevelle (Deluxe)	3904586	R.H.	14.35	body sill
67-69	Camaro	3904540	2	12.85	body sill, left or right
67	Impala (S.S.)	3904649	L.H.	15.85	body sill
67	Impala (S.S.)	3904650	R.H.	15.85	body sill
68-69	Pass. (exc. Bel Air, Caprice, exterior Mldg.), Biscayne	3927546	2	12.85	body sill
68-74	Nova w/Custom Exterior	3927547	L.H.	13.20	body sill
68-74	Nova w/Custom Exterior	3927548	R.H.	14.35	body sill
68	Chevelle (2-Dr.)	3928426	R.H.	15.85	body sill
68	Chevelle (4-Dr.) El Camino	3928427	L.H.	15.85	body sill
68	Chevelle (4-Dr.) El Camino	3928428	R.H.	15.85	body sill
69	Chevelle Deluxe (2-Dr.) (exc. El Camino), El Camino (exc. Custom)	3952495	2	11.30	body sill
69	Chevelle Deluxe (4-Dr.), El Camino (Deluxe)	3952496	2	11.30	body sill
70-72	Greenbrier	3952496	2	11.30	body sill
69	Impala, Caprice w/wheel skirt, exterior Mldg.)	3953845	L.H.	17.40	body sill
69	Impala, Caprice w/wheel skirt, exterior Mldg.)	3953846	R.H.	17.40	body sill
69	Caprice (exc. wheel skirt), Impala, Kingswood w/interior Mldg. (exc. wheel skirt)	3953641	L.H.	17.40	body sill
69	Caprice (exc. wheel skirt), Impala, Kingswood w/interior Mldg. (exc. wheel skirt)	3953642	R.H.	17.40	body sill
70	Biscayne, Brookwood	3927546	2	12.85	body sill
70	Pass. (exc. Wheel Opening Cover)	3980817	L.H.	15.85	body sill (2 <sup>3</sup> / <sub>4</sub> " wide)
70	Pass. (exc. Wheel Opening Cover)	3980818	R.H.	15.85	body sill (2 <sup>3</sup> / <sub>4</sub> " wide)
70	Pass. w/Wheel Opening Cover	3980815	L.H.	15.85	body sill (2 <sup>3</sup> / <sub>4</sub> " wide)
70	Pass. w/Wheel Opening Cover	3980816	R.H.	15.85	body sill (2 <sup>3</sup> / <sub>4</sub> " wide)
70-72	Monte Carlo	3974201	L.H.	14.35	body sill
70-72	Monte Carlo	3974202	R.H.	14.35	body sill
70-72	Concours (exc. Estate Wag.), Malibu (4-Dr.)	3980799	L.H.	14.35	body sill

**SHEET METAL—HEATER**

**8.304 MOULDING UNIT— CAP UNIT, Body Sill (Con't)**

70-72	Concours (exc. Estate Wag.),				
70-72	Malibu (4-Dr.)	3980800	R.H.	14.35	body sill
70-71	Malibu (2-Dr.) (exc. 396, 454),				
72	Malibu (2-Dr.) (exc. S.S.)	3980807	L.H.	14.00	body sill
70-71	Malibu (2-Dr.) (exc. 396, 454),				
72	Malibu (2-Dr.) (exc. S.S.)	3980808	R.H.	14.00	body sill
70-75	Camaro	481539	R.H.	11.30	body sill
70-75	Camaro	481540	L.H.	11.30	body sill
71-72	Biscayne, Bel Air,				
73-75	Pass. (exc. Sta. Wag.)	338231	2	15.85	body sill
71-72	Brookwood, Townsman,				
73-75	Bel Air, Impala (Sta. Wag.)	338232	2	15.85	body sill
75	Nova	498166	2	16.10	body sill
64	Malibu S.S., El Camino Custom	3848347	L.H.	2.35	CAP UNIT, rear mldg.
64	Malibu S.S., El Camino Custom	3848348	R.H.	2.60	CAP UNIT, rear mldg.

**8.309 CLIP— NUT— RETAINER— SCREW, Body Sill Moulding**

64	Chevy (exc. Nova)	3788028	8	.11	body sill mldg.
65	Pass. (exc. Caprice, Impala),				
65	Caprice (4-Dr. Spt. Sedan),				
66	Impala,				
68-69	Pass. (exc. Bel Air, Caprice),				
69	Chevelle (Deluxe) (exc. 396),				
70	Biscayne, Brookwood,				
70	El Camino,				
70-72	Greenbrier	3858437	8	.11	body sill mldg.
70	Monte Carlo	4674640	12	.16	body sill mldg. retainer— (12.118)
70-72	Camaro	4510031	10	.18	body sill mldg. retainer— (12.075)
67	Chevelle Deluxe	3893995	8	.16	body sill mldg.
65-66	Pass.	9422836	12	.05	NUT, moulding (No. 10— 16) (spl. "U" shape sprg.)
64	Chevy (exc. Nova),				
65	Pass. (exc. Caprice, Impala),				
65	Caprice (4-Dr. Spt. Sedan),				
66	Impala,				
68-69	Pass. (exc. Bel Air, Caprice),				
69	Chevelle (Deluxe) (exc. 396),				
70	Biscayne, Brookwood,				
70	El Camino,				
70-72	Greenbrier	3844414	4	.16	NUT, sill moulding (No. 10— 16)
70	Monte Carlo (Spt. Cpe.)	3884940	2	.13	NUT (No. 10) nylon— (9.744)
62-64	Chevy,				
64	El Camino, Malibu (exc. S.S.),				
65	Impala (exc. S.S.),				
65-68	Chevelle,				
66-67	Nova (exc. S.S.),				
66	Caprice (exc. Sta. Wag.),				
66-67	Impala, S.S.,				
68	Bel Air, Impala,				
68-75	Nova,				
69-70	Caprice, Impala,				
70-72	Malibu, Concours	3886638	4	.18	RETAINER, sill moulding (1 <sup>3</sup> / <sub>4</sub> " )
62-63	Chevy,				
64	Nova	3838388	4	.44	RETAINER, moulding
67	Camaro,				
68	Camaro (exc. R.S.),				
69-70	Camaro	3899871	2	.71	RETAINER, moulding
71-72	Biscayne, Bel Air,				
71-72	Brookwood, Townsman,				
73-75	Pass.	3986976	12	.11	RETAINER (snap type)
71-72	Biscayne, Bel Air,				
71-72	Brookwood, Townsman,				
73-75	Pass.	3986977	2	.11	RETAINER (bolt type)
71-75	Camaro	3898145	4	.26	
62-69	All	9417706	6	.11	SCREW, sill moulding (No. 10— 24 x <sup>3</sup> / <sub>4</sub> " )— (8.908)
64-65	Chevy (exc. Nova),				
65	Pass. (exc. Caprice, Impala),				
65	Caprice (4-Dr. Spt. Sedan),				
66	Impala	3849368	4	.11	SCREW, sill moulding (No. 10— 16 x 1)

**8.800 REPAIR UNIT— ADHESIVE**

71-75	Vega, Monza	1051223	1	9.50	defogger heating element (Note 1)
-------	-------------	---------	---	------	-----------------------------------

*NOTE 1: Consists of Bliss-Bond 200 Epoxy, related mixing and application tools and instructions for repairing an Electric Rear Window Defogger broken heating element.*

**SHEET METAL—HEATER**

---

**8.800 REPAIR UNIT— ADHESIVE (Con't)**

71-75 Vega, Monza ..... 1051518 1 4.00 ADHESIVE, disc brake pads .....

**SHEET METAL—HEATER**

**8.820 JACK— BASE ASSY.— BOLT— BRACKET— BUMPER— CLAMP— CLIP— COVER— NUT— PAD— RETAINER— SLEEVE— STOP ASSY.— SUPPORT, Auto.**



**BASE**

3909111  
3866476  
3995122  
332302  
329747  
1602221



**BASE**

9781295



**BASE**

1387967  
3995121  
3769624



**BASE**

3756315  
332376



**BASE**

3997317

- 62-65 Chevy, Chevelle,
  - 65-68 Pass.,
  - 69 Pass. (Sta. Wag.),
  - 66 Chevy,
  - 67-68 Chevelle (Sta. Wag., El Camino),
  - 68 Chevelle (exc. Sta. Wag., El Camino),
  - 68-72 Chevelle (exc. Monte Carlo),
  - 72 Monte Carlo,
  - 71-72 Nova, Camaro,
  - 73 Camaro . . . . . **3920032** 1 10.30 mech. bumper type (Note 1) . . . . .
- NOTE 1 Jack assemblies are packaged less the bracket assy., load rest. The bracket assy., load rest must be purchased separately when ordering the Jack Assemblies.*
- 67-70 Chevy, Camaro,

**SHEET METAL—HEATER**

**8.820 JACK— BASE ASSY.— BOLT— BRACKET— BUMPER— CLAMP— CLIP— COVER— NUT— PAD— RETAINER— SLEEVE— STOP ASSY.— SUPPORT, Auto. (Con't)**

67	Chevelle (exc. Sta. Wag., El Camino)	3909108	1	10.65	mech. bumper type
69-72	Pass., Monte Carlo	3997420	1	10.85	mech. bumper type
71-72	Vega	325178	1	11.00	
73-75	Chevelle (exc. Laguna)	6259499	1	10.30	mech. bumper type
73-75	Laguna	6259500	1	10.30	mech. bumper type
73-75	Pass.	6259755	1	10.85	mech. bumper type
73-74	Nova,				
74-75	Camaro	6259501	1	10.30	mech. bumper type
75	Monza	6259502	1	11.30	
73-75	Vega, Nova	374586	1	12.45	
62-67	Chevy,				
64-67	Chevelle (exc. Sta. Wag., El Camino)	9781295	1	2.80	<b>BASE ASSY.</b> (Note 2)
62-67	Chevy,				
64-69	Chevelle (Sta. Wag., El Camino),				
65-70	Pass.,				
71-72	All (exc. Pass.),				
73	Camaro	3866476	1	2.40	<b>BASE ASSY.</b> (Note 2)
64-67	Chevelle (Sta. Wag., El Camino),				
68	Chevelle,				
69-70	Pass., Chevelle,				
71-72	All,				
73	Camaro	3997317	1	2.85	<b>BASE ASSY.</b> (Note 2)
67-70	Camaro,				
68	Chevy,				
70	Nova	3909111	1	2.30	<b>BASE ASSY.</b> (Note 2)
67-70	Camaro,				
68-70	Chevy,				
71-72	Pass.	3995121	1	2.75	<b>BASE ASSY.</b> (Note 2)
71-72	Pass.	3995122	1	2.75	<b>BASE ASSY.</b> (Note 2)
71-72	Vega	3866476	1	2.40	<b>BASE ASSY.,</b> jack
73	Nova,				
74-75	Camaro, Nova	329747	1	2.40	<b>BASE ASSY.</b> (Note 1)
73-75	Chevelle, Pass.	1602221	1	3.30	<b>BASE ASSY.</b> (Note 1)
73-75	Pass., Nova,				
73-75	Chevelle (exc. Laguna)	332376	1	2.85	<b>BASE ASSY.</b> (Note 1)
73-75	Vega	329747	1	2.40	<b>BASE ASSY.,</b> jack
<i>NOTE 2: Listed on the preceding page are typical drawings of each jack base serviced with the part numbers that are similar listed below each.</i>					
71-75	Pass.,				
73	Vega	3989197	1	.38	<b>BOLT,</b> jack column
72	Pass.	6273771	1	.32	<b>BOLT,</b> jack column
73	Chevelle (exc. Sta. Wag., El Camino)	414068	1	.28	<b>BOLT,</b> jack hold down
74-75	Chevelle (exc. Sta. Wag., El Camino)	417103	1	.28	<b>BOLT,</b> auto. jack hold down
73-75	El Camino	3999722	1	.52	<b>BOLT,</b> w/clip jack hold down
71-72	Vega,				
73-75	Nova	333734	1	.98	<b>BOLT,</b> auto jack stowage brkt. (1/4" — 20 x 2 11/16" O.L.)
74-75	Camaro	341067	1	.52	<b>BOLT,</b> auto. jack stowage
74-75	Vega, Monza	339048	1	.31	<b>BOLT,</b> jack stowage
68	Camaro	3929955	1	.23	<b>BRACKET,</b> frt. bumper jack— (7.869)
70	Pass.	587988	1	.36	<b>BRACKET,</b> jack hold down
71-72	Vega	3991307	1	.36	<b>BRACKET,</b> jack hold down
71-72	Vega	3986527	1	3.00	<b>BRACKET,</b> jackload rest
74-75	Pass. (exc. Sta. Wag.)	342325	L.H.	.63	<b>BRACKET,</b> rr. bumper jacking pad
74-75	Pass. (exc. Sta. Wag.)	342326	R.H.	.63	<b>BRACKET,</b> rr. bumper jacking pad
75	Monza	353939	2	.70	<b>BRACKET,</b> frt. bpr. impact bar jacking
75	Laguna	356969	1	5.95	<b>BRACKET,</b> load rest
62-65	Chevy, Chevelle	3869728	1	1.70	<b>BRACKET ASSY.,</b> jack load rest
65	Pass.	3878116	1	1.70	<b>BRACKET ASSY.,</b> jack load rest (Note 3)
<i>NOTE 3 Used with special bumper 3870503.</i>					
66	Pass.	3892192	1	2.10	<b>BRACKET ASSY.,</b> jack load rest
66	Chevy, Chevelle,				
67	Chevy	3898170	1	1.70	<b>BRACKET ASSY.,</b> jack load rest
67	Chevelle	3897539	1	1.90	<b>BRACKET ASSY.,</b> jack load rest
67-68	Camaro	3919088	1	2.00	<b>BRACKET ASSY.,</b> jack load rest
67	Pass.	3899562	1	2.00	<b>BRACKET ASSY.,</b> jack load rest
68	Pass. (exc. Sta. Wag.)	3922800	1	2.30	<b>BRACKET ASSY.,</b> jack load rest
68	Sta. Wag.	3922802	1	2.65	<b>BRACKET ASSY.,</b> jack load rest
68-72	Chevy	3914774	1	2.30	<b>BRACKET ASSY.,</b> jack load rest

**SHEET METAL—HEATER**

**8.820 JACK— BASE ASSY.— BOLT— BRACKET— BUMPER— CLAMP— CLIP— COVER— NUT— PAD— RETAINER— SLEEVE— STOP ASSY.— SUPPORT, Auto. (Con't)**

68	Chevelle	3922804	1	2.30	BRACKET ASSY., jack load rest
69	Camaro	3949734	1	2.20	BRACKET ASSY., jack load rest
69	Camaro w/spec. bumper	3949782	1	3.70	BRACKET ASSY., jack load rest
69	Chevelle	3947973	1	2.10	BRACKET ASSY., jack load rest
69	Pass. (exc. Sta. Wag.)	3941290	1	2.10	BRACKET ASSY., jack load rest
69	Pass., Sta. Wag.	3945601	1	2.60	BRACKET ASSY., jack load rest
70-72	Monte Carlo	3965975	1	2.85	BRACKET ASSY., load rest
70	Chevelle (Sta. Wag., El Camino)	3965976	1	2.60	BRACKET ASSY., load rest
70	Chevelle (exc. Sta. Wag., El Camino, Monte Carlo)	3965977	1	2.85	BRACKET ASSY., load rest
70	Pass. (exc. Sta. Wag.)	3945397	1	2.40	BRACKET ASSY., load rest
72	Pass. (exc. Sta. Wag.)	6273770	1	2.65	BRACKET ASSY., load rest
70	Pass. (Sta. Wag.)	3945396	1	2.85	BRACKET ASSY., load rest
70-72	Chevelle	3965934	2	.32	BRACKET ASSY., jack pad
70-73	Camaro	3990416	1	2.60	BRACKET ASSY., jack load rest
71	Pass.,				
72	Pass. (Sta. Wag.),				
73	Monte Carlo	3986971	1	2.85	BRACKET ASSY., load rest
71-72	Chevelle (exc. Sta. Wag., El Camino)	3999704	1	2.35	BRACKET ASSY., load rest
71-72	Chevelle (Sta. Wag., El Camino)	3977765	1	2.35	BRACKET ASSY., load rest
71-72	Nova	3986518	1	.81	BRACKET ASSY., jack hold down
73	Chevelle (Sta. Wag., El Camino),				
74-75	El Camino	328920	1	2.85	BRACKET ASSY., load rest
74-75	Camaro	341097	2	.22	BUMPER, frt. bumper jacking support
70	Pass. (exc. Sta. Wag.)	587989	1	.32	CLAMP, auto. jack column
71-72	Nova	3986519	1	.28	CLAMP, jack hold down
73-75	Chevelle (Sta. Wag.)	325235	1	.22	CLAMP, jack hold down
73	Vega	3844390	1	.18	CLIP, jack stowage outer retainer bracket (push-in-type)— (2.559)
73-75	Chevelle (Sta. Wag., El Camino)	391889	2	.58	CLIP, wheel wrench
70-73	Camaro	3984010	1	1.60	COVER, auto. jack
70	Pass.,				
71-74	All	9427872	1	.12	NUT, wing ( <sup>5</sup> / <sub>16</sub> "— 18)
71-72	Vega	9785616	1	.68	NUT, jack bolt ( <sup>5</sup> / <sub>16</sub> "— 18)— (7.633)
73	Chevelle (Sta. Wag., El Camino),				
74-75	El Camino	331774	2	.34	PAD, jack
73	Pass.	327106	2	.34	PAD, jack
73-75	El Camino	6264841	1	.28	RETAINER, jack stowage
74-75	Camaro	341066	1	.28	RETAINER, jack stowage
75	Pass. (Sta. Wag.)	1658576	1	2.35	RETAINER, jack stowage col. front
75	Monza (Towne Cpe.)	1672833	L.H.	3.75	RETAINER, jack col. stowage
75	Monza (Towne Cpe.)	1672832	R.H.	2.90	RETAINER, jack col. stowage
68-70	Chevelle (exc. Sta. Wag., El Camino),				
73-74	Pass. (exc. Sta. Wag.),				
73-74	Chevelle (exc. Sta. Wag., El Camino)	9781956	1	.78	SLEEVE, wheel wrench stow.
74-75	Vega	339049	1	.83	SPRING, jack stowage
69-72	Chevelle (Sta. Wag.) w/dual T/gate	3958358	R.H.	2.50	STOP ASSY., bumper jacking support
69-72	Chevelle (Sta. Wag.) w/dual T/gate	3958300	R.H.	.98	SUPPORT, bumper jacking support
74-75	Camaro	341093	L.H.	2.65	SUPPORT, frt. bumper jacking
74-75	Camaro	341094	R.H.	2.65	SUPPORT, frt. bumper jacking
75	Nova	9676137	R.H.	2.15	SUPPORT, jack col. stowage rear
75	Nova (exc. Hatchback)	9676138	R.H.	4.55	SUPPORT, jack col. stowage, front
75	Monza (exc. Towne Cpe.)	354000	2	.27	SCREW, frt. bpr. impact bar jacking brkt.

NOTE 1: Listed on the preceding page are typical drawings of each jack base serviced with the part numbers that are similar listed below each.

**8.821 WRENCH— FLAG— FLARE ASSY., Wheel and Tire**

62-70	All,				
71-75	All (exc. Pass.)	326740	1	3.20	wheel ( <sup>3</sup> / <sub>4</sub> " hex.)
71-75	Pass.	1238072	1	2.15	wheel ( <sup>13</sup> / <sub>16</sub> " hex.)
62-73	All	3891443	1	.83	FLAG (distress)
62-73	All	3891442	1	1.35	FLARE ASSY. (distress)

**8.845 HEATER ASSY.— BRACKET— COVER— GASKET— SHAFT— NUT— VALVE ASSY.— WARMER UNIT— WIRE, Hot Water**

69-70	Pass. (exc. C.A.C.)	3940248	1	63.00	
71-72	Pass. (exc. C.A.C.)	3022578	1	110.00	w/defr.
70-74	Camaro (exc. C.A.C.)	3023736	1	64.75	w/defr.

**SHEET METAL—HEATER**

**8.845 HEATER ASSY.— BRACKET— COVER— GASKET— SHAFT— NUT— VALVE ASSY.— WARMER UNIT— WIRE, Hot Water (Con't)**

72-74	Vega (exc. C.A.C.)	3022587	1	2.45	BRACKET, htr. temp. valve
72-74	Vega (exc. C.A.C.)	3022586	1	2.45	BRACKET, htr. defr. valve
71-74	Vega (exc. C.A.C.)	3022614	1	3.00	CONTROL VALVE, heater temp.
71-74	Vega (exc. C.A.C.)	6262661	1	60.25	w/defr.
75	Vega (exc. C.A.C.)	3032001	1	62.75	w/defr.
68	Chevy, Camaro (exc. C.A.C., 396),				
69	Camaro (exc. 396, C.A.C.),				
69	Chevy (exc. 396 H/Per.),				
70	Nova, Camaro (exc. C.A.C.)	3929024	1	.66	GASKET, heater and defr. to dash
72-73	Pass. w/C.A.C.	3831934	1	.11	NUT, htr. case flange
75	Monza (exc. C.A.C.),				
75	Vega (122)	3031507	1	3.15	LINK, defr. lvr. to temp. lvr.
72-74	Vega (exc. C.A.C.)	3022594	1	.59	SHAFT ASSY., htr. temp. valve, w/lever
72-74	Vega (exc. C.A.C.)	3022593	1	.71	SHAFT ASSY., htr. shut-off, w/pins
72-74	Vega (exc. C.A.C.)	3022788	1	.59	SHAFT AND LEVER ASSY., purge valve
75	Monza (exc. C.A.C.),				
75	Vega (122)	3031040	1	3.70	SHAFT AND LEVER ASSY., purge valve
75	Monza (exc. C.A.C.),				
75	Vega (122)	3031041	1	3.70	SHAFT AND LEVER ASSY., temp. valve
75	Monza (exc. C.A.C.),				
75	Vega (122)	3031042	1	3.90	SHAFT AND LEVER ASSY., defr. valve
72-75	Monza (exc. C.A.C.),				
75	Vega (122)	3022791	1	3.00	VALVE ASSY., purge
75	Monza (exc. C.A.C.),				
75	Vega (122)	3031005	1	9.80	VALVE ASSY., defr.
75	Monza (exc. C.A.C.),				
75	Vega (122)	3031243	1	8.15	VALVE ASSY., htr. temp.
71-74	Vega (exc. C.A.C.)	3022812	1	.12	WIRE, htr. slave link
72-73	Pass. w/C.A.C.	3025960	1	5.95	VALVE ASSY., defr.
71-75	All	992384	1	22.50	WARMER UNIT, car interior

**8.846 HOSE— CLIP— PIPE ASSY.— RETAINER, Heater (See Group 1.166 for Clamps)**

All	All	482434	1	RL/.67	(5/8" I.D.) (50 ft. roll)— (8.962) (Note 1)
All	All	482420	1	RL/.80	(3/4" I.D.) (50 ft. roll)— (8.962) (Note 1)
					<i>NOTE 1 Quantity of 1 denotes one 50 ft. roll.</i>
65-67	Chevelle w/327 Sp. H/Per.,				
66-67	Chevy w/327 Sp. H/Per.,				
67-69	Camaro (302)	3794094	1	1.20	heater outlet
75	Monza (exc. Towne Cpe.) (Rotary) (exc. C.A.C.)	346182	1	2.65	htr. to eng. inlet
75	Monza (exc. Towne Cpe.) (Rotary) (exc. C.A.C.)	482434	1	RL/.67	htr. to eng. outlet
75	Vega, Monza (122)	331943	1	1.30	heater to cylinder head
75	Vega, Monza (122)	346178	1	3.60	htr. to car htr. pipe
75	Vega, Monza w/C.A.C. (8 cyl.)	364014	1	3.60	car htr. to w/pump
74-75	Vega, Monza (122)	331942	1	3.40	car htr. to w/pump
65-69	Pass.,				
73-74	Nova, Camaro, Vega, Monza w/C.A.C.	3825416	2	.50	CLIP, double hose
65-69	Pass.	3771163	A.R.	.12	CLIP (1")
75	Pass., Chevelle w/C.A.C. (454)	362528	1	1.30	CLIP, htr. hose
75	Vega, Monza (140)	344867	1	.50	CLIP, car htr. hose
65-69	Pass.	3816659	A.R.	.31	RETAINER, hose— (2.559)

**8.849 CONTROL ASSY.— PLATE, Heater**

64-65	Chevelle (exc. C.A.C.)	3843244	1	11.60	heater
64-65	Chevelle w/Air Cond.	3843997	1	14.35	heater— (9.273)
65-66	Pass. w/C.A.C.	3875805	1	21.25	heater— (9.273)
65-66	Pass. (exc. C.A.C.)	3875803	1	21.25	heater
66	Pass. w/Auto. Temp. Cont.	3891720	1	58.50	heater— (9.273)
66-67	Chevy w/C.A.C.	3870241	1	20.55	heater— (9.273)
66	Chevelle w/C.A.C.	3870223	1	22.45	heater— (9.273)
66-67	Chevelle (exc. C.A.C.)	3899760	1	19.60	heater
67	Chevelle w/C.A.C.	3899764	1	25.50	heater— (9.273)
67-68	Camaro (exc. C.A.C.)	3925775	1	20.55	heater
67	Camaro w/C.A.C.	3891797	1	17.70	heater— (9.273)
67	Pass. (exc. C.A.C.)	3891755	1	21.25	heater
67	Pass. w/C.A.C.	3891786	1	21.25	heater— (9.273)
67	Pass. w/Auto. Temp. Cont.	3891782	1	58.50	heater— (9.273)
68	Pass. (exc. C.A.C.)	3919502	1	20.65	heater
68	Pass. w/C.A.C.	3919503	1	22.90	heater— (9.273)
68	Pass. w/Auto. Temp. Cont.	3919504	1	57.25	heater— (9.273)



**SHEET METAL—HEATER**

**8.849 CONTROL ASSY.— PLATE, Heater (Con't)**

68	Camaro w/C.A.C.	3919581	1	20.55	heater— (9.273)
68	Chevy (exc. C.A.C.)	3909009	1	21.65	heater
68	Chevy w/C.A.C.	3940277	1	26.75	heater— (9.273)
68	Chevelle (exc. C.A.C.)	3938542	1	21.65	heater
68-69	Chevelle w/C.A.C.	3946900	1	28.50	heater (Note 1)— (9.273)
<i>NOTE 1 When using 3946900 in place of 3938543 or 3909037 the center vacuum/port No. 2 must be sealed off.</i>					
69	Chevelle (exc. C.A.C.)	3949980	1	22.30	heater
69	Chevy, Camaro w/C.A.C.,				
70-72	Nova w/C.A.C.	6273372	1	20.00	heater— (9.273)
69	Chevy, Camaro (exc. C.A.C.),				
70-75	Nova (exc. C.A.C.)	6273371	1	22.30	heater
69-70	Pass. (exc. C.A.C.)	3937124	1	22.30	heater
69	Pass. w/Auto. Temp. Control	7307601	1	69.00	heater— (9.273)
69-70	Pass. w/C.A.C. (exc. Auto Temp Cont.)	7308301	1	28.75	heater— (9.273)
70	Pass. w/Auto. Temp. Control	7311681	1	78.60	heater— (9.273)
71	Pass. (exc. C.A.C.)	3992109	1	31.75	heater
72	Pass. (exc. C.A.C.)	6273373	1	27.00	heater
71-72	Chevelle (exc. C.A.C.)	6273367	1	23.05	heater
70	Chevelle (exc. C.A.C.)	3963700	1	24.50	heater
70-72	Camaro w/C.A.C.	6273370	1	32.50	heater— (9.273)
70-72	Camaro (exc. C.A.C.)	3963768	1	25.00	heater
71	Pass. w/Auto. Temp. Control	7930281	1	41.55	heater— (9.273)
71-72	Pass. w/C.A.C.	7938671	1	30.79	heater— (9.273)
71-73	Vega (exc. C.A.C.)	6273362	1	19.55	
73-75	Pass. (exc. C.A.C.)	336404	1	27.00	heater
73-75	Chevelle (exc. C.A.C.)	3992186	1	23.05	heater
73-75	Camaro (exc. C.A.C.)	6273369	1	25.00	heater
74-75	Vega, Monza (exc. C.A.C.)	340454	1	19.55	
75	Monza (Towne Cpe.) (exc. C.A.C.)	362508	1	19.55	
75	Monza w/C.A.C.	354815	1	8.50	PLATE, dash pnl. htr. hole cover
75	Monza (Towne Cpe.) (exc. C.A.C.)	362509	1	3.25	PLATE, htr. control face— (9.279)

**8.850 VALVE ASSY.— ACTUATOR ASSY.— SWITCH ASSY., Heater Vacuum Actuating**

66	Pass. w/Auto. Temp. Control	1222401	1	5.65	htr. and A.C. sensor assy. vac. servo— (9.786)
66	Pass. w/Auto. Temp. Control	3895935	1	9.70	htr. temp. control vac.
67	Pass., Camaro w/C.A.C.	1222845	1	3.54	heater and A.C. sensor
67-68	Pass. w/Auto. Temp. Control	1222689	1	5.75	htr. and A.C. sensor assy. vac. servo
67-68	Pass. w/Auto. Temp. Control	3902263	1	9.70	htr. temp. control vac.
67-68	Pass. w/Auto. Temp.	1222687	1	4.51	heater and A.C. sensor vacuum control
69	Chevelle w/C.A.C.	7309741	1	3.54	heater and A.C. vacuum
69-70	Pass. w/C.A.C.	7308934	1	2.67	htr. and A.C. vac. control (9 ports, top lever)— (9.280)
70	All w/C.A.C. (exc. Nova),				
71-72	Camaro w/C.A.C.,				
72	Chevelle w/C.A.C.	7308935	1	2.67	htr. & A/C vac. cont.— (9.280)
70-72	Chevelle w/C.A.C.	7313861	1	4.64	htr. & A/C cont. air defr.— (9.280)
69-70	Pass. w/Auto. Temp. Control	7309014	1	3.54	htr. and A.C. sensor assy.
71	Pass. (exc. Air Cond.),				
71	All (exc. Pass.) w/C.A.C.,				
72	All w/C.A.C.	1485553	1	1.60	control check (color white) (7/8" dia.)
68	Pass. w/C.A.C.	7304857	1	4.46	heater and A.C. sensor control
73-75	Pass. (exc. C.A.C.)	3022723	1	3.10	heater temp.
73-75	Pass., Nova, Camaro w/C.A.C.	1485553	1	1.60	a/c vac. check
73-74	Chevelle w/C.A.C.	7936651	1	4.16	vac. select. 9 port htr. and a/c
69	Pass. w/C.A.C.	1222259	1	3.54	VALVE UNIT, heater and C.A.C. vacuum control
71-72	Pass. (exc. C.A.C.)	1998984	1	4.28	ACTUATOR ASSY., htr. air door

**8.852 SWITCH ASSY.— ARM— KNOB— BOARD UNIT— BRACKET— BEZEL— HARNESS ASSY.— INSERT— LENS— LEVER— SUPPORT— SPRING— COVER— ESCUTCHEON— FILTER— GUIDE— INSERT— NUT— CLIP— CAP— ROLLER— BUSHING— WASHER— PIN— PLATE— RETAINER— SHAFT— DIAL— TRANSDUCER, Heater**

*NOTE. See group 9.786 for vacuum valve details and part numbers.*

62-65	Chevy	3793768	1	3.10	heater, blower w/control cable
64	Chevelle w/Air Cond.	3849122	1	1.70	heater control
64-65	Chevelle (exc. C.A.C.),				
66-67	Chevy (exc. C.A.C.)	3843245	1	1.70	heater
65	Chevelle w/C.A.C.	3860509	1	1.75	heater control
65-66	Pass. (exc. C.A.C.)	3857416	1	1.55	heater control

**SHEET METAL—HEATER**

**8.852 SWITCH ASSY.— ARM— KNOB— BOARD UNIT— BRACKET— BEZEL—  
HARNASS ASSY.— INSERT— LENS— LEVER— SUPPORT— SPRING—  
COVER— ESCUTCHEON— FILTER— GUIDE— INSERT— NUT— CLIP—  
CAP— ROLLER— BUSHING— WASHER— PIN— PLATE— RETAINER—  
SHAFT— DIAL— TRANSDUCER, Heater (Con't)**

65-66	Pass. w/C.A.C. (exc. Auto. Temp. Cont.)	3857992	1	1.55	heater control
65-66	Pass. w/C.A.C.,				
66-67	Chevelle w/C.A.C. (exc. Auto. Temp. Cont.),				
68	All w/C.A.C. (exc. Auto. Temp. Control)	3870286	1	1.70	heater and C.A.C. blower (push button type w/2 term.)
66	Pass. w/Auto. Temp. Cont.	3875847	1	3.54	blower
66-67	Chevy w/C.A.C.	3870242	1	3.55	heater control
66-67	Chevelle (exc. C.A.C.)	3895923	1	1.70	heater control
68-69	Chevelle (exc. C.A.C.)				heater control,
67-68	Pass., Camaro (exc. C.A.C.)	3885148	1	1.50	heater control
67	Pass. w/Air Cond.,				
67-68	Camaro w/C.A.C.,				
68	Pass. w/C.A.C. (exc. Auto. Temp. Cont.)	3891795	1	1.70	heater and C.A.C. blower fan 4 terminals
67	Pass., Camaro w/C.A.C.	3891796	1	1.70	heater and C.A.C. outlet 2 terminal
68	Pass. w/C.A.C. (exc. Auto. Temp. Control)	3919586	1	3.20	heater and C.A.C. control w/bracket
68	Chevy (exc. C.A.C.)	3909015	1	1.70	heater control
68	Chevy w/C.A.C.	3909017	1	2.00	heater and C.A.C. blower low
68-69	Chevelle w/C.A.C.	3909064	1	2.00	heater and C.A.C. outlet
68	Chevelle w/C.A.C.	3929060	1	2.85	heater and A.C. blower
68	Camaro w/C.A.C.	3925724	1	3.45	heater and C.A.C. control
69	Chevy, Camaro (exc. C.A.C.),				
70-75	Nova (exc. C.A.C.)	3967939	1	1.55	heater control, blower
69	Chevy, Camaro w/C.A.C.,				
70	Nova w/C.A.C.	7308825	1	3.75	heater and C.A.C. control vac.
69	Chevy, Camaro w/C.A.C.,				
70-74	Nova w/C.A.C.	3973728	1	2.45	heater and A/C control, blower, low— (9.275) (Note 1)
<i>NOTE 1 When 3973728 is used on 1969 models bend terminal tang flush with terminal before inserting into female connector.</i>					
69	Chevy, Camaro w/C.A.C.,				
70-72	Nova w/C.A.C.	6273385	1	3.55	heater and C.A.C. control, fan— (9.275)
69	Chevelle w/C.A.C.	3942656	1	2.75	heater and C.A.C., blower
69	Pass. (exc. C.A.C.)	3937155	1	1.60	heater control blower
69-70	Pass. w/C.A.C. (exc. Auto. Temp. Cont.)	6273391	1	1.80	heater and C.A.C. blower— (9.275)
69	Pass. w/C.A.C.	7308940	1	3.87	heater and C.A.C. master— (9.275)
69	Pass. w/C.A.C.	7308941	1	3.23	heater and C.A.C. blower— (9.275)
70	Chevelle w/C.A.C.	7314261	1	3.65	car heater & A/C
70-72	Chevelle w/C.A.C. (8 cyl.)	6273383	1	3.55	car heater and A/C control fan
70-72	Chevelle (exc. C.A.C.)	3963743	1	2.00	car heater control
70	Pass. (exc. C.A.C.)	3967938	1	1.60	htr. cont. blower
71-75	Pass. (exc. C.A.C.)	7933482	1	1.60	htr. blower control
71-72	Pass. (exc. C.A.C.)	7932989	1	4.95	htr. vac. control
72	Pass. (exc. C.A.C.)	6273329	1	1.60	htr. blower control
70-75	Camaro (exc. C.A.C.)	3963769	1	1.55	htr. control blower
71-75	Vega, Monza (exc. Towne Coupe) (exc. C.A.C.)	3973763	1	1.40	htr. blower
73-75	Chevelle,				
73-75	Pass. (exc. Auto. Temp. Control),				
74-75	Camaro w/C.A.C.,				
75	Nova w/C.A.C.	6490609	1	4.30	htr. low blower delay
73-74	Chevelle w/C.A.C.	6273310	1	10.00	heater and a/c master
73-75	Chevelle (exc. C.A.C.)	336407	1	1.70	heater control
73-75	Chevelle w/C.A.C.	336408	1	1.55	heater and a/c control
75	Monza (exc. Towne Cpe.) w/C.A.C. (8 cyl.)	6490609	1	4.30	htr. low blower delay
75	Monza (Towne Cpe.) (exc. C.A.C.)	362550	1	2.25	htr. blower
66	Chevelle w/C.A.C.	3904628	1	1.20	ARM, air control (Note 8)
66-67	Chevelle w/C.A.C.	3904629	1	1.20	ARM, heater A.C. outlet control (Note 8)
66	Chevelle w/C.A.C.	3904630	1	1.20	ARM, temp. control (Note 8)
68	Chevy	3935043	1	1.45	ARM, heater air cont. (Note 8)
68	Chevy	3935044	1	1.45	ARM, heater temp. cont. (Note 8)
68	Chevy	3935045	1	1.45	ARM, heater defroster cont. (Note 8)
70	Chevelle w/C.A.C.	3979708	1	1.30	ARM, heater and A/C temp. control
66-67	Chevelle	3904618	1	2.95	ARM UNIT, air and fan (w/switch and knob)

**SHEET METAL—HEATER**

**8.852 SWITCH ASSY.— ARM— KNOB— BOARD UNIT— BRACKET— BEZEL— HARNESS ASSY.— INSERT— LENS— LEVER— SUPPORT— SPRING— COVER— ESCUTCHEON— FILTER— GUIDE— INSERT— NUT— CLIP— CAP— ROLLER— BUSHING— WASHER— PIN— PLATE— RETAINER— SHAFT— DIAL— TRANSDUCER, Heater (Con't)**

66-67	Chevelle	3904615	1	.84	ARM ASSY., w/lever, heater air and fan control (Note 8)
66-67	Chevelle	3904616	1	.84	ARM ASSY., w/lever, heater temp. control (Note 8)
66-67	Chevelle	3904617	1	.84	ARM ASSY., w/lever, heater defr. control (Note 8)
66	Chevelle w/C.A.C.	3904631	1	1.20	ARM ASSY., defroster cont. (Note 8)
67	Chevelle w/C.A.C.	3907133	1	1.20	ARM ASSY., w/lever air control (Note 8)
67	Chevelle w/C.A.C.	3907134	1	1.20	ARM ASSY., temp. control (Note 8)
67	Chevelle w/C.A.C.	3907135	1	1.20	ARM ASSY., defroster control (Note 8)
62-64	Chevy	3792753	A.R.	.59	KNOB, air inlet, temp. blower switch and air control (black tenite)
64-65	Chevelle	3000172	1	2.66	KNOB, shut-off valve control (AIR)
65	Pass.,				
65-66	Chevy, Chevelle,				
66	Pass. (exc. Caprice, Spt. Cpe.)	3857878	A.R.	.64	KNOB, blow., temp., switch (Note 2)
	<i>NOTE 2 Obtain from DELCO RADIO No. 7292955.</i>				
67-68	Chevelle, w/C.A.C.,				
68	Chevy w/C.A.C.,				
68	Camaro,				
69	Chevelle,				
70-75	All	7295955	A.R.	.50	KNOB, control lever
68-69	Chevelle	3899700	1	1.10	KNOB, temp. cont.
62-64	Nova	3793010	A.R.	.64	KNOB ASSY., temp., def., blower and air inlet control (chrome)
66-67	Pass. w/Auto. Temp. Cont.	7300234	1	8.65	KNOB ASSY., w/potentiometer, control— (9.275)
68-69	Chevelle	3899701	1	1.85	KNOB ASSY., heater blower and temp. control cable
68	Pass. w/Auto. Temp. Control	7303868	1	9.30	KNOB ASSY., w/potentiometer control— (9.275)
69-70	Pass. w/Auto. Temp. Control	7309015	1	8.40	KNOB ASSY., w/potentiometer control— (9.275)
73-75	Camaro, Nova (exc. C.A.C.)	3012703	1	.12	BEARING PIN, temp. valve
73	Chevelle,				
74-75	Chevelle (exc. C.A.C.),				
75	Monza (exc. Towne Cpe.)	336406	A.R.	.71	KNOB, htr. control
71-72	Pass. w/C.A.C. (exc. Auto. Temp. Control)	1223345	1	5.75	BOARD UNIT, car htr. and A/C— (9.275)
70-72	Chevelle	3963770	1	.11	BRACKET, htr. and control
73-75	Camaro (exc. C.A.C.)	8908278	1	8.95	HARNESS ASSY.
75	Vega, Monza (exc. C.A.C.)	8908508	1	10.30	HARNESS ASSY., htr. wiring
73-75	Nova (exc. C.A.C.)	3967911	1	.18	INSERT, htr. a/c cont. lens
73-75	Pass. (exc. C.A.C.)	3992114	1	.64	INSERT, heater control
	<i>NOTE 3 When using on models with light filter, discard filter.</i>				
69	Chevy, Camaro (exc. C.A.C.),				
70	Nova (exc. C.A.C.)	3946918	1	1.10	LENS, heater control
70-71	Camaro	3979738	1	1.50	LENS, htr. control
70-72	Chevelle w/C.A.C.	6273375	1	1.35	LENS, heater and A/C control
71	Pass. (exc. C.A.C.)	3992115	1	2.45	LENS, control heater
71	Nova (exc. C.A.C.)	3984609	1	1.20	LENS, heater control
71	Nova, Camaro w/C.A.C.	3984658	1	1.95	LENS, htr. & A/C cont. (not used with filter)
72-74	Nova w/C.A.C.	6273379	1	1.95	LENS, car htr. & A/C cont.
72	Nova (exc. C.A.C.)	6273378	1	1.20	LENS, htr. control
72	Chevelle (exc. C.A.C.)	6273374	1	2.50	LENS, car htr. control
72-75	Camaro (exc. C.A.C.)	6273376	1	1.50	LENS, htr. control
72	Camaro w/C.A.C.	6273377	1	1.50	LENS, car htr. & A/C control— (9.279)
72-73	Pass. (exc. C.A.C.)	336405	1	2.50	LENS, control, heater
73-74	Chevelle (exc. C.A.C.)	3998466	1	2.50	LENS, car htr. control
73-74	Chevelle w/C.A.C.	3998460	1	1.35	LENS, htr. and a/c control— (9.279)
74	Pass. (exc. C.A.C.)	336295	1	2.50	LENS, htr. control
75	Chevelle w/C.A.C.	356155	1	1.95	LENS, heater control
75	Nova (exc. C.A.C.)	344841	1	2.60	LENS, heater control
75	Chevelle (exc. C.A.C.)	344840	1	2.60	LENS, heater control
64	Chevelle w/Air Cond.	3000285	1	1.74	LEVER ASSY., A.C. control arm w/guide
64-65	Chevelle	3000181	2	.87	LEVER ASSY., w/guide (def., temp.) (Note 4)
	<i>NOTE 4 The above part consists of one each 3000176, 3000182, 3141791, 3150992, 3156445.</i>				
64-65	Chevelle	3000183	1	.93	LEVER ASSY., w/guide (air) (Note 5)
	<i>NOTE 5 The above part consists of one each 3141791, 3150992, 3156445, 3000175, 3000182.</i>				
65-70	Pass. (exc. C.A.C.)	3003949	1	.42	LEVER ASSY., defroster

**SHEET METAL—HEATER**

**8.852 SWITCH ASSY.— ARM— KNOB— BOARD UNIT— BRACKET— BEZEL—  
HARNES ASSY.— INSERT— LENS— LEVER— SUPPORT— SPRING—  
COVER— ESCUTCHEON— FILTER— GUIDE— INSERT— NUT— CLIP—  
CAP— ROLLER— BUSHING— WASHER— PIN— PLATE— RETAINER—  
SHAFT— DIAL— TRANSDUCER, Heater (Con't)**

67-70	Pass. (exc. C.A.C.)	3012983	1	.56	LEVER ASSY., w/shaft temp.
68	Chevy w/C.A.C.	3935056	1	1.45	LEVER ASSY., heater and A.C. cont. w/air arm (Note 6)
<i>NOTE 6 Use 1-7295955 knob when servicing 3909016 cont. assy.</i>					
68	Chevelle w/C.A.C.	3935058	1	1.45	LEVER ASSY., heater and A.C. control air (Note 7)
68	Chevelle w/C.A.C.	3935060	1	1.45	LEVER ASSY., heater and A.C. air outlet (Note 7)
<i>NOTE 7 Use 1-7295955 knob when servicing 3909036 and 37 control assy.</i>					
70	Camaro	3021597	1	.61	LEVER ASSY., w/shaft (temp.)
70	Camaro	3021611	1	.61	LEVER ASSY., w/shaft (air)
71-72	Pass. w/C.A.C. Auto. Temp. Control	7932343	1	.56	LEVER ASSY., htr. & A/C cont. selector— (9.278)
71-73	Pass. w/C.A.C. (exc. Auto. Temp. Control)	7932344	1	.92	LEVER ASSY., htr. & A/C cont.— (9.278)
73-75	Nova (exc. C.A.C.)	3008472	1	.61	LEVER ASSY., w/shaft (def.)— (9.786)
66-68	Chevelle,				
69	Chevy (exc. C.A.C.),				
68-69	Pass.,				
70	All,				
71-75	Camaro, Nova w/C.A.C.	7282187	2	.15	SPRING, control bezel retainer
71-75	Pass. (exc. C.A.C.)	7308915	2	.31	SPRING, htr. control
72-75	Pass. (exc. C.A.C.)	6262638	1	.11	SPRING, htr. control lever
62-65	Chevy	3791114	1	.32	ESCUTCHEON, blower switch and air control (AIR-FAN)
69-70	Chevy	3955909	1	.24	FILTER, heater control
70	Chevelle	3963751	1	.24	FILTER, htr. and A/C control
69-70	Camaro,				
71	Camaro, Nova,				
72	Camaro, Chevelle,				
73	Camaro w/C.A.C.,				
74	Nova, Camaro	3984603	1	.18	FILTER, htr. & a/c control
66-68	Chevelle w/C.A.C.	3940256	2	.12	GUIDE, heater and A/C control arm
69	Chevy, Camaro (exc. C.A.C.),				
70-72	Nova (exc. C.A.C.)	3967911	1	.18	INSERT, htr. control lens trim
69	Chevy, Camaro w/C.A.C.,				
70	Nova w/C.A.C.,				
70	Chevelle w/C.A.C.	3979709	1	.18	INSERT, htr. A/C control trim
71-72	Pass. (exc. C.A.C.)	3992114	1	.64	INSERT, control heater
64-66	Pass., Chevelle	7312660	1	.16	NUT, lever pivot pin push on <sup>3</sup> / <sub>16</sub> " (U-type)
71-75	Pass. (exc. C.A.C.)	7934105	2	.06	NUT, heater control
66-67	Pass. w/Auto. Temp. Cont.	7277348	3	.10	CLIP, control lever retainer
64-72	Chevelle (exc. C.A.C.),				
67	Camaro (exc. C.A.C.),				
65-70	Pass. (exc. Air Cond.),				
72	Nova (exc. C.A.C.),				
74	Pass. (exc. C.A.C.),				
73-74	Vega	3158190	1	.13	CAP, temp. shaft end
64-67	Chevelle,				
65-67	Pass. w/C.A.C.,				
71-72	Pass. w/C.A.C.	3150822	1	.12	ROLLER, heater cam
64-68	All,				
69	Chevelle (exc. C.A.C.)	3843466	1	.16	BUSHING, control switch lever
67	Chevelle (exc. C.A.C.)	3895924	1	.11	BUSHING, control switch
67	Pass. w/Auto. Temp. Cont.				BUSHING, control arm,
67	Camaro w/C.A.C.,				
68	Chevy, Chevelle w/C.A.C.,				
71-72	Chevelle				heater and C.A.C., contr. arm,
69	Pass., Chevy, Camaro (exc. C.A.C.),				
71-74	Nova, Camaro				control switch,
69	Camaro w/C.A.C.,				
70	All,				
71-74	Vega w/C.A.C.,				
73-75	Nova (exc. C.A.C.),				
75	Camaro (exc. C.A.C.)	3891794	2	.28	vacuum switch, C.A.C.
66	Pass. w/Auto. Temp. Cont.,				
70-74	Chevelle, Nova	3141791	1	.32	WASHER, control lever retainer
65-72	Chevelle,				
68-69	Chevy,				

**SHEET METAL—HEATER**

**8.852 SWITCH ASSY.— ARM— KNOB— BOARD UNIT— BRACKET— BEZEL— HARNESS ASSY.— INSERT— LENS— LEVER— SUPPORT— SPRING— COVER— ESCUTCHEON— FILTER— GUIDE— INSERT— NUT— CLIP— CAP— ROLLER— BUSHING— WASHER— PIN— PLATE— RETAINER— SHAFT— DIAL— TRANSDUCER, Heater (Con't)**

68	Chevy	3150992	A.R.	.05	PIN, heater control lever guide
68	Chevy	3909014	1	.24	PLATE, heater cont. arm rest
68	Chevelle (exc. C.A.C.),				
69	Chevelle,				
71	Camaro	3937162	1	3.30	PLATE, heater control backing
71	Pass. (exc. C.A.C.)	3992110	1	4.55	PLATE, htr. control backing
72-73	Pass. (exc. C.A.C.)	6262408	1	4.55	PLATE, htr. control backing
74-75	Pass. (exc. C.A.C.)	336294	1	3.75	PLATE, htr. cont. backing
75	Nova w/C.A.C.	3030759	1	3.95	PLATE, case frt. htr.
73-75	Chevelle (exc. C.A.C.)	328225	1	.11	RETAINER, htr. air defr. shaft
73	Chevelle (exc. C.A.C.)	328222	1	1.30	SHAFT, htr. air defr.
74-75	Chevelle (exc. C.A.C.)	336493	1	1.30	SHAFT ASSY., htr. air defr.
75	Pass. (exc. Auto. Temp. Control)	1223574	1	2.23	DIAL PACKAGE
75	Pass. w/Auto. Temp. Control	1223593	1	3.46	DIAL PACKAGE
71-73	Pass. w/Auto Temp. Cont.	7932545	1	16.38	TRANSDUCER, htr. and a/c control— (9.275)

NOTE 8: Use 7295955 knob with this assy.

**8.854 CORE— BAFFLE— CASE— GASKET— CLAMP— SEAL— SHAFT AND LEVER ASSY.— SHROUD AND BAFFLE ASSY.— YOKE, Heater**

62-63	Chevy	3153164	1	35.75	heater
64-67	Chevy	3005383	1	43.10	heater, w/fittings
64-67	Chevelle w/C.A.C.	3004817	1	45.25	heater, w/fittings
64-67	Chevelle (exc. C.A.C.),				
65-68	Pass. (exc. C.A.C.)	3022069	1	44.15	heater, w/fittings
65-68	Pass. w/C.A.C.,				
68	Chevelle w/C.A.C.	3021826	1	48.30	heater
67	Camaro (exc. 396)	3022071	1	40.50	heater, w/fittings
67-68	Camaro (exc. C.A.C.),				
68	Chevy (396) (exc. C.A.C.),				
68	Camaro (396) (exc. C.A.C.)	3022072	1	31.75	heater, w/fittings
67-68	Camaro w/C.A.C.,				
68	Chevy w/C.A.C. (exc. 396)	3022068	1	51.70	heater, w/fittings (A.C. heater)
68-72	Chevelle (exc. C.A.C.)	3014083	1	42.10	heater, w/fittings
68	Chevy, Camaro (exc. 396, C.A.C.)	3022074	1	39.25	heater, w/fittings
69	Chevy, Camaro w/C.A.C.,				
70-75	Nova w/C.A.C.	3018489	1	51.70	heater, w/fittings
69-73	Chevy, Camaro (exc. C.A.C., 396)	3016842	1	44.55	heater, w/fittings
70-75	Camaro w/C.A.C.	3020374	1	45.00	heater, w/fittings
69	Chevy, Camaro (396) (exc. C.A.C.),				
70	Nova (396) (exc. C.A.C.)	3018864	1	39.05	heater, w/fitting, C.A.C., heater
69	Pass. w/C.A.C., Auto. Temp. Control,				
69-72	Chevelle w/C.A.C.,				
70	Pass. w/C.A.C.	3014782	1	46.60	heater, w/fittings
71-72	Pass.	3022696	1	43.55	heater, w/fittings
69-70	Pass.	3011414	1	44.15	heater, w/fittings
71-75	Vega w/C.A.C.	3022919	1	37.60	a/c heater
71-75	Vega (exc. C.A.C.),				
75	Monza (Towne Cpe.) (exc. C.A.C.)	3022606	1	36.80	w/fittings
73-75	Pass. w/C.A.C.	3022696	1	43.55	heater, w/fittings
73-75	Chevelle (exc. C.A.C.)	3024661	1	40.95	heater, w/fittings
73-75	Chevelle w/C.A.C.	3024923	1	43.10	heater, w/fittings
73-74	Nova, Camaro (exc. C.A.C.),				
75	Nova (exc. C.A.C.)	3016842	1	44.55	heater, w/fittings
75	Nova w/C.A.C.	3030797	1	44.90	heater, w/fittings
75	Camaro (exc. C.A.C.)	3023736	1	64.75	heater, w/fittings
75	Monza (262, 350) (exc. C.A.C.)	3031488	1	36.45	htr.
75	Monza w/C.A.C. (exc. Towne Cpe.)	3031570	1	43.65	htr.
75	Vega (122)	3033872	1	37.00	CORE, heater
73-75	Chevelle w/C.A.C.	336439	1	.46	BAFFLE, heater and defroster
75	Nova w/C.A.C.	3018773	1	6.60	BAFFLE, air adj.
67-69	Camaro,				
68	Chevy (396) (exc. C.A.C.),				
70	Nova (396) (exc. C.A.C.)	3015141	1	32.50	CASE, w/shroud, distributor
68-72	Chevelle (exc. C.A.C.)	3017881	1	30.75	CASE, w/shroud, distributor
68-69	Chevelle w/C.A.C.	3015591	1	41.25	CASE, w/shroud, distributor
68-69	Chevy, Camaro (exc. 396, C.A.C.),				

**SHEET METAL—HEATER**

**8.854 CORE—BAFFLE—CASE—GASKET—CLAMP—SEAL—SHAFT AND LEVER ASSY.—SHROUD AND BAFFLE ASSY.—YOKE, Heater (Con't)**

70-75	Nova (exc. C.A.C.)	3015134	1	32.50	CASE, w/shroud, distributor
69	Chevy, Camaro w/C.A.C.,				
69-70	Pass. w/C.A.C.	3023582	1	53.25	CASE, front plate and valve assy.
70-74	Nova w/C.A.C.	3018763	1	41.00	CASE, front plate and valve assy.
70-72	Chevelle w/C.A.C.	3023566	1	54.25	CASE, htr. frt. plate and valve assy.
70-72	Chevelle w/C.A.C.	3023568	1	46.25	CASE, heater
71-75	Pass. (exc. C.A.C.)	3022721	1	35.00	CASE, heater
71	Vega (exc. C.A.C.)	3022628	1	31.00	CASE
72-74	Vega (exc. C.A.C.)	3026097	1	31.00	CASE
73-75	Chevelle (exc. C.A.C.)	3024866	1	26.00	CASE, w/seat brkt. and valves
75	Vega (140, 122) (exc. C.A.C.)	3022018	1		CASE
75	Monza (exc. Towne Cpe.) (exc. C.A.C.)	3030996	1	35.75	CASE
67-69	Camaro w/C.A.C.,				
68-74	Chevy w/C.A.C.	3889483	1	1.75	GASKET, heater & C.A.C. air selector duct
70	Camaro w/C.A.C.	3963725	1	.80	GASKET, htr. and A/C air selector duct
71-75	Nova, Camaro (exc. C.A.C.)	3929024	1	.66	GASKET, heater defroster to dash
62-67	Chevy,				
64-66	Chevelle w/C.A.C.	3143486	2	.87	CLAMP, core mounting
65-68	Pass.,				
65-67	Chevelle, Camaro,				
68	Chevy, Camaro (exc. 396)	3004671	1	.31	CLAMP, heater core mtg. tank head
65-67	Chevelle, Camaro,				
65-68	Pass.,				
68	Chevy, Camaro	3004672	1	.23	CLAMP, heater core mtg.
69	Chevy, Camaro w/C.A.C.,				
70-73	Nova w/C.A.C.	3018453	1	.66	CLAMP, core mtg. in-out tank
67-68	Chevelle,				
70-72	All (exc. Pass.),				
73-75	Nova, Camaro (exc. C.A.C.)	3011428	1	.66	CLAMP, core mtg. in-out tank
72-75	Vega, Monza w/C.A.C.	1470030	1	.73	CLAMP, htr. to w/pump hose (green)
71-75	Vega, Monza w/C.A.C.	3022976	1	.98	CLAMP, a/c core mtg.
71-75	Vega, Monza w/C.A.C.	3021665	1	.98	CLAMP, a/c core mtg. in and out tank
71-75	Vega, Monza (exc. C.A.C.)	3022597	1	.59	CLAMP, core mtg. header tank
71-75	Vega, Monza (exc. C.A.C.)	3022596	1	.59	CLAMP, core mtg. in and out tank
73-75	Chevelle w/C.A.C.	3028862	1	.66	CLAMP, core mtg. inlet, outlet tank
73-75	Chevelle w/C.A.C.	3024912	1	.56	CLAMP, core mtg. header tank
73-75	Chevelle (exc. C.A.C.)	3024673	1	.66	CLAMP, core mtg. inlet, outlet tank
73-74	Chevelle (exc. C.A.C.)	3025501	1	1.50	CLAMP, core mtg. header tank
73	Nova w/C.A.C.				CLAMP, heater core mtg. in/out tank
73-75	Nova, Camaro (exc. C.A.C.)				CLAMP, htr. core in-out tank
73-75	Nova w/C.A.C.				CLAMP, htr. core mtg.
74-75	Nova w/C.A.C.	3021665	1	.98	CLAMP, htr. core mtg. in/out tank
74	Vega w/C.A.C.	3156915	2	.54	CLAMP, core mt. in-out tank
74-75	Vega, Monza w/C.A.C.	408427	1	.12	CLAMP, htr. to inlet manifold hose (brown)
69	All w/Air Cond.,				
70-71	Pass., Nova, Camaro w/Air Cond.,				
72	Nova, Camaro,				
73-75	Nova w/C.A.C.	3014168	1	.50	CLAMP, htr. core mtg.
71-75	Pass. (exc. C.A.C.)	3022708	1	.23	CLAMP, core mtg. inlet, outlet tank
71-75	Pass. w/C.A.C.	3022734	1	.23	CLAMP, core mtg. inlet, outlet tank
71-75	Pass.	3022712	1	.23	CLAMP, core mtg. heater tank
64-67	Pass. Chevelle, Camaro,				
68	Pass., Chevy, Camaro (exc. 396),				
69-70	Pass. (exc. C.A.C.)	9776917	1	.48	SEAL, heater to dash gasket
67-69	Camaro w/C.A.C.,				
68-75	Chevy w/C.A.C.	3889484	1	.74	SEAL, core tube and heater
68-69	Chevy (396),				
68-72	Chevelle,				
69-70	Pass.	9791362	1	.12	SEAL, heater core tubes to dash
71-75	Camaro w/C.A.C.	3973717	1	.29	SEAL, heater core pipe
72-75	Pass.	3023773	1	1.60	SEAL, inlet pipe
72-74	Pass. w/C.A.C.	3023774	1	1.60	SEAL, outlet pipe
71-75	Vega, Monza (exc. C.A.C.)	3984659	1	.38	SEAL, core pipe
73-75	Chevelle (exc. C.A.C.)	3024861	1	.61	SEAL, core pipe
73-75	Chevelle w/C.A.C.	3024925	1	.23	SEAL, core pipe
75	Nova w/C.A.C.	3018766	1	.70	SEAL, yoke
75	Vega, Monza w/C.A.C.	3984663	1	.64	SEAL, core pipe
75	Camaro (exc. C.A.C.)	3021597	1	.61	SHAFT & LEVER ASSY., temp. valve
75	Vega, Monza (exc. C.A.C.)	3031091	1	11.60	SHROUD AND BAFFLE ASSY., htr.
75	Monza (exc. Towne Cpe.) w/C.A.C.	3031556	1	.98	STRAP, core mtg.

**SHEET METAL—HEATER**

**8.854 CORE— BAFFLE— CASE— GASKET— CLAMP— SEAL— SHAFT AND LEVER ASSY.— SHROUD AND BAFFLE ASSY.— YOKE, Heater (Con't)**

75	Monza (exc. Towne Cpe.) w/C.A.C. ....	3031557	1	.98	STRAP, core mtg. ....
76	Vega, Monza (exc. C.A.C.) .....	3022597	1	.59	STRAP, core mtg. ....
75	Nova w/C.A.C. ....	3018725	1	1.90	YOKE, baffle bi-level .....

**8.855 MOTOR— RESISTOR ASSY., Heater and Evaporator**

62-67	Chevy (exc. C.A.C.) .....	4914921	1	25.20	blower .....
62-66	Chevy w/C.A.C. ....	5044516	1	36.75	blower— (9.215) .....
64-68	Pass., Chevelle, Camaro (exc. C.A.C.),				
68	Chevy (exc. C.A.C.),				
65	Pass., Chevelle w/Air Cond.,				
66-67	Pass., Chevelle w/C.A.C., Auto. Temp. Cont.,				
67-68	Camaro w/C.A.C.,				
68	Nova w/C.A.C.,				
69	All w/C.A.C. (exc. Nova),				
70-75	All w/C.A.C. ....	4960538	1	31.80	blower, a/c .....
69-75	All (exc. C.A.C.) .....	4960505	1	25.15	MOTOR UNIT, heater .....
71-73	Pass. w/Auto. Temp. Cont. ....	1223462	1	11.13	MOTOR ASSY., vacuum htr. and a/c— (9.280) .....
66	Pass. w/Auto. Temp. Control ...	3929049	1	3.55	RESISTOR ASSY., blower .....
67-68	Pass. w/Auto. Temp. Control ...	3955970	1	3.40	RESISTOR ASSY., blower .....
62-75	All Pass. (exc. C.A.C.) .....	3929052	1	1.25	RESISTOR ASSY., blower .....
71-75	Pass. (exc. C.A.C.),				
73-75	Chevelle (exc. C.A.C.) .....	9796480	1	1.35	RESISTOR ASSY., blower .....
71-75	Pass. w/C.A.C.,				
73-75	Chevelle w/C.A.C. ....	3998401	1	1.75	RESISTOR ASSY., blower .....

**8.856 BOLT ASSY., Heater and Defroster Motor**

73-74	Chevelle (exc. C.A.C.) .....	3024769	1	5.60	front plate .....
-------	------------------------------	---------	---	------	-------------------

**8.857 FAN ASSY.— BLOWER ASSY.— CASE ASSY.— NUT— RETAINER— SEAL, Heater**

62-70	All,				
71-72	All (exc. Camaro),				
71-72	Camaro (exc. C.A.C.),				
72-73	Vega (exc. C.A.C.),				
73-75	Chevelle (exc. C.A.C.),				
75	Vega, Monza .....	3027031	1	5.95	heater assembly .....
71	Vega (exc. C.A.C.),				
73-74	Nova, Pass. (exc. C.A.C.),				
75	Nova w/C.A.C.,				
74	Vega (exc. C.A.C.) .....	3905776	1	4.34	FAN ASSY., car heater .....
71-72	Camaro w/C.A.C. ....	3000443	1	5.70	car heater— (9.216) .....
65-69	Pass. (exc. C.A.C.) .....				BLOWER ASSY., .....
65-69	Chevelle, Camaro (exc. C.A.C., 396),				
68-70	Chevy (exc. C.A.C. 396),				
70	All (exc. Nova, C.A.C.),				
71-74	All (exc. C.A.C., Pass.) .....	3014734	1	47.00	heater w/inlet .....
67-68	Camaro .....	3013588	1	11.30	CASE ASSY., w/cut-off .....
71-74	Pass. (exc. C.A.C.) .....	3022589	1	8.95	CASE ASSY., w/cut-off heater .....
65	Pass.,				
67-68	Pass.,				
68-69	Nova, Chevelle, Camaro (exc. C.A.C.),				
70	All (exc. C.A.C.),				
71-72	Nova, Chevelle, Camaro (exc. C.A.C.),				
73-75	Nova, Camaro (exc. C.A.C.) .....	3016905	1	7.50	CASE ASSY., cut-off heater .....
71-74	Vega (exc. C.A.C.) .....	3022585	1	11.20	CASE ASSY., heater .....
73	Nova w/C.A.C. ....	3018763	1	41.00	CASE, heater plate & valve .....
73-74	Chevelle (exc. C.A.C.) .....	3024617	1	15.90	CASE ASSY., w/cut-off .....
75	Monza (exc. Towne Cpe.) (140) (exc. C.A.C.) .....	3030936	1	17.10	CASE ASSY. ....
75	Monza (exc. Towne Cpe.) (8 cyl.) (exc. C.A.C.) .....	3031615	1	12.05	CASE ASSY. ....
62	Chevy,				
65-68	Pass.,				
69	Chevelle w/C.A.C.,				
69	Chevy, Camaro (396),				
70	All w/C.A.C. (exc. Camaro) .....	3130804 A.R.		.11	NUT (No. 10— 32) .....
71-74	Chevelle, Nova w/C.A.C. ....	3011293	1	.12	NUT (10— 32) .....

**SHEET METAL—HEATER**

**8.857 FAN ASSY.— BLOWER ASSY.— CASE ASSY.— NUT— RETAINER— SEAL, Heater (Con't)**

75	Chevelle w/C.A.C. ....	3027134	1	.05	NUT, heater blower motor fan to blower ...
70-74	Nova .....	3949921	1	.36	SEAL, htr. defr. outlet .....
71-75	Vega, Monza .....	3973789	1	.32	SEAL, htr. and defr. outlet .....
75	Vega, Monza (exc. C.A.C.) .....	346113	1	.32	SEAL, htr. and defr. outlet .....

**8.858 VALVE— SHAFT, Heater Air Deflector**

71-72	Pass. ....	3022723	1	3.10	air deflector temp. control .....
70-72	Camaro,				
73-75	Camaro (exc. C.A.C.) .....	3021625	1	4.90	air deflector w/baffle heater def. shut-off ..
71-72	Pass.,				
73-75	Pass. (exc. C.A.C.) .....	3022706	1	2.85	air deflector w/seal, purge .....
71-72	Camaro,				
73-75	Camaro (exc. C.A.C.) .....	3021611	1	.61	SHAFT, w/lever, air .....
71-72	Camaro,				
73-75	Camaro (exc. C.A.C.) .....	3021597	1	.61	SHAFT, w/lever, temp. valve .....

**8.866 VALVE ASSY.— NIPPLE— RETAINER— CAP— FITTING ASSY., Heater**

65-69	Pass. w <sup>5</sup> / <sub>8</sub> " hose .....	3857131	1	3.80	water shut-off (hose insert type) .....
65-69	Pass. w <sup>3</sup> / <sub>4</sub> " hose .....	3741428	1	3.95	water shut-off (hose insert type) .....
71-72	All w/C.A.C. (exc. Chevelle),				
73-75	Chevelle w/C.A.C. ....	3992098	1	10.85	heater and a/c water shut-off .....
65-69	Pass. w <sup>5</sup> / <sub>8</sub> " hose (short) (exc. 8 cyl.) .....	3106066	A.R.	.99	NIPPLE, hose coupling ( <sup>3</sup> / <sub>8</sub> " ) .....
65-69	Pass. w <sup>5</sup> / <sub>8</sub> " hose (8 cyl.) (long) .	3719486	1	.67	NIPPLE, hose, coupling ( <sup>3</sup> / <sub>8</sub> " x 2 <sup>3</sup> / <sub>4</sub> " ) .....
64-68	Pass., Chevelle (8 cyl.) w/Air Cond., A.I.R. (w <sup>5</sup> / <sub>8</sub> " hose),				
66-68	Chevy, Chevelle, Camaro,				
69	Biscayne, Impala (6 cyl. w/C.A.C.) .....	3849848	1	.76	NIPPLE, water pump hose (2 <sup>25</sup> / <sub>32</sub> " O.L.) ....
62-64	Chevy w/C.A.C.,				
64	Chevelle,				
69	Pass. (8 cyl.) (exc. 396, 427),				
70-75	All (exc. Vega, Monza) .....	331968	1	.76	NIPPLE, heater to inlet manifold hose .....
71-74	Vega .....	6262626	1	.50	htr. to inlet manifold hose .....
64-70	Chevy, Chevelle, Camaro,				
65-70	Pass. (6 cyl.) (exc. S.S.),				
71-72	All .....	1191141	1	.40	CAP, water pump heater hose pipe— (1.070) .....
67	Pass. w/Speed and Cruise Cont.	3905376	1	1.75	FITTING ASSY., inlet manifold .....

**8.873 COMPASS UNIT, Auto**

70-75	All .....	983335	1	7.05	
-------	-----------	--------	---	------	--

**8.890 LAMP, Underhood**

73-74	All .....	994317	1	3.70	
75	All .....	994694	1	5.00	LAMP UNIT, underhood (Note 1) .....

*NOTE 1: It may be necessary to splice wire or change terminal for some applications.*

**8.891 CONTAINER— DISPENSER UNIT— RIVET, Litter, Tissue**

73	All w/bench seat (exc. Power Seat) .....	981798	1	4.45	underseat (litter) .....
74-75	All w/bench seat .....	981935	1	4.45	underseat (litter) .....
74-75	Pass. ....	9614740	R.H.	4.65	litter shroud side (prime and paint as reqd.)
74-75	Chevelle .....	9691040	R.H.	4.90	litter shroud side (prime and paint as reqd.)
73-75	All .....	994476	1	3.25	CONTAINER UNIT (litter and tissue) (black)
73-75	All .....	981799	1	4.95	DISPENSER UNIT, underseat (tissue) .....
74-75	All .....	994664	1	4.95	DISPENSER UNIT, center floor mount (tissue) .....
74	Pass., Chevelle .....	9615208	2	.07	RIVET, litter container to shroud panel .....
75	All .....	1479948	2	.12	RIVET, litter container to shroud panel .....





# CHEVROLET CHASSIS GROUP 9.000



## BODY MOUNTING—AIR CONDITIONING — INSTRUMENT CLUSTER

### ALPHABETICAL INDEX

<b>A</b>			
ACTUATOR, Air Conditioning Electrical Temperature and Blower Motor Control..	9.275	BEZEL, Radio Control.....	9.649
ACTUATOR, Air Conditioning Vacuum Control.....	9.280	BEZEL, Rear Window Defogger.....	9.778
ACTUATOR, Cowl.....	9.789	BEZEL, Safety Light.....	9.773
ADAPTER, Air Conditioning Evaporator Air Distributor and Astro-Ventilation.....	9.262	BEZEL, Seat Belt, Check Doors and Low Fuel Warning Lights.....	9.765
ADAPTER, Air Flow.....	9.786	BLOWER CASE, Rear Window Defogger.....	9.778
ADAPTER, Antenna.....	9.647	BOARD UNIT, Air Conditioning Electrical Temperature and Blower Motor Control..	9.275
ADAPTER, Rear Window Defogger.....	9.778	BODY ASSY., Air Conditioning less Clutch....	9.170
AMPLIFIER ASSY., Air Conditioning Electrical Temperature and Blower Motor Control.....	9.275	BOLT, Air Conditioning Compressor Mounting Attaching Parts.....	9.173
ANTENNA UNIT, Radio.....	9.645	BOLT, Air Conditioning Compressor Mounting.....	9.171
ARM, Air Conditioning Control.....	9.281	BOLT AND CLIP ASSY., Radio and Stereo Mounting.....	9.667
ARM, Air Flow.....	9.786	BOLT AND CLIP ASSY., Rear and Auxiliary Speakers.....	9.665
ARM ASSY., Air Conditioning Electrical Temperature and Blower Motor Control..	9.275	BOLT, Body.....	9.008
ARM, Cowl.....	9.789	BOLT, Rear Window Defogger.....	9.778
ASPIRATOR ASSY., Air Conditioning Electrical Temperature and Blower Motor Control.....	9.275	BOLT, Speedometer and Odometer (Miles)....	9.761
		BOOT, Instrument Case.....	9.749
		BRACE, Air Conditioning Compressor Mounting.....	9.171
		BRACE, Air Conditioning Evaporator Blower Motor.....	9.216
		BRACE, Radio and Stereo Mounting.....	9.667
		BRACKET, Air Conditioning Compressor Mounting.....	9.171
		BRACKET, Air Conditioning Control.....	9.281
		BRACKET, Air Conditioning Electrical.....	9.277
		BRACKET, Air Conditioning Evaporator Air Distributor and Astro-Ventilation.....	9.262
		BRACKET, Air Conditioning Evaporator Blower Motor.....	9.216
		BRACKET, Air Conditioning Evaporator Core Housing.....	9.211
		BRACKET, Air Conditioning Evaporator Expansion Valve.....	9.214
		BRACKET, Air Conditioning Hose.....	9.242
		BRACKET, Air Conditioning Refrigerant.....	9.190
		BRACKET, Air Conditioning Refrigerant.....	9.196
		BRACKET, Air Duct Intake (Outside Air).....	9.784
		BRACKET, Air Flow Control with Tube.....	9.787
		BRACKET, Air Flow.....	9.786
		BRACKET, Antenna.....	9.647
		BRACKET, By-Pass Mounting.....	9.199
		BRACKET, Clock Mounting and Attaching.....	9.772
		BRACKET, Cowl.....	9.789
		BRACKET, Defroster.....	9.779
		BRACKET, Front Center Speaker Mounting....	9.655
		BRACKET, Radio and Stereo Mounting.....	9.667
		BRACKET, Rear Window Defogger.....	9.778
		BRACKET, Safety Light.....	9.773
		BRACKET, Speed Indicator.....	9.762
		BUMPER, Air Conditioning Compressor Suction and Discharge.....	9.226
		BUMPER, Air Conditioning Refrigerant.....	9.190
		BUMPER, Instrument Case.....	9.749
		BUMPER, Speedometer and Odometer (Miles).....	9.761
		BUSHING, Air Conditioning Compressor (Internal).....	9.172
		BUSHING, Air Conditioning Compressor Mounting.....	9.171

### B

BACK PLATE, Air Conditioning Evaporator Core Housing.....	9.211
BACKPLATE, Instrument.....	9.743
BACK, Rear Window Defogger.....	9.778
BAFFLE, Air Conditioning Evaporator Air Inlet.....	9.218
BAFFLE, Air Conditioning Evaporator By- Pass.....	9.198
BAFFLE, Air Conditioning Refrigerant.....	9.190
BAFFLE, Air Flow.....	9.786
BAFFLE ASSY., Defroster.....	9.779
BAFFLE ASSY., Rear and Auxiliary Speakers.	9.665
BALL, Air Conditioning Compressor (Internal).....	9.172
BASE, Instrument Case.....	9.746
BASE, Instrument.....	9.743
BASE PLATE, Air Conditioning Control.....	9.279
BEARING, Air Conditioning Compressor (Internal).....	9.172
BEARING ASSY., Air Conditioning Compressor Pulley.....	9.181
BEARING PKG., Air Conditioning Electrical Temperature and Blower Motor Control..	9.275
BEZEL, Air Conditioning Evaporator Core Housing.....	9.211
BEZEL, Air Conditioning Remote Evaporator Air Distributor Outlet.....	9.264
BEZEL, Antenna.....	9.647
BEZEL, Cigarette Lighter.....	9.709
BEZEL, Cowl.....	9.789
BEZEL, Instrument Case Face.....	9.748
BEZEL, Instrument Case.....	9.746
BEZEL, Instrument.....	9.743

## ALPHABETICAL INDEX

BUSHING, Speedometer and Odometer (Miles).....	9.761
BUZZER ASSY., Speed Indicator.....	9.762
<b>C</b>	
CABLE ASSY., Air Conditioning Control.....	9.281
CABLE ASSY., Air Flow Control with Tube....	9.787
CABLE ASSY., Antenna.....	9.647
CABLE ASSY., Safety Light.....	9.773
CABLE ASSY., Speed Indicator.....	9.762
CAM, Air Conditioning Electrical Temperature and Blower Motor Control..	9.275
CAM, Air Flow.....	9.786
CAM ASSY., Air Conditioning Control.....	9.281
CAM ASSY., Air Conditioning Vacuum Control.....	9.280
CAPACITOR ASSY., Rear Window Defogger..	9.778
CAPACITOR, Radio Noise Suppression.....	9.663
CAPACITOR, Radio.....	9.654
CAP, Air Conditioning Compressor Oil Test...	9.177
CAP, Air Conditioning Evaporator By-Pass....	9.198
CAP, Antenna.....	9.647
CARRIER, Instrument.....	9.743
CASE, Air Conditioning Evaporator Core Housing.....	9.211
CASE, Air Flow.....	9.786
CASE ASSY., Instrument.....	9.743
CASE, Rear Window Defogger.....	9.778
CIRCUIT BOARD ASSY., Air Conditioning Electrical Temperature and Blower Motor Control.....	9.275
CIRCUIT, Instrument Case.....	9.744
CLAMP, Air Conditioning Control.....	9.279
CLAMP, Air Conditioning Control.....	9.281
CLAMP, Air Conditioning Evaporator Core Housing.....	9.211
CLAMP, Air Conditioning Evaporator Expansion Valve.....	9.214
CLAMP, Air Conditioning Hose.....	9.242
CLAMP, Air Conditioning Refrigerant Line (Fitting Pkgs. Include 'O' Rings and Hose Clamps).....	9.222
CLAMP, Air Conditioning Refrigerant.....	9.190
CLAMP, Air Conditioning Refrigerant.....	9.196
CLAMP, Air Flow Control with Tube.....	9.787
CLAMP, Air Flow.....	9.786
CLAMP, By-Pass Mounting.....	9.199
CLIP, Air Conditioning Compressor Suction and Discharge.....	9.226
CLIP, Air Conditioning Control.....	9.281
CLIP, Air Conditioning Electrical Temperature and Blower Motor Control..	9.275
CLIP, Air Conditioning Evaporator Air Distributor and Astro-Ventilation.....	9.262
CLIP, Air Conditioning Evaporator Expansion Valve.....	9.214
CLIP, Air Conditioning Hose.....	9.242
CLIP, Air Conditioning Refrigerant.....	9.190
CLIP, Air Conditioning Refrigerant.....	9.196
CLIP, Air Flow Control with Tube.....	9.787
CLIP, Air Flow.....	9.786
CLIP, Body Mounting.....	9.023
CLIP, Clock Mounting and Attaching.....	9.772
CLIP, Cluster Gauge.....	9.735
CLIP, Defroster.....	9.779
CLIP, Instrument Case Face.....	9.748
CLIP, Instrument Case.....	9.744
CLIP, Instrument Face Glass.....	9.747
CLIP, Instrument.....	9.743
CLIP, Radio Noise Suppression.....	9.663
CLIP, Rear Window Defogger.....	9.778
CLOCK, Clock Mounting and Attaching.....	9.772
CLUTCH DRIVE ASSY., Air Conditioning Compressor Clutch Actuating.....	9.186
COIL, Air Conditioning Compressor Clutch Actuating.....	9.186
CONDENSER REPAIR UNIT, Air Conditioning Refrigerant.....	9.190
CONDENSER, Air Conditioning Refrigerant....	9.190
CONNECTOR, Air Conditioning Control.....	9.281

CONNECTOR, Air Conditioning Electrical Temperature and Blower Motor Control..	9.275
CONNECTOR, Air Conditioning Evaporator Air Distributor and Astro-Ventilation.....	9.262
CONNECTOR, Air Conditioning Evaporator By-Pass.....	9.198
CONNECTOR, Air Conditioning Evaporator....	9.220
CONNECTOR, Air Flow.....	9.786
CONNECTOR, Cowl.....	9.789
CONSOLE, Instrument.....	9.743
CONTROL ASSY., Air Conditioning Evaporator Air Distributor and Astro- Ventilation.....	9.262
CONTROL ASSY., Air Conditioning Instrument Panel.....	9.273
CONTROL ASSY., Air Flow Control with Tube.....	9.787
CONTROL ASSY., Radio Control.....	9.649
CONNECTOR AND LEAD ASSY., Stereo Tape Player.....	9.670
CORE, Air Conditioning Compressor Oil Test.	9.177
CORE, Air Conditioning Evaporator By-Pass...	9.198
CORE ASSY., Air Conditioning Evaporator....	9.210
COVER, Air Conditioning Compressor (Internal).....	9.172
COVER, Air Conditioning Electrical Temperature and Blower Motor Control..	9.275
COVER, Air Conditioning Evaporator Air Distributor and Astro-Ventilation.....	9.262
COVER, Air Conditioning Evaporator By-Pass	9.198
COVER, Air Conditioning Evaporator Core Housing.....	9.211
COVER, Air Flow.....	9.786
COVER, Antenna.....	9.647
COVER, Clock Mounting and Attaching.....	9.772
COVER, Cowl.....	9.789
COVER, Instrument Case.....	9.746
COVER, Rear Window Defogger.....	9.778
CRANK, Cowl.....	9.789
CUP, Air Conditioning Evaporator By-Pass....	9.198
CUSHION, Body Mounting.....	9.023
CYLINDER ASSY., Air Conditioning less Clutch.....	9.170

## D

DAMPER ASSY., Air Conditioning less Clutch.....	9.170
DEFLECTOR UNIT, Rain.....	9.694
DEFLECTOR, Air Conditioning Evaporator Air Distributor and Astro-Ventilation.....	9.262
DEFLECTOR, Air Conditioning Evaporator Core Housing.....	9.211
DEFLECTOR, Air Conditioning Remote Evaporator Air Distributor Outlet.....	9.264
DEFLECTOR, Air Flow.....	9.786
DEFLECTOR, Cowl.....	9.789
DEFLECTOR, Rain.....	9.694
DEFOGGER UNIT, Rear Window Defogger....	9.778
DEHYDRATOR ASSY., Air Conditioning Refrigerant (with Dehydrator).....	9.195
DESICCANT, Air Conditioning Refrigerant (with Dehydrator).....	9.195
DIAL, Air Conditioning Control.....	9.279
DIAL AND POINTER UNIT, Drive and Engine.	9.750
DIAL, Instrument Case Face.....	9.748
DIAPHRAGM, Air Conditioning Evaporator By-Pass.....	9.198
DISTRIBUTOR ASSY., Defroster.....	9.779
DISTRIBUTOR, Air Conditioning Evaporator Air Distributor and Astro-Ventilation.....	9.262
DOOR, Cowl.....	9.789
DUCT, Air Conditioning Evaporator Air Distributor and Astro-Ventilation.....	9.262
DUCT, Air Flow.....	9.786
DUCT, Cowl.....	9.789
DUCT, Rear Window Defogger.....	9.778

# ALPHABETICAL INDEX

## E

ELBOW, Air Conditioning Evaporator Air Inlet.....	9.218
ELEMENT, Air Conditioning Control.....	9.281
ELEMENT, Air Conditioning Vacuum Control.....	9.280
ELEMENT, Cigarette Lighter.....	9.709
ELEMENT, Cowl.....	9.789
ESCUTCHEON, Air Conditioning Control.....	9.279
EXTENSION, Air Conditioning Evaporator Air Distributor and Astro-Ventilation .....	9.262
EXTINGUISHER.....	9.990

## F

FAN ASSY., Air Conditioning Evaporator Blower Motor.....	9.216
FAN ASSY., Rear Window Defogger.....	9.778
FASTENER, Cowl.....	9.789
FELT, Air Flow.....	9.786
FERRULE, Air Conditioning Evaporator Air Distributor and Astro-Ventilation .....	9.262
FILLER, Air Conditioning Evaporator Air Distributor and Astro-Ventilation .....	9.262
FILLER, Instrument.....	9.743
FILTER, Air Conditioning Control.....	9.279
FILTER ASSY., Drive and Engine.....	9.750
FILTER, Instrument Case Face.....	9.748
FILTER, Radio.....	9.654
FILTER, Seat Belt, Check Doors and Low Fuel Warning Lights.....	9.765
FITTING, Air Conditioning Refrigerant.....	9.190
FITTING ASSY., Air Conditioning Compressor Suction and Discharge.....	9.226
FITTING PKG., Air Conditioning Refrigerant Line (Fitting Pkgs. Include 'O' Rings and Hose Clamps).....	9.222
FUSE ASSY., Air Conditioning Compressor (Internal).....	9.172

## G

GASKET, Air Conditioning Compressor Oil Test.....	9.177
GASKET, Air Conditioning Compressor Pressure Relief.....	9.178
GASKET, Air Conditioning Electrical Temperature and Blower Motor Control..	9.275
GASKET, Air Conditioning Evaporator Air Distributor and Astro-Ventilation .....	9.262
GASKET, Air Conditioning Evaporator Core Housing.....	9.211
GASKET, Air Conditioning Evaporator Expansion Valve.....	9.214
GASKET, Air Flow.....	9.786
GASKET, Antenna.....	9.647
GASKET, Clock Mounting and Attaching .....	9.772
GASKET, Cowl.....	9.789
GASKET, Instrument Case.....	9.749
GASKET, Rear and Auxiliary Speakers.....	9.665
GASKET, Rear Window Defogger.....	9.778
GEAR, Safety Light.....	9.773
GRILLE, Air Conditioning Control.....	9.279
GRILLE, Air Conditioning Remote Evaporator Air Distributor Outlet.....	9.264
GRILLE, Cowl.....	9.789
GRILLE, Rear and Auxiliary Speakers.....	9.665
GRILLE, Rear Window Defogger .....	9.778
GROMMET.....	9.775
GROMMET, Air Conditioning Control.....	9.281
GROMMET, Air Conditioning Electrical Temperature and Blower Motor Control..	9.275
GROMMET, Air Conditioning Evaporator Core Housing.....	9.211
GROMMET, Air Conditioning Refrigerant.....	9.196
GUARD, Air Conditioning Evaporator Expansion.....	9.213

GUIDE, Air Flow Control with Tube.....	9.787
--	-------

## H

HANDLE ASSY., Safety Light.....	9.773
HARNESS, Air Conditioning Compressor (Internal).....	9.172
HARNESS ASSY., Air Conditioning Electrical Temperature and Blower Motor Control..	9.275
HARNESS ASSY., Air Conditioning, Electrical.....	9.276
HARNESS ASSY., Radio and Speaker Wiring.....	9.656
HARNESS ASSY., Rear Window Defogger.....	9.778
HARNESS, Seat Belt, Check Doors and Low Fuel Warning Lights.....	9.765
HEAD, Air Conditioning Compressor (External).....	9.174
HEAD ASSY., Speedometer and Odometer (Miles).....	9.761
HOSE, Air Conditioning Control .....	9.281
HOSE, Air Conditioning Electrical Temperature and Blower Motor Control..	9.275
HOSE, Air Conditioning Evaporator Air Distributor and Astro-Ventilation .....	9.262
HOSE, Air Conditioning Evaporator Air.....	9.260
HOSE, Air Conditioning Evaporator Core Housing.....	9.211
HOSE, Air Conditioning Refrigerant Line (Fitting Pkgs. Include 'O' Rings and Hose Clamps).....	9.222
HOSE, Air Conditioning.....	9.225
HOSE, Air Flow.....	9.786
HOSE, Defroster.....	9.779
HOSE, Rear Window Defogger.....	9.778
HOUSING, Air Conditioning Evaporator Air Distributor and Astro-Ventilation .....	9.262
HOUSING, Air Conditioning Refrigerant (with Dehydrator).....	9.195
HOUSING, Air Flow Control with Tube.....	9.787
HOUSING, Air Flow.....	9.786
HOUSING, Cigarette Lighter.....	9.709
HOUSING, Cowl.....	9.789
HOUSING, Instrument Case Face.....	9.748
HOUSING, Instrument Case.....	9.746
HOUSING, Rear Window Defogger.....	9.778

## I

INLET ASSY., Air Conditioning Refrigerant (with Dehydrator).....	9.195
INLET ASSY., Air Flow.....	9.786
INLET, Cowl.....	9.789
INSERT, Air Conditioning Control.....	9.279
INSULATION, Air Conditioning Evaporator Expansion Valve.....	9.214
INSULATION, Air Conditioning Evaporator Expansion.....	9.213
INSULATOR ASSY., Air Conditioning Refrigerant.....	9.190
INSULATOR, Air Conditioning Electrical Temperature and Blower Motor Control..	9.275
INSULATOR, Air Conditioning Evaporator Air Distributor and Astro-Ventilation .....	9.262
INSULATOR, Air Conditioning.....	9.225
INSULATOR, Instrument Case.....	9.749
INSULATOR, Rear Window Defogger.....	9.778

## K

KEY, Air Conditioning Compressor Clutch Actuating.....	9.188
KNOB, Air Conditioning Control.....	9.278
KNOB, Air Conditioning Evaporator Air Distributor and Astro-Ventilation .....	9.262
KNOB, Air Flow Control with Tube.....	9.787

# ALPHABETICAL INDEX

KNOB ASSY., Air Conditioning Electrical Temperature and Blower Motor Control..	9.275
KNOB ASSY., Rear Window Defogger .....	9.778
KNOB, Cigarette Lighter.....	9.709
KNOB, Clock Mounting and Attaching .....	9.772
KNOB, Radio Control .....	9.649

## L

LAMP, Cigarette Lighter.....	9.709
LAMP, Rear Luggage Compartment.....	9.988
LAMP UNIT, Safety Light.....	9.773
LEAD ASSY., Antenna.....	9.647
LENS, Clock Mounting and Attaching .....	9.772
LENS, Instrument Case Face .....	9.748
LENS PLATE, Air Conditioning Control.....	9.279
LEVER, Air Conditioning Control.....	9.278
LEVER, Air Conditioning Evaporator Air Distributor and Astro-Ventilation .....	9.262
LEVER AND SEAL ASSY., Cowl.....	9.789
LEVER ASSY., Air Flow.....	9.786
LIGHT ASSY., Seat Belt, Check Doors and Low Fuel Warning Lights .....	9.765
LIGHTER UNIT, Cigarette Lighter.....	9.709
LINK, Air Flow.....	9.786
LINK ASSY., Air Conditioning, Electrical .....	9.276
LINK, Cowl.....	9.789
LUBRICATING OIL, Maintenance Items, Air Conditioning .....	9.282

## M

MOTOR ASSY., Air Conditioning Evaporator Blower .....	9.215
MOTOR ASSY., Air Conditioning Vacuum Control .....	9.280
MOTOR, Rear Window Defogger .....	9.778
MUFFLER, Air Conditioning Compressor Suction and Discharge .....	9.226
MUFFLER PKG., Air Conditioning Refrigerant Line (Fitting Pkgs. Include 'O' Rings and Hose Clamps) .....	9.222

## N

NOZZLE ASSY., Rear Window Defogger .....	9.778
NUT, Air Conditioning Compressor Pulley .....	9.181
NUT, Air Conditioning Electrical Temperature and Blower Motor Control..	9.275
NUT, Air Conditioning Evaporator Air Distributor and Astro-Ventilation .....	9.262
NUT, Air Conditioning Evaporator Blower Motor .....	9.216
NUT, Air Conditioning Evaporator By-Pass.....	9.198
NUT, Air Conditioning Evaporator Core Housing .....	9.211
NUT, Air Conditioning Refrigerant.....	9.190
NUT, Air Duct.....	9.782
NUT, Air Flow Control with Tube.....	9.787
NUT, Air Flow.....	9.786
NUT AND GUIDE ASSY., Antenna .....	9.647
NUT, Cargo Tie Down Hook .....	9.025
NUT, Clock Mounting and Attaching .....	9.772
NUT, Instrument Case Face .....	9.748
NUT, Instrument Case.....	9.744
NUT, Instrument.....	9.743
NUT KIT, Air Conditioning less Clutch .....	9.170
NUT, Radio and Stereo Mounting .....	9.667
NUT, Rear Window Defogger.....	9.778

## O

ORIFICE ASSY., Air Conditioning Evaporator Expansion .....	9.213
OUTLET, Air Conditioning Evaporator Air Distributor and Astro-Ventilation .....	9.262
OUTLET, Air Flow .....	9.786
OUTLET ASSY., Defroster.....	9.779
OUTLET, Cowl.....	9.789
OUTLET, Rear Window Defogger.....	9.778

## P

PIN, Air Conditioning Compressor Pressure Relief.....	9.178
PIN, Air Flow.....	9.786
PIN, Cowl.....	9.789
PIN, Safety Light.....	9.773
PISTON, Air Conditioning Compressor (Internal).....	9.172
PISTON, Air Conditioning Evaporator By- Pass.....	9.198
PLATE, Air Conditioning Compressor Clutch Actuating .....	9.188
PLATE, Air Conditioning Evaporator Core Housing .....	9.211
PLATE, Air Conditioning Refrigerant.....	9.190
PLATE, Air Flow.....	9.786
PLATE, Clock Mounting and Attaching .....	9.772
PLATE, Instrument Case Face.....	9.748
PLATE, Instrument Case.....	9.744
PLATE, Instrument .....	9.743
PLATE, Rear Window Defogger.....	9.778
PLATE, Safety Light.....	9.773
PLIERS, Air Flow Control with Tube .....	9.787
PLUG, Air Conditioning Control.....	9.281
POINTER, Speedometer and Odometer (Miles).....	9.761
PROGRAMMER ASSY., Air Conditioning Electrical Temperature and Blower Motor Control.....	9.275
PULLEY, Air Conditioning Compressor Drive ..	9.180
PUMP UNIT, Air Conditioning Compressor (Internal).....	9.172

## R

RACE, Air Conditioning Compressor (Internal).....	9.172
RADIO UNIT, Radio Primary .....	9.650
RECEIVER ASSY., Air Conditioning Refrigerant (with Dehydrator).....	9.195
REFRIGERANT, Maintenance Items, Air Conditioning .....	9.282
REINFORCEMENT, Cowl.....	9.789
REINFORCEMENT, Instrument.....	9.743
REINFORCEMENT, Rear and Auxiliary Speakers .....	9.665
RELAY ASSY., Air Conditioning Electrical.....	9.277
RELAY ASSY., Air Conditioning Evaporator Blower .....	9.215
RELAY ASSY., Rear Window Defogger .....	9.778
RELAY ASSY., Seat Belt, Check Doors and Low Fuel Warning Lights .....	9.765
REPAIR KIT, Drive and Engine .....	9.750
REPAIR KIT, Rear Window Defogger.....	9.778
RESISTOR, Air Conditioning Electrical Temperature and Blower Motor Control..	9.275
RETAINER ASSY., Front Center Speaker Mounting.....	9.655
RETAINER, Air Conditioning less Clutch.....	9.170
RETAINER, Air Conditioning Compressor (Internal).....	9.172
RETAINER, Air Conditioning Compressor Shaft.....	9.175
RETAINER, Air Conditioning Electrical Temperature and Blower Motor Control..	9.275

## ALPHABETICAL INDEX

RETAINER, Air Conditioning Evaporator Air Distributor and Astro-Ventilation .....	9.262	SEALED BEAM, Safety Light .....	9.773
RETAINER, Air Conditioning Evaporator Expansion Valve .....	9.214	SEAL, Instrument Case .....	9.749
RETAINER, Air Conditioning Hose .....	9.242	SEAL KIT, Air Conditioning less Clutch .....	9.170
RETAINER, Air Conditioning Refrigerant .....	9.190	SEAL, Maintenance Items, Air Conditioning .....	9.282
RETAINER, Air Conditioning Remote Evaporator Air Distributor Outlet .....	9.264	SEAL, Rear Window Defogger .....	9.778
RETAINER, Air Flow Control with Tube .....	9.787	SEAL RING, Air Conditioning Evaporator Expansion Valve .....	9.214
RETAINER, Air Flow .....	9.786	SEAL RING, Air Conditioning Evaporator .....	9.220
RETAINER, Cigarette Lighter .....	9.709	SEAL RING, Air Conditioning Freon Inspection .....	9.202
RETAINER, Instrument Face Glass .....	9.747	SEAL RING, Air Conditioning Refrigerant .....	9.196
RETAINER, Rear and Auxiliary Speakers .....	9.665	SEAT, Air Conditioning Compressor (Internal) .....	9.172
RETAINER, Rear Window Defogger .....	9.778	SEAT, Air Conditioning Evaporator Core Housing .....	9.211
RIM, Air Conditioning Compressor Drive .....	9.180	SENSOR ASSY., Air Conditioning Electrical Temperature and Blower Motor Control .....	9.275
RING, Air Conditioning Compressor (Internal) .....	9.172	SERVO ASSY., Air Conditioning Vacuum Control .....	9.280
RING, Air Conditioning Compressor Pulley .....	9.181	SHAFT, Air Conditioning Evaporator Air Distributor and Astro-Ventilation .....	9.262
RING, Air Conditioning Compressor Shaft .....	9.175	SHAFT, Air Flow Control with Tube .....	9.787
RING, Air Conditioning Refrigerant (with Dehydrator) .....	9.195	SHAFT, Air Flow .....	9.786
RING, Air Flow Control with Tube .....	9.787	SHAFT ASSY., Air Conditioning less Clutch .....	9.170
RING, Antenna .....	9.647	SHAFT ASSY., Air Conditioning Evaporator Core Housing .....	9.211
RING, Rear and Auxiliary Speakers .....	9.665	SHAFT ASSY., Defroster .....	9.779
RING, Safety Light .....	9.773	SHAFT, Cowl .....	9.789
ROD, Air Flow Control with Tube .....	9.787	SHAFT UNIT, Drive and Engine .....	9.750
ROD, Air Flow .....	9.786	SHELL, Air Conditioning Refrigerant (with Dehydrator) .....	9.195
ROD AND MAST ASSY., Antenna .....	9.647	SHELL ASSY., Air Conditioning less Clutch .....	9.170
ROD, Cowl .....	9.789	SHIELD, Air Conditioning Refrigerant .....	9.190
ROLLER, Air Flow .....	9.786	SHIELD ASSY., Clock Mounting and Attaching .....	9.772
ROTOR AND BEARING ASSY., Air Conditioning Compressor (Internal) .....	9.172	SHIM, Air Conditioning Compressor Mounting .....	9.171
<b>S</b>			
SCREEN, Air Conditioning Compressor (Internal) .....	9.172	SIGHT GLASS KIT, Air Conditioning Freon Inspection .....	9.202
SCREEN, Air Conditioning Evaporator Core Housing .....	9.211	SLEEVE, Air Conditioning Compressor (Internal) .....	9.172
SCREEN, Air Conditioning Evaporator Expansion Valve .....	9.214	SLEEVE, Air Conditioning Refrigerant .....	9.196
SCREEN, Air Conditioning Refrigerant (with Dehydrator) .....	9.195	SLEEVE, Air Conditioning .....	9.225
SCREEN, Rear Window Defogger .....	9.778	SLEEVE, Air Duct .....	9.782
SCREW, Air Conditioning Compressor Drive .....	9.180	SLEEVE, Clock Mounting and Attaching .....	9.772
SCREW, Air Conditioning Compressor Oil Test .....	9.177	SLEEVE, Instrument Case Face .....	9.748
SCREW, Air Conditioning Evaporator Air Distributor and Astro-Ventilation .....	9.262	SOCKET, Instrument Case .....	9.744
SCREW, Air Conditioning Refrigerant (with Dehydrator) .....	9.195	SPACER, Air Conditioning Compressor Mounting .....	9.171
SCREW AND WASHER ASSY., Air Conditioning Evaporator Expansion Valve .....	9.214	SPACER, Air Conditioning Compressor Pulley .....	9.181
SCREW ASSY., Air Conditioning Evaporator Air .....	9.260	SPACER, Air Conditioning Evaporator Air Distributor and Astro-Ventilation .....	9.262
SCREW ASSY., Speed Indicator .....	9.762	SPACER, Air Conditioning Evaporator Air .....	9.260
SCREW, Cargo Tie Down Hook .....	9.025	SPACER, Air Conditioning Evaporator Core Housing .....	9.211
SCREW, Rear and Auxiliary Speakers .....	9.665	SPACER, Air Conditioning Hose .....	9.242
SCREW, Safety Light .....	9.773	SPACER, Air Conditioning Remote Evaporator Air Distributor Outlet .....	9.264
SEAL .....	9.775	SPACER, Body Mounting .....	9.023
SEAL, Air Conditioning Compressor (Internal) .....	9.172	SPACER, Radio Control .....	9.649
SEAL, Air Conditioning Compressor Shaft .....	9.175	SPACER, Rear Window Defogger .....	9.778
SEAL, Air Conditioning Compressor Suction and Discharge .....	9.226	SPACER, Speedometer and Odometer (Miles) .....	9.761
SEAL, Air Conditioning Electrical Temperature and Blower Motor Control .....	9.275	SPEAKER, Radio Primary .....	9.650
SEAL, Air Conditioning Evaporator Air Distributor and Astro-Ventilation .....	9.262	SPEAKER, Rear and Auxiliary Speakers .....	9.665
SEAL, Air Conditioning Evaporator Blower Motor .....	9.216	SPEAKER UNIT, Rear and Auxiliary Speakers .....	9.665
SEAL, Air Conditioning Evaporator By-Pass .....	9.198	SPRING, Air Conditioning Electrical Temperature and Blower Motor Control .....	9.275
SEAL, Air Conditioning Evaporator Core Housing .....	9.211	SPRING, Air Conditioning Evaporator Air Distributor and Astro-Ventilation .....	9.262
SEAL, Air Conditioning Evaporator Expansion .....	9.213	SPRING, Air Conditioning Evaporator By-Pass .....	9.198
SEAL, Air Conditioning Refrigerant .....	9.190	SPRING, Air Conditioning Evaporator Core Housing .....	9.211
SEAL, Air Duct .....	9.782	SPRING, Air Conditioning Vacuum Control .....	9.280
SEAL, Air Flow .....	9.786	SPRING, Air Flow .....	9.786
SEAL, Defroster .....	9.779	SPRING, Cowl .....	9.789
		SPRING, Radio Control .....	9.649
		STRAP, Air Conditioning Evaporator Air .....	9.260
		STRAP, Air Conditioning Hose .....	9.242
		STRAP, Air Conditioning Remote Evaporator Air Distributor Outlet .....	9.264

## ALPHABETICAL INDEX

STRAP, Cluster Gauge.....	9.735
STRAP, Radio Noise Suppression.....	9.663
STUD, Air Conditioning Compressor Mounting.....	9.171
STUD, Air Conditioning Electrical Temperature and Blower Motor Control..	9.275
STUD, Air Conditioning Evaporator Air Distributor and Astro-Ventilation .....	9.262
STUD, Air Conditioning Remote Evaporator Air Distributor Outlet.....	9.264
STUD ASSY., Air Conditioning Evaporator Blower.....	9.215
SUPPORT, Air Conditioning Compressor Mounting.....	9.171
SUPPORT, Air Flow Control with Tube .....	9.787
SUPPORT, Air Flow .....	9.786
SUPPORT ASSY., Radio and Stereo Mounting.....	9.667
SUPPORT, Rear Window Defogger .....	9.778
SUPPORT, Stereo Tape Player.....	9.670
SUPPRESSION PKG., Radio Noise Suppression .....	9.663
SWITCH, Air Conditioning Electrical Temperature and Blower Motor Control..	9.275
SWITCH, Air Conditioning Vacuum Control..	9.280
SWITCH ASSY., Air Conditioning Compressor (Internal) .....	9.172
SWITCH ASSY., Air Flow Control with Tube .	9.787
SWITCH ASSY., Antenna.....	9.647
SWITCH ASSY., Instrument Case .....	9.746
SWITCH ASSY., Instrument Cluster.....	9.755
SWITCH ASSY., Rear Window Defogger.....	9.778
SWITCH ASSY., Seat Belt, Check Doors and Low Fuel Warning Lights .....	9.765
SWITCH, Safety Light.....	9.773

### T

TACHOMETER, Drive and Engine.....	9.750
TANK ASSY., Air Conditioning Control .....	9.281
TEE, Air Conditioning Control .....	9.281
TEE, Air Conditioning Evaporator By-Pass .....	9.198
TEE, Instrument Cluster.....	9.755
TERMINAL, Cluster Gauge .....	9.735
THRUST WASHER KIT, Air Conditioning less Clutch.....	9.170
TIMER ASSY., Rear Window Defogger .....	9.778
TIMER, Seat Belt, Check Doors and Low Fuel Warning Lights.....	9.765
TRANSDUCER ASSY., Air Conditioning Electrical Temperature and Blower Motor Control.....	9.275
TUBE, Air Conditioning Compressor (Internal).....	9.172
TUBE, Air Conditioning Evaporator Air Inlet..	9.208
TUBE, Air Conditioning Evaporator Air Inlet..	9.218
TUBE, Air Conditioning Evaporator Core Housing .....	9.211
TUBE, Air Conditioning Refrigerant (with Dehydrator) .....	9.195
TUBE, Air Conditioning Refrigerant.....	9.196
TUBE ASSY., Air Conditioning Evaporator.....	9.220

### U

UP RING, Rear Window Defogger .....	9.778
-------------------------------------	-------

### V

VACUUM ELEMENT, Defroster.....	9.779
VACUUM GAUGE, Instrument Cluster.....	9.755
VALVE, Air Conditioning Compressor (Internal).....	9.172
VALVE, Air Conditioning Evaporator Air Distributor and Astro-Ventilation .....	9.262

VALVE, Air Conditioning Vacuum Control .....	9.280
VALVE, Air Flow .....	9.786
VALVE ASSY., Air Conditioning Compressor Pressure Relief.....	9.178
VALVE ASSY., Air Conditioning Control.....	9.281
VALVE ASSY., Air Conditioning Evaporator By-Pass.....	9.198
VALVE ASSY., Air Conditioning Evaporator Core Housing.....	9.211
VALVE ASSY., Air Conditioning Evaporator Expansion .....	9.213
VALVE ASSY., Defroster .....	9.779
VALVE ASSY., Heater Water Temp.....	9.795
VALVE, Cowl .....	9.789

### W

WASHER, Air Conditioning Compressor Drive .....	9.180
WASHER, Air Conditioning Compressor Mounting Attaching Parts .....	9.173
WASHER, Air Conditioning Evaporator Air Distributor and Astro-Ventilation .....	9.262
WASHER, Air Conditioning Evaporator Blower Motor.....	9.216
WASHER, Air Conditioning Evaporator Core Housing .....	9.211
WASHER, Air Flow .....	9.786
WASHER, Hold-Down Bolt .....	9.011
WASHER, Instrument Case .....	9.744
WASHER, Radio and Stereo Mounting.....	9.667
WIRE, Air Flow Control with Tube.....	9.787
WIRE ASSY., Air Conditioning, Electrical.....	9.276
WIRE ASSY., Clock Mounting and Attaching.....	9.772
WIRE ASSY., Radio and Speaker Wiring.....	9.656
WIRE ASSY., Rear Luggage Compartment.....	9.988
WIRE ASSY., Rear Window Defogger .....	9.778

**BODY MTG.— AIR COND.— INSTRUMENTS**

<b>9.008 BOLT, Body</b>					
68-72	Chevy	3932784	2	.63	No. 2 (5/8" — 11 x 3 3/4")
68-69	Chevelle	3816560	2	.95	rear axle arm, rear axle lower control arm at frame (1/2" — 13 x 3 3/4")
73-75	Nova	332620	2	.67	No. 2 (5/8" — 11 x 4")
<b>9.011 WASHER, Hold-Down Bolt</b>					
62-69	All	3859708	A.R.	.16	WASHER (1 5/32" I.D. x 1 7/8" O.D. x 1/8" thk.)
67	Pass.	3908042	4	.17	WASHER, body mtg. strut
68-75	Nova, Camaro	3901365	A.R.	.22	WASHER, No. 1, 2, 3 body bolt (2 15/32" O.D. x 2 1/32" I.D.)
67-69	Camaro,				
68-69	Chevy	3914049	4	.11	WASHER, spring, No. 2, 3 body bolt (1 5/8" O.D. x 2 1/32" I.D.)
<b>9.023 CUSHION— CLIP— SPACER, Body Mounting</b>					
64	Chevelle	3772260	2	.32	No. 3, body bolt (1 5/8" I.D. x 3/4" thk.)
65	Pass., Chevelle	3866470	2	.26	No. 7 body bolt
65-66	Pass.				No. 1, 2,
64	Chevelle				No. 1, 2, 4, 5, 6, 7 body bolt,
65-67	Chevelle				No. 2, 5, 6, 7,
65-67	Chevelle (Conv.)				No. 1,
65-67	Chevelle (Sta. Wag., Conv., El Camino)				No. 4,
66-67	Pass.				No. 7,
67	Chevelle				No. 3,
68-72	Chevelle	3843678	A.R.	.24	No. 7
65	Pass. (Conv.)				No. 3 body bolt,
65-66	Pass. (Conv., Sta. Wag.)				No. 6,
65-66	Pass.				No. 4, 5,
68-70	Pass.	3868996	2	.36	No. 7
67	Pass.				No. 1, 4,
67-70	Pass. (Sedan) (exc. Spt. Sed.)				No. 5,
67-70	Pass., (Spt. Mdls., Sta. Wag.)				No. 6,
68-70	Pass.	3906747	2	.24	No. 1
67-75	Camaro,				
68-75	Nova	3893159	2	.21	No. 1 body bolt
67-68	Camaro,				
68-72	Chevy	3914802	4	.35	No. 2, 3 body bolt
67-70	Pass. (exc. H.D. Susp.)				No. 2,
67-70	Pass. (Conv.),				
68-72	Chevelle (exc. Conv.)				No. 3,
68-70	Chevelle (Std.) (2-Dr. Sed.),				
67-70	Pass. (Conv., Sta. Wag.) (exc. H.D. Susp.),				
68-71	Chevelle (Sta. Wag., El Camino),				
67-70	Police, Taxi,				
72	Chevelle (exc. Sta. Wag.)	3906748	2	.63	No. 5
68	Pass.	3926935	2	.32	No. 4
68-72	Chevelle (Conv.)				No. 1, 3,
68-72	Chevelle				No. 2, 4, 6,
69-70	Pass.	3930745	2	.42	rad. support
65	Pass. (exc. Impala, Caprice)				No. 5 body bolt,
65	Pass. (Spt. Cpe., Conv.),				
65	Caprice				No. 4, 6,
66	Pass.				No. 4,
66	Pass. (Spt. Mdls., Sta. Wag.)				No. 6,
66	Pass. (exc. Spt. Sed., Spt. Cpe.)	396784	A.R.	2.00	No. 5
70-72	Nova				No. 3,
70-72	Camaro	332654	2	.58	No. 2, 3
72	Chevelle (Sta. Wag., El Camino)	3987870	2	1.20	No. 5 upper
64-67	Chevelle	481377	2	1.20	CUSHION ASSY., No. 3 body bolt (w/spacer)
65	Pass. (Conv., Sta. Wag.)				CUSHION ASSY., No. 6,
65	Pass.				No. 4,
65-66	Pass. (Conv.)	3866196	2	.78	No. 3
65-66	Pass. (Spt. Sed.)				CUSHION ASSY., No. 1, 2, 7,
67-70	Pass.	3926945	A.R.	.96	No. 7
67-75	Camaro,				
68-75	Nova	3893156	2	.70	CUSHION ASSY., No. 1 body bolt
67-72	Camaro,				
68-72	Chevy	3928380	2	1.10	CUSHION ASSY., No. 2 body bolt
67-72	Camaro,				
68-72	Chevy	3901361	2	.96	CUSHION ASSY., No. 3 body bolt
67	Chevelle (Conv.)				CUSHION ASSY., No. 1,
64-67	Chevelle				No. 1, 2, 4, 5, 6, 7,
67	Chevelle (Conv., Sta. Wag., El Camino)	3904029	A.R.	1.15	No. 4

**BODY MTG.— AIR COND.— INSTRUMENTS**

**9.023 CUSHION— CLIP— SPACER, Body Mounting (Con't)**

67	Pass. . . . .			CUSHION ASSY., No. 1, . . . . .
67	Biscayne, Bel Air (Sta. Wag.) (1st design),			
67	Pass. (2nd design) (exc. Conv., Sta. Wag.),			
68	Pass. (exc. H.D. Susp., Spec. Susp., Caprice) . . . . .			No. 4, . . . . .
67-70	Taxi, Police . . . . .			CUSHION ASSY., No. 1, 4, . . . . .
68-70	Chevelle,			
71-72	Monte Carlo . . . . .			CUSHION ASSY., No. 1 body bolt, . . . . .
71-72	Chevelle (exc. Sta. Wag.) . . . . .			No. 4, 6, body bolt, . . . . .
69-70	Pass. . . . .	3906746 A.R.	1.15	No. 1 . . . . .
67	Biscayne, Bel Air (Sta. Wag.) (2nd design) (exc. H.D. Susp., Spec. Susp.),			
67	Pass. (Spt. Cpe.) (1st design),			
67	Impala (4 Dr. Sed.) (1st design),			
67	Impala, Caprice (Spt. Mdls., Sta. Wag.) (exc. Cpe.) . . . . .			CUSHION ASSY., No. 4, . . . . .
67-68	Pass. (Sedan) (exc. Spt. Sed., H.D. Susp., Spec. Susp.),			
69-70	Biscayne, Bel Air (exc. Taxi, Police),			
69-70	Impala (4-Dr. Sed.) (exc. Spt. Sed.),			
69	Caprice, Estate Wagon . . . . .			No. 5, . . . . .
67-68	Pass. (Spt. Mdls., Sta. Wag.) (exc. H.D. Susp., Spec. Susp.),			
69-70	Brookwood, Townsman (exc. Police),			
69	Kingswood, Impala (Spt. Mdls.) . . . . .			No. 6, . . . . .
67-68	Pass. w/H.D. Chassis (exc. Sta. Wag.),			
68-70	Police (exc. Sta. Wag.) . . . . .	3906749 A.R.	.83	CUSHION ASSY., No. 5 . . . . .
71-72	Pass. (exc. Police, Taxi) . . . . .	3989098 2	1.30	CUSHION ASSY., No. 1, 2 body bolt upper No. 5 upper, . . . . .
71-72	Pass. (Sta. Wag.) . . . . .			
71-72	Police, Taxi . . . . .	3989099 2	1.10	CUSHION ASSY., No. 1, 2 body bolt upper CUSHION ASSY., No. 1, 2, 4, 6 body bolt lower, . . . . .
71-72	Pass. . . . .			No. 5 body bolt lower . . . . .
71-72	Pass. (Sta. Wag.) . . . . .	3989101 A.R.	1.30	
71-72	Pass. (exc. Police, Taxi, Sta. Wag.) . . . . .			CUSHION ASSY., No. 4, body bolt upper, . . . . .
71-72	Pass. (exc. Sta. Wag.) . . . . .	3989102 2	1.30	No. 6, body bolt upper . . . . .
71-72	Pass. (Sta. Wag.),			
71-72	Police, Taxi . . . . .			CUSHION ASSY., No. 4, body bolt upper, . . . . .
71-72	Biscayne, Bel Air, Brookwood, Townsman . . . . .	3989103 2	1.10	No. 6, body bolt upper . . . . .
71-72	Pass. (exc. Police, Taxi) . . . . .	3989104 2	1.30	CUSHION ASSY., No. 7, body bolt upper . . . . .
71-72	Police, Taxi . . . . .	3989105 2	1.10	CUSHION ASSY., No. 7, body bolt upper . . . . .
71	Pass. (exc. Police, Taxi, Sta. Wag.) . . . . .	3989107 2	1.15	CUSHION ASSY., No. 5, body bolt . . . . .
71	Police . . . . .	3989108 2	1.10	CUSHION ASSY., No. 5, body bolt . . . . .
71-72	Pass. . . . .	3991230 2	.38	CUSHION ASSY., No. 7, body bolt lower . . . . .
71	Pass. (Sta. Wag., Conv.),			
73	Pass. (exc. Sta. Wag., Police, Taxi) . . . . .	3991291 2	.38	CUSHION ASSY., No. 3, lower . . . . .
71-72	Pass. (Sta. Wag.) . . . . .	3991229 2	1.10	CUSHION ASSY., No. 3, body bolt upper . . . . .
67-68	Pass. (Sta. Wag.) w/H.D. Chassis,			
68-70	Police (Sta. Wag.) . . . . .			No. 4, 6, . . . . .
69-70	Police (Sta. Wag.) . . . . .	3906749 2	.83	No. 6 . . . . .
68-72	Chevelle . . . . .	3920609 2	.76	CUSHION ASSY., No. 7 . . . . .
68-72	Chevelle (Conv.) . . . . .			CUSHION ASSY., No. 3, . . . . .
68-72	Chevelle . . . . .			No. 2, . . . . .
68	Chevelle (Spt. Cpe.) . . . . .	3930746 2	1.35	No. 1 . . . . .
68-70	Pass. (exc. Taxi, Police) . . . . .	3934012 2	1.20	CUSHION ASSY., No. 4 . . . . .
69-70	Pass. (exc. Sta. Wag.) . . . . .	3939118 2	.70	CUSHION ASSY., No. 4 body bolt . . . . .
72	Chevelle (Sta. Wag.) . . . . .	6263638 4	1.10	CUSHION ASSY., No. 4, 6 . . . . .
72	Pass. (exc. Police, Taxi, Sta. Wag.) . . . . .	3993727 2	1.10	CUSHION ASSY., No. 5, body bolt . . . . .
72	Pass. (Sta. Wag.),			
73	Pass. (Taxi, Police, Sta. Wag.) . . . . .	3993679 2	1.30	CUSHION ASSY., No. 3, lower . . . . .
73-75	Pass. (exc. Sta. Wag.) . . . . .	331219 2	1.80	No. 1, 2, 4, 6, 7 body bolt lower . . . . .
73-75	Nova, Camaro . . . . .	332654 2	.58	No. 2, 3 body bolt lower . . . . .



**BODY MTG.— AIR COND.— INSTRUMENTS**

**9.023 CUSHION— CLIP— SPACER, Body Mounting (Con't)**

73-75	Pass. (Police, Taxi) (exc. 4-Dr. Sedan)				No. 3, body bolt, upper
72-75	Pass. (Police, Taxi) (exc. Sta. Wag.)	330949	2	1.15	No. 5, body bolt
73-75	Pass. (Sta. Wag.)				<b>CUSHION ASSY., No. 1, 2, 4, 6, 7, body bolt, lower</b>
73-75	Chevelle				No. 2, 4, 6, 7, body bolt, lower
73-75	Chevelle (Sedan, Sta. Wag.)	330989	2	1.55	No. 3, body bolt, lower
73-75	Chevelle (exc. Spt. Cpe.)				<b>CUSHION ASSY., No. 1, body bolt, upper</b>
73-75	Chevelle (Sta. Wag., Sedan)				No. 2, body bolt, upper
73-75	Chevelle (exc. Monte Carlo, El Camino)				No. 6, body bolt, upper
73-75	Pass. (Sta. Wag.)	330942	2	1.65	No. 4, body bolt, upper
73-75	Pass. (Police) (exc. Sedan, Cpe.)	330943	2	1.90	<b>CUSHION ASSY., No. 1, 4, body bolt, upper</b>
73-75	Pass. (Sta. Wag.) (exc. Police)	330944	2	1.10	<b>CUSHION ASSY., No. 1, 2, body bolt, upper</b>
73-75	Nova, Camaro				<b>CUSHION ASSY., No. 1 body bolt</b>
73-75	Camaro	332608	2	1.10	<b>CUSHION ASSY., No. 2 body bolt</b>
73-74	Nova	332610		1.35	<b>CUSHION ASSY., No. 2 body bolt</b>
73-75	Camaro, Nova	332609	2	1.35	<b>CUSHION ASSY., No. 3 body bolt</b>
73-75	Pass. (exc. Sta. Wag., Taxi, Police)	330955	2	1.55	<b>CUSHION ASSY., No. 3 body bolt upper</b>
73-74	Pass. (Sta. Wag.)	330996	2	1.10	<b>CUSHION ASSY., No. 3 body bolt, upper</b>
73-75	Pass., Chevelle	330992	2	1.75	<b>CUSHION ASSY., No. 7 body bolt, upper, rod supt.</b>
73-75	Pass. (exc. Sta. Wag., Taxi, Police)	330985	2	1.90	<b>CUSHION ASSY., No. 4, body bolt, upper</b>
73-74	Pass. (Police, Taxi) (exc. Sta. Wag.)	330987	2	1.30	<b>CUSHION ASSY., No. 4, body bolt, upper</b>
73-75	Pass. (exc. Sta. Wag., Police, Taxi)				<b>CUSHION ASSY., No. 1, 6, 7, body bolt, upper</b>
73-75	Chevelle (Spt. Cpe.) (exc. Monte Carlo)				No. 1, body bolt, upper
73-75	Chevelle (Spt. Cpe., El Camino)				No. 2, 7, body bolt, upper
73-75	Chevelle (Monte Carlo, El Camino)				No. 6, body bolt, upper
73-75	Chevelle	330951	2	1.90	No. 4, body bolt, upper
73-75	Pass. (Police, Taxi) (exc. Cpe., Sta. Wag.)	330956	2	1.10	<b>CUSHION ASSY., No. 3, body bolt, upper</b>
73-75	Pass. (Police, Taxi) (exc. Sta. Wag.)				<b>CUSHION ASSY., No. 1, body bolt, upper</b>
73-75	Pass. (Police, Taxi)				No. 6, 7, body bolt, upper
73-75	Chevelle (exc. El Camino)	330952	2	1.90	No. 7, body bolt, upper
73-75	Chevelle (Sedan, Sta. Wag.)	330953	2	1.90	<b>CUSHION ASSY., No. 3, body bolt, upper</b>
73-75	Pass. (exc. Conv., Sedan)				
73-75	Chevelle (Monte Carlo, El Camino, Spt. Cpe.)				<b>CUSHION ASSY., No. 3, body bolt, upper</b>
73-75	Pass., Chevelle (exc. Sta. Wag.)	6271662	2	1.30	No. 5, body bolt, upper
74-75	Pass. (Sedan, Conv.) (exc. Police, Taxi)	343203	2	1.30	<b>CUSHION ASSY., No. 3, body bolt, lower</b>
74-75	Pass. (Police, Taxi) (exc. Sta. Wag.)	343204		1.30	<b>CUSHION ASSY., No. 3, body bolt, lower</b>
75	Nova	356514	2	1.40	<b>CUSHION ASSY., No. 3, body bolt lwr.</b>
75	Nova	356515	2	1.40	<b>CUSHION ASSY., No. 2, body bolt lwr.</b>
75	Nova	356549	2	1.35	<b>CUSHION ASSY., No. 2, body bolt, upr.</b>
75	Chevelle (Sta. Wag.)	356913	1	1.75	<b>CUSHION ASSY., No. 4, body bolt, upr.</b>
75	Nova	348080	2	1.40	<b>CUSHION ASSY., No. 1, body bolt, lwr.</b>
75	Chevelle (Spt. Sedan, El Camino)	356912	2	1.75	<b>CUSHION ASSY., No. 4 body bolt upper</b>
74-75	Pass. (exc. Cpe., Sta. Wag.)	343149	2	.11	<b>CLIP, No. 3 body bolt lower (closed type-4-tang-black)</b>
68-72	Chevy (1st design)	3920260	2	.70	<b>SPACER, No. 2 and 3 body bolt (1/2" thk.)</b>

**9.025 NUT— SCREW, Cargo Tie Down Hook**

75	All 80	1730250	8	.45	tie down hook
75	All 80	9732971	8	.19	<b>SCREW, tie down hook</b>

**9.170 BODY ASSY.— CYLINDER ASSY.— DAMPER ASSY.— NUT KIT— "O" RING KIT— RETAINER— SEAL KIT— SHAFT ASSY.— SHELL ASSY.— THRUST WASHER KIT, Air Conditioning less Clutch**

64-70	Chevelle, Camaro,				
65-70	Pass.,				
68-70	Chevy,				
71-72	All,				
73-75	All w/Axial Cmpr. (exc. Vega, Monza)	6598423	1	182.10	cmpr.

**BODY MTG.— AIR COND.— INSTRUMENTS**

**9.170 BODY ASSY.— CYLINDER ASSY.— DAMPER ASSY.— NUT KIT— "O" RING KIT— RETAINER— SEAL KIT— SHAFT ASSY.— SHELL ASSY.— THRUST WASHER KIT, Air Conditioning less Clutch (Con't)**

64-66	Pass., Chevelle, w/Cool Pack, Custom,				
62-67	Chevy,				
69-70	All w/Acc. Air Cond.,				
73-75	Vega w/axial Cmpr. ....	5910432	1	163.70	cmpr. ....
75	All w/Radial Cmpr. ....	6598696	1	175.40	air cond. compressor ....
75	Monza (exc. Towne Cpe.) w/axial cmpr. ....	6598452	1	182.10	
62-68	Chevy, Camaro,				
64-67	Chevelle w/Custom,				
73-75	Vega, Monza w/axial Cmpr. ....	5914810	1	105.00	CYLINDER ASSY., w/pistons, wobble plate and shaft ....
62-75	All w/Axial Cmpr. ....	5914807	1	38.25	CYLINDER ASSY., w/drive shaft brg. ....
65-67	All w/Cool Pack, Custom,				
64-68	Pass., Chevelle,				
69-72	All,				
71-72	Vega w/Axial Cmpr.,				
73-75	All w/Axial Cmpr. (exc. Vega, Monza) ....	5914809	1	104.80	CYLINDER ASSY., w/pistons, wobble plate and shaft ....
76	All w/Radial Cmpr. ....	6598709	1	126.55	CYLINDER AND SHAFT ASM., compr. (superheat type) ....
76	All w/Radial Cmpr. ....	6598710	1	126.55	CYLINDER AND SHAFT ASM., compr. (non-superheat type) ....
71-75	Vega, Monza w/Axial Cmpr. (4 cyl.) ....	3992138	1	9.20	DAMPER ASSY., comp. vib. ....
62-75	All w/Axial Cmpr. ....	6590589	1	3.19	NUT KIT, drive shaft and head ....
75	All w/Radial Cmpr. ....	9956746	1	3.49	"O" RING KIT ....
71-75	Vega, Monza w/Axial Cmpr. (4 cyl.) ....	3992142	1	.36	RETAINER, a/c comp. vib. damper ....
62-75	All w/Axial Cmpr. ....	6591956	1	4.48	SEAL KIT (Note 2) ....
73-75	All w/Radial Cmpr. ....	9956695	1	9.60	SEAL KIT, shaft ....
<i>NOTE 2: Consists of 8 Seals "O" Rings. When using on 1962-63 models formerly requiring Cover Gasket Seal, it is mandatory that cover 6555755 Grp. 9.172 be used in lieu of this cover gasket.</i>					
62-75	All w/Axial Cmpr. ....	5914705	1	27.75	SHAFT ASSY., w/wobble plate ....
62-75	All w/Axial Cmpr. ....	5914808	1	32.00	SHELL ASSY. ....
75	All w/Radial Cmpr. ....	6598711	1	21.85	SHELL ASSY., cmpr. ....
75	All w/Radial Cmpr. ....	9956685	1	3.00	THRUST WASHER KIT (Note 1) ....

*NOTE 1: Contains 2 thrust and 1 Belleville washers.*

**9.171 BRACKET— BRACE— BOLT— BUSHING— SHIM— SPACER— STUD— SUPPORT, Air Conditioning Compressor Mounting**

*NOTE Original equipment braces may be replaced by service braces which will require drilling of attaching hole and forming.*

64-67	Chevelle, Camaro (8 cyl.),				
65	Pass. (8 cyl.) (exc. 396, 409),				
66-68	Pass. (8 cyl.) (exc. 396),				
68	Chevy, Chevelle, Camaro (307, 327, 350) ....	3841698	1	3.20	front ....
64-67	Chevelle, Camaro (8 cyl.),				
65-68	Pass. (8 cyl.) (exc. 396, 409),				
68	Chevy, Chevelle, Camaro (307, 327, 350) ....	3841699	1	1.30	rear ....
64-69	All (6 cyl.)				
70	All (6 cyl.) (exc. Camaro),				
74	Nova (6 cyl.) ....	3843249	1	4.05	front ....
64-69	All (exc. 8 cyl.) (6 cyl.),				
70	All (6 cyl.) (exc. Camaro),				
74	Nova (6 cyl.) ....	3843250	1	2.30	rear ....
65-68	Pass., Chevelle (396, 427),				
68	Camaro (396) ....	3872785	1	3.20	front ....
65-68	Pass., Chevelle (396, 427),				
68	Camaro (396) ....	3878268	1	1.10	rear ....
67	Camaro, Chevelle w/A.I.R. (8 cyl.) (exc. 396, Sp. H/Per.),				
67	Pass. w/A.I.R. (283, 327),				
68	Chevy, Chevelle, Camaro (307, 327, 350),				
68	Pass. (307, 327) (exc. A.T.),				
68	Chevelle w/P.G. (exc. 327 Sp. H/Per.),				
69	Chevelle (Sta. Wag.) (exc. P.G.)	3896983	1	.79	rear brace support ....
69-70	Chevy (8 cyl.),				

**BODY MTG.— AIR COND.— INSTRUMENTS**

**9.171 BRACKET— BRACE— BOLT— BUSHING— SHIM— SPACER— STUD—  
SUPPORT, Air Conditioning Compressor Mounting (Con't)**

69-70	Pass., Chevelle, Camaro (8 cyl.) (exc. 396, 427, 400 w/4BC, 454),					
71-74	All (8 cyl.) (exc. 400 w/4BC, 402, 454) (Vega) . . . . .	3932433	1	2.80	front . . . . .	
69	All (396, 427),					
70	Pass., Chevelle w/C.A.C. (396, 400 w/4BC, 454) . . . . .	3940949	1	2.35	front . . . . .	
69	Chevy, Camaro w/Acc. Air Cond. (396),					
69	Chevelle (8 cyl.),					
69	Chevy, Camaro (8 cyl.),					
69	Pass. w/Acc. Air Cond. (427) (exc. Sp. H/Per.),					
69	Pass. w/C.A.C. (8 cyl.) . . . . .				rear . . . . .	
70	Pass., Chevelle w/Acc. Air Cond. (396, 400 w/4BC, 454),					
70	Pass., Nova, Chevelle w/Acc. Air Cond. (8 cyl.) . . . . .				rear brace to comp. brkt. . . . .	
70	Pass., Nova, Chevelle . . . . .	3932493	1	1.10	rear . . . . .	
70	Camaro w/C.A.C. (396 H/Per.),					
71-73	All (400, w/4BC, 402, 454),					
74-75	All (454) . . . . .	336054	1	3.60	front (repl. 3969916) . . . . .	
70	Camaro (396 H/Per.),					
71-73	All (400 w/4BC, 402, 454) (exc. Vega) . . . . .	3969911	1	5.80	rear . . . . .	
71-72	All (exc. 400 w/4BC, 402, 454, Vega),					
73-75	All (8 cyl.) (exc. 454) . . . . .	351690	1	6.50	rear (repl. 3998946) . . . . .	
71-74	Vega w/axial cmpr. (4 cyl.) . . . . .	3980270	1	2.00	a/c compressor rear lower . . . . .	
71-75	Vega, Monza w/axial cmpr. (4 cyl.) . . . . .	3973173	1	2.00	a/c compressor front . . . . .	
71-75	Vega, Monza w/axial cmpr. (4 cyl.) . . . . .	3992200	1	3.85	a/c compressor rear upper . . . . .	
74-75	All (454) . . . . .	3999280	1	5.80	rear . . . . .	
75	All (6 cyl.) . . . . .	355724	1	4.05	a/c comp. adj. . . . .	
75	All (6 cyl.) . . . . .	355722	1	12.90	a/c comp. adj. . . . .	
75	Camaro (6 cyl.) . . . . .	357606	1	8.50	cmpr. . . . .	
75	Camaro (6 cyl.) . . . . .	357607	1	6.15	cmpr. adj. . . . .	
75	Vega, Monza w/axial cmpr. (4 cyl.) . . . . .	355756	1	3.60	cmpr., rear, lwr. . . . .	
75	Vega, Monza w/axial cmpr. (8 cyl.) . . . . .	354336	1	3.85	cmpr., frt. . . . .	
75	Vega, Monza w/axial cmpr. (8 cyl.) . . . . .	354337	1	22.30	<b>BRACKET ASSY., cmpr., rear</b> . . . . .	
65-67	Chevelle, Camaro (8 cyl.),					
65-68	Pass. (283, 307, 327),					
68	All (307, 327, 350) (exc. Pass.) . . . . .	3854059	1	.47	<b>BRACE, comp., rear</b> . . . . .	
65	Chevelle (8 cyl.) (exc. Sp. H/Per.),					
65-67	Pass. (283, 327) (exc. A.I.R.),					
66-67	Chevelle (exc. A.I.R., 396),					
68	All w/P.G. (307, 327, 350) (exc. Pass., Sp. H/Per.),					
68	Pass. w/A.T. (307, 327) . . . . .	3881805	1	.80	<b>BRACE, comp. frt.</b> . . . . .	
65-68	Pass. (396, 427),					
66-68	Chevelle (396),					
68	Camaro (396),					
69	Pass. w/C.A.C., H/Per. (427) . . . . .	3872720	1	.65	<b>BRACE, comp., rear</b> . . . . .	
65-68	Pass. (396, 427),					
66-68	Chevelle (396),					
68	Camaro (396) . . . . .	3906682	1	.96	<b>BRACE, comp. front</b> . . . . .	
68	Pass., Camaro, Chevelle w/C.A.C. (396, 427) (exc. Sp. H/Per.) . . . . .	3921950	1	1.10	<b>BRACE, comp. rear</b> . . . . .	
69-70	All (396, 427, 400, 454) . . . . .	3940947	1	2.70	<b>BRACE, comp. adj. rear</b> . . . . .	
70	Camaro (396 H/Per.),					
71-75	All (400 w/4BC, 402, 454) (exc. Vega, Monza) . . . . .	3969910	1	2.65	<b>BRACE, comp. rear</b> . . . . .	
75	All (6 cyl.) . . . . .	355725	1	8.65	<b>BRACE, cmpr. adj. (radial)</b> . . . . .	
75	All (6 cyl.) . . . . .	354510	1	13.40	<b>BRACE, cmpr. adj.</b> . . . . .	
75	Camaro (6 cyl.) . . . . .	357608	1	8.65	<b>BRACE, cmpr. adj.</b> . . . . .	
70	Camaro (exc. 396),					

**BODY MTG.— AIR COND.— INSTRUMENTS**

**9.171 BRACKET— BRACE— BOLT— BUSHING— SHIM— SPACER— STUD—  
SUPPORT, Air Conditioning Compressor Mounting (Con't)**

70	All w/Acc. Air Cond. (8 cyl.) (exc. Camaro),				
71	All (exc. 400 w/4BC, 454) (exc. Vega)	3973372	1	10.80	BRACE ASSY., comp. rear
72	All (exc. Vega),				
73-75	All (8 cyl.) (exc. 454)	6271051	1	2.95	BRACE ASSY., comp. rear
75	Vega, Monza w/axial cmpr. (8 cyl.)	354338	1	7.50	BRACE ASSY., a/c cmpr., upper
64	Chevelle (8 cyl.)	3841724	1	.46	BOLT, exh. mfld. (3rd hold, right)— (3.275)
68	Pass., Camaro, Chevelle (396, 427)	3921953	2	.31	BOLT, comp. rear lower bracket support to manifold
62-64	Chevy, Chevelle,				
65-67	Chevy (8 cyl.),				
65	Pass. (409)	3813383	A.R.	1.10	BUSHING, bracket, frt. and rr.
64-70	All (exc. 8 cyl.),				
74	Nova (6 cyl.)	3850581	A.R.	.50	SHIM, comp. bracket rear (4 <sup>15</sup> / <sub>16</sub> " long)
64-70	All (8 cyl.)	3852876	A.R.	.14	SHIM, comp. bracket rear (3" long)
65	Pass. (409)	3755656	1	.14	SPACER, bracket support
64-70	All w/Acc. Air Cond. (8 cyl.),				
71	Nova, Camaro, Chevelle (8 cyl.) (exc. 400 w/4BC, 454),				
72-75	All (8 cyl.) (exc. 454, Vega, Monza)	3841722	1	.59	SPACER, bracket rear support
69-70	All (8 cyl.)	3932437	1	.39	SPACER, rear bracket to comp.
68	Pass., Chevelle, Camaro (396, 427)	3928906	1	.52	STUD, compressor stud— (3.275)
	Not required in this group. See Group 3.601, 1.073	3903324	A.R.	1.45	STUD
64-67	Chevelle, Camaro (8 cyl.),				
65-68	Pass. (283, 307, 327),				
68	All (307, 327, 350) (exc. Pass.),				
75	Vega, Monza w/Axial cmpr. (8 cyl.)	3841697	1	7.90	SUPPORT, bracket front
65	Chevelle (8 cyl.),				
65	Pass. (283, 327),				
66-67	Chevelle, Camaro (exc. 396),				
66-67	Pass. (283, 327),				
68	All (307, 327, 350) (exc. Pass.)	351688	1	22.30	SUPPORT, comp. bracket rear
64-67	Chevelle, Camaro (8 cyl.) (exc. A.I.R., El Camino w/396),				
65-67	Pass. (283, 327) (exc. A.I.R.),				
68	All (307, 327, 350) (exc. Pass.)	3854060	1	3.95	SUPPORT, brace rear
65-68	Pass. (396, 427),				
66-68	Chevelle (396)	3878269	1	14.70	SUPPORT, compressor
65-68	Pass. w/A.T. (396, 427) (exc. A.I.R.),				
66-68	Chevelle w/A.T. (396) (exc. A.I.R.),				
68	Camaro w/396 (exc. A.I.R.)	3872726	1	4.05	SUPPORT, comp. rear bracket
68	Pass., Camaro, Chevelle w/C.A.C. (396, 427) (exc. Sp. H/Per.)	3921952	1	.80	SUPPORT, comp. rr. lwr. bracket
69	Chevy w/Air Cond. (8 cyl.),				
69	Pass., Camaro, Chevelle w/Air Cond. (8 cyl.) (exc. 396, 427),				
70-71	All (8 cyl.) (exc. 396, 400 w/4BC, 454, Camaro, Vega)	3932432	1	6.30	SUPPORT, comp. front bracket
69	Chevy (8 cyl.),				
69	Pass., Camaro, Chevelle (8 cyl.) (exc. 396, 427),				
70-71	All (8 cyl.) (exc. 396, 400 w/4BC, 454, Camaro, Vega),				
72-75	All (8 cyl.) (exc. 454)	3932435	1	6.05	SUPPORT, comp. rear bracket
69	All (396, 427),				
70	All (396, 400 w/4BC, 454) (exc. Camaro)	3940948	1	10.25	SUPPORT, comp. front bracket
69	All (396, 427),				
70	All (396, 400 w/4BC, 454) (exc. Camaro)	3940946	1	7.75	SUPPORT, comp. rear bracket
70	Camaro (396 H/Per.),				
71-75	All (400 w/4BC, 402, 454)	3969917	1	14.65	SUPPORT, front bracket
70	Camaro (396 H/Per.),				
71-72	All (400 w/4BC, 402, 454)	3969912	1	6.80	SUPPORT, rear bracket

**BODY MTG.— AIR COND.— INSTRUMENTS**

**9.171 BRACKET— BRACE— BOLT— BUSHING— SHIM— SPACER— STUD— SUPPORT, Air Conditioning Compressor Mounting (Con't)**

72	All (exc. 402, 454),				
73-75	All (8 cyl.) (exc. 454)	3997796	1	16.40	SUPPORT, front bracket
71-75	Vega, Monza w/axial cmpr. (4 cyl.)	3973171	1	22.30	SUPPORT, front
71-75	Vega, Monza w/axial cmpr. (4 cyl.)	3973172	1	5.70	SUPPORT, rear
73-75	Pass., Chevelle (454)	329227	1	6.10	SUPPORT, rear bracket
75	All (6 cyl.)	355723	1	.53	SUPPORT, a/c brkt.
75	Vega, Monza w/axial cmpr. (8 cyl.)	351688	1	22.30	SUPPORT, a/c cmpr. brkt., rear
65-70	All (exc. 8 cyl.)	3843248	1	14.15	SUPPORT ASSY., bracket

**9.172 PUMP UNIT— BALL— BEARING— BUSHING— COVER— FUSE ASSY.— HARNESS— "O" RING— PISTON— RACE— RETAINER— RING— ROTOR AND BEARING ASSY.— SCREEN— SEAL— SEAT— SLEEVE— SWITCH ASSY.— TUBE— VALVE, Air Conditioning Compressor (Internal)**

65-75	All w/Axial Cmpr.	6590594	1	7.20	oil (Note 1)
	<i>NOTE 1: Consists of 1 inner and outer rotor.</i>				
62-75	All w/Axial Cmpr.	6555258	6	1.55	BALL, piston drive
62-75	All w/Axial Cmpr.	6555259	2	2.30	BEARING, wobble plate thrust
62-75	All w/Axial Cmpr.	148406	2	2.30	BEARING, drive shaft
75	All w/Radial Cmpr.	6556572	1	2.40	BEARING, front head main
75	All w/Axial Cmpr.	6555440	1	2.80	BUSHING, discharge tube
62-75	All w/Axial Cmpr.	6555755	1	1.95	COVER, manifold suction crossover passage
72-74	All w/C.A.C. (exc. Vega, Monza)	6556440	1	2.30	FUSE ASSY., cut-out switch thermal
75	All w/C.A.C.	6551258	1	2.15	FUSE ASSY., thermal limiter
72	All	8908651	1	4.85	HARNESS, a/c comp. head and switch wire
73-75	All w/Axial Cmpr.	5929144	1	.66	"O" RING, oil inlet tube
75	All w/Radial Cmpr.	6556621	1	.36	"O" RING, suction disc port
75	All w/Radial Cmpr.	6556590	1	.91	"O" RING, cylinder to shell
64-72	All,				
71-72	Vega w/Axial Cmpr.,				
73-75	All w/Axial Cmpr. (exc. Vega, Monza)	6555255	3	6.40	PISTON, high compression ratio
62-70	All w/Acc. Air Cond.,				
73-75	Vega, Monza w/Axial Cmpr.	6555318	3	7.10	PISTON, low compression ratio
62-75	All w/axial cmpr.	6590594	1	7.20	PUMP UNIT, compr. oil (inner and outer rotor)
62-75	All w/Axial Cmpr.	6556000 A.R.		1.75	RACE, wobble plate thrust brg. (stamped 0)
62-75	All w/Axial Cmpr.	6556050 A.R.		1.65	RACE, wobble plate thrust brg. (stamped 5)
62-75	All w/Axial Cmpr.	6556055 A.R.		1.65	RACE, wobble plate thrust brg. (stamped 5.5)
62-75	All w/Axial Cmpr.	6556060 A.R.		1.65	RACE, wobble plate thrust brg. (stamped 6)
62-75	All w/Axial Cmpr.	6556065 A.R.		1.65	RACE, wobble plate thrust brg. (stamped 6.5)
62-75	All w/Axial Cmpr.	6556070 A.R.		1.65	RACE, wobble plate thrust brg. (stamped 7)
62-75	All w/Axial Cmpr.	6556075 A.R.		1.65	RACE, wobble plate thrust brg. (stamped 7.5)
62-75	All w/Axial Cmpr.	6556080 A.R.		1.65	RACE, wobble plate thrust brg. (stamped 8)
62-75	All w/Axial Cmpr.	6556085 A.R.		1.65	RACE, wobble plate thrust brg. (stamped 8.5)
62-75	All w/Axial Cmpr.	6556090 A.R.		1.65	RACE, wobble plate thrust brg. (stamped 9)
62-75	All w/Axial Cmpr.	6556095 A.R.		1.65	RACE, wobble plate thrust brg. (stamped 9.5)
62-75	All w/Axial Cmpr.	6556100 A.R.		1.65	RACE, wobble plate thrust brg. (stamped 10)
62-75	All w/Axial Cmpr.	6556105 A.R.		1.65	RACE, wobble plate thrust brg. (stamped 10.5)
62-75	All w/Axial Cmpr.	6556110 A.R.		1.65	RACE, wobble plate thrust brg. (stamped 11)
62-75	All w/Axial Cmpr.	6556115 A.R.		1.65	RACE, wobble plate thrust brg. (stamped 11.5)
62-75	All w/Axial Cmpr.	6556120 A.R.		1.65	RACE, wobble plate thrust brg. (stamped 12)
73-75	All w/Axial Cmpr.	6556408	1	.85	RETAINER, superheat switch ring
62-75	All w/Axial Cmpr.	6555254	6	1.75	RING, piston
73-75	All w/Axial Cmpr.	6556407	1	.32	RING, a/c comp. super heat switch
75	All w/Radial Cmpr.	6556734	1	.96	RING, retainer, brg. to frt. head
75	All w/Radial Cmpr.	6556767	1	.87	RING, retainer, seal seat
75	All w/Radial Cmpr.	6556589	1	1.01	RING, retainer, valve plate
75	All w/Radial Cmpr.	6551216	1	39.40	ROTOR AND BEARING ASSY.
62-75	All w/Axial Cmpr.	6555299		1.22	SCREEN, freon inlet
64-75	All w/Axial Cmpr.	5929144	1	.66	SEAL, oil inlet tube

**BODY MTG.— AIR COND.— INSTRUMENTS**

**9.172 PUMP UNIT— BALL— BEARING— BUSHING— COVER— FUSE ASSY.— HARNESS— "O" RING— PISTON— RACE— RETAINER— RING— ROTOR AND BEARING ASSY.— SCREEN— SEAL— SEAT— SLEEVE— SWITCH ASSY.— TUBE— VALVE, Air Conditioning Compressor (Internal) (Con't)**

75	All w/Radial Cmpr. ....	6556592	1	.48	SEAL, frt. head to cyl. ....
62-75	All w/Axial Cmpr. ....	6557000 A.R.		2.05	SEAT, piston drive ball (stamped 0) ....
62-75	All w/Axial Cmpr. ....	6556175 A.R.		1.90	SEAT, piston drive ball (stamped 17.5) ....
62-75	All w/Axial Cmpr. ....	6556180 A.R.		1.90	SEAT, piston drive ball (stamped 18) ....
62-75	All w/Axial Cmpr. ....	6556185 A.R.		1.90	SEAT, piston drive ball (stamped 18.5) ....
62-75	All w/Axial Cmpr. ....	6556190 A.R.		1.90	SEAT, piston drive ball (stamped 19) ....
62-75	All w/Axial Cmpr. ....	6556195 A.R.		1.90	SEAT, piston drive ball (stamped 19.5) ....
62-75	All w/Axial Cmpr. ....	6556200 A.R.		1.90	SEAT, piston drive ball (stamped 20) ....
62-75	All w/Axial Cmpr. ....	6556205 A.R.		1.90	SEAT, piston drive ball (stamped 20.5) ....
62-75	All w/Axial Cmpr. ....	6556210 A.R.		1.90	SEAT, piston drive ball (stamped 21) ....
62-75	All w/Axial Cmpr. ....	6556215 A.R.		1.90	SEAT, piston drive ball (stamped 21.5) ....
63-75	All w/Axial Cmpr. ....	6556220 A.R.		1.90	SEAT, piston drive ball (stamped 22) ....
62-75	All w/Axial Cmpr. ....	6555440	2	2.80	SLEEVE, manifold discharge crossover tube
67	Pass., Camaro w/C.A.C. ....	1998874	1	2.48	SWITCH ASSY., a/c compressor ....
72-75	All w/Axial Cmpr. (exc. V8) ....	6599306	1	10.25	SWITCH UNIT, super heat ....
71-73	Vega w/Axial Cmpr. ....	6272089	1	5.15	SWITCH ASSY., a/c comp. cut-off, pressure (Note 1) ....
<i>NOTE 1: Part includes "O" ring gasket.</i>					
71	Vega w/axial cmpr. ....	6272140	1	4.05	SWITCH UNIT, a/c discharge pressure conv. ....
75	All V8 w/Axial Cmpr. ....	9956790	1	10.05	SWITCH KIT, super heat ....
62-75	All w/Axial Cmpr. ....	6555298	1	.89	TUBE, oil pump suction ....
62-75	All w/Axial Cmpr. ....	6590592	1	10.30	TUBE UNIT, manifold discharge crossover (Note 3) ....
<i>NOTE 3: Consists of 1 each Tube Assy. and Bushing.</i>					
62-75	All w/Axial Cmpr. ....	6555279	2	6.00	VALVE, suction ....
62-75	All w/Axial Cmpr. ....	5914706	1	10.95	VALVE PLATE, front discharge w/valves ....
62-75	All w/Axial Cmpr. ....	5914709	1	10.95	VALVE PLATE, rear discharge w/valves ...
75	All w/Radial Cmpr. ....	6551141	1	7.00	VALVE PLATE, rear discharge w/valves ...

**9.173 BOLT— WASHER, Air Conditioning Compressor Mounting Attaching Parts**

64	Chevelle w/Air Cond. (8 cyl.) ...	3887348	1	.16	comp. to support (3/8"— 16 x 9/4") ....
68	Pass. w/C.A.C. (396) ....	3921953	2	.31	rear lower bracket support to manifold ....
65-70	Pass. ....	3754153	1	.21	WASHER, bracket support— (5.383) ....

**9.174 HEAD, Air Conditioning Compressor (External)**

62-75	All w/Axial Cmpr. ....	6555283	1	23.85	front ....
62-75	All w/Axial Cmpr. ....	6598439	1	27.20	w/switch, rear ....
75	All w/Radial Cmpr. ....	6551142	1	20.85	front ....

**9.175 SEAL— RETAINER— RING, Air Conditioning Compressor Shaft**

69-75	All w/Axial Cmpr. ....	6556077	1	.25	sleeve ....
62-75	All w/Axial Cmpr. ....	6599114	1	10.35	SEAL UNIT (ceramic seal seat) ....
69-75	All w/Axial Cmpr. ....	6556076	1	.20	RETAINER, seal ....
62-75	All w/Axial Cmpr. ....	6555330	1	1.25	RING, coil housing retaining ....
62-75	All w/Axial Cmpr. ....	6555328	1	.95	RING, drive shaft drive hub retaining ....
62-75	All w/Axial Cmpr. ....	6555292	1	1.35	RING, drive shaft seal ....

**9.177 CAP— CORE— GASKET— SCREW, Air Conditioning Compressor Oil Test**

62-67	Chevy, Chevelle,				
65-68	Pass., Camaro,				
69	Chevy, Chevelle, Camaro,				
69	Pass. w/Acc. Air Cond. (8 cyl.) (exc. 427),				
70	Nova w/C.A.C.,				
70	Pass., Chevelle w/Acc. Air Cond. (396, 400, 454),				
71-72	Vega w/Axial Cmpr. ....	3792359	2	.79	compressor fitting valve ....
75	All (exc. Vega, Monza) ....	3141348	1	.56	CORE, test valve ....
62-75	All w/Axial Cmpr. ....	5858696	1	.46	GASKET, on oil fitting ....
62-75	All ....	5858694	1	.77	SCREW, oil drain hole (5/8"— 24 x 21/32") ...

**9.178 VALVE ASSY.— GASKET— PIN, Air Conditioning Compressor Pressure Relief**

62-75	All w/Axial Cmpr. ....	5914435	1	8.05	(440 lbs.) ....
62-70	All ....	640044	1	.36	GASKET ....
73-74	All ....	3143468	1	.36	GASKET, pressure relief valve ....
62-64	All ....	274795	1	.04	PIN, head locator— (8.939) ....
62-75	All w/Axial Cmpr. ....	6590686	1	.87	PIN, cylinder locator ....

**9.180 PULLEY— RIM— SCREW— WASHER, Air Conditioning Compressor Drive**

62-70	All,				
-------	------	--	--	--	--

**BODY MTG.— AIR COND.— INSTRUMENTS**

**9.180 PULLEY— RIM— SCREW— WASHER, Air Conditioning Compressor Drive (Con't)**

73-74	Camaro (Z-28) .....	5914745	1	60.70	w/bearing use w/5910717, 0706, 0741 ...
68-69	Pass. w/T.H. 396),				
69	Chevy, Chevelle, Camaro,				
70-72	All,				
73-75	All (8 cyl.) (exc. Z-28 Camaro) ..	6550750	1	60.80	w/bearing use w/5910737, 0738, 0740 ...
71-75	Vega, Monza w/Axial Cmpr. ....	6551023	1	53.00	w/bearing .....
75	All w/Radial Cmpr. ....	6556715	1	8.80	RIM, pulley .....
75	All w/Radial Cmpr. ....	6556658	6	.26	SCREW, pulley rim mtg. ....
75	All w/Radial Cmpr. ....	6556660	6	.26	WASHER, pulley rim mtg. screw .....

**9.181 BEARING ASSY.— NUT— RING— SPACER, Air Conditioning Compressor Pulley**

62-72	All,				
71-72	Vega w/Axial Cmpr.,				
73	All w/Axial Cmpr. (exc. Vega),				
75	All w/Axial Cmpr. ....	907257	1	20.04	pulley .....
73-74	Vega w/Axial Cmpr.,				
74	All (exc. Vega) .....	908126	1	33.16	
62-75	All w/Axial Cmpr. ....	6555385	1	.70	NUT, drive shaft .....
62-75	All w/Axial Cmpr. (exc. Vega, Monza) .....	6590589	1	3.19	NUT KIT, drive shaft and head— (9.170) ...
62-75	All w/Axial Cmpr. ....	6555329	1	1.35	RING, pulley bearing to hd. ret. ....
62-75	All w/Axial Cmpr. ....	6555338	1	.29	RING, bearing to pulley hub retaining .....
62-75	All w/Axial Cmpr. ....	6555384	1	1.25	SPACER, drive shaft nut to hub .....

**9.186 COIL— CLUTCH DRIVE ASSY., Air Conditioning Compressor Clutch Actuating**

62-75	All w/Axial Cmpr. ....	6550835	1	32.20	w/housing .....
75	All w/Radial Cmpr. ....	6551217	1	24.15	w/housing .....
75	All w/Radial Cmpr. ....	6551220	1	17.50	CLUTCH DRIVE ASSY., cmpr. ....

**9.188 PLATE— KEY, Air Conditioning Compressor Clutch Actuating**

62-75	All w/Axial Cmpr. ....	5914719	1	19.85	w/hub (Note 1) .....
62-75	All w/Axial Cmpr. ....	6555320	1	.97	KEY, drive hub to drive shaft .....

**9.190 CONDENSER— CONDENSER REPAIR UNIT— BAFFLE— BRACKET— BUMPER— CLAMP— CLIP— FITTING— INSULATOR ASSY.— NUT— PLATE— RETAINER— SEAL— SHIELD, Air Conditioning Refrigerant**

62-66	Chevy .....	3857132	1	104.90	refrigerant .....
64-66	Chevelle .....	3859770	1	96.40	refrigerant .....
65-66	Pass. ....	3856228	1	97.10	refrigerant .....
67	Pass., Chevelle,				
67-68	Chevelle w/Acc. Air Cond.,				
67-68	Camaro,				
68	Chevy,				
68	Pass. w/Acc. Air Cond. ....	3899793	1	94.85	refrigerant .....
67	Chevy .....	3895999	1	78.00	refrigerant .....
68	Chevelle .....	3919596	1	103.75	refrigerant .....
68	Camaro (6 cyl.),				
68	Camaro (396) (exc. Sp. H/Per.) .	3925731	1	93.30	refrigerant .....
68	Pass. ....	3919577	1	106.15	refrigerant .....
69	Pass. ....	3997404	1	106.85	refrigerant .....
69	Chevelle .....	3937140	1	96.80	refrigerant .....
69	Camaro .....	3937170	1	90.35	refrigerant .....
69	Chevy .....	3937190	1	96.80	refrigerant .....
69-70	All w/Acc. Air Cond. ....	3940259	1	94.85	refrigerant .....
70	Pass. ....	3967935	1	116.00	refrigerant .....
70-72	Chevelle .....	3967948	1	116.20	refrigerant .....
70-74	Nova (350) .....	3973752	1	98.75	refrigerant .....
70-71	Camaro (1st design) .....	3967920	1	119.30	refrigerant (top tube snap coupling fitting) .
71-72	Camaro (2nd design),				
73	Camaro .....	3992158	1	125.95	refrigerant (top tube hex. nut fitting) .....
71-72	Pass. ....	3024548	1	147.25	refrigerant .....
71	Vega (1st design) .....	3979755	1	110.00	a/c (Note 1) .....
	<i>NOTE 1: Compressor fitting at condenser joined horizontal to radiator. Use fitting assy. 3984676 in Group 9.226.</i>				
71-73	Vega (2nd design) .....	3992163	1	115.75	a/c (Note 2) .....
	<i>NOTE 2: Compressor fitting at condenser joined at 45 degree angle. Use with fitting assy. 3992162 in Group 9.226.</i>				
73	Pass., Chevelle .....	3027198	1	147.25	
74-75	Vega .....	340495	1	113.55	
74-75	Pass. ....	3029535	1	145.40	
74-75	Chevelle .....	3030455	1	136.55	
74	Camaro .....	3029589	1	123.55	

**BODY MTG.— AIR COND.— INSTRUMENTS**

**9.190 CONDENSER— CONDENSER REPAIR UNIT— BAFFLE— BRACKET— BUMPER— CLAMP— CLIP— FITTING— INSULATOR ASSY.— NUT— PLATE— RETAINER— SEAL— SHIELD, Air Conditioning Refrigerant (Con't)**

74	Nova (6 cyl.)	3028607	1	100.15	
75	Nova	3031046	1	112.30	
75	Camaro	3031783	1	116.75	
75	Monza (Hatchback)	3031558	1	122.15	
69	Pass. Auto. Temp. Control	3997508	1	15.80	CONDENSER REPAIR UNIT, A/C
73	Pass., Chevelle	358282	1	13.00	CONDENSER REPAIR UNIT (Note 1)
<i>NOTE 1: Consist of -2 fittings, 1 hose, 1 nut, 1 clip and instr. sheet.</i>					
69-72	Chevy	3940212	1	8.25	BAFFLE, condenser air lower
73-74	Nova	413489	1	8.75	BAFFLE, condenser air lower
69	Chevelle	3937142	R.H.	.79	BRACKET, condenser
69-73	Chevy	3937191	L.H.	.46	BRACKET, condenser lower
69-74	Chevy	3937192	R.H.	.46	BRACKET, condenser lower
69-74	Chevy	3937193	2	.22	BRACKET, condenser upper
70	Pass.	3967933	L.H.	1.20	BRACKET, A.C. condenser, left
70	Pass.	3967934	R.H.	1.75	BRACKET, A.C. condenser, right
70-72	Chevelle	3967949	L.H.	.46	BRACKET, A.C. condenser, lower, left
70-72	Chevelle	3967950	R.H.	.46	BRACKET, A.C. condenser, lower, right
70-72	Chevelle	3967951	2	.46	BRACKET, A.C. condenser, upper
71-72	Pass.	3984619	L.H.	.32	BRACKET, left, A/C cond., upper
71-72	Pass.	3984620	R.H.	.32	BRACKET, right, A/C cond., upper
71-74	Vega	328226	R.H.	.48	BRACKET, a/c condenser
71-74	Vega	3984685	L.H.	.50	BRACKET, a/c condenser
73	Camaro	3967975	1	.28	BRACKET, a/c condenser
73-74	Pass., Chevelle,				
75	Pass.	3996257	2	.38	BRACKET, a/c condenser upper
74	Nova	340414	L.H.	.11	BRACKET, a/c condenser, lower
75	Nova	346117	L.H.	.11	BRACKET, a/c condenser
71-72	Pass.	3984621	2	.53	BRACKET ASSY., A/C cond. lower
70-72	Chevelle,				
73-75	Pass., Chevelle,				
74-75	Camaro	3973777	4	.28	BUMPER, condenser
70-73	Camaro	3841098	2	.11	BUMPER, condenser upper mounting
70-73	Camaro	3973757	2	.28	BUMPER, condenser lower mounting
70-73	Camaro	3979777	1	.93	CLAMP, A/C condenser inlet tube
71-73	Pass.,				
75	Monza (exc. Towne Cpe.)	3023832	1	.05	CLIP, cond. to dryer line
70-73	Nova	3879573	4	.11	CLIP, condsr. air lower baffle to bumper— (8.154)
70-72	Chevelle	3984628	1	.11	CLIP, condenser crossover pipe
73	Pass., Chevelle	358280	1		FITTING, male (45° flare) part of condenser repair unit 358282
70-75	All (exc. Nova)	331959	4	1.05	INSULATOR ASSY., condenser
67-68	All w/Acc. Air Cond.	3844999	A.R.	.21	NUT (U shape 1/4" — 20) — (1.303)
70-75	Camaro	3973790	10	.10	RETAINER, condenser air upper seal
69-74	Nova	3942626	2	.66	SEAL, condenser to rad. support
71-75	Vega, Monza w/C.A.C. (exc. Auto. Temp. Control)	6262658	1	1.20	SEAL, a/c condenser rad. sup. lower
69	Camaro (396)	3949856	1	12.75	SHIELD, condenser air

**9.195 RECEIVER ASSY.— DEHYDRATOR ASSY.— DESICCANT— HOUSING— INLET ASSY.— RING— SCREEN— SCREW— SHELL— TUBE, Air Conditioning Refrigerant (with Dehydrator)**

62-63	Chevy	3153090	1	30.25	refrigerant
64-67	All	3155342	1	30.25	refrigerant
68-73	All,				
74	Nova (6 cyl.),				
71-72	Vega	3012944	1	27.95	refrigerant
74-75	All w/V.I.R. (1st design) (exc. Monza)	6598830	1	73.90	w/valves (V.I.R.) (Note 2)
75	Monza (exc. Towne Cpe.)	9956810	1	80.11	(V.I.R.)
75	All w/V.I.R. (2nd design) (exc. Monza)	9956651	1	75.40	w/valves (V.I.R.) (Note 2)
73-75	Vega (4 cyl.)	3028128	1	52.25	DEHYDRATOR ASSY., accumulator
74-75	All w/V.I.R.	6598832	1	8.85	DESICCANT, a/c drier kit
74-75	All w/V.I.R. (1st design)	6599446	1	28.30	HOUSING, a/c V.I.R. valve kit (Note 1, 2)
<i>NOTE 1: Consist of Valve Housing, Sight Glass Assy., Seal Ring Kit and Internal Retaining Ring.</i>					
75	All w/V.I.R. (2nd design)	9956653	1	29.20	HOUSING, (V.I.R.) valve kit (Note 2)
74-75	All w/V.I.R.	6599443	1	11.90	INLET ASSY., comp.
75	Monza (exc. Towne Cpe.)	9956748	1	14.81	INLET ASSY., shell
74-75	All w/V.I.R.	6556489	1	.33	RING, a/c ret. P/U tube
74-75	All w/V.I.R.	6599455	1	1.12	SCREEN, a/c filter P/U tube



**BODY MTG.— AIR COND.— INSTRUMENTS**

**9.195 RECEIVER ASSY.— DEHYDRATOR ASSY.— DESICCANT— HOUSING—  
INLET ASSY.— RING— SCREEN— SCREW— SHELL— TUBE, Air  
Conditioning Refrigerant (with Dehydrator) (Con't)**

74-75	All w/V.I.R. ....	6556487	10	.24	SCREW, c inlet conn. shell assy. and recr. shell mounting .....
74-75	All w/V.I.R. ....	6598833	1	8.50	SHELL, a/c recr. kit (Note 1) .....
	<i>NOTE 1: When using in place of 6599448 it will be necessary to buy pick-up tube 6598831 and replace desiccant bag with 6598832.</i>				
74-75	All w/V.I.R. ....	6598831	1	9.45	TUBE, a/c pick-up kit .....
	<i>NOTE 2: 2nd design distinguished by Gold housing and Red label or 1/4" high letter "E" on housing.</i>				

**9.196 TUBE— BRACKET— CLAMP— CLIP— GROMMET— SEAL RING— SLEEVE,  
Air Conditioning Refrigerant**

*NOTE If specific (Tube or Tube Assy.) usage can not be found, use applicable fittings from group 9.222 and cut hose from group 9.220 to desired length.*

64-68	Chevelle,				
66-67	Chevy,				
67-68	Pass. ....	3840352	1	1.50	receiver and dehydrator .....
	<i>NOTE 1 On pass. models this tube used on A/C conversion unit 986949.</i>				
62-66	Chevy,				
68	Pass. ....	3792317	1	2.30	receiver and dehydrator outlet .....
64-66	Chevy .....	3840341	1	.34	BRACKET, receiver mounting .....
64-69	Chevelle,				
67-68	Pass.,				
68-72	Chevy,				
71-72	Vega,				
73	Nova, Camaro,				
74	Nova (6 cyl.) .....	3849849	1	.36	BRACKET, receiver and dehydrator .....
68	Camaro (w/R.S.) (6 cyl.),				
68	Camaro (w/C.A.C., R.S.) (396) (exc. Sp. H/Per.),				
69	Camaro,				
71-72	Vega .....	3925733	1	.34	BRACKET, receiver and dehydrator lower ..
68	Chevy, Chevelle,				
68	Pass. w/Acc. Air Cond.,				
69-74	Nova .....	3917321	1	.46	BRACKET, receiver and dehydrator (upper) .
69-72	Pass. ....	3984667	2	.27	BRACKET, receiver dehydrator .....
66	Pass.,				
67	Camaro,				
68	All,				
69-70	Camaro,				
70	Nova,				
71-72	Vega .....	3859062	1	.11	CLAMP, refrig. control valve outlet tube bracket .....
70	Chevelle .....	3967945	1	.16	CLAMP, control valve tube to comp. fitting and muffler .....
70	Camaro .....	3973725	1	.33	CLAMP, cont. valve outlet tube .....
73	Pass., Chevelle .....	328236	1	.34	CLAMP, receiver dehydrator .....
75	Monza .....	354814	1	.48	CLAMP, a/c revr. and valve .....
69-70	Pass.,				
70-72	Chevelle .....	3949918	1	.11	CLIP, receiver and dehydrator to expansion valve hose and tube .....
72-73	Nova, Pass. ....	328238	1	.16	CLIP, a/c condenser outlet tube assy. ....
72	All .....	3754940	1	.12	CLIP, a/c refrig. vac. chk. vlv.— (3.162) ....
73-75	Chevelle, Pass., Camaro .....	328281	1	.11	CLIP, receiver and dehydrator to expansion valve hose and tube .....
73-75	Nova .....	6273386	1	.16	CLIP, condenser outlet tube .....
69	Pass. ....	3949970	1	.17	GROMMET, receiver and dehydrator to expansion valve hose tube .....
70-73	Camaro .....	3967926	1	.16	GROMMET, condenser inlet tube .....
71-73	Pass. ....	3984635	1	.17	GROMMET, a/c rcvr. & dehydr. to exp. vlv. hose & tube .....
75	Vega, Monza .....	3979756	1	.28	GROMMET, a/c condenser tube .....
74-75	All w/V.I.R. ....	6556526	1	.56	SEAL RING, a/c inlet conn. shell assy. to valve housing .....
74-75	All w/V.I.R. ....	6556524	1	.56	SEAL RING, a/c P.O.A. valve .....
74-75	All w/V.I.R. ....	6555088	2	.56	SEAL RING, a/c P/U tube and cond. line conn. ....
74-75	All w/V.I.R. ....	6556525	1	.56	SEAL RING, a/c valve housing to recr. shell
74-75	All w/V.I.R. ....	6556712	1	.55	SEAL RING, valve housing to recr. shell (radius) .....
74-75	All w/V.I.R. ....	6599447	1	6.33	SEAL RING KIT, a/c V.I.R. (Note 1) .....
	<i>NOTE 1: Consists of the following Seal Rings. (2) 6555088, (1) 655533, (3) 6556521, (2) 6556523, (1) 6556524-25-26-27, (1) 9948028.</i>				

**BODY MTG.— AIR COND.— INSTRUMENTS**

**9.198 VALVE ASSY.— BAFFLE— CAP— CONNECTOR— CORE— COVER— CUP— DIAPHRAGM— NUT— PISTON— SEAL— SPRING— TEE, Air Conditioning Evaporator By-Pass**

64-65	Chevelle	5910498	1	45.50	freon control (throttling suction valve)
65	Pass.	5910527	1	45.50	freon control (throttling suction valve)
66-70	Chevelle,				
67	Camaro,				
69	Camaro,				
70	Nova,				
71-73	Nova, Chevelle,				
74	Nova (6 cyl.)	5910593	1	39.45	a/c refrig. cont.
66-70	Pass.,				
70-71	Camaro,				
72-73	Pass., Camaro,				
71-72	Vega	5910594	1	39.45	A/C refrigerant control
74-75	All w/V.I.R.	6599444	1	20.00	a/c refrigerant control
74-75	All w/V.I.R.	6556559	1	.30	BAFFLE, P.O.A. valve
65-66	Pass. w/C.A.C.,				
69-75	All	5911737	1	.94	CAP, freon control valve
65-66	Pass., Chevelle,				
69	All,				
75	Monza (exc. Towne Cpe.)	6551178	1	.65	CORE, liquid bleed valve
64-66	Pass., Chevelle	6555595	1	1.05	CUP, freon cont. valve spring ret. (yellow)
64-66	Pass., Chevelle	5914931	1	9.35	DIAPHRAGM, freon control valve vacuum
64-66	Pass., Chevelle	6550597	1	10.55	PISTON, throttling valve
65-66	Pass.,				
75	Monza (exc. Towne Cpe.)	6555533	1	.47	SEAL, "O" ring, evaporator gauge connector
65-66	Impala (S.S.) (6 cyl.)	3926844	1	.34	TEE, engine vacuum gauge hose— (2.760)
72-75	Pass.	3992117	1	.40	TEE, a/c vac. hose
	Not required in this group. See group 1.745, 3.278, 3.820,				
	4.931	3794176		3.70	TEE

**9.199 BRACKET— CLAMP, By-Pass Mounting**

67-70	Pass.,				
67-70	Camaro (exc. 396),				
68-70	Chevy,				
68-69	Chevelle,				
71-72	Vega,				
72-73	All (exc. Pass.),				
74	Nova (6 cyl.)	3902244	1	.31	refrig. cont. valve
71-73	Camaro	3021783	1	2.25	valve mounting
71-72	Chevelle	3967945	1	.16	CLAMP, control valve to compressor fitting
71-74	Camaro,				
73-74	Chevelle	3973725	1	.33	CLAMP, control valve outlet tube
71-73	Nova, Camaro	3859062	1	.11	CLAMP, control valve outlet tube bracket
73	Pass., Nova, Chevelle	3017087	1	.27	CLAMP, P.O.A. valve
74-75	All w/V.I.R.	3030942	1	.50	CLAMP, P.O.A. valve

**9.202 SIGHT GLASS KIT— SEAL RING, Air Conditioning Freon Inspection**

62-72	All	3149478	1	2.75	repair kit (Note 1)
	<i>NOTE 1 Consists of sight glass, retainer, "O" ring, washer and instructions.</i>				
74-75	All w/V.I.R.	6599451	1	2.83	(Note 1)
	<i>NOTE 1: Consists of the following (1) sight glass-6556480, (1) washer-6556481, (1) retainer-6556507, (1) seal ring-6556527.</i>				
74-75	All w/V.I.R.	6556527		.56	SEAL RING, sight glass to housing

**9.208 TUBE, Air Conditioning Evaporator Air Inlet**

68	Chevy	3023655	1	4.67	receiver dehydrator inlet
----	-------	---------	---	------	---------------------------

**9.210 CORE ASSY., Air Conditioning Evaporator**

64-65	Chevelle	3000785	1	126.80	evaporator w/pipe
65	Pass.	3005020	1	126.90	evaporator
66	Chevelle (1st design)	3006074	1	121.15	evaporator (Note 1)
	<i>NOTE 1 Used when evaporator is mounted on fire wall.</i>				
66	Chevelle (2nd design)	3002716	1	126.80	evaporator (Note 2)
	<i>NOTE 2 Used when evaporator is mounted under fender.</i>				
66-67	Pass.	3006025	1	126.80	evaporator
67	Camaro,				
68	Chevy	3012117	1	128.60	evaporator A/C evap.
67	Chevelle	3013254	1	122.20	evaporator A/C evap.
68-69	Chevy, Camaro (exc. 396),				
70	Camaro,				
70-73	Nova,	3015635	1	127.50	evaporator w/fittings
68-69	Camaro (396)	3013663	1	113.95	evaporator
68	Chevelle	3015641	1	122.20	evaporator w/fittings

**BODY MTG.— AIR COND.— INSTRUMENTS**

**9.210 CORE ASSY., Air Conditioning Evaporator (Con't)**

68-69	All w/Acc. Air Cond. . . . .	3015267	1	122.20	evaporator w/pipes . . . . .
68	Pass. Auto. Temp. Cont.,				
69-70	Pass. . . . .	3016980	1	119.30	evaporator w/fittings . . . . .
69-72	Chevelle . . . . .	3016987	1	122.20	evaporator w/fittings . . . . .
70-73	Camaro w/A.T. (exc. NB-2) . . . . .	3021534	1	164.00	evaporator A/C service . . . . .
71-73	Pass. . . . .	3027185	1	175.95	evaporator w/fittings . . . . .
71-72	Vega . . . . .	3022875	1	144.55	
73	Chevelle . . . . .	3024627	1	127.80	w/fitting . . . . .
73-75	Vega (4 cyl.) . . . . .	3028131	1	144.55	
74-75	Camaro . . . . .	3029586	1	168.15	w/fitting . . . . .
74-75	Pass. . . . .	3029630	1	175.95	w/fitting . . . . .
74-75	Chevelle . . . . .	3027593	1	127.80	w/fittings . . . . .
74	Nova (8 cyl.) . . . . .	3029687	1	127.50	w/fitting . . . . .
74	Nova (6 cyl.) . . . . .	3029465			w/fittings . . . . .
75	Nova . . . . .	3030924	1	166.20	w/fittings . . . . .
75	Monza (exc. Towne Cpe.) . . . . .	3031662	1	165.45	evaporator . . . . .

**9.211 CASE— BACK PLATE— BEZEL— BRACKET— CLAMP— COVER— DEFLECTOR— GASKET— GROMMET— HOSE— NUT— PLATE— SEAL— SEAT— SCREEN— SHAFT ASSY.— SPACER— SPRING— TUBE— VALVE ASSY.— WASHER, Air Conditioning Evaporator Core Housing**

66-67	Chevelle w/C.A.C. (2nd design) . . . . .	3007456	1	12.75	evap. inlet (Note 4) . . . . .
	<i>NOTE 4 Used when evaporator is mounted under fender.</i>				
66-68	Pass. w/Auto. Temp. Cont. . . . .	3007301	1	11.20	evap. outlet . . . . .
67-70	All w/Acc. Air Cond. . . . .	3012080	1	7.20	evap. lower . . . . .
67-68	Camaro,				
68	Chevy . . . . .	3012265	1	28.50	inlet baffle and bracket assy. . . . .
67-68	Camaro (exc. 396),				
68	Chevy . . . . .	3010078	1	10.70	evap. outlet . . . . .
68-69	Chevelle . . . . .	3016395	1	7.45	evap. outlet . . . . .
68-72	Chevelle . . . . .	3020119	1	27.00	inlet w/bracket . . . . .
68	Camaro w/396 . . . . .	3016551	1	24.85	inlet w/baffle . . . . .
68	Chevy, Camaro (exc. 396),				
69	Camaro (exc. 396),				
70-73	Nova . . . . .	3015520	1	24.85	inlet . . . . .
68-70	Pass. . . . .	3018044	1	28.50	inlet w/baffle . . . . .
69-70	Pass. . . . .	3018041	1	7.10	outlet . . . . .
69	Camaro (exc. 396),				
69-73	Nova . . . . .	3018791	1	11.50	outlet . . . . .
69-72	Chevelle . . . . .	3018795	1	14.95	outlet . . . . .
70	Pass. w/Acc. Air Cond. . . . .	3021857	1	7.95	upper . . . . .
71-72	Pass. . . . .	3023165	1	30.75	inlet w/bracket . . . . .
71-72	Pass. . . . .	3022673	1	22.95	evaporator outlet . . . . .
71-72	Vega . . . . .	3028455	1	23.45	a/c lower inlet, w/brackets . . . . .
71-72	Vega . . . . .	3028454	1	20.45	a/c evap. outlet . . . . .
73	Chevelle . . . . .	3024641	1	38.75	inlet w/bracket . . . . .
73	Pass. w/C.A.C. . . . .	3025918	1	30.75	inlet w/bracket . . . . .
73	Chevelle . . . . .	3024636	1	35.25	evaporator outlet . . . . .
73	Pass. w/C.A.C. . . . .	3024686	1	22.95	evaporator outlet . . . . .
73-74	Vega . . . . .	3028118	1	20.45	a/c evap. outlet . . . . .
73-75	Vega . . . . .	3028133	1	36.25	a/c lower inlet w/brackets . . . . .
74-75	Chevelle . . . . .	3027597	1	29.25	evaporator outlet . . . . .
74-75	Camaro . . . . .	3029574	1	11.95	evaporator outlet . . . . .
74-75	Pass. . . . .	3022673	1	22.95	evaporator outlet . . . . .
75	Nova . . . . .	3030681	1	14.40	evap. outlet . . . . .
75	Vega, Monza (4 cyl.) . . . . .	3031460	1	20.45	a/c evap. outlet . . . . .
75	Vega, Monza . . . . .	3034841	1	22.10	inlet and blower . . . . .
75	Monza (exc. Towne Cpe.) . . . . .	3031709	1	36.75	w/fitting, distr. . . . .
75	Monza (exc. Towne Cpe.) . . . . .	3031583	1	6.50	evap. lower . . . . .
75	Monza (Towne Cpe.) . . . . .	3033617	1	36.25	w/fitting, distr. . . . .
75	Monza (exc. Towne Cpe.) . . . . .	3031584	1	9.10	evap. upper . . . . .
66-67	Pass. . . . .	3014784	1	28.00	CASE ASSY., inlet baffle and bracket assy. . . . .
70-72	Camaro . . . . .	3025609	1	52.75	CASE ASSY., outlet . . . . .
70-72	Camaro . . . . .	3020546	1	28.00	CASE ASSY., w/baffle inlet . . . . .
72	Nova . . . . .	3025606	1	7.90	CASE ASSY., outlet A/C . . . . .
73-74	Nova w/C.A.C. (8 cyl.) . . . . .	3025606	1	7.90	CASE ASSY., outlet . . . . .
73	Camaro w/A.T. (exc. NB-2) . . . . .	3025609	1	52.75	CASE ASSY., outlet . . . . .
73	Camaro w/A.T. (exc. NB-2) . . . . .	3020546	1	28.00	CASE ASSY., w/baffle inlet . . . . .
74-75	Chevelle . . . . .	3027598	1	32.00	CASE ASSY., inlet w/bracket . . . . .
74-75	Camaro . . . . .	3029571	1	28.00	CASE ASSY., w/backplate, inlet . . . . .
74-75	Pass. . . . .	3029620	1	28.00	CASE ASSY., w/backplate, inlet . . . . .
74	Nova w/C.A.C. (8 cyl.) . . . . .	3029682	1	24.85	CASE ASSY., inlet w/bracket . . . . .
74	Nova w/C.A.C. (6 cyl.) . . . . .	3016551	1	24.85	CASE ASSY., inlet w/baffle . . . . .
74	Nova w/C.A.C. (6 cyl.) . . . . .	3030355	1		CASE ASSY., outlet w/brkt. . . . .
75	Nova . . . . .	3030913	1	19.00	CASE ASSY., evap. inlet . . . . .

**BODY MTG.— AIR COND.— INSTRUMENTS**

**9.211 CASE— BACK PLATE— BEZEL— BRACKET— CLAMP— COVER— DEFLECTOR— GASKET— GROMMET— HOSE— NUT— PLATE— SEAL— SEAT— SCREEN— SHAFT ASSY.— SPACER— SPRING— TUBE— VALVE ASSY.— WASHER, Air Conditioning Evaporator Core Housing (Con't)**

71-72	Vega	3022838	1	4.15	BACK PLATE, a/c
75	Monza (exc. Towne Cpe.)	3031708	1	5.35	BACKPLATE, w/stud, mtg.
67-70	All w/Acc. Air Cond.	3012073	1	.74	BRACKET, evap. pipe support
68-69	All w/Acc. Air Cond.	3012085	1	1.30	BRACKET, motor mtg.
70-71	Camaro	3021783	1	2.25	BRACKET, valve mtg.
71-73	Vega	3021513	1	1.25	BRACKET, a/c vacuum element mtg.
73	Camaro w/A.T. (exc. NB-2)	3021513	1	1.25	BRACKET, vac. element mtg.
73-75	Camaro	3973783	1	.11	BRACKET, car heater and a/c air selector duct assy.
75	Monza (exc. Towne Cpe.)	3031559	1	1.65	BRACKET, cable adj.
75	Monza (Towne Cpe.)	3033618	1	1.65	BRACKET, cable adj.
62-68	All w/Custom	8530980	1	.12	CLAMP, outlet tube mtg.
65-69	Pass.,				
66-67	Chevelle,				
67-68	Camaro,				
68-69	Chevy,				
69	Camaro (exc. 396)	2471945	1	.73	CLAMP, drain hose (1 <sup>1</sup> / <sub>4</sub> " dia.)
67	Camaro, Chevelle,				
65-68	Pass., Auto. Temp. Cont.,				
68	All,				
69	Pass. (exc. Chevy),				
70	All (exc. Camaro),				
71	All (exc. Pass., Vega),				
72	Chevelle, Camaro,				
73	Chevelle, Nova,				
73	Camaro w/A.T. (exc. NB-2),				
74	Nova w/C.A.C. (6 cyl.),				
73-74	Vega	3017085	1	.13	CLAMP, evap. core outlet tube supt. (black)
68-69	All w/Acc. Air Cond.	3012083	1	.66	CLAMP, motor
75	Monza (exc. Towne Cpe.)	356121	1	.34	DEFLECTOR, evap. drain
69	All w/Acc. Air Cond.,				
62-75	All	8526398	A.R.	.25	GASKET, "O" ring (5 <sup>1</sup> / <sub>16</sub> " I.D.)
64-67	Pass., Chevelle, Camaro				GASKET, "O" ring (compressor fitting end), control valve outlet tube
71-75	All	6556521	A.R.	.56	
65	Pass., Chevelle,				
67-69	All w/Acc. Air Cond.,				
70	All w/Acc. Air Cond. (exc. Camaro)	3140748	2	.38	GASKET, control valve outlet tube to comp.
71-75	Vega	3973787	1	.25	GASKET, a/c air outlet
73-75	Pass.	3022854	1	3.35	GASKET, mounting
75	Monza (Hatchback)	3031870	1	.81	GASKET, mounting
75	Monza (exc. Towne Cpe.)	3031870	1	.81	GASKET, mounting
75	Monza (exc. Towne Cpe.)	3145607	1	.21	GASKET, evap. core
75	Monza (exc. Towne Cpe.)	356120	1	.27	GROMMET, evap. drain
75	Monza (exc. Towne Cpe.)	3142670	1	.16	GROMMET, evap. inlet pipe
62-69	All	3986028	A.R.	RL/.24	HOSE, drain (7 <sup>1</sup> / <sub>16</sub> " I.D.) (10 ft. roll)— (8.962)
71-72	Vega	3016305	1	.33	HOSE, a/c evap. drain
65-70	Pass.,				
65-66	Chevelle,				
68	Camaro,				
68-69	Chevy, Chevelle,				
65-69	Pass.	1365065	2	.11	NUT, evap. rear left bracket— (7.238)
72-75	Pass.	3022732	1	.05	NUT, htr. and def.
73-74	Chevelle	3024904	1	4.60	PLATE, front a/c heater case
75	Monza (exc. Towne Cpe.)	3031602	1	2.40	PLATE, front
75	Monza (exc. Towne Cpe.)	3031591	1	1.05	PLATE, core retainer
62-66	All,				
62-72	All	5887997	2	.22	SEAL (5 <sup>1</sup> / <sub>16</sub> " x 9 <sup>9</sup> / <sub>16</sub> " thk.)
69	All w/Acc. Air Cond.,				
73	Camaro w/A.T. (exc. NB-2)	3018180	A.R.	.28	SEAL, evap. core bottom
65-68	Pass., w/Auto. Temp. Control,				
67-69	Camaro,				
68-74	Nova,				
69-70	Pass.	3002090	1	.97	SEAL, evap. core
64-73	Chevelle	3003215	1	.16	SEAL, evap. inlet pipe
67-68	All w/Acc. Air Cond.	3012078	2	.05	SEAL, evap. core bottom
67-69	Camaro,				
68-73	Chevy	3889484	1	.74	SEAL, core tube and heater— (8.854)
67-69	All w/Acc. Air Cond.	3012075	1	.16	SEAL, evap. core pipe
67-69	All w/Acc. Air Cond.	3919753	2	.59	SEAL, evap. core lower, upper
68-75	Chevelle,				
70-75	Camaro	3014159	1	1.95	SEAL, evap. core

**BODY MTG.— AIR COND.— INSTRUMENTS**

**9.211 CASE— BACK PLATE— BEZEL— BRACKET— CLAMP— COVER— DEFLECTOR— GASKET— GROMMET— HOSE— NUT— PLATE— SEAL— SEAT— SCREEN— SHAFT ASSY.— SPACER— SPRING— TUBE— VALVE ASSY.— WASHER, Air Conditioning Evaporator Core Housing (Con't)**

68-69	Camaro (8 cyl.),					
74	Nova (cyl.)	3015525	1	.16	SEAL, evap. to dash	
68-72	Chevelle, Camaro,					
74-75	Pass.	3015129	2	.11	SEAL, evap. case (12")	
70-73	Camaro	3973717	1	.29	SEAL, heater core pipe	
71-74	Vega	3022917	1	.12	SEAL, a/c evap. core outlet pipe	
71-73	Vega	3984663	1	.64	SEAL, heater core pipe	
71-75	Vega	3021029	1	.24	SEAL, a/c inlet pipe	
71-72	Vega	3022840	1	.12	SEAL, a/c evap. case	
71-72	Vega	3022841	1	.97	SEAL, a/c evap. core	
73	Nova w/C.A.C.,					
73	Camaro w/A.T. (exc. NB-2)	3008845	A.R.		SEAL, evap. core	
73	Chevelle	3024925	1	.23	SEAL, core pipe	
73-74	Vega	3028121	1	.97	SEAL, evaporator core	
74	Pass., Camaro, Nova	3022827	3	.29	SEAL, evap. case	
74-75	Pass.	3023989	1	.97	SEAL, evap. core	
75	Monza (exc. Towne Cpe.)	3031898	1	.33	SEAL, tube	
75	Monza (exc. Towne Cpe.)	3031911	1	.48	SEAL, tube	
75	Nova	3020539	1	2.00	SEAL, evap. core	
75	Nova	3030882	1	.93	SEAL, tube	
75	All (exc. Vega)	3027215	1	.11	SEAL, evap. inlet pipe	
75	Vega, Monza	3016894	1	.11	SEAL, evaporator core	
75	Vega	3027515	1		SEAL, evap. inlet pipe	
75	Monza (exc. Towne Cpe.)	3031778	1	3.20	SEAL, core	
75	Monza (exc. Towne Cpe.)	3031869	1	1.65	SEAL	
75	Monza (exc. Towne Cpe.)	3031872	1	3.20	SEAL, tube	
73-74	Chevelle	3024797	1	7.10	SEAL ASSY., air valve	
68-69	All w/Acc. Air Cond.	3014349	1	.66	SCREEN, core	
67-69	All w/Acc. Air Cond.	3012074	2	.80	SCREEN, evap. blower	
70	All w/Acc. Air Cond.	3014349	1	.66	SCREEN, evap. core	
73-75	Chevelle	3024640	1	3.40	SEAT, core	
70-73	Camaro w/A.T. (exc. NB-2)	3021517	1	1.15	SHAFT ASSY., w/lever a/c purge valve	
68-69	All w/Acc. Air Cond.	3012084	1	.16	SPACER, motor mtg.	
70	All (exc. Chevelle),					
65	Chevy w/Acc. Air Cond.,					
67-69	All w/Acc. Air Cond.,					
70	All w/Acc. Air Cond. (exc. Camaro)	3945890	1	.12	SPRING, evap. drain hose	
70-73	Camaro w/A.T. (exc. NB-2)	3023878	1	.87	SPRING, a/c purge valve	
65-70	All,					
71	Nova,					
74	Nova (6 cyl.)	3021960	1	.36	TUBE, drain	
69	Chevelle, Camaro,					
71-73	Pass., Chevelle	3016305	1	.33	TUBE, case drain	
73-74	Chevelle	3024954	1	2.35	VALVE, bi-level slave	
70-73	Camaro w/A.T. (exc. NB-2)	3020364	1	8.05	VALVE ASSY., w/seals a/c purge valve	
70-72	Camaro	3021273	1	1.35	VALVE SEAT, a/c purge valve	

**9.213 VALVE ASSY.— GUARD— INSULATION— ORIFICE ASSY.— SEAL, Air Conditioning Evaporator Expansion**

62-66	Chevy,					
64-66	Pass., Chevelle w/Cool Pack, Custom,					
67-69	All w/Acc. Air Cond.	5910744	1	34.35	thermostatic expansion (Note 1)	
	<i>NOTE 1 Must be used on jobs equipped with white plastic ball outlets.</i>					
64-67	Chevelle,					
65-72	Pass.,					
67	Camaro,					
68	Chevy, Chevelle, Camaro,					
69	Chevy, Camaro,					
70	Nova,					
71-72	Nova, Camaro,					
73	Pass., Nova, Chevelle,					
73	Camaro w/A.T. (exc. NB-2),					
74	Nova w/C.A.C. (6 cyl.),					
71-73	Vega	5910766	1	37.55	thermostatic expansion	
69	Chevelle	5910746	1	44.00	thermostatic expansion	
70-72	Chevelle	5910767	1	37.55	thermostatic expansion	
73-75	All w/V.I.R. (1st design)	6599445		13.95	thermostatic expansion (V.I.R.) (Note 1, 2)	
75	All w/V.I.R. (2nd design)	9956652	1		thermostatic expansion (V.I.R.) (Note 2)	

*NOTE 1: Consists of the following, (1) TXV valve assy.-6551104, (1) seal ring-6556523, (1) seal ring-6556526, (1) seal ring-6556521.*

**BODY MTG.— AIR COND.— INSTRUMENTS**

**9.213 VALVE ASSY.— GUARD— INSULATION— ORIFICE ASSY.— SEAL, Air Conditioning Evaporator Expansion (Con't)**

73-75	Chevelle	3024634	1	1.25	GUARD, bleed tube
All	All	3014431	1	.93	INSULATION, A/C evap. therm. expn. vlv. cply. tube bulb
73-75	Vega	3031086	1	5.80	ORIFICE ASSY., w/gasket, evap. core expan. tube
73-75	Vega, Monza	3144517	1	.24	SEAL, "O" ring, evap. core expn. tube

*NOTE 2: 2nd design distinguished by gold housing and red label or 1/4" high letter "E" on housing.*

**9.214 BRACKET— CLAMP— CLIP— GASKET— INSULATION— RETAINER— SCREEN— SCREW AND WASHER ASSY.— SEAL RING, Air Conditioning Evaporator Expansion Valve**

*NOTE: If specific Pipe Assy. or Tube Assy. usage cannot be found use applicable fittings from group 9.222 and cut hose from group 9.220 to desired length.*

68-72	Chevelle	3015639	1	.11	expansion valve mounting
70-73	All,				
71-73	Vega,				
74	Nova (6 cyl.)	3017086	1	.24	CLAMP (black)
62-65	Chevy, Chevelle,				
66	Chevelle w/Acc. Air Cond.,				
65-66	Pass. w/Cool Pack, Custom,				
67-68	Chevy, Chevelle, Camaro,				
67	Pass. (1st design),				
70	All,				
71	Chevelle, Camaro, Nova,				
71-73	Vega,				
73	All	3147034 A.R.		.18	CLAMP, a/c evap. thermo. expn. valve cap tube (1/16" I.D.)
71-72	Pass.	3017087	1	.27	CLAMP
62-66	All w/Cool Pack, Custom,				
68-72	All Auto. Temp. Cont.	3017086	1	.24	CLAMP (black)
65-69	Pass.	3749810 A.R.		.74	CLAMP, expansion valve inlet tube (strap-adjustable type)— (1.166)
66	Chevelle,				
66-70	Pass., w/Auto. Temp. Cont.	3147463	1	.61	CLAMP, valve capillary tube bulb
67	Pass. (2nd design) (exc. S.S.),				
67-69	Chevy, Chevelle, Camaro w/Acc. Air Cond.,				
68-69	Pass. w/Acc. Air Cond.	3014058	2	.16	CLAMP, a/c evap. thermo. expn. vlv. cap tube (13/16" I.D.)
74-75	Nova w/C.A.C. (6 cyl.)	3147463	1	.61	CLAMP, expan. bulb
69-70	Pass.	3152029	1	.16	CLIP, thermo. capillary tube
65-73	All,				
74	Nova (6 cyl.)	8526645 A.R.		.16	GASKET, "O" ring freon tube fitting, outlet tube gasket (3/16" I.D. x 9/32" O.D.)
62-64	Chevy,				
72-74	All (exc. Chevelle),				
75	Vega, Monza	3140600	1	.33	GASKET, "O" ring, condenser inlet tube (7/16" I.D. x 9/16" O.D.)
71-72	Vega	3014431	1	.93	INSULATION, a/c cap. tube bulb
75	Monza w/A.C.	3145607	1	.21	RETAINER, capillary stake
62	Chevy	5914631	1	1.05	SCREEN, filter
67-70	All w/Acc. Air Cond.	3012074	2	.80	SCREEN, evap. blower
74-75	All w/V.I.R.	6551143	2	.70	SCREW AND WASHER ASSY., valve capsule
74-75	All w/V.I.R.	6556521 A.R.		.56	SEAL RING, a/c evap. outlet conn. to V.I.R. a/c therm. expan. valve lower, a/c V.I.R. expan. valve and evap. outlet conn.
74-75	All w/V.I.R.	6556523	2	.56	SEAL RING, a/c therm. expan. valve capsule, a/c V.I.R. expan. valve
74-75	All w/V.I.R.	9948028	1	.56	SEAL RING, a/c evap. inlet line conn.

**9.215 MOTOR ASSY.— RELAY ASSY.— STUD ASSY., Air Conditioning Evaporator Blower**

62-66	Chevy	5044516	1	36.75	blower
63-66	All (exc. Chevy),				
67-75	All (exc. Vega, Monza)	4960538	1	31.80	blower— (8.855)
64	Chevelle w/Custom,				
65-66	All w/Acc. Air Cond.	5044576	1	32.75	blower
67-69	All w/Acc. Air Cond.	3012082 A.R.		65.50	blower
71-75	Vega, Monza	4939679	1	28.05	
73-75	Chevelle w/C.A.C.	3027939	1	42.25	w/fan, a/c blower
74	Chevelle,				
75	Chevelle w/C.A.C.	4960846	1	28.25	a/c blower
69-70	Pass. w/Auto Temp. Cont.	1115858	2	11.15	RELAY ASSY., motor cutout relay— (9.277)

**BODY MTG.— AIR COND.— INSTRUMENTS**

**9.215 MOTOR ASSY.— RELAY ASSY.— STUD ASSY., Air Conditioning Evaporator Blower (Con't)**

67-71	Camaro,				
68-71	Chevy,				
73-75	Nova, Camaro	3895910	1	.34	STUD ASSY., evap. & blower

**9.216 FAN ASSY.— BRACE— BRACKET— NUT— SEAL— WASHER, Air Conditioning Evaporator Blower Motor**

62-63	Chevy,				
64-66	Chevelle,				
65-68	Pass.,				
67-68	Chevy, Chevelle, Camaro,				
69	All,				
70-71	Chevy, Chevelle,				
70	Pass.,				
71	Pass. w/Acc. Air Cond.	3905776	1	4.34	blower— (8.857)
70-71	Camaro	3000443	1	5.70	blower
71-72	Pass.,				
73-75	Camaro w/A.T. (exc. NB-2),				
73-75	Pass., Chevelle,				
75	Nova	3027062	1	6.15	blower
71-75	Vega, Monza (exc. Auto. Temp. Control)	3027063	1	4.75	FAN UNIT, blower
69	Chevy, Camaro w/Acc. Air Cond.	3955998	R.H.	1.60	BRACKET, evap. and blower
70	Nova	3130804	1	.11	NUT, hex. locking (10-32)— (8.851)
67-69	Camaro,				
68-74	Nova	3902250	1	.11	SEAL, evap. and blower
71	Camaro,				
72-75	All (exc. Pass.)	3015545	1	.05	WASHER, fan support

**9.218 TUBE— BAFFLE— ELBOW, Air Conditioning Evaporator Air Inlet**

*NOTE: If specific Tube or Tube Assy. usage cannot be found, use applicable fittings from Group 9.222 and cut hose from Group 9.222 to desired length.*

65-66	Pass.	3000092	1	.58	motor cooling
<i>NOTE 1 Used only on past model air cond. conversion Unit 986949.</i>					
66-68	Pass. w/Auto Temp. Control,				
66-69	Pass., Camaro,				
70	Pass., Chevelle,				
71-72	Chevelle	3158817	1	1.25	htr. blower motor cooling
64	Chevelle w/Custom Deluxe	3000092	1	.58	motor cooling inlet
68	Chevy, Camaro,				
70-74	Nova, Camaro,				
75	Camaro	3015608	1	1.05	motor cooling
71-75	Pass.,				
75	Nova	3022657	1	.61	blower mtr. cooling
71-75	Vega, Monza (exc. Auto. Temp. Control)	3022839	1	1.10	a/c blower mtr. cooling
73-75	Chevelle w/C.A.C.,				
75	Nova w/C.A.C.	3024633	1	1.05	motor cooling
71-75	Camaro	3998417	1	1.85	BAFFLE, plenum inlet
66-68	Pass. w/Auto Temp. Control	3013476	1	.31	ELBOW, motor cooling tube
67-70	Pass. w/C.A.C.,				
69-72	Chevelle w/C.A.C.	3018945	1	.16	ELBOW, motor cooling
71-75	Nova, Camaro w/C.A.C.	3013475	1	.31	ELBOW, motor cooling

**9.220 TUBE ASSY.— CONNECTOR— SEAL RING, Air Conditioning Evaporator**

*NOTE: See Group 9.225 for Hose and Tube Assy.*

64	Chevelle w/Custom,				
67	Pass., Camaro w/C.A.C. (exc. 396),				
68	All w/C.A.C.	3981964	1	CL/2.27	expansion valve inlet
65-66	Pass.,				
66-67	Chevelle w/C.A.C.	3859059	1	1.50	expansion valve inlet
69	Chevy w/C.A.C.	3937195	1		condenser outlet
70-72	Chevelle w/C.A.C.	6262628	1	2.60	recv./dehy. inlet
71	Vega	6272140	1	4.05	cnldr. to recv.
71-72	Vega	3998435	1	5.80	recv. to expan. valve
72-73	Vega	6273359	1	7.50	cnldr. to recv.
73-75	Vega	340448	1	10.00	cnldr. outlet to evap.
74	Nova (6 cyl.)	487791	1	3.80	refrig. control valve, outlet
75	Monza	366453	1	9.55	cnldr. outlet
75	Monza (exc. Towne Cpe.)	366402	1	3.60	evap. inlet
62-69	All	3023688	1	3.61	CONNECTOR (1/2" O.D. x 3 1/4" O.L.) (Note 1)
62-69	All	3023689	1	3.83	CONNECTOR (5/8" O.D. x 3 1/4" O.L.) (Note 1)

**BODY MTG.— AIR COND.— INSTRUMENTS**

**9.220 TUBE ASSY.— CONNECTOR— SEAL RING, Air Conditioning Evaporator  
(Con't)**

62-70	All .....	3023687	1	3.64	CONNECTOR (3/8" O.D. x 3 1/4" O.L.) (Note 1) .....
72	Pass. w/C.A.C. .... <i>NOTE 1: To be used with 2-3909030 clamps.</i>	3984671	1	.22	CONNECTOR, a/c vac. hose .....
62-69	All .....	3960197	1	3.35	CONNECTOR ASSY., w/schrader valve (1/2" O.D.) (Parker Hannifin No. 5-1568-1) (Note 2) .....
	<i>NOTE 2: Used as refrigerant in-line Schrader valve connector.</i>				
74	All .....	6555533		.47	SEAL RING, a/c liquid bleed line conn. ....



**BODY MTG.— AIR COND.— INSTRUMENTS**

**9.222 FITTING PKG.— MUFFLER PKG.— HOSE— CLAMP— "O" RING, Air Conditioning Refrigerant Line (Fitting Pkgs. Include "O" Rings and Hose Clamps)**

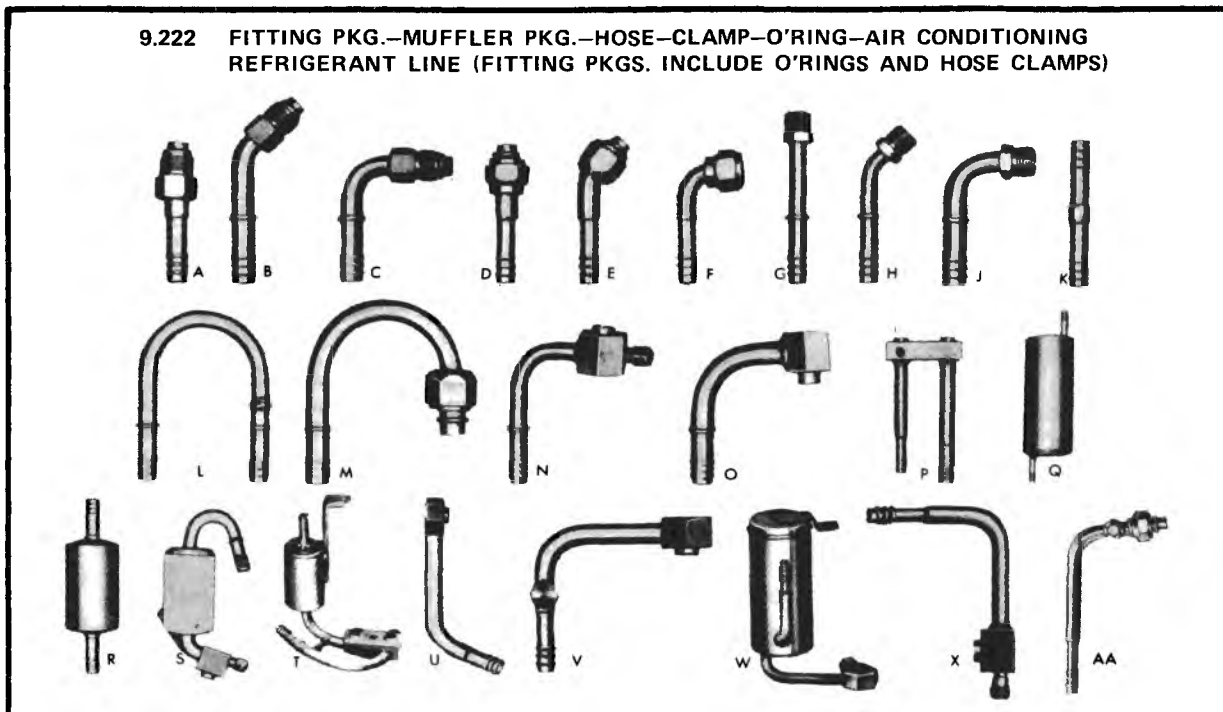

**9.222 FITTING PKG.—MUFFLER PKG.—HOSE—CLAMP—O'RING—AIR CONDITIONING REFRIGERANT LINE (FITTING PKGS. INCLUDE O'RINGS AND HOSE CLAMPS)**

PART NO.	TYPE	THREAD SIZE	HOSE I.D.	PART NO.	TYPE	THREAD SIZE	HOSE I.D.	PART NO.	TYPE	THREAD SIZE	HOSE I.D.
3024535	A	11/16-16	5/16	3023675	E	3/4-16	13/32	3027769	J	3/4-16	13/32
3023691	A	5/8-18	5/16	3023676	E	7/8-14	1/2	3023686	K		5/16
3023692	A	3/4-18	13/32	3023677	E	1- 1/16-14	5/8	3023687	K		13/32
3023693	A	7/8-18	1/2	3023678	E	5/8-18	13/32	3023688	K		1/2
3023694	A	1- 1/16-16	5/8	3023679	E	3/4-16	1/2	3023689	K		5/8
3023695	A	5/8-18	13/32	3023680	E	7/8-14	5/8	3023718	L		1/2
3023696	A	3/4-18	1/2	3023657	F	5/8-18	5/16	3023719	L		5/8
3023668	B	5/8-18	5/16	3030183	F	3/4-16	13/32	3024791	M	5/8-18 (Male)	5/16
3023669	B	3/4-18	13/32	3023658	F	3/4-16	13/32	3023722	M	1 1/16-14 (Female)	5/8
3023670	B	7/8-18	1/2	3023659	F	7/8-14	1/2	3023715	N		13/32
3023671	B	1- 1/16-16	5/8	3023660	F	1- 1/16-14	5/8	3023716	N		1/2
3023672	B	5/8-18	13/32	3023661	F	5/8-18	13/32	3023717	O		5/8
3023673	B	3/4-18	1/2	3023662	F	3/4-16	1/2	3023721	P		13/32-5/8
3024537	C	11/16-16	5/16	3023663	F	7/8-14	5/8	3023720	Q		13/32
3023651	C	5/8-18	5/16	3024534	G	5/8-18	5/16	3027763	R		1/2
*3925751	C	11/16-16	13/32	3023711	G	5/8-18	13/32	*3981880	R		1/2
3023652	C	3/4-18	13/32	3027763	G	3/4-16	13/32	*3923139	S		1/2-5/8
3023653	C	7/8-18	1/2	3023712	G	3/4-16	1/2	*3970541	T		1/2-5/8
3023654	C	1- 1/16-16	5/8	3023713	G	7/8-14	5/8	3024788	U		5/8
3023655	C	5/8-18	13/32	3023714	G	1- 1/16-14	5/8	3030185	U		13/32
3023656	C	3/4-18	1/2	3023682	H	5/8-18	13/32	3024789	V		13/32
3023697	D	5/8-18	5/16	3027766	H	3/4-16	13/32	*231296	W		13/32
3023698	D	3/4-16	13/32	3023683	H	3/4-16	1/2	*231297	W		13/32
3023699	D	7/8-14	1/2	3023684	H	7/8-14	5/8	*231298	W		13/32
3023700	D	1- 1/16-14	5/8	3023685	H	1- 1/16-14	5/8	3027483	X		13/32
3023701	D	5/8-18	13/32	3024536	J	5/8-18	5/16	3030977	AA	5/8-18	5/16
3023709	D	3/4-16	1/2	3023664	J	5/8-18	13/32	* FITTING ONLY			
3023710	D	7/8-14	5/8	3023665	J	3/4-16	1/2				
3023674	E	5/8-18	5/16	3023666	J	7/8-14	5/8				
3028285	E	11/16-16	5/16	3023667	J	1- 1/16-14	5/8				

**HOSE, CLAMP, O RINGS**

230882	Hose, Refrig.	(5/16" I.D. x 15')	8526398	O'Ring (3/8" I.D.)
230883	Hose, Refrig.	(13/32" I.D. x 15')	3140600	O'Ring (1/2" I.D.)
230884	Hose, Refrig.	(1/2" I.D. x 15')	3140748	O'Ring (5/8" I.D.)
230885	Hose, Refrig.	(5/8" I.D. x 15')	3140852	O'Ring (3/4" I.D.)
			5887997	O'Ring, Fitting to Comp.
3909030	Clamp, Adj. Hose (with Locator Tab)			

**BODY MTG.— AIR COND.— INSTRUMENTS**

**9.225 HOSE— INSULATOR— SLEEVE, Air Conditioning**

**Compressor and Condenser**

*NOTE: Hose Assemblies may be replaced by bulk hose.*

*NOTE: If specific Tube or Tube Assy. usage cannot be found, use applicable fittings from Group 9.222 and cut hose from Group 8.962-9.222 to desired length.*

*For hoses with muffler and fittings see Group 9.226.*

62-70	All	9798788 A.R.	RL/3.35	evap. to comp. (5/8" I.D. x 1 1/8" O.D.) (Note 1)— (8.962)
62-70	All	3981964 A.R.	CL/2.27	rec. to dehyd. to evap., temp. cont. valve pipe to evap. (1 3/32" I.D. x 39/32" O.D.) (Note 1)— (8.962)
<i>NOTE 1: Quantity of one when ordering denotes one 10 ft. roll.</i>				
71-72	All (exc. Vega)	230884 A.R.	RL/3.00	evap. core to comp. to condenser (1/2" I.D.) (Note 2)— (8.962)
71-72	All (exc. Vega)	230885 A.R.	RL/3.45	evap. to comp. (5/8" I.D.) (Note 2)— (8.962)
71-72	All (exc. Vega)	230883 A.R.	RL/2.27	rec. to dehyd. to evap. temp. control valve pipe to evap. (1 3/32" I.D.) (Note 2)— (8.962)
<i>NOTE 2: Quantity of one when ordering denotes one 15 ft. roll.</i>				
65-66	Pass.	3859059	1 1.50	w/tube, expansion valve inlet
69	Camaro	3949903	1 12.70	w/tube, to receiver and dehydrator
69-73	Nova	3998432	1 13.00	w/tube, A/C condenser to receiver
69	Camaro (exc. 396)	3949904	1 9.60	w/tube, receiver and dehydrator to expansion valve
69	Camaro (396)	3949905	1 14.95	w/tube, receiver and dehydrator to expansion valve
69-73	Nova	3998433	1 11.65	w/tube, receiver and dehydrator to expansion valve
69	Chevelle	3949916	1 19.00	w/tube, receiver and dehydrator to expansion valve
69	Pass.	3949917	1 14.50	w/tube, receiver and dehydrator to expansion valve
70	Pass.	3967932	16.05	w/tube, receiver and dehydrator to expansion valve
70-71	Camaro,			
73	Camaro	331935	1 16.60	w/tube receiver dehydrator outlet
70-72	Chevelle	6273324	1 18.40	w/tube receiver and dehy. outlet
70-72	Chevelle	6262628	1 2.60	w/tube a/c receiver and dehydrator inlet
70-73	Camaro	3998429	1 11.10	w/tube receiver dehydrator inlet
71-72	Pass.	3998419	1 15.35	w/tube, a/c rcvr. & dehydr. to exp. vlv.
73	Pass., Chevelle	328250	1 13.15	w/tube receiver/dehydrator to expan. valve
73	Camaro		1	w/tube, rec./dehy., inlet
73	Camaro		1	w/tube, rec./dehy., outlet
73	Monte Carlo	6262606	1 19.45	w/tube, rec./dehy., to expansion valve
73	Nova		1	w/tube, rec./dehy. to expansion valve
74	Nova (6 cyl.)	491786	1 11.90	w/tube, condenser to receiver/dehydrator
74-75	Pass. w/C.A.C.	340412	1	w/tube, a/c condenser to evaporator
74	Nova (8 cyl.)	336449	1 11.90	w/tube, condenser outlet
74	Chevelle (exc. Monte Carlo)	344870	1 12.50	w/tube, condenser outlet
74	Monte Carlo	344869	1 12.50	w/tube, condenser outlet
74	Camaro	336475	1 11.90	w/tube, condenser outlet
75	Camaro (8 cyl.) (1st design)	346192	1 12.40	w/tube, condenser outlet (Note 3)
75	Camaro (2nd design)	344872	1 12.50	w/tube, condenser outlet (Note 3)
<i>NOTE 3: 2nd design part has 2 pressure taps.</i>				
75	Nova (350)	346119	1 12.40	w/tube, condenser outlet
75	Chevelle (8 cyl.) (exc. Monte Carlo)	344809	1 1.10	w/tube, condenser outlet
75	Monte Carlo	354725	1	w/tube, condenser outlet
75	Chevelle (6 cyl.)	344871	1 12.50	w/tube, condenser outlet
75	Nova (6 cyl.)	354818	1 12.40	w/tube, condenser outlet
75	Camaro (6 cyl.)	356157	1 31.75	w/tube, condenser outlet
75	Vega, Monza (8 cyl.)	344878	1 8.50	w/tube, condenser outlet
75	Nova (6 cyl.)	356125	1 1.00	INSULATOR, hose type for fitting and muffler assy.
75	Nova (6 cyl.)	480317	1 .87	INSULATOR, suc. hose
69	Pass., Chevelle w/Acc. Air Cond.,			
70	Pass. w/Acc. Air Cond.	9788818 A.R.	1.60	SLEEVE, comp. fitting and muffler to cond. hose

**9.226 FITTING ASSY.— BUMPER— CLIP— MUFFLER— SEAL, Air Conditioning**  
**Compressor Suction and Discharge**

64-68	Chevelle w/C.A.C. (6 cyl.)	3923139	1 22.80	w/muffler only
64-68	Chevelle w/C.A.C. (8 cyl.),			
65-68	Pass. w/C.A.C. (8 cyl.),			

**BODY MTG.— AIR COND.— INSTRUMENTS**

**9.226 FITTING ASSY.— BUMPER— CLIP— MUFFLER— SEAL, Air Conditioning Compressor Suction and Discharge (Con't)**

68	Camaro w/C.A.C. (396)	3970541	1	34.65	w/muffler only
67-68	All w/Acc. Air Cond.,				
69	All w/Acc. Air Cond. (6 cyl.)	3902251	1	18.45	w/muffler only
67	Camaro w/C.A.C.,				
68	Chevy w/C.A.C.	3895914	1	20.10	w/muffler only
69	Nova, Camaro, Chevelle w/C.A.C. (6 cyl.)	3949900	1	61.25	w/muffler and hoses, complete
69	Camaro w/C.A.C. (8 cyl.) (exc. 396)	3949901	1	53.75	w/muffler and hoses, complete
69	Camaro (396)	3949902	1	45.25	w/muffler and hoses, complete
69	Pass. (6 cyl.)	3949906	1	34.25	w/muffler and hoses, complete
69-70	All w/8 cyl. (exc. Camaro, Monte Carlo)	6272174	1	57.10	w/muffler and hoses, complete
<i>NOTE 1: When used with Retractable Headlamp, tape piece of sponge rubber or equiv. where hose contacts vacuum bottle-insulate hose from all contacting surfaces with sponge rubber &amp; tape-maintain adequate clearance from all sharp &amp; moving objects allowing for 2 inch engine rock conditions.</i>					
69	All w/Acc. Air Cond. (8 cyl.) (exc. Nomad),				
70	All w/Acc. Air Cond. (8 cyl.) (exc. Camaro)	3942689	1	45.25	w/muffler only
70	Monte Carlo (400, 454),				
71	Chevelle	3984614	1	47.00	w/muffler and hoses, complete
70-72	Camaro	3973719	1	44.75	w/muffler and hoses, complete
71-72	Pass.	3992161	1	34.75	w/muffler and hoses, complete
71-73	Nova	6273390	1	61.00	w/muffler and hoses, complete
71	Monte Carlo (2nd design),				
72	Chevelle,				
73	Camaro	3998422	1	44.25	w/muffler and hoses, complete
71	Vega (1st design)	3984676	1	44.00	cmpr. (Note 1, 3)
71	Vega (2nd design)	3992162	1	48.50	cmpr. (Note 2, 3)
72	Vega	6262686	1	58.00	
<i>NOTE 1: Compressor fitting at condenser horizontal to radiator. Use with condenser 3979755.</i>					
<i>NOTE 2: Compressor fitting at condenser at 45 degree angle to radiator. Use with condenser 3992163.</i>					
73	Pass.	3998418	1	34.75	complete w/hoses and fittings
73	Chevelle (exc. 454)	3998489	1	44.25	complete w/hoses and fittings
73	Chevelle (454)	3998490	1	44.25	complete w/hoses and fittings
73	Vega	331976	1	48.50	
74	Nova (8 cyl.)	336448	1	48.25	complete w/hoses and fittings
74	Nova (6 cyl.)	487782	1	20.15	w/muffler only
74	Pass. (454)	340410	1	44.25	complete w/hoses and fittings
74	Pass. (exc. 454)	340411	1	44.25	complete w/hoses and fittings
74	Chevelle (exc. 454)	336459	1	44.25	complete w/hoses and fittings
74	Chevelle (454)	336460	1	49.50	complete w/hoses and fittings
74	Camaro	336474	1	44.25	complete w/hoses and fittings
74-75	Vega	340405	1	48.50	complete w/hoses and fittings
75	Chevelle (454) (exc. Monte Carlo)	354724	1	44.75	complete w/hoses and fittings
75	Chevelle (exc. Monte Carlo, 454)	354722	1	44.75	complete w/hoses and fittings
75	Camaro (8 cyl.)	346191	1	27.50	complete w/hoses and fittings
75	Camaro (6 cyl.)	356156	1	20.15	complete w/hoses and fittings
75	Nova (8 cyl.)	346118	1	45.50	complete w/hoses and fittings
75	Nova (6 cyl.)	354817	1	45.75	complete w/hoses and fittings
75	Pass. (454)	346197	1	45.75	complete w/hoses and fittings
75	Pass. (exc. 454)	346199	1	45.75	complete w/hoses and fittings
75	Monte Carlo (454)	354723	1	44.75	complete w/hoses and fittings
75	Monte Carlo (exc. 454)	354721	1	44.75	complete w/hoses and fittings
75	Chevelle (6 cyl.)	356126	1	35.25	complete w/hoses and fittings
75	Monza (4 cyl.)	356123	1	46.25	complete w/hoses and fittings
75	Monza (8 cyl.)	366456	1	44.75	complete w/hoses and fittings
74-75	Vega, Monza	340406	1	.45	<b>BUMPER</b> , a/c comp. fitting
75	Monza (4 cyl.)	356176	1		<b>CLIP</b> , cmpr. hose to batt. tray
62-72	All w/Acc. Air Cond.	3981880	1	16.10	<b>MUFFLER</b> , in line
71-72	Vega,				
73-75	All w/Axial Cmpr.	5887997	2	.22	<b>SEAL</b> , "O" ring ( <sup>51</sup> / <sub>64</sub> " x <sup>9</sup> / <sub>64</sub> " thk.) (suction disc ports)

**9.242 BRACKET— CLAMP— CLIP— RETAINER— SPACER— STRAP, Air Conditioning Hose**

66	Chevy w/Acc. Air Cond.,				
67-69	All w/Acc. Air Cond.,				
70	All w/Acc. Air Cond. (exc. Camaro)	3870237	4	.17	a/c hose
62-64	All				<b>CLAMP</b> , evap. core to comp. freon (both ends and center),

**BODY MTG.— AIR COND.— INSTRUMENTS**

**9.242 BRACKET— CLAMP— CLIP— RETAINER— SPACER— STRAP, Air Conditioning Hose (Con't)**

62-70	All	3909030 A.R.	.93	freon hoses, dehyd. to evap. comp. to cond.
62-69	All,			
73	Nova, Camaro	2494772 A.R.	.65	CLAMP, miniature worm drive type (range 1/4" x 5/8")— (1.166)
65	Pass.	3017085	1	.13 CLAMP, evap. core outlet tube support
68-69	Pass., Camaro (8 cyl.),			
69-70	Pass., Camaro w/Acc. Air Cond.,			
71-74	Pass.	3925746	1	.17 CLAMP, a/c refrig. cont. vlv. tube to a/c comp. ftg. and muff. hose
70	Chevelle w/Air Cond.	3967947	.17	CLAMP, comp. ftg. and muff. to condser. hose and tube
64-68	All w/Air Cond. (8 cyl.)	3853968	1	.41 CLIP, heater hose to compressor
68	Pass. (6 cyl.)	3979355	1	CLIP, comp. fitting and muffler to condenser hose and tube
69-70	Pass.	3900412	1	.28 CLIP, comp. fitting and muff. to cond. hose (1" hose)
65-67	Pass.,			
69	Nova	3879573	4	.11 CLIP, condenser air lower baffle to bumper— (8.154)
69-70	Pass.	3955922	1	.11 CLIP, receiver and dehydrator to expansion valve hose and tube (27/32" I.D.)
72	Chevelle	3984628	2	.11 CLIP, a/c cond. c/ovr. pipe
71-74	Pass.	3998481	1	.27 CLIP, A/C vac. hose clip
71-74	Pass.	3017087	1	.27 CLIP, a/c refrig. hose to alt. brkt.
74-75	Nova (6 cyl.)	3851320	1	1.30 CLIP, htr. hose to comp.
75	Pass.	346196	1	.76 CLIP, a/c refrig. hose to alta. brkt.
69-71	Chevelle,			
70	Pass.			
71-72	Chevelle, Camaro	3942664	1	.11 RETAINER, vacuum control hose
73-74	Camaro			RETAINER, a/c vac. control hose,
74	Pass. (exc. Auto. Temp. Control)	6262602	1	.11 htr. and a/c vac. control switch
73-75	All	3917385 A.R.	.11	STRAP, refrig. & htr. hose
73-75	Chevelle	6262614	1	.11 STRAP, a/c air center duct
73-75	Chevelle w/C.A.C.	336456	1	STRAP, a/c air dist. duct to heater

**9.260 HOSE— SCREW ASSY.— SPACER— STRAP, Air Conditioning Evaporator Air**

All	All (exc. Vega, Monza)	1234989 A.R.	12.20	heater (4 x 72 O.L.)
All	All (exc. Vega, Monza)	1234984	1	6.15 heater air dist. duct outlet hose (1 1/2" I.D. x 72" long)
All	All (exc. Vega, Monza)	1234985 A.R.	7.50	heater defr. a/c (2" I.D. x 72" O.L.)
All	All (exc. Vega, Monza)	1234986 A.R.	7.55	rear window defogger air outlet (2 1/4" I.D. x 72" O.L.)
All	All (exc. Vega, Monza)	1234988 A.R.	8.60	(3 1/4" I.D. x 72" O.L.)
All	All (exc. Vega, Monza)	1234278 A.R.	8.65	(2 3/4" I.D. x 72")— (8.962)
68-69	Chevelle	1234987	1	9.50 left evap. air outlet
69	Pass. w/Auto. Temp. Control	3987362	1	RL/.12 w/connector, air inlet— (8.962)
69-70	Pass.			left air lower outlet,
70	Chevelle			outlet lower air distr. duct hose,
71	Camaro	3119719	1	2.75 a/c air lower right outlet
71	Pass. w/Auto. Temp. Cont.	3992133	1	2.00 a/c sensor aspirator
69	Chevy, Camaro			SCREW ASSY., air side outlet left duct,
69	Camaro (exc. C.A.C.),			
70-71	Nova, Camaro, Chevelle	9422207	4	.13 upper vent. side outlet deflector
<i>NOTE: Hose Assemblies may be replaced by bulk hose.</i>				
67-68	Camaro	9776399	2	.05 SPACER, air center outlet
67-72	All (exc. Vega, Monza)	3917385	1	.11 STRAP, refrig. and htr. hose

**9.262 OUTLET— ADAPTER— BRACKET— CLIP— CONNECTOR— CONTROL ASSY.— COVER— DEFLECTOR— DISTRIBUTOR— DUCT— EXTENSION— FERRULE— FILLER— GASKET— HOSE— HOUSING— INSULATOR— KNOB— LEVER— NUT— RETAINER— SCREW— SEAL— SHAFT— SPACER— SPRING— STUD— VALVE— WASHER, Air Conditioning Evaporator Air Distributor and Astro-Ventilation**

67-68	Pass., Camaro	3929062	1	3.70 air dist. duct
67-69	All w/Acc. Air Cond.	3012087	2	8.30 bezel louver
69	Chevy, Camaro,			
70-74	Nova	340436	1	21.90 air center (black)
69	Camaro, Chevy,			
70-75	Nova	3998414 R.H.	8.75	air side
69	Chevelle	3942682	1	10.30 air center
69	Camaro (exc. C.A.C.)	3939632 R.H.	7.85	upper vent. side
69-70	Pass.	3949996	1	6.25 right air lower
69-70	Pass.	3937183	1	6.95 air center

**BODY MTG.— AIR COND.— INSTRUMENTS**

**9.262 OUTLET— ADAPTER— BRACKET— CLIP— CONNECTOR— CONTROL ASSY.— COVER— DEFLECTOR— DISTRIBUTOR— DUCT— EXTENSION— FERRULE— FILLER— GASKET— HOSE— HOUSING— INSULATOR— KNOB— LEVER— NUT— RETAINER— SCREW— SEAL— SHAFT— SPACER— SPRING— STUD— VALVE— WASHER, Air Conditioning Evaporator Air Distributor and Astro-Ventilation (Con't)**

69-70	Pass.	3940295	L.H.	7.75	left upper air side
69-70	Pass.	3942607	R.H.	8.55	right, upper air side
69	Pass. (exc. C.A.C.)	3939649	L.H.	7.55	left upper vent. side
69	Pass. (exc. C.A.C.)	3939628	R.H.	7.75	right upper vent. side
69-70	Pass.	3963737	L.H.	6.25	air lower
70	Chevelle	6262670	1	19.15	air ctr.
70	Chevelle (exc. 396)	3963701	L.H.	10.85	air side
70-72	Chevelle (exc. C.A.C.)	3989233	L.H.	6.80	upper vent side,
70	Chevelle (exc. C.A.C.)	3957086	R.H.	8.15	upper vent side,
70-71	Chevelle	3967957	L.H.	7.60	air lwr.
70-72	Camaro	331988	1		air center (black) (paint to match)
70	Camaro	3973795	1	19.55	air center (sandalwood)
70	Camaro	3973732	1	19.55	air center (blue)
70	Camaro	3963727	L.H.	21.90	air side,
70	Camaro	3963728	R.H.	21.90	air side,
70-75	Camaro	331978	R.H.	13.40	air lower (black)
70	Camaro (exc. C.A.C.)	3967918	R.H.	7.60	upper vent. side,
70	Chevelle (exc. 396),				
71-72	Chevelle	3998448	R.H.	10.70	air side right
71-72	Chevelle	3992167	1	19.60	air ctr.
71-72	Chevelle (exc. C.A.C.)	3989234	R.H.	6.80	upper vent. side, right
70-72	Chevelle	3992196	R.H.	7.60	air lower, right
71-72	Chevelle	3992195	L.H.	7.60	air lower left
71-74	Pass.	336442	1	8.75	air lower
71	Pass.	3979776	R.H.	.53	right, air front
71	Pass.	3979722	R.H.	14.50	right, A/C air
71-72	Pass. (exc. C.A.C.)	3989273	1	.79	upper vent. center duct front
71	Pass.	6262666	1	14.50	a/c air center
71-72	Pass.,				
71	Pass. (exc. C.A.C.) (1st design)	354774	1	8.95	upper vent. center duct
72-74	Pass.	6262609	1	.50	a/c air front
72-74	Pass.	6262613	1	.79	a/c air R.H. front lower
71-75	Pass.	3979747	L.H.	6.60	left, A/C air
71-72	Camaro	340445	1	13.40	air, center (beige)
71-72	Camaro	3998405	1	12.65	air, center (dk. jade)
71-75	Camaro	3998407	L.H.	10.70	air side, left
71-75	Camaro	3998408	R.H.	10.70	air side, right
71-75	Camaro	331977	L.H.	13.40	air lower, left (black)
70-75	Camaro (exc. C.A.C.)	6262667	L.H.	10.70	upper vent. side, left
71-75	Camaro (exc. C.A.C.)	6262668	R.H.	7.60	upper vent. side, right
72-75	Pass.	6262665	1	6.60	a/c air ctr. left
72-74	Pass.	6262672	1	8.45	a/c air ctr. & right
71-72	Chevelle	6262669	L.H.	10.70	air side left
73-75	Chevelle	3998483	1	10.10	air center (instr. panel)
73-75	Chevelle	3998482	R.H.	7.60	a/c air outlet lower
73-74	Chevelle	3998457	L.H.	7.60	a/c air outlet lower
73-75	Chevelle (exc. C.A.C.)	3998455	1	10.10	instr. panel center vent.
73-74	Pass. (exc. C.A.C.)	6262611	1		upper vent. center duct, rear
73-75	Pass. (exc. C.A.C.)	354774	1	8.95	upper vent. center duct
73-75	Chevelle	3998443	L.H.	7.75	a/c air upper
73-75	Chevelle	3998444	R.H.	7.75	a/c air upper
73-75	Camaro	340445	1	13.40	a/c air center (paint as required)
75	Pass.	346165	1	10.85	a/c air lower
75	Nova	346123	1	5.50	a/c air center
75	Pass.	354771	R.H.	11.25	a/c air
75	Pass.	354772	1	10.05	a/c air center and right
75	Pass.	354775	1	.60	upr. vent. center duct front and R.H.
75	Pass. (exc. C.A.C.)	354774	1	8.95	upr. vent. center duct
75	Chevelle	328209	R.H.	2.50	a/c air front
75	Chevelle	328210	R.H.	5.70	a/c air rear
75	Chevelle	328211	L.H.	5.70	a/c air front
75	Chevelle	328212	L.H.	5.70	a/c air rear
71-73	Vega	3973784	1	17.25	OUTLET ASSY., a/c center
71-73	Vega	331994	R.H.	5.30	OUTLET ASSY., a/c lap cooler
71-73	Vega	331993	L.H.	5.30	OUTLET ASSY., a/c lap cooler
74-75	Vega	336484	R.H.	10.15	OUTLET ASSY., lap cooler
74-75	Vega	336487	L.H.	10.15	OUTLET ASSY., lap cooler
74-75	Vega	336486	1	5.90	OUTLET ASSY., a/c air center
75	Monza (exc. Towne Cpe.)	346149	1	6.95	OUTLET ASSY., a.c. air center
75	Monza (Towne Cpe.)	362544	1	7.15	OUTLET ASSY., a.c. air center

**BODY MTG.— AIR COND.— INSTRUMENTS**

**9.262 OUTLET— ADAPTER— BRACKET— CLIP— CONNECTOR— CONTROL ASSY.— COVER— DEFLECTOR— DISTRIBUTOR— DUCT— EXTENSION— FERRULE— FILLER— GASKET— HOSE— HOUSING— INSULATOR— KNOB— LEVER— NUT— RETAINER— SCREW— SEAL— SHAFT— SPACER— SPRING— STUD— VALVE— WASHER, Air Conditioning Evaporator Air Distributor and Astro-Ventilation (Con't)**

75	Monza (Towne Cpe.)	362554	2	5.25	OUTLET ASSY., a.c. air side
75	Monza (Towne Cpe.)	362548	R.H.	10.15	OUTLET ASSY., lap cooler
75	Monza (Towne Cpe.)	362579	L.H.	9.65	OUTLET ASSY., lap cooler
69-75	Nova	3937119	1	3.45	ADAPTER, center outlet duct
70-72	Chevelle	3973727	L.H.	.81	ADAPTER, a/c air side outlet, left
69-75	Nova	3998413	L.H.	1.30	ADAPTER, air side outlet
71-75	Pass. (exc. C.A.C.)	3979788	1	6.90	ADAPTER, upper vent. center duct
73-75	Chevelle	484422	1	.74	ADAPTER, a/c air distr. duct to htr.
73-75	Chevelle	3998485	1	.96	ADAPTER, a/c air outlet, left
73-75	Nova	3998413	L.H.	1.30	ADAPTER, air side outlet, left
75	Monza (Towne Cpe.) (exc. A.T.C.)	362553	1	1.60	ADAPTER, a.c. air center outlet
65-68	Pass. w/upper level vent.,				
66	Chevelle,				
67	Camaro, Chevelle,				
69-72	Chevelle				ADAPTER ASSY., evap. air outlet,
69	Chevelle (Spt. Cpe., Conv.) (exc. C.A.C.)	3906099	2	1.85	upper vent side outlet deflector housing
67-68	Pass.,				
67-69	Camaro,				
68-75	Nova	3906004	A.R.	.31	ADAPTER ASSY., air dist. duct
69-75	Nova	3946959	1	.34	BRACKET, left air side outlet duct
70-74	Camaro	3973735	1	.34	BRACKET, dist. upper duct
70-74	Camaro	3020477	1	.98	BRACKET, divider valve adjuster
70-74	Camaro	3021523	1	1.25	BRACKET, bowden cable
70	Camaro	3989200	1	.16	BRACKET, air dist. upr. duct to L.H. duct
70	Camaro	3989203	1	.12	BRACKET, air side outlet
71-75	Camaro (exc. C.A.C.)	3967941	2	.38	BRACKET, upper vent. side outlet duct
71-75	Camaro	3989201	1	.11	BRACKET, air dist. upper duct to instr. panel
71-75	Camaro	3989205	L.H.	.12	BRACKET, left, air dist. upper duct to air center outlet
71-75	Camaro	3989206	R.H.	.11	BRACKET, right, air dist. upper duct to air center outlet
64-66	Chevy				CLIP, air deflector,
67-68	Camaro,				
68-74	Nova	3781362	2	.12	air inlet plenum valve house
70-74	Camaro	3973793	1	.16	CLIP, air dist. upper duct
73-74	Pass., Chevelle,				
75	Pass.	3022746	2	.05	CONNECTOR, diverter vac. link
71-75	Pass. (exc. C.A.C.)	3989199	1	1.60	CONTROL ASSY., upper vent. center duct
70-71	Chevelle (Spt. Cpe., Conv.) (exc. C.A.C.),				
70-72	El Camino (396, 454),				
70	El Camino w/Instr. Panel Gauges (exc. 396)	3972004	1	.81	COVER, a/c center outlet
71-74	Caprice	6264793	1	.67	COVER, upper level vent. control
71-74	Pass. (exc. Caprice, Estate Wag.)	6264792	1	.16	COVER, upper level vent. control
75	Caprice	346685	1	1.30	COVER, upper level vent. control— (9.789)
65-68	Pass.,				
66-68	Chevelle, Camaro,				
69	Chevelle	331918	2	3.15	DEFLECTOR, evaporator air outlet
69	Pass. (exc. C.A.C.)				DEFLECTOR ASSY., upper vent side outlet,
69	Pass., Chevy, Camaro,				
70-72	Nova	3963790	1	4.20	air side outlet
71-72	Pass.	3979751	2	4.00	DEFLECTOR ASSY., a/c air outlet
69	Chevy, Camaro,				
70-74	Nova	3940296	1	12.75	DISTRIBUTOR ASSY., car heater and defroster
69-74	Nova,				
75	Nova w/C.A.C.	346116	L.H.	5.00	DUCT, a/c side outlet
69	Camaro (Spt. Cpe., Conv.) w/C.A.C.	3937175	L.H.	8.35	DUCT, air side outlet
69	Chevelle w/C.A.C.	3942683	1	5.05	DUCT, air center outlet
70	Monte Carlo w/C.A.C.,				
71-72	Chevelle w/C.A.C., Instr. pnl. gauges	3967977	L.H.	4.90	DUCT, a/c air side outlet, left
70-72	Camaro w/C.A.C.	3963731	1	5.55	DUCT, air side outlet
70-75	Camaro	6262627	1	5.85	DUCT, a/c air dist. upr. (Note 1)

**BODY MTG.— AIR COND.— INSTRUMENTS**

**9.262 OUTLET— ADAPTER— BRACKET— CLIP— CONNECTOR— CONTROL ASSY.— COVER— DEFLECTOR— DISTRIBUTOR— DUCT— EXTENSION— FERRULE— FILLER— GASKET— HOSE— HOUSING— INSULATOR— KNOB— LEVER— NUT— RETAINER— SCREW— SEAL— SHAFT— SPACER— SPRING— STUD— VALVE— WASHER, Air Conditioning Evaporator Air Distributor and Astro-Ventilation (Con't)**

*NOTE 1: When using 6262627 in place of 3963795, it is necessary to discard molded plastic outlet from the center dist duct to the L.H. side outlet & purchase & install approx. 27.00 in. of 1234988 hose, between the center outlet & L.H. side outlet.*

70-75	Camaro (exc. C.A.C.)	3967927	L.H.	4.90	DUCT, upper vent. side outlet, left
70-75	Camaro (exc. C.A.C.)	3967928	R.H.	4.90	DUCT, upper vent. side outlet, right
71-75	Pass.	3984610	1	7.30	DUCT, air dist. to lower outlet
71-75	Pass.	3992118	1	.81	DUCT, left air outside center
67-68	Pass., Camaro	3929061	1	5.05	DUCT ASSY., air distributor
67-68	Camaro	3919551	1	3.20	DUCT ASSY., air dist.
69	Camaro,				
72-75	Nova	3917320	1	4.70	DUCT ASSY., air distributor
69-70	Pass., Chevelle (exc. Auto. Temp. Cont.),				
71-72	Chevelle	3984650	1	76.00	DUCT ASSY., htr. & a/c air selector
69-75	Nova	3937118	1	4.80	DUCT ASSY., center outlet
69	Camaro	3937166	1	5.85	DUCT ASSY., center outlet
69	Chevelle	3949816	1	5.55	DUCT ASSY., air dist. lower
69-70	Pass.	3937197	1	4.55	DUCT ASSY., air dist.
69	Pass. (exc. Auto. Temp. Control)	3984650	1	76.00	DUCT ASSY., car heater and a/c air selector— (9.786)
69-70	Pass. (exc. Auto. Temp. Control)	3018564	1	40.25	DUCT ASSY., air inlet plenum
69-70	Pass. w/Auto. Temp. Control	3022571	1	44.75	DUCT ASSY., air inlet plenum
70	Chevelle (exc. Monte Carlo),				
71-72	Chevelle w/C.A.C. (exc. Instr. pnl. gauges, Monte Carlo)	3963791	L.H.	4.90	DUCT ASSY., a/c air side outlet, left
70-75	Camaro,				
72	Chevelle	3026061	1	70.00	DUCT ASSY., heater and a/c air selector
70-75	Camaro	3963783	1	3.55	DUCT ASSY., air dist. lower
70-72	Chevelle	3992154	1	6.15	DUCT ASSY., a/c air dist.
71-72	Pass.	3973791	1	5.35	DUCT ASSY., heater and a/c air distr.
71-75	Pass. (exc. C.A.C.)	3979787	1	7.75	DUCT ASSY., upper vent. center
71-74	Vega	6262662	1	68.00	DUCT ASSY., a/c htr. air selector
71-73	Vega	3973786	1	6.70	DUCT ASSY., a/c air outlet
73-75	Chevelle w/C.A.C.	3998457	1	7.60	DUCT ASSY., left, a/c air outlet lower
73-75	Pass. w/C.A.C.	3973791	1	5.35	DUCT ASSY., heater and a/c air distr.
74-75	Vega	336483	1	2.35	DUCT ASSY., a/c air outlet to dist., left side
74-75	Vega	370150	1	8.70	DUCT ASSY., a/c air distributor
75	Nova (6 cyl.)	347585	1	5.15	DUCT ASSY., air intake felx.
75	Vega, Monza	3031788	1	70.50	DUCT ASSY., htr. and a/c air selector
75	Monza (Towne Cpe.)	362512	1	34.50	DUCT ASSY., ctr. htr. and a.c. air distr. (modular)
75	Monza (exc. Towne Cpe.)	354801	1	6.95	DUCT ASSY., a.c. air distr.
75	Monza (exc. Towne Cpe.)	354811	1	5.75	DUCT ASSY., htr. and a.c. distr.
75	Monza (Towne Cpe.)	364035	1	4.90	DUCT ASSY., a.c. air distr.
75	Monza (Towne Cpe.)	362522	1	2.75	EXTENSION, air distr. mod.
75	Monza (Towne Cpe.)	364040	1	1.60	EXTENSION, air distr. mod. duct
68	Caprice (Spt. Cpe.) (exc. C.A.C.),				
68	Camaro (exc. C.A.C.)	7740319	2	.21	FERRULE, side outlet upper duct vlv. act. rod knob
<i>NOTE 1: Paint as required.</i>					
70-75	Camaro (exc. floor console)	331979	1	.98	FILLER, a/c air lower outlet
67-69	Camaro,				
68-69	Chevelle,				
68-74	Nova	3949817	1	.22	GASKET, air dist. lower duct
70-75	Camaro	3963784	1	.23	GASKET, air dist. duct lower
73-75	Pass.	3022855	1	.29	GASKET, a/c recirculating inlet opening
74-75	Vega, Monza	336488	1	3.70	HOSE, a/c air dist. duct to a/c air outlet, R.H.
69	Camaro (exc. C.A.C.)	3939681	1	.98	HOUSING, left upper vent side outlet deflector
70	Pass. w/Auto. Temp. Cont.	3018577	1	4.55	HOUSING, valve air inlet
68	Camaro (exc. C.A.C.)	7730548	2	.12	KNOB, side outlet lower duct vlv. act. rod
68	Camaro (exc. C.A.C.)	9813799	2	.55	KNOB, side outlet lower duct valve act. rod (black)— (10.559)
68	Camaro (exc. C.A.C.)	7799356	2	.37	KNOB, side outlet lower duct valve act. rod (red)— (10.559)
68	Camaro (exc. C.A.C.)	7799357	2	.37	KNOB, side outlet lower duct valve act. rod (turq.)— (10.559)
68	Camaro (exc. C.A.C.)	7799363	2	.37	KNOB, side outlet lower duct valve act. rod (blue)— (10.559)

**BODY MTG.— AIR COND.— INSTRUMENTS**

**9.262 OUTLET— ADAPTER— BRACKET— CLIP— CONNECTOR— CONTROL ASSY.— COVER— DEFLECTOR— DISTRIBUTOR— DUCT— EXTENSION— FERRULE— FILLER— GASKET— HOSE— HOUSING— INSULATOR— KNOB— LEVER— NUT— RETAINER— SCREW— SEAL— SHAFT— SPACER— SPRING— STUD— VALVE— WASHER, Air Conditioning Evaporator Air Distributor and Astro-Ventilation (Con't)**

68	Camaro (exc. C.A.C.)	7799365	2	.37	KNOB, side outlet lower duct valve act. rod (saddle)— (10.559)
68	Camaro (exc. C.A.C.)	7799366	2	.37	KNOB, side outlet lower duct valve act. rod (gold)— (10.559)
68	Camaro (exc. C.A.C.)	7799368	2	.37	KNOB, side outlet lower duct valve act. rod (gray)— (10.559)
	Not required in this group. See				
	Group 9.778	3825815	2	.74	KNOB ASSY.
70-72	Nova	3940255	1	1.45	LEVER, air center outlet valve
72-75	Vega, Monza	3022962	1	.74	LEVER ASSY., w/shaft, temp. control
67	Pass.	3895965	1	.12	NUT, evaporator air outlet bezel
70-74	Camaro	3973794	A.R.	.93	RETAINER, air dist. upper duct
71-72	Pass. w/Auto. Temp. Control	381700	1	.05	RETAINER, air inlet plenum duct
71-74	Pass.	408365	1	.11	RETAINER, air dist. duct
71-75	Vega, Monza	3979753	1	.11	RETAINER, a/c outlet to instr. panel
67-68	Pass.	3906007	1	.11	SCREW, heater and air cond. air seal evap., blower and seal (1/4" — 14 x 1 1/4")
71-72	Pass.	3984608	3	.11	SCREW, air lower outlet (8-18R211)
69	Chevy, Camaro	9414754	2	.11	SCREW ASSY., air center outlet
66-67	Chevelle, Camaro				SEAL, evap. air outlet adapter seal,
68	Pass., upper level vent.				evap. air outlet bezel adapter,
69	All	3937189	A.R.	.17	upper vent. side outlet deflector
67-69	Camaro,				
68	Nova,				
68-72	Chevelle	3969803	A.R.	.13	SEAL, evap. air center outlet bezel
68-69	Chevelle,				
72	Nova,				
73-75	Pass.	3929027	1	.12	SEAL, a/c air dist. upper duct
69	Camaro (exc. C.A.C.)				upper vent. side outlet deflector housing
69	Pass., Chevy, Camaro w/Auto. Temp. Control				center outlet duct,
70-75	Pass. w/Auto. Temp. Cont.				htr. and air defr. duct seal,
70-75	Chevelle				htr. defr. outlet seal,
70-75	Nova				air side R.H. outlet spacer, center outlet duct front seal,
70-75	Camaro	3942649	A.R.		SEAL, air lower outlet of lower seal
69	Camaro				upper vent. side outlet deflector housing to inst. carrier,
69-75	Nova	3937172	A.R.	.36	SEAL, air side outlet duct
69-75	Nova				left, air side outlet duct bumper,
69-71	Camaro	3937174	3	.17	SEAL, air side outlet duct
70-75	Nova	3937135	1	.36	SEAL, center outlet duct rear
	<i>NOTE 1: Cut as required.</i>				
68-72	Chevelle,				
69-70	Pass.	3929034	4	.12	SEAL, heater and a/c air selector duct studs
68	Pass. w/Upper Level Vent. (exc. C.A.C.),				
69-70	Pass. (exc. C.A.C.),				SEAL, upper vent. side outlet duct to plenum (Note 1),
69-71	Chevy				
69	Camaro,				a/c air outlet ctr. duct,
71	Pass.				a/c air dist. duct seal
71	Pass.	3929027	2	.12	
69	Chevy, Camaro,				SEAL, dist. duct rear
70-75	Nova				
71	Camaro,				
70-72	Chevelle	3937137	1	.23	air side outlet adapt. air dist. duct
70	Pass., Chevelle, Camaro w/Auto. Temp. Cont.,				
71-72	Chevelle, Camaro,				
73-75	Camaro	3949851	2	.32	SEAL, air lower L.H. and R.H. outlet valve seal
71-75	Pass., Vega, Monza	3989222	3	.20	SEAL, air lower outlet valve
71-75	Pass. (exc. C.A.C.)	3984598	1	.22	SEAL, upper vent. center duct
71-73	Vega				SEAL, a/c center and right outlet,
71	Pass.	3999511	1	.80	air left outlet ctr. duct
71-74	Vega	3984697	1	.24	SEAL, a/c htr. air sel. duct
71-75	Vega	3992175	1	3.55	SEAL, a/c condenser radiator support upper
73-74	Camaro	3021884	2	.29	SEAL, core pipe



**BODY MTG.— AIR COND.— INSTRUMENTS**

**9.262 OUTLET— ADAPTER— BRACKET— CLIP— CONNECTOR— CONTROL ASSY.— COVER— DEFLECTOR— DISTRIBUTOR— DUCT— EXTENSION— FERRULE— FILLER— GASKET— HOSE— HOUSING— INSULATOR— KNOB— LEVER— NUT— RETAINER— SCREW— SEAL— SHAFT— SPACER— SPRING— STUD— VALVE— WASHER, Air Conditioning Evaporator Air Distributor and Astro-Ventilation (Con't)**

73-75	Chevelle	3998484	1	.36	SEAL, a/c air dist., right lower
75	Chevelle	484421	1	1.10	SEAL, air dist. duct adapter
75	Nova	346132	1	.16	SEAL, a/c air center outlet
75	Vega, Monza	3999572	1	.92	SEAL, a/c outlet
72	Vega	3969803	1	.13	SEAL ASSY., trans. cont. ind. light leak (cut as reqd.)
69	Chevy, Camaro,				
69-72	Chevy	3940247	1	1.90	SHAFT, left air side outlet valve
69	Chevy, Camaro,				
70-72	Nova	3940253	1	14.95	SHAFT, air center outlet valve
70-74	Camaro	3020370	1	.98	SHAFT ASSY., w/lever divider valve
70-74	Camaro	3020363	1	.98	SHAFT ASSY., w/lever slave valve
70-73	Camaro	3022553	2	.17	SPACER, a/c spring
75	Monza (exc. Towne Cpe.)	3031899	2	.48	SPACER, plastic
65-68	Pass.	3003411	1	.23	SPRING, air outlet valve
66	Chevelle,				
65-66	Pass.	3887070	1	.16	SPRING, ctr. outlet deflector
69	Chevy, Camaro,				
70-73	Nova	3955903	1	.11	SPRING, air center outlet
71-74	Vega	3138393	1	.33	SPRING, a/c defroster valve
72-74	Camaro	6273332	2	.91	STUD, a/c air center outlet
69-72	Chevy	3940245	1	.98	VALVE, left air side outlet
69	Chevy, Camaro,				
70-72	Nova	3940252	1	.98	VALVE, air center outlet
69	Chevy, Camaro,				
70-72	Nova, Chevelle	3942662	1	.34	VALVE, air side outlet duct
69-72	Pass.	3937198	2	.18	VALVE, air dist. duct
70	Pass., Chevelle, Camaro w/C.A.C., Auto. Temp. Cont.,				
71-72	Chevelle, Camaro,				
73-75	Camaro	3949849	2	1.10	VALVE, air lower L.H. and R.H. outlet valve
70-72	Camaro	3963726	1	1.10	VALVE, air side outlet
71-75	Pass., Vega, Monza	3989223	3	1.05	VALVE, air lower outlet
75	Pass. w/Auto. Temp. Control	3031250	1	6.25	VALVE, w/seal, a/c air, lower
75	Pass.	3031279	1	4.25	VALVE, w/seal, a/c air, lower
75	Pass. w/Auto. Temp. Control	3031307	1	6.25	VALVE, w/seal, a/c air, upper
75	Pass.	3031280	1	4.25	VALVE, w/seal, a/c air, upper
64-66	Chevelle,				
68	Camaro (exc. C.A.C.)	1348879	4	.12	WASHER, outlet valve rod
69-70	Chevy				WASHER, a/c air ctr. lwr. wa.,
69	Camaro				a/c air ctr. otlt. lwr. wa.,
69	Chevelle	3731921	1	.12	a/c air ctr. otlt. defl. lever wa.— (4.312)

**9.264 BEZEL— DEFLECTOR— GRILLE— RETAINER— SPACER— STRAP— STUD, Air Conditioning Remote Evaporator Air Distributor Outlet**

67	Camaro,				
68	Camaro	3937121	L.H.	3.25	air outlet
	<i>NOTE 2: Paint as required.</i>				
67-68	Camaro	3937122	1	3.25	evap. air outlet right
69	Chevy, Camaro,				
70-75	Nova	3937149	1	1.45	air side outlet
70	Nova (exc. bucket seat)	3973709	2	.76	a/c air shut-off cbl.
71-72	Nova	3989293	2	.71	dir. shut-off cable (black) paint as reqd.
73-75	Chevelle	3998456	1	1.30	upper level vent. center outlet
69	Chevelle				BEZEL ASSY., evap. air outlet,
69	Chevelle (Spt. Cpe., Conv.) (exc. C.A.C.)	3937185	L.H.	3.30	upper vent. side outlet,
69	Chevelle				BEZEL ASSY., evap. air outlet,
69	Chevelle (Spt. Cpe., Conv.) (exc. C.A.C.)	3946966	R.H.	4.50	upper vent. side outlet
65-66	Pass. w/Custom (exc. Deluxe),				
74	Chevelle,				
71-75	Pass. (exc. C.A.C.)	3984636	1	4.50	DEFLECTOR, upper vent. center duct outlet
73-75	Pass.,				
74-75	Chevelle	3979751	2	4.00	DEFLECTOR, upper vent. center duct (chrome)
73-75	Nova	3963790	1	4.20	DEFLECTOR, a/c air outlet
75	Monza (Towne Cpe.)	362551	2	2.75	DEFLECTOR, center outlet
68-69	All w/Acc. Air Cond.	3157835	2	1.25	GRILLE, evaporator side
62-64	Chevy, Chevelle,				

**BODY MTG.— AIR COND.— INSTRUMENTS**

**9.264 BEZEL— DEFLECTOR— GRILLE— RETAINER— SPACER— STRAP— STUD, Air Conditioning Remote Evaporator Air Distributor Outlet (Con't)**

65-66	All w/Cool Pack, Custom,				
68	All,				
69	All w/Acc. Air Cond.				RETAINER, side grille
71-74	Nova	3146637	2	.17	evap. side outlet grille
67-68	Camaro	3885180	2	.16	RETAINER, evap. air outlet bezel
73-74	Chevelle	336456	1		STRAP, a/c air dist. duct to heater— (9.242)
74-75	Camaro	6273332	2	.91	STUD, a/c air center outlet (10-24)

**9.273 CONTROL ASSY., Air Conditioning Instrument Panel**

64-65	Chevelle w/Air Cond.	3843997	1	14.35	a/c
65-66	Pass. w/C.A.C.	3875805	1	21.25	a/c
66	Pass. w/Auto. Temp. Cont.	3891720	1	58.50	a/c
66-67	Chevy w/C.A.C.	3870241	1	20.55	a/c
66	Chevelle w/C.A.C.	3870223	1	22.45	a/c
67	Chevelle w/C.A.C.	3899764	1	25.50	a/c
67	Camaro w/C.A.C.	3891797	1	17.70	a/c
67	Pass. w/C.A.C.	3891786	1	21.25	a/c
67	Pass. w/Auto. Temp. Cont.	3891782	1	58.50	a/c
68	Pass. w/C.A.C.	3919503	1	22.90	a/c
68	Pass. w/Auto. Temp. Cont.	3919504	1	57.25	a/c
68	Camaro w/C.A.C.	3919581	1	20.55	a/c
68	Chevy w/C.A.C.	3940277	1	26.75	a/c
68-69	Chevelle w/C.A.C.	3946900	1	28.50	a/c (Note 1)

*NOTE 1 When using 3946900 in place of 3938543 or 3909037 the center vacuum/port No. 2 must be sealed off.*

69	Pass. w/Auto. Temp. Control	7307601	1	69.00	a/c
69-70	Pass. w/C.A.C. (exc. Auto. Temp. Cont.)	7308301	1	28.75	a/c
69	Chevy, Camaro w/C.A.C.,				
70-74	Nova	6273372	1	20.00	a/c
70-72	Chevelle w/C.A.C.	6273368	1	25.75	a/c
70-72	Camaro w/C.A.C.	6273370	1	32.50	a/c
70	Pass. w/Auto. Temp. Control	7311681	1	78.60	a/c
71	Pass. w/Auto. Temp. Control	7930281	1	41.55	a/c
71-74	Pass. w/C.A.C. (exc. Auto. Temp. Control)	7938671	1	30.79	a/c
72-75	Pass. w/Auto. Temp. Control	9347091	1	59.47	a/c
73	Chevelle	3992194	1	25.75	
73	Camaro	340494	1	26.75	
74-75	Camaro (1st design)	340421	1	26.75	(Note 1)
74	Chevelle	340419	1	25.75	
75	Camaro (2nd design)	362595	1	27.25	(Note 1)
75	Nova	346101	1	30.25	
75	Chevelle	356154	1	30.25	
75	Pass. (exc. Auto. Temp. Control)	9346641	1	32.12	
71-75	Vega, Monza (exc. Towne Cpe.)	356174	1	30.25	
75	Monza (Towne Cpe.)	362501	1	16.85	

*NOTE 1: 2nd design has the word "MAX" in the upper lever nomenclature.*

**9.275 SWITCH— ACTUATOR— AMPLIFIER ASSY.— ARM ASSY.— ASPIRATOR ASSY.— BEARING PKG.— BOARD UNIT— CAM— CIRCUIT BOARD ASSY.— CLIP— CONNECTOR— COVER— HARNESS ASSY.— GASKET— GROMMET— HOSE— INSULATOR— KNOB ASSY.— NUT— PROGRAMMER ASSY.— RESISTOR— RETAINER— SEAL— SENSOR ASSY.— SPRING— STUD— TRANSDUCER ASSY., Air Conditioning Electrical Temperature and Blower Motor Control**

62-67	Chevy,				
64	Chevelle w/Custom Deluxe	3828946	1	3.05	blower motor control
64-65	Chevelle	3864392	1	3.20	blower motor control
64	Chevelle w/Custom (exc. Deluxe)	3159535	1	11.55	evap. blower
64	Chevelle	3849122	1	1.70	heater control— (8.852)
65	Chevelle	3860509	1	1.75	htr. control
65-68	Pass.,				
66-68	Chevelle,				
68	Chevy, Camaro	3870286	1	1.70	htr. and air cond. blower (push button w/2 term)— (8.852)
65	Pass.,				
66	Pass. (exc. Auto. Temp.)	3857992	1	1.55	htr. cont.— (8.852)
65-66	All w/Acc. Air Cond.	3003539	1	9.80	evap. blower
65-66	All w/Acc. Air Cond.,				
67	Chevy	3003540	1	22.80	evap. ranco control
66	Pass. w/Auto. Temp. Control	3875847	1	3.54	htr. and air cond. blower— (8.852)
66	Chevelle (exc. C.A.C.)	3895923	1	1.70	htr. control— (8.852)

**BODY MTG.— AIR COND.— INSTRUMENTS**

**9.275 SWITCH— ACTUATOR— AMPLIFIER ASSY.— ARM ASSY.— ASPIRATOR ASSY.— BEARING PKG.— BOARD UNIT— CAM— CIRCUIT BOARD ASSY.— CLIP— CONNECTOR— COVER— HARNESS ASSY.— GASKET— GROMMET— HOSE— INSULATOR— KNOB ASSY.— NUT— PROGRAMMER ASSY.— RESISTOR— RETAINER— SEAL— SENSOR ASSY.— SPRING— STUD— TRANSDUCER ASSY., Air Conditioning Electrical Temperature and Blower Motor Control (Con't)**

66-67	Chevelle	3870224	1	3.75	heater and air cond. control
67-69	Pass. w/Auto. Temp. Control	7299920	1	4.57	heater and air cond. Servo Fan
67-69	All w/Acc. Air Cond.	3012089	1	6.15	A/C blower control
67	Camaro,				
67	Pass. (exc. Auto. Temp. Control)	3891796	1	1.70	htr. and A/C outlet— (8.852)
67	Pass. w/Air Cond.,				
67	Camaro,				
68	Pass. (exc. Auto. Temp. Control)	3891795	1	1.70	htr. and A/C blower fan 4 term— (8.852)
68	Pass. (exc. Auto. Temp. Control)	3919586	1	3.20	heater and A/C control (4 term w/brkt.)— (8.852)
68-69	All w/Acc. Air Cond.	3015259	1	21.90	Ranco
68	Pass. (exc. Auto. Temp. Control),				
68-69	Chevy, Chevelle, Camaro,				
69	Pass.,				
70-71	All, Vega,				
72	Pass.,				
73-75	All	483326	1	3.80	heater and A/C ambient (Note 1)
	<i>NOTE 1 This switch cuts off elect. supply to comp. at 29 degrees F. and below to protect comp. shaft seal assy. from damage.</i>				
68	Chevy	3909017	1	2.00	htr. and A/C blower, low— (8.852)
68	Chevelle	3929060	1	2.85	htr. and A/C blower— (8.852)
68	Chevelle	3909064	1	2.00	htr. and A/C outlet— (8.852)
68	Camaro	3925724	1	3.45	htr. and A/C control— (8.852)
68	Chevy	3909018	1	3.90	htr. and A/C Spd. control
69	Nova, Camaro,				
70-74	Nova	3973728	1	2.45	heater & A/C control blower low
69	Chevy, Camaro w/C.A.C.,				
70-75	Nova	6273385	1	3.55	heater and A/C control fan
69	All w/C.A.C. (exc. Pass.),				
70-75	Nova	3955900	1	1.95	comp. and low blower
69	Chevelle	3942656	1	2.75	heater and A/C blower— (8.852)
69-70	Pass.,				
70-72	Chevelle	7308940	1	3.87	heater and A/C master
69-70	Pass.,				
70-72	Chevelle	7308941	1	3.23	temp. cont.
69-70	Pass. (exc. Auto. Temp. Cont.)	6273391	1	1.80	heater and A/C blower
70	Chevelle	7314261	1	3.65	car heater and A/C
70-72	Chevelle	6273383	1	3.55	heater and A/C control fan— (8.852)
70-72	Camaro	7313841	1	3.50	A/C master
70-72	Camaro	7313831	1	3.44	A/C compressor
70-72	Camaro	6273384	1	3.55	htr. and A/C blower
71-75	Pass. w/Auto. Temp. Control	6490043	1	4.19	A/C thermo. (threads into rear of engine cyl. head)
71-74	Pass. (exc. Auto. Temp. Control)	7933480	1	3.01	blower
71-75	Vega, Monza	7931444	1	4.37	a/c compressor
71-75	Vega	483326	1	3.80	a/c htr. ambient (on blower)
71-75	Vega, Monza (1BC w/A.T.) (4 cyl.)	3996265	1	4.60	a/c comp. cutoff (at carb.) (Note 2)
	<i>NOTE 2: Used to cut out compressor during full throttle condition.</i>				
71-75	Vega, Monza	3979719	1	3.50	htr. and a/c blower (on control)
71-72	Vega (2BC w/A.T.)	6273320	1	4.50	a/c comp. cut off (at carb.)
73	Chevelle	6273310	1	10.00	heater and a/c master— (8.852)
73-75	Camaro	331928	1	3.55	heater and a/c blower
73	Camaro	331929	1	3.55	heater and a/c master
73-75	All (exc. Auto. Temp. Control, Vega, Monza)	6490609	1	4.30	car htr. low blower delay, engine thermo. (2 terminals, insulator color blue) (threads into rear of engine cyl. head)— (8.852)
73-75	Chevelle	336408	1	1.55	htr. and a/c control blower
73-75	Vega, Monza (2BC w/A.T.) (4 cyl.)	331972	1	4.50	a/c comp. cut off (at carb.)
73-75	Vega (4 cyl.)	3030062	1	24.25	a/c w/cover (evap. and blower)
74-75	Chevelle, Camaro, Nova	340427	1	7.25	a/c vac. and elect.—(13 ports and 3 term.)—(rectangular)
74-75	Vega, Monza	339848	1	6.30	a/c comp. cut-off, pressure, at sight glass
75	Nova	346109	1	2.45	htr. and a/c control blower, low
75	Pass. (exc. Auto. Temp. Control)	9346460	1	3.34	select rotary
75	Pass. (exc. Auto. Temp. Control)	1223590	1	2.88	blower
75	Camaro w/A.C.	362590	1	7.35	vac.-elect. (9-port)

**BODY MTG.— AIR COND.— INSTRUMENTS**

**9.275 SWITCH— ACTUATOR— AMPLIFIER ASSY.— ARM ASSY.— ASPIRATOR ASSY.— BEARING PKG.— BOARD UNIT— CAM— CIRCUIT BOARD ASSY.— CLIP— CONNECTOR— COVER— HARNESS ASSY.— GASKET— GROMMET— HOSE— INSULATOR— KNOB ASSY.— NUT— PROGRAMMER ASSY.— RESISTOR— RETAINER— SEAL— SENSOR ASSY.— SPRING— STUD— TRANSDUCER ASSY., Air Conditioning Electrical Temperature and Blower Motor Control (Con't)**

75	Monza (Towne Cpe.)	9348809	1	4.63	htr. and a.c.
75	Monza (Towne Cpe.)	362549	1	3.80	htr. and a.c. blower control
75	Vega, Monza (exc. Towne Cpe.)	3023514	1	3.40	blower, air inlet
73	Pass. w/Auto. Temp. Control	1996507	1	3.90	ACTUATOR, a/c inlet vac.
66	Pass. w/Auto. Temp. Control	1222253	1	29.15	AMPLIFIER ASSY., htr. control
67-68	Pass. w/Auto. Temp. Control	7300021	1	22.90	AMPLIFIER ASSY., htr. control
69	Pass. w/Auto. Temp. Control	7308992	1	24.90	AMPLIFIER ASSY., heater control circuit board
70-71	Pass. w/Auto. Temp. Control	7311618	1	20.25	AMPLIFIER ASSY., car htr. cont. circuit board
71-75	Pass. w/Auto. Temp. Control	1223114	1	2.25	ARM ASSY., wiper contacts
74	Pass. w/Auto. Temp. Control	1223462	1	11.13	ARM ASSY., mix door oper., htr. and a/c
71-72	Pass. w/Auto. Temp. Control	487308	1	.98	ASPIRATOR ASSY., in car sensor
71-72	Pass. (exc. Auto. Temp. Control)	1223345	1	5.75	BOARD UNIT, circuit/car htr. and a/c
75	Pass. w/Auto. Temp. Control	1223221	1	.41	BEARING PKG.
71-74	Pass. (exc. Auto. Temp. Control)	7932904	1	.56	CAM, control cable
71-74	Pass. (exc. Auto. Temp. Control)	7932907	1	.47	CAM, temp. control
71-74	Pass. w/Auto. Temp. Control	7932502	1	7.85	CIRCUIT BOARD ASSY., resistor blower
71-74	Pass. w/Auto. Temp. Control	1223165	1	20.51	CIRCUIT BOARD ASSY., Darlington amplifier
73	Pass. w/C.A.C. (exc. Auto. Temp. Control)	1223345	1	5.75	CIRCUIT BOARD ASSY., blower
74-75	Pass. w/C.A.C. (exc. Auto. Temp. Control)	9340540	1	6.47	CIRCUIT BOARD ASSY., blower
75	Pass. w/Auto. Temp. Control	9344071	1	8.00	CIRCUIT BOARD ASSY., blower
75	Pass. w/Auto. Temp. Control	1223685	1	24.85	CIRCUIT BOARD ASSY., includes pot, amp., terminals and transducer
71-74	Pass. w/Auto. Temp. Control	7932516	1	.25	CLIP, heat sink
75	Pass. w/Auto. Temp. Control	8917014	1	.46	CONNECTOR, body 6-pin
66-68	Pass. (exc. Auto. Temp. Control)				GASKET, htr. and a/c blower mtr. resistor,
75	Pass. w/Auto. Temp. Control	9344237	1	3.96	COVER, black plastic front
67-69	Pass. w/Auto. Temp. Control,				GROMMET, a/c htr. vac. element
69-70	Pass.	3002381	1	.27	HARNESS ASSY., w/circuit board
75	Pass. w/Auto. Temp. Control	9346166	1	12.14	HOSE, a/c htr. vac. element hose (25" O.L.)— (8.962)
67	Pass. w/Auto. Temp. Cont.	3987362	1	RL/.12	INSULATOR, heat sink
71-74	Pass. w/Auto. Temp. Control	7932507	1	.20	KNOB ASSY., w/potentiometer htr. cont.— (8.852)
71-74	Pass. w/Auto. Temp. Cont.	9340400	1	11.55	KNOB ASSY., w/potentiometer htr. cont.— (8.852)
66-67	Pass. w/Auto. Temp. Control	7300234	1	8.65	KNOB ASSY., w/potentiometer control
68	Pass. w/Auto. Temp. Control	7303868	1	9.30	KNOB ASSY., w/potentiometer htr. cont.— (8.852)
69-70	Pass. w/Auto. Temp. Control	7309015	1	8.40	KNOB ASSY., w/potentiometer htr.— (8.852)
75	Pass. w/Auto. Temp. Control	9347269	1	7.58	KNOB ASSY., w/potentiometer htr. cont.
65-66	All w/Acc. Air Cond.,				NUT, speed ("U" shape)
67	Chevy	3000142	4	.05	PROGRAMMER ASSY.
71-74	Pass. w/Auto. Temp. Control	7930135	1	74.75	PROGRAMMER ASSY.
75	Pass. w/Auto. Temp. Control	9341576	1	77.75	PROGRAMMER ASSY.
71-75	Vega, Monza	3979727	1	1.65	RESISTOR ASSY., a/c heater blower mtr.
62-65	Chevy	3929098	1	1.55	RESISTOR, blower motor
68	Pass. w/Auto. Temp. Control	1222885	1	4.63	RESISTOR, htr. and a/c duct feedback potentiometer variable
69-70	Pass. w/Auto. Temp. Control	7309729	1	3.80	RESISTOR, heater and a/c duct feedback potentiometer variable
64	Chevelle w/C.A.C.	3929046	1	2.80	RESISTOR ASSY., blower motor
66	Pass. w/Auto. Temp. Control	3929049	1	3.55	RESISTOR ASSY., htr. & a/c blower motor
65-67	Chevelle, Camaro,				
65-68	Pass.,				
68	Chevy	3929055	1	1.50	RESISTOR ASSY., blower motor
66	Chevy,				
66	Pass. w/Acc. Air Cond. (exc. Caprice),				
66	Chevelle w/Acc. Air Cond.,				
66	Caprice w/Acc. Air Cond. (exc. Spt. Cpe.)	3866430	1	1.55	RESISTOR ASSY., heater blower
67-70	Pass. w/Auto. Temp. Control	3955970	1	3.40	RESISTOR ASSY., htr. & a/c blower mtr.
67-68	All w/Acc. Air Cond.,				

**BODY MTG.— AIR COND.— INSTRUMENTS**

**9.275 SWITCH— ACTUATOR— AMPLIFIER ASSY.— ARM ASSY.— ASPIRATOR ASSY.— BEARING PKG.— BOARD UNIT— CAM— CIRCUIT BOARD ASSY.— CLIP— CONNECTOR— COVER— HARNESS ASSY.— GASKET— GROMMET— HOSE— INSULATOR— KNOB ASSY.— NUT— PROGRAMMER ASSY.— RESISTOR— RETAINER— SEAL— SENSOR ASSY.— SPRING— STUD— TRANSDUCER ASSY., Air Conditioning Electrical Temperature and Blower Motor Control (Con't)**

70	All w/Acc. Air Cond. (exc. Camaro) .....	3929051	1	2.65	RESISTOR ASSY., blower motor .....
69	Chevy, Camaro,				
70-72	Nova .....	3942651	1	2.85	RESISTOR ASSY., heater and a/c blower motor .....
69-71	Chevelle .....	3949879	1	2.75	RESISTOR ASSY., heater and a/c blower motor .....
69	Pass.,				
70	Pass. (exc. Auto. Temp. Cont.) ..	3949920	1	2.60	RESISTOR ASSY., heater and a/c blower motor .....
70-72	Camaro .....	3963755	1	2.80	RESISTOR ASSY., htr. and a/c blower motor .....
71-74	Pass. (exc. Auto. Temp. Control) .	3998401	1	1.75	RESISTOR ASSY., heater and a/c blower motor .....
72	Chevelle .....	6262651	1	2.75	RESISTOR ASSY., heater and a/c blower motor .....
71-75	Vega, Monza .....	3979727	1	1.65	RESISTOR ASSY., a/c heater blower mtr. . .
73-75	Chevelle w/C.A.C. ....	487392	1	1.60	RESISTOR ASSY., heater and a/c blower motor .....
73-75	Nova w/C.A.C. ....	6262652	1	2.75	RESISTOR ASSY., heater and a/c blower motor .....
73-75	Camaro w/C.A.C. ....	6262655	1	2.75	RESISTOR ASSY., htr. and a/c blower motor .....
71-74	Pass. w/Auto. Temp. Control ...	3984693	1	.11	RETAINER, control to heater, defroster ...
71-75	Pass. w/Auto. Temp. Control ...	7933230	1	.36	RETAINER, power .....
65-68	Pass. (exc. Auto. Temp. Control),				
65-68	Chevelle, Camaro,				
68	Chevy .....	3979313	1	.05	SEAL, blower mtr. resistor assy. ....
69	Chevelle w/C.A.C.,				
70	All w/C.A.C. (exc. Camaro) (exc. Auto. Temp. Cont.),				
71-72	Nova, Chevelle,				
71-74	Vega,				
73-74	Nova .....	3942653	1	.18	SEAL, blower mtr. resistor assy. ....
66-67	Pass. w/Auto. Temp. Control ...	3885192	1	14.55	SENSOR ASSY., htr. and air cond. ambient air .....
67	Pass. w/Auto. Temp. Control ...	1222692	1	17.00	SENSOR ASSY., htr. and a/c duct air .....
67-68	Pass. w/Auto. Temp. Control ...	1222691	1	14.95	SENSOR ASSY., htr. and a/c servo assy. blower relay w/thermister .....
67-68	Pass. w/Auto. Temp. Control ...	3899753	1	5.95	SENSOR ASSY., htr. and a/c air dash .....
68	Pass. w/Auto. Temp. Control ...	3929068	1	12.35	SENSOR ASSY., htr. and air cond. ambient air .....
69-70	Pass. w/Auto. Temp. Control ...	3937120	1	5.50	SENSOR ASSY., heater and a/c in car air ..
69-70	Pass. w/Auto. Temp. Control ...	7309732	1	9.85	SENSOR ASSY., w/thermistor and lead, heater and a/c servo .....
69	Pass. w/Auto. Temp. Control ...	7308821	1	5.55	SENSOR ASSY., heater and a/c ambient air
70	Pass. w/Auto. Temp. Cont. ....	7313821	1	7.70	SENSOR ASSY., car htr. and a/c ambient ..
71-75	Pass. w/Auto. Temp. Cont. ....	7930251	1	4.61	SENSOR ASSY., car htr. and a/c in car air ..
71-75	Pass. w/Auto. Temp. Cont. ....	7934224	1	5.16	SENSOR ASSY., car htr. and a/c ambient ..
71-75	Pass. w/Auto. Temp. Control ...	7932552	1	.51	SPRING, power .....
72-74	Nova, Camaro .....	3895910	1	.34	STUD, evap. and blower .....
75	Pass. w/Auto. Temp. Control ...	7932544	1	.41	STUD, valve retainer .....
66	Pass. w/Auto. Temp. Control ...	3875854	1	19.95	TRANSDUCER ASSY., htr. and air cond. ...
67-69	Pass. w/Auto. Temp. Control ...	3895949	1	20.83	TRANSDUCER ASSY., htr. and air cond. ...
70	Pass. w/Auto. Temp. Cont. ....	7308912	1	16.80	TRANSDUCER ASSY., car htr. and a/c .....
71-74	Pass. w/Auto. Temp. Control ...	7932545	1	16.38	TRANSDUCER ASSY., car htr. and a/c control .....

**9.276 HARNESS ASSY.— LINK ASSY.— WIRE ASSY., Air Conditioning, Electrical**

67	Camaro w/C.A.C. ....	6290626	1	20.30	(56 <sup>19</sup> / <sub>32</sub> " O.L.) .....
68	Pass. w/C.A.C. ....	6295098	1	25.50	wiring .....
68	Chevelle w/C.A.C. ....	6295096	1	20.55	A/C wiring .....
69	Chevelle w/C.A.C. ....	6297517	1	22.45	wiring .....
69	Chevy, Camaro w/C.A.C.,				
70	Nova w/C.A.C. ....	8901577	1	23.30	wiring .....
69-70	Pass. w/C.A.C. (exc. Auto. Temp. Control) .....	6297561	1	26.50	wiring .....
70	Chevelle w/C.A.C. ....	8901429	1	23.30	wiring .....
71	Pass. w/Auto. Temp. Control ...	8901769	1	36.75	A/C wrng. ....

**BODY MTG.— AIR COND.— INSTRUMENTS**

**9.276 HARNESS ASSY.— LINK ASSY.— WIRE ASSY., Air Conditioning, Electrical (Con't)**

71	Chevelle w/C.A.C. ....	8901894	1	43.00	wiring .....
71	Nova w/C.A.C. ....	8901892	1	40.00	wiring .....
71-74	Pass. w/Auto. Temp. Control ...	7934058	1	13.52	w/circuit bd. ....
71	Pass. w/C.A.C. (exc. Auto. Temp. Cont.) .....	8901780	1	26.00	wiring .....
71	Camaro w/C.A.C. ....	8901893	1	40.75	wiring .....
72	Chevelle w/C.A.C. ....	8908074	1	33.50	wiring .....
72	Nova w/C.A.C. ....	8908041	1	40.00	wiring .....
72	Camaro w/C.A.C. ....	8908040	1	40.75	wiring .....
71	Vega .....	8901939	1	24.50	comp. wrg. ....
71-73	Vega .....	8901567	1	24.35	a/c wiring .....
72-74	Pass. w/Auto. Temp. Control ...	8908231	1	39.25	wiring .....
72	Vega .....	8908118	1	24.35	a/c wiring .....
73-74	Vega .....	8908276	1	24.35	a/c wiring .....
73	Chevelle .....	8908183	1	27.50	wiring .....
73-74	Nova .....	8908233	1	40.00	wiring .....
73-75	Pass. (exc. Auto. Temp. Cont.) ...	8908230	1	31.00	wiring .....
73-75	Camaro .....	8908542	1	36.25	wiring .....
74	Chevelle .....	8908419	1	27.50	wiring .....
75	Nova (6 cyl.) .....	8916205	1		wiring .....
75	Chevelle .....	8908563	1	33.75	wiring .....
75	Pass. w/Auto. Temp. Control ...	8908516	1	47.75	wiring .....
75	Monza (exc. Towne Cpe.) .....	8916180	1	27.00	a.c. wiring .....
75	Monza (Towne Cpe.) (4 cyl.) .....	8916264	1	24.35	a.c. wiring .....
75	Monza (8 cyl.) (exc. Towne Cpe.) .....	8916358	1	30.75	a.c. wiring .....
75	Monza (Towne Cpe.) (8 cyl.) .....	8916265	1	24.35	a.c. wiring .....
75	Vega .....	8916178	1	36.00	a/c wiring .....
75	Vega, Monza (8 cyl.) .....	8916359	1	9.55	a/c comp. cut-off .....
75	Pass. w/Auto. Temp. Control ...	9345259	1	12.14	HARNESS, programmer adapter .....
66-70	Pass. w/Auto. Temp. Control ...	7311191	1	3.56	LINK ASSY., htr. and A/C servo .....
71-75	Pass. w/Auto. Temp. Control ...	7932695	1	2.36	LINK ASSY., programmer .....
71-73	Vega .....	8909961	1		WIRE ASSY., a/c comp. to pressure switch .....
73-75	All (8 cyl.) .....	8908219	1	6.75	WIRE ASSY., a/c compressor .....
75	All (6 cyl.) .....	8908597	1	6.75	WIRE ASSY., a/c compressor .....

**9.277 RELAY ASSY.— BRACKET, Air Conditioning Electrical**

62-68	All,				
69	Pass. w/Auto. Temp. Control ...	1365166	1	5.00	blower motor cut out (terminals) .....
69	All w/C.A.C. (exc. Auto. Temp. Control),				
70	All,				
71-75	All (exc. Pass., Vega) .....				blower mtr. cutout, .....
71-75	Pass. w/Auto. Temp. Control ...	1115881	A.R.	6.65	system turn on .....
71-72	Nova, Chevelle (8 cyl.) .....	3996204	1	2.70	anti dieseling blocking— (3.440) .....
71-75	Pass. w/Auto. Temp. Control ...	7930501	1	3.79	vacuum checking .....
71-72	Pass. (exc. Auto. Temp. Cont.),				
73-75	Pass., Chevelle, Camaro,				
75	Monza (exc. Towne Cpe.) .....	1115858	1	11.15	blower mtr. cut-out .....
71-72	All w/C.A.C. (8 cyl.) .....	6273301	1	6.90	anti-dieseling— .....
73	Vega .....	3996296	1	2.25	a/c compressor time delay— (4.075) .....
73-75	Vega .....	3961573	1	2.85	a/c compressor current control— (4.075) ..
74-75	Pass. (Sta. Wag.) .....	496218	1	5.85	pwr. operated tail gate .....
74-75	Vega, Monza (4 cyl.) .....	336447	1	2.25	a/c compressor time delay— (4.075) .....
75	Vega, Monza (8 cyl.) .....	346150	1	19.05	a/c compressor time delay— (4.075) .....
75	Monza (exc. Towne Cpe.) .....	366408	1	11.30	a.c. compr. cut-out-engine temp. ....
72-75	Pass. w/Auto. Temp. Control ...	3989215	1	.11	BRACKET, relay .....

**9.278 KNOB— LEVER, Air Conditioning Control**

62	Chevy .....	3792753	A.R.	.59	air cond. blower switch, air inlet and defroster control— (8.852) .....
67-69	All w/Acc. Air Cond. ....	3012091	1	1.15	evap. air control .....
67-69	All w/Acc. Air Cond. ....	3015260	1	1.15	temp. ....
71-75	Pass. w/C.A.C., Auto. Temp. Cont. ....	7932343	1	.56	htr. and A/C cont. selector .....
71-74	Pass. w/C.A.C. (exc. Auto. Temp. Cont.) .....	7932344	1	.92	htr. and A/C cont. ....
75	Pass. w/C.A.C. (exc. Auto. Temp. Control) .....	9346642	1	1.01	htr. and a/c temp. control .....
75	Pass. w/C.A.C. (exc. Auto. Temp. Control) .....	9346640	1	.96	htr. and a/c selector control .....
75	Monza (exc. Towne Cpe.) .....	364025	2	1.60	htr. and a.c. control .....
75	Monza (exc. Towne Cpe.) .....	3031850	1	.81	LEVER, a.c. control .....
75	Monza (Towne Cpe.) .....	3033619	1	.81	LEVER, div. valve control .....
75	Monza (Towne Cpe.) .....	3033626	1	.81	LEVER, air valve control .....

**BODY MTG.— AIR COND.— INSTRUMENTS**

**9.279 DIAL— BASE PLATE— CLAMP— ESCUTCHEON— FILTER— GRILLE—  
INSERT— LENS PLATE, Air Conditioning Control**

71-74	Pass. w/C.A.C. (exc. Auto. Temp. Control)	7932341	1	3.04	BASE PLATE, htr. and a/c control
73-75	Vega, Monza (4 cyl.)	3027846	1	.38	CLAMP, accum. freeze throttle valve
62-64	Chevy	3791114	1	.32	ESCUTCHEON, heater and blower switch (AIR— FAN)— (8.852)
67-69	All w/Acc. Air Cond.	3012320	1	1.30	ESCUTCHEON, evap. bezel
72-74	Pass. w/C.A.C. (exc. Auto. Temp. Control)	1223328	1	1.94	ESCUTCHEON
72-74	Pass. w/Auto. Temp. Control	1223327	1	3.32	ESCUTCHEON
71-72	Chevelle w/C.A.C.	3963751	1	.24	FILTER
71-75	Pass. w/Auto. Temp. Control	331980	1	.67	GRILLE, in car sensor
71-72	Chevelle	3979709	1	.18	INSERT, control trim
71-74	Nova	3967913	1	.18	INSERT, control lens trim
70-74	Chevelle	3998460	1	1.35	LENS, heater, a/c control
70-71	Camaro	3979743	1	1.50	LENS, heater, A/C control
72	Camaro	6273377	1	1.50	LENS, heater, A/C control
73	Camaro	331927	1	1.50	LENS, heater, a/c control
74-75	Camaro	340457	1	1.50	LENS, htr. and a/c control
73	Camaro	331926	1	3.15	PLATE, htr. and a/c control bracket
74-75	Camaro	340456	1	3.15	PLATE, htr. and a/c control bracket
75	Monza (Notchback)	362505	1	3.55	PLATE, htr. and a/c control
75	Monza (Towne Cpe.)	362505	1	3.55	PLATE, htr. and a/c control

**9.280 ACTUATOR— CAM ASSY.— ELEMENT— MOTOR ASSY.— SERVO  
ASSY.— SWITCH— SPRING— VALVE, Air Conditioning Vacuum Control**

65-66	Pass. w/Prod. C.A.C.	1998905	1	7.10	air adap. vac.
65-70	Pass. w/C.A.C., Auto. Temp. Control,				
70	Chevelle, Camaro w/C.A.C., Auto. Temp. Control,				
71-72	Chevelle w/C.A.C.	1998999	1	5.45	heater air dist. vac.
70-72	Camaro w/C.A.C.	1998972	1		plenum air inlet plenum valve
73-74	Chevelle	1998997	2	4.69	diverter valve
73-75	Pass.	1996507	1	3.90	a/c inlet vacuum
75	Monza (Towne Cpe.)	1996553	1	4.33	diverter valve front
75	Monza (Towne Cpe.)	1996554	1	6.85	diverter valve rear
75	Monza (Towne Cpe.)	1996557	1	4.10	dist. duct
73-75	Camaro	1996509	1	4.46	ACTUATOR ASSY., air inlet plenum vlv.
73	Nova, Camaro	1996505	1	3.48	ACTUATOR ASSY., air inlet side shrd. vac.
66	Pass. w/Auto. Temp. Control	1998923	1	4.14	ELEMENT, htr. diverter valve vacuum
67-68	Pass. w/C.A.C.	3150944	1	3.93	ELEMENT, air adap. vac.
67-70	Pass. w/Auto. Temp. Control	1998930	1	6.35	ELEMENT, heater defroster vac.
69-70	Pass. w/Auto. Temp. Control	1998964	1	6.85	ELEMENT, air inlet vacuum
70-73	Camaro w/A.T. (exc. NB-2)	1998994	1	4.17	ELEMENT, evap. purge valve
71-75	Pass.	1998981 A.R.		3.98	ELEMENT, vacuum diverter
71-73	Pass.	1998985	1	4.28	ELEMENT, vacuum, air valve
71-75	Vega, Monza	1998986	1	4.03	ELEMENT, vac. diverter valve
71-75	Vega, Monza	1998987	1	3.55	ELEMENT, vac. defroster valve
73-74	Camaro,				
75	Nova	1998999	1	5.45	ELEMENT, htr. and a/c diverter vacuum
71-75	Pass. w/Auto. Temp. Control	1223462	1	11.13	MOTOR ASSY., vacuum
66	Pass. w/Auto. Temp. Control	3875852	1	44.00	SERVO ASSY., htr. & a/c
67	Pass. w/Auto. Temp. Control	3895947	1	46.05	SERVO ASSY., htr. & a/c
68	Pass. w/Auto. Temp. Control	3923179	1	42.35	SERVO ASSY., htr. & a/c
69-70	Pass. w/Auto. Temp. Control	7308831	1	44.20	SERVO ASSY., vacuum power
71-75	Pass. w/Auto. Temp. Control	7932535	1	.20	SPRING, vacuum valve
66	Pass. w/Auto. Temp. Control	7302385	1	10.23	SWITCH, vacuum
69	Camaro w/C.A.C.,				
69-71	Chevy w/C.A.C.,				
72-74	Nova	7308825	1	3.75	SWITCH, vacuum (3 port)
70-72	Camaro w/C.A.C.	7313851	1	4.36	SWITCH, vacuum (9 port)
73	Camaro	7308935	1	2.67	SWITCH ASSY., a/c vacuum (3 port)
73	Camaro	9343991	1	5.25	SWITCH ASSY., a/c vac. (9 port)
74	Chevelle, Camaro	340427		7.25	SWITCH ASSY., a/c vac. and elect.-(13 ports and 3 term.)-(rectangular)— (9.275)
75	Camaro w/A.C.	362590	1	7.35	SWITCH ASSY., control assy. (9-port)
69	Pass. w/C.A.C.,				
67-68	Pass. w/Auto. Temp. Control	7311063	1	6.80	VALVE, a/c vacuum relay
70-72	Nova	1222690	1	3.60	VALVE ASSY., heater and a/c sensor assy. vacuum controlled (2 port)
69	Pass. (exc. Auto. Temp. Control),				
70	All w/C.A.C. (exc. Nova),				
71-72	Camaro w/C.A.C.,				

**BODY MTG.— AIR COND.— INSTRUMENTS**

**9.280 ACTUATOR— CAM ASSY.— ELEMENT— MOTOR ASSY.— SERVO ASSY.— SWITCH— SPRING— VALVE, Air Conditioning Vacuum Control (Con't)**

72	Chevelle w/C.A.C. . . . .	7308935	1	2.67	VALVE ASSY., heater and a/c vac. control (3 ports, temp., lever) . . . . .
70	Pass. w/C.A.C. . . . .	7308934	1	2.67	VALVE ASSY., htr. and a/c vac. cont. (9 port valve actuated by mode lever) . . . . .
70-72	Chevelle w/C.A.C. . . . .	7313861	1	4.64	VALVE ASSY., htr. & a/c cont. air defr. (9 port) . . . . .
71-74	All (exc. Vega, Monza) . . . . .	1485553	1	1.60	VALVE ASSY., refrig. vac. control (white 7/16" dia.)— (8.850) . . . . .
71-75	Pass. w/Auto. Temp. Control . . . . .	9346156	1	4.75	VALVE ASSY. (9 port) selector . . . . .
71-72	Pass. w/Auto. Temp. Control . . . . .	1223351	1	5.50	VALVE ASSY. (9 port) control . . . . .
71-72	Pass. w/C.A.C. (exc. Auto. Temp. Control) . . . . .	7932345	1	3.26	VALVE ASSY., hot water (3 port) . . . . .
71-72	Pass. w/C.A.C. (exc. Auto. Temp. Control) . . . . .	7932421	1	3.88	VALVE ASSY. (9 port) selector . . . . .
71-74	Vega . . . . .	7930591	1	3.29	VALVE ASSY., htr. and a/c vac. control . . . . .
73-74	Pass. w/Auto. Temp. Control . . . . .	1223351	1	5.50	VALVE ASSY. (9 port) control . . . . .
73-74	Pass. (exc. Auto. Temp. Control) . . . . .	7932345	1	3.26	VALVE ASSY., hot water (3 port) . . . . .
73-74	Pass. (exc. Auto. Temp. Control) . . . . .	7932421	1	3.88	VALVE ASSY. (9 port) selector, htr. and a/c
73	Chevelle . . . . .	7936661	1	4.36	VALVE ASSY., hot water (3 port) . . . . .
73	Chevelle . . . . .	7936651	1	4.16	VALVE ASSY. (9 port) selector, htr. and a/c— (8.850) . . . . .
75	Pass. (exc. Auto. Temp. Control) . . . . .	9345580	1	3.52	VALVE ASSY., selector (9 port) . . . . .
75	Pass. w/Auto. Temp. Control . . . . .	9345255	1		VALVE ASSY., vacuum . . . . .
75	Monza (Towne Cpe.) . . . . .	9348238	1	4.55	VALVE ASSY., htr. and a.c. vac. control . . . . .

**9.281 ARM— BRACKET— CABLE ASSY.— CAM ASSY.— CLAMP— CLIP— CONNECTOR— ELEMENT— GROMMET— HOSE— PLUG— TANK ASSY.— TEE— VALVE ASSY., Air Conditioning Control**

68-72	Chevelle w/C.A.C. . . . .	3923189	1	.50	a/c air inlet side shroud vac. actuator . . . . .
71	Chevelle w/C.A.C. . . . .	3979708	1	1.30	temp. control . . . . .
71-75	Pass. w/Auto. Temp. Control . . . . .	7937916		1.07	ARM ASSY., mechanism, feed back (potentiometer), . . . . .
66	Pass. w/C.A.C. . . . .	3902244	1	.31	BRACKET, refrig. cont. valve— (9.198) . . . . .
71	Nova w/C.A.C. . . . .	3946999	1	.61	BRACKET, air shut-off cable . . . . .
74-75	Camaro . . . . .	340479	1	.34	BRACKET, a/c vac. tank . . . . .
74-75	All (exc. Camaro, Vega, Monza) . . . . .	340484	1	.36	BRACKET, a/c vac. tank . . . . .
74	Chevelle . . . . .	340471	1	1.60	CABLE ASSY., temp. control— (9.787) . . . . .
74	Camaro . . . . .	340459	1		CABLE ASSY., temp. control— (9.787) . . . . .
71-75	Pass. w/Auto. Temp. Control . . . . .	7931934	1	3.79	CAM ASSY., w/wipers selector . . . . .
71	Pass. w/C.A.C. . . . .	3022737	1	4.75	CAM ASSY., w/support, air cond. . . . .
62-72	All . . . . .	2494772	A.R.	.65	CLAMP (range: 1/4"— 5/8") . . . . .
70-71	Nova w/C.A.C. . . . .	3127960	1	.11	CLIP, air shut-off cable . . . . .
66-69	Pass. w/Auto. Temp. Control . . . . .				CONNECTOR, air selector, . . . . .
69	Pass. w/C.A.C.,				
70-71	Pass. w/C.A.C., Auto. Temp. Cont.,				
70-72	Chevelle w/C.A.C.,				
70-71	Camaro w/C.A.C. . . . .				air selector air inlet plenum duct (1/8" O.D. x 1/16" I.D. x 3/4" O.L.), . . . . .
73-74	Chevelle, Camaro . . . . .	399577	1	.18	htr. and a/c vac. cont. hose connector . . . . .
71	Pass. w/C.A.C. . . . .	3984671	1	.22	CONNECTOR, vac. hose (9 port) . . . . .
73-74	Chevelle . . . . .	1998995	1	4.33	ELEMENT, air valve . . . . .
73-74	Camaro,				
75	Nova . . . . .	3020362	1	.13	GROMMET, a/c vac. hose . . . . .
62-69	All . . . . .	3987362	1	RL/.12	HOSE, vac. (3/32" I.D.)— (8.962) (Note 1) . . . . .
	<i>NOTE 1: 25 ft. coil, used for servicing vac. hose unit 3895945.</i>				
67-68	Pass. w/Auto. Temp. Control . . . . .	3987364	1	RL/.14	HOSE, vac. (7/32" I.D.)— (8.962) (Note 2) . . . . .
	<i>NOTE 2: 25 ft. coil, used for servicing vac. hose unit 3895945.</i>				
67-68	Pass. w/Auto. Temp. Control . . . . .	3917364	1	27.50	HOSE ASSY., a/c vacuum . . . . .
69-70	Pass. w/C.A.C. (exc. Auto. Temp. Control) . . . . .	3946942	1	7.35	HOSE ASSY., heater and a/c vacuum . . . . .
70	Pass. w/C.A.C. (exc. Auto. Temp. Control),				
70-72	Camaro w/C.A.C. . . . .	3992166	1	8.55	HOSE ASSY., vac. control . . . . .
70-71	Chevelle w/C.A.C. . . . .	3992101	1	8.05	HOSE ASSY., vac. cont. . . . .
71	Pass. w/Auto. Temp. Control . . . . .	3989230	1	4.85	HOSE ASSY., vacuum control to connector . . . . .
71	Pass. w/C.A.C. (exc. Auto. Temp. Control) . . . . .	3992157	1	7.65	HOSE ASSY., vacuum control connector to heater def. . . . .
71	Pass. w/C.A.C. (exc. Auto. Temp. Control) . . . . .	3984672	1	7.65	HOSE ASSY., vacuum control to connector . . . . .
72-73	Pass. (exc. Auto. Temp. Control) . . . . .	6262632	1	8.55	HOSE ASSY., htr. & a/c vacuum cont. connector/to htr. & defroster . . . . .



**BODY MTG.— AIR COND.— INSTRUMENTS**

**9.281 ARM— BRACKET— CABLE ASSY.— CAM ASSY.— CLAMP— CLIP— CONNECTOR— ELEMENT— GROMMET— HOSE— PLUG— TANK ASSY.— TEE— VALVE ASSY., Air Conditioning Control (Con't)**

71-74	Vega	331995	1	5.75	HOSE ASSY., a/c vacuum control
73	Camaro	331930	1	12.75	HOSE ASSY., vac. control (Note 1)
73	Chevelle	3998486	1	5.10	HOSE ASSY., a/c vac. control to connector
73-74	Pass. w/Auto. Temp. Control	6262635	1	5.10	HOSE ASSY., a/c vac. control to connector
73-75	Pass.	3992133	1	2.00	HOSE ASSY., a/c in car sensor aspirator
73-74	Pass.	6262633	1	8.55	HOSE ASSY., htr. and a/c vac. control to conn.
73	Pass. (exc. Auto. Temp. Control)				HOSE ASSY., htr. and a/c vac. conn. to htr. and def.
73	Pass. w/Auto. Temp. Control	6262634	1	13.85	HOSE ASSY., a/c vac. control conn. to htr. and def.
73	Chevelle	6262601	1	7.95	HOSE ASSY., a/c vac. control to htr. and def.
74	Chevelle	340480	1	5.45	HOSE ASSY., a/c vac. control to htr. and def.
74	Pass. (exc. Auto. Temp. Control)	340461	1	7.20	HOSE ASSY., htr. and a/c vac. control to htr. and def.
74-75	Pass. w/Auto. Temp. Control	340475	1	13.85	HOSE ASSY., a/c vac. control conn. to htr. and def.
74-75	Chevelle	340422	1	5.10	HOSE ASSY., a/c vac. control to connector
74-75	Camaro (1st design)	336415	1	14.10	HOSE ASSY., a/c vac. control (Note 1)
75	Camaro (2nd design)	362600	1	12.60	HOSE ASSY., a.c. vac. control (Note 1)
	<i>NOTE 1: 2nd design has the word "MAX" on a.c. control</i>				
75	Nova	346110	1	10.25	HOSE ASSY., a/c vac. control
75	Pass. w/Auto. Temp. Control	356191	1	5.10	HOSE ASSY., a/c vac. conn. to conn.
75	Pass. (exc. Auto. Temp. Control)	356147	1	7.55	HOSE ASSY., a.c. control to conn.
75	Pass. (exc. Auto. Temp. Control)	356148	1	8.55	HOSE ASSY., a.c. control conn. to htr. & def.
75	Chevelle	364001	1	5.45	HOSE ASSY., a/c vac. connector to htr. and def.
75	Vega	346163	1	4.00	HOSE ASSY., a/c vacuum control
75	Monza (exc. Towne Cpe.)	356112	1	3.60	HOSE ASSY., a.c. vac. control
75	Monza (Towne Cpe.)	364026	1	9.80	HOSE ASSY., a.c. vac. control
66-68	Pass. w/Auto. Temp. Control	1486495	1	.56	PLUG, vac. hose unit
71	Pass. w/Air Cond.,				
74-75	Chevelle	3992104	1	.17	PLUG, vac. control hose
65-71	Pass. w/C.A.C.,				
68-71	Chevelle w/C.A.C.,				
68-70	Nova w/C.A.C.,				
67-70	Camaro w/C.A.C.	385076	1	4.10	TANK ASSY., a/c refrig. vac. cont. (black 4 <sup>9</sup> / <sub>32</sub> " dia.)
66	Pass. w/Temp. Cont.	3875856	1	9.65	TANK ASSY., vac. cont.
73-75	Vega, Monza	336467	1	5.35	TANK ASSY., a/c vacuum
74-75	All (exc. Vega, Monza)	340483	1	3.90	TANK ASSY., a/c vac.
65	Pass. w/C.A.C.	3866868	1	.22	TEE, refrig. vac. control hose
67-68	Pass., Chevelle, Camaro w/C.A.C., Cruise Control,				
69	Pass., Chevelle, Camaro w/Acc. Air Cond. (8 cyl.),				
70	Pass. w/Acc. Air Cond.	3752621	1	.22	TEE, refrig. vac. cont. hose
66-68	Pass. w/Auto. Temp. Control,				
67-69	Camaro,				
68-69	Chevy, Chevelle,				
70-74	Nova	3895904	1	.59	TEE, vac. control hose
67-68	Pass. w/Auto. Temp. Control	570266	1	.33	TEE, hose unit to eng. vac. conn.
67-68	Pass. w/Auto. Temp. Control	1477536	1	.32	TEE, hose unit to transducer conn. (5/16" O.D.)
69	Pass. (exc. Sta. Wag.)	3929022	1	1.40	TEE, heater and a/c air and water valve vac. control hose
71-74	Pass.,				
73-74	Chevelle	3992117	1	.40	TEE, vacuum hose (5/64" I.D. x 3/16" I.D. x 3/16" O.D.)
67-74	All (exc. Vega),				
75	Monza (Rotary)	1485553	1	1.60	VALVE ASSY., refrig. vac. cont. (white 7/16" dia.)— (8.850)

*NOTE 1: May be necessary to cut off moulded connectors and plug into receptacles as required.*

**9.282 LUBRICATING OIL— REFRIGERANT— SEAL, Maintenance Items, Air Conditioning**

62-70	All	5416939	A.R.	QT/3.40	refrigerant line (1 qt. container-525 viscosity)— (8.800)
62-70	All	1050807	A.R.	17.15	REFRIGERANT (consists of 1— 12 lb. throw away)— (8.800) (Note 1)

**BODY MTG.— AIR COND.— INSTRUMENTS**

**9.282 LUBRICATING OIL— REFRIGERANT— SEAL, Maintenance Items, Air Conditioning (Con't)**

62-70	All	1050121 A.R.	3.11	REFRIGERANT (consists of 1— 15 oz. can)— (8.800)
-------	-----	--------------	------	--

NOTE 1 Price shown is per pound.

**9.645 ANTENNA UNIT, Radio**

73-75	All (exc. Citizens Band)	994993	1	8.95	fender
73-75	All w/C.B.	994463	1	24.95	less lead-in (base station)
73-75	All w/C.B.	994465	1	27.50	bumper mounted
73-75	All w/C.B.	994466	1	27.50	deck lid mounted
74-75	Pass. w/C.B.	994691	1	31.00	magnet mounted
75	Pass. w/Electric Ant.	994747	1	40.50	

**9.647 ADAPTER— BEZEL— BRACKET— CABLE ASSY.— CAP— COVER— GASKET— LEAD ASSY.— NUT AND GUIDE ASSY.— RING— ROD AND MAST ASSY.— SWITCH ASSY., Antenna**

73-75	Camaro, Nova	9815438	1	1.70	antenna lead-in
73-75	Pass., Chevelle	9835797	1	1.15	antenna lead-in
73-75	Vega, Monza	9841202	1	1.40	windshield antenna
73-75	Pass., Nova	3897333	1	.92	BEZEL, fender antenna (994316)
73-75	Camaro	3937665	1	.92	BEZEL, fender antenna (994316)
73-75	Vega, Monza	3863220	1	.46	BEZEL, fender antenna (994316)
75	Pass. w/Electric Ant.	356141	1	.92	BEZEL, antenna (994747)
75	Pass. w/Electric Ant.	356142	1	1.65	BRACKET, antenna mtg. (994747)
73-75	All (exc. Chevelle)	6270474	1	5.90	CABLE ASSY., w/body, fender antenna (994316)
74-75	All w/Electric Ant.	1603015	1	5.85	CABLE ASSY., lead-in
73-75	All (exc. Chevelle)	3943656	1	.71	CAP, fender antenna (994316)
75	Pass. w/Electric Ant.	356143	1	4.65	COVER, antenna skirt (994747)
73-75	All (exc. Chevelle)	3820672	1	.22	GASKET, fender antenna (994316)
73-75	Camaro, Nova	9614424	1	3.15	LEAD ASSY., windshield antenna to receiver
73	Pass., Chevelle	9614425	1	3.15	LEAD ASSY., windshield antenna to receiver
73-75	Vega, Monza	9614422	1	3.30	LEAD ASSY., windshield antenna to recr. (Note 1)
74-75	Pass., Chevelle	9614423	1	3.15	LEAD ASSY., windshield antenna to receiver
75	Monza w/C.A.C. (exc. Towne Cpe.)	362566	1	3.30	LEAD ASSY., w/s antenna to recr. (approx. 6 1/2" with L-shaped end)
74-75	All w/Electric Ant.	1243086	1	1.95	NUT AND GUIDE ASSY., ant. mtg.
73-75	All (exc. Chevelle)	3863239	1	.26	RING, fender antenna ground (994316)
73-75	All (exc. Chevelle)	3943653	1	4.25	ROD AND MAST ASSY., fender antenna (994316)
75	Pass. w/Electric Ant.	356179	1	40.75	ROD AND MAST ASSY., antenna (994747)
74-75	Pass. w/Electric Ant.	356177	1	12.50	SWITCH ASSY., antenna (994747)

NOTE 1: When using on Monza (Hatchback) w/C.A.C. it may be necessary to use 362566 Lead Assy.

**9.649 CONTROL ASSY.— BEZEL— KNOB— SPACER— SPRING, Radio Control**

73-75	Chevelle, Vega, Monza w/Accessory Aux. Speaker	7933011	1	9.65	fader w/staked on knob (994318-19)
73-75	Pass. w/Accessory Aux. Speaker	7934061	1	9.85	fader w/staked on knob (994103-04)
73-75	Camaro, Nova w/Accessory Aux. Speaker	7309211	1	5.20	fader w/staked on knob (994121-455)
73-74	Nova	3948922	1	1.53	BEZEL, radio trim
73-75	All	3986829	1	.62	KNOB, outer, tuning
73-75	All	3986872	1	.62	KNOB, outer, volume
73-75	Pass., Nova	3986873 A.R.	1	1.05	KNOB, inner tone or fader w/factory aux. speakers
73-75	Chevelle, Camaro, Vega, Monza	3980197 A.R.	1	.62	KNOB, inner tone or fader w/factory aux. speakers
74-75	Nova	3986874	1	1.35	KNOB, aux. speaker control
73-75	Nova	3948920	1	.31	SPACER, inner rear, vol. control
73-75	Nova	3948921	1	.31	SPACER, inner rear, sel. control
73-75	Nova (exc. Aux. Speakers)	3986876	1	.53	SPACER, inner front, sel. control
73-75	Pass. (exc. Aux. Speakers)	3986875	1	1.05	SPACER, inner, sel. control
73-75	Chevelle, Vega, Monza (exc. Aux. Speakers)	3983898	1	.74	SPACER, inner, sel. control
73-74	Camaro (exc. Aux. Speakers)	3990806	1	.44	SPACER, inner, sel. control
73-75	Pass., Chevelle w/Stereo Tape	9773946	1	.21	SPRING, tone control knob
71	All	9348267	1	16.00	ESCUTCHEON, radio dial

**9.650 RADIO UNIT— SPEAKER, Radio Primary**

73-75	All w/C.B.	995107	1	159.50	primary 23 channel
-------	------------	--------	---	--------	--------------------

**BODY MTG.— AIR COND.— INSTRUMENTS**

**9.650 RADIO UNIT— SPEAKER, Radio Primary (Con't)**

73-75	All w/C.B. . . . .	994462	1	45.00	primary base station, power supply . . . . .
73-75	Vega, Monza w/AM . . . . .	994826	1	N.L.	(also order 994910) (repl. 994368) . . . . .
75	Camaro w/AM . . . . .	994715	1		(also order 995055) (repl. 994715) . . . . .
75	Chevelle w/AM . . . . .	994826	1	N.L.	(also order 994908) (repl. 994748) . . . . .
75	Pass. w/AM/FM . . . . .	994756	1		
75	Chevelle w/AM/FM . . . . .	994749	1		
75	Pass. w/Stereo Radio . . . . .	994757	1		
75	Nova w/Stereo Radio . . . . .	994744	1		
75	Chevelle w/Stereo Radio . . . . .	994750	1		
75	Pass. w/AM-Stereo Tape . . . . .	994685	1	N.L.	
75	Nova w/AM-Stereo Tape . . . . .	994788	1	N.L.	
75	Camaro w/AM-Stereo Tape . . . . .	994740	1	N.L.	
75	Chevelle w/AM-Stereo Tape . . . . .	994751	1		
75	Chevelle w/AM/FM-Stereo Tape . . . . .	994752	1	N.L.	
73-75	Pass., Chevelle (exc. Stereo) . . . . .	7933362	1	12.25	<b>SPEAKER, front center (Note 1) . . . . .</b>
73-74	Chevelle w/Stereo . . . . .	7933741	2	12.25	<b>SPEAKER, front center (Note 1) . . . . .</b>
<i>NOTE 1: Chevelle mounts in Retainer Assy. See Group 9.655.</i>					
73-75	Nova . . . . .	7933961	1	12.90	<b>SPEAKER, front center u/w brkt. 7298516 . . . . .</b>
73-75	Camaro . . . . .	7933971	1	12.90	<b>SPEAKER, front center u/w brkt. 7932455 . . . . .</b>
73-75	Vega, Monza (exc. C.B.) . . . . .	7930571	1	12.00	<b>SPEAKER, front center . . . . .</b>

**9.654 CAPACITOR— FILTER, Radio**

73-74	Chevelle, Camaro,				
75	All . . . . .	6258252	1	1.30	fuse panel . . . . .
73-74	Vega . . . . .	1851428	1	5.15	
74-75	All (exc. Vega, Monza) . . . . .	346161	1	1.30	lead w/plug to dist. . . . .
75	Vega, Monza . . . . .	346175	1		
73	All w/Gauges,				
74	All w/Gauges (exc. Z-28, Vega) . . . . .	6262620	1	6.20	<b>FILTER, tachometer . . . . .</b>
74	Camaro (Z-28),				
75	All (exc. Vega, Monza) . . . . .	348784	1	6.75	<b>FILTER, tachometer . . . . .</b>

**9.655 BRACKET— RETAINER ASSY., Front Center Speaker Mounting**

73-75	Nova . . . . .	7298516	1	1.21	u/w speaker 7933961 . . . . .
73-75	Camaro . . . . .	7932455	1	1.25	u/w speaker 7933971 . . . . .
73-75	Vega, Monza (exc. C.B.) . . . . .	7930557	1	.91	
73	Chevelle (exc. Stereo) . . . . .	3991777	1	2.35	<b>RETAINER ASSY., u/w speaker 7933362 . . . . .</b>
74-75	Chevelle (exc. Stereo) . . . . .	332025	1	1.45	<b>RETAINER ASSY., u/w speaker 7933362 . . . . .</b>
73-74	Chevelle w/Stereo . . . . .	3991779	1	2.95	<b>RETAINER ASSY., u/w speaker 7933741 . . . . .</b>

**9.656 HARNESS ASSY.— WIRE ASSY., Radio and Speaker Wiring**

73-75	Nova (exc. Stereo, Aux. Speaker)	8901421	1	3.95	radio (instr. panel) . . . . .
73-75	Camaro (exc. Stereo, Aux. Speaker)	8901425	1	3.95	radio (instr. panel) . . . . .
73-75	Nova, Camaro w/Aux. Speaker . . . . .	8908079	1	8.30	radio (instr. panel) . . . . .
73-75	Nova, Camaro w/Stereo Radio (exc. Aux. Speaker) . . . . .	7930747	1		radio (instr. panel) . . . . .
73-75	Nova, Camaro . . . . .	7313885	1	7.15	radio aux. speaker control (instr. panel) . . . . .
73-75	Pass., Chevelle . . . . .	8901792	1	6.90	radio aux. speaker control (instr. panel) . . . . .
73-75	Chevelle . . . . .	8901791	1	9.00	stereo rear speaker (instr. panel) . . . . .
73-75	Nova . . . . .	8901684	1	14.70	stereo tape player (instr. panel) . . . . .
73-75	Camaro w/Rear Speakers,				
75	Nova . . . . .	9874224	1	7.20	rear speaker (body) . . . . .
73-74	Nova w/Rear Speakers . . . . .	9874201	1	7.50	rear speaker (body) . . . . .
73-74	Pass. w/Rear Aux. Speaker (exc. Sta. Wag.) . . . . .	9821110	1	6.30	rear speaker (body) . . . . .
73-75	Pass. (Sta. Wag.) w/Rear Aux. Speaker . . . . .	9821117	1	6.25	rear speaker (body) . . . . .
73-74	Pass. w/Rear Stereo Speakers (exc. Sta. Wag.) . . . . .	9821146	1	18.65	rear speaker (body) . . . . .
73-75	Pass. (Sta. Wag.) w/Rear Stereo Speakers,				
73-75	Chevelle (Sta. Wag.) w/Rear Aux. or Stereo Speakers,				
75	Vega, Monza w/Aux. Speaker . . . . .	1690184	1	24.65	rear speaker (body) . . . . .
73-75	Vega, Monza w/Accessory Aux. Speaker (exc. Towne Cpe.) . . . . .	8908288	1	5.30	from radio to front speaker, aux. speaker and fader control harnesses . . . . .
75	Chevelle w/Rear Aux. Speaker (exc. Sta. Wag.) . . . . .	1690184	1	24.65	<b>WIRE ASSY., rear speaker . . . . .</b>
75	Chevelle w/o Rear Stereo Speakers (exc. Sta. Wag.) . . . . .	9840148	1	10.75	<b>WIRE ASSY., rear speakers . . . . .</b>
73-75	Pass., Vega, Monza (exc. Stereo) . . . . .	8901764	1	5.15	<b>WIRE ASSY., front speaker . . . . .</b>
73-75	Pass. w/Stereo . . . . .	8908249	1	4.20	<b>WIRE ASSY., front speakers . . . . .</b>
73-75	Chevelle (exc. Stereo) . . . . .	8901959	1	4.85	<b>WIRE ASSY., front speaker . . . . .</b>

**BODY MTG.— AIR COND.— INSTRUMENTS**

**9.656 HARNESS ASSY.— WIRE ASSY., Radio and Speaker Wiring (Con't)**

73-75	Chevelle w/Stereo	8901976	1	3.95	WIRE ASSY., front speakers
73-75	Camaro, Nova (exc. Hatchback)	8901919	1	6.20	WIRE ASSY., radio aux. speaker control extension
73-75	Nova (Hatchback)	9614403	1	14.70	WIRE ASSY., radio aux. speaker control extension
73-75	Vega w/Aux. Speaker	9814651	1	5.65	WIRE ASSY., aux. speaker (161" O.L.)
75	Pass. w/Electric Ant.	356169	1	9.40	WIRE ASSY., antenna switch (994747)

**9.663 CAPACITOR— CLIP— STRAP— SUPPRESSION PKG., Radio Noise Suppression**

73-75	All	1852715	1	1.27	ignition coil
73-75	All	3906187	1	4.16	blower motor
74-75	Camaro, Nova	346160	1	.84	CLIP, radio hood ground
73-75	All	8908394	1	3.05	STRAP, ground (double type)
73-75	All	6290315	1	.84	STRAP, ground (13" ctr. to ctr. of holes)
73-75	Vega, Monza	8901921	1	.52	STRAP, ground (10 1/2" center to center of holes)
75	Chevelle	356118	1	.93	STRAP ASSY., air cleaner to dash
75	All (exc. Vega, Monza)	994930	1	10.50	SUPPRESSION PKG., radio

**9.665 SPEAKER UNIT— SPEAKER— BAFFLE ASSY.— BOLT AND CLIP ASSY.— GASKET— GRILLE— REINFORCEMENT— RETAINER— RING— SCREW, Rear and Auxiliary Speakers**

73-75	Pass. (Sta. Wag.)	994104	1	N.L.	rear
73-75	Camaro, Nova (exc. Hatchback)	994121	1	N.L.	rear
73-75	Nova (Hatchback)	994455	1	N.L.	rear
73-75	Chevelle (exc. Sta. Wag.)	994318	1	N.L.	rear
73-75	Chevelle (Sta. Wag.)	994319	1	N.L.	rear
73-75	Vega (Cpe., Sta. Wag.)	994441	1	N.L.	
74-75	Vega (Sedan)	994440	1	N.L.	
75	Monza (exc. Towne Cpe.)	994860	1	N.L.	(repl. 994774)
73-75	Pass. (exc. Sta. Wag., Custom Coupe, Conv.), Camaro, Nova (exc. Hatchback)	7934231	1	12.90	SPEAKER ASSY., rear (994103-121)
73-74	Vega (Coupe, Sta. Wag.)				
73-75	Pass. (Sta. Wag., Custom Coupe), Chevelle (Sta. Wag.)				
73-75	Nova (Hatchback)	7933542	1	11.55	SPEAKER ASSY., rear (994104-319-441-455)
73-75	Vega (Sedan), Pass. (Conv.), Chevelle (exc. Sta. Wag.)	7937455	1	12.20	SPEAKER ASSY., rear (994318-440)
73-75	Pass. w/Stereo	9341561	2	11.30	SPEAKER ASSY., front, L.H. or R.H.
73-75	Chevelle w/Stereo	7933741	2	12.25	SPEAKER ASSY., front center L.H. or R.H.— (9.650)
75	Vega (Cpe., Sta. Wag.)	9347820	1	13.85	SPEAKER ASSY., aux.
73-75	Pass. (Sta. Wag., Custom Coupe)	9858896	1	4.90	BAFFLE ASSY., aux. speaker
73-75	All (exc. Sta. Wag., Custom Coupe, Hatchback)	9858895	1	4.25	BAFFLE ASSY., aux. speaker
73-74	Chevelle	9613125	1	.67	GRILLE, rr. speaker
73-74	Pass.	9779906	4	.25	BOLT AND CLIP ASSY., rear aux. speaker
75	Camaro	7313296	1	1.08	BRACKET, rear speaker cover
73-75	Pass. w/Stereo	326283	2	.16	GASKET, speaker grille, front, L.H. or R.H.
73-75	Pass. w/Stereo	326281	L.H.	2.85	GRILLE, front aux. speaker
73-75	Pass. w/Stereo	326282	R.H.	2.85	GRILLE, front aux. speaker
73-75	Chevelle (Sta. Wag.)	9617168	1	2.00	GRILLE, rear aux. speaker (994319)
73-75	Nova (Hatchback), Vega (Cpe., Sta. Wag.)	9825769	1	2.25	GRILLE, aux. speaker
75	Pass. (Sta. Wag.), Vega (Coupe, Sta. Wag.)	9859748	1	4.25	GRILLE, rear aux. speaker
75	Pass., Chevelle (exc. Sta. Wag.)	9613125	A.R.	.67	GRILLE, rear speaker
73-74	Vega (Sedan), Pass. (exc. Sta. Wag., Custom Coupe), Nova (exc. Hatchback), Camaro	7938725	1	3.11	GRILLE, rear aux. speaker (994060-103-121-440)
75	Monza (exc. Towne Cpe.)	1669237	1	4.90	GRILLE, aux. speaker
75	Monza (Towne Cpe.)	1710795	1	2.25	GRILLE, aux. speaker, rear
75	Monza (exc. Towne Cpe.)	1669238	L.H.	2.80	REINFORCEMENT, aux. speaker rear qtr.
73-75	All (exc. Sta. Wag., Hatchback, Custom Coupe, Vega, Monza)	3973666	1	.06	RETAINER, aux. speaker baffle
73-75	All (exc. Sta. Wag., Conv., Vega, Monza)	9684182	A.R.	2.80	RETAINER ASSY., rear aux. speaker

**BODY MTG.— AIR COND.— INSTRUMENTS**

<b>9.665 SPEAKER UNIT— SPEAKER— BAFFLE ASSY.— BOLT AND CLIP ASSY.— GASKET— GRILLE— REINFORCEMENT— RETAINER— RING— SCREW, Rear and Auxiliary Speakers (Con't)</b>					
73-75	Chevelle w/Stereo	3991779	1	2.95	RETAINER ASSY., front center speaker u/w speaker 7933741— (9.655)
75	Monza (Towne Cpe.)	1694484	2	4.25	RETAINER, rear speaker
73-75	Chevelle (Sta. Wag.)	9421832	4	.05	RING, rear aux. speaker grille (994319)
73-74	Chevelle (Sta. Wag.)	9606577	4		SCREW, rear aux. speaker (994319)
<b>9.667 BOLT AND CLIP ASSY.— BRACE— BRACKET— NUT— SUPPORT ASSY.— WASHER, Radio and Stereo Mounting</b>					
73-75	Pass., Chevelle	3996266	A.R.	.46	
73-75	Camaro (exc. Tape)	3973667	1	1.40	BRACE
73-75	Nova (exc. Stereo)	340401	1	.44	BRACKET
73-75	Camaro w/AM	3973670	1	.16	BRACKET
73-75	Camaro w/FM, Stereo Radio	3973671	1	.28	BRACKET
74-75	Camaro w/Tape	3973672	1	.87	BRACKET
75	Nova w/Stereo Tape	356149	1	.33	BRACKET
73-75	Vega, Monza w/AM	3990801	1	.50	BRACKET, receiver mounting
73-75	Vega, Monza w/AM/FM	3984631	1	.48	BRACKET, receiver mounting
75	Monza (Towne Cpe.)	362529	L.H.	.55	BRACKET, receiver mounting
75	Monza (Towne Cpe.)	362530	R.H.	.55	BRACKET, receiver mounting
73-75	Nova	3937646	2	.11	NUT, recv. to instr. panel (spl. round)
73-75	All (exc. Nova)	7279805	2	.10	NUT, recv. to instr. panel
73-75	Pass. w/AM	3986852	L.H.	.46	SUPPORT ASSY.
73-75	Pass. (exc. AM)	3986853	L.H.	.46	SUPPORT ASSY.
73-75	Pass.	3986854	R.H.	.16	SUPPORT ASSY.
<b>9.670 CONVECTOR AND LEAD ASSY.— SUPPORT, Stereo Tape Player</b>					
73-75	Pass.	7932321	1	12.30	CONVECTOR AND LEAD ASSY.
73-75	Chevelle	7938431	1	30.50	CONVECTOR AND LEAD ASSY.
73-75	Chevelle w/Stereo Tape	6270663	1	.42	SUPPORT, convector and lead assy.
<b>9.694 DEFLECTOR— DEFLECTOR UNIT, Rain</b>					
68-72	Chevelle (Sta. Wag., 4-Dr. Sed.) (exc. Spt. Sed.)	3930153	L.H.	12.90	front door
68-72	Chevelle (Sta. Wag.)	3930157	L.H.	12.90	rear door
68-72	Chevelle (Sta. Wag.)	3930158	R.H.	12.90	rear door
75	Pass. (4-Dr. Sedan) (exc. Spt. Sedan)	361841	L.H.	5.70	rear door
75	Pass. (4-Dr. Sedan) (exc. Spt. Sedan)	361842	R.H.	5.70	rear door
71-75	Pass. (Sta. Wag.)	994149		13.75	DEFLECTOR UNIT
75	Pass. (4-Dr. Sedan) (exc. Spt. Sed.)	994833	1	14.50	DEFLECTOR UNIT
<b>9.709 BEZEL— ELEMENT— HOUSING— KNOB— LAMP— LIGHTER UNIT— RETAINER, Cigarette Lighter</b>					
68	Chevelle	3927334	1	.98	lighter
68	Pass.	3934209	1	.63	lighter
70	Chevelle	3972040	1	1.00	lighter
62-63	Chevy,				
65	All,				
66-67	Pass.	7021055	1	.96	ELEMENT, heating (Roch.)
68-69	Pass.	7028638	1	.99	ELEMENT, heating (Rochester)
63-74	All	3794302	1	4.15	ELEMENT, heating (Casco)
70-74	All	7025459	1	1.10	ELEMENT, heating (Rochester)
62-69	All	7027910	1	2.05	HOUSING (Rochester)
70-71	All (exc. Vega)	7028056	1	2.60	HOUSING (Rochester)
63-69	All,				
70	Nova, Chevelle, Pass.,				
71-75	All	3986869	1	1.45	HOUSING (Casco)
72-75	All (exc. Nova)	7028145	1	1.90	HOUSING (Rochester)
62-64	Chevy	7026520	1	2.90	KNOB, w/element (Roch.)
63	Nova,				
64	Chevy,				
65-66	Pass., Chevy	3861472	1	3.55	KNOB, w/element (Casco)
65	Chevelle	7028870	1	2.80	KNOB, w/element (Roch.)
65-66	Pass., Nova	7028979	1	2.55	KNOB, w/element (Roch.)
64-66	Chevelle	7025975	1	2.40	KNOB, w/element (Roch.)
67	All,				
68	Camaro	7031884	1	2.35	KNOB, w/element (Roch.)
67	All (exc. Chevelle),				
68	Camaro	3897308	1	3.45	KNOB, w/element (Casco)
68	Chevy w/Custom Interior	7034617	1	2.90	KNOB, w/element (Rochester)
68	Pass.	3937699	1	3.55	KNOB, w/element (Casco)

**BODY MTG.— AIR COND.— INSTRUMENTS**

**9.709 BEZEL— ELEMENT— HOUSING— KNOB— LAMP— LIGHTER UNIT—  
RETAINER, Cigarette Lighter (Con't)**

69	Pass., Chevelle	7025141	1	2.90	KNOB, w/element (Roch.)
69	Pass., Chevelle,				
70	Pass., Camaro	3954207	1	3.50	KNOB, w/element (Casco)
69	Chevy, Camaro	7027625	1	2.90	KNOB, w/element (Roch.)
68	Pass., Chevelle	7035724	1	2.50	KNOB, w/element (Roch.)
70-72	Chevelle (exc. instr. panel gauges, Monte Carlo)	7021701	1	3.40	KNOB, w/element (Rochester)
70	Pass., Camaro, Monte Carlo,				
70	Chevelle w/instr. panel gauges	7021700	1	2.90	KNOB, w/element (Rochester)
70-75	Nova,				
73-75	Chevelle	7021684	1	2.90	KNOB, w/element (Rochester)
71-72	Monte Carlo (S.S.),				
71-75	Camaro, Vega,				
72-75	Pass.	7028146	1	2.90	KNOB, w/element (Rochester)
71-72	Pass.,				
71-72	Monte Carlo (exc. S.S.),				
73-74	Nova, Chevelle	344803	1	2.85	KNOB, w/element (Casco)
71	Monte Carlo,				
71	Pass.	7029278	1	3.15	KNOB, w/element (Rochester)
71-72	Chevelle (S.S.)	7040944	1	3.35	KNOB, w/element (Rochester)
71-72	Chevelle (exc. S.S., Monte Carlo)	7040945	1	3.35	KNOB, w/element (Rochester)
71-75	Vega	344803	1	2.85	KNOB ASSY., w/element (Casco)
74-75	Chevelle, Nova	344802	1	3.20	KNOB, w/element (Casco)
74-75	Pass., Camaro	344803	1	2.85	KNOB, w/element
75	Monza (Towne Cpe.)	366488	1	3.05	KNOB ASSY., w/element (Casco)
75	Monza (Towne Cpe.)	7028151	1	3.15	KNOB ASSY., w/element (Rochester)
62-67	Chevy (Std.)	3849799	1	.76	LAMP, lighter
63-68	Chevy, Camaro,				
65-68	Pass.,				
69	All,				
70	All,				
73-74	Nova	994668	1	5.50	LIGHTER UNIT (Casco)
74-75	Vega, Monza	994667	1	5.50	LIGHTER UNIT
71-75	Nova	3710839	1	.32	RETAINER (Casco)
62-67	All,				
69	All,				
70	All (exc. Chevelle),				
71-75	Nova	7002184	1	.38	RETAINER (Roch.)
68	Chevelle (Std.)	3922888	1	.12	RETAINER, cig. lighter hole cover
68	Pass.	3934208	1	.24	RETAINER, w/housing 3794298
68	Pass.	7036065	1	.43	RETAINER
70-71	Chevelle	7002184	1	.38	RETAINER (Rochester)
71-75	All (exc. Nova)	3986870	1	.34	RETAINER (Casco)
71-75	Pass., Camaro, Vega, Monza	7028147	1	.78	RETAINER (Rochester)
73-75	Chevelle	7048116	1	.74	RETAINER (Rochester)

**9.735 TERMINAL— CLIP— STRAP, Cluster Gauge**

69	Camaro,				
69	Chevelle (2-Dr.)	6431192	R.H.	.35	gas gauge
69	Camaro,				
69	Chevelle (2-Dr.)	6431201	1	.35	gas gauge, center
68-69	Chevy, Chevelle w/Speed Warning,				
70	Nova	6408978	1	.20	CLIP, speedo. head ground
75	A	6497449	1	.23	STUD, instr. cluster mtg.

**9.743 CASE ASSY.— BACKPLATE— BASE— BEZEL— CARRIER— CLIP—  
CONSOLE— FILLER— NUT— PLATE— REINFORCEMENT, Instrument**

68	Chevelle (exc. speed warning, inst. panel gauges)	6480646	1	4.90	cluster
69	Chevelle (exc. speed warning)	6482974	1	4.69	cluster
69-70	Chevy (exc. speed warning)	6482966	1	7.29	cluster
69-70	Pass. (exc. speed warning)	6482754	1	2.18	instrument cluster
71-72	Chevelle w/instr. panel gauges	6473698	L.H.	1.67	cluster
70-72	Chevelle w/instr. panel gauges	6493176	R.H.	2.45	temp. & fuel
70-72	Chevelle (exc. Monte Carlo, S.S., inst. pnl. ga.)	6497813	1	9.70	cluster
70-71	Camaro w/clock (exc. Inst. Panel Gauges),				
70-75	Camaro w/Inst. Panel Gauges	6493587	1	9.33	cluster
70-75	Camaro (exc. Inst. Panel Gauges, Clock, Deluxe Int.)	6493138	1	9.46	cluster
72	Chevelle (S.S.), Monte Carlo (exc. A.T., Inst. Gauges),				

**BODY MTG.— AIR COND.— INSTRUMENTS**

**9.743 CASE ASSY.— BACKPLATE— BASE— BEZEL— CARRIER— CLIP—  
CONSOLE— FILLER— NUT— PLATE— REINFORCEMENT, Instrument  
(Con't)**

72	Chevelle (S.S.), Monte Carlo (floor Console w/A.T.) (exc. Inst. Gauges),				
72	Chevelle w/Inst. Gauges (exc. A.T.),				
72	Chevelle (A.T. w/floor console) w/Inst. Gauges . . . . .	6493052	1	7.36	inst. cstr. . . . .
72-75	Nova (Gauges w/Console) . . . . .	6496634	1	5.79	console cluster base . . . . .
73-74	Chevelle (exc. Round Instr.) . . . . .	6496999	1	17.49	
73-75	Chevelle w/Round Instr. (exc. Gauges) . . . . .	6497035	1	7.36	
73-74	Chevelle (Round Instr. w/Gauges) . . . . .	6497036	1	7.36	
75	Chevelle w/instr. gauges . . . . .	8986111	1	16.56	
72-73	Nova (Gauges w/Console) . . . . .	6496665	1	.98	BACKPLATE, fuel and oil gauge . . . . .
72-73	Nova (Gauges w/Console) . . . . .	6496666	1	.98	BACKPLATE, temp. and batt. gauge . . . . .
75	Vega w/instr. pnl. gauges . . . . .	5658092	1	1.72	BACKPLATE, instr. cluster . . . . .
67	Camaro (8 cyl.) . . . . .	6458141	1	21.10	BASE, console bezel . . . . .
75	Nova w/console instr. cluster . . . . .	6496634	1	5.79	BASE, cluster gauges . . . . .
66	Chevelle w/P.G.,				
67	Chevelle . . . . .	6455959	1	17.08	BEZEL, cluster (cut as required) . . . . .
67-68	Camaro . . . . .	6457951	1	23.35	BEZEL, cluster (paint as required) . . . . .
67	Pass. . . . .	3897521	1	17.75	BEZEL, cluster . . . . .
68	Chevy w/Radio (exc. C.A.C.) . . . . .	6481103	1	25.89	BEZEL, cluster . . . . .
68	Impala (exc. S.S.) . . . . .	3916585	1	16.10	BEZEL, cluster . . . . .
68-69	Camaro w/floor cluster . . . . .	6480875	1	26.08	BEZEL, console . . . . .
68-69	Chevy w/floor cluster . . . . .	6481920	1	25.89	BEZEL, console . . . . .
70-72	Chevelle (exc. Monte Carlo, instr. pkg., col. mtg. A.T.) . . . . .	6492167	1		BEZEL (repl. 6497525) . . . . .
69	Pass. (Spd. Warning w/A.T.) (exc. Bucket Seats),				
70	Pass. (exc. Speed Warning) . . . . .	6482722	1	10.32	BEZEL, instr. cluster tell-tale . . . . .
71-75	Vega (exc. C.A.C., Instr. Panel Gauges) . . . . .	6499950	1	17.65	BEZEL ASSY., instr. panel to carrier . . . . .
71-75	Vega w/C.A.C. (exc. Instr. Panel Gauges) . . . . .	6499952	1	13.00	BEZEL ASSY., instr. panel to carrier . . . . .
71-75	Vega w/Instr. Panel Gauges (exc. C.A.C., Cosworth) . . . . .	6264781	1	15.25	BEZEL ASSY., instr. panel to carrier . . . . .
71-75	Vega (Instr. Panel Gauges w/C.A.C.) (exc. Cosworth) . . . . .	6264780	1	15.25	BEZEL ASSY., instr. panel to carrier . . . . .
73	Chevelle (Laguna) w/C.A.C. (exc. gauges) . . . . .	6499765	1	44.94	BEZEL ASSY., lens filter and applique . . . . .
73	Chevelle (S.S.) (exc. gauges),				
73	Chevelle w/gauges (exc. Monte Carlo) . . . . .	6497041	1	32.02	BEZEL ASSY., w/lens and filter . . . . .
73	Chevelle w/C.A.C. (exc. Monte Carlo, Laguna, S.S., gauges) . . . . .	6496995	1	32.12	BEZEL ASSY., w/lens and filter . . . . .
73	Chevelle (exc. C.A.C., Monte Carlo, Laguna, S.S., gauges) . . . . .	6499495	1	16.07	BEZEL ASSY., w/lens and filter . . . . .
73	Monte Carlo . . . . .	6499605	1	59.41	BEZEL ASSY., w/lens and filter . . . . .
74-75	Chevelle (Classic) (exc. gauges, S.S., S.P.) . . . . .	8985394	1	44.94	BEZEL ASSY. (black) . . . . .
74	Chevelle (Classic) (exc. gauges, S.S., S.P.) . . . . .	8985395	1	44.94	BEZEL ASSY. (mid. blue) . . . . .
74	Chevelle (Classic) (exc. gauges, S.S., S.P.) . . . . .	8985396	1	44.94	BEZEL ASSY. (neutral) . . . . .
74-75	Chevelle (Classic) (exc. gauges, S.S., S.P.) . . . . .	8985397	1	44.94	BEZEL ASSY. (green) . . . . .
74	Chevelle (Classic) (exc. gauges, S.S., S.P.) . . . . .	8985398	1	44.94	BEZEL ASSY. (saddle) . . . . .
74-75	Chevelle (Classic) (exc. gauges, S.S., S.P.) . . . . .	8985399	1	44.94	BEZEL ASSY. (oxblood) . . . . .
74-75	Chevelle (exc. Classic, Monte Carlo, Laguna, S.S., S.P., gauges) . . . . .	8985400	1	32.12	BEZEL ASSY. (black) . . . . .
74-75	Chevelle (Classic) w/gauges, S.S., S.P. . . . .	8985454	1	32.02	BEZEL ASSY. (black) . . . . .
74-75	Chevelle w/gauges . . . . .	8985447	1	59.41	BEZEL ASSY. (black) . . . . .
74	Chevelle (Monte Carlo, Laguna) (exc. gauges) . . . . .	8985451	1	59.41	BEZEL ASSY. (saddle) . . . . .
74-75	Chevelle (Monte Carlo, Laguna) . . . . .	8985452	1	59.41	BEZEL ASSY. (oxblood) . . . . .
74	Chevelle (Monte Carlo) (exc. gauges) . . . . .	8985448	1	59.41	BEZEL ASSY. (mid. blue) . . . . .

**BODY MTG.— AIR COND.— INSTRUMENTS**

**9.743 CASE ASSY.— BACKPLATE— BASE— BEZEL— CARRIER— CLIP—  
CONSOLE— FILLER— NUT— PLATE— REINFORCEMENT, Instrument  
(Con't)**

74	Chevelle (Monte Carlo) (exc. gauges) . . . . .	8985449	1	59.41	BEZEL ASSY. (neutral) . . . . .
74-75	Chevelle (Monte Carlo) (exc. gauges) . . . . .	8985450	1	59.41	BEZEL ASSY. (med. green) . . . . .
75	Chevelle w/gauges, Monte Carlo	8985450	1	59.41	BEZEL ASSY. (med. green) . . . . .
75	Chevelle (Classic) . . . . .	8986885	1	51.91	BEZEL ASSY. (dr. sandstone) . . . . .
75	Chevelle (Classic) . . . . .	8986884	1	51.91	BEZEL ASSY. (dr. blue) . . . . .
75	Chevelle (Classic) . . . . .	8987097	1	51.91	BEZEL ASSY. (dr. saddle) . . . . .
75	Chevelle w/A.T. & instr. gauges	8987094	1	60.85	BEZEL ASSY., cluster (saddle) . . . . .
75	Monte Carlo, Laguna . . . . .	8985447	1	59.41	BEZEL ASSY. (black) . . . . .
75	Monte Carlo . . . . .	8986948	1	60.85	BEZEL ASSY. (dr. blue) . . . . .
75	Monte Carlo, Chevelle (Classic) .	8986949	1	65.56	BEZEL ASSY. (dr. sandstone) . . . . .
75	Vega (Cosworth) . . . . .	332103	1	17.65	BEZEL ASSY., instr. panel to carrier . . . . .
75	Pass. w/instr. gauges . . . . .	5658092	1	1.72	BRACKET, instr. cluster mtg. . . . .
75	Monza (exc. Towne Cpe.) . . . . .	332189	1	18.40	BEZEL ASSY., instr. cluster . . . . .
75	Monza Towne Coupe . . . . .	8987825	1	29.54	BEZEL ASSY., instr. cluster . . . . .
69-72	Nova . . . . .	3994588	1	13.80	CARRIER, cluster . . . . .
70-72	Camaro (exc. deluxe interior) . . .	3999448	1	24.65	CARRIER, instr. cluster . . . . .
68	Chevelle w/C.A.C. . . . .	6481002	1	32.31	CARRIER ASSY., cluster (Note 1) . . . . .
68	Chevelle (exc. C.A.C.) . . . . .	6480995	1	32.31	CARRIER ASSY., cluster (Note 1) . . . . .
69	Chevelle (exc. C.A.C., Spt. Cpe., Conv.) . . . . .	6482239	1	30.90	CARRIER ASSY. (Note 1) . . . . .
69	Chevelle w/C.A.C. . . . .	6482247	1	30.90	CARRIER ASSY. (Note 1) . . . . .
69	Camaro (exc. tach.) . . . . .	6482858	1	27.86	CARRIER ASSY. . . . .
69	Camaro w/tach. . . . .	6482870	1	27.86	CARRIER ASSY. . . . .
69-70	Pass. . . . .	6482710	1	20.96	CARRIER ASSY., cluster (paint as reqd.) . . . . .
71	Caprice, Kingswood (Estate Wag.) . . . . .	6496109	1	47.96	CARRIER ASSY., instr. cluster . . . . .
70-72	Camaro w/deluxe interior . . . . .	3999449	1	31.00	CARRIER ASSY., instr. cluster . . . . .
71-74	Pass. (exc. Caprice, Police, gauges) . . . . .	6499608	1	30.62	CARRIER ASSY., instr. cluster . . . . .
73-74	Nova . . . . .	6264726	1	21.90	CARRIER ASSY. . . . .
73-74	Camaro (exc. Deluxe Interior) . . .	6264711	1	22.45	CARRIER ASSY. . . . .
73	Camaro w/Deluxe Interior . . . . .	6264712	1	41.75	CARRIER ASSY., I.P. (wood grain) . . . . .
73	Caprice (exc. gauges) . . . . .	6499621	1	47.96	CARRIER ASSY. . . . .
74	Camaro w/Deluxe Interior . . . . .	332021	1	29.50	CARRIER ASSY. . . . .
74	Caprice . . . . .	8985605	1	47.96	CARRIER ASSY., I.P., w/comb. 806, 808, 840 (black) . . . . .
74	Caprice, Impala (Spt. Cpe.) . . . . .	8985606	1	47.96	CARRIER ASSY., I.P., w/comb. 804, 813, 843 (midnight blue) . . . . .
74	Caprice . . . . .	8985607	1	47.96	CARRIER ASSY., I.P., w/comb. 819, 841 (light neutral) . . . . .
74	Caprice . . . . .	8985608	1	47.96	CARRIER ASSY., I.P., w/comb. 850, 855 (med. green) . . . . .
74	Caprice . . . . .	8985609	1	47.96	CARRIER ASSY., I.P., w/comb. 849 (med. saddle) . . . . .
74	Caprice, Impala (Spt. Cpe.) . . . . .	8985610	1	47.96	CARRIER ASSY., I.P., w/comb. 809, 857 (dark oxblood) . . . . .
74	Caprice . . . . .	8985611	1	47.96	CARRIER ASSY., I.P., w/comb. 896 (med. taupe) . . . . .
75	Pass. (exc. Tach.) . . . . .	8986505	1	48.57	CARRIER ASSY., I.P., w/comb. 191 (black) . . . . .
75	Pass. (exc. Tach.) . . . . .	8986506	1	57.13	CARRIER ASSY., I.P., w/comb. 551 (med. sandstone) . . . . .
75	Pass. (exc. Tach.) . . . . .	8986507	1	57.13	CARRIER ASSY., I.P., w/comb. 441 (dk. green) . . . . .
75	Pass. (exc. Tach.) . . . . .	8986508	1	57.13	CARRIER ASSY., I.P., w/comb. 261 (dk. blue) . . . . .
75	Pass. (exc. Tach.) . . . . .	8986509	1	57.13	CARRIER ASSY., I.P., w/comb. 631 (dk. saddle) . . . . .
75	Pass. (exc. Tach.) . . . . .	8986510	1	57.13	CARRIER ASSY., I.P., w/comb. 731 (dk. oxblood) . . . . .
75	Pass. (Bel Air) . . . . .	8987204		44.76	CARRIER ASSY., I.P. (black) . . . . .
75	Caprice . . . . .	8986518	1	44.76	CARRIER ASSY., I.P. (dark sandstone) . . . . .
75	Caprice . . . . .	8986519	1	44.76	CARRIER ASSY., I.P. (dark green) . . . . .
75	Caprice . . . . .	8986520	1	44.76	CARRIER ASSY., I.P. (dark blue) . . . . .
75	Caprice . . . . .	8986521	1	44.76	CARRIER ASSY., I.P. (dark saddle) . . . . .
75	Caprice . . . . .	8986522	1	44.76	CARRIER ASSY., I.P. (dark oxblood) . . . . .
75	Impala . . . . .	8986517	1	44.76	CARRIER ASSY., I.P. (black) . . . . .
75	Camaro (exc. Custom Trim) . . . . .	332242	1	24.70	CARRIER ASSY. . . . .
75	Camaro w/Custom Trim . . . . .	332241	1	33.75	CARRIER ASSY., I.P. (black) . . . . .
75	Camaro (LT) . . . . .	346695	1	28.25	CARRIER ASSY., I.P. (dark graystone) . . . . .
75	Camaro (LT) . . . . .	346696	1	28.25	CARRIER ASSY., I.P. (dark sandstone) . . . . .
75	Camaro (LT) . . . . .	346697	1	28.25	CARRIER ASSY., I.P. (dark saddle) . . . . .



**BODY MTG.— AIR COND.— INSTRUMENTS**

**9.743 CASE ASSY.— BACKPLATE— BASE— BEZEL— CARRIER— CLIP—  
CONSOLE— FILLER— NUT— PLATE— REINFORCEMENT, Instrument  
(Con't)**

75	Camaro (LT) . . . . .	346698	1	28.25	CARRIER ASSY., I.P. (dark oxblood) . . . . .
75	Nova (Std.) (exc. C.A.C., Custom Trim) . . . . .	332206	1	14.95	CARRIER ASSY. . . . .
75	Nova (Std.) w/C.A.C. (exc. Custom Trim) . . . . .	332207	1	14.95	CARRIER ASSY. . . . .
75	Nova (Custom) (exc. C.A.C.) . . . . .	332208	1	25.50	CARRIER ASSY. . . . .
75	Nova (Custom) w/C.A.C. . . . .	332209	1	25.50	CARRIER ASSY. . . . .
75	Nova (Std.) w/Custom Trim (exc. C.A.C.) . . . . .	332210	1	14.95	CARRIER ASSY. . . . .
75	Nova (Std.) (Custom Trim w/C.A.C.) . . . . .	332211	1	14.95	CARRIER ASSY. . . . .
75	Nova (LN) (exc. C.A.C.) . . . . .	332212	1	25.50	CARRIER ASSY. . . . .
75	Nova (LN) w/C.A.C. . . . .	332213	1	25.50	CARRIER ASSY. . . . .
75	Monza Towne Coupe (exc. gauges) . . . . .	8988427	1	46.78	CARRIER ASSY. (black) . . . . .
75	Monza Towne Coupe (exc. gauges) . . . . .	8988428	1	50.90	CARRIER ASSY. (saddle) . . . . .
75	Monza Towne Coupe w/instr. pnl. gauges . . . . .	8988431	1	46.78	CARRIER ASSY. (saddle) . . . . .
75	Monza Towne Coupe (exc. gauges) . . . . .	8988429	1	50.90	CARRIER ASSY. (firethorn) . . . . .
75	Monza Towne Coupe (w/gauges)	8988430	1	46.78	CARRIER ASSY. (black) . . . . .
75	Monza Towne Coupe (w/gauges)	8988432	1	46.78	CARRIER ASSY. (firethorn) . . . . .
73	Chevelle (Laguna) (exc. C.A.C., gauges) . . . . .	6499763	1	44.94	CARRIER ASSY., I.P. . . . .
67-69	Camaro,				
70	Pass. . . . .	6457866	A.R.	.42	CLIP, bezel . . . . .
73-74	Pass. (exc. Police) . . . . .	6492511	2	.26	CLIP, mtg., retainer to housing . . . . .
64	Chevelle (exc. Air Cond.) . . . . .	3837659	1	35.10	CONSOLE ASSY., cluster . . . . .
	<i>NOTE 2: When used on the Impala add 9<sup>19</sup>/<sub>64</sub> x 1<sup>19</sup>/<sub>64</sub> slots and 10<sup>5</sup>/<sub>64</sub> holes at the moulding attaching points using old part as guide.</i>				
69-70	Pass. . . . .	3957072	2	.22	FILLER, cluster to instrument panel (7 <sup>3</sup> / <sub>4</sub> " ) . . . . .
	<i>NOTE 1: When used on models equipped w/C.A.C. or tachometer use replaced console as template to cut required opening.</i>				
72	Vega . . . . .	3909593	2	.11	NUT, trans. cont. lever and bracket (8— 18)
73	Vega . . . . .	325822	2	.11	NUT, trans. cont. lever and bracket (8— 18)
69	Camaro . . . . .	6482854	2	2.24	PLATE, cluster mtg. illum. . . . .
71-75	Vega . . . . .	346687	1	4.25	REINFORCEMENT ASSY., inst. panel carrier . . . . .
75	Monza (Towne Cpe.) . . . . .	346743	1	2.75	REINFORCEMENT ASSY., instr. panel carrier . . . . .

**9.744 PLATE— CIRCUIT— CLIP— NUT— SOCKET— WASHER, Instrument Case**

68-69	Chevy, Camaro w/floor cluster,				
70	Nova w/floor console . . . . .	6480878	1	.98	gas and oil gauge back . . . . .
66	Pass. . . . .	6291588	1	10.20	CIRCUIT, cluster printed wiring . . . . .
67	Pass. (exc. inst. panel gauges) . . . . .	6292099	1	8.05	CIRCUIT, inst. cluster printed wiring . . . . .
67-68	Camaro . . . . .	6290070	1	9.60	CIRCUIT, inst. cluster printed wiring . . . . .
68-75	Nova . . . . .	6295087	1	8.75	CIRCUIT, inst. cluster printed wiring . . . . .
68	Camaro w/inst. cluster console . . . . .	6295093	1	10.40	CIRCUIT, inst. cluster printed wiring . . . . .
68	Pass. (exc. inst. panel gauges) . . . . .	6295091	1	10.65	CIRCUIT, inst. cluster printed wiring . . . . .
68	Pass. w/inst. panel gauges . . . . .	6295092	1	11.85	CIRCUIT, inst. cluster printed wiring . . . . .
70-72	Chevelle w/inst. panel gauges . . . . .	8901487	1	13.55	CIRCUIT, inst. cluster prt. wrg. . . . .
70	Chevelle (exc. 396, 454, inst. panel gauges, Monte Carlo),				
71-72	Chevelle (exc. Monte Carlo, inst. pnl. gauges, S.S. Package) . . . . .	8901450	1	7.60	CIRCUIT, inst. cluster prt. wrg. . . . .
70	Monte Carlo (exc. inst. panel gauges),				
70	Chevelle (396, 454) (exc. inst. pnl. gauges),				
71-72	Monte Carlo (exc. inst. pnl. gauges),				
71-72	Chevelle w/S.S. Package (exc. inst. pnl. gauges) . . . . .	8901486	1	14.15	CIRCUIT, inst. cluster prt. wrg. . . . .
70-75	Camaro (exc. inst. pnl. gauges) . . . . .	8901670	1	7.10	CIRCUIT, inst. cluster printed wiring . . . . .
70-75	Camaro w/inst. pnl. gauges . . . . .	8901671	1	7.50	CIRCUIT, inst. cluster printed wiring . . . . .
73-75	Chevelle (exc. Instr. Panel gauges, S.S., Monte Carlo) . . . . .	8908198	1	3.65	CIRCUIT, instr. cluster painted . . . . .
73-75	Chevelle (S.S.) (exc. Instr. Panel gauges),				
73-75	Monte Carlo (exc. Instr. Panel gauges) . . . . .	8908199	1	9.50	CIRCUIT, instr. cluster printed . . . . .

**BODY MTG.— AIR COND.— INSTRUMENTS**

**9.744 PLATE— CIRCUIT— CLIP— NUT— SOCKET— WASHER, Instrument Case (Con't)**

73-74	Chevelle w/Instr. Panel gauges . . . . .	8908200	1	16.45	CIRCUIT, instr. panel printed . . . . .
75	Chevelle w/Instr. Panel gauges . . . . .	8986113	1	15.95	CIRCUIT, instr. panel printed . . . . .
75	Chevelle w/Instr. Panel gauges . . . . .	5658337	1	80.01	CIRCUIT, instr. panel printed w/terminal assy. . . . .
75	Pass. w/Low Fuel Indicator . . . . .	1597211	1	24.53	CIRCUIT, board, low fuel . . . . .
75	Vega . . . . .	8987845	1	11.53	CIRCUIT, instr. cluster wiring . . . . .
75	Monza w/instr. gauges . . . . .	8787846	1		CIRCUIT, instr. cluster printed . . . . .
68	Camaro w/instr. cluster console (327, 350),				
69-70	Chevelle w/instr. pnl. gauges,				
70	Camaro,				
71-72	Camaro, Chevelle,				
73-74	Camaro . . . . .	6468882	1	29.91	CIRCUIT ASSY., tach. . . . .
69	Camaro . . . . .	6482886	4	.63	CLIP, connector . . . . .
73-74	Chevelle . . . . .	8905981	A.R.	.43	CLIP, instr. cluster printed wiring circuit . . . . .
66-67	Chevelle,				
65-66	Pass.,				
70	Pass. w/Acc. Air Cond. . . . .	3884940	A.R.	.13	NUT, console assy. (black nylon) . . . . .
65	Chevelle (S.S.),				
65	Pass. (exc. S.S.) . . . . .	134530	1		NUT, cluster gas, gauge— (8.915) . . . . .
67-68	Pass. . . . .	3919773	A.R.	.12	NUT, bezel at upper end, panel compartment, cluster upper . . . . .
62-72	All . . . . .	2988412	1	1.15	SOCKET, w/wire . . . . .
67-68	Camaro,				
67-70	Pass.,				
68-71	Chevy,				
72-75	All (exc. Pass.) . . . . .	5655006	A.R.	.81	SOCKET, instr. cluster (bayonet) . . . . .
66-70	Pass.,				
67-72	Camaro,				
68-72	Chevy, Chevelle,				
75	Monza . . . . .	6288046	1	.22	SOCKET, instr. pnl. . . . .
73-74	Camaro, Nova . . . . .	3886902	A.R.	.14	WASHER, instr. cstr. printed circuit . . . . .

**9.746 BASE— BEZEL— COVER— HOUSING— SWITCH ASSY., Instrument Case**

68-69	Chevy, Camaro w/floor cluster,				
70	Nova w/floor console . . . . .	6480876	1	6.37	console . . . . .
73-75	Nova w/floor console . . . . .	6481920	1	25.89	BEZEL, console . . . . .
69-70	Pass. . . . .	6482723	4	.34	COVER, cluster tell-tale bezel screw . . . . .
70-72	Chevelle (exc. Monte Carlo, instr. pkg.) . . . . .	6492178	1	.41	COVER, cluster, snap-in . . . . .
72-75	Nova . . . . .	3994592	1	.76	HOUSING, seat belt warning light . . . . .

**9.747 RETAINER— CLIP, Instrument Face Glass**

68-69	Chevy, Camaro w/floor cluster,				
70	Nova w/floor console . . . . .	6480884	1	7.29	gas and oil gauge (words on part) . . . . .
69-70	Chevy . . . . .	6482965	1	6.23	instr. cluster lens . . . . .
69	Chevelle w/A.T. (exc. floor console) . . . . .	6491167	1	17.68	w/lens . . . . .
69	Chevelle w/floor shift . . . . .	6483281	1	16.97	w/lens . . . . .
70-75	Camaro w/deluxe interior . . . . .	6493585	1	19.90	lens and filter assy. . . . .
70-75	Camaro (exc. deluxe interior) . . . . .	6493584	1	23.06	lens & filter assy. . . . .
71-74	Pass. . . . .	6497639	1	11.80	lens . . . . .
73-74	Nova . . . . .	6496621	1	6.23	console instr. cluster lens . . . . .
73-74	Vega w/Instr. Panel gauges . . . . .	6496407	1	8.35	
75	Nova (L.N.) (exc. Console) . . . . .	8985988	1	17.07	instr. cluster lens . . . . .
75	Pass. (exc. Tach.) . . . . .	8986414	1	24.75	instr. cluster face glass (w/applique) . . . . .
75	Pass. . . . .	8986415	1	12.56	instr. cluster lens . . . . .
75	Nova (exc. A.T.) . . . . .	8985777	1	3.87	instr. cluster face glass . . . . .
75	Nova w/A.T. . . . .	8985502	1	6.57	instr. cluster lens . . . . .
68	Pass., Chevelle . . . . .	6480703	A.R.	.14	CLIP, lens retaining . . . . .

**9.748 LENS— BEZEL— CLIP— DIAL— FILTER— HOUSING— NUT— PLATE— SLEEVE, Instrument Case Face**

67	Pass. . . . .	6458237	1	8.78	
67-68	Camaro . . . . .	6457871	A.R.	.63	cluster, brake and oil tell tale . . . . .
67-68	Camaro . . . . .	6457874	A.R.	.63	cluster, gen. and temp. tell tale . . . . .
67	Camaro . . . . .	6458143	1	5.20	cluster, console oil and ammeter . . . . .
68	Camaro (exc. floor console inst. cluster) . . . . .	6481576	1	6.67	cluster . . . . .
68	Chevelle w/instr. panel gauges . . . . .	6480642	1	5.58	cluster tach. . . . .
68	Chevelle . . . . .	6480641	1	3.08	speedo. . . . .
68	Chevy,				
68	Camaro w/T.H. 350 . . . . .	6481082	1	6.18	cluster . . . . .
68-70	Chevy . . . . .	6481086	1	.98	gen. tell tale . . . . .

**BODY MTG.— AIR COND.— INSTRUMENTS**

<b>9.748</b>		<b>LENS— BEZEL— CLIP— DIAL— FILTER— HOUSING— NUT— PLATE— SLEEVE, Instrument Case Face</b>		<b>(Con't)</b>	
68-70	Chevy	6481087	1	.98	oil tell tale
68-70	Chevy	6481088	2	.65	dir. sign. tell tale
68-72	Chevy	6481095	1	.98	brake tell tale
68-70	Chevy (exc. floor cluster)	6481096	1	.98	temp. tell tale
68-69	Camaro, Chevy w/floor cluster,				
70-74	Nova w/floor console	6480882	2	2.02	cluster console
68	Pass.	6480702	1	7.98	cluster face
69-70	Pass.	6482724	1	.47	left cluster directional signal tell tale speedo
69-70	Pass.	6482730	1	.47	right cluster directional signal tell tale
69-70	Pass.	6482725	1	.91	cluster hot oil tell tale
69-70	Pass.	6482726	1	.47	cluster brake, low fuel, check doors, seat belt tell tale
69-70	Pass.	6482727	1	.47	cluster hi beam tell tale
69-70	Pass.	6482728	1	.43	cluster generator tell tale
69-70	Pass. w/P.G.	6482736	1	3.92	cluster trans. indicator— (4.020)
69-70	Pass. w/T.H.	6482737	1	3.92	cluster trans. indicator— (4.020)
69	Camaro	6482840	1	11.50	w/tell tale speedo.
69	Camaro (exc. tell tale)	6482842	1	8.53	speedo.
69	Camaro	6482841	1	11.44	w/tell tale cluster fuel gauge
69	Camaro (exc. tell tale)	6482843	1	8.53	cluster fuel gauge
69	Camaro w/tach. (exc. A.T.)	3961554	1	1.90	fuel gauge
69	Camaro	6482846 R.H.		.69	cluster directional signal tell tale
69	Camaro	6482847 L.H.		.63	cluster directional signal tell tale
69	Camaro	6482848	1	.63	cluster tell tale bright
69	Camaro	6482849	1	.63	cluster generator tell tale
69	Camaro	6482850	1	.68	cluster brake and gas tell tale
69	Camaro	6482856	2	1.05	cluster illumination
69-75	Nova	6482964	1	7.04	inst. cluster
70-72	Chevelle (exc. Monte Carlo, Instr. Pkg.)	6492175	1	8.28	instr. cluster
70-72	Monte Carlo,				
70-72	Chevelle w/inst. panel gauges	6493181	1	.51	brake tell tale
71-75	Pass. (exc. Police)	6496111	1	6.74	inst. cluster
72	Camaro (exc. Deluxe Inter.),				
73-75	Camaro	6264750	1	3.25	inst. panel (fasten seat belts)
71-75	Vega (exc. Instr. Panel Gauges)	6493671	1	7.66	instr. panel
71-73	Vega w/Instr. Panel gauges	6496406	1	15.51	instr. panel
74	Vega w/Instr. Panel gauges	8985566	1	15.51	instr. panel
75	Nova (L.N.)	8985798	1	5.70	instr. cluster
75	Nova w/Instr. Panel gauges	6481087	1	.98	oil tell-tale
75	Nova	6481095	1	.98	brake tell-tale
75	Vega, Monza w/instr. gauges	8986834	1	16.51	instr. pnl.
75	Vega (122 Eng.)	8988259	1	20.30	instr. panel
70-72	Monte Carlo, Chevelle (S.S.),				
70-72	Chevelle w/inst. panel gauges	6496697	1	29.41	LENS ASSY., w/retainer
70-72	Chevelle w/T.H. (exc. Monte Carlo, instr. pkg., floor console)	6497523	1	10.75	LENS ASSY., w/bezel
70-71	Chevelle w/P.G. (exc. Monte Carlo, instr. pkg., floor console)	6497522	1	10.75	LENS ASSY., w/bezel
71-72	Pass. (exc. Police)	6492511	2	.26	CLIP, mtg. retainer to housing
73	Chevelle	8905981 A.R.		.43	CLIP, instr. cluster printed wiring— (2.480)
73-74	Pass.	332060	1	.19	CONDUCTOR, w/S/W light switch— (2.580)
75	Pass.	346737	1	.16	CONDUCTOR, w/S/W light switch— (2.580)
70	Monte Carlo (exc. Col. Mtd., A.T.),				
70	Chevelle w/instr. pkg. (exc. Col. Mtd., A.T.)	6493059	1	2.30	DIAL, round w/o A.T. indicator
70	Monte Carlo w/Col. Mtd., A.T.,				
70	Chevelle (instr. pkg. w/Col. Mtd., A.T.)	6493070	1	2.65	DIAL, round w/A.T. indicator
70	Chevelle (exc. Monte Carlo, instr. pkg.)	6492199	1	3.80	DIAL, rectangular
71-73	Pass. (exc. Police)	6496130	1	5.48	DIAL, instr. clstr. speedo
70-74	Camaro	6497173	1	3.53	DIAL, speedo-miles
71-72	Malibu, Monte Carlo, El Camino (Custom) w/A.T. (exc. Console)	6496642	1	2.09	DIAL, speedo
71-73	Vega (exc. G.T.)	6493682	1	5.63	DIAL, instr. cluster speedo. ind.
71-72	Vega (G.T.)	6496412	1	2.55	DIAL, speedo. indicator
72	Chevelle w/instr. panel gauges	6497858	1	.36	FILTER, instr. panel seat belt wiring
73-75	Monte Carlo w/gauges,				
73-75	Chevelle w/gauges	5657624	1	.51	FILTER, brake and oil

**BODY MTG.— AIR COND.— INSTRUMENTS**

**9.748 LENS— BEZEL— CLIP— DIAL— FILTER— HOUSING— NUT— PLATE— SLEEVE, Instrument Case Face (Con't)**

73-75	Monte Carlo (exc. gauges),				
73-75	Chevelle (S.S.) (exc. gauges) . . . . .	6497034	1	.51	FILTER, brake tell-tale . . . . .
73-75	Chevelle (exc. C.A.C., S.S., Monte Carlo, Laguna, gauges),				
73-75	Laguna (exc. gauges) . . . . .	6497808	1	2.15	FILTER, turn signal, hi-beam, and brake . . .
73-74	Nova . . . . .	6481095	1	.98	FILTER, brake tell-tale . . . . .
75	Monza (exc. instr. gauges) . . . . .	8987850	R.H.	.62	FILTER, turn signal . . . . .
75	Monza (exc. instr. gauges) . . . . .	8987848	L.H.	.63	FILTER, turn signal . . . . .
75	Monza w/instr. gauges . . . . .	8987851	R.H.	.78	FILTER, turn signal . . . . .
75	Monza w/instr. gauges . . . . .	8989454	L.H.	.42	FILTER, turn signal (repl. 8987849) . . . . .
75	Pass. . . . .	8987078	R.H.	1.67	FILTER, turn signal . . . . .
75	Pass. . . . .	8986394	L.H.	1.46	FILTER, turn signal . . . . .
71-74	Vega w/Instr. Panel gauges . . . . .	6499799	1	29.95	HOUSING, instr. cluster . . . . .
71-74	Vega (exc. Instr. Panel gauges) . . . . .	6499797	1	27.75	HOUSING, instr. cluster . . . . .
75	Vega w/lux. interior & gauges . . . . .	8987526	1	43.29	HOUSING, instr. cluster (drk. oxblood) . . . . .
75	Vega w/lux. interior & gauges . . . . .	8987724	1	35.65	HOUSING, instr. cluster (dk. blue) . . . . .
75	Vega (exc. Instr. Panel gauges) . . . . .	8986954	1	30.69	HOUSING, instr. cluster . . . . .
75	Vega w/Instr. Panel gauges . . . . .	8987670	1	35.41	HOUSING, instr. cluster . . . . .
75	Vega w/luxury interior (exc. Instr. Panel gauges) . . . . .	8987520	1	41.51	HOUSING, instr. cluster (dk. blue-comb. 261) (ZJ-9) . . . . .
75	Vega w/luxury interior (exc. Instr. Panel gauges) . . . . .	8987521	1	41.51	HOUSING, instr. cluster (dk. sandstone- comb. 55 1) (ZJ-9) . . . . .
75	Vega w/luxury interior (exc. Instr. Panel gauges) . . . . .	8987522	1	41.51	HOUSING, instr. cluster (dk. oxblood-comb. 731) (ZJ-9) . . . . .
75	Monza (exc. Towne Cpe.) . . . . .	8986930	1	38.67	HOUSING, instr. cluster (graystone) (161) . .
75	Monza (exc. Towne Cpe.) . . . . .	8986931	1	38.67	HOUSING, instr. cluster (dk. blue) (261) . . .
75	Monza (exc. Towne Cpe.) . . . . .	8986932	1	38.67	HOUSING, instr. cluster (saddle) (631) . . . .
75	Monza (exc. Towne Cpe.) . . . . .	8986933	1	38.67	HOUSING, instr. cluster (sandstone) (55 1) .
75	Monza (exc. Towne Cpe.) . . . . .	8986934	1	38.67	HOUSING, instr. cluster (oxblood) (731) . . .
75	Vega (Sedan) . . . . .	8986955		30.53	HOUSING, instr. cluster . . . . .
68-70	Chevy . . . . .	6481085	R.H.	.93	HOUSING, gen. oil tell tale . . . . .
69	Camaro . . . . .	6482845	2	1.11	HOUSING, cluster generator, temp. brake, oil tell-tale . . . . .
69	Camaro w/A.T. (exc. tach. console),				
69	Camaro w/console gauges (exc. tach.) . . . . .	3951215	2	.11	NUT, trans. control indicator dial lens— (9.772) . . . . .
68-70	Chevy . . . . .	6481640	1	.22	SLEEVE, hi-beam tell-tale . . . . .

**9.749 GASKET— BOOT— BUMPER— INSULATOR— SEAL, Instrument Case**

62-64	Chevy, Chevelle,				
65-66	All,				
69	Chevy . . . . .	1587911	5	.18	tell-tale lens . . . . .
65	Pass. (exc. S.S.) . . . . .	1582954	1	.36	gas gauge and tell-tale lens . . . . .
68-70	Chevy . . . . .	6481097	2	.75	gen. temp. brake and oil lens . . . . .
71-74	Pass. . . . .	6497917	1	.40	inst. cluster speedometer . . . . .
63-65	Chevy . . . . .	1588312	A.R.	.26	BOOT, shield (1" I.D.) rubber . . . . .
65-66	All (S.S.),				
66	Caprice (Spt. Cpe.),				
67-68	Camaro (8 cyl.),				
68	Chevy (8 cyl.),				
69	All . . . . .				INSULATOR, ammeter, . . . . .
69	Chevelle (2-Dr.) (exc. Sed.) . . . . .				fuel and oil gauge, . . . . .
70	All . . . . .	6430382	1	.44	amp. meter— (2.515) . . . . .
69	Chevelle . . . . .	6401900	1	.18	INSULATOR, temp. gauge . . . . .
62-66	Chevy, Chevelle, Camaro . . . . .	1568724	A.R.	.30	SEAL, speedometer case dust . . . . .

**9.750 TACHOMETER— DIAL AND POINTER UNIT— FILTER ASSY.— REPAIR KIT— SHAFT UNIT, Drive and Engine**

*NOTE For F.I. Distributor tachometer Drive Parts, See Group 3.340, also see group 2.374.*

66	Pass. (8 cyl.) (exc. 427, T/Ign.) . . . . .	6412548	1	82.00	
67	Camaro w/console gauges (327) . . . . .	6468909	1	82.00	(stamped 6468909) . . . . .
67	Camaro w/console gauges (350, 396) . . . . .	6468910	1	90.75	(stamped 6468910) . . . . .
68-70	Chevy w/console gauges (exc. H/Per., Sp. H/Per.),				
71-75	Nova w/console gauges . . . . .	5657301	1	101.00	
68	Camaro w/console instr. cluster (327, 350) . . . . .	6468713	1	104.00	w/clock (Note 1) . . . . .

**BODY MTG.— AIR COND.— INSTRUMENTS**

**9.750 TACHOMETER— DIAL AND POINTER UNIT— FILTER ASSY.— REPAIR KIT— SHAFT UNIT, Drive and Engine (Con't)**

68	Camaro w/console instr. cluster (396) (exc. Sp. H/Per.)	6468714	1	104.00	w/clock (Note 1)
	<i>NOTE 1 These tach. assys. are located up in the dash.</i>				
69	Camaro w/console gauges (396) (exc. Sp. H/Per.)	6469382	1	93.25	
69	Chevelle w/instr. panel gauges (396) (exc. Sp. H/Per.)	6469404	1	71.18	
69	Chevelle (instr. panel gauges w/Sp. H/Per.) (396)	6469408	1	71.18	
69	Chevelle w/inst. panel gauges (8 cyl.) (exc. 396)	6491312	1	104.00	w/gauges and case
69	Chevelle w/inst. panel gauges (396) (exc. Sp. H/Per.)	6491313	1	104.00	w/gauges and case
69	Chevelle (inst. panel gauges w/Sp. H/Per.) (396)	6491314	1	106.00	w/gauges and case
69	Camaro w/console gauges, speed warning (302)	6469780	1	90.75	
70	Chevelle (inst. panel gauges w/H/Per.) (396, 400 w/4BC, 454)	6469985	1	96.00	
70	Chevelle (inst. panel gauges w/Sp. H/Per.) (396, 454)	6469983	1	96.00	
70-72	Camaro (307, 350) (exc. Sp. H/Per.)	5657040	1	99.75	
70-72	Camaro w/Sp. H/Per. (350)	5657056	1	99.75	
70	Camaro (396),				
71	Camaro w/4BC (400),				
72	Camaro (402)	5657048	1	99.75	
71	Malibu, El Camino, Monte Carlo w/instrument panel gauges (Sp. H/Per. 454)	5657407	1	95.25	
71	Monte Carlo w/instrument panel gauges (400, 454) (exc. 2BC),				
71	Malibu, El Camino w/instrument panel gauges (400, 454) (exc. Sp. H/Per.),				
72	Chevelle (402, 454)	5657406	1	95.25	
71	Malibu, El Camino, Monte Carlo (307, 350),				
71	Monte Carlo (400 w/2BC),				
72	Chevelle (307, 350)	5657405	1	95.25	
71-72	Nova w/console gauges	5657301	1	101.00	
71-73	Vega w/Tachometer	5657308	1	111.00	
73-74	Camaro w/Sp. H/Per. (350)	5658154	1	99.75	
73-75	Camaro (307, 350) (exc. Sp. H/Per.)	5657040	1	99.75	
73-74	Chevelle	5657612	1	95.25	
74	Vega w/Tachometer (exc. Cosworth)	5658085	1	111.00	
75	Chevelle	5658382	1	95.25	
75	Monza (8 cyl.) (exc. Towne Cpe.)	5658484	1	140.00	
75	Monza (4 cyl.) (exc. Towne Cpe.)	5658487	1	138.00	
75	Vega (exc. Cosworth)	5658468	1	111.00	
75	Vega (Cosworth)	5658469	1	111.00	
75	Nova w/console	5658477	1	114.00	
75	Monza (8 cyl. w/instr. gauges)	5658540	1	140.00	
73-74	All (exc. Vega)	6262620	1	6.20	FILTER ASSY., noise— (9.654)
75	All w/Tach. (exc. Vega, Monza)	348784	1	6.75	FILTER ASSY., noise
75	Vega, Monza w/Tachometer	356129	1	6.75	FILTER, tach.
74	Nova w/Console	5657430	1	72.36	REPAIR KIT
75	Chevelle	5658383	1	22.03	REPAIR KIT
62-70	All	6477499	1	3.70	SHAFT UNIT, includes cable and tip (81" long) (Note 2)

*NOTE 2: Cut to required length.*

**9.755 TEE— VACUUM GAUGE— SWITCH ASSY., Instrument Cluster**

65	Pass. (S.S.) (8 cyl.) (exc. tach., 4-Spd.)	3760758	1	.49	spark cont. hose to vac. gauge hose— (10.155)
75	Pass. (exc. Tach.)	6464205	1	29.96	VACUUM GAUGE
75	Chevelle (exc. Tach.)	6464602	1	51.01	VACUUM GAUGE (repl. 6464448)
75	Vega (exc. instr. gauges)	6464495	1		VACUUM GAUGE, instr. cluster fuel econ.
75	Vega w/instr. gauges	6464502	1	37.57	VACUUM GAUGE, instr. cluster fuel econ.
75	Nova, Camaro w/vac. gauge	344856	1	3.05	SWITCH ASSY., vac. gauge

**BODY MTG.— AIR COND.— INSTRUMENTS**

**9.761 HEAD ASSY.— BOLT— BUMPER— BUSHING— POINTER— SPACER,  
Speedometer and Odometer (Miles)**

62-64	Chevy	6406815	1	28.86	speedo.
65	Pass.	6456245	1	28.74	speedo.
66	Pass.	6456802	1	26.76	speedo.
67	Chevy (exc. speed warning)	6459272	1	38.13	speedo.
67	Biscayne, Bel Air w/Speed Warning (exc. instr. panel gauges),				
67	Caprice, Impala (exc. Speed Warning, instr. panel gauges)	6458279	1	29.98	speedo.
67	Pass. w/instr. panel gauges (exc. Speed Warning)	6480593	1	31.22	speedo.
68	Pass. (exc. Speed Warning, instr. panel gauges)	6480714	1	27.86	speedo.
68	Chevelle (exc. speed warning)	6492545	1	27.00	speedo.
68	Chevy w/P.B. Radio (exc. console instr. cluster, speed warning)	6481090	1	28.30	speedo.
69	Camaro (exc. speed warning)	6492572	1	32.20	speedo.
69	Chevy w/floor cluster, speed warning	6492596	1	32.00	speedo.
69-70	Chevy (exc. Speed Warning, Console),				
71-74	Nova (exc. floor cluster)	6496615	1	35.84	speedo.
69	Chevelle (exc. speed warning)	6492542	1	31.03	speedo.
69-70	Pass. (exc. Police, Speed Warning)	6491802	1	47.45	speedo. w/lens and dial
69-70	Pass. w/Speed Warning	6491803	1	64.33	speedo. w/lens and dial
70-74	Camaro	6497236	1	37.46	speedo.
70-72	Monte Carlo w/Col. Mtd. A.T.,				
70-72	Chevelle (Instr. Pkg. w/Col. Mtd. A.T.)	6496643	1	36.16	speedo. round w/A.T. indicator
70-72	Chevelle (exc. Monte Carlo, Instr. Pkg.)	6497814	1	31.94	speedo. rectangular
71-74	Pass. (exc. Police)	8985369	1	31.22	speedo.
71-72	Police	6496124	1	32.63	speedo.
71-74	Vega (exc. instr. panel gauges)	6497685	1	36.40	
71-73	Vega w/instr. panel gauges	6497697	1	35.48	
73-74	Chevelle (exc. round instr.)	6497006	1	31.94	
73-74	Chevelle (round instr. w/A.T. indicator)	6497432	1	37.88	
72-74	Nova w/floor cluster	6496617	1	35.54	
73-74	Chevelle (round instr. w/o A.T. indicator)	6497012	1	37.88	
73-74	Pass. (Police)	6497915	1	32.63	
73-75	Chevelle (Police)	8985298	1	31.94	
75	Nova (exc. Console)	8985943	1	38.64	
75	Pass. w/vac. gauge	8986995		38.03	speedo.
75	Nova w/Fuel Economy Indicator	8987563		39.05	speedo.
75	Pass. (exc. vac. gauge)	8986802		38.03	speedo.
75	Camaro (exc. Clock, Interior Decor Group)	8987262		35.38	speedo.
75	Chevelle (exc. round instr.)	8986854		45.49	speedo.
75	Camaro w/Interior Decor Group	8987263		36.26	speedo.
75	Chevelle w/round instr.	8986987		46.84	speedo.
75	Chevelle 3-Spd. M.T. w/instr. gauges	8987602	1	46.84	
75	Pass. (Police)	8985371		32.63	speedo.
75	Nova w/Floor Cluster	8986577		39.29	speedo.
75	Nova Police Car	8988404	1	48.74	
74	Vega w/instr. panel gauges	8985554	1	32.99	
75	Vega (exc. instr. panel gauges)	8986889	1	37.81	
75	Vega w/instr. panel gauges	8987205	1	38.12	
75	Monza	8987853	1	38.74	
65-69	Pass.	5655222	1	.14	BOLT, speedometer mounting (8-32 x 7/16" @
62-70	All	1564429	A.R.	.06	BUSHING, head to back cover (rubber)
71-74	Pass.	6492512	1	1.79	PLATE, speedo. lens trim
70-71	Chevelle (exc. Monte Carlo, Instr. Pkg.)	6493329	1	2.52	POINTER, used on rectangular speedo.
70-72	Monte Carlo,				
70-72	Chevelle w/Instr. Pkg.	6493060	1	2.85	POINTER, used on round speedo.
71-72	Pass.	6496133	1	2.84	POINTER, speedo.
71-74	Vega (exc. instr. panel gauges)	6493679	1	2.93	POINTER
71-74	Vega w/instr. panel gauges	6496413	1	2.45	POINTER
68-70	Chevy	6481535	2	.26	SPACER, dial

**BODY MTG.— AIR COND.— INSTRUMENTS**

**9.762 BUZZER ASSY.— BRACKET— CABLE ASSY.— SCREW ASSY., Speed Indicator**

67-69	Pass. ....	3904843	1	3.20	indicator .....
67	Chevelle,				
68-69	Chevy .....	1386278	1	5.20	indicator .....
67	All,				
68	Camaro, Chevy,				
69	Chevy .....	6454841	1	6.93	CABLE ASSY., buzzer .....
67-68	Camaro,				
67-68	Camaro .....	6459427	2	.15	SCREW ASSY., head assy. ....

**9.765 SWITCH ASSY.— BEZEL— FILTER— HARNESS— LIGHT ASSY.— RELAY ASSY.— TIMER, Seat Belt, Check Doors and Low Fuel Warning Lights**

67	Camaro w/console,				
68-69	Chevy, Camaro w/gauges,				
69	Pass. ....	6431323	1	21.14	seat belt warning .....
70-72	Nova w/gauges .....	1596409	1	19.97	low fuel warning .....
69-70	Pass. ....	6431323	1	21.14	low fuel warning .....
71-72	Pass. ....	1596747	1	22.88	low fuel warning .....
70-75	Camaro .....	6493596	1	.81	FILTER, inst. brake tell tale .....
71-72	Chevelle .....	6492172	1	.24	FILTER, telltale (gen.) .....
71-72	Chevelle .....	6492171	1	.51	FILTER, telltale (oil & hot) .....
71-72	Chevelle .....	6492170	1	.24	FILTER, telltale (bright) .....
71-72	Chevelle .....	6497524	2	.41	FILTER, right, telltale (directional signal) ...
71-74	Pass. ....	6496115	R.H.	1.30	FILTER, right, telltale (brake) .....
72	Chevelle w/A.T. (exc. Monte Carlo I.P.G. S.S.) .....	6497818	1	.84	FILTER, inst. cluster/fasten seat belt .....
72-74	Pass. ....	6497640	L.H.	1.20	FILTER, left, telltale (amm) .....
71-74	Vega (exc. instr. panel gauges) ..	6493676	1	.78	FILTER, inst. cstr. brk. & oil .....
71-74	Vega (exc. instr. panel gauges) ..	6493674	1	.53	FILTER, instr. cluster tell tale (gen. and temp.) .....
71	Vega (G.T.) .....	6492509	1	.50	FILTER, inst. cstr. tell tale (brake) .....
72-75	Vega, Monza w/instr. panel gauges .....	6497700	1	.94	FILTER, inst. cstr. tell tale (brake & seat belt) .....
72-75	Vega (exc. instr. panel gauges) ..	6497909	1	.66	FILTER, seat belt .....
73-75	Vega, Monza w/instr. panel gauges .....	6496408	1	.47	FILTER, instr. cluster tell tale (hi-beam) .....
73-75	Vega, Monza w/instr. panel gauges .....	6496409	2	.50	FILTER, instr. cluster tell tale (direction signal tell tale) .....
75	Chevelle w/Low Fuel Indicator ..	6499320	1	.50	FILTER, low fuel tell-tale .....
69-72	Pass. ....	3961500	1	2.25	RELAY ASSY., seat belt warning, door check .....
72	All (exc. Pass.) .....	3961573	1	2.85	RELAY ASSY., seat belt warning and park brake— (4.075) .....
75	H w/M.T. ....	494882	1	4.35	RELAY ASSY., park. brake alarm sw. & brkt. ....
75	All .....	1726241	1	3.80	TIMER, seat belt warning— (13.095) .....

**9.772 CLOCK— BRACKET— CLIP— COVER— GASKET— KNOB— LENS— NUT— PLATE— SHIELD ASSY.— SLEEVE— WIRE ASSY., Clock Mounting and Attaching**

65	Caprice w/4-Spd., H/Per. (327, 396) (exc. close ratio, H.D., S.S.),				
65	Impala, Caprice w/close ratio 4-Spd. (exc. S.S.),				
65	Caprice w/H.D. 4-Spd.,				
66	Impala, Caprice w/4-Spd. (396, 427) (exc. H.D., close ratio, floor console w/gauges),				
67	Impala, Caprice w/H.D., close ratio 4-Spd. (exc. floor console w/gauges),				
67	Impala, Caprice w/4-Spd. (396, 427) (exc. H.D. close ratio) ..	3864404	1	28.75	assy. mounted on instr. panel .....
66	Biscayne, Bel Air,				
66	Impala, Caprice (exc. Tach., 4-Spd.) .....	3877204	1	24.50	instr. cluster .....
67	Pass. ....	3897352	1	23.35	assy. ....
69-74	Nova .....	3986834	1	27.75	instrument cluster .....
70-72	Camaro .....	3901632	1	22.65	(floor mounted) .....
70-75	Camaro .....	3980116	1	27.50	(inst. cluster) .....
71-75	Pass. ....	994674	1	19.15	instrument cluster .....
70-72	Monte Carlo,				

**BODY MTG.— AIR COND.— INSTRUMENTS**

<b>9.772 CLOCK— BRACKET— CLIP— COVER— GASKET— KNOB— LENS— NUT— PLATE— SHIELD ASSY.— SLEEVE— WIRE ASSY., Clock Mounting and Attaching (Con't)</b>					
70-72	Chevelle w/inst. panel gauges . . .	3990803	1	22.00	round . . . . .
71-73	Vega w/instr. panel gauges . . . . .	340447	1	21.85	(repl. 3986836) . . . . .
74-75	Vega, Monza w/instr. panel gauges (exc. 27) (1st type) . . . . .	340447	1	21.85	w/white hands . . . . .
73-75	Chevelle (exc. Monte Carlo, Instrument Panel gauges) . . . . .	994768	1	19.15	rectangular . . . . .
73-75	Monte Carlo, Chevelle w/Inst. Panel gauges . . . . .	6270685	1	22.00	round . . . . .
75	Nova . . . . .	994769	1	18.15	inst. cluster (round) . . . . .
75	Monte Carlo, Chevelle w/Inst. Panel Gauges . . . . .	344832	1	28.75	
75	Vega, Monza w/Instr. Panel Gauges (exc. 27) (2nd type) . . . . .	551962	1	21.85	w/red hands . . . . .
75	Monza (Towne Cpe.) (exc. Fuel Econ. Gauge) . . . . .	364020	1	24.45	
65	Chevelle (exc. tach.) . . . . .	3863459	1	28.25	CLOCK ASSY., inst. cluster . . . . .
66-67	Chevy (exc. tach.) . . . . .	3874712	1	23.75	CLOCK ASSY., inst. cluster . . . . .
67	Camaro w/console gauges . . . . .	3901613	1	23.35	CLOCK ASSY., console . . . . .
68	Camaro w/floor console . . . . .	3921410	1	41.00	CLOCK ASSY., seat sep. compt. . . . .
68	Chevelle w/electric clock (exc. gauges) . . . . .	3919015	1	22.30	CLOCK ASSY., inst. cluster . . . . .
68	Pass. . . . .	3934233	1	21.55	CLOCK ASSY. . . . .
69	Camaro w/electric clock, console gauges . . . . .	3951213	1	27.00	CLOCK ASSY. . . . .
69	Chevelle . . . . .	3948956	1	23.10	CLOCK ASSY., inst. cluster . . . . .
70-72	Chevelle (exc. Monte Carlo, Instrument Panel Gauges) . . . . .	3990802	1	22.00	CLOCK ASSY., square . . . . .
69-70	Pass. . . . .	3965110	1	19.70	CLOCK ASSY., inst. cluster . . . . .
71-75	Vega (exc. Monza) (exc. instr. panel gauges) . . . . .	994014	1	18.15	CLOCK UNIT, instr. cluster . . . . .
65-66	Pass., Chevelle . . . . .	3864405	1	.16	BRACKET, mounted on instr. panel . . . . .
67-69	Camaro (exc. console gauges), Chevelle w/instr. panel gauges (exc. front compartment console),	3901633	1	.11	BRACKET, floor mounting . . . . .
71-72	Camaro . . . . .	3901633	1	.11	BRACKET, floor mounting . . . . .
69	Camaro w/electric clock, console gauges . . . . .	6481602	2	.07	CLIP, inst. cluster inst. panel clock— (4.020) . . . . .
73-75	Chevelle . . . . .	6497325	1	2.10	COVER, clock light shield . . . . .
75	Monza (Towne Cpe.) (exc. Fuel Econ. Gauge) . . . . .	8987887	1	5.52	COVER, instr. cluster gauge opening . . . . .
75	Monza (Towne Cpe.) (exc. Instr. Panel Gauges) . . . . .	8987891	1	5.50	COVER, instr. cluster clock opening . . . . .
63-69	Chevy, Chevelle, 66 Pass. (4-Spd. w/Tach.) w/console gauges (396, 427),				
67-69	Camaro w/console gauges,				
67-70	Pass. w/electric clock,				
71-75	Nova w/electric clock, console gauges . . . . .	3794017	1	.16	KNOB, reset stem . . . . .
65	Pass. . . . .	3876125	1	.22	KNOB, reset stem . . . . .
70	Chevelle, Camaro w/electric clock, inst. panel gauges,				
71-75	All (exc. Nova) . . . . .	3973601	1	.18	KNOB, reset stem . . . . .
66	Pass. (exc. Impala, Caprice),				
66	Impala, Caprice (exc. Tach., 4- Spd.) . . . . .	3877205	1	.22	KNOB, reset stem . . . . .
73-75	Chevelle . . . . .	3996275	1	.16	KNOB, reset stem . . . . .
69	Camaro . . . . .	3943617	1	1.50	LENS ASSY., clock, instr. cluster console (repl. 3943616) . . . . .
63-69	Chevy, Chevelle, Camaro, 66 Impala, Caprice (exc. Tach., 4- Spd.),				
67-69	Pass. w/electric clock,				
70-75	All (exc. Chevelle) . . . . .	3794018	1	.24	NUT, reset stem knob (No. 1-72NF 2B thd.)
73-75	Chevelle . . . . .	3996276	1	.22	NUT, reset stem . . . . .
69	Camaro w/tach., electric clock . . . . .	3951215	2	.11	NUT, clock . . . . .
69	Camaro w/electric clock . . . . .				SHIELD ASSY., inst. cluster clock lamp, . . . . .
69	Camaro w/console gauges . . . . .	3951214	1	1.50	inst. panel clock lamp . . . . .
70	Monte Carlo,				
70	Chevelle w/inst. panel gauges . . . . .	3973634	1	.18	SLEEVE, reset stem . . . . .



**BODY MTG.— AIR COND.— INSTRUMENTS**

**9.772 CLOCK— BRACKET— CLIP— COVER— GASKET— KNOB— LENS— NUT—  
PLATE— SHIELD ASSY.— SLEEVE— WIRE ASSY., Clock Mounting and  
Attaching (Con't)**

70	Chevelle (exc. Monte Carlo, inst. panel gauges) . . . . .	3973603	1	.18	SLEEVE, reset stem . . . . .
68-69	Chevy, Chevelle w/electric clock, Pass.,				
68	Pass.,				
69	Chevelle w/inst. panel gauges . . . . .	6295103	1	2.75	WIRE ASSY., cluster clock . . . . .
69-70	Pass. . . . .	8901781	1	2.75	WIRE ASSY., inst. cluster clock (repl. 6297523) . . . . .
71	Pass. (exc. Caprice, Estate Wag.) . . . . .	8901781	1	2.75	WIRE ASSY., inst. cluster clock . . . . .

**9.773 LAMP UNIT— BRACKET— BEZEL— CABLE ASSY.— GEAR— HANDLE  
ASSY.— PLATE— PIN— RING— SCREW— SEALED BEAM— SWITCH,  
Safety Light**

62-75	All . . . . .	994777	1	10.00	portable (12 volt) (Nelmor) (repl. 987112) . . . . .
65-68	Pass.,				
66-67	Chevelle . . . . .	3864177	1	1.35	BEZEL, control . . . . .
64	Chevelle . . . . .	3738382	1	2.40	GEAR, shaft (driven gear) . . . . .
64-67	Chevelle . . . . .	3738381	1	5.80	HANDLE ASSY. (incl. drive gear) . . . . .
65-67	Pass.,				
66-67	Chevelle . . . . .	273337	2	.05	PIN, spotlight roll— (8.939) . . . . .
65-67	Pass.,				
66-67	Chevelle . . . . .	274612	1	.11	RING, spotlight retaining— (8.934) . . . . .
67	Pass. . . . .	531211	1	.46	SCREW, spot lamp handle cap (6— 32 x 1 1/2") . . . . .
62-66	All . . . . .	455242	1	4.22	SEALED BEAM (use w/portable lamp) (No. 4416) . . . . .
62-75	All . . . . .	3696948	1	1.75	SWITCH, port. spot lamp . . . . .

**9.775 GROMMET— SEAL**

*NOTE Some grommets may require the addition of holes.*

62-74	All (exc. Vega) . . . . .	3884967	A.R.	.33	for one inch dia. hole— 3 openings equally spaced 1 1/32" dia. . . . .
65-67	Chevy . . . . .	3918672	1	.16	evaporator . . . . .
65-66	Pass. w/Air Cond.,				
67-75	Camaro,				
68	Pass., Chevy, Auto. Temp. Control,				
69-70	Pass.,				
70-75	Nova . . . . .	3142670	1	.16	evap. core inlet pipe (1 1/2" O.D. x 15/32" I.D.) . . . . .
65-69	Pass. . . . .		1		dome lamp wire, . . . . .
65-69	Pass. . . . .		1		car heater control lamp wire in dash, . . . . .
62-69	All . . . . .	3771184	1	.16	choke cable hole plug (in dash) (1 3/8" O.D. x 1" I.D.) . . . . .
63-66	All (exc. 8 cyl.) . . . . .	3989344	1	.22	c/case vent valve (1 7/32" O.D. x 29/32" I.D.)— (1.745) . . . . .
64-67	Chevelle,				
65-70	Pass. . . . .	3853970	1	.16	gas tank gas pipe . . . . .
64-66	Pass., Chevelle,				
67-68	Pass., Camaro, Chevelle,				
68-72	Chevy,				
69-72	Chevelle,				
73-75	Nova, Chevelle, Camaro . . . . .	3007277	1	.16	evap. core outlet pipe . . . . .
64-65	Chevelle w/air lift (exc. El Camino) . . . . .	3766236	2	.33	rr. shock absorber air inlet tube (3/4" I.D. x 1 1/2" O.D.) . . . . .
65-66	Pass. w/C.A.C. . . . .		2		inlet tube at rad. supt., . . . . .
62-67	Chevy,				
65	Chevelle w/4-Spd. (exc. close ratio),				
66-67	Chevelle w/4-Spd.,				
67	Chevelle w/Cruise Control,				
67-68	Pass.,				
70	Nova, Pass., Camaro . . . . .				speedometer shaft (13/16" I.D.) . . . . .
65-72	All,				
73-75	Camaro, Nova . . . . .	332650	1	.16	wiring harness in dash . . . . .
66	Chevelle . . . . .	3886908	1	.16	gen. and forward lamp wiring harness (9/16" I.D. x 1 1/8" O.D.) . . . . .
66-67	Chevy . . . . .	1350657	1	.11	bat. pos. cable and wiring harness (1 29/32" O.D. x 1 5/16" I.D.) . . . . .
66-67	Chevelle . . . . .	3875822	1	.52	wiring harness and control cable . . . . .
66	Chevelle w/Air Cond. . . . .	2973161	1	.38	A/C receiver and dehyd. asm. to condenser hose . . . . .
67-69	Camaro,				

**BODY MTG.— AIR COND.— INSTRUMENTS**

**9.775 GROMMET—SEAL (Con't)**

68	Chevelle,					
68-75	Nova	3895903	2	.34	vac. control hose	
67-69	Camaro,					
68-71	Chevy,					
74-75	Nova,					
75	Vega, Monza (8 cyl.) (exc. C.A.C.)	3885184	1	.76	heater core pipe	
67-68	Pass., Chevelle, Camaro,					
68	Chevy,					
70	All w/Acc. Air Cond.	3899759	1	3.15	A/C evap. and blower pipes	
69	Chevelle w/Acc. Air Cond.,					
69-70	Chevy w/C.A.C.				condenser inlet tube,	
69	Chevelle w/C.A.C.	3722970	1	.11	compressor fitting muffler and tube, receiver and dehyd. to exp. valve	
All	All	3845783	1	.34	vent. hose conn. (at rocker cover) (for 1" dia. hose— <sup>23</sup> / <sub>64</sub> " I.D. x <sup>17</sup> / <sub>32</sub> " O.D. x <sup>7</sup> / <sub>16</sub> " thk.)— (1.745)	
All	All	3884967	1	.33	speedo flex. shaft assy. ign. sw. to start sol. wrg. harn. assy., start & eng. wrg. harn. assy. & oil press. gauge pipe, w/w harn. assy., AC gen. wrg. harn. assy., body wrg. harn 1, for one inch dia. hole 3 openings equally spaced <sup>11</sup> / <sub>32</sub> " dia.	
69-75	All	3829698	1	.16	under hood lamp wire eng. compt. lid antenna unit	
70	Pass.,					
70	Nova w/C.A.C.	3722970	1	.11	<b>GROMMET</b> , spec.	
71-74	Chevelle (exc. Monte Carlo)	3961565	2	.16	front marker lamp lead to fwd. lamp harness ( <sup>13</sup> / <sub>8</sub> " I.D.)	
71-75	Pass.	6271679	1	.40	speedo flex. shaft ( <sup>27</sup> / <sub>32</sub> " O.D. x <sup>9</sup> / <sub>32</sub> " I.D.)	
71-74	Pass., Nova	3984684	1	.11	condenser inlet pipe	
73-74	Monte Carlo	6258217	1	.08	rear lic. plate lamp wire	
74-75	Nova	3012054	1	.16	a/c evap. core outlet pipe	
74-75	Camaro	3963723	1	.63	heater core pipe	
74-75	Chevelle, Pass.	3919057	1	.14	<b>GROMMET</b> , forward lamp harn. horn lead wire	
74-75	Camaro	3919057	1	.14	<b>GROMMET</b> , horn wiring in rad. supt.	
75	Monza (exc. Towne Cpe.)	356120	1	.27	a.c. evap. drain	
71-75	Vega, Monza	3984663	1	.64	<b>SEAL</b> , a/c heater pipe	

**9.778 DEFOGGER UNIT— ADAPTER— BACK-UP RING— BEZEL— BLOWER CASE— BOLT— BRACKET— CAPACITOR ASSY.— CASE— CLIP— COVER— DUCT— FAN ASSY.— GASKET— GRILLE— HARNESS ASSY.— HOSE— HOUSING— INSULATOR— KNOB ASSY.— MOTOR— NOZZLE ASSY.— NUT— OUTLET— PLATE— RELAY ASSY.— REPAIR KIT— RETAINER— SCREEN— SEAL— SPACER— SUPPORT— SWITCH ASSY.— TIMER ASSY.— WIRE ASSY., Rear Window Defogger**

71-75	Nova (exc. Hatchback)	994323	1	43.50	rear window	
71-72	Pass. (Sed.),					
73-74	Pass. (2-Dr.) (exc. Cust., Caprice),					
73-75	Pass. (4-Dr.) (exc. Sta. Wag.)	994332	1	43.50	rear window	
73-75	Camaro	994324	1	43.50	rear window	
73-75	Chevelle (exc. Sta. Wag.)	994671	1	43.50	rear window	
74-75	Impala (Custom) Caprice (2-Dr.)	994558	1	N.L.	rear window	
75	Nova (Hatchback)	994793	1	43.50	rear window	
74	Nova (Hatchback)	9657595	1	4.40	<b>ADAPTER</b> , defogger	
75	Pass. (Cpe.)	9836062	1	.91	<b>ADAPTER</b> , defogger	
71-72	All (exc. Chevelle Sta. Wag., Conv., El Camino)	3023589	1	.14	<b>BACK-UP RING</b> , defogger motor mtg.	
68-70	All (Sta. Wag.),					
71-72	Chevelle (Sta. Wag.)	3917390	1	1.55	<b>BEZEL</b> , defog. air inlet	
69	Camaro (exc. power top),					
69	Pass. (Sta. Wag.) (6-Pass.) (exc. elec. tailgate window),					
69	Chevy, Chevelle,					
69-70	Pass. (exc. Sta. Wag., Conv.),					
70-75	Nova	3940271	1	1.80	<b>BEZEL</b> , defogging switch	
70-72	Chevelle (exc. Sta. Wag., Conv., El Camino)	3973643	1	1.80	<b>BEZEL</b> , defogger switch	
70-75	Camaro	3973660	1	1.80	<b>BEZEL</b> , defogger switch	
71-75	Pass.	3989204	1	1.65	<b>BEZEL</b> , blower switch	
71-75	Vega, Monza (exc. Towne Cpe.)	3989226	1	4.05	<b>BEZEL</b> , defogger switch	
73-75	Chevelle	3998475	1	1.65	<b>BEZEL</b> , defogger switch	
75	Monza (Towne Cpe.)	362537	1	4.20	<b>BEZEL</b> , defogger switch	
69-71	Pass. w/electric defogger	3949993	1	7.50	<b>BEZEL ASSY.</b> , control	
75	Nova (Hatch-back)	1673944	1	47.00	<b>BLOWER ASSY.</b>	

**BODY MTG.— AIR COND.— INSTRUMENTS**

**9.778 DEFOGGER UNIT— ADAPTER— BACK-UP RING— BEZEL— BLOWER CASE— BOLT— BRACKET— CAPACITOR ASSY.— CASE— CLIP— COVER— DUCT— FAN ASSY.— GASKET— GRILLE— HARNESS ASSY.— HOSE— HOUSING— INSULATOR— KNOB ASSY.— MOTOR— NOZZLE ASSY.— NUT— OUTLET— PLATE— RELAY ASSY.— REPAIR KIT— RETAINER— SCREEN— SEAL— SPACER— SUPPORT— SWITCH ASSY.— TIMER ASSY.— WIRE ASSY., Rear Window Defogger (Con't)**

73-74	Chevelle (exc. Sta. Wag.) . . . . .	7731439	1	.11	BOLT, w/clip, rear window defog.— (2.668)
68-69	Camaro (Conv.) . . . . .	3929037	1	3.05	BRACKET, defog. blower . . . . .
70-71	Chevelle (exc. Sta. Wag., Conv.) . . . . .	3973645	1	.25	BRACKET, rear window defog. blower switch . . . . .
68-70	All (exc. Sta. Wag., Conv.),				
71-75	All . . . . .	3937157	1	6.40	CAPACITOR ASSY., defog. blower motor . . . . .
68-69	All (Sta. Wag., Conv.),				
69	Impala (Custom), Caprice (Spt. Cpe.),				
70	Pass., Chevelle . . . . .	3147661	1	4.60	CASE, blower inlet half . . . . .
68-70	All (Sta. Wag., Conv.) . . . . .	3015035	1	4.60	CASE, blower motor half . . . . .
68-69	All (exc. Sta. Wag., Conv.),				
70	Pass. w/Acc. Defog. (exc. Sta. Wag., Cust. Cpe., Conv.),				
70	Chevelle w/Acc. Defog. (exc. Sta. Wag., Conv.),				
70	Nova w/Acc. Defog. . . . .	3015043	1	4.05	CASE, blower motor half (shelf type) . . . . .
69	Pass. (Sed., Spt. Cpe.) (exc. Caprice, Custom),				
69	Chevelle (exc. Sta. Wag., Conv.),				
69	Caprice (Spt. Sed.),				
70	Camaro w/Acc. Defog.,				
70	Pass. (exc. Sta. Wag., Conv., Impala Cust., Caprice Spt. Cpe.),				
70	Chevelle (exc. Sta. Wag., Conv.) . . . . .	3017810	1	7.90	CASE, blower (barrier type) . . . . .
73-74	Chevelle (Sta. Wag.) . . . . .	3027683	1	4.05	CASE, rear window defogger blower . . . . .
71-74	Impala Custom, Caprice (Spt. Cpe.) . . . . .	3023638	1	4.05	CASE ASSY., defogger . . . . .
71-74	All (exc. Impala Cust., Caprice Spt. Cpe.) . . . . .	3023590	1	4.05	CASE ASSY., defogger . . . . .
69-70	Pass., Chevelle . . . . .	8801648	1	.13	CLIP, grille to shelf . . . . .
70	All (exc. Chevelle, Pass., Sta. Wag.),				
70	Pass. (Sta. Wag.) (6-Pass.),				
71	Nova, Camaro,				
71-75	Vega, Monza . . . . .	4154886	A.R.	.24	CLIP, rear window defog. switch— (10.777)
73-74	All (exc. Vega) . . . . .	3029699	1	.14	CLAMP, fan rear window defogger . . . . .
67	Camaro (exc. Conv.),				
68	All (exc. Conv., Sta. Wag.),				
69	Chevy, Camaro (exc. Conv.),				
70	Pass. w/Acc. Defog. (exc. Sta. Wag., Cust. Cpe., Conv.),				
70	Chevelle w/Acc. Defog. (exc. Sta. Wag., Conv.),				
70	Nova . . . . .	3899736	1	1.60	COVER, defogging hole trim . . . . .
64-67	Chevy, Chevelle (exc. Sta. Wag., Conv.),				
65-67	Pass.,				
68-69	Pass. (exc. Sta. Wag., Conv.),				
70	Impala, Custom, Caprice (Spt. Cpe.) . . . . .	401878	1	.77	COVER, defogging trim . . . . .
73-75	Pass. (exc. Cust. Cpe., Conv.) (Caprice 2-Dr.),				
73-75	Chevelle (exc. Conv.),				
73-75	Nova, Camaro . . . . .	9638234	1	.59	COVER, defog. hole trim . . . . .
73-75	Chevelle (exc. Sta. Wag., Monte Carlo) . . . . .	9657716	1	4.25	COVER, protector back window defogger, protector . . . . .
73-75	Monte Carlo . . . . .	9657717	1	8.70	COVER, back window defogger, protector . . . . .
71-72	Pass. w/Acc. Defog. (exc. Sta. Wag., Cust. Cpe., Conv.),				
71-72	Chevelle w/Acc. Defog. (exc. Sta. Wag., Conv.),				
71-72	Nova, Camaro . . . . .	9638234	1	.59	COVER, defog. hole trim . . . . .
68-70	All (Sta. Wag.),				
71-72	Chevelle (Sta. Wag.) . . . . .	3929070	1	2.25	DUCT, defog. air outlet . . . . .
71-73	Pass. (Spt. Cpe.) . . . . .	9834050	1	2.15	DUCT, defog. air inlet . . . . .
71-72	Chevelle (Conv.) . . . . .	9841740	1	4.75	DUCT, defog. outlet . . . . .

**BODY MTG.— AIR COND.— INSTRUMENTS**

**9.778 DEFOGGER UNIT— ADAPTER— BACK-UP RING— BEZEL— BLOWER CASE— BOLT— BRACKET— CAPACITOR ASSY.— CASE— CLIP— COVER— DUCT— FAN ASSY.— GASKET— GRILLE— HARNESS ASSY.— HOSE— HOUSING— INSULATOR— KNOB ASSY.— MOTOR— NOZZLE ASSY.— NUT— OUTLET— PLATE— RELAY ASSY.— REPAIR KIT— RETAINER— SCREEN— SEAL— SPACER— SUPPORT— SWITCH ASSY.— TIMER ASSY.— WIRE ASSY., Rear Window Defogger (Con't)**

73-74	Chevelle (Sta. Wag.)	1604087	1		DUCT, tailgate window defogger (repl. 9615714)
74-75	Pass. (Spt. Cpe.)	9671114	1	5.10	DUCT, rear window defog. air inlet
75	Chevelle (Sta. Wag.)	1684087	1		DUCT, rear window defog. air inlet (repl. 9615714)
63-68	Chevy, Chevelle, Camaro (exc. Conv., Sta. Wag.),				
65-68	Pass.	3157133	1	5.85	FAN ASSY.
68-70	Pass., Chevelle (Sta. Wag., Conv.),				
69-70	Impala (Custom) Caprice (Spt. Cpe.)	3030749	1	5.85	FAN ASSY.
71-74	All	3023588	1	5.75	FAN ASSY., defogger
68	All (exc. Sta. Wag., Conv.),				
69-70	Chevy,				
70	Pass. (exc. Sta. Wag., Cust. Cpe., Conv.),				
70	Chevelle (exc. Sta. Wag., Conv.)	3016769	1	5.75	FAN UNIT (shelf type)
69-70	Chevelle, Camaro,				
69-70	Pass. (exc. Sta. Wag., Conv.)	3018823	1	11.20	FAN UNIT (barrier type)
68-69	All,				
70	Pass., Nova,				
71	Camaro	3015030	1	.21	GASKET, motor mounting
71-74	Impala (Cust.) Caprice (2-Dr.)	9859900	1	.33	GASKET, defogger to shelf
68-70	All (Conv.),				
71	Impala (Custom) Caprice (2-Dr.),				
73-75	Chevelle (Sta. Wag.),				
73-75	Pass. (Spt. Cpe.)	9868549	1	2.05	GRILLE, defog. inlet (painted)
71	Chevelle (Conv.)	3923111	1	6.20	GRILLE, defog. air outlet
68-70	All (Sta. Wag.),				
71-72	Chevelle (Sta. Wag.)	3929071	1	1.30	GRILLE, defog. air outlet
73-74	Nova (Hatch back)	9657597	1	2.90	GRILLE, back window defogger air inlet
73-74	Nova (Hatch back)	9657600	1	5.00	GRILLE, back window defogger air outlet
75	Nova (Hatch-back)	1675846	1	2.85	GRILLE, back window defogger air outlet
73-75	Chevelle (Sta. Wag.),				
75	Nova (Hatch-back)	1673155	1	1.85	GRILLE, defogger air intake
64-67	Chevy, Chevelle (exc. Conv., Sta. Wag.),				
65-70	Pass.	3863251	1	7.75	GRILLE ASSY., defogging air outlet (unpainted)
69	Pass., Chevelle (exc. Conv., Sta. Wag., El Camino)	1386075	1	8.50	GRILLE ASSY., defogging air outlet
67	Camaro (exc. Conv.),				
68	Chevelle (exc. Sta. Wag., Conv.),				
68-70	Chevy, Camaro (exc. Conv.),				
71	Chevelle w/Acc. Defog. (exc. Sta. Wag., Conv.),				
71	Nova	3899746	1	8.75	GRILLE ASSY., defogging air outlet (unpainted)
70	All w/Acc. Defog. (exc. Nova, Impala Custom, Caprice (Spt. Cpe.)				
		1233479	1	8.90	GRILLE ASSY., defog. air outlet
71-75	Impala Cust., Caprice (2-Dr.)	9868546	1	5.25	GRILLE ASSY., defogger air outlet (painted)
71-75	Pass. (Sta. Wag.)	9876900	1	4.40	GRILLE ASSY., defogger
71	Chevelle, Nova, Camaro (exc. Sta. Wag., Conv., El Camino),				
72	Pass. (Sed.) Impala (Spt. Cpe.) (exc. Custom),				
72-75	Chevelle, Nova, Camaro, Pass. (exc. Sta. Wag., Conv., El Camino)	9884679	1	5.00	GRILLE ASSY., defog. air outlet
73-74	Pass. (Sed.) Impala (Spt. Cpe.) (exc. Custom),				
71-75	Pass. (Conv.)	9851696	1	3.75	GRILLE ASSY., defogger
73-75	Chevelle (exc. Sta. Wag.)	9624517	1	5.00	GRILLE ASSY., defogger air outlet
69-72	Chevy	8721802	1	6.90	HARNESS ASSY., wiring
70	Pass., Chevelle (Sta. Wag.),				
71-72	Chevelle (Sta. Wag.)	8779576	1	8.35	HARNESS ASSY., rear window defogger
70	Pass., Chevelle (exc. Sta. Wag.),				

**BODY MTG.— AIR COND.— INSTRUMENTS**

**9.778 DEFOGGER UNIT— ADAPTER— BACK-UP RING— BEZEL— BLOWER CASE— BOLT— BRACKET— CAPACITOR ASSY.— CASE— CLIP— COVER— DUCT— FAN ASSY.— GASKET— GRILLE— HARNESS ASSY.— HOSE— HOUSING— INSULATOR— KNOB ASSY.— MOTOR— NOZZLE ASSY.— NUT— OUTLET— PLATE— RELAY ASSY.— REPAIR KIT— RETAINER— SCREEN— SEAL— SPACER— SUPPORT— SWITCH ASSY.— TIMER ASSY.— WIRE ASSY., Rear Window Defogger (Con't)**

71-72	Chevelle (exc. Sta. Wag.)	8779575	1	8.15	HARNESS ASSY., rear window defogger
70-75	Camaro	8779479	1	8.05	HARNESS ASSY., rear window defog. wiring
71	Pass. (Conv.),				
71-75	Impala (Custom) Caprice (Spt. Cpe.)	9821104	1	12.00	HARNESS ASSY., defogger
72-75	Pass.	9821162	1	12.95	HARNESS ASSY., defogger
71-75	Vega w/rear window elec. defog.	9831940	1	5.35	HARNESS ASSY., htd. back window glass wiring
71-75	Vega (Coupe) w/rear window elec. defog.	9616070	1	3.55	HARNESS ASSY., htd. back window glass wiring
71-75	Vega (Coupe) w/rear window elec. defog.	9616071	1	2.35	HARNESS ASSY., htd. back window glass ground
73-74	Nova	9614404	1	12.10	HARNESS ASSY., defogger
75	Chevelle,				
75	Pass. (exc. Sta. Wag.)	1673681	1	13.70	HARNESS, defogger
75	Monza (exc. Towne Cpe.)	9737442	1	12.80	HARNESS ASSY., b/w glass
75	Monza (exc. Towne Cpe.)	1654917	1	2.20	HARNESS ASSY., b/w grid
75	Monza (Towne Cpe.)	8916267	1	12.15	HARNESS ASSY., b/w glass
68-70	All (Sta. Wag.)	1234986	1	7.55	HOSE, defog. air outlet
69	Chevy, Chevelle,				
69	Pass. (exc. Sta. Wag., Conv.),				
69	Camaro (exc. power top),				
69	Pass. (Sta. Wag.) (6-Pass.) (exc. electric window),				
70	Impala (Cust.) Caprice (Spt. Cpe.)	3937659	1	1.60	HOUSING, defogger switch
70-75	Nova,				
70	Pass. (exc. Conv.),				
70	Pass. w/Acc. Defog. (exc. Impala Cust., Caprice) (Spt. Cpe.)	3973620	1	1.60	HOUSING, defogger switch
70-75	Camaro	3973658	1	1.60	HOUSING, defogger switch
71-75	Vega, Monza	3989225	1	1.55	HOUSING, defogger switch
75	Nova (Hatch-back)	1660656	1	1.75	HOUSING, defogger switch
70	Pass., Chevelle, Nova,				
71	Chevelle, Nova	9817455	1	3.70	INSULATOR, back window defog.
67-68	Chevy, Chevelle, Camaro (exc. Sta. Wag., Conv.),				
67-68	Pass.	3899716	1	1.85	KNOB ASSY., blower switch
68	Chevelle, Camaro (Sta. Wag., Conv.),				
68	Pass. (Sta. Wag., Conv.),				
69	Chevelle (Sta. Wag., Conv.),				
69-70	Impala (Custom) Caprice (Spt. Cpe.)	4918682	1	24.70	MOTOR
68-70	All (exc. Sta. Wag., Conv.)	4918684	1	24.30	MOTOR (shelf type)
63-68	Chevy, Chevelle, Camaro (exc. Conv., Sta. Wag.),				
65-68	Pass.	5044597	1	20.95	MOTOR ASSY.
69-70	Chevelle (exc. Sta. Wag., Conv.),				
69-70	Sed., Spt. Cpe. (exc. Caprice, Custom),				
69	Caprice (Spt. Sed.)	4919550	1	22.75	MOTOR ASSY., defogger (barrier type)
71-74	All	4960848	1	20.95	MOTOR ASSY., defogger blower package
75	Pass. (Cpe.)	9836529	1	4.75	NOZZLE ASSY., defogger
71-72	All (exc. Chevelle Sta. Wag., El Camino)	144485	2	.06	NUT, defog. blower
73-74	Caprice (Spt. Cpe.) w/Acc. Defog.,				
73-74	Impala (Custom Cpe.) w/Acc. Defog.	3023843	1	.14	NUT, rear window defogger blow J-type
73-74	All	3025755	2	.14	NUT, w/lock, rear window defogger blower
69-70	Chevelle (exc. Conv., Sta. Wag., El Camino),				
69-70	Biscayne, Bel Air, Impala (exc. Custom, Conv.),				

**BODY MTG.— AIR COND.— INSTRUMENTS**

**9.778 DEFOGGER UNIT— ADAPTER— BACK-UP RING— BEZEL— BLOWER CASE— BOLT— BRACKET— CAPACITOR ASSY.— CASE— CLIP— COVER— DUCT— FAN ASSY.— GASKET— GRILLE— HARNESS ASSY.— HOSE— HOUSING— INSULATOR— KNOB ASSY.— MOTOR— NOZZLE ASSY.— NUT— OUTLET— PLATE— RELAY ASSY.— REPAIR KIT— RETAINER— SCREEN— SEAL— SPACER— SUPPORT— SWITCH ASSY.— TIMER ASSY.— WIRE ASSY., Rear Window Defogger (Con't)**

70	Camaro	1231119	1	4.70	OUTLET, defogging air
71-74	Impala Custom, Caprice (Spt. Cpe.)	3023760	1	3.70	PLATE, defogger
73-74	Chevelle (Sta. Wag.)	3027682	1	11.20	PLATE, rear window defogger blower
69-70	Pass. w/electric defogger	1115881	1	6.65	RELAY ASSM., switch (high position) (repl. 1115894)
69-70	Pass. w/electric defogger	1116992	1	11.20	RELAY ASSY., switch (low position)— (9.277)
69-75	All	1051223	1	9.50	REPAIR KIT, defogger heating element (Note 1)— (8.800)
<i>NOTE 1: Contains Epoxy, related mixing and application tools, and instructions for repairing element.</i>					
68-70	All (Sta. Wag.)				
71-72	Chevelle (Sta. Wag.)	3917391	1	.57	SCREEN, defog. air inlet bezel
70-71	Camaro	1231120	1	.43	SEAL, rear window defog. outlet
73-74	Chevelle (Sta. Wag.)	3029526	1	3.55	SEAL ASSY., rear window defogger blower package
68-70	All	3015031	1	.14	SPACER, motor mounting
71-75	Pass. (Conv.)	9824941	1	13.40	SUPPORT, defogger
65-68	All	3861697	1	5.30	SWITCH ASSY., blower
69	All,				
70	Pass., Nova	3959229	1	3.00	SWITCH ASSY., defogger blower (barrier type)
69-70	Pass. w/electric defogger	3949992	1	46.90	SWITCH ASSY.
70	Chevelle w/Defog.,				
70	Camaro, Chevelle w/Acc. Defog. (exc. Sta. Wag., Conv., El Camino),				
71-75	Nova,				
71	Camaro w/Acc. Defog.	3979737	1	3.05	SWITCH ASSY., defogger blower (barrier type)
70-75	Camaro	3974093	1	3.00	SWITCH ASSY., rear window defog. blower
71-72	Pass.	3989202	1	3.00	SWITCH ASSY., rear window defog. blower
71	Nova,				
71-72	Chevelle,				
73-75	Camaro	3979736	1	3.05	SWITCH ASSY., blower
71-75	Vega, Monza	3973644	1	4.00	SWITCH ASSY., defogger— (14.483)
73-75	Chevelle, Pass.	3998476	1	2.70	SWITCH ASSY., electric rear window defog. (blower)
71-75	Vega, Monza	1115903	1	37.20	TIMER ASSY.
71-74	Pass.,				
73-75	Chevelle	8908416	1	7.75	WIRE ASSY.
71-72	Vega	8908123	1	33.00	WIRE ASSY., defogger
73-74	Chevelle, Pass.	8908243	1	3.55	WIRE ASSY., rear window electric defogger extension
73-75	Chevelle	9840142	1	12.00	WIRE ASSY., blower, rear, rear
73-74	Vega	8908291	1	33.00	WIRE ASSY., defogger

**9.779 OUTLET ASSY.— BAFFLE ASSY.— BRACKET— CLIP— DISTRIBUTOR ASSY.— HOSE— SEAL— SHAFT ASSY.— VACUUM ELEMENT— VALVE ASSY., Defroster**

67-68	Camaro,				
68	Chevy	546205	1	8.30	heater defroster
69	Chevy, Camaro,				
70-75	Nova	3973729	1	5.75	
69-70	Pass.	3949971	1	6.25	
70-72	Chevelle	3984680	1	8.05	heater defroster
70-75	Camaro w/C.A.C.	3963721	1	5.85	heater and defroster
70-75	Camaro (exc. C.A.C.)	3967970	1	5.40	heater and defroster
71-72	Pass. w/C.A.C.	480713	1	7.05	heater defroster
71-72	Pass. (exc. C.A.C.)	480712	1	7.05	heater defroster
73-75	Chevelle (exc. C.A.C.)	484973	1	8.00	heater defroster
73-75	Chevelle w/C.A.C.	484777	1	8.00	heater defroster
73-75	Pass. w/C.A.C.	480713	1	7.05	heater and defroster
73-75	Pass. (exc. C.A.C.)	480712	1	7.05	heater and defroster
73-75	Chevelle (exc. C.A.C.)	3024865	1	9.70	BAFFLE ASSY., def. valve seal
69	Chevy, Camaro,				
70-73	Nova	3949975	1	.12	BRACKET, heater and defroster outlet
70-72	Camaro w/C.A.C.	3967975	A.R.	.28	BRACKET, a/c condenser
74-75	Nova	340408	1	.11	BRACKET, car htr. defr. outlet

**BODY MTG.— AIR COND.— INSTRUMENTS**

**9.779 OUTLET ASSY.— BAFFLE ASSY.— BRACKET— CLIP— DISTRIBUTOR ASSY.— HOSE— SEAL— SHAFT ASSY.— VACUUM ELEMENT— VALVE ASSY., Defroster (Con't)**

74	Nova w/C.A.C.	3940296	1	12.75	DISTRIBUTOR ASSY., htr. and defr. ....
62-74	All (exc. Vega)	1234989	A.R.	12.20	HOSE, heater, defroster (4 x 72" O.L.)— (9.260) .....
62-74	All (exc. Vega)	1234988	1	8.60	HOSE, heater duct to conn. (3 1/4" I.D. x 72" long) .....
62-69	All	1234277	A.R.	7.55	HOSE, defroster and outside air inlet (2 1/2" O.D. x 25" O.L.) .....
75	Camaro	3119719	1	2.75	HOSE, a.c. air lwr. outlet .....
69	Chevy, Camaro	3949921	1	.36	SEAL, htr. defrost outlet .....
67-70	Pass. w/C.A.C.,				
70-72	Camaro, Chevelle w/C.A.C.,				
73-74	Camaro w/C.A.C.,				
75	Nova w/C.A.C.	3012476	1	.36	SHAFT ASSY., w/lever, def. valve .....
73-75	Chevelle (exc. C.A.C.)	3030059	1	1.40	SHAFT ASSY., car heater air defroster .....
73-75	Pass. (exc. C.A.C.)	3023199	1	.61	SHAFT ASSY., def. ....
70-74	Camaro w/C.A.C.,				
75	Nova	1998992	1	5.60	VACUUM ELEMENT, defroster, purge valve .....
71-72	Chevelle w/C.A.C.	1998993	1	5.75	VACUUM ELEMENT .....
71-75	Pass. w/C.A.C. Auto. Temp. Control,				
73-74	Chevelle w/C.A.C.	1998980	1	6.85	VACUUM ELEMENT, defroster .....
64-69	Camaro (exc. C.A.C.),				
65-67	Chevelle (exc. C.A.C.),				
68-75	Nova (exc. C.A.C.)	3000410	1	1.20	VALVE ASSY., defroster .....
65-70	Pass. (exc. C.A.C.)	3002736	1	1.35	VALVE ASSY., htr. defr. control .....
67-70	Pass. w/Auto. Temp. Control,				
67-74	Camaro w/C.A.C.,				
69	Pass. w/C.A.C.	3021035	1	3.10	VALVE ASSY., a/c htr. defroster .....
68-70	Chevelle (exc. C.A.C.),				
71-72	Chevelle	3014071	1	1.60	VALVE ASSY., heater defroster .....
70	Camaro	3021625	1	4.90	VALVE ASSY., w/baffle, heater defroster and shut-off .....
71-75	Pass. (exc. C.A.C.)	3022722	1	2.15	VALVE ASSY., defroster w/seal .....
71	Pass. w/Air Cond.	3023851	1	5.95	VALVE ASSY., defroster .....
72-74	Pass. w/C.A.C.	3025960	1	5.95	VALVE ASSY., defroster .....
72	Camaro w/C.A.C.,				
75	Nova	3031194	1	10.10	VALVE ASSY., defroster .....
75	Pass. w/C.A.C.	3031246	1	7.50	VALVE ASSY., defr. ....

**9.782 SEAL— NUT— SLEEVE, Air Duct**

67-69	Camaro w/C.A.C.,				
68-70	Chevy,				
71-75	Nova w/C.A.C.	3891708	1	.74	air inlet plenum valve housing plate .....
67-69	Camaro w/C.A.C.,				
68-75	Nova w/C.A.C.	3895959	1	.40	air inlet plenum valve housing to plenum, rear .....
68	Pass. w/Upper level vent.,		2		side outlet to duct .....
72-74	Nova	3929027	1	.12	A/C air dist. upper duct— (9.260) .....
69	Pass.,				
70-72	Chevelle w/Acc. Air Cond.,				
72	Pass.	3866846	A.R.	.12	NUT, w/L/washer, air cond. evap. ctr. outlet bezel .....

**9.784 BRACKET, Air Duct Intake (Outside Air)**

68	Pass. w/Upper level vent.	3935952	1	.33	side outlet to plenum duct valve actv. cable (2 holes) (Note 1) .....
----	---------------------------	---------	---	-----	--

*NOTE 1 When using 3935952 in place of 3930116, 3935954 must be used.*

**9.786 ADAPTER— ARM— BAFFLE— BRACKET— CAM— CASE— CLAMP— CLIP— CONNECTOR— COVER— DEFLECTOR— DUCT— FELT— GASKET— HOSE— HOUSING— INLET ASSY.— LEVER ASSY.— LINK— NUT— OUTLET— PIN— PLATE— RETAINER— ROD— ROLLER— SEAL— SHAFT— SPRING— SUPPORT— VALVE— WASHER, Air Flow**

71-72	Pass.	3979788	1	6.90	upper vent. ctr. duct— (9.262) .....
68	Chevelle w/C.A.C.	3917319	1	.46	ARM, air cond. inlet side shroud vacuum control .....
69	All w/C.A.C.,				
70-74	Nova	3018726	1	1.80	BAFFLE, heater and a/c linearity .....
70-73	Camaro	3998417	1	1.85	BAFFLE ASSY., air inlet plenum— (9.218) .....
68-69	Chevy, Chevelle, Camaro,				
68	Pass. w/C.A.C.,				
70-74	Nova w/C.A.C.	3014908	1	.66	BRACKET, valve adj. ....
72-73	Pass. (exc. C.A.C.)	481460	1	.63	BRACKET, heater defr. cont. cable .....

**BODY MTG.— AIR COND.— INSTRUMENTS**

**9.786 ADAPTER— ARM— BAFFLE— BRACKET— CAM— CASE— CLAMP— CLIP— CONNECTOR— COVER— DEFLECTOR— DUCT— FELT— GASKET— HOSE— HOUSING— INLET ASSY.— LEVER ASSY.— LINK— NUT— OUTLET— PIN— PLATE— RETAINER— ROD— ROLLER— SEAL— SHAFT— SPRING— SUPPORT— VALVE— WASHER, Air Flow (Con't)**

71-74	Vega	3022966	1	1.95	BRACKET, a/c defroster
71-75	Pass. w/C.A.C.	3022737	1	4.75	CAM, w/support
69	Chevelle	3017881	1	30.75	CASE, w/shroud, heater dist.— (8.854)
69	Nova, Camaro w/C.A.C.,				
70-74	Nova w/C.A.C.	3018763	1	41.00	CASE ASSY., frt. plate and valves
71	Pass. w/C.A.C.	3023052	1	94.50	CASE ASSY., w/valves, heater
71-72	Pass. w/Auto. Temp. Control	3029552	1	94.50	CASE ASSY., w/valves, heater (repl. 3025958)
72-73	Pass. w/C.A.C.	3028827	1	94.50	CASE ASSY., w/valves, heater (repl. 3026000)
73-75	Camaro w/C.A.C.	3027013	1	71.75	CASE ASSY., w/frt. plate and valves
73-75	Chevelle w/C.A.C.	3024959	1	68.50	CASE ASSY., w/frt. plate and valves
74	Pass. w/C.A.C.	3028827	1	94.50	CASE ASSY., w/valves, heater
74	Pass. w/Auto. Temp. Control	3029552	1	94.50	CASE ASSY., w/front plate and valves
75	Nova w/C.A.C.	3030862	1	41.00	CASE ASSY., w/frt. plate and valves
75	Pass. w/C.A.C. (exc. Auto. Temp. Control)	3031282	1	42.25	CASE ASSY., w/frt. plate and valve
75	Pass. w/Auto. Temp. Control	3031309	1	94.50	CASE ASSY., w/frt. plate and valves
75	Vega w/C.A.C.	3031789	1	40.75	CASE ASSY., w/fitting, htr. and a/c
76	Vega, Monza w/A.C.	3022989	1	15.90	CASE & VALVE ASSY.
62-69	All	2260846	A.R.	.80	CLAMP, heater cooling air hose (3 <sup>3</sup> / <sub>16</sub> " dia.)— (1.166)
67-68	Pass. w/Auto. Temp. Control,				
70	Pass. w/C.A.C., Auto. Temp. Control,				
73-74	Camaro w/C.A.C.,				
75	Nova, Camaro w/C.A.C.	3012473	1	.18	CLAMP, a/c, htr. div. vac. hose
65-71	Pass. w/C.A.C., Auto. Temp. Control,				
67-75	Nova, Chevelle, Camaro w/C.A.C.	3013531	1	.12	CLIP, valve short retainer
66-75	Pass. w/Auto. Temp. Control	1484109	2	.11	CLIP, htr. and air cond. servo. link
73-75	Camaro w/C.A.C.	3012291	1	.12	CLIP, a/c outlet mounting
69-70	Pass. w/C.A.C., Auto. Temp. Control,				
71-73	Camaro w/C.A.C.	3018715	1	.12	CONNECTOR, a/c and heater diverter valve link
70-72	Malibu (Spt. Cpe., Conv.) (exc. C.A.C., 396, 454, inst. panel gauges)	3965471	L.H.	1.60	CONNECTOR, upper vent side outlet adapter to plenum, left
70-72	Monte Carlo (exc. C.A.C.),				
70-72	Chevelle w/inst. panel gauges,				
70-72	Chevelle (396, 454) (exc. C.A.C.)	3965473	L.H.	1.50	CONNECTOR, upper vent side outlet adapter to plenum, left
70-72	Chevelle (Spt. Cpe., Conv.) (exc. C.A.C.),				
70	El Camino (396, 454) (exc. C.A.C.),				
70	El Camino w/inst. panel gauges (exc. C.A.C., 396, 454),				
71-72	El Camino (exc. C.A.C.)	3965472	R.H.	1.50	CONNECTOR, upper vent. side outlet adapter to plenum, right
75	Pass. w/C.A.C.	3022746	2	.05	CONNECTOR, diverter vac. link
70-72	Camaro w/C.A.C.	3967980	1	1.30	COVER, air inlet side shroud vac. control
73-75	Camaro w/C.A.C.	331909	1	1.30	COVER, air inlet side shroud vac. cont.
66	Chevelle w/C.A.C.,				
67-69	Pass., Camaro w/C.A.C.,				
68-75	Nova w/C.A.C.	3906002	1	2.75	DEFLECTOR, air dist. duct
68-69	Camaro (exc. C.A.C., floor console)	3917382	1	1.45	DUCT
69-74	Nova w/C.A.C. (exc. floor console)	3942658	1	2.30	DUCT, heater air dist.
70-75	Camaro (exc. C.A.C.)	3973723	1	1.80	DUCT, heater air dist.
67-69	Camaro (exc. C.A.C.),				
68-75	Nova w/floor console	346135	1	4.65	DUCT ASSY., air dist.
69	Camaro w/C.A.C.,				
69-74	Nova (Spt. Cpe.) w/C.A.C., floor console	3942642	1	4.10	DUCT ASSY., heater air dist.
70-75	Camaro w/C.A.C., floor console	3967989	1	4.10	DUCT ASSY., heater air dist.
71-75	Vega, Monza	3992149	1	1.40	DUCT ASSY., htr. air distributor



**BODY MTG.— AIR COND.— INSTRUMENTS**

**9.786 ADAPTER— ARM— BAFFLE— BRACKET— CAM— CASE— CLAMP— CLIP— CONNECTOR— COVER— DEFLECTOR— DUCT— FELT— GASKET— HOSE— HOUSING— INLET ASSY.— LEVER ASSY.— LINK— NUT— OUTLET— PIN— PLATE— RETAINER— ROD— ROLLER— SEAL— SHAFT— SPRING— SUPPORT— VALVE— WASHER, Air Flow (Con't)**

75	Nova w/C.A.C. (exc. floor console)	346136	1	1.55	DUCT ASSY., htr. air distr.
75	Nova (6 cyl.)	347585	1	5.15	DUCT ASSY., air intake flex.
66-67	Camaro, Chevelle w/C.A.C.,				
67-68	Pass. w/C.A.C.,				
68-70	Camaro, Chevy w/C.A.C.,				
71-75	Nova w/C.A.C.	3906003	A.R.	.11	FELT, a/c air dist. duct deflector
71-75	Camaro w/C.A.C.	3963725	1	.80	GASKET, heater and a/c selector duct
76	Vega, Monza w/A.C.	3022985	1	.83	GASKET, air inlet
76	Vega, Monza w/A.C.	3022986	1	.12	GASKET, mounting
66-67	Chevelle w/C.A.C.	1234987	1	9.50	HOSE (9.260)
69	Camaro, Chevy	1234988	1	8.60	HOSE, upper vent. side deflector housing conn. to plenum duct— (8.962)
66-68	Pass. w/C.A.C. (exc. Auto temp. control)	3987362	1	RL/.12	HOSE, heater and air cond. vacuum control to tank— (8.962)
All	All	1234277		7.55	HOSE, heater defr. (2 1/2" I.D. x 72" O.L.)
All	All	1234278		8.65	HOSE, heater defr. (2 3/4" I.D. x 72" O.L.)
71-74	Vega	1234985	1	7.50	HOSE, a/c left outlet (2" O.D. x 6 ft. O.L.)
67-69	Camaro w/C.A.C.,				
68-75	Nova w/C.A.C.	3891701	1	1.60	HOUSING, a/c air inlet plenum valve
68-69	Chevy, Camaro w/C.A.C.,				
70-74	Nova w/C.A.C.	3015723	1	7.90	HOUSING, temp. cont. valve
73-74	Chevelle w/C.A.C.	3031164	1	25.75	HOUSING, temp. valve
73-74	Nova w/C.A.C.	3018762	1	25.25	HOUSING, w/valve heater
75	Nova w/C.A.C.	3030948	1	25.25	HOUSING, w/valve, temp., htr. and a/c
75	Pass. (exc. Auto. Temp. Control)	3031313	1	26.00	HOUSING, w/valve, temp.
75	Pass. w/Auto. Temp. Control	3031310	1	39.50	HOUSING, w/valve, temp.
75	Vega w/C.A.C.	3031253	1	25.25	HOUSING, w/fitting, temp.
75	Monza w/C.A.C. (exc. Towne Cpe.)	3031555	1	12.20	HOUSING, temp. valve
75	Monza (Towne Cpe.)	3033614	1	15.10	HOUSING, temp. valve
69-72	Chevelle w/C.A.C.	3018755	1	22.85	HOUSING ASSY., htr. temp. valve
71-74	Pass. w/C.A.C.	3022740	1	21.90	HOUSING ASSY., w/valves, temp.
71	Pass. w/C.A.C. (exc. Auto. Temp. Control)	3022743	1	9.60	HOUSING, temp. control valve
70-75	Camaro w/C.A.C.	3979732	1	7.05	INLET ASSY., plenum air
75	Vega, Monza w/C.A.C. (exc. Towne Cpe.)	3979724	1	23.10	INLET ASSY., a.c. air
75	Monza (Towne Cpe.)	3033427	1	23.10	INLET ASSY., a.c. air
64-67	Chevelle w/C/Deluxe	3014057	1	.61	LEVER ASSY., w/shaft (temp.)
66-67	Chevelle (exc. A.C.);				
67-69	Camaro,				
68-75	Nova (exc. C.A.C.)	3008472	1	.61	LEVER ASSY., w/shaft (def.)
67-69	Camaro,				
68-75	Nova (exc. C.A.C.)	3013526	1	.56	LEVER ASSY., w/shaft (heater, temp.)
68-72	Chevelle (exc. C.A.C.)	3014067	1	.50	LEVER ASSY., w/shaft (temp.)
68-69	Chevelle,				
70-72	Chevelle (exc. C.A.C.)	3014901	1	.66	LEVER ASSY., w/shaft (def.)
72-73	Pass.	3023199	1	.61	LEVER ASSY., w/shaft (defroster)
73-74	Nova w/C.A.C.	3020512	1	4.90	LEVER ASSY., w/shaft (temp.)
75	Nova w/C.A.C.	3030793	1	1.35	LEVER ASSY., defroster
67-68	Pass. w/Auto. Temp. Control	3012206	1	2.75	LINK, w/seal, a/c htr. div. valve
67-70	Pass. w/Auto. Temp. Control	3012471	1	.05	LINK, a/c htr. div. valve
67-69	Camaro w/C.A.C.,				
68-75	Nova w/C.A.C.	3891702	1	.55	LINK, air inlet plenum valve
68-72	Chevelle w/C.A.C.	3909049	1	.78	LINK, air cond. air inlet plenum valve
68-72	Chevelle w/C.A.C.	3917318	1	.28	LINK, air cond. inlet side shroud vacuum actuator
70-71	Chevelle w/C.A.C.,				
70-72	Pass. w/Auto. Temp. Control	3012296	1	.12	LINK, slave
70-72	Chevelle w/C.A.C.,				
70	Pass. w/Auto. Temp. Control	3018691	1	.12	LINK, diverter
70-75	Camaro w/C.A.C.	3020528	1	.16	LINK, diverter A/C
70-75	Camaro w/C.A.C.	3963736	1	.24	LINK, plenum air inlet valve
70-75	Camaro w/C.A.C.	3021756	1	.17	LINK, slave a/c
71-75	Pass. w/C.A.C.	3022747	2	.17	LINK, diverter
71-72	Pass. w/C.A.C.	3022758	1	.07	LINK, a/c htr. div. valve
71-72	Pass. w/C.A.C.	3015231	1	.80	LINK, slave
71-75	Vega w/C.A.C.	3022963	1	.49	LINK, a/c diverter valve
73-75	Chevelle w/C.A.C.	3024916	2	.17	LINK, diverter

**BODY MTG.— AIR COND.— INSTRUMENTS**

**9.786 ADAPTER— ARM— BAFFLE— BRACKET— CAM— CASE— CLAMP— CLIP— CONNECTOR— COVER— DEFLECTOR— DUCT— FELT— GASKET— HOSE— HOUSING— INLET ASSY.— LEVER ASSY.— LINK— NUT— OUTLET— PIN— PLATE— RETAINER— ROD— ROLLER— SEAL— SHAFT— SPRING— SUPPORT— VALVE— WASHER, Air Flow (Con't)**

73-75	Chevelle w/C.A.C.	3024911	1	.17	LINK, diverter
73-74	Pass. w/C.A.C.	3015230	1	.66	LINK, slave valve
73-75	Chevelle (exc. C.A.C.)	328223	1	.11	LINK, car heater air shaft
73-75	Chevelle (exc. C.A.C.)	328224	1	.11	LINK, car heater defroster
73-75	Chevelle w/C.A.C.	331914	1	.11	LINK, car heater and a/c temp. control cable
75	Nova w/C.A.C.	3017819	1	.76	LINK, car htr. and a/c temp. control cable
75	Nova w/C.A.C.	3020073	1	.81	LINK, air adj.
73-75	Pass. w/Auto. Temp. Control	7932695	1	2.36	LINK ASSY., programmer
65-69	Pass.	3713542	A.R.	.12	NUT, duct to dash (14— 10— "J"-shape)— (1.269)
65-68	Pass. (exc. Tape Player),				
69-70	Pass.	3899729	1	1.10	OUTLET, air duct.
68-70	Chevelle w/floor console	3919589	1	3.20	OUTLET, heater air dist.
70	Camaro w/floor console,				
71-75	Camaro w/floor console, C.A.C.	3967993	1	.93	OUTLET, heater air dist. duct
71	Pass. w/C.A.C.	481192	1	1.20	OUTLET, heater air distr.
72-74	Pass. w/Auto. Temp. Cont.	9795550	1	1.20	OUTLET, heater air distributor
72	Chevelle	484937	1	4.25	OUTLET, car heater air
68-70	Chevelle (exc. floor console)	9790487	1	1.20	OUTLET, heater air dist.
73-75	Chevelle w/C.A.C. (exc. Console)	484662	1	1.10	OUTLET, heater and a/c air
73-75	Chevelle (exc. C.A.C.),				
73-75	Chevelle (C.A.C. w/Console)	494572	1	4.55	OUTLET, heater and a/c air
75	Pass. w/Auto. Temp. Control	493904	1	1.05	OUTLET, htr. air dist.
69	Pass. w/C.A.C.	3940295	L.H.	7.75	OUTLET ASSY., upper air side— (9.262)
69	Pass. w/C.A.C.	3942607	R.H.	8.55	OUTLET ASSY., upper air side— (9.262)
69	Pass. (exc. C.A.C.)	3939649	L.H.	7.55	OUTLET ASSY., upper vent side— (9.262)
69	Pass. (exc. C.A.C.)	3939628	R.H.	7.75	OUTLET ASSY., upper vent side— (9.262)
68-70	Chevy,				
71-75	Nova (exc. Console, C.A.C.)	3909066	1	1.20	OUTLET ASSY., heater air distributor
68-69	Chevelle	3906067	1	5.75	OUTLET ASSY., heater defroster
72	Pass. w/C.A.C.	3979747	1	6.60	OUTLET ASSY., a/c air left— (9.262)
72	Pass. w/C.A.C.	6262665	1	6.60	OUTLET ASSY., a/c air ctr. left— (9.262)
75	Pass. (exc. C.A.C.)	481153	1	1.05	OUTLET ASSY., htr. air distr.
71-75	Vega	3973788	1	5.05	OUTLET ASSY., a/c htr. and defr.
75	Vega, Monza (exc. C.A.C.)	346112	1	6.60	OUTLET ASSY., heater defroster
75	Monza w/C.A.C. (exc. Towne Cpe.)	354769	1	5.55	OUTLET ASSY., htr. defr.
67-72	Camaro,				
68-72	Chevy	3012703	1	.12	PIN, temp. valve bearing
67-69	Camaro w/C.A.C.,				
68-75	Nova w/C.A.C.	3891703	1	1.60	PLATE, air inlet plenum valve housing
68-72	Chevelle w/C.A.C.	3925707	1	1.50	PLATE, air cond. air inlet plenum valve tapping
68-72	Chevelle w/C.A.C.	3909051	1	2.20	PLATE, air cond. air inlet plenum valve
71-75	Pass. w/C.A.C.	3025894	1	8.05	PLATE, front
71-75	Pass. w/C.A.C.	3022741	1	.12	RETAINER, valve shaft
68	Camaro (exc. C.A.C.)	3929908	2	.38	ROD, side outlet duct vlv. act.
71-75	Pass. w/C.A.C.	3150822	1	.12	ROLLER, cam
73-74	Nova (exc. C.A.C.)	3158826	1	.13	ROLLER, heater cam.
69-70	Pass. w/C.A.C.,				
70-72	Chevelle w/C.A.C.	3937199	1	.17	SEAL, air dist. duct
71-75	Pass. w/C.A.C.	3973792	1	.17	SEAL, air distr. duct
72	Pass. w/C.A.C.	3023774	1	1.60	SEAL, outlet pipe
73-74	Chevelle w/C.A.C.	484421	1	1.10	SEAL, air dist. duct
73-75	Pass.	3023774	1	1.60	SEAL, outlet pipe
73	Chevelle w/C.A.C.	3024917	1	.12	SEAL, diverter valve shaft
73	Chevelle w/C.A.C.	3024797	1	7.10	SEAL, air valve
73-75	Chevelle w/C.A.C.	3024962	1	4.55	SEAL, diverter valve
73-75	Chevelle (exc. C.A.C.)	3024868	1	4.90	SEAL, w/valve, purge valve
73-75	Chevelle (exc. C.A.C.)	3024867	1	3.95	SEAL, w/valve, temp. valve
74	Pass. w/C.A.C.	3026188		5.95	SEAL, w/valve diverter valve
74-75	Nova w/C.A.C.	3891708	1	.74	SEAL, inlet plenum valve housing plate
74-75	Nova w/C.A.C.	3895959	1	.40	SEAL, inlet plenum valve housing, rear
75	Monza w/C.A.C. (exc. Towne Cpe.)	356194	1	1.10	SEAL, a.c. air distr. duct
69	Camaro w/C.A.C.,				
69-72	Nova w/C.A.C.	3937151	1	.33	SHAFT, right air side outlet duct
70-72	Chevelle w/C.A.C.	3019132	1	.80	SHAFT, w/lever, slave valve
70-72	Chevelle w/C.A.C.	3018723	1	.80	SHAFT, w/lever, diverter valve
72-75	Pass. (exc. C.A.C.)	3022710	1	.50	SHAFT, temp. valve

**BODY MTG.— AIR COND.— INSTRUMENTS**

**9.786 ADAPTER— ARM— BAFFLE— BRACKET— CAM— CASE— CLAMP— CLIP— CONNECTOR— COVER— DEFLECTOR— DUCT— FELT— GASKET— HOSE— HOUSING— INLET ASSY.— LEVER ASSY.— LINK— NUT— OUTLET— PIN— PLATE— RETAINER— ROD— ROLLER— SEAL— SHAFT— SPRING— SUPPORT— VALVE— WASHER, Air Flow (Con't)**

71-75	Vega w/C.A.C.	3022964	1	.71	SHAFT, a/c diverter valve
73-75	Chevelle w/C.A.C.	3024953	1	.50	SHAFT, w/lever, slave valve
73-75	Chevelle w/C.A.C.	3024956	1	.66	SHAFT, w/lever, diverter valve
75	Monza w/C.A.C. (exc. Towne Cpe.)	3031702	1	.38	SHAFT, mode select
71-75	Camaro w/C.A.C.	3963735	1	.76	SHAFT ASSY., plenum air inlet valve hgs.
71	Pass. w/C.A.C.	3022759	1	.61	SHAFT ASSY., w/lever, diverter valve
71	Pass. w/C.A.C.	3022760	1	1.25	SHAFT ASSY., w/lever, slave
73-75	Chevelle (exc. C.A.C.)	3024854	1	.80	SHAFT ASSY., purge valve
73-75	Chevelle (exc. C.A.C.)	3024855	1	.80	SHAFT ASSY., temp. valve
75	Nova w/C.A.C.	3019133	1	1.65	SHAFT ASSY., w/lever diverter valve
66	Pass. w/Auto. Temp. Control	3157142	1	.23	SPRING, def. divider valve
67-75	Camaro w/C.A.C.,				
68-75	Chevy w/C.A.C.	3891706	1	.11	SPRING, air inlet plenum valve to plate
68-72	Chevelle w/C.A.C.,				
71-75	Vega, Monza	3909052	1	.12	SPRING, air cond. inlet plenum valve actuator to link
70-74	Camaro w/C.A.C.,				
75	Nova w/C.A.C.	3022539	1	.17	SPRING, a/c valve
73-75	Camaro w/C.A.C.	3022553	1	.17	SPRING, spacer a/c valve
68	Pass., Camaro w/upper level vent.				SPRING ASSY., air side outlet to plenum duct detent,
69	Chevelle w/C.A.C.	3949984	2	.28	air outlet duct shaft
71-75	Pass. w/Air Cond.,				
73-75	Chevelle	3022829	1	.50	SPRING, defroster
74	Pass. w/C.A.C.	3023630	2	.31	STUD, retaining a/c mtg.
74-75	Pass. w/C.A.C.	3024884	2	.31	STUD, retaining a/c mounting
71-74	Vega	3023514	1	3.40	SWITCH, a/c air inlet
67	Camaro w/C.A.C.,				
67-68	Pass. w/C.A.C.	3012298	1	3.80	VALVE, w/shaft a/c heater temp. cont.
69-70	Chevy, Camaro w/C.A.C.,				
71-72	Nova w/C.A.C.	3018762	1	25.25	VALVE, w/housing, car heater
69	All w/C.A.C. (exc. Pass.),				
70-72	Nova, Chevelle w/C.A.C.,				
73-74	Nova w/C.A.C.	3020512	1	4.90	VALVE, w/shaft, heater and a/c temp.
69-72	Pass. w/C.A.C.	3018717	1	25.25	VALVE, w/housing, car heater
69-70	Pass. w/C.A.C., Auto. Temp. Control	3018716	1	4.10	VALVE, w/seal, diverter
69-70	Pass. w/C.A.C., Auto. Temp. Control,				
71-72	Chevelle w/C.A.C., Auto. Temp. Cont.	3018731	1	3.95	VALVE, w/link, heater and a/c diverter
69	Pass. w/Auto. Temp. Control,				
71-72	Pass. w/Auto. Temp. Cont.	3018738	1	25.25	VALVE, w/housing, heater
69-70	Pass. w/C.A.C.	3020510	1	3.95	VALVE, w/shaft, temp.
71	Pass. w/C.A.C.	3022761	1	4.60	VALVE, slave
72-75	Camaro w/C.A.C.	3024687	1	4.20	VALVE, w/line arity baffle-temp.
71-75	Vega w/C.A.C.	3022957	1	4.65	VALVE, a/c heater temp. control, w/shaft
71-75	Vega w/C.A.C.	3023596	1	4.05	VALVE, a/c diverter, w/seal
64	Chevelle w/C/Deluxe,				
65-69	Pass., Chevelle,				
67-69	Camaro,				
68-70	Chevy,				
71-72	All,				
73-75	Nova, Camaro (exc. C.A.C.)	3157840	1	3.30	VALVE ASSY., temp. control air
65-66	Pass. w/C.A.C.	3003536	1	4.95	VALVE ASSY., w/shaft, temp. control
67-69	Camaro w/C.A.C.,				
68-75	Nova w/C.A.C.	3891700	1	4.25	VALVE ASSY., air inlet plenum
68-72	Chevelle w/C.A.C.	3940291	1	2.10	VALVE ASSY., air inlet plenum
69	Pass. w/C.A.C.	7308934	1	2.67	VALVE ASSY., htr. and a/c vac. control (9 ports, top lever)— (8.850)
69	Pass. w/C.A.C.	7308935	1	2.67	VALVE ASSY., htr. and a/c vac. control (3 ports, temp. lever)— (9.280)
69-70	Pass. w/Auto. Temp. Control	1222973	1	3.75	VALVE ASSY., htr. and a/c vac. relay
70-72	Chevelle w/C.A.C.	7313861	1	4.64	VALVE ASSY., htr. and a/c cont. air defr.
70-74	Camaro w/C.A.C.	3020530	1	8.05	VALVE ASSY., w/link, diverter a/c
71	Camaro w/C.A.C.	3020515	1	7.50	VALVE ASSY., w/shaft, temp. control a/c
71-75	Pass. w/C.A.C.	3022742	1	8.05	VALVE ASSY., w/shaft, temp. control
71-72	Pass. w/Air Cond.	3023851	1	5.95	VALVE ASSY., defroster
71-74	Pass. w/Air Cond.	3022769	1	5.35	VALVE ASSY., diverter lower

**BODY MTG.— AIR COND.— INSTRUMENTS**

**9.786 ADAPTER— ARM— BAFFLE— BRACKET— CAM— CASE— CLAMP—  
CLIP— CONNECTOR— COVER— DEFLECTOR— DUCT— FELT—  
GASKET— HOSE— HOUSING— INLET ASSY.— LEVER ASSY.— LINK—  
NUT— OUTLET— PIN— PLATE— RETAINER— ROD— ROLLER— SEAL—  
SHAFT— SPRING— SUPPORT— VALVE— WASHER, Air Flow (Con't)**

71-74	Pass. w/Air Cond. ....	3022765	1	4.60	VALVE ASSY., diverter upper .....
71-75	Camaro w/C.A.C. ....	3963733	1	1.85	VALVE ASSY., plenum air inlet .....
71-72	Pass. w/Auto. Temp. Control ...	3022877	1	21.90	VALVE ASSY., w/housing, temp. ....
72-75	Pass. w/C.A.C. ....	3022881	1	8.20	VALVE ASSY., w/shaft (temp. control) .....
71-74	Vega .....	3022615	1	1.50	VALVE ASSY., defroster, w/baffle and bumper .....
71-75	Vega, Monza .....	3022992	1	3.30	VALVE ASSY., a/c air .....
73-75	Chevelle w/C.A.C. ....	3024915	1	5.95	VALVE ASSY., w/shaft, temp. control .....
73-75	Camaro w/C.A.C. ....	3020523	1	21.90	VALVE ASSY., w/housing, A/C .....
73-75	Chevelle w/C.A.C. ....	3024963	1	4.60	VALVE ASSY., w/seal, diverter upper and lower .....
73-75	Chevelle w/C.A.C. ....	3024958	1	26.50	VALVE ASSY., w/shaft, temp. control .....
73-74	Pass. w/C.A.C. ....	3026188	1	5.95	VALVE ASSY., w/seal def. ....
73-74	Pass. w/Auto. Temp. Control ...	3022877	1	21.90	VALVE ASSY., w/housing temp. ....
75	Nova w/C.A.C. ....	3030866	1	6.20	VALVE ASSY., w/link, diverter .....
75	Nova w/C.A.C. ....	3030946	1	7.50	VALVE ASSY., w/fitting, temp. ....
75	Monza w/C.A.C. (exc. Towne Cpe.) .....	3031568	1	5.35	VALVE ASSY., w/shaft def. ....
75	Monza w/C.A.C. (exc. Towne Cpe.) .....	3031560	1	4.25	VALVE ASSY., w/shaft temp. ....
75	Monza w/C.A.C. (exc. Towne Cpe.) .....	3031695	1	4.90	VALVE ASSY., mode select .....
75	Monza (Towne Cpe.) w/C.A.C. ..	3033627	1	4.55	VALVE ASSY., w/shaft air .....
75	Monza (Towne Cpe.) w/C.A.C. ..	3033620	1	4.05	VALVE ASSY., diverter, front .....
75	Monza (Towne Cpe.) w/C.A.C. ..	3033623	1	5.55	VALVE ASSY., diverter, rear .....
65-67	Pass. w/C.A.C.,				
67	Camaro w/C.A.C.,				
71-75	Vega, Monza .....	3003065	1	.13	WASHER, htr. slave valve link spring .....

**BODY MTG.— AIR COND.— INSTRUMENTS**

**9.787 CABLE ASSY.— BRACKET— CLAMP— CLIP— CONTROL ASSY.— GUIDE— HOUSING— KNOB— NUT— PLIERS— RETAINER— RING— ROD— SHAFT— SUPPORT— SWITCH ASSY.— WIRE, Air Flow Control with Tube**

*NOTE Some cables may be replaced by bulk cables and retainers. Cables with color keyed knobs will be replaced by cables with black knobs.*

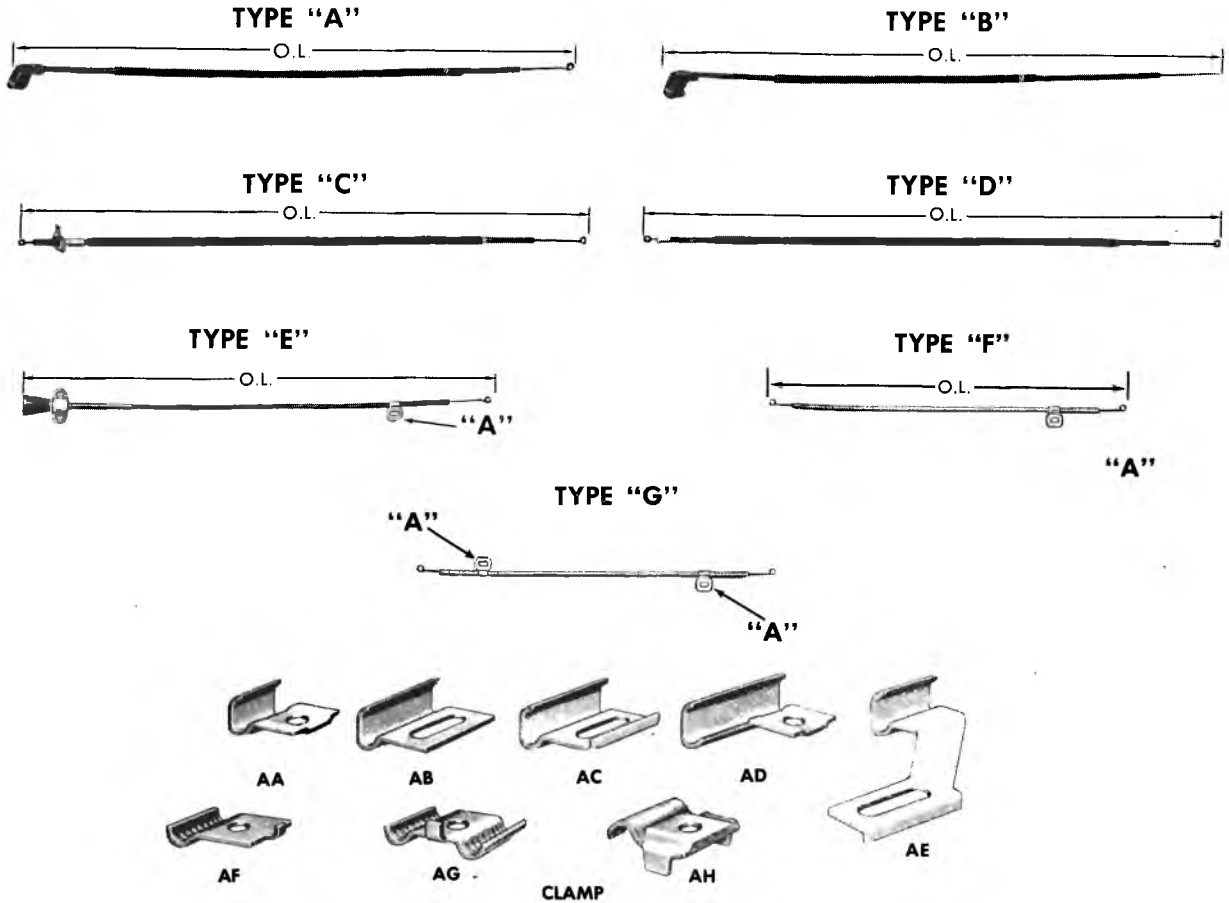

*NOTE 4 Use replaced cable as a guide to cut to required length.*

<b>62-65</b>	Chevy (exc. C.A.C.)— (E) . . . . .	<b>3793769</b>	A.R.	2.75	defroster and temp. control . . . . .
<b>64-66</b>	Chevelle— (E) . . . . .	<b>4501890</b>	2	3.35	cowl duct panel (complete) . . . . .
<b>65-66</b>	Pass.— (B) . . . . .	<b>7630575</b>	2	2.05	(cowl duct pnl. air) w/knob . . . . .
<b>66-67</b>	Chevy w/C.A.C. . . . .	<b>3005834</b>	1	6.15	evap. air inlet . . . . .
<i>NOTE 11 For companion parts see group 12.804.</i>					
<b>67</b>	Pass.— (A) . . . . .	<b>7663285</b>	1	2.20	w/knob (cowl duct panel air) (right) . . . . .
<b>67</b>	Pass.— (A) . . . . .	<b>7663286</b>	1	2.20	w/knob (cowl duct panel air) (left) . . . . .
<b>67</b>	Chevelle . . . . .	<b>7735914</b>	2	2.85	w/knob (cowl duct panel air) (repl. 7614559) . . . . .
<b>68</b>	Camaro w/C.A.C.— (F) . . . . .	<b>3925718</b>	1	1.70	heater and air cond. temp. control . . . . .
<b>68-72</b>	Chevelle (exc. C.A.C.)— (G) . . . . .	<b>3940231</b>	1	1.35	air control . . . . .

**BODY MTG.— AIR COND.— INSTRUMENTS**

**9.787 CABLE ASSY.— BRACKET— CLAMP— CLIP— CONTROL ASSY.—  
GUIDE— HOUSING— KNOB— NUT— PLIERS— RETAINER— RING—  
ROD— SHAFT— SUPPORT— SWITCH ASSY.— WIRE, Air Flow Control  
with Tube (Con't)**

68-72	Chevelle (exc. C.A.C.)— (G) . . . . .	3940229	1	1.70	temp. control . . . . .
68	Chevy (exc. C.A.C.)— (G) . . . . .	3909068	1	1.20	defroster cont. . . . .
67-68	Camaro— (E) . . . . .	7734862	2	3.00	w/knob (cowl duct panel air) . . . . .
68-69	Chevelle . . . . .	3851071	1	9.30	heater temp. control . . . . .
68	Pass. w/upper level vent.— (E) . . . . .	3935954	1	3.60	air side outlet to plenum duct valve actv. (4 1/8" long) . . . . .
68	Pass. . . . .	7735915	1	2.85	w/knob, cowl duct panel air . . . . .
69	Pass. (exc. Air Cond.) . . . . .	8744849	1	2.20	left, cowl center duct panel air (Note 9) . . . . .
	<i>NOTE 9 Production deviation.</i>				
69-70	Pass. (exc. Air Cond.) . . . . .	8718071	1	2.75	left, cowl center duct panel air . . . . .
69-70	Pass. w/C.A.C. . . . .	8756277	1	2.30	right, cowl center duct panel air . . . . .
65	Chevy, . . . . .				
69-71	Camaro (exc. Air Cond.), . . . . .				
69-70	Pass. w/C.A.C., . . . . .				
69-70	Chevelle (Spt. Cpe., Conv.) . . . . .	8756278	1	2.45	left, cowl center duct panel air . . . . .
69-70	Pass. (exc. Air Cond., Spt. Cpe.) . . . . .	8722474	2	2.10	(cowl side duct panel air) . . . . .
69	Chevelle, Chevy, Camaro w/C.A.C., . . . . .				
70	Nova . . . . .	3946982	A.R.	1.95	air shut-off (black) . . . . .
69	Camaro (exc. Air Cond.) . . . . .	8745294	2	1.55	cowl center duct panel (Note 5) (Note 7) . . . . .
69	Camaro (exc. Air Cond.) . . . . .	8745294	2	1.55	cowl side duct panel (repl. 8745188) (Note 5, 7) . . . . .
	<i>NOTE 5 Paint as required.</i>				
69-72	Nova w/C.A.C. . . . .	6258364	1	15.85	car heater and a/c defr. control (repl. 3942629) . . . . .
71-72	Nova w/C.A.C. . . . .	3989283	L.H.	2.25	left, A/C air shut-off (black) (Note 5) . . . . .
71-72	Nova w/C.A.C. . . . .	3989284	R.H.	3.30	right, A/C air shut-off (black) (Note 5) . . . . .
71-72	Chevelle w/C.A.C. . . . .	3967987	1	1.60	heater and A/C temp. . . . .
71-75	Vega, Monza (exc. C.A.C.) . . . . .	8756278	2	2.45	cowl side duct panel air (5 1/2" O.L.) (Note 1) . . . . .
	<i>NOTE 1: Cut and rework as required.</i>				
71-75	Vega, Monza (Hatchback) w/C.A.C. . . . .	3979720	1	1.25	<b>CABLE ASSY.</b> , htr. and a.c. temp. . . . .
73	Chevelle w/C.A.C. . . . .	3998495	1	1.45	heater and a/c temp. control . . . . .
73-75	Camaro w/C.A.C., . . . . .				
75	Nova w/C.A.C. . . . .	3012468	A.R.	.17	a/c htr. div. valve Bowden adjuster . . . . .
73-75	Pass. (exc. C.A.C.) . . . . .	481460	1	.63	defroster cable . . . . .
73-75	Nova (exc. C.A.C.) . . . . .	3010617	1	.70	htr. Bowden cable and valve adjuster . . . . .
73-75	Chevelle (exc. C.A.C.) . . . . .	6262639	1	.16	heater air control cable . . . . .
73-75	Nova w/C.A.C. . . . .	3018703	1	1.05	car heater Bowden cable temp. vlv. . . . .
73-74	Nova w/C.A.C. . . . .	6258364	1	15.85	htr. and a/c defr. control . . . . .
74-75	Chevelle (exc. C.A.C.) . . . . .	332049	1	.22	shroud vent. outlet control cable . . . . .
74	Chevelle w/C.A.C. . . . .	340471	1	1.60	heater and a/c temp. control . . . . .
75	Nova w/C.A.C. . . . .	346111	1	1.80	htr. and a/c temp. control . . . . .
75	Monza (Notchback) w/C.A.C. . . . .	3979720	1	1.25	htr. and a/c temp. (repl. 362506) . . . . .
73-75	All . . . . .	6258364	1	15.85	<b>CABLE UNIT</b> , vent htr. air cond. cables (Note 1) . . . . .
	<i>NOTE 1: Unit consists of 13 ft. of housing, 60 ft. of wire and 36 clamps. This unit is used with pliers, part number 3862204.</i>				
67-70	Pass., Camaro, . . . . .				
68-70	Chevy, Chevelle, . . . . .				
71-72	Nova, Chevelle (exc. C.A.C.) . . . . .	3010617	1	.70	<b>BRACKET</b> , htr. cable and valve adjuster . . . . .
67-69	Pass. w/Auto. Temp. Control, . . . . .				
70-72	Pass., Camaro w/C.A.C. . . . .	3012468	1	.17	<b>BRACKET</b> , a/c htr. div. valve Bowden adjuster . . . . .
67-68	Pass. (exc. S.S.) . . . . .	3902262	1	.93	<b>BRACKET</b> , a/c vent control, left . . . . .
68-72	Chevelle (exc. C.A.C.) . . . . .	3929008	1	.11	<b>BRACKET</b> , heater defroster control cable . . . . .
69	Chevy, Chevelle, Camaro w/C.A.C., . . . . .				
70-72	Nova w/C.A.C. . . . .	3018703	1	1.05	<b>BRACKET</b> , Bowden cable temp. valve . . . . .
69-70	Pass. w/C.A.C. . . . .	3940200	1	.22	<b>BRACKET</b> , left, air dist. duct valve control cable . . . . .
69	Pass. w/C.A.C. . . . .	3949881	1	.16	<b>BRACKET</b> , right, air dist. duct valve control cable . . . . .
70	Pass. w/C.A.C. . . . .	3949881	R.H.	.16	<b>BRACKET</b> , air dist. duct valve control cable, right . . . . .
70-72	Chevelle (exc. C.A.C.) . . . . .	3923153	1	.16	<b>BRACKET</b> , heater air control cable . . . . .
70-72	Camaro w/C.A.C. . . . .	3973783	1	.11	<b>BRACKET</b> , htr. and a/c air selector duct assy. . . . .
71-72	Pass. (exc. C.A.C.) . . . . .	481460	1	.63	<b>BRACKET</b> , defroster cable . . . . .
71-75	Vega w/C.A.C. . . . .	3022961	1	1.05	<b>BRACKET</b> , a/c Bowden cable adj. temp. control . . . . .

**BODY MTG.— AIR COND.— INSTRUMENTS**

**9.787 CABLE ASSY.— BRACKET— CLAMP— CLIP— CONTROL ASSY.—  
GUIDE— HOUSING— KNOB— NUT— PLIERS— RETAINER— RING—  
ROD— SHAFT— SUPPORT— SWITCH ASSY.— WIRE, Air Flow Control  
with Tube (Con't)**

75	Nova w/A.C.	3033363	2	.43	BRACKET, spring torsion adj.
62	Chevy,				
65-69	Pass. (AG)	3846998	1	.07	CLAMP, heater control
62-69	All (AA)	3853554	A.R.	.17	CLAMP (5/8" O.L.)
62-69	All (AC)	3856539	A.R.	.17	CLAMP (1" O.L.)
62-69	All (AD)	3856543	A.R.	.17	CLAMP (1 1/4" O.L.)
62-69	All (AB)	3856545	A.R.	.17	CLAMP (1" O.L.)
62-69	All (AE)	3856547	A.R.	.17	CLAMP (2 1/16" O.L.)
64	Chevelle (exc. Prod. Air Cond.)	7010773	1	.08	CLIP, heater air cont. cable (at htr. end)— (3.762)
65-68	Pass. w/C.A.C.,				
65-67	Chevelle w/C.A.C.,				
69-70	Pass. w/C.A.C., Auto. Temp. Control,				
71	Pass. w/C.A.C.,				
71-74	Vega	3158826	1	.13	CLIP, diverter valve to deflector valve
66-67	Pass.	7630539	2	.19	CLIP, cowl air outlet cont. ret.— (12.804)
67-69	Camaro,				
67-70	Pass. (exc. C.A.C.),				
68-75	Nova (exc. C.A.C.)	3895957	1	.05	CLIP, heater control cable
68-75	All	7783546	2	.14	CLIP, cowl panel air outlet cont.
68-69	Chevy, Camaro w/C.A.C.,				
70-72	Nova	3127960	1	.11	CLIP, air shut-off cable— (9.281)
68-72	Chevelle (exc. C.A.C.)	3929023	1	.11	CLIP, heater air control cable
69-72	Chevelle (Spt. Cpe., Conv.) (exc. Air Cond.),				
71-72	El Camino (exc. C.A.C.)	8720601	2	.11	CLIP, cowl air outlet door hinge rod
70-72	Chevelle (Spt. Cpe., Conv., El Camino Cust.) (exc. Air Cond.)	8799875	2	.17	CLIP, cowl side duct panel air outlet
70	All	7783546	A.R.	.14	CLIP, cowl panel air outlet cont.
71-75	Camaro (exc. C.A.C.)	3992136	1	.11	CLIP, heater control cable
71-75	Pass. (exc. C.A.C.)	9870651	L.H.	.28	CLIP, cowl ctr. duct panel air outlet, left
71-75	All (exc. C.A.C.)	9870124	R.H.	.05	CLIP, cowl vent. duct outlet door
71-75	All (exc. C.A.C.)	9870125	L.H.	.12	CLIP, cowl vent. duct outlet door
73-75	All (exc. C.A.C., Vega, Monza)	9884695	2	.16	CLIP, shroud control cable
68	Pass.,				
69-70	Chevy (exc. Air Cond.),				
68-72	Chevelle,				
71-72	Camaro (exc. C.A.C.)	7735914	2	2.85	CONTROL ASSY., cowl side duct panel air
71-75	Pass. (exc. C.A.C.)	9837573	R.H.	2.40	CONTROL ASSY., right, cowl ctr. duct panel air
71-75	Pass. (exc. C.A.C.)	9837574	L.H.	1.90	CONTROL ASSY., left, cowl ctr. duct panel air
71-75	Nova (exc. C.A.C.)	9838212	2	1.75	CONTROL ASSY., cowl duct panel air (paint as reqd.)
71-75	Camaro (exc. C.A.C.)	8756278	2	2.45	CONTROL ASSY., cowl center duct panel air outlet, right, left
72	Camaro	9624086	L.H.	2.20	CONTROL ASSY., cowl center duct air
73	Chevelle (exc. C.A.C.)	3994518	1	2.30	CONTROL ASSY., shrd. vent. center outlet
73-75	Chevelle (exc. C.A.C.)	3994547	L.H.	2.20	CONTROL ASSY., shrd. vent. outlet
73-75	Chevelle (exc. C.A.C.)	3999454	R.H.	2.20	CONTROL ASSY., shrd. vent. outlet
73-75	Camaro	9624085	2	2.40	CONTROL ASSY., center duct air, right and left
73	Nova (Cpe.) (exc. C.A.C., Custom)	9627839	1	1.95	CONTROL ASSY., shroud duct panel air (painted)
74-75	Chevelle (exc. C.A.C.)	332050	1	2.30	CONTROL ASSY., shroud vent. center outlet
73-75	Chevelle w/C.A.C.	331913	1	.11	GUIDE, htr. and a/c temp. control cable link
62-74	All	3986084	1	RL/.48	HOUSING, cont. cable (Note 10)
62-64	Chevy w/C.A.C.,				
65	Chevy	3783381	1	.59	KNOB, distributor temp. control
68	Pass. w/upper level vent (exc. C.A.C.),				
69	Camaro (exc. C.A.C.)	9813799	1	.55	KNOB, air side outlet to plenum valve control— (10.559)
62-74	All	381700	A.R.	.05	NUT, cable (spec. push-on spring) (5/32" shaft)
65-69	Pass.	3863839	A.R.	.11	NUT, vent control rod, diverter valve control
68	Chevelle w/C.A.C.	3929059	1	.16	NUT, a/c air inlet plenum valve link
All	All	3862204	1	11.85	PLIERS, cable working (Note 3)

NOTE 3: This tool is used with cable unit 6258364.

**BODY MTG.— AIR COND.— INSTRUMENTS**

**9.787 CABLE ASSY.— BRACKET— CLAMP— CLIP— CONTROL ASSY.— GUIDE— HOUSING— KNOB— NUT— PLIERS— RETAINER— RING— ROD— SHAFT— SUPPORT— SWITCH ASSY.— WIRE, Air Flow Control with Tube (Con't)**

69-70	Pass. ....	8738441	2	.24	RETAINER, cowl center air outlet control cable .....
69-70	Pass. (exc. Air Cond.) .....	8738859	1	.24	RETAINER, rihgt, cowl center duct air outlet drive .....
69-70	Pass. (exc. Air Cond.) .....	8738860	1	.24	RETAINER, left, cowl center duct air outlet drive .....
65	Pass. ....	4500965	2	.12	RING, cowl air outlet control retainer .....
75	All (exc. Vega, Monza) .....	9436681	1	.05	RING, push on (1/2") .....
68	Camaro w/upper level vent. (1st design) .....	3929910	2	.32	ROD, side outlet duct valve (flat 1 <sup>23</sup> / <sub>32</sub> ") .....
68	Camaro w/upper level vent. (2nd design) .....	3939614	2	.32	ROD, side outlet duct valve (2 <sup>1</sup> / <sub>2</sub> " O.L. flat) ..
69-70	Pass. w/C.A.C. ....	3940201	1	.28	SHAFT, air dist. duct valve .....
69-70	Pass. w/C.A.C. ....	3940202	1	.28	SHAFT, air dist. duct .....
68	Pass. ....	7761922	2	.43	SUPPORT, cowl duct pnl. air cont. (cable brkt.) (plastic) .....
70-75	Camaro .....	7810538	1	.58	SUPPORT, htr. control cable at column .....
71	Camaro .....	3992135	1	1.20	SUPPORT, heater control cable .....
62-63	Chevy .....	3793768	1	3.10	SWITCH ASSY., blower w/air control cable— (8.852) .....
66-67	Chevy w/C.A.C. ....	3870242	1	3.55	SWITCH ASSY., a/c and htr. control— (8.852) .....
62-69	All,				
71-74	Vega .....	3986027	1	RL/.06	WIRE, cont. cables (Note 8) .....

NOTE 1: Without clamp A.  
 NOTE 5: Paint as required.  
 NOTE 7: Snap-in grille type.  
 NOTE 8: One coil containing 60 feet.  
 NOTE 10: Consists of a 13 ft. roll used as ventilator, heater, or air-cond. control cable housing.

**9.789 OUTLET— ACTUATOR— ARM— BEZEL— BRACKET— CONNECTOR— COVER— CRANK— DEFLECTOR— DOOR— DUCT— ELEMENT— FASTENER— GASKET— GRILLE— HOUSING— INLET— LEVER AND SEAL ASSY.— LINK— PIN— REINFORCEMENT— ROD— SHAFT— SPRING— VALVE, Cowl**

65-68	Pass. ....	4412939	1	5.85	right, side air duct .....
71-74	Pass. (exc. C.A.C.) .....	9828749	1	2.20	shroud vent. center duct .....
71-74	Pass. (exc. C.A.C.) .....	481153	1	1.05	htr. air dist. ....
71-72	Chevelle .....	9790487	1	1.20	htr. air dist. ....
72-74	Pass. w/C.A.C. ....	6262609	1	.50	a/c air frt.— (9.262) .....
72-75	Pass. w/C.A.C. ....	6262613	1	.79	a/c air rh frt. lower— (9.262) .....
73-75	Chevelle .....	9868626	1	4.05	center duct panel center (plenum) .....
73-75	Chevelle .....	9868627	R.H.	7.10	center duct panel outer (plenum) .....
73-75	Chevelle .....	9667576	L.H.	10.15	center duct panel outer (plenum) .....
73-74	Pass. (exc. C.A.C.) .....	6262611	1		upper vent. center duct, rear— (9.262) .....
69-70	Pass. (exc. Air Cond.) .....	8801938	1	2.65	OUTLET ASSY., right, cowl center duct air ..
69-70	Pass. (exc. Air Cond.) .....	8801939	1	2.35	OUTLET ASSY., left, cowl center duct air ..
69-70	Chevelle (Spt. Cpe., Conv.),				
71-72	Chevelle (Spt. Cpe., Conv., El Camino Custom) (exc. Air Cond.) .....	8715632	R.H.	2.95	OUTLET ASSY., duct upper air .....
69-70	Chevelle (Spt. Cpe., Conv.),				
71-72	Chevelle (Spt. Cpe., Conv., El Camino Custom) (exc. Air Cond.) .....	8715633	L.H.	1.95	OUTLET ASSY., duct upper air .....
69	Camaro (exc. Air Cond.) .....	8727520	R.H.	5.30	OUTLET ASSY., cowl center duct air .....
69	Camaro (exc. Air Cond.) .....	8727521	L.H.	5.10	OUTLET ASSY., cowl center duct air .....
70-75	Camaro (exc. C.A.C.) .....	8796843	L.H.	4.00	OUTLET ASSY., cowl center duct air side, left .....
70-75	Camaro (exc. C.A.C.) .....	9824751	R.H.	4.55	OUTLET ASSY., cowl center duct air side, right .....
70	Pass. (exc. C.A.C.) .....	3939649	L.H.	7.55	OUTLET ASSY., upper vent side, left .....
70	Pass. (exc. C.A.C.) .....	3939628	R.H.	7.75	OUTLET ASSY., upper vent side, right— (9.262) .....
71	Pass. (exc. C.A.C.) (1st design) ..	354774	1	8.95	OUTLET ASSY., upper vent. center duct (repl. 6262610)— (9.262) .....
71-75	Pass. (exc. C.A.C.) .....	9872168	R.H.	3.20	OUTLET ASSY., cowl vent. center duct panel outer .....
71-75	Pass. (exc. C.A.C.) .....	9851857	L.H.	4.15	OUTLET ASSY., left, vent. center duct panel .....
71-72	Pass. (exc. C.A.C.) .....	9827760	1	3.90	OUTLET ASSY., cowl vent. center duct panel (repl. 9851855) .....



**BODY MTG.— AIR COND.— INSTRUMENTS**

**9.789 OUTLET— ACTUATOR— ARM— BEZEL— BRACKET— CONNECTOR— COVER— CRANK— DEFLECTOR— DOOR— DUCT— ELEMENT— FASTENER— GASKET— GRILLE— HOUSING— INLET— LEVER AND SEAL ASSY.— LINK— PIN— REINFORCEMENT— ROD— SHAFT— SPRING— VALVE, Cowl (Con't)**

71-72	Pass. (exc. C.A.C.)	3989273	1	.79	OUTLET ASSY., upper vent. center duct front— (9.262)
71-74	Pass. (exc. C.A.C.)	354774	1	8.95	OUTLET ASSY., upper vent. center duct— (9.262)
72	Pass. (exc. C.A.C.)	9872168	R.H.	3.20	OUTLET ASSY., right, vent. center duct panel
72-74	Pass. w/C.A.C.	6262672	1	8.45	OUTLET ASSY., right & center a/c air center— (9.262)
73-75	Pass. (exc. C.A.C.)	9827760	1	3.90	OUTLET ASSY., cowl vent. center duct center
73-74	Chevelle (exc. C.A.C.)	3998455	1	10.10	OUTLET ASSY., upper level vent. center (instr. panel)— (9.262)
67-72	Camaro w/C.A.C.,				
67-68	Camaro w/C.A.C.,				
68	Chevelle w/C.A.C.,				
68-69	Nova w/C.A.C.				a/c air inlet plenum
69-71	Chevelle w/C.A.C.,				
69-70	Camaro w/C.A.C.,				
70-75	Nova w/C.A.C.	1996501	1	4.53	ACTUATOR, a/c air recirculating valve (repl. 1998927)
67-69	Camaro w/C.A.C.,				
68-69	Chevy, Chevelle w/C.A.C.,				
70	Chevelle, Nova, Camaro w/C.A.C.,				
72-75	All (exc. Pass.) w/C.A.C.	1996505	1	3.48	ACTUATOR, air inlet side shroud, vacuum
73-75	Nova w/C.A.C.	1996501	1	4.53	ACTUATOR ASSY., a/c air inlet plenum valve vac.
73-75	Camaro w/C.A.C.	1998972	1		ACTUATOR ASSY., a/c air inlet plenum valve
67-69	Camaro w/C.A.C.,				
68-75	Nova w/C.A.C.	3895928	1	.46	ARM, air inlet side shroud vac. control
70-75	Camaro w/C.A.C.	3967983	1	.55	ARM, air inlet side shroud vac. control
68	Camaro	3937121	R.H.	3.25	BEZEL, air outlet— (9.262)
68	Camaro	3937122	L.H.	3.25	BEZEL, air outlet— (9.262)
69	Chevelle w/C.A.C.	3949833	2	.64	BEZEL, air shut-off cable (black)
67-69	Camaro w/C.A.C.,				
68-75	Nova w/C.A.C.	3895927	1	.38	BRACKET, air inlet side shroud vac. control
70-75	Camaro w/C.A.C.	3967981	1	.53	BRACKET, air inlet side shroud vac.
73-74	Pass. (exc. C.A.C.)	3022707	1	.88	BRACKET, Bowden cable and valve adjusting
73-74	Chevelle w/C.A.C.	3024794	1	11.20	CASE, air inlet
70-72	Chevelle (exc. C.A.C.)	3965473	L.H.	1.50	CONNECTOR, left, upper vent. side outlet adapt. to plenum
69-72	Chevelle w/C.A.C.	8732446	L.H.	3.20	COVER, cowl duct air outlet
71-75	Pass. (exc. C.A.C.)	6264791	1	2.70	COVER, inst. pnl. a/c left outlet
69-75	Nova w/C.A.C.	331910	1	2.40	COVER, air inlet side shroud valve control
73-75	Pass. w/C.A.C. (exc. Caprice)	6264792	1	.16	COVER, upper level vent. control
73-74	Caprice w/C.A.C.	6264793	1	.67	COVER, upper level vent. control
75	Caprice w/C.A.C.	346685	1	1.30	COVER, upper level vent. control
73-74	Chevelle w/C.A.C.	3024796	1	1.40	CRANK, air valve
71-72	Pass. (exc. C.A.C.)	3984636	1	4.50	DEFLECTOR, upper vent. center duct outlet— (9.264)
<i>NOTE 3: Production deviation.</i>					
62-67	Chevy	4846504	R.H.	2.35	DOOR, air outlet
62-67	Chevy	4846505	L.H.	2.35	DOOR, air outlet
65-68	Pass.	4838830	1	2.85	DOOR, right, air outlet
65-68	Pass.	4838831	1	2.85	DOOR, left, air outlet
67-75	Camaro,				
68-75	Chevy	7640929	L.H.	2.40	DOOR ASSY., cowl panel air outlet
67-75	Camaro,				
68-75	Chevy	7640928	R.H.	2.40	DOOR ASSY., cowl panel air outlet
68-72	Chevelle	7727258	R.H.	2.80	DOOR ASSY., cowl panel air outlet
68-72	Chevelle	7727259	L.H.	2.80	DOOR ASSY., cowl panel air outlet
69-70	Chevelle (Spt. Cpe., Conv.) (exc. Air Cond.),				
71-72	Chevelle (Spt. Cpe., Conv., El Camino Custom) (exc. Air Cond.)	8719918	R.H.	2.25	DOOR ASSY., cowl side duct panel air outlet
69-70	Chevelle (Spt. Cpe., Conv.) (exc. Air Cond.),				

**BODY MTG.— AIR COND.— INSTRUMENTS**

**9.789 OUTLET— ACTUATOR— ARM— BEZEL— BRACKET— CONNECTOR— COVER— CRANK— DEFLECTOR— DOOR— DUCT— ELEMENT— FASTENER— GASKET— GRILLE— HOUSING— INLET— LEVER AND SEAL ASSY.— LINK— PIN— REINFORCEMENT— ROD— SHAFT— SPRING— VALVE, Cowl (Con't)**

71-72	Chevelle (Spt. Cpe., Conv., El Camino Custom) (exc. Air Cond.)	8719919	L.H.	2.20	DOOR ASSY., cowl side duct panel air outlet
69	Camaro (exc. Air Cond.)	8727523	R.H.	1.65	DOOR ASSY., cowl center duct air outlet
69-70	Pass. (exc. Air Cond.)	8717540	1	1.70	DOOR ASSY., right, cowl center duct air outlet
69-70	Pass. (exc. Air Cond.)	8717541	1	1.50	DOOR ASSY., left, cowl center duct air outlet
69-70	Pass. (exc. Air Cond.)	8717587	1	2.75	DOOR ASSY., right, cowl side duct panel air outlet
69	Pass. (exc. Air Cond.)	8717588	1	2.75	DOOR ASSY., left, cowl side duct panel air outlet
69	Pass. (exc. Air Cond.)	8745805	1	2.75	DOOR ASSY., right, cowl side duct panel air outlet (Note 3)
69	Pass. (exc. Air Cond.)	8745806	1	2.85	DOOR ASSY., left, cowl side duct panel air outlet (Note 3)
70-75	Camaro				DOOR ASSY., cowl center duct air outlet, left
70-75	Camaro (exc. C.A.C.)	9824752	R.H.	2.25	DOOR ASSY., cowl center duct air outlet, right
71-74	Pass. (exc. C.A.C.)	9831503	R.H.	2.80	DOOR ASSY., right, cowl center duct air outlet side
71-75	Pass.	9735168	1	2.75	DOOR ASSY., cowl center duct air outlet center
71-75	Pass. (exc. C.A.C.)	9735169	L.H.	2.80	DOOR ASSY., left, cowl center duct air outlet side
71-75	Vega, Monza (Hatchback) (exc. C.A.C.)	9824449	L.H.	2.60	DOOR ASSY., cowl side duct air outlet
71-75	Vega, Monza (Hatchback) (exc. C.A.C.)	9824448	R.H.	2.60	DOOR ASSY., cowl side duct air outlet
73-74	Chevelle	9870515	R.H.	3.95	DOOR ASSY., air outlet shroud center duct outer
73-74	Chevelle	9870516	L.H.	2.80	DOOR ASSY., air outlet shroud center duct outer
73-74	Chevelle	9870517	1	2.80	DOOR ASSY., air outlet shroud center duct center
75	Pass. (exc. C.A.C.)	9735166	R.H.	2.75	DOOR ASSY., cowl center duct air outlet
71-72	Pass. w/C.A.C.	3992118	L.H.	.81	DUCT, left air outlet center— (9.262)
71-75	Vega, Monza w/C.A.C.,				ELEMENT, air valve
73-74	Chevelle w/C.A.C.	1998995	1	4.33	FASTENER, inst. panel compt. door
72-75	Vega, Monza	3955982	2	.12	GASKET, air inlet mounting
73-74	Chevelle w/C.A.C.	3025543	1	4.00	GRILLE, cowl trim panel (black) (paint as reqd.)
68-71	Chevelle	7739452	R.H.	1.30	GRILLE, cowl trim panel (black) (paint as reqd.)
68-71	Chevelle	7739453	L.H.	1.30	GRILLE, side finish panel (paint to match)
69	Chevelle (exc. Air Cond.)	7739452	R.H.	1.30	GRILLE, side finish panel (paint to match)
69	Chevelle (exc. Air Cond.)	7739453	L.H.	1.30	
71	Malibu, El Camino (Custom) (exc. Spt. Sed., Air Cond.),				
71	Monte Carlo, Concours (exc. Air Cond.),				
72	Chevelle (exc. Air Cond.)	7739452	R.H.	1.30	GRILLE, right side cowl finish panel (paint as reqd.)
70	Malibu (Spt. Cpe., Conv.) (exc. Air Cond.),				
71	Malibu, El Camino (Custom) (exc. Spt. Sed., Air Cond.),				
71	Monte Carlo, Concours (exc. Air Cond.),				
71	Chevelle (exc. Sta. Wag., El Camino),				
72	Chevelle (exc. Air Cond.)	7739453	L.H.	1.30	GRILLE, left, cowl side finish panel (paint as reqd.)
71-72	Nomad, Greenbrier,				
71-72	Chevelle (Deluxe) El Camino (exc. Custom)	9858271	L.H.	1.55	GRILLE, left, cowl side finish panel (med. saddle)
71-75	Pass. (exc. C.A.C.)	9828748	R.H.	1.85	GRILLE, right, cowl center duct outer outlet
71-74	Pass. (exc. C.A.C.)	9828749	L.H.	2.20	GRILLE, left, cowl center duct outer outlet

**BODY MTG.— AIR COND.— INSTRUMENTS**

**9.789 OUTLET— ACTUATOR— ARM— BEZEL— BRACKET— CONNECTOR— COVER— CRANK— DEFLECTOR— DOOR— DUCT— ELEMENT— FASTENER— GASKET— GRILLE— HOUSING— INLET— LEVER AND SEAL ASSY.— LINK— PIN— REINFORCEMENT— ROD— SHAFT— SPRING— VALVE, Cowl (Con't)**

73-75	Chevelle	9667577	L.H.	1.30	GRILLE, shroud center duct panel outer outlet
70-74	Camaro w/C.A.C.	3963732	1	4.25	HOUSING, plenum air inlet
69-72	Chevelle w/C.A.C.	3946947	1	3.15	HOUSING, side shroud control valve
71-75	Pass. w/C.A.C.	3028591	1	19.15	INLET, a/c air
73-75	Chevelle w/C.A.C.	3024558	1	36.50	INLET ASSY., a/c air
73-75	Pass. w/C.A.C.	3028593	1	11.30	LEVER AND SEAL ASSY., a/c inlet valve
67-75	Camaro w/C.A.C.,				
68-75	Chevy w/C.A.C.	3895929	1	.28	LINK, air inlet side shroud vac. control
68-75	Nova, Camaro w/C.A.C.	3895930	1	.11	PIN, air inlet side shroud vac. control
68	Pass. w/upper level vent.	3930112	1	.12	REINFORCEMENT, inner, air side outlet to plenum duct
73	Pass. w/C.A.C.	3022860	1	6.05	SHAFT, w/seal, air valve
67-69	Camaro w/C.A.C.,				
68-71	Chevy, Chevelle w/C.A.C.,				
72-75	Nova w/C.A.C.	3895931	1	.16	SPRING, air inlet side shroud vac. control
70-75	Camaro w/C.A.C.	3967982	1	.22	SPRING, air inlet side shroud vac.
	<i>NOTE 5: 1st design part does not have holes thru it.</i>				
	<i>NOTE 6: 2nd design part has holes thru it.</i>				
68	Camaro w/upper level vent (1st design)	3919574	2	.28	VALVE, air side outlet lower duct (no ribs)
68	Camaro w/upper level vent (2nd design)	3935976	2	2.15	VALVE, air side outlet to plenum duct (has ribs)
69-70	Pass. w/C.A.C.	3018579	1	4.10	VALVE, w/seal air inlet
69-70	Pass. w/Auto. Temp. Control	3019212	1	4.10	VALVE, w/seal air inlet
71-75	All (exc. Vega, Monza)	9609899	2	1.75	VALVE, drain center duct panel
73-74	Chevelle w/C.A.C.	3024795	1	4.75	VALVE ASSY., w/crank, air

**9.795 VALVE ASSY., Heater Water Temp.**

68	Pass. w/C.A.C. (exc. Auto. Temp. Control)	1479664	1	11.10	heater water shut-off
69-70	All w/C.A.C.	3984641	1	10.85	heater vac. water shut-off (mounted on skirt)
71-72	All w/C.A.C.,				
73-74	Chevelle w/C.A.C.	3992098	1	10.85	heater vac. water shut-off (mounted on engine)— (8.866)
73-75	Nova, Chevelle (exc. A/C)	3157840	1	3.30	heater temp. air— (9.786)
74-75	Chevelle w/L6 Eng.	500956	1	9.95	htr. water shut-off

**9.988 LAMP— WIRE ASSY., Rear Luggage Compartment**

70-75	Camaro	993997	1	4.35	
73-75	Pass., Chevelle	994274	1	3.25	
73-75	Nova (exc. Hatchback)	994469	1	3.50	
73-75	Pass., Chevelle, Nova	9623100	1	3.25	LAMP ASSY., lugg. compt. (deck lid mounted)
71-72	Pass. (exc. Sta. Wag.)	9899624	1	1.90	LAMP ASSY.
73-75	Nova	3943629	1		LAMP ASSY., rr. compt.
73-74	Nova (Hatchback)	9664297	1	1.45	SWITCH, compt. lid jamb
75	Nova (Hatchback)	1699149	1	3.25	SWITCH, compt. lid jamb (mercury)
71-72	Pass. (exc. Sta. Wag.)	9821168	1	1.10	WIRE ASSY.

**9.990 EXTINGUISHER**

62-75	All	3907132	1	10.00	fire (17 ounce dry chem.)
-------	-----	---------	---	-------	---------------------------



# CHEVROLET BODY GROUP 10.000



## DOORS — REGULATORS — WINDSHIELD — WIPER — WASHER

### ALPHABETICAL INDEX

<b>A</b>			
ACTUATOR ASSY., Vacuum Power Door		BUMPER, Door Window.....	10.716
Lock.....	10.485	BUMPER, Instrument Panel Compartment	
APPLIQUE, Seat Separator.....	10.240	Door.....	10.263
ARM ASSY., Windshield Wiper Motor Aux.....	10.151	BUMPER, Seat Separator.....	10.242
ARM ASSY., Windshield Wiper.....	10.147	BUMPER, Side Door.....	10.587
ARMATURE ASSY., Rear Door Window.....	10.791	BUMPER, Windshield Pillar Weatherstrip.....	10.093A
ARMATURE ASSY., Windshield Wiper.....	10.150	BUSHING, Door Hinge.....	10.464
ARMATURE UNIT, Front Door Window.....	10.783	BUSHING, Door Window Lower Sash.....	10.747
ARMATURE UNIT, Rear Door Window.....	10.791	BUSHING, Door Window Regulator Manual	
ARM, Inside Rear View Mirror.....	10.187	or Electric.....	10.792
ARM, Seat Separator.....	10.242	BUSHING, Front Door Glass Lower Sash	
		Channel.....	10.687
		BUSHING, Front Door Window Glass Lower	
		Sash.....	10.685
		BUSHING, Rear Door Window.....	10.768
		BUSHING, Rear View Mirror.....	10.186
		BUTTON, Door Handle Push Button.....	10.529
<b>B</b>		<b>C</b>	
BALL, Windshield Wiper.....	10.150	CAM AND RING UNIT, Windshield Washer...	10.153
BELLOWS, Windshield Washer.....	10.153	CAM ASSY., Door Window Regulator	
BEZEL, Instrument Panel Compartment Door		Manual or Electric.....	10.792
Lock.....	10.267	CAM, Front Door Glass Lower Sash Channel.	10.687
BEZEL, Seat Separator.....	10.242	CAM, Rear Door Lower Window Sash	
BEZEL, Windshield Wiper Control.....	10.166	Channel.....	10.748
BEZEL, Windshield Wiper.....	10.163	CAM, Windshield Washer.....	10.153
BLADE, Windshield Wiper.....	10.146	CAP ASSY., Inside Rear View Mirror.....	10.187
BOARD ASSY., Windshield Washer.....	10.153	CAP ASSY., Windshield Wiper.....	10.150
BOARD ASSY., Windshield Wiper.....	10.150	CAP, Door Outside Handle Push Button and	
BOLT, Door Hinge to Hinge Pillar.....	10.463	Lock Cylinder.....	10.552
BOLT, Door Window Lower Sash.....	10.747	CAP, Door Window Regulator Manual or	
BOLT, Door Window Regulator Manual or		Electric.....	10.792
Electric.....	10.792	CAP, Door Window.....	10.716
BOLT, Front Door Window Glass Lower		CAP, Front Door Window Glass Lower Sash..	10.685
Sash.....	10.685	CAP, Windshield Washer.....	10.153
BOLT, Windshield Wiper.....	10.150	CAP, Windshield Wiper Motor Aux.....	10.151
BOX, Front Door, Lower.....	10.454	CAP, Windshield Wiper Parts.....	10.154
BOX, Front Door, Upper.....	10.450	CASE ASSEMBLY, Instrument Panel	
BOX, Instrument Panel Compartment.....	10.260	Compartment Door.....	10.266
BRACE, Instrument Panel to Dash.....	10.230	CASE ASSY., Instrument Panel Compartment	
BRACKET, Front Door Window.....	10.783	Door.....	10.266
BRACKET, Instrument Panel to Dash.....	10.230	CASE, Windshield Wiper.....	10.150
BRACKET, Instrument Panel Compartment,		CHANNEL ASSY., Division Rear Door	
Seat Separator Compartment and		Ventilator Glass.....	10.826
Courtesy.....	10.275	CHANNEL ASSY., Rear Door Stationary	
BRACKET, Instrument Panel Compartment....	10.260	Ventilator Glass Division.....	10.829
BRACKET, Instrument Panel.....	10.252	CHANNEL ASSY., Windshield Glass.....	10.092
BRACKET, Radio Instrument Panel.....	10.256	CHANNEL, Door Glass Sash.....	10.689
BRACKET, Rear Door Window.....	10.791	CHANNEL, Door Window Lower Sash.....	10.747
BRACKET, Rear View Mirror.....	10.186	CHANNEL, Front Door Glass Run.....	10.701
BRACKET, Seat Separator.....	10.240	CHANNEL, Front Door Vent Division.....	10.688
BRACKET, Windshield Wiper Motor		CHANNEL, Front Door Ventilator Glass (with	
Mounting Parts.....	10.152	tee shaft).....	10.655
BRACKET, Windshield Wiper Parts.....	10.154	CHANNEL, Front Door Window Glass Lower	
BRACKET, Windshield Wiper.....	10.150	Sash.....	10.685
BRUSH ASSY., Windshield Wiper.....	10.150	CHANNEL, Rear Door Window Glass.....	10.759
BRUSH UNIT, Windshield Wiper.....	10.150	CLIP, Door Edge.....	10.352A
BUMPER ASSY., Front Door Ventilator.....	10.670	CLIP, Door Handle Push Button.....	10.529
BUMPER, Door Lock Remote Control		CLIP, Door Inside Locking Rod.....	10.565
Connecting.....	10.506A	CLIP, Door Window Reveal Moulding.....	10.708
BUMPER, Door Lock Inside.....	10.512		
BUMPER, Door Window Regulator Manual			
or Electric.....	10.792		

# ALPHABETICAL INDEX

CLIP, Electric Window Lift.....	10.777
CLIP, Front and Rear Door Lock.....	10.474
CLIP, Front Door Ventilator.....	10.661
CLIP, Front Door Window Glass Lower Sash.....	10.685
CLIP, Front Door Window Reveal.....	10.707
CLIP, Instrument Panel to Dash.....	10.230
CLIP, Instrument Panel.....	10.252
CLIP, Rear Quarter Ventilator and Back Window Drain.....	10.997
CLIP, Rear View Mirror.....	10.186
CLIP, Side Roof Rail.....	10.721
CLIP, Vacuum Power Door Lock.....	10.485
CLIP, Windshield Garnish Moulding.....	10.056
CLIP, Windshield Pillar Weatherstrip.....	10.093A
CLIP, Windshield Reveal Moulding.....	10.096
CLIP, Windshield Wiper Parts.....	10.156
CLIP, Windshield Wiper.....	10.147
CLIP, Windshield Wiper.....	10.159
COMPARTMENT ASSY., Seat Separator.....	10.240
COMPARTMENT, Instrument Panel Compartment.....	10.260
CONDUCTOR, Fluid Level.....	10.154A
CONDUCTOR, Windshield Wiper.....	10.163
CONDUIT, Electric Window Lift.....	10.777
CONDUIT, Front and Rear Door.....	10.778
CONNECTOR, Windshield Wiper Pipe.....	10.155
CONTROL, Door Lock Remote.....	10.500
COVER, Radio Instrument Panel.....	10.256
COVER, Seat Separator.....	10.240
COVER, Seat Separator.....	10.242
COVER, Side Door.....	10.587
COVER, Windshield Washer.....	10.153
COVER, Windshield Wiper Motor Aux.....	10.151
CRANK ASSY., Windshield Wiper Motor Aux.....	10.151
CYLINDER ASSY., Door Lock Outside Locking Handle.....	10.550
CYLINDER, Instrument Panel Compartment Door.....	10.266
CYLINDER UNIT, Door Lock Outside Locking Handle.....	10.550

## D

DECAL, Also See Group 8.800 for Stencil Units.....	10.354
DEFLECTOR UNIT, Front Door (less glass)....	10.650
DEFLECTOR, Front Panel Access Hole.....	10.355
DISC, Windshield Wiper.....	10.150
DOOR ASSY., Instrument Panel Compartment.....	10.261
DOOR ASSY., Seat Separator.....	10.242
DOOR, Front (less paint, trim and hardware)..	10.351
DOOR, Rear (less paint, trim and hardware)...	10.373
DRIVE SHAFT ASSY., Windshield Wiper.....	10.159

## E

EMBLEM, Instrument Panel.....	10.254
EMBLEM, Seat Separator.....	10.242
ESCUTCHEON, Door Lock Inside Handle Escutcheon (Trim Protector).....	10.515
ESCUTCHEON, Door Outside Handle Ferrule.....	10.537
ESCUTCHEON, Instrument Panel Compartment Door Lock.....	10.267
ESCUTCHEON, Rear View Mirror.....	10.186
ESCUTCHEON, Windshield Garnish.....	10.051A
ESCUTCHEON, Windshield Pillar Weatherstrip.....	10.093A
ESCUTCHEON, Windshield Wiper.....	10.147
EXTENSION ASSY., Door Window.....	10.716
EXTENSION, Instrument Panel to Dash.....	10.230

## F

FASTENER, Door Weatherstrip.....	10.695
FASTENER, Front Door Window Glass Lower Sash.....	10.685
FASTENER, Rear Door Window Glass.....	10.759
FASTENER, Rear View Mirror.....	10.186
FERRULE, Door Inside Locking Rod.....	10.560
FILLER, Door Window Lower Sash.....	10.747
FILLER, Front Door Ventilator Glass (with tee shaft).....	10.655
FILLER, Front Door Window Glass Lower Sash.....	10.685
FILTER NUT, Windshield Washer.....	10.153
FILTER, Windshield Wiper Parts.....	10.154
FOLLOWER UNIT, Windshield Washer.....	10.153
FRAME, Front Door Ventilator.....	10.656
FRAME, Seat Separator.....	10.240

## G

GASKET, Door Handle Push Button.....	10.529
GASKET, Door Lock Inside Handle.....	10.517
GASKET, Door Outside Handle Ferrule.....	10.537
GASKET, Door Outside Lock Handle.....	10.551
GASKET, Door Ventilator Regulator.....	10.664
GASKET, Rear View Mirror.....	10.186
GASKET, Windshield Washer.....	10.153
GASKET, Windshield Wiper Motor Mounting Parts.....	10.152
GASKET, Windshield Wiper.....	10.163
GEAR, Front Door Window.....	10.783
GEAR, Rear Door Window.....	10.791
GEAR, Windshield Wiper Motor Aux.....	10.151
GLASS, Front Door Ventilator (safety).....	10.658
GLASS, Front Door Window (Safety).....	10.681
GLASS, Rear Door (safety).....	10.741
GLASS, Rear Door Ventilator.....	10.827
GLASS, Rear View Mirror.....	10.186
GLASS, Windshield (safety).....	10.027
GROMMET, Inside Rear View Mirror.....	10.187
GROMMET, Sunshade.....	10.219
GROMMET, Windshield Wiper Motor Aux.....	10.151
GROMMET, Windshield Wiper Motor Mounting Parts.....	10.152
GROMMET, Windshield Wiper.....	10.150
GUARD, Door Edge.....	10.352
GUARD UNIT, Door Edge.....	10.352A
GUARD UNIT, Door Inside Locking Rod.....	10.559
GUIDE, Front Door Window Glass Lower Sash.....	10.685
GUTTER, Rear Quarter Ventilator and Back Window Drain.....	10.997

## H

HANDLE, Door Lock Inside.....	10.512
HANDLE, Door Outside Locking (less cylinder).....	10.527
HANDLE, Door Ventilator Regulator.....	10.664
HANDLE, Door Window Regulator.....	10.797
HARNES ASSY., Instrument Panel Compartment, Seat Separator Compartment and Courtesy.....	10.275
HINGE ASSY., Front Door, Upper.....	10.450
HINGE, Front Door, Lower.....	10.454
HINGE, Instrument Panel Compartment Door.....	10.262
HINGE, Rear Door, Lower.....	10.460
HINGE, Rear Door, Upper.....	10.456
HINGE, Seat Separator.....	10.242
HINGE, Sunshade.....	10.219
HOLDER, Front Door Window.....	10.783
HOLDER, Rear Door Window.....	10.791
HOLDER, Windshield Wiper.....	10.150
HOSE, Windshield Wiper Pipe.....	10.155

# ALPHABETICAL INDEX

HOUSING ASSY., Instrument Panel Compartment, Seat Separator Compartment and Courtesy.....	10.275
HOUSING, Door Outside Handle Push Button and Lock Cylinder.....	10.552
HOUSING, Fluid Level.....	10.154A
HOUSING, Windshield Wiper Control.....	10.166
HOUSING, Windshield Wiper.....	10.159

## I

INSERT ASSY., Windshield Wiper.....	10.146
INSERT, Door Ventilator Regulator.....	10.664
INSERT, Front Door Window Glass Lower Sash.....	10.685
INSERT, Seat Separator.....	10.242

## J

JAR, Windshield Wiper Parts.....	10.154
----------------------------------	--------

## K

KEY, Door Lock Outside Locking Handle.....	10.550
KEY, Instrument Panel Compartment Door.....	10.266
KIT, Windshield (Safety).....	10.027A
KNOB ASSY., Windshield Wiper.....	10.163
KNOB, Door Inside Locking Rod.....	10.559
KNOB, Rear View Mirror.....	10.186
KNOB, Windshield Wiper Control.....	10.164

## L

LAMP UNIT, Instrument Panel Compartment, Seat Separator Compartment and Courtesy.....	10.275
LATCH, Windshield Washer.....	10.153
LENS, Inside Rear View Mirror.....	10.187
LENS, Instrument Panel Compartment, Seat Separator Compartment and Courtesy.....	10.275
LEVEL INDICATOR, Fluid Level.....	10.154A
LINK, Front Door Hinge Hold Open.....	10.455
LINK, Rear Door, Lower.....	10.460
LINK, Windshield Wiper.....	10.159
LOCK, Front Door.....	10.470
LOCK, Rear Door.....	10.473
LOUVER, Front Door Window Reveal.....	10.707

## M

MAGNET ASSY., Windshield Washer.....	10.153
MAGNET, Windshield Wiper.....	10.150
MIRROR ASSEMBLY, Rear View.....	10.185
MIRROR UNIT, Vanity Visor.....	10.195
MOTOR ASSY., Front Door Window.....	10.783
MOTOR ASSY., Rear Door Window.....	10.791
MOTOR, Windshield Wiper.....	10.150
MOULDING ASSY., Front Door Window Reveal.....	10.707
MOULDING, Front Door Window Reveal.....	10.707
MOULDING, Instrument Panel.....	10.252
MOULDING, Rear Door Window Reveal.....	10.772
MOULDING, Seat Separator.....	10.240
MOULDING, Seat Separator.....	10.242
MOULDING, Side Roof Rail.....	10.721
MOULDING, Windshield Garnish.....	10.051
MOULDING, Windshield Reveal.....	10.093

## N

NOZZLE ASSY., Windshield Wiper Parts.....	10.156
NUT, Door Lock Inside.....	10.512
NUT, Door Outside Handle Ferrule.....	10.537
NUT, Door Window Lower Sash.....	10.747
NUT, Door Window Regulator Manual or Electric.....	10.792
NUT, Door Window.....	10.716
NUT, Door Window.....	10.728
NUT, Front Door Ventilator.....	10.670
NUT, Front Door Window Glass Lower Sash.....	10.685
NUT, Rear Door Lower Window Sash Channel.....	10.748
NUT, Rear Door Window.....	10.768
NUT, Rear Door Window.....	10.791
NUT, Rear View Mirror.....	10.186
NUT, Vanity Visor.....	10.195
NUT, Windshield Wiper Motor Aux.....	10.151
NUT, Windshield Wiper.....	10.159
NUT, Windshield Wiper.....	10.163

## P

PACKAGE ASSY., Front Door Window.....	10.783
PACKAGE ASSY., Rear Door Window.....	10.791
PACKAGE, Door Edge.....	10.352A
PAD, Door Lock Inside Handle Escutcheon (Trim Protector).....	10.515
PAD, Rear View Mirror.....	10.186
PANEL, Instrument Panel to Dash.....	10.230
PANEL, Seat Separator.....	10.240
PANEL, Seat Separator.....	10.242
PAWL, Door Outside Lock Handle.....	10.551
PAWL, Windshield Washer.....	10.153
PAWL, Windshield Wiper Motor Aux.....	10.151
PIN ASSY., Front Door Window Glass Lower Sash.....	10.685
PIN, Door Handle Push Button.....	10.529
PIN, Door Hinge.....	10.466
PIN, Door Ventilator Regulator.....	10.664
PIN, Front and Rear Door Lock.....	10.474
PISTON ASSY., Windshield Washer.....	10.153
PLATE ASSY., Radio Instrument Panel.....	10.256
PLATE ASSY., Windshield Wiper Motor Mounting Parts.....	10.152
PLATE, Door Dovetail Bumper Wedge.....	10.584
PLATE, Door Lock Inside Handle Escutcheon (Trim Protector).....	10.515
PLATE, Door Lock Striker.....	10.571
PLATE, Door Window Lower Sash.....	10.747
PLATE, Door Window Regulator Handle.....	10.805
PLATE, Door Window Regulator Manual or Electric.....	10.792
PLATE, Door Window.....	10.728
PLATE, Electric Window Lift.....	10.777
PLATE, Front Door Window Glass Lower Sash.....	10.685
PLATE, Front Door, Lower.....	10.454
PLATE, Front Door, Upper.....	10.450
PLATE, Instrument Panel.....	10.252
PLATE, Instrument Panel.....	10.254
PLATE, Rear View Mirror.....	10.186
PLATE, Seat Separator.....	10.240
PLATE, Vacuum Power Door Lock.....	10.485
PLUG, Front Door Window.....	10.783
PLUG, Instrument Panel.....	10.252
PLUG, Side Door.....	10.587
PLUG, Weatherstrip, Door Opening.....	10.694A
PLUG, Windshield Wiper.....	10.150
PLUG, Windshield Wiper.....	10.159
PLUNGER ASSY., Door Inside Locking Rod....	10.559
PLUNGER ASSY., Windshield Washer.....	10.153
PLUNGER, Seat Separator.....	10.242
PUMP ASSY., Windshield Washer.....	10.153

# ALPHABETICAL INDEX

## R

RAIL, Door Window Lower Sash.....	10.747
RATCHET, Windshield Washer.....	10.153
REFLECTOR, Seat Separator.....	10.242
REGULATOR, Front Door Ventilator.....	10.661
REGULATOR, Front Door Window.....	10.783
REGULATOR, Rear Door Window.....	10.791
REINFORCEMENT ASSY., Instrument Panel Compartment.....	10.260
REINFORCEMENT, Electric Window Lift.....	10.777
REINFORCEMENT, Front Door Ventilator Tee	10.657
REINFORCEMENT, Instrument Panel to Dash	10.230
REINFORCEMENT, Rear View Mirror.....	10.186
REINFORCEMENT, Vacuum Power Door Lock.....	10.485
RELAY ASSY., Windshield Wiper.....	10.150
RELAY ASSY., Windshield Wiper.....	10.163
RESERVOIR, Windshield Wiper Parts.....	10.154
RETAINER ASSY., Windshield Pillar Weatherstrip.....	10.093A
RETAINER, Center Pillar Weatherstrip.....	10.730
RETAINER, Door Safety Lock.....	10.551A
RETAINER, Door Lock Inside.....	10.512
RETAINER, Door Outside Lock Handle.....	10.551
RETAINER, Electric Window Lift.....	10.777
RETAINER, Instrument Panel Compartment Door Lock.....	10.267
RETAINER, Instrument Panel.....	10.252
RETAINER, Rear Door Glass Run Channel.....	10.703
RETAINER, Rear Door Window Glass.....	10.759
RETAINER, Rear View Mirror.....	10.186
RETAINER, Seat Separator.....	10.240
RETAINER, Seat Separator.....	10.242
RETAINER, Side Roof Rail.....	10.721
RETAINER, Sunshade.....	10.219
RETAINER UNIT, Lock Tumbler.....	10.553A
RETAINER, Vacuum Power Door Lock.....	10.485
RETAINER, Windshield Pillar Weatherstrip.....	10.093A
RETAINER, Windshield Washer.....	10.153
RETAINER, Windshield Wiper Transmission..	10.160
RING, Door Handle Push Button.....	10.529
RING, Door Hinge.....	10.466
RING, Rear View Mirror.....	10.186
RING, Windshield Washer.....	10.153
RING, Windshield Wiper Motor Aux.....	10.151
RING, Windshield Wiper Motor Mounting Parts.....	10.152
RIVET, Front Door Hinge Hold Open.....	10.455
RIVET, Front Door Vent Division.....	10.688
RIVET, Front Door Ventilator Glass (with tee shaft).....	10.655
RIVET, Front Door Ventilator.....	10.669
RIVET, Front Door Ventilator.....	10.670
RIVET, Rear View Mirror.....	10.186
RIVET, Seat Separator.....	10.242
ROD ASSY., Windshield Wiper.....	10.147
ROD, Door Handle Push Button.....	10.529
ROD, Door Inside Lock to Knob.....	10.563
ROD, Door Lock Remote Control Connecting.	10.506
ROD, Rear Quarter Ventilator and Back Window Drain.....	10.997
ROD, Vacuum Power Door Lock.....	10.485
ROLLER ASSY., Door Window Regulator Manual or Electric.....	10.792
ROLLER ASSY., Front Door Hinge Hold Open	10.455
ROLLER ASSY., Front Door Window Glass Lower Sash.....	10.685
ROLLER, Door Window Lower Sash.....	10.747
ROLLER, Front Door Window.....	10.783
ROLLER, Rear Door Window Frame.....	10.763
ROLLER, Rear Door Window.....	10.791

## S

SCALP, Rear Door Stationary Ventilator Glass Division.....	10.829
SCREW, Door Hinge to Hinge Pillar.....	10.463
SCREW, Door Inside Locking Control.....	10.556
SCREW, Door Lock Inside.....	10.512

SCREW, Door Lock Remote Control Connecting.....	10.506A
SCREW, Door Lock Striker to Pillar.....	10.570
SCREW, Door Outside Locking (less cylinder).....	10.527
SCREW, Door Ventilator Regulator.....	10.664
SCREW, Door Weatherstrip.....	10.695
SCREW, Door Window Lower Sash.....	10.747
SCREW, Door Window Regulator Manual or Electric.....	10.792
SCREW, Door Window.....	10.716
SCREW, Front and Rear Door Lock.....	10.474
SCREW, Front Door Glass Lower Sash Channel.....	10.687
SCREW, Front Door Glass Run.....	10.701
SCREW, Front Door Ventilator.....	10.661
SCREW, Front Door Ventilator.....	10.670
SCREW, Front Door Window Glass Lower Sash.....	10.685
SCREW, Front Door Window Reveal.....	10.707
SCREW, Front Door Window.....	10.783
SCREW, Inside Rear View Mirror.....	10.187
SCREW, Instrument Panel to Dash.....	10.230
SCREW, Instrument Panel Compartment Door Lock.....	10.267
SCREW, Instrument Panel Compartment Door.....	10.262
SCREW, Instrument Panel Compartment, Seat Separator Compartment and Courtesy.....	10.275
SCREW, Instrument Panel Compartment.....	10.260
SCREW, Instrument Panel.....	10.252
SCREW, Rear Door Lower Window Sash Channel.....	10.748
SCREW, Rear Door Window Frame.....	10.763
SCREW, Rear Door Window Glass.....	10.759
SCREW, Rear Door Window.....	10.768
SCREW, Rear Door Window.....	10.791
SCREW, Rear View Mirror.....	10.186
SCREW, Seat Separator.....	10.240
SCREW, Sunshade.....	10.219
SCREW, Windshield Garnish Moulding.....	10.056
SCREW, Windshield Reveal Moulding.....	10.096
SCREW, Windshield Washer.....	10.153
SCREW, Windshield Wiper Motor Aux.....	10.151
SCREW, Windshield Wiper Motor Mounting Parts.....	10.152
SCREW, Windshield Wiper.....	10.150
SEAL, Seat Separator.....	10.240
SEAL, Windshield Washer.....	10.153
SEAL, Windshield Wiper Parts.....	10.154
SHAFT, Front Door Ventilator Tee.....	10.657
SHAFT, Windshield Wiper Motor Aux.....	10.151
SHIELD, Instrument Panel Compartment Door.....	10.262
SHIELD, Windshield Wiper Motor Aux.....	10.151
SHIELD, Windshield Wiper.....	10.150
SHOE, Door Inside Lock to Knob.....	10.563
SHROUD, Instrument Panel.....	10.252
SILENCER, Door Lock Remote.....	10.500
SILENCER, Windshield Garnish.....	10.051A
SLEEVE, Door Window Regulator Manual or Electric.....	10.792
SLEEVE, Sunshade.....	10.219
SOCKET UNIT, Windshield Wiper Transmission.....	10.160
SPACER, Door Dovetail Bumper Wedge.....	10.584
SPACER, Door Inside Locking Rod.....	10.565
SPACER, Door Lock Striker.....	10.571
SPACER, Door Ventilator Regulator.....	10.664
SPACER, Door Window Lower Sash.....	10.747
SPACER, Front Door Window (Safety).....	10.681
SPACER, Front Door Window Glass Lower Sash.....	10.685
SPACER, Instrument Panel to Dash.....	10.230
SPACER, Window Regulator Handle Escutcheon Plate.....	10.806
SPACER, Windshield (Safety).....	10.027A
SPACER, Windshield Garnish Moulding.....	10.056
SPACER, Windshield Garnish.....	10.051A
SPACER, Windshield Reveal Moulding.....	10.096
SPACER, Windshield Wiper Control.....	10.164
SPRING, Door Handle Push Button.....	10.529

## ALPHABETICAL INDEX

SPRING, Door Lock Inside Handle	
Escutcheon.....	10.516
SPRING, Door Lock Remote.....	10.500
SPRING, Door Ventilator Regulator.....	10.664
SPRING, Front and Rear Door Lock.....	10.474
SPRING, Front Door Hinge Hold Open.....	10.455
SPRING, Front Door Vent Reg. Handle.....	10.666
SPRING, Front Door Ventilation Channel.....	10.660
SPRING, Rear Door, Lower.....	10.460
SPRING, Seat Separator.....	10.242
SPRING UNIT, Lock Tumbler.....	10.553A
SPRING, Window Regulator Handle	
Escutcheon Plate.....	10.806
SPRING, Windshield Washer.....	10.153
SPRING, Windshield Wiper Motor Aux.....	10.151
SPRING, Windshield Wiper.....	10.150
STOP ASSY., Front Door Window Glass	
Lower Sash.....	10.685
STOP, Door Window.....	10.716
STOP, Front Door Ventilation Channel.....	10.660
STOP, Instrument Panel and Seat Separator	
Compartment Lock.....	10.268
STOP, Instrument Panel Compartment Door...	10.262
STOP, Rear Door Window.....	10.768
STOP, Seat Separator.....	10.242
STRAP, Front Door, Lower.....	10.454
STRAP, Front Door, Upper.....	10.450
STRAP, Instrument Panel Compartment Door	10.262
STRAP, Windshield Wiper.....	10.150
STRIKER, Door Lock.....	10.569
STRIKER, Instrument Panel and Seat	
Separator Compartment Lock.....	10.268
STRIKER, Seat Separator.....	10.242
STRIP ASSY., Front Door Window (Outer-	
Inner).....	10.710
STRIP ASSY., Rear Door Window.....	10.774
STRIP, Door Opening and Windshield Pillar..	10.694
STRIP, Also See Group 8.800 for Stencil	
Units.....	10.354
STRIP, Front Door Window (Safety).....	10.681
STRIP, Side Roof Rail.....	10.721
STUD, Division Rear Door Ventilator Glass....	10.826
STUD, Door Ventilator Regulator.....	10.664
STUD, Door Window Regulator Manual or	
Electric.....	10.792
STUD, Door Window.....	10.728
STUD, Front Door Glass Run.....	10.701
STUD, Front Door Ventilator.....	10.670
STUD, Front Door Window (Outer-Inner).....	10.710
STUD, Front Door Window Glass Lower	
Sash.....	10.685
STUD, Rear Door Window Glass.....	10.759
STUD, Rear Door Window.....	10.768
STUD, Seat Separator.....	10.242
SUNSHADE ASSEMBLY.....	10.203
SUPPORT, Door Ventilator Regulator.....	10.664
SUPPORT, Door Window.....	10.716
SUPPORT, Door Window.....	10.728
SUPPORT, Front Door Glass Lower Sash	
Channel.....	10.687
SUPPORT, Front Door Ventilator.....	10.669
SUPPORT, Inside Rear View Mirror.....	10.187
SUPPORT, Instrument Panel to Dash.....	10.230
SUPPORT, Instrument Panel Compartment,	
Seat Separator Compartment and	
Courtesy.....	10.275
SUPPORT, Rear Door Lower Window Sash	
Channel.....	10.748
SUPPORT, Seat Separator.....	10.240
SUPPORT, Sunshade.....	10.219
SUPPORT, Windshield (Safety).....	10.027A
SUPPORT, Windshield Wiper Parts.....	10.154
SWITCH ASSY., Electric Window Lift.....	10.777
SWITCH ASSY., Instrument Panel	
Compartment, Seat Separator	
Compartment and Courtesy.....	10.275
SWITCH ASSY., Vacuum Power Door Lock....	10.485
SWITCH ASSY., Windshield Wiper.....	10.163
SWITCH, Windshield Washer.....	10.153

### T

TANK ASSY., Vacuum Power Door Lock.....	10.485
TAPE, Door Outside Locking (less cylinder)...	10.527
TEE, Vacuum Power Door Lock.....	10.485
TEE, Windshield Wiper Pipe.....	10.155
TERMINAL BOARD, Windshield Wiper.....	10.150
TRANS. ASSY., Windshield Wiper.....	10.159
TRANSFER, Also See Group 8.800 for	
Stencil Units.....	10.354
TRAY, Seat Separator.....	10.240
TUBE ASSY., Door Window Lower Sash.....	10.747
TUBE ASSY., Door Window.....	10.728
TUMBLER UNIT, Door Lock Cylinder.....	10.553

### V

VALVE ASSY., Vacuum Power Door Lock.....	10.485
VALVE ASSY., Windshield Washer.....	10.153
VALVE, Rear Quarter Ventilator and Back	
Window Drain.....	10.997
VALVE, Windshield Wiper.....	10.150
VENTILATOR ASSEMBLY, Front Door (less	
glass).....	10.650

### W

WASHER, Door Handle Push Button.....	10.529
WASHER, Door Inside Locking Control.....	10.556
WASHER, Door Lock Inside Handle.....	10.517
WASHER, Door Lock Remote.....	10.500
WASHER, Door Lock Striker.....	10.571
WASHER, Door Ventilator Regulator.....	10.664
WASHER, Door Window Lower Sash.....	10.747
WASHER, Door Window Regulator Manual	
or Electric.....	10.792
WASHER, Door Window Regulator.....	10.797
WASHER, Door Window.....	10.728
WASHER, Front Door Glass Run.....	10.701
WASHER, Front Door Vent.....	10.665
WASHER, Front Door Ventilation Channel.....	10.660
WASHER, Front Door Window Glass Lower	
Sash.....	10.685
WASHER, Instrument Panel Compartment	
Door.....	10.266
WASHER, Rear Door Ventilator.....	10.824
WASHER, Rear Door Window Glass.....	10.759
WASHER, Rear Door Window.....	10.791
WASHER, Windshield Garnish Moulding.....	10.056
WASHER, Windshield Wiper Control.....	10.164
WASHER, Windshield Wiper Motor Aux.....	10.151
WASHER, Windshield Wiper Transmission....	10.160
WASHER, Windshield Wiper.....	10.150
WEATHERSTRIP ASSY., Front Door	
Ventilator.....	10.652
WEATHERSTRIP, Door Opening and	
Windshield Pillar.....	10.694
WEATHERSTRIP, Rear Door Window Frame..	10.764
WEATHERSTRIP, Side Roof Rail.....	10.721
WEDGE, Door Dovetail Bumper Wedge.....	10.584
WHEEL UNIT, Windshield Washer.....	10.153
WIRE ASSY., Instrument Panel	
Compartment, Seat Separator	
Compartment and Courtesy.....	10.275
WIRE ASSY., Windshield Wiper.....	10.150





**WINDSHIELD—DOORS—CONTROLS**

**10.027 GLASS, Windshield (safety)**

**PASSENGER**

65-68	(exc. Spt. Mdls.)	7584398	1	134.00	(clear)
65-68	(exc. Spt. Mdls.)	7584399	1	165.00	(tinted)
65-68	Spt. Mdls.	7584478	1	125.00	(clear)
65-68	Spt. Mdls.	7584479	1	152.00	(tinted)
69	Sed. (exc. Spt. Sed.),				
69	(Spt. Mdls.)	7790810	1	150.00	(tinted)
69	Sed. (exc. Spt. Sed.),				
69	Sta. Wag.	7790808	1	162.00	(tinted)
69-70	(Spt. Mdls.)	7790809	1	143.00	(clear)
69-70	Sta. Wag.	7790807	1	131.00	(clear)
70	Pass. (2-Dr., Spt. Sed.)	8780460	1	174.00	(tinted) w/windshield antenna
70	Pass. (4-Dr.) (exc. Spt. Sed.)	8780458	1	185.00	(tinted) w/windshield antenna
70	Pass. (2-Dr., Spt. Sed.)	9808842	1	149.00	(clear) w/windshield antenna
70	Pass. (4-Dr.) (exc. Spt. Sed.)	9808841	1	159.00	(clear) w/windshield antenna
71-75	Pass. (4-Dr.) (exc. Spt. Sed.)	9820470	1	157.00	(clear)
71-75	Impala (Conv.)	9838384	1	155.00	(clear) w/mirror support
71-75	Pass. (2-Dr., Spt. Sed.)	9804275	1	182.00	(clear) w/mirror support
71-75	Pass. (4-Dr.) (exc. Spt. Sed.)	9804087	1	198.00	(clear) w/mirror support, w/windshield antenna
71-75	Pass. (4-Dr.) (exc. Spt. Sed.)	9820327	1	232.00	(tinted) w/mirror support, w/windshield antenna
71-75	Pass. (Spt. Cpe., Spt. Sed.)	9820288	1	202.00	(clear) w/mirror support, w/windshield antenna
71-75	Pass. (Spt. Cpe., Spt. Sed.)	9820289	1	237.00	(tinted) w/mirror support, w/windshield antenna
71-75	Impala (Conv.)	9804349	1	197.00	(clear) w/windshield antenna
71-75	Impala (Conv.)	9820328	1	229.00	(tinted) w/mirror support, w/windshield antenna
75	Pass. (Spt. Cpe., Spt. Sed.)	9664044	1	195.00	tinted w/mirror support
75	Pass. (4-Dr.) (exc. Spt. Sed.)	9664046	1	200.00	tinted w/mirror support

**CHEVELLE**

64-65	Chevelle,				
66-67	(Exc. Spt. Cpe., Conv.)	7584394	1	86.25	(clear)
64-65	Chevelle,				
66-67	(Exc. Spt. Cpe., Conv.)	7584395	1	107.00	(tinted)
66-67	(Spt. Cpe., Conv.)	4539495	1	83.00	(clear)
66-67	(Spt. Cpe., Conv.)	4539496	1	113.00	(tinted)
68-69	(4-Dr.)	7711314	1	142.00	(tinted)
68-69	(2-Dr.) (exc. Conv.)	7711316	1	131.00	(tinted)
68-69	(Conv.)	7711318	1	139.00	(tinted)
68-72	(2-Dr.) (exc. Conv.)	9869856	1	110.00	(clear)
68-71	Chevelle (Conv.)	9869854	1	152.00	(clear)
68-72	Chevelle (4-Dr.)	9869857	1	119.00	(clear)
70-72	Chevelle (4-Dr.)	9869851	1	162.00	(clear) w/windshield antenna
70-72	Chevelle (4-Dr.)	9869852	1	187.00	(tinted) w/windshield antenna (repl. 8780308)
70-71	Chevelle (Conv.)	9869855	1	176.00	(tinted) w/windshield antenna
70-72	Chevelle (2-Dr.) (exc. Conv.)	9864151	1	138.00	(clear) w/windshield antenna
70-72	Chevelle (2-Dr.) (exc. Conv.)	9864152	1	170.00	(tinted) w/windshield antenna
70-72	Chevelle (Conv.)	9869854	1	152.00	(clear) w/windshield antenna
73-75	Chevelle (4-Dr.)	9864777	1	197.00	tinted w/windshield antenna
73-75	Chevelle (2-Dr.)	9864779	1	201.00	tinted w/windshield antenna
73-75	Chevelle (4-Dr.)	9864776	1	171.00	clear w/windshield antenna
73-75	Chevelle (2-Dr.)	9864778	1	164.00	clear w/windshield antenna
73-75	Chevelle (4-Dr.)	9867199	1	140.00	clear
73-75	Chevelle (2-Dr.)	9867198	1	134.00	clear
75	Chevelle (2-Dr.)	1735274	1	195.00	tinted
75	Chevelle (4-Dr.)	1735273	1	194.00	tinted

**CHEVY—NOVA**

62-66	(Exc. Spt. Cpe., Conv.)	7584388	1	92.00	(clear)
62-67	(Exc. Spt. Cpe., Conv.)	7584389	1	130.00	(tinted)
62-67	Nova (Spt. Cpe., Conv.)	7584390	1	104.00	(clear)
62-65	Nova (Spt. Cpe., Conv.),				
66-67	(Spt. Cpe.)	7584391	1	123.00	(tinted)
68-69	(Sed.)	7712045	1	132.00	(tinted)
68-69	(Spt. Cpe.)	7724621	1	132.00	(tinted)
68-72	Nova (2-Dr.)	9869866	1	93.25	(clear)
68-72	Nova (4-Dr.)	9869867	1	97.50	(clear)
70-72	Nova (4-Dr.)	9869865	1	161.00	(tinted) w/windshield antenna
70-72	Nova (2-Dr.)	9869863	1	155.00	(tinted) w/windshield antenna

**WINDSHIELD—DOORS—CONTROLS**

**10.027 GLASS, Windshield (safety) (Con't)**

70-72	Nova (4-Dr.)	9869864	1	139.00	(clear) w/windshield antenna
70-72	Nova (2-Dr.)	9869862	1	135.00	(clear) w/windshield antenna
73-74	Nova (4-Dr.)	9618856	1	145.00	clear w/windshield antenna
73-74	Nova (4-Dr.)	9618857	1	167.00	tinted w/windshield antenna
73-74	Nova (2-Dr.)	9618854	1	125.00	clear w/windshield antenna
73-74	Nova (2-Dr.)	9618855	1	143.00	tinted w/windshield antenna
73-74	Nova (2-Dr.)	9618864	1	91.75	clear
73-74	Nova (4-Dr.)	9618865	1	113.00	clear
75	Nova (4-Dr.)	9692563	1	159.00	clear w/windshield antenna
75	Nova (4-Dr.)	9692564	1	182.00	tinted w/windshield antenna
75	Nova (2-Dr.)	9692566	1	153.00	clear w/windshield antenna
75	Nova (2-Dr.)	9692567	1	177.00	tinted w/windshield antenna
75	Nova (2-Dr.)	9692565	1	122.00	clear
75	Nova (2-Dr.)	1735276	1	167.00	tinted
75	Nova (4-Dr.)	9692562	1	127.00	clear
75	Nova (4-Dr.)	1735275	1	173.00	tinted

**CAMARO**

67-69	(Spt. Cpe.)	7631031	1	91.75	(clear)
67-69	(Spt. Cpe.)	7631032	1	114.00	(tinted)
67-69	(Conv.)	7631034	1	131.00	(tinted)
70	Camaro (1st design)	9825352	1	144.00	(clear) w/mirror support, w/shield antenna (Note 1)
70	Camaro (1st design)	9825353	1	179.00	(tinted) w/mirror support, w/shield antenna (Note 1)
70	Camaro (2nd design),				
71-75	Camaro	9841588	1	132.00	(tinted) w/mirror support (Note 1)
70	Camaro (2nd design),				
71-75	Camaro	9841590	1	144.00	(clear) w/shield antenna, w/mirror support
70	Camaro (2nd design),				
71-75	Camaro	9841589	1	179.00	(tinted) w/mirror support, w/shield antenna (Note 1)
75	Camaro	1735277	1	170.00	tinted

**VEGA— MONZA**

71-75	Vega (exc. H.B.)	9851753	1	157.00	(tinted) w/mirror support, windshield antenna
71-75	Vega (exc. H.B.)	9851752	1	128.00	(clear) w/mirror support, windshield antenna
71-75	Vega (exc. H.B.)	9851751	1	97.50	(clear) w/mirror support, w/o windshield antenna
71-75	Vega (H.B.)	9851699	1	158.00	(tinted) w/mirror support, windshield antenna
71-75	Vega (H.B.)	9851698	1	128.00	(clear) w/mirror support, windshield antenna
71-75	Vega (H.B.)	9851697	1	97.50	(clear) w/mirror support, w/o windshield antenna
75	Monza (exc. Towne Cpe.)	9730084	1	114.00	clear less antenna
75	Monza (exc. Towne Cpe.)	9730085	1	146.00	clear with antenna
75	Monza (exc. Towne Cpe.)	9730086	1	183.00	tinted with antenna
75	Monza	1735270	1	159.00	tinted less antenna
75	Vega (exc. Hatchback)	1735271	1	145.00	tinted less antenna
75	Vega (exc. Hatchback)	1735272	1	145.00	tinted less antenna

*NOTE 1: 1st design part has long ball mirror support. 2nd design part has short flat mirror support.*

**10.027A KIT— SPACER— SUPPORT, Windshield (Safety)**

62-75	All	9631000 A.R.	10.70	caulking unit (Note 1)
<i>NOTE 1 For use in replacing windshield glass, back window glass (exc. Sta. Wagons) and rear quarter stationary window glass on Sta. Wagons.</i>				
64-69	Chevelle,			
68-69	Chevy	4404196	12	.11 SPACER, adhesive caulked glass (1 <sup>9</sup> / <sub>64</sub> " x 7 <sup>1</sup> / <sub>16</sub> " x 1— rubber)
64-66	Chevelle,			
65-66	Pass.	4421823	3	.16 SPACER, adhesive caulked glass (1 <sup>1</sup> / <sub>5</sub> " x 5 <sup>5</sup> / <sub>8</sub> " x 1 plus rubber)
64-66	Chevelle (exc. Sta. Wag.),			
65	Pass.,			
66	Pass. (exc. Sta. Wag.)	4410043 A.R.		.11 SPACER (1 <sup>1</sup> / <sub>16</sub> " x 1 <sup>1</sup> / <sub>4</sub> " x 3 <sup>3</sup> / <sub>4</sub> " )
65-66	Chevelle,			
67-69	All (exc. Pass.)	4871330 A.R.		.11 SPACER, adhesive caulked glass (1 <sup>11</sup> / <sub>32</sub> " x 7 <sup>1</sup> / <sub>16</sub> " x 1)
65-66	Chevelle,			
67-75	All (exc. Conv.)	4459429 A.R.		.18 SPACER (1 <sup>13</sup> / <sub>64</sub> " x 5 <sup>5</sup> / <sub>8</sub> " x 1) glass adhesive kit
67-70	All	4534314 A.R.		.18 SPACER (3 <sup>3</sup> / <sub>8</sub> " x 7 <sup>1</sup> / <sub>16</sub> " )
71-72	All	7694478 A.R.		.28 SPACER, glass

**WINDSHIELD—DOORS—CONTROLS**

**10.027A KIT— SPACER— SUPPORT, Windshield (Safety) (Con't)**

71-73	Vega (Sta. Wag., Panel) . . . . .	9848544 A.R.	.21	<b>SPACER</b> , adhesive caulk. kit ( <sup>33</sup> / <sub>64</sub> " x <sup>7</sup> / <sub>16</sub> " x <sup>3</sup> / <sub>4</sub> " ) . . . . .
72-75	Vega, Monza . . . . .	4459429 A.R.	.18	<b>SPACER</b> , glass adhesive caulk. kit ( <sup>13</sup> / <sub>64</sub> " x <sup>1</sup> / <sub>2</sub> " x 1) . . . . .
73-75	All,			
74-75	Vega, Monza . . . . .	1662675	1 .13	<b>SPACER</b> , glass adhesive kit (snap on) . . . . .
65-67	Spt. Mdls. (exc. Conv.) . . . . .	4470779	1 19.00	left, side . . . . .
65-67	Spt. Mdls. (exc. Conv.) . . . . .	4470778	1 19.00	right, side . . . . .
67	Biscayne, Bel Air,			
67	Impala (4-Dr.) (exc. Spt. Sed.) . . . . .	7660092	1 11.25	right, side (paint as reqd.) . . . . .
67	Biscayne, Bel Air,			
67	Impala (4-Dr.) (exc. Spt. Sed.) . . . . .	7660093	1 11.25	left, side (paint as reqd.) . . . . .
69-70	Pass. (exc. Conv.) . . . . .	8751168	1 3.65	right, upper (paint as reqd.) . . . . .
69-70	Pass. (exc. Conv.) . . . . .	8751169	1 3.65	left, upper (paint as reqd.) . . . . .
71-72	Pass. (4-Dr.) (exc. Spt. Sed.) . . . . .	9658814	L.H. 19.00	left side . . . . .
71-72	Pass. (4-Dr.) (exc. Spt. Sed.) . . . . .	9658813	R.H. 19.00	right side . . . . .
71-75	Impala, Caprice (Spt. Cpe., Spt. Sed.) . . . . .	9828583	L.H. 15.35	left, side (Note 1) . . . . .
71-75	Impala, Caprice (Spt. Cpe., Spt. Sed.) . . . . .	9828582	R.H. 15.35	right side (Note 1) . . . . .
71-75	Impala (Conv.) . . . . .	9829793	L.H. 19.00	side . . . . .
71-75	Impala (Conv.) . . . . .	9829792	R.H. 19.00	side . . . . .
71-75	Pass. (Conv.) . . . . .	9725523	1 28.00	upper (painted) . . . . .
71-75	Pass. (Spt. Sed., Spt. Cpe.) . . . . .	9860851	1 6.70	upper (painted) . . . . .
71-75	Pass. (4-Dr.) (exc. Spt. Sed.) . . . . .	9860772	1 6.70	upper (painted) . . . . .
73-75	Pass. (4-Dr.) (exc. Spt. Sed.) . . . . .	9658813	R.H. 19.00	side . . . . .
73-75	Pass. (4-Dr.) (exc. Spt. Sed.) . . . . .	9658814	L.H. 19.00	side . . . . .

**CHEVELLE**

68-69	El Camino,			
68-69	(2-Dr. Sed.) . . . . .	7735264	R.H. 19.00	side (black) (plastic type) (Note 1) . . . . .
68-72	(Conv.) . . . . .	7742776	R.H. 16.50	upper . . . . .
68-72	(Conv.) . . . . .	7742777	L.H. 16.50	upper . . . . .
69-71	(Conv.) . . . . .	8736054	R.H. 19.00	
69-71	(Conv.) . . . . .	8736055	L.H. 19.00	
70-72	Chevelle (4-Dr.) exc. Spt. Sed. . . . .	8767269	L.H. 11.25	left, side (Note 1) . . . . .
70-72	Chevelle (4-Dr.) exc. Spt. Sed. . . . .	8767268	R.H. 11.25	right, side (Note 1) . . . . .
70-72	Chevelle (Spt. Cpe.) . . . . .	8767257	L.H. 11.25	left, side (Note 1) . . . . .
70-72	Chevelle (Spt. Cpe.) . . . . .	8767256	R.H. 11.25	right, side (Note 1) . . . . .
70-72	Chevelle (Spt. Sed.) . . . . .	8767273	L.H. 11.25	left, side (Note 1) . . . . .
70-72	Chevelle (Spt. Sed.) . . . . .	8767272	R.H. 11.25	right, side (Note 1) . . . . .
70-72	Chevelle (2-Dr. Plr. Cpe., El Camino) . . . . .	8767277	L.H. 11.25	left, side (Note 1) . . . . .
70-72	Chevelle (2-Dr. Plr. Cpe., El Camino) . . . . .	8767276	R.H. 11.25	right, side (Note 1) . . . . .
71	Chevelle (Conv.) . . . . .	9845531	L.H. 19.00	left, side (comb. 731, 732) (dk. jade) . . . . .
71	Chevelle (Conv.) . . . . .	9845530	R.H. 19.00	right, side (comb. 731, 732) (dk. jade) . . . . .
71	Chevelle (Conv.) . . . . .	9845527	1 19.00	left, side (comb. 721, 722) (dk. saddle) . . . . .
71	Chevelle (Conv.) . . . . .	9845526	1 19.00	right, side (comb. 721, 722) (dk. saddle) . . . . .
72	Chevelle (Conv.) . . . . .	9896751	L.H. 19.00	w/s side (comb. 713) . . . . .
72	Chevelle (Conv.) . . . . .	9896750	R.H. 19.00	w/s side (comb. 713) . . . . .
72	Chevelle (Conv.) . . . . .	9896745	L.H. 19.00	w/s side (comb. 704, 743) . . . . .
72	Chevelle (Conv.) . . . . .	9896744	R.H. 19.00	w/s side (comb. 704, 743) . . . . .
73	Chevelle (2-Dr.) . . . . .	9652274	R.H. 3.20	side (Note 1) . . . . .
73	Chevelle (2-Dr.) . . . . .	9652275	L.H. 3.20	side (Note 1) . . . . .
73-75	Chevelle (4-Dr.) . . . . .	9649500	1 3.55	upper (Note 1) . . . . .
73-75	Chevelle (2-Dr.) . . . . .	9651073	1 2.95	upper (Note 1) . . . . .
73-75	Chevelle (4-Dr.) . . . . .	9678552	R.H. 3.20	side (Note 1) . . . . .
73-75	Chevelle (4-Dr.) . . . . .	9678553	L.H. 3.20	side (Note 1) . . . . .
74-75	Chevelle (2-Dr.) . . . . .	9681252	R.H. 3.20	side (Note 1) . . . . .
74-75	Chevelle (2-Dr.) . . . . .	9681253	L.H. 3.20	side (Note 1) . . . . .

**CHEVY— NOVA**

69	(Spt. Cpe.) . . . . .	8721214	R.H. 19.00	(black) . . . . .
70	Nova (2-Dr.) . . . . .	8767299	L.H. 11.25	left, side (Note 1) . . . . .
70-72	Nova (4-Dr.) . . . . .	9842105	R.H. 9.60	right side (Note 1) . . . . .
70-72	Nova (2-Dr.) . . . . .	9842102	L.H. 9.60	left side (Note 1) . . . . .
71-72	Nova (2-Dr.) . . . . .	9842101	R.H. 9.60	right side (Note 1) . . . . .
70-72	Nova (4-Dr.) . . . . .	9842106	L.H. 9.60	left side (Note 1) . . . . .
73-74	Nova (2-Dr.) . . . . .	9663067	L.H. 9.60	side (Note 1) . . . . .
73-74	Nova (2-Dr.) . . . . .	9663066	R.H. 9.60	side (Note 1) . . . . .
73-74	Nova (4-Dr.) . . . . .	9663081	L.H. 9.60	side (Note 1) . . . . .
73-74	Nova (4-Dr.) . . . . .	9663080	R.H. 9.60	side (Note 1) . . . . .
73-74	Nova . . . . .	9652464	1 14.10	upper (painted) . . . . .
75	Nova . . . . .	1661776	1 10.80	upper (painted) . . . . .

**WINDSHIELD—DOORS—CONTROLS**

**10.027A KIT— SPACER— SUPPORT, Windshield (Safety) (Con't)**

75	Nova (4-Dr.)	1661102 R.H.	6.40	side (Note 1)
75	Nova (4-Dr.)	1661103 L.H.	6.40	side (Note 1)
75	Nova (2-Dr.)	1661652 R.H.	4.50	side (Note 1)
75	Nova (2-Dr.)	1661653 L.H.	4.50	side (Note 1)

**CAMARO**

67	(Conv.)	7639925 L.H.	5.70	side (bright)
67	(Spt. Cpe.)	7664894 R.H.	3.95	side
67	(Spt. Cpe.)	7664895 L.H.	3.60	side
67	(Spt. Cpe.)	7657638 R.H.	11.60	side (bright)
67	(Spt. Cpe.)	7657639 L.H.	11.60	side (bright)
68	(Spt. Cpe.)	7756294 R.H.	19.00	side (black)
69	(Spt. Cpe.)	8721204 R.H.	19.00	(black)
69	(Spt. Cpe.)	8721205 L.H.	19.00	(black)
70	Camaro	9801947 R.H.	12.90	
70-72	Camaro	9847794 L.H.	13.50	
71-72	Camaro	9847793 R.H.	13.50	
73	Camaro (1st design)	9663052 R.H.	13.50	side (Note 1, 2)
73	Camaro (1st design)	9663053 L.H.	13.50	side (Note 1, 2)
73-75	Camaro (2nd design)	9666791 1	10.80	upper (Note 1, 4)
73-75	Camaro (2nd design)	9666806 R.H.	13.50	side (painted) (Note 3)
73-75	Camaro (2nd design)	9666807 L.H.	13.50	side (painted) (Note 3)

**VEGA— MONZA**

71-75	Vega	9837421 1	6.50	upper (prime and paint as reqd.)
71-73	Vega (exc. Coupe)	9837453 L.H.	6.40	(prime and paint as reqd.)
71-75	Vega (H.B.)	9668886 R.H.	6.40	(prime and paint as reqd.)
71-75	Vega (H.B.)	9668887 L.H.	6.40	side (prime and paint as reqd.)
71-75	Vega (exc. H.B.)	9668876 R.H.	6.40	side (prime and paint as reqd.)
74-75	Vega (exc. H.B.)	9668877 L.H.	6.40	side (prime and paint as reqd.)
75	Monza (exc. Towne Cpe.)	1698086 R.H.	10.20	side
75	Monza (exc. Towne Cpe.)	1698087 L.H.	10.20	side
75	Monza (exc. Towne Cpe.)	1661153 1	10.80	upper
75	Monza (Towne Cpe.)	1707248 R.H.	6.40	side (prime and paint as reqd.)
75	Monza (Towne Cpe.)	1707249 L.H.	6.40	side (prime and paint as reqd.)
75	Monza (Towne Cpe.)	1707300 1	10.80	upper (prime and paint as reqd.)

**10.051A SILENCER— ESCUTCHEON— SPACER, Windshield Garnish**

67-68	Pass. (exc. Conv.),			
69	Impala (4-Dr.) (exc. Spt. Sed.)	7696299 A.R.	.12	garnish moulding (use with 2nd design moulding)
73	Chevelle (2-Dr.),			
74-75	El Camino	9652428 R.H.	1.90	ESCUTCHEON, upper corner (Note 1)
73	Chevelle (2-Dr.),			
74-75	El Camino	9652429 L.H.	1.90	ESCUTCHEON, upper corner (Note 1)
70	Nova	7689573 2	.18	SPACER, lower corner reveal moulding

NOTE 1: Paint as required.  
 NOTE 2: Soft headlining trim assembly.  
 NOTE 3: Hard headlining panel assembly.  
 NOTE 4: May require part number 9817906 in Group 14.650.

**10.056 CLIP— SCREW— SPACER— WASHER, Windshield Garnish Moulding**

All	All	9416819 A.R.	.18	side garnish moulding to pillar (No. 8-18 x 1 1/4" oval hd. cr. rec.)— (11.128)
73-75	Chevelle	9603259 5	.11	windshield upper to roof
69-70	Pass.	7729249 2	.11	side
70-72	Camaro			SCREW, pillar garnish moulding,
70-72	Chevelle	4529319 2	.11	side garnish lower
73	Camaro	4529319 2	.11	SCREW, pillar garnish moulding
74	Pass.	9739531 2	.11	SPACER, side lower
74	Pass. (Spt. Sed., Spt. Cpe.)	9739535 L.H.	.16	SPACER, side upper
74	Pass. (Spt. Sed., Spt. Cpe.)	9739534 R.H.	.16	SPACER, side upper
74	Pass. (4-Dr.) (exc. Spt. Sed.)	9739533 L.H.	.34	SPACER, side upper
74	Pass. (4-Dr.) (exc. Spt. Sed.)	9739532 R.H.	.34	SPACER, side upper

**10.092 CHANNEL ASSY., Windshield Glass**

62-67	Chevy (exc. Spt. Cpe., Conv.)	4873834 1	19.50	
-------	-------------------------------	-----------	-------	--

**10.093 MOULDING, Windshield Reveal**

**PASSENGER**

65-68	Pass. (exc. Spt. Mdls.)	4467600 1	4.65	upper
65-68	Spt. Mdls.	4467604 1	4.65	upper
65-67	Pass. (exc. Spt. Mdls.)	7685034 1	3.95	side, right

**WINDSHIELD—DOORS—CONTROLS**

**10.093 MOULDING, Windshield Reveal (Con't)**

65-67	Pass. (exc. Spt. Mdls.)	7685035	1	3.95	side, left
65-67	Pass. (exc. Conv.)	4467229	1	8.15	lower, left
65-67	Pass. (exc. Conv.)	4467228	1	8.15	lower, right
65-67	Spt. Mdls.	7685038	1	3.95	side, right
65-67	Spt. Mdls.	7685039	1	3.95	side, left
68	Pass. (exc. Spt. Mdls.)	7765226	1	4.20	right, w/s side reveal
68	Pass. (exc. Spt. Mdls.)	7765227	1	4.20	left, w/s side reveal
68	Pass.	8738876	1	21.55	lower
68	Spt. Mdls.	7765228	1	4.20	right, w/s side reveal
68	Spt. Mdls.	7765229	1	4.20	left, w/s side reveal
68-70	Conv.	8784489	1	29.75	w/s header
69-70	Sed. (exc. Spt. Sed.),				
69-70	Sta. Wag.	8711812	1	4.50	upper
69-70	Spt. Mdls.	8711813	1	4.50	upper
69-70	Pass.	8712542	1	22.20	lower
69-70	Sed. (exc. Spt. Sed.),				
69-70	Sta. Wag.	8712720	1	4.05	right, side reveal
69-70	Sed. (exc. Spt. Sed.),				
69-70	Sta. Wag.	8712721	1	4.05	left, side reveal
69-70	Spt. Mdls. (exc. Conv.)	8712722	1	4.05	right, w/s side reveal
69-70	Spt. Mdls. (exc. Conv.)	8712723	1	4.05	left, w/s side reveal
69-70	Pass. (Conv.)	8715890	1	29.00	right, w/s side reveal
71-72	Biscayne, Bel Air, Brookwood, Townsmen,				
73-74	Bel Air	9833785	L.H.	4.25	upper corner
71-72	Biscayne, Bel Air, Brookwood, Townsmen,				
73-74	Bel Air	9833784	R.H.	4.25	upper corner
71-73	Pass. (Spt. Cpe., Spt. Sed.),				
74	Pass. (Spt. Sed.)	9833779	L.H.	4.25	upper corner
71-73	Pass. (Spt. Cpe., Spt. Sed.),				
74	Pass. (Spt. Sed.)	9833778	R.H.	4.25	upper corner
69-70	Pass. (Conv.)	8715891	1	29.00	left, w/s side reveal
71-74	Pass. (4-Dr.) (exc. Spt. Sed.)	9833781	L.H.	4.25	upper corner
71-74	Pass. (4-Dr.) (exc. Spt. Sed.)	9833780	R.H.	4.25	upper corner
71-74	Pass. (4-Dr.) (exc. Spt. Sed.)	9739351	1	9.10	upper
71-75	Pass. (Spt. Sed., Spt. Cpe.)	9739353	1	9.10	upper (Note 1)
71-75	Impala (Conv.)	9828331	L.H.	16.70	finish pillar
71-75	Impala (Conv.)	9828330	R.H.	16.70	finish pillar
71-75	Impala (exc. Conv.)	9826851	1	23.35	lower
71-75	Pass. (Conv.)	9875745	1	22.00	lower
71-75	Pass. (exc. Conv.)	9833857	L.H.	4.65	side
71-75	Pass. (exc. Conv.)	9833856	R.H.	4.65	side
71-75	Pass. (Conv.)	9690669	L.H.	7.80	side
71-75	Pass. (Conv.)	9690668	R.H.	7.80	side
71-75	Pass. (Conv.)	9690662	1	7.80	upper
71-75	Pass. (Conv.)	9828271	L.H.	25.00	header
71-75	Pass. (Conv.)	9828270	R.H.	25.00	header
74-75	Pass. (Spt. Cpe.),				
75	Pass. (Spt. Sed.)	9687181	R.H.	4.25	upper corner
74-75	Pass. (Spt. Cpe.),				
75	Pass. (Spt. Sed.)	9687182	L.H.	4.25	upper corner
74-75	Pass. (Spt. Sed.),				
75	Pass. (4-Dr.) (exc. Spt. Sed.)	9738697	1	9.10	upper
75	Bel Air	9738698	R.H.	4.25	upper corner
75	Bel Air	9738699	L.H.	4.25	upper corner
75	Bel Air w/rf. drip mldg./vinyl rf.,				
75	Impala, Caprice (4-Dr.) (exc. Spt. Sed.)	9738807	R.H.	4.25	upper corner
75	Bel Air w/rf. drip mldg./vinyl rf.,				
75	Impala, Caprice (4-Dr.) (exc. Spt. Sed.)	9738808	L.H.	4.25	upper corner

NOTE 1: It might be necessary to cut equal length off of each end of mldg.

**CHEVELLE**

64-65	Chevelle,				
66-67	Spt. Cpe., Conv.	4430502	R.H.	7.10	upper (stainless steel)
64-65	Chevelle,				
66-67	(2nd design) (exc. Spt. Cpe., Conv.)	4430503	L.H.	6.40	upper (stainless steel)
64-65	Chevelle,				
66-67	(exc. Spt. Cpe., Conv.)	4430500	R.H.	5.80	side (stainless steel)
64	Chevelle,				
65	(4-Dr.),				
66-67	(exc. Spt. Cpe., Conv.)	4430501	L.H.	5.80	side (stainless steel)

## WINDSHIELD—DOORS—CONTROLS

### 10.093 MOULDING, Windshield Reveal (Con't)

64-65	Chevelle,				
66-67	Chevelle			5.80	lower (stainless steel)
64-67	El Camino Custom	4430558	1	7.85	pillar finishing
64-67	El Camino Custom	7626294	R.H.	7.85	pillar finishing
66-67	(Spt. Cpe., Conv.)	7626295	L.H.	6.40	upper
66-67	(Spt. Cpe., Conv.)	4541648	R.H.	6.40	upper
66-67	(Spt. Cpe., Conv.)	4541649	L.H.	5.80	side
66-67	(Spt. Cpe., Conv.)	4541650	R.H.	5.80	side
66-67	(Spt. Cpe., Conv.)	4541651	L.H.	6.95	w/s upper
68-72	(2-Dr.) (exc. Conv.)	7726034	1	5.65	w/s side
68-72	(2-Dr.) (exc. Conv.)	7725634	R.H.	5.65	w/s side
68-72	(2-Dr.) (exc. Conv.)	7725635	L.H.	6.95	w/s upper
68-72	(4-Dr.)	7726032	1	5.65	w/s side
68-72	(4-Dr.)	7725632	R.H.	5.65	w/s side
68-72	(4-Dr.)	7725633	L.H.	6.95	w/s upper
68-72	(Conv.)	7726036	1	6.95	w/s upper
68-72	(Conv.)	7728954	R.H.	19.35	w/s side
68-72	(Conv.)	7728955	L.H.	19.35	w/s side
68-70	Malibu, Concours, S.S.,				
68-72	(Deluxe, Nomad, Greenbriar,				
	Custom 9-Pass.) w/Sp. W/S				
	Wiper	7731088	1	23.05	lower
68-72	(Exc. Malibu, Concours, S.S.)	7737629	1	19.35	lower
73-75	Chevelle (4-Dr.)	9739208	1	9.10	upper
73-75	Chevelle (4-Dr.)	9690664	R.H.	7.80	side
73-75	Chevelle (2-Dr.)	9875615	L.H.	7.60	finishing, windshield pillar (Note 1)
73-75	Chevelle (2-Dr.)	9875614	R.H.	7.60	finishing, windshield pillar (Note 1)
73-75	Chevelle (2-Dr.) w/pad vinyl	9685237	L.H.	8.80	finishing, windshield pillar (Note 1)
73-75	Chevelle (2-Dr.) w/pad vinyl	9685236	R.H.	8.80	finishing, windshield pillar (Note 1)
73-75	Chevelle (4-Dr.)	9875609	L.H.	7.60	finishing, windshield pillar (Note 1)
73-75	Chevelle (4-Dr.)	9875608	R.H.	7.60	finishing, windshield pillar (Note 1)
73-75	Chevelle (4-Dr.) w/pad vinyl	9685235	L.H.	8.80	finishing, windshield pillar (Note 1)
73-75	Chevelle (4-Dr.) w/pad vinyl	9685234	R.H.	8.80	finishing, windshield pillar (Note 1)
73-74	Chevelle (4-Dr.)	9690665	L.H.	7.80	MOULDING ASSY., side
73-75	Chevelle (2-Dr.)	9690667	L.H.	7.80	MOULDING ASSY., side
73-75	Chevelle (2-Dr.)	9690666	R.H.	7.80	MOULDING ASSY., side
73-75	Chevelle (2-Dr.)	9739209	1	6.95	MOULDING ASSY., upper
74-75	Chevelle (4-Dr.)	9690664	R.H.	7.80	MOULDING ASSY., side

NOTE 1: Paint as required.

### CHEVY—NOVA

62-67	(Exc. Spt. Cpe., Conv.)	4842066	1	10.80	upper
62-67	Chevy	4842068	1	12.25	lower
62-67	(Exc. Spt. Cpe., Conv.)	4842155	R.H.	6.40	side
62-67	(Exc. Spt. Cpe., Conv.)	4842156	L.H.	6.40	side
62-67	Nova (Spt. Cpe., Conv.)	4842319	1	10.80	upper
62-67	Nova (Spt. Cpe., Conv.)	4842157	R.H.	6.40	side
62-67	Nova (Spt. Cpe., Conv.)	4842158	L.H.	6.40	side
68-74	Nova (4-Dr.)	1651134	L.H.	9.10	upper and side
68-74	(Spt. Cpe.)	1651136	R.H.	9.10	upper and side
68-74	Chevy	8780430	R.H.	11.10	lower
68-74	Chevy	8780431	L.H.	11.10	lower
68-74	Nova (2-Dr.)	1651137	L.H.	9.10	upper and side
68-74	Nova (4-Dr.)	1651133	R.H.	9.10	upper and side
75	Nova (4-Dr.)	9735926	R.H.	9.10	side
75	Nova (4-Dr.)	9735927	L.H.	9.10	side
75	Nova (2-Dr.)	9735930	R.H.	9.10	side
75	Nova (2-Dr.)	9735931	L.H.	9.10	side
75	Nova	9735955	1	9.10	upper
75	Nova	1653307	1	6.95	MOULDING ASSY., lower

### CAMARO

67-69	(Spt. Cpe.)	7638868	1	5.80	upper
67-69	(Spt. Cpe.)	7639926	R.H.	10.15	lower
67-69	(Spt. Cpe.)	7639927	L.H.	10.15	lower
67-69	(Spt. Cpe.)	7639558	R.H.	5.40	side
67-69	(Spt. Cpe.)	7639559	L.H.	5.40	side
67	(Conv.)	7639786	R.H.	17.80	w/s header
67-69	(Conv.)	7638870	1	5.80	upper
67-69	(Conv.)	7648736	R.H.	7.85	lower
67-69	(Conv.)	7648737	L.H.	7.85	lower
67-69	(Conv.)	7648738	R.H.	9.90	pillar finish
67-69	(Conv.)	7648739	L.H.	9.90	pillar finish
67-69	(Conv.)	7639560	R.H.	5.40	right, side
67-69	(Conv.)	7639561	L.H.	5.40	side
68	(Conv.)	8714979	L.H.	20.85	w/s header

**WINDSHIELD—DOORS—CONTROLS**

**10.093 MOULDING, Windshield Reveal (Con't)**

68-69	(Conv.)	8714978	R.H.	20.85	w/s header
70-75	Camaro	9739207	1	6.20	upper
70	Camaro	9841149	L.H.	6.70	side
70-75	Camaro	9868730	R.H.	8.25	side
70	Camaro	9841146	R.H.	.83	finish outer lower corner
70	Camaro	9841147	L.H.	.83	finish outer lower corner
71-75	Camaro	9868728	R.H.	1.00	finish outer lower corner
71-75	Camaro	9868729	L.H.	1.00	finish outer lower corner
72-75	Camaro	9868731	L.H.	8.25	side

**VEGA— MONZA**

71-75	Vega (H.B.)	9816702	L.H.	6.55	upper
71-75	Vega	9826371	1	6.55	lower
71-75	Vega (exc. H.B.)	9826372	R.H.	4.60	side
71-75	Vega (exc. H.B.)	9826373	L.H.	4.60	side
71-75	Vega (exc. H.B.)	9816048	R.H.	6.55	upper
71-75	Vega (exc. H.B.)	9816049	L.H.	6.55	upper
71-75	Vega (H.B.)	9826374	R.H.	4.60	side
71-75	Vega (H.B.)	9826375	L.H.	4.60	side
71-75	Vega (H.B.)	9816701	R.H.	6.55	upper
75	Monza	9737434	1	11.10	upper
75	Monza	9739918	R.H.	11.10	side
75	Monza	9739919	L.H.	11.10	side
75	Monza	1650976	R.H.	12.55	lower
75	Monza	1650977	L.H.	12.55	lower
75	Monza (Towne Cpe.)	1726582	R.H.	5.95	belt rvl. at w/s plr.
75	Monza (Towne Cpe.)	1726583	L.H.	5.95	belt rvl. at w/s plr.

**10.093A RETAINER— RETAINER ASSY.— BUMPER— CLIP— ESCUTCHEON, Windshield Pillar Weatherstrip**

**PASSENGER**

65-66	Impala (Spt. Cpe., Spt. Sed.)		1		windshield pillar upper
65-66	Caprice (Spt. Sed.)	4465109	2	.58	corner w/strip
66	Caprice (Spt. Cpe.)	4541989	2	1.00	windshield pillar upper corner w/strip
67	Spt. Cpe., Spt. Sed.,				
68	Spt. Cpe. (exc. Caprice),				right, windshield pillar
68	Spt. Sed.	7641930	1	1.00	upper corner w/strip
67	Spt. Cpe., Spt. Sed.,				
68	Spt. Cpe. (exc. Caprice),		1		left, windshield pillar
68	Spt. Sed.	7641931	1	1.00	upper corner w/strip
68	Caprice (Spt. Cpe.)	7657094	2	1.45	windshield pillar upper corner w/strip
69-70	Spt. Mdls. (exc. Conv.)	8713144	1	3.95	right, windshield pillar w/strip
69-70	Spt. Mdls. (exc. Conv.)	8713145	1	3.95	left, windshield pillar w/strip
69-70	Conv.	8713862	1	4.35	left, windshield pillar w/strip
69-70	(Spt. Cpe., Spt. Sed.)	9842875	2	3.40	upper corner
71-72	Impala, Caprice (Spt. Cpe., Spt. Sed.)	9827197	L.H.	5.80	left, plr. w/strip
71-72	Impala, Caprice (Spt. Cpe., Spt. Sed.)	9827196	R.H.	5.80	right, plr. w/strip
71-75	Impala (Conv.)	9664211	L.H.	2.85	left, plr. w/strip
71-75	Impala (Conv.)	9664210	R.H.	2.85	right, plr. w/strip
73-75	Pass. (Spt. Cpe., Spt. Sed.)	9664209	L.H.	5.80	plr. w/strip
73-75	Pass. (Spt. Cpe., Spt. Sed.)	9664208	R.H.	5.80	plr. w/strip
71-75	Pass. (Spt. Cpe., Spt. Sed.)	9664215	L.H.	2.95	RETAINER ASSY., left, plr. upper corner w/strip
71-75	Pass. (Spt. Cpe., Spt. Sed.)	9664214	R.H.	2.95	RETAINER ASSY., right, plr. upper corner w/strip

**CHEVELLE**

66-67	(Spt. Mdls.) (exc. Conv.)	4541989	2	1.00	upper corner (Note 1)
68-72	(Spt. Sed.)	7717802	R.H.	3.35	windshield pillar w/strip
68-72	(Spt. Sed.)	7717803	L.H.	3.35	windshield pillar w/strip
68	(Spt. Cpe.)	7717805	L.H.	3.35	windshield pillar w/strip
68	(Spt. Cpe., Spt. Sed.),				
69-72	(Spt. Sed.)	7657094	2	1.45	windshield pillar upper corner w/strip (Note 1)
69-72	(Spt. Cpe.)	8714570	R.H.	4.50	windshield pillar w/strip
69-72	(Spt. Cpe.)	8714571	L.H.	4.50	windshield pillar w/strip
69-72	(Conv.)	8716152	R.H.	3.75	windshield w/strip
69-72	(Conv.)	8716153	L.H.	4.15	windshield w/strip
69-72	(Spt. Cpe., Spt. Sed.)	9842875	2	3.40	pillar upper corner (Note 1)
72	All	9891400	A.R.	.10	CLIP (emergency use)

NOTE 1 Also listed in Camaro Section.



**WINDSHIELD—DOORS—CONTROLS**

**10.093A RETAINER— RETAINER ASSY.— BUMPER— CLIP— ESCUTCHEON,  
Windshield Pillar Weatherstrip (Con't)**

**CHEVY**

72 All ..... 9891400 A.R. .10 CLIP (emergency use) .....

**CAMARO**

67 (Spt. Cpe.) ..... 7641930 R.H. 1.00 windshield pillar upper corner .....  
 67 (Spt. Cpe.) ..... 7641931 L.H. 1.00 windshield pillar upper corner .....  
 68 (Spt. Cpe.) ..... 7657094 2 1.45 windshield pillar upper corner w/strip (Note  
 2) .....

68-69 (Spt. Cpe.) ..... 7719488 R.H. 4.35 windshield pillar w/strip .....  
 68-69 (Spt. Cpe.) ..... 7719489 L.H. 4.35 windshield pillar w/strip (Note 2) .....  
 69 (Spt. Cpe.) ..... 9842875 2 3.40 upper corner (Note 2) .....  
 70-72 Camaro ..... 9816924 1 2.20 upper trim .....  
 73 Camaro ..... 9816924 1 2.20 upper trim .....

*NOTE 2 Also listed in Chevelle Section.*

72 All ..... 9891400 A.R. .10 CLIP (emergency use) .....  
 75 Nova ..... 1653310 R.H. 4.65 ESCUTCHEON, lower corner .....  
 75 Nova ..... 1653311 L.H. 4.65 ESCUTCHEON, lower corner .....

**10.096 CLIP— SCREW— SPACER, Windshield Reveal Moulding**

64-72 Chevelle (exc. Conv.),  
 68-74 Nova,  
 65-75 Pass.,  
 70-71 Camaro ..... 8736590 A.R. .11 (emergency use) (screw on type) .....  
 64 Chevelle ..... 4895602 A.R. .18 upper, lower side (emergency use)—  
 (11.209) .....

65-66 Pass. (exc. Conv.),  
 68 Chevelle ..... 4506041 A.R. .12  
 64-66 Chevelle,  
 65-72 Pass.,  
 67-69 Camaro,  
 67-69 Chevelle (exc. Spt. Cpe., Conv.),  
 68-69 Chevy (Spt. Cpe.),  
 70 All (exc. Impala, Conv.),  
 72 All ..... 9891400 A.R. .10 emergency use .....  
 65-67 Pass. .... 7589682 1 .18 left, lower side .....  
 65-67 Pass. .... 4488989 8 .12 lower center .....

67 Chevelle,  
 67-69 Pass. (exc. Conv.),  
 70 Brookwood  
 67-69 Chevy,  
 67-69 Camaro (Spt. Cpe.) ..... 8736586 A.R. .11  
 67 Camaro, Chevelle w/vinyl top,  
 67-69 Pass. (Spt. Mdls.) w/vinyl top,  
 68-69 Chevelle (Conv.),  
 73-74 Nova ..... 7639528 A.R. .18  
 67-69 Camaro,  
 68-75 Nova ..... 1651460 A.R. .16 lower center .....  
 68-69 Chevelle w/special w/s/w ..... 4880689 2 .18 lower reveal moulding .....  
 69-73 Chevy w/vinyl top ..... 8791826 A.R. .27 upper and side .....

68-71 Chevelle (exc. Conv.),  
 68-74 Chevy,  
 69-74 Pass.,  
 72 Camaro,  
 72-74 Chevelle ..... 9895598 A.R. .05  
 69 Pass. (exc. Conv.) ..... 8736591 A.R. .11 side, upper— (11.209) .....  
 69 Chevy, Camaro,  
 69 Pass. (exc. Conv.) ..... w/s upper, emergency use, .....  
 67-69 Chevelle (exc. Concours, Spt.  
 Cpe., Conv.) ..... upper, lower (w/alum. mldg.), .....

68 Chevy, Camaro w/vinyl top,  
 69 Chevelle (Spt. Cpe., Spt. Sed.)  
 (exc. Deluxe) ..... upper and side, .....

68 Pass. (Impala Spt. Cpe.),  
 68 Caprice (Sed.),  
 72 Chevelle ..... 9606232 4 .16 upper otr. ....  
 70-75 All ..... 8717859 A.R. .15 w/s reveal mldg., upper & upper corner ....  
 71-72 Vega (Sed., Cpe.),  
 74 Pass. (Conv.) ..... upper and side, .....  
 74 Camaro ..... 8736589 A.R. .24 w/s rvl. mldg. (before glass) .....  
 71-75 Pass. (exc. Conv.) ..... 9851875 6 .11 side .....  
 72-75 All ..... 9891400 A.R. .10 (Emergency use) .....  
 73 Pass. (exc. Conv.),

**WINDSHIELD—DOORS—CONTROLS**

**10.096 CLIP— SCREW— SPACER, Windshield Reveal Moulding (Con't)**

<b>74-75</b>	Camaro w/Vinyl Roof,				
<b>73-75</b>	Pass., Chevelle (exc. Sta. Wag.)	<b>9662950</b>	A.R.	.11	reveal moulding w/s side
<b>73-74</b>	All,				
<b>75</b>	Nova, Monza (Hatchback)	<b>1654047</b>	A.R.	.11	upper and side— (11.209)
<b>75</b>	Pass., Chevelle,				
<b>75</b>	All	<b>4471409</b>	A.R.	.11	w/s rvl. moulding (after glass)
<b>74-75</b>	Vega, Monza	<b>9731301</b>	A.R.	.36	upr. mldg. to roof— (11.209)
<b>75</b>	Nova w/Vinyl Roof	<b>1654048</b>	A.R.	.12	upper and side
<b>75</b>	Nova	<b>9735939</b>	L.H.	.18	lower corner
<b>75</b>	Nova	<b>9735938</b>	R.H.	.18	lower corner
<b>71</b>	Nova	<b>9431918</b>	2	.11	<b>SCREW</b> , lower mldg. to pillar
<b>66-67</b>	Chevelle (Spt. Cpe.)	<b>4531604</b>	6	.15	<b>SPACER</b> , back window reveal moulding (anti-squeak)
<b>67-68</b>	Camaro,				
<b>68-69</b>	Chevy	<b>7689573</b>	2	.18	<b>SPACER</b> , lower corner
<b>71-73</b>	Pass. (exc. Conv.)	<b>9833550</b>	4	.12	<b>SPACER</b> , side, anti-rattle

**10.146 BLADE— INSERT ASSY., Windshield Wiper**

<b>62-65</b>	Nova (Spt. Cpe., Conv.)	<b>3941970</b>	2	3.55	(Trico) (12 <sup>7</sup> / <sub>8</sub> " long)
<b>62-66</b>	Chevy (exc. Spt. Cpe., Conv.),				
<b>64-66</b>	Chevelle,				
<b>65</b>	Pass.	<b>3941969</b>	2	4.15	(14 <sup>7</sup> / <sub>8</sub> " long) (Trico)
<b>62-64</b>	Chevy (exc. Spt. Cpe., Conv.),				
<b>65</b>	All (exc. Chevy),				
<b>66-67</b>	Pass.,				
<b>66-68</b>	Chevelle, Camaro,				
<b>65-67</b>	Chevy (exc. Spt. Cpe.),				
<b>69</b>	Camaro	<b>3779741</b>	2	4.15	(Anco) (15 <sup>5</sup> / <sub>32</sub> " long)
<b>66-67</b>	Pass.,				
<b>66-69</b>	Chevy, Chevelle, Camaro (exc. Nova Spt. Cpe.)	<b>3899508</b>	2	4.15	(14 <sup>7</sup> / <sub>8</sub> " long) (Trico) (Note 2)
	<i>NOTE 2 For insert assy. replacement use 3819074.</i>				
<b>66-67</b>	Nova (Spt. Cpe.) (2nd design)	<b>3919082</b>	2	3.55	(Anco) (13 1/6" long) (dull) (Note 1)
	<i>NOTE 1 For Insert Assy. replacement use 3792926.</i>				
<b>68-70</b>	All,				
<b>70-75</b>	Camaro w/Spec. Wipers	<b>9664093</b>	2	4.90	(Trico)
<b>71-75</b>	Pass.	<b>1672838</b>	2	4.90	(Anco)
<b>71-75</b>	Vega	<b>9825369</b>	2	4.35	(Trico)
<b>71-72</b>	All (exc. Pass.),				
<b>73-75</b>	Chevelle, Nova, Camaro	<b>1664394</b>	A.R.	4.35	(Anco)
<b>74-75</b>	Vega	<b>9665929</b>	2	4.35	(Anco)
<b>74-75</b>	Vega (H.B.) w/black w/s wiper,				
<b>75</b>	Monza	<b>9738945</b>	2	6.65	(Trico)
<b>62-63</b>	Chevy (exc. Spt. Cpe., Conv.)	<b>3821753</b>	2	2.75	<b>INSERT ASSY.</b> (Anco) (15 <sup>5</sup> / <sub>32</sub> " long)
<b>62-67</b>	Nova (Spt. Mdls.)	<b>3792926</b>	2	2.40	<b>INSERT ASSY.</b> (Anco) (13 <sup>1</sup> / <sub>16</sub> " long)
<b>62-67</b>	Nova (Spt. Cpe., Conv.)	<b>3819073</b>	2	2.40	<b>INSERT ASSY.</b> (Trico) (12 <sup>7</sup> / <sub>8</sub> " long)— (16.062)
<b>68-75</b>	All	<b>9673996</b>	2	2.85	<b>INSERT ASSY.</b> , blade (Trico) (15 <sup>7</sup> / <sub>8</sub> " long)
<b>67-68</b>	Camaro	<b>3819074</b>	2	2.75	<b>INSERT ASSY.</b> (Trico) (14 <sup>7</sup> / <sub>8</sub> " long)
<b>68-70</b>	Pass., Chevelle,				
<b>62-64</b>	Chevy, Chevelle (exc. Spt. Cpe., Conv.),				
<b>65-67</b>	Chevy, Chevelle (exc. Nova Spt. Cpe.),				
<b>65-67</b>	Pass.,				
<b>68-70</b>	Pass., Chevelle,				
<b>72</b>	Nova, Chevelle,				
<b>73-74</b>	Chevelle	<b>1664395</b>	2	2.85	<b>INSERT ASSY.</b> (Anco) (16 <sup>5</sup> / <sub>16</sub> " long)
<b>70</b>	Camaro w/Sp. w/S/W,				
<b>71-74</b>	Pass.	<b>9664091</b>	2	3.10	<b>INSERT ASSY.</b> (Anco)
<b>72</b>	Camaro w/Spec. w/S/W,				
<b>71-75</b>	Pass., Camaro w/Special Wipes	<b>9664094</b>	2	3.10	<b>INSERT ASSY.</b> (Trico)
<b>75</b>	Pass.	<b>1672839</b>	2	3.10	<b>INSERT ASSY.</b> (Anco)
<b>75</b>	Chevelle, Nova	<b>1664395</b>	A.R.	2.85	<b>INSERT ASSY.</b> (Anco)
<b>74</b>	Vega, Monza	<b>9665930</b>	2	2.85	<b>INSERT ASSY.</b> , blade (Anco)
<b>75</b>	Vega	<b>1664395</b>	2	2.85	<b>INSERT ASSY.</b> , blade (Anco)

**10.147 ROD ASSY.— ARM ASSY.— CLIP— ESCUTCHEON, Windshield Wiper**

<b>62-67</b>	Chevy	<b>3886675</b>	2	4.95	(Trico)
<b>64-66</b>	Chevelle	<b>3887573</b>	2	4.95	
<b>67-68</b>	Camaro (Conv.)	<b>3916688</b>	2	4.95	(Trico)
<b>67-69</b>	Camaro (Spt. Cpe.)	<b>3916690</b>	2	4.95	(Trico)
<b>67</b>	Chevelle	<b>393832</b>	2	4.95	
<b>68-75</b>	Nova (Spt. Cpe.)	<b>3914789</b>	2	7.60	
<b>68-72</b>	Nova (Sed.)	<b>3914793</b>	2	7.60	

**WINDSHIELD—DOORS—CONTROLS**

**10.147 ROD ASSY.— ARM ASSY.— CLIP— ESCUTCHEON, Windshield Wiper  
(Con't)**

68-72	Chevelle (Std., Nomad, Deluxe) (exc. spec. w/s/w)	3913611	1	7.60	left (Trico)
68-72	Chevelle	3913612	1	7.60	right (Trico)
68-72	Chevelle w/special w/s/w	3913613	1	8.70	left (Trico)
68-70	Pass.	3919947	1	10.05	left
68-70	Pass.	3919948	1	7.60	right
65	Pass. w/2-Spd. motor, deluxe equip.	3862389	1	4.20	ARM ASSY., left
66-67	Pass.	3887569	1	4.95	ARM ASSY., left (dull)
65	Pass. w/2-Spd. motor, deluxe equip.,				
66-67	Pass.	3887570	1	4.95	ARM ASSY., right (dull)
70-75	Camaro	9806040	2	7.60	ARM ASSY., wiper non depressed park
70-75	Camaro w/Sp. w/s/w	9806043	L.H.	10.05	ARM ASSY., left wiper depressed park
70-75	Camaro w/Sp. w/s/w	9806042	R.H.	9.75	ARM ASSY., right wiper depressed park
71-75	Pass. (exc. Conv.)	9697793	L.H.	11.45	ARM ASSY., left (Trico)
71-75	Pass. (Conv.)	9697794	L.H.	11.45	ARM ASSY., left (Trico)
71-75	Pass. (exc. Conv.)	9697795	R.H.	7.60	ARM ASSY., right (Anco)
71-75	Vega	9825139	2	4.95	ARM ASSY.
73-75	Chevelle	9736579	R.H.	7.60	ARM ASSY.
73-75	Chevelle	9697798	L.H.	8.70	ARM ASSY.
74-75	Vega (H.B.) w/black w/s wiper	9738944	2	7.85	ARM ASSY.
75	Nova	9738920	2	8.65	ARM ASSY.
75	Monza	1702639	2	7.85	ARM ASSY.
68-69	Chevelle w/Special w/s/w,				
68-69	Pass. (1st design)	3937059	1	.50	CLIP, rod articulating arm lock (use with flat stock)
69-70	Pass. (2nd design)	3963821	1	.43	CLIP, articulating arm lock (use with round stock)
74-75	Vega (Hatchback) w/black w/s wiper,				
75	Monza (exc. Towne Cpe.)	1663650	2	.25	ESCUTCHEON, arm pivot

**10.150 MOTOR— ARMATURE ASSY.— BALL— BOARD ASSY.— BOLT—  
BRACKET— BRUSH ASSY.— BRUSH UNIT— CAP ASSY.— CASE— DISC—  
GROMMET— HOLDER— MAGNET— PLUG— RELAY ASSY.— SCREW—  
SHIELD— SPRING— STRAP— TERMINAL BOARD— VALVE— WASHER—  
WIRE ASSY., Windshield Wiper**

62	Chevy w/Sgl. Spd.	4910214	1	39.75	
63-67	Nova (2-Spd.),				
65-67	Chevelle,				
67	Camaro	4911476	1	46.50	
63-65	All w/Sgl. Spd. (exc. Pass.)	4911945	1	42.70	
64	Chevelle w/2-Spd.	4914164	1	58.50	(exc. pump) (Note 3)
65	Pass. w/Sgl. Spd.	4911528	1	42.70	
65	Chevelle w/2-Spd.,				
65-66	Pass.	4915948	1	51.10	
67	Pass.	4917639	1	51.10	
68-72	Pass.,				
73	Pass., Chevelle (1st design)	4918342	1	51.40	(Note 1)
68-72	Chevelle (Nomad, Greenbrier, El Camino) (exc. Custom),				
68-75	Camaro (exc. Depressed Park),				
68-75	Nova,				
71-75	Vega, Monza	4918442	1	46.50	
69	All w/hlp. washer (exc. Pass.)	4919624	1	46.50	
68-69	Chevelle w/special w/s/w,				
70-72	Camaro w/Depressed Park,				
70-72	Chevelle (Concours, El Camino Custom, Malibu, Monte Carlo)	4939586	1	51.10	(depressed park)
73	Camaro w/Spl. w/w (1st design)	4939586	1	51.10	(depressed park) (round) (Note 1)
73	Pass., Chevelle (2nd design),				
74-75	Pass., Chevelle	4960974	1	51.40	(Note 2)
73	Camaro w/Spl. w/w (2nd design),				
74-75	Camaro w/Spl. w/w	4960951	1	51.10	(Note 2)
75	Pass. w/pulse wiper (1st design)	4960910	1	51.40	(use w/4960912 pump)
75	Pass., Chevelle w/pulse wpr. (2nd design)	4961608	1	49.45	(use with 4961606 pump)
62-67	All w/2-Spd. (exc. Pass.),				
65-66	Pass.,				
68-75	All (exc. Depressed Park)	4910164	1	17.65	ARMATURE ASSY.
62-66	All w/Sgl. Spd.	4909915	1	13.80	ARMATURE ASSY., motor
67	Pass.,				

**WINDSHIELD—DOORS—CONTROLS**

**10.150 MOTOR— ARMATURE ASSY.— BALL— BOARD ASSY.— BOLT—  
BRACKET— BRUSH ASSY.— BRUSH UNIT— CAP ASSY.— CASE— DISC—  
GROMMET— HOLDER— MAGNET— PLUG— RELAY ASSY.— SCREW—  
SHIELD— SPRING— STRAP— TERMINAL BOARD— VALVE— WASHER—  
WIRE ASSY., Windshield Wiper (Con't)**

68-72	All w/Depressed Park (exc. Pass.),				
73-75	Camaro w/Spl. w/w	4960639	1	12.75	ARMATURE ASSY., motor
68-75	Pass., Chevelle	4960317	1	14.95	ARMATURE ASSY., motor
75	Pass., Chevelle, Camaro w/pulse wiper	7002117	1	.05	BALL, armature motor thrust— (3.825)
62-65	All w/Sgl. Spd.	4910350	1	2.49	BOARD ASSY., motor terminal
62-67	All w/2-Spd. (exc. Pass.),				
65-66	Pass.,				
69	Chevy, Camaro,				
69	Chevelle (exc. Nomad, Greenbrier, Deluxe),				
71-75	Vega, Monza	4910515	1	3.51	BOARD ASSY.
65	Pass., Chevelle w/2-Spd.	4914726	1	.73	BOARD ASSY., motor terminal
66-71	Pass.	4916862	1	.75	BOARD ASSY., motor terminal
62-75	All	4907157	2	.11	BOLT, motor through (No. 10-32, 11/64" x 4 <sup>15</sup> /32")
70-75	All	4903428	A.R.	.05	BOLT, motor through (No. 10-32, 11/64" x 37/8")
62-65	All (exc. Pass.),				
65-66	Pass. w/Sgl. Spd. motor	4904212	1	.05	BRACKET, brush holder mounting— (10.738)
64-65	Chevelle,				
65	Pass. w/2-Spd.	4904640	2	.61	BRUSH ASSY., motor
66-67	Pass.,				
68-75	All w/Depressed Park	4915872	2	.61	BRUSH ASSY., motor
66	Chevelle,				
66-69	Pass.,				
62-68	All (exc. Pass.),				
65-66	Pass. w/Sgl. Spd. motor,				
70-75	All (exc. Depressed Park)	4910516	1	1.32	BRUSH UNIT, replacement
62-68	All (exc. Pass.),				
65-66	Pass. w/Sgl. Spd.,				
69-75	All (exc. Depressed Park)	4910424	1	1.61	CAP ASSY., motor end
68-75	Pass.,				
75	Chevelle	4918810	1	16.90	CASE, w/coil, motor field
73-75	Camaro w/Spl. w/w	4916258	1	15.70	CASE, w/coil, motor field
71-75	Vega, Monza	4910291	1	17.60	COIL, motor field
66-67	Pass.,				
66	Chevelle,				
62-64	All w/2-Spd. (exc. Pass.),				
65-67	Chevy w/2-Spd.,				
68-74	All (exc. Depressed Park),				
75	Vega, Monza, Camaro, Nova (exc. Spl. w/w),				
73-75	Pass., Chevelle, Camaro	4903696	1	.05	DISC, motor thrust (rubber)
75	Pass., Chevelle, Camaro	5092145	1	.05	DISC, motor thrust (steel)
66-75	All w/Depressed Park (exc. Vega, Monza)	4916000	1	.11	GROMMET, motor case
73-75	Vega, Monza,				
73-75	Nova, Camaro (exc. Spl. w/w)	4918094	1	.36	GROMMET, w/ground strap motor
62-69	All (exc. Pass.),				
65-66	Pass. w/Sgl. Spd.,				
70-72	All (exc. Depressed Park),				
73-75	Camaro, Nova w/2-Spd. (exc. Recessed Park),				
71-75	Vega, Monza	4960569	1	1.12	HOLDER, motor brush
66-67	Pass.,				
66	Chevelle,				
68-69	Chevelle,				
70-72	All w/Depressed Park (exc. Pass.),				
73-75	Camaro w/Spl. w/w	4916269	1	2.63	HOLDER, brush holder and circuit breaker
68-75	Pass.,				
73-75	Chevelle	4918718	1	2.63	HOLDER, brush and circuit breaker
70-74	Nova	4919822	1	3.67	MAGNET, w/coil and pawl spring
73	Pass., Chevelle (1st design),				
73	Camaro w/Spl. w/w (1st design)	4919641		6.35	MAGNET AND SWITCH ASSY., w/s/w motor (Note 1)
74-75	Pass. w/pulse wiper	4961250	1		MAGNET AND SWITCH ASM., w/s/w motor

**WINDSHIELD—DOORS—CONTROLS**

**10.150 MOTOR— ARMATURE ASSY.— BALL— BOARD ASSY.— BOLT— BRACKET— BRUSH ASSY.— BRUSH UNIT— CAP ASSY.— CASE— DISC— GROMMET— HOLDER— MAGNET— PLUG— RELAY ASSY.— SCREW— SHIELD— SPRING— STRAP— TERMINAL BOARD— VALVE— WASHER— WIRE ASSY., Windshield Wiper (Con't)**

62-69	All,				
70-75	All (exc. Depressed Park)	4909914	1	.05	PLUG, armature shaft thrust
64	Chevelle w/2-Spd.	4904339	1	8.20	RELAY ASSY., motor (Note 3)
65-67	Pass. w/2-Spd.,				
65-66	Chevelle w/2-Spd.	4939546	1	6.35	RELAY ASSY., motor control
70	Pass., Chevelle w/elect. tip w/shield wiper control	3973683	1	22.75	RELAY ASSY., demand w/shield wiper and washer
68-69	Pass., Chevelle,				
70	Camaro,				
70-72	Chevelle (Malibu, El Camino Custom, Monte Carlo),				
70-72	Pass.	4919641	1	6.35	RELAY ASSY., w/s/w motor
64-75	All	4906744	1	.11	SCREW, armature end play adj. (1/4"— 28 x 7/8")
68-75	All	4915593	1	.05	SCREW (No. 10— 32 x 3/8")
70	Chevelle (Nomad, Greenbrier, El Camino) (exc. Custom),				
70	Nova, Camaro	4911218	1	.05	SCREW, set (No. 10— 32 x 5/16")
74	Pass.	3824124	3	.11	SCREW, w/s wiper motor to panel
75	Pass., Chevelle, Camaro	120613	1		SCREW, lock nut adj.
75	Vega (H.B.)	364081	1	17.00	SHIELD, wiper motor heat
62-68	All (exc. Pass.),				
65-67	Pass. w/Sgl. Spd.,				
70-72	Chevelle (Nomad, Greenbrier, El Camino) (exc. Custom),				
70-75	Camaro,				
70-75	Nova,				
71-75	Vega, Monza	4913805	2	.22	SPRING, w/s/w mtr. brush
65-68	All w/2-Spd.,				
69-75	All w/Depressed Park	4900364	2	.05	SPRING, motor brush
69-70	Chevy, Camaro,				
69-70	Chevelle (Nomad, Greenbrier, 300 deluxe)	4919825	1	.11	SPRING, armature pawl
68	All (exc. Pass.),				
69-70	Chevy, Camaro,				
72	Nova,				
75	Camaro, Nova w/2-Spd.,				
75	Vega, Monza (exc. Recessed Park)	4904213	2	.05	SPRING, w/s/w motor brush
69-70	Chevelle (exc. Concours, Malibu),				
71-72	Chevelle (Nomad, Greenbrier, El Camino) (exc. Custom)	4918094	1	.36	STRAP, motor guard
70-72	Chevelle (Nomad, Greenbrier, El Camino) (exc. Custom),				
70	Camaro,				
70-72	Nova,				
73-75	Nova, Camaro (exc. Spl. w/w)	4910510	1		TERMINAL BOARD, motor
73	Pass., Chevelle (1st design),				
73	Camaro w/Spl. w/w	4916862	1	.75	TERMINAL BOARD, motor (Note 1)
73-75	Pass., Chevelle (2nd design),				
73-75	Camaro w/Spl. w/w (2nd design)	4960755	1	7.00	TERMINAL BOARD AND SWITCH ASSY., motor (Note 2)
75	Pass., Chevelle w/pulse wpr.	4961604	1	6.70	TERMINAL BOARD & SWITCH ASSY., motor
70	All	4919991	2	1.56	VALVE, washer check— (2.780)
68-75	All (exc. Pass.)	4910039	1	.05	WASHER (flat) armature end play
68-75	All (exc. Pass.)	4910513	1	.05	WASHER (wave) armature
73-75	Nova, Camaro, Vega, Monza (exc. Spl. w/w)	4910343	1	.05	WASHER, spacer
73-75	Vega, Monza	4909940	1	.05	WASHER, motor spring
75	Vega, Monza	4910199	1	.05	WASHER, armature w/s/w motor
75	Pass., Chevelle, Camaro	5093788	1	.05	WASHER (felt)
66	Chevelle	6290312	1	2.85	WIRE ASSY., wiper motor and washer pump

NOTE 1: Used with separate switch and terminal board.

NOTE 2: Used with integrated switch and terminal board.

NOTE 3: Used only w/depressed w/s wiper motor and pump.

**WINDSHIELD—DOORS—CONTROLS**

**10.151 ARM ASSY.— CAP— COVER— CRANK ASSY.— GEAR— GROMMET—  
NUT— PAWL— RING— SCREW— SHAFT— SHIELD— SPRING—  
WASHER, Windshield Wiper Motor Aux.**

67	Camaro	4917117	1	1.20	crank w/pin
68-70	Pass.	4918809	1	1.20	motor crank
68	Chevelle,				
69	Chevelle (exc. Concours, Malibu)	4918096	1	1.20	motor crank
68-70	Camaro,				
70-75	Nova	4918326	1	1.20	motor crank
68-69	Chevelle w/special w/s/w	4918179	1	1.20	motor crank
70-75	Camaro w/special windshield wiper	4939588	A.R.	1.41	motor crank
70-75	Camaro (exc. special windshield wiper)	4939236	A.R.	1.23	motor crank
70	Chevelle,				
71-72	Chevelle (Concours, El Camino Custom, Malibu, Monte Carlo)	4939135	1	1.20	motor crank
70-72	Chevelle (Nomad, Greenbrier, El Camino) (exc. Custom)	4939137	1	1.20	w/s/w mtr. crank
71-75	Pass.	4939468	A.R.	1.41	w/s/w motor
73-75	Chevelle	4960261	1	1.41	w/s/w motor
62-65	All w/Sgl. Spd.,				
63-67	All w/2-Spd. (exc. Pass.),				
73-75	Nova, Camaro (exc. Spl. w/w),				
71-75	Vega, Monza	4909948	1	.05	CAP, drive shaft protector
64-65	Pass., Chevelle w/Sgl. Spd.,				
69-70	All (exc. Pass., Concours, Malibu),				
71-72	Chevelle (Nomad, Greenbrier, El Camino) (exc. Custom),				
71-72	Nova,				
73-75	Nova, Camaro (exc. Spl. w/w),				
71-75	Vega, Monza	4914394	1	.25	CAP, drive shaft sealing
68-69	Pass., Chevelle	4917478	1	.36	CAP, motor seal
65-67	Pass.,				
70	Pass., Camaro,				
70-72	Chevelle (Concours, El Camino Custom, Malibu, Monte Carlo),				
73-75	Pass., Chevelle,				
73-75	Camaro w/Spl. w/w	4919826	1	.36	CAP, motor seal
68	All (exc. Pass.)	4912095	1	10.20	COVER, gear train, w/plate
68-70	Pass., Chevelle,				
71-72	Chevelle (Concours, El Camino Custom, Malibu, Monte Carlo),				
73	Pass., Chevelle (1st design),				
73	Camaro w/Spl. w/w (1st design)	4918437	1	1.22	COVER, motor gear box
68	All (exc. Pass.),				
69-70	Camaro,				
69-70	Chevelle (exc. Concours, Malibu, hdlp. washer),				
69-72	Nova,				
71-72	Chevelle (Nomad, Greenbrier, El Camino) (exc. Custom),				
73-75	Nova, Camaro (exc. Spl. w/w),				
71-75	Vega, Monza	4918441	1	11.10	COVER UNIT, motor gear
71-75	Vega, Monza	4939394	1	1.41	CRANK ASSY., w/s/w motor
62-65	All w/Sgl. Spd.	4910140	1	.53	GEAR, intermediate w/pinion
62-67	All w/2-Spd. (exc. Pass.),				
65-66	Pass.,				
68	All (exc. Pass.),				
69-70	All (exc. Pass., Concours, Malibu),				
71-72	Chevelle (Nomad, Greenbrier, El Camino) (exc. Custom),				
71-72	Nova,				
71-75	Vega, Monza,				
73-75	Nova, Camaro (exc. Spl. w/w)	4909941	1	.53	GEAR, intermediate w/plate
69-75	Pass.,				
73-75	Chevelle	4919832	1	4.38	GEAR, w/shaft
69-70	Chevelle (2nd design),				
71-72	Chevelle (Concours, El Camino Custom, Malibu, Monte Carlo),				
73-75	Camaro w/Spl. w/w	4919833	1	4.38	GEAR, w/shaft
69	Chevelle	4918176	1	4.38	GEAR, w/shaft (blue) (Note 1)
70-72	Camaro	4910343	A.R.	.05	GEAR, w/shaft end play washer, motor
73-75	Nova, Camaro (exc. Spl. w/w)	4909942	1	2.49	GEAR, w/shaft motor

**WINDSHIELD—DOORS—CONTROLS**

**10.151 ARM ASSY.— CAP— COVER— CRANK ASSY.— GEAR— GROMMET—  
NUT— PAWL— RING— SCREW— SHAFT— SHIELD— SPRING—  
WASHER, Windshield Wiper Motor Aux. (Con't)**

71-75	Vega, Monza	4910180	3	.25	GROMMET, w/s/w motor mtg.
73-75	Camaro w/Spl. w/w,				
73-75	Pass., Chevelle	4960706	1	.05	NUT, motor crank arm
65-66	Chevelle,				
65-68	Pass. w/2-Spd.	4917885	1	.31	PAWL, lock
65-69	Pass. w/2-Spd.,				
65-66	Chevelle,				
68-69	Chevelle,				
70-75	Pass., Camaro.				
70-75	Chevelle (Concours, El Camino Custom, Malibu, Monte Carlo)	4914592	1	.25	PAWL, drive
68-69	Chevelle,				
70-75	Pass., Camaro,				
70-75	Chevelle (Concours, El Camino Custom, Malibu, Monte Carlo)	4918079	1	.31	PAWL, locking
62-70	All (exc. Pass.),				
65-66	Pass. w/Sgl. Spd.,				
71-72	Chevelle (Nomad, Greenbrier, El Camino) (exc. Custom),				
71-75	Nova, Camaro, Vega, Monza	9411494	1	.12	RING, drive shaft retaining
64	Chevelle	4904998	1	.05	RING, drive gear shield retain (to drive shaft)
65-66	Chevelle w/2-Spd.,				
65-70	Pass. w/Sgl. Spd.,				
68-70	Chevelle,				
71-75	Pass.,				
71-75	Chevelle	4960012	1	.05	RING, drive shaft retaining
70-72	Pass., Camaro,				
70-72	Chevelle (Concours, El Camino Custom, Malibu, Monte Carlo)	4915593 A.R.		.05	SCREW (No. 10— 32 x <sup>47</sup> / <sub>64</sub> " )
74	Vega, Monza	4911218	1	.05	SCREW, w/s/w pump motor
62-65	All w/Sgl. Spd.	4910139	1	2.49	SHAFT, drive, w/gear
65-66	Chevelle,				
65-67	Pass. w/2-Spd.	4914589	1	1.61	SHAFT, drive w/plate
68-69	Pass., Chevelle,				
70-75	Pass., Camaro,				
70-75	Chevelle	4960192	1	1.61	SHAFT, drive w/plate
62-68	All (exc. Pass.),				
66	Pass.,				
69-70	All (exc. Pass., El Camino, Concours, Malibu),				
71-72	Chevelle (Nomad, Greenbrier, El Camino) (exc. Custom),				
71-72	Nova, Camaro,				
71-75	Vega, Monza	4909942	1	2.49	SHAFT ASSY., drive w/gear
68-69	Pass.	4918638	1	4.38	SHAFT ASSY., drive w/gear
68-69	Pass., Chevelle	4918265	1	.11	SHIELD (sintered iron)
69-70	Pass., Chevelle,				
71-72	Chevelle (Concours, El Camino Custom, Malibu, Monte Carlo),				
73-75	Pass., Chevelle,				
73-75	Camaro w/Spl. w/w	4919828	1	.11	SHIELD, w/s/w mtr. (flat steel) (2nd design)
65	Chevelle,				
65-67	Pass. w/2-Spd.,				
69-75	Chevelle,				
69-75	Pass.,				
71	Chevelle (Concours, El Camino Custom, Malibu, Monte Carlo)	4914596	1	.11	SPRING, locking pawl to drive pawl
66-75	Pass.,				
68-75	Chevelle,				
70-75	Camaro,				
71-72	Chevelle (Concours, El Camino Custom, Malibu, Monte Carlo)	4904307	2	.05	WASHER, drive gear shield and eccentric shaft spacer (1 <sup>1</sup> / <sub>2</sub> " )
70-75	Nova,				
70-75	Camaro,				
70-72	Chevelle (Nomad, Greenbrier, El Camino) (exc. Custom)	4910199 A.R.		.05	WASHER
70	Camaro,				
70-72	Nova,				
70-72	Chevelle (Nomad, Greenbrier, Sed., El Camino)	4910343	1	.05	WASHER, w/s/w motor gear & shaft end play

**WINDSHIELD—DOORS—CONTROLS**

**10.151 ARM ASSY.— CAP— COVER— CRANK ASSY.— GEAR— GROMMET— NUT— PAWL— RING— SCREW— SHAFT— SHIELD— SPRING— WASHER, Windshield Wiper Motor Aux. (Con't)**

73	Pass., Chevelle	4911262	1	.05	WASHER, end play adjust
73-75	Nova, Camaro (exc. Spl. w/w)	4909940	1	.05	WASHER, inter. gear pinion spacer

*NOTE 1 Used w/depressed w/s wiper motor pump.*

**10.152 GROMMET— BRACKET— GASKET— PLATE ASSY.— RING— SCREW, Windshield Wiper Motor Mounting Parts**

62-68	All (exc. Pass.),				
65-66	Pass. w/Sgl. Spd.,				
65-66	Pass.,				
70-72	Nova,				
70	Camaro,				
70-72	Chevelle (Nomad, Greenbrier, El Camino) (exc. Custom),				
73-75	Nova, Camaro (exc. Spl. w/w)	4910180	A.R.	.25	w/spacer
64-70	Chevelle,				
65-72	Pass. w/2-Spd.,				
71-72	Chevelle (Concours, El Camino Custom, Malibu, Monte Carlo),				
73-75	Pass., Chevelle,				
73-75	Camaro w/Spl. w/w	4911142	A.R.	.41	w/spacer (Note 1)
	<i>NOTE 1 To be used w/5044582 and 4914164 depressed w/w motors on Chevelle.</i>				
65-72	Pass. w/2-Spd.,				
65-66	Chevelle w/2-Spd.,				
68-70	Chevelle,				
71-72	Chevelle (Concours, El Camino Custom, Malibu, Monte Carlo),				
73-75	Pass., Chevelle,				
73-75	Camaro w/Spl. w/w	4914625	2	.36	w/ground strap
70-72	Chevelle (Nomad, Greenbrier, El Camino) (exc. Custom)	3963325	1	1.70	BRACKET, motor
62	All,				
64-65	Chevelle,				
65-70	Pass.,				
68-70	Chevelle w/Sp. windshield wiper,				
71-72	Chevelle (Concours, El Camino Custom, Malibu, Monte Carlo)	542675	1	.17	GASKET
72	Chevelle (Nomad, Greenbrier, El Camino) (exc. Custom)	3980378	1	.23	GASKET, w/s/w mtr.
64-67	Chevelle w/Sgl. Spd.	3840795	1	.29	GASKET
68-69	Chevelle w/Sp. windshield wiper	3918294	1	.61	GASKET, w/w motor bracket
68-69	Chevelle (Std., Nomad, Deluxe) (exc. Sp. windshield wiper),				
68-72	Chevy, Camaro,				
71-75	Vega, Monza,				
73-75	Nova, Camaro (exc. Spl. w/w)	3914792	1	.32	GASKET
70-72	Camaro w/special windshield wiper	3918294	1	.61	GASKET, adapter plate to dash
70-75	Camaro w/special windshield wiper,				
71-75	Pass., Chevelle	9832955	1	.29	GASKET, motor to plate
70-75	Camaro w/special windshield wiper	9823154	1	1.40	PLATE ASSY., motor adapter
All	All	274676	A.R.	.22	RING, wsw operating rod retainer, wsw motor retainer
70-72	All	546575	3	.11	SCREW, w/lock washer, motor bracket (10— 24 x 5/8")
71-75	All	4911218	3	.05	SCREW, 10-32 x 5/16"

**10.153 PUMP ASSY.— BELLOWS— BOARD ASSY.— CAM— CAM AND RING UNIT— CAP— COVER— FILTER NUT— FOLLOWER UNIT— GASKET— LATCH— MAGNET ASSY.— PAWL— PISTON ASSY.— PLUNGER ASSY.— RETAINER— RATCHET— RING— SCREW— SEAL— SPRING— SWITCH— VALVE ASSY.— WHEEL UNIT, Windshield Washer**

62	Chevy	4911521	1	17.95	
63-68	All (exc. Pass.),				
65	Pass. w/Sgl. Spd.,				
69	All (exc. Pass., Concours, Malibu),				
70-72	All (exc. Depressed Park),				
73-74	Nova, Camaro (exc. Spl. w/w)	4919332	1	17.95	
64	Chevelle	4914510	1	19.50	(Note 2)
65	Chevelle w/2-Spd.,				



**WINDSHIELD—DOORS—CONTROLS**

**10.153 PUMP ASSY.— BELLOWS— BOARD ASSY.— CAM— CAM AND RING UNIT— CAP— COVER— FILTER NUT— FOLLOWER UNIT— GASKET— LATCH— MAGNET ASSY.— PAWL— PISTON ASSY.— PLUNGER ASSY.— RETAINER— RATCHET— RING— SCREW— SEAL— SPRING— SWITCH— VALVE ASSY.— WHEEL UNIT, Windshield Washer (Con't)**

65-66	Pass. w/2-Spd. ....	4914680	1	17.95	
67	Pass. ....	4917714	1	17.95	
68-69	Pass., Chevelle,				
70-72	All w/Depressed Park,				
73	Pass., Chevelle (1st design),				
73	Camaro w/Spl. w/w (1st design)	4918180	1	17.95	washer .....
73-74	Camaro w/Spl. w/w (2nd design) .....	4960771	1	17.95	washer (Note 3) .....
73-75	Pass., Chevelle (exc. pulse wiper)	4960771	1	17.95	washer .....
75	Pass. w/pulse wiper (1st design)	4960912	1	17.95	(use w/4960910 motor) .....
75	Pass., Chevelle w/pulse wpr. (2nd design) .....	4961606	1	19.55	(use with 4961608 motor) .....
75	Nova, Camaro, Vega, Monza ...	4961623	1	11.70	w/washer .....
71-73	Vega, Monza .....	5045630	1	6.35	w/s/w .....
74	Vega, Monza .....	4961251	1	15.05	
62-68	All (exc. Pass.),				
65-66	Pass. w/2-Spd. ....	4914074	1	.80	BELLOWS, pump valve .....
64-66	Chevelle,				
65-67	Pass. ....	4913726	1	.80	BELLOWS UNIT, pump valve .....
71-73	Vega, Monza .....	4939511	1	1.58	BELLOWS UNIT, w/s/w pump .....
62-69	All .....	4916802	1	3.54	BOARD ASSY., pump terminal .....
64-66	Chevelle,				
65-67	Pass. ....	4913725	1	2.63	BOARD ASSY., pump terminal .....
68-75	All w/Depressed Park .....	4918444	1	2.63	BOARD UNIT, pump terminal .....
63-67	All w/Sgl. Spd. (exc. Pass.),				
65-66	Pass. w/Sgl. Spd.,				
67	Chevelle, Chevy w/2-Spd.,				
68	All (exc. Pass.) .....	4918233	1	.34	CAM, pump (4 lobe) .....
65-67	Pass. w/2-Spd.,				
65-66	Chevelle w/2-Spd. ....	4914683	1	.41	CAM, pump .....
68-69	Pass., Chevelle,				
70-73	All w/Depressed Park .....	4918071	1	.41	CAM, pump .....
69-74	All (exc. Depressed Park) .....	4918982	1	.41	CAM, pump drive .....
73-74	Camaro (w/Spl. w/w),				
73-75	Pass., Chevelle .....	4960408	1	.53	CAM AND RING UNIT .....
75	Pass., Chevelle w/pulse wiper ..	4960918	1	.53	CAM & RING PKG. ....
75	Vega, Monza .....	4961310	1	.19	CAP, reservoir w/s pump .....
62-68	Chevy, Chevelle,				
65-66	Pass.,				
68	Camaro .....	4910949	1	.80	COVER, upper pump .....
68-69	Pass., Chevelle,				
70-72	All w/Depressed Park,				
73	Pass., Chevelle (1st design),				
73	Camaro w/Spl. w/w (1st design)	4918070	1	.30	COVER, pump (Note 2) .....
69-74	All (exc. Depressed Park) .....	4918976	1	.53	COVER, w/s/w pump (3-terminal)— (16.065) .....
70	Camaro,				
73-74	Nova, Camaro (exc. Spl. w/w) ..	4919052 A.R.		.58	COVER, w/s/w pump (4-terminal) .....
73-75	Camaro w/Spl. w/w (2nd design) .....	4960775	1	.30	COVER, w/s/w pump (Note 3) .....
75	Pass., Chevelle w/pulse wiper (2nd design) .....	4961228	1	.31	COVER, pump .....
75	Nova, Camaro, Vega, Monza ...	4961309	1	.29	FILTER NUT, pump .....
68-69	Pass., Chevelle,				
70-72	All,				
75	Pass., Chevelle, Vega, Monza ...	4918320	1	.11	GASKET, pump .....
75	Nova, Camaro, Vega, Monza ...	4961308	1	.10	GASKET, pump .....
74	Vega, Monza .....	4961260	1	.11	LATCH, spring w/s washer pump .....
74	Vega, Monza .....	4961259	1	.11	LATCH, w/s washer pump .....
69	Chevelle (exc. special w/s/w) ...	4919822	1	3.67	MAGNET ASSY., w/pawl, spring, coil .....
70-74	All (exc. Depressed Park) .....	4919845	1	3.38	MAGNET ASSY., w/s/w pump .....
69-74	All (exc. Depressed Park) .....	4919841	1	.10	PAWL, pump armature .....
64-66	Chevelle,				
65-67	Pass. w/2-Spd. ....	4914935	1	.22	PAWL UNIT, pump ratchet .....
68-69	Pass., Chevelle,				
70-75	All w/Depressed Park .....	4918446	1	.20	PAWL UNIT, pump .....
68-69	Pass., Chevelle,				
70-75	All w/Depressed Park (exc. Vega) .....	4918445	1	4.38	PISTON, pump .....
69-74	All (exc. Depressed Park Vega) ..	4918790	1	4.38	PISTON, pump .....
74	Vega .....	4961363	1	4.38	PISTON, w/s/w pump .....

**WINDSHIELD—DOORS—CONTROLS**

**10.153 PUMP ASSY.— BELLOWS— BOARD ASSY.— CAM— CAM AND RING UNIT— CAP— COVER— FILTER NUT— FOLLOWER UNIT— GASKET— LATCH— MAGNET ASSY.— PAWL— PISTON ASSY.— PLUNGER ASSY.— RETAINER— RATCHET— RING— SCREW— SEAL— SPRING— SWITCH— VALVE ASSY.— WHEEL UNIT, Windshield Washer (Con't)**

69-72	All (exc. Depressed Park),				
73	Nova, Camaro (exc. Spl. w/w),				
74	Nova	4918971	1	.17	PLUNGER ASSY., pump
64-75	All	9416094	1	.11	RETAINER, ring pawl— (8.934)
73-74	Pass., Chevelle, Camaro	9416094	1	.11	RETAINER, ring pawl (8.934)
75	Pass.	4961600	1	4.59	RELAY
65-66	Chevelle,				
65-67	Pass. w/2-Spd.	4913247	1	.20	RATCHET, pump
68-69	Pass., Chevelle,				
70-72	All w/Depressed Park,				
73-75	Pass., Chevelle,				
73-74	Camaro w/Spl. w/w	4939314	1	.25	RATCHET AND SPRING PACKAGE, w/s washer
69-74	All (exc. Depressed Park)	4918963	1	.11	RATCHET SPRING, pump
75	Pass., Chevelle w/pulse wiper	4919946	1	.11	RATCHET SPRING, pump
75	Pass., Chevelle w/pulse wiper	4919971	1	.20	RATCHET WHEEL, pump
69-74	All (exc. Depressed Park),				
73-75	Nova, Camaro	4961519	1	.24	RATCHET, plunger package
All	All	274692	1	.16	RING, pump retaining (type T ext.)— (8.934) (Note 1)
<i>NOTE 1 Used on pumps with a snap ring groove in end of cam shaft.</i>					
64-66	Chevelle,				
65-69	Pass. w/2-Spd.,				
68-69	Chevelle,				
70-72	All w/Depressed Park	4913242	1	.05	RING, ratchet and cam retaining
64-74	All	4914358	1	.05	SCREW, pump dog spring
75	Pass., Chevelle w/pulse wiper	4960908	1	.05	SCREW, switch mtg.
75	Pass., Chevelle, Camaro	4961450	1	.05	SCREW, dog spring
69-70	Chevy, Camaro,				
69-70	Chevelle (exc. Concours, Malibu),				
71-72	Chevelle (Nomad, Greenbrier, El Camino) (exc. Custom),				
71-72	Nova,				
73-74	Nova, Camaro (exc. Spl. w/w)	4918983	1	.11	SEAL, pump dust
70-74	All (exc. Depressed Park)	4910917	1	.12	SEAL, washer pump terminal
75	Pass., Chevelle w/pulse wiper	4961227	1	.11	SHIELD, washer pump dust
62-68	All (exc. Pass.)	4910124	1	.05	SPRING, pump ratchet pawl
64-66	Chevelle,				
65-67	Pass. w/2-Spd.	4913248	1	.05	SPRING, pump dog
62-68	All (exc. Pass.),				
65	Pass.	4913551	1	.05	SPRING, pump dog
68-74	All w/Depressed Park	4918069	1	.05	SPRING, pump dog
69-74	All (exc. Depressed Park)	4918974	1	.11	SPRING, pump plunger
69-74	All (exc. Depressed Park)	4918975	1	.05	SPRING, pump pawl dog
70-72	Pass.	4939314	1	.25	SPRING, pump ratchet
70-74	All (exc. Depressed Park)	4919825	1	.11	SPRING, pump armature pawl
75	Chevelle (std. wiper)	4911450	1		SPRING, pump pawl dog
75	Pass., Chevelle, Camaro	4961449	1	.07	SPRING, pump pawl dog
75	Pass., Chevelle w/pulse wiper (2nd design)	4961602	1	4.60	SWITCH
62-69	All (exc. Pass.),				
65-67	Pass. w/2-Spd.,				
70-74	All (exc. Depressed Park)	4914357	1	3.67	VALVE ASSY., pump
67	Camaro,				
68-75	All w/Depressed Park	4914356	1	3.36	VALVE ASSY., pump
68	All (exc. Pass.)	4918794	1	.25	WHEEL UNIT, pump ratchet

*NOTE 1: Used on pumps with a snap ring groove in end of cam shaft.*

*NOTE 2: Use with separate magnet, switch and terminal board.*

*NOTE 3: Use with intergrated switch and terminal board.*

**10.154 JAR— BRACKET— CAP— FILTER— RESERVOIR— SEAL— SUPPORT, Windshield Wiper Parts**

62-69	All,				
70	Nova	3840083	1	1.93	
70	Pass., Chevelle, Camaro,				
71-72	Nova, Chevelle,				
71-72	Vega,				
73-74	Nova	3990892	1	2.40	
71-74	Camaro	3996244	1	1.70	
71-72	Pass.	1236158	1	1.90	

**WINDSHIELD—DOORS—CONTROLS**

**10.154 JAR— BRACKET— CAP— FILTER— RESERVOIR— SEAL— SUPPORT,  
Windshield Wiper Parts (Con't)**

73-74	Pass., Chevelle	1238291	1	1.90	
73-74	Vega	331964	1	1.90	
75	Pass., Chevelle	231493	1	1.80	
75	Camaro, Nova	4961312	1	3.54	
71-72	Pass.	1236159	1	1.10	BRACKET, washer jar
71-72	Camaro	3990891	1	1.25	BRACKET, washer jar
64-69	All (exc. Chevy),				
70-72	Nova	548935	1	1.05	BRACKET ASSY., washer jar
65-66	Pass. w/2-Spd.	3833218	1	1.80	BRACKET ASSY., washer jar
69	Pass. (exc. retrac. hdlp. cover)	3951208	1	1.05	BRACKET ASSY., washer jar
73-75	Pass.	1238289	1	1.35	BRACKET, washer jar
73-75	Chevelle	1238290	1	1.10	BRACKET, washer jar mounting
75	Camaro	362527	1	1.45	BRACKET, washer jar mounting
62-69	All w/2-Spd. (exc. Pass.),				
65-68	Pass.,				
70-74	All,				
71-75	Vega, Monza,				
75	Pass., Chevelle	3798372	1	.42	CAP, washer jar
72	All,				
71-73	Vega	1231266	1	.18	CAP, jar
75	Camaro, Nova	4961310	1	.19	CAP, jar
62-67	All,				
70	Nova, Chevelle, Camaro,				
71-74	All	3986821	1	.31	FILTER, washer jar
75	Camaro, Nova	4961309	1	.29	FILTER ASSY., pump (part of pkg. 4961623)
75	Vega, Monza	4961353	1	3.54	RESERVOIR, pump
75	Camaro, Nova	4961308	1	.10	SEAL, pump (part of pkg. 4961623)

**10.154A HOUSING— LEVEL INDICATOR— CONDUCTOR, Fluid Level**

70-72	All	8900644	1	1.55	lever indicator
70-72	All	8900646	1	4.60	LEVEL INDICATOR, s/sending unit, fluid level
70-72	All	8901484	1	5.20	CONDUCTOR, jar lever (fiber optic)

**10.155 TEE— CONNECTOR— HOSE, Windshield Wiper Pipe**

*NOTE For hose and tubing see group 10.154 and 8.964.*

62-67	All	336013	1	1.05	W/S/W check valve (3/8"— 18 pipe thd. 1 1/4" hose take-off— (7.447)
70-75	All	3760758	1	.49	w/shield washer spray connector
70-72	Chevelle (Concours, El Camino Custom, Malibu, Monte Carlo)	4919539	1	.11	CONNECTOR
All	All	3987364	1	RL/.14	HOSE, jar to pump (7/32" I.D.)— (8.962)
71-73	Vega	336494	1	2.30	(repl. 6262687) (Note 1)

*NOTE 1: Includes 3 hoses, fitting at pump assy. and grommet.*

**10.156 NOZZLE ASSY.— CLIP, Windshield Wiper Parts**

62-67	Chevy w/2-Spd.	3791388	2	1.10	washer spray
64-67	Chevelle	3880753	2	.53	washer spray
65-66	Pass.	3859226	2	.53	washer spray
67	Pass.	3897316	2	.63	washer spray
67-69	Camaro	3886973	2	.53	washer spray
68	Pass.	3928776	2	.63	washer spray
68-75	Chevy, Nova	346194	1	.73	washer spray
68	Chevelle	3928766	2	.63	
69	Pass.	3961537	2	.76	washer spray (1/2" offset)
69	Chevelle	3776301	1	2.75	washer spray
70-75	Camaro	3976377	A.R.	.64	spray
70	Pass.	3961559	2	.70	spray
70	Chevelle (396, 454)		2		
70	Chevelle (exc. 396, 454),				
71-72	Chevelle (S.S.)	3983955	R.H.	.63	spray
70	Chevelle (exc. 396, 454),				
71-72	Chevelle (S.S.)	3976328	L.H.	.63	spray
71-72	Chevelle (exc. S.S.)	3986818	2	.70	spray
71-75	Pass.	1236160	2	.76	spray
73-75	Chevelle	1238324	2	.84	spray
71-75	Vega, Monza	3980189	2	.61	spray
68-73	Chevelle	9793032	1	.87	CLIP, washer pump to spray nozzle hose— (2.765)

**10.159 DRIVE SHAFT ASSY.— CLIP— HOUSING— LINK— NUT— PLUG— TRANS. ASSY., Windshield Wiper**

73-75	Nova	4918672	L.H.	7.60	left, w/housing
-------	------	---------	------	------	-----------------

**WINDSHIELD—DOORS—CONTROLS**

**10.159 DRIVE SHAFT ASSY.— CLIP— HOUSING— LINK— NUT— PLUG— TRANS. ASSY., Windshield Wiper (Con't)**

73-75	Nova	4918670	R.H.	8.20	right, w/housing
68-69	Pass. (1st design),				
68	Chevelle w/special w/s/w	3937059	1	.50	CLIP, rod articulating arm lock (use with flat stock)— (10.147)
69-70	Pass. (2nd design)	3963821	1	.43	CLIP, articulating arm lock (use with round stock)— (10.147)
65-67	Pass.	4915369	L.H.	8.80	HOUSING ASSY., left w/link
65-67	Pass.	4915370	R.H.	8.75	HOUSING ASSY., right w/link
68-70	Pass.	4918610	R.H.	9.20	HOUSING ASSY., right, w/link
68-70	Pass.	4918612	L.H.	9.60	HOUSING ASSY., left, w/link
62-67	Chevy	4916746	R.H.	6.40	HOUSING ASSY., drive, w/shaft
62-67	Chevy	4916756	L.H.	5.50	HOUSING ASSY., drive, w/shaft
68-72	Chevy	4918670	R.H.	8.20	HOUSING ASSY., drive, w/shaft
68-72	Chevy	4918672	L.H.	7.60	HOUSING ASSY., drive, w/shaft
67-69	Camaro	4917574	R.H.	9.55	HOUSING, w/link
67	Camaro	4917576	L.H.	8.35	HOUSING, w/link
68-69	Camaro	4918754	L.H.	8.35	HOUSING, w/link
68-72	Chevelle w/Depressed Park	4918624	L.H.	8.15	HOUSING ASSY., left, w/connector link
68-72	Chevelle (exc. Depressed Park)	4918620	L.H.	7.65	HOUSING ASSY., left, w/connector link
68-72	Chevelle	4918758	R.H.	8.35	HOUSING ASSY., right, w/motor drive link
70-75	Camaro w/Depressed Park	4939188	L.H.	8.30	HOUSING, w/link, trans.
70-75	Camaro w/Depressed Park	4939184	R.H.	8.85	HOUSING, w/link, trans.
70-75	Camaro (exc. Depressed Park)	4939196	L.H.	8.85	HOUSING, w/link, trans.
70-75	Camaro (exc. Depressed Park)	4939192	R.H.	10.10	HOUSING, w/link, trans.
71-75	Pass. (exc. C.A.C.)	4939676	L.H.	9.00	HOUSING, w/link
71-75	Pass.	4939674	R.H.	8.85	HOUSING, w/link
72-75	Pass. w/C.A.C.	4960490	L.H.	9.00	HOUSING, w/link, wiper trans.
71-75	Vega	4960374	R.H.	8.05	HOUSING, w/link
71-75	Vega	4960376	L.H.	7.35	HOUSING, w/link
73-75	Chevelle	4960850	R.H.	7.65	HOUSING, w/link
73-75	Chevelle	4960852	L.H.	8.35	HOUSING, w/link
75	Monza (N.B.)	362523	1	2.05	HOUSING, wiper & washer lettering lamp
62-67	Chevy	4910136	1	4.14	LINK, operating rod (long)
62-67	Chevy	4910138	1	4.14	LINK, operating rod (short)
64-67	Chevelle	4913655	L.H.	7.65	LINK, trans. connecting
64-67	Chevelle	4913654	R.H.	8.35	LINK, trans. to mtr. drive (26 <sup>1</sup> / <sub>4</sub> " O.L.)
64-66	Chevelle	4914095	R.H.	8.40	LINK, trans. to motor drive (27 <sup>3</sup> / <sub>4</sub> " O.L.)
					(Note 1)
71-75	Vega, Monza	9881122	2	.61	NUT, w/s/w trans. to panel ( <sup>9</sup> / <sub>16</sub> "— 16)
65-70	Pass.	3860105	1	.11	PLUG, link access hole (2 <sup>11</sup> / <sub>16</sub> " x 1 <sup>3</sup> / <sub>4</sub> ")
75	H	9433072	2	.26	RING, wiper trans. nut retainer
75	Monza	4961612	R.H.	8.55	TRANS. ASSY., w/s/w
75	Monza	4961614	L.H.	7.75	TRANS. ASSY., w/s/w

NOTE 1: Used w/depressed W/S wiper motor and pump.

**10.160 RETAINER— SOCKET UNIT— WASHER, Windshield Wiper Transmission**

62-67	Chevy	4905636	1	.05	link (to motor) ( <sup>5</sup> / <sub>16</sub> " dia. stud)
64-67	Chevelle	4912427	1	.11	link (to motor) (used w/ <sup>3</sup> / <sub>8</sub> " dia. stud)
65-70	All	4918562	1	.53	SOCKET UNIT, w/s/w linkage
64-72	Chevelle	4906868	1	.05	WASHER, operating link spring
71-75	Vega	9879525	2	.50	WASHER, w/s/w housing

**10.163 SWITCH ASSY.— BEZEL— CONDUCTOR— GASKET— KNOB ASSY.— NUT— RELAY ASSY., Windshield Wiper**

62-64	Chevy w/Sgl. Spd. (exc. washer)	1993441	1	3.27	
62-64	Chevy (Sgl. Spd. w/washer)	1993541	1	3.61	
62	Chevy w/2-Spd.	1993527	1	4.13	
63-64	Chevy (2-Spd. w/washer)	1993584	1	4.24	
64	Chevelle (Sgl. Spd. w/washer)	1993633	1	4.14	
64	Chevelle w/Sgl. Spd.	1993634	1	2.56	
64	Chevelle (2-Spd. w/washer) (1st design)	1993632	1	5.10	
64	Chevelle w/2-Spd. (2nd design)	1993665	1	4.93	
65	All w/2-Spd. (exc. C.C. Equip.)	1993677	1	2.61	
65	Chevelle w/2-Spd.,				
65-66	Pass. (C.C. Equip.) w/2-Spd.	1993678	1	4.44	
65	All (Sgl. Spd. w/washer)	1993680	1	4.18	
65-66	Chevy (C.C. Equip.) w/2-Spd.,				
66	Chevelle	1993679	1	4.99	
67	Pass.	1993394	1	3.51	
67-68	All (exc. Pass.)	1993395	1	3.74	
68	Chevelle w/special w/s/w,				
68	Pass.	1993442	1	3.47	
68	Chevelle (exc. special w/s/w)	1993443	1	3.56	

**WINDSHIELD—DOORS—CONTROLS**

**10.163 SWITCH ASSY.— BEZEL— CONDUCTOR— GASKET— KNOB ASSY.— NUT— RELAY ASSY., Windshield Wiper (Con't)**

69-70	Pass. ....	1993463	1	5.95	
69-71	Chevy,				
69-71	Chevelle (Greenbrier, Nomad, Deluxe) (exc. Sp. w/s/w),				
69	Camaro .....	1993464	1	4.66	
69-71	Chevelle w/Sp. w/s/w .....	1993465	1	4.66	
70-71	Camaro w/special windshield wiper .....	1994097	1	4.73	
70-71	Camaro (exc. special windshield wiper) .....	1994098	1	4.73	
71-72	Pass. ....	1994112	1	5.20	
71-73	Vega, Monza .....	1994104	1	6.55	
72-74	Nova,				
72	Chevelle (Nomad, Greenbrier, El Camino) (exc. Custom) .....	1994150	1	4.56	
72	Chevelle (Concours, El Camino Custom, Malibu, Monte Carlo) .	1994131	1	4.85	
72	Camaro w/Special Windshield Wiper,				
73-74	Camaro w/Special Windshield Wiper .....	1994147	1	8.15	
72-74	Camaro (exc. Special Windshield Wiper) .....	1994148	1	8.30	
73-75	Pass. (exc. pulse wpr.) .....	1994142	1	5.25	
73-75	Chevelle (exc. pulse wpr.) .....	1994123	1	4.90	
74-75	Vega, Monza .....	1994182	1	6.55	
75	Chevelle w/Special Windshield Wiper .....	346157	1	12.30	
75	Pass. w/pulse wpr. ....	344823	1	13.80	
75	Chevelle w/pulse wiper .....	4961602	1	4.60	pump .....
75	Camaro w/Special Windshield Wiper .....	1994177	1	9.65	
75	Camaro (exc. Special Windshield Wiper) .....	1994176	1	9.55	
75	Nova .....	1994180	1	6.15	
75	Nova .....	356114	1	16.85	pulse .....
75	Nova w/pulse wiper .....	370145	1	2.15	BEZEL, pulse wiper switch knob .....
73-74	Pass. ....	332060	1	.19	CONDUCTOR, w/s/w switch light— (9.748)
75	Pass. ....	346737	1	.16	CONDUCTOR, w/s/w switch light— (9.748)
62-67	Chevy .....	6256578	2	.06	GASKET, housing shaft operating lever ....
75	Nova .....	356138	1	1.00	KNOB ASSY., pulse w/s/w switch .....
62-67	Chevy,				
65-67	Pass. ....	3820531	1	.36	NUT, control switch .....
67-68	Camaro .....	3904859	1	.34	NUT, control switch .....
68-70	Chevy .....	3916709	1	.16	NUT, control switch .....
70	Pass., Chevelle w/Electro-Tip w/w control .....	3973683	1	22.75	RELAY ASSY., demand w/s/w & w/a .....

**10.164 KNOB— SPACER— WASHER, Windshield Wiper Control**

62-64	Nova w/Sgl. Spd. (exc. washer),				
64	Chevy Deluxe w/Sgl. Spd. (exc. washer) .....	3780348	1	.64	
62-64	Chevy (2-Spd. w/washer) .....	1990992	1	1.45	wiper and washer (bright chrome) .....
65-66	All w/Sgl. Spd. (exc. Pass.),				
65	Pass. w/Sgl. Spd. ....	3859221	1	.71	wiper .....
65-66	All (2-Spd. w/washer) .....	3859222	1	.64	wiper and washer .....
67	All,				
68	Camaro .....	3906147	1	.64	
68	Pass. ....	3943621	1	.58	
68	Chevy .....	3916708	1	.63	
68	Chevelle .....	3943622	1	.71	wiper and washer .....
68	Pass. ....	3919018	1	.16	SPACER, switch .....
68	Pass. ....	3937645	1	.11	WASHER, switch knob .....

**10.166 BEZEL— HOUSING, Windshield Wiper Control**

67-68	Camaro .....	3923941	1	.98	BEZEL ASSY. ....
68	Chevelle .....	3927331	1	1.05	BEZEL ASSY., switch .....
68	Pass. ....	3923983	1	1.05	BEZEL ASSY., switch .....
74-75	Nova .....	328258	1	1.10	HOUSING .....

**10.185 MIRROR ASSEMBLY, Rear View**

62-67	Nova,				
64-67	Chevelle,				
65-66	Impala, Nomad, Caprice,				

**WINDSHIELD—DOORS—CONTROLS**

**10.185 MIRROR ASSEMBLY, Rear View (Con't)**

65-67	Impala, Caprice . . . . .	911957	1	8.05	inside (chrome) . . . . .
63-72	Nova,				
64-68	Chevelle,				
67	Camaro,				
68	Pass. (exc. Spt. Cpe.),				
73-74	Nova (Taxi) . . . . .	3909197	2	10.30	outside (round) . . . . .
64-66	All (exc. Pass.),				
66	Chevy (Std.),				
66	Pass. w/C.C. equip. (exc. Caprice),				
66	Caprice (Sta. Wag.),				
67	All (exc. Pass.) . . . . .	3961371	1	20.20	outside (remote) (Note 1) . . . . .
	<i>NOTE 1 It will be necessary to add 1966 controls when installing on 1965 vehicles.</i>				
65	Chevy, Chevelle . . . . .	3912201	1	10.30	outside . . . . .
67	Pass. . . . .	3901861	1	10.30	left, outside . . . . .
67-68	Chevy, Camaro,				
67	Pass. . . . .	3901862	1	10.30	outside R.H. . . . .
68	Pass. (Spt. Cpe.),				
68-69	Camaro,				
69	Chevelle,				
69	Pass.,				
70	Pass.,				
70-72	Chevelle (Sta. Wag.), El Camino .	3914753	L.H.	10.30	outside rear view (rectangular) . . . . .
70	Pass.,				
71-72	Chevelle (Sta. Wag., El Camino) .	3914754	R.H.	10.30	outside rear view (rectangular) . . . . .
69-70	Pass.,				
69-72	Chevelle (w/o map lamp) . . . . .	911581	1	13.00	inside . . . . .
69-72	Pass., Chevelle w/map lamp . . .	911712	1	14.70	inside rear view map . . . . .
70	Pass.,				
70-71	Nova,				
70	Nomad,				
70-72	Chevelle (exc. Sta. Wag., El Camino) . . . . .	3965921	2	10.30	right or left, outside . . . . .
70	Camaro (1st design) . . . . .	911261	1	9.65	inside (does not include 2 piece arm) . . . . .
70-75	Camaro,				
73-75	Nova . . . . .	911582	1	10.60	inside (10 inch) . . . . .
70-75	Camaro . . . . .	9814436	1	10.30	outside . . . . .
70-75	Camaro,				
74-75	Vega, Monza w/Custom Mirror . . . . .	9626972	R.H.	12.40	right, outside (Custom) (bullet type) . . . . .
71-75	Pass.,				
73-75	Chevelle . . . . .	911620	1	11.45	inside (12 inch) (tilt) . . . . .
71-72	Pass.,				
73-75	Nova . . . . .	9826594	1	10.30	outside rear view right or left side . . . . .
71-72	Pass. . . . .	9829432	1	31.50	left, outside (remote) . . . . .
71-72	Chevelle . . . . .	9878201	L.H.	27.00	outside (custom) (bullet type) (remote) . . . . .
70-75	Camaro,				
74-75	Vega w/Custom Mirror . . . . .	9865801	L.H.	27.00	outside (remote) (custom) (bullet type) . . . . .
71-75	Nova . . . . .	9882068	L.H.	27.00	outside (remote) (custom) (bullet type) . . . . .
71-74	Vega, Monza . . . . .	9816637	1	10.30	frt. door o/s (Note 1) . . . . .
	<i>NOTE 1: Used as left or right hand.</i>				
71-75	Vega, Monza,				
75	Nova w/8 in. tilt . . . . .	911619	1	11.75	inside . . . . .
72	Nova . . . . .	9885008	L.H.	31.50	outside rear view (remote) . . . . .
73-75	Pass. . . . .	9614195	L.H.	31.50	left, outside (remote) (chrome) . . . . .
73-75	Chevelle . . . . .	9873991	L.H.	28.75	outside (remote) . . . . .
73-74	Pass. (Sta. Wag.) . . . . .				right, . . . . .
73-75	Pass., Chevelle . . . . .	9614194	A.R.	10.30	left (manual) . . . . .
73-75	Chevelle . . . . .	9657788	L.H.	27.00	outside (remote) (custom bullet type) (paint as reqd.) . . . . .
73-75	Chevelle . . . . .	9657789	R.H.	12.40	outside (custom bullet type) (paint as reqd.) . . . . .
73-75	Nova . . . . .	9614426	L.H.	29.75	outside rear view (remote) (chrome) . . . . .
73-75	Nova . . . . .	9626974	R.H.	12.40	(custom bullet type) (paint as reqd.) . . . . .
74-75	Pass. . . . .	9698816	R.H.	31.50	outside rear view (remote) . . . . .
74	Impala (Spt. Cpe.) (exc. Custom),				
75	Pass. . . . .	9658561	L.H.	27.00	outside remote control (custom) (bullet type) (painted) . . . . .
75	Chevelle, Pass. (Custom) . . . . .	1672793	R.H.	27.00	outside (remote control) (painted) . . . . .
75	Chevelle . . . . .	1672841	R.H.	31.50	outside (remote control) (chrome) . . . . .
75	Nova w/sport type . . . . .	1701306	R.H.	27.00	outside (remote control) (paint) . . . . .
75	Vega . . . . .	994814	L.H.	10.00	frt. door o/s (manual) . . . . .
75	Monza . . . . .	1657629	R.H.	11.75	o/s (manual) . . . . .
75	Monza . . . . .	1654676	L.H.	15.40	o/s (manual) (chrome) . . . . .
75	Monza . . . . .	1654677	R.H.	15.40	o/s (manual) (chrome) . . . . .
75	Monza w/Custom Mirror (Sport) . . . . .	1696225	L.H.	27.00	remote control . . . . .
75	Monza (Sport) . . . . .	1720174	R.H.	13.60	(paint to match) . . . . .

**WINDSHIELD—DOORS—CONTROLS**

**10.185 MIRROR ASSEMBLY, Rear View (Con't)**

65-66	Pass. ....	3898937	1	10.30	MIRROR UNIT, outside .....
62-67	Chevy (exc. Nova),				
64	Chevelle Std.,				
65	Pass. (exc. Impala, Nomad, Sed.),				
65	Chevelle,				
66	Pass. (exc. Impala, Caprice, C.C. equip.),				
66	Chevelle (Std. Deluxe),				
67	Camaro (Std.),				
67-68	Pass., Chevelle,				
69	Chevy, Camaro,				
70-72	Nova (1st design) .....	3633013	1	9.65	MIRROR UNIT, inside (non-glare) .....
70-72	Nova (2nd design) .....	3997559	1	9.20	MIRROR UNIT, inside .....
68	All (exc. Caprice) (Spt. Cpe.) ....	352701	1	31.50	MIRROR UNIT, outside (remote) (Note 3) ..
	<i>NOTE 3 Order 1-3921834 escutcheon with 3921816 mirror unit.</i>				
68	Caprice (Spt. Cpe.) .....	3929971	1	28.25	MIRROR UNIT, outside (remote) (Note 4) ..
	<i>NOTE 4 Order 1-3921833 escutcheon with 3929971 mirror unit.</i>				
69-70	Pass. ....	3949226	1	29.25	MIRROR UNIT, outside (remote) .....
69	Chevelle,				
70-72	Chevelle (Sta. Wag.) El Camino .	3957200	1	29.25	MIRROR UNIT, outside (remote) .....
69	Camaro .....	3957203	1	29.25	MIRROR UNIT, outside (remote) .....
69-71	Chevy .....	3957206	1	29.25	MIRROR UNIT, outside (remote) .....
70-75	Camaro .....	994039	1	7.50	MIRROR UNIT, right outside .....
70-72	Chevelle (exc. El Camino, Sta. Wag.) .....	3975399	1	29.25	MIRROR UNIT, outside (remote) .....
All	All .....	994543	1	29.05	MIRROR UNIT, trailing, fender mtd. ....
73-75	Chevelle .....	981920	L.H.	21.75	MIRROR UNIT (remote) (complete) .....
73-75	Nova .....	983410	L.H.	21.75	MIRROR UNIT (remote) (complete) .....
73-75	Pass., Chevelle .....	980026	1	9.50	MIRROR UNIT, outside (manual) (Note 2) (chrome) .....
73-75	Pass., Chevelle, Nova .....	994442	R.H.	7.50	MIRROR UNIT, outside (manual) (Note 1) (chrome) .....

*NOTE 1: Does not match L.H. remote control mirror.*

*NOTE 2: Matches L.H. remote control mirror.*

**10.186 BRACKET—BUSHING—CLIP—ESCUTCHEON—FASTENER—GASKET—GLASS—KNOB—NUT—PAD—PLATE—REINFORCEMENT—RETAINER—RING—RIVET—SCREW, Rear View Mirror**

64-67	Chevy, Chevelle .....	5955717	1	.98	outside remote mounting .....
66	Caprice w/C.C. equip. (exc. Sta. Wag.) .....	9784859	1	1.30	outside remote mirror mounting .....
66-68	All (exc. Pass.),				
67	Pass. ....	3913615	1	.16	left, outside mounting .....
67	All (exc. Pass.) .....	3899859	1	1.40	outside remote .....
67	Pass. ....	3913616	1	.27	right outside mounting .....
68-69	All .....	3949200	1	1.10	outside remote mirror .....
68	Pass.,				
69	All,				
70	Pass. (2nd Design) .....				use w/unit 993595 .....
70-71	Nova,				
70-71	Chevelle (Sta. Wag., El Camino) .	3953067	1	.22	outside mirror mtg. ....
70	Pass. (1st Design)				
70-72	Chevelle (exc. Sta. Wag., El Camino),				
70-72	Nova .....	3965931	1	.41	outside .....
62-65	All (exc. Sed.) .....	565801	1	.05	BUSHING, rear view mirror stud (Note 5) ..
	<i>NOTE 5 Used with 899769, 910453 mirror assy.</i>				
71-75	Pass. ....	9876485	L.H.	.36	CLIP, left, outside mirror cable .....
73-75	Pass. ....	4614452	A.R.	.16	CLIP, outside mirror remote control right or left .....
74-75	Pass. ....	4844379	R.H.	.16	CLIP, outside mirror remote control .....
68	Caprice (Spt. Cpe.),				
68	Camaro .....	3921833	1	2.40	ESCUTCHEON, outside remote mirror control .....
68-69	Camaro w/deluxe interior .....	3945998	1	2.25	ESCUTCHEON, outside rear view mirror remote .....
68	Pass. (exc. Caprice, Spt. Cpe.),				
68	Chevy, Chevelle .....	3921834	1	1.65	ESCUTCHEON, outside remote control .....
69	Pass.,				
69	Camaro (exc. deluxe interior),				
69	Chevelle (Spt. Cpe., Conv.),				
70-71	Pass., Nova,				
70-72	Chevelle (exc. El Camino, Sta. Wag.) .....	3958372	1	1.20	ESCUTCHEON, outside control (remote) ...
70-72	Chevelle (Sta. Wag.) El Camino .	3945996	1	1.05	ESCUTCHEON, outside (remote) .....

**WINDSHIELD—DOORS—CONTROLS**

**10.186 BRACKET— BUSHING— CLIP— ESCUTCHEON— FASTENER— GASKET—  
GLASS— KNOB— NUT— PAD— PLATE— REINFORCEMENT—  
RETAINER— RING— RIVET— SCREW, Rear View Mirror (Con't)**

71	Chevelle w/Custom Mirror,					
70-75	Camaro w/Custom Mirror,					
73-75	Nova w/Custom Mirror . . . . .	1387797	L.H.	2.80	ESCUTCHEON, outside rear view mirror left (remote control) . . . . .	
71-75	Pass. . . . .	9874500	1	3.15	ESCUTCHEON, left, outside (remote) . . . . .	
73-75	Chevelle (exc. Monte Carlo w/Custom Mirror) . . . . .	9874429	1	1.20	ESCUTCHEON, outside rear view remote mirror control . . . . .	
74-75	Vega, Monza w/Custom Mirror . . . . .	9730229	L.H.	6.05	ESCUTCHEON, o/s remote control mirror left . . . . .	
74	Pass. . . . .	332102	1	1.45	ESCUTCHEON, right, outside (remote) . . . . .	
75	Chevelle . . . . .	346713	1	3.00	ESCUTCHEON, r/cont. mirror lvr. (paint as reqd.) . . . . .	
75	Pass. . . . .	346735	R.H.	1.35	ESCUTCHEON, r/cont. mirror lvr. (paint as reqd.) . . . . .	
75	Nova w/Sport Mirror . . . . .	1707201	2	3.35	ESCUTCHEON, outside rear view (remote) (painted) . . . . .	
75	Pass., Chevelle w/Right hand remote mirror (exc. elect. wdo./Dr. & St. . . . .	8732474	2	.12	FASTENER, outside remote control mirror right hand . . . . .	
66-69	All (exc. Pass., C.C. equip.),					
68-69	Pass.,					
71-74	Nova (Taxi) . . . . .	3874250	1	.12	GASKET, outside rear view (manual) . . . . .	
67	All (exc. Pass.) . . . . .	3899860	1	.52	GASKET, outside mirror . . . . .	
67	Pass. . . . .	3903174	1	.12	GASKET, outside (base) . . . . .	
68-69	Camaro,					
70	Chevelle (Sta. Wag., El Camino),					
70	Nova . . . . .	3927398	1	.17	GASKET, outside mirror . . . . .	
68	Pass. (exc. Caprice Spt. Cpe.),					
68-69	All (exc. Pass.),					
69	Pass.,					
70	Nova,					
70	Chevelle (Sta. Wag., El Camino),					
73-75	Nova . . . . .	3921835	1	.23	GASKET, outside (remote) . . . . .	
69	All,					
70	Pass. (2nd Design) . . . . .	3953066	1	.23	GASKET, outside mirror . . . . .	
69-71	Pass. . . . .	3950338	1	.23	GASKET, outside (remote) . . . . .	
70-71	Chevelle (exc. Sta. Wag., El Camino) Nova					
70-72	Pass. (1st Design),					
73-75	Pass., Monte Carlo . . . . .	9874035	1	.23	GASKET, outside (R.H. or L.H.) . . . . .	
70-71	Chevelle (exc. El Camino, Sta. Wag.),					
70	Monte Carlo w/remote control,					
72	Chevelle (exc. El Camino, Sta. Wag.) . . . . .	3975403	1	.52	GASKET, outside rear view . . . . .	
71-72	Monte Carlo w/Custom Mirror . . . . .	9872030	1	.97	GASKET, front door outside rear view mirror . . . . .	
70-72	Camaro w/dealer installed mirror,					
75	Camaro . . . . .	9816862	R.H.	.22	GASKET, o/s rear view mtg. . . . .	
70-75	Camaro w/Custom mirror,					
75	Vega, Monza w/Custom mirror . . . . .	9832126	2	.23	GASKET, o/s rear view (R.H. or L.H.) . . . . .	
70-75	Camaro . . . . .	9816863	L.H.	.22	GASKET, remote control . . . . .	
71-73	Pass. . . . .	9829666	1	.23	GASKET, outside (right or left) . . . . .	
71-75	Nova w/Custom Mirror . . . . .	9877665	L.H.	.17	GASKET, outside rear view, left . . . . .	
71-72	Chevelle (Spt. Cpe., Conv.) . . . . .	9872029	1	.97	GASKET, outside, remote control . . . . .	
71-75	Vega, Monza . . . . .	9814443	R.H.	.19	GASKET, frt. door o/s . . . . .	
71-75	Vega . . . . .	9814444	L.H.	.15	GASKET, frt. door o/s . . . . .	
73-75	Chevelle (exc. Monte Carlo),					
75	Chevelle w/Pass. remote control (exc. Monte Carlo) . . . . .	9874030	A.R.	.23	GASKET, outside mirror (L.H. manual) (R.H. remote) . . . . .	
73-75	Chevelle (exc. Monte Carlo) . . . . .	9874835	A.R.	.23	GASKET, outside custom mirror (R.H. or L.H.) . . . . .	
73-74	Monte Carlo . . . . .	9874837	A.R.	.23	GASKET, outside custom mirror . . . . .	
73-75	Nova (exc. Taxi) . . . . .	9829667	L.H.	.17	GASKET, outside mirror base . . . . .	
75	Pass., Monte Carlo w/Custom Mirror . . . . .	1726325	A.R.	.16	GASKET, outside rear view (R.H. or L.H.) (repl. 9732975) . . . . .	
75	Nova w/Custom Mirror . . . . .	1701311	2	.23	GASKET, o/s rear view mir. . . . .	
74-75	Vega, Monza w/Custom Mirror . . . . .	9832127	L.H.	.25	GASKET, o/s remote control (R.H. or L.H.) . . . . .	



**WINDSHIELD—DOORS—CONTROLS**

**10.186 BRACKET—BUSHING—CLIP—ESCUTCHEON—FASTENER—GASKET—GLASS—KNOB—NUT—PAD—PLATE—REINFORCEMENT—RETAINER—RING—RIVET—SCREW, Rear View Mirror (Con't)**

75	Monza (exc. Towne Cpe.)	1654679	R.H.	.18	GASKET, frt. door o/s (manual)
75	Monza	1654678	L.H.	.14	GASKET, frt. door o/s (manual)
75	Monza w/Sport Mirror	1657573	2	.22	GASKET, frt. door o/s (manual)
71-72	Chevelle (Spt. Cpe., Conv.),				
73-75	Chevelle w/Sport Mirror,				
74-75	Pass.,				
74	Impala (Spt. Cpe.) (exc. Custom)	9606230	1	3.75	GLASS, outside rear view remote cont. mirror
71-72	Camaro,				
73-75	Camaro, Nova w/Custom Mirror,				
74-75	Vega w/Custom Mirror	9606231	1	3.85	GLASS, outside rear view remote control mirror
71-72	Pass.,				
71-75	Chevelle (exc. Sta. Wag., El Camino, Sport Window)	9864800	1	3.95	GLASS, front door outside, rear view remote control
74-75	Pass.,				
73-75	Chevelle	9683157	R.H.	4.00	GLASS ASSY., outside manual control
73-75	Nova, Camaro, Vega w/Custom Mirror	9683156	R.H.	4.00	GLASS ASSY., outside
75	Nova w/L.H. remote mirror (exc. Custom)	1708924	1	4.00	GLASS ASSY., outside rear view mirror
75	Monza w/Sport Mirror	1708925	R.H.	4.35	GLASS ASSY., outside rear view mirror
70-75	Camaro	9866562	1	1.30	KNOB, mirror
75	Nova w/Custom Mirror				KNOB, right, remote control,
73-75	Pass.	9837099	1	1.35	left, remote control
75	Pass., Chevelle	1657049	R.H.	1.35	KNOB, frt. door o/s rear view remote cont.
75	Nova	1702048	L.H.	1.20	KNOB, frt. door o/s rear view remote cont.
75	Chevelle	1711086	L.H.	1.20	KNOB, remote control
64-66	All (exc. Pass.),				
65-66	Pass. w/C.C. equip. (exc. Caprice),				
66	Caprice (Sta. Wag.) w/C.C. equip.	3849842	2	.11	NUT ("J" shape) outside remote
64-66	All (exc. Pass.),				
65-66	Pass. w/C.C. equip. (exc. Caprice),				
66	Caprice (Sta. Wag.) w/C.C. equip.	5955685	1	1.20	PLATE, outside (remote) mirror pivot
74-75	Pass.	332101	1	.22	PLATE, right, outside (remote) lvr. mt.
75	Chevelle	346708	1	.16	PLATE, r/cont. mirror lvr. mt.
73	Pass. (Sta. Wag.)	9614257	R.H.	1.30	REINFORCEMENT, front door outer panel at mirror
74-75	Pass. (4-Dr.) w/remote control mirror (exc. Spt. Sed.),				
75	Monte Carlo w/remote control mirror	9699089	R.H.	1.20	REINFORCEMENT, front door outer panel at mirror
74-75	Pass. (Spt. Sed., 2-Dr.) w/remote control mirror	9699086	R.H.	1.30	REINFORCEMENT, front door outer panel at mirror
74-75	Vega	1697429	R.H.	1.65	REINFORCEMENT, f/d otr. pnl. at mirror
75	Nova w/Custom Mirror	9879082	R.H.	1.20	REINFORCEMENT, front door outer panel at mirror
75	Monza (exc. Towne Cpe.) w/Custom Mirror	9739097	R.H.	3.55	REINFORCEMENT, f/d otr. pnl. at mirror remote control
75	Monza (Towne Cpe.)	1696939	R.H.	3.55	REINFORCEMENT, f/d otr. pnl. at mirror
66-67	All w/C.C. equip. (2nd design) (exc. Pass.),				
66-67	Caprice w/C.C. equip. (exc. Sta. Wag.)	4526624	1	.19	RETAINER, outside remote mirror control
68	All (exc. Caprice, Camaro),				
68	Caprice (4-Dr.)	3927447	1	.18	RETAINER, outside remote mirror
68	Camaro (exc. deluxe interior),				
68-69	Caprice,				
70	Caprice,				
70-72	Camaro	3927448	1	.31	RETAINER, outside remote control mirror
68	Camaro w/deluxe interior,				
69	Camaro (exc. deluxe interior)	3927449	1	.28	RETAINER, outside rear view mirror (remote)
69	Camaro (exc. deluxe interior),				
69	Chevelle (Spt. Cpe., Conv.),				

**WINDSHIELD—DOORS—CONTROLS**

**10.186 BRACKET— BUSHING— CLIP— ESCUTCHEON— FASTENER— GASKET—  
GLASS— KNOB— NUT— PAD— PLATE— REINFORCEMENT—  
RETAINER— RING— RIVET— SCREW, Rear View Mirror (Con't)**

69	Pass. (exc. Caprice),					
70-71	Pass.,					
70-71	Chevelle (Spt. Cpe., Conv.)	3958373	1	.16	RETAINER, outside remote control mirror	
69-71	Chevy,					
69-72	Chevelle (exc. Spt. Cpe., Conv.)	3948502	1	.16	RETAINER, outside remote	
70-75	Camaro, Vega, Monza w/Custom Mirror	9814442	L.H.	1.10	RETAINER, outside rear view mirror (left)	
70-75	Camaro, Vega, Monza w/Custom mirror	9831859	R.H.	1.35	RETAINER, outside rear view mirror (manual)	
70-75	Camaro w/custom mirror,					
73-75	Nova, Vega, Monza w/custom mirror	9805683	L.H.	.22	RETAINER, outside rear view remote control escutcheon (left)	
71-75	Nova	9885007	1	.31	RETAINER, mirror o/s rear view/manual	
70-75	Camaro (exc. custom mirror),					
71-75	Vega, Monza	9814441	L.H.	.57	RETAINER, outside rear view mirror (left) (Note 1)	
71-72	Chevelle w/Custom Mirror	9872031	1	.61	RETAINER, outside remote cont.	
71-72	Pass.,					
73-75	Nova	9826886	A.R.	.55	RETAINER, manual	
73-75	Chevelle	9890823	1	.16	RETAINER, outside remote control mirror	
73-75	Camaro, Nova w/Custom Mirror,					
74-75	Pass.	3927448	L.H.	.31	RETAINER, outside rear view remote cont. escutcheon (left)	
74-75	Vega, Monza w/Custom Mirror	9730234	L.H.	.12	RETAINER, o/s mirror escut. rem. cont. (on door inner)	
75	Monza w/Custom Mirror	1674339	1	.53	RETAINER, o/s (manual) retainer to pillar,	
70-71	Camaro w/custom mirror		2			
71-75	All	9420772	2	.16	RIVET, frt. dr. rr. view mirror outside R.H.— (8.967)	
62-64	Chevy (exc. Conv.)	9419989	1	.05	SCREW, support (oval head cr. recess) (10— 32 x 5/8")— (8.977)	
62-70	All,					
71-72	Chevelle, Nova	565842	1	.05	SCREW (oval hd. cr. recess) (No. 10— 32 x 9/16")	
63-64	Chevy,					
67	Pass.	3903176	1	.13	SCREW, outside (oval hd. cr. recess) (No. 8— 32 x 13/16")	
64-67	Chevy,					
65-67	Impala (Conv.),					
66-67	Chevelle (exc. Std. Deluxe Conv.)	9414754	2	.11	SCREW (No. 8— 18 x 3/4") chrome, support— (8.977)	
65	Pass.	9414768	A.R.	.11	SCREW, support (No. 10— 16 x 1 1/2")— (8.977)	
65-67	Pass., Chevy	9416819	A.R.	.18	SCREW, support (No. 8— 18 x 1 1/2")— (8.977)	
66	Caprice w/C.C. equipment (exc. Sta. Wag.)	9784907	1	.75	SCREW, outside remote mirror (No. 10— 24 x 1 3/16")	
68-69	All	9426939	1	.22	SCREW, escut. to control (remote)	
69-71	All (exc. Camaro),					
72	Chevelle, Nova	9796652	1	.11	SCREW, remote mirror outside (8— 32 x 9/16")	
72-75	All	9428077	1	.16	SCREW (10— 24 x 13/16")	
70	Camaro	9417639	2	.07	SCREW, mirror retainer— (8.977)	

**10.187 SUPPORT— ARM— CAP ASSY.— GROMMET— LENS— SCREW, Inside Rear View Mirror**

62-65	Chevy (exc. Conv., Spt. Cpe.),					
66	Chevy	4867668	1	6.55		
64	Chevy (exc. Conv.),					
66	Malibu, Chevelle S.S. (exc. Conv.)	4440430	1	7.65		
68	Pass. (Spt. Cpe.)	8752693	1	9.60		
70-75	All	9831062	1	1.25	inside rr. view (short flat type)	
67	Pass. (Conv.)	7729447	1	9.10	SUPPORT ASSY., L/cap	
67	Impala, Caprice (Spt. Cpe.)	9711722	1	8.90	SUPPORT ASSY., L/cap	
67	Bel Air (2-Dr.),					
67	Pass. (4-Dr.)	9711718	1	8.90	SUPPORT ASSY., L/cap	
67	Biscayne	9711716	1	8.90	SUPPORT ASSY., L/cap	
67	Camaro (Spt. Cpe.)	7729476	1	9.10	SUPPORT ASSY., L/cap	
67	Camaro (Conv.)	9711724	1	9.10	SUPPORT ASSY., L/cap	

**WINDSHIELD—DOORS—CONTROLS**

**10.187 SUPPORT— ARM— CAP ASSY.— GROMMET— LENS— SCREW, Inside Rear View Mirror (Con't)**

67	Chevelle (Std., Deluxe)	7729442	1	9.10	SUPPORT ASSY., L/cap
67	Chevelle (Conv.)	7729448	1	9.10	SUPPORT ASSY., L/cap
67	Chevelle (exc. Conv., Std., Deluxe)	7729443	1	9.10	SUPPORT ASSY., L/cap
67	Chevy	9711901	1	6.65	SUPPORT ASSY., L/cap
68	Pass. (Spt. Sed.)	8752693	1	9.60	SUPPORT ASSY., L/cap
68-70	Pass. (Conv.)	7740298	1	9.60	SUPPORT ASSY., L/cap
68-70	Chevy (Sed.),				
68-70	Chevelle (2-Dr.) (exc. El Camino, Conv.),				
68-69	Chevelle (Sed.),				
68-69	Camaro (Spt. Cpe.),				
71-72	Nova (4-Dr.),				
71-72	Malibu, Monte Carlo	8752692	1	9.20	SUPPORT ASSY., L/cap
68-72	Chevelle (Conv.)	7740301	1	9.80	SUPPORT ASSY., L/cap
68	Pass. (4-Dr.) (exc. Spt. Sed.),				
68	Biscayne, Bel Air,				
68-70	Chevy, (Spt. Cpe.),				
68-70	El Camino, Sta. Wag.,				
71	Nova (2-Dr.),				
71-72	Chevelle (Spt. Cpe., Sed.)	8711847	1	9.60	SUPPORT ASSY., L/cap
69-70	Pass. (Spt. Cpe.)	8754751	1	9.20	SUPPORT ASSY.
69-70	Pass. (Sta. Wag.)	8719551	1	9.20	SUPPORT ASSY.
69-70	Pass. (exc. Sta. Wag., Spt. Cpe., Conv.)	8754752	1	9.20	SUPPORT ASSY.
69	Bel Air (4-Dr.), 2-Dr. Sed.,				
69-70	Impala, Caprice w/map lamp (exc. Spt. Cpe., Conv.)	8767381	1	11.70	SUPPORT ASSY.
69-70	Chevelle (exc. Conv., Sta. Wag., El Camino) w/lamp map				
71-72	Malibu, Monte Carlo w/map lamp	8767382	1	11.05	SUPPORT ASSY.
70	Camaro (1st des.)	9825121	1	4.75	SUPPORT ASSY. (long support w/ball) (Note 1)
NOTE 1 If the rear view mirror support is not attached to a replacement windshield glass, installation may be performed with the use of Loctite Minute-Bond Adhesive 312, Catalog No. 0144, as available from all Loctite distributors, or an equivalent.					
70	Camaro (1st des.)	9816722 L.H.	✓ 1	4.80	ARM, left (long support w/arms) (Note 2)
70	Camaro (1st des.)	9816721 R.H.	✓ 1	4.80	ARM, right (long support w/arms) (Note 2)
NOTE 2 The arm is an integral part of the mirror on 2nd design installations.					
67	Pass. (exc. Biscayne, Conv.)	9712047	1	1.80	CAP ASSY. (black)
67	Camaro (Spt. Cpe.)	7729515	1	2.35	CAP ASSY. (black)
67	Camaro (Conv.)	9711985	1	1.80	CAP ASSY. (gray)
67	Chevelle (Conv.)	7729512	1	2.90	CAP ASSY. (gray)
68-70	Impala (Conv.)	7768389	1	3.55	CAP ASSY. (black)
68-69	Camaro (Spt. Cpe.),				
68-71	Malibu, Concours, S.S. (exc. Conv.)	7764898	1	2.30	CAP ASSY. (black)
68-72	Chevy, Nova,				
68-70	Chevelle (exc. Malibu, S.S. Concours),				
71	Nomad, Greenbrier,				
71-72	Nova,				
71-72	Chevelle (exc. Conv.)	7767284	1	2.30	CAP ASSY. (black)
69-70	Bel Air, Townsman,				
69-70	Impala, Caprice, Kingswood (exc. Conv.)	8751988	1	2.20	CAP ASSY. (black)
69-70	Pass.,				
69-71	Chevelle	5965502	1	.27	GROMMET, inside map lamp
69-70	Pass.,				
69-71	Chevelle	5961836	1	1.35	LENS, inside map lamp
70	Camaro	9809937	2	.27	SCREW, support arm (long support w/arms)
67	Biscayne, Chevy				SCREW ASSY., front,
67	Chevelle (Std., Deluxe),				
67	Pass. (Conv.)	4720885 A.R.		.21	rear (8— 18 x 3/4")
67	Camaro (Conv.)	9418792	2	.16	SCREW ASSY. (8— 18 x 1/2")
<b>10.195 MIRROR UNIT— NUT, Vanity Visor</b>					
69-75	All	994521	1		(3 <sup>3</sup> / <sub>8</sub> " x 8")
71-75	All	480890	1	2.60	(3 <sup>3</sup> / <sub>8</sub> " x 7")
75	Pass., Camaro, Nova	981825	1	2.50	MIRROR PKG.
67	All (exc. Pass.)	125847	2	.27	NUT (8— 32 x 1/2")— (8.924)
69-73	All	9785408	2	.11	NUT (3/8" x 1/2" O.D. .003 I.D.)

**WINDSHIELD—DOORS—CONTROLS**

**10.203 SUNSHADE ASSEMBLY**

**1967 PASSENGER**

		<b>BLUE (Comb. 832-845, 848)</b>	<b>BLACK (Comb. 810-821)</b>
Biscayne . . . . .	L or R	7662425	
Caprice . . . . .	L or R		7636113
Impala (Conv.) . . . . .	L or R		7706362
Impala (exc. Conv.) . . . . .	L or R		7665430

**1968 PASSENGER**

		<b>BLACK (Comb. 802-814)</b>	<b>DK. BLUE (Comb. 815-824)</b>	<b>MED GOLD (Comb. 830-841)</b>	<b>PARCH MENT (Comb. 858-859)</b>
Impala (Spt. Cpe.) . . . . .	L or R	7636113	—	7733399*	—
Impala (Sed.) . . . . .	L or R	7637874†	—	7736936	—
Impala (Conv.) . . . . .	L or R	7706362†	—	—	7706362†
Impala (Sta. Wag.) . . . . .	L or R	7637874†	—	—	—
Caprice (Sta. Wag.) . . . . .	L or R	7637874†	—	—	—
Caprice (exc. Sta. Wag.) . . . . .	L or R	7636113	—	7733399	—

† Priced at 7.10  
\* NOTE: Spec. Hd. Lng.

**1969 PASSENGER**

	<b>BLACK (Comb. 802-809 812, 813 858, 859)</b>	<b>MED. BLUE (Comb. 815, 816 818, 819, 822)</b>	<b>DARK BLUE (Comb. 820, 821 824, 826)</b>	<b>MED. GREEN (Comb. 849, 850 852, 853 856, 862)</b>	<b>MID. GREEN (Comb. 858, 855 857, 860 861)</b>	<b>MED. SADDLE (Comb. 838, 831)</b>	<b>MED. TURQ. (Comb. 844, 846)</b>	<b>MED. GOLD (Comb. 837, 840)</b>
Biscayne . . . . .	8774777	8774778						
Bel Air . . . . .	8774782	8774783		8774784				
Impala (4-Dr. Sed.) . . . . .	8774787		8774788				8774791	
Impala (exc. 4-Dr. Sed.) . . . . .	8774852 8774862*							8774855
Caprice . . . . .	8774862							
Conv. . . . .	8765332							
Kingswood, Est. Wag. . . . .	8774793		8774792		8774794	8765349		

\* NOTE: With Body Insulation Package— On IMPALA only.

**1966 CHEVELLE**

		<b>BLACK (Comb.) 760-761 762-763</b>
CONV. . . . .	L or R	7630473

**WINDSHIELD—DOORS—CONTROLS**

**1967 CAMARO**

**BLACK  
(Comb.)  
706-707-756  
760-765  
767-797**

SPT. CPE. ....	L or R	7666115
CONV. ....	L or R	7666122

**1968 CAMARO**

**BLACK  
(Comb.)  
712-713-714  
715-730-749**

SPT. CPE. ....	L or R	7766101
CONV. ....	L or R	7666122

**1969 CHEVY, CHEVELLE, CAMARO**

*NOTE: See Dealer Price Schedule (P&A26) for Applicable Prices*

	<b>Black (Comb. 701, 711-713, 727, 729-733, 750-756, 790, 791)</b>	<b>Medium Blue (Comb. 759- 761)</b>	<b>Dark Blue (Comb. 704, 715, 716, 735-737, 762-765)</b>	<b>Midnight Green (Comb. 723, 725, 744, 745, 782 794-796)</b>
Chevy II L or R .....	8743228	8743230		
Camaro (Spt. Cpe.) L or R	8765281			8765285
Camaro (Conv.) L or R ..	8765289			
Chevelle (Conv.) L or R ..	8765296			
Malibu (Spt. Cpe.) L or R				8765307
Malibu (Sed.) L or R 4 Dr.	8765321		8765316	8765319
Chevelle (exc. Malibu, Concours) L or R .....	8743228	8743230		
Chevelle (Sta. Wag.) (exc. Concours) L or R .....				8765307
Concours L or R .....	8765304			8765307
El Camino (Deluxe) L or R		8743230		
El Camino (Custom) L or R .....	8765304			
Malibu (exc. Conv.) L or R .....	8765304			8765307

**PASS.**

<b>70</b>	Pass. (Conv.) .....	<b>8765332</b>	2	25.75	(comb. 806) (black) .....
<b>70</b>	Impala, Caprice .....	<b>8806525</b>	2	25.75	(black) .....
<b>70</b>	Impala, Caprice .....	<b>8806529</b>	2	25.75	(comb. 855, 860, 861) (dk. green) .....
<b>70</b>	Impala, Caprice .....	<b>8806528</b>	2	25.75	(comb. 837, 840, 841) (med. gold) .....
<b>70</b>	Impala .....	<b>8806526</b>	2	25.75	(comb. 820, 821, 822) (med. blue) .....
<b>71</b>	Pass. (exc. Conv.) .....	<b>9868518</b>	2	25.75	(dk. jade) .....
<b>71</b>	Pass. (Conv.) .....	<b>9854155</b>	2	25.75	(comb. 835) (dk. jade) .....
<b>71</b>	Pass. (exc. Conv.) .....	<b>9868519</b>	2	25.75	(maize) .....
<b>72</b>	Pass. (1st design) .....	<b>9897511</b>	2	25.75	(lt. convert) (comb. 815, 816, 817, 818, 819) (w/diagonal stitch) .....
<b>72</b>	Pass. (1st design) .....	<b>9897512</b>	2	25.75	(dk. green) (comb. 828, 829, 830, 831, 833) (w/diagonal stitch) .....
<b>72</b>	Pass. (Spt. Cpe., Conv.) (1st design) .....	<b>9897514</b>	2	25.75	(med. pewter) (comb. 834, 835, 836) (w/diagonal stitch) .....
<b>71-72</b>	Biscayne, Bel Air, Brookwood, Townsmen (1st design) .....	<b>9856895</b>	2	25.75	(black) .....
<b>72</b>	Biscayne, Bel Air, Brookwood, Townsmen (2nd design),				
<b>73</b>	Bel Air (Sta. Wag.) 1st design ..				(neutral) (comb. 817) (Note 1) .....
<b>71-72</b>	Pass. (Conv.) .....	<b>9854154</b>	2	25.75	(black) .....

**WINDSHIELD—DOORS—CONTROLS**

**10.203 SUNSHADE ASSEMBLY (Con't)**

71-72	Pass. (exc. Conv., Brookwood, Townsman) . . . . .	9856898	2	25.75	(black) . . . . .
71-72	Brookwood, Townsman . . . . .	9856895	2	25.75	(blue) . . . . .
71-72	Pass. (exc. Conv., Brookwood, Townsman) (1st design) . . . . .	9856899	2	25.75	(blue) (w/diagonal stitch) . . . . .
71	Pass. (exc. Sta. Wag., Conv.) . . . . .	9856900	2	25.75	(lt. sandalwood) . . . . .
72	Brookwood, Townsman (1st design) . . . . .	9875828	2	25.75	(dk. saddle) (w/diagonal stitch) . . . . .
71-72	Pass. (Conv.) . . . . .	9855751	2	25.75	(dk. saddle) . . . . .
71-72	Pass. (exc. Conv.) (1st design) . . . . .	9856898	2	25.75	(dk. saddle) (w/diagonal stitch) . . . . .
72	Pass. (exc. Conv., Brookwood, Townsman) (2nd design) . . . . .	9625010	2	25.75	(blue) (less diagonal stitch) . . . . .
72	Impala, Kingswood (2nd design) . . . . .	9625011	2	25.75	(saddle) (less diagonal stitch) . . . . .
72	Brookwood, Townsman (2nd design) . . . . .	9625012	2	25.75	(saddle) (less diagonal stitch) . . . . .
72-73	Pass. (exc. Sta. Wag.) (1st design) . . . . .	9645845	2	25.75	(black) (Note 1) . . . . .
73	Pass. (exc. Conv.) (2nd design) . . . . .				(comb. 802, 803, 804, 805, 806, 840) (Note 2), . . . . .
73-75	Pass. (exc. Conv.) . . . . .	9676068	2	25.75	(black) (paint as reqd.) . . . . .
73	Impala, Caprice (exc. Conv.) (1st design) . . . . .	9645849	2	25.75	(midnight blue) . . . . .
73	Impala, Caprice (exc. Conv.) (2nd design) . . . . .				(comb. 812, 813, 843) (Note 2), . . . . .
73	Pass., Bel Air (Sed.) (1st design) . . . . .	9645846	2	25.75	(green) (Note 1) . . . . .
73	Impala, Caprice (exc. Sta. Wag., Conv.) (1st design) . . . . .	9645847	2	25.75	(neutral) (comb. 815, 818, 841) (Note 1) . . . . .
73	Impala, Caprice (exc. Conv.) (2nd design) . . . . .				(comb. 815, 816, 841) (Note 2), . . . . .
73-74	Pass. (Conv.) . . . . .	9645844	2	25.75	(neutral) (comb. 818, 819) . . . . .
73	Bel Air (Sta. Wag.) (2nd design) . . . . .	9676064	2	25.75	(comb. 817) (neutral) (Note 2) . . . . .
73	Caprice (exc. Sta. Wag., Conv.) (1st design) . . . . .	9645850	2	25.75	(oxblood) (Note 1) . . . . .
73	Caprice (Spt. Cpe., Sed.) (2nd design) . . . . .				(comb. 836) (Note 2), . . . . .
73	Impala, Caprice (Sta. Wag.) (1st design) . . . . .	9645848	2	25.75	(saddle) (comb. 826) (Note 1) . . . . .
73	Impala, Caprice (Sta. Wag.) (2nd design), . . . . .				
73	Bel Air (Sta. Wag.) (1st design) . . . . .	9646410	2	25.75	(saddle) (comb. 825) (Note 1) . . . . .
73	Bel Air (Sta. Wag.) (2nd design) . . . . .	9676065	2	25.75	(comb. 825) (saddle) (Note 2) . . . . .
72-75	Pass. (Conv.) . . . . .	9645840	2	25.75	paint as reqd. . . . .
74	Pass. (Conv.) . . . . .	9693201	2	25.75	(comb. 855) . . . . .
74	Pass. . . . .	9678271	2	25.75	(comb. 896) . . . . .

**CHEVELLE, NOVA**

70	Chevelle (exc. Sta. Wag., Conv.), . . . . .	8765296	2	18.05	(black) . . . . .
70	Chevelle (Conv.) . . . . .				
71-72	Nova, . . . . .				
71	Nomad, Greenbrier, . . . . .				
71-72	Concours (2nd design) . . . . .	9868652	2	18.05	short type (comb. 705) (black) . . . . .
71	Chevelle (Deluxe, El Camino) . . . . .				(comb. 707, 708, 710), . . . . .
71	Malibu (exc. Conv.), . . . . .				
71-72	El Camino (Custom) (2nd design), . . . . .				
71-72	Monte Carlo . . . . .	9868658	2	18.05	short type (comb. 704, 705, 706, 721, 722) (black) paint as reqd. . . . .
71-72	Chevelle (Conv.) . . . . .	9868688	2	18.05	(black) . . . . .
71	Nova, . . . . .				
71	Concours (2nd design) . . . . .	9868656	2	18.05	short type (comb. 721) (dk. saddle) . . . . .
71-72	Nova, . . . . .				
72	Chevelle (Deluxe) (Spt. Cpe.) . . . . .	9868653	2	18.05	(blue) (comb. 723) . . . . .
72	Malibu, El Camino Custom . . . . .	9896240	2		(lt. covert) . . . . .
72	Nova . . . . .				(dk. green) (comb. 759, 760, 761), . . . . .
72	Chevelle (Deluxe), Greenbrier, Concours . . . . .	9890894	2	18.05	(comb. 710, 711, 713) . . . . .
72	Nova . . . . .	9890869	2	18.05	(lt. covert) (comb. 763, 764, 765) . . . . .
72	Monte Carlo . . . . .		2		(saddle) (comb. 723, 735) . . . . .
73	Chevelle (exc. Deluxe) . . . . .				(comb. 701, 702, 703, 705, 709, 738, 747, 891, 704, 706, 707, 708, 712, 723, 724, 725, 726, 727, 728, 729, 730, 745, 830, 893) . . . . .
73-75	Chevelle . . . . .	9624831	2	18.05	<b>SUNSHADE ASSY.</b> (black) (paint as reqd.) . . . . .
73	Chevelle (Deluxe, El Camino) . . . . .	9624830	2	18.05	(black) (comb. 701, 702) . . . . .

**WINDSHIELD—DOORS—CONTROLS**

**10.203 SUNSHADE ASSEMBLY (Con't)**

73	Laguna (Spt. Cpe.) El Camino (Cust.)				
73	Malibu (exc. Spt. Sed.)				
73	Nova (1st design)	9648389	2	18.05	(black) (comb. 750, 751, 752, 753, 754, 755, 765) (Note 1)
73	Nova (2nd design)	9671827	2	18.05	<b>SUNSHADE ASSY.</b> (black) (comb. 751, 753, 754, 755, 765, 750, 752) (Note 2) (paint as reqd.)
73	Nova (exc. Custom) (1st design)	9648393	2	18.05	(blue) (Note 1)
73	Nova 2-Dr. (exc. Custom) (1st design)	9648392	2	18.05	(chamois) (Note 1)
73	Nova (1st design)	9648391	2	18.05	(green) (Note 1)
73	Nova (exc. 4-Dr. Custom) (1st design)	9648390	2	18.05	(neutral) (comb. 768) (Note 1)
74-75	Nova	9691876	2	18.05	<b>SUNSHADE ASSY.</b> (paint as reqd.)

**CAMARO**

70	Camaro	9818936	2	18.05	(black)
70	Camaro	9818939	2	18.05	(comb. 720, 723, 724) (dk. green)
71-73	Camaro (1st design)	9648375	2	18.05	(black) (paint as reqd.) (Note 1)
73	Camaro (2nd design)				<b>SUNSHADE ASSY.</b> (comb. 773, 774, 775, 776, 785, 786, 787) (Note 2)
74-75	Camaro	9684259	2	18.05	<b>SUNSHADE ASSY.</b> (paint as reqd.)

**VEGA—MONZA**

71-72	Vega	9836702	2	15.45	(black) (paint as reqd.)
72	Vega	9893352	2	15.45	(comb. 869, 874) (covert)
73-74	Vega	9667677	2	15.45	(paint as reqd.) (black)
73	Vega (Sed., Sta. Wag., Cpe.)	9648383	2	15.45	(comb. 864) (green)
73	Vega (Sta. Wag.)	9648386	2	15.45	(comb. 867) (saddle)
75	Vega, Monza	1669394	2	15.45	(black) (paint as reqd.)

NOTE 1: Soft headlining.

NOTE 2: Hard headlining.

**10.219 SUPPORT—GROMMET—HINGE—RETAINER—SCREW—SLEEVE, Sunshade**

61-64	Chevy (exc. Conv.)	4424610	R.H.	3.50	
61-64	Chevy (exc. Conv.)	4424611	L.H.	3.50	
65-67	Pass. (Conv.)	7602296	R.H.	12.50	striker
65-68	All (exc. Conv.),				
69	Nova, Chevelle, Camaro (exc. Conv.),				
70-73	Nova, Chevelle (exc. Conv.)	7790753	2	3.45	
67-68	Camaro (Conv.)	7758562	R.H.	12.65	striker
67-69	Camaro (Conv.)	7758563	L.H.	12.65	striker
68-70	Pass. (Conv.)	7758560	R.H.	12.45	striker
68-70	Pass. (Conv.)	7758561	L.H.	12.45	striker
68-72	Malibu, S.S. (Conv.)	7735476	R.H.	3.45	
68-72	Malibu, S.S. (Conv.)	7735477	L.H.	3.50	
69-70	Sed. (exc. Spt. Sed.),				
69-70	Sta. Wag. w/dual t/gate	8726303	1	3.70	right
69-70	Sed. (exc. Spt. Sed.),				
69-70	Sta. Wag. w/dual t/gate	8726304	1	3.70	left
69-70	Spt. Cpe., Spt. Sed.	8726305	1	3.70	right
69-70	Spt. Cpe., Spt. Sed.	8726306	1	3.70	left
70-75	Camaro,				
74-75	Nova	9689897	2	4.05	
71-75	Pass. (exc. Conv.),				
73-75	Chevelle (exc. Conv.)	9834642	2	3.60	s/shade
71-75	Pass. (Conv.)	9832958	1	12.30	right, s/shade and striker
71-75	Pass. (Conv.)	9832959	1	12.30	left, s/shade and striker
71-72	Vega, Monza	9847485	L.H.	4.10	(comb. 860, 861, 862, 866, 867, 873, 874) (black) (paint as reqd.)
71-72	Vega, Monza	9847484	R.H.	4.10	(comb. 860, 861, 862, 866, 867, 873, 874) (black) (paint as reqd.)
71	Vega (exc. Panel)	9847490	R.H.	4.10	(comb. 878, 879) (dk. green)
72	Vega, Monza	9896958	R.H.	4.10	(comb. 868, 869, 874)
73	Vega (exc. Panel),				
73-75	Vega, Monza	9661923	L.H.	3.65	(comb. 858, 860, 861, 862, 869, 871, 873, 875, 879, 880, 881, 883, 887) (black) (paint as required)
73	Vega (exc. Panel),				
74-75	Vega, Monza	9661922	R.H.	3.65	(comb. 858, 860, 861, 862, 868, 869, 870, 871, 873, 874, 875, 879, 880, 881, 883, 887) (black) (paint as required)

**WINDSHIELD—DOORS—CONTROLS**

**10.219 SUPPORT— GROMMET— HINGE— RETAINER— SCREW— SLEEVE,  
Sunshade (Con't)**

73	Vega (exc. Panel),					
75	Monza (exc. Towne Cpe.)	9661925	L.H.	3.65	(comb. 872) (blue and black)	
73	Vega, Monza	9661927	L.H.	3.65	(comb. 863, 864) (green)	
73	Vega, Monza	9661926	R.H.	3.65	(comb. 863, 864) (green)	
74	Vega (H.B.)	1674396	R.H.	3.45	(comb. 867)	
74	Vega (H.B.)	1674397	L.H.	3.45	(comb. 867)	
65-67	Bel Air, Impala, Caprice,					
65	Malibu (Conv.),					
66-67	Malibu, Chevelle S.S.,					
68	Malibu, Concours, S.S.,					
68	Camaro,					
68	Bel Air, Impala (exc. Conv.),					
70	Chevelle					<b>GROMMET, rod at mirror</b>
70	Pass., Camaro,					
71	Taxi,					
72	Pass. (Conv.)	7742764	2	.11	<b>GROMMET, S/S rod at ret.</b>	
73-74	Vega, Monza	9660020	2	.36	<b>HINGE, s/s pnl.</b>	
70-71	Camaro	9813126	1	3.50	<b>RETAINER, rod (black) (paint as reqd.)</b>	
71-75	Pass. (Conv.)	9725545	1	3.50	<b>RETAINER, rod (black) (paint as reqd.)</b>	
62-63	Nova (Conv.)	9419728	6	.16	<b>SCREW, support to body (1/4"— 20 x 1)—</b> (8.977)	
62-63	Chevy (exc. Conv.)	4887070	6	.12	<b>SCREW (No. 12— 11 x 5/8") (ov. hd.)</b> chrome	
64	Chevy (exc. Conv.)	9414754	A.R.	.11	<b>SCREW, support to body (No. 818 x 3/4")</b> (chrome)— (8.977)	
64-65	Chevelle (Conv.),					
65-69	Impala (Conv.),					
67-69	Camaro (Conv.)	9419834	6	.13	<b>SCREW, support to body (1/4"— 20 x 3/4")</b> (chrome)— (8.977)	
69-72	Pass. (exc. Conv.),					
73-75	All	9828626	2	.24	<b>SCREW, retainer clamp to support</b>	
71	Pass., Camaro	9898643	1	.16	<b>SCREW, sunshade</b>	
65-68	All,					
69	All (exc. Pass.),					
70-72	Nova, Chevelle,					
70-72	Pass. (Conv.),					
73	Nova	4424600	2	.16	<b>SLEEVE (plastic)</b>	
69-72	Pass. (exc. Conv.),					
71-74	Vega, Monza,					
73	Pass., Chevelle, Camaro,					
74-75	All	8740843	2	.22	<b>SLEEVE, support</b>	
68-72	Chevelle (Conv.)	7793341	2	.18	<b>WASHER, pivot at garnish moulding</b>	

**10.230 PANEL— BRACE— BRACKET— CLIP— EXTENSION— REINFORCEMENT—  
SCREW— SPACER— SUPPORT, Instrument Panel to Dash**

**PASSENGER**

71-75	Pass.	9660432	1	18.40	lower
-------	-------	---------	---	-------	-------

**CHEVY— NOVA**

69-72	Chevy (exc. Air Cond.)	1665463	1	77.25	instrument (repl. 9686910)
69-72	Chevy w/Air Cond.	1665464	1	77.25	instrument (repl. 9686911)
73-75	Nova (exc. C.A.C.)	1665463	1	77.25	
73-75	Nova w/C.A.C.	1665464	1	77.25	(repl. 9686911)
75	Chevelle w/C.A.C.	346650	1		(paint as required)



**WINDSHIELD—DOORS—CONTROLS**

**1970 CHEVELLE— PANEL ASSY.**

	BLACK	DARK BLUE	DARK SADDLE	DARK GREEN	DARK TURQ.	DARK RED	DARK GOLD	DARK SANDAL-WOOD
70 Monte Carlo . . . . .	—	3965487	3965488	3965489	—	—	3965490	3965491
70 Chevelle w/round instrumentation (exc. Monte Carlo) . . . . .	3965475	—	—	—	—	—	—	—
70 Chevelle (rectangular instrumentation, w/C.A.C., Astro-Vent . . .	3965419	—	3965493	3965494	—	3965496	—	—
70 Chevelle w/rectangular instrumentation (exc. C.A.C., Astro-Vent) . . . . .	3957051	—	—	3965479	3965480	—	3965481	—

**CHEVELLE— PANEL ASSY.**

70-72 Monte Carlo . . . . .	3999460	1	75.25	w/seat belt warning indicator, black (paint as reqd.) . . . . .
70-71 Chevelle w/round instrumentation (exc. Monte Carlo),				
70-72 Chevelle w/round instrumentation (exc. Monte Carlo) . . . . .	3999456	1	75.25	black (paint as reqd.) . . . . .
70-72 Chevelle w/rectangular instrumentation w/C.A.C., Astro. Vent. (exc. Monte Carlo)	3965419	1	70.25	black (paint as reqd.) . . . . .
70-72 Chevelle w/rectangular instrumentation (exc. C.A.C., Astro. Vent. Monte Carlo) . . . . .	3957051	1	70.75	black (paint as reqd.) . . . . .
73 Chevelle (exc. C.A.C.) . . . . .	3994500	1	79.25	w/pad (paint as required) . . . . .
73 Chevelle w/C.A.C. . . . .	3994552	1	78.75	w/pad (paint as required) . . . . .
74 Chevelle w/C.A.C. . . . .	332072	1	84.50	(paint as required) . . . . .
74-75 Chevelle (exc. C.A.C.) . . . . .	346649	1	78.25	(paint as required) . . . . .
75 Chevelle w/C.A.C. . . . .	346712	1	84.50	(paint as reqd.) . . . . .

**CAMARO**

69 Camaro . . . . .	8716458	1	74.75	instrument . . . . .
70-72 Camaro . . . . .	3994523	1	3.55	left . . . . .
70-75 Camaro . . . . .	6264754	1	11.30	right . . . . .
73-75 Camaro (exc. L.T., intr. Decor Group) . . . . .	6264751	L.H.	1.35	
73-75 Camaro w/intr. Decor Group . . . . .	6264753	L.H.	3.55	

**VEGA— MONZA**

71-74 Vega, Monza . . . . .	8788709	1	16.55	instrument upper . . . . .
71 Vega, Monza . . . . .	9806169	1	8.15	instrument lower . . . . .
72-74 Vega, Monza . . . . .	9875725	1	8.15	instrument lower . . . . .
75 Vega, Monza . . . . .	9674140	1	12.45	instrument lower . . . . .
75 Vega . . . . .	1657695	1	16.55	instrument upper . . . . .
75 Monza (exc. Towne Cpe.) . . . . .	9674146	1	16.55	instrument upper . . . . .
75 Monza (Towne Cpe.) . . . . .	1655673	1	19.85	PANEL, instrument lower . . . . .
75 Monza (Towne Cpe.) . . . . .	1655674	1	16.55	PANEL, instrument upper . . . . .
66 Chevy (w/P.B.) . . . . .	3878368	1	.93	BRACE, dash panel . . . . .
67-69 Camaro,				
69-73 Nova . . . . .	9687809	1	.96	inst. panel to center duct . . . . .
74-75 Nova . . . . .	9737121	1	.96	BRACE, panel to ctr. duct . . . . .
73-74 Chevelle (exc. C.A.C.) . . . . .	332006	1	.39	BRACE, inst. panel . . . . .
73-75 Chevelle . . . . .	3994540	R.H.	.28	BRACKET, instrument panel reinforcement . . . . .
69 Pass. . . . .	9787809	6	.16	CLIP, upper panel retainer . . . . .
71-75 Pass. . . . .	9811353	1	2.35	EXTENSION, support to center duct . . . . .
70-72 Chevelle . . . . .	3957070	R.H.	2.10	REINFORCEMENT, right, side . . . . .
70-72 Chevelle . . . . .	3980376	1	.46	REINFORCEMENT . . . . .
70-72 Chevelle . . . . .	3980377	1	.46	REINFORCEMENT . . . . .
70-75 Camaro . . . . .	6264782	1	2.40	REINFORCEMENT . . . . .
70-75 Camaro . . . . .	3972078	1	.63	REINFORCEMENT, panel to pillar . . . . .
70-72 Chevelle . . . . .	3977631	1	3.10	REINFORCEMENT . . . . .
71-72 Pass. . . . .	9732425	1	8.50	REINFORCEMENT, lower flange . . . . .
73-75 Chevelle . . . . .	3994507	L.H.	1.85	REINFORCEMENT ASSY., left . . . . .

**WINDSHIELD—DOORS—CONTROLS**

**10.230 PANEL— BRACE— BRACKET— CLIP— EXTENSION— REINFORCEMENT—  
SCREW— SPACER— SUPPORT, Instrument Panel to Dash (Con't)**

73-75	Chevelle	3994508	R.H.	2.10	REINFORCEMENT ASSY., right
All	All	3785130	1	.11	SCREW, instrument panel brace to cowl— (1.750)
74-75	Camaro	3949991	4		SCREW, inst. cluster bezel
65	Pass. (exc. S.S.),				
66	Pass. (exc. Caprice Spt. Cpe.)	3823058	1	.81	SPACER, inst. panel reinforcement to dash brace
69-72	Pass.	7750641	1	2.45	SUPPORT, right end
69-72	Pass.	7750643	1	2.45	SUPPORT, left end
71-75	Pass.	9811359	R.H.	.74	SUPPORT, right, end upper
71-75	Pass.	8793152	R.H.	.76	SUPPORT, right, end
72-75	Pass.	8793153	L.H.	.76	SUPPORT, panel end
71-75	Pass.	9732424	1	2.70	SUPPORT, to center duct (repl. 9811358)
75	Nova	1677150	L.H.	4.35	SUPPORT ASSY., panel end
75	Nova	7779470	R.H.	1.30	SUPPORT ASSY., panel end
68-72	Chevelle	8774374	R.H.	1.40	SUPPORT, right panel end
70-72	Chevelle	8801725	L.H.	1.40	SUPPORT, left panel end
70-72	Chevelle	8776849	L.H.	2.95	SUPPORT, left, panel end upper (walnut)
70-72	Chevelle	8776848	R.H.	2.95	SUPPORT, right, panel end upper (walnut)
73-75	Chevelle	9830221	R.H.	1.30	SUPPORT, right panel end
73-75	Chevelle	9830222	L.H.	1.30	SUPPORT, left panel end
70-72	Camaro	9803660	R.H.	3.55	SUPPORT, w/nut, panel end (right)
70-72	Camaro	9803661	L.H.	3.55	SUPPORT, w/nut, panel end (left)
73-75	Camaro	9803660	R.H.	3.55	SUPPORT ASSY., w/nut, panel end (right)
73-75	Camaro	9803661	L.H.	3.55	SUPPORT ASSY., w/nut, panel end (left)
71-75	Vega, Monza (exc. Towne Cpe.)	9815184	1	3.45	SUPPORT ASSY., instrument panel center
71-75	Vega, Monza	9814737	L.H.	2.00	SUPPORT ASSY., intr. panel end
71-75	Vega, Monza	8788747	R.H.	1.55	SUPPORT ASSY., instrument panel end
75	Monza (N.B.)	1742721	RH	1.65	SUPPORT ASSY., inst. panel end
75	Monza (Towne Cpe.)	1717688	1	4.40	SUPPORT ASSY., instrument panel center

**10.240 COMPARTMENT ASSY.— APPLIQUE— BRACKET— COVER— FRAME—  
PANEL— PLATE— COVER— RETAINER— SEAL— MOULDING—  
SUPPORT— SCREW— TRAY, Seat Separator**

**PASSENGER**

68-69	Caprice (A.T. w/strato bucket seats),				
68	Impala (A.T. w/S.S. equip),				
69	Impala (w/A.T.)	3957241	1	22.15	upper
69	Impala, Caprice (2-Dr.) w/bucket seats w/A.T.	3957241	1	22.15	upper (w/o buckle stow) (Note 1)

*NOTE 1 Paint as required.*

**NOVA**

68-72	Nova w/floor console	3921893	1	17.20	
73-74	Nova (2-Dr.) w/floor console	345528	1	35.75	(repl. 327546)
75	Nova ("LN")	346766	1	2.15	APPLIQUE, upper panel

**CHEVELLE**

66-67	Chevelle (floor console w/4- Spd., H.D. 3-Spd.),				
67	El Camino (floor console w/H.D. 4-Spd.)	3876407	1	28.00	
68	Chevelle w/floor console,				
69	Malibu,				
70-72	Malibu, El Camino (Custom) Monte Carlo w/floor console	6264879	1	17.80	

**CAMARO**

67	Camaro w/floor console	3918725	1	26.50	
67	Camaro w/instr. cluster	3919081	1	27.25	
68-69	Camaro	3938640	1	26.50	upper
68-69	Camaro	3938644	1	12.30	lower
70-72	Camaro w/floor console	3975798	1	26.75	upper front
70-72	Camaro w/floor console	3975807	1	2.40	end upper
70-72	Camaro w/floor console	3975808	1	3.40	end lower
67	Camaro w/floor console	3893889	1	.28	BRACKET, compt.
68-74	Nova w/floor console	3921894	1	.63	BRACKET, compt. front, center
68-69	Camaro w/console	3949617	1	.76	BRACKET (Note 2)
70-72	Camaro (exc. A.T.)	3975846	1	4.90	BRACKET, compartment front
70-72	Camaro w/A.T.	3975847	1	.46	BRACKET, compartment front
70-72	Camaro (exc. A.T.)	3975848	1	2.15	BRACKET, compartment center

**WINDSHIELD—DOORS—CONTROLS**

**10.240 COMPARTMENT ASSY.— APPLIQUE— BRACKET— COVER— FRAME—  
PANEL— PLATE— COVER— RETAINER— SEAL— MOULDING—  
SUPPORT— SCREW— TRAY, Seat Separator (Con't)**

70-72	Camaro w/A.T. ....	3975849	1	1.30	BRACKET, compartment center .....
70-72	Camaro w/floor console .....	3975850	1	.28	BRACKET, compartment rear .....
75	Nova (2-Dr.) w/floor console ...	346719	1	.65	BRACKET, lower panel .....
75	Monza (exc. Towne Cpe.) .....	346744	1	.57	BRACKET, panel rear .....
<i>NOTE 2 It may be necessary to cut off warning harness connector clip.</i>					
68-69	Caprice, Impala w/strato bucket seats (exc. tape player),				
68	Impala w/S.S. equip. (exc. tape player) .....	3919968	1	2.30	COVER, upper compt. ....
68-72	Chevelle w/floor console .....	3919973	1	2.40	COVER, compt. (paint as required) .....
70-72	Camaro w/floor console .....	3975801	1	.71	COVER, compartment upper front .....
67	Camaro w/floor console .....	3918724	1	28.50	FRAME, compt. ....
70	Chevelle w/floor console .....	3920086	1	1.80	MOULDING, compartment door .....
70-72	Camaro w/floor console .....	3975799	L.H.	4.15	PANEL, lower front, left .....
70-72	Camaro w/floor console .....	3975800	R.H.	4.15	PANEL, lower front, right .....
73-75	Camaro w/A.T. ....	6264777	1	71.00	PANEL (paint as reqd.) .....
73-75	Camaro (exc. A.T.) .....	6264778	1	71.00	PANEL (paint as reqd.) .....
73-75	Chevelle w/A.T. ....	352375	1	54.00	PANEL, upper (paint as reqd.) (repl. 3994513) .....
73-74	Chevelle w/4-Spd. ....	3994512	1	28.25	PANEL, upper (paint as reqd.) .....
73-75	Chevelle .....	3994511	1	26.75	PANEL, lwr. ....
75	Chevelle .....	352375	1	54.00	PANEL, upper (black) .....
75	Nova w/A.T. ....	332178	1	26.25	PANEL, upper (paint as reqd.) .....
75	Nova w/A.T. ....	332179	1	43.00	PANEL, lower .....
75	Nova w/S.T. ....	332232	1	6.80	PANEL, upper .....
75	Nova w/S.T. ....	332233	1	46.50	PANEL, lower .....
75	Monza (exc. Towne Cpe.) .....	332222	1	54.00	PANEL ASSY. (dark graystone) (paint as reqd.) .....
68	Malibu (P.G. w/floor console),				
68-69	S.S., A.T. w/floor console,				
70-72	Chevelle w/A.T. (exc. Monte Carlo) .....	3926727	1	18.60	PLATE, compt. trim .....
68-69	w/floor console (exc. A.T.),				
70-72	Chevelle (exc. A.T., Monte Carlo)	3934153	1	18.60	PLATE, trim .....
70-72	Monte Carlo w/A.T. ....	3968573	1	18.75	PLATE, trim .....
70-72	Monte Carlo w/4-Spd. ....	3968575	1	18.75	PLATE, trim .....
73-75	Camaro .....	478558	1	.87	PLATE, rear cover (paint as reqd.) .....
75	Monza (exc. Towne Cpe.) w/3- Spd. ....	332227	1	8.15	PLATE ASSY., trim .....
75	Monza (exc. Towne Cpe.) w/console .....	346736	1	8.15	PLATE ASSY., trim .....
71-72	Camaro w/floor console .....	3984475	1	.18	RETAINER, comp. upper front cover seal ..
70-72	Camaro w/floor console .....	3984473	1	.36	SEAL, compartment upper front cover .....
75	Nova w/floor console .....	1655249	1	2.30	SUPPORT, floor pan .....
69	Chevelle w/console .....	9420695	2	.07	SCREW, compt. to underbody .....
73-75	Camaro .....	489941	4	.16	SCREW, st. sep. trim plate (hex. soc. hd. cap 8-18 x 3/4") .....
75	Monza .....	1651239	1	6.70	SUPPORT, console floor pan .....
75	Monza (exc. Towne Cpe.) .....	346663	1	1.90	TRAY, seat sep. assy. ....

**10.242 DOOR ASSY.— HINGE— ARM— BEZEL— BUMPER— COVER— EMBLEM—  
INSERT— MOULDING— PANEL— PLUNGER— REFLECTOR— RETAINER—  
RIVET— SPRING— STOP— STRIKER— STUD, Seat Separator**

**PASSENGER**

66-67	S.S. w/A.T. ....	3883707	1	9.15	seat separator compt. ash tray .....
66-67	Caprice (Spt. Cpe.) w/bucket seat .....	3883711	1	17.60	seat separator compt. ....
68	Impala (A.T. w/S.S. equip.) (exc. strato bench) .....	3920341	1	9.65	seat separator compt. ash tray .....
68	Caprice w/Strato bucket seat,				
68	Impala w/S.S. equip.,				
69	Pass. w/Strato bucket seats ....	3950780	1	5.10	outer door (Note 1) .....
<i>NOTE 1 When service replacement is made paint as required to match part being replaced.</i>					
69	Pass. w/Strato bucket seats ....	3950781	1	2.20	inner door .....

**CHEVELLE**

66-67	w/floor console,				
66	(S.S.) w/4-Spd. ....	3876409	1	6.80	separator compartment .....
68	w/floor console,				
69	(Spt. Cpe., Conv.),				
69	El Camino (Custom) .....	3953095	1	3.75	seat separator compt. ....

**WINDSHIELD—DOORS—CONTROLS**

**10.242 DOOR ASSY.—HINGE—ARM—BEZEL—BUMPER—COVER—EMBLEM—  
INSERT—MOULDING—PANEL—PLUNGER—REFLECTOR—RETAINER—  
RIVET—SPRING—STOP—STRIKER—STUD, Seat Separator (Con't)**

70-72	El Camino,				
70-72	Chevelle (Spt. Cpe., Conv.)	3972990	1	3.75	compartment
73-75	Chevelle	3991781	1	16.00	compartment (paint as required)

**CAMARO**

68-69	w/floor console	3919069	1	4.25	compartment
70-72	Camaro	3975803	1	1.65	compartment ash tray
70-72	Camaro	3972012	1	11.30	compartment
73-75	Camaro	326210	1	28.50	compartment (paint as reqd.)
68-69	Caprice w/Strato bucket seats,				
68-69	Impala (Spt. Mdls.) w/Strato bucket seats	3916582	1	2.20	HINGE, seat separator compt. door
70-72	El Camino,				
68-72	Chevelle (Spt. Cpe., Conv.)	3972997	1	5.40	HINGE, door
68-69	Camaro w/floor console	3919071	1	1.45	HINGE ASSY., compt. door
70-72	Camaro	3972016	1	2.95	HINGE ASSY., compartment door pad
67	Camaro w/floor console	3899867	1	.11	ARM, compt. door spring
68-69	Impala,				
68-69	Caprice w/Strato bucket seats	3916584	1	.26	ARM, seat separator door spring
68-69	Camaro w/floor console	3919072	1	.11	ARM, compt. door spring
68-72	Camaro w/floor console	3919070 A.R.		.11	BUMPER, compt. door ash tray
67	Camaro w/floor console	3893862	1	1.55	COVER, compartment ash tray
68-69	Camaro w/floor console	3929928	1	1.50	COVER, compt. ash tray
66-67	Pass. (S.S.),				
66-67	Caprice w/bucket seat	3887500	1	17.10	BEZEL, seat separator compt. door
68-69	Camaro w/floor console (exc. cluster, clock)	3916614	1	1.20	EMBLEM
69-72	Chevy w/console (exc. cluster, clock)	3947627	1	1.05	EMBLEM, compt.
68	Camaro w/floor console (exc. instrument cluster)	3921826	1	2.00	INSERT, compt. trim
69-71	Chevy w/console (exc. cluster, clock)	3406551	1	2.10	INSERT, compt. trim
72	Nova	3927632	1	.26	INSERT, compartment trim
69	Camaro w/console	3949586	1	2.10	INSERT, compt. trim
73-75	Nova	333728	1	3.60	INSERT, compartment trim
68-72	Chevelle w/floor console	3920086	1	1.80	MOULDING, compt. door
69	Chevelle w/flr. console	3953091	1	3.25	PANEL, compt. inner door
70-72	Chevelle	3972991	1	1.85	PANEL, compartment inner door
69	Chevelle w/floor console	3953092	1	.11	PLUNGER, compt. door spring
68-69	Camaro w/floor console	3919199	1	.12	REFLECTOR, rear seat courtesy lamp
68-72	Chevy w/floor console,				
73-75	Nova (2-Dr.)	3925443	4	.12	RETAINER, compt. trim instrument
68-72	Camaro w/floor console	3919075	2	.11	RIVET, compartment ash tray cover
67	Camaro w/floor console	3899868	1	.12	SPRING, compartment door
67	Camaro w/floor console	3842306	2	.11	SPRING, compt. ash tray cover
68-69	Camaro w/floor console	3929942	2	.11	SPRING, compt. ash tray cover
68-69	Chevelle w/floor console	3920084	1	.12	SPRING, compt. door
68-69	Camaro w/floor console	3919073	1	.11	SPRING, compt. door
69	Malibu w/floor console,				
70	Malibu, El Camino (Custom)	3953093	1	.12	SPRING, comp. door
70-72	Camaro w/floor console	3984477	2	.11	SPRING, ash tray door
73-75	Chevelle	5964082	1	.60	SPRING, compt. door latch— (10.268)
74	Chevelle	345077	1	.58	SPRING, compt. door hold open
69	Chevelle w/console	3954587	1	1.50	STRIKER, compt. door (red)
70-72	Chevelle w/console	3975449	1	.28	STRIKER, door lock
68-72	Chevelle w/floor console	3927632	10	.26	STUD, compt. moulding

**10.252 MOULDING—BRACKET—CLIP—PLATE—PLUG—RETAINER—  
SCREW—SHROUD, Instrument Panel**

**PASSENGER**

68	Caprice (exc. Spt. Cpe., C.A.C.),				
68	Impala (exc. C.A.C.)	3920095	1	1.85	left
68	Impala, Caprice (exc. stereo radio, tape player)	3920096	1	2.75	right, w/ash tray cut out
68	Impala, Caprice w/C.A.C.	3920097	1	2.05	left (Note 1)
<i>NOTE 1 When used as replacement on vehicle equipped with upper level ventilation it will be necessary to drill one 15/64" diameter hole, at existing dimple, to accommodate ventilator knob.</i>					
70	Impala (C.A.C.)	3965435	1	8.20	panel trim
71-72	Pass.	3984460	1	.26	comp. opg.
73-74	Caprice (exc. C.A.C.)	6258809	1	4.00	panel trim plate (Note 1)

**WINDSHIELD—DOORS—CONTROLS**

**10.252 MOULDING— BRACKET— CLIP— PLATE— PLUG— RETAINER—  
SCREW— SHROUD, Instrument Panel (Con't)**

73-74	Caprice w/C.A.C. ....	6258810	1	3.15	panel trim plate (Note 1) .....
73-74	Caprice w/Auto Temp. ....	6258811	1	9.70	panel trim plate (Note 1) .....
73-75	Pass. ....	3984460	1	.26	compartment opg. ....

**CHEVY**

65	Nova .....	3860249	1	2.80	center .....
----	------------	---------	---	------	--------------

**CHEVELLE**

69	(396) .....	3948533	1	5.25	instr. panel .....
68	Malibu (exc. Spec. Spt. Sed.) ...	3922828	1	5.10	
68	(S.S.) .....	3922832	1	5.10	

**CAMARO**

68	Camaro .....	7745716	R.H.	14.70	instr. panel cover finishing .....
68	Camaro .....	7745717	L.H.	14.70	instr. panel cover finishing .....
69	w/interior decor package .....	3939692	1	6.15	instr. panel .....

**PASSENGER**

68-69	Biscayne, Bel Air,				
69	Brookwood, Townsman,				
69	Camaro, w/interior decor.				
	package .....	3922826	A.R.	.18	<b>BRACKET, w/screw, trim plate</b> .....
70-71	Chevelle (exc. Monte Carlo) ....	3965417	1	.12	<b>BRACKET, radio control hole</b> .....
63	Nova (S.S.) .....	3793560	3	.13	<b>CLIP, door mldg.</b> .....
68	Pass. (exc. Caprice) .....	3918201	1	5.80	<b>PLATE, instr. panel center trim</b> .....
69	Pass. ....	3950046	1	1.55	<b>PLATE, instr. panel, astro vent</b> .....
69-70	Biscayne, Bel Air,				
69-70	Brookwood, Townsman .....	3939621	1	10.05	<b>PLATE, instrument panel</b> .....
71-72	Biscayne, Bel Air, Brookwood,				
	Townsman (exc. C.A.C.) .....	3984448	1	6.30	<b>PLATE, trim</b> .....
71	Biscayne, Bel Air, Brookwood,				
	Townsman w/C.A.C. ....	3984451	1	5.95	<b>PLATE, trim</b> .....
71-72	Impala (exc. C.A.C.) .....	3984449	1	9.65	<b>PLATE, trim</b> .....
71	Impala w/C.A.C. ....	3984452	1	7.50	<b>PLATE, trim</b> .....
71-72	Caprice (exc. C.A.C.) .....	3984450	1	10.20	<b>PLATE, trim</b> .....
71	Caprice w/C.A.C. ....	3984453	1	8.55	<b>PLATE, trim</b> .....
71	Kingswood w/C.A.C. ....	3994531	1	4.15	<b>PLATE, trim</b> .....
71-72	Kingswood (exc. C.A.C.) .....	3994530	1	4.15	<b>PLATE, trim</b> .....
72	Biscayne, Bel Air, Brookwood,				
	Townsman w/C.A.C. ....	3994541	1	5.95	<b>PLATE, trim</b> .....
72	Impala w/C.A.C. ....	3994542	1	5.95	<b>PLATE, trim</b> .....
72	Caprice w/C.A.C. ....	3994543	1	5.25	<b>PLATE, trim</b> .....
72	Kingswood w/C.A.C. ....	3994544	1	5.95	<b>PLATE, trim</b> .....
69-70	Impala, Caprice,				
69-70	Kingswood .....	3945917	1	10.90	<b>PLATE ASSY., instrument panel</b> .....
73-75	Bel Air (exc. C.A.C.) .....	6264746	1	9.25	<b>PLATE, panel trim</b> .....
73-75	Bel Air w/C.A.C. ....	6264747	1	5.80	<b>PLATE, panel trim</b> .....
73-74	Impala (exc. C.A.C.) .....	6264784	1	9.65	<b>PLATE, panel trim</b> .....
73-74	Impala w/C.A.C. ....	6264786	1	5.95	<b>PLATE, panel trim</b> .....
73-74	Caprice (exc. C.A.C., Sta. Wag.) .	6258807	1	10.20	<b>PLATE, panel trim (Note 2)</b> .....
73-74	Caprice w/C.A.C. (exc. Sta.				
	Wag., Conv.) .....	6258808	1	10.20	<b>PLATE, panel trim (Note 2)</b> .....
73-74	Caprice, Sta. Wag. (exc. C.A.C.) .	6264785	1	9.65	<b>PLATE, panel trim</b> .....
73-74	Caprice, Sta. Wag. w/C.A.C. ....	6264787	1	5.95	<b>PLATE, panel trim</b> .....
74	Impala (Spt. Cpe.) (exc. Custom)				
	(exc. C.A.C.) .....	346606	1	13.85	<b>PLATE ASSY., trim (comb. 804-midnight</b> <b>blue)</b> .....
74	Impala (Spt. Cpe.) (exc. Custom)				
	w/C.A.C. ....	346607	1	13.85	<b>PLATE ASSY., trim (comb. 804-midnight</b> <b>blue)</b> .....
74	Impala (Spt. Cpe.) (exc. Custom)				
	w/Auto. Temp. ....	346608	1	11.55	<b>PLATE ASSY., trim (comb. 804-midnight</b> <b>blue)</b> .....
74	Impala (Spt. Cpe.) (exc. Custom)				
	(exc. C.A.C.) .....	346609	1	13.85	<b>PLATE ASSY., trim (comb. 809-dr. oxblood)</b>
74	Impala (Spt. Cpe.) (exc. Custom)				
	w/C.A.C. ....	346610	1	11.55	<b>PLATE ASSY., trim (comb. 809-dr. oxblood)</b>
74	Impala (Spt. Cpe.) (exc. Custom)				
	w/Auto. Temp. ....	346611	1	11.55	<b>PLATE ASSY., trim (comb. 809-dr. oxblood)</b>
75	Caprice (exc. C.A.C., Sta. Wag.) .	346601	1	6.05	<b>PLATE ASSY., trim</b> .....
75	Caprice w/C.A.C. (exc. Sta.				
	Wag.) .....	346602	1	6.05	<b>PLATE ASSY., trim</b> .....
75	Caprice Sta. Wag. (exc. C.A.C.) .	346689	1	5.95	<b>PLATE ASSY., trim</b> .....
75	Impala (exc. C.A.C.) .....	346603	1	6.60	<b>PLATE ASSY., trim</b> .....

**WINDSHIELD—DOORS—CONTROLS**

**10.252 MOULDING— BRACKET— CLIP— PLATE— PLUG— RETAINER—  
SCREW— SHROUD, Instrument Panel (Con't)**

75	Impala w/C.A.C. ....	346605	1	6.60	PLATE ASSY., trim .....
75	Caprice Sta. Wag. w/C.A.C. ....	346690	1	6.05	PLATE ASSY., trim .....

**CHEVY**

67	Nova .....	3898103	1	4.15	PLATE, compt. door trim .....
----	------------	---------	---	------	-------------------------------

*NOTE 2 Paint as required.*

**CHEVELLE**

68	Chevelle .....	3918257	1	.66	PLATE, ash tray face .....
69	(Spt. Cpe., Conv.) .....	3950046	1	1.55	PLATE, instr. panel (astro-vent) (Note 3) ...
66-67	Malibu .....	3897551	1	7.20	PLATE ASSY., lower trim .....
73	Chevelle (Deluxe) .....	332010	1	2.85	PLATE, trim .....
73	Malibu (exc. S.S.) .....	332011	1	2.85	PLATE, trim .....
73	Laguna .....	332012	1	2.85	PLATE, trim .....
73	El Camino (exc. S.S.) .....	332013	1	2.85	PLATE, trim .....
73	Malibu, El Camino (S.S.) .....	332014	1	2.85	PLATE, trim .....
73	Monte Carlo .....	332016	1	2.85	PLATE, trim .....
74-75	El Camino (exc. S.S.) .....	332076	1	3.00	PLATE, trim .....
74-75	Monte Carlo w/Landau .....	332077		3.00	PLATE, trim .....
74-75	Monte Carlo (exc. Landau) .....	332078		3.00	PLATE, trim .....
74-75	El Camino (S.S.) .....	332079		3.00	PLATE, trim .....
74-75	Laguna .....	332080		3.00	PLATE, trim .....
74-75	Malibu (exc. Classic) .....	332182	1	3.00	PLATE, trim .....
74-75	Malibu (Classic) .....	332183	1	3.00	PLATE, trim .....

*NOTE 3 Also in Camaro Section.*

**CAMARO**

67	(exc. C.A.C.),				
68	(exc. floor console, deluxe interior, C.A.C.) .....	3891665	1	5.90	PLATE, panel trim .....
67	w/C.A.C.,				
68	w/C.A.C. (exc. floor console, deluxe interior) .....	3893821	1	3.40	PLATE, panel trim .....
69-70	Camaro .....	3950046	1	1.55	PLATE, instr. panel (astro-vent) (Note 4) ...
68	(exc. C.A.C.) .....	3921857	1	9.50	PLATE ASSY., trim (wood grain) .....
68	(C.A.C. w/floor console w/interior decor package .....	3921859	1	10.80	PLATE ASSY., instr. panel trim .....
69	w/interior decor package .....	3945983	1	3.60	PLATE ASSY., radio hole cover .....
69	w/deluxe interior .....	3945913	1	12.90	PLATE ASSY., instr. panel .....

*NOTE 4 Also in Chevelle Section.*

69-71	Chevelle .....	3954594	1	.12	PLUG .....
72	Chevelle,				
73-75	Pas\$, Chevelle (exc. T.H. 350) ..	1233424	1	.17	PLUG, trans. detent cable .....
67-68	Camaro .....	3893822	1	.22	RETAINER, instrument panel trim .....
66	All .....	446617	A.R.	.05	SCREW (10-16 x 1/2") panel end plate— (8.977) .....
64	El Camino .....				SCREW, door name plate, .....
65-67	Conv. .....	4403686	A.R.	.12	windshield upper garnish mldg. to panel (No. 8-18 x 3/8") .....
70	Brookwood, Townsman,				
70	Biscayne, Bel Air .....	3922826	A.R.	.18	SCREW, panel trim plate (w/bracket) .....
71-72	Caprice, Kingswood Estate .....	3984416	1	23.55	SHROUD, cluster to carrier .....
71-75	Pass. (exc. Caprice) .....	6264743	1	23.55	SHROUD, cluster to carrier (repl. 3984415) ..
73	Caprice .....	6264742	1	23.55	SHROUD, cluster to carrier .....
74	Pass. .....	332052	1	23.55	SHROUD ASSY., cluster to carrier (paint as required) .....
74	Impala .....	346613	1	11.65	SHROUD, instr. panel to carrier (dk. oxblood) .....
75	Caprice (exc. Sta. Wag., Conv.) ..	346614	1	26.25	SHROUD ASSY., instrument panel to carrier (dark gray) .....
75	Caprice (exc. Conv.) .....	346615	1	26.25	SHROUD ASSY., instrument panel to carrier (dark blue) .....
75	Caprice .....	346617	1	26.25	SHROUD ASSY., instrument panel to carrier (dark sandstone) .....
75	Caprice (exc. Sta. Wag., Conv.) ..	346618	1	26.25	SHROUD ASSY., instrument panel to carrier (dark saddle) .....
75	Caprice .....	332297	1	26.25	SHROUD ASSY., instrument panel to carrier (black) .....
75	Caprice (exc. Sta. Wag., Conv.) ..	332298	1	26.25	SHROUD ASSY., instrument panel to carrier (dark oxblood) .....
75	Caprice .....	332299	1	26.25	SHROUD ASSY., instrument panel to carrier (dark green) .....
75	Impala .....	346621	1	11.65	SHROUD ASSY., instr. panel to carrier (dk. blue) .....

**WINDSHIELD—DOORS—CONTROLS**

**10.252 MOULDING— BRACKET— CLIP— PLATE— PLUG— RETAINER—  
SCREW— SHROUD, Instrument Panel (Con't)**

75	Impala .....	346623	1	11.65	SHROUD ASSY., instr. panel to carrier (dk. sandstone) .....
75	Impala .....	346624	1	11.65	SHROUD ASSY., instr. panel to carrier (dk. saddle) .....

**10.254 EMBLEM— PLATE, Instrument Panel**

**CHEVY**

62-64	Nova (exc. S.S.),				
64-66	Deluxe .....	3793666	1	1.35	door .....
67	Nova (S.S.) .....	3914740	1	1.60	instr. panel .....
67	Nova (exc. S.S.) .....	3898160	1	1.65	instr. panel .....

**CAMARO**

69	Camaro .....	3950003	1	.98	instr. panel .....
----	--------------	---------	---	-----	--------------------

**PASSENGER**

**CHEVELLE**

65	Malibu (S.S.) .....	4483663	1	5.90	PLATE, door name .....
65	El Camino (Custom) .....	4483661	1	2.85	PLATE, door name .....

**CAMARO**

68	.....	3921874	1	1.30	PLATE, door name .....
----	-------	---------	---	------	------------------------

**NOVA**

69-74	Nova .....	8745807	1	1.55	PLATE, instr. pnl. cvr. name/Nova .....
-------	------------	---------	---	------	---

**10.256 COVER— BRACKET— PLATE ASSY., Radio Instrument Panel**

**PASSENGER**

69-70	Biscayne, Bel Air (exc. radio),				
69-70	Brookwood, Townsman (exc. radio) .....	3948563	1	1.90	radio control hole .....
71-72	Pass. (Caprice, Kingswood Estate),				
73-75	Pass. (exc. Caprice) .....	6264789	1	.80	radio control hole .....
69-70	Impala, Caprice, Kingswood (exc. radio) .....	3948559	1	3.60	COVER ASSY., radio control hole .....
71-72	Caprice, Kingswood Estate,				
73-74	Caprice .....	6264788	1	3.80	COVER ASSY., radio cont. hole .....
75	Caprice .....	346679	1	3.95	COVER ASSY., radio control hole .....

**CHEVY— NOVA**

75	Nova Custom (exc. H.B.) .....	332224		3.75	COVER, radio control hole (black) .....
----	-------------------------------	--------	--	------	---

**CHEVELLE**

73-75	Chevelle (exc. El Camino) .....	3994519	1	2.60	radio control hole (paint as required) .....
-------	---------------------------------	---------	---	------	--

**CAMARO**

67-68	(exc. radio) .....	3893845	1	1.20	radio control hole .....
69	(exc. radio) .....	3945981	1	2.60	radio control hole .....
70-75	Camaro (exc. radio) .....	3975828	1	.63	radio speaker hole .....
70-75	Camaro (exc. radio) .....	6264755	1	1.45	radio control hole (paint as reqd.) .....

**VEGA— MONZA**

71-75	Vega, Monza (exc. Radio) .....	326202	1	1.30	radio control hole .....
70-72	Chevelle w/instrument panel gauges .....	3975861	1	.28	BRACKET, control hole .....
72	Chevelle (exc. Monte Carlo) .....	3965417	1	.12	BRACKET, radio control hole .....
70-72	Chevelle (exc. Monte Carlo) .....	3965416	1	1.25	PLATE ASSY., control hole .....
70-72	Monte Carlo .....	3975859	1	4.65	PLATE ASSY., control hole (woodgrain) .....
70-72	Chevelle (2-Dr.) (exc. Monte Carlo) w/instrument panel gauges .....	3975860	1	4.65	PLATE ASSY., control hole .....

**10.260 BOX— BRACKET— COMPARTMENT— REINFORCEMENT ASSY.—  
SCREW, Instrument Panel Compartment**

65-66	Pass. w/Prod. C.A.C. (exc. auto. temp. cont.) .....	3870231	1	4.80	
65-66	Pass. (exc. C.A.C.) .....	3861659	1	2.25	

**WINDSHIELD—DOORS—CONTROLS**

**10.260 BOX— BRACKET— COMPARTMENT— REINFORCEMENT ASSY.—  
SCREW, Instrument Panel Compartment (Con't)**

62-65	Chevy	3791661	1	1.75	
66-67	Chevy	3876693	1	1.30	
64-65	Chevelle	3862694	1	1.50	
66-67	Chevelle (exc. C.A.C.)	3878159	1	2.85	
66-67	Chevelle w/Prod. C.A.C.	3885196	1	1.65	
69-72	Pass. w/C.A.C.	3950049	1	.16	BRACKET, compt. door
68	Pass. w/C.A.C.	3927621	1	5.50	COMPARTMENT
69-70	Pass. w/C.A.C.	3948915	1	5.70	COMPARTMENT
71-75	Pass.	3984459	1	1.75	COMPARTMENT
68	Pass. (exc. Caprice, Spt. Cpe., C.A.C., upper level ventilation)	3919981	1	1.70	COMPARTMENT ASSY.
68	Caprice (exc. C.A.C.),				
68	Impala w/upper level ventilation,				
68	Caprice w/upper level ventilation (exc. Spt. Cpe.)	3934139	1	3.70	COMPARTMENT ASSY.
69-70	Pass. (exc. C.A.C.)	3939657	1	1.95	COMPARTMENT ASSY.
68	Chevy	3919509	1	5.20	COMPARTMENT ASSY., complete
69-75	Nova (exc. C.A.C.)	3939609	1	1.60	COMPARTMENT ASSY.
69-75	Nova w/C.A.C.	3939611	1	1.50	COMPARTMENT ASSY.
68-69	Chevelle	3919510	1	6.40	COMPARTMENT ASSY.
68-69	Chevelle w/C.A.C.	3930197	1	7.15	COMPARTMENT ASSY.
68-69	Chevelle (exc. C.A.C.)	3939635	1	1.90	COMPARTMENT ASSY.
73-75	Chevelle w/C.A.C.	6264776	R.H.	4.80	
73-75	Chevelle w/gauges	3994549	L.H.	1.60	
72-75	Chevelle (exc. C.A.C.)	332081	R.H.	5.20	
67-68	Camaro (exc. C.A.C.)	3891671	1	1.35	COMPARTMENT ASSY.
67-68	Camaro w/C.A.C.	3891766	1	1.40	COMPARTMENT ASSY.
69	Camaro (exc. C.A.C.)	3939609	1	1.60	COMPARTMENT ASSY.
69	Camaro w/C.A.C.	3939611	1	1.50	COMPARTMENT ASSY.
70-75	Camaro (exc. C.A.C.)	3975883	1	1.60	COMPARTMENT ASSY.
70-75	Camaro w/C.A.C.	3975884	1	1.60	COMPARTMENT ASSY.
72-75	Vega,				
75	Monza (exc. Towne Cpe.) (exc. C.A.C.)	3994571	1	2.65	COMPARTMENT ASSY.
74-75	Vega (Cpe.) w/Cosworth	332029	1	5.25	COMPARTMENT ASSY.
75	Monza (exc. Towne Cpe.) w/C.A.C.	346734	1	5.15	COMPARTMENT ASSY.
75	Monza (Towne Cpe.)	346783	1	3.90	COMPARTMENT ASSY.
70-75	Camaro	3980356	1	1.35	REINFORCEMENT ASSY., center upper
70-75	Camaro	3991784	1	1.30	REINFORCEMENT ASSY., center lower
74-75	Chevelle	3994554	1	1.80	REINFORCEMENT ASSY.
75	X	3848539	6	.11	SCREW, cowl panel-lower (w/washer)

**10.261 DOOR ASSY., Instrument Panel Compartment**

**PASSENGER**

68	w/C.A.C.	3927617	1	8.70	
68	(exc. C.A.C.)	3913691	1	9.75	
69-70	w/C.A.C.	3935971	1	10.20	
69-70	(exc. C.A.C.)	3935947	1	10.20	
71-75	Pass.	332048	1	10.20	
67	Nova	3898101	1	7.55	
68	Chevy	3916699	1	5.15	
69-75	Nova	3991755	1	5.80	
66-67	Chevelle	3871013	1	9.75	
68-69	(exc. C.A.C.)	3927641	1	7.25	
68-69	w/C.A.C.	3930193	1	7.95	
70-72	Chevelle	3991762	1	1.30	inner
70-72	Chevelle	3957090	1	2.95	outer
73-75	Chevelle	332047	1	3.30	outer (Note 1)
73-75	Chevelle	3991791	1	1.30	inner (Note 1)
68	Camaro	3921873	1	5.20	
69	(exc. deluxe interior)	3991755	1	5.80	
69	w/deluxe interior	3945905	1	8.30	
70-75	Camaro	6264757	1	5.80	outer (Note 3)
70-71	Camaro	3991759	1	1.30	inner
72-75	Camaro	3999447	1	1.55	inner
72	Vega, Monza	3994573	1	6.55	
73-75	Vega, Monza	326203	1	6.55	outer
75	Monza (Towne Cpe.)	346782	1	6.55	

NOTE 1: Paint as required.

NOTE 3 When using 3972041 on models without deluxe interior it will be necessary to paint bright area black.



**WINDSHIELD—DOORS—CONTROLS**

**10.262 HINGE— SCREW— SHIELD— STOP— STRAP, Instrument Panel  
Compartment Door**

66-67	Chevy	3876694	1	2.75	
67-68	Camaro	3898178	1	1.35	
65	Pass.	3725168 A.R.		.11	SCREW, hinge, lock striker (No. 10-12 x 7/16")
69-70	Pass. w/C.A.C. glove compt. lamp	3954259	1	.16	SHIELD, light bulb
70-71	Camaro	3984465	1	.18	STOP
72-75	Camaro	3994597	1	.16	STOP
72-75	Vega, Monza	3994574	1	.18	
70-75	Camaro	3975885	1	.38	STRAP, compartment to dash
73	Chevelle (exc. C.A.C.)	6264783	1	.28	STRAP, compartment

**10.263 BUMPER, Instrument Panel Compartment Door**

62-69	All,				
70-75	Pass., Nova	3765243	2	.11	(1 1/32" O.D. x 1 1/16" O.L.)
62-65	Chevy, Chevelle,				
66-69	Chevy, Camaro,				
67-69	Pass.,				
70-75	Pass., Nova, Vega, Monza	4566397	1	.12	door stop
65	Chevy,				
66-68	Chevelle,				
70-72	Chevelle, Camaro,				
73-75	Camaro	3820023	1	.12	door stop
66-67	Chevelle,				
70-75	Chevelle, Camaro	3957096	2	.11	door

**10.266 CASE ASSEMBLY— CASE ASSY.— CYLINDER— KEY— WASHER,  
Instrument Panel Compartment Door**

62-65	Chevy	6260553	1	2.00	w/lock bolt and spring (repl. 4757908)
64-65	Chevelle	7658079	1	1.10	instr. panel door lock cylinder
65	Impala (S.S.)		1		with lock bolt and spring,
66-67	Pass. (Super Sport) (Caprice w/bucket seat),				
66	Chevelle w/floor console	1380873	1	1.25	seat separator compt. door lock cylinder case assy.
65	Pass.,				
66	Pass. (exc. Caprice)	6260552	1	1.40	
66	Caprice	3883768	1	.76	lock cylinder
66-67	Chevelle	3899587	1	1.50	instr. panel door lock cylinder
67	Pass.,				
67	Chevy, Camaro,				
66	Chevy,				
68	Camaro	6260554	1	2.40	instr. panel door lock cylinder
68-69	Chevelle,				
69	Camaro,				
68-75	Pass., Nova	3934137	1	1.75	lock cylinder
70	Camaro w/Console,				
70-72	Chevelle w/Console	6260553	1	2.00	seat sep. compt. door (repl. 3972993)
72-75	Vega, Monza,				
70-73	Chevelle, Camaro,				
74-75	H	3991767	1	1.70	lock cylinder
70-72	All,				
74-75	All (exc. Nova)	3991767	1	1.70	CASE ASSY.
62-65	All,				
65-66	Chevy,				
66	Pass. (exc. Caprice)	4709555	1	1.30	CYLINDER (uncoded-less keys)
64-65	Chevelle	7645835	1	1.30	CYLINDER, with case (coded w/2 keys) (repl. 3851706)
66	Spt. Cpe., Conv. w/bucket seats,				
66	Chevelle w/floor console	4566764	1	1.30	CYLINDER, console lock, inst. panel compt. latch button
66	Caprice	7595854	1	1.35	CYLINDER (uncoded-less keys)
66	Caprice	3889791	1	2.20	CYLINDER with case (coded w/2 keys)
66	Chevelle	4818080	1	1.30	CYLINDER, lock (uncoded)
67	Pass. (S.S. w/Strato bench seat),				
67	Caprice w/Strato bucket seat,				
67	Chevelle w/floor console	7645831	1	1.55	CYLINDER, seat separator compt. lock (uncoded)
67	Pass., Chevy, Camaro,				
71	Chevelle w/Console	7645835	1	1.30	CYLINDER, inst. panel door lock (uncoded)
67	Chevelle	7645833	1	1.30	CYLINDER, compt. door lock (uncoded)
68	All (exc. Camaro),				
72	Pass., Nova	347101	1	2.30	CYLINDER, lock (uncoded)
68	Camaro	7743438	1	1.35	CYLINDER, compt. door lock (uncoded)

**WINDSHIELD—DOORS—CONTROLS**

**10.266 CASE ASSEMBLY— CASE ASSY.— CYLINDER— KEY— WASHER,  
Instrument Panel Compartment Door (Con't)**

69	All,				
73-75	Pass., Nova	6259305	1	2.15	CYLINDER (uncoded) instr. panel compt. door
70	Pass., Nova	1154153	1	2.10	CYLINDER, lock (uncoded) (repl. 8786144)
70-74	Chevelle, Camaro	345075	1	3.40	CYLINDER, lock (B & S 590821) (uncoded)
70	Chevelle w/Console	8786146	1	1.50	CYLINDER, seat sep.compt. door (uncoded)
71-75	Pass., Nova	9832569	1	2.25	CYLINDER, lock (B & S 604836) (uncoded)
71-75	Chevelle, Camaro	9832567	1	2.15	CYLINDER, lock (B & S 604838) (uncoded)
72	Chevelle, Camaro,				
72-75	Vega, Monza	6260421	1	3.60	CYLINDER, lock (B & S 605260) (uncoded)
73	Chevelle, Camaro	6259509	1	3.40	
74	Pass., Nova	1154153	1	2.10	(B & S 604277) (uncoded)
62-65	All	3694624	1	.16	KEY, blank (octagon head)
73	All	7025014	A.R.	.33	KEY, sq. hd. (uncoded) (2-187)
73	All	7025019	A.R.	.33	KEY, rd. hd. (uncoded) (2.187)
66-67	Chevelle (exc. Malibu, S.S.),				
68	All (exc. Camaro),				
69	Camaro,				
72	Vega, Monza,				
74-75	Pass., Nova	4416740	1	.24	WASHER, lock,

**10.267 RETAINER— BEZEL— ESCUTCHEON— SCREW, Instrument Panel  
Compartment Door Lock**

62-66	Chevy	4767835	1	.46	door lock cyl. case
70	Biscayne, Bel Air, Brookwood, Townsmen (Police) (V-8),				
70-72	Camaro w/floor console	3975844	1	.58	cyl. case
70-72	El Camino,				
70-72	Chevelle (Spt. Cpe., Conv.)	3972994	1	.58	cylinder and case
66-67	Malibu, Chevelle S.S.	3876536	1	.22	BEZEL, door lock
66-67	Chevelle	4416741	1	.68	ESCUTCHEON, door lock
68-69	All (exc. Camaro),				
69	Camaro,				
70-75	Pass., Nova	3922831	1	.27	ESCUTCHEON, case
70-75	Chevelle, Camaro,				
72-75	Vega, Monza	3957093	1	.33	ESCUTCHEON, case

**10.268 STRIKER— STOP, Instrument Panel and Seat Separator Compartment  
Lock**

62-65	Chevy	3791319	1	.28	
64-65	Chevelle	4412506	1	.32	
65-66	Pass.	3859185	1	.46	
65-66	Impala (S.S.)	3859749	1	.12	seat separator compt. door lock
66-67	Chevy	3886632	1	.38	
66-67	Chevelle	3877811	1	.28	
67	Pass.	3892134	1	.22	inst. panel compt. door lock
67-68	Camaro	3891672	1	.34	
68	Pass.	3916539	1	.34	inst. panel compt. door lock
68-69	Chevelle,				
70-72	Camaro w/floor console	3975845	1	.28	
68	Chevy	3919061	1	.38	
69	Chevy, Camaro,				
70-75	Nova	3984446	1	.28	
69-70	Pass.	3935997	1	.34	
70-72	Chevelle	3980365	1	.40	instrument panel
70-75	Camaro	3975839	1	.34	instrument panel
71-75	Pass.	3980375	1	.40	instrument panel
72-75	Vega, Monza	3994572	1	.36	STRIKER
75	Vega, Monza	346701	1	.36	STRIKER
70-72	Chevelle	3957095	1	.28	STOP, compt. door
73-75	Chevelle	3991793	1	.40	instrument panel

**10.275 HARNESS ASSY.— BRACKET— LAMP UNIT— LENS— HOUSING ASSY.—  
SCREW— SUPPORT— SWITCH ASSY.— WIRE ASSY., Instrument Panel  
Compartment, Seat Separator Compartment and Courtesy**

69	All w/courtesy light,				
70-72	All (exc. Caprice, Kingswood, Conv.)	6297528	1	4.75	courtesy lamp
74-75	Camaro w/aux. lighting	8908277	1	12.60	HARNESS ASSY., frt. seat courtesy lamp
75	Vega, Monza w/glove box light	356180	1	.11	BRACKET
75	Monza (Towne Cpe.)	364090	1	.11	BRACKET, compt. lamp
75	Vega, Monza w/glove box light	994779	1	3.10	LAMP UNIT
64-65	Malibu (S.S.),				
64	El Camino (Custom)	3857332	1	.22	LENS, rear of console

**WINDSHIELD—DOORS—CONTROLS**

**10.275 HARNESS ASSY.— BRACKET— LAMP UNIT— LENS— HOUSING ASSY.— SCREW— SUPPORT— SWITCH ASSY.— WIRE ASSY., Instrument Panel Compartment, Seat Separator Compartment and Courtesy (Con't)**

65	Impala (S.S.) w/4-Spd. ....	3859752	1	.24	LENS, seat separator compt. light .....
66-69	Pass. (Spt. Cpe., Conv.) w/S.S. equip. ....	3877290	1	1.35	LENS, seat separator courtesy light .....
67	Camaro w/floor console .....	3893869	1	1.35	LENS, rear courtesy lamp .....
68-69	Camaro w/floor console .....	3919077	1	.70	LENS, rear courtesy lamp .....
70-73	Camaro w/floor console .....	3975805	1	1.30	LENS, rear seat courtesy lamp .....
70-75	Camaro (C.A.C. w/Aux. Lighting) (w/Deluxe Interior) .....	3983952	1	.34	LENS, instrument panel compartment lamp .
65-66	Taxi .....	5939863	1	1.85	LENS, (door opening warning lamp— (4.260)
66	Impala (S.S.),				
66-67	Caprice (Spt. Cpe.) w/strato bucket,				
70-75	Camaro (C.A.C. w/Deluxe Interior) w/Aux. Lighting .....	3983951	1	1.35	HOUSING ASSY., w/wire, instrument panel compartment lamp .....
68-69	Chevelle,				
74	All .....	3917371	A.R.	.24	SCREW, instr. panel courtesy lamp instr. panel lamp support (7/16" x 5/8") .....
62-63	Chevy,				
67	All (exc. Pass.),				
67-68	Pass. (exc. Spt. Cpe., Conv.),				
67-69	Impala (exc. Conv.) .....				SUPPORT, courtesy lamp, .....
67-69	All (exc. Pass.),				
67-68	Caprice, Conv.,				
70	All,				
65-66	Pass. (Spt. Cpe., Conv.),				
71-75	Nova, Camaro .....	3935929	2	.22	instr. panel courtesy lamp .....
62-69	All .....				SWITCH ASSY., panel light, .....
66-69	Pass. (Spt. Cpe., Conv.) w/strato bucket, S.S. equip. ....	3879595	1	1.55	SWITCH ASSY., seat separator compt. ....
70-72	Chevelle .....	3973627	1	1.20	SWITCH ASSY., inst. panel compt. light ...
72-75	Pass., Nova, Camaro,				
75	Vega, Monza w/glove box light .	1244006	1	.63	SWITCH ASSY., inst. panel compt. light ...
70-75	Camaro (exc. C.A.C.) .....	993982	1	5.25	SWITCH UNIT, instrument panel compartment light .....
73-75	Nova .....	994796	1	3.95	SWITCH UNIT, inst. pnl. comp. light .....
75	Camaro .....	3973637	1	1.25	SWITCH ASSY., inst. pnl. comp. light .....
74-75	Camaro w/interior decor., aux. lighting (exc. C.A.C.) .....	8901594	1	3.15	WIRE ASSY., instr. pnl. compt. lamp .....

**10.351 DOOR, Front (less paint, trim and hardware)**

**PASSENGER**

68	Impala (Spt. Cpe., Conv.) .....	7748887	L.H.	163.00	
68	Spt. Sed. ....	7748914	R.H.	158.00	
68	4-Dr. (exc. Spt. Sed.) .....	7748920	R.H.	159.00	
68	4-Dr. (exc. Spt. Sed.) .....	7748921	L.H.	159.00	
69	Spt. Cpe., Conv. ....	8728782	R.H.	179.00	
71-72	(Spt. Cpe.),				
69	Spt. Cpe., Conv. ....	8728783	L.H.	179.00	
69-70	Spt. Sed. ....	9803452	R.H.	171.00	
69-70	Spt. Sed. ....	9611711	L.H.	4.15	
69-70	Pass. (4-Dr.) (exc. Spt. Sed.) ....	9803451	L.H.	171.00	
69-70	Pass. (4-Dr.) (exc. Spt. Sed.) ....	9803450	R.H.	171.00	
70	(2-Dr.) .....	9803429	L.H.	179.00	
70	(2-Dr.) .....	9803428	R.H.	179.00	
71-72	Pass. (Spt. Sed.) .....	9683462	L.H.		(repl. 9668065) .....
71-72	Pass. (Spt. Sed.) .....	9683455	R.H.	162.00	
71-75	Pass. (4-Dr.) (exc. Spt. Sed.) ....	1664422	L.H.	214.00	
71-75	Pass. (4-Dr.) (exc. Spt. Sed.) ....	1664421	R.H.	214.00	(repl. 9682606) .....
71-75	Pass. (2-Dr.) .....	1661929	L.H.	224.00	
71-74	Pass. (2-Dr.) .....	9682028	R.H.	186.00	
73-75	Pass. (Spt. Sed.) .....	1686102	L.H.	214.00	(repl. 9683462) .....
73-74	Pass. (Spt. Sed.) .....	9683455	R.H.	162.00	
75	Pass. (2-Dr.) .....	1661928	R.H.	224.00	
75	Pass. (Spt. Sed.) .....	1686101	R.H.	214.00	

**CHEVY— NOVA**

68	(4-Dr. Sed.) .....	7742282	R.H.	138.00
68	(4-Dr. Sed.) .....	7742283	L.H.	138.00
68-72	Nova (2-Dr.) .....	9877671	L.H.	146.00
69-72	Nova (4-Dr.) .....	9667874	R.H.	152.00

**WINDSHIELD—DOORS—CONTROLS**

**10.351 DOOR, Front (less paint, trim and hardware) (Con't)**

69-72	Nova (4-Dr.)	9667875	L.H.	152.00	
68-70	(Spt. Cpe.)				
71-72	Nova (2-Dr.)	9873610	R.H.	146.00	
73	Nova (4-Dr.) (1st design) (exc. Taxi)	9612558	R.H.	152.00	(Note 1)
73-74	Nova (Sed.) (2nd design) (exc. Taxi)	9667872	R.H.	152.00	(Note 2)
73-74	Nova (Sed.) (exc. Taxi)	9667873	L.H.	152.00	(Note 2)
73-74	Nova (Taxi)	9667874	R.H.	152.00	(Note 2)
73-74	Nova (Taxi)	9667875	L.H.	152.00	(Note 2)
73-74	Nova (2-Dr.)	9667902	R.H.	165.00	(Note 2)
73-74	Nova (2-Dr.) (2nd design)	9667903	L.H.	165.00	(Note 2)
75	Nova (2-Dr.)	1651753	R.H.	211.00	
75	Nova (2-Dr.)	1651756	L.H.	211.00	
75	Nova (4-Dr.)	1651767	R.H.	222.00	
75	Nova (4-Dr.)	1719774	R.H.	222.00	(Note 3)
75	Nova (4-Dr.)	1719775	L.H.	222.00	(Note 3)

**CHEVELLE**

64-65	Malibu (2-Dr.)	4492507	L.H.	141.00	
66-67	(Spt. Cpe., Conv.)	7661580	R.H.	141.00	
66-67	(4-Dr.) (exc. Spt. Sed.)	7661598	R.H.	138.00	
66-67	(4-Dr.) (exc. Spt. Sed.)	7661599	L.H.	138.00	
68	(Spt. Cpe., Conv.)	7742314	R.H.	141.00	
68	(Spt. Cpe., Conv.)	7742315	L.H.	141.00	
68-72	El Camino	9888121	L.H.	141.00	
68-72	El Camino	9888120	R.H.	141.00	
69	(Spt. Cpe., Conv.)	8716910	R.H.	141.00	
69	(Spt. Cpe., Conv.)	8716911	L.H.	141.00	
68-69	Chevelle (4-Dr.) (exc. Spt. Sed.)				
70-72	Chevelle (Sta. Wag.) (exc. Spt. Sed.)	9898819	L.H.	153.00	
68-69	Chevelle (4-Dr.) (exc. Spt. Sed.)				
70-72	Chevelle (Sta. Wag.)	9898818	R.H.	153.00	
70-72	Chevelle (Spt. Sed.)	9898823	L.H.	138.00	
70-72	Chevelle (Spt. Sed.)	9898822	R.H.	138.00	
70-72	Chevelle (Sed.)	9898821	L.H.	151.00	
70-72	Chevelle (Sed.) (exc. Spt. Sed.)	9898820	R.H.	153.00	
70-72	Monte Carlo	9888161	L.H.	177.00	
70-72	Monte Carlo	9888160	R.H.	177.00	
70-72	Chevelle (Spt. Cpe., Conv.) (exc. Monte Carlo)	9888153	L.H.	153.00	
70-72	Chevelle (Spt. Cpe., Conv.) (exc. Monte Carlo)	9888152	R.H.	153.00	
73	Chevelle (2-Dr.) (exc. Monte Carlo) (1st design)	9623803	L.H.	224.00	(Note 1)
73-75	Chevelle (2-Dr.) (exc. Monte Carlo) (2nd design)	1659553	L.H.	224.00	(Note 2)
73-75	Chevelle (4-Dr.)	9736193	R.H.	192.00	(Note 2)
73-75	Chevelle (4-Dr.)	1659551	L.H.	192.00	(Note 2)
73-74	Monte Carlo	9736195	R.H.	186.00	(Note 2)
73-74	Monte Carlo	9661457	L.H.	186.00	(Note 2)
75	Monte Carlo	1659572	R.H.	224.00	
75	Monte Carlo	1659555	L.H.	224.00	
73-75	Chevelle (2-Dr.) (exc. Monte Carlo)	9699002	R.H.	224.00	

**CAMARO**

67	Camaro	7645892	R.H.	135.00	
67	Camaro	7645893	L.H.	135.00	
68	Camaro	7742292	R.H.	135.00	
68	Camaro	7742293	L.H.	135.00	
69	Camaro	8723785	R.H.	135.00	
69	Camaro	8723786	L.H.	135.00	
70-72	Camaro	9681671	L.H.	160.00	
70-72	Camaro	9681670	R.H.	160.00	
73-74	Camaro	9681671	L.H.	160.00	
73-74	Camaro	9681670	R.H.	160.00	
75	Camaro	1669261	R.H.	214.00	
75	Camaro	1669262	L.H.	214.00	

**VEGA—MONZA**

71-75	Vega (H.B.)	9666493	R.H.	121.00	
71-75	Vega (exc. H.B.)	9686896	L.H.	121.00	window regulator
71-75	Vega (exc. H.B.) (2nd Design)	9666491	R.H.	121.00	(Note 2)

**WINDSHIELD—DOORS—CONTROLS**

**10.351 DOOR, Front (less paint, trim and hardware) (Con't)**

71-75	Vega (H.B.)	9686894	L.H.	121.00	
75	Monza (exc. Towne Cpe.)	1671401	R.H.	166.00	
75	Monza (exc. Towne Cpe.)	1745513	L.H.	166.00	(repl. 1727121)
75	Monza (Towne Cpe.)	1699418	R.H.	121.00	
75	Monza (N.B.)	1699419	L.H.	121.00	

*NOTE 2: (2nd design) To be used on bodies built after Jan. 1, 1973.*

*NOTE 3: When used for jobs with electric windows built prior to Jan. 1975, use window cam 6279352—Group 10.792.*

**10.352 GUARD, Door Edge**

**PASSENGER**

65-66	Pass. (2-Dr.)	3860523	L.H.	4.15	
65-66	Pass. (2-Dr.)	3860524	R.H.	4.15	
65-66	Pass. (4-Dr.)	3860525	L.H.	4.15	front
65-66	Pass. (4-Dr.)	3860526	R.H.	4.15	front
65-66	Pass. (4-Dr.)	3860527	L.H.	4.15	rear
65-66	Pass. (4-Dr.)	3860528	R.H.	4.15	rear
67-68	2-Dr.	3926707	L.H.	3.80	front
67-68	2-Dr.	3926708	R.H.	3.80	front
68	4-Dr.	3926709	L.H.	3.80	front
67	4-Dr. (exc. Caprice), Caprice (Spt. Sed.),				
68	4-Dr.	3926710	R.H.	3.80	front
67	4-Dr. (exc. Caprice), Caprice (Spt. Sed.),				
68	4-Dr. (exc. Caprice Sta. Wag.)	3926711	L.H.	3.80	rear
68	4-Dr. (exc. Caprice Sta. Wag.)	3926712	R.H.	3.80	rear
69-70	Pass. (2-Dr.)	3939333	L.H.	4.15	front
69-70	Pass. (2-Dr.)	3939334	R.H.	4.15	front
69-70	Pass. (4-Dr.)	3939335	L.H.	4.15	front
69-70	Pass. (4-Dr.)	3939336	R.H.	4.15	front
69-70	Pass. (4-Dr.)	3939337	L.H.	4.15	rear
69-70	Pass. (4-Dr.)	3939338	R.H.	4.15	rear
71-72	(Spt. Cpe.)	9611708	R.H.	4.15	
73-75	Pass. (2-Dr.)	9611708	R.H.	4.15	
74-75	Pass. (2-Dr.)	9611709	L.H.	4.15	
71-72	(4-Dr.),				
73	Pass. (Spt. Cpe.),				
73-75	Pass. (4-Dr.)	9611707	L.H.	4.15	front
71-75	(4-Dr.)	9611706	R.H.	4.15	front
71-74	(Sed.),				
75	Pass. (Spt. Sed.)	9611710	R.H.	4.15	rear
71-74	(Sed.),				
75	Pass. (Spt. Sed.)	9611711	L.H.	4.15	rear
74-75	Pass. (Sta. Wag.)	9611712	R.H.	4.15	rear
71-75	(Sta. Wag.)	9611713	L.H.	4.15	rear
71-73	(Sta. Wag.)	9835288	R.H.	4.15	rear
75	Pass. (Sed.) (exc. Spt. Sed.)	1668405	R.H.	4.15	GUARD, rear
75	Pass. (Sed.) (exc. Spt. Sed.)	1668406	L.H.	4.15	GUARD, rear

**CHEVY—NOVA**

62-65	(2-Dr.)	3796843	L.H.	4.15	
62-65	(2-Dr.)	3796844	R.H.	4.15	
66-67	(2-Dr.)	3876643	L.H.	4.15	
66-67	(2-Dr.)	3876644	R.H.	4.15	
66-67	(4-Dr.)	3876646	R.H.	4.15	front
68-72	(Spt. Cpe.),				
73-74	Nova (2-Dr.)	3919093	L.H.	3.80	
68-72	(Spt. Cpe.),				
73-74	Nova (2-Dr.)	3919094	R.H.	3.80	
68-74	(4-Dr.)	3919095	L.H.	3.80	front
68-74	(4-Dr.)	3919096	R.H.	3.80	front
68-74	(4-Dr.)	3919097	L.H.	3.80	rear
68-74	(4-Dr.)	3919098	R.H.	3.80	rear

**CHEVELLE**

64-65	(2-Dr.)	3841279	L.H.	4.15	
64-65	(2-Dr.)	3841280	R.H.	4.15	
66-67	(2-Dr.)	3880961	L.H.	4.15	front
66-67	(2-Dr.)	3880962	R.H.	4.15	front
68-69	(2-Dr.),				
70-72	El Camino	3926701	L.H.	3.80	
68-69	(2-Dr.),				

**WINDSHIELD—DOORS—CONTROLS**

**10.352 GUARD, Door Edge (Con't)**

70-72	El Camino	3926702	R.H.	3.80	
68-69	(4-Dr.),				
70-72	(Sta. Wag.)	3926703	L.H.	3.80	front
68-69	(4-Dr.),				
70-72	(Sta. Wag.)	3926704	R.H.	3.80	front
68-69	(4-Dr.),				
70-72	(Sta. Wag.)	3926705	L.H.	3.80	rear
68-69	(4-Dr.),				
70-72	(Sta. Wag.)	3926706	R.H.	3.80	rear
70-72	Monte Carlo	3963241	L.H.	3.80	
70-72	Monte Carlo	3963242	R.H.	3.80	
70-72	(2-Dr.) (exc. Monte Carlo, El Camino)	3963243	L.H.	3.80	
70-72	(2-Dr.) (exc. Monte Carlo, El Camino)	3963244	R.H.	3.80	
70-72	(4-Dr.) (exc. Sta. Wag.)	3963246	R.H.	3.80	front
70-72	(4-Dr.) (exc. Sta. Wag.)	3963248	R.H.	3.80	rear
73-75	Chevelle 2-Dr. (exc. Monte Carlo)	9870703	R.H.	3.80	
73-75	Chevelle 2-Dr. (exc. Monte Carlo)	9870704	L.H.	3.80	
73-75	Monte Carlo	9870705	R.H.	3.80	
73-75	Monte Carlo	9870706	L.H.	3.80	
73-75	Chevelle 4-Dr.	9870701	R.H.	3.80	front
73-75	Chevelle 4-Dr.	1744007	L.H.	4.20	front
73-75	Chevelle 4-Dr.	9870707	R.H.	3.80	rear
73-75	Chevelle 4-Dr.	9870708	L.H.	3.80	rear

**CAMARO**

67-68	Camaro	3921837	L.H.	3.80	
67-68	Camaro	3921838	R.H.	3.80	
69	Camaro	3949501	L.H.	4.15	
69	Camaro	3949502	R.H.	4.15	
70-75	Camaro	3974595	L.H.	3.80	
70-75	Camaro	3974596	R.H.	3.80	

**VEGA— MONZA**

71-75	Vega	9825098	R.H.	3.80	
71-75	Vega	9825099	L.H.	3.80	
75	Monza (exc. Towne Cpe.)	9737428	R.H.	2.45	
75	Monza (exc. Towne Cpe.)	9737429	L.H.	2.45	
75	Monza (Towne Cpe.)	1704397	R.H.	3.80	
75	Monza (Towne Cpe.)	1704398	L.H.	3.80	

**10.352A GUARD UNIT— PACKAGE— CLIP, Door Edge**

70-72	Monte Carlo,				
72-74	Pass., Chevelle (exc. Sta. Wag.) Nova, Camaro, Vega, Monza	994695		5.95	cut to length (repl. 994330)
70-75	Camaro	993964	1	7.50	
71-75	Pass. (2-Dr.)	994139	1	N.L.	
71-75	Pass. (Sta. Wag.)	994141	1	11.70	
71-75	Pass. (4-Dr.) (exc. Sta. Wag.)	994140	1	N.L.	
71-75	Vega	994071	1	7.50	GUARD UNIT (stainless steel)
75	Monza (exc. Towne Cpe.)	994753	1	7.50	GUARD UNIT
75	Monza (N.B.)	995105	1	7.35	GUARD UNIT
75	Pass., Chevy, Chevelle, Camaro, Vega	994695	1	5.95	GUARD UNIT (vinyl)
73-75	Chevelle 4-Dr.	994499	1	11.70	PACKAGE, front and rear door
73-75	Chevelle (2-Dr.) (exc. Monte Carlo)	994498	1	7.50	PACKAGE, front door
73-75	Monte Carlo	994497	1	7.50	PACKAGE, front door
75	Pass. (4-Dr.) (exc. Spt. Sed.)	994738	1	11.70	PACKAGE, front and rear door
75	Nova (2-Dr.)	982011	1	7.50	PACKAGE, front door
75	Nova (4-Dr.)	982012	1	11.70	PACKAGE, front and rear door
62-67	Pass., Chevy,				
64-65	Chevelle,				
67	All	3745836	A.R.	.11	CLIP

**10.354 TRANSFER— STRIPE— DECAL, Also See Group 8.800 for Stencil Units**

**PASSENGER**

*NOTE: 1966 Caprice wood grain finish tailgate listed in Group 12.180A as moulding unit.*

66	Caprice (Sta. Wag.)	3995735	A.R.	RL/3.20	(walnut) (roll) (Note 1)
66	Caprice (Sta. Wag.)	3995735	1	RL/3.20	left, rear door outer panel (walnut)— (8.132)
67	Caprice (Sta. Wag.)	7649483	1	18.40	left, rear fender panel (walnut)
67-68	Caprice (Sta. Wag.)	6259399	A.R.	RL/4.75	(walnut) (roll) (Note 1)

**WINDSHIELD—DOORS—CONTROLS**

**10.354 TRANSFER— STRIPE— DECAL, Also See Group 8.800 for Stencil Units  
(Con't)**

68	Caprice (Sta. Wag.)	7734799	1	3.95	left, rear of rear fender (walnut)
69	Estate Wag.				left, rear fender outer panel
69	Estate Wag.	8728278	1	11.60	right, front door outer panel
69	Estate Wag.	8728279	1	11.60	left, front door outer panel
69	Estate Wag.	8728932	1	11.60	right, rear door outer panel
69	Estate Wag.	8728933	1	11.60	left, rear door outer panel
69	Estate Wag.				tailgate outer panel,
69	Estate Wag.	325007	1	33.75	right, rear of rear fender outer panel (Note 1, 2)
69	Estate Wag.	8737485	1	3.80	left, rear of rear fender outer panel
70-71	Kingswood (Estate Wag.)	6259401 A.R.		RL/4.75	roll (90") (24' wide)— (8.132) (Note 1, 2)
71	Kingswood (Estate Wag.)	9840779	1	11.10	tailgate outer
72	Kingswood, Concours, Estate	231619	1	RL/4.27	frt. door, rear door, qtr. panel tailgate (82" roll)
73-74	All w/Woodgrain	6258806	1	RL/4.75	frt. door, rear door, qtr. panel tailgate (90" roll)— (8.132)
75	All w/Woodgrain	1154151	1	RL/7.35	(8.132)

**CHEVELLE**

67-68	Concours	7731844	1	11.75	tailgate outer
68-69	Concours, El Camino (exc. Deluxe, S.S.)	6259399 A.R.		RL/4.75	tailgate outer (walnut) (roll) (Note 1, 2)
68-69	Concours	325007 A.R.		33.75	roll— (8.132) (Note 1, 2)
70-71	Concours (Estate Wag.)	6259401 A.R.		RL/4.75	front & rear doors (82" roll) (Note 1, 2)
67	(S.S.)	3913641 A.R.		3.00	<b>STRIPE</b> , door (black) (2 strips 1/8" and 3/8") (Note 1)
67	(S.S.)	3913643 A.R.		3.20	<b>STRIPE</b> , door (white) (2 strips 1/8" and 3/8") (Note 1)
68-69	(S.S.)	3934104 A.R.		3.70	<b>STRIPE</b> , rear quarter, door (black)— (8.132) (Note 1)
68	(S.S.)	3934118 A.R.		3.35	<b>STRIPE</b> , rear quarter and doors (red)— (8.132) (Note 1)
68	(S.S.)	3934117 A.R.		4.65	<b>STRIPE</b> , rear quarter and doors (white)— (8.132) (Note 1)
69	Malibu, El Camino w/body accent stripe	3950080	2	3.70	<b>STRIPE</b> , side door upper (red)
69	Malibu, El Camino w/body accent stripe	3950068	2	3.45	<b>STRIPE</b> , side door (black)
69	Chevelle w/body accent stripe	3950071	2	3.45	<b>STRIPE</b> , body side upper rear (black)
69	El Camino w/body accent stripe	3950073	2	3.45	<b>STRIPE</b> , body side upper rear (black)
69	Malibu, El Camino w/body accents stripe	3950074	2	3.45	<b>STRIPE</b> , side door upper (white)
69	Malibu w/body accent stripe	3950077	2	3.45	<b>STRIPE</b> , body side rear upper (white)
69	Malibu w/body accent stripe	3950078	2	3.45	<b>STRIPE</b> , body side rear upper (red)
69	El Camino w/body accent stripe (deluxe),	3950079	2	3.45	<b>STRIPE</b> , body side rear upper (white)
69	Malibu (Spt. Cpe.),				
69	El Camino w/body accent stripe	3957000	2	3.75	<b>STRIPE</b> , side door upper (blue)
71-72	Chevelle (Hvy. Chevy)	6259365 L.H.		13.40	<b>STRIPE</b> , side door (black)
71-72	Chevelle (Hvy. Chevy)	6259363 L.H.		13.40	<b>STRIPE</b> , side door rear quarter panel (white)
71-72	Chevelle (Hvy. Chevy)	6259364 R.H.		13.40	<b>STRIPE</b> , side door rear quarter panel (white)
71-72	Chevelle (Hvy. Chevy)	6261941 L.H.		4.70	<b>STRIPE</b> , rear quarter panel (black)
71-72	Chevelle (Hvy. Chevy)	6259366 R.H.		13.40	<b>STRIPE</b> , rear quarter panel (black)
73-75	Chevelle	6259373 L.H.		12.20	<b>STRIPE UNIT</b> , body accent (white) (Note 4)— (8.132)
73-75	Chevelle	6259374 R.H.		12.20	<b>STRIPE UNIT</b> , body accent (white) (Note 4)— (8.132)
73-75	Chevelle	6259375 L.H.		12.20	<b>STRIPE UNIT</b> , body accent (black) (Note 4)— (8.132)
73-75	Chevelle	6259376 R.H.		12.20	<b>STRIPE UNIT</b> , body accent (black) (Note 4)— (8.132)
73-75	El Camino	6259367 L.H.		12.20	<b>STRIPE UNIT</b> , body accent (white) (Note 4)— (8.132)
73-75	El Camino	6259368 R.H.		12.20	<b>STRIPE UNIT</b> , body accent (white) (Note 4)— (8.132)
73-75	El Camino	6259369 L.H.		12.20	<b>STRIPE UNIT</b> , body accent (black) (Note 4)— (8.132)
73-75	El Camino	6259370 R.H.		12.20	<b>STRIPE UNIT</b> , body accent (black) (Note 4)— (8.132)
73-75	El Camino (Custom)	336386	1	9.10	<b>STRIPE UNIT</b> , end gate accent (black)
73-75	El Camino (Custom)	336394	1	9.10	<b>STRIPE UNIT</b> , end gate accent (white)
71-72	Chevelle (Hvy. Chevy)	6261943	1	5.25	<b>DECAL</b> , hood panel (white)— (8.015)

**WINDSHIELD—DOORS—CONTROLS**

**10.354 TRANSFER— STRIPE— DECAL, Also See Group 8.800 for Stencil Units  
(Con't)**

71-72	Chevelle (Hvy. Chevy)	6261944	1	5.25	DECAL, hood panel (black)— (8.015)
<b>CAMARO</b>					
68	(350, 396)				STRIPE, door (black),
69	Camaro	3957064	A.R.	4.85	hood and door (Note 3)
68	(350, 396)				STRIPE, door (white),
69	Camaro	3957065	2	4.85	hood and door
<b>NOVA</b>					
71-72	Nova w/Rally Package	6259358	R.H.	15.60	STRIPE, body accent
71-72	Nova w/Rally package	6259355	L.H.	15.60	STRIPE, side (white) (Note 4)
71-72	Nova w/Rally package	6259356	R.H.	15.60	STRIPE, side (white) (Note 4)
71-72	Nova w/Rally package	6274357	L.H.	4.10	STRIPE, door, side (black)
71-72	Nova w/Rally package	6259357	L.H.	15.60	STRIPE, rear quarter, body accent (black)
71-72	Nova w/Rally package	6259358	R.H.	15.60	STRIPE, door side, rear quarter (black)
71-72	Nova w/Rally package	327557	1	14.75	STRIPE, rear end panel (white)
71-72	Nova w/Rally package	6274365	1	14.75	STRIPE, rear end panel (black)
73-74	Nova	6259359	L.H.	20.50	STRIPE UNIT, body accent (white) (Note 4)— (8.132)
73-74	Nova	6259360	R.H.	20.50	STRIPE UNIT, body accent (white) (Note 4)— (8.132)
73-74	Nova	6259361	L.H.	20.50	STRIPE UNIT, body accent (black) (Note 4)— (8.132)
73-74	Nova	6259362	R.H.	20.50	STRIPE UNIT, body accent (black) (Note 4)— (8.132)
71-72	Nova w/Rally Package	3998848	1	2.75	DECAL, hood panel (white)— (8.015)
71-72	Nova w/Rally Package	3998846	1	2.75	DECAL, hood panel (black)— (8.015)
<b>VEGA-MONZA</b>					
71-73	Vega Sta. Wag.	9887853	1	6.40	TRANSFER (black)
71-73	Vega Sta. Wag.	9887854	1	6.40	TRANSFER (white)
73-74	Vega Sta. Wag.	6258806	A.R.	RL/4.75	TRANSFER, woodgrain— (8.132)
73-74	Vega (Cpe.)	9692326	R.H.	7.60	TRANSFER, front fender (silver-black-silver)— (8.132)
73-74	Vega (Cpe.)	9692327	L.H.	7.60	TRANSFER, front fender (silver-black-silver)— (8.132)
73-74	Vega (Cpe.)	9692338	R.H.	10.40	TRANSFER, front door (silver-black-silver)
73-74	Vega (Cpe.)	9692339	L.H.	10.40	TRANSFER, front door (silver-black-silver)
73-74	Vega (Cpe.)	9692350	R.H.	21.60	TRANSFER, rear fender (silver-black-silver)
73-74	Vega (Cpe.)	9692351	L.H.	21.60	TRANSFER, rear fender (silver-black-silver)
73-74	Vega (Cpe.)	9692328	R.H.	7.60	TRANSFER, front fender (black-white-black)— (8.132)
73-74	Vega (Cpe.)	9692329	L.H.	7.60	TRANSFER, front fender (black-white-black)— (8.132)
73-74	Vega (Cpe.)	9692340	R.H.	10.40	TRANSFER, front door (black-white-black)
73-74	Vega (Cpe.)	9692341	L.H.	10.40	TRANSFER, front door (black-white-black)
73-74	Vega (Cpe.)	9692352	R.H.	21.60	TRANSFER, rear fender (black-white-black)
73-74	Vega (Cpe.)	9692353	L.H.	21.60	TRANSFER, rear fender (black-white-black)
73-74	Vega (Cpe.)	9692330	R.H.	8.75	TRANSFER, front fender (red-white-blue)— (8.132)
73-74	Vega (Cpe.)	9692331	L.H.	8.75	TRANSFER, front fender (red-white-blue)— (8.132)
73-74	Vega (Cpe.)	9692342	R.H.	11.95	TRANSFER, front door (red-white-blue)
73-74	Vega (Cpe.)	9692343	L.H.	11.95	TRANSFER, front door (red-white-blue)
73-74	Vega (Cpe.)	9692354	R.H.	25.00	TRANSFER, rear fender (red-white-blue)
73-74	Vega (Cpe.)	9692355	L.H.	25.00	TRANSFER, rear fender (red-white-blue)
73-74	Vega (Cpe.)	9692332	R.H.	8.75	TRANSFER, front fender (red-white-green)— (8.132)
73-74	Vega (Cpe.)	9692333	L.H.	8.75	TRANSFER, front fender (red-white-green)— (8.132)
73-74	Vega (Cpe.)	9692344	R.H.	11.95	TRANSFER, front door (red-white-green)
73-74	Vega (Cpe.)	9692345	L.H.	11.95	TRANSFER, front door (red-white-green)
73-74	Vega (Cpe.)	9692356	R.H.	25.00	TRANSFER, rear fender (red-white-green)
73-74	Vega (Cpe.)	9692357	L.H.	25.00	TRANSFER, rear fender (red-white-green)
73-74	Vega (Cpe.)	9692334	R.H.	8.75	TRANSFER, front fender (red-yellow-orange)— (8.132)
73-74	Vega (Cpe.)	9692335	L.H.	8.75	TRANSFER, front fender (red-yellow-orange)— (8.132)
73-74	Vega (Cpe.)	9692346	R.H.	11.95	TRANSFER, front door (red-yellow-orange)
73-74	Vega (Cpe.)	9692347	L.H.	11.95	TRANSFER, front door (red-yellow-orange)
73-74	Vega (Cpe.)	9692358	R.H.	25.00	TRANSFER, rear fender (red-yellow-orange)
73-74	Vega (Cpe.)	9692359	L.H.	25.00	TRANSFER, rear fender (red-yellow-orange)
73-74	Vega (Cpe.)	9692336	R.H.	7.60	TRANSFER, front fender (white-black-white)— (8.132)



**WINDSHIELD—DOORS—CONTROLS**

**10.354 TRANSFER— STRIPE— DECAL, Also See Group 8.800 for Stencil Units  
(Con't)**

73-74	Vega (Cpe.)	9692337	L.H.	7.60	TRANSFER, front fender (white-black-white)— (8.132)
73-74	Vega (Cpe.)	9692348	R.H.	10.40	TRANSFER, front door (white-black-white)
73-74	Vega (Cpe.)	9692349	L.H.	10.40	TRANSFER, front door (white-black-white)
73-74	Vega (Cpe.)	9692360	R.H.	21.60	TRANSFER, rear fender (white-black-white)
73-74	Vega (Cpe.)	9692361	L.H.	21.60	TRANSFER, rear fender (white-black-white)
74	Vega (Sta. Wag., Cpe.)	9734704	2	8.75	TRANSFER, front door (black)
74	Vega (Sta. Wag., Cpe.)	9734705	2	8.75	TRANSFER, front door (white)
74	Vega (Sta. Wag., Cpe.)	9734707	L.H.	17.50	TRANSFER, rear fender (black)
74	Vega (Sta. Wag., Cpe.)	9734706	R.H.	17.50	TRANSFER, rear fender (black)
74	Vega (Sta. Wag., Cpe.)	9734709	L.H.	17.50	TRANSFER, rear fender (white)
74	Vega (Sta. Wag., Cpe.)	9734708	R.H.	17.50	TRANSFER, rear fender (white)
74-75	Vega (Sta. Wag., Cpe.)	9734700	R.H.	13.80	TRANSFER, frt. fender (black)— (8.132)
74-75	Vega (Sta. Wag., Cpe.)	9734701	L.H.	13.80	TRANSFER, frt. fender (black)— (8.132)
74-75	Vega (Sta. Wag., Cpe.)	9734702	R.H.	13.80	TRANSFER, frt. fender (white)— (8.132)
74-75	Vega (Sta. Wag., Cpe.)	9734703	L.H.	13.80	TRANSFER, frt. fender (white)— (8.132)
74	Vega (Cpe.) w/Spirit of America	1676748		5.95	TRANSFER, rear end strip right side (red)
74-75	Vega (Cpe.) w/Rally Stripe	1676749	L.H.	4.90	TRANSFER, rear end stripe and emblem (red)
74-75	Vega (Cpe.) w/frt. & body si. stripe	1657534	R.H.	9.95	TRANSFER, frt. whl. opng. (gold)
74-75	Vega (Cpe.) w/frt. & body si. stripe	1657535	L.H.	9.95	TRANSFER, frt. whl. opng. (gold)
75	All Vega, Monza w/woodgrain	1154151	A.R.	RL/7.35	TRANSFER, dr. qtr. t/gate— (8.132)
74-75	Vega (Sta. Wag.)	9734699	1	9.65	DECAL, back door outer panel (white)
74-75	Vega (Sta. Wag.)	9734698	1	9.65	DECAL, back door outer panel (black)

NOTE 1: May be used on various panels by cutting as required.  
NOTE 2: Also in Chevelle subgroup, or Passenger subgroup.  
NOTE 3: May be necessary to trim as required.  
NOTE 4: Consists of all striping or one complete side.

**10.355 DEFLECTOR, Front Panel Access Hole**

62-67	All (exc. Pass.),				
65-68	Pass.,				
70-74	All (exc. Camaro)	4780514	4	.83	door and quarter inner panel water
68	Caprice (Spt. Sed.) w/vacuum door lock,				
69	Chevelle w/vacuum door lock,				
71-72	Chevelle	7795988	R.H.	.83	right, inner at water lock
68	Caprice (Spt. Sed.) w/vacuum door lock,				
69	Chevelle w/vacuum door lock,				
71-72	Chevelle	7795989	L.H.	.81	left, inner at water lock
68	Chevelle (Sta. Wag.),				
70-72	Chevelle (Sta. Wag.) w/std. t/gate	7739964	1	.37	t/gate inner panel water
69-72	Chevelle (Sta. Wag.) w/dual t/gate	8742226	1	.44	t/gate inner panel water
70-74	Camaro	8801363	R.H.	.52	right, frt. door inner panel water
70-74	Camaro	8801364	L.H.	.52	left, frt. door inner panel water

**10.373 DOOR, Rear (less paint, trim and hardware)**

**PASSENGER**

67	4-Dr. Sed. (exc. Spt. Sed.)	7660415	L.H.	159.00	
68	Spt. Sed.	7748966	R.H.	159.00	
68	Spt. Sed.	7748967	L.H.	159.00	
68	Sta. Wag.	7748969	L.H.	159.00	
68	4-Dr. Sed. (exc. Spt. Sed.)	7748974	R.H.	159.00	
68	4-Dr. Sed. (exc. Spt. Sed.)	7748975	L.H.	159.00	
69-70	Sta. Wag.	9803718	R.H.	171.00	
69-70	Sta. Wag.	9803719	L.H.	171.00	
69-70	4-Dr. Sed. (exc. Spt. Sed.)	9803720	R.H.	171.00	
69-70	4-Dr. Sed. (exc. Spt. Sed.)	9803721	L.H.	171.00	
69-70	Spt. Sed.	9803722	R.H.	171.00	
69-70	Spt. Sed.	9803723	L.H.	171.00	
71-73	Pass. (Spt. Sed.)	9668104	R.H.	178.00	(repl. 9655976) (Note 2)
71-73	Pass. (Sed.) (exc. Spt. Sed.)	9668106	R.H.	178.00	(Note 2)
71-73	Pass. (Sed.) (exc. Spt. Sed.)	9668107	L.H.	178.00	(Note 2)
71-73	Pass. (Spt. Sed.)	9668105	L.H.	178.00	(Note 2)
71-72	Pass. (Sta. Wag.),				
74	Pass. (Sed.) (exc. Spt. Sed.)	9679551	R.H.	178.00	
74	Pass. (Sed.) (exc. Spt. Sed.)	9679552	L.H.	178.00	

**WINDSHIELD—DOORS—CONTROLS**

**10.373 DOOR, Rear (less paint, trim and hardware) (Con't)**

74	Pass. (Spt. Sed.)	9679563 R.H.	178.00
74	Pass. (Spt. Sed.)	9679564 L.H.	178.00
74-75	Pass. (Sta. Wag.)	1662616 R.H.	240.00
71-74	Pass. (Sta. Wag.)	9679871 L.H.	240.00
75	Pass. (Sed.) (exc. Spt. Sed.)	1664002 R.H.	214.00
75	Pass. (Sed.) (exc. Spt. Sed.)	1664003 L.H.	214.00
75	Pass. (Spt. Sed.)	1663465 R.H.	238.00
75	Pass. (Spt. Sed.)	1663466 L.H.	238.00
75	Pass. (Sta. Wag.)	1696719 L.H.	240.00

**CHEVY—NOVA**

68-72	(4-Dr.)	9875967 R.H.	130.00
68-72	(4-Dr.)	9875968 L.H.	130.00
73	Nova (1st design)	9624988 R.H.	149.00
73-74	Nova (Sed.) (2nd design)	9667904 R.H.	149.00
73-74	Nova (Sed.)	9667905 L.H.	149.00
75	Nova (Sedan)	1651774 R.H.	211.00
75	Nova (Sedan)	1651775 L.H.	211.00

(Note 2)

**CHEVELLE**

66-67	(Spt. Sed.)	7661604 R.H.	138.00
68-69	(Spt. Sed.)	8727948 R.H.	138.00
68-69	(4-Dr. Sed.) (exc. Spt. Sed.)	8745318 R.H.	138.00
68-69	(4-Dr. Sed.) (exc. Spt. Sed.)	8745319 L.H.	138.00
70-72	Chevelle (Sed.) exc. Spt. Sed.	9898851 L.H.	151.00
70-72	Chevelle (Sed.) exc. Spt. Sed.	9898850 R.H.	151.00
70-72	Chevelle (Sta. Wag.)	9898849 L.H.	151.00
70-72	Chevelle (Sta. Wag.)	9898848 R.H.	151.00
70-72	Chevelle (Spt. Sed.)	9898852 R.H.	151.00
71-72	Chevelle (Spt. Sed.)	9898853 L.H.	151.00
73-75	Chevelle	9661526 R.H.	188.00
73-75	Chevelle	9661527 L.H.	188.00

(Note 2)

(Note 2)

*NOTE 1: (1st design) To be used on bodies built before Jan. 1, 1973.*

*NOTE 2: (2nd design) To be used on bodies built after Jan. 1, 1973.*

**10.450 HINGE ASSY.—BOX—PLATE—STRAP, Front Door, Upper**

62-66	Chevy	7580738	2	10.15	
64-65	Chevelle	4409743	2	10.60	
66-67	Camaro, Chevelle	7642529	2	11.30	
67	Chevy	7642731	2	11.30	
68-72	Chevelle	7722170	2	9.90	
68	Camaro	8736244	R.H.	9.90	
68	Camaro	8736245	L.H.	9.90	
68	Chevy	7722192	R.H.	9.90	
68	Chevy	7722193	L.H.	9.90	
69-70	Pass.	8720943	R.H.	12.55	
69-70	Pass.	8720944	L.H.	12.55	
69	Camaro,				
69-75	Nova	9817407	L.H.	9.90	
69-75	Nova	9817406	R.H.	9.90	
70-75	Camaro,				
71-75	Pass.	9868458	L.H.	13.90	
70-75	Camaro,				
71-75	Pass.	9868457	R.H.	13.90	
73-75	Chevelle	9617202	L.H.	10.60	
73-75	Chevelle	9617201	R.H.	10.60	
71-75	Vega	9840410	4	2.35	front door hinge anchor door side
75	Monza (exc. Towne Cpe.)	1651285	2	1.25	front door hinge anchor door side
65-66	Pass.	5719425	2	2.50	BOX, hinge
67-68	Pass.	9710342	2	2.50	BOX, hinge
70-75	Nova	8712081	2	1.20	PLATE, hinge anchor door side
73-74	Nova	7707492	2	1.65	PLATE, upper hinge anchor (body side)
75	Nova	1697100	R.H.	1.90	PLATE, anchor upper and lower hinge body side
65-66	Pass.	5719426	2	7.50	STRAP, hinge
67	Pass.	9712246	1	8.25	STRAP, right, hinge
67-68	Pass.	9714726	2	8.25	STRAP, hinge
70-75	Nova	9712701	2	3.70	STRAP, hinge (female) (weld on type)
70-75	Nova	9713144	L.H.	4.90	STRAP, hinge (male) (weld on type)
70-75	Nova	9713145	R.H.	4.90	STRAP, hinge (male) (weld on type)
71-75	Vega, Monza	9838168	2	6.65	STRAP ASSY., front door upper hinge door side
71-72	Vega, Monza (1st design)	9822191	L.H.	7.25	STRAP ASSY., front door upper hinge body side (Note 1)

**WINDSHIELD—DOORS—CONTROLS**

**10.450 HINGE ASSY.— BOX— PLATE— STRAP, Front Door, Upper (Con't)**

71-72	Vega, Monza (1st design) . . . . .	9822190 R.H.	7.25	STRAP ASSY., front door upper hinge body side (Note 1) . . . . .
72	Vega, Monza (2nd design),			
73-75	Vega . . . . .	9624204 2	8.20	STRAP ASSY., front door upper hinge body side (Note 1) . . . . .
75	Monza . . . . .	9736666 2	8.20	STRAP ASSY., upper body side . . . . .
75	Monza . . . . .	9736672 2	7.25	STRAP ASSY., upper door side . . . . .
75	Monza . . . . .	9736682 2	6.30	STRAP & BUSHING ASSY., upper door side . . . . .

*NOTE 1: First design parts are used with torque rod and retainer while the second design part eliminates the torque rod and retainer.*

**10.454 HINGE— BOX— PLATE— STRAP, Front Door, Lower**

62-67	Chevy . . . . .	4841356 R.H.	15.70	
62-67	Chevy . . . . .	4841357 L.H.	15.70	
64-65	Chevelle . . . . .	4506971 R.H.	15.70	
64-65	Chevelle . . . . .	4506972 L.H.	15.70	
66-67	Chevelle, Camaro . . . . .	7663424 R.H.	14.75	
66-67	Chevelle, Camaro . . . . .	7663425 L.H.	14.75	
68-72	Chevelle . . . . .	7722087 R.H.	16.20	
68-72	Chevelle . . . . .	7722088 L.H.	16.20	
68	Camaro . . . . .	8736248 R.H.	16.20	
68	Camaro . . . . .	8736249 L.H.	16.20	
68	Chevy . . . . .	7722194 R.H.	16.20	
69	Chevy, Camaro,			
70-75	Nova . . . . .	9817408 R.H.	16.20	
69	Camaro,			
68-75	Nova . . . . .	9817409 L.H.	16.20	
73-75	Chevelle . . . . .	9625376 2	7.90	
71-72	Vega, Monza . . . . .	9861611 L.H.	3.80	front door hold open rod . . . . .
71-72	Vega, Monza . . . . .	9861612 R.H.	3.80	front door hold open rod . . . . .
69-75	Pass.,			
70-75	Camaro . . . . .	9816926 2	14.25	
65-66	Pass. . . . .	5719594 R.H.	6.15	BOX . . . . .
65-66	Pass. . . . .	5719595 L.H.	6.15	BOX . . . . .
67	Pass. . . . .	9709314 R.H.	5.95	BOX, hinge . . . . .
67	Pass. . . . .	9709315 L.H.	5.95	BOX, hinge . . . . .
68	Pass. . . . .	9713086 R.H.	5.60	BOX, hinge . . . . .
68	Pass. . . . .	9713087 L.H.	5.60	BOX, hinge . . . . .
70-75	Nova . . . . .	7722315 2	1.95	PLATE, hinge anchor door side . . . . .
70-74	Nova . . . . .	7707492 4	1.65	PLATE, front door upper and lower hinge anchor body side . . . . .
65-66	Pass. . . . .	5719598 R.H.	10.55	STRAP, hinge . . . . .
65-66	Pass. . . . .	5719599 L.H.	10.55	STRAP, hinge . . . . .
67	Pass. . . . .	9709318 R.H.	10.85	STRAP, hinge . . . . .
67	Pass. . . . .	9709319 L.H.	10.85	STRAP, hinge . . . . .
68	Pass. . . . .	9713090 R.H.	10.15	STRAP, hinge . . . . .
68	Pass. . . . .	9713091 L.H.	10.15	STRAP, hinge . . . . .
70-75	Nova . . . . .	9712707 L.H.	4.50	STRAP, hinge (female) (weld on type) . . . . .
70-75	Nova . . . . .	9712706 R.H.	4.50	STRAP, hinge (female) (weld on type) . . . . .
70-75	Nova . . . . .	9713141 L.H.	5.85	STRAP, hinge (male) (weld on type) . . . . .
70-75	Nova . . . . .	9713140 R.H.	5.85	STRAP, hinge (male) (weld on type) . . . . .
71-75	Vega . . . . .	9822188 2	5.95	STRAP ASSY., front door lower hinge body side . . . . .
71-75	Vega . . . . .	9861610 2	4.20	STRAP ASSY., front door lower hinge door side . . . . .
75	Monza . . . . .	9736678 2	5.95	STRAP ASSY., lower hinge body side . . . . .
75	Monza . . . . .	9736676 2	8.50	STRAP ASSY., lower hinge door side . . . . .

**10.455 SPRING— LINK— RIVET— ROLLER ASSY., Front Door Hinge Hold Open**

65-66	Pass. . . . .	5719561 2	1.20	lower . . . . .
65-67	Chevelle, Camaro . . . . .	9704190 2	1.20	lower . . . . .
67-68	Pass. . . . .	9709320 2	1.10	lower . . . . .
68-72	Chevelle . . . . .	9712668 2	1.05	
70-75	Nova . . . . .	9713143 2	.40	lower hinge (weld on type) . . . . .
71-72	Vega, Monza . . . . .	9861614 L.H.	2.95	
71-72	Vega, Monza . . . . .	9861613 R.H.	2.70	
72-75	Vega . . . . .	9627931 1	1.15	SPRING, front door hinge upper strap . . . . .
75	Monza . . . . .	9736668 2	.40	SPRING, hinge strap upper body side . . . . .
70-75	Nova . . . . .	9712663 2	.76	LINK, lower hinge detent . . . . .
70-74	Nova . . . . .	9720330 2	.28	RIVET, lower hinge detent link . . . . .
70-75	Nova . . . . .	9724207 2	2.85	ROLLER ASSY., lower hinge . . . . .

**WINDSHIELD—DOORS—CONTROLS**

**10.456 HINGE, Rear Door, Upper**

**PASSENGER**

65-68	Spt. Sed.	7642815	L.H.	14.40	
65-68	Spt. Sed.	7642814	R.H.	14.40	(repl. 4493110)
68-70	4-Dr. (exc. Spt. Sed.)	7722180	R.H.	13.50	
68-70	4-Dr. (exc. Spt. Sed.)	7722181	L.H.	13.50	
69-70	Spt. Sed.	8719901	R.H.	13.80	
69-70	Spt. Sed.	8719902	L.H.	13.80	
71-75	Pass. (4-Dr.)	9825393	L.H.	11.10	
71-75	Pass. (4-Dr.)	9825392	R.H.	11.10	

**CHEVY**

62-67	(4-Dr.)	7663430	2	11.05	
68-75	(4-Dr.)	7722196	R.H.	10.85	
68-75	(4-Dr.)	7722197	L.H.	10.85	

**CHEVELLE**

68-72	(Spt. Sed.)	7722171	R.H.	12.25	
68-72	(Spt. Sed.)	7722172	L.H.	12.25	
68-72	(4-Dr.) (exc. Spt. Sed.)	7722173	R.H.	10.60	
68-72	(4-Dr.) (exc. Spt. Sed.)	7722174	L.H.	10.60	
73-75	Chevelle	9875591	L.H.	10.60	
73-75	Chevelle	9875590	R.H.	10.60	

**10.460 HINGE— LINK— SPRING, Rear Door, Lower**

**PASSENGER**

65-67	(4-Dr.)	7664860	R.H.	17.90	(Note 1)
65-67	(4-Dr.)	7664861	L.H.	17.90	(Note 1)
68	(4-Dr.)	7722182	R.H.	19.80	
68	(4-Dr.)	7722183	L.H.	19.80	
69-70	(4-Dr.)	8720773	R.H.	18.95	
69-70	(4-Dr.)	8720774	L.H.	18.95	
71-75	Pass. (4-Dr.)	9881999	L.H.	19.95	
71-75	Pass. (4-Dr.)	9881998	R.H.	19.95	

*NOTE 1 Also in Chevelle section.*

**CHEVY**

62-67	(4-Dr.)	7667156	R.H.	12.00	
67	(4-Dr.)	7667157	L.H.	12.00	
68-72	(4-Dr.),				
73-74	Nova (exc. Taxi rear door check)	7762385	R.H.	13.10	
68-72	(4-Dr.),				
73-74	Nova (exc. Taxi rear door check)	7762386	L.H.	13.10	
73-74	Nova (Taxi)	7722176	L.H.	19.80	
73-74	Nova (Taxi)	7722175	R.H.	19.80	
75	Nova w/rear door check	1696026	R.H.	24.15	
75	Nova w/rear door check	1696027	L.H.	24.15	

**CHEVELLE**

64-67	(4-Dr.) (exc. Spt. Sed.)	7663432	L.H.	15.35	
64-67	(4-Dr.) (exc. Spt. Sed.)	7663431	R.H.	15.35	
66-67	(Spt. Sed.)	7664860	R.H.	17.90	(Note 1)
66-67	(Spt. Sed.)	7664861	L.H.	17.90	(Note 1)
68-72	(4-Dr.)	7722175	R.H.	19.80	
68-72	(4-Dr.)	7722176	L.H.	19.80	
73-75	Chevelle	9875417	L.H.	11.10	
73-75	Chevelle	9875416	R.H.	11.10	

*NOTE 1 Also in Pass. Section.*

65-67	Pass. (4-Dr.),				
66-67	Malibu (Spt. Sed.)	5719297	2	.96	SPRING, hinge
68-70	Pass. (4-Dr.)	9627931	2	1.15	SPRING, hinge
72-75	Pass.	9828342	2	.58	SPRING, hinge

**10.463 BOLT— SCREW, Door Hinge to Hinge Pillar**

64-67	Chevelle, Camaro				front door lower hinge to door,
64-70	Chevy, Chevelle (4-Dr.)				rear door hinge to door bolt,
65-70	Pass. (4-Dr.) (exc. Spt. Sed.)				rear door lower hinge to door bolt,
68-70	Pass. (Spt. Sed.),				
71	All				rear door upper hinge to body and door bolt,
71-75	Vega,				
74	All (4-Dr.)	7667647	A.R.	.18	rear door, upper or lower

**WINDSHIELD—DOORS—CONTROLS**

**10.463 BOLT— SCREW, Door Hinge to Hinge Pillar (Con't)**

65-73	All	4405445 A.R.	.21	front door lower and upper hinge to body bolt (w/L/washer) ( <sup>5</sup> / <sub>16</sub> "— 18 x 1) ( <sup>3</sup> / <sub>8</sub> " O.D.)
65-67	Pass. (4-Dr.),			
66-67	Malibu (Spt. Sed.)	4532721 6	.18	rear door, lower hinge to body bolt (w/L/washer) ( <sup>5</sup> / <sub>16</sub> "— 18 x 1 <sup>1</sup> / <sub>2</sub> ")
67-68	Pass.	7668482 A.R.	.18	front door hinge to body end door
68-75	All	9659235 A.R.	.05	front door hinge to door bolt (w/washer) (— R/ <sub>16</sub> "— 18 x 1 <sup>1</sup> / <sub>4</sub> ") (275-M steel)
67-70	Chevy,			
67	Chevelle, Camaro,			
68	Chevelle			<b>SCREW</b> , upper hinge to body and door, upper hinge to door, front upper hinge to body and door
68-69	Pass.,			
70-72	Pass., Chevelle, Nova (4-Dr.)	7640995 A.R.	.18	rear door lower hinge to body and door ( <sup>5</sup> / <sub>16</sub> "— 18 x 1 <sup>1</sup> / <sub>64</sub> ")
68-70	All (exc. Pass.)			<b>SCREW</b> , upper or lower hinge to door and body,
68-70	Pass. (4-Dr.),			
71-73	All	8750275 A.R.	.24	rear door upper or lower door or body
68-73	All (4-Dr.)	8750774 A.R.	.22	upper hinge to body or tailgate
69-73	Pass.,			
71-72	Vega, Monza	8746511 2	.18	<b>SCREW</b> , upper or lower hinge to door inner

**10.464 BUSHING, Door Hinge**

62-75	All	4110660 A.R.	.16	front and rear dr. hinge pin
71-75	Vega, Monza	9822198 8	.18	frt. dr. hinge dr. side strap

**10.466 PIN— RING, Door Hinge**

62-67	Chevy, Chevelle	4		front and rear
65-67	Pass. (4-Dr.)	5716449 2	.28	rear lower
65-70	Pass. (4-Dr.),			
68-75	Nova (4-Dr.)	9715083 2	.58	rear, upper <sup>11</sup> / <sub>32</sub> " x <sup>3</sup> / <sub>32</sub> "
65-67	Pass.	5719209 4	.58	front, upper and lower
67	All,			
73-75	Chevelle (4-Dr.)	9715454 A.R.	.37	rr. dr. upr.
68-75	Pass. (4-Dr.),			
73-75	Nova (4-Dr.) (Taxi)	9712826 2	.37	rr. dr. lwr. hinge
68-69	Chevy, Camaro			front upper and lower hinge,
68	Pass.			front door lower hinge,
70	Nova	9710702 2	.58	front door upper and lower
68-75	Chevelle (4-Dr.)	9715522 2	.58	rear, upper hinge
70	Pass. (4-Dr.)	9716887 2	.56	rear door lower
70-72	Chevelle,			
72-75	Pass., Camaro	9712804 A.R.	.58	front door upper & lwr., rr. dr. upr.
71-75	Nova	9806723 4	.34	front door upper & lower
71-75	Vega, Monza	9655646 4	.98	
70-74	Nova,			
71-74	Vega, Monza	9421540 4	.18	<b>RING</b> , front door upper and lower hinge pin retainer

**10.470 LOCK, Front Door**

**PASSENGER**

65-66	4-Dr.	7617603 R.H.	19.85	
65-66	4-Dr.	7617604 L.H.	19.85	
65-66	2-Dr.	4548368 R.H.	19.85	
65-66	2-Dr.	4548369 L.H.	19.85	
67	2-Dr.	7730474 R.H.	19.85	
67	2-Dr.	7730475 L.H.	19.85	
67	4-Dr.	7730536 R.H.	19.85	
67	4-Dr.	7730537 L.H.	19.85	
68	2-Dr.	7730078 R.H.	19.85	(Note 1)
68	2-Dr.	7730079 L.H.	19.85	(Note 1)
68	4-Dr.	7740486 R.H.	19.85	(Note 1)
68	4-Dr.	7740487 L.H.	19.85	(Note 1)
69-70	4-Dr.	8800007 R.H.	18.95	(Note 1)
69	4-Dr.	8800008 L.H.	18.95	(Note 1)
69-70	2-Dr.	8800004 R.H.	18.95	(Note 1)
69	2-Dr.	8800005 L.H.	18.95	(Note 1)
70	4-Dr.	8800009 L.H.	19.85	(Note 1)
70	2-Dr.	8800006 L.H.	19.85	(Note 1)
71-75	Pass. (4-Dr.)	9827989 L.H.	21.10	

**WINDSHIELD—DOORS—CONTROLS**

**10.470 LOCK, Front Door (Con't)**

<b>71-75</b>	Pass. (4-Dr.) . . . . .	<b>9827988</b>	R.H.	21.10
<b>71-75</b>	Pass. (Spt. Cpe., Conv.) . . . . .	<b>9866775</b>	L.H.	19.90
<b>71-75</b>	Pass. (Spt. Cpe., Conv.) . . . . .	<b>9866774</b>	R.H.	19.90

*NOTE 1 Also in Chevelle section.*

**CHEVY—NOVA**

<b>62</b>	Chevy . . . . .	<b>4803908</b>	R.H.	19.85
<b>62</b>	Chevy . . . . .	<b>4803909</b>	L.H.	19.85
<b>63-65</b>	Chevy,			
<b>66-67</b>	(2-Dr.) . . . . .	<b>7670396</b>	R.H.	19.85
<b>63-65</b>	Chevy,			
<b>66-67</b>	(2-Dr.) . . . . .	<b>7670397</b>	L.H.	19.85
<b>66-67</b>	(4-Dr.) . . . . .	<b>7670394</b>	R.H.	19.85
<b>66-67</b>	(4-Dr.) . . . . .	<b>7670395</b>	L.H.	19.85
<b>68</b>	(2-Dr.) . . . . .	<b>7728387</b>	R.H.	19.85
<b>68</b>	(2-Dr.) . . . . .	<b>7728388</b>	L.H.	19.85
<b>68</b>	(4-Dr.) . . . . .	<b>7740483</b>	L.H.	19.85
<b>69-70</b>	(2-Dr.) . . . . .	<b>8720401</b>	R.H.	19.85
<b>69-70</b>	(2-Dr.) . . . . .	<b>8720402</b>	L.H.	19.85
<b>69</b>	(4-Dr.) . . . . .	<b>8800007</b>	R.H.	18.95
<b>69</b>	(4-Dr.) . . . . .	<b>8800008</b>	L.H.	18.95
<b>70</b>	(4-Dr.) . . . . .	<b>8800009</b>	L.H.	19.85
<b>71-75</b>	Nova (2-Dr.) . . . . .	<b>9829707</b>	L.H.	19.85
<b>71-75</b>	Nova (2-Dr.) . . . . .	<b>9829706</b>	R.H.	19.85
<b>71-72</b>	Nova (4-Dr.) . . . . .	<b>9829702</b>	R.H.	19.85
<b>71-72</b>	Nova (4-Dr.) . . . . .	<b>9829703</b>	L.H.	19.85
<b>73-75</b>	Nova (4-Dr.) . . . . .	<b>1698464</b>	L.H.	25.50
<b>73-75</b>	Nova (4-Dr.) . . . . .	<b>1698463</b>	R.H.	25.50

*NOTE 1 Also in Camaro Section*

*NOTE 2 Also in Chevelle Section*

(Note 1) . . . . .  
 (Note 1) . . . . .  
 (Note 2) . . . . .  
 (Note 2) . . . . .  
 (Note 1) . . . . .

**CHEVELLE**

<b>64-65</b>	Chevelle . . . . .	<b>4545370</b>	R.H.	18.15
<b>64-65</b>	Chevelle . . . . .	<b>4545371</b>	L.H.	18.15
<b>66</b>	(exc. Spt. Sed.) . . . . .	<b>4548366</b>	R.H.	19.85
<b>66</b>	(exc. Spt. Sed.) . . . . .	<b>4548367</b>	L.H.	19.85
<b>67</b>	(exc. Spt. Sed.) . . . . .	<b>7656082</b>	R.H.	19.85
<b>67</b>	(exc. Spt. Sed.) . . . . .	<b>7656083</b>	L.H.	19.85
<b>68</b>	(2-Dr.) . . . . .	<b>7730078</b>	R.H.	19.85
<b>68</b>	(2-Dr.) . . . . .	<b>7730079</b>	L.H.	19.85
<b>68</b>	(4-Dr.) . . . . .	<b>7740486</b>	R.H.	19.85
<b>68</b>	(4-Dr.) . . . . .	<b>7740487</b>	L.H.	19.85
<b>69-70</b>	(2-Dr.) . . . . .	<b>8800004</b>	R.H.	18.95
<b>69</b>	(2-Dr.) . . . . .	<b>8800005</b>	L.H.	18.95
<b>69</b>	(4-Dr.) . . . . .	<b>8800007</b>	R.H.	18.95
<b>69</b>	(4-Dr.) . . . . .	<b>8800008</b>	L.H.	18.95
<b>70</b>	(2-Dr.) . . . . .	<b>8800006</b>	L.H.	19.85
<b>70</b>	(4-Dr.) . . . . .	<b>8800009</b>	L.H.	19.85
<b>71-72</b>	Chevelle, Nova (4-Dr.) . . . . .	<b>9829703</b>	L.H.	19.85
<b>71-72</b>	Chevelle, Nova (4-Dr.) . . . . .	<b>9829702</b>	R.H.	19.85
<b>71-72</b>	Chevelle (2-Dr.) . . . . .	<b>9829705</b>	L.H.	19.85
<b>71-72</b>	Chevelle (2-Dr.) . . . . .	<b>9829704</b>	R.H.	19.85
<b>73-75</b>	Chevelle . . . . .	<b>9667168</b>	L.H.	19.85
<b>73-75</b>	Chevelle . . . . .	<b>9667167</b>	R.H.	19.85

*NOTE 1 Also in Pass. Section*

(Note 1) . . . . .  
 (Note 1) . . . . .  
 (Note 1) . . . . .  
 (Note 1) . . . . .  
 (Note 1) . . . . .  
 (Note 1) . . . . .  
 (Note 1) . . . . .  
 (Note 1) . . . . .  
 (Note 1) . . . . .  
 (Note 1) . . . . .  
 (Note 1) . . . . .  
 (Note 1) . . . . .

**CAMARO**

<b>67</b>	Camaro . . . . .	<b>7648724</b>	R.H.	19.85
<b>67</b>	Camaro . . . . .	<b>7730535</b>	L.H.	19.85
<b>68</b>	Camaro . . . . .	<b>7740484</b>	R.H.	19.85
<b>68</b>	Camaro . . . . .	<b>7740485</b>	L.H.	19.85
<b>69</b>	Camaro . . . . .	<b>8720401</b>	R.H.	19.85
<b>69</b>	Camaro . . . . .	<b>8720402</b>	L.H.	19.85
<b>70-72</b>	Camaro . . . . .	<b>9801702</b>	L.H.	19.85
<b>70-72</b>	Camaro . . . . .	<b>9801701</b>	R.H.	19.85
<b>73-75</b>	Camaro . . . . .	<b>9801702</b>	L.H.	19.85
<b>73-75</b>	Camaro . . . . .	<b>9801701</b>	R.H.	19.85

(Note 1) . . . . .  
 (Note 1) . . . . .

**VEGA—MONZA**

<b>71-75</b>	Vega, Monza . . . . .	<b>9817427</b>	L.H.	13.10
<b>71-75</b>	Vega, Monza . . . . .	<b>9817426</b>	R.H.	13.10

*NOTE 1 Also in Chevy Section.*

**10.473 LOCK, Rear Door**

<b>63-67</b>	Chevy (4-Dr.) . . . . .	<b>7670398</b>	R.H.	15.85
--------------	-------------------------	----------------	------	-------

**WINDSHIELD—DOORS—CONTROLS**

**10.473 LOCK, Rear Door (Con't)**

63-67	Chevy (4-Dr.)	7670399	L.H.	15.85	
64-67	Chevelle (4-Dr.),				
65-67	Pass.	7730540	R.H.	15.85	
65-67	Pass., Chevelle (4-Dr.)	7730541	L.H.	15.85	
68-70	All (4-Dr.)	8800010	R.H.	15.85	(Note 1)
68-70	All (4-Dr.)	8800011	L.H.	15.15	(Note 1)
71-75	Pass.,				
73-75	Chevelle	9869138	L.H.	15.50	
71-75	Pass.,				
73-75	Chevelle	9869137	R.H.	16.55	
71-72	Chevelle,				
71-75	Nova	9829709	L.H.	16.90	
71-72	Chevelle,				
71-75	Nova	9829708	R.H.	16.90	

*NOTE 1 Use on Pass. vehicles built after body date code 10A, use on Chevy vehicles built after body date code 2A.*

*NOTE 2 Used on vehicles built prior to body date code 10A.*

*NOTE 3 Use on vehicles built prior to body date code 02A.*

**10.474 SPRING—CLIP—PIN—SCREW, Front and Rear Door Lock**

64-67	Pass., Chevelle,				
68-70	Camaro, Chevelle (2-Dr.),				
68-70	Chevy, Chevelle (4-Dr.),				
71-72	All (exc. Pass.),				
71-74	Vega, Monza,				
73-75	Nova (4-Dr.),				
73-75	Nova, Camaro (2-Dr.)	9886517	R.H.	.24	front, over center
64-67	Pass., Chevelle (4-Dr.)	9712745	2	.24	rear, push button return
64-70	Chevelle (Spt. Sed.)				right, front door lock over center,
65-70	Pass.				left and right, front, over center,
66-70	Camaro (Spt. Cpe., Conv.),				
71-72	All (exc. Pass.),				
71-74	Vega, Monza,				
73-75	Nova (4-Dr.),				
73-75	Nova, Camaro (2-Dr.)	9886516	1	.24	left front door lock over center
71-75	Pass.,				
73-75	Chevelle, Nova	9886515	L.H.	.16	front and rear door lock over center
71-75	Pass.,				
73-75	Chevelle, Nova	9886514	R.H.	.22	front and rear door lock over center
65-68	Chevelle (exc. Spt. Sed.),				
65-66	Pass., Chevelle (4-Dr.),				
67	Pass. (4-Dr.),				
67	Chevelle (Spt. Sed.),				
70	All (4-Dr.),				
72	All (4-Dr.) (exc. Pass.),				
73-75	Nova (4-Dr.)	9724184	R.H.	.32	front door lock push button return
67	Pass. (4-Dr.),				
67	Chevelle (Spt. Sed.),				
70	All (4-Dr.),				
72	All (4-Dr.) (exc. Pass.),				
73-75	Nova (4-Dr.)	9724185	L.H.	.28	front door lock push button return
68-70	All (4-Dr.),				
73-75	Nova (4-Dr.)	9712002	2	.22	rear door lock push button return
72-75	Pass.,				
73-75	Chevelle	9827950	2	.22	front door lock push button return
65-68	Pass., Camaro (2-Dr.),				
69-71	All (2-Dr.)				front push button return,
72	All (2-Dr.) (exc. Pass.),				
71-75	Vega, Monza,				
73-75	Nova, Camaro (2-Dr.)	9720761	L.H.	.24	door lock, push button return
65-72	All (2-Dr.),				
71-75	Vega, Monza,				
73-75	Nova, Camaro (2-Dr.)	9720760	R.H.	.31	door lock, push button return
71-72	All (4-Dr.) (exc. Pass.)	9712002	2	.22	rear door, push button return
71-72	Pass.	9827960	A.R.	.33	front & rear door lock fork return
62-67	Chevy	5711576	2	.18	CLIP, lock spring (front door)
64-65	Chevelle				CLIP, lock spring (front door),
62-64	Chevy, Chevelle (4-Dr.),				
65-68	Chevy (4-Dr.),				
65-72	Chevelle, Camaro,				
65-75	Pass.,				
73-75	All	5712678	A.R.	.21	door lock spring (front and rear)
73-75	Pass., Chevelle	9827961	2	.12	PIN, frt. dr. lk. push btn. return
62-75	All	8788000	A.R.	.21	SCREW (repl. 8714746)

**WINDSHIELD—DOORS—CONTROLS**

**10.485 TANK ASSY.— ACTUATOR ASSY.— CLIP— PLATE— REINFORCEMENT—  
RETAINER— ROD— SWITCH ASSY.— TEE— VALVE ASSY., Vacuum  
Power Door Lock**

**PASSENGER**

67	Pass.				
68-69	Pass. (1st design)	3917463	1	9.05	
	<i>NOTE 1 Located on door lock.</i>				
67	2-Dr. (2nd design)				ACTUATOR ASSY., right, front door
68	2-Dr.	7731146	R.H.	9.75	vacuum lock (Note 2)
67	2-Dr. (2nd design)				ACTUATOR ASSY., left, front door
68	2-Dr.	7731147	L.H.	9.75	vacuum lock (Note 2)
67	4-Dr. (2nd design)				ACTUATOR ASSY., right, front door
68	4-Dr.	8730957	R.H.	15.75	ACTUATOR ASSY., front door vacuum lock (Note 2)
67-68	4-Dr.	8730958	L.H.	15.75	ACTUATOR ASSY., front door vacuum lock (Note 2)
67	4-Dr. (2nd design)				ACTUATOR ASSY., right, rear door,
68	4-Dr.	7731226	R.H.	9.75	vacuum lock (Note 2)
67	4-Dr. (2nd design)				ACTUATOR ASSY., left, rear door
68	4-Dr.	7731227	L.H.	9.75	vacuum lock (Note 2)
	<i>NOTE 2 Located on door panel.</i>				
69	4-Dr.	8731008	R.H.	15.75	ACTUATOR ASSY., right, front door vacuum lock
69	4-Dr.	8731009	L.H.	15.75	ACTUATOR ASSY., left, front door vacuum lock
69	Pass.	8738433	R.H.	15.15	ACTUATOR ASSY., right, rear door vacuum lock
69	Pass.	8738434	L.H.	15.15	ACTUATOR ASSY., left, rear door vacuum lock
70-75	Pass. (2-Dr.)	8791129	R.H.	23.35	ACTUATOR ASSY., front
70-75	Pass. (2-Dr.)	8791128	L.H.	23.35	ACTUATOR ASSY., front
70	Pass. (4-Dr.)	8791127	L.H.	23.35	ACTUATOR ASSY., front
70	Pass. (4-Dr.)	8791126	R.H.	22.85	ACTUATOR ASSY., front
70	Pass. (4-Dr.)	8791131	L.H.	22.85	ACTUATOR ASSY., rear
70	Pass. (4-Dr.)	8791130	R.H.	22.85	ACTUATOR ASSY., rear
71-75	Pass. (4-Dr.)	9836225	L.H.	24.35	ACTUATOR ASSY., front
71-75	Pass. (4-Dr.)	9836224	R.H.	24.35	ACTUATOR ASSY., front
71-75	Pass. (4-Dr.)	9835517	L.H.	24.35	ACTUATOR ASSY., rear
71-75	Pass. (4-Dr.)	9835516	R.H.	24.35	ACTUATOR ASSY., rear

**CHEVELLE**

69	(2-Dr.)	8730955	R.H.	15.75	ACTUATOR ASSY., front door vacuum lock
69	(2-Dr.)	8730956	L.H.	15.75	ACTUATOR ASSY., front door vacuum lock
69	(4-Dr.)	8730957	R.H.	15.75	ACTUATOR ASSY., front door vacuum lock
69	(4-Dr.)	8730958	L.H.	15.75	ACTUATOR ASSY., front door vacuum lock
70-72	Chevelle (2-Dr.)	8790969	L.H.	23.35	ACTUATOR ASSY., front
70-72	Chevelle (2-Dr.)	8790968	R.H.	23.35	ACTUATOR ASSY., front
70-72	Chevelle (4-Dr.)	8790971	L.H.	22.85	ACTUATOR ASSY., front
70-72	Chevelle (4-Dr.)	8790970	R.H.	23.35	ACTUATOR ASSY., front
70-72	Chevelle (4-Dr.)	8790973	L.H.	23.35	ACTUATOR ASSY., rear
70-72	Chevelle (4-Dr.)	8790972	R.H.	23.35	ACTUATOR ASSY., rear
73-75	Chevelle (2-Dr.)	8791129	R.H.	23.35	ACTUATOR, front
73-75	Chevelle (2-Dr.)	8791128	L.H.	23.35	ACTUATOR, front
73-75	Chevelle (4-Dr.)	9606887	2	23.35	ACTUATOR, rear door
73-75	Chevelle (4-Dr.)	9662889	L.H.	23.35	ACTUATOR, front door
73-75	Chevelle (4-Dr.)	9662888	R.H.	23.35	ACTUATOR, front door

**CHEVY— NOVA**

75	Nova (4-Dr.)	1652896	2	21.65	ACTUATOR, front door
75	Nova (2-Dr.)	9606887	2	23.35	ACTUATOR, front door
75	Nova (4-Dr.)	9606887	2	23.35	ACTUATOR, rear door

**CAMARO**

75	Camaro	8790968	R.H.	23.35	ACTUATOR, front door
75	Camaro	8790969	L.H.	23.35	ACTUATOR, front door

**VEGA— MONZA**

75	Monza (exc. Towne Cpe.)	1717692	2		ACTUATOR
----	-------------------------	---------	---	--	----------

**PASSENGER**

**CHEVELLE**



**WINDSHIELD—DOORS—CONTROLS**

**10.485 ■ TANK ASSY.— ACTUATOR ASSY.— CLIP— PLATE— REINFORCEMENT—  
RETAINER— ROD— SWITCH ASSY.— TEE— VALVE ASSY., Vacuum  
Power Door Lock (Con't)**

70-74	Pass., Chevelle w/electric door lock,				
75	All	9722397	4	.11	CLIP, front door lock control switch ret. . . .
70	All	7762203	2	.11	CLIP (10.565) . . . . .
70-74	Pass., Chevelle w/elect. door lock	8799901	2	.32	REINFORCEMENT, front door trim pad at switch . . . . .
67-69	Pass., Chevelle	4787541	2	.24	RETAINER, control valve . . . . .
70-72	Chevelle (2-Dr.)	8791977	L.H.	.34	ROD, actuator to lock, left . . . . .
70-72	Chevelle (2-Dr.)	8791976	R.H.	.28	ROD, actuator to lock, right . . . . .
70-72	Chevelle (4-Dr.)	8797646	L.H.	.32	ROD, left, actuator to lock . . . . .
70-72	Chevelle (4-Dr.)	8797645	R.H.	.32	ROD, right, actuator to lock . . . . .
73-75	Chevelle (2-Dr.)	9873797	2	.38	ROD, actuator to lock, front door . . . . .
73-75	Chevelle (4-Dr.)	9872742	2	.32	ROD, actuator to lock, front door . . . . .
75	Nova (4-Dr.)	1651233	R.H.	.29	ROD, actuator to lock front door . . . . .
75	Nova (4-Dr.)	1651234	L.H.	.29	ROD, actuator to lock front door . . . . .
75	Nova (2-Dr.)	1652898	2	.34	ROD, actuator to lock front door . . . . .
75	Nova (4-Dr.)	1688214	R.H.	2.35	ROD ASSY., rear door elect. lock . . . . .
75	Nova (4-Dr.)	1688215	L.H.	2.35	ROD ASSY., rear door elect. lock . . . . .
75	Monza (Towne Cpe.)	1718873	2		ROD, actuator to lock . . . . .
70	Pass., Chevelle	8792174	2	10.20	SWITCH ASSY., front door lock control on trim pad . . . . .
71-72	Pass., Chevelle,				
75	All	9825444	2	11.30	SWITCH ASSY., front door lock control on trim pad . . . . .
67-69	Pass. w/retrac. h/lamp cover	3926844	1	.34	TEE, tank hose— (2.760) . . . . .
67	Pass.				VALVE ASSY., right, front door vacuum, . . . . .
68-69	Pass. (exc. Caprice)				lock control on door trim pad, . . . . .
68-69	Caprice (exc. Spt. Cpe.)	4871142	1	7.25	left, valve assy. . . . .
67	Pass.				VALVE ASSY., left, front door vacuum, . . . . .
68-69	Pass. (exc. Caprice)				lock control on door trim pad, . . . . .
68-69	Caprice (exc. Spt. Cpe.)				right, valve assy., . . . . .
69	Chevelle	4871143	1	7.25	left, front door vacuum lock . . . . .

**10.500 CONTROL— SILENCER— SPRING— WASHER; Door Lock Remote**

62-65	Chevy	4404572	R.H.	3.60	front . . . . .
62-65	Chevy	4404573	L.H.	3.70	left, front . . . . .
65	Chevelle,				
66-67	Chevelle (exc. Spt. Sed.)	4410759	L.H.	3.70	door lock remote . . . . .
65-67	Biscayne, Bel Air,				
66-67	Malibu (Spt. Sed.),				
67	Camaro (Std.)	4469683	R.H.	3.70	front and rear doors . . . . .
65-67	Biscayne, Bel Air,				
66-67	Malibu (Spt. Sed.),				
67	Camaro (Std.)	4469684	L.H.	3.70	assy., front and rear doors . . . . .
65-67	Impala	4505857	R.H.	3.75	assy., front and rear doors . . . . .
65-67	Impala	4505858	L.H.	3.70	assy., front and rear doors . . . . .
66	Chevy	7600345	L.H.	3.60	front . . . . .
67	Camaro	7660551	R.H.	3.75	
67	Chevy	7661001	R.H.	8.20	front . . . . .
67	Chevy	7715528	L.H.	8.20	front . . . . .
68	Camaro w/deluxe trim	8726277	R.H.	3.50	
68-69	Camaro w/deluxe trim	8726278	L.H.	3.55	
68	Camaro,				
68	Chevelle (exc. Malibu, Concours, S.S.),				
68-70	Bel Air, Biscayne,				
69-70	Brookwood, Townsman,				
69-70	Chevelle,				
71-72	Chevelle (exc. Monte Carlo, Conv.)	8789692	R.H.	3.80	
68	Camaro,				
68	Chevelle (exc. Malibu, Concours, S.S.),				
68-70	Bel Air, Biscayne,				
69-70	Brookwood, Townsman,				
69-70	Chevelle,				
71-72	Chevelle (exc. Monte Carlo, Conv.)	8789693	L.H.	3.80	
68	El Camino (Custom),				
68	Malibu, Concours (4-Dr.),				
69-70	Impala, Caprice, Kingswood,				
71-72	Monte Carlo	8789690	R.H.	3.70	

**WINDSHIELD—DOORS—CONTROLS**

**10.500 CONTROL— SILENCER— SPRING— WASHER, Door Lock Remote  
(Con't)**

68	El Camino (Custom),				
68	Malibu Concours (4-Dr.),				
69-70	Impala, Caprice, Kingswood,				
71-72	Monte Carlo	8789691	L.H.	3.70	
68-75	Nova	8789684	R.H.	3.40	front
68-75	Chevy	8789685	L.H.	3.70	front
68-72	Chevy (4-Dr.)	8789686	R.H.	3.40	rear (Note 1)
68-71	Chevy (4-Dr.),				
72-74	Nova (4-Dr.)	8789687	L.H.	3.40	rear
68	Impala, Caprice, Kingswood,				
68-69	Malibu (Spt. Mdls.)	8789688	R.H.	3.70	
68	Impala, Caprice, Kingswood,				
68-69	Malibu (Spt. Mdls.)	8789689	L.H.	3.75	
	<i>NOTE 1 Use on vehicles built after body date code 02A.</i>				
	<i>NOTE 2 Use on vehicles built prior to body code 02A.</i>				
68	Camaro,				
69	Pass. w/remote dr. lk.	8726276	2	.44	SPRING, control assy.
69	Camaro	8728943	2	.70	SPRING, control assy.
65-70	Pass.,				
65-69	Malibu (exc. Spt. Sed.),				
71-72	Chevelle, Nova	7591000	A.R.	.12	WASHER, spindle, front and rear door

**10.506 ROD, Door Lock Remote Control Connecting**

**PASSENGER**

68	2-Dr.	7798493	L.H.	1.00	frt. dr. lock remote cont. to lock
68	4-Dr.	7798498	R.H.	.52	rear to lock (Note 1)
	<i>NOTE 1 Use on vehicles built after body date code 10A.</i>				
69-70	2-Dr.	8723628	R.H.	.63	front to lock
69-70	2-Dr.	8723629	L.H.	.63	front to lock
69-70	4-Dr.	8727923	L.H.	.58	front to lock
69-70	4-Dr.	8746498	L.H.	.76	rear door lock remote control to lock
71-72	Pass. (exc. Spt. Cpe., Conv.),				
73-75	Pass. (4-Dr.)	9876543	L.H.	.91	front to lock (Note 1)
71-72	Pass. (exc. Spt. Cpe., Conv.),				
73-75	Pass. (4-Dr.)	9876542	R.H.	.81	front to lock (Note 2)
71-75	Pass. (4-Dr.) (Sta. Wag.)	9876540	R.H.	1.20	rear to lock (Note 2)
	<i>NOTE 1 End has 90 degree bend.</i>				
71-72	Pass. (Sed.) (2nd design),				
73-75	Pass. (Sed.)	9876539	L.H.	1.05	rear to lock (Note 2)
71-72	Pass. (Sed.) (2nd design)	9876538	R.H.	1.05	rear to lock (Note 2)
71	Pass. (Sed.) (1st design),				
71-75	Pass. (Sta. Wag.) (2nd design)	9876541	L.H.	1.20	rear to lock (Note 2)
71-75	Pass. (2-Dr.) (2nd design)	9876545	L.H.	.70	front to lock (repl. 9837038) (Note 2)
71-75	Pass. (2-Dr.) (2nd design)	9876544	R.H.	.70	front to lock (repl. 9837037) (Note 2)
	<i>NOTE 2 Rod end is S shaped.</i>				

**CHEVY**

68-74	(4-Dr.)	7728894	R.H.	.52	front lock remote cont. to lock
68-74	(4-Dr.)	7728895	L.H.	.71	front lock remote control to lock
68-74	(2-Dr.)	7733786	R.H.	1.10	front remote control to lock
68-74	(2-Dr.)	7733787	L.H.	1.10	front remote control to lock
68-74	(4-Dr.)	7790811	R.H.	.52	rear control to lock (Note 2)
68-74	(4-Dr.)	7790812	L.H.	.52	rear control to lock (Note 2)
75	Nova (4-Dr.)	1651228	R.H.	.65	front to lock
75	Nova (4-Dr.)	1651229	L.H.	.65	front to lock
75	Nova (2-Dr.)	1651230	R.H.	.65	front to lock
75	Nova (2-Dr.)	1651231	L.H.	.65	front to lock
75	Nova (4-Dr.)	1651232	2	.48	rear to lock
	<i>NOTE 2 Use on vehicles built after body date code 02A.</i>				

**CHEVELLE**

68-72	(4-Dr.)	7798488	R.H.	.53	front remote control to lock
68-72	(4-Dr.)	7798489	L.H.	.76	front remote control to lock
68-72	(4-Dr.)	7798494	R.H.	.76	rear remote control to lock
68-72	(4-Dr.)	7798495	L.H.	.96	rear remote control to lock
68-72	(2-Dr.)	7726920	R.H.	.38	front control to lock
68-72	(2-Dr.)	7798487	L.H.	.76	front control to lock
70-72	Chevelle (2-Dr.) (exc. El Camino)	8791978	R.H.	.63	front remote control to lock
70-72	Chevelle (2-Dr.) (exc. El Camino)	8791979	L.H.	.63	front remote control to lock
73-75	Chevelle (4-Dr.)	9628217	L.H.	.46	rear to lock
73-75	Chevelle (4-Dr.)	9628216	R.H.	.46	rear to lock
73-75	Chevelle (4-Dr.)	9872912	L.H.	.78	front to lock

**WINDSHIELD—DOORS—CONTROLS**

**10.506 ROD, Door Lock Remote Control Connecting (Con't)**

73-75	Chevelle (4-Dr.)	9872911 R.H.	.53	front to lock
73-75	Chevelle (2-Dr.)	9889486 L.H.	.70	front lock to lock
73-75	Chevelle (2-Dr.)	9889485 R.H.	.34	front lock to lock
73-75	Monte Carlo	9612835 L.H.	.63	cylinder to door lock
73-75	Monte Carlo	9612834 R.H.	.63	cylinder to door lock

**CAMARO**

68-69	Camaro	7798484 R.H.	.52	front remote control to lock
68-69	Camaro	7798485 L.H.	.76	front remote control to lock
70-72	Camaro	8800995 L.H.	.71	frt. to lock
70-72	Camaro	8800994 R.H.	.70	frt. to lock
73-74	Camaro	8800995 L.H.	.71	frt. to lock
73-74	Camaro	8800994 R.H.	.70	frt. to lock
75	Camaro	1671463 L.H.	.65	front to lock
75	Camaro	1671462 R.H.	.65	front to lock
75	Camaro	9813797 R.H.	.34	front to lock
75	Camaro	9813798 L.H.	.37	front to lock

**VEGA—MONZA**

71-75	Vega	9827202 L.H.	1.55	front door lock remote control to lock
71-75	Vega	9827201 R.H.	1.55	front door lock remote control to lock
75	Monza	1650621 R.H.	.73	to lock
75	Monza	1650622 L.H.	.73	to lock

**10.506A BUMPER— SCREW, Door Lock Remote Control Connecting**

*NOTE 3 Use on vehicles built prior to body date code 10A.*

*NOTE 4 Used on vehicles built prior to body date code 02A.*

67	Camaro	9870205	1	.24	inner panel dust— rubber— (12.934)
64-65	Chevy, Chevelle	4405526	A.R.	.14	SCREW, control to panel (w/canical washer) (1/4"— 20 x 1/2")— (12.180)
71-73	Vega, Monza	8788000	2	.21	SCREW, front door lock remote control handle to inner panel

**10.512 HANDLE— BUMPER— NUT— RETAINER— SCREW, Door Lock Inside**

62-63	Nova,				
64	Chevy (Deluxe), Malibu	4753532	2	2.85	remote control
63-64	Chevy, Chevelle (Std.),				
64-65	El Camino (exc. Custom),				
65	Chevy (Std.),				
65	Chevelle (Deluxe)	3764017	A.R.	3.50	remote control, front and rear doors
65-67	Impala, Caprice	4787463	A.R.	4.05	right, front and rear
65-67	Impala, Caprice	4787464	A.R.	4.05	left, front and rear
65-67	All (exc. Pass.),				
65-67	Biscayne, Bel Air	4468414	A.R.	2.85	remote control
67	Camaro (Deluxe)	7712035	R.H.	7.15	remote control
67	Camaro (Deluxe)	7712036	L.H.	7.15	remote control
68-70	Taxi,				
70	Nova,				
70-71	Nomad	7743519	2	4.75	rear, lock remote control
68-70	All,				
71-72	Nova (4-Dr.) w/Custom trim				right, rear
71-72	Nova (exc. Custom trim)				front only,
71-72	Chevelle	7743520	A.R.	2.85	right, front and rear remote control
68-70	All				left, lock remote control
71-72	Nova (4-Dr.) w/Custom build-up				left, rear,
71-72	Nova				front only,
71-72	Chevelle	7743521	A.R.	2.85	left, front and rear remote control
68-69	Camaro w/custom trim	7759094	R.H.	6.75	remote control
68-69	Camaro w/custom trim	7759095	L.H.	6.75	remote control
70-74	Camaro (exc. Custom Trim)	9836343	L.H.	11.50	frt. door lock remote control
70-74	Camaro (exc. Custom Trim)	9836342	R.H.	11.50	frt. door lock remote control
70-71	Camaro w/Custom Trim	9809375	L.H.	8.80	frt. door lock remote control
70-71	Camaro w/Custom Trim	9809374	R.H.	8.80	frt. door lock remote control
71	Pass.	9834753	L.H.	7.20	front and rear remote control (Note 1)
71	Pass.	9834752	R.H.	7.20	front and rear remote control (Note 1)
72	Pass.	9882023	R.H.	7.10	f/d lock remote cont. also used on rear door
72	Pass.	9882024	L.H.	7.10	f/d lock remote cont. also used on rear door
72	Camaro w/custom trim	9836342	R.H.	11.50	front door lock remote control
72	Camaro w/custom trim	9836343	L.H.	11.50	front door lock remote control
73-75	Pass.	9882023	R.H.	7.10	f/d lock remote cont. also used on rear door
73-75	Pass.	9882024	L.H.	7.10	f/d lock remote cont. also used on rear door
73-75	Chevelle	9878319	L.H.	7.10	front and rear remote control
73-75	Chevelle	9878318	R.H.	7.10	front and rear remote control
73-74	Nova (4-Dr.) (Custom)				rear,
73-74	Nova	7743521	L.H.	2.85	front remote control

**WINDSHIELD—DOORS—CONTROLS**

**10.512 HANDLE— BUMPER— NUT— RETAINER— SCREW, Door Lock Inside  
(Con't)**

73-74	Nova (4-Dr.) (Custom)			rear,
73-74	Nova	7743520 R.H.	2.85	front remote control
73-74	Nova (4-Dr.) (exc. Custom)	7743519 2	4.75	rear, remote control
75	Nova, Camaro, Monza	9736730 R.H.	7.55	front and rear remote control
75	Nova, Camaro, Monza	9736731 L.H.	7.55	front and rear remote control
71-75	Vega	9836737 L.H.	7.25	front door lock remote control
71-75	Vega	9836736 R.H.	7.25	front door lock remote control
71	Pass. (exc. Conv.),			
73-74	Pass., Chevelle	4880572 A.R.	.16	<b>BUMPER</b> , remote control
71-75	Vega	9837022 2	.88	<b>NUT</b> , front door lock remote control spring
62-75	All	4168122 A.R.	.12	<b>RETAINER</b> , retaining spring (steel snap on type)
65-68	Impala, Caprice	273156 A.R.	.06	<b>SCREW</b> , remote control handle (No. 10— 24 x 3/8")— (8.913)
67	Camaro (Deluxe)	7719680 2	.12	<b>SCREW</b> , remote control handle
68	Camaro w/custom trim	7740945 4	.12	<b>SCREW</b> , remote control handle

**10.515 PLATE— ESCUTCHEON— PAD, Door Lock Inside Handle Escutcheon (Trim Protector)**

62-67	All	4506696 A.R.	.16	remote control handle
68	All (exc. Caprice),			
68	Caprice (exc. Spt. Cpe.)			front door window and ventilator regulator handle bearing,
68	Pass., Chevy (4-Dr.)			rear door window,
70-73	Camaro			front reg. hdl. bearing,
70-73	Pass., Chevelle			vent. reg. hdl. bearing,
70-73	Pass., Nova, Camaro, Vega, Monza,			
74-75	All (exc. Chevelle)	7731353 2	.12	front and rear reg. hdl. bearing
70-71	Camaro w/custom equip.	9809373 L.H.	1.15	<b>ESCUTCHEON</b> , front door lock remote control handle
70-71	Camaro w/custom equip.	9809372 R.H.	1.15	<b>ESCUTCHEON</b> , front door lock remote control handle
72	Camaro w/custom equip.,			
73-74	Camaro w/L.T.	9836341 L.H.		<b>ESCUTCHEON</b> , front door lock remote control handle
70	Camaro (exc. custom equip.),			
72	Camaro w/custom equip.,			
73-74	Camaro w/L.T.	9836340 R.H.	.91	<b>ESCUTCHEON</b> , front door lock remote control handle
70-72	Camaro,			
73-74	Camaro (exc. L.T.)	9826079 L.H.	.83	<b>ESCUTCHEON</b> , front door lock remote control handle (black)
70-72	Camaro,			
73-74	Camaro (exc. L.T.)	9826078 R.H.	.83	<b>ESCUTCHEON</b> , front door lock remote control handle (black)
73-75	Vega (exc. H.B.)	9687745 R.H.	2.20	<b>ESCUTCHEON</b> , handle remote trim pad
73-75	Vega (exc. H.B.)	9687746 L.H.	2.20	<b>ESCUTCHEON</b> , handle remote trim pad
75	Nova (exc. Custom)	9738254 R.H.	1.90	<b>ESCUTCHEON</b> , front and rear door lock remote control handle (black)
75	Nova (exc. Custom)	9738255 L.H.	1.90	<b>ESCUTCHEON</b> , front and rear door lock remote control handle (black)
75	Nova, Camaro L.T.	9738257 L.H.	2.30	<b>ESCUTCHEON</b> , front and rear door lock remote control handle (bright)
75	Nova, Camaro L.T.	9738256 R.H.	2.30	<b>ESCUTCHEON</b> , front and rear door lock remote control handle (bright)
75	Camaro (exc. L.T.)	1678617 R.H.	.84	<b>ESCUTCHEON</b> , front door lock remote control handle (painted)
75	Camaro (exc. L.T.)	1678618 L.H.	.84	<b>ESCUTCHEON</b> , front door lock remote control handle (painted)
75	Monza (exc. Towne Cpe.)	1658094 R.H.	2.30	<b>ESCUTCHEON</b> , remote hdl.
75	Monza (exc. Towne Cpe.)	1658095 L.H.	2.30	<b>ESCUTCHEON</b> , remote hdl.
75	Monza (Towne Cpe.)	9738256 R.H.	2.30	<b>ESCUTCHEON</b> , remote hdl. (bright)
75	Monza (Towne Cpe.)	9738257 L.H.	2.30	<b>ESCUTCHEON</b> , remote hdl. (bright)
71-73	Pass.	9862900 2	.46	<b>PAD</b> , front and rear door lock remote control handle
74-75	Pass., Chevelle	9666749 2	.46	<b>PAD</b> , frt. & rr. dr. lk. remote control handle

**10.516 SPRING, Door Lock Inside Handle Escutcheon**

65	Pass. (exc. Impala)	4078002 A.R.	.22	front and rear doors— (10.666)
----	---------------------	--------------	-----	--------------------------------

**10.517 WASHER— GASKET, Door Lock Inside Handle**

62-72	All	7591000 2	.12	sealing— (10.500)
-------	-----	-----------	-----	-------------------

**WINDSHIELD—DOORS—CONTROLS**

**10.517 WASHER— GASKET, Door Lock Inside Handle (Con't)**

Not required in this group. See group 11.041

4460659 .15 GASKET

**10.527 HANDLE— SCREW— TAPE, Door Outside Locking (less cylinder)**

62-64	Chevy	A.R.			front and rear,
65-68	Pass.	9702886	A.R.	6.20	right, front
62-64	Chevy	A.R.			front and rear,
65-68	Pass.	9702887	A.R.	6.20	left, front
68-75	Nova	R.H.			front and rear
64-67	Chevelle,				
67-69	Camaro	1693820	A.R.	6.65	right, front (less button)
68-75	Nova	L.H.			front and rear
64-67	Chevelle,				
67-69	Camaro	9706523	A.R.	6.65	left, front (less button)
65-67	Pass. (Spt. Sed.)	4234331	A.R.	6.20	left front and rear
65-66	Pass. (4-Dr.)				right, rear door
66-67	Chevy,				
66	Nova (Spt. Cpe.) (exc. S.S.)				right, front and rear
69-70	Pass. (4-Dr.)	5719142	1	6.20	right, front and rear
65-66	Pass. (4-Dr.)				left, rear door
66-67	Chevy,				
66	Nova, (Spt. Cpe.) (exc. S.S.),				
69-70	Pass. (4-Dr.)	5719143	1	6.20	left, front and rear
65	Chevy				right, front and rear,
67-68	Pass. (4-Dr.)	9702888	1	6.65	right, rear door
65	Chevy				left, front and rear,
67-68	Pass. (4-Dr.)	9702889	1	6.65	left, rear door
68-69	Chevelle,				
70-72	Chevelle (Sta. Wag., El Camino)	9712350	R.H.	6.55	(less button)
68-69	Chevelle,				
70-72	Chevelle (Sta. Wag., El Camino)	9712351	L.H.	6.55	(less button)
69-70	Pass. (2-Dr.),				
70-72	Chevelle (exc. Sta. Wag.)	9717592	1	6.40	right, front door
69-70	Pass. (2-Dr.),				
70-72	Chevelle (exc. Sta. Wag.)	9717593	1	6.40	left front door
70-75	Camaro,				
71-75	Pass.	9827571	L.H.	10.75	left, front & rear door o/s
70-75	Camaro,				
71-75	Pass.	9827570	R.H.	10.75	right, front & rear door o/s
73-75	Chevelle	9870363	L.H.	7.15	front and rear
73-75	Chevelle	9870362	R.H.	7.15	front and rear
71-75	Vega, Monza	9827571	L.H.	10.75	front
71-75	Vega, Monza	9827570	R.H.	10.75	front
64-69	All,				
70-72	All (exc. Camaro),				
73-74	All,				
75	Nova, Vega	4430409	A.R.	.11	SCREW, handle to door (w/conical washer) (1/4" — 20 x 1/2")
70-72	Camaro,				
71	Pass.,				
73-74	All (exc. Nova)	3998270	A.R.	.66	TAPE (paint as reqd.)
74	Camaro w/door handle decor	9730270	A.R.	IN/.16	TAPE, outside handle (silver taupe)— (2.681)
74	Vega, Monza,				
74	Camaro w/door handle decor	9730271	A.R.	IN/.16	TAPE, outside handle (bright blue)— (2.681)
74	Camaro w/door handle decor	9730272	A.R.	IN/.16	TAPE, outside handle (dark blue)— (2.681)
74	Vega, Monza,				
74	Camaro (exc. L.T.) w/door handle decor	9730274	A.R.	IN/.16	TAPE, outside handle (russet orange)— (2.681)
74-75	Vega, Monza,				
74	Camaro w/door handle decor	9730276	A.R.	IN/.16	TAPE, outside handle (dark green)— (2.681)
74	Vega, Monza,				
74	Camaro w/door handle decor	9730278	A.R.	IN/.16	TAPE, outside handle (bright aqua)— (2.681)
74	Camaro w/door handle decor	9730279	A.R.	IN/.16	TAPE, outside handle (bright green)— (2.681)
74-75	Camaro w/door handle decor	9730280	A.R.	IN/.16	TAPE, outside handle (cream beige)— (2.681)
74-75	Vega, Monza				
74	Camaro w/door handle decor	9730281	A.R.	IN/.16	TAPE, outside handle (colonial gold)— (2.681)
74-75	Camaro w/door handle decor	9730282	A.R.	IN/.16	TAPE, outside handle (red)
74-75	Vega, Monza,				

**WINDSHIELD—DOORS—CONTROLS**

**10.527 HANDLE— SCREW— TAPE, Door Outside Locking (less cylinder) (Con't)**

74-75	Camaro w/door handle decor	9730268 A.R.	IN/.16	TAPE, outside handle (white)— (2.681)
74-75	Vega,			
74	Vega, Monza w/door handle decor	9730277 A.R.	IN/.16	TAPE, outside handle (dark taupe)— (2.681)
74	Vega, Monza w/door handle decor	9730273 A.R.	IN/.16	TAPE, outside handle (dark green)— (2.681)
75	Camaro	9736015 A.R.	5.40	TAPE, outside handle (silver met.) (36 inch roll)
75	Monza (Towne Cpe.),			
75	Camaro	9730275 A.R.	IN/.16	TAPE, outside handle (med. green)
75	Chevelle	1681057 A.R.	5.40	TAPE, outside handle (med. red)
75	Camaro	1681059 A.R.	5.40	TAPE, outside handle (graystone)
75	Vega, Monza,			
75	Camaro	1681061 A.R.	5.40	TAPE, outside handle (med. blue)
75	Vega, Monza,			
75	Camaro	1681063 A.R.	5.40	TAPE, outside handle (brt. blue met.)
75	Vega, Monza,			
75	Camaro	1681065 A.R.	5.40	TAPE, outside handle (dark blue met.)
75	Camaro	1681067 A.R.	5.40	TAPE, outside handle (dark green met.)
75	Vega, Monza,			
75	Camaro	1681071 A.R.	5.40	TAPE, outside handle (sandstone)
75	Vega, Monza,			
75	Camaro	1681073 A.R.	5.40	TAPE, outside handle (light saddle met.)
75	Camaro	1681075 A.R.	5.40	TAPE, outside handle (persimmon met.)
75	Camaro, Vega, Monza	1154242 A.R.	IN/.16	TAPE, outside handle (dk. blue met.) (60 in. roll)
75	Camaro, Vega, Monza	1154246 A.R.	IN/.16	TAPE, outside handle (firethorn met.) (60 in. roll)
75	Camaro, Vega, Monza	1154247 A.R.	IN/.16	TAPE, outside handle (mahogany) (60 in. roll)
75	Camaro, Vega, Monza	9667128 A.R.	5.40	TAPE, outside handle (red) (36" roll)
75	Vega, Monza	1681702 A.R.	5.40	TAPE, outside handle (orange met.) (36 inch roll)
75	Vega, Monza	1681704 A.R.	5.40	TAPE, outside handle (silver blue) (36 inch roll)
75	Vega, Monza	1681706 A.R.	5.40	TAPE, outside handle (burgundy met.) (36 inch roll)
75	Vega	1681708 A.R.	5.40	TAPE, outside handle (dark sandstone) (36 inch roll)
75	HV	1737858 A.R.	RL/.15	TAPE, outside handle (lt. blue) (36 in. roll)
75	HV	1737862 A.R.	RL/.15	TAPE, outside handle (dk. yellow) (36 in. roll)
75	HV	1737860 A.R.	RL/.15	TAPE, outside handle (lime green) (36 in. roll)
75	Vega, Monza	1681710 A.R.	5.40	TAPE, outside handle (med. graystone) (36 inch roll)
75	Monza (Towne Cpe.)	1721509 A.R.	RL/.15	TAPE, outside handle (firethorn) (36 inch roll)
75	Monza (Towne Cpe.)	1721511 A.R.	RL/.15	TAPE, outside handle (dk. blue met.) (36 inch roll)

**10.529 BUTTON— CLIP— GASKET— PIN— RING— ROD— SPRING— WASHER, Door Handle Push Button**

62-65	Chevy	5712416 A.R.	2.05	BUTTON, w/shaft	
64-65	Chevelle (4-Dr.)	5716883	2	2.05	BUTTON, w/shaft, front door
64-65	Chevelle (2-Dr.),				
65-66	Pass.	9632427	2	2.35	BUTTON, w/shaft, front
65-66	Pass. (4-Dr.)	9703695	2	4.60	BUTTON, w/shaft, rear door
66-67	Chevy (4-Dr.)	5716891	2	1.85	BUTTON, w/shaft, front door
66-67	Chevy (4-Dr.),				
66-67	Chevelle,				
73-75	Nova (4-Dr.)	9632427	2	2.35	BUTTON, w/shaft, front door (repl. 9706052)
66-67	Chevelle (4-Dr.),				
66-67	Chevy (2-Dr.),				
67	Pass.,				
68	Pass. (4-Dr.)	5714344	2	2.30	BUTTON, w/shaft, front door
70-72	Chevelle (Sed., Spt. Sed.)	9706048	2	4.60	BUTTON, w/shaft, rear door
67	Pass. (4-Dr.)	9709051	2	4.60	BUTTON, w/shaft, rear door
67-68	Camaro	9709600	2	4.60	BUTTON, w/shaft, front door
68	Pass. (2-Dr.),				
70-72	Monte Carlo	9632427	2	2.35	BUTTON, w/shaft, front
68	Pass. (4-Dr.)	9713215	2	4.15	BUTTON, w/shaft, rear
68-69	Chevelle (4-Dr.),				
70-72	Chevelle (Sta. Wag.)	9709056	2	4.60	BUTTON, w/shaft, rear

**WINDSHIELD—DOORS—CONTROLS**

**10.529 BUTTON—CLIP— GASKET— PIN— RING— ROD— SPRING— WASHER,  
Door Handle Push Button (Con't)**

68-73	Chevy (2-Dr.)	9713466	2	3.55	BUTTON, w/shaft, front
68-74	Chevy (4-Dr.)	9713469	2	4.15	BUTTON, w/shaft, rear
68-69	Chevelle (2-Dr.),				
70-72	El Camino	9715117	2	4.60	BUTTON, w/shaft, front
68-69	Chevelle (4-Dr.),				
70-72	Chevelle (Sta. Wag.)	9715120	2	4.60	BUTTON, w/shaft, front
69-72	Pass. (4-Dr.)	9709045	2	1.80	BUTTON, w/shaft (front)
69-72	Pass. (2-Dr.)	9717536	2	2.70	BUTTON, w/shaft (front)
69-72	Pass. (4-Dr.)	9717552	2	3.95	BUTTON, w/shaft rear
69	Camaro	9719686	2	4.40	BUTTON, w/shaft, front
70-72	Chevelle (2-Dr.) (exc. El Camino, Monte Carlo)	9721649	2	5.25	BUTTON, w/shaft
70-72	Chevelle (Sed., Spt. Sed.)	9721651	2	5.25	BUTTON, front, w/shaft
74-75	Nova (2-Dr.)	1722245	2	3.35	BUTTON, w/shaft (repl. 9883058)
71-75	Pass., Vega, Monza,				
70-75	Camaro,				
73-75	Camaro	3998009	2	.77	CLIP, front door outside handle spring
62-69	All,				
73-75	All	4587931	2	.23	GASKET, door lock cylinder— (12.249)
73	Malibu (Estate),				
73	Laguna (exc. Estate),				
73	Impala (Custom Cpe.)	9827961	2	.12	PIN, frt. dr. lock push button retainer spring
62-69	All,				
70	All (exc. Camaro),				
71-72	Chevelle,				
71-75	Nova	4156548 A.R.		.21	RING, push button-front and rear door handle
71-72	Pass.	9873992	2	.59	ROD, front door outside handle to lock
70-72	Camaro	9816544	2	.36	ROD, front door outside handle to lock
73-75	Pass.	9873992	2	.59	ROD, front door outside handle to lock
73-74	Pass. (4-Dr.)	9837222	2		ROD, rear door outside handle to lock
73-75	Camaro	9816544	2	.36	ROD, door outside handle to lock
74-75	Chevelle (Spt. Cpe.) (exc. Monte Carlo)	1657561	2	.36	ROD, front door outside handle to lock emer. (length 4 <sup>1</sup> / <sub>64</sub> " blue)
73-75	Chevelle (4-Dr.)	9665590	2	.42	ROD ASSY., rear door outside handle to lock
73-74	Monte Carlo	9881337	2	.36	ROD ASSY., front door outside handle to lock (length 4 <sup>1</sup> / <sub>8</sub> "
73-74	Monte Carlo	9881338	2	3.50	ROD ASSY., front door outside handle to lock emerg. (length 3 <sup>3</sup> / <sub>4</sub> "
73-75	Chevelle (4-Dr.)	9665592	2	3.50	ROD ASSY., rear door outside handle to lock emerg. (length 3 <sup>19</sup> / <sub>64</sub> "
73-75	Chevelle (4-Dr.)	9665591	2	3.50	ROD ASSY., rear door outside handle to lock emerg. (length 3 <sup>21</sup> / <sub>32</sub> " (yellow)
73-75	Chevelle (exc. Monte Carlo)	9874198	2	.41	ROD ASSY., front door outside handle to lock (length 4 <sup>21</sup> / <sub>32</sub> " (repl. 9665593)
73-75	Chevelle (exc. Monte Carlo)	9874199	2	.59	ROD ASSY., front door outside handle to lock (length 4 <sup>27</sup> / <sub>32</sub> " (yellow) (repl. 9665594)
73-74	Chevelle (exc. Monte Carlo),				
74	Malibu 4-Dr., Laguna,				
75	Chevelle 2-Dr. (exc. Monte Carlo)	9874200	2	2.80	ROD ASSY., front door outside handle to lock (length 4 <sup>15</sup> / <sub>32</sub> " (red) (repl. 9665595)
71-75	Monza (Towne Cpe.),				
73-75	Monte Carlo	9881336	2	.79	ROD ASSY., front door outside handle to lock (length 3 <sup>15</sup> / <sub>16</sub> " (repl. 9665596)
75	Monza (Towne Cpe.)				
74-75	Monte Carlo	9881337	2	.36	ROD ASSY., front door outside handle to lock (length 4 <sup>1</sup> / <sub>8</sub> " (green)
75	Monza (Towne Cpe.),				
74-75	Monte Carlo	9881338	2	3.50	ROD ASSY., front door outside handle to lock (length 3 <sup>3</sup> / <sub>4</sub> " (orange)
71-75	Vega	9829276	2	.42	ROD, front door outside handle to lock
62-70	All,				
71-75	Nova (Sed.),				
71-72	Chevelle	9831249 A.R.		.23	SPRING, push button-frt. and rear door (repl. 4301742)
71	Pass.,				
70-75	Camaro,				
73-75	Pass., Chevelle, Vega, Monza	9724320 R.H.		.26	SPRING, right front door outside handle
71	Pass.,				
70-75	Camaro,				
73-75	Pass., Chevelle, Vega, Monza	9724321 L.H.		.26	SPRING, left front door o/s handle

**WINDSHIELD—DOORS—CONTROLS**

**10.529 BUTTON—CLIP—GASKET—PIN—RING—ROD—SPRING—WASHER,  
Door Handle Push Button (Con't)**

64-65	Chevelle,				
66-67	Chevy (2-Dr.)				front and rear door stop, . . . . .
68-69	Chevelle				front door handle-push-button stop, . . . . .
65	Pass. (1st type),				
66-69	Pass.,				
69	Bel Air (2-Dr.)	4237766 A.R.		.39	frt. and rr. dr. push button stop . . . . .
65	Chevy,				
66-67	Chevy (4-Dr.), Chevelle,				
68-75	Nova (4-Dr.)		A.R.		front door stop, . . . . .
69-70	4-Dr.	5719092 A.R.		.15	frt. and rr. dr. push button stop (Note 1) . . . . .

NOTE 1: Used w/5719142-3 door handles.

**10.537 GASKET—ESCUTCHEON—NUT, Door Outside Handle Ferrule**

68-69	Chevelle	7779225 A.R.		.17	rear . . . . .
64-69	Chevelle,				
65-69	Pass.,				
66-71	Camaro, Chevy,				
70	All (exc. Camaro),				
73-75	Nova	3772582 A.R.		.25	GASKET UNIT (repl. 8715708) . . . . .
70-72	Camaro,				
71-72	Pass.,				
73-75	All (exc. Nova)	9827572	2	.73	ESCUTCHEON, front door outside handle . . . . .
71-73	Vega, Monza	4801719	2	.18	NUT ASSY., to panel . . . . .

**10.550 CYLINDER UNIT—CYLINDER ASSY.—KEY, Door Lock Outside Locking Handle**

62-66	Chevy, Chevelle,				
65-66	Pass.	3888860	2	2.15	front door (uncoded) . . . . .
65	Spt. Sed.	3987265	2	5.45	front door (uncoded) . . . . .
65	Pass. (exc. Spt. Sed.)	6259416	2	3.50	front door (uncoded) (repl. 6259416) . . . . .
67	All,				
71	Chevelle, Nova, Vega, Monza	3901066 A.R.		3.40	front door (uncoded) . . . . .
68	All,				
72	Chevelle, Nova, Vega, Monza	3929566	2	3.40	front door (uncoded) . . . . .
69	All,				
73	All (exc. Pass.)	3961302	2	3.40	front door (uncoded) . . . . .
70	All (exc. Camaro)	3981843	2	2.00	(uncoded) . . . . .
70	Camaro	1394733	2	3.05	(uncoded) . . . . .
71	Pass.	3996650	2	1.90	
72	Pass.	6263178	2	1.90	(uncoded) . . . . .
71	Camaro	6259416	2	3.50	front door (uncoded) (repl. 1361260) . . . . .
72	Camaro	1394244	2	3.05	(uncoded) . . . . .
73	All	695452 A.R.		4.65	universal, w/keys . . . . .
73	Pass.	6259507 A.R.		1.90	(uncoded) . . . . .
73	Chevelle, Nova				(uncoded), . . . . .
73	Camaro	6259416 A.R.		3.50	(uncoded) (repl. 1394451) . . . . .
74	Pass., Camaro	345073	1	3.05	(uncoded) . . . . .
74	Chevelle, Nova, Vega, Monza	345074	1	3.40	(uncoded) . . . . .
75	Chevelle, Nova, Vega, Monza	9632726	1	3.40	CYLINDER ASSY. (uncoded) . . . . .
75	Pass.	9632727	1	3.40	CYLINDER ASSY. (uncoded) . . . . .
75	Camaro	9632729	1	3.40	CYLINDER ASSY. (uncoded) . . . . .
62-68	All	3694624 A.R.		.16	KEY (octagon hd.—w/knockout plug-ignition, door and tire locks) (series 8000-9499) . . . . .
67	All	7033454 A.R.		.16	KEY, octagon hd., ignition and door lock . . . . .
68	All	7034680 A.R.		.16	KEY, hexagon hd., uncoded . . . . .
69	All	7025014 A.R.		.33	KEY, square hd., uncoded . . . . .
70	All	7025282 A.R.		.33	KEY, square hd., uncoded . . . . .
71	All,				
71-73	Vega, Monza	7027275 A.R.		.27	KEY, sq. hd. uncoded . . . . .
72	All	7024229 A.R.		.33	KEY, sq. hd. uncoded . . . . .

**10.551 PAWL—GASKET—RETAINER, Door Outside Lock Handle**

62-65	Chevy,				
66-67	Chevy (2-Dr.)	7020725 R.H.		.34	front . . . . .
62-65	Chevy,				
66-67	Chevy (2-Dr.)	7020726 L.H.		.34	front . . . . .
65-66	Pass. (2-Dr.)	7029375	2	.28	front door lock cylinder . . . . .
66-67	Chevelle,				
67	Pass. (4-Dr.)	7031753	1	.22	front door lock cylinder (right) . . . . .
66-67	Chevelle,				
67	Pass. (4-Dr.)	7031754	1	.22	front door lock cylinder (left) . . . . .
67-69	Camaro,				
67-69	Pass. (2-Dr.),				



**WINDSHIELD—DOORS—CONTROLS**

**10.551 PAWL— GASKET— RETAINER, Door Outside Lock Handle (Con't)**

68-72	Chevelle (4-Dr.) (2-Dr. Sed.)	7031555	1	.28	front door lock cylinder (left)
67-69	Camaro, Pass. (2-Dr.),				
68-72	Chevelle (4-Dr.) (2-Dr. Sed.)	7031554	1	.28	front door lock cylinder (right)
68-72	Chevy (2-Dr.),				
69-70	Pass. (2-Dr.)	7033393	R.H.	.46	front door lock cyl.
68-72	Chevy (2-Dr.),				
69-70	Pass. (2-Dr.)	7033394	L.H.	.46	front door lock cyl.
68-71	Chevy (Sedan),				
69-70	Pass. (Sed., Sta. Wag.)	7025106	R.H.	.46	front lock cyl.
69-70	Pass. (Sed., Sta. Wag.)	7025107	L.H.	.46	front lock cyl.
69-72	Chevelle (2-Dr.) (exc. Sedan)	7029382	R.H.	.28	front lock cylinder
69-72	Chevelle (2-Dr.) (exc. Sedan)	7029383	L.H.	.28	front lock cylinder
72	Nova, Chevelle (Sed., Monte Carlo)	7029380	R.H.	.28	front
72	Nova, Chevelle (Sed., Monte Carlo)	7029381	L.H.	.28	front
70-72	Camaro	3990963	L.H.	.50	front, lock cyl.
70-72	Camaro	3990962	R.H.	.50	front, lock cyl.
71-75	Pass. (4-Dr.)	9839201	R.H.	.53	front door lock cyl.
71-75	Pass. (4-Dr.)	9839202	L.H.	.53	front door lock cyl.
71-75	Pass. (2-Dr.)	9839203	R.H.	.53	front door lock cyl.
71-75	Pass. (2-Dr.)	9839204	L.H.	.53	front door lock cyl.
73-75	Chevelle (exc. Monte Carlo)	9628063	L.H.	.28	front door lock cylinder
73-75	Chevelle (exc. Monte Carlo)	9628064	R.H.	.28	front door lock cylinder
73-75	Monte Carlo	9612832	A.R.	.17	front door lock cylinder
73-75	Nova (4-Dr.)	7029381	L.H.	.28	front door lock cylinder
73-75	Nova (4-Dr.)	7029380	R.H.	.28	front door lock cylinder
73-75	Nova (2-Dr.)	7033394	L.H.	.46	front door lock cylinder
73-75	Nova (2-Dr.)	7033393	R.H.	.46	front door lock cylinder
71-75	Camaro	3990963	L.H.	.50	front door lock cylinder
71-75	Camaro	3990962	R.H.	.50	front door lock cylinder
74	Camaro	9677890	R.H.	.53	front door lock cylinder
74	Camaro	9677891	L.H.	.53	front door lock cylinder
71-75	Vega	7029766	L.H.	.38	front
71-75	Vega	7029765	R.H.	.38	front
74-75	Vega (Pnl., Sta. Wag.)	9667000	1	.28	back door lock cyl.
75	Monza (exc. Towne Cpe.)	7031554	R.H.	.28	front
75	Monza (exc. Towne Cpe.)	7031555	L.H.	.28	front
75	All	4587931	A.R.	.23	GASKET, front door lock cylinder— (12.249)
62-64	Chevy, Chevelle	7015683	A.R.	.42	RETAINER, front cyl. pawl
62-70	All,				
71-72	Nova				RETAINER, side door lock cyl.,
72	Pass., Chevelle, Camaro,				
75	Chevelle (Sta. Wag.),				
71-75	Vega, Monza,				
73-75	All	9728247	A.R.	.58	front door lock cyl.
64	Chevelle	4406509	2	.62	RETAINER, front door lock cylinder

**10.551A RETAINER, Door Safety Lock**

65-67	Pass. (exc. Spt. sed.)				front door lock cylinder pawl,
67-69	Sta. Wag. (6-Pass.)				rear compartment lock,
70	Pass. (Sta. Wag.) (6-Pass.)				under body storage compt. lock,
70-72	Pass. (Sta. Wag.) (9-Pass.)	7011819	A.R.	.16	luggage compt. lock catch
65-69	Sta. Wag. (6-Pass.) w/rear compt. lock				front,
70-72	Pass. (Sta. Wag.) (6-Pass.)	4888243	A.R.	.46	luggage compt. lock cyl.

**10.552 HOUSING— CAP, Door Outside Handle Push Button and Lock Cylinder**

62-69	All,				
70	All (exc. Camaro),				
72	All (exc. Camaro)	3924150	1	.63	door lock cylinder
65-70	Pass.,				
71-75	All	230018	A.R.	.42	CAP, front door outside lock case (B & S 320395)
74	Camaro	9786897	1	.54	CAP, rear compt. lid lock case

**10.553 TUMBLER UNIT, Door Lock Cylinder**

62-75	All	3901064	A.R.	3.00	(No. 4) (unit contains 100 pcs.)
62-75	All	3901061	A.R.	3.00	(No. 1) (unit contains 100 pcs.)
62-75	All	3901063	A.R.	3.00	(No. 3) (unit contains 100 pcs.)
67-75	All	3901062	A.R.	3.00	(No. 2) (unit contains 100 pcs.)
67-75	All	3901065	A.R.	3.00	(No. 5) (unit contains 100 pcs.)

**WINDSHIELD—DOORS—CONTROLS**

**10.553 TUMBLER UNIT, Door Lock Cylinder (Con't)**

73-75	All	6259309 A.R.	4.65	(No. 1) (snap in type) (unit contains 100 pcs.)
73-75	All	6259310 A.R.	4.65	(No. 2) (snap in type) (unit contains 100 pcs.)
73-75	All	6259311 A.R.	4.65	(No. 3) (snap in type) (unit contains 100 pcs.)
73-75	All	6259312 A.R.	4.65	(No. 4) (snap in type) (unit contains 100 pcs.)
73-75	All	6259313 A.R.	5.15	(No. 5) (snap in type) (unit contains 100 pcs.)

**10.553A SPRING UNIT— RETAINER UNIT, Lock Tumbler**

62-75	All	3901067 A.R.	1.30	(unit contains 100 pcs.)
73-75	All	6259315 A.R.	1.30	SPRING, lock cylinder tumbler (snap in type) (unit contains 100 pcs.)
65-75	All	601261 1	.66	RETAINER UNIT (unit contains 12 retainers)
73-75	All	6259314 A.R.	3.80	RETAINER, lock cylinder tumbler spring (snap in type) (unit contains 12 retainers)

**10.556 SCREW— WASHER, Door Inside Locking Control**

62-69	(4-Dr.),			
70-72	Chevelle,			
70-72	Pass., Nova (4-Dr.)	4405522 2	.11	(w/shoulder and face washer) (1/4" — 20 x 9/16") lk. to lk. rod rr. dr. lk. to lk. rod
73-74	Pass., Chevelle			
75	Chevelle (4-Dr.)			
65-71	Pass. (4-Dr.),			
62-67	Chevy, Chevelle (4-Dr.)	4622521 2	.06	WASHER, rear to lock rod
68-72	Chevy, Chevelle (4-Dr.),			
73	Pass. (4-Dr.)	6284005 2	.06	WASHER, rear to lock rod (w/7/64" dia. hole)
71-73	All (4-Dr.),			
73-75	Chevelle (4-Dr.)	9428369 2	.12	WASHER, rear door inside locking to lock rod— (8.928)

**10.559 KNOB— GUARD UNIT— PLUNGER ASSY., Door Inside Locking Rod**

62	Chevy (4-Dr.)	4824972 A.R.	.37	(red)
62-66	All	7649291 A.R.	.31	(chrome)

**1967**

CHROME	MED. BLUE
7649291 7661003R.H.* 7715529L.H.*	7665327

\*NOTE: 1967 - Chevy Release.

**1968**

BLACK	RED	TURQ.	BLUE	TEAL
	7799356	7799357	7759036	7759037

**WINDSHIELD—DOORS—CONTROLS**

SADDLE	GOLD	PARCH- MENT	GRAY	WHITE
7759038	7799366	7759040	7799368	7799354

**1969**

	8740200	
--	---------	--

<b>70</b>	Camaro,			
<b>71-75</b>	All	<b>9813799</b>	2	.55
<b>71-75</b>	All (4-Dr.)	<b>994137</b>	1	4.97
<b>68</b>	4-Dr.	<b>3929934</b>	2	1.90

**GUARD UNIT**, rear door lock . . . . .  
**PLUNGER ASSY.**, rear door lock guard . . . . .

**10.560 FERRULE, Door Inside Locking Rod**

<b>64-67</b>	Chevy, Chevelle	<b>4839529</b>	A.R.	.16	
<b>65-67</b>	Pass.	<b>7616552</b>	A.R.	.18	
<b>67</b>	Camaro	<b>4474707</b>	A.R.	.18	
<b>68-69</b>	4-Dr.	<b>3929935</b>	2	.11	rear door lock . . . . .
<b>68-72</b>	All,				
<b>74-75</b>	All	<b>9665901</b>	A.R.	.28	
<b>71-75</b>	Vega	<b>7740319</b>	2	.21	

**10.563 ROD—SHOE, Door Inside Lock to Knob**

**PASSENGER**

<b>68</b>	2-Dr.	<b>7730686</b>	1	.32	front, inside locking to lock . . . . .
<b>69-70</b>	4-Dr.	<b>8724168</b>	1	.32	right front door inside locking to lock . . . . .
<b>69-70</b>	4-Dr.	<b>8724169</b>	1	.32	left front door inside locking to lock . . . . .
<b>69-70</b>	4-Dr.	<b>8769276</b>	1	2.15	right, rear door inside locking to lock (Note 1) . . . . .
<b>69-70</b>	4-Dr.	<b>8769277</b>	1	2.15	left, rear door inside locking to lock (Note 1) . . . . .
<b>71-75</b>	Pass. (Spt. Cpe., Conv.) w/electric door lock	<b>9836218</b>	A.R.	.34	right, locking lever to actuator . . . . .
<b>71-75</b>	Pass. (4-Dr.) w/electric door lock	<b>9836250</b>	2	.34	locking lever to actuator . . . . .
<b>71-72</b>	Pass. (4-Dr.)	<b>9874401</b>	2	.35	rear outside handle to lock . . . . .
<b>71-72</b>	Pass. (4-Dr.)	<b>9876543</b>	L.H.	.91	left, front door lock remote control to lock . . . . .
<b>71-72</b>	Pass. (4-Dr.)	<b>9836917</b>	R.H.		right, front door lock remote control to lock . . . . .
<b>69-70</b>	2-Dr.	<b>8723753</b>	2	2.15	<b>ROD ASSY.</b> , inside locking to lock . . . . .
<b>71-74</b>	Pass. (Spt. Cpe., Conv.)	<b>1656325</b>	L.H.	2.20	<b>ROD ASSY.</b> , left, front door inside locking to lock (repl. 9836681) . . . . .
<b>71-74</b>	Pass. (Spt. Cpe., Conv.)	<b>9836680</b>	R.H.	2.15	<b>ROD ASSY.</b> , right, front door inside locking to lock . . . . .
<b>71-75</b>	Pass. (4-Dr.)	<b>9836685</b>	L.H.	.46	<b>ROD ASSY.</b> , left, front door inside locking to lock . . . . .
<b>71-75</b>	Pass. (4-Dr.)	<b>9836684</b>	R.H.	.46	<b>ROD ASSY.</b> , right, front door inside locking to lock . . . . .
<b>71-75</b>	Pass. (4-Dr.) w/electric door lock	<b>9642084</b>	L.H.	2.25	<b>ROD ASSY.</b> , left, rear door inside locking to actuator . . . . .
<b>71-75</b>	Pass. (4-Dr.) w/electric door lock	<b>9642083</b>	R.H.	2.25	<b>ROD ASSY.</b> , rear door inside locking to actuator . . . . .
<b>71-73</b>	Pass. (Sed., Spt. Sed.)	<b>9836329</b>	L.H.	2.40	<b>ROD ASSY.</b> , rear door inside locking to lock . . . . .
<b>71-73</b>	Pass. (Sed., Spt. Sed.)	<b>9836328</b>	R.H.	2.40	<b>ROD ASSY.</b> , rear door inside locking to lock . . . . .
<b>71-73</b>	Pass. (Sta. Wag.)	<b>9673521</b>	L.H.	2.15	<b>ROD ASSY.</b> , rear door inside locking to lock . . . . .
<b>71-72</b>	Pass. (Sta. Wag.)	<b>9836536</b>	R.H.	2.40	<b>ROD ASSY.</b> , rear door inside locking to lock . . . . .
<b>73</b>	Pass. (Sta. Wag.)	<b>9673520</b>	2	2.15	<b>ROD ASSY.</b> , rear door inside locking to lock . . . . .
<b>74</b>	Pass. (Sta. Wag.)	<b>9739667</b>	L.H.	2.15	<b>ROD ASSY.</b> , rear door inside locking to lock . . . . .
<b>75</b>	Pass. (4-Dr.)	<b>9874401</b>	2	.35	rear door outside handle to lock . . . . .
<b>74-75</b>	Pass. (Sed.)	<b>9726952</b>	R.H.	2.40	<b>ROD ASSY.</b> , rear door inside locking to lock . . . . .
<b>74-75</b>	Pass. (Sed.)	<b>9726953</b>	L.H.	2.40	<b>ROD ASSY.</b> , rear door inside locking to lock . . . . .
<b>74-75</b>	Pass. (Sta. Wag.)	<b>1660506</b>	R.H.	2.15	<b>ROD ASSY.</b> , rear door inside locking to lock . . . . .
<b>75</b>	Pass. (Sta. Wag.)	<b>1660507</b>	L.H.	2.15	<b>ROD ASSY.</b> , rear door inside locking to lock . . . . .

## WINDSHIELD—DOORS—CONTROLS

### 10.563 ROD—SHOE, Door Inside Lock to Knob (Con't)

75	Pass. (2-Dr.)	1656324 R.H.	2.20	ROD ASSY., front door inside locking to lock
75	Pass. (2-Dr.)	1656325 L.H.	2.20	ROD ASSY., front door inside locking to lock
74-75	Pass. (4-Dr.)	9726950 2	.16	SHOE, rear door inside locking to lock

### CHEVY

68	(2-Dr.)	7733785 2	.32	front
68-72	(4-Dr.)	8769258 R.H.	2.15	rear (Note 3)
68-72	(4-Dr.)	8769259 L.H.	2.15	rear (Note 3)
69-72	(2-Dr.)	9824775 2	2.00	front
69-75	(4-Dr.)	8756235 R.H.	.28	front
69-75	(4-Dr.)	8756236 L.H.	.28	front
73-74	Nova (4-Dr.)	9642724 L.H.	1.95	ROD ASSY., rear door inside locking to lock
73-74	Nova (4-Dr.)	9642723 R.H.	1.95	ROD ASSY., rear door inside locking to lock
73-75	Nova (2-Dr.)	9824775 2	2.00	ROD ASSY., front door inside locking to lock
75	Nova (4-Dr.)	1651383 R.H.	3.10	ROD ASSY., rear door inside locking to lock
75	Nova (4-Dr.)	1651384 L.H.	3.10	ROD ASSY., rear door inside locking to lock

### CHEVELLE

*NOTE 2 Rod 7771451 can be used on 1964-1965 and 1966 models built prior to Dec. 1965 by enlarging hole in dr. inn. pnl. This rod has an offset in the vertical portion of the rod.*

64-65	Chevelle,			
66-67	(Exc. Spt. Sed.)	4418984 R.H.	.32	front
68	(2-Dr.)	7795904 1	.37	right or left, front
68-72	(4-Dr.)	9819803 R.H.	2.00	rear (Note 3)
68-70	(4-Dr.)	9819804 L.H.	2.20	rear (Note 3)
69-70	(2-Dr.) (exc. El Camino)	8723822 1	.98	front
69-70	(4-Dr.) w/vacuum door lock	9819805 R.H.	2.25	rear (Note 3)
69-70	(4-Dr.) w/vacuum door lock	9819806 L.H.	2.20	rear
69-72	(4-Dr.)	8756233 R.H.	.32	front
69-72	(4-Dr.)	8756234 L.H.	.32	front
70-72	Chevelle (4-Dr.) w/elect. dr. lock	8801301 R.H.	.34	right, inside locking lever to actuator
70-72	Chevelle (4-Dr.) w/elect. dr. lock	8801302 L.H.	.34	left, inside locking lever to actuator
71-72	Chevelle (2-Dr.)	8723822 2	.98	ROD ASSY., front door inside locking to lock
71-72	Chevelle (4-Dr.) w/electric door lock	9819806 L.H.	2.20	ROD ASSY., left, rear door inside locking to lock (Note 1)
71-72	Chevelle (4-Dr.) w/electric door lock	9819805 R.H.	2.25	ROD ASSY., right, rear door inside locking to lock (Note 1)
71-72	Chevelle (4-Dr.)	9819804 L.H.	2.20	ROD ASSY., left, rear door inside locking to lock (Note 1)
73-75	Chevelle (2-Dr.)	9873799 L.H.	1.10	ROD ASSY., front inside locking to lock
73-75	Chevelle (2-Dr.)	9873798 R.H.	1.20	ROD ASSY., front inside locking to lock
73-75	Chevelle (4-Dr.) w/electric door lock	9872756 L.H.	2.15	ROD ASSY., rear door inside locking to actuator
73-75	Chevelle (4-Dr.) w/electric door lock	9872755 R.H.	2.15	ROD ASSY., rear door inside locking to actuator
73-75	Chevelle (4-Dr.)	9871999 L.H.	1.50	ROD ASSY., rear door inside locking to lock
73-75	Chevelle (4-Dr.)	9871998 R.H.	1.50	ROD ASSY., rear door inside locking to lock
73-75	Chevelle (4-Dr.)	9872749 L.H.	.46	front inside locking to lock
73-75	Chevelle (4-Dr.)	9872748 R.H.	.46	front inside locking to lock

### CAMARO

68	Camaro	7733785 2	.32	front
69	Camaro	9824775 2	2.00	front
70-75	Camaro	9834751 2	1.90	front door i/s locking to lock

*NOTE 1 See model usage clarification section in the front of catalog for illustration on 1st and 2nd design parts.*

*NOTE 3 When installing a new rod it will be necessary to reverse the clip position on the door lock.*

### VEGA—MONZA

71-75	Vega	9827683 L.H.	.36	front
71-75	Vega	9827682 R.H.	.36	front

**WINDSHIELD—DOORS—CONTROLS**

**10.563 ROD— SHOE, Door Inside Lock to Knob (Con't)**

75	Monza	1653306 L.H.	3.10	locking to lock
75	Monza	1653305 R.H.	3.10	locking to lock
75	Monza (Towne Cpe.)	9726950 2	.16	SHOE, front door remote control rod

**10.565 CLIP— SPACER, Door Inside Locking Rod**

62-68	Chevy (4-Dr.)			rear door control to lock rod,
64-69	Chevelle (2-Dr.),			
65-66	Pass.,			
68-69	Chevy (2-Dr.)			frt. door lock remote control rod,
64-68	Chevelle (4-Dr.),			
65-67	Pass. (4-Dr.),			
68	Pass. (Sta. Wag.) (9-Pass.),			
68	Malibu (4-Dr. Spt. Sed.)			rear door inner locking to lock rod,
68	Pass.	4711608 A.R.	.16	rear door lock remote control to panel
65	Pass.			front door lock remote control to lock rod anti-rattle,
64-67	Pass., Chevelle			front door lock cyl. to lock rod anti-rattle,
62-67	Pass., Chevy (4-Dr.),			
64-68	Chevelle (4-Dr.)			rear door lock remote control to lock rod anti-rattle,
65-66	Pass.			anti-rattle,
68-72	All			front door remote control to lock rod,
68-70	4-Dr.,			
73-75	All	7762203 A.R.	.11	front door inner locking to lock rod, rear door remote control to lock rod
67-69	Camaro,			
69-73	Chevy (2-Dr.)	7675436 2	.11	front door lock remote control rod
68-69	All			rear or front door lock remote control to panel,
69-71	4-Dr.,			
72-73	Pass. (Spt. Cpe.)			front door lock remote control rod to pnl.
72-73	All (exc. Pass.),			
72-73	Pass. (4-Dr.)	9673046 A.R.	.21	rear door lock rod to panel
69-75	2-Dr.	8733856 4	.11	front
71-72	Pass. (exc. Conv.)	9815325 A.R.	.11	front door lock remote control handle (Note 1)
74	Pass. (2-Dr.) w/Electric Door Lock	9815324		frt. dr. inside lever to actuator
	<i>NOTE 1 Used w/rod with 90 degree bend.</i>			
70	Chevelle (Conv.)	4537587 A.R.	.12	SPACER, front door wedge plate to door

**10.569 STRIKER, Door Lock**

62	Chevy	4802791 L.H.	5.70	front and rear
63-67	Chevy	4418916 L.H.	6.75	
64-67	All (exc. Chevy),			
68-70	All,			
71-72	All (exc. Pass.),			
71-75	Vega, Monza,			
73-75	Nova, Camaro	8770193 A.R.	2.15	
71-72	Pass.,			
73-75	Pass., Chevelle	9601750 A.R.	3.40	front and rear

**10.570 SCREW, Door Lock Striker to Pillar**

63	Nova (Conv.)	4892564 A.R.	.12	front, rear ( <sup>5</sup> / <sub>16</sub> "— 18 x 1 <sup>7</sup> / <sub>32</sub> ")
----	--------------	--------------	-----	--

**10.571 SPACER— PLATE— WASHER, Door Lock Striker**

65-68	Pass. (Sta. Wag.)	4800021 A.R.	.24	back door lock striker— (12.237)
65-67	Conv. (exc. Pass.),			
65-67	Nova (Spt. Cpe.),			
68-69	Camaro (Conv.)	4523881 A.R.	.11	plate to door
68-69	Chevelle (Conv.)	4537580 A.R.	.12	wedge plate to door spacer (emergency)
62	Chevy (2-Dr.)			PLATE, door, adjusting rear,
62	Chevy (4-Dr.),			
67-71	Chevelle (Sta. Wag.) El Camino			rear door lower,
72	El Camino	4649282 2	.12	side door lock striker adjuster rear
62	Chevy			PLATE, front and rear door adjusting upper
72	El Camino	4849938 2	.12	door lock striker adjuster upper
71-72	Pass.,			
73-75	Pass., Chevelle	9825362 A.R.	1.15	PLATE, anchor
64	Chevelle (4-Dr.),			
65-72	Chevelle (Spt. Sed.),			
65-70	Pass. (4-Dr.)	4465224 2	.37	PLATE, front door striker anchor
65-70	Pass., Chevelle, Camaro			PLATE, front and rear door striker anchor,
68-70	Chevy,			
71-72	All (exc. Pass.),			

**WINDSHIELD—DOORS—CONTROLS**

**10.571 SPACER— PLATE— WASHER, Door Lock Striker (Con't)**

71-72	Vega, Monza,				
73-75	Camaro (2-Dr.),				
73-75	Nova	4469685 A.R.	1.05	front anchor	
65-67	All (exc. Chevy),				
65-67	Chevelle (4-Dr.),				
66	Malibu (Spt. Sed.)	4413734 2	.83	PLATE, front anchor	
68-72	Chevy, Chevelle (4-Dr.) (exc. Spt. Sed.),				
73-75	Nova (4-Dr.)	7721972 2	.93	PLATE, front, anchor	
73-75	Vega, Monza	9665418 2	.92	lock striker anc.	
65-67	All (exc. Chevy),				
68-70	All,				
71-75	All (exc. Pass.)	4469196 A.R.	.12	WASHER (5/64" thick) (repl. 4469194)	
65-67	All (exc. Chevy),				
68-70	All,				
71-75	All (exc. Pass.)	4469197 A.R.	.21	WASHER (5/32" thick)	
65-67	All	4491024 A.R.	.12	WASHER (plastic)	
71-75	Pass.,				
73-75	Chevelle	9827154 A.R.	.34	WASHER (29/32" thick)	
71-75	Pass., Chevelle	120390 A.R.		WASHER (5/32" thick)— (8.929)	

**10.584 PLATE— SPACER— WEDGE, Door Dovetail Bumper Wedge**

62-63	Nova (2-Dr.),				
64	Chevelle (Conv.),				
65	Nova (Spt. Cpe.)	4843705 R.H.	.39	door side	
62-64	Nova (2-Dr.),				
64-67	Chevelle, Camaro (Conv.),				
65-67	Conv.,				
65-67	Nova (Spt. Cpe.),				
68-69	Camaro (Conv.)	4523880 2	.37	door side	
64-65	Nova (Spt. Mdls.),				
64-67	All (Conv.),				
68-69	Camaro (Conv.)	4426757 R.H.	.72	door wedge body side plate	
64-65	Nova (Spt. Mdls.),				
65-66	Pass. (Conv.),				
68-69	Camaro (Conv.)	4426758 L.H.	.72	door wedge body side plate	
65-66	Pass. (Conv.),				
68-72	Chevelle (Conv.),				
71-74	Vega (Pnl., Sta. Wag.)	4537549 2	.43	door side	
65-66	Pass. (Conv.),				
68-72	Chevelle (Conv.) (exc. Monte Carlo),				
71-74	Vega (Pnl., Sta. Wag.)	4538269 2	.36	body side	
67-69	Pass. (Conv.)	8716722 2	7.05	door wedge door side	
71-72	Pass. (Conv.)	9826799 2	2.15	door side	
72-75	Pass. (Conv.)	9826416 2	.63	body side	
65-66	Pass. (Conv.),				
70-72	Chevelle (Conv.),				
71	Vega (H.B.)	4537587 A.R.	.12	SPACER, plate (emergency use)	
65-66	Pass. (Conv.),				
68-72	Chevelle (Conv.),				
71-74	Vega (Pnl., Sta. Wag.)	4537580 2	.12	SPACER, door wedge plate, body side	
65-67	Conv. (exc. Pass.),				
65-67	Nova (Spt. Cpe.),				
67-70	Pass. (Conv.)	7652096 2	.12	SPACER, plate door side	
68-69	Camaro (Conv.)	4523881 A.R.	.11	SPACER, plate to door	
71-75	Pass. (Conv.)	9826417 A.R.	.11	SPACER, wedge plate, body side (1/16" thk.)	
71-75	Pass. (Conv.)	9826418 A.R.	.11	SPACER, wedge plate, body side (.02" thk.)	
73-75	Pass. (Conv.)	9661767 2	.34	WEDGE, dr. side	

**10.587 BUMPER— COVER— PLUG, Side Door**

62-75	All	4565591 A.R.	.18	door lock pillar on body and door	
62-66	Chevy,				
64-67	Chevelle (4-Dr.)	7635877 A.R.	.24	front door lock pillar upper and lower on door	
64-67	Chevelle (2-Dr.)	7719779 4	.52	front door lock pillar upper and lower on door	
67-69	Camaro			front door lock pillar upper and lower on door,	
67-70	Pass. (2-Dr.),				
68-75	Chevy (4-Dr.)	7637192 A.R.	.22	front door lock pillar upper on door	
68-75	Chevy (Spt. Cpe.)	7639207 2	.34	front door lock pillar lower on door	
68-69	Chevelle (4-Dr.)			front and rear door lock, upper and lower,	
69	Pass. (Spt. Sed.),				
71-72	Chevelle (4-Dr.),			back door side lock	

**WINDSHIELD—DOORS—CONTROLS**

**10.587 BUMPER— COVER— PLUG, Side Door (Con't)**

75	Chevelle			frt. and rr. dr. lk. plr. upr. and lwr. dr. si., . . .
71-75	Vega, Monza			(emergency use) . . . . .
69-75	Pass. (4-Dr.)	4565592 A.R.	.46	side door lock pillar (emergency) . . . . .
70-72	Camaro	4565671 2	.18	door lock pillar upper body side . . . . .
70	(Sta. Wag.)			
71-75	Caprice (Spt. Sed.)	9883617 2	.18	lock pillar lower door side (emergency use) .
71-72	Chevelle (Sta. Wag.)	4573914 A.R.	.24	door lock pillar upper body side . . . . .
74-75	Pass. (4-Dr.)	9825663 A.R.	.11	front door lock pillar upper door side . . . . .
67	Pass. (Spt. Cpe., Conv.)	7645222 2	.64	<b>COVER</b> , front door inner panel access hole— (12.941) . . . . .
ALL	All	4751839 2	.12	<b>PLUG</b> , rr. dr. lock pillar access hole (on dr.)
71-75	Vega, Monza	9874840 2	.12	<b>PLUG</b> , frt. door inner panel access hole . . . . .
75	Monza (Towne Cpe.)	1707500 2		<b>PLUG</b> , frt. door arm rest lock hole (paint as reqd.) . . . . .

**10.650 VENTILATOR ASSEMBLY— DEFLECTOR UNIT, Front Door (less glass)**

**PASSENGER**

65	Spt. Mdls.,			
66	Spt. Mdls. (exc. Conv.)	4467756 R.H.	82.75	
65	Spt. Mdls.,			
66	Spt. Mdls. (exc. Conv.)	4467757 L.H.	82.75	
65-66	(Exc. Spt. Mdls.)	4536190 R.H.	41.50	
65-66	(Exc. Spt. Mdls.)	4536191 L.H.	41.50	
67-68	(Exc. Spt. Mdls.)	9708374 R.H.	40.00	
67-68	(Exc. Spt. Mdls.)	9708375 L.H.	40.00	
67-68	Spt. Sed.	9708386 R.H.	80.75	
67-68	Spt. Sed.	9708387 L.H.	80.75	
67-68	Spt. Cpe.	9713341 L.H.	80.75	

**CHEVY**

62-67	(Exc. Spt. Mdls.)	4841306 R.H.	40.00	
62-67	(Exc. Spt. Mdls.)	4841307 L.H.	40.00	
62-67	Nova (Spt. Mdls.)	4842031 L.H.	42.75	
68-74	(4-Dr.) (Taxi)	9712358 R.H.	38.25	
68-74	(4-Dr.) (Taxi)	9712359 L.H.	38.25	
68-72	(2-Dr.)	9713824 R.H.	38.25	
68-72	(2-Dr.)	9713825 L.H.	38.25	

**CHEVELLE**

64-67	(Exc. Spt. Mdls.)	4493026 R.H.	39.50	
64-67	(Exc. Spt. Mdls.)	4493027 L.H.	39.50	
64-65	(Spt. Mdls.)	4411073 L.H.	88.50	
66-67	(Spt. Cpe., Conv.)	9706198 R.H.	80.75	
66-67	(Spt. Cpe., Conv.)	9706199 L.H.	80.75	
68-72	(4-Dr.) (exc. Spt. Sed.)	9712408 R.H.	38.25	
68-72	(4-Dr.) (exc. Spt. Sed.)	9712409 L.H.	38.25	
68	(Spt. Cpe.)	9712502 R.H.	84.75	
68	(Spt. Cpe.)	9712503 L.H.	84.75	
68-72	(Spt. Sed.)	9712456 R.H.	83.50	
68-72	(Spt. Sed.)	9712457 L.H.	83.50	
68-70	(2-Dr. Sed.),			
68-72	El Camino	9712548 R.H.	38.25	
68-70	(2-Dr. Sed.),			
68-72	El Camino	9712549 L.H.	38.25	

**CAMARO**

67	Camaro	9708691 L.H.	82.75	
73-75	Vega, Monza	994531 1	32.95	<b>DEFLECTOR UNIT</b> . . . . .

**10.652 WEATHERSTRIP ASSY., Front Door Ventilator**

**PASSENGER**

65-66	(exc. Spt. Mdls.)	4496456 2	1.90	front door window glass run sealing at vent.
65-68	Spt. Mdls.	5719312 R.H.	8.95	
65-68	Spt. Mdls.	5719313 L.H.	8.95	
65-68	(exc. Spt. Mdls.)	9712296 R.H.	8.95	
65-68	(exc. Spt. Mdls.)	9712297 L.H.	8.95	
65-68	Spt. Mdls.	5719332 R.H.	1.90	vent channel . . . . .
65-68	Spt. Mdls.	5719333 L.H.	1.90	vent channel . . . . .
65-68	(exc. Spt. Mdls.)	5719562 R.H.	2.60	vent channel . . . . .
65-68	(exc. Spt. Mdls.)	5719563 L.H.	2.60	vent channel . . . . .

**WINDSHIELD—DOORS—CONTROLS**

**10.652 WEATHERSTRIP ASSY., Front Door Ventilator (Con't)**

**CHEVY—NOVA**

62-67 (exc. Spt. Mdls.)	5712172 R.H.	8.95	
62-67 (exc. Spt. Mdls.)	5712173 L.H.	8.95	
62-67 Nova (Spt. Mdls.)	5712884 R.H.	8.95	
62-67 Nova (Spt. Mdls.)	5712885 L.H.	8.95	
68-74 (4-Dr.) (Taxi)	9712364 R.H.	8.95	
68-74 (4-Dr.) (Taxi)	9712365 L.H.	8.95	
68-74 Chevy (Taxi)	9712380 R.H.	1.90	division channel
68-74 Chevy (Taxi)	9712381 L.H.	1.90	division channel
62-67 Chevy	5712178 R.H.	1.90	WEATHERSTRIP, vent division channel
62-67 Chevy	5712179 L.H.	1.90	WEATHERSTRIP, vent division channel
68-72 (2-Dr.)	9713808 R.H.	8.95	WEATHERSTRIP
68-72 (2-Dr.)	9713809 L.H.	8.95	WEATHERSTRIP

**CHEVELLE**

64-67 (exc. Spt. Mdls.)	5717252 R.H.	8.95	
65-66 (exc. Spt. Mdls.)	4496456 2	1.90	front door window glass run sealing at vent.
66-67 (Spt. Cpe., Conv.)	9706597 L.H.	8.95	
68-72 (4-Dr.) (exc. Spt. Sed.)	9712414 R.H.	8.95	
68-72 (4-Dr.) (exc. Spt. Sed.)	9712415 L.H.	8.95	
68-72 (4-Dr.) (exc. Spt. Sed.)	9712432 R.H.	1.90	division channel
68-72 (4-Dr.) (exc. Spt. Sed.)	9712433 L.H.	1.90	division channel
68-72 (Spt. Sed.)	9712460 R.H.	8.95	
68-72 (Spt. Sed.)	9712461 L.H.	8.95	
68-72 (Spt. Sed.)	9712478 R.H.	3.80	division channel
68-72 (Spt. Sed.)	9712479 L.H.	3.80	division channel
68 (Spt. Cpe., Conv.)	9712506 R.H.	8.95	
68-70 (2-Dr. Sed.)			
68-72 El Camino	9712570 R.H.	2.35	division channel
68-70 (2-Dr. Sed.)			
68-72 El Camino	9712571 L.H.	1.90	division channel
64-65 Chevelle,			
66-67 (exc. Spt. Mdls.)	5717194 R.H.	1.90	vent. division channel
66-67 (Spt. Cpe., Conv.)	9706502 R.H.	1.90	vent. division channel
68-70 (2-Dr. Sed.)			
68-72 El Camino	9712554 R.H.	8.95	
68-70 (2-Dr. Sed.)			
68-72 El Camino	9712555 L.H.	8.95	

**CAMARO**

**10.655 CHANNEL—FILLER—RIVET, Front Door Ventilator Glass (with tee shaft)**

**PASSENGER**

65-68 Spt. Mdls.	5719342 R.H.	13.55	
65-68 Spt. Mdls.	5719343 L.H.	13.55	
65-66 (exc. Spt. Mdls.)	5719568 R.H.	12.45	
65-66 (exc. Spt. Mdls.)	5719569 L.H.	12.45	
67-68 (exc. Spt. Mdls.)	9708506 R.H.	12.45	
67-68 (exc. Spt. Mdls.)	9708507 L.H.	12.45	

**CHEVY**

62-67 Chevy	5712196 R.H.	15.75	
62-67 Chevy	5712197 L.H.	15.75	
68-72 Chevy,			
73-74 Nova (Taxi)	9712390 R.H.	16.90	
68-72 Chevy,			
73-74 Nova (Taxi)	9712391 L.H.	16.90	

**CHEVELLE**

64-67 Chevelle (exc. Spt. Mdls.)	5718112 R.H.	12.05	
64-67 Chevelle (exc. Spt. Mdls.)	5718113 L.H.	12.05	
64-65 Chevelle (exc. Spt. Mdls.)	5717994 R.H.	12.45	
64-65 Chevelle (Spt. Mdls.)	5717995 L.H.	12.45	
66-67 Malibu (Spt. Sed.)	9705074 R.H.	12.70	(less handle)
66-67 Malibu (Spt. Sed.)	9705075 L.H.	12.70	(less handle)
66-67 Chevelle (Spt. Cpe., Conv.)	9706224 R.H.	12.45	(less handle)
66-67 Chevelle (Spt. Cpe., Conv.)	9706225 L.H.	12.45	(less handle)
68-72 Chevelle (4-Dr.) (exc. Spt. Sed.)	9712440 R.H.	11.35	
68-72 Chevelle (4-Dr.) (exc. Spt. Sed.)	9712441 L.H.	11.35	
68-72 Chevelle (Spt. Sed.)	9712488 R.H.	12.45	



**WINDSHIELD—DOORS—CONTROLS**

**10.655 CHANNEL— FILLER— RIVET, Front Door Ventilator Glass (with tee shaft)  
(Con't)**

68-72	Chevelle (Spt. Sed.)	9712489	L.H.	12.70	
68	Chevelle (Spt. Cpe., Conv.)	9712532	R.H.	12.45	
68	Chevelle (Spt. Cpe., Conv.)	9712533	L.H.	12.45	
68-70	Chevelle (2-Dr. Sed.)				
68-72	El Camino	9712578	R.H.	10.90	
68-70	Chevelle (2-Dr. Sed.)				
68-72	El Camino	9712579	L.H.	11.35	

**CAMARO**

67	Camaro	9708672	R.H.	12.45	(less handle)
67	Camaro	9708673	L.H.	12.45	(less handle)
62-69	All	370389	A.R.	RL/.12	FILLER, channel (.032" thick) (60 ft. roll)— (10.685)
62-69	All	370390	A.R.	RL/.15	FILLER, channel (.047" thick) (40 ft. roll)— (10.685)
65	Chevelle (exc. Spt. Cpe., Conv.)	4627417	2	.14	RIVET, vent. division to glass run channel— (10.688)

**10.656 FRAME, Front Door Ventilator**

**PASSENGER**

65	Spt. Mdls.,				
66	Spt. Mdls. (exc. Conv.)	5719311	L.H.	33.00	
67-68	Spt. Mdls. (exc. Conv.)	9708380	R.H.	33.25	
67-68	Spt. Mdls. (exc. Conv.)	9708381	L.H.	33.25	

**CHEVY**

66-67	Nova (Spt. Cpe.)	4539494	L.H.	13.10	
-------	------------------	---------	------	-------	--

**CHEVELLE**

66-67	Malibu (Spt. Sed.)	9705038	R.H.	29.50	
66-67	Malibu (Spt. Sed.)	9705039	L.H.	29.50	
66-67	(Spt. Cpe., Conv.)	9706200	R.H.	30.25	
68	(Spt. Cpe.)	9712504	R.H.	32.75	
68	(Spt. Cpe.)	9712505	L.H.	32.75	
68-72	(Spt. Sed.)	9712458	R.H.	32.00	
68-72	(Spt. Sed.)	9712459	L.H.	32.00	

**10.657 SHAFT— REINFORCEMENT, Front Door Ventilator Tee**

67-68	Pass. (exc. Spt. Mdls.)	9708501	L.H.	2.30	
68	Chevelle,				
69-72	Chevelle (exc. Spt. Cpe., Conv.)	9712450	R.H.	2.80	glass channel
68	Chevelle,				
69-72	Chevelle (exc. Spt. Cpe., Conv.)	9712451	L.H.	2.80	glass channel
68	Chevelle,				
69-72	Chevelle (exc. Spt. Cpe., Conv.)	7723816	R.H.	.52	REINFORCEMENT, front door outer panel at vent.
68	Chevelle,				
69-72	Chevelle (exc. Spt. Cpe., Conv.)	7723817	L.H.	.52	REINFORCEMENT, front door outer panel at vent.

**10.658 GLASS, Front Door Ventilator (safety)**

**PASSENGER**

65-67	Spt. Mdls.,				
68	Spt. Mdls. (exc. Caprice),				
68	Caprice (Spt. Sed.)	4462312	R.H.	18.10	(clear)
65-67	Spt. Mdls.,				
68	Spt. Mdls. (exc. Caprice),				
68	Caprice (Spt. Sed.)	4462313	L.H.	18.10	(clear)
65-67	Spt. Mdls.,				
68	Spt. Mdls. (exc. Caprice),				
68	Caprice (Spt. Sed.)	4462314	R.H.	19.95	(tinted)
65-67	Spt. Mdls.,				
68	Spt. Mdls. (exc. Caprice),				
68	Caprice (Spt. Sed.)	4462315	L.H.	14.85	left (tinted)
65-68	(Exc. Spt. Mdls.)	4462308	R.H.	18.10	right (clear)
65-68	(Exc. Spt. Mdls.)	4462309	L.H.	18.10	left (clear)
65-68	(Exc. Spt. Mdls.)	4462310	R.H.	19.95	right (tinted)
65-68	(Exc. Spt. Mdls.)	4462311	L.H.	19.95	left (tinted)

**WINDSHIELD—DOORS—CONTROLS**

**10.658 GLASS, Front Door Ventilator (safety) (Con't)**

**CHEVY**

62-67	Chevy	4894866	2	14.35	(clear)
68-72	Chevy,				
73-74	Nova (Taxi)	9712324	R.H.	18.10	(clear)
68-72	Chevy,				
73-74	Nova (Taxi)	9712325	L.H.	18.10	(clear)
68-72	Chevy	9712388	R.H.	19.95	(tinted)
68-72	Chevy	9712389	L.H.	19.95	(tinted)

**CHEVELLE**

64-65	Chevelle,				
66-67	(Exc. Spt. Mdls.)	4409664	R.H.	18.10	(clear)
64-65	Chevelle,				
66-67	(Exc. Spt. Mdls.)	4409665	L.H.	18.10	(clear)
64-67	(Exc. Spt. Mdls.)	4409666	R.H.	19.95	(tinted)
66-67	(Spt. Cpe., Conv.)	4537088	R.H.	18.10	(clear)
66-67	(Spt. Cpe., Conv.)	4537089	L.H.	18.10	(clear)
66-67	(Spt. Cpe., Conv.)	4537090	R.H.	18.35	(tinted)
66-67	(Spt. Cpe., Conv.)	4537091	L.H.	19.95	(tinted)
68-72	(4-Dr.) (exc. Spt. Sed.)	9712452	R.H.	18.10	(clear)
68-72	(4-Dr.) (exc. Spt. Sed.)	9712453	L.H.	18.10	(clear)
68-72	(4-Dr.) (exc. Spt. Sed.)	9712454	R.H.	19.95	(tinted)
68-72	(4-Dr.) (exc. Spt. Sed.)	9712455	L.H.	19.95	(tinted)
68-72	(Spt. Sed.)	9712498	R.H.	18.10	(clear)
68-72	(Spt. Sed.)	9712499	L.H.	18.10	(clear)
68-72	(Spt. Sed.)	9712500	R.H.	19.95	(tinted)
68-72	(Spt. Sed.)	9712501	L.H.	19.95	(tinted)
68	(Spt. Cpe., Conv.)	9712540	R.H.	13.50	(clear)
68	(Spt. Cpe., Conv.)	9712541	L.H.	18.10	(clear)
68	(Spt. Cpe., Conv.)	9712542	R.H.	19.95	(tinted)
68	(Spt. Cpe., Conv.)	9712543	L.H.	19.95	(tinted)
68-70	(2-Dr. Sed.),				
68-72	El Camino	9712586	R.H.	18.10	(clear)
68-70	(2-Dr. Sed.),				
68-72	El Camino	9712587	L.H.	18.10	(clear)
68-70	(2-Dr. Sed.),				
68-72	El Camino	9712588	R.H.	19.95	(tinted)
68-70	(2-Dr. Sed.),				
68-72	El Camino	9712589	L.H.	19.95	(tinted)

**CAMARO**

67	Camaro	9708666	R.H.	18.10	(clear)
67	Camaro	9708667	L.H.	18.10	(clear)
67	Camaro	9708686	R.H.	19.95	(tinted)
67	Camaro	9708687	L.H.	19.95	(tinted)

**10.660 WASHER— SPRING— STOP, Front Door Ventilation Channel**

62-67	All (exc. Pass.),				
68-72	Chevy,				
73-74	Nova (Taxi)	4305060	4	.12	friction unit
62-67	All (exc. Pass.),				
68-72	Chevy,				
73-74	Nova (Taxi)	4305061	2	.12	spring retaining
62-67	All (exc. Pass.),				
68-72	Chevy,				
73-74	Nova (Taxi)	4305062	2	.12	friction tab unit
70-72	Nova,				
73-74	Nova (Taxi)	3696038	2	.06	vent. glass channel handle
65-67	Chevelle, Camaro,				
65-72	Chevy,				
73-74	Nova (Taxi)	9705003	2	.41	SPRING, friction unit
62-67	Chevelle, Chevy	4305287	2	.12	STOP, friction unit
68-72	Chevy,				
73-74	Nova (Taxi)	9714192	2	.24	STOP, friction unit

**10.661 REGULATOR— CLIP— SCREW, Front Door Ventilator**

65	Pass. (exc. Spt. Mdls.),				
66-68	Pass. (4-Dr.) (exc. Spt. Sed.)	7609582	R.H.	7.85	
65-68	Pass. (Spt. Mdls.)	7609580	R.H.	7.85	
65	Pass. (exc. Spt. Mdls.),				
66-68	Pass. (4-Dr.) (exc. Spt. Sed.)	7609583	L.H.	7.85	
66	Caprice (Spt. Cpe.),				
66-68	Impala (Spt. Mdls.)	7609581	L.H.	7.85	

**WINDSHIELD—DOORS—CONTROLS**

**10.661 REGULATOR— CLIP— SCREW, Front Door Ventilator (Con't)**

67	Caprice (Spt. Mdls.),				
68	Caprice (Spt. Sed.) . . . . .	7609586	R.H.	7.85	
67	Caprice (Spt. Mdls.),				
68	Caprice (Spt. Sed.) . . . . .	7609587	L.H.	7.85	
68	Malibu (exc. Sta. Wag.),				
68	Concours, S.S.,				
69	Chevelle (Sed.) El Camino,				
70	Chevelle (exc. Spt. Cpe., Conv.),				
71-72	Chevelle (4-Dr.) El Camino . . . . .	7719731	R.H.	5.70	
68	Malibu (exc. Sta. Wag.),				
68	Concours, S.S.,				
69	Chevelle (Sed.) El Camino,				
70	Chevelle (exc. Spt. Cpe., Conv.),				
71-72	Chevelle (4-Dr.) El Camino . . . . .	7719732	L.H.	5.70	
68	Chevelle (Sed.) (exc. Malibu),				
68	Chevelle (Deluxe),				
68	Malibu (Sta. Wag.),				
69	Deluxe (exc. Spt. Cpe., Sta. Wag.),				
69	Chevelle (Sta. Wag.) . . . . .	7771369	L.H.	7.85	
68	Chevelle (Sed.) (exc. Malibu),				
68	Chevelle (Deluxe),				
68	Malibu (Sta. Wag.),				
69	Deluxe (exc. Spt. Cpe., Sta. Wag.),				
69	Chevelle (Sta. Wag.) . . . . .	7771368	R.H.	7.85	
65-67	Pass.,				
68	Chevelle,				
68	Pass. (exc. Caprice),				
68	Caprice (exc. Spt. Cpe.),				
69-70	Chevelle (exc. Spt. Cpe., Conv.),				
71-72	Chevelle (4-Dr.) . . . . .	9703379	2	.18	CLIP, regulator tee shaft . . . . .
68-70	Pass., Chevelle . . . . .				regulator to inner panel . . . . .
68	Chevelle (exc. Spt. Sed.) . . . . .	4405527	6	.15	SCREW, to inner panel— (11.040) . . . . .

**10.664 HANDLE— GASKET— INSERT— PIN— SCREW— SPACER— SPRING— STUD— SUPPORT— WASHER, Door Ventilator Regulator**

62-64	Chevy, Chevelle,				
65-67	Chevy,				
65	Chevellé,				
66-67	Chevelle (exc. Spt. Mdls.) . . . . .	4305052	R.H.	2.50	glass channel . . . . .
62-64	Chevy, Chevelle,				
65-67	Chevy,				
65	Chevelle,				
66-67	Chevelle (exc. Spt. Mdls.) . . . . .	4305053	L.H.	2.50	glass channel . . . . .
65-66	Impala . . . . .	4468653	2	4.05	
66-67	Chevelle (Spt. Mdls.) . . . . .	9706878	R.H.	2.40	glass channel . . . . .
66-67	Chevelle (Spt. Mdls.) . . . . .	9706879	L.H.	2.40	glass channel . . . . .
67	Impala, Caprice . . . . .	7690284	2	4.40	(dark gold) . . . . .
67	Pass. . . . .	7680651	2	4.35	front door (black) . . . . .
67	Camaro . . . . .	9708670	R.H.	2.85	glass channel . . . . .
67	Camaro . . . . .	9708671	L.H.	2.85	glass channel . . . . .
68	All . . . . .	7752486	2	4.50	(black) . . . . .
68	All . . . . .	7765716	2	4.35	(red) . . . . .
68	All . . . . .	7765717	2	4.50	(turquoise) . . . . .
68	All . . . . .	7765719	2	4.50	(blue) . . . . .
68	All . . . . .	7765726	2	4.50	(teal) . . . . .
68	All . . . . .	7765727	2	4.50	(saddle) . . . . .
68	All . . . . .	7765728	2	4.50	(gold) . . . . .
68	All . . . . .	7765730	2	4.50	(green) . . . . .
68-72	Chevy,				
73-74	Nova (Taxi) . . . . .	9712394	R.H.	2.85	glass channel . . . . .
68-72	Chevy,				
73-74	Nova (Taxi) . . . . .	9712395	L.H.	2.85	glass channel . . . . .
69-70	Chevelle (exc. Spt. Cpe., Conv.),				
71-72	Chevelle (4-Dr.) . . . . .	8732960	2	4.35	
66-67	Chevelle, Camaro (Spt. Mdls.) . . . . .	9708629	2	.12	GASKET, glass channel handle . . . . .
66-67	Chevelle, Camaro (Spt. Mdls.) . . . . .	9708694	1	.11	INSERT, glass channel handle . . . . .
62-67	Chevy,				
67	Chevelle (exc. Spt. Mdls.) . . . . .	9411599	2	.18	PIN, glass channel handle— (8.939) . . . . .
66-67	Chevelle (Spt. Mdls.) . . . . .	456351	2	.11	PIN, glass channel handle— (8.939) . . . . .
66-67	Chevelle (2-Dr. Sed.),				
66-67	Chevelle (4-Dr.) (exc. Spt. Sed.),				
66-67	El Camino (Custom),				

**WINDSHIELD—DOORS—CONTROLS**

**10.664 HANDLE— GASKET— INSERT— PIN— SCREW— SPACER— SPRING—  
STUD— SUPPORT— WASHER, Door Ventilator Regulator (Con't)**

68-74	Chevy	5717193	4	.31	SCREW, lock handle support drive (No. 8— 8 x 5/16" drive screw)
65	Spt. Mdls.	4469108	A.R.	.24	SPACER (10.747)
66-67	Chevelle, Camaro (Spt. Mdls.)	9708469	2	.76	SPACER, glass channel handle
65	Pass.	4566746	A.R.	.22	SPRING, handle— (10.806)
66-67	Chevelle, Camaro (Spt. Mdls.)	9705069	2	1.95	STUD, glass channel handle
66-67	Chevelle (exc. Spt. Mdls.)	5717210	1	3.15	SUPPORT, right, link handle
66-67	Chevelle (exc. Spt. Mdls.)	5717211	1	3.20	SUPPORT, left, link handle
62-67	Chevy,				
66-67	Chevelle (exc. Spt. Mdls.)	3696038	2	.06	WASHER, glass channel handle special spring— (10.824)
66-67	Chevelle, Camaro (Spt. Mdls.)	9708138	2	.13	WASHER, glass channel handle (plastic)
66-67	Chevelle, Camaro (Spt. Mdls.)	9428369	2	.12	WASHER, glass channel handle spring

**10.665 WASHER, Front Door Vent.**

65-67	Pass.,				
68-69	Chevelle	4877342	2	.12	regulator sealing

**10.666 SPRING, Front Door Vent Reg. Handle**

70-72	Chevelle (exc. Spt. Cpe., Conv.)	7747302	2	.24	
-------	----------------------------------	---------	---	-----	--

**10.669 RIVET— SUPPORT, Front Door Ventilator**

65	Pass. (exc. Spt. Cpe. Conv.),				
66-67	Pass. (exc. Spt. Mdls.),				
70-74	Nova (Taxi),				
70	Chevelle (exc. Spt. Sed., Spt. Cpe., Conv.),				
71-72	El Camino,				
71-72	Chevelle (4-Dr.) (exc. Spt. Cpe.)	9704875	2	.12	pivot hinge (5/32")
68-72	Chevelle (exc. Spt. Mdls.)	9712421	L.H.	.52	SUPPORT, left, upper pivot
68-72	Chevelle (exc. Spt. Mdls.)	9712420	R.H.	.52	SUPPORT, right, upper pivot

**10.670 STUD— BUMPER ASSY.— NUT— RIVET— SCREW, Front Door Ventilator**

64-66	Chevelle (2-Dr.),				
67-69	Camaro	4868577	A.R.	.18	vent. to inner panel, front, lower division channel, lower,
64	Chevelle (exc. Spt. Mdls.)				
62-63	Chevy,				
65-66	Chevelle (exc. Spt. Mdls.)				to inner panel, lower,
64-65	Chevy (4-Dr.),				
65-66	Pass. (Spt. Sed.)				rear division channel, lower,
64	Malibu (4-Dr.)	4405500	2	.16	to inner panel, rear, lower
64-67	Nova (Spt. Mdls.)	4405502	2	.12	frame to inner panel
65-68	Pass. (Spt. Mdls.)				to hinge pillar panel,
66-72	Malibu (Spt. Mdls.)				to inner panel, rear, lower,
68-72	Chevy (4-Dr.)				front and rear to inner panel,
68-72	Chevy (2-Dr.)	7602989	1	.63	front to inner panel
73	Nova (Taxi)	7602989		.63	rr./frt. div. channel stud
65-68	Pass. (exc. Spt. Mdls.),				
67-68	Camaro	4405501	2	.18	to hinge pillar panel
67	Camaro	7657975	2	.37	vent. to inner panel, rear lower
68	Chevelle,				
69-72	Chevelle (exc. Spt. Cpe., Conv.)	7730793	2	.52	to inner panel
66-67	Nova (Spt. Cpe.)	9705207	L.H.	.70	BUMPER ASSY., frame
65-68	Spt. Mdls.	4407502	A.R.	.18	NUT, to inner panel upper
73	Pass. (2-Dr.)	9673678	2	.14	inner panel upper
63-67	Nova (Spt. Cpe., Conv.)	5713137	2	.12	RIVET, bumper frame
65-67	Chevelle	9419372	2	.11	SCREW, vent. to inner panel at belt (No. 10— 16 x 2 1/2") chrome
65-67	Chevy	9414770	2	.12	SCREW, vent. to inner panel at belt (No. 10— 16 x 2) chrome— (8.977)
68	Pass., Chevelle,				
69-72	Chevelle (exc. Spt. Cpe., Conv.)	4406206	2	.18	SCREW, regulator to tee shaft
71-72	Chevelle (exc. Spt. Cpe., Conv.)	7679150	2	.18	SCREW, vent. to filler

**10.681 GLASS— SPACER— STRIP, Front Door Window (Safety)**

**PASSENGER**

65-68	4-Dr. (exc. Spt. Sed.)	4463432	R.H.	30.75	(clear)
65-68	4-Dr. (exc. Spt. Sed.)	4463433	L.H.	30.75	(clear)
65-68	4-Dr. (exc. Spt. Sed.)	4463434	R.H.	33.75	(tinted)
65-68	4-Dr. (exc. Spt. Sed.)	4463435	L.H.	33.75	(tinted)
65	Spt. Sed.,				
67-68	Spt. Sed.	4463416	R.H.	36.00	(clear)

**WINDSHIELD—DOORS—CONTROLS**

**10.681 GLASS— SPACER— STRIP, Front Door Window (Safety) (Con't)**

65	Spt. Sed.,			
67-68	Spt. Sed. ....	4463418 R.H.	39.75	(tinted) .....
65	Spt. Sed.,			
67-68	Spt. Sed. ....	4463419 L.H.	39.75	(tinted) .....
66	Impala (Spt. Cpe.)	4548028 R.H.	44.50	(clear) .....
66	Impala (Spt. Cpe.)	4548029 L.H.	44.50	(clear) .....
66	Spt. Sed.	4548185 L.H.	38.75	(tinted) .....
67-68	2-Dr. Sed.	7639788 R.H.	30.50	(clear) .....
67-68	2-Dr. Sed.	7639789 L.H.	30.50	(clear) .....
67-68	2-Dr. Sed.	7639790 R.H.	41.75	(tinted) .....
67-68	2-Dr. Sed.	7639791 L.H.	33.75	(tinted) .....
67-68	Impala (Spt. Cpe.) (exc. Custom)	7641906 R.H.	46.75	(clear) .....
67-68	Impala (Spt. Cpe.) (exc. Custom)	7641907 L.H.	46.75	(clear) .....
67-68	Impala (Spt. Cpe.) (exc. Custom)	7641908 R.H.	51.50	(tinted) .....
67-68	Impala (Spt. Cpe.) (exc. Custom)	7641909 L.H.	38.25	(tinted) .....
67-68	Conv.	7641914 R.H.	35.50	(clear) .....
67-68	Conv.	7641915 L.H.	35.50	(clear) .....
67-68	Conv.	7641916 R.H.	39.50	(tinted) .....
67-68	Conv.	7641917 L.H.	52.75	(tinted) .....
68	Caprice (Spt. Cpe.)	8724383 R.H.	59.25	(clear) .....
68	Caprice (Spt. Cpe.)	8724385 R.H.	65.00	(tinted) .....
68	Caprice (Spt. Cpe.)	8724386 L.H.	65.00	(tinted) .....
68	Impala (Custom)	7754417 L.H.	33.00	(clear) .....
68	Impala (Custom)	7754418 R.H.	36.25	(tinted) .....
68	Impala (Custom)	7754419 L.H.	36.25	(tinted) .....
69	Pass. (Spt. Cpe., Conv.)	8712135 L.H.	64.50	(clear) .....
69	Pass. (Spt. Cpe., Conv.)	8712136 R.H.	70.00	(tinted) .....
69	Pass. (Spt. Cpe., Conv.)	8712137 L.H.	70.00	(tinted) .....
69-70	Spt. Sed.	8712510 R.H.	56.00	(clear) .....
69-70	Spt. Sed.	8712511 L.H.	56.00	(clear) .....
69-70	Spt. Sed.	8712512 R.H.	61.00	(tinted) .....
69-70	Spt. Sed.	8712513 L.H.	61.00	(tinted) .....
69	2-Dr. Sed.	8712776 R.H.	38.75	(clear) .....
69	2-Dr. Sed.	8712777 L.H.	38.75	(clear) .....
69	2-Dr. Sed.	8712778 R.H.	42.25	(tinted) .....
69	2-Dr. Sed.	8712779 L.H.	42.25	(tinted) .....
69-70	4-Dr. (exc. Spt. Sed.)	8712780 R.H.	44.25	(clear) .....
69-70	4-Dr. (exc. Spt. Sed.)	8712781 L.H.	44.25	(clear) .....
69-70	4-Dr. (exc. Spt. Sed.)	8712782 R.H.	48.50	(tinted) .....
69-70	4-Dr. (exc. Spt. Sed.)	8712783 L.H.	48.50	(tinted) .....
70	Pass. (2-Dr.)	8780407 L.H.	57.75	(clear) .....
70	Pass. (2-Dr.)	8780406 R.H.	57.75	(clear) .....
70	Pass. (2-Dr.)	8780409 L.H.	62.50	(tinted) .....
70	Pass. (2-Dr.)	8780408 R.H.	62.50	(tinted) .....
71-75	Pass. (4-Dr.) (exc. Spt. Sed.)	9805623 L.H.	39.00	(clear) (solid tempered) .....
71-75	Pass. (4-Dr.) (exc. Spt. Sed.)	9805622 R.H.	39.00	(clear) (solid tempered) .....
71-75	Pass. (4-Dr.) (exc. Spt. Sed.)	9824377 L.H.	42.25	(tinted) (solid tempered) .....
71-75	Pass. (4-Dr.) (exc. Spt. Sed.)	9824376 R.H.	42.25	(tinted) (solid tempered) .....
71	Pass. (Spt. Sed.)	9805627 L.H.	35.25	(clear) (solid tempered) .....
71	Pass. (Spt. Sed.)	9805626 R.H.	35.25	(clear) (solid tempered) .....
71	Pass. (Spt. Sed.)	9824381 L.H.	38.75	(tinted) (solid tempered) .....
72-75	Pass. (Spt. Sed.)	9616351 L.H.	48.75	(clear) .....
72-75	Pass. (Spt. Sed.)	9616350 R.H.	48.75	(clear) .....
72-75	Pass. (Spt. Sed.)	9616353 L.H.	53.25	(tinted) .....
71-75	Pass. (Spt. Sed.)	9616352 R.H.	49.00	(tinted) .....
71-73	Pass. (Spt. Cpe.)	9805629 L.H.	57.75	(clear) (solid tempered) .....
71-73	Pass. (Spt. Cpe.)	9805628 R.H.	57.75	(clear) (solid tempered) .....
71-73	Pass. (Spt. Cpe.)	9824383 L.H.	63.00	(tinted) (solid tempered) .....
71-73	Pass. (Spt. Cpe.)	9824382 R.H.	63.00	(tinted) (solid tempered) .....
71-75	Pass. (Conv.)	9805631 L.H.	60.00	(clear) (solid tempered) .....
71-75	Pass. (Conv.)	9805630 R.H.	60.00	(clear) (solid tempered) .....
71-75	Pass. (Conv.)	9824385 L.H.	65.25	(tinted) (solid tempered) .....
71-75	Pass. (Conv.)	9824384 R.H.	65.25	(tinted) (solid tempered) .....
74-75	Pass. (Spt. Cpe.) (exc. Custom)	9665188 R.H.	60.25	(clear) .....
74-75	Pass. (Spt. Cpe.) (exc. Custom)	9665189 L.H.	60.25	(clear) .....
74-75	Pass. (Spt. Cpe.) (exc. Custom)	9665190 R.H.	66.50	(tinted) .....
74-75	Pass. (Spt. Cpe.) (exc. Custom)	9665191 L.H.	66.50	(tinted) .....
74-75	Impala (Custom) Caprice (Spt. Cpe.)	9665196 R.H.	58.00	(clear) .....
74-75	Impala (Custom) Caprice (Spt. Cpe.)	9665197 L.H.	58.00	(clear) .....
74-75	Impala (Custom) Caprice (Spt. Cpe.)	9665198 R.H.	63.50	(tinted) .....
74-75	Impala (Custom) Caprice (Spt. Cpe.)	9665199 L.H.	63.50	(tinted) .....

**WINDSHIELD—DOORS—CONTROLS**

**10.681 GLASS— SPACER— STRIP, Front Door Window (Safety) (Con't)**

**CHEVELLE**

64-67	(4-Dr.)	4405024	R.H.	23.05	(clear)
64-67	(4-Dr.)	4405025	L.H.	21.15	(clear)
64-67	(4-Dr.)	4405026	R.H.	26.00	(tinted)
64-67	(4-Dr.)	4405027	L.H.	33.75	(tinted)
64-67	(2-Dr. Sed.)	4405115	R.H.	40.75	(clear)
64-67	(2-Dr. Sed.)	4405116	L.H.	40.75	(clear)
64-67	(2-Dr. Sed.)	4405117	R.H.	33.25	(tinted)
64-67	(2-Dr. Sed.)	4405118	L.H.	33.25	(tinted)
64-67	El Camino	4405184	R.H.	29.75	(clear)
64-67	El Camino	4405186	R.H.	32.75	(tinted)
64-67	El Camino	4405187	L.H.	30.75	(tinted)

*NOTE 1 To be used with bolt-on sash channel.*

66-67	Malibu (Spt. Sed.)	4540914	R.H.	31.50	(clear)
66-67	Malibu (Spt. Sed.)	4540915	L.H.	29.25	(clear)
66-67	Malibu (Spt. Sed.)	4540916	R.H.	34.25	(tinted)
66-67	(Spt. Cpe., Conv.)	4541588	R.H.	43.50	(clear)
66-67	(Spt. Cpe., Conv.)	4541589	L.H.	43.50	(clear)
66-67	(Spt. Cpe., Conv.)	4541591	L.H.	35.75	(tinted)
68	Chevelle (Spt. Cpe., Conv.)	7723063	R.H.	39.25	(clear) (solid tempered)
68	Chevelle (Spt. Cpe., Conv.)	7723064	L.H.	39.25	(clear) (solid tempered)
68	Chevelle (Spt. Cpe., Conv.)	7723065	R.H.	32.25	(tinted) (solid tempered)
68	Chevelle (Spt. Cpe., Conv.)	7723066	L.H.	32.25	(tinted) (solid tempered)
68-70	(2-Dr.) (Plr. Cpe.)	7723056	L.H.	29.50	(clear) (solid tempered)
68-70	(2-Dr.) (Plr. Cpe.)	7723055	R.H.	29.50	(clear) (solid tempered)
68-70	(2-Dr.) (Plr. Cpe.)	7723058	L.H.	32.50	(tinted) (solid tempered)
68-70	(2-Dr.) (Plr. Cpe.)	7723057	R.H.	32.50	(tinted) (solid tempered)
68-72	(4-Dr.) (exc. Spt. Sed.)	7721907	R.H.	21.50	(clear) (solid tempered)
68-72	(4-Dr.) (exc. Spt. Sed.)	7721908	L.H.	21.50	(clear) (solid tempered)
68-72	(4-Dr.) (exc. Spt. Sed.)	7721910	R.H.	23.55	(tinted) (solid tempered)
68-72	(4-Dr.) (exc. Spt. Sed.)	7721911	L.H.	23.55	(tinted) (solid tempered)
68-72	(Spt. Sed.)	7722117	R.H.	26.25	(clear) (solid tempered)
68-72	(Spt. Sed.)	7722118	L.H.	26.25	(clear) (solid tempered)
68-72	(Spt. Sed.)	7722120	R.H.	28.75	(tinted) (solid tempered)
68-72	(Spt. Sed.)	7722121	L.H.	28.75	(tinted) (solid tempered)
68-72	El Camino	7723061	R.H.	27.00	(clear) (solid tempered)
68-72	El Camino	7723062	L.H.	27.00	(clear) (solid tempered)
68-72	El Camino	7723067	R.H.	29.50	(tinted) (solid tempered)
68-72	El Camino	7723068	L.H.	29.50	(tinted) (solid tempered)
69	Chevelle (Spt. Cpe., Conv.)	8713454	L.H.	67.25	(tinted)
69	Chevelle (Spt. Cpe., Conv.)	8713453	R.H.	67.25	(tinted)
70-72	Chevelle (2-Dr.)	9822329	L.H.	56.75	(tinted) (solid tempered)
70-72	Chevelle (2-Dr.)	9822328	R.H.	56.75	(tinted) (solid tempered)
70-72	Chevelle (2-Dr.)	9822327	L.H.	52.25	(clear) (solid tempered)
70-72	Chevelle (2-Dr.)	9822326	R.H.	52.25	(clear) (solid tempered)
73-75	Chevelle (Spt. Cpe.)	9867417	L.H.	79.75	(tinted)
73-75	Chevelle (Spt. Cpe.)	9867416	R.H.	79.75	(tinted)
73-75	Chevelle (Spt. Cpe.)	9867415	L.H.	74.00	(clear)
73-75	Chevelle (Spt. Cpe.)	9867414	R.H.	74.00	(clear)
73-75	Chevelle (4-Dr.)	9867403	L.H.	52.50	(clear)
73-75	Chevelle (4-Dr.)	9867402	R.H.	52.50	(clear)
73-75	Chevelle (4-Dr.)	9867405	L.H.	56.75	(tinted)
73-75	Chevelle (4-Dr.)	9867404	R.H.	56.75	(tinted)
73-75	Monte Carlo	9867419	L.H.	72.25	(clear)
73-75	Monte Carlo	9867418	R.H.	72.25	(clear)
73-75	Monte Carlo	9867421	L.H.	78.25	(tinted)
73-75	Monte Carlo	9867420	R.H.	78.25	(tinted)
73-75	El Camino	9867425	L.H.	79.75	(tinted)
73-75	El Camino	9867424	R.H.	79.75	(tinted)
73-75	El Camino	9867423	L.H.	74.00	(clear)
73-75	El Camino	9867422	R.H.	74.00	(clear)

**CHEVY— NOVA**

62-67	(2-Dr. Sed.)	4842259	2	16.40	(clear)
62-67	(2-Dr. Sed.)	4842260	2	16.00	(tinted)
62-67	(4-Dr.)	4841363	2	14.35	(clear)
62-67	(4-Dr.)	4841364	2	13.45	(tinted)
66-67	Nova (Spt. Cpe.)	4547696	2	14.05	(clear)
66-67	Nova (Spt. Cpe.)	4547697	2	19.90	(tinted)
68-72	(2-Dr.)	7725944	R.H.	30.50	(clear)
68-72	(2-Dr.)	7725945	L.H.	30.50	(clear)
68-72	(2-Dr.)	7725946	R.H.	33.50	(tinted)
68-72	(2-Dr.)	7725947	L.H.	33.50	(tinted)

**WINDSHIELD—DOORS—CONTROLS**

**10.681 GLASS— SPACER— STRIP, Front Door Window (Safety) (Con't)**

68-72	(4-Dr.)	7717530 R.H.	24.05	(clear)
68-72	(4-Dr.)	7717531 L.H.	24.05	(clear)
68-72	(4-Dr.)	7717532 R.H.	26.25	(tinted)
68-72	(4-Dr.)	7717533 L.H.	26.25	(tinted)
73-74	Nova (2-Dr.)	9612569 L.H.	41.75	(tinted)
73-74	Nova (2-Dr.)	9612568 R.H.	41.75	(tinted)
73-74	Nova (2-Dr.)	9612567 L.H.	38.00	(clear)
73-74	Nova (2-Dr.)	9612566 R.H.	38.00	(clear)
73-74	Nova (4-Dr.)	9611269 L.H.	34.25	(tinted)
73-74	Nova (4-Dr.)	9611268 R.H.	34.25	(tinted)
73-74	Nova (4-Dr.) (exc. Taxi)	9611267 L.H.	31.50	(clear)
73-74	Nova (4-Dr.) (exc. Taxi)	9611266 R.H.	31.50	(clear)
73-74	Nova (Taxi)	7717531 L.H.	24.05	(clear)
73-74	Nova (Taxi)	7717530 R.H.	24.05	(clear)
75	Nova (2-Dr.)	9699093 L.H.	43.75	(clear)
75	Nova (2-Dr.)	1705341 L.H.	52.50	(tinted) (repl. 9699095)
75	Nova (4-Dr.)	1705335 L.H.	38.75	(clear) (repl. 9726391)
75	Nova (4-Dr.)	1705337 L.H.	41.25	(tinted) (repl. 9726393)
75	Nova (4-Dr.)	9726392 R.H.	39.00	(tinted)
75	Nova (4-Dr.)	1705334 R.H.	38.75	(clear) (repl. 9726390)
75	Nova (2-Dr.)	1705340 R.H.	52.50	(tinted) (repl. 9699094)
75	Nova (2-Dr.)	1705338 R.H.	48.00	(clear) (repl. 9699092)

**CAMARO**

67	Camaro	7636736 R.H.	34.00	(clear)
67	Camaro	7636737 L.H.	34.00	(clear)
67	Camaro	7636738 R.H.	49.75	(tinted)
67	Camaro	7636739 L.H.	49.75	(tinted)
68-69	Camaro	7777404 R.H.	64.00	(clear)
68-69	Camaro	7777405 L.H.	64.00	(clear)
68	Camaro w/elec. wdo.,			
69	Camaro	7777400 R.H.	69.50	(tinted)
68	Camaro w/elec. wdo.,			
69	Camaro	7777401 L.H.	69.50	(tinted)
70	Camaro	8780304 L.H.	61.75	(clear)
70	Camaro	8780303 R.H.	61.75	(clear)
70	Camaro	8780306 L.H.	67.25	(tinted)
70	Camaro	8780305 R.H.	67.25	(tinted)
71-75	Camaro	9864177 L.H.	58.75	(clear)
71-75	Camaro	9864176 R.H.	58.75	(clear)
71-75	Camaro	9864179 L.H.	63.50	(tinted)
71-75	Camaro	9864178 R.H.	63.50	(tinted)

**VEGA— MONZA**

71-75	Vega (exc. H.B.)	9805659 L.H.	35.50	(clear) (solid tempered)
71-75	Vega (exc. H.B.)	9805658 R.H.	35.50	(clear) (solid tempered)
71-75	Vega (exc. H.B.)	9817193 L.H.	39.25	(tinted) (solid tempered)
71-75	Vega (exc. H.B.)	9817192 R.H.	39.25	(tinted) (solid tempered)
71-75	Vega (H.B.)	9805661 L.H.	33.75	(clear) (solid tempered)
71-75	Vega (H.B.)	9805660 R.H.	33.75	(clear) (solid tempered)
71-75	Vega (H.B.)	9817195 L.H.	37.00	(tinted) (solid tempered)
71-75	Vega (H.B.)	9817194 R.H.	37.00	(tinted) (solid tempered)
75	Monza (exc. Towne Cpe.)	9726378 R.H.	48.25	clear
75	Monza (exc. Towne Cpe.)	9726379 L.H.	48.25	clear
75	Monza (exc. Towne Cpe.)	9726380 R.H.	53.00	tinted
75	Monza (exc. Towne Cpe.)	9726381 L.H.	53.00	tinted
75	Monza (Towne Cpe.)	1696270 R.H.	45.25	GLASS, clear
75	Monza (Towne Cpe.)	1696271 L.H.	45.25	GLASS, clear
75	Monza (Towne Cpe.)	1696272 R.H.	49.75	GLASS, tinted
75	Monza (Towne Cpe.)	1696273 L.H.	49.75	GLASS, tinted
65	Spt. Mdls.	4469108 A.R.	.24	SPACER (10.747)
71	Pass.	9609344 1	.27	STRIP, sealing, dr. glass

**10.685 CHANNEL— BOLT— BUSHING— CAP— CLIP— FASTENER— FILLER— GUIDE— INSERT— NUT— PIN ASSY.— PLATE— ROLLER ASSY.— SCREW— SPACER— STOP ASSY.— STUD— WASHER, Front Door Window Glass Lower Sash**

**PASSENGER**

67-68	2-Dr. Sed.	7653760 R.H.	7.00
67-68	2-Dr. Sed.	7653761 L.H.	7.00
67-68	4-Dr. (exc. Spt. Sed.)	7663134 R.H.	5.95
67-68	4-Dr. (exc. Spt. Sed.)	7663135 L.H.	5.95
67	Spt. Cpe., Conv.,		

**WINDSHIELD—DOORS—CONTROLS**

**10.685 CHANNEL— BOLT— BUSHING— CAP— CLIP— FASTENER— FILLER— GUIDE— INSERT— NUT— PIN ASSY.— PLATE— ROLLER ASSY.— SCREW— SPACER— STOP ASSY.— STUD— WASHER, Front Door Window Glass Lower Sash (Con't)**

68	Impala (Spt. Mdls.) (exc. Spt. Sed.)	7734657 R.H.	9.60	
67	Spt. Cpe., Conv.,			
68	Impala (Spt. Mdls.) (exc. Spt. Sed.)	7734658 L.H.	9.60	
67-68	4-Dr. (Spt. Sed.)	7684956 L.H.	9.40	
70	Pass. (2-Dr.)	8788763 2	6.95	(Note 1)

*NOTE 1 Also in Chevelle Section.*

**CHEVY— NOVA**

62-67	(2-Dr. Sed.)	4857463 R.H.	4.15	lower
62-65	Nova (Spt. Cpe., Conv.)	4403720 R.H.	12.60	lower
62-65	Nova (Spt. Cp., Conv.)	4403721 L.H.	12.60	lower
66-67	Nova (Spt. Cpe.)	7580923 L.H.	6.80	lower sash
68-72	(2-Dr.)	7740285 2	3.10	lower sash
68-72	(4-Dr.)	7730020 R.H.	2.60	lower sash
68-72	(4-Dr.)	7730021 L.H.	2.60	lower sash
73-74	Nova (Taxi)	7730021 L.H.	2.60	
73-74	Nova (Taxi)	7730020 R.H.	2.60	
73-75	Nova	9739698 2	3.85	CHANNEL ASSY.

**CHEVELLE**

68-72	(4-Dr.) (exc. Spt. Sed.)	7726603 R.H.	2.75	lower sash
68-72	(4-Dr.) (exc. Spt. Sed.)	7726604 L.H.	2.75	lower sash
68-69	(2-Dr. Sed.)	7730017 2	4.20	lower sash
68-72	El Camino	7731528 R.H.	5.30	lower sash
68-72	El Camino	7731529 L.H.	5.30	lower sash
68-72	(Spt. Sed.)	8760220 R.H.	8.65	lower sash
68-72	(Spt. Sed.)	8760221 L.H.	8.70	lower sash
70	Chevelle (2-Dr.)	8788763 2	6.95	

**CAMARO**

67		7653719 L.H.	8.50	lower sash
68-69		7734320 R.H.	8.30	lower sash, front
68-69		7734321 L.H.	8.30	lower sash, front
68-69		7777406 R.H.	5.45	lower sash, rear
68-69		7777407 L.H.	5.45	lower sash, rear

**VEGA— MONZA**

71-75	Vega	9739698 2	3.85	
75	Monza (exc. Towne Cpe.)	9739259 2	13.80	
75	Monza	1697750 2	6.20	
65	Malibu (2-Dr.)			
65-67	Pass. (Spt. Mdls.)	4534340 A.R.	.39	BOLT, glass to lwr. channel, <sup>13</sup> / <sub>16</sub> " G.M. Spec. 4435M Code "A"
66	Impala, Caprice (Spt. Mdls.)			
67-68	Impala (Spt. Cpe.)	7614967 A.R.	.39	BOLT, glass to lwr. channel, <sup>87</sup> / <sub>64</sub> " G.M. Spec. 4400-M Code 20
73-74	Pass. (2-Dr.)			
68-72	Chevelle (Spt. Sed.)	7775159 2	.21	BOLT, to lower channel front
68-69	Camaro	7734900 6	.31	BOLT, lower channel to glass
68-69	Camaro	7727193 4	.87	BOLT, front door lower sash rear channel upper
68	Caprice (Spt. Cpe.)			
69	Chevelle (Spt. Cpe., Conv.)			
70-72	Pass. (2-Dr., Spt. Sed.)	9833748 4	.21	BUSHING, front upper— (10.792)
68	Chevelle (Spt. Mdls.) (exc. El Camino)			
69	Pass. (4-Dr.)	4491087 A.R.	.14	BUSHING, glass to lower channel, idler cam to glass— (11.007)
71-72	Camaro, Nova (2-Dr.)			
71-72	Chevelle (Spt. Mdls.)			
71-72	Pass. (4-Dr.)			
73-75	All	9804150 A.R.	.16	BUSHING
68	Caprice (Spt. Cpe.)	7698790 2	.22	CAP (4 frt. door upper bushing, 2 frt. door lower bushing)— (10.792)
69	Chevelle (Spt. Mdls.)			
69	Pass. (Spt. Cpe., Conv.)			
70	Pass.,			
70-72	Camaro,			
70-72	Chevelle (2-Dr., Spt. Sed.)	8737225 4	.23	CAP (bearing fastener)
73-75	Nova	9658820 2	.27	CLIP ASSY., guide front door window
70-72	Chevelle (2-Dr.)			FASTENER, bearing,



**WINDSHIELD—DOORS—CONTROLS**

**10.685 CHANNEL— BOLT— BUSHING— CAP— CLIP— FASTENER— FILLER—  
GUIDE— INSERT— NUT— PIN ASSY.— PLATE— ROLLER ASSY.—  
SCREW— SPACER— STOP ASSY.— STUD— WASHER, Front Door  
Window Glass Lower Sash (Con't)**

70-72	Chevelle (Spt. Sed.)	9834131	4	.27	rr. door wdo. glass bearing upper (repl. 7698788)
71-73	Pass.	9874347	A.R.	.27	FASTENER, bearing
73-74	Camaro	9833748	2	.21	FASTENER, door window glass bearing, front
75	Monza	4876498	A.R.	.12	FASTENER
62-69	All	370389	A.R.	RL/.12	FILLER (1/2" thick x 1 1/2" wide— 60 ft. roll)
62-69	All	370390	A.R.	RL/.15	FILLER (3/64" thick x 1 1/2" wide— 40 ft. roll)
62-64	Chevy (exc. Spt. Mdls.),				
65-67	Chevy (exc. Spt. Cpe.)	4418510	A.R.	1.15	FILLER, lower sash channel
67-68	Pass. (2-Dr.) (Sed.)		1		FILLER, rear quarter lower channel,
67-68	Pass. (4-Dr.) (exc. Spt. Sed.)	7647683	A.R.	1.15	lower channel
67	Camaro	9815089	2	.63	FILLER, lower sash channel (repl. 7702302)
67	Chevy, Chevelle (Spt. Mdls.),				
68	Chevy, Chevelle,				
70-72	Nova,				
70-72	Chevelle (4-Dr.) (exc. Spt. Sed.)	8712670	4	.79	FILLER, lower sash channel (repl. 7702605)
68-69	Camaro	7777389	2	.46	FILLER, rear, lower sash channel
70-72	Chevelle (2-Dr.)	8781660	1	.27	FILLER, upper stop retaining plate
73-74	Nova,				
73-75	Vega	9625738	2	.76	FILLER, sash channel front and rear door lower
71-72	Vega, Monza	9815089	2	.63	FILLER, front door window lower sash channel
70	Pass.,				
70-71	Chevelle (2-Dr.)	8789918	2	8.70	GUIDE, upper
72	Chevelle (Spt. Cpe., Conv.)	9891847	2	8.70	GUIDE, upper
70	Pass.,				
70-72	Chevelle (2-Dr.)	8788763	2	6.95	GUIDE ASSY., lower
71-75	Pass. (Spt. Cpe., Conv.)	9669422	2	8.65	GUIDE ASSY.
72-75	Pass. (Spt. Sed.)	9614715	1	1.95	GUIDE ASSY., front door window stab. pin
73-75	Chevelle (2-Dr.)	9616543	2	1.95	GUIDE ASSY., front door window stabilizer, on glass
73-75	Chevelle	1654549	2	2.05	GUIDE ASSY., front door window stabilizer, on panel
73	Pass. (Spt. Sed.)				INSERT, front dr. wdo. stab. pin,
73-74	Pass. (2-Dr.)	9615422		.27	gde. pit. front door window lower sash
65-68	Pass. (Spt. Mdls.),				
67	Camaro	4533795	A.R.	.33	NUT, to lower channel
69	Pass. (exc. Spt. Cpe., Conv.),				
69	Chevelle (Spt. Mdls.)				NUT, channel, cam roller— (10.792),
72	Pass. (2-Dr.)				front door window lower sash guide plate,
72	Chevelle				front door window glass to lower sash
72	Camaro	4491088	A.R.	.16	front door window rear upper stop to glass,
72	Chevelle,				
73-75	All	4801719	A.R.	.18	NUT, guide plate & upper guide
72-75	Pass. (Spt. Cpe., Conv.)	9614711	L.H.	1.95	PIN ASSY., front door window stab. guide
72-75	Pass. (Spt. Cpe., Conv.)	9614710	R.H.	1.95	PIN ASSY., front door window stab. guide
72-75	Pass. (Spt. Sed.)	9614713	L.H.	1.95	PIN ASSY., front door window stab. guide
72-75	Pass. (Spt. Sed.)	9614712	R.H.	1.95	PIN ASSY., front door window stab. guide
70-72	Chevelle (2-Dr.)	9812528	4	.36	PLATE, upper stop retainer rear
70-72	Chevelle (2-Dr.)	9832189	2	.59	PLATE, upper stop retainer front
68-72	Chevelle (Spt. Sed.)	9713250	2	1.70	ROLLER ASSY., lower sash channel
69-70	Pass. (Spt. Sed.)	8733933	4	3.20	ROLLER ASSY., front door wdo. guide front— (10.792)
69	Pass. (Spt. Cpe., Conv.)	8727914	2	1.10	ROLLER ASSY., front door wdo. guide rear— (10.792)
69-70	Pass. (4-Dr.) (exc. Spt. Sed.)	9813199	2	1.05	ROLLER ASSY., rear guide
69-70	Impala, Caprice (Spt. Cpe., Conv.)	9813200	2	1.15	ROLLER ASSY., wdo. guide front
70-72	Malibu (Spt. Sed.)	9813312	2	1.75	ROLLER ASSY., wdo. guide front
75	Monza (exc. Towne Cpe.)	9734805	2	.92	ROLLER ASSY., guide
70-72	Chevelle (2-Dr.)				SCREW, guide plate,
70-75	Pass. (2-Dr.)	9820349	A.R.	.21	front upper stop to glass
65-66	Pass. (Spt. Mdls.)	4469108	A.R.	.24	SPACER (10.747)
71-73	Vega, Monza	9873872	2	6.35	SPACER, frt. door window anti-rattle window frame
70-75	Camaro	8762077	2	.36	STOP ASSY., upper frt.
73-74	Nova	9619380	2	.36	STOP, window regulator sector
73-75	Chevelle (4-Dr.)	9615767	2	.36	STUD, window on glass
73-75	Chevelle (2-Dr.)	9621440	2	.36	STUD, rear door window on glass
69	Camaro,				

**WINDSHIELD—DOORS—CONTROLS**

**10.685 CHANNEL— BOLT— BUSHING— CAP— CLIP— FASTENER— FILLER— GUIDE— INSERT— NUT— PIN ASSY.— PLATE— ROLLER ASSY.— SCREW— SPACER— STOP ASSY.— STUD— WASHER, Front Door Window Glass Lower Sash (Con't)**

69	Pass. (4-Dr.) (exc. Spt. Sed.),				
71-72	Camaro,				
70-72	Nova,				
70-72	Chevelle (Spt. Sed.),				
70-72	Pass. (4-Dr.)	8731399	4	.14	WASHER, front stabilizer
69	Chevelle (Spt. Cpe.),				
70-72	Pass., Chevelle (2-Dr.) (exc. El Camino),				
73-75	All	7734899	4	.14	WASHER, front glass stabilizer, regulator cam to glass

*NOTE: When necessary, use old sash channel as guide and cut new channel as required.  
NOTE 1: To be used with bolt on sash channel.*

**10.687 CAM— BUSHING— SCREW— SUPPORT, Front Door Glass Lower Sash Channel**

*NOTE Also refer to group 10.685 for sash channel (with cam).*

67	Camaro	7653717	2	.91	(18" O.L.)
68-72	Chevelle (Spt. Sed.)	7734890	2	.91	
68	Chevelle (Spt. Cpe., Conv.)	7730072	2	.91	(10.748)
68-72	Chevelle (Spt. Sed.)	7734324	R.H.	7.65	CAM ASSY., window guide rear
68-72	Chevelle (Spt. Sed.)	7734325	L.H.	7.65	CAM ASSY., window guide, rear
75	Nova (4-Dr.)	1681194	R.H.	3.50	inner panel
75	Nova (4-Dr.)	1681195	L.H.	3.50	inner panel
69	Chevelle (Spt. Mdls.)	4491087	A.R.	.14	BUSHING, lower glass channel
65-66	Pass. (exc. Spt. Mdls.),				
67	Camaro,				
68	Chevelle (Spt. Cpe., Conv.),				
68	Chevelle (Spt. Sed.),				
69-70	Chevelle (Spt. Sed.),				
72	Chevelle (4-Dr.) (exc. Spt. Sed.)	4409392	4	.11	SCREW, front and rear— (10— 24 x 9/16")
67	Pass. (2-Dr. Sed.),				
67	Pass. (4-Dr.) (exc. Spt. Sed.)	4405527	2	.15	SCREW (10.759)
70-75	Camaro	8804681	L.H.	2.65	SUPPORT, left front door window guide rear cam upper
70-75	Camaro	8804680	R.H.	2.65	SUPPORT, right front door window guide rear cam upper
73-75	Chevelle (4-Dr.)	9600721	L.H.	2.65	SUPPORT, guide inner panel upper
73-75	Chevelle (4-Dr.)	9600720	R.H.	2.65	SUPPORT, guide inner panel upper
73-75	Chevelle (2-Dr.)	9600713	L.H.	2.65	SUPPORT, guide inner panel upper
73-75	Chevelle (2-Dr.)	9600712	R.H.	2.65	SUPPORT, guide inner panel upper

**10.688 CHANNEL— RIVET, Front Door Vent Division**

**PASSENGER**

65-66	Spt. Mdls.	5719324	R.H.	9.50	vent, division w/scalp
65-66	Spt. Mdls.	5719325	L.H.	9.50	vent, division w/scalp
65-68	Pass. (exc. Spt. Mdls.)	5719560	2	4.60	glass run front
65	Spt. Mdls.,				
66-67	Spt. Mdls.,				
68	Spt. Mdls. (exc. Conv.)	9711381	2	6.60	glass run front
66-68	Conv.	9713425	L.H.	5.45	door glass run front upper
67	Spt. Cpe.,				
68	Impala (Spt. Cpe., Conv.)	9713486	R.H.	5.50	door glass run front lower
67	Spt. Cpe.,				
68	Impala (Spt. Cpe., Conv.)	9713487	L.H.	5.45	door glass run front lower
67	Impala (Spt. Cpe.),				
68	Impala (Spt. Cpe., Conv.)	9713347	2	5.45	upper, window glass run
67	Spt. Cpe., Conv.,				
68	Impala (Spt. Cpe., Conv.)	9713343	L.H.	11.95	vent, division w/scalp
67-68	Pass. (exc. Spt. Mdls.)	9710306	R.H.	8.85	w/scalp
67-68	Pass. (exc. Spt. Mdls.)	9710307	L.H.	8.85	w/scalp
67-68	Pass. (Spt. Sed.)	9710316	R.H.	8.85	w/scalp
67-68	Pass. (Spt. Sed.)	9710317	L.H.	8.85	w/scalp

**CHEVELLE**

64-65	Malibu (2-Dr.)	5717179	2	6.70	glass run front w/bumper
70-72	Chevelle (Spt. Sed.)	9722967	L.H.	10.75	w/scalp
70-72	Chevelle (Spt. Sed.)	9722966	R.H.	10.75	w/scalp
64-67	Chevelle (exc. Spt. Mdls.)	5717261	L.H.	6.95	CHANNEL ASSY., front door vent. division w/scalp
66-67	Chevelle (Spt. Cpe., Conv.)	9706210	R.H.	11.00	CHANNEL ASSY., front door vent. division

**WINDSHIELD—DOORS—CONTROLS**

**10.688 CHANNEL— RIVET, Front Door Vent Division (Con't)**

66-67	Chevelle (Spt. Cpe., Conv.)	9706211	L.H.	11.00	CHANNEL ASSY., front door vent. division
68-69	(Spt. Sed.)	9712482	R.H.	6.65	CHANNEL ASSY., front door window glass run front, upper
68-69	(Spt. Sed.)	9712483	L.H.	6.65	CHANNEL ASSY., front door window glass run front, upper
68	(Spt. Cpe., Conv.)	9712986	R.H.	5.45	CHANNEL ASSY., front door window glass run front, upper
68	(Spt. Cpe., Conv.)	9722973	L.H.	7.20	CHANNEL ASSY., front door window glass run front, upper (repl. 9712987)
68-70	(2-Dr. Sed.),				
68-72	(4-Dr.) (exc. Spt. Sed.),				
68-72	El Camino	9713038	R.H.	5.15	CHANNEL ASSY., front glass run, front
68-72	(4-Dr.) (exc. Spt. Sed.),				
68-70	(2-Dr. Sed.),				
68-72	El Camino	9713039	L.H.	4.95	CHANNEL ASSY., front glass run, front
68-69	(Spt. Mdls.)	9713647	1	6.85	CHANNEL ASSY., front glass run, lower
68-72	Chevelle (4-Dr.) (exc. Spt. Sed.)	9712424	R.H.	8.30	CHANNEL ASSY., front door vent. division w/scalp
68-72	Chevelle (4-Dr.) (exc. Spt. Sed.)	9712425	L.H.	8.30	CHANNEL ASSY., front door vent. division w/scalp
68-69	Chevelle (Spt. Sed.)	9722967	L.H.	10.75	CHANNEL ASSY., front door vent. division w/scalp
68-69	Chevelle (Spt. Cpe., Conv.)	9712517	L.H.	10.50	CHANNEL ASSY., front door vent. division w/scalp
68-70	Chevelle (2-Dr. Sed.),				
68-72	El Camino	9712562	R.H.	8.30	CHANNEL ASSY., front door vent. division w/scalp
68-70	Chevelle (2-Dr. Sed.),				
68-71	El Camino	9712563	L.H.	8.30	CHANNEL ASSY., front door vent. division w/scalp
70-71	Chevelle (Spt. Sed.)	9722973	L.H.	7.20	CHANNEL ASSY., front run upper
70-71	Chevelle (Spt. Sed.)	9722972	R.H.	6.50	CHANNEL ASSY., front run upper

**CHEVY**

62-67	(exc. Spt. Cpe., Conv.)	5712814	A.R.	2.50	glass run front
68-72	(4-Dr.),				
73-74	Nova (Taxi)	9713262	R.H.	5.05	front glass run, front
68-72	(4-Dr.),				
73-74	Nova (Taxi)	9713263	L.H.	5.05	front glass run, front
68-72	(2-Dr.)	9713822	R.H.	4.95	front glass run, front
68-72	(2-Dr.)	9713823	L.H.	5.05	front glass run, front
68-72	Chevy (4-Dr.),				
73-74	Nova (Taxi)	9712372	R.H.	10.50	CHANNEL ASSY., front door vent. division w/scalp
68-72	Chevy (4-Dr.),				
73-74	Nova (Taxi)	9712373	L.H.	9.80	CHANNEL ASSY., front door vent. division w/scalp
68-72	Chevy (2-Dr.)	9713814	R.H.	9.80	CHANNEL ASSY., front door vent. division w/scalp
68-72	Chevy (2-Dr.)	9713815	L.H.	9.80	CHANNEL ASSY., front door vent. division w/scalp

**CAMARO**

67	Camaro	9708650	R.H.	10.20	CHANNEL ASSY., front door vent. division w/scalp
67	Camaro	9708651	L.H.	10.20	CHANNEL ASSY., front door vent. division w/scalp
67	Biscayne, Bel Air,				
67	Pass. (4-Dr.) (exc. Spt. Sed.),				
68	Chevelle (exc. Spt. Mdls.)	4627417	2	.14	RIVET, vent. div. to glass run
68	Chevelle (Spt. Mdls.),				
69-72	Chevelle (Spt. Sed.)	9712836	4	.16	RIVET, vent. division channel to support

**10.689 CHANNEL, Door Glass Sash**

62-65	Nova (Spt. Cpe., Conv.)	4842843	L.H.	27.75	front upper
-------	-------------------------	---------	------	-------	-------------

**10.694 WEATHERSTRIP— STRIP, Door Opening and Windshield Pillar**

**PASSENGER**

65-66	2-Dr. Sed.	4455933	R.H.	20.60	front
65-66	4-Dr. Sed.	4455952	R.H.	22.75	rear
65-66	4-Dr. (exc. Spt. Sed.)	4455941	L.H.	22.75	front
65-66	Spt. Sed.	7622278	R.H.	20.60	front
65-66	Spt. Cpe., Conv.	4456006	R.H.	20.60	front

**WINDSHIELD—DOORS—CONTROLS**

**10.694 WEATHERSTRIP— STRIP, Door Opening and Windshield Pillar (Con't)**

65-66	Spt. Cpe., Conv.	4456007 L.H.	20.60	front
65	Conv.	7590326 R.H.	11.90	windshield pillar
65	Conv.	7590327 L.H.	11.90	windshield pillar
66-68	Conv.	7602728 R.H.	11.90	windshield pillar
66-68	Conv.	7602729 L.H.	11.90	windshield pillar
67-68	Spt. Sed.	7640860 R.H.	20.60	rear door
67-68	Sta. Wag.	7642274 R.H.	22.75	rear door
67-68	Sta. Wag.	7642275 L.H.	22.75	rear door
67-68	4-Dr. Sed. (exc. Spt. Sed.)	7642113 R.H.	22.75	rear door
67-68	4-Dr. Sed. (exc. Spt. Sed.)	7642114 L.H.	22.75	rear door
67-68	2-Dr. Sed.	7645980 R.H.	20.60	front door
67-68	2-Dr. Sed.	7645981 L.H.	20.60	front door
67	Spt. Cpe., Conv.,			
68	Impala (Spt. Cpe., Conv.)	7648132 R.H.	20.60	front door
67	Spt. Cpe., Conv.,			
68	Impala (Spt. Cpe., Conv.)	7648133 L.H.	20.60	front door
67-68	Spt. Sed.	7670344 R.H.	20.60	front door
67-68	Spt. Sed.	7670345 L.H.	20.60	front door
67-68	4-Dr. (exc. Spt. Sed.)	7670346 R.H.	22.75	front door
67-68	4-Dr. (exc. Spt. Sed.)	7670347 L.H.	22.75	front door
69-70	Sta. Wag.	8717696 R.H.	22.75	rear
69-70	Sta. Wag.	9818329 L.H.	22.75	rear
69-70	4-Dr. Sed. (exc. Spt. Sed.)	9818327 L.H.	22.75	rear door
69-70	4-Dr. Sed. (exc. Spt. Sed.)	9818326 R.H.	22.75	rear door
69-70	4-Dr. (exc. Spt. Sed.)	8712358 R.H.	22.75	front door
69-70	4-Dr. (exc. Spt. Sed.)	8712359 L.H.	22.75	front door
69-70	Conv.	8723727 L.H.	11.90	windshield pillar
69-70	Conv.	8723726 R.H.	11.90	windshield pillar
69-70	Spt. Cpe., Conv.	8781162 R.H.	20.60	front door
69-70	Spt. Cpe., Conv.	8781163 L.H.	20.60	front door
69-70	4-Dr. Spt. Sed.	8781161 L.H.	20.60	front door
69-70	4-Dr. Spt. Sed.	8781160 R.H.	20.60	front door
69	2-Dr. Sed.	8712357 L.H.	22.75	front door
71-75	Pass. (Spt. Sed.)	9824513 L.H.	20.60	front door complete
71-75	Pass. (Spt. Sed.)	9824512 R.H.	20.60	front door complete
71-74	Pass. (Spt. Sed.)	9697677 L.H.	20.60	rear door complete
71-74	Pass. (Spt. Sed.)	9697676 R.H.	20.60	rear door complete
71-72	Pass. (Spt. Cpe., Conv.),			
73	Pass. (2-Dr.),			
74-75	Pass. (Spt. Cpe., Conv.) (exc. Custom)	9824515 L.H.	20.60	front door complete
71-72	Pass. (Spt. Cpe., Conv.),			
73	Pass. (2-Dr.),			
74-75	Pass. (Spt. Cpe., Conv.) (exc. Custom)	9824514 R.H.	20.60	front door complete
71-75	Pass. (4-Dr.) (exc. Spt. Sed.)	9824871 L.H.	22.75	front door complete
71-75	Pass. (4-Dr.) (exc. Spt. Sed.)	9824870 R.H.	22.75	front door complete
71-74	Pass. (Sed.) (exc. Spt. Sed.)	9824873 L.H.	22.75	rear door complete
71-74	Pass. (Sed.) (exc. Spt. Sed.)	9824872 R.H.	22.75	rear door complete
71-75	Pass. (Sta. Wag.)	9824875 L.H.	22.75	rear door complete
71-75	Pass. (Sta. Wag.)	9824874 R.H.	22.75	rear door complete
71-75	Pass. (Conv.)	9835059 L.H.	11.90	windshield pillar
71-75	Pass. (Conv.)	9835058 R.H.	11.90	windshield pillar
74-75	Pass. (Custom) (Spt. Cpe.)	9678884 R.H.	20.60	front door complete
74-75	Pass. (Custom) (Spt. Cpe.)	9678885 L.H.	20.60	front door complete
75	Pass. (Spt. Sed.)	9736301 R.H.	22.75	rear door complete
75	Pass. (Spt. Sed.)	9736302 L.H.	22.75	rear door complete
75	Pass. (Sed.) (exc. Spt. Sed.)	1651254 R.H.	22.75	rear door complete
75	Pass. (Sed.) (exc. Spt. Sed.)	1651255 L.H.	22.75	rear door complete

**CHEVY—NOVA**

62-65	(4-Dr. Sed.)	4449540 R.H.	22.75	rear door
62-65	(4-Dr. Sed.)	4449541 L.H.	22.75	rear door
62-67	(2-Dr. Sed.)	4449535 R.H.	22.75	front door
62-67	(2-Dr. Sed.)	4449536 L.H.	22.75	front door
62-67	(4-Dr.)	4449537 R.H.	22.75	front door
62-67	(4-Dr.)	4449538 L.H.	22.75	front door
62-67	(Sta. Wag.)	4449547 L.H.	22.75	rear door
66-67	Nova (Spt. Cpe.)	4547214 L.H.	20.60	front door
68-72	(4-Dr.)	7719491 L.H.	22.75	front door
68-72	(4-Dr.)	7719490 R.H.	22.75	front door
68-72	(2-Dr.)	7719492 R.H.	20.60	front door
68-72	(2-Dr.)	7719493 L.H.	20.60	front door
68-72	(4-Dr.) (exc. Spt. Sed.)	9801978 2	22.75	rear door
73-74	Nova (2-Dr.)	9608052 L.H.	20.60	front door

**WINDSHIELD—DOORS—CONTROLS**

**10.694 WEATHERSTRIP— STRIP, Door Opening and Windshield Pillar (Con't)**

73-74	Nova (2-Dr.)	9608051	R.H.	20.60	front door
73-74	Nova (4-Dr.)	9608054	L.H.	22.75	rear door
73-74	Nova (4-Dr.)	9608053	R.H.	22.75	rear door
73-74	Nova (4-Dr.)	9607999	L.H.	22.75	front door
73-74	Nova (4-Dr.)	9607998	R.H.	22.75	front door
75	Nova (2-Dr.)	1650296	R.H.	20.60	front door
75	Nova (2-Dr.)	1650297	L.H.	20.60	front door
75	Nova (4-Dr.)	1650248	R.H.	22.75	front door
75	Nova (4-Dr.)	1650249	L.H.	22.75	front door
75	Nova (4-Dr.)	1650298	R.H.	22.75	rear door
75	Nova (4-Dr.)	1650299	L.H.	22.75	rear door

**CHEVELLE**

64-65	El Camino	4406680	R.H.	22.75	front
64-65	El Camino	4406681	L.H.	22.75	front
66-67	El Camino	4540802	R.H.	22.75	front door
66-67	El Camino	4540803	L.H.	22.75	front door
66-67	(4-Dr. Sed.)	4540806	R.H.	22.75	rear door
66-67	(4-Dr. Sed.)	4540807	L.H.	22.75	rear door
66-67	(Conv.)	7616692	R.H.	11.90	windshield pillar
68	(Conv.)	7726960	R.H.	11.90	windshield pillar
68-72	(Spt. Sed.)	7717752	R.H.	25.50	front door
68-72	(Spt. Sed.)	7717753	L.H.	25.50	front door
68-69	(Spt. Cpe., Conv.)	7717754	R.H.	25.50	front door
68-69	(Spt. Cpe., Conv.)	7717755	L.H.	25.50	front door
68-72	(Spt. Sed.)	7717758	R.H.	3.20	rear door hinge pillar at belt
68-72	(Spt. Sed.)	7717759	L.H.	3.20	rear door hinge pillar at belt
68-69	(Spt. Sed.)	7717762	R.H.	20.60	rear door
68-69	(Spt. Sed.)	7717763	L.H.	20.60	rear door
68-72	(4-Dr.) (exc. Spt. Sed.)	7717764	R.H.	20.60	front door
68-72	(4-Dr.) (exc. Spt. Sed.)	7717765	L.H.	20.60	front door
68-69	(2-Dr. Sed.)	7717767	L.H.	20.60	front door
68-69	(2-Dr. Sed.)	7717766	R.H.	20.60	front door
68-72	El Camino	7717768	R.H.	22.75	front door
68-72	El Camino	7717769	L.H.	22.75	front door
68-72	(Sta. Wag.)	9801984	R.H.	22.75	rear door
68-72	(Sta. Wag.)	9801985	L.H.	22.75	rear door
68-72	Chevelle (Sed.) (exc. Spt. Sed.)	9801982	R.H.	22.75	rear door
69-72	(Conv.)	9823138	R.H.	11.90	windshield pillar
69-72	(Conv.)	9823139	L.H.	11.90	windshield pillar
69-72	(Spt. Cpe., Conv.)	8781165	L.H.	25.50	front door
69-72	(Spt. Cpe., Conv.)	8781164	R.H.	25.50	front door
70-72	(Spt. Sed.)	8775922	L.H.	20.60	rear door
70-72	(Spt. Sed.)	8775921	R.H.	20.60	rear door
70	(Spt. Cpe., Conv.)	9818498	2	.81	w/s pillar at belt
70	(Spt. Sed.)	9818500	2	.81	w/s pillar at belt
71-72	Chevelle (Sed.)	9801983	L.H.	22.75	rear door
73-75	Monte Carlo	9870847	L.H.	20.60	front door
73-75	Monte Carlo	9870846	R.H.	20.60	front door
73-75	Chevelle (2-Dr.) (exc. Monte Carlo)	9870753	L.H.	20.60	front door
73-75	Chevelle (2-Dr.) (exc. Monte Carlo)	9870752	R.H.	20.60	front door
73-75	Chevelle (4-Dr.)	9870657	L.H.	22.75	front door
73-75	Chevelle (4-Dr.)	9870656	R.H.	22.75	front door
73-75	Chevelle (4-Dr.)	9870663	L.H.	22.75	rear door
73-75	Chevelle (4-Dr.)	9870662	R.H.	22.75	rear door

**CAMARO**

67	Camaro	7638506	R.H.	25.50	front door
67	Camaro	7638507	L.H.	25.50	front door
67	Camaro (Conv.)	7647398	R.H.	11.90	w/shield pillar
68	Camaro (Conv.)	7729792	L.H.	11.90	windshield pillar
68-69	Camaro	7719476	R.H.	20.60	front door
68-69	Camaro	7719477	L.H.	20.60	front door
70	Camaro	9806320	2	.38	front body hinge at belt
70	Camaro	9820062	1	.55	w/s pillar at belt
70	Camaro	9828951	2	.38	body lk. plr. w/str. ret.
70-75	Camaro	9868431	L.H.	20.60	front door complete
70-75	Camaro	9868430	R.H.	20.60	front door-complete
71-75	Vega (exc. H.B.)	9883772	L.H.	22.75	
71-75	Vega (exc. H.B.)	9883771	R.H.	22.75	
71-75	Vega (H.B.)	9883774	L.H.	22.75	
71-75	Vega (H.B.)	9883773	R.H.	22.75	
75	Monza (exc. Towne Cpe.)	9738166	R.H.	22.75	front door complete

**WINDSHIELD—DOORS—CONTROLS**

**10.694 WEATHERSTRIP— STRIP, Door Opening and Windshield Pillar (Con't)**

75	Monza (exc. Towne Cpe.)	9738167	L.H.	22.75	front door complete
75	Monza (Towne Cpe.)	1699444	R.H.	18.45	front door complete
75	Monza (Towne Cpe.)	1699445	L.H.	18.45	front door complete
75	Monza (Towne Cpe.)	1732327	R.H.	11.10	frt. dr. bottom auxiliary
75	Monza (Towne Cpe.)	1732328	L.H.	11.10	frt. dr. bottom auxiliary

**PASSENGER**

67-70	Caprice (Spt. Cpe.),				
69-70	Impala (Spt. Cpe.) w/body insulation package	4531756	2	2.50	STRIP, front door bottom aux. sealing
67-70	Caprice (exc. Spt. Cpe.),				
69-70	Impala (Spt. Sed.) w/body insulation	4531757	2	2.95	STRIP, front door bottom aux. sealing
67	Caprice (exc. Spt. Cpe.),				
68-69	Caprice,				
69	Sta. Wag.,				
69	Impala,				
71-72	Pass. (Spt. Mdls.)	4489247	8	.18	STRIP, door bottom drain hole sealing— (12.269)
69-70	4-Dr. (Spt. Sed.)	8721490	R.H.	2.25	STRIP, rear door hinge pillar
69-70	4-Dr. (Spt. Sed.)	8721491	L.H.	2.25	STRIP, rear door hinge pillar
71	Pass. (Spt. Cpe., Spt. Sed.)	9840273	L.H.	.78	STRIP, w/s pillar at belt
71	Pass. (Spt. Cpe., Spt. Sed.)	9840272	R.H.	.78	STRIP, w/s pillar at belt
71-72	Caprice (Spt. Sed.),				
71-72	Kingswood Estate Wagon,				
73-74	Pass. (4-Dr.) (exc. Caprice)	9890834	2	1.95	STRIP, front door bottom aux.
71-74	Pass. (Spt. Cpe.)	9890835	2	2.30	STRIP, front door trim aux.
71-73	Caprice (Spt. Sed.)	9890836	2	.46	STRIP, rear door bottom aux.
71-73	Kingswood Estate	9890837	2	1.35	STRIP, left, rear door bottom aux.
74-75	Pass. (2-Dr.)	9739028	2	7.25	STRIP, front door bottom aux.
74-75	Pass. (4-Dr.)	9739029	2	5.70	STRIP, front door bottom aux.
74-75	Pass. (Sed.)	9739033	L.H.	4.70	STRIP, rear door bottom aux.
74-75	Pass. (Sed.)	9739032	R.H.	4.70	STRIP, rear door bottom aux.
74-75	Pass. (Sta. Wag.)	9739035	L.H.	5.35	STRIP, rear door bottom aux.
74-75	Pass. (Sta. Wag.)	9739034	R.H.	5.35	STRIP, rear door bottom aux.

**CHEVELLE**

69	Chevelle (Spt. Sed.)	4531757	2	2.95	STRIP, bottom, front door auxiliary sealing
70	Chevelle (Spt. Cpe., Conv.)	9818498	2	.81	STRIP, w/s pillar at belt
70	Chevelle (Spt. Sed.)	9818500	2	.81	STRIP, w/s pillar at belt
71-72	Chevelle (Sta. Wag.)	4489247	8	.18	STRIP, door bottom drain hole sealing— (12.269)
73-74	Monte Carlo	9658058	2	.63	STRIP, front door bottom aux.
74-75	Malibu (Classic) (Sta. Wag.)	9736540	2	.28	STRIP, front door bottom aux.
74-75	Malibu (Classic) (Sta. Wag.)	9736541	2	.28	STRIP, rear door bottom aux.
75	Monte Carlo				STRIP, frt. door bottom aux.
75	Malibu (Classic) (Sed.)	1703718	R.H.	3.75	rear door bottom aux.
75	Monte Carlo				STRIP, frt. door bottom aux.
75	Malibu (Classic) (Sed.)	1703719	L.H.	3.75	rear door bottom aux.

**CAMARO**

67	Camaro	7645256	R.H.	3.20	STRIP, body lock pillar upper corner sealing
67	Camaro	7645257	L.H.	3.20	STRIP, body lock pillar upper corner sealing
68-69	Camaro	7731446	R.H.	4.65	STRIP, body lock pillar upper corner sealing
68-69	Camaro	7731447	L.H.	4.65	STRIP, body lock pillar upper corner sealing
70-72	Camaro	9828951	2	.38	STRIP, body lock pillar w/strip retainer
71-72	Camaro	9820062	1	.55	STRIP, w/s pillar at belt
71-75	Camaro	9806320	2	.38	STRIP, front body hinge at belt

**10.694A PLUG, Weatherstrip, Door Opening**

62-63	Chevy,				
67	Chevelle,				
68-69	Chevy				door wthrstrp. front body hinge pillar switch, body front emblem stud,
69	Pass.				rear door w/strip attaching hole,
70-72	Nova				hood panel mldg. emblem stud plug,
70	El Camino	4770719	2	.12	t/gate supt. asst. spring plug

**10.695 FASTENER— SCREW, Door Weatherstrip**

62	Nova (2-Dr.)				windshield pillar and door w/strip,
64-65	Nova (Spt. Mdls.),				

**WINDSHIELD—DOORS—CONTROLS**

**10.695 FASTENER— SCREW, Door Weatherstrip (Con't)**

64	Malibu (Spt. Cpe.)			side roof rail w/strip,
64-65	Nova (Spt. Mdls.)			front door w/strip,
64	Malibu (Spt. Mdls.)			windshield pillar w/strip
64	Malibu (Conv.)	4841194 A.R.	.11	door hinge pillar,
62	Chevy (Sta. Wag.)			tailgate window glass run channel,
63-65	Chevy (Sta. Wag.)			folding top ext. header and side frt. w/strip,
65-67	Conv.			folding top compt. bag to body fastener
68-69	Impala (Conv.)	4653672 A.R.	.11	
64-68	Chevy, Chevelle,			front door weatherstrip,
65-66	Pass. (exc. Spt. Cpe., Conv.),			rear door weatherstrip,
67-70	Pass.			
64-68	Chevy, Chevelle,			
65-70	4-Dr.			
65-68	Conv.,			
71	Pass. (Spt. Sed.),			
72	Caprice (Sed.),			
74-75	All (exc. Nova)	4876498 A.R.	.12	front roof rail
67-68	Camaro (Spt. Cpe.)			side roof rail,
67-68	Camaro (Conv.)			w/shield pillar,
67-68	Camaro			front door,
68	Chevelle (Sta. Wag.)			tailgate opening,
68	Chevelle (Spt. Sed., Spt. Cpe.)			side roof rail opening,
68	Chevelle (Spt. Mdls.)			front door panel,
68	Chevelle (Conv.)			windshield pillar,
68	Chevelle (Spt. Sed.),			
69	Chevelle (Spt. Cpe., Conv.),			
73-75	All (exc. Nova)	8731909 A.R.	.11	hinge pillar, lock pillar, rear to panel and hinge pillar
72	Pass. (exc. Sed., Sta. Wag.)	9418793 2	.12	SCREW, front door hinge pillar upper

**10.701 CHANNEL— SCREW— STUD— WASHER, Front Door Glass Run**

**PASSENGER**

*NOTE 2 Used on door with dim. of 6 5/8 inches from glass run chan. supt. attaching screw hole to upr. door lock attaching screw.*

*NOTE 3 Used on door with dim. of 6 inches from glass run chan. supt. attaching screw hole to upr. door lock attaching screw.*

65-68	4-Dr. (exc. Spt. Sed.)	4470528 R.H.	15.75	
65-68	4-Dr. (exc. Spt. Sed.)	4470529 L.H.	15.75	
67-68	2-Dr. Sed.	7657432 R.H.	13.75	
69-70	4-Dr. (exc. Spt. Sed.)	8761783 L.H.	16.20	upper
69-70	4-Dr. (exc. Spt. Sed.)	8761782 R.H.	16.20	upper
69	4-Dr. (exc. Spt. Sed.)	8761785 L.H.	8.95	lower
69	4-Dr. (exc. Spt. Sed.)	8761784 R.H.	8.95	lower
71-72	Pass. (4-Dr.) (exc. Spt. Sed.)	9827113 2	3.40	
73-74	Pass. (4-Dr.) (exc. Spt. Sed.)	9623987 2	3.30	(Note 1)
75	Pass. (4-Dr.) (exc. Spt. Sed.)	1670018 2	3.45	

**CHEVY**

62-63	(exc. Spt. Mdls.),			
64	Chevy,			
65-67	(exc. Spt. Cpe.)	7663050 A.R.	4.90	front
68-72	(2-Dr.)	7725786 2	3.70	
68-74	(4-Dr.)	1670017 2	3.25	(repl. 7725787)
73-74	Nova (exc. Taxi)	9623987 2	3.30	(Note 1)
75	Nova (4-Dr.)	1670018 2	3.45	
75	Nova (2-Dr.)	9736584 2	3.45	

**CHEVELLE**

64-67	(exc. Spt. Mdls.)	4439775 A.R.	4.10	
64-65	Malibu (2-Dr.)	4406329 L.H.	6.30	
66-67	(Conv., Spt. Cpe.)	7582389 L.H.	5.65	
68-72	(exc. Spt. Cpe., Spt. Sed., Conv.)	7726559 2	2.00	
70	(2-Dr.)	8782290 2	3.45	anti-rattle

**CAMARO**

67	Camaro	9711388 R.H.	5.35	
----	--------	--------------	------	--

**VEGA— MONZA**

71-75	Vega, Monza	1703025 2	5.05	
67	Camaro	9711389 L.H.	5.20	
69	Pass. (2-Dr. Sed.)	4409791 2	.12	SCREW, front window channel lower— (10.792)
69	Biscayne, Bel Air,			

**WINDSHIELD—DOORS—CONTROLS**

**10.701 CHANNEL— SCREW— STUD— WASHER, Front Door Glass Run (Con't)**

69	Kingswood,				
65-66	Impala (Spt. Cpe., Conv.)	4405501	2	.18	STUD, channel— (10.670)
65	Pass. (exc. Spt. Sed.),				
66	Pass. (exc. Spt. Sed., Caprice, S.S.)	4868577	2	.18	STUD, channel— (10.670)
67	Chevelle (Spt. Mdls.)	7602989	A.R.	.63	STUD, channel lower— (10.670)
65-66	Pass. (4-Dr.) (exc. Spt. Sed.),				
66-67	Chevy, Chevelle (Spt. Mdls.)				WASHER, channel, upper,
69-70	Pass. (4-Dr.) (exc. Spt. Sed.)	8714748	2	.12	front door window glass run channel upper

**10.703 RETAINER, Rear Door Glass Run Channel**

68-72	El Camino	8717853	R.H.	4.65	front window, lower
68-72	El Camino	8717854	L.H.	4.65	front window, lower
73-75	Nova	9610559	L.H.	6.15	lower
73-75	Nova	9610558	R.H.	6.15	lower
75	Monza (Towne Cpe.)	1673126	R.H.	6.15	RETAINER ASSY., lower front
75	Monza (Towne Cpe.)	1673127	L.H.	6.15	RETAINER ASSY., lower front

**10.707 MOULDING— MOULDING ASSY.— CLIP— LOUVER— SCREW, Front Door Window Reveal**

**PASSENGER**

65	Spt. Mdls. (exc. S.S.),				
67	Caprice (Spt. Cpe.)	7653451	R.H.	8.80	at vent
65	Spt. Mdls.,				
67	Caprice (Spt. Cpe.)	7653452	L.H.	8.80	window reveal at vent
66-68	4-Dr. (exc. Spt. Sed.)	7653457	R.H.	9.50	at vent
66-68	Impala (Spt. Mdls.),				
66-68	Caprice (Spt. Sed.)	7653453	R.H.	8.80	window reveal at vent
66-68	Impala (Spt. Mdls.),				
66-68	Caprice (Spt. Sed.)	7653454	L.H.	9.50	window reveal at vent
67-68	4-Dr. (exc. Spt. Sed.)	7653458	L.H.	9.50	window reveal at vent
67-70	4-Dr. (exc. Spt. Sed.)	4482060	R.H.	5.10	window vertical rear scalp
67-70	4-Dr. (exc. Spt. Sed.)	4482061	L.H.	5.10	window vertical rear scalp
67-68	Pass. (exc. Spt. Mdls.)	4482778	R.H.	6.65	window frame front scalp
67-68	Pass. (exc. Spt. Mdls.)	4482779	L.H.	4.80	window frame front scalp
67-70	4-Dr. (exc. Spt. Sed.)	7629776	R.H.	4.80	window frame upper scalp
67-70	4-Dr. (exc. Spt. Sed.)	7629777	L.H.	4.80	window frame upper scalp
69-70	4-Dr. (exc. Spt. Sed.),				
69	2-Dr. Sedan	8719370	R.H.	4.60	scalp front door frame
69-70	4-Dr. (exc. Spt. Sed.),				
69	2-Dr. Sedan	8719371	L.H.	4.60	scalp front door frame
67	Caprice (Spt. Cpe.)	7646822	R.H.	13.65	
67	Caprice (Spt. Cpe.)	7646823	L.H.	13.65	
71-75	(4-Dr.) (exc. Spt. Sed.)	9841127	L.H.	8.75	front scalp
71-75	(4-Dr.) (exc. Spt. Sed.)	9841126	R.H.	8.75	front scalp
71-75	(4-Dr.) (exc. Spt. Sed.)	9841129	L.H.	5.50	vertical rear scalp
71-75	(4-Dr.) (exc. Spt. Sed.)	9841128	R.H.	5.50	vertical rear scalp
71-75	(4-Dr.) (exc. Spt. Sed.)	9841131	L.H.	6.95	upper scalp
71-75	(4-Dr.) (exc. Spt. Sed.)	9841130	R.H.	6.95	upper scalp
71-75	(4-Dr.) (exc. Spt. Sed.)	9852132	L.H.	9.75	outer panel belt reveal
71-75	(4-Dr.) (exc. Spt. Sed.)	9852131	R.H.	9.75	outer panel belt reveal
71-72	Impala, Caprice (2-Dr.) (Spt. Sed.)	9848548	L.H.	11.00	outer panel belt reveal
71-72	Impala, Caprice (2-Dr.) (Spt. Sed.)	9848547	R.H.	11.00	outer panel belt reveal
73-75	Pass. (Spt. Sed.),				
73-75	Pass. (2-Dr.)	9848548	L.H.	11.00	outer panel belt reveal
73-75	Pass. (Spt. Sed.),				
73-75	Pass. (2-Dr.)	9848547	R.H.	11.00	outer panel belt reveal

**CHEVY— NOVA**

66-67	(Spt. Cpe.)	4548216	R.H.	11.30	window reveal
66-67	(Spt. Cpe.)	4548217	L.H.	11.30	window reveal
68-74	(4-Dr.) w/window frame moulding	7734172	R.H.	9.30	front window frame, upper scalp
68-74	(4-Dr.) w/window frame moulding	7734173	L.H.	9.30	front window frame, upper scalp
68-74	(4-Dr.) w/window frame moulding	7734782	R.H.	2.45	front window vertical rear scalp
68-74	(4-Dr.) w/window frame moulding	7734783	L.H.	2.45	front window vertical rear scalp



**WINDSHIELD—DOORS—CONTROLS**

**10.707 MOULDING— MOULDING ASSY.— CLIP— LOUVER— SCREW, Front Door Window Reveal (Con't)**

<b>68-74</b>	(2-Dr.) w/window frame moulding	<b>7736055</b>	R.H.	2.40	front window vertical rear scalp
<b>68-74</b>	(2-Dr.) w/window frame moulding	<b>7736056</b>	L.H.	2.40	front window vertical rear scalp
<b>68-72</b>	(4-Dr.) w/window frame moulding	<b>7738112</b>	R.H.	2.45	rear window vertical front scalp
<b>68-72</b>	(4-Dr.) w/window frame moulding	<b>7738113</b>	L.H.	2.45	rear window vertical front scalp
<b>68-74</b>	(2-Dr.) w/window frame moulding	<b>7734630</b>	R.H.	10.20	front window frame, upper scalp
<b>68-74</b>	(2-Dr.) w/window frame moulding	<b>7734631</b>	L.H.	10.20	front window frame, upper scalp
<b>74</b>	Nova (2-Dr.) w/padded side window reveal moulding	<b>9733189</b>	L.H.	9.30	front door window frame upper w/Spirit of America
<b>74</b>	Nova (2-Dr.) w/padded side window reveal moulding	<b>9733188</b>	R.H.	9.30	front door window frame upper w/Spirit of America
<b>74</b>	Nova (2-Dr.) w/padded side window reveal moulding	<b>9733193</b>	L.H.	4.35	front door window frame vertical w/Spirit of America
<b>74</b>	Nova (2-Dr.) w/padded side window reveal moulding	<b>9733192</b>	R.H.	4.35	front door window frame vertical w/Spirit of America
<b>75</b>	Nova (2-Dr.)	<b>1653426</b>	R.H.	2.95	vertical rear scalp
<b>75</b>	Nova (2-Dr.)	<b>1653427</b>	L.H.	2.95	vertical rear scalp
<b>75</b>	Nova (4-Dr.)	<b>1653428</b>	R.H.	3.00	vertical rear scalp
<b>75</b>	Nova (4-Dr.)	<b>1653429</b>	L.H.	3.00	vertical rear scalp
<b>75</b>	Nova (2-Dr.)	<b>1653430</b>	R.H.	12.25	frame upper scalp
<b>75</b>	Nova (2-Dr.)	<b>1653431</b>	L.H.	12.25	frame upper scalp
<b>75</b>	Nova (4-Dr.)	<b>1653432</b>	R.H.	11.20	frame upper scalp
<b>75</b>	Nova (4-Dr.)	<b>1653433</b>	L.H.	11.20	frame upper scalp

**CHEVELLE**

<b>64-67</b>	El Camino (Custom)	<b>4410650</b>	R.H.	7.25	upper
<b>64-67</b>	El Camino (Custom),				
<b>66-67</b>	Chevelle (4-Dr.) w/window frame mldg. (exc. Spt. Sed.)	<b>4411952</b>	R.H.	4.35	front
<b>64-67</b>	El Camino (Custom),				
<b>66-67</b>	(4-Dr.) w/window frame mldg. (exc. Spt. Sed.)	<b>4411953</b>	L.H.	4.35	front
<b>68-70</b>	(2-Dr. Sed.)	<b>7727174</b>	R.H.	5.80	front window frame, scalp
<b>68-70</b>	(2-Dr. Sed.) w/window frame moulding	<b>7727175</b>	L.H.	5.80	front window frame, front scalp
<b>68-72</b>	(4-Dr.) w/window frame moulding	<b>7727232</b>	R.H.	4.90	front window frame, front scalp
<b>68-72</b>	(4-Dr.) w/window frame moulding	<b>7727233</b>	L.H.	4.90	front window frame, front scalp
<b>68-70</b>	(4-Dr.) w/window frame moulding,				
<b>71-72</b>	(4-Dr.) (exc. Spt. Sed.)	<b>7728606</b>	R.H.	4.35	front window frame, upper scalp
<b>68-70</b>	(4-Dr.) w/window frame moulding,				
<b>71-72</b>	(4-Dr.) (exc. Spt. Sed.)	<b>7728607</b>	L.H.	4.35	front window frame, upper scalp
<b>68-72</b>	(4-Dr.) w/window frame moulding	<b>7728720</b>	R.H.	2.50	front window vertical rear scalp
<b>68-72</b>	(4-Dr.) w/window frame moulding	<b>7728721</b>	L.H.	2.50	front window vertical rear scalp
<b>68-70</b>	(2-Dr. Sed.) w/window frame moulding	<b>7729385</b>	R.H.	2.85	front window vertical rear scalp
<b>68-70</b>	(2-Dr. Sed.) w/window frame moulding	<b>7729386</b>	L.H.	2.85	front window vertical rear scalp
<b>68-70</b>	(2-Dr. Sed.) w/window frame moulding	<b>7730851</b>	R.H.	5.60	front window frame, upper scalp
<b>68-70</b>	(2-Dr. Sed.) w/window frame moulding	<b>7730852</b>	L.H.	5.60	front window frame, upper scalp
<b>68-72</b>	El Camino w/window frame moulding	<b>7734897</b>	R.H.	8.35	front window frame, upper scalp
<b>68-72</b>	El Camino w/window frame moulding	<b>7734898</b>	L.H.	8.35	front window frame, upper scalp
<b>68-72</b>	El Camino	<b>7746588</b>	R.H.	5.10	front window frame, front scalp
<b>68-72</b>	El Camino	<b>7746589</b>	L.H.	5.10	front window frame, front scalp
<b>70-72</b>	Monte Carlo	<b>8724405</b>	L.H.	20.65	
<b>70-72</b>	Monte Carlo	<b>8724404</b>	R.H.	20.65	
<b>73-75</b>	Chevelle	<b>9882795</b>	L.H.	6.10	reveal, front door belt

**WINDSHIELD—DOORS—CONTROLS**

**10.707 MOULDING— MOULDING ASSY.— CLIP— LOUVER— SCREW, Front Door Window Reveal (Con't)**

73-75	Chevelle	9882794	R.H.	6.10	reveal, front door belt
<b>CAMARO</b>					
68-69	w/window frame moulding	7737901	R.H.	17.45	front window reveal
68-69	w/window frame moulding	7737902	L.H.	17.45	front window reveal
70-75	Camaro	9828344	L.H.	15.00	reveal, frt. door belt
70-75	Camaro	9828343	R.H.	15.00	reveal, frt. door belt
<b>VEGA— MONZA</b>					
71-75	Vega (exc. H.B.)	9822464	R.H.	9.90	front
71-75	Vega (exc. H.B.)	9822465	L.H.	9.90	front
71-75	Vega (exc. H.B.)	9822468	R.H.	2.80	vertical rear
71-75	Vega (exc. H.B.)	9822469	L.H.	2.80	vertical rear
71-75	Vega (H.B.)	9822466	R.H.	9.90	front
71-75	Vega (H.B.)	9822467	L.H.	9.90	front
71-75	Vega (H.B.)	9822470	R.H.	2.80	vertical rear
71-75	Vega (H.B.)	9822471	L.H.	2.80	vertical rear
75	Monza (exc. Towne Cpe.)	1656376	R.H.	4.60	lower front
75	Monza (exc. Towne Cpe.)	1656377	L.H.	4.60	lower front
75	Monza (Towne Cpe.)	1673074	R.H.	7.60	upper front
75	Monza (Towne Cpe.)	1673075	L.H.	7.60	upper front
75	Monza (Towne Cpe.)	1673103	R.H.	3.00	vertical rear
75	Monza (Towne Cpe.)	1673104	L.H.	3.15	vertical rear
71-75	Vega (H.B.)	9868584	2	10.10	<b>MOULDING ASSY.,</b> reveal front door window
75	Monza (exc. Towne Cpe.)	9739092	L.H.	11.75	<b>MOULDING ASSY.,</b> reveal front door window
75	Monza (exc. Towne Cpe.)	9739091	R.H.	11.75	<b>MOULDING ASSY.,</b> reveal front door window
75	Monza (exc. Towne Cpe.)	1667370	R.H.	13.75	<b>MOULDING ASSY.,</b> scalp front dr. wdo. frm. upper
75	Monza (exc. Towne Cpe.)	1667371	L.H.	13.75	<b>MOULDING ASSY.,</b> scalp front dr. wdo. frm. upper
75	Monza (Towne Cpe.)	1673070	R.H.	18.40	<b>MOULDING ASSY.,</b> reveal front door wdo.
75	Monza (Towne Cpe.)	1673071	L.H.	18.40	<b>MOULDING ASSY.,</b> reveal front door wdo.
70-72	Camaro	9815829	4	.32	<b>CLIP,</b> rvl. mldg. frt. and rear
70-75	Camaro	9815840	12	.22	<b>CLIP,</b> rvl. mldg. center
71-72	Monte Carlo	9419740	6	.11	<b>SCREW,</b> mldg. to panel
71-72	Monte Carlo	9422647	A.R.	.11	<b>SCREW,</b> mldg. to panel (emer. use)
75	Monza (exc. Towne Cpe.)	1698845	R.H.	7.45	<b>LOUVER,</b> frt. dr. outer panel (chrome)
75	Monza (exc. Towne Cpe.)	1698846	L.H.	7.90	<b>LOUVER,</b> frt. dr. outer panel (chrome)
75	Monza (exc. Towne Cpe.)	1726574	R.H.	5.25	<b>LOUVER,</b> frt. dr. otr. (argent silver)
75	Monza (exc. Towne Cpe.)	1726575	L.H.	5.25	<b>LOUVER,</b> frt. dr. otr. (argent silver)

**10.708 CLIP, Door Window Reveal Moulding**

62-65	Nova (Spt. Cpe., Conv.)	4852349	A.R.	.12	
66-67	Nova (Spt. Cpe.)	4547703	4	.12	
75	Monza (exc. Towne Cpe.)	1663377	12	.11	wdo. frm. upr. scalp mldg.

**10.710 STRIP ASSY.— STUD, Front Door Window (Outer— Inner)**

**PASSENGER**

65	Spt. Sed.	9706942	R.H.	7.05	outer glass run
65	Spt. Cpe., Conv.	9706920	R.H.	7.05	outer glass run
66-67	Spt. Sed.,				
66-67	Spt. Sed.,				
68	Impala (Spt. Sed.)	7755888	L.H.	7.05	inner, at belt
66	Caprice (Spt. Cpe.)	9706946	R.H.	7.05	outer
66	Caprice (Spt. Cpe.)	9706947	L.H.	8.75	outer
66	Impala (Spt. Cpe., Conv.)	4548007	R.H.	7.05	outer at belt
66	Impala (Spt. Cpe., Conv.)	4548008	L.H.	7.05	outer at belt
67-68	Biscayne, Bel Air (exc. 2-Dr.)	7656051	R.H.	7.05	outer at belt
67-68	Biscayne, Bel Air (exc. 2-Dr.)	7656052	L.H.	7.05	outer at belt
67-68	Impala, Caprice (exc. Spt. Mdls.)	7656053	R.H.	7.05	outer at belt
67-68	Impala, Caprice (exc. Spt. Mdls.)	7656054	L.H.	7.05	outer at belt
67-68	Spt. Sed.	7656055	R.H.	7.05	outer at belt
67-68	Spt. Sed.	7656056	L.H.	7.05	outer at belt
67-68	Biscayne, Bel Air (exc. 2-Dr.)	7646965	2		inner at belt (repl. 7646964)
67-68	Impala (Spt. Cpe., Conv.)	7645966	R.H.	7.05	outer at belt
67-68	Impala (Spt. Cpe., Conv.)	7645967	L.H.	7.05	outer at belt
67	Spt. Cpe., Conv.,				
68	Impala (Spt. Cpe., Conv.)	7799177	L.H.	7.05	inner at belt
67	Spt. Mdls.	7694483	2	1.05	inner anti-rattle— (10.774)

**WINDSHIELD—DOORS—CONTROLS**

**10.710 STRIP ASSY.—STUD, Front Door Window (Outer— Inner) (Con't)**

69	Spt. Mdls. (exc. Spt. Sedan) . . . . .	8719330 R.H.	7.05	outer at belt . . . . .
69	Spt. Mdls. (exc. Spt. Sedan) . . . . .	8807633 L.H.	7.05	outer at belt . . . . .
69	4-Dr. (exc. Spt. Sedan) . . . . .	8807630 R.H.	7.05	outer at belt (repl. 8721492) . . . . .
69	4-Dr. (exc. Spt. Sedan) . . . . .	8721493 L.H.	7.05	outer at belt . . . . .
69	Impala (Spt. Sedan) . . . . .	8726299 L.H.	7.05	outer at belt . . . . .
69-70	Impala, 4-Dr. Sed. (exc. Spt. Sed.),			
69-70	Kingswood, Estate Wag. . . . .	8791149 1	7.05	inner at belt . . . . .
69-70	Spt. Mdls. (exc. Spt. Sedan) . . . . .	8717601 2	7.05	inner at belt . . . . .
69-70	Spt. Sed. . . . .	8771669 2	7.05	inner at belt . . . . .
70	Impala, Caprice (Spt. Sed.) . . . . .			rear door . . . . .
69-70	Pass. . . . .	9818406 A.R.	2.85	front door wdo. anti-rattle . . . . .
70	Pass. (4-Dr.) (exc. Spt. Sed.) . . . . .	8807631 L.H.	7.05	outer at belt . . . . .
70	Pass. (4-Dr.) (exc. Spt. Sed.) . . . . .	8807630 R.H.	7.05	outer at belt . . . . .
70	Pass. (Spt. Cpe., Conv.) . . . . .	8807632 R.H.	7.05	outer at belt . . . . .
70	Pass. (Spt. Sed.) . . . . .	8807635 L.H.	7.05	outer at belt . . . . .
70	Pass. (Spt. Sed.) . . . . .	8807634 R.H.	7.05	outer at belt . . . . .
68	Caprice (Spt. Cpe.) . . . . .	7660878 4	1.45	anti-rattle . . . . .
69-70	All (exc. Spt. Mdls.) . . . . .	8727969 2	1.35	from glass run— (11.015) . . . . .
69	Caprice (Spt. Sed.) . . . . .	8726299 L.H.	7.05	outer glass run . . . . .
71-74	Pass. (4-Dr.) (exc. Spt. Sed.) . . . . .	9829751 2	7.05	inner at belt . . . . .
71-75	Pass. (Spt. Sed.) . . . . .	9829752 2	7.05	inner at belt . . . . .
71	Pass. (4-Dr.) (exc. Spt. Sed.) . . . . .	9845621 L.H.	5.80	outer at belt . . . . .
71	Pass. (4-Dr.) (exc. Spt. Sed.) . . . . .	9845620 R.H.	5.80	outer at belt . . . . .
72-75	Pass. (4-Dr.) (exc. Spt. Sed.) . . . . .	9611801 L.H.	7.05	outer at belt . . . . .
72-75	Pass. (4-Dr.) (exc. Spt. Sed.) . . . . .	9611800 R.H.	7.05	outer at belt . . . . .
71-75	Pass. (2-Dr.) . . . . .	9829753 2	7.05	inner at belt . . . . .
71-75	Pass. (Spt. Cpe., Conv.) . . . . .	9611799 L.H.	7.05	outer at belt . . . . .
71-75	Pass. (Spt. Cpe., Conv.) . . . . .	9611798 R.H.	7.05	outer at belt . . . . .
71	Pass. (Spt. Sed.) . . . . .	9845623 L.H.	7.25	outer at belt . . . . .
71	Pass. (Spt. Sed.) . . . . .	9845622 R.H.	7.25	outer at belt . . . . .
72-75	Pass. (Spt. Sed.) . . . . .	9611803 L.H.	7.05	outer at belt . . . . .
72-75	Pass. (Spt. Sed.) . . . . .	9611802 R.H.	7.05	outer at belt . . . . .

**CHEVY—NOVA**

62-65	(Spt. Cpe., Conv.) . . . . .	5713989 L.H.	4.35	outer . . . . .
66-67	(2-Dr. Sed.) . . . . .	4544940 2	3.30	outer, at belt . . . . .
66-67	(Spt. Cpe.) . . . . .	7636860 R.H.	4.50	inner at belt (brt. stainless steel bead) . . . . .
68	(2-Dr.),			
70-72	Nova (2-Dr.) . . . . .	7759724 R.H.	4.45	inner at belt . . . . .
68	(2-Dr.),			
70-72	Nova (2-Dr.) . . . . .	7759725 L.H.	4.45	inner at belt . . . . .
68	(4-Dr.),			
70-74	(4-Dr.) (Taxi) . . . . .	7759722 R.H.	7.05	inner at belt . . . . .
68	(4-Dr.),			
70-74	(4-Dr.) (Taxi) . . . . .	7759723 L.H.	7.05	inner at belt . . . . .
68-74	(4-Dr.) (Taxi) . . . . .	7732343 R.H.	7.05	outer at belt . . . . .
68-74	(4-Dr.) (Taxi) . . . . .	7732344 L.H.	7.05	outer at belt . . . . .
68-72	(2-Dr.) . . . . .	7732345 R.H.	7.05	outer at belt . . . . .
68-72	(2-Dr.) . . . . .	7732346 L.H.	7.05	outer at belt . . . . .
66-67	(Spt. Cpe.) . . . . .	9706701 2	4.05	outer . . . . .
73-75	Nova (4-Dr.) (exc. Taxi) . . . . .	9620749 L.H.	7.05	inner at belt . . . . .
73-75	Nova (4-Dr.) (exc. Taxi) . . . . .	9620748 R.H.	7.05	inner at belt . . . . .
73-75	Nova (2-Dr.) . . . . .	9620746 2	7.05	outer at belt (w/stainless steel bead) . . . . .
73-75	Nova (4-Dr.) (exc. Taxi) . . . . .	9620745 2	7.05	outer at belt (w/stainless steel bead) . . . . .
73-75	Nova (2-Dr.) . . . . .	1711415 R.H.	7.05	inner at belt (w/stainless steel bead) (repl. 9620750) . . . . .
73-75	Nova (2-Dr.) . . . . .	1711416 L.H.	7.05	inner at belt (w/stainless steel bead) (repl. 9620751) . . . . .
75	Nova (4-Dr.) . . . . .	1653432 R.H.	11.20	frame upr. scalp . . . . .

**CHEVELLE**

64-65	Malibu (Conv.) . . . . .	4453601 L.H.	7.05	outer . . . . .
64-65	Malibu (Spt. Cpe.) . . . . .	4453600 R.H.		outer (repl. 4452280) . . . . .
65	(Spt. Mdls.) . . . . .	4407831 R.H.	7.05	inner . . . . .
66-67	(2-Dr. Sed.) El Camino . . . . .	7580167 L.H.	3.70	outer, at belt . . . . .
66-67	(4-Dr.) . . . . .	7580168 R.H.	7.05	outer, at belt (19 <sup>3</sup> / <sub>4</sub> " long) . . . . .
66-67	(4-Dr.) . . . . .	7580169 L.H.	7.05	outer, at belt (19 <sup>3</sup> / <sub>4</sub> " long) . . . . .
66-67	Malibu (Spt. Sed.) . . . . .	7580388 R.H.	7.05	outer, at belt . . . . .
66-67	Malibu (Spt. Sed.) . . . . .	7580389 L.H.	7.05	outer, at belt . . . . .
66-67	(Conv., Spt. Cpe.) . . . . .	7636857 R.H.	4.15	inner at belt (brt. stainless steel bead) . . . . .
66-67	(Conv., Spt. Cpe.) . . . . .	7636858 L.H.	4.70	inner at belt (brt. stainless steel bead) . . . . .
66-67	(Spt. Cpe., Conv.) . . . . .	7645818 R.H.	7.05	outer at belt . . . . .
66-67	(Spt. Cpe., Conv.) . . . . .	7645819 L.H.	7.05	outer at belt . . . . .
66-67	(4-Dr.) (exc. Spt. Sed.) (2nd type) . . . . .	7581296 2	7.05	inner at belt (brt. stainless steel bead) . . . . .

**WINDSHIELD—DOORS—CONTROLS**

**10.710 STRIP ASSY.— STUD, Front Door Window (Outer— Inner) (Con't)**

66-67	Malibu (Spt. Sed.) (2nd type) . . .	7609556 L.H.	7.05	inner at belt (brt. stainless steel bead) . . . . .
68-69	(2-Dr. Sed.) . . . . .	8769440 R.H.	7.05	outer at belt . . . . .
68-69	(2-Dr. Sed.) . . . . .	8769441 L.H.	7.05	outer at belt . . . . .
68	(Spt. Cpe., Conv.) . . . . .	7726810 R.H.	7.05	outer at belt . . . . .
68	(Spt. Cpe., Conv.) . . . . .	7726811 L.H.	7.05	outer at belt . . . . .
68-72	El Camino . . . . .	7726814 R.H.	4.45	outer at belt . . . . .
68-72	El Camino . . . . .	7726815 L.H.	4.45	outer at belt . . . . .
68-72	(Spt. Sed.) . . . . .	7783448 R.H.	7.05	outer at belt . . . . .
68-72	(Spt. Sed.) . . . . .	7783449 L.H.	7.05	outer at belt . . . . .
68-72	(4-Dr.) (exc. Spt. Sed.) . . . . .	7726818 R.H.	7.05	outer at belt . . . . .
68-72	(4-Dr.) (exc. Spt. Sed.) . . . . .	7726819 L.H.	7.05	outer at belt . . . . .
68	(Spt. Cpe.) . . . . .	7759714 R.H.	7.05	inner at belt . . . . .
68	(Spt. Cpe.) . . . . .	7759715 L.H.	7.05	inner at belt . . . . .
68	(4-Dr.) . . . . .			
70-72	(4-Dr.) . . . . .	7759716 R.H.	7.05	inner at belt . . . . .
68	(4-Dr.) . . . . .			
70-72	(4-Dr.) . . . . .	7759717 L.H.	7.05	inner at belt . . . . .
68	El Camino . . . . .			
70-72	El Camino . . . . .	7759718 R.H.	2.70	inner at belt . . . . .
68	El Camino . . . . .			
70-72	El Camino . . . . .	7759719 L.H.	2.70	inner at belt . . . . .
68	(Spt. Cpe., Conv.) . . . . .	7759720 R.H.	7.05	inner at belt . . . . .
68	(Spt. Cpe., Conv.) . . . . .	7759721 L.H.	7.05	inner at belt . . . . .
69-72	(Spt. Cpe., Conv.) . . . . .	8784487 4	1.45	front/rear, anti-rattle . . . . .
69	(Spt. Cpe., Conv.) . . . . .	8723391 R.H.	7.05	front, outer anti-rattle . . . . .
69	(Spt. Cpe., Conv.) . . . . .	8723392 L.H.	7.05	front, outer anti-rattle . . . . .
69	(Spt. Cpe., Conv.) . . . . .			
70-72	Monte Carlo . . . . .	8765653 2	7.05	inner at belt . . . . .
70-72	Chevelle (Spt. Cpe., Conv.) . . . . .	8807627 L.H.	7.05	outer at belt (brt. stainless steel bead) . . . . .
70-72	Chevelle (spt. Cpe., Conv.) . . . . .	8807626 R.H.	7.05	outer at belt (brt. stainless steel bead) . . . . .
70-72	Monte Carlo . . . . .	9718149 L.H.	7.05	outer glass run . . . . .
70-72	Monte Carlo . . . . .	9718148 R.H.	7.05	outer glass run . . . . .
68-69	(Spt. Mdls.) . . . . .	7660878 2	1.45	anti-rattle . . . . .
73-75	Chevelle (2-Dr.) (exc. Monte Carlo) . . . . .	9882229 L.H.	7.05	inner at belt . . . . .
73-75	Chevelle (2-Dr.) (exc. Monte Carlo) . . . . .	9882228 R.H.	7.05	inner at belt . . . . .
73-75	Monte Carlo . . . . .	9882231 L.H.	7.05	inner at belt . . . . .
73-75	Monte Carlo . . . . .	9882230 R.H.	7.05	inner at belt . . . . .
73-75	Chevelle (4-Dr.) . . . . .	9661948 L.H.	7.05	inner at belt . . . . .
73-75	Chevelle (4-Dr.) . . . . .	9661947 R.H.	7.05	inner at belt . . . . .
73-75	Monte Carlo . . . . .	9673657 L.H.	7.05	outer at belt . . . . .
73-75	Monte Carlo . . . . .	9673656 R.H.	7.05	outer at belt . . . . .
73-75	Chevelle (4-Dr.) . . . . .	9673654 R.H.	7.05	outer at belt . . . . .
73-75	El Camino . . . . .	9673659 L.H.	7.05	outer at belt . . . . .
73-75	El Camino . . . . .	9673658 R.H.	7.05	outer at belt . . . . .
73-75	Chevelle (Spt. Cpe.) (exc. Monte Carlo) . . . . .	9673652 R.H.	7.05	outer at belt . . . . .
73-75	Chevelle (Spt. Cpe.) (exc. Monte Carlo) . . . . .	9673653 L.H.	7.05	outer at belt . . . . .
73-75	Chevelle (4-Dr.) . . . . .	9673655 L.H.	7.05	outer at belt . . . . .

**CAMARO**

67	Camaro . . . . .	7711145 R.H.	7.05	outer at belt . . . . .
67	Camaro . . . . .	7711146 L.H.	7.05	outer at belt . . . . .
68-69	Camaro . . . . .	7698542 2	1.55	anti-rattle, front . . . . .
68-69	Camaro . . . . .	7698543 2	1.10	anti-rattle, rear . . . . .
68-69	Camaro . . . . .	7729998 2	7.05	outer at belt . . . . .
68-69	Camaro . . . . .	7731200 2	7.05	inner at belt (standard trim) . . . . .
68-69	Camaro w/custom trim . . . . .	7755881 2	7.05	inner at belt . . . . .
70-72	Camaro . . . . .			
75	Camaro . . . . .			
73-75	Camaro (LT) . . . . .	8808230 R.H.	7.05	inner at belt . . . . .
70-72	Camaro . . . . .			
75	Camaro . . . . .			
73-75	Camaro (LT) . . . . .	8808231 L.H.	7.05	inner at belt . . . . .
70-75	Camaro . . . . .	9612537 L.H.	7.05	outer at belt (repl. 9809073) . . . . .
70-75	Camaro . . . . .	9612536 R.H.	7.05	outer at belt . . . . .
70-71	Camaro w/Belt Mldg. . . . .	9815575 L.H.	7.05	outer at belt . . . . .
70-71	Camaro w/Belt Mldg. . . . .	9815574 R.H.	7.05	outer at belt . . . . .
72-75	Camaro w/ext. mldg. . . . .	9612541 L.H.	7.05	outer at belt . . . . .
72-75	Camaro w/ext. mldg. . . . .	9612540 R.H.	7.05	outer at belt . . . . .
67	Camaro . . . . .	7642496 R.H.	7.05	STRIP, inner at belt . . . . .
67	Camaro . . . . .	7642497 L.H.	7.05	STRIP, inner at belt . . . . .
68	Camaro . . . . .	9715110 2	7.05	STRIP, outer glass run . . . . .

**WINDSHIELD—DOORS—CONTROLS**

**10.710 STRIP ASSY.— STUD, Front Door Window (Outer— Inner) (Con't)**

**VEGA— MONZA**

71-75 Vega	9825753	2	7.05	inner at belt
71-75 Vega	9888021	L.H.	7.05	outer at belt
71-75 Vega	9888020	R.H.	7.05	outer at belt
71-75 Vega (H.B.)	9825096	2	7.05	outer glass run
75 Monza (exc. Towne Cpe.)	1650090	R.H.	7.05	front door wdo. inner at belt
75 Monza (exc. Towne Cpe.)	1650091	L.H.	7.05	front door wdo. inner at belt
75 Monza (exc. Towne Cpe.)	9739081	R.H.	7.05	front door wdo. reveal mldg.
75 Monza (exc. Towne Cpe.)	9739082	L.H.	7.05	front door wdo. reveal mldg.
75 Monza (Towne Cpe.)	1704134	R.H.	4.50	STRIP ASSY., frt. dr. inner at belt
75 Monza (Towne Cpe.)	1704135	L.H.	4.50	STRIP ASSY., frt. dr. inner at belt
70-72 Chevelle (Spt. Cpe., Conv.)	8720595	2	.27	STUD, front door window anit-rattle rear strip

**10.716 BUMPER— CAP— EXTENSION ASSY.— NUT— SCREW— STOP— SUPPORT, Door Window**

65-67 Pass. (Spt. Sed.)	8785295	2	.22	stop (rr. dr. window)— (12-212)
66-69 Pass.,				
70 Pass. (Sed.) exc. Spt. Sed.,				
70 Pass. (Sta. Wag.) (6-Pass.)	7656148	2	.18	front door window stop
66-67 Malibu (Spt. Sed.),				
71-75 Pass. (Spt. Sed.)	9848458	4	.58	front and rear
70 Pass. (2-Dr.),				
71-72 Pass. (4-Dr.),				
73-75 Pass.,				
70-75 Camaro,				
70-72 Chevelle	9810036	A.R.	.35	frt. door window stop
68-69 Chevy (2-Dr.),				
74-75 Chevelle, Vega	9621474	2	.28	BUMPER, front door wdo. stop
75 Chevelle (4-Dr.)	6277407	2	.28	BUMPER, front door inner at electric window regulator (repl. 1671321)
71-75 Pass. (Spt. Sed.)	9835954	4	.16	CAP, frt. & rear door window upper stop on panel
70-72 Nova (4-Dr.),				
73 Nova (2-Dr.)	7770508	2	2.05	EXTENSION ASSY., front dr. window bracket support
70-72 Pass.,				
71-72 Camaro	4801719	A.R.	.18	NUT, side door window glass
62-65 Nova (Spt. Cpe., Conv.),				
64-65 Chevelle (Spt. Mdls.)	4838019	A.R.	.37	STOP, door front
65-68 Pass. (Spt. Mdls.)	4470225	2	.37	STOP, front door window front
66 Nova (Spt. Cpe.),				
66 Chevelle (Spt. Mdls.)— (11.012)	4482848	2	.32	STOP, frt. door window front
68-69 Chevelle (Spt. Cpe. Conv.),				
68 Pass. (Spt. Mdls.)				STOP, front door window upper rear,
68-69 Chevelle (4-Dr. Spt. Sed.)	7720257	2	.37	front and rear upper
68-69 Camaro (Spt. Mdls.)	7723492	2	.83	STOP, front door window, front
68-72 Chevelle (Spt. Mdls.)	7720238	2	1.15	STOP, front door window front upper
69 Pass. (Spt. Cpe., Conv.),				
68-69 Chevelle (4-Dr. Spt. Sed.)	8768481	2	.96	STOP, front door window rear upper or support
70 Pass. (2-Dr.)				rear door,
70 Pass. (Spt. Sed.)	9809568	4	.83	STOP, front upper on panel
70-72 Chevelle (Spt. Cpe., Conv.)	8768471	2	.52	STOP, front, upper on glass front
70-72 Chevelle (2-Dr.)	9812756	2	.32	STOP, front, upper on glass rear
70 Pass. (2-Dr.)				STOP, front, upper on glass,
70-71 Pass. (2-Dr.)	9822309	2	1.05	front door wdo. rear upper on glass
70 Pass. (Spt. Sed.)	9812617	2	.45	STOP, front, rear upper
71-72 Pass.,				
73 Pass. (Spt. Sed.)	8768481	2	.96	STOP, rear door wdo. rear stop, front upper on pnl.
71-75 Pass. (Spt. Sed.)	9833767	4	1.15	STOP, front door wdo. rear upper on panel
71-75 Pass. (Spt. Sed.)	9847589	2	1.15	STOP, front door wdo. upper on panel
72-75 Pass. (Spt. Cpe., Conv.)	9614709	2	1.05	STOP, front door wdo. front and rear upper on glass
73-75 Chevelle	1653800	2	1.65	front door upper front on reinf.
73-74 Chevelle	1655695	2	1.15	front door window upper rear
72-73 Vega, Monza	9723669	2	.34	
75 Monza	9621474	2	.28	
67-68 Pass. (Spt. Mdls.)	4470226	2	.37	STOP ASSY., front door window rear
69 Pass. (Spt. Sed.)	8722349	2	.52	STOP ASSY., front door window rear upper
69-72 Chevelle (Spt. Mdls.),				

**WINDSHIELD—DOORS—CONTROLS**

**10.716 BUMPER—CAP— EXTENSION ASSY.— NUT— SCREW— STOP—  
SUPPORT, Door Window (Con't)**

69-70	Pass. (Sed.) (exc. 4-Dr.)				STOP ASSY., rear window front and rear upper, . . . . .
73	Pass. (Sta. Wag.)				tailgate wind. lwr. . . . .
69-70	Pass. (Spt. Mdls)	8753026	2	.46	front window front stop . . . . .
66-67	Chevy				SUPPORT, door window bumper, . . . . .
66-67	Chevelle,				
68-72	Chevy (4-Dr.),				
68-72	Chevelle (exc. Spt. Mdls.),				
73-74	Nova (Taxi),				
75	Nova	4542061	A.R.	.91	front door window bumper . . . . .
70	Pass. (2-Dr.)				SUPPORT, front, window bumper, . . . . .
70-72	Chevelle (2-Dr.)	9816787	A.R.	.91	front, bumper rear . . . . .
70-72	Chevelle (2-Dr.)	9815294	1	1.65	SUPPORT, front, bumper front . . . . .
71	Pass. (exc. Spt. Sed., Conv.)				
70-75	Camaro	9832942	1	4.10	SUPPORT, front door wdo. bumper . . . . .
71-75	Pass. (Spt. Cpe., Conv.)	9839673	4	2.35	SUPPORT, front door window bumper . . . . .
72-75	Pass. (exc. Spt. Cpe., Conv.)	9615739	2	4.10	SUPPORT ASSY., frt. door window bumper . . . . .
73-75	Chevelle	9862630	2	1.65	SUPPORT, front door wdo. bumper front . . . . .

**10.721 WEATHERSTRIP— STRIP— CLIP— MOULDING— RETAINER, Side Roof Rail**

**PASSENGER**

65-66	Impala (Spt. Cpe.)	7627682	R.H.	29.25	
65-66	Impala (Spt. Cpe.)	7627683	L.H.	29.25	
65-66	Spt. Sed.	7647766	R.H.	37.75	
65-66	Spt. Sed.	7647767	L.H.	37.75	
66	Caprice (Spt. Cpe.)	7628177	L.H.	29.25	
67	Caprice (Spt. Cpe.)	7725479	L.H.	29.25	side roof rail . . . . .
67-68	Spt. Sed.	7725483	L.H.	37.75	side roof rail . . . . .
67-68	Spt. Sed.	7725482	R.H.	37.75	side roof rail . . . . .
67-68	Impala (Spt. Cpe.)	7725480	R.H.	29.25	roof rail . . . . .
67-68	Impala (Spt. Cpe.)	7725481	L.H.	29.25	roof rail . . . . .
68	Caprice (Spt. Cpe.)	7723521	R.H.	29.25	side roof rail . . . . .
68	Impala (Custom)	7754423	L.H.	29.25	side roof rail . . . . .
69-70	Spt. Sed.	9812630	R.H.	37.75	
69-70	Spt. Sed.	9812631	L.H.	37.75	
69-70	Impala (Spt. Cpe.)	9812635	L.H.	29.25	
69-70	Impala (Custom) Caprice (Spt. Cpe.)	9820544	R.H.	29.25	
69-70	Impala (Spt. Cpe.)	9812634	R.H.	29.25	
70	Impala (Custom) Caprice (Spt. Cpe.)	9820545	L.H.	29.25	
71-72	Pass. (Spt. Sed.)	9726973	L.H.	37.75	
71-72	Pass. (Spt. Sed.)	9726972	R.H.	37.75	
71-73	Impala (Spt. Cpe.) (exc. Custom)	9615599	L.H.	29.25	
71-73	Impala (Spt. Cpe.) (exc. Custom)	9615598	R.H.	29.25	
71-73	Impala (Custom) Caprice (Spt. Cpe.)	9615597	L.H.	43.50	
71-73	Impala (Custom) Caprice (Spt. Cpe.)	9615596	R.H.	43.50	
74-75	Impala (Spt. Cpe.) (exc. Custom)	9678188	R.H.	29.25	WEATHERSTRIP, side roof rail . . . . .
74-75	Impala (Spt. Cpe.) (exc. Custom)	9678189	L.H.	29.25	WEATHERSTRIP, side roof rail . . . . .
74-75	Impala (Custom),				
74-75	Caprice (Spt. Cpe.)	9678190	R.H.	29.25	WEATHERSTRIP, side roof rail . . . . .
74-75	Impala (Custom),				
74-75	Caprice (Spt. Cpe.)	9678191	L.H.	29.25	WEATHERSTRIP, side roof rail . . . . .
73-74	Pass. (Spt. Sed.)	9726972	R.H.	37.75	WEATHERSTRIP . . . . .
73-74	Pass. (Spt. Sed.)	9726973	L.H.	37.75	WEATHERSTRIP . . . . .
75	Pass. (Spt. Sed.)	9736040	R.H.	37.75	WEATHERSTRIP, side roof rail . . . . .
75	Pass. (Spt. Sed.)	9736041	L.H.	37.75	WEATHERSTRIP, side roof rail . . . . .

**CHEVY**

66-67	Nova (Spt. Cpe.)	7725460	R.H.	29.25	
66-67	Nova (Spt. Cpe.)	7725461	L.H.	29.25	
73-74	Nova (2-Dr.)	9627722	2	.28	STRIP, sealing side roof rail outer to quarter baffel . . . . .

**CHEVELLE**

64-65	Malibu (Spt. Cpe.)	4409034	R.H.	29.25
64-65	Malibu (Spt. Cpe.)	4409035	L.H.	29.25
66-67	(Spt. Cpe.)	7725458	R.H.	29.25
66-67	(Spt. Cpe.)	7725459	L.H.	29.25

**WINDSHIELD—DOORS—CONTROLS**

**10.721 WEATHERSTRIP— STRIP— CLIP— MOULDING— RETAINER, Side Roof Rail (Con't)**

66-67	Malibu (Spt. Sed.)	7725452 R.H.	37.75	
66-67	Malibu (Spt. Sed.)	7725453 L.H.	37.75	
68-69	(Spt. Sed.)	7717778 R.H.	37.75	
68-69	(Spt. Sed.)	7717779 L.H.	37.75	
68	(Spt. Cpe.)	7717780 R.H.	29.25	
68	(Spt. Cpe.)	7717781 L.H.	29.25	
69-72	(Spt. Cpe.) (exc. Monte Carlo)	9823126 R.H.	29.25	
69-72	(Spt. Cpe.) (exc. Monte Carlo)	9823127 L.H.	29.25	
70-72	(Spt. Sed.)	9875977 L.H.	37.75	
70-72	(Spt. Sed.)	9875976 R.H.	37.75	
70-72	Monte Carlo	9825323 L.H.	29.25	side rail
70-72	Monte Carlo	9825322 R.H.	29.25	side roof rail
73	Chevelle (2-Dr.) (exc. El Camino)	9629697 L.H.	29.25	WEATHERSTRIP, side roof rail
73	Chevelle (2-Dr.) (exc. El Camino)	9629696 R.H.	29.25	WEATHERSTRIP, side roof rail
73	Chevelle (Spt. Sed.)	9629693 L.H.	29.25	WEATHERSTRIP, side roof rail rear
73	Chevelle (Spt. Sed.)	9629692 R.H.	29.25	WEATHERSTRIP, side roof rail rear
73-75	Chevelle (Sta. Wag.)	9878797 L.H.	27.00	WEATHERSTRIP, side roof rail rear
73-75	Chevelle (Sta. Wag.)	9878796 R.H.	27.00	WEATHERSTRIP, side roof rail rear
73	Monte Carlo	9629701 L.H.	29.25	WEATHERSTRIP, side roof rail
73	Monte Carlo	9629700 R.H.	29.25	WEATHERSTRIP, side roof rail
73-74	El Camino	9629705 L.H.	13.60	WEATHERSTRIP, side roof rail
73-75	El Camino	9878790 R.H.	13.60	WEATHERSTRIP, side roof rail
74-75	Chevelle (Spt. Cpe.) (exc. Monte Carlo)	9878789 L.H.	29.25	WEATHERSTRIP, side roof rail
74-75	Chevelle (Spt. Cpe.) (exc. Monte Carlo)	9878788 R.H.	29.25	WEATHERSTRIP, side roof rail
74-75	Monte Carlo	9878787 L.H.	29.25	WEATHERSTRIP, side roof rail
74-75	Monte Carlo	9878786 R.H.	29.25	WEATHERSTRIP, side roof rail
74-75	El Camino	9878791 L.H.	13.60	WEATHERSTRIP, side roof rail
74-75	Chevelle (Sed.)	9878795 L.H.	29.25	WEATHERSTRIP, side roof rail rear
74-75	Chevelle (Sed.)	9629692 R.H.	29.25	WEATHERSTRIP, side roof rail rear (repl. 9878794)
73-75	Chevelle (4-Dr.)	9878793 L.H.	27.00	WEATHERSTRIP, side roof rail front
73-75	Chevelle (4-Dr.)	9878792 R.H.	27.00	WEATHERSTRIP, side roof rail front

**CAMARO**

67	(Spt. Cpe.)	7725488 R.H.	29.25	
67	(Spt. Cpe.)	7725489 L.H.	29.25	
68-69	(Spt. Cpe.)	7719482 R.H.	29.25	
68-69	(Spt. Cpe.)	7719483 L.H.	29.25	
70-75	Camaro	9858881 L.H.	29.25	roof rail complete
70-75	Camaro	9858880 R.H.	29.25	roof rail complete
67	All (Spt. Mdls.) (exc. Conv.)			
68	Pass. (Spt. Mdls.) (exc. Conv.)			
68	Malibu S.S. (Spt. Cpe., Spt. Sed.)	7647553 2	1.95	STRIP, roof rail retainer sealing
69	All (Spt. Mdls.) (exc. Conv.)	4536042 2	2.05	STRIP, side roof rail retainer

**VEGA— MONZA**

75	Monza (exc. Towne Cpe.)	1691398 R.H.	6.75	p/w
75	Monza (exc. Towne Cpe.)	1691399 L.H.	6.75	p/w

**PASSENGER**

71-73	Impala (Spt. Cpe.) (exc. Custom)	9827189 L.H.	7.95	RETAINER
71-73	Impala (Spt. Cpe.) (exc. Custom)	9827188 R.H.	7.95	RETAINER
71-72	Pass. (Spt. Sed.)	9826797 L.H.	9.60	RETAINER, roof rail
71-72	Pass. (Spt. Sed.)	9826796 R.H.	9.60	RETAINER, roof rail
71-73	Impala (Custom) Caprice (Spt. Cpe.)	9827195 L.H.	6.95	RETAINER
71-73	Impala (Custom) Caprice (Spt. Cpe.)	9827194 R.H.	6.95	RETAINER
69-70	Spt. Sed.	8711920 R.H.	10.25	RETAINER ASSY., w/strip
69-70	Spt. Sed.	8711921 L.H.	10.25	RETAINER ASSY., w/strip
69	Custom, Caprice (Spt. Cpe.)			
70	Caprice (Spt. Cpe.)	9820540 R.H.	10.55	RETAINER ASSY., w/strip
69	Custom, Caprice (Spt. Cpe.)			
70	Caprice (Spt. Cpe.)	9820541 L.H.	10.55	RETAINER ASSY., w/strip
69	Impala (Spt. Cpe.) (exc. Custom)			
70	Pass. (Spt. Cpe.)	8712281 R.H.	8.25	RETAINER ASSY., w/strip
69	Impala (Spt. Cpe.) (exc. Custom)			
70	Pass. (Spt. Cpe.)	8712282 L.H.	8.95	RETAINER ASSY., w/strip
73-74	Pass. (Spt. Sed.)	9625737 L.H.	9.60	roof rail
73-74	Pass. (Spt. Sed.)	9625736 R.H.	9.60	roof rail
74-75	Caprice (Spt. Cpe.) Impala (Custom)	9665484 R.H.	1.00	w/str. body lk. plr. upr. corner

**WINDSHIELD—DOORS—CONTROLS**

**10.721 WEATHERSTRIP— STRIP— CLIP— MOULDING— RETAINER, Side Roof Rail (Con't)**

74-75	Caprice (Spt. Cpe.) Impala (Custom)	9665485	L.H.	1.00	w/str. body lk. plr. upr. corner
74-75	Caprice (Spt. Cpe.) Impala (Custom)	9665488	2	6.40	w/str. body lk. plr. upr.
74-75	Caprice (Spt. Cpe.) Impala (Custom)	9668460	R.H.	4.60	w/str. side roof rail
74-75	Caprice (Spt. Cpe.) Impala (Custom)	9668461	L.H.	4.60	w/str. side roof rail
74-75	Impala (Spt. Cpe.) (exc. Custom)	9668456	R.H.	6.40	w/str. side roof rail
74-75	Impala (Spt. Cpe.) (exc. Custom)	9668457	L.H.	6.40	w/str. side roof rail
75	Pass. (Spt. Sed.)	9736212	R.H.	5.90	roof rail
75	Pass. (Spt. Sed.)	9736213	L.H.	5.90	roof rail
75	Pass. (Spt. Sed.)	9735588	R.H.	4.15	w/str. body lk. plr. upr.
75	Pass. (Spt. Sed.)	9735589	L.H.	4.15	w/str. body lk. plr. upr.

**CHEVY**

**CHEVELLE**

70-72	Chevelle (Spt. Sed.)	8782296	L.H.	11.85	RETAINER
70-72	Chevelle (Spt. Sed.)	8782295	R.H.	11.85	RETAINER
70-72	Monte Carlo (Spt. Cpe.)	9820157	L.H.	10.20	RETAINER
70-72	Monte Carlo (Spt. Cpe.)	9820156	R.H.	10.20	RETAINER
68-72	(Spt. Cpe.) (exc. Monte Carlo)	8752972	R.H.	11.80	RETAINER ASSY., weatherstrip
68-70	(Spt. Cpe.) (exc. Monte Carlo)	8752971	L.H.	9.65	RETAINER ASSY., weatherstrip
71-72	(Spt. Cpe.) (exc. Monte Carlo)	8752973	L.H.	11.80	RETAINER ASSY., weatherstrip
73-75	Chevelle (Spt. Sed.)	9628673	2	4.15	body lock pillar
73-75	Chevelle (Spt. Sed.)	9878831	L.H.	3.65	side roof rail front
73-75	Chevelle (Spt. Sed.)	9878830	R.H.	3.65	side roof rail front
73-75	Chevelle (Spt. Cpe.) (exc. Monte Carlo)	9670773	L.H.	9.40	side roof rail
73-75	Chevelle (Spt. Cpe.) (exc. Monte Carlo)	9670772	R.H.	9.40	side roof rail
73-75	Monte Carlo	9670769	L.H.	9.40	side roof rail front
73-75	Monte Carlo	9670768	R.H.	9.40	side roof rail front
73-75	Monte Carlo	9600886	R.H.	4.15	side roof rail w/str./lk. plr.
73-75	Monte Carlo	9600887	L.H.	4.15	side roof rail w/str./lk. plr.
73-75	Chevelle (Spt. Cpe.) (exc. Monte Carlo)	9878849	L.H.	5.65	side roof rail lock pillar
73-75	Chevelle (Spt. Cpe.) (exc. Monte Carlo)	9878848	R.H.	5.65	side roof rail lock pillar
73-75	Chevelle (4-Dr.)	9670771	L.H.	9.40	side roof rail front
73-75	Chevelle (4-Dr.)	9670770	R.H.	9.40	side roof rail front
73-75	Chevelle (Sta. Wag.)	9607373	L.H.	4.15	side roof rail lock pillar
73-75	Chevelle (Sta. Wag.)	9607372	R.H.	4.15	side roof rail lock pillar
73-75	Chevelle (Sta. Wag.)	9645911	L.H.	4.60	side roof rail rear
73-75	Chevelle (Sta. Wag.)	9645910	R.H.	4.60	side roof rail rear
73-75	El Camino	1690371	L.H.	9.40	side roof rail front
73-75	El Camino	9670774	R.H.	6.90	side roof rail front
73-75	El Camino	9878847	L.H.	5.65	side roof rail rear
73-75	El Camino	9878846	R.H.	5.65	side roof rail rear
73	Chevelle	9630948	1	.27	CLIP UNIT, side roof rail weatherstrip (blowout)

**CAMARO**

68-69	(Spt. Cpe.)	8771865	R.H.	7.10	RETAINER
68-69	(Spt. Cpe.)	8771866	L.H.	7.10	RETAINER
70	Camaro	9814587	L.H.	9.90	RETAINER
70	Camaro	9814586	R.H.	9.90	RETAINER
70	Camaro	9814589	L.H.	4.50	RETAINER, above belt
70	Camaro	9814588	R.H.	4.50	RETAINER, above belt
70-75	Camaro	9814744	L.H.	1.20	RETAINER, upper rear corner
70-75	Camaro	9814743	R.H.	1.20	RETAINER, upper rear corner
71-75	Camaro	9874902	L.H.	10.50	RETAINER, roof rail
71-75	Camaro	9874901	R.H.	10.50	RETAINER, roof rail
71-75	Camaro	9864181	L.H.	5.70	RETAINER, lock pillar above belt
71-75	Camaro	9864180	R.H.	5.70	RETAINER, lock pillar above belt
67	(Spt. Cpe.)	7642166	R.H.	7.50	RETAINER ASSY., w/strip
67	(Spt. Cpe.)	7642167	L.H.	7.50	RETAINER ASSY., w/strip
75	Nova (2-Dr.) (exc. H.B.)	1726288	R.H.	9.55	MOULDING, rr. bdy. lk. plr. fin. above belt
75	Nova (2-Dr.) (exc. H.B.)	1726289	L.H.	9.55	MOULDING, rr. bdy. lk. plr. fin. above belt



**WINDSHIELD—DOORS—CONTROLS**

**10.728 PLATE— NUT— SUPPORT— STUD— TUBE ASSY.— WASHER, Door Window**

67	Pass. (Spt. Cpe., Conv.),				
68	Impala (Spt. Cpe., Conv.)	7682222	R.H.	4.85	(front window guide rear)
67	Pass. (Spt. Cpe., Conv.),				
68	Impala (Spt. Cpe., Conv.)	7682223	L.H.	4.85	front window guide rear
67-68	Pass. (Spt. Sed.)	7682226	R.H.	4.35	front window guide rear (stamped 9711074)
67-68	Pass. (Spt. Sed.)	7682227	L.H.	4.35	front window guide rear (stamped 9711075)
69-72	Chevelle (Spt. Mdls.) (exc. Spt. Sed.)	8718075	2	1.25	front guide (front and rear)
70	Pass. (Spt. Cpe., Conv.),				
70-72	Chevelle (Spt. Cpe., Conv.)	9822151	R.H.	4.90	lower sash guide
70	Pass. (Spt. Cpe., Conv.),				
70-72	Chevelle (Spt. Cpe., Conv.)	9822152	L.H.	4.90	lower sash guide
71-75	Pass. (2-Dr.)	9669418	R.H.	6.90	front, lower sash guide w/stab. guide
71-75	Pass. (2-Dr.)	9669419	L.H.	6.90	front, lower sash guide w/stab. guide (repl. 9614717)
71-72	Pass. (exc. Sed., Sta. Wag.)	9609344	A.R.	.27	front door outer sealing strip guide
71-72	Pass. (2-Dr.)	9867781	2	2.30	door, window glass stabilizer
69-70	Pass. (Spt. Mdls.)	8732273	4	1.20	PLATE ASSY. (front guide) (frt. or rr.)
69-70	Pass. (Spt. Sed.)	8743785	1	.52	PLATE ASSY., left frt. upper guide rear
73	Chevelle,				
74-75	Chevelle (exc. Sta. Wag.)	9605748	2	1.25	front door glass on reinf.
73	Pass., Chevelle	4801719	4	.18	NUT, window guide tube and lower sash upper guide
68	Chevelle (Spt. Sed.)	7787304	R.H.	2.05	SUPPORT, rear door window guide front cam upper
68	Chevelle (Spt. Sed.)	7787305	L.H.	2.05	SUPPORT, rear door window guide front cam upper
68	Chevelle (Spt. Mdls.),				
69-72	Chevelle (Spt. Sed.)	8781955	L.H.		SUPPORT, front door window guide cam lower (repl. 7723814)
68	Chevelle (Spt. Mdls.),				
69-72	Chevelle (Spt. Sed.)	8781954	R.H.		SUPPORT, front door window guide cam lower (repl. 7723813)
70	Pass., Chevelle (Spt. Cpe., Conv.)	9816787	A.R.	.91	SUPPORT, front door window bumper
71-75	Pass. (Spt. Sed.)	9838192	2	1.40	SUPPORT, front door window guide rear cam
71-75	Pass. (4-Dr.)	9731183	L.H.	1.20	SUPPORT ASSY., front door window guide rear cam & c/nut (repl. 9838194)
73-75	Pass. (4-Dr.)	9731182	R.H.	1.20	SUPPORT ASSY., front door window guide rear cam & c/nut
73-75	Pass. (Spt. Sed.)	9838192	2	1.40	SUPPORT, rear door window guide cam
65-66	Pass. (Spt. Sed.)	4405500	A.R.	.16	STUD, rear guide cam lower— (10.670)
67	Chevelle (Spt. Sed.),				
68	Chevelle	7602989	A.R.	.63	STUD, front and rear cam, door vent to hinge reinf. upper— (10.670)
70	Pass. (Spt. Cpe., Conv.)	8789940	2	8.70	TUBE ASSY., guide
70-72	Chevelle (Spt. Cpe., Conv.)	8789941	2	6.80	TUBE ASSY., guide
69	Pass. (Spt. Sed.)	8740675	4	.11	WASHER, frt. roller to glass
70-72	Pass., Chevelle (Spt. Cpe., Conv.)	9822273	2	.18	WASHER, front door window guide tube

**10.730 RETAINER, Center Pillar Weatherstrip**

73-75	Chevelle (4-Dr.)	9607375	L.H.	2.80	center pillar, front and rear
73-75	Chevelle (4-Dr.)	9607374	R.H.	2.80	center pillar, front and rear

**10.741 GLASS, Rear Door (safety)**

**PASSENGER**

67-68	Spt. Sed.	7642694	R.H.	37.25	(clear)
67-68	Spt. Sed.	7642695	L.H.	30.75	(clear)
67-68	Spt. Sed.	7642696	R.H.	45.00	(tinted)
67-68	Spt. Sed.	7642697	L.H.	33.50	(tinted)
67-68	4-Dr. Sed. (exc. Spt. Sed.)	7640954	R.H.	33.50	(clear)
67-68	4-Dr. Sed. (exc. Spt. Sed.)	7640955	L.H.	33.50	(clear)
67-68	4-Dr. Sed. (exc. Spt. Sed.)	7640956	R.H.	34.00	(tinted)
67-68	4-Dr. Sed. (exc. Spt. Sed.)	7640957	L.H.	37.00	(tinted)
67-68	Sta. Wag.	7640962	R.H.	33.50	(clear)
67-68	Sta. Wag.	7640963	L.H.	25.00	(clear)
67-68	Sta. Wag.	7640964	R.H.	27.50	(tinted)
67-68	Sta. Wag.	7640965	L.H.	34.00	(tinted)
69-70	Spt. Sed.	8746516	R.H.	48.50	(clear)
69-70	Spt. Sed.	8746517	L.H.	48.50	(clear)

**WINDSHIELD—DOORS—CONTROLS**

**10.741 GLASS, Rear Door (safety) (Con't)**

69-70	Spt. Sed.	8746518	R.H.	52.50	(tinted)
69-70	Spt. Sed.	8746519	L.H.	52.50	(tinted)
69-70	(Sta. Wag.)	7799553	R.H.	35.50	(clear)
69-70	(Sta. Wag.)	7799554	L.H.	35.50	(clear)
69-70	(Sta. Wag.)	7799555	R.H.	39.00	(tinted)
69-70	(Sta. Wag.)	7799556	L.H.	39.00	(tinted)
69-70	4-Dr. Sed. (exc. Spt. Sed.)	7799558	R.H.	35.50	(clear)
69-70	4-Dr. Sed. (exc. Spt. Sed.)	7799559	L.H.	35.50	(clear)
69-70	4-Dr. Sed. (exc. Spt. Sed.)	7799560	R.H.	39.00	(tinted)
69-70	4-Dr. Sed. (exc. Spt. Sed.)	7799561	L.H.	39.00	(tinted)
71-74	(Sed.) (exc. Spt. Sed.)	9824395	L.H.	35.25	tinted
71-74	(Sed.) (exc. Spt. Sed.)	9824394	R.H.	35.25	tinted
71-74	(Sed.) (exc. Spt. Sed.)	9805639	L.H.	32.25	clear
71-74	(Sed.) (exc. Spt. Sed.)	9805638	R.H.	32.25	clear
71-74	(Spt. Sed.)	9824397	L.H.	39.00	tinted
71-74	(Spt. Sed.)	9824396	R.H.	39.00	tinted
71-74	(Spt. Sed.)	9805641	L.H.	35.75	clear
71-74	(Spt. Sed.)	9805640	R.H.	35.75	clear
71-75	(Sta. Wag.)	9824405	L.H.	39.75	tinted
71-75	(Sta. Wag.)	9824404	R.H.	39.75	tinted
71-75	(Sta. Wag.)	9805637	L.H.	36.25	clear
71-75	(Sta. Wag.)	9805636	R.H.	36.25	clear
73-75	Pass. (Sta. Wag.)	9805637	L.H.	36.25	clear
73-75	Pass. (Sta. Wag.)	9805636	R.H.	36.25	clear
75	Pass. (Spt. Sed.)	9728680	R.H.	38.00	clear
75	Pass. (Spt. Sed.)	9728681	L.H.	38.00	clear
75	Pass. (Spt. Sed.)	9728682	R.H.	41.50	tinted
75	Pass. (Spt. Sed.)	9728683	L.H.	41.50	tinted
75	Pass. (Sed.) (exc. Spt. Sed.)	9728688	R.H.	31.25	clear
75	Pass. (Sed.) (exc. Spt. Sed.)	9728689	L.H.	31.25	clear
75	Pass. (Sed.) (exc. Spt. Sed.)	9728690	R.H.	34.25	tinted
75	Pass. (Sed.) (exc. Spt. Sed.)	9728691	L.H.	34.25	tinted

**CHEVY—NOVA**

62-65	(4-Dr. Sedan)	4841359	2	14.35	(clear)
66-67	(4-Dr. Sed.)	4547119	2	11.90	(clear)
66-67	(4-Dr. Sed.)	4547120	2	13.50	(tinted)
68	(4-Dr.)	7717534	R.H.	22.60	(clear)
68	(4-Dr.)	7717536	R.H.	24.95	(tinted)
68	(4-Dr.)	7717537	L.H.	20.20	(tinted)
69-72	(4-Dr.)	8752682	R.H.	20.70	(clear)
69-72	(4-Dr.)	8752683	L.H.	20.70	(clear)
69-72	(4-Dr.)	8752684	R.H.	22.70	(tinted)
69-72	(4-Dr.)	8752685	L.H.	22.70	(tinted)
73-74	Nova	9612221	L.H.	21.00	tinted
73-74	Nova	9612220	R.H.	21.00	tinted
73-74	Nova	9612219	L.H.	19.35	clear
73-74	Nova	9612218	R.H.	19.35	clear
75	Nova	9726383	L.H.	22.75	clear
75	Nova	9726385	L.H.	25.00	tinted
75	Nova	9726382	R.H.	22.75	clear
75	Nova	9726384	R.H.	25.00	tinted

**CHEVELLE**

66-67	(4-Dr. Sed.) (exc. Spt. Sed.)	4540550	R.H.	29.50	(clear)
66-67	(4-Dr. Sed.) (exc. Spt. Sed.)	4540551	L.H.	27.50	(clear)
66-67	(4-Dr. Sed.) (exc. Spt. Sed.)	4540552	R.H.	40.00	(tinted)
66-67	(4-Dr. Sed.) (exc. Spt. Sed.)	4540553	L.H.	32.50	(tinted)
66-67	(Sta. Wag.)	4540556	L.H.	29.50	(clear)
66-67	(Sta. Wag.)	4540557	L.H.	27.50	(clear)
66-67	(Sta. Wag.)	4540558	R.H.	32.50	(tinted)
66-67	(Sta. Wag.)	4540559	L.H.	32.50	(tinted)
66-67	Malibu (Spt. Sed.)	4541119	L.H.	48.00	(clear)
66-67	Malibu (Spt. Sed.)	4541120	R.H.	38.75	(tinted)
66-67	Malibu (Spt. Sed.)	4541121	L.H.	38.75	(tinted)
68-69	(Sta. Wag.)	7722153	R.H.	29.50	(clear)
68-69	(Sta. Wag.)	7722155	R.H.	32.50	(tinted)
68-69	(Sta. Wag.)	7722156	L.H.	24.10	(tinted)
68-72	(4-Dr.) (exc. Spt. Sed.)	7722238	R.H.	28.00	(clear)
68-72	(4-Dr.) (exc. Spt. Sed.)	7722239	L.H.	28.00	(clear)
68-72	(4-Dr.) (exc. Spt. Sed.)	7722240	R.H.	30.75	(tinted)
68-72	(4-Dr.) (exc. Spt. Sed.)	7722241	L.H.	30.75	(tinted)
68-69	(Spt. Sed.) w/elect. wind.	7722278	R.H.	48.00	(clear)
68-69	(Spt. Sed.) w/elect. wind.	7722279	L.H.	48.00	(clear)
68-69	(Spt. Sed.)	7722280	R.H.	39.00	(tinted)

**WINDSHIELD—DOORS—CONTROLS**

**10.741 GLASS, Rear Door (safety) (Con't)**

68-69	(Spt. Sed.) w/elect. wind. ....	7722281 L.H.	39.00	(tinted) .....
70-72	(Spt. Sed.) .....	8776029 L.H.	42.25	clear .....
70-72	(Spt. Sed.) .....	8776028 R.H.	42.25	clear .....
70-72	(Spt. Sed.) .....	8776031 L.H.	45.75	tinted .....
70-72	(Spt. Sed.) .....	8776030 R.H.	45.75	tinted .....
70-72	(Sta. Wag.) .....	8776297 L.H.	28.00	clear .....
70-72	(Sta. Wag.) .....	8776296 R.H.	28.00	clear .....
70-72	(Sta. Wag.) .....	8776299 L.H.	30.75	tinted .....
70-72	(Sta. Wag.) .....	8776298 R.H.	30.75	tinted .....

**CHEVELLE**

73-75	Chevelle (Spt. Sed.) .....	9867409 L.H.	37.00	tinted .....
73-75	Chevelle (Spt. Sed.) .....	9867408 R.H.	37.00	tinted .....
73-75	Chevelle (Spt. Sed.) .....	9867407 L.H.	34.25	clear .....
73-75	Chevelle (Spt. Sed.) .....	9867406 R.H.	34.25	clear .....
73-75	Chevelle (Sta. Wag.) .....	9867413 L.H.	40.25	tinted .....
73-75	Chevelle (Sta. Wag.) .....	9867412 R.H.	40.25	tinted .....
73-75	Chevelle (Sta. Wag.) .....	9867411 L.H.	37.00	clear .....
73-75	Chevelle (Sta. Wag.) .....	9867410 R.H.	37.00	clear .....

**10.747 CHANNEL— BOLT— BUSHING— FILLER— NUT— PLATE— RAIL—  
ROLLER— SCREW— SPACER— TUBE ASSY.— WASHER, Door Window  
Lower Sash**

**PASSENGER**

65-66	Spt. Sed. ....	7632206 R.H.	5.85	front vertical .....
65-66	Spt. Sed. ....	7632207 L.H.	5.85	front vertical .....
67-68	Spt. Sed. ....	7653126 R.H.	5.85	front sash .....
67-68	Spt. Sed. ....	7653127 L.H.	5.85	front sash .....
67-68	Spt. Sed. ....	7715225 L.H.	14.90	lower sash .....
67-68	4-Dr. (exc. Spt. Sed.) .....	7653720 R.H.	3.15	lower sash .....
69-70	Spt. Sed. ....	8720802 L.H.	5.65	front .....
69-70	Spt. Sed. ....	8720801 R.H.	5.65	front .....
71-75	Pass. (Spt. Sed.) .....	9738987 L.H.	12.70	front sash .....
71-75	Pass. (Spt. Sed.) .....	9738986 R.H.	12.70	front sash .....

**CHEVY**

62-67	(4-Dr.) .....	4858946 2	2.95	right or left .....
68-72	(4-Dr.),			
73-74	Nova .....	7730022 R.H.	2.90	lower sash .....
68-72	(4-Dr.),			
73-74	Nova .....	7730023 L.H.	2.90	lower sash .....

**CHEVELLE**

66-67	Malibu (Spt. Sed.) .....	7632204 R.H.	6.40	front sash .....
66-67	Malibu (Spt. Sed.) .....	7632205 L.H.	6.40	front sash .....
68	(Spt. Sed.) .....	7728567 R.H.	7.20	front sash .....
68	(Spt. Sed.) .....	7728568 L.H.	7.05	front sash .....
68-72	(4-Dr.) (exc. Spt. Sed.) .....	8712671 2	4.25	lower sash .....
69-72	(Spt. Sed.) .....	8734088 R.H.	7.20	front sash .....
69-72	(Spt. Sed.) .....	8734089 L.H.	7.20	front sash .....
75	Nova (4-Dr.) .....	9739521 R.H.		lower sash .....
75	Nova (4-Dr.) .....	9739522 L.H.		lower sash .....
66-68	Malibu (Spt. Sed.) .....	4534340 8	.39	<b>BOLT</b> , to lower channel— (10.685) .....
68	Chevelle (Spt. Sed.),			
65-68	Pass. (Spt. Sed.) .....	4534340 A.R.	.39	<b>BUSHING</b> , front roller to glass— (11.007) ..
69	Pass. (Spt. Mdls.) .....	4491087 A.R.	.14	<b>BUSHING</b> , front roller to glass— (11.007) ..
71-75	Pass. (Spt. Sed.) .....	9839949 2	.63	<b>BUSHING</b> , plate roller .....
62-69	All .....	370389 A.R.	RL/.12	<b>FILLER</b> (1/2" thick x 1 1/2" wide— 60 ft. roll)— (10.685) .....
62-69	All .....	370390 A.R.	RL/.15	<b>FILLER</b> (3/64" thick x 1 1/32" wide— 40 ft. roll)— (10.685) .....
68	Chevy, Chevelle .....	8712670 4	.79	<b>FILLER</b> , lower sash channel— (10.685) .....
66-68	Pass., Malibu (Spt. Sed.) .....	4533795 6	.33	<b>NUT</b> , to sash channel— (10.685) .....
69	Pass. (exc. Spt. Cpe., Conv.),			
72	Caprice (Sed.) (exc. Spt. Sed.) ..	4491088 A.R.	.16	<b>NUT</b> , rear door window guide roller tree— (10.792) .....
68-72	Chevelle (Spt. Sed.) .....	7728412 4	1.35	<b>PLATE</b> , guide front and rear .....
69	Pass. (Spt. Sed.) .....	8732273 4	1.20	<b>PLATE</b> , front and rear guide— (10.728) .....
71-75	Pass. (Spt. Sed.) .....	9839944 L.H.	10.80	<b>PLATE ASSY.</b> .....
71-75	Pass. (Spt. Sed.) .....	9839943 R.H.	10.80	<b>PLATE ASSY.</b> .....
73-75	Chevelle .....	9605742 R.H.	10.80	<b>PLATE ASSY.</b> , window sash lower .....
73-75	Chevelle .....	9605743 L.H.	10.80	<b>PLATE ASSY.</b> , window sash lower .....
65-67	Pass. (4-Dr.) (exc. Spt. Sed.) .....	3856002 2	.78	<b>RAIL</b> (16.261) .....

**WINDSHIELD—DOORS—CONTROLS**

**10.747 CHANNEL—BOLT—BUSHING—FILLER—NUT—PLATE—RAIL—  
ROLLER—SCREW—SPACER—TUBE ASSY.—WASHER, Door Window  
Lower Sash (Con't)**

65	Pass. (Spt. Sed.)	9704300	6	1.05	ROLLER, lwr. sash channel— (11.007)
65-67	Pass. (Spt. Sed.)				ROLLER, front cam,
67-68	Pass. (Spt. Sed.)				lower and rear,
68-69	Camaro	7640704	2	.83	front lower sash
66-67	Chevelle (Spt. Sed.),				
67-68	Pass. (Spt. Sed.),				
67-69	Camaro,				
68	Chevelle (Spt. Cpe., Conv.)	9711820	2	.55	ROLLER, lower sash upper front
68-70	Chevelle (Spt. Sed.)	9813312	2	1.75	ROLLER ASSY., guide front— (10.685)
68-70	Chevelle (Spt. Sed.),				
72	Chevelle (Spt. Sed.)	7765583	2	1.40	ROLLER ASSY., window guide rear
69-71	Pass. (4-Dr.) (exc. Spt. Sed.)	9813199	2	1.05	ROLLER ASSY., front guide— (10.685)
69-70	Pass. (Spt. Sed.)	8733933	4	3.20	ROLLER ASSY., rear guide— (10.792)
71-75	Pass. (Spt. Sed.)	9828175	2	.70	ROLLER ASSY., plate lower
71-75	Pass. (Spt. Sed.)	9837242	2	.63	ROLLER ASSY., plate upper
74-75	Chevelle (exc. El Camino)	9885269	4	.28	SCREW, rear door window sash guides to plate, frt. dr. wdo. glass reg. cam to glass
65-66	Pass. (Spt. Sed.),				
66	Malibu (Spt. Sed.)	4469108	6	.24	SPACER, glass
73-75	Chevelle (4-Dr.)	9628214	2	9.80	TUBE ASSY., window guide
69-71	Pass. (Spt. Sed.),				
73	Pass. (Spt. Sed.),				
70-73	Camaro	8740675	4	.11	WASHER, rear guide roller to glass— (10.728)
71-72	Pass. (4-Dr.) (exc. Spt. Sed.),				
73	All	7734899	4	.14	WASHER, rear door window glass to cam
73	Chevelle	9822273	2	.18	WASHER, rear window guide tube

**10.748 CAM—NUT—SCREW—SUPPORT, Rear Door Lower Window Sash  
Channel**

68-72	Chevelle (4-Dr.) (exc. Spt. Sed.)	7730072	2	.91	lower sash channel
70-72	Chevelle (Spt. Sed.)	9713963	2	3.50	
70	Bel Air, Townsman, Brookwood,				
70	Chevelle (Spt. Sed.),				
71-72	Camaro	4801719	A.R.	.18	NUT (10.716)
65-67	Pass. (Sta. Wag.),				
66-67	Malibu (Spt. Sed.),				
67-69	Chevelle (4-Dr.),				
68	Pass. (Spt. Mdls.) (exc. Conv.)	4409392	A.R.	.11	SCREW (No. 10-24 x 7/16")— (10.687)
All	All	4409793	A.R.	.16	SCREW ASSY. (1/4" — 20 x 3/4")— (9.743)
68-72	Malibu (Spt. Sed.)	7787304	R.H.	2.05	SUPPORT, front cam upper
68-72	Malibu (Spt. Sed.)	7787305	L.H.	2.05	SUPPORT, front cam upper

**10.759 CHANNEL—FASTENER—RETAINER—SCREW—STUD—WASHER, Rear  
Door Window Glass**

62-63	Chevy (exc. Spt. Mdls.),				
65-67	Chevy (exc. Spt. Cpe.)	7663050	A.R.	4.90	run— (10.701)
64-67	Chevelle (exc. Spt. Mdls.)	4439775	A.R.	4.10	right and left— (10.701)
65-66	Pass. (4-Dr. Sed.)	4470520	R.H.	16.50	glass run
67-68	Pass. (4-Dr. Sed.) (exc. Spt. Sed.)	7639930	R.H.	16.00	glass run
67-68	Pass. (4-Dr. Sed.) (exc. Spt. Sed.)	7639931	L.H.	16.00	glass run
67-68	Pass. (Sta. Wag.)	7639934	R.H.	16.50	glass run
68-72	Chevelle (exc. Spt. Mdls.)	7726559	A.R.	2.00	(10.701)
68-72	Chevy (4-Dr.)	1670017	2	3.25	run (repl. 7725788)
69-70	Pass. (4-Dr. Sedan) (exc. Spt. Sed.)	8719880	R.H.	15.70	glass run
69-70	Pass. (4-Dr. Sedan) (exc. Spt. Sed.)	8719881	L.H.	15.45	glass run
69-70	Pass. (Sta. Wag.)	8719882	R.H.	15.70	glass run
69-70	Pass. (Sta. Wag.)	8719883	L.H.	15.70	glass run
71-72	Pass. (Sta. Wag.)	9827115	2	3.90	glass run
71-72	Pass. (Sed.) (exc. Spt. Sed.)	9827114	2	3.90	glass run
73-74	Pass., Nova (4-Dr.)	9623987	2	3.30	(Note 1)
75	Nova	9736586	2	3.60	
75	Pass., Nova (4-Dr.)	1670018	2	3.45	glass run— (10.701)
72	Pass., Chevelle (Spt. Sed.)	9833748	A.R.	.21	FASTENER, glass bearing
70-72	Chevelle (Sta. Wag.)	8768874	L.H.	4.80	RETAINER, left, glass run
70-72	Chevelle (Sta. Wag.)	8768873	R.H.	4.80	RETAINER, right glass run
71-75	Pass. (4-Dr.) (exc. Spt. Sed.)	9828377	L.H.	5.30	RETAINER, left, glass run
71-75	Pass. (4-Dr.) (exc. Spt. Sed.)	9828376	R.H.	5.30	RETAINER, right, glass run
68-72	Chevelle (4-Dr.) (exc. Spt. Sed., Sta. Wag.)	7733811	R.H.	4.40	RETAINER ASSY., rear run channel

**WINDSHIELD—DOORS—CONTROLS**

**10.759 CHANNEL—FASTENER—RETAINER—SCREW—STUD—WASHER, Rear Door Window Glass (Con't)**

68-72	Chevelle (4-Dr.) (exc. Spt. Sed., Sta. Wag.)	7733812 L.H.	4.40	RETAINER ASSY., rear run channel
65	Pass. (4-Dr.) (exc. Spt. Sed.)			SCREW, glass run channel rear,
70	All			run channel retainer to panel,
68	Chevelle (4-Dr.) (exc. Spt. Sed.)			guide front cam to panel (1/4"—20 x 1/2")
68	Chevelle (Spt. Sed.)			STUD, glass run channel front— (10.670)
70	All	4405527 A.R.	.15	WASHER, channel to panel— (10.701)
65-68	Pass. (4-Dr.) (exc. Spt. Sed.)	4405502 2	.12	
69	Biscayne, Kingswood	8714748 A.R.	.12	

**10.763 ROLLER—SCREW, Rear Door Window Frame**

62-69	All	9421576 2	.06	SCREW, lower front (8—32 x 5/8")— (8.977)
-------	-----	-----------	-----	---

**10.764 WEATHERSTRIP, Rear Door Window Frame**

**PASSENGER**

65-66	(Spt. Sed.)	8734078 R.H.	5.95	rear window frame vertical
65-66	(Spt. Sed.)	4468989 L.H.	5.95	rear window frame vertical
67-70	(Spt. Sed.)	8734078 R.H.	5.95	vertical
67-70	(Spt. Sed.)	8734079 L.H.	5.95	vertical
71-75	(Spt. Sed.)	9829427 L.H.	5.95	sash channel
71-75	(Spt. Sed.)	9829426 R.H.	5.95	sash channel

**CHEVELLE**

66-67	(Spt. Sed.)	7639530 R.H.	7.75	vertical
66-67	(Spt. Sed.)	7639531 L.H.	7.75	vertical
68-72	(Spt. Sed.)	7717806 2	5.95	vertical

**10.768 NUT—BUSHING—SCREW—STOP—STUD, Rear Door Window**

72	Impala, Caprice	4491088 4	.16	rear door window front stud to glass
73-74	All	9804150 A.R.	.16	BUSHING, glass guide— (10.685)
68	Chevelle (Spt. Sed.)	4405527 A.R.	.15	SCREW, front stop to cam support— (10.759)
68-69	Pass., Chevelle (Spt. Sed.)	8768481 2	.96	STOP, rear
68	Chevelle (Spt. Sed.)	7720257 2	.37	STOP, front, upper— (10.716)
70	Pass. (Spt. Sed.)	9809568 4	.83	STOP
70-72	Chevelle (Spt. Sed.)	8778942 2	.96	STOP
71-75	Pass. (Spt. Sed.)	8768481 4	.96	STOP
71-72	Chevelle (Spt. Sed.)	8753026 2	.46	STOP, front upper— (10.716)
73-75	Pass. (Spt. Sed.)	9833767 2	1.15	STOP, front upper on supt.
73-75	Chevelle	1653800 2	1.65	STOP, front upper
71-75	Pass. (Spt. Sed.)	9843417 2	.32	STUD, front on glass
75	A (4-Dr.)	9621440 2	.36	STUD, stop on glass— (10.685)

**10.772 MOULDING, Rear Door Window Reveal**

**PASSENGER**

67-70	4-Dr. Sed. (exc. Spt. Sed.)	7646845 R.H.	9.15	frame upper scalp
67-70	4-Dr. Sed. (exc. Spt. Sed.)	7646846 L.H.	9.15	frame upper scalp
67	Impala, Caprice (exc. Spt. Mdls.)			
67-70	4-Dr. (exc. Spt. Sed.)	7646876 R.H.	6.70	vertical front scalp
67-70	4-Dr. (exc. Spt. Sed.)	7646877 L.H.	6.70	vertical front scalp
67-70	Sta. Wag.	7648198 R.H.	6.70	vertical rear scalp
67-70	Sta. Wag.	7648199 L.H.	6.70	vertical rear scalp
67-70	Sta. Wag.	7663380 R.H.	4.20	frame upper scalp
67-70	Sta. Wag.	7663381 L.H.	4.20	frame upper scalp
69-70	Spt. Sed. w/vinyl roof	8728936 R.H.	7.15	outer belt
69-70	Spt. Sed. w/vinyl roof	8728937 L.H.	7.15	outer belt
71-74	(Spt. Sed.) w/vinyl top-2 tone paint	9837447 L.H.	4.80	outer panel belt
71-74	(Spt. Sed.) w/vinyl top-2 tone paint	9837446 R.H.	4.80	outer panel belt
71-74	(Sed.) w/vinyl top (exc. Spt. Sed.)	9838036 L.H.	4.80	outer panel belt
71-74	(Sed.) w/vinyl top (exc. Spt. Sed.)	9838035 R.H.	4.80	outer panel belt
71-74	(Sed.) (exc. Spt. Sed.)	9841137 L.H.	6.05	frame upper scalp
71-74	(Sed.) (exc. Spt. Sed.)	9841136 R.H.	6.05	frame upper scalp
71-74	(Sed.) (exc. Spt. Sed.)	9841141 L.H.	6.05	vertical rear scalp
71-74	(Sed.) (exc. Spt. Sed.)	9841140 R.H.	6.05	vertical rear scalp

**WINDSHIELD—DOORS—CONTROLS**

**10.772 MOULDING, Rear Door Window Reveal (Con't)**

71-74 (4-Dr.) (exc. Spt. Sed.),				
75 Pass. ....	9841133 L.H.	3.80	vertical front scalp	
71-74 (4-Dr.) (exc. Spt. Sed.),				
75 Pass. ....	9841132 R.H.	3.80	vertical front scalp	
71-75 (Sta. Wag.) ....	9841135 L.H.	6.05	vertical rear scalp	
71-75 (Sta. Wag.) ....	9841134 R.H.	6.05	vertical rear scalp	
71-75 (Sta. Wag.) ....	9841139 L.H.	4.80	frame upper scalp	
71-75 (Sta. Wag.) ....	9841138 R.H.	4.80	frame upper scalp	
75 Pass. (Sed.) (exc. Spt. Sed.)	9735572 R.H.	2.50	frame upper scalp	
75 Pass. (Sed.) (exc. Spt. Sed.)	9735573 L.H.	2.50	frame upper scalp	
75 Pass. (Sed.) (exc. Spt. Sed.)	9735574 R.H.	2.50	vertical front scalp	
75 Pass. (Sed.) (exc. Spt. Sed.)	9735575 L.H.	2.50	vertical front scalp	
75 Pass. (Sed.) (exc. Spt. Sed.)	9735738 R.H.	6.05	vertical rear scalp	
75 Pass. (Sed.) (exc. Spt. Sed.)	9735739 L.H.	6.05	vertical rear scalp	
75 Pass. (Spt. Sed.) w/vinyl top/two-tone paint	1739918 R.H.	2.25	MOULDING, outer panel belt	
75 Pass. (Spt. Sed.) w/vinyl top/two-tone paint	1685947 L.H.	2.20	MOULDING, outer panel belt	

**CHEVY—NOVA**

68-72 (4-Dr. Sed.) ....	7735736 R.H.	8.80	frame upper scalp	
68-72 (4-Dr. Sed.) ....	7735737 L.H.	8.80	frame upper scalp	
73-74 Nova ....	9613713 L.H.	8.80	scalp rear door window frame upper	
73-74 Nova ....	9613712 R.H.	8.80	scalp rear door window frame upper	
73-74 Nova ....	7738113 L.H.	2.45	scalp vertical front	
73-74 Nova ....	7738112 R.H.	2.45	scalp vertical front	
75 Nova ....	1653436 R.H.	4.80	scalp rear door window frame upper	
75 Nova ....	1653437 L.H.	4.80	scalp rear door window frame upper	
75 Nova ....	1653438 R.H.	3.30	scalp rear door window vertical front	
75 Nova ....	1653439 L.H.	3.30	scalp rear door window vertical front	
75 Nova ....	1653440 R.H.	6.05	scalp rear door window vertical rear	
75 Nova ....	1653441 L.H.	6.05	scalp rear door window vertical rear	

**CHEVELLE**

68-70 (Sta. Wag., 4-Dr.) w/window frame mldgs.,				
71-72 (4-Dr.) (exc. Spt. Sed.)	7728801 R.H.	2.50	vertical front scalp	
68-70 (Sta. Wag., 4-Dr.) w/window frame mldgs.,				
71-72 (4-Dr.) (exc. Spt. Sed.)	7728802 L.H.	2.50	vertical front scalp	
68-69 (4-Dr. Sed.) w/window frame moulding	9801754 R.H.	9.55	frame rear scalp	
68-69 (4-Dr. Sed.) w/window frame moulding	9801755 L.H.	9.55	frame rear scalp	
68-72 (Sta. Wag.) w/window frame moulding	7731142 R.H.	9.15	rear window frame, upper scalp	
68-72 (Sta. Wag.) w/window frame moulding	7731143 L.H.	8.80	rear window frame, upper scalp	
70-72 (Sed.) (exc. Spt. Sed.)	8789902 L.H.	9.60	rear door window frame rear	
70-72 (Sed.) (exc. Spt. Sed.)	8789901 R.H.	9.60	rear door window frame rear	
70 Malibu (4-Dr.) w/vinyl top	8787573 L.H.	8.85	outer panel belt	
70 Malibu (4-Dr.) w/vinyl top	8787572 R.H.	8.85	outer panel belt	
70 Chevelle (Std.) w/vinyl top,				
70-72 Chevelle (4-Dr.) w/vinyl top	8787575 L.H.	9.60	outer panel belt	
70 Chevelle (Std.) w/vinyl top,				
70-72 Chevelle (4-Dr.) w/vinyl top	8787574 R.H.	9.60	outer panel belt	

*NOTE 1 Paint as required.*

**10.774 STRIP ASSY., Rear Door Window**

**PASS.**

65-68 Spt. Sed. ....	7694483 2	1.05	inner anti-rattle	
67-68 4-Dr. (exc. Spt. Sed.)	7644800 R.H.	7.05	outer at belt	
67-68 4-Dr. (exc. Spt. Sed.)	7644801 L.H.	7.05	outer at belt	
67-68 Spt. Sed. ....	7644802 R.H.	7.05	outer at belt	
67-68 Spt. Sed. ....	7644803 L.H.	7.05	outer at belt	
69 Spt. Sed., Kingswood	9818406 A.R.	2.85	anti-rattle	
69-70 Spt. Sed. ....	8807638 R.H.	7.05	outer at belt (repl. 8714146)	
69-70 Spt. Sed. ....	8807639 L.H.	7.05	outer at belt (repl. 8714147)	
69-70 4-Dr. (exc. Spt. Sed.)	8807636 R.H.	7.05	outer at belt	
69-70 4-Dr. (exc. Spt. Sed.)	8807637 L.H.	7.05	outer at belt (repl. 8714149)	
69-70 Impala, Caprice (4-Dr.) (exc. Spt. Sed.),				
69-70 Kingswood	8715268 R.H.	7.05	inner at belt	

**WINDSHIELD—DOORS—CONTROLS**

**10.774 STRIP ASSY., Rear Door Window (Con't)**

69-70	Impala, Caprice (Spt. Sed.)	8783131 L.H.	7.05	inner at belt
71-74	(Spt. Sed.)	9829759 L.H.	7.05	inner at belt
71-74	(Spt. Sed.)	9829758 R.H.	7.05	inner at belt
71	(Spt. Sed.)	9846004 L.H.	8.85	outer at belt
71-74	(Spt. Sed.)	9611840 R.H.	8.85	outer at belt (repl. 9846003)
71-74	Pass. (Sed.) (exc. Spt. Sed.)	9829757 L.H.	7.05	inner at belt
71-74	(Sed.) (exc. Spt. Sed.)	9829756 R.H.	7.05	inner at belt
71	(Sed.) (exc. Spt. Sed.)	9846002 L.H.	8.85	outer at belt
71-74	(Sed.) (exc. Spt. Sed.)	9611838 R.H.	7.05	outer at belt
71-75	(Sta. Wag.)	9829755 L.H.	7.05	inner at belt
71-75	(Sta. Wag.)	9829754 R.H.	7.05	inner at belt
71-75	(Sta. Wag.)	9611843 L.H.	8.85	outer at belt (repl. 9845625)
71	(Sta. Wag.)	9845624 R.H.	8.85	outer at belt
72-74	(Spt. Sed.)	9611841 L.H.	8.85	outer at belt
72-74	(Sed.) (exc. Spt. Sed.)	9611839 L.H.	7.05	outer at belt
72-75	(Sta. Wag.)	9611842 R.H.	8.85	outer at belt
75	Pass. (Sed.) (exc. Spt. Sed.)	9737290 R.H.	7.05	outer at belt
75	Pass. (Sed.) (exc. Spt. Sed.)	9737291 L.H.	7.05	outer at belt
75	Pass. (Spt. Sed.)	9732973 R.H.	7.05	inner at belt
75	Pass. (Spt. Sed.)	9732974 L.H.	7.05	inner at belt
75	Pass. (Sed.) (exc. Spt. Sed.)	9735827 R.H.	7.05	inner at belt
75	Pass. (Sed.) (exc. Spt. Sed.)	9735828 L.H.	7.05	inner at belt
75	Pass. (Spt. Sed.)	9738438 R.H.	7.05	outer at belt
75	Pass. (Spt. Sed.)	9738439 L.H.	7.05	outer at belt

**CHEVY—NOVA**

68-72	(4-Dr.)	7727182 R.H.	7.05	outer at belt
68-72	(4-Dr.)	7727183 L.H.	7.05	outer at belt
68	(4-Dr.),			
70-72	(4-Dr.)	7727184 R.H.	7.05	inner at belt
68	(4-Dr.),			
70-72	(4-Dr.)	7727185 L.H.	7.05	inner at belt
73-74	Nova	9620747 2	7.05	outer at belt
73-74	Nova	9620753 L.H.	7.05	inner at belt
73-74	Nova	9620752 R.H.	7.05	inner at belt
75	Nova	1650846 R.H.	7.05	inner at belt (w/stainless steel bead)
75	Nova	1650847 L.H.	7.05	inner at belt (w/stainless steel bead)
75	Nova (4-Dr.)	9739359 2	7.05	outer at belt (w/stainless steel bead)

**CHEVELLE**

66-67	Malibu (Spt. Sed.)	7581145 R.H.	7.05	outer at belt
66-67	Malibu (Spt. Sed.)	7581146 L.H.	7.05	outer at belt
68	(4-Dr.) (exc. Spt. Sed.),			
70-72	(Sta. Wag.)	7724426 R.H.	7.05	inner at belt
68-69	(4-Dr.) (exc. Spt. Sed.),			
70-72	(Sta. Wag.)	7724845 R.H.	7.05	outer at belt
68-69	(4-Dr.) (exc. Spt. Sed.),			
70-72	(Sta. Wag.)	7724846 L.H.	7.05	outer at belt
68-69	(Spt. Sed.)	7724847 R.H.	7.05	outer at belt
68-69	(Spt. Sed.)	7724848 L.H.	7.05	outer at belt
70-72	(Sed.) (exc. Spt. Sed.)	8780329 L.H.	7.05	inner at belt
70-72	(Sed.) (exc. Spt. Sed.)	8780328 R.H.	7.05	inner at belt
70-72	(Spt. Sed.)	8780327 L.H.	7.05	inner at belt
70-72	(Spt. Sed.)	8780326 R.H.	7.05	inner at belt
70-72	(Sed.) (exc. Spt. Sed.)	8779847 L.H.	7.05	outer at belt
70-72	(Sed.) (exc. Spt. Sed.)	8779846 R.H.	7.05	outer at belt
70-72	(Spt. Sed.)	8779849 L.H.	7.05	outer at belt
70-72	(Spt. Sed.)	8779848 R.H.	7.05	outer at belt
73-75	Chevelle	9620809 L.H.	7.05	outer at belt
73-75	Chevelle	9620808 R.H.	7.05	outer at belt
73-75	Chevelle (4-Dr.)	9882235 L.H.	7.05	inner at belt
73-75	Chevelle (4-Dr.)	9882234 R.H.	7.05	inner at belt

**10.777 SWITCH ASSY.—CLIP—CONDUIT—PLATE—REINFORCEMENT—RETAINER, Electric Window Lift**

64-69	All,			
71	All (exc. Camaro)	4432790 A.R.	5.55	w/escutch. right (one button) front and rear door, qtr. window
64-69	All,			
70	All (exc. Camaro),			
71	El Camino (Custom),			
73-75	Camaro w/pwr. wdo.	4432793 L.H.	6.85	w/escutch. frt. dr. window (two button)
64-69	All,			
70	El Camino (Custom)	4432791 1	11.95	w/escutch. frt. dr. window, left (four button)
70	All (exc. El Camino)	8795462 L.H.	11.35	left (four button)

**WINDSHIELD—DOORS—CONTROLS**

**10.777 SWITCH ASSY.—CLIP—CONDUIT—PLATE—REINFORCEMENT—  
RETAINER, Electric Window Lift (Con't)**

71-72	Pass., Monte Carlo w/electric window,				
73-75	Pass., Chevelle,				
75	Nova	9825443	L.H.	17.35	front door wdo. escutcheon (4 button)
71-72	Chevelle (9-Pass.),				
71-72	Pass. w/electric window (exc. Biscayne, Brookwood),				
71-72	Monte Carlo w/electric window,				
73-75	Pass., Chevelle,				
75	Nova	9825442	A.R.	6.75	wdo. escutcheon (1 button)
73-75	Chevelle (2-Dr.),				
74	Impala (Custom) Caprice (Spt. Cpe.),				
75	Nova	9871796	L.H.	13.40	window escutcheon (2 button)
	Not required in this group. See group 12.195	4723098	1	4.70	
71	Pass., Monte Carlo				CLIP, frt. door wdo. sw. ret. clip,
71	Pass. (4-Dr.),				
73-74	Pass., Chevelle, Nova,				
75	Pass., Chevelle	9722397	A.R.	.11	rear door wdo. sw. ret. clip— (10.485)
73-75	Nova, Camaro	4154886		.24	CLIP
70-72	Malibu, El Camino	8730959	A.R.	3.80	CONDUIT, front door electric wiring
68-69	Pass. w/vacuum operated door,				
69-72	Pass.	8743791	2	.32	PLATE, front dr. wiring protector
64-69	Chevelle (exc. El Camino),				
65	Pass.,				
66-68	Bel Air (4-Dr.),				
66-68	Impala, Caprice,				
67-69	Camaro,				
69	Pass.	4722740	L.H.	.52	REINFORCEMENT, front door trim pad at window switch
64-69	Chevelle,				
65	Pass.,				
66-69	Bel Air (exc. 2-Dr.),				
66-68	Impala, Caprice,				
67-69	Camaro	4722347	A.R.	.18	REINFORCEMENT, front dr. rear and qtr. window trim pad
64-71	El Camino,				
73-75	Camaro w/pwr. wdo.	4757868	1	.18	REINFORCEMENT, frt. dr. trim at window switch
67-71	Camaro (Deluxe)	7682080	R.H.	1.40	REINFORCEMENT, door trim at window switch
70-72	Chevelle (exc. El Camino, Nomad, Greenbrier),				
70-72	Pass. (exc. Biscayne, Brookwood)	9813987	L.H.	.52	REINFORCEMENT, left front door trim pad at window switch
70	Chevelle (exc. El Camino, Nomad, Greenbrier),				
70	Pass. (exc. Biscayne, Brookwood),				
71	Chevelle, Concours, Estate Wag.,				
71	Monte Carlo	9813989	R.H.	.18	REINFORCEMENT, right front door trim pad at window switch
71-72	Pass. w/electric window (exc. Biscayne, Brookwood),				
71-72	Chevelle w/electric window (exc. Nomad, Greenbrier, El Camino)	9826809	L.H.	2.50	REINFORCEMENT, front door trim pad at wdo.
73-75	Pass., Chevelle, Nova	8799901	2	.32	REINFORCEMENT, trim pad at window switch (1 button)
73-75	Chevelle (2-Dr.),				
75	Nova,				
75	Impala (Custom) Caprice (Spt. Cpe.)	9871799	L.H.	.52	REINFORCEMENT, trim pad at window switch (2 button)
73-75	Pass., Chevelle, Nova	9826809	L.H.	2.50	REINFORCEMENT, trim pad at window switch (4 button)
64-68	Chevelle,				
65	Pass.,				
66-68	Bel Air (exc. 2-Dr.),				
66-68	Impala, Caprice,				
67-68	Camaro	4722455	A.R.	.40	RETAINER, window lift switch (one button)
64-69	Chevelle,				



**WINDSHIELD—DOORS—CONTROLS**

**10.777 SWITCH ASSY.— CLIP— CONDUIT— PLATE— REINFORCEMENT—  
RETAINER, Electric Window Lift (Con't)**

65	Pass.,				
66	Caprice,				
66	Bel Air (4-Dr.),				
67-68	Camaro,				
67-69	Pass. (exc. 2-Dr. Sed.)	7711130	1	.37	RETAINER, window lift switch (four button)
64	Chevelle (2-Dr. Sta. Wag.),				
64-71	El Camino,				
73-75	Camaro w/pwr. wdo.	4757731	1	.12	RETAINER, window lift switch (two-button)
70	Chevelle (exc. El Camino, Nomad, Greenbrier),				
70	Pass. (exc. Biscayne, Brookwood)	9813988	L.H.	.28	RETAINER, left front door window switch escutcheon on trim pad
70	Chevelle (exc. El Camino, Nomad, Greenbrier),				
70	Pass. (exc. Biscayne, Brookwood)	9813990	R.H.	.18	RETAINER, right front door window switch escutcheon on trim pad

**10.778 CONDUIT, Front and Rear Door**

65	Bel Air, Impala w/elect. window,				
66	Bel Air, Impala w/elect. window (exc. 2-Dr. Sed.),				
66	Caprice (Spt. Cpe., Spt. Sed.) w/elect. window,				
67	Pass. w/elect. window, vacuum door lock,				
68	Bel Air, Impala w/electric window, vacuum door lock,				
68	Caprice w/electric window, vacuum door lock	4479837	1	2.80	front
69-70	Pass. (4-Dr.) (exc. Spt. Sed.) w/vac. door lock	8718000	2	4.15	front door hose
69-72	Chevelle w/vacuum dr. lk. (exc. Deluxe)	8731000	2	2.90	center pillar hose, center pillar elect.
69-72	Chevelle w/vacuum dr. lk.	8730959	2	3.80	front door hose
69-72	Chevelle 4-Dr. (exc. Spt. Sed.)	8729450	A.R.	3.10	center pillar hose, center pillar elect.
70-72	Camaro w/aux. speaker	8919354	R.H.	RL/.66	protr. at rkr. pnl.
70	Camaro w/elec. wdo., door lock	8798850	2	2.90	front door
71-75	Pass.	9837507	2	3.20	front door electric wiring
71-75	Pass.	9837508	2	2.10	rear door electric wiring
73	Chevelle,				
71-75	Pass.	8905127	A.R.	5.10	protr. side and on rkr. pnl.
73-75	Chevelle	8905943	2	5.50	front door elec.
73-75	Chevelle (4-Dr.)	9879000	2	3.15	center pillar elec.
73-75	Camaro w/aux. speaker, rear wdo. defogger, tp. player	8919354	1	RL/.66	protr. at rkr. pnl.
74	Chevelle (Spt. Cpe.),				
74-75	Chevelle	9682624	R.H.	13.25	at rkr. pnl.
74	Chevelle (exc. Spt. Cpe.),				
75	Chevelle (4-Dr.)	9682625	L.H.	13.25	at rkr. pnl.
74-75	Camaro w/Power Wdo.	8798850	2	2.90	front door elec.
75	Nova w/elect. wdo. (exc. elect. door lock)	1699801	2	3.20	CONDUIT, wiring frt. dr. elect.

**10.783 REGULATOR— ARMATURE UNIT— BRACKET— GEAR— HOLDER—  
MOTOR ASSY.— PACKAGE ASSY.— PLUG— ROLLER— SCREW, Front  
Door Window**

**PASSENGER**

65-66	2-Dr. (exc. elect. window)	7609588	R.H.	24.60	
65-66	2-Dr. (exc. elect. window)	7609589	L.H.	24.60	
65-66	Spt. Cpe., Conv. w/elect. window	9707762	R.H.	36.25	less motor
65-66	Spt. Cpe., Conv. w/elect. window	9707763	L.H.	36.25	less motor
65-66	4-Dr. (exc. elect. window)	7609593	L.H.	21.95	
65-66	4-Dr. (exc. elect. window)	7609592	R.H.	21.95	
65-66	4-Dr. w/elect. window (exc. Spt. Sed.)	9711798	R.H.	39.25	less motor (repl. 9706848)
65-67	Spt. Sed. w/elect. window	9705751	L.H.	36.25	less motor
67	Impala, Caprice (2-Dr.),				
68	2-Dr. Sed.,				

**WINDSHIELD—DOORS—CONTROLS**

**10.783 REGULATOR— ARMATURE UNIT— BRACKET— GEAR— HOLDER—  
MOTOR ASSY.— PACKAGE ASSY.— PLUG— ROLLER— SCREW, Front  
Door Window (Con't)**

68	Impala (Spt. Cpe., Conv.)	7658110 R.H.	23.60	(manual)	.....
67	Impala, Caprice (2-Dr.),				
68	2-Dr. Sed.,				
68	Impala (Spt. Cpe., Conv.)	7658111 L.H.	23.60	(manual)	.....
67	Spt. Cpe., Conv. w/elect. window,				
68	Impala (Spt. Cpe., Conv.)	9709212 R.H.	39.75	less motor	.....
67	Spt. Cpe., Conv. w/elect. window,				
68	Impala (Spt. Cpe., Conv.)	9709213 L.H.	39.75	less motor	.....
67	2-Dr. Sed.	7658112 R.H.	24.15	(manual)	.....
67	2-Dr. Sed.	7658113 L.H.	23.60	(manual)	.....
67	Impala, Caprice (4-Dr.)	7702352 R.H.	20.15	(manual)	.....
67	Impala, Caprice (4-Dr.)	7702353 L.H.	19.85	(manual)	.....
67	Biscayne, Bel Air (4-Dr.)	7702355 L.H.	19.85	(manual)	.....
67	Pass. w/elect. windows	9711798 R.H.	39.25	less motor	.....
68	Caprice (Spt. Cpe.) w/elect. wind.	9714349 L.H.	42.75	less motor	.....
68	Spt. Sed. w/elect. window	9714926 R.H.	37.50	less motor	.....
68	Spt. Sed. w/elect. window	9714927 L.H.	36.25	less motor	.....
68	Caprice (Spt. Cpe.)	7738041 L.H.	37.50	manual	.....
68	4-Dr.	7746422 R.H.	19.45	manual	.....
68	4-Dr.	7746423 L.H.	19.45	manual	.....
69	2-Dr.	8760744 R.H.	30.75	(manual)	.....
69	2-Dr.	8760745 L.H.	30.75	(manual)	.....
69-70	4-Dr.	8721008 R.H.	20.00	(manual)	.....
69-70	4-Dr.	8721009 L.H.	20.00	(manual)	.....
69-70	4-Dr. w/elect. windows	9721856 R.H.	39.50	(less motor)	.....
69-70	4-Dr. w/elect. windows	9721857 L.H.	39.50	(less motor)	.....
69	2-Dr. w/elect. windows	9717672 R.H.	44.25	(less motor)	.....
69	2-Dr. w/elect. windows	9717673 L.H.	44.25	(less motor)	.....
70	(Spt. Cpe., Conv.)	9829791 L.H.	47.00	front door window elect. (less motor)	.....
70	(Spt. Cpe., Conv.)	9829790 R.H.	47.00	front door window elect. (less motor)	.....
70	(Spt. Cpe., Conv.)	8789937 L.H.	30.75	manual	.....
70	(Spt. Cpe., Conv.)	8789936 R.H.	30.75	manual	.....
70	(4-Dr.)	9721856 R.H.	39.50	front door window elect. (less motor)	.....
71	(Spt. Cpe., Conv.)	9828154 L.H.	25.50	manual	.....
71-72	(Spt. Cpe., Conv.),				
73-75	Pass. (2-Dr.)	9615740 R.H.	25.50	manual	.....
71-72	(Spt. Cpe., Conv.),				
73-75	Pass. (2-Dr.)	9831931 L.H.	58.75	elect. less motor	.....
71-72	(Spt. Cpe., Conv.),				
73-75	Pass. (2-Dr.)	9831930 R.H.	58.75	elect. less motor	.....
71-75	(4-Dr.)	1659637 L.H.	36.75	front door window elect. (less motor) (repl. 9688471)	.....
71-75	(4-Dr.)	9688470 R.H.	61.50	front door window elect. (less motor)	.....
71	(4-Dr.)	9878606 R.H.	30.75	manual	.....
71-75	(4-Dr.)	9622487 L.H.	36.50	manual	.....
72-75	(4-Dr.)	9622486 R.H.	36.50	manual	.....
72	(Spt. Cpe., Conv.),				
73-75	Pass. (2-Dr.)	1657387 L.H.	25.50	manual (repl. 9615741)	.....

**CHEVY— NOVA**

**MANUAL WINDOW**

62-65	(2-Dr.)	4842000 R.H.	24.15		
62-65	(2-Dr.)	4842001 L.H.	23.60		
62-67	(4-Dr.)	4842942 R.H.	15.95		
62-67	(4-Dr.)	4842943 L.H.	16.75		
66-67	(2-Dr.)	4542781 L.H.	24.15		
68	(2-Dr.)	7740283 R.H.	22.80		
68	(2-Dr.)	7740284 L.H.	22.20		
68	(4-Dr.)	7724367 L.H.	17.35		
69-72	(2-Dr.)	8767854 R.H.	23.35		
69-72	(2-Dr.)	8767855 L.H.	23.35		
69-72	(4-Dr.)	8767856 R.H.	17.35		
69-72	(4-Dr.)	8767857 L.H.	17.35		
73-74	Nova (2-Dr.)	9620755 L.H.	23.35	manual	.....
73-74	Nova (2-Dr.)	9620754 R.H.	23.35	manual	.....
73-74	Nova (4-Dr.)	9620677 L.H.	17.35	manual	.....
73-74	Nova (4-Dr.)	9620676 R.H.	17.35	manual	.....
73-74	Nova (Taxi)	8767857 L.H.	17.35	manual	.....

**WINDSHIELD—DOORS—CONTROLS**

**10.783 REGULATOR—ARMATURE UNIT— BRACKET— GEAR— HOLDER—  
MOTOR ASSY.— PACKAGE ASSY.— PLUG— ROLLER— SCREW, Front  
Door Window (Con't)**

<b>73-74</b>	Nova (Taxi) .....	<b>8767856</b> R.H.	17.35	manual .....
<b>75</b>	Nova (2-Dr.) .....	<b>1704842</b> R.H.	22.75	manual .....
<b>75</b>	Nova (2-Dr.) .....	<b>1704843</b> L.H.	22.75	manual .....
<b>75</b>	Nova (4-Dr.) .....	<b>1704844</b> R.H.	14.80	manual (repl. 9737068) .....
<b>75</b>	Nova (4-Dr.) .....	<b>1704845</b> L.H.	14.80	manual .....

**ELECTRIC WINDOW**

<b>75</b>	Nova .....	<b>1684412</b> R.H.	61.50	electric (less motor) .....
<b>75</b>	Nova .....	<b>1684413</b> L.H.	61.50	electric (less motor) .....

**CHEVELLE**

**MANUAL WINDOW**

<b>64-67</b>	(4-Dr.) .....	<b>4408604</b> R.H.	17.00	
<b>64-67</b>	(4-Dr.) .....	<b>4408605</b> L.H.	16.60	
<b>64-65</b>	Std. (2-Dr.), <b>65</b> (2-Dr. Sed.),			
<b>64-65</b>	El Camino .....	<b>4407847</b> L.H.	23.60	
<b>64-65</b>	Malibu (2-Dr.) .....	<b>4407848</b> R.H.	24.15	
<b>64-65</b>	Malibu (2-Dr.) .....	<b>4407849</b> L.H.	23.60	
<b>66-67</b>	(2-Dr.) .....	<b>4541854</b> R.H.	23.60	
<b>66-67</b>	(2-Dr.) .....	<b>4541855</b> L.H.	23.60	
<b>66-67</b>	Malibu (Spt. Sed.) .....	<b>7635910</b> R.H.	24.15	
<b>66-67</b>	Malibu (Spt. Sed.) .....	<b>7635911</b> L.H.	23.60	
<b>68-72</b>	(4-Dr.) (exc. Spt. Sed.) .....	<b>7724356</b> R.H.	17.00	
<b>68-72</b>	(4-Dr.) (exc. Spt. Sed.) .....	<b>7724357</b> L.H.	17.00	
<b>68-72</b>	(Spt. Sed.) .....	<b>7724362</b> R.H.	22.20	
<b>68-72</b>	(Spt. Sed.) .....	<b>7724363</b> L.H.	22.20	
<b>68-70</b>	(2-Dr. Sed.),			
<b>68-72</b>	El Camino .....	<b>7726276</b> R.H.	22.20	
<b>68-70</b>	(2-Dr. Sed.),			
<b>68-72</b>	El Camino .....	<b>7726277</b> L.H.	22.20	
<b>68</b>	(Spt. Cpe., Conv.) .....	<b>7726501</b> R.H.	22.20	
<b>68</b>	(Spt. Cpe., Conv.) .....	<b>7726502</b> L.H.	22.20	
<b>69</b>	(Spt. Cpe., Conv.) .....	<b>8730923</b> R.H.	30.75	
<b>69</b>	(Spt. Cpe., Conv.) .....	<b>8730924</b> L.H.	30.75	
<b>70-72</b>	(Spt. Cpe., Conv.) .....	<b>8789925</b> L.H.	30.75	
<b>70-72</b>	(Spt. Cpe., Conv.) .....	<b>8789924</b> R.H.	30.75	
<b>73-75</b>	Chevelle (2-Dr.) .....	<b>9600707</b> L.H.	26.50	manual .....
<b>73-75</b>	Chevelle (2-Dr.) .....	<b>9600706</b> R.H.	26.50	manual .....
<b>73-75</b>	Chevelle (4-Dr.) .....	<b>9873203</b> L.H.	20.40	manual .....
<b>73-75</b>	Chevelle (4-Dr.) .....	<b>9873202</b> R.H.	20.40	manual .....

**ELECTRIC WINDOW**

<b>68-71</b>	(Spt. Sed.) .....	<b>9712906</b> R.H.	35.75	less motor .....
<b>68-71</b>	(Spt. Sed.) .....	<b>9712907</b> L.H.	35.75	less motor .....
<b>68-71</b>	El Camino (Custom) .....	<b>9713046</b> R.H.	35.75	less motor .....
<b>68-71</b>	El Camino (Custom) .....	<b>9713047</b> L.H.	35.75	less motor .....
<b>68</b>	(Spt. Cpe., Conv.) .....	<b>9713085</b> L.H.	35.75	less motor .....
<b>68-71</b>	Malibu, Concours (4-Dr.) (exc. Spt. Sed.) .....	<b>9716738</b> R.H.	35.75	less motor .....
<b>68-71</b>	Malibu, Concours (4-Dr.) (exc. Spt. Sed.) .....	<b>9716739</b> L.H.	35.75	less motor .....
<b>69</b>	(Spt. Cpe., Conv.) .....	<b>9717698</b> R.H.	39.00	(less motor) .....
<b>69</b>	(Spt. Cpe., Conv.) .....	<b>9717699</b> L.H.	39.00	(less motor) .....
<b>70-72</b>	(Spt. Cpe., Conv.) .....	<b>9721899</b> L.H.	44.25	(less motor) .....
<b>70-72</b>	(Spt. Cpe., Conv.) .....	<b>9721898</b> R.H.	44.25	(less motor) .....
<b>73-75</b>	Chevelle (2-Dr.) .....	<b>9619213</b> L.H.	58.75	electric (less motor) .....
<b>73-75</b>	Chevelle (2-Dr.) .....	<b>9619212</b> R.H.	58.75	electric (less motor) .....
<b>73-75</b>	Chevelle (4-Dr.) .....	<b>9872023</b> L.H.	43.25	electric (less motor) .....
<b>73-75</b>	Chevelle (4-Dr.) .....	<b>9872022</b> R.H.	43.25	electric (less motor) .....

**CAMARO**

**MANUAL WINDOW**

<b>67</b>	(Deluxe) .....	<b>7651903</b> R.H.	25.25
<b>67</b>	(Deluxe) .....	<b>7651904</b> L.H.	24.60
<b>67</b>	(Std.) .....	<b>7681466</b> R.H.	24.60
<b>67</b>	(Std.) .....	<b>7681467</b> L.H.	24.60
<b>68-69</b>	Camaro .....	<b>7740411</b> R.H.	35.25
<b>68-69</b>	Camaro .....	<b>7740412</b> L.H.	35.25

**WINDSHIELD—DOORS—CONTROLS**

**10.783 REGULATOR—ARMATURE UNIT—BRACKET—GEAR—HOLDER—MOTOR ASSY.—PACKAGE ASSY.—PLUG—ROLLER—SCREW, Front Door Window (Con't)**

68-69	w/Custom trim	7726802 L.H.	35.25	
68-69	w/Custom trim	7726801 R.H.	35.25	
70-71	w/Custom Equip.	9833313 L.H.	37.50	
70-71	w/Custom Equip.	9833312 R.H.	37.50	
70-72	(exc. Custom Equip.),			
73-75	Camaro	1657381 L.H.	25.75	( <sup>7</sup> / <sub>8</sub> " spindle length)
70-74	(exc. Custom Equip.),			
75	Camaro	9833310 R.H.	44.75	( <sup>7</sup> / <sub>8</sub> " spindle length)
72-73	w/Custom Equip.	9614525 L.H.	28.50	(1 <sup>1</sup> / <sub>4</sub> " spindle length)
72-73	w/Custom Equip.	9614524 R.H.	37.50	(1 <sup>1</sup> / <sub>4</sub> " spindle length)

**ELECTRIC WINDOW**

67	Camaro	9709129 L.H.	39.25	less motor
68-69	Camaro	9712928 R.H.	39.25	less motor
68-69	Camaro	9712929 L.H.	39.25	less motor
74-75	Camaro	9723312 R.H.	50.25	electric (less motor) (1 <sup>3</sup> / <sub>4</sub> " spindle length)
74-75	Camaro	1659627 L.H.	39.00	electric (less motor) (1 <sup>3</sup> / <sub>4</sub> " spindle length)

**VEGA—MONZA**

71	Vega, Monza	9814487 L.H.	17.00	
71	Vega, Monza	9814486 R.H.	17.00	
72-75	Vega	9886479 L.H.	20.40	
72-75	Vega	9886478 R.H.	20.40	
75	Monza (Towne Coupe)	1714023 R.H.	26.50	
75	Monza (Towne Coupe)	1714024 L.H.	26.50	
75	Monza (exc. Towne Coupe)	9737476 R.H.	24.15	
75	Monza (exc. Towne Coupe)	9737477 L.H.	24.15	

64-65	Chevelle w/elect. window,			
65-67	Pass. w/elect. wind.	4909702 2	19.95	ARMATURE UNIT, regulator (sqr. mtr.)
65-67	All w/elect. window,			
68	Chevelle, Camaro w/elect. window	4904212 A.R.	.05	BRACKET, brush holder (square motor)
64-68	All w/elect. wind.	4900085 2	6.60	GEAR, regulator motor
64-67	All w/elect. window	4917191 2	6.25	HOLDER, brush (square motor)
64-65	Chevelle w/elect. window,			
65-68	Pass. w/elect. window (exc. 2-Dr. Sed., Spt. Mdls.),			
66-68	Chevelle w/electric window (exc. Spt. Sed.),			
70	Chevelle (4-Dr., El Camino) (exc. Spt. Sed.)			
70	Malibu, Monte Carlo (2-Dr.)	5045639 R.H.	41.55	MOTOR ASSY., front, rear door, right, rear quarter (repl. 5045589)
65-69	Pass. (exc. 2-Dr. Sed.),			
66-68	Chevelle (Spt. Sed.) w/elect. window,			
67-69	Camaro w/elect. window,			
69	Chevelle (Spt. Cpe., Conv.),			
70	Malibu, Monte Carlo (2-Dr.),			
70	Pass.			MOTOR ASSY., front door, quarter window,
70	Impala, Caprice (2-Dr.)			
70	Pass., Chevelle (Spt. Sed.),			
71-72	Pass. (exc. Biscayne, Brookwood),			
71-72	Monte Carlo	5045639 R.H.	41.55	right, rear door (Note 1)
	<i>NOTE 1 On 1971 Pass. 4-Dr. Models 5045587 is used as a L.H. part on the Frt. Dr. on the Rr. Dr. and on 2-Dr. Models it is a R.H. part.</i>			
65-69	Pass. (exc. 2-Dr. Sed.),			
66-68	Chevelle (Spt. Sed.) w/elect. window,			
67-69	Camaro w/elect. window,			
69	Chevelle (Spt. Cpe., Conv.),			
70	Malibu, Monte Carlo (2-Dr.),			
70	Pass.			MOTOR ASSY., front door, quarter window,
70	Impala, Caprice (2-Dr.)			
70	Pass., Chevelle (Spt. Sed.),			
71-72	Pass. (exc. Biscayne, Brookwood),			
71-72	Monte Carlo	5045640 L.H.	41.55	left, rear door (Note 2)
	<i>NOTE 2: On 1971 Pass. 4-Dr. Models 5045588 is used as a R.H. part on the Frt. Dr. on the Rr. Dr. and on 2-Dr. Models it is a L.H. part.</i>			
69	Chevelle (exc. Spt. Cpe., Conv.),			
70	Chevelle (4-Dr., El Camino) (exc. Spt. Sed.)			MOTOR ASSY., front, rear door,

**WINDSHIELD—DOORS—CONTROLS**

**10.783 REGULATOR— ARMATURE UNIT— BRACKET— GEAR— HOLDER— MOTOR ASSY.— PACKAGE ASSY.— PLUG— ROLLER— SCREW, Front Door Window (Con't)**

70	Malibu, Monte Carlo (2-Dr.) . . . .	5045590 L.H.	51.00	left, rear quarter . . . . .
68-69	Bel Air (4-Dr.),			
68-69	Impala, Caprice,			
68-69	Malibu, Concours (S.S.),			
70	Pass., Chevelle,			
71-72	Chevelle (Concours, El Camino Custom, Malibu, Monte Carlo),			
71-72	Pass. (exc. Biscayne, Brookwood) . . . . .	4919192 1	6.60	PACKAGE ASSY., window motor service . . . . .
65-67	Pass. w/elect. window,			
67-68	Chevelle, Camaro w/elect. window . . . . .	5098080 A.R.	.15	PLUG, motor armature thrust . . . . .
75	Vega . . . . .	9724575 4	.34	ROLLER, swivel wdo. reg. frt. dr. . . . .
64-67	Chevelle, Camaro w/elect. window,			
65-67	Pass. w/elect. window (exc. 2-Dr. Sed.) . . . . .	5096732 A.R.	.46	SCREW, motor set ( <sup>5</sup> / <sub>16</sub> "— 24 x <sup>11</sup> / <sub>16</sub> ") . . . . .
All	All . . . . .	4405526 A.R.	.14	SCREW, reg. to inner pnl. ( <sup>1</sup> / <sub>4</sub> "— 20 x <sup>1</sup> / <sub>2</sub> " w/washer)— (12.180) . . . . .
68-69	All (exc. Pass.) . . . . .			SCREW, front door to inner panel, . . . . .
68-69	Chevelle,			regulator to inner panel, . . . . .
69	Chevy, Camaro . . . . .			rear door to inner panel, . . . . .
68	Chevelle (4-Dr.) . . . . .			
68-69	Pass., Chevelle,			
68	Camaro w/elect. window . . . . .	4405527	.15	SCREW, door window regulator to inner panel— (10.759) . . . . .
74-75	Vega, Monza . . . . .	9820793 1	.23	SCREW, regulator to inr. pnl. . . . .

**10.791 REGULATOR— ARMATURE ASSY.— ARMATURE UNIT— BRACKET— GEAR— HOLDER— MOTOR ASSY.— NUT— PACKAGE ASSY.— ROLLER— SCREW— WASHER, Rear Door Window**

**PASSENGER**

65-66	Spt. Sed. (exc. elect. window) . . . .	4541176 R.H.	14.40	
67-68	Spt. Sed. . . . .	7725371 R.H.	14.45	(manual) . . . . .
67	Impala, Caprice (4-Dr.) (exc. Spt. Sed.),			
67	Biscayne, Bel Air (4-Dr.),			
68	Pass. (4-Dr.) . . . . .	7694290 R.H.	14.05	(manual) . . . . .
67	Pass. (4-Dr.) (exc. Spt. Sed.),			
68	Pass. (4-Dr.) . . . . .	7694291 L.H.	14.05	(manual) . . . . .
69-70	Spt. Sed. w/elect. windows . . . . .	9718084 R.H.	29.00	(less motor) . . . . .
69-70	Spt. Sed. w/elect. windows . . . . .	9718085 L.H.	29.00	(less motor) . . . . .
69-70	4-Dr. Sed. w/elect. windows (exc. Biscayne, Spt. Sed.),			
69-70	Townsmen, Kingswood . . . . .	9717724 R.H.	31.00	(less motor) . . . . .
69-70	4-Dr. Sed. w/elect. windows (exc. Biscayne, Spt. Sed.),			
69-70	Townsmen, Kingswood . . . . .	9717725 L.H.	31.00	(less motor) . . . . .
69	Spt. Cpe., Conv. . . . .	9717672 R.H.	44.25	less motor . . . . .
69	Spt. Cpe., Conv. . . . .	9717673 L.H.	44.25	less motor . . . . .
69	Biscayne (4-Dr. Sed.),			
69	Brookwood . . . . .	8722375 L.H.	14.50	manual . . . . .
69-70	4-Dr. (exc. Spt. Sed.) . . . . .	8722374 R.H.	14.50	(manual) . . . . .
69-70	4-Dr. (exc. Spt. Sed.) . . . . .	8722375 L.H.	14.50	(manual) . . . . .
70	Impala (Spt. Sed.) . . . . .	8798353 L.H.	18.85	manual . . . . .
70	Impala (Spt. Sed.) . . . . .	8798352 R.H.	18.85	manual . . . . .
71-75	(Spt. Sed.) . . . . .	9834699 L.H.	33.00	elect. (less motor) . . . . .
71-75	(Spt. Sed.) . . . . .	9834698 R.H.	33.00	elect. (less motor) . . . . .
71-75	(4-Dr.) (exc. Spt. Sed.) . . . . .	9672052 L.H.	22.20	manual (repl. 9832581) . . . . .
71-75	(4-Dr.) (exc. Spt. Sed.) . . . . .	9672051 R.H.	22.20	manual . . . . .
71-75	(4-Dr.) (exc. Spt. Sed.) . . . . .	9832991 L.H.	34.25	elect. (less motor) . . . . .
71-75	(4-Dr.) (exc. Spt. Sed.) . . . . .	1659638 R.H.	27.00	elect. (less motor) (repl. 9832990) . . . . .
71-74	Caprice (Spt. Sed.),			
75	Pass. (Spt. Sed.) . . . . .	9615886 R.H.	23.80	manual . . . . .
71-74	Caprice (Spt. Sed.),			
75	Pass. (Spt. Sed.) . . . . .	9615887 L.H.	23.80	manual . . . . .
71-74	Impala (Spt. Sed.) . . . . .	9615883 L.H.	14.50	manual . . . . .
71-74	Impala (Spt. Sed.) . . . . .	9615882 R.H.	14.50	manual . . . . .

**CHEVY— NOVA**

**WINDSHIELD—DOORS—CONTROLS**

**10.791 REGULATOR— ARMATURE ASSY.— ARMATURE UNIT— BRACKET— GEAR— HOLDER— MOTOR ASSY.— NUT— PACKAGE ASSY.— ROLLER— SCREW— WASHER, Rear Door Window (Con't)**

**MANUAL WINDOW**

<b>68-74</b> (4-Dr.)	.....	<b>8752680</b> R.H.	13.30	.....
<b>68-74</b> (4-Dr.)	.....	<b>8752681</b> L.H.	13.30	.....
<b>75</b> Nova	.....	<b>1652474</b> R.H.	15.95	manual
<b>75</b> Nova	.....	<b>1712153</b> L.H.	16.20	manual (less motor) (repl. 1652475)

**ELECTRIC WINDOW**

<b>75</b> Nova	.....	<b>1684414</b> R.H.	49.25	electric (less motor)
<b>75</b> Nova	.....	<b>1684415</b> L.H.	49.25	electric (less motor)

**CHEVELLE**

**MANUAL WINDOW**

<b>68-72</b> (Spt. Sed.)	.....	<b>7726267</b> R.H.	16.95	.....
<b>68-72</b> (Spt. Sed.)	.....	<b>7726268</b> L.H.	16.95	.....
<b>68-72</b> (4-Dr.) (exc. Spt. Sed.)	.....	<b>7726955</b> R.H.	16.95	.....
<b>68-72</b> (4-Dr.) (exc. Spt. Sed.)	.....	<b>7726956</b> L.H.	16.95	.....
<b>73-75</b> Chevelle	.....	<b>1657385</b> L.H.	12.90	manual (repl. 9605739)
<b>73-75</b> Chevelle	.....	<b>1657384</b> R.H.	12.90	manual (repl. 9605738)

**ELECTRIC WINDOW**

<b>68-70</b> Malibu, Concours (4-Dr.) (exc. Spt. Sed.)	.....	<b>9723059</b> L.H.	32.00	less motor (repl. 9713105)
<b>68-70</b> (Spt. Sed.)	.....	<b>9713118</b> R.H.	29.75	less motor
<b>68-70</b> (Spt. Sed.)	.....	<b>9713119</b> L.H.	29.75	less motor
<b>68-70</b> (4-Dr.) (exc. Spt. Sed.)	.....	<b>9723058</b> R.H.	32.00	(less motor)
<b>73-75</b> Chevelle	.....	<b>1659629</b> L.H.	36.25	electric (less motor) (repl. 9619358)
<b>73-75</b> Chevelle	.....	<b>9619357</b> R.H.	35.75	electric (less motor)
<b>64-65</b> Pass., Chevelle w/elect. window, 66 Bel Air w/elect. window (exc. 2-Dr.),	.....			
<b>66</b> Impala, Caprice w/elect. window (exc. Spt. Sed.)	.....	<b>4909702</b> 2	19.95	<b>ARMATURE UNIT</b> (square motor)— (10.783)
<b>65-66</b> Pass. w/elect. window	.....	<b>4904212</b> 2	.05	<b>BRACKET</b> , brush holder (square motor)— (10.783)
<b>64-66</b> Chevelle w/elect. window,	.....			
<b>65-67</b> Pass. w/elect. window	.....	<b>4900085</b> 2	6.60	<b>GEAR</b> , regulator motor— (10.783)
<b>64-68</b> Chevelle w/elect. window,	.....			
<b>65-67</b> Pass. w/elect. window	.....	<b>4917191</b> 2	6.25	<b>HOLDER</b> , brush (square motor)— (10.783)
<b>65-68</b> Pass. (Spt. Mdls.) w/elect. window,	.....			
<b>66-68</b> Chevelle (Spt. Sed.) w/elect. window,	.....			
<b>64-69</b> Chevelle (Spt. Cpe., Conv.),	.....			
<b>69-72</b> Pass. (exc. 2-Dr. Sed.),	.....			<b>MOTOR ASSY.</b> (10.783)
<b>73-75</b> Pass., Chevelle, Camaro	.....	<b>5045640</b> A.R.	41.55	<b>MOTOR ASSY.</b> , electric (Note 2)
<b>69-70</b> Chevelle (Spt. Cpe., Conv.),	.....			
<b>69-72</b> Pass. (exc. 2-Dr. Sed.),	.....			<b>MOTOR ASSY.</b> (10.783)
<b>73-75</b> Pass., Chevelle, Camaro	.....	<b>5045639</b> A.R.	41.55	<b>MOTOR ASSY.</b> , electric (Note 1)
<b>69</b> Chevelle (exc. Spt. Cpe., Conv.),	.....			
<b>69-72</b> Pass. (4-Dr.) (exc. Spt. Sed.),	.....			
<b>73</b> Chevelle	.....	<b>5045590</b> L.H.	51.00	<b>MOTOR ASSY.</b> (10.783)
<b>74</b> Nova, Chevelle	.....	<b>1494257</b> A.R.	.34	<b>NUT</b> , spring door window to inner panel
<b>73-75</b> All	.....	<b>4919192</b> A.R.	6.60	<b>PACKAGE ASSY.</b> , motor service (includes gear and pinion)— (10.783)
<b>73-75</b> Pass., Chevelle	.....	<b>9666748</b> A.R.	.27	<b>ROLLER</b> , door window reg. lwr. balance arm— (10.783)
<b>73-75</b> Pass., Camaro, Chevelle	.....	<b>9666748</b> A.R.	.27	<b>ROLLER</b> , door window lower balance arm
<b>75</b> Chevelle (4-Dr.),	.....			
<b>75</b> Nova, Camaro	.....	<b>9724575</b> A.R.	.34	<b>ROLLER</b> , swivel wdo. reg. frt. dr.
<b>64-65</b> Chevelle w/elect. window,	.....			
<b>65-66</b> Pass. w/elect. window	.....	<b>5096732</b> A.R.	.46	<b>SCREW</b> , motor set ( <sup>9</sup> / <sub>16</sub> "— 24 x <sup>11</sup> / <sub>16</sub> "— (10.783)
<b>62-72</b> All	.....	<b>4405526</b> A.R.	.14	<b>SCREW</b> , reg. to inner pnl. ( <sup>1</sup> / <sub>4</sub> "— 20 x <sup>1</sup> / <sub>2</sub> "— (12.180)
<b>73-75</b> All	.....	<b>9642853</b> A.R.	.64	<b>SCREW</b> , door window regulator inner panel
<b>66-67</b> Chevelle (4-Dr.)	.....	<b>4877342</b> 2	.12	<b>WASHER</b> , regulator seal— (10.664)

*NOTE 1: On 1973-75 4-Dr. Models 5045639 is used as a L.H. part on the Frt. Dr. on the Rr. Dr. and on 2-Dr. Models it is a R.H. part.*

**WINDSHIELD—DOORS—CONTROLS**

**10.791 REGULATOR— ARMATURE ASSY.— ARMATURE UNIT— BRACKET— GEAR— HOLDER— MOTOR ASSY.— NUT— PACKAGE ASSY.— ROLLER— SCREW— WASHER, Rear Door Window (Con't)**

*NOTE 2: On 1973-75 4-Dr. Models 5045640 is used as a R.H. part on the Frt. Dr. on the Rr. Dr. and on 2-Dr. Models it is a L.H. part.*

**10.792 CAM ASSY.— BOLT— BUMPER— BUSHING— CAP— NUT— PLATE— ROLLER ASSY.— SCREW— SLEEVE— STUD— WASHER, Door Window Regulator Manual or Electric**

**PASS.**

65-68	2-Dr. ....	4812813	2	.96	front door inner panel .....
67-68	Spt. Sed. ....	7708188	L.H.	8.80	rear door window guide rear .....
67	Spt. Sed. ....	7682225	L.H.	8.30	front door window guide rear .....
67-70	4-Dr. ....	7688956	2	.91	rear door inner panel .....
67	Spt. Cpe., Conv. ....	7732247	L.H.	7.75	front window guide, rear .....
68	4-Dr. ....	8712984	L.H.	.96	front door inner panel .....
68	Impala (Spt. Cpe., Conv.) .....	7791367	L.H.	11.80	front door window guide, rear .....
68	Impala, Caprice (4-Dr. Spt. Sed.) .....	7791365	L.H.	11.80	front door window guide, rear .....
68	Impala, Caprice (4-Dr. Spt. Sed.) .....	7791364	R.H.	11.80	front door window guide, rear .....
69-70	4-Dr. (exc. Spt. Sed.) .....	8723891	R.H.	11.55	rear guide .....
69-70	4-Dr. (exc. Spt. Sed.) .....	8723892	L.H.	11.55	rear guide .....
69-70	4-Dr. (exc. Spt. Sed.) .....	8723893	R.H.	3.20	regulator .....
69-70	4-Dr. (exc. Spt. Sed.) .....	8723894	L.H.	3.20	regulator .....
69-70	4-Dr. (exc. Spt. Sed.) .....	8732249	2	1.85	rear regulator .....
69-70	Spt. Sed. ....	8727814	L.H.	10.65	front door front guide .....
69-70	Spt. Sed. ....	9812618	R.H.	7.50	front door rear guide .....
69-70	Spt. Sed. ....	9812619	L.H.	7.65	front door rear guide .....
69-70	Spt. Sed. ....	8730916	L.H.	9.00	rear door front guide .....
69-70	Spt. Sed. ....	8727812	2	3.00	front door glass regulator .....
70	(Spt. Sed.) .....	9812619	L.H.	7.65	guide rear .....
71-74	(4-Dr.) (exc. Spt. Sed.) .....	9835714	L.H.	3.60	glass regulator front door .....
71-74	(4-Dr.) (exc. Spt. Sed.) .....	9835713	R.H.	3.60	glass regulator front door .....
71-74	(4-Dr.) (exc. Spt. Sed.) .....	9835717	L.H.	11.80	front door wdo. guide, rear .....
71-74	(4-Dr.) (exc. Spt. Sed.) .....	9835716	R.H.	11.80	front door wdo. guide, rear .....
71-72	(Spt. Sed.) .....	9676269	L.H.	10.15	front door wdo. guide, rear .....
71-74	(Spt. Sed.) .....	9676268	R.H.	10.15	front door wdo. guide, rear .....
71-74	(Spt. Sed.) .....	9836419	L.H.	10.15	guide front, front door wdo. guide, front .....
71-74	(Spt. Sed.) .....	9836418	R.H.	10.15	front door wdo. guide, front .....
71-74	(4-Dr.) (exc. Spt. Sed.) .....	9839819	L.H.	4.35	front door wdo. guide, front .....
71-74	(4-Dr.) (exc. Spt. Sed.) .....	9839818	R.H.	4.35	glass regulator (electric) front .....
71-74	(Spt. Sed.) .....	9836829	L.H.	4.35	glass regulator front .....
71-74	(Spt. Sed.) .....	9836828	R.H.	4.35	glass regulator front .....
71-72	(exc. Spt. Cpe., Conv.), .....				
73-75	Pass. (4-Dr.) .....	4722599	2	.91	inner panel front .....
71-72	(4-Dr.) (exc. Spt. Sed.) .....	9832595	2	.76	inner panel .....
71-72	(4-Dr.) (exc. Spt. Sed.) .....	9832592	2	4.35	glass regulator .....
71-72	(Spt. Sed.) .....	9838177	L.H.	16.65	guide .....
71-72	(Spt. Sed.) .....	9838176	R.H.	16.65	guide .....
64-66	(Spt. Mdls.) .....	4722599	2	.91	front door inner panel .....
65-69	(4-Dr. Sed., Sta. Wag.) .....	9655398	2	.83	rear door inner panel (repl. 4459521) .....
66-67	Malibu (Spt. Sed.) .....	4547829	2	1.00	rear door inner panel .....
68-70	Malibu (4-Dr.) w/elect. window (exc. Spt. Sed.), .....				
68-70	Concours w/elect. window, .....				
68-72	(Spt. Sed.) .....	6279352	2	.70	rear door, inner panel .....
68-72	(4-Dr.) .....	4803484	2	.96	rear, door inner panel .....
68-72	(Spt. Sed.) .....				rear, door rear guide, .....
69	(Spt. Cpe., Conv.) .....	7723823	2	.96	front door idler cam .....
68-72	(Spt. Sed.) .....	7787306	R.H.	9.05	rear, door front guide .....
68-72	(Spt. Sed.) .....	7787307	L.H.	9.05	rear, door front guide .....
68-72	(Spt. Sed.) .....	8786041	R.H.	9.55	rear door guide, rear .....
68-72	(Spt. Sed.) .....	8786042	L.H.	9.55	rear door guide, rear .....
68	(2-Dr.), .....				
69-70	(2-Dr. Sed.), .....				
69-72	El Camino (Custom) .....	7746617	4	.96	front door inner panel .....
69	(Spt. Cpe., Conv.) .....	8722459	2	2.10	front door window regulator (manual) .....
69	(Spt. Cpe., Conv.) .....	8722460	R.H.	7.50	front door window guide front .....
69	(Spt. Cpe., Conv.) .....	8722461	L.H.	7.50	front door window guide front .....
69	(Spt. Cpe., Conv.) .....	8722462	R.H.	7.50	front door window guide rear .....
69	(Spt. Cpe., Conv.) .....	8722463	L.H.	7.50	front door window guide rear .....
67	Camaro .....	4812813	1	.96	front door inner panel .....
67	Camaro .....	7653715	R.H.	6.70	front door window guide rear .....
68-69	Camaro .....	7734315	2	1.85	front door glass regulator .....
68-69	Camaro .....	7734316	R.H.	7.75	front door guide, front .....

**WINDSHIELD—DOORS—CONTROLS**

**10.792 CAM ASSY.— BOLT— BUMPER— BUSHING— CAP— NUT— PLATE—  
ROLLER ASSY.— SCREW— SLEEVE— STUD— WASHER, Door Window  
Regulator Manual or Electric (Con't)**

68-69	Camaro	7734317 L.H.	7.75	front door guide, front
68	Camaro	7734318 R.H.	7.75	front door guide, rear
68	Camaro	7734319 L.H.	7.75	front door guide, rear
69	Camaro	8727958 R.H.	7.50	front door window guide rear
69	Camaro	8727959 L.H.	7.50	front door window guide rear
70-72	Camaro	4667911 2	.52	inner panel
70-75	Camaro	9806087 L.H.	7.85	wdo. guide rear
70-75	Camaro	9806086 R.H.	7.85	wdo. guide rear
70-74	Camaro	9806089 L.H.	2.95	glass regulator
70-74	Camaro	9806088 R.H.	2.95	glass regulator
70-74	Camaro	9825898 R.H.	7.85	wdo. guide front
70-74	Camaro	9825899 L.H.	7.85	wdo. guide front
73-75	Chevelle (2-Dr.)	9663145 L.H.	11.80	front door window guide
73-75	Chevelle (2-Dr.)	9663144 R.H.	11.80	front door window guide
73-75	Chevelle (2-Dr.)	9600711 L.H.	3.60	front door window glass regulator
73-75	Chevelle (2-Dr.)	9600710 R.H.	3.60	front door window glass regulator
73-75	Chevelle (4-Dr.)	9600716 L.H.	11.80	front door window guide
73-75	Chevelle (4-Dr.)	9600715 R.H.	11.80	front door window guide
73-75	Chevelle (4-Dr.)	9600718 L.H.	3.60	front door window glass regulator
73-75	Chevelle (4-Dr.)	9600717 R.H.	3.60	front door window glass regulator
73-75	Chevelle (4-Dr.)	4803484 2	.96	inner panel
73-75	Chevelle (2-Dr.), Camaro	9832595 2	.76	door inner panel
68-74	Nova,			
75	Vega, Monza	9655398 2	.83	inner panel (repl. 4459521)
73	Camaro	4667911 2	.52	inner
75	Nova	6279352 2	.70	inner panel
73-75	Pass. (4-Dr.) (exc. Spt. Sed.)	9832595 2	.76	inner panel
73-74	Pass. (4-Dr.) (exc. Spt. Sed.)	9832592 2	4.35	glass regulator
73-74	Pass. (Spt. Sed.)	9838177 L.H.	16.65	guide
73-74	Pass. (Spt. Sed.)	9838176 R.H.	16.65	guide
71-74	Vega, Monza	4547829 2	1.00	
68	Caprice (Spt. Cpe.)			<b>BOLT</b> , guide front cam lower,
68-69	Caprice (Spt. Cpe.)	7699334 2	.24	<b>BOLT</b> , guide rear cam to glass
68-70	Camaro	7659791 4	.24	<b>BOLT</b> , door window glass regulator cam to glass
69	Pass.	8712549 4	.22	<b>BOLT</b> , front and rear reg. to glass
69	Chevelle,			
69	Pass. (4-Dr.)			<b>BOLT</b> , rear door window glass to cam,
70-72	Pass., Camaro	9820349 A.R.	.21	<b>BOLT</b> , front and rear door window glass to cam (repl. 8778929)
67-69	Pass. (Spt. Sed.),			
68-69	Pass. (Spt. Mdls.)	7711527 4	.13	<b>BUMPER</b> , front and rear cam
69	Camaro,			
69	Chevelle (Spt. Cpe., Conv.)	8773643 A.R.	.12	<b>BUMPER</b> , front door window guide front or rear cam
68	Caprice (Spt. Cpe.),			
70-72	Chevelle (Spt. Sed.)	7762557 4	.12	<b>BUMPER</b> , front door window guide front or rear cam
68	Chevelle (Spt. Sed.)			<b>BUSHING</b> , rear door bearing upper,
68	Caprice (Spt. Cpe.),			
69-71	Pass., Chevelle (Spt. Cpe., Conv.)			front glass bearing upper,
70	Pass. (Spt. Sed.),			
70-71	Camaro	9833748 A.R.	.21	<b>BUSHING</b> , front and rear glass bearing
68-69	Caprice (Spt. Cpe.)			<b>BUSHING</b> , guide front roller to glass,
69	Pass. (4-Dr.)	4491087 A.R.	.14	front door idler cam to glass rear— (11.007)
68	Chevelle (Spt. Sed.)	7698790 4	.22	<b>CAP</b> , rear door bearing
68-72	Camaro, Chevelle,			
69-70	Biscayne, Bel Air,			
69-70	Impala, Caprice (Spt. Sed.)			<b>NUT</b> , front door window glass reg. cam to glass,
69-70	Brookwood, Townsman	4801719 4	.18	rear door window glass to cam
69	Chevelle (Spt. Mdls.),			
69	Pass.,			
70-75	Pass., Camaro,			
70-72	Nova (Spt. Cpe.),			
70-75	Chevelle (exc. 4-Dr. Sed., El Camino)	4491088 A.R.	.16	<b>NUT</b> , front and rear door glass to cam
74	Nova (Sedan)	1494257 A.R.	.34	<b>NUT</b> , spring rear door window regulator to inner panel
68-69	Camaro	7717597 2	.18	<b>PLATE</b> , front door window rear guide cam-adjuster



**WINDSHIELD—DOORS—CONTROLS**

**10.792 CAM ASSY.— BOLT— BUMPER— BUSHING— CAP— NUT— PLATE—  
ROLLER ASSY.— SCREW— SLEEVE— STUD— WASHER, Door Window  
Regulator Manual or Electric (Con't)**

68-69	Camaro	8782577	4	1.30	PLATE, front door window guide front and rear
68	Caprice	7666601	2	3.20	ROLLER ASSY., front door guide front roller
69-70	Pass. (Spt. Sed.)		2		ROLLER ASSY., frt. dr. window guide rear,
69-70	Pass. (Spt. Cpe., Conv.)	9813200	2	1.15	front dr. window guide front— (10.685)
68-69	Chevelle (Spt. Sed.),				
69-70	Pass. (Spt. Sed.)	8733933	4	3.20	ROLLER ASSY., front door window guide frt.
69	Pass. (Spt. Cpe., Conv.)	8727914	2	1.10	ROLLER ASSY., front door window guide rear
69	Chevelle (Spt. Cpe., Conv.)	7765583	2	1.40	ROLLER ASSY., front door front guide
69	Chevelle (Spt. Cpe., Conv.)	9813312	2	1.75	ROLLER ASSY., front door window guide rear
70	Pass. (Spt. Sed., Spt. Cpe., Conv.)	9813200	2	1.15	ROLLER ASSY., front door window guide rear
70-72	Camaro	9804075	2	3.45	ROLLER ASSY., front door wdo. guide front
70-72	Camaro	9820729	2	.99	ROLLER ASSY., front door window guide rear
71-72	Pass. (Spt. Sed.)	9607012	2	3.10	ROLLER ASSY., front door window glass guide rear
71-72	Pass. (Spt. Sed.)	9836835	2	4.35	ROLLER ASSY., front door window glass guide
72-74	Pass. (exc. Spt. Cpe.),				
75	Pass. (4-Dr.)	8732651	2	.70	ROLLER ASSY., front door window guide rear
73-75	Chevelle	9648321	2	3.10	ROLLER ASSY., front door window guide rear
73-75	Pass. (Spt. Sed.),				
75	Chevelle	9607012	2	3.10	ROLLER ASSY., front door window glass guide rear
73-74	Pass. (Spt. Sed.)	9836835	2	4.35	ROLLER ASSY., front door window glass guide
73-75	Camaro	9804075	2	3.45	ROLLER ASSY., front door wdo. guide front
73-74	Camaro	9820729	2	.99	ROLLER ASSY., front door window guide rear
62-72	All				SCREW, regulator to inner panel (1/4"— 20 x 1/2")— (12.180),
65-72	Pass. (Spt. Cpe., Conv.)	4405526		.14	front door window guide front cam
67-69	Pass. (Spt. Cpe.)	4409791	A.R.	.12	SCREW, qtr. window guide to upper support
69	Chevelle,				
69	Pass. (2-Dr. Sedan),				
70-73	All	4405527	A.R.	.15	SCREW, 1/4"— 20 x 1/2"
70	Pass., Chevelle (Spt. Sed.)	4409793	A.R.	.16	SCREW, front door window rear guide cam support— (10.765)
70	Pass. (4-Dr.) (exc. Spt. Sed.)	8719784	2	.34	SCREW, front window rear guide cam to panel
74-75	Pass. (4-Dr.)	9820349	4	.21	SCREW, regulator cam to glass
73	Chevelle	9885269	A.R.	.28	SCREW, regulator cam to glass, sash glass to plate, glass cam to glass
68	Impala (Spt. Cpe., Conv.)	4424600	2	.16	SLEEVE, door window guide rear cam— (10.219)
68-72	Chevelle (Spt. Sed.),				
68	Caprice (Spt. Cpe.),				
69	Chevelle (Spt. Cpe., Conv.)	7660876	6	.57	STUD, front or rear cam to glass
69	Pass. (Spt. Cpe., Conv.)	8721100	2	.18	STUD, front idler cam front
69	Pass. (4-Dr.) (exc. Spt. Sed.)	8719784	2	.34	STUD, front window rear guide cam to panel
68-69	Malibu (Spt. Sed.),				
69	Spt. Cpe., Conv.				WASHER, rear door front and rear guide cam to glass, rear front roller to glass,
68	Chevelle (Deluxe) (Spt. Cpe.)				front door window glass to rear channel,
68-69	Caprice (Spt. Cpe.)	7582188	A.R.	.23	guide front pillar, front and rear cam, rear guide cam to glass (1/2" O.D. rubber)
68-72	Caprice (Spt. Cpe.),				
74-75	Chevelle	4491086	A.R.	.21	WASHER, guide front pillar front and rear cam, rear guide cam to glass (1 3/8" O.D. steel)— (11.007)
69	Pass.	8731399	4	.14	WASHER, front door cam to glass
69-71	Pass. (Spt. Sed.),				
70-71	Camaro,				

**WINDSHIELD—DOORS—CONTROLS**

**10.792 CAM ASSY.— BOLT— BUMPER— BUSHING— CAP— NUT— PLATE—  
ROLLER ASSY.— SCREW— SLEEVE— STUD— WASHER, Door Window  
Regulator Manual or Electric (Con't)**

74-75	Pass. (Spt. Sed.)	8740675 A.R.	.11	WASHER, guide roller to glass
74	All	7734899 A.R.	.14	WASHER, front door window reg. cam to glass— (10.685)

**10.797 HANDLE— WASHER, Door Window Regulator**

62-64	Nova, Malibu	4807923 2	5.45	
63-64	Chevy, Chevelle (Std.)	3725377 A.R.	7.45	(repl. 4619388)
65-67	Chevy, Camaro,			
65-66	Biscayne, Bel Air,			
67	Chevelle (Std.)	4472076 A.R.	5.45	front
65-66	Impala,			
66	Chevelle (exc. Std., Deluxe),			
66	Caprice	4468651 A.R.	4.50	
67	Chevelle (Spt. Sed.),			
67	Caprice (exc. Sta. Wag.)	7689681 A.R.	5.05	(plum)
67	Nova (Sed.),			
67	Malibu (Sed., Spt. Cpe.),			
67	Impala (Spt. Cpe., Sed.)	7689680 A.R.	5.05	(maroon)
67	Impala (Spt. Cpe., Conv.)	7689670 2	5.05	(parchment)
67	Chevy (exc. S.S.),			
67	Chevelle (Std., Deluxe),			
67	Biscayne, Bel Air	7689672 A.R.	5.05	(fawn)
67	All (exc. Camaro)	7680653 A.R.	5.45	(black)
67	Caprice (Sta. Wag.),			
67	Camaro (Std.),			
67	Malibu, Concours S.S.,			
67	Impala, Bel Air	7689671 A.R.	5.05	(turquoise)
67	Nova (S.S.),			
67	Camaro (Std.),			
67	El Camino (Custom),			
67	Chevelle (Spt. Cpe., Conv.),			
67	Malibu, Concours (Sta. Wag.),			
67	Impala (exc. Sed.)	7689668 A.R.	5.45	(red)
67	Camaro (Std.),			
67	All (exc. Camaro)	7689676 A.R.	5.05	(dark blue)
67	Camaro (Std.),			
67	Nova, Malibu, Concours S.S.			
67	Impala, Caprice	7689673 A.R.	5.05	(gold)
67	Chevy (exc. S.S.),			
67	Camaro (Std.),			
67	Pass., Chevelle	7689677 A.R.	4.90	(med. blue)
67	Chevy (S.S.),			
67	Impala, Chevelle (Spt. Cpe., Conv.)	7719273 2	3.90	(med. brt. blue)
67	Camaro (Deluxe)	7689652 2	5.45	(yellow)
67	Camaro (Deluxe)	7689653 2	5.45	(red)
67	Camaro (Deluxe)	7689654 2	5.45	(parchment)
67	Camaro (Deluxe)	7689657 2	5.20	(gold)
67	Camaro (Deluxe)	7689655 2	5.45	(turquoise)
67	Camaro (Deluxe)	7689660 2	5.20	(blue)
67	Camaro (Deluxe)	7680654 2	5.45	(black)
67	Camaro (Deluxe)	7719282 2	4.85	(med. brt. blue)
68	Camaro,			
68	Impala (Conv.),			
68	Chevelle (Spt. Cpe., Conv.) (exc. Deluxe)	7767319 4	5.45	door and rear quarter (red)
68	Bel Air, Impala (exc. Conv.),			
68	Caprice (Sta. Wag.),			
68	Camaro,			
68	Chevelle (Sta. Wag.) (exc. Nomad)			(turquoise),
68	Bel Air (2-Dr.),			
68	Impala (Spt. Cpe.),			
68	Camaro	7767320 A.R.	5.45	rear quarter window regulator (blue),
68	Pass. (exc. Conv.)			
68	Biscayne, Bel Air, Chevelle (2-Dr.),			
68	All (Spt. Cpe.) (exc. Pass.),			
68	Impala (Spt. Cpe.)	7767322 A.R.	5.45	rear quarter window regulator
68	Malibu S.S. (Spt. Mdls.),			
68	Impala (Spt. Cpe., Conv.)	7767323 A.R.	5.45	(teal) rear quarter window regulator
68	All (exc. Pass., Chevelle),			

**WINDSHIELD—DOORS—CONTROLS**

**10.797 HANDLE— WASHER, Door Window Regulator (Con't)**

68	Pass., Chevelle (exc. Sta. Wag., El Camino) . . . . .			(gold), . . . . .
68	2-Dr. (exc. El Camino) . . . . .	7767325 A.R.	5.45	rear quarter window regulator . . . . .
68	Camaro, Impala (Spt. Cpe., Conv.), Malibu S.S. (Spt. Cpe., Conv.) . . . . .	7767326	2	5.45 (parchment) . . . . .
68	Impala, Caprice (exc. Sta. Wag.)			(green), . . . . .
68	Malibu (Spt. Cpe.) (Sed.), Impala, Caprice (Spt. Cpe.) . . . . .	7767327 A.R.	5.45	rear quarter window regulator . . . . .
68	Sta. Wag., El Camino . . . . .	7767324 A.R.	4.25	(saddle) . . . . .
68	All . . . . .	7752485 A.R.	6.65	rear quarter window (black) . . . . .
68	Camaro . . . . .	7767333	4	5.95 door window and rear quarter regulator (white) . . . . .
69-70	All,			
71	Chevelle, Nova,			
72	Nova,			
69	Camaro . . . . .			quarter window req. . . . .
70-72	Camaro . . . . .			front door window reg., . . . . .
71-72	Pass.,			
73-75	All (exc. Vega, Monza) . . . . .	8732962 A.R.	6.55	front door, rear door, qtr. window reg. . . . .
71-75	Vega, Monza . . . . .	7752485	2	6.65 front door . . . . .
	Not required in this group. See group 11.044 . . . . .	7689667		
63-66	Chevy (4-Dr.) . . . . .	7591000	2	.12 <b>WASHER, rear, handle sealing washer— (10.517)</b> . . . . .

**10.805 PLATE, Door Window Regulator Handle**

65-66	All (exc. Pass.),			
65	Pass. (exc. elect. window control) . . . . .	4506696 A.R.	.16	bearing, front and rear— (10.515) . . . . .

**10.806 SPRING— SPACER, Window Regulator Handle Escutcheon Plate**

62-64	Chevelle,			
65-69	Biscayne . . . . .			front, . . . . .
65-67	Pass. (4-Dr.) . . . . .			rear, . . . . .
65	Pass.,			
65-67	Chevelle . . . . .	4566746 A.R.	.22	front and rear . . . . .
62-66	Chevy (4-Dr.),			
66-67	Chevelle (4-Dr.) . . . . .			rear door lock handle, . . . . .
64-66	Chevy,			
68	Chevelle . . . . .			front door lock handle, . . . . .
68	Camaro . . . . .			front door regulator handle, . . . . .
69	Chevy . . . . .			front and rear door regulator handle, . . . . .
69	Chevelle (4-Dr.) . . . . .	4078002	2	.22 emergency use— (10.666) . . . . .
70-72	Camaro . . . . .	9816876	2	.22 <b>SPACER, front (black) (paint as reqd.)</b> . . . . .
72-73	Camaro w/Custom Equip. . . . .	9601766	2	.22 <b>SPACER (paint as reqd.)</b> . . . . .
73-75	Vega w/custom built-up . . . . .	9690291	2	.24 <b>SPACER, frt. door (prime and paint)</b> . . . . .

**10.824 WASHER, Rear Door Ventilator**

Not required in this group. See group 10.664 . . . . . **3696038**

**10.826 CHANNEL ASSY.— STUD, Division Rear Door Ventilator Glass**

68-72	Chevy (4-Dr.) . . . . .	7726300	2	3.35 stationary . . . . .
62-66	Chevy (4-Dr.) . . . . .	4405500	2	.16 <b>STUD, channel lower— (10.670)</b> . . . . .
73-74	Nova . . . . .	9623963	2	3.35 <b>STUD, stationary vent.</b> . . . . .

**10.827 GLASS, Rear Door Ventilator**

62-67	Chevy (Sta. Wag.) . . . . .	4841505	2	11.90 stationary (clear) . . . . .
66-67	Chevy (4-Dr. Sed.) . . . . .	4547116	2	11.90 stationary (clear) . . . . .
66-67	Chevy (4-Dr. Sed.) . . . . .	4547117	2	13.05 stationary (tinted) . . . . .
68-72	Chevy (4-Dr.) . . . . .	7720182 R.H.		18.10 stationary (clear) . . . . .
68-72	Chevy (4-Dr.) . . . . .	7720183 L.H.		18.10 stationary (clear) . . . . .
68-72	Chevy (4-Dr.) . . . . .	7720184 R.H.		19.95 stationary (tinted) . . . . .
68-72	Chevy (4-Dr.) . . . . .	7720185 L.H.		19.95 stationary (tinted) . . . . .
73-74	Nova . . . . .	9612359 L.H.		13.25 clear . . . . .
73-74	Nova . . . . .	9612358 R.H.		13.25 clear . . . . .
73-74	Nova . . . . .	9612361 L.H.		14.40 tinted . . . . .
73-74	Nova . . . . .	9612360 R.H.		14.40 tinted . . . . .
75	Pass. (Sed.) (exc. Spt. Sed.) . . . . .	9728694 R.H.		14.55 tinted . . . . .
75	Pass. (Sed.) (exc. Spt. Sed.) . . . . .	9728695 L.H.		14.55 tinted . . . . .
75	Nova . . . . .	9726387 L.H.		13.40 clear . . . . .
75	Nova . . . . .	9726389 L.H.		14.55 tinted . . . . .
75	Pass. (Sed.) (exc. Spt. Sed.) . . . . .	9728692 R.H.		13.40 clear . . . . .
75	Pass. (Sed.) (exc. Spt. Sed.) . . . . .	9728693 L.H.		13.40 clear . . . . .

**WINDSHIELD—DOORS—CONTROLS**

**10.827 GLASS, Rear Door Ventilator (Con't)**

75	Nova	9726386 R.H.	13.40	clear
75	Nova	9726388 R.H.	14.55	tinted
75	Nova (4-Dr.) (Luxury)	1689138 R.H.	17.90	clear ("LN" crest)
75	Nova (4-Dr.) (Luxury)	1689139 L.H.	17.90	clear ("LN" crest)
75	Nova (4-Dr.) (Luxury)	1689140 R.H.	18.95	tinted ("LN" crest)
75	Nova (4-Dr.) (Luxury)	1689141 L.H.	18.95	tinted ("LN" crest)

**10.829 CHANNEL ASSY.— SCALP, Rear Door Stationary Ventilator Glass Division**

68-72	Chevy (4-Dr.)	7731368 R.H.	5.70	
68-72	Chevy (4-Dr.)	7731369 L.H.	5.70	
75	Nova	1650844 2	5.15	
75	Pass. (Sed.) (exc. Spt. Sed.)	9732918 2	4.60	
73-74	Nova	9611627 L.H.	5.70	glass division
73-74	Nova	9611626 R.H.	5.70	glass division
75	Pass. (Sed.) (exc. Spt. Sed.)	9738136 R.H.	3.35	SCALP, channel inner
75	Pass. (Sed.) (exc. Spt. Sed.)	9738137 L.H.	3.35	SCALP, channel inner
75	Pass. (Sed.) (exc. Spt. Sed.)	9738138 R.H.	3.35	SCALP, channel outer
75	Pass. (Sed.) (exc. Spt. Sed.)	9738139 L.H.	3.35	SCALP, channel outer

**10.997 GUTTER— CLIP— ROD— VALVE, Rear Quarter Ventilator and Back Window Drain**

70-72	Chevelle (Conv.)	9817850 1	13.90	top compartment
71-74	Pass. (Conv.)	987276 1	.28	CLIP, fldg. top compt. qtr. rod & brace
71-74	Pass. (Conv.)	9876074 1	5.10	ROD, fldg. top compt. qtr. ret.
73	Pass., Chevelle	9609899 2	1.75	VALVE, drain ctr. duct pnl.



# CHEVROLET BODY GROUP 11.000



## REAR GLASS — SEAT PARTS — ADJUSTER

### ALPHABETICAL INDEX

<b>A</b>		
ACTUATOR ASSY., Front Seat Adjuster.....	11.561	CLIP, Front Seat Back Lock..... 11.390
ACTUATOR ASSY., Front Seat Back Lock.....	11.390	CLIP, Front Seat Bottom with Frame, Springs and Padding (less trim cover).....
ACTUATOR, Seat Back Reclining.....	11.377	11.419
ADJUSTER, Front Seat.....	11.561	CLIP, Garnish Moulding (sheet metal type).....
ARM ASSY., Folding Seat (For Load Floor Parts See Group 12.977).....	11.620	11.128
ARMATURE, Quarter Window.....	11.041	CLIP, Quarter Window Glass Run.....
		11.024
		CLIP, Quarter Window Lower Sash.....
		11.007A
		CLIP, Quarter Window Reveal Midg., Tailgate Moulding Clips.....
		11.032
		CLIP, Quarter Window Reveal.....
		11.031
		CLIP, Quarter Window.....
		11.041
		CONTROL ASSY., Front Seat Back Lock.....
		11.390
		COUPLING, Front Seat Adjuster.....
		11.561
		COVER, Electric Seat Adjuster.....
		11.556
		COVER, Folding Seat (For Load Floor Parts See Group 12.977).....
		11.620
		COVER, Front Seat Back Lock.....
		11.390
		COVER, Front Seat Hinge Arm.....
		11.375
		COVER, Seat Adjuster Track.....
		11.573
		CUSHION ASSY., Folding Seat (For Load Floor Parts See Group 12.977).....
		11.620
		CUSHION, Front Seat Bottom with Frame, Springs and Padding (less trim cover).....
		11.419
		CUSHION, Rear Seat Back with Frame, Springs, and Padding (less trim cover).....
		11.628A
		CUSHION, Rear Seat Bottom (Less Trim Cover).....
		11.610
		<b>D</b>
		DOG, Electric Seat Adjuster.....
		11.556
		<b>E</b>
		ESCUTCHEON, Back Window Glass Reveal Moulding.....
		11.209
		ESCUTCHEON, Dome Lamp Switch.....
		11.938
		ESCUTCHEON, Electric Seat Adjuster Switch.....
		11.558
		ESCUTCHEON, Folding Seat (For Load Floor Parts See Group 12.977).....
		11.620
		ESCUTCHEON, Front Seat Back Lock.....
		11.390
		ESCUTCHEON, Front Seat Headrest.....
		11.376
		ESCUTCHEON, Garnish Moulding.....
		11.133
		ESCUTCHEON, Quarter Window Garnish and Quarter Belt Finishing.....
		11.119
		ESCUTCHEON, Quarter Window Reveal.....
		11.031
		EXTENSION, Front Door Sill.....
		11.175
		<b>F</b>
		FASTENER, Folding Seat (For Load Floor Parts See Group 12.977).....
		11.620
		FASTENER, Front Seat Hinge Arm.....
		11.375
		FASTENER, Garnish Moulding (sheet metal type).....
		11.128

## ALPHABETICAL INDEX

FASTENER, Seat Adjuster Track.....	11.573
FILLER, Quarter Window Lower Sash .....	11.007
FILLER, Rear Seat Back.....	11.629
FOUNDATION ASSY., Rear Seat Back with Frame, Springs, and Padding (less trim cover).....	11.628A
FRAME ASSEMBLY, Rear Seat Back, with Springs.....	11.628
FRAME ASSY., Front Seat Back, with Springs (less Cushion).....	11.373
FRAME ASSY., Front Seat Bottom with Frame, Springs and Padding (less trim cover).....	11.419
FRAME ASSY., Quarter Window Glass.....	11.010
FRAME ASSY., Rear Seat Bottom (Less Trim Cover).....	11.610

### G

GASKET, Folding Seat (For Load Floor Parts See Group 12.977).....	11.620
GASKET, Quarter Window .....	11.041
GEAR, Electric Seat Adjuster.....	11.556
GEAR, Front Seat Adjuster.....	11.561
GEARNUT, Front Seat Adjuster.....	11.561
GEAR, Quarter Window.....	11.041
GLASS, Back Window (Safety) .....	11.204
GLASS, Quarter Window (safety).....	11.011
GROMMET, Channel Quarter Vent. window hinge .....	11.008
GROMMET, Dome Lamp Door Jamb.....	11.950
GROMMET, Front Seat Back Lock.....	11.390
GROMMET, Quarter Window Glass.....	11.010
GUIDE ASSY., Front Seat Headrest.....	11.376
GUIDE, Folding Seat (For Load Floor Parts See Group 12.977).....	11.620
GUIDE, Rear Quarter Window.....	11.040

### H

HANDLE ASSY., Folding Seat (For Load Floor Parts See Group 12.977).....	11.620
HANDLE, Front Seat Back Lock.....	11.390
HANDLE, Quarter Window Regulator.....	11.044
HANDLE, Seat Back Reclining .....	11.377
HINGE ASSY., Quarter Window Glass.....	11.010
HOLDER, Quarter Window.....	11.041
HOUSING ASSY., Dome Lamp .....	11.927

### I

INSULATOR, Back Window Garnish.....	11.120
-------------------------------------	--------

### J

JACKSCREW, Front Seat Adjuster.....	11.561
-------------------------------------	--------

### K

KIT, Back Window (Safety).....	11.204
KIT, Folding Seat (For Load Floor Parts See Group 12.977).....	11.620
KIT, Quarter Window (safety).....	11.011
KNOB, Front Seat Adjuster.....	11.588
KNOB, Front Seat Back Lock .....	11.390
KNOB, Seat Back Reclining .....	11.377

### L

LAMP PKG., Dome Lamp.....	11.927
LATCH ASSY., Quarter Window Glass.....	11.010
LATCH, Folding Seat (For Load Floor Parts See Group 12.977).....	11.620
LENS, Dome Lamp .....	11.928
LINK ASSY., Folding Seat (For Load Floor Parts See Group 12.977).....	11.620
LOCK ASSY., Folding Seat (For Load Floor Parts See Group 12.977).....	11.620
LOCK ASSY., Front Seat Back Lock.....	11.390

### M

MOTOR, Electric Seat Adjuster.....	11.556
MOTOR, Quarter Window.....	11.041
MOULDING ASSY., Front Door Belt Trim Finish .....	11.075
MOULDING ASSY., Rear Door Belt Trim Finish .....	11.089
MOULDING, Back Window Garnish .....	11.120
MOULDING, Back Window Glass Reveal .....	11.208
MOULDING, Quarter Window Garnish and Quarter Belt Finishing .....	11.119
MOULDING, Quarter Window Lower Sash.....	11.007A
MOULDING, Quarter Window Reveal .....	11.031

### N

NUT, Back Window Glass Reveal Moulding...	11.209
NUT, Dome Lamp Door Jamb.....	11.950
NUT, Front Seat Adjuster .....	11.561
NUT, Quarter Window Garnish and Quarter Belt Finishing .....	11.119
NUT, Quarter Window Glass .....	11.010
NUT, Quarter Window Lower Sash.....	11.007A
NUT, Quarter Window Upper Sash.....	11.005

### P

PACKAGE ASSY., Quarter Window .....	11.041
PAD ASSY., Front Seat Bottom with Frame, Springs and Padding (less trim cover).....	11.419
PAD ASSY., Front Seat Headrest.....	11.376
PAD, Electric Seat Adjuster .....	11.556
PANEL ASSY., Front Seat Back, with Springs (less Cushion).....	11.373
PANEL ASSY., Front Seat Side Lower.....	11.362
PANEL ASSY., Rear Seat Back, with Springs.....	11.628
PANEL, Front Seat Back .....	11.358
PANEL, Front Seat Center Arm Rest.....	11.374
PANEL, Front Seat Headrest.....	11.376
PANEL, Front Seat Side Lower .....	11.362
PIN, Electric Seat Adjuster Switch .....	11.558
PIN, Front Seat Adjuster.....	11.561
PIN, Quarter Window Glass.....	11.010
PIN, Quarter Window Lower Sash.....	11.007A
PLATE ASSY., Quarter Window Lower Sash..	11.007A
PLATE, Folding Seat (For Load Floor Parts See Group 12.977).....	11.620
PLATE, Front Door Sill.....	11.175
PLATE, Front Seat Adjuster .....	11.561
PLATE, Front Seat Hinge Arm.....	11.375
PLATE, Quarter Window Regulator Handle....	11.047
PLATE, Rear Door Sill.....	11.179
PLUNGER, Electric Seat Adjuster.....	11.556
PULLEY, Electric Seat Adjuster.....	11.556

## ALPHABETICAL INDEX

### R

REFLECTOR, Dome Lamp .....	11.927
REGULATOR, Quarter Window .....	11.041
REINFORCEMENT, Seat Adjuster Track .....	11.573
RETAINER, Folding Seat (For Load Floor Parts See Group 12.977) .....	11.620
RETAINER, Front Seat Adjuster .....	11.561
RETAINER, Front Seat Adjusting Lock .....	11.589
RETAINER, Front Seat Back Lock .....	11.390
RETAINER, Front Seat Back, Side Panels .....	11.368
RETAINER, Front Seat Center Arm Rest .....	11.374
RETAINER, Front Seat Headrest .....	11.376
RETAINER, Front Seat Hinge Arm .....	11.375
RETAINER, Quarter Window Garnish and Quarter Belt Finishing .....	11.119
RETAINER, Quarter Window Glass Run .....	11.024
RETAINER, Quarter Window Glass .....	11.010
RETAINER, Quarter Window Lower Sash .....	11.007A
RETAINER, Quarter Window Reveal Mldg., Tailgate Moulding Clips .....	11.032
RETAINER, Rear Seat Bottom (Less Trim Cover) .....	11.610
RIM, Dome Lamp .....	11.928
RING, Electric Seat Adjuster .....	11.556
RING, Front Seat Back, with Springs (less Cushion) .....	11.373
RIVET, Front Seat Adjuster .....	11.561
ROD, Folding Seat (For Load Floor Parts See Group 12.977) .....	11.620
ROD, Front Seat Back Lock .....	11.390
ROLLER, Quarter Window Lower Sash .....	11.007A
ROLLER, Quarter Window Upper Sash .....	11.005
ROLLER, Quarter Window .....	11.041

### S

SCREW, Back Window Glass Reveal Moulding .....	11.209
SCREW, Electric Seat Adjuster .....	11.556
SCREW, Folding Seat (For Load Floor Parts See Group 12.977) .....	11.620
SCREW, Front Seat Adjuster .....	11.561
SCREW, Front Seat Center Arm Rest .....	11.374
SCREW, Garnish Moulding (sheet metal type) .....	11.128
SCREW, Quarter Window Glass .....	11.012
SCREW, Quarter Window Lower Sash .....	11.007A
SCREW, Quarter Window Regulator Handle .....	11.047
SCREW, Quarter Window Reveal .....	11.031
SCREW, Quarter Window .....	11.041
SCREW, Rear Quarter Window .....	11.040
SEALING, Quarter Window Glass Rubber .....	11.015
SHAFT, Electric Seat Adjuster .....	11.556
SHOE, Front Seat Adjuster .....	11.561
SILENCER, Back Window Garnish .....	11.120
SLEEVE, Folding Seat (For Load Floor Parts See Group 12.977) .....	11.620
SLEEVE, Front Seat Back Lock .....	11.390
SLEEVE, Seat Back .....	11.381
SOCKET ASSY., Dome Lamp .....	11.927
SOLENOID ASSY., Front Seat Back Lock .....	11.390
SOLENOID, Electric Seat Adjuster .....	11.556
SPACER, Back Window (Safety) .....	11.204
SPACER, Back Window Glass Reveal Moulding .....	11.209
SPACER, Front Seat Adjuster .....	11.561
SPACER, Front Seat Back, Side Panels .....	11.368
SPACER, Front Seat Center Arm Rest .....	11.374
SPACER, Quarter Window (safety) .....	11.011
SPACER, Quarter Window Glass .....	11.010
SPACER, Quarter Window Reveal Mldg., Tailgate Moulding Clips .....	11.032
SPACER, Quarter Window Reveal .....	11.013
SPRING, Electric Seat Adjuster .....	11.556
SPRING, Folding Seat (For Load Floor Parts See Group 12.977) .....	11.620
SPRING, Front Seat Adjuster .....	11.561
SPRING, Front Seat Adjuster .....	11.581
SPRING, Front Seat Back Lock .....	11.390

SPRING, Front Seat Headrest .....	11.376
SPRING, Quarter Window Lower Sash .....	11.007A
SPRING, Quarter Window Regulator Handle .....	11.047
SPRING, Quarter Window Upper Sash .....	11.005
STOP, Folding Seat (For Load Floor Parts See Group 12.977) .....	11.620
STOP, Front Seat Adjuster .....	11.561
STOP, Quarter Window Glass .....	11.012
STRIKER, Folding Seat (For Load Floor Parts See Group 12.977) .....	11.620
STRIKER, Front Seat Back Lock .....	11.390
STRIP ASSY., Quarter Window Glass Rubber .....	11.015
STRIP, Back Window Glass Reveal Moulding .....	11.209
STRIP, Quarter Window Glass Run .....	11.021
STUD, Rear Quarter Window .....	11.040
STUD, Seat Back .....	11.381
SUPPORT ASSY., Quarter Window Glass Rubber .....	11.015
SUPPORT, Door Opening Carpet .....	11.176
SUPPORT, Electric Seat Adjuster Switch .....	11.558
SUPPORT, Electric Seat Adjuster .....	11.556
SUPPORT, Folding Seat (For Load Floor Parts See Group 12.977) .....	11.620
SUPPORT, Front Seat Adjuster .....	11.561
SUPPORT, Front Seat Back Lock .....	11.390
SUPPORT, Front Seat Back, Side Panels .....	11.368
SUPPORT, Front Seat Center Arm Rest .....	11.374
SUPPORT, Quarter Window Glass .....	11.010
SUPPORT, Rear Quarter Window .....	11.040
SUPPORT, Rear Seat Back .....	11.629
SUPPORT, Seat Adjuster Track .....	11.573
SWITCH, Dome Lamp Door Jamb .....	11.950
SWITCH, Dome Lamp .....	11.935
SWIVEL, Front Seat Adjuster .....	11.561

### T

TRANS. ASSY., Electric Seat Adjuster .....	11.556
TUBE ASSY., Front Seat Adjuster .....	11.561
TUBE, Front Seat Headrest .....	11.376

### W

WASHER, Electric Seat Adjuster .....	11.556
WASHER, Folding Seat (For Load Floor Parts See Group 12.977) .....	11.620
WASHER, Front Seat Adjuster .....	11.561
WASHER, Front Seat Back Lock .....	11.390
WASHER, Quarter Window Lower Sash .....	11.007A
WASHER, Quarter Window Regulator Handle .....	11.047
WASHER, Quarter Window Upper Sash .....	11.005
WASHER, Seat Back .....	11.381
WEATHERSTRIP, Quarter Window Glass Rubber .....	11.015
WIRE ASSY., Front Seat Adjusting Lock .....	11.589
WIRE, Front Seat Center Arm Rest .....	11.374





**REAR GLASS—SEAT AND ADJUSTER**

**11.005 ROLLER—BOLT—NUT—SPRING—WASHER, Quarter Window Upper Sash**

67-68	Impala (Spt. Cpe.) (exc. Custom)	9724575	6	.34	lower sash channel
66-67	Caprice (Spt. Cpe.),				
69	Brookwood (8 cyl.)	7667128	A.R.	.15	BOLT, channel to glass
65-67	Pass. (Spt. Cpe., Conv.),				
68	Impala (Spt. Cpe.) (exc. Custom)	4533795	6	.33	NUT, to upper filler and to lower channel— (10.685)
69	Pass. (2-Dr.)	8767802	2	.65	SPRING, front channel roller
66-68	Caprice (Spt. Cpe.),				
67	Chevelle (Spt. Cpe., Conv.)	7582188	2	.23	WASHER, rear guide roller
67-69	Camaro,				
68-69	Chevelle (Spt. Cpe., Conv.),				
69	Pass. (Spt. Cpe., Conv.)	7647276	2	.21	WASHER, lower guide roller

**11.007 CHANNEL— FILLER, Quarter Window Lower Sash**

*NOTE When necessary cut off new channel using old channel as guide. Rubber w/strip should protrude 3/16 in. beyond ends.*

**PASSENGER**

65-68	2-Dr. Sedan	4543218	R.H.	8.20	lower sash
65-68	2-Dr. Sedan	4543219	L.H.	8.20	lower sash
65-66	Spt. Cpe., Conv.	7632214	R.H.	14.35	front (chrome) (fastens to glass)
65-66	Spt. Cpe., Conv.	7632215	L.H.	14.35	front (chrome) (fastens to glass)
65-66	Impala (Spt. Cpe.)	4490681	L.H.	19.30	lower sash
67-68	Impala (Spt. Cpe.) (exc. Custom)	7664944	R.H.	17.80	rear
67-68	Impala (Spt. Cpe.) (exc. Custom)	7664945	L.H.	17.80	rear
67-68	Caprice (Spt. Cpe.),				
67-68	Impala (Conv.),				
68	Impala (Custom)	7656805	R.H.	17.60	rear front
67-68	Caprice (Spt. Cpe.),				
67-68	Impala (Conv.),				
68	Impala (Custom)	7656806	L.H.	17.80	rear front
67-68	Impala (Spt. Cpe.)	7646853	R.H.	17.80	rear front
67-68	Impala (Spt. Cpe.)	7646854	L.H.	17.80	rear front
67-69	2-Dr. (Sed.)	7685720	R.H.	7.35	rear front sash
67-69	2-Dr. (Sed.)	7685721	L.H.	7.55	rear front sash
69-70	Spt. Cpe., Conv.	8731301	R.H.	11.05	lower sash
69-70	Spt. Cpe., Conv.	8731302	L.H.	11.05	lower sash
69-72	(Spt. Cpe., Conv.)	8734082	R.H.	17.05	front sash (Note 1)
69-72	(Spt. Cpe., Conv.)	8734083	L.H.	17.05	front sash (Note 1)
71-72	Pass. (Spt. Cpe., Conv.),				
73	Pass. (2-Dr.)	9738995	L.H.	19.05	CHANNEL ASSY., front
71-72	Pass. (Spt. Cpe., Conv.),				
73	Pass. (2-Dr.)	9738994	R.H.	19.05	CHANNEL ASSY., front
73-75	Pass. (Conv.)	9738995	L.H.	19.05	CHANNEL ASSY., front
74-75	Impala (Spt. Cpe.)	9738998	R.H.	20.35	CHANNEL ASSY., front
74-75	Impala (Spt. Cpe.)	9738999	L.H.	20.35	CHANNEL ASSY., front
74-75	Pass. (Conv.)	9738994	R.H.	19.05	CHANNEL ASSY., front
69	Pass. (Spt. Cpe., Conv.)	8767802	2	.65	FILLER (3/64" thick 1 1/2" wide 40 ft. roll)— (10.696)
69-70	Spt. Cpe., Conv.	8719721	2	.39	FILLER, lower sash channel
71-72	Pass. (Spt. Cpe., Conv.)				FILLER, lower sash plate
73	Pass. (2-Dr.)				
74	Impala (Spt. Cpe.) Caprice,				
75	Pass. (2-Dr.)	9839703	2	.36	FILLER, plate

*NOTE 1 Also appears in Chevelle Section.*

**CHEVY**

66	(Spt. Cpe.)	7632219	L.H.	11.95	rear quarter window front sash
66	(Spt. Cpe.)	7632218	R.H.	11.95	rear quarter window front sash
68-74	2-Dr. (Conv.)	7693011	L.H.	4.65	front sash (Note 1)
68-74	2-Dr.	7693010	R.H.	4.65	front sash (Note 1)
62-67	(Exc. Spt. Mdls.)	4418510	A.R.	1.15	FILLER, lower sash channel— (10.685)

*NOTE 1 Also appears in Chevelle Section.*

**CHEVELLE**

64-65	Malibu (Spt. Cpe.)	4496438	R.H.	8.20	front sash (chrome) (fastens to glass)
64-65	Malibu (Spt. Cpe.)	4496439	L.H.	8.20	front sash (chrome) (fastens to glass)
64-65	Malibu (Conv.)	4496436	R.H.	8.20	front sash (stainless steel) (fastens to glass)
64-65	Malibu (Conv.)	4496437	L.H.	8.20	front sash (stainless steel) (fastens to glass)
66-72	(2-Dr. Sed.)	7693010	R.H.	4.65	front sash (Note 2)
66-72	(2-Dr. Sed.)	7693011	L.H.	4.65	front sash (Note 2)
66-67	(Spt. Cpe., Conv.)	7632210	R.H.	12.20	front sash
66-67	(Spt. Cpe., Conv.)	7632211	L.H.	12.20	front sash
68-72	(Spt. Cpe., Conv.)	7798692	R.H.	6.25	rear
68-72	(Spt. Cpe., Conv.)	7798693	L.H.	6.25	rear

**REAR GLASS—SEAT AND ADJUSTER**

**11.007 CHANNEL— FILLER, Quarter Window Lower Sash (Con't)**

68	(Spt. Cpe., Conv.)	7763301 R.H.	11.50	front sash
68	(Spt. Cpe., Conv.)	7763302 L.H.	11.50	front sash
69-72	(Spt. Cpe., Conv.)	8734082 R.H.	17.05	front sash (Note 3)
69-72	(Spt. Cpe., Conv.)	8734083 L.H.	17.05	front sash (Note 3)
73-75	Chevelle (Spt. Sed.)	9877443 L.H.	4.65	front sash
73-75	Chevelle (Spt. Sed.)	9877442 R.H.	4.65	front sash
68-69	Chevelle (Spt. Cpe., Conv.)	8767802 2	.65	FILLER (3/64" thick 1 1/2" wide 40 ft. roll)— (10.696)
68-72	(Spt. Cpe., Conv.)	7723457 2	.36	FILLER, lower sash channel

*NOTE 2 Also appears in Chevy Section.*  
*NOTE 3 Also appears in Pass. Section.*

**CAMARO**

67-69	Camaro	7699428 R.H.	6.15	lower sash
67-69	Camaro	7699429 L.H.	6.15	lower sash
67-69	Camaro	7707460 R.H.	11.70	front sash
67-69	Camaro	7707461 L.H.	11.70	front sash
67-69	Camaro	8767802 2	.65	FILLER (3/64" thick 1 1/2" wide 40 ft. roll)— (10.696)
67-69	Camaro	7648134 2	.36	FILLER, lower sash channel
67-69	Camaro	3703899 A.R.	RL/.12	FILLER (1/2" thick— 1 1/2" wide— 60 ft. roll)— (10.685)
67-69	Camaro	370390 A.R.	RL/.15	FILLER (3/64" thick-1 1/2" wide-40 ft. roll)— (10.685)

**11.007A BOLT— BUSHING— CLIP— MOULDING— NUT— PIN— PLATE ASSY.—  
RETAINER— ROLLER— SCREW— SPRING— WASHER, Quarter Window  
Lower Sash**

65-67	Pass. (Spt. Cpe., Conv.)	4534340 6	.39	to lower channel— (10.685)
67-69	Camaro,			
69	Pass. (Spt. Cpe., Conv.),			
69	Brookwood (8 cyl.)	7667128 A.R.	.15	channel to glass
69-72	Chevelle (Spt. Cpe., Conv.),			
70	Pass. (Spt. Cpe., Conv.),			
74-75	Conv.,			
74-75	Impala (Spt. Cpe.) (exc. Custom)	7775159 4	.21	BOLT, guide plate— (10.685)
66-69	Caprice, Nova (Spt. Cpe.),			
66-69	Chevelle (Spt. Cpe., Conv.),			
68-69	Camaro			BUSHING, guide roller,
69	Pass.,			
68-69	Chevelle (Spt. Sed.)	4491087 6	.14	lower, roller guide and lower sash to glass
67	Pass. (Conv., Spt. Cpe.) (exc. S.S.),			
68	Pass. (Conv.),			
68	Caprice, Impala Custom (Spt. Cpe.)	7667153 6	.62	BUSHING, rear guide roller
70-72	Camaro, Nova (2-Dr.),			
70-72	Chevelle (2-Dr.) (exc. El Camino),			
70-72	Chevelle (Spt. Sed.),			
71-72	Pass. (exc. Spt. Cpe.),			
73	All,			
74	Pass. (2-Dr.)	9804150 A.R.	.16	BUSHING (10.768)
73	Chevelle (Sta. Wag.) w/rear swing out window	9666649 A.R.	.36	CLIP, reveal mldg. qtr. vent. div. channel
74-75	Chevelle (Spt. Sed.)	9638946 R.H.	.74	MOULDING, qtr. window front channel inner (prime and paint as reqd.)
74-75	Chevelle (Spt. Sed.)	9638947 L.H.	.74	MOULDING, qtr. window front channel inner (prime and paint as reqd.)
65-67	Pass. (Spt. Cpe., Conv.),			
68	Impala (Spt. Cpe.) (exc. Custom)	4533795 6	.33	NUT, to upper filler and to lower channel— (10.685)
66-69	Malibu (Spt. Cpe., Conv.) w/elect. window,			
66-68	Caprice (Spt. Cpe.),			
67-68	Impala (Conv.),			
70-72	Pass. (Spt. Cpe., Conv.)	4491088 A.R.	.16	NUT, guide roller tee, glass to lower channel— (10.792)
67-69	Camaro,			
68-72	Chevelle (Spt. Cpe., Conv.)	7791597 2	.36	PIN, sash channel front roller
71-75	Pass. (Spt. Cpe.)	9625047 L.H.	8.45	PLATE ASSY., lower sash guide
71-75	Pass. (Spt. Cpe.)	9625046 R.H.	8.45	PLATE ASSY., lower sash guide
71-75	Pass. (Conv.)	9625051 L.H.	11.05	PLATE ASSY., lower sash guide
71-75	Pass. (Conv.)	9625050 R.H.	11.05	PLATE ASSY., lower sash guide
71-72	Vega, Monza w/swing-out window	9870576 A.R.	.17	RETAINER, qtr. window channel frt. & side

**REAR GLASS—SEAT AND ADJUSTER**

**11.007A BOLT— BUSHING— CLIP— MOULDING— NUT— PIN— PLATE ASSY.—  
RETAINER— ROLLER— SCREW— SPRING— WASHER, Quarter Window  
Lower Sash (Con't)**

71-75	Vega (Panel) . . . . .	9896101	8	.15	RETAINER, qtr. window insert . . . . .
65-66	Impala (Spt. Cpe. Conv.) . . . . .	9704300	6	1.05	ROLLER, lower sash channel . . . . .
67-68	Impala (Spt. Cpe.) (exc. Custom)	9724575	6	.34	ROLLER, lower sash channel . . . . .
66-67	Caprice (Spt. Cpe.),				
67-68	Pass. (Conv.) . . . . .	7583902	6	.72	ROLLER, window guide . . . . .
67-69	Camaro,				
68-72	Chevelle (Spt. Cpe., Conv.) . . . . .	9709291	1	.21	ROLLER, front channel . . . . .
67-69	Camaro . . . . .	7648823	2	.53	ROLLER, lower guide . . . . .
68-72	Chevelle (Spt. Cpe., Conv.) . . . . .	7794097	2	.77	ROLLER, lower guide . . . . .
68	Impala Custom, Caprice (Spt. Cpe.) . . . . .	7748074	6	.87	ROLLER, rear guide upper and lower . . . . .
69-70	Pass. (Spt. Cpe., Conv.) . . . . .	8731349	2	.92	ROLLER, lower guide . . . . .
66-67	Nova (Spt. Cpe.),				
66-67	Chevelle (Spt. Cpe., Conv.) . . . . .	4491089	6	.39	ROLLER ASSY., guide . . . . .
71-75	Pass. (2-Dr.) . . . . .	9831696	2	.84	ROLLER ASSY., lower guide . . . . .
64-65	Malibu (Spt. Mdls.),				
65-66	Pass. (Conv.) . . . . .	4409392	A.R.	.11	SCREW, channel cam (10— 24 x 3/16")— (10.687) . . . . .
65	Nova (Spt. Cpe.) . . . . .	9421576	4	.06	SCREW, upper to lower sash channel (No. 8— 32 x 3/8" flat head tapping)— (8.977) . . . . .
69	Pass. (2 Dr. Sed.),				
69-70	Chevy, Chevelle (Spt. Cpe.),				
71-74	Nova (2-Dr.) . . . . .	7763443	2	.59	SCREW, qtr. wind. to reg. . . . .
69	Chevelle (Spt. Cpe., Conv.) . . . . .	8767802	1	.65	SPRING, sash channel front roller . . . . .
66-68	Caprice, Nova (Spt. Cpe.),				
66-71	Chevelle (Spt. Cpe., Conv.),				
67-68	Pass. (Conv.),				
67-72	Camaro,				
68	Impala Custom,				
69	Pass. (Spt. Cpe.),				
70-72	Pass.,				
70-72	Malibu (Spt. Sed.),				
73-74	Pass. (Spt. Cpe., Conv.) . . . . .	4491086	2	.21	WASHER, roller guide (steel) . . . . .
66-68	Caprice (Spt. Cpe.),				
67-68	Pass. (Conv.),				
66-69	Chevelle (2-Dr. Sed.) . . . . .	7582188	2	.23	WASHER, rear guide roller (1 1/2" O.D. rubber) . . . . .
67-69	Camaro,				
68-69	Chevelle (Spt. Cpe., Conv.),				
69	Pass. (Spt. Cpe., Conv.) . . . . .	7647276	2	.21	WASHER, lower guide roller . . . . .
70-72	Chevelle (Spt. Cpe., Conv.),				
73	All . . . . .	7734899	A.R.	.14	WASHER (10.747) . . . . .

**11.008 GROMMET, Channel Quarter Vent. window hinge**

73	Chevelle (Sta. Wag.) w/swing out window, rear seat assy. . . . .	9629230	4	.21	
----	---	---------	---	-----	--

**11.010 LATCH ASSY.— BUSHING— FRAME ASSY.— GROMMET— HINGE  
ASSY.— NUT— PIN— RETAINER— SPACER— SUPPORT, Quarter Window  
Glass**

71	Vega (N.B. & H.B.) . . . . .	9824817	2	11.95	
72-75	Vega (N.B. & H.B.) . . . . .	9881462	2	13.50	
73-75	Chevelle (Sta. Wag.) w/swing out window . . . . .	9629226	2	12.70	
75	Nova (2-Dr.) w/swing vent . . . . .	1676399	2	13.60	
71-75	Vega (N.B. & H.B.) . . . . .				BUSHING, qtr. window latch . . . . .
73-75	Chevelle (Sta. Wag.) w/swing out window,				
75	Nova w/swing out window . . . . .	9824824	4	.15	latch to supt. . . . .
73-75	Chevelle (Sta. Wag.) w/swing out rear window . . . . .	1662711	L.H.	10.55	FRAME ASSY., vent. qtr. wdo. . . . .
73-75	Chevelle (Sta. Wag.) w/swing out rear window . . . . .	1662710	R.H.	10.55	FRAME ASSY., vent. qtr. window . . . . .
73-75	Chevelle (Sta. Wag.) w/swing out window . . . . .	9629230	4	.21	GROMMET, vent window hinge . . . . .
75	Nova (2-Dr.) w/swing vent . . . . .	1677750	4	.47	HINGE ASSY., flip/out . . . . .
71-75	Vega (N.B. & H.B.),				
75	Nova (2-Dr.) w/swing vent . . . . .	9831778	4	.84	HINGE, on body . . . . .
74-75	Vega (N.B. & H.B.) . . . . .	9831779	4	.84	HINGE, flip out . . . . .
71-75	Vega (N.B.) w/swing out window,				
73-75	Chevelle (Sta. Wag.) w/swing out window,				

**REAR GLASS—SEAT AND ADJUSTER**

**11.010 LATCH ASSY.— BUSHING— FRAME ASSY.— GROMMET— HINGE ASSY.— NUT— PIN— RETAINER— SPACER— SUPPORT, Quarter Window Glass (Con't)**

75	Nova w/swing out window	9658025	2	1.90	NUT, latch
73-75	Chevelle (Sta. Wag.) w/swing out window	9414469	2	.06	PIN, supt. to latch (8.939)
71-75	Vega (N.B. & H.B.),				
75	Monza (Towne Cpe.)	1707450	2	3.20	RETAINER, qtr. window glass, lower
75	Nova w/swing out vent window	9870693	A.R.	.26	SPACER, qtr. wdo. latch to panel (emerg.)
71-75	Vega (N.B. & H.B.),				
75	Nova w/swing vent	1697430	A.R.	.55	SPACER, hinge/on body
71-75	Vega (N.B. & H.B.),				
73-75	Chevelle (Sta. Wag.) w/swing out window	9824822	2	2.60	SUPPORT, latch
75	Nova (2-Dr.) w/swing vent	1678105	2	4.60	SUPPORT, latch

**11.011 GLASS— KIT— SPACER, Quarter Window (safety)**

**PASSENGER**

65-66	Conv.	4462911	L.H.	28.50	(clear)
65-70	Sta. Wag.	4463408	R.H.	53.50	(clear)
65-70	Sta. Wag.	4463409	L.H.	53.50	(clear)
65-70	Sta. Wag.	4463410	R.H.	59.00	(tinted)
65-70	Sta. Wag.	4463411	L.H.	59.00	(tinted)
67-68	Impala (Spt. Cpe.) (exc. Custom)	7639952	R.H.	41.50	rear
67-68	Impala (Spt. Cpe.) (exc. Custom)	7639953	L.H.	41.50	rear
67-68	Impala (Spt. Cpe.) (exc. Custom)	7639956	R.H.	45.50	rear (tinted)
67-68	Impala (Spt. Cpe.) (exc. Custom)	7639957	L.H.	45.50	rear (tinted)
67-68	Impala (Conv.)	7639622	R.H.	36.75	rear
67-68	Impala (Conv.)	7639626	R.H.	37.00	rear (tinted)
67-68	Impala (Conv.)	7639627	L.H.	40.50	rear (tinted)
67	Caprice (Spt. Cpe.)	7642214	R.H.	38.75	rear
67	Caprice (Spt. Cpe.)	7642215	L.H.	42.25	rear
67	Caprice (Spt. Cpe.)	7642216	R.H.	34.00	rear (tinted)
67	Caprice (Spt. Cpe.)	7642217	L.H.	45.75	rear (tinted)
67-68	2-Dr. (Sed.)	7642234	R.H.	26.25	rear
67-68	2-Dr. (Sed.)	7642235	L.H.	19.50	rear
67-68	2-Dr. (Sed.)	7642236	R.H.	21.65	rear (tinted)
67-68	2-Dr. (Sed.)	7642237	L.H.	21.65	rear (tinted)
68	Caprice (Spt. Cpe.),				
68	Impala Custom	7722661	L.H.	33.25	(clear)
68	Caprice (Spt. Cpe.),				
68	Impala Custom	7722662	R.H.	27.00	(tinted)
68	Caprice (Spt. Cpe.),				
68	Impala Custom	7722663	L.H.	36.25	(tinted)
69	2-Dr. (Sed.)	7799766	R.H.	26.75	(clear)
69	2-Dr. (Sed.)	7799767	L.H.	19.95	(clear)
69	2-Dr. (Sed.)	7799768	R.H.	21.70	(tinted)
69	2-Dr. (Sed.)	7799769	L.H.	21.70	(tinted)
69-70	Impala (Custom),				
69-70	Caprice (Spt. Cpe.)	8746524	R.H.	28.75	(clear)
69-70	Impala (Custom),				
69-70	Caprice (Spt. Cpe.)	8746525	L.H.	28.75	(clear)
69-70	Impala (Custom),				
69-70	Caprice (Spt. Cpe.)	8746526	R.H.	31.75	(tinted)
69-70	Impala (Custom),				
69-70	Caprice (Spt. Cpe.)	8746527	L.H.	31.75	(tinted)
69-70	Impala (Spt. Cpe.) (exc. Custom)	8746532	R.H.	30.50	(clear)
69-70	Impala (Spt. Cpe.) (exc. Custom)	8746533	L.H.	30.50	(clear)
69-70	Impala (Spt. Cpe.) (exc. Custom)	8746534	R.H.	33.25	(tinted)
69-70	Impala (Spt. Cpe.) (exc. Custom)	8746535	L.H.	33.25	(tinted)
69-70	Conv.	8746540	R.H.	33.75	(clear)
69-70	Conv.	8746541	L.H.	33.75	(clear)
69-70	Conv.	8746542	R.H.	33.75	(tinted)
69-70	Conv.	8746543	L.H.	36.50	(tinted)
71-75	(Sta. Wag.)	9816869	L.H.	77.50	rear stationary (clear)
71-75	(Sta. Wag.)	9816868	R.H.	77.50	rear stationary (clear)
71-75	(Sta. Wag.)	9820083	L.H.	84.50	rear stationary (tinted)
71-75	(Sta. Wag.)	9820082	R.H.	84.50	rear stationary (tinted)
71-73	Impala Custom, Caprice (Spt. Cpe.)	9805609	L.H.	26.25	(clear)
71-73	Impala Custom, Caprice (Spt. Cpe.)	9805608	R.H.	26.25	(clear)
71-73	Impala Custom, Caprice (Spt. Cpe.)	9824653	L.H.	28.50	(tinted)

**REAR GLASS—SEAT AND ADJUSTER**

**11.011 GLASS—KIT—SPACER, Quarter Window (safety) (Con't)**

71-73	Impala Custom, Caprice (Spt. Cpe.)	9824652 R.H.	28.50	(tinted)
71-73	Impala (Spt. Cpe.) (exc. Custom)	9824655 L.H.	23.55	(clear)
71-73	Impala (Spt. Cpe.) (exc. Custom)	9824654 R.H.	23.55	(clear)
71-73	Impala (Spt. Cpe.) (exc. Custom)	9824657 L.H.	25.50	(tinted)
71-73	Impala (Spt. Cpe.) (exc. Custom)	9824656 R.H.	25.50	(tinted)
71-75	(Conv.)	9805615 L.H.	29.00	(clear)
71-75	(Conv.)	9805614 R.H.	29.00	(clear)
71-75	(Conv.)	9824627 L.H.	31.75	(tinted)
71-75	(Conv.)	9824626 R.H.	31.75	(tinted)
74-75	Impala (Cust.) Caprice (Spt. Cpe.)	9666203 R.H.	27.75	(clear) (stationary)
74-75	Impala (Cust.) Caprice (Spt. Cpe.)	9666204 L.H.	27.75	(clear) (stationary)
74-75	Impala (Cust.) Caprice (Spt. Cpe.)	9666205 R.H.	31.00	(tinted) (stationary)
74-75	Impala (Cust.) Caprice (Spt. Cpe.)	9666206 L.H.	31.00	(tinted) (stationary)
74-75	Impala (Spt. Cpe.) (exc. Cust.)	9667174 R.H.	28.50	(clear)
74-75	Impala (Spt. Cpe.) (exc. Cust.)	9667175 L.H.	28.50	(clear)
74-75	Impala (Spt. Cpe.) (exc. Cust.)	9667176 R.H.	31.50	(tinted)
74-75	Impala (Spt. Cpe.) (exc. Cust.)	9667177 L.H.	31.50	(tinted)
75	Pass. (Spt. Sed.)	9730472 R.H.	19.30	(clear) (stationary)
75	Pass. (Spt. Sed.)	9730473 L.H.	19.30	(clear) (stationary)
75	Pass. (Spt. Sed.)	9730474 R.H.	21.10	(tinted) (stationary)
75	Pass. (Spt. Sed.)	9730475 L.H.	21.10	(tinted) (stationary)

**CHEVY**

62-67	(Sta. Wag.)	4842361	2	23.35	(tinted)
66-67	(2-Dr. Sed.)	4549910	2	11.90	(clear)
66-67	(2-Dr. Sed.)	4549911	2	13.65	(tinted)
66-67	(Spt. Cpe.)	4549994	2	14.35	(clear)
66-67	(Spt. Cpe.)	4549995	2	16.75	(tinted)
68-72	(Spt. Cpe.)	7734893	R.H.	21.80	(clear)
68-72	(Spt. Cpe.)	7734894	L.H.	21.80	(clear)
68-72	(Spt. Cpe.)	7734895	R.H.	23.65	(tinted)
68-72	(Spt. Cpe.)	7734896	L.H.	23.65	(tinted)
73-74	Nova (2-Dr.)	9610277	L.H.	22.15	(clear)
73-74	Nova (2-Dr.)	9610276	R.H.	22.15	(clear)
73-74	Nova (2-Dr.)	9610279	L.H.	24.00	(tinted)
73-74	Nova (2-Dr.)	9610278	R.H.	24.00	(tinted)
75	Nova (2-Dr.)	1650763	R.H.	26.75	(clear)
75	Nova (2-Dr.)	1650764	L.H.	26.75	(clear)
75	Nova (2-Dr.) (formal wind.)	1726304	R.H.	31.75	stationary (clear)
75	Nova (2-Dr.) (formal wind.)	1726305	L.H.	31.75	stationary (clear)
75	Nova (2-Dr.) (formal wind.)	1726306	R.H.	34.75	stationary (tinted)
75	Nova (2-Dr.) (formal wind.)	1726307	L.H.	34.75	stationary (tinted)
75	Nova (2-Dr.) (exc. swing out, body emb.)	1650765	R.H.	29.25	stationary (tinted)
75	Nova (2-Dr.) (exc. swing out, body emb.)	1650766	L.H.	29.25	stationary (tinted)
75	Nova (2-Dr.) w/swing vent	1677743	R.H.	41.25	include hinge and clip (clear)
75	Nova (2-Dr.) w/swing vent	1677744	L.H.	41.25	include hinge and clip (clear)
75	Nova (2-Dr.) w/swing vent	1678101	R.H.	51.00	include hinge and pin (tinted)
75	Nova (2-Dr.) w/swing vent	1678102	L.H.	51.00	includes hinge and pin (tinted)
75	Nova (Custom) (2-Dr.) w/body emb. (exc. H.B.)	1689134	R.H.	32.75	stationary (clear)
75	Nova (Custom) (2-Dr.) w/body emb. (exc. H.B.)	1689135	L.H.	32.75	stationary (clear)
75	Nova (Custom) (2-Dr.) w/body emb. (exc. H.B.)	1689136	R.H.	35.25	stationary (tinted)
75	Nova (Custom) (2-Dr.) w/body emb. (exc. H.B.)	1689137	L.H.	35.25	stationary (tinted)
75	Nova (Custom) (2-Dr.) w/swing vent. and body emb. (exc. H.B.)	1689145	R.H.	54.25	includes hinge and clips (clear)
75	Nova (Custom) (2-Dr.) w/swing vent. and body emb. (exc. H.B.)	1689146	L.H.	54.25	includes hinge and clips (clear)
75	Nova (Custom) (2-Dr.) w/swing vent. and body emb. (exc. H.B.)	1689147	R.H.	57.50	includes hinge and clips (tinted)
75	Nova (Custom) (2-Dr.) w/swing vent. and body emb. (exc. H.B.)	1689148	L.H.	57.50	includes hinge and clips (tinted)

**CHEVELLE**

66-67	(2-Dr. Sed.)	4538101	L.H.	32.00	(clear)
66-67	(2-Dr. Sed.)	4538103	L.H.	26.00	(tinted)

**REAR GLASS—SEAT AND ADJUSTER**

**11.011 GLASS—KIT— SPACER, Quarter Window (safety) (Con't)**

66-67 (Sta. Wag.)	4536735 R.H.	65.75	(clear)
66-67 (Sta. Wag.)	4536736 L.H.	60.25	(clear)
66-67 (Sta. Wag.)	4536737 R.H.	53.75	(tinted)
66-67 (Sta. Wag.)	4536738 L.H.	50.50	(tinted)
66-67 (Spt. Cpe.)	4540580 R.H.	43.50	(clear)
66-67 (Spt. Cpe.)	4540581 L.H.	40.00	(clear)
66-67 (Spt. Cpe.)	4540582 R.H.	47.50	(tinted)
66-67 (Spt. Cpe.)	4540583 L.H.	47.50	(tinted)
66-67 (Conv.)	4539476 R.H.	36.75	(clear)
68-69 (2-Dr. Sed.)	7719706 R.H.	20.10	(clear)
68-69 (2-Dr. Sed.)	7719707 L.H.	20.10	(clear)
68-69 (2-Dr. Sed.)	7719708 R.H.	21.85	(tinted)
68-69 (2-Dr. Sed.)	7719709 L.H.	21.85	(tinted)
68-71 (Sta. Wag.)	7722251 R.H.	50.25	(clear)
68-72 (Sta. Wag.)	7722252 L.H.	50.25	(clear)
68-72 (Sta. Wag.)	7722253 R.H.	59.25	(tinted)
68-72 (Sta. Wag.)	7722254 L.H.	59.25	(tinted)
68-72 (Conv.)	7763324 R.H.	24.35	(clear)
68-72 (Conv.)	7763325 L.H.	24.35	(clear)
68-72 (Conv.)	7763326 R.H.	26.50	(tinted)
68-72 (Conv.)	7763327 L.H.	26.50	(tinted)
68-69 (Spt. Cpe.)	7763308 R.H.	30.50	(clear)
68-69 (Spt. Cpe.)	7763309 L.H.	30.50	(clear)
68-69 (Spt. Cpe.)	7763310 R.H.	33.00	(tinted)
68-69 (Spt. Cpe.)	7763311 L.H.	33.00	(tinted)
70-72 Malibu (Spt. Cpe.)	8781141 L.H.	27.50	(clear)
70-72 Malibu (Spt. Cpe.)	8781140 R.H.	27.50	(clear)
70-72 Malibu (Spt. Cpe.)	8781143 L.H.	29.75	(tinted)
70-72 Malibu (Spt. Cpe.)	8781142 R.H.	29.75	(tinted)
70-72 Monte Carlo	8781144 R.H.	22.15	(clear)
70-72 Monte Carlo	8781145 L.H.	22.15	(clear)
70-72 Monte Carlo	8781147 L.H.	23.85	(tinted)
70-72 Monte Carlo	8781146 R.H.	23.85	(tinted)
73-75 Chevelle (Spt. Sed.)	9868579 L.H.	16.35	(tinted)
73-75 Chevelle (Spt. Sed.)	9868578 R.H.	16.35	(tinted)
73-75 Chevelle (Spt. Sed.)	9868577 L.H.	15.10	(clear)
73-75 Chevelle (Spt. Sed.)	9868576 R.H.	15.10	(clear)
73 Chevelle (Spt. Cpe.) (exc. Monte Carlo),			
74-75 Malibu (Spt. Cpe.) (exc. Classic),			
74 Malibu Classic, Laguna (Spt. Cpe.) (1st design)	9867677 L.H.	26.00	stationary (clear) (Note 1)
73 Chevelle (Spt. Cpe.) (exc. Monte Carlo),			
74-75 Malibu (Spt. Cpe.) (exc. Classic),			
74 Malibu Classic, Laguna (Spt. Cpe.) (1st design)	9867676 R.H.	26.00	stationary (clear)(Note 1)
73 Chevelle (Spt. Cpe.) (exc. Monte Carlo),			
74-75 Malibu (Spt. Cpe.) (exc. Classic),			
74 Malibu Classic, Laguna (Spt. Cpe.) (1st design)	1688925 L.H.	29.50	stationary (tinted) (Note 1)
73 Chevelle (Spt. Cpe.) (exc. Monte Carlo),			
74-75 Malibu (Spt. Cpe.) (exc. Classic),			
74 Malibu Classic, Laguna (Spt. Cpe.) (1st design)	9867678 R.H.	26.00	stationary (tinted) (Note 1)
73 Monte Carlo	9870387 L.H.	13.25	stationary (clear)
73 Monte Carlo	9870386 R.H.	13.25	stationary (clear)
73 Monte Carlo	9870389 L.H.	14.40	stationary (tinted)
73 Monte Carlo	9870388 R.H.	14.40	stationary (tinted)
73-75 Chevelle (Sta. Wag.) (exc. swing out window)	9869823 L.H.	44.00	(clear)
73-75 Chevelle (Sta. Wag.) (exc. swing out window)	9869822 R.H.	44.00	(clear)
73-75 Chevelle (Sta. Wag.) (exc. swing out window)	9869825 L.H.	48.00	(tinted)
73-75 Chevelle (Sta. Wag.) (exc. swing out window)	9869824 R.H.	48.00	(tinted)
73-75 Chevelle (Sta. Wag.) w/swing out window	9610961 L.H.	37.00	(tinted)
73-75 Chevelle (Sta. Wag.) w/swing out window	9610960 R.H.	37.00	(tinted)
73-75 Chevelle (Sta. Wag.) w/swing out window	9610959 L.H.	34.00	(clear)

**REAR GLASS—SEAT AND ADJUSTER**

**11.011 GLASS—KIT—SPACER, Quarter Window (safety) (Con't)**

73-75	Chevelle (Sta. Wag.) w/swing out window	9610958 R.H.	34.00	(clear)
74-75	Malibu Classic, Laguna (Spt. Cpe.) (2nd design)	9735910 R.H.	13.40	stationary (clear) (Note 1)
74-75	Malibu Classic, Laguna (Spt. Cpe.) (2nd design)	9735911 L.H.	13.40	stationary (clear) (Note 1)
74	Malibu Classic, Laguna (Spt. Cpe.) (2nd design),			
75	Malibu Classic (Spt. Cpe.) (exc. ext. body emblem)	9735912 R.H.	14.55	stationary (tinted) (Note 1)
74	Malibu Classic, Laguna (Spt. Cpe.) (2nd design),			
75	Malibu Classic (Spt. Cpe.) (exc. ext. body emblem)	9735913 L.H.	14.55	stationary (tinted) (Note 1)
74-75	Monte Carlo	9870386 R.H.	13.25	stationary (clear)
74-75	Monte Carlo	9870387 L.H.	13.25	stationary (clear)
74-75	Monte Carlo	9870388 R.H.	14.40	stationary (tinted)
74-75	Monte Carlo	9870389 L.H.	14.40	stationary (tinted)
73-74	Chevelle (Sta. Wag.) w/swing out window	9619798 L.H.	14.45	includes hinge (tinted)
73-74	Chevelle (Sta. Wag.) w/swing out window	9619797 R.H.	14.45	includes hinge (tinted)
73-75	Chevelle (Sta. Wag.) w/swing out window	9619796 L.H.	14.45	includes hinge (clear)
73-75	Chevelle (Sta. Wag.) w/swing out window	9619795 R.H.	14.45	includes hinge (clear)
75	Malibu (Classic) (Spt. Cpe.) w/body emb.	1700544 R.H.	18.40	stationary (clear)
75	Malibu (Classic) (Spt. Cpe.) w/body emb.	1700545 L.H.	18.40	stationary (clear)
75	Malibu (Classic) (Spt. Cpe.) w/body emb.	1700546 R.H.	19.45	stationary (tinted)
75	Malibu (Classic) (Spt. Cpe.) w/body emb.	1700547 L.H.	19.45	stationary (tinted)

*NOTE 1: To aid in identifying first design, a metal insert was required to fill void in quarter panel used for tear drop window design. Second design quarter panel will have added metal in sail area.*

**CAMARO**

67	(Conv.)	7707448 R.H.	21.65	(clear)
67	(Conv.)	7707454 R.H.	23.35	(tinted)
67	(Conv.)	7707455 L.H.	23.35	(tinted)
67	(Spt. Cpe.)	7707436 R.H.	29.75	(clear)
67	(Spt. Cpe.)	7707437 L.H.	29.75	(clear)
67	(Spt. Cpe.)	7707442 R.H.	29.75	(tinted)
68-69	(Spt. Cpe.)	7720356 R.H.	18.10	(clear)
68-69	(Spt. Cpe.)	7720357 L.H.	18.10	(clear)
68-69	(Spt. Cpe.)	7720358 R.H.	19.95	(tinted)
68-69	(Spt. Cpe.)	7720359 L.H.	19.95	(tinted)
68-69	(Conv.)	7720360 R.H.	19.50	(clear)
68-69	(Conv.)	7720361 L.H.	19.50	(clear)
68-69	(Conv.)	7720362 R.H.	19.40	(tinted)
68-69	(Conv.)	7720363 L.H.	21.10	(tinted)

**VEGA—MONZA**

71-75	Vega (N.B.)	9658459 L.H.	37.50	(swing out) (tinted) incl. hge./clips
71-75	Vega (N.B.)	9658458 R.H.	37.50	(swing out) (tinted) w/clips
71-75	Vega (N.B.)	9658457 L.H.	33.00	(swing out) (clear) w/clips
71-75	Vega (N.B.)	9658456 R.H.	33.00	(swing out) (clear) w/clips
71-75	Vega (H.B.)	9658461 L.H.	32.50	(swing out) (clear) w/clips
71-75	Vega (H.B.)	9658460 R.H.	32.50	(swing out) (clear) w/clips
71-75	Vega (H.B.)	9658463 L.H.	33.75	(swing out) (tinted) w/clips
71-75	Vega (H.B.)	9658462 R.H.	33.75	(swing out) (tinted) w/clips
71-75	Vega (Sta. Wag.)	9817809 L.H.	41.50	(tinted)
71-75	Vega (Sta. Wag.)	9817808 R.H.	41.50	(tinted)
71-75	Vega (Sta. Wag.)	9805665 L.H.	37.50	(clear)
71-75	Vega (Sta. Wag.)	9805664 R.H.	37.50	(clear)
71-75	Vega (N.B.)	9805667 L.H.	23.10	stationary (clear)
71-75	Vega (N.B.)	9805666 R.H.	23.10	stationary (clear)
71-75	Vega (N.B.)	9816654 L.H.	25.50	stationary (tinted)
71-75	Vega (N.B.)	9816653 R.H.	25.50	stationary (tinted)
71-75	Vega (H.B.)	9817227 L.H.	22.55	(stationary) (tinted)
71-75	Vega (H.B.)	9817226 R.H.	22.55	(stationary) (tinted)
71-75	Vega (H.B.)	9805669 L.H.	18.25	(stationary) (clear)
71-75	Vega (H.B.)	9805668 R.H.	18.25	(stationary) (clear)
75	Monza (exc. Towne Cpe.)	9730981 R.H.	25.50	stationary (clear)

**REAR GLASS—SEAT AND ADJUSTER**

**11.011 GLASS—KIT— SPACER, Quarter Window (safety) (Con't)**

75	Monza (exc. Towne Cpe.)	9730982	L.H.	25.50	stationary (clear)
75	Monza (exc. Towne Cpe.)	9730983	R.H.	27.75	stationary (tinted)
75	Monza (exc. Towne Cpe.)	9730984	L.H.	27.75	stationary (tinted)
75	Monza (Towne Cpe.) w/formal qtr. wdo.	1674305	R.H.	13.40	(stationary) (clear)
75	Monza (Towne Cpe.) w/formal qtr. wdo.	1674306	L.H.	13.40	(stationary) (clear)
75	Monza (Towne Cpe.) w/formal qtr. wdo.	1674307	R.H.	14.55	(stationary) (tinted)
75	Monza (Towne Cpe.) w/formal qtr. wdo.	1674308	L.H.	14.55	(stationary) (tinted)
All	All	4226000	A.R.	11.30	KIT, adhesive caulked— (10.027)
64	Chevelle,				
65	Pass.,				
66-67	Pass. (exc. Sta. Wag.)	4404196	A.R.	.11	SPACER, adhesive caulked glass (5/16" x 7/16" 1— rubber— (10.027)
64	Chevelle	4459429	4	.18	SPACER, adhesive caulked glass (5/16" x 1/2" x 1)— (10.027)
67-70	All, Pass., Chevelle, Nova, Camaro	4534314	A.R.	.18	SPACER (3/8" x 7/16")— (10.027)

**11.012 STOP— SCREW, Quarter Window Glass**

65-67	Chevelle (Spt. Mdls.),				
65-68	Pass. (Spt. Cpe., Conv.) (exc. Caprice Custom),				
66-67	Nova (Spt. Cpe., Conv.),				
69-72	Chevelle (Spt. Cpe.) (exc. Conv.)	4482848	2	.32	upper
67-69	Camaro	7666676	2	.44	upper
71-74	Pass. (2-Dr.),				
74-75	Impala (Spt. Cpe.) Caprice (Conv.)	9840764	2	.53	upper front
71-74	Pass. (2-Dr.) (exc. Conv.),				
75	Impala (Spt. Cpe.) (exc. Custom)	9847540	2	.53	upper rear
71-75	Pass. (2-Dr.) (exc. Conv.)	9840765	2	.53	lower, manual
71-72	Pass. (Spt. Cpe., Conv.),				
73	Pass. (2-Dr.) w/power operated window,				
74-75	Impala (Spt. Cpe.) Caprice (Conv.) w/power operated window	9841342	L.H.	.53	lower, electric
71-72	Pass. (Spt. Cpe., Conv.),				
73	Pass. (2-Dr.) w/power operated window,				
74-75	Impala (Spt. Cpe.) Caprice (Conv.) w/power operated window	9841341	R.H.	.53	lower, electric
71-75	Pass. (Conv.)	9840249	2	.58	lower, manual
71-75	Pass. (Conv.)	9840363	2	.53	upper rear
71-72	Chevelle (Conv.)	7793500	2	.55	upper front
68-72	Chevelle (Conv.)	7793499	2		STOP ASSY., upper rear
68-72	Chevelle (Spt. Cpe.)	7727247	1	.58	STOP ASSY., upper rear
68-72	Chevelle (2-Dr.) (exc. El Camino)	7727099	2	.53	STOP ASSY., lower
73-75	Chevelle (4-Dr.)	9605735	2	.53	rear door upper rear
69	Pass. (Spt. Cpe.)	8780456	2		STOP ASSY., lower
71-72	All	4405527	A.R.	.15	SCREW, quarter wdo. stop to inner panel (1/4"— 20 x 1/2")

**11.013 SPACER, Quarter Window Reveal**

65-66	Pass. (Spt. Cpe., Conv.) (exc. Caprice)	4469108	6	.24	window— (10.747)
-------	--	---------	---	-----	------------------

**11.015 WEATHERSTRIP— STRIP ASSY.— SEALING— SUPPORT ASSY., Quarter Window Glass Rubber**

**PASSENGER**

65-66	Spt. Cpe. (exc. Caprice)	4468994	R.H.	4.25	frame vertical
65-66	Spt. Cpe. (exc. Caprice)	4468995	L.H.	4.25	frame vertical
65-66	Conv.	4468992	R.H.	4.25	frame vertical
65-66	Conv.	4468993	L.H.	4.25	frame vertical
66	Caprice (Spt. Cpe.)	7582487	R.H.	4.25	frame vertical
66	Caprice (Spt. Cpe.)	7582488	L.H.	4.25	frame vertical
67-68	Impala (Spt. Cpe.)	7645156	R.H.	4.25	frame vertical
67-68	Impala (Spt. Cpe.)	7645157	L.H.	4.25	frame vertical
67-68	Impala (Conv.)	7645158	R.H.	4.25	frame vertical



**REAR GLASS—SEAT AND ADJUSTER**

**11.015 WEATHERSTRIP— STRIP ASSY.— SEALING— SUPPORT ASSY., Quarter Window Glass Rubber (Con't)**

67-68	Impala (Conv.)	7645159	L.H.	4.25	frame vertical
67-68	Caprice (Spt. Cpe.)	7645164	R.H.	4.25	frame vertical
67-68	Caprice (Spt. Cpe.)	7645165	L.H.	4.25	frame vertical
69-70	Spt. Cpe., Conv.	7794353	R.H.	5.40	vertical
69-70	Spt. Cpe., Conv.	7794354	L.H.	5.40	vertical
71-72	Impala, Caprice (Spt. Cpe., Conv.),				
73-74	Pass. (2-Dr.),				
75	Pass. (Conv.)	9829540	R.H.	4.25	front sash channel
71-72	Impala, Caprice (Spt. Cpe., Conv.),				
73-74	Pass. (2-Dr.),				
75	Pass. (Conv.)	9829541	L.H.	4.25	front sash channel
74-75	Impala (Spt. Cpe.) (exc. Custom)	9829542	R.H.	4.25	front sash channel
74-75	Impala (Spt. Cpe.) (exc. Custom)	9829543	L.H.	4.25	front sash channel
65-66	Spt. Cpe., Conv.	7648775	L.H.	3.20	STRIP ASSY., lock pillar upper corner
65-68	2-Dr. Sed.	4508157	R.H.	5.35	STRIP ASSY., inner belt
65-68	2-Dr. Sed.	4508158	L.H.	5.35	STRIP ASSY., inner at belt
66	Impala (Spt. Cpe.)	4542748	R.H.	5.35	STRIP ASSY., rear outer at belt
66	Impala (Spt. Cpe.)	4542749	L.H.	5.35	STRIP ASSY., rear outer at belt
67	Impala (Spt. Cpe.),				
67-68	Caprice (Spt. Cpe.),				
67-68	Impala (Conv.)	7648096	R.H.	3.20	STRIP ASSY., body lock pillar upper corner
67	Impala (Spt. Cpe.),				
67-68	Caprice (Spt. Cpe.),				
67-68	Impala (Conv.)	7648097	L.H.	3.20	STRIP ASSY., body lock pillar upper corner
67-68	Conv.	7657787	R.H.	5.35	STRIP ASSY., rear outer at belt
67-68	Conv.	7657788	L.H.	5.35	STRIP ASSY., rear outer at belt
67-68	Impala (Spt. Cpe.)	7656801	R.H.	5.35	STRIP ASSY., rear outer at belt
67-68	Impala (Spt. Cpe.)	7656802	L.H.	5.35	STRIP ASSY., rear outer at belt
68	Impala Custom	7754420	R.H.	5.35	STRIP ASSY., outer at belt
68	Caprice (Spt. Cpe.)	7729727	R.H.	5.35	STRIP ASSY., outer at belt
68	Caprice (Spt. Cpe.)	7729728	L.H.	5.35	STRIP ASSY., outer at belt
69-70	Spt. Cpe., Conv.	8753074	R.H.	3.20	STRIP ASSY., body lock pillar upper
69-70	Spt. Cpe., Conv.	8753075	L.H.	3.20	STRIP ASSY., body lock pillar upper
69-70	Impala (Spt. Cpe.) (exc. Custom)	8716590	R.H.	5.35	STRIP ASSY., inner at belt
69-70	Impala (Spt. Cpe.) (exc. Custom)	8807644	R.H.	5.35	STRIP ASSY., outer at belt
69-70	Impala (Spt. Cpe.) (exc. Custom)	8807645	L.H.	5.35	STRIP ASSY., outer at belt
69-70	Impala (Custom),				
69-70	Caprice (Spt. Cpe.)	8723032	R.H.	5.35	STRIP ASSY., inner at belt
69-70	Impala (Custom),				
69-70	Caprice (Spt. Cpe.)	8723033	L.H.	5.35	STRIP ASSY., inner at belt
69	Caprice (Spt. Cpe.),				
69	Impala (Custom)	8726294	R.H.	5.35	STRIP ASSY., outer
69	Caprice (Spt. Cpe.),				
69	Impala (Custom)	8726295	L.H.	5.35	STRIP ASSY., outer
69-70	Impala Custom, Caprice (Spt. Cpe.)	9808510	R.H.	4.25	STRIP ASSY., rear vert. inner
69	Impala (Custom),				
69	Caprice (Spt. Cpe.)	9808511	L.H.	4.25	STRIP ASSY., inner glass run
69-70	Pass. (exc. Spt. Cpe., Spt. Sed., Conv.)	8727969	2	1.35	STRIP ASSY., front and rear glass run channel
70	Impala Custom, Caprice (Spt. Cpe.)	8807647	L.H.	5.35	STRIP ASSY., outer at belt
70	Impala Custom, Caprice (Spt. Cpe.)	8807646	R.H.	5.35	STRIP ASSY., outer at belt
70	Impala Custom, Caprice (Spt. Cpe.)	9808511	L.H.	4.25	STRIP ASSY., rear vert. inner
71-72	(Conv.)	9838416	L.H.	5.35	STRIP ASSY., inner at belt
71-72	(Conv.)	9838415	R.H.	5.35	STRIP ASSY., inner at belt
71-72	(Conv.)	9852623	L.H.	5.35	STRIP ASSY., outer at belt
71-72	(Conv.)	9852622	R.H.	5.35	STRIP ASSY., outer at belt
71-72	Impala (Spt. Cpe.) (exc. Custom)	9845340	R.H.	5.35	STRIP ASSY., otr. at belt
71-72	Impala (Spt. Cpe.) (exc. Custom)	9845341	L.H.	5.35	STRIP ASSY., otr. at belt
71-72	Impala Custom, Caprice (Spt. Cpe.)	9846802	L.H.	5.35	STRIP ASSY., complete
71-72	Caprice, Impala (Custom)	9846801	R.H.	5.35	STRIP ASSY., otr. (complete)
71-72	Impala (Spt. Cpe.) (exc. Custom)	9835256	L.H.	5.35	STRIP ASSY., inner at belt
71-72	Impala (Spt. Cpe.) (exc. Custom)	9835255	R.H.	5.35	STRIP ASSY., inner at belt
71-72	Impala Custom, Caprice (Spt. Cpe.)	9836814	L.H.	5.35	STRIP ASSY., inner sealing
71-72	Impala Custom, Caprice (Spt. Cpe.)	9836813	R.H.	5.35	STRIP ASSY., inner sealing

**REAR GLASS—SEAT AND ADJUSTER**

**11.015 WEATHERSTRIP— STRIP ASSY.— SEALING— SUPPORT ASSY., Quarter Window Glass Rubber (Con't)**

71-72	Impala, Caprice (Spt. Cpe.) . . . . .	9883427 L.H.	3.20	STRIP ASSY., body lock pillar upper rear corner . . . . .
71-72	Impala, Caprice (Spt. Cpe.) . . . . .	9883426 R.H.	3.20	STRIP ASSY., body lock pillar upper rear corner . . . . .
73-74	Pass. (2-Dr.) . . . . .	9640451 R.H.	3.20	STRIP ASSY., body lock plr. upper rear corner . . . . .
73-74	Pass. (2-Dr.) . . . . .	9640452 L.H.	3.20	STRIP ASSY., body lock plr. upper rear corner . . . . .
73-75	Pass. (Conv.) . . . . .	1671309 L.H.	5.35	STRIP ASSY., inner at belt . . . . .
73-75	Pass. (Conv.) . . . . .	1671308 R.H.	5.35	STRIP ASSY., inner at belt . . . . .
73-75	Pass. (Conv.) . . . . .	9852623 L.H.	5.35	STRIP ASSY., outer at belt . . . . .
73-75	Pass. (Conv.) . . . . .	9852622 R.H.	5.35	STRIP ASSY., outer at belt . . . . .
73	Impala (Spt. Cpe.) (exc. Custom)	9845340 R.H.	5.35	STRIP ASSY., otr. at belt . . . . .
73	Impala (Spt. Cpe.) (exc. Custom)	9845341 L.H.	5.35	STRIP ASSY., otr. at belt . . . . .
73	Impala (Custom) Caprice (Spt. Cpe.) . . . . .	9846801 R.H.	5.35	STRIP ASSY., otr. (complete) sealing . . . . .
73	Impala (Custom) Caprice (Spt. Cpe.) . . . . .	9846802 L.H.	5.35	STRIP ASSY., otr. (complete) sealing . . . . .
73	Impala (Spt. Cpe.) (exc. Custom)	9642733 L.H.	5.35	STRIP ASSY., inner at belt . . . . .
73	Impala (Spt. Cpe.) (exc. Custom)	9642732 R.H.	5.35	STRIP ASSY., inner at belt . . . . .
73	Impala (Custom) Caprice (Spt. Cpe.) . . . . .	9642737 L.H.	5.35	STRIP ASSY., inner sealing . . . . .
73	Impala (Custom) Caprice (Spt. Cpe.) . . . . .	9642736 R.H.	5.35	STRIP ASSY., inner sealing . . . . .
74-75	Impala (Spt. Cpe.) (exc. Custom),			
74-75	Pass. (Conv.) . . . . .	9733948 R.H.	3.00	STRIP ASSY., body lock plr. upper corner . . . . .
74-75	Impala (Spt. Cpe.) (exc. Custom),			
74-75	Pass. (Conv.) . . . . .	9733949 L.H.	3.00	STRIP ASSY., body lock plr. upper corner . . . . .
74-75	Impala (Spt. Cpe.) (exc. Custom)	9680740 R.H.	7.05	SEALING STRIP ASSY., quarter window inner at belt . . . . .
74-75	Impala (Spt. Cpe.) (exc. Custom)	9680741 L.H.	7.05	SEALING STRIP ASSY., quarter window inner at belt . . . . .
74-75	Impala (Spt. Cpe.) (exc. Custom)	9686770 R.H.	7.05	SEALING STRIP ASSY., quarter window outer at belt . . . . .
74-75	Impala (Spt. Cpe.) (exc. Custom)	9686771 L.H.	7.05	SEALING STRIP ASSY., quarter window outer at belt . . . . .
71	Impala (Spt. Cpe.) (exc. Custom)	9875371 L.H.	6.65	SUPPORT ASSY., inner s/str. at belt . . . . .
71	Impala (Spt. Cpe.) (exc. Custom)	9875370 R.H.	6.65	SUPPORT ASSY., inner s/str. at belt . . . . .
71-72	Impala Custom, Caprice (Spt. Cpe.) . . . . .	9836535 L.H.	5.20	SUPPORT ASSY., inner s/str. at belt . . . . .
71-72	Impala Custom, Caprice (Spt. Cpe.) . . . . .	9836534 R.H.	5.20	SUPPORT ASSY., inner s/str. at belt . . . . .
72	Impala (Spt. Cpe.) (exc. Custom)	9833898 L.H.	5.00	SUPPORT ASSY., inner s/str. at belt . . . . .
72	Impala (Spt. Cpe.) (exc. Custom)	9833897 R.H.	5.00	SUPPORT ASSY., inner s/str. at belt . . . . .
73-75	Pass. (Conv.) . . . . .	9642091 L.H.	5.35	SUPPORT ASSY., inner s/str. at belt . . . . .
73-75	Pass. (Conv.) . . . . .	9642090 R.H.	5.35	SUPPORT ASSY., inner s/str. at belt . . . . .

**CHEVY**

62-65	Nova (Spt. Mdls.) . . . . .	4846554 R.H.	5.35	window frame . . . . .
62-65	Nova (Spt. Mdls.) . . . . .	4846555 L.H.	5.35	window frame . . . . .
66-67	Nova (Spt. Cpe.) . . . . .	4548020 R.H.	4.25	frame vertical . . . . .
66-67	Nova (Spt. Cpe.) . . . . .	4548021 L.H.	4.25	frame vertical . . . . .
66-67	Nova (Spt. Cpe.) . . . . .	9706663 L.H.	5.35	STRIP, glass run outer . . . . .
62-67	(2-Dr. Sed.) . . . . .	7636878 1	1.65	STRIP ASSY., inner glass run, inner (brt. stainless steel) . . . . .
66	Nova (Spt. Cpe.) (2nd type),			
67	Nova (Spt. Cpe.) . . . . .	7636873 L.H.	5.35	STRIP ASSY., inner at belt (brt. stainless steel bead) . . . . .
68	(Spt. Cpe.),			
70-72	(Spt. Cpe.) . . . . .	7753326 R.H.	5.35	STRIP ASSY., inner at belt . . . . .
68-72	(Spt. Cpe.) . . . . .	7753327 L.H.	5.35	STRIP ASSY., inner at belt . . . . .
68-72	(Spt. Cpe.) . . . . .	7753788 R.H.	5.35	STRIP ASSY., outer at belt . . . . .
68-72	(Spt. Cpe.) . . . . .	7753789 L.H.	5.35	STRIP ASSY., outer at belt . . . . .
70-72	(Spt. Cpe.) . . . . .	7589409 2	.33	STRIP ASSY., front channel run . . . . .
70-72	(Spt. Cpe.) . . . . .	4486342 2	.55	STRIP ASSY., rear channel run . . . . .
73-74	Nova (2-Dr.) . . . . .	9619668 L.H.	5.35	STRIP ASSY., outer at belt . . . . .
73-74	Nova (2-Dr.) . . . . .	9619667 R.H.	5.35	STRIP ASSY., outer at belt . . . . .
73-74	Nova (2-Dr.) . . . . .	7589409 2	.33	STRIP ASSY., front channel run . . . . .
73	Nova (2-Dr.) . . . . .	9619671 L.H.	5.35	STRIP ASSY., inner at belt . . . . .
73	Nova (2-Dr.) . . . . .	9619670 R.H.	5.35	STRIP ASSY., inner at belt . . . . .

**CHEVELLE**

64-65	Malibu (Spt. Cpe.) . . . . .	4407840 R.H.	4.25	window frame . . . . .
64-65	Malibu (Spt. Cpe.) . . . . .	4407841 L.H.	4.25	window frame . . . . .

**REAR GLASS—SEAT AND ADJUSTER**

**11.015 WEATHERSTRIP— STRIP ASSY.— SEALING— SUPPORT ASSY., Quarter Window Glass Rubber (Con't)**

64-65	Malibu (Conv.)	4407842 R.H.	4.25	window frame
64-65	Malibu (Conv.)	4407843 L.H.	4.25	window frame
66-67	(Spt. Cpe., Conv.)	4542977 R.H.	2.75	frame vertical
66-67	(Spt. Cpe., Conv.)	4542978 L.H.	2.75	frame vertical
68-69	Spt. Cpe., Conv.			frame vertical,
70-72	Spt. Cpe., Conv.	8734084 R.H.	4.25	front sash channel
68-69	Spt. Cpe., Conv.			frame vertical,
70-72	Spt. Cpe., Conv.	8734085 L.H.	4.25	front sash channel
73-74	Chevelle (Sta. Wag.) w/swing out rear window	9610953 L.H.	13.60	vent. qtr. window
73-74	Chevelle (Sta. Wag.) w/swing out rear window	9610952 R.H.	13.60	vent. qtr. window
75	Chevelle (Sta. Wag.) w/swing out window	9737274 R.H.	13.60	vent. qtr. window
75	Chevelle (Sta. Wag.) w/swing out window	9737275 L.H.	13.60	vent. qtr. window
73-74	Chevelle (Sta. Wag.)	9678139 2	5.35	STRIP, reveal mldg. filler anti-squeak
74-75	Laguna (Spt. Cpe.)	1653316 R.H.	1.90	STRIP, qtr. wdo. opg. blackout
74-75	Laguna (Spt. Cpe.)	1653317 L.H.	1.90	STRIP, qtr. wdo. opg. blackout
64-65	Malibu (Spt. Cpe.)	4482535 L.H.	5.35	STRIP ASSY., glass run outer
65-67	(2-Dr. Sed.)	4496456 2	1.90	STRIP ASSY., glass run frt. and rear seal— (10.686)
66-67	(Spt. Cpe.)	7630956 R.H.	5.35	STRIP ASSY., outer
66-67	(Spt. Cpe.)	7630957 L.H.	5.35	STRIP ASSY., outer
66-67	(Conv.)	7580843 R.H.	5.35	STRIP ASSY., outer
66-67	(Conv.)	7580844 L.H.	5.35	STRIP ASSY., outer
66-67	(Spt. Cpe.)	7636871 L.H.	5.35	STRIP ASSY., inner at belt (brt. stainless steel bead)
66-67	(Spt. Cpe.)	7636870 R.H.	5.35	STRIP ASSY., inner at belt (brt. stainless steel bead)
68-69	(Spt. Cpe.)	7723786 L.H.	5.35	STRIP ASSY., inner at belt
68-70	(Spt. Cpe., Conv.)	7790755 L.H.	3.20	STRIP ASSY., body lock pillar upper corner seal
68-70	(Spt. Cpe., Conv.)	7790754 R.H.	3.20	STRIP ASSY., body lock pillar upper corner seal
68	(Spt. Cpe.)	7725400 R.H.	5.35	STRIP ASSY., outer at belt
68-69	(2-Dr. Sed.)	7725403 L.H.	5.35	STRIP ASSY., outer at belt
68	(Coupe)	7725401 L.H.	5.35	STRIP ASSY., outer at belt
68	(Conv.)	7725568 R.H.	5.35	STRIP ASSY., outer at belt
68	(Conv.)	7725569 L.H.	5.35	STRIP ASSY., outer at belt
68-72	(Conv.)	7726205 R.H.	5.35	STRIP ASSY., inner at belt
68-72	(Conv.)	7726206 L.H.	5.35	STRIP ASSY., inner at belt
69	(Spt. Cpe.)	9806548 R.H.	5.35	STRIP ASSY., outer at belt
69	(Spt. Cpe.)	9806549 L.H.	5.35	STRIP ASSY., outer at belt
69-72	(Conv.)	8807640 R.H.	5.35	STRIP ASSY., outer at belt
69	(2-Dr. Sed.)	8727969 4	1.35	STRIP ASSY., front and rear glass run channel
70-72	Chevelle (Conv.)	8807641 L.H.	5.35	STRIP ASSY., outer at belt
70-72	Malibu (Spt. Cpe.)	8790318 L.H.	5.35	STRIP ASSY., outer at belt (sealing)
70-72	Malibu (Spt. Cpe.)	8790317 R.H.	5.35	STRIP ASSY., outer at belt (sealing)
70-72	Malibu (Spt. Cpe.)	9808515 L.H.	4.25	STRIP ASSY., rear vert. inner
70-72	Malibu (Spt. Cpe.)	9808514 R.H.	4.25	STRIP ASSY., rear vert. inner
70-72	Malibu (Spt. Cpe.)	8781734 L.H.	5.35	STRIP ASSY., inner at belt (sealing)
70-72	Malibu (Spt. Cpe.)	8781733 R.H.	5.35	STRIP ASSY., inner at belt (sealing)
70-72	Monte Carlo	8784585 L.H.	5.35	STRIP ASSY., inner at belt (sealing)
70-72	Monte Carlo	8784584 R.H.	5.35	STRIP ASSY., inner at belt (sealing)
70-72	Monte Carlo	8784589 L.H.	5.35	STRIP ASSY., outer at belt (sealing)
70-72	Monte Carlo	8784588 R.H.	5.35	STRIP ASSY., outer at belt (sealing)
70-72	Monte Carlo	9722203 L.H.	5.35	STRIP ASSY., outer glass run
70-72	Monte Carlo	9722202 R.H.	5.35	STRIP ASSY., outer glass run
70-72	Monte Carlo	9808556 L.H.	4.25	STRIP ASSY., rear vert. outer
70-72	Monte Carlo	9808555 R.H.	4.25	STRIP ASSY., rear vert. outer
70-72	Monte Carlo	9808517 L.H.	4.25	STRIP ASSY., rear vert. inner
70-72	Monte Carlo	9808516 R.H.	4.25	STRIP ASSY., rear vert. inner
71-72	(Spt. Cpe., Conv.)	7790755 L.H.	3.20	STRIP ASSY., body lock pillar upper corner seal
71-72	(Spt. Cpe., Conv.)	7790754 R.H.	3.20	STRIP ASSY., body lock pillar upper corner seal
73-74	Chevelle (Spt. Sed.)	9678381 2	.33	SEALING, strip qtr. wdo. glass channel, front
73-75	Chevelle (Spt. Sed.)	9678380 2	1.05	SEALING, strip qtr. wdo. glass channel, rear
75	Chevelle (Spt. Sed.)	1740839 2	.43	SEALING, strip qtr. wdo. glass channel, front

**REAR GLASS—SEAT AND ADJUSTER**

**11.015 WEATHERSTRIP— STRIP ASSY.— SEALING— SUPPORT ASSY., Quarter Window Glass Rubber (Con't)**

**CAMARO**

67-69	Camaro	7707462	R.H.	4.25	frame vertical
67-69	Camaro	7707463	L.H.	4.25	frame vertical
67-69	(Conv.)	7725936	R.H.	5.35	STRIP ASSY., outer at belt
67-69	(Conv.)	7725937	L.H.	5.35	STRIP ASSY., outer at belt
67-69	(Spt. Cpe.)	7725935	L.H.	5.35	STRIP ASSY., outer at belt
67	(Spt. Cpe.) (Conv.)	7642401	R.H.	5.35	STRIP ASSY., inner at belt
67	(Spt. Cpe.) (Conv.)	7642402	L.H.	5.35	STRIP ASSY., inner at belt
67-69	(Spt. Cpe.)	7725934	R.H.	5.35	STRIP ASSY., outer at belt
68-69	(Spt. Cpe.)	7726630	R.H.	5.35	STRIP ASSY., inner at belt (standard trim)
68-69	(Spt. Cpe.)	7726631	L.H.	5.35	STRIP ASSY., inner at belt (standard trim)
68-69	(Conv.)	7726632	R.H.	5.35	STRIP ASSY., inner at belt (standard trim)
68-69	(Conv.)	7726633	L.H.	5.35	STRIP ASSY., inner at belt (standard trim)
68-69	(Spt. Cpe.) w/Custom trim	7762326	R.H.	5.35	STRIP ASSY., inner at belt
68-69	(Spt. Cpe.) w/Custom trim	7762327	L.H.	5.35	STRIP ASSY., inner at belt

**11.021 CHANNEL— STRIP, Quarter Window Glass Run**

**PASSENGER**

65-68	2-Dr. (exc. Spt. Mdls.)	4536290	2	4.10	glass run front
68	Caprice (Spt. Cpe.)				
68	Impala (Custom)	7727230	R.H.	8.70	
68	Caprice (Spt. Cpe.)				
68	Impala (Custom)	7727231	L.H.	8.70	

**CHEVY**

62-67	(2-Dr. Sed.)	4865160	2	1.95	front
68-72	(Spt. Cpe.)	7748133	R.H.	8.15	rear
68-72	(Spt. Cpe.)	7748134	L.H.	8.15	rear
68-74	Nova (2-Dr.)	7748848	R.H.	2.25	front
68-74	Nova (2-Dr.)	7748849	L.H.	2.15	front
73-74	Nova (2-Dr.)	9612556	L.H.	8.15	rear
73-74	Nova (2-Dr.)	9612555	R.H.	8.15	rear
75	Nova (2-Dr.)	1668432	R.H.	11.80	pivot window
75	Nova (2-Dr.)	1668433	L.H.	11.80	pivot window
75	Nova (2-Dr.)	1654708	R.H.	15.80	stationary window
75	Nova (2-Dr.)	1654709	L.H.	15.80	stationary window
75	Nova (2-Dr.) w/side wdo. rvl. mldg.	1687588	R.H.	15.80	stationary window
75	Nova (2-Dr.) w/side wdo. rvl. mldg.	1687589	L.H.	12.10	stationary window

**CHEVELLE**

64-67	(2-Dr. Sed.)	4543162	2	4.60	front
68-69	(2-Dr. Sed.)	7729266	R.H.	8.15	rear
68-69	(2-Dr. Sed.)	7729267	L.H.	8.25	rear
68-69	(2-Dr. Sed.)	7743262	1	1.95	front
73-75	Chevelle (Spt. Sed.)	9627021	L.H.	8.70	stationary
73-75	Chevelle (Spt. Sed.)	9627020	R.H.	8.70	stationary

**VEGA— MONZA**

71-75	Vega (H.B.)	9876596	L.H.	23.35	qtr. window swing out
71-75	Vega (H.B.)	9876595	R.H.	23.35	qtr. window swing out
71-75	Vega (N.B.)	9876594	L.H.	23.35	qtr. window swing out
71-75	Vega (N.B.)	9876593	R.H.	23.35	qtr. window swing out
71-74	Vega (Sta. Wag.)	9827887	L.H.		qtr. window stationary
71-75	Vega (Sta. Wag.)	9738813	R.H.	10.15	qtr. window stationary
71-75	Vega (Panel)	9828624	L.H.	10.15	qtr. window stationary
71-75	Vega (Panel)	9828623	R.H.	10.15	qtr. window stationary
71-74	Vega (N.B.) w/side wdo. revel. mldg.	9827889	L.H.	9.20	qtr. window stationary
71-74	Vega (N.B.) w/side wdo. revel. mldg.	9827888	R.H.	9.20	qtr. window stationary
71-75	Vega (H.B.)	9733630	R.H.	9.20	qtr. window stationary (repl. 9827890)
71-75	Vega (H.B.)	9733631	L.H.	8.75	qtr. window stationary
74	Vega (N.B.)	9865939	L.H.	11.45	qtr. window stationary
74	Vega (N.B.)	9827888	R.H.	9.20	qtr. window stationary
75	Vega (Sta. Wag.)	9738814	L.H.	10.15	qtr. window stationary
75	Vega (Panel)	9828624	L.H.	10.15	qtr. window stationary (repl. 9738816)
75	Vega (N.B.) w/side wdo. rvl. mldg.	9733632	R.H.	9.20	qtr. window stationary

**REAR GLASS—SEAT AND ADJUSTER**

**11.021 CHANNEL— STRIP, Quarter Window Glass Run (Con't)**

75	Vega (N.B.) w/side wdo. rvl. mldg. ....	9733633 L.H.	9.20	qtr. window stationary .....
75	Vega (N.B.) .....	9737526 R.H.	8.70	qtr. window stationary .....
75	Vega (N.B.) .....	9737527 L.H.	8.70	qtr. window stationary .....
71-72	Vega, Monza .....	9877446 A.R.	.50	STRIP, quarter window glass channel .....

**11.024 CLIP— RETAINER, Quarter Window Glass Run**

73-74	Chevelle (exc. Spt. Sed.) .....	9609744 A.R.	.28	stationary glass .....
75	Pass. (Spt. Sed.) .....	1690550 4	.16	stationary glass .....
75	Pass., Chevelle, Monza (Towne Cpe.) .....	1698296 A.R.	.16	stationary glass .....
73-75	Chevelle (Spt. Sed.) .....	9624089 2	.50	RETAINER, front stationary channel .....
74-75	Chevelle (Spt. Sed.) .....	9667243 R.H.	8.10	RETAINER, stationary channel .....
74-75	Chevelle (Spt. Sed.) .....	9667244 L.H.	8.10	RETAINER, stationary channel .....
75	Nova (2-Dr.) (formal wind.) .....	1726309 A.R.	.66	RETAINER, stationary glass .....
75	Monza (exc. Towne Cpe.) .....	1715847 2	7.65	RETAINER, qtr. wdo. glass .....

**11.031 MOULDING— ESCUTCHEON— CLIP— SCREW, Quarter Window Reveal**

**PASSENGER**

65-66	Impala, Caprice (Sta. Wag.) ....	4467598 R.H.	11.90	upper .....
65-66	Impala, Caprice (Sta. Wag.) ....	4467599 L.H.	12.30	upper .....
65-66	Impala, Caprice (Sta. Wag.) ....	4467208 R.H.	10.45	lower .....
65-66	Impala, Caprice (Sta. Wag.) ....	4467209 L.H.	10.45	lower .....
65-70	Sta. Wag. (exc. door and window moulding) .....	7639390 R.H.	7.80	rear lower .....
65-70	Sta. Wag. (exc. door and window moulding) .....	7639391 L.H.	7.80	rear lower .....
67-70	Sta. Wag. w/door and window frame mldg. ....	7639392 R.H.	10.45	rear lower .....
67-70	Sta. Wag. w/door and window frame mldg. ....	7639393 L.H.	10.45	rear lower .....
65-70	Sta. Wag. (exc. door and window moulding) .....	7639448 R.H.	8.45	rear upper .....
65-70	Sta. Wag. (exc. door and window moulding) .....	7639449 L.H.	8.45	rear upper .....
67-70	Sta. Wag. w/door and window frame mldg. ....	7639450 R.H.	12.05	rear upper .....
67-70	Sta. Wag. w/door and window frame mldg. ....	7639451 L.H.	12.05	rear upper .....
71-72	(Sta. Wag.) (exc. door and window mldg.), .....			
73-75	Bel Air (Sta. Wag.) .....	9831585 L.H.	9.10	lower .....
71-72	(Sta. Wag.) (exc. door and window mldg.), .....			
73-75	Bel Air (Sta. Wag.) .....	9831584 R.H.	9.10	lower .....
71-72	(Sta. Wag.) w/door and window frame mldg., .....			
73-75	Impala, Caprice (Sta. Wag.), .....			
73-75	Bel Air (Sta. Wag.) vinyl top, two tone paint .....	1686469 L.H.	11.70	lower .....
71-72	(Sta. Wag.) w/door and window frame mldg., .....			
73-75	Impala, Caprice (Sta. Wag.), .....			
73-75	Bel Air (Sta. Wag.) vinyl top, two tone paint .....	1686468 R.H.	11.70	lower .....
71-72	(Sta. Wag.) (exc. door and window mldg.) .....	9831589 L.H.	7.40	upper .....
71-72	(Sta. Wag.) (exc. door and window mldg.) .....	9831588 R.H.	7.40	upper .....
71-72	(Sta. Wag.) w/door and window frame mldg. ....	1686465 L.H.	10.10	upper .....
71-72	(Sta. Wag.) w/door and window frame mldg. ....	1686464 R.H.	10.10	upper .....
71-72	Brookwood, Townsman (exc. door and window mldg.), .....			
73-75	Bel Air (Sta. Wag.) .....	9831593 L.H.	7.60	front .....
71-72	Brookwood, Townsman (exc. door and window mldg.), .....			
73-75	Bel Air (Sta. Wag.) .....	9831592 R.H.	7.60	front .....
71-72	Kingswood, .....			
71-72	Brookwood, Townsman w/door and window frame mldg., .....			
73-75	Impala, Caprice (Sta. Wag.), .....			

**REAR GLASS—SEAT AND ADJUSTER**

**11.031 MOULDING— ESCUTCHEON— CLIP— SCREW, Quarter Window Reveal  
(Con't)**

73-75	Bel Air (Sta. Wag.) w/vinyl top, two tone paint	1686461 L.H.	11.95	front
71-72	Kingswood,			
71-72	Brookwood, Townsman w/door and window frame mldg.,			
73-75	Impala, Caprice (Sta. Wag.),			
73-75	Bel Air (Sta. Wag.) w/vinyl top, two tone paint	1686460 R.H.	11.95	front
73-75	Impala, Caprice (Sta. Wag.),			
73-75	Bel Air (Sta. Wag.) w/vinyl top, two tone paint	1686465 L.H.	10.10	upper
73-75	Impala, Caprice (Sta. Wag.),			
73-75	Bel Air (Sta. Wag.) vinyl top, two tone paint	1686464 R.H.	10.10	upper
73-75	Bel Air (Sta. Wag.)	9831589 L.H.	7.40	upper
73-75	Bel Air (Sta. Wag.)	9831588 R.H.	7.40	upper
74-75	Impala (Custom) Caprice (Spt. Cpe.)	1684076 R.H.	8.45	stationary
74-75	Impala (Custom) Caprice (Spt. Cpe.)	1684077 L.H.	8.45	stationary
74-75	Impala (Custom) Caprice (Spt. Cpe.) w/padded vinyl roof	1684078 R.H.	11.70	stationary
74-75	Impala (Custom) Caprice (Spt. Cpe.) w/padded vinyl roof	1684079 L.H.	11.70	stationary
75	Pass. (Spt. Sed.)	9733926 R.H.	9.00	stationary
75	Pass. (Spt. Sed.)	9733927 L.H.	9.00	stationary
75	Pass. (Spt. Sed.) w/padded vinyl roof	9733928 R.H.	9.70	stationary
75	Pass. (Spt. Sed.) w/padded vinyl roof	9733929 L.H.	9.70	stationary
75	Pass. (Sta. Wag.) (exc. Bel Air),			
75	Bel Air (Sta. Wag.) w/padded vinyl roof, two tone paint	1686465 L.H.	10.10	upper

*NOTE 1 This unit consists of 1 moulding, 4 nuts, 7 clips.*

*Note 2. This unit consists of 1 moulding, 8 clips, 2 fasteners.*

*Note 3. This unit consists of 1 moulding, 5 clips, 2 retainers, 4 screws, 4 nuts.*

*Note 4. This unit consists of 1 moulding, 1 clip.*

*Note 5. This unit consists of 1 moulding, 1 retainer, 2 screws, 1 clip.*

67-68	Sed. (exc. Spd. Sed.) w/two-tone paint	3914080 R.H.	12.30	<b>MOULDING UNIT</b> , rear quarter belt reveal— (12.116)
67-68	Sed. (exc. Spt. Sed.) w/two-tone paint	3914079 L.H.	11.20	<b>MOULDING UNIT</b> , rear quarter belt reveal— (12.116)
67-68	Spt. Sed. w/vinyl top, two-tone paint	3914084 R.H.	11.65	<b>MOULDING UNIT</b> , rear quarter belt reveal— (12.116)
67-68	Spt. Sed. w/vinyl top, two-tone paint	3914083 L.H.	12.30	<b>MOULDING UNIT</b> , rear quarter belt reveal— (12.116)
67	Impala (Spt. Cpe.) w/vinyl top, two-tone paint,			
68	Impala (Spt. Cpe.) w/two-tone paint (exc. Custom)	3914090 R.H.	11.95	<b>MOULDING UNIT</b> , rear quarter belt reveal— (12.116)
67	Impala (Spt. Cpe.) w/vinyl top, two-tone paint,			
68	Impala (Spt. Cpe.) w/two-tone paint (exc. Custom)	3914089 L.H.	11.95	<b>MOULDING UNIT</b> , rear quarter belt reveal— (12.116)

**CHEVY— NOVA**

68-71	(Spt. Cpe.) (exc. door and wdo. frame mldg.),			
73-74	Nova (2-Dr.) (exc. side window mldg.)	7781524 R.H.	3.80	front
68-74	(Spt. Cpe.) (exc. door and wdo. frame mldg.)	7781525 L.H.	3.80	front
68-74	(Spt. Cpe.) w/door window frame mldg.	7783017 R.H.	3.95	front, bright finish
68-74	(Spt. Cpe.) w/door window frame mldg.	7783018 L.H.	3.95	front, bright finish
68-72	(Spt. Cpe.) (exc. door and wdo. frame mldg.)	7748135 R.H.	8.70	rear

**REAR GLASS—SEAT AND ADJUSTER**

**11.031 MOULDING— ESCUTCHEON— CLIP— SCREW, Quarter Window Reveal  
(Con't)**

68-72	(Spt. Cpe.) (exc. door and wdo. frame mldg.)	7748136 L.H.	8.70	rear
68-72	(Spt. Cpe.) w/door window frame mldg.	7748137 R.H.	14.50	rear
68-72	(Spt. Cpe.) w/door window frame mldg.	7748138 L.H.	14.50	rear
73-74	Nova (2-Dr.) (exc. side window mldg.)	9622702 L.H.	8.70	rear
73-74	Nova (2-Dr.) (exc. side window mldg.)	9622701 R.H.	8.70	rear
73-74	Nova (2-Dr.) w/side window mldg.	9622704 L.H.	14.50	rear, bright finish
73-74	Nova (2-Dr.) w/side window mldg.	9622703 R.H.	14.50	rear, bright finish
74	Nova (2-Dr.) w/side window mldg.	9733196 R.H.	3.80	front, painted w/Spirit of America
74	Nova (2-Dr.) w/side window mldg.	9733197 L.H.	3.80	front, painted w/Spirit of America
74	Nova (2-Dr.) w/side window mldg.	9733200 R.H.	14.50	rear, painted w/Spirit of America
74	Nova (2-Dr.) w/side window mldg.	9733201 L.H.	14.50	rear, painted w/Spirit of America
75	Nova (2-Dr.) (exc. side window mldg.)	1651464 R.H.	7.60	upper
75	Nova (2-Dr.) (exc. side window mldg.)	1651465 L.H.	7.60	upper
75	Nova (2-Dr.) (exc. side window mldg.)	1651466 R.H.	3.80	front
75	Nova (2-Dr.) (exc. side window mldg.)	1651467 L.H.	3.80	front
75	Nova (2-Dr.) w/side wdo. mldg. & extr. orna. (exc. swing out & formal wdo.)	1687796 R.H.	8.45	upper (chrome)
75	Nova (2-Dr.) w/side wdo. mldg. & extr. orna. (exc. swing out & formal wdo.)	1687797 L.H.	8.45	upper (chrome)
75	Nova (2-Dr.) w/side wdo. mldg. & extr. orna. (exc. swing out & formal wdo.)	1689174 R.H.	6.75	front (chrome)
75	Nova (2-Dr.) w/side wdo. mldg. & extr. orna. (exc. swing out & formal wdo.)	1689175 L.H.	7.15	front (chrome)
75	Nova (2-Dr.) w/side wdo. mldg. & extr. orna. (exc. swing out & formal wdo.)	1689480 R.H.	7.60	lower (chrome)
75	Nova (2-Dr.) w/side wdo. mldg. & extr. orna. (exc. swing out & formal wdo.)	1689481 L.H.	7.60	lower (chrome)
75	Nova (2-Dr.) w/swing vent. and side window mldg.	1668436 R.H.	9.00	upper
75	Nova (2-Dr.) w/swing vent. and side window mldg.	1668437 L.H.	9.00	upper
75	Nova (2-Dr.) w/swing out and side wdo. mldg.	1668434 2	3.80	front
75	Nova (2-Dr.) w/painted side wdo. mldg. (exc. swing out, st. wdo. rvl. mldg.)	1688336 R.H.	3.80	front
75	Nova (2-Dr.) w/painted side wdo. mldg. (exc. swing out, st. wdo. rvl. mldg.)	1688337 L.H.	3.80	front
75	Nova (2-Dr.) w/painted side wdo. mldg. (exc. swing out, st. wdo. rvl. mldg.)	1688340 R.H.	7.60	upper
75	Nova (2-Dr.) w/painted side wdo. mldg. (exc. swing out, st. wdo. rvl. mldg.)	1688341 L.H.	7.60	upper
75	Nova (2-Dr.) w/swing out and side wdo. mldg.	1688230 R.H.	13.65	MOULDING, lower/pivot
75	Nova (2-Dr.) w/swing out and side wdo. mldg.	1688231 L.H.	13.65	MOULDING, lower/pivot
75	Nova (2-Dr.) w/swing out and side wdo. mldg.	1688245 R.H.	7.95	MOULDING, upper/pivot
75	Nova (2-Dr.) w/swing out and side wdo. mldg.	1688246 L.H.	7.95	MOULDING, upper/pivot

**REAR GLASS—SEAT AND ADJUSTER**

**11.031 MOULDING— ESCUTCHEON— CLIP— SCREW, Quarter Window Reveal  
(Con't)**

75	Nova (2-Dr.) w/swing out and side wdo. mldg. ....	1688252 R.H.	3.20	MOULDING, front/pivot .....
75	Nova (2-Dr.) w/swing out and side wdo. mldg. ....	1688253 L.H.	3.20	MOULDING, front/pivot .....
75	Nova (2-Dr.) w/formal wind. ....	1735060 R.H.	46.00	MOULDING .....
75	Nova (2-Dr.) w/formal wind. ....	1735061 L.H.	46.00	MOULDING .....
66-67	Nova (Spt. Cpe.) .....	4548395 R.H.	11.45	MOULDING ASSY., reveal .....
66-67	Nova (Spt. Cpe.) .....	4548396 L.H.	11.45	MOULDING ASSY., reveal .....
66-67	(Sed.) (exc. Nova) .....	3893523 L.H.	7.60	MOULDING UNIT, rr. belt reveal— (12.116)

**CHEVELLE**

66-67	Malibu (Sta. Wag.), Deluxe (Sta. Wag.) w/door window frame mouldings .....	4541768 L.H.	10.00	lower reveal .....
68-69	(2-Dr. Sed., Spt. Cpe.) w/two tone paint (exc. Malibu, S.S.), (Spt. Cpe.) w/vinyl top, two tone paint .....	3941891 L.H.	18.25	rr. qtr. wind. rr. reveal— (12.116) .....
68-69	(2-Dr. Sed., Spt. Cpe.) w/two tone paint (exc. Malibu, S.S.), (Spt. Cpe.) w/vinyl top, two tone paint .....	3941892 R.H.	16.60	rr. qtr. wind. rr. reveal— (12.116) .....
68-69	(2-Dr. Sed.) .....	7723876 R.H.	4.85	front .....
68-69	(2-Dr. Sed.) .....	7723877 L.H.	4.85	front .....
68-69	(2-Dr. Sed.) w/door and window mldg. ....	7723878 R.H.	5.45	front .....
68-69	(2-Dr. Sed.) w/door and window mldg. ....	7723879 L.H.	5.45	front .....
68-72	Nomad, Greenbrier (exc. door and window mldg.) .....	7724129 L.H.	6.80	lower .....
68-72	Nomad, Greenbrier (exc. door and window mldg.) .....	7724128 R.H.	6.80	lower .....
68-70	Concours, Malibu (Sta. Wag.), Nomad, Greenbrier w/door window frame mldg. ....	7724130 R.H.	9.65	lower reveal .....
68-70	Concours, Malibu (Sta. Wag.), Nomad, Greenbrier w/door window frame mldg. ....	7724131 L.H.	9.65	lower reveal .....
68-72	Nomad, Greenbrier (exc. door and window mldg.) .....	7724461 L.H.	9.25	upper .....
68-72	Nomad, Greenbrier (exc. door and window mldg.) .....	7724460 R.H.	9.25	upper .....
68-72	Concours, Malibu (Sta. Wag.), Nomad, Greenbrier w/door window frame mldg. ....	7724462 R.H.	11.75	upper reveal .....
68-72	Concours, Malibu (Sta. Wag.), Nomad, Greenbrier w/door window frame mldg. ....	7724463 L.H.	9.65	upper reveal .....
70-72	Monte Carlo w/belt mldg. ....	9809070 R.H.	13.05	reveal .....
70-72	Monte Carlo w/belt mldg. ....	9809071 L.H.	13.05	reveal .....
73-75	Chevelle (Spt. Sed.) w/roof drip mldg., vinyl top .....	9883126 2	1.90	front sash outer .....
73	Chevelle (Spt. Cpe.) w/vinyl top (exc. Monte Carlo) .....	9727043 R.H.	8.50	lower (repl. 9686772) .....
73	Monte Carlo (2nd design) .....	9674954 2	1.80	and escutcheon .....
73-75	Chevelle (Sta. Wag.) .....	1683715 L.H.	10.75	front .....
73-75	Chevelle (Sta. Wag.) .....	1683714 R.H.	10.75	front .....
73-75	Chevelle (Sta. Wag.) .....	1683721 L.H.	16.15	upper .....
73-75	Chevelle (Sta. Wag.) .....	1683720 R.H.	16.15	upper .....
73-75	Chevelle (Sta. Wag.) w/swing out window .....	9665203 L.H.	20.00	div. chnl. vent. ....
73-75	Chevelle (Sta. Wag.) w/swing out window .....	9665202 R.H.	20.00	div. chnl. vent. ....
73-75	Chevelle (Sta. Wag.) .....	1683719 L.H.	15.50	lower .....
73-75	Chevelle (Sta. Wag.) .....	1683718 R.H.	15.50	lower .....
73-74	Monte Carlo .....	9680701 R.H.	4.95	one piece front and rear .....
73-74	Monte Carlo .....	9680702 L.H.	4.95	one piece front and rear .....
73	Chevelle (Spt. Cpe.) (exc. Monte Carlo),			
74	Malibu (Spt. Cpe.) (exc. Classic) .	9686772 R.H.		
73	Chevelle (Spt. Cpe.) (exc. Monte Carlo),			
73-74	Malibu (Spt. Cpe.) (exc. Classic) .	9686773 L.H.	7.00	



**REAR GLASS—SEAT AND ADJUSTER**

**11.031 MOULDING— ESCUTCHEON— CLIP— SCREW, Quarter Window Reveal  
(Con't)**

74	Malibu Classic, Laguna (Spt. Cpe.)	9735172 R.H.	4.75	
74	Malibu Classic, Laguna (Spt. Cpe.)	9735173 L.H.	4.75	
74-75	Chevelle (Spt. Sed.)	1710772 R.H.	2.30	stationary glass channel
74-75	Chevelle (Spt. Sed.)	1710773 L.H.	2.30	stationary glass channel
75	Monte Carlo	9695096 R.H.	4.95	
75	Monte Carlo	9695097 L.H.	4.95	
75	Monte Carlo w/pad vinyl roof	9695384 R.H.	4.50	
75	Monte Carlo w/pad vinyl roof	9695385 L.H.	4.50	
75	Malibu (Spt. Cpe.) (exc. Classic)	9727043 R.H.	8.50	
75	Malibu (Spt. Cpe.) (exc. Classic)	9727044 L.H.	8.50	
75	Malibu (Spt. Cpe.) (exc. Classic) w/pad vinyl roof	9733885 R.H.	13.20	
75	Malibu (Spt. Cpe.) (exc. Classic) w/pad vinyl roof	9733886 L.H.	13.20	
75	Malibu Classic (Spt. Cpe.)	9735922 R.H.	7.20	
75	Malibu Classic (Spt. Cpe.)	9735923 L.H.	7.20	
75	Malibu Classic (Spt. Cpe.) w/vinyl roof	9735924 R.H.	7.20	
75	Malibu Classic (Spt. Cpe.) w/vinyl roof	9735925 L.H.	7.20	
66-67	(Spt. Cpe.) w/vinyl top, two-tone paint	3890183 L.H.	9.10	MOULDING UNIT, rr. quarter reveal— (12.116)
66-67	(Spt. Cpe.) w/vinyl top, two-tone paint	3890184 R.H.	9.10	MOULDING UNIT, rr. belt quarter reveal— (12.116)
66-67	(Spt. Cpe.) w/vinyl top, two-tone paint	3890182 R.H.	14.05	MOULDING UNIT, rr. belt inner reveal— (12.116)
66-67	(Spt. Cpe.) w/vinyl top, two-tone paint	3890181 L.H.	14.05	MOULDING UNIT, rr. belt inner reveal— (12.116)

**CAMARO**

68	(Spt. Cpe.) w/exterior reveal mldg.	7737903 R.H.	18.15	
68	(Spt. Cpe.) w/exterior reveal mldg.	7737904 L.H.	18.15	
68	(Conv.) w/exterior reveal mldg.	7743628 R.H.	15.90	
68	(Conv.) w/exterior reveal mldg.	7743629 L.H.	15.65	
67-68	w/vinyl roof	3914077 L.H.	12.30	MOULDING UNIT, rear quarter belt reveal— (12.116)
67-68	w/vinyl roof	3914078 R.H.	12.30	MOULDING UNIT, rear quarter belt reveal— (12.116)

**VEGA— MONZA**

71-75	Vega (Coupe)	9828213 R.H.	6.25	qtr. window belt reveal
71-75	Vega (Coupe)	9828214 L.H.	6.25	qtr. window belt reveal
71-75	Vega (H.B.) w/swing-out qtr. window	9833916 R.H.	9.25	qtr. window upper reveal
71-75	Vega (H.B.) w/swing-out qtr. window	9833917 L.H.	9.25	qtr. window upper reveal
71-75	Vega (N.B.) w/swing-out qtr. window, door and window frame mldg.	9833912 R.H.	9.25	qtr. window upper reveal
71-75	Vega (N.B.) w/swing-out qtr. window, door and window frame mldg.	9833913 L.H.	9.25	qtr. window upper reveal
71-75	Vega (Sta. Wag.)	9826347 R.H.	8.90	qtr. window upper reveal
71-75	Vega (Sta. Wag.)	9826348 L.H.	8.90	qtr. window upper reveal
71-75	Vega (N.B.) w/swing-out qtr. window (exc. door and window frame mldg.)	9888429 L.H.	8.65	qtr. window upper reveal
71-75	Vega (N.B.) w/swing-out qtr. window (exc. door and window frame mldg.)	9888428 R.H.	8.65	qtr. window upper reveal
71-75	Vega (N.B.) (exc. swing-out qtr. window, door and window frame mldg.)	9824867 L.H.	6.35	qtr. window upper reveal (painted)
71-75	Vega (N.B.) (exc. swing-out qtr. window, door and window frame mldg.)	9824866 R.H.	6.35	qtr. window upper reveal (painted)

**REAR GLASS—SEAT AND ADJUSTER**

**11.031 MOULDING— ESCUTCHEON— CLIP— SCREW, Quarter Window Reveal  
(Con't)**

71-75	Vega (H.B.) (exc. swing-out qtr. window) . . . . .	9826401 L.H.	5.95	qtr. window upper reveal . . . . .
71-75	Vega (H.B.) (exc. swing-out qtr. window) . . . . .	9826400 R.H.	5.95	qtr. window upper reveal . . . . .
71-75	Vega (N.B.) w/door and window frame mldg. (exc. swing-out qtr. window) . . . . .	9826345 R.H.	5.95	qtr. window upper reveal (chrome) . . . . .
71-75	Vega (N.B.) w/door and window frame mldg. (exc. swing-out qtr. window) . . . . .	9826346 L.H.	5.95	qtr. window upper reveal (chrome) . . . . .
71-75	Vega (Sta. Wag.) . . . . .	9826396 R.H.	5.05	reveal qtr. window rear . . . . .
71-75	Vega (Sta. Wag.) . . . . .	9826397 L.H.	5.05	reveal qtr. window rear . . . . .
71-75	Vega (H.B.) (exc. swing-out qtr. window) . . . . .	9870902 2	3.95	qtr. window front reveal . . . . .
71-75	Vega (N.B.) (Sta. Wag.) (exc. swing-out qtr. window) . . . . .	9870901 2	3.95	qtr. window front reveal (chrome) . . . . .
71-75	Vega (N.B.) (exc. swing-out vent., side wdo. reveal mldg.) . . . . .	9881121 2	3.85	qtr. window front reveal (painted) . . . . .
71-75	Vega (N.B.) w/swing-out qtr. window (exc. side reveal mouldings) . . . . .	9680700 2	3.60	qtr. window front reveal (painted) . . . . .
71-75	Vega (H.B.) w/swing-out qtr. window . . . . .	9680699 2	4.90	qtr. window front reveal . . . . .
71-75	Vega (N.B.) (swing-out qtr. window w/si. reveal mldg.) . . . . .	9680698 2	4.90	qtr. window front reveal . . . . .
75	Monza (exc. Towne Cpe.) . . . . .	9739098 R.H.	21.90	lower . . . . .
75	Monza (exc. Towne Cpe.) . . . . .	9739099 L.H.	21.90	lower . . . . .
75	Monza (exc. Towne Cpe.) . . . . .	1721096 R.H.	10.30	upper . . . . .
75	Monza (exc. Towne Cpe.) . . . . .	1721097 L.H.	10.30	upper . . . . .
75	Monza (Towne Cpe.) w/formal rear wdo. . . . .	1672970 R.H.	3.30	qtr. window (stationary) . . . . .
75	Monza (Towne Cpe.) w/formal rear wdo. . . . .	1672971 L.H.	3.30	qtr. window (stationary) . . . . .

**ESCUTCHEON— CLIP— SCREW, Quarter Window Reveal**

65-66	(Sta. Wag.) (exc. Impala) . . . . .	4480463 2	2.60	reveal mldg. rear . . . . .
67-70	Pass. (Sta. Wag.) (exc. door and window moulding) . . . . .	8717536 2	3.40	rear mldg., rear . . . . .
67-70	Pass. (Sta. Wag.), . . . . .			
67-70	Pass. (Sta. Wag.) w/door and window mldg. . . . .	8717537 2	3.40	rear mldg., rear . . . . .
68-70	Nomad, Greenbrier w/door and window mldg., . . . . .			
68-72	Malibu, Concours (Sta. Wag.) . . . . .	8726840 R.H.	5.10	reveal mldg. upper front . . . . .
68-70	Nomad, Greenbrier w/door and window mldg. . . . .			
68-72	Malibu, Concours (Sta. Wag.) . . . . .	8726841 L.H.	5.10	reveal mldg. upper front . . . . .
69-72	Nomad, Greenbrier . . . . .	8726837 R.H.	3.40	reveal mldg. upper front . . . . .
69-72	Nomad, Greenbrier . . . . .	8726838 L.H.	3.40	reveal mldg. upper front . . . . .
71-72	Pass. (Sta. Wag.), . . . . .			
73-75	Bel Air (Sta. Wag.) . . . . .	9888342 L.H.	11.70	upper rear . . . . .
71-72	Pass. (Sta. Wag.), . . . . .			
73-75	Bel Air (Sta. Wag.) . . . . .	9888341 R.H.	11.70	upper rear . . . . .
71-72	Pass. (Sta. Wag.) w/door and window frame mldg., . . . . .			
73-74	Impala, Caprice (Sta. Wag.), . . . . .			
73-75	Bel Air (Sta. Wag.) w/vinyl top, two tone paint . . . . .	9888345 L.H.	14.25	upper rear . . . . .
71-72	Pass. (Sta. Wag.) w/door and window frame mldg., . . . . .			
73-75	Impala, Caprice (Sta. Wag.), . . . . .			
73-75	Bel Air (Sta. Wag.) w/vinyl top, two tone paint . . . . .	9888344 R.H.	14.25	upper rear . . . . .
73-74	Chevelle (Spt. Cpe.) (exc. Monte Carlo) . . . . .	9651579 2	1.70	
74-75	Monte Carlo . . . . .	9695390 2	3.40	stationary . . . . .
74	Caprice (Spt. Cpe.) . . . . .			rear, . . . . .
74	Impala (Custom) Caprice (Spt. Cpe.) (1st design) . . . . .	9698290 2	3.40	upper front . . . . .
74	Impala (Custom) Caprice (Spt. Cpe.) (2nd design) . . . . .	1657558 2	1.10	center . . . . .
75	Pass. (Spt. Sed.) . . . . .	9739293 2	.75	stationary . . . . .
75	Chevelle (Spt. Cpe.) (exc. Monte Carlo) w/formal window . . . . .	9727045 2	3.40	

**REAR GLASS—SEAT AND ADJUSTER**

**11.031 MOULDING— ESCUTCHEON— CLIP— SCREW, Quarter Window Reveal (Con't)**

75	Nova (2-Dr.) w/side wdo. mldg. (exc. swing out) . . . . .	1687577	2	5.10	rvl. mldg. qtr. wdo. rear (chrome) . . . . .
75	Monza (Towne Cpe.) w/formal rear qtr. wdo. . . . .	1702068	2	1.15	qtr. window . . . . .
71-72	Pass. (Sta. Wag.) . . . . .	9851196	2	.18	CLIP, upper front . . . . .
71-72	Pass. (Sta. Wag.) . . . . .	8736590	A.R.	.11	CLIP, qtr. window reveal— (11.209) . . . . .
71-72	Monte Carlo . . . . .	9422647	A.R.	.11	SCREW, mldg. to panel (emer. use) . . . . .
71-72	Monte Carlo . . . . .	9419740	6	.11	SCREW, wdo. rvl. mldg. to pnl.— (10.707) . . . . .

**11.032 CLIP— RETAINER— SPACER, Quarter Window Reveal Mldg., Tailgate Moulding Clips**

62-65	Nova . . . . .	4852349	A.R.	.12	rear quarter window reveal— (10.708) . . . . .
64-67	Chevelle Std. (2-Dr. Sed.) . . . . .	4418717	A.R.	.06	upper reveal mldg. . . . .
64	Chevelle (Sta. Wag., Spt. Cpe.) . . . . .	4895602	A.R.	.18	upper and lower reveal mldg. (emergency use)— (11.209) . . . . .
65-72	Pass., Chevelle (Sta. Wag.),				
74	Pass., Chevelle (Sta. Wag.) . . . . .	4471409	A.R.	.11	after glass . . . . .
66	Pass., Chevelle (Sta. Wag.) . . . . .	4506041	A.R.	.12	screw on type— (10.096) . . . . .
67	Chevelle (Sta. Wag.),				
67-69	Pass. (Sta. Wag.) . . . . .	8736586	A.R.	.11	qtr. wdo. rvl. mldg. (weld on type)— (10.096) . . . . .
64-65	Chevelle (2-Dr. Sta. Wag.),				
66-70	Chevelle (Sta. Wag.) . . . . .				upper and lower reveal mldg., . . . . .
67-71	Pass. (Sta. Wag.) . . . . .	8736590	A.R.	.11	(emergency use)— (10.096) . . . . .
68-69	Pass., Chevelle (Sta. Wag.) . . . . .	7741144	4	.15	lower, rear anode— (11.209) . . . . .
68-70	Chevy, Chevelle (2-Dr. Sedan),				
71-74	Nova (2-Dr.) . . . . .	4549993	A.R.	.16	front reveal mldg. . . . .
68-72	Chevelle (Sta. Wag.) . . . . .	8736585	A.R.	.16	lower ctr. rr., lower frt., upper ctr.— (10.096) . . . . .
65-68	Pass. (Sta. Wag.),				
68-72	Chevelle (Sta. Wag.) . . . . .				lower center, upper and lower, front, . . . . .
72	Chevelle, Pass.,				
75	Chevelle (Sta. Wag.) . . . . .	9891400	4	.10	upper rear— (10.096) . . . . .
73-74	Pass., Chevelle,				
75	Pass. (Sta. Wag.) . . . . .	8717859	A.R.	.15	upper front and rear, lower— (11.209) . . . . .
73	Vega (N.B.) (H.B.),				
74-75	Vega (N.B.) (H.B.) w/swing-out qtr. wdo.,				
75	Nova w/swing out window . . . . .	9880449	A.R.	.12	mldg. ret. qtr. wdo. f/out . . . . .
75	Nova (2-Dr.) (exc. H.B.) w/formal wind. . . . .	1726320	A.R.	.10	qtr. wind. rvl. mldg. . . . .
75	Nova (2-Dr.) (exc. H.B.) w/formal wind.,				
75	Monza (exc. Towne Cpe.) . . . . .	1690550	A.R.	.16	qtr. wind. glass retainer (repl. 1657696) . . . . .
75	Monza (exc. Towne Cpe.) . . . . .	1660280	6	.12	rvl. mldg. lower . . . . .
75	Monza (exc. Towne Cpe.) . . . . .	1660281	6	.12	rvl. mldg. upper . . . . .
75	Monza (exc. Towne Cpe.) . . . . .	1663670	R.H.	.32	rvl. mldg. lower rear . . . . .
75	Monza (exc. Towne Cpe.) . . . . .	1663671	L.H.	.32	rvl. mldg. lower rear . . . . .
66-67	Chevelle (4-Dr. Sed.) w/two-tone paint (exc. Spt. Sed.) . . . . .	7584569	2	.27	CLIP ASSY., rear qtr. belt reveal moulding rear— (12.118) (Note 1) . . . . .
71-72	Pass. (Sed.) (exc. Spt. Sed.) . . . . .				CLIP ASSY., back window before glass, qtr. window reveal mldg. . . . .
71-72	Pass. (Sta. Wag.) . . . . .	8736589	A.R.	.24	CLIP ASSY., qtr. window— (11.209) . . . . .
	<i>NOTE 1 This assy. consists of unit 3890185-186.</i>				
65-66	Spt. Cpe., Spt. Sed. w/two-tone paint (exc. Caprice),				
65	Caprice w/two-tone paint,				
65-66	Spt. Mdls. w/vinyl top . . . . .	4510010	2	.41	RETAINER, rr. qtr. belt reveal moulding— (12.118) . . . . .
66-67	Chevelle (Spt. Cpe.) w/two-tone paint or vinyl top . . . . .	7617597	A.R.	.80	RETAINER, qtr. belt reveal mldg. qtr. front and rear retainer— (12.180) . . . . .
75	Nova (H.B.) . . . . .	1721924	R.H.	.21	RETAINER, trim fin. pnl. (repl. 1682816) . . . . .
75	Nova (H.B.) . . . . .	1721925	L.H.	.21	RETAINER, trim fin. pnl. (repl. 1682817) . . . . .
68-72	Chevelle (Sta. Wag.) . . . . .	8726836	2	.22	SPACER, upper front mldg. escnt. . . . .

**11.040 GUIDE— SCREW— STUD— SUPPORT, Rear Quarter Window**

67-69	Camaro . . . . .	7652547	R.H.	10.85	rear . . . . .
67-69	Camaro . . . . .	7652548	L.H.	10.85	rear . . . . .
68-72	Chevelle (Spt. Cpe.) . . . . .	7725671	R.H.	7.05	rear . . . . .
68-72	Chevelle (Spt. Cpe.) . . . . .	7725672	L.H.	7.05	rear . . . . .
68-72	Chevelle (Conv.) . . . . .	7727172	R.H.	13.60	rear . . . . .
68-72	Chevelle (Conv.) . . . . .	7727173	L.H.	13.60	rear . . . . .

**REAR GLASS—SEAT AND ADJUSTER**

**11.040 GUIDE— SCREW— STUD— SUPPORT, Rear Quarter Window (Con't)**

69-70	Pass. (Spt. Cpe., Conv.)	8721474	R.H.	12.90	
69-70	Pass. (Spt. Cpe., Conv.)	8721475	L.H.	12.90	
71-72	Pass. (Spt. Cpe.),				
73	Pass. (2-Dr.) (exc. Conv.),				
74-75	Impala (Spt. Cpe.) (exc. Custom)	9826569	L.H.	15.40	
71-72	Pass. (Spt. Cpe.),				
73	Pass. (2-Dr.) (exc. Conv.),				
74-75	Impala (Spt. Cpe.) (exc. Custom)	9826568	R.H.	15.40	
71-75	Pass. (Conv.)	9827517	L.H.	15.95	
71-75	Pass. (Conv.),				
73	Pass. (2-Dr.)	9827516	R.H.	15.95	qtr. wdo. gde. lwr. supt. inr. . . . .
67	Camaro,				
All	All	4405527	A.R.	.15	<b>SCREW</b> , rear door channel rear, driver inner cam to panel, door vent. reg.— (10.792) . .
69	Pass. (Spt. Cpe.)	4409791	A.R.	.12	<b>SCREW</b> , guide to upper support— (10.792)
71	Pass. (2-Dr.)	7679150	2	.18	<b>SCREW</b> , qtr. window guide lower support— (10.670) . . . . .
74-75	Conv.,				
74-75	Impala (Spt. Cpe.) (exc. Custom)	9673678	2	.14	<b>SCREW AND WASHER ASSY.</b> , guide lwr. . .
64-65	Nova (Spt. Mdls.)				<b>STUD</b> , inner panel adj. upper, . . . . .
68	Impala (Custom), Caprice (Spt. Cpe.)	4406615	8	.22	front guide upper and lower . . . . .
64-66	Chevelle (Conv.)	4405500	2	.16	<b>STUD</b> , front guide lower— (10.670) . . . . .
64	Malibu (Spt. Mdls.),				
65	Malibu (Conv.),				
66-67	Chevelle (Conv.)				<b>STUD</b> , front guide lower, . . . . .
65-67	Chevelle (Spt. Cpe.),				
64-67	Chevelle (Conv.)				rear guide lower, . . . . .
67-69	Camaro				guide upper, . . . . .
65-67	Spt. Cpe., Conv.,				
68	Conv.	4868577	4	.18	front guide— (10.670) . . . . .
69	Camaro	4405501	2	.18	<b>STUD</b> , guide lower . . . . .
68-72	Chevelle (Spt. Cpe., Conv.)	9875520	2	2.10	<b>SUPPORT ASSY.</b> , qtr. window guide lower support to panel . . . . .
68-72	Chevelle (Spt. Cpe.)	7737834	R.H.	2.25	<b>SUPPORT</b> , upper guide . . . . .
68-72	Chevelle (Spt. Cpe.)	7737835	L.H.	2.25	<b>SUPPORT</b> , upper guide . . . . .
71-73	Pass. (2-Dr.),				
74-75	Impala (Spt. Cpe.) (exc. Custom),				
74-75	Pass. (Conv.)	9837443	L.H.	1.45	<b>SUPPORT ASSY.</b> , guide upper . . . . .
71-73	Pass. (2-Dr.),				
74-75	Impala (Spt. Cpe.) (exc. Custom),				
74-75	Pass. (Conv.)	9837442	R.H.	1.45	<b>SUPPORT ASSY.</b> , guide upper . . . . .
71-75	Pass. (Conv.)	9838069	L.H.	2.15	<b>SUPPORT ASSY.</b> , guide lower . . . . .
71-75	Pass. (Conv.)	9838068	R.H.	2.15	<b>SUPPORT ASSY.</b> , guide lower . . . . .
71-72	Impala, Caprice (Spt. Cpe.),				
73	Pass. (2-Dr.) (exc. Conv.),				
74-75	Impala (Spt. Cpe.) (exc. Custom)	9874329	L.H.	2.25	<b>SUPPORT ASSY.</b> , guide lower . . . . .
71-72	Impala, Caprice (Spt. Cpe.),				
73	Pass. (2-Dr.) (exc. Conv.),				
74-75	Impala (Spt. Cpe.) (exc. Custom)	9874328	R.H.	2.25	<b>SUPPORT ASSY.</b> , guide lower . . . . .

**11.041 REGULATOR— ARMATURE— BRACKET— CLIP— GASKET— GEAR— HOLDER— MOTOR— PACKAGE ASSY.— ROLLER— SCREW, Quarter Window**

65-69	Pass. (2-Dr. Sedan)	4487975	R.H.	15.75	manual . . . . .
65-69	Pass. (2-Dr. Sedan)	4487976	L.H.	15.75	manual . . . . .
65-66	Pass. (Spt. Cpe., Conv.)	4486027	R.H.	15.75	manual . . . . .
66-67	Chevelle (Conv.)	4549901	L.H.	16.65	manual . . . . .
67	Camaro	7660238	R.H.	19.30	manual . . . . .
67	Camaro	7660239	L.H.	19.30	manual . . . . .
67-69	Camaro w/elect. window	9709640	R.H.	34.00	less motor . . . . .
67-69	Camaro w/elect. window	9709641	L.H.	34.00	less motor . . . . .
68-71	Chevy (Spt. Cpe.)	7746387	R.H.	15.15	manual . . . . .
68-71	Chevy (Spt. Cpe.)	7746388	L.H.	15.15	manual . . . . .
68-69	Chevelle (2-Dr.)	7727570	R.H.	15.55	manual . . . . .
68-69	Chevelle (2-Dr.)	7727571	L.H.	15.55	manual . . . . .
68-72	Chevelle (Spt. Cpe., Conv.) (exc. Monte Carlo)	9614135	R.H.	15.65	manual . . . . .
68-72	Chevelle (Spt. Cpe., Conv.) (exc. Monte Carlo)	9614136	L.H.	15.65	manual . . . . .
68-72	Chevelle (Spt. Cpe., Conv.) w/elect. window	9713498	R.H.	35.50	less motor . . . . .
68-72	Chevelle (Spt. Cpe., Conv.) w/elect. window	9713499	L.H.	35.50	less motor . . . . .
68-69	Camaro	7774450	R.H.	17.95	rear, manual . . . . .

**REAR GLASS—SEAT AND ADJUSTER**

**11.041 REGULATOR— ARMATURE— BRACKET— CLIP— GASKET— GEAR—  
HOLDER— MOTOR— PACKAGE ASSY.— ROLLER— SCREW, Quarter  
Window (Con't)**

68-69	Camaro	7777451 L.H.	17.95	rear, manual
69-70	Impala (Spt. Cpe., Conv.)	8731305 R.H.	15.55	manual
69-70	Impala (Spt. Cpe., Conv.)	8731306 L.H.	15.55	manual
69-70	Caprice (Spt. Cpe.)	8768092 R.H.	15.80	manual
69-70	Caprice (Spt. Cpe.)	8768093 L.H.	15.80	manual
69-70	Impala Custom, Caprice (Spt. Cpe., Conv.) w/electric windows	9718068 R.H.	34.75	less motor
69-70	Impala (Spt. Cpe., Conv.) w/electric window	9718069 L.H.	34.75	less motor
70-71	Monte Carlo w/vinyl top,			
72	Chevelle (Spt. Cpe. Conv.)	9614135 R.H.	15.65	manual
71-75	Impala (Spt. Cpe., Conv.),			
73-75	Pass. (Conv.)	9835569 L.H.	20.45	(manual)
71-75	Impala (Spt. Cpe., Conv.),			
73-75	Pass. (Conv.)	9835568 R.H.	20.45	(manual)
71-73	Caprice (Spt. Cpe.)	9871634 L.H.	19.05	(manual)
71-73	Caprice (Spt. Cpe.)	9871633 R.H.	19.05	(manual)
71-75	Pass. (Spt. Cpe., Conv.) w/elect. window	9887856 L.H.	33.25	(less motor)
71-75	Pass. (Spt. Cpe., Conv.) w/elect. window	1666565 R.H.	33.75	(less motor) (repl. 9887855)
72	Nova (2-Dr.)	9890571 L.H.	14.10	manual
72	Nova (2-Dr.)	9890570 R.H.	14.10	manual
73-74	Nova (2-Dr.)	9620385 L.H.	14.10	manual
73-74	Nova (2-Dr.)	9620384 R.H.	14.10	manual
65	Bel Air, Impala w/elect. window,			
66	Bel Air w/elect. window (exc. 2-Dr.),			
66	Impala, Caprice w/elect. window (exc. Spt. Sed.),			
64-65	Chevelle (2-Dr.) w/elect. window,			
67-68	Camaro w/elect. window,			
67-68	Chevelle w/elect. window (exc. Std., Spt. Sed.)	4909702 1	19.95	ARMATURE, reg. motor— (10.783)
65-66	Pass. w/elect. window,			
64-65	Chevelle w/elect. window,			
66	Chevelle w/elect. window (exc. Sta. Wag.),			
67-68	Camaro w/elect. window,			
67-68	Chevelle w/elect. window (exc. Std.)	4904212 4	.05	BRACKET, motor brush holder— (10.783)
65-69	Pass., Chevelle (2-Dr. Sed.)			CLIP, reg. to channel retainer,
69	Chevy (Spt. Cpe.),			
71-74	Nova (2-Dr.)	4542715 2	.15	CLIP, regulator to window assy.
64-67	Chevelle (Spt. Cpe., Conv.),			
65-68	Pass. (2-Dr. Sed.),			
67	Pass. (Conv.)	4460659 2	.15	GASKET, spindler
65	Bel Air, Impala w/elect. window,			
66-67	Bel Air (4-Dr.) w/elect. window,			
64-66	Chevelle (2-Dr.) w/elect. window (exc. Conv.)	4900085 2	6.60	GEAR, reg. motor (12 teeth)— (10.783)
64-68	Chevelle w/elect. window,			
67-68	Camaro w/elect. window,			
65-67	Pass. w/elect. window	4917191 2	6.25	HOLDER, brush (square motor)— (10.783)
64-70	Chevelle, Camaro,			
65-69	Pass.,			
67-68	Impala, Caprice (Spt. Cpe., Conv.),			
69	Bel Air, Camaro,			
69	Malibu,			
70-71	Impala, Caprice (Spt. Cpe., Conv.),			
73-74	Malibu (4-Dr.) Laguna (Spt. Sed., Estate),			
74-75	Impala (Spt. Cpe.) Caprice (Conv.) w/power wdo.	5045639 A.R.	41.55	MOTOR ASSY., electric regulator— (10.783)
64-70	Chevelle, Camaro,			
65-69	Pass.	5045590 L.H.	51.00	MOTOR ASSY. (10.783)
74-75	Impala (Spt. Cpe.) Caprice (Conv.) w/power wdo.	5045640 A.R.	41.55	MOTOR ASSY., electric regulator— (10.783)

**REAR GLASS—SEAT AND ADJUSTER**

**11.041 REGULATOR— ARMATURE— BRACKET— CLIP— GASKET— GEAR— HOLDER— MOTOR— PACKAGE ASSY.— ROLLER— SCREW, Quarter Window (Con't)**

68-69	Camaro,				
68-70	Concours, Malibu, El Camino (Custom),				
70	Monte Carlo,				
68-71	Pass. (exc. Biscayne, Brookwood),				
73-75	Pass. (2-Dr.)	4919192	2	6.60	PACKAGE ASSY., electric motor (service) (includes gear & pinion)— (10.783)
74	Impala (Spt. Cpe.),				
74-75	Pass. (Conv.)	9666748	2	.27	ROLLER, regulator lift arm— (10.783)
64-65	Chevelle w/elect. window,				
68	Chevelle (Sta. Wag.) w/elect. window	5096732	2	.46	SCREW, motor attaching— (10.783)

**11.044 HANDLE, Quarter Window Regulator**

62	Nova,				
64	Malibu	4807923	A.R.	5.45	(10.797)
63-64	Chevy, Chevelle (Std.)	3725377	4	7.45	(black knob w/o insert)— (10.797)
65-67	Chevy, Camaro,				
65-66	Biscayne, Bel Air	4472076	A.R.	5.45	(10.797)
65-66	Chevelle (exc. Std., Deluxe),				
65-66	Pass. (Spt. Cpe., Conv.)	4468651	2	4.50	(10.797)
67	Camaro (Deluxe)	7689667	2	3.75	(yellow)— (10.797)
67	Pass. (2-Dr. Sed.)	7689672	2	5.05	(fawn)— (10.797)
67	Pass. (2-Dr. Sed.)	7689660	2	5.20	(dark blue)— (10.797)
67	Impala (Spt. Cpe.) (exc. S.S.)	7689680	2	5.05	(maroon)— (10.797)
67	Camaro (Deluxe),				
67	Impala (Spt. Cpe., Conv.)	7689670	2	5.05	(parchment)— (10.797)
67	Camaro (Std.),				
67	All (exc. Camaro)	7680653	A.R.	5.45	(black)— (10.797)
67	Impala (Spt. Cpe., Conv.) (exc. S.S.),				
67	Chevelle, Camaro (Spt. Cpe., Conv.),				
67	Bel Air (2-Dr.)	7689671	2	5.05	(turquoise)— (10.797)
67	Pass. (Spt. Cpe., Conv.)	7689668	2	5.45	(red)— (10.797)
67	Pass. (Spt. Cpe., Conv.)	7689676	2	5.05	(blue)— (10.797)
67	Pass. (Spt. Cpe., Conv.)	7689673	2	5.05	(gold)— (10.797)
67	Chevelle,				
67	Chevy (exc. S.S.),				
67	Camaro (Std.),				
67	Pass.	7689677	A.R.	4.90	(med. blue)— (10.797)
67	Chevy, Camaro,				
67	Impala, Chevelle (Spt. Cpe., Conv.)	7719273	4	3.90	(med. brt. blue)
67	Caprice (Spt. Cpe.)	7689681	2	5.05	(plum)— (10.797)

**11.047 PLATE— SCREW— SPRING— WASHER, Quarter Window Regulator Handle**

65-67	Pass., Chevelle, Nova, Camaro	4506696	A.R.	.16	handle bearing— (10.515)
68	Pass. (2-Dr.)	7731353	2	.12	rear bearing— (10.515)
64-65	Chevelle (2-Dr. Sta. Wag.)	4871646	2	.12	SCREW, catch handle (No. 8-32 x 9/16" chrome)
62-63	Nova (Conv.),				
65	Biscayne, Bel Air,				
64-68	Chevelle (Conv.),				
65-66	Impala (Conv.),				
66	Caprice (Spt. Cpe.),				
68	Impala (Conv.)	4078002	A.R.	.22	SPRING, handle— (10.666)
65	Pass. (2-Dr. Sedan)	4566746	A.R.	.22	SPRING, handle— (10.806)
63-66	Chevy (2-Dr.),				
64-65	Chevelle (2-Dr.) (exc. Spt. Mdls.)	7591000	2	.12	WASHER, regulator spindle— (10.500)

**11.075 MOULDING ASSY., Front Door Belt Trim Finish**

70-72	Camaro	9816835	L.H.	13.70	(black) (paint to match)
70-72	Camaro	9816834	R.H.	13.70	(black) (paint to match)
73	Deluxe (4-Dr.),				
74-75	Malibu (4-Dr.) (exc. Classic)	9646593	L.H.	13.70	(prime and paint as reqd.)
73	Deluxe (4-Dr.),				
74-75	Malibu (4-Dr.) (exc. Classic)	9646592	R.H.	13.70	(prime and paint as reqd.)
73	Deluxe (Coupe),				
74-75	Malibu (Coupe) (exc. Classic)	9646609	L.H.	18.05	(prime and paint as reqd.)
73	Deluxe (Coupe),				

**REAR GLASS—SEAT AND ADJUSTER**

**11.075 MOULDING ASSY., Front Door Belt Trim Finish (Con't)**

<b>74-75</b>	Malibu (Coupe) (exc. Classic) . . .	<b>9646608</b>	R.H.	18.05	(prime and paint as reqd.) . . . . .
<b>73-75</b>	El Camino (exc. Custom) . . . . .	<b>9646621</b>	L.H.	13.70	(prime and paint as reqd.) . . . . .
<b>73-75</b>	El Camino (exc. Custom) . . . . .	<b>9646620</b>	R.H.	13.70	(prime and paint as reqd.) . . . . .
<b>73-75</b>	Camaro (exc. L.T.) . . . . .	<b>9816835</b>	L.H.	13.70	(prime and paint as reqd.) . . . . .
<b>73-75</b>	Camaro (exc. L.T.) . . . . .	<b>9816834</b>	R.H.	13.70	(prime and paint as reqd.) . . . . .

**11.089 MOULDING ASSY., Rear Door Belt Trim Finish**

<b>71-73</b>	Vega (Sta. Wag.) . . . . .	<b>9837651</b>	1	2.15	upper (black) (paint as reqd.) . . . . .
<b>71-73</b>	Vega (Sta. Wag.) . . . . .	<b>9837654</b>	1	2.35	lower (black) (paint as reqd.) . . . . .
<b>71-73</b>	Vega (Sta. Wag.) . . . . .	<b>9837263</b>	L.H.	2.65	side (black) (paint as reqd.) . . . . .
<b>71-73</b>	Vega (Sta. Wag.) . . . . .	<b>9837262</b>	R.H.	2.65	side (black) (paint as reqd.) . . . . .
<b>73</b>	Deluxe (4-Dr.) . . . . .				
<b>74-75</b>	Malibu (4-Dr.) (exc. Classic) . . . . .	<b>9646601</b>	L.H.	12.50	(prime and paint as reqd.) . . . . .
<b>73</b>	Deluxe (4-Dr.) . . . . .				
<b>74-75</b>	Malibu (4-Dr.) (exc. Classic) . . . . .	<b>9646600</b>	R.H.	12.50	(prime and paint as reqd.) . . . . .

**11.119 MOULDING—BUMPER—ESCUTCHEON—NUT—RETAINER, Quarter Window Garnish and Quarter Belt Finishing**

**PASSENGER**

<b>65-66</b>	Sta. Wag. . . . .	<b>4489014</b>	L.H.	8.10	window garnish lower (Note 1) . . . . .
<b>68-70</b>	Sta. Wag. . . . .	<b>7746564</b>	L.H.	11.20	window garnish upper (Note 1) . . . . .
<b>69-70</b>	Sta. Wag. . . . .	<b>8751502</b>	R.H.	5.85	<b>MOULDING ASSY., lower rear garnish</b> (Note 1) . . . . .
<b>69-70</b>	Sta. Wag. . . . .	<b>8751520</b>	L.H.	8.45	<b>MOULDING ASSY., lower garnish (Note 1)</b> . . . . .
<b>71-75</b>	(Sta. Wag.) . . . . .	<b>9604881</b>	R.H.	5.60	<b>MOULDING ASSY., lower rear panel (Note</b> <b>1)</b> . . . . .
<b>71-75</b>	(Sta. Wag.) . . . . .	<b>9628182</b>	R.H.	9.60	<b>MOULDING ASSY., lower rear corner panel</b> (Note 1) . . . . .
<b>71-75</b>	(Sta. Wag.) . . . . .	<b>9628187</b>	L.H.	8.10	<b>MOULDING ASSY., lower rear corner panel</b> (Note 1) . . . . .
<b>71-74</b>	(Sta. Wag.) . . . . .	<b>9857196</b>	R.H.	5.15	<b>MOULDING ASSY., upper panel (Note 1)</b> . . . . .
<b>71-74</b>	(Sta. Wag.) . . . . .	<b>9857197</b>	L.H.	5.15	<b>MOULDING ASSY., upper panel (Note 1)</b> . . . . .
<b>71-75</b>	(Sta. Wag.) . . . . .	<b>9857186</b>	R.H.	8.70	<b>MOULDING ASSY., lower front (Note 1)</b> . . . . .
<b>71-75</b>	(Sta. Wag.) . . . . .	<b>9857176</b>	L.H.	12.05	<b>MOULDING ASSY., lower front (Note 1)</b> . . . . .

**CHEVELLE**

<b>64-67</b>	Chevelle (Sta. Wag.) . . . . .	<b>4411352</b>	R.H.	6.05	lwr. rear window garnish . . . . .
<b>68-70</b>	Chevelle (2-Dr. Sed.) . . . . .	<b>7791326</b>	R.H.	2.70	front window, garnish (painted) . . . . .
<b>68-70</b>	Chevelle (2-Dr. Sed.) . . . . .	<b>7791327</b>	L.H.	2.70	front window garnish (painted) . . . . .
<b>68-72</b>	Chevelle (Sta. Wag.) . . . . .	<b>7671796</b>	R.H.	2.95	lower rear garnish extension . . . . .
<b>68-72</b>	Chevelle (Sta. Wag.) . . . . .	<b>8760899</b>	L.H.	6.30	garnish lower front . . . . .
<b>68-72</b>	Chevelle (Sta. Wag.) . . . . .	<b>8760898</b>	R.H.	6.30	garnish lower front . . . . .
<b>68-70</b>	Chevelle (Sta. Wag.) . . . . .	<b>7671796</b>	R.H.	2.95	window garnish lower rear ext. . . . .
<b>68-72</b>	Chevelle (Sta. Wag.) . . . . .	<b>7723396</b>	R.H.	6.60	window garnish lower rear . . . . .
<b>68-72</b>	Chevelle (Sta. Wag.) . . . . .	<b>7723690</b>	L.H.	6.30	window garnish lower rear ext. . . . .
<b>73-74</b>	Chevelle (Sta. Wag.) w/swing out window . . . . .	<b>9654503</b>	2	3.15	vent. divider channel (painted) . . . . .
<b>73</b>	Chevelle (Spt. Cpe.) (exc. Monte Carlo) . . . . .	<b>9652347</b>	L.H.	6.20	wdo. front (Note 1) . . . . .
<b>73</b>	Chevelle (Spt. Cpe.) (exc. Monte Carlo) . . . . .	<b>9652346</b>	R.H.	6.20	wdo. front (Note 1) . . . . .
<b>73</b>	Chevelle (Spt. Cpe.) (exc. Monte Carlo) . . . . .	<b>9652363</b>	L.H.	5.20	wdo. rear (Note 1) . . . . .
<b>73</b>	Chevelle (Spt. Cpe.) (exc. Monte Carlo) . . . . .	<b>9652362</b>	R.H.	5.20	wdo. rear (Note 1) . . . . .
<b>73-75</b>	Chevelle (Spt. Sed.) . . . . .	<b>9638947</b>	L.H.	.74	frt. chan. inner (Note 1) . . . . .
<b>73-75</b>	Chevelle (Spt. Sed.) . . . . .	<b>9638946</b>	R.H.	.74	frt. chan. inner (Note 1) . . . . .
<b>74-75</b>	Malibu (Spt. Cpe.) (exc. Classic), <b>74</b> Malibu Classic, Laguna (Spt. Cpe.) (1st design) . . . . .	<b>9681466</b>	R.H.	6.20	front garnish (Note 1 & 2) . . . . .
<b>74-75</b>	Malibu (Spt. Cpe.) (exc. Classic), <b>74</b> Malibu Classic, Laguna (Spt. Cpe.) (1st design) . . . . .	<b>9681467</b>	L.H.	6.20	front garnish (Note 1 & 2) . . . . .
<b>74-75</b>	Malibu (Spt. Cpe.) (exc. Classic), <b>74</b> Malibu Classic, Laguna (Spt. Cpe.) (1st design) . . . . .	<b>9681482</b>	R.H.	5.20	rear garnish (Note 1 & 2) . . . . .
<b>74-75</b>	Malibu (Spt. Cpe.) (exc. Classic), <b>74</b> Malibu Classic, Laguna (Spt. Cpe.) (1st design) . . . . .	<b>9681483</b>	L.H.	5.20	rear garnish (Note 1 & 2) . . . . .
<b>74</b>	Malibu Classic, Laguna (Spt. Cpe.) (2nd design), . . . . .				
<b>75</b>	Chevelle (Spt. Cpe.) w/rr. formal wdo. (exc. Monte Carlo) . . . . .	<b>1686828</b>	R.H.	19.85	

**REAR GLASS—SEAT AND ADJUSTER**

**11.119 MOULDING— BUMPER— ESCUTCHEON— NUT— RETAINER, Quarter Window Garnish and Quarter Belt Finishing (Con't)**

74	Malibu Classic, Laguna (Spt. Cpe.) (2nd design).				
75	Chevelle (Spt. Cpe.) w/rr. formal wdo. (exc. Monte Carlo)	1686829	L.H.	19.85	
74-75	Chevelle (Sta. Wag.) (exc. swing out window)	9688222	2	8.70	at belt
74-75	Chevelle (Sta. Wag.) w/swing out window	9688223	2	8.70	at belt
75	Chevelle (Sta. Wag.) w/swing out window	1667922	2	3.15	vent div. channel

**CHEVY**

68-72	Chevy (Spt. Cpe.)	7748300	R.H.	2.90	front window garnish (paint as req.)
68-72	Chevy (Spt. Cpe.)	7748301	L.H.	2.90	front window garnish (paint as req.)
73-74	Nova (2-Dr.)	9690388	R.H.	2.65	front garnish (Note 1)
73-74	Nova (2-Dr.)	9690389	L.H.	2.65	front garnish (Note 1)
75	Monza (exc. Towne Cpe.)	1668398	R.H.	9.60	at belt
75	Monza (exc. Towne Cpe.)	1668399	L.H.	9.60	at belt
64-66	Chevelle (Sta. Wag.)	4569867	A.R.	.36	<b>BUMPER</b> , quarter window lower rear garnish moulding— (12.945)
73-75	Monte Carlo	9617175	2	.44	<b>ESCUTCHEON</b> , trim mldg.
74-75	Chevelle (Spt. Cpe.) (exc. Monte Carlo)	9667403	4	.18	<b>NUT</b> , mldg. garn. qtr. sta. wdo. frt.
73-75	Chevelle (Spt. Cpe.) (exc. Monte Carlo),				
74	Malibu (Spt. Cpe.) (exc. Classic),				
74-75	Malibu Classic, Laguna (Spt. Cpe.) (1st design)	9629479	L.H.	6.30	<b>RETAINER</b> , front lower mldg. (Note 2)
73-75	Chevelle (Spt. Cpe.) (exc. Monte Carlo),				
74	Malibu (Spt. Cpe.) (exc. Classic),				
74-75	Malibu Classic, Laguna (Spt. Cpe.) (1st design)	9629478	R.H.	6.30	<b>RETAINER</b> , front lower mldg. (Note 2)
74-75	Impala (Spt. Cpe.) w/vinyl roof cover (exc. Custom)	1652974	2	1.05	<b>RETAINER</b> , rvl. mldg. qtr. otr. belt
74-75	Malibu Classic, Laguna (Spt. Cpe.) (2nd design)	9737141	2	2.35	<b>RETAINER</b> , mldg. garn. (Note 2)

*NOTE 1: (Paint as required).*

*NOTE 2: To aid in identifying first design, a metal insert was required to fill void in quarter panel used for tear drop window design. Second design quarter panel will have added metal in sail area.*

**11.120 MOULDING— CLIP— INSULATOR— SILENCER, Back Window Garnish**

71-73	Impala Custom, Caprice (Spt. Cpe.)	9841227	L.H.	12.10	upper (Note 1)
71-73	Impala Custom, Caprice (Spt. Cpe.)	9841226	R.H.	12.10	upper (Note 1)
71-74	Pass. (Spt. Sed.)	9855303	L.H.	12.10	upper and side (painted)
71-74	Pass. (Spt. Sed.)	9855302	R.H.	12.10	upper and side (painted)
71-74	Pass. (Sed.) (exc. Spt. Sed.)	9858627	L.H.	5.10	upper and side (painted)
71-74	Pass. (Sed.) (exc. Spt. Sed.)	9858626	R.H.	5.10	upper and side (painted)
71-74	Pass. (Sed.) (exc. Spt. Sed.)	9858643	L.H.	3.25	lower corner and side (painted)
71-74	Pass. (Sed.) (exc. Spt. Sed.)	9858642	R.H.	3.25	lower corner and side (painted)
71-74	Pass. (Spt. Sed.)	9858659	L.H.	10.45	lower corner and side (painted)
71-74	Pass. (Spt. Sed.)	9858658	R.H.	10.45	lower corner and side (painted)
71-73	Impala (Spt. Cpe.) (exc. Custom)	9858689	L.H.	10.45	side (painted)
71-73	Impala (Spt. Cpe.) (exc. Custom)	9858688	R.H.	10.45	side (painted)
71-73	Impala (Spt. Cpe.) (exc. Custom)	9647404	1	10.45	upper (painted)
71-75	Vega (N.B.)	9837414	1	2.40	
71-75	Vega (H.B.)	9821325	1	5.30	
73-75	Chevelle (Spt. Sed.)	9629077	1	2.40	upper (Note 1)
73-75	El Camino	9627773	1	2.40	upper (Note 1)
73-75	Chevelle (Spt. Cpe.) (exc. Monte Carlo)	9650041	1	3.25	upper (Note 1)
73-75	Monte Carlo	9649250	1	3.80	upper (Note 1)
73-74	Nova (Sed.)	9650562	1	12.10	upper (painted)
73-74	Nova (Coupe) (exc. H.B.)	9638698	1	10.45	upper (painted)
73-75	Camaro	9667054	1	10.45	upper (Note 1)
74-75	Impala (Spt. Cpe.) (exc. Custom)	9729334	R.H.	10.45	side (painted)
74-75	Impala (Spt. Cpe.) (exc. Custom)	9729335	L.H.	10.45	side (painted)
74-75	Impala (Spt. Cpe.) (exc. Custom)	9681918	1	10.45	lower (painted)
74-75	Impala (Custom) Caprice (Spt. Cpe.)	9729292	R.H.	12.10	upper (painted)
74-75	Impala (Custom) Caprice (Spt. Cpe.)	9729293	L.H.	12.10	upper (painted)



**REAR GLASS—SEAT AND ADJUSTER**

**11.120 MOULDING— CLIP— INSULATOR— SILENCER, Back Window Garnish  
(Con't)**

74-75	Impala (Custom) Caprice (Spt. Cpe.)	9729322 R.H.	10.45	side (painted)
74-75	Impala (Custom) Caprice (Spt. Cpe.)	9729323 L.H.	10.45	side (painted)
74-75	Impala (Spt. Cpe.) (exc. Custom)	9729304 R.H.	12.10	upper (painted)
74-75	Impala (Spt. Cpe.) (exc. Custom)	9729305 L.H.	12.10	upper (painted)
74-75	Impala (Custom) Caprice (Spt. Cpe.)	9673691 R.H.	.36	lower
74-75	Impala (Custom) Caprice (Spt. Cpe.)	9673692 L.H.	.36	lower
75	Pass. (Sed.) (exc. Spt. Sed.)	1662180 R.H.	3.25	lower corner
75	Pass. (Sed.) (exc. Spt. Sed.)	1662181 L.H.	3.25	lower corner
75	Pass. (Sed.) (exc. Spt. Sed.)	1662196 R.H.	5.10	upper and side
75	Pass. (Sed.) (exc. Spt. Sed.)	1662197 L.H.	5.10	upper and side
75	Nova (H.B. Coupe)	1654577 1	3.25	
75	Monza (exc. Towne Cpe.)	1698090 1	7.45	upper
75	Monza (Towne Cpe.)	1707304 1	4.65	upper (painted)
69-70	Pass. (Spt. Sed.)	8748871 1	12.10	MOULDING ASSY., upper garnish (Note 1)
69-70	Pass. (Spt. Sed.)	8748887 2	9.25	MOULDING ASSY., side garnish (Note 1)
75	Pass. (Spt. Sed.)	1663694 2	5.75	MOULDING ASSY., side
75	Pass. (Spt. Sed.)	1661751 1	8.60	MOULDING ASSY., upper
75	Nova (Sed.)	1658126 1	10.45	MOULDING ASSY., upper
75	Nova (Coupe) (exc. H.B.)	1658134 1	10.75	MOULDING ASSY., upper
73-75	El Camino	9610126 14	.13	CLIP ASSY., finish mldg. t/gate belt, rr. qtr. P/W
74-75	Impala (Spt. Cpe.) (exc. Custom)	9681015 4	.56	CLIP, back window lower
71-72	Vega, Monza	9872137 R.H.	1.15	INSULATOR, b/w garnish mldg. side
71-72	Vega, Monza	9872138 L.H.	1.15	INSULATOR, b/w garnish mldg. side
67-68	Pass. (Spt. Mdls.) (exc. Conv.)	7696299 A.R.	.12	SILENCER, moulding— (10.051)

*NOTE 1 Paint as required.*

**11.128 SCREW— CLIP— FASTENER, Garnish Moulding (sheet metal type)**

62-69	Pass.	9416819 2	.18	(8— 18 x 1 1/2")— (8.977)
67-68	Impala (Spt. Cpe.) (exc. Custom)	7660066 5	.12	CLIP, back window lower
75	Chevelle (2-Dr.) (exc. El Camino)	9883583 A.R.	.16	FASTENER, upper mldg.— (14.683)

**11.133 ESCUTCHEON, Garnish Moulding**

67-68	Camaro (Spt. Cpe.)	7638524 R.H.	3.15	back window lower corner
69-70	Impala (Spt. Cpe.) (exc. Custom)	8748842 R.H.	.44	back win. lwr. cor.
69-70	Pass. (Spt. Sed.)	8748784 R.H.	.70	back win. lwr. cor.
69-70	Pass. (Spt. Sed.)	8748785 L.H.	.70	back win. lwr. cor.
69-70	Pass. (Spt. Sed.)	8760458 2	.44	back window upper cor.
71-73	Impala Custom, Caprice (Spt. Cpe.)	9858459 L.H.	11.85	back window lower corner (painted)
71-73	Impala Custom, Caprice (Spt. Cpe.)	9858458 R.H.	11.85	back window lower corner (painted)
71-73	Impala (Spt. Cpe.) (exc. Custom)	9858709 L.H.	6.20	back window lower corner (painted)
71-73	Impala (Spt. Cpe.) (exc. Custom)	9858708 R.H.	6.20	back window lower corner (painted)
75	Pass. (Spt. Sed.)	1661816 R.H.	2.90	back window upper corner
75	Pass. (Spt. Sed.)	1661817 L.H.	2.90	back window upper corner
75	Pass. (Spt. Sed.)	1661832 R.H.	5.00	back window lower corner
75	Pass. (Spt. Sed.)	1661833 L.H.	5.00	back window lower corner

**11.175 PLATE— EXTENSION, Front Door Sill**

62-67	Chevy (2-Dr.) (exc. Conv.)	4531247 R.H.	7.80	
62-67	Chevy (2-Dr.) (exc. Conv.)	4531248 L.H.	7.80	
62-67	Chevy (4-Dr.)	4531501 L.H.	6.95	
64-67	Chevelle (2-Dr.)	4531243 2	5.95	
64-67	Chevelle (4-Dr.)	4531244 2	5.15	
65-70	Pass. (2-Dr.)	4474766 R.H.	6.50	
65-70	Pass. (2-Dr.)	4474767 L.H.	6.50	
65-70	Pass. (4-Dr.)	4474850 R.H.	5.30	
65-70	Pass. (4-Dr.)	4474851 L.H.	5.30	
67-69	Camaro	7644760 2	7.80	
68-75	Nova (2-Dr.)	7728956 R.H.	7.55	
68-75	Nova (2-Dr.)	7728957 L.H.	7.55	
68-75	Nova (4-Dr.)	7728960 2	6.60	
68-72	Chevelle (2-Dr.)	7753966 R.H.	5.80	
68-72	Chevelle (2-Dr.)	7753967 L.H.	5.80	
68-72	Chevelle (4-Dr.)	7725701 2	5.85	
70-75	Camaro	9819033 R.H.	8.15	
70-75	Camaro	9819034 L.H.	8.15	
71-75	Pass. (2-Dr.)	9873980 2	4.50	
71-75	Pass. (4-Dr.)	9873984 2	4.10	

**REAR GLASS—SEAT AND ADJUSTER**

**11.175 PLATE— EXTENSION, Front Door Sill (Con't)**

73-75	Chevelle (4-Dr.)	9873909	L.H.	5.85	
73-75	Chevelle (4-Dr.)	9873908	R.H.	5.85	
73-75	Chevelle (2-Dr.)	9873912	L.H.	5.85	
73-75	Chevelle (2-Dr.)	9873911	R.H.	5.85	
71	Vega, Monza	9824778	2	6.65	
72-73	Vega, Monza	9884673	R.H.	6.10	
74-75	Vega, Monza	9678810	R.H.	6.10	
72-75	Vega, Monza	9678811	L.H.	6.10	
68-72	Chevy (Spt. Cpe.)	7735970	2	2.95	EXTENSION, plate

**11.176 SUPPORT, Door Opening Carpet**

70-75	Camaro	1680403	R.H.	6.85	front
70-75	Camaro	1680404	L.H.	6.55	front

**11.179 PLATE, Rear Door Sill**

62-67	Chevy (4-Dr.)	4531502	R.H.	4.65	
64-67	Chevelle (4-Dr.)	4531245	2	4.55	
65-70	Pass. (4-Dr.)	4474856	R.H.	4.55	
65-70	Pass. (4-Dr.)	4474857	L.H.	4.55	
68-75	Nova (4-Dr.)	7728958	2	4.50	
68-72	Chevelle (4-Dr.)	7725700	2	4.35	
71-75	Pass. (4-Dr.) (exc. Sta. Wag.)	9873978	2	1.90	rear
71-75	Pass. (Sta. Wag.)	9873976	2	4.50	rear
73-75	Chevelle (4-Dr.)	9873910	2	4.35	

**11.204 GLASS— KIT— SPACER, Back Window (Safety)**

**PASSENGER**

66-67	Caprice (Spt. Cpe.)	4541846	1	60.25	(clear)
66-67	Caprice (Spt. Cpe.)	4541847	1	66.50	(tinted)
67-68	Impala (Spt. Cpe.) (exc. Custom)	7631145	1	81.00	(clear)
67-68	Impala (Spt. Cpe.) (exc. Custom)	7631146	1	89.00	(tinted)
67-68	Spt. Sed.	7635892	1	80.00	(clear)
67-68	Spt. Sed.	7635893	1	88.00	(tinted)
67-68	Sed. (exc. Spt. Sed.)	7635888	1	104.00	(clear)
67-68	Sed. (exc. Spt. Sed.)	7635889	1	114.00	(tinted)
68	Caprice (Spt. Cpe.)				
68	Impala Custom	7715566	1	47.00	(clear)
68	Caprice (Spt. Cpe.)				
68	Impala Custom	7715567	1	51.75	(tinted)
69-70	Spt. Sed.	7786764	1	115.00	(clear)
69-70	Spt. Sed.	7786765	1	125.00	(tinted)
69-70	Sed. (exc. Spt. Sed.)	7786766	1	90.25	(clear)
69-70	Sed. (exc. Spt. Sed.)	7786767	1	98.00	(tinted)
69-70	Impala (Spt. Cpe.) (exc. Custom)	7794128	1	67.00	(clear)
69-70	Impala (Spt. Cpe.) (exc. Custom)	7794129	1	79.50	(tinted)
69-70	Impala Custom, Caprice (Spt. Cpe.) w/electric defogger	8769429	1	159.00	(tinted only)
71-74	Pass. (Spt. Sed.)	9804076	1	116.00	(clear)
71-74	Pass. (Spt. Sed.)	9818126	1	127.00	(tinted)
71-73	Impala (Spt. Cpe.) (exc. Custom)	9804077	1	105.00	(clear)
71-73	Impala (Spt. Cpe.) (exc. Custom)	9817509	1	115.00	(tinted)
71-74	Pass. (Sed.) (exc. Spt. Sed.)	9804078	1	103.00	(clear)
71-74	Pass. (Sed.) (exc. Spt. Sed.)	9817535	1	112.00	(tinted)
71-73	Impala Custom, Caprice (Spt. Cpe.)	9805603	1	94.50	(clear)
71-73	Impala Custom, Caprice (Spt. Cpe.)	9819289	1	103.00	(tinted)
74-75	Impala (Custom) Caprice (Spt. Cpe.)	9665903	1	94.00	(clear)
74-75	Impala (Custom) Caprice (Spt. Cpe.)				
74-75	Impala (Spt. Cpe.)	9665904	1	104.00	(tinted)
74-75	Impala (Spt. Cpe.)	9666357	1	91.00	(clear)
74-75	Impala (Spt. Cpe.)	9666358	1	101.00	(tinted)
75	Pass. (Spt. Sed.)	9729958	1	90.25	clear
75	Pass. (Spt. Sed.)	9729959	1	98.50	tinted
75	Pass. (Sed.) (exc. Spt. Sed.)	9678392	1	112.00	clear
75	Pass. (Sed.) (exc. Spt. Sed.)	9678393	1	123.00	tinted

**CHEVELLE**

66-67	Malibu (Spt. Sed.)	4533700	1	73.25	(clear)
66-67	Malibu (Spt. Sed.)	4533701	1	68.25	(tinted)
66-67	Chevelle (Spt. Cpe.)	4535459	1	25.75	(clear)
66-67	Chevelle (Spt. Cpe.)	4535460	1	36.50	(tinted)

**REAR GLASS—SEAT AND ADJUSTER**

**11.204 GLASS—KIT—SPACER, Back Window (Safety) (Con't)**

68-72	Chevelle (Spt. Cpe.)	7695842	1	78.25	(clear)
68-72	Chevelle (Spt. Cpe.)	7695844	1	85.00	(tinted)
68-72	El Camino	7715573	1	31.25	(clear)
68-72	El Camino	7715574	1	36.50	(tinted)
68-72	Chevelle (4-Dr.) (exc. Sta. Wag.)	7699359	1	70.00	(clear)
68-72	Chevelle (4-Dr.) (exc. Sta. Wag.)	7699360	1	76.50	(tinted)
73-75	El Camino	9869818	1	37.25	(clear)
73-75	El Camino	9869819	1	40.50	(tinted)
73-75	Chevelle (Spt. Cpe.) (exc. Monte Carlo)	9846449	1	73.75	(clear)
73-75	Chevelle (Spt. Cpe.) (exc. Monte Carlo)	9846450	1	80.25	(tinted)
73-75	Chevelle (4-Dr.) (exc. Sta. Wag.)	9861427	1	83.00	(clear)
73-75	Chevelle (4-Dr.) (exc. Sta. Wag.)	9861428	1	89.75	(tinted)
73-75	Monte Carlo	9864206	1	83.50	(clear)
73-75	Monte Carlo	9864207	1	89.75	(tinted)

**CHEVY**

66-67	Nova (Spt. Cpe.)	4544840	1	70.25	(clear)
66-67	Nova (Spt. Cpe.)	4544841	1	77.75	(tinted)
68-74	Nova (2-Dr.) (exc. H.B.)	7725685	1	88.00	(clear)
68-74	Nova (2-Dr.) (exc. H.B.)	7725686	1	95.25	(tinted)
68-74	Nova (4-Dr.)	7715236	1	75.25	(clear)
68-74	Nova (4-Dr.)	7715237	1	81.75	(tinted)
73-74	Nova (H.B.)	9610248	1	71.50	(clear)
73-74	Nova (H.B.)	9610249	1	77.25	(tinted)
75	Nova (Coupe) (exc. H.B.)	9697870	1	97.00	clear
75	Nova (Coupe) (exc. H.B.)	9697871	1	106.00	tinted
75	Nova (4-Dr.)	9697872	1	82.25	clear
75	Nova (4-Dr.)	9697873	1	89.50	tinted
75	Nova (H.B.)	9731340	1	82.75	clear
75	Nova (H.B.)	9731341	1	90.50	tinted

**CAMARO**

67-69	Camaro (Spt. Cpe.)	7600989	1	59.75	(clear)
67-69	Camaro (Spt. Cpe.)	7600990	1	50.75	(tinted)
70-74	Camaro	8775901	1	73.25	(clear)
70-74	Camaro	8775902	1	78.50	(tinted)
75	Camaro	9733868	1	90.75	clear
75	Camaro	9733869	1	99.25	tinted

**VEGA—MONZA**

71-75	Vega (Sta. Wag.) (Panel) (exc. rear window electric defogger)	9805657	1	38.25	(clear)
71-75	Vega (Sta. Wag.) (Panel) (exc. rear window electric defogger)	9815274	1	44.75	(tinted)
71-73	Vega (Sta. Wag.) (Panel) w/rear window electric defogger	9869870	1	107.00	(tinted)
71-75	Vega (H.B.) (exc. rear window electric defogger)	9805654	1	71.25	(clear)
71-75	Vega (H.B.) (exc. rear window electric defogger)	9815201	1	82.00	(tinted)
71-75	Vega (H.B.) w/rear window electric defogger	9616072	1	144.00	(tinted)
71-75	Vega (N.B.) (exc. rear window electric defogger)	9805653	1	67.75	(clear)
71-75	Vega (N.B.) (exc. rear window electric defogger)	9815151	1	77.75	(tinted)
71-75	Vega (N.B.) w/rear window electric defogger	9831647	1	109.00	(tinted)
74-75	Vega (Sta. Wag.) (Panel) w/rear wdo. electric defogger	9699565	1	99.00	(tinted)
75	Monza (exc. Towne Cpe.)	9693315	1	89.00	(clear)
75	Monza (exc. Towne Cpe.) (exc. elect. rear wdo. defogger)	9693316	1	96.75	(tinted)
75	Monza (exc. Towne Cpe.) w/elect. rear wdo. defogger	9693317	1	149.00	(tinted)
75	Monza (Towne Cpe.)	1674309	1	65.75	(clear)
75	Monza (Towne Cpe.)	1674320	1	71.00	(tinted)
75	Monza (Towne Cpe.) w/elect. rear wdo. defogger	1706184	1	119.00	(tinted)

**KIT—SPACER**

62-75	All	4226000 A.R.	11.30	KIT, adhesive caulking— (10.027)	
-------	-----	--------------	-------	----------------------------------	--

**REAR GLASS—SEAT AND ADJUSTER**

**11.204 GLASS—KIT—SPACER, Back Window (Safety) (Con't)**

64	Chevelle	4410043	8	.11	SPACER, adhesive caulked glass ( <sup>3</sup> / <sub>16</sub> " x <sup>1</sup> / <sub>4</sub> " x <sup>3</sup> / <sub>4</sub> " rubber)— (10.027)
64	Chevelle	4421823	3	.16	SPACER, adhesive caulked glass bottom ( <sup>13</sup> / <sub>64</sub> " x <sup>5</sup> / <sub>8</sub> " x 1)— (10.027)
65-72	Pass., Chevelle, Nova, Camaro	4459429	A.R.	.18	SPACER, adhesive caulked glass, ( <sup>3</sup> / <sub>16</sub> " x <sup>1</sup> / <sub>2</sub> " x 1)— (10.027)
64	Chevelle,				
65-70	All, Pass., Chevelle, Nova, Camaro	4871330	6	.11	SPACER, adhesive caulked glass ( <sup>1</sup> / <sub>32</sub> " x <sup>7</sup> / <sub>16</sub> " x 1) lower spacer— (10.027)
64	Chevelle,				
65-67	Pass.	4404196	A.R.	.11	SPACER, adhesive caulked glass ( <sup>5</sup> / <sub>16</sub> " x <sup>7</sup> / <sub>16</sub> " x 1"— rubber)— (10.027)
67-70	All, Pass., Chevelle, Nova, Camaro	4534314	A.R.	.18	SPACER ( <sup>3</sup> / <sub>8</sub> " x <sup>7</sup> / <sub>16</sub> ")— (10.027)

**11.208 MOULDING, Back Window Glass Reveal**

**PASSENGER**

65-66	Pass. (Sedan) (exc. Spt. Sed.)	4537486	R.H.	5.60	side
65-66	Pass. (Sedan) (exc. Spt. Sed.)	4537487	L.H.	5.60	side
65-66	Pass. (Sedan) (exc. Spt. Sed.)	4481975	R.H.	7.35	lower
65-66	Pass. (Sedan) (exc. Spt. Sed.)	4481976	L.H.	7.35	lower
65-66	Impala (Spt. Cpe.)	4478990	R.H.	6.70	side
65-66	Impala (Spt. Cpe.)	4478991	L.H.	6.70	side
65-66	Impala (Spt. Cpe.)	4478793	R.H.	7.30	lower
65-66	Impala (Spt. Cpe.)	4478794	L.H.	7.30	lower
65-66	Impala (Spt. Cpe.)	4478769	1	5.80	upper
65-66	Pass. (Spt. Sed.)	4479106	R.H.	6.85	side
65-66	Pass. (Spt. Sed.)	4479104	R.H.	7.35	lower
65-66	Pass. (Spt. Sed.)	4479105	L.H.	7.35	lower
65-66	Pass. (Spt. Sed.)	4478962	1	6.10	upper
66-67	Caprice (Spt. Cpe.)	4547912	1	5.85	lower
66-67	Caprice (Spt. Cpe.)	4547616	R.H.	7.65	upper
66-67	Caprice (Spt. Cpe.)	4547617	L.H.	7.65	upper
67-68	Impala (Spt. Cpe.) (exc. Custom)	7646717	R.H.	7.35	upper
67-68	Impala (Spt. Cpe.) (exc. Custom)	7646718	L.H.	7.35	upper
67-68	Sedan (exc. Spt. Sed.)	7646796	R.H.	7.35	lower
67-68	Sedan (exc. Spt. Sed.)	7646797	L.H.	7.35	lower
67-68	Impala (Spt. Cpe.) (exc. Custom)	7647558	R.H.	6.70	side
67-68	Impala (Spt. Cpe.) (exc. Custom)	7647559	L.H.	6.70	side
67-68	Pass. (Spt. Sed.)	7648026	1	5.95	upper
67-68	Pass. (Sedan) (exc. Spt. Sed.)	7648027	R.H.	7.35	upper and side
67-68	Pass. (Sedan) (exc. Spt. Sed.)	7648028	L.H.	7.35	upper and side
67-68	Pass. (Spt. Sed.)	7648030	R.H.	7.35	lower
67-68	Pass. (Spt. Sed.)	7648031	L.H.	7.35	lower
67-68	Pass. (Spt. Sed.)	7649794	R.H.	6.70	side
67-68	Pass. (Spt. Sed.)	7649795	L.H.	6.70	side
67-68	Impala (Spt. Cpe.) (exc. Custom)	7660862	1	11.95	lower
68	Caprice (Spt. Cpe.),				
68	Impala Custom	7730310	R.H.	7.25	upper
68	Caprice (Spt. Cpe.),				
68	Impala Custom	7730311	L.H.	7.25	upper
68	Caprice (Spt. Cpe.),				
68	Impala Custom	7726248	R.H.	6.80	side
68	Caprice (Spt. Cpe.),				
68	Impala Custom	7726249	L.H.	6.80	side
68	Caprice (Spt. Cpe.),				
68	Impala Custom	7726250	1	5.60	lower
69-70	Impala (Spt. Cpe.) (exc. Custom)	8715509	1	7.10	upper
69-70	Pass. (Spt. Sed.)	8775834	1	8.05	upper
69-70	Pass. (Spt. Sed.)	8775832	R.H.	8.05	lower and side
69-70	Pass. (Spt. Sed.)	8775833	L.H.	8.05	lower and side
69-70	Impala (Spt. Cpe.) (exc. Custom)	8715868	R.H.	8.35	side
69-70	Impala (Spt. Cpe.) (exc. Custom)	8715869	L.H.	8.35	side
69-70	Caprice (Spt. Cpe.),				
69-70	Impala (Custom)	8775844	R.H.	18.45	upper and side
69-70	Caprice (Spt. Cpe.),				
69-70	Impala (Custom)	8775845	L.H.	18.45	upper and side
69-70	Pass. (Sed.) (exc. Spt. Sed.)	8775837	R.H.	8.05	lower
69-70	Pass. (Sed.) (exc. Spt. Sed.)	8775838	L.H.	8.05	lower
69	Pass. (Sed.) (exc. Spt. Sed.)	8775840	R.H.	8.05	side, upper
69	Pass. (Sed.) (exc. Spt. Sed.)	8775841	L.H.	8.05	side, upper
69-70	Impala (Spt. Cpe.) (exc. Custom)	9811304	R.H.	12.20	lower

**REAR GLASS—SEAT AND ADJUSTER**

**11.208 MOULDING, Back Window Glass Reveal (Con't)**

69-70	Impala (Spt. Cpe.) (exc. Custom)	9811305 L.H.	12.20	lower
71	Impala Custom, Caprice (Spt. Cpe.)	9831442 1	16.85	upper center
71	Impala Custom, Caprice (Spt. Cpe.)	9831444 L.H.	15.00	side
71	Impala Custom, Caprice (Spt. Cpe.)	9831443 R.H.	15.00	side
71-73	Pass. (Spt. Sed.)	9825969 1	1.85	upper
71-74	Pass. (Spt. Sed.)	9690612 L.H.	7.20	side
71-73	Pass. (Spt. Sed.)	9825970 R.H.	6.95	side
71-74	Pass. (Spt. Sed.)	9690609 L.H.	13.00	lower side corner
71-74	Pass. (Spt. Sed.)	9690608 R.H.	13.00	lower side corner
71-74	Pass. (Sed.) (exc. Spt. Sed.)	9690603 1	8.65	upper
71-74	Pass. (Sed.) (exc. Spt. Sed.)	9690607 L.H.	7.20	side
71-74	Pass. (Sed.) (exc. Spt. Sed.)	9690606 R.H.	7.20	side
71-74	Pass. (Sed.) (exc. Spt. Sed.)	9690605 L.H.	13.00	lower side corner
71-74	Pass. (Sed.) (exc. Spt. Sed.)	9690604 R.H.	13.00	lower side corner
71-73	Impala (Spt. Cpe.) (exc. Custom)	9690649 L.H.	10.60	upper
71-73	Impala (Spt. Cpe.) (exc. Custom)	9690648 R.H.	10.60	upper
71-73	Impala (Spt. Cpe.) (exc. Custom)	9690650 1	10.60	lower
71-73	Impala (Spt. Cpe.) (exc. Custom)	9690652 L.H.	8.70	side
71-73	Impala (Spt. Cpe.) (exc. Custom)	9690651 R.H.	8.70	side
72-73	Impala Custom, Caprice (Spt. Cpe.)	9690639 1	17.45	upper center
72-73	Impala Custom, Caprice (Spt. Cpe.)	9690647 L.H.	15.65	side
72-73	Impala Custom, Caprice (Spt. Cpe.)	9690646 R.H.	15.65	side
74-75	Impala (Custom) Caprice (Spt. Cpe.)	9690568 R.H.	17.45	upper
74-75	Impala (Custom) Caprice (Spt. Cpe.)	9690569 L.H.	15.00	upper
74	Pass. (Spt. Sed.)	9690610 1	9.10	upper
74	Pass. (Spt. Sed.)	9690611 R.H.	7.20	side
74-75	Impala (Custom) Caprice (Spt. Cpe.)	9690570 R.H.	10.20	side
74-75	Impala (Custom) Caprice (Spt. Cpe.)	9690571 L.H.	10.20	side
74-75	Impala (Spt. Cpe.) (exc. Custom)	9690572 R.H.	10.20	upper
74-75	Impala (Spt. Cpe.) (exc. Custom)	9690573 L.H.	10.20	upper
74-75	Impala (Spt. Cpe.) (exc. Custom)	9690574 R.H.	8.30	side
74-75	Impala (Spt. Cpe.) (exc. Custom)	9690575 L.H.	8.30	side
74-75	Impala (Spt. Cpe.)	9690576 1	10.20	lower
75	Pass. (Sed.) (exc. Spt. Sed.)	9739914 R.H.	10.20	side
75	Pass. (Sed.) (exc. Spt. Sed.)	9739915 L.H.	10.20	side
75	Pass. (Sed.) (exc. Spt. Sed.)	9739023 R.H.	10.20	upper
75	Pass. (Sed.) (exc. Spt. Sed.)	9739024 L.H.	10.20	upper
75	Pass. (Sed.) (exc. Spt. Sed.)	9739289 1	14.85	lower
75	Pass. (Spt. Sed.)	9739217 R.H.	10.20	upper
75	Pass. (Spt. Sed.)	9739218 L.H.	10.20	upper
75	Pass. (Spt. Sed.)	9739324 R.H.	10.20	side
75	Pass. (Spt. Sed.)	9739325 L.H.	10.20	side
75	Pass. (Spt. Sed.)	9739050 1	10.20	lower
72	All	9891400 1	.10	CLIP, rvl. mldg. bk. wdo. qtr. wdo. w/s

**CHEVELLE**

64-65	Malibu (Spt. Cpe.)	4430548 1	6.25	lower
64-65	Malibu (Spt. Cpe.)	4430552 R.H.	9.10	upper
64-67	El Camino	4408576 R.H.	8.15	lower side
64-67	El Camino	4408577 L.H.	8.15	lower side
64-67	El Camino	4408580 R.H.	9.75	upper side
64-67	El Camino	4408581 L.H.	9.75	upper side
64-67	El Camino	7695647 R.H.	17.95	side finishing
64-67	El Camino	7695648 L.H.	17.95	side finishing
65-67	El Camino	7695646 L.H.	21.80	roof panel rear finish
66-67	Chevelle (Sedan)	4542514 R.H.	8.30	lower
66-67	Chevelle (Sedan)	4542515 L.H.	8.30	lower
66-67	Chevelle (Spt. Cpe.)	7580180 R.H.	10.60	upper
66-67	Chevelle (Spt. Cpe.)	7580181 L.H.	10.60	upper
66-67	Chevelle (Spt. Cpe.)	7581670 R.H.	10.30	lower
66-67	Chevelle (Spt. Cpe.)	7581671 L.H.	10.30	lower
68-72	El Camino	7727617 L.H.	15.75	upper reveal
68-72	El Camino	7727616 R.H.	15.75	upper reveal
68-72	El Camino	7741450 1	6.75	lower reveal
68-72	Chevelle (Coupe)	7725807 R.H.	8.30	lower

**REAR GLASS—SEAT AND ADJUSTER**

**11.208 Moulding, Back Window Glass Reveal (Con't)**

68-72	Chevelle (Coupe)	7725808	L.H.	8.30	lower
68-72	Chevelle (Coupe)	7727134	R.H.	8.85	upper and side
68-72	Chevelle (Coupe)	7727135	L.H.	8.85	upper and side
68-69	Chevelle (4-Dr. Sed.)	8775858	R.H.	8.35	upper
68-69	Chevelle (4-Dr. Sed.)	8775859	L.H.	8.35	upper
68-69	Chevelle (4-Dr. Sed.)	8775860	R.H.	9.70	lower and side
68-69	Chevelle (4-Dr. Sed.)	8775861	L.H.	9.70	lower and side
70-72	Chevelle (4-Dr.) (exc. Sta. Wag.)	9813786	R.H.	8.35	upper
70-72	Chevelle (4-Dr.) (exc. Sta. Wag.)	9813787	L.H.	8.35	upper
70-72	Chevelle (4-Dr.) (exc. Sta. Wag.)	9813788	R.H.	10.30	lower and side
70-72	Chevelle (4-Dr.) (exc. Sta. Wag.)	9813789	L.H.	9.75	lower and side
73-75	Chevelle (Spt. Sed.)	9690600	1	10.75	lower
73-75	Chevelle (Spt. Sed.)	9690599	L.H.	8.75	upper
73-75	Chevelle (Spt. Sed.)	9690598	R.H.	8.75	upper
73-75	Chevelle (Spt. Sed.)	9690602	L.H.	10.75	side
73-75	Chevelle (Spt. Sed.)	9690601	R.H.	10.75	side
73-75	Chevelle (Spt. Cpe.) (exc. Monte Carlo)	9690552	L.H.	9.10	upper
73-75	Chevelle (Spt. Cpe.) (exc. Monte Carlo)	9690551	R.H.	9.10	upper
73-75	Chevelle (Spt. Cpe.) (exc. Monte Carlo)	9690555	L.H.	10.60	side
73-75	Monte Carlo	9690557	L.H.	9.10	upper
73-75	Monte Carlo	9690556	R.H.	11.30	upper
73-75	Monte Carlo	9690595	L.H.	10.60	lower and side
73-75	Monte Carlo	9690594	R.H.	13.00	lower and side
73-75	Monte Carlo w/vinyl top	9695329	L.H.	7.55	lower (prime and paint)
73-75	Monte Carlo w/vinyl top	9695328	R.H.	7.55	lower (prime and paint)
73-75	Monte Carlo w/vinyl top	9696399	L.H.	10.20	side (prime and paint)
73-75	Monte Carlo w/vinyl top	9696398	R.H.	8.70	side (prime and paint)
73-75	Chevelle (Spt. Cpe.) (exc. Monte Carlo)	9690553	1	10.60	lower
73-75	El Camino	9690642	R.H.	8.35	upper
73-75	El Camino	9690643	L.H.	8.35	upper
73-75	El Camino	9690644	R.H.	6.75	lower
73-75	El Camino	9690645	L.H.	6.75	lower
73-75	Chevelle (Spt. Cpe.) (exc. Monte Carlo)	9690554	R.H.	10.60	side
73-75	Monte Carlo w/vinyl top	9695304	R.H.	12.50	upper (prime and paint)
73-75	Monte Carlo w/vinyl top	9695305	L.H.	8.95	upper (prime and paint)

**CHEVY**

62-65	Nova (Spt. Cpe.)	4846229	L.H.	10.10	upper
62-65	Nova (Spt. Cpe.)	4846230	R.H.	4.70	side
66-67	Chevy (Sedan)	4545263	R.H.	8.15	lower
66-67	Chevy (Sedan)	4545264	L.H.	8.15	lower
66-67	Chevy (Sedan)	4545266	L.H.	4.65	side
66-67	Nova (Spt. Cpe.)	7581303	R.H.	8.45	upper
66-67	Nova (Spt. Cpe.)	7581304	L.H.	8.45	upper
66-67	Nova (Spt. Cpe.)	7581305	1	12.15	lower
66-67	Nova (Spt. Cpe.)	7581307	R.H.	7.25	side
66-67	Nova (Spt. Cpe.)	7581308	L.H.	7.25	side
68-74	Nova (exc. H.B.)	9891474	R.H.	8.85	lower
68-74	Nova (exc. H.B.)	9891475	L.H.	7.60	lower
68-74	Nova (Cpe.)	7741472	R.H.	7.05	upper and side
68-74	Nova (Cpe.)	7741473	L.H.	8.85	upper and side
68-74	Nova (4-Dr.)	7722526	R.H.		upper and side
68-74	Nova (4-Dr.)	7722527	L.H.	7.60	upper and side
73-74	Nova (H.B.)	9616874	R.H.	12.95	
73-74	Nova (H.B.)	9616875	L.H.	12.95	
75	Nova (H.B.)	1650153	1	4.90	upper
75	Nova (H.B.)	1650247	1	8.85	lower
75	Nova (H.B.)	1650842	R.H.	10.60	side
75	Nova (H.B.)	1650843	L.H.	10.60	side
75	Nova (4-Dr.)	9738926	R.H.	9.95	
75	Nova (4-Dr.)	9738927	L.H.	9.95	
75	Nova (4-Dr.)	9738433	1	9.95	upper
75	Nova (Coupe) (exc. H.B.)	9738695	1	11.05	lower
75	Nova (Coupe) (exc. H.B.)	9738918	R.H.	8.85	upper
75	Nova (Coupe) (exc. H.B.)	9738919	L.H.	8.85	upper
75	Nova (Coupe) (exc. H.B.)	9739085	R.H.	8.35	side
75	Nova (Coupe) (exc. H.B.)	9739086	L.H.	8.35	side

**CAMARO**

67-69	Camaro (Spt. Cpe.)	8775869	1	6.15	upper
-------	--------------------	---------	---	------	-------

**REAR GLASS—SEAT AND ADJUSTER**

**11.208 MOULDING, Back Window Glass Reveal (Con't)**

67-69	Camaro (Spt. Cpe.)	8775872	R.H.	7.65	side
67-69	Camaro (Spt. Cpe.)	8775873	L.H.	8.05	side
67-69	Camaro (Spt. Cpe.)	8775874	R.H.	8.05	lower
67-69	Camaro (Spt. Cpe.)	8775875	L.H.	8.05	lower
70-74	Camaro	9690565	1	7.65	upper
70-74	Camaro	9690567	L.H.	11.75	lower and side
70-74	Camaro	9690566	R.H.	11.75	lower and side
75	Camaro	9738198	1	11.05	upper
75	Camaro	9738210	R.H.	11.05	side
75	Camaro	9738211	L.H.	11.05	side
75	Camaro	9738212	1	11.05	lower

**VEGA— MONZA**

71-74	Vega (H.B.)	9818480	R.H.	6.80	lower reveal
71-74	Vega (H.B.)	9818481	L.H.	6.80	lower reveal
71-75	Vega (N.B.)	9818337	R.H.	6.30	lower reveal
71-75	Vega (N.B.)	9818338	L.H.	6.30	lower reveal
71-75	Vega (H.B.)	9826370	1	4.50	upper reveal
71-75	Vega (N.B.)	9826365	1	5.15	upper reveal
71-75	Vega (H.B.)	9826368	R.H.	4.50	side reveal
71-75	Vega (H.B.)	9826369	L.H.	4.50	side reveal
71-74	Vega (N.B.)	9826367	L.H.	4.50	side reveal
75	Monza (exc. Towne Cpe.)	9739996	1	9.60	upper
75	Monza (exc. Towne Cpe.)	1650448	1	9.60	lower
75	Monza (exc. Towne Cpe.)	1650446	R.H.	11.65	side
75	Monza (exc. Towne Cpe.)	1650447	L.H.	11.65	side
75	Monza (Towne Cpe.)	1673683	1	12.25	lower
75	Monza (Towne Cpe.)	1673685	1	8.75	upper
75	Monza (Towne Cpe.)	1673708	R.H.	10.30	side
75	Monza (Towne Cpe.)	1673709	L.H.	10.30	side
75	Monza (Towne Cpe.) w/pad vinyl roof	1712039	1	25.75	lower
75	Vega (H.B.)	1704383	R.H.	10.30	side
75	Vega (H.B.)	1704384	L.H.	10.30	side
75	Vega (N.B.)	1704386	R.H.	11.85	side
75	Vega (N.B.)	1704387	L.H.	11.85	side

**11.209 ESCUTCHEON— CLIP— NUT— SCREW— SPACER— STRIP, Back Window Glass Reveal Moulding**

88-72	El Camino	7741519	2	3.60	lower, corner
69-70	Pass. (Spt. Sed.)	8775836	2	1.80	corner, upper
69-70	Pass. (Spt. Sed.)	8775835	1	1.70	center, lower
69	Impala Custom, Caprice (Spt. Cpe.)	8775842	R.H.	4.20	corner, lower
69	Impala Custom, Caprice (Spt. Cpe.)	8775843	L.H.	4.20	corner, lower
70-74	Camaro	9854741	L.H.	2.90	upper corner
70-74	Camaro	9854740	R.H.	2.90	upper corner
62-65	Nova (Spt. Cpe.)	4847515	A.R.	.15	CLIP, lower, side and upper
64	Chevelle (Spt. Cpe.)	4895602	A.R.	.18	CLIP, side (emergency use)
64-67	El Camino	4877401	2	.16	CLIP, rear of rear wheel opening mldg. clip— (12.118)
65-68	Pass. (exc. Conv., Sta. Wag.),				
65	Chevelle (exc. Conv.),				
66-67	Chevy (exc. Sta. Wag.),				
66	El Camino,				
66-67	Chevelle (Sed.),				
67-69	Camaro (Spt. Cpe.),				
68-69	Chevy (Spt. Cpe.),				
68-69	Chevelle (Coupe),				
69-70	Pass. (4-Dr.),				
70	Nova, Impala (Spt. Cpe.),				
70	Chevelle (exc. Conv.)	4471409	A.R.	.11	CLIP, emergency use (screw-on type)— (10.096)
65-67	Camaro (exc. Conv.),				
65	Chevelle (exc. Sta. Wag., Conv.),				
66	Chevelle (2-Dr.),				
66-67	Chevy (exc. Sta. Wag.),				
67-68	Chevelle (Sed., El Camino),				
69-70	El Camino,				
67-68	Camaro (Spt. Cpe.),				
65-66	Pass. (exc. Sta. Wag.)	8736586	A.R.	.11	CLIP (use w/weld-on type stud) (screw-on type)— (10.096)
64	Chevelle,				
65	Chevelle (exc. Sta. Wag., Conv.),				

**REAR GLASS—SEAT AND ADJUSTER**

**11.209 ESCUTCHEON— CLIP— NUT— SCREW— SPACER— STRIP, Back Window Glass Reveal Moulding (Con't)**

66-67	Chevy (exc. Sta. Wag.),				
66-68	Chevelle (Sed.),				
66-67	El Camino,				
65	Chevelle w/vinyl top,				
68	Chevy (Spt. Cpe.),				
68	Chevelle (Coupe),				
67-68	Camaro (Spt. Cpe.),				
65-68	Pass. (exc. Conv., Sta. Wag.) . . . . .	8736590 A.R.	.11	CLIP, emergency use— (10.096) . . . . .	
66-67	Chevelle (Spt. Cpe.) . . . . .	7634583 A.R.	.14	CLIP, upper and lower . . . . .	
66	Chevelle (Spt. Cpe.),				
70	Impala Custom, Caprice (Spt. Cpe.) . . . . .	7635394 A.R.	.14	CLIP, emergency use . . . . .	
67	Chevy, Camaro w/vinyl top,				
67	Chevelle w/vinyl top (exc. Spt. Cpe.),				
67	Pass. (Spt. Mdls.) w/vinyl top . . . . .	7639528 A.R.	.18	CLIP (10.096) . . . . .	
67-68	Camaro (Spt. Cpe.),				
67-68	Chevelle (exc. Sta. Wag., Conv.),				
67-68	Pass. (Sed.),				
67-68	Caprice (Spt. Cpe.),				
68	Impala Custom,				
69	Impala (2-Dr.) (exc. Conv., Custom) . . . . .	7741144 4	.15	CLIP, anode . . . . .	
69	Chevy, Camaro (Spt. Cpe.),				
69	Pass. (Sed.),				
70	Camaro,				
70	Pass., Chevelle (exc. Conv., El Camino),				
71	Pass. (Sed.) (exc. Spt. Sed.) . . . . .	8736590 A.R.	.11	CLIP, emergency use— (10.096) . . . . .	
68	Pass. (Spt. Mdls.) (exc. Conv.),				
68-72	Chevelle, Chevy, Camaro w/vinyl top (exc. Conv.),				
69-71	Pass. (exc. Sta. Wag.),				
70-71	Camaro . . . . .	8736591 A.R.	.11	CLIP (10.096) . . . . .	
68-69	Chevelle (Sed., Spt. Cpe.),				
68-70	Chevy,				
70	Chevelle (exc. Conv., El Camino),				
70	Pass. (4-Dr.) (exc. Sta. Wag.) . . . . .	8736585 A.R.	.16	CLIP (10.096) . . . . .	
68	Chevelle (Coupe),				
71	Pass. (Sed.) (exc. Spt. Sed.),				
72-73	Pass. (exc. Sta. Wag.),				
72-73	Camaro . . . . .	8736589 A.R.	.24	CLIP, back window before glass— (10.096)	
69-70	Impala (Custom),				
69-70	Caprice (Spt. Cpe.) . . . . .	8734067 14	.23	CLIP, reveal, mldg. . . . .	
69-70	Impala (Spt. Cpe.) (exc. Custom),				
71-72	Camaro,				
71-72	Pass. (Conv.) (Sta. Wag.),				
71-72	El Camino,				
73-75	All . . . . .	8717859 A.R.	.15	CLIP . . . . .	
69-71	Nova w/vinyl top . . . . .	8791826 A.R.	.27	CLIP, reveal mldg.— (10.096) . . . . .	
72	Nova . . . . .	9891400 A.R.	.10	CLIP, emer. use— (11.032) . . . . .	
72	Nova . . . . .	9895598 1	.05	CLIP, also reveal mldg. w/shield upper & side . . . . .	
69-70	Impala (Custom) . . . . .	4421810 2	.11	CLIP, bk. wdo. lwr. cor. rvl. mldg. escut. . . . .	
73	El Camino . . . . .	9613200 A.R.	.11	CLIP, lower— (11.031) . . . . .	
73-75	Chevelle,				
75	Pass. . . . .	9662950 A.R.	.11	reveal mldg. upper, lower, side— (10.096) . . . . .	
75	Nova (H.B.) . . . . .			lwr., . . . . .	
75	Nova, Monza (exc. Towne Cpe.) . . . . .	1654047 A.R.	.11	upper and side . . . . .	
75	Pass., Chevelle, Camaro . . . . .			CLIP, back wdo. upr. side & lwr. to pnl., . . . . .	
75	Pass., Chevelle, Vega . . . . .	9731301 A.R.	.36	side, upr. lwr. tail gate wdo., qtr. wdo. front— (10.096) . . . . .	
75	Nova w/vinyl roof . . . . .	1654048 A.R.	.12	CLIP, upper and side— (10.096) . . . . .	
75	Nova (2-Dr.) (exc. H.B.) . . . . .	4510031 A.R.	.18	CLIP, back wdo. rvl. mldg., lwr.— (12.075) . . . . .	
75	Nova, Monza . . . . .	1661300 A.R.	.15	CLIP, back wdo. rvl. mldg., screw on (emergency use) . . . . .	
64	Malibu (exc. Sta. Wag., El Camino) . . . . .			NUT, rr. of rear fender inner moulding, . . . . .	
65-67	El Camino . . . . .	9419766 A.R.	.11	roof panel rear finishing mldg. and back window side finishing mldg.— (8.921) . . . . .	
66-73	All . . . . .	4492963 A.R.	.14	SCREW, emergency use, quarter belt reveal moulding clip— (12.118) . . . . .	
68-69	Chevelle (Sed.) . . . . .	7748859 A.R.	.23	SPACER (anti-squeak) . . . . .	
71	Pass. (Sed.) . . . . .	9842717 4	.15	SPACER, side anti-squeak . . . . .	



**REAR GLASS—SEAT AND ADJUSTER**

**11.209 ESCUTCHEON— CLIP— NUT— SCREW— SPACER— STRIP, Back Window Glass Reveal Moulding (Con't)**

73	Chevelle (2-Dr.) (exc. El Camino)	9678805	2	.39	STRIP, side anti/sq. ....
<b>11.358 PANEL, Front Seat Back</b>					
69-72	Pass., Chevelle,				
69-71	Nova,				
69-72	El Camino	8744617	2	13.20	pass. and driver (black) ....
71-72	Camaro, Nova (Spt. Cpe.), Vega (exc. Panel)	9837716	2	14.35	pass. and driver fin. (black) (paint) ....
68	Impala (Spt. Cpe., Conv.),				
68-70	Caprice (exc. Sta. Wag.)	7729214	1	8.20	PANEL ASSY., pass. side outer ....
68	Impala (Spt. Cpe., Conv.),				
68-70	Caprice (exc. Sta. Wag.)	7729215	1	8.20	PANEL ASSY., driver side outer ....
71-72	Caprice (Spt. Sed.) w/bench seats,				
71	Caprice (Spt. Cpe.) w/electric seat back lock release,				
73-74	Caprice (Sed.) w/bench st.,				
75	Pass. w/bench st. (exc. cig. ltr.)	9826382	1	16.75	PANEL ASSY., pass. seat back side outer trim ....
71	Caprice (Spt. Sed.) w/bench seats,				
71	Caprice (Spt. Cpe.) w/electric seat back lock release,				
73-74	Caprice (Sed.) w/bench st.,				
75	Pass. w/bench st. (exc. cig. ltr.)	9826383	1	16.75	PANEL ASSY., driver seat back side outer trim ....
71-72	Caprice (Spt. Cpe.),				
74-75	Chevelle w/split notch bk.,				
73-75	Pass. (exc. Wagon)	9823122	2	1.90	PANEL ASSY., pass. & driv. seat back inner
71-72	Caprice (Spt. Cpe.),				
73-75	Caprice (Spt. Cpe.) Impala (Custom)	9826378	1	15.40	PANEL ASSY., pass. seat back side outer trim ....
71-72	Caprice (Spt. Cpe.),				
73-75	Caprice (Spt. Cpe.) Impala (Custom)	9826379	1	15.40	PANEL ASSY., driver seat back side outer trim ....
71-72	Pass. (Spt. Cpe., Conv.)	9663776	1	54.00	PANEL ASSY., driver seat back
71-72	Pass. (Spt. Cpe., Conv.)	9663775	1	54.00	PANEL ASSY., pass. seat back
73-75	All w/swivel st.	9653250	2	11.95	PANEL ASSY., driver and pass. finish (paint as required)
73-74	Vega (exc. Panel),				
73-75	Camaro, Nova (2-Dr.),				
75	Vega, Monza w/bkt. and frt. cust./spec. design st.	1653515	2	9.00	PANEL, front seat back finish driver and pass. (paint as reqd.)
73-75	Caprice (Spt. Cpe.) w/recl. seat	1684867	1	17.35	PANEL ASSY., pass. seat back outer
73-75	Caprice (Spt. Cpe.) w/recl. seat	1684868	1	17.35	PANEL ASSY., drive seat back outer
74-75	Caprice (Sed.)	1684865	1	17.35	PANEL ASSY., trim pass. seat back otr.
74-75	Caprice (Sed.)	9640655	1	15.20	PANEL ASSY., trim driver seat back otr.
75	Nova w/European st.	1663924	2	5.65	PANEL ASSY., pass. and driver seat back
<b>11.362 PANEL— PANEL ASSY., Front Seat Side Lower</b>					
65-66	Caprice,				
65-66	Impala (exc. S.S.),				
67-70	Caprice (exc. Sta. Wag.),				
68	Pass., Spt. Cpe., Conv.	4467796	R.H.	6.75	seat side
65-66	Caprice,				
65-66	Impala (exc. S.S.),				
67-70	Caprice (exc. Sta. Wag.),				
68	Pass. (Spt. Cpe., Conv.)	4467797	L.H.	6.75	seat side
69-70	Malibu (2-Dr.) (exc. Sed.),				
69	Caprice				right side,
69	Impala, Caprice (exc. Sed.),				
69-71	Nova (2-Dr.),				
70-72	Chevelle (El Camino, Custom) (Spt. Cpe., Conv.) (exc. Deluxe)	7793910	1	3.55	driver inner, pass. outer (black)
69-70	Malibu (2-Dr.) (exc. Sed.),				
69	Caprice				left side,
69	Impala, Caprice (exc. Sed.),				
69-71	Nova (2-Dr.),				
70-72	Chevelle (El Camino Custom) (Spt. Cpe., Conv.) (exc. Deluxe)	7793911	1	3.55	driver outer, pass. inner (black)
71	Caprice w/electric seat control,				

**REAR GLASS—SEAT AND ADJUSTER**

**11.362 PANEL— PANEL ASSY., Front Seat Side Lower (Con't)**

72-74	Caprice w/6-way power bench	9826137 L.H.	12.70	PANEL ASSY., seat side
71	Caprice,			
72	Caprice w/6-way bench seats,			
73-75	Caprice w/bench st.	9826134 L.H.	12.70	PANEL ASSY., front seat side
71	Caprice,			
72-75	Caprice (w/bench seats)	9826133 R.H.	12.70	PANEL ASSY., front seat side
73-75	All w/reclining st.	9640652 1	10.55	PANEL ASSY., pass.
73-75	All w/reclining st.	9640653 1	10.55	PANEL ASSY., driver
73-75	All w/6-way reclining st.	9658349 1	12.70	PANEL ASSY., driver
75	Pass. w/6-way pwr. bench/notch bk.	9826137 1	12.70	PANEL ASSY., front seat side (repl. 1688906)

**11.368 SUPPORT— RETAINER— SPACER, Front Seat Back, Side Panels**

68-72	Pass., Chevelle, Nova w/Strato. seats	7737871 A.R.	.37	right, driver inner and pass. outer, side panel rear
68-72	Pass., Chevelle, Nova w/Strato. seats	7737872 A.R.	.24	left, driver inner and pass. outer, side panel rear
71-72	Caprice,			
73-75	Caprice (Sed., Spt. Cpe.) w/bench st.	9803612 L.H.	.37	rear
71-72	Caprice,			
73-75	Caprice (Sed., Spt. Cpe.) w/bench st.	9803611 R.H.	.37	rear
71-72	Impala Custom, Caprice (Spt. Cpe.) (Spt. Sed.),			
71	Pass. (exc. Spt. Cpe., Conv.),			
73-75	Caprice (Spt. Cpe., Sed.) w/bench st.	9827636 1	.44	pass. outer trim panel
71-72	Impala Custom, Caprice (Spt. Cpe.) (Spt. Sed.),			
71	Pass. (exc. Spt. Cpe., Conv.),			
73-75	Caprice (Spt. Cpe., Sed.) w/bench st.	9827637 1	.44	driver outer trim panel
71-72	Caprice,			
73-75	All w/reclining st.	9827640 2	.52	front
72	Nova (exc. Sed.),			
71-72	Camaro,			
71-75	Vega (exc. Panel) Monza (exc. Towne Cpe.),			
73-75	Nova, Camaro	1651214 2	2.30	pass. and driver st. bk. fin. pnl.
73-75	All w/reclining st.	9827636 1	.44	driver & pass. seat back outer trim panel (repl. 9654867)
73	Monte Carlo w/bench st.,			
74-75	Chevelle w/split notch back	9668815 1	1.35	driver seat back otr. mldg.
73	Monte Carlo w/bench seat,			
74-75	Chevelle w/split notch back	9668814 1	1.35	pass. seat back outer mldg.
74-75	Chevelle w/front seat split notch back	9862746 1	5.00	pass. seat
74-75	Chevelle w/front seat split notch back	9862747 1	5.00	driver seat
66-70	Caprice (Spt. Cpe.)	7661230 2	1.70	RETAINER, inner trim
71	Caprice (Spt. Cpe.),			
73-75	Pass. (Conv.) w/bench st.,			
75	Monte Carlo w/bench st.	9803645 2	.63	RETAINER, pass. and driver frame bar trim inner
71	Caprice (Spt. Sed.),			
73-75	Caprice (Spt. Sed.)	9803654 1	1.55	RETAINER, trim at center arm rest

**11.373 RING— PANEL ASSY.— FRAME ASSY., Front Seat Back, with Springs (less Cushion)**

62-69	Pass., Chevelle, Nova, Camaro	4556605 A.R.	.02	trim— (8.900)
71-75	Pass. (4-Dr.) w/bench seat	9727490 1	54.00	PANEL ASSY., front seat back
73-75	Pass. (2-Dr.) w/bench seat	9663776 1	54.00	PANEL ASSY., driver
73-75	Pass. (2-Dr.) w/bench seat	9663775 1	54.00	PANEL ASSY., pass.
73-75	Chevelle, Nova (2-Dr.) w/bench seat	9663097 1	35.25	PANEL ASSY., driver
73-75	Chevelle, Nova (2-Dr.) w/bench seat	9663096 1	35.25	PANEL ASSY., pass.
73	All w/swivel seat	9876509 2	61.00	PANEL ASSY., driver and pass.
73	Bel Air (Sed.) w/bench st., Police, Taxi	9666783 1	54.00	PANEL ASSY., front seat back/comp.

**REAR GLASS—SEAT AND ADJUSTER**

**11.373 RING— PANEL ASSY.— FRAME ASSY., Front Seat Back, with Springs  
(less Cushion) (Con't)**

73-75	Chevelle, Nova (4-Dr.) w/bench seat	9727489	1	54.00	PANEL ASSY., front seat bk.
74-75	Chevelle w/swiv. bucket seat	1697562	2	71.00	PANEL ASSY., pass. and driver seat
74-75	Chevelle w/front seat split notch back	9698958	1	38.00	PANEL ASSY., pass. seat back
74-75	Chevelle w/front seat split notch back	9698959	1	38.00	PANEL ASSY., driver seat back
71-72	Chevelle (2-Dr.)	9816998	1	51.50	FRAME ASSY., pass. seat back
68-72	Nova, Chevelle (4-Dr.)	9862980	1	58.75	FRAME ASSY., front seat back
71	Camaro,				
71-75	Vega (exc. Panel), Monza,				
72-74	Nova, Camaro w/bucket seats	9678918	1	54.50	FRAME ASSY., pass. seat back
71	Camaro,				
71-73	Vega, Monza,				
72-73	Nova, Camaro w/bucket seat	9628571	1	54.50	FRAME ASSY., driver seat back
73	Caprice (Sed.) w/reclining seat	9663142	1	32.75	FRAME ASSY., driver
74	Caprice (Spt. Cpe.) w/reclining seat	9683610	1	32.75	FRAME ASSY., pass.
74	Caprice (Spt. Cpe.) w/reclining seat	9683611	1	32.75	FRAME ASSY., driver
74	Caprice (Sed.) w/reclining seat	9683612	1	32.75	FRAME ASSY., pass.
74	Caprice (Sed.) w/reclining seat	9683613	1	32.75	FRAME ASSY., driver
74	Camaro, Nova (2-Dr.) w/bucket seats,				
74-75	Vega (exc. Panel), Monza	9678919	1	54.50	FRAME ASSY., driver
75	Chevelle w/reclining seat,				
75	Pass. (2-Dr.) w/reclining seat	1671764	1	34.00	FRAME ASSY., pass.
75	Chevelle w/reclining seat,				
75	Pass. (2-Dr.) w/reclining seat	1671765	1	34.00	FRAME ASSY., driver
75	Pass. w/reclining seat (exc. 2-Dr.)	1671766	1	34.00	FRAME ASSY., pass.
75	Pass. w/reclining seat (exc. 2-Dr.)	1671767	1	34.00	FRAME ASSY., driver
75	Nova (Custom) (2-Dr.) w/European st. (exc. H.B.)	1706438	1	166.00	FRAME ASSY., pass.
75	Nova (Custom) (2-Dr.) w/European st. (exc. H.B.)	1706439	1	166.00	FRAME ASSY., driver
75	Nova (Custom) (4-Dr.) w/European st.	1706440	1	166.00	FRAME ASSY., pass.
75	Nova (Custom) (4-Dr.) w/European st.	1706441	1	166.00	FRAME ASSY., driver
75	Camaro, Nova w/bucket sts.	1693418	1	54.50	FRAME ASSY., pass.
75	Camaro, Nova w/bucket sts.	1693419	1	54.50	FRAME ASSY., driver

**11.374 PANEL— RETAINER— SUPPORT— SCREW— SPACER— WIRE, Front Seat Center Arm Rest**

74-75	Chevelle (4-Dr.) w/frt. st. split notch back	9640489	1	3.10	(prime and paint)
74-75	Chevelle (2-Dr.) w/frt. st. split notch back	9856274	1	2.85	(prime and paint)
71-72	Caprice (Spt. Sed.),				
73	Caprice (Spt. Sed.) w/bench st. (exc. reclining)	9815543	1	.18	RETAINER front seat center arm rest panel trim
71-72	Caprice (Spt. Sed.),				
74-75	Caprice (Sedan) w/bench seat	9733907	1	17.20	SUPPORT ASSY.
73	Caprice (Sed.) w/bench st. (exc. reclining)	9733907	1	17.20	SUPPORT ASSY.
74-75	Chevelle w/front seat split notch back	1656379	1	20.70	SUPPORT ASSY.
67-68	Camaro w/Strato bench seat	7682325	2	1.80	SCREW
71-72	Caprice (Spt. Sed.)	9829719	1	1.70	WIRE ASSY., front seat back center arm rest

**11.375 PLATE— COVER— FASTENER— RETAINER, Front Seat Hinge Arm,**

67	Nova (Spt. Cpe.) (exc. S.S.),				
67-69	El Camino,				
67-69	Chevelle (2-Dr.) (exc. Std.),				
68	Chevelle (Spt. Cpe., Conv.),				
70-72	Chevelle (2-Dr.)	7667276	R.H.	.76	COVER, back outer (black)
67	Nova (Spt. Cpe.) (exc. S.S.),				
67-69	El Camino,				
67-69	Chevelle (2-Dr.) (exc. Std.),				
68	Chevelle (Spt. Cpe., Conv.),				

**REAR GLASS—SEAT AND ADJUSTER**

**11.375 PLATE— COVER— FASTENER— RETAINER, Front Seat Hinge Arm  
(Con't)**

70-72	Chevelle (2-Dr.)	7667277 L.H.	.76	COVER, back outer (black)
67-70	Camaro	7684910 2	.83	COVER, pass., seat back inner arm (black) driver, seat back outer arm
70-72	Chevelle (2-Dr.)	7667277 L.H.	.76	COVER, back outer (black)
70-72	Chevelle (2-Dr.)	7667276 R.H.	.76	COVER, back outer (black)
71-72	Pass. (Spt. Cpe., Conv.),			
73-75	Pass., Chevelle, Nova (Spt. Cpe., Conv.)	9852254 1	.85	COVER, pass. seat bk. outer hinge arm (Note 1)
71-72	Pass. (Spt. Cpe., Conv.),			
73-75	Pass., Chevelle, Nova (Spt. Cpe., Conv.)	9852255 1	.85	COVER, driver st. bk. outer hinge arm (Note 1)
71-72	Pass. (Spt. Cpe., Conv.),			
73-75	Pass., Chevelle, Nova (Spt. Cpe., Conv.)	9854682 1	.34	COVER, frt. st. bottom frame center hinge arm (Note 1)
72	Nova (2-Dr.)	9616891 1	1.30	COVER, hge. arm pass. st. bk. otr.
72	Nova (2-Dr.)	9616892 1	1.30	COVER, hge. arm driver st. bk. otr.
74-75	Pass., Chevelle w/frt. seat split notch back	9854648 1	.36	COVER, driver st. bottom inner hinge (prime and paint)
74-75	Chevelle w/frt. seat split notch back	9854751 1	.36	COVER, pass. st. bottom inn. hge. (prime & paint)
75	Nova (Custom) w/European st.	1674515 2	.90	COVER, pass. outer, driver inner
75	Nova (Custom) w/European st.	1674516 2	.90	COVER, driver outer, pass. inner
67-70	Camaro,			
67	Nova (exc. S.S.),			
67-72	Chevelle (2-Dr.),			
67	Camaro (Std.) w/strato bucket			FASTENER, inner and outer arm cover, outer arm cover,
69	Impala (2-Dr.),			
69-72	Pass. (2-Dr.)			back outer hinge arm cover,
71-75	Vega			front seat back outer hinge arm cover
73-75	All	7719698 A.R.	.06	driver and passenger st. bk. inr. and otr. hge. arm cvr. driver and passenger st. bk. inner & otr. hge. arm cvr.
62-64	Nova w/bucket seats,			
65-67	Biscayen (2-Dr. Sed.),			
67	Camaro	4630023 A.R.	.05	RETAINER, pass. and driver seat back inner to hinge pin retainer (3/4" dia.)
64-66	Chevelle (2-Dr.),			
65	Malibu, El Camino w/bucket seats			RETAINER, back frame to extension pin to inner and outer bar
62-67	Chevy Deluxe (2-Dr.),			
67-70	Chevelle (2-Dr.)			back frame to extension pin,
67	Camaro w/strato bench			frame to hinge pin,
67-70	Camaro,			
68	Chevy (Spt. Cpe.),			
68	Chevelle (2-Dr.) (exc. Malibu, El Camino, S.S.)			(7/8" O.D. 6" prongs),
65-68	Pass. (2-Dr.) (exc. Sdl.),			
69-70	Pass. (2-Dr.),			
71-72	All (2-Dr.)			arm support and hinge pin,
71-75	Vega, Monza			seat back frame outer bar hinge pass. and driver,
73-75	All (2-Dr.) (w/bench st.)	4495047 A.R.	.12	RETAINER, pass. seat back frm. otr. bar hge.

NOTE 1: Paint as required.

**11.376 ESCUTCHEON— GUIDE ASSY.— PAD ASSY.— PANEL— RETAINER— SPRING— TUBE, Front Seat Headrestraint**

NOTE: For head restraint assy., see group 14.924.

66-67	Pass., Chevelle, Nova (exc. Astro. seat)	7642729 2	1.30	front seat headrestraint panel support
69	Camaro	8756596 2	.70	pass. and driver support
69	All (exc. Camaro)	8756591 2	.63	pass. and driver support
69	Pass., Chevelle, Nova w/strato bucket seats	8756593 4	.44	pass. and driver support
70	Pass., Chevelle, Nova, Camaro w/strato bench	8785953 2	1.60	pass. and driver seat back support
70-72	Chevelle, Nova w/strato bucket	8785952 4	1.35	pass. and driver seat back support

**REAR GLASS—SEAT AND ADJUSTER**

**11.376 ESCUTCHEON— GUIDE ASSY.— PAD ASSY.— PANEL— RETAINER—  
SPRING— TUBE, Front Seat Headrest (Con't)**

71	Pass. ....				pass. and driver seat back support .....
73-75	All w/bench .....	<b>9859922</b>	1	1.70	driver & pass. seat back support (paint as required) .....
71	Nova, Chevelle .....	<b>9851153</b>	2	1.70	pass. and driver .....
66-69	Pass. (exc. Astro. seat) .....	<b>8768735</b>	2	11.30	<b>GUIDE ASSY.</b> , front seat back headrest support .....
69	All (exc. Camaro) .....	<b>8748950</b>	1	24.00	<b>PAD ASSY.</b> , w/panel, pass. and driver .....
69-70	All (exc. Camaro) .....	<b>9843289</b>	2	.76	<b>PANEL</b> , pass. and driver (paint as required) .....
70	Impala, Caprice (exc. Sta. Wag., Conv.), .....				
71-72	Pass. ....	<b>9847061</b>	2	.76	<b>PANEL</b> , pass. and driver .....
70	Malibu (4-Dr. Sed.) .....		2		<b>PANEL</b> , pass. driver finish (med. turq.) .....
71-72	Nova, Chevelle .....	<b>9843289</b>	2	.76	<b>PANEL</b> , pass. and driver .....
73	All w/bench .....	<b>9657321</b>	2	.76	<b>PANEL</b> , driver & pass. (painted) .....
74-75	All w/bench seats .....	<b>9694440</b>	2	.76	<b>PANEL</b> , pass. and driver (painted) .....
70-72	Pass., Chevelle, Nova (2-Dr.) .....	<b>8785958</b>	4	.32	<b>RETAINER</b> , support escutcheon .....
70	Camaro, .....				
70-72	Pass., Chevelle, Nova (exc. strato buckets), .....				
73-75	All w/bench .....	<b>8785959</b>	2	.32	<b>RETAINER</b> , support escutcheon .....
71-72	Pass., .....				
73	Pass., Malibu (Estate) w/bench seat, .....				
73	Laguna (Sta. Wag.) w/bench seat (exc. Estate), .....				
74-75	All w/bench st. ....	<b>9818575</b>	2	.16	<b>SPRING</b> , pass. and driver seat pnl. supt. gde. ....
69-70	Pass., Chevelle, Nova, Camaro, .....				
71-72	Nova, Chevelle .....	<b>9825150</b>	2	.12	<b>SPRING ASSY.</b> , pass. and driver seat panel support guide .....
70-72	All (exc. strato seat, Camaro) ...	<b>9873802</b>	2	.76	<b>TUBE</b> , pass. and driver support guide .....
70-72	Chevelle, Nova w/strato seat ...	<b>8788200</b>	4	.58	<b>TUBE</b> , pass. and driver support guide .....
71-72	Pass., .....				
73-75	Pass. w/bench .....	<b>9867649</b>	2	.63	<b>TUBE ASSY.</b> , pass. and driver seat back head rest support .....
73-75	Chevelle, Nova w/bench seat ...	<b>9871075</b>	2	.59	<b>TUBE ASSY.</b> , pass. and driver support guide .....

**11.377 ACTUATOR— CABLE ASSY.— HANDLE— KNOB, Seat Back Reclining**

73-75	All .....	<b>9664870</b>	1	32.50	pass. back reclining on bottom frame .....
75	Nova w/European st. ....	<b>9733107</b>	1	28.25	pass. st. back reclining .....
75	Nova (Custom) w/European st. (exc. H.B.) .....	<b>9733108</b>	1	28.25	driver st. back reclining .....
75	Nova w/European st. ....	<b>9733110</b>	2	2.00	<b>CABLE ASSY.</b> , pass., drive st. bk. reclining .....
75	Nova w/European st. ....	<b>1656901</b>	1	9.10	<b>HANDLE</b> , pass. seat back reclining .....
75	Nova w/European st. ....	<b>1656902</b>	1	9.10	<b>HANDLE</b> , driver seat back reclining .....
75	Nova w/European st. ....	<b>1657540</b>	1	4.65	<b>KNOB</b> , pass. seat back reclining handle ...
75	Nova w/European st. ....	<b>1657541</b>	1	4.65	<b>KNOB</b> , driver seat back reclining handle ...

**11.381 BUMPER— CAP— CABLE— SLEEVE— STUD— WASHER, Seat Back**

69-72	Pass., Chevelle, Nova w/strato buckets .....	<b>7712537</b>	4	.28	pass. and driver .....
71	Sta. Wag. ....	<b>7726729</b>	R.H.	.18	right fldg. 2nd seat on wheel house .....
71	Chevelle, Nova (2-Dr.) .....	<b>6278019</b>	2	.22	pass. and driver frame inner .....
71	Pass. (Sta. Wag.) (9-Pass.) .....	<b>4879757</b>	2	.16	2nd 1/3 seat back link bumper— (12.975) ..
65-69	Pass. (2-Dr.) (w/Astro Seat), .....				
66-68	Nova, Chevelle (S.S.), .....				
66-68	El Camino (Custom), .....				
69	Chevy, Chevelle w/Strato seats, .....				
66	Caprice (Spt. Sed.), .....				
70-71	Pass. (2-Dr.), .....				
72	Nova (Spt. Cpe.), .....				
72	Chevelle (exc. Sta. Wag., Conv.) w/bucket seats .....				pass. & driver seat back inner bumper, ....
62-63	Nova w/bucket seats (exc. Sta. Wag.), .....				
65-68	Chevelle (2-Dr.), .....				
64-68	Chevy (2-Dr.), .....				
65-66	Nova (S.S.), .....				
64-65	Chevelle (S.S.), .....				
67-68	Camaro, .....				
67	Camaro w/strato bench, .....				
62-65	Chevy, .....				
64-65	El Camino w/bucket seat, .....				

**REAR GLASS—SEAT AND ADJUSTER**

**11.381 BUMPER— CAP— CABLE— SLEEVE— STUD— WASHER, Seat Back  
(Con't)**

71	Chevelle, Nova (2-Dr.)				pass. outer and driver inner frame
72	Pass. (Spt. Cpe., Conv.)				pass. and driver seat bottom frame outer bottom
73-74	Chevelle w/bucket seats				pass. & driver seat back inner bumper,
73-75	All (2-Dr.) w/bench sts.				pass. and driver seat bottom frame inner bottom
74	Chevelle w/front seat split notch back	7712536	1	.22	pass. and driver st. back frame inner
73-75	Nova (Cpe.)	4880572	2	.16	fldg. rear seat filler panel— (12.945)
70-72	Pass., Chevelle (Sta. Wag.)	8761591	2	.16	CAP, fldg. 2nd seat back link support frt.
73-75	Pass. (Sta. Wag.)	9660699	A.R.	.16	CAP, finish fldg. seat
67-68	Camaro	7726498	1	1.70	CABLE ASSY., pass. seat back stop inner
71	Camaro	9887353	2	.11	SLEEVE, pass. seat back
73-74	Pass. (Sta. Wag.) (9-Pass.)	9619794	1	.34	STUD, fldg. 3rd seat link lower frame
65-66	Nova (Spt. Cpe.)	4860758	10	.11	WASHER, frt. st. bk. stop cable— L.H.

**11.390 CONTROL ASSY.— ACTUATOR ASSY.— BOLT— BUTTON ASSY.— CAP— CLIP— COVER— ESCUTCHEON— GROMMET— KNOB— HANDLE— LOCK ASSY.— RETAINER— ROD— SLEEVE— SOLENOID ASSY.— SPRING— STRIKER— SUPPORT— WASHER, Front Seat Back Lock**

71-73	Pass. (Spt. Cpe., Conv.) w/bench st. (exc. reclining)	9873860	1	4.70	seat back lock, pass.
71-73	Pass. (Spt. Cpe., Conv.) w/bench st. (exc. reclining)	9873861	1	4.70	seat back lock, driver
70	Pass. (Spt. Cpe., Conv.) w/electric seat back release	9829732	1	23.85	ACTUATOR ASSY., pass.
70	Pass. (Spt. Cpe., Conv.) w/electric seat back release	9829733	1	23.85	ACTUATOR ASSY., driver
70-71	Chevelle w/electric seat back release, bucket seat	9817754	2	51.75	ACTUATOR ASSY., pass. and driver
70	Chevelle w/electric seat back release	9829730	1	23.85	ACTUATOR ASSY., pass.
70	Chevelle w/electric seat back release	9829731	1	23.85	ACTUATOR ASSY., driver
71	Chevelle (Spt. Cpe., Conv.) w/electric seat back release	9839712	1	23.95	ACTUATOR ASSY., pass.
71	Chevelle (Spt. Cpe., Conv.) w/electric seat back release	9839713	1	23.95	ACTUATOR ASSY., driver
71	Chevelle w/electric seat back release, bucket seat	9817754	2	51.75	ACTUATOR ASSY., pass. and driver
69-72	Pass., Chevelle, Nova w/strato bucket	8734070	2	3.55	BUTTON ASSY., pass. and driver, push
73-75	Camaro, Monza, Vega (exc. Panel)	9674974	2	.12	CAP, pass. & driver st. bk. frame hge. hook
67	Nova (S.S.),				
67	Pass. (Conv.),				
67-68	Pass., Chevelle, Nova (2-Dr.) w/strato seats	9716582	1	.12	CLIP, seat back lock
71-72	Camaro,				
71-75	Vega (exc. Panel), Monza (exc. Towne Cpe.),				
72	Nova (Spt. Cpe.) w/bucket seat,				
73-75	Camaro, Nova w/bucket st.	9837934	1	.66	COVER, pass. seat back armlock (paint as required)
71-72	Camaro,				
71-75	Vega (exc. Panel), Monza (exc. Towne Cpe.),				
72	Nova (Spt. Cpe.) w/bucket seat,				
73-75	Camaro, Nova w/bucket st.	9851244	1	.98	COVER, driver seat back armlock (paint as required) (repl. 9837935)
67-72	Chevy (2-Dr.) (exc. S.S.),				
67-72	Chevelle (2-Dr.),				
73-75	Chevelle, Nova (2-Dr.) w/bench st.	9826034	2	1.85	ESCUTCHEON, pass./driver lock handle
71-72	Pass. (Conv.) (Spt. Cpe.),				
73-75	Pass. (2-Dr.) w/bench st. (exc. reclining),				
75	Monte Carlo w/reclining st.	9827606	2	1.85	ESCUTCHEON, pass. and driver seat back lock handle
71	Chevelle, Nova (2-Dr.)	9826034	2	1.85	ESCUTCHEON, lock handle
68	Pass., Chevelle, Nova w/strato bucket seats	7740343	1	1.55	ESCUTCHEON ASSY., pass. knob
68	Pass., Chevelle, Nova w/strato bucket seats	7740344	1	1.55	ESCUTCHEON ASSY., driver knob

**REAR GLASS—SEAT AND ADJUSTER**

**11.390 CONTROL ASSY.— ACTUATOR ASSY.— BOLT— BUTTON ASSY.— CAP— CLIP— COVER— ESCUTCHEON— GROMMET— KNOB— HANDLE— LOCK ASSY.— RETAINER— ROD— SLEEVE— SOLENOID ASSY.— SPRING— STRIKER— SUPPORT— WASHER, Front Seat Back Lock (Con't)**

70-71	Chevelle (Spt. Cpe., Conv.) . . . . .	7620864	4	.76	GROMMET, pass. and driver . . . . .
67-69	Pass. (2-Dr.) w/Strato seats . . . . .	7712051	2	1.40	KNOB, driver and pass., rod push button . . . . .
71-73	Vega (exc. Panel),				
72	Camaro, Nova (w/bucket seats),				
73	Nova (2-Dr.) w/bucket st.,				
73-75	Chevelle (2-Dr.) w/bench st.,				
74-75	Nova (2-Dr.) w/bench st. . . . .	9615575	2	.34	KNOB, pass. and driver st. back lock . . . . .
67	Pass., Chevelle, Nova, Camaro (2-Dr.) (exc. S.S.),				
68-72	Pass., Chevelle, Nova (2-Dr.) (exc. S.S.) . . . . .	7661259	A.R.	1.65	KNOB ASSY., driver and pass. . . . .
68-70	Camaro . . . . .	7767487	2	1.65	KNOB ASSY., driver and pass. handle . . . . .
67-72	Pass., Chevelle, Nova 2-Dr. (exc. S.S.),				
71-72	Chevelle, Nova (2-Dr.) . . . . .	9825855	R.H.	.44	HANDLE . . . . .
67-72	Pass., Chevelle, Nova 2-Dr. (exc. S.S.),				
67	Camaro . . . . .	9825856	L.H.	.44	HANDLE . . . . .
71-72	Pass. (Spt. Cpe., Conv.) . . . . .	9830864	1	1.95	HANDLE, pass. seat back lock . . . . .
71-72	Pass. (Spt. Cpe., Conv.),				
73-75	Impala (Spt. Cpe.) Caprice (Conv.) w/bench st.,				
75	Monte Carlo w/reclining st. . . . .	9835631	1	3.25	HANDLE, driver seat back lock . . . . .
73-75	Impala (Spt. Cpe.) Caprice (Conv.) w/bench st.,				
75	Monte Carlo w/reclining st. . . . .	9835630	1	3.25	HANDLE, pass. seat back lock . . . . .
73-75	Caprice w/reclining seat,				
75	Monte Carlo w/reclining st. . . . .	7681728	1	1.70	HANDLE, pass. seat reclining unit— (11.620) . . . . .
70	Pass. (2-Dr.) w/electric seat back release,				
70-71	Chevelle (Malibu, Monte Carlo) w/electric seat back release,				
70-71	Chevelle Std. (Spt. Cpe.) w/electric seat back release . . . . .	9829404	1	3.55	HANDLE ASSY., pass. . . . .
70	Pass. (2-Dr.) w/electric seat back release,				
70-71	Chevelle (Malibu, Monte Carlo) w/electric seat back release,				
70-71	Chevelle (Std., Spt. Cpe.) w/electric seat back release . . . . .	9829405	1	3.55	HANDLE ASSY., driver . . . . .
71-72	Pass. (Spt. Cpe., Conv.) . . . . .	9611426	2	6.15	HANDLE ASSY., pass. and driver seat back lock (painted) . . . . .
68-69	Chevy, Chevelle w/Strato seats,				
68-69	Pass. (2-Dr.) w/Strato seats . . . . .	7737854	2	.27	RETAINER, driver and pass. panel trim at knob . . . . .
71-72	Pass. (Spt. Cpe.),				
73	All (2-Dr.) w/bench st.,				
74-75	Pass. (2-Dr.) . . . . .	9605892	1	.87	ROD, pass. seat back locking . . . . .
71-72	Pass. (Spt. Cpe.),				
73	All (2-Dr.) w/Bench St.,				
74-75	Pass. (2-Dr.) . . . . .	9605893	1	.87	ROD, driver seat back locking . . . . .
73-75	Camaro, Nova w/bucket sts. . . . .	9887353	2	.11	SLEEVE, pass. seat back . . . . .
70-71	Chevelle (Spt. Cpe., Conv.) w/electric seat back release, bucket seat . . . . .	9722039	2	23.95	SOLENOID ASSY., pass. and driver . . . . .
70	Pass. (Spt. Cpe., Conv.) w/electric seat back release,				
70-71	Chevelle (Spt. Cpe., Conv.) w/electric seat back release . . . . .	9829734	1	27.00	SOLENOID ASSY., pass. actur. . . . .
70	Pass. (Spt. Cpe., Conv.) w/electric seat back release,				
70-71	Chevelle (Spt. Cpe., Conv.) w/electric seat back release . . . . .	9829735	1	27.00	SOLENOID ASSY., driver actur. . . . .
71	Pass. (Spt. Cpe., Conv.) w/electric seat back release . . . . .	9836674	1	26.75	SOLENOID ASSY., pass. seat back actuator lock . . . . .
71	Pass. (Spt. Cpe., Conv.) w/electric seat back release . . . . .	9836675	1	26.75	SOLENOID ASSY., driver seat back actuator lock . . . . .
67-68	Pass., Chevelle, Nova (Spt. Cpe., Conv.) (exc. S.S.),				

**REAR GLASS—SEAT AND ADJUSTER**

**11.390 CONTROL ASSY.— ACTUATOR ASSY.— BOLT— BUTTON ASSY.— CAP— CLIP— COVER— ESCUTCHEON— GROMMET— KNOB— HANDLE— LOCK ASSY.— RETAINER— ROD— SLEEVE— SOLENOID ASSY.— SPRING— STRIKER— SUPPORT— WASHER, Front Seat Back Lock (Con't)**

69-70	Pass., Chevelle, Nova (2-Dr.) (exc. Camaro),				
71-72	Chevelle, Nova (2-Dr.)	9710444	R.H.	.32	SPRING, lock bolt
67-68	Pass., Chevelle, Nova (Spt. Cpe., Conv.) (exc. S.S.),				
69-70	Pass., Chevelle, Nova (2-Dr.) (exc. Camaro),				
71-72	Chevelle, Nova (2-Dr.)	9710445	L.H.	.32	SPRING, lock bolt
70	Pass., Chevelle, Nova (2-Dr.),				
71-72	Chevelle, Nova (2-Dr.)	9723854	R.H.	.18	SPRING, detent
70	Pass., Chevelle, Nova (2-Dr.),				
71-72	Chevelle, Nova (2-Dr.)	9723855	L.H.	.18	SPRING, detent
71-72	Pass. (Spt. Cpe., Conv.),				
73-75	Pass., Chevelle, Nova (2-Dr.) (exc. Conv.)	9836668	1	.32	SPRING, pass. and driver seat back actuator lock
71	Impala, Caprice (Spt. Cpe., Conv.)	9888790	2	.37	SPRING, pass. & driver seat back actuator lock (electric)
72-75	Vega (exc. Panel) Monza (exc. Towne Cpe.),				
73-75	Camaro, Nova w/bucket st.	9846547	1	.18	SPRING, drive outer hinge arm
72-75	Vega (exc. Panel) Monza (exc. Towne Cpe.),				
73-75	Camaro, Nova w/bucket st.	9846546	1	.18	SPRING, pass. outer hinge arm
67-70	Pass. (2-Dr.) (exc. S.S.)	7661253	2	2.85	STRIKER
67-71	Chevy (exc. S.S.),				
67-71	Chevelle (2-Dr.),				
72	Nova	7666998	R.H.	2.95	STRIKER
67-71	Chevy (exc. S.S.),				
67-72	Chevelle (2-Dr.),				
72	Nova	7666999	L.H.	2.95	STRIKER
67-70	Camaro	7702776	1	4.05	STRIKER, pass.
67-70	Camaro	7702777	1	4.05	STRIKER, driver
71	Pass. (2-Dr.)				STRIKER, pass. and driver seat back lock outer
73-75	All (2-Dr.) w/bench st.				STRIKER, pass. & driver outer,
71-72	Camaro,				
71-75	Vega, Monza				STRIKER, st. bk. lk.
72	Nova				driver outer,
72	Pass. (Sta. Wag.) (9-Pass.)				folding 3rd seat back lock
73-75	Nova, Camaro w/bucket st.	9848534	2	1.40	STRIKER, pass. outer & inner
67-70	Pass., Chevelle, Nova (2-Dr.) (exc. S.S.),				
71-72	Chevelle, Nova	7661271	2	.37	SUPPORT, handle escutcheon
75	Monte Carlo, w/reclining st.,				
75	Pass. (Sta. Wag., Conv.) w/reclining st.	1668458	1	.91	SUPPORT, pass. st. control handle escut. WASHER, pass. inner and outer,
71	Camaro				fldg. 3rd seat,
71	Pass. (Sta. Wag.) (9-Pass.)				pass. outer and inner
71	Pass. (Spt. Cpe., Conv.)				frt. st. bk. lk.
71-75	Vega, Monza				
73-75	All	9848535	A.R.	.13	WASHER, pass. and driver inner & outer
67-69	Pass., Chevelle, Nova (2-Dr.) (exc. Camaro)	8761646	R.H.	10.65	LOCK ASSY.
67-68	Pass., Chevelle, Nova (2-Dr.) (exc. S.S.)	7661252	L.H.	10.30	LOCK ASSY.
69	Chevy, Chevelle w/Strato seats,				
69	Pass. (2-Dr.) w/Strato seats (exc. Sed.)	8734069	1	11.25	LOCK ASSY., center
69-70	Pass., Chevelle, Nova (2-Dr.) (exc. Camaro)	9806795	L.H.	11.25	LOCK ASSY.
70-72	Nova, El Camino (Custom) w/bucket seats,				
70-72	Chevelle (Spt. Cpe., Conv.) w/bucket seats	9817755	1	15.65	LOCK ASSY., driver and pass. center
70-71	Chevelle (Spt. Cpe., Conv.) w/electric seat back release, bucket seats	8799316	1	13.30	LOCK ASSY., pass.
70-71	Chevelle (Spt. Cpe., Conv.) w/electric seat back release, bucket seats	8799317	1	13.30	LOCK ASSY., driver



**REAR GLASS—SEAT AND ADJUSTER**

**11.390 CONTROL ASSY.— ACTUATOR ASSY.— BOLT— BUTTON ASSY.— CAP— CLIP— COVER— ESCUTCHEON— GROMMET— KNOB— HANDLE— LOCK ASSY.— RETAINER— ROD— SLEEVE— SOLENOID ASSY.— SPRING— STRIKER— SUPPORT— WASHER, Front Seat Back Lock (Con't)**

71	Pass. (Spt. Cpe., Conv.) w/electric seat back release	9673008	1	51.00	LOCK ASSY., pass.
71	Pass. (Spt. Cpe., Conv.) w/electric seat back release	9836519	1	51.00	LOCK ASSY., driver
71-72	Pass. (2-Dr.)	9666602	1	6.70	LOCK ASSY., pass. manual
71-75	Pass. (Spt. Cpe., Conv.) w/bench st.	9836521	1	6.70	LOCK ASSY., driver manual
71-72	Chevelle, Nova (2-Dr.)	9806795	L.H.	11.25	LOCK ASSY.
70-72	Chevelle, Nova (2-Dr.)	9806794	R.H.	11.25	LOCK ASSY.
71	Camaro, Vega (exc. Panel)	9847192	1	10.60	LOCK ASSY., pass.
71	Camaro, Vega (exc. Panel)	9847193	1	10.60	LOCK ASSY., driver
73-75	Chevelle, Nova (2-Dr.) w/bench st.	9874702	1	6.70	LOCK ASSY., driver (manual)
73-75	Chevelle, Nova (2-Dr.) w/bench seat	9681100	1	6.70	LOCK ASSY., pass. (manual)
73-75	Pass. (2-Dr.) w/bench seat	9666602	1	6.70	LOCK ASSY., pass. (manual)
72-73	Nova, Camaro w/bucket seats, Vega (exc. Panel)	9889707	1	12.30	LOCK ASSY., pass., seat back frame hinge outer arm

**11.419 CUSHION— CLIP— FRAME ASSY.— PAD ASSY., Front Seat Bottom with Frame, Springs and Padding (less trim cover)**

71-72	Chevelle (2-Dr.)	9865955	1	160.00	front seat (bench)
71-72	Pass. (4-Dr.),				
74-75	All	4562491	A.R.	.12	CLIP, cushion helical tie wire, horizontal and vertical
73	All (4-Dr.) w/Bench St. (exc. reclining)	9870601	1	71.50	FRAME ASSY., frt. seat bottom w/spring
71-72	Pass. (2-Dr.),				
73-75	All (2-Dr.) w/Bench St.	9726334	1	100.00	FRAME ASSY., frt. seat bottom w/spring & padding
73	All w/reclining st.	9667154	1		FRAME ASSY., pass. seat bottom w/spring
73	All w/reclining st.	9667155	1		FRAME ASSY., driver seat bottom w/spring
73-74	Camaro, Nova (2-Dr.) w/bucket seats, Vega (exc. Panel)	9726336	2	67.25	FRAME ASSY., driver & pass. seat bottom support
74-75	Pass., Nova, Malibu (4-Dr.) w/bench seat	9726333	1	71.50	FRAME ASSY., front seat bottom w/spring
74	Caprice (Sed.) (Spt. Sed.) reclining split seat	9726337	1	197.00	FRAME ASSY., pass. seat bottom
74	Caprice (Sed.) (Spt. Sed.) reclining split seat	9726338	1	73.50	FRAME ASSY., driver seat bottom
75	All w/reclining st.	1683129	1	207.00	FRAME ASSY., pass. st., bottom w/spring and padding
75	All w/reclining st.	1683130	1	77.75	FRAME ASSY., driver st., bottom w/spring and padding
75	Vega (exc. Panel), Monza (exc. Towne Cpe.),				
75	All w/bucket st., reclining st.	1683135	2	67.25	FRAME ASSY., pass., driver st. bottom supt.
75	All w/notch back st.	9726335	1	100.00	FRAME ASSY., driver st., bottom w/spring and padding
75	Nova w/European St.	1708789	1	135.00	FRAME ASSY., pass.
75	Nova w/European St.	1708790	1	135.00	FRAME ASSY., driver
71-72	Camaro,				
72	Nova	9818475	2	33.50	PAD ASSY., pass. and driver bucket seat bottom wire

**11.556 MOTOR— COVER— DOG— GEAR— PAD— PLUNGER— PULLEY— RING— SCREW— SHAFT— SOLENOID— SPRING— SUPPORT— TRANS. ASSY.— WASHER, Electric Seat Adjuster**

64-67	Chevelle	4939298	1	41.30	horizontal and vertical
65-68	Pass. (6-way),				
69	Caprice, Estate Wag. (6-Way) (exc. Strato bench),				
69-70	Bel Air, Impala (6-Way),				
70-72	Chevelle w/4-way bench seat		1		horizontal and vertical
73-75	All w/6-way reclining st.	4960550	1	40.30	front seat adj.
66	Chevelle (Malibu, S.S.) w/4-way bucket seats,				
66-67	Impala (S.S.) w/4-way bucket seats,				

**REAR GLASS—SEAT AND ADJUSTER**

**11.556 MOTOR— COVER— DOG— GEAR— PAD— PLUNGER— PULLEY— RING—  
SCREW— SHAFT— SOLENOID— SPRING— SUPPORT— TRANS. ASSY.—  
WASHER, Electric Seat Adjuster (Con't)**

66-68	Caprice (Spt. Cpe.) w/4-way bucket seats,				
68	Impala Cust., Impala w/4-way bucket seats (Spt. Cpe., Conv.),				
70-72	Monte Carlo (1st. design) . . . . .	4939203	1	40.45	horizontal and vertical (Note 1) . . . . .
72	Monte Carlo (2nd. design) . . . . .	9625772	1	40.45	horizontal and vertical (Note 2) . . . . .
66-68	All (4-way bucket seat),				
70-72	Chevelle w/4-way bucket seats . . . . .	9705351	1	2.15	COVER, seat adj. trans. pulley . . . . .
73-74	All w/6-way reclining st. . . . .	1707214	1	2.15	COVER, driver seat adj. trans. motor . . . . .
75	All w/6-way . . . . .	1707214 A.R.		2.15	COVER, pass. & driver seat adj. trans. . . . .
64-67	Chevelle,				
65-68	Pass. (6-way) (4-way bucket seat),				
69	Caprice, Estate Wag. w/6-way (exc. Strato bench),				
69	Bel Air, Impala w/6-way,				
70-72	Pass., Chevelle . . . . .				DOG, trans. clutch shaft . . . . .
73-75	All w/6-way bench seat . . . . .	5711126	3	.39	DOG, st. adj. trans. clutch shaft . . . . .
64-67	Chevelle,				
65-68	Pass. (6-way) (4-way bucket seat),				
69	Caprice, Estate Wag. w/6-way (exc. Strato bench),				
69	Bel Air, Impala w/6-way,				
70	Pass., Chevelle,				
71-72	Pass. w/6-way,				
72	Monte Carlo w/elec. seat . . . . .				GEAR, trans. front vent. and horiz. . . . .
73-75	All w/6-way bench st. . . . .	5711128	2	1.45	GEAR, frt. adj. horiz. & vert. . . . .
65-68	Pass. (6-way),				
69	Caprice, Estate Wag. w/6-way (exc. Strato bench),				
69	Bel Air, Impala w/6-way,				
70	Pass., Chevelle,				
71-72	Pass. w/6-way . . . . .				GEAR, trans. rear vertical. . . . .
73-75	All w/6-way bench st. . . . .	5711129	1	1.00	GEAR, rear adj. vertical . . . . .
66-67	Chevelle (exc. El Camino),				
66-68	Pass. (6-way),				
69	Caprice, Estate Wag. w/6-way (exc. Strato bench),				
69	Bel Air, Impala w/6-way,				
70-71	Chevelle w/4-way bench,				
72	Pass. w/6-way bench seat,				
73-75	All w/6-way bench st. . . . .	9707154	1	1.45	GEAR, adj. trans. driving . . . . .
66	Chevelle w/bucket seats (exc. El Camino),				
66-68	Pass. (4-way bucket seat),				
70-72	Chevelle w/4-way bucket seats . . . . .	9705328	1	7.45	GEAR, trans. driving . . . . .
73-75	All w/6-way reclining st. . . . .	9881698 A.R.		1.45	GEAR, pass., driver st. adj. trans. driving . . . . .
73-75	All w/6-way reclining st. . . . .	9881697	1	1.05	GEAR, driver st. adj. trans. rear vert. driving . . . . .
73-75	All w/6-way reclining st. . . . .	9718265	1	1.30	GEAR, driver st. adj. trans. idler . . . . .
64-67	Chevelle,				
65-68	Pass. (6-way) (4-way bucket seat),				
69	Caprice, Estate Wag. w/6-way (exc. Strato bench),				
69	Bel Air, Impala w/6-way,				
71-72	Chevelle w/4-way bench . . . . .	5711115	1	.56	PAD, adjuster trans. support . . . . .
64-67	Chevelle,				
65-68	Pass. w/sgl. mtr. construction (6-way) (4-way bucket seat),				
69	Caprice, Estate Wag. w/6-way (exc. Strato bench),				
69	Bel Air, Impala w/6-way,				
70-71	Pass., Chevelle,				
72	Monte Carlo, Bel Air,				
72	Townsmen (9-Pass.),				
72	Impala, Caprice w/6-way bench seat,				
73-75	All w/6-way bench seat . . . . .	4306361	2	1.55	PLUNGER ASSY., trans. clutch shaft . . . . .
66	Chevelle w/bucket seats,				
66-68	Pass. (4-way bucket seat),				
70-72	Chevelle w/4-way bucket seats . . . . .	9705348	1	.87	PULLEY, seat adj. trans. at transmission . . . . .
66	Chevelle w/bucket seats,				

**REAR GLASS—SEAT AND ADJUSTER**

**11.556 MOTOR—COVER—DOG—GEAR—PAD—PLUNGER—PULLEY—RING—SCREW—SHAFT—SOLENOID—SPRING—SUPPORT—TRANS. ASSY.—WASHER, Electric Seat Adjuster (Con't)**

66-68	Pass. (4-way bucket seat),					
70-72	Chevelle w/4-way bucket seats	9705349	1	.87	PULLEY, seat adj. trans. at motor	
66	Chevelle w/bucket seats,					
66-68	Pass. (4-way bucket seat),					
70-72	Chevelle w/4-way bucket seats	9705350	1	1.45	RING, seat adj. trans. pulley (rubber)	
65-68	Pass. (6-way) (4-way bucket seat),					
69	Caprice, Estate Wag. w/6-way (exc. Strato bench),					
69	Bel Air, Impala w/6-way,					
70	Pass. w/6-way,					
71-72	Chevelle w/4-way bench	5714673	2	.15	SCREW, seat adj. transmission support	
70	Chevelle w/4-way bench,					
71-72	Pass., Chevelle				SCREW, trans. support	
73-75	All w/6-way bench seat	9721847	2	.15	SCREW, f/seat adj. supt. to motor	
64-67	Chevelle,					
65-68	Pass. w/sgl. mtr. construction (6-way) (4-way bucket seat),					
69	Caprice, Estate Wag. w/6-way (exc. Strato bench),					
69	Bel Air, Impala w/6-way,					
70-72	Pass., Chevelle,					
73-75	All w/6-way seat	5711693	3	1.80	SHAFT, trans. clutch	
64	Chevelle	4306547	1	16.50	SOLENOID ASSY., trans.	
65-68	Pass. (6-way) (exc. Astro. bench seat),					
69	Caprice, Estate Wag. w/6-way (exc. Strato bench),					
69	Bel Air, Impala w/6-way,					
70-72	Pass., w/6-way	5717845	1	20.90	SOLENOID ASSY., trans.	
65-67	Chevelle,					
65	Pass. (S.S.) w/4-way bucket seat,					
70-72	Monte Carlo w/4-way bench seat	5719228	1	16.35	SOLENOID ASSY., tran.	
65-66	Chevelle w/bucket seats,					
66-68	Pass. w/4-way bucket seat,					
70-72	Monte Carlo w/4-way bucket seats	9724476	1	17.35	SOLENOID ASSY., trans.	
73-75	All w/6-way bench st.	9616492	1	17.35	SOLENOID ASSY., trans.	
73-75	All w/6-way reclining st.	9881699	1	17.35	SOLENOID ASSY., driver st. adj. trans.	
64-66	Chevelle	5714673	2	.15	SPRING, trans. support	
64-67	Chevelle,					
65-68	Pass. (6-way) (4-way bucket seat),					
69	Caprice, Estate Wag. w/6-way (exc. Strato bench),					
69	Bel Air, Impala w/6-way,					
70-72	Pass., Chevelle,					
73-75	All w/6-way Bench st.	5711127	3	.14	SPRING, trans. clutch shaft	
72	Monte Carlo w/4-way bucket seats	9605377	1	9.85	SUPPORT, driver seat adj. trans. (w/actuator)	
72	Monte Carlo	9625773	1	8.95	SUPPORT, drivers seat motor	
73-75	All w/6-way reclining st.	9733895	1	9.80	SUPPORT, driver st. adj. trans. motor	
70-72	Monte Carlo w/4-way bucket seats	9721864	1	9.85	SUPPORT ASSY., trans. and motor	
70-72	Monte Carlo w/4-way bench	9721868	1	4.40	SUPPORT ASSY., trans. and motor	
71-72	Pass. w/6-way,					
73-75	All w/6-way Bench st.	9839015	1	3.10	SUPPORT ASSY., trans. motor	
64	Chevelle	9707157	1	47.00	TRANS. ASSY., horizontal and vertical	
65	Pass. (4-way),					
65	Chevelle (exc. El Camino),					
66-67	Chevelle w/bucket seats,					
70-72	Monte Carlo w/4-way bench seat	9707135	1	44.25	TRANS. ASSY., horizontal and vertical	
66	Chevelle,					
66-68	Pass. (4-way bucket seat)	9705313	1	46.25	TRANS. ASSY., horizontal and vertical	
65-68	Pass. (6-way),					
69-70	Caprice, Estate Wag. w/6-way (exc. Strato bench),					
69-70	Bel Air, Impala w/6-way,					
71-72	Pass. w/6-way	9707156	1	53.75	TRANS ASSY., horizontal and vertical	

**REAR GLASS—SEAT AND ADJUSTER**

**11.556 MOTOR—COVER—DOG—GEAR—PAD—PLUNGER—PULLEY—RING—SCREW—SHAFT—SOLENOID—SPRING—SUPPORT—TRANS. ASSY.—WASHER, Electric Seat Adjuster (Con't)**

70-72	Chevelle w/4-way bucket seat . . .	9724475	1	49.50	TRANS. ASSY., horizontal and vertical . . . .
73-75	All w/6-way bench st. . . . .	9616490	1	53.75	TRANS. ASSY., horiz. and vert. . . . .
73-75	All w/6-way reclining st. . . . .	9881694	1	77.00	TRANS. ASSY., horiz. and vert. . . . .
66	Chevelle (Spt. Cpe., Conv.),				
65	Pass. w/sgl. mtr. construction (6-way) (4-way bucket seat),				
66-68	Pass. w/4-way bucket seat,				
70-72	Chevelle w/4-way bucket seats . . .	4307436 A.R.		.21	WASHER, trans. driving gear . . . . .
74-75	All w/6-way bench seat . . . . .	4306371	3	.14	WASHER, adj. trans. clutch shaft . . . . .

NOTE 1: Mounting holes located in side of motor frame.

NOTE 2: Mounting holes located in bottom of mounting frame. C11.561-0

**11.558 ESCUTCHEON—SUPPORT—BUTTON—CAP—BAR ASSY.—BASE ASSY.—PIN—CLIP—BREAKER, Electric Seat Adjuster Switch**

64-66	Chevelle,				
65	S.S. (4-way bucket seat),				
66-68	Pass. (4-way bucket seat),				
70-72	Monte Carlo w/strato bucket . . .	4309919	1	3.20	side panel switch, driver outer . . . . .
65-67	Bel Air, Parkwood, Kingswood (6-way),				
68	Pass. (6-way) (exc. Spt. Cpe., Conv.),				
69-72	Pass. w/6-way (exc. Caprice),				
73-75	All w/6-way seat . . . . .	4305819	1	3.15	side panel switch . . . . .
65-67	Impala, Nomad (6-way),				
65-68	Caprice,				
67	S.S. (6-way),				
65-67	Caprice,				
68	Spt. Cpe., Conv. (6-way),				
68	Caprice (Spt. Sed.) (6-way),				
69-72	Caprice w/6-way,				
73-75	All w/6-way bench seat . . . . .	9870917	1	4.60	side panel switch . . . . .
73-75	All w/6-way reclining st. . . . .	9717027	1	6.80	side panel switch . . . . .
75	All w/6-way st. (exc. reclining) . .	9627907	1	6.80	driver, side panel switch . . . . .
67	Chevelle w/4-way seat,				
71-72	Pass. w/6-way (exc. Caprice) . . .				SUPPORT, escutcheon and switch, . . . . .
71-72	Caprice w/6-way . . . . .	9803653	1	1.80	trans. at switch . . . . .
70-72	Monte Carlo w/4-way bench . . .	7667875	1	3.70	SUPPORT, switch . . . . .
69-70	Caprice w/6-way, Strato bench . .	7793680	1	1.70	SUPPORT, front seat side panel trim at switch . . . . .
75	All w/6-way . . . . .	1668469	1	4.90	SUPPORT ASSY., side adj. switch . . . . .
65-72	Pass. (6-way) . . . . .				BUTTON, switch vertical . . . . .
73-75	All w/6-way . . . . .	4303440 A.R.		.58	BUTTON, vertical . . . . .
64-67	Chevelle,				
65	S.S. (4-way bucket seat),				
66-68	Pass. (4-way bucket seat),				
70-72	Monte Carlo . . . . .	4309920	1	1.80	BUTTON, driver outer . . . . .
65-67	Pass. (6-way) . . . . .	9711696	1	4.65	BUTTON, w/switch bar-horizontal . . . . .
65-72	Pass. (6-way) . . . . .				CAP, switch vertical button . . . . .
73-75	All w/6-way . . . . .	4303439 A.R.		1.10	CAP, vertical button . . . . .
67-72	Pass. (6-way),				
73-75	All w/6-way . . . . .	9711696	1	4.65	BAR ASSY. . . . .
64-67	Chevelle,				
65	Pass., Chevelle (S.S.) (4-way bucket seat),				
66-68	Pass., Chevelle (Spt. Mdls.) (4-way bucket seat),				
70-72	Monte Carlo . . . . .	4306608	1	6.40	BASE ASSY., driver outer . . . . .
65-72	Pass. (6-way),				
73-75	All w/6-way . . . . .	9711651	1	6.30	BASE ASSY. . . . .
73-75	All w/6-way reclining st. . . . .	9711654	1	6.30	BASE ASSY., driver seat side panel switch . . . . .
65-68	Pass. (6-way),				
70-72	Pass. w/6-way . . . . .				PIN, switch vertical button . . . . .
73-75	All w/6-way . . . . .	4303438 A.R.		.11	PIN, vertical button . . . . .
64-67	Chevelle,				
65-66	Bel Air, Impala,				
65-68	Pass. (6-way),				
65-68	Pass., Chevelle, Spt. Cpe., Conv. w/bucket seat (4-way),				
66-68	Caprice,				
69	Pass. w/6-way,				
70-72	Pass., Chevelle,				
73-75	All w/6-way . . . . .	4306804 A.R.		.11	CLIP, switch to escutcheon . . . . .

**REAR GLASS—SEAT AND ADJUSTER**

**11.558 ESCUTCHEON— SUPPORT— BUTTON— CAP— BAR ASSY.— BASE ASSY.— PIN— CLIP— BREAKER, Electric Seat Adjuster Switch (Con't)**

65	Pass. ....	4849850	1	3.40	BREAKER, elect. front seat control— (13.095) .....
65-68	Chevelle .....	4850166	1	3.30	BREAKER ASSY. (12.095) .....

**11.561 ADJUSTER, Front Seat**

**PASSENGER**

65-66	Pass. (exc. bucket seats) .....	7636704	R.H.	21.70	manual .....
65-66	Pass. (exc. bucket seats) .....	4477531	L.H.	21.70	manual .....
66-68	Pass. (4-way bucket seat) .....	7659717	1	48.00	driver, outer .....
67-70	Pass. ....	8768006	L.H.	21.25	(manual) .....
67-70	Pass. ....	7659790	R.H.	22.60	(manual) .....
68-69	Pass. w/strato bucket (exc. 4- way) .....	7779415	1	21.05	driver, outer (manual) .....
71	Pass. (1st design) (exc. taxi) ....	9819051	R.H.	85.75	(electric) (Note 2) .....
71	Pass. (1st design) (exc. taxi) ....	9819052	L.H.	85.75	(electric) (Note 2) .....
71	Pass. (2nd. design) (exc. taxi),				(manual) (Note 3) .....
72	Pass. (exc. taxi) .....				(manual) (Note 3) .....
73-75	Pass. w/Bench Seat .....	9625836	R.H.	18.05	(manual) .....
71	Pass. (2nd. design) (exc. taxi),				(manual) (Note 3) D11.561-49D11.561-
72	Pass. (exc. taxi) .....				50D11.561-51 .....
73-74	Bel Air (New York Taxi) w/bench seat,				
73-75	Pass. w/bench seat .....	9669005	L.H.	18.95	(manual) .....
71	Biscayne (New York Taxi) (1st design) .....	9870928	L.H.	19.80	(manual) (Note 1) .....
71	Biscayne (New York Taxi) (1st design) .....	9870927	R.H.	18.75	(manual) (Note 1) .....
71-72	Biscayne (New York Taxi) (2nd design) w/bench seat .....	9625873	L.H.	19.80	(manual) (Note 3) .....
71-72	Pass. w/6-way (2nd design) ....				(electric) (Note 4) .....
73-75	Pass. w/bench seat, 6-way seat .	9899612	R.H.	85.75	(electric) .....
71-72	Pass. w/6-way (2nd design) ....				(electric) (Note 4) .....
73-75	Pass. w/bench seat, 6-way seat .	9899613	L.H.	85.75	(electric) .....
71	Pass. w/6-way (1st design) ....	9819193	R.H.	26.00	(electric) less actr. and gearnut (Note 2) ...
71	Pass. w/6-way (1st design) ....	9819194	L.H.	26.00	(electric) less actr. and gearnut (Note 2) ...
71-72	Pass. w/6-way (2nd design) ....				(electric) less actr. and gearnut (Note 4) ...
73-75	Pass. w/6-way bench st. ....	9899980	R.H.	28.00	less actuator and gearnut .....
71-72	Pass. w/6-way (2nd design) ....	9899981	L.H.	28.00	(electric) less actr. and gearnut (Note 4) ...
73	Bel Air (exc. New York Taxi) w/bench seat .....	9625873	L.H.	19.80	(manual) .....
73-75	All w/reclining st. ....	9669006	1	18.40	pass. st. outer (manual) .....
73-75	All w/reclining st. ....	9645391	1	17.40	pass. st. inner (manual) .....
73-75	All w/6-way reclining st. ....	9658646	1	95.75	driver st. inner (electric) .....
73-75	All w/6-way reclining st. ....	9658647	1	92.75	driver st. outer (electric) .....
73-75	All w/6-way reclining st. ....	9899983	1	28.00	driver st. outer less actuator gear nut .....
73-75	All w/6-way reclining st. ....	9899982	1	28.00	driver st. inner less actuator gear nut .....
75	Pass. w/6-way bench/notch bk. .	9899981	L.H.	28.00	less actuator & gearnut .....

*NOTE 1 Used on vehicles built before March 15, 1971*

*NOTE 2 Used on vehicles built before April 1, 1971*

*NOTE 3 Used on vehicles built after March 15, 1971*

*NOTE 4 Used on vehicles built after April 1, 1971*

**CHEVELLE**

64-67	Chevelle w/elect. seat (4-way),				
70-72	Monte Carlo w/4-way bench seat .....	7659728	R.H.	48.50	
64-67	Chevelle w/elect. seat (4-way),				
70-72	Monte Carlo w/4-way bench seat .....	7659729	L.H.	48.50	
64-66	Chevelle (exc. El Camino) .....	4411994	R.H.	19.70	manual .....
64-66	Chevelle (exc. El Camino, S.S.),				
64-65	Malibu (S.S.),				
66	Chevelle (S.S.) .....	7628330	1	18.55	driver seat outer .....
66-68	Chevelle w/bucket seats .....	7779417	1	17.20	driver, outer (manual) (Note 1) .....
66-70	Chevelle (Spt. Cpe., Conv.)				
68-70	El Camino (Custom),				
71	Chevelle w/strato buckets (exc. El Camino) .....				pass. inner (manual), .....
71	El Camino w/strato buckets,				
72	El Camino Custom (1st design) .	4547730	2	10.25	driver and pass., inner (manual) .....

**REAR GLASS—SEAT AND ADJUSTER**

**11.561 ADJUSTER, Front Seat (Con't)**

67-68	Chevelle (exc. El Camino) (2nd design),				
68-69	El Camino,				
70-72	Chevelle	7712007 R.H.	19.30	(manual)	
68-69	El Camino	7779432 L.H.	16.90	(manual)	
67	Chevelle (exc. El Camino),				
68-72	Chevelle	7779428 L.H.	17.20	(manual) (Note 1)	
71-72	El Camino Custom w/strato bucket	7779417 1	17.20	driver outer (manual) (Note 1)	
	<i>NOTE 1 When using on past models it is necessary to use knob 7778975.</i>				
68-70	El Camino w/strato bucket seats (exc. Deluxe),				
66-70	Chevelle (Spt. Cpe., Conv.) w/bucket seats,				
69	Malibu (Spt. Cpe., Conv.) w/strato bucket seats,				
71-72	Monte Carlo w/strato bucket (1st design)	8768007 1	17.70	pass., outer (manual)	
70-72	Chevelle (Spt. Cpe., Conv.) w/strato bucket	8792547 1	8.10	driver inner (manual)	
70-72	Monte Carlo w/4-way bucket seat	8792548 1	72.25	driver outer (electric)	
70-72	Monte Carlo w/4-way bucket seat	8792549 1	33.50	driver inner (electric)	
71	Chevelle	9818158 R.H.	21.40	manual (field fix)	
71	Chevelle	9818159 L.H.	26.00	manual (field fix)	
72	El Camino Custom,				
72	Malibu (2-Dr.) w/bucket seat (2nd design),				
72	Monte Carlo w/buckets seat (2nd design)	9895586 1	17.70	pass. outer manual (w/arm)	
72	Malibu (Spt. Cpe., Conv.) w/bucket seats (2nd design),				
72	Monte Carlo w/bucket seats (exc. 4-way pwr. bucket seats)	9896870 1	13.70	driver (otr. manual) (w/arm)	
72	Monte Carlo w/bucket seat (2nd design) (w/4-way bucket seats)	9896871 1	8.10	driver seat inr. manual (w/arm)	
72	Monte Carlo w/4-way bucket seat (2nd design)	9605359 1	53.00	driver seat inner (w/actuator)	
72	El Camino Custom (2nd design)	9895588 1	10.25	(lock bar w/arm)	
72	El Camino Custom, Monte Carlo w/bucket seats	9895587 1	10.25	pass. seat inner (lock bar w/arm)	
72	El Camino Custom w/bucket seats (2nd design)	9895589 1	17.20	driver seat outer (manual) (w/arm)	
73	Chevelle w/6-way bench	9870367 L.H.	85.75	front seat (electric)	
73	Chevelle w/6-way bench st.	9870366 R.H.	85.75	front seat (electric)	
73	Chevelle w/6-way bench st.	9613951 L.H.	28.00	seat less actuator & gear nut	
73	Chevelle w/6-way bench st.	9613950 R.H.	28.00	seat less actuator & gear nut	
73	Chevelle w/bench seat	9677752 L.H.	26.00	(manual)	
73	Chevelle w/bench seat	9677751 R.H.	21.40	(manual)	
73-75	Chevelle w/swivel seat	9881583 1	17.20	drive st. outer (manual)	
73-75	Chevelle w/swivel seat	9881582 1	17.20	pass. st. outer (manual)	
73-75	Chevelle w/6-way bench st.	9678021 L.H.	28.00	less act./gearnut	
73-75	Chevelle w/6-way bench st.	9678020 R.H.	28.00	less act./gearnut	
73-74	Chevelle w/swivel seat	9881578 1	17.20	pass. st. inner (manual)	
73-75	Chevelle w/swivel seat	9613229 1	8.10	drive st. inner (manual)	
74	Chevelle w/bench seat	9677065 R.H.	17.20	(manual)	
74	Chevelle w/bench seat	9677066 L.H.	17.70	(manual)	
74-75	Chevelle w/6-way power seat	9677920 R.H.	85.75	front seat (electric)	
74-75	Chevelle w/6-way power seat	9677921 L.H.	85.75	front seat (electric)	
75	Chevelle w/bench seat	9695768 R.H.	21.40	front seat (manual)	
75	Chevelle w/bench seat	9695769 L.H.	26.00	front seat (manual)	
75	Chevelle w/swivel bucket	1653552 1	17.20	pass. inner (manual)	
75	Chevelle w/60/40 notchback	9695769 1	26.00	driver seat, outer (manual)	
75	Chevelle w/50/50 seat	9697010 1	18.50	driver seat, inner (manual)	
75	Chevelle w/50/50 reclining st., 6-way pwr.	9678022 1	28.00	driver outer less act/gearnut	
75	Chevelle w/50/50 reclining st., 6-way pwr.	9678023 1	28.00	driver inner less act/gearnut	
75	Chevelle w/50/50 pass. reclining, 6-way pwr.	9678017 1	92.75	driver inner (electric)	
75	Chevelle w/50/50 pass. reclining, 6-way pwr.	9678016 1	92.75	driver outer (electric)	
75	Chevelle w/reclining st.	1655880 1	16.95	pass. inner (manual)	

**REAR GLASS—SEAT AND ADJUSTER**

**11.561 ADJUSTER, Front Seat (Con't)**

75	Chevelle w/reclining st. ....	9695772	1	18.75	pass. outer (manual) .....
<b>CHEVY—NOVA</b>					
62-65	Chevy (exc. S.S., 4-Spd.) .....	4866770	R.H.	19.70	
68-72	Chevy (exc. strato bucket) .....	7723851	R.H.	16.90	(manual) .....
68-72	Chevy (exc. strato bucket) .....	7779402	L.H.	16.55	(manual) .....
68-71	Chevy w/strato bucket seats .....	7735486	2	16.90	driver and pass., inner (manual) .....
68-71	Chevy w/strato bucket seats .....	8768012	1	18.15	pass., outer (manual) .....
68-71	Chevy w/strato bucket seats .....	7779404	1	16.90	driver, outer (manual) .....
72	Nova w/bucket seat .....	9881929	1	14.70	driver & pass. inner (manual) .....
73	Nova (New York Taxi) w/bench st. ....	9730462	L.H.	16.90	(manual) .....
73	Nova (New York Taxi) w/bench st. ....	9730458	R.H.	16.55	(manual) .....
73	Nova w/bench seat (exc. New York Taxi) .....	9615878	R.H.	16.90	(manual) .....
73	Nova w/bench seat (exc. New York Taxi) .....	9615879	L.H.	16.55	(manual) .....
73-75	Nova (2-Dr.) w/bucket seats .....	9615890	1	16.90	pass. outer (manual) .....
73-75	Nova (2-Dr.) w/bucket seats .....	1653014	1	16.90	drive outer (manual) .....
73-75	Nova (2-Dr.) w/bucket seats .....	1653015	1	16.55	pass. inner (manual) .....
73-75	Nova (2-Dr.) w/bucket seats .....	9615893	1	8.10	drive inner (manual) .....
74-75	Nova w/bench seat (exc. Taxi) ..	9695770	R.H.	16.90	front seat (manual) .....
74-75	Nova w/bench seat (exc. Taxi) ..	9695771	L.H.	16.55	front seat (manual) .....
74	Nova (Taxi) w/bench st. ....	9730458	R.H.	16.55	(manual) .....
74	Nova (Taxi) w/bench st. ....	9730462	L.H.	16.90	(manual) .....
75	Nova w/bucket st. ....	9615890	1	16.90	pass. outer (manual) .....
75	Nova w/bucket st. ....	9615893	1	8.10	driver inner (manual) .....
<b>CAMARO</b>					
67	Camaro .....	7644518	1	19.30	driver, outer (manual) .....
67	Camaro .....	7644519	1	19.80	pass., outer (manual) .....
67-69	Camaro .....	7659752	2	10.25	driver and pass., inner (manual) .....
68-69	Camaro .....	8727193	1	17.20	driver outer (manual) .....
68-69	Camaro .....	8727194	1	17.20	pass., outer (manual) .....
70	Camaro .....	9809495	1	18.45	driver outer (manual) .....
70	Camaro .....	9809494	1	18.45	pass. outer (manual) .....
70	Camaro .....	9809496	1	11.25	driver and pass. inner (manual) .....
71-72	Camaro .....	9865444	1	11.35	driver outer pass. inner (manual) .....
71-72	Camaro .....	9607871	1	16.90	driver seat inner (manual) pass. seat outer (manual) w/lock bar & spring .....
73-75	Camaro .....	1664408	1	18.05	driver seat inner (manual) pass. seat outer (manual) (w/lock bar & spring) .....
73-74	Camaro .....	9883756	1	18.45	driver outer pass. inner (manual) .....
75	Camaro .....	1652301	1	17.05	driver outer (manual) .....
75	Camaro .....	1724574	1	17.30	pass. inner (manual) (repl. 1652302) .....
75	Camaro .....	1652303	1	17.05	driver inner (manual) .....
<b>VEGA-MONZA</b>					
71	Vega (H.B.) .....				driver seat outer, .....
71	Vega (Panel),				
71	Vega (N.B.) (Sta. Wag.) (1st design) .....	9826802	1	17.90	pass. seat inner, driver seat outer .....
71	Vega, Monza (1st design),				
72	Vega (N.B.) (Panel) (2nd design)	9624233	1	17.90	pass. seat outer, driver seat inner .....
71	Vega (N.B.) (Sta. Wag.) (2nd design),				
72	Vega (N.B.) (Sta. Wag.) .....	9624230	1	17.90	pass. seat outer, driver seat inner .....
71	Vega (N.B.) (Sta. Wag.) (2nd design) .....	9865870	1	12.55	pass. seat inner, driver seat outer .....
72	Vega (N.B.) (Sta. Wag.) (2nd design) .....	9624222	1	12.55	pass. seat inner, driver seat outer .....
72	Vega (H.B.) (Panel) .....	9624227	1	17.90	pass. seat inner, driver seat outer .....
73-74	Vega (N.B.) (Sta. Wag.) (1st design) .....	1653013	1	16.90	<b>ADJUSTER ASM.</b> , pass. seat inner, driver seat outer (manual) (Note 2) .....
73-74	Vega (N.B.) (Sta. Wag.) (1st design) .....	9883678	1	17.90	<b>ADJUSTER ASM.</b> , pass. seat outer, driver seat inner (manual) (Note 2) .....
73-74	Vega (H.B.) (Panel) (1st design) ..	9883676	1	13.70	<b>ADJUSTER ASM.</b> , pass. seat outer, driver seat inner (manual) (Note 2) .....
73-74	Vega (H.B.) (Panel) .....	1653012	1	12.95	pass. seat inner, driver seat outer (repl. 9883677) .....

**REAR GLASS—SEAT AND ADJUSTER**

**11.561 ADJUSTER, Front Seat (Con't)**

74	Vega (H.B.) (Panel) w/rt. aux. (1st design) . . . . .	1653012	1	12.95	ADJUSTER ASM., pass. seat inner driver outer (manual) (Note 2) . . . . .
74-75	Vega, Monza w/bucket st. (2nd design) . . . . .	1655328	1	16.95	ADJUSTER ASM., driver outer (manual) (Note 2) . . . . .
74-75	Vega, Monza w/2 way manual, bucket st. (exc. panel) (2nd design) . . . . .	1655329	1	16.95	ADJUSTER ASM., pass. inner (manual) (Note 2) . . . . .
74-75	Vega, Monza w/rt. aux. (2nd design) . . . . .	1655330	1	16.95	ADJUSTER ASM., pass. inner (manual) (Note 2) . . . . .
74-75	Vega, Monza w/bucket st., rt. aux. 2 way manual (2nd design) . . . . .	9730551	1	17.90	ADJUSTER ASM., driver inner, pass. outer (manual) (Note 2) . . . . .
75	Vega, Monza w/bucket st. . . . .	1713755	1	16.95	ADJUSTER ASM., driver outer (manual) . . .
75	Vega (exc. Panel), Monza w/bucket st. 2-way manual . . .	1713759	1	20.65	ADJUSTER ASM., pass. inner (manual) . . .

*NOTE 2: To eliminate assist spring chatter, engineering has redesigned the presently specified seat adjusters by removing the component assist spring support and replacing the 4<sup>27</sup>/<sub>64</sub> inch assist spring (1st design) with a new longer 8<sup>39</sup>/<sub>64</sub> inch assist spring (2nd design) to attach to a notch in the front of lower channel.*

**11.561 ACTUATOR ASSY.— BOLT— CABLE ASSY.— CAM ASSY.— CLIP—  
COUPLING— GEAR— GEAR NUT— JACKSCREW— NUT— PIN— PLATE—  
RETAINER— RIVET— SCREW— SHOE— SPACER— SPRING— STOP—  
SUPPORT— SWIVEL— TUBE ASSY.— WASHER, Front Seat Adjuster**

64-66	Chevelle w/4-way elect. seats, Caprice (Spt. Cpe.) (4-way bucket seat) . . . . .	5712218	2	11.10	ACTUATOR ASSY., driver outer . . . . .
65	Pass., S.S. (4-way bucket seat),				
65-66	Pass. w/elect. seat (6-way) . . . . .	5717490	2	11.10	ACTUATOR ASSY., adjuster horizontal . . . .
67	Chevelle w/4-way elect. seats,				
67	Caprice, S.S. (4-way bucket seat),				
68	Pass. (4-way bucket seat),				
71-72	Chevelle w/elect. seat . . . . .	9721549	1	12.25	ACTUATOR ASSY., driver, outer adjuster . .
67-68	Pass. w/elect. seat (6-way),				
69-70	Caprice, Estate Wag. w/6-way (exc. Strato bench),				
69-70	Bel Air, Impala w/6-way . . . . .	9710651	2	14.45	ACTUATOR ASSY., horizontal . . . . .
72	Pass. (exc. Biscayne),				
73-75	All w/6-way . . . . .	9819063	A.R.	12.00	ACTUATOR ASSY., frt. seat adj. horiz. . . . .
65-75	All . . . . .	4405445	A.R.	.21	BOLT, seat adjuster to floor pan (5/16" — 18 x 1) — (10.463) . . . . .
67-68	Pass. w/elect. seat (6-way) (exc. Caprice),				
67-68	Caprice w/Strato bench, elect. seat (6-way),				
69-70	Caprice, Estate Wag. w/6-way (exc. Strato bench),				
69-70	Bel Air, Impala w/6-way,				
71-72	Pass. w/6-way . . . . .	9711796	4	.12	BOLT ASSY., horizontal adjuster (No. 12— 24 x 7/8") w/crown washer w/teeth . . . . .
65-67	Chevelle w/elect. seat (4-way),				
70-72	Chevelle w/4-way bench seat . .	9704938	1	9.50	CABLE ASSY., trans. to right vertical (green) (33.11" lg.) . . . . .
65-67	Chevelle w/elect. seat (4-way),				
70-72	Chevelle w/4-way bench seat . .	9704947	1	5.90	CABLE ASSY., trans. to left horizontal (black) (11.86" lg.) . . . . .
65	Chevelle (Std.),				
65-67	Chevelle w/elect. seat (4-way),				
70-72	Chevelle w/4-way bench seat . .	9704941	1	8.15	CABLE ASSY., trans. to right vertical (black) (32.30" lg.) . . . . .
65	Chevelle (Std.),				
65-67	Chevelle w/elect. seat (4-way),				
70-72	Chevelle w/4-way bench seat . .	9704944	1	6.55	CABLE ASSY., trans. to left vertical (green) (11.40" lg.) . . . . .
65-66	Pass. w/elect. seat (6-way) . . . . .	5717596	1	7.10	CABLE ASSY., trans. to left adjuster horizontal (black) (11.30" lg.) . . . . .
65-68	Pass. w/elect. seat (6-way),				
69-70	Caprice, Estate Wag. w/6-way (exc. Strato bench),				



**REAR GLASS—SEAT AND ADJUSTER**

**11.561 ACTUATOR ASSY.— BOLT— CABLE ASSY.— CAM ASSY.— CLIP—  
COUPLING— GEAR— GEARNUT— JACKSCREW— NUT— PIN— PLATE—  
RETAINER— RIVET— SCREW— SHOE— SPACER— SPRING— STOP—  
SUPPORT— SWIVEL— TUBE ASSY.— WASHER, Front Seat Adjuster  
(Con't)**

69-70	Bel Air, Impala w/6-way . . . . .	5717593	1	6.50	CABLE ASSY., trans. to left adjuster frt. vertical (yellow) (10.80" lg.) . . . . .
65-68	Pass. w/elect. seat (6-way),				
69-70	Caprice, Estate Wag. w/6-way (exc. Strato bench),				
69-70	Bel Air, Impala w/6-way . . . . .	5717590	1	7.10	CABLE ASSY., trans. to right adjust. rr. vertical (blue) (14.75" lg.) . . . . .
65-68	Pass. w/elect. seat (6-way) (exc. Astro bench seat),				
69-70	Caprice, Estate Wag. w/6-way (exc. Strato bench),				
69-70	Bel Air, Impala w/6-way . . . . .	9827629	1	8.65	CABLE ASSY., trans. to right adjust. frt. vertical (black) (33.11" lg.) . . . . .
65-68	Pass. w/elect. seat (6-way) (exc. Astro bench seat),				
69-70	Caprice, Estate Wag. w/6-way (exc. Strato bench),				
69-70	Bel Air, Impala w/6-way . . . . .	5719610	1	8.90	CABLE ASSY., trans. to right adjust. rr. vertical . . . . .
65-68	Pass. w/elect. seat (6-way) (exc. Astro bench seat),				
69-70	Caprice, Estate Wag. w/6-way (exc. Strato bench),				
69-70	Bel Air, Impala w/6-way . . . . .	5719616	1	8.90	CABLE ASSY., trans. to right adjust. horizontal . . . . .
66-67	Chevelle w/4-way bucket seats,				
66-68	Pass. (4-way bucket seat),				
70-72	Chevelle w/4-way bucket seats . . . . .	9708188	1	5.00	CABLE ASSY., trans. to left adj. vertical (green) (9.92" lg.) . . . . .
66-67	Pass. (4-way bucket seat),				
68	Chevelle w/4-way bucket seats,				
68	Impala (Spt. Cpe., Conv.),				
70-72	Chevelle w/4-way bucket seats . . . . .	9705344	1	6.15	CABLE ASSY., trans. to left adjuster horizontal (black) (12.40" lg.) . . . . .
66-69	Caprice w/elect. seat (6-way), Astro bench seat (exc. Sta. Wag.),				
67	Pass. (S.S.) w/elect. seat (6-way),				
68	Impala (Spt. Cpe.) w/elect. seat (6-way), Astro bench seat . . . . .	9705023	1	7.85	CABLE ASSY., trans. to right adjuster horizontal (black) (32.77" lg.) . . . . .
66-69	Caprice w/elect. seat (6-way), Astro bench seat (exc. Sta. Wag.),				
67	Pass. (S.S.) w/elect. seat (6-way)	9705020	1	8.60	CABLE ASSY., trans. to right adjuster front vertical (yellow) (31.02" lg.) . . . . .
66-69	Caprice w/elect. seat (6-way), Astro bench seat (exc. Sta. Wag.),				
67	Pass. (S.S.) w/elect. seat (6-way),				
68	Impala (Spt. Cpe.) w/elect. seat . . . . .	9705013	1	8.60	CABLE ASSY., trans. to right adjuster rear vertical (orange) (35.74" lg.) . . . . .
64	Chevelie w/elect. seat (4-way),				
67-68	Pass. w/elect. seat (6-way),				
69-70	Caprice, Estate Wag. w/6-way (exc. Strato bench),				
69-70	Bel Air, Impala w/6-way . . . . .	5717596	1	7.10	CABLE ASSY., trans. to left adj. horz. (black) (11.30" lg.) . . . . .
71-72	Pass. w/6-way,				
73-75	All w/6-way . . . . .	9827248	1	9.60	CABLE ASSY., trans. to right adj. rear vertical (blue) (37" lg.) . . . . .
71-72	Pass. w/6-way,				
73-75	All w/6-way . . . . .	9827249	1	9.60	CABLE ASSY., trans. to right adj. front vertical (red) (31.50" lg.) . . . . .
71-72	Pass. w/6-way,				
73-75	All w/6-way . . . . .	9827250	1	9.60	CABLE ASSY., trans. to right adj. horizontal (black) (33" lg.) . . . . .
71-72	Pass. w/6-way,				
73-75	All w/6-way . . . . .	9827262	1	6.30	CABLE ASSY., trans. to left adj. rear vertical (blue) (14.80" lg.) . . . . .
71-72	Pass. w/6-way,				

**REAR GLASS—SEAT AND ADJUSTER**

**11.561 ACTUATOR ASSY.— BOLT— CABLE ASSY.— CAM ASSY.— CLIP—  
COUPLING— GEAR— GEARNUT— JACKSCREW— NUT— PIN— PLATE—  
RETAINER— RIVET— SCREW— SHOE— SPACER— SPRING— STOP—  
SUPPORT— SWIVEL— TUBE ASSY.— WASHER, Front Seat Adjuster  
(Con't)**

73-75	All w/6-way	9827263	1	7.60	CABLE ASSY., trans. to left adj. front vertical (red) (11.50" lg.)
71-72	Pass. w/6-way,				
73-75	All w/6-way	9827264	1	7.60	CABLE ASSY., trans. to left adj. horizontal (black) (10.88" lg.)
64-66	Chevelle w/elect. seat (4-way),				
72	Monte Carlo w/4-way bucket seat	9642350	1	8.25	CABLE ASSY., seat adj. trans. to left adj. vertical (w/actuator) (green) (46" lg.)
72	Monte Carlo w/4-way bucket seat	9642250	1	7.15	CABLE ASSY., seat adj. trans. to left adj. horizontal (w/actuator) (black) (32.42" lg.)
73-75	All w/6-way reclining st.	9655815	1	8.20	CABLE ASSY., driver seat adj. trans. right rear horizontal (yellow) (12.08" lg.)
73-75	All w/6-way reclining st.	9655817	1	7.30	CABLE ASSY., driver seat adj. trans. left rear vertical (yellow) (16.70" lg.)
73-75	All w/6-way reclining st.	9655821	1	6.85	CABLE ASSY., driver seat adj. trans. left front vertical (black) (7.82" lg.)
73-75	All w/6-way reclining st.	9881704	1	9.60	CABLE ASSY., driver seat adj. trans. right front vertical & horizontal (2.86" lg.)
71-75	Camaro	9876715	1	16.55	CAM ASSY., driver seat adjustable back
75	Monza w/bucket st.	1692688	1	17.95	CAM ASSY., driver seat adj. back
71-75	Vega w/adj. dr. st. bk., bucket st.	9846909	1	17.95	CAM & HANDLE ASSY., driver st. adj. back
71	Pass. (Spt. Cpe., Spt. Sed.)	9826802	A.R.	17.90	CLIP, roof inner side front mldg., panel
65	Pass. w/elect. seat	5711116	1	2.10	COUPLING, motor to trans. drive
66-67	Chevelle w/elect. seat (4-way),				
66-72	Pass. w/elect. seat (6-way),				
70-72	Chevelle w/elect. seat (6-way),				
73-75	All w/6-way	9707155	1	1.85	COUPLING, motor to trans. driver
70	Pass. w/6-way	5711129	1	1.00	GEAR, trans., rear vertical
65-68	Pass. w/elect. seat (6-way),				
69-70	Caprice, Estate Wag. w/6-way (exc. Strato bench),				
69-70	Bel Air, Impala w/6-way	5719134	1	16.10	GEARNUT, right, front vertical
65-68	Pass. w/elect. seat (6-way),				
69-70	Caprice, Estate Wag. w/6-way (exc. Strato bench),				
69-70	Bel Air, Impala w/6-way	5719135	1	16.10	GEARNUT, left, front vertical
65-68	Pass. w/electric seat (6-way),				
69-70	Caprice, Estate Wag. w/6-way (exc. Strato bench),				
69-70	Bel Air, Impala w/6-way	9703410	1	16.10	GEARNUT, right, rear vertical
65-68	Pass. w/electric seat (6-way),				
69-70	Caprice, Estate Wag. w/6-way (exc. Strato bench),				
69-70	Bel Air, Impala w/6-way	9703411	1	16.10	GEARNUT, left, rear vertical
64-67	Chevelle w/4-way elect. seats,				
65	Pass. (S.S.) (exc. Caprice) (4-way bucket seat),				
66	Chevelle, Pass. (4-way bucket seat) (1st design),				
70-72	Chevelle w/4-way bench seats	5716130	1	10.50	GEARNUT, frt. seat adj. jackscrew, driver outer
66	Chevelle, Pass. (4-way bucket seat) (2nd design),				
67-68	Pass. (4-way bucket seat),				
70-72	Monte Carlo w/4-way bucket seats	9708526	1	13.20	GEARNUT, adj. jackscrew, driver outer
71-72	Pass. w/6-way,				
73-75	All w/6-way bench seat, notch back	9840790	R.H.	17.50	GEARNUT ASSY., front vert.
71-72	Pass. w/6-way,				
73-75	All w/6-way bench seat, notch back	9840791	L.H.	17.50	GEARNUT ASSY., front vert.
71-72	Pass. w/6-way,				
73-75	All w/6-way pwr.	9840792	R.H.	17.50	GEARNUT ASSY., rear vert.
71-72	Pass. w/6-way	9840793	R.H.	15.90	GEARNUT ASSY., right rear vert.
73-75	All w/6-way pwr.	9673356	2	17.50	GEARNUT ASSY., pass. outer, driver inner, adjuster rear vert.

**REAR GLASS—SEAT AND ADJUSTER**

**11.561 ACTUATOR ASSY.— BOLT— CABLE ASSY.— CAM ASSY.— CLIP—  
COUPLING— GEAR— GEARNUT— JACKSCREW— NUT— PIN— PLATE—  
RETAINER— RIVET— SCREW— SHOE— SPACER— SPRING— STOP—  
SUPPORT— SWIVEL— TUBE ASSY.— WASHER, Front Seat Adjuster  
(Con't)**

73-75	All w/6-way pwr. . . . .	9673357	2	17.50	GEARNUT ASSY., pass. inner, driver outer adjuster rear vertical . . . . .
64-67	Chevelle w/4-way elect. seats,				
65	Impala (S.S.) (4-way bucket seat) (exc. Caprice),				
70-72	Chevelle w/4-way bench seats . . . . .	9721482	1	6.90	JACKSCREW, driver outer seat adjuster . . . . .
70-72	Chevelle w/4-way bucket seats . . . . .	9721484	A.R.	6.90	JACKSCREW, driver outer adj. . . . .
64-67	Chevelle w/elect. seat (4-way),				
70-72	Monte Carlo w/4-way bench seats . . . . .	5716269	L.H.	2.75	JACKSCREW . . . . .
66-68	Pass. (4-way bucket seat) (2nd design) . . . . .	9721483	1	6.15	JACKSCREW, driver outer seat adjuster . . . . .
65-68	Pass. w/electric seat (6-way) (2nd type),				
69	Caprice, Estate Wag. w/6-way (exc. Strato bench),				
69	Bel Air, Impala w/6-way,				
70-72	Pass., Chevelle w/elect. seat . . . . .				NUT, adjuster gearnut (Note 2), . . . . .
73-75	All w/6-way Bench Seat . . . . .	9703412	A.R.	.11	NUT, gearnut . . . . .
71-75	Vega . . . . .	9869427	4	.42	NUT, pass. and driver seat adjuster to floor . . . . .
73-74	Vega (Panel) . . . . .	1494253	1	.12	NUT, pass. & driver st. adj. frt. supt. to seat . . . . .
	<i>NOTE 2: Must be used w/gearnut assy. 9703410 or 9703411.</i>				
65	Impala (S.S.) (4-way bucket seat) (exc. Caprice),				
64-67	Chevelle w/4-way elect. seats,				
66	Caprice (Spt. Cpe.) (4-way bucket seat),				
70-72	Monte Carlo w/4-way bench seats . . . . .	5715157	1	.18	PIN, driver outer adj. plate, front . . . . .
64-67	Chevelle w/4-way elect. seats,				
65	Impala (S.S.) (4-way bucket seat) (exc. Caprice),				
66	Caprice (Spt. Cpe.) (4-way bucket seat),				
70-72	Chevelle w/4-way bench seats . . . . .	5716501	1	.24	PIN, driver outer adj. plate, rear . . . . .
67-68	Pass. w/4-way bucket seat,				
70-72	Chevelle w/4-way bucket seats . . . . .	9712177	2	.70	PIN, driver outer adj., top . . . . .
71	Camaro,				
71-72	Vega, Monza (exc. adj. seat back) . . . . .	9710624	1	.12	PIN ASSY., front seat adj. cam . . . . .
65-68	Pass. w/elect. seat (6-way),				
69-70	Caprice, Estate Wag. w/6-way (exc. Strato bench),				
69-70	Bel Air, Impala w/6-way,				
71-72	Pass. w/6-way . . . . .	5717588	2	.98	PLATE, cable attaching . . . . .
65-67	Chevelle w/4-way elect. seats,				
65	Impala (S.S.) (exc. Caprice),				
70-72	Chevelle w/4-way bench seats . . . . .	5717692	1	.44	PLATE, cable attaching . . . . .
71-75	Camaro, Vega, Monza . . . . .	9867825	1	2.30	PLATE, driver seat adjustable back cam outer anchor . . . . .
73	All w/6-way bench st. . . . .	5717588	2	.98	PLATE, st. adj. cable attaching . . . . .
73-75	All w/6-way reclining st. . . . .	9881716	1	1.10	PLATE, driver st. adj. cable attaching . . . . .
74-75	All w/6-way pwr. adj. & bench seat . . . . .	5717588	2	.98	PLATE, st. adj. cable attaching . . . . .
67	Camaro . . . . .	4630023	2	.05	RETAINER, driver and pass. seat frame hinge pin— (11.375) . . . . .
64-67	Chevelle w/4-way bucket seats,				
65	Impala (S.S.) (4-way bucket seat) (exc. Caprice),				
66-68	Pass. (4-way bucket seat),				
70-72	Chevelle w/elect. seat . . . . .	5715154	1	.12	RIVET, driver outer adj. jackscrew . . . . .
64-67	Chevelle w/4-way elect. seats,				
66-68	Pass. (4-way bucket seat),				
70-72	Chevelle w/elect. seat . . . . .	5712220	4	.12	SCREW, driver outer (12— 24 x 1/2" x 1/2" O.D. lockwasher) . . . . .
64-67	Chevelle w/4-way elect. seats,				
65	Impala (S.S.) (4-way bucket seat) (exc. Caprice),				
66-68	Pass. (4-way bucket seat),				
70-72	Chevelle w/elect. seat . . . . .	5715155	2	.37	SCREW, driver outer adj. gearnut . . . . .
68	Pass. (6-way) w/elect. seat,				

**REAR GLASS—SEAT AND ADJUSTER**

**11.561 ACTUATOR ASSY.— BOLT— CABLE ASSY.— CAM ASSY.— CLIP—  
COUPLING— GEAR— GEARNUT— JACKSCREW— NUT— PIN— PLATE—  
RETAINER— RIVET— SCREW— SHOE— SPACER— SPRING— STOP—  
SUPPORT— SWIVEL— TUBE ASSY.— WASHER, Front Seat Adjuster  
(Con't)**

69-70	Caprice, Estate Wag. w/6-way (exc. Strato bench),				
69-70	Bel Air, Impala w/6-way,				
71-72	Pass. w/6-way				SCREW, front seat adjuster gearnut, . . . . .
73	Vega (exc. Panel)				st. bk. adj. cam driver, . . . . .
73	Camaro,				
73-75	All w/6-way bench seat	9710624 A.R.	.12		adjuster gearnut & pin . . . . .
70-72	Pass., Chevelle, Nova, Camaro	7679145 A.R.	.12		SCREW, adjuster to floor . . . . .
70-73	Camaro	4406838	8	.15	SCREW, pass. and driver seat adj. to cross bar— (12.184) . . . . .
71-72	Vega, Monza	8746511	4	.18	SCREW, adj. side bar and support . . . . .
73-75	All w/6-way	9711796 A.R.		.12	SCREW, front seat adj. horiz. actu. . . . .
64-67	Chevelle w/4-way elect. seats,				
65-66	Pass. w/elect. seat,				
67-68	Pass. w/4-way bucket seat,				
70-72	Chevelle w/elect. seat	4307433	4	.16	SHOE, adj. lower channel . . . . .
65-66	Chevelle (S.S.) w/4-way elect. seats,				
65-66	Pass. w/elect. seat				SHOE, drive seat inner adj. lower, . . . . .
67-68	Pass. w/4-way bucket seat,				
70-72	Chevelle w/4-way bucket seats	4307433 A.R.		.16	channel . . . . .
67	Chevelle w/4-way elect. seats,				
67-68	Pass. (4-way bucket seat),				
70-72	Chevelle w/elect. seat	9710895	1	.98	SHOE, driver outer adj. lower channel, center . . . . .
69-70	Pass. w/elect. seat (6-way),				
69-70	Caprice, Estate Wag. w/6-way (exc. Strato bench),				
69-70	Bel Air, Impala w/6-way,				
71-72	Pass. w/6-way,				
73-75	All w/6-way bench seat	9710619 A.R.		.22	SHOE, adjuster lower chan. . . . .
67	Camaro	4891948	2	.37	SPACER, driver seat adjuster (2 <sup>1</sup> / <sub>4</sub> " x 1 <sup>1</sup> / <sub>2</sub> " x 1 <sup>1</sup> / <sub>4</sub> ") fiber board . . . . .
65-68	Pass. w/elect. seat (6-way),				
69-70	Caprice, Estate Wag. w/6-way (exc. Strato bench),				
69-70	Bel Air, Impala w/6-way,				
71-72	Pass. w/6-way,				
73-75	All w/6-way bench seat	9715450 A.R.		.16	SPRING, gearnut . . . . .
73-75	Camaro, Nova w/Bucket Seats, Vega (exc. Panel)	9620694 A.R.		.18	SPRING, pass. & drive bottom st. pad support frame . . . . .
64-67	Chevelle w/4-way elect. seats,				
65	Impala (S.S.) (4-way bucket seat) (exc. Caprice),				
66-68	Pass. (4-way bucket seat)	9703412	1	.11	STOP, jackscrew frt. right . . . . .
70	Caprice w/6-way	7793680	1	1.70	SUPPORT, side panel trim at switch . . . . .
71	Vega (Panel)	9874994 R.H.		.87	SUPPORT ASSY., seat adj. frt. (Note 1) . . . . .
71	Vega (Panel)	9874995 L.H.		.87	SUPPORT ASSY., seat adj. frt. (Note 1) . . . . .
71	Vega (Panel)	9874996	2	.66	SUPPORT ASSY., seat adj. rear (Note 1) . . . . .
71-75	Vega (N.B.)				SUPPORT ASSY., pass. seat to floor inner and outer (use with 1/2" spacer), . . . . .
72	Nova (2-Dr.) w/frt. bucket sts. (exc. 2-way mainst.)	9612810	2	6.10	pass. seat to fir. inr. & otr. man. . . . .
72-73	Vega (Panel)	9607530 R.H.		.87	SUPPORT ASSY., seat adj. frt. (Note 1) . . . . .
72-73	Vega (Panel)	9607531 L.H.		.87	SUPPORT ASSY., seat adj. frt. (Note 1) . . . . .
72	Vega (Panel)	9607532	2	.66	SUPPORT ASSY., seat adj. rear (Note 1) . . . . .
73-75	Camaro, Nova w/Bucket St., Vega (exc. Panel)	1694519	2	.91	SUPPORT ASSY., pass. & driver bottom . . . . .
73-75	Vega (Panel)	9663020	1	.87	SUPPORT ASSY., pass. & driver seat adj. rear (Note 1) . . . . .
74-75	Vega (Panel)	9663018 R.H.		.87	SUPPORT ASSY., pass. & driver st. adj. frt. (Note 1) . . . . .
74-75	Vega (Panel)	9663019 L.H.		.87	SUPPORT ASSY., pass. & driver st. adj. frt. (Note 1) . . . . .
75	Vega (N.B.) w/bucket (exc. 2- way manual)	1658099	1	6.50	SUPPORT ASSY., pass. st. to flr. inner (manual) . . . . .
73-75	Chevelle w/swivel seat	9697478	1	37.25	SWIVEL ASSY., pass. seat adj. (manual) . . . . .
73-75	Chevelle w/swivel seat	9697479	1	37.25	SWIVEL ASSY., driver seat adj. (manual) . . . . .

NOTE 1: Used between adjuster assy. and seat.

**REAR GLASS—SEAT AND ADJUSTER**

**11.561 ACTUATOR ASSY.— BOLT— CABLE ASSY.— CAM ASSY.— CLIP— COUPLING— GEAR— GEARNUT— JACKSCREW— NUT— PIN— PLATE— RETAINER— RIVET— SCREW— SHOE— SPACER— SPRING— STOP— SUPPORT— SWIVEL— TUBE ASSY.— WASHER, Front Seat Adjuster (Con't)**

66	Chevelle w/4-way bucket seats,				
66-68	Pass. (4-way bucket seat),				
70-72	Monte Carlo w/4-way bucket seats	4540022	1	6.60	TUBE ASSY., seat adj. torque
65-66	Pass. w/elect. seat (6-way)	5717485	4	.37	WASHER, adjuster gearnut
67-68	Pass. w/elect. seat (6-way),				
69-70	Caprice, Estate Wag. w/6-way (exc. Strato bench),				
69	Bel Air, Impala w/6-way,				
71-72	Pass. w/6-way,				
73-75	All w/6-way Bench Seat	9710650 A.R.		.28	WASHER, adjuster gearnut

**11.573 COVER— FASTENER— REINFORCEMENT— SUPPORT, Seat Adjuster Track**

64-67	Chevelle w/elect. seat,				
70-72	Monte Carlo w/4-way bench seat	4479216	2	.58	lower, driver
64-67	Chevelle w/elect. seat,				
70-72	Monte Carlo w/4-way bench seat	7715653	L.H.	1.20	upper, outer
64-69	Pass. w/6-way Strato bench	4480421	L.H.	1.55	lower
66	Chevelle w/4-way bucket seats,				
66-68	Pass. (Spt. Mdls.) w/elec. (4-way bucket seats),				
66-69	Impala, Caprice w/elect. (6-way) seat, Astro. bench seat,				
71-72	Pass. w/6-way,				
73-75	All w/6-way bench st.	9613131	2	.70	upper
71-72	Pass. w/6-way,				
73-74	All w/6-way	9832760	R.H.	1.25	right track lower
71-72	Pass. w/6-way,				
73-74	All w/6-way	9832762	L.H.	1.25	left track lower
71-72	Chevelle w/4-way bucket seat	9819134	L.H.	1.60	driver switch protector
70	Monte Carlo w/4-way bucket seats,				
66-69	Caprice (Spt. Mdls.) w/elect. 6-way seat, Astro. bench seat	7580196	R.H.	1.20	upper
66-69	Caprice (Spt. Mdls.) w/elect. 6-way seat, Astro. bench seat	7580197	L.H.	1.30	upper
66	Chevelle w/elect. 4-way bucket seat,				
70-72	Monte Carlo w/4-way bucket seats	4548383	1	2.00	inner, upper
66	Chevelle w/elect. 4-way bucket seat,				
70-72	Monte Carlo w/4-way bucket seats	4548384	1	1.55	outer, upper
66	Chevelle w/elect. 4-way bucket seat,				
70-71	Monte Carlo w/4-way bucket seats	4550263	1	1.30	inner and outer, lower
67-70	Pass. w/elect. seat (6-way) (exc. S.S.)	8726287	R.H.	1.65	lower
67-68	Pass. w/elect. seat (6-way) (exc. S.S.),				
67-70	Caprice w/strato bench (6-way),				
69-70	Impala (Spt. Cpe.) w/6-way,				
69-70	Estate Wag. w/6-way	7657267	2	.76	rear, upper
72	Nova (Spt. Cpe.),				
73	Nova (Spt. Cpe.) w/Bucket St.	9609894	1	1.25	driver seat inner, pass. seat outer
72	Nova (Spt. Cpe.),				
73	Nova (Spt. Cpe.) w/Bucket St.	9609895	1	1.25	driver seat outer, pass. seat inner
73-75	All w/Reclining St.	9837548	1	.58	pass. st. adj. track outer rear (manual)
73-75	All w/Swivel Seat	9638115	1	3.95	driver st. (paint as reqd.)
73-74	All w/Swivel Seat	9638114	1	3.95	pass. st. (paint as reqd.)
73-74	All w/6-way Reclining St.	9832764	1	1.30	driver st. inner adj. lower track
73-74	All w/6-way Reclining St.,				
75	All w/6-way Pwr., Reclining	9675803	1	1.30	pass. inner driver seat outer adjuster track lower, front st. (L.H.)
75	All w/6-way Pwr., Reclining	9675802	1	1.30	pass. outer driver, inner, front adj. trk. lower (R.H.)

**REAR GLASS—SEAT AND ADJUSTER**

**11.573 COVER—FASTENER—REINFORCEMENT—SUPPORT, Seat Adjuster Track (Con't)**

75	Chevelle w/Swivel	1678477	1	4.10	pass. st.
64-67	Chevelle w/elect. seats,				
65-67	Pass. w/elect. seat	8731909	14	.11	FASTENER, adjuster track cover
72	Monte Carlo w/4-way bucket seat	9610098	1	.58	driver, trans. cable
68	Pass. w/elect. seat (6-way),				
69	Pass. (exc. Bel Air, Townsman)				FASTENER, adjuster track lower cover,
68	Impala (custom),				
68	Caprice (Spt. Cpe.) w/elect. seat (4-way)				driver seat adjuster cover,
68-69	Impala, Caprice w/Strato Bench (6-way)				seat adjuster track upper cover— (10.695)
75	Pass., Chevelle w/6-way Pwr.	8731909	A.R.	.11	FASTENER, lower cover— (10.695)
74	All w/Reclining Seat	338759	1	3.35	REINFORCEMENT, c/bar underbody
75	Pass. w/Reclining St.	344952	1	5.45	REINFORCEMENT, c/bar underbody
65-66	Pass. w/elect. seat (6-way),				
67-68	Impala, Caprice (exc. 6-way seat, strato bench seat, Sta. Wag.),				
69	Caprice w/6-way Strato bench	4434935	4	.37	SUPPORT, upper cover
70-72	Monte Carlo w/4-way bucket seats	4539563	R.H.	1.15	SUPPORT, front upper cover
70-72	Monte Carlo	8791886	2	1.85	SUPPORT, driver seat adj. trunk upper cover rear

**11.581 SPRING, Front Seat Adjuster**

62-70	Chevy, Chevelle, Camaro,				
71-72	Chevelle, Nova	4854893	A.R.	.52	right or left, assist
65-72	Pass.,				
73	Monte Carlo w/Bench,				
73-75	Pass. w/Bench St. (exc. 6-way)	4813043	2	.58	assist
66-68	Caprice (Spt. Cpe.) w/bucket seats (exc. 4-way bucket seat),				
66-68	Impala (S.S.),				
69	Pass. w/Strato Bucket Seats				driver and pass., assist
73-74	Vega, Monza		1		frt. st. adj. pass. & driver assist,
74	Nova w/Bkt. St.	7599381	2	.61	pass./driver seat adj.
66	Chevelle (Spt. Cpe., Conv.)				driver seat assist.,
66-67	Chevelle w/bucket seat				pass. seat assist.,
66-68	Nova (S.S.),				
66-69	El Camino (Custom) w/bucket seat,				
67-72	Chevelle (Spt. Cpe., Conv.) w/strato bucket,				
68-71	Chevy w/strato bucket	7599398	2	.81	driver and pass. assist.
67-69	Chevy (exc. S.S.),				
67-69	Chevelle,				
67	Camaro (Spt. Cpe.) w/strato bench seat,				
67-69	Pass. (Taxi) (New York type),				
67-69	Caprice, S.S. w/Strato bench seat (exc. 6-way),				
68-72	Pass.,				
71-72	Biscayne (New York Taxi),				
71-72	Chevelle, Nova w/Strato Buckets				lock bar,
73-75	Chevelle, Nova, Pass.				driver and pass. outer & inr. lock bar,
73	Bel Air (New York Taxi),				
73	Pass. w/Power Seats, Bench St.,				
74-75	Pass. w/Reclining Seat	9711041	1	.58	front seat adj. lock bar
67-68	Camaro, Chevy (S.S.),				
67-68	Chevelle w/strato bucket seats (exc. 4-way),				
69	Camaro,				
69-70	Chevy, Chevelle w/strato bucket seats,				
67	S.S.,				
67	Caprice (Spt. Cpe.) w/Strato bucket seat,				
68-69	Pass. w/Strato bucket seat,				
71-72	Chevelle, Nova w/Strato buckets	9711040	A.R.	.70	driver and pass., outer lock bar
67-68	Chevy (exc. S.S.),				
67-68	Chevelle,				
72	Nova, Camaro w/Bucket Seats,				
72-75	Vega				driver seat outer and pass. seat inner adj. lock bar,

**REAR GLASS—SEAT AND ADJUSTER**

**11.581 SPRING, Front Seat Adjuster (Con't)**

73-75	Nova, Camaro, Chevelle (exc. 6-way),				
74-75	Pass. (exc. 6-way, Reclining) . . .	9711038 A.R.	.73	adj. lock bar . . . . .	
70-75	Camaro,				
71-72	Vega, Monza,				
72-73	Nova,				
74-75	Nova w/Bench St. . . . .	9801835 A.R.	.66	driver and pass. assist. . . . .	
70-72	Camaro,				
71-74	Vega, Monza,				
73-75	Nova (2-Dr.),				
73-75	Chevelle w/Swivel Bucket Seat . . .	9826897 2	.73	pass. and driver outer seat adj. lock bar . . .	
74	Pass. (exc. Cust. Cpe.) w/6-way Pwr. Seats, Bench Seats . . . . .	9711038 A.R.	.73	pass./driver adj. lock bar . . . . .	
74	Chevelle w/Bench (exc. 6-way),				
75	Camaro . . . . .	9728051 2	.63	assist front seat adjuster . . . . .	
75	Chevelle, Nova w/Bucket, European Bucket, Reclining (exc. 6-way), Vega, Monza . . . . .	9620424 2	.53	driver/pass. seat adj. . . . .	

**11.588 KNOB, Front Seat Adjuster**

64-65	Chevelle,				
65	El Camino w/bucket seat,				
66	Chevelle (1st design) (exc. S.S., El Camino),				
65-66	Pass. . . . .	4413116 1	2.20		
66	Pass. (Spt. Cpe., Conv.),				
66	Pass. (Spt. Cpe.) w/bucket seat . . .			driver and pass., . . . . .	
66	Chevy, Chevelle (Spt. Cpe., Conv.),				
66	El Camino (Custom),				
66	Pass. (Spt. Sedan) w/Astro bench seat . . . . .	4537004 1	2.20	pass. . . . .	
	<i>NOTE 1 To be used with part 7628330 adjuster.</i>				
67	Chevy, Camaro,				
67	Chevelle (exc. S.S.),				
67	Chevelle w/strato bucket seats (exc. 4-way),				
67	Pass.,				
67	Caprice w/strato seats . . . . .	7665300 A.R.	.58	driver and pass. . . . .	
68-72	Pass., Chevelle, Nova, Camaro,				
71-75	Vega, Monza,				
73-75	All (exc. Swivel St.) . . . . .	9834636 2	.65	driver and pass. . . . .	
73-75	Chevelle w/Swivel St. . . . .	9617482 2	.28	driver and pass. . . . .	

**11.589 RETAINER— WIRE ASSY., Front Seat Adjusting Lock**

65-72	Pass.,				
73-75	All w/Bench St. (exc. 6-way) . . .	4486075 1	.11	auxiliary lock wire . . . . .	
62-66	Chevy (exc. S.S.),				
64-66	Chevelle (exc. bucket seats),				
64-65	Chevelle (exc. Spt. Sed., S.S.),				
66-72	Chevelle,				
67-68	Camaro w/strato bench seat,				
69-72	Chevy,				
73-74	Chevelle, Nova w/Bench St. . . . .	4415868 1	.11	auxiliary . . . . .	
66-67	Caprice w/Astro. bench seat (exc. elect. seat, Sta. Wag.),				
67-68	Camaro (Spt. Cpe.) w/strato bench seat,				
67	Impala (S.S.) w/strato bench (exc. 6-way), <sup>1</sup>				
68-69	Pass. w/strato bench (exc. 6-way) . . . . .	4543290 1	.88	WIRE ASSY., auxiliary locking . . . . .	
67-72	Chevelle,				
67	Chevy (exc. S.S.) . . . . .	7689748 1	.46	WIRE ASSY., auxiliary locking . . . . .	
68-72	Chevy,				
73	Monte Carlo 6-way Bench St.,				
73	Nova w/Bucket . . . . .	7745225 1	.40	WIRE ASSY., auxiliary . . . . .	
65	Pass.,				
66-68	Pass. (exc. S.S.),				
69-70	Pass. . . . .	8745292 1	.40	WIRE ASSY., auxiliary locking . . . . .	
71-72	Pass.,				
73-75	All w/Bench Seat . . . . .	9680013 1	.46	WIRE ASSY., auxiliary . . . . .	
73-74	Caprice w/Reclining St. . . . .			WIRE ASSY., auxiliary, . . . . .	
72-74	Nova, Camaro, Vega, Monza . . .	9831550 1	.42	WIRE ASSY., pass. & driver seat adj. aux. lkg. (Note 1) . . . . .	

**REAR GLASS—SEAT AND ADJUSTER**

**11.589 RETAINER— WIRE ASSY., Front Seat Adjusting Lock (Con't)**

72	Malibu (Spt. Cpe., Conv.),				
72	El Camino Custom,				
72	Monte Carlo w/bucket seat (exc. 4-way pwr. seats) . . . . .	9607335	1	.46	WIRE ASSY., pass. & driver . . . . .
73-74	Chevelle w/Swivel St.,				
75	Nova w/Bucket St. . . . .	9616251	1	.40	WIRE ASSY., pass. & driver . . . . .
75	Camaro w/Bucket St. . . . .				WIRE ASSY., driver, pass. st. adj. aux. locking, . . . . .
75	Vega, Monza . . . . .	1652315	1	.71	WIRE ASSY., pass. st. adj. aux. locking . . . . .
73-75	Pass., Chevelle . . . . .				WIRE ASSY., driver, pass. st. adj. aux. locking . . . . .
75	Vega, Monza . . . . .	9654029	1	.46	WIRE ASSY., driver st. adj. aux. locking . . . . .

**11.610 CUSHION— FRAME ASSY.— RETAINER, Rear Seat Bottom (Less Trim Cover)**

**PASSENGER**

71-73	Pass. (Sta. Wag.) (9-Pass.) . . . . .	9823900	1	18.50	FRAME ASSY., fldg. 3rd seat cushion . . . . .
71-75	Pass. (Spt. Cpe., Conv.) . . . . .	9726349	1	56.50	FRAME ASSY., w/spring . . . . .
72-75	Pass. (Sed.) . . . . .	9726348	1	50.75	FRAME ASSY., w/spring . . . . .
73-75	Pass. (Sta. Wag.) (9-Pass.) . . . . .	9667164	1	18.50	FRAME ASSY., folding 2nd 2/3 seat cush. w/springs . . . . .
73-75	Pass. (Sta. Wag.) (6-Pass.) . . . . .	9667162	1	65.25	FRAME ASSY., fldg. 2nd seat cushion, w/springs . . . . .
73-75	Pass. (Sta. Wag.) (9-Pass.) . . . . .	9667163	1	65.25	FRAME ASSY., fldg. 2nd 1/3 seat cushion . . . . .
73	Bel Air (New York Taxi) . . . . .	9661617	1		FRAME ASSY., w/spring rear seat cushion . . . . .
74-75	Pass. (Taxi) . . . . .	9726347	1	87.00	FRAME ASSY., w/springs . . . . .
74-75	Pass. (Sta. Wag.) (9-Pass.) . . . . .	9726352	1	99.25	FRAME ASSY., fldg., 3rd seat cushion w/springs . . . . .

**CHEVELLE**

70-71	Chevelle (Sta. Wag.) . . . . .	9866012	1	78.25	fldg. 3rd seat less trim . . . . .
73-75	Chevelle (Sta. Wag.) . . . . .	9667160	1	37.50	FRAME ASSY., fldg. 2nd seat cushion . . . . .
73-75	Chevelle (Sta. Wag.) w/rear seat assy. . . . .	9667161	1	50.75	FRAME ASSY., fldg. 3rd seat . . . . .
73	Chevelle (Sed.) . . . . .	9661599	1	37.50	FRAME ASSY., w/spring . . . . .
73-75	Chevelle (2-Dr.) (exc. El Camino)	9726346	1	37.50	FRAME ASSY., w/springs . . . . .
74-75	Chevelle (Spt. Sed.) . . . . .	9726345	1	37.50	FRAME ASSY., w/springs . . . . .

**CHEVY**

70-72	Nova (2-Dr.) . . . . .	9606477	1	80.50	rear seat less trim . . . . .
73-74	Nova (2-Dr.) . . . . .	9691637	1	37.50	FRAME ASSY., w/springs . . . . .
73-75	Nova (4-Dr.) . . . . .	1701317	1	37.50	FRAME ASSY., w/springs . . . . .
75	Nova (2-Dr.) . . . . .	1701316	1	37.50	FRAME ASSY., w/springs . . . . .

**CAMARO**

74-75	Camaro . . . . .	9726344	1	37.50	FRAME ASSY., w/springs . . . . .
-------	------------------	---------	---	-------	----------------------------------

**VEGA— MONZA**

71-74	Vega (N.B.) w/Sensor Warning System (exc. Custom Seat),				
75	Vega (exc. Panel) . . . . .	9605802	1	39.00	
75	Monza . . . . .	1662390	R.H.	2.10	RETAINER, rr. seat cushion frame . . . . .
75	Monza . . . . .	1662391	L.H.	2.10	RETAINER, rr. seat cushion frame . . . . .

**11.620 LINK ASSY.— ARM ASSY.— BOLT— BUMPER— BUSHING— CABLE ASSY.— CATCH— CLIP— COVER— CUSHION ASSY.— ESCUTCHEON— FASTENER— GASKET— GUIDE— HANDLE ASSY.— KIT— LATCH— LOCK ASSY.— PLATE— RETAINER— ROD— SCREW— SLEEVE— SPRING— SUPPORT— STRIKER— STOP— WASHER, Folding Seat (For Load Floor Parts See Group 12.977)**

68-70	Chevelle (Sta. Wag.) . . . . .	9848460	R.H.	14.00	fldg. second seat mtg. supt. . . . .
68-70	Chevelle (Sta. Wag.) . . . . .	9848461	L.H.	14.00	fldg. second seat mtg. supt. . . . .
68-70	Chevelle (3 seat Sta. Wag.) . . . . .	8720995	L.H.	8.60	third seat back . . . . .
68-71	Chevelle (Sta. Wag.) (9-Pass.) . . . . .	8740826	R.H.	8.60	third seat back . . . . .
68-70	Pass. (Sta. Wag.) (9-Pass.) . . . . .	8740830	R.H.	11.35	third seat back side . . . . .
71	Pass. (Sta. Wag.) (9-Pass.) . . . . .	9837611	L.H.	1.40	folding 3rd seat back front . . . . .
71	Pass. (Sta. Wag.) (9-Pass.) . . . . .	9837610	R.H.	1.55	folding 3rd seat back front . . . . .
71-72	Pass. (Sta. Wag.) (9-Pass.) . . . . .	9852659	L.H.	1.50	folding 3rd seat back (Note 1) . . . . .
71-72	Pass. (Sta. Wag.) (9-Pass.) . . . . .	9852658	R.H.	1.50	folding 3rd seat back (Note 1) . . . . .
71-72	Chevelle (Sta. Wag.) (9-Pass.) . . . . .	9838986	L.H.	5.15	folding 3rd seat back . . . . .
71-72	Chevelle (Sta. Wag.) (9-Pass.) . . . . .	9838981	R.H.	11.05	folding 3rd seat back . . . . .
71-72	Chevelle (Sta. Wag.) . . . . .	9848461	L.H.	14.00	2nd seat back mounting support (Note 1) . . . . .



**REAR GLASS—SEAT AND ADJUSTER**

**11.620 LINK ASSY.— ARM ASSY.— BOLT— BUMPER— BUSHING— CABLE ASSY.— CATCH— CLIP— COVER— CUSHION ASSY.— ESCUTCHEON— FASTENER— GASKET— GUIDE— HANDLE ASSY.— KIT— LATCH— LOCK ASSY.— PLATE— RETAINER— ROD— SCREW— SLEEVE— SPRING— SUPPORT— STRIKER— STOP— WASHER, Folding Seat (For Load Floor Parts See Group 12.977) (Con't)**

71-72	Chevelle (Sta. Wag.)	9848460 R.H.	14.00	2nd seat back mounting support (Note 1)
71-72	Pass. (Sta. Wag.) (9-Pass.)	9862995 1	2.70	3rd seat back panel retainer (Note 1)
71	Pass. (Sta. Wag.) (9-Pass.)	9854562 1	14.00	2nd 2/3 seat back outer (Note 1)
71-75	Pass. (Sta. Wag.) (9-Pass.)	9854592 1	10.20	2nd 1/3 seat back front (Note 1)
71	Pass. (Sta. Wag.) (6-Pass.)	9854603 L.H.	12.95	2nd seat mtg. supt. (Note 1)
71	Pass. (Sta. Wag.) (6-Pass.)	9854602 R.H.	12.95	2nd seat mtg. supt. (Note 1)
71	Pass. (Sta. Wag.) (9-Pass.)	9856172 1	29.25	2nd 1/3 seat back inner (Note 1)
71	Pass. (Sta. Wag.) (9-Pass.)	9880490 1	27.50	2nd 2/3 seat back inner (Note 1)
71	Chevelle (Sta. Wag.) (9-Pass.)	8720995 L.H.	8.60	fldg. third seat backside
71	Pass. (Sta. Wag.) (9-Pass.) (1st design)	9870836 1	20.80	2nd 1/3 seat back outer (Note 1)
71	Pass. (Sta. Wag.) (9-Pass.) (2nd design)	9875633 1	20.80	2nd 1/3 seat back outer, used w/offset slot and tapped hole (Note 1)
71	Pass. (Sta. Wag.)	9886956 1	6.75	fldg. 2nd seat back lock
71-74	Vega (Sta. Wag.) (H.B.)	9624508 R.H.	5.95	fldg. rear seat back mounting support
71-74	Vega (Sta. Wag.) (H.B.)	9624509 L.H.	5.95	fldg. rear seat back mounting support
72	Pass. (Sta. Wag.) (9-Pass.)			
73-74	Pass. (Sta. Wag.) (6-Pass.)	9895149 L.H.	12.95	left, 2nd seat mtg. supt. (Note 1)
72	Pass. (Sta. Wag.) (9-Pass.)			
73-74	Pass. (Sta. Wag.) (6-Pass.)	9895148 L.H.	12.95	left, 2nd seat mtg. supt. (Note 1)
72-75	Pass. (Sta. Wag.) (9-Pass.)	9895158 1	20.30	2nd 2/3 st. bk. otr. painted
72-74	Pass. (Sta. Wag.) (9-Pass.)	9896758 R.H.	1.40	fldg. 3rd st. bk. frt.
72-74	Pass. (Sta. Wag.) (9-Pass.)	9896759 L.H.	1.40	fldg. 3rd st. bk. frt.
73-75	Pass. (Sta. Wag.) (9-Pass.)	9895261 1	20.80	2nd 1/3 st. bk. outer (painted)
73-75	Pass. (Sta. Wag.) (9-Pass.)	9862995 1	2.70	3rd seat back panel retainer (Note 1)
73-75	Chevelle (Sta. Wag.)	9627251 L.H.	10.20	left, 2nd seat back mounting support (Note 1)
73-75	Chevelle (Sta. Wag.)	9627250 R.H.	10.20	right, 2nd seat back mounting support (Note 1)
73-75	Nova (H.B. Cpe.)	1657632 L.H.	4.95	fldg. rear seat back
73-75	Nova (H.B. Cpe.)	1657631 R.H.	3.95	fldg. rear seat back
73-75	Pass. (Sta. Wag.) (9-Pass.)	9604947 1	20.80	2nd 1/3 bk. outer lower (painted)
74-75	Pass. (Sta. Wag.) (6-Pass.)	9728164 R.H.	12.95	2nd seat mounting supt. (painted)
74-75	Pass. (Sta. Wag.) (6-Pass.)	9728165 L.H.	12.95	2nd seat mounting supt. (painted)
73-75	Pass. (Sta. Wag.) (9-Pass.)	9895256 1	29.25	LINK, 2nd 1/3 seat back inner (painted)
73	Pass. (Sta. Wag.) (9-Pass.)	9895251 1	27.50	LINK, 2nd 2/3 st. bk. inner (painted)
74-75	Pass. (Sta. Wag.) (9-Pass.)	9679725 1	29.25	LINK, 2nd 1/3 st. bk. inner (painted)
74-75	Vega (Sta. Wag.) (H.B.)	1672850 L.H.	8.20	ARM ASSY., fldg. r/seat back pivot (repl. 9680227)
74-75	Vega (Sta. Wag.) (H.B.)	9680226 R.H.	4.95	ARM ASSY., fldg. r/seat back pivot
75	Monza (exc. Towne Cpe.)	1654996 L.H.	4.95	ARM ASSY., fldg. rear st. back pivot
75	Monza (exc. Towne Cpe.)	1654995 R.H.	4.25	ARM ASSY., fldg. rear st. back pivot
75	Nova (H.B.)	1657631 R.H.	3.95	ARM, fldg. rear seat back pivot
75	Nova (H.B.)	1657632 L.H.	4.95	ARM, fldg. rear seat back pivot
62-65	Chevy, Chevelle (Sta. Wag.)			
65-67	Sta. Wag. w/split seat	4829139 4	.34	BOLT, second seat link to bar ( <sup>5</sup> / <sub>16</sub> "— 18 x <sup>29</sup> / <sub>32</sub> ")
68-72	Chevelle (Sta. Wag.) (9-Pass.)	8731946 2	1.35	BOLT, third seat back link to support
71-73	Vega (Sta. Wag.) (H.B.)	4405445 4	.21	BOLT, rear seat to floor pan
68-69	Camaro w/folding rear seat			BUMPER, rear seat back,
62-67	Chevy (Sta. Wag.)			2nd seat back on catch,
71-72	Pass. (Sta. Wag.) (9-Pass.)			2nd 1/3 seat back on wheelhouse,
71-75	Vega (Sta. Wag.) (H.B.)			BUMPER, rear seat fldg. back/on wheelhouse,
73-75	Pass. (Sta. Wag.) (9-Pass.)			BUMPER, fldg. 3rd st. back,
74-75	Nova (2-Dr.)	4767527 A.R.	.18	2nd 1/3 seat back panel support str.
65-71	Sta. Wag.			BUMPER, folding second seat back on wheelhouse,
71-74	Vega (Sta. Wag.) (H.B.)	4868380 L.H.	.18	BUMPER, rear seat fldg. back/on wheelhouse
65-68	Sta. Wag. (9-Pass.)			BUMPER, fldg. 3rd seat cushion ( <sup>1</sup> / <sub>2</sub> " O.L.),
69-72	Sta. Wag. (9-Pass.)			fldg. 3rd seat link supt.,
69-72	Sta. Wag.			2nd seat back on compt. pan bumper, 3rd st. bk. fil. pnl. frt.,
73-75	Pass. (Sta. Wag.)			BUMPER, 3rd st. bk. fil. panel front
74-75	Vega (exc. N.B.)	4587944 A.R.	.12	BUMPER, qtr. inner pnl., fldg. 2nd st. bk. compt. front. comp. front panel anti/r., compt. rear panel anti/rattle

**REAR GLASS—SEAT AND ADJUSTER**

**11.620 LINK ASSY.— ARM ASSY.— BOLT— BUMPER— BUSHING— CABLE ASSY.— CATCH— CLIP— COVER— CUSHION ASSY.— ESCUTCHEON— FASTENER— GASKET— GUIDE— HANDLE ASSY.— KIT— LATCH— LOCK ASSY.— PLATE— RETAINER— ROD— SCREW— SLEEVE— SPRING— SUPPORT— STRIKER— STOP— WASHER, Folding Seat (For Load Floor Parts See Group 12.977) (Con't)**

65-66	Pass. (Sta. Wag.)	4500728	2	.24	BUMPER, folding second seat back on wheelhouse
65-67	Pass. (Sta. Wag.) (9-Pass.),				
70	Pass. (Sta. Wag.) (9-Pass.)	9643798	2	.34	BUMPER, folding third seat cushion floor positive— (12.977)
65-70	Pass. (Sta. Wag.) (9-Pass.)				BUMPER, folding 3rd seat cushion ride positive,
69-70	Pass. (Sta. Wag.)	4872948	2	.12	2nd seat back on compt. panel— (12.212)
66-67	Chevy (Sta. Wag.),				
71	Pass. (Sta. Wag.) (9-Pass.)	4879757	A.R.	.16	BUMPER, right, folding second seat back on catch (emergency use)
67-69	Pass. (Sta. Wag.) w/split second seat,				
68	Chevelle (Sta. Wag.)				BUMPER, folding second seat on wheelhouse R.H.,
68-71	Chevelle (Sta. Wag.),				
69-70	Kingswood Estate Wag.,				L.H. fldg. second seat on wheelhouse,
71-72	Pass. (Sta. Wag.)				BUMPER, fldg. 3rd seat link supt.,
73	Pass. (Sta. Wag.) (6-Pass.)				
73-75	Pass. Chevelle (Sta. Wag.) (6-Pass.)	7726729	1	.18	BUMPER, folding 2nd, 2/3, 3rd seat back
68-71	Chevelle (Sta. Wag.) (9-Pass.)	4595786	2	.18	BUMPER, folding third seat, link support— (12.212)
64-66	Chevelle (Sta. Wag.),				
68-70	Camaro	7731448	L.H.	.34	BUMPER, rear seat folding back
71	Pass. (Sta. Wag.) (9-Pass.)	4658668	2	.14	BUMPER, folding 3rd seat cushion floor
71	Pass. (Sta. Wag.) (6-Pass.)	4721222	2	.12	BUMPER, folding 2nd seat back support
71-75	Pass. (Sta. Wag.) (9-Pass.)	9833989	2	.32	BUMPER, folding 3rd seat back filler on pnl.
71-75	Pass. (Sta. Wag.) (6-Pass.)	9841451	1	.16	BUMPER, folding 2nd seat back lock side
74-75	Pass. (Sta. Wag.) (9-Pass.)	4839962	2	.28	BUMPER, fldg. 2nd 1/3 & 2/3 st. bk. fin. pnl.
74-75	Pass. (Sta. Wag.) (9-Pass.)	9623092	A.R.	.16	BUMPER, 3rd seat back filler panel on seat
68-70	Chevelle (Sta. Wag.) (9-Pass.),				
65-68	Pass. (Sta. Wag.),				
71-72	Greenbrier, Concours (9-Pass.)	8721269	A.R.	.12	BUSHING, luggage compt. frt. panel supt. 3rd seat back and cushion supt. and side link
68	Chevelle (Sta. Wag.) (9-Pass.),				
71-73	Pass. (Sta. Wag.) (9-Pass.)	4499189	2	.11	BUSHING, fldg. third seat back link
71-72	Townsmen, Kingswood,				
73	Pass. (Sta. Wag.) (9-Pass.)	7740302	2	.11	BUSHING, folding 3rd seat back hinge pin
74-75	Pass. (Sta. Wag.) (9-Pass.)	9673827	1	8.20	CABLE ASSY., fldg. 2nd 2/3 st. bk. lk. rem.
74-75	Pass. (Sta. Wag.) (9-Pass.)	9675863	1	9.15	CABLE ASSY., rem. cont. fldg. 3rd st. bk. lk.
71-74	Pass. (Sta. Wag.) (9-Pass.)	9828449	2	1.70	CATCH, folding 3rd seat back filler panel
73-75	Chevelle (Sta. Wag.)	9674247	1	1.85	CATCH, folding 3rd seat bottom frame
74-75	Pass. (Sta. Wag.) (9-Pass.)	9815325	2	.11	CLIP, folding 2nd 2/3 st. back lock handle
74-75	Pass. (Sta. Wag.) (9-Pass.)	9828207	1	.11	CLIP, fldg. 3rd st. bk. lk. handle
67-69	Camaro	7664664	2	.63	COVER, rear seat folding back retainer (black)
67-70	Pass., Chevelle (Sta. Wag.),				
67	Pass. (Sta. Wag.) w/split seat,				
71-72	Chevelle (Sta. Wag.)	7716100	R.H.	.27	COVER, second seat back lock
68-72	Chevelle (Sta. Wag.) (9-Pass.)	7756351	1	.70	COVER, second seat back bpr. supt. (black) (paint as reqd.)
69-72	Chevelle (Sta. Wag.) (9-Pass.)	8761982	R.H.	.63	COVER, fldg. 3rd seat lock protr.
68-72	Pass., Chevelle (Sta. Wag.) (9-Pass.)	8721004	R.H.	.63	COVER, fldg. 3rd seat back lock protr. (blue) (paint as reqd.)
71-72	Pass. (Sta. Wag.) (6-Pass.)				COVER, folding 2nd seat back lock side,
71-74	Pass. (Sta. Wag.) (9-Pass.)	9834770	A.R.	.31	right, folding 2nd 1/3, 2/3 seat back lock
72-73	Pass. (Sta. Wag.) (9-Pass.)	9661748	R.H.	5.55	COVER, fldg. 3rd st. bk. supt. (Note 1)
72-73	Pass. (Sta. Wag.) (9-Pass.)	9661753	L.H.	5.55	COVER, fldg. 3rd st. bk. supt. (Note 1)
74-75	Pass. (Sta. Wag.) (9-Pass.)	9685793	R.H.	1.20	COVER, fldg. 3rd st. bk. supt. (Note 1)
73-75	Chevelle (Sta. Wag.)	9653786	L.H.	1.60	COVER, 3rd seat pivot supt. prime and paint (Note 1)
73-75	Chevelle (Sta. Wag.)	9653785	R.H.	1.60	COVER, 3rd seat pivot supt. prime and paint (Note 1)
73-75	Chevelle (Sta. Wag.)	9676926	1	1.80	COVER, folding 3rd seat hinge (Note 1)

**REAR GLASS—SEAT AND ADJUSTER**

**11.620 LINK ASSY.— ARM ASSY.— BOLT— BUMPER— BUSHING— CABLE ASSY.— CATCH— CLIP— COVER— CUSHION ASSY.— ESCUTCHEON— FASTENER— GASKET— GUIDE— HANDLE ASSY.— KIT— LATCH— LOCK ASSY.— PLATE— RETAINER— ROD— SCREW— SLEEVE— SPRING— SUPPORT— STRIKER— STOP— WASHER, Folding Seat (For Load Floor Parts See Group 12.977) (Con't)**

74-75	Pass. (Sta. Wag.) (9-Pass.)	9685799	L.H.	1.25	COVER, fldg. 3rd st. bk. support (prime & paint)
75	Monza (exc. Towne Cpe.)	1698080	R.H.	1.15	COVER, fldg. rear st. bk. arm
75	Monza (exc. Towne Cpe.)	1698081	L.H.	1.15	COVER, fldg. rear st. bk. arm
71	Chevelle (Sta. Wag.) (9-Pass.)	9866012	1	78.25	CUSHION ASSY., fldg. 3rd seat less cover
74-75	Pass. (Sta. Wag.) (9-Pass.)	9691301	1	.76	ESCUTCHEON, fldg. 3rd st. back (prime & paint)
67-70	Sta. Wag.				FASTENER, R.H. second seat cover to lock,
67	Pass. (Sta. Wag.) w/split seat,				
71-74	Pass. (Sta. Wag.)	7689719	1	.11	second seat cover to lock L.H.
74	Vega (Sta. Wag.) (H.B.)	1688625	2	.11	GASKET, fldg. rear st. back panel bumper support (R.H. & L.H.)
71-73	Pass. (Sta. Wag.) (9-Pass.)	9892223	1	.80	GUIDE, 3rd st. cush.
67	Pass. (Sta. Wag.) w/split seat				HANDLE ASSY., second seat back lock L.H.,
67-70	Pass., Chevelle (Sta. Wag.),				
71-72	Pass. (Sta. Wag.) (6-Pass.),				
71	Chevelle (Sta. Wag.),				
71-72	Pass. (Sta. Wag.) (9-Pass.)				HANDLE ASSY., second 1/3, 2/3 seat back R.H.,
73-75	Pass., Chevelle (Sta. Wag.)	7681728	A.R.	1.70	HANDLE ASSY., second seat lock, right hand fldg. 2nd 1/3, 2/3 seat lock
71	Pass. (Sta. Wag.)	9835631	L.H.	3.25	HANDLE ASSY., folding 2nd seat back lock
71	Pass. (Sta. Wag.)	9830864	R.H.	1.95	HANDLE ASSY., folding 2nd seat back lock
74-75	Pass. (Sta. Wag.) (9-Pass.)	9675842	1	11.35	HANDLE ASSY., fldg. 3rd st. bk. rem. cont.
74-75	Pass. (Sta. Wag.) (9-Pass.)	1650074	1	7.95	HANDLE ASSY., fldg. 2nd 2/3 st. bk. lk. rem.
71	Pass. (Sta. Wag.) (6-Pass.)	8704235	1	4.20	KIT, fldg. 2nd seat cushion frame (field fix) (Note 2)
71	Pass. (Sta. Wag.) (9-Pass.)	8704245	1	2.60	KIT, fldg. 2nd seat cushion frame (field fix) (Note 3)
<i>NOTE 2: Kit consists of two, 9611038 Retainers, two, 9420805 Screws and two, 9431877 Nuts.</i>					
<i>NOTE 3: Kit consists of one, 9611039 Retainer. One 9611038 Retainer. Two, 9418804 Screws, one 9420805 Screw and one 9431877 Nut.</i>					
72-73	Pass. (Sta. Wag.) (9-Pass.)	9887354	1	4.00	LATCH, fldg. 2nd 1/2 seat back
73	Pass. (Sta. Wag.) (9-Pass.)	9887354	1	4.00	LATCH, fldg. 2nd 1/2 seat back
74-75	Pass. (Sta. Wag.) (9-Pass.)	9673819		5.30	LATCH, fldg. 2nd 1/3 st. bk.
68-72	Chevelle (Sta. Wag.) (9-Pass.)	8761981	1	12.25	LOCK ASSY., 3rd seat back
71-73	Pass. (Sta. Wag.) (9-Pass.)	9838073	1	5.65	LOCK ASSY., folding 3rd seat back
71-73	Pass. (Sta. Wag.) (9-Pass.)	9839824	L.H.	6.75	LOCK ASSY., folding 2nd 2/3 seat back
71-74	Vega (Sta. Wag.) (H.B.)	9829298	R.H.	3.75	LOCK ASSY., fldg. rear seat back
67-75	Pass., Chevelle (Sta. Wag.)				LOCK ASSY., folding 2nd st. bk.,
72	Pass. (Sta. Wag.)	9886956	R.H.	6.75	folding 1/3 seat back lock
73-75	Chevelle (Sta. Wag.) w/rear seat assy.	9878240	1	11.60	LOCK ASSY., fldg. 3rd st. bk.
73-75	Nova (H.B. Cpe.)				LOCK ASSY., fldg. rear seat bk.
74-75	Vega (Sta. Wag.) (Panel)	9619628	R.H.	5.95	LOCK ASSY., fldg. r/seat back
74-75	Pass. (Sta. Wag.) (9-Pass.)	1691477	R.H.	6.75	LOCK ASSY., fldg. 2nd 1/3 seat back
74-75	Pass. (Sta. Wag.) (9-Pass.)	1691478	L.H.	6.75	LOCK ASSY., fldg. 2nd 2/3 seat back
71	Pass. (Sta. Wag.) (9-Pass.)	9845353	1	1.65	PLATE, 2nd 1/3 seat outer link striker
67-72	Pass., Chevelle (Sta. Wag.)				RETAINER, folding second seat back,
73-75	All (Sta. Wag.) (6-Pass.)	7715684	R.H.	1.20	RETAINER, second seat link
67	Pass. (Sta. Wag.) w/split second seat,				
71-75	Pass. (Sta. Wag.) (9-Pass.)	7715685	L.H.	1.35	RETAINER, folding second seat back lock
71-74	Pass. (Sta. Wag.) (9-Pass.)	9825182	1	1.45	RETAINER, folding 3rd seat back hinge pin
71-73	Pass. (Sta. Wag.) (9-Pass.)	9827919	L.H.	1.80	RETAINER, left, 3rd seat back filler panel catch floor
71-73	Pass. (Sta. Wag.) (9-Pass.)	9827918	R.H.	1.80	RETAINER, right, 3rd seat back filler panel catch floor
72-75	Pass. (Sta. Wag.) (6-Pass.)	9613250	R.H.	.96	RETAINER, fldg. 2nd seat cushion frame
72-75	Pass. (Sta. Wag.) (6-Pass.)	9613252	L.H.	.96	RETAINER, fldg. 2nd seat cushion frame
73-75	Chevelle (Sta. Wag.) w/rr. seat assy.	9847149	3	.52	RETAINER, fldg. 3rd st. bk. panel trim
73-75	Chevelle (Sta. Wag.)	9674246	1	.96	RETAINER, folding 3rd seat bottom frame
73-75	Pass. (Sta. Wag.) (9-Pass.)	1494981	1	.11	RETAINER, latch fldg. 2nd 1/3 st. bk.
74-75	Pass. (Sta. Wag.) (9-Pass.)	9673676	R.H.	1.90	RETAINER, 3rd st. bk. fil. pnl. striker
74-75	Pass. (Sta. Wag.) (9-Pass.)	9673677	L.H.	1.90	RETAINER, 3rd st. bk. fil. pnl. striker
74-75	Pass. (Sta. Wag.) (9-Pass.)	9675824	1	.52	RETAINER, fldg. 3rd st. bk. torq. rod
74-75	Pass. (Sta. Wag.) (9-Pass.)	9675867	1	1.45	RETAINER, 3rd seat bk. remote cont. hdl.

**REAR GLASS—SEAT AND ADJUSTER**

**11.620 LINK ASSY.— ARM ASSY.— BOLT— BUMPER— BUSHING— CABLE ASSY.— CATCH— CLIP— COVER— CUSHION ASSY.— ESCUTCHEON— FASTENER— GASKET— GUIDE— HANDLE ASSY.— KIT— LATCH— LOCK ASSY.— PLATE— RETAINER— ROD— SCREW— SLEEVE— SPRING— SUPPORT— STRIKER— STOP— WASHER, Folding Seat (For Load Floor Parts See Group 12.977) (Con't)**

74-75	Pass. (Sta. Wag.) (9-Pass.)	9677222 R.H.	1.35	RETAINER, fldg. 3rd seat bk. hge. pin
74-75	Pass. (Sta. Wag.) (9-Pass.)	9677223 L.H.	.96	RETAINER, fldg. 3rd seat bk. hinge pin
74-75	Pass. (Sta. Wag.) (9-Pass.)	9694155 R.H.	5.65	RETAINER, carpet fldg. 3rd st. bk. filler
74-75	Pass. (Sta. Wag.) (9-Pass.)	9694156 L.H.	5.65	RETAINER, carpet fldg. 3rd st. bk. filler
71-73	Pass. (Sta. Wag.) (9-Pass.)	9872761 R.H.	7.50	RETAINER ASSY., fldg. 3rd seat back hinge pin
71-72	Pass. (Sta. Wag.) (9-Pass.)	9870396 1	2.75	ROD, 2nd 1/3 seat back outer torq. w/offset slot and tapped hole
73-75	Pass. (Sta. Wag.) (9-Pass.)	1652834 1	2.45	ROD, 2nd 1/3 seat back inner torq.
74-75	Pass. (Sta. Wag.) (9-Pass.)	9675850 1	2.45	ROD, torque, fldg. 3rd seat back
74-75	Pass. (Sta. Wag.) (9-Pass.)	9673826 1	1.70	ROD ASSY., fldg. 2nd 1/3 st. bk. lk. rem.
62-64	Chevy, Malibu (3 Seat Sta. Wag.)	4536298 2	.18	SCREW, third seat back link to floor (1/4" — 20 x 11/16" w/3/16" shoulder)
65-68	Pass. (Sta. Wag.)	4499188 A.R.	.52	SCREW, luggage compt. frt. panel supt. fldg. 3rd seat back and link
68	Pass. (Sta. Wag.) (6-Pass.)			
68-70	Pass. (Sta. Wag.) (9-Pass.)			
69-72	Chevelle (Sta. Wag.) (9-Pass.)			SCREW, lub. compt. frt. pnl. support, 3rd seat link to support, cushion to supt.
71-73	Vega (Sta. Wag.) (H.B.)	8727559 3	.36	SCREW, mounting support to rear frame
72	Pass. (Sta. Wag.) (9-Pass.)			
73-74	Pass. (Sta. Wag.)			SCREW, fldg. 3rd st. bk. link,
73-74	Chevelle (6-Pass., Sta. Wag.)	1650900 2	.38	compt. pnl. pivot bush.
73-75	Pass. (Sta. Wag.) (9-Pass.)	9899997 1	.34	SCREW, 2nd 1/3 seat inner & outer link to seat
75	Chevelle (Sta. Wag.)			SCREW, compt. pnl. pivot bush.,
75	Pass. (Sta. Wag.) (9-Pass.)	1650900 A.R.	.38	fldg. 3rd st. bk. link/supt./pnl.
74-75	Pass. (Sta. Wag.) (9-Pass.)	9677224 2	.11	SLEEVE, 3rd seat back hge. pin
74-75	Pass. (Sta. Wag.) (9-Pass.)	9675840 2	.11	SLEEVE, 3rd seat back torq. rod
71-73	Pass. (Sta. Wag.) (9-Pass.)	9874700 1	1.20	SPRING, fldg. 3rd st. bottom cushion assist
73-74	Pass. (Sta. Wag.) (9-Pass.)	9887358 1	.16	SPRING, latch fldg. 2nd 1/3 st. bk.
74-75	Pass. (Sta. Wag.) (9-Pass.)	9730649 1	.11	SPRING, bolt fldg. 3rd st. bk. lk.
74-75	Pass. (Sta. Wag.) (9-Pass.)	9730648 1	1.20	SPRING, dtnt. fldg. 3rd st. bk. lk.
74-75	Pass. (Sta. Wag.) (9-Pass.)	9677849 1	.11	SPRING, fldg. 3rd seat bk. lk. cable return
68-72	Chevelle (3 Seat Sta. Wag.)	8727468 R.H.	11.10	SUPPORT, fldg. third seat back on bar
68-72	Chevelle (3 Seat Sta. Wag.)	8727469 L.H.	11.10	SUPPORT, fldg. third seat back on bar
73-75	Chevelle (Sta. Wag.) w/rear seat assy.	9847150 2	3.30	SUPPORT, fldg. 3rd seat cushion
73-75	Nova (H.B.),			
75	Vega (Sta. Wag.) (H.B.)	9619407 L.H.	1.95	SUPPORT, fldg. rr. seat back pnl. bumper
75	Monza (exc. Towne Cpe.)	1652564 R.H.	2.65	SUPPORT, fldg. rear st. back pivot on w/h
75	Monza (exc. Towne Cpe.)	1652565 L.H.	2.05	SUPPORT, fldg. rear st. back pivot on w/h
71-73	Pass. (Sta. Wag.) (9-Pass.)	9837870 R.H.	22.85	SUPPORT ASSY., folding 3rd seat bk. on bar
71-73	Vega (Sta. Wag.) (H.B.)	8788560 2	1.00	SUPPORT, fldg. rear seat back bumper/on seat
72	Pass. (Conv.)	9888554 L.H.	3.60	SUPPORT, rr. seat to qtr. inr. fil.
72	Pass. (Conv.)	9888553 R.H.	3.60	SUPPORT, rr. seat to qtr. inr. fil.
71-73	Pass. (Sta. Wag.) (9-Pass.)	9847591 1	22.85	SUPPORT ASSY., folding 3rd seat cushion
71-73	Pass. (Sta. Wag.) (9-Pass.)	9846071 L.H.	19.20	SUPPORT ASSY., left folding 3rd seat back on bar
71	Greenbrier, Concours	8727469 L.H.	11.10	SUPPORT ASSY., left third seat on bar
71	Greenbrier, Concours	8727468 R.H.	11.10	SUPPORT ASSY., right third seat on bar
73-74	Chevelle (Sta. Wag.)	9884009 L.H.	3.60	SUPPORT ASSY., piv. lug. compt. panel
73-74	Chevelle (Sta. Wag.)	9884008 R.H.	3.60	SUPPORT ASSY., piv. lug. compt. panel
74-75	Pass. (Sta. Wag.) (9-Pass.)	9675825 L.H.	19.20	SUPPORT ASSY., fldg. 3rd seat back on bar
74-75	Pass. (Sta. Wag.) (9-Pass.)	9731246 1	22.85	SUPPORT ASSY., fldg. 3rd st. bk. lk.
71-72	Pass. (Sta. Wag.) (6-Pass.)			STRIKER, folding 2nd seat back lock,
71-75	Pass. (Sta. Wag.) (9-Pass.)	9839275 A.R.	5.00	right, folding 2nd 1/3 seat back lock, left, folding 2nd 2/3 seat back lock
67-70	Sta. Wag.,			
71-72	Chevelle (Sta. Wag.)	7681730 R.H.	3.25	STRIKER, folding and seat back
71-75	Pass. (Sta. Wag.) (9-Pass.)	9848534 1	1.40	STRIKER, folding 3rd seat back lock— (11.390)
71-74	Vega (Sta. Wag.) (H.B.)	9883704 R.H.	8.45	STRIKER, fldg. rear seat back lock
73-75	Chevelle (Sta. Wag.)	9876523 1	4.65	STRIKER, fldg. 2nd seat back lock
73-75	Nova (H.B.),			
75	Vega (Sta. Wag.) (H.B.)	9619408 R.H.	3.80	STRIKER, fldg. rr. seat back pnl. bumper

**REAR GLASS—SEAT AND ADJUSTER**

**11.620 LINK ASSY.— ARM ASSY.— BOLT— BUMPER— BUSHING— CABLE ASSY.— CATCH— CLIP— COVER— CUSHION ASSY.— ESCUTCHEON— FASTENER— GASKET— GUIDE— HANDLE ASSY.— KIT— LATCH— LOCK ASSY.— PLATE— RETAINER— ROD— SCREW— SLEEVE— SPRING— SUPPORT— STRIKER— STOP— WASHER, Folding Seat (For Load Floor Parts See Group 12.977) (Con't)**

74-75	Pass. (Sta. Wag.) (9-Pass.)	9673672	R.H.	.98	STRIKER, fldg. 3rd seat back filler panel
74-75	Pass. (Sta. Wag.) (9-Pass.)	9673673	L.H.	.98	STRIKER, fldg. 3rd seat back filler panel
71	Pass. (Sta. Wag.) (9-Pass.),				
73-75	Nova (Cpe.) Pass. (Sta. Wag.) (9-Pass.)	9845650	2	.46	STOP, fldg. 2nd 1/3 and 2/3 seat back fil.
71-73	Pass. (Sta. Wag.) (9-Pass.)	9869868	1	.32	STOP, fldg. 3rd seat cushion
72	Pass. (Sta. Wag.) (9-Pass.)	9888551	1	.53	STOP, fldg. 2nd 1/3 seat back
63-65	Chevy, Chevelle (Sta. Wag.),				
65-67	Pass. (Sta. Wag.) w/split seat (exc. Caprice)	4722812	4	.12	WASHER, folding second link to bar
63	Chevy (3 seat Sta. Wag.),				
65-67	Conv.	4574152	2	.12	WASHER, special spring— (14.162)
74	Pass. (Sta. Wag.) (9-Pass.)	9848535	A.R.	.13	WASHER, pass./driver seat bk. inr. and otr. hge./frt.— (11.390)

NOTE 1: Paint as required.

**11.628 FRAME ASSEMBLY— PANEL ASSY., Rear Seat Back, with Springs**

71-72	Chevelle (Spt. Cpe.)	9887104	1	87.25	w/spring rear seat back
70-72	Chevelle (Conv.)	9887129	1	87.25	w/spring rear seat back
71-73	Camaro	9844939	1	87.25	w/spring rear seat back
71-73	Pass. (Sta. Wag.) (6-Pass.)	9828518	1	27.00	fldg. 2nd seat back
71-75	Pass. (Sta. Wag.) (9-Pass.)	9673829	1	22.50	fldg. 2nd 1/3 seat back
71-73	Pass. (Sta. Wag.) (9-Pass.)	9828520	1	22.50	fldg. 2nd 2/3 seat back
73-75	Pass. (Sta. Wag.) (9-Pass.)	9673830	1	22.50	fldg. 2nd 2/3 seat back
73-75	Nova (Cpe.) (exc. H.B.)	1710400	1	35.50	rear seat back (repl. 9623191)
73-75	Nova (Sedan)	9623197	1	35.25	rear seat back
73-75	Chevelle (Sta. Wag.)	9611033	1	11.85	fldg. 2nd seat back
73-75	Chevelle (2-Dr.)	9668808	1	16.35	rear seat back
73-75	Chevelle (Sedan)	9668849	1	13.55	rear seat back
74-75	Pass. (Sta. Wag.)	9677789	1	27.00	fldg. 2nd seat back
74-75	Camaro	9836895	1	35.50	rear seat back
75	Pass. (Sed.)	1669521	1	23.45	rear seat back
75	Impala (Spt. Cpe.) (exc. Custom),				
75	Pass. (Conv.)	1669524	1	12.30	rear seat back
75	Caprice (Spt. Cpe.),				
75	Impala (Custom)	1706114	1	10.70	rear seat back
75	Monza (Towne Cpe.)	1698700	1	35.50	rr. st. bk.
75	Vega (H.B.) (Sta. Wag.), Monza (exc. Towne Cpe.)	1670545	1	19.10	PANEL ASSY., filler

**11.628A CUSHION— BACK ASSY.— FOUNDATION ASSY., Rear Seat Back with Frame, Springs, and Padding (less trim cover)**

68-71	Chevelle (Sed.)	9812441	1	87.25	BACK ASSY., rear seat less cover
71-72	Chevelle (Spt. Cpe.)	9615771	1	86.25	BACK ASSY., fldg. 3rd seat less trim
70	Townsmen, Kingswood (9-Pass.)	9812409	1	82.75	BACK ASSY., rear seat less trim
70-71	Nova (4-Dr.)	9812431	1	89.00	BACK ASSY., rear seat less trim
68-72	Nova (2-Dr.)	9812432	1	87.25	BACK ASSY., rear seat less trim
70	Camaro	9865995	1	86.25	BACK ASSY., rear seat less trim
70	Camaro	9865996	1	86.25	BACK ASSY., rear seat (custom trim)
71-73	Camaro	9662532	1	87.25	BACK ASSY., rear seat less cover
71-72	Chevelle (Conv.)	9615772	1	86.25	BACK ASSY., rear seat less cover
71-74	Pass. (4-Dr.) (exc. Sta. Wag.),				
74	Impala (Spt. Sedan) Caprice (Sedan)	9887242	1	17.10	FOUNDATION ASSY., r/seat back/frmd.
71-74	Pass. (Spt. Cpe., Conv.)	9887209	1	11.85	FOUNDATION ASSY., rear seat back formed
71-73	Pass. (Sta. Wag.) (9-Pass.)	9842058	1	9.40	FOUNDATION ASSY., fldg. 3rd seat back
72	Biscayne (New York Taxi),				
74	Bel Air (Taxi)	9621348	1	17.10	FOUNDATION ASSY., r/seat bk./frmd.
73-75	Chevelle (Sta. Wag.)	9866674	1	9.40	FOUNDATION, folding 3rd seat back frame

**11.629 FILLER— SUPPORT, Rear Seat Back**

70-72	Chevelle (Spt. Cpe.)	7672117	L.H.	2.05	rear seat to qtr. panel
70-72	Chevelle (Spt. Cpe.)	7672116	R.H.	2.05	rear seat to qtr. panel
71-72	Pass. (Spt. Cpe.)				outer panel (paint as required),
71-72	Pass. (Conv.)				qtr. panel,
74-75	Pass. (Conv.)	9855968	R.H.	2.75	rear seat back to qtr. pnl. (prime and paint)
73-75	Pass. (Conv.)	9666186	1	.22	rear/seat back panel extension
74-75	Impala (Custom),				
74-75	Caprice (Spt. Cpe.)	9686054	R.H.	10.60	rear seat to qtr. panel (prime and paint)

**REAR GLASS—SEAT AND ADJUSTER**

**11.629 FILLER— SUPPORT, Rear Seat Back (Con't)**

74-75	Impala (Custom),				
74-75	Caprice (Spt. Cpe.)	9686055	L.H.	10.60	rear seat to qtr. panel (prime and paint) . . . . .
71-72	Pass. (Spt. Cpe.)				outer panel (paint as required) . . . . .
71-72	Pass. (Conv.)				qtr. panel, . . . . .
74-75	Pass. (Conv.)	9855969	L.H.	2.75	rear seat back to qtr. pnl. (prime and paint) .
71-72	Pass. (Spt. Cpe.)				qtr. panel, . . . . .
71-72	Pass. (Conv.)				outer panel (paint as required), . . . . .
73	Pass. (Spt. Cpe., Conv.),				
74-75	Impala (Spt. Cpe.) (exc. Custom)	9854623	L.H.	2.15	rear seat back to qtr. panel (prime and
					paint) . . . . .
71-72	Pass. (Spt. Cpe.)				qtr. panel, . . . . .
71-72	Pass. (Conv.)				outer panel (paint as required) . . . . .
73	Pass. (Spt. Cpe., Conv.),				
74-75	Impala (Spt. Cpe.) (exc. Custom)	9854622	R.H.	2.15	rear seat back to qtr. panel (prime and
					paint) . . . . .
75	Monza (Towne Cpe.)	1717116	R.H.	1.25	upper, to qtr. panel (paint to match) . . . . .
75	Monza (Towne Cpe.)	1717117	L.H.	1.25	upper, to qtr. panel (paint to match) . . . . .
75	Monza (Towne Cpe.)	1717108	R.H.	1.35	lower, to qtr. panel (paint to match) . . . . .
75	Monza (Towne Cpe.)	1717109	L.H.	1.35	lower, to qtr. panel (paint to match) . . . . .
71	Pass. (Conv.),				
73-75	Pass. (Conv.)	9888554	L.H.	3.60	<b>SUPPORT</b> , rear st. to qtr. inner filler . . . . .
71	Pass. (Conv.),				
73-75	Pass. (Conv.)	9888553	R.H.	3.60	<b>SUPPORT</b> , rear st. to qtr. inner filler . . . . .

**11.927 REFLECTOR— HOUSING ASSY.— LAMP PKG.— SOCKET ASSY., Dome Lamp**

62-71	Chevy,				
64-67	Chevelle (exc. Conv., El Camino),				
67-69	Camaro	4866918	1	2.10	
68	Chevelle (Sta. Wag.) (9-Pass.),				
69-72	Concours (9-Pass.)	4650248	L.H.	6.80	courtesy lamp . . . . .
65-67	Pass. (Spt. Sed.),				
67	Pass. (Spt. Cpe.)	4826802	2	9.20	side roof rail lamp w/socket, rear compt.
					lamp . . . . .
65-66	Impala (Spt. Cpe.),				
65-66	Caprice (Spt. Mdls.),				
67	Camaro (Spt. Cpe.) (Deluxe)	4765599	2	4.80	rear quarter corner lamp . . . . .
68-70	Chevelle (exc. El Camino, Conv.)	7731129	1	4.50	
68-75	El Camino	8732781	1	5.10	
68	Pass. (exc. Conv.)	7742509	1	1.45	
69-70	Pass., Camaro (exc. Conv.),				
71	Nova	8732778	1	4.40	
71-75	All (exc. Conv., El Camino),				
71-74	Vega,				
75	Vega (Sta. Wag.) (Panel) w/bk.				
	body ctsy. lamp	8732779	1	4.20	
73-74	Nova (H.B.)	9835738	L.H.	3.55	rear compt. ctsy. lamp . . . . .
75	Nova (H.B.)	9835739	1	3.35	rear compt. ctsy. lamp . . . . .
73-74	Chevelle (Sta. Wag.) w/rear seat				
	assy.	8788109	1	10.00	<b>REFLECTOR ASSY.</b> , bk. body opening hdr.
					ctsy. lamp . . . . .
73-74	Pass. (exc. Conv.)	8780505	1	16.85	<b>REFLECTOR ASSY.</b> , w/dome & reading
					lamp . . . . .
75	Pass., Chevelle	1695626	1	16.85	<b>REFLECTOR ASSY.</b> , dome & reading lamp .
75	Chevelle (Sta. Wag.), Vega (Sta.				
	Wag., Panel) w/rear seat asm.	1699923	1	10.00	<b>REFLECTOR</b> , back body opening header
					courtesy lamp . . . . .
73-74	Pass. (exc. Conv.)	8780506	1	18.55	<b>HOUSING ASSY.</b> , w/dome & read. lamp . . .
75	Pass., Chevelle	1695635	1	18.95	<b>HOUSING ASSY.</b> , w/dome & read. lamp . . .
73-75	Chevelle (exc. sun roof)	981911	1	8.75	<b>LAMP PKG.</b> , map lamp . . . . .
65-67	Impala (exc. Conv.),				
67	Caprice (exc. Sta. Wag.)				<b>SOCKET ASSY.</b> , side roof rail lamp, . . . . .
66	Caprice (exc. Sta. Wag.)				courtesy rear compt., . . . . .
67	Camaro (Spt. Cpe.)	4234956	2	2.30	rear quarter corner lamp . . . . .

**11.928 RIM— LENS, Dome Lamp**

64-67	El Camino	4577221	1	1.05	
65-67	Pass. (Sedan) (exc. Spt. Sed.),				
65-67	Pass. (Sta. Wag.),				
68	Pass. (exc. Conv.)	4156597	1	1.65	w/o lens (5 1/4" dia.) . . . . .
65-67	Pass. (Spt. Sed.),				
67	Caprice,				
67	Pass. (Spt. Cpe.)	4826802	2	9.20	
62-70	Nova,				
65-67	Chevelle (exc. Conv., El Camino),				

**REAR GLASS—SEAT AND ADJUSTER**

<b>11.928 RIM— LENS, Dome Lamp (Con't)</b>					
67-69	Camaro (Spt. Cpe.)	6279669	1	1.25	LENS, dome lamp
68-75	El Camino	7731130	1	.96	LENS, dome lamp
68-70	Chevelle (exc. Conv. & El Camino)	7731128	1	1.15	LENS, dome lamp
65-68	Pass. (Sta. Wag.) (9-Pass.),				
68	Chevelle (Sta. Wag.) (9-Pass.)				LENS, rear corner lamp side roof rail lamp,
69-72	Concours (9-Pass.),				
70	Pass. (Sta. Wag.) (9-Pass.)	4605664	L.H.	1.05	qtr. courtesy lamp
65-67	Pass. (exc. Spt. Mdls.),				
68	Pass. (exc. Conv.)	5711725	1	1.20	LENS (3 <sup>3</sup> / <sub>4</sub> " dia.)
65-68	Impala (Spt. Sed.),				
67	Pass. (Spt. Cpe.)	4837868	A.R.	1.05	LENS, side roof rail dome lamp, rear compt. lamp
65-66	Caprice,				
65-66	Impala (Spt. Cpe.),				
67	Camaro (Spt. Cpe.) (Deluxe)	4765600	2	1.10	LENS, rear quarter corner lamp
69-70	Pass., Camaro (exc. Conv.)	8732776	1	1.10	LENS
71-75	All (exc. Conv., El Camino)	8732777	1	1.05	LENS
71-75	Vega	8732777	1	1.05	LENS
73-75	Pass. (exc. Conv.)	8780507	1	.70	LENS, w/dome and reading lamp (white)
73-75	Chevelle (Sta. Wag.) w/rr. seat assy.	8788120	1	1.30	LENS, back body opening hdr. ctsy. lr.
73-74	Nova (2-Dr.)	8770219	L.H.	.58	LENS, rear compt. ctsy. lamp
75	Nova (H.B.)	1676593	L.H.	.55	LENS, rear compt. ctsy. lamp
75	Vega (Sta. Wag.) (Panel) w/bk. body ctsy. lamp	8788120	1	1.30	LENS
<b>11.935 SWITCH, Dome Lamp</b>					
65-68	Sta. Wag. (9-Pass.)	4673705	1	1.35	left, qtr. courtesy lamp
69-70	Sta. Wag. (9-Pass.),				
71-72	Concours (9-Pass.),				
75	Nova (H.B.)	8751802	L.H.	1.35	lamp
<b>11.938 ESCUTCHEON, Dome Lamp Switch</b>					
65-72	Sta. Wag. (9-Pass.)	4767829	1	3.55	qtr. switch and courtesy lamp
<b>11.950 SWITCH— NUT— GROMMET, Dome Lamp Door Jamb</b>					
64	Chevelle (Taxi)	4826444	2	1.30	front door
62	Chevy	6276718	2	1.25	
63	Chevy,				front door,
64-69	Chevelle, Camaro				front and rear door,
65-69	Taxi				rear,
65-69	Caprice (exc. Spt. Cpe.)				
70	Pass., Chevelle, Nova, Camaro,				
71-72	Nomad				front and rear (R.H. or L.H.),
73-74	Nova	4891633	A.R.	1.35	frt. dr. R.H. rear dr.
64-65	Chevy (Taxi)				front and rear door,
64-67	Nova				front door,
67	Chevy (Std.)	4889278	A.R.	.87	front door
68-70	Pass., Chevelle, Nova, Camaro,				
71-75	Camaro, Chevelle, Nova,				
73-75	Pass.	9662504	A.R.	.93	dome lamp, frt. door jamb
71	Chevelle (2-Dr.) (exc. El Camino)	9847950	2	1.20	front door jamb
71	Pass.,				
71-72	Caprice,				
71	Biscayne, Bel Air (Taxi)				rear door jamb,
73-75	Pass., Chevelle,				
75	Nova	9662505	R.H.	.70	frt. door jamb (rear door R.H., L.H.)
71-75	Vega, Monza	9816526	1	1.15	front door jamb switch
73	Vega, Monza	354745	1	1.65	parking brake and seat belt warning alarm
74-75	Vega, Monza	354745	1	1.65	park. brake alarm
70	Pass., Chevelle (2-Dr.) (exc. El Camino)	7235968	A.R.	.11	NUT, front door jamb switch
71-73	Vega, Monza	9836246	1	.39	GROMMET, front door jamb switch



# CHEVROLET BODY GROUP 12.000



## BODY MOLDINGS — SHEET METAL

### ALPHABETICAL INDEX

<b>A</b>			
APPLIQUE, Gas Tank Filler Neck Compartment.....	12.945		
ARMATURE, Tailgate.....	12.195		
<b>B</b>			
BAR ASSY., Front Door Outer.....	12.895		
BAR ASSY., Rear Compartment Floor.....	12.981		
BAR ASSY., Rear Door Outer.....	12.913		
BAR, Rear Compartment End.....	12.986		
BASE, Roof Luggage and Ski.....	12.815		
BEZEL, Rear Quarter Outer.....	12.940A		
BEZEL, Tailgate.....	12.195		
BLADE ASSY., Tail Gate.....	12.180B		
BOLT ASSY., Rear Compartment Lid or Tailgate Hinge.....	12.187		
BOLT, Luggage Compartment.....	12.977		
BOLT, Rear Compartment Front and Shelf.....	12.971		
BOLT, Rear Compartment Lid.....	12.184		
BOLT, Tail Gate.....	12.184A		
BOLT, Tailgate.....	12.195		
BOW, Roof.....	12.952		
BOX ASSY., Rear Compartment Lid.....	12.184		
BOX, Floor (less Rear Compartment Floor Pan).....	12.980		
BRACE ASSY., Dash to Chassis Frame.....	12.650		
BRACE, Center Body.....	12.491		
BRACE, Folding Top Compartment (See Group 15.100 for TRIM ASSY.).....	12.989		
BRACE, Hinge Pillar to Floor.....	12.659		
BRACE, Lock Pillar.....	12.684		
BRACE, Rear Quarter Side Inner.....	12.941A		
BRACE, Rear Compartment End.....	12.986		
BRACE, Rear Compartment Floor.....	12.981		
BRACE, Rear Compartment Lid.....	12.996		
BRACE, Wheelhouse.....	12.944		
BRACKET, Back Door Reveal.....	12.180C		
BRACKET, Cowl.....	12.803		
BRACKET, Roof Luggage and Ski.....	12.815		
BRACKET, Tail Gate.....	12.180B		
BRACKET, Tailgate.....	12.195		
BREAKER ASSY., Tailgate.....	12.195		
BUMPER, Ash Receiver.....	12.009		
BUMPER, Body Back Lower (Rear End).....	12.966		
BUMPER, End Gate Lock.....	12.237A		
BUMPER, End Gate Rear Door.....	12.242A		
BUMPER, Front Door Outer Panel.....	12.112		
BUMPER, Gas Tank Filler Neck Compartment.....	12.945		
BUMPER, Load Floor (for Folding Seat Parts see Group 11.620).....	12.977		
BUMPER, Load Floor.....	12.975		
BUMPER, Rear Compartment.....	12.212		
BUMPER, Spare Tire Cover.....	12.579		
BUMPER, Tail Gate.....	12.180B		
BUMPER, Tail Gate.....	12.180		
BUMPER, Tail Gate.....	12.184A		
BUMPER, Tailgate.....	12.195		
		BUSHING, Load Floor.....	12.975
		BUSHING, Tail Gate.....	12.184A
		<b>C</b>	
		CABLE ASSY., Load Floor (for Folding Seat Parts see Group 11.620).....	12.977
		CABLE ASSY., Tail Gate.....	12.180B
		CABLE ASSY., Tail Gate.....	12.180
		CABLE ASSY., Tailgate.....	12.195
		CAM ASSY., Tail Gate.....	12.180
		CAM, Rear Compartment Lock Handle.....	12.252
		CAP, Load Floor (for Folding Seat Parts see Group 11.620).....	12.977
		CAP, Luggage Deck Lid.....	12.815B
		CAP, Roof Drip.....	12.075
		CAP, Roof Luggage and Ski.....	12.815
		CAP UNIT, Rear Quarter Outer.....	12.940A
		CAP UNIT, Tail and Stop Lamp.....	12.943
		CARRIER UNIT, Roof Luggage and Ski.....	12.815
		CATCH ASSY., Spare Tire Cover.....	12.579
		CATCH, Luggage Compartment.....	12.977
		CHANNEL ASSY., Back Door Reveal.....	12.180C
		CHANNEL, Tail Gate.....	12.180
		CLAMP, Roof Luggage and Ski.....	12.815
		CLAMP, Sliding Sun Roof.....	12.809
		CLIP.....	12.971
		CLIP, Ash Tray.....	12.012
		CLIP ASSY., Body Rear Panel.....	12.121
		CLIP ASSY., Rear Compartment Lid.....	12.183
		CLIP ASSY., Tail Gate.....	12.180B
		CLIP, Back Body Opening.....	12.968
		CLIP, Belt Moulding, Door and Quarter Mldg. Attaching Parts.....	12.118
		CLIP, Body Back Lower (Rear End).....	12.966
		CLIP, Cowl Side.....	12.804
		CLIP, End Gate Lock Handle.....	12.247A
		CLIP, End Gate Rear Door.....	12.242A
		CLIP, End Gate.....	12.203
		CLIP, Front Door Outer Panel.....	12.112
		CLIP, Headlining Wire.....	12.954
		CLIP, Load Floor (for Folding Seat Parts see Group 11.620).....	12.977
		CLIP, Rear Compartment Lid or Tailgate Hinge.....	12.187
		CLIP, Rear Compartment Lid.....	12.183
		CLIP, Rear Door Outer Panel.....	12.114
		CLIP, Roof Drip.....	12.075
		CLIP, Roof Ski.....	12.815A
		CLIP, Sliding Sun Roof.....	12.809
		CLIP, Spare Tire Cover.....	12.579
		CLIP, Tail Gate.....	12.180
		CLIP, Tailgate.....	12.195
		CLIP, Top Roof Outer.....	12.810
		CLUTCH, Tailgate.....	12.195
		CONDUCTOR ASSY., Ash Tray.....	12.016
		CONDUIT ASSY, Tail Gate.....	12.180B
		CONDUIT, Sliding Sun Roof.....	12.809
		CONDUIT, Tailgate.....	12.195
		CONTROL ASSY., Rear Compartment Lid Opener.....	12.243



## ALPHABETICAL INDEX

CONTROL, End Gate Rear Door.....	12.242A
COUPLING ASSY., Rear Compartment Lid Opener.....	12.243
COVER.....	12.971
COVER ASSY., Spare Tire Cover.....	12.579
COVER, Back Body Opening.....	12.968
COVER, Cowl Side.....	12.804
COVER, Door Rocker.....	12.934
COVER, End Gate Rear Door.....	12.242A
COVER, End Gate.....	12.203
COVER, Floor (less Rear Compartment Floor Pan).....	12.980
COVER, Folding Top Compartment (See Group 15.100 for TRIM ASSY.).....	12.989
COVER, Gas Tank Filler Neck Compartment..	12.945
COVER, Load Floor (for Folding Seat Parts see Group 11.620).....	12.977
COVER, Rear Compartment (Less Hardware)..	12.181
COVER, Rear Compartment End.....	12.986
COVER, Rear Compartment Floor.....	12.981
COVER, Rear Compartment Lid and Rear End Panel.....	12.182
COVER, Rear Compartment Lid or Tailgate Hinge.....	12.187
COVER, Rear Quarter Side Inner.....	12.941A
COVER, Roof Panel.....	12.812
COVER, Tail Gate.....	12.180
COVER, Tailgate.....	12.195
COVER, Top Roof Outer.....	12.810
COVER UNIT, Roof Luggage and Ski.....	12.815
COVER UNIT, Roof Ski.....	12.815A
COVER, Wheelhouse.....	12.944
CROSSMEMBER, Roof Luggage and Ski.....	12.815
CYLINDER ASSY., Load Floor (For Folding Seat Parts See Group 11.620).....	12.977
CYLINDER ASSY., Luggage Compartment.....	12.977
CYLINDER ASSY., Rear Compartment Lid Opener.....	12.243
CYLINDER ASSY., Tailgate.....	12.195
CYLINDER, Rear Compartment or Tail Gate Lock.....	12.248

### D

DECAL, Back Door Reveal.....	12.180C
DECAL, Rear Compartment Lid and Rear End Panel.....	12.182
DEFECTOR ASSY., Tail Gate.....	12.180B
DEFECTOR UNIT, Tail Gate.....	12.180B
DEFLECTOR, Back Door Reveal.....	12.180C
DEFLECTOR, Cowl Side.....	12.804
DEFLECTOR, Rear Quarter Outer.....	12.940A
DEFLECTOR, Rear Quarter Side Inner.....	12.941A
DEFLECTOR, Sliding Sun Roof.....	12.809
DEFLECTOR, Top Roof Outer.....	12.810
DOOR ASM., Gas Tank Filler Neck Compartment.....	12.945
DOOR ASSY., Lower End (Less Hardware).....	12.179
DRIVER, Tailgate.....	12.195

### E

EMBLEM ASSY., Roof Panel.....	12.812
EMBLEM, Rear Compartment Lid and Rear End Panel.....	12.182
EMBLEM, Tail Gate.....	12.180
EMBLEM UNIT.....	12.116A
EMBLEM UNIT, Rear Compartment Lid and Rear End Panel.....	12.182
EMBLEM UNIT, Roof Panel.....	12.812
ESCUTCHEON ASSY., End Gate Lock Handle.....	12.247A
ESCUTCHEON ASSY., Rear Compartment Lid Lock Cylinder.....	12.249
ESCUTCHEON ASSY.....	12.116A
ESCUTCHEON UNIT, Body Rear Panel.....	12.121
ESCUTCHEON, Ash Tray.....	12.048
ESCUTCHEON, Back Door Reveal.....	12.180C

ESCUTCHEON, End Gate Rear Door.....	12.242A
ESCUTCHEON, Load Floor.....	12.976
ESCUTCHEON, Luggage Compartment.....	12.977
ESCUTCHEON, Roof Drip.....	12.075
ESCUTCHEON, Tail Gate.....	12.180
ESCUTCHEON, Tail Gate.....	12.184A
ESCUTCHEON, Tailgate.....	12.195
EXTENSION UNIT.....	12.116A
EXTENSION, Back Body Opening.....	12.968
EXTENSION, Body Back Lower (Rear End)....	12.966
EXTENSION, Center Body.....	12.491
EXTENSION, Cowl Side.....	12.804
EXTENSION, Dash to Chassis Frame.....	12.650
EXTENSION, Door Rocker.....	12.934
EXTENSION, Lock Pillar.....	12.684
EXTENSION, Rear Body Lock Pillar.....	12.942
EXTENSION, Rear Compartment (Less Hardware).....	12.181
EXTENSION, Rear Compartment End.....	12.986
EXTENSION, Rear Compartment Floor.....	12.981
EXTENSION, Rear Compartment Front and Shelf.....	12.971
EXTENSION, Rear Compartment Lid.....	12.996
EXTENSION, Rear Quarter Outer.....	12.940A
EXTENSION, Rear Quarter Side Inner.....	12.941A
EXTENSION, Roof Drip.....	12.075
EXTENSION, Roof Luggage and Ski.....	12.815
EXTENSION, Spare Tire Cover.....	12.579
EXTENSION, Wheelhouse.....	12.944

### F

FASTENER, End Gate.....	12.269A
FASTENER, Top Roof Outer.....	12.810
FILLER ASSY., Tailgate.....	12.195
FILLER, Back Body Opening.....	12.968
FILLER, Body Back Lower (Rear End).....	12.966
FILLER, Cowl Ventilator.....	12.800
FILLER, Gas Tank Filler Neck Compartment..	12.945
FILLER, Load Floor.....	12.975
FILLER, Rear Body Lock Pillar.....	12.942
FILLER, Rear Compartment End.....	12.986
FILLER, Rear Compartment Floor.....	12.981
FILLER, Rear Quarter Outer.....	12.940A
FILLER, Rear Quarter Side Inner.....	12.941A
FILLER, Spare Tire Cover.....	12.579
FILLER, Tail Gate.....	12.180B
FILLER, Wheelhouse.....	12.944
FILTER, Rear Compartment (Less Hardware)..	12.181
FOUNDATION, Spare Tire Cover.....	12.579
FRAME ASSY., Windshield Upper & Lower....	12.807
FRAME, Rear Compartment Floor.....	12.981
FRAME, Windshield Side.....	12.808

### G

GASKET, Back Door Reveal.....	12.180C
GASKET, End Gate Lock Handle.....	12.247A
GASKET, Luggage Compartment.....	12.977
GASKET, Rear Body Lock Pillar.....	12.942
GASKET, Rear Compartment Lid Lock Cylinder.....	12.249
GASKET, Rear Compartment Lid Lock.....	12.247
GASKET, Rear Compartment Lid Opener.....	12.243
GASKET, Rear Quarter Side Inner.....	12.941A
GASKET, Roof Luggage and Ski.....	12.815
GASKET, Tail and Stop Lamp.....	12.943
GASKET, Tail Gate or Rear Door Lock Cylinder.....	12.249A
GASKET, Tail Gate.....	12.180B
GASKET, Tailgate.....	12.195
GATE ASSY., Lower End (Less Hardware).....	12.179
GLASS, Tail Gate.....	12.180
GRILLE, Cowl Ventilator.....	12.800
GRILLE, Rear Quarter Side Inner.....	12.941A
GROMMET, End Gate.....	12.203
GROMMET, Rear Compartment Lid or Tailgate Hinge.....	12.187

## ALPHABETICAL INDEX

GROMMET, Sliding Sun Roof.....	12.809
GUARD, Rear Compartment Lid Lock Cylinder.....	12.249
GUIDE ASSY., Tail Gate.....	12.180B
GUIDE, End Gate Lock.....	12.237A
GUTTER, Rear Compartment Lid.....	12.996

### H

HANDLE, Ash Receiver.....	12.009
HANDLE ASSY., Load Floor (For Folding Seat Parts See Group 11.620).....	12.977
HANDLE, End Gate Rear Door.....	12.242A
HANDLE, Tailgate.....	12.195
HARNES ASSY., Rear Compartment Lid Opener.....	12.243
HINGE ASSY., Load Floor (For Folding Seat Parts See Group 11.620).....	12.977
HINGE ASSY., Rear Compartment Lid.....	12.184
HINGE ASSY., Tail Gate.....	12.184A
HINGE, Tail Gate.....	12.184A
HOLDER, Tailgate.....	12.195
HOSE, Gas Tank Filler Neck Compartment.....	12.945
HOSE, Sliding Sun Roof.....	12.809
HOUSING ASSY., Rear Compartment Floor....	12.981
HOUSING ASSY., Sliding Sun Roof.....	12.809
HOUSING, Gas Tank Filler Neck Compartment.....	12.945
HOUSING, Rear Compartment End.....	12.986
HOUSING, Rear Compartment Lid Lock Cylinder.....	12.249
HOUSING, Rear Compartment Lock Handle...	12.252
HOUSING, Tailgate.....	12.195

### I

INSULATOR, Floor (less Rear Compartment Floor Pan).....	12.980
INSULATOR, Roof Luggage and Ski.....	12.815

### K

KNOB, Tailgate.....	12.195
---------------------	--------

### L

LACE, Hood Ledge (Cowl).....	12.801
LACE, Roof Drip.....	12.075
LATCH.....	12.971
LATCH ASSY., End Gate Rear Door.....	12.242A
LID ASSY., Rear Compartment (Less Hardware).....	12.181
LID, Rear Compartment (Less Hardware).....	12.181
LINK ASSY., Rear Compartment Lid or Tailgate Hinge.....	12.187
LINK, Rear Compartment Lid or Tailgate Hinge.....	12.187
LOCK ASSY., Rear Compartment or Tail Gate Lock.....	12.248
LOCK ASSY., Rear Compartment Lid Opener.	12.243
LOCK ASSY., Rear Compartment Lid.....	12.242
LOCK, End Gate Rear Door.....	12.242A
LOUVER, Quarter Stationary Window.....	12.811
LOUVER, Rear Body Lock Pillar.....	12.942
LOUVER, Roof Panel.....	12.812

### M

MOLDING, Back Body Opening.....	12.968
---------------------------------	--------

MOLDING, Gas Tank Filler Neck Compartment.....	12.945
MOLDING, Load Floor.....	12.976
MOTOR ASSY., Tailgate.....	12.195
MOULDING.....	12.971
MOULDING ASSY., Rear Compartment Lid and Rear End Panel.....	12.182
MOULDING ASSY., Tailgate.....	12.195
MOULDING, Back Body Opening.....	12.180A
MOULDING, Back Door Reveal.....	12.180C
MOULDING, Center Pillar Scalp.....	12.113
MOULDING, Console.....	12.240
MOULDING, Front Door Outer Panel.....	12.112
MOULDING, Rear Body Lock Pillar.....	12.942
MOULDING, Rear Door Outer Panel.....	12.114
MOULDING, Roof Drip.....	12.075
MOULDING, Roof Panel.....	12.812
MOULDING, Tail Gate.....	12.180
MOULDING UNIT, Back Door Reveal.....	12.180C
MOULDING UNIT, Body Rear Panel.....	12.121
MOULDING UNIT, Front Door Outer Panel....	12.112
MOULDING UNIT, Rear Compartment Lid and Rear End Panel.....	12.182
MOULDING UNIT, Rear Fender Outer Panel..	12.116

### N

NUT.....	12.971
NUT ASSY., Back Door Reveal.....	12.180C
NUT ASSY., Rear Compartment Lid and Rear End Panel.....	12.182
NUT ASSY., Tail Gate.....	12.180B
NUT, Belt Moulding, Door and Quarter Mldg. Attaching Parts.....	12.118
NUT, End Gate Lock.....	12.237A
NUT, End Gate.....	12.203
NUT, Gas Tank Filler Neck Compartment.....	12.945
NUT, Rear Compartment Emblem.....	12.246
NUT, Rear Compartment Lid.....	12.183
NUT, Roof Luggage and Ski.....	12.815
NUT, Tail Gate.....	12.180
NUT, Tail Gate.....	12.184A
NUT, Tailgate.....	12.195

### O

ORNAMENT.....	12.116A
ORNAMENT, Front Door Outer Panel.....	12.112
ORNAMENT, Rear Door Outer Panel.....	12.114
ORNAMENT, Tail Gate.....	12.180

### P

PACKAGE ASSY., Tailgate.....	12.195
PAN ASSY., Rear Compartment Floor.....	12.981
PANEL ASSY., Door Rocker.....	12.934
PANEL ASSY., Front Door Outer.....	12.895
PANEL ASSY., Rear Quarter Side Inner.....	12.941
PANEL ASSY., Sliding Sun Roof.....	12.809
PANEL, Back Body Opening.....	12.968
PANEL, Back Window Inner.....	12.964
PANEL, Body Back Lower (Rear End).....	12.966
PANEL, Cowl Side.....	12.804
PANEL, Folding Top Compartment (See Group 15.100 for TRIM ASSY.).....	12.989
PANEL, Front Body Hinge.....	12.840
PANEL, Front Door Outer.....	12.895
PANEL, Gas Tank Filler Neck Compartment...	12.945
PANEL, Load Floor.....	12.975
PANEL, Lower End (Less Hardware).....	12.179
PANEL, Rear Body Lock Pillar.....	12.942
PANEL, Rear Compartment Floor.....	12.981
PANEL, Rear Compartment Front and Shelf...	12.971
PANEL, Rear Door Outer.....	12.913
PANEL, Rear Quarter Outer.....	12.940A

# ALPHABETICAL INDEX

PANEL, Rear Quarter Side Inner.....	12.941
PANEL, Rear Quarter Side Outer (Outer Panel Only).....	12.940
PANEL, Spare Tire Cover.....	12.579
PANEL, Tailgate.....	12.195
PANEL, Top Roof Outer.....	12.810
PANEL, Wheelhouse.....	12.944
PAWL ASSY., Tailgate.....	12.195
PAWL, Luggage Compartment.....	12.977
PAWL, Rear Compartment Lid Lock Cylinder.....	12.249
PILLAR ASSY., Center Body.....	12.491
PIN, Luggage Deck Lid.....	12.815B
PIN, Rear Compartment Hinge, Tail Gate.....	12.186
PIN, Rear Compartment Lid or Tailgate Hinge.....	12.187
PIN, Rear Compartment Lid.....	12.184
PIN, Tailgate.....	12.195
PLATE, Ash Receiver.....	12.009
PLATE ASSY., Back Door Reveal.....	12.180C
PLATE ASSY., Cowl Side.....	12.804
PLATE ASSY., Cowl.....	12.803
PLATE ASSY., Roof Panel.....	12.812
PLATE ASSY., Wheelhouse.....	12.944
PLATE ASSY.....	12.116A
PLATE, Door Rocker.....	12.934
PLATE, End Gate Lock.....	12.237A
PLATE, Floor (less Rear Compartment Floor Pan).....	12.980
PLATE, Luggage Compartment.....	12.977
PLATE, Luggage Deck Lid.....	12.815B
PLATE, Rear Body Lock Pillar.....	12.942
PLATE, Rear Compartment End.....	12.986
PLATE, Rear Compartment Floor.....	12.981
PLATE, Rear Compartment Lid and Rear End Panel.....	12.182
PLATE, Rear Compartment Lid or Tailgate Hinge.....	12.187
PLATE, Rear Compartment Lid Lock Cylinder.....	12.249
PLATE, Rear Compartment Lid Lock.....	12.237
PLATE, Rear Quarter Side Inner.....	12.941A
PLATE, Roof Panel.....	12.812
PLATE, Spare Tire Cover.....	12.579
PLATE, Tail and Stop Lamp.....	12.943
PLATE, Tail Gate.....	12.180
PLATE, Tailgate.....	12.195
PLATE UNIT, Roof Panel.....	12.812
PLATE UNIT.....	12.116A
PLUG, Center Body.....	12.491
PLUG, Cowl Side.....	12.804
PLUG, End Gate Rear Door.....	12.242A
PLUG, Floor (less Rear Compartment Floor Pan).....	12.980
PLUG, Front Body Hinge.....	12.840
PLUG, Rear Body Lock Pillar.....	12.942
PLUG, Rear Compartment (Less Hardware).....	12.181
PLUG, Rear Compartment End.....	12.986
PLUG, Rear Compartment Floor.....	12.981
PLUG, Rear Compartment.....	12.212
PLUG, Rear Quarter Side Inner.....	12.941A
PLUG, Tail Gate.....	12.180B
PLUG, Wheelhouse.....	12.944
POCKET ASSY., Gas Tank Filler Neck Compartment.....	12.945
POCKET, Rear Compartment Floor.....	12.981
POCKET, Tail and Stop Lamp.....	12.943

## R

RACK ASSY., Luggage Deck Lid.....	12.815B
RACK ASSY., Roof Ski.....	12.815A
RACK UNIT, Roof Ski.....	12.815A
RACK UNIT, Roof Luggage and Ski.....	12.815
RAIL ASSY., Side Roof-Outer.....	12.956
RAIL, Rear Compartment End.....	12.986
RAIL, Rear Quarter Belt-Outer.....	12.428
RAIL, Roof Luggage and Ski.....	12.815
RAIL, Side Roof-Inner.....	12.957
RAIL UNIT, Top Roof Outer.....	12.810
REGULATOR ASSY., Tail Gate.....	12.184A
REGULATOR ASSY., Tailgate.....	12.195
REINFORCEMENT, Back Body Opening.....	12.968

REINFORCEMENT, Body Back Lower (Rear End).....	12.966
REINFORCEMENT, Center Body.....	12.491
REINFORCEMENT, Cowl Side.....	12.804
REINFORCEMENT, Dash to Chassis Frame.....	12.650
REINFORCEMENT, Door Rocker.....	12.934
REINFORCEMENT, Floor (less Rear Compartment Floor Pan).....	12.980
REINFORCEMENT, Hinge Pillar to Floor.....	12.659
REINFORCEMENT, Rear Body Lock Pillar.....	12.942
REINFORCEMENT, Rear Compartment End.....	12.986
REINFORCEMENT, Rear Compartment Floor.....	12.981
REINFORCEMENT, Rear Compartment Front and Shelf.....	12.971
REINFORCEMENT, Rear Quarter Outer.....	12.940A
REINFORCEMENT, Rear Quarter Side Inner.....	12.941A
REINFORCEMENT, Top Roof Outer.....	12.810
REINFORCEMENT, Wheelhouse.....	12.944
RELEASE UNIT, Rear Compartment Lid Opener.....	12.243
RETAINER, Ash Receiver.....	12.009
RETAINER, Ash Tray Anti-Rattle.....	12.050
RETAINER, Ash Tray.....	12.012
RETAINER, Back Body Opening.....	12.968
RETAINER, Belt Moulding, Door and Quarter Midg. Attaching Parts.....	12.118
RETAINER, Body Back Lower (Rear End).....	12.966
RETAINER, End Gate Rear Door.....	12.242A
RETAINER, End Gate.....	12.269A
RETAINER, Floor (less Rear Compartment Floor Pan).....	12.980
RETAINER, Gas Tank Filler Neck Compartment.....	12.945
RETAINER, Hood Ledge (Cowl).....	12.801
RETAINER, Load Floor (For Folding Seat Parts See Group 11.620).....	12.977
RETAINER, Load Floor.....	12.975
RETAINER, Luggage Compartment.....	12.977
RETAINER, Rear Compartment Floor.....	12.981
RETAINER, Rear Compartment Lid or Tailgate Hinge.....	12.187
RETAINER, Rear Compartment Lid Lock Cylinder.....	12.249
RETAINER, Rear Compartment Lid.....	12.183
RETAINER, Rear Compartment Lid.....	12.269
RETAINER, Rear Quarter Side Inner.....	12.941A
RETAINER, Roof Drip.....	12.075
RETAINER, Roof Luggage and Ski.....	12.815
RETAINER, Spare Tire Cover.....	12.579
RETAINER, Tail Gate or Rear Door Lock Cylinder.....	12.249A
RETAINER, Tail Gate.....	12.180B
RETAINER, Tail Gate.....	12.180
RETAINER, Tailgate.....	12.195
RETAINER, Top Roof Outer.....	12.810
RING, Tailgate.....	12.195
RIVET, End Gate Rear Door.....	12.242A
RIVET, Rear Compartment Lid Lock Cylinder.....	12.249
ROD, End Gate Rear Door.....	12.242A
ROD, Rear Compartment Lid or Tailgate Hinge.....	12.187
ROD, Rear Compartment Lid.....	12.184
ROLLER ASSY., Rear Compartment Lid or Tailgate Hinge.....	12.187
ROLLER ASSY., Tail Gate.....	12.180B
ROLLER, Rear Compartment Lid or Tailgate Hinge.....	12.187
ROLLER, Tailgate.....	12.195

## S

SCALP, Roof Drip.....	12.075
SCREEN, Cowl Ventilator.....	12.800
SCREW, Back Door Reveal.....	12.180C
SCREW, Belt Moulding, Door and Quarter Midg. Attaching Parts.....	12.118
SCREW, End Gate Lock.....	12.237A
SCREW, End Gate Rear Door.....	12.242A
SCREW, End Gate.....	12.203
SCREW, Luggage Deck Lid.....	12.815B

# ALPHABETICAL INDEX

SCREW, Rear Compartment Lid or Tailgate Hinge.....	12.187	STRIP, Hood Ledge (Cowl).....	12.801
SCREW, Rear Compartment Lid Lock.....	12.237	STRIP, Rear Quarter Side Inner.....	12.941A
SCREW, Rear Compartment Lid.....	12.183	STRIP, Roof Drip.....	12.075
SCREW, Rear Compartment Lid.....	12.184	STRIP, Tailgate.....	12.195
SCREW, Rear Compartment Lid.....	12.242	STUD, End Gate.....	12.203
SCREW, Roof Drip.....	12.075	STUD, Sliding Sun Roof.....	12.809
SCREW, Roof Luggage and Ski.....	12.815	SUPPORT ASSEMBLY, End Gate.....	12.203
SCREW, Tail Gate.....	12.180B	SUPPORT ASSY., End Gate Lock.....	12.237A
SCREW, Tail Gate.....	12.180	SUPPORT, Back Body Opening.....	12.968
SCREW, Tail Gate.....	12.184A	SUPPORT, Body Back Lower (Rear End).....	12.966
SCREW, Tailgate.....	12.195	SUPPORT, Cowl Side.....	12.804
SCREW, Trim.....	12.946	SUPPORT, Dash to Chassis Frame.....	12.650
SEAL, Cowl Ventilator.....	12.800	SUPPORT, Dome Lamp.....	12.953
SEAL, Hood Ledge (Cowl).....	12.801	SUPPORT, Door Rocker.....	12.934
SEALING, Load Floor (For Folding Seat Parts See Group 11.620).....	12.977	SUPPORT, Floor (less Rear Compartment Floor Pan).....	12.980
SEALING STRIP, Floor (less Rear Compartment Floor Pan).....	12.980	SUPPORT, Front Body Hinge.....	12.840
SEALING STRIP, Rear Compartment Floor.....	12.981	SUPPORT, Gas Tank Filler Neck Compartment.....	12.945
SEALING STRIP, Rear Compartment Front and Shelf.....	12.971	SUPPORT, Headlining Wire.....	12.954
SEALING STRIP, Top Roof Outer.....	12.810	SUPPORT, Load Floor (for Folding Seat Parts see Group 11.620).....	12.977
SHAFT, Rear Compartment Lock Handle.....	12.252	SUPPORT, Luggage Deck Lid.....	12.815B
SLEEVE, Luggage Deck Lid.....	12.815B	SUPPORT, Rear Compartment End.....	12.986
SLIDERS UNIT, Top Roof Outer.....	12.810	SUPPORT, Rear Compartment Floor.....	12.981
SOCKET, Ash Tray.....	12.012	SUPPORT, Rear Compartment Lid or Tailgate Hinge.....	12.187
SOCKET ASSY., Ash Tray.....	12.016	SUPPORT, Rear Compartment Lid.....	12.184
SOLENOID ASSY., Rear Compartment Lid Opener.....	12.243	SUPPORT, Rear Quarter Outer.....	12.940A
SPACER, Back Window Inner.....	12.964	SUPPORT, Rear Quarter Side Inner.....	12.941A
SPACER, Body Back Lower (Rear End).....	12.966	SUPPORT, Roof Luggage and Ski.....	12.815
SPACER, Body Rear Panel.....	12.121	SUPPORT, Tail and Stop Lamp.....	12.943
SPACER, End Gate Lock.....	12.237A	SUPPORT, Tail Gate.....	12.180
SPACER, Luggage Compartment.....	12.977	SUPPORT, Top Roof Outer.....	12.810
SPACER, Rear Compartment Lid Lock.....	12.237	SUPPORT, Wheelhouse.....	12.944
SPACER, Tailgate.....	12.195	SWITCH ASSY., End Gate Rear Door.....	12.242A
SPRING, Ash Receiver.....	12.009	SWITCH ASSY., Rear Compartment Lid Opener.....	12.243
SPRING, Ash Tray Anti-Rattle.....	12.050	SWITCH ASSY., Tailgate.....	12.195
SPRING, End Gate Rear Door.....	12.242A		
SPRING, End Gate.....	12.203	<b>T</b>	
SPRING, Gas Tank Filler Neck Compartment.....	12.945		
SPRING, Rear Compartment Floor.....	12.981		
SPRING, Rear Compartment Lid Lock Cylinder.....	12.249		
SPRING, Tail Gate or Rear Door Lock Cylinder.....	12.249A	TAPE.....	12.116A
SPRING, Tail Gate.....	12.180B	TAPE ASSY., Roof Panel.....	12.812
SPRING, Tailgate.....	12.195	TAPE, Front Door Outer Panel.....	12.112
STABILIZER, Floor (less Rear Compartment Floor Pan).....	12.980	TAPE, Rear Door Outer Panel.....	12.114
STICK, Trim.....	12.946	TRANSFER, Front Door Outer Panel.....	12.112
STIFFENER, Rear Body Lock Pillar.....	12.942	TRANSFER, Rear Compartment Lid and Rear End Panel.....	12.182
STIFFENER, Rear Compartment Floor.....	12.981	TRANSRER.....	12.116A
STIFFENER, Rear Quarter Side Inner.....	12.941A	TRAY ASSEMBLY, Ash.....	12.030
STIFFENER, Wheelhouse.....	12.944	TRAY ASSY., Ash (in arm rest).....	12.045
STOP ASSY., Tail Gate.....	12.180B	TRAY ASSY., Ash Receiver.....	12.009
STOP, Cowl Side.....	12.804	TRIM STICK ASSY., Trim.....	12.946
STOP, Load Floor (For Folding Seat Parts See Group 11.620).....	12.977	TUBE ASSY., Rear Compartment Lid or Tailgate Hinge.....	12.187
STOP, Rear Compartment Floor.....	12.981	TUMBLER UNIT, Rear Compartment Lid Lock Cylinder.....	12.249
STOP, Rear Compartment.....	12.212		
STOP, Tailgate.....	12.195	<b>V</b>	
STOP, Top Roof Outer.....	12.810		
STOP, Windshield Side.....	12.808		
STRAP ASSY., Rear Compartment Lid.....	12.184	VALVE ASSY., Rear Compartment (Less Hardware).....	12.181
STRAP, Rear Compartment Lid or Tailgate Hinge.....	12.187	VALVE ASSY., Roof Panel.....	12.812
STRAP, Roof Luggage and Ski.....	12.815	VALVE, Rear Body Lock Pillar.....	12.942
STRAP, Tail Gate.....	12.184A	VALVE, Rear Quarter Side Inner.....	12.941A
STRIKER ASSY., Rear Quarter Side Inner.....	12.941A		
STRIKER, End Gate Lock.....	12.237A	<b>W</b>	
STRIKER, Load Floor (For Folding Seat Parts See Group 11.620).....	12.977		
STRIKER, Luggage Compartment.....	12.977	WASHER, Belt Moulding, Door and Quarter Mldg. Attaching Parts.....	12.118
STRIKER, Rear Compartment Lid Lock.....	12.237	WASHER, End Gate Lock.....	12.237A
STRIKER, Spare Tire Cover.....	12.579	WASHER, Load Floor (For Folding Seat Parts See Group 11.620).....	12.977
STRIP ASSY., Roof Luggage and Ski.....	12.815	WASHER, Rear Compartment Floor.....	12.981
STRIP ASSY., Tail Gate.....	12.180		
STRIPE, Front Door Outer Panel.....	12.112		
STRIP, End Gate.....	12.269A		
STRIPE, Rear Compartment Lid and Rear End Panel.....	12.182		
STRIP, Gas Tank Filler Neck Compartment.....	12.945		

## ALPHABETICAL INDEX

WASHER, Rear Compartment Lid and Rear End Panel.....	12.182
WASHER, Rear Compartment Lid .....	12.183
WASHER, Roof Luggage and Ski.....	12.815
WASHER, Tail and Stop Lamp.....	12.943
WASHER, Tail Gate .....	12.180
WASHER, Tailgate .....	12.195
WEATHERSTRIP, End Gate.....	12.269A
WEATHERSTRIP, Hood Ledge (Cowl).....	12.801
WEATHERSTRIP, Rear Compartment Lid .....	12.269
WEATHERSTRIP, Top Roof Outer.....	12.810
WIRE ASSY., Rear Compartment Lid Opener.	12.243
WIRE, Headlining Listing Support .....	12.955

**METAL TRIM—CLIPS AND PANELS**

**12.009 TRAY ASSY.—BUMPER—HANDLE—PLATE—SPRING—RETAINER, Ash Receiver**

62-65	Chevy,				
66	Chevy (4-Dr.)	3791164	1	2.65	instrument panel
66-67	Chevelle	3871014	1	1.90	w/face plate
67	Pass.	3892167	1	3.35	w/retainer
66-67	Chevy	3875053	1	3.25	w/face plate
67	Camaro	3891667	1	4.40	w/face plate
67	Pass.	3892167	1	3.35	w/retainer
68	Chevelle	3918255	1	1.50	
68	Camaro (exc. console, intr. decor. pack)	3919123	1	2.25	w/face plate
68	Chevy	3935982	1	3.50	w/face plate (Note 2)
	<i>NOTE 2 When using 3935982 in place of 3913949 use one 3935980 retainer.</i>				
68	Camaro w/console	3927460	1	2.15	w/face plate (black)
68	Camaro w/console	3921861	1	5.30	w/face plate (woodgrain)
68	Pass. (exc. Impala, Caprice) (exc. stereo, stereo tape)	3916523	1	3.35	w/retainer
68	Pass. (exc. Biscayne, Bel Air) (exc. stereo, stereo tape)	3916561	1	5.10	w/retainer
68	Pass. w/stereo tape, stereo	3926735	1	3.50	
69-70	Pass.	3935987	1	3.30	w/retainer
69	Chevelle	3945901	1	4.25	w/retainer
69	Chevy, Camaro (exc. deluxe int.),				
70-75	Nova	3965143	1	4.35	w. retainer
69	Camaro w/deluxe int.	3965144	1	5.90	w/retainer
70-72	Chevelle w/inst. panel gauges	3965457	1	4.05	
70-72	Chevelle (exc. Monte Carlo)	3965411	1	4.05	
70-75	Camaro (exc. L.T.)	332027	1	3.35	(paint as reqd.) use w/332028
71-75	Pass.	3980384	1	4.05	
71-75	Vega, Monza	6264735	1	1.85	w/o retainer
73-75	Chevelle	346738	1	6.25	
75	Camaro (L.T.)	332151	1	3.35	prime and paint as reqd.
75	Monza (exc. Town Cpe.)	346663	1	1.90	seat sep.
75	Monza (Town Cpe.)	346749	1	3.00	ash
65	Pass.,				
68	Chevy,				
66	Pass. (exc. bucket seat)	6257945	1	.12	BUMPER (1.035)
67-68	Pass.				BUMPER, ash tray,
68-69	Impala w/S.S. equip.,				
68-69	Caprice (Spt. Cpe.) w/strato bucket seats,				
70-72	Chevelle (2-Dr.) w/floor console	3918212	2	.13	BUMPER, seat sep. comp. door
69-70	Pass.	3935946	2	.13	BUMPER, ash tray (attached to panel)
69	Chevelle				BUMPER, ash tray,
70	Camaro	3939670	A.R.	.13	BUMPER, inst. panel compt. door
69	Camaro	3765243	A.R.	.11	BUMPER, ash tray— (10.263)
69-75	Chevy	9785929	2	.26	BUMPER, ash tray
70	Pass., Chevelle,				
71-72	Chevelle (Sta. Wag.)	3948583	1	.13	BUMPER, attached to inside of tray
70-72	Pass.	3945980	1	.13	BUMPER, attached to outside of tray
71-75	Pass.	3980386	2	.13	BUMPER (attached)
75	Pass.	3948583	1	.13	BUMPER, ash tray inside
75	Pass.	3945980	2	.13	BUMPER, ash tray outside
68	Chevy	3929939	1	1.20	HANDLE, ash tray
	Not required in this group. See group 16.120				
		3853594		3.40	HANDLE
68	Chevelle	3918257	1	.66	PLATE, ash tray
69	Chevelle	3945903	1	.73	PLATE, ash tray
70-71	Camaro	3972006	1	1.40	PLATE, face
71-75	Pass.	6264795	1	1.05	PLATE, trim
72-73	Camaro	6264767	1	1.40	PLATE, face
68	Pass. (exc. stereo)	3916563	1	.98	PLATE ASSY., ash tray trim
68	Caprice w/stereo tape	3926789	1	3.30	PLATE ASSY., ash tray trim
69-70	Pass.	3939607	1	1.00	PLATE ASSY., trim
64-68	Chevelle	3840170	1	1.00	RETAINER
68	Chevy	3935980	1	1.55	RETAINER
67-68	Camaro	3925471	1	1.65	RETAINER ASSY.
68-69	Chevelle	3930105	1	4.25	RETAINER ASSY.
73-75	Vega, Monza	6264736	1	1.70	RETAINER ASSY.
74-75	Camaro	332028	1	4.10	RETAINER ASSY.
75	Monza (Town Cpe.)	346750	1	1.70	RETAINER ASSY.

**12.012 CLIP— RETAINER— SOCKET, Ash Tray**

68-69	All,
70	Chevelle, Nova w/ash tray lamp,

**METAL TRIM—CLIPS AND PANELS**

**12.012 CLIP— RETAINER— SOCKET, Ash Tray (Con't)**

71-75	All w/ash tray (exc. Vega, Monza) . . . . .	1382116		.13	fiber optic . . . . .
68-69	All . . . . .				RETAINER, ash tray lamp, . . . . .
70	Nova, Chevelle, Camaro, . . . . .				
71-75	All w/ash tray lamp (exc. Vega, Monza) . . . . .	6288831	1	1.20	RETAINER, fiber optic . . . . .

**12.016 SOCKET ASSY.— CONDUCTOR ASSY., Ash Tray**

70	Nova, Chevelle, Camaro, . . . . .				
71-74	All (exc. Caprice, Vega) . . . . .	6288601	1	1.30	ash tray lamp— (2.584) . . . . .
73-74	All w/ash tray lamp (exc. Vega) . . . . .	6293975		4.25	CONDUCTOR ASSY. (2.580) . . . . .

**12.030 TRAY ASSEMBLY, Ash**

66-67	S.S., Caprice (Spt. Cpe.) (Conv.) (exc. A.T.), . . . . .				
68-69	Caprice (Spt. Cpe.) w/A.T., . . . . .				
68-69	Impala (Spt. Cpe., Conv.) w/A.T., . . . . .				
69	Impala, Caprice (Spt. Cpe., Conv.) w/bucket seat . . . . .	3877292	1	1.10	console . . . . .
67	Camaro w/floor console . . . . .	3893868	1	1.90	seat separator . . . . .
73-75	Chevelle (4-Dr.) . . . . .	9876569	1	4.75	frt. seat back . . . . .
75	Monza (exc. Towne Coupe) . . . . .	4812543	1	.62	ESCUTCHEON, seat separator ash tray . . . . .

**12.045 TRAY ASSY., Ash (in arm rest)**

64-67	Chevelle (Conv.), . . . . .				
65-67	Pass. (Spt. Cpe., Conv.) . . . . .	4725854	2	2.70	(door type lid) . . . . .
62-66	Chevy (Std.), . . . . .				
65-67	Biscayne . . . . .	3940479	2	2.40	rear qtr., rr. door . . . . .
62-67	Chevy (Deluxe) (4-Dr.), . . . . .				
65-67	Bel Air (4-Dr.) (exc. Spt. Sed.) . . . . .				rear door, . . . . .
62-67	Chevy, Chevelle (2-Dr.) (exc. Conv.), . . . . .				
65-67	Bel Air (2-Dr.) (exc. Spt. Cpe.) . . . . .	4790111	R.H.	2.70	rear qtr. . . . .
62-67	Chevy (Deluxe) (4-Dr.), . . . . .				
65-67	Bel Air (4-Dr.) (exc. Spt. Sed.) . . . . .				rear door, . . . . .
62-67	Chevy, Chevelle (2-Dr.) (exc. Conv.), . . . . .				
65-67	Bel Air (2-Dr.) (exc. Spt. Cpe.) . . . . .	4790112	L.H.	3.00	rear qtr. . . . .
68	Pass. (2-Dr. Sed.) . . . . .	7740365	2	3.20	rear door arm rest . . . . .
67	Camaro, . . . . .				
68-69	Chevelle (Conv.), . . . . .				
68-69	Pass. (Spt. Cpe., Conv.) . . . . .	8761458	2	3.35	rear quarter arm rest . . . . .
68	Malibu (S.S.) (Spt. Cpe.) . . . . .				qtr. arm rest, . . . . .
68-75	Chevelle (Sed.) . . . . .				front door arm rest, . . . . .
68-75	Pass. (4-Dr.) . . . . .	9847777	2	4.10	rear door arm rest (cut out 2 <sup>7</sup> / <sub>16</sub> " x 1 <sup>1</sup> / <sub>2</sub> ") . . . . .
68	Pass. (4-Dr.), . . . . .				
68-70	Chevy (4-Dr.), . . . . .				
68-69	Chevelle (4-Dr.) (exc. Nomad), . . . . .				
70	Chevelle (Sta. Wag.) (exc. Nomad), . . . . .				
71-75	Nova (4-Dr.) . . . . .	7748808	2	2.60	(cut-out 2 <sup>21</sup> / <sub>32</sub> " x 1 <sup>1</sup> / <sub>4</sub> ") . . . . .
69	Camaro, . . . . .				
69	Biscayne, Bel Air (2-Dr. Sed.), . . . . .				
70-75	Nova (2-Dr.), . . . . .				
70-72	Chevelle (Spt. Cpe.), . . . . .				
73-75	Chevelle (Sta. Wag.), . . . . .				
74	Camaro . . . . .	8795489	2	2.90	quarter ash . . . . .
68-72	Camaro w/floor console . . . . .	3919076	1	.76	seat separator compt. . . . .
70-71	Chevelle (Conv.), . . . . .				
70-75	Pass. (Spt. Cpe., Conv.) . . . . .	8801663	2	3.25	rear qtr. ash tray assy. . . . .
72-75	Vega, Monza, Towne Coupe . . . . .	9607422	1	3.70	door & qtr. . . . .
75	Nova (2-Dr.) (Custom) . . . . .	8712297	1	2.35	

**12.048 ESCUTCHEON, Ash Tray**

62-64	Nova, . . . . .				
64-67	Pass. (Spt. Cpe., Conv.) . . . . .	4146967	2	1.10	reqr qtr. arm rest . . . . .

**12.050 SPRING— RETAINER, Ash Tray Anti-Rattle**

62-67	Nova, Chevelle (Conv.), . . . . .				
65-66	Spt. Mdls. (exc. 4-Dr.) . . . . .	4088916	2	.12	rear qtr. tray cover . . . . .
62-64	Chevy (4-Dr.), . . . . .				
65-67	Bel Air (4-Dr.), . . . . .				
65	Impala (4-Dr.), . . . . .				
66	Caprice (Spt. Sed., Sta. Wag.), . . . . .				
67	Pass. (Spt. Cpe., Conv.) . . . . .				rr. door tray cover, . . . . .

**METAL TRIM—CLIPS AND PANELS**

**12.050 SPRING— RETAINER, Ash Tray Anti-Rattle (Con't)**

65	Bel Air (2-Dr.) (exc. Spt. Cpe.),				
68-69	All (4-Dr.)			rr. qtr. tray cover,	
70-72	Nova (4-Dr.)			custom trim,	
70-75	Pass. (4-Dr.),				
71-72	Chevelle (4-Dr.) (exc. Spt. Sed.),				
73-75	Nova (4-Dr.) (Custom),				
73-75	Chevelle (Spt. Cpe.)	4783275	2	.11	door ash tray cover
67-68	All (exc. 4-Dr.),				
71-72	Chevelle (Conv.),				
73-75	Pass. (2-Dr.)	7653737	2	.24	rear qtr. ash tray cover

**12.075 MOULDING— CAP— CLIP— ESCUTCHEON— EXTENSION— LACE— RETAINER— SCALP— SCREW— STRIP, Roof Drip**

62-65	Chevy, Deluxe (exc. Spt. Mdls.),				
66-67	Nova (4-Dr.)	4844247	L.H.	7.90	windshield pillar drip
65-68	Bel Air,				
65-66	Impala (4-Dr.) (exc. spt. Sed.),				
66-68	Caprice (Sta. Wag.),				
67-68	Biscayne w/roof drip mldg.,				
67-68	Impala, Caprice (4-Dr.) w/roof drip mldg. (exc. Spt. Sed.)	7685044	R.H.	8.85	w/s pillar drip
65-68	Bel Air,				
65-68	Impala (4-Dr.) (Spt. Sed.),				
66-68	Caprice (Sta. Wag.),				
67-68	Biscayne	7685045	L.H.	8.20	w/s pillar drip
65-66	Pass. (Spt. Mdls.) (exc. Conv.)	7670128	R.H.	5.95	w/s pillar drip
65-68	Pass. (Spt. Mdls.) (exc. Conv.)	7670129	L.H.	5.95	w/s pillar drip
65-70	Pass. (Sta. Wag.)	4464441	L.H.	4.40	front
66-67	Nova (Spt. Cpe.)	4542700	R.H.	7.60	windshield pillar drip
66-67	Nova (Spt. Cpe.)	4542701	L.H.	7.60	windshield pillar drip
66-67	Chevelle (Spt. Cpe.)	4543285	R.H.	8.95	
66-67	Chevelle (Spt. Cpe.)	4543286	L.H.	8.95	
67-69	Camaro (Spt. Cpe.)	7637324	R.H.	5.40	
67-69	Camaro (Spt. Cpe.)	7637325	L.H.	5.40	
67-69	Camaro (Spt. Cpe.)	7656808	L.H.	6.20	windshield pillar drip
67-70	Pass. (Sta. Wag.)	7639357	L.H.	2.40	rear
67-68	4-Dr. Sed. (exc. Spt. Sed.)	7641884	R.H.	5.60	
67-68	Impala, Caprice (Spt. Cpe., Spt. Sed.)	7670128	R.H.	5.95	w/s pillar drip
67-68	Impala, Caprice (Spt. Cpe., Spt. Sed.)	7670129	L.H.	5.95	w/s pillar drip
68-72	Chevy (4-Dr.)	7717390	R.H.	5.50	
68-72	Chevy (4-Dr.)	7717391	L.H.	5.50	
68-72	El Camino	7722310	R.H.	6.50	
68-72	El Camino	7722311	L.H.	6.50	
68-69	Chevelle (2-Dr. Sed., Spt. Cpe.)	7722330	R.H.	7.90	
68-69	Chevelle (2-Dr. Sed., Spt. Cpe.)	7722331	L.H.	7.90	
68-72	Chevy (4-Dr.)	7722454	R.H.	6.80	windshield pillar drip
68-72	Chevy (4-Dr.)	7722455	L.H.	6.80	windshield pillar drip
68-72	Chevelle (Sta. Wag.)	7723071	R.H.	5.60	front
68-72	Chevelle (Sta. Wag.)	7723072	L.H.	5.60	front
68-72	Chevelle (Sta. Wag.)	7723073	R.H.	4.35	rear
68-72	Chevelle (Sta. Wag.)	7723074	L.H.	4.35	rear
68-70	Chevelle (Sta. Wag., 4-Dr. Sed.),				
71-72	Chevelle (4-Dr.) (exc. Spt. Sed.)	7723664	R.H.	6.90	windshield pillar drip
68-70	Chevelle (Sta. Wag., 4-Dr. Sed.),				
71-72	Chevelle (4-Dr.) (exc. Spt. Sed.)	7723665	L.H.	6.90	windshield pillar drip
68-72	Chevelle (Spt. Sed.)	7723666	R.H.	12.90	windshield pillar drip
68-72	Chevelle (Spt. Sed.)	7723667	L.H.	12.90	windshield pillar drip
68-70	Chevelle (2-Dr. Sed.) El Camino,				
71-72	El Camino	7723668	R.H.	6.65	windshield pillar drip
68-70	Chevelle (2-Dr. Sed.) El Camino,				
71-72	Chevelle	7723669	L.H.	6.65	windshield pillar drip
68-72	Chevelle (Spt. Cpe.)	7723670	R.H.	6.75	windshield pillar drip
68-72	Chevelle (Spt. Cpe.)	7723671	L.H.	6.75	windshield pillar drip
68-72	Chevy (Spt. Cpe.)	7738097	R.H.	7.10	
68-72	Chevy (Spt. Cpe.)	7738098	L.H.	6.95	
68-72	Chevy (Spt. Cpe.)	7738130	R.H.	7.10	w/s pillar drip
68-72	Chevy (Spt. Cpe.)	7738131	L.H.	7.10	w/s pillar drip
69-70	Pass. (4-Dr. Sed.) (exc. Spt. Sed.)	7799387	R.H.	6.90	
69-70	Pass. (4-Dr. Sed.) (exc. Spt. Sed.)	7799388	L.H.	6.90	
69-70	Pass. (Spt. Sed.)	7799385	R.H.	6.75	
69-70	Pass. (Spt. Sed.)	7799386	L.H.	6.75	
69-70	Impala (Spt. Cpe.) (exc. Custom)	8712343	R.H.	8.15	
69-70	Impala (Spt. Cpe.) (exc. Custom)	8712344	L.H.	8.15	



**METAL TRIM—CLIPS AND PANELS**

**12.075 MOULDING— CAP— CLIP— ESCUTCHEON— EXTENSION— LACE—  
RETAINER— SCALP— SCREW— STRIP, Roof Drip (Con't)**

69-70	Impala Custom, Caprice (Spt. Cpe.)	7798412 R.H.	7.95	
69-70	Pass. (Sed., Sta. Wag.) (exc. Spt. Sed.)	8784776 R.H.	8.50	w/s pillar drip
69-70	Pass. (Sed., Sta. Wag.) (exc. Spt. Sed.)	8784777 L.H.	8.50	w/s pillar drip
69-70	Pass. (Spt. Cpe., Spt. Sed.)	8784778 R.H.	8.15	w/s pillar drip
69-70	Pass. (Spt. Cpe., Spt. Sed.)	8784779 L.H.	8.15	w/s pillar drip
70-72	Chevelle (Spt. Cpe.) (exc. Monte Carlo)	8778770 R.H.	8.85	
70-72	Chevelle (Spt. Cpe.) (exc. Monte Carlo)	8778771 L.H.	8.85	
70-72	Chevelle (4-Dr. Sed.) (exc. Spt. Sed.)	7721938 R.H.	9.95	
70-72	Chevelle (4-Dr. Sed.) (exc. Spt. Sed.)	7721939 L.H.	9.95	
70-72	Chevelle (Spt. Sed.)	7721940 R.H.	10.40	
70-72	Chevelle (Spt. Sed.)	7721941 L.H.	10.40	
70-72	Monte Carlo (Spt. Cpe.)	8778767 R.H.	9.05	
70-72	Monte Carlo (Spt. Cpe.)	8778768 L.H.	9.05	
70	Monte Carlo (Spt. Cpe.) w/two-tone paint (1st design)	8792122 R.H.	6.75	panel cover front side (not extended to w/s) (Note 1)
70	Monte Carlo (Spt. Cpe.) w/two-tone paint (1st design)	8792123 L.H.	6.75	panel cover front side (not extended to w/s) (Note 1)
<i>NOTE 1 No comparable 2nd design part. This part not required on 2nd design models.</i>				
70	Monte Carlo (Spt. Cpe.) w/two-tone paint (1st design)	8792207 R.H.	4.55	panel cover side front (not extended to w/s)
70	Monte Carlo (Spt. Cpe.) w/two-tone paint (1st design)	8792208 L.H.	4.50	panel cover side front (not extended to w/s)
70-72	Monte Carlo (Spt. Cpe.) w/two-tone paint (2nd design)	9837103 R.H.	8.85	panel cover side front (extended forward to w/s)
70-72	Monte Carlo (Spt. Cpe.) w/two-tone paint (2nd design)	9837104 L.H.	8.85	panel cover side front (extended forward to w/s)
70-72	Monte Carlo (Spt. Cpe.) w/two-tone paint	8792676 R.H.	9.90	panel cover side rear
70-72	Monte Carlo (Spt. Cpe.) w/two-tone paint	8792677 L.H.	9.90	panel cover side rear
70	Camaro w/exterior ornamentation (exc. vinyl top)	8800812 R.H.	13.15	right
70	Camaro w/exterior ornamentation (exc. vinyl top)	8800813 L.H.	13.15	left
70	Camaro w/vinyl top	9816514 R.H.		right panel
70-75	Camaro w/vinyl top	1652949 L.H.	3.60	left panel (repl. 9816515-9605613)
71-72	Impala (Spt. Cpe.) (exc. Custom)	9827511 L.H.	20.35	(bright)
71-72	Impala (Spt. Cpe.) (exc. Custom)	9827510 R.H.	20.35	(bright)
71-72	Pass. (Spt. Sed.)	9828265 L.H.	16.65	
71-72	Pass. (Spt. Sed.)	9828264 R.H.	16.65	
71-72	Biscayne, Bel Air (Sed.), Impala (Sed.) (exc. Spt. Sed.)	9828281 L.H.	11.85	front
71-72	Biscayne, Bel Air (Sed.), Impala (Sed.) (exc. Spt. Sed.)	9828280 R.H.	11.85	front
71-72	Impala (Custom), Caprice (Spt. Cpe.)	9828386 L.H.	20.35	
71-72	Impala (Custom), Caprice (Spt. Cpe.)	9828385 R.H.	20.35	
71-72	Brookwood, Townsman w/vinyl top,			
71-72	Kingswood	9829881 L.H.	8.80	rear
71-72	Brookwood, Townsman w/vinyl top,			
71-72	Kingswood	9829880 R.H.	8.80	rear
71-72	Brookwood, Townsman w/vinyl top,			
71-72	Kingswood	9829885 L.H.	13.70	front
71-72	Brookwood, Townsman w/vinyl top,			
71-72	Kingswood	9829884 R.H.	13.70	front
71-72	Biscayne, Bel Air (Sed.), Impala (Sed.) (exc. Spt. Sed.), vinyl top)	9831182 R.H.	6.30	rear

**METAL TRIM—CLIPS AND PANELS**

**12.075 MOULDING— CAP— CLIP— ESCUTCHEON— EXTENSION— LACE—  
RETAINER— SCALP— SCREW— STRIP, Roof Drip (Con't)**

71-72	Biscayne, Bel Air (Sed.),				
71-72	Impala (Sed.) (exc. Spt. Sed., vinyl top) .....	9831183 L.H.	6.30	rear .....	
71	Camaro w/interior ornamentation (exc. vinyl top) .....	9605611 L.H.	3.60	finish roof panel (repl. 9862677) .....	
71	Camaro w/interior ornamentation (exc. vinyl top) .....	9605610 R.H.	3.60	finish roof panel (repl. 9862676) .....	
71-75	Camaro w/vinyl top .....	1652948 R.H.	3.60	drip roof panel .....	
71-74	Vega (Panel) .....	9660571 L.H.	1.25	drip back body pillar (paint as reqd.) .....	
72	Camaro w/interior ornamentation (exc. vinyl top) .....	9605611 L.H.	3.60	finish roof panel .....	
72	Camaro w/interior ornamentation (exc. vinyl top) .....	9605610 R.H.	3.60	finish roof panel .....	
72	Monte Carlo w/vinyl top .....	9610751 R.H.	10.30	roof panel cover side front .....	
72	Monte Carlo w/vinyl top .....	9610752 L.H.	10.30	roof panel cover side front .....	
72	Monte Carlo w/vinyl top .....	9610768 R.H.	10.15	roof panel cover side rear .....	
72	Monte Carlo w/vinyl top .....	9610769 L.H.	10.15	roof panel cover side rear .....	

**PASS.**

73	Impala (Spt. Cpe.) (exc. Custom)	9827511 L.H.	20.35	(bright) .....	
73	Impala (Spt. Cpe.) (exc. Custom)	9827510 R.H.	20.35	(bright) .....	
73-74	Pass. (Spt. Sed.) .....	9627016 L.H.	16.65		
73-74	Pass. (Spt. Sed.) .....	9627015 R.H.	16.65		
73-74	Pass. (Sedan) (exc. Spt. Sed.) w/padded vinyl top .....	9828281 L.H.	11.85	front .....	
73-74	Pass. (Sedan) (exc. Spt. Sed.) w/padded vinyl top .....	9828280 R.H.	11.85	front .....	
73	Impala (Custom) Caprice (Spt. Cpe.) .....	9828386 L.H.	20.35		
73	Impala (Custom) Caprice (Spt. Cpe.) .....	9828385 R.H.	20.35		
73-75	Pass. (Sta. Wag.) (w/roof drip mldg. & padded vinyl top) .....	9829881 L.H.	8.80	rear .....	
73-75	Pass. (Sta. Wag.) (w/roof drip mldg. & padded vinyl top) .....	9829880 R.H.	8.80	rear .....	
73-74	Pass. (Sta. Wag.) (w/roof drip mldg. & padded vinyl top) .....	9829885 L.H.	13.70	front .....	
73-74	Pass. (Sta. Wag.) (w/roof drip mldg. & padded vinyl top) .....	9829884 R.H.	13.70	front .....	
73-74	Pass. (Sed.) (exc. Spt. Sed.) w/padded vinyl top .....	9831182 R.H.	6.30	rear .....	
73-74	Pass. (Sed.) (exc. Spt. Sed.) w/padded vinyl top .....	9831183 L.H.	6.30	rear .....	
73-74	Vega (Panel, Sta. Wag.) .....	9660570 R.H.	1.25	drip back body pillar (paint as reqd.) .....	
74-75	Impala (Custom) Caprice (Spt. Cpe.) .....	9671090 R.H.	10.80	front .....	
74-75	Impala (Custom) Caprice (Spt. Cpe.) .....	9671091 L.H.	10.80	front .....	
74-75	Impala (Custom) Caprice (Spt. Cpe.) .....	9671760 R.H.	8.60	rear .....	
74-75	Impala (Custom) Caprice (Spt. Cpe.) .....	9671761 L.H.	8.60	rear .....	
74-75	Impala (Spt. Cpe.) (exc. Custom)	9671775 R.H.	11.85	front .....	
74-75	Impala (Spt. Cpe.) (exc. Custom)	9671776 L.H.	11.85	front .....	
74-75	Impala (Spt. Cpe.) (exc. Custom)	9671780 R.H.	9.75	rear .....	
74-75	Impala (Spt. Cpe.) (exc. Custom)	9671781 L.H.	9.75	rear .....	
74	Impala (Spt. Cpe.) w/vinyl roof (exc. Custom) .....	9737857 1	19.20	finish roof panel cover front .....	
74	Impala (Spt. Cpe.) w/vinyl roof (exc. Custom) .....	9737862 R.H.	11.85	finish roof panel cover side .....	
74	Impala (Spt. Cpe.) w/vinyl roof (exc. Custom) .....	9737863 L.H.	11.85	finish roof panel cover side .....	
75	Pass. (Coupe) w/vinyl roof .....	1725064 R.H.	15.50	roof panel cover .....	
75	Pass. (Coupe) (w/vinyl roof) .....	1725065 L.H.	15.50	roof panel cover .....	
75	Pass. (Sed.) (exc. Spt. Sed.) .....	9732596 R.H.	14.20	front .....	
75	Pass. (Sed.) (exc. Spt. Sed.) .....	9732597 L.H.	14.20	front .....	
75	Pass. (Sed.) (exc. Spt. Sed.) .....	9732598 R.H.	7.55	rear .....	
75	Pass. (Sed.) (exc. Spt. Sed.) .....	9732599 L.H.	7.55	rear .....	
75	Pass. (Spt. Sed.) .....	9735818 R.H.	10.70	front .....	
75	Pass. (Spt. Sed.) .....	9735819 L.H.	10.70	front .....	
75	Pass. (Spt. Sed.) .....	1733370 R.H.	6.95	rear (repl. 9735820) .....	
75	Pass. (Spt. Sed.) .....	1733371 L.H.	6.95	rear (repl. 9735821) .....	
75	Pass. (Sta. Wag.) w/vinyl roof .....	9737528 R.H.	9.85	front .....	
75	Pass. (Sta. Wag.) w/vinyl roof .....	9737529 L.H.	9.85	front .....	

**METAL TRIM—CLIPS AND PANELS**

**12.075 MOULDING— CAP— CLIP— ESCUTCHEON— EXTENSION— LACE—  
RETAINER— SCALP— SCREW— STRIP, Roof Drip (Con't)**

75	Pass. (Spt. Cpe.)	9727078 A.R.	.11	CLIP, rvl. mid. qtr. belt
75	Impala (Spt. Cpe.)	9727078 A.R.	.11	CLIP, qtr. belt frt. & rr.

**CHEVELLE**

73-75	Chevelle (Spt. Sed.) w/vinyl top, drip mldg.	9611705 L.H.	17.50	at qtr. wdo.
73-75	Chevelle (Spt. Sed.) w/vinyl top, drip mldg.	9611704 R.H.	17.50	at qtr. wdo.
73-75	Chevelle (Spt. Cpe.) (exc. Monte Carlo) w/vinyl top, drip mldg.	9685051 L.H.	8.75	front
73-75	Chevelle (Spt. Cpe.) w/vinyl top, drip mldg. (exc. Monte Carlo)	9685050 R.H.	8.75	front
73-75	Chevelle (Spt. Cpe.) w/vinyl top (exc. Monte Carlo)	9871272 L.H.	6.75	rear
73-75	Chevelle (Spt. Cpe.) w/vinyl top (exc. Monte Carlo)	9871271 R.H.	6.75	rear
73-75	Monte Carlo	9664902 L.H.	6.35	rear
73-75	Monte Carlo	9664901 R.H.	6.35	rear
73-75	Monte Carlo	9685049 L.H.	8.75	front
73-75	Monte Carlo	9685048 R.H.	8.75	front
73-75	El Camino	9878332 1	7.95	finish roof panel center at back window
73-75	El Camino w/vinyl top, 2 tone paint	9880597 L.H.	12.30	
73-75	El Camino w/vinyl top, 2 tone paint	9880596 R.H.	12.30	
73	Chevelle (4-Dr.) w/drip mldg., vinyl top	1667097 L.H.	10.75	w/s pillar
73-74	Chevelle (4-Dr.) w/drip mldg., vinyl top	1667096 R.H.	10.75	w/s pillar
73-75	Chevelle (Sta. Wag.) w/drip mldg.	9679915 L.H.	16.40	rear
73-75	Chevelle (Sta. Wag.) w/roof drip mldg.	9679914 R.H.	16.40	rear
73-75	Chevelle (Sta. Wag.) w/drip mldg.	9670184 R.H.	7.85	rear lower
73-75	Chevelle (Spt. Sed.) w/roof drip mldg., vinyl top	9679906 R.H.	14.90	rear
73-75	Chevelle (Spt. Sed.) w/roof drip mldg., vinyl top	9679907 L.H.	14.90	rear
73-75	Chevelle (4-Dr.) w/drip mldg., vinyl top	9679910 R.H.	13.40	front
73-75	Chevelle (4-Dr.) w/roof drip mldg., vinyl top	9679911 L.H.	13.40	front
73-74	Chevelle (2-Dr.) w/roof drip mldg., vinyl top,			
75	Chevelle (2-Dr.)	9683794 R.H.	14.75	windshield pillar
73-74	Chevelle (2-Dr.) w/roof drip mldg., vinyl top,			
75	Chevelle (2-Dr.)	9683795 L.H.	14.75	windshield pillar
74-75	Malibu (Classic) (Coupe) w/padded vinyl top	9730077 L.H.	9.40	finish roof panel cover rear
74-75	Malibu (Classic) w/padded vinyl top	9730076 R.H.	9.40	finish roof panel cover rear
73-75	Monte Carlo w/padded vinyl top	9685257 L.H.	8.85	finish roof panel cover (painted)
73-75	Monte Carlo w/padded vinyl top	9685256 R.H.	7.95	finish roof panel cover (painted)
74-75	Laguna w/Landau top	9685265 L.H.	6.75	finish roof panel cover (painted)
74-75	Laguna w/Landau top	9685264 R.H.	5.20	finish roof panel cover (painted)
74-75	Chevelle (Sed.) w/drip mldg., vinyl top	9611705 L.H.	17.50	at quarter window
74-75	Chevelle (Sed.) w/drip mldg., vinyl top	9611704 R.H.	17.50	at quarter window
74-75	Chevelle (Sta. Wag.) w/drip mldg.	9670185 L.H.	7.85	rear lower
74-75	Chevelle	994663 1	8.95	MOULDING UNIT, roof drip

**NOVA**

73-74	Nova (4-Dr.)	9600859 L.H.	4.15	
73-74	Nova (4-Dr.)	9600858 R.H.	4.15	
73-74	Nova (4-Dr.)	7722455 L.H.	6.80	w/s pillar drip (primed)
73-75	Nova (4-Dr.)	7722454 R.H.	6.80	w/s pillar drip (primed)
73	Nova (2-Dr.)	9668773 L.H.	7.10	
73	Nova (2-Dr.)	9668772 R.H.	7.10	
73-74	Nova (2-Dr.)	7738131 L.H.	7.10	w/s pillar drip (primed)
73-74	Nova (2-Dr.)	7738130 R.H.	7.10	w/s pillar drip (primed)

**METAL TRIM—CLIPS AND PANELS**

**12.075 MOULDING— CAP— CLIP— ESCUTCHEON— EXTENSION— LACE—  
RETAINER— SCALP— SCREW— STRIP, Roof Drip (Con't)**

74	Nova (H.B.) w/vinyl top, 2 tone paint	9629628 R.H.	8.75	roof panel cover at lid opening
74	Nova (H.B.) w/vinyl top, 2 tone paint	9629629 L.H.	8.75	roof panel cover at lid opening
73-74	Nova (H.B. Cpe.) w/Landau	9623105 1	8.85	finish roof panel cover
75	Nova (H.B.) w/vinyl roof, 2 tone paint	1667747 1	10.50	roof panel cover upr. lid opening
75	Nova (H.B.) w/vinyl roof, 2 tone paint	1667774 R.H.	13.70	roof panel cover side lid opening
75	Nova (H.B.) w/vinyl roof, 2 tone paint	1667775 L.H.	13.70	roof panel cover side lid opening
75	Nova (N.B.) w/formal window	1726290 R.H.	10.60	roof panel cover finish
75	Nova (N.B.) w/formal window	1726291 L.H.	10.60	roof panel cover finish

**CAMARO**

73-75	Camaro w/drip mldg. (exc. pad vinyl top)	9605611 L.H.	3.60	finish roof panel
73-75	Camaro w/drip mldg. (exc. pad vinyl top)	9605610 R.H.	3.60	finish roof panel
74-75	Camaro	4510031 10	.18	CLIP, moulding

**VEGA — MONZA**

74-75	Vega (Coupe)	1652875 L.H.	8.75	finish roof panel cover
74	Vega (Coupe)	1652874 R.H.	8.15	finish roof panel cover
74-75	Vega w/vinyl roof	9663668 R.H.	10.85	roof pnl. at w/s corner
74-75	Vega w/vinyl roof	9663669 L.H.	10.85	roof pnl. at w/s corner
75	Vega (Coupe)	1652874 R.H.	8.15	finish roof panel cover
73-75	Vega (Sta. Wag.)	9738812 2	.50	CAP, roof drip scalp
70	Bel Air (4-Dr.)			
70	Pass. w/vinyl top (exc. Bel Air)	8732670 2	.12	CLIP, scalp rear
74-75	Impala (Spt. Cpe.) w/vinyl roof (exc. Custom)	1676243 A.R.	.44	CLIP, finish mldg. roof panel cover front, side
75	Impala (Spt. Cpe.)	1688175 2	.37	CLIP, roof panel cover upper
	Not required in this group. See group 8.309	4510031	.18	CLIP
62-67	Chevy Std. (Sta. Wag.)			ESCUTCHEON, back body opening mldg.,
65-67	Chevelle (Std.) (exc. Sta. Wag.)			
64-67	El Camino (exc. Custom)			ESCUTCHEON, w/s pillar drip mldg.
66	Chevelle (Std.) (4-Dr.)	7636829 A.R.	.32	ESCUTCHEON, w/s pillar drip
67-69	Camaro (Spt. Cpe.) w/vinyl top, roof drip mldg.,			
68	Chevelle (exc. Sed., Conv., El Camino),			
68	Malibu S.S. (4-Dr. Sed., El Camino),			
69	Chevelle (Deluxe) (exc. Sta. Wag., El Camino),			
69	Malibu (exc. Conv.),			
70-72	Chevelle (Sta. Wag.) (exc. Nomad, Monte Carlo)			
70-72	Malibu (exc. Conv.)	7661072 R.H.	1.55	ESCUTCHEON, w/s pillar scalp
67-69	Camaro (Spt. Cpe.) w/vinyl top, roof drip mldg.,			
68	Chevelle (exc. Sed., Conv., El Camino),			
68	Malibu S.S. (4-Dr. Sed., El Camino),			
69	Chevelle (Deluxe) (exc. Sta. Wag., El Camino),			
69	El Camino,			
69	Malibu (exc. Conv.),			
70-72	Chevelle (Sta. Wag.) (exc. Nomad),			
70-72	Malibu (exc. Conv.)	7661073 L.H.	1.55	ESCUTCHEON, w/s pillar scalp
67-69	Camaro,			
68-72	Nova, Nomad,			
73	Nova (Sedan),			
73-74	Nova (exc. Custom),			
68-70	Chevelle (Deluxe),			
71-72	Chevelle (Std.) El Camino (exc. Cust.)	7664482 2	.52	ESCUTCHEON, w/s pillar drip mldg.
68-72	Nomad	4407290 2	.32	ESCUTCHEON, roof drip mldg.
75	Pass. (Coupe) (w/vinyl roof)	1729716 R.H.	2.75	ESCUTCHEON, belt moulding (paint)

**METAL TRIM—CLIPS AND PANELS**

**12.075 MOULDING— CAP— CLIP— ESCUTCHEON— EXTENSION— LACE—  
RETAINER— SCALP— SCREW— STRIP, Roof Drip (Con't)**

75	Pass. (Coupe) (w/vinyl roof) . . . . .	1729717 L.H.	2.75	ESCUTCHEON, belt moulding (paint) . . . . .
71-73	Vega (Panel) . . . . .	9824892 2	.18	ESCUTCHEON, back body pillar drip moulding . . . . .
71-73	Vega (Sta. Wag.) . . . . .	9835528 R.H.	1.30	ESCUTCHEON, back body pillar drip scalp moulding . . . . .
71-73	Vega (Sta. Wag.) . . . . .	9835529 L.H.	1.30	ESCUTCHEON, back body pillar drip scalp moulding . . . . .
75	Pass. (Coupe) w/vinyl roof . . . . .	1703409 1	1.90	ESCUTCHEON, roof panel cover finish moulding . . . . .
75	Nova (Coupe) (exc. Custom) . . . . .	1651470 2	.26	ESCUTCHEON, mldg. ext. . . . .
75	Nova (Coupe) (exc. Custom),			
74	Nova (2-Dr.) . . . . .	1654821 L.H.	4.50	EXTENSION, roof drip mldg. . . . .
74	Nova (2-Dr.) . . . . .	1654820 R.H.	4.50	EXTENSION, roof drip mldg. . . . .
75	XX27, XY27 w/formal window . . . . .	9739540 1	1.85	ESCUTCHEON, roof panel cover finish moulding . . . . .
74	Impala (Spt. Cpe.) w/vinyl roof (exc. Custom) . . . . .	9739873 R.H.	3.55	LACE, mldg. roof panel cover side (white) . .
74	Impala (Spt. Cpe.) w/vinyl roof (exc. Custom) . . . . .	9739874 L.H.	3.55	LACE, mldg. roof panel cover side (white) . .
74	Impala (Spt. Cpe.) w/vinyl roof (exc. Custom) . . . . .	1674615 R.H.	4.35	LACE ASSY., mldg. qtr. belt reveal (white) . .
74	Impala (Spt. Cpe.) w/vinyl roof (exc. Custom) . . . . .	1674616 L.H.	4.35	LACE ASSY., mldg. qtr. belt reveal (white) . .
75	Nova (2-Dr.) (exc. H.B.) . . . . .	1732851 R.H.	15.05	LACE, qtr. upper above belt (clear) . . . . .
75	Nova (2-Dr.) (exc. H.B.) . . . . .	1732852 L.H.	15.05	LACE, qtr. upper above belt (clear) . . . . .
75	Impala (Custom), Caprice (Spt. Cpe.) . . . . .	1734326 R.H.	3.30	LACE, qtr. belt moulding (black) . . . . .
75	Impala (Custom), Caprice (Spt. Cpe.) w/rear vinyl . . . . .	1734327 L.H.	3.30	LACE, qtr. belt moulding (black) . . . . .
75	Impala (Custom), Caprice (Spt. Cpe.) w/rear vinyl . . . . .	1734328 R.H.	3.30	LACE, qtr. belt moulding (white) . . . . .
75	Impala (Custom), Caprice (Spt. Cpe.) w/rear vinyl . . . . .	1734329 L.H.	3.30	LACE, qtr. belt moulding (white) . . . . .
75	Impala (Custom), Caprice (Spt. Cpe.) w/rear vinyl . . . . .	1734330 R.H.	3.30	LACE, qtr. belt moulding (silver) . . . . .
75	Impala (Custom), Caprice (Spt. Cpe.) w/rear vinyl . . . . .	1734331 L.H.	3.30	LACE, qtr. belt moulding (silver) . . . . .
75	Impala (Custom), Caprice (Spt. Cpe.) w/rear vinyl . . . . .	1734332 R.H.	3.30	LACE, qtr. belt moulding (maroon) . . . . .
75	Impala (Custom), Caprice (Spt. Cpe.) w/rear vinyl . . . . .	1734333 L.H.	3.30	LACE, qtr. belt moulding (maroon) . . . . .
75	Impala (Custom), Caprice (Spt. Cpe.) w/rear vinyl . . . . .	1734334 R.H.	3.10	LACE, qtr. belt moulding (green) . . . . .
75	Impala (Custom), Caprice (Spt. Cpe.) w/rear vinyl . . . . .	1734335 L.H.	3.30	LACE, qtr. belt moulding (green) . . . . .
75	Impala (Custom), Caprice (Spt. Cpe.) w/rear vinyl . . . . .	1734336 R.H.	3.30	LACE, qtr. belt moulding (blue) . . . . .
75	Impala (Custom), Caprice (Spt. Cpe.) w/rear vinyl . . . . .	1734337 L.H.	3.30	LACE, qtr. belt moulding (blue) . . . . .
75	Impala (Custom), Caprice (Spt. Cpe.) w/rear vinyl . . . . .	1734338 R.H.	3.30	LACE, qtr. belt moulding (beige) . . . . .
75	Impala (Custom), Caprice (Spt. Cpe.) w/rear vinyl . . . . .	1734339 L.H.	3.30	LACE, qtr. belt moulding (beige) . . . . .
75	Nova (2-Dr.) (exc. H.B.) (rr. vinyl) . . . . .	1732898 R.H.	3.25	LACE, qtr. belt moulding (white) . . . . .
75	Nova (2-Dr.) (exc. H.B.) (rr. vinyl) . . . . .	1732899 L.H.	3.25	LACE, qtr. belt moulding (white) . . . . .
75	Nova (2-Dr.) (exc. H.B.) (rr. vinyl) . . . . .	1732900 R.H.	3.25	LACE, qtr. belt moulding (silver) . . . . .
75	Nova (2-Dr.) (exc. H.B.) (rr. vinyl) . . . . .	1732901 L.H.	3.25	LACE, qtr. belt moulding (silver) . . . . .
75	Nova (2-Dr.) (exc. H.B.) (rr. vinyl) . . . . .	1732902 R.H.	3.25	LACE, qtr. belt moulding (black) . . . . .
75	Nova (2-Dr.) (exc. H.B.) (rr. vinyl) . . . . .	1732903 L.H.	3.25	LACE, qtr. belt moulding (black) . . . . .
75	Nova (2-Dr.) (exc. H.B.) (rr. vinyl) . . . . .	1732904 R.H.	3.25	LACE, qtr. belt moulding (blue) . . . . .
75	Nova (2-Dr.) (exc. H.B.) (rr. vinyl) . . . . .	1732905 L.H.	3.25	LACE, qtr. belt moulding (blue) . . . . .
75	Nova (2-Dr.) (exc. H.B.) (rr. vinyl) . . . . .	1732906 R.H.	3.25	LACE, qtr. belt moulding (green) . . . . .
75	Nova (2-Dr.) (exc. H.B.) (rr. vinyl) . . . . .	1732907 L.H.	3.25	LACE, qtr. belt moulding (green) . . . . .
75	Nova (2-Dr.) (exc. H.B.) (rr. vinyl) . . . . .	1732908 R.H.	3.25	LACE, qtr. belt moulding (sandstone) . . . . .
75	Nova (2-Dr.) (exc. H.B.) (rr. vinyl) . . . . .	1732909 L.H.	3.25	LACE, qtr. belt moulding (sandstone) . . . . .
75	Nova (2-Dr.) (exc. H.B.) (rr. vinyl) . . . . .	1732910 R.H.	3.25	LACE, qtr. belt moulding (maroon) . . . . .
75	Nova (2-Dr.) (exc. H.B.) (rr. vinyl) . . . . .	1732911 L.H.	3.25	LACE, qtr. belt moulding (maroon) . . . . .
75	Impala (Custom), Caprice (Spt. Cpe.) w/rear vinyl . . . . .	1734340 1	3.30	LACE, roof panel cover (black) . . . . .
75	Impala (Custom), Caprice (Spt. Cpe.) w/rear vinyl . . . . .	1734341 1	3.30	LACE, roof panel cover (white) . . . . .
75	Impala (Custom), Caprice (Spt. Cpe.) w/rear vinyl . . . . .	1734342 1	3.30	LACE, roof panel cover (silver) . . . . .

**METAL TRIM—CLIPS AND PANELS**

**12.075 MOULDING— CAP— CLIP— ESCUTCHEON— EXTENSION— LACE—  
RETAINER— SCALP— SCREW— STRIP, Roof Drip (Con't)**

75	Impala (Custom), Caprice (Spt. Cpe.) w/rear vinyl	1734343	1	3.30	LACE, roof panel cover (maroon)
75	Impala (Custom), Caprice (Spt. Cpe.) w/rear vinyl	1734344	1	3.30	LACE, roof panel cover (green)
75	Impala (Custom), Caprice (Spt. Cpe.) w/rear vinyl	1734345	1	3.30	LACE, roof panel cover (blue)
75	Impala (Custom), Caprice (Spt. Cpe.) w/rear vinyl	1734346	1	3.30	LACE, roof panel cover (beige)
75	Nova (2-Dr.) (exc. H.B.) (rr. vinyl)	1732884	1	3.95	LACE, roof panel cover/compt. lid (white)
75	Nova (2-Dr.) (exc. H.B.) (rr. vinyl)	1732885	1	3.95	LACE, roof panel cover/compt. lid (silver)
75	Nova (2-Dr.) (exc. H.B.) (rr. vinyl)	1732886	1	3.95	LACE, roof panel cover/compt. lid (black)
75	Nova (2-Dr.) (exc. H.B.) (rr. vinyl)	1732887	1	3.95	LACE, roof panel cover/compt. lid (blue)
75	Nova (2-Dr.) (exc. H.B.) (rr. vinyl)	1732888	1	3.95	LACE, roof panel cover/compt. lid (green)
75	Nova (2-Dr.) (exc. H.B.) (rr. vinyl)	1732889	1	3.95	LACE, roof panel cover/compt. lid (sandstone)
75	Nova (2-Dr.) (exc. H.B.) (rr. vinyl)	1732890	1	3.95	LACE, roof panel cover/compt. lid (maroon)
69	Pass. (exc. Spt. Cpe., Conv., Spt. Sed.),				
70	Bel Air,				
70	Kingswood (Estate)	8745168	2	.18	RETAINER, w/s plr. drip
64-65	Chevelle (Spt. Cpe.)	4456073	L.H.	9.60	SCALP, front
64-67	El Camino w/vinyl top	7643205	R.H.	8.75	SCALP
64-66	El Camino (Custom),				
67	El Camino (Deluxe) w/vinyl top	7643206	L.H.	8.75	SCALP
66-67	Nova (Spt. Cpe.)	7582513	R.H.	5.10	SCALP
66-67	Nova (Spt. Cpe.)	7582514	L.H.	5.10	SCALP
66-67	Chevelle (Spt. Cpe.)	4547733	R.H.	13.25	SCALP
66-67	Chevelle (Spt. Cpe.)	4547734	L.H.	13.25	SCALP
66-67	Malibu (Spt. Sed.)	4540945	R.H.	8.95	SCALP, front
65-68	Pass. (Sta. Wag.) (exc. Biscayne),				
67-68	Pass. (Sta. Wag.) (exc. Bel Air) w/roof drip mldg.,				
68	Impala (Sta. Wag.) w/roof drip mldg.,				
69	Estate Wag.	4468346	R.H.	11.30	SCALP, front
65-68	Pass. (Sta. Wag.) (exc. Biscayne),				
67-68	Pass. (Sta. Wag.) (exc. Bel Air) w/roof drip mldg.,				
68	Impala (Sta. Wag.) w/roof drip mldg.	4468347	L.H.	11.30	SCALP, front
65-66	Pass. (Spt. Cpe.) (exc. Caprice)	4481690	R.H.	13.65	SCALP
65-66	Pass. (Spt. Cpe.) (exc. Caprice)	4481691	L.H.	13.65	SCALP
67-68	Pass. (Spt. Sed.)	7647431	R.H.	9.30	SCALP
67-68	Pass. (Spt. Sed.)	7647432	L.H.	9.30	SCALP
67-68	Pass. (4-Dr. Sed.) (exc. Caprice)	7648328	R.H.	9.30	SCALP
67-68	Pass. (4-Dr. Sed.) (exc. Caprice)	7648329	L.H.	9.30	SCALP
67-68	Impala (Spt. Cpe.) (exc. Custom)	7650000	R.H.	13.75	SCALP
67-68	Impala (Spt. Cpe.) (exc. Custom)	7650001	L.H.	13.75	SCALP
67-68	Camaro (Spt. Cpe.) w/roof drip moulding, vinyl top,				
69	Camaro (Spt. Cpe.) w/roof drip mldg.	7639406	R.H.	4.90	SCALP
67-68	Camaro (Spt. Cpe.) w/roof drip moulding, vinyl top,				
69	Camaro (Spt. Cpe.) w/roof drip mldg.	7639407	L.H.	4.90	SCALP
67-68	Camaro (Spt. Cpe.) w/roof drip moulding, vinyl top,				
69	Camaro (Spt. Cpe.) w/roof drip mldg.	7656810	R.H.	3.80	SCALP, w/s pillar drip
67-68	Camaro (Spt. Cpe.) w/roof drip moulding, vinyl top,				
69	Camaro (Spt. Cpe.) w/roof drip mldg.	7656811	L.H.	3.80	SCALP, w/s pillar drip
68	Malibu, Concours (4-Dr.),				
69-72	Chevelle (4-Dr.) (exc. Sta. Wag.) (Nomad)	7726065	R.H.	2.35	SCALP, w/s pillar drip
68	Malibu, Concours (4-Dr.),				
68-72	Chevelle (4-Dr.) (exc. Nomad) w/vinyl top	7726066	L.H.	2.35	SCALP, w/s pillar drip
68-69	Malibu (4-Dr. Sed.) (exc. Spt. Sed.),				
69-72	Chevelle (4-Dr. Sed.) w/vinyl top (exc. Spt. Sed.)	7721950	R.H.	10.55	SCALP, drip moulding

**METAL TRIM—CLIPS AND PANELS**

**12.075 MOULDING— CAP— CLIP— ESCUTCHEON— EXTENSION— LACE—  
RETAINER— SCALP— SCREW— STRIP, Roof Drip (Con't)**

68-69	Malibu (4-Dr. Sed.) (exc. Spt. Sed.),				
69-72	Chevelle (4-Dr. Sed.) w/vinyl top (exc. Spt. Sed.)	7721951 L.H.	10.55	SCALP, drip moulding	
68-72	El Camino w/vinyl top,				
68-72	El Camino (Custom)	7723362 R.H.	4.55	SCALP	
68	El Camino w/vinyl top,				
68-69	El Camino (Custom),				
71-72	Chevelle (Sta. Wag.)	7723363 L.H.	4.55	SCALP	
68-69	Malibu, S.S. (Spt. Cpe.)	7723584 R.H.	8.60	SCALP	
68-69	Malibu, S.S. (Spt. Cpe.)	7723585 L.H.	8.60	SCALP	
68-72	Chevelle (Sta. Wag.) (exc. Nomad Std.)	7723762 R.H.	8.00	SCALP	
68-72	Chevelle (Sta. Wag.) (exc. Nomad Std.)	7723763 L.H.	8.00	SCALP	
68-69	Malibu, S.S. (Spt. Cpe., El Camino) (Custom),				
70	Malibu, El Camino (Custom) Monte Carlo,				
71-72	Chevelle (2-Dr.) (exc. Deluxe, Conv.)	7726067 R.H.	2.65	SCALP, w/s pillar drip mldg.	
68-72	Chevelle (Spt. Cpe., El Camino) w/vinyl top,				
68-69	Malibu, S.S. (Spt. Cpe., El Camino) (Custom),				
70	Malibu, El Camino (Custom) Monte Carlo,				
71-72	Chevelle (2-Dr.) (exc. Deluxe, Conv.)	7726068 L.H.	2.65	SCALP, w/s pillar drip mldg.	
68-69	Malibu, S.S. (Spt. Cpe.) w/vinyl top,				
69	Chevelle (Deluxe) (exc. 4-Dr. Sed.) w/vinyl top	7753596 R.H.	7.60	SCALP	
68-69	Malibu, S.S. (Spt. Cpe.) w/vinyl top,				
69	Chevelle (Deluxe) (exc. 4-Dr. Sed.) w/vinyl top	7753597 L.H.	7.60	SCALP	
68-72	Chevy (4-Dr.) w/vinyl top	7719293 R.H.	3.90	SCALP	
68-72	Chevy (4-Dr.) w/vinyl top	7719294 L.H.	3.90	SCALP	
68-74	Chevy (4-Dr.) w/vinyl top	7722776 R.H.	3.70	SCALP, w/s pillar drip	
68-74	Chevy (4-Dr.) w/vinyl top	7722777 L.H.	3.70	SCALP, w/s pillar drip	
68-72	Chevy (Spt. Cpe.) w/vinyl top	7738095 R.H.	4.65	SCALP, front	
68-72	Chevy (Spt. Cpe.) w/vinyl top	7738096 L.H.	4.65	SCALP, front	
68-74	Chevy (Spt. Cpe.) w/vinyl top	7740281 R.H.	4.55	SCALP, w/s pillar drip	
68-74	Chevy (Spt. Cpe.) w/vinyl top	7740282 L.H.	4.55	SCALP, w/s pillar drip	
68-72	Chevy (Spt. Cpe.) w/vinyl top	7741463 R.H.	4.05	SCALP, rear	
68-72	Chevy (Spt. Cpe.) w/vinyl top	7741464 L.H.	4.05	SCALP, rear	
68	Caprice, Impala Custom (Spt. Cpe.)	7761578 R.H.	5.15	SCALP, front	
68	Caprice, Impala Custom (Spt. Cpe.)	7761580 R.H.	12.65	SCALP, rear	
69-70	Pass. (Spt. Sed.)	8711796 R.H.	5.95	SCALP, front	
69-70	Pass. (Spt. Sed.)	8711797 L.H.	5.95	SCALP, front	
69-70	Pass. (Spt. Sed.)	8712888 R.H.	6.50	SCALP, rear	
69-70	Pass. (Spt. Sed.)	8712889 L.H.	6.50	SCALP, rear	
69-70	Impala (Spt. Cpe.) (exc. Custom)	8713316 R.H.	6.15	SCALP, front	
69-70	Impala (Spt. Cpe.) (exc. Custom)	8713317 L.H.	6.15	SCALP, front	
69-70	Impala (Spt. Cpe.) (exc. Custom)	8715172 R.H.	7.50	SCALP, rear	
69-70	Impala (Spt. Cpe.) (exc. Custom)	8715173 L.H.	7.50	SCALP, rear	
69-70	Impala Custom, Caprice (Spt. Cpe.)	8712747 R.H.	5.00	SCALP, front	
69-70	Impala Custom, Caprice (Spt. Cpe.)	8712748 L.H.	5.00	SCALP, front	
69-70	Impala Custom, Caprice (Spt. Cpe.)	8714836 R.H.	15.35	SCALP, rear	
69-70	Impala Custom, Caprice (Spt. Cpe.)	8714837 L.H.	15.35	SCALP, rear	
69	Estate Wag., Townsman, Bel Air, Pass. w/roof drip, mldg.,				
70	Kingswood (Estate),				
70	Pass. (Sed.) (exc. Spt. Sed.)	8784782 R.H.	10.90	SCALP, w/s plr.	
69	Estate Wag., Townsman, Bel Air, Pass. w/roof drip mldg.,				
70	Kingswood (Estate),				

**METAL TRIM—CLIPS AND PANELS**

<b>12.075 MOULDING— CAP— CLIP— ESCUTCHEON— EXTENSION— LACE— RETAINER— SCALP— SCREW— STRIP, Roof Drip (Con't)</b>					
70	Pass. (Sed.) (exc. Spt. Sed.)	8784783	L.H.	10.90	SCALP, w/s plr.
69	4-Dr. Sed. w/roof drip mldg. (exc. Spt. Sed.)				
70	Pass. (Sed.) (exc. Spt. Sed.) w/vinyl top	8729164	R.H.	11.25	SCALP
69	4-Dr. Sed. w/roof drip mldg. (exc. Spt. Sed.)				
70	Pass. (Sed.) (exc. Spt. Sed.) w/vinyl top	8729165	L.H.	11.25	SCALP
69-70	Pass. (Spt. Cpe., Spt. Sed.)	8784784	R.H.	10.90	SCALP, w/s plr.
69-70	Pass. (Spt. Cpe., Spt. Sed.)	8784785	L.H.	10.90	SCALP, w/s plr.
69	Pass. (Sta. Wag.) w/roof drip mldg.,				
70	Kingswood (exc. Kingswood Estate) w/vinyl top,				
70	Kingswood (Estate)	8751788	R.H.	12.00	SCALP, front
69	Pass. (Sta. Wag.) w/roof drip mldg.,				
70	Kingswood (exc. Kingswood Estate) w/vinyl top,				
70	Kingswood (Estate)	8751789	L.H.	12.00	SCALP, front
69	Townsmen,				
69	Kingswood, Brookwood w/door, wind. mldg. (exc. Estate),				
70	Kingswood (exc. Kingswood Estate) w/vinyl top,				
70	Kingswood (Estate)	8751790	R.H.	6.60	SCALP, rear
69	Townsmen,				
69	Kingswood, Brookwood w/door, wind. mldg. (exc. Estate),				
70	Kingswood (exc. Kingswood Estate) w/vinyl top,				
70	Kingswood (Estate)	8751791	L.H.	6.60	SCALP, rear
68-72	Chevelle (Spt. Sed.) w/vinyl top	8741070	R.H.	11.10	SCALP, frt. Note 1
68-72	Chevelle (Spt. Sed.) w/vinyl top	8741071	L.H.	11.10	SCALP, frt. Note 1
70-72	Chevelle (Spt. Sed.)	8736851	R.H.	6.05	SCALP, rear
70-72	Chevelle (Spt. Sed.)	8736852	L.H.	8.00	SCALP, rear
70	Malibu (Spt. Cpe.),				
70	Chevelle Deluxe (Spt. Cpe.) w/vinyl top,				
70-72	Malibu (Spt. Cpe.),				
70-72	Chevelle (Spt. Cpe.) w/ext. orn. (exc. vinyl top),				
71-72	Chevelle (Spt. Cpe.) w/vinyl top	8782461	L.H.	9.05	SCALP
70	Chevelle Deluxe (Spt. Cpe.) w/vinyl top,				
70-72	Malibu (Spt. Cpe.),				
70-72	Chevelle (Spt. Cpe.) w/ext. orn. (exc. vinyl top),				
71-72	Chevelle (Spt. Cpe.) w/vinyl top	8782460	R.H.	9.05	SCALP
70-72	Monte Carlo	9809051	R.H.	5.00	SCALP, front
70-72	Monte Carlo	9809052	L.H.	5.00	SCALP, front
70-72	Monte Carlo	9809053	R.H.	2.95	SCALP, rear
70-72	Monte Carlo	9809054	L.H.	2.75	SCALP, rear
71-73	Vega (Sta. Wag.)	9826766	R.H.	5.35	SCALP, body back pillar drip moulding
71-73	Vega (Sta. Wag.)	9826767	L.H.	5.35	SCALP, body back pillar drip moulding
71-73	Vega (Sed. Cpe.) w/vinyl roof, ext. ornaments,				
74	Vega (Panel),				
71-74	Vega (Sta. Wag.)	9738811	2	5.70	SCALP, roof drip moulding (85 <sup>3</sup> / <sub>4</sub> " (Note 1)
73	Vega (Cpe.) w/vinyl roof	9823901	2	5.80	SCALP ASSY., roof drip moulding (85) (Note 2)
74	Vega (Cpe.) w/vinyl roof	9692736	2	5.80	SCALP, roof drip moulding (80 <sup>5</sup> / <sub>16</sub> " (Note 1)
74	Vega (Cpe.) (exc. vinyl roof)	9667858	2	5.50	SCALP, roof drip moulding (84 <sup>1</sup> / <sub>8</sub> " (Note 1)
73-74	Nova (2-Dr.) w/drip mldg., vinyl top	9668775	L.H.	3.25	SCALP, rear
73-74	Nova (2-Dr.) w/drip mldg., vinyl top	9668774	R.H.	3.25	SCALP, rear
73-74	Nova (2-Dr.) w/drip mldg., vinyl top	9621534	L.H.	4.65	SCALP, front
73-74	Nova (2-Dr.) w/drip mldg., vinyl top	9621533	R.H.	4.65	SCALP, front



**METAL TRIM—CLIPS AND PANELS**

**12.075 MOULDING— CAP— CLIP— ESCUTCHEON— EXTENSION— LACE—  
RETAINER— SCALP— SCREW— STRIP, Roof Drip (Con't)**

73-74	Nova (4-Dr.) w/drip mldg., vinyl top	9617067 L.H.	5.60	SCALP
73-74	Nova (4-Dr.) w/drip mldg., vinyl top	9617066 R.H.	5.60	SCALP
74-75	Nova (2-Dr.) w/padded vinyl top	9738811 2	5.70	SCALP, roof drip mldg.
74-75	Nova (4-Dr.) w/vinyl top or two tone paint	1708771 L.H.	4.95	SCALP, roof drip (repl. 1659473)
74-75	Nova (4-Dr.) w/vinyl top or two tone paint	1708770 R.H.	4.95	SCALP, roof drip (repl. 1659472, 1707426)
75	Nova (2-Dr.) w/padded vinyl roof	1707347 R.H.	5.70	SCALP, roof drip
75	Nova (2-Dr.) w/padded vinyl roof	1707348 L.H.	5.70	SCALP, roof drip
75	Nova (2-Dr.) w/rear vinyl	1732317 2	7.05	SCALP, roof drip
75	Vega (exc. Sta. Wag. & Panel) Monza Towne Coupe	1699922 2	5.80	SCALP, roof drip mldg. 85.38" long
75	Vega, Monza (Notchback) (exc. Panel)	9738811 2	5.70	SCALP, roof drip
75	Vega, Monza Towne Coupe (exc. Panel)	1732317 2	7.05	SCALP, roof drip
<i>NOTE 1: It may be necessary to cut as required.</i>				
65-67	Pass.	588546 A.R.	.11	SCREW, side roof front and rear (No. 8-18 x 7/16")— (12.118)
70	Camaro	9827271 2	.22	STRIP, roof panel finish mldg. protector
<i>NOTE 1 When used with vinyl top trim vinyl for proper fit.</i>				

**12.112 MOULDING— MOULDING UNIT— BUMPER— STRIPE— ORNAMENT—  
TAPE— CLIP— TRANSFER, Front Door Outer Panel**

*NOTE 2 Paint as required.*

62	Chevy Deluxe (2-Dr.) (exc. Nova Sedan)			MOULDING UNIT, lower, upper (depressed area black) (Note 1)
62	Nova (2-Dr. Sed.)	3793389 L.H.	8.40	
62	Chevy Deluxe (2-Dr.) (exc. Nova Sedan)			MOULDING UNIT, lower, upper (depressed area black) (Note 1)
62	Nova (2-Dr. Sed.)	3793390 R.H.	8.55	
<i>NOTE 1 It may be necessary to remove the paint from the depressed area on earlier models.</i>				
63	Chevy Deluxe (4-Dr.) (exc. Nova)	3832652 R.H.	10.15	MOULDING UNIT, lower
63	Chevy Deluxe (4-Dr.) (exc. Nova)	3832651 L.H.	9.45	MOULDING UNIT, lower
63	Nova (4-Dr.)	3832658 R.H.	10.15	MOULDING UNIT, lower (ivory and black)
63	Nova (Super Sport)	3832655 L.H.	10.55	MOULDING UNIT, lower (silver and black)
64	Nova (2-Dr.)	3851726 R.H.	8.40	MOULDING UNIT, lower
64	Nova (2-Dr.)	3851725 L.H.	8.40	MOULDING UNIT, lower
64	Nova (4-Dr.)	3851728 R.H.	7.85	MOULDING UNIT, lower
64	Nova (4-Dr.)	3851727 L.H.	7.85	MOULDING UNIT, lower
64	Chevelle (2-Dr.)	3852508 2	7.85	MOULDING UNIT, lower
64	Chevelle (4-Dr.)	3852511 2	6.75	MOULDING UNIT, lower
64	Malibu (S.S.)	3852509 L.H.	7.85	MOULDING UNIT, upper peak
65	Nova (Spt. Cpe.) (exc. S.S.)	3870968 R.H.	10.50	MOULDING UNIT, lower
65	Nova (4-Dr.)	3870969 L.H.	9.70	MOULDING UNIT, lower
65	Nova (4-Dr.)	3870970 R.H.	9.70	MOULDING UNIT, lower
65	Nova (S.S.)	3870973 L.H.	9.75	MOULDING UNIT, lower
65	Nova (S.S.)	3870974 R.H.	9.75	MOULDING UNIT, lower
65	Malibu (2-Dr.) (exc. S.S.)	3871609 L.H.	7.85	MOULDING UNIT, lower
65	Malibu (2-Dr.) (exc. S.S.)	3871610 R.H.	7.85	MOULDING UNIT, lower
65	Malibu (4-Dr.)	3871611 L.H.	6.75	MOULDING UNIT, lower
65	Malibu (4-Dr.)	3871612 R.H.	6.75	MOULDING UNIT, lower
65	Bel Air (4-Dr.)	3870850 2	7.55	MOULDING UNIT, lower
66	Bel Air (4-Dr.)	4227271 2	7.55	MOULDING UNIT, lower
66	Impala (4-Dr.)	4227270 2	8.70	MOULDING UNIT, lower
66	Impala (Spt. Cpe., Conv.)	4227273 2	9.55	MOULDING UNIT, lower
66	Chevelle Deluxe (4-Dr.)	4227210 2	6.75	MOULDING UNIT, lower
66	Chevelle Deluxe (2-Dr.)			
66	El Camino (exc. Custom)	4227211 2	7.85	MOULDING UNIT, lower
66	Nova (Spt. Cpe.) (exc. S.S.)	4227226 2	8.40	MOULDING UNIT, lower
66	Nova (4-Dr.)	4227164 2	7.55	MOULDING UNIT, lower
67	Nova (4-Dr.)	4229559 2	7.55	MOULDING UNIT, lower
67	Nova (Spt. Cpe.) (exc. S.S.)	4229558 2	8.40	MOULDING UNIT, lower
67	Nova (S.S.)	4229557 L.H.	9.80	MOULDING UNIT, lower
67	Camaro w/body side mldg.	4229491 R.H.	15.85	MOULDING UNIT, lower
67	Camaro w/body side mldg.	4229492 L.H.	15.85	MOULDING UNIT, lower
67	Malibu (4-Dr.)	4229754 R.H.	6.75	MOULDING UNIT, lower
67	Malibu (4-Dr.)	4229755 L.H.	6.75	MOULDING UNIT, lower
67	Malibu, El Camino (2-Dr.)	4229756 R.H.	7.85	MOULDING UNIT, lower
67	Malibu, El Camino (2-Dr.)	4229757 L.H.	7.85	MOULDING UNIT, lower
67	Bel Air (2-Dr.)	4229459 2	9.55	MOULDING UNIT, lower

**METAL TRIM—CLIPS AND PANELS**

**12.112 MOULDING— MOULDING UNIT— BUMPER— STRIPE— ORNAMENT—  
TAPE— CLIP— TRANSFER, Front Door Outer Panel (Con't)**

67	Bel Air (4-Dr.)	4229460 R.H.	7.55	MOULDING UNIT, lower
67	Bel Air (4-Dr.)	4229461 L.H.	7.55	MOULDING UNIT, lower
67	Impala (Spt. Cpe., Conv.) (exc. S.S.)	4229462 R.H.	9.55	MOULDING UNIT, lower
67	Impala (Spt. Cpe., Conv.) (exc. S.S.)	4229463 L.H.	9.55	MOULDING UNIT, lower
67	Impala (4-Dr.)	4229464 2	8.40	MOULDING UNIT, lower
67	Caprice (Spt. Sed.)	4229470 R.H.	8.40	MOULDING UNIT, lower
67	Caprice (Spt. Sed.)	4229471 L.H.	8.40	MOULDING UNIT, lower
67	Caprice (Spt. Cpe.)	4229468 R.H.	9.55	MOULDING UNIT, lower
67	Caprice (Spt. Cpe.)	4229469 L.H.	9.55	MOULDING UNIT, lower
67	Caprice (Sta. Wag.)	4229488 R.H.	7.55	MOULDING UNIT, upper finish
67	Caprice (Sta. Wag.)	4229489 L.H.	7.55	MOULDING UNIT, upper finish
67	Caprice (Sta. Wag.)	4229485 2	6.75	MOULDING UNIT, lower
68	Caprice (Spt. Cpe.)	7795012 R.H.	13.25	MOULDING UNIT, frt. door outer lwr.
68	Caprice (Spt. Cpe.)	7795013 L.H.	13.25	MOULDING UNIT, frt. door outer lwr.
68	Caprice (Sta. Wag.)	7795436 R.H.	12.85	MOULDING UNIT, transfer upper finish
68	Caprice (Sta. Wag.)	7795437 L.H.	12.85	MOULDING UNIT, transfer upper finish
68	Caprice (Sta. Wag.)	7795438 1	8.40	MOULDING UNIT, transfer lower finish
68	Caprice (Sed.)	7795014 R.H.	12.10	MOULDING UNIT, lower
68	Caprice (Sed.)	7795015 L.H.	12.10	MOULDING UNIT, lower
68	Bel Air (2-Dr. Sed.)	7795022 1	8.70	MOULDING UNIT, lower
68	Bel Air w/Side Body Mldg. (exc. 2-Dr.)	7795023 1	7.55	MOULDING UNIT, lower
68	Impala (2-Dr.) (1st design)	8700055 2	11.30	MOULDING UNIT, outer lower (black)
68	Impala (4-Dr. Sed.)	8700048 1	12.65	MOULDING UNIT, otr. lower (black) (smooth)
68	Impala (2-Dr.) (2nd design)	7795579 L.H.	11.30	MOULDING UNIT, outer lower (black) (stipple)
68	Impala (2-Dr.) (2nd design)	7795578 R.H.	11.30	MOULDING UNIT, outer lower (black) (stipple)
68	Impala (Sta. Wag.)			
68	Impala (4-Dr. Sed.) (2nd design)	7795580 R.H.	11.30	MOULDING UNIT, outer lower (black) (stipple molded)
68	Impala (4-Dr. Sed.) (2nd design)	7795581 L.H.	11.30	MOULDING UNIT, outer lower (black) (stipple molded)
68-69	Chevelle (2-Dr.) El Camino (exc. Deluxe)	7795006 R.H.	7.85	MOULDING UNIT, lower
68-69	Chevelle (2-Dr.) El Camino (exc. Deluxe)	7795007 L.H.	7.85	MOULDING UNIT, lower
68-69	Malibu (4-Dr.)	7795010 R.H.	6.75	MOULDING UNIT, lower
68-69	Malibu (4-Dr.)	7795011 L.H.	6.75	MOULDING UNIT, lower
68	Camaro w/side body mldg.	7795016 R.H.	11.70	MOULDING UNIT, lower
68	Camaro w/side body mldg.	7795017 L.H.	11.70	MOULDING UNIT, lower
68	Chevy (Spt. Cpe.) w/side body mldg.	7795018 2	9.80	MOULDING UNIT, lower
68	Chevy (Sed.) w/side body mldg.	7795019 2	9.05	MOULDING UNIT, lower
68-69	Malibu (Spt. Sed.) w/side body mldg.	7795020 R.H.	12.10	MOULDING UNIT, lower
68-69	Malibu (Spt. Sed.) w/side body mldg.	7795021 L.H.	12.10	MOULDING UNIT, lower
68	Concours,			
69	Concours (Estate Wag.)	7795403 R.H.	6.75	MOULDING UNIT, trans. upper finish
68	Concours,			
69	Concours (Estate Wag.)	7795404 L.H.	6.75	MOULDING UNIT, trans. upper finish
68	Concours,			
69	Concours (Estate Wag.)	7795405 R.H.	6.75	MOULDING UNIT, transfer lower finish
68-70	Chevy (Spt. Cpe.)	7795024 2	9.80	MOULDING UNIT, lower
69-71	Chevy (4-Dr. Sed.) w/body side mldg.	8705638 L.H.	12.85	MOULDING UNIT, lower
69	Caprice (Spt. Cpe.)	8701208 R.H.	12.10	MOULDING UNIT, outer lower
69	Caprice (Spt. Cpe.)	8701209 L.H.	12.10	MOULDING UNIT, outer lower
69	Impala (Spt. Cpe., Conv.)	8701240 R.H.	13.55	MOULDING UNIT, outer lower (black)
69	Impala (Spt. Cpe., Conv.)	8701241 L.H.	13.55	MOULDING UNIT, outer lower (black)
69	Impala (Spt. Cpe., Conv.)	8701242 R.H.	13.55	MOULDING UNIT, outer lower (blue)
69	Impala (Spt. Cpe., Conv.)	8701243 L.H.	13.55	MOULDING UNIT, outer lower (blue)
69	Impala (Spt. Cpe., Conv.)	8701244 R.H.	13.55	MOULDING UNIT, outer lower (green)
69	Impala (Spt. Cpe., Conv.)	8701245 L.H.	13.55	MOULDING UNIT, outer lower (green)
69	Impala (Spt. Cpe., Conv.)	8701246 R.H.	13.55	MOULDING UNIT, outer lower (red)
69	Impala (Spt. Cpe., Conv.)	8701247 L.H.	13.55	MOULDING UNIT, outer lower (red)
69	Impala (Spt. Cpe., Conv.)	8701248 R.H.	13.55	MOULDING UNIT, outer lower (brown)
69	Impala (Spt. Cpe., Conv.)	8701249 L.H.	13.55	MOULDING UNIT, outer lower (brown)
69	Estate Wag.	8701329 R.H.	9.05	MOULDING UNIT, transfer lower finish
69	Estate Wag.	8701330 L.H.	9.05	MOULDING UNIT, transfer lower finish

**METAL TRIM—CLIPS AND PANELS**

**12.112 MOULDING— MOULDING UNIT— BUMPER— STRIPE— ORNAMENT—  
TAPE— CLIP— TRANSFER, Front Door Outer Panel (Con't)**

69	Estate Wag. ....	8701135 R.H.	9.05	MOULDING UNIT, transfer upper finish ...
69	Estate Wag. ....	8701136 L.H.	9.05	MOULDING UNIT, transfer upper finish ...
69	Bel Air (2-Dr. Sed.) ....	8701097 1	8.40	MOULDING UNIT, lower ...
69-70	Townsmen, Bel Air (4-Dr.) ....	8701098 1	7.55	MOULDING UNIT, lower ...
69	Caprice (Spt. Sed.) ....	8701210 R.H.	10.55	MOULDING UNIT, frt. dr. lower ...
69	Caprice (Spt. Sed.) ....	8701211 L.H.	10.55	MOULDING UNIT, frt. dr. lower ...
69	Impala, Kingswood (4-Dr.) ....	8701250 R.H.	11.30	MOULDING UNIT, lower (black) ...
69	Impala, Kingswood (4-Dr.) ....	8701251 L.H.	11.30	MOULDING UNIT, lower (black) ...
69	Impala, Kingswood (4-Dr.) ....	8701252 R.H.	11.30	MOULDING UNIT, lower (blue) ...
69	Impala, Kingswood (4-Dr.) ....	8701253 L.H.	11.30	MOULDING UNIT, lower (blue) ...
69	Impala, Kingswood (4-Dr.) ....	8701254 R.H.	11.30	MOULDING UNIT, lower (green) ...
69	Impala, Kingswood (4-Dr.) ....	8701255 L.H.	11.30	MOULDING UNIT, lower (green) ...
69	Impala, Kingswood (4-Dr.) ....	8701256 R.H.	11.30	MOULDING UNIT, lower (red) ...
69	Impala, Kingswood (4-Dr.) ....	8701257 L.H.	11.30	MOULDING UNIT, lower (red) ...
69	Impala, Kingswood (4-Dr.) ....	8701258 R.H.	11.30	MOULDING UNIT, lower (brown) ...
69	Impala, Kingswood (4-Dr.) ....	8701259 L.H.	11.30	MOULDING UNIT, lower (brown) ...
69-70	Nova (2-Dr.) (1st design) ....	8701150 L.H.	11.65	MOULDING UNIT, lower (black vinyl insert)
69-72	Nova (2-Dr.) (2nd design) ....	8705636 L.H.	14.50	MOULDING UNIT, front door outer panel lower (painted insert) ...
69-72	Nova (2-Dr.) (2nd design) ....	8705635 R.H.	14.50	MOULDING UNIT, front door outer panel lower (painted insert) ...
70	Pass. (Estate Wag.) ....	8702948 R.H.	9.80	MOULDING UNIT, trans. lower ...
70	Pass. (Estate Wag.) ....	8702949 L.H.	9.80	MOULDING UNIT, trans. lower ...
70	Pass. (Estate Wag.) ....	8702946 R.H.	10.55	MOULDING UNIT, trans. upper ...
70	Pass. (Estate Wag.) ....	8702947 L.H.	10.55	MOULDING UNIT, trans. upper ...
70	Impala (exc. Sed.) ....	8702892 R.H.	13.55	MOULDING UNIT, lower (saddle) ...
70	Impala (exc. Sed.) ....	8702893 L.H.	13.55	MOULDING UNIT, lower (saddle) ...
70	Impala (exc. Sed.) ....	8700852 R.H.	13.55	MOULDING UNIT, lower (black) ...
70	Impala (exc. Sed.) ....	8700853 L.H.	13.55	MOULDING UNIT, lower (black) ...
70	Impala (exc. Sed.) ....	8702888 R.H.	13.55	MOULDING UNIT, lower (blue) ...
70	Impala (exc. Sed.) ....	8702889 L.H.	13.55	MOULDING UNIT, lower (blue) ...
70	Impala (exc. Sed.) ....	8702855 R.H.	13.55	MOULDING UNIT, lower (green) ...
70	Caprice (Spt. Cpe.) ....	8702970 R.H.	12.10	MOULDING UNIT, front lower ...
70	Caprice (Spt. Cpe.) ....	8702971 L.H.	12.10	MOULDING UNIT, front lower ...
70	Caprice (Spt. Sed.) ....	8702972 R.H.	11.30	MOULDING UNIT, front lower ...
70	Caprice (Spt. Sed.) ....	8702973 L.H.	11.30	MOULDING UNIT, front lower ...
70	Biscayne, Bel Air ....	8701098 1	7.55	MOULDING UNIT, lower ...
70	Impala (exc. Sed.) ....	8702856 L.H.	13.55	MOULDING UNIT, lower (green) ...
70	Impala (exc. Sed.) ....	8702890 R.H.	13.55	MOULDING UNIT, lower (gold) ...
70	Impala (exc. Sed.) ....	8702891 L.H.	13.55	MOULDING UNIT, lower (gold) ...
70	Impala (Sed.), Kingswood (exc. Estate) ....	8702925 R.H.	11.30	MOULDING UNIT, lower (saddle) ...
70	Impala (Sed.), Kingswood (exc. Estate) ....	8702926 L.H.	11.30	MOULDING UNIT, lower (saddle) ...
70	Impala (Sed.), Kingswood (exc. Estate) ....	8702923 R.H.	11.30	MOULDING UNIT, lower (gold) ...
70	Impala (Sed.), Kingswood (exc. Estate) ....	8702924 L.H.	11.30	MOULDING UNIT, lower (gold) ...
70	Impala (Sed.), Kingswood (exc. Estate) ....	8702921 R.H.	11.30	MOULDING UNIT, lower (blue) ...
70	Impala (Sed.), Kingswood (exc. Estate) ....	8702922 L.H.	11.30	MOULDING UNIT, lower (blue) ...
70	Impala (Sed.), Kingswood (exc. Estate) ....	8702919 R.H.	11.30	MOULDING UNIT, lower (green) ...
70	Impala (Sed.), Kingswood (exc. Estate) ....	8702920 L.H.	11.30	MOULDING UNIT, lower (green) ...
70	Impala (Sed.), Kingswood (exc. Estate) ....	8702917 R.H.	11.30	MOULDING UNIT (black) ...
70	Impala (Sed.), Kingswood (exc. Estate) ....	8702918 L.H.	11.30	MOULDING UNIT (black) ...
70-72	Concours Estate ....	8702991 R.H.	11.30	MOULDING UNIT, trans. finish upper ...
70-72	Concours Estate ....	8702992 L.H.	11.30	MOULDING UNIT, trans. finish upper ...
70-72	Concours Estate ....	8702993 R.H.	11.30	MOULDING UNIT, trans. finish lower ...
70-72	Concours Estate ....	8702994 L.H.	11.30	MOULDING UNIT, trans. finish lower ...
70	Malibu (Sed.) ....	8701410 R.H.	9.80	MOULDING UNIT, peak front ...
70	Malibu (Sed.) ....	8701411 L.H.	9.80	MOULDING UNIT, peak front ...
70	Malibu (Spt. Cpe., Conv.) ....	8701412 2	11.00	MOULDING UNIT, peak front ...
70-72	Monte Carlo ....	8701417 R.H.	15.85	MOULDING UNIT, front lower ...
70-72	Monte Carlo ....	8701418 L.H.	15.85	MOULDING UNIT, front lower ...
70-72	El Camino ....	8701414 R.H.	13.15	MOULDING UNIT, front lower ...
70-72	El Camino ....	8701415 L.H.	13.15	MOULDING UNIT, front lower ...
71	Pass. (2-Dr.) ....	8704103 L.H.	21.10	MOULDING UNIT, lower (chrome) ...
71	Pass. (2-Dr.) ....	8704102 R.H.	21.10	MOULDING UNIT, lower (chrome) ...
71	Pass. (2-Dr.) w/body side mldg. .	8704485 1	12.85	MOULDING UNIT, upper (vinyl insert) ...

**METAL TRIM—CLIPS AND PANELS**

**12.112 MOULDING— MOULDING UNIT— BUMPER— STRIPE— ORNAMENT—  
TAPE— CLIP— TRANSFER, Front Door Outer Panel (Con't)**

71	Impala, Caprice (4-Dr.),				
71	Kingswood (exc. Kingswood Estate)	8704490 R.H.	18.05	MOULDING UNIT, lower (chrome)	
71-72	Kingswood Estate	8704514 L.H.	11.30	MOULDING UNIT, finish front door outer panel transfer upper	
71-72	Kingswood Estate	8704513 R.H.	11.30	MOULDING UNIT, finish front door outer panel transfer upper	
71-72	Kingswood Estate	8704516 L.H.	11.30	MOULDING UNIT, finish front door outer panel transfer lower	
71-72	Kingswood Estate	8704515 R.H.	11.30	MOULDING UNIT, finish front door outer panel transfer lower	
71	Impala, Caprice (4-Dr.),				
71	Kingswood (exc. Kingswood Estate)	8704517 1	18.10	MOULDING UNIT, lower (chrome)	
71	Impala, Caprice (4-Dr.),				
71	Kingswood			MOULDING UNIT, upper,	
71	Biscayne, Bel Air,				
71	Brookwood, Townsman	8704520 1	11.30	MOULDING UNIT, lower (chrome)	
71-72	Nova (4-Dr.) (2nd design)	8705638 L.H.	12.85	MOULDING UNIT, front door outer panel lower (painted insert)	
71-72	Nova (4-Dr.) (2nd design)	8705637 R.H.	12.85	MOULDING UNIT, front door outer panel lower (painted insert)	
71-72	Vega	8704084 R.H.	9.60	MOULDING UNIT, outer panel front door upper	
71-72	Vega	8704085 L.H.	9.60	MOULDING UNIT, outer panel front door upper	
71-75	Vega (exc. Panel) w/body side lwr. mldg.	8704092 2	11.60	MOULDING UNIT, outer panel front door lower	
72	Impala (Sed.) Kingswood (exc. Estate)	8705693 2	11.30	MOULDING UNIT, lower (chrome)	
72	Pass. (4-Dr.) w/body side mldg. (exc. Estate)	8705687 2	11.30	MOULDING UNIT, lower (vinyl insert)	
72	Pass. (2 dr.) w/body side mldg.	8704736 2	17.40	MOULDING UNIT, upper (vinyl insert)	
72	Caprice (Sed.)	8705375 R.H.	18.10	MOULDING UNIT, front door lower (chrome)	
72	Caprice (Sed.)	8705376 L.H.	18.10	MOULDING UNIT, front door lower (chrome)	
72	Caprice (Spt. Cpe.)	8705379 R.H.	21.10	MOULDING UNIT, front door lower (chrome)	
72	Caprice (Spt. Cpe.)	8705380 L.H.	21.10	MOULDING UNIT, front door lower (chrome)	
72	Chevelle (Spt. Cpe., Conv.) w/body side mldg.	8703329 2	7.85	MOULDING UNIT, lower	
72	Chevelle (Sed.) w/body side mldg.	8703325 2	9.80	MOULDING UNIT, lower	
72	Chevelle (Sta. Wag.)	8703326 2	9.80	MOULDING UNIT, lower	
72	El Camino w/body side mldg.	8703328 2	7.85	MOULDING UNIT, lower	
72	Impala (Spt. Cpe., Conv.) (exc. Custom)	8705698 2	12.85	MOULDING UNIT, lower	
<b>1973-75 PASS.</b>					
73-75	Caprice (Sta. Wag.)	8704514 L.H.	11.30	finish front door outer panel transfer upper	
73-75	Caprice (Sta. Wag.)	8704513 R.H.	11.30	finish front door outer panel transfer upper	
73-75	Caprice (Sta. Wag.)	8704516 L.H.	11.30	finish front door outer panel transfer lower	
73-75	Caprice (Sta. Wag.)	8704515 R.H.	11.30	finish front door outer panel transfer lower	
73-74	Impala (4-Dr.)	8707814 2	11.30	lower (chrome)	
73	Caprice (Sed.)	8707789 L.H.	18.10	lower (chrome)	
73	Caprice (Sed.)	8707788 R.H.	18.10	lower (chrome)	
73	Bel Air, Impala w/body side mldg. (exc. Spt. Cpe.)			lower	
73	Caprice (Sed.) w/body side mldg.	8704440 2	15.10	upper (vinyl insert)	
73	Impala (Spt. Cpe.) w/body side mldg. (exc. Custom)			lower,	
73	Impala (Custom) w/body side mldg.,				
73	Caprice (2-Dr.) w/body side mldg.	8705400 2	17.40	upper (vinyl insert)	
73-74	Impala (Spt. Cpe.) (exc. Custom)	8707812 2	12.85	lower (chrome)	
73	Caprice (Spt. Cpe., Conv.)	8707787 L.H.	21.10	lower (chrome)	
73	Caprice (Spt. Cpe., Conv.)	8707786 R.H.	21.10	lower (chrome)	
74	Caprice (Sed.)	9632209 R.H.	18.10	lower	
74	Caprice (Sed.)	9632210 L.H.	18.10	lower	

**METAL TRIM—CLIPS AND PANELS**

**12.112 MOULDING— MOULDING UNIT— BUMPER— STRIPE— ORNAMENT—  
TAPE— CLIP— TRANSFER, Front Door Outer Panel (Con't)**

74	Caprice (2-Dr.)	9632213	R.H.	21.10	lower
74	Caprice (2-Dr.)	9632214	L.H.	21.10	lower
74	Pass. w/body side mldg. (exc. Custom Coupe)	347058	1	13.55	lower
74	Impala (Spt. Cpe.) w/body side wide lower mldg. (exc. Custom),				
73-75	All w/body side mouldings	1154223	A.R.	RL/1.50	<b>MOULDING</b> , 17 ft. roll speared both ends (black) <sup>9</sup> / <sub>16</sub> "— (8.132)
73-75	All w/body side mouldings	1154224	A.R.	RL/1.50	<b>MOULDING</b> , 17 ft. roll speared both ends (silver) — R/— \$"— (8.132)
75	Bel Air,				
75	Impala w/opt. mldg.	360001	2	RL/3.15	(argent) insert w/chrome borders (1 <sup>11</sup> / <sub>32</sub> " wide) (17 ft. roll)— (8.132)
75	Impala (exc. opt. mldg.)	360000	2	RL/2.20	chrome insert with (black) borders (1 <sup>2</sup> / <sub>16</sub> " wide) (17 ft. roll)— (8.132)
75	Caprice (Sta. Wag.)	1724717	2		<b>MOULDING</b> , lower woodgrain
75	Caprice (Sedan)	9632651	R.H.	10.50	lower (black)
75	Caprice (Sedan)	9632652	L.H.	10.50	lower (black)
75	Caprice (Sedan) w/vinyl top w/o pad	9632653	R.H.	10.50	lower (white)
75	Caprice (Sedan) w/vinyl top w/o pad	9632654	L.H.	10.50	lower (white)
75	Caprice (Sedan)	9632655	R.H.	10.50	lower (silver)
75	Caprice (Sedan)	9632656	L.H.	10.50	lower (silver)
75	Caprice (Sedan)	9632657	R.H.	10.50	lower (green)
75	Caprice (Sedan)	9632658	L.H.	10.50	lower (green)
75	Caprice (Sedan)	9632663	R.H.	10.50	lower (beige)
75	Caprice (Sedan)	9632664	L.H.	10.50	lower (beige)
75	Caprice (Spt. Cpe., Conv.)	9631884	R.H.	11.85	lower (black)
75	Caprice (Spt. Cpe., Conv.)	9631885	L.H.	11.85	lower (black)
75	Caprice (Spt. Cpe.) w/vinyl top w/o pad, two-tone paint,				
75	Caprice (Conv.)	9631886	R.H.	11.85	lower (white)
75	Caprice (Spt. Cpe.) w/vinyl top w/o pad, two-tone paint,				
75	Caprice (Conv.)	9631887	L.H.	11.85	lower (white)
75	Caprice (Spt. Cpe.)	9631888	R.H.	11.85	lower (silver)
75	Caprice (Spt. Cpe.)	9631889	L.H.	11.85	lower (silver)
75	Caprice (Spt. Cpe.)	9631890	R.H.	11.85	lower (green)
75	Caprice (Spt. Cpe.)	9631891	L.H.	11.85	lower (green)
75	Caprice (Spt. Cpe.)	9631896	R.H.	11.85	lower (beige)
75	Caprice (Spt. Cpe.)	9631897	L.H.	11.85	lower (beige)
75	Caprice (Spt. Cpe.)	9631892	R.H.	12.85	<b>MOULDING UNIT</b> , lower (maroon)
75	Caprice (Spt. Cpe.)	9631893	L.H.	12.85	<b>MOULDING UNIT</b> , lower (maroon)
75	Caprice (Spt. Cpe.)	9631894	R.H.	12.85	<b>MOULDING UNIT</b> , lower (dk. blue)
75	Caprice (Spt. Cpe.)	9631895	L.H.	12.85	<b>MOULDING UNIT</b> , lower (dk. blue)
75	Caprice (Sedan)	9632661	R.H.	11.30	<b>MOULDING UNIT</b> , lower (dk. blue)
75	Caprice (Sedan)	9632662	L.H.	11.30	<b>MOULDING UNIT</b> , lower (dk. blue)
75	Caprice (Sedan)	9632659	R.H.	11.30	<b>MOULDING UNIT</b> , lower (maroon)
75	Caprice (Sedan)	9632660	L.H.	11.30	<b>MOULDING UNIT</b> , lower (maroon)

**1973-75 CHEVELLE**

73-75	Malibu, Laguna (Estate)				transfer,
73-74	Malibu, Laguna (Sed., Sta. Wag.),				
74-75	Malibu (4-Dr.) (Classic)	8707756	L.H.	11.30	lower
73-75	Malibu, Laguna (Estate)				transfer,
73-74	Malibu, Laguna (Sed., Sta. Wag.),				
74-75	Malibu (4-Dr.) (Classic)	8707755	R.H.	11.30	lower
73-75	Chevelle (4-Dr.) w/body side mldg.	8707810	2	9.80	upper
73-75	Malibu, Laguna (Estate)	8707895	L.H.	13.55	finish transfer upper front
73-75	Malibu, Laguna (Estate)	8707894	R.H.	13.55	finish transfer upper front
73-75	Malibu, Laguna (Estate)	8707865	L.H.	3.05	finish transfer upper rear
73-75	Malibu, Laguna (Estate)	8707864	R.H.	3.05	finish transfer upper rear
73-75	Chevelle (2-Dr.) w/body side mldg. (exc. Monte Carlo)	8707809	2	12.85	lower, upper
73-74	Malibu (Classic),				
73-75	El Camino (Custom)	8707758	L.H.	18.85	lower
73-75	Malibu Classic,				
73-75	El Camino (Custom)	8707757	R.H.	18.85	lower
73-74	Monte Carlo	8707760	L.H.	18.85	lower

**METAL TRIM—CLIPS AND PANELS**

**12.112 MOULDING— MOULDING UNIT— BUMPER— STRIPE— ORNAMENT—  
TAPE— CLIP— TRANSFER, Front Door Outer Panel (Con't)**

73-74	Monte Carlo	8707759	R.H.	18.85	lower
73-74	Monte Carlo w/body side mldg.	8707811	2	12.85	upper
73-75	El Camino w/wood grain	8707867	L.H.	11.20	finish transfer upper front
73-75	El Camino w/wood grain	8707866	R.H.	11.20	finish transfer upper front
73-75	El Camino w/wood grain	8707868	2	4.90	transfer upper rear finish transfer upper rear
75	Monte Carlo w/body side protection mldg.	9631865	R.H.	11.85	upper (black)
75	Monte Carlo w/body side protection mldg.	9631866	L.H.	11.85	upper (black)
75	Monte Carlo w/body side protection mldg.	9631867	R.H.	11.85	upper (white)
75	Monte Carlo w/body side protection mldg.	9631868	L.H.	11.85	upper (white)
75	Monte Carlo w/body side protection mldg.	9631869	R.H.	11.85	upper (silver)
75	Monte Carlo w/body side protection mldg.	9631870	L.H.	11.85	upper (silver)
75	Monte Carlo w/body side protection mldg.	9631871	R.H.	11.85	upper (green)
75	Monte Carlo w/body side protection mldg.	9631872	L.H.	11.85	upper (green)
75	Monte Carlo w/body side protection mldg.	9631873	R.H.	11.85	upper (maroon)
75	Monte Carlo w/body side protection mldg.	9631874	L.H.	11.85	upper (maroon)
75	Monte Carlo w/body side protection mldg.	9631875	R.H.	11.85	upper (blue)
75	Monte Carlo	9631576	L.H.	11.85	upper (blue)
75	Monte Carlo	9631577	R.H.	11.85	upper (beige)
75	Monte Carlo	9631578	L.H.	11.85	upper (beige)
75	Monte Carlo	9632871	R.H.	12.20	lower (chrome)
75	Monte Carlo	9632872	L.H.	12.20	lower (chrome)
75	Chevelle (4-Dr.), Camaro (L.T.)	1248176	2	RL/1.25	upper (black)

**1973-75 NOVA**

73-74	Nova (2-Dr.) w/body side mldg.	8705636	L.H.	14.50	front door outer panel lower (painted insert)
73-74	Nova (2-Dr.) w/body side mldg.	8705635	R.H.	14.50	front door outer panel lower (painted insert)
73-74	Nova (4-Dr.) w/body side mldg.	8705638	L.H.	12.85	front door outer panel lower (painted insert)
73-74	Nova (4-Dr.) w/body side mldg.	8705637	R.H.	12.85	front door outer panel lower (painted insert)
75	Nova	359999		RL/3.00	MOULDING, lower (roll)— (8.132)

**1973-75 CAMARO**

73-74	Camaro w/body side mldg.	8705649	2	15.00	lower
73-75	Camaro (L.T.) (exc. body side mldg.)	8707771	L.H.	9.80	lower
73-75	Camaro (L.T.) (exc. body side mldg.)	8707770	R.H.	9.80	lower
75	Camaro (L.T.) w/body side mldg.	1248176	2	RL/1.25	upper (black)

**1973-75 VEGA — MONZA**

73-74	Vega (Coupe) w/body side mldg., stripes	9692376	R.H.	8.30	MOULDING, outer panel (adhesive) (white)
73-74	Vega (Coupe) w/body side mldg.	9692377	L.H.	8.30	MOULDING, outer panel (adhesive) (white)
73-74	Vega (Coupe) w/body side mldg., stripes	9692374	R.H.	8.30	MOULDING, outer panel (adhesive) (orange)
73-74	Vega (Coupe) w/body side mldg., stripes	9692375	L.H.	8.30	MOULDING, outer panel (adhesive) (orange)
73-74	Vega (Coupe) w/body side mldg., stripes	9692372	R.H.	8.30	MOULDING, outer panel (adhesive) (green)
73-74	Vega (Coupe) w/body side mldg., stripes	9692373	L.H.	8.30	MOULDING, outer panel (adhesive) (green)
73-74	Vega (Coupe) w/body side mldg., stripes	9692370	R.H.	8.30	MOULDING, outer panel (adhesive) (blue)
73-74	Vega (Coupe) w/body side mldg., stripes	9692371	L.H.	8.30	MOULDING, outer panel (adhesive) (blue)
73-74	Vega (Coupe) w/body side mldg.	9692369	L.H.	8.30	MOULDING, outer panel (adhesive) (black)
73-74	Vega	8707808	2	9.60	MOULDING UNIT, outer panel front door upper
75	Monza (Notchback) w/body side lower mldg.	9633304	R.H.		MOULDING UNIT, outer panel front door lower

**METAL TRIM—CLIPS AND PANELS**

**12.112 MOULDING— MOULDING UNIT— BUMPER— STRIPE— ORNAMENT—  
TAPE— CLIP— TRANSFER, Front Door Outer Panel (Con't)**

75	Monza (Notchback) w/body side lower mldg. . . . .	9633305 L.H.			MOULDING UNIT, outer panel front door lower . . . . .
73-75	Vega (Sta. Wag.) w/wood grain . . . . .	9630095 R.H.	9.60		MOULDING UNIT, upper . . . . .
73-75	Vega (Sta. Wag.) w/wood grain . . . . .	9630096 L.H.	9.60		MOULDING UNIT, upper . . . . .
73	Vega (Sta. Wag.) w/wood grain . . . . .	9630097 R.H.	9.60		MOULDING UNIT, outer lower transfer . . . . .
73	Vega (Sta. Wag.) w/wood grain . . . . .	9630098 L.H.	9.60		MOULDING UNIT, outer lower transfer . . . . .
74-75	Vega (Sta. Wag.) w/wood grain . . . . .	9631739 R.H.	9.60		MOULDING UNIT, outer panel transfer lower . . . . .
74-75	Vega (Sta. Wag.) w/wood grain . . . . .	9631740 L.H.	9.60		MOULDING UNIT, outer panel transfer lower . . . . .
74-75	Vega, Monza (exc. Towne Coupe) w/body side mldg. . . . .	347058 2	13.55		MOULDING UNIT, outer panel 10 ft. long— (8.132) . . . . .
73-74	Vega (Coupe) w/body side mldg., stripe . . . . .	9692386 2	8.30		MOULDING UNIT, outer panel (adhesive) (white) . . . . .
73-74	Vega (Coupe) w/body side mldg., stripe . . . . .	9692384 2	8.30		MOULDING UNIT, outer panel (adhesive) (orange) . . . . .
73-74	Vega (Coupe) w/body side mldg., stripe . . . . .	9692382 2	8.30		MOULDING UNIT, outer panel (adhesive) (green) . . . . .
73-74	Vega (Coupe) w/body side mldg., stripe . . . . .	9692380 2	8.30		MOULDING UNIT, outer panel (adhesive) (blue)— (12.116) . . . . .
75	Monza (Notchback) . . . . .	8707770 R.H.	9.80		MOULDING UNIT, outer panel f/d lower . . . . .
75	Monza (Notchback) . . . . .	8707771 L.H.	9.80		MOULDING UNIT, outer panel f/d lower . . . . .
73-75	El Camino . . . . .	9672068 2	.22		BUMPER . . . . .
74	Impala (Spt. Cpe.) (exc. Custom) . . . . .	349102 2	3.15		STRIPE, side door w/Spirit of America . . . . .
75	Camaro . . . . .	360671 L.H.	7.05		STRIPE (dk. blue-med. blue-lt. blue) . . . . .
75	Camaro . . . . .	360672 R.H.	7.05		STRIPE (dk. blue-med. blue-lt. blue) . . . . .
75	Camaro . . . . .	360673 L.H.	7.05		STRIPE (red-orange-lt. yellow) . . . . .
75	Camaro . . . . .	360674 R.H.	7.05		STRIPE (red-orange-lt. yellow) . . . . .
75	Camaro . . . . .	360675 L.H.	7.05		STRIPE (dk. gray-med. gray-lt. gray) . . . . .
75	Camaro . . . . .	360676 R.H.	7.05		STRIPE (dk. gray-med. gray-lt. gray) . . . . .
75	Camaro . . . . .	360677 L.H.	7.05		STRIPE (dk. red-med. red-lt. red) . . . . .
75	Camaro . . . . .	360678 R.H.	7.05		STRIPE (dk. red-med. red-lt. red) . . . . .
75	Camaro . . . . .	360679 L.H.	7.05		STRIPE (orange-yellow orange-yellow) . . . . .
75	Camaro . . . . .	360680 R.H.	7.05		STRIPE (orange-yellow orange-yellow) . . . . .
68	Caprice (Sta. Wag.) . . . . .	9713869 A.R.	1.40		ORNAMENT, trans. upr. fin. mldg., rr. fdr., and t/gate trans. upr. fin. mldg. . . . .
69	Caprice . . . . .	3981905 1	RL/.32		TAPE, mldg. (vinyl) (black)— (8.132) (Note 3) . . . . .
69	Caprice . . . . .	3981906 1	RL/.32		TAPE, mldg. (vinyl) (white)— (8.132) (Note 3) . . . . .
69	Caprice . . . . .	3981907 1	RL/.32		TAPE, mldg. (vinyl) (maroon)— (8.132) (Note 3) . . . . .
69	Caprice . . . . .	3981908 1	RL/.32		TAPE, mldg. (vinyl) (yellow)— (8.132) (Note 3) . . . . .
69	Caprice . . . . .	3981909 1	RL/.32		TAPE, mldg. (vinyl) (champagne)— (8.132) (Note 3) . . . . .
69	Caprice . . . . .	3981910 1	RL/.32		TAPE, mldg. (vinyl) (bright blue)— (8.132) (Note 3) . . . . .
69	Caprice . . . . .	3981911 1	RL/.32		TAPE, mldg. (vinyl) (silver)— (8.132) (Note 3) . . . . .
69	Caprice . . . . .	3981912 1	RL/.32		TAPE, mldg. (vinyl) (med. blue)— (8.132) (Note 3) . . . . .
69	Caprice . . . . .	3981913 1	RL/.32		TAPE, mldg. (vinyl) (turq.)— (8.132) (Note 3) . . . . .
69	Caprice . . . . .	3981914 1	RL/.32		TAPE, mldg. (vinyl) (dark blue)— (8.132) (Note 3) . . . . .
69	Caprice . . . . .	3981915 1	RL/.32		TAPE, mldg. (vinyl) (lime)— (8.132) (Note 3) . . . . .
69	Caprice . . . . .	3981916 1	RL/.32		TAPE, mldg. (vinyl) (green)— (8.132) (Note 3) . . . . .
69	Caprice . . . . .	3981917 1	RL/.32		TAPE, mldg. (vinyl) (red)— (8.132) (Note 3) . . . . .
69	Caprice . . . . .	3981918 1	RL/.32		TAPE, mldg. (vinyl) (gold)— (8.132) (Note 3) . . . . .
69	Caprice . . . . .	3981919 1	RL/.32		TAPE, mldg. (vinyl) (brown)— (8.132) (Note 3) . . . . .
70	Caprice . . . . .	3980833 1	RL/.32		TAPE, side moulding (vinyl) (black)— (8.132) (Note 3) . . . . .
70	Caprice . . . . .	3980834 1	RL/.32		TAPE, side moulding (vinyl) (maroon)— (8.132) (Note 3) . . . . .
70	Caprice . . . . .	3980835 1	RL/.32		TAPE, side moulding (vinyl) (white)— (8.132) (Note 3) . . . . .

**METAL TRIM—CLIPS AND PANELS**

**12.112 MOULDING— MOULDING UNIT— BUMPER— STRIPE— ORNAMENT—  
TAPE— CLIP— TRANSFER, Front Door Outer Panel (Con't)**

70	Caprice	3980836	1	RL/.32	TAPE, side moulding (vinyl) (brown)— (8.132) (Note 3)
70	Caprice	3980837	1	RL/.32	TAPE, side moulding (vinyl) (silver)— (8.132) (Note 3)
70	Caprice	3980838	1	RL/.32	TAPE, side moulding (vinyl) (dk. green)— (8.132) (Note 3)
70	Caprice	3980839	1	RL/.32	TAPE, side moulding (vinyl) (dk. gold)— (8.132) (Note 3)
70	Caprice	3980841	1	RL/.32	TAPE, side moulding (vinyl) (med. turq.)— (8.132) (Note 3)
70	Caprice	3980842	1	RL/.32	TAPE, side moulding (vinyl) (med. gold)— (8.132) (Note 3)
70	Caprice	3980843	1	RL/.32	TAPE, side moulding (vinyl) (yellow)— (8.132) (Note 3)
70	Caprice	3980844	1	RL/.32	TAPE, side moulding (vinyl) (med. green)— (8.132) (Note 3)
70	Caprice	3980845	1	RL/.32	TAPE, side moulding (vinyl) (med. blue)— (8.132) (Note 3)
70	Caprice	3980846	1	RL/.32	TAPE, side moulding (vinyl) (dk. blue)— (8.132) (Note 3)
70	Caprice	3980847	1	RL/.32	TAPE, side moulding (vinyl) (saddle)— (8.132) (Note 3)
74	Nova	347528	R.H.	3.75	TAPE ASSY., vinyl w/spirit of America
74	Nova	347527	L.H.	3.75	TAPE ASSY., vinyl w/spirit of America
71	Impala, Caprice (Spt. Cpe.)	9833770	4	.28	CLIP, outer panel mldg. front and rear door lower rear
73-74	Vega (Coupe) w/body side moulding	9692344	R.H.	11.95	TRANSFER (red-white-green)
73-74	Vega (Coupe) w/body side moulding	9692345	L.H.	11.95	TRANSFER (red-white-green)
73-74	Vega (Coupe) w/body side moulding	9692348	R.H.	10.40	TRANSFER (white-black-white)
73-74	Vega (Coupe) w/body side moulding	9692349	L.H.	10.40	TRANSFER (white-black-white)
73-74	Vega (Coupe) w/body side moulding	9692346	R.H.	11.95	TRANSFER (red-yellow-orange)
73-74	Vega (Coupe) w/body side moulding	9692347	L.H.	11.95	TRANSFER (red-yellow-orange)
73-74	Vega (Coupe) w/body side moulding	9692342	R.H.	11.95	TRANSFER (red-white-blue)
73-74	Vega (Coupe) w/body side moulding	9692343	L.H.	11.95	TRANSFER (red-white-blue)
73-74	Vega (Coupe) w/body side moulding	9692338	R.H.	10.40	TRANSFER (silver-black-silver)
73-74	Vega (Coupe) w/body side moulding	9692339	L.H.	10.40	TRANSFER (silver-black-silver)
73-74	Vega (Coupe) w/body side moulding	9692340	R.H.	10.40	TRANSFER (black-white-black)
74	Vega (Coupe)	1676740	R.H.	6.70	TRANSFER, w/Spirit of America
74	Vega (Coupe)	1676741	L.H.	6.70	TRANSFER, w/Spirit of America
74	Vega (Coupe) w/front and body side stripe	1657526	R.H.	3.10	TRANSFER (gold)
74	Vega (Coupe) w/front and body side stripe	1657527	L.H.	3.10	TRANSFER (gold)
75	Vega (Coupe) w/front and body side stripe	1661997	R.H.	2.95	TRANSFER, outer panel rear (gold)
75	Vega (Coupe) w/front and body side stripe	1661998	L.H.	2.95	TRANSFER, outer panel rear (gold)
75	Vega (Coupe) w/front and body side stripe	1657526	R.H.	3.10	TRANSFER, outer panel front (gold)
75	Vega (Coupe) w/front and body side stripe	1657527	L.H.	3.10	TRANSFER, outer panel front (gold)
75	Vega (Cpe., Sta. Wag.)	9734704	2	8.75	TRANSFER, f/d (black)
75	Vega (Cpe., Sta. Wag.)	9734705	2	8.75	TRANSFER, f/d (white)

*NOTE 3 Comes in 50 foot roll.*

**12.113 MOULDING, Center Pillar Scalp**

68-72	Chevelle (Sta. Wag., 4-Dr. Sed.) (exc. Spt. Sed.)	7728722	R.H.	6.90	vertical
68-72	Chevelle (Sta. Wag., 4-Dr. Sed.) (exc. Spt. Sed.)	7728723	L.H.	6.90	vertical
68-74	Chevy, Nova (4-Dr. Sed.) w/door wind. frame mldg.	7737938	R.H.	6.90	



**METAL TRIM—CLIPS AND PANELS**

**12.113 MOULDING, Center Pillar Scalp (Con't)**

68-74	Chevy, Nova (4-Dr. Sed.) w/door wind. frame mldg. ....	7737939 L.H.	6.90	
75	Nova (4-Dr.) .....	1653434 R.H.	6.90	scalp .....
75	Nova (4-Dr.) .....	1653435 L.H.	6.90	scalp .....

**12.114 MOULDING— ORNAMENT— TAPE— CLIP, Rear Door Outer Panel**

66	Caprice (Sta. Wag.) .....	7600682 R.H.	17.85	rear outer lower .....
68	Biscayne (4-Dr.) w/body side ...	3941206 R.H.	6.35	rr. door side mldg. ....
68	Biscayne (4-Dr.) w/body side ...	3941205 L.H.	6.95	rr. door side mldg. ....
69	Biscayne,			
69	Brookwood w/body side .....	3955012 R.H.	6.95	rr. door side mldg., rr. qtr. pnl. side .....
69	Biscayne,			
69	Brookwood w/body side .....	3955011 L.H.	8.70	rr. door side mldg., rr. qtr. pnl. side .....
62	Chevy Deluxe (4-Dr.) (exc. Nova Sed.) .....			MOULDING UNIT, lower, .....
71-75	All w/body side mouldings .....	1154223 A.R.	RL/1.50	MOULDING, 17 ft. roll speared both ends (black) 5/8" wide— (8.132) .....
71-75	All w/body side mouldings .....	1154224 A.R.	RL/1.50	MOULDING, 17 ft. roll speared both ends (silver) 5/8" wide— (8.132) .....
75	Bel Air,			
75	Impala (exc. opt. mldg.) .....	360000 2	RL/2.20	MOULDING, chrome insert (black) borders (13/16" wide) (17 ft. roll)— (8.132) .....
75	Impala (w/opt. mid.) .....	360001 2	RL/3.15	MOULDING, argent insert with chrome borders (111/32" wide) (17 ft. roll)— (8.132)
75	Nova .....	359999 2	RL/3.00	MOULDING, lower (roll)— (8.132) .....
62	Nova (4-Dr. Sed.) .....	3793394 R.H.	6.45	upper (depressed area black) .....
62	Chevy Deluxe (4-Dr.) (exc. Nova Sed.) .....			MOULDING UNIT, lower, .....
62	Nova (4-Dr. Sed.) .....	3793393 L.H.	6.45	upper (depressed area black) .....
63	Chevy Deluxe (4-Dr.) (exc. Nova)	3832647 L.H.	5.25	MOULDING UNIT, lower .....
63	Nova (4-Dr.) .....	3832826 R.H.	6.70	MOULDING UNIT, lower (ivory) .....
64	Nova (4-Dr.) .....	3852487 L.H.	7.55	MOULDING UNIT, lower .....
64	Nova (4-Dr.) .....	3852488 R.H.	7.55	MOULDING UNIT, lower .....
64	Chevelle Std. (4-Dr.) .....	3852512 2	6.75	MOULDING UNIT, lower .....
64	Malibu (4-Dr.) .....	3852513 2	11.00	MOULDING UNIT, lower (white) .....
65	Nova (4-Dr.) .....	3870971 L.H.	8.05	MOULDING UNIT, lower .....
65	Nova (4-Dr.) .....	3870972 R.H.	8.05	MOULDING UNIT, lower .....
65	Malibu (4-Dr.) .....	3871617 L.H.	6.75	MOULDING UNIT, lower .....
65	Malibu (4-Dr.) .....	3871618 R.H.	6.75	MOULDING UNIT, lower .....
65	Chevelle Deluxe (4-Dr.) .....	3871620 R.H.	8.75	MOULDING UNIT, lower .....
65	Bel Air (4-Dr.) .....	3870852 2	7.55	MOULDING UNIT, lower .....
66	Impala (4-Dr.) .....	4227052 2	8.70	MOULDING UNIT, lower .....
66	Bel Air (4-Dr.) .....	4227053 R.H.	7.55	MOULDING UNIT .....
66	Bel Air (4-Dr.) .....	4227054 L.H.	7.55	MOULDING UNIT .....
66	Caprice (Sta. Wag.) .....	4227005 L.H.	7.55	MOULDING UNIT, front lower .....
66	Nova (4-Dr.) .....	4227225 2	6.75	MOULDING UNIT, lower .....
66	Chevelle Deluxe (4-Dr.) .....	4227208 R.H.	6.75	MOULDING UNIT, lower .....
66	Chevelle Deluxe (4-Dr.) .....	4227209 L.H.	6.75	MOULDING UNIT, lower .....
67	Nova (4-Dr.) .....	4229560 2	6.75	MOULDING UNIT, lower .....
67	Concours .....	4229747 L.H.	6.45	MOULDING UNIT, lower .....
67	Malibu (4-Dr.) .....	4229748 R.H.	6.45	MOULDING UNIT, lower .....
67	Malibu (4-Dr.) .....	4229749 L.H.	6.45	MOULDING UNIT, lower .....
67	Bel Air (4-Dr.),			
67	Biscayne (4-Dr.) w/body side ...	4229457 R.H.	6.45	MOULDING UNIT, lower .....
67	Bel Air (4-Dr.),			
67	Biscayne (4-Dr.) w/body side ...	4229458 L.H.	7.55	MOULDING UNIT, lower .....
67	Impala (4-Dr.) .....	4229465 R.H.	7.55	MOULDING UNIT, lower .....
67	Impala (4-Dr.) .....	4229466 L.H.	7.55	MOULDING UNIT, lower .....
67	Caprice (Sta. Wag.) .....	4229486 R.H.	7.85	MOULDING UNIT, upper .....
67	Caprice (Sta. Wag.) .....	4229487 L.H.	7.85	MOULDING UNIT, upper .....
67	Caprice (Sta. Wag.) .....	4229484 2	6.05	MOULDING UNIT, lower .....
67	Caprice (Spt. Sed.) .....	4229467 2	7.25	MOULDING UNIT, lower .....
68	Bel Air (exc. 2-Dr.) .....	7795029 1	7.55	MOULDING UNIT, lower .....
68	Impala (4-Dr.) .....	7795582 R.H.	11.30	MOULDING UNIT, rr. door outer panel lower (black) .....
68	Impala (4-Dr.) .....	7795583 L.H.	11.30	MOULDING UNIT, rr. door outer panel lower (black) .....
68	Caprice (Sta. Wag.) .....	7795440 L.H.	14.35	MOULDING UNIT, trans. upper finish .....
68	Caprice (Sta. Wag.) .....	7795439 R.H.	14.35	MOULDING UNIT, trans. upper finish .....
68	Caprice (Sed.) .....	7795025 R.H.	12.10	MOULDING UNIT, lower .....
68	Caprice (Sed.) .....	7795026 L.H.	12.10	MOULDING UNIT, lower .....
68	Caprice (Sta. Wag.) .....	7795441 R.H.	7.55	MOULDING UNIT, trans. lower finish .....
68	Caprice (Sta. Wag.) .....	7795442 L.H.	7.55	MOULDING UNIT, trans. lower finish .....
68	Impala (4-Dr. Sed.) .....	8700049 1	12.65	MOULDING UNIT, lower (black) (smooth) ..

**METAL TRIM—CLIPS AND PANELS**

**12.114 MOULDING— ORNAMENT— TAPE— CLIP, Rear Door Outer Panel  
(Con't)**

71-75	Kingswood Estate . . . . .	8704508	L.H.	11.30	MOULDING UNIT, finish r/door otr. pan. trans. . . . .
71-75	Kingswood Estate . . . . .	8704507	R.H.	11.30	MOULDING UNIT, finish r/door otr. pan. upr. . . . .
	<i>NOTE 2 When used 4-Dr. Sedan it will be necessary to cut as reqd. rr. qtr. panel side mldg. left and right.</i>				
68-69	Malibu (4-Dr.),				
69	Concours (exc. Estate Wag.) . . . . .	7795401	R.H.	6.45	MOULDING UNIT, lower . . . . .
68-69	Malibu (4-Dr.),				
69	Concours (exc. Estate Wag.) . . . . .	7795402	L.H.	6.45	MOULDING UNIT, lower . . . . .
68	Chevy (Sed.) w/side body mldg. . . . .	7795400	1	8.40	MOULDING UNIT, lower . . . . .
68-69	Malibu (Spt. Sed.) w/body side mldg. . . . .	7795027	R.H.	11.30	MOULDING UNIT, lower . . . . .
68	Concours,				
69	Concours (Estate Wag.) . . . . .	7795406	R.H.	6.75	MOULDING UNIT, transfer upper finish . . . . .
68	Concours,				
69	Concours (Estate Wag.) . . . . .	7795407	L.H.	6.75	MOULDING UNIT, transfer upper finish . . . . .
68	Concours,				
69	Concours (Estate Wag.) . . . . .	7795408	R.H.	6.45	MOULDING UNIT, transfer lower finish . . . . .
68	Concours,				
69	Concours (Estate Wag.) . . . . .	7795409	L.H.	6.45	MOULDING UNIT, transfer lower finish . . . . .
69-70	Chevelle (2-Dr.) w/body side mldg. . . . .	3960124	1	33.75	MOULDING UNIT, body side (Note 1) . . . . .
69	Chevelle (4-Dr. exc. Estate Wag.) . . . . .				MOULDING UNIT, rr. qtr. pnl. side, frt. and rear door side, de, rr. qtr. pnl. side, . . . . .
69	Chevelle (exc. 4-Dr.) w/body side mldg. . . . .	3955012	R.H.	6.95	rr. qtr. pnl. side, side door . . . . .
69	Chevelle (4-Dr. exc. Estate Wag.) . . . . .				MOULDING UNIT, rr. qtr. pnl. side, frt. and rear door side, de, rr. qtr. pnl. side, . . . . .
69	Chevelle (exc. 4-Dr.) w/body side mldg. . . . .	3955011	L.H.	8.70	rr. qtr. pnl. side, side door . . . . .
	<i>NOTE 1 On all models exc. El Camino cut as required for rear qtr. For models equipped with RPO D96 cut as required for front fender side.</i>				
	<i>NOTE 4 When used on sedans cut as required for rear quarter.</i>				
69	Biscayne (2-Dr.) . . . . .	3957930	1	36.25	MOULDING UNIT, body side (Note 3) . . . . .
	<i>NOTE 3 Includes mouldings for complete vehicle.</i>				
69	Caprice (Spt. Sed.) . . . . .	8701212	R.H.	10.55	MOULDING UNIT, rear door outer panel lower . . . . .
69	Caprice (Spt. Sed.) . . . . .	8701213	L.H.	10.55	MOULDING UNIT, rear door outer panel lower . . . . .
69	Estate Wag. . . . .	8701331	R.H.	8.70	MOULDING UNIT, transfer lower finish . . . . .
69	Estate Wag. . . . .	8701332	L.H.	8.70	MOULDING UNIT, transfer lower finish . . . . .
69	Estate Wag. . . . .	8701137	R.H.	9.05	MOULDING UNIT, transfer upper . . . . .
69	Estate Wag. . . . .	8701138	L.H.	9.05	MOULDING UNIT, transfer upper . . . . .
69	Bel Air (exc. 2-Dr.),				
69	Townsmen . . . . .	8701099	1	7.55	MOULDING UNIT, rear door lower . . . . .
69	Impala, Kingswood (4-Dr.) (exc. Estate) . . . . .	8701260	R.H.	10.55	MOULDING UNIT, rr. door lower (black) . . . . .
69	Impala, Kingswood (4-Dr.) (exc. Estate) . . . . .	8701261	L.H.	10.55	MOULDING UNIT, rr. door lower (black) . . . . .
69	Impala, Kingswood (4-Dr.) (exc. Estate) . . . . .	8701262	R.H.	10.55	MOULDING UNIT, rr. door lower (blue) . . . . .
69	Impala, Kingswood (4-Dr.) (exc. Estate) . . . . .	8701263	L.H.	10.55	MOULDING UNIT, rr. door lower (blue) . . . . .
69	Impala, Kingswood (4-Dr.) (exc. Estate) . . . . .	8701264	R.H.	10.55	MOULDING UNIT, rr. door lower (green) . . . . .
69	Impala, Kingswood (4-Dr.) (exc. Estate) . . . . .	8701265	L.H.	10.55	MOULDING UNIT, rr. door lower (green) . . . . .
69	Impala, Kingswood (4-Dr.) (exc. Estate) . . . . .	8701266	R.H.	10.55	MOULDING UNIT, rr. door lower (red) . . . . .
69	Impala, Kingswood (4-Dr.) (exc. Estate) . . . . .	8701267	L.H.	10.55	MOULDING UNIT, rr. door lower (red) . . . . .
69	Impala, Kingswood (4-Dr.) (exc. Estate) . . . . .	8701268	R.H.	10.55	MOULDING UNIT, rr. door lower (brown) . . . . .
69	Impala, Kingswood (4-Dr.) (exc. Estate) . . . . .	8701269	L.H.	10.55	MOULDING UNIT, rr. door lower (brown) . . . . .
70	Impala (4-Dr.),				
70	Kingswood (exc. Estate) . . . . .	8702935	R.H.	10.50	MOULDING UNIT, lower (saddle) . . . . .
70	Impala (4-Dr.),				
70	Kingswood (exc. Estate) . . . . .	8702936	L.H.	10.50	MOULDING UNIT, lower (saddle) . . . . .
70	Impala (4-Dr.),				
70	Kingswood (exc. Estate) . . . . .	8702933	R.H.	10.50	MOULDING UNIT, lower (gold) . . . . .
70	Impala (4-Dr.),				
70	Kingswood (exc. Estate) . . . . .	8702934	L.H.	10.50	MOULDING UNIT, lower (gold) . . . . .
70	Impala (4-Dr.),				

**METAL TRIM—CLIPS AND PANELS**

**12.114 MOULDING— ORNAMENT— TAPE— CLIP, Rear Door Outer Panel  
(Con't)**

70	Kingswood (exc. Estate) . . . . .	8702927 R.H.	10.50	MOULDING UNIT, lower (black) . . . . .
70	Impala (4-Dr.),			
70	Kingswood (exc. Estate) . . . . .	8702928 L.H.	10.50	MOULDING UNIT, lower (black) . . . . .
70	Impala (4-Dr.),			
70	Kingswood (exc. Estate) . . . . .	8702931 R.H.	10.50	MOULDING UNIT, lower (blue) . . . . .
70	Impala (4-Dr.),			
70	Kingswood (exc. Estate) . . . . .	8702932 L.H.	10.50	MOULDING UNIT, lower (blue) . . . . .
70	Impala (4-Dr.),			
70	Kingswood (exc. Estate) . . . . .	8702929 R.H.	10.50	MOULDING UNIT, lower (green) . . . . .
70	Impala (4-Dr.),			
70	Kingswood (exc. Estate) . . . . .	8702930 L.H.	10.50	MOULDING UNIT, lower (green) . . . . .
70	Kingswood Estate . . . . .	8702952 R.H.	9.05	MOULDING UNIT, trans. lower . . . . .
70	Kingswood Estate . . . . .	8702953 L.H.	9.05	MOULDING UNIT, trans. lower . . . . .
70	Kingswood Estate . . . . .	8702950 R.H.	10.15	MOULDING UNIT, trans. upper . . . . .
70	Kingswood Estate . . . . .	8702951 L.H.	10.15	MOULDING UNIT, trans. upper . . . . .
70	Caprice (4-Dr.) . . . . .	8702974 R.H.	10.55	MOULDING UNIT, rear door lower . . . . .
70	Caprice (4-Dr.) . . . . .	8702975 L.H.	10.55	MOULDING UNIT, rear door lower . . . . .
70	Bel Air . . . . .	8701099 1	7.55	MOULDING UNIT, outer panel rear dr. lower . . . . .
70-72	Concours Estate . . . . .	8702997 R.H.	9.80	MOULDING UNIT, trans. lower . . . . .
70-72	Concours Estate . . . . .	8702998 L.H.	9.80	MOULDING UNIT, trans. lower . . . . .
70	Malibu (4-Dr.) . . . . .	8701416 R.H.	9.30	MOULDING UNIT, peak . . . . .
70	Malibu (4-Dr.) . . . . .	8701413 L.H.	9.30	MOULDING UNIT, peak . . . . .
70-72	Concours Estate . . . . .	8702995 R.H.	11.00	MOULDING UNIT, fin. rear door outer panel trans. upr. . . . .
70-72	Concours Estate . . . . .	8702996 L.H.	11.00	MOULDING UNIT, fin. rear door outer panel trans. upr. . . . .
69-72	Nova (4-Dr.) (2nd design) . . . . .	8705640 L.H.	10.15	MOULDING UNIT, rear door outer panel lower (painted insert) . . . . .
69-72	Nova (4-Dr.) (2nd design) . . . . .	8705639 R.H.	10.15	MOULDING UNIT, rear door outer panel lower (painted insert) . . . . .
71-75	Kingswood/Caprice Estate . . . . .	8704507 R.H.	11.30	MOULDING UNIT, fin. rear door otr. pnl. trans. upr. . . . .
71-75	Kingswood/Caprice Estate . . . . .	8704508 L.H.	11.30	MOULDING UNIT, fin. rear door otr. pnl. trans. upr. . . . .
71	Brookwood, Townsman w/body side mldg. . . . .			MOULDING UNIT, lower, . . . . .
71	Kingswood w/body side mldg. (exc. Estate) . . . . .	8704487 L.H.	11.30	upper (w/black painted insert) . . . . .
71	Brookwood, Townsman w/body side mldg. . . . .			MOULDING UNIT, lower, . . . . .
71	Kingswood w/body side mldg. (exc. Estate) . . . . .	8704486 R.H.	11.30	upper (w/black painted insert) . . . . .
71	Kingswood (exc. Estate) . . . . .	8704494 L.H.	15.85	MOULDING UNIT, lower (chrome) . . . . .
71	Kingswood (exc. Estate) . . . . .	8704493 R.H.	15.85	MOULDING UNIT, lower (chrome) . . . . .
71-72	Kingswood Estate . . . . .	8704510 L.H.	10.55	MOULDING UNIT, panel transfer lower . . . . .
71-72	Kingswood Estate . . . . .	8704509 R.H.	10.55	MOULDING UNIT, panel transfer lower . . . . .
71	Impala, Caprice (Sed.) . . . . .	8704519 L.H.	15.10	MOULDING UNIT, lower (chrome) . . . . .
71	Impala, Caprice (Sed.) . . . . .	8704518 R.H.	15.10	MOULDING UNIT, lower (chrome) . . . . .
71	Biscayne, Bel Air w/body side mldg. . . . .			MOULDING UNIT, lower, . . . . .
71	Impala, Caprice (Sed.) w/body side mldg. . . . .	8704522 L.H.	11.30	upper (w/black painted insert) . . . . .
71	Biscayne, Bel Air w/body side mldg. . . . .			MOULDING UNIT, lower, . . . . .
71	Impala, Caprice (Sed.) w/body side mldg. . . . .	8704521 R.H.	11.30	upper (w/black painted insert) . . . . .
72	Kingswood (exc. Estate) . . . . .	8705696 R.H.	11.30	MOULDING UNIT, lower (chrome) . . . . .
72	Kingswood (exc. Estate) w/body side mldg. . . . .	8705697 L.H.	11.30	MOULDING UNIT, lower (chrome) . . . . .
72	Impala (Sed.) . . . . .	8705694 R.H.	11.30	MOULDING UNIT, lower (chrome) . . . . .
72	Impala (Sed.) . . . . .	8705695 L.H.	11.30	MOULDING UNIT, lower (chrome) . . . . .
72	Pass. (Sta. Wag.) w/body side mldg. . . . .	8705690 R.H.	11.30	MOULDING UNIT, lower (vinyl insert) . . . . .
72	Pass. (Sta. Wag.) w/body side mldg. . . . .	8705691 L.H.	11.30	MOULDING UNIT, lower (vinyl insert) . . . . .
72	Pass. (Sed.) w/body side mldg. . . . .	8705688 R.H.	11.30	MOULDING UNIT, lower (vinyl insert) . . . . .
72	Pass. (Sed.) w/body side mldg. . . . .	8705689 L.H.	11.30	MOULDING UNIT, lower (vinyl insert) . . . . .
72	Chevelle (4-Dr.) w/body side mldg. . . . .	8703327 2	9.20	MOULDING UNIT, lower . . . . .
72	Caprice (Sed.) . . . . .	8705377 R.H.	15.10	MOULDING UNIT, lower (chrome) . . . . .
72	Caprice (Sed.) . . . . .	8705378 L.H.	15.10	MOULDING UNIT, lower (chrome) . . . . .
73-75	Caprice (Sta. Wag.) . . . . .	8704510 L.H.	10.55	MOULDING UNIT, finish rear door otr. pnl. transfer lwr. . . . .

**METAL TRIM—CLIPS AND PANELS**

**12.114 MOULDING— ORNAMENT— TAPE— CLIP, Rear Door Outer Panel  
(Con't)**

73-75	Caprice (Sta. Wag.)	8704509	R.H.	10.55	MOULDING UNIT, finish rear door otr. pnl. transfer lwr.
73	Bel Air, Impala (Sta. Wag.) w/body side moulding	8707699	2	11.30	MOULDING UNIT, lower (vinyl insert)
73-74	Impala (Sta. Wag.)	8707694	2	11.30	MOULDING UNIT, lower (chrome)
73-74	Impala (Sed.)	8706450	2	11.30	MOULDING UNIT, upr. lower (chrome)
73	Caprice (Sed.)	8707692	2	15.10	MOULDING UNIT, lower (chrome)
73	Caprice (Sed.) w/body side mldg.				MOULDING UNIT, upper,
73	Bel Air, Impala (Sed.) w/body side mldg.	8704650	2	15.85	MOULDING UNIT, lower (vinyl insert)
73-75	Deluxe, Malibu, Laguna (4-Dr.) w/body side mldg.	8706449	2	9.20	MOULDING UNIT, upper lower
73	Malibu, Laguna (Spt. Sed., Sta. Wag.)				MOULDING UNIT, lower,
73	Malibu, Laguna,				
74-75	Malibu (4-Dr.) (Classic)	8707702	L.H.	9.80	MOULDING UNIT, transfer lower
73	Malibu, Laguna (Spt. Sed., Sta. Wag.)				MOULDING UNIT, lower,
73	Malibu, Laguna,				
74-75	Malibu (4-Dr.) (Classic)	8707701	R.H.	9.80	MOULDING UNIT, transfer lower
73-75	Malibu, Laguna (Estate)	8707905	L.H.	11.00	MOULDING UNIT, finish transfer upper frt.
73-75	Malibu, Laguna (Estate)	8707904	R.H.	11.00	MOULDING UNIT, finish transfer upper frt.
73-75	Malibu, Laguna (Estate)	8707906	2	3.05	MOULDING UNIT, finish transfer upper rr.
74	Malibu (Estate) Monte Carlo w/body side mldg.	8707811	2	12.85	front door upper
73-74	Nova (4-Dr.) w/body side mldg.	8705640	L.H.	10.15	rear door outer panel lower (painted insert)
73-74	Nova (4-Dr.) w/body side mldg.	8705639	R.H.	10.15	rear door outer panel lower (painted insert)
74	Caprice (Sed.)	9632211	R.H.	15.10	lower
74	Caprice (Sed.)	9632212	L.H.	15.10	lower
74	Bel Air, Impala (4-Dr.) w/body side mldg.	347058	1	13.55	MOULDING UNIT, lower (10 ft. speared at one end)
75	Bel Air-Impala-Caprice (Sta. Wag.)	1719247	2		MOULDING, adhesive lower woodgrain
75	Impala (4-Dr.) w/body side mldg.	1654667	R.H.	RL/2.75	lower (adhesive mldg.)
75	Impala (4-Dr.) w/body side mldg.	1654668	L.H.	RL/2.75	lower (adhesive mldg.)
75	Caprice (Sedan)	9632676	R.H.	10.50	lower (black)
75	Caprice (Sedan)	9632677	L.H.	10.50	lower (black)
75	Caprice (Sedan) w/vinyl top w/o pad	9632678	R.H.	10.50	lower (white)
75	Caprice (Sedan) w/vinyl top w/o pad	9632679	L.H.	10.50	lower (white)
75	Caprice (Sedan)	9632680	R.H.	10.50	lower (silver)
75	Caprice (Sedan)	9632681	L.H.	10.50	lower (silver)
75	Caprice (Sedan)	9632682	R.H.	10.50	lower (green)
75	Caprice (Sedan)	9632683	L.H.	10.50	lower (green)
75	Caprice (Sedan)	9632688	R.H.	10.50	lower (beige)
75	Caprice (Sedan)	9632689	L.H.	10.50	lower (beige)
75	Caprice (Sedan)	9632684	R.H.	11.30	MOULDING UNIT, lower (maroon)
75	Caprice (Sedan)	9632685	L.H.	11.30	MOULDING UNIT, lower (maroon)
75	Caprice (Sedan)	9632686	R.H.	11.30	MOULDING UNIT, lower (dk. blue)
75	Caprice (Sedan)	9632687	L.H.	11.30	MOULDING UNIT, lower (dk. blue)
68	Caprice (Sta. Wag.)	9713869	A.R.	1.40	ORNAMENT, rr. dr., rr. fdr. and t/gate trans. upr. fin. mldg.— (12.112)
69	Caprice	3981905	1	RL/.32	TAPE, mldg. (vinyl) (black)— (8.132) (Note 4)
69	Caprice	3981906	1	RL/.32	TAPE, mldg. (vinyl) (white)— (8.132) (Note 4)
69	Caprice	3981907	1	RL/.32	TAPE, mldg. (vinyl) (maroon)— (8.132) (Note 4)
69	Caprice	3981908	1	RL/.32	TAPE, mldg. (vinyl) (yellow)— (8.132) (Note 4)
69	Caprice	3981909	1	RL/.32	TAPE, mldg. (vinyl) (champagne)— (8.132) (Note 4)
69	Caprice	3981910	1	RL/.32	TAPE, mldg. (vinyl) (bright blue)— (8.132) (Note 4)
69	Caprice	3981911	1	RL/.32	TAPE, mldg. (vinyl) (silver)— (8.132) (Note 4)
69	Caprice	3981912	1	RL/.32	TAPE, mldg. (vinyl) (med. blue)— (8.132) (Note 4)
69	Caprice	3981913	1	RL/.32	TAPE, mldg. (vinyl) (turq.)— (8.132) (Note 4)
69	Caprice	3981914	1	RL/.32	TAPE, mldg. (vinyl) (dark blue)— (8.132) (Note 4)

**METAL TRIM—CLIPS AND PANELS**

**12.114 MOULDING— ORNAMENT— TAPE— CLIP, Rear Door Outer Panel**  
(Con't)

69	Caprice	3981915	1	RL/.32	TAPE, mldg. (vinyl) (lime)— (8.132) (Note 4)
69	Caprice	3981916	1	RL/.32	TAPE, mldg. (vinyl) (green)— (8.132) (Note 4)
69	Caprice	3981917	1	RL/.32	TAPE, mldg. (vinyl) (red)— (8.132) (Note 4)
69	Caprice	3981918	1	RL/.32	TAPE, mldg. (vinyl) (gold)— (8.132) (Note 4)
69	Caprice	3981919	1	RL/.32	TAPE, mldg. (vinyl) (brown)— (8.132) (Note 4)
70	Caprice	3980833	1	RL/.32	TAPE, side moulding (vinyl) (black)— (8.132) (Note 4)
70	Caprice	3980834	1	RL/.32	TAPE, side moulding (vinyl) (maroon)— (8.132) (Note 4)
70	Caprice	3980835	1	RL/.32	TAPE, side moulding (vinyl) (white)— (8.132) (Note 4)
70	Caprice	3980836	1	RL/.32	TAPE, side moulding (vinyl) (brown)— (8.132) (Note 4)
70	Caprice	3980837	1	RL/.32	TAPE, side moulding (vinyl) (silver)— (8.132) (Note 4)
70	Caprice	3980838	1	RL/.32	TAPE, side moulding (vinyl) (dr. green)— (8.132) (Note 4)
70	Caprice	3980839	1	RL/.32	TAPE, side moulding (vinyl) (dr. gold)— (8.132) (Note 4)
70	Caprice	3980840	1	RL/.32	TAPE, side moulding (vinyl) (red)— (8.132) (Note 4)
70	Caprice	3980841	1	RL/.32	TAPE, side moulding (vinyl) (med. turq.)— (8.132) (Note 4)
70	Caprice	3980842	1	RL/.32	TAPE, side moulding (vinyl) (med. gold)— (8.132) (Note 4)
70	Caprice	3980843	1	RL/.32	TAPE, side moulding (vinyl) (yellow)— (8.132) (Note 4)
70	Caprice	3980844	1	RL/.32	TAPE, side moulding (vinyl) (med. green)— (8.132) (Note 4)
70	Caprice	3980845	1	RL/.32	TAPE, side moulding (vinyl) (med. blue)— (8.132) (Note 4)
70	Caprice	3980846	1	RL/.32	TAPE, side moulding (vinyl) (dr. blue)— (8.132) (Note 4)
70	Caprice	3980847	1	RL/.32	TAPE, side moulding (vinyl) (saddle)— (8.132) (Note 4)
71	Impala, Caprice (exc. Conv.)	9833770	A.R.	.28	CLIP, outer panel mldg. rear door lower rear— (12.112)
71	Impala, Caprice (4-Dr.) Kingswood (exc. Kingswood Estate)	9835033	A.R.	.16	CLIP, outer panel mldg. rear door lower center— (12.118)
71	Impala, Caprice (4-Dr.) Kingswood (exc. Kingswood Estate)	9833769	2	.52	CLIP ASSY., outer panel mldg. front of whl.— (12.118)

NOTE 4 Comes in 50 foot roll.

**12.116 MOULDING UNIT, Rear Fender Outer Panel**

**OUTER PANEL REAR FENDER**

**PASS.**

65	Bel Air (2-Dr.)	3870839	L.H.	14.35	rr. fender, lower
65	Bel Air (4-Dr. Sed.)	3870841	L.H.	11.30	rr. fender, lower
65	Bel Air (4-Dr. Sed.)	3870842	R.H.	11.30	rr. fender, lower
65	Bel Air (Sta. Wag.)	3870843	2	12.40	rr. fender, lower
65	Biscayne (4-Dr. Sed.)	3870846	R.H.	11.30	rr. fender peak
66	Caprice (exc. Sta. Wag.)	4226983	R.H.	4.85	rr. fender vertical at bumper
66	Caprice (exc. Sta. Wag.)	4226984	L.H.	4.85	rr. fender vertical at bumper
66	Bel Air (2-Dr.)	4227203	R.H.	12.85	rr. fender lower
66	Bel Air (2-Dr.)	4227204	L.H.	12.85	rr. fender lower
66	Bel Air (exc. 2-Dr.)	4227123	R.H.	11.00	rr. fender lower
66	Bel Air (exc. 2-Dr.)	4227124	L.H.	11.00	rr. fender lower
66	Impala (4-Dr.)	4227205	2	14.35	rr. fender lower
66	Impala (exc. 4-Dr.)	4227202	2	17.40	rr. fender lower
67-68	Caprice (Sta. Wag.)	4229544	R.H.	6.05	rr. fender frt. finish
67-68	Caprice (Sta. Wag.)	4229545	L.H.	6.05	rr. fender frt. finish
67	Caprice (Sta. Wag.)	4229539	2	9.05	rr. fender upr. finish
67	Bel Air (Sta. Wag.)	4229760	R.H.	11.70	rr. fender lwr.
67	Bel Air (Sta. Wag.)	4229761	L.H.	11.70	rr. fender lwr.

**METAL TRIM—CLIPS AND PANELS**

**12.116 MOULDING UNIT, Rear Fender Outer Panel (Con't)**

67	Bel Air (4-Dr. Sed.)	4229762 R.H.	11.30	rr. fender lwr.
67	Bel Air (4-Dr. Sed.)	4229763 L.H.	11.30	rr. fender lwr.
67	Bel Air (2-Dr.)	4229764 R.H.	15.40	rr. fender lwr.
67	Bel Air (2-Dr.)	4229765 L.H.	15.40	rr. fender lwr.
68	Impala (Sta. Wag.)	7792912 R.H.	18.10	rear fender lower (black)
68	Impala (Sta. Wag.)	7792913 L.H.	18.10	rear fender lower (black)
68	Impala (4-Dr. Sed.) (1st design)	8700050 R.H.	17.15	rr. fender lwr. (black) (smooth finish)
68	Impala (4-Dr. Sed.) (1st design)	8700051 L.H.	17.15	rr. fender lwr. (black) (smooth finish)
68	Impala (4-Dr. Sed.) (2nd design)	7795525 R.H.	15.10	rr. fender lwr. (black) (stipple) finish
68	Impala (4-Dr. Sed.) (2nd design)	7795526 L.H.	15.10	rr. fender lwr. (black) (stipple) finish
68	Bel Air (4-Dr. Sed.)	7795079 1	10.35	rear fender lower
68	Impala (2-Dr.) (1st design)	7795584 R.H.	18.85	rear fender lower (black)
68	Impala (2-Dr.) (1st design)	7795585 L.H.	18.85	rear fender lower (black)
68	Impala (Spt. Cpe., Conv.) (1st design)	8700056 R.H.	25.75	rear fender lower (black) (smooth)
68	Impala (Spt. Cpe., Conv.) (1st design)	8700057 L.H.	25.75	rear fender lower (black) (smooth)
68	Bel Air (2-Dr. Sed.)	7795078 1	15.10	rear fender lower
68	Bel Air (Sta. Wag.)	7795080 1	12.10	rear fender lower
69	Caprice (Spt. Cpe.)	8701214 R.H.	15.85	rear fender lower (Note 2)
69	Caprice (Spt. Cpe.)	8701215 L.H.	15.85	rear fender lower (Note 2)
69	Caprice (Spt. Sed.)	8701216 R.H.	12.85	rear fender lower (Note 2)
69	Caprice (Spt. Sed.)	8701217 L.H.	12.85	rear fender lower (Note 2)
69	Impala (2-Dr.)	8701270 R.H.	21.10	rear fender lower (black)
69	Impala (2-Dr.)	8701271 L.H.	21.10	rear fender lower (black)
69	Impala (2-Dr.)	8701272 R.H.	21.10	rear fender lower (blue)
69	Impala (2-Dr.)	8701273 L.H.	21.10	rear fender lower (blue)
69	Impala (2-Dr.)	8701274 R.H.	21.10	rear fender lower (green)
69	Impala (2-Dr.)	8701275 L.H.	21.10	rear fender lwr. (green)
69	Impala (2-Dr.)	8701276 R.H.	21.10	rear fender lower (red)
69	Impala (2-Dr.)	8701277 L.H.	21.10	rear fender lower (red)
69	Impala (2-Dr.)	8701278 R.H.	21.10	rear fender lower (brown)
69	Impala (2-Dr.)	8701279 L.H.	21.10	rear fender lower (brown)
69	Bel Air (2-Dr. Sed.)	8701146 1	15.85	lower rear fender panel outer
69-70	Townsmen	8701147 1	12.85	lower rear fender panel outer
69-70	Bel Air (4-Dr. Sed.)	8701148 1	12.10	lower rear fender panel outer
69	Impala (4-Dr.)	8701220 1	15.85	lower rear fender panel outer (black)
69	Impala (4-Dr.)	8701221 1	15.85	lower rear fender panel outer (blue)
69	Impala (4-Dr.)	8701222 1	15.85	lower rear fender panel outer (green)
69	Impala (4-Dr.)	8701223 1	15.85	lower rear fender panel outer (red)
69	Impala (4-Dr.)	8701224 1	15.85	lower rear fender panel outer (brown)
69	Kingswood	8701225 1	15.85	lower rear fender panel outer (black)
69	Kingswood	8701226 1	15.85	lower rear fender panel outer (blue)
69	Kingswood	8701227 1	15.85	lower rear fender panel outer (green)
69	Kingswood	8701228 1	15.85	lower rear fender panel outer (red)
69	Kingswood	8701229 1	15.85	lower rear fender panel outer (brown)
70	Kingswood (exc. Estate)	8702940 1	14.35	(gold)
70	Kingswood (exc. Estate)	8702941 1	14.35	(saddle)
70	Kingswood (exc. Estate)	8702937 1	14.35	(black)
70	Kingswood (exc. Estate)	8702938 1	14.35	(green)
70	Kingswood (exc. Estate)	8702939 1	14.35	(blue)
70	Caprice (Spt. Cpe.)	8702961 R.H.	18.85	
70	Caprice (Spt. Cpe.)	8702962 L.H.	18.85	
70	Caprice (Spt. Sed.)	8702966 R.H.	15.10	
70	Caprice (Spt. Sed.)	8702967 L.H.	15.10	
70	Impala (Sed.)	8702752 1	15.85	(black)
70	Impala (Sed.)	8702753 1	15.85	(green)
70	Impala (Sed.)	8702754 1	15.85	(blue)
70	Impala (Sed.)	8702755 1	15.85	(gold)
70	Impala (Sed.)	8702756 1	15.85	(saddle)
70	Impala (Spt. Cpe., Conv.)	8702757 R.H.	21.10	(black)
70	Impala (Spt. Cpe., Conv.)	8702758 L.H.	21.10	(black)
70	Impala (Spt. Cpe., Conv.)	8702759 R.H.	21.10	(green)
70	Impala (Spt. Cpe., Conv.)	8702760 L.H.	21.10	(green)
70	Impala (Spt. Cpe., Conv.)	8702761 R.H.	21.10	(blue)
70	Impala (Spt. Cpe., Conv.)	8702762 L.H.	21.10	(blue)
70	Impala (Spt. Cpe., Conv.)	8702763 R.H.	21.10	(gold)
70	Impala (Spt. Cpe., Conv.)	8702764 L.H.	21.10	(gold)
70	Impala (Spt. Cpe., Conv.)	8702765 R.H.	21.10	(saddle)
70	Impala (Spt. Cpe., Conv.)	8702766 L.H.	21.10	(saddle)
71	Pass. (2-Dr.) w/body side mldg.	8704474 L.H.	20.40	lower (painted insert)
71	Pass. (2-Dr.) w/body side mldg.	8704473 R.H.	20.40	lower (painted insert)
71	Pass. (2-Dr.)	8704482 L.H.	11.30	outer pnl. frt. of whl. opening
71	Pass. (2-Dr.)	8704481 R.H.	11.30	outer pnl. frt. of whl. opening
71	Pass. (4-Dr.) (exc. Sta. Wag.)	8704480 L.H.	4.50	outer pnl. frt. of whl. opening

**METAL TRIM—CLIPS AND PANELS**

**12.116 MOULDING UNIT, Rear Fender Outer Panel (Con't)**

71	Pass. (4-Dr.) (exc. Sta. Wag.) . . .	8704479 R.H.	4.50	outer pnl. frt. of whl. opening . . . . .
71	Pass. . . . .	8704478 L.H.	15.85	outer pnl. rear of whl. opening . . . . .
71	Pass. . . . .	8704477 R.H.	15.85	outer pnl. rear of whl. opening . . . . .
71	Pass. (Sed.) w/body side mldg. . . .	8704476 L.H.	15.85	lower (painted insert) . . . . .
71	Pass. (Sed.) w/body side mldg. . . .	8704475 R.H.	15.85	lower (painted insert) . . . . .
71	Pass. (Sta. Wag.) w/body side mldg. . . . .	8704489 L.H.	14.35	lower (painted insert) . . . . .
71	Pass. (Sta. Wag.) w/body side mldg. . . . .	8704488 R.H.	14.35	lower (painted insert) . . . . .
71	Kingswood (exc. Estate) . . . . .	8705437 L.H.	4.15	outer pnl. frt. of whl. opening . . . . .
71	Kingswood (exc. Estate) . . . . .	8705436 R.H.	4.15	outer pnl. frt. of whl. opening . . . . .
71-75	All w/body side mouldings . . . . .	1154223 A.R.	RL/1.50	<b>MOULDING</b> , 17 ft. roll speared both ends (black) 5/8" wide— (8.132) . . . . .
71-75	All w/body side mouldings . . . . .	1154224 A.R.	RL/1.50	<b>MOULDING</b> , 17 ft. roll speared both ends (silver) 5/8" wide— (8.132) . . . . .
72	Caprice (Spt. Cpe) w/body side mldg. . . . .			upper, . . . . .
72	Impala (2 Dr.) w/body side mldg. . . . .	8703709 2	20.40	lower (vinyl insert) . . . . .
72	Pass. (Sed.) w/body side mldg. . . .	8703711 2	15.85	lower (vinyl insert) . . . . .
72	Pass. (Sta. Wag.) w/body side mldg. . . . .	8700454 L.H.	14.35	lower (vinyl insert) . . . . .
72	Pass. (Sta. Wag.) w/body side mldg. . . . .	8700453 R.H.	14.35	lower (vinyl insert) . . . . .
72	Impala (Spt. Cpe., Conv.) (exc. Custom) . . . . .	8703714 L.H.	20.40	lower (chrome) . . . . .
72	Impala (Spt. Cpe., Conv.) (exc. Custom) . . . . .	8703713 R.H.	20.40	lower (chrome) . . . . .
72	Impala (Sed.) . . . . .	8703716 L.H.	15.85	lower (chrome) . . . . .
72	Impala (Sed.) . . . . .	8703715 R.H.	15.85	lower (chrome) . . . . .
72	Kingswood (exc. Estate) . . . . .	8700452 L.H.	14.35	lower (chrome) . . . . .
72	Kingswood (exc. Estate) . . . . .	8700451 R.H.	14.35	lower (chrome) . . . . .
73	Bel Air, Impala (Sta. Wag.) w/body side mldg. . . . .	8706499 2	14.35	lower (vinyl insert) . . . . .
73	Impala (Sta. Wag.) . . . . .	8706494 2	14.35	lower (chrome) . . . . .
73	Pass. (Sed.) w/body side mldg. . . .	8706495 2	15.85	lower (vinyl insert) . . . . .
73-74	Impala (Sed.) . . . . .	8706498 2	15.85	lower (chrome) . . . . .
73	Impala (Custom), Caprice (Spt. Cpe., Conv.) w/body side mldg. . . . .	8706496 2	20.40	(vinyl insert) . . . . .
73-74	Impala (2-Dr.) . . . . .	8706497 2	20.40	lower (chrome) . . . . .
73-75	Chevelle (2-Dr.) w/body side mldg. (exc. Monte Carlo) . . . . .	8706502 1	8.70	
74	Impala (Sta. Wag.) . . . . .	9632318 1	14.35	center lower . . . . .
73-75	El Camino (Custom, Classic) . . . . .	9631077 L.H.	21.90	rear fender outer panel (Note 1) . . . . .
73-75	El Camino (Custom, Classic) . . . . .	9631076 R.H.	21.90	rear fender outer panel (Note 1) . . . . .
74	Pass. w/body side mldg. . . . .	347058 1	13.55	lower . . . . .
75	Caprice (Spt. Cpe., Conv.) . . . . .	9631626 R.H.	18.90	outer panel rear fender (black) . . . . .
75	Caprice (Spt. Cpe., Conv.) . . . . .	9631627 L.H.	18.90	outer panel rear fender (black) . . . . .
75	Caprice (Spt. Cpe., Conv.) . . . . .	9631628 R.H.	18.90	outer panel rear fender (white) . . . . .
75	Caprice (Spt. Cpe., Conv.) . . . . .	9631629 L.H.	18.90	outer panel rear fender (white) . . . . .
75	Caprice (Spt. Cpe.) . . . . .	9631630 R.H.	18.90	outer panel rear fender (silver met.) . . . . .
75	Caprice (Spt. Cpe.) . . . . .	9631631 L.H.	18.90	outer panel rear fender (silver met.) . . . . .
75	Caprice (Spt. Cpe.) . . . . .	9631632 R.H.	18.90	outer panel rear fender (med. green) . . . . .
75	Caprice (Spt. Cpe.) . . . . .	9631633 L.H.	18.90	outer panel rear fender (med. green) . . . . .
75	Caprice (Spt. Cpe.) (w/vinyl roof w/pad) . . . . .	9631634 R.H.	18.90	outer panel rear fender (maroon) . . . . .
75	Caprice (Spt. Cpe.) (w/vinyl roof w/pad) . . . . .	9631635 L.H.	18.90	outer panel rear fender (maroon) . . . . .
75	Caprice (Spt. Cpe.) (w/vinyl roof w/pad) . . . . .	9631636 R.H.	18.90	outer panel rear fender (dk. blue) . . . . .
75	Caprice (Spt. Cpe.) (w/vinyl roof w/pad) . . . . .	9631637 L.H.	18.90	outer panel rear fender (dk. blue) . . . . .
75	Caprice (Spt. Cpe.) . . . . .	9631638 R.H.	18.90	outer panel rear fender (lt. beige) . . . . .
75	Caprice (Spt. Cpe.) . . . . .	9631639 L.H.	18.90	outer panel rear fender (lt. beige) . . . . .
75	Caprice (Sedan) (w/vinyl roof w/pad) . . . . .	9631640 R.H.	14.65	outer panel rear fender (black) . . . . .
75	Caprice (Sedan) (w/vinyl roof w/pad) . . . . .	9631641 L.H.	14.65	outer panel rear fender (black) . . . . .
75	Caprice (Sedan) (w/vinyl roof w/pad) . . . . .	9631642 R.H.	14.65	outer panel rear fender (white) . . . . .
75	Caprice (Sedan) (w/vinyl roof w/pad) . . . . .	9631643 L.H.	14.65	outer panel rear fender (white) . . . . .
75	Caprice (Sedan) (w/vinyl roof w/pad) . . . . .	9631644 R.H.	14.65	outer panel rear fender (silver met.) . . . . .

**METAL TRIM—CLIPS AND PANELS**

**12.116 MOULDING UNIT, Rear Fender Outer Panel (Con't)**

75	Caprice (Sedan) (w/vinyl roof w/pad) . . . . .	9631645	L.H.	14.65	outer panel rear fender (silver met.) . . . . .
75	Caprice (Sedan) (w/vinyl roof w/pad) . . . . .	9631646	R.H.	14.65	outer panel rear fender (med. green) . . . . .
75	Caprice (Sedan) (w/vinyl roof w/pad) . . . . .	9631647	L.H.	14.65	outer panel rear fender (med. green) . . . . .
75	Caprice (Sedan) (w/vinyl roof w/pad) . . . . .	9631652	R.H.	14.65	outer panel rear fender (lt. beige) . . . . .
75	Caprice (Sedan) (w/vinyl roof w/pad) . . . . .	9631653	L.H.	14.65	outer panel rear fender (lt. beige) . . . . .
75	Caprice (Sedan) . . . . .	9631648	R.H.	15.85	outer panel rear fender (maroon) . . . . .
75	Caprice (Sedan) . . . . .	9631649	L.H.	15.85	outer panel rear fender (maroon) . . . . .
75	Caprice (Sedan) . . . . .	9631650	R.H.	15.85	outer panel rear fender (dk. blue) . . . . .
75	Caprice (Sedan) . . . . .	9631651	L.H.	15.85	outer panel rear fender (dk. blue) . . . . .
75	Bel Air, . . . . .				
75	Impala (exc. opt. mid.) . . . . .	360000	2	RL/2.20	<b>MOULDING, chrome insert (black) borders</b> <b>(<sup>13</sup>/<sub>16</sub>" wide) (17 ft. roll)— (8.132) . . . . .</b>
75	Impala (w/opt. mld.) . . . . .	360001	2	RL/3.15	<b>MOULDING, (argent) insert with chrome</b> <b>mylar borders (<sup>11</sup>/<sub>32</sub>" wide) (17 ft. roll)—</b> <b>(8.132) . . . . .</b>

**CHEVELLE**

64	Chevelle (2-Dr. Sed.) . . . . .	3852946	1	14.35	rr. fndr. lwr. . . . .
64	Chevelle Std. (4-Dr. Sed.) . . . . .	3852948	2	10.55	rr. fndr. lwr. . . . .
64	Malibu (4-Dr. Sed.) . . . . .	3852951	2	12.85	rr. fndr. lwr. . . . .
64	Malibu (Spt. Cpe.) (exc. S.S.) . . . . .	3852949	2	15.85	rr. fndr. lwr. (white) . . . . .
64	Malibu (Sta. Wag.) . . . . .	3852950	2	12.85	rr. fndr. lwr. (white) . . . . .
65	Malibu (2-Dr.) (exc. S.S.) . . . . .	3871625	L.H.	14.35	rr. fender, lwr. . . . .
65	Malibu (2-Dr.) (exc. S.S.) . . . . .	3871626	R.H.	14.35	rr. fender, lwr. . . . .
65	Malibu (4-Dr.) (exc. Sta. Wag.) . . . . .	3871627	L.H.	10.55	rr. fender, lwr. . . . .
65	Malibu (4-Dr.) (exc. Sta. Wag.) . . . . .	3871628	R.H.	10.55	rr. fender, lwr. . . . .
65	Malibu (Sta. Wag.) . . . . .	3871629	L.H.	10.55	rr. fender, lwr. . . . .
65	Malibu (Sta. Wag.) . . . . .	3871630	R.H.	10.55	rr. fender, lwr. . . . .
66	Chevelle Deluxe (2-Dr. Sed.) . . . . .	4226975	L.H.	14.35	rr. fender lwr. . . . .
66	Chevelle Deluxe (4-Dr. Sed.) . . . . .	4226994	2	10.55	rr. fender lwr. . . . .
66	El Camino (exc. Malibu) . . . . .	4226978	R.H.	12.40	rr. fender lwr. . . . .
66	Chevelle (Sta. Wag., El Camino) (exc. Malibu) . . . . .	4226993	L.H.	6.00	rr. fender lwr. rr. . . . .
66	Chevelle (Sta. Wag., El Camino) (exc. Malibu) . . . . .	4226995	1	3.75	gas tank filler door . . . . .
67	Concours . . . . .	4229662	R.H.	3.75	fender vertical rr. lwr. finish . . . . .
67	Concours . . . . .	4229665	L.H.	4.15	fender vertical rr. upr. rr. finish . . . . .
72	Chevelle (2-Dr.) (exc. Monte Carlo) w/body side mldg. . . . .	8705699	2	8.70	
72	El Camino (Custom) . . . . .	8705845	R.H.	24.90	rr. fndr. upr. (Note 1) . . . . .
72	El Camino (Custom) . . . . .	8705846	L.H.	24.90	rr. fndr. upr. (Note 1) . . . . .
75	Monte Carlo . . . . .	9632863	R.H.	6.65	qtr. otr. pnl. ext. . . . .
75	Monte Carlo . . . . .	9632864	L.H.	6.65	qtr. otr. pnl. ext. . . . .

*NOTE 1: Part of Z02 option-fiesta special exterior 2-tone paint treatment.*

**NOVA**

62	Chevy Deluxe (2-Dr.) (exc. Nova Sed.) . . . . .				lower, . . . . .
62	Nova (2-Dr. Sed.) . . . . .	3793386	2	11.40	upper (depressed area black) . . . . .
62	Chevy Deluxe (4-Dr. Sed.) (exc. Nova Sed.) . . . . .				lower, . . . . .
62	Nova (4-Dr. Sed.) . . . . .	3793387	2	9.05	upper (depressed area black) . . . . .
62-64	Chevy Deluxe, Nova (exc. Sta. Wag.) . . . . .				
65	Nova (Spt. Cpe.) . . . . .	3792664	R.H.	5.30	rear . . . . .
62-64	Chevy Deluxe, Nova (exc. Sta. Wag.) . . . . .				
65	Nova (Spt. Cpe.) . . . . .	3792663	L.H.	5.30	rear . . . . .
62-64	Chevy Deluxe (Sta. Wag.) . . . . .	3792666	R.H.	5.30	rear . . . . .
62-64	Chevy Deluxe (Sta. Wag.) . . . . .	3792665	L.H.	5.30	rear . . . . .
63	Nova (Sta. Wag.) . . . . .	3832836	R.H.	9.80	lower (ivory) . . . . .
63	Nova (2-Dr.) . . . . .	3832837	L.H.	14.35	lower (ivory) . . . . .
63	Nova (2-Dr.) . . . . .	3832840	R.H.	14.35	lower (silver) . . . . .
64	Nova (2-Dr.) . . . . .	3852490	R.H.	11.30	rr. fndr. lwr. . . . .
64	Nova (4-Dr. Sed.) . . . . .	3852495	2	9.80	rr. fndr. lwr. . . . .
64	Nova (Sta. Wag.) . . . . .	3852496	2	9.80	rr. fndr. lwr. . . . .
65	Nova (Spt. Cpe.) (exc. S.S.) . . . . .	3870985	2	14.35	rr. fender, lower . . . . .
65	Nova (4-Dr.) (exc. Sta. Wag.) . . . . .	3870986	2	9.80	rr. fender, lower . . . . .
66	Nova (4-Dr.) (exc. Sta. Wag.) . . . . .	4227017	1	9.05	rr. fender lower . . . . .
66	Nova (Sta. Wag.) . . . . .	4227018	2	9.05	rr. fender lower . . . . .



**METAL TRIM—CLIPS AND PANELS**

**12.116 MOULDING UNIT, Rear Fender Outer Panel (Con't)**

66	Nova (Spt. Cpe.) (exc. S.S.)	4227019	2	11.40	rr. fender lower
67	Nova (Spt. Cpe.) (exc. S.S.)	4229528	1	11.30	rr. fender lwr.
67	Nova (Sta. Wag.)	4229527	1	9.05	rr. fender lwr.
67	Nova (Sed.)	4229526	1	9.05	rr. fender lwr.
68	Chevy (Spt. Cpe.)	7795055	1	13.25	rear fender lower
68	Chevy (Sed.)	7795056	1	9.80	rear fender lower
69-74	Nova (2-Dr.)	8705641	2	18.85	(painted insert)
69-74	Nova (4-Dr.)	8705642	2	15.85	(painted insert)
75	XX27, XY27 w/formal wdo.	1726296	R.H.	9.80	MOULDING, qtr. belt reveal front
75	XX27, XY27 w/formal wdo.	1726297	L.H.	9.80	MOULDING, qtr. belt reveal front
75	XX27, XY27 w/formal wdo.	1726298	R.H.	9.20	MOULDING, qtr. belt reveal rear
75	XX27, XY27 w/formal wdo.	1726299	L.H.	9.20	MOULDING, qtr. belt reveal rear
75	Nova	359999	2	RL/3.00	MOULDING, lower (roll)— (8.132)
75	XY27-69 w/extra ornamentation	9632712	2	4.90	MOULDING PKG., rear of rear fender— (12.182)

**CAMARO**

67	Camaro w/R.S.	3912089	L.H.	8.40	rr. qtr. panel
67-69	Camaro w/R.S.	3912090	R.H.	8.40	rr. qtr. pnl.
69	Camaro w/body side mldg.	8701059	R.H.	13.75	rr. qtr. panel fdr. louver
69	Camaro w/body side mldg.	8701060	L.H.	13.75	rr. qtr. panel fdr. louver

**TRANSFER MOULDING**

**PASS.**

67	Caprice (Sta. Wag.)	4229535	R.H.	7.25	rr. fender transfer vertical finish
67	Caprice (Sta. Wag.)	4229536	L.H.	7.25	rr. fender transfer vertical finish
68	Caprice (Sta. Wag.)	7795445	R.H.	12.10	rear of rear fender trans. finish
68	Caprice (Sta. Wag.)	7795446	L.H.	12.10	rear of rear fender trans. finish
68	Caprice (Sta. Wag.)	7795450	1	15.10	rear fender upper transfer finish
68	Caprice (Sta. Wag.)	7795448	R.H.	3.05	frt. of wheel opening transfer lower
68	Caprice (Sta. Wag.)	7795449	L.H.	3.05	frt. of wheel opening transfer lower
68	Caprice (Sta. Wag.)	7795451	R.H.	6.75	rear of rear wheel open. trans.
68	Caprice (Sta. Wag.)	7795452	L.H.	6.75	rear of wheel open. trans.
68	Caprice (Sta. Wag.)	7795453	R.H.	12.10	rr. fndr. transfer rear vert. finish
68	Caprice (Sta. Wag.)	7795454	L.H.	12.10	rr. fndr. transfer rear vert. finish
69	Kingswood	8701042	R.H.	9.80	rear of rear fender transfer upper
69	Kingswood	8701043	L.H.	9.80	rear of rear fender transfer upper
69	Estate Wag.	8701334	R.H.	4.50	front of whl. open. trans. finish lower
69	Estate Wag.	8701335	L.H.	4.50	front of whl. open. trans. finish lower
69	Estate Wag.	8701336	1	7.55	rr. of wheel opening transfer lower
69	Estate Wag.	8701339	R.H.	7.55	rr. fender transfer rr. vertical upper
69	Estate Wag.	8701340	L.H.	7.55	rr. fender transfer rr. vertical upper
69	Estate Wag.	8701341	R.H.	6.75	rr. fender transfer rr. vertical lower
69	Estate Wag.	8701342	L.H.	6.75	rr. fender transfer rr. vertical lower
69	Estate Wag.	8701139	1	12.10	upper transfer finish
70	Kingswood (Estate)	8701396	R.H.	5.70	finish rear of rear fender transfer lower at bpr. (painted brown)
70	Kingswood (Estate)	8701397	L.H.	5.70	finish rear of rear fender transfer lower at bpr. (painted brown)
70	Kingswood (Estate)	8701400	R.H.	4.50	rear of rear fender transfer vert.
70	Kingswood (Estate)	8701401	L.H.	4.50	rear of rear fender transfer vert.
70	Kingswood (Estate)	8702769	R.H.	6.45	finish rear fender transfer front
70	Kingswood (Estate)	8702770	L.H.	6.45	finish rear fender transfer front
70	Kingswood (Estate)	8702956	R.H.	3.05	finish front of wheelhouse opening
70	Kingswood (Estate)	8702957	L.H.	3.05	finish front of wheelhouse opening
70	Kingswood (Estate)	8702958	R.H.	7.55	finish rear of wheelhouse opening
70	Kingswood (Estate)	8702959	L.H.	7.55	finish rear of wheelhouse opening
70	Kingswood (Estate)	8702960	1	14.35	finish rear fender transfer upper
71-72	Kingswood Estate	9632894	L.H.	6.00	finish rear fender transfer front
71-72	Kingswood Estate	8705772	R.H.	6.00	finish rear fender transfer front
71-72	Kingswood Estate	8704542	L.H.	5.30	rear fender transfer rear vertical upper
71-72	Kingswood Estate	8704500	R.H.	5.30	rear fender transfer rear vertical upper
71-72	Kingswood Estate	8704502	L.H.	5.70	rear fender transfer rear vertical lower
71-72	Kingswood Estate	8704501	R.H.	5.70	rear fender transfer rear vertical lower
71-72	Kingswood Estate	8704505	1	14.35	finish rear fender transfer upper
71-72	Kingswood Estate	8704512	L.H.	11.70	finish rear wheel opening transfer
71-72	Kingswood Estate	8704511	R.H.	11.70	finish rear wheel opening transfer
73	Caprice (Sta. Wag.)	8704542	L.H.	5.30	rear fender transfer rear vertical upper
73	Caprice (Sta. Wag.)	8704500	R.H.	5.30	rear fender transfer rear vertical upper
73	Caprice (Sta. Wag.)	8704502	L.H.	5.70	rear fender transfer rear vertical lower
73	Caprice (Sta. Wag.)	8704501	R.H.	5.70	rear fender transfer rear vertical lower
73	Caprice (Sta. Wag.)	8703708	L.H.	9.80	rear of wheel opening transfer finish lower
73	Caprice (Sta. Wag.)	8703707	R.H.	9.80	rear of wheel opening transfer finish lower

**METAL TRIM—CLIPS AND PANELS**

**12.116 MOULDING UNIT, Rear Fender Outer Panel (Con't)**

73	Caprice (Sta. Wag.)	8704505	1	14.35	finish rear fender transfer upper
73-75	Caprice (Sta. Wag.)	8707965	L.H.	6.00	finish rear fender transfer front
73-75	Caprice (Sta. Wag.)	8707964	R.H.	6.00	finish rear fender transfer front
74-75	Caprice (Sta. Wag.)	9632314	R.H.	9.80	finish rear of wheel opening transfer lower
74-75	Caprice (Sta. Wag.)	9632315	L.H.	9.80	finish rear of wheel opening transfer lower
74-75	Caprice (Sta. Wag.)	9632313	2	14.35	rear fender transfer upper
74-75	Caprice (Sta. Wag.)	9632311	R.H.	10.35	finish rear fender transfer vertical rear
74-75	Caprice (Sta. Wag.)	9632312	L.H.	10.35	finish rear fender transfer vertical rear
75	Caprice (Sta. Wag.)	9632893	R.H.	6.00	finish rear fender outer panel transfer front
75	Caprice (Sta. Wag.)	9632894	L.H.	6.00	finish rear fender outer panel transfer front

**CHEVELLE**

68	Concours,				
69	Concours (Estate Wag.)	7795494	R.H.	4.15	rear fen. vert. rear lower transfer
68	Concours,				
69	Concours (Estate Wag.)	7795495	L.H.	4.15	rear fen. vert. rear lower transfer
68	Concours,				
69	Concours (Estate Wag.)	7795486	R.H.	10.55	upper transfer finish
68	Concours,				
69	Concours (Estate Wag.)	7795487	L.H.	7.25	upper transfer finish
68	Concours,				
69	Concours (Estate Wag.)	7795489	L.H.	5.70	upper rear finish
68	Concours,				
69	Concours (Estate Wag.)	7795488	L.H.	3.75	gas tank filler door transfer finish
68	Concours,				
69	Concours (Estate Wag.)	7795492	R.H.	3.75	rear fender vert. rear upper transfer
68	Concours,				
69	Concours (Estate Wag.)	7795493	L.H.	3.75	rear fender vert. rear upper transfer
68	Concours,				
69	Concours (Estate Wag.)	7795490	R.H.	3.75	rear of rear wheel opening transfer finish
68	Concours,				
69	Concours (Estate Wag.)	7795491	L.H.	3.75	rear of rear wheel opening transfer finish
70-71	Concours (Estate)	8700896	R.H.	3.75	finish rear of rear from transfer vert.
70-71	Concours (Estate)	8700897	L.H.	3.75	finish rear of rear from transfer vert.
70-72	Concours (Estate)	8702481	R.H.	8.40	finish rear fender transfer front
70-72	Concours (Estate)	8702482	L.H.	11.30	finish rear fender transfer front
70-72	Concours (Estate)	8702976	R.H.	17.40	rear fender transfer upper finish
70-72	Concours (Estate)	8702977	L.H.	9.80	rear fender transfer upper finish
70-72	Concours (Estate)	8702978	1	4.15	rear fender transfer upper finish rear
70-72	Concours (Estate)	8702979	L.H.	6.45	gas tank finish door transfer finish
70-72	Concours (Estate)	8702980	1	2.60	front of wheelhouse opening transfer finish
70-72	Concours (Estate)	8702981	1	9.80	rear of wheelhouse opening transfer finish
70-72	Concours (Estate)	8702982	R.H.	5.30	rear of rear fender upper transfer finish
70-72	Concours (Estate)	8702474	R.H.	8.85	finish rr. fdr. trans. vert.
70-72	Concours (Estate)	8702475	L.H.	8.85	finish rr. fdr. trans. vert.
70-72	Concours (Estate)	8702983	L.H.	5.30	rear of rear fender upper transfer finish
70-72	Concours (Estate)	8702984	R.H.	2.25	finish rear of rear fender transfer lower
70-72	Concours (Estate)	8702985	L.H.	2.25	finish rear of rear fender transfer lower
73-75	Chevelle (Estate)	8707948	R.H.	9.80	finish rear fender transfer lower
73-75	Chevelle (Estate)	8707940	L.H.	4.15	rear fender transfer upper rear
73-75	Chevelle (Estate)	8707987	R.H.	6.45	finish gas tank door transfer
73-75	El Camino (Custom, Classic) w/wood grain	8707953	L.H.	10.70	finish rear fender transfer front
73-75	El Camino (Custom, Classic) w/wood grain	8707952	R.H.	10.70	finish rear fender transfer front
73-75	El Camino (Custom, Classic) w/wood grain	8707984	L.H.	8.75	finish rear of rear fender transfer
73-75	El Camino (Custom, Classic) w/wood grain	8707983	R.H.	8.75	finish rear of rear fender transfer
73	El Camino (Custom) w/wood grain,				
74-75	El Camino (Classic)	8707935	L.H.	19.70	finish rear fender outer panel transfer
73	El Camino (Custom) w/wood grain,				
74-75	El Camino (Classic)	8707934	R.H.	22.30	finish rear fender outer panel transfer
73-75	El Camino (Custom) w/wood grain	8707925	L.H.	10.70	finish rear of wheel opening transfer
73-75	El Camino (Custom) w/wood grain	8707924	R.H.	10.70	finish rear of wheel opening transfer
75	El Camino (Classic)	9632899	R.H.	9.75	finish rear of wheel opening transfer
75	El Camino (Classic)	9632900	L.H.	9.75	finish rear of wheel opening transfer
73-75	Chevelle (Estate)	8707937	L.H.	4.70	finish rear fender transfer frt.
73-75	Chevelle (Estate)	8707936	R.H.	4.70	finish rear fender transfer frt.
73-75	Chevelle (Estate)	8707939	L.H.	9.80	finish rear fender transfer upper frt.
73-75	Chevelle (Estate)	8707938	R.H.	17.40	finish rear fender transfer upper frt.

**METAL TRIM—CLIPS AND PANELS**

**12.116 MOULDING UNIT, Rear Fender Outer Panel (Con't)**

<b>73-75</b>	Chevelle (Estate) . . . . .	<b>8707949</b>	L.H.	9.80	finish rear fender transfer lower . . . . .
<b>73-75</b>	Chevelle (Sta. Wag.) . . . . .	<b>8707848</b>	R.H.		finish rear fender transfer lower . . . . .

**REVEAL QUARTER BELT**

**PASS.**

<b>67-68</b>	Sedan w/2-tone paint (exc. Spt. Sed.) . . . . .	<b>3914079</b>	L.H.	11.20	belt rev. . . . .
<b>67-68</b>	Sedan w/2-tone paint (exc. Spt. Sed.) . . . . .	<b>3914080</b>	R.H.	12.30	belt rev. . . . .
<b>67-68</b>	Impala (Spt. Sed.) w/vinyl top or 2-tone paint, . . . . .				
<b>67-68</b>	Impala (Spt. Sed.) w/vinyl top or 2-tone paint, . . . . .				
<b>67-68</b>	Caprice (Spt. Sed.) . . . . .	<b>3914084</b>	R.H.	11.65	belt rev. . . . .
<b>67-68</b>	Impala (Spt. Cpe.) w/vinyl top or 2-tone paint, . . . . .				
<b>68</b>	Impala (Spt. Cpe.) w/2-tone paint (exc. Custom) . . . . .	<b>3914089</b>	L.H.	11.95	belt rev. . . . .
<b>67</b>	Impala (Spt. Cpe.) w/vinyl top or 2-tone paint, . . . . .				
<b>68</b>	Impala (Spt. Cpe.) w/2-tone paint (exc. Custom) . . . . .	<b>3914090</b>	R.H.	11.95	belt rev. . . . .
<b>68</b>	Impala, Custom, Caprice (Spt. Cpe.) w/vinyl top, w/two-tone paint . . . . .	<b>3940505</b>	L.H.	18.45	rr. qtr. belt reveal . . . . .
<b>68</b>	Impala, Custom, Caprice (Spt. Cpe.) w/vinyl top, w/two-tone paint . . . . .	<b>3940506</b>	R.H.	18.45	rr. qtr. belt reveal . . . . .
<b>69-70</b>	Impala (Spt. Cpe.) w/vinyl top, 2-tone paint (exc. Custom) . . . . .	<b>3962868</b>	R.H.	17.60	belt rev. . . . .
<b>69-70</b>	Impala (Spt. Cpe.) w/vinyl top, 2-tone paint (exc. Custom) . . . . .	<b>3962869</b>	L.H.	17.60	belt rev. . . . .
<b>69-70</b>	Pass. (4-Dr. Sed.) w/vinyl top, 2-tone paint . . . . .	<b>3962872</b>	R.H.	16.45	belt rev. . . . .
<b>69-70</b>	Pass. (4-Dr. Sed.) w/vinyl top, 2-tone paint . . . . .	<b>3962871</b>	L.H.	16.45	belt rev. . . . .
<b>69-70</b>	Impala (Custom) . . . . .	<b>3962894</b>	R.H.	15.70	belt rev. (paint as reqd.) . . . . .
<b>69-70</b>	Impala (Custom) . . . . .	<b>3962895</b>	L.H.	15.70	belt rev. (paint as reqd.) . . . . .
<b>69-70</b>	Impala (Spt. Sed.) w/vinyl top, 2-tone paint . . . . .	<b>3962896</b>	R.H.	16.45	belt rev. . . . .
<b>69-70</b>	Impala (Spt. Sed.) w/vinyl top, 2-tone paint . . . . .	<b>3962897</b>	L.H.	16.45	belt rev. . . . .
<b>71-72</b>	Pass. (Sed.) (exc. Spt. Sed.) w/vinyl top, special two-tone paint . . . . .	<b>9831723</b>	L.H.	6.05	
<b>71-72</b>	Pass. (Sed.) (exc. Spt. Sed.) w/vinyl top, special two-tone paint . . . . .	<b>9831722</b>	R.H.	6.05	
<b>71-72</b>	Pass. (Spt. Sed.) w/vinyl top, special two-tone paint . . . . .	<b>9832025</b>	L.H.	5.70	
<b>71-72</b>	Pass. (Spt. Sed.) w/vinyl top, special two-tone paint . . . . .	<b>9832024</b>	R.H.	5.70	
<b>71-72</b>	Impala (Spt. Cpe.) w/vinyl top, special two-tone paint (exc. Custom) . . . . .	<b>9835882</b>	L.H.	5.10	front . . . . .
<b>71-72</b>	Impala (Spt. Cpe.) w/vinyl top, special two-tone paint (exc. Custom) . . . . .	<b>9835881</b>	R.H.	5.10	front . . . . .
<b>71-72</b>	Impala (Spt. Cpe.) w/vinyl top, special two-tone paint (exc. Custom) . . . . .	<b>9836387</b>	L.H.	8.60	rear . . . . .
<b>71-72</b>	Impala (Spt. Cpe.) w/vinyl top, special two-tone paint (exc. Custom) . . . . .	<b>9836386</b>	R.H.	8.60	rear . . . . .
<b>71-72</b>	Impala Custom, Caprice w/vinyl top . . . . .	<b>9860753</b>	L.H.	13.90	front (painted) . . . . .
<b>71-72</b>	Impala Custom, Caprice w/vinyl top . . . . .	<b>9860752</b>	R.H.	13.90	front (painted) . . . . .
<b>71</b>	Impala Custom, Caprice w/vinyl top . . . . .	<b>9859985</b>	L.H.	13.70	rear (painted) . . . . .
<b>71</b>	Impala Custom, Caprice w/vinyl top . . . . .	<b>9859984</b>	R.H.	13.70	rear (painted) . . . . .

**METAL TRIM—CLIPS AND PANELS**

**12.116 MOULDING UNIT, Rear Fender Outer Panel (Con't)**

72	Impala Custom, Caprice (Spt. Cpe.)	9685298 R.H.	13.90	front (painted)
72	Impala Custom, Caprice (Spt. Cpe.)	9685299 L.H.	13.90	front (painted)
72	Impala Custom, Caprice w/vinyl top	9685303 L.H.	13.70	rear (painted) (repl. 9610809)
72	Impala Custom, Caprice w/vinyl top	9685302 R.H.	13.70	rear (painted)
72	Monte Carlo w/vinyl top	9610772 R.H.	22.30	
72	Monte Carlo w/vinyl top	9610773 L.H.	22.30	

**REVEAL QUARTER BELT**

73-74	Pass. (Sed.) (exc. Spt. Sed.) w/vinyl top, special two-tone paint	9831723 L.H.	6.05	
73-74	Pass. (Sed.) (exc. Spt. Sed.) w/vinyl top, special two-tone paint	9831722 R.H.	6.05	
73-74	Pass. (Spt. Sed.) w/vinyl top, special two-tone paint	9832025 L.H.	5.70	
73-74	Pass. (Spt. Sed.) w/vinyl top, special two-tone paint	9832024 R.H.	5.70	
74	Impala (Spt. Cpe.) w/vinyl top (exc. Custom)	9737864 R.H.	10.25	
74	Impala (Spt. Cpe.) w/vinyl top (exc. Custom)	9737865 L.H.	10.25	
73	Impala (Spt. Cpe.) w/vinyl top, special two-tone paint (exc. Custom)	9835882 L.H.	5.10	front
73	Impala (Spt. Cpe.) w/vinyl top, special two-tone paint (exc. Custom)	9835881 R.H.	5.10	front
73	Impala (Spt. Cpe.) w/vinyl top, special two-tone paint (exc. Custom)	9836387 L.H.	8.60	rear
73	Impala (Spt. Cpe.) w/vinyl top, special two-tone paint (exc. Custom)	9836386 R.H.	8.60	rear
73	Impala (Custom) Caprice (Spt. Cpe.)	9685298 R.H.	13.90	front (painted)
73	Impala (Custom) Caprice (Spt. Cpe.)	9685299 L.H.	13.90	front (painted)
73	Caprice	9685303 L.H.	13.70	rear (painted) (repl. 9610809)
73	Caprice	9685302 R.H.	13.70	rear (painted)
73	Camaro w/vinyl top	9841311 L.H.	11.30	
73	Camaro w/vinyl top	9841310 R.H.	11.30	
73-75	El Camino w/vinyl top, special two-tone paint	9611780 R.H.	8.50	front
73-75	El Camino w/vinyl top, special two-tone paint	9611781 L.H.	8.50	front
74-75	Impala (Spt. Cpe.) w/padded vinyl roof, two tone paint (exc. Custom)	9673797 L.H.	6.15	
74-75	Impala (Spt. Cpe.) w/padded vinyl roof, two tone paint (exc. Custom)	9673796 R.H.	6.15	
74-75	Impala (Custom) Caprice (Spt. Cpe.) w/padded vinyl top two-tone paint	9693779 L.H.	16.70	(prime and paint as reqd.)
74-75	Impala (Custom) Caprice (Spt. Cpe.) w/padded vinyl top two-tone paint	9693778 R.H.	16.70	(prime and paint as reqd.)
75	Pass. (Sedan) (w/vinyl roof w/pad) (exc. Spt. Sed.)	1685984 R.H.	13.30	
75	Pass. (Sedan) (w/vinyl roof w/pad) (exc. Spt. Sed.)	1685985 L.H.	13.30	
75	Pass. (Spt. Sed.) (w/vinyl roof w/pad)	1686000 R.H.	11.10	
75	Pass. (Spt. Sed.) (w/vinyl roof w/pad)	1686001 L.H.	11.10	
75	Impala (Custom) Caprice (Spt. Cpe.) w/full vinyl roof	1725062 R.H.	11.70	
75	Impala (Custom) Caprice (Spt. Cpe.) w/full vinyl roof	1725063 L.H.	11.70	

**METAL TRIM—CLIPS AND PANELS**

**12.116 MOULDING UNIT, Rear Fender Outer Panel (Con't)**

**CHEVELLE**

66-67	Chevelle (Spt. Cpe.) w/vinyl top or two-tone paint	3890182 R.H.	14.05	rear qtr. belt inner reveal
66-67	Chevelle (Spt. Cpe.) w/vinyl top or two-tone paint	3890181 L.H.	14.05	rr. qtr. belt inner reveal
66-67	Chevelle (Spt. Cpe.) w/vinyl top or two-tone paint	3890183 L.H.	9.10	rr. qtr. belt outer reveal
66-67	Chevelle (Spt. Cpe.) w/vinyl top or two-tone paint	3890184 R.H.	9.10	rr. qtr. belt outer reveal
68-69	Chevelle (2-Dr.) w/two-tone paint, vinyl top (exc. Conv.)	3940514 R.H.	7.80	rr. qtr. belt reveal
68-69	Chevelle (2-Dr.) w/2-tone paint, vinyl top (exc. Conv.)	3940513 L.H.	7.80	rr. qtr. belt reveal
68	Chevelle (2-Dr. Sed., Spt. Cpe.) w/2-tone paint (exc. Malibu, S.S.),			
68	Chevelle (Spt. Cpe.) w/vinyl top, two-tone paint (exc. Deluxe),			
69	Chevelle (2-Dr.) (exc. Conv.)	3941891 L.H.	18.25	rr. qtr. win. rr. reveal
68	Chevelle (2-Dr. Sed., Spt. Cpe.) w/two-tone paint (exc. Malibu, S.S.),			
68	Chevelle (Spt. Cpe.) w/vinyl top, two-tone paint (exc. Deluxe),			
69	Chevelle (2-Dr.) (exc. Conv.)	3941892 R.H.	16.60	rr. qtr. win. rr. reveal
68-69	Chevelle (4-Dr. Sed.) w/2-tone paint vinyl top	3940520 R.H.	18.25	qtr. belt reveal
68-69	Chevelle (4-Dr. Sed.) w/2-tone paint, vinyl top	3940519 L.H.	18.25	qtr. belt reveal
70-71	Malibu (Spt. Cpe.) w/vinyl top, special two-tone paint	8788124 R.H.	16.05	rear
70-72	Malibu (Spt. Cpe.) w/vinyl top, special two-tone paint	8788125 L.H.	16.05	rear
70	Malibu (Spt. Cpe.) w/vinyl top, special two-tone paint (exc. wheel opening mldg.)	8789272 R.H.	6.75	front
70	Malibu (Spt. Cpe.) w/vinyl top, special two-tone paint (exc. wheel opening mldg.)	8789273 L.H.	6.75	front
70-72	Malibu (Spt. Cpe.) (wheel opening mldg. w/vinyl top, spec. two-tone paint)	9811346 L.H.	14.70	front
70-72	Malibu (Spt. Cpe.) (wheel opening mldg. w/vinyl top, spec. two-tone paint)	9811345 R.H.	14.70	front
70-72	Chevelle (Sed.) w/vinyl top, sec. two-tone paint	8782952 L.H.	6.00	front
70-72	Chevelle (Sed.) w/vinyl top, spec. two-tone paint	8782951 R.H.	6.00	front
70-72	Chevelle (Sed.) w/vinyl top, spec. two-tone paint	8781178 R.H.	9.00	rear
70-72	Chevelle (Sed.) w/vinyl top, spec. two-tone paint	8781179 L.H.	9.00	rear
70-72	Monte Carlo (Spt. Cpe.) w/spec. two-tone paint	8792121 L.H.	17.75	
70-72	Monte Carlo (Spt. Cpe.) w/spec. two-tone paint	8792120 R.H.	17.75	
70-71	Monte Carlo (Spt. Cpe.) w/vinyl top	9809422 R.H.	24.90	
70-71	Monte Carlo (Spt. Cpe.) w/vinyl top	9809423 L.H.	24.90	
73-75	Monte Carlo w/padded vinyl top	9685273 L.H.	19.00	(painted)
73-75	Monte Carlo w/padded vinyl top	9685272 R.H.	19.00	(painted)
73-75	Monte Carlo w/vinyl top	1656494 R.H.	16.45	(painted)
73-75	Monte Carlo w/vinyl top	1656495 L.H.	16.45	(painted)
73-75	Chevelle (Spt. Cpe.) w/padded vinyl top, special two-tone paint (exc. Monte Carlo)	1655452 L.H.	21.55	
73-75	Chevelle (Spt. Cpe.) w/padded vinyl top, special two-tone paint (exc. Monte Carlo)	1655451 R.H.	21.55	
73-74	Chevelle (Sed.) w/vinyl top, special two-tone paint	9610121 L.H.	13.75	

**METAL TRIM—CLIPS AND PANELS**

**12.116 MOULDING UNIT, Rear Fender Outer Panel (Con't)**

<b>73-74</b>	Chevelle (Sed.) w/vinyl top, special two-tone paint . . . . .	<b>9610120</b> R.H.	13.75	
<b>74-75</b>	Malibu w/padded vinyl top . . . . .	<b>9731539</b> L.H.	21.55	
<b>74-75</b>	Malibu w/padded vinyl top . . . . .	<b>9731538</b> R.H.	21.55	

**CHEVY**

<b>66-67</b>	Chevy (Std.) (exc. Sta. Wag.) . . . . .	<b>3893523</b> L.H.	7.60	rr. qtr. belt reveal . . . . .
<b>68-72</b>	Chevy (Spt. Cpe.) w/vinyl top, 2- tone paint . . . . .	<b>3940509</b> L.H.	10.05	rr. qtr. belt front reveal . . . . .
<b>68-72</b>	Chevy (Spt. Cpe.) w/vinyl top, 2- tone paint . . . . .	<b>3940510</b> R.H.	10.05	rr. qtr. belt front reveal . . . . .
<b>68-72</b>	Chevy (Sed.) w/vinyl top, two- tone paint . . . . .	<b>3940508</b> R.H.	9.65	rear qtr. belt front reveal . . . . .
<b>68-72</b>	Chevy (Sed.) w/vinyl top, two- tone paint . . . . .	<b>8741116</b> L.H.	9.60	rear qtr. belt front reveal . . . . .
<b>68-72</b>	Chevy w/vinyl top, two-tone paint . . . . .	<b>3940512</b> R.H.	10.10	rear qtr. belt rear reveal . . . . .
<b>68-72</b>	Chevy w/vinyl top, two-tone paint . . . . .	<b>3940511</b> L.H.	10.10	rear qtr. belt rear reveal . . . . .
<b>73-74</b>	Nova (4-Dr.) w/vinyl top, special two-tone paint . . . . .	<b>8741116</b> L.H.	9.60	front . . . . .
<b>73-74</b>	Nova (4-Dr.) w/vinyl top, special two-tone paint . . . . .	<b>3940508</b> R.H.	9.65	front . . . . .
<b>73-74</b>	Nova (2-Dr.) w/vinyl top, special two-tone paint (exc. H.B.) . . . . .	<b>9626546</b> L.H.	6.75	front . . . . .
<b>73-74</b>	Nova (2-Dr.) w/vinyl top, special two-tone paint (exc. H.B.) . . . . .	<b>9626545</b> R.H.	6.75	front . . . . .
<b>73-74</b>	Nova w/vinyl top, special two- tone paint (exc. H.B.) . . . . .	<b>3940511</b> L.H.	10.10	rear . . . . .
<b>73-74</b>	Nova w/vinyl top, special two- tone paint (exc. H.B.) . . . . .	<b>3940512</b> R.H.	10.10	rear . . . . .
<b>74</b>	Nova (H.B.) w/special two-tone paint . . . . .	<b>9629631</b> L.H.	8.75	front . . . . .
<b>74</b>	Nova (H.B.) w/special two-tone paint . . . . .	<b>9629630</b> R.H.	8.75	front . . . . .
<b>74</b>	Nova (H.B.) w/special two-tone paint . . . . .	<b>9629633</b> L.H.	8.80	rear . . . . .
<b>74</b>	Nova (H.B.) w/special two-tone paint . . . . .	<b>9629632</b> R.H.	8.80	rear . . . . .
<b>75</b>	Nova (2-Dr.) w/vinyl top, two- tone paint . . . . .	<b>1654733</b> 2	2.95	front (*1) . . . . .
<b>75</b>	Nova (2-Dr.) (w/padded vinyl roof, two tone paint) . . . . .	<b>1661421</b> R.H.	8.10	rear (*1) . . . . .
<b>75</b>	Nova (2-Dr.) (w/padded vinyl roof, two-tone paint) . . . . .	<b>1661422</b> L.H.	8.10	rear (*1) . . . . .
<b>75</b>	Nova (2-Dr.) w/padded vinyl roof, two tone paint . . . . .	<b>1701556</b> R.H.	11.00	<b>MOLDING (*2)</b> . . . . .
<b>75</b>	Nova (2-Dr.) w/padded vinyl roof, two tone paint . . . . .	<b>1701557</b> L.H.	11.00	<b>MOLDING (*2)</b> . . . . .
<b>74</b>	Nova . . . . .	<b>347536</b> R.H.	5.65	<b>TAPE ASSY. (Spirit of America)</b> . . . . .
<b>74</b>	Nova . . . . .	<b>347535</b> L.H.	5.65	<b>TAPE ASSY. (Spirit of America)</b> . . . . .
<b>75</b>	Nova w/formal wdo. . . . .	<b>1726297</b> L.H.	9.80	<b>MOLDING, qtr. belt front reveal</b> . . . . .
<b>75</b>	Nova w/formal wdo. . . . .	<b>1726296</b> R.H.	9.80	<b>MOLDING, qtr. belt front reveal</b> . . . . .
<b>75</b>	Nova w/formal wdo. . . . .	<b>1726299</b> L.H.	9.20	<b>MOLDING, qtr. belt rear reveal</b> . . . . .
<b>75</b>	Nova w/formal wdo. . . . .	<b>1726298</b> R.H.	9.20	<b>MOLDING, qtr. belt rear reveal</b> . . . . .

*NOTE 1: 1st design 3 piece molding.*

*NOTE 2: 2nd design 2 piece molding.*

**CAMARO**

<b>67-68</b>	Camaro (Spt. Cpe.) w/vinyl top . . . . .	<b>3914077</b> L.H.	12.30	rr. qtr. belt reveal . . . . .
<b>67-68</b>	Camaro (Spt. Cpe.) w/vinyl top . . . . .	<b>3914078</b> R.H.	12.30	rr. qtr. belt reveal . . . . .
<b>69</b>	Camaro (Spt. Cpe.) w/vinyl top . . . . .	<b>3962878</b> R.H.	19.65	qtr. belt reveal . . . . .
<b>69</b>	Camaro (Spt. Cpe.) w/vinyl top . . . . .	<b>3962879</b> L.H.	19.65	qtr. belt reveal . . . . .
<b>70-72</b>	Camaro w/vinyl top . . . . .	<b>9841310</b> R.H.	11.30	
<b>70-72</b>	Camaro w/vinyl top . . . . .	<b>9841311</b> L.H.	11.30	
<b>75</b>	Camaro w/padded vinyl roof . . . . .	<b>1650780</b> R.H.	13.05	
<b>75</b>	Camaro w/padded vinyl roof . . . . .	<b>1650781</b> L.H.	13.05	

**VEGA—MONZA**

<b>75</b>	Vega (Town Cpe.) . . . . .	<b>1672960</b> R.H.	15.15	
<b>75</b>	Vega (Town Cpe.) . . . . .	<b>1672961</b> L.H.	15.15	

**QUARTER PINCHWELD MOULDING**

**METAL TRIM—CLIPS AND PANELS**

**12.116 MOULDING UNIT, Rear Fender Outer Panel (Con't)**

**PASS.**

69-70	Conv. . . . .	8713072 R.H.	41.50	finish otr. p/w at belt . . . . .
69-70	Conv. . . . .	8713073 L.H.	41.50	finish otr. p/w at belt . . . . .
71-72	Impala (Conv.) . . . . .	9876922 R.H.	42.25	finish qtr. p/w at belt . . . . .
71-72	Impala (Conv.) . . . . .	9876923 L.H.	42.25	finish qtr. p/w at belt . . . . .
75	Pass. (Conv.) . . . . .	9876922 R.H.	42.25	<b>MOLDING</b> , finish qtr. p/w at belt . . . . .
75	Pass. (Conv.) . . . . .	9876923 L.H.	42.25	<b>MOLDING</b> , finish qtr. p/w at belt . . . . .

**QUARTER PINCHWELD MOULDING**

73	Pass. (Conv.) . . . . .	9876923 L.H.	42.25	finish qtr. at belt . . . . .
73	Pass. (Conv.) . . . . .	9876922 R.H.	42.25	finish qtr. at belt . . . . .

**CHEVELLE**

64-67	El Camino . . . . .	3853668 2	17.80	rr. qtr. pinchweld finish front . . . . .
64-67	El Camino . . . . .	3869284 R.H.	11.75	rr. qtr. pinchweld finishing rear . . . . .
64-67	El Camino . . . . .	3869283 L.H.	11.75	rr. qtr. pinchweld finishing rear . . . . .
68	Chevelle (Conv.) . . . . .	3940526 R.H.	24.55	rr. qtr. p/weld finish . . . . .
68	Chevelle (Conv.) . . . . .	3940525 L.H.	25.50	rr. qtr. p/weld finish . . . . .
68-72	El Camino . . . . .	3940524 R.H.	20.75	qtr. p/weld fin. at belt . . . . .
68-72	El Camino . . . . .	3940523 L.H.	20.75	qtr. p/weld fin. at belt . . . . .
68-72	El Camino . . . . .	3940522 R.H.	11.45	qtr. pinchweld, frt. corner fin. . . . .
68-72	El Camino . . . . .	3940521 L.H.	11.45	qtr. pinchweld, frt. corner fin. . . . .
69-72	Chevelle (Conv.) . . . . .	3962892 R.H.	47.75	qtr. p/weld finish . . . . .
69-72	Chevelle (Conv.) . . . . .	3962893 L.H.	47.75	qtr. p/weld finish . . . . .
73-75	El Camino . . . . .	9675553 R.H.	13.75	finish qtr. rr. (repl. 9878330) . . . . .
73-75	El Camino . . . . .	9675554 L.H.	13.75	finish qtr. rr. . . . .
73-75	El Camino . . . . .	9877626 R.H.	21.65	finish qtr. frt. . . . .
73-75	El Camino . . . . .	9877627 L.H.	21.65	finish qtr. frt. . . . .
73-75	El Camino . . . . .	9675551 R.H.	13.60	finish qtr. corner at back wdo. . . . .
73-75	El Camino . . . . .	9675552 L.H.	13.60	finish qtr. corner at back wdo. . . . .

**CAMARO**

67-69	Camaro (Conv.) (exc. ext. ornament) . . . . .	3914091 L.H.	19.30	rr. qtr. pinchweld finish . . . . .
67-69	Camaro (Conv.) (exc. belt reveal mldg.) . . . . .	3914092 R.H.	21.05	rr. qtr. pinchweld finish . . . . .

**BODY LOCK PILLAR BELT REVEAL**

68-72	El Camino w/vinyl top . . . . .	3940503 L.H.	8.80	body lk. plr. belt reveal . . . . .
68-72	El Camino w/vinyl top . . . . .	3940504 R.H.	8.80	body lk. plr. belt reveal . . . . .
71-72	Pass. (Sta. Wag.) w/vinyl top, special two-tone paint . . . . .	9845997 R.H.	6.55	body lk. plr. belt reveal . . . . .
71-72	Pass. (Sta. Wag.) w/vinyl top, special two-tone paint . . . . .	9845998 L.H.	6.55	body lk. plr. belt reveal . . . . .
73-75	Pass. (Sta. Wag.) w/vinyl top, special two-tone paint . . . . .	9845998 L.H.	6.55	
73-75	Pass. (Sta. Wag.) w/vinyl top, special two-tone paint . . . . .	9845997 R.H.	6.55	

**PEAK QUARTER WINDOW OUTER PANEL**

64	Malibu (S.S.) . . . . .	3869237 L.H.	11.30	rr. fndr. rr. peak . . . . .
70	Malibu (Spt. Cpe.) . . . . .	8702660 R.H.	8.70	
70	Malibu (Spt. Cpe.) . . . . .	8702661 L.H.	8.70	
70	Malibu (Conv.) . . . . .	8702662 R.H.	8.70	
70	Malibu (Conv.) . . . . .	8702663 L.H.	8.70	
63-64	Nova (Super Sport) . . . . .	3793854 R.H.	11.00	peak front . . . . .
63-64	Nova (Super Sport) . . . . .	3793853 L.H.	11.00	peak front . . . . .
63-64	Nova (Super Sport) . . . . .	3793856 R.H.	5.30	peak rear . . . . .
63-64	Nova (Super Sport) . . . . .	3793855 L.H.	5.30	peak rear . . . . .
65	Nova (exc. Sta. Wag.) . . . . .	3870996 R.H.	7.85	rr. of rr. fender peak . . . . .

**GARNISH BACK WINDOW SIDE**

**REAR OF REAR FENDER**

**PASS.**

65	Bel Air (Sta. Wag.) . . . . .	3870704 1	8.40	rr. of rr. fender, upper, lower . . . . .
65	Impala (Sta. Wag.) . . . . .	3870705 L.H.	13.55	rr. of rr. fender, lower . . . . .
65	Impala (Sta. Wag.) . . . . .	3870706 R.H.	13.55	rr. of rr. fender, lower . . . . .
65	S.S., Caprice . . . . .	3870833 L.H.	14.35	rr. of rr. fender (black) . . . . .
65	S.S., Caprice . . . . .	3870834 R.H.	14.35	rr. of rr. fender (black) . . . . .

**METAL TRIM—CLIPS AND PANELS**

**12.116 MOULDING UNIT, Rear Fender Outer Panel (Con't)**

65	S.S., Caprice	3870835 L.H.	12.85	rr. of rr. fender (black and gray)
65	S.S., Caprice	3870836 R.H.	14.35	rr. of rr. fender (black)
66	Caprice (Sta. Wag.)	4227077 L.H.	13.25	rr. of rr. fender grain fin.
66	Bel Air	4227040 R.H.	5.30	rr. of rr. fender
66	Bel Air	4227041 L.H.	5.30	rr. of rr. fender
66	Impala,			
66	Caprice (exc. Sta. Wag.)	4227042 R.H.	8.45	rr. of rr. fender
66	Impala,			
66	Caprice (exc. Sta. Wag.)	4227043 L.H.	5.70	rr. of rr. fender
67	Impala (Spt. Cpe.)	4229575 R.H.	6.75	rr. of rr. fender
67	Impala (Spt. Cpe.)	4229576 L.H.	6.75	rr. of rr. fender
67	Impala (exc. Sta. Wag., Spt. Cpe.),			
67	Caprice (exc. Sta. Wag.)	4229573 R.H.	6.45	rr. of rr. fender
67	Impala (exc. Sta. Wag., Spt. Cpe.),			
67	Caprice (exc. Sta. Wag.)	4229574 L.H.	6.45	rr. of rr. fender
67	Sta. Wag.	4229548 R.H.	6.75	rr. of rr. fender lwr.
67	Sta. Wag.	4229549 L.H.	6.75	rr. of rr. fender lwr.
67	Caprice (Sta. Wag.)	4229546 R.H.	7.25	rr. of rr. fender upr.
67	Caprice (Sta. Wag.)	4229547 L.H.	7.25	rr. of rr. fender upr.
68	Caprice (exc. Sta. Wag.)	7795030 R.H.	5.30	rear of rear fender
68	Caprice (exc. Sta. Wag.)	7795031 L.H.	5.30	rear of rear fender
69	Caprice	8700982 R.H.	6.00	rear of rear fender
69	Caprice	8700983 L.H.	6.00	rear of rear fender
72	Caprice	8704210 L.H.	3.90	outer panel
72	Caprice	8703952 R.H.	3.90	outer panel

**CHEVELLE**

65	Chevelle (exc. Sta. Wag., El Camino)	3871643 L.H.	7.50	rr. of rr. fender
65	Chevelle (exc. Sta. Wag., El Camino)	3871644 R.H.	7.50	rr. of rr. fender
67	Chevelle (Deluxe) (Sed.)	4229429 R.H.	8.50	rr. of rr. fender
67	Chevelle (Deluxe) (Sed.)	4229430 L.H.	8.50	rr. of rr. fender
68-72	El Camino	7795036 R.H.	5.30	rear of rear fender upper
68-72	El Camino	7795037 L.H.	5.30	rear of rear fender upper
68	Malibu (Sta. Wag.),			
69	El Camino (Custom)	7795040 R.H.	2.25	rr. of rear fender lower inner
68	Malibu (Sta. Wag.),			
68	El Camino (Custom)	7795041 L.H.	2.25	rear of rear fen. lower inner
68	Malibu (Sta. Wag.),			
68	El Camino (Custom)	7795042 R.H.	3.60	rear of rear fen. upper inner
68	Malibu (Sta. Wag.),			
68	El Camino (Custom)	7795043 L.H.	2.25	rear of rear fen. upper inner
68-72	El Camino	7795038 R.H.	4.15	rear of rear fender lower outer
68-72	El Camino	7795039 L.H.	4.15	rear of rear fender lower outer

**OUTER PANEL REAR OF REAR FENDER**

**PASSENGER**

65	Bel Air (Sta. Wag.)	3870708 R.H.	4.50	vert. at bumper
65	Impala (exc. Sta. Wag.)	3870709 L.H.	13.55	rr. of rr. otr. pnl.
65	Impala (exc. Sta. Wag.)	3870710 R.H.	13.55	rr. of rr. otr. pnl.
65	Bel Air (exc. Sta. Wag.)	3870711 L.H.	7.55	rr. of rr. upper
65	Bel Air (exc. Sta. Wag.)	3870712 R.H.	7.55	rr. of rr. upper
65	Bel Air (exc. Sta. Wag.)	3870715 L.H.	11.30	rr. of rr. lower
65	Bel Air (exc. Sta. Wag.)	3870713 R.H.	11.30	rr. of rr. lower
68	Biscayne (4-Dr.)	3941206 R.H.	6.35	rr. qtr. pnl. side
68	Biscayne (4-Dr.)	3941205 L.H.	6.95	rr. qtr. pnl. side
70	Impala (2-Dr., 4-Dr.) (exc. Sta. Wag.) w/rear end panel mldg.	8700982 R.H.	6.00	
70	Impala (2-Dr., 4-Dr.) (exc. Sta. Wag.) w/rear end panel mldg.	8700983 L.H.	6.00	
70	Kingswood (exc. Estate Wagon)	8701042 R.H.	9.80	upper
70	Kingswood (exc. Estate Wagon)	8701043 L.H.	9.80	upper
70	Kingswood (Estate)	8701394 R.H.	6.05	
70	Kingswood (Estate)	8701395 L.H.	6.05	
70	Caprice	8702964 R.H.	6.75	
70	Caprice	8702965 L.H.	6.75	
73	Caprice (exc. Sta. Wag.)	8704210 L.H.	3.90	outer panel
73	Caprice (exc. Sta. Wag.)	8703952 R.H.	3.90	outer panel

**CHEVELLE**



**METAL TRIM—CLIPS AND PANELS**

**12.116 MOULDING UNIT, Rear Fender Outer Panel (Con't)**

64	Chevelle (exc. Sta. Wag., El Camino) . . . . .	<b>3853434</b> R.H.	7.50	rr. of rr. fndr. outer pnl. outer . . . . .
64	Chevelle (exc. Sta. Wag., El Camino) . . . . .	<b>3853433</b> L.H.	7.50	rr. of rr. fndr. outer pnl. outer . . . . .
64	Malibu (exc. Sta. Wag.) . . . . .	<b>3853432</b> R.H.	7.75	rr. of rr. fndr. outer pnl. inner . . . . .
69	Chevelle (2-Dr.) w/body side mldg. . . . .	<b>3960124</b> 1	33.75	body side— (12.114) (Note 1) . . . . .
73-75	El Camino (Custom) . . . . .	<b>9631079</b> L.H.	8.60	outer panel (Note 2) . . . . .
73-75	El Camino (Custom) . . . . .	<b>9631078</b> R.H.	8.60	outer panel (Note 2) . . . . .

*NOTE 1 Cut as required.*

*NOTE 2: Part of D91 option-special exterior 2-tone paint treatment.*

**NOVA**

75	Nova (Custom) w/rr. end oran. (exc. H.B.) . . . . .	<b>1660410</b> R.H.	4.90	outer panel . . . . .
75	Nova (Custom) w/rear end oran. (exc. H.B.) . . . . .	<b>9632712</b> 2	4.90	<b>MOULDING UNIT</b> , outer panel . . . . .

**WHEELHOUSE OPENING MOULDING**

**PASS.**

65	Biscayne, Bel Air, Impala (Spt. Mdls.) . . . . .	<b>3865892</b> R.H.	15.85	rr. whl. opening outer pnl. . . . .
65	Biscayne, Bel Air, Impala (Spt. Mdls.) . . . . .	<b>3865891</b> L.H.	15.85	rr. whl. opening outer pnl. . . . .
65	Impala (Sta. Wag.) . . . . .	<b>3870853</b> L.H.	14.00	rr. wheel opening . . . . .
65	Impala (Sta. Wag.) . . . . .	<b>3870854</b> R.H.	14.00	rr. wheel opening . . . . .
65	Impala (exc. Sta. Wag.) . . . . .	<b>3870855</b> L.H.	13.25	rr. of rr. wheel opening . . . . .
65	Impala (exc. Sta. Wag.) . . . . .	<b>3870856</b> R.H.	13.25	rr. of rr. wheel opening . . . . .
65	Impala (Sta. Wag.) . . . . .	<b>3870857</b> L.H.	13.25	rr. of rr. wheel opening . . . . .
65	Impala (Sta. Wag.) . . . . .	<b>3870858</b> R.H.	13.25	rr. of rr. wheel opening . . . . .
66	All (exc. Sta. Wag.) . . . . .	<b>3884064</b> R.H.	13.25	rr. wheel opening . . . . .
66	All (exc. Sta. Wag.) . . . . .	<b>3884063</b> L.H.	13.25	rr. wheel opening . . . . .
66	Sta. Wag. (exc. Caprice) . . . . .	<b>3884066</b> R.H.	14.00	rr. wheel opening . . . . .
66	Sta. Wag. (exc. Caprice) . . . . .	<b>3884065</b> L.H.	14.00	rr. wheel opening . . . . .
67	Caprice (Sta. Wag.) . . . . .	<b>4229537</b> R.H.	6.45	rr. of wheel opening finish . . . . .
67	Caprice (Sta. Wag.) . . . . .	<b>4229538</b> L.H.	6.45	rr. of wheel opening finish . . . . .
67	Caprice (Sta. Wag.), Sta. Wag. . . . .	<b>4229540</b> R.H.	13.25	rr. wheel opening . . . . .
67	Caprice (Sta. Wag.), Sta. Wag. . . . .	<b>4229541</b> L.H.	13.25	rr. wheel opening . . . . .
67	Caprice (Sta. Wag.) . . . . .	<b>4229543</b> L.H.	3.05	frt. of wheel opening lwr. . . . .
67	Impala . . . . .	<b>4229772</b> R.H.	8.40	rr. of rr. wheel opening . . . . .
67	Impala . . . . .	<b>4229773</b> L.H.	8.40	rr. of rr. wheel opening . . . . .
67	Impala (Spt. Cpe., Conv.) (exc. S.S.) . . . . .	<b>4229778</b> R.H.	6.75	frt. of rr. wheel opening . . . . .
67	Impala (Spt. Cpe., Conv.) (exc. S.S.) . . . . .	<b>4229779</b> L.H.	6.75	frt. of rr. wheel opening . . . . .
67	Impala (4-Dr.) . . . . .	<b>4229776</b> R.H.	4.15	frt. of rr. wheel opening . . . . .
67	Impala (4-Dr.) . . . . .	<b>4229777</b> L.H.	4.15	frt. of rr. wheel opening . . . . .
67	S.S. . . . . .	<b>4229770</b> R.H.	11.00	rr. of rr. wheel opening . . . . .
67	S.S. . . . . .	<b>4229771</b> L.H.	11.00	rr. of rr. wheel opening . . . . .
67-68	S.S., Caprice (exc. Sta. Wag.), Impala (exc. Sta. Wag.) . . . . .	<b>4229774</b> R.H.	13.25	rr. wheel opening . . . . .
67-68	S.S., Caprice (exc. Sta. Wag.), Impala (exc. Sta. Wag.) . . . . .	<b>4229775</b> L.H.	13.25	rr. wheel opening . . . . .
67	Caprice (Spt. Sed.) . . . . .	<b>4229766</b> R.H.	3.75	frt. of rr. wheel opening . . . . .
67	Caprice (Spt. Sed.) . . . . .	<b>4229767</b> L.H.	3.75	frt. of rr. wheel opening . . . . .
67	Caprice (Spt. Cpe.) . . . . .	<b>4229768</b> R.H.	5.95	frt. of rr. wheel opening . . . . .
67	Caprice (Spt. Cpe.) . . . . .	<b>4229769</b> L.H.	6.45	frt. of rr. wheel opening . . . . .
67	Caprice (Spt. Mdls.) . . . . .	<b>4229758</b> R.H.	7.85	rr. of rr. wheel opening . . . . .
67	Caprice (Spt. Mdls.) . . . . .	<b>4229759</b> L.H.	7.85	rr. of rr. wheel opening . . . . .
68	Impala w/fender skirt . . . . .	<b>3928488</b> R.H.	5.50	rr. wheel opening cover . . . . .
68	Impala w/fender skirt . . . . .	<b>3928487</b> L.H.	5.50	rr. wheel opening cover . . . . .
68	Impala w/fender skirt . . . . .	<b>3928490</b> R.H.	2.85	rr. wheel opening cover extension frt. . . . .
68	Impala w/fender skirt . . . . .	<b>3928489</b> L.H.	2.85	rr. wheel opening cover extension frt. . . . .
68	Impala w/fender skirt . . . . .	<b>3928492</b> R.H.	2.85	rr. wheel opening cover extension rear . . . . .
68	Impala w/fender skirt . . . . .	<b>3928491</b> L.H.	2.85	rr. wheel opening cover extension rear . . . . .
68	Caprice (Spt. Cpe.) . . . . .	<b>7795046</b> R.H.	9.05	frt. of rear wheel opening . . . . .
68	Caprice (Spt. Cpe.) . . . . .	<b>7795047</b> L.H.	9.05	frt. of rear wheel opening . . . . .
68	Caprice (Sed.) . . . . .	<b>7795048</b> R.H.	5.70	front of rear wheel opening . . . . .
68	Caprice (Sed.) . . . . .	<b>7795049</b> L.H.	5.70	front of rear wheel opening . . . . .
68	Caprice (exc. Sta. Wag.) . . . . .	<b>7795034</b> R.H.	12.85	rear of rear wheel opening . . . . .
68	Caprice (exc. Sta. Wag.) . . . . .	<b>7795035</b> L.H.	12.85	rear of rear wheel opening . . . . .

**METAL TRIM—CLIPS AND PANELS**

**12.116 MOULDING UNIT, Rear Fender Outer Panel (Con't)**

69-70	Impala, Caprice (exc. Wag.) . . . . .	8700995 R.H.	12.40	rear whl. opening . . . . .
69-70	Impala, Caprice (exc. Wag.) . . . . .	8700996 L.H.	12.40	rear whl. opening . . . . .
69-70	Kingswood, Estate Wag. . . . .	8700997 R.H.	12.40	rear whl. opening . . . . .
69-70	Kingswood . . . . .	8700998 L.H.	12.40	rear whl. opening . . . . .
71	Impala, Caprice (exc. Sta. Wag.) . . . . .	8704478 L.H.	15.85	outer panel rear of wheelhouse opening . . . . .
71	Impala, Caprice (exc. Sta. Wag.) . . . . .	8704477 R.H.	15.85	outer panel rear of wheelhouse opening . . . . .
71	Impala, Caprice (Sed.) . . . . .	8704480 L.H.	4.50	outer panel front of wheelhouse opening . . . . .
71	Impala, Caprice (Sed.) . . . . .	8704479 R.H.	4.50	outer panel front of wheelhouse opening . . . . .
71	Pass. (2-Dr.) . . . . .	8704482 L.H.	11.30	outer panel front of wheelhouse opening . . . . .
71	Pass. (2-Dr.) . . . . .	8704481 R.H.	11.30	outer panel front of wheelhouse opening . . . . .
71	Impala . . . . .	8704484 L.H.	10.15	outer panel rear wheelhouse opening . . . . .
71	Impala . . . . .	8704483 R.H.	10.15	outer panel rear wheelhouse opening . . . . .
71	Kingswood (exc. Estate) . . . . .	8704496 L.H.	15.10	outer panel rear of wheelhouse opening . . . . .
71	Kingswood (exc. Estate) . . . . .	8704495 R.H.	15.10	outer panel rear of wheelhouse opening . . . . .
71	Kingswood (exc. Estate) . . . . .	8704498 L.H.	12.40	outer panel rear wheelhouse opening . . . . .
71	Kingswood (exc. Estate) . . . . .	8704497 R.H.	12.40	outer panel rear wheelhouse opening . . . . .
71	Kingswood (exc. Estate) . . . . .	8705437 L.H.	4.15	outer panel front of wheelhouse opening . . . . .
71	Kingswood (exc. Estate) . . . . .	8705436 R.H.	4.15	outer panel front of wheelhouse opening . . . . .
72-75	Pass. (exc. Caprice & Sta. Wag.) . . . . .	8703718 L.H.	10.15	outer panel rear wheelhouse opening . . . . .
72-75	Pass. (exc. Caprice & Sta. Wag.) . . . . .	8703717 R.H.	10.15	outer panel rear wheelhouse opening . . . . .
72	Caprice (Sed.) . . . . .	8705371 R.H.	4.50	outer panel front of wheelhouse opening (Note 1) . . . . .
72	Caprice (Sed.) . . . . .	8705372 L.H.	4.50	outer panel front of wheelhouse opening (Note 1) . . . . .
72	Caprice (Spt. Cpe.) . . . . .	8705369 R.H.	11.30	outer panel front of wheelhouse opening (Note 1) . . . . .
72	Caprice (Spt. Cpe.) . . . . .	8705370 L.H.	11.30	outer panel front of wheelhouse opening (Note 1) . . . . .
72	Caprice (exc. Sta. Wag.) . . . . .	8705373 R.H.	15.85	outer panel rear of wheelhouse opening (Note 1) . . . . .
72	Caprice (exc. Sta. Wag.) . . . . .	8705374 L.H.	15.85	outer panel rear of wheelhouse opening (Note 1) . . . . .
72	Kingswood (Estate), Caprice . . . . .	4725264	.12	rr. & whl. brg. upr. . . . .
72-75	Pass. (Sta. Wag.) (exc. Estate) w/wheel opening mldg., . . . . .			
72	Kingswood w/side body mldg., . . . . .	8700456 L.H.	12.40	outer panel rear wheelhouse opening . . . . .
72-75	Pass. (Sta. Wag.) (exc. Estate) w/wheel opening mldg., . . . . .			
72	Kingswood w/side body mldg., . . . . .	8700455 R.H.	12.40	outer panel rear wheelhouse opening . . . . .
71-72	Kingswood Estate . . . . .	8703708 L.H.	9.80	finish rear of wheelhouse opening outer panel . . . . .
71-72	Kingswood Estate . . . . .	8703707 R.H.	9.80	finish rear of wheelhouse opening outer panel . . . . .
73	Caprice (Sed.) . . . . .	8706519 L.H.	4.50	outer panel front of wheel opening . . . . .
73	Caprice (Sed.) . . . . .	8706518 R.H.	4.50	outer panel front of wheel opening . . . . .
73	Caprice (exc. Sta. Wag.) . . . . .	9630063 L.H.	15.85	outer panel rear of wheel opening . . . . .
73	Caprice (exc. Sta. Wag.) . . . . .	9630062 R.H.	15.85	outer panel rear of wheel opening . . . . .
73	Pass. (2-Dr.) . . . . .	8706515 L.H.	11.30	outer panel front of wheel opening . . . . .
73	Pass. (2-Dr.) . . . . .	8706514 R.H.	11.30	outer panel front of wheel opening . . . . .
73-75	Caprice (Sta. Wag.) . . . . .	8704511 R.H.	11.70	rear wheel opening . . . . .
73-75	Caprice (Sta. Wag.) . . . . .	8704512 L.H.	11.70	rear wheel opening . . . . .
74	Impala (Spt. Cpe.) (exc. Custom) w/body side wide lwr. mldg., . . . . .			
74	Caprice (Spt. Cpe., Conv.) . . . . .	9632346 R.H.	10.35	outer panel front of wheel opening . . . . .
74	Impala (Spt. Cpe.) (exc. Custom) w/body side wide lwr. mldg., . . . . .			
74	Caprice (Spt. Cpe., Conv.) . . . . .	9632347 L.H.	10.35	outer panel front of wheel opening . . . . .
74	Caprice (Sed.) . . . . .	9632348 R.H.	5.45	outer panel front of wheel opening . . . . .
74	Caprice (Sed.) . . . . .	9632349 L.H.	5.45	outer panel front of wheel opening . . . . .
74	Impala (Spt. Cpe.) (exc. Custom) w/body side wide lwr. mldg., . . . . .			
74	Caprice (exc. Sta. Wag.) . . . . .	9631751 R.H.	15.75	outer panel rear of wheel opening . . . . .
74	Impala (Spt. Cpe.) (exc. Custom) w/body side wide lwr. mldg., . . . . .			
74	Caprice (exc. Sta. Wag.) . . . . .	9631752 L.H.	15.75	outer panel rear of wheel opening . . . . .
75	Caprice (exc. Sta. Wag.) . . . . .	9631654 R.H.	9.10	outer panel rear of wheel opening . . . . .
75	Caprice (exc. Sta. Wag.) . . . . .	9631655 L.H.	9.10	outer panel rear of wheel opening . . . . .

NOTE 1: Paint as required.

**CHEVELLE**

64	Malibu (S.S.) . . . . .	3852957 L.H.	12.40	rr. wheel opening . . . . .
64	Malibu (S.S.) . . . . .	3852958 R.H.	12.40	rr. wheel opening . . . . .
64	El Camino Deluxe . . . . .	3852955 L.H.	12.40	rr. wheel opening . . . . .
64	El Camino Deluxe . . . . .	3852956 R.H.	12.40	rr. wheel opening . . . . .
64	El Camino Deluxe . . . . .	3852959 L.H.	13.25	rr. or rr. wheel opening . . . . .

**METAL TRIM—CLIPS AND PANELS**

**12.116 MOULDING UNIT, Rear Fender Outer Panel (Con't)**

64	El Camino Deluxe	3852960 R.H.	13.25	rr. of rr. wheel opening
65	Malibu (exc. Sta. Wag.)	3871621 L.H.	12.40	rr. wheel opening
65	Malibu (exc. Sta. Wag.)	3871622 R.H.	12.40	rr. wheel opening
65	Malibu (Sta. Wag.),			
65	El Camino Custom	3871623 L.H.	12.40	rr. wheel opening
65	Malibu (Sta. wag.),			
65	El Camino Custom	3871624 R.H.	12.40	rr. wheel opening
65	Chevelle Deluxe (2-Dr.),			
65	El Camino (exc. Custom)	3871631 L.H.	6.85	frt. of wheel opening
65	Chevelle Deluxe (2-Dr.),			
65	El Camino (exc. Custom)	3871632 R.H.	7.45	frt. of wheel opening
66	Chevelle (S.S.)	4226985 R.H.	13.25	rr. of rr. wheel opening
66	Chevelle (S.S.)	4226986 L.H.	13.25	rr. of rr. wheel opening
66	El Camino (Custom)	4226987 R.H.	14.70	rr. of rr. wheel opening
66	El Camino (Custom)	4226988 L.H.	14.70	rr. of rr. wheel opening
66	Chevelle (exc. Sta. Wag., El Camino)	3884034 R.H.	14.35	rr. wheel opening
66	Chevelle (exc. Sta. Wag., El Camino)	3884033 L.H.	14.35	rr. wheel opening
66	Chevelle (Sta. Wag.) (El Camino)	3884036 R.H.	14.35	rr. wheel opening
66	Chevelle (Sta. Wag.) (El Camino)	3884035 L.H.	14.35	rr. wheel opening
67	Malibu (exc. Sta. Wag., El Camino)	4229718 R.H.	7.25	rr. of rr. wheel opening
67	Malibu (exc. Sta. Wag., El Camino)	4229719 L.H.	7.25	rr. of rr. wheel opening
67	Malibu (4-Dr.)	4229722 R.H.	2.25	frt. of wheel opening
67	Malibu (4-Dr.)	4229723 L.H.	2.25	frt. of wheel opening
67	Malibu (2-Dr.)	4229724 R.H.	6.05	frt. of wheel opening
67	Malibu (2-Dr.)	4229725 L.H.	6.05	frt. of wheel opening
67	Malibu (Sta. Wag., El Camino)	4229726 R.H.	7.25	rr. of rr. wheel opening
67	Malibu (Sta. Wag., El Camino)	4229727 L.H.	7.25	rr. of rr. wheel opening
67	Chevelle (S.S.)	4229720 R.H.	14.35	rr. wheel opening
67	Chevelle (S.S.)	4229721 L.H.	14.35	rr. wheel opening
67	Concours	4229674 L.H.	2.25	front of rr. wheel opening finish
67	Concours	4229675 R.H.	14.35	rr. wheel opening
67	Concours	4229676 L.H.	14.35	rr. wheel opening
68	Concours	7795053 R.H.	12.40	rear wheel opening
68	Concours	7795054 L.H.	12.40	rear wheel opening
68	S.S. (exc. El Camino)	7795069 1	7.25	rear of rear wheel opening
68	El Camino (Custom)	7795070 1	6.80	rear of rear wheel opening
68	El Camino (Custom)	7795071 1	5.40	front of rear wheel opening
68	Malibu, S.S. (Spt. Cpe., Conv.),			
69	Chevelle (2-Dr.) (exc. Conv.)	7795072 1	6.05	front of rear wheel opening
68	Malibu (Spt. Sed.)	7795032 R.H.	12.40	rear wheel opening
68	Malibu (Spt. Sed.)	7795033 L.H.	12.40	rear wheel opening
69	El Camino (Custom)	8701162 2	6.45	front of wheel opening
69	El Camino (Custom)	8701163 2	7.55	rear of wheel opening
69	Malibu (Spt. Mdls.) (exc. S.S.)	8700938 R.H.	7.20	rear of wheel opening
69	Malibu (Spt. Mdls.) (exc. S.S.)	8700939 L.H.	7.20	rear of wheel opening
69	Concours	8700366 R.H.	10.50	rear whl. opening
69	Concours	8700367 L.H.	10.50	rear whl. opening
69	Chevelle (Spt. Cpe., Conv.)	8701345 A.R.	6.05	front wheel opening outer
69	Malibu (Spt. Sed.) w/body side mldg.	8701318 R.H.	9.80	rear outer panel rr. of whl. opg.
69	Malibu (Spt. Sed.) w/body side mldg.	8701319 L.H.	9.80	rear outer panel rr. of whl. opg.
69	Malibu (exc. 4-Dr. Sed.),			
69	El Camino (exc. Custom),			
69	Chevelle (Deluxe) (exc. 4-Dr.)	8700946 R.H.	12.40	rear outer panel wheel opening
69	Malibu (exc. 4-Dr. Sed.),			
69	El Camino (exc. Custom),			
69	Chevelle (Deluxe) (exc. 4-Dr.)	8700947 L.H.	12.40	rear outer panel wheel opening
70-72	Concours	8702472 R.H.	12.40	outer panel rear wheelhouse opening
70-72	Concours	8702473 L.H.	12.40	outer panel rear wheelhouse opening
70-72	El Camino (Custom)	8702999 R.H.	12.40	outer panel rear wheelhouse opening
70-72	El Camino (Custom)	8703000 L.H.	12.40	outer panel rear wheelhouse opening
70-72	El Camino (Custom)	8702511 2	9.80	outer panel rear of wheelhouse opening
70-72	Monte Carlo	8702556 R.H.	8.40	outer panel front of wheelhouse opening
70-72	Monte Carlo	8702557 L.H.	8.40	outer panel front of wheelhouse opening
70-72	Monte Carlo	8702558 R.H.	14.35	outer panel rear of wheelhouse opening
70-72	Monte Carlo	8702559 L.H.	14.35	outer panel rear of wheelhouse opening
70	Malibu (Spt. Cpe., Conv.),			
71-72	Malibu	8702560 R.H.	12.40	outer pnl. rear wheel opening
70	Malibu (Spt. Cpe., Conv.),			
71-72	Malibu	8702561 L.H.	12.40	outer pnl. rear wheel opening

**METAL TRIM—CLIPS AND PANELS**

**12.116 MOULDING UNIT, Rear Fender Outer Panel (Con't)**

70-72	El Camino (Custom)	8702954 R.H.	7.85	outer panel front of wheelhouse opening lower
70-72	El Camino (Custom)	8702955 L.H.	7.85	outer panel front of wheelhouse opening lower
70-72	Monte Carlo	8702562 R.H.	12.40	outer panel rear w/house opening
70-72	Monte Carlo	8702563 L.H.	12.40	outer panel rear w/house opening
73-75	Laguna, Malibu (4-Dr.)	8706507 L.H.	2.30	outer panel front of wheel opening
73-75	Laguna, Malibu (4-Dr.)	8706506 R.H.	2.30	outer panel front of wheel opening
73-74	Laguna (2-Dr.),			
73-75	Malibu (2-Dr.)	8706509 L.H.	11.30	outer panel front of wheel opening
73-74	Laguna (2-Dr.),			
73-75	Malibu (2-Dr.)	8706508 R.H.	11.30	outer panel front of wheel opening
73	Monte Carlo	8706511 L.H.	11.30	outer panel front of wheel opening
73	Monte Carlo	8706510 R.H.	11.30	outer panel front of wheel opening
73-75	El Camino (Custom, Classic)	8706527 L.H.	9.10	outer panel front of wheel opening
73-75	El Camino (Custom, Classic)	8706526 R.H.	9.10	outer panel front of wheel opening
73	El Camino (Custom) w/wood grain,			
73	Malibu, Laguna (Spt. Cpe., Spt. Sed.) (Classic)	8706535 L.H.	10.55	outer panel rear wheel opening
73	El Camino (Custom) w/wood grain,			
73	Malibu, Laguna (Spt. Cpe., Spt. Sed.) (Classic)	8706534 R.H.	12.40	outer panel rear wheel opening
73	Deluxe (Sta. Wag.),			
74-75	Malibu (Sta. Wag.) (exc. Classic)	8706533 L.H.	12.40	outer panel rear wheel opening
73	Deluxe (Sta. Wag.),			
74-75	Malibu (Sta. Wag.) (exc. Classic)	8706532 R.H.	12.40	outer panel rear wheel opening
73	El Camino, Deluxe (Spt. Cpe., Spt. Sed.),			
74-75	El Camino (Classic),			
74-75	Malibu (exc. Sta. Wag.), Laguna	8706531 L.H.	12.40	outer panel rear wheel opening
73	El Camino, Deluxe (Spt. Cpe., Spt. Sed.),			
74-75	El Camino (Classic),			
74-75	Malibu (exc. Sta. Wag.), Laguna	8706530 R.H.	12.40	outer panel rear wheel opening
73-75	Monte Carlo	9631094 L.H.	12.40	outer panel rear wheel opening
73-75	Monte Carlo	9631093 R.H.	12.40	outer panel rear wheel opening
73	Monte Carlo	9630061 L.H.	14.35	outer panel rear of wheel opening
73	Monte Carlo	9630060 R.H.	14.35	outer panel rear of wheel opening
73-75	Malibu, Laguna (Sta. Wag.)	9630057 L.H.	12.40	outer panel rear wheel opening
73-75	Malibu, Laguna (Sta. Wag.)	9630056 R.H.	12.40	outer panel rear wheel opening
74	Monte Carlo	9632265 R.H.	14.35	outer panel rear of wheel opening
74	Monte Carlo	9632266 L.H.	14.35	outer panel rear of wheel opening
74	Monte Carlo	8706510 R.H.	11.30	quarter panel front of wheel opening
74	Monte Carlo	8706511 L.H.	11.30	quarter panel front of wheel opening
75	Monte Carlo w/body side protection mldg.	9631581 R.H.	10.40	outer panel front of rear wheel opening (black)
75	Monte Carlo w/body side protection mldg.	9631582 L.H.	10.40	outer panel front of rear wheel opening (black)
75	Monte Carlo w/body side protection mldg.	9631583 R.H.	10.40	outer panel front of rear wheel opening (white)
75	Monte Carlo w/body side protection mldg.	9631584 L.H.	10.40	outer panel front of rear wheel opening (white)
75	Monte Carlo w/body side protection mldg.	9631585 R.H.	10.40	front of rear wheel opening (silver met.)
75	Monte Carlo w/body side protection mldg.	9631586 L.H.	10.40	front of rear wheel opening (silver met.)
75	Monte Carlo w/body side protection mldg.	9631587 R.H.	10.40	front of rear wheel opening (med. green)
75	Monte Carlo w/body side protection mldg.	9631588 L.H.	10.40	front of rear wheel opening (med. green)
75	Monte Carlo w/body side protection mldg.	9631589 R.H.	10.40	front of rear wheel opening (maroon)
75	Monte Carlo w/body side protection mldg.	9631590 L.H.	10.40	front of rear wheel opening (maroon)
75	Monte Carlo w/body side protection mldg.	9631591 R.H.	10.40	front of rear wheel opening (dk. blue)
75	Monte Carlo w/body side protection mldg.	9631592 L.H.	10.40	front of rear wheel opening (dk. blue)

**METAL TRIM—CLIPS AND PANELS**

**12.116 MOULDING UNIT, Rear Fender Outer Panel (Con't)**

75	Monte Carlo w/body side protection mldg. ....	9631593 R.H.	10.40	front of rear wheel opening (lt. beige) .....
75	Monte Carlo w/body side protection mldg. ....	9631594 L.H.	10.40	front of rear wheel opening (lt. beige) .....
75	Monte Carlo .....	9632882 R.H.	14.35	<b>MOULDING UNIT</b> , outer panel rear of wheel opening lower .....
75	Monte Carlo .....	9632883 L.H.	14.35	<b>MOULDING UNIT</b> , outer panel rear of wheel opening lower .....
75	Monte Carlo .....	9632884 R.H.	11.30	<b>MOULDING UNIT</b> , panel front of wheel opening .....
75	Monte Carlo .....	9632885 L.H.	11.30	<b>MOULDING UNIT</b> , panel front of wheel opening .....
75	AH57 .....	9632863 R.H.	6.65	<b>MOLDING</b> , qtr. panel extension .....
75	AH57 .....	9632864 L.H.	6.65	<b>MOLDING</b> , qtr. panel extension .....

**NOVA**

64	Nova .....	3852491 L.H.	7.25	rr. wheel opening frt. ....
64	Nova .....	3852492 R.H.	7.25	rr. wheel opening frt. ....
64	Nova (exc. Sta. Wag.) .....	3852494 1	8.70	rr. wheel opening rr. ....
64	Nova (Sta. Wag.) .....	3852493 12	8.70	rr. wheel opening rr. ....
65	Nova (S.S.) .....	3870979 L.H.	11.80	rr. of wheel opening, outer panel .....
65	Nova (S.S.) .....	3870982 R.H.	9.80	rr. wheel opening .....
66-67	Nova (S.S.) .....	4227002 L.H.	12.40	rr. wheel opening .....
66	Nova (S.S.) .....	4227015 R.H.	13.25	rr. of rr. wheel opening .....
67	Nova (S.S.) .....	4229529 R.H.	7.25	frt. of rr. wheel opening lwr. ....
67	Nova (S.S.) .....	4229530 L.H.	6.70	frt. of rr. wheel opening lwr. ....
67	Nova (S.S.) .....	4229524 R.H.	8.70	rr. of rr. wheel opening .....
67	Nova (S.S.) .....	4229525 L.H.	8.70	rr. of rr. wheel opening .....
68-72	Chevy .....	7795061 R.H.	13.25	rear of rear wheel opening lower .....
68-72	Chevy .....	7795062 L.H.	13.25	rear of rear wheel opening lower .....
68-70	Chevy (Spt. Cpe.) .....	7795083 R.H.	7.25	frt. of rear wheel opening .....
68-70	Chevy (Spt. Cpe.) .....	7795084 L.H.	7.25	frt. of rear wheel opening .....
68-70	Chevy (Spt. Cpe.) .....	7795085 2	8.70	upper, rear of rear wheel opening .....
75	Nova .....	9632698 R.H.	13.25	<b>MOULDING UNIT</b> , outer panel rear wheel opening .....
75	Nova .....	9632699 L.H.	13.25	<b>MOULDING UNIT</b> , outer panel rear wheel opening .....
75	Nova Custom .....	9632853 R.H.	8.40	<b>MOLDING UNIT</b> , rear of wheel opening .....
75	Nova Custom .....	9632854 L.H.	8.40	<b>MOLDING UNIT</b> , rear of wheel opening .....

**CAMARO**

67	Camaro .....	4229493 R.H.	14.35	rr. wheel opening .....
67	Camaro .....	4229494 L.H.	14.35	rr. wheel opening .....
68	Camaro .....	7795050 R.H.	7.50	frt. of rear wheel opening .....
68	Camaro .....	7795051 L.H.	7.50	frt. of rear wheel opening .....
68	Camaro .....	7795063 R.H.	14.35	rear wheel opening .....
68	Camaro .....	7795064 L.H.	14.35	rear wheel opening .....
69	Camaro .....	8700967 R.H.	14.35	rear outer panel wheel house opening .....
69	Camaro .....	8700969 L.H.	14.35	rear outer panel wheel house opening .....
73-74	Camaro w/body side mldg. ....	8705554	5.70	outer panel frt. of wheel opening .....
73-75	Camaro (L.T.) (exc. body side mldg.) .....	8706513 L.H.	5.70	outer panel frt. of wheel opening .....
73-75	Camaro (L.T.) (exc. body side mldg.) .....	8706512 R.H.	5.70	outer panel frt. of wheel opening .....
75	Camaro w/body side mldg. ....	1248176 2	RL/1.25	(black) frt. of wheel opening .....

**1971-75 VEGA — MONZA**

74-75	Vega (Coupe) w/vinyl roof .....	9692734 R.H.	5.85	rvl. qtr. belt rear .....
74-75	Vega (Coupe) w/vinyl roof .....	9692735 L.H.	5.85	rvl. qtr. belt rear .....
73-75	Vega (Sedan) w/vinyl roof .....	9663664 R.H.	15.45	<b>MOULDING ASSY.</b> , reveal qtr. belt .....
73-75	Vega (Sedan) w/vinyl roof .....	9663665 L.H.	15.45	<b>MOULDING ASSY.</b> , reveal qtr. belt .....
75	Monza (Towne Coupe) .....	1672960 R.H.	15.15	<b>MOULDING ASSY.</b> , rvl. qtr. belt .....
75	Monza (Towne Coupe) .....	1672961 L.H.	15.15	<b>MOULDING ASSY.</b> , rvl. qtr. belt .....
73-74	Vega (Coupe) w/body side mldg., stripes .....	9692386 2	8.30	<b>MOULDING ASSY.</b> , rear fender outer panel (adhesive) (white)— (12.112) .....
73-74	Vega (Coupe) w/body side mldg., stripes .....	9692384 2	8.30	<b>MOULDING ASSY.</b> , rear fender outer panel (adhesive) (orange)— (12.112) .....
73-74	Vega (Coupe) w/body side mldg., stripes .....	9692382 2	8.30	<b>MOULDING ASSY.</b> , rear fender outer panel (adhesive) (green)— (12.112) .....
73-74	Vega (Coupe) w/body side mldg., stripes .....	9692380 2	8.30	<b>MOULDING ASSY.</b> , rear fender outer panel (adhesive) (blue) .....

**METAL TRIM—CLIPS AND PANELS**

**12.116 MOULDING UNIT, Rear Fender Outer Panel (Con't)**

<b>73-75</b>	Vega w/body side mldg., stripes	<b>347058</b>	<b>2</b>	<b>13.55</b>	<b>MOULDING ASSY., rear fender outer panel (adhesive) (black)— (8.132)</b>
<b>71-72</b>	Vega	<b>8704094</b>	<b>2</b>	<b>10.30</b>	<b>MOULDING UNIT, outer panel rear fender upper</b>
<b>71-75</b>	Vega (exc. Panel)	<b>8704086</b>	<b>R.H.</b>	<b>5.95</b>	<b>MOULDING UNIT, outer panel rear wheel opening</b>
<b>71-75</b>	Vega (exc. Panel)	<b>8704087</b>	<b>L.H.</b>	<b>5.95</b>	<b>MOULDING UNIT, outer panel rear wheel opening</b>
<b>71-75</b>	Vega (exc. Panel)	<b>8704096</b>	<b>R.H.</b>	<b>3.35</b>	<b>MOULDING UNIT, front of rear wheel opening</b>
<b>71-75</b>	Vega (exc. Panel)	<b>8704097</b>	<b>L.H.</b>	<b>3.35</b>	<b>MOULDING UNIT, front of rear wheel opening</b>
<b>73-74</b>	Vega	<b>8706491</b>	<b>2</b>	<b>10.30</b>	<b>MOULDING UNIT, outer panel rear fender upper</b>
<b>73</b>	Vega (Sta. Wag.) w/wood grain	<b>9631003</b>	<b>R.H.</b>	<b>5.05</b>	<b>MOULDING UNIT, front of whl. opening lower</b>
<b>73</b>	Vega (Sta. Wag.) w/wood grain	<b>9631004</b>	<b>L.H.</b>	<b>5.05</b>	<b>MOULDING UNIT, front of wheel opening lower</b>
<b>73</b>	Vega (Sta. Wag.) w/wood grain	<b>9631005</b>	<b>R.H.</b>	<b>6.75</b>	<b>MOULDING UNIT, rear of rear wheel opening</b>
<b>73</b>	Vega (Sta. Wag.) w/wood grain	<b>9631006</b>	<b>L.H.</b>	<b>6.75</b>	<b>MOULDING UNIT, rear of rear wheel opening</b>
<b>73</b>	Vega (Sta. Wag.) w/wood grain	<b>9631009</b>	<b>R.H.</b>	<b>6.15</b>	<b>MOULDING UNIT, rear fender vertical front</b>
<b>73</b>	Vega (Sta. Wag.) w/wood grain	<b>9631010</b>	<b>L.H.</b>	<b>6.15</b>	<b>MOULDING UNIT, rear fender vertical front</b>
<b>73</b>	Vega (Sta. Wag.) w/wood grain	<b>9631007</b>	<b>R.H.</b>	<b>4.70</b>	<b>MOULDING UNIT, rear fender vertical rear</b>
<b>73</b>	Vega (Sta. Wag.) w/wood grain	<b>9631008</b>	<b>L.H.</b>	<b>4.70</b>	<b>MOULDING UNIT, rear fender vertical rear</b>
<b>73-75</b>	Vega (Sta. Wag.) w/wood grain	<b>9631001</b>	<b>R.H.</b>	<b>9.60</b>	<b>MOULDING UNIT, rear fender upper</b>
<b>73-75</b>	Vega (Sta. Wag.) w/wood grain	<b>9631002</b>	<b>L.H.</b>	<b>9.60</b>	<b>MOULDING UNIT, rear fender upper</b>
<b>74-75</b>	Vega (Sta. Wag.)	<b>9632322</b>	<b>R.H.</b>	<b>5.05</b>	<b>MOULDING UNIT, frt. of rear wheel opening</b>
<b>74-75</b>	Vega (Sta. Wag.) w/wood grain	<b>9632323</b>	<b>L.H.</b>	<b>5.05</b>	<b>MOULDING UNIT, frt. of rear wheel opening rear</b>
<b>74</b>	Vega (Sta. Wag.) w/wood grain	<b>9631715</b>	<b>R.H.</b>	<b>5.05</b>	<b>MOULDING UNIT, rear of front wheel opening transfer</b>
<b>74</b>	Vega (Sta. Wag.) w/wood grain	<b>9631716</b>	<b>L.H.</b>	<b>5.05</b>	<b>MOULDING UNIT, rear of front wheel opening transfer</b>
<b>74-75</b>	Vega (Sta. Wag.) w/wood grain	<b>9631705</b>	<b>R.H.</b>	<b>4.70</b>	<b>MOULDING UNIT, rear fender transfer vertical rear</b>
<b>74-75</b>	Vega (Sta. Wag.) w/wood grain	<b>9631706</b>	<b>L.H.</b>	<b>4.70</b>	<b>MOULDING UNIT, rear fender transfer vertical rear</b>
<b>74-75</b>	Vega (Sta. Wag.) w/wood grain	<b>9631703</b>	<b>R.H.</b>	<b>6.75</b>	<b>MOULDING UNIT, rear of rear wheel opening transfers</b>
<b>74-75</b>	Vega (Sta. Wag.) w/wood grain	<b>9631704</b>	<b>L.H.</b>	<b>6.75</b>	<b>MOULDING UNIT, rear of rear wheel opening transfers</b>
<b>75</b>	Vega (Sta. Wag.) w/wood grain	<b>9632897</b>	<b>R.H.</b>	<b>2.95</b>	<b>MOULDING UNIT, rear fender transfer vertical lower</b>
<b>75</b>	Vega (Sta. Wag.) w/wood grain	<b>9632898</b>	<b>L.H.</b>	<b>2.95</b>	<b>MOULDING UNIT, rear fender transfer vertical lower</b>
<b>74-75</b>	Vega (Sta. Wag.) w/wood grain	<b>9632324</b>	<b>R.H.</b>	<b>14.40</b>	<b>MOULDING UNIT, rear wheel opening transfer</b>
<b>74-75</b>	Vega (Sta. Wag.) w/wood grain	<b>9632325</b>	<b>L.H.</b>	<b>14.40</b>	<b>MOULDING UNIT, rear wheel opening transfer</b>
<b>75</b>	Monza	<b>9631697</b>	<b>R.H.</b>	<b>4.80</b>	<b>MOULDING UNIT, rear wheel opening</b>
<b>75</b>	Monza	<b>9631698</b>	<b>L.H.</b>	<b>4.80</b>	<b>MOULDING UNIT, rear wheel opening</b>
<b>75</b>	Monza (Notchback)	<b>9633434</b>	<b>L.H.</b>	<b>5.45</b>	<b>MOLDING UNIT, at bumper cove</b>
<b>75</b>	Monza (Notchback)	<b>9633433</b>	<b>R.H.</b>	<b>5.45</b>	<b>MOLDING UNIT, at bumper cove</b>
<b>75</b>	Monza (Notchback)	<b>9633435</b>	<b>1</b>	<b>6.80</b>	<b>MOLDING UNIT, rear end</b>

**12.116A EMBLEM UNIT— ESCUTCHEON ASSY.— EXTENSION UNIT— ORNAMENT— PLATE UNIT— PLATE ASSY.— TAPE— TRANSFER**

<b>66-67</b>	Chevelle (Deluxe)	<b>4226979</b>	<b>2</b>	<b>3.50</b>	<b>rr. fender ("300 Deluxe")</b>
<b>67</b>	Impala (exc. S.S.)	<b>4229496</b>	<b>2</b>	<b>4.15</b>	<b>(Impala)</b>
<b>63</b>	Nova (exc. S.S.)	<b>3832827</b>	<b>2</b>	<b>3.55</b>	<b>rr. fender (Nova Chevy II)</b>
<b>63</b>	Nova (S.S.)	<b>3832828</b>	<b>2</b>	<b>4.10</b>	<b>rr. fender (Nova S.S.)</b>
<b>68</b>	Chevy	<b>7755833</b>	<b>1</b>	<b>2.45</b>	<b>rear fender name (Nova) (Note 3)</b>
<i>NOTE 3: Requires 2-9421827 nut for installation.</i>					
<b>71</b>	Kingswood (exc. Estate)	<b>9850327</b>	<b>L.H.</b>	<b>7.10</b>	<b>ESCUTCHEON ASSY., rear of wheelhouse opening moulding marker lamp</b>
<b>71</b>	Kingswood (exc. Estate)	<b>9850326</b>	<b>R.H.</b>	<b>7.10</b>	<b>ESCUTCHEON ASSY., rear of wheelhouse opening moulding marker lamp</b>
<b>75</b>	XX27, XY27 w/formal wdo.	<b>1726294</b>	<b>R.H.</b>	<b>7.55</b>	<b>ESCUTCHEON, qtr. belt front reveal molding</b>
<b>75</b>	XX27, XY27 w/formal wdo.	<b>1726295</b>	<b>L.H.</b>	<b>7.55</b>	<b>ESCUTCHEON, qtr. belt front reveal molding</b>

*NOTE 2: Requires 1-8736600 clip for installation.*

**METAL TRIM—CLIPS AND PANELS**

**12.116A EMBLEM UNIT— ESCUTCHEON ASSY.— EXTENSION UNIT—  
ORNAMENT— PLATE UNIT— PLATE ASSY.— TAPE— TRANSRER  
(Con't)**

66	Malibu, S.S. (exc. Sta. Wag.) . . .	4227400	R.H.	22.25	EXTENSION UNIT, qtr. pnl. at tail lamp— (12.940) . . . . .
66	Malibu, S.S. (exc. Sta. Wag.) . . .	4227401	L.H.	22.25	EXTENSION UNIT, qtr. pnl. at tail lamp— (12.940) . . . . .
66	Chevelle (Std., Deluxe) (Sed.) . . .	4227402	R.H.	22.25	EXTENSION UNIT, qtr. pnl. at tail lamp— (12.940) . . . . .
66	Chevelle (Std., Deluxe) (Sed.) . . .	4227403	L.H.	22.25	EXTENSION UNIT, qtr. pnl. at tail lamp— (12.940) . . . . .
67	Chevelle (Std.),				
67	Chevelle (S.S.),				
67	Malibu (exc. Sta. Wag., El Camino) . . . . .	4229425	R.H.	22.25	EXTENSION UNIT, qtr. otr. panel at tail lamp— (12.940) . . . . .
67	Chevelle (Std.),				
67	Chevelle (S.S.),				
67	Malibu (exc. Sta. Wag., El Camino) . . . . .	4229426	L.H.	22.25	EXTENSION UNIT, qtr. otr. panel at tail lamp— (12.940) . . . . .
67	Chevelle (Deluxe) (Sed.) . . . . .	4229427	R.H.	22.25	EXTENSION UNIT, qtr. otr. panel at tail lamp— (12.940) . . . . .
67	Chevelle (Deluxe) (Sed.) . . . . .	4229428	L.H.	22.25	EXTENSION UNIT, qtr. otr. panel at tail lamp— (12.940) . . . . .
74-75	Impala (Spt. Cpe.) w/vinyl top (exc. Custom) . . . . .	9739540	1	1.85	ESCUTCHEON, rvl./mldg. qtr. belt, below back window . . . . .
68	Caprice (Sta. Wag.) . . . . .	9713869	A.R.	1.40	ORNAMENT, rr. dr., rr. fdr. and t/gate trans. upr. fin. mldg.— (12.112) . . . . .
64	Malibu (S.S.) . . . . .	3853533	2	5.00	PLATE UNIT, rr. fndr. name ("Malibu S.S.") . . . . .
64	Malibu (exc. S.S.) . . . . .	3853534	2	3.40	PLATE UNIT, rr. fender name ("Malibu") . . . . .
65-67	Chevy (Std.) . . . . .	3870999	2	3.65	PLATE UNIT, rr. fender name ("Chevy II") . . . . .
65	Nova (exc. S.S.) . . . . .	3871501	2	3.65	PLATE UNIT, rr. fender name ("Nova Chevy II") . . . . .
65	El Camino . . . . .	3871635	2	7.30	PLATE UNIT, rr. fender name ("El Camino") . . . . .
65	Malibu (S.S.) . . . . .	3871637	1	5.30	PLATE UNIT, rr. fender name ("Malibu S.S.") . . . . .
65	Malibu (exc. S.S.) . . . . .	3871638	2	5.20	PLATE UNIT, rr. fender name ("Malibu") . . . . .
65-66	Biscayne . . . . .	3870860	2	3.80	PLATE UNIT ("Biscayne") . . . . .
65-66	Bel Air . . . . .	3870864	2	4.10	PLATE UNIT ("Bel Air") . . . . .
66-67	Nova (S.S.) . . . . .	4227012	2	3.80	PLATE UNIT, rr. fender name ("Nova S.S.") . . . . .
66-67	Nova . . . . .	4226981	2	3.55	PLATE UNIT, rr. fndr. name ("Nova") . . . . .
66-67	Malibu (exc. El Camino) . . . . .	4229716	2	3.70	PLATE UNIT, rr. fender name ("Malibu") . . . . .
66	El Camino . . . . .	4227313	2	7.05	PLATE UNIT, rr. fender name ("El Camino") . . . . .
66	Chevelle (S.S.) . . . . .	4227377	2	5.10	PLATE UNIT, rr. fender name ("Super Sport") . . . . .
67	Chevelle (S.S.) . . . . .	4229717	2	4.35	PLATE UNIT, rr. fender name ("Super Sport") . . . . .
67	El Camino . . . . .	4229728	2	6.10	PLATE UNIT, rr. fender name ("El Camino") . . . . .
67	Biscayne . . . . .	4229780	2	3.85	PLATE UNIT ("Biscayne") . . . . .
67	Bel Air . . . . .	4229657	2	4.00	PLATE UNIT ("Bel Air") . . . . .
67	Impala (exc. S.S.) . . . . .	4229431	2	4.40	PLATE UNIT ("Impala") . . . . .
68-70	El Camino . . . . .	7795052	1	6.70	PLATE UNIT, rr. fender name ("El Camino") . . . . .
69-71	Concours (Estate Wag.) . . . . .	8740611	2	2.90	PLATE UNIT, rr. fender name ("Estate") . . . . .
69	Malibu . . . . .	8701037	1	3.65	PLATE UNIT, rr. fender name ("Malibu") . . . . .
69-71	Concours . . . . .	8740612	2	3.05	PLATE ASSY., rr. fender name ("Concours") . . . . .
69-71	Brookwood . . . . .	8751550	2	2.80	PLATE ASSY., rr. fdr. name (Brookwood) . . . . .
69-71	Greenbrier . . . . .	8733948	2	2.95	PLATE ASSY., rear fender name (Greenbrier) . . . . .
69-71	Kingswood (Estate Wag.) . . . . .	9616496	2	2.60	PLATE ASSY., rr. fdr. name (Estate Wag.) . . . . .
69-71	Townsmen . . . . .	9836765	2	2.45	PLATE ASSY., rr. fdr. name (Townsmen) (Note 4) . . . . .
69-72	Kingswood . . . . .	9616495	2	2.60	PLATE ASSY., rr. fdr. name (Kingswood) . . . . .
70-72	Nomad . . . . .	9816719	2	2.40	PLATE ASSY., rear fender name (Nomad) . . . . .
73	Bel Air (Sta. Wag.) . . . . .	9625393	2	2.75	PLATE, rear fender name (Bel Air) . . . . .
73	Impala (Sta. Wag.) . . . . .	9625394	2	2.90	PLATE, rear fender name (Impala) . . . . .
73-74	Caprice (Sta. Wag.) . . . . .	9625395	2	2.90	PLATE, rear fender name (Caprice Estate) . . . . .
74	Caprice (Conv.) . . . . .	8707822	2	4.55	PLATE, rear fender name (Caprice, Classic) . . . . .
74-75	Chevelle, Vega (Sta. Wag.) . . . . .	9730726	2	2.90	PLATE ASSY., rear fender name (Chevelle, Vega, Estate) . . . . .
74	Vega (Sta. Wag.) . . . . .	9885757	2	2.70	PLATE ASSY., outer panel rear fender (Kammback)— (12.180) . . . . .
75	Caprice (Conv.) . . . . .	9633484	2	3.00	PLATE ASSY., name "Caprice Classic" . . . . .

**METAL TRIM—CLIPS AND PANELS**

**12.116A EMBLEM UNIT— ESCUTCHEON ASSY.— EXTENSION UNIT—  
ORNAMENT— PLATE UNIT— PLATE ASSY.— TAPE— TRANSRER  
(Con't)**

75	Chevelle (Sedan, Coupe) (exc. Monte Carlo) . . . . .	9633282	1			PLATE KIT, name outer ext. (Chevrolet)— (12.182) . . . . .
75	Nova w/formal wdo. . . . .	1740506	2	3.55		PLATE ASSY., name "Cabriolet" . . . . .
75	Chevelle (Sedan, Coupe) Vega Dlx. (exc. Monte Carlo) . . . . .	1746150	1	3.55		PLATE, qtr. extension name "Chevrolet" . . . . .
74	Impala (Spt. Cpe.) (exc. Custom)	349105	2	1.70		STRIPE, rear qtr. panel front accent w/Spirit of America . . . . .
74	Impala (Spt. Cpe.) (exc. Custom)	349106	2	1.90		STRIPE, rear wheel opp. cover accent w/Spirit of America . . . . .
74	Impala (Spt. Cpe.) (exc. Custom)	349107	L.H.	1.90		STRIPE, rear qtr. panel rear lower accent w/Spirit of America . . . . .
74	Impala (Spt. Cpe.) (exc. Custom)	349108	R.H.	1.90		STRIPE, rear qtr. panel rear lower accent w/Spirit of America . . . . .
74	Impala (Spt. Cpe.) (exc. Custom)	349110	1	3.95		STRIPE, rear deck lid accent w/Spirit of America . . . . .
74	Impala (Spt. Cpe.) (exc. Custom)	349111	L.H.	1.10		STRIPE, rear qtr. panel rear upper accent w/Spirit of America . . . . .
74	Impala (Spt. Cpe.) (exc. Custom)	349112	R.H.	1.10		STRIPE, rear qtr. panel rear upper accent w/Spirit of America . . . . .
69	Caprice . . . . .	3981905	1	RL/.32		TAPE, mldg. (vinyl) (black)— (8.132) (Note 1) . . . . .
69	Caprice . . . . .	3981906	1	RL/.32		TAPE, mldg. (vinyl) (white)— (8.132) (Note 1) . . . . .
69	Caprice . . . . .	3981907	1	RL/.32		TAPE, mldg. (vinyl) (maroon)— (8.132) (Note 1) . . . . .
69	Caprice . . . . .	3981908	1	RL/.32		TAPE, mldg. (vinyl) (yellow)— (8.132) (Note 1) . . . . .
69	Caprice . . . . .	3981909	1	RL/.32		TAPE, mldg. (vinyl) (champagne)— (8.132) (Note 1) . . . . .
69	Caprice . . . . .	3981910	1	RL/.32		TAPE, mldg. (vinyl) (bright blue)— (8.132) (Note 1) . . . . .
69	Caprice . . . . .	3981911	1	RL/.32		TAPE, mldg. (vinyl) (silver)— (8.132) (Note 1) . . . . .
69	Caprice . . . . .	3981912	1	RL/.32		TAPE, mldg. (vinyl) (med. blue)— (8.132) (Note 1) . . . . .
69	Caprice . . . . .	3981913	1	RL/.32		TAPE, mldg. (vinyl) (turq.)— (8.132) (Note 1) . . . . .
69	Caprice . . . . .	3981914	1	RL/.32		TAPE, mldg. (vinyl) (dark blue)— (8.132) (Note 1) . . . . .
69	Caprice . . . . .	3981915	1	RL/.32		TAPE, mldg. (vinyl) (lime)— (8.132) (Note 1) . . . . .
69	Caprice . . . . .	3981916	1	RL/.32		TAPE, mldg. (vinyl) (green)— (8.132) (Note 1) . . . . .
69	Caprice . . . . .	3981917	1	RL/.32		TAPE, mldg. (vinyl) (red)— (8.132) (Note 1) . . . . .
69	Caprice . . . . .	3981918	1	RL/.32		TAPE, mldg. (vinyl) (gold)— (8.132) (Note 1) . . . . .
69	Caprice . . . . .	3981919	1	RL/.32		TAPE, mldg. (vinyl) (brown)— (8.132) (Note 1) . . . . .
70	Caprice . . . . .	3980833	1	RL/.32		TAPE, side moulding (vinyl) (black)— (8.132) (Note 1) . . . . .
70	Caprice . . . . .	3980834	1	RL/.32		TAPE, side moulding (vinyl) (maroon)— (8.132) (Note 1) . . . . .
70	Caprice . . . . .	3980835	1	RL/.32		TAPE, side moulding (vinyl) (white)— (8.132) (Note 1) . . . . .
70	Caprice . . . . .	3980836	1	RL/.32		TAPE, side moulding (vinyl) (taupe)— (8.132) (Note 1) . . . . .
70	Caprice . . . . .	3980837	1	RL/.32		TAPE, side moulding (vinyl) (silver)— (8.132) (Note 1) . . . . .
70	Caprice . . . . .	3980838	1	RL/.32		TAPE, side moulding (vinyl) (dk. green)— (8.132) (Note 1) . . . . .
70	Caprice . . . . .	3980839	1	RL/.32		TAPE, side moulding (vinyl) (dk. gold)— (8.132) (Note 1) . . . . .
70	Caprice . . . . .	3980840	1	RL/.32		TAPE, side moulding (vinyl) (red)— (8.132) (Note 1) . . . . .
70	Caprice . . . . .	3980841	1	RL/.32		TAPE, side moulding (vinyl) (med. turq.)— (8.132) (Note 1) . . . . .
70	Caprice . . . . .	3980842	1	RL/.32		TAPE, side moulding (vinyl) (med. gold)— (8.132) (Note 1) . . . . .
70	Caprice . . . . .	3980843	1	RL/.32		TAPE, side moulding (vinyl) (yellow)— (8.132) (Note 1) . . . . .
70	Caprice . . . . .	3980844	1	RL/.32		TAPE, side moulding (vinyl) (med. green)— (8.132) (Note 1) . . . . .
70	Caprice . . . . .	3980845	1	RL/.32		TAPE, side moulding (vinyl) (med. blue)— (8.132) (Note 1) . . . . .



**METAL TRIM—CLIPS AND PANELS**

**12.116A EMBLEM UNIT— ESCUTCHEON ASSY.— EXTENSION UNIT—  
ORNAMENT— PLATE UNIT— PLATE ASSY.— TAPE— TRANSFER**  
(Con't)

70	Caprice	3980846	1	RL/.32	TAPE, side moulding (vinyl) (dk. blue)— (8.132) (Note 1)
70	Caprice	3980847	1	RL/.32	TAPE, side moulding (vinyl) (saddle)— (8.132) (Note 1)
74	Nova	347535	L.H.	5.65	TAPE ASSY., rear qtr. vinyl w/Spirit of America
73-74	Vega (Coupe) w/body side moldings	9692350	R.H.	21.60	TRANSFER, rear fender (silver-black-silver)
73-74	Vega (Coupe) w/body side moldings	9692351	L.H.	21.60	TRANSFER, rear fender (silver-black-silver)
73-74	Vega (Coupe) w/body side moldings	9692352	R.H.	21.60	TRANSFER, rear fender (black-white-black)
73-74	Vega (Coupe) w/body side moldings	9692353	L.H.	21.60	TRANSFER, rear fender (black-white-black)
73-74	Vega (Coupe) w/body side moldings	9692354	R.H.	25.00	TRANSFER, rear fender (red-white-blue)
73-74	Vega (Coupe) w/body side moldings	9692355	L.H.	25.00	TRANSFER, rear fender (red-white-blue)
74	Vega (Coupe)	1676746	R.H.	11.50	TRANSFER, w/Spirit of America
74	Vega (Coupe)	1676747	L.H.	11.50	TRANSFER, w/Spirit of America
74-75	Vega (Coupe) w/frt. & body si. stripe	1657528	R.H.	3.50	TRANSFER, rear fdr. otr. pnl. (gold)
74-75	Vega (Coupe) w/frt. & body si. stripe	1657529	L.H.	3.50	TRANSFER, rear fdr. otr. pnl. (gold)
74-75	Vega (Coupe) w/frt. & body si. stripe	1657530	R.H.	10.00	TRANSFER, otr. pnl. rr. whl. opng. (gold)
74-75	Vega (Coupe) w/frt. & body si. stripe	1657531	L.H.	10.00	TRANSFER, otr. pnl. rr. whl. opng. (gold)
75	Vega (Cpe., Sta. Wag.)	9734706	R.H.	17.50	TRANSFER, rr. fdr. (black)
75	Vega (Cpe., Sta. Wag.)	9734707	L.H.	17.50	TRANSFER, rr. fdr. (black)
75	Vega (Cpe., Sta. Wag.)	9734708	R.H.	17.50	TRANSFER, rr. fdr. (white)
75	Vega (Cpe., Sta. Wag.)	9734709	L.H.	17.50	TRANSFER, rr. fdr. (white)

NOTE 1: Comes in 50 foot roll.

NOTE 2: It will be necessary to add required color insert tape.

NOTE 4: Requires 1-8736600 clip for installation.

**12.118 CLIP— NUT— RETAINER— WASHER— SCREW, Belt Moulding, Door and  
Quarter Mldg. Attaching Parts**

66	Pass. (Spt. Sed.) w/2-Tone Paint (2nd design),				
67	Pass. (Spt. Cpe., Sed.) w/2-Tone Paint,				
69	4-Dr. (Sed.) (exc. Spt. Sed.)				rear qtr. belt rvl.,
68	All w/2-Tone Paint (exc. Custom)				rear qtr. belt rvl. mldg. frt.,
68-69	Impala, Chevelle (Spt. Sed.) w/2- Tone Paint				rear qtr. belt rvl. mldg. rear,
68-69	Impala, Chevelle (Spt. Sed.)	7587044	6	.12	rr. qtr. belt reveal frt. and rr., rr. end belt reveal
67-68	Sta. Wag. w/2-Tone Paint (exc. Caprice)	7656440	4	.18	bk. body pillar belt reveal mldg.
67	Sta. Wag. w/2-Tone Paint (exc. Caprice)	7657426	2	.18	t/gate belt reveal mldg. end
67	Sta. Wag. w/2-Tone Paint (exc. Caprice)	7657696	6	.18	t/gate reveal mldg. ctr.
	Not required in this group. See Group 17.507,				
71-72	Kingswood, Concours (exc. Estate)	9838109		.12	qtr. pnl. mldg. t/gate upr. & lwr. clip
70-72	Concours (Estate)	8791843	2	.16	mldg. t/gate trfer. upper
62	Nova (Sedan)				rr. fndr. upper mldg. rr.,
62	Chevy Deluxe,				
63	Chevy Deluxe (exc. Nova),				
64	Chevelle (Std.)	4837358	A.R.	.24	rr. fndr. lwr. mldg. rr.
62-64	Chevy Deluxe (Sta. Wag.)	4846597	A.R.	.12	rr. of rr. fndr. mldg., tail gate outer lwr. mldg. ctr.
62-63	Chevy Deluxe (Sta. Wag.)	4848479	2	.18	tail gate outer mldg. end
62-64	Chevy (Sta. Wag.)				tail gate emblem,
62-64	Chevy Deluxe (Sta. Wag.),				
65-66	Pass. (Sta. Wag.)	4871712	A.R.	.12	rr. of rr. fndr. mldg.
62	Chevy Deluxe (2-Dr.) (exc. Nova),				
62	Nova (Sed.)	4866009	A.R.	.18	dr. outer panel lwr. mldg. frt. and rr. dr. outer panel upr. mldg. frt. and rr.
62	Nova (Spt. Cpe., Conv.)				rr. fndr. lwr. mldg. frt.,

METAL TRIM—CLIPS AND PANELS

12.118 CLIP— NUT— RETAINER— WASHER— SCREW, Belt Moulding, Door and Quarter Mldg. Attaching Parts (Con't)

62	Chevy Deluxe,						
63	Chevy Deluxe (exc. Nova)					frt. and rr. door outer lwr. mldg. ctr.,	
62	Nova (Sedan)					frt. and rr. door outer upper mldg. ctr., rr.	
						fndr. upper mldg. frt.,	
64	Chevelle (Sed.) (exc. El Camino),						
64	Malibu (exc. S.S., Sed., 2-Seat						
	Sta. Wag.)	4853108	A.R.	.16		frt. and rr. dr. mldgs., rr. fndr. mldgs.	
62	Chevy Deluxe (4-Dr.),						
63	Chevy Deluxe (4-Dr.) (exc. Nova)	4825955	2	.16		rr. dr. outer lwr. mldg. frt.	
62-64	Chevy Deluxe (Sta. Wag.)	4404918	8	.16		rr. of rr. fndr. mldg.	
62-63	Nova (Sedan),						
64	Nova (exc. S.S.)					rr. fndr. lwr. mldg. rr.,	
64	Nova (S.S.)					rr. whl. opening rr. mldg. rr.,	
65	Nova (4-Dr.),						
65-69	Biscayne, Bel Air					rr. fndr. upr. mldg. rr., rr. dr. and rr. fndr.	
						peak mldg.,	
66	Chevelle (Deluxe),						
67	Chevelle (exc. Std., Sta. Wag.)					rear fender lower mldg.,	
68	Chevy (Std.)	4837349	4	.24		rear fender upper mldg. rear	
62	Nova (4-Dr. Sed.)	4831843	2	.18		rr. dr. outer panel upr. mldg. frt.	
62	Nova (Sedan)					frt. dr. outer panel lwr. mldg. frt., rr. fndr.	
						lwr. mldg. front,	
62	Nova (4-Dr. Sed.)					rr. dr. outer lwr. mldg. center,	
64	Nova (2-Dr. Sed.)					frt. door outer panel peak, rr. fndr. frt. peak	
						frt.,	
64	Chevelle (S.S.)	4440304	8	.11		rr. fndr. upper peak mldg. rr.	
62	Nova (Sedan)					frt. dr. outer lwr. mldg. upr. rr.,	
62	Nova (4-Dr. Sed.)					rr. dr. outer panel upr. mldg. rr.,	
63-64	Nova (Super Sport),						
64	Nova (2-Dr. Sed.)	4816119	2	.12		frt. door outer panel peak	
63-64	Nova (Super Sport)					rr. fndr. frt. peak mldg. rr.,	
64	Nova (2-Dr. Sed.)	4847490	A.R.	.36		rr. fndr. rr. peak mldg. lower	
63	Chevy Deluxe					frt. door outer lwr. mldg. ctr. frt.,	
63	Nova					frt. door outer lwr. mldg. ctr. rr., rr. fndr. lwr.	
						mldg. frt.,	
63	Nova (4-Dr.)	4896334	A.R.	.18		rr. door outer lwr. mldg. ctr.	
63	Chevy (Deluxe)					frt. door outer panel lwr. mldg. frt.,	
63	Nova					frt. door outer panel lwr. mldg. rr.,	
63	Nova (4-Dr.)	4410048	2	.18		rr. door outer panel lwr. mldg. rr.	
63	Nova (4-Dr.)	4896336	2	.18		rr. door outer panel lwr. mldg. frt.	
63	Nova	4896853	6	.18		rr. fndr. lwr. mldg. rr.	
63-64	Chevy (Deluxe)	4401627	2	.18		frt. door outer panel lwr. mldg. ctr.	
63	Chevy Deluxe (exc. Nova)					frt. and rr. door outer panel lwr. mldg. rr.,	
64	Nova (exc. S.S.)					frt. dr. outer pnl. lwr. mldg. frt. and rr.,	
64	Nova (4-Dr.)	4417599	2	.11		rr. dr. outer pnl. lwr. mldg. frt.	
64	Nova (4-Dr.)	4458521	2	.41		rr. dr. outer pnl. lwr. mldg. rr.	
64	Chevelle (exc. El Camino)	4886720	A.R.	.11		frt. and rr. drs.	
64	Malibu (4-Dr.)	4879482	2	.11		rr. dr. outer pnl. lwr. mldg. rr.	
64	El Camino,						
66	El Camino,						
66	Chevelle (S.S.),						
70	Impala Cust., Caprice	4421810	A.R.	.11		rear of w/opg. mldg.	
64-67	El Camino	4416722	10	.18		qtr. pinchweld finish mldg. frt.	
66	Chevelle (Deluxe) (Sta. Wag., El						
	Camino)	4540459	2	.16		center rr. qtr. belt reveal mldg. rr. fndr. lwr.	
						mldg. rr.	
65	Nova (Spt. Cpe.)					rr. fndr. peak mldg. frt. and center,	
65	Nova (4-Dr.)					rr. dr. and fender outer peak mldg. ctr.,	
65	Nova (4-Dr. Sed.)	4489209	A.R.	.18		rr. fender peak mldg. frt.	
65	Nova (4-Dr.)					frt. dr. outer pnl. lwr. mldg. frt. and rr., rr. dr.	
						outer pnl. lwr. mldg. frt. t. and rr.,	
65	Nova (Spt. Cpe.) (exc. S.S.)	4489217	A.R.	.12		frt. dr. outer pnl. lwr. mldg. frt. and rr.	
65	All (S.S.)	4880486	6	.12		rr. of wheel opening mldg.	
65	Chevelle (exc. Sta. Wag., El						
	Camino)	4495258	10	.12		rr. of rr. fndr. mldg.	
65	Chevelle Deluxe, Malibu (exc.						
	S.S.)	4490159	A.R.	.12		frt. and rr. drs.	
65	Chevelle Deluxe, Malibu (exc.						
	S.S., El Camino Custom)	4877451	A.R.	.12		frt. and rr. door outer pnl. lwr. mldg., rr.	
						fndr. lwr. mldg., frt. of whl. opg. mldg.	
66-67	Chevelle (Conv.)	7584999	16	.18		rr. qtr. pinchweld finishing mldg.	
65	Pass., Chevelle (Spt. Cpe.) w/2-						
	Tone Paint,						
66-67	Chevelle (Sed.) w/2-Tone Paint,						

**METAL TRIM—CLIPS AND PANELS**

**12.118 CLIP— NUT— RETAINER— WASHER— SCREW, Belt Moulding, Door and Quarter Mldg. Attaching Parts (Con't)**

66	Pass., Chevelle (Spt. Cpe.) w/vinyl top			rr. qtr. belt reveal mldg.,
66-67	Chevelle (Sta. Wag., Sed., El Camino),			
67	Concours			rr. fndr. frt. mldg.,
68-69	Chevy (Spt. Cpe.)			rear of wheel opening upper front,
68	Concours			fender upper or lower vert. transfer finish,
68	All (Sta. Wag.)			back body pillar belt reveal mldg.,
70	Townsmen			rear fender lower mldg. rear,
70	Malibu (Spt. Cpe. Conv.)	7584569 A.R.	27	peak mldg. qtr. window rear
66-68	Nova (Spt. Cpe.) w/2-Tone Paint,			
68	Concours			transfer fin. mldg.,
68-69	Chevy, Bel Air,			
69	Chevy (Spt. Cpe.) w/body rear moulding,			
69	Townsmen Estate Wag.			rr. fndr. lower mldg. frt., rr. of whl. opg. upper mldg. rr.,
70	Malibu (Spt. Cpe., Conv. 4-Dr. Sed.)			peak mldg. front and rear door, qtr. window front,
70	Impala (Spt. Cpe.)			rear fender lower mldg. front,
70	Townsmen, Kingswood (exc. Kingswood Estate)			rear fender lower mldg. front, rear door lower mldg. center,
70	Nova (2-Dr.)			rear of w/house opening mldg.
72	Kingswood (exc. Estate) w/body side mldg.			outer pnl. mldg. rr. fender lower front (rh. lh.)
67-68	Malibu, Pass.	4437487 A.R.	16	rr. whl. opening mldg.
67-69	All (Spt. Cpe.) w/vinyl top			frt. and rr. belt reveal mldg.,
68	Malibu, S.S. (Spt. Cpe., Spt. Sed.) w/vinyl top			front rr. end belt reveal mldg. inner,
68-70	El Camino w/vinyl top			body lock pillar belt reveal mldg. front,
68	Malibu (Spt. Sed.) w/vinyl top			rr. end belt reveal mldg. ctr.,
70	Chevelle (Spt. Cpe., Sed.)			qtr. belt rvl. mldg. front, center, rear, rear end belt rvl. mldg. inner center
72	Chevelle (Spt. Cpe.) (exc. Monte Carlo) (Conv., El Camino) w/body side mldgs.,			
72	Caprice w/vinyl top, spec. two tone paint	8799350 A.R.	12	outer pnl. mldg. frt. & rr. dr. lwr. rear
67-69	Pass., Camaro (Conv.)	7672609 A.R.	18	qtr. pinchweld fin. mldg.
68-69	Chevelle (Spt. Sed.) w/side mldg.	7660309	6	11 door outer lwr. mldg. center, rear of, wheel opening mldg.
68-69	El Camino	7731309	2	38 qtr. pinchweld mldg. at belt rear
68-69	El Camino	7731336	14	18 qtr. pinchweld mldg. at belt center
68	Chevelle (Conv.)	7742626	8	18 qtr. pinchweld mldg. at belt
68-69	Chevy			rear of wheel opening rear, rr. of wheel opening lower rr. mldg.,
70	Kingswood			trfer. fin. mldg. rr. wh/opg. rr. fdr. upr., rr. dr. upr. and lwr. frt., frt. dr. upr. and lwr. ctr.,
70-72	Nova w/rear body mldg.	7732342 A.R.	16	rr. of whl./opg. lwr. rr. mldg.
67-69	Biscayne, Bel Air			rear of wheel opening,
68	Malibu (4-Dr.), El Camino,			
69	Chevelle (4-Dr. Sed.),			
68	Malibu, S.S.			front door outer lower center,
68-69	Impala, Malibu			rear door outer lower center,
68	S.S. (exc. Conv.)			frt. of wheel opening mldg.,
70	Pass. (Sta. Wag.) w/two tone paint,			
71-72	El Camino (Custom)	4457495 A.R.	11	finish mldg. t/gate center
68-72	Chevy (Spt. Cpe.)	7661013 A.R.	11	frt. of wheel opening mldg., frt. dr. outer lwr. mldg. ctr.
68-69	Malibu (Sta. Wag., El Camino)			t/gate upper and lwr. mldg. end,
68-69	Concours, Concours Estate Wag.			gas tank dr. trans. mldg., rr. dr. trans.,
68-69	El Camino (S.S.)			mldg. lwr. rr. and upper frt., frt. dr. lwr. trans. mldg. frt. and rr. fr frt. dr. upper trans. mldg.,
68	Chevy			front and rear dr. outer panel lwr. mldg. frt. and rr.,
70	Bel Air, Impala			frt. or rr. otr. pnl. lower mldg. rear,

**METAL TRIM—CLIPS AND PANELS**

**12.118 CLIP— NUT— RETAINER— WASHER— SCREW, Belt Moulding, Door and Quarter Mldg. Attaching Parts (Con't)**

70	Malibu (Conv. Spt. Cpe., Spt. Sed.)	8727925 A.R.	.27	peak mldg. frt. dr. otr. rear
68-72	El Camino w/vinyl top			body lock pillar belt reveal mldg. rr.,
70-72	Camaro w/vinyl top,			
72	Monte Carlo			qtr. belt rvl. mldg. rear
73-74	Camaro w/vinyl top,			
75	Nova (2-Dr.)	7669866 A.R.	.12	rear mldg. quarter belt rear
68-69	Chevy	7739969 2	.16	rr. whl. opg. lwr. frt. mldg.
68	Caprice (exc. Sta. Wag.)	7738636 A.R.	.37	frt. of wheel opening mldg. frt. and rr. frt. dr. outer lower, frt. and rr. door outer lower frt.
68	Caprice (Spt. Cpe.)	7739032 A.R.	.18	frt. door outer lwr. mldg. center
68	Caprice (Sta. Wag.)	7739809 2	.18	frt. and rear door lwr. transfer mldg. front and rear
68	Caprice (Sta. Wag.)	7739816 2	.18	frt. of wheel transfer fin. mldg.
68	Caprice (exc. Sta. Wag.)			frt. door outer lwr. mldg. frt. or rear,
68	Caprice (Spt. Sed.)	7740150 2	.18	rear door outer lwr. mldg. frt. or rear
68	Caprice (Spt. Sed.)	7742781 18	.18	front and rear door outer lwr. mldg. center, rr. door, otr. lower
68	Caprice (Sta. Wag.)			frt. and rr. door upr. trfer. mldg. end,
70	Kingswood Estate	4759394 A.R.	.37	fin. mldg. frt. dr. trfer. upr. frt., lwr. frt. and rear
69	Caprice	8742229 A.R.	.16	otr. pnl. mldg. frt. door lwr., frt. door lwr. rr., rr. door lwr. rr., rr. door lwr. frt.
65	Bel Air	4489216 A.R.	.18	lower mldg. frt. and rr. (Note 1)
68	Caprice (exc. Sta. Wag.)	7740500 4	.18	rear of wheel opening mldg. center
69	Caprice	8784764 A.R.	.46	rr. fdr. lower rr., rr. door lwr. frt.
69	Camaro w/2-Tone Paint	7669865 2	.12	fr. pnl. cvr. side mldg. frt.
69	Chevy (Spt. Cpe.)			otr. pnl. mldg. frt. dr. lwr. frt. and ctr., frt. of wheel opening frt. of rear, mldg. rr. of wheel opg. upper rear,
69-72	Chevy	7732342 A.R.	.16	mldg. rr. of wheel opening lwr. rear
69	Malibu	4507117 2	.18	rear end upper end
66	Caprice (Sta. Wag.)	7602722 A.R.	.18	left fender lower rear insert mldg.
66	Caprice (Sta. Wag.)	7602720 A.R.	.18	fndr. insert mldg.
66	Caprice (Sta. Wag.)	7602721 2	.18	left rear of rear fdr. insert mldg., rr. of rr. fndr. insert mldg., t/gate insert mldg. ctr. of otr.
66	Caprice (Sta. Wag.)			left rr. fndr. pnl. mldg.,
70	Caprice	9812842 2	.24	outer panel mldg. rear of rear fender
68	Caprice (Sta. Wag.)			frt. and rr. door lower transfer mldg., rear of wheel transfer fin. mldg. rear
74-75	Monte Carlo	7737942 A.R.	.18	outer panel mldg. rr. of wheel opening
68	Caprice (exc. Sta. Wag.)	4487924 2	.34	rr. of wheel opening mldg. rr.
69	Caprice	8741203 A.R.	.16	rr. dr. and rr. fdr. lwr.
69	Estate Wag.			transfer fin. mldg., frt. dr. upr. frt. and rr., frt. dr. lwr. frt. and rr., rr. dr. upr. and lwr. rr.
73	El Camino (Custom) w/wood grain	8731902 A.R.	.18	transfer finish mldg. (Custom)
69	Kingswood			rr. of rr. fdr. at t/lamp lwr.,
69	Estate Wag.			upr. mldg. rr. of rr. fdr. transfer lwr.,
70	Kingswood (exc. Estate)	8738892 4	.16	rr. of rr. fender at t/lp. lower
69	Kingswood, Estate Wag.	7742183 2	.38	rr. of rr. fdr. upr. transfer, rr. of rr. fdr. at tail lamp upr.
68	Caprice (Sta. Wag.),			
69	Kingswood	4817164 2	.24	left fender rear lwr. mldg.
69-72	Kingswood,			
70-72	Concours,			
73	Laguna (Estate),			
73	El Camino (Custom) w/wood grain,			
73	Pass.,			
74-75	El Camino w/wood grain,			
74-75	Malibu (Estate),			
74-75	Caprice (Sta. Wag.)	7656277 A.R.	.05	fin. moulding
69	Estate Wag.	4418669 A.R.	.12	outer panel mldg. t/gate (Note 1)
67	Caprice (Spt. Mdls.)			dr. otr. lwr. mldg. ctr.,
67	Caprice (Spt. Cpe.)	4417917 A.R.	.12	frt. of wheel opening mldg.
68	Impala (Sta. Wag.)			R.H., rr. fndr. rr. mldg., R.H.,
68	Impala (exc. Sta. Wag.)	4418655 A.R.	.18	moulding
70	Kingswood	8792199 2	.22	front door outer panel moulding lower rear
70	Nova,			
71-72	Pass. (exc. Spt. Cpe.),			
73-75	All (exc. Vega, Monza)	8799350 A.R.	.12	mldg. qtr. belt frt.

**METAL TRIM—CLIPS AND PANELS**

**12.118 CLIP— NUT— RETAINER— WASHER— SCREW, Belt Moulding, Door and Quarter Mldg. Attaching Parts (Con't)**

70	Kingswood Estate	9808869	2	.16	front door rear moulding (Note 1)
70-72	Chevelle (Sta. Wag.),				
71-72	Concours (Estate),				
73-75	Caprice (Sta. Wag.)				door trim upper and lower mldg.
73-75	Malibu, Laguna (Estate)				gas tank filler dr. transfer finish mldg.
73	El Camino	4817155	2	.17	upper moulding
70	Monte Carlo (Spt. Cpe.) Camaro w/vinyl top				reveal qtr. front, rear end belt outer,
73	Camaro w/vinyl top	8740380	2	.18	rear end belt
70-72	Monte Carlo	8800556	6	.16	rr. of w/opg. moulding rr.
70-72	Monte Carlo	8801238	2	.24	front door outer panel lower moulding rear
70	Kingswood w/vinyl top, two-tone paint,				
70	Brookwood, Townsman w/two-tone paint,				
72	Caprice w/body side mldg,				
72	Monte Carlo w/two-tone paint, vinyl top	8806263	4	.18	qtr. belt reveal mldg.
70	Townsman	8736600	6	.12	rear fender outer name plate— (12.183)
71-73	Impala (Custom) Caprice	9829814	2	.18	reveal mldg. front qtr. belt front
74-75	Caprice (Sta. Wag.)	9832184	2	.16	mldg. rear fender transfer rear vert.
71-72	Kingswood (Estate)				finish mldg. rear fender outer panel trfer.
71	Pass. (Spt. Cpe., Conv.)	9833770	2	.28	outer panel mldg. front door lower rear— (12.112)
71	Impala, Caprice (4-Dr.), Kingswood (exc. Kingswood Estate),				
73-75	Monte Carlo	9835033	A.R.	.16	outer panel mldg. front door lower center
71	Monte Carlo w/two-tone paint, vinyl top				reveal mldg. qtr. belt front, roof panel cover side mldg. front,
71	Camaro w/vinyl top	8740380	2	.18	rear end belt outer
71-75	Camaro w/vinyl top	7657449	A.R.	.16	mldg. qtr. belt frt. and rear
71-72	Monte Carlo w/two-tone paint, vinyl top	9821334	2	.16	qtr. belt reveal mldg. front
71	Nova w/side body mldg.,				
73-75	Camaro (L.T.),				
73	Nova w/body side mldg.	7661013	A.R.	.11	front of whl./opg. mldg.
71-73	Vega,				
74-75	Vega (exc. Panel)	7737942	A.R.	.18	front door lower front, outer panel, front of rear wheel
71-72	Vega	8727925	2	.27	outer panel mldg. frt. dr. upper rear
71-74	Vega	4673034	2	.18	outer panel mldg., frt. dr. lower mldg. to panel
71-72	Vega (Sed., Cpe.)	4817162	2	.27	outer panel mldg. frt. and rear fender upper, body side upper
71-72	Vega	9838109	A.R.	.12	outer panel mldg., rear fender upper frt., door upper frt., rr. door upper frt. and body side upper, tailgate upper,
71-75	Vega, Monza				qtr. panel mldg. rear fender upper
71-72	Vega (Panel, Sta. Wag.)	7584569	4	.27	outer panel mldg. front door lower frt. & rear door lower rear
72	Caprice	9888391	R.H.	.38	outer panel mldg. front door lower frt. & rear door lower rear
72	Caprice	9888392	L.H.	.38	outer panel mldg. front door lower frt. & rear door lower rear
72	Impala (Spt. Sed.)				outer panel mldg. rear door lower frt.
72	Impala Custom, Caprice (Spt. Sed., Spt. Cpe.)	9889325	1	.38	outer panel mldg. front door lower rear
72	Chevelle (Concours Estate)				t/gate transfer,
72	Kingswood				mldg. front door transfer upper & lower frt.
72	El Camino Custom				rr. whl. opng. frt. bolt, otr. frt. dr. lwr. frt.,
72	Nova w/body side mldg.				otr. mldg. frt. dr. lwr. frt., otr. mldg. frt. dr. lwr. rr., otr. mldg. rr. fdr. lwr. r/dr. lower frt.
73	Laguna (Estate),				
73-75	Caprice (Sta. Wag.) Nova, Impala (Spt. Cpe.)	9600857	1	.16	t/gate transfer lower end rear for transfer
74-75	Nova	9838109	A.R.	.12	rr. of rr. fender mldg.
73	Impala (Custom), Caprice (exc. Sta. Wag.)	9619030	A.R.	.11	otr. panel mldg. frt./door lwr. center, otr. panel mldg. rr./door lwr. center, otr. mldg. frt./fender lwr. center w/opening, outer mldg. front

**METAL TRIM—CLIPS AND PANELS**

**12.118 CLIP— NUT— RETAINER— WASHER— SCREW, Belt Moulding, Door and Quarter Mldg. Attaching Parts (Con't)**

73	Caprice (exc. Sta. Wag.)	9619031	2	.38	outer panel mldg. frt./door, rr./door lwr. frt. outer panel mldg. frt./door, rr./door lwr. rear
73-74	Pass.				outer panel mldg. rear/door lwr. front, panel t/gate mldg. to panel, panel mldg. rear fender lwr. front,
74-75	Nova	9838109	A.R.	.12	rr. of rr. fdr. mldg.
73-75	Monte Carlo	9651524	2	.32	outer panel front door lower
73	El Camino	4825958	2	.16	t/gate mldg.
73-74	El Camino	9610126	A.R.	.13	finish mldg. t/gate belt
73	Nova w/body side mldg.	9622984	2	.18	outer panel mldg. front door lower front
73-75	Chevelle (Sta. Wag.)	9615512	R.H.	.53	outer panel mldg. rear door lower rear
73-75	Malibu, El Camino (Custom), Laguna	9613285	2	.44	outer panel mldg. frt./door lwr. rear and rear door lwr. frt.
73-75	Malibu, El Camino (Custom), Laguna	9613286	A.R.	.16	frt. of w/opening outer panel mldg., outer panel mldg. frt./door lwr. ctr. and rear door lwr. center
73-75	Chevelle (Sta. Wag.)	9615513	L.H.	.53	outer panel mldg. rear door lower rear
73-75	Chevelle (Spt. Sed.)	9615512	R.H.	.53	outer panel mldg. rear door lower rear
73-75	El Camino	9610126	A.R.	.13	finish mldg. t/gate belt
73-75	Malibu, Laguna (Estate)	9618331	2	.70	finish mldg. frt./door outer transfer rear
73-75	Camaro (L.T.)	4777809	2	.13	panel frt. door lwr. mldg. rear panel
73-75	Camaro (L.T.)	4846160	1	.21	frt. wheel opening lwr. mldg. rear panel (repl. 4440303)
73	Vega (exc. Panel)				outer panel mldg. front door upper, outer panel mldg. rear fender upper,
74-75	Vega, Monza	8799350	A.R.	.12	reveal mldg.
74-75	Vega (Sta. Wag.)	4817155	2	.17	mldg. frt. dr. transfer upper and lower fin. rr.
73-75	Vega (Sta. Wag.)	4846160	4	.21	mldg. vert. transfer front fender
73-75	Vega (Sta. Wag.)	9832184	A.R.	.16	CLIP, rear fender transfer rear vert. mldg.
73-75	Vega (Sta. Wag.)	7656277	A.R.	.05	CLIP, frt. door transfer upper frt. mldg.
74-75	Malibu (Estate)				mldg. rear door transfer upper frt.,
74-75	Caprice (Sta. Wag.)	8737239	2	1.10	mldg. frt. and rear door transfer upper and lower frt.
74	Impala (Spt. Cpe.),				
74	Caprice (exc. Sta. Wag., Custom)	8798548	A.R.	.16	outer panel mldg. frt. & rr. door, lower rear, center, front
74	Caprice (exc. Sta. Wag., Custom)	9677919	1	.38	rear of wheel opening mldg. rear
74	Impala (Spt. Cpe.),				
74	Caprice (exc. Sta. Wag., Custom)	9672958	2	.28	outer panel lower mldg. front and rear door
74	Caprice (exc. Sta. Wag.)	9673661	2	.34	front and rear of wheel mldg.
74-75	Caprice (Sta. Wag.),				
74-75	El Camino	4846160	2	.21	rear door transfer
74-75	Monte Carlo w/vinyl top,				
74-75	Impala w/vinyl top (exc. Sta. Wag., Custom),				
74-75	Bel Air w/vinyl top	9658424	A.R.	.11	
74	Impala (Spt. Cpe.) w/vinyl top (exc. Custom)	9726473	A.R.	.16	rvl. mldg. qtr. belt frt. (nylon)— (12.966)
75	Caprice (exc. Sta. Wag.)	1661425	A.R.	.11	frt. and rear dr. lwr. and rr./fdr. mldg.
75	Monte Carlo	1656449	A.R.	.11	at frt. and rear of wheel opng., and f/dr. lwr. ctr.
75	Monte Carlo	1656450	A.R.	.16	frt. dr. lwr. rear mldg.
75	Nova (Custom) (exc. H.B.)	4540459	2	.16	w/exter. orna. rear end
75	Monte Carlo	9835033	A.R.	.16	frt. of wheel opening to qtr. pnl.
75	Bel Air, Caprice (Sta. Wag.)	9600857	A.R.	.16	rr. whl. opng.
75	Nova	3829006	A.R.	.18	qtr. belt, roof ext. pnl. louver
75	Nova w/formal wdo.	9658424	A.R.	.11	CLIP, roof pnl. cover or qtr. belt to pnl.
64	Nova (Sta. Wag.)				CLIP ASSY., rr. whl. opening rr. mldg. rr., rr. fndr. lwr. mldg. rr., rr. of rr. fndr. mldg.,
64	Chevelle (exc. Sta. Wag.)				
64-66	Chevelle w/2-Tone Paint, vinyl top (exc. Conv., Sta. Wag.)				qtr. belt reveal mldg.,
68-69	Sta. Wag.				rr. of wheel trans. fin. mldg. front, fndr. upper trans. finish mldg. center right,
70	Malibu (4-Dr. Sed.)				peak mldg. front and rear door outer panel front, center,
70	Pass. (exc. Biscayne, Caprice, Kingswood Estate)				outer panel mldg. front and rear door lower front and rear,
70	Bel Air, Impala	4817162	A.R.	.27	rear fdr. lower mldg. rear
64	Malibu (exc. S.S.)	4880485	A.R.	.12	CLIP ASSY., rr. fndr. lwr. mldg. rr.

**METAL TRIM—CLIPS AND PANELS**

**12.118 CLIP— NUT— RETAINER— WASHER— SCREW, Belt Moulding, Door and Quarter Mldg. Attaching Parts (Con't)**

64-65	Chevelle (Sedan) w/spec. 2-Tone,				
65	Bel Air (Sta. Wag.)	4440305	6	.22	CLIP ASSY., rr. qtr. belt reveal mldg. frt. . . .
64	Malibu (4-Dr.)				CLIP ASSY., rr. dr. outer lwr. mldg. center
64	Malibu (Spt. Cpe., Conv.)	4883164	A.R.	.12	rr. fndr. lwr. mldg. frt., . . . . .
64	Nova	7600028	A.R.	.11	CLIP ASSY., ornaments, emblem, and name plates . . . . .
64	Nova (exc. S.S.)				CLIP ASSY., rr. fndr. lwr. mldg. frt., . . . . .
64	Chevelle (S.S.),				dr. outer upper peak mldg. center, rr. fndr.
66	Pass.				upper peak mldg. frt., . . . . .
65	Biscayne,				
65-66	Nova (Sta. Wag.),				
66	Chevelle (Deluxe),				
66	Nova (exc. S.S.),				
67	Concours				rr. fndr. peak mldg., . . . . .
70	Chevelle (Spt. Sed.),				
70	Pass. (exc. Caprice, Kingswood Estate)	4403445	A.R.	.11	frt. and rr. dr. outer lower mldg. ctr. rr. fdr. lower mldg. frt. . . . .
64-67	El Camino	4446313	4	.54	CLIP ASSY., tail gate belt finish mldg. . . . .
64	Nova				CLIP ASSY., frt. dr. outer lwr. mldg. center,
64	Nova (2-Dr.) (exc. S.S.)				rr. fndr. outer pnl. lwr. mldg., . . . . .
64	Nova (4-Dr.)				rr. dr. outer pnl. lwr. mldg. center, . . . . .
64	Chevelle (exc. S.S. 2-Dr. Sta. Wag.)				frt. dr. outer lwr. mldg. center, . . . . .
64	Chevelle (2-Dr. Sta. Wag.)				frt. dr. outer pnl. mldg. center, . . . . .
68-69	Pass., Chevelle (Spt. Mdls.)	4462016	A.R.	.11	frt. and rr. of wheel opening mldg. frt. and rr. . . . .
64	Nova (2-Dr.) (exc. S.S.)				CLIP ASSY., fndr. lwr. mldg. at joint plate, . . . . .
64	Nova (4-Dr.)	4458529	2	.11	rr. dr. outer lwr. mldg. center rr. . . . .
64-65	Nova, Bel Air				CLIP ASSY., rr. whl. opening rr. mldg. frt., . . . . .
69	Malibu	4409860	A.R.	.11	outer upper panel rear center . . . . .
65	Nova (exc. S.S.)				CLIP ASSY., frt. dr. outer lwr. mldg. ctr., rr. fndr. lwr. mldg. frt., . . . . .
65	Nova (4-Dr.)	4488801	A.R.	.18	rr. dr. outer lwr. mldg. center . . . . .
65	Nova (exc. S.S.)	4489208	2	.18	CLIP ASSY., rr. fndr. lwr. mldg. rr. . . . .
65	Nova (S.S.)	4490166	16	.12	CLIP ASSY., frt. dr. outer lwr. mldg. ctr., frt. of wheel opening mldg. . . . .
65	Nova (exc. Sta. Wag.)	4497077	2	.36	CLIP ASSY., rr. fndr. peak mldg. joint . . . . .
65	Nova (Sta. Wag.)	4496448	2	.47	CLIP ASSY., rr. fndr. peak mldg. joint . . . . .
65	Chevelle Deluxe (2-Dr.),				
65	El Camino (exc. Custom)	4888312	2	.18	CLIP ASSY., frt. of whl. opening mldg. ctr. . . . .
65	Nova				CLIP ASSY., rr. of rr. fender peak mldg., . . . . .
65	Nova (exc. Sta. Wag.)	4492925	A.R.	.18	rr. fender peak mldg., rear . . . . .
65	Nova	4495221	A.R.	.12	CLIP ASSY., rr. fender peak mldg., frt. and center . . . . .
65	Malibu (exc. S.S.)	4518736	2	.18	CLIP ASSY., rr. fender lwr. mldg., rear . . . . .
65	Chevelle (Deluxe)	4674640	A.R.	.16	CLIP ASSY., dr. outer pnl. lwr. mldg. frt. . . . .
65	Bel Air	4489216	A.R.	.18	CLIP ASSY., rr. dr. lwr. mldg., frt. and rr. (Note 1) . . . . .
65	Bel Air (Sedan)	4489224	6	.18	CLIP ASSY., rr. of rr. fender lwr. mldg. . . . .
65	Impala (exc. Sta. Wag.)	4489225	6	.18	CLIP ASSY., rr. of rr. fender mldg. . . . .
65	Impala (Sta. Wag.)	4495053	4	.32	CLIP ASSY., rr. of rr. fender mldg. . . . .
66	Caprice (Sta. Wag.)	7601222	A.R.	.12	CLIP ASSY., t/gate insert mldg. inr., frt. and rr. mldg., rr. fndr. mldg. . . . .
66	Caprice (Sta. Wag.)	7601223	A.R.	.16	CLIP ASSY., frt. and rr. dr. insert mldg. . . . .
66-67	Pass. (exc. Sta. Wag.)				
66	Sta. Wag. (exc. Biscayne)	7636662	A.R.	.18	CLIP ASSY., rr. lower mldg., t/gate outer lower mldg. . . . .
66	Nova (exc. S.S.),				
66	Chevelle Deluxe				CLIP ASSY., door outer panel lwr. mldg., . . . . .
65-67	Biscayne,				
66	Chevelle Deluxe (Sta. Wag.),				gas tank filler door mldg., . . . . .
66	El Camino (exc. Custom)				frt. door transfer mldg. . . . .
67	Concours	4490167	A.R.	.11	
66	Malibu, S.S. (exc. Sta. Wag., El Camino)	7634600	A.R.	.18	CLIP ASSY., rr. end outer pnl. upper and lower mldg. . . . .
67	Nova (S.S.)	7664492	A.R.	.18	CLIP ASSY., frt. and rr. whl. opening mldg. . . . .
67	Malibu (exc. Sta. Wag., El Camino),				

**METAL TRIM—CLIPS AND PANELS**

**12.118 CLIP— NUT— RETAINER— WASHER— SCREW, Belt Moulding, Door and Quarter Mldg. Attaching Parts (Con't)**

68-69	Chevy (Spt. Cpe.)	4518711	A.R.	.32	CLIP ASSY., frt. of whl. opening mldg. frt. of rr. clip
67	Malibu				CLIP ASSY., rr. dr. outer pnl. mldg. frt.,
69	Malibu	4534215	8	.16	rear end lower outer panel mldg. center
67	Chevelle (Deluxe) (Sed.)	4817160	4	.18	CLIP ASSY., rr. of rr. fender mldg.
67	Nova (exc. S.S.)	7656131	2	.18	CLIP ASSY., rr. fender lower mldg. rr.
67	Nova (exc. S.S.)	7656132	A.R.	.18	CLIP ASSY., frt. and rr. door rr. outer pnl. lwr. mldg.
67	Nova (exc. S.S.)	7656366	A.R.	.18	CLIP ASSY., rr. fender lwr. mldg. frt., frt. and rr. door outer pnl. lwr. mldg.
67	Camaro w/body side mldg.	7663779	4	.18	CLIP ASSY., frt. door outer lwr. mldg. ctr. frt.
67	Camaro	7666724	2	.18	CLIP ASSY., frt. door outer pnl. lwr. mldg. rr.
67	Camaro	7668638	2	.18	CLIP ASSY., frt. door outer pnl. lwr. mldg. frt.
67	Chevelle (2-Dr.), El Camino	7737949	5	.32	CLIP, front door outer panel lower molding
67	Impala, Chevy (Spt. Cpe.) w/vinyl top,				
67	Concours	4817162	6	.27	CLIP ASSY., rr. qtr. belt reveal mldg. (repl. 4500953)
67-69	Camaro (Spt. Cpe.) w/vinyl top				CLIP ASSY., rr. qtr. belt reveal mldg. ctr.,
67-68	Chevelle (Sed. Spt. Cpe.) w/vinyl top, 2-Tone Paint				rr. qtr. belt reveal mldg. rear center and front, rr. end belt reveal mldg. ctr. outer and outer rr. qtr. window rr. reveal mldg.,
68	All, Deluxe (Spt. Cpe.) w/2-Tone Paint				rr. end and qtr. belt reveal mldg. rr. and ctr. outer,
68	Malibu (Spt. Sed., Spt. Cpe.) (exc. Deluxe, S.S.)				rr. qtr. and end belt reveal mldg. rr. ctr. outer and outer,
68	All (Spt. Cpe.) w/vinyl top, 2-Tone Paint				rr. qtr. and end belt reveal mldg. rr. and ctr. outer,
70	Chevelle (Spt. Cpe., Sed.) (exc. Monte Carlo),				
70	Pass. (Sed.)				rear qtr. belt rvl. mldg. frt. ctr. rear, end belt rvl. mldg. outer end,
70	Impala (Spt. Cpe.) (exc. Custom),				
71	Camaro w/vinyl top,				
71	Nova,				
71-72	Chevelle (Spt. Cpe.) (exc. Monte Carlo),				
71-72	Chevelle (4-Dr.) (exc. Sta. Wag.),				
71-72	Pass. (Sed.) Impala (Spt. Cpe.)				rear qtr. belt rear bolt rvl. mldg.,
73-74	Chevelle (Spt. Cpe.) 4-Dr. w/two-tone paint, vinyl top,				
74	Pass., Nova (H.B.) w/vinyl top, two-tone paint (exc. Sta. Wag.)	7669079	2	.12	CLIP ASSY., reveal mldg. rear end belt end mldg. front door transfer upper fin. rr.
67	Malibu (2-Dr.)				CLIP ASSY., frt. of rr. wheel opening mldg. rr.,
67	Malibu (4-Dr.)	7748866	2	.18	frt. of wheel opening mldg.
67	Nova (S.S.)	7649490	10		CLIP ASSY., frt. door outer pnl., lwr. mldg. frt. and rr.
67	Camaro w/body side mldg.	7661402	4	.52	CLIP ASSY., frt. door outer lwr. mldg. ctr.
67	Malibu	7658311	A.R.	.16	CLIP ASSY., frt. and rr. door outer pnl. lwr. mldg. rr.
67	S.S.	7584788	8	.25	CLIP ASSY., rr. of wheel opening mldg.
67	Impala (exc. S.S.)				
68	Caprice (Sta. Wag.)	7722079	4	.38	
67	Impala (Spt. Cpe., Conv.) (exc. S.S.)	7649293	A.R.	.18	frt. of wheel opening mldg. frt. clip
67	Sta. Wag.				
67	Caprice (Sta. Wag.),				
69	Camaro w/vinyl top				CLIP ASSY., rr. of rr. fender lwr. mldg., rr. fender upr. mldg. lwr. clip,
70	Kingswood (Estate),				
72	Concours (Estate)	7667622	2	.18	fin. mldg. rr. of rr. fdr. trfer. vert.
67	Caprice (Spt. Mdls.)	4547914	A.R.	.32	CLIP ASSY., dr. otr. pnl. lwr. mldg.
67	Impala (exc. S.S.)	7649202	2	.18	CLIP ASSY., frt. of wheel opening mldg. (Note 2)

NOTE 2 Part of units 4229776-77 and 4229778-79.



**METAL TRIM—CLIPS AND PANELS**

**12.118 CLIP— NUT— RETAINER— WASHER— SCREW, Belt Moulding, Door and Quarter Mldg. Attaching Parts (Con't)**

67	Caprice (Spt. Mdls.)	7668747	2	.52	CLIP ASSY., frt. of wheel opening ctr., rr., clip
67	Bel Air, Biscayne,				
69	Kingswood (exc. Estate Wag.),				
70-72	Nova w/body side mldg.	4518711	2	.32	CLIP ASSY., rear fen. lower mldg. rr.
68	Caprice (Sta. Wag.)				CLIP ASSY., fender rr. vert. transfer mldg. upr. and lwr.
70	Monte Carlo (Spt. Cpe.)	7752286	A.R.	.16	body sill mldg. ret.
68-72	Nova	7739969	2	.16	CLIP ASSY., rr. of wheel opening mldg. lower front
68	Impala	4866009	2	.18	CLIP ASSY., outer panel lower frt. & rr.
68	Camaro	7737838	A.R.	.18	CLIP ASSY., frt. of wheel opening mldg. ctr., frt. door outer lwr. ctr.
68	Camaro	7740805	A.R.	.18	CLIP ASSY., frt. of wheel opening mldg. frt. and rr. frt. door outer lwr. mldg. ctr.
68	Chevelle (Spt. Sed.) w/body side moulding	7742809	2	.37	CLIP ASSY., frt. of wheel opening
68	Malibu				CLIP ASSY., right and center,
68	Malibu (exc. Sta. Wag., El Camino, S.S.)				rr. of wheel opening frt., rr. end outer pnl. upper,
68	Malibu, S.S.				frt. of wheel opening mldg. center,
70-72	El Camino	7742182	2	.12	rear of whl. opng. mldg. front
67	Impala,				
68-69	Malibu (Spt. Sed.),				
69	Malibu (Spt. Cpe.)	7649201	A.R.	.18	CLIP ASSY., frt. and rear door outer panel lower
67	Pass. (4-Dr.),				
68	Malibu, S.S.				CLIP ASSY., rr. door outer panel lwr. mldg., frt. door outer panel lwr. mldg.,
68	Chevy (Spt. Cpe.)	7767523	2	.12	front door outer panel lwr. mldg. front
69-70	Chevy (Spt. Cpe.)	4848954	A.R.	.18	CLIP ASSY., lower frt. and rear mldg.
69	Concours,				
71-72	Concours Estate,				
71-72	Malibu (Spt. Cpe.) w/two-tone paint, vinyl top				CLIP ASSY., rear of rear fdr. transfer outer panel mldg.— (12.118),
73	El Camino,				
73-74	Nova	4888347	A.R.	.11	outer panel and rr. comp. emblem
69	Chevy (Spt. Cpe.) w/ext. ornament	7648808	2	.18	CLIP ASSY., center front window opg.
69-70	Pass. (Sta. Wag.) w/2-tone paint	8720900	4		CLIP ASSY., reveal mldg. bk. body plr. belt
69-70	Camaro (Spt. Cpe.) w/vinyl top, 2-Tone Paint	7787373	4	.18	CLIP ASSY., rf. pnl. cvr. side mldg. rear
69	Caprice	8784764	2	.46	CLIP ASSY., otr. pnl. mldg. rr. fdr. lwr. ctr., outer pnl. mldg. frt. dr. lwr. frt.
69-70	Estate Wag.	8748155	6	.28	CLIP ASSY., mldg. r/fdr. transfer rr. lower and upper
69	Caprice				CLIP ASSY., otr. mldg. rr. of rear fdr.,
69	Impala, Caprice				rr. end panel mldg.,
70	Impala (Spt. Cpe., Spt. Sed.)	8771975	4	.18	rear of rear fdr.
70	Caprice	9808871	2	.16	CLIP ASSY., ctr. mldg. (Note 1)
70	Caprice	9808870	2	.28	CLIP ASSY., outer panel mldg. (Note 1)
71-73	Impala (Custom) Caprice (Spt. Cpe.)	9829424	6	.37	CLIP ASSY., reveal mldg. front qtr. belt rear
71	Impala (exc. Spt. Cpe., Conv.),				
71	Caprice	9833769	4	.52	CLIP ASSY., outer panel mldg. front and rear door lower front
71	Chevelle (Spt. Cpe.) w/two-tone paint, vinyl top	7669079	2	.12	CLIP ASSY., reveal mldg. rear end belt end (repl. 9806533)
70-72	Monte Carlo	8801650	A.R.	.16	CLIP ASSY., front door outer panel lower mldg. center, w/opg. lower mldg.
71	Kingswood (exc. Estate),				
71	Pass. (exc. Sta. Wag.),				
73	Monte Carlo	3986976	8	.11	CLIP ASSY., outer panel mldg. rear of whl./opg.— (12.180)
71	Concours Estate	7667622	2	.18	CLIP ASSY., finish mldg. rear of rear fender transfer vertical
72	Caprice	9885005	2	.53	CLIP ASSY., outer mldg. rear w/opening cent.
72	Caprice	9885004	2	.53	CLIP ASSY., outer mldg. rear w/opening rear
72	Impala, Kingswood				outer panel mldg. front & rear door lower

**METAL TRIM—CLIPS AND PANELS**

**12.118 CLIP— NUT— RETAINER— WASHER— SCREW, Belt Moulding, Door and Quarter Mldg. Attaching Parts (Con't)**

71-72	Caprice, Biscayne, Bel Air, Brookwood, Townsman w/body side mldg. . . . .				outer panel mldg. front door lower . . . . .
72	Nova w/body side mldg. . . . .				outer panel rear fender lower mldg. . . . .
70-72	Monte Carlo w/body side mldg. . . . .				reveal mldg. r/end belt, . . . . .
73	Pass.,				
74-75	Chevelle, Camaro . . . . .	9885433 A.R.	.24		CLIP ASSY., mldg. frt. and rear upper front
72	Impala Custom, Caprice (Spt. Sed., Spt. Cpe.) . . . . .	9877925 A.R.	.16		CLIP ASSY., outer panel frt. of w/opening, rear fdr. lower center . . . . .
75	Caprice (exc. Sta. Wag.) . . . . .	1664051	2	.24	CLIP AND BOLT ASSY., frt. door lwr. mldg.
75	Monte Carlo . . . . .	1667734 A.R.	.16		CLIP AND BOLT ASSY., frt. door and rear fdr. lwr. . . . .
73	Impala, Bel Air, Chevelle (4-Dr.) w/body side mldg.,				
73	Caprice (2-Dr.),				
74-75	Impala, Chevelle (4-Dr.) . . . . .	9645350	2	.12	CLIP ASSY., outer panel rear door lower
73	Laguna (Estate) . . . . .	7767523	2	.12	CLIP ASSY., mldg. t/gate transfer upper outer . . . . .
73-74	Nova . . . . .				outer panel mldg. frt. & rear door lower frt. & rear, . . . . .
73	Malibu (Estate) . . . . .	7649377	2	.18	CLIP ASSY., t/gate transfer upper outer
74-75	Impala (Spt. Cpe.) (exc. Custom)	8741258 A.R.	.43		CLIP ASSY., qtr. belt rvl. . . . .
73	Caprice (Spt. Sed.) . . . . .				outer mldg. frt. of wheel opening, . . . . .
73	Caprice (Spt. Cpe.) . . . . .	9623392	2	.40	CLIP ASSY., otr. mldg. frt. of wheel opening rear . . . . .
74	Caprice (Sta. Wag.) . . . . .				mldg. front door transfer upper fin. rr., . . . . .
74	El Camino (Classic) . . . . .	4846160	2	.21	CLIP ASSY., mldg. rr. of rear fender transfer . . . . .
73-74	Vega . . . . .	9645350	2	.12	CLIP ASSY., outer panel front door upper mldg. . . . .
74-75	Vega (exc. Panel) . . . . .	4673034	2	.18	CLIP ASSY., panel front door lower mldg. to panel . . . . .
75	Impala Custom, Caprice Coupe . . . . .	1676243 A.R.	.44		CLIP, reveal molding qtr. belt to panel w/formal wdo. . . . .
75	Camaro . . . . .	4510031	10	.18	CLIP, body side molding retaining . . . . .
75	Impala . . . . .	9727078 A.R.	.11		CLIP, qtr. belt frt. & rr. molding . . . . .
75	Impala Custom . . . . .	9727078 A.R.	.11		CLIP, qtr. belt to panel molding . . . . .
75	Nova Custom (exc. H.B.) . . . . .	9838109 A.R.	.12		CLIP, rear of rr. fender molding . . . . .
75	Vega (Sta. Wag.) . . . . .	9838109 A.R.	.12		CLIP, B/D outer pnl. transfer molding . . . . .
75	Chevelle (4-Dr.) . . . . .	9885433 A.R.	.24		CLIP, w/bolt-rear door lwr. frt. mid. . . . .
75	Malibu (4-Dr.) . . . . .	9885433 A.R.	.24		CLIP, w/bolt-front door lwr. frt. mld. . . . .
75	Malibu Classic (4-Dr.) . . . . .	9885433 A.R.	.24		CLIP, w/bolt-rear door upr. frt. mld. . . . .
62-67	All (exc. Sta. Wag.) . . . . .	4837002 A.R.	.11		rr. fndr. mldg., rr. compt. lid mldg., rr. dr. peak mldg., rr. end pnl. mldg. . . . .
62-65	Chevy,				
64	Chevelle . . . . .				NUT, rr. fndr. name plate, . . . . .
65-66	Nova (S.S.) . . . . .	9420202 A.R.	.11		compt. lid name plate (1/8" self.threading w/sealer) . . . . .
62-63	Chevy Deluxe (4-Dr.) . . . . .				NUT, rr. door outer lwr. mldg. frt. clip, . . . . .
62	Nova (4-Dr. Sed.) . . . . .				rr. door outer panel upr. mldg. frt. clip, . . . . .
65	Chevelle Deluxe (2-Dr.),				
65	El Camino (exc. Custom) . . . . .	4644959	2	.11	NUT, frt. of wheel opening mldg. center clip— (12.110) . . . . .
62	Chevy Deluxe (exc. Sta. Wag.) . . . . .				NUT, rr. of rr. fender mldg., . . . . .
63-64	Nova (Super Sport) . . . . .	4843565 A.R.	.12		rr. fender peak mldg. joint clip, rr. fndr. rr. peak mldg. lwr. clip, rr. fndr. frt. peak mldg. frt. clip, rr. fndr. frt. peak mldg. rr.— (12.183) . . . . .
63-64	Chevy Deluxe, Nova (exc. Sta. Wag.),				
65	Nova (S.S.) (exc. Sta. Wag.) . . . . .	9419761 A.R.	.11		NUT, rr. of rr. fndr. mldg.— (8.921) . . . . .
64	Chevelle (S.S.),				
65	Nova (Spt. Cpe.) . . . . .	4889446	2	.11	NUT, rr. fndr. upper peak mldg., rear end outer panel mldg. clip . . . . .
66	Chevy (exc. Spt. Cpe.),				
65-67	Biscayne, Bel Air,				
66	Chevelle (exc. El Camino),				
67	Caprice (Sta. Wag.) . . . . .	9421827 A.R.	.12		NUT, rr. fndr. and tailgate name plate— (8.921) . . . . .
67	Nova (Sta. Wag.) . . . . .				qtr. lwr. fin. at t/lamp cap nut, . . . . .
70-71	Nova . . . . .	9419766	4	.11	NUT, qtr. pnl. rr. end . . . . .
75	Chevelle, Camaro, Vega, Monza . . . . .	4801719 A.R.	.18		NUT, lock washer and sealer . . . . .

**METAL TRIM—CLIPS AND PANELS**

**12.118 CLIP— NUT— RETAINER— WASHER— SCREW, Belt Moulding, Door and Quarter Mldg. Attaching Parts (Con't)**

65-66	Spt. Cpe., Sed. w/2 tone paint (exc. Caprice),				
65	Caprice w/2 tone paint,				
65-66	Spt. Mlds. w/vinyl top	4510010	2	.41	RETAINER, rr. qtr. belt reveal mldg.
66-67	Chevelle (Spt. Cpe.) w/vinyl top, 2-Tone Paint	7617597	A.R.	.80	RETAINER, qtr. belt reveal mldg.— (12.180)
65	Chevelle (Deluxe),				
72	Monte Carlo	4777621		.22	RETAINER (8.309)
	Not required in this group. See Group 17.507	7752286		.16	RETAINER ASSY.
75	Impala Custom, Caprice Coupe	1652790	4	.96	RETAINER, reveal molding qtr. belt to panel
62	Chevy Deluxe (exc. Sta. Wag.)				WASHER, rr. of rr. fndr.,
64	Malibu (S.S.)	4670360	A.R.	.06	rr. fndr. upper peak mldg.
63-64	Chevy Deluxe, Nova (exc. Sta. Wag.),				
65-68	Nova (S.S.)				WASHER, rr. of rr. fndr.,
66	Chevy (Sta. Wag.)	4817285	A.R.	.11	qtr. lower fin. at t/lamp
65	Pass. (exc. Sta. Wag.),				
66	All (exc. Sta. Wag., Caprice),				
66	Caprice (Spt. Cpe.)	4501682	6	.11	WASHER, qtr. otr. ext. at t/lamp
65-66	Pass. (exc. Sta. Wag.),				
66-72	Pass., Chevelle (exc. 6-Pass. Sta. Wag., El Camino),				
66-72	Impala, Caprice (Spt. Cpe., Conv.),				
67-72	Impala (Spt. Cpe.),				
68-72	Chevelle (exc. Sta. Wag., El Camino)	4500771	2	.11	WASHER, rr. qtr. ext. to pnl. inr., lwr., qtr. otr. ext. at t/lamp
66	Caprice (Sta. Wag.)	4757330	A.R.	.06	WASHER, door, fender, tailgate mldg inside attaching
65-75	All (exc. Vega)	588546	A.R.	.11	SCREW, frt. fndr. whlse. opening mldg. and cap., rr. wheel opening mldg., rr. of rr. wheel opening cover (No. 8— 18 x 7/16")
66-72	All (exc. Vega),				
71	Pass., Camaro, El Camino (Custom),				
73-75	All (exc. Vega, Monza)	4492963	A.R.	.14	SCREW, reveal, transfer mldg.
66	Nova (S.S.)	7628241	4	.18	SCREW ASSY., w/chrome sealer (No. 8— 18 x 3/4")
68-72	Pass. (exc. Biscayne, Brookwood),				
68-72	Malibu, Concours, S.S.	7681463	A.R.		SCREW ASSY., doors and t/gate

**12.121 MOULDING UNIT— CLIP ASSY.— SPACER— ESCUTCHEON UNIT, Body Rear Panel**

65	Bel Air (exc. Sta. Wag.)	3870716	1	9.80	rr. end outer panel
68	Chevelle (4-Dr. Sed.) w/2-Tone Paint,				
68	Chevelle (Spt. Sed.) w/2-Tone Paint, w/vinyl top,				
69	Chevelle (4-Dr. Sed.)	3940518	1	5.90	rear end belt reveal
68	Chevelle (2-Dr. Sed., Spt. Cpe.) w/2-Tone Paint,				
68	Malibu, S.S. (Spt. Cpe.) w/vinyl top,				
69	Chevelle (2-Dr.) w/vinyl top, 2-Tone Paint	3940516	R.H.	7.10	rr. end belt side reveal
68	Chevelle (2-Dr. Sed., Spt. Cpe.) w/2-Tone Paint,				
68	Malibu, S.S. (Spt. Cpe.) w/vinyl top,				
69	Chevelle (2-Dr.) w/vinyl top, w/2-Tone Paint	3940515	L.H.	7.85	rr. end belt side reveal
68	Chevelle (2-Dr. Sed., Spt. Cpe.) w/2-Tone Paint,				
68	Malibu, S.S. (Spt. Cpe.) w/vinyl top,				
69	Chevelle (2-Dr.) w/vinyl top, 2-Tone Paint	3940517	1	8.85	center, rr. end belt reveal
69-70	Impala w/vinyl top, 2-tone paint (exc. Custom)	3962867	1	9.40	rr. end belt rvl.

**METAL TRIM—CLIPS AND PANELS**

**12.121 MOULDING UNIT— CLIP ASSY.— SPACER— ESCUTCHEON UNIT, Body Rear Panel (Con't)**

69-70	Pass., 4-Dr. Sed. w/vinyl top, 2-tone paint (exc. Spt. Sed.)	3962870	1	11.45	rr. end belt rvl.
69	2-Dr. Sed. w/2-tone paint	3962873	1	9.40	rr. end belt rvl.
69-70	Pass., Spt. Sed. w/vinyl top, 2-tone paint	3965100	1	15.65	rr. end belt rvl.
70-71	Chevelle (Spt. Cpe.) w/vinyl top, two tone paint (exc. Monte Carlo)	8799265	1	7.30	rear end
70-71	Monte Carlo (Spt. Cpe.) w/vinyl top	9809452	1	13.05	rear end belt painted
71-74	Pass. (Sed.) (exc. Spt. Sed.) w/vinyl top, special two-tone paint	9832552	L.H.	15.35	rear end belt
71-74	Pass. (Sed.) (exc. Spt. Sed.) w/vinyl top, special two-tone paint	9832551	R.H.	15.35	rear end belt
71-74	Pass. (Spt. Sed.) w/vinyl top, special two-tone paint	9834667	L.H.	13.05	rear end belt
71-74	Pass. (Spt. Sed.) w/vinyl top, special two-tone paint	9834666	R.H.	13.05	rear end belt
71-74	Impala (Spt. Cpe.) w/vinyl top, special two-tone paint (exc. Custom)	9835543	1	10.80	rear end belt
71-72	Monte Carlo w/two-tone paint	8779829	1	9.15	rear end belt
70-74	Camaro w/vinyl top	9841307	1	12.50	rear end belt
72	Monte Carlo w/vinyl top	9610819	1	16.90	rear end belt (painted)
73-75	Chevelle (Spt. Cpe.) w/padded vinyl top, special two-tone paint (exc. Monte Carlo)	9874026	1	14.55	rear end belt
73-75	Chevelle (Spt. Sed.) w/padded vinyl top, special two-tone paint	9610119	1	16.00	rear end belt
73-75	Monte Carlo w/padded vinyl top	9685295	1	11.00	rear end belt
74-75	Impala (Spt. Cpe.) w/padded vinyl top and special two-tone paint	9678232	1	13.00	rear end belt
75	Malibu Classic (Spt. Cpe.) w/rr. end oran.	9632724	1	7.55	ctr. at lic.
75	Malibu Classic (Spt. Cpe.) w/rr. end oran.	9632855	R.H.	11.45	side at lic.
75	Malibu Classic (Spt. Cpe.) w/rr. end oran.	9632856	L.H.	11.45	side at lic.
75	Nova (2-Dr.) w/rr. qtr. formal style	1726302	1	11.45	rear end belt on lid
65	Impala (Sta. Wag.)	4536848	2	2.45	CLIP ASSY., rr. end pnl. mldg.
65	Bel Air (Sedan)	4489224	6	.18	CLIP ASSY., rr. end pnl. mldg.— (12.118)
68	Malibu, S.S. (exc. Sta. Wag., El Camino)	7742182	2	.12	CLIP ASSY., rear end outer panel upper and lower mldg.— (12.118)
71	Monte Carlo w/vinyl top, two-tone paint	9885433	4	.24	CLIP ASSY., reveal mldg. rear end belt end— (12.118)
70	Pass. (Sed.), Camaro,				
70	Impala (Spt. Cpe.) w/vinyl top, two-tone paint (exc. Custom),				
71-72	Pass. (Sed.)	8799350	A.R.	.12	CLIP ASSY., reveal mldg. rear end belt— (12.118)
73	Chevelle (Sed., Spt. Cpe.)	8799350	A.R.	.12	CLIP, reveal mldg. rear end belt— (12.118)
75	Nova (2-Dr.) Coupe w/formal wdo.	1652790	AR	.96	RETAINER, rear end belt
65	Bel Air (Sedan)	4489200	6	.05	SPACER, rr. end outer pnl. mldg.
74	Chevelle (Spt. Cpe., Spt. Sed.)	9631773	1	.97	ESCUTCHEON UNIT, finish

**12.179 GATE ASSY.— DOOR ASSY.— PANEL, Lower End (Less Hardware)**

62-64	Chevy (Sta. Wag.)	4459536	1	180.00
64-67	Chevelle (Sta. Wag.)	7663064	1	192.00
65	Biscayne, Bel Air (Sta. Wag.)	4439445	1	235.00
66-67	Chevy (Sta. Wag.)	4545139	1	180.00
67	El Camino	7660966	1	196.00
67	Pass. (Sta. Wag.)	7661465	1	219.00
68	Biscayne, Bel Air (Sta. Wag.)	7696451	1	225.00
68	Impala, Caprice (Sta. Wag.)	7696453	1	225.00
68	Chevelle (Sta. Wag.)	7790927	1	211.00
68	El Camino	7687327	1	192.00

**METAL TRIM—CLIPS AND PANELS**

**12.179 GATE ASSY.— DOOR ASSY.— PANEL, Lower End (Less Hardware)  
(Con't)**

69	Chevelle (Sta. Wag.) (exc. dual action)	8728826	1	221.00	
69-70	Brookwood, Townsman	8807937	1	218.00	
69-70	Kingswood, Estate Wag.	8807934	1	236.00	
71	Pass. (Sta. Wag.)	9867750	1	142.00	
69-72	El Camino	9862703	1	209.00	
69-72	Chevelle (Sta. Wag.)	9856608	1	224.00	
72-75	Pass. (Sta. Wag.)	9674975	1	172.00	(structural adhesive)
73-75	El Camino	9622485	1	251.00	tail (structural adhesive)
73-74	Chevelle (Sta. Wag.)	9738176	1	224.00	tail
75	Chevelle (Sta. Wag.)	1708275	1	224.00	tail (repl. 9735083)
71-73	Vega (Panel, Sta. Wag.)	9608218	1 <sup>b</sup>	138.00	DOOR ASSY.
74-75	Vega (Panel, Sta. Wag.)	9728382	1	133.00	DOOR ASSY.
64-66	El Camino	4883711	1	53.00	PANEL, outer
67	El Camino	7661700	1	53.00	PANEL, outer
68	El Camino	7672387	1	49.50	PANEL, tail gate outer
72-75	Pass. (Sta. Wag.)	9603300	1	37.75	PANEL, t/gate outer
<i>NOTE 1 Does not have moulding and emblem piercings.</i>					
64-67	Chevelle (Sta. Wag.)	7663065	1	103.00	PANEL ASSY., outer
65	Biscayne, Bel Air (Sta. Wag.)	4473674	1	113.00	PANEL ASSY., outer
66-67	Chevy (Sta. Wag.)	4545236	1	85.75	PANEL ASSY., outer
66	Pass. (Sta. Wag.)	7614413	1	103.00	PANEL ASSY., outer
67	Pass. (Sta. Wag.)	7661624	1	103.00	PANEL ASSY., outer
68	Biscayne, Bel Air (Sta. Wag.)	7696460	1	110.00	PANEL ASSY., tail gate outer
68	Impala, Caprice (Sta. Wag.)	7696462	1	110.00	PANEL ASSY., tail gate outer
68	Chevelle (Sta. Wag.)	7687328	1	98.50	PANEL ASSY., tail gate outer
69-70	Kingswood, Estate Wag.	8807935	1	124.00	PANEL ASSY., outer
69-70	Brookwood Townsman	8807938	1	121.00	PANEL ASSY., outer
71	Pass. (Sta. Wag.)	8793037	1	31.50	PANEL, t/gate outer
69-72	El Camino	9862702	1	54.75	PANEL ASSY., outer
69-72	Chevelle (Sta. Wag.)	9856350	1	110.00	PANEL ASSY., outer
74	Pass. (Sta. Wag.)	9675146	1	9.75	PANEL, t/gate upper finish
75	Pass. (Sta. Wag.)	1652615	1	11.70	PANEL, t/gate upper finish
73	Chevelle (Sta. Wag.)	9846092	1	110.00	PANEL ASSY., t/gate outer
74-75	Chevelle (Sta. Wag.)	9737424	1	132.00	PANEL ASSY., t/gate outer

**12.180 GLASS— BUMPER— CABLE ASSY.— CHANNEL— MOULDING— STRIP ASSY.— ESCUTCHEON— RETAINER— ORNAMENT— CLIP— SUPPORT— SCREW— WASHER— PLATE— EMBLEM— CAM ASSY.— COVER— NUT— SUPPORT, Tail Gate**

62-67	Chevy (Sta. Wag.)	4850530	1	28.50	(clear)
62-67	Chevy (Sta. Wag.)	4850531	1	22.90	(tinted)
64-67	Chevelle (Sta. Wag.)	4405583	1	56.50	(clear)
64-67	Chevelle (Sta. Wag.)	4405584	1	79.75	(tinted)
65-68	Pass. (Sta. Wag.)	4464912	1	75.75	(clear)
65-68	Pass. (Sta. Wag.)	4464913	1	83.25	(tinted)
68-72	Chevelle (Sta. Wag.)	7698862	1	51.75	(clear)
68-72	Chevelle (Sta. Wag.)	7698864	1	56.50	(tinted)
69-70	Pass. (Sta. Wag.)	8723099	1	67.25	(clear)
69-70	Pass. (Sta. Wag.)	8723100	1	73.25	(tinted)
71-73	Pass. (Sta. Wag.)	9809570	1	68.75	t/gate window (clear)
71-73	Pass. (Sta. Wag.)	9820160	1	85.75	t/gate window (tinted)
73-75	Chevelle (Sta. Wag.)	9869820	1	65.75	t/gate window stat. (clear)
73-75	Chevelle (Sta. Wag.)	9869821	1	70.75	t/gate window stat. (tinted)
74-75	Pass. (Sta. Wag.)	9672962	1	69.50	t/gate window (clear)
74-75	Pass. (Sta. Wag.)	9672963	1	76.75	t/gate window (tinted)
75	Pass. (Sta. Wag.)	1654932	1	65.50	t/gate window (clear) w/rubber retainer
75	Pass. (Sta. Wag.)	9869821	1	70.75	t/gate window (tinted) (repl. 1654933)
73	Pass. (Sta. Wag.)	9898506 L.H.		.50	BUMPER, t/gate lift arm side hge.
72-75	Pass. (Sta. Wag.)	9736226	1	3.10	CABLE ASSY., t/gate window stop (repl. 9865433)
71-75	Pass. (Sta. Wag.)	9842147	1	20.00	CABLE ASSY., t/gate window guide cam drive
62-67	Chevy (Sta. Wag.)	4848964	1	11.60	CHANNEL, glass
65-67	Pass., Chevelle (Sta. Wag.)				
68	Pass. (Sta. Wag.)	4545159	1	6.75	CHANNEL, tail gate window glass run on body
74-75	Pass. (Sta. Wag.)	9667084 R.H.		19.50	CHANNEL, t/gate guide
74-75	Pass. (Sta. Wag.)	9667085 L.H.		19.50	CHANNEL, t/gate guide
62-67	Chevy (Sta. Wag.)	4544624	1	10.50	CHANNEL ASSY., lower sash
64-67	Chevelle (Sta. Wag.)	4414146	1	14.90	CHANNEL ASSY., lower sash
62-65	Chevy (Sta. Wag.)	4481719	2	6.30	CHANNEL ASSY., glass run side
65-70	Pass. (Sta. Wag.)	4489212	1	16.75	CHANNEL ASSY., wind. lwr. sash
65-68	Pass. (Sta. Wag.)	4482048 R.H.		6.15	CHANNEL ASSY., glass run side

**METAL TRIM—CLIPS AND PANELS**

**12.180 GLASS— BUMPER— CABLE ASSY.— CHANNEL— MOULDING— STRIP ASSY.— ESCUTCHEON— RETAINER— ORNAMENT— CLIP— SUPPORT— SCREW— WASHER— PLATE— EMBLEM— CAM ASSY.— COVER— NUT— SUPPORT, Tail Gate (Con't)**

65-68	Pass. (Sta. Wag.)	4482049	L.H.	6.15	CHANNEL ASSY., glass run side
68-73	Chevelle (Sta. Wag.)	7791187	1	6.20	CHANNEL ASSY., glass (on body)
68-72	Chevelle (Sta. Wag.)	7731788	1	16.20	CHANNEL ASSY., lower sash
69-70	Pass. (Sta. Wag.)	8719518	R.H.	7.15	CHANNEL ASSY., window glass run side
69-70	Pass. (Sta. Wag.)	8719519	L.H.	7.15	CHANNEL ASSY., window glass run side
69-70	Pass. (Sta. Wag.)	8732271	1	6.65	CHANNEL ASSY., window glass run on body
69-72	Chevelle (Sta. Wag.)	8732497	R.H.	9.55	CHANNEL ASSY., glass run side
69-72	Chevelle (Sta. Wag.)	8732498	L.H.	9.55	CHANNEL ASSY., glass run side
71-75	Pass. (Sta. Wag.)	9840383	1	10.90	CHANNEL ASSY., t/gate window upper sash
71-73	Pass. (Sta. Wag.)	9835850	L.H.	16.55	CHANNEL ASSY., t/gate side guide
71	Pass. (Sta. Wag.)	9835842	R.H.	16.55	CHANNEL ASSY., t/gate
62-67	Chevy (Sta. Wag.)	4846128	L.H.	6.40	MOULDING, side reveal (w/strip)
62-64	Chevy Deluxe (Sta. Wag.)	4853668	1	9.90	MOULDING, outer panel lwr.
68-72	Chevelle (Sta. Wag.)	7727132	R.H.	20.40	MOULDING, t/gate wind. side reveal
68-72	Chevelle (Sta. Wag.)	7727133	L.H.	19.95	MOULDING, t/gate wind. side reveal
68-72	Chevelle (Sta. Wag.)	7725782	1	8.85	MOULDING, upper reveal
68-72	El Camino (exc. Custom)	7724457	1	24.45	MOULDING, belt finish
70-72	El Camino (Custom)	8700901	1	14.65	MOULDING, t/gate transfer lower
69-72	Chevelle (Sta. Wag.)	8744859	1	1.25	MOULDING, fin. bk. body plr. si.-R.H.
70-72	Chevelle (Sta. Wag.)	8784000	L.H.	1.35	MOULDING, fin. bk. body plr. si.
74-75	Chevelle (Sta. Wag.)	9627380	R.H.	1.75	MOULDING, finish back body pillar lower
74-75	Chevelle (Sta. Wag.)	9627381	L.H.	1.75	MOULDING, finish back body pillar lower
74-75	Pass. (Sta. Wag.)	9727623	1	21.10	MOULDING, reveal t/gate window
74-75	Pass. (Sta. Wag.) w/power tail gate	9727624	1	21.10	MOULDING, reveal t/gate window
73-75	Chevelle (Sta. Wag.)	9726469	1	8.25	MOULDING, reveal t/gate window lower
73-75	Chevelle (Sta. Wag.)	9726468	1	7.55	MOULDING, reveal t/gate window upper
73-75	Pass. (Sta. Wag.)	9732296	L.H.	8.25	MOULDING, finish back body pillar (prime & paint)
73-75	Pass. (Sta. Wag.)	9629497	R.H.	13.65	MOULDING, finish back body pillar (prime & paint)
74-75	Chevelle (Sta. Wag.)	9627417	1	3.40	MOULDING, garnish tailgate window
74-75	Chevelle (Sta. Wag.)	9627366	R.H.	4.60	MOULDING, finish back body pillar upper
74-75	Chevelle (Sta. Wag.)	9627367	L.H.	4.60	MOULDING, finish back body pillar upper
67-68	Impala, Caprice (Sta. Wag.),				
69-70	Kingswood	8715619	1	22.85	MOULDING ASSY., window lower reveal
71-74	Pass. (Sta. Wag.)	9727624	1	21.10	MOULDING ASSY., t/gate window reveal
71-72	Pass. (Sta. Wag.)	9727623	2	21.10	MOULDING ASSY., t/gate reveal
71	Pass. (Sta. Wag.)	9725497	L.H.	11.35	MOULDING ASSY., fin. back body pillar (comb. 802, 804, 806) (black)
71	Pass. (Sta. Wag.)	9725496	R.H.	11.35	MOULDING ASSY., fin. back body pillar (comb. 802, 804, 806) (black)
75	El Camino (exc. Classic)	1694502	1	14.75	MOULDING, finish outer panel tailgate trfer. lower
73-74	Pass. (Sta. Wag.)	9727623	2	21.10	MOULDING ASSY., reveal t/gate window w/o strip & cover
73-75	Chevelle (Sta. Wag.)	9726470	R.H.	10.65	MOULDING ASSY., t/gate window side reveal
73-75	Chevelle (Sta. Wag.)	9726471	L.H.	10.65	MOULDING ASSY., t/gate window side reveal
75	Caprice (Sta. Wag.)	1654147	1	24.50	MOULDING ASSY., fin. t/gate o/p trfer.
75	Impala (Sta. Wag.) w/deluxe body side mldg.	1686441	1	RL/2.68	MOULDING ASSY., outer panel t/gate (adhesive mldg.)
64-67	El Camino	3853673	1	31.25	MOULDING UNIT, tailgate belt finishing
65	Impala (Sta. Wag.)	3870701	1	24.65	MOULDING UNIT, outer panel lower
65	Bel Air (Sta. Wag.)	3870702	2	12.30	MOULDING UNIT, outer panel upper and lower
66	Bel Air (Sta. Wag.)	4227046	1	17.75	MOULDING UNIT, lower
66	Impala (Sta. Wag.)	4227045	1	19.45	MOULDING UNIT, lower
67	Malibu, Concours (Sta. Wag.),				
67	El Camino (Custom)	4229503	1	23.60	MOULDING UNIT, outer panel upr.
67	Malibu, Concours (Sta. Wag.),				
67	El Camino (Custom)	4229504	1	23.60	MOULDING UNIT, outer panel lwr.
67	Malibu, Concours (Sta. Wag., El Camino)	4229979	R.H.	8.60	MOULDING UNIT, otr. pnl. vert.
67	Pass. (Sta. Wag.) (exc. Impala)	4229551	1	14.15	MOULDING UNIT, outer panel lower
67	Impala (Sta. Wag.)	4229555	1	35.00	MOULDING UNIT, outer panel lower w/emblem

**METAL TRIM—CLIPS AND PANELS**

**12.180 GLASS—BUMPER—CABLE ASSY.—CHANNEL—MOULDING—STRIP ASSY.—ESCUTCHEON—RETAINER—ORNAMENT—CLIP—SUPPORT—SCREW—WASHER—PLATE—EMBLEM—CAM ASSY.—COVER—NUT—SUPPORT, Tail Gate (Con't)**

67-68	Pass. (Sta. Wag.) w/2-tone paint (exc. Caprice) . . . . .	4229554	1	10.90	MOULDING UNIT, belt reveal . . . . .
68-69	Malibu (Sta. Wag., El Camino), Sta. Wag. (exc. Nomad, Greenbrier) . . . . .	7795086	1	11.65	MOULDING UNIT, t/gate outer panel lower
68-69	Malibu (Sta. Wag., El Camino), Sta. Wag. (exc. Nomad, Greenbrier) . . . . .	7795087	1	11.65	MOULDING UNIT, t/gate outer panel upper
68	Concours . . . . .	7795501	1	11.05	MOULDING UNIT, t/gate transfer upper and lower finish . . . . .
68	Caprice (Sta. Wag.) . . . . .	7795443	1	19.90	MOULDING UNIT, t/gate outer transfer upper finish . . . . .
68	Caprice (Sta. Wag.) . . . . .	7795444	1	11.10	MOULDING UNIT, t/gate outer transfer lower finish . . . . .
69-70	Pass. (Sta. Wag.) w/2-tone paint (exc. Estate Wag.) . . . . .	8700999	1	13.70	MOULDING UNIT, outer panel finish . . . . .
69-70	Kingswood . . . . .	8701127	1	14.15	MOULDING UNIT, outer transfer upper . . . . .
69-70	Kingswood . . . . .	8701157	1	16.15	MOULDING UNIT, outer panel lower, lower transfer finish . . . . .
69-70	Pass. (Sta. Wag.) w/2-tone paint	3962898	R.H.	16.75	MOULDING UNIT, back body plr. belt rvl. . . . .
69-70	Pass. (Sta. Wag.) w/2-tone paint	3962899	L.H.	16.75	MOULDING UNIT, back body plr. belt rvl. . . . .
69	Concours, El Camino (Custom),				
70-72	Concours (exc. Estate) . . . . .	8701103	1	11.70	MOULDING UNIT, upper, outer panel . . . . .
69	Concours, El Camino (Custom),				
70-72	Concours (exc. Estate) . . . . .	8701104	1	11.70	MOULDING UNIT, lower, outer panel . . . . .
70	Kingswood Estate . . . . .	8702968	1	16.15	MOULDING UNIT, t/gate transfer lower . . . . .
70	Kingswood Estate . . . . .	8702969	1	16.15	MOULDING UNIT, t/gate transfer upper . . . . .
70-72	El Camino (Custom) . . . . .	8700900	1	14.65	MOULDING UNIT, t/gate transfer upper . . . . .
70-71	El Camino (Custom) . . . . .	8700901	1	14.65	MOULDING UNIT, t/gate transfer finish lower . . . . .
70-72	Concours (Estate) . . . . .	8702986	1	15.15	MOULDING UNIT, t/gate transfer fin. lower
70-72	Concours (Estate) (6-Pass.) . . . . .	8702987	R.H.	9.90	MOULDING UNIT, t/gate transfer finish rear . . . . .
70	Concours (Estate) (6-Pass.) . . . . .	8702988	L.H.	9.90	MOULDING UNIT, t/gate transfer finish rear . . . . .
70-72	Concours (Estate) . . . . .	8702989	R.H.	10.30	MOULDING UNIT, t/gate outer panel transfer fin. upper . . . . .
70-72	Concours (Estate) . . . . .	8702990	L.H.	10.30	MOULDING UNIT, t/gate outer panel transfer fin. upper . . . . .
73-74	Impala (Sta. Wag.),				
71-72	Kingswood (exc. Estate) . . . . .	8704104	1	13.20	MOULDING UNIT, outer panel t/gate . . . . .
71-72	Kingswood (Estate) . . . . .	8704499	1	7.50	MOULDING UNIT, finish t/gate transfer side . . . . .
73-74	Caprice (Sta. Wag.),				
71-72	Kingswood (Estate) . . . . .	8704506	1	12.05	MOULDING UNIT, finish t/gate transfer upper and lower . . . . .
73-75	El Camino w/body side mldg., two-tone paint . . . . .	9631022	1	16.20	MOULDING UNIT, t/gate outer panel (Note 1) . . . . .
	<i>NOTE 1: Part of D91 option-special exterior two-tone paint treatment.</i>				
73	Caprice (Sta. Wag.) . . . . .	8704499	1	7.50	MOULDING UNIT, finish t/gate transfer side . . . . .
73-75	Malibu, Laguna (Estate) . . . . .	8707994	1	10.70	MOULDING UNIT, finish t/gate transfer upper . . . . .
73-75	Malibu, Laguna (Estate) . . . . .	8707997	1	10.75	MOULDING UNIT, finish t/gate transfer lower . . . . .
73-75	El Camino . . . . .	8707989	1	28.00	MOULDING UNIT, finish t/gate belt . . . . .
73-75	El Camino w/wood grain . . . . .	8707992	L.H.	7.05	MOULDING UNIT, finish t/gate transfer lower side . . . . .
73-75	El Camino w/wood grain . . . . .	8707991	R.H.	7.05	MOULDING UNIT, finish t/gate transfer lower side . . . . .
73-74	El Camino w/wood grain . . . . .	8707993	1	16.20	MOULDING UNIT, finish t/gate transfer lower . . . . .
73-75	El Camino w/wood grain . . . . .	8707990	1	16.20	MOULDING UNIT, finish t/gate transfer upr. . . . .
74	Caprice (Sta. Wag.) . . . . .	9632326		8.00	MOULDING UNIT, t/gate transfer vert. . . . .
75	Malibu (Sta. Wag.) . . . . .	9632328	1	9.30	MOULDING UNIT, finish t/gate transfer lower . . . . .
65-68	Impala, Caprice (Sta. Wag.),				
69-70	Kingswood . . . . .	9702521	1	5.15	STRIP, window outer glass run . . . . .

**METAL TRIM—CLIPS AND PANELS**

**12.180 GLASS— BUMPER— CABLE ASSY.— CHANNEL— MOULDING— STRIP ASSY.— ESCUTCHEON— RETAINER— ORNAMENT— CLIP— SUPPORT— SCREW— WASHER— PLATE— EMBLEM— CAM ASSY.— COVER— NUT— SUPPORT, Tail Gate (Con't)**

62-65	Chevy (Sta. Wag.)	7582965	1	4.70	STRIP ASSY., glass run inner
65-68	Pass. (Sta. Wag.) (exc. Impala, Caprice)	4479755	1	4.95	STRIP ASSY., window outer at belt
65-68	Pass. (Sta. Wag.)	4481628	1	4.95	STRIP ASSY., window inner at belt
65-67	Chevelle (Sta. Wag.)	4499046	1	5.35	STRIP ASSY., glass run inner
66-67	Chevy (Sta. Wag.)	7582964	1	5.65	STRIP ASSY., glass run outer
66-67	Chevy (Sta. Wag.)	7582965	1	4.70	STRIP ASSY., glass run inner
68	Chevelle (Sta. Wag.),				
69-70	Pass. (Sta. Wag.)	8731952	1	8.15	STRIP ASSY., window inner at belt
69	Nomad, Greenbrier w/Std. t/gate	7725519	1	8.15	STRIP ASSY., glass run inner
68	Chevelle (Sta. Wag.),				
69	Nomad, Greenbrier w/Std. t/gate	7725521	1	5.75	STRIP ASSY., glass run outer
69-70	Brookwood, Townsman	8741130	1	3.20	STRIP ASSY., t/gate window outer at belt
69-72	Chevelle (Sta. Wag.)	8741131	1	2.90	STRIP ASSY., wind. otr. at belt
69-72	Chevelle (Sta. Wag.)	8731951	1	8.15	STRIP ASSY., wind. inner at belt
71-75	Pass. (Sta. Wag.)	9831029	L.H.	5.95	STRIP ASSY., t/gate window inner side filler
71-75	Pass. (Sta. Wag.)	9831028	R.H.	5.95	STRIP ASSY., t/gate window inner side filler
74-75	Pass. (Sta. Wag.)	9677580	R.H.	10.05	STRIP ASSY., t/gate window inner side filler
74-75	Pass. (Sta. Wag.)	9677581	L.H.	10.05	STRIP ASSY., t/gate window inner side filler
74-75	Pass. (Sta. Wag.)	9671388	1	8.30	STRIP ASSY., t/gate to bumper filler on gate
74-75	Chevelle (Sta. Wag.)	9882918	R.H.	5.70	STRIP ASSY., finish back body opening
74-75	Chevelle (Sta. Wag.)	9882919	L.H.	5.70	STRIP ASSY., finish back body opening
75	Chevelle (Sta. Wag.)	1654934	1	5.90	STRIP, tailgate window lk. channel
73-75	Chevelle (Sta. Wag.) w/swing out rear window	9624107	2	.53	ESCUTCHEON, mldg. finish back body pillar
71-75	Pass. (Sta. Wag.)	9607311	2	2.70	RETAINER, back body pillar side fin. moulding
68-72	Chevelle (Sta. Wag.)	7724622	R.H.	4.15	RETAINER, glass run channel
68-72	Chevelle (Sta. Wag.)	8753172	L.H.	3.75	RETAINER, glass run channel
68	Caprice (Sta. Wag.)	9713869	A.R.	1.40	ORNAMENT, t/gate trans. upr. fin. mldg.— (12.116)
65-68	Impala, Caprice (Sta. Wag.)	4491306	6	.22	CLIP, wind. lwr. reveal mldg.
65-68	Pass. (Sta. Wag.)	4490942	1	1.90	CLIP, glass anti-rattle
66	Caprice (Sta. Wag.)	4424679	2	.12	CLIP, t/gate outer panel mldg.
66	Caprice (Sta. Wag.)	7602721	2	.18	CLIP, t/gate insert mldg. center outer— (12.118)
68-72	El Camino	7729768	4	.21	CLIP, t/gate belt finish mldg.
68	Caprice (Sta. Wag.)	8799350	6	.12	CLIP, t/gate lower transfer mldg. center— (12.118)
68	Malibu (Sta. Wag.), El Camino,				
69	Concours, El Camino	9838109	14	.12	CLIP, t/gate upper and lower mldg. center— (12.118)
69-70	Pass. (Sta. Wag.) w/two tone paint (exc. Estate)	7648808	2	.18	CLIP, finish mldg. t/gate end right and left (repl. 7661130)
70	Pass. (Sta. Wag.), El Camino (Custom)	8736600	1	.12	CLIP, t/gate outer panel name plate— (12.183)
72	Kingswood (Estate),				
70	Concours (Estate),				
73	Chevelle (Estate)	8737239	4	1.10	CLIP, finish mldg. t/gate transfer upper and lower end
70-71	Concours (Estate)	8791843	2	.16	CLIP, rear of rear fender panel mldg.
70	Kingswood	7737942	6	.18	CLIP, t/gate lower center mldg.
70-73	El Camino (Custom)	8790889	7	.16	CLIP, finish mldg. t/gate transfer upper
70-72	El Camino (Custom),				
71-72	Malibu	8799874	2	.16	CLIP, t/gate transfer finish mldg. end
71-72	Kingswood (Estate)	9832184	L.H.	.16	CLIP, outer panel mldg. t/gate transfer— (12.118)
71-75	Pass. (Sta. Wag.)	9827897	A.R.	.18	CLIP, reveal mldg. back body
71-72	Kingswood Estate				CLIP, finish mldg., front and rear door outer panel transfer, transfer finish upper and lower
71-72	Townsman	8736600	1	.12	t/gate outer



**METAL TRIM—CLIPS AND PANELS**

**12.180 GLASS— BUMPER— CABLE ASSY.— CHANNEL— MOULDING— STRIP ASSY.— ESCUTCHEON— RETAINER— ORNAMENT— CLIP— SUPPORT— SCREW— WASHER— PLATE— EMBLEM— CAM ASSY.— COVER— NUT— SUPPORT, Tail Gate (Con't)**

72	Kingswood Estate				CLIP, finish mldg., front and rear door outer panel transfer, transfer finish upper and lower, . . . . .
72	Concours Estate	9600857	2	.16	finish mldg. t/gate transfer upper and lower end . . . . .
73	Pass. (Sta. Wag.),				
74-75	Pass. (Sta. Wag.)	9844525	1	.25	CLIP, conduit cam t/gate window guide . . .
73	Chevelle	8717859	A.R.	.15	CLIP, reveal moulding upper— (11.209) . . .
74	Chevelle (Sta. Wag.)	4471409	A.R.	.11	CLIP, reveal mldg. t/gate window after glass . . . . .
74	Chevelle (Sta. Wag.)	8717859	A.R.	.15	CLIP, reveal mldg. side lower, upper, t/gate window . . . . .
	Not required in this group. See Group 12.118	3986976		.11	CLIP ASSY. . . . .
67	Pass. (Sta. Wag.)	7584569	A.R.	.27	CLIP ASSY., t/gate bolt reveal mldg. ctr. tail gate lower mldg.— (12.118) . . . . .
65	Bel Air, (Sta. Wag.),				
66	Bel Air, Impala (Sta. Wag.)	4817162	2	.27	CLIP ASSY., t/gate otr. lwr. mldg. end t/gate/lr. ctr. inner mldg.— (12.118) . . . . .
66	Pass. (Sta. Wag.) (exc. Caprice)	4540459	A.R.	.16	CLIP ASSY., lower mldg. center)(12.118) . . .
67	Impala (Sta. Wag.)	7668933	4	.22	CLIP ASSY., t/gate lower mldg. inner— (12.183) . . . . .
68	Caprice (Sta. Wag.)	4815593	2	.22	CLIP ASSY., outer panel mldg.— (12.183) . . .
68-69	Chevelle (Sta. Wag.)	7729600	1	2.70	CLIP ASSY., glass anti-rattle . . . . .
69-70	Pass., Chevelle (Sta. Wag.),				
71-72	Chevelle (Sta. Wag.)	8712453	1	1.75	CLIP ASSY., t/gate wdo. glass and anti-rattle . . . . .
69	Kingswood Estate				CLIP ASSY., finish mldg. t/gate transfer upper end, . . . . .
69	Kingswood (exc. Estate)	8720350	2	.32	t/gate mldg. upper end . . . . .
69	Kingswood Estate				CLIP ASSY., finish t/gate lower transfer end, . . . . .
69-70	Kingswood (exc. Estate)	8738865	2	.32	mldg. t/gate lower end . . . . .
69-70	Kingswood	7741960	6	.06	CLIP ASSY., reveal mldg. t/gate wdo. lower
69	Kingswood	3986976	5	.11	CLIP ASSY., outer panel mldg. t/gate upper— (12.118) . . . . .
70	Kingswood	8790225	A.R.	.18	CLIP ASSY., t/gate outer panel mldg. . . . .
70	Kingswood	8796901	2	.28	CLIP ASSY., t/gate outer panel upper mldg. end . . . . .
68	Chevelle (Sta. Wag.),				
70-72	Chevelle (Sta. Wag.)	8718058	2	.22	CLIP ASSY., t/gate reveal mldg. side lower
68	Chevelle (Sta. Wag.),				
70-72	Chevelle (Sta. Wag.)	8718059	A.R.	.22	CLIP ASSY., t/gate rear mldg. side upper t/gate window upper reveal mldg. clip . . .
71-72	Pass. (Sta. Wag.)	9833766	L.H.	1.00	SUPPORT, t/gate roller . . . . .
62-64	Chevy (Sta. Wag.)	9416819	A.R.	.18	SCREW, belt finish mldg. window upper garnish mldg.— (11.128) . . . . .
All	All	4405526	A.R.	.14	SCREW, wind. regulator to inner panel, wind. regulator to plate . . . . .
67	Pass.	9425424	2	.06	SCREW, frt. fender lamp (19— 24 x 7/8")— (8.909) . . . . .
64-66	El Camino				WASHER, outer pnl. emblem, . . . . .
65	Malibu (Sta. Wag.)	4411710	2	.06	outer panel mldg. ctr. . . . .
64-65	Chevelle (Sta. Wag.),				
67	Concours,				
69	Malibu (Spt. Cpe.)	4485531	2	.13	WASHER, back body pillar outer finish mldg., t/gate outer panel upper and lower mldg. . . . .
65	Nova (Sta. Wag.)				WASHER, t/gate otr. pnl. upr. and lwr. mldg., . . . . .
65-66	Malibu (Sta. Wag.)	4401600	A.R.	.11	outer upr. and lwr. pnl. mldg. center— (12.183) . . . . .
65	Malibu (Sta. Wag.),				
66-67	Nova (Sta. Wag.),				
66	Chevelle Std. (Sta. Wag.)	4422670	A.R.	.06	WASHER, outer pnl. mldg. name plate . . . . .
66	Chevelle (Sta. Wag.) (exc. Malibu),				
69	Concours,				
69	El Camino (Custom)	4452339	A.R.	.06	WASHER, outer pnl. lwr. mldg. . . . .
68	Malibu	7740129	1	4.10	PLATE, name (Chevelle) (Note 2) . . . . .
68	Nomad	7746717	1	3.60	PLATE, name (Nomad) (Note 2) . . . . .

NOTE 2 Requires 3-94 19764 nut for installation.

**METAL TRIM—CLIPS AND PANELS**

**12.180 GLASS— BUMPER— CABLE ASSY.— CHANNEL— MOULDING— STRIP ASSY.— ESCUTCHEON— RETAINER— ORNAMENT— CLIP— SUPPORT— SCREW— WASHER— PLATE— EMBLEM— CAM ASSY.— COVER— NUT— SUPPORT, Tail Gate (Con't)**

*NOTE 3 Requires 3-4422112 washer and 2-9419764 nut for installation.*

68	Pass. (exc. Caprice) . . . . .	7731108	1	2.90	PLATE, tail gate name ("CHEVROLET")— (12.182) . . . . .
68	Caprice . . . . .	7731109	1	3.70	PLATE, name ("CAPRICE BY CHEVROLET") (Note 1) . . . . .
70-72	El Camino (Custom) . . . . .	8704039	1	4.60	PLATE, t/gate outer panel name letter (S) . .
70	Pass. (exc. Sta. Wag.) . . . . .				PLATE, compt. lid name (Chevrolet), . . . . .
70	Pass. (Sta. Wag.) . . . . .	8704041	1	4.60	t/gate name (Chevrolet) . . . . .
	<i>NOTE 1 Requires 3-9419764 nut for installation.</i>				
64-65	Chevelle, . . . . .				
66	El Camino . . . . .	3853422	1	8.75	PLATE UNIT, tail gate to name— (12.182) . .
66	Caprice (Sta. Wag.) . . . . .	4227048	1	4.10	PLATE UNIT, rr. compt. lid and tailgate ("CAPRICE BY CHEVROLET")— (12.182) . .
67	El Camino . . . . .	4229507	1	4.85	PLATE UNIT ("Chevrolet") . . . . .
68	El Camino (S.S.), . . . . .				
68-70	El Camino (Custom) . . . . .	7795093	1	4.25	PLATE UNIT, t/gate NA/SS396 . . . . .
68-69	El Camino . . . . .	7795089	1	3.60	PLATE UNIT, name (Chevrolet) . . . . .
70-72	El Camino . . . . .	8700891	1	5.90	PLATE UNIT, t/gate name (Chevrolet) . . . . .
69-70					
69	Pass. (Sta. Wag.), . . . . .				
71-75	Pass., Chevelle (Sta. Wag.) . . . . .	9831025	1	4.35	PLATE ASSY., t/gate name (Chevrolet) . . . .
73-75	El Camino . . . . .	9622483	1	3.60	PLATE ASSY., t/gate name (El Camino) . . .
73	Chevelle (Sta. Wag.) . . . . .	9620101	1	2.90	PLATE ASSY., t/gate outer pnl.— (12.182) . .
74	Chevelle (Sta. Wag.) . . . . .	9728248	1		PLATE ASSY., t/gate outer— (12.182) . . . .
	<i>NOTE 1 Requires 2-9419764 nut for installation.</i>				
64-65	El Camino . . . . .	3871647	1	7.55	EMBLEM UNIT, tail gate . . . . .
67	El Camino . . . . .	4229508	1	6.30	EMBLEM UNIT, tail gate . . . . .
67-68	Chevelle Deluxe (Sta. Wag.) . . . . .	4229505	1	12.05	EMBLEM UNIT, tail gate . . . . .
67	Pass. (Sta. Wag.), . . . . .				
68	Impala (Sta. Wag.) . . . . .	4229552	1	11.80	EMBLEM UNIT, tailgate outer panel . . . . .
68-70	El Camino . . . . .	8701343	1	5.65	EMBLEM UNIT, tail gate . . . . .
62-67	Chevy, Chevelle (Sta. Wag.) . . . . .				CAM ASSY., lower sash channel, . . . . .
68-72	Chevelle (Sta. Wag.), . . . . .				
68	Chevy (Spt. Cpe.) Camaro . . . . .				front door inner panel, . . . . .
65-70	Pass. (Sta. Wag.) . . . . .	9655398	2	.83	window lower sash channel . . . . .
71-73	Pass. (Sta. Wag.) . . . . .	9840364	L.H.	18.35	CAM ASSY., t/gate window guide . . . . .
71-72	Pass. (Sta. Wag.) . . . . .	9840373	R.H.	73.25	CAM ASSY., t/gate window guide . . . . .
73-75	Pass. (Sta. Wag.) . . . . .	9614864	R.H.	73.25	CAM ASSY., t/gate window guide . . . . .
73-75	Pass. (Sta. Wag.) w/power operated . . . . .	9840373	R.H.	73.25	CAM ASSY., t/gate window guide . . . . .
74-75	Pass. (Sta. Wag.) . . . . .	9672965	L.H.	22.00	CAM ASSY., t/gate window guide . . . . .
74-75	Pass. (Sta. Wag.) . . . . .	9679849	1	16.20	COVER, t/gate upper housing opening . . . .
65-67	Malibu, Concours (Sta. Wag.), . . . . .				
67	El Camino (Custom) . . . . .	4877816	A.R.	.14	NUT, tail gate outer pnl. mldg. end, front end outer panel mldg. . . . .
65-67	Nova, Malibu (Sta. Wag.) . . . . .	9419766	A.R.	.11	NUT, tail gate outer pnl. mldg.— (8.921) . . . .
	Not required in this grp. See Grp. 12.815 . . . . .	6264396		.27	NUT ASSY. . . . .
73-75	Pass. (Sta. Wag.) . . . . .	9833766	L.H.	1.00	SUPPORT, t/gate roller . . . . .
73-75	Chevelle (Sta. Wag.) . . . . .	9621307	2	3.75	SUPPORT, air defl. . . . .
74-75	Pass. (Sta. Wag.) . . . . .	9888339		.25	SUPPORT, mldg. back body opening upper reveal . . . . .

**12.180A MOULDING, Back Body Opening**

65-70	Pass. (Sta. Wag.) . . . . .	4468416	1	7.05	back body opg. upper reveal . . . . .
65-70	Pass. (Sta. Wag.) . . . . .	8736672	R.H.	18.35	back body opening side reveal . . . . .
65-70	Pass. (Sta. Wag.) . . . . .	8736673	L.H.	18.35	back body opening side reveal . . . . .
71-75	Pass. (Sta. Wag.) . . . . .	9829622	L.H.	13.80	back body opening side . . . . .
71-75	Pass. (Sta. Wag.) . . . . .	9829621	R.H.	13.80	back body opening side . . . . .
73-75	Bel Air, Biscayne (Sta. Wag.), . . . . .				
71-72	Brookwood, Townsman . . . . .	9888340	1	9.20	back body opening upper . . . . .
71-75	Pass. (Sta. Wag.) . . . . .	9888343	1	14.00	back body opening upper . . . . .
73-75	Bel Air, Biscayne (Sta. Wag.), . . . . .				
72	Brookwood, Townsman . . . . .	9829386	R.H.	10.55	reveal back body opening . . . . .
73-75	Bel Air, Biscayne (Sta. Wag.), . . . . .				
72	Brookwood, Townsman . . . . .	9829387	L.H.	10.55	reveal back body opening . . . . .
73-75	Pass. (Sta. Wag.) . . . . .	9663101	1	13.80	MOULDING, back body opg. upper panel (paint as reqd.) . . . . .
73-75	Chevelle (Sta. Wag.) . . . . .	9621251	1	10.65	MOULDING ASSY., finish bk. body opening upper . . . . .

**METAL TRIM—CLIPS AND PANELS**

**12.180B DEFECTOR UNIT— DEFECTOR ASSY.— BLADE ASSY.— BRACKET— BUMPER— CABLE ASSY.— CLIP ASSY.— CONDUIT ASSY.— FILLER— GASKET— GUIDE ASSY.— NUT ASSY.— PLUG— RETAINER— ROLLER ASSY.— SCREW— SPRING— STOP ASSY., Tail Gate**

65-68	Pass. (Sta. Wag.)	3873722	1	23.35	t/gate window air
69	Pass. (Sta. Wag.)	3950697	1	56.75	DEFLECTOR ASSY., t/gate, wdo. air
73-75	Chevelle (Sta. Wag.)	994392	1	26.50	DEFLECTOR UNIT, t/gate window air
73-75	Chevelle (Sta. Wag.)	9621309	1	36.25	DEFLECTOR, air
74-75	Vega (Sta. Wag.)	994267	1	26.50	DEFLECTOR, t/gate wdo. air
70	Pass. (Sta. Wag.)	3981937	1	33.00	BLADE ASSY., t/gate window air deflector
65-68	Pass. (Sta. Wag.)	3873725	2	4.80	BRACKET
70	Pass. (Sta. Wag.)	3981936	1	6.70	BRACKET, t/gate window air deflector roof mounting
70-71	Chevelle (Sta. Wag.)	325177	1	4.85	BRACKET, wdo. air deflector rlf. mtg.
71-72	Pass. (Sta. Wag.)	9898506	L.H.	.50	BUMPER, t/gate lift arm side hinge
71	Pass. (Sta. Wag.)	9736226	1	3.10	CABLE ASSY., t/gate window stop (repl. 9865433)
71-72	Pass. (Sta. Wag.)	9842147	R.H.	20.00	CABLE ASSY., t/gate window guide cam drive
69	Kingswood, Estate Wag.	8712453	1	1.75	CLIP ASSY., anti-rattle window glass
71-75	Pass. (Sta. Wag.)	9851309	R.H.	20.45	CONDUIT ASSY., t/gate window guide cam
71	Pass. (Sta. Wag.)	9893403	2	.66	FILLER, t/gate inner panel
69-72	Chevelle (Sta. Wag.),				
69-70	Pass. (Sta. Wag.)	325164	R.H.	1.40	GASKET, t/gate window air deflector end cap
69-72	Chevelle (Sta. Wag.),				
69-70	Pass. (Sta. Wag.)	325163	L.H.	1.40	GASKET, t/gate window air deflector end cap
65-70	Pass., Chevelle (Sta. Wag.)	3950713	2	.19	GASKET, deflector to roof
70	Pass., Chevelle (Sta. Wag.),				
71-72	Chevelle (Sta. Wag.)	3979947	3	.19	GASKET, deflector bracket
73-75	Chevelle (Sta. Wag.)	9621308	1	.19	GASKET, air defl.
71-75	Pass. (Sta. Wag.)	9837311	1	13.20	GUIDE ASSY. (electric)
65-68	Pass., Chevelle (Sta. Wag.),				
71	Chevelle (Sta. Wag.)	528846	4	.27	NUT ASSY., deflector attaching (1/4" — 20 special sealing)— (12.815)
69-72	Pass., Chevelle (Sta. Wag.)	8789350	1	.53	PLUG, t/gate inner panel extension
73-75	Pass. (Sta. Wag.)	9607311	2	2.70	RETAINER, back body plr. side finish mldg.
71-75	Pass. (Sta. Wag.)	9865416	R.H.	6.15	ROLLER ASSY. & LINK ASSY., t/gate window guide lower
71-75	Pass. (Sta. Wag.)	9840402		2.70	ROLLER ASSY. & LINK ASSY., t/gate window guide lower
71-75	Pass. (Sta. Wag.)	9840391	L.H.	5.25	ROLLER ASSY., t/gate window guide lower
71-75	Pass. (Sta. Wag.)	9840404	R.H.	11.35	ROLLER ASSY., t/gate window guide upper
71-75	Pass. (Sta. Wag.)	9840398	L.H.	5.70	ROLLER ASSY., t/gate window guide upper
65-68	Pass., Chevelle (Sta. Wag.)	3873766	4	.13	SCREW, chrome plated (10— 24 x 5/8")
69	Pass. (Sta. Wag.)	163217	2	.05	SCREW, deflector ctr. bracket (chrome plated) (10-16 x 1/2)
69	Pass. (Sta. Wag.),				
71	Chevelle (Sta. Wag.)	9428175	A.R.	.16	SCREW, deflector 1/4" — 20 x 1 1/8"
71	Pass. (Sta. Wag.)	4406866	A.R.	.12	SCREW (1/4" — 20 x 3/4") — (12.237)
71-75	Pass. (Sta. Wag.)	9846890	A.R.	.23	SCREW, t/gate guide channel assy., R.H. roller to panel, left hand synch. torq., tube panel and lift arm hinge elect., and power operated t/gate— (12.184)
73	All (exc. Vega)	4405526	A.R.	.14	SCREW, t/gate window reg.
73	Chevelle (Sta. Wag.)	9433495	A.R.	.34	SCREW, chrome air deflector mtg.— (8.977)
71-75	Pass. (Sta. Wag.)	9865432	1	.22	SPRING, t/gate window stop
72-75	Pass. (Sta. Wag.)	9614861	1	.65	SPRING, adj. t/gate wdo. stop
72	Pass. (Sta. Wag.)	9614864	R.H.	73.25	SPRING, adj. t/gate wdo. stop
71-75	Pass. (Sta. Wag.)	9865425	1	6.25	STOP ASSY., t/gate window

**12.180C MOULDING— MOULDING UNIT— BRACKET— CHANNEL ASSY.— DECAL— DEFLECTOR— ESCUTCHEON— GASKET— NUT ASSY.— PLATE ASSY.— SCREW, Back Door Reveal**

71-73	Vega (Panel, Sta. Wag.)	9824955	1	5.05	window, lower
71-73	Vega (Panel, Sta. Wag.)	9826671	L.H.	4.05	window, side
71-73	Vega (Panel, Sta. Wag.)	9826670	R.H.	4.05	window, side
71-73	Vega (Panel, Sta. Wag.)	9827171	L.H.	3.80	window, upper
71-73	Vega (Panel, Sta. Wag.)	9827170	R.H.	3.80	window, upper
71-73	Vega (Panel, Sta. Wag.)	9837252	L.H.	2.40	fin. back body pillar (black)
71-73	Vega (Panel, Sta. Wag.)	9837251	R.H.	2.40	fin. back body pillar (black)
73	Vega (Sta. Wag.) w/wood grain	9630099	1	11.25	tailgate panel upper
73-74	Vega (Sta. Wag.) w/wood grain	9679920	1	9.85	finish t/gate transfer lower
74-75	Vega (Panel, Sta. Wag.)	9683771	2	4.60	window upper, side

**METAL TRIM—CLIPS AND PANELS**

**12.180C MOULDING— MOULDING UNIT— BRACKET— CHANNEL ASSY.—  
DECAL— DEFLECTOR— ESCUTCHEON— GASKET— NUT ASSY.— PLATE  
ASSY.— SCREW, Back Door Reveal (Con't)**

74	Vega (Sta. Wag.)	9632239	2	11.25	MOULDING UNIT, t/gate transfer upper
75	Vega (Sta. Wag.) w/wood grain	9632691	R.H.	5.70	MOULDING UNIT, back door o/p transfer side
75	Vega (Sta. Wag.) w/wood grain	9632692	L.H.	5.70	MOULDING UNIT, back door o/p transfer side
72-75	Vega (Panel, Sta. Wag.)	6264392	2	17.20	BRACKET, t/gate window air deflector
74-75	Vega (Panel, Sta. Wag.)	9683770	1	15.65	CHANNEL ASSY., back door wdo. glass
73	Vega (Sta. Wag.)	9687670	1	4.75	DECAL, b/d outer panel (Estate)
72-75	Vega (Panel, Sta. Wag.)	994267	1	26.50	DEFLECTOR UNIT, tailgate window air
72-75	Vega (Panel, Sta. Wag.)	6264391	1	22.10	DEFLECTOR ASSY., t/gate window air
74	Vega (Panel, Sta. Wag.)	9696369	1	.27	ESCUTCHEON, back door wdo. rvl. mldg.
75	Vega (Panel, Sta. Wag.)	1724132	1	.27	ESCUTCHEON, back door wdo. rvl. mldg.
72-75	Vega (Panel, Sta. Wag.)	6264389	2	.23	GASKET, t/gate window air deflector bracket
72-75	Vega (Panel, Sta. Wag.)	6264396	4	.27	NUT ASSY., t/gate window air deflector bracket (10— 32 x 7/32")
71-74	Vega (Sta. Wag.)	9885757	1	2.70	PLATE ASSY., back door name (Kammback)
74	Vega (Panel, Sta. Wag.)	9614435	1	2.10	PLATE ASSY., back door name otr. panel
72-73	Vega (Panel, Sta. Wag.)	9419834	2	.13	SCREW, t/gate window air deflector (1/2"— 20 x 3/4")
75	Vega (Panel, Sta. Wag.)	9846890	A.R.	.23	SCREW, back door striker to anc. plt.

**12.181 LID— LID ASSY.— EXTENSION— PLUG— VALVE ASSY.— COVER—  
FILTER, Rear Compartment (Less Hardware)**

65	Biscayne, Bel Air (Sed.)	4439520	1	174.00	
65	Impala (Sed. Conv.)	4439521	1	174.00	
65	Impala (Spt. Cpe.)	4461753	1	174.00	
62-64	Chevy (exc. Sta. Wag.)	4896947	1	127.00	
64	Chevelle (exc. Sta. Wag., El Camino)				
65	Chevelle w/pierced holes (exc. Sta. Wag., S.S., El Camino)	4493013	1	155.00	
65	Chevy (exc. Sta. Wag.)	4488606	1	127.00	
65	Malibu (S.S.) w/o pierced holes	4490148	1	155.00	LID ASSY.
66-67	Chevelle (exc. Sta. Wag., El Camino)	7620526	1	155.00	LID ASSY.
66-67	Chevy (exc. Sta. Wag.)	7661139	1	127.00	LID ASSY.
66	Pass. (exc. Sta. Wag., Spt. Cpe., Caprice)				
66	Caprice (exc. Sta. Wag.)	7619931	1	174.00	LID ASSY.
66	Impala (Spt. Cpe.)	7637032	1	174.00	LID ASSY.
67	Impala (Spt. Cpe.)	7611954	1	174.00	LID ASSY.
67	Pass. (exc. Caprice, Sta. Wag., Spt. Cpe.)				
67	Caprice (exc. Sta. Wag.)	7665143	1	174.00	LID ASSY.
67-69	Camaro	8783521	1	108.00	LID ASSY.
68	Chevelle (exc. Sta. Wag., El Camino)				
69-72	Chevelle	8761214	1	163.00	LID ASSY.
68	Pass. (exc. Sta. Wag., Spt. Cpe.)	7722128	1	174.00	LID ASSY.
68	Impala (Spt. Cpe.)	7696314	1	174.00	LID ASSY.
68-72	Chevy	9676350	1	127.00	LID ASSY.
69-70	Pass. (exc. Sta. Wag., Spt. Cpe.)	9813061	1	174.00	LID ASSY.
69-70	Impala Cust., Caprice (Spt. Cpe.)	9813059	1	174.00	LID ASSY.
70-75	Camaro	9819030	1	108.00	LID ASSY.
71	Pass. (exc. Impala Custom, Caprice Spt. Cpe.)	9890063	1	174.00	LID ASSY.
71	Impala (Custom) Caprice (Spt. Cpe.)	9803396	1	174.00	LID ASSY.
71-73	Vega (Sedan)	9865440	1	65.25	LID ASSY.
71-73	Vega (Coupe)	9867700	1	95.00	LID ASSY.
72-73	Impala (Custom) Caprice	9877370	1	159.00	LID ASSY.
72-73	Pass. (Sed.) Impala (Spt. Cpe., Conv.) (exc. Custom)	9649788	1	159.00	LID ASSY. (structural adhesive)
73	Chevelle (Spt. Cpe., Sed.) (exc. Monte Carlo)	9846143	1	155.00	LID ASSY.
73	Monte Carlo	9846142	1	155.00	LID ASSY.
73-74	Nova (H.B. Cpe.)	9614847	1	127.00	LID ASSY.
73-74	Nova (exc. H.B.)	9676350	1	127.00	LID ASSY.
74-75	Caprice (Cpe.) Impala (Custom)	9650975	1	159.00	LID ASSY.
74	Chevelle (exc. Monte Carlo, Sta. Wag.)	9658884	1	155.00	LID ASSY.

**METAL TRIM—CLIPS AND PANELS**

**12.181 LID— LID ASSY.— EXTENSION— PLUG— VALVE ASSY.— COVER— FILTER, Rear Compartment (Less Hardware) (Con't)**

74-75	Monte Carlo	9647526	1	155.00	LID ASSY.
74-75	Pass. (Cpe.) Impala (Custom)	9659632	1	159.00	LID ASSY.
74-75	Vega (Sedan)	9657634	1	78.25	LID ASSY.
74-75	Vega (Coupe)	9657723	1	114.00	LID ASSY.
75	Vega (Coupe)	1715231	1	104.00	LID ASSY., use with 3/8" ball studs
75	Nova (H.B.)	1697769	1	127.00	LID ASSY.
75	Nova (exc. H.B.)	1697767	1	127.00	LID ASSY.
75	Chevelle (exc. S.W., Monte Carlo)	1653319	1	155.00	LID ASSY. (structural adhesive)
75	Monza (Hatchback)	9686832	1	104.00	LID ASSY.
75	Monza (Notchback)	1687300	1	80.75	LID ASSY.
75	Monza (exc. Town Cpe.) Heavy Duty	3965798	1	153.00	LID ASSY.
69	Camaro	3949798	1	37.00	EXTENSION, lid (spoiler)
70-73	Camaro (2nd design)	3990475	L.H.	16.60	EXTENSION, left qtr. panel spoiler (part of 3 piece unit)
70-73	Camaro (2nd design)	3990476	R.H.	16.60	EXTENSION, right qtr. panel spoiler (part of 3 piece unit)
70-72	Camaro (exc. Spoilers 1st design)	3974538	1	37.50	EXTENSION ASSY. (1 piece unit)
70-74	Camaro w/Spoilers (2nd design)	480161	1	35.75	EXTENSION ASSY. (part of 3 piece unit)
67-68	Camaro	3916633	1	33.75	EXTENSION ASSY., spoiler lid
74-75	Camaro w/Spoilers	339434	R.H.	11.65	EXTENSION ASSY., rear compt. lid quarter panel (Z28)
74-75	Camaro w/Spoilers	339433	L.H.	11.65	EXTENSION ASSY., rear compt. lid quarter panel (Z28)
75	Monza (exc. Towne Coupe)	356675	1	33.25	EXTENSION, rear compartment lid
75	Monza (exc. Towne Coupe)	356677	L.H.	10.85	EXTENSION, rear compartment lid qtr. panel
75	Monza (exc. Towne Coupe)	356678	R.H.	10.85	EXTENSION, rear compartment lid qtr. panel
67	Pass. (exc. Sta. Wag.)	4859119	6	.12	PLUG, compt. lid inner access hole— (12.804)
71-75	Pass.	9883011	4	1.55	VALVE ASSY., compt. lid and t/gate inner panel drain
73-75	Nova (H.B.)	9646283	2	.99	COVER, acc. hole compt. lid i/pnl.
71	Pass.	410754	2	.78	FILTER, rear deck lid vent.

**12.182 EMBLEM— EMBLEM UNIT— COVER— PLATE— MOULDING ASSY.— MOULDING UNIT— DECAL— STRIPE— TRANSFER— NUT ASSY.— WASHER, Rear Compartment Lid and Rear End Panel**

62	Chevy (exc. Sta. Wag.)	3790800	1	7.00	compt. lid
63-64	Nova (Super Sport)	3793606	1	2.65	compt. lid
63	Chevy (exc. Sta. Wag.)	3793409	1	8.75	
64	Nova (exc. Sta. Wag.)	3848421	1	11.20	lid
68	Chevelle (Std. Deluxe)	7726922	1	4.85	rear end panel (Note 1)
<i>NOTE 1 Requires 4-9419764 not for installation.</i>					
65	Pass. (exc. Sta. Wag.)	3870722	1	6.10	EMBLEM UNIT, body rear
66	Pass., Caprice (Spt. Mdls.)	4227047	1	6.25	EMBLEM UNIT, rr. compt. lid (Note 1)
<i>NOTE 1 Part No. 4227047 can also be used as tail gate emblem on Sta. Wagons.</i>					
66	Malibu (exc. Sta. Wag.)	4227109	1	6.90	EMBLEM UNIT
67	Chevelle (Deluxe, Sed.)	4229433	1	5.60	EMBLEM UNIT, rr. end panel
67	Chevelle (S.S.)	4229992	1	4.15	EMBLEM UNIT, rr. end pnl. ("S.S., 396")
67	Biscayne, Bel Air (Sed.)	4229584	1	10.95	EMBLEM UNIT, rr. compt. lid otr. pnl.
69	Camaro	8701158	1	6.50	EMBLEM UNIT, rear end outer panel (bow tie)
70-71	Camaro w/Spec. H/Per. 350	3981889	1	5.05	EMBLEM UNIT, rear compt. lid ext. (Z-28)
71-72	Monte Carlo	8705455	1	4.00	EMBLEM UNIT, rear end outer panel (S.S.)
73-74	Nova (S.S.)	6259618	1	3.00	EMBLEM UNIT, front fender (S.S.)— (8.147)
73	Monte Carlo	9873274	1	4.25	EMBLEM ASSY., compt. lid panel/crest
75	Camaro	9633286	1	2.65	EMBLEM ASSY., compt. lid (Camaro)
75	Caprice (exc. Sta. Wag.)	1654400	1		EMBLEM ASSY., compt. lid outer panel
75	Nova	9633292	1	3.90	EMBLEM ASSY., rr. end pnl. (Nova LN)
71-73	Vega (Coupe)	9837257	1	13.20	COVER, compt. lid inner panel finish (black) (paint as reqd.)
75	Monza (Hatchback) w/140/293 Eng.	358316	1	5.70	COVER, rear compt. lid lock
68	Pass. (exc. Sta. Wag., Caprice)	7731108	1	2.90	PLATE, rr. compt. name ("CHEVROLET") (Note 2)
68	Caprice	7731109	1	3.70	PLATE, name ("Caprice by Chevrolet") (Note 3)
68	Impala (Spt. Cpe., Conv.)	7752253	1	2.90	PLATE, compt. lid name ("Impala S.S.") (Note 3)

**METAL TRIM—CLIPS AND PANELS**

**12.182 EMBLEM— EMBLEM UNIT— COVER— PLATE— MOULDING ASSY.—  
MOULDING UNIT— DECAL— STRIPE— TRANSFER— NUT ASSY.—  
WASHER, Rear Compartment Lid and Rear End Panel (Con't)**

68	Impala (Spt. Cpe., Conv.) . . . . .	7752254	1	2.90	PLATE, compt. lid name ("S.S. 427") (Note 2) . . . . .
68	Concours, Malibu (Spt. Sed.) . . . . .	7732349	1	4.25	PLATE, compt. lid name (Concours) (Note 2)
	<i>NOTE 2 Requires 4-9419764 nut for installation.</i>				
68	S.S. . . . . .	7745748	1	3.35	PLATE, rear end panel name (S.S., 396) (Note 3) . . . . .
	<i>NOTE 3 Requires 2-4485531 washer and 2-9419764 nut for installation.</i>				
68	Chevy . . . . .	7745749	1	3.35	PLATE, name (Chevy II by Chevrolet) (Note 4) . . . . .
	<i>NOTE 4 Requires 2-9421828 nut for installation.</i>				
68-69	Camaro . . . . .	7752901	1	2.85	PLATE, rear compt. name (Note 5) . . . . .
	<i>NOTE 5 Requires 4-9419764 nut for installation.</i>				
68	Malibu . . . . .	7740129	1	4.10	PLATE, name (Chevelle)— (12.180) (Note 6)
	<i>NOTE 6 Requires 3-9419764 nut for installation.</i>				
70	Chevelle (exc. Monte Carlo, Sta. Wag., El Camino) . . . . .	8791686	1	3.90	PLATE, compt. lid (CHEVELLE by CHEVROLET) (Note 7) . . . . .
71-72	Monte Carlo . . . . .	9861029	1	3.20	PLATE, rear end name (CHEVROLET) (Note 8) . . . . .
	<i>NOTE 8 Requires 2-7583551 Washer, 2-9421828 Nut for installation.</i>				
	<i>NOTE 7 Requires 2-9421828 Nut for installation.</i>				
71	Caprice . . . . .	9835943	1	3.75	PLATE, compt. lid otr. panel name . . . . .
71	Chevelle (exc. Monte Carlo) (Sta. Wag.) . . . . .	9834999	1	4.95	PLATE, compartment lid outer panel name . . . . .
73	Malibu (Spt. Cpe.) w/body side mldg. . . . .	8707821	1	1.90	PLATE, name rear end outer panel (S.S.) . . . . .
73	Nova . . . . .	328740	1	2.85	PLATE, name lid (Nova) and bow tie . . . . .
73-75	Caprice (Spt. Cpe., Spt. Sed.) . . . . .	9882650	1	4.50	PLATE, compt. lid otr. panel (Caprice) . . . . .
75	Camaro (L.T.) . . . . .	1695874	1		PLATE, name rear end panel (Type L.T.) . . . . .
75	Camaro . . . . .	9633286	1	2.65	PLATE, rr. compt. name (Camaro) . . . . .
72	Caprice . . . . .	9882650	1	4.50	PLATE ASSY., compt. lid outer panel (Caprice by Chevrolet) . . . . .
69	Impala S.S. . . . . .	8737750	1	3.25	PLATE ASSY., compt. lid outer panel name ("S.S.") . . . . .
71-72	Pass. (exc. Caprice) . . . . .	9831025	1	4.35	PLATE ASSY., name (Chevrolet)— (12.180)
70-72	Camaro . . . . .	9869701	1	5.85	PLATE ASSY., compartment name (Camaro)
71-72	Vega . . . . .	9870383	1	4.25	PLATE ASSY., back door outer panel name (CHEVROLET VEGA 2300) . . . . .
73-74	Vega . . . . .	9614435	1	2.10	PLATE ASSY., rear end outer panel name (Vega by Chevrolet) . . . . .
73	Chevelle (exc. Monte Carlo, El Camino) . . . . .	9620101	1	2.90	PLATE ASSY., name t/gate outer panel . . . . .
73-74	Monte Carlo . . . . .	9631842	1	3.90	PLATE ASSY., name compt. lid (Monte Carlo) . . . . .
73	Camaro . . . . .	8707740	1	3.25	PLATE ASSY., compt. lid name (Camaro) . . . . .
74	Camaro (exc. LT) . . . . .	9632310	1	3.25	PLATE ASSY., rear end finish panel (Camaro) . . . . .
74	Camaro (L.T.) . . . . .	9630078	2	3.10	PLATE ASSY., rear end finish panel . . . . .
74	Pass. (exc. Sta. Wag.) . . . . .	9831025	1	4.35	PLATE ASSY. (Chevrolet) . . . . .
75	Camaro . . . . .	9633382	1	2.80	PLATE KIT, end panel (type L.T.) . . . . .
75	Nova (exc. Custom) . . . . .	9633290	1	2.60	PLATE ASSY., name rr. end pnl. (Nova) . . . . .
75	Nova (Custom) . . . . .	9633291	1	2.90	PLATE ASSY., name rr. end pnl. (Custom) . . . . .
75	Chevelle (2-Dr.) (exc. Monte Carlo, El Camino) . . . . .	9632723	1	3.00	PLATE ASSY., name r/end panel (Chevelle)
75	Chevelle (Sta. Wag.) . . . . .	1746150	1	3.55	PLATE, name t/gate outer (Chevrolet) (repl. 9633282) . . . . .
75	Monza (Hatchback) . . . . .	1746150	1	3.55	PLATE KIT, name compt. lid (Chevrolet) (repl. 9633282) . . . . .
75	Vega . . . . .	1700895	1		PLATE ASSY., rr. end (Vega by Chevrolet) . . . . .
75	Laguna . . . . .	9633295	1	4.90	PLATE KIT, rear end panel (Laguna Type S-3) . . . . .
64-65	Chevelle, El Camino . . . . .	3853422	1	8.75	PLATE UNIT, lid name . . . . .
66	Chevelle (S.S.) . . . . .	4227376	1	5.00	PLATE UNIT, rr. end pnl. name ("S.S., 396")
66	Malibu (exc. Sta. Wag.) . . . . .	4227111	1	3.15	PLATE UNIT, rr. compt. lid name ("Chevelle") . . . . .
66	Chevy (2-Dr. Sed.), Chevy (Sta. Wag.) (exc. Nova) . . . . .	4227227	1	3.50	PLATE UNIT ("Chevy II") . . . . .
66	Chevelle (Sed.) (exc. Malibu), Chevelle (S.S.), Chevelle (Sed.) (exc. Malibu, Deluxe) . . . . .	4229439	1	5.00	PLATE UNIT, rear end panel name ("Chevelle") . . . . .

**METAL TRIM—CLIPS AND PANELS**

**12.182 EMBLEM— EMBLEM UNIT— COVER— PLATE— MOULDING ASSY.—  
MOULDING UNIT— DECAL— STRIPE— TRANSFER— NUT ASSY.—  
WASHER, Rear Compartment Lid and Rear End Panel (Con't)**

66	Biscayne, Bel Air, Impala (exc. S.S.)	4227044	1	2.45	PLATE UNIT, rr. compt. lid and t/gate name ("Chevrolet")
66	Caprice	4227048	1	4.10	PLATE UNIT, rr. compt. lid and tailgate ("Caprice by Chevrolet")
67	Pass. (exc. Caprice)	4229977	1	3.65	PLATE UNIT, rr. compt. lid and tailgate ("Chevrolet")
67	Caprice	4229550	1	4.55	PLATE UNIT, rr. compt. lid and tailgate ("Caprice by Chevrolet")
67	Camaro	4229839	1	4.10	PLATE UNIT, rr. compt. lid name ("Camaro")
67	Chevelle (exc. El Camino)	4229502	1	3.65	PLATE UNIT, rr. end panel and t/gate name (Chevelle)
68-69	Camaro	7795106	1	4.10	PLATE UNIT, rr. compt. lid name ("Camaro")
69	Camaro	8701129	1	5.70	PLATE UNIT, rear end outer panel name ("R.S.")
69	Chevelle (exc. Sta. Wag.)	8701218	1	3.65	PLATE UNIT, compt. lid ("Chevelle By Chevrolet")
69	Camaro	8701333	1	5.70	PLATE UNIT, rear end name ("Z 28")
69	Chevelle (Spt. Cpe., Conv.)	8701346	1	3.10	PLATE UNIT, rear end outer panel name ("S.S., 396")
69	Caprice	8701019	1	4.50	PLATE UNIT, compt. lid name ("Caprice by Chevrolet")
69-70	Pass. (exc. Caprice, Sta. Wag.)	8704041	1	4.60	PLATE UNIT, name (CHEVROLET)— (12.180)
70	Caprice	8702629	1	4.65	PLATE UNIT, name (CAPRICE BY CHEVY)
70	Monte Carlo	8700883	1	3.95	PLATE UNIT, name (BY CHEVROLET)
70-72	Monte Carlo	8700885	1	4.35	PLATE UNIT, name (MONTE CARLO)
69	Chevy,				
70-72	Nova	8701089	1	3.65	PLATE UNIT, name (NOVA BY CHEVROLET)
70	Camaro	8704053	1	3.95	PLATE UNIT, lid name CAMARO BY CHEVY
74	Nova (exc. S.S.)	6260837	1	2.85	PLATE UNIT, rear compt. lid name (Note 1)— (8.055)
74	Camaro (exc. L.T.)	9632310	1	3.25	PLATE UNIT, rear end name (Camaro) (Note 1)
74-75	Chevelle (exc. Laguna)	9631844	1	2.85	PLATE UNIT, name rear end panel, t/gate outer panel
74	Laguna	9631843		8.95	PLATE UNIT, name rear end panel (Laguna)
75	Monte Carlo	9632861	1	4.10	PLATE UNIT, compt. lid outer
75	Chevelle (Sta. Wag.), Monza, Nova	1746150	1	3.55	PLATE, T/G or compt. lid name "CHEVROLET"
72-73	Impala Custom, Caprice (Spt. Cpe., Spt. Sed.)	8705700	1	12.45	MOULDING, outer panel compt. lid
73	Monte Carlo	9685295	1	11.00	MOULDING, rear end belt (painted)
74-75	Camaro (L.T.)	9698821	R.H.	2.20	MOULDING, finish panel upper
74-75	Camaro (L.T.)	9698822	L.H.	2.20	MOULDING, finish panel upper
74-75	Camaro (L.T.)	9698823	R.H.	1.40	MOULDING, finish panel lower
74-75	Camaro (L.T.)	9698824	L.H.	1.40	MOULDING, finish panel lower
75	Monte Carlo	9632865	R.H.	7.35	MOULDING, otr. pnl. rr. end side
75	Monte Carlo	9632866	L.H.	7.35	MOULDING, otr. pnl. rr. end side
75	Malibu Classic Coupe w/vinyl roof w/o pad	9632725	1	7.35	MOULDING, fin. rr. end pnl. at t/lamp
62-65	Chevy Deluxe, Nova (exc. Sta. Wag.)	3871605	1	8.55	MOULDING ASSY., outer panel
64	Chevelle (exc. Sta. Wag., El Camino)	3853435	1	7.05	MOULDING UNIT, lid upper
64	Chevelle (exc. Sta. Wag., El Camino)	3853436	1	7.30	MOULDING UNIT, lid lower
64	Malibu (exc. Sta. Wag.)	3853430	1	30.50	MOULDING UNIT, outer pnl. center
65	Bel Air (exc. Sta. Wag.)	3870723	1	8.90	MOULDING UNIT, outer panel
65	Impala (exc. S.S., Sta. Wag.)	3870726	1	19.15	MOULDING UNIT, rr. end panel
65	Impala (exc. Sta. Wag.)	3870727	1	12.75	MOULDING UNIT, lid outer
65	Pass. (S.S.)	3870837	1	25.50	MOULDING UNIT, rr. end panel (black and red)
65	Pass. (S.S.)	3870838	1	25.50	MOULDING UNIT, rr. end panel (black, red and gray)
65	Nova (exc. Sta. Wag.)	3871604	1	37.00	MOULDING UNIT, rr. compt. lid, w/emblem
65	Malibu (exc. Sta. Wag.)	3871641	1	20.55	MOULDING UNIT, rr. compt. lid center upper

**METAL TRIM—CLIPS AND PANELS**

**12.182 EMBLEM— EMBLEM UNIT— COVER— PLATE— MOULDING ASSY.—  
MOULDING UNIT— DECAL— STRIPE— TRANSFER— NUT ASSY.—  
WASHER, Rear Compartment Lid and Rear End Panel (Con't)**

65	Malibu (exc. Sta. Wag.)	3871642	1	20.55	MOULDING UNIT, rr. compt. lid center lower
65	Chevelle (exc. Sta. Wag., El Camino)	3871639	1	9.75	MOULDING UNIT, upper
65	Chevelle (exc. Sta. Wag., El Camino)	3871640	1	9.75	MOULDING UNIT, lower
66	Impala, Caprice (exc. Sta. Wag.)	4227026	1	14.70	MOULDING UNIT
66	Bel Air (Sedan)	4227303	1	12.50	MOULDING UNIT
66	Malibu (exc. Sta. Wag.), Chevelle (S.S.)	4227108	2	10.40	MOULDING UNIT, upper lower
66	Nova (exc. Sta. Wag.)	4227228	1	39.00	MOULDING UNIT
66	Nova (S.S.)	4227229	1	41.75	MOULDING UNIT, rr. compt. lid w/emblem
67	Caprice	4229585	1	34.00	MOULDING UNIT, rr. compt. lid otr. pnl.
67	Impala (Sed., Conv.)	4229586	1	34.00	MOULDING UNIT, rr. compt. lid otr. pnl.
67	Impala (Spt. Cpe.) (exc. S.S.)	4229587	1	33.00	MOULDING UNIT, rr. compt. lid otr. pnl.
67	Pass. (S.S.) (Spt. Cpe.)	4229589	1	27.75	MOULDING UNIT, rr. compt. lid otr. pnl.
67	Nova (Spt. Cpe., Sed.) (exc. S.S.)	4229498	1	53.75	MOULDING UNIT, rr. compt. lid w/emblem
67	Nova (S.S.)	4229497	1	53.75	MOULDING UNIT, rr. compt. lid otr. panel
67	Chevelle (S.S.), Malibu (exc. El Camino)	4229432	1	18.75	MOULDING UNIT, rr. end pnl. lwr.
67	Chevelle (S.S.), Malibu (exc. El Camino)	4229434	1	12.95	MOULDING UNIT, rr. end pnl. upr.
67	Chevelle (S.S.), Malibu (exc. El Camino)	4229435	1	13.30	MOULDING UNIT, rr. compt. lid otr. pnl.
67	Chevelle (Deluxe) (Sed.)	4229436	1	11.20	MOULDING UNIT, rr. end pnl. lwr.
68	Malibu, S.S. (exc. Sta. Wag., El Camino)	7795095	1	10.80	MOULDING UNIT, rear end outer panel lower
68	Malibu, S.S. (exc. Sta. Wag., El Camino)	7795096	1	10.80	MOULDING UNIT, rear end outer panel upper
68	Malibu (Spt. Sed.)	7795094	1	52.00	MOULDING UNIT, rr. end outer panel
68-69	Chevy	7795098	1	41.75	MOULDING UNIT, rr. end panel
68-69	Chevy (S.S.)	7795107	1	50.75	MOULDING UNIT, rr. end panel
68	Caprice (exc. Sta. WAg.)	7795102	1	9.80	MOULDING UNIT, rear compt. lid outer panel
69	Impala Caprice (exc. Sta. Wag.)	8700984	1	14.05	MOULDING UNIT, outer panel compt. lid
69	Malibu				
69	Chevelle (Deluxe) (exc. 4-Dr.)	8701337	1	10.70	MOULDING UNIT, rear end panel upper
69	Malibu				
69	Chevelle (Deluxe) (exc. 4-Dr.)	8701338	1	13.20	MOULDING UNIT, rear end panel lower
70	Caprice	8702963	1	14.05	MOULDING UNIT, outer panel compt. lid
71	Caprice	8705430	1	37.00	MOULDING UNIT, outer panel rear end
70-71	Monte Carlo	8700888	1	13.60	MOULDING UNIT, rear end ctr.
70-71	Monte Carlo	8700889	R.H.	5.50	MOULDING UNIT, side rear end
70-71	Monte Carlo	8700890	L.H.	5.50	MOULDING UNIT, side rear end
70-72	Nova (Spt. Cpe.) w/Body Emblem	8702427	1	49.00	MOULDING UNIT, outer rear
70-72	Nova w/Deck Lid Ornament	8702426	1	40.50	MOULDING UNIT, outer rear
71	Monte Carlo	8705550	L.H.	7.75	MOULDING UNIT, outer panel rear end side upper
71	Monte Carlo	8705549	R.H.	7.75	MOULDING UNIT, outer panel rear end side upper
72	Monte Carlo	8703720	L.H.	7.75	MOULDING UNIT, outer panel rear end side
72	Monte Carlo	8703719	R.H.	7.75	MOULDING UNIT, outer panel rear end side
72	Monte Carlo	8703641	1	25.75	MOULDING UNIT, outer panel rear end center upper and lower
73	Monte Carlo	8707914	1	29.50	MOULDING UNIT, rear end outer panel
74	Monte Carlo	9632258	R.H.	8.20	MOULDING UNIT, outer panel rear end side
74	Monte Carlo	9632259	L.H.	8.20	MOULDING UNIT, outer panel rear end side
74	Monte Carlo	9632260	1	13.90	MOULDING UNIT, outer panel rear end center
74	Malibu (Spt. Cpe., Spt. Sed.) w/rear end oran.	9631766	R.H.	7.45	MOULDING UNIT, rear end panel center
74	Malibu (Spt. Cpe., Spt. Sed.)	9631767	L.H.	7.45	MOULDING UNIT, rear end panel center
74	Malibu, Laguna (Spt. Cpe., Spt. Sed.) w/rear end oran.	9631768	R.H.	6.70	MOULDING UNIT, finish rear end panel side



**METAL TRIM—CLIPS AND PANELS**

**12.182 EMBLEM— EMBLEM UNIT— COVER— PLATE— MOULDING ASSY.—  
MOULDING UNIT— DECAL— STRIPE— TRANSFER— NUT ASSY.—  
WASHER, Rear Compartment Lid and Rear End Panel (Con't)**

74	Malibu, Laguna (Spt. Cpe., Spt. Sed.) w/rear end oran. ....	9631769	L.H.	6.70	MOULDING UNIT, finish rear end panel side
75	Nova w/ext. oran. rr. end	9632711	1	14.95	MOULDING UNIT, otr. pnl. compt. lid
75	Monte Carlo	9632862	1	12.60	MOULDING UNIT, otr. pnl. rr. end lic. opg.
75	Vega (Sta. Wag.) w/wood grain	9632690	1	2.15	MOULDING UNIT, back door o/p transfer upper
75	Vega (Sta. Wag.) w/wood grain	9632693	1	8.55	MOULDING UNIT, back door o/p transfer lwr.
75	Vega (Sta. Wag.) w/wood grain	9632694	1	6.50	MOULDING UNIT, back door transfer at lic. plate
75	Vega (Town Cpe.)	9633435	1	6.80	MOLDING UNIT, outer panel rear end
		9632712	2	4.90	MOLDING PKG., see 12.116 for usage
71	Chevelle w/Hvy. Chevy	6261946	1	5.25	DECAL, rr. deck lid (white)
71	Chevelle w/Hvy. Chevy	6261947	1	5.25	DECAL, rr. deck lid (black)
73-75	Camaro	3994698	1	.57	DECAL, rr. deck lid (Z-28)
74	Nova	347534	1	3.30	DECAL, rear deck lid w/Spirit of America
74-75	Nova (S.S.) w/black stripe	341068	1	3.05	DECAL, rear deck lid (black and gold)
74-75	Nova (S.S.) w/Bench Seat	344373	1	2.25	DECAL, rr. deck lid (gold and red)
75	Nova (S.S.)	347598	1	2.15	DECAL, rr. deck lid (Nova S.S.) silver
75	Nova (S.S.)	347599	1	2.15	DECAL, rr. deck lid (Nova S.S.) red
75	Nova (S.S.)	347597	1	2.15	DECAL, rr. deck lid (white)
75	Nova	360645	1	2.15	DECAL, rr. deck lid (gold)
75	Nova	360644	1	1.90	DECAL, rr. deck lid (black)
75	Camaro	360688	R.H.	3.00	DECAL, rr. spoiler outer stripe (dk. gray-med. gray-lt. gray)
75	Camaro	360687	L.H.	3.00	DECAL, rr. spoiler outer stripe (dk. gray-med. gray-lt. gray)
75	Camaro	360667	1	10.80	DECAL, rr. spoiler center stripe (dk. gray-med. gray-lt. gray)
75	Camaro	360690	R.H.	3.00	DECAL, rr. spoiler outer stripe (dk. red-med. red-lt. red)
75	Camaro	360689	L.H.	3.00	DECAL, rr. spoiler outer stripe (dk. red-med. red-lt. red)
75	Camaro	360668	1	10.80	DECAL, rr. spoiler center stripe (dk. red-med. red-lt. red)
75	Camaro	360686	R.H.	3.00	DECAL, rr. spoiler outer stripe (red-orange-lt. yellow)
75	Camaro	360685	L.H.	3.00	DECAL, rr. spoiler outer stripe (red-orange-lt. yellow)
75	Camaro	360694	1	10.80	DECAL, rr. spoiler center stripe (red-orange-lt. yellow)
75	Camaro	360684	R.H.	3.00	DECAL, rr. spoiler outer stripe (dk. blue-med. blue-lt. blue)
75	Camaro	360683	L.H.	3.00	DECAL, rr. spoiler outer stripe (dk. blue-med. blue-lt. blue)
75	Camaro	360693	1	10.80	DECAL, rr. spoiler center stripe (dk. blue-med. blue-lt. blue)
75	Camaro	360692	R.H.	3.00	DECAL, rr. spoiler outer stripe (orange-yellow)
75	Camaro	360691	L.H.	3.00	DECAL, rr. spoiler outer stripe (orange-yellow orange-yellow)
75	Camaro	360669	1	10.80	DECAL, rr. spoiler center stripe (orange-yellow orange-yellow)
74-75	AD80	336394	1	9.10	STRIPE, end gate accent (white)
74-75	AD80	336386	1	9.10	STRIPE, end gate accent (black)
74-75	Vega (Sta. Wag.)	9734698	1	9.65	DECAL, back door (black)
74-75	Vega (Sta. Wag.)	9734699	1	9.65	DECAL, back door (white)
74-75	Camaro w/Spoilers, Spt. Striping	341091	1	12.90	STRIPE, rear deck lid ext. (Z28)
74	Camaro w/spoilers, Spt. Striping	341064	1	27.75	STRIPE, rear deck lid (Z28)
74-75	Nova (Coupe) w/paint stripe	344379	1	8.75	STRIPE, rr. deck lid (black and gold)
74-75	Nova (Coupe) w/paint stripe	344380	1	8.75	STRIPE, rr. deck lid (red and gold)
74-75	Nova (H.B.) w/paint stripe	344381	L.H.	9.65	STRIPE, rr. deck lid (black and gold)
74-75	Nova (H.B.) w/paint stripe	344382	R.H.	9.65	STRIPE, rr. deck lid (black and gold)
74-75	Nova (H.B.) w/paint stripe	344383	L.H.	9.65	STRIPE, rr. deck lid (red and gold)
74-75	Nova (H.B.) w/paint stripe	344384	R.H.	9.65	STRIPE, rr. deck lid (red and gold)
73-74	Vega (Coupe) w/body side mldg. silver	9692362	1	15.10	TRANSFER (silver black silver)
73-74	Vega (Coupe) w/body side mldg. black	9692363	1	15.10	TRANSFER (black white black)
73-74	Vega (Coupe) w/body side mldg. green	9692364	1	15.10	TRANSFER (red white blue)

**METAL TRIM—CLIPS AND PANELS**

**12.182 EMBLEM— EMBLEM UNIT— COVER— PLATE— MOULDING ASSY.—  
MOULDING UNIT— DECAL— STRIPE— TRANSFER— NUT ASSY.—  
WASHER, Rear Compartment Lid and Rear End Panel (Con't)**

73-74	Vega (Coupe) w/body side mldg. green	9692365	1	15,10	TRANSFER (red white green)
73-74	Vega (Coupe) w/body side mldg. orange	9692366	1	15,10	TRANSFER (red yellow orange)
73-74	Vega (Coupe) w/body side mldg. orange	9692367	1	15,10	TRANSFER (white black white)
75	Vega (Coupe) w/front and body side stripe	1659482	R.H.	9.05	TRANSFER, outer panel rear end (gold)
75	Vega (Coupe) w/front and body side stripe	1659483	L.H.	9.05	TRANSFER, outer panel rear end (gold)
75	Vega (122)	1659874	1	3.65	TRANSFER, rear end (Cosworth twin cam)
<i>NOTE 1: Consists of 1 plate, 1 clip.</i>					
70-75	Camaro	9433050	1	.11	NUT, lid outer panel name (Camaro)
All	Pass.	9419761	A.R.	.11	NUT ASSY., name plate, emblem and ornament (1/8") (Cadmium)— (8.147)
All	Pass.	9420202	A.R.	.11	NUT ASSY., name plate, emblem and ornament (1/8") (Phos.)— (8.921)
62	Chevy (exc. Sta. Wag.)	9419763	2	.11	NUT ASSY. (special 3/16")— (8.147)
68	Impala (Spt. Cpe.) (exc. Custom)	7583551	12	.11	WASHER, (Special)

**12.183 CLIP— CLIP ASSY.— SCREW— NUT— WASHER— RETAINER, Rear Compartment Lid**

63-64	Nova (S.S.)	4888347	A.R.	.11	rr. compt. lid emblem— (12.118)
65	Chevelle (exc. El Camino)	4490712	A.R.	.19	lwr. mldg., R.H., upr. mldg., L.H.
67	Chevelle (S.S.),				
67	Malibu (exc. Sta. Wag., El Camino)	4510031	8	.18	rr. compt. lid ctr. mldg.
69	Malibu	4424679	2	.12	rear lower end, outer panel
66	Caprice (Sta. Wag.)				t/gate & rear fender outer pnl. mldg.
69	Malibu (exc. Sta. Wag., El Camino),				
69	Chevelle (Deluxe) (2-Dr.) (exc. El Camino)				otr. pnl. mldg. rear end lower end,
71-72	Kingswood (Estate)	4424679	A.R.	.12	finish mldg. rear wheel opening & rear fender upper outer,
70	Chevelle (Spt. Cpe., Conv.) (exc. Monte Carlo),				
70	El Camino, Camaro,				
69-72	Chevelle, Camaro, Impala (Spt. Cpe., Conv.)	8736600	A.R.	.12	compt. lid name plate (S.S.)
75	Malibu Classic	9600857	A.R.	.16	CLIP, rr. end panel
75	Malibu, Monte Carlo, Impala, El Camino	8699350	A.R.		CLIP, rr. end belt revel, t/gate mldg.
64	Chevelle (exc. Sta. Wag., El Camino)	4817162	A.R.	.27	CLIP ASSY., upper mldg. center— (12.118)
64	Chevelle (exc. El Camino)	4816119	A.R.	.12	CLIP ASSY., lwr. mldg.— (12.118)
65	Bel Air (Sed.)	4815593	6	.22	CLIP ASSY., outer pnl. mldg.
65	Bel Air (Sed.)	4489224	6	.18	CLIP ASSY., rr. end panel mldg— (12.118C)
65	Chevelle (exc. Sta. Wag., El Camino)	4490710	6	.12	CLIP ASSY., upr. mldg. center
66	Malibu S.S. (exc. Sta. Wag., El Camino)	7634600	A.R.	.18	CLIP ASSY., rr. end otr. pnl. upr. and lwr. mldg.— (12.118)
67	Chevelle (S.S.),				
67	Malibu (exc. Sta. Wag., El Camino)	7663443	6	.52	CLIP ASSY., rr. end lwr. pnl. mldg.
67	Malibu (exc. Sta. Wag.),				
67	Chevelle (S.S.)	7636662	2	.18	CLIP ASSY., rr. compt. lid mldg.— (12.118)
67	Impala (exc. Sta. Wag.),				
67	Caprice (Spt. Sed.)	7668933	4	.22	CLIP ASSY., otr. mldg. ctr.
67	Pass. (Sta. Wag.)		2		t/gate lwr. mldg. inner
74-75	Chevelle (exc. El Camino, Sta. Wag.),				
74-75	Pass. (4-Dr.) (exc. Sta. Wag.)	7669079	A.R.	.12	CLIP ASSY., revel. mldg. r/end belt and bolt— (12.118)
68-71	Caprice (exc. Sta. Wag.)	7767523	8	.12	CLIP ASSY., outer panel mldg. & front dr. outer pnl. lower mldg.
68	Malibu, S.S. (exc. Sta. Wag., El Camino)	4401685	12	.11	CLIP ASSY., center rr. end outer upper and lwr.
69	Impala, Caprice,				
70	Caprice, Kingswood (exc. Estate)	4698648	8	.18	CLIP ASSY., otr. pnl. mldg.

**METAL TRIM—CLIPS AND PANELS**

**12.183 CLIP— CLIP ASSY.— SCREW— NUT— WASHER— RETAINER, Rear  
Compartment Lid (Con't)**

69	Impala (Sed.),								
69	Kingswood (exc. Estate Wag.)	7742182	A.R.	.12	CLIP ASSY., frt. rr. lwr. mldg., outer panel mldg. frt. door lwr. frt., rr. dr. lwr. frt. . . . .				
71-75	Pass. (exc. Sta. Wag., Caprice)	9823096	A.R.	.07	CLIP ASSY., outer panel name . . . . .				
71-75	Vega, Monza	9875547	A.R.	.12	CLIP ASSY. . . . .				
72	Monte Carlo	9601064	2	.22	CLIP ASSY., rear end side mldg. ext. outer . . . . .				
72	Monte Carlo	9601065	2	.22	CLIP ASSY., rear end side mldg. ext. inner & rear end center mldg. end . . . . .				
72	Monte Carlo	9647459	6	.16	CLIP ASSY., rear end outer panel center mldg. . . . .				
	Not required in this group. See group 12.118 . . . . .	4888347		.11	CLIP ASSY., . . . . .				
72	Caprice w/body side mldg. (Spt. Cpe.) (Spt. Sed.) . . . . .	8727925	2	.27	CLIP ASSY., otr. pnl. mldg. frt. dr. upper rr. . . . .				
72	Nova . . . . .	7767523	2	.12	CLIP ASSY., rear compt. lid outer panel mldg. . . . .				
73	Monte Carlo . . . . .	9875825	6	.53	CLIP ASSY., rear end panel mldg. . . . .				
73-74	Impala (Sta. Wag.) . . . . .	9838109	18	.12	CLIP ASSY., panel t/gate mldg. to panel . . . . .				
74-75	Malibu (Estate) . . . . .	7649377	2	.18	CLIP ASSY., mldg. t/gate transfer upper outer . . . . .				
74	El Camino (Classic), w/wood grain . . . . .				CLIP ASSY., mldg. t/gate transfer upper center . . . . .				
74	Malibu (Estate) Caprice (Sta. Wag.) . . . . .	7656277	A.R.	.05	CLIP ASSY., mldg. t/gate transfer upper and lower . . . . .				
74	Camaro, w/vinyl roof . . . . .	7657449	5	.16	CLIP ASSY., revel. mldg. r/end belt center . . . . .				
74	Malibu w/ext. orna. r/end (exc. Sta. Wag.) . . . . .	1658611	8	.24	CLIP ASSY., mldg. to r/end finish panel . . . . .				
74-75	El Camino (Classic), w/wood grain and tailgate mldg. . . . .	8731902	2	.18	CLIP ASSY., mldg. t/gate transfer upper outer . . . . .				
74	Camaro, w/padded vinyl roof . . . . .	8740380	2	.18	CLIP ASSY., revel. mldg. r/end belt . . . . .				
74	Pass. (Sed.), Impala (Spt. Cpe.) w/two-tone paint, . . . . .								
74	Chevelle w/vinyl roof, two-tone paint (exc. Sta. Wag., El Camino) . . . . .	8799350	A.R.	.12	CLIP ASSY., revel. mldg. r/end belt . . . . .				
74	El Camino . . . . .	9610126	3	.13	CLIP ASSY., finish mldg. t/gate belt . . . . .				
74-75	All . . . . .	9875547	A.R.	.12	CLIP ASSY., outer panel name . . . . .				
74	Vega (Sta. Wag.) w/wood grain . . . . .	4817155	2	.17	CLIP ASSY., mldg. t/gate upper transfer . . . . .				
74	Vega (Sta. Wag.) w/wood grain . . . . .	7656277	4	.05	CLIP ASSY., mldg. t/gate outer panel upper . . . . .				
74-75	Vega (Sta. Wag.) (Panel) . . . . .	9823096	A.R.	.07	CLIP ASSY., back door name— (8.148) . . . . .				
75	Monte Carlo . . . . .	1671173	A.R.	.32	CLIP ASSY., rear end side mldg. . . . .				
75	Vega (Sta. Wag.) . . . . .	9838109	3	.12	back door otr. pnl. transfer mldg. . . . .				
75	X27 w/rear vinyl . . . . .	4404877	2	.24	CLIP, rear end belt reveal molding . . . . .				
67	Malibu (exc. Sta. Wag.), . . . . .								
72-73	All (exc. Vega) . . . . .	4492963	A.R.	.14	SCREW, compt. lid mldg. ctr. clip— (11.209) . . . . .				
62	Chevy Deluxe, Nova (exc. Sta. Wag.) . . . . .	4843565	A.R.	.12	NUT, clip . . . . .				
65	Nova, Malibu (S.S.) . . . . .	9419766	A.R.	.11	NUT, rr. compt. lid outer pnl. mldg.— (8.921) . . . . .				
67	Biscayne, Bel Air (Sed.) . . . . .	9419763	4	.11	NUT, rear lid outer panel emblem— (8.921) . . . . .				
75	Chevelle (2-Dr.) . . . . .	9436884	A.R.	.18	NUT, panel assy. fin. to r/end pnl., rear lamp assy. to r/end pnl. (repl. 9434255) . . . . .				
65	Nova, Malibu (exc. Sta. Wag.), . . . . .								
66	Malibu (Sta. Wag.) . . . . .	4401600	6	.11	WASHER, rr. outer lid lwr. and upr. center mldg. rr. qtr. lid emblem and mldg. . . . .				
65	S.S., . . . . .								
65	Nova (S.S.) . . . . .	4445612	6	.06	WASHER, rr. compt. lid outer mldg. and emblem— (12.118) . . . . .				
68	Pass. (Spt. Cpe.) w/vinyl top . . . . .				WASHER, rr. compt. lid outer panel mldg., rear compt. lid ext. . . . .				
70-75	Camaro w/spoiler . . . . .	7583551	16	.11	WASHER, rr. compt. lid outer mldg. and emblem . . . . .				
66	Nova (S.S.) . . . . .	4416715	6	.11	WASHER, heater hole cover plate . . . . .				
75	Monza w/A.C. . . . .	7631337	3						
67	Chevelle (S.S.), . . . . .								
67	Malibu (exc. Sta. Wag., El Camino) . . . . .	7667945	2	1.70	RETAINER, rr. compt. lid otr. pnl. mldg. . . . .				

**12.184 HINGE ASSY.— BOX ASSY.— BOLT— PIN— ROD— SCREW— STRAP  
ASSY.— SUPPORT, Rear Compartment Lid**

71-75	Vega (Coupe) . . . . .	9825276	1	5.75	rear compt. lid, body side . . . . .
-------	------------------------	---------	---	------	--------------------------------------

**METAL TRIM—CLIPS AND PANELS**

**12.184 HINGE ASSY.— BOX ASSY.— BOLT— PIN— ROD— SCREW— STRAP ASSY.— SUPPORT, Rear Compartment Lid (Con't)**

71-75	Vega (Coupe)	9825384	L.H.	2.05	rear compt. lid, lid side
71-75	Vega (Coupe)	9825383	R.H.	2.05	rear compt. lid, lid side
74-75	Vega (Panel, Sta. Wag.)	1651785	L.H.	27.75	back door
74-75	Vega (Panel, Sta. Wag.)	1651784	R.H.	27.75	back door
75	Monza (Hatchback)	9736563	2	2.05	body side
66	Pass. (Sed.),				
66	Caprice (Spt. Cpe.),				
65-68	Pass. (exc. Sta. Wag., Spt. Cpe.),				
68	Impala Custom	9711414	R.H.	8.45	BOX ASSY., hinge
67	Impala (Spt. Cpe.)	9710012	R.H.	8.30	BOX ASSY., hinge
67	Impala (Spt. Cpe.)	9710013	L.H.	8.30	BOX ASSY., hinge
69-70	Pass. (exc. Impala Custom, Caprice),				
69-70	Caprice (Spt. Sed.)	9717640	R.H.	8.30	BOX ASSY., hinge
69-70	Pass. (exc. Impala Custom, Caprice),				
69-70	Caprice (Spt. Sed.)	9717641	L.H.	8.15	BOX ASSY., hinge
71-73	Impala (Custom) Caprice (Spt. Cpe.)	9616086	L.H.	11.65	BOX ASSY., hinge
71-73	Impala (Custom) Caprice (Spt. Cpe.)	9616085	R.H.	11.65	BOX ASSY., hinge
71-75	Pass. (exc. Impala Custom, Caprice Spt. Cpe.)	9832633	L.H.	9.95	BOX ASSY., hinge
71-75	Pass. (exc. Impala Custom, Caprice Spt. Cpe.)	9832632	R.H.	9.95	BOX ASSY., hinge
71-73	Vega (Panel, Sta. Wag.)	9824923	L.H.	7.20	BOX, back door hinge
71-73	Vega (Panel, Sta. Wag.)	9824922	R.H.	7.20	BOX, back door hinge
73-75	Chevelle (exc. Sta. Wag., Monte Carlo)	9877645	L.H.	12.70	BOX ASSY., hinge
73-75	Chevelle (exc. Sta. Wag., Monte Carlo)	9877644	R.H.	12.70	BOX ASSY., hinge
73-75	Monte Carlo	9877656	L.H.	12.70	BOX ASSY., hinge
73-75	Monte Carlo	9877655	R.H.	12.70	BOX ASSY., hinge
74-75	Impala (Custom) Caprice (Spt. Cpe.)	9670940	R.H.	11.65	BOX ASSY., hinge
74-75	Impala (Custom) Caprice (Spt. Cpe.)	9670941	L.H.	11.65	BOX ASSY., hinge
74-75	El Camino	9726440	R.H.	17.10	BOX ASSY., tailgate
74-75	El Camino	9726441	L.H.	17.10	BOX ASSY., tailgate
65-68	Pass. (exc. Sta. Wag.)	4405445	4	.21	BOLT, hinge to lid ( <sup>5</sup> / <sub>16</sub> "— 18 x 1.0)— (10.463)
71-73	Vega (Panel, Sta. Wag.)	9824930	2	.34	PIN, back door hinge
71-73	Vega (Sedan)	9823155	1	3.90	ROD, compt. lid hinge torque
69-70	Caprice,				
71	Impala (Custom) Caprice (Spt. Cpe.)	8744880	4	.64	SCREW, hinge to lid
65-66	Chevy (exc. Sta. Wag.)	4406838	4	.15	SCREW, hinge to lid ( <sup>5</sup> / <sub>16</sub> "— 18 x 1)
71-74	Vega (Panel, Sta. Wag.)	9824936	L.H.	16.85	STRAP ASSY., back door hinge w/link
71-74	Vega (Panel, Sta. Wag.)	9824935	R.H.	16.85	STRAP ASSY., back door hinge w/link
75	Camaro	9723492	R.H.	7.25	STRAP, hinge
75	Camaro	9723493	L.H.	7.25	STRAP, hinge
66-68	Chevy, Chevelle (exc. Sta. Wag., El Camino),				
69-71	Chevelle (exc. Sta. Wag., Conv.)	9706256	R.H.	4.25	SUPPORT, hinge
66-68	Chevy, Chevelle (exc. Sta. Wag., El Camino),				
69-71	Chevelle (exc. Sta. Wag., Conv.)	9706257	L.H.	4.25	SUPPORT, hinge
67-69	Camaro	9709422	R.H.	5.10	SUPPORT, hinge
67-69	Camaro	9709423	L.H.	5.10	SUPPORT, hinge
68-71	Chevelle (Conv.)	9723615	L.H.	9.70	SUPPORT, rear compt. lid hinge
68-74	Chevy, Nova (exc. H.B.)	9843830	R.H.	7.90	SUPPORT, rr. compartment lid hinge
70-75	Camaro	9723494	L.H.	1.85	SUPPORT, lower side
70-75	Camaro	9723495	R.H.	1.85	SUPPORT, lower side
71	Malibu (Conv.)	9723614	R.H.	9.70	SUPPORT, hinge
69-74	Nova (exc. H.B.)	9843831	L.H.	7.90	SUPPORT, hinge
75	Nova (exc. H.B.)	9736524	R.H.	7.90	SUPPORT, hinge
75	Nova (exc. H.B.)	9736525	L.H.	7.90	SUPPORT, hinge
75	Monza (Notchback)	1700542	R.H.	4.90	SUPPORT, rear compt. lid hinge
75	Monza (Notchback)	1700543	L.H.	4.90	SUPPORT, rear compt. lid hinge

**12.184A HINGE— HINGE ASSY.— ESCUTCHEON— STRAP— BUSHING— BUMPER— BOLT— SCREW— NUT— REGULATOR ASSY., Tail Gate**

62-67	Chevy (Sta. Wag.)	4846598	R.H.	13.55
62-67	Chevy (Sta. Wag.)	4846599	L.H.	13.55

**METAL TRIM—CLIPS AND PANELS**

**12.184A HINGE—HINGE ASSY.—ESCUTCHEON—STRAP—BUSHING—  
BUMPER—BOLT—SCREW—NUT—REGULATOR ASSY., Tail Gate  
(Con't)**

69-72	Chevelle (Sta. Wag.)	8742334	L.H.	31.75	HINGE ASSY., w/striker t/gate upr. body side
69-72	Chevelle (Sta. Wag.)	8767052	L.H.	119.00	HINGE ASSY., t/gate lower side
69-70	Pass. (Sta. Wag.)	8742332	L.H.	31.75	HINGE ASSY., w/Striker upr. body
69-70	Pass. (Sta. Wag.)	8767053	L.H.	93.50	HINGE ASSY., t/gate lower side
71-73	Pass. (Sta. Wag.)	9890262	L.H.	54.75	HINGE ASSY., t/gate lift arm side
73	El Camino	9881245	L.H.	17.10	
73	El Camino	9881244	R.H.	17.10	
73-75	Nova (H.B.)	9616022	2	4.25	HINGE ASSY., compt. lid body side
73-74	Nova (H.B.)	9616041	L.H.	4.25	HINGE ASSY., compt. lid/lid side
73-74	Nova (H.B.)	9616040	R.H.	4.25	HINGE ASSY., compt. lid/lid side
75	Nova (H.B.)	1652890	R.H.	11.65	HINGE ASSY., compt. lid
75	Nova (H.B.)	1652891	L.H.	11.65	HINGE ASSY., compt. lid
74-75	Pass. (Sta. Wag.)	9674025	1	54.75	HINGE ASSY., t/gate lift arm side
74-75	El Camino	9726441	L.H.	17.10	HINGE ASSY.
74-75	El Camino	9726440	R.H.	17.10	HINGE ASSY.
64-67	Chevelle (Sta. Wag., El Camino)	4464284	2	.36	ESCUTCHEON, hinge (Note 2)
<i>NOTE 2 Serves as hinge cover. (Plastic).</i>					
64-67	Chevelle (Sta. Wag., El Camino)	5717018	R.H.	5.10	STRAP, hinge gate side
64-67	Chevelle (Sta. Wag., El Camino)	5717019	L.H.	5.10	STRAP, hinge gate side
65-68	Pass. (Sta. Wag.)	9703082	R.H.	8.10	STRAP, hinge body side
65-68	Pass. (Sta. Wag.)	9703083	L.H.	8.10	STRAP, hinge body side
65-68	Pass. (Sta. Wag.)	9703080	R.H.	9.80	STRAP, hinge gate side
65-68	Pass. (Sta. Wag.)	9703081	L.H.	9.80	STRAP, hinge gate side
68-70	Chevelle (Sta. Wag., El Camino)				
71-72	El Camino	9712976	R.H.	10.00	STRAP, hinge to body side
68-70	Chevelle (Sta. Wag., El Camino)				
71-72	El Camino	9712977	L.H.	10.00	STRAP, hinge to body side
68	Chevelle (Sta. Wag., El Camino)	9716659	L.H.	13.40	STRAP, hinge to gate side
69-70	El Camino,				
69-70	Nomad, Greenbrier w/single action t/gate,				
71-72	El Camino	9719758	R.H.	14.10	STRAP, hinge to gate side
69-70	El Camino,				
69-70	Nomad, Greenbrier w/single action t/gate,				
71-72	El Camino	9719759	L.H.	14.10	STRAP, hinge to gate side
73-75	Chevelle (Sta. Wag.)	9881480	1	4.80	STRAP, hinge gate side
73-75	Chevelle (Sta. Wag.)	9881479	1	11.65	STRAP ASSY., hinge body side
64-67	Chevelle (Sta. Wag., El Camino)	5717022	R.H.	6.35	STRAP UNIT, hinge body side
64-67	Chevelle (Sta. Wag., El Camino)	5717023	L.H.	6.35	STRAP UNIT, hinge body side
64-69	Chevelle (Sta. Wag., El Camino),				
65-68	Pass. (Sta. Wag.),				
70-72	El Camino	9724315	2	.27	BUSHING, hinge
Not required in this group. See Group 16.323					
		4110660		.16	BUSHING
Not required in this group. See Groups 16.323 and 10.464					
		4150462		.11	BUSHING
71-73	Pass. (Sta. Wag.)	9675393	L.H.	.77	BUMPER, t/gate lift arm side hinge
71*	Pass. (Sta. Wag.)	9898506	L.H.	.50	BUMPER, t/gate lift arm side hinge
74-75	Pass. (Sta. Wag.)	9677449	L.H.	.16	BUMPER, t/gate lift arm hinge
64-67	Chevy (Sta. Wag.)				BOLT, hinge to body,
64-67	Chevelle (Sta. Wag., El Camino)	4409370	A.R.	.21	hinge to body and gate
65-68	Pass. (Sta. Wag.)	4405445	A.R.	.21	BOLT, hinge to body ( <sup>5</sup> / <sub>16</sub> "— 18 x 1) (hex hd. w/ <sup>7</sup> / <sub>8</sub> " dia. conical washer)— (10.463)
65-69	Pass. (Sta. Wag.),				
68	Chevelle (Sta. Wag., El Camino)				BOLT, hinge to gate,
70	Pass., Chevelle (Sta. Wag.),				
71-72	Chevelle (Sta. Wag.)	4534205	A.R.	.21	hinge to body, lower hinge to rear cross bar
65-75	Pass. (Sta. Wag.)	7667647	6	.18	BOLT, t/gate hinge to body— (10.463) ( <sup>5</sup> / <sub>16</sub> "— 18 x 1 <sup>1</sup> / <sub>8</sub> ")
68-70	Chevelle (Sta. Wag., El Camino),				
71-73	El Camino	7740373	1	.59	BOLT, tailgate supt. to gate
68-70	Chevelle (Sta. Wag., El Camino),				
71-75	El Camino	7740374	1	.72	BOLT, tailgate supt. to body
68-70	Chevelle (Sta. Wag., El Camino),				
69	Pass. (Sta. Wag.),				
71	El Camino	7785359	3	.21	BOLT, hinge to gate
69-72	Pass., Chevelle (Sta. Wag.)	8761950	1	.79	BOLT, t/gate support lower hinge
69-72	Chevelle (Sta. Wag.)	8761949	1	.36	BOLT, t/gate lower hinge to anc. pit.
69-72	El Camino	7668482	6	.18	BOLT, t/gate hinge to body
71	Pass. (Sta. Wag.)	9420792	1	.05	SCREW, bumper t/gate lift arm hinge

**METAL TRIM—CLIPS AND PANELS**

**12.184A HINGE— HINGE ASSY.— ESCUTCHEON— STRAP— BUSHING— BUMPER— BOLT— SCREW— NUT— REGULATOR ASSY., Tail Gate (Con't)**

71-75	Pass. (Sta. Wag.)	9846890 A.R.		.23	SCREW, t/gate guide channel assy., roller support to panel, synch. torq. tube panel and lift arm hinge lgtd. lift to hinge on body
74-75	El Camino	9888389 A.R.		.32	SCREW, t/gate hge. to body or gate
69-70	Pass., Chevelle (Sta. Wag.)				
69-72	Chevelle (Sta. Wag.)	8745810 A.R.		.22	NUT, upr. and lwr. hinge to gate
71-73	Pass. (Sta. Wag.) w/electric t/gate	9675398	1	58.25	REGULATOR ASSY., lift arm hinge (electric)
74	Pass. (Sta. Wag.)	9674084	1	58.25	REGULATOR ASSY., t/gate lift arm hinge (electric)
75	Pass. (Sta. Wag.) w/pwr. t/gate	1655884	1	58.25	REGULATOR ASSY., t/gate lift arm hinge

**12.186 PIN, Rear Compartment Hinge, Tail Gate**

66-67	Chevy,				
65-72	Chevelle (exc. Sta. Wag., El Camino),				
73	Pass. (exc. Sta. Wag., El Camino)	9707593	2	.22	lid hinge (repl. 9707580)
65-72	Pass. (exc. Sta. Wag., SDL.)	9707593	2	.22	hinge
67-69	Camaro	9709437	2	.24	
68-75	Nova (exc. H.B.),				
75	Monza (Notchback)	9714079	2	.16	
70-75	Camaro	9723490	2	.32	lid hinge
64-68	Pass., Chevelle (Sta. Wag., El Camino)	5712852	2	.16	hinge
68-70	Chevelle (Sta. Wag., El Camino),				
71-72	El Camino	9712980	2	.18	hinge
72-74	Nova (Sed.)	9715083	2	.58	hinge— (10.466)
72	Pass (Sta. Wag.)	9839659	1	.44	t/gate hinge torq. rod retainer
73-75	Pass. (Sta. Wag.)	9839659	1	.44	t/gate hinge torq. rod retainer
73-75	Chevelle, Pass. (Sed., Spt. Cpe.)	9707593	2	.22	lid hinge
73-74	Nova (H.B.)				PIN ASSY., compt. lid hinge body side
71-74	Vega (Coupe),				
73-75	Chevelle (Sta. Wag.),				
75	Monza (Hatchback)	9850419 A.R.		.93	tail gate hinge

**12.187 STRAP— BOLT ASSY.— CLIP— COVER— LINK— LINK ASSY.— GROMMET— PIN— PLATE— ROD— RETAINER— ROLLER— ROLLER ASSY.— SUPPORT— SCREW— TUBE ASSY., Rear Compartment Lid or Tailgate Hinge**

64-65	Chevelle (exc. Sta. Wag., El Camino)	5717153	2	4.80	hinge
65-66	Pass. (Spt. Cpe.)	9707446	2	6.15	w/link
65-66	Pass. (Conv.)	9708167	2	5.75	w/link
67	Impala (Spt. Cpe.)	9710020	2	6.15	w/link assy
67-69	Camaro	9709424 R.H.		5.45	hinge
67-69	Camaro	9709425 L.H.		5.45	hinge
68	Impala (Spt. Cpe.)	9715312	2	6.85	w/link assy
65-68	Pass. (exc. Conv., Sta. Wag.),				
69-70	Biscayne, Bel Air, Impala (exc. Custom)	9721855	2	4.15	w/link assy.
69-73	Impala Cust., Caprice (Spt. Cpe.)	9610894	2	10.00	w/link assy.
66-67	Chevy, Chevelle (exc. Sta. Wag., El Camino)	9706258 R.H.		6.15	w/link assy., hinge
66-67	Chevy, Chevelle (exc. Sta. Wag., El Camino)	9706259 L.H.		6.15	w/link assy., hinge
68-72	Chevelle (Conv.)	9720628	2	7.00	w/link assy., rear compt. lid hinge
68-74	Chevy, Nova (exc. H.B.)	9714082	2	6.85	w/link assy., rear compt. lid hinge
68-69	Chevelle (exc. Sta. Wag., El Camino, Conv.),				w/link assy., rear compt. lid hinge
70-72	Chevelle (exc. Conv., El Camino, Sta. Wag.)	9722033	2	6.55	w/link assy.
70-75	Camaro	9723492 R.H.		7.25	lid hinge
70-75	Camaro	9723493 L.H.		7.25	lid hinge
71-75	Pass. (exc. Impala Custom, Caprice, Sta. Wag.)	9856330	2	6.30	w/link assy.
74-75	Impala (Custom), Caprice (Spt. Cpe.)	9731376	2	11.60	STRAP AND LINK ASSY., lid hinge
73-75	Chevelle (Spt. Cpe., Sed.)	9877650	2	7.00	STRAP AND LINK ASSY., lid hinge
73-75	Monte Carlo	9877659	2	8.15	STRAP AND LINK ASSY., lid hinge
75	Nova (exc. H.B.)	9736242	2	6.85	STRAP AND LINK ASSY., lid hinge
75	Monza (Notchback)	1700388	1	4.65	STRAP AND LINK ASSY.

**METAL TRIM—CLIPS AND PANELS**

**12.187 STRAP— BOLT ASSY.— CLIP— COVER— LINK— LINK ASSY.—  
GROMMET— PIN— PLATE— ROD— RETAINER— ROLLER— ROLLER  
ASSY.— SUPPORT— SCREW— TUBE ASSY., Rear Compartment Lid or  
Tailgate Hinge (Con't)**

71-72	Pass. ....	9851450	2	.58	BOLT ASSY., t/gate syn. link to support ...
74-75	Vega (Sedan) ....	4558315	2	.11	CLIP, compt. lid hge. pin torq. ....
71-75	Pass. (Sta. Wag.) ....	9660486	R.H.	.63	COVER, hinge torq. rod end ....
71-75	Pass. (Sta. Wag.) ....	9660487	L.H.	.63	COVER, hinge torq. rod end ....
73-75	Chevelle (Sta. Wag.) ....	9621473	L.H.	.52	COVER, counter/balance supt. upper ....
73-75	Chevelle (Sta. Wag.) ....	9621472	R.H.	.52	COVER, counter/balance supt. upper ....
75	Nova (H.B.) ....	1709962	R.H.	1.30	COVER, hinge opening ....
75	Nova (H.B.) ....	1709963	L.H.	1.30	COVER, hinge opening ....
74-75	Chevelle (El Camino) ....	9726436	R.H.	2.75	COVER, t/gate hinge (primed) ....
74-75	Chevelle (El Camino) ....	9726437	L.H.	2.75	COVER, t/gate hinge (primed) ....
74-75	Vega (Panel, Sta. Wag.) ....	9684254	L.H.	1.10	COVER, back door hinge wiring harness ...
71-73	Vega (Panel, Sta. Wag.) ....	9837707	L.H.	7.50	COVER ASSY., rear compt. lid or door hinge torque rod (black) ....
71-73	Vega (Panel, Sta. Wag.) ....	9837706	R.H.	7.50	COVER ASSY., rear compt. lid or door hinge torque rod (black) ....
70-72	Chevelle (Sta. Wag.) ....	8780612	1	5.65	LINK, hinge torq. rod ....
69	Chevelle (Sta. Wag.) ....	8744104	1	5.50	LINK ASSY., t/gate hinge torq. rod ....
71-73	Vega (Coupe) ....	9826163	L.H.	6.25	LINK ASSY., compt. lid torque rod ....
71-73	Vega (Coupe) ....	9826162	R.H.	6.25	LINK ASSY., compt. lid torque rod ....
69-70	Pass., Chevelle (Sta. Wag.),				
71-72	Chevelle (Sta. Wag.) ....	9719299	A.R.	.32	GROMMET, t/gate hinge torque rod link ...
72	Nova (Sed.) ....	9715083	2	.58	PIN, hinge pin— (10.466) ....
74	Vega (Hatchback) ....	9676092	1	1.95	PLATE ASSY., counter balance support on roof inner ....
65-68	Pass. (Sta. Wag.) ....	4496164	1	8.15	ROD, torque ....
66	Chevelle (exc. Sta. Wag., El Camino) ....	7587202	L.H.	4.00	ROD, hinge torque ....
66-67	Chevy (Sed.),				
66-67	Nova (Spt. Cpe.) (exc. S.S.) ....	7590016	R.H.	5.45	ROD, hinge torque ....
66-67	Chevy Std. (Sed.) ....	7590017	L.H.	6.15	ROD, hinge torque ....
67-69	Camaro ....	7661531	R.H.	3.20	ROD, hinge torque ....
67-69	Camaro ....	7661532	L.H.	3.20	ROD, hinge torque ....
67	Chevelle (exc. Sta. Wag., El Camino) ....	7667097	L.H.	4.00	ROD, hinge torque ....
68-69	Chevy ....	8770159	L.H.	5.10	ROD, rr. compt. lid hinge torque (repl. 7754542) ....
68-71	Malibu, S.S. (Conv.) ....	7725940	R.H.	4.55	ROD, hinge torque ....
68-72	Chevelle (exc. Conv., Sta. Wag.) .	7754534	R.H.	4.75	ROD, hinge torque ....
68-72	Chevelle (exc. Conv., Sta. Wag.) .	7754535	L.H.	4.10	ROD, hinge torque ....
68	Pass. (exc. Impala Custom, Sta. Wag., Spt. Cpe.) ....	7752927	L.H.	5.20	ROD, hinge torque ....
69-70	Biscayne, Bel Air (exc. Sta. Wag.),				
69-70	Impala (exc. Cust., Sta. Wag.),				
69-70	Caprice (Spt. Sed.) ....	8743759	R.H.	5.60	ROD, hinge torque ....
69-70	Biscayne, Bel Air (exc. Sta. Wag.),				
69-70	Impala (exc. Cust., Sta. Wag.),				
69-70	Caprice (Spt. Sed.) ....	8743760	L.H.	5.60	ROD, hinge torque ....
69-72	Chevelle (Sta. Wag.) ....	8780611	1	13.90	ROD, t/gate hinge torque ....
68-74	Chevy, Nova (exc. H.B.) ....	8770158	R.H.	5.10	ROD, side compt. lid hinge torque ....
69-74	Chevy, Nova (exc. H.B.) ....	8770159	L.H.	5.10	ROD, side compt. lid hinge torque ....
70-75	Camaro ....	9868538	R.H.	3.75	ROD, torq. (repl. 9814722) ....
70-75	Camaro ....	9868539	L.H.	3.40	ROD, torq. (repl. 9814723) ....
70-72	Camaro w/rear compt. lid ext. ...	9868540	1	4.35	ROD, right torq. side ....
71-72	Pass. (exc. Impala Custom, Caprice Spt. Cpe., Sta. Wag.) .	9841101	L.H.	5.40	ROD, torq. side ....
71-75	Pass. (exc. Impala Custom, Caprice Spt. Cpe., Sta. Wag.) .	9621937	R.H.	5.55	ROD, torq. side (repl. 9838042) ....
71-72	Impala (Custom) Caprice (Spt. Cpe.) ....	9838041	L.H.	7.95	ROD, torq. ....
71-72	Impala (Custom) Caprice (Spt. Cpe.) ....	9838040	R.H.	7.95	ROD, torq. ....
71-73	Vega (Coupe) ....	9826161	L.H.	6.60	ROD, rear compt. lid torque side ....
71-73	Vega (Coupe) ....	9826160	R.H.	6.60	ROD, rear compt. lid torque side ....
71-73	Vega (Panel, Sta. Wag.) ....	9824921	L.H.	5.40	ROD, rear compt. lid on door hinge torque .
71-73	Vega (Panel, Sta. Wag.) ....	9824920	R.H.	5.40	ROD, rear compt. lid on door hinge torque .
72	Chevelle (Conv.) ....	7725940	R.H.	4.55	ROD, torq. ....
73-75	Pass. (exc. Impala Custom, Caprice Spt. Cpe., Sta. Wag.) .	9662534	L.H.	5.40	ROD, torq. side ....
73	Impala (Custom) Caprice (Spt. Cpe.) ....	9622752	L.H.	7.20	ROD, torq. hinge side ....

**METAL TRIM—CLIPS AND PANELS**

**12.187 STRAP— BOLT ASSY.— CLIP— COVER— LINK— LINK ASSY.—  
GROMMET— PIN— PLATE— ROD— RETAINER— ROLLER— ROLLER  
ASSY.— SUPPORT— SCREW— TUBE ASSY., Rear Compartment Lid or  
Tailgate Hinge (Con't)**

73	Impala (Custom) Caprice (Spt. Cpe.)	9622751 R.H.	7.20	ROD, torq. hinge side
73-75	Chevelle (Spt. Cpe., Sed.)	9881345 L.H.	3.90	ROD, torq. hinge side
73-75	Chevelle (Spt. Cpe., Sed.)	9881344 R.H.	3.90	ROD, torq. hinge side
73	Monte Carlo	9883934 R.H.	5.55	ROD, torq. hinge side
74-75	Monte Carlo	9678185 R.H.	5.55	ROD, torq. hinge side
73-75	Monte Carlo	9883935 L.H.	5.55	ROD, torq. hinge side
73-75	Camaro w/spoilers	9868540 R.H.	4.35	ROD, torq. side
74-75	Impala (Custom), Caprice (Spt. Cpe.)	9677896 R.H.	7.20	ROD, torque compt. lid hinge
74-75	Impala (Custom), Caprice (Spt. Cpe.)	9677897 L.H.	7.20	ROD, torque compt. lid hinge
74-75	Vega (Panel, Sta. Wag.)	9682654 R.H.	5.40	ROD, back door hinge torque
74-75	Vega (Panel, Sta. Wag.)	9682655 L.H.	5.40	ROD, back door hinge torque
74-75	Vega (Notchback)	9678184 1	7.65	ROD, compt. lid hinge torque
75	Nova (exc. H.B.)	1650070 R.H.	4.60	ROD, torq.
75	Nova (exc. H.B.)	1650071 L.H.	4.60	ROD, torq.
75	Monza (Notchback)	1697351 R.H.	2.10	ROD, compt. lid hinge
75	Monza (Notchback)	1697352 L.H.	2.10	ROD, compt. lid hinge
71-74	Pass. (Sta. Wag.)	9861249 1	8.70	ROD ASSY., hinge torq.
71	Chevelle (Sta. Wag.)	8780611 1	13.90	ROD ASSY., hinge torq.
74-75	Pass. (Sta. Wag.)	9697700 1	7.65	ROD ASSY., torque t/gate hinge
69-70	Pass., Chevelle (Sta. Wag.),			
71-72	Chevelle (Sta. Wag.)	8723087 2	2.45	RETAINER, hinge torque rod ctr. and lower
69-72	Chevelle (Sta. Wag.)	8780036 1	.76	RETAINER, hinge torq. rod lower
69-70	Pass., Chevelle (Sta. Wag.),			
71-72	Chevelle (Sta. Wag.)	8732610 1	2.45	RETAINER, torque rod link on body pillar
65-69	Pass., Chevelle (Sta. Wag.)	4479774 L.H.	1.80	RETAINER ASSY., torque rod on body
71-75	Pass. (Sta. Wag.)	9837198 1	2.70	RETAINER, torq. rod
71-75	Vega (Coupe)	9825394 1	1.25	RETAINER, compt. lid torque rod center
71-75	Pass. (Sta. Wag.)	9835839 L.H.	3.50	ROLLER ASSY., shaft
72-75	Pass. (Sta. Wag.)	9835835 1	3.85	ROLLER ASSY., t/gate synchro. torq.
73-74	Nova	9631825 2	36.00	SUPPORT ASSY., counter/balance upper
73-75	Chevelle (Sta. Wag.)	9879528 2	3.75	SUPPORT ASSY., counter/balance upper
74-75	Vega (Coupe)	9631832 2	21.15	SUPPORT UNIT, counter balance compt. lid/gas
75	Monza (Hatchback)	9633346 1	15.85	SUPPORT UNIT, counter balance compt. lid/gas
75	Nova (H.B.)	9633347 2	18.45	SUPPORT ASSY., counter balance (gas type)
69	Pass. (Sta. Wag.) (exc. Estate Wag.)	7715110 A.R.	.22	SCREW, torq. rod link ret.
69	Chevelle (Sta. Wag.)	9424877 A.R.	.21	SCREW, torq. rod link ret.— (8.900) (repl. 9431559)
71	Pass. (Sta. Wag.)	9846890 A.R.	.23	SCREW, t/gate guide channel assy., right hand roller support to panel and t/gate lift arm hinge lgtd. and power operated t/gate— (12.184)
71-74	Pass. (Sta. Wag.)	9835830 1	37.50	TUBE ASSY., synchro. torq.

**12.195 PANEL— ARMATURE— BEZEL— BOLT— BRACKET— BREAKER ASSY.—  
BUMPER— CABLE ASSY.— CLIP— CLUTCH— CONDUIT— COVER—  
CYLINDER ASSY.— DRIVER— ESCUTCHEON— FILLER ASSY.—  
GASKET— HANDLE— HOUSING— HOLDER— KNOB— MOTOR ASSY.—  
MOULDING ASSY.— NUT— PACKAGE ASSY.— PAWL ASSY.— PIN—  
PLATE— REGULATOR ASSY.— RETAINER— RING— ROLLER— SCREW—  
SPACER— SPRING— STRIP— STOP— SWITCH ASSY.— WASHER,  
Tailgate**

68-72	El Camino	7671589 1	17.90	tailgate inner cover
69-72	Chevelle (Sta. Wag.)	8741208 1	46.50	inner cover (black)
71	Pass. (Sta. Wag.)	8793048 1	27.50	inner cover (black)
71	Concours	9840432 1	47.50	inner cover (dk. jade)
71	Nomad, Greenbrier	9840433 1	47.50	inner cover (med. saddle)
71	Nomad, Greenbrier	9840430 1	47.50	inner cover (lt. sandalwood)
72-73	Pass. (Sta. Wag.)	9603275 1	27.50	t/gate inner cover
72	Greenbrier, Concours	9888907 1	47.50	t/gate inner cover (green)
73	Chevelle (Sta. Wag.) w/rear window defogger	9662389 1	26.00	inner cover
73-74	Chevelle (Sta. Wag.)	9627394 1	14.90	inner cover (prime and paint)
75	Chevelle (Sta. Wag.)	9697277 2	14.90	inner cover (prime and paint)
74-75	Chevelle (Sta. Wag.), w/rear wdo. defogger	9697284 1	29.25	inner cover (prime and paint)



**METAL TRIM—CLIPS AND PANELS**

**12.195 PANEL— ARMATURE— BEZEL— BOLT— BRACKET— BREAKER ASSY.— BUMPER— CABLE ASSY.— CLIP— CLUTCH— CONDUIT— COVER— CYLINDER ASSY.— DRIVER— ESCUTCHEON— FILLER ASSY.— GASKET— HANDLE— HOUSING— HOLDER— KNOB— MOTOR ASSY.— MOULDING ASSY.— NUT— PACKAGE ASSY.— PAWL ASSY.— PIN— PLATE— REGULATOR ASSY.— RETAINER— RING— ROLLER— SCREW— SPACER— SPRING— STRIP— STOP— SWITCH ASSY.— WASHER, Tailgate (Con't)**

62-64	Chevy (Sta. Wag.) w/elect. wind.,				
64-65	Chevelle (2-Seat Sta. Wag.),				
65	Pass. (Sta. Wag.) (1st design),				
66-67	Chevelle (Sta. Wag.) w/elect. window,				
67	Chevy (Sta. Wag.) w/elect. window	4909702 A.R.	19.95	ARMATURE, motor— (10.783)	
69	Pass., Chevelle (Sta. Wag.) (exc. Brookwood),				
70	Pass. (Sta. Wag.)	3943613	1	2.15	BEZEL, t/gate window switch
71-72	Pass. (Sta. Wag.)	3986868	1	2.60	BEZEL, t/gate window switch
70-72	Chevelle (Sta. Wag.)	3973642	1	2.75	BEZEL, t/gate window switch
73-75	Pass. (Sta. Wag.) (exc. pwr. t/gate)	3986868	1	2.60	BEZEL, window switch
73-75	Pass. (Sta. Wag.) w/pwr. t/gate	6258221	1	2.90	BEZEL, window switch
73-75	Chevelle (Sta. Wag.) w/elect. t/gate	3996274	1	1.65	BEZEL, window switch
71-75	Pass. (Sta. Wag.)	9836072	2	.40	BOLT, window guide upper & lower roller to glass (R.H., L.H.)
65-68	Chevelle (Sta. Wag.) (4-Dr.),				
65-66	Pass. (Sta. Wag.)	4904212	1	.05	BRACKET, brush holder— (10.783)
65	Chevy (Sta. Wag.),				
65	Pass. (Sta. Wag.) (6-Pass.)	4849850	1	3.40	BREAKER ASSY., circuit (40 amp.)— (13.095)
68	Chevelle (Sta. Wag.) w/elect. t/gate window	4850166	1	3.30	BREAKER ASSY., circuit— (13.095)
62-67	Chevy (Sta. Wag.),				
64-69	Chevelle (Sta. Wag.),				
65-69	Pass. (Sta. Wag.),				
71-72	Chevelle (Sta. Wag.)	8785295	2	.22	BUMPER, tailgate window— (12.212)
71-75	Pass. (Sta. Wag.)	9838928	1	3.80	CABLE ASSY., t/gate window regulator motor
62	Chevy (3-Seat Sta. Wag.)	4306804 A.R.		.11	CLIP, window switch— (11.558)
65-66	Sta. Wag.,				
69	Pass., Chevelle (Sta. Wag.)	4302363	1	.38	CLIP, t/gate lock cyl. switch
65-68	Sta. Wag.	4154886	4	.24	CLIP, t/gate wind. switch on inst. panel— (10.777)
63-68	Chevy, Chevelle (Sta. Wag.)				CLIP, remote control to locking rod, remote control to lock rod, frt. and rear door rem. cont. to panel, rr. dr. inr. locking rod to panel, frt. dr. lk. rem. cont. to panel, t/gate lk. rem. cont. to panel, rr. dr. inr. lkg. rod to pnl., t/gate and frt. dr. lk. rem. cont. to pnl. clip, rr. dr. inr. lkg. rod to pnl. clip— (10.565)
65-68	Pass. (Sta. Wag.)			.24	CLIP, window switch— (10.777)
68	Chevelle, Chevy				
68	El Camino				
69	Chevy (Sed.)				
69	Chevelle	4711608 A.R.		.16	t/gate and frt. dr. lk. rem. cont. to pnl. clip, rr. dr. inr. lkg. rod to pnl. clip— (10.565)
65-69	Pass. (Sta. Wag.)	4154886	4	.24	CLIP, window switch— (10.777)
68	Chevelle (Sta. Wag.) (exc. Concours),				
68	El Camino	7762203	2	.11	CLIP, remote control to lock rod— (10.565)
73-75	Pass. (Sta. Wag.) w/pwr. t/gate	9842552	1	.17	CLIP, lk. rel. electric window
62-67	Chevy (2-Seat Sta. Wag.)	5713277	1	1.65	CLUTCH, window outer handle cyl.
64	Chevelle (2-Seat Sta. Wag.)	5715942	1	2.25	CLUTCH, window outer handle cyl.
65-70	Pass., Chevelle (Sta. Wag.) (6-Pass.),				
71-72	Chevelle (Sta. Wag.)	9702916	1	1.85	CLUTCH, window outer handle cyl.
71-75	Pass. (Sta. Wag.)	9869621	1	1.25	CONDUIT, t/gate window regulator cable stowage
68-69	Chevelle (Sta. Wag.)	7712094	2	3.15	COVER, inner access hole
68-72	El Camino	7712098	2	3.25	COVER, inner access hole
69-72	Chevelle (Sta. Wag.)	8723152	2	3.40	COVER, inner access hole
71	Pass. (Sta. Wag.)	9829550	2	3.40	COVER, t/gate housing access hole
71-75	Pass. (Sta. Wag.) (2nd design)	9874669	2	3.40	COVER, t/gate housing access hole
71-73	Vega (Panel, Sta. Wag.)	8788486	1	1.80	COVER, inner panel access hole
69-70	Pass., Chevelle (Sta. Wag.),				
71-72	Chevelle (Sta. Wag.)	8717579 L.H.		1.30	COVER, t/gate inr. pnl. ext. seal
73-75	El Camino	9880331 A.R.		3.40	COVER, access hole

**METAL TRIM—CLIPS AND PANELS**

**12.195 PANEL— ARMATURE— BEZEL— BOLT— BRACKET— BREAKER ASSY.— BUMPER— CABLE ASSY.— CLIP— CLUTCH— CONDUIT— COVER— CYLINDER ASSY.— DRIVER— ESCUTCHEON— FILLER ASSY.— GASKET— HANDLE— HOUSING— HOLDER— KNOB— MOTOR ASSY.— MOULDING ASSY.— NUT— PACKAGE ASSY.— PAWL ASSY.— PIN— PLATE— REGULATOR ASSY.— RETAINER— RING— ROLLER— SCREW— SPACER— SPRING— STRIP— STOP— SWITCH ASSY.— WASHER, Tailgate (Con't)**

74-75	Pass. (Sta. Wag.)	1650437	L.H.	3.40	COVER, inner panel access hole
74-75	Pass. (Sta. Wag.)	1650436	R.H.	3.40	COVER, inner panel access hole
63-66	(Sta. Wag.)	6259467	1	8.15	CYLINDER ASSY., tailgate window lock cylinder— (12.248)
64-70	Chevelle (2-Seat Sta. Wag.) (2nd type),				
65-70	Pass. (Sta. Wag.) (6-Pass.),				
71-72	Chevelle (Sta. Wag.) (6-Pass.)	9703346	A.R.	8.85	DRIVER, wind. reg. outer handle
65-66	Pass. (Sta. Wag.),				
68	Pass. (Sta. Wag.)	3840096	1	1.75	ESCUTCHEON, tailgate window switch
69-72	Chevelle (Sta. Wag.)	8734103	1	6.05	ESCUTCHEON, lock cylinder
68	Pass. (Sta. Wag.)	9713781	1	9.60	ESCUTCHEON ASSY., lock cylinder
68-70	Pass. (Sta. Wag.) (6-Pass.),				
71-72	Chevelle (Sta. Wag.) w/elect. t/gate window	9713785	1	10.05	ESCUTCHEON ASSY., t/gate window regulator outer handle
72-75	Pass. (Sta. Wag.)	9608039	1	5.25	ESCUTCHEON, t/gate lock rel. (manual)
65-67	Pass. (Sta. Wag.) (2nd design),				
70-72	Chevelle (Sta. Wag.)	8780403	1	9.05	FILLER ASSY., t/gate to bumper
68-70	Pass., Chevelle (Sta. Wag.) (6-Pass.),				
71-72	Chevelle (Sta. Wag.) (6-Pass.)	7729379	1	.14	GASKET, window reg. outer handle
69-72	Chevelle (Sta. Wag.) w/elect. wind.	8741256	1	.14	GASKET, lock cyl. escut.
69-70	Pass. (Sta. Wag.)	8742230	1	.26	GASKET, lk. cyl. escut.
71-73	Pass. (Sta. Wag.)	9829419	2	1.15	GASKET, housing access hole cover
71	Pass. (Sta. Wag.) (1st design)	9839603	1	3.70	GASKET, upper to lower housing
71-73	Pass. (Sta. Wag.) (2nd design)	9874671	1	3.40	GASKET, upper to lower housing, used with flat surface
73-74	Chevelle (Sta. Wag.)	4471426	1	.14	GASKET, cyl. lock
62-67	Chevy (2-Seat Sta. Wag.)	5715091	1	14.90	HANDLE, w/knob, window reg. outer (pin connection on top)
64	Chevelle (2-Seat Sta. Wag.) (1st type)	9703582	1	10.80	HANDLE, w/knob, window reg. outer
64-72	Chevelle (2-Seat Sta. Wag.) (2nd type),				
65-70	Pass. (Sta. Wag.) (6-Pass.)	9703344	1	7.35	HANDLE, w/knob, window reg. outer
64-67	Chevelle (Sta. Wag.),				
65-66	Pass. (Sta. Wag.),				
66-67	Chevy (Sta. Wag.),				
68	Pass., Chevelle (Sta. Wag.) w/electric t/gate window	3921418	1	1.45	HOUSING, switch
70	Impala, Caprice	3937659	1	1.60	HOUSING, rear window defogger switch
62-66	Chevy w/elect. window,				
64-66	Chevelle w/elect. window,				
65	Pass. (Sta. Wag.) (1st design)	4917191	A.R.	6.25	HOLDER, brush control and electric mtr.— (10.783)
72-75	Pass. (Sta. Wag.)	9608038	1	5.45	KNOB, t/gate lock release (manual)
62-63	Chevy (Sta. Wag.)	5045656	1	46.00	MOTOR ASSY., window regulator
65-68	Pass., Chevelle, Chevy (Sta. Wag.),				
69	Chevelle (Sta. Wag.) (6-Pass.) Std. t/gate w/elect. t/gate window,				
68-69	Chevelle (Sta. Wag.) Std. t/gate	5045611	1	47.90	MOTOR ASSY., t/gate wdo. reg.
69-70	Pass. (Sta. Wag.)	5045639	1	41.55	MOTOR ASSY., regulator
69-72	Chevelle (Sta. Wag.) Dual Action t/gate	5045610	1	44.05	MOTOR ASSY., regulator
71-73	Pass. (Sta. Wag.)	9815882	1	37.95	MOTOR ASSY., window regulator
71-75	Pass. (Sta. Wag.) w/electric t/gate window	9815876	1	46.40	MOTOR ASSY., t/gate electric
74-75	Pass. (Sta. Wag.)	9668549	1	37.95	MOTOR ASSY., window regulator
71-75	Pass. (Sta. Wag.)	9846540	4	.19	NUT, t/gate window guide lower and upper roller to glass
69-74	Sta. Wag.,				
71-72	Chevelle (Sta. Wag.)	9808347	1	.22	NUT, t/gate wdo. wrg. rr. harn. switch
74	Pass. (Sta. Wag.)	9849429	1	1.25	NUT, lock striker to panel

**METAL TRIM—CLIPS AND PANELS**

**12.195 PANEL— ARMATURE— BEZEL— BOLT— BRACKET— BREAKER ASSY.— BUMPER— CABLE ASSY.— CLIP— CLUTCH— CONDUIT— COVER— CYLINDER ASSY.— DRIVER— ESCUTCHEON— FILLER ASSY.— GASKET— HANDLE— HOUSING— HOLDER— KNOB— MOTOR ASSY.— MOULDING ASSY.— NUT— PACKAGE ASSY.— PAWL ASSY.— PIN— PLATE— REGULATOR ASSY.— RETAINER— RING— ROLLER— SCREW— SPACER— SPRING— STRIP— STOP— SWITCH ASSY.— WASHER, Tailgate (Con't)**

64-69	Chevy, Chevelle (Sta. Wag.) w/elect. window,				
64	Chevelle (3-Seat Sta. Wag.),				
65-69	Pass. (Sta. Wag.)	4913821	1	7.15	PACKAGE ASSY., electric motor service . . .
71-72	Chevelle (Sta. Wag.) w/elect. t/gate window	4919851	1	6.60	PACKAGE ASSY., motor service . . . . .
63-67	Chevy (Sta. Wag.),				
64-70	Chevelle (2-Seat Sta. Wag.),				
65-70	Pass. (Sta. Wag.),				
72-75	Pass. (Sta. Wag.)	9621559	1	2.85	PAWL ASSY., t/gate switch (manual) . . . . .
64-67	Chevy (Sta. Wag.),				
64-70	Chevelle (Sta. Wag.),				
65-70	Pass. (Sta. Wag.),				
71-72	Chevelle (Sta. Wag.)	4158246	A.R.	.34	PIN, tailgate wind. reg. . . . .
64-70	Sta. Wag. (6-Pass.),				
71-72	Chevelle (Sta. Wag.) (6-Pass.)	5717887	1	.26	PIN, outer handle drive hinge . . . . .
72	Pass. (Sta. Wag.)	9719381	1	.70	PIN, adj. t/gate lk. switch (manual) . . . . .
62-67	Chevy (Sta. Wag.) w/elect. window	4868347	1	1.85	PLATE, electrical contact on gate (ground switch) . . . . .
70-72	Chevelle (Sta. Wag.)	8731353	2	1.95	PLATE, t/gate wire harness protector . . . . .
72-73	Pass. (Sta. Wag.)	9608046	1	3.25	PLATE, plate t/gate lk. rel. (manual) . . . . .
62-67	Chevy (Sta. Wag.) (exc. elect. window)	4846239	1	39.75	REGULATOR ASSY., window . . . . .
64-67	Chevelle (Sta. Wag.) w/elect. window	5717085	1	48.25	REGULATOR ASSY., window . . . . .
64	Chevelle (2-Seat Sta. Wag.)	4456294	1	45.25	REGULATOR ASSY., window . . . . .
65-67	Chevelle (Sta. Wag.)	4489213	1	39.75	REGULATOR ASSY., window . . . . .
65-67	Pass. (Sta. Wag.) (6-Pass.)	4489210	1	39.75	REGULATOR ASSY., window (manual) . . . . .
65-67	Pass. (Sta. Wag.) w/elec. t/gate	9703611	1	44.50	REGULATOR ASSY., window . . . . .
68-70	Sta. Wag. w/elect. t/gate window,				
71-72	Chevelle (Sta. Wag.) w/elect. t/gate window	9718129	1	44.50	REGULATOR ASSY., elect. wind. . . . .
68	Pass., Chevelle (Sta. Wag.) (6-Pass.),				
69-72	Chevelle (Sta. Wag.) (6-Pass.)	8727911	1	36.00	REGULATOR ASSY., manual window . . . . .
69-70	Pass. (Sta. Wag.)	8736259	1	36.00	REGULATOR ASSY., window . . . . .
71-75	Pass. (Sta. Wag.)	9837138	1	30.35	REGULATOR ASSY., window elect. . . . .
62-67	Chevy (Sta. Wag.),				
64-70	Sta. Wag. (6-Pass.),				
71-72	Chevelle (Sta. Wag.) (6-Pass.)	5713278	1	.19	RETAINER, gate window outer handle cyl. . . . .
62-64	Chevy, Chevelle (3-Seat Sta. Wag.),				
69	Sta. Wag. (9-Pass.)	4722455	1	.40	RETAINER, window escn. switch— (10.777)
65-68	Chevy, Chevelle (Sta. Wag.) w/elect. window,				
65-68	Pass. (Sta. Wag.)	5713260	1	.57	RETAINER, window lock cyl. . . . .
71-72	Chevelle (Sta. Wag.)	8741367	1	.45	RETAINER, lk. cyl. switch (Note 1) . . . . .
72-75	Pass. (Sta. Wag.)	9608043	1	.34	RETAINER, t/gate lk. switch . . . . .
74-75	Vega (Panel, Sta. Wag.)	9739253	1	.26	RETAINER, inner upper and side panel . . . . .
	<i>NOTE 1: Also used with elect. wind.</i>				
	Not required in this group. See group 16.353				
65-70	Sta. Wag. (6-Pass.),	4168356	21	.26	RING . . . . .
71-76	Chevelle (Sta. Wag.) (6-Pass.)	5713276	1	.22	RING, handle cylinder case retainer . . . . .
72-75	Pass. (Sta. Wag.)	9608040	1	.76	RING, seal otr. pnl. to lk. rel. . . . .
72-75	Pass. (Sta. Wag.)	9608041	1	.61	RING, seal switch t/gate lk. cyl. . . . .
72	Pass. (Sta. Wag.)	9433303	1	.16	RING, ret. t/gate lk. rel. (manual) . . . . .
73-74	Chevelle (Sta. Wag.) (6-Pass.)	5713276	1	.22	RING, window outer handle cyl. retainer . . . . .
64-72	Chevelle (Sta. Wag.),				
66-67	Chevy (Sta. Wag.),				
65-72	Pass. (Sta. Wag.)	4158245	A.R.	.13	ROLLER, tailgate wind. reg. . . . .
65-68	Chevelle, Chevy (Sta. Wag.),				
65	Pass. (Sta. Wag.)	5096732	A.R.	.46	SCREW, tailgate window regulator motor— (10.783) . . . . .
68-70	Chevelle (Sta. Wag., El Camino),				
71-72	El Camino	7671704	A.R.	.44	SPACER, tailgate hinge to body . . . . .

**METAL TRIM—CLIPS AND PANELS**

**12.195 PANEL— ARMATURE— BEZEL— BOLT— BRACKET— BREAKER ASSY.— BUMPER— CABLE ASSY.— CLIP— CLUTCH— CONDUIT— COVER— CYLINDER ASSY.— DRIVER— ESCUTCHEON— FILLER ASSY.— GASKET— HANDLE— HOUSING— HOLDER— KNOB— MOTOR ASSY.— MOULDING ASSY.— NUT— PACKAGE ASSY.— PAWL ASSY.— PIN— PLATE— REGULATOR ASSY.— RETAINER— RING— ROLLER— SCREW— SPACER— SPRING— STRIP— STOP— SWITCH ASSY.— WASHER, Tailgate (Con't)**

69-70	Pass., Chevelle (Sta. Wag.),				
71-72	Chevelle (Sta. Wag.)	8723090	A.R.	4.75	SPACER, upr. hinge pnt. 25
69-70	Pass., Chevelle (Sta. Wag.),				
71-72	Chevelle (Sta. Wag.)	8723092	A.R.	2.20	SPACER, upr. hinge pnt. 31
69-70	Pass., Chevelle (Sta. Wag.),				
71-72	Chevelle (Sta. Wag.)	8723093	A.R.	1.65	SPACER, t/gate upr. hge. pnt. 22
69-70	Pass., Chevelle (Sta. Wag.),				
71-72	Chevelle (Sta. Wag.)	8723094	A.R.	1.45	SPACER, t/gate upr. hge. pnt. 19
69-70	Pass., Chevelle (Sta. Wag.),				
71-72	Chevelle (Sta. Wag.)	8776037	A.R.	1.15	SPACER, t/gate upr. hge. pnt. 12
70	Pass., Chevelle (Sta. Wag.),				
71-72	Chevelle (Sta. Wag.)	8806279	A.R.	1.90	SPACER, t/gate upper hinge point 16
71-75	Pass. (Sta. Wag.)	9836071	2	.13	SPACER, window guide upper and lower roller to glass left hand
73-75	Pass. (Sta. Wag.)	9836071	2	.13	SPACER, window guide upper and lower roller to glass left hand
74-75	Chevelle (Sta. Wag.)	9694941	2	1.15	SPACER, counter balance
62-67	Chevy (2-Seat Sta. Wag.)	5713270	1	1.10	SPRING, window outer handle plunger
62-67	Chevy (2-Seat Sta. Wag.),				
64-71	Chevelle (2-Seat Sta. Wag.),				
65-66	Pass. (Sta. Wag.) (6-Pass.),				
68-75	Pass. (Sta. Wag.) (6-Pass.)	4303911	1	.19	SPRING, outer handle cyl. pawl
72-75	Pass. (Sta. Wag.)	9608042	1	.83	SPRING, knob return t/gate
71-73	Pass. (Sta. Wag.)	9666605	1	12.10	SPRING ASSY., window lift (repl. 9840386)
69-70	Pass., Chevelle (Sta. Wag.),				
71-72	Chevelle (Sta. Wag.)	8744881	1	.61	STRIP, right inner pnl. at handle
71-73	Pass. (Sta. Wag.)	9838197	1	22.90	STRIP, bumper filler on body
71-73	Pass. (Sta. Wag.)	9600156	1	9.00	STRIP ASSY., t/gate to bumper filler on gate
72-75	Pass. (Sta. Wag.)	9600154	R.H.	1.25	STRIP ASSY., t/gate to body filler on gate
72-75	Pass. (Sta. Wag.)	9600155	L.H.	1.25	STRIP ASSY., t/gate to body filler on gate
71-75	Pass. (Sta. Wag.)	8753026	L.H.	.46	STOP, t/gate window lower
69	Pass. (Sta. Wag.) (9-Pass.),				
69	Pass. (Sta. Wag.) (6-Pass.)				
	w/elect. t/gate wind.	9721538	R.H.	3.40	SWITCH ASSY., upper side— (12.242)
69-70	Pass., Chevelle (Sta. Wag.),				
71	Chevelle (Sta. Wag.) w/elect. t/gate window	3996651	1	8.05	SWITCH ASSY., t/gate window lock cyl.
70-72	Chevelle (Sta. Wag.)	3973644	1	4.00	SWITCH ASSY., t/gate window switch (on instr. pnl.)
73-75	Chevelle w/elect. t/gate,				
71-75	All (Sta. Wag.) w/elect. t/gate window	6270643	1	3.70	SWITCH ASSY.
71	Pass. (Sta. Wag.) (exc. power operated t/gate)	9842553	1	19.10	SWITCH ASSY., t/gate lk. rel. electric window
71-75	Pass. (Sta. Wag.) w/power operated t/gate	9842526	1	19.10	SWITCH ASSY., t/gate lock rel. electric window
65-68	Bel Air, Impala (Sta. Wag.),				
62-63	Chevy (3-Seat Sta. Wag.)	4723098	A.R.	4.70	SWITCH ASSY., window on left qtr.— (10.777)
62-66	Chevy (Sta. Wag.) w/elect. wind.	3814719	1	3.65	SWITCH ASSY., control lift— (14.483)
64	Chevelle (Sta. Wag.)	4823445	1	3.50	SWITCH ASSY., right, window jamb
64-68	Chevelle (Sta. Wag.),				
66-69	Caprice (Sta. Wag.)	4432790	A.R.	5.55	SWITCH ASSY., window (on left qtr.) (includes escutcheon)— (10.777)
64-68	Chevelle (Sta. Wag.),				
65-66	Pass. (Sta. Wag.)	3840095	1	5.10	SWITCH ASSY., window (on instr. pnl.)
65-70	Chevelle (Sta. Wag.) w/electric windows,				
65-68	Pass. (Sta. Wag.)	4493796	1	4.25	SWITCH ASSY., window jamb, left side
67-68	Pass., Chevelle (Sta. Wag.)	3906118	1	2.20	SWITCH ASSY., special (window)
69	Sta. Wag. w/elect. t/gate,				
70	Pass. (Sta. Wag.)	3959230	1	4.15	SWITCH ASSY., t/gate window
73-75	Pass. (Sta. Wag.) w/elect. t/gate window	6258220	1	3.70	SWITCH ASSY. (Note 1)

**METAL TRIM—CLIPS AND PANELS**

**12.195 PANEL— ARMATURE— BEZEL— BOLT— BRACKET— BREAKER ASSY.— BUMPER— CABLE ASSY.— CLIP— CLUTCH— CONDUIT— COVER— CYLINDER ASSY.— DRIVER— ESCUTCHEON— FILLER ASSY.— GASKET— HANDLE— HOUSING— HOLDER— KNOB— MOTOR ASSY.— MOULDING ASSY.— NUT— PACKAGE ASSY.— PAWL ASSY.— PIN— PLATE— REGULATOR ASSY.— RETAINER— RING— ROLLER— SCREW— SPACER— SPRING— STRIP— STOP— SWITCH ASSY.— WASHER, Tailgate (Con't)**

73-75	Pass. (Sta. Wag.)	9608046	1	3.25	SWITCH ASSY., plate lock rel. (manual)
73-75	Chevelle (Sta. Wag.)	9890847	1	.94	SWITCH ASSY., warn. light jamb
<i>NOTE 1: Located on instrument panel.</i>					
71-75	Pass. (Sta. Wag.)	9836070	L.H.	.13	WASHER, right t/gate window guide upper left lower roller to glass
65-70	Sta. Wag. (6-Pass.)				
71-72	Chevelle (Sta. Wag.) (6-Pass.)	5713274	1	.19	WASHER, t/gate outer handle cyl. case

**12.203 SUPPORT ASSEMBLY— CLIP— COVER— GROMMET— NUT— SCREW— SPRING— STUD, End Gate**

62-67	Chevy (Sta. Wag.)				
64-67	Chevelle (Sta. Wag., El Camino)	4434937	L.H.	12.70	
64-67	Chevy (Sta. Wag.)				
64-67	Chevelle (Sta. Wag., El Camino)	4434936	R.H.	12.70	
65-68	Pass. (Sta. Wag.)	4484983	L.H.	13.05	
68	Chevelle (Sta. Wag.)	7732272	2	3.25	tailgate cable type
68-75	El Camino	7732274	2	3.25	tailgate cable type
69-72	Chevelle (Sta. Wag.)	8767060	1	4.15	t/gate cable type
69-70	Pass. (Sta. Wag.)	8767061	1	4.15	t/gate cable type
73-75	Chevelle (Sta. Wag.)	9631824	2	43.75	counter/balance
73-75	Chevelle (Sta. Wag.) w/rear seat assy., rear window defogger	9631823	2	43.75	counter/balance
74-75	Vega (Coupe)				
75	Monza (Hatchback)	9728426	2	.16	CLIP, compt. lid supt. ball ret.
75	Vega (Coupe)	1650239	2	.11	COVER, counter balance support on body
75	Monza (Hatchback)	1660122	2	.11	COVER, counter balance compt. lid supt. on body
73-75	Chevelle (Sta. Wag.)	9661946	2	.58	GROMMET, cross/balance supt.
73-74	Nova (H.B.) Chevelle (Sta. Wag.)	1650725	4	.16	NUT, cross/balance support anchor plate (repl. 9664875)
75	Chevelle (Sta. Wag.)	1650725	A.R.	.16	NUT, counter/balance supt. to anchor plate
64-67	Chevy (Sta. Wag.)				
64-67	Chevelle (Sta. Wag.) (exc. 3-Seat)				
64-67	El Camino				
65-68	Pass. (Sta. Wag.)	4439627	12	.16	SCREW, support (5/16" — 18 x 3/4") w/nylon
74-75	Chevelle (Sta. Wag.)	9433554	2	.16	SCREW, t/gate hge. strap strip
68-70	Chevelle (Sta. Wag., El Camino)				
71-75	El Camino	9890358	R.H.	.46	SPRING, t/gate support assist.
68-70	Chevelle (Sta. Wag., El Camino)				
71-75	El Camino	9890359	L.H.	.46	SPRING, t/gate support assist.
69-70	Pass., Chevelle (Sta. Wag.)				
71-72	Chevelle (Sta. Wag.)	8716171	1	.34	SPRING, support
74-75	Nova (H.B.)				
74-75	Vega (Coupe)	9733629	A.R.	.98	STUD, plate mtg. counter balance support
75	Monza (Hatchback)	9737549	4	.76	STUD, counter balance support 1/4" — 20 thread 1st type
75	Monza (Hatchback)	1715241	4	.76	STUD, counter balance support 3/8" — 16 thread 2nd type

**12.212 BUMPER— STOP— PLUG, Rear Compartment**

62-67	Chevy (exc. Sta. Wag.)				
64-67	Chevelle (Sed., Spt. Mdls.)				
67-69	Camaro				
65-69	Pass. (exc. Sta. Wag.)				
72	Pass. (Sta. Wag.)	4721222	2	.12	on lid
62-66	Chevy (Sta. Wag.)				tailgate supt. on body,
62-67	Chevy (exc. Sta. Wag.)				
64-67	Chevelle (Sed., Spt. Mdls.)				
67-69	Camaro				
65-69	Pass. (exc. Sta. Wag.)				
72	Pass. (Sta. Wag.)	4721222	2	.12	on lid
62-66	Chevy (Sta. Wag.)				tailgate supt. on body,
64-68	Chevelle (Sta. Wag., El Camino)				
65-67	Pass. (Sta. Wag.)	4730767	A.R.	.27	tailgate supt. on body and on gate
64-67	Chevelle (exc. Sta. Wag., El Camino)				lid on lid,
67-69	Camaro				

**METAL TRIM—CLIPS AND PANELS**

**12.212 BUMPER— STOP— PLUG, Rear Compartment (Con't)**

70-73	Chevelle (exc. Sta. Wag.),				
71-73	El Camino	4595786 A.R.	.18	on bumper	
65-70	Pass. (Sta. Wag.) (6-Pass.)			front and rear luggage compt.,	
68	Pass. (Sta. Wag.)	4687558 A.R.	.16	front and rear panel	
67	Pass. (Sta. Wag.)			on lid,	
68	Chevelle (exc. 6-Pass., Sta. Wag., El Camino),				
69	Pass., Chevy (exc. Sta. Wag.),				
70	All (exc. Sta. Wag., El Camino),				
71-72	Chevelle (Sta. Wag.),				
71-75	Pass. (exc. Sta. Wag.),				
71-72	Camaro,				
71-74	Vega,				
71-75	Nova,				
73-75	Chevelle (exc. Monte Carlo, Sta. Wag.),				
75	Monza (Hatchback)	4767559 A.R.	.21	on lid (emergency use)	
65-67	Nova (Sta. Wag.),				
65-69	Chevelle (Sta. Wag.),				
65-68	Pass. (Sta. Wag.),				
68-70	El Camino	7740806	2	tail gate lock striker	
65-69	Chevelle (Sta. Wag.),				
65-68	Pass. (Sta. Wag.),				
68-70	El Camino	7747339 A.R.	.24	tail gate lock striker (emergency)	
68-70	Chevelle (exc. Sta. Wag., El Camino),				
70	Chevy,				
71-74	All (exc. Sta. Wag., El Camino),				
71-75	Vega (Panel, Sta. Wag.),				
75	Monza (Hatchback),				
75	Nova	7724826 A.R.	.24	rear compt. lid (on lid)	
69	Pass., Chevelle (Sta. Wag.)	8785295	1	tailgate window	
70	Nova, Camaro,				
70	Chevelle (exc. Sta. Wag.),				
70	Bel Air, Impala, Caprice			compt. lid and lid side,	
71-74	All (exc. Sta. Wag., El Camino),				
74	Vega (Sedan, Coupe),				
75	Camaro, Nova,				
75	Monza (Hatchback)	4872948 A.R.	.12	lid and lid side (emergency use)	
73	Chevelle (Sta. Wag.)			lid,	
75	Pass. (exc. Sta. Wag.)	4721222	2	lid/lid side (emergency use)	
73-74	Chevelle (Sta. Wag.)	9657583	2	t/gate upper cor.	
73	El Camino	9672068	2	t/gate inner panel/at lock striker	
74	Vega (Panel, Sta. Wag.)	9727609	2	back door body side	
75	Nova (H.B.)	1655363	2	lug. compt. pnl. on supt.	
	Not required in this group. See group 10.587	4652531			
71-72	Pass. (Sta. Wag.) w/Power Tailgate	9874442	1	.28 STOP, t/gate upper stud at belt	
72-75	Pass. (Sta. Wag.) w/pwr. t/gate	9617249	1	.31 STOP, t/gate upr.	
72-75	Pass. (Sta. Wag.)	8753026 L.H.	.46	STOP, t/gate window lower	
73-75	Pass. (Sta. Wag.)	4805844	1	.22 PLUG, compt. pan, rear drain hole	
	Not required in this group. See group 10.587	4652531			
	Not required in this group. See group 12.242	7740806			
	Not required in this group. See group 12.242	7747339			
	Not required in this group. See group 12.195	8785295			

**12.237 STRIKER— PLATE— SCREW— SPACER, Rear Compartment Lid Lock**

62-65	Chevy (exc. Sta. Wag.)	4842159	1	2.75	
64-70	Chevy, Chevelle (exc. Sta. Wag., El Camino),				
65-70	Pass. (exc. Sta. Wag.)	7771161	1	2.90	
67-69	Camaro	7712075	1	3.35	
70	Camaro,				
71-73	All (exc. El Camino, Sta. Wag., Vega),				
74	Chevelle, Nova, Camaro,				
75	Chevelle, Camaro (exc. S.W.)	9672724	1	1.70	STRIKER, lid lock
71-73	Vega (Sedan, Cpe.)	9820665	1	1.70	rear compt. lid lock
74-75	Vega (Sedan, Cpe.), Monza (Hatchback)	9659575	1	1.70	compt. lid lock

**METAL TRIM—CLIPS AND PANELS**

**12.237 STRIKER— PLATE— SCREW— SPACER, Rear Compartment Lid Lock  
(Con't)**

71-75	Vega (Panel, Sta. Wag.)	9665914	1	1.30	back door lock
72	Pass. (exc. Sta. Wag.)	9843569	1	8.15	PLATE, anchor
67-68	Camaro	7759500	1	4.90	PLATE, striker anchor
68-72	Chevelle (exc. Sta. Wag., El Camino)				
		9844996	1	3.50	PLATE, striker anchor
68-72	Chevy	9844997	1	4.80	PLATE, striker anchor
69-70	Pass. (exc. Sta. Wag.)	7749834	1	2.90	PLATE, striker anchor
69	Camaro	7779490	1	5.50	PLATE, striker anchor
70-73	Camaro (exc. Custom)	8763459	1	3.45	PLATE, anchor body side
71	Pass. (exc. Sta. Wag.)	8794362	1	7.05	PLATE, striker anchor
71-73	Vega (Sed., Cpe.)	9831620	1	3.35	PLATE, compt. lid lk. anchor body side
73-74	Chevelle (exc. Sta. Wag.)	9611010	1	4.20	PLATE, striker anchor
73	Monte Carlo	9611011	1	4.20	PLATE, anchor compt. lid lock
74-75	Vega (Sedan, Cpe.)	9641649	1	3.35	PLATE, compt. lid lock anchor striker
74	Monte Carlo	1678375	1	4.20	PLATE, lid lock striker
74	Chevelle (exc. Sta. Wag., Monte Carlo)				
		9641989	1	4.20	PLATE, lid lock striker
74-75	Camaro	9646539	1	3.45	PLATE, lid lock striker
74-75	Pass. (exc. Sta. Wag.)	9666202	1	6.05	PLATE, anchor, lid lock striker
73-74	Nova	9730097	1	4.80	PLATE, anchor compt. lid lock striker
75	Chevelle (4-Dr.), Laguna	1678374	1	4.20	PLATE, anchor compt. lid lock striker
75	Monte Carlo	1678375	1	4.20	PLATE, anchor compt. lid lock striker
75	Nova	9676120	1	4.80	PLATE, anc. compt. lid lk. stkr.
75	Chevelle (Sta. Wag.)	7721972	1	.93	PLATE, t/gate lk. stkr. anc.
75	Monza (Notchback)	1672800	1	9.30	PLATE, compt. lid lock anchor
64-70	Chevy (exc. Sta. Wag.),				
64-70	Chevelle (Sed., Spt. Mdls.),				
67-70	Camaro,				
71-72	All (exc. El Camino, Sta. Wag.)	4406866 A.R.		.12	SCREW, motor compt. lid hinge to mfct. lid lock striker and lid hinge to body
71	Malibu (Conv.)	4537580 A.R.		.12	SPACER, lid wedge plate (emergency)
	Not required in this group. See group 16.335				
		3778601 A.R.		.22	SPACER
73	Nova (H.B.)	9727119	2	.07	SPACER, compt. lid (used as wedge)

**12.237A STRIKER— PLATE— BUMPER— SPACER— SCREW— NUT— WASHER— SUPPORT ASSY.— GUIDE, End Gate Lock**

62-69	Chevy, Chevelle (Sta. Wag., El Camino),				
65-68	Pass. (Sta. Wag.),				
70-72	El Camino	7741698 R.H.		3.55	tail gate lock
62-69	Chevy, Chevelle (Sta. Wag., El Camino),				
65-68	Pass. (Sta. Wag.),				
70-72	El Camino	7741699 L.H.		3.55	tail gate lock
69-70	Pass., Chevelle (Sta. Wag.),				
71-72	Chevelle (Sta. Wag.)	9813034	1	1.70	right upper
71-75	Pass. (Sta. Wag.)	9607290 R.H.		1.60	
73-75	Chevelle (Sta. Wag.)	9878743	1	1.70	STRIKER ASSY.
73-75	El Camino	9618050 R.H.		3.55	STRIKER ASSY.
73-75	El Camino	9618051 L.H.		3.55	STRIKER ASSY.
65-66	Pass. (Sta. Wag.)	4649281 A.R.		.12	PLATE, adjusting upper-tail gate— (10.571)
62-68	Chevy, Chevelle (Sta. Wag., El Camino),				
65-68	Pass. (Sta. Wag.)	4649282	2	.12	PLATE, lock striker adjusting lower— (10.571)
62-67	Chevy, Chevelle (Sta. Wag., El Camino),				
68	Chevelle (Sta. Wag., El Camino),				
65-69	Pass. (Sta. Wag.)	4849938 A.R.		.12	PLATE, adjusting upper— tail gate— (10.571)
69-70	Pass. (Sta. Wag.),				
71	Chevelle (Sta. Wag.)	4469685	3	1.05	PLATE, lock striker anchor— (10.571)
74	Chevelle (Sta. Wag.)	7721972	1	.93	PLATE, t/gate lock striker anchor
69-70	Pass. (Sta. Wag.)	8734092	1	7.95	PLATE ASSY., right lower gate lock anchor
70-71	Chevelle (Sta. Wag.)	9815883	1	8.35	PLATE ASSY., lower lock anchor
72	Chevelle (Sta. Wag.)	9609515 R.H.		8.35	PLATE ASSY., lower anchor
62-67	Nova (Sta. Wag.)	7747339	2	.24	BUMPER, striker— (12.212)
65-68	Pass. (Sta. Wag.)	4762474	1	3.35	BUMPER, wedge plate
65	Pass. (Sta. Wag.)	3778601 A.R.		.22	SPACER, center lock striker adjuster (2 <sup>3</sup> / <sub>64</sub> " x 2 <sup>1</sup> / <sub>32</sub> ") (Note 1)

*NOTE 1 This part is shown in both the end Gate Lock and Lid Compartment Lock Sub. groups.*

62-69 Chevy, Chevelle (Sta. Wag., El Camino),

**METAL TRIM—CLIPS AND PANELS**

**12.237A STRIKER— PLATE— BUMPER— SPACER— SCREW— NUT— WASHER—  
SUPPORT ASSY.— GUIDE, End Gate Lock (Con't)**

65-68	Pass. (Sta. Wag.)				
70-72	El Camino	4800021	A.R.	.24	SPACER, lock striker (emergency side)
70-72	Chevelle (Sta. Wag.)	9815850	1	2.35	SPACER, right lower lock
71-75	Vega (Panel, Sta. Wag.)	9825776	1	.61	SPACER, door lock striker emerg.
73-75	El Camino	9890301	1	.22	SPACER, striker
69-70	Pass. (Sta. Wag.)				
71-72	Chevelle (Sta. Wag.)	8741222	4	.22	SCREW, right, t/gate lk. stkr. lower side supt.
69	Pass. (Sta. Wag.)	9718487	1	.24	SCREW, t/gate lock rem. cont. assy.
71	Pass. (Sta. Wag.)	9420695	1	.07	SCREW, lock (1/4"— 14 x 1/2") (use w/9888920 guide)
71	Pass. (Sta. Wag.)	9815884	1	.06	SCREW, guide lock (1/4"— 20 x 7/8") (use w/9888920 guide)
71-75	Pass. (Sta. Wag.)	9849429	1	1.25	NUT, t/gate lock striker to panel
69-70	Pass., Chevelle (Sta. Wag.)				
71-72	Chevelle (Sta. Wag.)	8737249	1	.46	NUT, right, stkr. to mtg. plate
65-70	Sta. Wag.,				
71-72	Chevelle (Sta. Wag.)	4469196	A.R.	.12	WASHER, lock striker point (1/16" thk.)— (10.571) (repl. 4469194, 4469195)
65-70	Sta. Wag.,				
71	Chevelle (Sta. Wag.)	4469197	A.R.	.21	WASHER, lock striker point (5/32" thk.)— (10.571)
69-70	Pass. (Sta. Wag.)	8761738	1	17.75	SUPPORT ASSY., lower lock striker
69-72	Chevelle (Sta. Wag.)	8731954	R.H.	14.45	SUPPORT ASSY., lower stkr.
71-75	Pass. (Sta. Wag.)	9888920	1	1.90	GUIDE, lock striker lower

**12.240 MOULDING, Console**

68-70	Malibu, S.S. (2-Dr., El Camino) w/console,				
71-72	Chevelle (2-Dr.) (exc. Deluxe)	3922813	2	1.30	frt. sep. compt.

**12.242 LOCK ASSY.— SCREW, Rear Compartment Lid**

62-70	All (exc. Sta. Wag.),				
71-72	Nova, Chevelle (exc. Sta. Wag., El Camino)	4753019	1	8.00	
70	Pass. (Sta. Wag.)	1230695	1	22.60	lid release (electric short)
70	Monte Carlo,				
70	Pass. w/electric lid release,				
71-72	Monte Carlo w/elect. lid release	7660686	1	17.35	(for model built before 6-1-71)
70	Camaro	9808480	1	5.10	
71-72	Pass., Camaro (exc. Sta. Wag.),				
73	All (exc. Sta. Wag., Vega),				
74	All (exc. Pass., Sta. Wag., Vega),				
71-75	Vega (Sedan, Coupe) Monza (Notchback)	9849686	1	8.45	
71-73	Vega (Panel, Sta. Wag.)	9814145	1	8.45	back door
74-75	Vega (Panel, Sta. Wag.)	9665285	1	8.45	back door
75	Chevelle, Camaro (exc. Sta. Wag.)	9849686	1	8.45	
74-75	Pass. (exc. Sta. Wag.),				
75	Nova	9672342	1	7.55	compt. lid
	Not required in this group. See Group (10.506)	4239231			
	Not required in this group. See group 16.350	4577250		.11	SCREW
69	Pass. (Sta. Wag.)	9718487	1	.24	SCREW, remote control assy. (L.H. thread)
64-68	Chevelle (Sed., Spt. Mdls.),				
65-68	Chevy (exc. Sta. Wag.)				SCREW, lid hinge to body,
65-69	Pass. (exc. Sta. Wag.)	4406866	A.R.	.12	striker and lock to rnct.— (12.237)

**12.242A LOCK— LATCH ASSY.— HANDLE— ROD— CONTROL— SPRING—  
SCREW— CLIP— COVER— PLUG— SWITCH ASSY.— RIVET— BUMPER—  
ESCUTCHEON— RETAINER, End Gate Rear Door**

62-67	Chevelle, Chevy (Sta. Wag., El Camino),				
68	Pass. (Sta. Wag.)	4480359	L.H.	8.35	
62-67	Chevelle, Chevy (Sta. Wag., El Camino),				
65-67	Pass. (Sta. Wag.)	4480358	R.H.	8.35	tail gate
68-70	Chevelle (Sta. Wag., El Camino),				
68	Pass. (Sta. Wag.),				
71-72	El Camino	7733777	R.H.	8.50	tail gate
68-70	Chevelle (Sta. Wag., El Camino),				
68	Pass. (Sta. Wag.),				



**METAL TRIM—CLIPS AND PANELS**

**12.242A LOCK— LATCH ASSY.— HANDLE— ROD— CONTROL— SPRING—  
SCREW— CLIP— COVER— PLUG— SWITCH ASSY.— RIVET— BUMPER—  
ESCUTCHEON— RETAINER, End Gate Rear Door (Con't)**

71-72	El Camino	7733778	L.H.	8.50	tail gate
69-70	Pass., Chevelle (Sta. Wag.)				
71-72	Chevelle (Sta. Wag.) (6-Pass.)	8742335	R.H.	29.00	upper side (manual)
69-70	Pass. (Sta. Wag.)	8742317	L.H.	30.50	w/hinge upper gate side
69-70	Pass.	8742338	R.H.	26.75	lower side
69-70	Pass., Chevelle (Sta. Wag.) w/elect. t/gate wind.,				
71-72	Chevelle (Sta. Wag.) w/elect. t/gate window	8804715	R.H.	33.75	upper side
69-72	Chevelle (Sta. Wag.)	8742333	L.H.	31.25	w/hinge upr. side gate
69-72	Chevelle (Sta. Wag.)	8742337	R.H.	26.75	lwr. side
71	Pass. (Sta. Wag.)	9833002	R.H.	15.90	side
72-73	Pass. (Sta. Wag.)	9610583	R.H.	19.00	side
73	Pass. (Sta. Wag.)	6272120	1	3.65	(electric) (coded) (B&S 605308 & 604798)
73-75	Chevelle (Sta. Wag.)	9621414	1	19.00	
73-75	El Camino	9888000	2	2.20	<b>LATCH ASSY.</b>
64-68	Chevelle (Sta. Wag., El Camino),				
70-72	El Camino	4411638	1	1.55	<b>HANDLE, remote control</b>
71-75	Pass. (Sta. Wag.)	9868310	1	9.90	<b>HANDLE, t/gate outer panel grip</b>
65-70	Pass. (Sta. Wag.),				
73-75	El Camino	9878951	1	7.25	<b>HANDLE, remote control</b>
73-75	Chevelle (Sta. Wag.)	9878651	1	14.90	<b>HANDLE, t/gate outer panel</b>
70-72	Chevelle (Sta. Wag.)	4495180	1	8.75	<b>HANDLE ASSY., tail gate lock remote control</b>
69-70	Pass. (Sta. Wag.)	8736691	1	14.90	<b>HANDLE ASSY., inside and side R.H.</b>
70-72	Chevelle (Sta. Wag.)	8736690	1	15.35	<b>HANDLE ASSY., t/gate inside and side R.H.</b>
73	Chevelle (Sta. Wag.) (exc. Laguna),				
73-75	Chevelle (Sta. Wag.)	9653259	1	5.10	<b>HANDLE ASSY., t/gate inside pull (comb.) (black) (paint as reqd.)</b>
68-72	El Camino	7725971	R.H.	.37	<b>ROD, tailgate remote cont. to lock</b>
68-72	El Camino	7726253	L.H.	.34	<b>ROD, tailgate remote cont. to lock</b>
69-72	Chevelle (Sta. Wag.)	8742344	1	2.15	<b>ROD, upr. to lwr. lk. conn.</b>
69-72	Chevelle (Sta. Wag.)	8742340	1	1.70	<b>ROD, rem. cont. hdl.</b>
69-72	Chevelle (Sta. Wag.)	8742342	1	4.25	<b>ROD, w/guide lock blackout</b>
69-70	Pass. (Sta. Wag.)	8742343	1	2.40	<b>ROD, upper to lower lock conn.</b>
69-70	Pass. (Sta. Wag.)	8742341	1	3.85	<b>ROD, w/guide lock blackout</b>
69-70	Pass. (Sta. Wag.)	8742339	1	1.65	<b>ROD, lock remote control handle</b>
69-70	Pass. (Sta. Wag.)	8732949	L.H.	2.95	<b>ROD, remote control</b>
69-70	Pass. (Sta. Wag.)	8732950	R.H.	1.25	<b>ROD, remote control</b>
69-72	Chevelle (Sta. Wag.)	8732913	R.H.	2.30	<b>ROD, t/gate lock rem. cont. to lock</b>
69-72	Chevelle (Sta. Wag.)	8732914	L.H.	2.65	<b>ROD, t/gate lock rem. cont. to lock</b>
73-75	El Camino	9877525	2	.38	<b>ROD, remote control to lock</b>
74-75	Vega (Panel, Sta. Wag.)	9665537	1	.36	<b>ROD, remote control b/d lk to lk</b>
69-70	(Sta. Wag.),				
71-72	Chevelle (Sta. Wag.)	8731348	1	9.90	<b>CONTROL ASSY., tail gate lock remote</b>
68-72	El Camino	7741883	1	5.90	<b>CONTROL ASSY., remote</b>
73-75	El Camino	9878307	1	9.70	<b>CONTROL ASSY., lock remote</b>
68	Pass. (Sta. Wag.),				
68-70	Chevelle (Sta. Wag., El Camino),				
71-72	El Camino	9714952	R.H.	.32	<b>SPRING, tail gate lock hook lever</b>
68	Pass. (Sta. Wag.),				
68-70	Chevelle (Sta. Wag., El Camino),				
71-72	El Camino	9714953	L.H.	.32	<b>SPRING, tail gate lock hook lever</b>
68-72	El Camino	9714956	1	1.10	<b>SPRING, remote control</b>
64-70	Chevelle (Sta. Wag., El Camino),				
71-72	El Camino	4422699	1	.11	<b>SCREW, remote control (8— 32 x 1/2" w/nylon washer)</b>
69-70	Pass., Chevelle (Sta. Wag.),				
71-72	Chevelle (Sta. Wag.)	9718487	1	.24	<b>SCREW, t/gate lock rem. cont. assy.</b>
69	Pass. (Sta. Wag.)	8782501	2	.16	<b>SCREW, right inside hole to inner panel (repl. 8736417)</b>
70	Pass., Chevelle,				
71-72	Chevelle (Sta. Wag.)	8782501	R.H.	.16	<b>SCREW, inside hole to inner panel, t/gate lock rem. cont. handle</b>
71	Pass. (Sta. Wag.)	4406866	A.R.	.12	<b>SCREW (1/4"— 20 x 3/4")— (12.237)</b>
64-68	Chevelle (Sta. Wag., El Camino),				
65-67	Pass. (Sta. Wag.)	4234830	6	.11	<b>CLIP, remote control spring— (10.474)</b>
64-67	Chevy, Chevelle (Sta. Wag., El Camino),				
65-68	Pass. (Sta. Wag.),				
69-72	El Camino	4455192	2	.11	<b>CLIP, remote control to lock rod</b>
65-68	Chevelle (Sta. Wag., El Camino)	4711608	A.R.	.16	<b>CLIP, remote control to panel— (10.565)</b>

**METAL TRIM—CLIPS AND PANELS**

**12.242A LOCK— LATCH ASSY.— HANDLE— ROD— CONTROL— SPRING—  
SCREW— CLIP— COVER— PLUG— SWITCH ASSY.— RIVET— BUMPER—  
ESCUTCHEON— RETAINER, End Gate Rear Door (Con't)**

65-68	Pass. (Sta. Wag.)	4304714	1	.37	CLIP, tail gate lock remote control
68	Chevelle (Sta. Wag.) (exc. Concours),				
68	El Camino	4755827	2	.05	CLIP, remote control to lock rod— (10.565)
69	Pass. (Sta. Wag.)	5712678	1	.21	CLIP, remote control— (10.474)
71	Pass. (Sta. Wag.)	9845059	R.H.	.32	CLIP, t/gate lock (electric)
72-75	Pass. (Sta. Wag.)	9610585	R.H.	.22	CLIP, t/gate elec.
69-70	Pass. (Sta. Wag.)	9721470	R.H.	1.40	CABLE ASSY., inside handle
69-72	Chevelle (Sta. Wag.)	9721471	R.H.	1.45	CABLE ASSY., hdl.
69-70	Pass. (Sta. Wag.)	8732954	R.H.	2.35	COVER, lower lock
69-70	Pass., Chevelle (Sta. Wag.),				
71-72	Chevelle (Sta. Wag.)	8767726	1	.70	COVER, upr. hge. lk.
69-75	Chevelle (Sta. Wag.)	8732951	R.H.	2.95	COVER, lwr. lk.
71-75	Pass. (Sta. Wag.)	9677147	L.H.	5.70	COVER, linkage
71-75	Pass. (Sta. Wag.)	9638438	1	5.70	COVER, t/gate hinge torq. rod
71-72	Pass. (Sta. Wag.) (6-Pass.)	9867800	1	1.80	COVER, t/gate inner panel at handle
73-74	Chevelle (Sta. Wag.)	9610175	1	1.80	COVER, lock
75	Monza (Hatchback)	1702501	1	.43	COVER, compt. lid lock striker (paint)
69-70	Pass., Chevelle (Sta. Wag.),				
71-72	Chevelle (Sta. Wag.)	8741423	1	.18	PLUG, upper lock
69-70	Pass., Chevelle (Sta. Wag.),				
71-72	Chevelle (Sta. Wag.)	8743753	1	.18	PLUG, lower lock
69	Sta. Wag. w/elect. t/gate wido. (1st design)	9721538	R.H.	3.40	SWITCH ASSY., upper side (mounted on outboard side)
69-70	Sta. Wag. w/elect. t/gate wido. (2nd design),				
71	Chevelle (Sta. Wag.) w/elect. t/gate window	9722797	R.H.	3.65	SWITCH ASSY., upper side electric lock (mounted on inboard side)
69-70	Pass., Chevelle (Sta. Wag.),				
71-72	Chevelle (Sta. Wag.)	9718488	R.H.	.16	RIVET, inside handle cable
69-70	Sta. Wag.,				
71-72	Chevelle (Sta. Wag.)	9718489	R.H.	.12	BUMPER, inside handle cable
68-72	El Camino	7740806	2	.22	BUMPER, lock striker— (12.212)
68-71	El Camino	7747339	A.R.	.24	BUMPER, lock striker emergency— (12.212)
64-69	Chevelle (Sta. Wag., El Camino),				
70-72	El Camino	4409003	1	.24	ESCUTCHEON, remote control handle
72-74	Pass. (Sta. Wag.) w/t/gate power operated	9610100		.22	RETAINER, t/gate lock & SWITCH (elec.)
72-74	Pass. (Sta. Wag.) w/t/gate power operated	9610130		.22	RETAINER, t/gate lock regulator switch (manual)

**12.243 CYLINDER ASSY.— COUPLING ASSY.— CONTROL ASSY.— GASKET—  
HARNESS ASSY.— SOLENOID ASSY.— RELEASE UNIT— LOCK ASSY.—  
SWITCH ASSY.— WIRE ASSY., Rear Compartment Lid Opener**

63-68	Chevy, Chevelle,				
65-68	Pass. (exc. Sta. Wag.)	3825538	1	9.95	vacuum release
63-67	Chevy, Chevelle,				
65-68	Pass.,				
68	Chevy, Camaro, Chevelle	3775637	1	2.85	COUPLING ASSY., vacuum release cyl.
63-67	Chevy, Chevelle,				
65-69	Pass.,				
68	Chevy, Camaro, Chevelle	3868724	1	8.95	CONTROL ASSY., vacuum
68	Pass. (exc. Sta. Wag., Impala Std. Spt. Cpe.)	7734970	2	.27	GASKET, rr. qtr. ext. at tail lamp
71-72	Pass. w/elect. lid release (exc. Sta. Wag.),				
73	Pass., Chevelle, Nova, Camaro (exc. Monte Carlo),				
74	Chevelle, Nova, Camaro	9866538	1	4.90	HARNESS ASSY.
71-72	Pass. w/elect. lid release (exc. Sta. Wag.),				
73	Pass., Chevelle, Nova, Camaro (exc. Monte Carlo),				
74-75	Chevelle, Nova, Camaro	9808558	1	14.75	SOLENOID ASSY., lid lock
74-75	Pass. (exc. Sta. Wag.),				
75	Nova	1653752	1	14.75	SOLENOID ASSY., lid lock
73-75	Chevelle (Sta. Wag.) w/elect. liftgate lock release	9879393	1	14.75	SOLENOID, t/gate release

**METAL TRIM—CLIPS AND PANELS**

**12.243 CYLINDER ASSY.— COUPLING ASSY.— CONTROL ASSY.— GASKET—  
HARNES ASSY.— SOLENOID ASSY.— RELEASE UNIT— LOCK ASSY.—  
SWITCH ASSY.— WIRE ASSY., Rear Compartment Lid Opener (Con't)**

69	Impala, Caprice w/vacuum control	7722159	1	14.65	RELEASE UNIT, vacuum
71-74	Nova,				
71-75	Chevelle (exc. Sta. Wag., Monte Carlo)				
72-73	Pass. (exc. Sta. Wag.),				
73-75	Camaro	994763	1	17.40	RELEASE UNIT (electric)
75	Pass. w/bumper guards (exc. Sta. Wag.),				
75	Nova (exc. H.B.)	994762	1	17.40	RELEASE UNIT, electric trunk lid
70	Monte Carlo,				
70	Pass. (exc. Sta. Wag.),				
71	Pass., Chevelle, Nova (exc. Sta. Wag.)	1230695	1	22.60	LOCK ASSY., rear compt. lid release electric short 1-2
70-71	Monte Carlo,				
70-71	Pass. (exc. Sta. Wag.)	478282	1	1.60	SWITCH ASSY., rear lid release (electric)
73	Pass., Chevelle, Nova, Camaro (exc. Monte Carlo),				
74-75	Chevelle, Nova, Pass., Camaro,				
70-72	Monte Carlo,				
70	Pass. (exc. Sta. Wag.)	1230697	1	15.45	WIRE ASSY., lock release
71-72	Nova, Chevelle (exc. Sta. Wag., Monte Carlo)	3990888	1	2.10	WIRE ASSY., lid lock release

**12.246 NUT, Rear Compartment Emblem**

65-69	Pass.	9427101	A.R.	.16	w/sealer (hex. No. 10— 24)— (8.921)
-------	-------	---------	------	-----	-------------------------------------

**12.247 GASKET, Rear Compartment Lid Lock**

62-65	Chevy, Chevelle (exc. Sta. Wag.),				
65-66	Pass. (exc. Sta. Wag.),				
66-67	Chevy (exc. Sta. Wag.)	4848783	1	.15	
68-70	Pass. (exc. Sta. Wag.)	7734766	1	.15	cylinder retainer
68-71	Chevy,				
68-72	Chevelle (exc. Sta. Wag., El Camino),				
72	Pass. (Sta. Wag.) t/gate power operated	9629864	1	.12	GASKET, lock & rel. switch escut.
73	Nova	7746680	1	.15	
73	Nova,				
73	Monte Carlo	9880567	1	.15	cylinder
73-75	Chevelle (Sta. Wag.)	9613578	2	.12	GASKET, handle t/gate outer panel
74	Nova	7746680	1	.15	lock cylinder retainer
74-75	Chevelle (exc. Sta. Wag.)	9869467	1	.22	lock cylinder retainer (repl. 9686041)
74-75	Pass. (exc. Sta. Wag.)	9831544	1	.15	lock cylinder
74	Pass. (exc. Sta. Wag.)	9869467	1	.22	lock cylinder retainer
73-74	Chevelle (Sta. Wag.)				cylinder, tailgate lock handle,
75	Chevelle, Nova (exc. Sta. Wag.)	4471426	1	.14	lock cylinder
75	Camaro	9869618	1	.28	to pnl.

**12.247A ESCUTCHEON ASSY.— CLIP— GASKET, End Gate Lock Handle**

65-67	Pass. (Sta. Wag.) (6-Pass.)	9703347	1	9.30	window reg. outer handle
64-70	Sta. Wag. (6-Pass.),				
71-72	Chevelle (Sta. Wag.) (6-Pass.)	5716615	2	.64	CLIP, outer reg. handle knob
72	Pass. (Sta. Wag.)	6278529	1	.15	GASKET, lug. compt. lock cylinder

**12.248 CYLINDER— LOCK ASSY., Rear Compartment or Tail Gate Lock**

64-66	Chevelle (Sta. Wag.),				
65-66	Pass. (Sta. Wag.) (6-Pass.) (exc. electric tailgate window)	338285	1	3.40	tailgate (uncoded) (repl. 3794445)
67	Pass., Chevy (exc. Sta. Wag.),				
71	Chevelle, Nova (exc. El Camino, Sta. Wag.)	3910570	1	2.65	rear compt. (uncoded)
67	Chevy (Sta. Wag.)	3910569		1.25	
72	Pass. (Sta. Wag.)	328758	1	7.95	CYLINDER ASSY., t/gate (univ.)
73	Pass. (Sta. Wag.)	328758	1	7.95	CYLINDER ASSY. (manual) (univ.) tailgate (B&S605567)
74-75	Pass. (Sta. Wag.)	345181	1	7.60	CYLINDER ASSY., t/gate (B&S 606493)
74-75	Pass. (Sta. Wag.)	345182	1	3.80	CYLINDER ASSY., t/gate (electric) (B&S 606494)
75	Camaro	483871	1	3.25	CYLINDER ASSY. (uncoded) (B&S 605102)
68	Camaro	3931616	1	2.35	CYLINDER UNIT, rear compt. lock (uncoded)

**METAL TRIM—CLIPS AND PANELS**

**12.248 CYLINDER— LOCK ASSY., Rear Compartment or Tail Gate Lock (Con't)**

67	Camaro,					
68	All (exc. Sta. Wag., Camaro),					
71-72	Pass., Chevelle,					
71-72	Vega (Sedan, Coupe),					
72	Monte Carlo, Nova	3931615	1	3.80	CYLINDER UNIT, rear compt. lid (uncoded) (B&S 590492)	
69	Camaro	3961304	1	2.25	CYLINDER UNIT, rear compt. lock (uncoded)	
69	All (exc. Sta. Wag., Camaro),					
73	Pass. (exc. Sta. Wag., Conv.),					
73	Chevelle (Spt. Cpe.) (exc. Monte Carlo),					
73	Nova (exc. H.B.)	3961303	1	2.25	CYLINDER UNIT, compartment lock uncoded	
70	All (exc. Sta. Wag., Camaro, Vega),					
74	Chevelle,					
74	Pass., Nova (exc. Sta. Wag., H.B.)	3981844	1	2.00	CYLINDER UNIT, rear compt.	
71-73	Camaro	3996652	1	4.00	CYLINDER UNIT, rear compt. lock less shaft and spring (coded)	
73-74	Nova (H.B.),					
73-75	Vega (Sedan, Coupe) Monza (Hatchback),					
75	Chevelle (Sta. Wag.)	3990959	1	3.80	CYLINDER UNIT (coded) (B&S 590608) t/gate	
73	Monte Carlo	6259508	1	4.60	CYLINDER UNIT (coded) (B&S 590718)	
75	Pass., Chevelle, Nova (exc. Sta. Wag.)	3910570	1	2.65	CYLINDER UNIT (uncoded) (B&S 603611) (Note 1)	
74	Camaro	482552	1	2.40	CYLINDER UNIT (B&S 604834)	
	<i>NOTE 1: Discard cyl. case when using on theft deterrent models.</i>					
	<i>NOTE 3 Includes cyl. assy.-rear compt. lk. (uncoded), case cap. Shutter assy. and spring.</i>					
62-72	All (Sta. Wag.) (exc. Vega)	338285	1	3.40	LOCK ASSY. (coded) t/gate	
71	Vega (Panel, Sta. Wag.)	9632726	1	3.40	LOCK ASSY. (coded) less cam (B&S 590507) (repl. 3990960)	
69-70	Pass., Chevelle (Sta. Wag.) w/elect. t/gate window,					
71-72	Chevelle (Sta. Wag.) w/elect. t/gate window	3996651	1	8.05	LOCK ASSY., t/gate electric (coded)	
70	Camaro	3996652	1	4.00	LOCK ASSY. (coded)	
71-72	Pass. (Sta. Wag.)	6272120	1	3.65	LOCK ASSY., t/gate electric (coded)	
75	Monza (Hatchback)	9632736	1	4.20	LOCK ASSY. (coded) (B&S 590975)	
62-66	All (Sta. Wag.),					
67-68	Nova, Chevelle (Sta. Wag.),					
67-68	Pass. (Sta. Wag.) (9 pass.)	6259467	1	8.15	LOCK UNIT, t/gate elec. (coded)	

**12.249 SPRING— ESCUTCHEON ASSY.— TUMBLER UNIT— RETAINER—  
GASKET— GUARD— HOUSING— RIVET— PAWL— PLATE, Rear  
Compartment Lid Lock Cylinder**

62	Chevy (exc. Sta. Wag.),				
67-70	Pass., Chevelle (exc. Sta. Wag.),				
71-72	All (exc. Sta. Wag., Vega),				
71	Vega (Sedan, Coupe),				
72-75	Vega, Monza	7001087	1	.35	cylinder
62-66	Chevy, Chevelle,				
65-70	Pass., Chevy, Chevelle	3901067 A.R.		1.30	SPRING UNIT (10.553)
65-67	Pass., Chevelle	5717432	1	10.30	ESCUTCHEON ASSY., t/gate win lock cylinder
70-73	Camaro	9659628	1	5.20	ESCUTCHEON ASSY., lid lock
72-75	Pass. (Sta. Wag.) t/gate power operated	9610128	1	1.90	ESCUTCHEON, t/gate lock & rel. switch
65-67	Pass.,				
67-68	Chevy, Chevelle	3901061 A.R.		3.00	TUMBLER UNIT, No. 1— (10.553)
67-68	Pass., Chevy, Chevelle	3901062 A.R.		3.00	TUMBLER UNIT, No. 2— (10.553)
65-70	Pass., Chevy, Chevelle	3901063 A.R.		3.00	TUMBLER UNIT, No. 3— (10.553)
67-68	Pass., Chevy, Chevelle	3901064 A.R.		3.00	TUMBLER UNIT, No. 4— (10.553)
67-68	Pass., Chevy, Chevelle	3901065 A.R.		3.00	TUMBLER UNIT, No. 5— (10.553)
65	Pass. (exc. Sta. Wag.)	4478938	1	.36	RETAINER, lock cylinder
66-67	Chevy, Chevelle (exc. Sta. Wag.),				
66	Pass. (exc. Sta. Wag.)	7779159	1	.65	RETAINER, lock cylinder
66-67	Chevelle (exc. Sta. Wag., El Camino)	4545497	1	.33	RETAINER, cylinder
67	Pass. (exc. Sta. Wag.)	7647099	1	.39	RETAINER, lock cylinder
67-68	Camaro	7717576	1	.65	RETAINER, cylinder

**METAL TRIM—CLIPS AND PANELS**

**12.249 SPRING— ESCUTCHEON ASSY.— TUMBLER UNIT— RETAINER— GASKET— GUARD— HOUSING— RIVET— PAWL— PLATE, Rear Compartment Lid Lock Cylinder (Con't)**

68-72	Chevelle (exc. Sta. Wag., El Camino)	7731804	1	.25	RETAINER, cylinder
68-74	Chevy, Nova	7729767	1	.25	RETAINER, cylinder
68	Pass. (exc. Sta. Wag.)	7731350	1	.25	RETAINER, lock cylinder
69-70	Pass. (exc. Sta. Wag.)	8724400	1	.33	RETAINER, lock cylinder
69	Camaro	8733875	1	1.15	RETAINER, cylinder
71	Pass. (exc. Sta. Wag.)	9831445	1	.88	RETAINER, cylinder
71-73	Vega (Sedan, Coupe)	9818567	1	.39	RETAINER, rear compt. lid
72-73	Pass. (exc. Sta. Wag.)	9877699	1	.60	RETAINER, lock cylinder
73	Chevelle (exc. Sta. Wag., El Camino, Monte Carlo)	9872534	1	.36	RETAINER, cyl.
73	Monte Carlo	9872550	1	.98	RETAINER, cyl.
74-75	Chevelle (exc. Sta. Wag., El Camino)	9678168	1	.39	RETAINER, cyl.
74-75	Pass. (exc. Sta. Wag.)	9668576	1	.54	RETAINER, lid lock cyl.
74-75	Vega (Sedan, Coupe)	9726528	1	1.25	RETAINER, lock cyl.
75	Nova	1697770	1	.52	RETAINER, lock cyl. (repl. 9737548)
75	Monza (Hatchback)	348267	1	.72	RETAINER, rear compt. lid lock cover
75	Monza (Hatchback)	9728247	1	.58	RETAINER, lock cyl. compt. lid (repl. 1651798)— (10.551)
75	Vega (Coupe)	9728247	1	.58	RETAINER, compt. lid lock cyl.— (10.551)
75	Monza (Notchback)	1706924	1	.57	RETAINER, lock cylinder
62-68	Chevy, Chevelle,				
65-69	Pass.	601261 A.R.		.66	RETAINER UNIT (10.553)
65-67	Pass., Chevelle	4418528	1	.14	GASKET, t/gate lock cyl. escut.
65-70	All (exc. Sta. Wag., El Camino)				GASKET, lock cylinder,
71	Nova, Chevelle (exc. Sta. Wag., El Camino) Impala (Conv.)				lid lock cyl. to panel,
71	Pass. (exc. Sta. Wag., Conv.),				
75	Chevelle, Nova (exc. Sta. Wag.),				
75	Vega (Sedan, Cpe.) Monza	4471426	1	.14	lid lock cyl.
74-75	Pass. (Sta. Wag.)	4587931		.23	GASKET, t/gate lock release switch escutcheon
74-75	Camaro	9683103	1	1.10	GUARD, lid lock cyl.
62-71	Chevy, Chevelle (exc. Sta. Wag.),				
62-65	Chevelle,				
67	Camaro,				
65-72	Pass. (exc. Sta. Wag.),				
71-72	Vega (Sedan, Coupe)	7015899	1	.38	HOUSING, lock cylinder
72	Chevelle (Spt. Cpe.),				
73-75	Chevelle, Pass. (exc. Sta. Wag.)	9426957	1	.11	RIVET, compt. lid lock cylinder retainer
65-72	Pass., Chevelle	5713268	1	.88	PAWL, t/gate window outer handle cylinder
73	Pass. (exc. Sta. Wag.)	9843569	1	8.15	PLATE, compt. lid lock striker anchor

**12.249A RETAINER— GASKET— SPRING, Tail Gate or Rear Door Lock Cylinder**

65-69	Sta. Wag.	4888243	1	.46	lock cylinder— (10.551)
71-73	Vega (Panel, Sta. Wag.)	9822279	1	1.25	lock cylinder
68-69	Chevelle,				
71-75	Vega (Panel, Sta. Wag.)	4587931	1	.23	GASKET
73	Pass. (Sta. Wag.)				SPRING, rear compt. lock cyl. coil,
73-75	Chevelle (Sta. Wag.)	7001087	1	.35	tailgate lock cyl. return

**12.252 SHAFT— CAM— HOUSING, Rear Compartment Lock Handle**

62-66	Chevy, Chevelle (exc. Sta. Wag.),				
67-75	Camaro,				
67	Chevy (exc. Sta. Wag.),				
74	Vega,				
75	Vega (Sed., Cpe.)	3788294	1	.28	(3 <sup>7</sup> / <sub>8</sub> " long)
75	Monza (Hatchback)	1650160	1	.28	
	<i>NOTE 1 Cut for required length.</i>				
65	Pass. (exc. Sta. Wag.)	9705434	1	.34	
66	Pass. (exc. Sta. Wag.),				
66-67	Chevelle (exc. Sta. Wag.),				
71	Pass. (exc. Sta. Wag.),				
73	Chevelle (Sta. Wag.)	8732480	1	.38	tailgate
67	Pass. (exc. Sta. Wag.),				
73	Monte Carlo,				
74	Chevelle,				
74	Pass. (exc. Sta. Wag.)	9705434	1	.34	(repl. 5717329)
68	Pass. (exc. Sta. Wag.),				
68-70	Chevelle (exc. 6-Pass. Sta. Wag.),				
68-73	Chevy, Nova,				

**METAL TRIM—CLIPS AND PANELS**

**12.252 SHAFT— CAM— HOUSING, Rear Compartment Lock Handle (Con't)**

68-72	Chevelle (exc. Sta. Wag., El Camino, Monte Carlo),				
71	Vega (Sedan, Coupe),				
72-73	Vega	9845977	1	.46	lock cyl. (repl. 9714052)
69-70	Pass. (exc. Sta. Wag.)	7581070	1	1.65	
69-70	Pass. (exc. Sta. Wag.)	9614429	1	.28	lock cyl.
71-72	Monte Carlo,				
73	Pass. (exc. Sta. Wag., Conv.)	9845977	1	.46	cyl.
72	Pass.	9877519	1	.28	
73	Chevelle (Spt. Cpe., Spt. Sed.) (exc. Monte Carlo)	9877518	1	.23	rear compt.
74	Nova	9845977	1	.46	lid lock cylinder
75	Nova	1652614	1	.31	
71	Vega (Panel, Sta. Wag.)	9823087	1	.42	<b>CAM</b> , rear compt. lock
71	Pass., Chevelle, Nova (exc. Sta. Wag.)	7015899	1	.38	<b>HOUSING</b> , rear compt. lock cyl.

**12.269 WEATHERSTRIP— RETAINER, Rear Compartment Lid**

65-69	Pass. (exc. Sta. Wag.),				
67-69	Camaro	9825830	A.R.	RL/94	rr. compt. lid gutter
62-72	All (exc. Sta. Wag., Vega)	9825829	A.R.	.89	gutter
71	Vega	9824898	1	11.45	compt. lid gutter
71	Vega (Coupe),				
72-75	Vega (Sedan, Coupe)	9876477	1	RL/98	compt. lid gutter
73-75	All (exc. Sta. Wag., H.B. Cpe.)	9825829	A.R.	.89	gutter (serviced per foot)
73	Nova (H.B.)	9618858	1		<b>WEATHERSTRIP</b> , compt. lid gutter (198 inches)
74	Nova (H.B.)	9739576	1	19.00	gutter
75	Nova (2-Dr.) (exc. H.B.)	1691821	1	19.00	rear compt. seal
75	Nova (H.B.)	3061316	1	22.15	gutter (repl. 1703139)
75	Nova (H.B.)	1719399	2	1.45	upper aux. sealing
75	Monza (Hatchback)	1650475	1	11.45	compt. lid gutter
75	Monza (Notchback)	1693837	1	17.40	compt. lid gutter
73-74	Nova (H.B.)	9667240	2	.22	<b>RETAINER</b> , weatherstrip compartment lid gutter

**12.269A WEATHERSTRIP— RETAINER— STRIP— FASTENER, End Gate**

65-68	Pass. (Sta. Wag.)	4482277	R.H.	10.30	tail gate opg.
65-68	Pass. (Sta. Wag.)	4482278	L.H.	10.30	tail gate opg.
71	Vega (Panel, Sta. Wag.)	9826573	1	19.00	back door opening
72-73	Vega (Panel, Sta. Wag.)	9606576	1	19.00	back door opening
74-75	Vega (Panel, Sta. Wag.)	1671301	1	19.00	back door body side (14 1/4")
64-67	Chevelle (Sta. Wag.)	4472703	R.H.	10.30	<b>WEATHERSTRIP ASSY.</b> , opening
64-67	Chevelle (Sta. Wag.)	4472704	L.H.	10.30	<b>WEATHERSTRIP ASSY.</b> , opening
66-67	Chevy (Sta. Wag.)	7582897	L.H.	10.30	<b>WEATHERSTRIP ASSY.</b> , opening
69-70	Chevelle (Sta. Wag.)	8797133	R.H.	10.30	<b>WEATHERSTRIP ASSY.</b> , opening
69-70	Chevelle (Sta. Wag.)	8797134	L.H.	10.30	<b>WEATHERSTRIP ASSY.</b> , opening
69-70	Pass. (Sta. Wag.)	8797137	1	10.30	<b>WEATHERSTRIP ASSY.</b> , right, tailgate opening
69-70	Pass. (Sta. Wag.)	8797138	1	10.30	<b>WEATHERSTRIP ASSY.</b> , left tailgate opening
71-72	Chevelle (Sta. Wag.)	9873311	L.H.	10.30	<b>WEATHERSTRIP ASSY.</b> , opening complete
71-72	Chevelle (Sta. Wag.)	9873310	R.H.	10.30	<b>WEATHERSTRIP ASSY.</b> , opening complete
71-73	Pass. (Sta. Wag.)	9623426	R.H.	38.75	<b>WEATHERSTRIP ASSY.</b> , opening complete
71-73	Pass. (Sta. Wag.)	9623427	L.H.	38.75	<b>WEATHERSTRIP ASSY.</b> , opening complete
71-73	Pass. (Sta. Wag.)	9639134	1	9.20	<b>WEATHERSTRIP ASSY.</b> , at belt
73-75	Chevelle (Sta. Wag.)	9879669	1	10.30	<b>WEATHERSTRIP ASSY.</b> , t/gate opening complete
73-75	Chevelle (Sta. Wag.)	9877969	1	10.30	<b>WEATHERSTRIP</b> , t/gate lower
74-75	Pass. (Sta. Wag.)	9678052	1	9.20	<b>WEATHERSTRIP ASSY.</b> , t/gate at belt complete
74-75	Pass. (Sta. Wag.)	9680686	R.H.	38.75	<b>WEATHERSTRIP ASSY.</b> , t/gate opening complete
74-75	Pass. (Sta. Wag.)	9680687	L.H.	38.75	<b>WEATHERSTRIP ASSY.</b> , t/gate opening complete
69-72	Chevelle (Sta. Wag.) w/dual tailgate	8774173	L.H.	1.85	<b>RETAINER</b> , w/strip lwr. cor.
69-71	Chevelle (Sta. Wag.) (exc. dual tailgate)	8774172	L.H.	1.85	<b>RETAINER</b> , w/strip lwr. cor.
69-70	Pass., Chevelle (Sta. Wag.),				
71-72	Chevelle (Sta. Wag.)	8754522	R.H.	1.85	<b>RETAINER</b> , w/strip right lower corner
69-72	Chevelle (Sta. Wag.)	8723157	1	3.15	<b>RETAINER</b> , weatherstrip lower center
71-72	Pass. (Sta. Wag.)	8793102	1	7.05	<b>RETAINER</b> , gate opening weatherstrip on cross bar
71-75	Pass. (Sta. Wag.)	9815230	1	7.95	<b>RETAINER</b> , weatherstrip at belt

**METAL TRIM—CLIPS AND PANELS**

**12.269A WEATHERSTRIP— RETAINER— STRIP— FASTENER, End Gate (Con't)**

71-75	Pass. (Sta. Wag.)	9817511 L.H.	3.50	RETAINER, opening side weatherstrip lower
71-75	Pass. (Sta. Wag.)	9817510 R.H.	3.50	RETAINER, opening side weatherstrip lower
71-75	Pass. (Sta. Wag.)	9874957 R.H.	2.45	RETAINER, back body opening weatherstrip upper
71-75	Pass. (Sta. Wag.)	9828534 1	1.90	RETAINER, back body opening weatherstrip side
72-73	Pass. (Sta. Wag.)	9605421 1	4.80	RETAINER, t/gate w/strip on cross bar upper
73-75	Pass. (Sta. Wag.)	9817510 R.H.	3.50	RETAINER, opening side w/strip lower
73-75	Pass. (Sta. Wag.)	9817511 L.H.	3.50	RETAINER, t/gate opening side w/strip lower
73-75	Pass. (Sta. Wag.)	9874958 L.H.	2.45	RETAINER, opening back body w/strip upper
73-75	Chevelle (Sta. Wag.)	9878420 1	2.45	RETAINER, back body opening upper w/strip
73	Pass. (Sta. Wag.)	8793102 1	7.05	RETAINER, opening w/strip on center bar lower
74-75	Pass. (Sta. Wag.)	9680521 1	7.05	RETAINER, t/gate opening w/strip on bar
62-68	Chevy (Sta. Wag.),			
64-68	Chevelle (Sta. Wag.),			
66-68	Pass. (Sta. Wag.)	4489247 A.R.	.18	STRIP, t/gate bottom drain hole— (10.694)
62-65	Chevy (Sta. Wag.),			
64	Chevelle (Sta. Wag.)	4841194 A.R.	.11	FASTENER, weatherstrip— (10.695)
	Not required in this group. See group 13.384			
		8731909	.11	FASTENER

NOTE 1 To be used with part 4472703-04 w/strip and part 4474274 Retainer.

**12.428 RAIL, Rear Quarter Belt-Outer**

68-72	Chevelle (Sta. Wag.)	8760884 L.H.	12.70	belt
-------	----------------------	--------------	-------	------

**12.491 PILLAR ASSY.— BRACE— PLUG— REINFORCEMENT— EXTENSION, Center Body**

NOTE 1 When using on 1962 models, it will be necessary to use 1964 door lock assy. and door lock striker assy.

68-69	Chevelle (Sta. Wag., Sed.) (exc. Spt. Sed.)	8771790 R.H.	58.75	center
68-74	Chevy, Nova (Sed.)	9730715 R.H.	62.75	center
68-72	Chevelle (4-Dr.) (exc. Spt. Sed.),			
69-72	Chevelle (Sta. Wag.)	8784863 L.H.	60.75	center
68-72	Chevy (Sed.)	9730716 L.H.	62.75	center
70	Pass. (4-Dr.) (exc. Spt. Sed.)	7775336 R.H.	87.25	center
70	Pass. (4-Dr.) (exc. Spt. Sed.)	7775337 L.H.	87.25	center
68-70	Pass. (Spt. Sed.)	8761579 L.H.	78.25	center
70-72	Chevelle (Spt. Sed.)	8784860 R.H.	56.75	center
68-72	Chevelle (Spt. Sed.)	8784861 L.H.	56.75	center
70-72	Chevelle (4-Dr.) (exc. Spt. Sed.)	8784862 R.H.	60.75	
71-75	Pass. (Spt. Sed.)	9825162 L.H.	72.75	center (repl. 9825152)
71-75	Pass. (Spt. Sed.)	9825161 R.H.	78.75	center (repl. 9825151)
71-75	Pass. (4-Dr.) (exc. Spt. Sed.)	9827052 L.H.	82.25	center
71-75	Pass. (4-Dr.) (exc. Spt. Sed.)	9827051 R.H.	82.25	center
75	Chevelle (4-Dr.)	9664034 R.H.	72.75	center
75	Chevelle (4-Dr.)	9664035 L.H.	72.75	center
75	Nova (4-Dr.)	9735793 R.H.	62.75	center
75	Nova (4-Dr.)	9735794 L.H.	62.75	center
73	Chevelle (4-Dr.)	9664967 R.H.	60.75	center
73	Chevelle (4-Dr.)	9664968 L.H.	60.75	center
70-72	Chevelle (Spt. Sed.)	8769042 R.H.	5.90	BRACE, center plr. to floor pan lower
70-72	Chevelle (Spt. Sed.)	8769043 L.H.	5.90	BRACE, center plr. to floor pan lower
71-75	Pass. (Spt. Sed.)	8794765 L.H.	14.80	BRACE, center pillar to floor pan lower
71-75	Pass. (Spt. Sed.)	8794764 R.H.	14.80	BRACE, center pillar to floor pan lower
	Not required in this group. See Group 16.547			
		4744981	.12	PLUG
75	Pass.	8760446 2	.18	PLUG, center pillar electric conduit hole
70-72	Chevelle (Spt. Sed.)	9605407 R.H.	3.20	REINFORCEMENT, floor pan at center pillar
70-71	Chevelle (Spt. Sed.)	9605408 L.H.	3.20	REINFORCEMENT, floor pan at center pillar (repl. 8768479)
72	Chevelle (Spt. Sed.)	9605408 L.H.	3.20	REINFORCEMENT, floor pan cent. pillar
69-72	Chevelle (4-Dr.) (exc. Spt. Sed.)	8770251 R.H.	1.15	EXTENSION, ctr. plr. intr. panel
69-72	Chevelle (4-Dr.) (exc. Spt. Sed.)	8770252 L.H.	1.15	EXTENSION, ctr. plr. intr. panel
69-72	Chevy (4-Dr.)	9665136 R.H.	1.15	EXTENSION, ctr. plr. intr. panel
69-72	Chevy (4-Dr.)	9665137 L.H.	1.15	EXTENSION, ctr. plr. intr. panel (repl. 8770254)
71-73	Pass. (4-Dr.) (exc. Spt. Sed.)	9605955 L.H.	2.35	EXTENSION, center pillar inner panel to roof

**METAL TRIM—CLIPS AND PANELS**

**12.491 PILLAR ASSY.— BRACE— PLUG— REINFORCEMENT— EXTENSION,  
Center Body (Con't)**

71-73	Pass. (4-Dr.) (exc. Spt. Sed.)	9605954 R.H.	2.35	EXTENSION, center pillar inner panel to roof
73-74	Nova (4-Dr.)	9665137 L.H.	1.15	EXTENSION, center pillar inner panel
73-74	Nova (4-Dr.)	9665136 R.H.	1.15	EXTENSION, center pillar inner panel
74-75	Pass. (4-Dr.) (exc. Spt. Sed.)	1672918 R.H.	2.35	EXTENSION, center pillar inner panel to roof
74-75	Pass. (4-Dr.) (exc. Spt. Sed.)	1672919 L.H.	2.35	EXTENSION, center pillar inner panel to roof

**12.579 PANEL— RETAINER— EXTENSION— CATCH ASSY.— FILLER—  
FOUNDATION— BUMPER— PLATE— STRIKER— COVER ASSY.— CLIP,  
Spare Tire Cover**

69-70	Kingswood,			
71-75	Pass. (Sta. Wag.)	9865384 R.H.	16.45	(black) (polypropylene) (paint as reqd.)
68-70	Malibu, Concours (Sta. Wag.),			
74-75	Chevelle (Sta. Wag.)	9627222 1	18.55	(primed and painted)
75	Monza (exc. Towne Coupe) w/space saver tire	1653021 1	8.45	
71-72	Concours	9809916 R.H.	21.55	PANEL ASSY., cover
70	Pass., Chevelle (Sta. Wag.)	8754522 R.H.	1.85	RETAINER, w/strip lower corner
73-75	Chevelle (Sta. Wag.)	9624164 1	.32	RETAINER, spare tire cover lower rear
65-67	Pass. (Sta. Wag.),			
73-74	Chevelle (Sta. Wag.)	9645418 1	4.80	EXTENSION ASSY. (paint as required)
75	Chevelle (Sta. Wag.)	1653969 1	4.55	EXTENSION, panel
65-66	Pass., Chevelle (Sta. Wag.)	7661559 1	1.55	CATCH ASSY., panel
67	Pass., Chevelle (Sta. Wag.),			
68-70	Chevelle (Sta. Wag.),			
68-70	Pass. (Sta. Wag.),			
71-72	Chevelle (Sta. Wag.)	9852188 1	1.55	CATCH ASSY., panel (repl. 7661572)
71-75	Pass. (Sta. Wag.)	1653962 1	10.45	CATCH ASSY., panel (painted)
73-75	Chevelle (Sta. Wag.) w/swingout window	9652751 1	10.45	CATCH ASSY., panel (painted)
68-70	Pass., Chevelle (Sta. Wag.),			
71-72	Chevelle (Sta. Wag.)	7746711 1	1.25	FILLER, right, extension (black)
75	Vega (N.B.)	738544 1	3.60	FOUNDATION
64-72	Chevelle (Sta. Wag.),			
65-72	Pass. (Sta. Wag.)	4569867 A.R.	.36	BUMPER, catch and panel frt. upper— (12.945)
64-66	Chevelle (Sta. Wag.) (exc. Malibu),			
68	Chevelle (Sta. Wag.) (exc. Malibu, Concours),			
69-71	Brookwood, Townsman	4565671 2	.18	BUMPER, panel (repl. 4565463)— (12.941)
65-68	Biscayne, Bel Air (Sta. Wag.),			
69	Brookwood, Townsman	4880572 1	.16	BUMPER, panel at striker— (12.945)
69	Sta. Wag.	4573914 A.R.	.24	BUMPER, panel upper— (10.587)
64-67	Chevelle (Sta. Wag.) (exc. Malibu),			
68	Nomad,			
69-71	Nomad, Greenbrier	4818451 1	.14	BUMPER, panel to striker— (12.945)
65-68	Pass. (Sta. Wag.),			
69	Brookwood, Townsman	4880572 1	.16	BUMPER, panel at striker— (12.945)
65-67	Pass. (Sta. Wag.)			BUMPER, panel support,
65-67	Bel Air, Biscayne (Sta. Wag.),			
68	Chevelle (Sta. Wag.),			
69	Pass. (Sta. Wag.)	4573914 A.R.	.24	BUMPER, panel upper— (10.587)
73-74	Nova (H.B. Cpe.)	4561129 2	.24	BUMPER, lug. compt. panel/on supt.
75	Monza w/space saver tire	1669239 1	1.05	BUMPER, spare tire
64-68	Malibu (Sta. Wag.),			
65-68	Bel Air (Sta. Wag.) (9-Pass.),			
66	Concours,			
65-68	Impala (Sta. Wag.),			
69-72	Concours,			
69-70	Pass. (Sta. Wag.)	4528445 1	2.05	PLATE, spare tire conv. panel catch
68-72	Chevelle (Sta. Wag.)	7690342 R.H.	1.30	STRIKER, panel catch
73-75	Pass. (Sta. Wag.)	9737619 R.H.	2.10	STRIKER, cover panel catch
70-72	El Camino (Custom)	8809640 1	33.00	COVER ASSY. (comb. 704, 705, 756) (black)
70	El Camino (Custom)	8809642 1	33.00	COVER ASSY. (comb. 771) (med. saddle)
73-74	El Camino (Custom) w/swivel seat	9646447 1	35.75	COVER ASSY. (comb. 713, 714, 722, 732, 892) (neutral)
73-75	El Camino w/swivel seat	9646446 1	35.75	COVER ASSY. (black) (paint as reqd.)



**METAL TRIM—CLIPS AND PANELS**

**12.579 PANEL—RETAINER—EXTENSION—CATCH ASSY.—FILLER—FOUNDATION—BUMPER—PLATE—STRIKER—COVER ASSY.—CLIP, Spare Tire Cover (Con't)**

75	El Camino w/swivel bucket, notchback seat . . . . .	9665214	1	32.25	COVER ASSY. (comb. 63W) (saddle) . . . . .
	<i>NOTE 1 Production Deviation Trim Change.</i>				
68-70	Chevelle (Sta. Wag.) (6-Pass.) (exc. Nomad),				
71	Chevelle (Sta. Wag.) (6-Pass.),				
65-71	Pass. (Sta. Wag.) (6-Pass.),				
73-74	Nova (H.B.) (1st design) . . . . .	9874698	2	.38	lug. compt. panel hold down (support length is 27 inches) . . . . .
71	Pass. (Sta. Wag.),				
72	Pass. (Sta. Wag.) . . . . .	9643798	2	.34	CLIP, pnl. hold down . . . . .
73-75	Chevelle (Sta. Wag.) . . . . .	9624163	1	.53	CLIP, spare tire cover back body pillar . . . . .
74	Nova (H.B. Coupe) . . . . .	9874698	2	.38	CLIP, panel hold down lug. compt. . . . .

**12.650 BRACE ASSY.—EXTENSION—REINFORCEMENT—SUPPORT, Dash to Chassis Frame**

68-70	Chevelle (Conv.),				
70	Monte Carlo . . . . .	8801320	R.H.	17.50	dash to chassis . . . . .
68-69	Chevelle (Conv.) . . . . .	8801321	L.H.	15.00	dash to chassis (repl. 7786935) . . . . .
71-75	Pass. . . . .	9661626	L.H.	33.00	dash to chassis . . . . .
71-74	Pass. . . . .	9738925	R.H.	33.00	
68-72	Chevelle (Conv.), Monte Carlo . . . . .	8801320	R.H.	17.50	dash to chassis . . . . .
70-72	Chevelle (Conv.), Monte Carlo . . . . .	8801321	L.H.	15.00	
70-72	Chevelle (exc. Conv., Monte Carlo) . . . . .	8790430	R.H.	13.90	
70-72	Chevelle (exc. Conv., Monte Carlo) . . . . .	8790431	L.H.	14.70	
70-72	Nova . . . . .	1650430	R.H.	18.75	motor mount rail (repl. 8774492) . . . . .
70-74	Nova . . . . .	1650431	L.H.	22.30	motor mount rail . . . . .
70-75	Camaro . . . . .	9819940	R.H.	22.30	motor mount rail . . . . .
70-75	Camaro . . . . .	9727106	L.H.	22.30	motor mount rail . . . . .
73-74	Nova . . . . .	1654030	R.H.		motor mount rail . . . . .
75	Nova . . . . .	1702357	R.H.	18.75	motor mount rail . . . . .
73-75	Nova . . . . .	1702358	L.H.	22.30	motor mount rail . . . . .
75	Pass. . . . .	9733221	R.H.	33.00	motor mount rail . . . . .
73-75	Chevelle (exc. Laguna) . . . . .	9854838	L.H.	2.15	EXTENSION, floor pan/at dash . . . . .
73-75	Chevelle (exc. Laguna) . . . . .	9854837	R.H.	2.15	EXTENSION, floor pan/at dash . . . . .
71-75	Pass. . . . .	9865945	L.H.	4.10	REINFORCEMENT, dash to chassis frame bumper . . . . .
71-75	Pass. . . . .	9865944	R.H.	4.10	REINFORCEMENT, dash to chassis frame bumper . . . . .
75	Nova w/floor console . . . . .	1660105	1	2.70	SUPPORT, console on dash . . . . .

**12.659 BRACE—REINFORCEMENT, Hinge Pillar to Floor**

68-69	Chevy, Camaro,				
70	Nova . . . . .	9888849	R.H.	9.80	front body hinge pillar to rocker . . . . .
68-69	Chevy, Camaro,				
70	Nova . . . . .	7783635	L.H.	9.50	front body hinge to rocker . . . . .
68-72	Chevelle . . . . .	8714307	L.H.	6.75	REINFORCEMENT, front body hinge pillar to rocker . . . . .
68-72	Chevelle . . . . .	8714306	R.H.	6.75	REINFORCEMENT, frt. body hinge pillar to rocker . . . . .
67	Camaro (Spt. Cpe.),				
68-69	Nova, Camaro,				
71-74	Nova . . . . .	9888849	R.H.	9.80	REINFORCEMENT, front pillar to rocker . . . . .
67	Camaro (Spt. Cpe.),				
68-69	Nova, Camaro,				
71-74	Nova . . . . .	7783635	L.H.	9.50	REINFORCEMENT, front pillar to rocker . . . . .
68-74	Chevy, Nova . . . . .	8716462	R.H.	8.45	REINFORCEMENT ASSY., front body hinge pillar to duct . . . . .
68-74	Chevy, Nova . . . . .	8716463	L.H.	8.45	REINFORCEMENT ASSY., front body hinge pillar to duct . . . . .
73-75	Chevelle . . . . .	9867788	L.H.	5.40	REINFORCEMENT, front pillar to rocker . . . . .
73-75	Chevelle . . . . .	9867787	R.H.	5.40	REINFORCEMENT, front pillar to rocker . . . . .
75	Nova . . . . .	9731811	R.H.	9.80	REINFORCEMENT, front body hinge pillar to rocker . . . . .
75	Nova . . . . .	9731812	L.H.	9.80	REINFORCEMENT, front body hinge pillar to rocker . . . . .
75	Nova . . . . .	1704494	R.H.	8.45	REINFORCEMENT, front body hinge pillar to duct . . . . .
75	Nova . . . . .	1704495	L.H.	8.45	REINFORCEMENT, front body hinge pillar to duct . . . . .

**METAL TRIM—CLIPS AND PANELS**

**12.684 BRACE— EXTENSION, Lock Pillar**

68-70	Chevelle (2-Dr. Sed.)	8758244	R.H.	1.20	pillar to roof rail
68-70	Chevelle (2-Dr. Sed.)	8758245	L.H.	1.20	pillar to roof rail
70-72	Chevelle (Spt. Cpe., Conv.)	8799606	R.H.	5.40	lock pillar to floor pan
70-72	Chevelle (Spt. Cpe., Conv.)	8799607	L.H.	5.40	lock pillar to floor pan
71-75	Impala, Caprice (Conv.)	9882380	R.H.	8.25	body lock pillar to wheelhouse
71-75	Impala, Caprice (Conv.)	9882381	L.H.	8.25	body lock pillar to wheelhouse
71-75	Pass. (Spt. Cpe., Conv.)	9829992	L.H.	11.85	BRACE ASSY., body lock pillar to floor pan
71-75	Pass. (Spt. Cpe., Conv.)	9829991	R.H.	11.85	BRACE ASSY., body lock pillar to floor pan
73-75	El Camino	9864298	L.H.	.62	EXTENSION, body lock pillar outer upper
73-75	El Camino	9864297	R.H.	.62	EXTENSION, body lock pillar outer upper

**12.800 GRILLE— SEAL— SCREEN— FILLER, Cowl Ventilator**

64-67	Chevelle	4489189	1	12.10	
65-66	Pass.	3850212	1	13.70	top
67-69	Camaro	3891610	1	14.35	
68-74	Chevy, Nova	3909155	1	11.20	
75	Nova	344329	1	11.20	top vent.
70-75	Nova	3891661	2	.23	SEAL, top vent. grille
75	Nova	345515	2	.37	SEAL, top vent. grille
69	Pass.	3939384	1	2.15	SCREEN, cowl vent.
70	Pass.	3972817	1	2.35	SCREEN
70-75	Camaro	8800774	1	2.60	SCREEN, top
71-75	Pass.	9688242	1	5.15	SCREEN, top vent. and plastic
71-75	Camaro	8800774	1	2.60	SCREEN, top vent.
73-75	Chevelle	9694191	1	4.95	SCREEN, shroud top vent.

**12.801 SEAL— WEATHERSTRIP— LACE— RETAINER— STRIP, Hood Ledge (Cowl)**

67-69	Camaro,				
68-75	Chevy	3927464	1	.97	
68-70	Pass.,				
71-75	Camaro w/C.A.C.	3919951	1	3.80	
68-72	Chevelle,				
73-74	Camaro	3916517	2	2.40	shroud to hood panel (cut as required)
68-70	Pass.	3957316	1	2.40	panel to upper shroud ext.
69-75	Nova w/C.A.C.	3940279	1	3.20	upper
70-75	Camaro	3962999	1	1.40	upper
71-72	Nova	3927464	1	.97	
68-72	Chevelle	3917431	1	1.35	WEATHERSTRIP, hood panel (Note 1)

*NOTE 1 For those models equipped with spec. H/per. engines, it becomes necessary to cut as required from outer ends.*

71-75	Pass.	9886375	1	7.15	LACE
73-75	Chevelle	9869169	1	4.85	LACE
62-67	Chevy,				
65-70	Pass.,				
68-70	Chevelle,				
71-72	All (exc. Vega),				
73-74	Pass. (exc. Sta. Wag.),				
74	Vega,				
74-75	Camaro, Nova	480534	16	.11	RETAINER, lace retainer (see Group 8.154)
75	Vega, Monza	9829415	1	2.70	RETAINER, hood pnl. slstr.
71-75	Vega, Monza	9829415	1	2.70	STRIP, hood panel sealing

**12.803 PLATE ASSY.— BRACKET, Cowl**

74	Nova (H.B.)	344394	1	.79	cowl bracket
74	Nova (H.B.)	345501	1	2.00	BRACKET, cowl brace

**12.804 PANEL— CLIP— COVER— DEFLECTOR— PLATE ASSY.— PLUG— REINFORCEMENT— EXTENSION— STOP— SUPPORT, Cowl Side**

*NOTE Outlet Assy. and Grille is part of cowl trim pad, for 65-66 Chevy shown in group 14.630.*

**PASS.**

69-70	Pass.	7798853	R.H.	5.00	cowl lower
69-70	Pass.	7798855	L.H.	5.00	cowl lower
69-70	Pass.	8776661	R.H.	21.95	cowl vent. duct
69-70	Pass. (exc. C.A.C.)	8776662	L.H.	21.95	cowl vent. duct
71-75	Pass.	9731011	1	172.00	PANEL ASSY., dash (repl. 9697515)
71-72	Pass. (exc. C.A.C.)	9659399	1		PANEL ASSY., cowl (repl. 9890802)
71-72	Pass. (exc. C.A.C.)	9890803	1	144.00	PANEL ASSY., cowl vent. center duct
71-75	Pass. w/C.A.C.	9728730	1	86.75	PANEL ASSY., cowl vent. center duct
<i>NOTE 1: Now used w/A.C.</i>					
72-75	Pass. w/C.A.C.	1661269	1	40.50	PANEL ASSY., shroud
73-75	Pass. (exc. C.A.C.)	1661268	1	40.50	PANEL ASSY., shroud
73-75	Pass. (exc. C.A.C.)	9728729	1	86.75	PANEL ASSY., shroud vent. center duct
75	Pass.	9731011	1	172.00	PANEL ASSY., dash

**METAL TRIM—CLIPS AND PANELS**

**12.804 PANEL—CLIP—COVER—DEFLECTOR—PLATE ASSY.—PLUG—REINFORCEMENT—EXTENSION—STOP—SUPPORT, Cowl Side (Con't)**

**CHEVELLE**

68	Chevelle,				
69-70	Chevelle (exc. Spt. Cpe. Conv.),				
69-70	Chevelle (Spt. Cpe., Conv.) w/C.A.C.,				
71-72	Chevelle (Spt. Cpe., Conv.) El Camino Custom	9815243 L.H.	18.25	cowl side duct	
68-71	Chevelle	9815237 L.H.	10.70	cowl side lower	
68-71	Chevelle	9815236 R.H.	10.70	cowl lower	
69-70	Chevelle (exc. Spt. Cpe., Conv.),				
69-71	Chevelle (Spt. Cpe., Conv.),				
71-72	El Camino Custom	9815242 R.H.	18.25	side duct	
68-72	Chevelle	9845063 1	28.25	PANEL ASSY., cowl upper	
70-72	Chevelle	8784870 1	52.75	PANEL ASSY., ctr. duct	
70	Monte Carlo (exc. Air Cond.),				
70-71	Chevelle (Conv.) (exc. Air Cond.),				
71-72	Monte Carlo (exc. C.A.C.)	8784879 1	105.00	PANEL ASSY.	
70	Monte Carlo w/Air Cond.,				
70-72	Chevelle (Conv.) w/Air Cond.	8784880 1	155.00	PANEL ASSY.	
70-72	Chevelle (exc. Monte Carlo, Conv., Air Cond.)	8784875 1	108.00	PANEL ASSY.	
70-72	Chevelle w/C.A.C. (exc. Conv., Monte Carlo)	8784878 1	108.00	PANEL ASSY.	
73-74	Chevelle (exc. C.A.C.)	9882061 1	105.00	PANEL ASSY., center duct vent.	
73-75	Chevelle w/C.A.C.	1689822 1	105.00	PANEL ASSY., shroud vent. ctr. duct	
73-74	Chevelle (exc. C.A.C.)	9882001 1	108.00	PANEL ASSY., dash	
73-75	Chevelle w/C.A.C.	1687995 1	108.00	PANEL ASSY., dash	
73-74	Chevelle	9861616 1	41.75	PANEL ASSY., shroud	
75	Chevelle (exc. C.A.C.)	1689821 1	105.00	PANEL ASSY., shroud vent. duct center	
75	Chevelle (exc. C.A.C.)	1687994 1	108.00	PANEL ASSY., dash	
75	Chevelle	9738443 1	41.75	PANEL ASSY., shroud	

**NOVA**

68-74	Nova	1671948 R.H.	12.45	cowl lower (repl. 9671522) (Note 1)	
68-74	Nova	1671949 L.H.	12.45	cowl lower (Note 1)	
67-75	Nova	8761931 L.H.	16.70	cowl vent. duct side (Note 1)	
75	Nova	1671948 R.H.	12.45	shroud lower	
75	Nova	1671949 L.H.	12.45	shroud lower	
62-69	Nova	9872130 1	137.00	PANEL ASSY., dash (repl. 8760572)	
69	Nova w/C.A.C.	8760574 1	125.00	PANEL ASSY., dash	
68-73	Nova	9687875 1	39.25	PANEL ASSY., vent. duct ctr.	
70-71	Nova (exc. C.A.C.)	9872130 1	137.00	PANEL ASSY., dash	
70-74	Nova	9690548 1	36.25	PANEL ASSY., cowl upper	
72-74	Nova (exc. C.A.C.)	9678135 1	137.00	PANEL ASSY., dash	
70-74	Nova (w/C.A.C.)	9678136 1	137.00	PANEL ASSY., dash	
74	Nova	1667275 1	39.25	PANEL ASSY., shroud vent. duct ctr.	
75	Nova	1686100 1	39.25	PANEL ASSY., shroud upper	
75	Nova (exc. C.A.C.)	1660992 1	127.00	PANEL ASSY., dash	
75	Nova w/C.A.C.	1660993 1	127.00	PANEL ASSY., dash	
75	Nova (exc. C.A.C.)	1665560 1	54.25	PANEL ASSY., shroud vent. duct center	
75	Nova w/C.A.C.	1665561 1	54.25	PANEL ASSY., shroud vent. duct center	

NOTE 1: Also in Camaro Section.

**CAMARO**

67-69	Camaro	1671948 R.H.	12.45	cowl lower	
67-69	Camaro	1671949 L.H.	12.45	cowl lower (repl. 9671523)	
67-75	Camaro	9738118 R.H.	16.70	cowl vent. duct side	
67-69	Camaro	8761931 L.H.	16.70	cowl vent. duct side	
70	Camaro	8792243 1	36.25	upper inst.	
70-75	Camaro	8762091 R.H.	12.95	lower	
70-75	Camaro	8762092 L.H.	12.95	lower	
70-71	Camaro	8782297 R.H.	5.85	vent. side duct front	
70-71	Camaro	8782298 L.H.	5.85	vent. side duct front	
73-75	Camaro	8782297 R.H.	5.85	front cowl vent. side duct	
73-75	Camaro	8782298 L.H.	5.85	front cowl vent. side duct	
70-72	Camaro (exc. Air Cond.)	9678946 1	130.00	PANEL ASSY., dash (repl. 9866598)	
70	Camaro (exc. Air Cond.)	9816673 1	28.00	PANEL ASSY., ctr. vent. duct	
70-75	Camaro w/Air Cond.	9816674 1	28.00	PANEL ASSY., ctr. vent. duct	
70-72	Camaro	9601757 L.H.	31.00	PANEL ASSY., vent. duct side	
70-72	Camaro	9888850 R.H.	31.00	PANEL ASSY., cowl vent. duct side	
70-74	Camaro	9678947 1	130.00	PANEL ASSY., dash	
71-75	Camaro (exc. C.A.C.)	9816673 1	28.00	PANEL ASSY., cowl vent. center duct	

**METAL TRIM—CLIPS AND PANELS**

**12.804 PANEL— CLIP— COVER— DEFLECTOR— PLATE ASSY.— PLUG— REINFORCEMENT— EXTENSION— STOP— SUPPORT, Cowl Side (Con't)**

71-75	Camaro	9847800	1	54.25	PANEL ASSY., cowl upper instrument
73-74	Camaro	9601757	L.H.	31.00	PANEL ASSY., cowl vent. duct side
73	Camaro	9888850	R.H.	31.00	PANEL ASSY., cowl vent. duct side
74-75	Camaro	9739594	R.H.	31.00	PANEL ASSY., shroud vent. duct side
74-75	Camaro	1677739	L.H.	29.25	PANEL ASSY., shroud vent. duct side
73-74	Camaro (exc. C.A.C.)	9678946	1	130.00	PANEL ASSY., dash
75	Camaro w/C.A.C.	1660989	1	144.00	PANEL ASSY., dash
75	F less A.C.	1660988	1	146.00	PANEL, dash

**VEGA — MONZA**

71-74	Vega, Monza	9739746	R.H.	9.05	shroud lower
71-74	Vega, Monza	9739747	L.H.	9.05	shroud lower
75	Vega	9734266	R.H.	10.40	shroud lower
75	Vega	9734267	L.H.	10.40	shroud lower
75	Monza (exc. Towne Cpe.)	9733896	R.H.	10.40	shroud lower
75	Monza (exc. Towne Cpe.)	9733897	L.H.	10.40	shroud lower
75	Vega, Monza	1727497	1	46.50	PANEL ASSY., dash (repl. 1650574)
71-72	Vega, Monza	9695955	1	43.75	PANEL ASSY., dash (repl. 9657658)
71-74	Vega, Monza (exc. C.A.C.)	9890213	1	50.25	PANEL ASSY., cowl center duct
71-74	Vega, Monza w/C.A.C.	9890214	1	50.25	PANEL ASSY., cowl center duct
73-74	Vega, Monza	9695955	1	43.75	PANEL ASSY., dash
71-75	Vega	1680660	1	174.00	PANEL ASSY., shroud upper
75	Vega, Monza (exc. C.A.C.)	1660282	1	50.25	PANEL ASSY., shroud center duct
75	Vega, Monza w/C.A.C.	1660283	1	50.25	PANEL ASSY., shroud center duct
75	Vega	1688350	1	50.50	PANEL ASSY., dash
75	Monza (Towne Cpe.) (exc. C.A.C.)	1718292	1	46.50	PANEL ASSY., cowl center duct
75	Monza (Towne Cpe.) w/C.A.C.	1718293	1	46.50	PANEL ASSY., cowl center duct
67-68	Pass.	7630539	2	.19	CLIP, cowl air outlet cont. ret., L.H.
70	Camaro,				
71-72	Pass. (exc. C.A.C.)	9884695	A.R.	.16	CLIP, cowl center duct panel outlet-right hand (repl. 9808501)
71-73	Camaro (exc. C.A.C.)		1		CLIP, cowl center duct outlet cable clip
73-74	Chevelle (exc. C.A.C.)	9884695	A.R.	.16	cowl center duct panel outlet-right hand, left hand
72-74	Pass.	9870124	1	.05	CLIP, cowl unt. dct. ot/t. dr. ctr. & R.H. not used w/A.C.
73-74	Pass. (exc. C.A.C.)	9870125	L.H.	.12	CLIP, cowl unt. dct. otlt. dr. ctr. & not used w/a.c.
74	Pass. (exc. C.A.C.)	9870651	L.H.	.28	CLIP, shroud center duct panel air outlet
65-70	Pass.	7645222	2	.64	COVER, upper panel access hole— (12.941)
67-69	Camaro w/Air Cond.,				
68-75	Chevy w/Air Cond.	7633242	R.H.	2.95	DEFLECTOR, duct panel water
67-69	Camaro w/Air Cond.,				
68-75	Chevy, Nova w/Air Cond.	7661527	R.H.	2.90	PLATE ASSY., duct pnl. baffle
67	Pass. (exc. Sta. Wag.)	4859119	6	.12	PLUG, lwr. panel, compt. lid inner access hole
65-69	Chevelle,				
68	Camaro,				
68-69	Pass. (exc. Sta. Wag.)	4802102	A.R.	.22	PLUG, compt. pan to qtr. panel filler— (12.981)
70	Camaro				PLUG, right cowl vent. duct antenna hole— (12.981)
75	Chevelle	4805843	2	.22	upper shroud panel hole
74-75	Pass., Chevelle	1233424	1	.17	PLUG, trans. detent cbl.
74-75	Chevelle	8779680	2	.16	PLUG, upper shroud panel hole
70-72	Chevelle	9840658	R.H.	3.10	REINFORCEMENT, hood on cowl
70-72	Chevelle	9840659	L.H.	3.10	REINFORCEMENT, hood on cowl
73-75	Chevelle	9615189	2	1.95	REINFORCEMENT ASSY., dash panel/at fender
71	Pass.	9616386	R.H.	3.35	EXTENSION, cowl panel (repl. 9812830)
71-75	Pass.	9817131	L.H.	.91	EXTENSION, cowl vent. duct panel reinforcement
71-75	Pass.	9817130	R.H.	.62	EXTENSION, cowl vent. duct panel reinforcement
72-75	Pass.	9616386	R.H.	3.35	EXTENSION, cowl panel
73-75	Pass.	9888919	L.H.	2.05	EXTENSION, cowl panel
73-75	Chevelle	9830168	L.H.	3.70	EXTENSION, center duct panel reinf.
73-75	Chevelle	9830167	R.H.	3.70	EXTENSION, center duct panel reinf.
71-75	Pass.	9873621	2	.56	STOP, hood on cowl, upper panel
71-75	Pass.	9808550	1	4.50	SUPPORT, steering column on center duct
71-72	Chevelle	8776664	1	9.60	SUPPORT, steering column lower

**12.807 FRAME ASSY., Windshield Upper & Lower**

68-69	Camaro (Conv.)	7724780	1	24.10	inner upper
-------	----------------	---------	---	-------	-------------

**METAL TRIM—CLIPS AND PANELS**

**12.807 FRAME ASSY., Windshield Upper & Lower (Con't)**

68-71	Chevelle (Conv.)	7729552	1	25.75	inner upper
69-72	Nova (4-Dr. Sed.)	8713365	1	15.35	inner upper
69-72	Nova (Spt. Cpe.)	8713366	1	15.35	inner upper
69-71	Chevelle (exc. Conv.)	8717726	1	13.55	inner upper
70-71	Chevelle	9816957	1	6.05	lower
71-75	Impala, Caprice (Conv.)	9837600	1	35.00	upper

**12.808 FRAME— STOP, Windshield Side**

73-74	Nova (4-Dr.)	9619642	1	10.20	w/s inner upper
73-74	Nova (2-Dr.)	9619643	1	10.20	w/s inner upper
70-75	Nova	9808560	2	.44	STOP, front fender on w/s side frame

**12.809 PANEL ASSY.— CLAMP— CLIP— CONDUIT— DEFLECTOR— GROMMET— HOSE— HOUSING ASSY.— STUD, Sliding Sun Roof**

73	Chevelle	9652097	1	102.00	(complete)
74	Chevelle	1658419	1	85.50	(complete)
75	Chevelle (exc. soft trim roof cover)	1665814	1	95.00	(complete)
73-75	Chevelle	1470029	2	.73	CLAMP, drive hose housing rear
73-75	Chevelle, Nova	2494772	2	.65	CLAMP, drive hose housing front
73-74	Chevelle	3943626	2	.18	CLIP, rear hose to body
73-75	Chevelle	9639897	A.R.	.22	CLIP ASSY., bolt & housing to panel— (12.811)
73-75	Chevelle	8919356	2	RL/1.22	CONDUIT, sun roof panel rear drain hose upper
73-74	Chevelle	8919356	2	RL/1.22	CONDUIT, sun roof panel rear drain hose lower
73-75	Chevelle	9669612	R.H.	1.15	DEFLECTOR, water housing rear corner
73-75	Chevelle	9669613	L.H.	1.15	DEFLECTOR, water housing rear corner
73-75	Chevelle	3681088	2	.18	GROMMET, front hose to body
73-75	Chevelle (2-Dr.)	9652123	1	.40	HOSE, drain housing front
73-74	Chevelle,				
75	Monte Carlo (w/elec. sunroof)	1714299	2	1.70	HOSE, drain housing rear
75	Chevelle (exc. Monte Carlo)	1652575	2	2.00	HOSE, drain housing rear
73	Chevelle	9696881	1	194.00	HOUSING ASSY.
74-75	Chevelle	1710791	1	318.00	HOUSING ASSY., sliding compt.
74-75	Chevelle	9728385	A.R.	4.55	STUD, roof sliding panel frt. guide adj.

**12.810 PANEL— CLIP— COVER— FASTENER— DEFLECTOR— RAIL UNIT— REINFORCEMENT— RETAINER— SEALING STRIP— SLIDERS UNIT— STOP— SUPPORT— WEATHERSTRIP, Top Roof Outer**

64-67	El Camino	7596481	1	72.00	(less drip mouldings)
66-67	Chevelle (Spt. Cpe.)	4534268	1	72.00	(less drip mouldings)
67-69	Camaro (Spt. Cpe.)	7585083	1	59.50	(less drip mouldings)
68-72	Chevelle (Sta. Wag.)	7790424	1	117.00	(less drip mouldings)
68-72	El Camino	7790451	1	71.25	(less drip mouldings)
68-72	Malibu (Spt. Sed.)	7790420	1	76.50	(less drip mouldings)
68-70	Chevelle (2-Dr.) (exc. Conv.),				
71-72	Malibu (Spt. Cpe.)	7790418	1	72.00	(less drip mouldings)
68-72	Nova (Sed.)	7678496	1	69.75	(less drip mouldings)
68-72	Chevelle (4-Dr. Sed.)	7790422	1	72.50	(less drip mouldings)
68-72	Nova (Spt. Cpe.)	7722875	1	69.75	(less drip mouldings)
70-72	Monte Carlo	7783650	1	80.50	
70	Camaro	8787543	1	92.75	
71-72	Caprice (Spt. Cpe.)	9661637	1	159.00	
71-72	Impala (Spt. Cpe.) (exc. Custom)	9638485	1	147.00	w/structural adhesive
71-73	Pass. (Sta. Wag.)	9664300	1	289.00	
71-72	Camaro	9668359	1	114.00	
72-73	Nova (Spt. Cpe.)	490595	1	55.25	sun roof deflector
71-72	Pass. (Sed.) (exc. Spt. Sed.)	9638481	1	164.00	(repl. 9611661)
72-73	Pass. (Spt. Sed.)	9661692	1	137.00	
73	Pass. (Sed.) (exc. Spt. Sed.)	9638481	1	164.00	w/structural adhesive 35 "T" slots for hldng. atch.
73	Impala (Custom) Caprice (Spt. Cpe.)	9661637	1	159.00	
73	Impala (Spt. Cpe.) (exc. Custom)	9638485	1	147.00	w/structural adhesive
73-75	El Camino	9846093	1	197.00	
73	Chevelle (Spt. Sed.)	9846084	1	137.00	
73	Chevelle (Spt. Cpe.)	9846099	1	137.00	
73	Monte Carlo	9846109	1	137.00	
73	Chevelle (Sta. Wag.)	9846094	1	273.00	
73-74	Nova (H.B. Cpe.)	9609649	1	66.25	
73-74	Nova (Coupe) (exc. H.B.)	9879102	1	67.00	
73-74	Nova (Sed.)	9879099	1	67.00	
73	Camaro	9668359	1	114.00	w/structural adhesive

**METAL TRIM—CLIPS AND PANELS**

**12.810 PANEL—CLIP—COVER—FASTENER—DEFLECTOR—RAIL UNIT—  
REINFORCEMENT—RETAINER—SEALING STRIP—SLIDERS UNIT—  
STOP—SUPPORT—WEATHERSTRIP, Top Roof Outer (Con't)**

73	Chevelle (Spt. Cpe.) (exc. Monte Carlo)	9667714	1	311.00	compl. w/sun roof w/structural adhesive . . .
73	Monte Carlo	9667708	1	311.00	compl. w/sun roof w/structural adhesive . . .
74-75	Chevelle (Spt. Cpe.) (exc. Monte Carlo) (1st design)	1711082	1	378.00	w/structural adhesive (Note 1) . . . . .
74-75	Chevelle (Spt. Cpe.) (exc. Monte Carlo) (2nd design)	1711081	1	412.00	w/structural adhesive (Note 1) . . . . .
74-75	Monte Carlo	1711083	1	378.00	
74	Camaro	9739600	1	114.00	w/structural adhesive . . . . .
74	Pass. (Spt. Sed.)	9660594	1	137.00	
74-75	Impala (Custom) Caprice (Spt. Cpe.)	1682790	1	191.00	(repl. 9660639) . . . . .
74-75	Impala (Spt. Cpe.) (exc. Custom)	1682791	1	177.00	
74	Pass. (Sed.) (exc. Spt. Sed.)	9669460	1	164.00	
74-75	Chevelle (Spt. Cpe.) (exc. Monte Carlo) (1st design)	9670316	1	165.00	w/structural adhesive (Note 1) . . . . .
74-75	Chevelle (Spt. Cpe.) (exc. Monte Carlo) (2nd design)	9735875	1	165.00	w/structural adhesive (Note 1) . . . . .
74-75	Monte Carlo	9670322	1	165.00	
74-75	Chevelle (4-Dr.) (exc. Sta. Wag.)	9671133	1	165.00	w/structural adhesive . . . . .
74	Pass. (Sta. Wag.)	1654901	1	289.00	
74-75	Chevelle (Sta. Wag.)	1716881	1	410.00	
75	Pass. (Spt. Sed.)	9686179	1	165.00	
75	Pass. (Sed.) (exc. Spt. Sed.)	9684374	1	197.00	
75	Pass. (Sta. Wag.)	1660779	1	348.00	
75	Camaro	9698975	1	114.00	
75	Nova (2-Dr.)	9734061	1	373.00	
75	Nova (4-Dr.)	9732700	1	345.00	
75	Nova (H.B.)	1691785	1	345.00	w/structural adhesive . . . . .
71-73	Vega (Notchback Cpe.)	9662996	1	179.00	PANEL ASSY., roof complete . . . . .
71-73	Vega (Panel, Sta. Wag.)	9662997	1	353.00	PANEL ASSY., roof complete . . . . .
71-73	Vega (Hatchback Cpe.)	9662998	1	272.00	PANEL ASSY., roof complete . . . . .
74	Vega (Hatchback Cpe.)	9670328	1		PANEL ASSY., roof complete . . . . .
74	Vega (Panel, Sta. Wag.)	9729968	1	353.00	PANEL ASSY., roof complete . . . . .
75	Vega (Panel, Sta. Wag.)	1675474	1	530.00	PANEL ASSY. . . . .
74-75	Vega (Notchback Cpe.)	1675475	1	216.00	PANEL ASSY. . . . .
75	Vega (Hatchback Cpe.)	1675525	1	327.00	PANEL ASSY. . . . .
75	Monza (Hatchback)	1716898	1	408.00	PANEL ASSY. (use with 3/8" ball studs— 2nd type) . . . . .
75	Monza (Towne Cpe.)	1743150	1	.63	PANEL ASSY. . . . .
73	Chevelle	4510031	1	.18	CLIP, sun roof opening weatherstrip to panel . . . . .
74	Chevelle (2-Dr.) w/elect. sun roof	1689163	2	1.70	CLIP, sun roof sliding pnl. frt. . . . .
73	Nova (2-Dr.)	345242	1	165.00	COVER UNIT (black) . . . . .
73-75	Chevelle	1706828	2	.16	COVER, sun roof panel opening side reinforcement . . . . .
73	Chevelle (Spt. Cpe.) (exc. Monte Carlo)	4841194	2	.11	FASTENER, w/defl. to panel . . . . .
73	Nova (2-Dr.)	333774	1	49.50	FASTENER UNIT, sun roof top . . . . .
72-73	Nova (Spt. Cpe.)	491734	1	92.00	DEFLECTOR UNIT, sun roof . . . . .
73-75	Chevelle	9688773	2	.84	DEFLECTOR, water sun roof sliding panel . . . . .
72-73	Nova (Spt. Cpe.)	491736	1	58.75	RAIL UNIT, sun roof upper . . . . .
72-73	Nova (Spt. Cpe.)	491738	1	39.25	RAIL UNIT, sun roof upper to roof seal . . . . .
72-73	Nova (Spt. Cpe.)	491737	1	67.50	RAIL UNIT, sun roof lower trim . . . . .
72-73	Nova (Spt. Cpe.)	491739	1	145.00	RAIL UNIT, sun roof side upper & lower . . . . .
71-72	Camaro	9888572	R.H.	2.00	REINFORCEMENT, inner to qtr. inner panel . . . . .
71-72	Camaro	9888573	L.H.	2.00	REINFORCEMENT, inner to qtr. inner panel . . . . .
75	Vega (Sta. Wag.)	9667507	R.H.	13.90	REINFORCEMENT, inner panel at quarter window . . . . .
75	Vega (Sta. Wag.)	9667508	L.H.	13.90	REINFORCEMENT, inner panel at quarter window . . . . .
75	Monza (exc. Towne Coupe)	9730243	R.H.	3.20	REINFORCEMENT, roof inner panel extension . . . . .
75	Monza (exc. Towne Coupe)	9730244	L.H.	3.20	REINFORCEMENT, roof inner panel extension . . . . .
71-73	Vega (Panel, Sta. Wag.)	9728616	L.H.	19.45	REINFORCEMENT ASSY., inner panel at qtr. window . . . . .
71-73	Vega (Panel, Sta. Wag.)	9728615	R.H.	19.45	REINFORCEMENT ASSY., inner panel at qtr. window . . . . .
74	Vega (Panel, Sta. Wag.)	9667507	2	13.90	REINFORCEMENT ASSY., roof pnl. inner at qtr. wdo. (repl. 9671738-9) . . . . .
75	Monza (Towne Coupe)	1742815	R.H.	3.55	REINFORCEMENT, inner panel extension . . . . .
75	Monza (Towne Coupe)	1742816	L.H.	3.55	REINFORCEMENT, inner panel extension . . . . .

**METAL TRIM—CLIPS AND PANELS**

**12.810 PANEL—CLIP—COVER—FASTENER—DEFLECTOR—RAIL UNIT—REINFORCEMENT—RETAINER—SEALING STRIP—SLIDERS UNIT—STOP—SUPPORT—WEATHERSTRIP, Top Roof Outer (Con't)**

73-75	Chevelle	9665522	1	2.80	RETAINER, sliding sun roof panel cover
73-75	Monte Carlo	9652090	2	1.85	RETAINER, sun roof sliding panel guide rail
73-75	Chevelle	9670922	1	.47	RETAINER, sun roof sliding panel rear guide plate
73-74	Chevelle	9698998	1		SEALING STRIP, sliding housing
72-73	Nova (Spt. Cpe.)	490591	1	13.50	SLIDER UNIT, sun roof
75	Chevelle	9667514	2	.47	SLIDE, sliding panel
73-75	Chevelle	9652092	2	.39	STOP, sun roof sliding panel rear
73-75	Chevelle	9671197 R.H.	1	1.40	STOP, sun roof sliding panel
73-75	Chevelle	9671198 L.H.	1	1.40	STOP, sun roof sliding panel
73-75	Chevelle	9670650	2	.91	SUPPORT, sun roof sliding panel
73-75	Chevelle	1685425	1	2.40	WEATHERSTRIP, sun roof sliding panel
73-75	Chevelle	9652118	1	1.05	WEATHERSTRIP, sun roof sliding panel rear
73-74	Chevelle (exc. vinyl top)	9736550	1	15.15	WEATHERSTRIP, sun roof opening
73-75	Chevelle w/vinyl top	9736551	1	15.15	WEATHERSTRIP, sun roof opening
75	Chevelle (2-Dr.) w/sun roof	1668449	1	15.15	WEATHERSTRIP, roof opening

NOTE 1: To aid in identifying first design, a metal insert was required to fill void in quarter panel used for tear drop window design. Second design quarter panel will have added metal in sail area.

**12.811 LOUVER, Quarter Stationary Window**

74-75	Laguna	9735917 R.H.	27.50	qtr. stat. window
74-75	Laguna	9735918 L.H.	23.85	qtr. stat. window
75		1745719	12.20	(See Grp. 12.812 for usage)
75		1745718	12.20	(See Grp. 12.812 for usage)
75		9639897	.22	see Group (12.809) for usage
75	X (4-Dr.)	1651461	3.20	VALVE, roof extension panel right side
75	XX69, XY69	1745387 R.H.	12.90	LOUVER, roof extension panel
75	XX69, XY69	1745388 L.H.	12.90	LOUVER, roof extension panel

**12.812 EMBLEM UNIT—PLATE UNIT—PLATE ASSY.—PLATE—MOULDING—COVER—EMBLEM ASSY.—LOUVER—TAPE ASSY.—VALVE ASSY., Roof Panel**

73-75	Monte Carlo w/short vinyl roof w/o pad	9657609	2	4.25	roof panel extension (LANDAU)
73-75	Monte Carlo	9619799	2	4.25	roof extension panel
73-74	Caprice (Spt. Cpe., Sed.)	8707822	2	4.55	roof extension panel (CAPRICE CLASSIC)
74	Impala (Spt. Cpe.) (exc. Custom)	1666455	2	4.25	roof panel w/body emblem (Spirit of America)
73-75	Impala (Custom)	9840507	2	3.55	PLATE, roof extension panel name (IMPALA CUSTOM)
73	Camaro (L.T.)	9630078	2	3.10	PLATE, roof name and rear end extension panel (TYPE L.T.)
73-75	Nova (H.B. Cpe.)	9621962	2	3.70	PLATE, roof name extension (HATCHBACK)
74-75	Camaro (L.T.)	9633382	2	2.80	PLATE, roof name and rear end extension panel (TYPE L.T.)
75	Nova (4-Dr.)	1675599 R.H.	5.70	PLATE, baffle roof ext. panel louver	
67-68	Caprice (Spt. Mdls.)	3914086	2	2.45	PLATE UNIT, ext. name ("Caprice")
69-70	Impala (Custom)	8719724	2	3.40	PLATE ASSY. (Impala Custom) ext.
69-70	Caprice (exc. vinyl top)	8723850	2	2.65	PLATE ASSY. (Caprice) extension
69-70	Caprice w/soft trim cover	8723851	2	2.45	PLATE ASSY. ("Caprice") roof extension panel
71-73	Impala (Sed., Spt. Cpe.) (exc. Custom)	9837199	2	2.40	PLATE ASSY., roof panel name (IMPALA)
71-72	Impala (Custom)	9840507	2	3.55	PLATE ASSY., roof panel name (IMPALA CUSTOM)
70-72	Monte Carlo	9870585	2	2.35	PLATE ASSY., roof panel name (MONTE CARLO)
75	BN39-47-69	9633484	1	3.00	PLATE, kit name roof (Caprice Classic)—(12.116)
75	Monza (Towne Cpe.)	1737450	2	3.00	PLATE, name "Towne Coupe" roof extension panel
75	Camaro (Custom)	1695874	2		PLATE, name roof extension panel type LT—(12.182)
74	Camaro (Custom)	1650500	1		PLATE, name roof panel type LT
70	Camaro w/vinyl top	8809938 R.H.	7.05	MOULDING, ext. panel	
70	Camaro w/vinyl top	8809939 L.H.	7.05	MOULDING, ext. panel	
71-75	Camaro w/vinyl top	9864183 L.H.	7.35	MOULDING, extension panel	
71-75	Camaro w/vinyl top	9864182 R.H.	7.35	MOULDING, extension panel	
71-72	Pass. (Sta. Wag.)	9835253	1	.83	COVER, roof inner panel access hole
71-72	Caprice	9856613	2	4.15	EMBLEM ASSY., roof extension panel name (CAPRICE)
72	Monte Carlo w/vinyl top	9604833	2	2.00	EMBLEM, roof extension panel (custom)

**METAL TRIM—CLIPS AND PANELS**

**12.812 EMBLEM UNIT— PLATE UNIT— PLATE ASSY.— PLATE— MOULDING— COVER— EMBLEM ASSY.— LOUVER— TAPE ASSY.— VALVE ASSY., Roof Panel (Con't)**

75	Nova (4-Dr.)	1745718 R.H.	12.20	LOUVER, extension (paint) Note *1
75	Nova (4-Dr.)	1745719 L.H.	12.20	LOUVER, extension (paint) Note *1
74	Nova	347522 1	18.45	TAPE ASSY., w/Spirit of America
75	Camaro w/Rally Sport Equip.	360698 1	17.75	DECAL, roof stripe (dk. gray-med. gray-lt. gray)
75	Camaro w/Rally Sport Equip.	360699 1	18.75	DECAL, roof stripe (light red-dk. red-med. red)
75	Camaro w/Rally Sport Equip.	360696 1	18.75	DECAL, roof stripe (dk. blue-med. blue-lt. blue)
75	F	360697 1	18.75	DECAL, roof stripe (red-orange-lt. yellow)
75	F	364901 1	18.75	DECAL, roof stripe (orange-yellow orange-yellow)
75	Nova (4-Dr.)	1745387 R.H.	12.90	LOUVER, roof extension panel (paint to match)
75	Nova (4 Dr.)	1745388 L.H.	12.90	LOUVER, roof ext. panel (paint to match)

NOTE \*1: On Chevy models use louver without tail extension.  
NOTE \*2: On Chevy models use Louver with tail extension.

**12.815 CARRIER UNIT— BRACKET— BASE— CAP— CLAMP— COVER UNIT— CROSSMEMBER— EXTENSION— GASKET— INSULATOR— SUPPORT— RAIL— RETAINER— RACK UNIT— NUT— SCREW— STRAP— STRIP ASSY.— WASHER, Roof Luggage and Ski**

70-75	Camaro	994628 1	55.00	lid luggage
73-75	Chevelle (Sta. Wag.) (exc. Classic Estate)	994547 1	72.35	roof luggage length 46— 1/2" x width 37"
71-75	Vega (Sta. Wag.)	994540 1	64.30	roof luggage, length 46 3/4" x width 37 3/4"
74-75	Vega (Hatchback Coupe)	994564 1	64.30	roof luggage, length 37 5/32" x width 30 1/4"
71-72	Pass. (Sta. Wag.)	3995175 L.H.	2.85	BRACKET, cross strap
71-72	Pass. (Sta. Wag.)	3995176 R.H.	2.85	BRACKET, cross strap
64-69	Chevelle (Sta. Wag.),			
65-68	Pass. (Sta. Wag.)	3892101 L.H.	3.20	BASE, support
64-68	Chevelle (Sta. Wag.),			
65-68	Pass. (Sta. Wag.)	3892102 R.H.	3.20	BASE, support
64-66	Chevy (Sta. Wag.),			
65-69	Pass. (Sta. Wag.)	3892104 L.H.	3.15	BASE, support
64-66	Chevy (Sta. Wag.),			
65-69	Pass. (Sta. Wag.)	3892103 R.H.	3.15	BASE, support
65-68	Pass., Chevelle (Sta. Wag.)	3843511 1	2.40	BASE, center, support
67-70	Pass. (Sta. Wag.),			
69-72	Chevelle (Sta. Wag.)	3897554 1	3.70	BASE, ctr. support (w/986898, 993620)
71-75	Vega (Sta. Wag.),			
75	Vega (Hatchback Cpe.)	3991362 2	6.70	BASE, roof luggage carrier support L.H.
71-75	Vega (Sta. Wag.),			
75	Vega (Hatchback Cpe.)	3991363 2	6.70	BASE, roof luggage carrier support R.H.
69-70	Pass., Chevelle (Sta. Wag.),			
71-72	Chevelle (Sta. Wag.)	1387570 R.H.	9.85	BASE, support (w/993620)
69-70	Pass., Chevelle (Sta. Wag.),			
71-72	Chevelle (Sta. Wag.)	1387571 L.H.	9.85	BASE, support (w/993620)
69	Chevelle (Sta. Wag.),			
71	Chevelle (Sta. Wag.)	3897554 1	3.70	BASE, center, carrier support
71-75	Vega (Sta. Wag.),			
75	Vega (Coupe)	3991362 2	6.70	BASE, roof luggage carrier support L.H.
71-75	Vega (Sta. Wag.),			
75	Vega (Coupe)	3991363 2	6.70	BASE, roof luggage carrier support R.H.
73	Camaro	3931559 A.R.	.28	CAP, deck lid luggage rack tube closure
75	Monza (exc. Towne Cpe.)	994798 1	64.30	CARRIER PACKAGE, roof luggage
75	Nova (2-Dr.) Hatchback Cpe.	994794 1	64.30	CARRIER PKG., roof luggage
71-72	Chevelle (Sta. Wag.)	3897588 2	.54	CLAMP, rr. rail ext.
75	Vega, Nova	995156 1	49.50	COVER PKG., roof luggage carrier
73-75	Chevelle (Sta. Wag.)	994697 1	52.75	COVER UNIT, roof luggage carrier (36" x 48")
73-75	Pass. (Sta. Wag.)	994698 1	52.75	COVER UNIT, roof luggage carrier
65-69	Pass. (Sta. Wag.),			
71-75	Vega (Sta. Wag.),			
75	Monza (2-Dr.)	368826 2	12.90	CROSSMEMBER, roof luggage carrier
71-72	Chevelle (Sta. Wag.)	3907699 2	3.85	EXTENSION, rr. rail (w/986898-993620)
69-70	Pass., Chevelle (Sta. Wag.),			
71-72	Chevelle (Sta. Wag.)	1387590 2	6.60	EXTENSION, rear side rail (w/993620)
69-70	Pass., Chevelle (Sta. Wag.),			
71-72	Chevelle (Sta. Wag.)	3949271 2	9.80	EXTENSION, front side rail (w/993620)
74-75	Vega (Hatchback Cpe.)	3834282 A.R.	.22	GASKET, support base center
65-69	Chevelle (Sta. Wag.),			
65-68	Pass. (Sta. Wag.)	3843512 4	.26	GASKET, support base corner



**METAL TRIM—CLIPS AND PANELS**

**12.815 CARRIER UNIT— BRACKET— BASE— CAP— CLAMP— COVER UNIT—  
CROSSMEMBER— EXTENSION— GASKET— INSULATOR— SUPPORT—  
RAIL— RETAINER— RACK UNIT— NUT— SCREW— STRAP— STRIP  
ASSY.— WASHER, Roof Luggage and Ski (Con't)**

67-68	Pass. (Sta. Wag.)	3897558	4	.17	GASKET, support base
67-70	Pass. (Sta. Wag.),				
69-72	Chevelle (Sta. Wag.)	3907678	1	.37	GASKET, support base center (w/986898, 993620)
69-70	Pass., Chevelle (Sta. Wag.),				
71-72	Chevelle (Sta. Wag.)	3949260	4	.25	GASKET, support base (w/993620)
71-72	Pass. (Sta. Wag.)	9851460	A.R.	.48	GASKET, luggage carrier center skid strip (factory installed unit)
71-75	Pass. (Sta. Wag.)	9851459	5	.61	GASKET, inner and outer skid strip (factory installed unit)
71-75	Pass. (Sta. Wag.)	9846023	2	1.00	GASKET, front support side roof lugg. carr.
71-75	Pass. (Sta. Wag.)	9846474	2	1.25	GASKET, front rail support rear
73-75	Pass. (Sta. Wag.)	9851460	A.R.	.48	GASKET, center skid strip
73-75	Chevelle (Sta. Wag.)	9657705	4	3.80	GASKET, lug. carrier rail support
73-75	Chevelle (Sta. Wag.)	9617556	1	.23	GASKET, skid strip lug. carrier
74-75	BL35-45, BN35-45	9845349	1	.95	GASKET, roof luggage carrier front support
75	Monza, Nova (2 Dr.)	360622	4	1.85	GASKET, roof lugg. carr. front side rail support
65-71	All	3788017	A.R.	.18	INSULATOR, strap (6" long) (Note 4)
65-71	All	3866577	A.R.	2.30	INSULATOR, strap (25 ft. roll) (curved surface) (3/32" thick) (Note 4 & 8)
71	Pass. (Sta. Wag.)	3866578	2		INSULATOR, inner (repl. 3995151)
71	Pass. (Sta. Wag.)	3995152	3	1.35	INSULATOR, outer
73-74	Vega (Hatchback Cpe.)	399024	1	206.60	INSULATOR, roof lug. carrier
75	Nova (2 Dr.)	360625	5	4.10	INSULATOR, roof lugg. carr. longitudinal strap
75	Nova (2 Dr.)	368847	5	3.60	INSULATOR, roof lugg. carr. longitudinal strap
<i>NOTE 1 On Chevy models use with carrier with rigid type rail supports.</i>					
<i>NOTE 2 Use with carrier with pivot type rail supports.</i>					
64-67	Chevy (Sta. Wag.),				
65-75	Pass. (Sta. Wag.)	3851622	R.H.	4.80	SUPPORT, front
64-67	Chevy (Sta. Wag.),				
65-75	Pass. (Sta. Wag.)	3851621	L.H.	4.80	SUPPORT, front
64-68	Chevelle (Sta. Wag.),				
65-68	Pass. (Sta. Wag.)	3843503	1	6.60	SUPPORT, center
64-67	Chevy, Chevelle (Sta. Wag.),				
65-69	Pass. (Sta. Wag.),				
68	Chevelle (Sta. Wag.)	3834274	R.H.	4.90	SUPPORT, rear
64-67	Chevy, Chevelle (Sta. Wag.),				
65-69	Pass. (Sta. Wag.),				
68	Chevelle (Sta. Wag.)	3834273	L.H.	4.90	SUPPORT, rear
64-65	Chevelle (Sta. Wag.),				
69-70	Pass., Chevelle (Sta. Wag.),				
71-72	Chevelle (Sta. Wag.)	1387572	R.H.	6.55	SUPPORT, side (w/993620)
69-70	Pass., Chevelle (Sta. Wag.),				
71-72	Chevelle (Sta. Wag.)	1387573	L.H.	6.55	SUPPORT, side (w/993620)
69-70	Pass., Chevelle (Sta. Wag.)	3949268	1	6.80	SUPPORT, center (w/993620)
71-75	Pass. (Sta. Wag.)	9845893	L.H.	13.60	SUPPORT, rear rail side
71-75	Pass. (Sta. Wag.)	9845892	R.H.	13.60	SUPPORT, rear rail side
71-75	Pass. (Sta. Wag.)	9845959	L.H.	11.65	SUPPORT, front rail side
71-75	Pass. (Sta. Wag.)	9845958	R.H.	11.65	SUPPORT, front rail side
71-75	Pass. (Sta. Wag.)	9845960	1	8.30	SUPPORT, front rail center
71	Chevelle (Sta. Wag.)	3949268	1	6.80	SUPPORT, center
74-75	AC-AD-AG35	9881126	R.H.	12.00	SUPPORT, luggage carrier rail
74-75	AC-AD-AG35	9881127	L.H.	12.00	SUPPORT, luggage carrier rail
75	Monza, Nova (2 Dr.)	360618	2	20.10	SUPPORT, roof luggage carrier R.H. frt. & L.H. rear
75	Monza, Nova (2 Dr.)	360619	2	20.10	SUPPORT, roof luggage carrier L.H. frt. & R.H. rear
65-68	Pass. (Sta. Wag.)	3889472	R.H.	8.00	RAIL, front
65-68	Pass. (Sta. Wag.)	3889474	R.H.	9.40	RAIL, side
65-68	Pass. (Sta. Wag.)	3891456	1	9.40	RAIL, rear
65-68	Pass. (Sta. Wag.)	3889471	L.H.	8.00	RAIL, front
69-72	Chevelle (Sta. Wag.)	3950010	1	12.75	RAIL, rear (w/993686)
69-72	Chevelle (Sta. Wag.)	3950011	2	10.25	RAIL, front (w/993686)
69-72	Chevelle (Sta. Wag.)	3950014	R.H.	21.15	RAIL ASSY., side (w/993686)
69-70	Pass. (Sta. Wag.)	3949264	1	10.05	RAIL, rear (w/993620)
69-70	Pass. (Sta. Wag.)	3949265	2	13.65	RAIL, front (w/993620)
69-70	Pass. (Sta. Wag.)	3949269	L.H.	11.45	RAIL ASSY., side (w/993620)
69-70	Pass. (Sta. Wag.)	3949270	R.H.	17.05	RAIL ASSY., side (w/993620)
71-75	Vega (Sta. Wag.)	3991361	2	11.70	RAIL, roof luggage carrier end

METAL TRIM—CLIPS AND PANELS

**12.815 CARRIER UNIT— BRACKET— BASE— CAP— CLAMP— COVER UNIT— CROSSMEMBER— EXTENSION— GASKET— INSULATOR— SUPPORT— RAIL— RETAINER— RACK UNIT— NUT— SCREW— STRAP— STRIP ASSY.— WASHER, Roof Luggage and Ski (Con't)**

71-75	Vega (Panel, Sta. Wag.)	3991360	2	16.90	RAIL, roof luggage carrier side
71-75	Pass. (Sta. Wag.)	9844801	1	11.30	RAIL, rear
71-75	Pass. (Sta. Wag.)	9844848	R.H.	5.95	RAIL, front
71-75	Pass. (Sta. Wag.)	9844849	L.H.	5.95	RAIL, front
71-75	Pass. (Sta. Wag.)	9845068	2	10.65	RAIL, side
73-75	Chevelle (Sta. Wag.)	9881130	2	13.45	RAIL, lug. carrier side
73-75	Chevelle (Sta. Wag.)	9881131	2	14.45	RAIL, lug. carrier/front/rear
74-75	Vega (Hatchback Cpe.)	339021	2	25.50	RAIL, roof luggage carrier side
74-75	Vega (Hatchback Cpe.)	339022	2	22.00	RAIL, roof luggage carrier end
75	Nova (2 Dr.)	360620	2	16.50	RAIL, roof lugg. carrier front & rear
75	Nova (2 Dr.)	360621	2	14.40	RAIL, roof lugg. carrier side
75	Monza (2 Dr.)	368804	2	11.05	RAIL, roof lugg. carrier side
75	Monza (2 Dr.)	368805	2	14.70	RAIL, roof lugg. carrier rear
72-75	Pass. (Sta. Wag.)	327182	6	.28	RETAINER, roof lugg. car. strap
73-75	Chevelle (Sta. Wag.)	331743	4	1.60	RETAINER, roof lugg. car. strip
74-75	F	3975867	6	.88	RETAINER, deck lid luggage carrier
73-75	Chevelle (Sta. Wag.)	331745	4	3.10	RETAINER ASSY., roof lugg. car. retainer strip
73	Pass., Chevelle, Nova	993782	1	50.75	RACK UNIT, ski demountable
65-75	All	528846	A.R.	.27	NUT, carrier to roof, deck lid carrier mounting (1/4"— 20, special sealing)
74-75	Camaro	342271	6	.22	NUT, deck lid lugg. carrier sealing
73-74	Pass., Chevelle, Nova (Sta. Wag., El Camino)	528846	A.R.	.27	NUT ASSY., support base (1/4"— 20)
	<i>NOTE 4 Cut as required.</i>				
	<i>NOTE 8 Furnished in 25 foot rolls.</i>				
65-69	All	3892100	4	.12	SCREW, cross strap to support, rail to frame (8— 32 x 1 1/8")
65-69	All	9419728	1	.16	SCREW, luggage carrier to base
66-68	All (exc. Sta. Wag., El Camino)	3895152	4	.16	SCREW (1/4"— 20 x 3/4")
67-70	Pass. (Sta. Wag.)				
69-72	Chevelle (Sta. Wag.)	3897590	2	.16	SCREW, rr. rail ext. clamp (1/4"— 20 x 3/4")
67-68	Pass. (Sta. Wag.)	3897592	4	.11	SCREW, cross strap (8— 32 x 5/8")
67-69	Pass., Chevelle (Sta. Wag.)				SCREW, luggage carrier supt. screw 10— 24 x .500
67-69	Pass. (Sta. Wag.)	9425160	4	.06	SCREW, otr. support (w/986898) (10— 24 x 3/4")— (8.909)
67-68	Pass. (Sta. Wag.)	3907697	4	.13	SCREW (w/986898) (10— 24 x 1 1/16")
69	Pass. (Sta. Wag.)				
71-72	Chevelle (Sta. Wag.)	9428175	A.R.	.16	SCREW, carrier frt. and rr. base, t/gate window air defl.
68	Pass., Chevelle (Sta. Wag.)				
74-75	Monza, Vega, Nova (2 Dr.)	3837709	8	.13	SCREW, roof lugg. carr. end rail extension
75	Vega (Panel, Sta. Wag.)	9775974	5	.16	SCREW ASSY., roof support
71-72	Pass. (Sta. Wag.)	3995154	4	.18	SCREW, cross strap bracket (to body) (oval head cross recess) (8— 18 x 3/4")
71-72	Pass. (Sta. Wag.)	9428418	10	.13	SCREW, lug. car. supt. rail to supt.
71-72	Pass. (Sta. Wag.)	9432510	10	.16	SCREW, lug. car./skid str. to pnl.
71-75	Vega (Sta. Wag.)	3994758	2	.12	SCREW, roof luggage carrier support base (10— 32 x 3/4")
71-75	Vega (Panel, Sta. Wag.)	3892100	4	.12	SCREW, roof lug. carrier strap
73-74	Chevelle (Sta. Wag.)	9428418	10	.13	SCREW, lug. car. rail to supt.
73-75	Pass. (Sta. Wag.)	9433365	10	.16	SCREW, lugg. carrier support to body (ov hd-10— 16 3/4")
65-70	Pass. (Sta. Wag.)	3880988	2	5.65	STRAP, carrier inner (w/986134-898-993620)
65-70	Pass. (Sta. Wag.)	3880990	2	4.80	STRAP, carrier rack outer (w/986134-898-993620)
68-72	Chevelle (Sta. Wag.)	3927602	2	4.95	STRAP, outer
68-72	Chevelle (Sta. Wag.)	3927604	2	4.95	STRAP, center
68-72	Chevelle (Sta. Wag.)	3927606	2	5.90	STRAP, center
65-70	Pass. (Sta. Wag.)	3880989	2	5.55	STRAP, carrier rack center (w/986134-898-993620)
65-69	Pass. (Sta. Wag.)	3880990	2	4.80	STRAP, carrier rack outer (w/986134-898-993620)
71	Pass. (Sta. Wag.)	3995147	L.H.	5.25	STRAP, outer (Note 7)
71	Pass. (Sta. Wag.)	3995148	R.H.	5.25	STRAP, outer (Note 7)
71	Pass. (Sta. Wag.)	3995150	2	5.65	STRAP, inner (Note 7)
71	Pass. (Sta. Wag.)	3995185	1	5.65	STRAP, inner center (Note 7)
71-75	Vega (Sta. Wag.)	3991364	6	4.60	STRAP, roof luggage carrier
72-75	Pass. (Sta. Wag.)	327179	2	4.60	STRAP, roof lugg. car., outer
72-75	Pass. (Sta. Wag.)	327180	1	4.10	STRAP, roof lugg. car., center

**METAL TRIM—CLIPS AND PANELS**

**12.815 CARRIER UNIT— BRACKET— BASE— CAP— CLAMP— COVER UNIT— CROSSMEMBER— EXTENSION— GASKET— INSULATOR— SUPPORT— RAIL— RETAINER— RACK UNIT— NUT— SCREW— STRAP— STRIP ASSY.— WASHER, Roof Luggage and Ski (Con't)**

72-75	Pass. (Sta. Wag.)	327181	2	4.60	STRAP, roof lugg. car., inner
72-75	Pass. (Sta. Wag.)	327183	2	2.70	STRAP, roof lugg. car., cross L.H.
72	Pass. (Sta. Wag.)	327184	2	2.70	STRAP, roof lugg. car., cross R.H.
73-75	Vega (Hatchback Cpe.)	339023	6	17.85	STRAP, roof luggage carrier inr.
73-75	Vega (Hatchback Cpe.)	339025	2	15.90	STRAP, roof luggage carrier inr.
71	Pass. (Sta. Wag.)	3995149	2	5.95	STRAP ASSY., cross (Note 7)
71-75	Vega (Sta. Wag.)	3991366	2	5.60	STRAP ASSY., roof luggage carrier
69-72	Chevelle (Sta. Wag.)	3950019	2	5.30	STRAP ASSY., cross (w/993686)
65-70	Pass. (Sta. Wag.)	3965109	2	5.50	STRAP ASSY., carrier rack cross
75	Nova (2 Dr.)	360623	5	10.80	STRAP, roof lugg. carr. longitudinal
75	Nova (2 Dr.)	360624	2	14.15	STRAP, roof lugg. carr. cross
<i>NOTE 7: Used with all package 994158</i>					
71-75	Pass. (Sta. Wag.)	9839263	2	6.10	STRIP ASSY., luggage carrier skid inner (factory installed unit)
71-75	Pass. (Sta. Wag.)	9839264	A.R.	5.70	STRIP ASSY., luggage carrier skid outer and center (factory installed)
73-75	Chevelle (Sta. Wag.)	9881132	5	6.10	STRIP ASSY., skid lug. carrier
73-75	Chevelle (Sta. Wag.)	331741	3	9.05	STRIP ASSY., roof lugg. car. inner
73-75	Chevelle (Sta. Wag.)	331742	2	9.05	STRIP ASSY., roof lugg. car. outer
73-75	Chevelle (Sta. Wag.)	331744	2	5.65	STRIP ASSY., roof lugg. car. retainer outer
75	Monza (2 Dr.)	368842	5	8.75	STRIP, roof lugg. carr. longitudinal
<i>NOTE 3 Used with carrier No. 986326.</i>					
67-70	Pass., Chevelle (Sta. Wag.)				
67-70	Pass., Chevelle (Sta. Wag.)				
71-72	Pass. (Sta. Wag.)	4860758	10	.11	WASHER, lug. carrier supt. to pnl.
74-75	Camaro	342273	6	.11	WASHER, deck lid lugg. carrier
<i>NOTE 7: Not to be used with roof lugg. carrier equipment.</i>					

**12.815A RACK UNIT— RACK ASSY.— CLIP— COVER UNIT, Roof Ski**

69	All,				
70	All exc. Camaro,				
71-72	Pass., Chevelle, Nova	993782	1	50.75	demountable ski
71-72	Pass. (Sta. Wag.)	3995156	6	1.15	CLIP, outer strap
71-72	Pass. (Sta. Wag.)	994698	1	52.75	COVER UNIT, roof luggage carrier

**12.815B CAP— SUPPORT— PLATE— SCREW— PIN— SLEEVE— RACK ASSY., Luggage Deck Lid**

67-69	Pass., Chevelle, Nova (exc. Sta. Wag.),				
70-72	All (exc. Sta. Wag., Vega)	3931559	A.R.	.28	tube closure
65	All	3874264	2	1.65	SUPPORT, frt. (1 1/4" long)
71-74	Vega (Panel, Sta. Wag.)	3851621	L.H.	4.80	SUPPORT, roof luggage carrier front
71-74	Vega (Panel, Sta. Wag.)	3851622	R.H.	4.80	SUPPORT, roof luggage carrier front
71-75	Vega (Sta. Wag.),				
75	Vega (Panel, Coupe)	3834273	L.H.	4.90	SUPPORT, roof luggage carrier rear
71-75	Vega (Sta. Wag.),				
75	Vega (Panel, Coupe)	3834274	R.H.	4.90	SUPPORT, roof luggage carrier rear
65-66	Chevelle, Chevy,				
65	Pass.,				
69-70	Camaro	3874282	4	1.65	PLATE, mounting
66-68	Pass., Chevelle (exc. Sta. Wag., El Camino),				
69-70	Camaro	3895152	4	.16	SCREW (1/4"— 20 x 3/4")

**12.840 PANEL— PLUG— SUPPORT, Front Body Hinge**

**PASS.**

69-70	Pass. (Conv.)	9803878	R.H.	67.25	pillar
71-75	Pass. (Spt. Cpe., Spt. Sed.)	9697528	L.H.	114.00	pillar
71-75	Pass. (Spt. Cpe., Spt. Sed.)	9659442	R.H.	114.00	pillar
71-75	Impala (Conv.)	9697529	L.H.	109.00	pillar
71-75	Impala, Caprice (Conv.)	9829310	R.H.	91.25	pillar
71-75	Pass. (4-Dr.) (exc. Spt. Sed.)	9659441	L.H.	83.00	pillar
71-75	Pass. (4-Dr.) (exc. Spt. Sed.)	9679990	R.H.	99.50	pillar

**CHEVELLE**

68-69	Chevelle (Conv.)	8800620	R.H.	72.25	pillar (repl. 8740730)
69-72	Chevelle (4-Dr.) (exc. Spt. Sed.)	8800616	R.H.	70.75	pillar
69-72	Chevelle (4-Dr.) (exc. Spt. Sed.)	8800617	L.H.	70.75	pillar
69	Chevelle (Spt. Sed.)	8800622	R.H.	72.25	pillar (repl. 8740724)
69	Chevelle (2-Dr. Sed.),				

**METAL TRIM—CLIPS AND PANELS**

**12.840 PANEL— PLUG— SUPPORT, Front Body Hinge (Con't)**

69-72	El Camino	8800614 R.H.	70.75	pillar
69	Chevelle (2-Dr. Sed.)			
69-72	El Camino	8800615 L.H.	70.75	pillar
69-72	Chevelle (Spt. Cpe.)	8800618 R.H.	72.25	pillar
69-72	Chevelle (Spt. Cpe.)	8800619 L.H.	72.25	pillar
70-72	Chevelle (Conv.)	8800620 R.H.	72.25	pillar
70-72	Chevelle (Conv.)	8800621 L.H.	72.25	pillar
70-72	Chevelle (Spt. Sed.)	8800622 R.H.	72.25	pillar
70-72	Chevelle (Spt. Sed.)	8800623 L.H.	72.25	pillar
73-75	Chevelle	9672996 R.H.	82.25	pillar lower
73-75	Chevelle	9672997 L.H.	82.25	pillar lower
73	Chevelle (Spt. Cpe.) El Camino	9878679 L.H.	30.00	pillar upper
73-75	Chevelle (4-Dr.)	9672994 R.H.	30.75	pillar upper
73-75	Chevelle (4-Dr.)	9672995 L.H.	30.75	pillar upper
73-75	Chevelle (2-Dr.)	9673010 R.H.	30.00	pillar upper
74-75	Chevelle (2-Dr.)	9673011 L.H.	30.00	pillar upper

**NOVA**

69-74	Chevy (4-Dr. Sed.)	9673873 R.H.	69.50	pillar
69-72	Chevy (4-Dr. Sed.)	8780607 L.H.	74.25	pillar
69-74	Chevy (Spt. Cpe.)	9673871 R.H.	74.25	pillar
69-74	Chevy (Spt. Cpe.)	9673872 L.H.	74.25	pillar
72	Nova (4-Dr.)	9605334 R.H.	69.50	pillar
73	Nova (4-Dr.)	9673874 L.H.	69.50	pillar (repl. 9622037)
74	Nova (4-Dr.)	9673874 L.H.	69.50	pillar
75	Nova	1723070 R.H.	54.00	PANEL ASSY., pillar
75	Nova	1723071 L.H.	54.00	PANEL ASSY., pillar

**CAMARO**

68	Camaro (Spt. Cpe.)	8736511 L.H.	68.00	pillar
70-75	Camaro	9739598 R.H.	45.25	plr. lower
70-75	Camaro	9739599 L.H.	45.25	plr. lower
70-75	Camaro	9739508 R.H.	26.75	plr. upper
70-72	Camaro	9739509 L.H.	26.75	plr. upper (repl. 9868293)
73-75	Camaro	9739509 L.H.	26.75	pillar upper

**VEGA — MONZA**

71-75	Vega (Panel, Cpe., Sta. Wag. Cpe.)	9808436 L.H.	23.05	
71-75	Vega (Panel, Cpe., Sta. Wag.)	9808435 R.H.	23.05	
75	Monza (exc. Towne Cpe.)	1691793 R.H.	25.50	
75	Monza (exc. Towne Cpe.)	1691794 L.H.	25.50	
75	Monza (Towne Cpe.)	1739847 R.H.	22.30	(repl. 1694393)
75	Monza (Towne Cpe.)	1739848 L.H.	22.30	(repl. 1694394)
66-70	Chevy, Camaro,			
69-72	Chevelle	4805843 1	.22	PLUG, front body hinge pillar antenna hole— (12.981)
69-74	Pass.	8761874 1	.18	PLUG, front body hinge pillar antenna hole
68	Chevelle (Sta. Wag., I Camino) (exc. Concours)	4770719 A.R.	.12	PLUG, pillar switch— (10.694)
75	Pass.	8779680 2	.16	PLUG, upper cowl gage drain hole

**12.895 PANEL— PANEL ASSY.— BAR ASSY., Front Door Outer**

**PASSENGER**

65-66	Sed. (2-Dr.)	4495143 R.H.	62.75	
65-66	Sed. (2-Dr.)	4495144 L.H.	62.75	
65-66	4-Dr. (exc. Spt. Sed.)	4495156 R.H.	59.75	
65-66	4-Dr. (exc. Spt. Sed.)	4495157 L.H.	59.75	
65-66	Spt. Sed.	4495162 R.H.	59.75	
65-66	Spt. Sed.	4495163 L.H.	59.75	
65-66	Spt. Cpe., Conv.	4495150 R.H.	62.75	
65-66	Spt. Cpe., Conv.	4495151 L.H.	62.75	
71-75	Pass. (4-Dr.)	9672890		
71-74	Pass. (2-Dr.)	9619056 R.H.	62.75	
71-74	Pass. (2-Dr.)	9685203		
67	Biscayne, Bel Air (2-Dr.)	7660439 L.H.	62.75	PANEL ASSY.
67	Spt. Cpe., Conv.	7660440 R.H.	62.75	PANEL ASSY.
67	Spt. Cpe., Conv.	7660441 L.H.	62.75	PANEL ASSY.
67	Spt. Sed.	7660442 R.H.	59.75	PANEL ASSY.
67	Spt. Sed.	7660443 L.H.	59.75	PANEL ASSY.
67	Pass. (4-Dr.) (exc. Spt. Sed.)	7660444 R.H.	59.75	PANEL ASSY.
67	Pass. (4-Dr.) (exc. Spt. Sed.)	7660445 L.H.	59.75	PANEL ASSY.
68	2-Dr. Sed.	7748879 L.H.	62.75	PANEL ASSY.

**METAL TRIM—CLIPS AND PANELS**

**12.895 PANEL— PANEL ASSY.— BAR ASSY., Front Door Outer (Con't)**

68	Caprice (Spt. Cpe.)	7748884 R.H.	62.75	PANEL ASSY.
68	Caprice (Spt. Cpe.)	7748885 L.H.	62.75	PANEL ASSY.
68	Impala (Spt. Cpe., Conv.)	7748888 R.H.	62.75	PANEL ASSY.
68	Impala (Spt. Cpe., Conv.)	7748889 L.H.	62.75	PANEL ASSY.
68	Spt. Sed.	7748916 R.H.	59.75	PANEL ASSY.
68	Spt. Sed.	7748917 L.H.	59.75	PANEL ASSY.
68	Sta. Wag., 4-Dr. Sed. (exc. Spt. Sed.)	7748922 R.H.	59.75	PANEL ASSY.
68	Sta. Wag., 4-Dr. Sed. (exc. Spt. Sed.)	7748923 L.H.	59.75	PANEL ASSY.
69-70	4-Dr. Spt. Sed.	9808821 R.H.	59.75	PANEL ASSY.
69-70	4-Dr. Spt. Sed.	9808822 L.H.	59.75	PANEL ASSY.
69	Biscayne, Bel Air (2-Dr.)	8728778 R.H.	62.75	PANEL ASSY.
69-70	Impala, Caprice (2-Dr.)	9803438 R.H.	62.75	PANEL ASSY.
69-70	Impala, Caprice (2-Dr.)	9803439 L.H.	62.75	PANEL ASSY.
69-70	4-Dr. (exc. Spt. Sed.)	7750104 R.H.	59.75	PANEL ASSY.
69-70	4-Dr. (exc. Spt. Sed.)	8728801 1	59.75	PANEL ASSY., left
71-74	Pass. (4-Dr.)	9682611 L.H.	59.75	PANEL ASSY.
75	Pass. (4-Dr.)	1664420 L.H.	59.75	PANEL ASSY.
75	Pass. (2-Dr.)	1664023 L.H.	62.75	PANEL ASSY.
75	Pass. (2-Dr.)	9672888 R.H.	62.75	PANEL ASSY.
73	Pass. (4-Dr.) (1st design)	9645200 2	21.75	BAR ASSY., panel (Note 1, 2)
73	Pass. (4-Dr.) (2nd design)			
74-75	Pass. (4-Dr.)	9665142 2	26.00	BAR ASSY., panel (Note 1, 3)
73	Pass. (2-Dr.)	9624261 2	29.25	BAR ASSY., panel (Note 1)
74-75	Pass. (2-Dr.)	9665143 2	35.00	BAR ASSY., panel
72	Pass. (2-Dr.)	9816010 2	29.25	BAR ASSY., panel
72	Pass. (4-Dr.)	9816011 2	21.75	BAR ASSY., panel

**CHEVY— NOVA**

62-65	Chevy (2-Dr. Sedan)	4845015 L.H.	53.25	
62-65	Nova (Spt. Cpe., Conv.)	4892945 R.H.	53.25	(Note 1)
62-65	Nova (Spt. Cpe., Conv.)	4892946 L.H.	53.25	(Note 1)
<i>NOTE 1 These doors do not have holes for attaching mouldings.</i>				
62-65	Chevy (4-Dr.)	4834051 R.H.	48.00	
62-65	Chevy (4-Dr.)	4834052 L.H.	48.00	
66-67	Chevy (4-Dr.)	4512146 R.H.	48.00	
66-67	Chevy (4-Dr.)	7695738 L.H.	48.00	
66-67	Chevy (Spt. Cpe.)	4545232 R.H.	53.25	
66-67	Chevy (Spt. Cpe.)	7695740 L.H.	53.25	
66-67	Chevy (2-Dr. Sed.)	4545230 R.H.	53.25	
66-67	Chevy (2-Dr. Sed.)	7695736 L.H.	53.25	
68	Chevy (4-Dr. Sed.)	7788954 R.H.	48.00	
68	Chevy (4-Dr. Sed.)	7742285 L.H.	48.00	
68-72	Chevy (Spt. Cpe.)	7788952 R.H.	53.25	
68-72	Chevy (Spt. Cpe.)	9877669 L.H.	53.25	
69-72	Chevy, Nova (4-Dr. Sed.) (New York Taxi)	8760405 R.H.	48.00	
69-72	Chevy, Nova (4-Dr. Sed.) (New York Taxi)	8760411 L.H.	48.00	
73-75	Nova (4-Dr.) (exc. New York Taxi)	9624987 L.H.	48.00	
73-75	Nova (4-Dr.) (exc. New York Taxi)	9879028 R.H.	48.00	
73-75	Nova (2-Dr.)	9611759 L.H.	53.25	
73-75	Nova (2-Dr.)	9879026 R.H.	53.25	
73	Nova (4-Dr.) (1st design)	9648138 2	24.30	BAR ASSY., panel (Note 2)
73	Nova (2-Dr.) (1st design)	9648137 2	34.00	BAR ASSY., panel (Note 2)
73-75	Nova (4-Dr.) (2nd design)	9665247 2	24.30	BAR ASSY., panel (Note 1, 3)
73-75	Nova (2-Dr.) (2nd design)	9667737 2	40.75	BAR ASSY., panel (Note 1, 3)
75	Nova (4-Dr.)	1690420 2	40.75	BAR ASSY., panel (Note 1)

**CHEVELLE**

64-65	Chevelle Std. (2-Dr.), El Camino	4408658 R.H.	53.25
64-65	Chevelle (Spt. Cpe., Conv.)	4408660 R.H.	53.25
64-65	Chevelle (Spt. Cpe., Conv.)	4408661 L.H.	53.25
64-65	Chevelle (4-Dr.)	4883657 R.H.	49.25
64-65	Chevelle (4-Dr.)	4492553 L.H.	49.25
66-67	Chevelle (2-Dr. Sed.), El Camino	7580476 R.H.	53.25
66-67	Chevelle (2-Dr. Sed.), El Camino	7695726 L.H.	53.25
66-67	Chevelle (Spt. Cpe., Conv.)	7580478 R.H.	53.25
66-67	Chevelle (Spt. Cpe., Conv.)	7695728 L.H.	53.25

**METAL TRIM—CLIPS AND PANELS**

**12.895 PANEL— PANEL ASSY.— BAR ASSY., Front Door Outer (Con't)**

66-67	Chevelle (4-Dr.) (exc. Spt. Sed.)	4498502 R.H.	49.25	
66-67	Chevelle (4-Dr.) (exc. Spt. Sed.)	7695732 L.H.	49.25	
66-67	Chevelle (Spt. Sed.)	7695730 L.H.	49.25	
68-72	El Camino	8800996 R.H.	53.25	
68-72	El Camino	8800997 L.H.	53.25	
68-69	Chevelle (2-Dr. Cpe.)	7742312 R.H.	53.25	
68-69	Chevelle (2-Dr. Cpe.)	7742313 L.H.	53.25	
68	Chevelle (Spt. Cpe., Conv.)	7742316 R.H.	53.25	
68	Chevelle (Spt. Cpe., Conv.)	7742317 L.H.	53.25	
68-69	Chevelle (4-Dr.) (exc. Spt. Sed.)			
70-72	Chevelle (Sta. Wag.)	7742352 R.H.	49.25	
68-69	Chevelle (4-Dr.) (exc. Spt. Sed.)			
70-72	Chevelle (Sta. Wag.)	7742353 L.H.	49.25	
68-69	Malibu (Spt. Sed.)	7742356 R.H.	49.25	
68-69	Malibu (Spt. Sed.)	7742357 L.H.	49.25	
69	Chevelle (Spt. Cpe., Conv.)	8716928 R.H.	53.25	
69	Chevelle (Spt. Cpe., Conv.)	8716929 L.H.	53.25	
70	Malibu (Spt. Cpe., Conv.)			
71-72	Chevelle (Spt. Cpe., Conv.) (exc. Monte Carlo)	8809736 R.H.	53.25	
70-72	Monte Carlo	8809738 R.H.	55.00	
70-72	Chevelle (Spt. Cpe., Conv.) exc. Monte Carlo	9867776 L.H.	53.25	outer
71-72	Monte Carlo	9867777 L.H.	55.00	
70-72	Malibu (Spt. Sed.)	9876030 R.H.	49.25	
70-72	Malibu (Spt. Sed.)	9876031 L.H.	49.25	
70	Chevelle (Sta. Wag.)	7742352 R.H.	49.25	
70	Chevelle (Sta. Wag.)	7742353 L.H.	49.25	
70-72	Malibu (Sed.) (exc. Spt. Sed.)	8809804 R.H.	49.25	
70-72	Malibu (Sed.) (exc. Spt. Sed.)	8809805 L.H.	49.25	
73-75	Chevelle (2-Dr.) (exc. Monte Carlo)	9623805 L.H.	59.00	(Note 1)
73-75	Chevelle (2-Dr.) (exc. Monte Carlo)	9830686 R.H.	59.00	
73-75	Chevelle (4-Dr.)	9623855 L.H.	56.00	(Note 1)
73-75	Chevelle (4-Dr.)	9830680 R.H.	56.00	
73-74	Monte Carlo	9830704 R.H.		
73-74	Monte Carlo	9623809 L.H.	59.00	(Note 1)
75	Monte Carlo	1659571 L.H.	59.00	
75	Monte Carlo	9674285 R.H.	53.50	
72	Chevelle (2-Dr.)	9888112 R.H.	28.00	BAR ASSY., panel
72	Chevelle (2-Dr.)	9888113 L.H.	28.00	BAR ASSY., panel
72	Chevelle (4-Dr.)	8781151 R.H.	22.30	BAR ASSY., panel
72	Chevelle (4-Dr.)	8781152 L.H.	22.30	BAR ASSY., panel
73	Chevelle (2-Dr.) (1st design)	9601434 L.H.	37.75	BAR ASSY., panel (Note 1, 2)
73	Chevelle (2-Dr.) (1st design)	9601433 R.H.	37.75	BAR ASSY., panel (Note 1, 2)
73	Chevelle (4-Dr.) (1st design)	9601436 L.H.	28.25	BAR ASSY., panel (Note 1, 2)
73	Chevelle (4-Dr.) (1st design)	9601435 R.H.	28.25	BAR ASSY., panel (Note 1, 2)
73-74	Chevelle (4-Dr.) (2nd design)	9661195 R.H.	28.25	BAR ASSY., panel (Note 1, 3)
73-75	Chevelle (2-Dr.)	9736181 R.H.	45.25	BAR ASSY., panel
73-75	Chevelle (2-Dr.)	1656923 L.H.	45.25	BAR ASSY., panel (Note 1, 3)
73-75	Chevelle (4-Dr.) (2nd design)	1656922 L.H.	34.00	BAR ASSY., panel (Note 1, 3)
75	Chevelle (4-Dr.)	9736180 R.H.	25.75	BAR ASSY., panel

**CAMARO**

67	Camaro	7645894 R.H.	52.00	
67	Camaro	7645895 L.H.	52.00	
68	Camaro	7742294 R.H.	52.00	
68	Camaro	7742295 L.H.	52.00	
69	Camaro	8723787 R.H.	52.00	
69	Camaro	8723788 L.H.	52.00	
70-75	Camaro	8762043 R.H.	52.00	front dr. outer
70-75	Camaro	9804217 L.H.	52.00	front dr. outer (Note 1)
72	Camaro	8783426 R.H.	34.50	BAR ASSY., panel
72	Camaro	8783427 L.H.	34.50	BAR ASSY., panel
73-75	Camaro	9663282 R.H.	41.50	BAR ASSY., panel
73-75	Camaro	9663283 L.H.	41.50	BAR ASSY., panel
71-75	Vega	9828253 L.H.		PANEL ASSY.
71-75	Vega	9828252 R.H.	34.75	PANEL ASSY.
74-75	Vega	9686895 L.H.	35.00	PANEL ASSY.
75	Monza (exc. Towne Cpe.)	1671406 L.H.	48.75	PANEL ASSY.
75	Monza (exc. Towne Cpe.)	9673176 R.H.	48.75	PANEL ASSY.
75	Monza (Towne Cpe.)	1699422 R.H.	48.75	PANEL ASSY.
75	Monza (Towne Cpe.)	1699421 L.H.	48.75	PANEL ASSY.
72	Vega	8798847	29.75	BAR ASSY., front door outer panel

**METAL TRIM—CLIPS AND PANELS**

**12.895 PANEL— PANEL ASSY.— BAR ASSY., Front Door Outer (Con't)**

73	Vega (1st design) . . . . .	9647500	2	29.75	BAR ASSY., front door outer panel (Note 3)
73-75	Vega (Pnl., Cpe., Sta. Wag.) (2nd design) . . . . .	9667762	2	35.75	BAR ASSY., front door outer panel (Note 3)
75	Monza (Coupe) . . . . .	9696767	R.H.	40.75	BAR ASSY., front door outer panel . . . . .
75	Monza (Coupe) . . . . .	9696768	L.H.	40.75	BAR ASSY., front door outer panel . . . . .

NOTE 1: Structural adhesive.

NOTE 2: To be used on bodies built before Jan. 1, 1973.

NOTE 3: To be used on bodies built after Jan. 1, 1973.

**12.913 PANEL— BAR ASSY., Rear Door Outer**

**PASSENGER**

65-66	4-Dr. (exc. Spt. Sed.) . . . . .	4425686	R.H.	59.75	
65-66	4-Dr. (exc. Spt. Sed.) . . . . .	4425687	L.H.	59.75	
65-66	Spt. Sed. . . . .	4529633	R.H.	59.75	
65-66	Spt. Sed. . . . .	4529634	L.H.	59.75	
67-68	Spt. Sed. . . . .	7660472	R.H.	59.75	
67-68	Spt. Sed. . . . .	7660473	L.H.	59.75	
67-68	4-Dr. (exc. Spt. Sed.) . . . . .	7592512	R.H.	59.75	
67-68	4-Dr. (exc. Spt. Sed.) . . . . .	7592513	L.H.	59.75	
69-70	4-Dr. (exc. Spt. Sed.) . . . . .	7750124	R.H.	59.75	
69-70	4-Dr. (exc. Spt. Sed.) . . . . .	7750125	L.H.	59.75	
71-74	Pass. (Spt. Sed.) . . . . .	9885266	L.H.	59.75	
71-74	Pass. (Spt. Sed.) . . . . .	9885265	R.H.	59.75	
71-74	Pass. (Sed.) (exc. Spt. Sed.) . . . . .	8794581	L.H.	59.75	
71-74	Pass. (Sed.) (exc. Spt. Sed.) . . . . .	8794580	R.H.	59.75	
71-75	Pass. (Sta. Wag.) . . . . .	8801675	L.H.	59.75	
71-75	Pass. (Sta. Wag.) . . . . .	8801674	R.H.	59.75	
67-68	(Pass.) Spt. Sed. . . . .	7660472	R.H.	59.75	
67-68	(Pass.) Spt. Sed. . . . .	7660473	L.H.	59.75	
69-70	(Pass.) Spt. Sed. . . . .	9808823	R.H.	59.75	
69-70	(Pass.) Spt. Sed. . . . .	9808824	L.H.	59.75	
75	Pass. (Spt. Sed.) . . . . .	9668262	R.H.	59.75	
75	Pass. (Spt. Sed.) . . . . .	9668263	L.H.	59.75	
75	Pass. (Sed.) (exc. Spt. Sed.) . . . . .	9668264	R.H.	59.75	
75	Pass. (Sed.) (exc. Spt. Sed.) . . . . .	9668265	L.H.	59.75	
72	Pass. (Sed.) . . . . .	9816013	R.H.	17.05	BAR ASSY., panel . . . . .
72	Pass. (Sed.) . . . . .	9816014	L.H.	17.05	BAR ASSY., panel . . . . .
72	Pass. (Sta. Wag.) . . . . .	9665144	R.H.	17.50	BAR ASSY., panel (repl. 9645 197) . . . . .
72	Pass. (Sta. Wag.) . . . . .	9665145	L.H.	17.50	BAR ASSY., panel (repl. 9645 198) . . . . .
73-75	Pass. (Sta. Wag.) . . . . .	9665145	L.H.	17.50	BAR ASSY., panel (Note 1, 2) . . . . .
73-75	Pass. (Sta. Wag.) . . . . .	9665144	R.H.	17.50	BAR ASSY., panel (Note 1, 2) . . . . .
73	Pass. (Sed.) (1st des.) . . . . .	9645194	L.H.	17.05	BAR ASSY., panel (Note 1, 2) . . . . .
73	Pass. (Sed.) (1st des.) . . . . .	9645193	R.H.	17.05	BAR ASSY., panel (Note 1, 2) . . . . .
73-75	Pass. (Sed.) (2nd des.) . . . . .	9665146	R.H.	17.05	BAR ASSY., panel (Note 1, 3) . . . . .
73-75	Pass. (Sed.) (2nd des.) . . . . .	9665147	L.H.	17.05	BAR ASSY., panel (Note 1, 3) . . . . .

**CHEVELLE**

64-65	Chevelle (4-Dr.) . . . . .	4492554	R.H.	56.00	
64-65	Chevelle (4-Dr.) . . . . .	4492555	L.H.	56.00	
66-67	Chevelle (4-Dr.) (exc. Spt. Sed.) . . . . .	4498506	R.H.	56.00	
66-67	Chevelle (4-Dr.) (exc. Spt. Sed.) . . . . .	4498507	L.H.	56.00	
66-67	Chevelle (Spt. Sed.) . . . . .	7599110	R.H.	56.00	
66-67	Chevelle (Spt. Sed.) . . . . .	7599111	L.H.	56.00	
68-69	Malibu (Spt. Sed.) . . . . .	7742418	R.H.	56.00	
68-69	Malibu (Spt. Sed.) . . . . .	7742419	L.H.	56.00	
68-69	Chevelle (4-Dr.) (exc. Spt. Sed.), . . . . .				
70-72	Chevelle (Sta. Wag.) . . . . .	7786866	R.H.	56.00	
68-69	Chevelle (4-Dr.) (exc. Spt. Sed.), . . . . .				
70-72	Chevelle (Sta. Wag.) . . . . .	7786867	L.H.	56.00	
70-72	Chevelle (Sedan exc. Spt. Sed.) . . . . .	8735754	R.H.	56.00	
70-72	Chevelle (Sedan exc. Spt. Sed.) . . . . .	8735755	L.H.	56.00	
70-72	Chevelle (Spt. Sed.) . . . . .	9876035	L.H.	56.00	
70-72	Malibu (Spt. Sed.) . . . . .	9876034	R.H.	56.00	
73-75	Chevelle (4-Dr.) . . . . .	9830683	L.H.	56.00	
73-75	Chevelle (4-Dr.) . . . . .	9830682	R.H.	56.00	
72	Chevelle (4-Dr.) . . . . .	8781153	R.H.	16.45	BAR ASSY., panel . . . . .
72	Chevelle (4-Dr.) . . . . .	8781154	L.H.	16.45	BAR ASSY., panel . . . . .
73	Chevelle (4-Dr.) (1st des.) . . . . .	9601438	L.H.	21.15	BAR ASSY., panel (Note 1, 2) . . . . .
73-75	Chevelle (4-Dr.) . . . . .	9661188	R.H.	21.15	BAR ASSY., panel (Note 1, 2) . . . . .
73-75	Chevelle (4-Dr.) (2nd des.) . . . . .	9661189	L.H.	21.15	BAR ASSY., panel (Note 1, 3) . . . . .

**CHEVY— NOVA**

62-65	Chevy (4-Dr.) . . . . .	4834055	R.H.	48.00	
-------	-------------------------	---------	------	-------	--

**METAL TRIM—CLIPS AND PANELS**

**12.913 PANEL— BAR ASSY., Rear Door Outer (Con't)**

66-67	Chevy (4-Dr.)	4512150 R.H.	48.00	
66-67	Chevy (4-Dr.)	4512151 L.H.	48.00	
68-72	Chevy (Sed.)	7788960 R.H.	48.00	
68-72	Chevy (Sed.)	7788961 L.H.	48.00	
73-74	Nova (4-Dr.)	9879031 L.H.	48.00	
73-74	Nova (4-Dr.)	9879030 R.H.	48.00	
75	Nova (4-Dr.)	9675744 R.H.	48.00	
75	Nova (4-Dr.)	9675745 L.H.	48.00	
73-74	Nova (Sed.)	9665249 L.H.	23.75	BAR ASSY., panel (Note 2)
73	Nova (Sed.) (1st des.)	9648140 R.H.	23.75	BAR ASSY., panel (Note 2)
73-74	Nova (4-Dr.) (2nd des.)	9665248 R.H.	23.75	BAR ASSY., panel (Note 1, 3)
75	Nova (4-Dr.)	9729961 R.H.	29.50	BAR ASSY., panel
75	Nova (4-Dr.)	9729962 L.H.	29.50	BAR ASSY., panel

NOTE 1: Structural adhesive.

NOTE 2: To be used on bodies built before January 1, 1973.

NOTE 3: To be used on bodies built after January 1, 1973.

**12.934 PANEL ASSY.— COVER— EXTENSION— PLATE— REINFORCEMENT— SUPPORT, Door Rocker**

**PASSENGER**

65-68	Pass. (4-Dr.)	7647498 R.H.	37.50	otr. opening
65-68	Pass. (4-Dr.)	7647499 L.H.	37.50	otr. opening
65-68	Pass. (2-Dr.)	4425077 R.H.	34.75	outer
65-68	Pass. (2-Dr.)	4425078 L.H.	34.75	outer
69-70	Pass. (2-Dr.)	7749956 R.H.	31.75	outer
69-70	Pass. (2-Dr.)	7749957 L.H.	31.75	outer
69-70	Pass.	7777207 L.H.	18.10	inner
69-70	Pass. (4-Dr.)	8720653 R.H.	34.75	outer
69-70	Pass. (4-Dr.)	8720654 L.H.	34.75	outer
71-75	Pass. (Sed.)	9692237 L.H.	52.50	
71-73	Pass. (Sed.)	9659271 R.H.		
71-75	Pass. (Spt. Cpe.)	9692232 R.H.	49.75	
71	Impala (Conv.)	9869387 L.H.	57.00	
71	Pass. (Sta. Wag.)	9869395 L.H.	52.50	
71	Pass. (Sta. Wag.)	9869394 R.H.	52.50	
72-73	Pass. (Spt. Cpe.)	9659276 L.H.	49.75	
72-73	Pass. (Conv.)	9659274 L.H.	57.00	
71-72	Impala (Conv.)	9659273 R.H.	57.00	(repl. 9611000)
72-75	Pass. (Sta. Wag.)	9692245 L.H.	52.50	
72-75	Pass. (Sta. Wag.)	9692244 R.H.	52.50	
73	Caprice (Conv.)	9659273 R.H.	57.00	
73-75	Pass. (Sed.)	9692236 R.H.	52.50	
74-75	Pass. (Spt. Cpe.)	9692233 L.H.	49.75	
74-75	Caprice (Conv.)	9692254 R.H.	57.00	
74-75	Caprice (Conv.)	9692255 L.H.	57.00	

**CHEVELLE**

64-67	Chevelle	7595782 R.H.	27.75	outer
64-67	Chevelle	7595783 L.H.	27.75	outer
68-72	Chevelle (4-Dr.), El Camino	7704344 R.H.	16.45	inner
68-72	Chevelle (4-Dr.), El Camino	7704345 L.H.	16.45	inner
68-72	Chevelle (4-Dr.)	7774270 R.H.	30.25	opening outer
68-72	Chevelle (4-Dr.)	7774271 L.H.	30.25	opening outer
68-72	Chevelle (2-Dr.)	7704346 R.H.	16.45	inner
68-72	Chevelle (2-Dr.)	7704347 L.H.	16.45	inner
68-72	Chevelle (2-Dr.) (exc. El Camino)	7773846 R.H.	27.75	outer
68-72	Chevelle (2-Dr.) (exc. El Camino)	7773847 L.H.	27.75	outer
68-72	El Camino	7773840 R.H.	27.75	outer
68-72	El Camino	7773841 L.H.	27.75	outer
73	Chevelle (Spt. Cpe.)	9659264 L.H.	73.50	
73-74	Chevelle (Spt. Cpe.)	9659263 R.H.	73.50	
73-75	Chevelle (4-Dr.), El Camino	9737150 L.H.	73.50	
74-75	Chevelle (2-Dr.) (exc. El Camino)	9737125 L.H.	73.50	
73-74	Chevelle (4-Dr.) El Camino	9733628 R.H.	73.50	
75	Chevelle (2-Dr.)	9698276 R.H.	73.50	
75	Chevelle (4-Dr.)	9698278 R.H.	73.50	

**CHEVY— NOVA**

62-67	Chevy (2-Dr.) (exc. Conv.)	4845356 R.H.	27.75	opening outer
62-67	Chevy (2-Dr.) (exc. Conv.)	4845357 L.H.	27.75	opening outer
62-67	Chevy (4-Dr.)	4845358 R.H.	27.75	opening outer
62-71	Nova	7787072 R.H.	15.15	inner
68-72	Nova	9883587 L.H.	15.15	inner



**METAL TRIM—CLIPS AND PANELS**

**12.934 PANEL ASSY.— COVER— EXTENSION— PLATE— REINFORCEMENT—  
SUPPORT, Door Rocker (Con't)**

68-72	Nova	9883586	R.H.	15.15	inner
68-75	Chevy, Nova	1688920	R.H.	27.75	outer
68-75	Chevy, Nova	1688921	L.H.	27.75	outer
73-74	Nova	9670206	R.H.	15.15	inner
73-75	Nova	9732485	L.H.	15.15	inner
75	Nova	9732484	R.H.	15.15	inner

**CAMARO**

67-69	Camaro (Spt. Cpe.)	9808988	R.H.	15.15	inner
67-69	Camaro (Spt. Cpe.)	9808989	L.H.	15.15	inner
67-69	Camaro (Spt. Cpe.)	7741311	L.H.	26.50	opening outer
67-69	Camaro (Spt. Cpe.)	7741310	R.H.	26.50	opening outer
70-75	Camaro	1680401	R.H.	26.50	outer
70-75	Camaro	1680402	L.H.	26.50	outer
70-75	Camaro	1655125	L.H.	15.15	inner
70-75	Camaro	1655124	R.H.	15.15	inner

**VEGA — MONZA**

71-74	Vega	8788511	L.H.	13.40	outer
71-74	Vega	9731815	R.H.	19.55	outer
71-72	Vega (1st design)	9843306	L.H.	16.10	inner (Note 1)
71-72	Vega (1st design)	9843305	R.H.	16.10	inner (Note 1)
72-74	Vega (2nd design)	9671731	L.H.	13.85	inner (Note 2)
72-74	Vega (2nd design)	9885190	R.H.	14.70	inner (Note 2)
75	Vega, Monza	1686403	R.H.	14.10	inner
75	Vega, Monza	1686404	L.H.	14.10	inner
75	Vega, Monza	9731815	R.H.	19.55	outer
75	Vega, Monza	9731816	L.H.	19.55	outer

*NOTE 1: 1st design on models built before Jan. 1, 1971.*

*NOTE 2: 2nd design on models built after Jan. 1, 1971.*

65-69	Chevy,				
67-73	Camaro,				
71-72	Pass. (2-Dr.)	9870205	2	.24	COVER, inner panel drain hole dust
73-75	Chevelle (2-Dr.)	9870205	2	.24	COVER, inner panel drain hole dust
71-75	Camaro w/C.A.C.	9833449	R.H.	3.75	PLATE, outer panel
67-69	Camaro (Spt. Cpe.)	7585233	R.H.	3.55	REINFORCEMENT, otr. panel
67-69	Camaro (Spt. Cpe.)	7585234	L.H.	3.55	REINFORCEMENT, otr. panel
68-75	Chevy, Nova	1688922	R.H.	2.50	REINFORCEMENT, outer panel rear
68-75	Chevy, Nova	1688923	L.H.	2.50	REINFORCEMENT, outer panel rear
75	Monza, Vega (Dlx.)	1705749	L.H.	10.05	REINFORCEMENT, outer panel
75	Monza, Vega (Dlx.)	1705748	R.H.	10.05	REINFORCEMENT, outer panel
68-75	Chevy, Nova	7731212	A.R.	.18	SUPPORT, sill plate

**12.940 PANEL, Rear Quarter Side Outer (Outer Panel Only)**

**PASSENGER**

*NOTE: When Quarter Panel Assemblies are not listed, component parts must be ordered.*

65	Sed. (2-Dr.)	4490423	R.H.	152.00
65	Sed. (2-Dr.)	4490424	L.H.	152.00
65	Sed. (4-Dr.)	4490638	R.H.	116.00
65	Sed. (4-Dr.)	4490639	L.H.	116.00
65	Conv.	4427012	R.H.	143.00
65	Conv.	4427013	L.H.	143.00
65	Sta. Wag.	4490636	R.H.	137.00
65	Sta. Wag.	4490637	L.H.	137.00
66	Sedan (2-Dr.)	4544646	R.H.	152.00
66	Sedan (2-Dr.)	4544647	L.H.	152.00
66	Sedan (4-Dr.)	4544650	R.H.	116.00
66	Sedan (4-Dr.)	4544651	L.H.	116.00
66	Spt. Sed.	7586826	R.H.	116.00
66	Spt. Sed.	7586827	L.H.	116.00
66	Impala (Spt. Cpe.)	4507248	R.H.	152.00
66	Impala (Spt. Cpe.)	4507249	L.H.	152.00
66	Caprice (Spt. Cpe.)	4534227	R.H.	152.00
66	Caprice (Spt. Cpe.)	4534228	L.H.	152.00
66	Conv.	4507258	R.H.	143.00
66	Conv.	4507259	L.H.	143.00
66	Sta. Wag. (exc. Caprice)	4544648	R.H.	137.00
66	Sta. Wag. (exc. Caprice)	4544649	L.H.	137.00
67	Caprice (Spt. Cpe.)	7593046	R.H.	152.00
67	Caprice (Spt. Cpe.)	7593047	L.H.	152.00

**METAL TRIM—CLIPS AND PANELS**

**12.940 PANEL, Rear Quarter Side Outer (Outer Panel Only) (Con't)**

67	2-Dr. Sed.	7660362 R.H.	152.00	
67	Spt. Sed.	7660364 R.H.	116.00	
67	Spt. Sed.	7660365 L.H.	116.00	
67	4-Dr. Sed. (exc. Spt. Sed.)	7660366 R.H.	116.00	
67	4-Dr. Sed. (exc. Spt. Sed.)	7660367 L.H.	116.00	
67	Sta. Wag. (exc. Caprice)	7660368 R.H.	137.00	
67	Sta. Wag. (exc. Caprice)	7660369 L.H.	137.00	
67	Conv.	7681952 R.H.	143.00	
67	Conv.	7681953 L.H.	143.00	
67	Impala (Spt. Cpe.)	7681954 R.H.	152.00	
67	Impala (Spt. Cpe.)	7681955 L.H.	152.00	
67	Caprice (Sta. Wag.)	7593094 R.H.	137.00	
67	Caprice (Sta. Wag.)	7593095 L.H.	137.00	
68	Caprice (Spt. Cpe.)	7684378 R.H.	152.00	
68	Caprice (Spt. Cpe.)	7684379 L.H.	152.00	
68	Sta. Wag.	7729926 R.H.	137.00	
68	Sta. Wag.	7729927 L.H.	137.00	
68	2-Dr. Sed.	7730326 R.H.	152.00	
68	2-Dr. Sed.	7730327 L.H.	152.00	
68	Impala, Caprice (Spt. Sed.)	7730328 R.H.	116.00	
68	Impala, Caprice (Spt. Sed.)	7730329 L.H.	116.00	
68	4-Dr. Sed.	7730332 R.H.	116.00	
68	4-Dr. Sed.	7730333 L.H.	116.00	
68	Impala (Spt. Cpe.) (exc. Custom)	7730334 R.H.	152.00	
68	Impala (Spt. Cpe.) (exc. Custom)	7730335 L.H.	152.00	
68	Impala Custom	7763290 R.H.	152.00	
68	Impala Custom	7763291 L.H.	152.00	
68	Conv.	8712910 R.H.	143.00	
69	4-Dr. Sed. (exc. Spt. Sed.)	8788948 R.H.	116.00	
69	4-Dr. Sed. (exc. Spt. Sed.)	8788949 L.H.	116.00	
69	Spt. Sed.	8788950 R.H.	116.00	
69	Spt. Sed.	8788951 L.H.	116.00	
69	2-Dr. Sed.	8788937 R.H.	152.00	
69	2-Dr. Sed.	8788938 L.H.	152.00	
69	Impala (Spt. Cpe.) (exc. Custom)	8788940 R.H.	152.00	
69	Impala (Spt. Cpe.) (exc. Custom)	8788941 L.H.	152.00	
69	Impala Custom, Caprice (Spt. Cpe.)	7749630 R.H.	152.00	
69	Impala Custom, Caprice (Spt. Cpe.)	7749631 L.H.	152.00	
69	Conv.	8788946 R.H.	143.00	
69	Conv.	8788947 L.H.	143.00	
69	Sta. Wag.	7750014 R.H.	137.00	
69	Sta. Wag.	7750015 L.H.	137.00	
70	Pass. (Sta. Wag.)	8738132 R.H.	137.00	
70	Pass. (Sta. Wag.)	8738133 L.H.	137.00	
70	Pass. (4-Dr. Sed.) (exc. Spt. Sed.)	8738226 R.H.	116.00	
70	Pass. (4-Dr. Sed.) (exc. Spt. Sed.)	8738227 L.H.	116.00	
70	Pass. (Spt. Sed.)	8738228 R.H.	116.00	
70	Pass. (Spt. Sed.)	8738229 L.H.	116.00	
70	Impala (2-Dr.)	8738232 R.H.	152.00	
70	Impala (2-Dr.)	8738233 L.H.	152.00	
70	Impala Cust. Caprice (2-Dr.)	8738234 R.H.	152.00	
70	Impala Cust. Caprice (2-Dr.)	8738235 L.H.	152.00	
70	Pass. (Conv.)	8738238 R.H.	143.00	
70	Pass. (Conv.)	8738239 L.H.	143.00	
71-73	Pass. (Sed.) (exc. Spt. Sed.)	9843581 L.H.	116.00	outer
71-73	Impala (exc. Custom)	9611789 L.H.	152.00	outer
71-73	Impala (Spt. Cpe.) (exc. Custom)	9611788 R.H.	152.00	outer
71-73	Impala (Custom) Caprice (Spt. Cpe.)	9611787 L.H.	152.00	outer
71-73	Impala (Custom) Caprice (Spt. Cpe.)	9611786 R.H.	152.00	outer
71-73	Pass. (Spt. Sed.)	9843583 L.H.	113.00	outer
71-73	Pass. (Spt. Sed.)	9843582 R.H.	113.00	outer
71	Pass. (Conv.)	9883429 L.H.	143.00	outer
71-73	Pass. (Conv.)	9657646 R.H.	143.00	outer
71-73	Pass. (Sta. Wag.)	9855323 L.H.	137.00	outer
71-73	Pass. (Sta. Wag.)	9855322 R.H.	137.00	outer
71-73	Pass. (Sed.) (exc. Spt. Sed.)	9843580 R.H.	116.00	outer
72-73	Pass. (Conv.)	9657647 L.H.	143.00	outer
73	Pass. (Sta. Wag.)	9865950 L.H.	21.60	outer extension (Note 1)
73	Pass. (Sta. Wag.)	9609361 R.H.	22.50	outer extension (Note 1)
74-75	Pass. (Sta. Wag.)	9660663 L.H.	22.50	outer extension
75	Pass. (Sta. Wag.)	9660659 R.H.	22.50	outer extension

**METAL TRIM—CLIPS AND PANELS**

**12.940 PANEL, Rear Quarter Side Outer (Outer Panel Only) (Con't)**

74	Impala (Custom), Caprice (Spt. Cpe.)			
75	Impala (Custom)	9660626 R.H.	177.00	PANEL ASSY., qtr. outer
74	Impala (Custom), Caprice (Spt. Cpe.)			
75	Impala (Custom)	9660627 L.H.	177.00	PANEL ASSY., qtr. outer
74-75	Impala (Spt. Cpe.) (exc. Custom)	9618546 R.H.	152.00	outer
74-75	Impala (Spt. Cpe.) (exc. Custom)	9618547 L.H.	152.00	outer
74	Caprice (Spt. Cpe.)	9618548 R.H.	166.00	PANEL, outer
74-75	Impala (Custom)	9618548 R.H.	166.00	PANEL, outer
74	Caprice (Spt. Cpe.)	9618549 L.H.	166.00	PANEL, outer
74-75	Impala (Custom)	9618549 L.H.	166.00	PANEL, outer
74	Pass. (Spt. Sed.)	9618570 R.H.	113.00	outer
74	Pass. (Spt. Sed.)	9618571 L.H.	113.00	outer
74	Pass. (Sed.) (exc. Spt. Sed.)	9618681 R.H.	116.00	outer
74	Pass. (Sed.) (exc. Spt. Sed.)	9618682 L.H.	116.00	outer
74-75	Pass. (Sta. Wag.)	9621344 R.H.	137.00	outer
74-75	Pass. (Sta. Wag.)	9621345 L.H.	137.00	outer
74	Pass. (Conv.)	9628912 R.H.	143.00	outer
74	Pass. (Conv.)	9628913 L.H.	143.00	outer
75	Caprice (Sed.) (exc. Spt. Sed.)	9668301 R.H.	116.00	outer
75	Caprice (Sed.) (exc. Spt. Sed.)	9668302 L.H.	116.00	outer
75	Caprice (Spt. Sed.)	9668305 R.H.	113.00	outer
75	Caprice (Spt. Sed.)	9668306 L.H.	113.00	outer
75	Caprice (Spt. Cpe.)	9671262 R.H.	166.00	outer
75	Caprice (Spt. Cpe.)	9671263 L.H.	166.00	outer
75	Pass. (Conv.)	9685728 R.H.	143.00	outer
75	Pass. (Conv.)	9685729 L.H.	143.00	outer
75	Impala (Spt. Sed.)	9728858 R.H.	116.00	outer
75	Impala (Spt. Sed.)	9728859 L.H.	116.00	outer
75	Bel Air, Impala (Sed.) (exc. Spt. Sed.)	9699398 R.H.	113.00	outer
75	Bel Air, Impala (Sed.) (exc. Spt. Sed.)			
75	Caprice (Spt. Cpe.)	9699399 L.H.	113.00	outer
75	Caprice (Spt. Cpe.)	9695983 R.H.	177.00	qtr. outer
75	Caprice (Spt. Cpe.)	9695984 L.H.	177.00	qtr. outer
75	Caprice (Spt. Sed.)	9686824 R.H.	128.00	qtr. outer
75	Caprice (Spt. Sed.)	9686825 L.H.	128.00	qtr. outer
75	Impala (Spt. Sed.)	9732146 R.H.	128.00	qtr. outer
75	Impala (Spt. Sed.)	9732147 L.H.	128.00	qtr. outer

**CHEVELLE**

73	Chevelle (Sta. Wag.)	9651063 L.H.	122.00	outer
73	Chevelle (Sta. Wag.)	9651062 R.H.	122.00	outer
73	Chevelle (Spt. Sed.)	9662891 L.H.	114.00	outer
73	Chevelle (Spt. Sed.)	9662890 R.H.	114.00	outer
73	Monte Carlo	9830367 L.H.	161.00	outer
73	Monte Carlo	9830366 R.H.	161.00	outer
73-75	El Camino	9830468 L.H.	124.00	outer
73-75	El Camino	9830467 R.H.	124.00	outer
73	Chevelle (Spt. Cpe.) (exc. Monte Carlo)	9662893 L.H.	147.00	outer
73	Chevelle (Spt. Cpe.) (exc. Monte Carlo)			
74	Monte Carlo	9662892 R.H.	147.00	outer
74	Monte Carlo	9733170 R.H.	161.00	outer
74	Monte Carlo	9733171 L.H.	161.00	outer
74	Malibu (Coupe) (exc. Classic), Malibu (Classic), Laguna (Coupe) (1st design),			
75	Malibu (2-Dr.) (exc. Classic)	1686902 R.H.	147.00	outer (Note 1)
74	Malibu (Classic), Laguna (Coupe) (1st design),			
75	Malibu (2-Dr.) (exc. Classic)	1686903 L.H.	147.00	outer (Note 1)

**CHEVELLE**

64	(4-Dr. Sedan)	4468408 R.H.	108.00
64	(4-Dr. Sedan)	4468409 L.H.	108.00
64-65	(4-Dr. Sta. Wag.)	4490693 R.H.	122.00
64-65	(4-Dr. Sta. Wag.)	4490694 L.H.	122.00
64-65	El Camino	4490695 R.H.	124.00
64	Malibu (Spt. Cpe.)	4409810 R.H.	139.00
64	Malibu (Spt. Cpe.)	4409811 L.H.	139.00
65	(2-Dr. Sed.)	4533825 R.H.	139.00
65	(4-Dr. Sed.)	4484745 R.H.	108.00
65	(4-Dr. Sed.)	4484746 L.H.	108.00

**METAL TRIM—CLIPS AND PANELS**

<b>12.940 PANEL, Rear Quarter Side Outer (Outer Panel Only)</b>		<b>(Con't)</b>		
65	Malibu (Spt. Cpe.)	4484741 R.H.	139.00	
65	Malibu (Spt. Cpe.)	4484742 L.H.	139.00	
66-67	(2-Dr. Sed.)	7580122 R.H.	139.00	
66-67	(2-Dr. Sed.)	7580123 L.H.	139.00	
66-67	(4-Dr. Sed.)	7580124 R.H.	108.00	
66-67	(4-Dr. Sed.)	7580125 L.H.	108.00	
66-67	(Spt. Sed.)	7690150 R.H.	108.00	
66-67	(Spt. Sed.)	7690151 L.H.	108.00	
66-67	(Spt. Cpe.)	7580162 R.H.	139.00	
66-67	(Spt. Cpe.)	7580163 L.H.	139.00	
66-67	(Conv.)	7580164 R.H.	130.00	
66-67	(Conv.)	7580165 L.H.	130.00	
66	(Sta. Wag.)	7653598 R.H.	122.00	
66	El Camino	4542622 R.H.	124.00	
67	El Camino	7598638 R.H.	124.00	
67	El Camino	7598639 L.H.	124.00	
68	(Sta. Wag.) (6-Pass.) (1st design)	7671475 L.H.	122.00	w/hole for side marker lamp
68	El Camino (1st design)	7671477 L.H.	124.00	(with marker light)
68	(4-Dr. Sed.)	7791646 R.H.	108.00	
68	(4-Dr. Sed.)	7791647 L.H.	108.00	
68	(2-Dr. Sed.)	7761614 R.H.	139.00	
68	(2-Dr. Sed.)	7761615 L.H.	139.00	
68	(Spt. Cpe.)	7761616 R.H.	139.00	
68	(Spt. Cpe.)	7761617 L.H.	139.00	
68	(Conv.)	7793618 L.H.	130.00	
68	(Spt. Sed.)	7791648 R.H.	108.00	
68	(Spt. Sed.)	7791649 L.H.	108.00	
68	El Camino (2nd design),			
69	El Camino	8738084 R.H.	124.00	
68	Sta. Wag.,			
70	Sta. Wag.,			
71-72	Chevelle (Sta. Wag.)	9866977 L.H.	122.00	outer
68	Sta. Wag.,			
70	Sta. Wag.,			
71-72	Chevelle (Sta. Wag.)	9866976 R.H.	122.00	outer
68-72	El Camino	8761648 R.H.	124.00	(with marker light)
69	El Camino	8738085 L.H.	124.00	
69	Sta. Wag.	8738082 R.H.	122.00	right w/hole for side marker lamp
69	Sta. Wag.	8738083 L.H.	122.00	left w/hole for side marker lamp
69	(4-Dr. Sed.) (exc. Spt. Cpe.)	7757056 R.H.	108.00	
69	(4-Dr. Sed.) (exc. Spt. Cpe.)	7757057 L.H.	108.00	
69	(Spt. Sed.)	7757060 R.H.	108.00	
69	(Spt. Sed.)	7757061 L.H.	108.00	
69	(2-Dr. Sed.)	7757064 R.H.	139.00	
69	(2-Dr. Sed.)	7757065 L.H.	139.00	
69	(Spt. Cpe.)	8768754 R.H.	139.00	
69	(Spt. Cpe.)	8768755 L.H.	139.00	
69	(Conv.)	8770137 L.H.	130.00	
70-72	Chevelle (Spt. Cpe.) (exc. Monte Carlo)	9815404 R.H.	139.00	
70-72	Chevelle (Spt. Cpe.) (exc. Monte Carlo)	9815405 L.H.	139.00	
70-72	Chevelle (Conv.)	8735905 R.H.	130.00	
70-72	Chevelle (Conv.)	8735906 L.H.	130.00	
70-72	Chevelle (4-Dr. Sed.) (exc. Spt. Sed.)	8735914 R.H.	108.00	
70-72	Chevelle (4-Dr. Sed.) (exc. Spt. Sed.)	8735915 L.H.	108.00	
70-72	Chevelle (Spt. Sed.)	8735916 R.H.	108.00	
70-72	Chevelle (Spt. Sed.)	8735917 L.H.	108.00	
70-72	Monte Carlo (Spt. Cpe.)	9870586 R.H.	161.00	
70-72	Monte Carlo (Spt. Cpe.)	9870587 L.H.	161.00	
70	Chevelle (Sta. Wag.)	8760883 R.H.	14.90	inner side
70-72	El Camino	8761649 L.H.	124.00	(with marker light)
72	Chevelle (Sta. Wag.)	9866981 L.H.	13.05	
72	Chevelle (Sta. Wag.)	9866980 R.H.	13.05	
73	Monte Carlo	9861605 R.H.	161.00	otr.
73	Monte Carlo	9861606 L.H.	161.00	otr.
73	Monte Carlo	9610290 R.H.		outer w/inner upper panel at window
73	Monte Carlo	9610291 L.H.		outer w/inner upper panel at window
73	Monte Carlo	9609338 R.H.	151.00	outer less inner upper panel at window
73	Monte Carlo	9609339 L.H.	151.00	outer less inner upper panel at window
74-75	Malibu (Classic), Laguna (Coupe) (2nd design)	1686906 R.H.	147.00	outer (Note 1)

**METAL TRIM—CLIPS AND PANELS**

**12.940 PANEL, Rear Quarter Side Outer (Outer Panel Only) (Con't)**

74-75	Malibu (Classic), Laguna (Coupe) (2nd design) . . . . .	1686907 L.H.	147.00	outer (Note 1) . . . . .
74-75	Chevelle (Spt. Sed.) . . . . .	1686904 R.H.	114.00	outer . . . . .
74-75	Chevelle (Spt. Sed.) . . . . .	1686905 L.H.	114.00	outer . . . . .
74-75	Chevelle (Sta. Wag.) . . . . .	9638020 R.H.	122.00	outer . . . . .
74-75	Chevelle (Sta. Wag.) . . . . .	9638021 L.H.	122.00	outer . . . . .
74-75	Malibu (Coupe) (exc. Classic), Malibu (Classic), Laguna (Coupe) (1st design) . . . . .	1686908 R.H.	161.00	outer (Note 1) . . . . .
74-75	Malibu (Coupe) (exc. Classic), Malibu (Classic), Laguna (Coupe) (1st design) . . . . .	1686909 L.H.	161.00	outer (Note 1) . . . . .
74-75	Malibu (Classic), Laguna (Coupe) (2nd design) . . . . .	1686912 R.H.	161.00	outer (Note 1) . . . . .
74-75	Malibu (Classic), Laguna (Coupe) (2nd design) . . . . .	1686913 L.H.	161.00	outer (Note 1) . . . . .
74-75	Monte Carlo . . . . .	1679720 R.H.	161.00	outer includes sail panel . . . . .
74	Monte Carlo . . . . .	9733173 L.H.	161.00	outer . . . . .
74-75	Chevelle (Spt. Sed.) . . . . .	1686910 R.H.	129.00	outer includes sail panel . . . . .
74-75	Chevelle (Spt. Sed.) . . . . .	1686911 L.H.	129.00	outer includes sail panel . . . . .
75	Monte Carlo . . . . .	1679721 L.H.	161.00	outer includes sail panel . . . . .
75	Monte Carlo . . . . .	1679722 R.H.	161.00	outer except sail panel . . . . .
75	Monte Carlo . . . . .	1679723 L.H.	161.00	outer except sail panel . . . . .

*NOTE 1: To aid in identifying first design, a metal insert was required to fill void in quarter panel used for tear drop window design. Second design quarter panel will have added metal in sail area.*

**CHEVY—NOVA**

62-64	(4-Dr. Sedan) . . . . .	4409681 L.H.	105.00	
62-65	(Sta. Wag.) . . . . .	4409686 R.H.	105.00	
62-65	(Sta. Wag.) . . . . .	4409687 L.H.	105.00	
62-65	Nova (Spt. Cpe.) . . . . .	4409684 R.H.	128.00	
62-65	Nova (Spt. Cpe.) . . . . .	4409685 L.H.	128.00	
65	(4-Dr. Sed.) . . . . .	4536066 R.H.	105.00	
65	(4-Dr. Sed.) . . . . .	4536067 L.H.	105.00	
66-67	(2-Dr. Sed.) . . . . .	7600822 R.H.	128.00	
66-67	(2-Dr. Sed.) . . . . .	7600823 L.H.	128.00	
66-67	(4-Dr. Sed.) . . . . .	7690148 R.H.	105.00	
66-67	(4-Dr. Sed.) . . . . .	7690149 L.H.	105.00	
66-67	(Spt. Cpe.) . . . . .	7690146 R.H.	128.00	
66-67	(Spt. Cpe.) . . . . .	7690147 L.H.	128.00	
66-67	(Sta. Wag.) . . . . .	7690144 R.H.	105.00	
68-69	(4-Dr. Sed.) . . . . .	8778518 R.H.	105.00	
68-69	(4-Dr. Sed.) . . . . .	8778519 L.H.	105.00	
68-69	(Spt. Cpe.) . . . . .	8778516 R.H.	128.00	
68-69	(Spt. Cpe.) . . . . .	8778517 L.H.	128.00	
70-72	Nova (2-Dr.) . . . . .	8756530 R.H.	128.00	
70-72	Nova (2-Dr.) . . . . .	8756531 L.H.	128.00	
70-72	Nova (4-Dr.) . . . . .	8756532 R.H.	105.00	
70-72	Nova (4-Dr.) . . . . .	8756533 L.H.	105.00	
73-74	Nova (H.B.) . . . . .	9609702 L.H.	128.00	outer . . . . .
73-74	Nova (H.B.) . . . . .	9609701 R.H.	128.00	outer . . . . .
73-74	Nova (2-Dr.) (exc. H.B.) . . . . .	9879119 L.H.	128.00	outer . . . . .
73-74	Nova (2-Dr.) (exc. H.B.) . . . . .	9879118 R.H.	128.00	outer . . . . .
73-74	Nova (4-Dr.) . . . . .	9879121 L.H.	105.00	outer . . . . .
73-74	Nova (4-Dr.) . . . . .	9879120 R.H.	105.00	outer . . . . .
75	Nova (H.B.) . . . . .	1651150 R.H.	154.00	outer . . . . .
75	Nova (H.B.) . . . . .	1651151 L.H.	154.00	outer . . . . .
75	Nova (2-Dr.) (exc. H.B.) . . . . .	1651152 R.H.	154.00	outer . . . . .
75	Nova (2-Dr.) (exc. H.B.) . . . . .	1651153 L.H.	154.00	outer . . . . .
75	Nova (4-Dr.) . . . . .	1651158 R.H.	102.00	outer . . . . .
75	Nova (4-Dr.) . . . . .	1651159 L.H.	102.00	outer . . . . .

**CAMARO**

67	(Spt. Cpe.) . . . . .	7585084 R.H.	125.00	
67	(Spt. Cpe.) . . . . .	7585085 L.H.	125.00	
67	(Conv.) . . . . .	7585087 L.H.	116.00	
68	(Spt. Cpe.) . . . . .	7738673 R.H.	125.00	
68	(Spt. Cpe.) . . . . .	7738674 L.H.	125.00	
68	(Conv.) . . . . .	7741301 R.H.	116.00	
68	(Conv.) . . . . .	7741302 L.H.	116.00	
69	(Spt. Cpe.) . . . . .	7779476 R.H.	125.00	
69	(Spt. Cpe.) . . . . .	7779477 L.H.	125.00	
69	(Conv.) . . . . .	7779480 R.H.	116.00	
69	(Conv.) . . . . .	7779481 L.H.	116.00	
70-73	Camaro . . . . .	9868287 L.H.	125.00	outer . . . . .

**METAL TRIM—CLIPS AND PANELS**

**12.940 PANEL, Rear Quarter Side Outer (Outer Panel Only) (Con't)**

70-73	Camaro	9868286 R.H.	125.00	outer
74	Camaro	9629798 R.H.	125.00	outer
74	Camaro	9629799 L.H.	125.00	outer
75	Camaro	9676207 R.H.	125.00	outer
75	Camaro	9676208 L.H.	125.00	outer

**VEGA — MONZA**

71-73	Vega (Hatchback Cpe.)	8788671 L.H.	81.75	qtr. outer
71-73	Vega (Hatchback Cpe.)	8788670 R.H.	81.75	qtr. outer
71-73	Vega (Hatchback Cpe.)	8804311 L.H.	1.55	qtr. outer ext. at lid opening
71-73	Vega (Hatchback Cpe.)	8804310 R.H.	1.55	qtr. outer ext. at lid opening
71-73	Vega (Notchback Cpe.)	9664002 L.H.	81.75	qtr. outer
71-73	Vega (Notchback Cpe.)	9664001 R.H.	81.75	qtr. outer
71-73	Vega (Notchback Cpe.)	8804313 L.H.	5.05	qtr. outer ext. at lid opening
71-73	Vega (Notchback Cpe.)	8804312 R.H.	5.05	qtr. outer ext. at lid opening
71-73	Vega (Panel, Sta. Wag.)	8788469 L.H.	76.00	qtr. outer
71-73	Vega (Panel, Sta. Wag.)	8788468 R.H.	76.00	qtr. outer
74-75	Vega (Hatchback Cpe.)	9629794 R.H.	81.75	qtr. outer
74-75	Vega (Hatchback Cpe.)	9629795 L.H.	81.75	qtr. outer
74-75	Vega (Notchback Cpe.)	9629796 R.H.	81.75	qtr. outer
74-75	Vega (Notchback Cpe.)	9629797 L.H.	81.75	qtr. outer
74-75	Vega (Panel, Sta. Wag.)	9734177 R.H.	91.25	qtr. outer
74-75	Vega (H.B. Coupe)	9638105 R.H.	1.40	qtr. outer ext. at lid opening
74-75	Vega (H.B. Coupe)	9638106 L.H.	1.40	qtr. outer ext. at lid opening
74-75	Vega (N.B. Cpe.)	9638107 R.H.	4.60	qtr. outer ext. at lid opening
74-75	Vega (N.B. Cpe.)	9638108 L.H.	4.60	qtr. outer ext. at lid opening
75	Monza (exc. Towne Cpe.)	9674242 R.H.	51.50	qtr. outer ext.
75	Monza (exc. Towne Cpe.)	9674243 L.H.	51.50	qtr. outer
75	Monza (exc. Towne Cpe.)	9674207 R.H.	4.60	qtr. outer ext. at lid opening
75	Monza (exc. Towne Cpe.)	9674208 L.H.	4.60	qtr. outer ext. at lid opening
74-75	Vega (Panel, Sta. Wag.)	9734178 L.H.	91.25	qtr. outer
75	Monza (Towne Cpe.)	1672617 R.H.	82.75	qtr. outer
75	Monza (Towne Cpe.)	1672618 L.H.	82.75	qtr. outer
75	Monza (Towne Cpe.) w/formal window	1692373 R.H.	81.75	qtr. outer
75	Monza (Towne Cpe.) w/formal window	1692374 L.H.	81.75	qtr. outer
71-74	Vega (Panel, Sta. Wag.)	9809331 L.H.	4.25	PANEL ASSY., qtr. outer ext. w/nut
71-74	Vega (Panel, Sta. Wag.)	9809330 R.H.	4.25	PANEL ASSY., qtr. outer ext. w/nut
74-75	Vega (Panel, Sta. Wag.)	9660697 R.H.	7.95	PANEL ASSY., qtr. outer ext.
74-75	Vega (Panel, Sta. Wag.)	9660698 L.H.	7.95	PANEL ASSY., qtr. outer ext.

**12.940A BEZEL— CAP UNIT— DEFLECTOR— EXTENSION— FILLER— PANEL— REINFORCEMENT— SUPPORT, Rear Quarter Outer**

73	Monte Carlo	9667271 L.H.	20.90	tail lamp— (2.681)
73	Monte Carlo	9667270 R.H.	20.90	tail lamp— (2.681)
74	Monte Carlo	9677436 R.H.	18.65	tail lamp— (2.681)
74	Monte Carlo	9677437 L.H.	18.65	tail lamp— (2.681)
73-75	El Camino	9630075 L.H.	1.65	CAP UNIT, outer end
73-75	El Camino	9630074 R.H.	1.65	CAP UNIT, outer end
71-75	Vega (Panel, Sta. Wag.)	9820757 L.H.	5.05	DEFLECTOR, qtr. outer panel water
71-75	Vega (Panel, Sta. Wag.)	9820756 R.H.	5.05	DEFLECTOR, qtr. outer panel water
65	Bel Air (exc. Sta. Wag.)	3870719 L.H.	16.40	EXTENSION, qtr. pnl. at tail light
65	Bel Air (exc. Sta. Wag.)	3870718 R.H.	16.40	EXTENSION, qtr. pnl. at tail light
65	Impala (exc. Sta. Wag.)	3870721 L.H.	16.40	EXTENSION, qtr. pnl. at tail light
65	Impala (exc. Sta. Wag.)	3870720 R.H.	16.40	EXTENSION, qtr. pnl. at tail light
66	Impala, Caprice (exc. Sta. Wag.)	4227058 R.H.	16.40	EXTENSION, qtr. pnl. at tail light
66	Impala, Caprice (exc. Sta. Wag.)	4227059 L.H.	16.40	EXTENSION, qtr. pnl. at tail light
66	Biscayne (exc. Sta. Wag.)	4227023 L.H.	14.15	EXTENSION, qtr. pnl. at tail light
66	Bel Air (exc. Sta. Wag.)	4227024 R.H.	16.40	EXTENSION, qtr. pnl. at tail light
66	Bel Air (exc. Sta. Wag.)	4227025 L.H.	16.40	EXTENSION, qtr. pnl. at tail light
66	Malibu, S.S. (exc. Sta. Wag.)	4227400 R.H.	22.25	EXTENSION, qtr. pnl. at tail lamp (Note 1)
66	Malibu, S.S. (exc. Sta. Wag.)	4227401 L.H.	22.25	EXTENSION, qtr. pnl. at tail lamp (Note 1)
66	Chevelle (Std., Deluxe) (Sed.)	4227402 R.H.	22.25	EXTENSION, qtr. pnl. at tail lamp (Note 1)
66	Chevelle (Std., Deluxe) (Sed.)	4227403 L.H.	22.25	EXTENSION, qtr. pnl. at tail lamp (Note 1)
<i>NOTE 1: Includes tail lamp housing.</i>				
67	Biscayne, Bel Air (Sed.)	4229577 R.H.	16.40	EXTENSION, qtr. otr. at tail lamp
67	Biscayne, Bel Air (Sed.)	4229578 L.H.	16.40	EXTENSION, qtr. otr. at tail lamp
67	Impala (exc. Sta. Wag., Spt. Cpe.),			
67	Caprice (exc. Sta. Wag.)	4229579 R.H.	16.40	EXTENSION, qtr. otr. at tail lamp
67	Impala (exc. Sta. Wag., Spt. Cpe.),			
67	Caprice (exc. Sta. Wag.)	4229580 L.H.	16.40	EXTENSION, qtr. otr. at tail lamp
67	Impala (Spt. Cpe.)	4229581 R.H.	16.40	EXTENSION, qtr. otr. at tail lamp

**METAL TRIM—CLIPS AND PANELS**

**12.940A BEZEL— CAP UNIT— DEFLECTOR— EXTENSION— FILLER— PANEL— REINFORCEMENT— SUPPORT, Rear Quarter Outer (Con't)**

67	Impala (Spt. Cpe.)	4229582 L.H.	16.40	EXTENSION, qtr. otr. at tail lamp
67	Malibu (exc. Sta. Wag., El Camino)			
67	Chevelle (Std.) (S.S.)	4229425 R.H.	22.25	EXTENSION, qtr. otr. panel at tail lamp
67	Chevelle (Std.) (S.S.)			
67	Malibu (exc. Sta. Wag., El Camino)	4229426 L.H.	22.25	EXTENSION, qtr. otr. panel at tail lamp
67	Chevelle (Deluxe) (Sed.)	4229427 R.H.	22.25	EXTENSION, qtr. otr. pnl. at tail lamp
67	Chevelle (Deluxe) (Sed.)	4229428 L.H.	22.25	EXTENSION, qtr. otr. pnl. at tail lamp
68	Biscayne, Bel Air, Impala (Custom)			
68	Impala (exc. Spt. Cpe., Sta. Wag.)	7795392 R.H.	15.10	EXTENSION, qtr. at t/lamp
68	Biscayne, Bel Air, Impala (Custom)			
68	Impala (exc. Spt. Cpe., Sta. Wag.)	7795393 L.H.	15.95	EXTENSION, qtr. at t/lamp
68	Impala (Spt. Cpe.) (exc. Custom)	7795388 R.H.	16.10	EXTENSION, qtr. outer at t/lamp
68	Impala (Spt. Cpe.) (exc. Custom)	7795389 L.H.	16.10	EXTENSION, qtr. outer at t/lamp
68	Chevelle (Std., Deluxe) (exc. Sta. Wag., El Camino)	7795384 R.H.	29.25	EXTENSION, qtr. otr. at tail lamp
68	Chevelle (Std., Deluxe) (exc. Sta. Wag., El Camino)	7795385 L.H.	29.25	EXTENSION, qtr. otr. at tail lamp
68	Malibu, S.S. (exc. Sta. Wag., El Camino)	7795386 R.H.	29.00	EXTENSION, qtr. otr. at tail lamp
68	Malibu, S.S. (exc. Sta. Wag., El Camino)	7795387 L.H.	29.00	EXTENSION, qtr. otr. at tail lamp
69	Chevelle (exc. Sta. Wag., El Camino)	8700942 R.H.	29.25	EXTENSION, at tail lamp
69	Chevelle (exc. Sta. Wag., El Camino)	8700943 L.H.	29.25	EXTENSION, at tail lamp
70-71	Monte Carlo	8700886 R.H.	29.50	EXTENSION, right at tail lamp
70-71	Monte Carlo	8700887 L.H.	29.50	EXTENSION, at tail lamp
72	Monte Carlo	9886863 L.H.	29.50	EXTENSION, outer panel at tail lamp
72	Monte Carlo	9886862 R.H.	29.50	EXTENSION, outer panel at tail lamp
73	Monte Carlo	8707883 L.H.	14.90	EXTENSION, outer panel at tail lamp
73	Monte Carlo	8707882 R.H.	14.90	EXTENSION, outer panel at tail lamp
72-73	Pass. (Sed., Spt. Cpe.)	9846888 R.H.	6.60	EXTENSION, qtr. outer to rear end panel
72-73	Pass. (Sed., Spt. Cpe.)	9846889 L.H.	6.60	EXTENSION, qtr. outer to rear end panel
74-75	Bel Air, Impala (exc. Sta. Wag.)	9618500 R.H.	8.95	EXTENSION, qtr. outer to rear end panel
74-75	Bel Air, Impala (exc. Sta. Wag.)	9618501 L.H.	8.95	EXTENSION, qtr. outer to rear end panel
74	Monte Carlo	9632255 R.H.	14.90	EXTENSION, qtr. outer panel (paint as reqd.)
74	Monte Carlo	9632256 L.H.	14.90	EXTENSION, qtr. outer panel (paint as reqd.)
74	Impala (Custom) Caprice (Spt. Cpe.)			
75	Impala (Custom)	9654132 R.H.	8.95	EXTENSION, qtr. outer to rear end panel
74	Impala (Custom) Caprice (Spt. Cpe.)			
75	Impala (Custom)	9654133 L.H.	8.95	EXTENSION, qtr. outer to rear end panel
75	Monte Carlo	9632859 R.H.	13.80	EXTENSION, qtr. outer panel
75	Monte Carlo	9632860 L.H.	13.80	EXTENSION, qtr. outer panel
75	Chevelle (Spt. Cpe., Sed.) (exc. Monte Carlo)	9632857 R.H.	10.75	EXTENSION, qtr. outer panel
75	Chevelle (Spt. Cpe., Sed.) (exc. Monte Carlo)	9632858 L.H.	10.75	EXTENSION, qtr. outer panel
75	Caprice (Spt. Cpe.)	9735255 R.H.	9.30	EXTENSION, quarter outer to rear end panel
75	Caprice (Spt. Cpe.)	9735256 L.H.	9.30	EXTENSION, quarter outer to rear end panel
75	Pass. (Conv. 4-Dr.) (exc. Sta. Wag.)	9735257 R.H.	9.30	EXTENSION, quarter outer to rear end panel
75	Pass. (Conv. 4-Dr.) (exc. Sta. Wag.)	9735258 L.H.	9.30	EXTENSION, quarter outer to rear end panel
75	Nova	9728844 R.H.	2.75	EXTENSION, qtr. pnl. to compt. pan fil.
75	Nova	9728845 L.H.	2.75	EXTENSION, qtr. pnl. to compt. pan fil.
75	Nova (Hatchback)	1705893 L.H.	5.10	EXTENSION, inner rear to roof inner
75	Nova (Hatchback)	1705892 R.H.	5.10	EXTENSION, inner rear to roof inner
75	Monza (Towne Cpe.)	9689136 R.H.	9.75	EXTENSION, qtr. otr. to rear end pnl.
75	Monza (Towne Cpe.)	9689137 L.H.	9.75	EXTENSION, qtr. otr. to rear end pnl.
75	Monza (Towne Cpe.)	1697405 R.H.	5.15	EXTENSION, qtr. otr. to rear end lower

**METAL TRIM—CLIPS AND PANELS**

**12.940A BEZEL— CAP UNIT— DEFLECTOR— EXTENSION— FILLER— PANEL—  
REINFORCEMENT— SUPPORT, Rear Quarter Outer (Con't)**

75	Monza (Towne Cpe.)	1697406 L.H.	5.15	EXTENSION, qtr. otr. to rear end lower
75	Monza (Towne Cpe.)	1708260 R.H.	1.60	EXTENSION, qtr. otr. to rear end upper
75	Monza (Towne Cpe.)	1708261 L.H.	1.60	EXTENSION, qtr. otr. to rear end upper
75	Monza	1654681 L.H.	2.25	EXTENSION, inner upper front
75	Monza	1654680 R.H.	2.25	EXTENSION, inner upper front
68-70	El Camino	7717690 R.H.	2.90	FILLER, qtr. outer panel at bk. window
68-70	El Camino	7717691 L.H.	2.90	FILLER, qtr. outer panel at bk. window
68-72	Chevelle (Sta. Wag.)	9808570 R.H.	4.25	FILLER, rear lower cor.
69-70	Pass. (Sta. Wag.)	8791465 R.H.	5.60	FILLER, rear lower outer
69-70	Pass. (Sta. Wag.)	8717836 L.H.	1.10	FILLER, rear lower corner
69-72	Chevelle (Sta. Wag.)	9808574 L.H.	4.55	FILLER, rear lower cor.
71-72	El Camino	7717691 L.H.	2.90	FILLER, outer panel at back window
71-72	El Camino	7717690 R.H.	2.90	FILLER, outer panel at back window
71-73	Pass. (Sta. Wag.)	9855325 L.H.	13.40	FILLER, back body pillar
71-73	Pass. (Sta. Wag.)	9855324 R.H.	13.40	FILLER, back body pillar
74-75	Monte Carlo	1691433 R.H.	1.10	FILLER, tail lamp bezel to rear end panel
74-75	Monte Carlo	1691434 L.H.	1.10	FILLER, tail lamp bezel to rear end panel
74-75	Camaro	9663177 L.H.	6.20	FILLER, otr. panel to tail lamp
74-75	Camaro	9663176 R.H.	6.20	FILLER, otr. outer panel at tail lamp
74-75	Vega (Cpe.)	9664026 R.H.	1.10	FILLER, qtr. pnl. at bpr. cover
74-75	Vega (Cpe.)	9664027 L.H.	1.10	FILLER, qtr. pnl. at bpr. cover
75	Nova	9728848 R.H.	7.80	FILLER, qtr. panel to compt. pan
75	Nova	9728849 L.H.	7.90	FILLER, qtr. panel to compt. pan
75	Nova	9738177 R.H.	4.75	FILLER, qtr. outer panel at bpr. cover
75	Nova	9738178 L.H.	4.75	FILLER, qtr. outer panel at bpr. cover
75	Nova (Towne Cpe.)	1726277 L.H.	34.25	FILLER, qtr. outer panel above belt w/formal wdo.
75	Nova (Towne Cpe.)	1726276 R.H.	34.25	FILLER, qtr. outer panel above belt w/formal wdo.

**PASSENGER**

68	Sta. Wag.	7715546 R.H.	9.80	PANEL
68	Sta. Wag.	7715970 L.H.	9.80	PANEL
69-70	Sta. Wag.	8727167 R.H.	10.15	PANEL
69-70	Sta. Wag.	8727168 L.H.	10.15	PANEL
71-72	Pass. (Sta. Wag.)	9865950 L.H.	21.60	PANEL, outer extension (structural adhesive)
71-72	Pass. (Sta. Wag.)	9609361 R.H.	22.50	PANEL, outer extension (structural adhesive)
71-73	Impala (Custom) Caprice (Spt. Cpe.)	9817211 L.H.	3.20	REINFORCEMENT, outer panel at belt
71-73	Impala (Custom) Caprice (Spt. Cpe.)	9817210 R.H.	3.20	REINFORCEMENT, outer panel at belt
71-73	Impala (Spt. Cpe.) (exc. Custom)	9821341 L.H.	9.25	REINFORCEMENT, outer panel
71-73	Impala (Spt. Cpe.) (exc. Custom)	9821340 R.H.	9.25	REINFORCEMENT, outer panel
74-75	Impala (Spt. Cpe.) (exc. Custom)	9618174 R.H.	8.45	REINFORCEMENT, qtr. outer at wdo.
74-75	Impala (Spt. Cpe.) (exc. Custom)	9618175 L.H.	8.45	REINFORCEMENT, qtr. outer at wdo. opening
74-75	Pass. (Sta. Wag.)	9671568 R.H.	1.55	SUPPORT, qtr. outer at roof joint
74-75	Pass. (Sta. Wag.)	9671569 L.H.	1.55	SUPPORT, qtr. outer at roof joint

**CHEVELLE**

67	El Camino	7624728 L.H.	10.80	upper
65	(exc. Sta. Wag., El Camino)	4492597 R.H.	15.15	
65	(exc. Sta. Wag., El Camino)	4492598 L.H.	14.75	
68	(Sta. Wag.)	8732618 L.H.	15.10	(repl. 7715881)
68-69	(Sta. Wag.)	8746279 R.H.	15.40	
69	(Sta. Wag.)	8732618 L.H.	15.10	
70	Chevelle (Sta. Wag.)	9866981 L.H.	13.05	ext. c/nut
70-71	Chevelle (Sta. Wag.)	9866980 R.H.	13.05	outer extension c/nut
68-72	Malibu (Conv.)	8800394 R.H.	1.20	REINFORCEMENT, qtr. panel at qtr. win. rear
70-72	Malibu (Conv.)	8800395 L.H.	1.20	REINFORCEMENT, qtr. panel at qtr. window rear

**CHEVY— NOVA**

66-67	(exc. Sta. Wag.)	4512041 L.H.	11.60	
74	Nova (H.B.)	1657520 R.H.	3.40	SUPPORT, jack column stowage front
73-74	Nova (exc. H.B.)	9654004 R.H.	.46	SUPPORT, jack column stowage rear

**CAMARO**



## METAL TRIM—CLIPS AND PANELS

### 12.941 PANEL— PANEL ASSY., Rear Quarter Side Inner

#### PASSENGER

67-68	Impala (Conv.)	7649219	L.H.	37.75	PANEL ASSY., lower
71-73	Impala (Custom) Caprice (Spt. Cpe.)				
74-75	Impala (Spt. Cpe.) (exc. Custom)	9824628	R.H.	47.75	PANEL ASSY., inner lower
71-73	Impala (Custom) Caprice (Spt. Cpe.)				
74-75	Impala (Spt. Cpe.) (exc. Custom)	9824629	L.H.	47.75	PANEL ASSY., inner lower
71-73	Impala (Spt. Cpe.) (exc. Custom)	9824630	R.H.	39.75	PANEL ASSY., inner lower
71-73	Impala (Spt. Cpe.) (exc. Custom)	9824631	L.H.	39.75	PANEL ASSY., inner lower
71-75	Impala (Conv.)	9831007	R.H.	60.25	PANEL ASSY., inner
71-75	Impala (Conv.)	9831008	L.H.	60.25	PANEL ASSY., inner
74-75	Impala (Custom) Caprice (Spt. Cpe.)	8794010	R.H.	25.75	PANEL ASSY., inner lower
74-75	Impala (Custom) Caprice (Spt. Cpe.)	8794011	L.H.	25.75	PANEL ASSY., inner lower
75	Pass. (Sed.) (exc. Spt. Sed.)	9728816	R.H.	28.75	PANEL ASSY., outer lower
75	Pass. (Sed.) (exc. Spt. Sed.)	9728817	L.H.	28.75	PANEL ASSY., outer lower

#### CHEVELLE

68-72	El Camino	7671536	R.H.	13.75	inner rear
68-72	El Camino	7671537	L.H.	13.75	inner rear
68-72	El Camino	7671562	R.H.	45.75	front upper
68-72	El Camino	7651563	L.H.		front upper
68-72	(4-Dr. Sed.) (exc. Spt. Sed.)	8782208	R.H.	17.10	inner lower
68-72	(4-Dr. Sed.) (exc. Spt. Sed.)	7791285	L.H.	16.85	inner lower
68-72	Malibu (Spt. Sed.)	7791287	L.H.	16.85	inner lower
68-72	El Camino	7787061	R.H.	13.75	front lower
68-72	El Camino	7787062	L.H.	13.75	front lower
69-72	(Sta. Wag.)	8760883	R.H.	14.90	side inner
68-72	Malibu (Spt. Sed.)	8770142	R.H.	16.85	rear inner lower
73-75	El Camino	9867727	R.H.	68.50	rear inner
73-75	El Camino	9867728	L.H.	68.50	rear inner
73-75	Chevelle (Spt. Sed.)	9652734	R.H.	3.50	rear inner lower (paint as reqd.)
73-75	Chevelle (Spt. Sed.)	9652735	L.H.	3.50	rear inner lower (paint as reqd.)
68-72	(Spt. Cpe.)	8801658	R.H.	37.75	PANEL ASSY., lower (fabric type)
68-72	(Spt. Cpe.)	8801659	L.H.	37.75	PANEL ASSY., lower (fabric type)
68-70	(2-Dr. Sed.)	8776742	R.H.	39.00	PANEL ASSY., inner lower (plastic type)
68-70	(2-Dr. Sed.)	8776743	L.H.	39.00	PANEL ASSY., inner lower (plastic type)
68-72	Chevelle (Conv.)	9816622	R.H.	46.50	PANEL ASSY., inner
68-72	Chevelle (Conv.)	9816623	L.H.	46.50	PANEL ASSY., inner

#### CHEVY— NOVA

68-72	(Spt. Cpe.)	7722883	R.H.	19.60	lower
68-72	(Spt. Cpe.)	7722884	L.H.	19.60	lower
68-72	(Sedan)	8772024	R.H.	26.00	inner
69-72	(Sedan)	8799869	L.H.	25.50	inner
73-74	Nova (4-Dr.)	9879112	R.H.	26.00	inner
73-74	Nova (4-Dr.)	9879113	L.H.	26.00	inner
73-74	Nova (2-Dr.)	9879116	R.H.	19.60	rear inner lower
73-74	Nova (2-Dr.)	9879117	L.H.	19.60	rear inner lower
75	Nova (2-Dr.)	9676150	R.H.	19.60	PANEL ASSY., quarter inner lower (repl. 1707844)
75	Nova (2-Dr.)	9676151	L.H.	19.60	PANEL ASSY., quarter inner lower (repl. 1707845)

#### CAMARO

#### VEGA — MONZA

71-73	Vega (H.B. Coupe)	9644957	L.H.	107.00	PANEL ASSY., qtr. side inner and wheelhouse
71-73	Vega (H.B. Coupe)	9644956	R.H.	107.00	PANEL ASSY., qtr. side inner and wheelhouse
71-73	Vega (N.B. Coupe)	9644959	L.H.	107.00	PANEL ASSY., qtr. inner and wheelhouse
71-73	Vega (N.B. Coupe)	9644958	R.H.	107.00	PANEL ASSY., qtr. inner and wheelhouse
71-73	Vega (Panel, Sta. Wag.)	9622369	L.H.	107.00	PANEL ASSY., qtr. inner and wheelhouse
71-73	Vega (Panel, Sta. Wag.)	9622368	R.H.	107.00	PANEL ASSY., qtr. inner and wheelhouse
71-75	Vega (Panel)	9820747	L.H.	24.50	PANEL ASSY., qtr. window opening insert
71-75	Vega (Panel)	9820746	R.H.	24.50	PANEL ASSY., qtr. window opening insert
74-75	Vega (N.B. Coupe)	9659227	R.H.	128.00	PANEL ASSY., qtr. inner and wheelhouse
74-75	Vega (N.B. Coupe)	9659228	L.H.	128.00	PANEL ASSY., qtr. inner and wheelhouse
74-75	Vega (Panel, Sta. Wag.)	9659231	R.H.	128.00	PANEL ASSY., qtr. inner and wheelhouse

**METAL TRIM—CLIPS AND PANELS**

**12.941 PANEL— PANEL ASSY., Rear Quarter Side Inner (Con't)**

74-75	Vega (Panel, Sta. Wag.)	9659232 L.H.	128.00	PANEL ASSY., qtr. inner and wheelhouse
74-75	Vega (H.B. Coupe)	9659233 R.H.	128.00	PANEL ASSY., qtr. inner and wheelhouse
74-75	Vega (H.B. Coupe)	9659234 L.H.		PANEL ASSY., qtr. inner and wheelhouse
75	Monza (exc. Towne Cpe.)	9736662 R.H.	24.85	PANEL ASSY., qtr. inner rear
75	Monza (exc. Towne Cpe.)	9736663 L.H.	24.85	PANEL ASSY., qtr. inner rear
75	Monza (exc. Towne Cpe.)	1698474 R.H.	128.00	PANEL ASSY., qtr. inner to wheelhouse
75	Monza (exc. Towne Cpe.)	1698475 L.H.	128.00	PANEL ASSY., qtr. inner to wheelhouse
75	Monza (Notchback)	1717318 R.H.	128.00	PANEL ASSY., qtr. inner and wheelhouse
75	Monza (Notchback)	1717319 L.H.	128.00	PANEL ASSY., qtr. inner and wheelhouse

**12.941A BRACE— COVER— DEFLECTOR— EXTENSION— FILLER— GASKET— GRILLE— PLATE— PLUG— REINFORCEMENT— RETAINER— STIFFENER— STRIKER ASSY.— STRIP— SUPPORT— VALVE, Rear Quarter Side Inner**

74-75	Impala (Custom) Caprice (Spt. Cpe.)	9692732 R.H.	3.10	qtr. wdo. frt. reinf. to pnl.
74-75	Impala (Custom) Caprice (Spt. Cpe.)	9692733 L.H.	3.10	qtr. wdo. frt. reinf. to pnl.
73-74	Nova (Coupe)	9617206 R.H.	5.95	qtr. inner upper to wheel housing
73-74	Nova (Coupe)	9617207 L.H.	5.95	qtr. inner upper to wheel housing
70-71	Camaro	8762198 R.H.	5.95	inner upper to w/h
70-71	Camaro	8762199 L.H.	5.95	inner upper to w/h
71-75	Vega, Monza	9735966 L.H.	13.25	BRACE ASSY., dia. qtr. inr. to compt. pan
71-75	Vega	9845035 R.H.	5.90	BRACE ASSY., dia. qtr. inr. to compt. pan
75	Monza (Towne Coupe)	1695820 R.H.	17.25	BRACE ASSY., dia. qtr. inner to compt. pan
68-72	El Camino	7671792 2	1.45	COVER, access rear
70	Pass.	7645222 2	.64	COVER, inner acc. hole front
70-75	El Camino	9817545 2	1.45	COVER, inner front lower acc.
70	Camaro	9866575 2	1.05	COVER, w/h inner access hole (repl. 8799791)
71-75	Pass. (Conv.)	8792947 R.H.	3.10	COVER, inner access hole
71-75	Pass. (Conv.)	8792948 L.H.	3.10	COVER, inner access hole
71-72	Pass. (exc. Sta. Wag., Conv.)	9615572 A.R.	.59	COVER, access hole in sail area
71-73	Impala (Custom) Caprice (Spt. Cpe.)	9833505 R.H.	2.35	COVER, inner upper panel access hole
71-73	Impala (Custom) Caprice (Spt. Cpe.)	9833506 L.H.	2.35	COVER, inner upper panel access hole
71	Camaro	9866575 2	1.05	COVER, w/h inner panel access hole
73-74	Monte Carlo	9869610 2	1.80	COVER, qtr. inner upper panel lower hole
73-75	El Camino	9873317 2	1.80	COVER, inner access rear
74-75	Caprice (Spt. Cpe.)			
75	Impala (Custom)	9618197 2	.71	COVER, access hole qtr. outer panel
68-72	Malibu, S.S. (Conv.)	7715910 R.H.	5.50	COVER ASSY., access hole
68-72	Malibu, S.S. (Conv.)	7715911 L.H.	5.50	COVER ASSY., access hole
65-68	Chevy, Chevelle, Camaro,			
65-67	Pass. (2-Dr.) (exc. Conv.)	4780514 2	.83	DEFLECTOR, water— (10.355)
68-70	Chevelle (Spt. Cpe.)	7724474 R.H.	1.70	EXTENSION, rear
68-70	Chevelle (Spt. Cpe.)	7724475 L.H.	1.70	EXTENSION, rear
72	Pass. (Sta. Wag., Spt. Sed.)	9605954 R.H.	2.35	EXTENSION, center pillar inner panel to roof
72	Pass. (Sta. Wag., Spt. Sed.)	9605955 L.H.	2.35	EXTENSION, center pillar inner panel to roof
73-75	El Camino	9866270 R.H.	16.85	EXTENSION, qtr. inner pnl. frt.
73-75	El Camino	9866271 L.H.	16.85	EXTENSION, qtr. inner pnl. frt.
73-75	El Camino	9866274 R.H.	13.25	EXTENSION, qtr. inner pnl. rear
73-75	El Camino	9866275 L.H.	13.25	EXTENSION, qtr. inner pnl. rear
75	Impala (Custom) Caprice (Spt. Cpe.)	9664858 R.H.	12.40	EXTENSION, inner lower pnl. at belt
75	Impala (Custom) Caprice (Spt. Cpe.)	9664859 L.H.	12.40	EXTENSION, inner lower pnl. at belt
75	Nova (H.B.)	1705892 R.H.	5.10	EXTENSION, qtr. inner rear to roof inner
75	Nova (H.B.)	1705893 L.H.	5.10	EXTENSION, qtr. inner rear to roof inner
68-72	(Spt. Cpe.)	7733888 R.H.	1.20	FILLER, qtr. wind. lower rr. corner
68-72	Nova (Spt. Cpe.)	7733888 R.H.	1.20	FILLER, qtr. wdo. lwr. rear cor.
68-72	Nova (Spt. Cpe.)	7733889 L.H.	1.20	FILLER, qtr. wdo. lwr. rear cor.
70-73	Pass. (Sta. Wag.)	9835619 1	3.90	FILLER, qtr. inner trim panel
70-72	Chevelle (Spt. Cpe.) (exc. Monte Carlo)	8801310 R.H.	1.35	FILLER, wdo. lower corner
70-72	Chevelle (Spt. Cpe.) (exc. Monte Carlo)	8801311 L.H.	1.35	FILLER, wdo. lower corner
70-72	Monte Carlo	8784510 R.H.	1.35	FILLER, wdo. lwr. rear cor.
70-72	Monte Carlo	8784511 L.H.	1.35	FILLER, wdo. lwr. rear cor.
73-75	Chevelle (Sta. Wag.)	9872155 R.H.	1.35	FILLER, qtr. wdo. lwr. cor.
73-75	Chevelle (Sta. Wag.)	9872156 L.H.	1.35	FILLER, qtr. wdo. lwr. cor.
73-74	Nova (2-Dr.)	9879092 R.H.	.71	FILLER, qtr. wdo. lwr. rear cor.
73-74	Nova (2-Dr.)	9879093 L.H.	.71	FILLER, qtr. wdo. lwr. rear cor.

**METAL TRIM—CLIPS AND PANELS**

**12.941A BRACE— COVER— DEFLECTOR— EXTENSION— FILLER— GASKET—  
GRILLE— PLATE— PLUG— REINFORCEMENT— RETAINER— STIFFENER—  
STRIKER ASSY.— STRIP— SUPPORT— VALVE, Rear Quarter Side Inner  
(Con't)**

74-75	Pass. (Sta. Wag.)	9668486	L.H.	.21	GASKET, cover w/h inr. pnl. acc. hole
71-72	Vega (Panel, Sta. Wag.)	9837947	2	1.30	GRILLE, inner w/h ext. (black)
71-75	Vega (H.B. Coupe)	9818597	L.H.	7.60	PLATE, qtr. inner panel baffle
71-75	Vega (H.B. Coupe)	9818596	R.H.	7.60	PLATE, qtr. inner panel baffle
66-67	Chevelle, Camaro,				
65-68	Pass. (Conv.)	4771203	A.R.	.12	PLUG, inner panel access hole frt.— (12.980)
71-74	Vega (N.B. Coupe)	9861336	2	.84	PLUG, qtr. inr. panel upper access hole
71-72	Pass. (Sed., Spt. Cpe.)				PLUG, qtr. a/c hole in sail area,
73	Bel Air (Sed.)				PLUG, qtr. a/c hole in sail area,
74	Pass. (exc. Sta. Wag.)				PLUG, qtr. a/c hole in sail area,
75	Pass. (Sed.) (exc. Spt. Sed.)	9615572	A.R.	.59	qtr. inr. pnl. upr. frt. or rear above belt
72-75	Vega (Panel, Sta. Wag.),				
75	Vega (Panel, Sta. Wag.)	9836063	A.R.	.54	PLUG, qtr. inr. lwr. panel
72	Chevelle (Spt. Sed.)	9605408	L.H.	3.20	REINFORCEMENT, fir. pan at center panel
75	Monza (Towne Coupe)	1672813	L.H.	4.65	REINFORCEMENT, diag. w/h inner to compt. pan
71-75	Vega (Panel, Sta. Wag.)	9837511	2	.44	RETAINER, qtr. panel drain valve
73	Nova (H.B.)	9658511	R.H.	7.65	STIFFENER, qtr. inner upper to w/h
73	Nova (H.B.)	9658512	L.H.	7.65	STIFFENER, qtr. inner upper to w/h
74	Nova (H.B.)	9732952	R.H.	5.50	STIFFENER, qtr. inner upper to w/h
74	Nova (H.B.)	9732953	L.H.	5.50	STIFFENER, qtr. inner upper to w/h
74	Vega (Coupe, Sta. Wag.)	9619408	R.H.	3.80	STRIKER ASSY., fldg. rear seat bk. panel bpr.
74-75	Vega (Coupe, Sta. Wag.) Nova	9619407	L.H.	1.95	SUPPORT, fldg. rear seat back panel bpr.
75	Monza	1715769	L.H.	1.95	SUPPORT, fldg. rear seat back pnl. bpr.
71-75	Vega (Panel, Sta. Wag.)	9837512	2	.48	VALVE, qtr. panel drain

**12.942 PANEL— EXTENSION— FILLER— GASKET— LOUVER— MOULDING—  
PLATE— PLUG— REINFORCEMENT— VALVE— STIFFENER, Rear Body  
Lock Pillar**

**PASSENGER**

67-68	Spt. Sed.	7593045	L.H.	22.45	outer lower
69-70	Sta. Wag.	7749664	R.H.	24.00	outer lower
69-70	Sta. Wag.	7749665	L.H.	24.00	outer lower
69-70	(4-Dr.)	7777202	L.H.	6.55	inner lower
69-70	Sta. Wag.	7749165	L.H.	12.90	outer upper
69-70	4-Dr. Sed. (exc. Spt. Sed.)	8716326	R.H.	24.00	outer lower
69-70	4-Dr. Sed. (exc. Spt. Sed.)	8716327	L.H.	24.00	outer lower
69-70	Spt. Sed.	8716328	R.H.	24.00	outer lower
69-70	Spt. Sed.	8716329	L.H.	24.00	outer lower
69-70	4-Dr. Sed. (exc. Spt. Sed.)	8716346	R.H.	18.25	inner lower
69-70	4-Dr. Sed. (exc. Spt. Sed.)	8716347	L.H.	18.25	inner lower
69-70	Sta. Wag.	8756535	L.H.	19.00	inner
69-70	Spt. Sed.	8771880	R.H.	18.60	inner lower
71-74	Pass. (Spt. Sed.)	9625733	L.H.	2.35	outer upper
71-74	Pass. (Spt. Sed.)	9625732	R.H.	2.35	outer upper
71-74	Pass. (Spt. Sed.)	9602981	L.H.	24.10	outer lower
71-73	Pass. (Spt. Sed.)	9885758	R.H.	24.10	outer lower
71-74	Pass. (Sed.) (exc. Spt. Sed.)	9602983	L.H.	24.10	outer lower
71-73	Pass. (Sed.) (exc. Spt. Sed.)	9885760	R.H.	24.10	outer lower
71-72	Pass. (Sta. Wag.)	9603291	L.H.	24.40	outer lower (repl. 9872697)
71-73	Pass. (Sta. Wag.)	9603290	R.H.	24.40	outer lower (repl. 9872696)
73	Pass. (Sta. Wag.)	9872753	R.H.	.83	inner
73-75	Pass. (Sta. Wag.)	9603291	L.H.	24.40	outer lower
74	Pass. (Spt. Sed.)	9602980	R.H.	24.10	outer lower
74	Pass. (Sed.) (exc. Spt. Sed.)	9602982	R.H.	24.10	outer lower
74-75	Pass. (Sta. Wag.)	9603290	R.H.	24.40	outer lower
75	Pass. (Spt. Sed.)	9728814	R.H.	28.75	outer lower
75	Pass. (Spt. Sed.)	9728815	L.H.	28.75	outer lower
75	Pass. (Sed. exc. Spt. Sed.)	9728816	R.H.	28.75	outer lower
75	Pass. (Sed. exc. Spt. Sed.)	9728817	L.H.	28.75	outer lower

**CHEVELLE**

68-69	(2-Dr. Sed.)	7730872	R.H.	16.90	upper
68-72	(4-Dr.)	7779962	R.H.	2.35	inner lower
68-72	(4-Dr.)	7779963	L.H.	2.35	inner lower
68-72	El Camino	7671583	R.H.	12.05	inner lower
68-72	El Camino	7671584	L.H.	12.05	inner lower
68-72	(Sta. Wag.)	8760892	R.H.	19.80	inner upper (plastic type)

**METAL TRIM—CLIPS AND PANELS**

**12.942 PANEL— EXTENSION— FILLER— GASKET— LOUVER— MOULDING—  
PLATE— PLUG— REINFORCEMENT— VALVE— STIFFENER, Rear Body  
Lock Pillar (Con't)**

68-72 (Sta. Wag.)	8760893 L.H.	19.80	inner upper (plastic type)
68-72 (Sta. Wag.)	8728280 R.H.	39.00	body lock plr. otr.
68-72 (Sta. Wag.)	8728281 L.H.	39.00	body lock plr. otr.
70-72 Chevelle (Spt. Sed.)	8735936 R.H.	20.10	outer lower
70-72 Chevelle (Spt. Sed.)	8735937 L.H.	20.10	outer lower
70-72 Chevelle (Sed.) (exc. Spt. Sed.)	8735938 R.H.	20.10	outer lower
70-72 Chevelle (Sed.) (exc. Spt. Sed.)	8735939 L.H.	20.10	outer lower
73-75 Chevelle (Spt. Sed.)	9619905 L.H.	26.75	outer lower
73-75 Chevelle (Spt. Sed.)	9619904 R.H.	26.75	outer lower
73-75 El Camino	9864296 L.H.	14.45	outer upper
73-75 El Camino	9864295 R.H.	14.45	outer upper
73-75 Chevelle (Sta. Wag.)	9867725 L.H.	11.30	outer upper
73-75 Chevelle (Sta. Wag.)	9867724 R.H.	11.30	outer upper
73-74 Chevelle (Sta. Wag.)	9830016 L.H.	24.40	inner upper
73-74 Chevelle (Sta. Wag.)	9830015 R.H.	24.40	inner upper
73-75 Chevelle (Spt. Cpe.)	9619769 L.H.	41.50	outer
73-75 Chevelle (Spt. Cpe.)	9619768 R.H.	41.50	outer
73-75 Monte Carlo	9619771 L.H.	41.50	outer
73-75 Monte Carlo	9619770 R.H.	41.50	outer
73-75 El Camino	9889975 L.H.	37.25	outer
73-75 El Camino	9889974 R.H.	37.25	outer
73-75 Chevelle (Sta. Wag.)	9878592 L.H.	36.00	outer lower
73-75 Chevelle (Sta. Wag.)	9878591 R.H.	36.00	outer lower
73-75 El Camino	1702997 R.H.	23.35	inner (repl. 9671624)
73-75 El Camino	1702998 L.H.	23.35	inner
75 Chevelle	9830015 R.H.	24.40	PANEL, inner upper
75 Chevelle	9830016 L.H.	24.40	PANEL, inner upper

**CHEVY— NOVA**

68-74 (Spt. Cpe.)	8768724 R.H.	13.15	PANEL ASSY., upper
68-74 (Spt. Cpe.)	8768725 L.H.	13.15	PANEL ASSY., upper
75 Nova (2-Dr.)	9676130 R.H.	3.50	PANEL, upper
75 Nova (2-Dr.)	9676131 L.H.	3.50	PANEL, upper

**VEGA— MONZA**

71-73 Vega (H.B. Cpe.)	8802391 L.H.	14.50	
71-73 Vega (H.B. Cpe.)	8802390 R.H.	14.50	
71-73 Vega (Pnl., N.B. Cpe., exc. H.B.)	8802389 L.H.	14.50	
71-73 Vega (Pnl., N.B. Cpe., exc. H.B.)	8802388 R.H.	14.50	
74-75 Vega (Pnl., N.B. Cpe., exc. H.B.)	9666438 R.H.	17.40	
74-75 Vega (Pnl., N.B. Cpe., exc. H.B.)	9666439 L.H.	17.40	
74-75 Vega (H.B. Cpe.)	9666440 R.H.	17.40	inner
74-75 Vega (H.B. Cpe.)	9666441 L.H.	17.40	inner
75 Monza (exc. Towne Cpe.)	9674202 R.H.	15.75	
75 Monza (exc. Towne Cpe.)	9674203 L.H.	15.75	
75 Monza (exc. Towne Cpe.)	1741554 R.H.	6.40	PANEL, inner upper (repl. 9674195)
75 Monza (exc. Towne Cpe.)	1741555 L.H.	6.40	PANEL, inner upper (repl. 9674196)
75 Monza (Towne Coupe)	1672760 R.H.	13.00	PANEL
75 Monza (Towne Coupe)	1672761 L.H.	13.00	PANEL
71-75 Vega (H.B. Coupe)	9738187 L.H.	8.10	PANEL ASSY., inner upper
71-75 Vega (H.B. Coupe)	9738186 R.H.	8.10	PANEL ASSY., inner upper
71-75 Vega (Pnl., Cpe., S/Wag., exc. H.B.)	1653068 R.H.	13.00	PANEL ASSY., inner upper
73-75 Vega (Pnl., Cpe., S/Wag., exc. H.B.)	1653069 L.H.	13.00	PANEL ASSY., inner upper
68-72 Chevelle (Sta. Wag.)	8718002 L.H.	9.75	EXTENSION, body lock pillar outer upper panel (plastic)
68-72 Chevelle (Sta. Wag.)	8718001 R.H.	9.75	EXTENSION, body lock pillar outer upper panel
73 Chevelle (Spt. Cpe.) (exc. Monte Carlo)	9879173 L.H.	3.10	EXTENSION, inner upper to reinforcement
73 Chevelle (Spt. Cpe.) (exc. Monte Carlo)	9879172 R.H.	3.10	EXTENSION, inner upper to reinforcement
73 Monte Carlo	9871035 L.H.	4.35	EXTENSION, inner upper to reinforcement
73 Monte Carlo	9871034 R.H.	4.35	EXTENSION, inner upper to reinforcement
74-75 Chevelle (2-Dr.) (exc. Monte Carlo)	9662498 R.H.	1.55	EXTENSION, inner upper to reinforcement
74-75 Chevelle (2-Dr.) (exc. Monte Carlo)	9662499 L.H.	1.55	EXTENSION, inner upper to reinforcement
74-75 Monte Carlo	9662500 R.H.	3.10	EXTENSION, inner upper to reinforcement
74-75 Monte Carlo	9662501 L.H.	3.10	EXTENSION, inner upper to reinforcement
74-75 Impala (Custom) Caprice (Spt. Cpe.)	9726161 R.H.	3.20	FILLER, lock plr. upr. corner

**METAL TRIM—CLIPS AND PANELS**

**12.942 PANEL— EXTENSION— FILLER— GASKET— LOUVER— MOULDING—  
PLATE— PLUG— REINFORCEMENT— VALVE— STIFFENER, Rear Body  
Lock Pillar (Con't)**

74-75	Impala (Custom) Caprice (Spt. Cpe.)	9726162 L.H.	3.20	FILLER, lock plr. upr. corner
69-70	Pass. (4-Dr. Sed.)	8756519 2	.29	GASKET, body press relief
73	Malibu (Sedan),			
72-74	Pass., Nova (4-Dr.),			
75	Chevelle (4-Dr.)	8756520 2	.29	GASKET, press relief valve
75	Nova (Coupe)	1689769 L.H.	22.30	LOUVER, above belt
75	Monza (exc. Towne Cpe.)	1698843 R.H.	13.85	LOUVER, chrome tipped
75	Monza (exc. Towne Cpe.)	1698844 L.H.	13.85	LOUVER, chrome tipped
75	Monza (exc. Towne Coupe)	1726573 L.H.		LOUVER, argent silver
75	Nova (Coupe)	1689768 R.H.	22.30	LOUVER, above belt
75	Monza (Towne Cpe.) w/formal window	1700711 R.H.	8.70	MOULDING, finish body lock pillar above belt
75	Monza (Towne Cpe.) w/formal window	1700712 L.H.	8.70	MOULDING, finish body lock pillar above belt
71-72	Pass. (Sta. Wag.)	9872753 L.H.	.83	PLATE, lower finish
71-75	Vega, Monza	9836063 2	.54	PLUG, access hole— (12.944)
67-69	Camaro	7779496 R.H.	7.55	REINFORCEMENT, body lock pillar
67-69	Camaro	7779497 L.H.	7.55	REINFORCEMENT, body lock pillar
67-68	Pass. (Spt. Cpe., Conv.)	7593658 R.H.	7.05	REINFORCEMENT
68	Caprice (Spt. Cpe.)	7725922 L.H.	7.25	REINFORCEMENT
68-72	Chevelle (4-Dr. Sed.)	7699336 R.H.	6.75	REINFORCEMENT, at lock striker
68-72	Chevelle (4-Dr. Sed.)	7699337 L.H.	6.75	REINFORCEMENT, at lock striker
68-72	El Camino	7721920 R.H.	7.10	REINFORCEMENT
68-72	El Camino	7721921 L.H.	7.10	REINFORCEMENT
68-74	Nova (Spt. Cpe.)	7731431 R.H.	5.00	REINFORCEMENT, outer panel
68-74	Nova (Spt. Cpe.)	7731432 L.H.	5.00	REINFORCEMENT, outer panel
68-72	Nova (4-Dr. Sed.)	8760437 R.H.	5.35	REINFORCEMENT, at lock striker
68-72	Nova (4-Dr. Sed.)	8760438 L.H.	5.35	REINFORCEMENT, at lock striker
69	Chevelle (2-Dr.) (exc. El Camino)	8768745 L.H.	8.10	REINFORCEMENT
69	Chevelle (2-Dr.) (exc. El Camino)	8768744 R.H.	8.10	REINFORCEMENT
69-70	Pass. (Spt. Cpe., Conv.)	7749508 R.H.	8.35	REINFORCEMENT, body lk. plr.
69-70	Pass. (Spt. Cpe., Conv.)	7749509 L.H.	8.35	REINFORCEMENT, body lk. plr.
69-70	Pass. (4-Dr.)	7749771 L.H.	3.15	REINFORCEMENT, lower
69-70	Pass. (Spt. Cpe., Conv.)	8722008 R.H.	2.90	REINFORCEMENT, flr. pan, at lk. plr.
69-70	Pass. (Spt. Cpe., Conv.)	8722009 L.H.	2.90	REINFORCEMENT, flr. pan, at lk. plr.
69	Pass. (2-Dr. Sed.)	8714247 L.H.	8.10	REINFORCEMENT, lower front
69	Pass. (2-Dr. Sed.)	8714249 L.H.	7.50	REINFORCEMENT, lower rear
69-70	Pass. (Spt. Cpe., Conv.)	8722009 L.H.	2.90	REINFORCEMENT, flr. pan, at lk. plr.
70-72	Chevelle (Spt. Cpe., Conv.)	7798326 R.H.	4.05	REINFORCEMENT, floor pan
70-72	Chevelle (Spt. Cpe., Conv.)	7798327 L.H.	4.05	REINFORCEMENT, floor pan
70-72	Malibu (Spt. Cpe., Conv.)	8735445 R.H.	8.60	REINFORCEMENT, lower
70-72	Malibu (Spt. Cpe., Conv.)	8735446 L.H.	8.60	REINFORCEMENT, lower
70-72	Monte Carlo	8776823 R.H.	8.60	REINFORCEMENT, lower
70-72	Monte Carlo	8776824 L.H.	8.60	REINFORCEMENT, lower
71	Pass. (Spt. Cpe., Conv.)	9602946 R.H.	15.60	REINFORCEMENT (repl. 8794060)
71-74	Pass. (Sta. Wag.)	1695647 L.H.	10.80	REINFORCEMENT, at belt (repl. 9604929)
71-74	Pass. (Sta. Wag.)	1695646 R.H.	10.80	REINFORCEMENT, at belt (repl. 9604928)
71-75	Pass. (Spt. Cpe., Conv.)	9611007 L.H.	4.10	REINFORCEMENT, floor pan
71-75	Pass. (Spt. Cpe., Conv.)	9611006 R.H.	4.10	REINFORCEMENT, floor pan
71-75	Pass. (Conv.)	9602947 L.H.	15.60	REINFORCEMENT, body lk. plr.
70	Camaro	3999497 1	1.55	REINFORCEMENT, column to pillar
71-75	Camaro	8762197 L.H.	17.20	REINFORCEMENT
71-75	Camaro	8762196 R.H.	17.20	REINFORCEMENT
72-75	Pass. (Conv.)	9602946 R.H.	15.60	REINFORCEMENT, body lk. plr.
75	Pass. (Spt. Cpe.)	9602949 L.H.	15.60	REINFORCEMENT, body lock pillar
72-75	Pass. (Spt. Cpe.)	9602948 R.H.	15.60	REINFORCEMENT, body lk. plr.
73-74	Nova (4-Dr.)	9879131 L.H.	6.05	REINFORCEMENT, at lock striker
73-74	Nova (4-Dr.)	9879130 R.H.	6.05	REINFORCEMENT, at lock striker
75	Pass. (Sta. Wag.)	1695646 R.H.	10.80	REINFORCEMENT, at belt
75	Pass. (Sta. Wag.)	1695647 L.H.	10.80	REINFORCEMENT, at belt
75	Nova (2-Dr.)	9678398 R.H.	6.05	REINFORCEMENT, lock plr. otr. panel
75	Nova (2-Dr.)	9678399 L.H.	6.05	REINFORCEMENT, lock plr. otr. panel
68	Caprice (Spt. Cpe.),			
69-70	Pass. (2-Dr.)	7728610 2	1.90	VALVE, lock pillar press relief
69-70	Pass. (4-Dr. Sed.)	8717996 R.H.	2.15	VALVE, body lock press relief
69-70	Pass. (4-Dr. Sed.)	8717997 L.H.	2.20	VALVE, body lock press relief
64-67	El Camino,			
68-69	Camaro	7738668 2	1.95	VALVE, lock pillar press relief
69	Chevelle (Spt. Cpe., Conv.)	8717589 1	2.05	VALVE, press relief
70-72	Chevelle (Spt. Cpe., Conv.),			

**METAL TRIM—CLIPS AND PANELS**

**12.942 PANEL— EXTENSION— FILLER— GASKET— LOUVER— MOULDING—  
PLATE— PLUG— REINFORCEMENT— VALVE— STIFFENER, Rear Body  
Lock Pillar (Con't)**

70-75	Camaro	8788235	2	2.15	VALVE, press rlf.
72-74	Pass.	1654747	2	.93	VALVE, press relief
75	Pass., Chevelle, Nova	1654747	2	.93	VALVE, press relief with formal style wdo.
74	Vega (N.B., H.B. Cpe.)	1654749	2		VALVE ASSY., body lk. pillar press. relief (repl. 8728739)
75	Vega (N.B., H.B. Cpe.)	1654747	2	.93	VALVE ASSY., body lk. pillar press. relief
68-71	El Camino	7791135	2	1.70	STIFFENER, qtr. otr. pnl. at lock pillar

**12.943 CAP UNIT— GASKET— PLATE— POCKET— SUPPORT— WASHER, Tail  
and Stop Lamp**

*NOTE 1 Consists of 1 cap, 1 gasket, 2 nuts.*

66-67	Chevy (Sta. Wag.)	7635749	2	.70	GASKET, rr. qtr. lwr. corner fin. cap
68-69	Chevelle (exc. Sta. Wag., El Camino)	7739831	1	.38	GASKET, rr. qtr. ext. at T/lamp
66	Cheveile (exc. Sta. Wag., El Camino),				
66	Pass. (exc. Sta. Wag.)	7589298	2	.28	GASKET, rr. qtr. extension at tail lamp
67	Pass. (exc. Sta. Wag., Spt. Cpe.),				
67	Caprice (Spt. Cpe.)	7674335	2	.28	GASKET, rr. qtr. ext. at tail lamp
67	Impala (Spt. Cpe.)	7674336	2	.28	GASKET, rr. qtr. ext. at tail lamp
68	Pass. (Sed., Conv.),				
68	Impala (Custom),				
68	Caprice (Spt. Cpe.)	7734970	2	.27	GASKET, rear qtr. ext. at tail lamp
68	Impala (Spt. Cpe.) (exc. Custom)	7734971	2	.26	GASKET, rear qtr. extension at tail lamp
70	Monte Carlo	8784578	2	.44	GASKET, outer panel ext.
71-72	Pass. (exc. Sta. Wag.)	9843300	A.R.	.79	GASKET, t/lamp sealing
70-71	Nova	8756528	R.H.	1.45	PLATE, mounting
70-71	Nova	8756529	L.H.	1.45	PLATE, mounting
68-69	El Camino	7738378	L.H.	2.35	POCKET, tail lamp
70-72	El Camino	8784890	R.H.	2.70	POCKET, c/nut
70-72	El Camino	8784891	L.H.	2.70	POCKET, c/nut
73	Chevelle (Spt. Cpe., Spt. Sed.) (exc. Monte Carlo)	9874119	2	2.95	SUPPORT, mounting upper
73	Chevelle (Spt. Cpe., Spt. Sed.) (exc. Monte Carlo)	9874127	2	4.25	SUPPORT, mounting lower
73	Chevelle (Spt. Cpe., Spt. Sed.) (exc. Monte Carlo)	9874126	2	4.25	SUPPORT, mounting lower
67	Impala (Spt. Cpe.)	4500771	1	.11	WASHER, qtr. otr. ext. at tail lamp— (12.118)

**12.944 PANEL— BRACE— COVER— EXTENSION— FILLER— PLUG— PLATE  
ASSY.— REINFORCEMENT— STIFFENER— SUPPORT, Wheelhouse**

**PASSENGER**

67-68	Sta. Wag.	7779780	R.H.	25.75	outer
67-68	Pass. (exc. Sta. Wag., Conv.)	7779776	R.H.	26.25	outer
67-68	Pass. (exc. Sta. Wag., Conv.)	7779777	L.H.	26.25	outer
69	Pass. (exc. Conv., Sta. Wag.),				
70	Pass.	9816694	R.H.	27.00	outer
69	Pass. (exc. Conv., Sta. Wag.),				
70	Pass.	9816695	L.H.	27.00	outer
69-70	Conv.	9816692	R.H.	27.00	outer
69-70	Pass. (Sta. Wag.)	7750024	R.H.	27.75	outer
71-75	Pass. (Sta. Wag.)	9621349	L.H.	68.75	outer
71-75	Pass. (Sta. Wag.)	9609806	R.H.	37.50	outer
71-75	Pass. (Spt. Cpe., Sed.)	9609789	L.H.	41.00	outer
71-75	Pass. (Spt. Cpe., Sed.)	9609788	R.H.	41.00	outer
71-75	(Conv.)	9836381	L.H.	41.00	outer
71-75	(Conv.)	9836380	R.H.	41.00	outer
71-73	Kingswood Estate, Caprice (Sta. Wag.)	9601728	L.H.	18.15	cover rear
71-75	Kingswood Estate, Caprice (Sta. Wag.)	9613233	L.H.	21.65	cover front
71	Brookwood, Townsman, Kingswood (exc. Estate)	9868471	R.H.	44.00	cover (black)
71	Kingswood (exc. Estate)	9870630	L.H.	36.25	cover frt. (textured metal) (maize)
71	Kingswood (exc. Estate) (1st design)	9609875	L.H.	49.00	cover rear (textured metal) (maize)
71	Kingswood (exc. Estate) (2nd design)	9870722	L.H.	13.85	cover rear (polyroplene) (maize)
71	Kingswood (exc. Estate)	9870632	R.H.	44.00	cover (textured metal) (med. maize)
71	Kingswood (exc. Estate)	9868472	R.H.	44.00	cover (textured metal) (saddle)

**METAL TRIM—CLIPS AND PANELS**

**12.944 PANEL— BRACE— COVER— EXTENSION— FILLER— PLUG— PLATE  
ASSY.— REINFORCEMENT— STIFFENER— SUPPORT, Wheelhouse  
(Con't)**

71	Kingswood (exc. Estate)	9865378 L.H.	36.25	cover frt. (saddle)
71	Kingswood (exc. Estate)	9865376 L.H.	36.25	cover rear (textured metal) (saddle)
71	Kingswood (exc. Estate)	9865379 L.H.	36.25	cover frt. (jade)
71	Kingswood (exc. Estate) (1st design)	9865377 L.H.	36.25	cover rear (textured metal) (jade)
71	Kingswood (exc. Estate) (1st design)	9868474 R.H.	44.00	cover (textured metal) (dk. jade)
71	Pass. (Sta. Wag.) (exc. Estate)	9868473 R.H.	44.00	cover (textured metal) (dk. blue)
71	Brookwood, Townsman, (1st design)	9868475 R.H.	44.00	cover (textured metal) (med. saddle)
71	(Sta. Wag.) (exc. Estate Wag.)	9841256 L.H.	40.25	cover front (black) (metal)
71	(Sta. Wag.) (exc. Estate Wag.)	9841257 R.H.	40.25	cover front (black) (metal)
71-72	(Sta. Wag.) (exc. Estate Wag.)	9865851 L.H.	17.75	cover frt. (black) (plastic)
71	Brookwood, Townsman	9841258 L.H.	40.25	cover front (saddle) (metal)
71	(Sta. Wag.) (exc. Estate Wag.)			
	1st design	9601744 L.H.	38.00	cover rear (black) (textured metal)
71	(Sta. Wag.) (exc. Estate Wag.)	9841260 L.H.	38.00	cover rear (blue) (metal)
72	(Sta. Wag.) (exc. Estate Wag.)			
	1st design	9865391 R.H.	17.75	cover front (black) (plastic)
72	Pass. (Spt. Cpe., Sed.)	9609789 L.H.	41.00	outer
72	Pass. (Spt. Cpe., Sed.)	9609788 R.H.	41.00	outer
72	Kingswood Estate	9683427 R.H.	34.00	cover rear
73	Bel Air, Impala (Sta. Wag.)	9896727 R.H.	16.10	cover (paint as required)
73	Bel Air, Impala (Sta. Wag.)	9896722 L.H.	16.10	cover (paint as required)
74-75	Caprice (Sta. Wag.)	9674929 L.H.	18.15	cover rear (metal)
69-70	Impala Custom, Caprice	8787222 R.H.	96.75	PANEL ASM.
69-70	4-Dr. Sed. (exc. Spt. Sed.)	9812692 R.H.	85.00	PANEL ASM.
69	Impala (Conv.)	9812697 L.H.		PANEL ASM. (repl. 8716785)
71	Kingswood (exc. Estate)	9870632 R.H.	44.00	PANEL ASM., cover (med. maize)
71	Impala (Custom), Caprice (Spt. Cpe.)	9827072 L.H.	156.00	PANEL ASM.
71-73	Impala (Custom), Caprice (Spt. Cpe.)	9610012 R.H.	156.00	PANEL ASM.
71-74	Pass. (Spt. Sed.)	9736043 L.H.	134.00	PANEL ASM.
71-74	Pass. (Spt. Sed.)	9736042 R.H.	134.00	PANEL ASM.
71-75	Pass. (Sta. Wag.)	9670803 L.H.	244.00	PANEL ASM.
71-72	Pass. (Sta. Wag.)	9687647 R.H.	198.00	PANEL ASM. (repl. 9609844)
71-73	Impala (Spt. Cpe.) (exc. Custom)	9610015 L.H.	156.00	PANEL ASM.
71-73	Impala (Spt. Cpe.) (exc. Custom)	9610014 R.H.	156.00	PANEL ASM.
71	Pass. (Sed.) (exc. Spt. Sed.)	9837404 R.H.	111.00	PANEL ASM.
71-75	(Conv.)	9841025 L.H.	176.00	PANEL ASM.
71-75	(Conv.)	9841024 R.H.	176.00	PANEL ASM.
71-75	(Sta. Wag.) (9-Pass.)	9683427 R.H.	34.00	PANEL ASM.
72-74	Pass. (Sed.) (exc. Spt. Sed.)	9609826 R.H.	111.00	PANEL ASM.
71-74	Pass. (Sed.) (exc. Spt. Sed.)	9609827 L.H.	111.00	PANEL ASM.
73-75	Pass. (Sta. Wag.)	9687647 R.H.	198.00	PANEL ASM.
74-75	Impala (Spt. Cpe.) (exc. Custom)	9687628 R.H.	187.00	PANEL ASM.
74-75	Impala (Spt. Cpe.) (exc. Custom)	9687629 L.H.	187.00	PANEL ASM.
75	Pass. (Spt. Sed.)	1667758 R.H.	161.00	PANEL ASM.
75	Pass. (Spt. Sed.)	1667759 L.H.	161.00	PANEL ASM.
75	Pass. (Sed.) (exc. Spt. Sed.)	1667760 R.H.	134.00	PANEL ASM.
75	Pass. (Sed.) (exc. Spt. Sed.)	1667761 L.H.	134.00	PANEL ASM.
74-75	Impala (Custom) Caprice (Spt. Cpe.)	1678118 R.H.	187.00	PANEL ASM.
75	Impala (Custom) Caprice (Spt. Cpe.)	1678119 L.H.	187.00	PANEL ASM.

**CHEVELLE**

66-67	(exc. Conv., Sta. Wag., El Camino)	7653056 L.H.	21.40	outer
68	Nomad,			
69-72	Nomad, Greenbrier	8719478 R.H.	29.50	cover (black) (Note 2)
68	Nomad (6-Pass.) (2nd design) (exc. Custom),			
69-70	Nomad	8719485 L.H.	67.50	qtr. inr. and whlhse. cover (black)
68	Nomad (Custom) (6-Pass.) (2nd design),			
69-72	Greenbrier (6-Pass.)	8719491 L.H.	67.50	qtr. inr. and whlhse. cover (black) (Note 2)
68	Malibu, Concours (Sta. Wag., 6-Pass.),			
69-72	Concours (6-Pass.)	8719498 L.H.	38.00	qtr. inr. and whlhse. cover (Note 2)
68-72	(Sta. Wag.)	7671556 L.H.	42.75	outer
68-72	(Sta. Wag.)	7707628 R.H.	26.50	outer

**METAL TRIM—CLIPS AND PANELS**

**12.944 PANEL— BRACE— COVER— EXTENSION— FILLER— PLUG— PLATE  
ASSY.— REINFORCEMENT— STIFFENER— SUPPORT, Wheelhouse  
(Con't)**

68	Malibu, Concours (Sta. Wag., 6-Pass.) (2nd design),				
68	Malibu, Concours (Sta. Wag., 9-Pass.),				
69-72	Concours . . . . .	8719481	R.H.	19.80	cover (Note 2) . . . . .
68-69	Chevelle (Conv.) . . . . .	7704253	L.H.	22.10	outer . . . . .
70-71	Monte Carlo . . . . .	8761104	R.H.	23.30	outer . . . . .
70-71	Monte Carlo . . . . .	8761105	L.H.	23.30	outer . . . . .
66-71	El Camino . . . . .	9815030	R.H.	22.30	outer . . . . .
70-71	El Camino . . . . .	9815031	L.H.	22.30	outer . . . . .
70-71	(Spt. Cpe., Sed.) . . . . .	9816858	R.H.	23.30	outer . . . . .
70-71	(Spt. Cpe., Sed.) . . . . .	9816859	L.H.	23.30	outer . . . . .
70-71	Malibu (Conv.) . . . . .	9816860	R.H.	23.30	outer . . . . .
70-71	Malibu (Conv.) . . . . .	9816861	L.H.	23.30	outer . . . . .
71-72	Concours (9-Pass.) . . . . .	8719498	L.H.	38.00	qtr. inner and w/h cover . . . . .
71-72	Greenbrier (9-Pass.) . . . . .	9870697	L.H.	75.25	qtr. inner and w/h cover (black) . . . . .
71	Nomad, Greenbrier . . . . .	9840100	R.H.	38.00	cover (saddle) . . . . .
71	Nomad . . . . .	9840094	L.H.	75.25	qtr. inner w/h cover (saddle) . . . . .
71	Greenbrier (6-Pass.) . . . . .	9840096	L.H.	75.25	qtr. inner w/h cover (saddle) . . . . .
71	Greenbrier (9-Pass.) . . . . .	9870699	L.H.	75.25	qtr. inner w/h cover (saddle) . . . . .
71	Nomad, Greenbrier . . . . .	9840099	R.H.	38.00	cover (sandalwood) . . . . .
71	Nomad . . . . .	9840093	L.H.	75.25	qtr. inner w/h cover (sandalwood) . . . . .
71-72	Greenbrier (6-Pass.) . . . . .	9840095	L.H.	75.25	qtr. inner w/h cover (sandalwood) . . . . .
71	Greenbrier (9-Pass.) . . . . .	9870698	L.H.	75.25	qtr. inner w/h cover (sandalwood) . . . . .
72	Monte Carlo . . . . .	8761105	L.H.	23.30	outer . . . . .
72	Monte Carlo . . . . .	8761104	R.H.	23.30	outer . . . . .
72	Chevelle (Spt. Cpe., Sed.) . . . . .	9816859	L.H.	23.30	outer . . . . .
72	Chevelle (Spt. Cpe., Sed.) . . . . .	9816858	R.H.	23.30	outer . . . . .
72	Chevelle (Conv.) . . . . .	9816861	L.H.	23.30	outer . . . . .
72	Chevelle (Conv.) . . . . .	9816860	R.H.	23.30	outer . . . . .
72	El Camino . . . . .	9815031	L.H.	22.30	outer . . . . .
72	El Camino . . . . .	9815030	R.H.	22.30	outer . . . . .
72	Nomad . . . . .	8719485	L.H.	67.50	qtr. inner & w/h cover (black) . . . . .
72	Nomad . . . . .	9888910	L.H.	75.25	qtr. inner w/h cover (tan) . . . . .
72	Greenbrier (6-Pass.) . . . . .	9888909	L.H.	75.25	qtr. inner w/h cover (tan) . . . . .
72	Greenbrier (9-Pass.) . . . . .	9888914	L.H.	75.25	qtr. inner w/h cover (tan) . . . . .
72	Nomad, Greenbrier . . . . .	9888894	R.H.	38.00	cover (tan) . . . . .
72	Greenbrier (6-Pass.) . . . . .	9888908	L.H.	75.25	qtr. inner w/h cover (green) . . . . .
72	Greenbrier (9-Pass.) . . . . .	9888913	L.H.	75.25	qtr. inner w/h cover (green) . . . . .
72	Greenbrier (9-Pass.) . . . . .	9888893	R.H.	38.00	cover (green) . . . . .
73-75	Monte Carlo . . . . .	9830396	L.H.	27.75	outer . . . . .
73-75	Monte Carlo . . . . .	9830395	R.H.	27.75	outer . . . . .
73-75	Chevelle (exc. Sta. Wag., Monte Carlo) . . . . .	9830353	L.H.	27.75	outer . . . . .
73-75	Chevelle (exc. Sta. Wag., Monte Carlo) . . . . .	9830352	R.H.	27.75	outer . . . . .
73-75	Chevelle (Sta. Wag.) . . . . .	9830626	R.H.	45.00	outer . . . . .
73-75	Chevelle (Sta. Wag.) . . . . .	9627215	L.H.	13.85	cover frt. (paint as required) . . . . .
73-75	Chevelle (Sta. Wag.) . . . . .	9627236	R.H.	13.85	cover (paint as required) . . . . .
73-75	Chevelle (Sta. Wag.) . . . . .	9627229	L.H.	10.10	rear cover (paint as required) . . . . .
73-75	Chevelle (Sta. Wag.) . . . . .	9638029	L.H.	68.75	outer . . . . .
68-72	El Camino . . . . .	9814166	R.H.	140.00	PANEL ASM. . . . .
68-72	El Camino . . . . .	9814167	L.H.	140.00	PANEL ASM. . . . .
68	Nomad (exc. Custom) . . . . .	8738041	L.H.	138.00	PANEL ASM. . . . .
68-72	Sta. Wag. (6-Pass.) (exc. Nomad) . . . . .	8738041	L.H.	138.00	PANEL ASM. (repl. 8738040) . . . . .
68-69	(Spt. Cpe.) . . . . .	9808448	R.H.	94.25	PANEL ASM. (plastic) . . . . .
68	(Spt. Cpe.) . . . . .	9808449	L.H.	94.25	PANEL ASM. . . . .
69-72	Sta. Wag. . . . .	8738041	L.H.	138.00	PANEL ASM. . . . .
68-72	(Sta. Wag.) . . . . .	8771718	R.H.	119.00	PANEL ASM. . . . .
69	(Spt. Cpe.) . . . . .	9808449	L.H.	94.25	PANEL ASM. . . . .
70-72	Chevelle (Sed.) . . . . .	8784188	R.H.	70.00	PANEL ASM. . . . .
70-72	Chevelle (Sed.) . . . . .	8784189	L.H.	70.00	PANEL ASM. . . . .
70-72	Monte Carlo . . . . .	8785103	R.H.	97.50	PANEL ASM. . . . .
70-72	Monte Carlo . . . . .	8785104	L.H.	97.50	PANEL ASM. . . . .
70-72	Malibu (Conv.) . . . . .	8785122	R.H.	116.00	PANEL ASM. . . . .
70-72	Malibu (Conv.) . . . . .	8785123	L.H.	116.00	PANEL ASM. . . . .
70-72	Malibu (Spt. Cpe.) . . . . .	8784912	R.H.	97.50	PANEL ASM. . . . .
70-72	Malibu (Spt. Cpe.) . . . . .	8784913	L.H.	97.50	PANEL ASM. . . . .
73-75	Chevelle (Sta. Wag.) . . . . .	9614446	R.H.	153.00	PANEL ASM. . . . .
73-75	Chevelle (Sed.) . . . . .	9733605	L.H.	107.00	PANEL ASM. . . . .
73-75	Chevelle (Sed.) . . . . .	9733604	R.H.	107.00	PANEL ASM. . . . .
73-75	Chevelle (Spt. Cpe.) (exc. Monte Carlo) . . . . .	9728061	L.H.	117.00	PANEL ASM. . . . .



**METAL TRIM—CLIPS AND PANELS**

**12.944 PANEL—BRACE—COVER—EXTENSION—FILLER—PLUG—PLATE  
ASSY.—REINFORCEMENT—STIFFENER—SUPPORT, Wheelhouse  
(Con't)**

73	Monte Carlo	9727806 R.H.	117.00	PANEL ASM.
73-75	El Camino	9876277 L.H.	168.00	PANEL ASM.
73-75	El Camino	9876276 R.H.	168.00	PANEL ASM.
73-75	Chevelle (Sta. Wag.)	9640879 L.H.	211.00	PANEL ASM.
74-75	Monte Carlo	9727806 R.H.	117.00	PANEL ASM.
73-75	Monte Carlo	9727807 L.H.	117.00	PANEL ASM.
73-75	Chevelle (Spt. Cpe.) (exc. Monte Carlo)	9728060 R.H.	117.00	PANEL ASM.

**CAMARO**

67-68	Camaro	7585103 R.H.	20.55	outer
67-68	Camaro	7585104 L.H.	20.55	outer
69	Camaro	7779484 R.H.	49.00	outer
69	Camaro	7779485 L.H.	49.00	outer
70-75	Camaro	8762178 R.H.	26.50	outer
70-75	Camaro	8762179 L.H.	26.50	outer
67-68	(Spt. Cpe.)	7728795 R.H.	96.50	PANEL ASM.
68	(Spt. Cpe.)	7728796 L.H.	96.50	PANEL ASM.
69	(Spt. Cpe.)	8716472 R.H.	103.00	PANEL ASM.
69	(Spt. Cpe.)	8716473 L.H.	106.00	PANEL ASM.
70-74	Camaro	9729706 L.H.	83.00	PANEL ASM.
70-74	Camaro	9729705 R.H.	83.00	PANEL ASM.
75	Camaro	1675638 R.H.	99.50	PANEL ASM.
75	Camaro	1675639 L.H.	99.50	PANEL ASM.

**CHEVY—NOVA**

68-74	Chevy, Nova	8778520 R.H.	22.30	outer
68-74	Chevy, Nova	8778521 L.H.	22.30	outer
75	Nova	9676172 R.H.	26.75	outer
75	Nova	9676173 L.H.	26.75	outer
68-74	(Spt. Cpe.), Nova (H.B.)	9892258 R.H.	70.75	PANEL ASM.
68-73	(Spt. Cpe.), Nova (H.B.)	9892259 L.H.	70.75	PANEL ASM.
68-74	Sed.	9646563 L.H.	70.75	PANEL ASM.
68-74	Sed.	9646562 R.H.	70.75	PANEL ASM.
73-74	Nova (Coupe) (exc. H.B.)	9620689 L.H.	70.75	PANEL ASM.
73-74	Nova (Coupe) (exc. H.B.)	9620688 R.H.	70.75	PANEL ASM.
74	Nova (H.B.)	9735957 R.H.	83.00	PANEL ASM.
75	Nova (H.B.)	1669830 R.H.	151.00	PANEL ASM.
75	Nova (H.B.)	1669831 L.H.	151.00	PANEL ASM.
75	Nova (Coupe) (exc. H.B.)	1669832 R.H.	107.00	PANEL ASM.
75	Nova (Coupe) (exc. H.B.)	1669833 L.H.	107.00	PANEL ASM.
75	Nova (4-Dr.)	1669834 R.H.	85.00	PANEL ASM.
75	Nova (4-Dr.)	1669835 L.H.	85.00	PANEL ASM.
75	Nova	1701058 1	31.50	PANEL ASM., rear end (repl. 9733884)

**VEGA—MONZA**

71-75	Vega (Pnl., N.B. Cpe., Sta. Wag., H.B. Cpe.)	8788412 L.H.	18.60	outer
71-73	Vega	8788411 R.H.	18.60	outer
74-75	Vega (Pnl., N.B. Cpe., Sta. Wag., H.B. Cpe.)	9641650 R.H.	22.30	outer
75	Monza (exc. Towne Cpe.)	1698842 L.H.	28.50	outer (repl. 9674239)
75	Monza	1745748 R.H.	28.25	outer (repl. 1708945)
75	Monza (Towne Cpe.)	1692082 L.H.	23.40	outer
68-72	Chevelle (Sta. Wag.)	7671635 R.H.	2.50	BRACE, whlhse. inr. panel to pan
68-72	Chevelle (Sta. Wag.)	7671636 L.H.	2.50	BRACE, whlhse. inr. panel to pan
69-70	Impala Custom, Caprice (Spt. Cpe.)	7799900 1	4.00	BRACE, rr. otr. diag.
70	Biscayne, Bel Air,			
70	Impala (exc. Impala Custom, Conv.)	9809661 L.H.	4.10	BRACE, rear qtr. diag.
70	Impala Custom, Caprice (Spt. Cpe.)	9809663 L.H.	4.10	BRACE, rear qtr. diag.
71-75	Pass. (exc. Conv., Sta. Wag., Custom, Caprice Spt. Cpe.)	9843421 L.H.	4.80	BRACE, compartment gutter to w/h
71-75	Pass. (exc. Conv., Sta. Wag., Custom, Caprice Spt. Cpe.)	9843420 R.H.	4.80	BRACE, compartment gutter to w/h
74-75	Nova (H.B.)	9734095 L.H.	2.90	BRACE, w/h inner stiffener to compartment pan
74-75	Nova (H.B.)	9734094 R.H.	2.90	BRACE, w/h inner stiffener to compartment pan
75	Nova (H.B.)	1657095 R.H.	2.90	BRACE, compartment gutter to w/h
75	Nova (H.B.)	1657096 L.H.	2.90	BRACE, compartment gutter to w/h

**METAL TRIM—CLIPS AND PANELS**

**12.944 PANEL— BRACE— COVER— EXTENSION— FILLER— PLUG— PLATE ASSY.— REINFORCEMENT— STIFFENER— SUPPORT, Wheelhouse (Con't)**

74-75	Pass. (Sta. Wag.)	9666729	L.H.	.83	COVER, acc. hole wheel house inner
68-72	Chevelle (Sta. Wag.)	7722257	1	1.85	EXTENSION, rr. wheelhouse cover panel
70-72	Chevelle (Sta. Wag.)	8754427	L.H.	5.05	EXTENSION, w/h inner panel to back body pillar
68-75	Chevy, (Nova, Sed.)	7678532	R.H.	.83	FILLER, front lower corner
68-75	Chevy, (Nova, Sed.)	7678533	L.H.	.83	FILLER, front lower corner
	Not required in this group. See group 12.942				
71-75	Vega (Panel, Sta. Wag.)	9836063		.54	PLUG
		9692878	R.H.	3.70	PLATE ASSY., back body pillar to inner w/h baffle
71-75	Vega (Panel, Sta. Wag.)	9692879	L.H.	3.70	PLATE ASSY., back body pillar to inner w/h baffle
75	BL-BN35, BL-BN45	1724275	1	.21	RETAINER, wheelhouse panel trim on luggage compt. fid. 3rd seat back (repl. 1724295)
75	Camaro	1689973	R.H.	2.60	STIFFENER, qtr. outer panel at belt
75	Camaro	1689974	L.H.	2.60	STIFFENER, qtr. outer panel at belt
75	Monza (Towne Cpe.)	1740692	2		STRIP, quarter outer panel stiffener
71-75	Pass. (Sta. Wag.) w/electric window	9840486	L.H.	3.75	SUPPORT, t/gate electric motor on wheelhouse
73-75	Chevelle (Sta. Wag.)	9624150	2	.22	SUPPORT, front cover
73-75	Chevelle (Sta. Wag.)	9624160	6	.22	SUPPORT, cover at belt

**12.945 DOOR ASM.— APPLIQUE— BUMPER— COVER— FILLER, Gas Tank Filler Neck Compartment**

64-65	Chevelle (exc. Sta. Wag., El Camino)	3853571	1	3.95	
64-65	Chevelle (Sta. Wag., El Camino)	4404371	1	9.95	
66-67	Chevelle (exc. Sta. Wag.),				
65-67	Pass. (exc. Sta. Wag.)	3872148	1	3.75	
67-68	Pass. (Sta. Wag.)	7653478	1	12.40	
66-67	Chevelle (Sta. Wag., El Camino),				
68-72	El Camino	7700914	1	12.70	
68-72	Chevy,				
68-71	Pass. (exc. Sta. Wag.) (1st design),				
69	Camaro,				
68-72	Chevelle (exc. Sta. Wag., El Camino),				
71-74	Vega	3913608	1	3.75	
69-70	Pass. (Sta. Wag.)	8716813	1	13.20	
68-72	Chevelle (Sta. Wag.)	8788059	1	14.35	
70-75	Camaro	3962910	1	3.75	
70-74	Nova	3962910	1	3.75	
71	Pass. (exc. Sta. Wag.) (2nd design),				
73	Chevelle (exc. Sta. Wag., El Camino)	410259	1	3.75	(Note 1)
72-73	Pass. (exc. Sta. Wag.),				
74-75	Chevelle (exc. Sta. Wag.)	3997359	1	3.75	
71-75	Pass. (Sta. Wag.)	9826038	1	20.10	
73-75	El Camino	9882888	1	12.70	
73-75	Chevelle (Sta. Wag.)	9882889	1	19.05	
74	Impala, Caprice (exc. Sta. Wag.)	337687	1	6.20	
74	Bel Air (Sed.)	339221	1	20.45	
75	Caprice (exc. Sta. Wag.)	342371	1	4.55	
75	Pass. (exc. Sta. Wag., Caprice)	354067	1	4.55	
75	Nova	344330	1	3.70	
74-75	Pass. (exc. Sta. Wag.)	354070	1	3.90	APPLIQUE, fuel tank filler door mounting
75	Caprice (exc. Sta. Wag.)	355303	1	3.90	APPLIQUE, filler, door mounting panel
65-66	Pass. (Sta. Wag.)	3765243	2	.11	BUMPER, filler door— (10.263)
65-69	Pass., Chevelle (Sta. Wag., El Camino),				
71-74	Vega,				
71-75	Pass., Chevelle (Sta. Wag.) (El Camino)	4880572	A.R.	.16	BUMPER, filler door
65	Pass. (exc. Sta. Wag.)	3841098	2	.11	BUMPER, filler door— (7.800)
66-69	Chevelle (exc. Sta. Wag., El Camino),				
69	Chevy,				
66-69	Pass.	3938600	2	.11	BUMPER, filler door— (7.800)
69-72	Camaro,				

**METAL TRIM—CLIPS AND PANELS**

**12.945 DOOR ASM.— APPLIQUE— BUMPER— COVER— FILLER, Gas Tank Filler Neck Compartment (Con't)**

73-74	Camaro, Nova,				
75	Camaro	3937590	2	.14	BUMPER, door
73	Chevelle (exc. Sta. Wag., El Camino)	3996995	1	.11	BUMPER, fuel tank filler door— (7.800)
75	Nova	344333	1	.14	BUMPER, fuel tank filler door
	Not required in this group. See Group 12.579	4818451		.14	BUMPER
	Not required in this group. See Group 10.587, 11.119, 12.579	4569867		.36	BUMPER
67-69	Camaro	7689431	1	1.85	COVER, neck
75	Chevelle (exc. El Camino, Sta. Wag.)	3997359	1	3.75	DOOR ASM., fuel tank filler
64-67	Chevelle (Sta. Wag., El Camino),				
68-72	El Camino	7793608	1	3.85	FILLER, door opening
68-72	Chevelle (Sta. Wag.)	7671631	1	4.15	FILLER, door opening
71-75	Pass. (Sta. Wag.)	8793651	1	5.85	FILLER, door opening
73-75	Chevelle (Sta. Wag.)	9830658	1	5.85	FILLER, door opening
73-75	El Camino	9830522	1	3.85	FILLER, door opening

NOTE 1: When using 410259 in place of 3913608 it will be necessary to drill (2) 1/32 dia. holes approx. 1/2 in. board from existing holes. Use old part as guide.

**12.945 HOUSING— HOSE— MOLDING— PANEL— POCKET ASSY.— RETAINER— SPRING— SUPPORT— STRIP— NUT, Gas Tank Filler Neck Compartment**

74	Pass. (exc. Sta. Wag.)	339222	1	11.85	fuel tank filler door
75	Bel Air (Sed.)	354065	1	13.30	fuel tank filler door
75	Impala (exc. Sta. Wag.)	354064	1	21.50	fuel tank filler door
75	Caprice (exc. Sta. Wag.)	354007	1	15.95	fuel tank filler door
67-68	Camaro	7707772	1	5.85	HOSE, tube protector
74	Pass. (exc. Sta. Wag.)	339223	1	3.95	MOULDING, fuel tank filler door housing
75	Caprice (exc. Sta. Wag.)	354008	1	5.75	MOULDING, fuel tank filler door housing
75	Caprice (exc. Sta. Wag.)	343589	1	5.75	PANEL, fuel tank filler door mounting
75	Bel Air (Sed.)	354069	1	16.60	PANEL, fuel tank filler door housing
75	Caprice (exc. Sta. Wag.)	354071	1	6.20	PANEL, fuel tank filler door housing
68-72	Chevelle (Sta. Wag.)	7721777	1	7.65	POCKET ASM.
72-75	Pass. (Sta. Wag.)	9824917	1	8.90	POCKET ASM.
73-75	Chevelle (Sta. Wag.)	9876560	1	9.20	POCKET ASM.
67-68	Camaro	7707773	1	1.15	RETAINER, fil. neck tube
64-67	Chevelle (Sta. Wag., El Camino),				
68-75	El Camino,				
69-75	Pass. (Sta. Wag.)	4411178	1	.21	SPRING, door hinge
65-66	Pass. (Sta. Wag.),				
68-70	Chevelle (Sta. Wag.)	4813235	2	.23	SPRING, door hinge
72*	Pass. (exc. Sta. Wag.)	3995192	1	5.70	SUPPORT, fuel filler door
73	Pass. (exc. Sta. Wag.)	6273791	1	5.70	SUPPORT
65-72	Sta. Wag.	4478989	1	.79	STRIP, gas tank filler pocket seal
71-75	Pass. (Sta. Wag.)	9828152	1	.79	STRIP, pocket
73-75	Chevelle (Sta. Wag.)	9877700	1	.72	STRIP, pocket sealing
75	All	4801719 A.R.		.18	NUT & SEALER, 1/4"— 20, filler door

**12.946 STICK— SCREW— TRIM STICK ASSY., Trim**

69-72	Chevelle (Conv.)	8746482	1	16.60	rear belt rail
69-72	Chevelle (Conv.)	8746486	2	.37	SCREW, rear rail trim to top hinge
71-75	Pass. (Conv.)	9607021	1	35.25	TRIM STICK ASM., fldg. top rear belt rail

**12.952 BOW, Roof**

**PASSENGER**

**CHEVY— NOVA**

68-70	(4-Dr.)	7761994	1	5.85	
68-74	Nova (2-Dr.)	9625601	1	6.70	
68-73	Nova (4-Dr.)	9625602	1	6.30	
74	Nova (4-Dr.)	9668744	1	6.30	

NOTE 1 This part also appears in the Chevelle subgroup.

**CHEVELLE**

68-72	(Sta. Wag.)	8780595	1	6.95	No. 1
68-72	(Sta. Wag.)	7671570	1	5.85	No. 2
68-72	(Sta. Wag.)	7671576	1	5.85	No. 3, 4, 5
68-69	(2-Dr. Sed., Spt. Cpe.),				
71-72	Spt. Cpe.	8780592	1	5.90	
68	(4-Dr. Sed.),				

**METAL TRIM—CLIPS AND PANELS**

**12.952 BOW, Roof (Con't)**

71	Sed. ....	8780593	1	6.95	
69	El Camino .....	8712078	1	6.40	longitudinal .....
69	(4-Dr. Sed.) .....	8713815	1	6.40	longitudinal .....
69-72	(4-Dr. Sed.) .....	8780593	1	6.95	

*NOTE 2 This part also appears in the Chevy subgroup.*

**CAMARO**

69	(Spt. Cpe.) .....	8784703	1	6.40	longitudinal .....
----	-------------------	---------	---	------	--------------------

**12.953 SUPPORT, Dome Lamp**

65-69	Pass. (Sta. Wag.) (9-Pass.),				
68-70	Pass., Chevelle (Sta. Wag.) (9-Pass.),				
71-72	Concours (9-Pass.) .....	8761642	L.H.	3.10	qtr. ctsy. lamp side .....

**12.954 CLIP— SUPPORT, Headlining Wire**

68-72	Chevy, Chevelle (Sed., Spt. Cpe.),				
69-70	Pass. (Sed., Spt. Cpe.) .....	8732500	6	.11	listing wire .....
68-72	Chevelle (Sta. Wag.) .....	4412285	A.R.	.16	No. 5, 6, 7, 8 .....
68-72	Chevelle (Sta. Wag.) .....	7759668	6	.18	listing wire .....
70	Nova,				
67-69	All (exc. Sta. Wag., Conv.),				
71-72	Nova .....	7704600	A.R.	.12	<b>SUPPORT</b> , roof bow listing wire .....
68-72	El Camino .....	7745460	2	.81	<b>SUPPORT</b> , headlining listing wire .....
70-73	Pass., Camaro (exc. Conv.) .....	9866994	A.R.	.22	<b>SUPPORT</b> , listing wire .....
71-75	Pass. (Sta. Wag.) .....	9828529	L.H.	2.95	<b>SUPPORT</b> , outer .....
71-75	Pass. (Sta. Wag.) .....	9828528	R.H.	2.95	<b>SUPPORT</b> , outer .....

**12.955 WIRE, Headlining Listing Support**

**PASSENGER**

69-70	Sed. (exc. Spt. Sed.) .....	7663679	A.R.	.83	No. 2 .....
71-73	Impala (Custom) Caprice (Spt. Cpe.) .....	9850822	A.R.	.34	No. 1, 2, 3, 4, 5 .....
71-73	Pass. (Sta. Wag.) .....	9850821	A.R.	.34	No. 2, 3, 4 .....
71-73	Pass. (Sed.) (exc. Spt. Sed.) .....	9850823	4	.38	No. 1, 2, 3, 4 .....
71-73	Pass. (Sta. Wag.) .....	9850820	4	.27	No. 5, 6, 7, 8 .....
71-73	Pass. (Spt. Sed.) .....	9850824	1	.47	No. 5 .....
71-73	Pass. (Sed.) (exc. Spt. Sed.) .....	9850825	1	.71	No. 5 .....

**CHEVY**

68-72	(Sed.) .....	7770744	1	.32	No. 3 .....
68-72	(Sed.) .....	7762496	1	.91	No. 1, 2 .....
68-72	(Sed.) .....	7762497	1	.87	No. 4 .....
68-72	(Sed.) .....	7762498	1	.91	No. 5, 6 .....
68-72	(Spt. Cpe.) .....	7768456	2	.91	No. 1, 2 .....
68-72	(Spt. Cpe.) .....	7770745	1	.91	No. 3 (Note 1) .....

*NOTE 1 This part also appears in the Chevelle subgroup.*

68-72	(Spt. Cpe.) .....	7768457	2	.91	No. 4 .....
68-72	(Spt. Cpe.) .....	7768458	2	.91	No. 5 .....

**CHEVELLE**

68-72	(4-Dr.) .....	7732359	1	.91	No. 1 .....
68-72	(Sta. Wag.) .....	7732360	A.R.	.91	No. 3 .....
68-72	(4-Dr. Sed.) .....	7732361	1	.91	No. 4 .....
68-72	(4-Dr. Sed.) .....	7732362	1	.91	No. 5 .....
68-72	(4-Dr. Sed.) .....	7732363	1	.91	No. 6 .....
68-72	El Camino .....	7743570	A.R.	.91	No. 1, 2, 3 .....
68-72	(2-Dr. Plr. Cpe., Spt. Cpe.) (exc. Monte Carlo) .....	7743572	2	.91	No. 5, 6 .....
68-72	(Sta. Wag.) .....	7765842	1	.87	No. 4 .....
68-72	(Sta. Wag.) .....	7765843	1	.87	No. 5 .....
68-72	(Sta. Wag.) .....	7765844	1	.87	No. 6 .....
68-72	(Sta. Wag.) .....	7765845	1	.87	No. 7 .....
68-72	(Sta. Wag.) .....	7765846	1	.87	No. 8 .....
69-72	Chevelle (Spt. Cpe.) .....	7770745	1	.91	No. 2 (Note 1) .....

*NOTE 1 This part also appears in the Chevy subgroup.*

69-72	(Spt. Cpe., 2-Dr. Plr. Cpe.) .....	8760444	1	.91	No. 4 .....
70-72	Monte Carlo .....	8760445	1	.91	<b>WIRE ASSY.</b> , No. 5 .....

**CAMARO**

70-73	Camaro .....	9816850	5	.27	No. 1, 2, 3, 4, 5 .....
-------	--------------	---------	---	-----	-------------------------

**METAL TRIM—CLIPS AND PANELS**

**12.956 RAIL ASSY., Side Roof-Outer**

**PASSENGER**

**CHEVY— NOVA**

68-72 (Spt. Cpe.)	9819560 R.H.	69.25	outer
68-72 (Spt. Cpe.)	9819561 L.H.	69.25	outer
70-72 Nova (4-Dr.)	8771784 R.H.	54.75	
73 Nova (2-Dr.)	9610312 R.H.		outer
74 Nova (2-Dr.)	9680728 R.H.	69.25	outer
74 Nova (2-Dr.)	9680729 L.H.	69.25	outer
73 Nova (4-Dr.)	9610315 L.H.	54.75	
73 Nova (4-Dr.)	9610314 R.H.	54.75	
74 Nova (4-Dr.)	9673016 R.H.	54.75	
74 Nova (4-Dr.)	9673017 L.H.	54.75	
73 Nova (2-Dr.)	9669257 L.H.	69.25	outer

**CHEVELLE**

68-72 Malibu (Spt. Sed.)	8776382 R.H.	69.50	
68-72 (Sta. Wag.)	8771788 R.H.	72.25	
68-72 (Sta. Wag.)	8771789 L.H.	72.25	
68-72 El Camino	7724146 R.H.	71.75	outer
68-72 El Camino	7724147 L.H.	71.75	outer
68-69 (4-Dr. Sed.) (exc. Spt. Sed.)	8771782 R.H.		(repl. 8756106)
70-72 Chevelle (Sed.) (exc. Spt. Sed.)	8771781 L.H.	74.25	
70-72 Chevelle (Sed.) (exc. Spt. Sed.)	8771780 R.H.	74.25	
68-72 (Spt. Sed.)	8776383 L.H.	69.50	
70-72 (Spt. Cpe.)	9859710 R.H.	84.25	
70-72 (Spt. Cpe.)	9859711 L.H.	84.25	
70-72 Monte Carlo	8784902 R.H.	78.50	
70-72 Monte Carlo	8784903 L.H.	78.50	

**CAMARO**

**VEGA**

71-73 Vega (Sta. Wag., Panel)	8788475 L.H.	8.90	rear
71-73 Vega (Sta. Wag., Panel)	8788474 R.H.	8.90	rear
74-75 Vega (Sta. Wag., Panel)	9683754 R.H.	8.90	rear
74-75 Vega (Sta. Wag., Panel)	9683755 L.H.	8.90	rear

**12.957 RAIL, Side Roof-Inner**

**PASSENGER**

**CHEVY— NOVA**

68-73 (Spt. Cpe.)	9620822 R.H.	9.75	inner
68-73 (Spt. Cpe.)	9620823 L.H.	9.75	inner
74 Nova (2-Dr.)	9672208 R.H.	9.75	
74 Nova (2-Dr.)	9672209 L.H.	9.75	

**CHEVELLE**

75 Nova (4-Dr.)	1696820 L.H.	.98	FILLER, roof extension panel louver
68 El Camino	8761895 1	11.90	inner
68 (4-Dr. Sed.)	7671899 1	7.60	inner
68 (2-Dr. Sed., Spt. Cpe.)	7672056 1	7.60	inner

**12.964 PANEL— SPACER, Back Window Inner**

**PASSENGER**

**CHEVY— NOVA**

68-72 (Spt. Cpe.)	7722880 1	7.60	inner
72-74 Nova (4-Dr.)	9624093 1	7.60	
73-74 Nova (2-Dr.) (exc. H.B.)	9621066 1	7.60	

**CHEVELLE**

68-72 (4-Dr. Sed.)	7671899 1	7.60	inner
68-72 (2-Dr. Sed., Spt. Cpe.)	7672056 1	7.60	inner
70-72 El Camino	8761895 1	11.90	

**METAL TRIM—CLIPS AND PANELS**

**12.964 PANEL— SPACER, Back Window Inner (Con't)**

68-69 El Camino ..... 8761895 1 11.90 inner .....

**CAMARO**

71-74 Vega (Notchback Cpe.) ..... 9817550 1 27.00 lower .....

74-75 Impala (Custom Caprice (2-Dr.) . . . . . 9669255 1 .05 SPACER, compt. front panel .....

75 Nova (4-Dr.) ..... 9669255 1 .05 SPACER, compt. front panel .....

75 Monza (Towne Cpe.) ..... 1671963 1 7.05 REINFORCEMENT, inner lower panel back window .....

**12.966 PANEL— BUMPER— EXTENSION— FILLER, Body Back Lower (Rear End)**

65 Pass. (exc. Sta. Wag.) ..... 4510099 1 31.00

68 Pass. (Sed., Spt. Cpe., Conv.)  
(exc. Impala Spt. Cpe.) ..... 7684327 1 31.50

68 Impala (Spt. Cpe.) ..... 7684329 1 31.50

69-70 Pass. (exc. Sta. Wag.) ..... 7749652 1 24.50 rear end .....

70 Monte Carlo ..... 9868869 1 29.00

72-73 Pass. (exc. Sta. Wag.) ..... 9621443 1 49.00

73 Chevelle (Spt. Cpe., Spt. Sed.) . . . . . 9662898 1 29.00

73 Monte Carlo (1st design) ..... 9830382 1 31.50 two studs on bezel .....

73 Monte Carlo (2nd design) ..... 9667248 1 31.50 three studs on bezel .....

74 Caprice (exc. Sta. Wag., Spt. Cpe.),  
Impala (exc. Custom, Sta. Wag.) 9618627 1 31.50

74 Impala, Caprice (Spt. Cpe., Custom) ..... 9654131 1 31.50

74 Bel Air,  
Impala (Spt. Cpe.) (exc. Custom) 9671412 1 29.00

74-75 Monte Carlo ..... 9629837 1 31.50 inner .....

74-75 Camaro ..... 9669024 1 51.75 finish .....

75 Caprice (Spt. Cpe.) ..... 9668339 1 31.50

75 Caprice ..... 9668338 1 31.50

75 Pass. (exc. Sta. Wag., Spt. Cpe.),  
Impala (Custom Cpe.) ..... 1690065 1 29.25

75 Impala (Spt. Cpe.) (exc. Custom) 1690066 1 29.25

75 Bel Air ..... 1690067 1 29.25

64-65 Chevelle (exc. Sta. Wag., El Camino) ..... 4884029 1 20.05 PANEL ASSY. ....

66 Chevelle (exc. Sta. Wag., El Camino) ..... 7586821 1 34.25 PANEL ASSY. ....

66 Impala, Caprice (exc. Sta. Wag.) 7648389 1 31.50 PANEL ASSY. ....

66-67 Chevy (exc. Sta. Wag.) ..... 4512039 1 17.35 PANEL ASSY. ....

67 Impala (Spt. Cpe.) ..... 7657665 1 31.50 PANEL ASSY. ....

67 Bel Air, Impala (exc. Sta. Wag., Spt. Cpe.),  
Caprice (exc. Sta. Wag.) ..... 7657666 1 31.50 PANEL ASSY. ....

67 Biscayne (Sed.) ..... 7657666 1 31.50 PANEL ASSY. (repl. 7657664) .....

67 Chevelle (exc. Sta. Wag., El Camino) ..... 7656125 1 34.25 PANEL ASSY. ....

67-68 Camaro ..... 7710985 1 42.00 PANEL ASSY. ....

68 Chevelle (exc. Sta. Wag., El Camino) ..... 7671846 1 27.25 PANEL ASSY. ....

68-69 Chevy ..... 7736116 1 31.50 PANEL ASSY. ....

69 Camaro ..... 8716470 1 42.00 PANEL ASSY. ....

69 Chevelle (exc. El Camino, Sta. Wag.) ..... 8746489 1 27.25 PANEL ASSY. ....

70-72 Nova ..... 8785408 1 31.50 PANEL ASSY. ....

70-72 Chevelle (exc. Monte Carlo) . . . . . 9861449 1 27.50

70-73 Camaro ..... 9839816 1 42.25 PANEL ASSY. ....

71 Impala, Caprice ..... 9836333 1 49.00 PANEL ASSY. ....

71 Biscayne, Bel Air ..... 9836332 1 46.25 PANEL ASSY. ....

71-72 Monte Carlo ..... 9868869 1 29.00 PANEL ASSY. ....

73-74 Nova ..... 9615775 1 51.75 PANEL ASSY. ....

74 Chevelle (Spt. Cpe., Spt. Sed.) (exc. Monte Carlo) ..... 9685034 1 37.00 PANEL ASSY. ....

74-75 Camaro ..... 9666207 1 49.50 PANEL ASSY. ....

75 Chevelle (Spt. Cpe., Sed.) (exc. Monte Carlo) ..... 1652550 1 68.00 PANEL ASSY., finish rear end .....

75 Monte Carlo ..... 9673386 1 PANEL ASSY., finish rear end .....

75 Chevelle (Spt. Cpe., Sed.) (exc. Monte Carlo) ..... 1657637 1 34.25 PANEL ASSY., rear end .....

75 Nova ..... 1701058 1 31.50 PANEL ASSY., rear end .....

71-73 Vega (N.B., H.B. Cpe.) ..... 9642852 1 20.60 PANEL ASSY. ....

71-73 (Sta. Wag., Panel) ..... 9815730 1 32.00 PANEL ASSY. ....

74-75 Vega (Sta. Wag., Panel) ..... 9659179 1 32.00 PANEL ASSY., rear end outer lower .....

**METAL TRIM—CLIPS AND PANELS**

**12.966 PANEL—BUMPER—EXTENSION—FILLER, Body Back Lower (Rear End)**  
(Con't)

74	Vega (N.B., H.B. Cpe.)	9659202	1	20.60	PANEL ASSY., rear end
75	Vega (N.B., H.B. Cpe.)	1705972	1	20.60	PANEL ASSY., rear end
75	Monza (exc. Towne Cpe.)	1679872	1	37.75	PANEL ASSY., rear end
74	Chevelle (Spt. Cpe., Spt. Sed.) (exc. Monte Carlo)	9632251	R.H.	35.25	PANEL UNIT, finish
74	Chevelle (Spt. Cpe., Spt. Sed.) (exc. Monte Carlo)	9632252	L.H.	35.25	PANEL UNIT, finish
74-75	Monte Carlo	9632257	1	43.00	PANEL UNIT, finish
75	Caprice, Impala	9618482	R.H.	2.65	BRACE, compartment gutter to wheelhouse
75	Caprice, Impala	9618483	L.H.	2.65	BRACE, compartment gutter to wheelhouse
73-75	Vega (N.B., H.B. Cpe.)	4691643	2	.39	BUMPER, r/end panel license plate
74-75	Camaro	9672176	R.H.	4.80	EXTENSION, finish
74-75	Camaro	9672177	L.H.	4.80	EXTENSION, finish
71	Pass. (Sta. Wag.)	9835279	L.H.	3.00	FILLER, to w/h extension
74-75	Vega (Sta. Wag., Panel)	9661940	R.H.	2.45	FILLER, pillar reinf. to rear end
74-75	Vega (Sta. Wag., Panel)	9661941	L.H.	2.45	FILLER, pillar reinf. to rear end

**12.966 CLIP—REINFORCEMENT—RETAINER—SPACER—SUPPORT, Body Back Lower (Rear End)**

75	Monza (Towne Cpe.)	1698864	1		PANEL, rear end
70	Camaro,				
70	Pass., Chevelle (exc. Sta. Wag., El Camino)	9816617	4	.18	panel snap on
73	Camaro (L.T.)	9875547	A.R.	.12	name plate, type LT
74	Monte Carlo	9679078	6	.16	outer panel r/end side mldg.
70	Camaro	9820342	R.H.	3.70	REINFORCEMENT, panel outer
70	Camaro	9820343	L.H.	3.70	REINFORCEMENT, panel outer
71	Pass. (Sta. Wag.)	9873822	L.H.	5.60	REINFORCEMENT, upper corner
71	Pass. (Sta. Wag.)	9873821	R.H.	5.60	REINFORCEMENT, upper corner
71-73	Vega (Sta. Wag., Panel)	8804667	L.H.	15.55	REINFORCEMENT, back body pillar
71-73	Vega (Sta. Wag., Panel)	8804666	R.H.	15.55	REINFORCEMENT, back body pillar
74-75	Vega (Sta. Wag., Panel)	9661938	R.H.	14.10	REINFORCEMENT, back body pillar
74-75	Vega (Sta. Wag., Panel)	9661939	L.H.	14.10	REINFORCEMENT, back body pillar
71	Chevelle (Sta. Wag.)	8783743	1	3.85	RETAINER, upper trim
75	Monza (Towne Cpe.)	1672832	R.H.	2.90	RETAINER, stow jack column
75	Monza (Towne Cpe.)	1672833	L.H.	3.75	RETAINER, stow jack column
73	Monte Carlo	9668485	2	.63	SPACER, panel moulding
70-73	Camaro	9839812	R.H.	1.90	SUPPORT, rear bumper on qtr. panel
70-73	Camaro	9839813	L.H.	1.90	SUPPORT, rear bumper on qtr. panel
71	Pass. (Sta. Wag.) w/electric t/gate window	9865441	1	2.80	SUPPORT, t/gate window motor mounting on panel
75	Monza (Towne Cpe.)	1662713	R.H.	2.60	SUPPORT, rr. bpr. impact bar upper cover
75	Monza (Towne Cpe.)	1662714	L.H.	2.60	SUPPORT, rr. bpr. impact bar upper cover

**12.968 PANEL—EXTENSION—FILLER—MOLDING, Back Body Opening**

**PASSENGER**

71-73	Sta. Wag.	9823339	L.H.	8.90	inner lower
71-73	Sta. Wag.	9823338	R.H.	8.90	inner lower
71-73	Sta. Wag.	9864303	1	5.05	upper center finish (black) (paint as reqd.)
69-70	Sta. Wag.	8715739	L.H.	109.00	PANEL, pillar
69-70	Sta. Wag.	8715739	L.H.	109.00	PANEL ASSY., pillar
71-73	Sta. Wag.	9890101	L.H.	165.00	PANEL ASSY.
71-73	Sta. Wag.	9890100	R.H.	165.00	PANEL ASSY.
74-75	Sta. Wag.	9737622	R.H.	165.00	PANEL, back body pillar
74-75	Sta. Wag.	9685062	L.H.	165.00	PANEL, back body pillar
74-75	Sta. Wag.	9664277	R.H.	15.50	PANEL, back body pillar lower rear
74-75	Sta. Wag.	9664278	L.H.	15.50	PANEL, back body pillar lower rear
73	Pass. (Sta. Wag.)	9835279	L.H.	3.00	FILLER, to w/h extension
74-75	Pass. (Sta. Wag.)	9674931	L.H.	3.05	FILLER, to w/h extension
74-75	Pass. (Sta. Wag.)	1666024	R.H.	17.45	FILLER, back body pillar to qtr. panel
74-75	Pass. (Sta. Wag.)	9621384	L.H.	17.45	FILLER, back body pillar to qtr. panel
74-75	Pass. (Sta. Wag.)	9739556	R.H.	2.85	FILLER, back body opening
74-75	Pass. (Sta. Wag.)	9739557	L.H.	2.85	FILLER, back body opening

**CHEVELLE**

68-72	Chevelle (Sta. Wag.)	8768903	R.H.	17.05	pillar outer upper
68-72	Chevelle (Sta. Wag.)	8768904	L.H.	17.05	pillar outer upper
69-72	Chevelle (Sta. Wag.)	8769200	L.H.	8.10	inner lower
69-72	Chevelle (Sta. Wag.) w/dual t/gate	8727860	R.H.	7.65	pillar inner lower

**METAL TRIM—CLIPS AND PANELS**

**12.968 PANEL— EXTENSION— FILLER— MOLDING, Back Body Opening (Con't)**

68-69	El Camino	7748330	R.H.	46.25	PANEL, pillar outer lower rr. panel ext.
68-69	El Camino	7748331	L.H.	46.25	PANEL ASSY., pillar outer lower rr. panel ext.
68-72	Chevelle (Sta. Wag.)	9815265	1	54.75	PANEL ASSY., upper center
70-72	Chevelle (Sta. Wag.)	8785134	R.H.	91.25	PANEL ASSY.
70-72	Chevelle (Sta. Wag.)	8785135	L.H.	91.25	PANEL ASSY.
70-72	El Camino	8784892	R.H.	32.00	PANEL ASSY., back body pillar outer lower
70-72	El Camino	8784893	L.H.	32.00	PANEL ASSY., back body pillar outer lower
71	El Camino	7725434	1	76.75	PANEL ASSY., upper compartment divider
73-75	El Camino	9889981	L.H.	8.10	PANEL ASSY.
73-75	El Camino	9889980	R.H.	8.10	PANEL ASSY.
73-75	Chevelle (Sta. Wag.)	9619567	L.H.	66.50	PANEL ASSY., back body pillar outer
73-75	Chevelle (Sta. Wag.)	9619566	R.H.	66.50	PANEL ASSY., back body pillar outer
73-75	Chevelle (Sta. Wag.)	9613127	L.H.	35.00	PANEL ASSY., pillar inner
73-75	Chevelle (Sta. Wag.)	9613126	R.H.	35.00	PANEL ASSY., pillar inner
71	Chevelle (Spt. Cpe.)	8769769	L.H.	4.90	EXTENSION, to back window panel side
71	Chevelle (Spt. Cpe.)	8769768	R.H.	4.90	EXTENSION, to back window panel side
71	Chevelle (Sed.)	8788804	L.H.	4.90	EXTENSION, to back window panel
71	Chevelle (Sed.)	8788803	R.H.	4.90	EXTENSION, to back window panel
73-75	Chevelle (Sta. Wag.)	9739556	R.H.	2.85	FILLER ASSY. (use w/9739557)
73-75	Chevelle (Sta. Wag.)	9878589	L.H.	9.80	FILLER, pillar lower
73-75	Chevelle (Sta. Wag.)	9878588	R.H.	9.80	FILLER, pillar lower
71	El Camino	7729430	1	8.00	MOLDING, divider upper panel at belt

**CAMARO**

71	Camaro	8780126	1	18.65	PANEL ASSY., front compartment
71	Camaro	8762195	L.H.	4.10	EXTENSION, to back window panel
71	Camaro	8762194	R.H.	4.10	EXTENSION, to back window panel

**NOVA**

71	Nova (4-Dr.)	7678535	L.H.	2.95	EXTENSION, to back window panel
71	Nova (4-Dr.)	7678534	R.H.	3.25	EXTENSION, to back window panel
71	Nova (2-Dr.)	7723471	L.H.	6.70	EXTENSION, to back window panel
71	Nova (2-Dr.)	7723470	R.H.	6.70	EXTENSION, to back window panel

**VEGA**

71-73	Vega (Sta. Wag., Panel)	8804647	L.H.	7.60	PANEL, back body pillar outer lower
71-73	Vega (Sta. Wag., Panel)	8804646	R.H.	7.60	PANEL, back body pillar outer lower
71-74	Vega (Sta. Wag., Panel)	8804655	L.H.	3.05	PANEL, back body inner upper
71-74	Vega (Sta. Wag., Panel)	8804654	R.H.	3.05	PANEL, back body inner upper
74-75	Vega (Sta. Wag., Panel)	9683758	R.H.	3.05	PANEL, pillar inner upper
74-75	Vega (Sta. Wag., Panel)	9683759	L.H.	3.05	PANEL, pillar inner upper
74-75	Vega (Sta. Wag., Panel)	9683764	R.H.	9.40	PANEL, pillar outer upper
74-75	Vega (Sta. Wag., Panel)	9683765	L.H.	9.40	PANEL, pillar outer upper
74-75	Vega (Sta. Wag., Panel)	9687697	R.H.	14.75	PANEL, pillar outer lower
74-75	Vega (Sta. Wag., Panel)	9687698	L.H.	14.75	PANEL, pillar outer lower
74-75	Vega (Sta. Wag., Panel)	9697316	R.H.	4.50	PANEL, opening side (prime and paint)
74-75	Vega (Sta. Wag., Panel)	9697317	L.H.	4.50	PANEL, opening side (prime and paint)
75	Vega (Sta. Wag.)	1701750	R.H.	6.50	PANEL, opening side
75	Vega (Sta. Wag.)	1701751	L.H.	6.50	PANEL, opening side
71-73	Vega (Sta. Wag., Panel)	9815737	1	126.00	PANEL ASSY., back body opening upper
71-72	Vega (Sta. Wag., Panel)	9815743	L.H.	9.40	PANEL ASSY., back body pillar outer upper
71-72	Vega (Sta. Wag., Panel)	9815742	R.H.	9.40	PANEL ASSY., back body pillar outer upper
73	Vega (Sta. Wag., Panel)	8804649	L.H.	9.40	PANEL ASSY., back body pillar outer upper
73	Vega (Sta. Wag., Panel)	8804648	R.H.	9.40	PANEL ASSY., back body pillar outer upper
74-75	Vega (Sta. Wag., Panel)	9683749	1	126.00	PANEL ASSY., back body opg. upper
74-75	Vega (Sta. Wag., Panel)	9694471	1	4.90	PANEL ASSY., finish back body opg. upper (prime and paint)

**12.968 CLIP— COVER— REINFORCEMENT— RETAINER— SUPPORT, Back Body Opening**

71	El Camino	7740303	A.R.	.16	divider belt mldg. center
71	El Camino	7745763	2	.41	divider belt mldg. end upper
71	El Camino	9817544	R.H.	1.85	COVER, divider lower panel access
71	Impala (Custom) Caprice (Spt. Cpe.)	9830979	1	24.70	REINFORCEMENT, to back window panel
71	Impala (Conv.)	9814602	1	32.00	REINFORCEMENT, front compartment panel
71	Chevelle (Conv.)	7672169	1	16.40	REINFORCEMENT, front compartment panel
72-74	Pass. (Sta. Wag.)	9873822	L.H.	5.60	REINFORCEMENT, upper corner
72-74	Pass. (Sta. Wag.)	9873821	R.H.	5.60	REINFORCEMENT, upper corner
72-75	Pass. (Sta. Wag.)	9883332	R.H.	6.75	REINFORCEMENT, upr. otr. corn.
72-75	Pass. (Sta. Wag.)	9883333	L.H.	6.75	REINFORCEMENT, upr. otr. corn.
68-72	Chevelle (Sta. Wag.)	8783743	1	3.85	RETAINER, upper trim



**METAL TRIM—CLIPS AND PANELS**

**12.968 CLIP— COVER— REINFORCEMENT— RETAINER— SUPPORT, Back Body Opening (Con't)**

<b>72-73</b>	Pass. (Sta. Wag.) w/electric t/gate window .....	<b>9865441</b>	<b>1</b>	<b>2.80</b>	<b>SUPPORT, t/gate window motor mounting on panel .....</b>
--------------	---	----------------	----------	-------------	---

**12.971 PANEL— BOLT— EXTENSION— REINFORCEMENT— SEALING STRIP, Rear Compartment Front and Shelf**

**PASSENGER**

<b>65-66</b>	Sed. ....	<b>4533978</b>	<b>1</b>	<b>17.95</b>	rr. compt. front .....
<b>65-66</b>	Spt. Cpe. (exc. Caprice) .....	<b>4533980</b>	<b>1</b>	<b>19.95</b>	rr. compt. front .....
<b>67-68</b>	Spt. Sed. ....	<b>7593030</b>	<b>1</b>	<b>19.95</b>	rr. compt. frt. ....
<b>69</b>	Spt. Sed. ....	<b>8788935</b>	<b>1</b>	<b>19.95</b>	compt. frt. ....
<b>69</b>	Impala (Spt. Cpe.) (exc. Custom)	<b>8788936</b>	<b>1</b>	<b>19.95</b>	compt. frt. ....
<b>69-70</b>	Impala Custom, Caprice (Spt. Cpe.) .....	<b>7749349</b>	<b>1</b>	<b>19.95</b>	compt. frt. ....
<b>69-70</b>	Sed. (exc. Spt. Sed.) .....	<b>8788939</b>	<b>1</b>	<b>17.95</b>	compt. frt. ....
<b>71-73</b>	Impala (Custom) Caprice (Spt. Cpe.) .....	<b>8794264</b>	<b>1</b>	<b>19.95</b>	front compartment .....
<b>71-73</b>	Impala (Custom) Caprice (Spt. Cpe.) .....	<b>8794280</b>	<b>1</b>	<b>31.50</b>	to back window .....
<b>71-73</b>	Impala (Spt. Cpe.) (exc. Custom)	<b>9813785</b>	<b>1</b>	<b>19.95</b>	front compartment .....
<b>71-73</b>	Impala (Spt. Cpe.) (exc. Custom)	<b>9824539</b>	<b>1</b>	<b>37.25</b>	to back window .....
<b>71-74</b>	Pass. (Spt. Sed.) .....	<b>9809924</b>	<b>1</b>	<b>19.95</b>	front compartment .....
<b>71-74</b>	Pass. (Sed.) (exc. Spt. Sed.) .....	<b>9812675</b>	<b>1</b>	<b>17.95</b>	front compartment .....
<b>71-75</b>	(Conv.) .....	<b>9814601</b>	<b>1</b>	<b>17.95</b>	front compartment .....
<b>71-74</b>	Pass. (Spt. Sed.) .....	<b>8794187</b>	<b>1</b>	<b>35.75</b>	to back window .....
<b>74-75</b>	Caprice (Spt. Cpe.) Impala (Custom) .....	<b>9695851</b>	<b>1</b>	<b>19.95</b>	front compartment .....
<b>74-75</b>	Caprice (Spt. Cpe.) Impala (Custom) .....	<b>9618117</b>	<b>1</b>	<b>28.50</b>	to back window .....
<b>75</b>	Pass. (Spt. Sed.) .....	<b>9671205</b>	<b>1</b>	<b>18.95</b>	front compartment .....
<b>75</b>	Pass. (Spt. Sed.) .....	<b>9668298</b>	<b>1</b>	<b>31.50</b>	rear seat to back window .....
<b>75</b>	Pass. (Sed.) (exc. Spt. Sed.) .....	<b>9668309</b>	<b>1</b>	<b>20.55</b>	front compartment .....
<b>75</b>	Pass. (Sed.) (exc. Spt. Sed.) .....	<b>9668299</b>	<b>1</b>	<b>31.50</b>	rear seat to back window .....
<b>69</b>	Spt. Sed. ....	<b>8798473</b>	<b>L.H.</b>		<b>EXTENSION, seat to back window panel (repl. 8729161) .....</b>
<b>72-75</b>	(Conv.) .....	<b>9814602</b>	<b>1</b>	<b>32.00</b>	<b>REINFORCEMENT, front compartment panel .....</b>
<b>72-73</b>	Impala (Custom) Caprice (Spt. Cpe.) .....	<b>9830979</b>	<b>1</b>	<b>24.70</b>	<b>REINFORCEMENT, to back window panel</b>
<b>74-75</b>	Impala (Custom) Caprice (Spt. Cpe.) .....	<b>9663187</b>	<b>1</b>	<b>22.50</b>	<b>REINFORCEMENT, rear seat to back window panel .....</b>
<b>71-74</b>	(Conv.) .....	<b>8760099</b>	<b>4</b>	<b>.16</b>	<b>SEALING STRIP, compt. frt. pnl. to reinf.</b>

**CHEVELLE**

<b>64-65</b>	(Sedan) .....	<b>4533829</b>	<b>1</b>	<b>16.60</b>	rr. compt. frt. ....
<b>68-72</b>	(Conv.) .....	<b>7672166</b>	<b>1</b>	<b>16.60</b>	rear compt. front .....
<b>68-72</b>	El Camino .....	<b>9826173</b>	<b>1</b>	<b>16.60</b>	lower compt. div. ....
<b>68-72</b>	(4-Dr. Sed.) .....	<b>9808830</b>	<b>1</b>	<b>16.60</b>	rear compt. front .....
<b>68-72</b>	Chevelle (Sed.) .....	<b>9861288</b>	<b>1</b>	<b>26.25</b>	rear seat to back window .....
<b>68-72</b>	El Camino .....	<b>7725434</b>	<b>1</b>	<b>76.75</b>	upper compt. division .....
<b>68-72</b>	El Camino .....	<b>7671554</b>	<b>1</b>	<b>18.55</b>	front seat to back window .....
<b>68-72</b>	(Spt. Cpe., 2-Dr. Sed.) .....	<b>7672009</b>	<b>1</b>	<b>18.65</b>	rear compt. front .....
<b>69-70</b>	(Spt. Cpe.) .....	<b>9812825</b>	<b>1</b>	<b>27.00</b>	rear seat to back window .....
<b>71-72</b>	Chevelle (Spt. Cpe.) .....	<b>9861287</b>	<b>1</b>	<b>31.00</b>	to back window .....
<b>73</b>	Chevelle (exc. Monte Carlo) .....	<b>9830339</b>	<b>1</b>	<b>24.70</b>	shelf .....
<b>73-75</b>	Monte Carlo .....	<b>9845067</b>	<b>1</b>	<b>28.00</b>	shelf .....
<b>73-75</b>	Monte Carlo .....	<b>9733164</b>	<b>1</b>	<b>26.50</b>	front compartment .....
<b>73-75</b>	Chevelle (Spt. Cpe.) (exc. Monte Carlo) .....	<b>9733349</b>	<b>1</b>	<b>42.50</b>	front compartment .....
<b>73-75</b>	Chevelle (Sed.) .....	<b>9733370</b>	<b>1</b>	<b>42.50</b>	front compartment .....
<b>73-75</b>	El Camino .....	<b>9830505</b>	<b>1</b>	<b>40.00</b>	compartment divider .....
<b>73-75</b>	El Camino .....	<b>9619750</b>	<b>1</b>	<b>13.25</b>	to back window .....
<b>74</b>	Monte Carlo .....	<b>9845067</b>	<b>1</b>	<b>28.00</b>	to back window .....
<b>74-75</b>	Chevelle (Spt. Cpe., Spt. Sed.) .....	<b>9830339</b>	<b>1</b>	<b>24.70</b>	to back window .....
<b>73-75</b>	Chevelle (Sta. Wag.) .....	<b>9677205</b>	<b>1</b>	<b>1.25</b>	<b>BOLT, panel pivot support</b>
<b>68-72</b>	(4-Dr. Sed.) .....	<b>8788803</b>	<b>R.H.</b>	<b>4.90</b>	<b>EXTENSION, rr. seat to back window reveal</b>
<b>68-72</b>	(4-Dr. Sed.) .....	<b>8788804</b>	<b>L.H.</b>	<b>4.90</b>	<b>EXTENSION, rr. seat to back window reveal</b>
<b>68-72</b>	(2-Dr. Sed., Spt. Cpe.) .....	<b>8769768</b>	<b>R.H.</b>	<b>4.90</b>	<b>EXTENSION, rear seat to back window panel .....</b>
<b>68-72</b>	(2-Dr. Sed., Spt. Cpe.) .....	<b>8769769</b>	<b>L.H.</b>	<b>4.90</b>	<b>EXTENSION, rear seat to back window panel .....</b>

**METAL TRIM—CLIPS AND PANELS**

**12.971 PANEL— BOLT— EXTENSION— REINFORCEMENT— SEALING STRIP, Rear Compartment Front and Shelf (Con't)**

68-72	Chevelle (Conv.)	7672169	1	16.40	REINFORCEMENT, rear compt. front panel
73-75	El Camino	9830536	1	10.10	REINFORCEMENT, compt. divider panel
70-75	Camaro	8780126	1	18.65	compartment front
70-75	Camaro	9683606	1	31.00	to back window
70-75	Camaro	8762194	R.H.	4.10	EXTENSION, seat to back window panel
70-75	Camaro	8762195	L.H.	4.10	EXTENSION, seat to back window panel

**CHEVY— NOVA**

71-74	Nova (4-Dr.)	9861282	1	31.00	to back window
71-74	Nova (2-Dr.)	9861283	1	31.00	to back window
75	Nova (2-Dr.) (exc. H.B.)	9676178	1	31.00	rear seat to back window
75	Nova (4-Dr.)	9676179	1	31.00	rear seat to back window
75	Monza (Towne Cpe.)	1671959	1	20.70	rear seat to back window
75	Nova (4-Dr.)	9676176	1	17.40	front compartment
75	XX69, XY69	1715911	2	1.35	CLIP, retainer compartment front panel
68-74	(Sed.)	7678534	R.H.	3.25	EXTENSION, rear seat to back window panel
68-74	(Sed.)	7678535	L.H.	2.95	EXTENSION, rear seat to back window panel
68-74	(Spt. Cpe.)	7723470	R.H.	6.70	EXTENSION, rear seat to back window panel
68-74	(Spt. Cpe.)	7723471	L.H.	6.70	EXTENSION, rear seat to back window panel
72-74	Nova	9621964	1	17.65	REINFORCEMENT, rr. seat & back window panel
75	Nova (4-Dr.)	9739114	1	22.20	REINFORCEMENT, rear seat to back window panel
75	Nova (Coupe) (exc. H.B.)	9676134	1	18.40	REINFORCEMENT, rear seat to back window panel
75	Monza (Towne Cpe.)	1713200	2	1.35	STIFFENER, lid hinge to rear seat panel
71-75	Vega (Notchback Cpe.)	8788410	1	20.70	PANEL, rear seat to back window
71-73	Vega (exc. Notchback)				PANEL ASSY., compt. rear floor,
74-75	Vega (Panel)				PANEL ASSY., compt. front filler,
74-75	Vega (exc. Notchback)	9679049	A.R.	34.50	PANEL ASSY., compt. floor rear

**12.971 CLIP— COVER— LATCH— MOULDING— NUT**

68-72	El Camino	7740303	7	.16	center compt. division belt mldg.
68-72	El Camino	7745763	2	.41	end, compt. div. shelf mldg.
70-72	El Camino	9817544	R.H.	1.85	COVER, compt. division lower panel access.
71-73	Vega (exc. Notchback)	9878338	1	4.55	LATCH, compt. rear floor panel
74-75	Vega (Panel)				LATCH ASSY., compt. floor panel front and rear
74-75	Vega, Monza (Sta. Wag., Cpe.)	9685150	A.R.	3.90	compt. floor panel rear
68-72	El Camino	7729430	1	8.00	MOLDING, compt. division upper panel at belt
71-73	Vega (exc. Notchback)	9878337	1	.39	NUT, compt. rear floor panel latch retaining

**12.975 PANEL— FILLER— RETAINER— BUMPER— BUSHING, Load Floor**

**PASSENGER**

71	Kingswood (9-Pass.)	9841383	1	14.85	luggage compartment filler (maize)
71	Brookwood, Townsman (9-Pass.)	9841387	1	14.85	luggage compartment filler (saddle)
71	Pass. (Sta. Wag.) (9-Pass.)	9691917	1	83.25	luggage compt. (black)
71	Pass. (Sta. Wag.) (9-Pass.)	9862860	1	78.25	fldg. 2nd 1/3 seat back (black)
71	Pass. (Sta. Wag.) (9-Pass.)	9616394	1	46.00	2nd 1/3 seat back filler (black)
71	Pass. (Sta. Wag.) (9-Pass.)	9862854	1	92.50	fldg. 2nd 2/3 seat back (black)
71	Pass. (Sta. Wag.) (6-Pass.)	9728488	1	121.00	fldg. 2nd seat back (black)
71	Kingswood (9-Pass.)	9862837	1	95.50	luggage compt. (maize)
71	Kingswood (6-Pass.)	9862675	1	97.50	luggage compt. front (maize)
71	Kingswood (9-Pass.)	9862861	1	78.25	fldg. 2nd 1/3 seat back (maize)
71	Kingswood (9-Pass.)	9862849	1	53.00	2nd 1/3 seat back filler (maize)
71	Kingswood (9-Pass.)	9862855	1	92.50	fldg. 2nd 2/3 seat back (maize)
71	Kingswood (9-Pass.)	9862843	1	76.00	2nd 2/3 seat back filler (maize)
71	Kingswood (6-Pass.)	9862831	1	138.00	fldg. 2nd seat back (maize)
71	Kingswood (6-Pass.)	9862663	1	104.00	fldg. 2nd seat back filler (maize)
71	Kingswood (9-Pass.)	9862873	1	106.00	fldg. 3rd seat back (maize)
71	Kingswood (9-Pass.)	9862867	1	79.75	fldg. 3rd seat back filler (maize)
71	Townsman (9-Pass.)	9862841	1	95.50	luggage compt. (saddle)
71	Brookwood, Townsman (6-Pass.)	9862829	1	97.50	luggage compt. front (saddle)
71	Brookwood, Townsman (6-Pass.)	9862673	1	87.25	luggage compt. rear (saddle)
71	Kingswood (9-Pass.)	9862862	1	78.25	fldg. 2nd 1/3 seat back (saddle)
71	Townsman (9-Pass.)	9862865	1	78.25	fldg. 2nd 1/3 seat back (saddle)
71	Townsman (9-Pass.)	9862853	1	53.00	2nd 1/3 seat back filler (saddle)

**METAL TRIM—CLIPS AND PANELS**

**12.975 PANEL— FILLER— RETAINER— BUMPER— BUSHING, Load Floor  
(Con't)**

71	Kingswood (9-Pass.)	9862856	1	92.50	fldg. 2nd 2/3 seat back (saddle)
71	Townsmen (9-Pass.)	9862859	1	92.50	fldg. 2nd 2/3 seat back (saddle)
71	Townsmen (9-Pass.)	9862847	1	87.00	2nd 2/3 seat back filler (saddle)
71	Brookwood, Townsmen (6-Pass.)	9862835	1	138.00	fldg. 2nd seat back (saddle)
71	Kingswood (6-Pass.)	9862664	1	104.00	fldg. 2nd seat back filler (saddle)
71	Brookwood, Townsmen (6-Pass.)	9862667	1	104.00	fldg. 2nd seat back filler (saddle)
71	Townsmen (9-Pass.)	9862877	1	106.00	fldg. 3rd seat back (saddle)
71	Kingswood (9-Pass.)	9688658	1	69.50	fldg. 3rd seat back-filler (saddle) (repl. 9616413)
71	Townsmen (9-Pass.)	9862871	1	79.75	fldg. 3rd seat back filler (saddle)
71	Pass. (Sta. Wag.) (9-Pass.)	9862863	1	78.25	fldg. 2nd 1/3 seat back (blue)
71	Pass. (Sta. Wag.) (9-Pass.)	9616414	1	79.75	fldg. 3rd seat back filler (blue)
71	Kingswood (9-Pass.)	9862840	1	95.50	luggage compt. (dk. jade)
71	Kingswood (6-Pass.)	9862828	1	97.50	luggage compt. front (dk. jade)
71	Kingswood (6-Pass.)	9862672	1	87.25	luggage compt. rear (dk. jade)
71	Kingswood (9-Pass.)	9862864	1	78.25	fldg. 2nd 1/3 seat back (dk. jade)
71	Kingswood (9-Pass.)	9862852	1	53.00	2nd 1/3 seat back filler (dk. jade)
71	Kingswood (9-Pass.)	9862858	1	92.50	fldg. 2nd 2/3 seat back (dk. jade)
71	Kingswood (9-Pass.)	9862846	1	76.00	2nd 2/3 seat back filler (dk. jade)
71	Kingswood (6-Pass.)	9862834	1	138.00	fldg. 2nd seat back (dk. jade)
71	Kingswood (6-Pass.)	9862666	1	104.00	fldg. 2nd seat back filler (dk. jade)
71	Kingswood (9-Pass.)	9862876	1	106.00	fldg. 3rd seat back (dk. jade)
71	Kingswood (9-Pass.)	9862870	1	79.75	fldg. 3rd seat back filler (dk. jade)
71	Kingswood (6-Pass.)	9867706	1	51.00	compartment floor at kick-up (maize)
71	Kingswood (6-Pass.)	9867709	1	51.00	compartment floor at kick-up (jade)
71	Brookwood, Townsmen (6-Pass.)	9867710	1	51.00	compartment floor at kick-up (med. saddle)
71-72	Pass. (Sta. Wag.) (9-Pass.)	9688670	1	14.85	luggage compartment filler (black)
71-72	Pass. (Sta. Wag.) (9-Pass.)	9841385	1	14.85	luggage compartment filler (blue)
71-72	Kingswood (9-Pass.)	9841386	1	14.85	luggage compartment filler (jade)
71-72	Kingswood (9-Pass.)	9841384	1	21.65	luggage compartment filler (saddle)
71-72	Pass. (Sta. Wag.) (6-Pass.)	9862674	1	90.50	luggage compt. front (black)
71-72	Pass. (Sta. Wag.) (6-Pass.)	9688658	1	69.50	luggage compt. rear (black)
71-72	Pass. (Sta. Wag.) (9-Pass.) (1st design)	9616403	1	66.00	2nd 2/3 seat back filler (black) (repl. 9891932)
71-72	Pass. (Sta. Wag.) (6-Pass.)	9862662	1	90.50	fldg. 2nd seat back filler (black)
71-72	Pass. (Sta. Wag.) (9-Pass.)	9688665	1	92.75	fldg. 3rd seat back (black)
71-72	Pass. (Sta. Wag.) (9-Pass.)	9688658	1	69.50	fldg. 3rd seat back filler (black) (repl. 9666218)
71-72	Kingswood (6-Pass.)	9616414	1	79.75	luggage compt. rear (maize)
71-72	Kingswood (9-Pass.)	9862838	1	95.50	luggage compt. (saddle)
71-72	Kingswood (6-Pass.)	9862826	1	97.50	luggage compt. front (saddle)
71-72	Kingswood (6-Pass.)	9862670	1	87.25	luggage compt. rear (saddle)
71-72	Kingswood (9-Pass.)	9616404	1	76.00	2nd 2/3 seat back filler (saddle)
71-72	Kingswood (6-Pass.)	9862832	1	138.00	fldg. 2nd seat back (saddle)
71-72	Kingswood (9-Pass.)	9657073	1	106.00	fldg. 3rd seat back (saddle)
71-72	Townsmen, Kingswood (9-Pass.)	9862839	1	95.50	luggage compt. (blue)
71-72	Pass. (Sta. Wag.) (6-Pass.)	9862827	1	97.50	luggage compt. front (blue)
71-72	Pass. (Sta. Wag.) (6-Pass.)	9862671	1	87.25	luggage compt. rear (blue)
71-72	Pass. (Sta. Wag.) (9-Pass.)	9616396	1	53.00	2nd 1/3 seat back filler (blue)
71-72	Pass. (Sta. Wag.) (9-Pass.)	9862857	1	92.50	fldg. 2nd 2/3 seat back (blue)
71-72	Pass. (Sta. Wag.) (9-Pass.)	9616405	1	76.00	2nd 2/3 seat back filler (blue)
71-72	Pass. (Sta. Wag.) (6-Pass.)	9862833	1	138.00	fldg. 2nd seat back (blue)
71-72	Pass. (Sta. Wag.) (6-Pass.)	9862665	1	104.00	fldg. 2nd seat back filler (blue)
71-72	Pass. (Sta. Wag.) (6-Pass.)	9867705	1	90.50	compartment floor at kick-up (black)
71-72	Kingswood (6-Pass.)	9867707	1	51.00	compartment floor at kick-up (dk. saddle)
71-72	Pass. (Sta. Wag.) (6-Pass.)	9867708	1	51.00	compartment floor at kick-up (blue)
71-73	Pass. (Sta. Wag.) (6-Pass.)	9862668	1	87.25	luggage compt. rear (black)
71-72	Pass. (9-Pass.) (1st design)	9616403	1	66.00	2nd 1/3 seat back filler (saddle) (repl. 9891923)
72	Pass. (Sta. Wag.) (9-Pass.)	9688620	1	68.25	fldg. 2nd 1/3 seat back (black)
72	Pass. (Sta. Wag.) (9-Pass.)	9616415	1	79.75	folding 3rd seat back filler (blue)
72	Pass. (Sta. Wag.) (9-Pass.)	9616416	1	79.75	folding 3rd seat back filler (covert)
72	Pass. (Sta. Wag.) (9-Pass.)	9616394	1	46.00	2nd 1/3 seat back filler (black)
72-73	Pass. (Sta. Wag.) (9-Pass.)	9891927	1	92.50	fldg. 2nd 2/3 seat back (black)
72	Pass. (9-Pass.)	9895727	1	78.25	fldg. 2nd 1/3 seat back (saddle)
72	Pass. (9-Pass.)	9891928	1	92.50	fldg. 2nd 2/3 seat back (saddle)
72	Kingswood (9-Pass.)	9895729	1	78.25	fldg. 2nd 1/3 seat back (green)
72	Kingswood (9-Pass.)	9616397	1	53.00	2nd 1/3 seat back filler (green)
72	Kingswood (9-Pass.)	9891930	1	92.50	fldg. 2nd 2/3 seat back (green)
72	Kingswood (9-Pass.) (1st design)	9891935	1	76.00	2nd 2/3 seat back filler (green)
72	Kingswood (9-Pass.)	9888799	1	106.00	fldg. 3rd seat back (green)
72	Kingswood (9-Pass.)	9888795	1	14.85	lug. compt. (green)
72	Kingswood (6-Pass.)	9888903	1	104.00	fldg. 2nd seat back filler (green)

**METAL TRIM—CLIPS AND PANELS**

**12.975 PANEL— FILLER— RETAINER— BUMPER— BUSHING, Load Floor  
(Con't)**

72	Kingswood (6-Pass.)	9888895	1	138.00	fldg. 2nd seat back (green)
72	Kingswood (6-Pass.)	9888901	1	87.25	lug. compt. rear (green)
72	Kingswood (6-Pass.)	9888897	1	51.00	compt. fir. at kick-up (green)
72	Kingswood (9-Pass.)	9891931	1	92.50	fldg. 2nd 2/3 seat back (lt. covert)
72	Kingswood (9-Pass.)	9888800	1	106.00	fldg. 3rd seat back (lt. covert)
72	Kingswood (9-Pass.)	9888794	1	114.00	lug. compt. (lt. covert)
72	Kingswood (9-Pass.)	9888796	1	14.85	lug. compt. filler (lt. covert)
72	Kingswood (6-Pass.)	9888896	1	138.00	fldg. 2nd seat back (lt. covert)
72	Kingswood (6-Pass.)	9888900	1	97.50	lug. compt. frt. (lt. covert)
72	Kingswood (6-Pass.)	9888898	1	51.00	compt. floor at kick-up (lt. covert)
72	Kingswood (9-Pass.)	9895730	1	78.25	fldg. 2nd 1/3 seat back (lt. covert)
72	Kingswood (9-Pass.)	9616398	1	53.00	2nd 1/3 seat back filler (lt. covert)
72	Kingswood (9-Pass.)	9891931	1	92.50	2nd 2/3 seat back (lt. covert)
72	Kingswood (6-Pass.)	9888902	1	87.25	lug. compt. rear (lt. covert)
72	Kingswood (6-Pass.)	9888904	1	104.00	fldg. 2nd seat back filler (lt. covert)
72	Pass. (Sta. Wag.) (9-Pass.)	9891929	1	92.50	fldg. 2nd 2/3 seat back (blue)
72	Pass. (9-Pass.) (2nd design)	9616394	1	46.00	2nd 1/3 st. bk. fil. (black)
72	Pass. (9-Pass.) (2nd design)	9616395	1	53.00	2nd 1/3 st. bk. fil. (saddle)
72	Pass. (9-Pass.) (2nd design)	9616403	1	66.00	2nd 2/3 st. bk. fil. (black)
72	Pass. (9-Pass.) (2nd design)	9616405	1	76.00	2nd 2/3 st. bk. fil. (blue)
72	Pass. (9-Pass.) (2nd design)	9616406	1	76.00	2nd 2/3 st. bk. fil. (green)
72	Pass. (9-Pass.)	9616407	1	76.00	2nd 2/3 st. bk. fil. (covert)
73	Pass. (Sta. Wag.) (9-Pass.)	9626493	1	14.85	lug. compt. filler (saddle)
73	Impala, Caprice (Sta. Wag.) (9-Pass.)	9626491	1	14.85	lug. compt. filler (green)
73	Impala, Caprice (Sta. Wag.) (9-Pass.)	9626479	1	53.00	2nd 1/3 st. bk. filler (green)
73	Impala, Caprice (Sta. Wag.) (9-Pass.)	9626503	1	76.00	2nd 2/3 st. bk. filler (green)
73	Impala, Caprice (Sta. Wag.) (9-Pass.)	9666219	1	79.75	fldg. 3rd st. bk. filler (green)
73	Impala, Caprice (Sta. Wag.) (9-Pass.)	9626494	1	114.00	lug. compt. (green)
73	Impala, Caprice (Sta. Wag.) (9-Pass.)	9656567	1	78.25	fldg. 2nd 1/3 st. bk. (green)
73	Impala, Caprice (Sta. Wag.) (9-Pass.)	9656570	1	92.50	2nd 2/3 st. bk. (green)
73	Impala, Caprice (Sta. Wag.) (9-Pass.)	9657077	1	106.00	fldg. 3rd st. bk. (green)
73	Impala, Caprice (Sta. Wag.) (9-Pass.)	9734601	1	80.25	fldg. 2nd 2/3 st. bk. (green)
73	Impala, Caprice (Sta. Wag.) (6-Pass.)	9626518	1	51.00	compt. floor at kick-up (green)
73	Impala, Caprice (Sta. Wag.) (6-Pass.)	9626515	1	104.00	fldg. 2nd st. bk. filler (green)
73	Impala, Caprice (Sta. Wag.) (6-Pass.)	9626512	1	138.00	fldg. 2nd st. bk. (green)
73	Impala, Caprice (Sta. Wag.) (6-Pass.)	9626509	1	97.50	lug. compt. frt. (green)
73	Impala, Caprice (Sta. Wag.) (6-Pass.)	9626506	1	87.25	lug. compt. rear (green)
73	Pass. (Sta. Wag.) (9-Pass.)	9691917	1	83.25	lug. compt. (neutral)
73	Bel Air (Sta. Wag.) (9-Pass.)	9656571	1	92.50	fldg. 2nd 2/3 st. bk. (neutral)
73	Pass. (Sta. Wag.) (9-Pass.)	9656572	1	92.50	fldg. 2nd 2/3 st. bk. (saddle)
73	Pass. (Sta. Wag.) (9-Pass.)	9657079	1	106.00	fldg. 3rd st. bk. (saddle)
73	Pass. (Sta. Wag.) (9-Pass.)	9656569	1	78.25	fldg. 2nd 1/3 st. bk. (saddle)
73	Pass. (Sta. Wag.) (9-Pass.)	9626481	1	53.00	2nd 1/3 st. bk. filler (saddle)
73	Pass. (Sta. Wag.) (9-Pass.)	9626505	1	76.00	2nd 2/3 st. bk. filler (saddle)
73	Pass. (Sta. Wag.) (9-Pass.)	9666221	1	79.75	3rd st. bk. filler (saddle)
73	Pass. (Sta. Wag.) (9-Pass.)	9626496	1	114.00	lug. compt. (saddle)
73	Pass. (Sta. Wag.) (6-Pass.)	9626514	1	138.00	fldg. 2nd st. bk. (saddle)
73	Pass. (Sta. Wag.) (6-Pass.)	9626520	1	51.00	compt. floor at kick-up (saddle)
73	Pass. (Sta. Wag.) (6-Pass.)	9626517	1	104.00	2nd st. bk. filler (saddle)
73	Pass. (Sta. Wag.) (6-Pass.)	9626511	1	97.50	lug. compt. frt. (saddle)
73	Pass. (Sta. Wag.) (6-Pass.)	9626508	1	87.25	lug. compt. rear (saddle)
73	Impala, Caprice (Sta. Wag.) (9-Pass.)	9666222	1	79.75	fldg. 3rd st. bk. filler (blue)
73	Impala, Caprice (Sta. Wag.) (9-Pass.)				
73	Impala, Caprice (Sta. Wag.) (9-Pass.)	9688645	1	80.25	fldg. 2nd 2/3 st. bk. (paint as reqd.)
73	Impala, Caprice (Sta. Wag.) (9-Pass.)	9665107	1	106.00	fldg. 3rd st. bk. (blue)
75	Impala, Caprice (Sta. Wag.)	4833642	1	.76	luggage compartment rear closing

**METAL TRIM—CLIPS AND PANELS**

**12.975 PANEL— FILLER— RETAINER— BUMPER— BUSHING, Load Floor  
(Con't)**

73-74	Pass. (Sta. Wag.) (6-Pass.)	9626519	1	90.50	compt. floor at kick-up (neutral)
73-75	Pass. (Sta. Wag.) (9-Pass.)	9691917	1	83.25	lug. compt. (paint as reqd.)
73-75	Pass. (Sta. Wag.) (9-Pass.)	9616403	1	66.00	fldg. 2nd 2/3 st. bk. filler (black)
73-75	Pass. (Sta. Wag.) (9-Pass.)	9688658	1	69.50	fldg. 3rd st. bk. filler (paint as reqd.)
73-75	Pass. (Sta. Wag.) (9-Pass.)	9616394	1	46.00	2nd 1/3 st. bk. filler (black)
73-75	Pass. (Sta. Wag.) (9-Pass.)	9688620	1	68.25	fldg. 2nd 1/3 st. bk. (paint as reqd.)
73-75	Pass. (Sta. Wag.) (6-Pass.)	9862662	1	90.50	fldg. 2nd st. back filler (black)
73-75	Pass. (Sta. Wag.) (6-Pass.)	9862674	1	90.50	lug. compt. frt. (black)
73-75	Impala, Caprice (Sta. Wag.) (6-Pass.)	9867705	1	90.50	compt. floor at kick-up (black)
73-75	Pass. (Sta. Wag.) (6-Pass.)	1655139	1	76.00	lug. compt. rear (paint as reqd.)
73-75	Pass. (Sta. Wag.) (6-Pass.)	9728488	1	121.00	fldg. 2nd st. bk. (paint as reqd.)
73-75	Pass. (Sta. Wag.) (9-Pass.)	9688665	1	92.75	fldg. 3rd st. bk. (paint as reqd.)
73-75	Pass. (Sta. Wag.) (9-Pass.)	9688670	1	14.85	lug. compt. filler (paint as reqd.)
74-75	Pass. (Sta. Wag.) (9-Pass.)	9688645	1	80.25	fldg. 2nd 2/3 st. bk. (paint as reqd.)
62-65	Chevy (Sta. Wag.)				
65-66	Pass., Sta. Wag. w/split seat	4587944	4	.12	<b>BUMPER</b> , rear floor filler panel on floor— (11.620)
71	Pass. (Sta. Wag.) (9-Pass.)	4879757	A.R.	.16	<b>BUMPER</b> , 2nd 1/3 seat back link bumper
72	Pass. (Sta. Wag.) (9-Pass.)	4868380	2	.18	<b>BUMPER</b> , 2nd 1/3 seat back link bumper
73-75	Pass. (Sta. Wag.) (9-Pass.)				
73-75	Chevelle (Sta. Wag.)	4821688	2	.11	<b>BUSHING</b> , fldg. 3rd st. bk. panel retainer, luggage compt. panel

**CHEVELLE**

68	(Sta. Wag.) (exc. Nomad Std.) (1st design)	7790368	1	78.75	luggage compt. (blue) (Note 1)
68	(Sta. Wag.) (6-Pass.) (2nd design) (exc. Nomad),				
69-72	(Sta. Wag.) (6-Pass.)	7798878	2	42.00	compt. flr. at kick-up (black) (Note 2)
68-70	(Sta. Wag.)	8720979	1	93.50	fldg. 3rd seat back cush. (black)
68-70	(Sta. Wag.)	7747656	1	75.75	rear floor filler (black)
68-72	Nomad (exc. Custom)	7790562	1	11.35	compt. floor at kick-up (black)
68-72	(Sta. Wag.) (9-Pass.)	7747559	1	28.25	compt. flr. at kick-up (black)
68-72	El Camino	7740357	1	7.15	rear cross bar to t/gate filler
68-72	(Sta. Wag.)	7747678	1	108.00	folding 2nd seat back (black)
69-70	(Sta. Wag.) (9-Pass.)	8768286	1	100.00	3rd seat back (black)
69-72	(Sta. Wag.) (6-Pass.)	7798890	1	70.50	luggage compt. (black) (Note 2)
<i>NOTE 1: 1st design flat hinge surface.</i>					
71	Nomad	9840454	1	15.55	compartment floor at kick-up (beige)
71	Greenbrier (9-Pass.)	9840452	1	33.00	compartment floor at kick-up (beige)
71	Concours (9-Pass.)	9840451	1	33.00	compartment floor at kick-up (jade)
71	Nomad	9840455	1	15.55	compartment floor at kick-up (saddle)
71	Greenbrier (9-Pass.)	9840453	1	33.00	compartment floor at kick-up (saddle)
71	Concours (9-Pass.)	9840450	1	33.00	compartment floor at kick-up (saddle)
71	Greenbrier (6-Pass.)	9840440	1	58.75	compartment floor at kick-up (beige)
71	Greenbrier (9-Pass.)	9840444	1	110.00	fldg. 3rd seat cushion (beige)
71	Greenbrier (9-Pass.)	9840448	1	116.00	fldg. 3rd seat back (beige)
71	Nomad, Greenbrier	9840458	1	88.50	rear floor filler (med. beige)
71	Nomad, Greenbrier	9840436	1	127.00	fldg. 2nd seat back (med. beige)
71	Greenbrier (6-Pass.)	9840428	1	114.00	luggage compartment (med. beige)
71	Chevelle (Sta. Wag.)	7747656	1	75.75	rear floor filler (black)
71	Chevelle (Sta. Wag.)	7747678	1	108.00	fldg. 2nd seat back (black)
71	Concours (6-Pass.)	9840439	1	58.75	compartment floor at kick-up (jade)
71	Concours (6-Pass.)	9840427	1	114.00	luggage compartment (dk. jade)
71	Concours	9840435	1	127.00	fldg. 2nd seat back (dk. jade)
71	Concours (9-Pass.)	9840443	1	110.00	fldg. 3rd seat cushion (dk. jade)
71	Concours (9-Pass.)	9840447	1	116.00	fldg. 3rd seat back (dk. jade)
71	Concours	9840457	1	88.50	rear floor filler (dk. jade)
71	Greenbrier (6-Pass.)	9840441	1	58.75	compartment floor at kick-up (saddle)
71	Greenbrier (9-Pass.)	9840445	1	110.00	fldg. 3rd seat cushion (saddle)
71	Greenbrier (9-Pass.)	9840449	1	116.00	fldg. 3rd seat back (saddle)
71	Concours (6-Pass.)	9840438	1	58.75	compartment floor at kick-up (saddle)
71	Concours (6-Pass.)	9840426	1	114.00	luggage compartment (dk. saddle)
71	Concours	9840456	1	88.50	rear floor filler (dk. saddle)
71	Concours	9840434	1	127.00	fldg. 2nd seat back (dk. saddle)
71	Concours (9-Pass.)	9840442	1	110.00	fldg. 3rd seat cushion (dk. saddle)
71	Greenbrier (6-Pass.)	9840429	1	114.00	luggage compartment (med. saddle)
71	Nomad, Greenbrier	9840437	1	127.00	fldg. 2nd seat back (med. saddle)
71	Nomad, Greenbrier	9840459	1	88.50	rear floor filler (med. saddle)
71-72	Greenbrier, Concours (9-Pass.)	8768286	1	100.00	fldg. 3rd seat back (black)
72	El Camino	7740357	1	7.15	rear cross bar to t/gate filler
72	Greenbrier, Concours (6-Pass.)	9888851	1	58.75	compt. floor at kick-up (green)
72	Greenbrier, Concours (6-Pass.)	9618067	1	118.00	lug. compt. (green)

**METAL TRIM—CLIPS AND PANELS**

**12.975 PANEL— FILLER— RETAINER— BUMPER— BUSHING, Load Floor  
(Con't)**

72	Greenbrier, Concours	9888906	1	127.00	fldg. 2nd seat back (green)
72	Chevelle (Sta. Wag.) (9-Pass.)	9888375	1	33.00	floor at kick-up (green)
72	Chevelle (Sta. Wag.) (9-Pass.)	9888911	1	110.00	fldg. 3rd seat cushion (green)
72	Chevelle (Sta. Wag.) (9-Pass.)	9888912	1	116.00	fldg. 3rd seat back (green)
72	Greenbrier, Concours	9888905	1	88.50	rear fldg. filler (green)
72	Chevelle (Sta. Wag.)	7747678	1	108.00	fldg. 2nd seat back (black)
72	Chevelle (Sta. Wag.)	9898503	1	75.75	floor filler (black)
73	Laguna (Sta. Wag.)	9641080	1	90.50	compt. floor at kick-up (oxblood)
73	Chevelle (Sta. Wag.)	9626823	1	51.00	compt. floor at kick-up (saddle)
73	Malibu, Laguna (Sta. Wag.)	9626821	1	51.00	compt. floor at kick-up (green)
73-75	Chevelle (Sta. Wag.)	9626824	1	90.50	lug. compt. rear (black)
73	Malibu, Laguna (Sta. Wag.)	9626787	1	138.00	fldg. 2nd st. bk. (green)
73	Malibu, Laguna (Sta. Wag.)	9626783	1	104.00	fldg. 2nd st. bk. filler (green)
73	Malibu, Laguna (Sta. Wag.)	9626825	1	97.50	lug. compt. rear (green)
73	Malibu, Laguna (Sta. Wag.)	9626829	1	97.50	lug. compt. frt. (green)
73	Malibu, Deluxe (Sta. Wag.)	9626789	1	138.00	fldg. 2nd st. bk. (saddle)
73	Malibu, Deluxe (Sta. Wag.)	9626785	1	104.00	fldg. 2nd st. bk. filler (saddle)
73	Chevelle (Sta. Wag.) (exc. Laguna)	9626827	1	97.50	lug. compt. rear (saddle)
73	Malibu, Deluxe (Sta. Wag.)	9626831	1	97.50	lug. compt. frt. (saddle)
73	Laguna (Sta. Wag.)	9638561	1	90.50	fldg. 2nd st. bk. filler (oxblood)
73	Laguna (Sta. Wag.)	9641081	1	90.50	lug. compt. frt. (oxblood)
73-75	Chevelle (Sta. Wag.)	9626820	1	51.00	compt. floor at kick-up (black)
73-75	Chevelle (Sta. Wag.)	9626786	1	121.00	fldg. 2nd st. bk. (paint as reqd.)
73-75	Chevelle (Sta. Wag.)	9626782	1	90.50	fldg. 2nd st. bk. filler (black)
73-75	Chevelle (Sta. Wag.)	9626828	1	90.50	lug. compt. frt. (black)

**NOVA**

73	Nova (H.B.)	9622699	1	7.30	lug. compartment front
73-74	Nova (H.B.)	9622705	R.H.	3.65	lug. compartment outer
73-74	Nova (H.B.)	9622706	L.H.	3.65	lug. compartment outer
73-74	Nova (H.B.)	1654395	1		lug. compt.
73-75	Nova (H.B.)	1650418	1	13.75	fldg. rear st. filler (painted)
73-74	Nova (H.B.)	9652818	1	5.70	trim finish compt. rear end (paint as required)
73-74	Nova (H.B.)	9729601	1	51.00	fldg. rear st. bk.
74-75	Nova (H.B.)	9732954	1	7.30	lug. compartment frt.
75	Nova (H.B.)	1651240	R.H.	4.05	lug. compt. outer
75	Nova (H.B.)	1651241	L.H.	4.05	lug. compt. outer
75	Nova (H.B.)	1652955	1	82.50	lug. compt. outer
75	Nova (H.B.)	1654496	1	51.00	fldg. rear seat back

**VEGA**

71-72	Vega (Sta. Wag., Cpe.)				
73	Vega (Panel) w/custom-build-up door,				
73	Vega (exc. Notchback)	9829349	2	2.85	compt. rear floor side filler
71-75	Vega (Panel)	9891052	L.H.	10.50	compt. front floor front corner filler
71-75	Vega (Panel)	9891051	R.H.	10.50	compt. front floor front corner filler
71-73	Vega (Sta. Wag.),				
72-74	Vega (Panel)	9891052	L.H.	10.50	compt. front floor front corner filler
74-75	Vega (Panel)	9673040	R.H.	6.10	compt. rear floor side filler
74-75	Vega (exc. Notchback) w/custom build-up door and qtr.	9685030	R.H.	1.90	compt. rear floor side filler
71-75	Vega (Panel)	9815570	R.H.	6.10	compt. front floor side filler
71-75	Vega (Panel)	9815571	L.H.	6.10	compt. front floor side filler
71	Vega (Sta. Wag., H.B.)	9814730	1	33.00	PANEL ASSY., fldg. rear seat back (w/fiber board design)
71-74	Vega (Panel)	9829696	L.H.	8.45	PANEL ASSY., compt. rear floor side filler
71-73	Vega (Panel)	9616537	R.H.	8.45	PANEL ASSY., compt. rear floor side filler
72-73	Vega (Sta. Wag., H.B. Cpe.)	9618621	1	33.00	PANEL ASSY., folding rear seat back (steel assy.)
72-74	Vega (Sta. Wag., H.B. Cpe.)	9615754	1	29.50	PANEL ASSY., folding rear seat filler (steel design)
74	Vega (Sta. Wag., H.B. Cpe.)	1689764	1	33.00	PANEL ASSY., fldg. r/seat back (repl. 9739297)
74	Vega (Sta. Wag., H.B. Cpe.)	9691133	1	29.50	PANEL ASSY., fldg. rear seat back filler (painted)
74	Vega (Sta. Wag., H.B. Cpe.)	1650412	1	29.50	PANEL ASSY., fldg. r/seat back filler (painted)
74	Vega (Sta. Wag., H.B. Cpe.)	1650418	1	13.75	PANEL ASSY., fldg. r/seat back filler (painted)
75	Vega (Sta. Wag., H.B. Cpe.)	1689764	1	33.00	PANEL ASSY., fldg. rear seat back
75	Monza (2+2)	9736700	1	57.50	PANEL ASSY., fldg. r/seat back

**METAL TRIM—CLIPS AND PANELS**

**12.975 PANEL— FILLER— RETAINER— BUMPER— BUSHING, Load Floor  
(Con't)**

75	Monza (exc. Towne Cpe.) Vega (H.B., Sta. Wag.)	1670545	1	19.10	PANEL, folding rear seat back filler
74	Vega (Sta. Wag., H.B. Cpe.)	9680234	1	.96	FILLER, fldg. r/seat back upper
74-75	Vega (Sta. Wag., H.B. Cpe.)	9680235	R.H.	.55	FILLER, fldg. r/seat back side
74-75	Vega (Sta. Wag., H.B. Cpe.)	9680236	L.H.	.55	FILLER, fldg. r/seat back side
71-74	Vega (Panel)	9824348	1	1.55	RETAINER, compt. front floor panel latch
74-75	Vega (Panel)	9687900	1	1.55	RETAINER, compt. front filler panel latch
73-74	Nova (H.B.)	9622694	A.R.	.06	RETAINER, trim finish panel compt. side
75	Nova (H.B.)	1704621	10	.06	RETAINER, trim fin. panel compt. side

**12.976 MOLDING— ESCUTCHEON, Load Floor**

66-70	Sta. Wag. w/load floor carpet	4474890	L.H.	4.25	lug. compt. front pnl. rear molding, lug. compt. rear pnl. front molding fldg. 3rd seat back pnl. fin. rear molding, 3rd seat cushion pnl. front fin. (repl. 4474892)
66-70	Sta. Wag. w/load floor carpet	4474890	2	4.25	compt. fin. frt. and rear ai kickup
66-70	Sta. Wag. w/load floor carpet	9833891	2		rear floor filler panel fin. side (repl. 4814685)
66-70	Sta. Wag. w/load floor carpet	4759254	2		rr. floor fil. pnl. fin. front 2nd seat back pnl. fin. pnl. (repl. 4814686)
66-71	Kingswood w/load floor carpet	9833891	6		finish luggage compartment panel side, front and rear panel side fldg. 2nd 1/3, 2/3 seat back panel outer
68-70	Sta. Wag. w/load floor carpet	4474890	2	4.25	compt. front panel front mldg., lug. compt. rear panel rear mldg., fldg. 3rd st. bk. panel fin. front mldg., 3rd st. cush. panel rear fin. mldg. (repl. 4474891)
71	Kingswood (6-Pass.) w/load floor carpet	9833891	2		finish floor at kick-up compartment side (repl. 9837598)
71	Kingswood (9-Pass.) w/load floor carpet	9833891	A.R.		fldg. 2nd 1/3 seat back filler panel upper and lower, inner and outer, 2nd 1/3 and 2/3 seat back panel inner and outer, upper and lower (repl. 9832926)
71	Kingswood w/load floor carpet	9833891	2		fldg. 2nd and 3rd seat back filler panel (repl. 9832929)
71	Kingswood (6-Pass.) w/load floor carpet	9833953	2	2.40	fldg. 2nd seat back panel side
71	Kingswood (6-Pass.)				finish luggage compartment filler panel front,
71	Kingswood w/load floor carpet	9832931	1	4.60	fldg. 3rd seat back panel lower (repl. 9832927)
71-75	Pass. (Sta. Wag.) (9-Pass.)	9832931	1	4.60	w/load floor carpet mid. fin. lug. compt. pnl. rear and lower
71-75	Pass. (Sta. Wag.) (9-Pass.)	9833951	R.H.	3.50	w/load floor carpet mldg. 3rd st. bk. panel side lower
71-75	Pass. (Sta. Wag.) (9-Pass.)	9833952	L.H.	3.50	w/load floor carpet mldg. 3rd st. bk. panel side lower
75	Pass. (Sta. Wag.) (9-Pass.)	9833891	A.R.		w/load floor carpet mldg. fin. lug. compt. pnl. side
66-75	Pass. (Sta. Wag.) (9-Pass.)	4760486	2	.83	ESCUTCHEON MLDG., used on rr. flr. fil. pnl. fin. mldg. fldg. 2nd st. bk. fin. mldg. lwr. lug. compt. frt. & r/pnl. mldg. fldg. 3rd st. cush. & bk. pnl. fin. mldg. fin. mldg. lug. compt. fil. fin. mldg. compt. fir. at k/up w/floor cvr. load floor carpet

**12.977 SUPPORT— BUMPER— CABLE ASSY.— CAP— CLIP— COVER, Load Floor  
(for Folding Seat Parts see Group 11.620)**

68-72	Chevelle (Sta. Wag.) (6-Pass.) (exc. Nomad Std.)	4419905	1	.98	luggage compt. cover
68-72	Chevelle (Sta. Wag.) (9-Pass.)	7730251	R.H.	3.55	3rd seat cushion
68-72	Chevelle (Sta. Wag.) (9-Pass.)	7730252	L.H.	3.55	3rd seat cushion
71-75	Pass. (Sta. Wag.)	9601725	1	9.60	luggage compartment cover panel hinge
72-75	Vega (Panel)	9615728	1	1.15	compt. floor panel
73-75	Pass. (Sta. Wag.) (9-Pass.)				
73-74	Nova (H.B.) (1st design)	4419905	1	.98	luggage compartment panel (27 inches)
74	Nova (H.B.) (2nd design)	1654390	1	1.10	lug. compt. panel (30 inches)
73-75	Chevelle (Sta. Wag.)	9878346	L.H.	9.90	filler rear floor otr. panel
73-75	Chevelle (Sta. Wag.)	9615828	R.H.	7.80	filler rear floor otr. panel
73	Chevelle (Sta. Wag.)				
74-75	El Camino	9871650	1	2.85	comp. floor panel
73-74	Nova (H.B.)	1654392	L.H.	4.20	lug. compt. cover panel outer

**METAL TRIM—CLIPS AND PANELS**

**12.977 SUPPORT— BUMPER— CABLE ASSY.— CAP— CLIP— COVER, Load Floor**  
**(for Folding Seat Parts see Group 11.620) (Con't)**

73-74	Nova (H.B.)	1654391 R.H.	4.20	lug. compt. cover panel outer
73	Nova (H.B.)	9623186 1	2.85	lug. compt. frt. panel
73-75	Nova (H.B.)	9616015 1	14.85	lug. compt. cover panel hinge
73-74	Nova (H.B.)	9616019 1	1.80	lug. compt. cover panel rear
73-74	Nova (H.B.)	9623187 2	.39	lug. compt. outer panel
74-75	Nova (H.B.)	9737140 1	2.85	lug. compt. frt. panel
74-75	Vega (H.B. Cpe.)	9698424 1	5.90	compt. floor pan rear
75	Nova (H.B.)	9731810 1	2.95	lug. compt. cover pnl. rear center
75	Nova (H.B.)	9733887 R.H.	5.55	lug. compt. cover pnl. outer
75	Nova (H.B.)	9733888 L.H.	5.55	lug. compt. cover pnl. outer
75	Nova (H.B.)	1655159 2	2.95	lug. compt. outer panel
75	Nova (H.B.)	1694395 1	1.15	lug. compt. panel
75	Chevelle (Sta. Wag.)	9884008 L.H.	3.60	piv. lug. compt. panel
75	Chevelle (Sta. Wag.)	9884009 L.H.	3.60	piv. lug. compt. panel
68	Pass. (Sta. Wag.)			
71	Pass. (Sta. Wag.) (6-Pass.)	4687558 4	.16	<b>BUMPER</b> , rear compt. lid body side— (12.212)
73-75	Pass. (Sta. Wag.) (6-Pass.)	4767559 4	.21	<b>BUMPER</b> , luggage compartment cover panel on stop
74-75	Chevelle (Sta. Wag.)	4721222 2	.12	<b>BUMPER</b> , lug. compt. panel stop
75	Chevelle (Sta. Wag.)	1676725 2	.28	<b>BUMPER</b> , lug. compt. rear pnl.
68-72	Greenbrier, Concours (6-Pass.)	8731346 L.H.	1.90	<b>CABLE ASSY.</b> , panel lim stop
73	Nova (H.B.)	8731346 L.H.	1.90	<b>CABLE ASSY.</b> , luggage compartment panel lim stop
65-72	Pass. (Sta. Wag.) (6-Pass.)			
69	Pass. (Sta. Wag.) (9-Pass.)			<b>CAP</b> , lug. compt. pnl. hge. screw, lug. compt. rr. pnl.,
74	Vega (Panel)	4725264 2	.12	compt. front and rear floor screw protector
73-74	Pass. (Sta. Wag.) (6-Pass.)			
74	Chevelle (exc. Sed.)			
75	Laguna	4725264 A.R.	.12	<b>CAP</b> , luggage compt. cover panel hinge, screw protector
71-72	Chevelle (Sta. Wag.) (6-Pass.)			
71-72	Pass. (Sta. Wag.) (9-Pass.)	9869875 1	.12	<b>CLIP</b> , luggage compartment cover support
72-75	Vega (Panel)			
74	Nova (H.B.) (1st design)			
75	Pass.	9869875 A.R.	.12	<b>CLIP</b> , lug. compt. panel supt. ret. (use only with 27 in. support not reqd. with 30 in.)
75	Pass.	1715911 2	1.35	<b>CLIP</b> , ret. compt. front panel
75	Nova (H.B.)	1650994 L.H.	1.15	<b>COVER</b> , compt. lid hge. wrg. harn.

**12.977 HANDLE ASSY.— CYLINDER ASSY.— RETAINER— STRIKER— WASHER,**  
**Load Floor (For Folding Seat Parts See Group 11.620)**

65-75	Pass. (Sta. Wag.)	4833642 1	.76	luggage compt. rear panel closing
65-68	Impala, Caprice (Sta. Wag.)			
68-72	Chevelle (Sta. Wag.) (exc. Nomad)			
69-72	Pass. (Sta. Wag.) (9-Pass.)	9664638 A.R.	2.35	fldg. floor and 3rd seat handle (black) (repl. 4887836)
71	Kingswood	9858910 A.R.	1.75	luggage compartment rear panel opening (comb. 835) (dk. jade)
71	Kingswood	9858907 1	2.65	luggage compartment rear panel opening (comb. 827) (med. maize)
71	Brookwood, Townsman	9858912 A.R.	1.90	luggage compartment rear panel opening (comb. 823, 824) (med. saddle)
73	All (Sta. Wag.) (exc. Bel Air)			
73	Chevelle (Sta. Wag.)			
73-75	Nova (H.B.)	9664638 1	2.35	lug. compt. panel opening (paint)
68-72	Pass. (exc. Spt. Cpe.)	6258011	6.25	<b>CYLINDER ASSY.</b> (coded w/keys)
73-75	Pass. (Sta. Wag.) (9-Pass.)			
73-74	Nova (H.B.)	9874339 1	.94	<b>RETAINER</b> , luggage compartment cover support
74	Chevelle (Sta. Wag.)	1662723 1	1.35	<b>RETAINER</b> , lug. compartment panel
74-75	Vega (Pnl., S/Wag., exc. N.B. Cpe.)	9434271 1	.07	<b>RETAINER</b> , compt. rr. floor panel latch
73-75	Chevelle (Sta. Wag.) w/rear seat assy.	9642849 L.H.	2.85	<b>STRIKER</b> , lug. compt. rear panel
73-75	Chevelle (Sta. Wag.) w/rear seat assy.	9642848 R.H.	2.85	<b>STRIKER</b> , lug. compt. rear panel
74-75	Chevelle (Sta. Wag.)	9848534 2	1.40	<b>STRIKER</b> , lock lug. compt. frt. panel— (11.390)
74	Chevelle (Sta. Wag.)	9848535 2	.13	<b>WASHER</b> , lug. compt. frt. panel striker



**METAL TRIM—CLIPS AND PANELS**

**12.977 HINGE ASSY.— SEALING— STOP, Load Floor (For Folding Seat Parts See Group 11.620)**

68	Chevelle (Sta. Wag.) (2nd design) (exc. Nomad),					
69-72	Chevelle (Sta. Wag.) (6-Pass.) (exc. Nomad)	7798793	1	3.85	luggage compt. cover (embossed)	
71	Brookwood, Townsman (6-Pass.)	9854672	1	12.10	luggage compartment cover panel (comb. 823, 824) (med. saddle)	
71	Kingswood (6-Pass.)	9854670	1	12.10	luggage compartment cover panel (comb. 835) (dk. jade)	
71	Kingswood (6-Pass.)	9854667	1	12.10	luggage compartment cover panel (comb. 827) (med. maize)	
71-72	Kingswood (6-Pass.)	9854668	1	11.00	luggage compartment cover panel (comb. 825) (dk. saddle)	
71-72	Pass. (Sta. Wag.)	9835271	1	11.00	luggage compartment cover panel	
71-73	Pass. (Sta. Wag.) (6-Pass.)	9854666	1	12.10	luggage compartment cover panel (comb. 802, 804, 806) (black)	
71-72	Pass. (Sta. Wag.) (6-Pass.)	9854669	1	12.10	luggage compartment cover panel (comb. 810, 812, 814) (dk. blue)	
72	Kingswood (6-Pass.)	9895702	1	11.00	luggage compt. center panel	
73	Impala, Caprice (Sta. Wag.)	9627244	1	11.00	lug. compt. cover panel rear (comb. 813) (midn. blue)	
73	Pass. (Sta. Wag.) (6-Pass.) (exc. Bel Air)	9627245	1	11.00	lug. compt. rear cover panel (comb. 830) (green)	
73	Pass. (Sta. Wag.)	9627247	1	11.00	lug. compt. rear cover panel (comb. 825, 826) (saddle)	
73	Pass. (Sta. Wag.)	9627246	1	11.00	lug. compt. rear cover panel (comb. 817, 818) (neutral)	
73-75	Pass. (Sta. Wag.)	9835271	1	11.00	luggage compartment cover panel	
73-75	Nova (H.B.)	7798793	1	3.85	luggage compartment cover	
65-75	Pass., Chevelle (Sta. Wag.)	9643798	2	.34	SEALING, strip on lug. compt. panel	
73-75	Nova (H.B.)	9643798	1	.34	SEALING, strip on lug. compt. pnl., anti-rattle, rear panel	
75	Pass. (Sta. Wag.)	9657605	1	.22	SEALING, strip lug. compt. anti-rattle	
71-75	Pass. (Sta. Wag.) (9-Pass.)	9861525	2	3.50	STOP, luggage compt. rear panel at hinge	
71-72	Pass. (Sta. Wag.)	1654349	2	3.50	STOP, luggage compartment rear panel at hinge (repl. 9825674)	
73-75	Pass. (Sta. Wag.) (6-Pass.)	1654349	2	3.50	STOP, luggage compartment rear panel at hinge	
73-75	Chevelle (Sta. Wag.)	9874097	L.H.	2.95	STOP, lug. compt. panel	
73-75	Chevelle (Sta. Wag.)	9874096	R.H.	2.30	STOP, lug. compt. panel	

**12.977 CYLINDER ASSY.— BOLT— CATCH— ESCUTCHEON— GASKET, Luggage Compartment**

65-69	Sta. Wag.,					
71	Pass., Chevelle (Sta. Wag.)	7753509	1	4.80	luggage compt. lock	
69	Sta. Wag.	6258011	1	6.25	underbody compt. lock uncoded	
75	Pass. (Sta. Wag.)	9677205	1	1.25	BOLT, compartment panel pivot support	
65-71	Sta. Wag. (6-Pass.)	4837855	1	.91	CATCH, luggage compt. lock	
65-71	Sta. Wag. (6-Pass.)	4832445	1	1.30	ESCUTCHEON, luggage compt. lock cyl.	
65-69	Sta. Wag. (6-Pass.),					
69	Kingswood, Estate Wagon (9-Pass.),					
71	Pass. (Sta. Wag.)	6278529	1	.15	GASKET, luggage compt. lock— (12.247)	
75	Vega (Hatchback Cpe., Sta. Wag.)	9685085	1	.91	NUT, spring compartment rear floor panel lateral	

**12.977 PAWL— PLATE— RETAINER— SPACER— STRIKER, Luggage Compartment**

71	Pass. (Sta. Wag.)	9837984	1	.63	luggage compt. lock	
72	Pass. (exc. Sta. Wag.)	9843569	1	8.15	PLATE, compt. lock striker anchor	
65-71	Sta. Wag.	7011819	A.R.	.16	RETAINER, luggage compt. lock catch— (10.551)	
65-71	Sta. Wag.	4888243	1	.46	RETAINER, luggage compt. lock cyl.— (10.551)	
71-72	Pass. (Sta. Wag.)	9892751	A.R.	.10	SPACER, luggage compt. lock striker to pan	
65-72	Sta. Wag. (6-Pass.)	4837852	1	2.85	STRIKER, luggage compt. lock	

**12.980 COVER— BOX— INSULATOR— PLATE— PLUG— REINFORCEMENT, Floor (less Rear Compartment Floor Pan)**

64-67	Chevelle w/4-Spd., H.D. 3-Spd.,					
68	S.S. (exc. El Camino),					
68-70	Chevelle (4-Dr.) (exc. A.T.),					

**METAL TRIM—CLIPS AND PANELS**

**12.980 COVER— BOX— INSULATOR— PLATE— PLUG— REINFORCEMENT, Floor (less Rear Compartment Floor Pan) (Con't)**

68-70	Malibu (exc. 4-Dr.),				
68-70	El Camino (S.S.) (exc. A.T., floor console),				
71-72	Chevelle w/4-Spd. (exc. floor console)	7759547	1	8.80	floor pan
68	Malibu, S.S. (Console w/4-Spd.),				
68	S.S. w/console, 3-Spd., P.G.,				
69-70	Chevelle (console w/4-Spd.),				
71-72	Malibu (Spt. Cpe. Conv.) w/4-Spd., floor console	7759125	1	9.50	floor pan
68-72	Chevy w/console	7762409	1	14.35	floor pan
70	Camaro	3984076	L.H.	.81	park brk. deptsn. frt. flr. pan
70-72	Camaro w/4-Speed	1699906	1	3.95	floor pan trans. opp. (repl. 8799889)
73	Chevelle,				
74-75	Nova	9621465	1	3.60	floor pan trans. opening
73-74	El Camino, Chevelle (Spt. Cpe.) (exc. Monte Carlo)	9830144	1	4.10	trans. floor pan
73-75	Camaro	1699906	1	3.95	floor pan trans. opening
73-74	Nova (2-Dr.) w/floor console	9623467	1	14.35	floor pan trans.
75	Vega (Panel) w/5-Spd.	1707651	1	7.30	trans. floor pan
75	Monza, Vega (Del.) w/5-Speed Trans.	1729892	1	4.05	trans. floor pan
75	Monza (exc. Towne Cpe.)	9739571	1	4.05	trans. floor pan
68-72	El Camino	7740151	1	22.90	BOX, back of front seat storage
73-75	El Camino	9873925	L.H.	5.65	BOX, back of front seat storage
70-75	Camaro	3984065	L.H.	.81	INSULATOR, front floor pan
71-73	Vega (Sta. Wag., H.B. Cpe.)	3852972	1	37.00	INSULATOR, load floor, underbody
72-75	Camaro,				
75	Camaro, Vega, Monza, Nova	9814139	1	1.30	PLATE, rr. shock absorber
All	All	4751839	A.R.	.12	PLUG (1/4"), underbody pnl. fixture location hole— (10.587)
All	All	4771203	A.R.	.12	PLUG (2" plastic)
All	All	4805844	A.R.	.22	PLUG, underbody drain hole (3/4")— (12.981)
73	Nova	9732481	L.H.	11.45	REINFORCEMENT, floor pan at rear spring front— (12.986)
73	Nova	9732480	R.H.	11.45	REINFORCEMENT, floor pan at rear spring front— (12.986)

**12.980 RETAINER— SEALING STRIP— STABILIZER— SUPPORT, Floor (less Rear Compartment Floor Pan)**

71-73	Vega (Sta. Wag., H.B. Cpe.)	3977775	8	.14	load floor insul.— (8.021)
73-75	El Camino	9878887	1	5.35	back of frt. seat stow. box
74-75	El Camino	9874448	1	1.70	SEALING STRIP, back of frt. seat stow. box
73-74	Chevelle (Sta. Wag.)	9667018	R.H.	3.55	STABILIZER, spare tire rear
68-69	Malibu, S.S. (Spt. Cpe., Conv., El Camino) w/floor console,				
70-72	Chevelle (2-Dr.) El Camino Custom, Monte Carlo w/floor console	7759548	1	1.35	SUPPORT, floor pan console
71-75	Camaro w/floor console	9818601	1	1.30	SUPPORT, floor pan console front
71-75	Camaro w/floor console	9818602	1	1.15	SUPPORT, floor pan console rear
73-75	Chevelle w/floor console	9613357	1	1.35	SUPPORT, floor pan console
74	Chevelle (Sta. Wag.)	9609492	1	11.80	SUPPORT, spare tire

**12.981 PAN ASSY.— BAR ASSY.— BRACE— EXTENSION— FILLER, Rear Compartment Floor**

**PASSENGER**

69-70	Sta. Wag. (6-Pass.)	9809219	1	238.00	compt.
69	Sed. (exc. Spt. Sed.)	9815134	1	195.00	compt.
69	Conv., Spt. Cpe., Spt. Sed.	9815135	1	195.00	compt.
70	Impala, Caprice (exc. Sed.)	9815339	1	201.00	
71-72	Pass. (exc. Sta. Wag.)	9623781	1	197.00	
71-73	Pass. (Sta. Wag.) (6-Pass.)	9659328	1	249.00	
71-75	Pass. (Sta. Wag.) (9-Pass.)	1697829	1	277.00	(repl. 9692668)
71-73	Vega, Monza	9620650	1	98.50	rear compartment
73	Pass. (exc. Sta. Wag.)	9617450	1	197.00	
74-75	Pass. (exc. Sta. Wag.)	1651000	1	197.00	
74-75	Pass. (Sta. Wag.) (6-Pass.)	9692667	1	249.00	
74-75	Vega	1690677	1	132.00	
75	Monza (exc. Towne Cpe.)	1681422	1	107.00	
71-72	Pass. (Sta. Wag.)	9829448	R.H.	13.70	BAR, pan longitudinal outer rr.

**METAL TRIM—CLIPS AND PANELS**

**12.981 PAN ASSY.— BAR ASSY.— BRACE— EXTENSION— FILLER, Rear  
Compartment Floor (Con't)**

71-75	Pass. (Sta. Wag.)	9676033 R.H.	30.50	BAR, pan longitudinal inner
73	Pass. (Sta. Wag.)	9829448 R.H.	13.70	BAR, pan longitudinal outer rr.
74-75	Pass. (Sta. Wag.)	9667274 1	30.50	BAR, pan longitudinal outer rr.
74-75	Vega	9642059 L.H.	4.15	BAR, longitudinal compt. pan rear
69	Pass. (exc. Sta. Wag.)	7749880 R.H.	10.40	FILLER, compt. pan to otr. pnl.
69	Pass. (exc. Sta. Wag.)	7749881 L.H.	10.40	FILLER, compt. pan to otr. pnl.
70	Pass. (exc. Sta. Wag.)	9815048 R.H.	11.10	FILLER, pan to panel
70	Pass. (exc. Sta. Wag.)	9815049 L.H.	11.10	FILLER, pan to panel

**PASSENGER**

71	Kingswood (6-Pass.)	9841270 R.H.	17.45	FILLER, pan to spare tire cover (jade)
71	Kingswood (9-Pass.)	9841380 R.H.	17.45	FILLER, pan to spare tire cover (jade)
71	Kingswood (6-Pass.)	9841288 L.H.	15.50	FILLER, pan longitudinal bar (jade)
71	Kingswood (9-Pass.)	9841294 L.H.	15.50	FILLER, pan longitudinal bar (jade)
71	Kingswood (6-Pass.)	9841267 R.H.	17.45	FILLER, pan to spare tire cover (maize)
71	Kingswood (9-Pass.)	9841377 R.H.	17.45	FILLER, pan to spare tire cover (maize)
71	Kingswood (6-Pass.)	9841285 L.H.	15.50	FILLER, pan longitudinal bar (maize)
71	Kingswood (9-Pass.)	9841291 L.H.	15.50	FILLER, pan longitudinal bar (maize)
71	Brookwood, Townsman (6-Pass.)	9841271 R.H.	17.45	FILLER, pan to spare tire cover (saddle)
71	Townsman (9-Pass.)	9841381 R.H.	17.45	FILLER, pan to spare tire cover (saddle)
71	Brookwood, Townsman (6-Pass.)	9841289 L.H.	15.50	FILLER, pan longitudinal bar (saddle)
71	Townsman (9-Pass.)	9841295 L.H.	15.50	FILLER, pan longitudinal bar (saddle)
71-72	Kingswood (6-Pass.)	9841268 R.H.	17.45	FILLER, pan to spare tire cover (saddle)
71-72	Kingswood (9-Pass.)	9841378 R.H.	17.45	FILLER, pan to spare tire cover (saddle)
71-72	Pass. (exc. Sta. Wag.)	9603218 L.H.	22.45	FILLER, pan to qtr. panel
71-72	Pass. (exc. Sta. Wag.)	9603217 R.H.	22.45	FILLER, pan to qtr. panel
71-75	Pass. (Sta. Wag.) (6-Pass.)	9841266 R.H.	17.45	FILLER, pan to spare tire cover (black)
71-73	Pass. (Sta. Wag.) (9-Pass.)	9841376 R.H.	17.45	FILLER, pan to spare tire cover (black)
71-75	Pass. (Sta. Wag.) (6-Pass.)	9688974 L.H.	15.50	FILLER, pan longitudinal bar (black)
71-75	Pass. (Sta. Wag.) (9-Pass.)	9689074 L.H.	15.50	FILLER, pan longitudinal bar (black)
71-72	Pass. (Sta. Wag.) (6-Pass.)	9841269 R.H.	17.45	FILLER, pan to spare tire cover (blue)
71-72	Townsman, Kingswood	9841379 R.H.	17.45	FILLER, pan to spare tire cover (blue)
71-72	Pass. (Sta. Wag.) (6-Pass.)	9841287 L.H.	15.50	FILLER, pan longitudinal bar (blue)
71-72	Townsman, Kingswood	9841293 L.H.	15.50	FILLER, pan longitudinal bar (blue)
71-72	Kingswood (6-Pass.)	9841286 L.H.	15.50	FILLER, pan longitudinal bar (saddle)
71-72	Kingswood (9-Pass.)	9841292 L.H.	15.50	FILLER, pan longitudinal bar (saddle)
72	Pass. (Sta. Wag., 6-Pass.)	9888822 R.H.	17.45	FILLER, pan to spare tire cover (green)
72	Pass. (Sta. Wag., 9-Pass.)	9888826 R.H.	17.45	FILLER, pan to spare tire cover (green)
72	Chevelle (Sta. Wag.) 6-Pass.	9888832 R.H.	11.70	FILLER, pan to spare tire cover (green)
72	Chevelle (Sta. Wag.) 6-Pass.	9888831 L.H.	5.45	FILLER, pan to spare tire cover (green)
72	Pass. (Sta. Wag., 9-Pass.)	9888827 R.H.	17.45	FILLER, pan to spare tire cover (covert)
72	Pass. (Sta. Wag., 9-Pass.)	9888823 R.H.	17.45	FILLER, pan to spare tire cover (covert)
72	Pass. (Sta. Wag., 9-Pass.)	9888829 L.H.	15.50	FILLER, c/pan longitudinal bar (covert)
72	Pass. (Sta. Wag., 6-Pass.)	9888825 L.H.	15.50	FILLER, c/pan longitudinal bar (covert)
72	Pass. (Sta. Wag., 9-Pass.)	9888828 L.H.	15.50	FILLER, c/pan longitudinal bar (green)
72	Pass. (Sta. Wag., 9-Pass.)	9888824 L.H.	15.50	FILLER, c/pan longitudinal bar (green)
73	Impala, Caprice (9-Pass.)	9626488 R.H.	17.45	FILLER, pan to spare tire cover (green)
73	Pass. (9-Pass.)	9626490 R.H.	17.45	FILLER, pan to spare tire cover (saddle)
73	Pass. (Sta. Wag.) (6-Pass.)	9841284 L.H.	17.45	FILLER, pan longitudinal bar (black)
73	Pass. (6-Pass.)	9626526 R.H.	17.45	FILLER, pan to spare tire cover (saddle)
73	Pass. (6-Pass.)	9626523 L.H.	15.50	FILLER, pan longitudinal bar (saddle)
73	Pass. (9-Pass.)	9626487 L.H.	15.50	FILLER, pan longitudinal bar (saddle)
73	Impala, Caprice (Sta. Wag.) (6-Pass.)	9626521 L.H.	15.50	FILLER, pan longitudinal bar (green)
73	Impala, Caprice (Sta. Wag.) (9-Pass.)	9626485 L.H.	15.50	FILLER, pan longitudinal bar (green)
73	Pass. (exc. Sta. Wag.)	9603218 L.H.	22.45	FILLER, pan to outer panel
73	Pass. (exc. Sta. Wag.)	9603217 R.H.	22.45	FILLER, pan to outer panel
73-75	Pass. (9-Pass.)	9688130 R.H.	17.45	FILLER, pan to spare tire cover (paint as reqd.)
74	Pass. (exc. Sta. Wag.)	9618512 R.H.	22.45	FILLER, compt. pan to quarter panel
74-75	Pass. (exc. Sta. Wag.)	9618513 L.H.	22.45	FILLER, compt. pan to quarter panel

**CHEVELLE**

68-72	Chevelle (Sta. Wag.) (9-Pass.)	7762553 1	102.00	rear compt.
68-72	Greenbrier, Concours (6-Pass.)	9889401 1	110.00	rr. compt. rr.
69	Chevelle (Sta. Wag.) (6-Pass.) (exc. Nomad)	9809169 1	334.00	rear compt.
70	Monte Carlo	9815375 1	153.00	
70-72	Chevelle (Sta. Wag.) (6-Pass.) (exc. Nomad)	9612553 1	250.00	(repl. 9809170)
69-72	Nomad	9818293 1	250.00	
71-72	Chevelle (exc. Sta. Wag., El Camino)	9623791 1	161.00	

**METAL TRIM—CLIPS AND PANELS**

**12.981 PAN ASSY.— BAR ASSY.— BRACE— EXTENSION— FILLER, Rear  
Compartment Floor (Con't)**

71-72	Monte Carlo	9623792	1	169.00	
72	Chevelle (9-Pass.)	9885645	1	99.00	rear
72	Greenbrier, Concours (6-Pass.)	9612553	1	250.00	
73-74	El Camino	9877696	1	334.00	
73	Chevelle (exc. Sta. Wag., El Camino)	9665564	1	155.00	
73-75	Chevelle (Sta. Wag.)	9692675	1	249.00	
74-75	El Camino	9698993	1	334.00	
74-75	Chevelle (exc. Sta. Wag., El Camino)	9692669	1	161.00	(repl. 1661984)
73-75	Chevelle (Sta. Wag.)	9892024	R.H.	49.00	BAR ASSY., longitudinal compt. pan rear
73-75	Chevelle (Sta. Wag.)	9657727	L.H.	4.70	BRACE, longitudinal bar to compt. pan
73-75	Chevelle (Sta. Wag.)	9657726	R.H.	4.70	BRACE, longitudinal bar to compt. pan
68-72	El Camino	7723600	L.H.	7.05	EXTENSION, pan to qtr. panel frt. filler
68-72	El Camino	7785126	R.H.	.88	EXTENSION, pan to qtr. panel filler, rear
68-72	El Camino	7785127	L.H.	.88	EXTENSION, compt. pan to qtr. panel filler
73-75	El Camino	9876702	L.H.	3.00	EXTENSION, pan to quarter panel filler
73-75	El Camino	9876701	R.H.	3.00	EXTENSION, pan to quarter panel filler
73-75	El Camino	9830458	L.H.	4.20	EXTENSION, pan to panel filler quarter upper
68-70	El Camino	9814156	R.H.	23.30	FILLER, compt. pan to qtr. panel
68-72	(Sta. Wag.) (6-Pass.) (exc. Nomad)	7747280	L.H.	4.05	FILLER, bar supt. to wheel (black)
68-72	(Sta. Wag.) (6-Pass.) (exc. Nomad)	7747703	R.H.	8.75	FILLER, pan to spare tire cover (black)
68-72	(Sta. Wag.) (9-Pass.)	8731938	R.H.	15.95	FILLER, compt. pan lgtdnl. bar (black)
68-70	El Camino	9814157	L.H.	23.30	FILLER, pan to panel
69	(exc. Sta. Wag., El Camino)	7732204	R.H.	13.70	FILLER, compt. pan to otr. pnl.
69	(exc. Sta. Wag., El Camino)	7732205	L.H.	13.70	FILLER, compt. pan to otr. pnl.
70	Chevelle (exc. Sta. Wag., El Camino)	9816854	R.H.	14.20	FILLER, pan to panel
70	Chevelle (exc. Sta. Wag., El Camino)	9816855	L.H.	14.20	FILLER, pan to panel
70-72	Monte Carlo	8761090	R.H.	14.85	FILLER, pan to panel
70-72	Monte Carlo	8761091	L.H.	14.85	FILLER, pan to panel
71	Greenbrier (6-Pass.)	9838950	R.H.	11.70	FILLER, pan to spare tire cover (beige)
71	Greenbrier (6-Pass.)	9838954	L.H.	5.45	FILLER, bar support to w/h (med. beige)
71	Concours (6-Pass.)	9838949	R.H.	11.70	FILLER, pan to spare tire cover (jade)
71	Concours (6-Pass.)	9838953	L.H.	5.45	FILLER, bar support to w/h (dk. jade)
71	Greenbrier (6-Pass.)	9838951	R.H.	11.70	FILLER, pan to spare tire cover (saddle)
71	Concours (6-Pass.)	9838948	R.H.	13.75	FILLER, pan to spare tire cover (saddle)
71	Concours (6-Pass.)	9838952	L.H.	5.45	FILLER, bar support to w/h (dk. saddle)
71	Greenbrier (6-Pass.)	9838955	L.H.	5.45	FILLER, bar support to w/h (med. saddle)
71	Greenbrier (9-Pass.)	9838997	L.H.	19.85	FILLER, pan longitudinal bar (med. beige)
71	Greenbrier (9-Pass.)	9838996	R.H.	19.85	FILLER, pan longitudinal bar (med. beige)
71	Concours (9-Pass.)	9838994	R.H.	19.85	FILLER, pan longitudinal bar (dk. jade)
71	Concours (9-Pass.)	9838993	L.H.	19.85	FILLER, pan longitudinal bar (dk. saddle)
71	Concours (9-Pass.)	9838992	R.H.	19.85	FILLER, pan longitudinal bar (dk. saddle)
71	Greenbrier (9-Pass.)	9838999	L.H.	28.50	FILLER, pan longitudinal bar (med. saddle)
71	Greenbrier (9-Pass.)	9838998	R.H.	28.50	FILLER, pan longitudinal bar (med. saddle)
71-72	El Camino	9814157	L.H.	23.30	FILLER, pan to qtr. panel
71-72	El Camino	9814156	R.H.	23.30	FILLER, pan to qtr. panel
71-72	Malibu	9816855	L.H.	14.20	FILLER, pan to qtr. panel
71-72	Malibu	9816854	R.H.	14.20	FILLER, pan to qtr. panel
72	Chevelle (Sta. Wag.) (9-Pass.)	9888835	L.H.	19.85	FILLER, pan longitudinal bar (green)
72	Chevelle (Sta. Wag.) (6-Pass.)	9888834	R.H.	19.85	FILLER, pan longitudinal bar (green)
72	Monte Carlo	8761091	L.H.	14.85	FILLER, pan to qtr. panel
72	Monte Carlo	8761090	R.H.	14.85	FILLER, pan to qtr. panel
73	Chevelle (Sta. Wag.) (exc. Laguna)	9626781	R.H.	13.65	FILLER, pan to spare tire cover (saddle)
73	Chevelle (Sta. Wag.) (exc. Laguna)	9626777	L.H.	25.75	FILLER, pan longitudinal (saddle)
73	Chevelle (Sta. Wag.) (exc. Deluxe)	9626775	L.H.	25.75	FILLER, pan longitudinal bar (green)
73	Chevelle (Sta. Wag.) (exc. Deluxe)	9626779	R.H.	13.65	FILLER, pan to spare tire cover (green)
73	Monte Carlo	9886021	L.H.	12.80	FILLER, compt. pan to quarter panel
73	Monte Carlo	9886020	R.H.	12.80	FILLER, compt. pan to quarter panel
73	Chevelle (Spt. Sed., Spt. Cpe.) (exc. Monte Carlo)	9886019	L.H.	12.80	FILLER, compt. pan to quarter panel
73	Chevelle (Spt. Sed., Spt. Cpe.) (exc. Monte Carlo)	9886018	R.H.	12.80	FILLER, compt. pan to quarter panel

**METAL TRIM—CLIPS AND PANELS**

**12.981 PAN ASSY.— BAR ASSY.— BRACE— EXTENSION— FILLER, Rear  
Compartment Floor (Con't)**

73-75	Chevelle (Sta. Wag.)	9626778 R.H.	13.65	FILLER, pan to spare tire cover (paint as reqd.)
73-75	Chevelle (Sta. Wag.)	9626774 L.H.	25.75	FILLER, compt. pan longitudinal bar (paint as reqd.)
73-75	El Camino	9830603 L.H.	23.30	FILLER, compt. pan to quarter panel
73-75	El Camino	9830602 R.H.	23.30	FILLER, compt. pan to quarter panel
74-75	Chevelle (Spt. Cpe., Spt. Sed.) (exc. Monte Carlo)	9639630 R.H.	12.80	FILLER, compt. pan to quarter panel
74-75	Chevelle (Spt. Cpe., Spt. Sed.) (exc. Monte Carlo)	9639631 L.H.	12.80	FILLER, compt. pan to quarter panel
74-75	Monte Carlo	9639632 R.H.	12.80	FILLER, compt. pan to quarter panel
74-75	Monte Carlo	9639633 L.H.	12.80	FILLER, compt. pan to quarter panel

**CAMARO**

71-72	Camaro	9665292	1	277.00	
73	Camaro	9665292	1	277.00	
74	Camaro	9692676	1	277.00	
75	Camaro	1660117	1	352.00	
67-68	Camaro	7585173 R.H.		8.00	FILLER, compt. pan to qtr. panel
67-68	Camaro	7585174 L.H.		8.00	FILLER, compt. pan to qtr. pnl.
69	Camaro	7779512 R.H.		9.55	FILLER, compt. pan to otr. pnl.
69	Camaro	7779513 L.H.		9.55	FILLER, compt. pan to otr. pnl.
70-72	Camaro	9864812 R.H.		12.80	FILLER, compt. pan to qtr. pnl. (repl. 8763472)
70-73	Camaro	9864813 L.H.		12.80	FILLER, compt. pan to qtr. pnl.
73	Camaro	9864812 R.H.		12.80	FILLER, compt. pan to quarter panel
74-75	Camaro	9638078 R.H.		12.80	FILLER, compt. pan to quarter panel
74-75	Camaro	9638079 L.H.		12.80	FILLER, compt. pan to quarter panel

**CHEVY— NOVA**

68	Chevy	9836896	1	89.75	rear compt. (repl. 8784431)
68-72	Chevy	9836896	1	89.75	rear compt.
70-72	Nova	9836896	1	89.75	
73-74	Nova	9663161	1	89.75	
74	Nova	1663392	1	89.75	
75	Nova	9677889	1	89.75	
68-70	Chevy	1698154	1		BAR, front compt. pan cross (repl. 1650018)
73-75	Nova	1698154	1		BAR, pan cross front
68-74	Chevy-Nova	9816856 R.H.		4.00	EXTENSION, compt. pan to qtr. panel filler
68-74	Chevy	9816857 L.H.		4.20	EXTENSION, compt. pan to qtr. panel filler
68-74	Nova	9816852 R.H.		9.55	FILLER, compt. pan to qtr. panel
68-72	Nova	7725355 R.H.		.88	FILLER, compt. pan to rear cross bar
68-72	Nova	7725356 L.H.		.88	FILLER, compt. pan to rear cross bar
70-74	Nova	9816853 L.H.		9.55	FILLER, left to panel

**12.981 HOUSING ASSY.— COVER— FRAME— PANEL— PLATE— PLUG, Rear  
Compartment Floor**

71	Pass. (Sta. Wag.) (1st design)	9829450	1	59.50	t/gate lower
71	Pass. (Sta. Wag.) (2nd design)				
72-75	Pass. (Sta. Wag.)	9665047	1	67.25	t/gate lower
71-73	Pass. (Sta. Wag.)	9624250	1	71.00	t/gate upper
63-75	All	9691872 A.R.		.64	COVER, filler and compt. pan drain hole
73-75	Vega	9691873 A.R.		.66	COVER, floor and compartment pan drain hole
74-75	Pass. (Sta. Wag.)	9667939	1	52.50	FRAME, t/gate upper housing
68-72	El Camino	9871894	1	33.00	PANEL, rear compt. floor
73-75	El Camino	9830135	1	33.00	PANEL, compt. floor
62-64	Chevy (exc. Sta. Wag.)				
65-74	All (exc. Sta. Wag., El Camino)	1678300	1	.60	PLATE, spare tire clamp anchor
67-68	Camaro	7665266	2	1.20	PLATE, slk. abs. mtg. on compt. pan
71-74	Vega, Monza	1678300	1	.60	PLATE, spare tire clamp anchor (repl. 9825851)
74-75	Nova (H.B.)	9734096		1.60	PLATE, compt. pan at wheelhouse stfmr. brace
73-75	Chevelle (Sta. Wag.)	9877952 L.H.		12.50	PLATE, lug. compt. panel pivot support
73-75	Chevelle (Sta. Wag.)	9877951 R.H.		12.50	PLATE, lug. compt. panel pivot support
62-70	All	4805844 A.R.		.22	PLUG, floor pan hole (3/4" dia.)
65-67	Chevy,				
69-71	Nova,				
69-71	Camaro,				
69-75	Chevelle	4805843 A.R.		.22	PLUG, floor pan access hole upr. shroud pnl.
62-75	All	4410574 A.R.		.22	PLUG, floor pan (1")

**METAL TRIM—CLIPS AND PANELS**

**12.981 HOUSING ASSY.— COVER— FRAME— PANEL— PLATE— PLUG, Rear  
Compartment Floor (Con't)**

70	Pass. (exc. Sta. Wag.)	4831842	1	.42	PLUG, compt. pan vent. tube hole
70	Pass. (exc. Sta. Wag.),				
71-72	Camaro, Chevelle (exc. El Camino),				
71-75	Vega, Monza	4410574	2	.22	PLUG, gage and drn. hole compt. pan (repl. 9813784)
70-75	Vega	9815342	2	1.40	PLUG, steel, 1.770 I.D. with 8 tabs
71	All				PLUG, floor pan hole (3/4" dia.)
73	Vega, Monza	9731275	A.R.	.50	wheelhouse panel acc. hole wheelhouse panel acc. hole (repl. 9812865)
75	Vega	9731275	2	.50	PLUG, w/h qtr. pnl. acc. hole
	Not required in this group. See Group 16.065	1178365		.18	PLUG

**12.981 POCKET— REINFORCEMENT— RETAINER— SEALING STRIP— SPRING,  
Rear Compartment Floor**

65-68	Pass. (Sta. Wag.)	7593694	R.H.	9.05	spare tire rr.
69-70	Pass. (Sta. Wag.)	7750049	R.H.	10.15	spare tire rear
68-72	Chevelle (Sta. Wag.)	7671654	R.H.	6.35	spare tire rear
68-72	Chevelle (Sta. Wag.)	7710984	R.H.	6.35	spare tire front
73	Pass. (Sta. Wag.)	9834820	R.H.	13.90	spare tire
74-75	Pass. (Sta. Wag.)	9687747	R.H.	13.90	spare tire
73-75	Chevelle (Sta. Wag.)	9830648	R.H.	11.70	spare tire
75	Monza (exc. Towne Cpe.)	9696072	1	17.45	spare tire
75	Monza (Towne Cpe.)	1701359	1	6.90	spare tire outer
69-72	Nova	9844531	L.H.	20.15	REINFORCEMENT, pan at gas tank
70	Pass., Chevelle (exc. Sta. Wag., Monte Carlo),				
71-72	Chevelle (Spt. Cpe., Sed., Conv.)	8776658	R.H.	.27	REINFORCEMENT, pan to filler
70	Pass., Chevelle (exc. Sta. Wag., Monte Carlo),				
71-72	Chevelle (Spt. Cpe., Sed., Conv.)	8776659	L.H.	.27	REINFORCEMENT, pan to filler
71-72	Nova	9844530	R.H.	18.25	REINFORCEMENT, pan at gas tank
71-75	Pass. (Sta. Wag.) (6-Pass.)	9825399	L.H.	3.55	REINFORCEMENT, pan side filler front
71-75	Pass. (Sta. Wag.) (6-Pass.)	9825398	R.H.	3.55	REINFORCEMENT, pan side filler front
71-75	Pass. (Sta. Wag.)	9825630	R.H.	3.55	REINFORCEMENT, pan side filler and rear
72-75	Pass. (Sta. Wag.)	9825631	L.H.	3.55	REINFORCEMENT, pan side filler and rear
73-74	Nova	1654281	L.H.	20.15	REINFORCEMENT, compt. pan at gas tank
73-74	Nova	1654280	R.H.	20.15	REINFORCEMENT, compt. pan at gas tank
73-75	Nova (H.B.)	9732945	L.H.	2.60	REINFORCEMENT, compt. pan to wheel
73-74	Nova (H.B.)	9732944	R.H.	2.60	REINFORCEMENT, compt. pan to wheel
74	Pass. (exc. Sta. Wag.)	9691462	2	2.60	REINFORCEMENT, compt. pan to rear end panel
74-75	Pass. (Conv.)	9669897	1	1.25	REINFORCEMENT, compt. pan/at spare tire
75	Pass. (exc. Sta. Wag.)	1651199	2	2.60	REINFORCEMENT, pan to rear end panel
73-75	Chevelle (Sta. Wag.)	9617918	1	10.00	RETAINER, stow jack column front
71-73	Vega (exc. N.B.)	9824347	1	2.15	RETAINER, compt. rear floor panel latch
75	Monza, Vega (exc. Notchback Cpe.)	9671600	1	1.65	RETAINER, compt. rear floor panel latch
71	Impala (Conv.)	8760099	4	.16	SEALING STRIP, compartment front panel to reinforcement
73-74	Chevelle (Sta. Wag.)	9610951	1	.80	SPRING, stow jack col. frt. retainer

**12.981 STIFFENER— STOP— SUPPORT— WASHER, Rear Compartment Floor**

74	Nova (H.B.)	1659836	L.H.	3.00	wheel house inner to compt. reinforcement
74	Nova (H.B.)	1659835	R.H.	3.00	wheelhouse inner to compt. reinforcement
68-72	Chevelle (Sta. Wag.)	7671619	1	5.70	SUPPORT, spare tire
69-70	Pass. (Sta. Wag.)	8776059	1	6.60	SUPPORT, spare tire
70-72	Nova Special Susp. w/4BC	9844526	R.H.	5.10	SUPPORT, stab bar on compt. pan
70-72	Nova Special Susp. w/4BC	9813863	L.H.	5.45	SUPPORT, stab bar on compt. pan
71-72	Pass. (Sta. Wag.)	8793796	1	7.05	SUPPORT, spare tire
71-72	Pass. (Sta. Wag.) w/elect. t/gate window	9865442	1	2.60	SUPPORT, t/gate window mounting on pocket
71-73	Vega, Monza	9815450	1	11.25	SUPPORT, compt. rear floor panel
72-74	Vega (Panel)	9615728	1	1.15	SUPPORT, compt. floor panel
72*	Pass. (Sta. Wag.)	9847217	1	1.35	SUPPORT, jack column
73	Nova (exc. H.B.)	1657520	R.H.	3.40	SUPPORT, jack col. frt. stowage
73-75	Chevelle (Sta. Wag.)	9609492	1	11.80	SUPPORT, spare tire
73-75	El Camino (Custom)	9883010	1	1.60	SUPPORT, jack col. stowage
73-74	Nova (exc. H.B.)	9654004	R.H.	.46	SUPPORT, jack col. stowage rr.
73-75	Nova (H.B.)	9629387	L.H.	3.90	SUPPORT, jack col. stowage
73-75	Nova (H.B.)	9629386	R.H.	3.90	SUPPORT, jack col. stowage

**METAL TRIM—CLIPS AND PANELS**

**12.981 STIFFENER— STOP— SUPPORT— WASHER, Rear Compartment Floor  
(Con't)**

73-74	Nova (H.B.)	1655161 L.H.	2.60	SUPPORT, lug. compt. panel side (repl. 9646402)
73-74	Nova (H.B.)	1655160 R.H.	2.60	SUPPORT, lug. compt. panel side (repl. 9646401)
73-74	Pass. (Sta. Wag.)	8793796 1	7.05	SUPPORT, spare tire
73-75	Nova w/special per. frt. & rear suspension	9663158 R.H.	5.45	SUPPORT, stab. bar/on compt. pan
73-75	Nova w/special per. frt. & rear suspension	9663159 L.H.	5.45	SUPPORT, stab. bar/on compt. pan
75	Nova (H.B.)	1655161 L.H.	2.60	SUPPORT, lug. compt. panel side
75	Nova (H.B.)	1655160 R.H.	2.60	SUPPORT, lug. compt. panel side
72-75	Pass., Chevelle	1347774 4	.13	WASHER, front bracket to reinforcement

**12.986 BAR— COVER— FILLER— REINFORCEMENT— SUPPORT, Rear Compartment End**

68-69	Chevelle (exc. Sta. Wag., El Camino)	8731352 1	26.00	rear cross
68-69	Chevelle (Sta. Wag.)	9819181 1	75.25	rear cross rear
68-70	El Camino	8778497 1	25.50	rear cross rear
68-70	El Camino	9809167 1	43.25	rear cross front
68	Chevelle (Sta. Wag.) w/std. t/gate,			
69	Chevelle (Sta. Wag.) (6-Pass.) w/standard, t/gate,			
69-70	Chevelle (Sta. Wag.) w/dual t/gate	9818292 1	75.25	rear cross front
69	Pass. (exc. Sta. Wag.)	8779809 1	45.25	rear cross
69-70	Pass. (Sta. Wag.)	8788810 1	74.50	rear cross rear
70	Pass. (exc. Sta. Wag.)	8774482 1	45.00	rear cross
70	Chevelle (Sta. Wag.)	9819181 1	75.25	rear cross rear
70-71	Chevelle (2-Dr.)	8775897 1	45.00	rear cross
70-72	Monte Carlo	8775898 1	45.00	rear cross
71-72	El Camino	9809167 1	43.25	rear cross front
71-72	Chevelle (Sta. Wag.)	9818292 1	75.25	rear cross front
71-72	Chevelle (Sta. Wag.)	9819181 1	75.25	rear cross rear
71-72	Chevelle (exc. Sta. Wag., El Camino)	9845744 1	49.00	rear cross
71-72	El Camino	8778497 1	25.50	rear cross rear
71-73	Pass. (exc. Sta. Wag.)	9611258 1	26.75	rear cross
71-74	Pass. (Sta. Wag.)	8793434 1	19.45	rear cross
71-75	Vega, Monza	1673149 1	15.95	rear cross
73	Chevelle (Sta. Wag.)	9830093 1	24.05	rear cross rear
73	Chevelle (Sta. Wag.)	9878638 1	13.60	rear cross front lower
74-75	Chevelle (Sta. Wag.)	9670672 1	24.05	rear cross rear
74-75	Chevelle (Sta. Wag.)	9678998 1	13.60	rear cross frt. lower
73-75	Chevelle (Sta. Wag.)	9624243 1	43.50	rear cross rear
73-74	El Camino	9878903 1	43.25	rear cross front
73-75	El Camino	9830134 1	19.45	rear cross rear
74-75	El Camino	9698992 1	43.25	
74	Vega, Monza	9692295 1	56.50	rear cross
75	Vega	1682350 1	56.50	rear cross
75	Monza (exc. Towne Cpe.)	9691012 1	17.70	rear cross
75	Pass. (exc. Sta. Wag.)	1659469 1	25.50	rear cross
69-72	Chevelle (Sta. Wag.) w/dual t/gate	9814172 R.H.	6.35	FILLER, rear cross bar rear
69-72	Chevelle (Sta. Wag.) w/dual t/gate	8731540 R.H.	4.50	FILLER, cross bar to bumper
69-72	Chevelle (Sta. Wag.) w/dual t/gate	8731541 L.H.	10.75	FILLER, cross bar to bumper side
68-72	Chevelle (Sta. Wag.)	9818289 L.H.	5.85	FILLER, rear cross bar end
69-72	Chevelle (Sta. Wag.) w/dual t/gate	8758774 L.H.	10.75	FILLER, cross bar to bumper at lower hinge
68-72	El Camino,			
68-72	Chevelle (Sta. Wag.)	7672358 R.H.	3.75	FILLER, rr. cross rr. lower bar
69-72	El Camino	8768994 L.H.	7.90	FILLER, rr. cross rr. lower bar end
69-70	Pass. (Sta. Wag.)	8784531 L.H.	17.90	REINFORCEMENT, rear cross bar front
70-73	Camaro	9885158 L.H.		REINFORCEMENT, at rear spring front
70-73	Camaro	9885157 R.H.	26.50	REINFORCEMENT, at rear spring front
71-73	Vega, Monza	9885187 L.H.	75.50	REINFORCEMENT, floor pan at rear spring
71-73	Vega, Monza	9885186 R.H.	75.50	REINFORCEMENT, floor pan at rear spring
73-74	Nova	9732480 R.H.	11.45	REINFORCEMENT, floor pan at rear spring frt.
73-74	Nova	9732481 L.H.	11.45	REINFORCEMENT, floor pan at rear spring

**METAL TRIM—CLIPS AND PANELS**

**12.986 BAR— COVER— FILLER— REINFORCEMENT— SUPPORT, Rear  
Compartment End (Con't)**

74-75	Camaro	9670844 R.H.	26.50	REINFORCEMENT, floor pan at rear spring front
74-75	Camaro	9670845 L.H.	26.50	REINFORCEMENT, floor pan at rear spring
74-75	Vega	9671962 R.H.	75.50	REINFORCEMENT, floor pan at rear spring
74	Vega, Monza	1745048 L.H.	75.50	REINFORCEMENT, floor pan at rear spring (repl. 9671963)
75	Monza (exc. Towne Cpe.)	1654482 R.H.	75.50	REINFORCEMENT, floor pan at rear spring
75	Monza (exc. Towne Cpe.)	1654483 L.H.	75.50	REINFORCEMENT, floor pan at rear spring
75	Camaro	1660115 R.H.	26.50	REINFORCEMENT, floor pan at rear spring frt.
69-72	Chevelle (Sta. Wag.) w/dual t/gate	8731407 1	1.35	SUPPORT, cross bar to bumper filler rear
70-73	Camaro w/special susp.	9820697 L.H.	3.85	SUPPORT, stab. bar on compt. rail
70-73	Camaro w/special susp.	9820696 R.H.	3.85	SUPPORT, stab. bar on compt. rail

**12.986 RAIL— BRACE— EXTENSION— HOUSING— PLATE— PLUG, Rear  
Compartment End**

67-68	Camaro	7729459 1	19.55	rr. end cross
68-72	Chevy	7704226 1	22.05	rear end cross rear
68-72	Chevy	9605515 1	12.40	rear end cross front
69	Camaro	7779521 1	20.95	rr. end cross
68-73	Nova	9659323 L.H.	105.00	pan side
68-73	Nova	9659322 R.H.	95.25	pan side
69	Camaro (Spt. Cpe.)	8716479 L.H.	83.25	compt. pan side
70-73	Camaro	9885160 L.H.	112.00	pan side
70-73	Camaro	9885159 R.H.	112.00	pan side
70-73	Camaro	9826894 1	21.40	rear end cross
73	Nova	9606158 1	22.05	rear end cross rear
73-74	Nova	9606159 1	13.60	rear end cross front
74-75	Camaro	9638205 1	21.40	rear end cross
74	Nova	9668722 1	22.05	rear end cross rear
75	Nova	1656830 1	22.05	rear end cross rear
74	Camaro	9643527 R.H.	162.00	pan side
74	Camaro	1693965 L.H.	162.00	pan side
74	Nova	1665563 R.H.	95.25	pan side
74-75	Nova	1652850 L.H.	105.00	pan side
68-70	Chevy	7725357 R.H.	3.95	BRACE, compt. side rail to rr. rail
68-70	Chevy	9870504 L.H.	4.60	BRACE, compt. side rail to rr. rail (repl. 7725358)
71-73	Nova	9870504 L.H.	4.60	BRACE, side rail to rear rail
71-73	Nova	9870503 R.H.	4.60	BRACE, side rail to rear rail
75	Monza (exc. Towne Cpe.),			
75	Vega (Panel)	1707145 2	4.05	BRACE, cont. arm bpr. stop to supt.
69-72	Chevelle (Sta. Wag.)	8731548 R.H.	5.50	EXTENSION, rear cross bar front
70-73	Camaro	9826893 1	1.65	EXTENSION, cross rail to qtr. panel
70-73	Camaro	9826892 1	1.65	EXTENSION, cross rail to qtr. panel
73-75	El Camino	9885131 L.H.	16.65	EXTENSION, rear cross front bar
73-75	El Camino	9885130 R.H.	16.65	EXTENSION, rear cross front bar
70-73	Camaro	8800757 L.H.	12.70	HOUSING, rear shk. abs.
70-73	Camaro	8800756 R.H.	14.70	HOUSING, rear shk. abs.
74-75	Camaro	9669733 R.H.	14.70	HOUSING, rear shock absorber
74-75	Camaro	1704848 L.H.	17.90	HOUSING, rear shock absorber (repl. 9669734)
74-75	Vega (Sta. Wag., Panel)	9683766 1	13.50	PLATE, sill back door
71	All	9731275 A.R.	.50	PLUG, rear end cross rail rear (repl. 9812865)— (12.981)
71-74	Camaro	9815342 2	1.40	PLUG, rear end cross rail to qtr. panel— (12.981)

**12.989 PANEL— BRACE— COVER, Folding Top Compartment (See Group 15.100 for TRIM ASSY.)**

**PASSENGER**

71-74	(Conv.)	8792940 1	11.90	fldg. top compartment rear
71-75	(Conv.)	9818211 L.H.	17.25	fldg. top compartment side upper
71-75	(Conv.)	9818210 R.H.	17.25	fldg. top compartment side upper
71-75	(Conv.)	9839049 L.H.	15.85	BRACE, fldg. top compartment to w/h
71-75	(Conv.)	9839048 R.H.	15.85	BRACE, fldg. top compartment to w/h

**CHEVELLE**

68-72	(Conv.)	8727188 1	10.40	rear
68-70	(Conv.)	8799697 L.H.	11.90	side trim lower
68-70	(Conv.)	7779219 L.H.	11.10	side upper trim



**METAL TRIM—CLIPS AND PANELS**

**12.989 PANEL— BRACE— COVER, Folding Top Compartment (See Group 15.100 for TRIM ASSY.) (Con't)**

68-71 (Conv.)	7779216 R.H.	12.50	fldg. top compartment side trim upper
71 (Conv.)	7779217 L.H.	12.50	fldg. top compartment side trim upper
71-72 (Conv.)	9869457 L.H.	11.85	fldg. top compartment side trim lower
71-72 (Conv.)	9869456 R.H.	11.85	fldg. top compartment side trim lower
72 (Conv.)	7779217 L.H.	12.50	fldg. top compartment side trim
72 (Conv.)	7779216 R.H.	12.50	fldg. top compartment side trim
70-72 (Conv.)	8735729 L.H.	6.15	<b>BRACE</b> , folding top compartment to w/house outer
70-72 (Conv.)	8735728 R.H.	7.15	<b>BRACE</b> , folding top compartment to w/house outer
68-72 (Conv.)	7711945 R.H.	1.20	<b>COVER</b> , side trim panel upper
68-72 (Conv.)	7711946 L.H.	1.20	<b>COVER</b> , side trim panel upper

**CAMARO**

**12.996 GUTTER— BRACE— EXTENSION, Rear Compartment Lid**

**PASSENGER**

68 Impala Custom, Sed.	7721977 R.H.	7.55	rear compt. lid side
68 Impala Custom, Sed.	7721978 L.H.	7.55	rear compt. lid side
69-70 Pass. (exc. Sta. Wag., Spt. Cpe.), Impala (Spt. Cpe.) (exc. Custom)	8712980 R.H.	7.75	compt. lid side
69-70 Pass. (exc. Sta. Wag., Spt. Cpe.), Impala (Spt. Cpe.) (exc. Custom)	8712981 L.H.	7.75	compt. lid side
69-70 Impala Custom, Caprice (Spt. Cpe.)	8714844 R.H.	7.75	compt. lid side
69-70 Impala Custom, Caprice (Spt. Cpe.)	8714845 L.H.	7.75	compt. lid side
71 Pass. (exc. Sta. Wag., Caprice, Custom Spt. Cpe.)	9825371 L.H.	7.80	lid side
71 Pass. (exc. Sta. Wag., Caprice, Custom Spt. Cpe.)	9825370 R.H.	7.80	lid side
71 Impala (Custom), Caprice (Spt. Cpe.)	9825375 L.H.	8.80	lid side
71 Impala (Custom), Caprice (Spt. Cpe.)	9825374 R.H.	8.80	lid side
72-73 Impala (Cust.) Caprice (Spt. Cpe.)	9873825 L.H.	6.30	compt. lid side
72-73 Impala (Cust.) Caprice (Spt. Cpe.)	9873824 R.H.	6.30	compt. lid side
72-73 Pass. (Sed., Conv.) (Spe. Cpe.) exc. Impala (Cust.) Caprice	9873864 R.H.	5.70	compt. lid side
72-73 Pass. (Sed., Conv.) (Spe. Cpe.) exc. Impala (Cust.) Caprice	9873865 L.H.	5.70	compt. lid side
74 Impala (Cust.) Caprice (Spt. Cpe.)	1665807 R.H.	7.55	lid side
74 Impala (Cust.) Caprice (Spt. Cpe.)	1665808 L.H.	7.55	lid side
74-75 Pass. (Sed., Conv.) Impala (Spt. Cpe.)	1665806 R.H.	6.85	lid side
74-75 Pass. (Sed., Conv.) Impala (Spt. Cpe.)	9666485 L.H.	6.85	lid side
71-73 Impala (Custom), Caprice (Spt. Cpe.)	8801421 L.H.	2.65	<b>BRACE</b> , gutter w/h
71-73 Impala (Custom), Caprice (Spt. Cpe.)	8801420 R.H.	2.65	<b>BRACE</b> , gutter to w/h
74-75 Caprice (Spt. Cpe.) Impala (Custom)	9618482 R.H.	2.65	<b>BRACE</b> , gutter to w/h
74-75 Caprice (Spt. Cpe.) Impala (Custom)	9618483 L.H.	2.65	<b>BRACE</b> , gutter to w/h
74-75 Impala (Spt. Cpe.) (exc. Custom), Pass. (4-Dr.) (exc. Sta. Wag.)	9843420 R.H.	4.80	<b>BRACE</b> , compt. gutter to w/h
74-75 Impala (Spt. Cpe.) (exc. Custom), Pass. (4-Dr.) (exc. Sta. Wag.)	9843421 L.H.	4.80	<b>BRACE</b> , compt. gutter to w/h

**CHEVELLE**

68 (exc. Sta. Wag., El Camino), 69 (exc. 4-Dr. Sed., Sta. Wag.), 70-72 (exc. Sta. Wag., El Camino)	7722162 R.H.	6.15	rear compt. lid side
68 (exc. Sta. Wag., El Camino)			

**METAL TRIM—CLIPS AND PANELS**

**12.996 GUTTER— BRACE— EXTENSION, Rear Compartment Lid (Con't)**

69	(exc. 4-Dr. Sed., Sta. Wag.),				
70-72	(exc. Sta. Wag., El Camino) . . . . .	7722163	L.H.	6.15	rear compt. lid side . . . . .
73	Chevelle (exc. Sta. Wag., Monte Carlo, El Camino) . . . . .	9871145	L.H.	7.65	lid side . . . . .
73	Chevelle (exc. Sta. Wag., Monte Carlo, El Camino) . . . . .	9871144	R.H.	6.30	lid side . . . . .
73	Monte Carlo . . . . .	9870915	L.H.	9.65	lid side . . . . .
73	Monte Carlo . . . . .	9870914	R.H.	8.35	lid side . . . . .
74-75	Monte Carlo . . . . .	9664869	L.H.	11.55	lid side . . . . .
74-75	Chevelle (exc. Sta. Wag., Monte Carlo, El Camino) . . . . .	9664310	R.H.	7.55	lid side . . . . .
74-75	Chevelle (exc. Sta. Wag., Monte Carlo, El Camino) . . . . .	9664311	L.H.	9.15	lid side . . . . .
74-75	Monte Carlo . . . . .	9664868	R.H.	10.05	lid side . . . . .
73-75	Monte Carlo . . . . .	9855984	R.H.	1.55	<b>BRACE</b> , compt. gutter to w/h . . . . .
73-75	Monte Carlo . . . . .	9855985	L.H.	1.55	<b>BRACE</b> , compt. gutter to w/h . . . . .

**CAMARO**

67-69	(Spt. Cpe.) . . . . .	7638608	R.H.	5.10	side . . . . .
67-69	(Spt. Cpe.) . . . . .	7638609	L.H.	5.10	side . . . . .
67-69	(Conv.) . . . . .	7645578	R.H.	5.65	side . . . . .
67-69	(Conv.) . . . . .	7645579	L.H.	5.65	side . . . . .
70-75	Camaro . . . . .	8797256	R.H.	7.05	side . . . . .
70-75	Camaro . . . . .	8797257	L.H.	7.05	side . . . . .

**CHEVY— NOVA**

73-74	Nova (H.B.) . . . . .	9609641	L.H.	8.35	lid side . . . . .
73-74	Nova (H.B.) . . . . .	9609640	R.H.	8.35	lid side . . . . .
73-74	Nova (H.B.) . . . . .	9658598	1	21.75	compt. lid upper . . . . .
75	Nova (H.B.) . . . . .	1706115	R.H.	15.80	lid side . . . . .
75	Nova (H.B.) . . . . .	1706116	L.H.	15.80	lid side . . . . .
68-69	Chevy . . . . .	7678548	L.H.	3.15	<b>BRACE</b> , compt. gutter to rear cross rail . . . . .
70-73	Nova . . . . .	9873285	R.H.	3.75	<b>BRACE</b> , gutter to rear cross rail . . . . .
70-73	Nova . . . . .	9873286	L.H.	3.75	<b>BRACE</b> , gutter to rear cross rail . . . . .
75	Nova (H.B.) . . . . .	1695798	R.H.	2.10	<b>EXTENSION</b> , compt. lid side to qtr. . . . .
75	Nova (H.B.) . . . . .	1695799	L.H.	2.10	<b>EXTENSION</b> , compt. lid side to qtr. . . . .



CHEVROLET

# CHEVROLET BODY GROUP 13.000



CHEVROLET

## CONVERTIBLE TOP TRIM — BODY WIRING

### ALPHABETICAL INDEX

B	M
BAG ASSY., Dust Boot Storage..... 13.450A	MOULDING, Vinyl Roof Panel Cover..... 13.260
BOOT, Top Dust (with Fasteners)..... 13.450	
BUSHING, Folding Top Back Window..... 13.395	
C	N
CIRCUIT BREAKER, Body Wiring..... 13.095	NAIL, Vinyl Roof Panel Cover..... 13.260
CLIP, Body Wiring (Also See Group 2.480 for additional Body Harnesses)..... 13.090	
CLIP, Fldg. Top and Dust Boot..... 13.384	
CLIP, Folding Top Back Window..... 13.395	
CLIP, Folding Top Bow Binding End..... 13.342	
CLIP, Vinyl Roof Panel Cover..... 13.260	
CONNECTOR, Body Wiring..... 13.100	
COVER, Body Wiring..... 13.100	
CURTAIN, Back (with glass)..... 13.389	
E	P
EXTENSION, Folding Top Back Window..... 13.395	PAD, Folding Top Cover (less Back Curtain).. 13.347
	PAD, Roof Panel (Exterior)..... 13.250
	PLATE, Folding Top Back Window..... 13.395
F	R
FASTENER, Fldg. Top and Dust Boot..... 13.384	RELAY, Body Wiring..... 13.095
	RETAINER, Body Wiring (Also See Group 2.480 for additional Body Harnesses)..... 13.090
	RETAINER, Fldg. Top and Dust Boot..... 13.384
	RETAINER, Vinyl Roof Panel Cover..... 13.260
G	S
GROMMET, Body Wiring (Also See Group 2.480 for additional Body Harnesses)..... 13.090	SENSOR, Body Wiring..... 13.095
	SUPPORT, Body Wiring (Also See Group 2.480 for additional Body Harnesses)..... 13.090
	SUPPORT, Folding Top Back Window..... 13.395
	SWITCH ASSY., Body Wiring..... 13.095
H	T
HARNESS ASSY., Body Wiring (Also See Group 2.480 for additional Body Harnesses)..... 13.090	TOP ASSY., Frame less trim..... 13.365
	TRIM ASSY., Folding Top Cover (less Back Curtain)..... 13.347
	TRIM ASSY., Roof Panel (Exterior)..... 13.250
L	W
LINING ASSY., Top Side Pad..... 13.349	WASHER..... 13.346
LINK ASSY., Folding Top Back Window..... 13.395	WASHER, Top Side Pad..... 13.349
LOGIC ASSY., Body Wiring..... 13.095	WEATHERSTRIP, Folding Top Cover (on side belt rail)..... 13.352
	WIRE ASSY., Body Wiring (Also See Group 2.480 for additional Body Harnesses)..... 13.090

# ALPHABETICAL INDEX

## Z

ZIPPER, Folding Top Cover (less Back Curtain).....	13.347
ZIPPER, F/Top Back Window.....	13.392

**BODY WIRING—FOLDING TOP TRIM**

**13.090 HARNESS ASSY.—WIRE ASSY.—CLIP—GROMMET—RETAINER—SUPPORT, Body Wiring (Also See Group 2.480 for additional Body Harnesses)**

**BODY WIRING**

65-67	El Camino	4532051	1	21.05	front
65-67	Pass. (Sed.)				
66-67	Impala, Caprice, S.S. (Spt. Cpe.)	4532071	1	13.50	front
69-72	Nova	8714662	1	10.60	rear
69	Camaro	8721692	1	40.25	rear
69-72	Chevelle (Sta. Wag.) (6-Pass.)	9819722	1	53.25	rear
70-72	El Camino	8779462	1	33.25	front
70-72	El Camino	8779419	1	47.00	rear
70-72	Chevelle (Spt. Cpe., Sed.)	8779390	1	26.50	front
70-72	Chevelle (Conv.)	9817617	1	39.75	front
70-71	Chevelle (Sta. Wag.) (6-Pass.)	9819722	1	53.25	rear
70-72	Monte Carlo	8779432	1	37.50	rear
70-72	Nova w/inst. panel courtesy lights	8779531	1	35.50	front
70	Nova (exc. inst. panel courtesy lights, door jamb switch)				
71-72	Nova	8779530	1	28.00	front
70	Nova w/inst. panel courtesy lights, door jamb switch				
71-72	Nova (exc. inst. panel courtesy lights)	9825048	1	27.50	front
70-72	Camaro	9817978	1	38.00	front
70-73	Camaro	8779276	1	38.00	rear
71-72	Pass. 1st Design	9821101	1	5.95	power ign. feed jumper
71-72	Pass. 2nd Design	9885209	1	5.95	power feed & ign. jumper
71-75	Taxi, Police	9870885	1	53.50	roof wire
71	Pass. (Sed.)	9821121	1	33.00	front
71	Biscayne, Bel Air	9821191	1	46.25	rear
71	Impala, Caprice	9821192	1	56.25	rear
71-73	Pass. (Sta. Wag.)	9821193	1	61.25	rear
71	Impala, Caprice (Spt. Cpe., Conv.)				
71-72	Pass. (Sta. Wag.)	9821240	1	32.00	front
72	Pass. (Sta. Wag.) (2nd des.)	9887045	1	32.00	frt. (w/sens. warn. sys.)
72	Chevelle (Sta. Wag.) (6-Pass.)	9887004	1	39.75	front
71-73	Vega (Panel, Sta. Wag.)	9874987	1	32.50	rear
71-73	Vega (N.B. and H.B.)	9886952	1	31.75	rear
72	Malibu (Conv.) (2nd des.)	9887003	1	39.75	front
72	El Camino (2nd des.)	9887001	1	39.75	front
72	Chevelle (exc. Sta. Wag., Conv.) (2nd design)	9624134	1	28.50	front
72	Nova	9887023	1	28.00	front
72	Nova w/court. lts. (2nd des.)	9887026	1	36.00	front
72	Nova w/court. lts. & dr. jamb sw.	9887025	1	29.25	front
72	Camaro (2nd des.)	9626036	1	38.00	front
72	Pass. (exc. Sta. Wag.)	9611367	1	19.30	front
72	Vega, Monza	9814598	1	24.00	front
72-73	Vega (N.B. and H.B.)	9663758	1	24.00	front
72-73	Vega (Panel, Sta. Wag.)	9663759	1	24.00	front
73	Pass. (exc. Sta. Wag.)	9611367	1	19.30	front
73	Pass. (Sta. Wag.)				
74-75	Pass.	9887045	1	32.00	front
73	Camaro	9626036	1	38.00	front
73-74	Chevelle (Coupe, Sedan)	9629754	1	32.00	front
73-75	Chevelle (Sta. Wag.)	9629754	1	32.00	front
73	El Camino	9840154 L.H.		27.75	front
73	El Camino	9657578 R.H.		39.75	front
73	Chevelle (Coupe, Sedan) (exc. Monte Carlo)	9840105	1	29.00	rear
73	Monte Carlo	9840106	1	26.75	rear
73-75	Chevelle (Sta. Wag.)	9840157	1	42.50	rear
73	Nova (exc. Custom)	9615850	1	28.00	front
73	Nova w/Courtesy Lamp	9615851	1	36.00	front
73	Nova	9614396	1	26.25	rear
73-74	Pass. w/elec. dr. lk., elec. wdo., elec. 6-way (exc. Sta. Wag., Conv.)				
73-75	Pass. (Sta. Wag., Conv.)	9885209	1	5.95	power and ignition feed jumper
73-75	Pass. (2-Dr.) (Police)	9605702	1	16.15	roof wire

**BODY WIRING—FOLDING TOP TRIM**

**13.090 HARNESS ASSY.—WIRE ASSY.—CLIP—GROMMET—RETAINER—SUPPORT, Body Wiring (Also See Group 2.480 for additional Body Harnesses) (Con't)**

73-74	Nova (Sed.) (Taxi) . . . . .	9615763	1	47.50	roof wire . . . . .
74	Pass. (Sedan) Impala (Spt. Cpe.) (exc. Custom) . . . . .	9887045	1	32.00	front . . . . .
74	Camaro . . . . .	9640632	1	112.00	front . . . . .
74	Bel Air (Sed.) . . . . .	9640345	1	47.00	rear . . . . .
74	Impala, Caprice (exc. Sta. Wag.) . . . . .	9640346	1	53.50	rear . . . . .
74-75	Monte Carlo . . . . .	9640499	1	38.00	rear . . . . .
74-75	Camaro . . . . .	1679863	1	58.75	rear (use with 8908397) . . . . .
74-75	Pass. (Sta. Wag.) . . . . .	9668983	1	53.75	rear . . . . .
74	Malibu (exc. Sta. Wag.) . . . . .	9684244	1	58.00	rear . . . . .
74-75	El Camino . . . . .	9690933	L.H.	27.75	front . . . . .
74	Nova . . . . .	9727674	1	42.75	rear . . . . .
74	Vega (N.B. and H.B.) . . . . .	9640523	1	24.00	front . . . . .
74	Vega (Panel, Sta. Wag.) . . . . .	9640524	1	24.00	front . . . . .
74-75	Vega (N.B. and H.B.) . . . . .	9640626	1	49.00	rear . . . . .
74-75	Vega (Panel, Sta. Wag.) . . . . .	9640627	1	45.75	rear . . . . .
75	Nova . . . . .	1650214	1	35.25	front . . . . .
75	Chevelle (exc. Sta. Wag.) . . . . .	9629754	1	32.00	front . . . . .
75	Chevelle (Coupe, Sedan) (exc. Monte Carlo) . . . . .	9695539	1	28.50	rear . . . . .
75	Impala, Caprice (exc. Sta. Wag.) . . . . .	9695547	1	54.75	rear . . . . .
75	Nova . . . . .	9695707	1	39.00	rear . . . . .
75	Monza (Towne Cpe.) . . . . .	1679841	1	31.75	rear . . . . .
75	Monza (exc. Towne Cpe.) . . . . .	9737441	1	49.00	rear . . . . .
75	Vega, Monza . . . . .	1690185	1	42.50	front . . . . .

**DOME— COURTESY— MAP AND READING LAMP**

67-69	Camaro Std. (Spt. Cpe.) . . . . .	7720060	1	2.45	wiring (repl. 4467043) . . . . .
68	Chevelle (2-Dr., Sta. Wag.) (exc. Conv.), . . . . .				
69-71	Chevelle (Sta. Wag.) . . . . .	7720040	1	2.40	wiring . . . . .
68-72	El Camino . . . . .	7719872	1	3.85	wiring . . . . .
69-70	Biscayne (4-Dr. Sed., New York Taxi) . . . . .	6297525	1	5.05	door opening warning lamp . . . . .
69-70	Pass., Chevelle w/map lamp . . . . .	8779552	1	3.00	lamp jumper . . . . .
69-70	Chevelle (Spt. Sed.), . . . . .				
69-71	Chevelle (Spt. Cpe.), . . . . .				
71-72	Malibu (Spt. Sed.) . . . . .	7720060	1	2.45	wiring (repl. 8728673) . . . . .
70	All (exc. Conv., Caprice, Kingswood Estate) . . . . .	6297528	1	4.75	courtesy lamp . . . . .
70	All w/map lamp . . . . .				
71	Chevelle w/map lamp . . . . .	8779552	1	3.00	inside rear view mirror . . . . .
70-72	Chevelle . . . . .	8901748	1	5.00	front seat courtesy lamp . . . . .
70	Chevelle (4-Dr. Sed.), . . . . .				
71-72	Chevelle (Sed.) (exc. Spt. Sed.) . . . . .	7720060	1	2.45	wiring (repl. 8728672) . . . . .
70-72	Nova (2-Dr.) . . . . .	7720060	1	2.45	wiring (repl. 8779592) . . . . .
70-74	Nova (4-Dr.) . . . . .	7720060	1	2.45	wiring (repl. 8779591) . . . . .
70-73	Camaro . . . . .	8779472	1	6.10	wiring . . . . .
71-72	Pass. (Sta. Wag.) . . . . .	9840113	1	6.70	wiring . . . . .
71-72	Pass. . . . .	9821123	1	12.65	door jamb switch wiring center . . . . .
71-75	Bel Air, Biscayne (Taxi) Caprice . . . . .	9821127	2	2.20	rear door jamb switch wiring rear . . . . .
71-72	Biscayne (Taxi) . . . . .	8901768	1	5.00	door opening warning lamp . . . . .
71-72	Chevelle . . . . .	9885236	1	1.95	r/view map lamp jmpr. . . . .
72	Pass. (Spt. Cpe.) . . . . .	9821139	1	5.30	wiring . . . . .
72	Pass. (2nd des.) . . . . .	9887032	4	15.75	dr. jamb sw. & st. belt warn. . . . .
73	Pass. (exc. Sta. Wag.) . . . . .	9821139	1	5.30	wiring . . . . .
73	Pass. (exc. Sta. Wag.) . . . . .	9821158	1	5.45	reading lamp wiring . . . . .
73	Pass. (Sta. Wag.) . . . . .	9821159	1	4.50	reading lamp wiring . . . . .
73	Chevelle (Sta. Wag.), Pass. (Sta. Wag.) . . . . .	9840113	1	6.70	wiring . . . . .
73	Nova (exc. Courtesy Lamp) . . . . .	9615852	1	36.00	front door jamb switch . . . . .
73	Chevelle . . . . .	9840173	1	15.50	door jamb switch center . . . . .
73-74	Nova (Sed.) (Taxi) . . . . .	7779105	1	28.25	rear door jamb switch . . . . .
73-75	El Camino . . . . .	7720060	1	2.45	wiring (repl. 9840161) . . . . .
73-75	Chevelle . . . . .	9840168	1	5.70	w/shield hdr. map lamp . . . . .
73-74	Chevelle (Sta. Wag.) . . . . .	9610550	1	2.45	rear head courtesy lamp . . . . .
73-74	Nova (H.B.) . . . . .	9664298	1	13.00	dome & rear compt. ctsy. lamp . . . . .
73-74	Nova (2-Dr.) (exc. H.B.) . . . . .	9614399	1	5.45	wiring . . . . .
73-74	Pass. (Taxi) . . . . .	8901768	1	5.00	door opening warning lamp . . . . .
73-74	Chevelle (Coupe, Sed.), . . . . .				
74	Pass., Chevelle (Sta. Wag.), . . . . .				
75	All . . . . .	1690187	1	16.35	wiring, dome and reading lamp . . . . .
74	Nova (2-Dr.) . . . . .	9738819	1	110.00	frt. dr. jamb sw. & court. lamp . . . . .

**BODY WIRING—FOLDING TOP TRIM**

**13.090 HARNESS ASSY.—WIRE ASSY.—CLIP—GROMMET—RETAINER—  
SUPPORT, Body Wiring (Also See Group 2.480 for additional Body  
Harnesses) (Con't)**

74	Pass. (Sta. Wag.)	9673622	1	7.80	reading lamp wiring
74	Camaro	9698098	1	9.80	wiring
74	Pass. (exc. Sta. Wag., Conv.),				
75	Nova (H.B.)	1699148	1	25.00	dome, lic. and rear compt. lamp
75	Nova (H.B.) (exc. Custom)	1650216	1	25.75	dome & rear compt. ctsy. lamp
75	Pass., Chevelle	1695628	1	3.60	dome lamp and reading
75	Chevelle (Sta. Wag.)	1699924	1	2.45	rear head courtesy lamp
75	Vega (Panel, Sta. Wag.)	1699908	1	13.00	rear compt. ctsy. lamp
75	Nova	1650222	2	3.90	rear door jamb switch
75	Nova	1650212	1	22.90	frt. dr. switch and inst. panel courtesy

**POWER WINDOW**

64-67	Chevelle (2-Dr. Sed., Spt. Cpe.),				
65-68	Pass. (Conv.)	4417661	2	2.50	rear qtr. window jumper
66-67	Chevelle	4531993	L.H.	19.65	front door window control wiring
68-69	Camaro	8721504	R.H.	13.10	front door window control
69	Malibu (Spt. Cpe., Conv.)	8728552	L.H.	40.25	front door window control wiring
69	Camaro	8728648	L.H.	25.75	front door window control wiring
70	Bel Air, Impala, Caprice, Townsmen, Kingswood (6- Pass.) (exc. elect. t/gate window)	8779406	L.H.	43.75	front door wdo. cont. wiring
70	Malibu (Spt. Sed.)	8779282	1	27.50	rear door wdo. control wiring front
70	Malibu, Monte Carlo (Spt. Cpe., Conv.)	8779350	L.H.	40.75	front door wdo. control wiring
70	Concours, Malibu (Sed.)	8779416	L.H.	32.75	left front door wdo. control wiring
70	Concours, Malibu (Sed.) (exc. Spt. Sed.)	8779284	2	19.20	rear door wdo. control wiring rear
70	Concours, Malibu (Sed.) (exc. Spt. Sed.)	8779289	1	26.75	rear door wdo. control wiring front
70	Concours, El Camino (Custom), Malibu (Sed.)	8779417	R.H.	17.65	front door wdo. control wiring
70	El Camino (Custom)	8779418	L.H.	72.75	front door wdo. control wiring
70	Malibu (Spt. Cpe., Conv.),				
70-72	Monte Carlo	8779465	1	43.25	qtr. wdo. control wiring
70-72	Malibu, Monte Carlo (Spt. Cpe., Conv.)	8779351	R.H.	21.95	front door wdo. control wiring
70-72	Chevelle (Sta. Wag.) (6-Pass.) w/elect. door lock, elect. t/gate window, elect. window	8779464	1	2.05	power feed
71-72	Pass. (exc. elec. door lock)	9821102	1	36.00	power window control wiring center
71-75	Pass. (2-Dr.)	9821103	R.H.	25.75	front door window control wiring
71-75	Pass. (2-Dr.)	9821105	L.H.	35.00	front door window wiring
71-75	Pass. (4-Dr.)	9821299	R.H.	23.30	front door window control wiring
71-75	Pass. (4-Dr.)	9866526	L.H.	32.00	front door window control wiring
71-75	Impala, Caprice (Spt. Cpe., Conv.)	9821111	2	23.00	qtr. window control wiring
71-74	Pass.	9821115	2	31.50	rear door window control wiring
72	Monte Carlo	9891204	L.H.	64.50	frt. dr. wdo. cont. wrg.
72	Pass. (exc. elec. dr. lks.)	9887035		27.50	pwr. wdo. cont. center
72	Pass. (4-Dr.)	9866526		32.00	frt. dr. wdo. cont. wrg.
73	Pass. (exc. elec. door lock)	9616987	1	27.50	control center wiring
73	Chevelle (4-Dr.) (exc. elec. door lock)	9840120	1	27.50	control center complete wiring
73	Chevelle (2-Dr.) (exc. elec. door lock)	9840153	1	32.75	control center wiring
73	Camaro	8779485	1	2.25	power feed
73-74	Camaro	9827721	1	21.25	left front door window control wiring
73-74	Chevelle (4-Dr.),				
75	Chevelle (4-Dr.) less vents	9840125	2	26.75	rear door window control wiring
73-74	Chevelle (2-Dr.),				
75	Chevelle (2-Dr.) less vents	9840121	L.H.	19.20	front door window control switch trim pad
73-75	Chevelle (4-Dr.)	9840122	L.H.	24.95	frt. door window control switch trim pad
73-75	Chevelle (2-Dr.) less vents	9840123	R.H.	18.90	frt. door window control switch trim pad
73-75	Chevelle (4-Dr.) less vents	9840124	R.H.	17.65	frt. door window control switch trim pad
73-75	Camaro	8779482	2	19.60	front door window control wiring
74	Pass. w/elec. dr. lock	9640437	1	61.75	control center complete
74	Camaro w/elec. dr. lock	8779485	1	2.25	power feed
74	Camaro w/elect. door lock	9640632	1	112.00	front
74-75	Chevelle w/elec. dr. lock	9640511	1	51.00	control center
74-75	Impala (Custom), Caprice (Spt. Cpe.)	9671757	R.H.	20.15	front door window control wiring

**BODY WIRING—FOLDING TOP TRIM**

**13.090 HARNESS ASSY.—WIRE ASSY.—CLIP—GROMMET—RETAINER—SUPPORT, Body Wiring (Also See Group 2.480 for additional Body Harnesses) (Con't)**

74-75	Impala (Custom), Caprice (Spt. Cpe.)	9671758 L.H.	24.45	front door window control wiring
75	Camaro	1677724 L.H.	20.75	front door window cont. in cnsl.
75	Impala (Spt. Cpe.) (exc. Custom), Pass. (Conv.)	9735902 2	31.00	wiring qtr. window control
75	Nova	1688608 1	35.00	power wdo. control center
75	Nova (2-Dr.)	1688609 R.H.	24.30	power wdo. control center
75	Nova (4-Dr.)	1688610 R.H.	28.00	power wdo. control center
75	Nova (2-Dr.)	1688611 L.H.	23.30	power wdo. control center
75	Nova (4-Dr.)	1688612 L.H.	38.00	power wdo. control center
75	Nova (4-Dr.)	1688613 2	54.50	rear door pwr. wdo. control & lock
75	Nova	8908541 1	8.00	power feed
75	Camaro w/elec. dr. lock	1685465 1	74.00	front window control wiring

**POWER SEAT**

65-68	Pass. w/elect. seat (exc. astro seat),			
68	Pass. w/6-way seat (exc. Biscayne),			
69	Pass. w/6-way seat (exc. Bel Air, Townsman),			
70	Pass. w/6-way elect. seat (exc. Biscayne, Brookwood)	4466203 1	13.35	seat adjuster wiring
66-69	Caprice (Spt. Sed., Spt. Cpe.) w/power strato bench seat,			
67	Impala (S.S.),			
68	Impala Custom w/power bench seat	4532025 1	11.00	6-way seat adjuster wiring
66	Chevelle (Spt. Cpe., Conv.),			
66-67	Impala (S.S.) Caprice (2-Dr.),			
68	Pass. (Spt. Cpe., Conv.),			
70-72	Monte Carlo	4532228 1	15.25	4-way seat adjuster control wiring
68-69	Malibu, Concours, S.S. w/elect. window,			
70	Townsman, Kingswood w/elect. t/gate (exc. Estate),			
70	Bel Air, Impala, Caprice,			
70	Malibu, Monte Carlo w/elect. window,			
71	Monte Carlo	8721680 1	.96	ign. feed jumper
70-72	Monte Carlo	8728665 1	12.70	4-way bench seat adjuster control wiring
71-72	Pass. w/6-way elec. seat (exc. Biscayne, Brookwood)	9663221 1	18.45	6-way seat adj. wiring
71-72	Pass.	9821150 1	4.80	6-way seat adj. feed wiring
73-75	Pass., Chevelle	9663221 1	18.45	seat adj. wiring
73-75	Pass., Chevelle	9821150 1	4.80	seat adj. feed
73-75	Caprice (Sedan, Spt. Cpe.)	9840174 1	11.70	seat adj. wiring
73-75	Chevelle	9840118 1	2.10	6-way, power feed jumper

**SEAT BELT—IGNITION INTERLOCK**

72-73	Pass.	9887046 R.H.	4.65	sensor warn. syst., rear
72-73	Pass.	9897249 L.H.	5.65	sensor warn. syst., rear
72-73	Camaro	9626036 R.H.	38.00	sensor warn. syst., rear
72-73	Nova	9887048 R.H.	6.65	sensor warn. syst., rear
72-73	Vega (exc. Panel)	9890217 1	4.90	warning center and rear, sensor warning switch
73	Chevelle w/4-Spd.	8908220 1	4.75	seat belt warn. & park. brake relay
73	Camaro, Nova w/3, 4-Spd.	8908272 1	4.10	seat belt warn. & park. brake relay
73	Pass.	9887032 1	15.75	door jamb switch and seat belt warning (sensor warning system)
73	Chevelle	9610591 R.H.	5.20	warning wiring
73	Chevelle	9610592 L.H.	3.25	warning wiring
74	Nova (3-Spd. w/floor shift, 4-Spd.),			
74	Camaro (exc. A.T.)	8908403 1	21.90	start interlock ext.
74-75	Nova w/3-Speed (exc. floor shift)	8908578 1	26.00	start interlock ext.
74-75	Chevelle (exc. El Camino) w/column three speed	8908575 1	18.40	seat belt start interlock ext.
74	Chevelle (2-Dr.) w/4-Speed (exc. Monte Carlo) close ratio	8908396 1	25.00	seat belt start interlock ext.
74	Vega (exc. Panel)	9679499 1	48.25	wiring ignition interlock system on underbody
74-75	El Camino	9690545 1	14.70	wiring seat belt warning



**BODY WIRING—FOLDING TOP TRIM**

**13.090 HARNESS ASSY.—WIRE ASSY.—CLIP—GROMMET—RETAINER—  
SUPPORT, Body Wiring (Also See Group 2.480 for additional Body  
Harnesses) (Con't)**

74-75	Pass., Chevelle w/bench seat	9738817 R.H.	56.75	on front end
74-75	Caprice (Sedan, Spt. Cpe.) w/reclining seat	9738818 R.H.	71.25	on front end
74-75	Pass. w/reclining seat	9736420 1	16.35	in pass. seat
74-75	Chevelle w/swivel bucket seats/European st.	9640509 1	9.10	in pass. seat
74-75	Pass., Chevelle w/bench seat (exc. El Camino)	9736419 1	17.40	in seat
74	Chevelle w/swivel bucket seats, All	9738820 1	71.75	on front end
74	Camaro, Nova (Coupe) w/bucket seat,			
74-75	Vega, Monza,			
75	Nova w/bucket seat	9640521 1	10.00	in drivers seat
74-75	Nova w/bench seat	9736429 1	10.45	in bench seat
74-75	Nova (Cpe.) w/bucket st.	9669263 1	7.25	sensor warn. syst. pass. seat, sensor jumper on underbody
75	All	1724700 1	16.00	wiring seat belt warning jumper
75	Chevelle w/4-Spd. (exc. close ratio)	8908576 1	25.00	seat belt interlock ext.
75	Camaro (exc. A.T.),			
75	Camaro w/3-Spd., 4-Spd.	8916140 1	15.15	seat belt start intlk. ext.
75	Nova w/3-Spd., 4-Spd., floor shift	8908577 1	21.90	seat belt interlock ext.
75	Nova w/4-Spd. floor shift	8916140 1	15.15	seat belt start intlk. ext.
75	Monte Carlo w/reclining split seat	1671322 1	55.25	
75	Camaro, Nova, Chevelle, Pass.	1724843 1	8.45	seat belt warning light
75	Vega, Monza	1724838 1	10.05	seat belt warning lamp
75	Vega, Monza	1725125 1	18.75	seat belt warning jumper
75	Vega (exc. Panel), Monza	9737439 1	47.00	wiring ignition interlock system on underbody
75	Monza (N.B.)	1693942 1	5.00	park. brake lamp w/frt. & rr. seat belt & shoulder harn.

**POWER DOOR LOCK— SEAT BACK LOCK**

70	Chevelle (Spt. Cpe., Conv.)	9817150 1	3.25	seat back lock solenoid
70-71	Chevelle (Spt. Cpe., Conv.)	9814457 1	15.70	front seat back lock wiring
70	Kingswood,			
70	Impala, Caprice (Sed.),			
70-72	Chevelle (4-Dr.) (exc. Spt. Sed.)	8779291 2	4.80	rear door elec. lock wiring rear
70	Malibu, Monte Carlo, Impala, Caprice (Spt. Cpe., Conv.) (exc. bucket seats),			
71-72	Chevelle (Spt. Cpe.) (exc. bucket st.)	8779468 2	6.70	seat back lock solenoid
70-72	Chevelle (Spt. Cpe., Conv.)	9817150 2	3.25	seat back lock solenoid
70-72	Chevelle (4-Dr.) (exc. Spt. Sed.)	9813898 1	9.10	rear door elec. lock wiring front
70-72	Malibu	8779250 1	9.40	rear door elec. lock wiring front
70-72	Malibu (Spt. Sed.)	8779290 2	4.15	rear door elec. lock wiring rear
70-72	El Camino	9814451 L.H.	34.50	front door elec. lock and seat lock wiring
70-72	Chevelle (Spt. Cpe., Conv.)	9814453 L.H.	34.75	front door lock control and seat back lock wiring
70-72	Chevelle (Spt. Cpe., Conv.)	9814454 R.H.	26.00	front door lock control and seat back lock wiring
70-72	Chevelle (Spt. Sed.)	9852126 L.H.	6.75	rear door wiring front
70-72	Chevelle (4-Dr.) (exc. Spt. Sed.)	9852127 L.H.	9.70	rear door wiring front
70-72	Chevelle (4-Dr.)	8779595 L.H.	34.00	front door elec. lock wiring
70-72	Chevelle (4-Dr.)	8779596 R.H.	19.20	front door elec. lock wiring
70-72	El Camino	9814452 R.H.	22.50	front door elec. lock wiring
71	Impala, Caprice (Spt. Cpe., Conv.) (exc. elec. window)	9821125 1	47.75	elec. door and seat back lock wiring center
71	Impala, Caprice (Spt. Cpe., Conv.) w/elec. door lock	9821126 1	61.25	door seat back lock window wiring center
71	Impala, Caprice (Spt. Cpe., Conv.)	9821144 1	8.45	elec. seat back lock wiring
71	Impala, Caprice (Spt. Cpe., Conv.)	9821145 2	5.20	elec. seat back lock wiring instr.
71-72	Pass. (exc. elec. window, seat back lock)	9821235 1	39.75	elec. door lock wiring center
71-72	Pass. w/elec. window	9821236 1	54.50	elec. door lock and window wiring center
71-75	Impala, Caprice (Spt. Cpe., Conv.)	9821253 2	21.90	front door elec. lock wiring

**BODY WIRING—FOLDING TOP TRIM**

**13.090 HARNESS ASSY.—WIRE ASSY.—CLIP—GROMMET—RETAINER—SUPPORT, Body Wiring (Also See Group 2.480 for additional Body Harnesses) (Con't)**

71-75	Pass. (4-Dr.)	9821141	2	13.55	front door elec. lock wiring
71-75	Pass. (4-Dr.)	9821143	2	11.80	rear door elec. lock wiring rear
72	Pass. (exc. pwr. wdos.) (2nd des.)	9887037	1	30.75	elec. dr. lk. wrg. cntr.
72	Pass. (exc. pwr. wdos.) (2nd des.)	9887041	1	37.50	elec. dr. lk. & wdo. cntrl. ctr.
73	Pass. (exc. power windows)	9616983	1	37.50	center
73	Pass. w/power windows (exc. Spt. Cpe.)	9616985	1	37.50	control
73	Chevelle (4-Dr.) w/power windows	9840169	1	34.25	control center
73	Chevelle (2-Dr.) w/power windows	9840170	1	34.50	control center
73	Chevelle (exc. pwr. windows)	9840137	1	25.75	wiring center
73	Camaro w/power windows	9626037	1	46.25	wiring body window and door lock front
73-75	Chevelle (2-Dr.)	9840103	2	26.00	front door wiring
73-75	Chevelle (4-Dr.)	9840112	2	9.25	rear door wiring
73-75	Chevelle (4-Dr.)	9840104	2	19.20	front door wiring
75	Nova (2-Dr.)	1650218	2	22.50	front door electric lock
75	Nova (4-Dr.)	1650219	1	29.75	front door electric lock
75	Nova	1650220	1	22.60	electric door lock center
75	Nova	1650221	2	11.55	rear door electric lock rear
75	Pass.	1671159	1	60.50	electric door lock center, power window cont. ctr., door jamb switch center (compl.)
75	Camaro	1675088	2	18.35	front door electric lock
75	Nova	8908541	1	8.00	power door lock power feed.

**TAILGATE WINDOW**

67	Pass. (Sta. Wag.)	4532092	1	61.00	t/gate window and body wiring, rear
68	Impala, Caprice (Sta. Wag.) (6-Pass.),				
68	Impala, Caprice (Sta. Wag.) (9-Pass.)	7719910	1	63.25	body and t/gate window wiring, rear
69	Chevelle (Sta. Wag.) (9-Pass.),				
69	Chevelle (Sta. Wag.) (6-Pass.)	8721544	1	13.15	power t/gate window, instr. panel
69	Nomad, Greenbrier	9808793	1	68.50	body power t/gate window wiring, rear
69-70	Chevelle (Sta. Wag.) (2nd design)	8728600	1	4.00	power t/gate window cut out switch jumper wire (10 1/2" O.L.)
69-70	Pass. (Sta. Wag.) (2nd design)	8728600	1	4.00	power t/gate window cut out switch jumper wire (10 1/2" O.L.)
69-70	Brookwood, Townsman	8789396	1	83.50	body t/gate window wiring, rear
70	Concours	8779489	1	19.05	power t/gate, side window wiring
70	Kingswood	8789397	1	95.25	body and power t/gate window wiring, rear
70	Concours, Greenbrier (9-Pass.),				
71	Greenbrier, Concours (9-Pass.)	8779454	1	70.00	body power t/gate window wiring, front
70-72	Chevelle (Sta. Wag.) (6-Pass.) 1st des.	9887016	1	55.00	body and power t/gate window wiring, front
70-72	Chevelle (Sta. Wag.)	8779488	1	18.25	power t/gate window, instr. panel
71	Greenbrier, Concours (9-Pass.) (2nd design)	9878316	1	20.95	power t/gate window instr. panel wiring No. 70 circuit
71-72	Greenbrier, Concours (9-Pass.) (2nd design)	9878317	1	89.00	power t/gate window instr. panel wiring No. 70 circuit
71-72	Chevelle (Sta. Wag.)	9861618	1	96.50	body and power t/gate window wiring, rear
71-72	Pass. (Sta. Wag.)	9821260	1	47.00	power t/gate and t/gate window
71-72	Chevelle (Sta. Wag.)	9861617	1	4.20	power t/gate window cut out switch jumper wire
71-72	Pass. (Sta. Wag.)	9821119	1	44.00	power t/gate window wiring, front
71-75	Pass. (Sta. Wag.) w/power window	9821164	1	41.75	power t/gate window wiring, front
71-75	Pass. (Sta. Wag.) (exc. power window)	9821165	1	33.00	power t/gate window wiring, rear
73	Pass. (Sta. Wag.)	8908308	1	47.00	power t/gate and t/gate window
73	Pass. (Sta. Wag.)	9609512	1	33.00	wiring rear
73	Malibu (Sta. Wag.) w/Rear Seat Assy. (A.T. w/S.S. 454 Equip.) (exc. Estate)	8908283	1	7.35	end gate unlock
73-74	Chevelle (Sta. Wag.) 3-Speed w/elec. t/gate lock	8908298	1	37.50	end gate unlock
73-75	Pass. (Sta. Wag.)	9866532	1	18.50	inst. panel switch

**BODY WIRING—FOLDING TOP TRIM**

**13.090 HARNESS ASSY.—WIRE ASSY.—CLIP—GROMMET—RETAINER—  
SUPPORT, Body Wiring (Also See Group 2.480 for additional Body  
Harnesses) (Con't)**

73-75	Pass. (Sta. Wag.) (exc. power tailgate) . . . . .	8908112	1	2.65	tailgate window jumper . . . . .
73-75	Chevelle (Sta. Wag.) (rr. wdo. defog. w/elec. liftgate lock release) . . . . .	9617648	1	18.45	warning lamp and lock and defg. front . . . . .
73-75	Chevelle (Sta. Wag.) (rr. wdo. defog. w/elec. liftgate lock release) . . . . .	9617649	1	18.45	warning lamp and lock and defg. rear . . . . .
73-75	Chevelle (Sta. Wag.) . . . . .	9610551	1	11.70	warning lamp and lock release frt. . . . .
73-75	Chevelle (Sta. Wag.) elec. liftgate lock release (exc. blower rear wdo. defg.) . . . . .	9610552	1	14.80	warning lamp release rear, warning lamp and defg. blower rear . . . . .
73-75	Chevelle (Sta. Wag.) . . . . .	9610548	1	7.35	warning lamp wiring front . . . . .
73-75	Chevelle (Sta. Wag.) . . . . .	9610549	1	7.35	warning lamp wiring rear . . . . .
73-75	Chevelle (Sta. Wag.) (Rr. Wdo. Defog.) (exc. elec. liftgate lock release) . . . . .	9617645	1	14.05	warning lamp and defog. blower frt. . . . .
74-75	Chevelle (Sta. Wag.) (A.T. w/power gate) . . . . .	8908412	1	9.25	end gate unlock . . . . .
74-75	Pass. (Sta. Wag.) . . . . .	8908415	1	47.00	power t/gate and t/gate window . . . . .
74-75	Pass. (Sta. Wag.) w/power tailgate . . . . .	9676009	1	47.50	wiring . . . . .
74-75	Pass. (Sta. Wag.) (exc. power tailgate) . . . . .	9676039	1	35.50	wiring . . . . .
74-75	Chevelle (Sta. Wag.) (A.T. w/elect. lift gate) w/instr. pnl. gauge . . . . .	8908413	1	8.65	end gate unlock . . . . .

**POWER TOP**

70	Chevelle (Conv.) . . . . .	9817617	1	39.75	right, front . . . . .
70-71	Malibu (Conv.) . . . . .	8901514	1	4.60	top switch jumper . . . . .
71-75	Pass. (Conv.) . . . . .	9891397	1	27.50	power top wiring . . . . .
73-74	Chevelle (exc. power windows) . . . . .	9657818	1	6.60	power sliding sun roof . . . . .
73-75	Chevelle w/power windows . . . . .	9652122	1	11.00	power sliding sun roof . . . . .
75	Chevelle (exc. power windows) . . . . .	1656675	1	10.05	power steel sliding sun roof . . . . .

**SEAT SEPARATOR COMPT.**

68-69	Camaro w/console, A.T. . . . .	6297578	1	9.00	wiring . . . . .
68-69	Camaro w/console instr. cluster, A.T. . . . .	6297579	1	15.45	wiring . . . . .
68-69	Camaro w/console (8 cyl.) (exc. A.T.) . . . . .	6297581	1	10.85	wiring . . . . .
68-72	El Camino, Chevelle (Spt. Cpe., Conv.) w/floor console, A.T. . . . .	6295108	1	9.30	wiring . . . . .
68-75	Nova (2-Dr.) w/console . . . . .	6295172	1	8.15	wiring . . . . .
69-71	Chevelle (Spt. Cpe., Conv.), . . . . .				
69-72	El Camino w/floor console, A.T. . . . .	6297609	1	9.75	extension . . . . .
70-72	Camaro w/floor console, A.T. . . . .	8901595	1	6.30	wiring . . . . .

**REAR LAMP**

70	Pass. (exc. Sta. Wag.) . . . . .	8901339	1	41.75	wiring (Note 1) . . . . .
	<i>NOTE 1: It may be necessary to cut off inboard tail and stop lamp connectors and insulate by taping bare end.</i>				
70	Malibu . . . . .	8901336	1	25.75	wiring . . . . .
71	Pass. (exc. Sta. Wag.) . . . . .	9821168	1	1.10	rear compartment lamp wiring . . . . .
73	Pass. (exc. Sta. Wag.) (1st design) . . . . .	8908217	1	54.00	wiring . . . . .
73	Pass. (exc. Sta. Wag.) (2nd design) . . . . .	8908310	1	54.00	wiring . . . . .
73-75	El Camino . . . . .	8916138	1	26.75	wiring . . . . .
74-75	Chevelle (Sta. Wag.) . . . . .	8908393	1	49.75	wiring . . . . .
74-75	El Camino . . . . .	9690934	R.H.	10.10	wiring marker rear lamp . . . . .
74-75	Vega (Panel, Sta. Wag.) . . . . .	9671427	L.H.	4.50	marker lamp jumper . . . . .

**LICENSE PLATE**

74-75	Pass. (Sta. Wag.) . . . . .	9670348	1	12.60	wiring license lamp jumper . . . . .
74-75	Monte Carlo . . . . .	9668850	1	26.75	wiring b/u and license lamp . . . . .
74-75	Vega (Panel, Sta. Wag.) . . . . .	9664738	1	13.85	wiring license lamp rear . . . . .
74-75	Vega (Panel, Sta. Wag.) w/elec. rear wdo. defg. . . . .	9696430	1	7.60	license lamp and htd. back window jumper . . . . .
74-75	Vega (Panel, Sta. Wag.) . . . . .	9696431	1	5.20	wiring license lamp jumper . . . . .

**BODY WIRING—FOLDING TOP TRIM**

**13.090 HARNESS ASSY.—WIRE ASSY.—CLIP—GROMMET—RETAINER—SUPPORT, Body Wiring (Also See Group 2.480 for additional Body Harnesses) (Con't)**

75	Nova	1656860	1	3.90	wiring lic. lamp jumper
75	Nova	9739298	1	7.75	wiring compt. lid lic. lamp
75	Nova (H.B.)	1699148	1	25.00	wiring dome lic. and rear compt. lamp
75	Monza (Towne Cpe.)	1679847	1	6.80	wiring license lamp rear

**REAR COMPARTMENT LID**

70-71	Monte Carlo (Spt. Cpe.)	9824326	1	7.95	elec. lock rel.
70-72	Camaro	8779532	1	3.70	rear compt. lid lamp
73-75	Camaro	8779532	1	3.70	rear compartment lid lamp
74	Nova (exc. H.B.)	6295252	1	4.25	rear compt. lamp to jumper
74	Pass., Monte Carlo,				
75	Pass., Nova	9606852	1	10.75	elec. lock rel.
74-75	Chevelle, Camaro	9866538	1	4.90	elec. lock rel.

**FUEL PUMP— FUEL TANK— PARK BRAKE LAMP— WINDSHIELD WIPER**

75	Vega	1690100	1	10.65	wiring fuel pump & gage jpr.
75	Monza	8908562	1	10.65	fuel tank ext.
75	Monza (Towne Cpe.) w/frt. & rr. seat belts & shldr. harn.,				
75	Vega (Panel)	1693942	1	5.00	park. brake lamp
70	Chevelle	8901518	1	12.30	demand wipe

**GROMMET— CLIP— RETAINER— SUPPORT, Body Wiring**

65-70	Chevelle (Spt. Cpe.),				
67-70	Chevelle (Conv.),				
68	Malibu S.S. (Spt. Cpe.),				
68	Chevelle Deluxe (2-Dr. Sed.),				
67-68	Pass. (Spt. Cpe., Conv.),				
71-72	Monte Carlo	4529659	2	.24	elect. rear qtr. window
70-73	Camaro	9812529	L.H.	.68	wiring rear seat to back window panel ext.
73-75	Chevelle (Sta. Wag.)	9623291		.22	t/gate inr. pnl. wire harn.
All	All	6270410	A.R.	.11	CLIP, body wiring harness ext. wire and main wiring harness assy.— (2.559)
73-75	El Camino	9837095		.24	RETAINER, body wrg. compt./pan to qtr. fil.
74-75	Pass. w/reclining seat,				
75	Chevelle	9697887	1	.33	RETAINER, electric mod. to pass. seat bottom frame
74-75	Pass., Nova w/bench seat (exc. reclining),				
74-75	Chevelle w/bench seat	9697949	1	.18	RETAINER, electric mod. bench seat on frame
74	Camaro, Nova (Coupe) w/bucket seat,				
75	Nova w/bucket seat	9699075	1	.35	RETAINER, electric mod. to pass. seat bottom frame
74-75	Pass., w/reclining seat	9733614	R.H.	1.35	RETAINER, wiring harness conduit under seat
75	Camaro (LT)	1677645	1	.60	RETAINER, electric mod. to supt.
75	Camaro (LT) w/man. A/C	1677646	1	.27	RETAINER, electric mod. to ctr. duct
75	Vega, Monza	9699075	1	.35	RETAINER, elect. mod. to driver st. btm. frm.
All	All	3816659	1	.31	RETAINER, adj. strap type (black plastic)— (9.242)
75	Camaro (LT)	1677644	1	.43	SUPPORT, retainer electric mod. to ctr. duct

**13.095 CIRCUIT BREAKER— LOGIC ASSY.— RELAY— SENSOR— SWITCH ASSY., Body Wiring**

67	Camaro	4749164	1	3.35	headlamp cover motor circuit
67	Nova (Sta. Wag.),				
67-70	Camaro, Chevelle (exc. El Camino, Std.),				
67-70	El Camino (Custom),				
67-70	Pass. (exc. Biscayne),				
71	Pass., Chevelle,				
73-74	Camaro w/power windows	4850166	1	3.30	body wiring harness extension (30 amp.)
73-75	Vega, Monza	336427	1	2.05	rear wdo. elec. defogger
75	Camaro, Nova w/electric side windows	4850166	1	3.30	electric door lock & window reg. motor circuit
74	Camaro (1st design),				
74	All (exc. Camaro),				

**BODY WIRING—FOLDING TOP TRIM**

**13.095 CIRCUIT BREAKER— LOGIC ASSY.— RELAY— SENSOR— SWITCH  
ASSY., Body Wiring (Con't)**

75	All	9736651	1	37.50	LOGIC ASSY., electronic ignition interlock system reverse side of buckle letter "O" with black wire
74	Camaro (2nd design)				LOGIC ASSY., relay ignition interlock system (marked with letter "X" with gray wire on reverse side of buckle), relay ignition interlock system
75	Vega, Monza	9679145	1	30.90	
64-67	Chevelle w/elect. seat,				
65-67	Bel Air, Impala, Caprice (exc. S.S.) w/elect. seat,				
67	Pass., S.S.,				
68	Bel Air, Impala (exc. Spt. Cpe.),				
68	Impala (Spt. Cpe.) w/pwr. seat,				
69-71	Pass. w/6-way seat,				
70-72	Monte Carlo w/4-way bench seat	5717528	1	5.70	RELAY, seat adjuster motor
64-67	Chevelle w/elect. seat,				
70-71	Monte Carlo w/4-way bench seat,				
70-72	Pass. w/6-way seat	5717528	1	5.70	RELAY, seat adjuster motor, fldg. top lift and motor assy.
67	Chevelle (Sta. Wag.) w/elect. wind., tailgate,				
67	Camaro	1116990	1	6.20	RELAY, elect. wind.
67-69	Chevelle, Camaro w/elect. windows, elect. tailgate window,				
68	Pass. w/elect. windows, elect. tailgate window,				
70	Pass. (Spt. Cpe., Conv.),				
70	Chevelle (Sta. Wag., 2-Dr.) (exc. El Camino),				
71-72	Chevelle w/elect. window, elect. t/gate window, st. bk. window	7728426	1	5.60	RELAY
67	Chevy (Sta. Wag.),				
69	Brookwood, Townsman w/elect. t/gate window,				
71-72	Chevelle (2-Dr.) w/spec. ducted hood	7729602	1	5.00	RELAY, electric
69-70	Pass. w/elec. wdo., elec. t/gate wdo.	8774426	1	4.80	RELAY
71-72	Pass. w/elec. window, elec. t/gate window, seat back lock	9831949	1	5.75	RELAY, electric
71-75	Pass. (Conv.)	9875101	1	4.70	RELAY, pwr. f/top
73	Nova, Camaro (3-Spd., 4-Spd. w/floor shift),				
73	Chevelle w/4-Spd.	6270694	1	2.15	RELAY, seat belt warn. & park. brake
73-74	Pass. (Sta. Wag.) w/power tailgate	9785034	1	8.30	RELAY, tailgate
73-75	Chevelle (Sta. Wag.) 3-Spd. w/elect. liftgate	1377993	1	2.35	RELAY, end gate unlock
73-74	Bel Air (Sta. Wag.),				
73-75	Pass., Chevelle w/electric wdo. control, sun roof	9831949	1	5.75	RELAY, electric
73-75	Camaro w/power window,				
75	Nova w/power wdo. (exc. vents)	7728426	1	5.60	RELAY, electric
73-74	Monte Carlo, Impala, Caprice, Chevelle w/6-way bench seat,				
75	Pass., Chevelle w/bench seat, split notch back, 6-way	5717528	1	5.70	RELAY, seat adj. motor
74-75	All	1997426	1	7.15	RELAY, seat belt interlock
74-75	All	1243384	1	5.35	RELAY, seat belt interlock override
74	Chevelle w/4-Spd.,				
74-75	Nova, Camaro w/man. trans.,				
75	Vega, Monza	3961573	1	2.85	RELAY, st. belt warn. and park. brake— (4.075)
75	Nova, Camaro w/man. trans.	494882	1	4.35	RELAY, seat belt warn. isolation & park. brake
	Not required in this group. See group 2.510	1115841		10.80	RELAY
	Not required in this group. See group 4.646	1116969		12.15	RELAY
72	Pass.	9886876	1	7.95	SENSOR, sw. assy. st. bit.
72	Camaro, Vega, Monza	9609898	1	1.90	SENSOR, sw. assy. st. bit.

**BODY WIRING—FOLDING TOP TRIM**

**13.095 CIRCUIT BREAKER— LOGIC ASSY.— RELAY— SENSOR— SWITCH ASSY., Body Wiring (Con't)**

72	Chevelle, Nova	9607253	1	5.75	SENSOR, sw. assy. st. blt.
73	All w/bench seat	9658592	1	12.90	SWITCH ASSY., sensor seat belt warning
73	Malibu, Laguna w/swivel bucket seat	9624247	1	11.90	SWITCH ASSY., seat belt warn.
73	Camaro, Nova w/bucket seat, Vega, Monza	9643275	1	6.10	SWITCH ASSY., seat belt warn.
74-75	All w/bench seat,				
74-75	Chevelle w/swivel bucket	9730851 A.R.		7.95	SWITCH ASSY., seat belt warn.
74-75	Camaro, Nova w/bucket, European st., Vega, Monza,				
75	Chevelle w/bucket st.	9679850	2	7.50	SWITCH ASSY., sensor seat belt warning
74-75	All (exc. bucket seat)	1674265	1	7.30	SWITCH ASSY., sensor driver seat belt warning
75	All	1726241	1	3.80	TIMER, seat belt warning

**13.100 CONNECTOR— COVER, Body Wiring**

68	Pass. w/elect. wind., 6-way seat,				
68	Pass. (Spt. Cpe., Conv.) w/4-way bucket seats,				
68	Pass. (Sta. Wag.) (6-Pass.) w/elect. t/gate wind.,				
68-70	Chevelle (Conv.) (elect. wind., w/power top),				
70	Townsmen, Kingswood (6-Pass.)	6294108	1	1.20	3-way power feed
71-75	Pass. (Conv.)	8905472	1	.62	rear comp. lamp wiring to harness
74-75	El Camino, Vega, Monza,				
75	Chevelle, Camaro	8911978	1	4.45	seat belt interlock relay by-pass
74-75	El Camino, Vega, Monza	8911920	1	1.50	COVER, seat belt interlock override relay conn.

**13.250 TRIM ASSY.— PAD, Roof Panel (Exterior)**

NOTE: For retainer see Group 12.080.

**PASS.**

70	Pass. (Sed.) (exc. Spt. Sed.)	9836083	1	129.00	white
71	Impala Custom, Caprice (Spt. Cpe.) w/vin. top	9889326	1	129.00	(white)
71-74	Pass. (Sta. Wag.)	1656307	1	134.00	(white)
71-74	Pass. (Sta. Wag.)	9645872	1	95.00	(black)
71-73	Impala (Spt. Cpe.) (exc. Custom)	9888956	1	158.00	(white)
72	Impala, Caprice (Spt. Sed.)	9645882	1	129.00	(black)
72-73	Pass. (Sed.) (exc. Spt. Sed.)	9645877	1	129.00	(black)
72	Impala, Caprice (Spt. Sed.)	9889304	1	129.00	(blue)
72	Pass. (Sed.) (exc. Spt. Sed.)	9889303	1	152.00	pewter
72	Pass. (Sta. Wag.)	9889301	1	152.00	(blue)
72-73	Impala, Caprice (Spt. Sed.)	9888951	1	158.00	(white)
72-73	Impala Custom, Caprice (Spt. Cpe.)	9889326	1	129.00	(white)
73	Impala (Spt. Cpe.) (exc. Custom)	9645890	1	146.00	maroon
73	Impala (Custom) Caprice (Spt. Cpe.)	9658790	1	146.00	maroon
73	Impala (Spt. Cpe.) (exc. Custom)	9645891	1	129.00	neutral
73	Pass. (Spt. Sed.)	9645882	1	129.00	black
73	Impala (Custom) Caprice (Spt. Cpe.)	9658788	1	129.00	chamois
73	Pass. (Spt. Sed.)	9645883	1	129.00	blue
73	Pass. (Sed.) (exc. Spt. Sed.)	9645878	1	129.00	blue
73	Pass. (Sed.) (exc. Spt. Sed.)	9645881	1	129.00	neutral
73-74	Pass. (Spt. Sed.)	9645885	1	129.00	maroon
73-74	Pass. (Sta. Wag.)	9645873	1	95.00	blue
73-74	Pass. (Sta. Wag.)	9645875	1	95.00	maroon
74-75	Pass. (Sta. Wag.)	1656310	1	134.00	green
74-75	Pass. (Sta. Wag.)	1656312	1	134.00	cream beige
74	Pass. (Sta. Wag.)	1656313	1	134.00	brown
74	Pass. (Sta. Wag.)	9699504	1	134.00	russet
74	Pass. (Sta. Wag.)	9699505	1	134.00	silver taupe
74-75	Impala (Spt. Cpe.) w/padded full cover (exc. Custom)	9699527	1	145.00	white
74-75	Impala (Spt. Cpe.) w/padded full cover (exc. Custom)	9699528	1	145.00	black
74	Impala (Spt. Cpe.) w/padded cover (exc. Custom)	9699529	1	145.00	blue
74	Impala (Spt. Cpe.) w/padded cover (exc. Custom)	9699530	1	145.00	cream beige

**BODY WIRING—FOLDING TOP TRIM**

**13.250 TRIM ASSY.— PAD, Roof Panel (Exterior) (Con't)**

74	Impala (Spt. Cpe.) w/padded cover (exc. Custom) . . . . .	9699531	1	145.00	brown . . . . .
74-75	Impala (Spt. Cpe.) w/padded full cover (exc. Custom) . . . . .	9699532	1	145.00	green . . . . .
74-75	Impala (Spt. Cpe.) w/padded cover (exc. Custom) . . . . .	9699533	1	145.00	maroon . . . . .
74	Impala (Spt. Cpe.) w/padded cover (exc. Custom) . . . . .	9699534	1	145.00	russet . . . . .
74	Impala (Spt. Cpe.) w/padded cover (exc. Custom) . . . . .	9699535	1	145.00	silver taupe . . . . .
74	Impala (Spt. Cpe.) w/padded cover (exc. Custom) . . . . .	9738205	1	145.00	med. saddle . . . . .
74-75	Impala (Custom),				
74-75	Caprice (Spt. Cpe.) . . . . .	9699519	1	145.00	white . . . . .
74-75	Impala (Custom),				
74-75	Caprice (Spt. Cpe.) . . . . .	9699520	1	145.00	black . . . . .
74	Impala (Custom),				
74	Caprice (Spt. Cpe.) . . . . .	9699521	1	145.00	blue . . . . .
74-75	Impala (Custom),				
74-75	Caprice (Spt. Cpe.) . . . . .	9699522	1	145.00	green . . . . .
74	Impala (Custom),				
74	Caprice (Spt. Cpe.) . . . . .	9699523	1	145.00	cream beige . . . . .
74	Impala (Custom),				
74	Caprice (Spt. Cpe.) . . . . .	9699524	1	145.00	brown . . . . .
74-75	Impala (Custom),				
74-75	Caprice (Spt. Cpe.) . . . . .	9699525	1	145.00	maroon . . . . .
74	Pass. (Sed.) (exc. Spt. Sed.) w/pad vnl. rf. . . . .	9733327	1	147.00	white . . . . .
74	Pass. (Sed.) (exc. Spt. Sed.) w/pad vnl. rf. . . . .	9733328	1	147.00	black . . . . .
74	Pass. (Sed.) (exc. Spt. Sed.) w/pad vnl. rf. . . . .	9733329	1	147.00	blue . . . . .
74	Pass. (Sed.) (exc. Spt. Sed.) w/pad vnl. rf. . . . .	9733330	1	147.00	maroon . . . . .
74	Pass. (Sed.) (exc. Spt. Sed.) w/pad vnl. rf. . . . .	9733331	1	147.00	silver taupe . . . . .
74	Pass. (Spt. Sed.) w/pad vnl. rf. . . . .	9733333	1	149.00	white . . . . .
74	Pass. (Spt. Sed.) w/pad vnl. rf. . . . .	9733334	1	149.00	black . . . . .
74	Pass. (Spt. Sed.) w/pad vnl. rf. . . . .	9733335	1	149.00	blue . . . . .
74	Pass. (Spt. Sed.) w/pad vnl. rf. . . . .	9733336	1	149.00	maroon . . . . .
74	Pass. (Spt. Sed.) w/pad vnl. rf. . . . .	9733337	1	149.00	silver taupe . . . . .
74	Pass. (Spt. Sed.) w/pad top . . . . .	9731284	1	149.00	med. saddle . . . . .
74	Pass. (Sedan) w/pad top . . . . .	9731286	1	147.00	med. saddle . . . . .
74	Pass. (Sta. Wag.) w/pad top . . . . .	1656315	1	134.00	med. saddle . . . . .
74	Pass. (Sed.) (exc. Spt. Sed.) w/pad vnl. roof . . . . .	9699506	1	147.00	med. green . . . . .
74	Pass. (Sed.) (exc. Spt. Sed.) w/pad vnl. roof . . . . .	9699507	1	147.00	cream beige . . . . .
74	Pass. (Sed.) (exc. Spt. Sed.) w/pad vnl. roof . . . . .	9699508	1	147.00	brown . . . . .
74	Pass. (Sed.) (exc. Spt. Sed.) w/pad vnl. roof . . . . .	9699509	1	147.00	russet . . . . .
74	Pass. (Spt. Sed.) w/pad vnl. roof . . . . .	9699510	1	149.00	med. green . . . . .
74	Pass. (Spt. Sed.) w/pad vnl. roof . . . . .	9699511	1	149.00	cream beige . . . . .
74	Pass. (Spt. Sed.) w/pad vnl. roof . . . . .	9699512	1	149.00	brown . . . . .
74	Pass. (Spt. Sed.) w/pad vnl. roof . . . . .	9699513	1	149.00	russet . . . . .
75	Pass. (Spt. Sed.) w/pad vnl. roof . . . . .	1679626	1	149.00	white . . . . .
75	Pass. (Spt. Sed.) w/pad vnl. roof . . . . .	1679627	1	149.00	silver met. . . . .
75	Pass. (Spt. Sed.) w/pad vnl. roof . . . . .	1679628	1	149.00	black . . . . .
75	Pass. (Spt. Sed.) w/pad vnl. roof . . . . .	1679629	1	149.00	dk. blue . . . . .
75	Pass. (Spt. Sed.) w/pad vnl. roof . . . . .	1679630	1	149.00	med. green . . . . .
75	Pass. (Spt. Sed.) w/pad vnl. roof . . . . .	1679631	1	149.00	sandstone . . . . .
75	Pass. (Spt. Sed.) w/pad vnl. roof . . . . .	1679633	1	149.00	red met. . . . .
75	Pass. (Sed.) w/pad vnl. roof (exc. Spt. Sed.) . . . . .	1679634	1	149.00	white . . . . .
75	Pass. (Sed.) w/pad vnl. roof (exc. Spt. Sed.) . . . . .	1679635	1	147.00	silver met. . . . .
75	Pass. (Sed.) w/pad vnl. roof (exc. Spt. Sed.) . . . . .	1679636	1	147.00	black . . . . .
75	Pass. (Sed.) w/pad vnl. roof (exc. Spt. Sed.) . . . . .	1679637	1	147.00	dk. blue . . . . .
75	Pass. (Sed.) w/pad vnl. roof (exc. Spt. Sed.) . . . . .	1679638	1	147.00	med. green . . . . .
75	Pass. (Sed.) w/pad vnl. roof (exc. Spt. Sed.) . . . . .	1679639	1	147.00	sandstone . . . . .

**BODY WIRING—FOLDING TOP TRIM**

**13.250 TRIM ASSY.— PAD, Roof Panel (Exterior) (Con't)**

75	Pass. (Sed.) w/pad vnl. roof (exc. Spt. Sed.)	1679641	1	147.00	red met.
75	Pass. (Sta. Wag.) w/pad vnl. roof	1656307	1	134.00	white
75	Pass. (Sta. Wag.) w/pad vnl. roof	1679644	1	134.00	silver met.
75	Pass. (Sta. Wag.) w/pad vnl. roof	1656308	1	134.00	black
75	Pass. (Sta. Wag.) w/pad vnl. roof	1679646	1	134.00	dk. blue
75	Pass. (Sta. Wag.) w/pad vnl. roof	1679648	1	134.00	sandstone
75	Pass. (Sta. Wag.) w/pad vnl. roof	1656311	1	134.00	red met.
75	Pass. (Sta. Wag.) w/pad vnl. roof	1679650	1	134.00	cordovan
75	Pass. (Sta. Wag.) w/pad vnl. roof	1679651	1	134.00	red
75	Impala (Spt. Cpe.) w/pad full vnl. roof (exc. Custom)	1680226	1	145.00	silver met.
75	Impala (Spt. Cpe.) w/pad full vnl. roof (exc. Custom)	1680227	1	145.00	dk. blue
75	Impala (Spt. Cpe.) w/pad full vnl. roof (exc. Custom)	1680228	1	145.00	sandstone
75	Impala (Custom) Caprice (Spt. Cpe.)	1680202	1	145.00	silver met.
75	Impala (Custom) Caprice (Spt. Cpe.)	1680205	1	145.00	dk. blue
75	Impala (Custom) Caprice (Spt. Cpe.)	1680206	1	145.00	sandstone
75	Impala, Caprice (Spt. Cpe.) w/Landau Top (exc. Custom)	1731511	1	119.00	white
75	Impala, Caprice (Spt. Cpe.) w/Landau Top (exc. Custom)	1731512	1	119.00	silver metallic
75	Impala, Caprice (Spt. Cpe.) w/Landau Top (exc. Custom)	1731513	1	119.00	black
75	Impala, Caprice (Spt. Cpe.) w/Landau Top (exc. Custom)	1731514	1	119.00	dk. blue
75	Impala, Caprice (Spt. Cpe.) w/Landau Top (exc. Custom)	1731515	1	119.00	med. green
75	Impala, Caprice (Spt. Cpe.) w/Landau Top (exc. Custom)	1731516	1	119.00	sandstone
75	Impala, Caprice (Spt. Cpe.) w/Landau Top (exc. Custom)	1731517	1	119.00	maroon

**CHEVELLE**

70-72	Monte Carlo	9889267	1	138.00	black
72	(Spt. Cpe.) (exc. Monte Carlo)	9888364	1	119.00	(black)
72	Spt. Cpe. (exc. Monte Carlo)	9888363	1	131.00	(white)
73-75	Chevelle (Coupe) (exc. Monte Carlo)	1678913	1	155.00	black
73-74	Chevelle (Coupe) (exc. Monte Carlo)	9643187	1	134.00	blue
73	Chevelle (Coupe) (exc. Monte Carlo)	9643188	1	134.00	green
73-74	Chevelle (Coupe) (exc. Monte Carlo)	9643185	1	119.00	white
73	Chevelle (Coupe) (exc. Monte Carlo)	9643189	1	119.00	neutral
73-75	Chevelle (Coupe) (exc. Monte Carlo)	1678918	1	155.00	maroon
73-75	Monte Carlo w/Landau Top w/o pad	1678954	1	88.75	white
73-75	Monte Carlo w/Vin. Top	1678939	1	155.00	white (repl. 9643193)
73-74	Monte Carlo w/Vin. Top	9643194	1	122.00	black
73-74	Monte Carlo w/Landau Top	9644633	1	77.75	blue
73-74	Monte Carlo w/Vin. Top	9643195	1	122.00	blue
73	Monte Carlo w/Vin. Top	9643196	1	122.00	green
73-75	Monte Carlo w/Vin. Top	1678943	1	155.00	maroon
73	Monte Carlo w/Landau Top	9658791	1	85.75	chamois
73-75	El Camino	9643207	1	68.50	white
73-75	El Camino	9643208	1	68.50	black
73-74	El Camino	9643209	1	68.50	blue
73-75	El Camino	9658567	1	68.50	maroon
73-75	Chevelle (Sedan)	9643178	1	119.00	black
73-74	Chevelle (Sedan)	9643179	1	119.00	blue
73-75	Chevelle (Sedan)	9643177	1	119.00	white
73-75	Chevelle (Sedan)	9643183	1	119.00	maroon
74	Chevelle (Sedan)	9671976	1	119.00	silver taupe
74	Chevelle (Sedan)	9699281	1	152.00	cream beige
74	Chevelle (Sedan)	9699282	1	152.00	brown
74-75	Chevelle (Sedan)	9699283	1	152.00	green
74	Chevelle (Sedan)	9699284	1	152.00	russet



**BODY WIRING—FOLDING TOP TRIM**

<b>13.250 TRIM ASSY.— PAD, Roof Panel (Exterior) (Con't)</b>					
74	Chevelle (Coupe) . . . . .	9671978	1	119.00	silver taupe . . . . .
74	Chevelle (Coupe) . . . . .	9699276	1	155.00	green . . . . .
74	Chevelle (Coupe) . . . . .	9699277	1	155.00	brown . . . . .
74	Chevelle (Coupe) . . . . .	9699278	1	155.00	cream beige . . . . .
74	Chevelle (Coupe) . . . . .	9699279	1	155.00	russet . . . . .
74	El Camino . . . . .	9699290	1	97.50	cream beige . . . . .
74	El Camino . . . . .	9699291	1	97.50	brown . . . . .
74-75	El Camino . . . . .	9699292	1	97.50	green . . . . .
74	El Camino . . . . .	9699293	1	97.50	russet . . . . .
74	El Camino . . . . .	9699294	1	97.50	silver taupe . . . . .
74	El Camino . . . . .	9738201	1	68.50	med. saddle . . . . .
74-75	Monte Carlo . . . . .	1678944	1	155.00	med. green . . . . .
74	Monte Carlo . . . . .	9699286	1	145.00	cream beige . . . . .
74	Monte Carlo . . . . .	9699287	1	145.00	brown . . . . .
74	Monte Carlo w/Landau Top . . . . .	9699569	1	88.75	cream beige . . . . .
74	Monte Carlo w/Landau Top . . . . .	9699570	1	88.75	brown . . . . .
74-75	Monte Carlo w/Landau Top w/pad . . . . .	1678954	1	88.75	white . . . . .
74-75	Monte Carlo w/Landau Top w/pad . . . . .	1678955	1	88.75	black . . . . .
74-75	Chevelle w/Landau Top w/o pad (exc. Monte Carlo) . . . . .	9736840	1	152.00	white . . . . .
74-75	Chevelle w/Landau Top w/o pad (exc. Monte Carlo) . . . . .	9736841	1	152.00	black . . . . .
74	Chevelle w/Landau Top (exc. Monte Carlo) . . . . .	9736842	1	152.00	med. blue . . . . .
74	Chevelle w/Landau Top (exc. Monte Carlo) . . . . .	9736843	1	152.00	cream beige . . . . .
74	Chevelle w/Landau Top (exc. Monte Carlo) . . . . .	9736844	1	152.00	brown . . . . .
74-75	Chevelle w/Landau Top w/o pad (exc. Monte Carlo) . . . . .	9736845	1	147.00	med. green . . . . .
74-75	Chevelle w/Landau Top w/o pad (exc. Monte Carlo) . . . . .	9736846	1	152.00	maroon . . . . .
74	Chevelle w/Landau Top (exc. Monte Carlo) . . . . .	9736847	1	152.00	russet . . . . .
74	Chevelle w/Landau Top (exc. Monte Carlo) . . . . .	9736848	1	152.00	silver taupe . . . . .
74	Chevelle w/Landau Top (exc. Monte Carlo) . . . . .	9736849	1	155.00	med. saddle . . . . .
74	Chevelle (Spt. Cpe.) . . . . .	9731281	1	155.00	med. saddle . . . . .
74	Chevelle (Spt. Sed.) . . . . .	9731282	1	152.00	med. saddle . . . . .
75	Chevelle (Spt. Cpe.) (exc. Monte Carlo) . . . . .	1678912	1	155.00	white . . . . .
75	Chevelle (Spt. Cpe.) (exc. Monte Carlo) . . . . .	1678914	1	155.00	dk. blue . . . . .
75	Chevelle (Spt. Cpe.) (exc. Monte Carlo) . . . . .	1678915	1	155.00	med. green . . . . .
75	Chevelle (Spt. Cpe.) (exc. Monte Carlo) . . . . .	1678916	1	155.00	sandstone . . . . .
75	Chevelle (Spt. Cpe.) (exc. Monte Carlo) . . . . .	1678917	1	155.00	cordovan . . . . .
75	Chevelle (Spt. Cpe.) (exc. Monte Carlo) . . . . .	1678919	1	155.00	red . . . . .
75	Chevelle (Spt. Cpe.) (exc. Monte Carlo) . . . . .	1678920	1	155.00	silver met. . . . .
75	Chevelle (Spt. Sed.) w/o pad . . . . .	1678923	1	180.00	dk. blue . . . . .
75	Chevelle (Spt. Sed.) w/o pad . . . . .	1678924	1	180.00	sandstone . . . . .
75	Chevelle (Spt. Sed.) w/o pad . . . . .	1678925	1	180.00	cordovan . . . . .
75	Chevelle (Spt. Sed.) w/o pad . . . . .	1678928	1	180.00	red . . . . .
75	Chevelle (Spt. Sed.) w/o pad . . . . .	1678929	1	180.00	silver met. . . . .
75	El Camino w/o pad . . . . .	1678932	1	115.00	dk. blue . . . . .
75	El Camino w/o pad . . . . .	1678933	1	115.00	sandstone . . . . .
75	El Camino w/o pad . . . . .	1678934	1	115.00	cordovan . . . . .
75	El Camino w/o pad . . . . .	1678937	1	115.00	red . . . . .
75	El Camino w/o pad . . . . .	1678938	1	115.00	silver met. . . . .
75	Monte Carlo w/pad . . . . .	1678940	1	155.00	black . . . . .
75	Monte Carlo w/pad . . . . .	1678941	1	155.00	dk. blue . . . . .
75	Monte Carlo w/pad . . . . .	1678942	1	155.00	sandstone . . . . .
75	Monte Carlo w/pad . . . . .	1678945	1	155.00	silver met. . . . .
75	Monte Carlo w/Landau Top . . . . .	1703980	1	94.00	sandstone (w/pad) . . . . .
75	Monte Carlo w/Landau Top . . . . .	1703981	1	94.00	silver met. (w/pad) . . . . .
75	Chevelle (Spt. Cpe.) w/short vinyl roof (exc. Monte Carlo) . . . . .	1678963	1	152.00	dk. blue . . . . .

**BODY WIRING—FOLDING TOP TRIM**

**13.250 TRIM ASSY.— PAD, Roof Panel (Exterior) (Con't)**

75	Chevelle (Spt. Cpe.) w/short vinyl roof (exc. Monte Carlo) . . .	1678964	1	152.00	sandstone . . . . .
75	Chevelle (Spt. Cpe.) w/short vinyl roof (exc. Monte Carlo) . . .	1678965	1	152.00	cordovan . . . . .
75	Chevelle (Spt. Cpe.) w/short vinyl roof (exc. Monte Carlo) . . .	1678968	1	152.00	red . . . . .
75	Chevelle (Spt. Cpe.) w/short vinyl roof (exc. Monte Carlo) . . .	1678969	1	152.00	silver met. . . . .

**NOVA**

72	Nova (2-Dr.) . . . . .	9646073	1	134.00	(black) . . . . .
72	Nova (4-Dr.) . . . . .	9888993	1	105.00	(white) . . . . .
72	Nova (2-Dr.) . . . . .	9888987	1	130.00	(white) . . . . .
73-74	Nova (2-Dr.) (exc. H.B.) . . . . .	9888987	1	130.00	white . . . . .
73-74	Nova (2-Dr.) (exc. H.B.) . . . . .	9646073	1	134.00	black . . . . .
73-74	Nova (2-Dr.) (exc. H.B.) . . . . .	9646074	1	105.00	blue . . . . .
73-74	Nova (H.B.) . . . . .	9650328	1	68.50	black . . . . .
73-74	Nova (H.B.) . . . . .	9650329	1	68.50	blue . . . . .
73-74	Nova (H.B.) . . . . .	9650327	1	71.25	white . . . . .
73	Nova (H.B.) . . . . .	9650331	1	68.50	neutral . . . . .
73-74	Nova (4-Dr.) . . . . .	9646077	1	105.00	black . . . . .
73-74	Nova (4-Dr.) . . . . .	9646078	1	105.00	blue . . . . .
73-74	Nova (H.B.) . . . . .	9650333	1	64.00	maroon . . . . .
73-74	Nova (2-Dr.) (exc. H.B.) . . . . .	9646082	1	105.00	maroon . . . . .
73-74	Nova (4-Dr.) . . . . .	9646084	1	105.00	maroon . . . . .
74	Nova (Sedan) . . . . .	9699136	1	128.00	cream beige . . . . .
74	Nova (Sedan) . . . . .	9699137	1	128.00	brown . . . . .
74	Nova (Sedan) . . . . .	9699138	1	128.00	green . . . . .
74	Nova (Sedan) . . . . .	9699139	1	128.00	russet . . . . .
74	Nova (Coupe) (exc. H.B.) . . . . .	9699131	1	127.00	cream beige . . . . .
74	Nova (Coupe) (exc. H.B.) . . . . .	9699132	1	127.00	brown . . . . .
74	Nova (Coupe) (exc. H.B.) . . . . .	9699133	1	127.00	green . . . . .
74	Nova (Coupe) (exc. H.B.) . . . . .	9699134	1	127.00	russet . . . . .
74	Nova (H.B.) w/Landau Top . . . . .	9699130	1	67.75	silver taupe . . . . .
74	Nova (H.B.) w/Landau Top . . . . .	9699129	1	67.75	russet . . . . .
74	Nova (H.B.) w/Landau Top . . . . .	9699128	1	67.75	cream beige . . . . .
74	Nova (H.B.) w/Landau Top . . . . .	9699127	1	67.75	green . . . . .
74	Nova (H.B.) w/Landau Top . . . . .	9699126	1	67.75	brown . . . . .
74	Nova (H.B.) w/Landau Top . . . . .	9738202	1	67.75	med. saddle . . . . .
74	Nova (Coupe) (exc. H.B.) . . . . .	9671996	1	105.00	silver taupe . . . . .
74	Nova (Sedan) . . . . .	9671998	1	105.00	silver taupe . . . . .
74	Nova (Sedan) . . . . .	9731278	1	127.00	med. saddle . . . . .
74	Nova (Coupe) (exc. H.B.) . . . . .	9731279	1	127.00	med. saddle . . . . .
75	Nova (2-Dr.) . . . . .	1678894	1	151.00	white (repl. 1706302) . . . . .
75	Nova (2-Dr.) . . . . .	1678895	1	151.00	black (repl. 1706303) . . . . .
75	Nova (2-Dr.) w/o pad . . . . .	1678896	1	151.00	dk. blue . . . . .
75	Nova (2-Dr.) w/o pad . . . . .	1678897	1	151.00	sandstone . . . . .
75	Nova (2-Dr.) w/o pad . . . . .	1678898	1	151.00	cordovan . . . . .
75	Nova (2-Dr.) w/o pad . . . . .	1678899	1	151.00	med. green . . . . .
75	Nova (2-Dr.) w/o pad . . . . .	1678900	1	151.00	maroon . . . . .
75	Nova (2-Dr.) w/o pad . . . . .	1678901	1	151.00	red . . . . .
75	Nova (2-Dr.) w/o pad . . . . .	1678902	1	151.00	silver met. . . . .
75	Nova (4-Dr.) w/o pad . . . . .	1678903	1	159.00	white . . . . .
75	Nova (4-Dr.) w/o pad . . . . .	1678904	1	159.00	black . . . . .
75	Nova (4-Dr.) w/o pad . . . . .	1678905	1	159.00	dk. blue . . . . .
75	Nova (4-Dr.) w/o pad . . . . .	1678906	1	159.00	sandstone . . . . .
75	Nova (4-Dr.) w/o pad . . . . .	1678907	1	159.00	cordovan . . . . .
75	Nova (4-Dr.) w/o pad . . . . .	1678908	1	159.00	med. green . . . . .
75	Nova (4-Dr.) w/o pad . . . . .	1678909	1	159.00	maroon . . . . .
75	Nova (4-Dr.) w/o pad . . . . .	1678910	1	159.00	red . . . . .
75	Nova (4-Dr.) w/o pad . . . . .	1678911	1	159.00	silver met. . . . .
75	Nova (2-Dr.) w/pad . . . . .	1706304	1	112.00	dk. blue . . . . .
75	Nova (2-Dr.) w/pad . . . . .	1706305	1	112.00	sandstone . . . . .
75	Nova (2-Dr.) w/pad . . . . .	1706306	1	112.00	cordovan . . . . .
75	Nova (2-Dr.) w/pad . . . . .	1706307	1	112.00	med. green . . . . .
75	Nova (2-Dr.) w/pad . . . . .	1706308	1	112.00	maroon . . . . .
75	Nova (2-Dr.) w/pad . . . . .	1706309	1	112.00	red . . . . .
75	Nova (2-Dr.) w/pad . . . . .	1706310	1	112.00	silver met. . . . .
75	Nova (4-Dr.) w/pad . . . . .	1706312	1	112.00	white . . . . .
75	Nova (4-Dr.) w/pad . . . . .	1706313	1	112.00	black . . . . .
75	Nova (4-Dr.) w/pad . . . . .	1706314	1	112.00	dk. blue . . . . .
75	Nova (4-Dr.) w/pad . . . . .	1706315	1	112.00	sandstone . . . . .
75	Nova (4-Dr.) w/pad . . . . .	1706316	1	112.00	cordovan . . . . .
75	Nova (4-Dr.) w/pad . . . . .	1706317	1	112.00	med. green . . . . .
75	Nova (4-Dr.) w/pad . . . . .	1706318	1	112.00	maroon . . . . .

**BODY WIRING—FOLDING TOP TRIM**

**13.250 TRIM ASSY.— PAD, Roof Panel (Exterior) (Con't)**

75	Nova (4-Dr.) w/pad	1706319	1	112.00	red
75	Nova (4-Dr.) w/pad	1706320	1	112.00	silver met.
75	Nova (Coupe) (exc. H.B.) w/Landau Top	3060289	1	138.00	white (repl. 1732477)
75	Nova (Coupe) (exc. H.B.) w/Landau Top	1732478	1	105.00	silver met.
75	Nova (Coupe) (exc. H.B.) w/Landau Top	1732479	1	105.00	black
75	Nova (Coupe) (exc. H.B.) w/Landau Top	1732480	1	99.75	dk. blue
75	Nova (Coupe) (exc. H.B.) w/Landau Top	1732481	1	105.00	med. green
75	Nova (Coupe) (exc. H.B.) w/Landau Top	1732482	1	105.00	sandstone
75	Nova (Coupe) (exc. H.B.) w/Landau Top	1732483	1	105.00	maroon
75	Nova (Coupe) (exc. H.B.) w/Landau Top	1732486	1	18.70	PAD, panel side cover for Landau

**CAMARO**

67-68	(Spt. Cpe.)	7680372	1	121.00	black
71-75	Camaro	1654133		145.00	white
73-75	Camaro	1654134	1	145.00	black (w/pad)
73-74	Camaro	9646086	1	109.00	maroon (w/o pad)
73-74	Camaro	1654135	1	145.00	blue
74-75	Camaro	1654139	1	145.00	maroon
74	Camaro	9699142	1	127.00	brown (w/o pad)
74	Camaro	1654137	1	109.00	brown (w/pad)
74-75	Camaro	1654138	1	145.00	green
74	Camaro	1654140	1	145.00	russet
74	Camaro	9671992	1	109.00	silver taupe (w/o pad)
74	Camaro	1654142	1	145.00	silver taupe (w/pad)
74	Camaro	9731280	1	127.00	med. saddle (w/o pad)
74	Camaro	1654141	1	145.00	med. saddle (w/pad)
74	Camaro	1654136	1	145.00	cream beige (w/pad)
75	Camaro	1678887	1	145.00	dk. blue (w/pad)
75	Camaro	1678888	1	145.00	cordovan
75	Camaro	1678891	1	145.00	red
75	Camaro	1678892	1	145.00	sandstone
75	Camaro	1678893	1	145.00	silver met.

**VEGA— MONZA**

74	Vega (N.B.)	9664113	1	88.75	blue
74	Vega (N.B.)	9699151	1	88.75	cream beige
74	Vega (N.B.)	9699152	1	88.75	brown
74	Vega (N.B.)	9699153	1	88.75	green
74-75	Vega (N.B.)	1705735	1	94.00	maroon
74	Vega (N.B.)	9699155	1	88.75	russet
74	Vega (N.B.)	9699156	1	88.75	silver taupe
74	Vega (N.B.)	9738203	1	88.75	med. saddle
74	Vega (H.B.)	9738204	1	79.25	med. saddle
74-75	Vega (H.B.)	1705727	1	84.25	white
74-75	Vega (H.B.)	1705728	1	84.25	black
74	Vega (H.B.)	9727793	1	79.25	blue
74	Vega (H.B.)	9727794	1	79.25	cream beige
74	Vega (H.B.)	9727795	1	79.25	brown
74-75	Vega (H.B.)	1705729	1	84.25	med. green
74-75	Vega (H.B.)	1705730	1	84.25	maroon
74	Vega (H.B.)	9727798	1	79.25	russet
74	Vega (H.B.)	9727799	1	79.25	silver taupe
75	Vega (N.B.)	1678213	1	88.75	dk. blue
75	Vega (N.B.)	1678214	1	88.75	sandstone
75	Vega (N.B.)	1678215	1	88.75	cordovan
75	Vega (N.B.)	1705734	1	94.00	med. green
75	Vega (N.B.)	1678217	1	88.75	red
75	Vega (N.B.)	1678219	1	88.75	silver met.
75	Vega (H.B.)	1678878	1	79.25	dk. blue
75	Vega (H.B.)	1678879	1	79.25	cordovan
75	Vega (H.B.)	1678881	1	79.25	red
75	Vega (H.B.)	1678883	1	79.25	sandstone
75	Vega (H.B.)	1678884	1	79.25	silver met.
75	Monza (Towne Cpe.)	1722513	1	123.00	white
75	Monza (Towne Cpe.)	1722514	1	123.00	silver met.
75	Monza (Towne Cpe.)	1722515	1	123.00	black
75	Monza (Towne Cpe.)	1722516	1	123.00	dk. blue

**BODY WIRING—FOLDING TOP TRIM**

**13.250 TRIM ASSY.— PAD, Roof Panel (Exterior) (Con't)**

75	Monza (Towne Cpe.)	1722517	1	123.00	dk. firethorn met.
75	Monza (Towne Cpe.)	1722518	1	123.00	mahogany met.
75	Monza (Towne Cpe.)	1722519	1	123.00	med. green
75	Monza (Towne Cpe.)	1722520	1	123.00	lt. buckskin
75	Monza (Towne Cpe.)	1722521	1	123.00	red

**13.260 MOULDING— CLIP— NAIL— RETAINER, Vinyl Roof Panel Cover**

**PASS.**

65-66	Spt. Sed., Spt. Cpe.	4483602	2	2.40	
67	Caprice (Spt. Cpe.)				
67-68	(exc. Caprice Spt. Cpe.)	7710853	2	2.40	clear (plastic)
69	Sed. (exc. Spt. Sed.)	8732670	2	.12	CLIP, roof drip mldg. scalp rr.

**CHEVELLE**

67	(exc. El Camino)				
68	(Sed.) (exc. Spt. Sed.)				
68-69	El Camino	7710853	2	2.40	clear (plastic)
	<i>NOTE 1: Emergency use only.</i>				
70	Chevelle (4-Dr.)	8735996	R.H.	1.65	lock pillar
70	Chevelle (4-Dr.)	8735997	L.H.	2.35	lock pillar
70	Monte Carlo (Spt. Cpe.) (1st design)	9809412	R.H.	12.70	roof panel cover front painted (not extended to w/s) (Note 1)
	<i>NOTE 1: No comparable 2nd design part. This moulding not required on 2nd design vinyl tops.</i>				
70	Monte Carlo (Spt. Cpe.) (1st design)	9809432	R.H.	8.75	roof panel cover side front painted (not extended to w/s)
70	Monte Carlo (Spt. Cpe.) (2nd design)				
71	Monte Carlo	9837106	R.H.	9.20	roof panel cover side front painted (extended forward to w/s)
70	Monte Carlo (Spt. Cpe.) (2nd design)				
71	Monte Carlo	9837107	L.H.	9.20	roof panel cover side front painted (extended forward to w/s)
70-71	Monte Carlo (Spt. Cpe.)	9809442	R.H.	12.90	roof panel cover side rear painted
70-71	Monte Carlo (Spt. Cpe.)	9809443	L.H.	12.90	roof panel cover side rear painted
70-71	Monte Carlo (Spt. Cpe.)	9809422	R.H.	24.90	reveal qtr. belt— (12.116)
70-71	Monte Carlo (Spt. Cpe.)	9809423	L.H.	24.90	reveal qtr. belt— (12.116)
70-71	Monte Carlo (Spt. Cpe.)	9809452	1	13.05	rear end belt painted— (12.121)
70-71	Monte Carlo	7669866	A.R.	.12	CLIP, roof panel cover side rear and front mldg., front end mldg.— (12.118)
72-75	All	8768802	A.R.	.11	NAIL
67-69	Nova,				
67-68	Camaro (Spt. Cpe.)	7710853	2	2.40	RETAINER, clear (plastic)
71-74	Impala, Caprice (Spt. Sed.)	9821352	L.H.	.63	RETAINER, roof panel cover at lock pillar
71-74	Impala, Caprice (Spt. Sed.)	9821351	R.H.	.63	RETAINER, roof panel cover at lock pillar
71-74	Pass. (Sed.) (exc. Spt. Sed.)	9821354	L.H.	.62	RETAINER, roof panel cover at lock pillar
71-74	Pass. (Sed.) (exc. Spt. Sed.)	9821353	R.H.	.62	RETAINER, roof panel cover at lock pillar
71-72	Chevelle (Sed.)	8735997	L.H.	2.35	RETAINER, roof panel cover at lock pillar
71-72	Chevelle (Sed.)	8735996	R.H.	1.65	RETAINER, roof panel cover at lock pillar
71-72	Chevelle (Spt. Cpe.) (exc. Monte Carlo)	9892707	2	.49	RETAINER, roof cover on compt. frt. pnl.
73-75	Chevelle (Sedan)	9659641	2	2.05	RETAINER, roof panel cover on center pillar
75	Pass.	1657740	R.H.	.81	RETAINER, roof panel cover at lock pillar
75	Pass.	1657741	L.H.	.60	RETAINER, roof panel cover at lock pillar
75	Impala (Custom Cpe.), Caprice (Cpe.) w/Landau Top	1678317	2	1.20	RETAINER, roof pnl. cover fin. mldg.

**VEGA**

74-75	Vega, Monza	8768802	A.R.	.11	NAIL
-------	-------------	---------	------	-----	------

**13.342 CLIP, Folding Top Bow Binding End**

65-71	All	7614749	2	.24	rear bow
-------	-----	---------	---	-----	----------

**13.346 WASHER**

Not required in this group. See group 7.447					
		3827499		.11	WASHER

**13.347 TRIM ASSY.— PAD— ZIPPER, Folding Top Cover (less Back Curtain)**

*NOTE: When ordering trim assy., the color of the top or cover assy. must be specified.*

**PASS.**

**BODY WIRING—FOLDING TOP TRIM**

**13.347 TRIM ASSY.— PAD— ZIPPER, Folding Top Cover (less Back Curtain)  
(Con't)**

67-70 (Conv.)	8747700	1	110.00	black
71-75 Pass. (Conv.)	9645123	1	36.50	gutter (black)
71-72 Impala (Conv.)	9645114	1	110.00	(white) must order zipper 9615837
71-72 Impala (Conv.)	9616928	1	104.00	black
71-75 Pass. (Conv.)	9645122	1	36.50	gutter (white)
73-75 Pass. (Conv.)	9645114	1	110.00	(white)
73-75 Pass. (Conv.)	9645115	1	110.00	(black)

**CHEVELLE**

68-69 (Conv.)	8774993	1	117.00	white
69-72 (Conv.)	8774994	1	117.00	black
70 Chevelle (Conv.)	8807046	1	118.00	white
71-72 Malibu (Conv.)	9850548	1	117.00	(white)

**CAMARO**

67-69 (Conv.)	7680368	1	103.00	black
71-75 Pass. (Conv.)	9640899	2	.93	PAD, front rail to rear bow
71-72 Impala (Conv.)	9615837	1	13.25	ZIPPER, back window

**13.349 LINING ASSY.— WASHER, Top Side Pad**

71-75 Pass. (Conv.)	9645100 R.H.	28.25	side qtr. pad (black)
71-75 Pass. (Conv.)	9645101 L.H.	28.25	side qtr. pad (black)
72-73 Pass. (Conv.)	9415113 A.R.	.11	WASHER, I.D. .510 O.D. .860 wave type— (4.037)

**13.352 WEATHERSTRIP, Folding Top Cover (on side belt rail)**

68-72 Chevelle (Conv.)	7724822 R.H.	3.80	side panel
68-72 Chevelle (Conv.)	7724823 L.H.	3.80	side panel
72-75 Pass. (Conv.)	9829353 R.H.	3.80	compt. side panel
72-75 Pass. (Conv.)	9829354 L.H.	3.80	compt. side panel

**13.365 TOP ASSY., Frame less trim**

71-75 Pass. (Conv.)	9612525	1	500.00	(black)
---------------------	---------	---	--------	---------

**13.384 FASTENER— RETAINER— CLIP, Fidg. Top and Dust Boot**

62-63 Nova (Conv.)	4841194 A.R.	.11	compt. bag. to body— (10.695)
62-72 All (Conv.),			
71 Chevelle (Conv.)	455520	4	.22 dust boot inner quarter fastener (8— 32 x 3/8")
62-75 All (Conv.) (exc. Nova)	4749582 A.R.	.22	dust boot cover
62-64 Nova (Conv.),			
65 Malibu (Conv.),			
65-66 Pass. (Conv.)	7595709 A.R.	.24	dust boot on belt (w/screw)
65-73 Pass. (Conv.)	4653672 A.R.	.11	compt. bag to body— (10.695)
65-67 Chevelle (Conv.),			
65-75 Pass. (Conv.)	7631319 A.R.	.24	dust boot pile ret. fastener w/screw
67-68 Pass. (Conv.)	7715568	22	.37 dust boot on belt
64-65 Malibu (Conv.)	4538285	16	.37 RETAINER, boot clip in boot (repl. 4458883)
66-69 Chevelle, Camaro (Conv.)	7664437 A.R.	.12	RETAINER, dust boot clip
71-75 Pass. (Conv.)	9838757 R.H.	4.45	RETAINER, rr./seat bk.
68-72 Chevelle (Conv.)	4868822	1	2.35 RETAINER, boot at rr. back
64-65 Malibu (Conv.)	4538284 A.R.	.32	CLIP, dust boot retainer (in boot)
66-67 Chevelle (Conv.)	7664975	4	.37 CLIP ASSY., dust boot at seam
67-69 Camaro (Conv.)	7663203	12	.31 CLIP ASSY., frt. and rr.
67-69 Camaro (Conv.)	7664436	4	.32 CLIP ASSY., ctr.
68 Chevelle (Conv.)	7740837	18	.37 CLIP ASSY., dust boot

**13.389 CURTAIN, Back (with glass)**

65-66 Pass. (Conv.)	4494721	1	170.00	black
67-70 Pass. (Conv.)	7700020	1	170.00	black
67-69 Pass. (Conv.)	7700024	1	170.00	white
67-69 Camaro (Conv.)	7703242	1	52.00	black
67-69 Camaro (Conv.)	7703243	1	52.00	white
68-72 Chevelle (Conv.) w/tntd. gls., rr. wind. unshaded	7772523	1	170.00	black
71-75 Pass. (Conv.)	9645084	1	143.00	(white) w/zipper
71-75 Pass. (Conv.)	9645085	1	143.00	(black) w/zipper

NOTE: Please specify color when ordering.

NOTE: When replacing Velcro-Type back wdo. curtain, Part Number 9615837 must be ordered.

**13.392 ZIPPER, F/Top Back Window**

72-75 Pass. (Conv.)	9615837	1	13.25
---------------------	---------	---	-------

**BODY WIRING—FOLDING TOP TRIM**

**13.395 CLIP— SUPPORT— BUSHING— LINK ASSY.— EXTENSION— PLATE,  
Folding Top Back Window**

65-67	Pass. (Conv.)	7595778	2	.12	glass support
71-75	Pass. (Conv.)	9838534	L.H.	.28	SUPPORT, glass inner
71-75	Pass. (Conv.)	9838533	R.H.	.28	SUPPORT, glass inner
71-75	Pass. (Conv.)	9888387	2	1.90	SUPPORT, back windo. glass link on w/h
71-75	Pass. (Conv.)	9888384	2	.16	BUSHING, rear qtr. trim retainer
71-75	Pass. (Conv.)	9888386	L.H.	10.40	LINK ASSY., glass guide control
71-75	Pass. (Conv.)	9888385	R.H.	10.40	LINK ASSY., glass guide control
72	Impala (Conv.)	9610318	L.H.	1.10	EXTENSION, hinge anchor plate on w/h
72	Impala (Conv.)	9845346	R.H.	3.10	PLATE, male hinge anchor
72	Impala (Conv.)	9610329	L.H.	2.65	PLATE, male hinge anchor

**13.450 BOOT, Top Dust (with Fasteners)**

**PASS.**

71-72	Impala (Conv.)	9865054	1	87.50	(comb. 806) (black)
71-72	Impala (Conv.)	9865055	1	87.50	(comb. 825) (dk. saddle)
73-74	Pass. (Conv.)	9646336	1	87.50	comb. 818, 819 (neutral)
73-74	Pass. (Conv.)	9646341	1	87.50	comb. 810, 816 (white)
74	Pass. (Conv.)	9646338	1	87.50	comb. 806 (black)
74	Pass. (Conv.)	9695027	1	87.50	comb. 855 (green)
75	Pass. (Conv.)	1677139	1	87.50	comb. 55W (sandstone)
75	Pass. (Conv.)	9646337	1	87.50	comb. 63E, 63W (saddle)
75	Pass. (Conv.)	1677140	1	87.50	comb. 11W, .02W, .04W, .07W) (white)

**CHEVELLE**

68	(Conv.)	7772514	1	87.50	black (comb. 765, 766) (765/158, 766/178)
69-72	(Conv.)	8766402	1	87.50	black (comb. 705, 706, 755, 756)
70	Malibu (Conv.)	8806909	1	87.50	(comb. 790, 791) (ivory)
72	Malibu (Conv.)	9893816	1	87.50	(comb. 743) (white)

**CAMARO**

67-69	(Conv.)	7680297	1	87.50	black (comb. 711, 712, 714, 760, 765, 767)
-------	---------	---------	---	-------	---

**13.450A BAG ASSY., Dust Boot Storage**

62-75	All (Conv.)	4485356	1	1.95	(polyethylene film) (black)
-------	-------------	---------	---	------	-----------------------------



# CHEVROLET BODY GROUP 14.000



## CONVERTIBLE TOP HARDWARE — INTERIOR TRIM — SEAT BELTS

### ALPHABETICAL INDEX

<b>A</b>		
ACTUATOR ASSY., Folding Top.....	14.475	
ARMATURE, Folding Top Motor and Pump....	14.482	
ARM REST ASSY., Arm Rest Front Seat.....	14.900	
<b>B</b>		
BALL, Folding Top Motor and Pump.....	14.482	
BASE ASSY., Belt Unit and Shoulder Strap Unit Components.....	14.875A	
BASE, Front Door Arm Rest.....	14.686	
BASE, Rear Door Arm-Less Tray.....	14.762	
BEARING, Folding Top.....	14.478	
BEZEL, Folding Top.....	14.483	
BEZEL, Instrument Panel.....	14.655A	
BOLT ASSY., Folding Top Hydraulic Motor and Pump.....	14.486	
BOLT, Belt Unit and Shoulder Strap Unit Components.....	14.875A	
BOLT, Folding Top Frame.....	14.155	
BOLT, Folding Top Front Roof Rail.....	14.080A	
BOLT, Folding Top No. 1-Center.....	14.215	
BOLT, Folding Top.....	14.310	
BOLT, Stop Folding Top-Rear.....	14.340	
BOOT, Belt Unit and Shoulder Strap Unit Components.....	14.875A	
BOW ASSY., Stop Folding Top-Rear.....	14.340	
BOW, Folding Top No. 1-Center.....	14.215	
BOW, Folding Top.....	14.130	
BOX, Front Door Trim Stowage.....	14.692	
BRACKET, Folding Top.....	14.483	
BRACKET, Instrument Panel Assist Handle....	14.660	
BRUSH, Folding Top Motor and Pump.....	14.482	
BUMPER, Folding Top Side Roof Rail.....	14.180	
BUSHING, Folding Top Motor and Pump.....	14.482	
BUSHING, Folding Top Side Roof Rail.....	14.160	
BUTTON ASSY., Seat Back and Trim Pad.....	14.804	
BUZZER, Belt Unit and Shoulder Strap Unit Components.....	14.875A	
<b>C</b>		
CABLE ASSEMBLY, Folding Top Trim Hold Down.....	14.102	
CABLE ASSY., Folding Top.....	14.475	
CABLE ASSY., Sliding Sunroof.....	14.550	
CAM ASSY., Folding Top Side Roof-Front.....	14.100	
CAP, Body Center Pillar (With Metal Inner Panel).....	14.730	
CAP, Folding Top Side Roof Rail-Rear.....	14.260	
CAP, Front Seat Side Trim (See Group 12.976 for 2nd and 3rd Seat Moulding and Escutcheon).....	14.818	
CAP, Lock Pillar Finishing.....	14.731	
CARRIER UNIT, Child Safety.....	14.870	
CATCH ASSY., Folding Top.....	14.310	
CLIP ASSY., Rear Quarter Upper-Above Belt..	14.645	
CLIP, Belt Unit and Shoulder Strap Unit Components.....	14.875A	
CLIP, Folding Top Side Roof Rail-Front.....	14.120	
CLIP, Folding Top.....	14.483	
CLIP, Front Seat Side Trim (See Group 12.976 for 2nd and 3rd Seat Moulding and Escutcheon).....	14.818	
CLIP, Headlining Finish and Back Window....	14.650	
CLIP, Headlining Trim.....	14.651A	
CLIP, Headlining Trim.....	14.651	
CLIP, Instrument Panel.....	14.655A	
CLIP, Roof Trim.....	14.640A	
CONTAINER, Belt Unit and Shoulder Strap Unit Components.....	14.875A	
COVER, Arm Rest Front Seat.....	14.900	
COVER ASSY., Front Door Arm Rest.....	14.686	
COVER ASSY., Front Seat Back Head Restraint.....	14.924	
COVER ASSY., Lock Pillar Finishing.....	14.731	
COVER ASSY., Rear Door Arm-Less Tray.....	14.762	
COVER, Belt Unit and Shoulder Strap Unit Components.....	14.875A	
COVER, Body Center Pillar (With Metal Inner Panel).....	14.730	
COVER, Folding Top Motor and Pump.....	14.482	
COVER, Front Door Trim Finish.....	14.691	
COVER, Instrument Panel Assist Handle.....	14.660	
COVER, Rear Door Trim Finish.....	14.764	
COVER, Seat Back.....	14.810	
COVER, Sliding Sunroof.....	14.550	
CUP, Door Arm Rest and Trim Pad.....	14.688	
CURTAIN, Arm Rest Front Seat.....	14.900	
<b>D</b>		
DEADENER, Seat Back.....	14.810	
DOOR, Belt Unit and Shoulder Strap Unit Components.....	14.875A	
<b>E</b>		
EMBLEM, Front Door Trim Finish.....	14.691	
EMBLEM, Rear Door Trim Finish.....	14.764	
ESCUTCHEON ASSY., Headlining Finish and Back Window.....	14.650	
ESCUTCHEON, Belt Unit and Shoulder Strap Unit Components.....	14.875A	
ESCUTCHEON, Folding Top.....	14.483	
ESCUTCHEON, Front Door Trim Finish.....	14.691	
ESCUTCHEON, Headlining Trim.....	14.651A	
ESCUTCHEON, Headlining Trim.....	14.651	
ESCUTCHEON, Rear Quarter Upper-Above Belt.....	14.645	
EXTENSION, Belt Unit and Shoulder Strap Unit Components.....	14.875A	
EXTENSION, Folding Top.....	14.310	

## ALPHABETICAL INDEX

### F

FASTENER, Belt Unit and Shoulder Strap Unit Components.....	14.875A
FASTENER, Body Center Pillar (With Metal Inner Panel).....	14.730
FASTENER, Folding Top Front Roof Rail.....	14.060
FASTENER, Folding Top Motor and Pump.....	14.482
FASTENER, Folding Top Side Roof Rail-Rear.....	14.260
FASTENER, Front Door Trim Binding Strip Replacement.....	14.683
FASTENER, Front Door Trim Finish.....	14.691
FASTENER, Instrument Panel.....	14.655A
FASTENER, Rear Door.....	14.760
FASTENER, Rear Quarter Upper-Above Belt.....	14.645
FASTENER, Seat Back and Trim Pad.....	14.804
FIELD ASSY., Folding Top Motor and Pump..	14.482

### G

GEAR.....	14.555
GEAR ASSY., Folding Top.....	14.478
GEAR, Folding Top Motor and Pump.....	14.482
GEAR & PINION ASSY., Folding Top.....	14.478
GROMMET, Folding Top Motor and Pump.....	14.482
GUIDE, Belt Unit and Shoulder Strap Unit Components.....	14.875A
GUIDE, Folding Top Hydraulic Motor and Pump.....	14.486
GUIDE, Folding Top Roof Rail.....	14.090
GUIDE, Sliding Sunroof.....	14.550

### H

HANDLE ASSY., Front Door Trim Finish.....	14.691
HANDLE ASSY., Instrument Panel Assist Handle.....	14.660
HANDLE ASSY., Instrument Panel.....	14.655A
HANDLE, Rear Door Trim Finish.....	14.764
HANDLE UNIT, Locking Sun Roof Panel Front Guide.....	14.570
HAND RAIL ASSY., Child Safety.....	14.870
HEADLINING ASSY.....	14.640
HEADLINING UNIT (Exc. Sun Roof).....	14.640
HEAD RESTRAINT ASSY., Front Seat Back Head Restraint.....	14.924
HINGE, Folding Top.....	14.310
HOLDER, Folding Top Motor and Pump.....	14.482
HOOK, Folding Top Front Roof Rail.....	14.080A
HOSE, Folding Top Motor to Operating Valve.....	14.472
HOUSING, Folding Top.....	14.483

### L

LACE ASSY., Body Lock Pillar.....	14.735
LACE, Body Center Pillar (With Metal Inner Panel).....	14.730
LACE, Headlining Finish and Back Window.....	14.650
LIFT ASSY., Folding Top.....	14.475
LINK, Folding Top Side Roof Rail Control.....	14.140
LOCK ASSY., Folding Top Front Roof Rail.....	14.080

### M

MOTOR ASSY., Folding Top.....	14.481
MOTOR, Sliding Sunroof.....	14.550
MOULDING, Belt Unit and Shoulder Strap Unit Components.....	14.875A
MOULDING, Body Center Pillar (With Metal Inner Panel).....	14.730

MOULDING, Door Arm Rest and Trim Pad.....	14.688
MOULDING, Front Door Trim Finish.....	14.691
MOULDING, Front Seat Side Trim (See Group 12.976 for 2nd and 3rd Seat Moulding and Escutcheon).....	14.818
MOULDING, Headlining Trim.....	14.651A
MOULDING, Instrument Panel.....	14.655A
MOULDING, Lock Pillar Finishing.....	14.731
MOULDING, Rear Door Trim Finish.....	14.764

### N

NUT, Belt Unit and Shoulder Strap Unit Components.....	14.875A
NUT, Front Door Arm Rest.....	14.686
NUT, Front Door Trim Binding Strip Replacement.....	14.683
NUT, Front Door Trim Finish.....	14.691
NUT, Instrument Panel.....	14.655A
NUT, Rear Door Arm-Less Tray.....	14.762
NUT, Rear Door Trim Finish.....	14.764
NUT, Roof Rail.....	14.157
NUT, Sliding Sunroof.....	14.550

### P

PACKAGE ASSY., Locking Sun Roof Panel Front Guide.....	14.570
PAD ASSY., Front Door Arm Rest.....	14.686
PAD ASSY., Front Seat Back.....	14.802
PAD ASSY., Front Seat Cushion.....	14.890
PAD ASSY., Instrument Panel.....	14.655
PAD ASSY., Roof Trim.....	14.640A
PAD, Child Safety.....	14.870
PAD, Front Seat Back Head Restraint.....	14.924
PAD, Rear Door Arm-Less Tray.....	14.762
PAD, Seat Back.....	14.810
PAD UNIT, Instrument Panel.....	14.655
PANEL ASSY., Front Door Trim Finish.....	14.691
PANEL ASSY., Rear Quarter Upper-Above Belt.....	14.645
PANEL, Cowl Trim.....	14.630
PANEL, Front Door.....	14.685A
PANEL, Lock Pillar Finishing.....	14.731
PANEL, Rear Door Trim Finish.....	14.764
PANEL, Rear Door.....	14.760
PANEL, Roof Trim.....	14.640A
PIN, Child Safety.....	14.870
PIN, Folding Top Front Roof Rail.....	14.080A
PINION, Folding Top Motor and Pump.....	14.482
PLATE ASSY., Folding Top Motor and Pump.....	14.482
PLATE, Belt Unit and Shoulder Strap Unit Components.....	14.875A
PLATE, Door Arm Rest and Trim Pad.....	14.688
PLATE, Door Arm Rest Trim.....	14.690
PLATE, Folding Top Side Roof.....	14.170
PLATE, Folding Top.....	14.310
PLATE, Front Door Trim Finish.....	14.691
PLATE, Front Door.....	14.685A
PLATE, Locking Sun Roof Panel Front Guide.....	14.570
PLATE, Rear Door Trim Finish.....	14.764
PLATE, Sliding Sunroof.....	14.550
PLUG, Belt Unit and Shoulder Strap Unit Components.....	14.875A
PLUG, Folding Top Hydraulic Motor and Pump.....	14.486
PLUG, Folding Top.....	14.478
PLUG, Front Door Trim Binding Strip Replacement.....	14.683
PLUG, Front Door.....	14.685A
PLUG, Rear Door Arm-Less Tray.....	14.762
PLUG, Roof Trim.....	14.640A
POCKET ASSY., Belt Unit and Shoulder Strap Unit Components.....	14.875A
PROTECTOR, Belt Unit and Shoulder Strap Unit Components.....	14.875A



## ALPHABETICAL INDEX

### R

RAIL ASSY., Folding Top Side Roof.....	14.170
RAIL ASSY., Folding Top Side Roof-Front.....	14.100
RAIL, Folding Top Front Roof.....	14.050
RAIL, Sliding Sunroof.....	14.550
RESERVOIR, Folding Top Hydraulic Motor and Pump.....	14.486
REST ASSY., Front Door Arm Rest.....	14.686
REST ASSY., Rear Door Arm-Less Tray.....	14.762
RETAINER ASM., Folding Top.....	14.478
RETAINER, Belt Unit and Shoulder Strap Unit Components.....	14.875A
RETAINER, Folding Top.....	14.130
RETAINER, Folding Top.....	14.475
RETAINER, Front Door Arm Rest.....	14.686
RETAINER, Front Door Trim Binding Strip Replacement.....	14.683
RETAINER, Front Door Trim Finish.....	14.691
RETAINER, Front Door.....	14.685A
RETAINER, Headlining Trim.....	14.651
RETAINER, Instrument Panel.....	14.655A
RETAINER, Rear Door Trim Finish.....	14.764
RETAINER, Rear Door.....	14.760
RETAINER, Roof Trim.....	14.640A
RETAINER, Seat Back and Trim Pad.....	14.804
RETAINER, Sun Roof Motor.....	14.560
RING, Folding Top.....	14.478
ROTOR, Folding Top Motor and Pump.....	14.482

### S

SCREW, Belt Unit and Shoulder Strap Unit Components.....	14.875A
SCREW, Child Safety.....	14.870
SCREW, Cowl Trim.....	14.630
SCREW, Folding Top Frame.....	14.155
SCREW, Folding Top Front Roof Rail.....	14.080A
SCREW, Folding Top.....	14.310
SCREW, Front Door Arm Rest.....	14.686
SCREW, Instrument Panel.....	14.655A
SCREW, Rear Door Arm-Less Tray.....	14.762
SCREW, Rear Door Trim Finish.....	14.764
SCREW, Sliding Sunroof.....	14.550
SCREW, Sun Roof Motor.....	14.560
SEAL, Folding Top Hydraulic Motor and Pump.....	14.486
SEAL, Folding Top Motor and Pump.....	14.482
SEAT ASSY, Front.....	14.896
SEAT BELT UNIT.....	14.875
SECTOR ASSY., Folding Top.....	14.478
SHAFT, Folding Top Motor and Pump.....	14.482
SHIM, Locking Sun Roof Panel Front Guide..	14.570
SHOULDER STRAP UNIT.....	14.875
SLEEVE, Seat Belt Deluxe.....	14.875B
SPACER, Belt Unit and Shoulder Strap Unit Components.....	14.875A
SPACER, Folding Top Roof Rail.....	14.090
SPACER, Folding Top.....	14.130
SPACER, Folding Top.....	14.475
SPACER, Instrument Panel.....	14.655A
SPACER, Locking Sun Roof Panel Front Guide.....	14.570
SPRING, Folding Top Front Roof Rail.....	14.080A
SPRING, Folding Top.....	14.475
STOP, Belt Unit and Shoulder Strap Unit Components.....	14.875A
STOP, Folding Top.....	14.310
STRAP ASSY., Front Door Trim Finish.....	14.691
STRAP, Belt Unit and Shoulder Strap Unit Components.....	14.875A
STRAP, Rear Door Trim Finish.....	14.764
STRIKER, Folding Top Front Roof Rail.....	14.080A
STRIP, Folding Top No. 1-Center.....	14.215
STRIP, Stop Folding Top-Rear.....	14.340
Sun Roof Motor.....	14.555
SUPPORT, Belt Unit and Shoulder Strap Unit Components.....	14.875A
SUPPORT, Folding Top Motor and Pump.....	14.482
SUPPORT, Folding Top.....	14.130

SUPPORT, Front Door Trim Binding Strip Replacement.....	14.683
SUPPORT, Sliding Sun Roof.....	14.565
SWITCH ASSY., Folding Top.....	14.483
SWITCH ASSY., Sliding Sun Roof.....	14.565

### T

TAB, Front Door Trim Binding Strip Replacement.....	14.683
TAB, Front Door.....	14.685A
TAB, Rear Door.....	14.760
TRIM ASSY., Bucket Seat Back (Passenger or Driver).....	14.800A
TRIM ASSY., Bucket Seats Cushion.....	14.880A
TRIM ASSY., Front Door (less arm rest).....	14.685
TRIM ASSY., Front Seat Back and Back of Back.....	14.800
TRIM ASSY., Front Seat Back Head Restraint.....	14.924
TRIM ASSY., Front Seat Bench Cushion Cover.....	14.880
TRIM ASSY., Lock Pillar Finishing.....	14.731
TRIM ASSY., Rear Door.....	14.760
TRIM ASSY., Rear Quarter Upper-Above Belt	14.645

### W

WASHER, Child Safety.....	14.870
WASHER, Folding Top Side Roof Rail.....	14.162
WASHER, Folding Top.....	14.478
WASHER, Sliding Sunroof.....	14.550
WASHER, Sun Roof Motor.....	14.560
WEATHERSTRIP, Folding Top Front Roof Rail.....	14.060
WEATHERSTRIP, Folding Top Side Roof Rail-Center.....	14.190
WEATHERSTRIP, Folding Top Side Roof Rail-Front.....	14.120
WEATHERSTRIP, Folding Top Side Roof Rail-Rear.....	14.260
WINDLACE ASSY., Body Center Pillar (With Metal Inner Panel).....	14.730
WIRE ASSY., Arm Rest Front Seat.....	14.900
WORM, Folding Top.....	14.478



**FOLDING TOP PARTS—INTERIOR TRIM**

**14.050 RAIL, Folding Top Front Roof**

68-72	Chevelle (Conv.)	7712520	1	66.75
67-69	Camaro (Conv.)	7702456	1	58.75
71-75	Impala (Conv.)	9827061	1	66.00

**14.060 WEATHERSTRIP— FASTENER, Folding Top Front Roof Rail**

**PASS.**

65	Conv.	4767086	1	7.80	front (black)
65	Conv.	7580350	1	7.80	front (black)
65-70	Conv.	4536998	2	.33	w/s header corner sealing
65-70	Conv.	7609510	1	11.65	front (repl. 4467868)
66-70	Conv.	7624669	1	7.80	front (black)
66-69	Conv.	7624671	1	7.80	front (white)
70	Impala (Conv.)	8803951	1	7.80	WEATHERSTRIP ASSY., front roof rail, front (white)
71-75	Impala (Conv.)	9833656	1	15.00	WEATHERSTRIP ASSY., front roof rail and compt.
71-75	Impala (Conv.)	7665021	1	15.00	WEATHERSTRIP ASSY., front roof rail, front (black)
71-75	Impala (Conv.)	9874067	1	11.55	WEATHERSTRIP ASSY., front roof rail, front (white)

**CHEVELLE**

65-67	Malibu (Conv.)	4536299	2	3.40	header corner sealing
64-65	Malibu (Conv.)	4406207	1	9.25	WEATHERSTRIP ASSY., front (no color)
68-72	(Conv.)	7773144	1	15.00	WEATHERSTRIP ASSY., front (black)
68-72	(Conv.)	7726803	1	20.65	WEATHERSTRIP ASSY., front
70-71	Chevelle (Conv.)	8803946	1	15.00	WEATHERSTRIP ASSY., front roof rail, front (white)
71-72	Chevelle (Conv.)	9874431	1	15.00	WEATHERSTRIP ASSY., front roof (white)

**CAMARO**

67-69	(Conv.)	7665022	1	15.00	WEATHERSTRIP ASSY., frt. (white)
67-69	(Conv.)	7665021	1	15.00	WEATHERSTRIP ASSY., frt. (black)
65-69	Pass., Chevelle, Camaro (Conv.)	4876498 A.R.		.12	FASTENER, front w/strip— (10.695)

**14.080 LOCK ASSY., Folding Top Front Roof Rail**

**PASS.**

65	Conv.	4506908	R.H.	13.10	
65	Conv.	4506909	L.H.	13.10	
68-70	Conv.	7762258	R.H.	12.80	frt. roof rail (painted)
66-70	Conv.	7762259	L.H.	12.80	frt. roof rail (painted)
71-75	(Conv.)	9623938	R.H.	13.50	
71-75	(Conv.)	9623939	L.H.	13.50	

**CHEVY**

62-63	Chevy (Conv.)	4813716	R.H.	14.95	
62-63	Chevy (Conv.)	4813717	L.H.	14.95	

**CHEVELLE**

64-65	Malibu (Conv.)	4484803	R.H.	11.45	painted
64-65	Malibu (Conv.)	4484804	L.H.	11.45	painted
66-67	(Conv.)	7590745	R.H.	12.80	painted
66-67	(Conv.)	7590746	L.H.	12.25	painted
68-70	(Conv.)	7762242	R.H.	12.70	painted
68-70	(Conv.)	7762243	L.H.	12.70	painted
71-72	(Conv.)	9842478	R.H.	13.35	
71-72	(Conv.)	9842479	L.H.	13.35	

**CAMARO**

67-69	(Conv.)	7762250	R.H.	12.05	painted
67-69	(Conv.)	7762251	L.H.	12.05	painted

**14.080A HOOK— BOLT— PIN— SCREW— SPRING— STRIKER, Folding Top Front Roof Rail**

64-69	Conv. (exc. Nova),				
70-72	Impala, Chevelle (Conv.)	5716613	2	1.05	lock handle
68	Chevelle (Conv.)	4402351	6	.22	BOLT, top male hinge to mtg. supt.
68-72	Chevelle (Conv.)	7723371	2	.76	BOLT, rail handle and lock
71-72	Impala (Conv.)	9871074	2	.40	PIN, side roof front rail lock
73-74	Caprice (Conv.)	9871074	2	.40	PIN, side roof front rail lock

**FOLDING TOP PARTS—INTERIOR TRIM**

**14.080A HOOK— BOLT— PIN— SCREW— SPRING— STRIKER, Folding Top Front Roof Rail (Con't)**

64-65	Malibu (Conv.),				
65-70	Pass. (Conv.)	7614625	1	.12	SCREW, handle and lock
70	Impala (Conv.)	5714492	2	.37	SPRING, lock handle return
66-69	Camaro, Chevelle (Conv.),				
70-72	Chevelle (Conv.)	9707561	2	.37	SPRING, lock handle return
68-72	Chevelle (Conv.)	7740912	R.H.	7.65	STRIKER, lock
68-72	Chevelle (Conv.)	7740913	L.H.	7.65	STRIKER, lock

**14.090 GUIDE— SPACER, Folding Top Roof Rail**

64-65	Malibu (Conv.),				
65-67	Pass. (Conv.),				
66-67	Chevelle (Conv.)	4550198	R.H.	.70	
66-67	Chevelle (Conv.)	4550199	L.H.	.63	
70	Chevelle (Conv.),				
70-72	Impala (Conv.)	7632169	A.R.	.91	left, side guide
67-69	Camaro (Conv.)	7644550	2	.52	SPACER, corner
68-72	Chevelle (Conv.)	7729377	1	.52	SPACER, center
71-75	Impala (Conv.)	9829697	1	1.10	SPACER

**14.100 RAIL ASSY— CAM ASSY., Folding Top Side Roof— Front**

**PASS.**

66-70	Conv.	7602401	R.H.	23.15	
66-70	Conv.	7602402	L.H.	26.00	
71-75	Pass. (Conv.)	9623923	R.H.	142.00	(complete)
71-75	Pass. (Conv.)	9623925	L.H.	142.00	(Note 2)
72-75	Pass. (Conv.)	9623958		1.00	CAM ASSY., lock on reinf.
72-75	Pass. (Conv.)	9623959		1.00	CAM ASSY., lock on reinf.

*NOTE 2: Use with Cam Assy. 9623959.*

**CHEVELLE**

68-70	(Conv.) w/power top	9801880	R.H.	83.25	front and center
68-70	Malibu (Conv.) w/power top	9801881	L.H.	83.25	front and center
71-72	(Conv.)	9842240	R.H.	92.50	(complete) (Note 1)
71-72	(Conv.)	9842241	L.H.	92.50	(complete) (Note 1)

*NOTE 1 Paint as reqd.*

**CAMARO**

67-69	(Conv.) (exc. elect. top)	7639042	R.H.	31.00	
67-69	(Conv.) w/elect. top	7639044	R.H.	31.00	
67-69	(Conv.) w/elect. top	7639045	L.H.	31.00	

**14.102 CABLE ASSEMBLY, Folding Top Trim Hold Down**

67-70	Pass. (Conv.)	7650196	R.H.	2.40	
67-70	Pass. (Conv.)	7650197	L.H.	2.40	
68-72	Chevelle (Conv.)	7756884	R.H.	2.85	
68-72	Chevelle (Conv.)	7756885	L.H.	2.85	
71	Impala (Conv.)	9868631	L.H.	6.60	fldg. top mat hold-down
71-72	Impala (Conv.)	9868630	2	6.60	material hold-down
72-75	Impala (Conv.)	9607018	R.H.	6.60	fldg. top mat hid. down
72-75	Impala (Conv.)	9607019	L.H.	6.60	fldg. top mat hid. down

**14.120 WEATHERSTRIP— CLIP, Folding Top Side Roof Rail— Front**

**PASS.**

65	Conv.	7589180	R.H.	8.70	
65	Conv.	3972329	L.H.	5.05	
68-70	Conv.	8715284	R.H.	9.85	
66-70	Conv.	8715285	L.H.	8.70	
71-75	(Conv.)	9829271	R.H.	17.35	
71-75	(Conv.)	9829272	L.H.	17.35	

**CHEVELLE**

68-72	(Conv.)	8715372	R.H.	8.70	(repl. 7783476)
68-72	(Conv.)	8715373	L.H.	8.70	(repl. 7783477)

71-75	Impala (Conv.)	9885448	2	.32	CLIP, front door window glass rtr. on side rail
-------	----------------	---------	---	-----	---

**14.130 SUPPORT— BOW— RETAINER— SPACER, Folding Top**

65-70	Pass. (Conv.)	4541724	2	1.10	frt. bow
68-72	Chevelle (Conv.)	9842476	1	12.80	BOW ASSY. (paint as reqd.)

**FOLDING TOP PARTS—INTERIOR TRIM**

**14.130 SUPPORT— BOW— RETAINER— SPACER, Folding Top (Con't)**

71-75	Impala (Conv.)	9607041		24.40	BOW ASSY., roof lks. (repl. 9842333)
68-72	Chevelle (Conv.)	7722722	1	1.30	RETAINER, frt. bow material
62-72	Conv.	4877298	4	.12	SPACER, front bow

**14.140 LINK, Folding Top Side Roof Rail Control**

67-69	Camaro (Conv.)	7639080	R.H.	6.55	
-------	----------------	---------	------	------	--

**14.155 BOLT— SCREW, Folding Top Frame**

62-72	Nova (Conv.) w/power top,				
65-70	Pass., Chevelle (Conv.),				
71	Chevelle (Conv.)	4867563	2	.70	top hinge side roof rr. rail to hinge
64-67	Chevelle (Conv.)				side roof rr. link and side roof ctr. to rr. rail,
65-70	Pass. (Conv.)				roof rail frt. bow supt. to link,
67-69	Camaro (Conv.)	4865925	A.R.	.18	cont. link to rr. rail (3/8"— 16 x 1/8")
64-66	Chevelle (Conv.),				
65-70	Pass. (Conv.)	9820098	A.R.	.28	rear bow control link to rr. rail bolt (3/8"— 16 x 1 1/8")
64-67	Chevelle (Conv.)				frt. rail link to rr. rail link,
65-70	Pass. (Conv.)	4865924	2	.52	side roof rail center to frt. link (3/8"— 16 x 61/64")
64-67	Chevelle (Conv.),				
67-69	Camaro (Conv.)				side roof front to center rail (3/8"— 16 x 7/32"),
65-70	Pass. (Conv.)	4410659	2	.18	frt. to control rail
68-69	Camaro (Conv.)				lift to rear rail,
66-67	Chevelle, Camaro (Conv.)				rr. rail to male hinge,
67-69	Camaro (Conv.) w/elect. top	7641987	2	.32	cont. link to frt. rail
69-70	Pass. (Conv.),				
71-72	Chevelle (Conv.)	4402351	A.R.	.22	folding top male hinge outer panel (3/8"— 16 x 1 1/4" hex. head w/1 1/8" O.D. tooth lock washer) (phos.)
67	Chevelle (Conv.),				
67-69	Camaro (Conv.)				center rail to male hinge,
69-75	Pass. (Conv.)	7695826	2	.24	side roof rail to male hge. bolt
69-74	Pass. (Conv.)	7695827	2		side roof rail to male hge. bushing
68-71	Chevelle (Conv.),				
69-72	Pass. (Conv.)	7723445	2	.52	top male hinge to lift shoulder
68-72	Chevelle (Conv.)	7723914	R.H.	.46	rear rail to center
68-72	Chevelle (Conv.)	7752669	2	.35	cont. link to rear rail
68-72	Chevelle (Conv.)	7723493	2	.52	top rear bow to male hinge
68-69	Chevelle (Conv.)				lift to rear rail,
68-70	Chevelle (Conv.)	4402351	A.R.	.22	top male hinge to mtg. supt., bolt (repl. 7793199)
68-72	Chevelle (Conv.)	7793604	2	.32	roof rail to male center rail
70-72	Chevelle (Conv.)	9820098	2	.28	rear bow to rail
71-75	Impala (Conv.)	9852059	2	.24	fldg. top front roof rail to side
71-75	Impala (Conv.)	9889123	2	.59	folding top rear rail to male hinge
71-75	Impala (Conv.)	9852065	A.R.	.32	fldg. top belt rail top striker hinge
71-75	Pass. (Conv.)	9633432	2	1.10	top control link
73-75	Pass. (Conv.)	7785359	6	.21	actu. to male hge.
62-70	All (Conv.),				
71-72	Chevelle (Conv.)	4412619	4	.18	SCREW, top front bow slat iron (1/4"— 28 x 3/4")
68-72	Chevelle (Conv.)	7759492	2	.32	SCREW, side roof front rail hinge
71-72	Impala (Conv.),				
75	Pass.	9432590	4	.16	SCREW, fldg. top front roof rail handle— (8.913)
71	Impala (Conv.)	9875489	2	.46	SCREW, actuator to fldg. top male hinge
71-75	Impala (Conv.)	7785359	2	.21	SCREW, fldg. top actuator to hinge
71-75	Impala (Conv.)	9857950	2	1.35	SCREW, fldg. top actuator to rear link
71-75	Impala (Conv.)	9862635	2	1.45	SCREW, fldg. top male hinge to qtr. inner
73-75	Impala (Conv.)	9888389	2	.32	SCREW, ctr. bow link rr. bow

**14.157 NUT, Roof Rail**

All	Conv. (exc. Pass.)	9422297	A.R.	.17	rr. rail to lift— (8.917)
71	Impala (Conv.)	9870851	2	.24	fldg. top male hinge to qtr. inner
72-75	Impala (Conv.)	8745810	2	.22	fldg. top male hinge to qtr. inner— (12.184)
72-75	Impala (Conv.)	9889124	2	.34	fldg. top rear rail to male hinge

**14.160 BUSHING, Folding Top Side Roof Rail**

62-63	Nova (Conv.) w/power top,				
64-65	Chevelle (Conv.) w/power top				rr. rail to lift,

## FOLDING TOP PARTS—INTERIOR TRIM

### 14.160 BUSHING, Folding Top Side Roof Rail (Con't)

66-70	Chevelle, Camaro (Conv.) w/power top				fldg. top lift to rr. rail,
65-69	Conv. (exc. Camaro),				
71-72	Chevelle (Conv.)	4613551 A.R.	.25		left to rr. rail ( $\frac{3}{8}$ " I.D. x $\frac{1}{2}$ " O.D.— $\frac{1}{2}$ " dia. hd.— $\frac{11}{32}$ " long shoulder)
62-64	All (Conv.),				
65-70	Pass. (Conv.)	4613555	2	.25	rear rail to male hinge bushing ( $\frac{1}{2}$ " x $\frac{3}{4}$ " O.L. w/ $\frac{15}{16}$ " dia. hd.)
62-67	Chevelle (Conv.),				
68-70	Pass., Camaro (Conv.)	4614589	2	.24	to center rail ( $\frac{1}{2}$ " lg. x $\frac{1}{2}$ " O.D.)
66-69	Chevelle, Camaro (Conv.) w/power folding top				fldg. top male hinge to lift bushing, top rear bow to rear rail bushing, top control link to rear rail bushing,
65-70	Chevelle (Conv.)				
67-69	Camaro (Conv.)				
67-69	Pass. (Conv.),				
71-72	Chevelle (Conv.)	4865916 A.R.	.16		fldg. top lift to male hinge bushing
62-65	Conv. (exc. Pass.),				
66-67	Chevelle (Conv.)				A.R.
65-66	Pass. (Conv.)	4865922	2	.52	center to rr. rail, side roof ctr. to rr. rail ( $\frac{3}{8}$ " I.D. x $\frac{1}{2}$ " O.D.— $\frac{1}{2}$ " dia. hd.— $\frac{11}{32}$ " long shoulder)
64-65	Malibu (Conv.) w/power top				male hinge to lift,
67-69	Camaro (Conv.)				rr. bow to rear rail,
68-70	Pass. (Conv.)	4865920	4	.18	No. 1 bow link male hinge to lift connecting link to rr. rail
65-70	Pass. (Conv.)	4726864	2	.12	rr. bow to male hinge, rr. bow connecting link to rr. rail
64-65	Malibu (Conv.)				frt. rail link to rear rail link,
66-67	Chevelle (Conv.) w/power top				top cont. link to frt. link,
65-70	Pass. (Conv.)	4408326	2	.18	center to frt. link
64-65	Malibu (Conv.)				roof rail front bow supt. to link,
66-67	Chevelle (Conv.) w/power top				side roof rail frt. link to supt.,
65-70	Pass. (Conv.)	4408329	2	.18	frt. link to supt.
67	Chevelle (Conv.)				top center rail to male hinge,
68-69	Camaro (Conv.),				
69-70	Pass. (Conv.)	9633432	2	1.10	side roof rail to male hinge
71-73	Pass. (Conv.)	9852064	2	1.10	control link hinge
66-72	Chevelle (Conv.),				
67-69	Camaro (Conv.)	7595835	2	.12	rr. rail to male hinge
67-69	Camaro (Conv.)	7641989	2	.32	side roof rr. to ctr. rail
68-72	Chevelle (Conv.)	7793606	2	.63	roof rail to male hinge center rail
68-72	Chevelle (Conv.)	4654306	2	.12	top rear bow to male hinge
68-72	Chevelle (Conv.)	7799217	2	.28	rear rail to center rail
71-75	Impala (Conv.)	9838057	2	.22	front roof rail to side
71-75	Impala (Conv.)	9883933	4	.58	rear rail to male hinge
71-75	Impala (Conv.)	9852066	4	.22	bow assy. to male hinge upper f/top ctr. bow link to rear
71-75	Impala (Conv.)	9888383	2	.16	back window guide link w/h
71-75	Impala (Conv.)	9852067 A.R.	.22		rear bow to t/stk., f/top t/stk. center bow and rail
71-75	Impala (Conv.)	9619442	2	.28	bow to male hinge lower

### 14.162 WASHER, Folding Top Side Roof Rail

65	Chevelle (Conv.)				front bow support to link
65-66	Pass. (Conv.)				link to support washer
67-69	Camaro (Conv.)				top cont. link to rear rail washer
67	Pass. (Conv.)				front bow support to link,
68-70	Chevelle (Conv.)				top cont. link to rear rail washer,
68-70	Chevelle (Conv.)				top rear bow to rear rail washer,
68-70	Chevelle (Conv.)				top rear bow to male hinge washer,
71-72	Chevelle (Conv.)				top rear bow to rear rail washer,
71-72	Chevelle (Conv.)				top rear bow to male hinge washer
66-68	Chevelle (Conv.) w/power top				link to support washer
67	Camaro (Conv.) w/power top	4574151 A.R.	.12		control link to front rail washer (repl. 4414102)
67-69	Pass. (Conv.)	9428369	2	.12	side roof ctr. to rr. rail washer
66-67	Chevelle (Conv.),				
67-69	Camaro (Conv.)				center rail to male hinge,
69	Conv.,				
70	Impala (Conv.)	4474829	2	.12	side roof rail to male hinge
68	Chevelle (Conv.),				
71-72	Chevelle (Conv.)	7793605	2	.63	male hinge center rail
71-72	Impala (Conv.)	120388	2		rear control link to hinge
71-74	Impala (Conv.)	120392	4		back window guide link with glass
73-74	Pass. (Conv.)	431530	2	.07	front bow and link rail

**FOLDING TOP PARTS—INTERIOR TRIM**

**14.170 RAIL ASSY.— PLATE, Folding Top Side Roof**

NOTE: For 1973-75 See Groups 14.100, 14.340.

**CENTER**

67-69	Camaro (Conv.) w/power top . . .	7639062 R.H.	36.50	right ctr. . . . .
67-69	Camaro (Conv.) w/power top . . .	7639063 L.H.	40.25	left ctr. . . . .

**REAR**

67-69	Camaro (Conv.) . . . . .	7639074 R.H.	33.50	right . . . . .
67-69	Camaro (Conv.) . . . . .	7639075 L.H.	37.50	left . . . . .
69-70	Pass. (Conv.) . . . . .	8712120 R.H.	37.25	right . . . . .
70	Chevelle (Conv.) w/power top . .	9801880 R.H.	83.25	right rear— (14.100) . . . . .
68-70	Chevelle (Conv.) w/power top . .	9801881 L.H.	83.25	left rear— (14.100) . . . . .
65-67	Pass. (Conv.) . . . . .	4426757 R.H.	.72	PLATE, right rr. bow wedge— (10.584) . . . . .
65-67	Pass. (Conv.) . . . . .	4426758 L.H.	.72	PLATE, left rr. bow wedge— (10.584) . . . . .

**14.180 BUMPER, Folding Top Side Roof Rail**

67-69	Camaro (Conv.) . . . . .	4868380	2	.18	(11.620) . . . . .
-------	--------------------------	---------	---	-----	--------------------

**14.190 WEATHERSTRIP, Folding Top Side Roof Rail— Center**

65	Pass. Conv. . . . .	4506662	1	7.55	right . . . . .
65	Pass. Conv. . . . .	4506663	1	7.55	left . . . . .
66-70	Pass. Conv. . . . .	7619496	1	7.55	right . . . . .
66-70	Pass. Conv. . . . .	7619497	1	7.55	left . . . . .
66-67	Chevelle (Conv.) . . . . .	4548206	L.H.	7.55	
68-72	Chevelle (Conv.) . . . . .	7783478	R.H.	8.70	
68-72	Chevelle (Conv.) . . . . .	7783479	L.H.	8.70	
67-69	Camaro (Conv.) . . . . .	7645432	R.H.	7.55	
67-69	Camaro (Conv.) . . . . .	7645433	L.H.	7.55	

**14.215 BOW— BOLT— STRIP, Folding Top No. 1— Center**

67-69	Camaro (Conv.) . . . . .	7762146	1	9.10	
71	Pass. (Conv.) . . . . .	9841439	1	46.75	
72-75	Pass. (Conv.) . . . . .	9607024	1	46.75	
68-72	Chevelle (Conv.) . . . . .	9842477	1	10.90	
72	Impala (Conv.) . . . . .	9607031	1	.28	BOLT, fldg. top ctr. bow act. cable . . . . .
72-75	Pass. (Conv.) . . . . .	9888301	A.R.	1.30	STRIP, fldg. top center bow skid . . . . .

**14.260 WEATHERSTRIP— FASTENER— CAP, Folding Top Side Roof Rail— Rear**

65-68	Pass. (Conv.) . . . . .	4506666	R.H.	7.55	
65-68	Pass. (Conv.) . . . . .	4506667	L.H.	7.55	
66-67	Chevelle (Conv.) . . . . .	4548208	L.H.	7.55	
68-72	Chevelle (Conv.) . . . . .	8796920	R.H.	7.55	
68-72	Chevelle (Conv.) . . . . .	8796921	L.H.	7.55	
71-75	Impala (Conv.) . . . . .	9882676	R.H.	7.55	
71-75	Impala (Conv.) . . . . .	9882677	L.H.	7.55	
69-70	Pass. (Conv.) . . . . .	8715959	L.H.	11.30	WEATHERSTRIP ASSY. . . . .
62-70	All (Conv.) . . . . .	4866841	2	.12	FASTENER, weatherstrip rear . . . . .
65	Pass. (Conv.) . . . . .	4725264	4	.12	CAP, weatherstrip screw protector— (12.977) . . . . .

**14.310 HINGE— BOLT— CATCH ASSY.— EXTENSION— PLATE— SCREW— STOP, Folding Top**

67-69	Camaro (Conv.) . . . . .	7639104	L.H.	7.35	male . . . . .
71	Impala (Conv.) . . . . .	9835048	R.H.	16.40	
71	Impala (Conv.) . . . . .	9835049	L.H.	16.40	
69-72	Chevelle (Conv.) . . . . .	8746493	R.H.	11.60	HINGE ASSY., male . . . . .
69-72	Chevelle (Conv.) . . . . .	8746494	L.H.	11.10	HINGE ASSY., male . . . . .
73-75	Pass. (Conv.) . . . . .	9896761	R.H.	17.45	HINGE ASSY. . . . .
73-75	Pass. (Conv.) . . . . .	9896763	L.H.	17.45	HINGE ASSY. . . . .
71	Impala (Conv.) . . . . .	4409370	R.H.	.21	BOLT (3/8" — 16 x 1 1/8") . . . . .
67-69	Camaro (Conv.) . . . . .	7658403	R.H.	5.65	CATCH ASSY., ctr. rail . . . . .
67-69	Camaro (Conv.) . . . . .	7658404	L.H.	5.65	CATCH ASSY., ctr. rail . . . . .
68-70	Chevelle (Conv.) . . . . .	7739959	2	4.30	CATCH ASSY., center rail . . . . .
72-75	Impala (Conv.) . . . . .	9849691	R.H.	1.60	EXTENSION, hge. anc. plt. on w/house . . . . .
71-75	Pass. (Conv.) . . . . .	9610318	L.H.	1.10	EXTENSION, hinge anchor plate on w/house . . . . .
72-75	Impala (Conv.) . . . . .	9896762	R.H.	11.70	PLATE, f/top hge. r/cont. link adj. . . . .
72-75	Impala (Conv.) . . . . .	9896764	L.H.	10.10	PLATE, f/top male hge. r/cont. . . . .
71-75	Pass. (Conv.) . . . . .	9845346	R.H.	3.10	PLATE, fldg. top male hinge anchor . . . . .
71-75	Pass. (Conv.) . . . . .	9610329	L.H.	2.65	PLATE, fldg. top male hinge anchor . . . . .
71	Pass. (Conv.) . . . . .	9888381	R.H.	10.20	PLATE, fldg. top hinge rear connecting link . . . . .
71	Pass. (Conv.) . . . . .	9888382	L.H.	8.65	PLATE, fldg. top hinge rear connecting link . . . . .

**FOLDING TOP PARTS—INTERIOR TRIM**

**14.310 HINGE— BOLT— CATCH ASSY.— EXTENSION— PLATE— SCREW— STOP, Folding Top (Con't)**

64	Malibu (Conv.)	9420587	3	.05	SCREW, fldg. top material to frt. bow
71-75	Pass. (Conv.)	9888303	L.H.	1.70	STOP, rear rail inner to outer left
71-75	Pass. (Conv.)	9888302	R.H.	1.55	STOP, rear rail inner to outer right

**14.340 BOW ASSY.— BOLT— STRIP, Stop Folding Top— Rear**

71-75	Impala (Conv.)	9846022	1	11.95	fldg. top rear
72	Impala (Conv.)	9607024	1	46.75	fldg. top cvr.
68-72	Chevelle (Conv.)	9842480	1	28.25	paint as reqd.

71	Impala (Conv.)	9852065	A.R.	.32	BOLT, folding top belt rail top striker hinge and bowunit to male hinge upper and lower— (14.155)
----	----------------	---------	------	-----	---

72-75	Impala (Conv.)	9890569	A.R.	1.30	STRIP, fldg. rr. bow skid
-------	----------------	---------	------	------	---------------------------

**14.472 HOSE, Folding Top Motor to Operating Valve**

63-72	Pass. (Conv.)	9812605	1	18.60	hyd. pump to top and bottom of lift (repl. 9812602)
-------	---------------	---------	---	-------	---

64-67	Chevelle, Camaro (Conv.) w/power top,				
68-69	Camaro (Conv.) w/power top	4881617	2	25.25	to bottom of lift hose
64-67	Chevelle (Conv.) w/power top	4888523	1	17.95	to top of lift
68-70	Chevelle (Conv.) w/power top	7727003	1	16.00	pump to top of lift
67-69	Camaro (Conv.)	7794131	1	15.05	pump to lift cyl. lower
71-72	Chevelle (Conv.)	9812601	1	30.25	pump to cylinder lower

**14.475 LIFT ASSY.— ACTUATOR ASSY.— CABLE ASSY.— RETAINER— SPRING— SPACER, Folding Top**

*NOTE. Use Delco No. 11 Brake Fluid for Hydraulic Lift. See Group 4.683.*

65-70	Pass. (Conv.)	9812596	2	50.25	hydraulic
64-67	Chevelle (Conv.) w/power lift	4407818	2	46.50	hydraulic
62-63	Nova (Conv.) w/power top	4865340	2	54.25	hydraulic
67-69	Camaro (Conv.) w/power top	7704518	2	48.75	hydraulic
68-72	Chevelle (Conv.) w/power top	9812594	2	48.75	fldg. top hyd.
72-75	Impala (Conv.)	9606712	R.H.	70.50	ACTUATOR ASSY.
72-75	Impala (Conv.)	9606713	L.H.	70.50	ACTUATOR ASSY.
71	Impala (Conv.)	9882562	R.H.	69.00	ACTUATOR ASSY.

71-75	Impala (Conv.)	9874738	R.H.	5.70	CABLE ASSY., actuator side
71-75	Impala (Conv.)	9874739	L.H.	5.70	CABLE ASSY., actuator side

72-75	Impala (Conv.)	9606157	2	.22	RETAINER, f/top actu. link bolt
-------	----------------	---------	---	-----	---------------------------------

71-75	Impala (Conv.)	9845368	2	1.55	SPRING, actuator
-------	----------------	---------	---	------	------------------

**14.478 BEARING— GEAR ASSY.— GEAR & PINION ASSY.— PLUG— RETAINER ASM.— RING— SECTOR ASSY.— WASHER— WORM, Folding Top**

72-75	Pass. (Conv.)	9839137	2	.32	rr. worm
72-75	Pass. (Conv.)	9839138	2	.32	frt. worm
72-75	Pass. (Conv.)	9607047	R.H.	8.05	GEAR ASM., actu. worm
72-75	Pass. (Conv.)	9607048	L.H.	8.05	GEAR ASM., actu. worm
72-75	Pass. (Conv.)	9839139	2	7.10	GEAR & PINION ASM., fldg. top actu.
72-75	Pass. (Conv.)	9703043	2	.12	PLUG, fldg./top actu. thrust
72-75	Pass. (Conv.)	9870925	2	.32	RETAINER ASM., w/balls fldg./top actu.
72	Pass. (Conv.)	9433036	2	.24	RING, f/top actu. cvr. asm.-ret.
72-75	Pass. (Conv.)	9876982	1	13.65	SECTOR ASM., fldg./top actu. shft.
72-75	Pass. (Conv.)	9876983	1	13.65	SECTOR ASM., fldg./top actu. shft.
72-75	Pass. (Conv.)	4306906	2	.18	WASHER, fldg. top actu.
72-75	Pass. (Conv.)	9882560	R.H.	3.65	WORM, fldg./top actu.
72-75	Pass. (Conv.)	9882561	L.H.	3.65	WORM, fldg./top actu.

**14.481 MOTOR ASSY., Folding Top**

65-70	Chevelle, Camaro (Conv.) w/power top,				
71-72	Chevelle (Conv.)	5044586	1	47.85	hydraulic
64-70	Chevelle, Camaro (Conv.) w/power top,				
71-72	Chevelle (Conv.)	7710923	1	109.00	w/pump, hydraulic
65-70	Pass. (Conv.)	7598791	1	110.00	w/pump, hydraulic
65-70	Pass. (Conv.)	5044611	1	47.85	w/o pump
71-75	Impala (Conv.)	5045632	1	39.45	actuator



**FOLDING TOP PARTS—INTERIOR TRIM**

**14.482 ARMATURE— BALL— BRUSH— BUSHING— COVER— FASTENER— FIELD ASSY.— GEAR— GROMMET— HOLDER— PLATE ASSY.— PINION— ROTOR— SEAL— SHAFT— SUPPORT, Folding Top Motor and Pump**

65-70	Pass. (Conv.),					
62-72	Chevelle Conv. w/power top,					
67-69	Camaro (Conv.)	4910507	1	14.95	hydraulic pump motor	
65-70	Pass. (Conv.),					
65-70	Chevelle (Conv.),					
67-69	Camaro (Conv.)	4912687	2	.25	BRUSH, hydraulic pump motor	
68	Pass. (Conv.)				BUSHING, hyd. lift upper support clevis pin,	
70	Impala (Conv.)				hyd. pkg. unit to rear rail bushing,	
70	Chevelle (Conv.) w/power top	4613551	1	.25	to lift bushing— (14.160)	
65-70	Pass. (Conv.),					
64-65	Malibu (Conv.),					
66-70	Chevelle, Camaro (Conv.)	104918	4	.11	BALL, hydraulic pump (steel)	
71-75	Impala (Conv.)	9839093	1	.59	BUSHING, reduction unit	
71-75	Impala (Conv.)	9839091	1	5.10	COVER, reduction unit	
73-74	Pass. (Conv.)	3698109	3	.24	FASTENER, motor red unit	
65-70	Pass. (Conv.),					
65-72	Chevelle Conv.,					
67-69	Camaro (Conv.)	4912446	1	13.20	FIELD ASSY., hydraulic pump motor	
71-75	Impala (Conv.)	9839092	1	3.15	GEAR, reduction unit	
62-69	Conv.,					
70-75	Pass. (Conv.)	3698109	4	.24	GROMMET, hydraulic pump mtg. (rubber— 1/2")	
64-70	Chevelle, Camaro (Conv.) w/power top,					
71-72	Chevelle (Conv.)	4914315	1	6.85	HOLDER, w/case, hydraulic pump motor brush (includes circuit breaker)	
65-72	Chevelle (Conv.),					
65-70	Pass. (Conv.),					
67-69	Camaro (Conv.)	4401295	1	6.00	PLATE ASSY., hydraulic pump cover	
71-75	Impala (Conv.)	9839089	1	2.60	PINION, reduction unit	
65-72	Chevelle (Conv.),					
65-70	Pass. (Conv.),					
67-69	Camaro (Conv.)	4868622	1	2.15	ROTOR, pump motor inner	
65-72	Chevelle (Conv.),					
65-70	Pass. (Conv.),					
71-72	Camaro (Conv.)	4868623	1	2.25	ROTOR, pump motor outer	
65-70	Pass. (Conv.),					
65-72	Chevelle (Conv.),					
67-69	Camaro (Conv.)	4868618	1	.58	SEAL, hyd. pump mtr. shaft	
67-69	Camaro (Conv.),					
65-70	Pass. (Conv.),					
65-72	Chevelle (Conv.)	4666766	2	.18	SEAL, hyd. motor hose to motor	
71-75	Impala (Conv.)	9839090	1	5.60	SHAFT, reduction unit	
71-75	Impala (Conv.)	9837408	1	7.50	SUPPORT, fldg. top motor	

**14.483 SWITCH ASSY.— BEZEL— BRACKET— CLIP— HOUSING— ESCUTCHEON, Folding Top**

62-63	Nova (Conv.)	3814719	1	3.65	(10.777)	
65	Conv.,					
68	Impala (Conv.)		1		(control) w/o escutcheon— (12.195)	
64-66	Chevelle (Conv.),					
68	Camaro (Conv.),					
68	Malibu, S.S. (Conv.)	3840095	1	5.10	(12.195)	
67	Chevelle, Camaro (Conv.),					
67-68	Pass. (Conv.)	3906118	1	2.20	(12.195)	
69-70	Impala (Conv.),					
69	Camaro, Malibu (Conv.) w/power top	3959230	1	4.15	(12.195)	
71-74	Impala (Conv.)	6270643	1	3.70	(12.195)	
70-72	Chevelle (Conv.) w/power top	3973644	1	4.00		
65-66	Pass. (Conv.),					
64-68	Chevelle (Conv.),					
67-68	Camaro (Conv.),					
71-75	Impala (Conv.)	3986867	1	2.25	BEZEL, switch	
69	Camaro, Malibu (Conv.) w/power top,					
69	Impala (Conv.)	3937660	1	1.55	BEZEL, switch	
70	Impala (Conv.) (exc. rear wdo. defroster and defogger)	3973660	1	1.80	BEZEL, switch	
70	Pass., Chevelle (Conv.) (exc. rear window defogger),					
71-72	Chevelle (Conv.)	3973641	1	2.25	BEZEL, switch	
70-72	Chevelle (Conv.) w/power top	3973645	1	.25	BRACKET, switch	

**FOLDING TOP PARTS—INTERIOR TRIM**

**14.483 SWITCH ASSY.— BEZEL— BRACKET— CLIP— HOUSING— ESCUTCHEON, Folding Top (Con't)**

62-68	Camaro (Conv.),				
64-68	Malibu, S.S. (Conv.) w/power top,				
65-68	Pass. (Conv.)	4154886	4	.24	CLIP, switch retainer— (10.777)
68	Impala (Conv.)	3921418	1	1.45	HOUSING, control switch— (12.195)
69-70	Camaro, Malibu (Conv.) w/power top	3937659	1	1.60	HOUSING, switch
65-66	Pass. (Conv.),				
64-67	Chevelle (Conv.),				
68	Impala (Conv.)	3840096	1	1.75	ESCUTCHEON, control top switch— (12.195)

**14.486 RESERVOIR— BOLT ASSY.— GUIDE— SEAL— PLUG, Folding Top Hydraulic Motor and Pump**

*NOTE. Use Delco No. 11 Brake Fluid for Hydraulic Lift. See Group 4.683.*

64-72	Chevelle, Camaro (Conv.)	7728615	1	6.80	
65-70	Pass. (Conv.),				
64-65	Malibu (Conv.),				
65-70	Chevelle, Camaro (Conv.),				
71-72	Chevelle (Conv.)	7596441	1	.83	BOLT ASSY., reservoir
75	Chevelle (Coupe) w/elec. sunroof	1710890	2	.07	GUIDE, sunroof sldg. pnl. frt. (inter-locking 2nd type)
65-70	Pass. (Conv.),				
65-72	Chevelle (Conv.),				
67-69	Camaro (Conv.)	4666395	2	.76	SEAL, reservoir
65-70	Pass. (Conv.),				
71-72	Chevelle (Conv.)	7596442	1	.53	PLUG, reservoir filler

**14.550 CABLE ASSY.— COVER— GUIDE— MOTOR— NUT— PLATE— RAIL— SCREW— WASHER, Sliding Sunroof**

73-74	Chevelle (Coupe) w/elec. sun roof	9652094 L.H.		18.90	sliding panel guide
73-75	Chevelle (Coupe) w/elec. sun roof	1695494 R.H.		18.90	CABLE ASSY., sliding panel guide (repl. 9652093)
75	Chevelle (Coupe) w/elec. sun roof	1695495 L.H.		18.90	CABLE ASSY., sliding panel guide
73-75	Chevelle (Coupe) w/elec. sun roof	9652086	1	2.60	COVER, panel cable front
73-75	Chevelle (Coupe) w/elec. sun roof	9652087	1	3.15	GUIDE, cable
73-75	Chevelle (Coupe) w/elec. sun roof	1657738	1	3.15	GUIDE, panel cable center
73-75	Chevelle (Coupe) w/elec. sun roof	9652111	2	3.90	GUIDE, panel front 1st type
73-75	Chevelle (Coupe) w/elec. sun roof	9652110	1	91.50	MOTOR ASSY., panel front
73-75	Chevelle (Coupe) w/elec. sun roof	9667512	2	2.15	NUT, panel front adjuster
73	Chevelle (Coupe) w/elec. sun roof	9660366	2	.53	NUT, panel rear guide adj.
74-75	Chevelle (Coupe) w/elec. sun roof	1695497	2	.81	NUT, panel rear guide adj.
73-75	Chevelle (Coupe) w/elec. sun roof	9661619	1	.64	PLATE, guide cable
73-75	Chevelle (Coupe) w/elec. sun roof	9660360	2	.24	PLATE, panel rear guide
73-75	Chevelle (Coupe) w/elec. sun roof	9652088 R.H.		8.30	RAIL, guide panel
73-75	Chevelle (Coupe) w/elec. sun roof	9652089 L.H.		8.30	RAIL, guide panel
75	Chevelle (Coupe) w/elec. sun roof	1710888 R.H.		14.95	RAIL, sliding pnl. guide (2nd type rail must use w/guide p/n 1710890) (inter-locking rail)
75	Chevelle (Coupe) w/elec. sun roof	1710889 L.H.		14.95	RAIL, sliding pnl. guide (2nd type rail must use w/guide p/n 1710890) (inter-locking rail)
73	Chevelle (Coupe) w/elec. sun roof	9660367	2	.73	SCREW, panel guide adj.

**FOLDING TOP PARTS—INTERIOR TRIM**

**14.550 CABLE ASSY.— COVER— GUIDE— MOTOR— NUT— PLATE— RAIL— SCREW— WASHER, Sliding Sunroof (Con't)**

74-75	Chevelle (Coupe) w/elec. sun roof	1695498	1	.73	SCREW, panel guide adj.
73	Chevelle (Coupe) w/elec. sun roof	9691616	2	.08	WASHER, rear guide plate adj.
75	Chevelle (Coupe)	1665847	2	.10	WASHER, rear guide plate adj.

**14.555 GEAR— Sun Roof Motor**

73-75	Chevelle (Coupe)	9726474	1	1.90	pinion drive
-------	------------------	---------	---	------	--------------

**14.560 RETAINER— SCREW— WASHER, Sun Roof Motor**

73-75	Chevelle (Coupe)	9726475	1	.28	pinion drive
73-75	Chevelle (Coupe)	9728383	1	.93	SCREW, hdl. at elect. mtr. emer.
73-75	Chevelle (Coupe)	9667517	4	.24	WASHER, clutch at elec. motor
73-75	Chevelle (Coupe)	9728384	1	.22	WASHER, lock emer. hdl. elec. mtr.

**14.565 SUPPORT— SWITCH ASSY., Sliding Sun Roof**

73-75	Chevelle (Coupe) w/elec. sun roof	9657820	1	.62	switch
73-75	Chevelle (Coupe) w/elec. sun roof	9657819	1	10.80	SWITCH ASSY., roof at w/shdr.

**14.570 HANDLE UNIT— PACKAGE ASSY.— PLATE— SHIM— SPACER, Locking Sun Roof Panel Front Guide**

72-73	Nova (2-Dr.)	490592	1	52.75	w/pivot hub
73-75	Chevelle (Coupe)	9677183	1	5.75	PACKAGE ASSY., wrench elec. sun roof clsg.
73-75	Chevelle (Coupe) w/elec. sun roof	9672143	2	.58	PLATE
74-75	Chevelle (Coupe) w/elec. sun roof	1658425	1	1.90	SHIM, door to rf. fr. sldg. pnl. hsg.
73-75	Chevelle (Coupe) w/elec. sun roof	9664976	1	.18	SPACER, sliding panel

**14.630 PANEL— SCREW, Cowl Trim**

*NOTE. Paint to match trim.*

**PASS.**

71-75	Pass. (exc. C.A.C.)	9844058	R.H.	3.10	side finish
71-75	Pass. (exc. C.A.C.)	9844059	L.H.	3.85	side finish
71-75	Pass. w/C.A.C.	9844040	R.H.	3.50	side finish
71-75	Pass. w/C.A.C.	9844041	L.H.	3.50	side finish

**CHEVELLE**

68	Chevelle, Nomad w/Air Cond. (exc. Sta. Wag.)				
69-72	Chevelle, Malibu S.S. w/C.A.C.	7739385	L.H.	3.10	(plastic)
69-72	Chevelle w/C.A.C., Monte Carlo	8731510	R.H.	3.00	side finish
69-72	Chevelle (exc. Spt. Cpe., Conv. Air Cond.)	8732504	R.H.	4.05	side finish
71	Chevelle (exc. Concours, Spt. Cpe., Conv., C.A.C.)				
71	El Camino w/dash side vent. (exc. C.A.C.)				
71	Malibu (Spt. Sed.) (exc. C.A.C.)				
71	Chevelle (Deluxe) (4-Dr. Sed.) (exc. C.A.C.)				
69-72	Chevelle (exc. Spt. Cpe., Conv. C.A.C.)	8732505	L.H.	4.05	side finish
69-71	Chevelle (Spt. Cpe., Conv.) (exc. Air Cond.)				
70-72	Chevelle (Spt. Cpe.) Monte Carlo (Conv.) El Camino (Custom) w/dash side vent. (exc. C.A.C.)				
70	Monte Carlo (Spt. Cpe.) (exc. C.A.C.)	8736426	R.H.	4.25	side finish
69-72	Chevelle (Spt. Cpe., Conv.) (exc. Air Cond.)				
69-72	El Camino (Custom) w/dash side vent, Monte Carlo (Spt. Cpe.) (exc. C.A.C.)	8736427	L.H.	4.25	side finish
71	Chevelle (Spt. Cpe., Conv.) (exc. C.A.C.)				

## FOLDING TOP PARTS—INTERIOR TRIM

### 14.630 PANEL— SCREW, Cowl Trim (Con't)

70-71	Chevelle, Malibu (Spt. Cpe.) (Conv.) (Deluxe), Nomad, Greenbrier w/C.A.C. ....	8731510 R.H.	3.00	side finish .....
70	Chevelle (Spt. Cpe., Sed.) w/C.A.C.,			
71	Chevelle, Malibu (Sed.) (Deluxe), Nomad, Greenbrier w/C.A.C. ...	7739385 L.H.	3.10	side finish .....
73-75	Chevelle .....	9668926 R.H.	3.00	side finish (prime and paint as reqd.) .....
73-75	Chevelle .....	9668927 L.H.	3.00	side finish (prime and paint as reqd.) .....

### CHEVY— NOVA

71-75	Nova w/C.A.C. (2nd design) ....	9882390 R.H.	6.15	shroud side finish (less control holes) (repl. 8752736 1st design) .....
71-75	Nova w/C.A.C. (2nd design) ....	9882391 L.H.	6.15	shroud side finish (less control holes) (repl. 8752737 1st design) .....
72	Nova w/C.A.C. ....	9605231 L.H.	5.50	shroud side finish .....
69-75	Chevy, Nova (exc. C.A.C.) .....	9614814 R.H.	4.50	shroud side finish .....
69-75	Nova (exc. C.A.C.) .....	9614815 L.H.	4.50	shroud side finish .....

*NOTE 1 Includes Outlet Assy. and grille.*

### CAMARO

67-68	Camaro (exc. C.A.C.) .....	7664671 R.H.	4.65	(plastic) .....
70-75	Camaro (exc. C.A.C.) .....	9816728 R.H.	4.75	finish .....
70-75	Camaro (exc. C.A.C.) .....	9816729 L.H.	4.50	finish .....
70-75	Camaro w/C.A.C. ....	9816746 R.H.	5.00	finish .....
70-75	Camaro w/C.A.C. ....	9816747 L.H.	5.00	finish (black) .....

### VEGA— MONZA

71-75	Vega (exc. C.A.C.) .....	9837288 R.H.	6.10	(paint as reqd.) .....
71-75	Vega (exc. C.A.C.) .....	9837289 L.H.	6.10	(paint as reqd.) .....
71-75	Vega w/C.A.C. ....	9837298 R.H.	3.95	(paint as reqd.) .....
71-75	Vega w/C.A.C. ....	9837299 L.H.	3.95	(paint as reqd.) .....
75	Monza (exc. Towne Cpe., C.A.C.)	1698066 L.H.	6.80	(paint as reqd.) .....
75	Monza (Towne Cpe.) (exc. C.A.C.)	1707242 R.H.	10.30	(paint as reqd.) .....
75	Monza (Towne Cpe.) (exc. C.A.C.)	1707243 L.H.	10.30	(paint as reqd.) .....
75	Monza (Towne Cpe.) w/C.A.C. ...	1707236 R.H.	6.80	(paint as reqd.) .....
75	Monza (Towne Cpe.) w/C.A.C. ...	1707237 L.H.	6.80	(paint as reqd.) .....
75	Monza w/C.A.C. (exc. Towne Cpe.) .....	1698067 R.H.	4.65	(paint as reqd.) .....
75	Monza w/C.A.C. (exc. Towne Cpe.) .....	1698068 L.H.	4.65	(paint as reqd.) .....
75	Monza (Hatchback) (exc. Towne Cpe.) .....	1698065 R.H.	6.90	(paint as reqd.) .....
75	Monza (Hatchback) (exc. Towne Cpe.) .....	1698066 L.H.	6.80	(paint as reqd.) .....

### 14.640 HEADLINING ASSY.— HEADLINING UNIT (Exc. Sun Roof)

(For Sun Roof Headlining— See Group 15.506)

### PASS.

71-72	Pass. (Spt. Sed.) .....	9644368	1	44.25	(comb. 805, 806, 807, 838) (black) .....
71-72	Kingswood .....	9859606	1		(comb. 806, 808) (black) .....
72	Kingswood .....	9893241	1	50.50	(comb. 830) (dk. green) .....
73	Impala (Spt. Cpe.) (2nd design) (exc. Custom) .....	9664613	1	42.00	(comb. 802, 805, 806) (black) (Note 2) ....
73	Impala (Custom), Caprice (Spt. Cpe.) (1st design) .....	9644378	1	41.25	(comb. 815, 818, 841) (neutral) (Note 1) ...
73	Pass. (Spt. Sed.) (1st design) ...	9644368	1	44.25	(comb. 802, 805, 806, 840) (black) (Note 1)
73	Pass. (Spt. Sed.) (1st design) ...	9644370	1	44.25	(comb. 829, 830, 842) (green) (Note 1) ....
73	Impala, Caprice (Sed.) (1st design) (exc. Spt. Sed.) .....	9644401	1	45.25	(comb. 815, 818, 841) (neutral) (Note 1) ...
73	Impala, Caprice (Sta. Wag.) (1st design) .....	9644362	1	54.25	(comb. 806) (black) (Note 1) .....
73	Impala, Caprice (Sta. Wag.) (1st design) .....	9644364	1	54.25	(comb. 818) (neutral) (Note 1) .....
73	Impala, Caprice (Sta. Wag.) (1st design) .....	9644363	1	54.25	(comb. 830) (green) (Note 1) .....
73	Impala, Caprice (Sta. Wag.) (2nd design) .....	9664160	1	54.25	(comb. 826) (saddle) (Note 2) .....
73	Impala (Custom) Caprice (Spt. Cpe.) .....	9664198	1	41.25	(comb. 802, 805, 806, 840) (black) .....

**FOLDING TOP PARTS—INTERIOR TRIM**

**14.640 HEADLINING ASSY.— HEADLINING UNIT (Exc. Sun Roof) (Con't)**

<b>73</b>	Impala (Spt. Cpe.) (2nd design) (exc. Custom) . . . . .	<b>9664613</b>	1	42.00	(comb. 802, 805, 806) (black) (Note 2) . . . .
<b>73-74</b>	Pass. (Spt. Sed.) (2nd design) . .	<b>9664189</b>	1	44.25	(comb. 802, 805, 806, 808, 840) (black) (Note 2) . . . . .
<b>73-74</b>	Pass. (Sed.) (exc. Spt. Sed.) . . . .	<b>9664171</b>	1	45.25	(comb. 802, 803, 804, 805, 806, 807, 840) (black) . . . . .
<b>73-74</b>	Pass. (Spt. Sed.) (2nd design) . .	<b>9664194</b>	1	44.25	(comb. 812, 813, 843, 847) (midnight blue) (Note 2) . . . . .
<b>74</b>	Bel Air (Sedan),				
<b>73-74</b>	Impala, Caprice (Sed.) (2nd design) (exc. Spt. Sed.) . . . . .	<b>9664176</b>	1	45.25	(comb. 812, 813, 843, 847) (midnight blue) (Note 2) . . . . .
<b>73</b>	Pass. (Spt. Sed.) (2nd design) . .	<b>9664191</b>	1	44.25	(comb. 829, 830, 842) (green) (Note 2) . . . .
<b>73-74</b>	Pass. (Spt. Sed.) (2nd design) . .	<b>9664192</b>	1	44.25	(comb. 815, 818, 819, 821, 841) (neutral) (Note 2) . . . . .
<b>73</b>	Impala, Caprice (Sed.) (2nd design) (exc. Spt. Sed.),				
<b>74</b>	Pass. (Sedan) (exc. Spt. Sed.) . . .	<b>9664174</b>	1	45.25	(comb. 815, 817, 818, 819, 821, 823, 841) (neutral) (Note 2) . . . . .
<b>73-74</b>	Caprice (Sed.) (2nd design) (exc. Spt. Sed.) . . . . .	<b>9664177</b>	1	45.25	(comb. 836, 857) (oxblood) (Note 2) . . . . .
<b>73-74</b>	Caprice (Spt. Sed.) . . . . .	<b>9664196</b>	1	44.25	(comb. 836, 857) (oxblood) . . . . .
<b>73-75</b>	Impala, Caprice (Sta. Wag.) (2nd design) . . . . .	<b>9664157</b>	1	54.25	(comb. 802, 806) (19W) (black) (Note 2) . . .
<b>73-74</b>	Impala, Caprice (Sta. Wag.) (2nd design) . . . . .	<b>9664161</b>	1	54.25	(comb. 813) (midnight blue) (Note 2) . . . . .
<b>73</b>	Impala, Caprice (Sta. Wag.) (2nd design),				
<b>74</b>	Pass. (Sta. Wag.) . . . . .	<b>9664159</b>	1	54.25	(comb. 817, 818, 819) (neutral) (Note 2) . . .
<b>73</b>	Impala, Caprice (Sta. Wag.) (2nd design) . . . . .	<b>9664158</b>	1	54.25	(comb. 830) (green) (Note 2) . . . . .
<b>73</b>	Impala, Caprice (Sta. Wag.) (2nd design),				
<b>75</b>	Impala, Caprice (Sta. Wag.) . . . .	<b>9664160</b>	1	54.25	(comb. 826) (63E, 63W) (saddle) (Note 2) . .
<b>73</b>	Bel Air (Sta. Wag.) (2nd design) . .	<b>9664155</b>	1	51.50	(comb. 825) (saddle) (Note 2) . . . . .
<b>73-74</b>	Bel Air (Sta. Wag.) (2nd design) . .	<b>9664154</b>	1	51.50	(comb. 817) (neutral) (Note 2) . . . . .
<b>74-75</b>	Pass. (Sta. Wag.) . . . . .	<b>9678253</b>	1	54.25	(comb. 851, 855, 859) (44W) (green) . . . . .
<b>74</b>	Pass. (Sta. Wag.) . . . . .	<b>9678254</b>	1	54.25	(comb. 849, 858) (saddle) . . . . .
<b>74</b>	Pass. (Sed.) (exc. Spt. Sed.) . . . .	<b>9678258</b>	1	41.25	(comb. 850, 851, 852, 853, 855) (green) . .
<b>74</b>	Pass. (Spt. Sed.) . . . . .	<b>9678264</b>	1	44.25	(comb. 850, 853, 854, 855) (green) . . . . .
<b>74-75</b>	Impala (Spt. Cpe.) (exc. Custom)	<b>9689111</b>	1	42.00	(comb. 802, 805, 806) (19D, 19W) (black) .
<b>74</b>	Impala (Spt. Cpe.) (exc. Custom)	<b>9689114</b>	1	42.00	(comb. 813, 847) (midn. blue) . . . . .
<b>74</b>	Impala (Spt. Cpe.) (exc. Custom)	<b>9689115</b>	1	42.00	(comb. 819, 821) (neutral) . . . . .
<b>74-75</b>	Impala (Spt. Cpe.) (exc. Custom)	<b>9689119</b>	1	42.00	(comb. 853, 855) (44D, 44W) (green) . . . .
<b>74</b>	Impala (Spt. Cpe.) (exc. Custom)	<b>9689120</b>	1	38.00	(comb. 849, 858) (saddle) . . . . .
<b>74-75</b>	Impala (Spt. Cpe.) (exc. Custom)	<b>1667386</b>	1	39.25	(comb. 804, 809) (white) (repl. 9689108) . .
<b>74</b>	Impala (Custom) . . . . .	<b>9732518</b>	1	41.25	(comb. 849, 858) (saddle) . . . . .
<b>74-75</b>	Impala (Custom) Caprice (Spt. Cpe.) . . . . .	<b>9689101</b>	1	41.25	(comb. 802, 805, 806, 808, 840) (19D, 19W, 19B, 19H) (black) . . . . .
<b>74</b>	Impala (Custom) Caprice (Spt. Cpe.) . . . . .	<b>9689102</b>	1	41.25	(comb. 813, 843, 847) (midn. blue) . . . . .
<b>74</b>	Impala (Custom) Caprice (Spt. Cpe.) . . . . .	<b>9689103</b>	1	41.25	(comb. 819, 821, 841) (neutral) . . . . .
<b>74-75</b>	Impala (Custom) Caprice (Spt. Cpe.) . . . . .	<b>9689105</b>	1	41.25	(comb. 850, 853, 855) (44D, 44W, 44B) (green) . . . . .
<b>74</b>	Impala (Sedan) (exc. Spt. Sed.) . .	<b>9678259</b>	1	45.25	(comb. 849) (saddle) . . . . .
<b>74</b>	Impala (Spt. Sed.) . . . . .	<b>9678265</b>	1	44.25	(comb. 849) (saddle) . . . . .
<b>74</b>	Caprice (Sed.) (exc. Spt. Sed.) . .	<b>9678260</b>	1	45.25	(comb. 896) (taupe) . . . . .
<b>74</b>	Caprice (Spt. Sed.) . . . . .	<b>9678266</b>	1	44.25	(comb. 896) (taupe) . . . . .
<b>74-75</b>	Caprice (Spt. Cpe.) . . . . .	<b>9689104</b>	1	41.25	(comb. 857) (73B) (oxblood) . . . . .
<b>74</b>	Caprice (Spt. Cpe.) . . . . .	<b>9689106</b>	1	41.25	(comb. 896) (taupe) . . . . .
	<i>NOTE 1: Wire Retainer.</i>				
	<i>NOTE 2: Plastic Retainer.</i>				
<b>75</b>	Pass. (Sedan) (exc. Spt. Sed.) . . .	<b>1674689</b>	1	59.50	(comb. 19C, 19D, 19W, 19B, 19H) (black) .
<b>75</b>	Pass. (Sedan) (exc. Spt. Sed.) . . .	<b>1674690</b>	1	59.50	(comb. 55C, 55D, 55W, 55B, 55H) (sandstone) . . . . .
<b>75</b>	Pass. (Sedan) (exc. Spt. Sed.) . . .	<b>1674691</b>	1	59.50	(comb. 26C, 26D, 26W, 26B) (blue) . . . . .
<b>75</b>	Pass. (Sedan) (exc. Spt. Sed.) . . .	<b>1674693</b>	1	59.50	(comb. 73B) (oxblood) . . . . .
<b>75</b>	Pass. (Sedan) (exc. Spt. Sed.) . . .	<b>1674696</b>	1	59.50	(comb. 44D, 44W, 44B) (green) . . . . .
<b>75</b>	Pass. (Sedan) (exc. Spt. Sed.) . . .	<b>1674697</b>	1	59.50	(comb. 63E, 63W) (saddle) . . . . .
<b>75</b>	Pass. (Spt. Sed.) . . . . .	<b>1671653</b>	1	53.25	(comb. 55D, 55W, 55B, 55H) (sandstone) . .
<b>75</b>	Pass. (Spt. Sed.) . . . . .	<b>1671656</b>	1	53.25	(comb. 19D, 19W, 19B, 19H) (black) . . . . .
<b>75</b>	Pass. (Spt. Sed.) . . . . .	<b>1671658</b>	1	53.25	(comb. 26D, 26W, 26B) (blue) . . . . .

**FOLDING TOP PARTS—INTERIOR TRIM**

**14.640 HEADLINING ASSY.— HEADLINING UNIT (Exc. Sun Roof) (Con't)**

75	Pass. (Spt. Sed.)	1671659	1	53.25	(comb. 73B) (oxblood)
75	Pass. (Spt. Sed.)	1671663	1	53.25	(comb. 44D, 44W, 44B) (green)
75	Pass. (Spt. Sed.)	1671664	1	53.25	(comb. 63E, 63W) (saddle)
75	Impala (Spt. Cpe.) (exc. Custom)	1667650	1	39.25	(comb. 63E, 63W) (saddle)
75	Impala (Spt. Cpe.) (exc. Custom)	1667649	1	39.25	(comb. 55D, 55W) (sandstone)
75	Impala (Spt. Cpe.) (exc. Custom)	1667648	1	39.25	(comb. 26D, 26W) (blue)
75	Impala (Custom), Caprice (Spt. Cpe.)	1670012	1	38.75	(comb. 26D, 26W, 26B) (blue)
75	Impala (Custom), Caprice (Spt. Cpe.)	1670013	1	38.75	(comb. 55W, 55B, 55H) (sandstone)
75	Impala (Custom)	1670015	1	38.75	(comb. 63E, 63W) (saddle)
75	Caprice (Spt. Cpe.)	1685451	1	38.75	(comb. 02W, 04W, 07W, 11W) (white)
75	Pass. (Sta. Wag.)	1671389	1	50.75	(comb. 26V, 26W) (blue)
75	Pass. (Sta. Wag.)	1671390	1	50.75	(comb. 55V, 55W) (sandstone)

**CHEVELLE**

70-72	Chevelle (Spt. Cpe.)	8795786	1	36.00	(comb. 704, 705, 706, 707, 708, 710, 748, 749, 751, 752, 753, 755, 756, 757, 790, 791, 797) (black)
72	Chevelle (Std.) (Spt. Cpe.)	9847201		29.50	(comb. 723) (blue)
72	Chevelle (Spt. Cpe.)	9898732	1	35.50	(comb. 730, 731, 732, 734) (covert)
72	Malibu, Monte Carlo (Spt. Cpe.)	9898731	1	35.50	(comb. 713, 715, 717) (dk. green)
72	Monte Carlo	9898733	1	35.50	(comb. 740) (med. pewter)
70-72	El Camino	8795805	1	19.50	(comb. 703, 705, 706, 752, 755, 756) (black)
70	Chevelle (Sta. Wag.)	9839468	1		(comb. 770, 773) (saddle)
70	Monte Carlo (Spt. Cpe.)	8809051	1	36.00	(comb. 792) (med. sandalwood)
71	Chevelle (Spt. Cpe.)	8795786	1	36.00	(black)
71	Malibu, Monte Carlo (Spt. Cpe.)	8809051	1	36.00	(comb. 714, 715, 716, 717, 718) (sandalwood)
71	El Camino	8795805	1	19.50	(comb. 703, 705, 706) (black)
73	Deluxe (Coupe)	9642259	1	32.00	(comb. 701, 702) (black)
73	Malibu, Laguna (Coupe)				
74-75	Chevelle (Coupe) (exc. Monte Carlo)	9642288	1	34.75	(comb. 701, 702, 703, 704, 706, 707, 708, 712, 738, 747, 891, 894) (19C, 19V, 19W, 19D) (black)
73	Malibu, Laguna (Coupe)				
75	Chevelle (Coupe)	9642291	1	34.75	(comb. 717, 720) (63W, 63E, 63Z) (saddle)
73	Deluxe (Coupe)	9642260	1	32.00	(comb. 710, 711) (green)
73-74	Laguna (Coupe)				
74-75	Malibu (Classic) (Coupe)	9642294	1	34.75	(comb. 709, 714, 719, 720, 743) (73D) (oxblood)
73	Deluxe (Coupe)	9642263	1	32.00	(comb. 733) (neutral)
73	Malibu, Laguna (Coupe)				
74	Malibu (Coupe)	9642292	1	34.75	(comb. 713, 714, 722, 732, 734, 892) (neutral)
73	Malibu, Laguna (Coupe)	9642290	1	34.75	(comb. 705, 719, 723, 724) (med. blue)
73-75	Monte Carlo	9642296	1	35.25	(comb. 705, 706, 708, 709) (19B, 19H, 19N) (black)
73	Monte Carlo	9642297	1	35.25	(comb. 715, 728) (green)
73-75	Monte Carlo	9642302	1	35.25	(comb. 740, 744) (73B, 73N) (oxblood)
73-74	Monte Carlo	9642300	1	35.25	(comb. 716, 731, 735) (neutral)
73-74	Monte Carlo	9645915	1	35.25	(comb. 725, 734, 737) (mid. blue)
75	Monte Carlo	1665440	1	33.00	(comb. 26B, 26H, 26N) (blue)
75	Monte Carlo	1665441	1	33.00	(comb. 55B, 55H, 55N) (sandstone)
73	Deluxe (Sedan)	9642165	1	34.75	(comb. 702) (black)
73	Malibu, Laguna (Sedan)				
74-75	Chevelle (Sedan)	9642277	1	39.50	(comb. 701, 702, 703, 704, 706, 707, 708, 712, 738, 747, 891, 894) (19C, 19V, 19D, 19W) (black)
73	Deluxe (Sedan)	9642166	1	34.75	(comb. 710, 711) (green)
73	Laguna (Sedan)				
74-75	Malibu (Classic) (Sedan)	9642282	1	39.50	(comb. 709, 714, 743) (73D) (oxblood)
73	Malibu, Laguna (Sedan)				
74	Chevelle (Sedan)	9642281	1	39.50	(comb. 711, 713, 714, 715, 722, 732, 734, 892) (neutral)
73	Malibu, Laguna (Sedan)	9642279	1	39.50	(comb. 723, 724) (med. blue)
73	Laguna (Sta. Wag.)	9666650	1	59.25	(comb. 709) (oxblood)
73	Deluxe (Sta. Wag.)	9642254	1	52.25	(comb. 722) (saddle)
73	Malibu, Laguna (Sta. Wag.)				
74-75	Chevelle (Sta. Wag.)	9642284	1	59.25	(comb. 704, 706, 707, 708, 891) (19V, 19W) (black)
73	Malibu, Laguna (Sta. Wag.)				
75	Chevelle (Sta. Wag.)	9642286	1	59.25	(comb. 720) (63W) (saddle)

**FOLDING TOP PARTS—INTERIOR TRIM**

**14.640 HEADLINING ASSY.— HEADLINING UNIT (Exc. Sun Roof) (Con't)**

<b>73</b>	Malibu, Laguna (Sta. Wag.),				
<b>74</b>	Chevelle (Sta. Wag.)	<b>9642287</b>	1	59.25	(comb. 713, 714, 715, 732, 734, 892) (neutral)
<b>73-75</b>	El Camino	<b>9642304</b>	1	20.90	(comb. 701, 702, 704, 706, 707, 891, 894) (19C, 19V, 19D, 19W) (black)
<b>73-74</b>	El Camino	<b>9642305</b>	1	20.90	(comb. 711, 713, 714, 715, 722, 732, 733, 892) (neutral)
<b>73</b>	El Camino (Custom),				
<b>75</b>	El Camino	<b>9665217</b>	1	20.90	(comb. 720) (63W) (saddle)
<b>74-75</b>	Chevelle (Sedan)	<b>9676778</b>	1	36.00	(comb. 723, 724, 725, 727, 728, 745, 830, 893) (44D; 44V) (green)
<b>74</b>	Malibu (Sedan) (exc. Classic)	<b>9676779</b>	1	36.00	(comb. 740) (saddle)
<b>74</b>	Malibu (Classic) (Sedan)	<b>9676780</b>	1	36.00	(comb. 732, 736) (midn. blue)
<b>74</b>	Malibu (Classic) (Sta. Wag.)	<b>9676781</b>	1	52.25	(comb. 735) (midn. blue)
<b>74</b>	Chevelle (Classic) (Sta. Wag.)	<b>9676784</b>	1	52.25	(comb. 728, 745, 830) (green)
<b>74</b>	Malibu (Classic) (Sta. Wag.)	<b>9676785</b>	1	52.25	(comb. 740) (saddle)
<b>74</b>	Malibu (Coupe)	<b>9676786</b>	1	34.75	(comb. 732, 749, 785, 897) (midn. blue)
<b>74</b>	Malibu (Coupe),				
<b>75</b>	Chevelle (Coupe)	<b>9676789</b>	1	32.00	(comb. 723, 724, 725, 727, 728, 745, 830, 893) (44V, 44D) (green)
<b>74</b>	Malibu (Classic) (Coupe)	<b>9676790</b>	1	34.75	(comb. 740, 718, 731) (saddle)
<b>74-75</b>	Monte Carlo	<b>9676793</b>	1	35.25	(comb. 726, 730) (44N) (green)
<b>74</b>	Monte Carlo	<b>9676794</b>	1	35.25	(comb. 742) (saddle)
<b>74</b>	El Camino	<b>9676796</b>	1	20.90	(comb. 732, 749, 785, 897) (midn. blue)
<b>74-75</b>	El Camino	<b>9676797</b>	1	20.90	(comb. 723, 724, 727, 728, 745, 830, 893) (44V, 44D) (green)
<b>74</b>	El Camino (Classic)	<b>9676798</b>	1	20.90	(comb. 740) (saddle)
<b>75</b>	Chevelle (Sedan)	<b>1667630</b>	1	36.75	(comb. 26C, 26V, 26D, 26W) (blue)
<b>75</b>	Chevelle (Sedan)	<b>1667631</b>	1	36.75	(comb. 55V, 55W) (sandstone)
<b>75</b>	Chevelle (Sedan)	<b>1667632</b>	1	36.75	(comb. 16D) (graystone)
<b>75</b>	Chevelle (Coupe)	<b>1665447</b>	1	32.50	(comb. 55V, 55W) (sandstone)
<b>75</b>	Chevelle (Coupe)	<b>1665448</b>	1	32.50	(comb. 16D) (graystone)
<b>75</b>	Chevelle (Coupe)	<b>1665450</b>	1	32.50	(comb. 26C, 26V, 26D, 26W) (blue)
<b>75</b>	Monte Carlo	<b>1665440</b>	1	33.00	(comb. 26B, 26H, 26N) (blue)
<b>75</b>	Monte Carlo	<b>1665441</b>	1	33.00	(comb. 55B, 55H, 55J, 55N) (sandstone)
<b>75</b>	Chevelle (Sta. Wag.)	<b>1665435</b>	1	49.00	(comb. 26W) (blue)
<b>75</b>	Chevelle (Sta. Wag.)	<b>1665437</b>	1	55.50	(comb. 55V, 55W) (sandstone)
<b>75</b>	El Camino	<b>1665430</b>	1	29.25	(comb. 55V, 55W) (sandstone)
<b>75</b>	El Camino	<b>1665433</b>	1	29.25	(comb. 26C, 26V, 26D, 26W) (blue)
<b>75</b>	El Camino	<b>1665431</b>	1	29.25	(comb. 16D) (graystone)
<b>75</b>	El Camino	<b>1665432</b>	1	29.25	(comb. 73D) (oxblood)
<b>75</b>	Monte Carlo	<b>1667635</b>	1	31.25	(comb. 02H, 04H, 07H, 11H) (white)
<b>75</b>	Laguna	<b>1701520</b>	1	32.50	(comb. 07E, 07Z, 11E, 11Z) (white)

**NOVA**

<b>70-72</b>	Nova (2-Dr.)	<b>8796430</b>	1	32.75	(comb. 731, 732, 733, 737) (black)
<b>72</b>	Nova (Cpe.) (exc. H.B.)	<b>490590</b>	1	164.00	<b>HEADLINING UNIT, w/bows, sun roof</b>

**CAMARO**

<b>70-72</b>	Camaro	<b>9648365</b>	1	34.00	(comb. 711, 712, 713, 725, 775, 778, 780, 785, 789) (black)
<b>70-71</b>	Camaro	<b>9818934</b>	1	28.50	(comb. 710, 730, 777) (sandalwood)
<b>72</b>	Camaro	<b>9600344</b>	1	29.25	(comb. 779, 788) (covert)
<b>73</b>	Camaro (1st design)	<b>9648365</b>	1	34.00	(comb. 773, 774, 775, 776, 785, 786) (black) (Note 1)
<b>73</b>	Camaro (1st design)	<b>9648367</b>	1	34.00	(comb. 777, 781) (green) (Note 1)
<b>73</b>	Camaro (1st design)	<b>9648366</b>	1	34.00	(comb. 779, 788) (neutral) (Note 1)
<b>73</b>	Camaro (exc. L.T.) (1st design)	<b>9648368</b>	1	34.00	(comb. 778) (saddle) (Note 1)
<b>73</b>	Camaro (exc. L.T.) (1st design)	<b>9648369</b>	1	34.00	(comb. 780) (chamois) (Note 1)

*NOTE 1: Soft.  
NOTE 2: Hard.*

**14.640A CLIP— PAD ASSY.— PLUG— RETAINER— PANEL, Roof Trim**

<b>73</b>	Chevelle (Spt. Cpe.) w/elec. sun roof,				
<b>75</b>	Chevelle (Spt. Cpe.) w/elec. sun roof	<b>9667515</b>	1	.35	sliding pin headliner frame
<b>73-74</b>	Pass., Chevelle (exc. Conv.)	<b>9659650</b>	A.R.	.11	retaining strip emergency
<b>73-75</b>	Chevelle (Spt. Cpe.) w/elec. sun roof	<b>9652115</b>	1	24.80	<b>PAD ASSY.,</b> fil. sliding panel
<b>73-75</b>	Chevelle (Spt. Cpe.) w/elec. sun roof	<b>9664907</b>	1	.63	<b>PLUG,</b> access hole (prime and paint as reqd.)

**FOLDING TOP PARTS—INTERIOR TRIM**

**14.640A CLIP— PAD ASSY.— PLUG— RETAINER— PANEL, Roof Trim (Con't)**

73	Chevelle (Spt. Cpe.) w/elec. sunroof	9652108	1	.52	RETAINER, sliding panel headlining at handle
75	Chevelle (Spt. Cpe.) w/elec. sunroof, manual sunroof	9667515 A.R.		.35	RETAINER, panel headlining frame
73-74	Chevelle (Spt. Cpe.) w/elec. sun roof	9673510	1	27.75	RETAINER ASSY., sliding panel hdng.
73-75	Chevelle w/elec. sun roof, manual sun roof	1658416	1	27.75	RETAINER ASSY., sliding panel hdng.
71-73	Vega (Notchback Cpe.)	9897626	1	43.00	PANEL (paint as reqd.)
71-73	Vega (Hatchback Cpe.)	9897632	1	43.00	PANEL (paint as reqd.)
71-73	Vega (Panel, Sta. Wag.)	9897629	1	43.00	PANEL (paint as reqd.)
74-75	Vega (Notchback Cpe.)	9690263	1	43.00	PANEL (paint as reqd.)
74-75	Vega (Hatchback Cpe.)	9690383	1	43.00	PANEL (paint as reqd.)
74-75	Vega (Panel, Sta. Wag.)	9690378	1	43.00	PANEL (paint as reqd.)
75	Monza (exc. Towne Cpe.)	1698069	1	25.75	PANEL (paint as reqd.)
73	Camaro (2nd design)	9666409	1	33.00	PANEL ASSY. (comb. 773, 774, 775, 776, 785, 786) (black) (Note 2)
73	Camaro (2nd design)	9666412	1	33.00	PANEL ASSY. (comb. 779, 788) (neutral) (Note 2)
73	Camaro (exc. L.T.) (2nd design)	9666413	1	33.00	PANEL ASSY. (comb. 778) (saddle) (Note 2)
<i>NOTE 1: Soft.</i>					
<i>NOTE 2: Hard.</i>					
74-75	Camaro	9675501	1	33.00	PANEL ASSY. (paint as reqd.)
74	Camaro (exc. L.T.)	9675506	1	33.00	PANEL ASSY. (comb. 792) (red)
74	Camaro (L.T.)	9675507	1	33.00	PANEL ASSY. (comb. 783, 784) (taupe)
73	Nova (2-Dr. Cpe.)	9655223	1	39.75	PANEL ASSY. (comb. 751, 752, 754, 755) (black)
73	Nova (2-Dr. Cpe.) (exc. Custom)	9655225	1	39.75	PANEL ASSY. (comb. 756) (blue)
73	Nova (2-Dr. Cpe.)	9655226	1	39.75	PANEL ASSY. (comb. 759, 760, 761) (green)
73	Nova (2-Dr. Cpe.)	9655227	1	39.25	PANEL ASSY. (comb. 763, 764, 771) (neutral)
73	Nova (4-Dr. Sed.)	9655167	1	39.75	PANEL ASSY. (comb. 750, 753, 765) (black)
73	Nova (4-Dr. Sed.)	9655219	1	39.75	PANEL ASSY. (comb. 772) (blue)
73	Nova (4-Dr. Sed.)	9655220	1	39.75	PANEL ASSY. (comb. 757, 758, 770) (green)
74	Nova (2-Dr.)	1653357	1	40.75	PANEL ASSY. (paint as reqd.)
74	Nova (2-Dr.)	9675508	1	39.75	PANEL ASSY. (comb. 750, 751, 752, 753, 754, 825) (black)
74	Nova (4-Dr.)	9675516	1	39.75	PANEL ASSY. (paint as reqd.)
75	Nova (2-Dr.)	1693701	1	53.00	PANEL ASSY., trim finish hdng. (paint as reqd.)
75	Nova (Sedan)	1693713	1	53.00	PANEL ASSY., trim finish hdng. (paint as reqd.)
75	Vega (Sta. Wag.) w/roof intr. fin. luxury design	1701768	1	62.25	PANEL ASSY. (painted)
75	Vega (Hatchback Cpe.) w/roof intr. fin. luxury design	1701762	1	62.25	PANEL ASSY. (painted)
75	Monza (Towne Cpe.)	1707308	1	15.25	trim finish headlining (painted)
75	Vega (Hatchback Cpe.) w/roof inter. fin. w/cloth	1701763	1	63.25	PANEL ASSY. (oxblood-73B-G)
75	Vega (Hatchback Cpe.) w/roof inter. fin. w/cloth	1701764	1	63.25	PANEL ASSY. (blue-26B-G)
75	Vega (Hatchback Cpe.) w/roof inter. fin. w/cloth	1701765	1	63.00	PANEL ASSY. (sandstone-55B)
75	Vega (Sta. Wag.) w/roof inter. fin. w/cloth	1701769	1	77.00	PANEL ASSY. (oxblood-73B-G)
75	Vega (Sta. Wag.) w/roof inter. fin. w/cloth	1701770	1	77.00	PANEL ASSY. (blue-26-G)
75	Vega (Sta. Wag.) w/roof inter. fin. w/cloth	1701771	1	77.00	PANEL ASSY. (sandstone-55B)

**14.645 TRIM ASSY.— CLIP ASSY.— ESCUTCHEON— FASTENER— PANEL ASSY., Rear Quarter Upper— Above Belt**

**PASS.**

71-73	Impala (Custom), Caprice (Spt. Cpe.)	9649302 R.H.		8.10	(paint as reqd.)
73	Impala (Spt. Cpe.) (exc. Cust.)	9649338 R.H.		7.20	(comb. 829, 830) (green)
73	Impala (Spt. Cpe.) (exc. Cust.)	9649339 L.H.		7.20	(comb. 829, 830) (green)



**FOLDING TOP PARTS—INTERIOR TRIM**

**14.645 TRIM ASSY.— CLIP ASSY.— ESCUTCHEON— FASTENER— PANEL ASSY.,  
Rear Quarter Upper— Above Belt (Con't)**

74	Impala (Spt. Cpe.)	9696914 R.H.	7.20	(comb. 802, 805, 806, 819, 821, 853, 855, 813, 847) (black)
74	Impala (Custom), Caprice (Spt. Cpe.)	9696902 R.H.	62.25	(black) (paint as reqd.)
74	Impala (Custom), Caprice (Spt. Cpe.)	9696903 L.H.	62.25	(comb. 802, 805, 806, 808, 813, 819, 821, 840, 841, 843, 847, 896) (black) (vinyl) (Note 1)
74-75	Impala (Spt. Cpe.) (exc. Custom)	9696914 R.H.	7.20	(paint as reqd.)
74-75	Impala (Spt. Cpe.) (exc. Custom)	9696915 L.H.	7.20	(paint as reqd.)

**CHEVELLE**

72	Chevelle (Std.) (Sed.)	8802671 L.H.	8.45	(paint to match)
73	Monte Carlo	9650948 R.H.	39.00	(comb. 706, 708) (black)
73	Monte Carlo	9650949 L.H.	39.00	(comb. 706, 708) (black)
73	Monte Carlo	9650950 R.H.	39.00	(comb. 715, 728) (green)
73	Monte Carlo	9650951 L.H.	39.00	(comb. 715, 728) (green)
73	Monte Carlo	9650952 R.H.	39.00	(comb. 731, 735) (neutral)
73	Monte Carlo	9650953 L.H.	39.00	(comb. 731, 735) (neutral)
73	Monte Carlo	9650954 R.H.	39.00	(comb. 740) (oxblood)
73	Monte Carlo	9650955 L.H.	39.00	(comb. 740) (oxblood)
73	Monte Carlo	9650956 R.H.	39.00	(comb. 725) (midn. blue)
73	Monte Carlo	9650957 L.H.	39.00	(comb. 725) (midn. blue)
74	Malibu (Classic) (Coupe)	9738478 R.H.	14.50	(comb. 724, 728) (green)
74	Malibu (Classic) (Coupe)	9738479 L.H.	14.50	(comb. 724, 728) (green)
74	Malibu (Classic) (Coupe)	9738490 R.H.	14.50	(comb. 732, 785) (mid. blue)
74	Malibu (Classic) (Coupe)	9738491 L.H.	14.50	(comb. 732, 785) (mid. blue)
74	Malibu (Classic) (Coupe)	9738480 R.H.	14.95	(comb. 714, 722) (neutral)
74	Malibu (Classic) (Coupe)	9738481 L.H.	14.95	(comb. 714, 722) (neutral)
74	Malibu (Classic), Laguna (Coupe)	9738482 R.H.	14.50	(comb. 719, 720, 743) (oxblood)
74	Malibu (Classic), Laguna (Coupe)	9738483 L.H.	14.50	(comb. 719, 720, 743) (oxblood)
74	Malibu (Classic), Laguna (Coupe)	9738484 R.H.	14.50	(comb. 718, 731, 740) (saddle)
74	Malibu (Classic), Laguna (Coupe)	9738485 L.H.	14.50	(comb. 718, 731, 740) (saddle)
74	Malibu (Classic), Laguna (Coupe)	9738486 R.H.	14.50	(comb. 702, 703, 704, 707, 708, 747) (black)
74	Malibu (Classic), Laguna (Coupe)	9738487 L.H.	14.50	(comb. 702, 703, 704, 707, 708, 747) (black)

**CHEVY— NOVA**

70-72	Nova (2-Dr.)	9824126 R.H.	7.10	(paint) (repl. 9848822, 9890922, 9890924)
70-72	Nova (2-Dr.)	9824127 L.H.	6.70	(paint) (repl. 9848823, 9890923, 9890925)
70	Nova (4-Dr.)	9824140 R.H.	7.10	(comb. 740, 741) (med. gold)
73-74	Nova (Cpe.) (exc. H.B.)	9652196 R.H.	4.40	(prime and paint as reqd.)
73-74	Nova (Cpe.) (exc. H.B.)	9652197 L.H.	4.40	(prime and paint as reqd.)
73-74	Nova (Sed.)	9652142 R.H.	5.40	(prime and paint as reqd.)
73-74	Nova (Sed.)	9652143 L.H.	5.40	(prime and paint as reqd.)
67-68	Pass. Sed. (4-Dr.) (exc. Spt. Sed.)	7690334	6	CLIP ASSY., upr. foundation
75	Pass. (Spt. Sed.)	1691845	2	1.40 ESCUTCHEON, lace trim ctr. upr. abv. belt
68-71	Chevy			FASTENER, qtr. upr. fdtn. to intr. pnl.
69-72	Camaro (Spt. Cpe.),			
69-72	Chevelle, Pass. (exc. Conv., Sta. Wag.)	9812626 A.R.	.24	FASTENER, qtr. intr. upr. pnl. above belt
63	Chevy, Chevelle,			
65-70	All	4500027 A.R.	.11	FASTENER, trim pad
74-75	Impala (Custom), Caprice (Spt. Cpe.), Nova (Coupe) (exc. H.B.)	9736462	4	.16 FASTENER, panel trim qtr. upr. above belt
74-75	Impala (Custom), Caprice (Spt. Cpe.)	1690308 R.H.	40.25	PANEL ASSY., trim qtr. upr. above belt (paint as reqd.)
74-75	Impala (Custom), Caprice (Spt. Cpe.)	1690309 L.H.	40.25	PANEL ASSY., trim qtr. upr. above belt (paint as reqd.)
74	Monte Carlo (1st design)	9696940 R.H.	54.25	PANEL ASSY. (black) (vinyl) (paint as reqd.) (repl. 9696948)
74	Monte Carlo (1st design)	9696941 L.H.	54.25	PANEL ASSY. (black) (paint as reqd.) (repl. 9696943)
74	Monte Carlo (1st design)	9696949 L.H.	54.25	PANEL ASSY. (comb. 742) (saddle) (vinyl)
74-75	Monte Carlo (2nd design)	1652578 R.H.	19.35	PANEL ASSY. (plastic) (paint as reqd.)
74-75	Monte Carlo (2nd design)	1652579 L.H.	19.35	PANEL ASSY. (plastic) (paint as reqd.)
75	Pass. (Spt. Sed.)	1691118 R.H.	31.75	PANEL ASSY., trim finish qtr. upr. abv. belt (prime and paint as reqd.)
75	Pass. (Spt. Sed.)	1691119 L.H.	31.75	PANEL ASSY., trim finish qtr. upr. abv. belt (prime and paint as reqd.)

**FOLDING TOP PARTS—INTERIOR TRIM**

**14.645 TRIM ASSY.— CLIP ASSY.— ESCUTCHEON— FASTENER— PANEL ASSY., Rear Quarter Upper— Above Belt (Con't)**

75	Monza (Towne Cpe.)	1707288 R.H.	11.85	PANEL ASSY., trim finish (prime and paint)
75	Monza (Towne Cpe.)	1707289 L.H.	11.85	PANEL ASSY., trim finish (prime and paint)
75	Camaro	1670180 R.H.	5.80	PANEL, trim (prime and paint as reqd.)
75	Nova (2-Dr.)	1732851 R.H.	15.05	PANEL, w/formal qtr. window, trim finish qtr. upr. above, belt (prime and paint as reqd.)
75	Nova (2-Dr.)	1732852 L.H.	15.05	PANEL, w/formal qtr. window, trim finish qtr. upr. above, belt (prime and paint as reqd.)
75	Camaro	1670181 L.H.	5.80	PANEL, trim (prime and paint as reqd.)
75	Nova (4-Dr.)	1662928 R.H.	6.30	PANEL, quarter upper above belt
75	Nova (4-Dr.)	1662929 L.H.	6.30	PANEL, quarter upper above belt

NOTE 1: For 2nd design use plastic panel assy. and paint as reqd.

**14.650 LACE— CLIP— ESCUTCHEON ASSY., Headlining Finish and Back Window**

**PASS.**

65-66	Sedan (exc. Spt. Sed.)	4495575	1	.18	back wind. escn. upr. (blue)
65-66	Sed. (exc. Spt. Sed.)	4468831	1	.24	back wind. escn. upr. (turquoise)
65	Sed. (exc. Spt. Sed.)				
65	Sed. (exc. Spt. Sed.)	4468830	1	.24	back wind. escn. upr. (fawn)
65-66	Sed. (exc. Spt. Sed.)	4495590	1	1.55	back wind. upr. and side, R.H. (fawn)
65-66	Sed. (exc. Spt. Sed.)	4495591	1	1.55	back wind. upr. and side, L.H. (fawn)
71-72	Impala (Conv.)	4458887	1	2.40	pinchweld front roof rail rear (black)
72	Pass. (Sta. Wag.) (Sed. exc. Spt. Sed.)	1695676	R.H.	3.10	finish roof inner side mldg. (black) (prime and paint)
72	Pass. (Sta. Wag.) (Sed. exc. Spt. Sed.)	1695677	L.H.	3.10	finish roof inner side mldg. (black) (prime and paint)
72	Pass. (Sta. Wag.) (Sed. exc. Spt. Sed.)	9616235	R.H.	2.20	finish roof inner side mldg. (comb. 824, 825, 826) (saddle)
73	Caprice (Sed.) (exc. Spt. Sed.)	1695680	R.H.	3.10	finish roof inner mldg. (comb. 836) (oxblood)
73	Caprice (Sed.) (exc. Spt. Sed.)	1695681	L.H.	3.10	finish roof finish mldg. (comb. 836) (oxblood)
73	Pass. (Sta. Wag.)	1695678	R.H.	3.10	(comb. 825, 826) (saddle)
73	Pass. (Sta. Wag.)	1695679	L.H.	3.10	(comb. 825, 826) (saddle)
73-75	Pass. (Conv.)	4495638	1	1.80	pinchweld frt. rf. rl. rr. (black)
74-75	Pass. (Spt. Cpe.)	9679620	2	.27	p/w finish back body lock plr.
73-74	Impala, Caprice (Sed., Sta. Wag.) (exc. Spt. Sed.) Bel Air (Sta. Wag.)	9666622	2	2.05	finish roof inr. side mldg. (comb. 815, 817, 818, 841) (neutral)
73-75	Bel Air (Sedan),				
73	Impala, Caprice (Sta. Wag.),				
74-75	Impala, Caprice (Sta. Wag., Sedan) (exc. Spt. Sed.)	1695676	R.H.	3.10	finish roof inner side mldg. (comb. 802, 803, 804, 805, 806, 808, 840, 19D, 19W, 19B) (black)
73-75	Bel Air (Sedan),				
73	Impala, Caprice (Sta. Wag.),				
74-75	Impala, Caprice (Sta. Wag., Sedan) (exc. Spt. Sed.)	1695677	L.H.	3.10	finish roof inner side mldg. (comb. 802, 803, 804, 805, 806, 808, 840) 19B, 19C, 19D, 19W (black)
73-74	Impala, Caprice (Sta. Wag., Sedan) (exc. Spt. Sed.)	9666616	R.H.	2.65	finish roof inner side mldg. (comb. 813, 843, 847) (midn. blue)
73-74	Impala, Caprice (Sta. Wag., Sedan) (exc. Spt. Sed.)	9666617	L.H.	2.05	finish roof inner side mldg. (comb. 813, 843, 847) (midn. blue)
74-75	Pass. (Sta. Wag.) (Sedan) (exc. Spt. Sed.)	1695682	R.H.	3.10	finish roof inner side mldg. (paint to match)
74-75	Pass. (Sta. Wag.) (Sedan) (exc. Spt. Sed.)	1695683	L.H.	3.10	finish roof inner side mldg. (paint to match)
74	Impala (Sedan) (exc. Spt. Sed.),				
74	Impala, Caprice (Sta. Wag.)	9676920	R.H.	2.05	finish roof inner side mldg. (comb. 849, 858) (saddle)
74	Impala (Sedan) (exc. Spt. Sed.),				
74	Impala, Caprice (Sta. Wag.)	9676921	L.H.	2.05	finish roof inner side mldg. (comb. 849, 858) (saddle)

**FOLDING TOP PARTS—INTERIOR TRIM**

**14.650 LACE— CLIP— ESCUTCHEON ASSY., Headlining Finish and Back Window (Con't)**

<b>74-75</b>	Caprice (Sedan) (exc. Spt. Sed.) . . . . .	<b>1695680</b>	R.H.	3.10	finish roof inner side mldg. (comb. 857, 73B, 73C) (oxblood) . . . . .
<b>74-75</b>	Caprice (Sedan) (exc. Spt. Sed.) . . . . .	<b>1695681</b>	L.H.	3.10	finish roof inner side mldg. (comb. 857, 73B, 73C) (oxblood) . . . . .
<b>74</b>	Caprice (Sedan) (exc. Spt. Sed.) . . . . .	<b>9676924</b>	R.H.	2.65	finish roof inner side mldg. (comb. 896) (taupe) . . . . .
<b>74</b>	Caprice (Sedan) (exc. Spt. Sed.) . . . . .	<b>9676925</b>	L.H.	2.65	finish roof inner side mldg. (comb. 896) (taupe) . . . . .
<b>75</b>	Pass. (Sta. Wag.) (Sedan) (exc. Spt. Sed.) . . . . .	<b>1695678</b>	R.H.	3.10	finish roof inner side mldg. (comb. 63E, 63W) (saddle) . . . . .
<b>75</b>	Pass. (Sta. Wag.) (Sedan) (exc. Spt. Sed.) . . . . .	<b>1695679</b>	L.H.	3.10	finish roof inner side mldg. (comb. 63E, 63W) (saddle) . . . . .
<b>75</b>	Pass. (Sedan) (exc. Spt. Sed.) . . . . .	<b>1695686</b>	R.H.	3.10	finish roof inner side mldg. (comb. 26B, 26C, 26D, 26W) (blue) . . . . .
<b>75</b>	Pass. (Sedan) (exc. Spt. Sed.) . . . . .	<b>1695687</b>	L.H.	3.10	finish roof inner side mldg. (comb. 26B, 26C, 26D, 26W) (blue) . . . . .
<b>75</b>	Pass. (Sta. Wag.) . . . . .	<b>1695687</b>	L.H.	3.10	finish roof inner side mldg. (comb. 26B, 26V) . . . . .
<b>75</b>	Pass. (Spt. Sed.) . . . . .	<b>1695688</b>	R.H.	3.10	finish roof inner side mldg. (comb. 55B, 55C, 55D, 55H, 55V) (sandstone) . . . . .
<b>75</b>	Pass. (Spt. Sed.) . . . . .	<b>1695689</b>	L.H.	3.10	finish roof inner side mldg. (comb. 55B, 55C, 55D, 55H, 55V) (sandstone) . . . . .
<b>75</b>	Pass. (Spt. Sed.) Impala (Custom) Caprice (Spt. Cpe.) . . . . .	<b>1657341</b>	1	11.00	qtr. window trim fin. panel . . . . .
	<i>NOTE 1: Soft.</i>				
	<i>NOTE 2: For second design see Group 11.120.</i>				
<b>69-70</b>	Sed. (exc. Spt. Sed.) . . . . .	<b>8746237</b>	L.H.	.76	<b>ESCUTCHEON ASSY.,</b> left b/w lwr. cor. (paint as required) . . . . .

**CHEVELLE**

<b>64-68</b>	(Conv.) . . . . .	<b>4458887</b>	1	2.40	frt. roof rail pinchweld (black) . . . . .
<b>70-72</b>	(Conv.) . . . . .	<b>4458887</b>	1	2.40	frt. roof rail pinchweld (black) . . . . .
<b>66</b>	Malibu (Spt. Sed.), El Camino (Custom),				
<b>67</b>	(Spt. Cpe., Conv., Sta. Wag.) . . . . .	<b>4417089</b>	1	.18	back wind. upper escut. (black) . . . . .
<b>68-71</b>	(exc. Conv.) . . . . .	<b>8776408</b>	1	1.80	w/s upper trim finish (black) . . . . .
<b>68-72</b>	El Camino . . . . .	<b>7740509</b>	1	3.25	back window upper and side trim (black) . . . . .
<b>71-72</b>	Chevelle (exc. Conv.) . . . . .	<b>8776408</b>	1	1.80	windshield upper trim finish (black) . . . . .
<b>71</b>	Monte Carlo . . . . .	<b>8806177</b>	L.H.	5.55	trim finish side roof rail (black) . . . . .
<b>71</b>	Chevelle (Spt. Cpe.) (exc. Monte Carlo) . . . . .	<b>8800136</b>	R.H.	5.55	trim finish side roof rail (comb. 701, 703, 704, 705, 706, 751, 752, 753, 755, 756, 790, 791) (black) . . . . .
<b>71</b>	Chevelle (Spt. Cpe.) (exc. Monte Carlo) . . . . .	<b>8800137</b>	L.H.	5.55	trim finish side roof rail (comb. 701, 703, 704, 705, 706, 751, 752, 753, 755, 756, 790, 791) (black) . . . . .
<b>71</b>	Chevelle (Sta. Wag.) . . . . .	<b>8719736</b>	2	3.40	trim finish side roof rail (black) . . . . .
<b>71</b>	El Camino . . . . .	<b>7753490</b>	2	1.85	trim finish side roof rail (black) . . . . .
<b>71-72</b>	Chevelle (Spt. Cpe., El Camino) . . . . .	<b>7740509</b>	1	3.25	back window upper and side (black) . . . . .
<b>72</b>	Chevelle (Sta. Wag.) Sed. (exc. Spt. Sed.) . . . . .	<b>8791459</b>	2	5.85	side roof rail finish . . . . .
<b>72</b>	Chevelle (Sta. Wag.) Sed. (exc. Spt. Sed.) . . . . .	<b>8719736</b>	2	3.40	trim finish si. rf. rail (comb. 719, 720, 721) . . . . .
<b>68-72</b>	El Camino . . . . .	<b>7753490</b>	2	1.85	<b>LACE ASSY.,</b> side roof rail trim finish (black) . . . . .
<b>70-72</b>	Monte Carlo (Spt. Cpe.) . . . . .	<b>8806177</b>	L.H.	5.55	<b>LACE ASSY.,</b> left trim finish side roof rail (comb. 748, 749, 757) (black) . . . . .
<b>70-72</b>	Malibu (Spt. Cpe.) . . . . .	<b>8800136</b>	R.H.	5.55	<b>LACE ASSY.,</b> right trim finish side roof rail (comb. 753, 755, 756, 790, 791) (black) . . . . .
<b>70-72</b>	Malibu (Spt. Cpe.) . . . . .	<b>8800137</b>	L.H.	5.55	<b>LACE ASSY.,</b> left trim finish side roof rail (comb. 753, 755, 756, 790, 791) (black) . . . . .
<b>68-72</b>	(4-Dr. Sed.) . . . . .	<b>7790838</b>	R.H.	.93	<b>ESCUTCHEON ASSY.,</b> right back window trim finish lwr. cor. (paint as required) . . . . .
<b>68-72</b>	(4-Dr. Sed.) . . . . .	<b>7790839</b>	L.H.	.93	<b>ESCUTCHEON ASSY.,</b> right back window lwr. cor. (paint as required) . . . . .
<b>68-71</b>	(2-Dr. Sed., Spt. Cpe.),				
<b>72</b>	Chevelle (Spt. Cpe.) . . . . .	<b>7740376</b>	R.H.	1.05	<b>ESCUTCHEON ASSY.,</b> right back window lwr. cor. (paint as required) . . . . .
<b>68-71</b>	(2-Dr. Sed., Spt. Cpe.),				
<b>72</b>	Chevelle (Spt. Cpe.) . . . . .	<b>7740377</b>	L.H.	1.10	<b>ESCUTCHEON ASSY.,</b> left back window lwr. cor. (paint as required) . . . . .

**FOLDING TOP PARTS—INTERIOR TRIM**

**14.650 LACE— CLIP— ESCUTCHEON ASSY., Headlining Finish and Back Window  
(Con't)**

*NOTE 1 Use 1st design with soft trim.*

*NOTE 2 Use 2nd design with plastic panel.*

**SUN ROOF**

73	Chevelle (Coupe) . . . . .	9727744	1	12.25	finish sun roof opening (comb. 701, 702, 703, 704, 706, 707, 708, 712) (black) . . . . .
73	Chevelle (Coupe) . . . . .	9727746	1	10.10	finish sun roof opening (comb. 710, 711, 715, 726, 727, 728, 730) (green) . . . . .
73	Malibu (Coupe) . . . . .	9727747	1	10.10	finish sun roof opening (comb. 716, 721) (chamois) . . . . .
73	Chevelle (Coupe) . . . . .	9727748	1	10.10	finish sun roof opening (comb. 731, 732, 733, 734, 735) (neutral) . . . . .
73	Malibu, Laguna (Coupe) . . . . .	9727749	1	10.10	finish sun roof opening (comb. 717, 720) (oxblood) . . . . .
73	Laguna (Coupe) Monte Carlo w/elec. sun roof, manual sun roof . . . . .	9727750	1	10.10	finish sun roof opening (comb. 709, 714, 740) (73D, N, E, Z) (oxblood) . . . . .
74-75	Chevelle (Coupe) w/elec. sun roof, manual sun roof . . . . .	9727742	1	10.10	sun roof opening (comb. 701, 702, 703, 704, 705, 706, 707, 708, 709, 738, 747, 891, 894) (19C, 19V, 19D, 19W, 19B, 19E, 19H, 19N, 19Z) (black) . . . . .
75	Chevelle, 73 Monte Carlo, 74 Chevelle (Coupe) . . . . .	9727745	1	10.10	sun roof opening (comb. 732, 734, 725, 737, 749, 785, 897) (mid. blue) . . . . .
74-75	Chevelle (Coupe) . . . . .	9727750	1	10.10	sun roof opening (comb. 719, 720, 743, 744) (73B, 73D, 73N) (oxblood) . . . . .
74	Chevelle (Coupe) . . . . .	9727748	1	10.10	sun roof opening (comb. 713, 714, 716, 722, 892) (neutral) . . . . .
74-75	Chevelle (Coupe) w/elec. sun roof, manual sun roof . . . . .	9727871	1	12.20	sun roof opening (comb. 723, 724, 726, 727, 728, 730, 745, 830, 893) (44V, 44D, 44N) (green) . . . . .
74	Chevelle (Coupe) . . . . .	9727870	1	12.20	sun roof opening (comb. 718, 731, 740, 742) (saddle) . . . . .
75	Malibu (Coupe) w/elec. sun roof, manual sun roof . . . . .	9727749	1	10.10	sun roof opening (comb. 63W) (saddle) . . . . .
75	Chevelle (Coupe) . . . . .	1685301	1	13.10	sun roof opening (comb. 26C, 26V, 26D, 26W, 26B, 26H, 26N) (blue) . . . . .
75	Chevelle (Coupe) . . . . .	1685302	1	13.10	sun roof opening (comb. 55V, 55W, 55B, 55H) (sandstone) . . . . .
75	Chevelle (Coupe) . . . . .	1685304	1	13.10	sun roof opening (comb. 16D) (graystone) . . . . .
75	Chevelle (Coupe) . . . . .	1685303	1	13.10	sun roof opening (white) . . . . .

**CHEVY— NOVA**

62-64	Chevy (Spt. Cpe.) . . . . .	4867165	1	2.05	back window upper trim (aqua) . . . . .
66	Chevy (Spt. Cpe.) (exc. S.S.) . . . . .	7594119	L.H.	.63	back wind. lwr. corner escut. (blue) . . . . .
67	(Sed.) . . . . .	4417089	1	.18	back wind. upper escut (black) . . . . .
68-71	Chevy . . . . .	8776408	1	1.80	windshield upper trim finish (black) (repl. 8776484) . . . . .
68-69	(Spt. Cpe.) . . . . .	8719736	2	3.40	side roof rail trim finish (black) . . . . .
68-72	Nova . . . . .	7740509	1	3.25	back window upper and side (black) . . . . .
70-72	Nova . . . . .	8791459	2	5.85	LACE ASSY., side roof rail trim finish (black) . . . . .
65	Pass. Sedan (exc. Spt. Sed.) . . . . .	7630626	4	.12	CLIP, side and upper trim (snap on) . . . . .
68-72	Chevy . . . . .	7733857	R.H.	.61	ESCUTCHEON ASSY., back wind. lower corner escutcheon (paint as reqd.) . . . . .
68-72	Chevy . . . . .	7733858	L.H.	.61	ESCUTCHEON ASSY., back wind. lower corner escutcheon (paint as reqd.) . . . . .

**CAMARO**

70	Camaro . . . . .	9817810	1	2.35	trim finish back window (comb. 711, 712, 713, 725) (black) . . . . .
70-72	Camaro . . . . .	9817906	1	1.85	trim finish windshield upper (comb. 711, 712, 713, 725) (black) . . . . .
71	Camaro . . . . .	9817810	1	2.35	trim finish back window (comb. 775, 785, 789) (black) . . . . .
71-72	Camaro . . . . .	9835764	1	2.45	trim finish back window black (paint as req.) . . . . .
73	Camaro (1st design) . . . . .	9817906	1	1.85	windshield upper (comb. 773, 774, 775, 776, 785, 786) (black) (Note 1, 2) . . . . .

**FOLDING TOP PARTS—INTERIOR TRIM**

**14.650 LACE— CLIP— ESCUTCHEON ASSY., Headlining Finish and Back Window  
(Con't)**

<b>73</b>	Camaro (1st design) . . . . .	<b>9835764</b>	<b>1</b>	<b>2.45</b>	back window (prime and paint as reqd.) (Note 1, 2) . . . . .
<b>69</b>	All (Spt. Cpe.) . . . . .	<b>8719736</b>	<b>A.R.</b>	<b>3.40</b>	<b>LACE ASSY.</b> , side rf. rail trim fin. (black) . . .
<b>67-68</b>	Pass., Camaro (Spt. Cpe.) . . . . .	<b>7630626</b>	<b>A.R.</b>	<b>.12</b>	<b>CLIP</b> , side and upper trim (snap-on) . . . . .

**VEGA— MONZA**

<b>71-73</b>	Vega (Panel) . . . . .	<b>9835074</b>	<b>1</b>	<b>3.00</b>	p/w finish back door window . . . . .
<b>75</b>	Monza (exc. Towne Cpe.) . . . . .	<b>1666009</b>	<b>2</b>	<b>.64</b>	opening . . . . .
<b>71-73</b>	Vega (Panel) . . . . .	<b>9835075</b>	<b>1</b>	<b>.67</b>	<b>ESCUTCHEON</b> , bk. window p/w fin. lace . . .

**14.651 RETAINER— CLIP— ESCUTCHEON, Headlining Trim**

**PASS.**

<b>74-75</b>	Impala (Custom), Caprice (Spt. Cpe.) . . . . .	<b>9667732</b>	<b>R.H.</b>	<b>1.15</b>	back window upper corner . . . . .
<b>74-75</b>	Impala (Custom), Caprice (Spt. Cpe.) . . . . .	<b>9667733</b>	<b>L.H.</b>	<b>1.15</b>	back window upper corner . . . . .
<b>65</b>	Sed. (exc. Spt. Sed.) . . . . .	<b>4479087</b>	<b>A.R.</b>	<b>.12</b>	<b>CLIP</b> , back wind. trim retainer . . . . .
<b>67</b>	Impala, Caprice (Spt. Sed.),				
<b>67-68</b>	Impala (Spt. Cpe.),				
<b>68</b>	Caprice (Spt. Cpe.),				
<b>69-70</b>	Impala, Caprice (Spt. Sed., Spt. Cpe.) . . . . .	<b>8732609</b>	<b>A.R.</b>	<b>.18</b>	<b>CLIP</b> , side rf. rail frt. and rr. mldg. . . . .
<b>71-72</b>	Pass. (Spt. Sed., Spt. Cpe.) . . . . .	<b>9827569</b>	<b>A.R.</b>	<b>.15</b>	<b>CLIP</b> , rf. inr. st. frt. mldg./pnl. . . . .
<b>72</b>	Pass. (Sta. Wag.) (Sed. exc. Spt. Sed.) . . . . .	<b>9899423</b>	<b>4</b>	<b>.16</b>	<b>CLIP</b> , rf. inr. side mldg. panel . . . . .
<b>73-75</b>	Pass. (Spt. Sed., Spt. Cpe.) . . . . .	<b>9660413</b>	<b>A.R.</b>	<b>.16</b>	<b>CLIP</b> , roof inr. si. frt. and rear mldg. panel . . .
<b>73</b>	Impala (Custom) Caprice (Spt. Cpe.) . . . . .	<b>9844979</b>	<b>2</b>	<b>.22</b>	<b>CLIP</b> , roof inr. side rr. mldg. to pnl. . . . .
<b>73</b>	Impala (Spt. Cpe.) (exc. Custom)	<b>9848750</b>	<b>2</b>	<b>.18</b>	<b>CLIP</b> , roof inner side rear mldg. panel upr. . .
<b>73</b>	Impala (Spt. Cpe.) (exc. Custom)	<b>9845325</b>	<b>2</b>	<b>.18</b>	<b>CLIP</b> , roof inner side rear mldg. panel lwr. . .
<b>73-74</b>	Pass. (Sta. Wag., Sed.) (exc. Spt. Sed.) . . . . .	<b>9899423</b>	<b>4</b>	<b>.16</b>	<b>CLIP</b> , roof inr. side mldg. panel . . . . .
<b>74-75</b>	Impala (Spt. Cpe.) (exc. Custom)	<b>9686132</b>	<b>2</b>	<b>.15</b>	<b>CLIP</b> , roof inr. pnl. side rr. mldg. . . . .
<b>74-75</b>	Impala (Custom) Caprice (Spt. Cpe.) . . . . .	<b>9685116</b>	<b>4</b>	<b>.16</b>	<b>CLIP</b> , roof inr. pnl. side mldg. . . . .

**CHEVELLE**

<b>68-72</b>	Chevelle (Sta. Wag.) . . . . .	<b>9606214</b>	<b>R.H.</b>		side roof rail trim (repl. 7746701) . . . . .
<b>74-75</b>	Monte Carlo w/Electric Sliding Sun Roof . . . . .	<b>9673224</b>	<b>R.H.</b>	<b>3.35</b>	roof inner at shoulder strap . . . . .
<b>74-75</b>	Monte Carlo w/Electric Sliding Sun Roof . . . . .	<b>9673225</b>	<b>L.H.</b>	<b>3.35</b>	roof inner at shoulder strap . . . . .
<b>74-75</b>	Chevelle (Coupe) w/Electric Sliding Sun Roof (exc. Monte Carlo) . . . . .	<b>9673226</b>	<b>R.H.</b>	<b>3.35</b>	roof inner at shoulder strap . . . . .
<b>74-75</b>	Chevelle (Coupe) w/Electric Sliding Sun Roof (exc. Monte Carlo) . . . . .	<b>9673227</b>	<b>L.H.</b>	<b>3.35</b>	roof inner at shoulder strap . . . . .
<b>64</b>	Chevelle (Sed., El Camino) . . . . .				<b>CLIP</b> , back wind. upr. trim retainer, . . . . .
<b>64-65</b>	Chevelle (4-Dr. Sta. Wag.) . . . . .				side roof rail trim retainer, . . . . .
<b>64</b>	Chevelle (2-Dr. Sed.) . . . . .				side roof rail trim rr. retainer, . . . . .
<b>64</b>	Chevelle (2-Dr. Sta. Wag.) . . . . .				side roof rail trim frt. retainer, . . . . .
<b>64-66</b>	Chevelle (exc. Conv.) . . . . .	<b>4479087</b>	<b>A.R.</b>	<b>.12</b>	windshield upr. trim retainer . . . . .
<b>73-75</b>	Chevelle . . . . .	<b>9617200</b>	<b>A.R.</b>	<b>.16</b>	<b>CLIP</b> , roof inr. side mldg. . . . .
<b>74-75</b>	El Camino . . . . .	<b>8790889</b>	<b>2</b>	<b>.16</b>	<b>CLIP</b> , finish mldg. roof pnl. ctr. to b/w finish mldg. p/w cor. b/w . . . . .

**CHEVY— NOVA**

<b>68-72</b>	Chevy (Spt. Cpe.) . . . . .	<b>7723476</b>	<b>R.H.</b>	<b>1.35</b>	back wind. side trim . . . . .
<b>73-74</b>	Nova . . . . .	<b>9734171</b>		<b>.34</b>	side roof rail frt. . . . .
<b>73-74</b>	Nova (H.B.) . . . . .	<b>9622480</b>	<b>R.H.</b>	<b>1.15</b>	back window . . . . .
<b>73-74</b>	Nova (H.B.) . . . . .	<b>9622481</b>	<b>L.H.</b>	<b>1.15</b>	back window . . . . .
<b>64-66</b>	Chevy, . . . . .				
<b>65-66</b>	Chevy . . . . .	<b>4479087</b>	<b>A.R.</b>	<b>.12</b>	<b>CLIP</b> , windshield, back window and side roof railtrim back wind. side trim retainer . .
<b>75</b>	Nova . . . . .	<b>1654500</b>	<b>A.R.</b>	<b>.16</b>	<b>CLIP</b> , roof side inner mldg. . . . .

**CAMARO**

<b>70-72</b>	Camaro . . . . .	<b>8763481</b>	<b>1</b>	<b>3.35</b>	back window upper trim . . . . .
<b>70-72</b>	Camaro . . . . .	<b>9816924</b>	<b>1</b>	<b>2.20</b>	w/s upper trim— (10.093) . . . . .
<b>73</b>	Camaro (1st design) . . . . .	<b>8763481</b>	<b>1</b>	<b>3.35</b>	back window upper (Note 1) . . . . .
<b>73</b>	Camaro (1st design) . . . . .	<b>9816924</b>	<b>1</b>	<b>2.20</b>	w/s upper (Note 1)— (10.093) . . . . .

**FOLDING TOP PARTS—INTERIOR TRIM**

**14.651 RETAINER— CLIP— ESCUTCHEON, Headlining Trim (Con't)**

73 Camaro (1st design) . . . . . 9812754 6 .16 CLIP, roof inner panel side mldg. (Note 1) . .

**14.651A MOULDING— CLIP— ESCUTCHEON, Headlining Trim**

**PASS.**

*NOTE 1 Paint as required.*

71-72	Impala (Custom) Caprice (Spt. Cpe.) . . . . .	9841239 L.H.	11.85	roof inner side front (paint as reqd.) . . . . .
71-72	Impala (Spt. Cpe.) (exc. Custom)	9850010 R.H.	6.55	roof inner side front (paint as reqd.) . . . . .
71-72	Impala (Spt. Cpe.) (exc. Custom)	9850011 L.H.	6.55	roof inner side front (paint as reqd.) . . . . .
71-72	Impala, Caprice (Spt. Sed.) . . . . .	9858438 R.H.	5.20	roof inner side front (paint as reqd.) . . . . .
71-72	Impala, Caprice (Spt. Sed.) . . . . .	9858439 L.H.	5.20	roof inner side front (paint as reqd.) . . . . .
71	Pass. (Sed.) (exc. Spt. Sed.),			
71	Pass. (Sta. Wag.) . . . . .	9852244 2	4.70	roof inner side front (comb. 802, 803, 804, 805, 806, 809) (black) . . . . .
71	Kingswood,			
71	Impala, Bel Air (Sed.) (exc. Spt. Sed.) . . . . .	9852245 2	4.70	roof inner side front (comb. 827, 829, 830) (med. maize) . . . . .
71	Kingswood,			
71	Impala (Sed.) (exc. Spt. Sed.) . . . . .	9852246 2	4.70	roof inner side front (comb. 825) (dk. saddle) . . . . .
71	Pass. (Sta. Wag.),			
71	Pass. (Sed.) (exc. Spt. Sed.) . . . . .	9852247 2	4.70	roof inner side front (comb. 810, 811, 812, 813, 814) (dk. blue) . . . . .
71	Kingswood,			
71	Impala, Bel Air (Sed.) (exc. Spt. Sed.) . . . . .	9852248 2	4.70	roof inner side front (comb. 832, 834, 835) (dk. jade) . . . . .
71	Biscayne, Bel Air (Sed.) (exc. Spt. Sed.) . . . . .	9852253 2	4.70	roof inner side front (comb. 818, 819) (lt. sandalwood) . . . . .
71-72	Impala (Custom) Caprice (Spt. Cpe.) . . . . .	9841676 R.H.	5.55	roof inner side rear (paint as reqd.) . . . . .
71-72	Impala (Custom) Caprice (Spt. Cpe.) . . . . .	9841677 L.H.	5.55	roof inner side rear (paint as reqd.) . . . . .
71-72	Impala, Caprice (Spt. Sed.) . . . . .	9849990 R.H.	5.70	roof inner side rear (paint as reqd.) . . . . .
71-72	Impala, Caprice (Spt. Sed.) . . . . .	9849991 L.H.	5.70	roof inner side rear (paint as reqd.) . . . . .
72	Pass. (Sed.) exc. Spt. Sed. . . . .	9601003 L.H.	10.05	roof inter side (painted) . . . . .
72	Pass. (Sed.) exc. Spt. Sed. . . . .	9601002 R.H.	10.05	roof inter side (painted) . . . . .
72-75	Pass. (Sta. Wag.) . . . . .	9601015 L.H.	10.05	roof inter side (painted) . . . . .
72-75	Pass. (Sta. Wag.) . . . . .	9601014 R.H.	10.05	roof inter side (painted) . . . . .
73	Impala (Custom), Caprice (Spt. Cpe.) . . . . .	9841239 L.H.	11.85	roof inner side front (prime and paint as reqd.) . . . . .
73	Impala (Spt. Cpe.) (exc. Custom)	9850010 R.H.	6.55	roof inner side front (prime and paint as reqd.) . . . . .
73	Impala (Spt. Cpe.) (exc. Custom)	9850011 L.H.	6.55	roof inner side front (prime and paint as reqd.) . . . . .
73	Impala (Custom), Caprice (Spt. Cpe.) . . . . .	9841676 R.H.	5.55	roof inner side rear (prime and paint as reqd.) . . . . .
73	Impala (Custom), Caprice (Spt. Cpe.) . . . . .	9841677 L.H.	5.55	roof inner side rear (prime and paint as reqd.) . . . . .
73-74	Impala, Caprice (Spt. Sed.) . . . . .	9849990 R.H.	5.70	roof inner side rear (paint as reqd.) . . . . .
73-74	Impala, Caprice (Spt. Sed.) . . . . .	9849991 L.H.	5.70	roof inner side rear (paint as reqd.) . . . . .
73-74	Impala, Caprice (Spt. Sed.) . . . . .	9858438 R.H.	5.20	roof inter side front (paint as reqd.) . . . . .
73-74	Impala, Caprice (Spt. Sed.) . . . . .	9858439 L.H.	5.20	roof inter side front (paint as reqd.) . . . . .
73-74	Pass. (Sed.) exc. Spt. Sed. . . . .	9601002 R.H.	10.05	roof inter side (paint as reqd.) . . . . .
73-74	Pass. (Sed.) exc. Spt. Sed. . . . .	9601003 L.H.	10.05	roof inter side (paint as reqd.) . . . . .
74-75	Impala (Custom) Caprice (Spt. Cpe.) . . . . .	9681406 R.H.	5.20	roof inner panel side (paint as reqd.) . . . . .
74-75	Impala (Custom) Caprice (Spt. Cpe.) . . . . .	9681407 L.H.	5.20	roof inner panel side (paint as reqd.) . . . . .
74-75	Impala (Spt. Cpe.) (exc. Custom)	9681390 R.H.	6.55	roof inner panel side (prime and paint as reqd.) . . . . .
74-75	Impala (Spt. Cpe.) (exc. Custom)	9681391 L.H.	6.55	roof inner panel side (prime and paint as reqd.) . . . . .
74-75	Impala (Spt. Cpe.) (exc. Custom)	9681398 R.H.	2.80	roof inner side rear (paint as reqd.) . . . . .
74-75	Impala (Spt. Cpe.) (exc. Custom)	9681399 L.H.	2.80	roof inner side rear (paint as reqd.) . . . . .
75	Pass. (Sedan) (exc. Spt. Sed.) . . . . .	1661848 R.H.	10.05	roof inner panel side . . . . .
75	Pass. (Sedan) (exc. Spt. Sed.) . . . . .	1661849 L.H.	10.05	roof inner panel side . . . . .
75	Pass. (Spt. Sed.) . . . . .	1661760 R.H.	5.20	roof inner panel side . . . . .

**FOLDING TOP PARTS—INTERIOR TRIM**

**14.651A MOULDING— CLIP— ESCUTCHEON, Headlining Trim (Con't)**

75	Pass. (Spt. Sed.)	1661761 L.H.	5.20	roof inner panel side
71	Impala (Spt. Cpe.) (exc. Custom)	9845325 2	.18	CLIP, right front inner side rear mldg. lower
71	Impala Custom (Spt. Cpe.)	9844979 2	.22	CLIP, right front inner side rear mldg. to pnl.
71	Impala (Spt. Cpe.) (exc. Custom)	9848750 2	.18	CLIP, right front inner side rear mldg. upper

**CHEVELLE**

73	Chevelle (Coupe) (exc. Monte Carlo)	9645276 R.H.	2.05	roof inner side (prime and paint as reqd.)
73	Chevelle (Coupe) (exc. Monte Carlo)	9645277 L.H.	2.05	roof inner side (prime and paint as reqd.)
73	Chevelle (Sedan)	9646658 R.H.	2.80	roof inner side (prime and paint as reqd.)
73	Chevelle (Sedan)	9646659 L.H.	2.80	roof inner side (prime and paint as reqd.)
73-75	Chevelle (Sta. Wag.)	9627280 R.H.	4.90	roof inner side (prime and paint as reqd.)
73-75	Chevelle (Sta. Wag.)	9627281 L.H.	4.90	roof inner side (prime and paint as reqd.)
73	Monte Carlo	9629030 R.H.	2.15	rf. inr. side (prime and paint as reqd.)
73	Monte Carlo	9629031 L.H.	2.15	rf. inr. side (prime and paint as reqd.)
74-75	Chevelle (Sedan)	9680458 R.H.	2.80	roof inner side rear (prime and paint as reqd.)
74-75	Chevelle (Sedan)	9680459 L.H.	2.80	roof inner side rear (prime and paint as reqd.)
74-75	Chevelle (Spt. Cpe.) (exc. Monte Carlo)	9681328 R.H.	2.80	roof inner panel side (prime and paint as reqd.)
74-75	Chevelle (Spt. Cpe.) (exc. Monte Carlo)	9681329 L.H.	2.80	roof inner panel side (prime and paint as reqd.)
74-75	Monte Carlo	9681344 R.H.	2.80	roof inner panel side (prime and paint as reqd.)
74-75	Monte Carlo	9681345 L.H.	2.80	roof inner panel side (prime and paint as reqd.)
73-75	Chevelle (Sta. Wag.)	9627256 R.H.	2.45	MOULDING ASSY., roof inner side ctr. (prime and paint as reqd.)
73-75	Chevelle (Sta. Wag.)	9627257 L.H.	2.45	MOULDING ASSY., roof inner side ctr. (prime and paint as reqd.)
73-75	Chevelle (Sta. Wag., Sedan)	9645726 R.H.	3.95	MOULDING ASSY., roof inner side frt. (prime and paint as reqd.)
73-75	Chevelle (Sta. Wag., Sedan)	9645727 L.H.	3.95	MOULDING ASSY., roof inner side frt. (prime and paint as reqd.)

NOTE 1: Soft.  
NOTE 2: Hard.

**NOVA**

73-74	Nova (H.B.)	9658520 1	7.35	finish rear headlining (paint as reqd.)
73	Nova (2-Dr.)	9640316 R.H.	4.65	rf. inr. side (paint as reqd.)
73	Nova (2-Dr.)	9640317 L.H.	4.65	rf. inr. side (paint as reqd.)
73	Nova (4-Dr.)	9640304 R.H.	4.80	rf. inr. side (paint as reqd.)
73	Nova (4-Dr.)	9640305 L.H.	4.80	rf. inr. side (paint as reqd.)
74	Nova (2-Dr.)	9674976 R.H.	4.65	roof inner side (prime and paint as reqd.)
74	Nova (2-Dr.)	9674977 L.H.	4.65	roof inner side (prime and paint as reqd.)
74	Nova (4-Dr.)	9674992 R.H.	4.80	roof inner side (prime and paint as reqd.)
74	Nova (4-Dr.)	9674993 L.H.	4.80	roof inner side (prime and paint as reqd.)
75	Nova (Coupe)	1663676 R.H.	5.65	roof inner panel side
75	Nova (Coupe)	1663677 L.H.	5.65	roof inner panel side
75	Nova (Sedan)	1661086 R.H.	4.80	roof inner panel
75	Nova (Sedan)	1661087 L.H.	4.80	roof inner panel

**CAMARO**

70-72	Camaro	9861230 R.H.	3.60	roof inner panel side (paint as reqd.) (repl. 9812751)
70-72	Camaro	9861231 L.H.	3.60	roof inner panel side (paint as reqd.)
73	Camaro (1st design)	9861230 R.H.	3.60	roof inner panel side (paint as reqd.) (Note 1)
73	Camaro (1st design)	9861231 L.H.	3.60	roof inner panel side (paint as reqd.) (Note 1)
73-75	Camaro (2nd design)	9667026 R.H.	3.20	roof inner panel side (paint as reqd.) (Note 2)
73-75	Camaro (2nd design)	9667027 L.H.	3.20	roof inner panel side (paint as reqd.) (Note 2)
71	Camaro	9812754 6	.16	CLIP, roof inner panel side mldg. to panel

**VEGA— MONZA**

71	Vega (exc. Hatchback)	9870208 R.H.	2.35	roof inner front (prime and paint as reqd.)
71-75	Vega (Panel, Sta. Wag.)	9837662 2	2.50	roof inner side rear (prime and paint as reqd.)

**FOLDING TOP PARTS—INTERIOR TRIM**

**14.651A MOULDING— CLIP— ESCUTCHEON, Headlining Trim (Con't)**

71-75	Vega (exc. Hatchback) . . . . .	9612290 R.H.	2.65	roof inner side front (prime and paint as reqd.) (repl. 9612264) . . . . .
71-75	Vega . . . . .	9612291 L.H.	2.65	roof inner side front (prime and paint as reqd.) . . . . .
75	Monza (exc. Towne Cpe.) . . . . .	1698092 R.H.	6.25	roof inner side front (repl. 1661118) . . . . .
75	Monza (exc. Towne Cpe.) . . . . .	1661119 L.H.	4.70	roof inner side front . . . . .
75	Monza (exc. Towne Cpe.) . . . . .	1698096 R.H.	4.75	roof inner side rear (repl. 1661128) . . . . .
75	Monza (exc. Towne Cpe.) . . . . .	1698097 L.H.	4.75	roof inner side rear (repl. 1661129) . . . . .
75	Monza (Towne Cpe.) . . . . .	1708138 R.H.	4.20	roof inner side rear (prime & paint as reqd.) . . . . .
75	Monza (Towne Cpe.) . . . . .	1708139 L.H.	4.20	roof inner side rear (prime & paint as reqd.) . . . . .

**14.655 PAD UNIT— PAD ASSY., Instrument Panel**

**PASS.**

65	Bel Air, Impala . . . . .	3871583	1	37.50	(blue) . . . . .
68	Pass. (exc. Air Cond.) . . . . .	7734031	1	54.00	PAD ASSY. (black) . . . . .
68	Pass. (exc. Conv. Air Cond.) . . . . .	7734033	1	54.00	PAD ASSY. (blue) . . . . .
68	Pass. (exc. Sta. Wag., Air Cond.) . . . . .	7734037	1		PAD ASSY. (gold) . . . . .
68	Bel Air w/Air Cond.,				
68	Impala w/Air Cond. (exc. Conv.),				
68	Caprice (Sta. Wag.) w/Air Cond.	8731891	1	53.00	PAD ASSY. (turquoise) . . . . .
69-70	Pass. (exc. C.A.C.) . . . . .	3935945	1	44.00	PAD ASSY. (black) . . . . .
69-70	Pass. w/C.A.C. . . . .	3939699	1	44.00	PAD ASSY. (black) (paint as reqd.) . . . . .
69	Pass. (exc. Conv., Air Cond.) . . . . .	3950024	1	35.50	PAD ASSY. (comb. 815, 818, 819, 820, 821, 822, 824, 826) (blue) . . . . .
69	Kingswood w/Air Cond.,				
69	Bel Air, Impala, Caprice w/Air Cond. (exc. Conv.) . . . . .	3950031	1	36.75	PAD ASSY. (comb. 848, 855, 857, 860, 861) (midnight green) . . . . .
69	Impala, Caprice (Spt. Cpe., Spt. Sed.) w/Air Cond. . . . .				PAD ASSY. (comb. 837, 840), . . . . .
70	Caprice w/C.A.C. . . . .	3950035	1		(comb. 841) (med. gold) . . . . .
70	Pass. w/C.A.C. (exc. Conv.) . . . . .	3939699	1	44.00	PAD ASSY. (comb. 815, 818, 819, 820, 821, 826) (dk. blue) . . . . .
70	Pass. w/C.A.C. (exc. Conv., Brookwood) . . . . .	3972089	1	48.25	PAD ASSY. (comb. 836, 837, 839, 840, 841, 843) (dk. gold) . . . . .
70	Pass. (exc. Biscayne, Brookwood, Townsman, C.A.C.) . . . . .	3972090	1	48.25	PAD ASSY. (comb. 848, 855, 860, 861) (dk. green) . . . . .
70	Pass. w/C.A.C. (exc. Biscayne, Brookwood, Townsman) . . . . .	3972091	1	48.25	PAD ASSY. (comb. 848, 855, 860, 861) (dk. green) . . . . .
70	Impala, Caprice (Sed., Spt. Cpe.) (exc. C.A.C.) . . . . .	3935945	1	44.00	PAD ASSY. (paint as reqd.) (repl. 3972092) . . . . .
71	Pass. . . . .	3994532	1	66.00	PAD ASSY. (black) (paint as reqd.) (repl. 3994537) . . . . .
72	Pass. . . . .	3994538	1	43.50	PAD ASSY. (paint as reqd.) . . . . .
73-75	Pass. . . . .	3999494	1	81.25	PAD ASSY. (paint as reqd.) . . . . .

**CHEVELLE**

67	Chevelle . . . . .	7643409	1	31.25	PAD ASSY. (dk. blue) . . . . .
68-69	Chevelle . . . . .	8741936	1	42.75	PAD ASSY. (black) . . . . .
68	Chevelle (exc. Sta. Wag., El Camino) . . . . .	8741941	1		PAD ASSY. (gold) . . . . .
69	Malibu (Sed., Spt. Cpe.),				
70-72	Chevelle w/center speaker . . . . .	3957052	1	73.50	PAD ASSY. (black) (paint as reqd.) . . . . .
70-72	Chevelle w/side speaker,				
70	Malibu (Spt. Cpe., Sed.),				
70	Monte Carlo w/center speaker,				
70	Malibu (Spt. Cpe., Sed.),				
70	Monte Carlo w/side speaker . . . . .	3965461	1	77.25	PAD ASSY. (black) (paint as reqd.) . . . . .
70	Chevelle w/side speaker . . . . .	3972071	1		PAD ASSY. (comb. 758, 759, 761, 762, 764, 765, 767, 768) (dk. blue) . . . . .
70	Chevelle w/side speaker (exc. Sed.) . . . . .	3972073	1		PAD ASSY. (comb. 769, 770, 771, 772, 773, 778) (dk. saddle) . . . . .
72	Chevelle w/center speaker outlet . . . . .	3965461	1	77.25	(paint as reqd.) (repl. 3999425) . . . . .

*NOTE: For Chevelle Pads after 1972 see Group 10.230 Panel.*

**CHEVY— NOVA**

68	Chevy . . . . .	8731742	1	45.50	PAD ASSY. (black) . . . . .
68	Chevy . . . . .	8731746	1	51.25	PAD ASSY. (gold) . . . . .
69-72	Chevy w/Air Cond. . . . .	8748935	1	54.75	PAD ASSY. (black) . . . . .



**FOLDING TOP PARTS—INTERIOR TRIM**

**14.655 PAD UNIT— PAD ASSY., Instrument Panel (Con't)**

69-72	Chevy, Nova (exc. C.A.C.)	8748945	1	54.75	PAD ASSY. (black)
70	Nova (exc. Air Cond.)	8798290	1		PAD ASSY. (comb. 744, 745) (dk. green)
70	Nova (exc. Air Cond.)	8798291	1	56.75	PAD ASSY. (comb. 740, 741, 742) (med. gold)
70	Nova (exc. Air Cond.)	8748945	1	54.75	PAD ASSY. (comb. 735, 736) (med. blue)
70	Nova w/C.A.C.	8798283	1	50.75	PAD ASSY. (comb. 735, 736) (med. blue)
73-74	Nova w/C.A.C.	9627820	1	36.50	PAD ASSY. (paint as reqd.)
73-74	Nova (exc. C.A.C.)	9627826	1	35.75	PAD ASSY. (paint as reqd.)
75	Nova (exc. C.A.C.)	332204	1	42.50	PAD ASSY. (prime and paint as reqd.)
75	Nova w/C.A.C.	332205	1	43.50	PAD ASSY. (prime and paint as reqd.)

**CAMARO**

68	Camaro	7733950	1	51.25	PAD ASSY. (black)
68	Camaro	7734029	1	50.25	PAD ASSY. (gold)
69	Camaro (exc. Air Cond.)	3935941	1	56.75	PAD ASSY. (black) (paint as reqd.) (repl. 3950038)
69	Camaro w/Air Cond.	3939653	1	76.75	PAD ASSY. (black) (paint as reqd.)
70-75	Camaro w/C.A.C.	6264733	1	51.25	PAD ASSY. (paint as reqd.)
70	Camaro (exc. C.A.C.)	3972003	1	59.75	PAD ASSY. (black)
70-72	Camaro (exc. C.A.C.)	3999438	1	59.75	PAD ASSY. (black) (paint as reqd.)
72-75	Camaro (exc. C.A.C.)	6264732	1	66.00	PAD ASSY. (paint as reqd.) (repl. 3999403)
72	Camaro w/C.A.C.	3999402	1	59.75	PAD ASSY. (paint as reqd.) (repl. 3999404)

**VEGA— MONZA**

71-75	Vega (exc. G.T.)	6264717	1	42.50	PAD ASSY. (prime and paint as reqd.)
73-75	Vega w/G.T.	6264718	1	42.50	PAD ASSY. (prime and paint as reqd.)
75	Monza (exc. Towne Cpe., C.A.C.)	346745	1	60.50	PAD ASSY. (prime and paint as reqd.)
75	Monza (exc. Towne Cpe.) w/C.A.C.	346759	1		PAD ASSY. (prime and paint as reqd.)
75	Monza (Towne Cpe.) (exc. C.A.C.)	346762	1	45.75	PAD ASSY. (prime and paint as reqd.)
75	Monza (Towne Cpe.) w/C.A.C.	346763	1	45.75	PAD ASSY. (prime and paint as reqd.)

**14.655A MOULDING— BEZEL— CLIP— FASTENER— HANDLE ASSY.— NUT— RETAINER— SCREW— SPACER, Instrument Panel**

69	Camaro w/decor. package	3945985	L.H.	.55	BEZEL, instr. pnl. assist handle
69	Camaro w/decor. package	3945986	R.H.	.55	BEZEL, instr. pnl. assist handle
68	Camaro	4877401	2	.16	CLIP, instr. panel cover— (11.209)
69	Camaro	3950099	6	.11	CLIP, instr. pnl. pad
69-75	Chevy	8754627	4	.18	CLIP, instr. pnl. cvr. to pnl.
70-73	Pass.	9787809	6	.16	CLIP, pad retainer
70-72	Chevelle	3965463	4	.16	CLIP, pad inner
70-72	Chevelle	3965462	2	.16	CLIP, pad outer
70-75	Camaro	3980355	2	.16	CLIP, pad to instrument panel
70-75	Camaro	3980361	1	.16	CLIP, pad to instrument panel
73-75	Pass.	9721360	2	.16	CLIP
71-75	Vega	3984470	3	.18	CLIP, instr. panel pad to instr. panel
75	Monza (exc. Towne Cpe.)	346731	2	.20	CLIP
63-64	Chevy	4851737	A.R.	.14	FASTENER, cover— (14.691)
65	Chevy	4870324	2	.11	FASTENER, cover— (14.730)
68-69	Camaro w/Deluxe Intr., Decor Pack	9787484	1	2.00	HANDLE ASSY., instr. panel asst. (black)
All	All	1231490	2	.34	NUT, special push in
70-71	Camaro	9431530	5	.05	NUT, pad to instrument panel (repl. 9420771)
69	Chevelle (Spt. Cpe., Conv.)	7750582	2	.24	RETAINER, frt. dr. belt trim supt.
63	Chevy	4667286	6	.05	SCREW, pad attaching (No. 8— 18— 6 x 5/8")— (17.112)
65	Pass.	4499086	7	.16	SCREW ASSY., cover to panel (10-24 x 3/8")
69	Camaro w/decor. package	3948552	2	.22	SPACER, instr. pnl. assist handle

**14.660 HANDLE ASSY.— BRACKET— COVER, Instrument Panel Assist Handle**

71-75	Vega w/G.T., L.X.	6264719	1	2.20	(prime and paint as reqd.)
71-75	Vega w/G.T.	332237	1	.37	BRACKET, assist handle (inner)
71-75	Vega w/G.T.	332238	1	.37	BRACKET, assist handle (outer)
75	Vega w/G.T.	332237	1	.37	BRACKET, assist handle (inner)
71	Vega w/G.T.	3984479	2	.40	COVER, instr. panel assist handle screw (prime and paint as reqd.)

**14.683 TAB— RETAINER— FASTENER— NUT— PLUG— SUPPORT, Front Door Trim Binding Strip Replacement**

65	Pass.	4081772	A.R.	.38	(1 long w/one nail emergency tab)
65	Pass.	6280765	A.R.	.12	panel (14.685)
68	Caprice (Spt. Cpe.)				

**FOLDING TOP PARTS—INTERIOR TRIM**

**14.683 TAB— RETAINER— FASTENER— NUT— PLUG— SUPPORT, Front Door Trim Binding Strip Replacement (Con't)**

69-70	Impala, Caprice (Spt. Cpe., Conv. Spt. Sed.)	7656000	2	.83	RETAINER, front dr. belt trim supt.
69-70	Pass. (2-Dr.)				RETAINER, front door belt trim support rear,
69-72	Chevelle (Spt. Cpe., Conv.)	7750582	2	.24	front door belt trim support front
69-72	Chevelle (Spt. Cpe., Conv.)	8713373	2	.24	RETAINER, frt. dr. belt trim supt. rear
71-72	Pass. (Spt. Cpe., Conv.)	8794990	4	1.40	RETAINER, front door belt trim support front and rear
71-72	Pass. (exc. Conv.)	8794993	A.R.	1.40	RETAINER, front door belt trim support front and rear, and rear door belt trim support front and rear
72	Pass. (Sta. Wag.) (Sed.)	9838831	4	.11	RETAINER, frt. dr. bind strip to inr. pnl.
71-73	Vega (Panel, Sta. Wag.)				RETAINER, back door hinge torque rod cover,
71-75	Pass., Camaro, Vega,				
75	Chevelle (4-Dr.), Camaro (exc. L.T.)	9883583	A.R.	.16	RETAINER, lower trim finish panel (repl. 329048)
73-75	Pass. (2-Dr.)	9658233	2	1.40	RETAINER, belt trim supt. front and rear
73-75	Pass. (4-Dr.)	9658234	2	1.40	RETAINER, belt trim supt. front and rear
73-75	Chevelle (exc. El Camino, Monte Carlo)	9830806	2	.81	RETAINER, belt trim supt. front and rear
73-75	Chevelle (2-Dr.)	9873923	2	1.40	RETAINER, belt trim supt. front, rear and ctr.
73-75	El Camino	9870399	2	1.55	RETAINER, belt trim supt. rear
70-75	Chevelle, Nova, Camaro	4500027	A.R.	.11	FASTENER, pad to inner panel— (14.645)
72-74	Camaro	9891850	8	.28	NUT, frt. dr. lower trim finish pnl.
65-69	Chevelle, Chevy, Camaro,				
73	Impala, Caprice (2-Dr.),				
73-75	Camaro, Nova (Sed.),				
73-74	Pass. (Spt. Cpe., Conv.)	4853962	A.R.	.11	PLUG, door trim pad sealing
69-72	Chevelle, Camaro (Plr. Cpe., Spt. Cpe., Conv.)	8768482	A.R.	.11	PLUG, qtr. trim pad seal to inr.
75	Monza (exc. Towne Cpe.)	9738445	R.H.	6.95	SUPPORT, upper
75	Monza (exc. Towne Cpe.)	9738446	L.H.	6.95	SUPPORT, upper

**14.685 TRIM ASSY., Front Door (less arm rest)**

*NOTE It may be necessary to punch holes in Trim Assembly to insure proper fit.*

*NOTE: For lower trim assys. use panel assy.*

**PASS.**

71	Impala (Conv.)	9854095	L.H.	50.75	upper (comb. 835) (dk. jade)
71	Caprice (Spt. Cpe.)	9845416	R.H.	13.40	lower finish panel w/carpet (comb. 821) (lt. sandalwood)
71	Impala (Spt. Cpe., Conv.)	9854095	L.H.	50.75	upper (comb. 834, 835) (dk. jade)
71-72	Impala (Sed.) (exc. Spt. Sed.)	9853664	R.H.	42.50	upper (comb. 805, 806) (black)
71-72	Kingswood	9898533	L.H.	41.50	upper (comb. 813, 814) (midnight blue)
71-72	Kingswood	9881383	L.H.	41.75	upper (comb. 825, 826) (saddle)
71-72	Bel Air, Townsman	9645468	R.H.	46.50	upper (comb. 803, 804) (black)
71-72	Bel Air, Townsman	9645469	L.H.	46.50	upper (comb. 803, 804) (black)
73	Kingswood	9898533	L.H.	41.50	upper (comb. 813) (blue)
72	Kingswood	9898537	L.H.	41.50	upper (comb. 830) (green)
72	Kingswood	9898534	R.H.	41.50	upper (comb. 818) (covert)
72	Kingswood	9898535	L.H.	41.50	upper (comb. 818) (covert)
71-72	Impala (Spt. Cpe.)	9898548	R.H.	48.25	upper (comb. 812, 813, 814) (blue)
72	Impala (2-Dr.)	9898549	L.H.	49.00	upper (comb. 812, 813) (blue)
72	Impala (Spt. Cpe.)	9898554	R.H.	49.00	upper (comb. 829, 830) (green)
72	Impala (Spt. Cpe.)	9898555	L.H.	49.00	upper (comb. 829, 830) (green)
72	Impala (Spt. Cpe.)	9898550	R.H.	49.00	upper (comb. 815, 818) (covert)
72	Impala (Spt. Cpe.)	9898551	L.H.	49.00	upper (comb. 815, 818) (covert)
72	Impala (Spt. Sed.)	9898538	R.H.	40.75	upper (comb. 812, 813) (blue)
72	Impala (Sed.) (exc. Spt. Sed.)	9898558	R.H.	40.50	upper (comb. 812) (blue)
72	Impala (Sed.) exc. Spt. Sed.	9898563	L.H.	41.75	upper (comb. 829, 830) (green)
73	Caprice (Spt. Cpe.)	9645553	L.H.	71.25	upper (comb. 840) (black)
73	Caprice (Spt. Cpe.)	9645556	R.H.	71.25	upper (comb. 842) (green)
73	Caprice (Spt. Cpe.)	9645557	L.H.	71.25	upper (comb. 842) (green)
73	Caprice (Spt. Cpe.)	9645555	L.H.	71.25	upper (comb. 841) (neutral)
73	Caprice (Spt. Cpe.)	9645560	R.H.	71.25	upper (comb. 836) (oxblood)
73	Caprice (Spt. Cpe.)	9645561	L.H.	71.25	upper (comb. 836) (oxblood)
73-74	Impala (Spt. Cpe.)				
74	Pass. (Conv.)	9645496	R.H.	48.50	upper (comb. 802, 805, 806) (black)
73-74	Impala (Spt. Cpe.)				
74	Pass. (Conv.)	9645497	L.H.	48.50	upper (comb. 802, 805, 806) (black)
73-74	Impala (Spt. Cpe.)	9645502	R.H.	48.50	upper (comb. 812, 813) (mid. blue)

**FOLDING TOP PARTS—INTERIOR TRIM**

**14.685 TRIM ASSY., Front Door (less arm rest) (Con't)**

73-74	Impala (Spt. Cpe.)	9645503 L.H.	48.50	upper (comb. 812, 813) (mid. blue)
73	Impala (Spt. Cpe.)	9645500 R.H.	48.50	upper (comb. 829, 830) (green)
73	Impala (Spt. Cpe.)	9645501 L.H.	48.50	upper (comb. 829, 830) (green)
73	Impala (Spt. Cpe.),			
73-74	Pass. (Conv.)	9645498 R.H.	48.50	upper (comb. 815, 818, 819, 821) (neutral)
73	Impala (Spt. Cpe.),			
73-74	Pass. (Conv.)	9645499 L.H.	48.50	upper (comb. 815, 818, 819, 821) (neutral)
73-74	Impala (Spt. Sed.)	9645488 R.H.	41.50	upper (comb. 802, 805, 806) (black)
73-74	Impala (Spt. Sed.)	9645489 L.H.	41.50	upper (comb. 802, 805, 806) (black)
73-74	Impala (Spt. Sed.)	9645494 R.H.	41.50	upper (comb. 812, 813, 847) (midn. blue)
73-74	Impala (Spt. Sed.)	9645495 L.H.	41.50	upper (comb. 812, 813, 847) (midn. blue)
73-74	Impala (Spt. Sed.)	9645490 R.H.	41.50	upper (comb. 815, 818, 819, 821) (neutral)
73-74	Impala (Spt. Sed.)	9645491 L.H.	41.50	upper (comb. 815, 818, 819, 821) (neutral)
73	Caprice (Spt. Sed.)	9645539 L.H.	57.25	upper (comb. 843) (midn. blue)
73-75	Bel Air (Sed.)	9645468 R.H.	46.50	upper (comb. 803, 804, 19C) (black)
73-75	Bel Air (Sed.)	9645469 L.H.	46.50	upper (comb. 803, 804, 19C) (black)
73	Bel Air (Sed.)	9645471 L.H.	29.00	upper (comb. 810) (med. blue)
73	Bel Air (Sed.)	9645472 R.H.	29.00	upper (comb. 827, 828) (green)
73	Bel Air (Sed.)	9645473 L.H.	29.00	upper (comb. 827, 828) (green)
73-74	Impala (4-Dr.) (exc. Spt. Sed.),			
73-74	Caprice (Sta. Wag.)	9645484 R.H.	41.50	upper (comb. 812, 813, 847) (blue)
73-74	Impala (4-Dr.) (exc. Spt. Sed.),			
73-74	Caprice (Sta. Wag.)	9645485 L.H.	41.50	upper (comb. 812, 813, 847) (blue)
73-74	Impala (4-Dr.) (exc. Spt. Sed.),			
73-74	Caprice (Sta. Wag.)	9645480 R.H.	41.50	upper (comb. 815, 818, 819, 821) (neutral)
73-74	Impala (4-Dr.) (exc. Spt. Sed.),			
73-74	Caprice (Sta. Wag.)	9645481 L.H.	41.50	upper (comb. 815, 818, 819, 821) (neutral)
73	Caprice (Sed.) (exc. Spt. Sed.)	9645547 L.H.	57.25	upper (comb. 842) (green)
73	Caprice (Sed.) (exc. Spt. Sed.)	9645544 R.H.	57.25	upper (comb. 841) (neutral)
73	Bel Air (Sta. Wag.),			
74	Bel Air	9645474 R.H.	29.00	upper (comb. 815, 817) (neutral)
73	Bel Air (Sta. Wag.),			
74	Bel Air	9645475 L.H.	29.00	upper (comb. 815, 817) (neutral)
73-74	Impala (Sed., Sta. Wag.) (exc. Spt. Sed.),			
73-74	Caprice (Sta. Wag.)	9645478 R.H.	41.50	upper (comb. 802, 805, 806) (black)
73-74	Impala (Sed., Sta. Wag.) (exc. Spt. Sed.),			
73-74	Caprice (Sta. Wag.)	9645479 L.H.	41.50	upper (comb. 802, 805, 806) (black)
73	Impala (Sed., Sta. Wag.) (exc. Spt. Sed.),			
73	Impala (Sed., Sta. Wag.) (exc. Spt. Sed.),			
73	Caprice (Sta. Wag.)	9645483 L.H.	41.50	upper (comb. 829, 830) (green)
73	Impala, Caprice (Sta. Wag.)	9645486 R.H.	41.50	upper (comb. 826) (saddle)
73	Impala, Caprice (Sta. Wag.)	9645487 L.H.	41.50	upper (comb. 826) (saddle)
73	Pass. (Conv.)	9645531 L.H.	48.50	upper (comb. 816) (white)
74	Bel Air	9691326 R.H.	29.00	upper (comb. 851, 852) (green)
74	Bel Air	9691327 L.H.	29.00	upper (comb. 851, 852) (green)
74	Impala (Spt. Sed.)	9691332 R.H.	41.00	upper (comb. 853, 855) (green)
74	Impala (Spt. Sed.)	9691333 L.H.	41.00	upper (comb. 853, 855) (green)
74	Impala (Spt. Sed.)	9732102 R.H.	41.50	upper (comb. 849) (saddle)
74	Impala (Spt. Sed.)	9732103 L.H.	41.50	upper (comb. 849) (saddle)
74	Impala (Spt. Cpe.)	9732104 R.H.	49.25	upper (comb. 849, 858) (saddle)
74	Impala (Spt. Cpe.)	9732105 L.H.	49.25	upper (comb. 849, 858) (saddle)
74	Impala (Spt. Cpe.) (exc. Custom)	1665360 R.H.	49.00	upper (comb. 804, 809) (white)
74	Impala (Spt. Cpe.) (exc. Custom)	1665361 L.H.	50.00	upper (comb. 804, 809) (white)
74	Pass. (Conv.)	1690510 R.H.	49.00	upper (comb. 810) (white)
74	Pass. (Conv.)	1690511 L.H.	49.00	upper (comb. 810) (white)
74	Impala (Spt. Cpe.) Pass. (Conv.)	9691338 R.H.	48.50	upper (comb. 853, 855) (green)
74	Impala (Spt. Cpe.) Pass. (Conv.)	9691339 L.H.	48.50	upper (comb. 853, 855) (green)
74	Impala (Sta. Wag., Sedan) (exc. Spt. Sed.), Caprice (Sta. Wag.)	9691328 R.H.	41.00	upper (comb. 849, 858) (saddle)
74	Impala (Sta. Wag., Sedan) (exc. Spt. Sed.), Caprice (Sta. Wag.)	9691329 L.H.	41.00	upper (comb. 849, 858) (saddle)
74	Impala (Sta. Wag., Sedan) (exc. Spt. Sed.),			
74	Caprice (Sta. Wag.)	9691334 R.H.	41.00	upper (comb. 853, 855, 859) (green)
74	Impala (Sta. Wag., Sedan) (exc. Spt. Sed.),			
74	Caprice (Sta. Wag.)	9691335 L.H.	41.00	upper (comb. 853, 855, 859) (green)
74	Caprice (Spt. Sed.)	9691342 R.H.	57.75	upper (comb. 840) (black)
74	Caprice (Spt. Sed.)	9691343 L.H.	57.75	upper (comb. 840) (black)
74	Caprice (Spt. Sed.)	9691344 R.H.	57.75	upper (comb. 857) (oxblood)
74	Caprice (Spt. Sed.)	9691345 L.H.	57.75	upper (comb. 857) (oxblood)

**FOLDING TOP PARTS—INTERIOR TRIM**

**14.685 TRIM ASSY., Front Door (less arm rest) (Con't)**

74	Caprice (Spt. Sed.)	9691346 R.H.	57.75	upper (comb. 896) (taupe)
74	Caprice (Spt. Sed.)	9691347 L.H.	57.75	upper (comb. 896) (taupe)
74	Caprice (Spt. Sed.)	9691348 R.H.	57.75	upper (comb. 850) (green)
74	Caprice (Spt. Sed.)	9691349 L.H.	57.75	upper (comb. 850) (green)
74	Caprice (Spt. Sed.)	9691350 R.H.	57.75	upper (comb. 843) (midn. blue)
74	Caprice (Spt. Sed.)	9691351 L.H.	57.75	upper (comb. 843) (midn. blue)
74	Caprice (Spt. Sed.)	9691352 R.H.	57.75	upper (comb. 808) (black)
74	Caprice (Spt. Sed.)	9691353 L.H.	57.75	upper (comb. 808) (black)
74	Caprice (Spt. Sed.)	9691354 R.H.	57.75	upper (comb. 841) (neutral)
74	Caprice (Spt. Sed.)	9691355 L.H.	57.75	upper (comb. 841) (neutral)
74	Caprice (Sedan) (exc. Spt. Sed.)	9691356 R.H.	57.75	upper (comb. 840) (black)
74	Caprice (Sedan) (exc. Spt. Sed.)	9691357 L.H.	57.75	upper (comb. 840) (black)
74	Caprice (Sedan) (exc. Spt. Sed.)	9691358 R.H.	57.75	upper (comb. 857) (oxblood)
74	Caprice (Sedan) (exc. Spt. Sed.)	9691359 L.H.	57.75	upper (comb. 857) (oxblood)
74	Caprice (Sedan) (exc. Spt. Sed.)	9691360 R.H.	57.75	upper (comb. 896) (taupe)
74	Caprice (Sedan) (exc. Spt. Sed.)	9691361 L.H.	57.75	upper (comb. 896) (taupe)
74	Caprice (Sedan) (exc. Spt. Sed.)	9691362 R.H.	57.75	upper (comb. 850) (green)
74	Caprice (Sedan) (exc. Spt. Sed.)	9691363 L.H.	57.75	upper (comb. 850) (green)
74	Caprice (Sedan) (exc. Spt. Sed.)	9691364 R.H.	57.75	upper (comb. 843) (midn. blue)
74	Caprice (Sedan) (exc. Spt. Sed.)	9691365 L.H.	57.75	upper (comb. 843) (midn. blue)
74	Caprice (Sedan) (exc. Spt. Sed.)	9691366 R.H.	57.75	upper (comb. 808) (black)
74	Caprice (Sedan) (exc. Spt. Sed.)	9691367 L.H.	57.75	upper (comb. 808) (black)
74	Caprice (Sedan) (exc. Spt. Sed.)	9691368 R.H.	57.75	upper (comb. 841) (neutral)
74	Caprice (Sedan) (exc. Spt. Sed.)	9691369 L.H.	57.75	upper (comb. 841) (neutral)
74	Caprice (Spt. Cpe.)	9691370 R.H.	71.25	upper (comb. 840) (black)
74	Caprice (Spt. Cpe.)	9691371 L.H.	71.25	upper (comb. 840) (black)
74	Caprice (Spt. Cpe.)	9691372 R.H.	71.25	upper (comb. 857) (oxblood)
74	Caprice (Spt. Cpe.)	9691373 L.H.	71.25	upper (comb. 857) (oxblood)
74	Caprice (Spt. Cpe.)	9691374 R.H.	71.25	upper (comb. 896) (taupe)
74	Caprice (Spt. Cpe.)	9691375 L.H.	71.25	upper (comb. 896) (taupe)
74	Caprice (Spt. Cpe.)	9691376 R.H.	71.25	upper (comb. 850) (green)
74	Caprice (Spt. Cpe.)	9691377 L.H.	71.25	upper (comb. 850) (green)
74	Caprice (Spt. Cpe.)	9691378 R.H.	71.25	upper (comb. 843) (midn. blue)
74	Caprice (Spt. Cpe.)	9691379 L.H.	71.25	upper (comb. 843) (midn. blue)
74	Caprice (Spt. Cpe.)	9691380 R.H.	71.25	upper (comb. 808) (black)
74	Caprice (Spt. Cpe.)	9691381 L.H.	71.25	upper (comb. 808) (black)
74	Caprice (Spt. Cpe.)	9691382 R.H.	71.25	upper (comb. 841) (neutral)
74	Caprice (Spt. Cpe.)	9691383 L.H.	71.25	upper (comb. 841) (neutral)
75	Pass. (1st design)	1680398 R.H.	54.25	upper (comb. 02W, 04W, 07W, 11W) (white) (perforated)
75	Pass. (1st design)	1680399 L.H.	54.25	upper (comb. 02W, 04W, 07W, 11W) (white) (perforated)
75	Pass. (4-Dr.) (1st design) (exc. Spt. Sed.)	1708278 R.H.	43.25	upper (comb. 19W, 19D) (black) (perforated) (repl. 1664376)
75	Pass. (4-Dr.) (1st design) (exc. Spt. Sed.)	1708279 L.H.	43.25	upper (comb. 19W, 19D) (black) (perforated) (repl. 1664377)
75	Pass. (4-Dr.) (1st design) (exc. Spt. Sed.)	1664378 R.H.	45.25	upper (comb. 26W, 26D) (blue) (perforated)
75	Pass. (4-Dr.) (1st design) (exc. Spt. Sed.)	1664379 L.H.	45.25	upper (comb. 26W, 26D) (blue) (perforated)
75	Pass. (4-Dr.) (1st design) (exc. Spt. Sed.)	1664380 R.H.	45.25	upper (comb. 44W, 44D) (green) (perforated)
75	Pass. (4-Dr.) (1st design) (exc. Spt. Sed.)	1664381 L.H.	45.25	upper (comb. 44W, 44D) (green) (perforated)
75	Pass. (4-Dr.) (1st design) (exc. Spt. Sed.)	1664382 R.H.	45.25	upper (comb. 55W, 55D) (sandstone) (perforated)
75	Pass. (4-Dr.) (1st design) (exc. Spt. Sed.)	1664383 L.H.	45.25	upper (comb. 55W, 55D) (sandstone) (perforated)
75	Pass. (4-Dr.) (1st design) (exc. Spt. Sed.)	1664386 R.H.	45.25	upper (comb. 63E, 63W) (saddle) (perforated)
75	Pass. (4-Dr.) (1st design) (exc. Spt. Sed.)	1664387 L.H.	45.25	upper (comb. 63E, 63W) (saddle) (perforated)
75	Impala (2-Dr.) (1st design)	1664722 R.H.	54.25	upper (comb. 19D, 19W) (black) (perforated)
75	Impala (2-Dr.) (1st design)	1664723 L.H.	54.25	upper (comb. 19D, 19W) (black) (perforated)
75	Impala (2-Dr.) (1st design)	1664724 R.H.	54.25	upper (comb. 26D, 26W) (blue) (perforated)

**FOLDING TOP PARTS—INTERIOR TRIM**

<b>14.685 TRIM ASSY., Front Door (less arm rest)</b>		<b>(Con't)</b>	
75	Impala (2-Dr.) (1st design) . . . . .	1664725 L.H.	54.25 upper (comb. 26D, 26W) (blue) (perforated)
75	Impala (2-Dr.) (1st design) . . . . .	1664726 R.H.	54.25 upper (comb. 44D, 44W) (green) (perforated)
75	Impala (2-Dr.) (1st design) . . . . .	1664727 L.H.	54.25 upper (comb. 44D, 44W) (green) (perforated)
75	Impala (2-Dr.) (1st design) . . . . .	1664728 R.H.	54.25 upper (comb. 55D, 55W) (sandstone) (perforated)
75	Impala (2-Dr.) (1st design) . . . . .	1664729 L.H.	54.25 upper (comb. 55D, 55W) (sandstone) (perforated)
75	Impala (2-Dr.) (1st design) . . . . .	1664730 R.H.	54.25 upper (comb. 63E, 63W) (saddle) (perforated)
75	Impala (2-Dr.) (1st design) . . . . .	1664731 L.H.	54.25 upper (comb. 63E, 63W) (saddle) (perforated)
75	Bel Air . . . . .	1659870 R.H.	46.50 upper (comb. 55V, 55C) (sandstone)
75	Bel Air . . . . .	1659871 L.H.	46.50 upper (comb. 55V, 55C) (sandstone)
75	Bel Air . . . . .	1663360 R.H.	46.50 upper (comb. 26V, 26C) (blue)
75	Bel Air . . . . .	1663361 L.H.	46.50 upper (comb. 26V, 26C) (blue)
75	Impala (Spt. Sed.) (1st design) . . . . .	1664712 R.H.	45.25 upper (comb. 19D, 19W) (black) (perforated)
75	Impala (Spt. Sed.) (1st design) . . . . .	1664713 L.H.	45.25 upper (comb. 19D, 19W) (black) (perforated)
75	Impala (Spt. Sed.) (1st design) . . . . .	1664714 R.H.	45.25 upper (comb. 26D, 26W) (blue) (perforated)
75	Impala (Spt. Sed.) (1st design) . . . . .	1664715 L.H.	45.25 upper (comb. 26D, 26W) (blue) (perforated)
75	Impala (Spt. Sed.) (1st design) . . . . .	1708294 R.H.	43.25 upper (comb. 44D, 44W) (green) (perforated) (repl. 1664716)
75	Impala (Spt. Sed.) (1st design) . . . . .	1664717 L.H.	45.25 upper (comb. 44D, 44W) (green) (perforated)
75	Impala (Spt. Sed.) (1st design) . . . . .	1664718 R.H.	45.25 upper (comb. 55D, 55W) (sandstone) (perforated)
75	Impala (Spt. Sed.) (1st design) . . . . .	1664719 L.H.	45.25 upper (comb. 55D, 55W) (sandstone) (perforated)
75	Impala (Spt. Sed.) (1st design) . . . . .	1664720 R.H.	45.25 upper (comb. 63E, 63W) (saddle) (perforated)
75	Impala (Spt. Sed.) (1st design) . . . . .	1664721 L.H.	45.25 upper (comb. 63E, 63W) (saddle) (perforated)
75	Pass. (2nd design) . . . . .	1708312 R.H.	52.75 upper (comb. 02W, 04W, 07W, 11W) (white) (non-perforated)
75	Pass. (2nd design) . . . . .	1708313 L.H.	52.75 upper (comb. 02W, 04W, 07W, 11W) (white) (non-perforated)
75	Pass. (4-Dr.) (2nd design) (exc. Spt. Sed.) . . . . .	1708278 R.H.	43.25 upper (comb. 19D, 19W) (black) (non-perforated)
75	Pass. (4-Dr.) (2nd design) (exc. Spt. Sed.) . . . . .	1708279 L.H.	43.25 upper (comb. 19D, 19W) (black) (non-perforated)
75	Pass. (4-Dr.) (2nd design) (exc. Spt. Sed.) . . . . .	1708280 R.H.	43.25 upper (comb. 26D, 26W) (blue) (non-perforated)
75	Pass. (4-Dr.) (2nd design) (exc. Spt. Sed.) . . . . .	1708281 L.H.	43.25 upper (comb. 26D, 26W) (blue) (non-perforated)
75	Pass. (4-Dr.) (2nd design) (exc. Spt. Sed.) . . . . .	1708282 R.H.	43.25 upper (comb. 44D, 44W) (green) (non-perforated)
75	Pass. (4-Dr.) (2nd design) (exc. Spt. Sed.) . . . . .	1708283 L.H.	43.25 upper (comb. 44D, 44W) (green) (non-perforated)
75	Pass. (4-Dr.) (2nd design) (exc. Spt. Sed.) . . . . .	1708284 R.H.	43.25 upper (comb. 55D, 55W) (sandstone) (non-perforated)
75	Pass. (4-Dr.) (2nd design) (exc. Spt. Sed.) . . . . .	1708285 L.H.	43.25 upper (comb. 55D, 55W) (sandstone) (non-perforated)
75	Pass. (4-Dr.) (2nd design) (exc. Spt. Sed.) . . . . .	1708286 R.H.	43.25 upper (comb. 63E, 63W) (saddle) (non-perforated)
75	Pass. (4-Dr.) (2nd design) (exc. Spt. Sed.) . . . . .	1708287 L.H.	43.25 upper (comb. 63E, 63W) (saddle) (non-perforated)
75	Impala (2-Dr.) (2nd design) . . . . .	1708302 R.H.	52.75 upper (comb. 19D, 19W) (black) (non-perforated)
75	Impala (2-Dr.) (2nd design) . . . . .	1708303 L.H.	52.75 upper (comb. 19D, 19W) (black) (non-perforated)
75	Impala (2-Dr.) (2nd design) . . . . .	1708304 R.H.	52.75 upper (comb. 26D, 26W) (blue) (non-perforated)

**FOLDING TOP PARTS—INTERIOR TRIM**

**14.685 TRIM ASSY., Front Door (less arm rest) (Con't)**

75	Impala (2-Dr.) (2nd design) . . . . .	1708305 L.H.	52.75	upper (comb. 26D, 26W) (blue) (non-perforated) . . . . .
75	Impala (2-Dr.) (2nd design) . . . . .	1708306 R.H.	52.75	upper (comb. 44D, 44W) (green) (non-perforated) . . . . .
75	Impala (2-Dr.) (2nd design) . . . . .	1708307 L.H.	52.75	upper (comb. 44D, 44W) (green) (non-perforated) . . . . .
75	Impala (2-Dr.) (2nd design) . . . . .	1708308 R.H.	52.75	upper (comb. 55D, 55W) (sandstone) (non-perforated) . . . . .
75	Impala (2-Dr.) (2nd design) . . . . .	1708309 L.H.	52.75	upper (comb. 55D, 55W) (sandstone) (non-perforated) . . . . .
75	Impala (2-Dr.) (2nd design) . . . . .	1708310 R.H.	52.75	upper (comb. 63E, 63W) (saddle) (non-perforated) . . . . .
75	Impala (2-Dr.) (2nd design) . . . . .	1708311 L.H.	52.75	upper (comb. 63E, 63W) (saddle) (non-perforated) . . . . .
75	Impala (Spt. Sed.) (2nd design) . . . . .	1708290 R.H.	43.25	upper (comb. 19D, 19W) (black) (non-perforated) . . . . .
75	Impala (Spt. Sed.) (2nd design) . . . . .	1708291 L.H.	43.25	upper (comb. 19D, 19W) (black) (non-perforated) . . . . .
75	Impala (Spt. Sed.) (2nd design) . . . . .	1708292 R.H.	43.25	upper (comb. 26D, 26W) (blue) (non-perforated) . . . . .
75	Impala (Spt. Sed.) (2nd design) . . . . .	1708293 L.H.	43.25	upper (comb. 26D, 26W) (blue) (non-perforated) . . . . .
75	Impala (Spt. Sed.) (2nd design) . . . . .	1708294 R.H.	43.25	upper (comb. 44D, 44W) (green) (non-perforated) . . . . .
75	Impala (Spt. Sed.) (2nd design) . . . . .	1708295 L.H.	43.25	upper (comb. 44D, 44W) (green) (non-perforated) . . . . .
75	Impala (Spt. Sed.) (2nd design) . . . . .	1708296 R.H.	43.25	upper (comb. 55D, 55W) (sandstone) (non-perforated) . . . . .
75	Impala (Spt. Sed.) (2nd design) . . . . .	1708297 L.H.	43.25	upper (comb. 55D, 55W) (sandstone) (non-perforated) . . . . .
75	Impala (Spt. Sed.) (2nd design) . . . . .	1708298 R.H.	43.25	upper (comb. 63E, 63W) (saddle) (non-perforated) . . . . .
75	Impala (Spt. Sed.) (2nd design) . . . . .	1708299 L.H.	43.25	upper (comb. 63E, 63W) (saddle) (non-perforated) . . . . .
75	Caprice (Sedan) (exc. Spt. Sed.) . . . . .	1664464 R.H.	74.25	upper (comb. 19B) (black) . . . . .
75	Caprice (Sedan) (exc. Spt. Sed.) . . . . .	1664465 L.H.	74.25	upper (comb. 19B) (black) . . . . .
75	Caprice (Sedan) (exc. Spt. Sed.) . . . . .	1664466 R.H.	74.25	upper (comb. 73B) (oxblood) . . . . .
75	Caprice (Sedan) (exc. Spt. Sed.) . . . . .	1664467 L.H.	74.25	upper (comb. 73B) (oxblood) . . . . .
75	Caprice (Sedan) (exc. Spt. Sed.) . . . . .	1664468 R.H.	74.25	upper (comb. 55B) (sandstone) . . . . .
75	Caprice (Sedan) (exc. Spt. Sed.) . . . . .	1664469 L.H.	74.25	upper (comb. 55B) (sandstone) . . . . .
75	Caprice (Sedan) (exc. Spt. Sed.) . . . . .	1664470 R.H.	74.25	upper (comb. 44B) (green) . . . . .
75	Caprice (Sedan) (exc. Spt. Sed.) . . . . .	1664471 L.H.	74.25	upper (comb. 44B) (green) . . . . .
75	Caprice (Sedan) (exc. Spt. Sed.) . . . . .	1664472 R.H.	74.25	upper (comb. 26B) (blue) . . . . .
75	Caprice (Sedan) (exc. Spt. Sed.) . . . . .	1664473 L.H.	74.25	upper (comb. 26B) (blue) . . . . .
75	Caprice (Sedan) (exc. Spt. Sed.) . . . . .	1664676 R.H.	74.25	upper (comb. 19H) (black) . . . . .
75	Caprice (Sedan) (exc. Spt. Sed.) . . . . .	1664677 L.H.	74.25	upper (comb. 19H) (black) . . . . .
75	Caprice (Sedan) (exc. Spt. Sed.) . . . . .	1664478 R.H.	74.25	upper (comb. 55H) (sandstone) . . . . .
75	Caprice (Sedan) (exc. Spt. Sed.) . . . . .	1664679 L.H.	74.25	upper (comb. 55H) (sandstone) . . . . .
75	Caprice (Spt. Cpe.) . . . . .	1658268 R.H.	85.25	upper (comb. 19B) (black) . . . . .
75	Caprice (Spt. Cpe.) . . . . .	1658269 L.H.	85.25	upper (comb. 19B) (black) . . . . .
75	Caprice (Spt. Cpe.) . . . . .	1658270 R.H.	85.25	upper (comb. 26B) (blue) . . . . .
75	Caprice (Spt. Cpe.) . . . . .	1658271 L.H.	85.25	upper (comb. 26B) (blue) . . . . .
75	Caprice (Spt. Cpe.) . . . . .	1658272 R.H.	85.25	upper (comb. 44B) (green) . . . . .
75	Caprice (Spt. Cpe.) . . . . .	1658273 L.H.	85.25	upper (comb. 44B) (green) . . . . .
75	Caprice (Spt. Cpe.) . . . . .	1658274 R.H.	85.25	upper (comb. 55B) (sandstone) . . . . .
75	Caprice (Spt. Cpe.) . . . . .	1658275 L.H.	85.25	upper (comb. 55B) (sandstone) . . . . .
75	Caprice (Spt. Cpe.) . . . . .	1658276 R.H.	85.25	upper (comb. 73B) (oxblood) . . . . .
75	Caprice (Spt. Cpe.) . . . . .	1658277 L.H.	85.25	upper (comb. 73B) (oxblood) . . . . .
75	Caprice (Spt. Cpe.) . . . . .	1658278 R.H.	85.25	upper (comb. 19H) (black) . . . . .
75	Caprice (Spt. Cpe.) . . . . .	1658279 L.H.	85.25	upper (comb. 19H) (black) . . . . .
75	Caprice (Spt. Cpe.) . . . . .	1658280 R.H.	85.25	upper (comb. 55H) (sandstone) . . . . .
75	Caprice (Spt. Cpe.) . . . . .	1658281 L.H.	85.25	upper (comb. 55H) (sandstone) . . . . .
75	Caprice (Spt. Sed.) . . . . .	1664448 R.H.	73.25	upper (comb. 19B) (black) . . . . .
75	Caprice (Spt. Sed.) . . . . .	1664449 L.H.	73.25	upper (comb. 19B) (black) . . . . .
75	Caprice (Spt. Sed.) . . . . .	1664450 R.H.	73.25	upper (comb. 73B) (oxblood) . . . . .
75	Caprice (Spt. Sed.) . . . . .	1664451 L.H.	73.25	upper (comb. 73B) (oxblood) . . . . .
75	Caprice (Spt. Sed.) . . . . .	1664452 R.H.	73.25	upper (comb. 55B) (sandstone) . . . . .
75	Caprice (Spt. Sed.) . . . . .	1664453 L.H.	73.25	upper (comb. 55B) (sandstone) . . . . .
75	Caprice (Spt. Sed.) . . . . .	1664454 R.H.	73.25	upper (comb. 44B) (green) . . . . .
75	Caprice (Spt. Sed.) . . . . .	1664455 L.H.	73.25	upper (comb. 44B) (green) . . . . .
75	Caprice (Spt. Sed.) . . . . .	1664456 R.H.	73.25	upper (comb. 26B) (blue) . . . . .
75	Caprice (Spt. Sed.) . . . . .	1664457 L.H.	73.25	upper (comb. 26B) (blue) . . . . .
75	Caprice (Spt. Sed.) . . . . .	1664460 R.H.	73.25	upper (comb. 19H) (black) . . . . .
75	Caprice (Spt. Sed.) . . . . .	1664461 L.H.	73.25	upper (comb. 19H) (black) . . . . .
75	Caprice (Spt. Sed.) . . . . .	1664462 R.H.	73.25	upper (comb. 55H) (sandstone) . . . . .

**FOLDING TOP PARTS—INTERIOR TRIM**

**14.685 TRIM ASSY., Front Door (less arm rest) (Con't)**

75	Caprice (Spt. Sed.)	1664463 L.H.	73.25	upper (comb. 55H) (sandstone)
<b>CHEVELLE</b>				
67	(Spt. Cpe., Conv.),			
67	El Camino (Custom)	7651441 L.H.	26.75	(comb. 759, 761, 763) (black)
69	El Camino (Custom)	8724990 R.H.	43.50	(comb. 755, 756) (black)
69	Malibu (Spt. Cpe., Conv.)	8724974 R.H.	43.50	(comb. 753, 755, 756) (black)
69	Malibu (Spt. Cpe., Conv.)	8724975 L.H.	43.50	(comb. 753, 755, 756) (black)
70-72	Malibu (Spt. Cpe.) (Conv.)	8796390 R.H.	49.00	right (comb. 704, 705, 706, 753, 755, 756) (black)
70-72	Malibu (Spt. Cpe.) (Conv.)	8796391 L.H.	49.00	left (comb. 704, 705, 706, 753, 755, 756) (black)
70-72	El Camino Custom	8796404 R.H.	43.25	right (comb. 705, 706, 755, 756) (black)
70-72	El Camino Custom	8796405 L.H.	48.00	left (comb. 705, 706, 755, 756) (black)
<i>NOTE 1 Production deviation trim change.</i>				
71-72	Monte Carlo	9839524 R.H.	97.00	(comb. 707, 708, 709, 710) (black)
71-72	Monte Carlo	9839525 L.H.	97.00	(comb. 707, 708, 709, 710) (black)
71	Monte Carlo	9839526 R.H.	97.00	(comb. 729, 733, 734, 735) (dk. jade)
71	Monte Carlo	9839527 L.H.	97.00	(comb. 729, 733, 734, 735) (dk. jade)
71-72	Monte Carlo	9839530 R.H.	97.00	(comb. 723) (dk. saddle)
71	Chevelle (Spt. Cpe.)	9839515 L.H.	51.25	(comb. 714, 715, 718) (lt. sandalwood)
71	Chevelle (Spt. Cpe.)	9897266 R.H.	48.50	(comb. 725) (dk. blue)
71	Chevelle (Deluxe) (Spt. Cpe.)	9862215 L.H.	42.75	(comb. 701, 703) (black)
71	Chevelle (Sed.)	9839509 L.H.	42.50	(comb. 725, 726) (dk. blue)
71	El Camino (Custom)	9839521 L.H.	50.25	(comb. 731, 732) (dk. jade)
71	El Camino (Custom)	9839523 L.H.	50.25	(comb. 721, 722) (dk. saddle)
71-72	Monte Carlo	9897283 L.H.	92.00	(comb. 725) (blue)
72	Monte Carlo	9611118 R.H.	97.00	(comb. 731, 734) (covert)
72	Monte Carlo	9611119 L.H.	97.00	(comb. 731, 734) (covert)
72	Malibu (Spt. Cpe.)	9897266 R.H.	48.50	(comb. 724) (blue)
71-72	Malibu (Spt. Cpe.)	9897267 L.H.	48.50	(comb. 724) (blue)
72	Malibu (Spt. Cpe., Conv.)	9897265 L.H.	48.50	(comb. 713) (green)
72	Malibu (Spt. Cpe.)	9897270 R.H.	48.50	(comb. 730, 732) (covert)
72	Malibu (Spt. Cpe.)	9897271 L.H.	48.50	(comb. 730, 732) (covert)
72	Malibu (Spt. Cpe.)	9897268 R.H.	48.50	(comb. 720) (tan)
72	Malibu (Spt. Cpe.)	9897269 L.H.	48.50	(comb. 720) (tan)
72	Malibu (Spt. Cpe.) (Conv.)	9897274 L.H.	48.50	(comb. 743) (white)
72	Malibu (Spt. Cpe.)	9897273 R.H.	48.50	(comb. 743) (white)
72	El Camino (Custom)	9897276 R.H.	48.50	(comb. 732) (covert)
72	El Camino (Custom)	9607245 L.H.	47.50	(comb. 720) (tan)
72	El Camino (exc. Custom)	9606290 R.H.	45.00	(comb. 701) (black)
73	Deluxe (2-Dr.)	9642249 L.H.	22.40	upper (comb. 710, 711) (green)
73	Deluxe (4-Dr.)	9642240 R.H.	14.95	upper (comb. 701, 702) (black)
73	Deluxe (Coupe),			
73	El Camino (exc. Custom)	9642376 R.H.	22.40	upper (comb. 733) (neutral)
73	Deluxe (Coupe),			
73	El Camino (exc. Custom)	9642377 L.H.	22.40	upper (comb. 733) (neutral)
73	Malibu (Coupe) El Camino (Custom)	9642404 R.H.	38.75	upper (comb. 703, 704) (black)
73	Malibu (Coupe) El Camino (Custom)	9642405 L.H.	38.75	upper (comb. 703, 704) (black)
73	Malibu (Coupe),			
73	El Camino (Custom)	9642394 R.H.	38.75	upper (comb. 705, 724) (med. blue)
73	Malibu (Coupe),			
73	El Camino (Custom)	9642395 L.H.	38.75	upper (comb. 705, 724) (med. blue)
73	Malibu (Coupe),			
73	El Camino (Custom)	9642396 R.H.	38.75	upper (comb. 713, 730) (green)
73	Malibu (Coupe),			
73	El Camino (Custom)	9642397 L.H.	38.75	upper (comb. 713, 730) (green)
73	Malibu (Coupe),			
73	El Camino (Custom)	9642402 R.H.	38.75	upper (comb. 720) (saddle)
73	Malibu (Coupe),			
73	El Camino (Custom)	9642403 L.H.	38.75	upper (comb. 720) (saddle)
73	Malibu (Coupe), El Camino (Custom)	9642406 R.H.	38.75	upper (comb. 732) (neutral)
73	Malibu (Coupe), El Camino (Custom)	9642407 L.H.	38.75	upper (comb. 732) (neutral)
73	Malibu,			
73	Laguna (Coupe)	9677629 L.H.	57.25	upper (comb. 707, 712) (black)
73	Laguna (Coupe)	9642419 L.H.		upper (comb. 719, 723) (med. blue)
73	Laguna (Coupe)	9642420 R.H.		upper (comb. 726, 727) (green)
73	Laguna (Coupe)	9642421 L.H.		upper (comb. 726, 727) (green)
73	Deluxe (Sedan)	9642242 R.H.	14.95	upper (comb. 710, 711) (green)
73	Malibu, Laguna (4-Dr.),			
73	Monte Carlo	9677646 R.H.	45.50	upper (comb. 734) (neutral)

**FOLDING TOP PARTS—INTERIOR TRIM**

**14.685 TRIM ASSY., Front Door (less arm rest) (Con't)**

73	Laguna (4-Dr.)	9642408 R.H.		upper (comb. 707, 712) (black)
73	Laguna (Sedan, Sta. Wag.) (exc. Estate)	9642409 L.H.		upper (comb. 707, 712) (black)
73	Laguna (Sedan, Sta. Wag.) (exc. Estate)	9642412 R.H.		upper (comb. 726, 727) (green)
73	Laguna (Sedan, Sta. Wag.) (exc. Estate)	9642413 L.H.		upper (comb. 726, 727) (green)
73	Malibu (Sedan, Sta. Wag.)	9642384 R.H.	29.75	upper (comb. 713, 730) (green)
73	Deluxe (Coupe), El Camino (exc. Custom)	9642379 L.H.	22.40	upper (comb. 701, 702) (black)
73-74	Monte Carlo	9642428 R.H.	75.75	upper (comb. 705, 706, 708, 709) (black)
73-74	Monte Carlo	9642429 L.H.	75.75	upper (comb. 705, 706, 708, 709) (black)
73-74	Monte Carlo	9642436 R.H.	75.75	upper (comb. 725, 734, 737) (midnite blue)
73-74	Monte Carlo	9642437 L.H.	75.75	upper (comb. 725, 734, 737) (midnite blue)
73	Monte Carlo	9642432 R.H.	75.75	upper (comb. 715, 728) (green)
73	Monte Carlo	9642433 L.H.	75.75	upper (comb. 715, 728) (green)
73-74	Monte Carlo	9642430 R.H.	75.75	upper (comb. 716, 731, 735) (neutral)
73-74	Monte Carlo	9642431 L.H.	75.75	upper (comb. 716, 731, 735) (neutral)
73-74	Monte Carlo	9642434 R.H.	75.75	upper (comb. 740, 744) (oxblood)
73-74	Monte Carlo	9642435 L.H.	75.75	upper (comb. 740, 744) (oxblood)
74	Malibu (4-Dr.) (exc. Classic)	9676952 R.H.	17.10	upper (comb. 723, 727, 745, 830, 893) (green)
74	Malibu (4-Dr.) (exc. Classic)	9676953 L.H.	17.10	upper (comb. 723, 727, 745, 830, 893) (green)
74	Malibu (4-Dr.) (exc. Classic)	9676954 R.H.	17.10	upper (comb. 713, 892) (neutral)
74	Malibu (4-Dr.) (exc. Classic)	9676955 L.H.	17.10	upper (comb. 713, 892) (neutral)
74	Malibu (4-Dr.) (exc. Classic)	9732662 R.H.	20.20	upper (comb. 701, 706, 738, 891, 894) (black)
74	Malibu (4-Dr.) (exc. Classic)	9732663 L.H.	20.20	upper (comb. 701, 706, 738, 891, 894) (black)
74	Malibu (Coupe) (exc. Classic), El Camino (exc. Classic)	9732656 R.H.	20.35	upper (comb. 701, 706, 738, 891, 894) (black)
74	Malibu (Coupe) (exc. Classic), El Camino (exc. Classic)	9732657 L.H.	20.35	upper (comb. 701, 706, 738, 891, 894) (black)
74	Malibu (Coupe) (exc. Classic), El Camino (exc. Classic)	9732658 R.H.	20.35	upper (comb. 713, 892) (neutral)
74	Malibu (Coupe) (exc. Classic), El Camino (exc. Classic)	9732659 L.H.	20.35	upper (comb. 713, 892) (neutral)
74	Malibu (Coupe) (exc. Classic), El Camino (exc. Classic)	9731228 R.H.	20.35	upper (comb. 749, 897) (mid. blue)
74	Malibu (Coupe) (exc. Classic), El Camino (exc. Classic)	9731229 L.H.	20.35	upper (comb. 749, 897) (mid. blue)
74	Malibu (Classic) (Sedan)	9732530 R.H.	50.50	upper (comb. 732) (mid. blue)
74	Malibu (Classic) (Sedan)	9732531 L.H.	50.50	upper (comb. 732) (mid. blue)
74	Malibu (Classic) (Sedan)	9731714 R.H.	57.25	upper (comb. 743) (oxblood)
74	Malibu (Classic) (Sedan)	9731715 L.H.	57.25	upper (comb. 743) (oxblood)
74	Malibu (Classic) (Sedan)	9732528 R.H.	57.25	upper (comb. 702) (black)
74	Malibu (Classic) (Sedan)	9732529 L.H.	57.25	upper (comb. 702) (black)
74	Malibu (Classic) (Sedan)	9732532 R.H.	57.25	upper (comb. 724) (green)
74	Malibu (Classic) (Sedan)	9732533 L.H.	57.25	upper (comb. 724) (green)
74	Malibu (Classic) (Sedan)	9732534 R.H.	50.50	upper (comb. 722) (neutral)
74	Malibu (Classic) (Sedan)	9732535 L.H.	50.50	upper (comb. 722) (neutral)
74	Malibu (Classic) (4-Dr.)	9731708 R.H.	52.25	upper (comb. 728) (green)
74	Malibu (Classic) (4-Dr.)	9731709 L.H.	52.25	upper (comb. 728) (green)
74	Malibu (Classic) (4-Dr.)	9731710 R.H.	52.25	upper (comb. 714) (neutral)
74	Malibu (Classic) (4-Dr.)	9731711 L.H.	52.25	upper (comb. 714) (neutral)
74	Malibu (Classic) (4-Dr.)	9731712 R.H.	52.25	upper (comb. 740) (saddle)
74	Malibu (Classic) (4-Dr.)	9731713 L.H.	52.25	upper (comb. 740) (saddle)
74-75	Malibu (Classic) (4-Dr.)	9731704 R.H.	52.25	upper (comb. 707, 19W) (black)
74-75	Malibu (Classic) (4-Dr.)	9731705 L.H.	52.25	upper (comb. 707, 19W) (black)
74	Malibu (Coupe) (exc. Classic), El Camino (exc. Classic)	9676956 R.H.	20.35	upper (comb. 723, 727, 745, 830, 893) (green)
74	Malibu (Coupe) (exc. Classic), El Camino (exc. Classic)	9676957 L.H.	20.35	upper (comb. 723, 727, 745, 830, 893) (green)
74	Malibu (Classic) (Coupe)	9731740 R.H.	75.00	upper (comb. 743) (oxblood)
74	Malibu (Classic) (Coupe)	9731741 L.H.	75.00	upper (comb. 743) (oxblood)
74	Malibu (Classic) (Coupe), El Camino (Classic)	9731742 R.H.	62.00	upper (comb. 714) (neutral)
74	Malibu (Classic) (Coupe), El Camino (Classic)	9731743 L.H.	62.00	upper (comb. 714) (neutral)



**FOLDING TOP PARTS—INTERIOR TRIM**

**14.685 TRIM ASSY., Front Door (less arm rest) (Con't)**

74	Malibu (Classic) (Coupe), El Camino (Classic) . . . . .	9731732 R.H.	62.00	upper (comb. 785) (white) . . . . .
74	Malibu (Classic) (Coupe), El Camino (Classic) . . . . .	9731733 L.H.	62.00	upper (comb. 785) (white) . . . . .
74	Malibu (Classic) (Coupe), El Camino (Classic) . . . . .	9731734 R.H.	62.00	upper (comb. 728) (green) . . . . .
74	Malibu (Classic) (Coupe), El Camino (Classic) . . . . .	9731735 L.H.	62.00	upper (comb. 728) (green) . . . . .
74	Malibu (Classic) (Coupe), El Camino (Classic) . . . . .	9731736 R.H.	62.00	upper (comb. 740) (saddle) . . . . .
74	Malibu (Classic) (Coupe), El Camino (Classic) . . . . .	9731737 L.H.	62.00	upper (comb. 740) (saddle) . . . . .
74-75	Malibu (Classic) (Coupe), El Camino (Classic) . . . . .	9731738 R.H.	68.25	upper (comb. 707, 747, 19W) (black) . . . . .
74-75	Malibu (Classic) (Coupe), El Camino (Classic) . . . . .	9731739 L.H.	68.25	upper (comb. 707, 747, 19W) (black) . . . . .
74	Malibu (Classic) (Coupe), El Camino (Classic) . . . . .	9732538 R.H.	75.00	upper (comb. 702) (black) . . . . .
74	Malibu (Classic) (Coupe), El Camino (Classic) . . . . .	9732539 L.H.	75.00	upper (comb. 702) (black) . . . . .
74	Malibu (Classic) (Coupe), El Camino (Classic) . . . . .	9732540 R.H.	67.25	upper (comb. 732) (mid. blue) . . . . .
74	Malibu (Classic) (Coupe), El Camino (Classic) . . . . .	9732541 L.H.	67.25	upper (comb. 732) (mid. blue) . . . . .
74	Malibu (Classic) (Coupe), El Camino (Classic) . . . . .	9732542 R.H.	75.00	upper (comb. 724) (green) . . . . .
74	Malibu (Classic) (Coupe), El Camino (Classic) . . . . .	9732543 L.H.	75.00	upper (comb. 724) (green) . . . . .
74	Malibu (Classic) (Coupe), El Camino (Classic) . . . . .	9732544 R.H.	67.25	upper (comb. 722) (neutral) . . . . .
74	Malibu (Classic) (Coupe), El Camino (Classic) . . . . .	9732545 L.H.	67.25	upper (comb. 722) (neutral) . . . . .
74	Malibu (Classic) (Sta. Wag.) . . . . .	9731706 R.H.	52.25	upper (comb. 735) (mid. blue) . . . . .
74	Malibu (Classic) (Sta. Wag.) . . . . .	9731707 L.H.	52.25	upper (comb. 735) (mid. blue) . . . . .
74	Laguna . . . . .	9731320 R.H.	40.25	upper (comb. 703, 704, 708, 748) (black) . . . . .
74	Laguna . . . . .	9731321 L.H.	40.25	upper (comb. 703, 704, 708, 748) (black) . . . . .
74	Laguna . . . . .	9736596 R.H.	38.75	upper (comb. 718, 731) (saddle) . . . . .
74	Laguna . . . . .	9736597 L.H.	38.75	upper (comb. 718, 731) (saddle) . . . . .
74	Laguna . . . . .	9736598 R.H.	38.75	upper (comb. 719, 720) (oxblood) . . . . .
74	Laguna . . . . .	9736599 L.H.	38.75	upper (comb. 719, 720) (oxblood) . . . . .
74	Monte Carlo . . . . .	9676980 R.H.	72.75	upper (comb. 726, 730) (green) . . . . .
74	Monte Carlo . . . . .	9676981 L.H.	72.75	upper (comb. 726, 730) (green) . . . . .
74	Monte Carlo . . . . .	9676982 R.H.	72.75	upper (comb. 742) (saddle) . . . . .
74	Monte Carlo . . . . .	9676983 L.H.	72.75	upper (comb. 742) (saddle) . . . . .
75	Malibu (Coupe) El Camino (exc. Classic) . . . . .	1659380 R.H.	22.35	upper (comb. 44V) (green) . . . . .
75	Malibu (Coupe) El Camino (exc. Classic) . . . . .	1659381 L.H.	22.35	upper (comb. 44V) (green) . . . . .
75	Malibu (Coupe) El Camino (exc. Classic) . . . . .	1659382 R.H.	22.30	upper (comb. 26C, 26V) (blue) . . . . .
75	Malibu (Coupe) El Camino (exc. Classic) . . . . .	1659383 L.H.	22.30	upper (comb. 26C, 26V) (blue) . . . . .
75	Malibu (Coupe) El Camino (exc. Classic) . . . . .	1659384 R.H.	22.35	upper (comb. 55V) (sandstone) . . . . .
75	Malibu (Coupe) El Camino (exc. Classic) . . . . .	1659385 L.H.	22.35	upper (comb. 55V) (sandstone) . . . . .
75	Malibu (Coupe), El Camino (exc. Classic) . . . . .	1659378 R.H.	22.30	upper (comb. 19C, 19V) (black) . . . . .
75	Malibu (Coupe), El Camino (exc. Classic) . . . . .	1659379 L.H.	22.30	upper (comb. 19C, 19V) (black) . . . . .
75	Malibu (Classic) (Sedan) . . . . .	9732528 R.H.	57.25	upper (comb. 19D) (black) . . . . .
75	Malibu (Classic) (Sedan) . . . . .	9732529 L.H.	57.25	upper (comb. 19D) (black) (repl. 1662439) . . . . .
75	Malibu (Classic) (Sedan) . . . . .	1662440 R.H.	57.25	upper (comb. 16D) (graystone) . . . . .
75	Malibu (Classic) (Sedan) . . . . .	1662441 L.H.	57.25	upper (comb. 16D) (graystone) . . . . .
75	Malibu (Classic) (Sedan) . . . . .	1662442 R.H.	57.25	upper (comb. 26D) (blue) . . . . .
75	Malibu (Classic) (Sedan) . . . . .	1662443 L.H.	57.25	upper (comb. 26D) (blue) . . . . .
75	Malibu (Classic) (Sedan) . . . . .	1662444 R.H.	57.25	upper (comb. 44D) (green) . . . . .
75	Malibu (Classic) (Sedan) . . . . .	1662445 L.H.	57.25	upper (comb. 44D) (green) . . . . .
75	Malibu (Classic) (Sedan) . . . . .	9731714 R.H.	57.25	upper (comb. 73D) (oxblood) (repl. 1662446) . . . . .
75	Malibu (Classic) (Sedan) . . . . .	9731715 L.H.	57.25	upper (comb. 73D) (oxblood) (repl. 1662447) . . . . .
75	Malibu (Sedan) (exc. Classic) . . . . .	1654464 R.H.	18.45	upper (comb. 26C, 26V) (dk. blue) . . . . .
75	Malibu (Sedan) (exc. Classic) . . . . .	1654465 L.H.	18.45	upper (comb. 26C, 26V) (dk. blue) . . . . .
75	Malibu (Sedan) (exc. Classic) . . . . .	1654462 R.H.	18.45	upper (comb. 44V) . . . . .

**FOLDING TOP PARTS—INTERIOR TRIM**

**14.685 TRIM ASSY., Front Door (less arm rest) (Con't)**

75	Malibu (Sedan) (exc. Classic) . . .	1654463 L.H.	18.45	upper (comb. 44V) . . . . .
75	Chevelle (4-Dr.) . . . . .	1654466 R.H.	19.40	upper (comb. 55V) (sandstone) . . . . .
75	Chevelle (4-Dr.) . . . . .	1654467 L.H.	19.40	upper (comb. 55V) (sandstone) . . . . .
75	Chevelle (4-Dr.) . . . . .	9650710 R.H.	12.50	lower (paint to match) . . . . .
75	Chevelle (4-Dr.) . . . . .	9650711 L.H.	12.50	lower (paint to match) . . . . .
75	Chevelle (4-Dr.) . . . . .	1662430 R.H.	52.25	upper (comb. 63W) (saddle) . . . . .
75	Chevelle (4-Dr.) . . . . .	1662431 L.H.	52.25	upper (comb. 63W) (saddle) . . . . .
75	Chevelle (4-Dr.) . . . . .	1662428 R.H.	52.25	upper (comb. 55W) (sandstone) . . . . .
75	Chevelle (4-Dr.) . . . . .	1662429 L.H.	52.25	upper (comb. 55W) (sandstone) . . . . .
75	Chevelle (4-Dr.) . . . . .	1662426 R.H.	52.25	upper (comb. 26W) (blue) . . . . .
75	Chevelle (4-Dr.) . . . . .	1662427 L.H.	52.25	upper (comb. 26W) (blue) . . . . .
75	Chevelle (4-Dr.) . . . . .	1654460 R.H.	18.45	upper (comb. 19C, 19V) (black) . . . . .
75	Chevelle (4-Dr.) . . . . .	1654461 L.H.	18.45	upper (comb. 19C, 19V) (black) . . . . .
75	Chevelle (2-Dr.) . . . . .	9732538 R.H.	75.00	upper (paint to match) (repl. 1662470) . . . . .
75	Chevelle (2-Dr.) . . . . .	9732539 L.H.	75.00	upper (paint to match) . . . . .
75	Chevelle (2-Dr.) . . . . .	1662472 R.H.	75.00	upper (comb. 16D) (graystone) . . . . .
75	Chevelle (2-Dr.) . . . . .	1662473 L.H.	75.00	upper (comb. 16D) (graystone) . . . . .
75	Chevelle (2-Dr.) . . . . .	1659378 R.H.	22.30	upper (comb. 19B-Y) (black) . . . . .
75	Chevelle (2-Dr.) . . . . .	1659379 L.H.	22.30	upper (comb. 19B-Y) (black) . . . . .
75	Chevelle (2-Dr.) . . . . .	1662474 R.H.	75.00	upper (comb. 26D) (blue) . . . . .
75	Chevelle (2-Dr.) . . . . .	1662475 L.H.	75.00	upper (comb. 26D) (blue) . . . . .
75	Chevelle (2-Dr.) . . . . .	9732542 R.H.	75.00	upper (comb. 44D) (green) (repl. 1662478) . . . . .
75	Chevelle (2-Dr.) . . . . .	1662479 L.H.	75.00	upper (comb. 44D) (green) . . . . .
75	Chevelle (2-Dr.) . . . . .	9731740 R.H.	75.00	upper (comb. 73D) (oxblood) . . . . .
75	Chevelle (2-Dr.) . . . . .	9731741 L.H.	75.00	upper (paint to match) . . . . .
75	Chevelle (2-Dr.) . . . . .	1662458 R.H.	68.25	upper (comb. 26W) (blue) . . . . .
75	Chevelle (2-Dr.) . . . . .	1662459 L.H.	68.25	upper (comb. 26W) (blue) . . . . .
75	Chevelle (2-Dr.) . . . . .	1662460 R.H.	68.25	upper (comb. 55W) (sandstone) . . . . .
75	Chevelle (2-Dr.) . . . . .	1662461 L.H.	68.25	upper (comb. 55W) (sandstone) . . . . .
75	Chevelle (2-Dr.) . . . . .	1662462 R.H.	68.25	upper (comb. 63W) (saddle) . . . . .
75	Chevelle (2-Dr.) . . . . .	1662463 L.H.	68.25	upper (comb. 63W) (saddle) . . . . .
75	Laguna . . . . .	1666816 R.H.	55.00	upper (comb. 07E, 07Z, 11E, 11Z) (white) . . . . .
75	Laguna . . . . .	1666817 L.H.	55.00	upper (comb. 07E, 07Z, 11E, 11Z) (white) . . . . .
75	Laguna . . . . .	1666818 R.H.	55.00	upper (comb. 19E, 19Z) (black) . . . . .
75	Laguna . . . . .	1666819 L.H.	55.00	upper (comb. 19E, 19Z) (black) . . . . .
75	Laguna . . . . .	1666820 R.H.	55.00	upper (comb. 63E, 63Z) (saddle) . . . . .
75	Laguna . . . . .	1666821 L.H.	55.00	upper (comb. 63E, 63Z) (saddle) . . . . .
75	Laguna . . . . .	1666822 R.H.	55.00	upper (comb. 73E, 73Z) (oxblood) . . . . .
75	Laguna . . . . .	1666823 L.H.	55.00	upper (comb. 73E, 73Z) (oxblood) . . . . .
75	Monte Carlo . . . . .	1674032 R.H.	70.75	upper (comb. 19B, 19H) (black) . . . . .
75	Monte Carlo . . . . .	1674033 L.H.	70.75	upper (comb. 19B, 19H) (black) . . . . .
75	Monte Carlo . . . . .	1674034 R.H.	70.75	upper (comb. 26B, 26H) (blue) . . . . .
75	Monte Carlo . . . . .	1674035 L.H.	70.75	upper (comb. 26B, 26H) (blue) . . . . .
75	Monte Carlo . . . . .	1674036 R.H.	74.50	upper (comb. 55B, 55H) (sandstone) . . . . .
75	Monte Carlo . . . . .	1674037 L.H.	74.50	upper (comb. 55B, 55H) (sandstone) . . . . .
75	Monte Carlo . . . . .	1674038 R.H.	74.50	upper (comb. 73B) (oxblood) . . . . .
75	Monte Carlo . . . . .	1674039 L.H.	74.50	upper (comb. 73B) (oxblood) . . . . .
75	Monte Carlo . . . . .	1676946 R.H.	86.50	upper (comb. 26N) (blue) . . . . .
75	Monte Carlo . . . . .	1676947 L.H.	86.50	upper (comb. 26N) (blue) . . . . .
75	Monte Carlo . . . . .	1676948 R.H.	86.50	upper (comb. 44N) (green) . . . . .
75	Monte Carlo . . . . .	1676949 L.H.	86.50	upper (comb. 44N) (green) . . . . .
75	Monte Carlo . . . . .	1676950 R.H.	86.50	upper (comb. 55N) (sandstone) . . . . .
75	Monte Carlo . . . . .	1676951 L.H.	86.50	upper (comb. 55N) (sandstone) . . . . .
75	Monte Carlo . . . . .	1676944 R.H.	85.50	upper (comb. 19N) (black) . . . . .
75	Monte Carlo . . . . .	1676945 L.H.	85.50	upper (comb. 19N) (black) . . . . .
75	Monte Carlo . . . . .	1676952 R.H.	86.50	upper (comb. 73N) (oxblood) . . . . .
75	Monte Carlo . . . . .	1676953 L.H.	86.50	upper (comb. 73N) (oxblood) . . . . .
75	Monte Carlo . . . . .	1690502 R.H.	70.75	upper (comb. 02H, 04H, 07H, 11H) (white) . . . . .
75	Monte Carlo . . . . .	1690503 L.H.	70.75	upper (comb. 02H, 04H, 07H, 11H) (white) . . . . .

**CHEVY—NOVA**

70	Nova (2-Dr.) . . . . .	8796263 L.H.	34.00	(comb. 731, 737) (black) . . . . .
70	Nova (2-Dr.) . . . . .	8796261 L.H.	34.00	(comb. 740) (med. gold) . . . . .
71	Nova (2-Dr.) . . . . .	9848306 R.H.	38.00	(comb. 750, 751) (black) . . . . .
71	Nova (2-Dr.) . . . . .	9848307 L.H.	38.00	(comb. 750, 751) (black) . . . . .
71	Nova (2-Dr.) . . . . .	9848309 L.H.	38.00	(comb. 756, 757) (dk. blue) . . . . .
71	Nova (2-Dr.) . . . . .	9848312 R.H.	38.00	(comb. 763) (sandalwood) . . . . .
71	Nova (2-Dr.) . . . . .	9848313 L.H.	38.00	(comb. 763) (sandalwood) . . . . .
72	Nova (2-Dr.) . . . . .	9892710 R.H.	39.00	(comb. 750, 751) (black) . . . . .
72	Nova (2-Dr.) . . . . .	9892711 L.H.	39.00	(comb. 750, 751) (black) . . . . .
72	Nova (2-Dr.) . . . . .	9890863 R.H.	47.50	(comb. 752, 753) (black) . . . . .
72	Nova (2-Dr.) . . . . .	9890864 L.H.	47.50	(comb. 752, 753) (black) . . . . .
72	Nova (2-Dr.) . . . . .	9892712 R.H.	38.00	(comb. 756) (blue) . . . . .
72	Nova (2-Dr.) . . . . .	9892713 L.H.	38.00	(comb. 756) (blue) . . . . .
72	Nova (2-Dr.) . . . . .	9890865 R.H.	46.25	(comb. 761) (green) . . . . .

**FOLDING TOP PARTS—INTERIOR TRIM**

<b>14.685 TRIM ASSY., Front Door (less arm rest)</b>		<b>(Con't)</b>	
72	Nova (2-Dr.)	9892714 R.H.	39.00 (comb. 759, 760) (green)
72	Nova (2-Dr.)	9892715 L.H.	39.00 (comb. 759, 760) (green)
72	Nova (2-Dr.)	9892716 R.H.	39.00 (comb. 763, 765) (covert)
72	Nova (2-Dr.)	9892717 L.H.	39.00 (comb. 763, 765) (covert)
72	Nova (2-Dr.)	9890882 R.H.	47.50 (comb. 764) (covert)
72	Nova (2-Dr.)	9890883 L.H.	47.50 (comb. 764) (covert)
72	Nova (2-Dr.)	9890885 L.H.	47.50 (comb. 766) (tan)
72	Nova (4-Dr.)	9890868 L.H.	32.50 (comb. 756) (blue)
72	Nova (4-Dr.)	9890871 L.H.	32.50 (comb. 759) (green)
73	Nova (Sed.) (exc. Custom)	9644844 R.H.	35.75 (comb. 753) (black)
73	Nova (Sed.) (exc. Custom)	9644845 L.H.	35.75 (comb. 753) (black)
73	Nova (Sed.) (exc. Custom)	9644847 L.H.	35.75 (comb. 757, 758) (green)
73	Nova (Custom) (Sed.)	9644851 L.H.	39.00 (comb. 750) (blk. & wht.)
73	Nova (Custom) (Sed.)	9644855 L.H.	39.00 (comb. 770) (green)
73-74	Nova (Cpe.)	9644830 R.H.	75.75 (black) (paint)
73-74	Nova (Cpe.)	9644831 L.H.	75.75 (black) (paint)
73	Nova (Cpe.)	9644833 L.H.	75.75 (comb. 759, 760, 761) (green)
73-74	Nova (Cpe.)	9644836 R.H.	75.75 (comb. 763, 764, 765, 766, 771, 829) (neutral)
73-74	Nova (Cpe.)	9644837 L.H.	75.75 (comb. 763, 764, 765, 766, 771, 829) (neutral)
73	Nova (Cpe.) (exc. Custom)	9644834 R.H.	75.75 (comb. 756) (blue)
73	Nova (Cpe.) (exc. Custom)	9644835 L.H.	75.75 (comb. 756) (blue)
73	Nova (Cpe.) (exc. Custom)	9644838 R.H.	75.75 (comb. 767) (chamois)
73	Nova (Cpe.) (exc. Custom)	9644839 L.H.	75.75 (comb. 767) (chamois)
74	Nova (2-Dr.)	9682586 R.H.	75.75 (comb. 755, 756, 758, 759, 828) (green)
74	Nova (2-Dr.)	9682587 L.H.	75.75 (comb. 755, 756, 758, 759, 828) (green)
74	Nova (2-Dr.)	9682590 R.H.	75.75 (comb. 771, 772, 826) (midn. blue)
74	Nova (2-Dr.)	9682591 L.H.	75.75 (comb. 771, 772, 826) (midn. blue)
74	Nova (H.B.) (exc. Custom)	9682588 R.H.	75.75 (comb. 773, 827) (saddle)
74	Nova (H.B.) (exc. Custom)	9682589 L.H.	75.75 (comb. 773, 827) (saddle)
74	Nova (H.B.) (exc. Custom)	9644842 R.H.	75.75 (comb. 774) (white)
74	Nova (H.B.) (exc. Custom)	9644843 L.H.	75.75 (comb. 774) (white)
74	Nova (Taxi)	9729270 R.H.	35.75 (comb. 768) (neutral)
74	Nova (Taxi)	9729271 L.H.	39.25 (comb. 768) (neutral)
74	Nova (Taxi)	9730303 R.H.	36.00 (comb. 769) (black)
74	Nova (Taxi)	9730304 L.H.	36.00 (comb. 769) (black)
74	Nova (Sedan) (exc. Custom)	9682674 R.H.	35.75 (comb. 772, 826) (mid. blue)
74	Nova (Sedan) (exc. Custom)	9682675 L.H.	35.75 (comb. 772, 826) (mid. blue)
74	Nova (Sedan)	9683120 R.H.	35.75 (comb. 750, 751, 753, 754, 825) (black)
74	Nova (Sedan)	9683121 L.H.	35.75 (comb. 750, 751, 753, 754, 825) (black)
74	Nova (Sedan)	9683122 R.H.	35.75 (comb. 756, 757, 758, 828) (green)
74	Nova (Sedan)	9683123 L.H.	35.75 (comb. 756, 757, 758, 828) (green)
74	Nova (Sedan)	9683124 R.H.	35.75 (comb. 764, 765, 766, 829) (neutral)
74	Nova (Sedan)	9683125 L.H.	35.75 (comb. 764, 765, 766, 829) (neutral)
75	Nova (Custom) (Sedan)	1666506 R.H.	118.00 (comb. 73G) (oxblood)
75	Nova (Custom) (Sedan)	1666507 L.H.	118.00 (comb. 73G) (oxblood)
75	Nova (Custom) (Sedan)	1666508 R.H.	118.00 (comb. 16G) (graystone)
75	Nova (Custom) (Sedan)	1666509 L.H.	118.00 (comb. 16G) (graystone)
75	Nova (Custom) (Sedan)	1666510 R.H.	118.00 (comb. 26G) (blue)
75	Nova (Custom) (Sedan)	1666511 L.H.	118.00 (comb. 26G) (blue)
75	Nova (Custom) (Sedan)	1666512 R.H.	118.00 (comb. 55G) (sandstone)
75	Nova (Custom) (Sedan)	1666513 L.H.	118.00 (comb. 55G) (sandstone)
75	Nova (Custom) (Coupe) (exc. H.B.)	1666498 R.H.	128.00 (comb. 73G) (oxblood)
75	Nova (Custom) (Coupe) (exc. H.B.)	1666499 L.H.	128.00 (comb. 73G) (oxblood)
75	Nova (Custom) (Coupe) (exc. H.B.)	1666500 R.H.	128.00 (comb. 16G) (graystone)
75	Nova (Custom) (Coupe) (exc. H.B.)	1666501 L.H.	128.00 (comb. 16G) (graystone)
75	Nova (Custom) (Coupe) (exc. H.B.)	1666502 R.H.	128.00 (comb. 26G) (blue)
75	Nova (Custom) (Coupe) (exc. H.B.)	1666503 L.H.	128.00 (comb. 26G) (blue)
75	Nova (Custom) (Coupe) (exc. H.B.)	1666504 R.H.	128.00 (comb. 55G) (sandstone)
75	Nova (Custom) (Coupe) (exc. H.B.)	1666505 L.H.	128.00 (comb. 55G) (sandstone)
75	Nova (Custom) (Sedan)	1655922 R.H.	51.50 (comb. 44D) (green)
75	Nova (Custom) (Sedan)	1655923 L.H.	51.50 (comb. 44D) (green)
75	Nova (Sedan)	1655914 R.H.	49.25 (comb. 19C, 19V, 19W, 19D) (black)
75	Nova (Sedan)	1655915 L.H.	(comb. 19C, 19V, 19W, 19D) (black)
75	Nova (Sedan)	1655916 R.H.	(comb. 26C, 26V, 26D) (blue)
75	Nova (Sedan)	1655917 L.H.	(comb. 26C, 26V, 26D) (blue)

**FOLDING TOP PARTS—INTERIOR TRIM**

**14.685 TRIM ASSY., Front Door (less arm rest) (Con't)**

75	Nova (Sedan)	1655918 R.H.	51.50	(comb. 55C, 55V, 55D, 55W) (sandstone)
75	Nova (Sedan)	1655919 L.H.	51.50	(comb. 55C, 55V, 55D, 55W) (sandstone)
75	Nova (Sedan)	1655920 R.H.	51.50	(comb. 63V, 63W) (saddle)
75	Nova (Sedan)	1655921 L.H.	51.50	(comb. 63V, 63W) (saddle)
75	Nova (Coupe)	1655902 R.H.	66.75	(comb. 19C, 19V, 19W, 19E) (black)
75	Nova (Coupe)	3061079 L.H.	51.25	(comb. 19C, 19V, 19W, 19E) (black) (repl. 1655903)
75	Nova (Coupe)	1655904 R.H.		(comb. 26C, 26V, 26D) (blue)
75	Nova (Coupe)	3061081 L.H.	51.25	(comb. 26C, 26V, 26D) (blue) (repl. 1655905)
75	Nova (Coupe)	1655906 R.H.	69.75	(comb. 55C, 55V, 55D, 55W) (sandstone)
75	Nova (Coupe)	1655907 L.H.	69.75	(comb. 55C, 55V, 55D, 55W) (sandstone)
75	Nova (Coupe)	1655910 R.H.	66.75	(comb. 02W, 04W, 07W, 11W) (white)
75	Nova (Coupe)	1655911 L.H.	66.75	(comb. 02W, 04W, 07W, 11W) (white)
75	Nova (Coupe)	1659138 R.H.	69.75	(comb. 44D) (green)
75	Nova (Coupe)	1659139 L.H.	69.75	(comb. 44D) (green)
75	Nova (Coupe)	1689914 R.H.	70.50	(comb. 73W) (oxblood)
75	Nova (Coupe)	3061091 L.H.	41.45	(comb. 73W) (oxblood) (repl. 1689915)
75	Nova (Coupe)	1655908 R.H.	70.50	(comb. 63V, 63E, 63W) (saddle)
75	Nova (Coupe)	1655909 L.H.	70.50	(comb. 63V, 63E, 63W) (saddle)

**CAMARO**

67	(Deluxe)	7721531 L.H.	64.75	(comb. 716, 732) (brt. blue)
68	Camaro	7751312 R.H.	39.25	(comb. 712, 713)
68	Camaro	7751313 L.H.	39.25	(comb. 712, 713)
68	Camaro	7772025 L.H.	92.00	(comb. 714, 715, 749)
69	Camaro	8725473 L.H.	41.25	(comb. 715) (blue)
70-71	Camaro	9814786 R.H.	23.35	(comb. 711, 775) (black)
70-71	Camaro	9814787 L.H.	25.75	(comb. 711, 775) (black)
70	Camaro	9814799 L.H.	34.00	(comb. 726) (med. saddle)
71	Camaro	9848332 R.H.	28.25	(comb. 776) (dk. blue)
71	Camaro	9848333 L.H.	28.25	(comb. 776) (dk. blue)
71	Camaro	9848334 R.H.	28.25	(comb. 777) (sandalwood)
71	Camaro	9848335 L.H.	28.25	(comb. 777) (sandalwood)
71	Camaro	9848339 L.H.	28.25	(comb. 779) (dk. saddle)
72	Camaro	9600354 R.H.	18.25	Upper (comb. 775) (black)
72	Camaro	9600355 L.H.	18.25	upper (comb. 775) (black)
72	Camaro	9600366 R.H.	69.50	Upper (comb. 785) (black)
72	Camaro	9600361 L.H.	18.25	upper (comb. 778) (tan)
73-75	Camaro (exc. L.T.)	9644814 R.H.	91.50	upper (black) (paint as reqd.)
73-75	Camaro (exc. L.T.)	9644815 L.H.	22.80	upper (black) (paint as reqd.)
73-74	Camaro (exc. L.T.)	9644816 R.H.	22.80	upper (comb. 779, 781) (neutral)
73-74	Camaro (exc. L.T.)	9644817 L.H.	22.80	upper (comb. 779, 781) (neutral)
73	Camaro (L.T.)	9644826 R.H.	68.50	upper (comb. 773, 785, 786) (black)
73	Camaro (L.T.)	9644827 L.H.	68.50	upper (comb. 773, 785, 786) (black)
73	Camaro (L.T.)	9644825 L.H.	68.50	upper (comb. 781) (black & green)
73	Camaro (L.T.)	9644829 L.H.	68.50	upper (comb. 788) (neutral)
74	Camaro (exc. L.T.)	9683176 R.H.	20.50	upper (comb. 786, 787) (green)
74	Camaro (exc. L.T.)	9683177 L.H.	20.50	upper (comb. 786, 787) (green)
74	Camaro (exc. L.T.)	9683178 R.H.	20.50	upper (comb. 796, 798) (saddle)
74	Camaro (exc. L.T.)	9683179 L.H.	20.50	upper (comb. 796, 798) (saddle)
74	Camaro (exc. L.T.)	9683180 R.H.	20.50	upper (comb. 792) (red)
74	Camaro (exc. L.T.)	9683181 L.H.	20.50	upper (comb. 792) (red)
74	Camaro (L.T.)	9687654 R.H.	93.50	less mldg. (comb. 776) (black)
74	Camaro (L.T.)	9687655 L.H.	93.50	less mldg. (comb. 776) (black)
74	Camaro (L.T.)	9687656 R.H.	93.50	less mldg. (comb. 780) (neutral)
74	Camaro (L.T.)	9687657 L.H.	93.50	less mldg. (comb. 780) (neutral)
74	Camaro (L.T.)	9687658 R.H.	93.50	less mldg. (comb. 797) (saddle)
74	Camaro (L.T.)	9687659 L.H.	93.50	less mldg. (comb. 797) (saddle)
74	Camaro (L.T.)	9687660 R.H.	93.50	less mldg. (comb. 783) (taupe)
74	Camaro (L.T.)	9687661 L.H.	93.50	less mldg. (comb. 783) (taupe)
74	Camaro (L.T.) (1st design)	9687664 R.H.	87.75	less mldg. (comb. 778) (black) (Note 1)
74	Camaro (L.T.) (1st design)	9687665 L.H.	87.75	less mldg. (comb. 778) (black) (Note 1)
74	Camaro (L.T.) (1st design)	9687666 R.H.	87.75	less mldg. (comb. 799) (saddle) (Note 1)
74	Camaro (L.T.) (1st design)	9687667 L.H.	87.75	less mldg. (comb. 799) (saddle) (Note 1)
74	Camaro (L.T.) (2nd design)	1656320 R.H.	88.50	less mldg. (comb. 784) (taupe) (Note 1)
74	Camaro (L.T.) (2nd design)	1656321 L.H.	88.50	less mldg. (comb. 784) (taupe) (Note 1)
74	Camaro (L.T.) (2nd design)	1656322 R.H.	88.50	less mldg. (comb. 799) (saddle) (Note 1)
74	Camaro (L.T.) (2nd design)	1656323 L.H.	88.50	less mldg. (comb. 799) (saddle) (Note 1)
74	Camaro (L.T.)	9687668 R.H.	87.75	less mldg. (comb. 784) (taupe)
74	Camaro (L.T.)	9687669 L.H.	87.75	less mldg. (comb. 784) (taupe)
75	Camaro (L.T.)	1680312 R.H.	129.00	less mldg. (comb. 16D) (graystone)
75	Camaro (L.T.)	1680313 L.H.	129.00	less mldg. (comb. 16D) (graystone)
75	Camaro (L.T.)	1680314 R.H.	129.00	less mldg. (comb. 55D) (sandstone)
75	Camaro (L.T.)	1680315 L.H.	129.00	less mldg. (comb. 55D) (sandstone)

**FOLDING TOP PARTS—INTERIOR TRIM**

**14.685 TRIM ASSY., Front Door (less arm rest) (Con't)**

75	Camaro (L.T.)	1680316 R.H.	129.00	less mldg. (comb. 63D) (saddle)
75	Camaro (L.T.)	1680317 L.H.	129.00	less mldg. (comb. 63D) (saddle)
75	Camaro (L.T.)	1680318 R.H.	129.00	less mldg. (comb. 73D) (oxblood)
75	Camaro (L.T.)	1680319 L.H.	129.00	less mldg. (comb. 73D) (oxblood)
75	Camaro (exc. L.T.)	1659120 R.H.	22.80	less mldg. (comb. 55C, 55V) (oxblood)
75	Camaro (exc. L.T.)	1659121 L.H.	22.80	less mldg. (comb. 55C, 55V) (oxblood)
75	Camaro (L.T.)	1680322 R.H.	123.00	less mldg. (comb. 55W) (sandstone)
75	Camaro (L.T.)	1680323 L.H.	123.00	less mldg. (comb. 55W) (sandstone)
75	Camaro (L.T.)	1680324 R.H.	123.00	less mldg. (comb. 63W) (saddle)
75	Camaro (L.T.)	1680325 L.H.	123.00	less mldg. (comb. 63W) (saddle)
75	Camaro (exc. L.T.)	1659122 R.H.	22.80	(comb. 63V) (saddle)
75	Camaro (exc. L.T.)	1659123 L.H.	22.80	(comb. 63V) (saddle)
75	Camaro (L.T.)	1698324 R.H.	143.00	less mldg. (comb. 632) (saddle)
75	Camaro (L.T.)	1698343 L.H.	143.00	less mldg. (comb. 632) (saddle)
75	Camaro (L.T.)	1703414 R.H.	143.00	less mldg. (comb. 732) (oxblood)
75	Camaro (L.T.)	1703415 L.H.	143.00	less mldg. (comb. 732) (oxblood)
<i>NOTE: To aid in identification first design vertical stitch line pattern dimension width is 7/16 inches, second design 5/16 inches.</i>				
71	Vega	9834146 R.H.	47.75	(comb. 873) (black)
71	Vega (exc. Panel)	9834111 L.H.	59.25	(comb. 874) (black)
72-74	Vega	9731667 L.H.		(comb. 860, 862, 873) (black) (repl. 9879957)
72-75	Vega	9606177 R.H.	43.00	(comb. 860, 862, 873) (19V, 19D, 19W) (black)
72	Vega (exc. Panel)	9606178 R.H.	43.00	(comb. 863) (dk. green)
72	Vega (exc. Panel)	9600297 L.H.	46.00	(comb. 863) (dk. green)
72	Vega (exc. Panel)	9606179 R.H.	43.00	(comb. 868) (covert)
72	Vega (exc. Panel)	9606180 R.H.	43.00	(comb. 866) (tan)
72	Vega (exc. Panel)	9600301 L.H.	46.00	(comb. 866) (tan)
72	Vega (exc. Panel)	9606181 R.H.	57.50	(comb. 861, 862) (black)
72	Vega (exc. Panel)	9879967 L.H.	60.50	(comb. 861, 862) (black)
73	Vega	9654005 L.H.	44.75	(comb. 863) (green)
73	Vega (Hatchback Cpe.)	9653992 R.H.	41.75	(comb. 859) (chamois)
73	Vega (Hatchback Cpe.)	9654006 L.H.	44.75	(comb. 859) (chamois)
73-74	Vega (exc. Panel)	9653993 R.H.	41.75	(comb. 868, 870) (neutral)
73-74	Vega (exc. Panel)	9654007 L.H.	44.75	(comb. 868, 870) (neutral)
73-75	Vega (exc. Panel)	1686066 R.H.	80.50	(comb. 861, 869, 871, 884, 887) (19E, 19Y) (black)
73-74	Vega (exc. Panel)	1686067 L.H.	80.50	(comb. 861, 869, 871, 884, 887) (black)
73-74	Vega (exc. Panel)	9686106 R.H.	81.00	(comb. 863) (neutral)
73-74	Vega (exc. Panel)	9686107 L.H.	81.00	(comb. 863) (neutral)
73	Vega (Sta. Wag.)			
75	Vega	9653994 R.H.	41.75	(comb. 866) (63W) (saddle)
73	Vega (exc. Panel)	9653996 L.H.	59.25	(comb. 860, 861, 871) (black)
73	Vega (exc. Panel)	9653955 R.H.	56.25	(comb. 860, 871) (black)
73	Vega (exc. Panel)	9653956 R.H.	56.25	(comb. 872) (blue and black)
73	Vega (Hatchback Cpe. Sta. Wag.)			
73	Vega (Notchback Cpe.) w/Custom Trim	9653998 L.H.	59.25	(comb. 863, 864) (green)
73	Vega (Hatchback Cpe., Sta. Wag.)			
73	Vega (Notchback Cpe.) w/Custom Trim	9653957 R.H.	56.25	(comb. 863, 864) (green)
73	Vega (exc. Panel)	9653959 R.H.	56.25	(comb. 868, 874) (neutral)
73	Vega (Hatchback Cpe.)	9654002 L.H.	59.25	(comb. 875) (oxblood)
74	Vega	9674301 R.H.	41.75	(comb. 879, 881, 883) (green)
74	Vega	9731663 L.H.	44.75	(comb. 879, 881, 883) (green)
74	Vega (exc. Panel)	9731664 L.H.	44.75	(comb. 888) (saddle)
74	Vega (exc. Panel)	9685496 R.H.	81.00	(comb. 880, 887) (green)
74	Vega (exc. Panel)	9685497 L.H.	81.00	(comb. 880, 887) (green)
74	Vega (exc. Panel)	9674302 R.H.	41.75	(comb. 888) (saddle)
74	Vega (Hatchback Cpe.)	1673880 R.H.	77.25	(comb. 867) (white)
74	Vega (Hatchback Cpe.)	1673881 L.H.	77.25	(comb. 867) (white)
74-75	Vega (Hatchback, Sta. Wag.)	9674303 R.H.	41.75	(comb. 884) (red)
74-75	Vega (Hatchback, Sta. Wag.)	9731665 L.H.	44.75	(comb. 884) (red)
74	Vega (exc. Panel)	9685498 R.H.	81.00	(comb. 890) (saddle)
74	Vega (exc. Panel)	9685499 L.H.	81.00	(comb. 890) (saddle)
75	Vega	9731661 L.H.	42.50	(comb. 19V, 19D, 19W) (black)
75	Vega (exc. Panel)	1686066 R.H.	80.50	(comb. 19E, 19Y) (black)
75	Vega (exc. Panel)	1686067 L.H.	80.50	(comb. 19E, 19Y) (black)
75	Vega (exc. Panel)	1681111 L.H.	43.75	(comb. 63W) (saddle)
75	Vega (exc. Panel)	1681109 R.H.	41.00	(comb. 26W) (blue)
75	Vega (exc. Panel)	1681112 L.H.	43.75	(comb. 26W) (blue)

**FOLDING TOP PARTS—INTERIOR TRIM**

**14.685 TRIM ASSY., Front Door (less arm rest) (Con't)**

75	Vega (Hatchback Cpe., Sta. Wag.)	1690506 R.H.	80.50	(comb. 02Y, 11Y) (white)
75	Vega (Hatchback Cpe., Sta. Wag.)	1690507 L.H.	80.50	(comb. 02Y, 11Y) (white)
75	Vega (exc. Panel)	1681110 R.H.	41.00	(comb. 55D, 55W) (sandstone)
75	Vega (exc. Panel)	1681113 L.H.	43.75	(comb. 55D, 55W) (sandstone)
75	Vega (exc. Panel)	1655198 R.H.	85.00	(comb. 63Y) (saddle)
75	Vega (exc. Panel)	1655199 L.H.	85.00	(comb. 63Y) (saddle)
75	Vega (Hatchback Cpe., Sta. Wag.)	1697054 R.H.	82.50	(comb. 73Y) (oxblood)
75	Vega (Hatchback Cpe., Sta. Wag.)	1697055 L.H.	82.50	(comb. 73Y) (oxblood)
75	Vega (Hatchback Cpe., Sta. Wag.)	1698486 R.H.	96.50	(comb. 55B, 55Y) (sandstone)
75	Vega (Hatchback Cpe., Sta. Wag.)	1698487 L.H.	96.50	(comb. 55B, 55Y) (sandstone)
75	Vega (Hatchback Cpe., Sta. Wag.)	1698490 R.H.	96.50	(comb. 73B, 73Y) (oxblood)
75	Vega (Hatchback Cpe., Sta. Wag.)	1698491 L.H.	96.50	(comb. 73B, 73Y) (oxblood)
75	Vega (Hatchback Cpe., Sta. Wag.)	1698492 R.H.	96.50	(comb. 26B, 02Y) (blue)
75	Vega (Hatchback Cpe., Sta. Wag.)	1698493 L.H.	96.50	(comb. 26B, 02Y) (blue)
75	Monza (exc. Towne Cpe.)	1659124 R.H.	112.00	(comb.-16G-Z) (graystone)
75	Monza (exc. Towne Cpe.)	1659125 L.H.	112.00	(comb.-16G-Z) (graystone)
75	Monza (exc. Towne Cpe.)	1698344 R.H.	98.50	(comb. 19G, 19Z) (black)
75	Monza (exc. Towne Cpe.)	1698345 L.H.	98.50	(comb. 19G, 19Z) (black)
75	Monza (exc. Towne Cpe.)	1659126 R.H.	112.00	(comb.-26G-Z) (blue)
75	Monza (exc. Towne Cpe.)	1659127 L.H.	112.00	(comb.-26G-Z) (blue)
75	Monza (exc. Towne Cpe.)	1659128 R.H.	112.00	(comb. 55G, 55Z) (sandstone)
75	Monza (exc. Towne Cpe.)	1659129 L.H.	112.00	(comb. 55G, 55Z) (sandstone)
75	Monza (exc. Towne Cpe.)	1659130 R.H.	112.00	(comb. 63G, 63Z, 632) (saddle)
75	Monza (exc. Towne Cpe.)	1659131 L.H.	112.00	(comb. 63G, 63Z, 632) (saddle)
75	Monza (exc. Towne Cpe.)	1659132 R.H.	112.00	(comb. 73G, 73Z, 732) (oxblood)
75	Monza (exc. Towne Cpe.)	1659133 L.H.	112.00	(comb. 73G, 73Z, 732) (oxblood)
75	Monza (Towne Cpe.)	1707684 R.H.	116.00	(comb. 71N, 71H) (firethorn)
75	Monza (Towne Cpe.)	1707685 L.H.	116.00	(comb. 71N, 71H) (firethorn)
75	Monza (Towne Cpe.)	1707686 R.H.	110.00	(comb. 07H, 11H) (white)
75	Monza (Towne Cpe.)	1707687 L.H.	116.00	(comb. 07H, 11H) (white)
75	Monza (Towne Cpe.)	1707688 R.H.	116.00	(comb. 19N, 19H, 193) (black)
75	Monza (Towne Cpe.)	1707689 L.H.	116.00	(comb. 19N, 19H, 193) (black)
75	Monza (Towne Cpe.)	1707692 R.H.	116.00	(comb. 64N, 64H, 64O, 643) (buckskin)
75	Monza (Towne Cpe.)	1707693 L.H.	116.00	(comb. 64N, 64H, 64O, 643) (buckskin)
75	Monza (exc. Towne Cpe.)	1699102 R.H.	112.00	(comb.-02J, 07J, 11J) (white)
75	Monza (exc. Towne Cpe.)	1699103 L.H.	112.00	(comb.-02J, 07J, 11J) (white)
75	Vega, Monza	1655174 R.H.	85.00	(comb. 55E, 55Y) (sandstone)
75	Vega, Monza	1655175 L.H.	85.00	(comb. 55E, 55Y) (sandstone)

**14.685A RETAINER—TAB— PLUG— PANEL— PLATE, Front Door**

65	Pass.	6280765 A.R.	.12	dr. binding strip to inner panel
65	Pass.			<b>TAB</b> , trim binding strip
70	Pass.	4081772 A.R.	.38	driver and quarter trim pad binding strip replacement— (14.685)
70-72	Chevelle, Nova, Camaro			<b>PLUG</b> , door trim pad seal plug
70-72	Pass., Chevelle (Spt. Cpe., Conv.)	4853962 A.R.	.11	quarter trim pad seal plug
71-75	Pass. (Sta. Wag., Sed.)	9845400 R.H.	16.05	<b>PANEL</b> , lower (black) (paint as reqd.)
71-75	Pass. (Sta. Wag., Sed.)	9845401 L.H.	16.05	<b>PANEL</b> , lower (black) (paint as reqd.)
71-75	Pass. (Spt. Cpe., Conv.)	9845416 R.H.	13.40	<b>PANEL</b> , lower (black) (paint as reqd.)
71-75	Pass. (Spt. Cpe., Conv.)	9845417 L.H.	13.40	<b>PANEL</b> , lower (black) (paint as reqd.)
72-75	Camaro	9600955 L.H.	22.95	<b>PANEL</b> , trim finish frt. door lower (paint as reqd.)
72-75	Camaro	9600954 R.H.	22.95	<b>PANEL</b> , trim finish frt. door lower (paint as reqd.)
75	Caprice (Sedan)	9845430 R.H.	17.25	<b>PANEL</b> , trim finish front door lower
75	Caprice (Sedan)	9845431 L.H.	17.25	<b>PANEL</b> , trim finish front door lower
70-71	Camaro	8800044 R.H.	20.55	<b>PANEL ASSY.</b> , right front door trim finish (comb. 712, 713, 714, 716, 720, 724, 725, 727, 730) (black)
70-71	Camaro	8800045 L.H.	20.55	<b>PANEL ASSY.</b> , left front door trim finish (comb. 712, 713, 714, 716, 720, 724, 725, 727, 730) (black)
75	Chevelle (2-Dr.), Monte Carlo w/custom build up & qtr.	9651154 R.H.	24.95	<b>PANEL ASSY.</b> , lower trim finish (paint as reqd.)

**FOLDING TOP PARTS—INTERIOR TRIM**

**14.685A RETAINER— TAB— PLUG— PANEL— PLATE, Front Door (Con't)**

75	Chevelle (2-Dr.), Monte Carlo w/custom build up & qtr. . . . .	9651155 L.H.	24.95	PANEL ASSY., lower trim finish (paint as reqd.) . . . . .
73-75	Caprice (Spt. Cpe.),			
74-75	Impala (Spt. Cpe.) Pass. (Conv.) .	9845446 R.H.	17.10	PANEL ASSY., lower (prime and paint as reqd.) . . . . .
73-75	Caprice (Spt. Cpe.),			
74-75	Impala (Spt. Cpe.) Pass. (Conv.) .	9845447 L.H.	17.10	PANEL ASSY., lower (prime and paint as reqd.) . . . . .
73-75	Chevelle (Spt. Sed., Sta. Wag.) . .	9650710 R.H.	12.50	PANEL ASSY., lower (prime and paint as reqd.) . . . . .
73-74	Chevelle (Spt. Sed., Sta. Wag.) . .	9650711 L.H.	12.50	PANEL ASSY., lower (prime and paint as reqd.) . . . . .
73-75	Chevelle (Spt. Cpe.), Monte Carlo . . . . .	9651136 R.H.	17.10	PANEL ASSY., lower (prime and paint as reqd.) . . . . .
73-75	Chevelle (Spt. Cpe.), Monte Carlo . . . . .	9651137 L.H.	17.10	PANEL ASSY., lower (prime and paint as reqd.) . . . . .
73-75	El Camino . . . . .	9650831 R.H.	15.85	PANEL ASSY., lower (prime and paint as reqd.) . . . . .
73-75	El Camino . . . . .	9650832 L.H.	15.85	PANEL ASSY., lower (prime and paint as reqd.) . . . . .
73	Camaro,			
74	Camaro (exc. L.T.) . . . . .	9892957 2	1.40	PLATE, lower panel hanger . . . . .

**14.686 REST ASSY.— COVER ASSY.— BASE— NUT— PAD ASSY.— RETAINER— SCREW, Front Door Arm Rest**

**PASS.**

66	Biscayne . . . . .	7611767 2	9.50	(comb. 860, 861, 865) (fawn) . . . . .
67	Biscayne . . . . .	7650701 2	9.50	(comb. 732, 740) (blue) . . . . .

**CHEVY, CHEVELLE, CAMARO**

62	Chevy Deluxe . . . . .	4332259 2	9.50	(comb. 772, 774, 775, 778, 781, 782, 785, 786, 820, 846, 856, 881) (red) . . . . . (comb. 701, 703), . . . . .
65	Nova (4-Dr.) . . . . .			
65	Malibu (S.S.),			
66-67	Chevelle (Spt. Mdls.),			
66-67	El Camino (Custom),			
67	Nova (4-Dr.) . . . . .	4473130 2	9.60	(comb. 741, 759, 761, 762, 763, 766, 789) (black) . . . . . (comb. 704, 714, 715, 719, 720, 860, 861, 865) (fawn) . . . . .
66	Chevy, Chevelle (Std.) . . . . .	7611767 2	9.50	(comb. 724, 733, 734) (blue) . . . . .
67	Chevy, Chevelle (Std.) . . . . .	7650701 2	9.50	(comb. 724, 733, 734) (blue) . . . . .
75	Nova . . . . .	1670172 R.H.	9.95	(comb. 44D) (green) . . . . .
75	Nova . . . . .	1670173 L.H.	9.95	(comb. 44D) (green) . . . . .
75	Nova . . . . .	1670430 R.H.	9.95	(comb. 55C, 55D, 55W, 55G-V) (sandstone)
75	Nova . . . . .	1670431 L.H.	9.95	(comb. 55C, 55D, 55W, 55G-V) (sandstone)
75	Nova . . . . .	1670164 R.H.	9.95	(comb. 19C, 19V, 19E, 19W, 19Z) (black) . .
75	Nova . . . . .	1670165 L.H.	9.95	(comb. 19C, 19V, 19E, 19W, 19Z) (black) . .
75	Nova . . . . .	1670166 R.H.	9.95	(comb. 02W, 04W, 07W, 11W) (white) . . . .
75	Nova . . . . .	1670167 L.H.	9.95	(comb. 02W, 04W, 07W, 11W) (white) . . . .
75	Nova . . . . .	1670168 R.H.	9.95	(comb. 63V, 63E, 63W, 63Z) (saddle) . . . .
75	Nova . . . . .	1670169 L.H.	9.95	(comb. 63V, 63E, 63W, 63Z) (saddle) . . . .
75	Nova . . . . .	1670170 R.H.	9.95	(comb. 73G, 73W) (oxblood) . . . . .
75	Nova . . . . .	1670171 L.H.	9.95	(comb. 73G, 73W) (oxblood) . . . . .
75	Nova . . . . .	1670426 R.H.	9.95	(comb. 16G) (graystone) . . . . .
75	Nova . . . . .	1670427 L.H.	9.95	(comb. 16G) (graystone) . . . . .
75	Nova . . . . .	1670428 R.H.	9.95	(comb. 26C, 26V, 26D, 26G) (blue) . . . . .
75	Nova . . . . .	1670429 L.H.	9.95	(comb. 26C, 26V, 26D, 26G) (blue) . . . . .
74	Camaro (L.T.) . . . . .	9674364 R.H.	12.70	(comb. 776, 778) (black) . . . . .
74	Camaro (L.T.) . . . . .	9674365 L.H.	12.70	(comb. 776, 778) (black) . . . . .
74	Camaro (L.T.) . . . . .	9674366 R.H.	12.70	(comb. 780) (neutral) . . . . .
74	Camaro (L.T.) . . . . .	9674367 L.H.	12.70	(comb. 780) (neutral) . . . . .
74	Camaro (L.T.) . . . . .	9674368 R.H.	12.70	(comb. 797, 799) (saddle) . . . . .
74	Camaro (L.T.) . . . . .	9674369 L.H.	12.70	(comb. 797, 799) (saddle) . . . . .
74	Camaro (L.T.) . . . . .	9674370 R.H.	12.00	(comb. 783, 784) (taupe) . . . . .
74	Camaro (L.T.) . . . . .	9674371 L.H.	12.00	(comb. 783, 784) (taupe) . . . . .
75	Camaro (L.T.) . . . . .	1667036 R.H.	12.70	(comb. 63D, 63W) (saddle) . . . . .
75	Camaro (L.T.) . . . . .	1667037 L.H.	12.70	(comb. 63D, 63W) (saddle) . . . . .
75	Camaro (L.T.) . . . . .	1667044 R.H.	12.70	(comb. 55D, 55W) (sandstone) . . . . .
75	Camaro (L.T.) . . . . .	1667045 L.H.	12.70	(comb. 55D, 55W) (sandstone) . . . . .
75	Camaro (L.T.) . . . . .	1667042 R.H.	12.70	(comb. 16D) (graystone) . . . . .

**FOLDING TOP PARTS—INTERIOR TRIM**

**14.686 REST ASSY.— COVER ASSY.— BASE— NUT— PAD ASSY.— RETAINER—  
SCREW, Front Door Arm Rest (Con't)**

75	Camaro (L.T.)	1667043 L.H.	12.70	(comb. 16D) (graystone)
75	Camaro (L.T.)	1667038 R.H.	12.70	(comb. 73D, 73Z) (oxblood)
75	Camaro (L.T.)	1667039 L.H.	12.70	(comb. 73D, 73Z) (oxblood)

**VEGA— MONZA**

73-75	Vega (exc. Panel)	9674364 R.H.	12.70	(comb. 861, 869, 871, 884, 887, 19E, 19Y) (black)
73-75	Vega (exc. Panel)	9674365 L.H.	12.70	(comb. 861, 869, 871, 884, 887, 19E, 19Y) (black)
73-74	Vega (exc. Panel)	9674366 R.H.	12.70	(comb. 863, 888) (neutral)
73-74	Vega (exc. Panel)	9674367 L.H.	12.70	(comb. 863, 888) (neutral)
74	Vega (exc. Panel)	9687405 R.H.	12.70	(comb. 880, 887) (green)
74	Vega (exc. Panel)	9687406 L.H.	12.70	(comb. 880, 887) (green)
74	Vega (exc. Panel)	9674368 R.H.	12.70	(comb. 890) (saddle)
74	Vega (exc. Panel)	9674369 L.H.	12.70	(comb. 890) (saddle)
74-75	Vega	1674370 R.H.	12.70	(comb. 867, 02Y, 11Y) (white)
74-75	Vega	1674371 L.H.	12.70	(comb. 867, 02Y, 11Y) (white)
75	Vega (exc. Panel)	1667036 R.H.	12.70	(comb. 63W, 63Y) (saddle)
75	Vega (exc. Panel)	1667037 L.H.	12.70	(comb. 63W, 63Y) (saddle)
75	Vega (exc. Panel)	1667044 R.H.	12.70	(comb. 55W, 55Y, 55E) (sandstone)
75	Vega (exc. Panel)	1667045 L.H.	12.70	(comb. 55W, 55Y, 55E) (sandstone)
75	Monza (exc. Towne Cpe.)	1667010 R.H.	17.65	(comb. 63G, 63Z, 632) (saddle)
75	Monza (exc. Towne Cpe.)	1667011 L.H.	17.65	(comb. 63G, 63Z, 632) (saddle)
75	Monza (exc. Towne Cpe.)	1667012 R.H.	17.65	(comb. 73G, 73Z, 732) (oxblood)
75	Monza (exc. Towne Cpe.)	1667013 L.H.	17.65	(comb. 73G, 73Z, 732) (oxblood)
75	Monza (exc. Towne Cpe.)	1667014 R.H.	17.65	(comb. 16G, 16Z) (graystone)
75	Monza (exc. Towne Cpe.)	1667015 L.H.	17.65	(comb. 16G, 16Z) (graystone)
75	Monza (exc. Towne Cpe.)	1667016 R.H.	17.65	(comb. 26G, 26Z) (blue)
75	Monza (exc. Towne Cpe.)	1667017 L.H.	17.65	(comb. 26G, 26Z) (blue)
75	Monza (exc. Towne Cpe.)	1667018 R.H.	17.65	(comb. 55G, 55Z) (sandstone)
75	Monza (exc. Towne Cpe.)	1667019 L.H.	17.65	(comb. 55G, 55Z) (sandstone)
75	Vega (Hatchback Cpe., Sta. Wag.)	1694044 R.H.	12.70	(comb. 26B) (blue)
75	Vega (Hatchback Cpe., Sta. Wag.)	1694045 L.H.	12.70	(comb. 26B) (blue)
75	Monza	1698075 R.H.	17.65	(comb. 19G, 19H, 19Z, 192) (black)
75	Monza	1698076 L.H.	17.65	(comb. 19G, 19H, 19Z, 192) (black)
75	Monza (Notchback) (Towne Cpe.)	1698077 R.H.	17.65	(comb. 11H, 07H) (white)
75	Monza (Notchback) (Towne Cpe.)	1698078 L.H.	17.65	(comb. 11H, 07H) (white)
75	Monza (Notchback) (Towne Cpe.)	1721403 R.H.	23.05	(comb. 64N, 64H, 643) (buckskin)
75	Monza (Notchback) (Towne Cpe.)	1721404 L.H.	23.05	(comb. 64N, 64H, 643) (buckskin)
75	Monza (Notchback) (Towne Cpe.)	1721401 R.H.	23.05	(comb. 71N, 71H) (firethorn)
75	Monza (Notchback) (Towne Cpe.)	1721402 L.H.	23.05	(comb. 71N, 71H) (firethorn)
75	Vega (Hatchback Cpe., Sta. Wag.)	1667038 R.H.	12.70	(comb. 73B, 73Y) (oxblood)
75	Vega (Hatchback Cpe., Sta. Wag.)	1667039 L.H.	12.70	(comb. 73B, 73Y) (oxblood)

**PASS.**

65-67	Impala, Caprice	4481123 2	7.80	<b>COVER ASSY., rest</b> (comb. 810, 811, 813, 814, 815, 816, 817, 818, 821)
68-69	Biscayne, Bel Air			<b>COVER ASSY.,</b> (comb. 802, 803, 804, 811, 829),
68-69	Impala, Caprice (exc. Spt. Cpe., Conv.),			(comb. 805, 806, 807, 808, 814),
69	Sta. Wag.			front and rear door arm rest (comb. 802, 803, 804, 805, 806, 807, 808, 813)
70	Pass. (4-Dr.)	7766490 R.H.	8.60	(black) (Note 1)
68-69	Biscayne, Bel Air			<b>COVER ASSY.,</b> (comb. 802, 803, 804, 811, 829),
68-69	Impala, Caprice (exc. Spt. Cpe., Conv.),			(comb. 805, 806, 807, 808, 811),
69	Sta. Wag.			front and rear door arm rest (comb. 802, 803, 804, 805, 806, 807, 808, 813)
70	Pass. (4-Dr.)	7766491 L.H.	8.60	(black) (Note 1)



**FOLDING TOP PARTS—INTERIOR TRIM**

<b>14.686 REST ASSY.— COVER ASSY.— BASE— NUT— PAD ASSY.— RETAINER—</b>		<b>SCREW, Front Door Arm Rest (Con't)</b>	
68	Biscayne, Bel Air		COVER ASSY., (comb. 816, 817, 818, 819),
68	Impala, Caprice (4-Dr.)	7766493 L.H.	8.60 (comb. 815, 820, 821, 822, 823)
68	Biscayne, Bel Air (exc. Sta. Wag.)		COVER ASSY., (comb. 831, 832, 865),
68	Impala, Caprice (4-Dr.) (exc. Sta. Wag.)	7766494 1	7.05 (comb. 830, 833, 834, 835)
68	Biscayne, Bel Air (exc. Sta. Wag.)		COVER ASSY., (comb. 831, 832, 865),
68	Impala, Caprice (4-Dr.) (exc. Sta. Wag.)	7766495 1	7.05 (comb. 830, 833, 834, 835)
68-69	Sta. Wag.	7766662 R.H.	7.05 COVER ASSY., (comb. 830, 831, 837, 838, 839)
68-69	Sta. Wag.	7766663 L.H.	7.05 COVER ASSY., (comb. 830, 831, 837, 838, 839)
68-70	Impala, Caprice (2-Dr.)	7766701 L.H.	8.75 COVER ASSY., (comb. 805, 806, 807, 808, 809, 812, 813)
69	Bel Air, Impala, Caprice (Sed.), Kingswood	8742619 L.H.	7.15 COVER ASSY., (midnight green)
69	Biscayne, Bel Air, Caprice (Sed.), Brookwood, Townsman	8742620 R.H.	7.15 COVER ASSY., (med. blue)
69	Biscayne, Bel Air, Caprice (Sed.), Brookwood, Townsman	8742621 L.H.	7.25 COVER ASSY., (med. blue)
70	Pass. (4-Dr.)	8803581 L.H.	7.25 COVER ASSY. (comb. 815, 818, 819, 820, 821, 822) (med. blue) (Note 1)
71	Pass.	9854210 2	9.60 COVER ASSY., lower pad (black)
71	Pass. (exc. Conv.)	9854211 2	9.60 COVER ASSY., lower pad (dk. blue)
71	Biscayne, Bel Air, Impala, Caprice (exc. Conv., 4-Dr. Sed.)	9854213 2	9.60 COVER ASSY., lower pad (lt. sandalwood)
71	Bel Air, Impala, Caprice, Kingswood	9854214 2	9.60 COVER ASSY., lower pad (med. maize)
71	Bel Air, Impala, Caprice, Kingswood	9854215 2	9.60 COVER ASSY., lower pad (dk. jade)

*NOTE 1 Also in Chevy, Chevelle, Camaro Section.*

**CHEVY, CHEVELLE, CAMARO**

68-72	Chevy, Nova	9645172 R.H.	8.45 COVER ASSY. (black)
68-72	Chevy, Nova	9645173 L.H.	8.45 COVER ASSY. (black)
68-72	Nova, Chevelle	9645166 R.H.	8.45 COVER ASSY., frt. dr. arm rest (comb. 761, 763, 765, 731D, 733D, 735D) (comb. 765, 930, 763, 217, 737, 753, 735) (comb. 750, 752, 755, 704, 731, 733, 734) (comb. 700, 703, 705, 701, 730, 732) (blue)
68-72	Nova, Chevelle	9645167 L.H.	8.45 COVER ASSY., frt. dr. arm rest (comb. 772) (blue)
68	Chevy		COVER ASSY. (comb. 706, 707, 737, 739, 740, 771, 773, 777) (dk. blue)
68	Chevelle (Sta. Wag.)	7769170 R.H.	7.30 COVER ASSY. (comb. 737, 739, 740, 771, 773, 777) (dk. blue)
68	Chevelle (Sta. Wag.)	7769171 L.H.	7.30 COVER ASSY. (comb. 737, 739, 740, 771, 773, 777) (dk. blue)
68	Chevy	7769173 L.H.	7.30 COVER ASSY. (comb. 709, 710, 741, 742, 743, 745) (gold)
68	Chevelle (exc. Sta. Wag.)		COVER ASSY. (comb. 760, 761, 762, 764, 765, 766, 768) (black), (comb. 711, 712, 713), (comb. 760/217/765/217/766/223), (comb. 760/217, 910), (comb. 765/118, 390), (comb. 765/118/765/960), (comb. 751, 752), (comb. 753, 754, 755, 756), (comb. 752, 755, 756) (Note 4),
68-69	Camaro		
68	El Camino		
68	Deluxe (2-Dr. Plr. Cpe.)		
68	Malibu (4-Dr. Sed.)		
68	Malibu (Spt. Cpe., Spt. Sed.)		
69	Chevelle (Deluxe)		
69	Malibu		
69	El Camino		
70-71	Chevelle (exc. Sta. Wag.),		
72	Chevelle (exc. Sta. Wag., Monte Carlo)	7766490 R.H.	8.60 right front door arm rest (comb. 701, 703, 707, 708, 709, 710, 748, 749, 754, 756, 757) (black)
68	Chevelle (exc. Sta. Wag.)		COVER ASSY. (comb. 760, 761, 762, 764, 765, 766, 768),
68-69	Camaro		(comb. 711, 712, 713),

FOLDING TOP PARTS—INTERIOR TRIM

14.686 REST ASSY.— COVER ASSY.— BASE— NUT— PAD ASSY.— RETAINER— SCREW, Front Door Arm Rest (Con't)

68	El Camino			(comb. 760/217/765/217/766/223),
68	Deluxe (2-Dr. Plr. Cpe.)			(comb. 760/217, 910),
68	Malibu (4-Dr. Sed.)			(comb. 765/118, 390),
68	Malibu (Spt. Cpe., Spt. Sed.)			(comb. 765/118/765/960),
69	Chevelle (Deluxe)			(comb. 751, 752),
69	Malibu			(comb. 753, 754, 755, 756),
69	El Camino			(comb. 752, 755, 756) (Note 4),
70-71	Chevelle (exc. Sta. Wag.)			
72	Chevelle (exc. Sta. Wag., Monte Carlo)	7766491 L.H.	8.60	COVER ASSY., left front door arm rest (comb. 701, 703, 707, 708, 709, 710, 748, 749, 754, 756, 757) (black) (comb. 765/158, 766/178),
68	Malibu, S.S. (Spt. Cpe., Conv.)			
68	Malibu, S.S. (Spt. Cpe.)	7766701 L.H.	8.75	COVER ASSY. (comb. 765/168/980/766/970) (black) (Note 4)
68	Chevelle (exc. Sta. Wag.)			COVER ASSY. (comb. 759, 770, 772, 773, 774, 776, 777),
68	Camaro, El Camino	7766493 L.H.	8.60	(comb. 717, 718) (dk. blue)
68	Chevelle (exc. Sta. Wag.)			COVER ASSY. (comb. 752, 754, 756, 778, 779, 780, 784),
68	Camaro	7766494 R.H.	7.05	(comb. 722, 723)
68	Chevelle (exc. Sta. Wag.)			COVER ASSY. (comb. 752, 754, 756, 778, 779, 780, 784),
68	Camaro	7766495 L.H.	7.05	(comb. 722, 723)
68-69	El Camino	7766662 R.H.	7.05	COVER ASSY. (comb. 758, 770, 771, 773, 782, 783) (saddle)
68-69	El Camino	7766663 L.H.	7.05	COVER ASSY. (comb. 758, 770, 771, 773, 782, 783) (saddle)
68	Chevelle (Spt. Cpe., Conv.) (exc. Deluxe)	7766807 L.H.	7.05	COVER ASSY. (comb. 792, 794)
69	Camaro, Malibu (Spt. Cpe., Sed.)	8742619 L.H.	7.15	COVER ASSY. (midnight green)
69	Chevelle (Deluxe)	8742620 R.H.	7.15	COVER ASSY. (med. blue)
69	Chevelle (Deluxe)	8742621 L.H.	7.25	COVER ASSY. (med. blue)
69	Malibu (Spt. Cpe., Conv.)	8742627 L.H.	7.15	COVER ASSY. (parchment)
70	Chevelle (exc. Sta. Wag.)	8803581 L.H.	7.25	COVER ASSY., left front door arm rest (comb. 758, 760, 761, 762, 764, 765, 768) (med. blue)
71	Monte Carlo			COVER ASSY. (comb. 707, 708, 709, 710),
71	Chevelle (exc. Sta. Wag., Monte Carlo)	7766490 R.H.	8.60	(comb. 701, 703, 704, 705, 706) (black)
71	Chevelle (exc. Sta. Wag., Conv.)	9847387 L.H.	9.00	COVER ASSY. (comb. 713, 714, 715, 716, 717, 718) (lt. sandalwood)
71	Malibu, Monte Carlo, (Exc. Spt. Sed., Sta. Wag.),			
72	Malibu (Spt. Sed.),			
72	Concours, Monte Carlo	9847391 L.H.	9.00	COVER ASSY. (comb. 721, 722, 723) (dk. saddle)
71	Monte Carlo, Malibu	9847393 L.H.	9.00	COVER ASSY. (comb. 724, 725, 726, 727, 728) (dk. blue)
71	Chevelle (exc. Sta. Wag., El Camino),			
71	El Camino (exc. Custom)	9847394 R.H.	9.00	COVER ASSY. (comb. 729, 730, 731, 732, 733, 734, 735, 736) (dk. jade)
71	Chevelle (exc. Sta. Wag., El Camino),			
71	El Camino (exc. Custom)	9847395 L.H.	9.00	COVER ASSY. (comb. 729, 730, 731, 732, 733, 734, 735, 736) (dk. jade)
72	Nova	9891356 R.H.	5.50	COVER ASSY. (comb. 761) (green)
72	Nova	9891357 L.H.	5.50	COVER ASSY. (comb. 761) (green)
72	Chevelle (Spt. Cpe., Conv.) (Sed.)	9893295 L.H.	8.45	COVER ASSY. (comb. 710, 711, 713, 715, 717) (green)
72	Nova	9891122 R.H.	7.95	COVER ASSY. (comb. 763, 764, 765) (covert)
72	Nova	9891123 L.H.	7.95	COVER ASSY. (comb. 763, 764, 765) (covert)
72	Monte Carlo,			
72	Malibu (Spt. Cpe., Sed.) El Camino Custom	9893203 L.H.	8.45	COVER ASSY. (comb. 730, 731, 732, 734) (covert)
72	Malibu (Spt. Cpe., Spt. Sed., Conv.)	9893207 L.H.	8.45	COVER ASSY. (comb. 743) (white)
73	Nova (Sed.)	9645164 R.H.	8.45	COVER ASSY. (comb. 757, 758, 770) (green)

**FOLDING TOP PARTS—INTERIOR TRIM**

<b>14.686 REST ASSY.— COVER ASSY.— BASE— NUT— PAD ASSY.— RETAINER—</b>		<b>SCREW, Front Door Arm Rest (Con't)</b>	
73	Nova (Sed.)	9645165 L.H.	8.45 COVER ASSY. (comb. 757, 758, 770) (green)
73	Nova (Sed.)	9645166 R.H.	8.45 COVER ASSY. (comb. 750, 753, 772) (blue)
73	Nova (Sed.)	9645167 L.H.	8.45 COVER ASSY. (comb. 772) (blue)
73	Nova (Sed.) (Custom),		
74	Nova (Sedan)	9645174 R.H.	8.45 COVER ASSY. (comb. 764, 765, 766, 768, 769, 829) (neutral)
73	Nova (Sed.) (Custom),		
74	Nova (Sedan)	9645175 L.H.	8.45 COVER ASSY. (comb. 764, 765, 766, 768, 829) (neutral)
73-74	Nova (Sed.)	9645172 R.H.	8.45 COVER ASSY. (comb. 750, 751, 753, 754, 825) (black)
73-74	Nova (Sed.)	9645173 L.H.	8.45 COVER ASSY. (comb. 750, 751, 753, 754, 769, 825) (black)
74	Nova (Sedan) (exc. Custom)	9694220 R.H.	8.45 COVER ASSY. (comb. 772, 826) (midn. blue)
74	Nova (Sedan) (exc. Custom)	9694221 L.H.	8.45 COVER ASSY. (comb. 772, 826) (midn. blue)
74	Nova (Sedan)	9694213 R.H.	8.45 COVER ASSY. (comb. 756, 757, 758, 828) (green)
74	Nova (Sedan)	9694214 L.H.	8.45 COVER ASSY. (comb. 756, 757, 758, 828) (green)

**PASS.**

65-67	Impala, Caprice	4493332 R.H.	5.85	BASE, rest
65-67	Impala, Caprice	4493333 L.H.	5.85	BASE, rest
68	Impala, Caprice (2-Dr.)	7755938 R.H.	7.00	BASE, rest (paint as required)
68	Impala, Caprice (2-Dr.)	7755939 L.H.	7.00	BASE, rest (paint as required)
68	Bel Air, Impala, Caprice (4-Dr.),			
68	Sta. Wag. (exc. Biscayne),			
68	Biscayne,			
69	Impala, Caprice (Sed.),			
69	Kingswood, Estate Wag.	7755978 R.H.	4.90	BASE (paint as reqd.) (Note 2)
68	Biscayne,			
68	El Camino (exc. Custom),			
68-69	Impala, Caprice (Sed.),			
68-69	Kingswood, Estate Wag.	7755979 L.H.	4.90	BASE (paint as reqd.) (Note 2)
69	Impala, Caprice (Sed.),			
69-70	Pass. (4-Dr.)	8769926 R.H.	5.20	BASE (black) (paint as reqd.)
69-70	Pass. (4-Dr.)	8769927 L.H.	5.20	BASE (black) (paint as reqd.)
69	Impala, Caprice (Sed.),			
69	Spt. Sed.	8769926 R.H.	5.20	BASE (paint as reqd.)
69	Sed.,			
69	Brookwood, Townsman	8769927 L.H.	5.20	BASE (paint as reqd.)
70	Pass. (4-Dr.)	8769807 L.H.	5.60	BASE (comb. 836, 837, 839, 840, 841, 843) (med. gold) (Note 1)

**CHEVY, CHEVELLE, CAMARO**

68	Chevy, Nomad	7770262 R.H.	4.90	BASE (std. trim) (Note 3)
68	Chevy, Chevelle (Sta. Wag.)	7770263 L.H.	4.90	BASE (std. trim) (Note 3)
68	Malibu (Spt. Cpe.)	7755938 R.H.	7.00	BASE (comb. 765/980) (black)
68	Malibu (Spt. Cpe.)	7755939 L.H.	7.00	BASE (comb. 765/980) (black)
68	Chevy,			
68	Chevelle (Std., Deluxe) (exc. Sta. Wag.)	7755979 L.H.	4.90	BASE (paint as required)
68	Chevelle (Std., Deluxe) (exc. Sta. Wag.),			
68	Camaro w/std. trim,			
68	Malibu, S.S. (Spt. Cpe., Conv.),			
68	El Camino (exc. Custom)	7755978 R.H.	4.90	BASE (paint as required)
69-74	Chevy, Nova,			
69-73	Chevelle (Sta. Wag.)	8769956 R.H.	5.20	BASE (black) (paint as req.)
69-74	Chevy, Nova,			
69-73	Chevelle (Sta. Wag.)	8769957 L.H.	5.20	BASE (black) (paint as req.) (repl. 8792471)
69-70	Pass. (4-Dr.),			
69	Camaro,			
69-70	Malibu (exc. Conv.),			
69-72	Chevelle (exc. Sta. Wag.)	8769926 R.H.	5.20	BASE (black) (paint as req.)
69	El Camino (exc. Custom),			
69	Camaro,			
69-70	Pass. (4-Dr.),			
69-72	Chevelle (exc. Sta. Wag.)	8769927 L.H.	5.20	BASE (black) (paint as reqd.) (repl. 8769939)

FOLDING TOP PARTS—INTERIOR TRIM

14.686 REST ASSY.— COVER ASSY.— BASE— NUT— PAD ASSY.— RETAINER— SCREW, Front Door Arm Rest (Con't)

69	Chevelle (Deluxe),				
70-71	Camaro	9816816	R.H.	6.25	BASE (black) (paint as req.)
70-71	Camaro	9816817	L.H.	6.25	BASE (black) (paint as reqd.) (repl. 9816819)
70	Chevelle (Spt. Cpe., Sed.)	8796807	L.H.	5.60	BASE (comb. 776, 777, 774) (med. gold)
70	Camaro	9816823	L.H.	5.60	BASE (comb. 720, 723, 724) (green)
68-69	Impala, Caprice,				
69	Kingswood (Estate),				
70-72	Monte Carlo	7765829	A.R.	.16	NUT, rest finish plate
68-69	Biscayne, Bel Air,				
62-64	Chevy	4833166	4	.12	NUT, rest to inner panel— (14.762)
68-69	Malibu, S.S. (Spt. Mds.)	7765829	A.R.	.16	NUT, door a/rest fin plate
70-71	Camaro	9814916	2	7.95	PAD ASSY. (comb. 711, 712, 713, 725) (black)
71	Camaro	9725054	2	8.15	PAD ASSY. (comb. 777) (lt. sandalwood)
71	Camaro	9725055	2	8.15	PAD ASSY. (comb. 776, 786) (dk. blue)
71	Camaro	9848229	2	9.25	PAD ASSY. (comb. 779, 792) (dk. saddle)
71	Vega (exc. Panel)	9814916	2	7.95	PAD ASSY. (comb. 873, 874) (black)
71	Vega (Notchback, Hatchback Cpe.)	9725054	2	8.15	PAD ASSY. (comb. 888) (lt. sandalwood)
71	Vega (Notchback, Hatchback Cpe.)	9725055	2	8.15	PAD ASSY. (comb. 892) (dk. blue)
71	Vega	9725057	2	8.15	PAD ASSY. (comb. 878, 879) (dk. green)
72	Vega	9600311	2	7.00	PAD ASSY. (comb. 863) (dk. green)
72-75	Vega	9879378	2	8.10	PAD ASSY. (comb. 860, 861, 862, 869, 871, 873) (19V, 19D, 19W) (black)
72	Vega (exc. Panel)	9600313	2	7.20	PAD ASSY. (comb. 866, 867) (tan)
72	Pass.	9879407	1	5.85	PAD ASSY. (comb. 801, 802, 803, 804, 805, 806, 807, 808, 838) (black)
72	Pass.	9892015	2	5.85	PAD ASSY. (comb. 828, 829, 830, 831, 833) (green)
72	Pass.	9892016	2	5.85	PAD ASSY. (comb. 819) (covert)
72	Pass.	9879410	1	5.85	PAD ASSY. (comb. 824, 825, 826) (saddle)
72	Pass. (exc. Conv.)	9614002	2	5.85	PAD ASSY. (blue)
72	Impala, Caprice (Spt. Cpe., Sed.)	9892013	2	6.55	PAD ASSY. (comb. 835, 836) (pewter)
72-75	Camaro	9600968	2	4.60	PAD, lower trim finish panel arm rest (comb. 773, 774, 775, 776, 777, 779, 785, 786, 19C, 19V) (black)
72	Camaro	9600973	2	4.60	PAD, lower trim finish panel arm rest (comb. 779, 788) (black)
72	Camaro	9600972	2	4.60	PAD, lower trim finish panel arm rest (comb. 777, 787) (green)
72	Camaro	9614010	2	4.60	PAD, lower trim finish panel arm rest (comb. 776, 786) (blue)
72	Camaro	9600971	2	4.60	PAD, lower trim finish panel rest (comb. 780) (white)
72	Camaro	9600974	2	4.60	PAD, lower trim finish panel arm rest (comb. 778) (tan)
73	Camaro	9651382	2	4.45	PAD, lower trim finish panel (comb. 777, 781) (green)
73	Camaro	9651387	2	4.45	PAD, lower trim finish panel (comb. 780) (chamois)
73	Camaro (exc. L.T.),				
75	Camaro (exc. L.T.)	9651392	2	4.45	PAD, lower trim finish panel (comb. 778, 63V) (saddle)
73-74	Bel Air (exc. Sta. Wag.) Impala,				
73-74	Caprice (4-Dr.),				
74	Pass. (Conv.),				
75	Pass. (4-Dr.) Impala (2-Dr.)	9879407	1	5.85	PAD ASSY. (comb. 801, 802, 803, 804, 805, 806, 807, 808, 838, 840, 19C, 19W, 19D, 19B, 19H) (black)
74	Impala (Spt. Cpe.)	9687381	2	3.50	PAD ASSY. (comb. 849, 858) (saddle)
73-75	Caprice (Spt. Cpe.)	9654577	2	3.35	PAD ASSY. (comb. 836, 857, 73B) (oxblood)
73-74	Caprice (Spt. Cpe.),				
74	Impala (Spt. Cpe.)	9654147	2	3.55	PAD ASSY. (comb. 813, 843, 847) (midn. blue)
73	Caprice (Spt. Cpe.)	9654148	2	3.55	PAD ASSY. (comb. 842) (green)
73-74	Caprice (Spt. Cpe.),				
74	Impala (Spt. Cpe.)	9654150	2	3.55	PAD ASSY. (comb. 819, 821, 841) (neutral)
73-75	Caprice (Spt. Cpe.),				
74	Impala (Spt. Cpe.)	9879418	2	8.25	PAD ASSY. (comb. 802, 805, 806, 808, 840, 19B, 19H) (black)

**FOLDING TOP PARTS—INTERIOR TRIM**

<b>14.686 REST ASSY.— COVER ASSY.— BASE— NUT— PAD ASSY.— RETAINER—</b>				<b>SCREW, Front Door Arm Rest (Con't)</b>	
73	Pass. (Conv.)	9892014	2	5.85	PAD ASSY. (comb. 816) (white)
73-75	Caprice (Sed.)	9651438	2	5.65	PAD ASSY. (comb. 836, 857, 73B) (oxblood)
73	Bel Air (Sed.)	9651408	2	5.65	PAD ASSY. (comb. 810) (blue)
73	Pass. (Sta. Wag.),				
75	Pass. (4-Dr.)	9651432	2	5.65	PAD ASSY. (comb. 825, 826, 63E, 63W-V-C-G-D-Z-B-H) (saddle)
75	BL47-57, BN67	9651432	2	5.65	PAD ASSY. (saddle) (63E-63W)
73	Bel Air (Sta. Wag.),				
74	Bel Air,				
73-74	Pass. (exc. Caprice Spt. Cpe.)	9651426	2	5.65	PAD ASSY. (comb. 815, 817, 818, 819, 821, 841) (neutral)
73	Bel Air (Sed.),				
73	Impala, Caprice (exc. Spt. Cpe.)	9651420	2	5.65	PAD ASSY. (comb. 827, 828, 829, 830, 842) (green)
73-74	Caprice (4-Dr.) Impala	9651414	2	5.65	PAD ASSY. (comb. 802, 805, 806, 808, 812, 813, 840, 843, 847) (midn. blue)
73-74	Laguna (Cpe.) Monte Carlo,				
74	Malibu (Classic),				
75	Chevelle (2-Dr.)	9650830	2	8.45	PAD ASSY., lower trim finish panel (comb. 709, 714, 719, 720, 740, 743, 744, 73D, 73B, 73N, 73E, 73Z) (oxblood)
73	Chevelle (Coupe),				
73	El Camino (Custom)	9650826	2	8.00	PAD ASSY., lower trim finish panel (comb. 710, 711, 713, 715, 726, 727, 728, 730) (green)
73	Monte Carlo,				
74	Chevelle (2-Dr.)	9650825	2	8.45	PAD ASSY., lower trim finish panel (comb. 725, 732, 734, 736, 737, 749, 770, 785, 897) (midn. blue)
73-75	Chevelle (2-Dr.)	9650822	2	8.45	PAD ASSY., lower trim finish panel (comb. 701, 702, 703, 704, 705, 706, 707, 708, 709, 712, 738, 747, 748, 891, 894, 19C, 19V, 19D, 19W) (black)
73	Malibu (Coupe)	9650827	2	8.80	PAD ASSY., lower trim finish panel (comb. 716, 721) (chamois)
73	Malibu, Laguna (Cpe.) El Camino (Custom),				
75	El Camino	9650829	2	8.45	PAD ASSY., lower trim finish panel (comb. 717, 720, 63W) (saddle)
73-74	Chevelle (2-Dr.)	9650828	2	8.00	PAD ASSY., lower trim finish panel (comb. 711, 713, 714, 715, 716, 722, 731, 732, 733, 734, 735, 892) (neutral)
73	Malibu, Laguna (Cpe.) El Camino (Custom)	9650824	2	8.00	PAD ASSY., lower trim finish panel (comb. 705, 719, 723, 724) (blue)
73	Malibu, Laguna (4-Dr.)	9650645	2	6.40	PAD ASSY., lower trim finish panel (comb. 705, 719, 723, 724) (blue)
73	Malibu, Laguna (4-Dr.),				
74	Malibu (4-Dr.) (exc. Classic),				
74	Malibu (Classic) (Estate)	9650649	2	6.40	PAD ASSY., lower trim finish panel (comb. 713, 714, 722, 732, 734, 892) (neutral)
73	Deluxe (Sed.) Malibu, Laguna (4-Dr.)	9650647	2	6.65	PAD ASSY., lower trim finish panel (comb. 710, 711, 713, 726, 727, 730) (green)
73	Chevelle (4-Dr.),				
74	Malibu (4-Dr.) (exc. Estate),				
75	Chevelle (4-Dr.)	9650643	2	6.40	PAD ASSY., lower trim finish panel (comb. 701, 702, 703, 704, 706, 707, 712, 738, 747, 891, 19C, 19D, 19V, 19W) (black)
73	Deluxe, Malibu (Sta. Wag.),				
75	Chevelle (4-Dr.)	9650650	2	6.40	PAD ASSY., lower trim finish panel (comb. 720, 722, 63W, 632, 63E) (saddle)
73	Laguna (4-Dr.),				
74	Malibu (Classic) (Sedan),				
75	Chevelle (4-Dr.)	9650651	2	6.40	PAD ASSY., lower trim finish panel (comb. 709, 714, 743, 73D, 73B, 73E) (oxblood)
73-74	Vega (exc. Panel)	9653765	2	6.55	PAD ASSY. (comb. 868, 870, 874) (neutral)
73	Vega (Sta. Wag.)				
75	Vega (exc. Panel)	9653767	2	6.55	PAD ASSY. (comb. 866, 867) (saddle)
73	Vega (Hatchback Cpe.)	9653763	2	6.55	PAD ASSY. (comb. 63W) (saddle)
74	Caprice (exc. Spt. Cpe.),				
75	Chevelle (4-Dr.)	9687426	2	6.15	PAD ASSY. (comb. 850, 851, 852, 853, 855, 44B, 44W, 44D) (green)

**FOLDING TOP PARTS—INTERIOR TRIM**

**14.686 REST ASSY.— COVER ASSY.— BASE— NUT— PAD ASSY.— RETAINER—  
SCREW, Front Door Arm Rest (Con't)**

74	Impala (exc. Sta. Wag.)						
74	Impala, Caprice (Sta. Wag.)	9687425	2	6.15	PAD ASSY. (comb. 849, 858) (saddle)		
74	Impala (Spt. Cpe.) Pass. (Conv.)						
	(exc. Custom)	1670284	2	5.10	PAD ASSY. (comb. 804, 809, 810) (white)		
74	Caprice (Sedan)	9687427	2	5.65	PAD ASSY. (comb. 896) (taupe)		
74	Caprice (Spt. Cpe.)	9687383	2	3.50	PAD ASSY. (comb. 896) (taupe)		
74	Pass. (Spt. Cpe.) (exc. Custom),						
75	Caprice (Spt. Cpe.)	9687382	2	3.50	PAD ASSY. (comb. 850, 853, 855, 44B)		
					(green)		
74	Malibu (Sedan),						
74	Malibu (Classic) (Sta. Wag.),						
75	Chevelle (4-Dr.)	9679391	2	3.90	PAD ASSY., lower trim finish panel arm		
					rest (comb. 723, 724, 727, 728, 745, 830,		
					893, 44D, 44V) (green)		
74-75	Chevelle (2-Dr.)	9679379	2	4.40	PAD ASSY., lower trim finish panel arm		
					rest (comb. 723, 724, 725, 726, 727, 728,		
					730, 745, 830, 893, 44D, 44V, 44N)		
					(green)		
74	Malibu (Classic) (Sedan, Sta.						
	Wag.)	9679390	2	5.15	PAD ASSY., lower trim finish panel arm		
					rest (comb. 740) (saddle)		
74	Malibu (Classic) Laguna, El						
	Camino (Classic) Monte Carlo						
	(2-Dr.)	9679378	2	4.40	PAD ASSY., lower trim finish panel arm		
					rest (comb. 740, 742) (saddle)		
74	Malibu (Classic) (4-Dr.)	9650646	2	6.40	PAD ASSY., lower trim finish panel (comb.		
					732, 735) (midn. blue)		
74	Camaro (exc. L.T.)	9679701	2	4.45	PAD ASSY., lower trim finish panel arm		
					rest (comb. 796, 798) (saddle)		
74	Camaro (exc. L.T.)	9679700	2	4.45	PAD, lower trim finish panel arm rest		
					(comb. 786, 787) (green)		
74	Camaro (exc. L.T.)	9679702	2	4.45	PAD, lower trim finish panel arm rest		
					(comb. 792) (red)		
74	Vega	9679016	2	6.55	PAD ASSY. (comb. 879, 880, 881, 883,		
					887) (green)		
74	Vega (exc. Panel)	9679017	2	6.55	PAD ASSY. (comb. 888, 890) (saddle)		
74	Vega (Hatchback Cpe., Sta.						
	Wag.)	9679018	2	6.55	PAD ASSY. (comb. 884) (red)		
73-74	Camaro	9679325	2	4.45	PAD, lower trim finish panel arm rest		
					(comb. 779, 781, 788) (neutral)		
75	Pass.	1670965	2	5.85	PAD ASSY. (comb. 26V, 26C, 26W, 26D,		
					26B) (blue)		
75	Pass.	1670966	2	6.20	PAD ASSY. (comb. 55V, 55C, 55W, 55D,		
					55B) (sandstone)		
75	Caprice (Spt. Cpe.)	1685184	1	8.75	PAD ASSY. (comb. 26B) (blue)		
75	Caprice (Spt. Cpe.)	1685185	1	8.75	PAD ASSY. (comb. 55B, 55H) (sandstone)		
75	Pass. (2-Dr.)	1670964	2	5.85	PAD ASSY. (comb. 02W, 07W) (white)		
75	Chevelle (4-Dr.)	1672453	2	8.70	PAD ASSY., lower trim finish panel (comb.		
					55V, 55W) (sandstone)		
75	Chevelle (4-Dr.)	1672452	2	8.70	PAD ASSY., lower trim finish panel (comb.		
					26C, 26V, 26D, 26W) (blue)		
75	Chevelle (4-Dr.)	1672451	2	8.70	PAD ASSY., lower trim finish panel (comb.		
					16D) (graystone)		
75	Chevelle (2-Dr.)	1672549	2	8.20	PAD ASSY., lower trim finish panel (comb.		
					16D) (graystone)		
75	Chevelle (2-Dr.)	1672548	2	8.20	PAD ASSY., lower trim finish panel (comb.		
					55V, 55W, 55B, 55H, 55N) (sandstone)		
75	Chevelle (2-Dr.)	1672533	2	8.20	PAD ASSY., lower trim finish panel (comb.		
					26C, 26V, 26D, 26W, 26B, 26H, 26N)		
					(blue)		
75	Chevelle (2-Dr.)	1673309	2	6.35	PAD ASSY., lower trim finish panel (comb.		
					11Z, 11E, 11H, 07Z, 02H, 04H, 07H)		
					(black, 07E, white)		
75	Camaro (exc. L.T.)	1672100	2	4.25	PAD, lower trim finish panel (comb. 55C,		
					55V) (sandstone)		
75	Vega (exc. Panel)	1681101	2	5.90	PAD ASSY. (comb. 55D, 55W) (sandstone)		
75	Vega (exc. Panel)	1681000	2	5.90	PAD ASSY. (comb. 26W) (blue)		
75	Nova	1705325	2	3.55	RETAINER		
62-63	Chevy	161742	A.R.	.11	SCREW, rest to inner panel— (8.977)		
68-69	Nova,						
68-69	Camaro, Pass. (exc. Impala,						
	Caprice, Kingswood),						
68	Chevelle (exc. Spt. Mdls.),						
69	Chevelle,						

**FOLDING TOP PARTS—INTERIOR TRIM**

<b>14.686 REST ASSY.— COVER ASSY.— BASE— NUT— PAD ASSY.— RETAINER— SCREW, Front Door Arm Rest (Con't)</b>					
70	All (exc. Nova) . . . . .	9824833 A.R.	.16	SCREW, front door a/rest to inner panel— (8.977) . . . . .	
68-69	Impala, Caprice, Kingswood,				
68-69	Chevelle (Spt. Mdis.),				
70	Caprice, Monte Carlo . . . . .	7768480	6	.18	SCREW, front door arm rest to inner panel .
70	Nova,				
69-70	Chevelle (Sta. Wag.),				
73-74	Nova (Sed.) . . . . .	9824832 A.R.	.22	SCREW, inner panel . . . . .	
70-71	Camaro . . . . .	9826575	22	.11	SCREW, front door arm rest, base to fender
70-72	Caprice (Spt. Cpe., Sed.) Monte Carlo . . . . .	9824835 A.R.	.16	SCREW, front door arm rest to inner panel .	
	<i>NOTE 4 Production deviation trim change.</i>				
	<i>NOTE 3 Paint as required.</i>				
	<i>NOTE 2 1969 Arm rest bases should not be painted due to the poor adhesive characteristic of the material from which they are made.</i>				
<b>14.688 MOULDING— CUP— PLATE, Door Arm Rest and Trim Pad</b>					
68	Pass. (S.S., Conv.) . . . . .				MOULDING, frt. door arm rest (comb. 765/158) (Note 1), . . . . .
68	Impala, Caprice (2-Dr.) . . . . .	7745386	2	.91	door arm rest . . . . .
68	Camaro, Nova, Malibu, Concours,				
68	Bel Air,				
68	Impala, Caprice (Sed.) . . . . .	7745078	2	.52	MOULDING, door arm rest, front and rear door . . . . .
71-75	Vega . . . . .	9725048	2	.34	CUP (prime and paint as reqd.) . . . . .
75	Camaro (L.T.) . . . . .	1718804 R.H.		.74	CUP, pull frt. dr. (prime and paint as reqd.) .
75	Camaro (L.T.) . . . . .	1718805 L.H.		.74	CUP, pull frt. dr. (prime and paint as reqd.) .
68	Impala, Caprice (2-Dr.),				
68	Malibu (Spt. Cpe.),				
68	Chevelle (Conv.),				
68	Chevelle S.S. (Spt. Cpe.) . . . . .	7745382 R.H.	9.05	PLATE, arm rest finish (comb. 765/158-178/168/980/766/970) (Note 1) . . . . .	
68	Impala, Caprice (2-Dr.),				
68	Malibu (Spt. Cpe.),				
68	Chevelle (Conv.),				
68	Chevelle S.S. (Spt. Cpe.) . . . . .	7745383 L.H.	9.25	PLATE, arm rest finish (comb. 765/158/178/168/980/766/970) (Note 1) . . . . .	
68	Chevelle,				
68	Impala, Caprice (4-Dr.) . . . . .	7743692 R.H.	5.65	PLATE, pass. door arm rest finish . . . . .	
68	Chevelle,				
68	Impala, Caprice (4-Dr.) . . . . .	7743693 L.H.	5.65	PLATE, driver door arm rest finish . . . . .	
69-72	Impala, Caprice (4-Dr.), Kingswood . . . . .	8717568 R.H.	2.90	PLATE, frt./rr. dr. a/rest fin. . . . .	
69-72	Impala, Caprice (4-Dr.), Kingswood . . . . .	8717569 L.H.	2.95	PLATE, frt./rr. dr. a/rest fin. . . . .	
69	Pass. (Spt. Cpe., Conv.) . . . . .	8717572 R.H.	3.95	PLATE, frt. door a/rest fin. . . . .	
69	Pass. (Spt. Cpe., Conv.) . . . . .	8717573 L.H.	4.15	PLATE, frt. door a/rest fin. . . . .	
68	Camaro . . . . .	7768150 R.H.	1.85	PLATE, remote control cover (black) . . . . .	
69	Malibu (Spt. Sed.), Monte Carlo w/deluxe, frt. and rr. a/rest,				
70-72	Monte Carlo . . . . .	8717568 R.H.	2.90	PLATE, frt./rr. dr. a/rest fin. . . . .	
69	Malibu (Spt. Sed.), Monte Carlo w/deluxe, frt. and rr. a/rest,				
70-72	Monte Carlo . . . . .	8717569 L.H.	2.95	PLATE, frt./rr. dr. a/rest fin. . . . .	
<b>14.690 PLATE, Door Arm Rest Trim</b>					
70-71	Camaro . . . . .	9808902	2	1.15	front door arm rest hinge . . . . .
71-75	Vega . . . . .	9818630	2	.88	front door hanger . . . . .
74-75	Vega w/Custom Trim (exc. Panel) . . . . .	9680002 R.H.	.81	front door hanger . . . . .	
74-75	Vega w/Custom Trim (exc. Panel) . . . . .	9680003 L.H.	.81	front door hanger . . . . .	
75	Monza (exc. Towne Cpe.) . . . . .	1659597 R.H.	4.10	front door hanger . . . . .	
75	Monza (exc. Towne Cpe.) . . . . .	1659598 L.H.	4.10	front door hanger . . . . .	
75	Monza (Towne Cpe.) . . . . .	1706410 R.H.	4.25	front door hanger . . . . .	
75	Monza (Towne Cpe.) . . . . .	1706411 L.H.	4.25	front door hanger . . . . .	
<b>14.691 MOULDING— COVER— EMBLEM— ESCUTCHEON— FASTENER— HANDLE ASSY.— NUT— PANEL ASSY.— PLATE— RETAINER— STRAP ASSY., Front Door Trim Finish</b>					
62-65	Chevy Deluxe, Nova (2-Dr.),				
66-67	Nova (Spt. Cpe.) . . . . .	4843126	2	4.85	frt. finish upper . . . . .

**FOLDING TOP PARTS—INTERIOR TRIM**

**14.691 MOULDING— COVER— EMBLEM— ESCUTCHEON— FASTENER— HANDLE ASSY.— NUT— PANEL ASSY.— PLATE— RETAINER— STRAP ASSY., Front Door Trim Finish (Con't)**

67	Camaro (Std.)	7639888	2	2.90	frt. pad upr.
68-69	Camaro	7743242	2	2.90	frt. pad, lower (custom trim)
68-69	Camaro	7737762	2	2.90	frt. pad, upper
68-69	Camaro	7742919	L.H.	2.90	frt. pad, upper (custom trim)
68	Nomad (Custom)	7721720	1	1.60	frt. trim pad
71-72	Caprice (Spt. Cpe.)	9826996	R.H.	23.75	trim pad front door upper
71-72	Caprice (Spt. Cpe.)	9826997	L.H.	23.75	trim pad front door upper
71-72	Caprice (Spt. Sed.)	9826980	R.H.	19.95	trim pad front door upper
71-72	Caprice (Spt. Sed.)	9826981	L.H.	19.95	trim pad front door upper
71-72	Monte Carlo	9845751	2	3.30	trim pad front door
68	Impala (Spt. Cpe., Conv.)	7722608	2	3.60	MOULDING ASSY., frt. door trim pad
70-71	Camaro (Custom trim)	9808557	2	2.75	MOULDING ASSY., trim pad front door lower
74-75	Malibu (Classic) (4-Dr.),				
75	Impala (4-Dr.)	9876630	2	2.10	MOULDING ASSY., trim pad upper
74-75	Malibu (Classic) (2-Dr.)	9875068	2	2.10	MOULDING ASSY., trim pad lower
74-75	Malibu (Classic) (Coupe),				
74	El Camino (Classic)	9874868	2	2.50	MOULDING ASSY., trim pad upper
74-75	Malibu (Classic) (Coupe),				
74	El Camino (Classic)	9875131	2	1.95	MOULDING ASSY., trim pad lower
73-74	Nova (Custom) (Cpe.),				
75	Nova (Custom) (Sedan)	9621970	2	1.75	MOULDING ASSY., trim pad upper-front (incl. escutcheon)
73-74	Nova (Custom) (Cpe.)	9621971	2	5.55	MOULDING ASSY., trim pad upper-rear (incl. escutcheon)
73-74	Nova (Custom) (Coupe)	9693901	2	1.75	MOULDING, upper pull strap
74	Nova (H.B.) (Custom)	1664074	2	1.80	MOULDING ASSY., trim pad upper frt.
74	Nova (H.B.) (Custom)	1663475	2	5.55	MOULDING ASSY., trim pad upper rear
74-75	Camaro (L.T.)	9668578	R.H.	11.70	MOULDING ASSY., trim pad
74-75	Camaro (L.T.)	9668579	L.H.	11.70	MOULDING ASSY., trim pad
74-75	Monte Carlo (2nd design)	1653249	4	.39	COVER, upper pull strap (plastic)
73-75	Caprice (Spt. Cpe., Sed.)	9643859	4	.14	COVER, upper pull strap (paint as reqd.)
71	Caprice	9828497	2	4.65	EMBLEM, front door upper trim pad
72	Caprice (exc. Sta. Wag.)	9872392	2	2.95	EMBLEM, front door upper trim pad— (14.764)
71-72	Impala	9840801	R.H.	.85	EMBLEM, front and rear door trim pad
71-72	Impala	9840802	L.H.	.85	EMBLEM, front and rear door trim pad
71-72	Kingswood (2nd design)	9876739	2	.39	EMBLEM, front door trim pad ( <sup>59</sup> / <sub>64</sub> " x <sup>5</sup> / <sub>8</sub> " )
72-73	Nova	9889491	1	3.05	EMBLEM, frt. dr. trim pad
74-75	Camaro w/power window (exc. L.T.)	9732120	2	3.05	EMBLEM ASSY., trim pad
74-75	Camaro (L.T.) w/power window	9732401	2	3.25	EMBLEM ASSY., trim pad
68-69	Camaro	7779662	2	2.10	ESCUTCHEON, right or left frt. door pull handle frt.
68-69	Camaro	7779663	2	2.10	ESCUTCHEON, right or left frt. door pull handle rear
70-74	Monte Carlo (1st design)	7799435	4	2.05	ESCUTCHEON, pull strap (die cast)
75	Monte Carlo (2nd design)	1676437	2	1.85	ESCUTCHEON, pull strap upper (plastic)
73-74	Vega w/Custom Trim	9687745	R.H.	2.20	ESCUTCHEON, handle remote trim pad
73-74	Vega w/Custom Trim	9687746	L.H.	2.20	ESCUTCHEON, handle remote trim pad
62	Chevy	4851737	A.R.	.14	FASTENER, trim pad
68-69	Camaro	7770614	2	4.65	HANDLE ASSY., door pull (black) (paint to match) (repl. 8744896, 8779682)
68	Camaro	7770615	2	7.05	HANDLE ASSY., dr. pull (white) (paint to match)
68	Camaro	7774101	2	5.05	HANDLE ASSY., door pull (parchment)
69	Camaro	8744900	2	5.20	HANDLE ASSY., dr. pull (midnight green)
65-66	Caprice	9419761	A.R.	.11	NUT, trim pad emblem
64-69	Nova,				
65	Pass. (S.S.),				
66-68	Malibu, Chevelle (S.S.),				
67-69	Camaro,				
68	Pass. (Spt. Cpe., Conv.),				
68	Concours,				
70-74	Chevelle,				
70-74	Nova,				
71-72	Impala, Caprice, Kingswood,				
75	Malibu, Monte Carlo (exc. Classic)	4450956	A.R.	.14	NUT, frt. dr. trim pad emblem, name plate, rear door, pad emblem
71-73	Vega w/Custom Trim	445164	A.R.	.15	NUT, front door insert trim ( <sup>9</sup> / <sub>16</sub> " x <sup>3</sup> / <sub>8</sub> " )



**FOLDING TOP PARTS—INTERIOR TRIM**

**14.691 MOULDING— COVER— EMBLEM— ESCUTCHEON— FASTENER—  
HANDLE ASSY.— NUT— PANEL ASSY.— PLATE— RETAINER— STRAP  
ASSY., Front Door Trim Finish (Con't)**

70-71	Camaro	8800045	L.H.	20.55	PANEL ASSY., left front door trim finish (comb. 712, 713, 714, 716, 720, 724, 725, 727, 730) (black)
71-72	Vega w/Custom Trim	9818632	L.H.	11.25	PANEL ASSY.
71-72	Vega w/Custom Trim	9818631	R.H.	11.25	PANEL ASSY.
73-74	Impala (4-Dr.) Caprice (Estate)	9615990	R.H.	15.25	PANEL ASSY., upper (prime and paint as reqd.)
73-74	Impala (4-Dr.) Caprice (Estate)	9615991	L.H.	15.25	PANEL ASSY., upper (prime and paint as reqd.)
73-74	Impala (Cpe.) Pass. (Conv.)	9615998	R.H.	5.20	PANEL ASSY., upper (prime and paint as reqd.)
73-74	Impala (Cpe.) Pass. (Conv.)	9615999	L.H.	5.20	PANEL ASSY., upper (prime and paint as reqd.)
73-74	Vega w/Custom Trim (exc. Panel)	9647394	R.H.	27.25	PANEL ASSY.
73-74	Vega w/Custom Trim (exc. Panel)	9647395	L.H.	27.25	PANEL ASSY.
74	Impala (Spt. Cpe.) (exc. Custom)	9615999	L.H.	5.20	PANEL ASSY., upper (prime and paint as reqd.)
74	Nova (Custom) (Sedan)	1663594	2	5.30	PANEL ASSY.
75	Nova (Custom) (Sedan)	1657101	2	9.75	PANEL ASSY.
75	Nova (Custom) (Coupe)	1657102	2	9.75	PANEL ASSY.
68	Malibu (S.S.)	7728773	2	2.10	PLATE, frt. door trim pad name (S.S. 396)
68-69	Camaro	7754200	2	2.10	PLATE, frt. door trim name (Camaro)
69	Chevelle (Spt. Sed.)	8717568	R.H.	2.90	PLATE, frt. rr. door a/rest fin.
69	Chevelle (Spt. Sed.)	8717569	L.H.	2.95	PLATE, frt. rr. door a/rest fin.
69-71	Chevy w/custom trim	7790752	2	2.25	PLATE, frt. dr. trim pad name (Nova)
69-72	Malibu, El Camino (exc. Deluxe), Malibu,				
74	Malibu (exc. Classic)	7793368	2	1.70	PLATE, frt. dr. trim pad name (Malibu)
70-72	Monte Carlo,				
73-75	Bel Air (Taxi)	8743792	4	.73	PLATE, front door pull handle hanger
70-72	Malibu (Spt. Cpe., Conv.),				
73	Malibu (Cpe., Sta. Wag.) (exc. Estate), El Camino (Custom)	9817279	2	2.25	PLATE, front door trim pad name (S.S.)
70-72	Camaro	8762078	2	1.35	PLATE, front door trim support hinge rr.
70-72	Camaro	9826685	2	1.40	PLATE, front dr. tr. supt. hanger at front
72-75	Camaro	9892957	2	1.40	PLATE, frt. dr. lower trim panel
71-75	Pass.	9830886	R.H.	3.55	PLATE, lower hanger support
71-75	Pass.	9830887	L.H.	3.55	PLATE, lower hanger support
71-75	Pass. (Spt. Cpe., Conv.)	9728052	2	1.05	PLATE, trim panel hanger front
73-75	Camaro	9826685	2	1.40	PLATE, support hanger front
73-74	Chevelle (2-Dr.)	9858526	2	3.25	PLATE, hanger lower panel
75	Chevelle (2-Dr.)	9688500	2	2.85	PLATE, lower trim panel
73	Laguna	9640853	2	1.20	PLATE, pad (Laguna)
73-75	Chevelle (4-Dr.)	9858528	2	2.95	PLATE, lower panel
73-75	Monte Carlo	9877526	1	.72	PLATE, upper (Monte Carlo)
73-75	Monte Carlo	9657485	1	.93	PLATE, upper pad (Landau)
73-75	El Camino (Custom)	9640658	2	.77	PLATE, upper pad (El Camino)
73	Nova (Taxi)	7790752	2	2.25	PLATE, pad name (Nova)
73-75	Pass. (Spt. Cpe., Conv.)	9728052	2	1.05	PLATE, hanger front
74	Nova (2-Dr.) (Custom)	9673122	2	1.65	PLATE, upper trim (Custom)
75	Caprice (Spt. Cpe., Sed.)	1655193	2	2.95	PLATE, upper Caprice Emer.
75	Laguna	1660795	2	2.40	PLATE, upper pad (S-3)
75	Malibu (exc. Classic, El Camino)	1682073	2	1.55	PLATE, pad name (Malibu)
75	Nova w/power windows	1680572	2	.94	PLATE, frt. door electric regular hanger
65-70	Pass.	6280765	A.R.	.12	RETAINER, dr. binding strip to inner panel— (14.685)
72-75	Camaro	9615760	4	1.65	RETAINER, frt. door belt trim supt. rear and center
70-71	Monte Carlo	8797351	2	8.15	STRAP ASSY., front door pull (comb. 748) (black)
70	Monte Carlo	8797353	2	8.15	STRAP ASSY., front door pull (comb. 780) (dk. green)
70	Monte Carlo (Spt. Cpe.)	9806600	2	7.85	STRAP ASSY., front door pull (comb. 774) (med. gold)
71-72	Monte Carlo	9870328	2	8.05	STRAP ASSY., door pull (comb. 707, 708, 710) (black)
71	Monte Carlo	9870330	2	8.05	STRAP ASSY., door pull (comb. 727, 728) (dk. blue)

**FOLDING TOP PARTS—INTERIOR TRIM**

**14.691 MOULDING— COVER— EMBLEM— ESCUTCHEON— FASTENER—  
HANDLE ASSY.— NUT— PANEL ASSY.— PLATE— RETAINER— STRAP  
ASSY., Front Door Trim Finish (Con't)**

71	Monte Carlo	9870331	2	8.05	STRAP ASSY., door pull (comb. 716, 717) (lt. sandalwood)
71-72	Monte Carlo	9870332	2	8.05	STRAP ASSY., door pull (comb. 723) (dk. saddle)
71	Monte Carlo (2nd design)	9870334	2	8.05	STRAP ASSY., door pull (comb. 729, 733, 734) (18" long) (dk. jade)
72	Monte Carlo	9891693	2	8.35	STRAP ASSY., frt. door pull (comb. 725) (blue)
72	Monte Carlo	9891694	2	8.05	STRAP ASSY., frt. door pull (comb. 715, 717) (green)
72	Monte Carlo	9891692	2	8.05	STRAP ASSY., frt. door pull (comb. 740) (pewter)
72	Monte Carlo	9891695	2	8.05	STRAP ASSY., front door pull (comb. 731, 734) (covert)
73	Caprice (Spt. Cpe., Sed.)	9643752	2	4.60	STRAP ASSY., upper pull (comb. 842) (green)
73-74	Caprice (Spt. Cpe., Sed.)	9643753	2	6.20	STRAP ASSY., upper pull (comb. 841) (neutral)
73-74	Caprice (Spt. Cpe., Sed.)	9643754	2	4.60	STRAP ASSY., upper pull (comb. 836, 837) (oxblood)
73-74	Caprice (Spt. Cpe., Sed.)	9643750	2	6.20	STRAP ASSY., upper pull (comb. 808, 840) (black)
73-74	Caprice (Spt. Cpe., Sed.)	9643751	2	4.60	STRAP ASSY., upper pull (comb. 843) (midn. blue)
73-75	Monte Carlo	9687442	2	5.65	STRAP ASSY., upper pull (black) (repl. 1657218) (Note 2)
73-74	Monte Carlo	1657219	2	6.25	STRAP ASSY., upper pull (Note 2)
73	Monte Carlo	9687446	2	5.65	STRAP ASSY., upper pull (comb. 715, 728) (green)
73-75	Monte Carlo	1657220	2	6.25	STRAP ASSY., upper pull (comb. 740, 744, 738, 73N) 2nd design (Note 2)
73-74	Monte Carlo	1657221	2	6.25	STRAP ASSY., upper pull (comb. 731, 735, 716) 2nd design (Note 2)
73-74	Monte Carlo	9687450	2	5.70	STRAP ASSY., upper pull (comb. 744, 73B, 73N) (oxblood) (Note 1)
73-74	Nova (Cpe.)	9657781	2	.58	STRAP ASSY., upper pull (black) (paint to match)
73	Nova (Cpe.)	9657784	2	.58	STRAP ASSY., upper pull (comb. 759, 760, 761) (green)
73-74	Nova (Cpe.)	9658645	2	.58	STRAP ASSY., upper pull (comb. 763, 764, 765, 766, 771, 829) (neutral)
73	Nova (Cpe.) (exc. Custom)	9657783	2	.58	STRAP ASSY., upper pull (comb. 756) (med. blue)
73	Nova (Cpe.) (exc. Custom)	9664095	1	.58	STRAP ASSY., upper pull (comb. 767) (chamois)
74	Caprice (Spt. Cpe., Sed.)	9686952	2	4.60	STRAP ASSY., upper pull (comb. 896) (taupe)
74	Caprice (Spt. Cpe., Sed.)	9686951	2	6.20	STRAP ASSY., upper pull (comb. 850) (green)
74-75	Monte Carlo	9687442	2	5.65	STRAP ASSY., upper pull (comb. 705, 709, 19B, 19H, 19J, 19N) (black)
74	Nova (2-Dr.)	9673901	2	.60	STRAP ASSY., upper pull (comb. 771, 772, 826) (midn. blue)
74	Nova (2-Dr.)	9657782	2	.58	STRAP ASSY., upper pull (comb. 774)
74	Nova (2-Dr.)	9673909	2	.60	STRAP ASSY., upper pull (comb. 755, 756, 757, 758, 759, 828) (green)
74	Nova (H.B.) (exc. Custom)	9673908	2	.60	STRAP ASSY., upper pull (comb. 773, 827) (saddle)
74	Monte Carlo	1657225	2	6.25	STRAP ASSY., upper pull 2nd design (Note 2)
74-75	Monte Carlo	1657224	2	5.40	STRAP ASSY., upper pull 2nd design (Note 2)
75	Monte Carlo	1693494	2	8.30	STRAP ASSY., upper pull (comb. 02H, 04H, 07H, 11H) (white)
75	Monte Carlo	1685292	2	8.30	STRAP ASSY., upper pull (comb. 26B, 26H, 26N) (blue)
75	Monte Carlo	1685293	2	8.30	STRAP ASSY. (55B, 55H, 55N) (sandstone)
75	Caprice (Spt. Cpe., Sed.)	1670935	2	4.70	STRAP ASSY., upper pull (comb. 19B, 19H) (black)
75	Caprice (Spt. Cpe., Sed.)	1672076	2	15.40	STRAP ASSY., upper pull (comb. 26B) (blue)
75	Caprice (Spt. Cpe., Sed.)	1671000	2	4.70	STRAP ASSY., upper pull (comb. 44B) (green)

**FOLDING TOP PARTS—INTERIOR TRIM**

**14.691 MOULDING— COVER— EMBLEM— ESCUTCHEON— FASTENER— HANDLE ASSY.— NUT— PANEL ASSY.— PLATE— RETAINER— STRAP ASSY., Front Door Trim Finish (Con't)**

75	Caprice (Spt. Cpe., Sed.)	1672077	2	15.40	STRAP ASSY., upper pull (comb. 55B, 55H) (sandstone)
75	Caprice (Spt. Cpe., Sed.)	1670975	2	4.70	STRAP ASSY., upper pull (comb. 73B) (oxblood)
75	Nova (Sedan) (exc. Custom)	9657785	2	.58	STRAP ASSY., upper pull (comb. 63V) (saddle)

*NOTE 1: When replacing door strap assist handle it may be necessary to order plastic escutcheon and discard die cast escutcheon.*

*NOTE 2: When using 2nd design use cvr., 1653249 and escut. 1676437 paint (paint to match)*

**14.692 BOX, Front Door Trim Stowage**

71-74	Vega	9725063	1	3.35	(prime and paint as reqd.)
71	Vega (exc. Panel)	9725063	2	3.35	(dk. green)
75	Vega, Monza	9731656	1	3.10	(prime and paint as reqd.)

**14.730 FASTENER— CAP— COVER— MOULDING— WINDLACE ASSY.— LACE, Body Center Pillar (With Metal Inner Panel)**

**PASS.**

*NOTE See group 15.520 for Pinchweld and Windlace yardage.*

65-66	4-Dr. (exc. Spt. Sed.)	4870324	A.R.	.11	center pillar foundation
66-69	4-Dr. (exc. Spt. Sed.)	7647530	4	.12	ctr.plr. foundation
65-68	Spt. Sed.	4500662	R.H.	.83	CAP, (paint as req.)
65-68	Spt. Sed.	4500663	L.H.	.83	CAP (paint as req.)
69-70	Spt. Sed.	8767866	R.H.	.58	CAP, center pillar fin. (paint as required)
69-70	Spt. Sed.	8767867	L.H.	.58	CAP, center pillar fin. (paint as required)
69-70	Spt. Sed.	8740861	L.H.		COVER (black) (paint as required) (repl. 8807673)
69-70	4-Dr. (exc. Spt. Sed.)	8741677	L.H.	3.60	COVER (comb. 802, 803, 804, 805, 806, 810) (black)
71-75	Pass. (Spt. Sed.)	9845538	R.H.	7.35	COVER (paint as reqd.)
71-75	Pass. (Spt. Sed.)	9845539	L.H.	6.80	COVER (paint as reqd.)
71	Kingswood, Bel Air,				
71	Kingswood, Bel Air,				
71	Pass. (4-Dr.) (exc. Spt. Sed.)	9850430	R.H.	3.45	COVER, upper (black) (paint as reqd.)
71	Pass. (4-Dr.) (exc. Spt. Sed.)	9850431	L.H.	3.45	COVER, upper (black) (paint as reqd.)
71-75	Pass. (4-Dr.) (exc. Spt. Sed.)	9850332	R.H.	3.45	COVER, lower (black) (paint as reqd.)
71-75	Pass. (4-Dr.) (exc. Spt. Sed.)	9850333	L.H.	3.45	COVER, lower (black) (paint as reqd.)
72-75	Pass. (4-Dr.) (exc. Spt. Sed.)	9885238	R.H.	3.45	COVER ASSY.
72-75	Pass. (4-Dr.) (exc. Spt. Sed.)	9885239	L.H.	3.45	COVER ASSY.

**CHEVELLE**

68-72	(4-Dr.)	7778818	R.H.	4.40	COVER, center pillar lower (black)
68-72	(4-Dr.)	7778819	L.H.	4.40	COVER, center pillar lower (black) (Note 1)
68-72	Malibu (Spt. Sed.)	7778788	R.H.	4.35	COVER, center pillar (black)
69-72	(4-Dr. Sed.) (exc. Spt. Sed.)	7738397	R.H.	5.15	COVER, center pillar upper (black)
69-72	(4-Dr. Sed.) (exc. Spt. Sed.)	7738398	L.H.	5.15	COVER, center pillar upper (black)
71	Concours,				
73	Chevelle (Sed., Sta. Wag.)	9628872	R.H.	4.20	COVER, lower (prime and paint as reqd.)
73	Chevelle (Sed., Sta. Wag.)	9628873	L.H.	4.20	COVER, lower (prime and paint as reqd.)
73	Chevelle (Sed., Sta. Wag.)	9628854	R.H.	4.00	COVER, upper (prime and paint as reqd.)
73	Chevelle (Sed., Sta. Wag.)	9628855	L.H.	4.00	COVER, upper (prime and paint as reqd.)
74-75	Chevelle (4-Dr.)	9674340	R.H.	2.00	COVER, upper (prime and paint as reqd.)
74-75	Chevelle (4-Dr.)	9674341	L.H.	2.00	COVER, upper (prime and paint as reqd.)
74-75	Chevelle (4-Dr.)	9674326	R.H.	3.10	COVER, lower (prime and paint as reqd.)
74-75	Chevelle (4-Dr.)	9674327	L.H.	3.00	COVER, lower (prime and paint as reqd.)

*NOTE 1 Paint as Required.*

**CHEVY— NOVA**

68-75	(4-Dr.)	7778846	R.H.	3.45	COVER, center pillar lower (black)
68-75	(4-Dr.)	7778847	L.H.	3.45	COVER, center pillar lower (black)
70	Nova (Sed.)	7731832	R.H.	3.75	COVER, center pillar upper (prime and paint as reqd.) (repl. 8798258)
70-72	Nova (4-Dr.)	7731833	L.H.	5.25	COVER ASSY., center pillar upper (black)
70-72	Nova (4-Dr.)	7731832	R.H.	3.75	COVER ASSY., center pillar upper (black)
73-74	Nova (Sedan)	9731642	R.H.	7.65	COVER ASSY., upper (prime and paint as reqd.)
73-74	Nova (Sedan)	9731643	L.H.	7.65	COVER ASSY., upper (prime and paint as reqd.)
75	Nova (Sedan)	1666916	R.H.	2.00	COVER ASSY., upper (prime and paint as reqd.)

**FOLDING TOP PARTS—INTERIOR TRIM**

**14.730 FASTENER— CAP— COVER— MOULDING— WINDLACE ASSY.— LACE,  
Body Center Pillar (With Metal Inner Panel) (Con't)**

75 Nova (Sedan) ..... 1666917 L.H. 2.00 COVER ASSY., upper (prime and paint as reqd.) .....

**14.731 CAP— COVER ASSY.— MOULDING— PANEL— TRIM ASSY., Lock Pillar  
Finishing**

65-67	Chevy (Spt. Cpe.)	7594114 R.H.	1.05	(paint as reqd.)
65-67	Chevy (Spt. Cpe.)	7594115 L.H.	1.05	(paint as reqd.)
66-67	(Spt. Cpe., Conv.)	7595626 R.H.	.52	(black)
66-67	(Spt. Cpe., Conv.)	7595627 L.H.	.46	(black)
67	(Spt. Cpe., Conv.)	7648228 R.H.	.48	(gold)
67	(Spt. Cpe., Conv.)	7648229 L.H.	.71	(gold)
68	Chevelle (Sta. Wag.) (6-Pass.) (2nd design),			
68	Chevelle (Sta. Wag.) (9-Pass.),			
69-70	Chevelle (Sta. Wag.)	8719596 R.H.		COVER ASSY., above belt (paint as reqd.)
68	Chevelle (Sta. Wag.) (6-Pass.) (2nd design),			
68	Chevelle (Sta. Wag.) (9-Pass.),			
69-72	Chevelle (Sta. Wag.)	8719585 L.H.	3.40	COVER ASSY., above belt (paint as reqd.)
72	Pass. (Sta. Wag.)	9606580 R.H.	5.70	COVER ASSY., above belt (paint as reqd.)
72	Pass. (Sta. Wag.)	9606581 L.H.	5.70	COVER ASSY., above belt (paint as reqd.)
72	Pass. (Sed.) (exc. Spt. Sed.)	9623214 R.H.	6.70	COVER ASSY., above belt (paint as reqd.)
72	Pass. (Sed.) (exc. Spt. Sed.)	9623215 L.H.	6.70	COVER ASSY., above belt (paint as reqd.)
71-75	Vega (exc. Hatchback Cpe.)	9687336 R.H.	3.40	COVER ASSY. (prime and paint as reqd.)
71-75	Vega (exc. Hatchback Cpe.)	9687337 L.H.	3.40	COVER ASSY. (prime and paint as reqd.)
71-75	Vega (Hatchback Cpe.)	9687326 R.H.	3.40	COVER ASSY. (prime and paint as reqd.)
71-75	Vega (Hatchback Cpe.)	9687327 L.H.	3.40	COVER ASSY. (prime and paint as reqd.)
73-75	Chevelle (Sta. Wag.)	9627418 R.H.	1.40	COVER ASSY., above belt (prime and paint as reqd.)
73-75	Chevelle (Sta. Wag.)	9627419 L.H.	1.40	COVER ASSY., above belt (prime and paint as reqd.)
71	Pass. (Sta. Wag.)	9857127 L.H.	5.10	MOULDING, left, finish above belt (comb. 802, 804, 806, 810, 812, 814) (black)
71	Pass. (Sta. Wag.)	9857126 R.H.	5.10	MOULDING, right, finish above belt (comb. 802, 804, 806, 810, 812, 814) (black)
70-72	Chevelle (4-Dr. Sed.)	8732883 L.H.	1.55	MOULDING, left, upper
70-72	Chevelle (4-Dr. Sed.)	8732882 R.H.	1.55	MOULDING, right, upper
73-75	Pass. (Sta. Wag.)	9606580 R.H.	5.70	MOULDING (prime and paint as reqd.)
73-75	Pass. (Sta. Wag.)	9606581 L.H.	5.70	MOULDING (prime and paint as reqd.)
73-74	Pass. (Sed.) (exc. Spt. Sed.)	9623214 R.H.	6.70	MOULDING, above belt (paint as reqd.)
73-74	Pass. (Sed.) (exc. Spt. Sed.)	9623215 L.H.	6.70	MOULDING, above belt (paint as reqd.)
73	Monte Carlo	9628778 R.H.	1.95	MOULDING, body (prime and paint as reqd.)
73	Monte Carlo	9628779 L.H.	1.95	MOULDING, body (prime and paint as reqd.)
74-75	Monte Carlo	9691184 R.H.	1.80	MOULDING, body lower (prime and paint as reqd.)
74-75	Monte Carlo	9691185 L.H.	1.70	MOULDING, body lower (prime and paint as reqd.)
74-75	Monte Carlo	9691202 R.H.	2.10	MOULDING, body upper (prime and paint as reqd.)
74-75	Monte Carlo	9691203 L.H.	2.10	MOULDING, body upper (prime and paint as reqd.)
75	Nova (Cpe.) (exc. H.B.)	1726288 R.H.	9.55	MOULDING, formal window lock pillar (prime and paint as reqd.)
75	Nova (Cpe.) (exc. H.B.)	1726289 L.H.	9.55	MOULDING, formal window lock pillar (prime and paint as reqd.)
73-74	El Camino	9627843 R.H.	2.60	PANEL, lower (prime and paint as reqd.)
73-74	El Camino	1703763 L.H.	2.75	PANEL, lower (prime and paint as reqd.) (repl. 9627844)
73-75	El Camino	9627847 R.H.	4.35	PANEL, upper
73-75	El Camino	9627848 L.H.	4.35	PANEL, upper
75	El Camino	1703762 R.H.	2.75	PANEL, lower (prime and paint as reqd.)
75	El Camino	1703763 L.H.	2.75	PANEL, lower (prime and paint as reqd.)
67-68	Camaro (Std.) (Spt. Cpe.) w/fldg. rr. seat,			
67	Camaro (Deluxe) (Spt. Cpe.)	7680332 R.H.	1.35	TRIM ASSY., body lwr. (comb. 711, 712, 713, 714, 715, 749, 756, 760, 765, 767) (blk.)
67-69	Camaro (Std.) (Spt. Cpe.) w/fldg. rr. seat,			

**FOLDING TOP PARTS—INTERIOR TRIM**

**14.731 CAP— COVER ASSY.— MOULDING— PANEL— TRIM ASSY., Lock Pillar Finishing (Con't)**

67	Camaro (Deluxe) (Spt. Cpe.) . . . . .	7680333 L.H.	1.35	TRIM ASSY., body lwr. (comb. 711, 712, 713, 714, 715, 749, 756, 760, 765, 767) (blk.) . . . . .
----	---------------------------------------	--------------	------	---

**14.735 LACE ASSY., Body Lock Pillar**

**PASS.**

*NOTE: It may be necessary to punch holes in Trim Assembly to insure proper fit.*

*NOTE See group 15.520 for Pinchweld and Windlace yardage.*

70	Pass. (Spt. Cpe., Conv.) . . . . .	8802088 R.H.	5.80	pinchweld finish (comb. 805, 806, 813) (black) . . . . .
70	Pass. (Spt. Cpe., Conv.) . . . . .	8802089 L.H.	5.70	pinchweld finish (comb. 805, 806, 813) (black) . . . . .
70	Pass. (Spt. Cpe., Conv.) . . . . .	8802099 L.H.	5.80	pinchweld finish (comb. 855, 860, 861) (dk. green) . . . . .
71-72	Pass. (Spt. Cpe., Conv.),			
73	Pass. (Spt. Cpe.),			
74	Pass. (2-Dr.),			
75	Impala (Spt. Cpe.) (exc. Custom)	9848398 R.H.	5.20	pinchweld finish (comb. 802, 805, 806, 807, 808, 838, 840, 19D, 19W, 19C) (black) . . . . .
71-72	Pass. (Spt. Cpe., Conv.),			
73	Pass. (Spt. Cpe.),			
74	Pass. (2-Dr.),			
75	Impala (Spt. Cpe.) (exc. Custom)	9848399 L.H.	5.20	pinchweld finish (comb. 802, 805, 806, 808, 840, 19D, 19W, 19C) (black) . . . . .
71	Pass. (Spt. Cpe., Conv.) . . . . .	9848432 R.H.	5.20	pinchweld finish (comb. 827, 828, 830) (maize) . . . . .
71	Pass. (Spt. Cpe., Conv.) . . . . .	9848433 L.H.	5.20	pinchweld finish (comb. 827, 828, 830) (maize) . . . . .
71-72	Impala (Spt. Cpe., Conv.) . . . . .	9848434 R.H.	5.20	pinchweld finish (comb. 825, 826) (saddle) . . . . .
71-72	Impala (Spt. Cpe., Conv.) . . . . .	9848435 L.H.	5.20	pinchweld finish (comb. 825, 826) (saddle) . . . . .
71-72	Pass. (Spt. Cpe.) . . . . .	9848442 R.H.	5.80	pinchweld finish (comb. 813, 814, 815) (blue) . . . . .
71-72	Pass. (Spt. Cpe.) . . . . .	9848443 L.H.	5.20	pinchweld finish (comb. 813, 814, 815) (blue) . . . . .
72	Impala, Caprice (Spt. Cpe.) . . . . .	9848439 L.H.	5.80	pinchweld finish (comb. 834, 835, 836) (pewter) . . . . .
72	Impala, Caprice (Spt. Cpe., Conv.) . . . . .	9893459 L.H.	5.20	pinchweld finish (comb. 829, 831, 833) (green) . . . . .
73-74	Pass. (Spt. Cpe.) . . . . .	9646633 R.H.	2.75	pinchweld finish (comb. 812, 813, 843, 847) (midn. blue) . . . . .
73-74	Pass. (Spt. Cpe.) . . . . .	9646634 L.H.	2.75	pinchweld finish (comb. 812, 813, 843, 847) (midn. blue) . . . . .
73-75	Caprice (Spt. Cpe.) . . . . .	9646654 R.H.	4.15	pinchweld finish (comb. 836, 857, 73B) (oxblood) . . . . .
73-75	Caprice (Spt. Cpe.) . . . . .	9646655 L.H.	3.70	pinchweld finish (comb. 836, 857, 73B) (oxblood) . . . . .
73	Pass. (2-Dr.) . . . . .	9646637 R.H.	2.75	pinchweld finish (comb. 829, 830, 842) (green) . . . . .
73	Pass. (2-Dr.) . . . . .	9646638 L.H.	2.75	pinchweld finish (comb. 829, 830, 842) (green) . . . . .
73-74	Pass. (2-Dr.) . . . . .	9646646 R.H.	2.75	pinchweld finish (comb. 815, 818, 819, 821, 841) (neutral) . . . . .
73-74	Pass. (2-Dr.) . . . . .	9646647 L.H.	2.75	pinchweld finish (comb. 815, 818, 819, 821, 841) (neutral) . . . . .
73	Pass. (Conv.),			
74	Impala (Spt. Cpe.) (exc. Custom)	9893454 R.H.	4.45	pinchweld finish (comb. 804, 809, 816) (white) . . . . .
73	Pass. (Conv.),			
74	Impala (Spt. Cpe.) (exc. Custom)	9893455 L.H.	4.45	pinchweld finish (comb. 804, 809, 816) (white) . . . . .
73	Caprice (Spt. Sed.) . . . . .	9645618 R.H.	53.25	upper (comb. 841) (neutral) . . . . .
73	Caprice (Spt. Sed.) . . . . .	9645623 L.H.	53.25	upper (comb. 843) (midn. blue) . . . . .
73	Caprice (Sed.) (exc. Spt. Sed.) . . . . .	9645630 R.H.	53.00	upper (comb. 842) (green) . . . . .
74	Impala (Spt. Cpe.) . . . . .	9697304 R.H.	2.60	pinchweld finish (comb. 849, 858) (saddle) . . . . .
74	Impala (Spt. Cpe.) . . . . .	9697305 L.H.	2.60	pinchweld finish (comb. 849, 858) (saddle) . . . . .
74-75	Pass. (Conv.)			
74-75	Impala (Spt. Cpe.) (exc. Custom)	9848426 R.H.	5.20	pinchweld finish (comb. 804, 809, 02W, 07W, 04W, 11W) (white) . . . . .
74-75	Pass. (Conv.)			

**FOLDING TOP PARTS—INTERIOR TRIM**

**14.735 LACE ASSY., Body Lock Pillar (Con't)**

74-75	Impala (Spt. Cpe.) (exc. Custom)	9848427 L.H.	5.20	pinchweld finish (comb. 804, 809, 02W, 07W, 04W, 11W) (white) .....
74	Pass. (Spt. Cpe., Conv.),			
75	Impala (Spt. Cpe.) (exc. Custom)	9697306 R.H.	3.45	pinchweld finish (comb. 850, 853, 855, 44D, 44W) (green) .....
74	Pass. (Spt. Cpe., Conv.),			
75	Impala (Spt. Cpe.) (exc. Custom)	9697307 L.H.	3.40	pinchweld finish (comb. 850, 853, 855, 44D, 44W) (green) .....
74	Caprice (Spt. Cpe.) .....	9697308 R.H.	3.40	pinchweld finish (comb. 896) (taupe) .....
74	Caprice (Spt. Cpe.) .....	9697309 L.H.	3.40	pinchweld finish (comb. 896) (taupe) .....
75	Impala (Spt. Cpe.) (exc. Custom)	1682180 R.H.	3.15	pinchweld finish (comb. 26D, 26W) (blue) ..
75	Impala (Spt. Cpe.) (exc. Custom)	1682181 L.H.	3.15	pinchweld finish (comb. 26D, 26W) (blue) ..
75	Impala (Spt. Cpe.) Pass. (Conv.) (exc. Custom) .....	1682182 R.H.	3.15	pinchweld finish (comb. 55D, 55W) (sandstone) .....
75	Impala (Spt. Cpe.) Pass. (Conv.) (exc. Custom) .....	1682183 L.H.	3.15	pinchweld finish (comb. 55D, 55W) (sandstone) .....
75	Impala (Custom) .....	1666996 R.H.	3.95	LACE ASSY., pinchweld finish (comb. 63E, 63W) (saddle) .....
75	Impala (Custom) .....	1666997 L.H.	3.95	LACE ASSY., pinchweld finish (comb. 63E, 63W) (saddle) .....
75	Impala (Custom) Caprice (Conv.)	9646650 R.H.	4.15	LACE ASSY., pinchweld finish (comb. 63E, 63W) (saddle) .....
75	Impala (Custom) Caprice (Conv.)	9646651 L.H.	4.15	LACE ASSY., pinchweld finish (comb. 63E, 63W) (saddle) .....
75	Caprice (Spt. Cpe.) .....	1666998 R.H.	3.50	LACE ASSY., pinchweld finish (comb. 73B) (oxblood) .....
75	Caprice (Spt. Cpe.) .....	1666999 L.H.	3.50	LACE ASSY., pinchweld finish (comb. 73B) (oxblood) .....
75	Impala (Custom) Caprice (Spt. Cpe.) .....	1666992 R.H.		LACE ASSY., pinchweld finish (comb.-19B, 19D, 19H, 19W) (black) .....
75	Impala (Custom) Caprice (Spt. Cpe.) .....	1666993 L.H.		LACE ASSY., pinchweld finish (comb.-19B, 19D, 19H, 19W) (black) .....
75	Impala (Custom) Caprice (Spt. Cpe.) .....	1667000 R.H.	3.95	LACE ASSY., pinchweld finish (comb. 44B, 44W, 44B) (green) .....
75	Impala (Custom) Caprice (Spt. Cpe.) .....	1667001 L.H.		LACE ASSY., pinchweld finish (comb. 44B, 44W, 44B) (green) .....
75	Impala (Custom) Caprice (Spt. Cpe.) .....	1667006 R.H.	3.95	LACE ASSY., pinchweld finish (comb. 26D, 26W, 26B) (blue) .....
75	Impala (Custom) Caprice (Spt. Cpe.) .....	1667007 L.H.	3.50	LACE ASSY., pinchweld finish (comb. 26D, 26W, 26B) (blue) .....
75	Impala (Custom) Caprice (Spt. Cpe.) .....	1667008 R.H.	3.50	LACE ASSY., pinchweld finish (comb. 55D, 55W, 55B, 55H) (sandstone) .....
75	Impala (Custom) Caprice (Spt. Cpe.) .....	1667009 L.H.	3.95	LACE ASSY., pinchweld finish (comb. 55D, 55W, 55B, 55H) (sandstone) .....

**CHEVELLE**

69-72	Chevelle (Spt. Cpe.) (Conv.) .....	8776214 R.H.	3.85	pinchweld finish (comb. 704, 705, 706, 707, 708, 710, 748, 749, 751, 752, 753, 755, 756, 757) (black) .....
70-72	Chevelle (Spt. Cpe.) .....	8776215 L.H.	3.85	pinchweld finish (comb. 704, 705, 706, 707, 708, 710, 748, 749, 751, 752, 753, 755, 756, 757) (black) .....
71-72	Chevelle (Spt. Cpe.) .....	9844167 L.H.	4.45	pinchweld finish (comb. 721, 722, 723) (dk. saddle) .....
71-72	Chevelle (Spt. Cpe.) .....	9844169 L.H.	4.45	pinchweld finish (comb. 724, 725, 727, 728) (dk. blue) .....
72	Chevelle (Spt. Cpe., Conv.) .....	9892281 L.H.	4.45	pinchweld finish (comb. 710, 711, 713, 715, 717) (green) .....
72	Malibu (Spt. Cpe.) (Conv.) .....	9892279 L.H.	4.45	pinchweld finish (comb. 743) (white) .....

**CHEVY—NOVA**

68-72	(Spt. Cpe.) .....	7759540 R.H.	1.90	(black) .....
68-72	(Spt. Cpe.) .....	7759541 L.H.	1.90	(black) .....
72	Nova (2-Dr.) .....	9892741 L.H.	4.45	pinchweld finish (comb. 763, 764, 765) (covert) .....

**FOLDING TOP PARTS—INTERIOR TRIM**

**14.735 LACE ASSY., Body Lock Pillar (Con't)**

72	Nova (2-Dr.)	9892739	L.H.	4.45	pinchweld finish (comb. 759, 760, 761) (green)
----	--------------	---------	------	------	--

**CAMARO**

71	Vega (Panel)	9835075	2	.67	pinchweld finish
72-75	Vega (Panel)	9606059	2	3.00	pinchweld finish

**14.760 TRIM ASSY.—TAB—FASTENER—PANEL—RETAINER, Rear Door**

**PASSENGER**

*NOTE It may be necessary to punch holes in Trim Assembly to insure proper fit.*

71-72	Caprice (Spt. Sed.)	9845480	R.H.	8.85	lower finish panel w/carpet (paint as reqd.)
71-72	Caprice (Spt. Sed.)	9845481	L.H.	8.85	lower finish panel w/carpet (paint as reqd.)
71-72	Bel Air	9645566	R.H.	30.50	upper (comb. 803, 804) (black)
71-72	Bel Air	9645567	L.H.	30.50	upper (comb. 803, 804) (black)
72	Impala (Sed.) (exc. Spt. Sed.)	9899095	L.H.	41.50	upper (comb. 815, 818) (covert)
72	Impala (Spt. Sed.)	9899083	L.H.	42.75	upper (comb. 818) (covert)
72	Caprice (Spt. Sed.)	9612202	R.H.	36.00	upper, less mldg. and emblem and insert (comb. 807, 838) (black)
72	Kingswood	9845464	R.H.	8.90	black, lower, paint as reqd.
72	Kingswood	9845465	L.H.	8.90	black, lower, paint as reqd.
73-74	Impala (Spt. Sed.)	9645578	R.H.	45.00	upper (comb. 802, 805, 806) (black)
73-74	Impala (Spt. Sed.)	9645579	L.H.	45.00	upper (comb. 802, 805, 806) (black)
73-74	Impala (Spt. Sed.)	9645580	R.H.	45.00	upper (comb. 815, 818, 819, 821) (neutral)
73-74	Impala (Spt. Sed.)	9645581	L.H.	45.00	upper (comb. 815, 818, 819, 821) (neutral)
73	Impala (Spt. Sed.)	9645583	L.H.	45.00	upper (comb. 829, 830) (green)
73-74	Impala (Spt. Sed.)	9645584	R.H.	45.00	upper (comb. 812, 813, 847) (midn. blue)
73-74	Impala (Spt. Sed.)	9645585	L.H.	45.00	upper (comb. 812, 813, 847) (midn. blue)
73-74	Impala (Sed.) (exc. Spt. Sed.)	9645586	R.H.	43.75	upper (comb. 802, 805, 806) (black)
73-74	Impala (Sed.) (exc. Spt. Sed.)	9645587	L.H.	43.75	upper (comb. 802, 805, 806) (black)
73	Impala (Sed.) (exc. Spt. Sed.)	9645588	R.H.	43.75	upper (comb. 815, 818, 819, 821) (neutral)
73	Impala (Sed.) (exc. Spt. Sed.)	9645589	L.H.	43.75	upper (comb. 815, 818, 819, 821) (neutral)
73-74	Impala (Sed.) (exc. Spt. Sed.)	9645592	R.H.	43.75	upper (comb. 812, 813, 847) (midn. blue)
73-74	Impala (Sed.) (exc. Spt. Sed.)	9645593	L.H.	43.75	upper (comb. 812, 813, 847) (midn. blue)
73-74	Bel Air (Sed.)	9645566	R.H.	30.50	upper (comb. 803, 804) (black)
73-74	Bel Air (Sed.)	9645567	L.H.	30.50	upper (comb. 803, 804) (black)
73	Bel Air (Sed.)	9645569	L.H.	30.50	upper (comb. 810) (blue)
73	Bel Air (Sed.)	9645570	R.H.	30.50	upper (comb. 827, 828) (green)
73-74	Bel Air (Sta. Wag.)	9645562	R.H.	34.25	upper (comb. 817) (neutral)
73-74	Bel Air (Sta. Wag.)	9645563	L.H.	34.50	upper (comb. 817) (neutral)
73-74	Impala, Caprice (Sta. Wag.)	9645572	R.H.	45.50	upper (comb. 802, 806) (black)
73-74	Impala, Caprice (Sta. Wag.)	9645573	L.H.	45.50	upper (comb. 802, 806) (black)
73	Impala, Caprice (Sta. Wag.)	9645575	L.H.	45.50	upper (comb. 830) (green)
73	Impala, Caprice (Sta. Wag.)	9645576	R.H.	45.50	upper (comb. 826) (saddle)
73	Impala, Caprice (Sta. Wag.)	9645577	L.H.	45.50	upper (comb. 826) (saddle)
73-74	Impala, Caprice (Sta. Wag.)	9665401	R.H.	45.50	upper (comb. 818, 819) (neutral)
73-74	Impala, Caprice (Sta. Wag.)	9665402	L.H.	45.50	upper (comb. 818, 819) (neutral)
73-74	Impala, Caprice (Sta. Wag.)	9665403	R.H.	45.50	upper (comb. 813) (midn. blue)
73-74	Impala, Caprice (Sta. Wag.)	9665404	L.H.	45.50	upper (comb. 813) (midn. blue)
74	Bel Air (Sedan)	9691506	R.H.	30.50	upper (comb. 815, 817) (neutral)
74	Bel Air (Sedan)	9691507	L.H.	30.50	upper (comb. 815, 817) (neutral)
74	Bel Air (Sedan)	9691508	R.H.	30.50	upper (comb. 851, 852) (green)
74	Bel Air (Sedan)	9691509	L.H.	30.50	upper (comb. 851, 852) (green)
74	Bel Air (Sta. Wag.)	9691504	R.H.	30.50	upper (comb. 851) (green)
74	Bel Air (Sta. Wag.)	9691505	L.H.	30.50	upper (comb. 851) (green)
74	Impala (Sedan) (exc. Spt. Sed.)	9691518	R.H.	43.75	upper (comb. 853, 855) (green)
74	Impala (Sedan) (exc. Spt. Sed.)	9691519	L.H.	43.75	upper (comb. 853, 855) (green)
74	Impala (Sedan) (exc. Spt. Sed.)	9732108	R.H.	43.75	upper (comb. 849) (saddle)
74	Impala (Sedan) (exc. Spt. Sed.)	9732109	L.H.	43.75	upper (comb. 849) (saddle)
74	Impala (Spt. Sed.)	9691514	R.H.	45.50	upper (comb. 853, 855) (green)
74	Impala (Spt. Sed.)	9691515	L.H.	45.50	upper (comb. 853, 855) (green)
74	Impala (Spt. Sed.)	9732106	R.H.	45.00	upper (comb. 849) (saddle)
74	Impala (Spt. Sed.)	9732107	L.H.	45.00	upper (comb. 849) (saddle)
74	Impala, Caprice (Sta. Wag.)	9691510	R.H.	45.50	upper (comb. 855, 859) (green)
74	Impala, Caprice (Sta. Wag.)	9691511	L.H.	45.50	upper (comb. 855, 859) (green)
74	Impala, Caprice (Sta. Wag.)	9691512	R.H.	45.50	upper (comb. 849, 858) (saddle)
74	Impala, Caprice (Sta. Wag.)	9691513	L.H.	45.50	upper (comb. 849, 858) (saddle)
74	Caprice (Sedan) (exc. Spt. Sed.)	9691562	R.H.	53.00	upper (comb. 840) (black)
74	Caprice (Sedan) (exc. Spt. Sed.)	9691563	L.H.	53.00	upper (comb. 840) (black)
74	Caprice (Sedan) (exc. Spt. Sed.)	9691564	R.H.	53.00	upper (comb. 857) (oxblood)
74	Caprice (Sedan) (exc. Spt. Sed.)	9691565	L.H.	53.00	upper (comb. 857) (oxblood)
74	Caprice (Sedan) (exc. Spt. Sed.)	9691566	R.H.	53.00	upper (comb. 896) (taupe)
74	Caprice (Sedan) (exc. Spt. Sed.)	9691567	L.H.	53.00	upper (comb. 896) (taupe)
74	Caprice (Sedan) (exc. Spt. Sed.)	9691568	R.H.	53.00	upper (comb. 850) (green)

**FOLDING TOP PARTS—INTERIOR TRIM**

**14.760 TRIM ASSY.—TAB—FASTENER—PANEL—RETAINER, Rear Door  
(Con't)**

74	Caprice (Sedan) (exc. Spt. Sed.)	9691569 L.H.	53.00	upper (comb. 850) (green)
74	Caprice (Sedan) (exc. Spt. Sed.)	9691570 R.H.	53.00	upper (comb. 843) (midn. blue)
74	Caprice (Sedan) (exc. Spt. Sed.)	9691571 L.H.	53.25	upper (comb. 843) (midn. blue)
74	Caprice (Sedan) (exc. Spt. Sed.)	9691572 R.H.	53.25	upper (comb. 808) (black)
74	Caprice (Sedan) (exc. Spt. Sed.)	9691573 L.H.	53.25	upper (comb. 808) (black)
74	Caprice (Sedan) (exc. Spt. Sed.)	9691574 R.H.	53.25	upper (comb. 841) (neutral)
74	Caprice (Sedan) (exc. Spt. Sed.)	9691575 L.H.	53.25	upper (comb. 841) (neutral)
74	Caprice (Spt. Sed.)	9691522 R.H.	53.00	upper (comb. 840) (black)
74	Caprice (Spt. Sed.)	9691523 L.H.	53.25	upper (comb. 840) (black)
74	Caprice (Spt. Sed.)	9691524 R.H.	53.00	upper (comb. 857) (oxblood)
74	Caprice (Spt. Sed.)	9691525 L.H.	53.00	upper (comb. 857) (oxblood)
74	Caprice (Spt. Sed.)	9691552 R.H.	53.00	upper (comb. 896) (taupe)
74	Caprice (Spt. Sed.)	9691553 L.H.	53.25	upper (comb. 896) (taupe)
74	Caprice (Spt. Sed.)	9691554 R.H.	53.00	upper (comb. 850) (green)
74	Caprice (Spt. Sed.)	9691555 L.H.	53.25	upper (comb. 850) (green)
74	Caprice (Spt. Sed.)	9691556 R.H.	53.00	upper (comb. 843) (midn. blue)
74	Caprice (Spt. Sed.)	9691557 L.H.	53.00	upper (comb. 843) (midn. blue)
74	Caprice (Spt. Sed.)	9691558 R.H.	53.25	upper (comb. 808) (black)
74	Caprice (Spt. Sed.)	9691559 L.H.	53.25	upper (comb. 808) (black)
74	Caprice (Spt. Sed.)	9691560 R.H.	53.00	upper (comb. 841) (neutral)
74	Caprice (Spt. Sed.)	9691561 L.H.	53.25	upper (comb. 841) (neutral)
75	Bel Air (Sedan)	1666722 R.H.	32.75	upper (comb. 19C) (black)
75	Bel Air (Sedan)	1666723 L.H.	32.75	upper (comb. 19C) (black)
75	Bel Air (Sedan)	1666724 R.H.	32.75	upper (comb. 26C) (blue)
75	Bel Air (Sedan)	1666725 L.H.	32.75	upper (comb. 26C) (blue)
75	Bel Air (Sedan)	1666726 R.H.	32.75	upper (comb. 55C, 55V) (sandstone)
75	Bel Air (Sedan)	1666727 L.H.	32.75	upper (comb. 55C, 55V) (sandstone)
75	Impala (Spt. Sed.) (1st design)	1665276 R.H.	47.00	upper (comb. 19D, 19W) (black) (perforated)
75	Impala (Spt. Sed.) (1st design)	1665277 L.H.	47.00	upper (comb. 19D, 19W) (black) (perforated)
75	Impala (Spt. Sed.) (1st design)	1665278 R.H.	47.00	upper (comb. 26D, 26W) (blue) (perforated)
75	Impala (Spt. Sed.) (1st design)	1665279 L.H.	47.00	upper (comb. 26D, 26W) (blue) (perforated)
75	Impala (Spt. Sed.) (1st design)	1665280 R.H.	47.00	upper (comb. 44D, 44W) (green) (perforated)
75	Impala (Spt. Sed.) (1st design)	1665281 L.H.	47.00	upper (comb. 44D, 44W) (green) (perforated)
75	Impala (Spt. Sed.) (1st design)	1665282 R.H.	47.00	upper (comb. 55D, 55W) (sandstone) (perforated)
75	Impala (Spt. Sed.) (1st design)	1665283 L.H.	47.00	upper (comb. 55D, 55W) (sandstone) (perforated)
75	Impala (Spt. Sed.) (1st design)	1665284 R.H.	47.00	upper (comb. 63E, 63W) (saddle) (perforated)
75	Impala (Spt. Sed.) (1st design)	1665285 L.H.	47.00	upper (comb. 63E, 63W) (saddle) (perforated)
75	Impala (Sedan) (exc. Spt. Sed.) (1st design)	1665286 R.H.	45.25	upper (comb. 19D, 19W) (black) (perforated)
75	Impala (Sedan) (exc. Spt. Sed.) (1st design)	1665287 L.H.	45.25	upper (comb. 19D, 19W) (black) (perforated)
75	Impala (Sedan) (exc. Spt. Sed.) (1st design)	1665288 R.H.	45.25	upper (comb. 26D, 26W) (blue) (perforated)
75	Impala (Sedan) (exc. Spt. Sed.) (1st design)	1665289 L.H.	45.25	upper (comb. 26D, 26W) (blue) (perforated)
75	Impala (Sedan) (exc. Spt. Sed.) (1st design)	1665290 R.H.	45.25	upper (comb. 44D, 44W) (green) (perforated)
75	Impala (Sedan) (exc. Spt. Sed.) (1st design)	1665291 L.H.	45.25	upper (comb. 44D, 44W) (green) (perforated)
75	Impala (Sedan) (exc. Spt. Sed.) (1st design)	1665292 R.H.	45.25	upper (comb. 55D, 55W) (sandstone) (perforated)
75	Impala (Sedan) (exc. Spt. Sed.) (1st design)	1665293 L.H.	45.25	upper (comb. 55D, 55W) (sandstone) (perforated)
75	Impala (Sedan) (exc. Spt. Sed.) (1st design)	1665294 R.H.	45.25	upper (comb. 63E, 63W) (saddle) (perforated)
75	Impala (Sedan) (exc. Spt. Sed.) (1st design)	1665295 L.H.	45.25	upper (comb. 63E, 63W) (saddle) (perforated)
75	Caprice (Spt. Sed.)	1664680 R.H.	62.50	upper (comb. 19B) (black)



FOLDING TOP PARTS—INTERIOR TRIM

14.760 TRIM ASSY.—TAB—FASTENER—PANEL—RETAINER, Rear Door  
(Con't)

75	Caprice (Spt. Sed.)	1664681 L.H.	62.50	upper (comb. 19B) (black)
75	Caprice (Spt. Sed.)	1664682 R.H.	62.50	upper (comb. 73B) (oxblood)
75	Caprice (Spt. Sed.)	1664683 L.H.	62.50	upper (comb. 73B) (oxblood)
75	Caprice (Spt. Sed.)	1664684 R.H.	62.50	upper (comb. 55B) (sandstone)
75	Caprice (Spt. Sed.)	1664685 L.H.	62.50	upper (comb. 55B) (sandstone)
75	Caprice (Spt. Sed.)	1664686 R.H.	62.50	upper (comb. 44B) (green)
75	Caprice (Spt. Sed.)	1664687 L.H.	62.50	upper (comb. 44B) (green)
75	Caprice (Spt. Sed.)	1664688 R.H.	62.50	upper (comb. 26B) (blue)
75	Caprice (Spt. Sed.)	1664689 L.H.	62.50	upper (comb. 26B) (blue)
75	Caprice (Spt. Sed.)	1664692 R.H.	62.50	upper (comb. 19H) (black)
75	Caprice (Spt. Sed.)	1664693 L.H.	62.50	upper (comb. 19H) (black)
75	Caprice (Spt. Sed.)	1664694 R.H.	62.50	upper (comb. 55H) (sandstone)
75	Caprice (Spt. Sed.)	1664695 L.H.	62.50	upper (comb. 55H) (sandstone)
75	Caprice (Sedan) (exc. Spt. Sed.)	1664696 R.H.	61.75	upper (comb. 19B) (black)
75	Caprice (Sedan) (exc. Spt. Sed.)	1664697 L.H.	61.75	upper (comb. 19B) (black)
75	Caprice (Sedan) (exc. Spt. Sed.)	1664698 R.H.	61.75	upper (comb. 73B) (oxblood)
75	Caprice (Sedan) (exc. Spt. Sed.)	1664699 L.H.	61.75	upper (comb. 73B) (oxblood)
75	Caprice (Sedan) (exc. Spt. Sed.)	1664700 R.H.	61.75	upper (comb. 55B) (sandstone)
75	Caprice (Sedan) (exc. Spt. Sed.)	1664701 L.H.	61.75	upper (comb. 55B) (sandstone)
75	Caprice (Sedan) (exc. Spt. Sed.)	1664702 R.H.	61.75	upper (comb. 44B) (green)
75	Caprice (Sedan) (exc. Spt. Sed.)	1664703 L.H.	61.75	upper (comb. 44B) (green)
75	Caprice (Sedan) (exc. Spt. Sed.)	1664704 R.H.	61.75	upper (comb. 26B) (blue)
75	Caprice (Sedan) (exc. Spt. Sed.)	1664705 L.H.	61.75	upper (comb. 26B) (blue)
75	Caprice (Sedan) (exc. Spt. Sed.)	1664708 R.H.	61.75	upper (comb. 19H) (black)
75	Caprice (Sedan) (exc. Spt. Sed.)	1664709 L.H.	61.75	upper (comb. 19H) (black)
75	Caprice (Sedan) (exc. Spt. Sed.)	1664710 R.H.	61.75	upper (comb. 55H) (sandstone)
75	Caprice (Sedan) (exc. Spt. Sed.)	1664711 L.H.	61.75	upper (comb. 55H) (sandstone)
75	Pass. (Sta. Wag.) (1st design)	1664732 R.H.	47.75	upper (comb. 19W) (black) (perforated)
75	Pass. (Sta. Wag.) (1st design)	1664733 L.H.	47.75	upper (comb. 19W) (black) (perforated)
75	Pass. (Sta. Wag.) (1st design)	1664734 R.H.	47.75	upper (comb. 26W) (blue) (perforated)
75	Pass. (Sta. Wag.) (1st design)	1664735 L.H.	47.75	upper (comb. 26W) (blue) (perforated)
75	Pass. (Sta. Wag.) (1st design)	1664736 R.H.	47.75	upper (comb. 44W) (green) (perforated)
75	Pass. (Sta. Wag.) (1st design)	1664737 L.H.	47.75	upper (comb. 44W) (green) (perforated)
75	Pass. (Sta. Wag.) (1st design)	1664738 R.H.	47.75	upper (comb. 55W) (sandstone) (perforated)
75	Pass. (Sta. Wag.) (1st design)	1664739 L.H.	47.75	upper (comb. 55W) (sandstone) (perforated)
75	Pass. (Sta. Wag.) (1st design)	1664740 R.H.	47.75	upper (comb. 63E, 63W) (saddle) (perforated)
75	Pass. (Sta. Wag.) (1st design)	1664741 L.H.	47.75	upper (comb. 63E, 63W) (saddle) (perforated)
75	Bel Air (Sta. Wag.)	1659872 R.H.	34.50	upper (comb. 55V) (sandstone)
75	Bel Air (Sta. Wag.)	1659873 L.H.	34.50	upper (comb. 55V) (sandstone)
75	Bel Air (Sta. Wag.)	1663358 R.H.	34.50	upper (comb. 26V) (blue)
75	Bel Air (Sta. Wag.)	1663359 L.H.	34.50	upper (comb. 26V) (blue)
75	Impala (Spt. Sed.) (2nd design)	1708328 R.H.	44.00	upper (comb. 19D, 19W) (black) (non-perforated)
75	Impala (Spt. Sed.) (2nd design)	1708329 L.H.	44.00	upper (comb. 19D, 19W) (black) (non-perforated)
75	Impala (Spt. Sed.) (2nd design)	1708330 R.H.	44.00	upper (comb. 26D, 26W) (blue) (non-perforated)
75	Impala (Spt. Sed.) (2nd design)	1708331 L.H.	44.00	upper (comb. 26D, 26W) (blue) (non-perforated)
75	Impala (Spt. Sed.) (2nd design)	1708332 R.H.	44.00	upper (comb. 44D, 44W) (green) (non-perforated)
75	Impala (Spt. Sed.) (2nd design)	1708333 L.H.	44.00	upper (comb. 44D, 44W) (green) (non-perforated)
75	Impala (Spt. Sed.) (2nd design)	1708334 R.H.	44.00	upper (comb. 55D, 55W) (sandstone) (non-perforated)
75	Impala (Spt. Sed.) (2nd design)	1708335 L.H.	44.00	upper (comb. 55D, 55W) (sandstone) (non-perforated)
75	Impala (Spt. Sed.) (2nd design)	1708336 R.H.	44.00	upper (comb. 63E, 63W) (sandstone) (non-perforated)
75	Impala (Spt. Sed.) (2nd design)	1708337 L.H.	44.00	upper (comb. 63E, 63W) (saddle) (non-perforated)
75	Impala (Sedan) (2nd design) (exc. Spt. Sed.)	1708340 R.H.	42.75	upper (comb. 19D, 19W) (black) (non-perforated)
75	Impala (Sedan) (2nd design) (exc. Spt. Sed.)	1708341 L.H.	42.75	upper (comb. 19D, 19W) (black) (non-perforated)
75	Impala (Sedan) (2nd design) (exc. Spt. Sed.)	1708342 R.H.	42.75	upper (comb. 26D, 26W) (blue) (non-perforated)

**FOLDING TOP PARTS—INTERIOR TRIM**

**14.760 TRIM ASSY.—TAB—FASTENER—PANEL—RETAINER, Rear Door  
(Con't)**

75	Impala (Sedan) (2nd design) (exc. Spt. Sed.)	1708343 L.H.	42.75	upper (comb. 26D, 26W) (blue) (non-perforated)
75	Impala (Sedan) (2nd design) (exc. Spt. Sed.)	1708344 R.H.	42.75	upper (comb. 44D, 44W) (green) (non-perforated)
75	Impala (Sedan) (2nd design) (exc. Spt. Sed.)	1708345 L.H.	42.75	upper (comb. 44D, 44W) (green) (non-perforated)
75	Impala (Sedan) (2nd design) (exc. Spt. Sed.)	1708346 R.H.	42.75	upper (comb. 55D, 55W) (sandstone) (non-perforated)
75	Impala (Sedan) (2nd design) (exc. Spt. Sed.)	1708347 L.H.	42.75	upper (comb. 55D, 55W) (sandstone) (non-perforated)
75	Impala (Sedan) (2nd design) (exc. Spt. Sed.)	1708348 R.H.	42.75	upper (comb. 63E, 63W) (saddle) (non-perforated)
75	Impala (Sedan) (2nd design) (exc. Spt. Sed.)	1708349 L.H.	42.75	upper (comb. 63E, 63W) (saddle) (non-perforated)
75	Pass. (Sta. Wag.) (2nd design)	1708316 R.H.	45.00	upper (comb. 19W) (black) (non-perforated)
75	Pass. (Sta. Wag.) (2nd design)	1708317 L.H.	45.00	upper (comb. 19W) (black) (non-perforated)
75	Pass. (Sta. Wag.) (2nd design)	1708318 R.H.	45.00	upper (comb. 26W) (blue) (non-perforated)
75	Pass. (Sta. Wag.) (2nd design)	1708319 L.H.	45.00	upper (comb. 26W) (blue) (non-perforated)
75	Pass. (Sta. Wag.) (2nd design)	1708320 R.H.	45.00	upper (comb. 44W) (green) (non-perforated)
75	Pass. (Sta. Wag.) (2nd design)	1708321 L.H.	45.00	upper (comb. 44W) (green) (non-perforated)
75	Pass. (Sta. Wag.) (2nd design)	1708322 R.H.	45.00	upper (comb. 55W) (sandstone) (non-perforated)
75	Pass. (Sta. Wag.) (2nd design)	1708323 L.H.	45.00	upper (comb. 55W) (sandstone) (non-perforated)
75	Pass. (Sta. Wag.) (2nd design)	1708324 R.H.	45.00	upper (comb. 63E, 63W) (saddle) (non-perforated)
75	Pass. (Sta. Wag.) (2nd design)	1708325 L.H.	45.00	upper (comb. 63E, 63W) (saddle) (non-perforated)

**CHEVELLE**

72	Chevelle (Sedan)	9897573 L.H.	38.75	(comb. 711) (green)
73	Deluxe (4-Dr.)			
74	Malibu (4-Dr.) (exc. Classic)	9643034 R.H.	13.90	upper (comb. 701, 702, 706, 738, 891, 894) (black)
73	Deluxe (4-Dr.)			
74	Malibu (4-Dr.) (exc. Classic)	9643035 L.H.	13.90	upper (comb. 701, 702, 706, 738, 891, 894) (black)
73	Maiibu (4-Dr.)	9643040 R.H.	27.25	upper (comb. 703, 704) (black)
74	Maiibu (4-Dr.) (exc. Classic)	9676984 R.H.	13.90	upper (comb. 723, 727, 745, 830, 893) (green)
74	Malibu (4-Dr.) (exc. Classic)	9676985 L.H.	13.80	upper (comb. 723, 727, 745, 830, 893) (green)
74	Maiibu (4-Dr.) (exc. Classic)	9676986 R.H.	13.80	upper (comb. 713, 892) (neutral)
74	Maiibu (4-Dr.) (exc. Classic)	9676987 L.H.	13.90	upper (comb. 713, 892) (neutral)
74	Malibu (Classic) (Sedan)	9731728 R.H.	53.25	upper (comb. 743) (oxblood)
74	Malibu (Classic) (Sedan)	9731729 L.H.	53.25	upper (comb. 743) (oxblood)
74	Malibu (Classic) (Sedan)	9732548 R.H.	53.25	upper (comb. 702) (black)
74	Malibu (Classic) (Sedan)	9732549 L.H.	53.25	upper (comb. 702) (black)
74	Malibu (Classic) (Sedan)	9732550 R.H.	47.50	upper (comb. 732) (mid. blue)
74	Malibu (Classic) (Sedan)	9732551 L.H.	47.50	upper (comb. 732) (mid. blue)
74	Malibu (Classic) (Sedan)	9732552 R.H.	53.25	upper (comb. 724) (green)
74	Maiibu (Classic) (Sedan)	9732553 L.H.	53.25	upper (comb. 724) (green)
74	Maiibu (Classic) (Sedan)	9732554 R.H.	53.25	upper (comb. 722) (neutral)
74	Maiibu (Classic) (Sedan)	9732555 L.H.	47.50	upper (comb. 722) (neutral)
74	Malibu (Classic) (4-Dr.)	9731718 R.H.	49.25	upper (comb. 707, 747) (black)
74	Malibu (Classic) (4-Dr.)	9731719 L.H.	49.25	upper (comb. 707, 747) (black)
74	Malibu (Classic) (4-Dr.)	9731722 R.H.	44.25	upper (comb. 728) (green)
74	Maiibu (Classic) (4-Dr.)	9731723 L.H.	44.25	upper (comb. 728) (green)
74	Maiibu (Classic) (4-Dr.)	9731724 R.H.	44.50	upper (comb. 714) (neutral)
74	Maiibu (Classic) (4-Dr.)	9731725 L.H.	44.50	upper (comb. 714) (neutral)
74	Malibu (Classic) (4-Dr.)	9731726 R.H.	44.50	upper (comb. 740) (saddle)
74	Malibu (Classic) (4-Dr.)	9731727 L.H.	44.50	upper (comb. 740) (saddle)
74	Malibu (Classic) (Sta. Wag.)	9731720 R.H.	44.50	upper (comb. 735, 785) (mid. blue)
74	Maiibu (Classic) (Sta. Wag.)	9731721 L.H.	44.50	upper (comb. 735, 785) (mid. blue)
75	Maiibu (Classic) (4-Dr.)	9731718 R.H.	49.25	upper (comb. 19W) (black)
75	Maiibu (Classic) (4-Dr.)	9731719 L.H.	49.25	upper (comb. 19W) (black)
75	Malibu (Classic) (Sedan)	9732548 R.H.	53.25	upper (comb. 19D) (black) (repl. 1662448)

FOLDING TOP PARTS—INTERIOR TRIM

14.760 TRIM ASSY.—TAB—FASTENER—PANEL—RETAINER, Rear Door  
(Con't)

75	Malibu (Classic) (Sedan)	1662449 L.H.		upper (comb. 19D) (black)
75	Malibu (Classic) (Sedan)	1662450 R.H.	53.25	upper (comb. 16D) (graystone)
75	Malibu (Classic) (Sedan)	1662451 L.H.	53.25	upper (comb. 16D) (graystone)
75	Malibu (Classic) (Sedan)	9732552 R.H.	53.25	upper (comb. 44D) (green)
75	Malibu (Classic) (Sedan)	9732553 L.H.	53.25	upper (comb. 44D) (green) (repl. 1662455)
75	Malibu (Classic) (Sedan)	9731728 R.H.	53.25	upper (comb. 73D) (oxblood)
75	Malibu (Classic) (Sedan)	9731729 L.H.	53.25	upper (comb. 73D) (oxblood)
75	Malibu (Classic) (Sedan)	1662452 R.H.	53.25	upper (comb. 26D) (blue)
75	Malibu (Classic) (Sedan)	1662453 L.H.	53.25	upper (comb. 26D) (blue)
75	Malibu (Sedan) (exc. Classic)	1654472 R.H.	15.80	upper (comb. 44V) (green)
75	Malibu (Sedan) (exc. Classic)	1654473 L.H.	15.80	upper (comb. 44V) (green)
75	Malibu (Sedan) (exc. Classic)	1654474 R.H.	15.00	upper (comb. 26C, 26V) (blue)
75	Malibu (Sedan) (exc. Classic)	1654475 L.H.	15.00	upper (comb. 26C, 26V) (blue)
75	Malibu (4-Dr.) (exc. Classic)	1659396 R.H.	15.80	upper (comb. 55V) (sandstone)
75	Malibu (4-Dr.) (exc. Classic)	1659397 L.H.	15.80	upper (comb. 55V) (sandstone)
75	Malibu (4-Dr.) (exc. Classic)	1654470 R.H.	15.00	upper (comb. 19C, 19V) (black)
75	Malibu (4-Dr.) (exc. Classic)	1654471 L.H.	15.00	upper (comb. 19C, 19V) (black)
75	Chevelle (4-Dr.)	1662432 R.H.	49.25	upper (comb. 55W) (sandstone)
75	Chevelle (4-Dr.)	1662435 L.H.	49.25	upper (comb. 55W) (sandstone)
75	Chevelle (4-Dr.)	1662432 R.H.	49.25	upper (comb. 26W) (blue)
75	Chevelle (4-Dr.)	1662433 L.H.	49.25	upper (comb. 26W) (blue)
75	Chevelle (Sta. Wag.)	1662436 R.H.	49.25	upper (comb. 63W) (saddle)
75	Chevelle (Sta. Wag.)	1662437 L.H.	49.25	upper (comb. 63W) (saddle)

CHEVY—NOVA

73	Nova (Custom) (Sedan)	9644891 L.H.	34.25	(comb. 750) (black & white)
73	Nova (Custom) (Sedan)	9644892 R.H.	34.50	(comb. 769) (neutral)
73-74	Nova (Sed.) (exc. Custom)	9644884 R.H.	30.75	(comb. 750, 751, 753, 754, 825) (black)
73-74	Nova (Sed.) (exc. Custom)	9644885 L.H.	31.00	(comb. 750, 751, 753, 754, 825) (black)
73	Nova (Sed.) (exc. Custom)	9644888 R.H.	30.75	(comb. 772) (blue)
73-74	Nova (Sed.) (exc. Custom) (Taxi)	9662686 R.H.	31.00	(comb. 765, 769) (black)
73-74	Nova (Sed.) (exc. Custom) (Taxi)	9662687 L.H.	31.00	(comb. 765, 769) (black)
74	Nova (Sedan) (exc. Custom)	9683482 R.H.	30.75	(comb. 756, 757, 758, 828) (green)
74	Nova (Sedan) (exc. Custom)	9683483 L.H.	30.75	(comb. 756, 757, 758, 828) (green)
74	Nova (Sedan) (exc. Custom)	9683484 R.H.	31.00	(comb. 772, 826) (mid. blue)
74	Nova (Sedan) (exc. Custom)	9683485 L.H.	31.00	(comb. 772, 826) (mid. blue)
74	Nova (Sedan) (exc. Custom)	9683486 R.H.	30.75	(comb. 764, 765, 766, 829) (neutral)
74	Nova (Sedan) (exc. Custom)	9683487 L.H.	31.00	(comb. 764, 765, 766, 829) (neutral)
75	Nova (Sedan)	1657886 R.H.	41.75	(comb. 19C, 19V, 19Y, 19W, 19Z) (black)
75	Nova (Sedan)	3061103 L.H.	33.50	(comb. 19C, 19V, 19Y, 19W, 19Z) (black) (repl. 1657887)
75	Nova (Sedan)	1657888 R.H.	44.00	(comb. 55C, 55V, 55D, 55W) (sandstone)
75	Nova (Sedan)	1657889 L.H.	44.00	(comb. 55C, 55V, 55D, 55W) (sandstone)
75	Nova (Sedan)	1657892 R.H.	41.75	(comb. 26C, 26V, 26D) (blue)
75	Nova (Sedan)	1657893 L.H.	41.75	(comb. 26C, 26V, 26D) (blue)
75	Nova (Sedan)	1657894 R.H.	44.00	(comb. 63V, 63W) (saddle)
75	Nova (Sedan)	1657895 L.H.	44.00	(comb. 63V, 63W) (saddle)
75	Nova (Custom) (Sedan)	1666514 R.H.	89.50	(comb. 73G) (oxblood)
75	Nova (Custom) (Sedan)	1666515 L.H.	89.50	(comb. 73G) (oxblood)
75	Nova (Custom) (Sedan)	1666516 R.H.	89.50	(comb. 16G) (graystone)
75	Nova (Custom) (Sedan)	1666517 L.H.	89.50	(comb. 16G) (graystone)
75	Nova (Custom) (Sedan)	1666518 R.H.	89.50	(comb. 26G) (blue)
75	Nova (Custom) (Sedan)	1666519 L.H.	89.50	(comb. 26G) (blue)
75	Nova (Custom) (Sedan)	1666520 R.H.	89.50	(comb. 55G) (sandstone)
75	Nova (Custom) (Sedan)	1666521 L.H.	89.50	(comb. 55G) (sandstone)
75	Nova (Custom) (Sedan)	1657896 R.H.	44.00	(comb. 44D) (green)
75	Nova (Custom) (Sedan)	1657897 L.H.	44.00	(comb. 44D) (green)
65-70	Pass.	4081772 A.R.	.38	TAB, trim binding strip—(14.683)
70-71	Nova, Chevelle, Camaro	4500027 A.R.	.11	FASTENER, trim pad to inner panel— (14.645)
71	Pass. (4-Dr.)	9883583 A.R.	.16	FASTENER, trim panel to inner—(14.683)
72-74	Pass. (Sed.),			
75	Pass. (Sed.) (exc. Caprice)	9845480 R.H.	8.85	PANEL, rear door lower trim finish (paint as reqd.)
72-74	Pass. (Sed.),			
75	Pass. (Sed.) (exc. Caprice)	9845481 L.H.	8.85	PANEL, rear door lower trim finish (paint as reqd.)
72-75	Pass. (Sta. Wag.)	9845464 R.H.	8.90	PANEL, rear door lower trim finish (paint as reqd.)
72-75	Pass. (Sta. Wag.)	9845465 L.H.	8.90	PANEL, rear door lower trim finish (paint as reqd.)
73-74	Impala (Sed.)	9616598 R.H.	2.15	PANEL, upr. trim finish

**FOLDING TOP PARTS—INTERIOR TRIM**

**14.760 TRIM ASSY.—TAB—FASTENER—PANEL—RETAINER, Rear Door**

(Con't)

73-74	Impala (Sed.)	9616599 L.H.	2.15	PANEL, upr. trim finish
73-74	Impala, Caprice (Sta. Wag.)	9616677 R.H.	2.40	PANEL, upr. trim finish
73-74	Impala, Caprice (Sta. Wag.)	9616678 L.H.	2.40	PANEL, upr. trim finish
73-75	Chevelle (4-Dr.)	9650694 R.H.	9.40	PANEL, lower (prime and paint as reqd.)
73-75	Chevelle (4-Dr.)	9650695 L.H.	9.40	PANEL, lower (prime and paint as reqd.)
75	Caprice (4-Dr.)	9845494 R.H.	7.20	PANEL, rear door lower trim finish (paint as reqd.)
75	Caprice (4-Dr.)	9845495 L.H.	7.20	PANEL, rear door lower trim finish (paint as reqd.)
69-70	Pass. (4-Dr.)	7750582 4	.24	RETAINER, rear door belt trim support— (14.683)

**14.762 REST ASSY.—BASE—COVER ASSY.—PAD—PLUG—SCREW—NUT, Rear Door Arm—Less Tray**

66	Malibu (4-Dr.)			(comb. 739, 742) (blue) (less tray)
66	Malibu (Spt. Sed.),			
67	Malibu, Nova (4-Dr.)	4473160 R.H.	12.00	(comb. 759, 761, 762, 785, 786) (black)— (15.108)
66	Malibu (Spt. Sed.),			
67	Malibu, Nova (4-Dr.)	4473161 L.H.	12.00	(comb. 759, 761, 762, 785, 786) (black)— (15.108)
75	Nova (Sedan)	1667026 R.H.		(comb. 73G) (oxblood)
75	Nova (Sedan)	1667027 L.H.		(comb. 73G) (oxblood)
75	Nova (Sedan)	1667028 R.H.	17.55	(comb. 44D) (green)
75	Nova (Sedan)	1667029 L.H.	17.65	(comb. 44D) (green)
75	Nova (Custom) (Sedan)	1667020 R.H.	17.55	(black) (paint to match)
75	Nova (Custom) (Sedan)	1667021 L.H.	17.55	(black) (paint to match)
75	Nova (Custom) (Sedan)	1667035 L.H.	17.65	(comb. 55D, 55G, 55W, 55C) (sandstone)
68	Pass., Sta. Wag., 4-Dr. Sed. (exc. Spt. Sed., Biscayne),			
68	Impala (Spt. Sed.),			
68	Malibu, Concours (Sta. Wag.),			
68	Malibu (Sed.),			
68	4-Dr. (exc. Biscayne),			
68	Nomad (Custom),			
68	Chevelle (Deluxe) (4-Dr. Sed.),			
68	Biscayne (4-Dr.)	7753076 R.H.	3.75	BASE (paint as reqd.) (cut-out 2.66 x 1.24)
68-70	Pass. (4-Dr.),			
68-72	Chevelle (Sedan)	8769898 R.H.	3.35	BASE (black) (paint as required)
68-70	Pass. (4-Dr.),			
68-72	Chevelle (Sed.)	8769899 L.H.	3.35	BASE (black) (paint as required)
69	Biscayne (4-Dr. Sed.)	8769926 R.H.	5.20	BASE, (comb. 829) (black)
69	Biscayne (4-Dr. sed.)	8769927 L.H.	5.20	BASE, (comb. 829) (black)
69-72	Chevelle (Sta. Wag.) (exc. Nomad)	8769592 R.H.	4.35	BASE (black) (paint as reqd.)
68	Pass., Chevelle (4-Dr.),			
69-72	Chevelle (Sta. Wag.) (exc. Nomad)	8769593 L.H.	4.35	BASE (black) (paint as reqd.)
69-74	Chevy (Sed.)	8769636 R.H.	4.35	BASE (black) (paint as reqd.)
69-74	Chevy (Sed.)	8769637 L.H.	4.35	BASE (black) (paint as reqd.)
68-70	Pass., Chevelle (4-Dr.),			
71-72	Chevelle (4-Dr.) (exc. Sta. Wag.)	7766744 R.H.	8.95	COVER ASSY. (comb. 701, 702, 703, 704, 705, 751, 752, 753, 754, 755, 757, 760, 762, 764, 765, 768, 803, 804, 805, 806, 808, 811, 814) (765/118, 390/765/960)
68-70	Pass., Chevelle (4-Dr.),			
71-72	Chevelle (4-Dr.) (exc. Sta. Wag.)	7766745 1	8.95	COVER ASSY., left (comb. 701, 702, 703, 704, 705, 751, 752, 753, 754, 755, 757, 760, 762, 764, 765, 768, 802, 803, 804, 805, 806, 807, 808, 811, 814) (765/118, 390/765/960) (black) (cut-out 2.44 x 1.52)
71-72	Chevelle (4-Dr.) (exc. Sta. Wag.)	7766745 1	8.95	COVER ASSY., left (comb. 701, 703, 704, 705, 751, 752, 753, 754, 755, 760, 762, 764, 765, 768, 802, 803, 804, 805, 806, 807, 808, 811, 814) (765/118, 390/765/960) (black) (cut-out 2.44 x 1.52)
68-72	Pass. (4-Dr.)	7766521 L.H.	6.80	COVER ASSY. (comb. 802, 803, 804, 805, 806, 807, 808, 811, 814) (black)
68	Pass. (4-Dr.),			
68	Pass. (4-Dr.),			
68	Chevelle (4-Dr.),			

**FOLDING TOP PARTS—INTERIOR TRIM**

**14.762 REST ASSY.— BASE— COVER ASSY.— PAD— PLUG— SCREW— NUT,  
Rear Door Arm— Less Tray (Con't)**

68	Chevelle, Sta. Wag. (exc. Nomad) . . . . .				<b>COVER</b> (comb. 703, 705, 752, 755, 802, 803, 804, 805, 806, 807, 808, 811, 814), (comb. 760, 762, 763, 764, 765, 768), . . . . .
69	Greenbrier, Concours . . . . .				
71-72	Chevelle (Sta. Wag.) (exc. Nomad) . . . . .	<b>7766521</b>	L.H.	6.80	(comb. 763/217/765/930) (black) (cut-out 2.66 x 1.25) (Note 2) . . . . .
68-72	Nova (4-Dr.),				
73-74	Nova (Custom) (Sedan) . . . . .	<b>9645372</b>	R.H.	6.35	<b>COVER ASSY.</b> (comb. 731, 731D, 732, 734, 752, 753, 750, 751, 754) (black) . . . . .
68-72	Nova (4-Dr.),				
73-74	Nova (Custom) (Sedan) . . . . .	<b>9645373</b>	L.H.	6.35	<b>COVER ASSY.</b> (comb. 731, 731D, 732, 734, 752, 753, 750, 751, 754) (black) . . . . .
72	Nova (4-Dr.) . . . . .	<b>9891356</b>	R.H.	5.50	<b>COVER ASSY.</b> (comb. 761) (dk. green) . . . . .
72	Nova (4-Dr.) . . . . .	<b>9891357</b>	L.H.	5.50	<b>COVER ASSY.</b> (comb. 761) (dk. green) . . . . .
73	Nova (Custom) (Sedan) . . . . .	<b>9645364</b>	R.H.	6.35	<b>COVER ASSY.</b> (comb. 770) (green) . . . . .
73	Nova (Custom) (Sedan) . . . . .	<b>9645365</b>	L.H.	6.35	<b>COVER ASSY.</b> (comb. 770) (green) . . . . .
73-74	Nova (Custom) (Sedan) . . . . .	<b>9645374</b>	R.H.	6.35	<b>COVER ASSY.</b> (comb. 766, 769) (neutral) . . . . .
73-74	Nova (Custom) (Sedan) . . . . .	<b>9645375</b>	L.H.	6.35	<b>COVER ASSY.</b> (comb. 766, 769) (neutral) . . . . .
74	Nova (Custom) (Sedan) . . . . .	<b>9695760</b>	R.H.	6.35	<b>COVER ASSY.</b> (comb. 757) (green) . . . . .
74	Nova (Custom) (Sedan) . . . . .	<b>9695761</b>	L.H.	6.35	<b>COVER ASSY.</b> (comb. 757) (green) . . . . .
72	Pass. (Sed.),				
73-75	Pass. (Sed.),				
75	Pass. (4-Dr.) . . . . .	<b>9879428</b>	R.H.	2.15	<b>PAD</b> (black) (paint to match) . . . . .
72	Pass. (Sed.),				
73-75	Pass. (Sed.),				
75	Pass. (4-Dr.) . . . . .	<b>9879429</b>	L.H.	2.15	<b>PAD</b> (black) (paint to match) . . . . .
72	Biscayne, Bel Air, Impala, Caprice (Spt. Sed.) . . . . .	<b>9879428</b>	R.H.	2.15	<b>PAD</b> (black) (paint to match) . . . . .
72	Biscayne, Bel Air, Impala, Caprice (Spt. Sed.) . . . . .	<b>9879429</b>	L.H.	2.15	<b>PAD</b> (black) (paint to match) . . . . .
72	Pass. (Sta. Wag.), Kingswood . . . . .	<b>9879448</b>	R.H.	2.45	<b>PAD</b> (black) (paint) (repl. 9879454, 9892306, 9892308) . . . . .
72	Pass. (Sta. Wag.), Kingswood . . . . .	<b>9879449</b>	L.H.	2.45	<b>PAD</b> (black) (paint) (repl. 9879455, 9892309) . . . . .
73	Bel Air (Sedan) . . . . .	<b>9879428</b>	R.H.	2.15	<b>PAD ASSY.</b> (paint to match) . . . . .
73	Bel Air (Sedan) . . . . .	<b>9879429</b>	L.H.	2.15	<b>PAD ASSY.</b> (paint to match) (repl. 9892292) . . . . .
73-74	Impala, Caprice (Sedan) . . . . .	<b>9879428</b>	R.H.	2.15	<b>PAD ASSY.</b> (paint to match) . . . . .
73-74	Impala, Caprice (Sedan) . . . . .	<b>9879429</b>	L.H.	2.15	<b>PAD ASSY.</b> (paint to match) . . . . .
73-75	Impala, Caprice (Sta. Wag.) . . . . .	<b>9879448</b>	R.H.	2.45	<b>PAD ASSY.</b> (black) (paint to match) . . . . .
73-75	Impala, Caprice (Sta. Wag.) . . . . .	<b>9879449</b>	L.H.	2.45	<b>PAD ASSY.</b> (comb. 802, 806, 19W) (black) (paint to match) . . . . .
73-75	Chevelle (4-Dr.),				
73	Laguna (4-Dr.) Malibu (Spt. Sed.),				
74	Malibu (Classic) (4-Dr.) . . . . .	<b>9650652</b>	2	5.50	<b>PAD ASSY.</b> , lower trim finish panel (black) (paint as reqd.) . . . . .
74-75	Pass. (Sedan) . . . . .	<b>9687106</b>	R.H.	1.25	<b>PAD ASSY.</b> (comb. 850, 851, 852, 853, 855, 44) (green) . . . . .
74-75	Pass. (Sedan) . . . . .	<b>9687107</b>	L.H.	1.25	<b>PAD ASSY.</b> (comb. 850, 851, 852, 853, 855, 44) (green) . . . . .
74	Chevelle (Sedan),				
74	Malibu (Classic) (Sta. Wag.),				
75	Chevelle (4-Dr.) . . . . .	<b>9650652</b>	2	5.50	<b>PAD ASSY.</b> , lower trim finish panel (paint as reqd.) . . . . .
75	Pass. (Sedan) . . . . .	<b>9654605</b>	R.H.		<b>PAD ASSY.</b> (comb. 63) (saddle) . . . . .
75	Pass. (Sedan) . . . . .	<b>9654606</b>	L.H.		<b>PAD ASSY.</b> (comb. 63) (saddle) . . . . .
75	Pass. (Sta. Wag.) . . . . .	<b>9879448</b>	R.H.	2.45	<b>PAD ASSY.</b> (paint to match) . . . . .
75	Pass. (Sta. Wag.) . . . . .	<b>9879449</b>	L.H.	2.45	<b>PAD ASSY.</b> (paint to match) . . . . .
75	Pass. (Sta. Wag.) . . . . .	<b>9879448</b>	R.H.	2.45	<b>PAD ASSY.</b> (paint to match) . . . . .
75	Pass. (Sta. Wag.) . . . . .	<b>9879449</b>	L.H.	2.45	<b>PAD ASSY.</b> (paint to match) . . . . .
68-72	Pass., Chevy, Chevelle (4-Dr.),				
69	Pass. 4-Dr. Sed.,				
68-70	Nova (Sed.),				
69	Sta. Wag. (exc. Townsman) . . . . .	<b>9818351</b>	2	.16	<b>PLUG</b> , base (black) . . . . .
70	Nova (4-Dr.) . . . . .				<b>PLUG</b> (comb. 744), . . . . .
70	Malibu (Sed.) . . . . .				(comb. 782, 786, 795), . . . . .
70	Bel Air, Impala, Caprice, Kingswood (4-Dr.) . . . . .	<b>9818351</b>	2	.16	<b>PLUG</b> , base (paint as reqd.) . . . . .
70	Impala, Caprice, Malibu (Sed.),				
71	Malibu (Sed.) (exc. Spt. Sed.),				

**FOLDING TOP PARTS—INTERIOR TRIM**

**14.762 REST ASSY.— BASE— COVER ASSY.— PAD— PLUG— SCREW— NUT,  
Rear Door Arm— Less Tray (Con't)**

73-74	Nova (Custom) (4-Dr.)	9818351	2	.16	PLUG, base (comb. 721, 779, 844, 845) (med. turq.)
68-69	Malibu (Spt. Sed.),				
68-70	Impala, Caprice, Kingswood (4- Dr.),				
70	Monte Carlo	7768480	6	.18	SCREW, rear door arm rest to inner panel— (14.686)
62-64	Chevy	161742	A.R.	.11	SCREW, arm rest to inner panel
62-63	Chevy Std. (4-Dr.)	447124	A.R.	.18	SCREW, arm rest to panel (No. 14— 10 x 2)
65	Chevy, Chevelle	9417479	2	.06	SCREW, arm rest to pnl. frt. (No. 8— 18 x 1)
68-70	Chevelle (4-Dr.) (exc. Nomad),				
68-70	Pass. (exc. Impala, Caprice, Kingswood)	9824833	6	.16	SCREW, rear door a/rest to inner panel (round head self drilling, 1/4"— 16 x 1 1/2")— (14.686)
62-64	Chevy	4833166	4	.12	NUT, anchor

**14.764 COVER— EMBLEM— HANDLE— MOULDING— NUT— PANEL— PLATE—  
RETAINER— SCREW— STRAP, Rear Door Trim Finish**

72-75	Bel Air (Taxi)	8791100	A.R.	1.60	rear door upper pull strap
71-72	Kingswood (2nd design)	9876739	2	.39	EMBLEM, rear door trim pad (59/64" x 5/8")— (14.691)
72	Caprice (exc. Sta. Wag.)	9872392	2	2.95	EMBLEM, rr. dr. upper trim pad
70	Biscayne	8802269	1		HANDLE ASSY., rr. door pull (repl. 8802275)
71	Biscayne (New York Taxi)	9874064	2	8.80	HANDLE ASSY., rear door pull (black)
72	Biscayne (New York Taxi)	9891765	2	10.85	HANDLE ASSY., rear door pull (black)
68	Malibu, Concours (4-Dr. Sed., Sta. Wag.),				
68	Bel Air, Impala, Caprice (4-Dr. Sed.) (exc. Biscayne)	7745078	4	.52	MOULDING ASSY., frt. rr. door— (14.688)
71-72	Caprice (Spt. Sed.)	9826986	R.H.	16.90	MOULDING ASSY., trim pad upper
71-72	Caprice (Spt. Sed.)	9826987	L.H.	16.90	MOULDING ASSY., trim pad upper
74-75	Malibu (Classic) (4-Dr.)	9825032	2	1.20	MOULDING ASSY., trim pad upper and lower
66	Nova (4-Dr.),				
69	Kingswood Estate Wag.	4450956	6	.14	NUT, trim pad emblem to fdtn.— (14.691)
72	Pass. (Sed.)	9845480	R.H.	8.85	PANEL, rear door lower trim finish (paint as reqd.)
72	Pass. (Sed.)	9845481	L.H.	8.85	PANEL, rear door lower trim finish (paint as reqd.)
72	Pass. (Sta. Wag.)	9845464	R.H.	8.90	PANEL, rear door lower trim finish (paint as reqd.)
72	Pass. (Sta. Wag.)	9845465	L.H.	8.90	PANEL, rear door lower trim finish (paint as reqd.)
71-75	Pass. (4-Dr. Sed.) (New York Taxi)	9826566	2	1.40	PLATE, trim panel hanger
71-75	Pass. (Sta. Wag.)	9664987	2	1.70	PLATE, trim panel hanger
71-75	Pass. (4-Dr.)	9830908	R.H.	3.10	PLATE, lower hanger support
71-75	Pass. (4-Dr.)	9830909	L.H.	3.10	PLATE, lower hanger support
71-72	Biscayne (New York Taxi)	9874046	2	.58	PLATE, pull handle hinge front
71-72	Biscayne (New York Taxi),				
74-75	Bel Air (Taxi)	9827699	2	.63	PLATE, pull handle hinge rear
73-75	Chevelle (4-Dr.)	9858530	2	1.80	PLATE, hanger lower trim panel
73-74	Chevelle (Sed., Sta. Wag.)	9873923	2	1.40	RETAINER ASSY., supt. front and rear— (14.683)
71	Caprice (Spt. Sed.),				
69	Taxi	9428078	4	.11	SCREW, pull handle to inner pnl. (New York Type)— (8.977)
72	Biscayne (New York Taxi)	9891765	2	10.85	STRAP, rear door upper pull (comb. 801) (black)
73-75	Bel Air (Taxi)	9643868	2	8.65	STRAP ASSY., upper pull escut.
75	Nova (Sedan) (exc. Custom)	9657781	2	.58	STRAP ASSY., upper pull (paint to match)

FOLDING TOP PARTS—INTERIOR TRIM

14.800 TRIM ASSY., Front Seat Back and Back of Back

PASS.

73-74	Impala (Spt. Cpe.)	9628313	1	78.75	pass. (comb. 802) (black & white)
73-74	Impala (Spt. Cpe.)	9628314	1	78.75	driver (comb. 802) (black & white)
73-74	Impala (Spt. Cpe.)				
74	Pass. (Conv.)	9628323	1	76.75	pass. (comb. 806) (black)
73-74	Impala (Spt. Cpe.)				
74	Pass. (Conv.)	9628324	1	76.75	driver (comb. 806) (black)
73-74	Impala (Spt. Cpe.)	9665295	1	76.75	driver (comb. 813) (midn. blue)
73-74	Impala (Spt. Cpe.)	9665296	1	76.75	pass. (comb. 813) (midn. blue)
73-74	Pass. (Conv.)				
73-74	Impala (Spt. Cpe.)	9628327	1	76.75	pass. (comb. 818, 819) (neutral)
73-74	Pass. (Conv.)				
73-74	Impala (Spt. Cpe.)	9628328	1	76.75	driver (comb. 818, 819) (neutral)
73-74	Caprice (Sta. Wag.)				
73-74	Impala (4-Dr.)	9732430	1	133.00	front seat (comb. 813) (midn. blue)
73-74	Caprice (Sta. Wag.)				
73-74	Impala (4-Dr.)	9732431	1	133.00	front seat (comb. 818, 819) (neutral)
73	Impala (Sed.)	9628306	1	139.00	front seat (comb. 815) (neutral)
73	Impala (Sed.)	9628307	1	139.00	front seat (comb. 829) (green)
73	Bel Air (Sed.)	9628294	1	103.00	front seat (comb. 827) (green)
73	Bel Air (Sed.)	9628297	1	103.00	front seat (comb. 828) (green)
73	Bel Air (Sta. Wag.)	9628293	1	103.00	front seat (comb. 825) (saddle)
73-74	Caprice (Sta. Wag.)	9628298	1	133.00	front seat (comb. 806) (black)
73	Impala 4-Dr.				
74	Bel Air (Sedan)	9675878	1	103.00	front seat (comb. 803) (black)
74	Bel Air (Sedan)	9675879	1	103.00	front seat (comb. 815) (neutral)
74	Bel Air (Sedan)	9675880	1	103.00	front seat (comb. 852) (green)
74	Bel Air	9675876	1	103.00	front seat (comb. 817) (neutral)
74	Bel Air	9675877	1	103.00	front seat (comb. 851) (green)
74	Impala (Spt. Cpe.)	9675649	1	78.75	pass. (comb. 805) (black)
74	Impala (Spt. Cpe.)	9675636	1	78.75	driver (comb. 805) (black)
74	Impala (Spt. Cpe.)	9675650	1	78.75	pass. (comb. 821) (neutral)
74	Impala (Spt. Cpe.)	9675637	1	78.75	driver (comb. 821) (neutral)
74	Impala (Spt. Cpe.)	9675651	1	78.75	pass. (comb. 847) (midn. blue)
74	Impala (Spt. Cpe.)	9675638	1	78.75	driver (comb. 847) (midn. blue)
74	Impala (Spt. Cpe.)	9675652	1	78.75	pass. (comb. 853) (green)
74	Impala (Spt. Cpe.)	9675639	1	78.75	driver (comb. 853) (green)
74	Impala (Spt. Cpe.)	9729458	1	78.75	pass. (comb. 849) (saddle)
74	Impala (Spt. Cpe.)	9729456	1	76.00	driver (comb. 849) (saddle)
74	Impala (Spt. Cpe.)	9729459	1	78.75	pass. (comb. 858) (saddle and black)
74	Impala (Spt. Cpe.)	9729457	1	78.75	driver (comb. 858) (saddle and black)
74	Impala (Spt. Cpe.)				
74	Impala (Spt. Cpe.) Pass. (Conv.) (exc. Custom)	1666306	1	80.25	pass. (comb. 804, 809, 810) (white)
74	Impala (Spt. Cpe.) Pass. (Conv.) (exc. Custom)	1666305	1	80.25	driver (comb. 804, 809, 810) (white)
74	Pass. (Conv.)	9675661	1	76.75	pass. (comb. 855) (green)
74	Impala (Spt. Cpe.)				
74	Pass. (Conv.)	9675648	1	78.75	driver (comb. 855) (green)
74	Impala (Sedan)	9675601	1	139.00	front seat (comb. 805) (black)
74	Impala (Sedan)	9675602	1	139.00	front seat (comb. 821) (neutral)
74	Impala (Sedan)	9675603	1	139.00	front seat (comb. 847) (midn. blue)
74	Impala (Sedan)	9675604	1	139.00	front seat (comb. 853) (green)
73-74	Impala (Sedan)				
74	Impala, Caprice (exc. Coupe)	9732434	1	139.00	front seat (comb. 802) (black and white)
74	Impala	9675614	1	133.00	front seat (comb. 855) (green)
74	Impala (Sedan, Sta. Wag.)	9732429	1	133.00	front seat (comb. 806) (black)
74	Impala (Sedan, Sta. Wag.)				
74	Impala, Caprice (Sta. Wag.)	1690376	1	139.00	front seat (comb. 858) (saddle and black)
74	Impala, Caprice (Sta. Wag.)	1690377	1	139.00	front seat (comb. 859) (black and green)
74	Caprice (Sta. Wag.)	9675613	1	133.00	front seat (comb. 849) (saddle)
74	Caprice (Spt. Cpe.)	9684146	1	116.00	pass. (comb. 840) (black)
74	Caprice (Spt. Cpe.)	9684139	1	116.00	driver (comb. 840) (black)
74	Caprice (Spt. Cpe.)	9684147	1	116.00	pass. (comb. 843) (midn. blue)
74	Caprice (Spt. Cpe.)	9684140	1	116.00	driver (comb. 843) (midn. blue)
74	Caprice (Spt. Cpe.)	9684148	1	116.00	pass. (comb. 850) (green)
74	Caprice (Spt. Cpe.)	9684141	1	116.00	driver (comb. 850) (green)
74	Caprice (Spt. Cpe.)	9684149	1	116.00	pass. (comb. 857) (oxblood)
74	Caprice (Spt. Cpe.)	9684142	1	116.00	driver (comb. 857) (oxblood)
74	Caprice (Spt. Cpe.)	9684150	1	116.00	pass. (comb. 896) (taupe)
74	Caprice (Spt. Cpe.)	9684143	1	116.00	driver (comb. 896) (taupe)
74	Caprice (Spt. Cpe.)	9684151	1	106.00	pass. (comb. 808) (black)
74	Caprice (Spt. Cpe.)	9684144	1	106.00	driver (comb. 808) (black)

FOLDING TOP PARTS—INTERIOR TRIM

14.800 TRIM ASSY., Front Seat Back and Back of Back (Con't)

74	Caprice (Spt. Cpe.)	9684152	1	106.00	pass. (comb. 841) (neutral)
74	Caprice (Spt. Cpe.)	9684145	1	106.00	driver (comb. 841) (neutral)
74	Caprice (Sedan)	9684076	1	862.00	front seat (comb. 840) (black)
74	Caprice (Sedan)	9684077	1	215.00	front seat (comb. 843) (midn. blue)
74	Caprice (Sedan)	9684078	1	215.00	front seat (comb. 850) (green)
74	Caprice (Sedan)	9684079	1	215.00	front seat (comb. 857) (oxblood)
74	Caprice (Sedan)	9684080	1	215.00	front seat (comb. 896) (taupe)
74	Caprice (Sedan)	9684081	1	197.00	front seat (comb. 808) (black)
74	Caprice (Sedan)	9684082	1	197.00	front seat (comb. 841) (neutral)
74	Caprice w/reclining seat	9684111	1	106.00	pass. (comb. 840) (black)
74	Caprice w/reclining seat	9684104	1	106.00	driver (comb. 840) (black)
74	Caprice w/reclining seat	9684112	1	106.00	pass. (comb. 843) (midn. blue)
74	Caprice w/reclining seat	9684105	1	106.00	driver (comb. 843) (midn. blue)
74	Caprice w/reclining seat	9684113	1	106.00	pass. (comb. 850) (green)
74	Caprice w/reclining seat	9684106	1	106.00	driver (comb. 850) (green)
74	Caprice w/reclining seat	9684114	1	106.00	pass. (comb. 857) (oxblood)
74	Caprice w/reclining seat	9684107	1	106.00	driver (comb. 857) (oxblood)
74	Caprice w/reclining seat	9684115	1	106.00	pass. (comb. 896) (taupe)
74	Caprice w/reclining seat	9684108	1	106.00	driver (comb. 896) (taupe)
74	Caprice w/reclining seat	9684116	1	96.75	pass. (comb. 808) (black)
74	Caprice w/reclining seat	9684109	1	96.75	driver (comb. 808) (black)
74	Caprice w/reclining seat	9684117	1	96.75	pass. (comb. 841) (neutral)
74	Caprice w/reclining seat	9684110	1	96.75	driver (comb. 841) (neutral)
75	Pass.	1662676	1	130.00	front seat (comb. 19C) (black)
75	Pass.	1662677	1	130.00	front seat (comb. 26C) (blue)
75	Pass.	1662678	1	130.00	front seat (comb. 55C) (sandstone)
75	Pass.	1663804	1	243.00	front seat (comb. 44B) (green)
75	Pass. (4-Dr.)	1658526	1	133.00	front seat (comb. 26V) (blue)
75	Pass. (4-Dr.)	1658527	1	133.00	front seat (comb. 55V) (sandstone)
75	Pass. (4-Dr.)	1663802	1	243.00	front seat (comb. 19B) (black)
75	Pass. (4-Dr.)	1663803	1	243.00	front seat (comb. 26B) (blue)
75	Pass. (4-Dr.)	1663805	1	243.00	front seat (comb. 55B) (sandstone)
75	Pass. (4-Dr.)	1663806	1	243.00	front seat (comb. 73B) (oxblood)
75	Pass. (4-Dr.)	1663807	1	216.00	front seat (comb. 19H) (black)
75	Pass. (4-Dr.)	1663808	1	216.00	front seat (comb. 55H) (sandstone)
75	Pass. (4-Dr.)	1665181	1	164.00	front seat (comb. 63W) (saddle)
75	Pass. (4-Dr.)	1665183	1	184.00	front seat (comb. 19D) (black)
75	Pass. (4-Dr.)	1665184	1	184.00	front seat (comb. 26D) (blue)
75	Pass. (4-Dr.)	1665185	1	184.00	front seat (comb. 44D) (green)
75	Pass. (4-Dr.)	1665186	1	184.00	front seat (comb. 55D) (sandstone)
75	Pass. (4-Dr.)	1665187	1	166.00	front seat (comb. 63E) (saddle)
75	Pass. (4-Dr.)	1665177	1	164.00	front seat (comb. 19W) (black)
75	Pass. (4-Dr.)	1665178	1	164.00	front seat (comb. 26W) (blue)
75	Pass. (4-Dr.)	1665179	1	164.00	front seat (comb. 44W) (green)
75	Pass. (4-Dr.)	1665180	1	164.00	front seat (comb. 55W) (sandstone)
75	Pass. (2-Dr.)	1665232	1	91.75	pass. (comb. 02W, 04W, 07W, 11W) (white)
75	Pass. (2-Dr.)	1665233	1	91.75	driver (comb. 02W, 04W, 07W, 11W) (white)
75	Pass. (2-Dr.)	1663848	1	153.00	pass. (comb. 19B) (black)
75	Pass. (2-Dr.)	1663849	1	153.00	driver (comb. 19B) (black)
75	Pass. (2-Dr.)	1663850	1	153.00	pass. (comb. 26B) (blue)
75	Pass. (2-Dr.)	1663851	1	153.00	driver (comb. 26B) (blue)
75	Pass. (2-Dr.)	1663852	1	153.00	pass. (comb. 44B) (green)
75	Pass. (2-Dr.)	1663853	1	153.00	driver (comb. 44B) (green)
75	Pass. (2-Dr.)	1663854	1	153.00	pass. (comb. 55B) (sandstone)
75	Pass. (2-Dr.)	1663855	1	153.00	driver (comb. 55B) (sandstone)
75	Pass. (2-Dr.)	1663856	1	153.00	pass. (comb. 73B) (oxblood)
75	Pass. (2-Dr.)	1663857	1	153.00	driver (comb. 73B) (oxblood)
75	Pass. (2-Dr.)	1663858	1	139.00	pass. (comb. 19H) (black)
75	Pass. (2-Dr.)	1663859	1	139.00	driver (comb. 19H) (black)
75	Pass. (2-Dr.)	1663860	1	139.00	pass. (comb. 55H) (sandstone)
75	Pass. (2-Dr.)	1663861	1	139.00	driver (comb. 55H) (sandstone)
75	Pass. (2-Dr.)	1665218	1	101.00	pass. (comb. 19D) (black)
75	Pass. (2-Dr.)	1665219	1	101.00	driver (comb. 19D) (black)
75	Pass. (2-Dr.)	1665220	1	101.00	pass. (comb. 26D) (blue)
75	Pass. (2-Dr.)	1665221	1	101.00	driver (comb. 26D) (blue)
75	Pass. (2-Dr.)	1665222	1	101.00	pass. (comb. 44D) (green)
75	Pass. (2-Dr.)	1665223	1	101.00	driver (comb. 44D) (green)
75	Pass. (2-Dr.)	1665224	1	101.00	pass. (comb. 55D) (sandstone)
75	Pass. (2-Dr.)	1665225	1	101.00	driver (comb. 55D) (sandstone)
75	Pass. (2-Dr.)	1665228	1	95.50	pass. (comb. 63E) (saddle)
75	Pass. (2-Dr.)	1665229	1	95.50	driver (comb. 63E) (saddle)
75	Pass. (2-Dr.)	1665232	1	91.75	pass. (comb. 02W, 07W, 11W) (white)
75	Pass. (2-Dr.)	1665233	1	91.75	driver (comb. 02W, 07W, 11W) (white)



**FOLDING TOP PARTS—INTERIOR TRIM**

**14.800 TRIM ASSY., Front Seat Back and Back of Back (Con't)**

75	Pass. (2-Dr.)	1665234	1	91.75	pass. (comb. 19W) (black)
75	Pass. (2-Dr.)	1665235	1	91.75	driver (comb. 19W) (black)
75	Pass. (2-Dr.)	1665236	1	91.75	pass. (comb. 26W) (blue)
75	Pass. (2-Dr.)	1665237	1	91.75	driver (comb. 26W) (blue)
75	Pass. (2-Dr.)	1665238	1	91.75	pass. (comb. 44W) (green)
75	Pass. (2-Dr.)	1665239	1	91.75	driver (comb. 44W) (green)
75	Pass. (2-Dr.)	1665240	1	91.75	pass. (comb. 55W) (sandstone)
75	Pass. (2-Dr.)	1665241	1	91.75	driver (comb. 55W) (sandstone)
75	Pass. (2-Dr.)	1665242	1	91.75	pass. (comb. 63W) (saddle)
75	Pass. (2-Dr.)	1665243	1	91.75	driver (comb. 63W) (saddle)
75	Pass. w/reclining seat	1666228	1	104.00	pass. (comb. 19D) (black)
75	Pass. w/reclining seat	1666229	1	104.00	driver (comb. 19D) (black)
75	Pass. w/reclining seat	1666230	1	104.00	pass. (comb. 26D) (blue)
75	Pass. w/reclining seat	1666231	1	104.00	driver (comb. 26D) (blue)
75	Pass. w/reclining seat	1666232	1	104.00	pass. (comb. 44D) (green)
75	Pass. w/reclining seat	1666233	1	104.00	driver (comb. 44D) (green)
75	Pass. w/reclining seat	1666234	1	104.00	pass. (comb. 55D) (sandstone)
75	Pass. w/reclining seat	1666235	1	104.00	driver (comb. 55D) (sandstone)
75	Pass. w/reclining seat	1666238	1	102.00	pass. (comb. 63E) (saddle)
75	Pass. w/reclining seat	1666239	1	102.00	driver (comb. 63E) (saddle)
75	Pass. w/reclining seat	1666242	1	98.00	pass. (comb. 26W) (blue)
75	Pass. w/reclining seat	1666243	1	98.00	driver (comb. 26W) (blue)
75	Pass. w/reclining seat	1666244	1	98.00	pass. (comb. 44W) (green)
75	Pass. w/reclining seat	1666245	1	98.00	driver (comb. 44W) (green)
75	Pass. w/reclining seat	1666246	1	98.00	pass. (comb. 55W) (sandstone)
75	Pass. w/reclining seat	1666247	1	98.00	driver (comb. 55W) (sandstone)
75	Pass. w/reclining seat	1666248	1	98.00	pass. (comb. 63W) (saddle)
75	Pass. w/reclining seat	1666249	1	98.00	driver (comb. 63W) (saddle)
75	Pass. w/reclining seat	1663830	1	133.00	pass. (comb. 19B) (black)
75	Pass. w/reclining seat	1663831	1	133.00	driver (comb. 19B) (black)
75	Pass. w/reclining seat	1663832	1	133.00	pass. (comb. 26B) (blue)
75	Pass. w/reclining seat	1663833	1	133.00	driver (comb. 26B) (blue)
75	Pass. w/reclining seat	1663834	1	133.00	pass. (comb. 44B) (green)
75	Pass. w/reclining seat	1663835	1	133.00	driver (comb. 44B) (green)
75	Pass. w/reclining seat	1663836	1	133.00	pass. (comb. 55B) (sandstone)
75	Pass. w/reclining seat	1663837	1	133.00	driver (comb. 55B) (sandstone)
75	Pass. w/reclining seat	1663838	1	133.00	pass. (comb. 73B) (oxblood)
75	Pass. w/reclining seat	1663839	1	133.00	driver (comb. 73B) (oxblood)
75	Pass. w/reclining seat	1663842	1	126.00	pass. (comb. 19H) (black)
75	Pass. w/reclining seat	1663843	1	126.00	driver (comb. 19H) (black)
75	Pass. w/reclining seat	1663844	1	126.00	pass. (comb. 55H) (sandstone)
75	Pass. w/reclining seat	1663845	1	126.00	driver (comb. 55H) (sandstone)

**CHEVY—NOVA**

69-70	(2-Dr.)	9848926	2		driver and pass. (black) (repl. 8718751)
72	Nova (2-Dr.)	9890614	1		pass. (comb. 760) (green)
72	Nova (4-Dr.)	9890632	1		front (comb. 764) (covert)
73	Nova (Cpe.) (exc. Custom)	9646034	1	52.50	driver (comb. 751) (black)
73	Nova (Cpe.) (exc. Custom)	9646038	1	53.00	driver (comb. 767) (chamois)
73	Nova (Sed.) (exc. Custom)	9662880	1		front seat (comb. 765) (black)
73	Nova (Sed.) (exc. Custom)	9662881	1		front seat (comb. 768) (neutral)
73	Nova (Sed.) (exc. Custom)	9646044	1	89.75	front seat (comb. 757) (green)
73	Nova (Custom) (Cpe.)	9646062	1	63.25	driver (comb. 752) (black & white)
73	Nova (Custom) (Cpe.)	9646067	1	63.25	pass. (comb. 764) (neutral)
73	Nova (Custom) (Cpe.)	9646066	1	63.25	driver (comb. 764) (neutral)
74	Nova (Sedan) (exc. Custom)	9692601	1	89.75	front seat (comb. 753) (black)
74	Nova (Sedan) (exc. Custom)	9692602	1	89.75	front seat (comb. 758) (green)
74	Nova (Sedan) (exc. Custom)	9692603	1	89.75	front seat (comb. 765) (neutral)
74	Nova (Sedan) (exc. Custom)	9692604	1	89.75	front seat (comb. 772) (midn. blue)
74	Nova (Sedan) (exc. Custom)	9692605	1	86.75	front seat (comb. 750) (black and white)
74	Nova (Sedan) (exc. Custom)	9692606	1	86.75	front seat (comb. 756) (green and black)
74	Nova (Sedan) (exc. Custom)	9692607	1	86.75	front seat (comb. 764) (neutral and black)
74	Nova (Sedan) (exc. Custom)	9732157	1	85.50	front seat (comb. 769) (black)
74	Nova (Sedan) (exc. Custom)	9732158	1	85.50	front seat (comb. 768) (neutral)
74	Nova (Sedan) (exc. Custom)	1658357	1	89.75	front seat (comb. 825) (black)
74	Nova (Sedan) (exc. Custom)	1658303	1	89.75	front seat (comb. 826) (mid. blue)
74	Nova (Sedan) (exc. Custom)	1658301	1	89.75	front seat (comb. 828) (green)
74	Nova (Sedan) (exc. Custom)	1658302	1	89.75	front seat (comb. 829) (neutral)
74	Nova (H.B.) (exc. Custom)	9692638	1	53.00	pass. (comb. 773) (saddle)
74	Nova (H.B.) (exc. Custom)	9692643	1	53.00	driver (comb. 773) (saddle)
74	Nova (H.B.) (exc. Custom)	1658317	1	53.00	pass. (comb. 827) (saddle)
74	Nova (H.B.) (exc. Custom)	1658312	1	53.00	driver (comb. 827) (saddle)
74	Nova (Coupe) (exc. Custom)	9692644	1	51.50	pass. (comb. 750) (black and white)
74	Nova (Coupe) (exc. Custom)	9692647	1	51.50	driver (comb. 750) (black and white)
74	Nova (Coupe) (exc. Custom)	9692645	1	51.50	pass. (comb. 756) (green and black)

**FOLDING TOP PARTS—INTERIOR TRIM**

**14.800 TRIM ASSY., Front Seat Back and Back of Back (Con't)**

74	Nova (Coupe) (exc. Custom) . . . . .	9692648	1	51.50	driver (comb. 756) (green and black) . . . . .
74	Nova (Coupe) (exc. Custom) . . . . .	9692646	1	51.50	pass. (comb. 764) (neutral and black) . . . . .
74	Nova (Coupe) (exc. Custom) . . . . .	9692649	1	51.50	driver (comb. 764) (neutral and black) . . . . .
74	Nova (Coupe) (exc. Custom) . . . . .	9692634	1	53.00	pass. (comb. 753) (black) . . . . .
74	Nova (Coupe) (exc. Custom) . . . . .	9692639	1	53.00	driver (comb. 753) (black) . . . . .
74	Nova (Coupe) (exc. Custom) . . . . .	9692635	1	53.00	pass. (comb. 758) (green) . . . . .
74	Nova (Coupe) (exc. Custom) . . . . .	9692640	1	53.00	driver (comb. 758) (green) . . . . .
74	Nova (Coupe) (exc. Custom) . . . . .	9692636	1	53.00	pass. (comb. 765) (neutral) . . . . .
74	Nova (Coupe) (exc. Custom) . . . . .	9692641	1	53.00	driver (comb. 765) (neutral) . . . . .
74	Nova (Coupe) (exc. Custom) . . . . .	9692637	1	53.00	pass. (comb. 772) (midn. blue) . . . . .
74	Nova (Coupe) (exc. Custom) . . . . .	9692642	1	53.00	driver (comb. 772) (midn. blue) . . . . .
74	Nova (Coupe) (exc. Custom) . . . . .	1658313	1	53.00	pass. (comb. 825) (black) . . . . .
74	Nova (Coupe) (exc. Custom) . . . . .	1658308	1	53.00	driver (comb. 825) (black) . . . . .
74	Nova (Coupe) (exc. Custom) . . . . .	1658314	1	53.00	pass. (comb. 828) (green) . . . . .
74	Nova (Coupe) (exc. Custom) . . . . .	1658309	1	53.00	driver (comb. 828) (green) . . . . .
74	Nova (Coupe) (exc. Custom) . . . . .	1658315	1	53.00	pass. (comb. 829) (neutral) . . . . .
74	Nova (Coupe) (exc. Custom) . . . . .	1658310	1	53.00	driver (comb. 829) (neutral) . . . . .
74	Nova (Coupe) (exc. Custom) . . . . .	1658316	1	53.00	pass. (comb. 826) (mid. blue) . . . . .
74	Nova (Coupe) (exc. Custom) . . . . .	1658311	1	53.00	driver (comb. 826) (mid. blue) . . . . .
74	Nova (Custom) (Sedan) . . . . .	9692608	1	110.00	front seat (comb. 751) (black) . . . . .
74	Nova (Custom) (Sedan) . . . . .	9692609	1	110.00	front seat (comb. 757) (green) . . . . .
74	Nova (Custom) (Sedan) . . . . .	9692610	1	97.75	front seat (comb. 766) (neutral) . . . . .
74	Nova (Custom) (Sedan) . . . . .	9733036	1	99.00	front seat (comb. 754) (black) . . . . .
74	Nova (Custom) (Coupe) . . . . .	9692650	1	63.25	pass. (comb. 751) (black) . . . . .
74	Nova (Custom) (Coupe) . . . . .	9693254	1	63.25	driver (comb. 751) (black) . . . . .
74	Nova (Custom) (Coupe) . . . . .	9693251	1	63.25	pass. (comb. 752) (black and white) . . . . .
74	Nova (Custom) (Coupe) . . . . .	9693255	1	63.25	driver (comb. 752) (black and white) . . . . .
74	Nova (Custom) (Coupe) . . . . .	9693252	1	63.25	pass. (comb. 755) (green and black) . . . . .
74	Nova (Custom) (Coupe) . . . . .	9693256	1	63.25	driver (comb. 755) (green and black) . . . . .
74	Nova (Custom) (Coupe) . . . . .	9693253	1	63.25	pass. (comb. 771) (midn. blue) . . . . .
74	Nova (Custom) (Coupe) . . . . .	9693257	1	63.25	driver (comb. 771) (midn. blue) . . . . .
74	Nova (Custom) (Coupe) . . . . .	9693262	1	55.25	pass. (comb. 766) (neutral) . . . . .
74	Nova (Custom) (Coupe) . . . . .	9693263	1	55.25	driver (comb. 766) (neutral) . . . . .
74	Nova (Custom) (Coupe) . . . . .	9733037	1	55.25	pass. (comb. 754) (black) . . . . .
74	Nova (Custom) (Coupe) . . . . .	9733038	1	55.25	driver (comb. 754) (black) . . . . .
75	Nova . . . . .	1693354	1	75.00	pass. (comb. 02W, 04W, 07W, 11W) (white) . . . . .
75	Nova . . . . .	1693355	1	75.00	driver (comb. 02W, 04W, 07W, 11W) (white) . . . . .
75	Nova (2-Dr.) . . . . .	1655078	1	65.50	pass. (comb. 19C) (black) . . . . .
75	Nova (2-Dr.) . . . . .	1655079	1	65.50	driver (comb. 19C) (black) . . . . .
75	Nova (2-Dr.) . . . . .	1655080	1	65.50	pass. (comb. 26C) (blue) . . . . .
75	Nova (2-Dr.) . . . . .	1655081	1	65.50	driver (comb. 26C) (blue) . . . . .
75	Nova (2-Dr.) . . . . .	1655082	1	65.50	pass. (comb. 55C) (sandstone) . . . . .
75	Nova (2-Dr.) . . . . .	1655083	1	65.50	driver (comb. 55C) (sandstone) . . . . .
75	Nova (2-Dr.) . . . . .	1655086	1	59.00	pass. (comb. 19V) (black) . . . . .
75	Nova (2-Dr.) . . . . .	1655087	1	59.00	driver (comb. 19V) (black) . . . . .
75	Nova (2-Dr.) . . . . .	1655088	1	56.25	pass. (comb. 26V) (blue) . . . . .
75	Nova (2-Dr.) . . . . .	1655089	1	56.25	driver (comb. 26V) (blue) . . . . .
75	Nova (2-Dr.) . . . . .	1655090	1	59.00	pass. (comb. 55V) (sandstone) . . . . .
75	Nova (2-Dr.) . . . . .	1655091	1	59.00	driver (comb. 55V) (sandstone) . . . . .
75	Nova (2-Dr.) . . . . .	1655092	1	59.00	pass. (comb. 63V) (saddle) . . . . .
75	Nova (2-Dr.) . . . . .	1655093	1	59.00	driver (comb. 63V) (saddle) . . . . .
75	Nova (2-Dr.) . . . . .	1657508	1	75.00	pass. (comb. 19W) (black) . . . . .
75	Nova (2-Dr.) . . . . .	1657490	1	75.00	driver (comb. 19W) (black) . . . . .
75	Nova (2-Dr.) . . . . .	1657509	1	75.00	pass. (comb. 55W) (sandstone) . . . . .
75	Nova (2-Dr.) . . . . .	1657491	1	75.00	driver (comb. 55W) (sandstone) . . . . .
75	Nova (2-Dr.) . . . . .	1657510	1	75.00	pass. (comb. 63W) (saddle) . . . . .
75	Nova (2-Dr.) . . . . .	1657492	1	75.00	driver (comb. 63W) (saddle) . . . . .
75	Nova (2-Dr.) . . . . .	1657511	1	75.00	pass. (comb. 73W) (oxblood) . . . . .
75	Nova (2-Dr.) . . . . .	1657493	1	75.00	driver (comb. 73W) (oxblood) . . . . .
75	Nova (2-Dr.) . . . . .	1657495	1	85.50	pass. (comb. 19E) (black) . . . . .
75	Nova (2-Dr.) . . . . .	1657477	1	85.50	driver (comb. 19E) (black) . . . . .
75	Nova (2-Dr.) . . . . .	1657496	1	85.50	pass. (comb. 26D) (blue) . . . . .
75	Nova (2-Dr.) . . . . .	1657478	1	85.50	driver (comb. 26D) (blue) . . . . .
75	Nova (2-Dr.) . . . . .	1657497	1	85.50	pass. (comb. 44D) (green) . . . . .
75	Nova (2-Dr.) . . . . .	1657479	1	85.50	driver (comb. 44D) (green) . . . . .
75	Nova (2-Dr.) . . . . .	1657498	1	85.50	pass. (comb. 55D) (sandstone) . . . . .
75	Nova (2-Dr.) . . . . .	1657480	1	85.50	driver (comb. 55D) (sandstone) . . . . .
75	Nova (2-Dr.) . . . . .	1657499	1	85.50	pass. (comb. 63E) (saddle) . . . . .
75	Nova (2-Dr.) . . . . .	1657481	1	94.00	driver (comb. 63E) (saddle) . . . . .
75	Nova (4-Dr.) . . . . .	1654287	1	98.00	front seat (comb. 19V) (black) . . . . .
75	Nova (4-Dr.) . . . . .	1654288	1	93.25	front seat (comb. 26V) (blue) . . . . .
75	Nova (4-Dr.) . . . . .	1654289	1	98.00	front seat (comb. 55V) (sandstone) . . . . .

**FOLDING TOP PARTS—INTERIOR TRIM**

**14.800 TRIM ASSY., Front Seat Back and Back of Back (Con't)**

75	Nova (4-Dr.)	1654290	1	98.00	front seat (comb. 63V) (saddle)
75	Nova (4-Dr.)	1654283	1	111.00	front seat (comb. 19C) (black)
75	Nova (4-Dr.)	1654285	1	111.00	front seat (comb. 55C) (sandstone)
75	Nova (4-Dr.)	1654284	1	111.00	front seat (comb. 26C) (blue)
75	Nova (4-Dr.)	1657452	1	156.00	front seat (comb. 26D) (blue)
75	Nova (4-Dr.)	1657453	1	156.00	front seat (comb. 44D) (green)
75	Nova (4-Dr.)	1657454	1	156.00	front seat (comb. 55D) (sandstone)
75	Nova (4-Dr.)	1657456	1	134.00	front seat (comb. 19W) (black)
75	Nova (4-Dr.)	1657457	1	134.00	front seat (comb. 55W) (sandstone)

**CHEVELLE**

71-72	Chevelle Deluxe (Spt. Cpe.),				
71	El Camino (exc. Custom)	9839345	1	50.00	driver (comb. 703) (black)
71-72	Malibu (Spt. Cpe., Conv.),				
71	El Camino (Custom)	9839363	1	56.25	driver (comb. 704, 705) (black)
71	Malibu (Spt. Cpe., Conv.),				
71	El Camino (Custom)	9839365	1	56.25	driver (comb. 721) (dk. saddle)
71	Malibu (Spt. Cpe., Conv.),				
71	El Camino (Custom)	9839367	1	56.25	driver (comb. 731) (dk. jade)
71-72	Chevelle (Spt. Cpe.) (exc. Monte Carlo)	9839373	1	57.75	driver (comb. 704) (black)
71-72	Malibu, El Camino	9839377	2	64.50	pass. and driver (comb. 704, 706) (black)
71	Concours,				
71	Malibu (Spt. Sed.)	9839351	1	101.00	front (comb. 731) (dk. jade)
71	Concours,				
71	Malibu (Sed.) (exc. Spt. Sed.)	9839352	1	101.00	front (comb. 721) (dk. saddle)
71	Chevelle (4-Dr. Sed.)	9839357	1	105.00	front (comb. 725) (dk. blue)
71	Chevelle (4-Dr. Sed.)	9839358	1	105.00	front (comb. 730) (dk. jade)
72	Chevelle (Spt. Cpe.) (exc. Monte Carlo) El Camino	9898223	1	55.50	driver (comb. 720) (tan)
72	Chevelle (Spt. Cpe.) (exc. Monte Carlo),				
72	El Camino	9898225	1	55.50	driver (comb. 732) (covert)
72	Chevelle (Spt. Cpe., Conv.) exc. Monte Carlo	9898221	1	55.50	driver (comb. 713) (green)
72	Chevelle (4-Dr.)	9898214	1	104.00	front (comb. 713) (green)
72	Chevelle (Sed.)	9898216	1	104.00	front (comb. 732) (covert)
72	Chevelle (4-Dr.) exc. Spt. Sed.	9898215	1	104.00	front (comb. 720) (tan)
73	Deluxe (Sed.)	9627061	1	103.00	front seat (comb. 710) (green)
73	Malibu (Coupe)	9627089	1	66.25	driver (comb. 703) (black and white)
73	Malibu (Coupe)	9627095	1	66.25	driver (comb. 730) (green and black)
73	Malibu (Cpe.) El Camino (Custom)	9627096	1	62.25	pass. (comb. 704) (black)
73	Malibu (Cpe.) El Camino (Custom)	9627097	1	62.25	driver (comb. 704) (black)
73	Malibu (Cpe.) El Camino (Custom)	9627106	1	62.25	pass. (comb. 732) (neutral)
73	Malibu (Cpe.) El Camino (Custom)	9627107	1	62.25	driver (comb. 732) (neutral)
73	Malibu, Laguna (Cpe.),				
74	Laguna	9627116	1	65.00	pass. (comb. 707, 708) (black)
73	Malibu, Laguna (Cpe.),				
74	Laguna	9627117	1	65.00	driver (comb. 707, 708) (black)
73	Laguna (Cpe.)	9627118	1	65.00	pass. (comb. 709) (oxblood)
73	Laguna (Cpe.)	9627119	1	65.00	driver (comb. 709) (oxblood)
73	Monte Carlo	9627128	1	72.50	pass. (comb. 706) (black)
73	Monte Carlo	9627129	1	72.50	driver (comb. 706) (black)
73	Monte Carlo	9627134	1	72.50	pass. (comb. 731) (neutral)
73	Monte Carlo	9627136	1	72.50	pass. (comb. 740) (oxblood)
73-74	Monte Carlo	9667422	1	72.50	pass. (comb. 708, 709) (black)
73-74	Monte Carlo	9667418	1	72.50	driver (comb. 708, 709) (black)
73	Monte Carlo	9667423	1	72.50	pass. (comb. 728) (green)
73	Monte Carlo	9667424	1	72.50	pass. (comb. 735) (neutral)
74	Malibu (Sedan) (exc. Classic)	9680601	1	105.00	front seat (comb. 701) (black)
74	Malibu (Sedan) (exc. Classic)	9680602	1	105.00	front seat (comb. 723) (green)
74	Malibu (Sedan) (exc. Classic)	9680611	1	106.00	front seat (comb. 727, 738) (green)
74	Malibu (Sedan) (exc. Classic)	1658454	1	107.00	front seat (comb. 893, 894) (green)
74	Malibu (4-Dr.) (exc. Classic)	9680609	1	106.00	front seat (comb. 706) (black)
74	Malibu (4-Dr.) (exc. Classic)	9680610	1	106.00	front seat (comb. 713, 745) (neutral)
74	Malibu (4-Dr.) (exc. Classic)	1658452	1	107.00	front seat (comb. 891) (black)
74	Malibu (4-Dr.) (exc. Classic)	1658453	1	107.00	front seat (comb. 830, 892) (neutral)
74	Malibu (Coupe) (exc. Classic),				
74	El Camino (exc. Classic)	9680757	1	59.75	pass. (comb. 706) (black)
74	Malibu (Coupe) (exc. Classic),				
74	El Camino (exc. Classic)	9680758	1	59.75	driver (comb. 706) (black)

**FOLDING TOP PARTS—INTERIOR TRIM**

**14.800 TRIM ASSY., Front Seat Back and Back of Back (Con't)**

74	Malibu (Coupe) (exc. Classic),				
74	El Camino (exc. Classic) . . . . .	9680759	1	59.75	pass. (comb. 713, 745) (neutral) . . . . .
74	Malibu (Coupe) (exc. Classic),				
74	El Camino (exc. Classic) . . . . .	9680760	1	59.75	driver (comb. 713, 745) (neutral) . . . . .
74	Malibu (Coupe) (exc. Classic),				
74	El Camino (exc. Classic) . . . . .	9680761	1	59.75	pass. (comb. 727, 738) (green) . . . . .
74	Malibu (Coupe) (exc. Classic),				
74	El Camino (exc. Classic) . . . . .	9680762	1	59.75	driver (comb. 727, 738) (green) . . . . .
74	Malibu (Coupe) (exc. Classic),				
74	El Camino (exc. Classic) . . . . .	9680621	1	59.75	pass. (comb. 701) (black) . . . . .
74	Malibu (Coupe) (exc. Classic),				
74	El Camino (exc. Classic) . . . . .	9680622	1	59.75	driver (comb. 701) (black) . . . . .
74	Malibu (Coupe) (exc. Classic),				
74	El Camino (exc. Classic) . . . . .	9680623	1	59.75	pass. (comb. 723) (green) . . . . .
74	Malibu (Coupe) (exc. Classic),				
74	El Camino (exc. Classic) . . . . .	9680624	1	59.75	driver (comb. 723) (green) . . . . .
74	Malibu (Coupe) (exc. Classic),				
74	El Camino (exc. Classic) . . . . .	9729944	1	59.75	pass. (comb. 749) (mid. blue) . . . . .
74	Malibu (Coupe) (exc. Classic),				
74	El Camino (exc. Classic) . . . . .	9729945	1	59.75	driver (comb. 749) (mid. blue) . . . . .
74	Malibu (Coupe) (exc. Classic), El				
74	Camino (exc. Classic) . . . . .	1658470	1	59.75	pass. (comb. 897) (mid. blue) . . . . .
74	Malibu (Coupe) (exc. Classic), El				
74	Camino (exc. Classic) . . . . .	1658465	1	59.75	driver (comb. 897) (mid. blue) . . . . .
74	Malibu (Coupe) (exc. Classic), El				
74	Camino (exc. Classic) . . . . .	1658471	1	59.75	pass. (comb. 891) (black) . . . . .
74	Malibu (Coupe) (exc. Classic), El				
74	Camino (exc. Classic) . . . . .	1658466	1	59.75	driver (comb. 891) (black) . . . . .
74	Malibu (Coupe) (exc. Classic), El				
74	Camino (exc. Classic) . . . . .	1658472	1	59.75	pass. (comb. 830, 892) (neutral) . . . . .
74	Malibu (Coupe) (exc. Classic), El				
74	Camino (exc. Classic) . . . . .	1658467	1	59.75	driver (comb. 830, 892) (neutral) . . . . .
74	Malibu (Coupe) (exc. Classic), El				
74	Camino (exc. Classic) . . . . .	1658473	1	59.75	pass. (comb. 893, 894) (green) . . . . .
74	Malibu (Coupe) (exc. Classic), El				
74	Camino (exc. Classic) . . . . .	1658468	1	59.75	driver (comb. 893, 894) (green) . . . . .
74	Malibu (Classic) (Sedan, Coupe)				
74	w/split notchback seat . . . . .	1671636	1	92.75	pass. (paint to match) . . . . .
74	Malibu (Classic) (Sedan, Coupe)				
74	w/split notchback seat . . . . .	1671637	1	92.75	driver (paint to match) . . . . .
74	Malibu (Classic) (Sedan, Coupe)				
74	El Camino (Classic) w/split				
74	notchback seat . . . . .	1671628	1	92.75	pass. (comb. 702) (black) . . . . .
74	Malibu (Classic) (Sedan, Coupe)				
74	El Camino (Classic) w/split				
74	notchback seat . . . . .	9729729	1	91.75	driver (comb. 702) (black) (1st type) (Note 1) . . . . .
74	Malibu (Classic) (Sedan, Coupe)				
74	El Camino (Classic) w/split				
74	notchback seat . . . . .	9729730	1	91.75	pass. (comb. 732) (mid. blue) (1st type) (Note 1) . . . . .
74	Malibu (Classic) (Sedan, Coupe)				
74	El Camino (Classic) w/split				
74	notchback seat . . . . .	1671631	1	92.75	driver (comb. 732) (mid. blue) . . . . .
74	Malibu (Classic) (Sedan, Coupe)				
74	El Camino (Classic) w/split				
74	notchback seat . . . . .	9729732	1	91.75	pass. (comb. 724) (green) (1st type) (Note 1)
74	Malibu (Classic) (Sedan, Coupe)				
74	El Camino (Classic) w/split				
74	notchback seat . . . . .	9729733	1	91.75	driver (comb. 724) (green) (1st type) (Note 1) . . . . .
74	Malibu (Classic) (Sedan, Coupe)				
74	El Camino (Classic) w/split				
74	notchback seat . . . . .	9729734	1	91.75	pass. (comb. 722) (neutral) (1st type) (Note 1) . . . . .
74	Malibu (Classic) (Sedan, Coupe)				
74	El Camino (Classic) w/split				
74	notchback seat . . . . .	1671635	1	92.25	driver (comb. 722) (neutral) . . . . .
74	Malibu (Classic) El Camino				
74	(Classic) w/split notchback				
74	seat . . . . .	1671642	1	87.00	pass. (comb. 707) (black) . . . . .
74	Malibu (Classic) El Camino				
74	(Classic) w/split notchback				
74	seat . . . . .	1671643	1	87.00	driver (comb. 707) (black) . . . . .

**FOLDING TOP PARTS—INTERIOR TRIM**

**14.800 TRIM ASSY., Front Seat Back and Back of Back (Con't)**

74	Malibu (Classic) El Camino (Classic) w/split notchback seat . . . . .	1671644	1	87.00	pass. (comb. 714) (neutral) . . . . .
74	Malibu (Classic) El Camino (Classic) w/split notchback seat . . . . .	1671645	1	87.00	driver (comb. 714) (neutral) . . . . .
74	Malibu (Classic) El Camino (Classic) w/split notchback seat . . . . .	1671646	1	87.00	pass. (comb. 740) (saddle) . . . . .
74	Malibu (Classic) El Camino (Classic) w/split notchback seat . . . . .	1671647	1	87.00	driver (comb. 740) (saddle) . . . . .
74	Malibu (Classic) El Camino (Classic) w/split notchback seat . . . . .	1671648	1	87.00	pass. (comb. 728) (green) (1st type) (Note 1)
74	Malibu (Classic) El Camino (Classic) w/split notchback seat . . . . .	1671649	1	87.00	driver (comb. 728) (green) (1st type) (Note 1) . . . . .
74	Malibu (Classic), El Camino (Classic) w/split notchback seat (exc. Sta. Wag.) . . . . .	1671640	1	87.00	pass. (comb. 747, 785) (white) . . . . .
74	Malibu (Classic), El Camino (Classic) w/split notchback seat (exc. Sta. Wag.) . . . . .	1671641	1	87.00	driver (comb. 747, 785) (white) . . . . .
74	Malibu (Classic) (Sta. Wag.) w/split notchback seat . . . . .	9729748	1	82.00	pass. (comb. 735) (mid. blue) . . . . .
74	Malibu (Classic) (Sta. Wag.) w/split notchback seat . . . . .	9729749	1	82.00	driver (comb. 735) (mid. blue) . . . . .
74	Laguna . . . . .	1680116	1	77.75	pass. (comb. 703) (black) . . . . .
74	Laguna . . . . .	1680117	1	77.75	driver (comb. 703) (black) . . . . .
74	Laguna . . . . .	1680118	1	77.75	pass. (comb. 704) (black and white) . . . . .
74	Laguna . . . . .	1680119	1	77.75	driver (comb. 704) (black and white) . . . . .
74	Laguna . . . . .	1680120	1	77.75	pass. (comb. 720) (oxblood) . . . . .
74	Laguna . . . . .	1680121	1	77.75	driver (comb. 720) (oxblood) . . . . .
74	Laguna . . . . .	1680122	1	77.75	pass. (comb. 731) (saddle) . . . . .
74	Laguna . . . . .	1680123	1	77.75	driver (comb. 731) (saddle) . . . . .
74	Laguna . . . . .	1680124	1	63.50	pass. (comb. 718) (saddle) . . . . .
74	Laguna . . . . .	1680125	1	63.50	driver (comb. 718) (saddle) . . . . .
74	Laguna . . . . .	9627118	1	65.00	pass. (comb. 719) (oxblood) . . . . .
74	Laguna . . . . .	9627119	1	65.00	driver (comb. 719) (oxblood) . . . . .
74	Monte Carlo . . . . .	9679970	1	64.75	pass. (comb. 730) (green) . . . . .
74	Monte Carlo . . . . .	9679966	1	64.75	driver (comb. 730) (green) . . . . .
74	Monte Carlo . . . . .	9679971	1	64.75	pass. (comb. 737) (midn. blue) . . . . .
74	Monte Carlo . . . . .	9679967	1	64.75	driver (comb. 737) (midn. blue) . . . . .
74	Monte Carlo . . . . .	9679972	1	64.75	pass. (comb. 716) (neutral) . . . . .
74	Monte Carlo . . . . .	9679968	1	64.75	driver (comb. 716) (neutral) . . . . .
74	Monte Carlo . . . . .	9679592	1	72.50	pass. (comb. 705) (black) . . . . .
74	Monte Carlo . . . . .	9679588	1	72.50	driver (comb. 705) (black) . . . . .
74	Monte Carlo . . . . .	9679593	1	72.50	pass. (comb. 726) (green) . . . . .
74	Monte Carlo . . . . .	9679589	1	72.50	driver (comb. 726) (green) . . . . .
74	Monte Carlo . . . . .	9679594	1	72.50	pass. (comb. 734) (midn. blue) . . . . .
74	Monte Carlo . . . . .	9679590	1	72.50	driver (comb. 734) (midn. blue) . . . . .
74	Monte Carlo . . . . .	9679595	1	72.50	pass. (comb. 744) (oxblood) . . . . .
74	Monte Carlo . . . . .	9679591	1	72.50	driver (comb. 744) (oxblood) . . . . .
75	Chevelle . . . . .	1666178	1	101.00	pass. (comb. 19B) (black) . . . . .
75	Chevelle . . . . .	1666143	1	101.00	driver (comb. 19B) (black) . . . . .
75	Chevelle . . . . .	1666179	1	101.00	pass. (comb. 26B) (blue) . . . . .
75	Chevelle . . . . .	1666144	1	101.00	driver (comb. 26B) (blue) . . . . .
75	Chevelle . . . . .	1666180	1	101.00	pass. (comb. 55B) (sandstone) . . . . .
75	Chevelle . . . . .	1666145	1	101.00	driver (comb. 55B) (sandstone) . . . . .
75	Chevelle . . . . .	1666181	1	101.00	pass. (comb. 73B) (oxblood) . . . . .
75	Chevelle . . . . .	1666146	1	101.00	driver (comb. 73B) (oxblood) . . . . .
75	Chevelle . . . . .	1666173	1	80.75	pass. (comb. 19H) (black) . . . . .
75	Chevelle . . . . .	1666138	1	80.75	driver (comb. 19H) (black) . . . . .
75	Chevelle . . . . .	1666174	1	80.75	pass. (comb. 26H) (blue) . . . . .
75	Chevelle . . . . .	1666139	1	80.75	driver (comb. 26H) (blue) . . . . .
75	Chevelle . . . . .	1666176	1	80.75	pass. (comb. 02H, 04H, 07H, 11H) (white) . . . . .
75	Chevelle . . . . .	1666141	1	80.75	driver (comb. 02H, 04H, 07H, 11H) (white) . . . . .
75	Chevelle . . . . .	1666175	1	80.75	pass. (comb. 55H) (sandstone) . . . . .
75	Chevelle . . . . .	1666140	1	80.75	driver (comb. 55H) (sandstone) . . . . .
75	Chevelle w/swivel seat . . . . .	1708646	1	217.00	pass. (comb. 19V) (black) (2nd design vertical pattern) . . . . .

**FOLDING TOP PARTS—INTERIOR TRIM**

**14.800 TRIM ASSY., Front Seat Back and Back of Back (Con't)**

75	Chevelle w/swivel seat . . . . .	1708647	1	217.00	pass. (comb. 55V) (sandstone) (2nd design vertical pattern) . . . . .
75	Chevelle w/Notchback seat . . . . .	1666157	1	106.00	pass. (comb. 19D) (black) . . . . .
75	Chevelle w/Notchback seat . . . . .	1666122	1	106.00	driver (comb. 19D) (black) . . . . .
75	Chevelle w/Notchback seat . . . . .	1666159	1	106.00	pass. (comb. 44D) (green) . . . . .
75	Chevelle w/Notchback seat . . . . .	1666124	1	106.00	driver (comb. 44D) (green) . . . . .
75	Chevelle w/Notchback seat . . . . .	1666162	1	98.50	pass. (comb. 19W) (black) . . . . .
75	Chevelle w/Notchback seat . . . . .	1666127	1	98.50	driver (comb. 19W) (black) . . . . .
75	Chevelle w/Notchback seat . . . . .	1666163	1	98.50	pass. (comb. 26W) (blue) . . . . .
75	Chevelle w/Notchback seat . . . . .	1666128	1	98.50	driver (comb. 26W) (blue) . . . . .
75	Chevelle w/Notchback seat . . . . .	1666164	1	98.50	pass. (comb. 55W) (sandstone) . . . . .
75	Chevelle w/Notchback seat . . . . .	1666129	1	98.50	driver (comb. 55W) (sandstone) . . . . .
75	Chevelle w/Notchback seat . . . . .	1666165	1	98.50	pass. (comb. 63W) (saddle) . . . . .
75	Chevelle w/Notchback seat . . . . .	1666130	1	98.50	driver (comb. 63W) (saddle) . . . . .
75	Chevelle w/Notchback seat . . . . .	1666156	1	106.00	pass. (comb. 16D) (graystone) . . . . .
75	Chevelle w/Notchback seat . . . . .	1666121	1	106.00	driver (comb. 16D) (graystone) . . . . .
75	Chevelle w/Notchback seat . . . . .	1666158	1	106.00	pass. (comb. 26D) (blue) . . . . .
75	Chevelle w/Notchback seat . . . . .	1666123	1	106.00	driver (comb. 26D) (blue) . . . . .
75	Chevelle w/Notchback seat . . . . .	1666160	1	106.00	pass. (comb. 73D) (oxblood) . . . . .
75	Chevelle w/Notchback seat . . . . .	1666125	1	106.00	driver (comb. 73D) (oxblood) . . . . .
75	Chevelle w/Reclining seat . . . . .	1667164	1	125.00	pass. (comb. 19N) (black) . . . . .
75	Chevelle w/Reclining seat . . . . .	1667159	1	125.00	driver (comb. 19N) (black) . . . . .
75	Chevelle w/Reclining seat . . . . .	1667165	1	125.00	pass. (comb. 26N) (blue) . . . . .
75	Chevelle w/Reclining seat . . . . .	1667160	1	125.00	driver (comb. 26N) (blue) . . . . .
75	Chevelle w/Reclining seat . . . . .	1667166	1	125.00	pass. (comb. 44N) (green) . . . . .
75	Chevelle w/Reclining seat . . . . .	1667161	1	125.00	driver (comb. 44N) (green) . . . . .
75	Chevelle w/Reclining seat . . . . .	1667167	1	125.00	pass. (comb. 55N) (sandstone) . . . . .
75	Chevelle w/Reclining seat . . . . .	1667162	1	125.00	driver (comb. 55N) (sandstone) . . . . .
75	Chevelle w/Reclining seat . . . . .	1667168	1	125.00	pass. (comb. 73N) (oxblood) . . . . .
75	Chevelle w/Reclining seat . . . . .	1667163	1	125.00	driver (comb. 73N) (oxblood) . . . . .
75	Malibu (Sedan) (exc. Classic) . . . . .	1666057	1	135.00	front seat (comb. 19C) (black) . . . . .
75	Malibu (Sedan) (exc. Classic) . . . . .	1666058	1	135.00	front seat (comb. 26C) (blue) . . . . .
75	Malibu (Sedan) (exc. Classic) . . . . .	1666053	1	134.00	front seat (comb. 26V) (blue) . . . . .
75	Malibu (Sedan) (exc. Classic) . . . . .	1666054	1	134.00	front seat (comb. 44V) (green) . . . . .
75	Malibu (Classic) (Sedan) . . . . .	1660727	1		front seat (comb. 26V) (blue) . . . . .
75	Chevelle (4-Dr.) . . . . .	1666052	1	134.00	front seat (comb. 19V) (black) . . . . .
75	Chevelle (4-Dr.) . . . . .	1666055	1	134.00	front seat (comb. 55V) (sandstone) . . . . .
75	Chevelle (4-Dr.) . . . . .	1708626	1	130.00	front seat (comb. 19V) (2nd design vertical pattern) . . . . .
75	Chevelle (4-Dr.) . . . . .	1708627	1	130.00	front seat (comb. 26V) (2nd design vertical pattern) . . . . .
75	Chevelle (4-Dr.) . . . . .	1708628	1	130.00	front seat (comb. 44V) (2nd design vertical pattern) . . . . .
75	Chevelle (4-Dr.) . . . . .	1708629	1	130.00	front seat (comb. 55V) (2nd design vertical pattern) . . . . .
75	Chevelle (2-Dr.) . . . . .	1666148	1	75.50	pass. (comb. 19C) (black) . . . . .
75	Chevelle (2-Dr.) . . . . .	1666113	1	75.50	driver (comb. 19C) (black) . . . . .
75	Chevelle (2-Dr.) . . . . .	1666149	1	75.50	pass. (comb. 26C) (blue) . . . . .
75	Chevelle (2-Dr.) . . . . .	1666114	1	75.50	driver (comb. 26C) (blue) . . . . .
75	Chevelle (2-Dr.) . . . . .	1666151	1	73.50	pass. (comb. 19V) (black) . . . . .
75	Chevelle (2-Dr.) . . . . .	1666116	1	73.50	driver (comb. 19V) (black) . . . . .
75	Chevelle (2-Dr.) . . . . .	1666152	1	73.50	pass. (comb. 26V) (blue) . . . . .
75	Chevelle (2-Dr.) . . . . .	1666117	1	73.50	driver (comb. 26V) (blue) . . . . .
75	Chevelle (2-Dr.) . . . . .	1666153	1	73.50	pass. (comb. 44V) (green) . . . . .
75	Chevelle (2-Dr.) . . . . .	1666118	1	73.50	driver (comb. 44V) (green) . . . . .
75	Chevelle (2-Dr.) . . . . .	1666154	1	73.50	pass. (comb. 55V) (sandstone) . . . . .
75	Chevelle (2-Dr.) . . . . .	1666119	1	73.50	driver (comb. 55V) (sandstone) . . . . .
75	Chevelle (2-Dr.) . . . . .	1708638	1	73.50	driver (comb. 19V) (black) (2nd design vertical pattern) . . . . .
75	Chevelle (2-Dr.) . . . . .	1708642	1	73.50	pass. (comb. 19V) (black) (2nd design vertical pattern) . . . . .
75	Chevelle (2-Dr.) . . . . .	1708639	1	73.50	driver (comb. 26V) (blue) (2nd design vertical pattern) . . . . .
75	Chevelle (2-Dr.) . . . . .	1708643	1	73.50	pass. (comb. 26V) (blue) (2nd design vertical pattern) . . . . .
75	Chevelle (2-Dr.) . . . . .	1708640	1	73.50	driver (comb. 44V) (green) (2nd design vertical pattern) . . . . .
75	Chevelle (2-Dr.) . . . . .	1708644	1	73.50	pass. (comb. 44V) (green) (2nd design vertical pattern) . . . . .
75	Chevelle (2-Dr.) . . . . .	1708641	1	73.50	driver (comb. 55V) (sandstone) (2nd design vertical pattern) . . . . .
75	Chevelle (2-Dr.) . . . . .	1708645	1	73.50	pass. (comb. 55V) (sandstone) (2nd design vertical pattern) . . . . .
75	Laguna . . . . .	1703329	1	82.50	pass. (comb. 73Z) (oxblood) . . . . .
75	Laguna . . . . .	1703330	1	82.50	driver (comb. 73Z) (oxblood) . . . . .

**FOLDING TOP PARTS—INTERIOR TRIM**

**14.800 TRIM ASSY., Front Seat Back and Back of Back (Con't)**

75	Laguna	1703327	1	82.50	pass. (comb. 63Z) (saddle)
75	Laguna	1703328	1	82.50	driver (comb. 63Z) (saddle)
75	Laguna	1703325	1	82.50	pass. (comb. 19Z) (black)
75	Laguna	1703326	1	82.50	driver (comb. 19Z) (black)
75	Laguna	1703319	1	91.00	pass. (comb. 73E) (oxblood)
75	Laguna	1703320	1	91.00	driver (comb. 73E) (oxblood)
75	Laguna	1703313	1	91.00	pass. (comb. 07E, 11E) (black)
75	Laguna	1703314	1	91.00	driver (comb. 07E, 11E) (black)
75	Laguna	1703315	1	91.00	pass. (comb. 19E) (black)
75	Laguna	1703316	1	91.00	driver (comb. 19E) (black)
75	Laguna	1703317	1	91.00	pass. (comb. 63E) (saddle)
75	Laguna	1703318	1	91.00	driver (comb. 63E) (saddle)
75	Laguna	1703323	1	81.25	pass. (comb. 07Z, 11Z) (white)
75	Laguna	1703324	1	81.25	driver (comb. 07Z, 11Z) (white)

**CAMARO**

71-72	Camaro	9872553	2	72.50	pass. and driver (comb. 775) (black)
72	Camaro	9893366	2	86.25	pass. and driver (comb. 785) (black)

**VEGA—MONZA**

71	Vega (exc. Panel),				
72	Vega (Hatchback, Notchback Cpe.)	9835992	2	104.00	driver and pass. (comb. 861, 874) (black)
72	Vega (exc. Panel)	9893362	2	44.25	driver and pass. (comb. 860) less embossed (black)
72	Vega (exc. Panel)	9893363	2	44.25	driver and pass. (comb. 863) less embossed (dk. green)
72	Vega (exc. Panel)	9893364	2	44.25	driver and pass. (comb. 866) less embossed (tan)
72	Vega (exc. Panel)	9893366	2	86.25	driver and pass. (comb. 862) (black)
72	Vega (Hatchback Cpe.)	9893369	2	76.00	driver and pass. (comb. 867) (tan)
73	Vega (Panel)	6258186	2	41.25	seat back cushion driver and pass.
73	Vega (exc. Panel)	9645980	2	46.00	driver and pass. (comb. 860) (black)
73	Vega (Hatchback Cpe.)	9645982	2	46.00	driver and pass. (comb. 858) (oxblood)
73	Vega (exc. Panel)	9645984	2	46.00	driver and pass. (comb. 868) (neutral)
73	Vega (exc. Panel)	9645959	2	81.00	driver and pass. (comb. 861, 884) (black)
73	Vega (exc. Panel)	9645960	2	81.00	driver and pass. (comb. 874, 888) (neutral)
73	Vega (exc. Panel)	9645961	2	81.00	driver and pass. (comb. 864) (green)
73	Vega (Sta. Wag.)	9645962	2	81.00	driver and pass. (comb. 867) (saddle)
73	Vega (Hatchback Cpe.)	9645963	2	81.00	driver and pass. (comb. 876) (chamois)
74	Vega (exc. Panel)	9686539	2	46.00	driver and pass. (comb. 862) (black)
74	Vega (exc. Panel)	9686540	2	46.00	driver and pass. (comb. 870, 881) (neutral)
74	Vega (exc. Panel)	9686541	2	46.00	driver and pass. (comb. 879) (green)
74	Vega (exc. Panel)	9686543	2	46.00	driver and pass. (comb. 888) (saddle)
74-75	Vega (exc. Panel)	9686501	2	85.00	driver and pass. (comb. 861) (19Y) (black)
74	Vega (exc. Panel)	9686503	2	81.00	driver and pass. (comb. 880) (green)
74	Vega (exc. Panel) (1st design)	9686591	2	46.00	driver and pass. (comb. 873) (black and white) (square pattern)
74	Vega (exc. Panel) (1st design)	9686592	2	46.00	driver and pass. (comb. 883) (green and black) (square pattern)
74	Vega (exc. Panel) (2nd design)	1694277	1	44.50	driver and pass. (comb. 873) (black) (stripe pattern)
74	Vega (exc. Panel) (2nd design)	1694278	1	44.50	driver and pass. (comb. 883) (green) (stripe pattern)
74	Vega (exc. Panel)	9686579	2	84.25	driver and pass. (comb. 871) (black and white)
74	Vega (exc. Panel)	9686580	2	84.25	driver and pass. (comb. 887) (green and black)
74	Vega (exc. Panel)	9733030	2	81.00	driver and pass. (comb. 863) (neutral)
74-75	Vega (exc. Panel)	9686501	2	85.00	pass. and driver (comb. 861, 19Y) (black)
74	Vega (exc. Panel)	9686504	2	58.00	driver and pass. (comb. 890) (saddle)
74	Vega (Hatchback Cpe.)	1674344	2	77.25	pass. and driver (comb. 867) (white)
74	Vega (Hatchback Cpe., Sta. Wag.)	9686502	2	81.00	driver and pass. (comb. 869) (black)
74	Vega (Hatchback Cpe., Sta. Wag.)	9686542	2	46.00	driver and pass. (comb. 884) (red)
75	Vega	1708201	2	50.25	driver and pass. (comb. 19W) (black) (2nd design horizontal pattern)
75	Vega	1708202	2	50.25	driver and pass. (comb. 26W) (blue) (2nd design horizontal pattern)
75	Vega	1708203	2	50.25	driver and pass. (comb. 55W) (sandstone) (2nd design horizontal pattern)
75	Vega	1708204	2	50.25	driver and pass. (comb. 63W) (saddle 63W) (2nd design horizontal pattern)

**FOLDING TOP PARTS—INTERIOR TRIM**

**14.800 TRIM ASSY., Front Seat Back and Back of Back (Con't)**

73-75	Vega (Panel) .....	6258186	2	41:25	pass. and driver (comb. 862 black-comb. 879 green) .....
75	Vega (Hatchback Cpe., Sta. Wag.) .....	1694536	2	121.00	pass. and driver (comb. 26B, 26W) (blue) ..
75	Vega (Hatchback Cpe., Sta. Wag.) .....	1694537	2	121.00	pass. and driver (comb. 55B, 55Y) (sandstone) .....
75	Vega (Hatchback Cpe., Sta. Wag.) .....	1694538	2	121.00	pass. and driver (comb. 73B, 73Y) (oxblood)
75	Vega (exc. Panel) .....	1661526	2	49.00	pass. and driver (comb. 19D) (black) .....
75	Vega (exc. Panel) .....	1661527	2	49.00	pass. and driver (comb. 55D) (sandstone) ..
75	Vega (exc. Panel) .....	1662717	2	88.00	pass. and driver (comb. 19E) (black) .....
75	Vega (exc. Panel) .....	1662718	2	88.00	pass. and driver (comb. 55E) (sandstone) ...
75	Monza (exc. Towne Cpe.) .....	1661540	2	103.00	pass. and driver (comb. 16G) (graystone) ...
75	Monza (exc. Towne Cpe.) .....	1661541	2	103.00	pass. and driver (comb. 26G) (blue) .....
75	Monza (exc. Towne Cpe.) .....	1661542	2	103.00	pass. and driver (comb. 55G) (sandstone) ..
75	Monza (exc. Towne Cpe.) .....	1661543	2	103.00	pass. and driver (comb. 63G) (saddle) .....
75	Monza (exc. Towne Cpe.) .....	1661544	2	103.00	pass. and driver (comb. 73G) (oxblood) .....
74-75	Vega (exc. Panel) .....	1661528	2	49.00	pass. and driver (comb. 862, 19W) (black) ..
75	Vega (exc. Panel) .....	1661529	2	49.00	pass. and driver (comb. 26W) (blue) .....
75	Vega (exc. Panel) .....	1661530	2	49.00	pass. and driver (comb. 55W) (sandstone) ...
75	Vega (exc. Panel) .....	1661531	2	49.00	pass. and driver (comb. 63W) (saddle) .....
75	Vega (Hatchback Cpe., Sta. Wag.) .....	1697530	2	80.00	pass. and driver (comb. 73Y) (oxblood) .....
75	Vega (exc. Panel) .....	1661565	2	85.00	pass. and driver (comb. 55Y) (sandstone) ...
75	Vega (exc. Panel) .....	1661566	2	85.00	pass. and driver (comb. 63Y) (saddle) .....
75	Vega (Hatchback Cpe., Sta. Wag.) .....	1694438	2	85.00	pass. and driver (comb. 02Y, 11Y) (white) ..
75	Vega (Panel) .....	358848	2	41.25	pass. and driver (blue) .....
75	Vega (Panel) .....	358849	2	41.25	pass. and driver (saddle) .....
75	Monza (exc. Towne Cpe.) .....	1661546	2	97.25	pass. and driver (comb. 16Z) (graystone) ...
75	Monza (exc. Towne Cpe.) .....	1661547	2	97.25	pass. and driver (comb. 26Z) (blue) .....
75	Monza (exc. Towne Cpe.) .....	1661548	2	97.25	pass. and driver (comb. 55Z) (sandstone) ...
75	Monza (exc. Towne Cpe.) .....	1661549	2	97.25	pass. and driver (comb. 63Z) (saddle) .....
75	Monza (exc. Towne Cpe.) .....	1661550	2	97.25	pass. and driver (comb. 73Z) (oxblood) .....
75	Monza (exc. Towne Cpe.) .....	1698552	2	208.00	pass. and driver (comb. 63Z) (saddle) .....
75	Monza (exc. Towne Cpe.) .....	1698553	2	208.00	pass. and driver (comb. 73Z) (oxblood) ...
75	Monza (exc. Towne Cpe.) .....	1700413	2	208.00	pass. and driver (comb. 19Z) (black) .....
75	Monza (exc. Towne Cpe.) .....	1700551	2	101.00	pass. and driver (comb. 19Z, H) (black) .....
75	Monza (exc. Towne Cpe.) .....	1700450	2	103.00	pass. and driver (comb. 19G) (black) .....
75	Monza (exc. Towne Cpe.) .....	1700408	2	97.25	pass. & driver (comb. 02, 07, 11J) .....

NOTE 1: 1st type 2 slots.

**14.800A TRIM ASSY., Bucket Seat Back (Passenger or Driver)**

**CHEVELLE**

73	Malibu (Coupe), El Camino (Custom) .....	9672077	2	162.00	pass. and driver (comb. 704) (black) .....
73	Malibu (Coupe) .....	9672078	2	162.00	pass. and driver (comb. 705) (blue) .....
73	Malibu (Coupe) .....	9672080	2	162.00	pass. and driver (comb. 721) (chamois) .....
73	Malibu (Coupe) El Camino (Custom) .....	9672079	2	162.00	pass. and driver (comb. 720) (saddle) .....
73	Malibu (Coupe) Laguna (Coupe) .....	9672084	2	162.00	pass. and driver (comb. 717) (saddle) .....
73	Laguna (Coupe) .....	1654127	2	227.00	pass. and driver (comb. 707) (black) .....
73	Laguna (Coupe) .....	9672085	2	162.00	pass. and driver (comb. 734) (neutral) .....
73	Monte Carlo .....	9672089	2	183.00	pass. and driver (comb. 715) (green) .....
73	Monte Carlo .....	9672090	2	176.00	pass. and driver (comb. 725) (mid. blue) ...
73	Monte Carlo .....	9672091	2	176.00	pass. and driver (comb. 740) (oxblood) .....
73	Monte Carlo .....	9672094	2	160.00	pass. and driver (comb. 728) (green) .....
73	Monte Carlo .....	9672095	2	160.00	pass. and driver (comb. 735) (neutral) .....
73-74	Monte Carlo .....	1654130	2	161.00	pass. and driver (comb. 708, 709) (black) ..
74	Malibu, El Camino (exc. Classic) .....	9729941	2	158.00	pass. and driver (comb. 713, 745) (neutral) .
74	Malibu, El Camino (exc. Classic) .....	9729942	2	158.00	pass. and driver (comb. 706) (black) .....
74	Malibu, El Camino (exc. Classic) .....	1658475	2	162.00	pass. and driver (comb. 830, 892) (neutral) .
74	Malibu, El Camino (exc. Classic) .....	1658476	2	648.00	pass. and driver (comb. 891) (black) .....
74	Malibu (Classic) (Coupe) .....	9729800	2	183.00	pass. and driver (comb. 743) (oxblood) .....
74	Malibu (Classic) .....				



**FOLDING TOP PARTS—INTERIOR TRIM**

**14.800A TRIM ASSY., Bucket Seat Back (Passenger or Driver) (Con't)**

74	El Camino (Classic) (exc. Sta. Wag.)	9729928	2	163.00	pass. and driver (comb. 747, 785) (white)
74	Malibu (Classic)				
74	El Camino (Classic)	9729799	2	183.00	pass. and driver (comb. 702) (black)
74	Malibu (Classic) El Camino (Classic)	9729927	2	163.00	pass. and driver (comb. 707) (black)
74	Malibu (Classic) El Camino (Classic)	9729929	2	163.00	pass. and driver (comb. 714) (neutral)
74	Malibu (Classic) El Camino (Classic)	9729930	2	163.00	pass. and driver (comb. 740) (saddle)
74	Malibu (Classic) El Camino (Classic)	9729931	2	163.00	pass. and driver (comb. 728) (green)
74	Malibu (Classic) (Sta. Wag.)	9729932	2	163.00	pass. and driver (comb. 735) (mid. blue)
74	Laguna	9736763	2	183.00	pass. and driver (comb. 703) (black)
74	Laguna	9736764	2	183.00	pass. and driver (comb. 720) (oxblood)
74	Laguna	9736765	2	183.00	pass. and driver (comb. 731) (saddle)
74	Laguna	9736766	2	166.00	pass. and driver (comb. 718) (saddle)
74-75	Laguna	9736767	2	227.00	pass. and driver (comb. 719, 73Z) (oxblood)
74	Laguna	9729937	2	183.00	pass. and driver (comb. 704) (black and white)
74-75	Laguna	1654127	2	227.00	pass. and driver (comb. 708, 19Z) (black)
74	Monte Carlo	9679958	2	178.00	pass. and driver (comb. 705) (black)
74	Monte Carlo	9679959	2	178.00	pass. and driver (comb. 726) (green)
74	Monte Carlo	9679960	2	178.00	pass. and driver (comb. 744) (oxblood)
74	Monte Carlo	9679974	2	160.00	pass. and driver (comb. 730) (green)
74	Monte Carlo	9679975	2	160.00	pass. and driver (comb. 742) (saddle)
75	Chevelle	1682213	2	236.00	pass. and driver (comb. 19W) (black)
75	Chevelle	1666186	2	236.00	pass. and driver (comb. 63W) (saddle)
75	Chevelle	1682214	2	255.00	pass. and driver (comb. 19D) (black)
75	Chevelle	1682215	2	255.00	pass. and driver (comb. 730) (oxblood)
75	Chevelle	1666200	2	239.00	pass. and driver (comb. 19N) (black)
75	Chevelle	1667151	2	239.00	pass. and driver (comb. 26N) (blue)
75	Chevelle	1667152	2	239.00	pass. and driver (comb. 44N) (green)
75	Chevelle	1667153	2	239.00	pass. and driver (comb. 55N) (sandstone)
75	Chevelle	1667154	2	239.00	pass. and driver (comb. 73N) (oxblood)
75	Chevelle (exc. Sedan)	1666183	2	230.00	pass. and driver (comb. 55V) (sandstone)
75	Chevelle (exc. Sedan)	1666182	2	230.00	pass. and driver (comb. 19V) (black)
75	Chevelle (exc. Sedan)	1666184	2	236.00	pass. and driver (comb. 26W) (blue)
75	Chevelle (exc. Sedan)	1666185	2	236.00	pass. and driver (comb. 55W) (sandstone)
75	Laguna	1703347	2	245.00	pass. and driver (comb. 19E) (black)
75	Laguna	1703348	2	245.00	pass. and driver (comb. 63E) (saddle)
75	Laguna	1703349	2	245.00	pass. and driver (comb. 73E) (oxblood)
75	Laguna	1703350	2	230.00	pass. and driver (comb. 63Z) (saddle)
75	Monte Carlo	1703460	2	226.00	pass. and driver (comb. 19B) (black)
75	Monte Carlo	1703461	2	226.00	pass. and driver (comb. 26B) (blue)
75	Monte Carlo	1703462	2	226.00	pass. and driver (comb. 73B) (oxblood)
75	Monte Carlo	1703463	2	213.00	pass. and driver (comb. 02H, 04H, 07H, 11H) (white)
75	Monte Carlo	1703464	2	213.00	pass. and driver (comb. 19H) (black)
75	Monte Carlo	1703465	2	213.00	pass. and driver (comb. 26H) (blue)
75	Monte Carlo	1703466	2	213.00	pass. and driver (comb. 55H) (sandstone)
<b>NOVA</b>					
74	Nova (Coupe) (exc. Custom)	9692630	2	50.00	pass. and driver (comb. 753) (black)
74	Nova (Coupe) (exc. Custom)	9692631	2	50.00	pass. and driver (comb. 758) (green)
74	Nova (Coupe) (exc. Custom)	9692632	2	50.00	pass. and driver (comb. 765) (oxblood)
74	Nova (Coupe) (exc. Custom)	9692633	2	50.00	pass. and driver (comb. 773) (saddle)
74	Nova (Coupe) (exc. Custom)	1658304	2	50.00	pass. and driver (comb. 825) (black)
74	Nova (Coupe) (exc. Custom)	1658305	2	50.00	pass. and driver (comb. 828) (green)
74	Nova (Coupe) (exc. Custom)	1658306	2	50.00	pass. and driver (comb. 829) (neutral)
74	Nova (H.B., Custom)	9693598	2		pass. and driver (comb. 774) (white)
74	Nova (H.B.) (exc. Custom)	1658307	2	50.00	pass. and driver (comb. 827) (saddle)
74	Nova (Custom) (Coupe)	9693261	2	67.25	pass. and driver (comb. 766) (neutral)
74	Nova (Custom) (Coupe)	9693259	2	67.25	pass. and driver (comb. 754) (black)
74	Nova (Custom) (Coupe)	9693258	2	74.00	pass. and driver (comb. 752) (black and white)
74	Nova (Custom) (Coupe)	9693260	2	67.25	pass. and driver (comb. 759) (green)
75	Nova	1693356	2	99.00	pass. and driver (comb. 02W, 04W, 07W, 11W) (white)
75	Nova (2-Dr.)	1665971	2	99.00	pass. and driver (comb. 19W) (black)
75	Nova (2-Dr.)	1665972	2	99.00	pass. and driver (comb. 55W) (sandstone)
75	Nova (2-Dr.)	1665973	2	99.00	pass. and driver (comb. 63W) (saddle)
75	Nova (2-Dr.)	1654788	2	64.00	pass. and driver (comb. 19V) (black)
75	Nova (2-Dr.)	1654789	2	64.00	pass. and driver (comb. 55V) (sandstone)
75	Nova (2-Dr.)	1654790	2	64.00	pass. and driver (comb. 63V) (saddle)

FOLDING TOP PARTS—INTERIOR TRIM

14.800A TRIM ASSY., Bucket Seat Back (Passenger or Driver) (Con't)

75	Nova (2-Dr.)	1657488	2	109.00	pass. and driver (comb. 19E) (black)
75	Nova w/european seat	1657483	2	203.00	pass. and driver (comb. 16G) (graystone)
75	Nova w/european seat	1657484	2	203.00	pass. and driver (comb. 26G) (blue)
75	Nova w/european seat	1657485	2	203.00	pass. and driver (comb. 55G) (sandstone)
75	Nova w/european seat	1657486	2	203.00	pass. and driver (comb. 73G) (oxblood)

CAMARO

73	Camaro (L.T.)	9663034	2	74.75	pass. and driver (comb. 773) (black)
74	Camaro (exc. L.T.)	9687195	2	80.00	pass. and driver (comb. 775) (black and white)
74	Camaro (exc. L.T.)	9687196	2	80.00	pass. and driver (comb. 796) (saddle and black)
74	Camaro (exc. L.T.)	9687197	2	80.00	pass. and driver (comb. 786) (green and black)
74	Camaro (exc. L.T.)	9686514	2	83.75	pass. and driver (comb. 777) (black)
74-75	Camaro (exc. L.T.)	9686515	2	72.50	pass. and driver (comb. 779) 19V (black)
74	Camaro (exc. L.T.)	9686516	2	72.50	pass. and driver (comb. 781) (neutral)
74	Camaro (exc. L.T.)	9686517	2	72.50	pass. and driver (comb. 798) (saddle)
74	Camaro (exc. L.T.)	9686518	2	72.50	pass. and driver (comb. 787) (green)
74	Camaro (exc. L.T.)	9686519	2	72.50	pass. and driver (comb. 792) (red)
74	Camaro (L.T.) (1st design)	9686568	2	74.75	pass. and driver (comb. 799) (saddle) (Note 1)
74	Camaro (L.T.)	9687260	2	85.75	pass. and driver (comb. 776) (black)
74	Camaro (L.T.)	9687261	2	85.75	pass. and driver (comb. 780) (neutral)
74	Camaro (L.T.)	9687262	2	85.75	pass. and driver (comb. 797) (saddle)
74	Camaro (L.T.)	9687263	2	85.75	pass. and driver (comb. 783) (taupe)
74	Camaro (L.T.) (1st design)	9686567	2	74.75	pass. and driver (comb. 778) (black) (Note 1)
74	Camaro (L.T.) (1st design)	9686569	2	74.75	pass. and driver (comb. 784) (taupe) (Note 1)
74	Camaro (L.T.) (2nd design)	1654182	2	79.75	pass. and driver (comb. 778) (black) (Note 1)
74	Camaro (L.T.) (2nd design)	1654183	2	79.75	pass. and driver (comb. 799) (saddle) (Note 1)
74	Camaro (L.T.) (2nd design)	1654184	2	79.75	pass. and driver (comb. 784) (taupe) (Note 1)
75	Camaro	1663511	2	94.50	pass. and driver (comb. 55D) (sandstone)
75	Camaro	1663510	2	94.50	pass. and driver (comb. 16D) (graystone)
75	Camaro	1663504	2	83.75	pass. and driver (comb. 91V) (white)
75	Camaro	1663503	2	79.75	pass. and driver (comb. 63V) (saddle)
75	Camaro	1663502	2	79.75	pass. and driver (comb. 55V) (sandstone)
75	Camaro	1663501	2	88.00	pass. and driver (comb. 55C) (sandstone)
75	Camaro	1663513	2	94.50	pass. and driver (comb. 73D) (oxblood)
75	Camaro	1663515	2	92.00	pass. and driver (comb. 55W) (sandstone)
75	Camaro	1663512	2	94.50	pass. and driver (comb. 63D) (saddle)
<i>NOTE 1: First design vertical stitch line pattern dimension width is 7/16 inches, second design 9/16 inches.</i>					
75	Camaro	1698552	2	208.00	pass. and driver (comb. 632) (saddle)
75	Camaro	1698553	2	208.00	pass. and driver (comb. 732) (oxblood)
75	Camaro	1663516	2	92.00	pass. and driver (comb. 63W) (saddle)
75	Camaro	1707455	2	88.00	pass. and driver (comb. 19C) (black) (repl. 1663500)

14.802 PAD ASSY., Front Seat Back

71	Monte Carlo				rear seat back, seat back button (comb. 707, 708, 709, 710),
71	Biscayne, Brookwood				seat back button (comb. 708, 709),
71	Camaro	9814868	A.R.	.56	pass. & driver seat back (comb. 775, 785, 789) (black)
72	Caprice (Spt. Cpe.)	9638597	1	19.80	pass. seat back wire (repl. 9826440)
72	Caprice (Spt. Cpe.)	9638598	1	19.80	driver seat back wire (repl. 9826441)
71-72	Impala, Caprice (Spt. Cpe., Conv.)	9663259	1	5.55	front seat back rear upper
72	Impala (Spt. Cpe., Conv.)	9642162	1	27.25	pass. seat back
72	Impala (Spt. Cpe., Conv.)	9642167	1		driver seat back (repl. 9821321)
72	Pass. 4-Dr. (exc. Spt. Sed.)	9819953	1		w/wire front seat back
72	Nova (2-Dr.) w/bucket seat (exc. custom seat)	9672365	1	60.75	pass. & driver seat back upper
72	Nova (2-Dr.)	9672365	1	60.75	pass. & driver seat back wire (repl. 9893404)
72	Camaro	9735849	2	60.75	pass. and driver seat back upper
71-72	Camaro,				
72	Nova	9868249	2		pass. & driver seat back
71	Biscayne, Bel Air,				
71	Kingswood, Caprice (Sed.) (exc. Spt. Sed.),				

**FOLDING TOP PARTS—INTERIOR TRIM**

<b>14.802 PAD ASSY., Front Seat Back</b>		<b>(Con't)</b>		
71	Impala (Sed.)	9819953	1	frt. seat back & wire assy.
71-72	Vega (exc. Panel) w/Custom Seat	9735849	2	60.75 upper driver and pass. (repl. 9872455)
71-75	Vega (exc. Panel) (exc. Custom Seat)	9672365	2	60.75 driver and pass.
73	Vega (exc. Panel) w/Custom Seat	9668358	2	67.00 upper driver and pass.
73-74	Impala (Spt. Cpe.) Pass. (Conv.) w/bench seat (exc. reclining seat)	9642162	1	27.25 pass. seat back
73-74	Impala (Spt. Cpe.) Pass. (Conv.) w/bench seat (exc. reclining seat)	9642163	1	27.25 driver seat back
73-74	Caprice (Spt. Cpe.) w/bench seat (exc. reclining seat)	9620780	1	26.25 pass. seat back wire
73-74	Caprice (Spt. Cpe.) w/bench seat (exc. reclining seat)	9620781	1	26.75 driver seat back wire
73-74	Caprice (Sedan) w/bench seat (exc. reclining seat)	9620346	1	45.75 front seat back wire
73-75	Bel Air, Impala (Sedan), Pass. (Sta. Wag.) w/bench seat (exc. reclining seat)	9639535	1	50.50 front seat back
73	Chevelle (2-Dr.) w/bench seat (exc. reclining seat, Monte Carlo),			
74-75	Malibu, Laguna (Coupe), El Camino w/bench seat (exc. Classic, notchback seat),			
75	Nova (2-Dr.) w/bench seat	9613045	1	15.70 pass. seat back
73	Chevelle (2-Dr.) w/bench seat (exc. notchback seat, Monte Carlo),			
74-75	Malibu, Laguna (Coupe) El Camino w/bench seat (exc. Classic, notchback seat),			
75	Nova (2-Dr.) w/bench seat	9613046	1	16.70 driver seat back
73-75	Chevelle (2-Dr.) w/swivel bucket seat (exc. Deluxe)	9673045	2	18.85 pass. and driver seat back wire
73-74	Chevelle (4-Dr.) Nova (Sedan) w/bench seat (exc. notchback seat),		1	front seat back rear upper,
73-74	Pass., Chevelle, Nova (2-Dr.) w/bench seat (exc. reclining, notchback seat)	9663259	1	5.55 pass. seat back rear upper
73-74	Pass., Chevelle, Nova (2-Dr.) w/bench seat (exc. reclining, notchback seat)	9683614	1	22.75 driver seat back rear upper
73	Chevelle (4-Dr.),			
74	Malibu (4-Dr.),			
73-75	Nova (Sedan) w/bench seat (exc. Classic, notchback seat)	9613044	1	29.75 front seat back
73	Caprice w/reclining seat	9683614	1	22.75 pass. seat back wire
73	Caprice w/reclining seat	9683615	1	22.75 driver seat back wire
73-74	Monte Carlo w/bench seat,			
74	Laguna w/bench seat	9613051	1	16.45 pass. seat back
73-74	Monte Carlo w/bench seat,			
74	Laguna w/bench seat	1657192	1	27.00 driver seat back
74-75	Vega (exc. Panel) w/Custom Seat	9735849	2	60.75 pass. and driver seat back wire
73	Nova, Camaro w/bucket seat	9668358	2	67.00 pass. and driver seat back wire and comp.
73-74	Nova (Coupe) w/bench seat	9611518	1	15.60 pass. seat back
73-74	Nova (Coupe) w/bench seat	9611519	1	15.60 driver seat back
73	Nova (Coupe) w/bucket seat (exc. Custom)	9668348	2	pass. and driver seat back wire and comp.
74	Caprice w/reclining seat	9683614	1	22.75 pass. seat back wire
74	Caprice w/reclining seat	9683615	1	22.75 driver seat back wire
74-75	Chevelle w/split notchback seat	9613057	1	19.20 pass. seat back wire
74-75	Chevelle w/split notchback seat	9613058	1	19.20 driver seat back wire
74	Chevelle w/split notchback seat	9639531	2	3.30 pass. and driver seat back wire (repl. 9874390)
74	Chevelle w/swivel bucket seat	9673045	2	18.85 pass. and driver seat back wire
74	Nova (Coupe) w/bucket seat (exc. Custom),			
75	Vega w/bucket seat (exc. Custom)	9672365	2	60.75 pass. and driver seat back wire and comp.

**FOLDING TOP PARTS—INTERIOR TRIM**

**14.802 PAD ASSY., Front Seat Back (Con't)**

74	Camaro (L.T.)	9669482	2	63.00	pass. and driver seat back wire and comp.
74	Nova (Custom, Coupe) w/bucket seat,				
74	Camaro (exc. L.T.)	9735849	2	60.75	pass. and driver seat back wire
75	Pass. w/50/50 seat	1654832	1	36.50	pass. st. back wire
75	Pass. w/50/50 seat	1654833	1	36.50	driver st. back wire
75	Caprice Classic (Sport Cpe.)	1654830	1	25.50	pass. st. back wire
75	Caprice Classic (Sport Cpe.)	1654831	1	25.50	driver st. back wire
75	Laguna, Monte Carlo w/bench st.	1657191	1	27.00	pass. st.
75	Laguna, Monte Carlo w/bench st.	1657192	1	27.00	driver st.
75	Monte Carlo w/reclining seat	1661520	1	27.25	50/50 pass. seat back wire
75	Monte Carlo w/reclining seat	1661521	1	27.25	50/50 driver seat back wire
75	Nova (Coupe) w/bucket seat (exc. Custom)	9672365	2	60.75	pass. and driver seat back wire (repl. 1694764)
75	Camaro w/bucket seat (L.T.)	9669482	2	63.00	pass. and driver seat back wire
75	Camaro, Nova (Custom, Coupe) w/bucket seat (exc. L.T.)	9735849	2	60.75	pass. and driver seat back wire
75	Monza,		2		pass. and driver seat back wire,
75	Vega	9669482	2	63.00	pass. and driver seat back wire w/bkt. seat special design
75	Vega w/bucket seat	9735849	2	60.75	pass. and driver seat back wire
75	Nova w/bucket seat	1659519	2	62.25	pass. and driver seat back wire

**14.804 BUTTON ASSY.—FASTENER—RETAINER, Seat Back and Trim Pad**

65-66	Caprice (exc. Sta. Wag.)				frt. and rr. dr. trim pad (comb. 815, 817, 818),
67	Caprice (Spt. Mdls.),				
69	Caprice (Spt. Sed., Spt. Cpe.)	7709708 A.R.		.52	(comb. 807, 808, 809, 813) (black)
70	Impala, Caprice	9814871 A.R.		.52	pass. and driver and rear seat cushion (comb. 855, 860, 861) (dk. green)
71	Camaro,				
71-72	Monte Carlo	9847259	8	.48	pass. and driver (comb. 779, 792) (dk. saddle)
71-72	Vega	9814868 A.R.		.56	(comb. 860, 861, 874) (black)
72	Vega (Hatchback, Notchback Cpe.)	9893372 A.R.		.39	(comb. 869, 874) (covert)
72	Camaro, Biscayne, Monte Carlo	9893372 A.R.		.39	seat back trim (comb. 731, 734, 779, 788, 816) (covert)
72	Monte Carlo	9893372 A.R.		.39	seat back trim (comb. 731, 734) (covert)
72	Monte Carlo	9896806 A.R.		.48	front door, qtr. (comb. 725) (blue)
72	Camaro	9814868 A.R.		.56	(comb. 775, 785, 789) (black)
72	Camaro, Monte Carlo	9898235 A.R.		.37	seat back (comb. 777, 787) (green)
73	Bel Air (Sedan) w/bench seat (exc. reclining seat)	9642320	4	.45	(comb. 827, 828) (green)
73	Bel Air (Sedan) w/bench seat (exc. reclining seat)	9642319	4	.45	(comb. 810) (blue)
73-75	Bel Air (Sedan) w/bench seat (exc. reclining seat),				
74	Malibu,				
75	Nova	9642317	4	.45	(comb. 803, 804, 891, 19C, 19E, 19W) (black)
73	Bel Air (Sta. Wag.) w/bench seat (exc. reclining seat),				
75	Nova (2-Dr.)	9642322 A.R.		.45	(comb. 825, 63E, 63W) (saddle)
73	Bel Air (Sta. Wag.) w/bench seat (exc. reclining seat),				
74	Bel Air w/bench seat (exc. reclining seat),				
74	Malibu	9642321 A.R.		.45	(comb. 815, 817, 830, 892) (neutral)
73	Pass. (Conv.) w/bench seat (exc. reclining seat)	9656509 A.R.		.40	(comb. 816) (white)
74-75	Pass.	1699907 A.R.		.52	(comb. 802, 19H) (black)
73	Impala (Spt. Sed., Spt. Cpe.) w/bench seat (exc. reclining seat)	9658581 A.R.		.46	(comb. 802) (black and white)
73	Impala, Caprice (Sta. Wag.),				
74	Impala (Sedan, Spt. Cpe.),				
74	Caprice (Sta. Wag.) w/bench seat (exc. reclining seat),				

**FOLDING TOP PARTS—INTERIOR TRIM**

**14.804 BUTTON ASSY.— FASTENER— RETAINER, Seat Back and Trim Pad  
(Con't)**

<b>73-74</b>	Monte Carlo w/bench, swivel bucket seat (exc. Notchback seat) .....	<b>9656508 A.R.</b>	<b>.57</b>	(comb. 725, 734, 737, 812, 813, 847) (mid. blue) .....
<b>73</b>	Impala (Spt. Cpe.) (Sta. Wag. 9-Pass.), w/bench seat (exc. reclining seat),			
<b>74</b>	Impala, Pass. (Conv.) w/bench seat (exc. reclining seat),			
<b>73</b>	Caprice (Estate) w/bench seat (exc. reclining seat),			
<b>74</b>	Caprice (Sta. Wag.) w/bench seat (exc. reclining seat),			
<b>73-74</b>	Camaro w/bucket seat,			
<b>73-74</b>	Monte Carlo w/bench, swivel bucket seat (exc. Notchback seat),			
<b>75</b>	Pass., Chevelle, Camaro .....	<b>9656501 A.R.</b>	<b>.43</b>	(comb. 705, 706, 708, 709, 773, 774, 775, 776, 777, 779, 785, 786, 802, 805, 806, 19B, 19H, 19C, 19V, 19W) (black) .....
<b>73</b>	Impala, Caprice (Sta. Wag., Conv.) w/bench seat (exc. reclining seat),			
<b>73</b>	Camaro w/bucket seat,			
<b>73</b>	Monte Carlo w/bench, swivel bucket seat (exc. Notchback seat) .....	<b>9656502 A.R.</b>	<b>.43</b>	(comb. 715, 728, 777, 781, 829, 830) (green) .....
<b>74</b>	Impala, Caprice (Sta. Wag.) w/bench seat (exc. reclining seat) .....	<b>1690817 A.R.</b>	<b>.47</b>	(comb. 859) (black and green) .....
<b>73</b>	Camaro w/bucket seat,			
<b>74</b>	Camaro w/bucket seat (exc. L.T.),			
<b>73</b>	Monte Carlo w/bench, swivel bucket seat (exc. Notchback seat),			
<b>74</b>	Monte Carlo w/bench seat (exc. Notchback seat) .....	<b>9656504 A.R.</b>	<b>.43</b>	(comb. 716, 731, 735, 779, 781, 788, 815, 818, 819, 821) (neutral) .....
<b>73</b>	Impala w/bench seat (exc. reclining),			
<b>74</b>	Impala (Spt. Cpe.) w/bench seat (exc. Custom, reclining seat),			
<b>75</b>	Pass., Chevelle, Camaro .....	<b>1667350 A.R.</b>	<b>.52</b>	(comb. 804, 809, 02H, 04H, 07H, 11H) (white) .....
<b>73</b>	Malibu (Sedan) w/bench seat (exc. Notchback seat),			
<b>73</b>	Malibu (Coupe) w/bench, swivel bucket (exc. Notchback seat) ..	<b>9659656 A.R.</b>	<b>.40</b>	(comb. 716, 721) (chamois) .....
<b>73</b>	Malibu, El Camino (Custom) w/bench seat (exc. Notchback seat),			
<b>73</b>	Malibu (Coupe) w/swivel bucket seat .....	<b>9659653 A.R.</b>	<b>.40</b>	(comb. 705, 724) (blue) .....
<b>73</b>	Malibu (Coupe, Sta. Wag.), El Camino (Custom) w/bench seat (exc. Notchback seat),			
<b>73</b>	Malibu (Coupe) El Camino (Custom) w/swivel bucket seat	<b>9659658 A.R.</b>	<b>.48</b>	(comb. 720) (saddle) .....
<b>73-74</b>	Monte Carlo w/bench seat, swivel bucket seat (exc. Notchback seat),			
<b>75</b>	Monte Carlo .....	<b>9656506 A.R.</b>	<b>.43</b>	(comb. 740, 744, 73B) (oxblood) .....
<b>73</b>	Malibu, El Camino (Custom) w/bench seat (exc. Notchback seat),			
<b>74</b>	Malibu (Classic) El Camino (Custom) w/split Notchback seat,			
<b>73</b>	Malibu (Coupe) El Camino (Custom) w/swivel bucket seat,			
<b>73-74</b>	Nova (Custom),			

**FOLDING TOP PARTS—INTERIOR TRIM**

**14.804 BUTTON ASSY.— FASTENER— RETAINER, Seat Back and Trim Pad  
(Con't)**

75	Chevelle w/Notchback seat . . . .	9659651 A.R.	.40	(comb. 702, 703, 704, 707, 750, 751, 752, 754, 19D, 19W) (black) . . . . .
73	Malibu, El Camino (Custom) w/split Notchback seat (exc. Sta. Wag.),			
74	Malibu (Classic) (Coupe) El Camino (Classic) w/split Notchback seat . . . . .	9659652 A.R.	.40	(comb. 747, 785) (white) . . . . .
73	Malibu, El Camino (Custom) w/bench seat (exc. Notchback seat),			
73	Malibu (Coupe) El Camino (Custom) w/swivel bucket seat,			
74	Malibu (Classic) w/split Notchback seat,			
73-74	Nova (Custom) w/bucket seat . .	9659657 A.R.	.57	(comb. 732, 764, 766, 769, 771) (neutral) .
74	Malibu,			
74	Bel Air w/bench seat exc. reclining seat,			
75	Nova . . . . .	9687997 A.R.	.46	(comb. 851, 852, 893, 894, 44D) (green) . .
74	Impala (Spt. Cpe.) w/bench seat (exc. reclining seat),			
74	Impala, Caprice (Sta. Wag.) . . . .	9736351 A.R.	.52	(comb. 858) (saddle and black) . . . . .
74	Malibu (Classic) (Coupe, Sedan) w/split Notchback seat, bucket seat,			
75	Chevelle w/Notchback seat . . . .	9659659 A.R.	.40	(comb. 743, 73D) (oxblood) . . . . .
74	Malibu (Classic) El Camino (Classic) w/split Notchback seat,			
74	Nova (2-Dr.) (Custom) w/bench seat . . . . .	9659654 A.R.	.37	(comb. 732, 735, 771) (mid. blue) . . . . .
74	Malibu w/bench seat (exc. Notchback) . . . . .	9736006 A.R.	.48	(comb. 897) (mid. blue) . . . . .
74	Malibu (Classic) w/split Notchback seat,			
74	Nova (Custom),			
75	Chevelle w/Notchback seat . . . .	9695404 A.R.	.52	(comb. 724, 728, 755, 757, 759, 44D) (green) . . . . .
74	Nova (H.B.) (Custom) . . . . .	9642812 A.R.	.25	(comb. 774) (white) . . . . .
74	Malibu (Classic) El Camino (Classic) w/split Notchback seat . . . . .	9695403 A.R.	.52	(comb. 740) (saddle) . . . . .
74	Malibu (Classic) (exc., Sta. Wag.),			
73-75	Vega (exc. Panel) . . . . .	9656501 A.R.	.43	(comb. 861, 869, 871, 884, 887, 19E, 19Y) (black) . . . . .
73	Vega (exc. Panel) . . . . .	9656502 A.R.	.43	(comb. 864) (green) . . . . .
73-74	Vega (exc. Panel) . . . . .	9656504 A.R.	.43	(comb. 863, 874, 888) (neutral) . . . . .
73	Vega (Hatchback Cpe.) . . . . .	9656506 A.R.	.43	(comb. 875) (oxblood) . . . . .
74-75	Vega (Hatchback Cpe.) . . . . .	1667350 A.R.	.52	(comb. 867, 02Y, 11Y) (white) . . . . .
74	Vega (exc. Panel) . . . . .	9695401 A.R.	.56	(comb. 890) (saddle) . . . . .
75	Chevelle . . . . .	9728785 A.R.	.52	(comb. 743, 73D) (oxblood) . . . . .
74	Chevelle . . . . .	9728787 2	.52	(comb. 732, 735, 785) (mid. blue) . . . . .
74-75	Chevelle . . . . .	9728786 2	.52	(comb. 702, 707, 747, 19D, 19W) (black) . .
74	Chevelle . . . . .	9728784 2	.52	(comb. 740) (saddle) . . . . .
74-75	Chevelle . . . . .	9728782 2	.52	(comb. 724, 728, 44D) (green) . . . . .
74	Chevelle . . . . .	9731948 2	.52	(comb. 714, 722) (neutral) . . . . .
74	Monte Carlo w/swivel bucket, Impala, Caprice w/bench seat (exc. reclining seat),			
74	Camaro w/bucket seat (exc. L.T.)	9695401 A.R.	.56	(comb. 742, 796, 798, 849) (saddle) . . . . .
74	Monte Carlo w/bench, swivel bucket seat,			
74	Impala (exc. Custom), Caprice (Sta. Wag., Conv.) w/bench seat (exc. reclining seat),			
74	Camaro w/bucket seat (exc. L.T.),			
75	Pass. . . . .	9695402 A.R.	.52	(comb. 726, 730, 786, 787, 853, 855, 44W) (green) . . . . .
74	Camaro w/bucket seat (exc. L.T.)	9699000 A.R.	.52	(comb. 792) (red) . . . . .
75	Pass., Nova . . . . .	1663013 A.R.	.78	(comb. 26V, 26C, 26D) (blue) . . . . .
75	Pass., Nova . . . . .	1663014 A.R.	.78	(comb. 55C, 55D, 55V) (sandstone) . . . . .

**FOLDING TOP PARTS—INTERIOR TRIM**

**14.804 BUTTON ASSY.— FASTENER— RETAINER, Seat Back and Trim Pad  
(Con't)**

75	Pass. ....	1697970 A.R.	.90	(comb. 19D) (black) (repl. 1669034) .....
75	Pass. ....	1697971 A.R.	.90	(comb. 44D) (green) .....
75	Pass. ....	1697972 A.R.	.90	(comb. 26D) (blue) (repl. 1669036) .....
75	Pass. ....	1697973 A.R.	.90	(comb. 55D) (sandstone) (repl. 1669037) ..
75	Pass., Chevelle .....	1693970 A.R.	.47	(comb. 26B, 26H, 26W) (blue) .....
75	Pass., Camaro, Chevelle, Vega ..	1679865 AR	.47	(comb. 55B, 55H, 55V, 55C, 55E, 55Y, 55W) (sandstone) .....
75	Pass., Camaro, Chevelle, Vega (exc. panel) .....	1677736 AR	.47	(comb. 63V, 63Y, 63E, 63W) (saddle) .....
75	Chevelle w/Notchback seat ....	1677120 A.R.	.47	(comb. 26D, 26W) (blue) .....
75	Chevelle .....	1662494 A.R.	.55	frt. door and qtr. (comb. 26D, 26W) (blue) ..
75	Chevelle w/Notchback seat ....	1679491 A.R.	.47	(comb. 16D) (graystone) .....
75	Chevelle .....	1662493 A.R.	.55	frt. door and qtr. (comb. 16D) (graystone) ..
75	Chevelle w/Notchback seat ....	1677121 A.R.	.47	(comb. 55W) (sandstone) .....
75	Chevelle .....	1662495 A.R.	.55	frt. door and qtr. (comb. 55W) (sandstone) ..
75	Chevelle .....	1678146 A.R.	.47	(comb. 63W) (saddle) .....
75	Chevelle .....	1662492 A.R.	.55	frt. door and qtr. (comb. 63W) (saddle) .....
75	Chevelle .....	9691258 AR	.46	(comb. 44N) (green) .....
75	Monte Carlo .....	9642819 A.R.	.25	(comb. 73N) (oxblood) .....
75	Nova (2-Dr.) .....	9642313 A.R.	.58	(comb. 73W) (oxblood) .....
75	Nova .....	1663012 A.R.	.90	(comb. 02W, 04W, 07W, 11W) (white) .....
75	Camaro .....	1680309 2	4.25	snap front door map pocket (comb. 55D, 55W) (sandstone) .....
75	Camaro .....	1680311 2	4.25	snap front door map pocket (comb. 73D, 732) (oxblood) .....
75	Camaro .....	1680308 2	4.25	snap front door map pocket (comb. 16D) (graystone) .....
75	Camaro .....	1680310 2	4.25	snap front door map pocket (comb. 63D, 63W) (saddle) .....
74	Camaro (exc. L.T.) .....	9731817 2	4.25	snap front door map pocket (comb. 776, 778) (black) .....
74	Camaro (exc. L.T.) .....	9731818 2	4.25	snap front door map pocket (comb. 780) (neutral) .....
74	Camaro (exc. L.T.) .....	9731819 2	4.25	snap front door map pocket (comb. 783, 784) (taupe) .....
74	Camaro (exc. L.T.) .....	9731820 2	4.25	snap front door map pocket (comb. 797, 799) (saddle) .....
74-75	Camaro (L.T.) .....	120019 2	.11	<b>FASTENER</b> , button front door map pocket eyelet .....
65	Impala, Caprice (exc. S.S.),			<b>RETAINER</b> , rr. of frt. st. bk., .....
66	Caprice (Spt. Cpe.) .....			frt. seat cush. and back, .....
66	Caprice w/bench seat .....			button driver and pass. st. cush. and back, ..
66	Caprice w/bucket seat .....			
67	Malibu (Spt. Sed.),			
68	Impala (exc. Spt. Cpe., Conv.),			
68	Malibu, S.S., Concours,			
68	Caprice (Sta. Wag.),			
69	Chevelle (Spt. Sed.),			
69	Camaro .....			seat back button, .....
68	Impala (Spt. Cpe., Conv.) .....			(standard trim), .....
68	Caprice (Spt. Cpe.) w/bucket sts.,			
68	Caprice (Spt. Sed.) w/bench sts.			front seat cushion and back, .....
70	Impala (Spt. Cpe., Conv.) .....			seat back button, .....
70	Caprice,			
71	Biscayne, Camaro,			
73-75	Monte Carlo, w/swivel bucket (less cust.),			
73-74	Impala,			
73-75	Caprice (Sta. Wag., Conv.),			
73	Camaro (L.T.) .....	4851794 A.R.	.12	cushion back trim button .....
66-67	Chevelle (S.S.),			
66	Malibu,			
67	Malibu (exc. Spt. Sed.),			
71-72	Pass. (Spt. Cpe., Conv.),			
73-75	Pass., Chevelle,			
73-75	Nova (2-Dr.) .....	9864218 R.H.	.63	<b>RETAINER</b> , front seat cushion trim at lock striker .....
71-72	Pass. (Spt. Cpe., Conv.),			
73-75	Pass., Chevelle, Nova (2-Dr.) ....	9864219 L.H.	.63	<b>RETAINER</b> , front seat cushion trim at lock striker .....
71-72	Camaro,			
73-74	Nova (Custom) w/bucket seats,			
73-75	Camaro w/Bucket Seats .....	7725675 8	.12	<b>RETAINER</b> , driver seat back trim button .....

**FOLDING TOP PARTS—INTERIOR TRIM**

**14.804 BUTTON ASSY.— FASTENER— RETAINER, Seat Back and Trim Pad  
(Con't)**

68	Malibu, S.S. (Conv., Spt. Cpe., 4-Dr. Sed.),				
71-72	Caprice,				
75	Impala, Caprice (Sta. Wag.),				
73-75	Bel Air . . . . .	7728569	A.R.	.24	RETAINER, seat back button (Note 1) . . . . .
71-75	Vega (exc. Panel) . . . . .	7725675	A.R.	.12	RETAINER, seat back button pass. and driver . . . . .
71-75	Vega (exc. Panel) . . . . .	4851794	A.R.	.12	RETAINER, rear seat back trim button stud
66-67	Impala,				
68	Bel Air,				
69	Chevy w/Custom trim,				
71-72	Bel Air, Impala,				
71-72	Townsmen, Kingswood,				
74	Malibu (Classic) w/split Notchback seat (exc. Coupe),				
75	Nova (Custom) (Coupe) w/bucket seat . . . . .	4541393	A.R.	.12	RETAINER, button (seat back) pass. and driver . . . . .
69	Caprice w/strato bench seat,				
71-72	Monte Carlo,				
73	Malibu, Laguna (Sta. Wag.),				
73	Nova (Custom),				
74	Malibu (Classic) El Camino (Classic),				
74	Monte Carlo,				
74	Nova (Custom),				
75	Chevelle . . . . .	7785339	A.R.	.25	RETAINER, button (seat back) . . . . .
72	Biscayne, Camaro . . . . .	4851794	12	.12	RETAINER, cushion back trim button . . . . .
73	Impala (Spt. Cpe., Spt. Sed.),				
74	Impala (Spt. Cpe.),				
75	Caprice (Sedan, Spt. Cpe.) . . . . .	9820698	A.R.	.16	RETAINER, pass. & driv. and rear seat back
74	Nova (H.B.) (exc. Custom),				
75	Monte Carlo w/swivel bucket . . . . .	9846235	A.R.	.16	RETAINER, pass. and driver seat back button . . . . .

NOTE 1 Production deviation trim change.

NOTE. Order sufficient amount of imitation leather of the desired color for both right and left sides.

**14.810 PAD— COVER— DEADENER, Seat Back**

71-72	Impala, Caprice (Spt. Cpe., Conv.) . . . . .				driver seat back rear upper . . . . .
73-74	Caprice (Spt. Cpe., Sed.) w/reclining pass. seat . . . . .				driver and pass., . . . . .
73-74	Pass. (4-Dr.) w/bench seat,				
75	Pass., Chevelle, Nova . . . . .	9663259	1	5.55	front seat back rear upper . . . . .
73-75	Camaro, Nova w/Bucket Seat . . . . .	9640479	2	1.95	COVER, pass. and driver . . . . .
75	Nova w/European seat . . . . .	1694880	2	21.30	COVER ASSY., pass. and driver seat back rear center (comb. 16G) (graystone) . . . . .
75	Nova w/European seat . . . . .	1694881	2	22.60	COVER ASSY., pass. and driver seat back rear center (comb. 26G) (blue) . . . . .
75	Nova w/European seat . . . . .	1694882	2	21.30	COVER ASSY., pass. and driver seat back rear center (comb. 55G) (sandstone) . . . . .
75	Nova w/European seat . . . . .	1694883	2	22.60	COVER ASSY., pass. and driver seat back rear center (comb. 73G) (oxblood) . . . . .
75	Vega . . . . .	9640479	2	1.95	COVER ASSY., pass. and driver, bottom frame . . . . .
75	El Camino . . . . .	1703016	1	16.85	DEADENER ASSY., comp. panel . . . . .

**14.818 MOULDING— CAP— CLIP, Front Seat Side Trim (See Group 12.976 for 2nd and 3rd Seat Moulding and Escutcheon)**

66-67	Impala, Nova (S.S.),				
66-67	Malibu w/astro. bucket seats (exc. 4-Dr.),				
66-67	Caprice (Spt. Cpe.) w/bucket seat . . . . .				driver and pass. st. bk. pnl. fin., . . . . .
66-67	Caprice (Spt. Cpe., Spt. Sed.) w/astro bench seat . . . . .	7600026	2	2.85	frt. seat bk. pnl. fin. mldg. . . . .
68	Malibu (Spt. Cpe., Spt. Sed.) (Conv.) . . . . .	4854957	1	9.05	pass. seat back side otr. (comb. 765/960, 765/168-980, 765/158) (Note 1) . . . . .
68	Malibu (Spt. Cpe., Spt. Sed.) (Conv.) . . . . .	4854958	1	9.05	driver seat back side otr. (comb. 765/960, 765/168-980, 765/158) (Note 1) . . . . .
69	Pass. w/bucket seats . . . . .				driver inner, pass outer, . . . . .

NOTE 1 Production Deviation Trim Change.



**FOLDING TOP PARTS—INTERIOR TRIM**

**14.818 MOULDING— CAP— CLIP, Front Seat Side Trim (See Group 12.976 for 2nd and 3rd Seat Moulding and Escutcheon) (Con't)**

69	Caprice w/strato bench seats	7793971 A.R.	2.00	right, frt. seat
69	Pass. w/bucket seats			driver outer, pass. inner,
69	Caprice w/strato bench seats	7793972 A.R.	2.00	left, frt. seat (driver outer, pass. inner)
69-72	Nova, Chevelle, Pass. w/bucket, strato bench seats	7793973	2	4.15 pass., driver seat back
73-75	Chevelle w/bench seat	4854959	1	6.15 pass. and driv. st. bk. otr.
75	Pass., Chevelle (2-Dr.) (exc. Caprice Spt. Cpe. w/reclining seat)	1671762		6.30 pass. and driver seat back outer
66-67	Chevelle, Nova (S.S.),			
66-67	El Camino,			
66-67	Impala, Caprice (2-Dr.) w/bucket seats			CAP, driver and pass. seat back mldg. end and side pnl. mldg. end,
66-67	Caprice, Impala (S.S.) w/bench seat	7584956	4	.18 front seat back pnl. mldg. end
68	Chevy, Malibu, S.S. (Spt. Cpe., Conv.) w/strato bench seat,			
68	El Camino (Custom) w/strato bench seat			CAP, pass. outer and driver inner seat back, right, pass. and driver seat back panel fin. mldg. end,
68	Impala (Conv.)			pass. seat side panel mldg. inner rear and outer frt., driver seat side panel and inner rear and outer front,
68	Pass. (Spt. Cpe., Conv.)			
68	Caprice (Sed.) w/strato bench seat			pass. and driver seat back panel fin. mldg. end,
68	Pass. (Spt. Cpe.) Caprice (Sed.)			frt. seat side panel mldg. rr. end (left), frt. seat side panel mldg. frt. end (right),
68	Pass. (Spt. Cpe.) w/strato bench, bucket seats	7738634 R.H.		.18 pass. and driver seat back panel fin. mldg. end
68	Chevy, Malibu, S.S. (Spt. Cpe., Conv.) w/strato bench seat,			
68	El Camino (Custom) w/strato bench seat			CAP, pass. inner and driver outer seat back,
68	Pass. (Spt. Cpe.) w/strato bench, bucket seats,			
68	Caprice (Sed.) w/strato bench seat,			
68	Impala (Conv.)			left, pass. and driver seat back panel fin. mldg. end,
68	Pass. (Spt. Cpe., Conv.)			pass seat side panel mldg. inner rr. and outer frt., driver seat side panel mldg. inner rr. and outer frt.,
68	Pass. (Spt. Cpe.) Caprice (Sed.) w/strato bench seat	7738635 L.H.		.18 frt. seat side panel mldg. rr. end (right) frt. seat side panel mldg. frt. end (left)
73-74	Chevelle (2-Dr.) w/Swivel Bucket	9625176 A.R.		.02 CLIP, pass. and driver seat side finish lace rear

**14.870 CARRIER UNIT— PIN— HAND RAIL ASSY.— PAD— SCREW— WASHER, Child Safety**

All	All	994259	1	N.L.	20 lbs. or under
All	All	9677326	1	N.L.	20 lbs. or over
All	All	9716540	2	.56	PIN, seat back to cush.
All	All	9726017	1	10.40	HAND RAIL ASSY., seat (parchment)
All	All	9607911	1	3.05	PAD, infant seat
All	All	446205	2	.11	WASHER, flat

**FOLDING TOP PARTS—INTERIOR TRIM**

**14.875 SEAT BELT UNIT— SHOULDER STRAP UNIT**

*NOTE: Components of Seat Belt Assemblies are not available separately. To comply with specified safety standards, it is not recommended that integral retractors, buckles and inserts which are sewn in. Both right and left hand seat belt sections should be replaced as a unit. Many designs of metal inserts and buckles may look alike, may "false-latch" one into the other without the specified strain.*

*NOTE: See Dealer Price Schedule (P&A 26) for applicable prices.*

*NOTE: All seat belt and strap unit packages contain all necessary parts for installation exc. stowage provisions.*

**1964 CHEVY— CHEVELLE**

	BELT UNITS				
	BLACK	RED	BLUE	FAWN	GREEN
STANDARD .....					
Front Seat .....					
All .....	3955366	3955367	3955368	—	—
CUSTOM .....					
Rear Seat & Front Ctr. Seat .....					
All .....	—	3957890	—	—	—
CUSTOM DELUXE .....					
Front Seat .....					
All .....	—	3955366	—	3948583	—

**1965 PASSENGER**

	BELT UNITS						
	BLACK	RED	BLUE	FAWN	AQUA	SADDLE	GREEN
STANDARD .....							
Front Seat and Folding Seats .....	3955366	3955367	3955368	—	—	—	—
CUSTOM .....							
Rear Seat and Front Ctr. Seat .....	—	3957870	—	—	—	—	—
CUSTOM DELUXE .....							
Front Seat .....	—	3955366	—	3957843	3957842	3957807	—
Rear Seat and Folding Seats .....	3955358	—	—	3955363	—	—	—
Front and Rear Ctr. Seat .....	3957856	3957851	—	—	—	—	—

**1965 CHEVY— CHEVELLE**

	BELT UNITS					
	BLACK	RED	BLUE	FAWN	AQUA	SADDLE
STANDARD .....						
Front Seat & Folding Seats .....						
All .....	3955366	3955367	3955368	—	—	—
Rear Seat & Front Ctr. Seat .....						
All .....	—	3957870	—	—	—	—
CUSTOM DELUXE .....						
Front Seat .....						
All .....	—	3955366	—	—	3957842	—
Rear Seat & Folding Seats .....						
All .....	3955358	—	—	3955363	—	—
Front Ctr. Seat & Rear Ctr. Seat .....						
All .....	3957856	3957851	—	—	—	—

**FOLDING TOP PARTS—INTERIOR TRIM**

**1966 PASSENGER**

	<b>BELT UNITS</b>						
	<b>BLACK</b>	<b>RED</b>	<b>BLUE</b>	<b>FAWN</b>	<b>TURQ.</b>	<b>GREEN</b>	<b>BRONZE</b>
STANDARD .....							
Front Seat .....	3955366	3955367	3955368	—	—	—	—
CUSTOM .....							
Rear Seat and Front and Rear Ctr. and Folding Seats .....	3955378	3955379	3955380	3955381	—	—	—
CUSTOM DELUXE .....							
Front Seat .....	3955370	3955372	3955373* 3955371**	—	3955375	3955376	3955377
Rear Seat and Rear Ctr. Seat and Folding Seats .	3955382	3955384	3955385* 3955383**	3955386	—	3955388	3955389
Front Ctr. Seat .....	3955391	—	3955394* 3955392**	3955395	3955396	3955397	—

*\*Dark Blue*

*\*\*Brt. Blue (used on S.S. models)*

**1966 CHEVY— CHEVELLE**

	<b>BELT UNITS</b>						
	<b>BLACK</b>	<b>RED</b>	<b>BLUE</b>	<b>FAWN</b>	<b>TURQ.</b>	<b>GREEN</b>	<b>BRONZE</b>
STANDARD .....							
Front Seat .....							
All .....	3955366	3955367	3955368	—	—	—	—
CUSTOM .....							
Rear Seat, Front & Rear Ctr. Seat & Folding Seats .....	3955378	3955379	3955389	3955381	—	—	—
CUSTOM DELUXE .....							
Front Seat .....							
All .....	3955370	3955372	3955373 3955371*	—	3955375	—	3955377
Rear Seat, Rear Ctr. Seat & Folding Seats .....							
All .....	3955382	3955384	3955385 3955383*	3955386	—	3955388	3955389
Front Ctr. Seat .....							
All .....	3955391	—	3955394 3955392*	3955395	—	3955397	—

*\*Brt. Blue (used on Spt. Cpe. and Conv. models)*

**FOLDING TOP PARTS—INTERIOR TRIM**

**1966 PASSENGER**

**SHOULDER STRAP UNITS**

	BLACK	RED	BLUE	FAWN	TURQ.	GREEN	BRONZE
STANDARD .....							
(Exc. Conv.) .....	—	4228422	4228423	4228424	—	—	—
Conv. ....	4228425	4228426	4228427	4228428	—	—	—
DELUXE .....							
(Exc. Conv.) .....	—	4228369	—	4228372	4228373	4228374	4228376
Conv. ....	4228380	4228382	4228368*	4228383	—	—	4228388
			4228381*	4228385			

*\*Brt. Blue (used on S.S. models)*

**1966 CHEVY— CHEVELLE**

**SHOULDER STRAP UNITS**

	BLACK	RED	BLUE	FAWN	TURQ.	BRONZE
STANDARD .....						
(Exc. Conv.) .....	—	4228422	4228423	4228424	—	—
Conv. ....	4228425	4228426	4228427	4228428	—	—
DELUXE .....						
(Exc. Conv.) .....	—	4228369	—	4228372	4228373	4228376
Conv. ....	4228380	4228382	4228368*	4228383	—	4228388
			4228381*	4228385		

*\*Brt. Blue (used on S.S. and Monza models)*

**1967 PASSENGER (FISHER COACH EMBLEM)**

**BELT UNITS**

	BLACK	BLUE	GOLD	TURQ.				
STANDARD .....								
Front Seat (RH) .....	8701648	8700472	8700762	8700476				
Front Ctr. Seat .....	—	8700458	8700459	—				
Front Seat (LH) .....	8701649	8700761	8700763	8700477				
Rear Seat and Rear Ctr. Seat and Folding Seats .	8700461	8700462	8700463	—				
DELUXE .....								
Front Seat (RH) .....	8700478	—	8700496	8700494	8700480	—	—	—
Front Seat (LH) .....	8700479	8700493*	8700497	8700733	8700725	8700487	8700503	—
Rear Seat and Rear Ctr. Seat and Folding Seat . .	8700510	8700516*	8700518	8700517	8700512	8700514	8700522	8700511
Front Ctr. Seat .....	8700523	8700519**	8700531	8700530	8700525	8700527	8705946	8700524
		8700529*						
		8700713**						

*\*Dark Blue*

*\*\*Brt. Blue (used on S.S. models)*

**FOLDING TOP PARTS—INTERIOR TRIM**

**1967 (MARK OF EXCELLENCE EMBLEM)**

	BLACK	BLUE	GOLD	TURQ.
STANDARD .....				
Front Seat (RH) .....	8701648	8700638	8700640	8700642
Front Seat (LH) .....	8701649	—	8700641	8700643
Front Ctr. Seat .....	8700651	8700652	8700653	8700654
Rear Seat .....	8700647	8700648	8700649	8700650

**1967 CHEVY— CHEVELLE— CAMARO (FISHER COACH EMBLEM)**

	BELT UNITS							
	BLACK	BLUE	GOLD	TURQ.	RED	MAROON	FAWN	PLUM
STANDARD .....								
Front Seat .....								
Chevy, Chevelle (RH) ...	8701648	8700472	8700762	8700476	—	—	—	—
Chevy, Chevelle (LH) ...	8701649	8700761	8700763	8700477	—	—	—	—
Camaro (RH) .....	8700618	8700684	8700632	8700624	—	—	—	—
Camaro (LH) .....	8701661	—	8700623	—	—	—	—	—
Rear Seat, Rear Ctr. Seats .....								
& Folding Seats .....								
All (exc. Rear Ctr. on Camaro) .....	8700461	8700462	8700463	—	—	—	—	—
Front Ctr. Seat .....								
All (exc. Camaro) .....	—	8700458	8700459	—	—	—	—	—
DELUXE .....								
Front Seat .....								
Chevy, Chevelle (RH) ...	8700478	—	8700496	8700494	8700480	8700486	—	—
Chevy, Chevelle (RH) (Standard) .....	—	—	—	—	—	—	8700500	—
Chevy, Chevelle (LH) ...	8700479	8700493	8700497	8700477	—	8700487	8700503	8700597
Camaro (RH) .....	8700690	8700616	8700614	—	—	—	—	—
Camaro (LH) .....	8700691	8700617	8700615	—	—	—	—	—
Rear Seat, Rear Ctr. Seat & Folding Seats .....								
All (exc. Rear Ctr. Seat on Camaro) .....	8700510	8700516* 8700519**	8700518	8700517	8700512	8700514	8700522	8700511
Front Ctr. Seat .....								
All (exc. Camaro) .....	8700523	8700529* 8700713**	8700531	8700530	8700525	8700527	8705946	8700524
Camaro (RH) .....	—	8700610	—	8700612	8700608	—	—	—
Camaro (LH) .....	—	8700611	—	8700613	8700609	—	—	—

\*Dark Blue

\*\*Brt. Blue (used on S.S. models)

**FOLDING TOP PARTS—INTERIOR TRIM**

**1967 (MARK OF EXCELLENCE EMBLEM)**

	BLACK	BLUE	GOLD	TURQ.
STANDARD				
Front Seat				
Chevy, Chevelle (RH)	8701648	8700638	8700640	8700642
Chevy, Chevelle (LH)	8700637	—	8700641	8700743
Camaro (RH)	8700618	8700630	8700632	—
Camaro (LH)	8700629	8700631	—	—
Front Ctr. Seat				
Chevelle	8700651	8700652	8700653	8700654
Rear Seat				
All (exc. El Camino)	8700647	8700648	8700649	8700650

**1967 PASSENGER**

**SHOULDER STRAP UNITS**

	BLACK	DARK BLUE	DARK GOLD	DARK TURQ.	MED. RED	MAROON	DARK FAWN	PLUM
STANDARD								
(Exc. Conv.)	7792095	7792096		7792098	—	—	—	—
Conv.	7792108	—	7792110	7792111	—	—	—	—
DELUXE								
(Exc. Conv.)	7792076	7792081	—	7792082	7792077	7792079	7792084	7792088
Conv.	7792099	7792104 7792107**	7792106	7792105	7792100	—	—	—

\*Dark Blue (used on Impala Spt. Cpe.)

\*\*Brt. Blue (used on Impala)

**1967 CHEVY— CHEVELLE— CAMARO**

**SHOULDER STRAP UNITS**

	BLACK	DARK BLUE	DARK GOLD	DARK TURQ.	MED. RED	MAROON	DARK FAWN	PLUM
STANDARD								
(Exc. Conv.)	7792095	7792096		7792098	—	—	—	—
Conv.	7792108	—	7792110	7792111	—	—	—	—
DELUXE								
(Exc. Conv.)	7792076	7792081	—	7792082	7792077	7792079	7792084	7792088
Conv.	7792099	7792104 7792107*	7792106	7792105	7792100	—	—	—

\*Dk. Brt. Blue (used on Camaro (Deluxe) and S.S. models)

**1968 PASSENGER**

**BELT UNITS**

	BLACK	BLUE	GOLD	TEAL	RED	TURQ.	SADDLE	GREEN
STANDARD								
Front Seat (RH)	8700758	8700760	8700762	8700764	—	—	—	—
Front Seat (LH)	8700759	8700761	8700763	8700765	—	—	—	—
Front Ctr. Seat	—	8700703	8700704	8700705	—	—	—	—
Rear Seat,								
Sta. Wag. (2nd & 3rd Seat)	8700706	8700707	8700708	8700709	—	—	—	—
DELUXE								
Front Seat (RH)	8705860	—	—	8700730	—	8700732	8700736	8700738
Front Ctr. Seat	8703465	8700713	8700716	8700714	8700711	8700715	8700717	—
Front Seat (LH)	8700723	8700729	8700735	8700731	8700725	8700733	8700737	8700739
Rear Seat,								
Sta. Wag. (2nd & 3rd Seat)	8701501	8700749	8700752	8700750	8700747	8700751	8700753	8700754

**FOLDING TOP PARTS—INTERIOR TRIM**

**1968 CHEVY— CHEVELLE— CAMARO**

	BELT UNITS							
	BLACK	BLUE	GOLD	TEAL	RED	TURQ.	SADDLE	GREEN
STANDARD .....								
Front Seat .....								
Camaro (RH) .....	8701660	8700684	8700686	—	—	—	—	—
Camaro (LH) .....	8701661	8700685	8700687	—	—	—	—	—
Chevy-Chevelle (RH) .....	8700758	8700760	8700762	8700764	—	—	—	—
Chevy-Chevelle (LH) .....	8700759	8700761	8700763	8700765	—	—	—	—
Chevy (Sed.) (RH) .....	8701656	8700840	—	—	—	—	—	—
Chevy (Sed.) (LH) .....	8701657	8700841	—	—	—	—	—	—
Front Seat Center .....								
All .....	—	8700703	8700704	8700705	—	—	—	—
Rear Seat .....								
All, .....								
Sta. Wag. (2nd and 3rd Seat) .....	8700706	8700707	8700708	8700709	—	—	—	—
DELUXE .....								
Front Seat .....								
Camaro (RH) .....	8700690	8700694	8700700	—	8700692	8700698	—	—
Camaro (LH) .....	8700691	8700695	8700701	—	8700693	8700699	—	—
Chevy-Chevelle (RH) .....	8705860	—	—	8700730	—	8700732	8700736	8700738
Chevy-Chevelle (LH) .....	8700723	8700729	8700735	8700731	8700725	8700733	8700737	8700739
Chevy (Sed.) (RH) .....	8701636	8700846	8703396	—	—	—	—	—
Chevy (Sed.) (LH) .....	8701637	8700847	8700849	—	—	—	—	—
Front Seat Center .....								
All .....	8703465	8700713	8700716	8700714	8700711	8700715	8700717	—
Rear Seat .....								
All, .....								
Sta. Wag. (2nd and 3rd Seat) .....	8701501	8700749	8700752	8700750	8700747	8700751	8700753	8700754

**1968 PASSENGER**

	SHOULDER STRAP UNITS							
	BLACK	BLUE	GOLD	TEAL	RED	TURQ.	SADDLE	GREEN
STANDARD .....								
(Exc. Spt. Cpe., Conv.) ..								
(Front) .....	8700192	8700193	8700194	—	—	—	—	—
(Spt. Cpe.) (Front) .....	8700177	8700178	8700179	8700180	—	—	—	—
Conv. (Front) .....	8700260	—	8700262	8700263	—	—	—	—
(Exc. Conv., Sta. Wag.) ..								
(Rear) .....	8700295	8700296	8700297	8700298	—	—	—	—
Sta. Wag. (2nd Seat) .....	—	7794931	—	—	—	—	—	—
DELUXE .....								
(Exc. Conv., Spt. Cpe.) ..								
(Front) .....	8700196	8700199	8700202	—	—	8700201	—	—
Spt. Cpe. (Front) .....	8700181	8700183	8700186	8700184	—	8700185	—	8700188
Conv. (Front) .....	8700250	—	7794917	7794915	7794912	8700268	—	—
(Exc. Conv., Sta. Wag.) ..								
(Rear) .....	8700283	7794950	8700289	7794951	—	7794952	—	—
Sta. Wag. (2nd Seat) .....	—	7794940	—	—	—	7794942	8700305	—
Front Seat .....								
Sta. Wag. .....							8700203	
Front Seat .....								
4-Dr. Sed. .....								8700204

**FOLDING TOP PARTS—INTERIOR TRIM**

**1968 CHEVY— CHEVELLE— CAMARO**

**SHOULDER STRAP UNITS**

	BLACK	BLUE	GOLD	TEAL	RED	TURQ.	SADDLE	GREEN
<b>STANDARD</b> .....								
Front Seat								
(Exc. Conv., El Camino)	8700192	8700193	8700194	8700195	—	—	—	—
El Camino	8700232	8700233	—	—	—	—	—	—
Rear Seat								
(Exc. Sta. Wag.)	8700295	8700296	8700297	—	—	—	—	—
Sta. Wag.	8700308	7794931	—	—	—	—	—	—
Front and Rear Seat								
Chevelle (Conv.)	8700246	8700247	—	—	—	—	—	—
Camaro (Conv.)	8700271	—	8700273	—	—	—	—	—
<b>DELUXE</b> .....								
Front Seat								
(Exc. Conv., El Camino)	8700196	8700199	8700202	—	—	8700201	—	8700204
El Camino	8700234	8700235	—	—	—	—	8700236	—
Rear Seat								
(Exc. Sta. Wag.)	8700283	7794950	8700289	7794951	—	7794952	—	—
Sta. Wag.	—	7794940	—	—	—	7794942	8700203	—
Front and Rear Seat								
Chevelle (Conv.)	8701532	8700241	8700244	—	—	—	—	—
Camaro (Conv.)	8700264	7794977	8700269	—	—	8700268	—	—
Chevelle (Spt. Cpe., Spt. Sed.)	—	—	—	8700200	8700197	—	—	—

**1969 PASSENGER**

**BELT UNITS**

	BLACK	BLUE	GOLD	GREEN				
<b>STANDARD</b> .....								
Front Seat (RH)	8701648	8701650	8701652	8701654				
Front Seat (LH)	8701649	8701651	8701653	8701655				
Front Seat Center	—	8701670	8701671	8701672				
Rear Seat								
Sta. Wag. (2nd Seat)	8701644	8701645	8701646	8701647				
<b>DELUXE</b> .....								
Front Seat (RH)	8702434	8702444	8702440	8702446	8702438	8702436	8702442	8702448
Front Seat (LH)	8702435	8702445	8702441	8702447	8702439	8702437	8702443	8702449
Front Seat Center	8701480	8701489	8701487	8701490	8701486	8701485	8701488	8701491
Rear Seat								
Sta. Wag. (2nd & 3rd Seat)	8701501	8701506	8701504	8701507	8701503	8701502	8701505	8701508



**FOLDING TOP PARTS—INTERIOR TRIM**

**1969 CHEVY— CHEVELLE— CAMARO**

**BELT UNITS**

	<b>BLACK</b>	<b>DARK BLUE</b>	<b>DARK GREEN</b>				
RH .....	8701656	8701658	8701667				
LH .....	8701657	8701659	8701668				
Chevy (Spt. Cpe.) .....							
RH .....	8703380	8703406	8701445				
LH .....	8703381	8703407	8701446				
Camaro .....							
RH .....	8701660	—	8701675				
LH .....	8701661	—	8701676				
Chevelle .....							
RH .....	8701648	8701650	8701654				
LH .....	8701649	8701651	8701655				
Front Seat Center .....							
All .....	—	8701670	8701672				
Rear Seat, All .....							
Sta. Wag. (2nd and 3rd Seat) .....	8701644	8701645	8701647				
	<b>BLACK</b>	<b>DARK BLUE</b>	<b>DARK GREEN</b>	<b>DARK RED</b>	<b>MID. GREEN</b>	<b>SADDLE</b>	<b>DARK TURQ.</b>
<b>DELUXE</b> .....							
Front Seat .....							
Chevy (Spt. Cpe.) .....							
RH .....	8701626	8701628	8701630	8701632	8701634	—	—
LH .....	8701627	8701629	8701631	8701633	8701635	—	—
Chevy (Sed.) .....							
RH .....	8701636	8701638	8701640	—	8701642	—	—
LH .....	8701637	8701639	8701641	—	8701643	—	—
Camaro .....							
RH .....	8701591	8701595	8701600	8701593	8701602	—	—
LH .....	8701592	8701596	8701601	—	8701603	—	—
Chevelle .....							
RH .....	8702434	8702438	8702442	8702444	8702448	8702436	8702446
LH .....	8702435	8702439	8702443	8702445	8702449	8702437	8702447
Front Seat Center .....							
All .....	8701480	8701486	8701488	8701489	8701491	8701485	8701490
Rear Seat, All .....							
2nd and 3rd Seat .....							
Sta. Wag. ....	8701501	8701503	8701505	8701506	8701508	8701502	8701507

**FOLDING TOP PARTS—INTERIOR TRIM**

**1969 PASSENGER**

**SHOULDER STRAP UNITS**

	<b>BLACK</b>	<b>BLUE</b>	<b>GOLD</b>	<b>DARK GREEN</b>				
<b>STANDARD</b> .....								
Front (Spt. Cpe.) .....	8701684	8701685	8701686	8701687				
Front or Rear (Conv.) ...	8701688	—	—	8701689				
Front (4-Dr.) .....	8701690	8701691	8701692	8701693				
Rear (Exc. Sta. Wag., Conv.) .....	8701695	8701697	8701700	8701701				
2nd Seat (Sta. Wag.) ...	8701696	8701698	—	8701702				
	<b>BLACK</b>	<b>BLUE</b>	<b>RED</b>	<b>GOLD</b>	<b>TURQ.</b>	<b>MID. GREEN</b>	<b>DARK GREEN</b>	<b>SADDLE</b>
<b>DELUXE</b> .....								
Front (Spt. Cpe.) .....	8701518	8701519	8701522	8701520	8701523	8701524	8701521	—
Front (4-Dr.) .....	8701599	8701605	—	8701606	8701609	8701610	8701607	8701604
Front or Rear (Conv.) ...	8701539	—	8701543	—	—	—	8701542	—
Rear Seat .....								
(Exc. Sta. Wag., Conv.) ..	8701552	8701557	8701563	8701559	8701565	8701566	8701561	—
Sta. Wag. (2nd Seat) ...	8701553	8701558	—	—	—	8701567	—	8701555

**1969 CHEVY— CHEVELLE— CAMARO**

**SHOULDER STRAP UNITS**

	<b>BLACK</b>	<b>DARK BLUE</b>	<b>DARK GREEN</b>				
<b>STANDARD</b> .....							
Front Seat .....							
Camaro (Spt. Cpe.), ...							
Chevy, Chevelle (exc. Conv., El Camino) .....	8701690	8701691	8701693				
El Camino .....	—	8705876	—				
Front and Rear Seat ...							
Camaro (Conv.) .....	—	8701678	8701680				
Chevelle (Conv.) .....	8701681	8701682	—				
Rear Seat .....							
Camaro (Spt. Cpe.) .....							
Chevy, .....							
Chevelle (Cpe., Sedan) ..	8701695	8701697	8701701				
2nd Seat Sta. Wag. ....	8701696	8701698	8701702				
	<b>BLACK</b>	<b>DARK BLUE</b>	<b>DARK GREEN</b>	<b>DARK RED</b>	<b>DARK TURQ.</b>	<b>MID. GREEN</b>	<b>DARK SADDLE</b>
<b>DELUXE</b> .....							
Front Seat .....							
Camaro (Spt. Cpe.), ...							
Chevy, Chevelle (exc. Conv., El Camino) .....	8701599	8701605	8701607	8701608	8701609	8701610	8701604
El Camino .....	8701551	8701556	—	—	—	—	8701554
Front or Rear Seat .....							
Camaro (Conv.) .....	8701526	8701527	8701529	8701531	—	8701530	—
Chevelle (Conv.) .....	8701532	8701533	—	8701536	—	—	—
Rear Seat .....							
Camaro (Spt. Cpe.), ...							
Chevy, .....							
Chevelle (Cpe., Conv.) ..	8701552	8701557	8701561	8701563	8701565	8701566	—
2nd Seat Sta. Wag. ....	8701553	8701558	—	—	—	8701567	8701555

**FOLDING TOP PARTS—INTERIOR TRIM**

**1970 PASSENGER**

**BELT UNITS**

	BLACK	DARK BLUE	MEDIUM GOLD	DARK GREEN				
<b>STANDARD</b>								
Front Seat (RH)	8703372	8703458	8703462	8703460				
Front Seat (LH)	8703373	8703459	8703463	8703461				
Front Seat Center	8703464	8703484	8703486	8703485				
Rear Seat, Sta. Wag. (2nd & 3rd Seat)	8703345	8703365	8703367	8703366				
	BLACK	SANDAL- WOOD	MEDIUM RED	DARK GREEN	DARK TURQ.	MEDIUM GOLD	DARK BLUE	MEDIUM SADDLE
<b>DELUXE</b>								
Front Seat (RH)	8703384	8703420	8703448	8703440	8703450	8703442	8703438	8703444
Front Seat (LH)	8703385	8703421	8703449	8703441	8703451	8703443	8703439	8703445
Front Seat Center	8703465	8703467	8703482	8703478	8703483	8703479	8703477	8703480
Rear Seat, Sta. Wag. (2nd & 3rd Seat)	8703346	8703348	8703363	8703359	8703364	8703360	8703358	8703361
Rear Seat Center (2-Dr.)	8707196	8706927	8706928	8706929	—	—	—	—

**1970 NOVA BELT UNITS**

	BLACK	DARK BLUE	MEDIUM GOLD	DARK GREEN		
<b>STANDARD</b>						
Front Seat (2-Dr.) (RH)	8703380 <sup>1</sup>	8703406 <sup>1</sup>	8703410 <sup>1</sup>	8703408 <sup>1</sup>		
Front Seat (2-Dr.) (LH)	8703381 <sup>1</sup>	8703407 <sup>1</sup>	8703411 <sup>1</sup>	8703409 <sup>1</sup>		
Front Seat (4-Dr.) (RH)	8703374 <sup>1</sup>	8703412 <sup>1</sup>	8703416 <sup>1</sup>	8703414 <sup>1</sup>		
Front Seat (4-Dr.) (LH)	8703375 <sup>1</sup>	8703413 <sup>1</sup>	8703417 <sup>1</sup>	8703415 <sup>1</sup>		
Front Seat Center	8703464 <sup>1</sup>	8703484 <sup>1</sup>	8703486 <sup>1</sup>	8703485 <sup>1</sup>		
Front Seat & Front Seat Ctr.	8705701 <sup>2</sup>	8705702 <sup>2</sup>	8705704 <sup>2</sup>	8705703 <sup>2</sup>		
Rear Seat	8703345	8703365	8703367	8703366		
	BLACK	SANDAL- WOOD	DARK GREEN	MEDIUM GOLD	DARK BLUE	
<b>DELUXE</b>						
Front Seat (2-Dr.) (RH)	8703382	8703398	8703402	8703404	8703400	
Front Seat (2-Dr.) (LH)	8703383	8703399	8703403	8703405	8703401	
Front Seat (4-Dr.) (RH)	8703378	8703390	8703394	8703396	8703392	
Front Seat (4-Dr.) (LH)	8703379	8703391	8703395	8703397	8703393	
Front Seat Center	8703465	8703467	8703478	8703479	8703477	
Rear Seat	8703346	8703348	8703359	8703360	8703358	

1 - First design with retractors  
2 - Second design without retractors

**1970 CHEVELLE BELT UNITS**

	BLACK	DARK BLUE	MEDIUM GOLD	DARK GREEN				
<b>STANDARD</b>								
Front Seat (RH)	8703372	8703458	8703462	8703460				
Front Seat (LH)	8703373	8703459	8703463	8703461				
Front Seat Center	8703464	8703484	8703486	8703485				
Rear Seat, Sta. Wag. (2nd & 3rd Seat)	8703345	8703365	8703367	8703366				
	BLACK	SANDAL- WOOD	MEDIUM RED	DARK GREEN	DARK TURQ.	MEDIUM GOLD	DARK BLUE	MEDIUM SADDLE
<b>DELUXE</b>								
Front Seat (RH)	8703384	8703420	8703448	8703440	8703450	8703442	8703438	8703444
Front Seat (LH)	8703385	8703421	8703449	8703441	8703451	8703443	8703439	8703445
Front Seat Center	8703465	8703467	8703482	8703478	8703483	8703479	8703477	8703480
Rear Seat, Sta. Wag. (2nd & 3rd Seat)	8703346	8703348	8703363	8703359	8703364	8703360	8703358	8703361

**FOLDING TOP PARTS—INTERIOR TRIM**

**1970 CAMARO BELT UNITS**

	<b>BLACK</b>	<b>DARK BLUE</b>	<b>DARK GREEN</b>			
<b>STANDARD</b> .....						
Front Seat .....	8703991	8703999	8703992			
Rear Seat .....	8704011	8704012	8704013			
	<b>BLACK</b>	<b>DARK GREEN</b>	<b>DARK BLUE</b>	<b>MED. RED</b>	<b>MED. SADDLE</b>	<b>SANDAL-WOOD</b>
<b>DELUXE</b> .....						
Front Seat (RH) .....	8705898	8704822	8705902	—	8703984	8703980
Front Seat (LH) .....	8704817	8704823	8703979	—	8703985	8703981
Rear Seat .....	8704014	8704017	8704016	—	—	8704015

**1970 PASSENGER**

**SHOULDER STRAP UNITS**

	<b>BLACK</b>	<b>MEDIUM GOLD</b>	<b>DARK GREEN</b>	<b>DARK BLUE</b>				
<b>STANDARD</b> .....								
Front Seat .....								
Impala, Caprice (Spt. Cpe.) .....	8703490	8703531	8703530	8703529				
Passenger (exc. Spt. Cpe., Conv.) .....	8703491	8703534	8701693	8703532				
	<b>BLACK</b>	<b>DARK TURQ.</b>	<b>MEDIUM GOLD</b>	<b>MEDIUM RED</b>	<b>MEDIUM SADDLE</b>	<b>DARK GREEN</b>	<b>DARK SANDAL-WOOD</b>	<b>DARK BLUE</b>
<b>DELUXE</b> .....								
Front Seat .....								
Impala, Caprice (Spt. Cpe.) .....	8703494	—	8703524	—	—	8703523	8703496	8703522
Passenger (exc. Spt. Cpe., Conv.) .....	8703497	—	8703511	—	—	8703510	—	8703509
Passenger (Conv.) .....	8703554	—	—	8703573	8703571	8703569	—	—
Impala, Caprice (Sed.) ..	—	8703515	—	—	—	—	—	—
Caprice (Spt. Cpe.) .....	—	8703528	—	—	—	—	—	—
Impala, Caprice (Spt. Cpe.) .....	—	—	—	—	—	—	8703499	—
Impala, Caprice (Spt. Sed.) .....	—	—	—	8703527	—	—	—	—
Impala (Spt. Cpe.) .....	—	—	—	—	8703525	—	—	—
Passenger (Sta. Wag.) ..	—	—	—	—	8703512	—	—	—
Rear Seat (exc. Sta. Wag.) .....	8703583	8703601	8703597	8703600	8703598	8703596	8703585	8703595
2nd and 3rd Seat (exc. Sta. Wag.) .....	8703620	—	8703625	—	8703626	8703624	—	8703623

**1970 NOVA**

**SHOULDER STRAP UNITS**

	<b>BLACK</b>	<b>MEDIUM GOLD</b>	<b>DARK GREEN</b>	<b>DARK BLUE</b>	
<b>STANDARD</b> .....					
Front Seat .....	8703491	8703534	8701693	8703532	
	<b>BLACK</b>	<b>MEDIUM GOLD</b>	<b>DARK GREEN</b>	<b>DARK SANDAL-WOOD</b>	<b>DARK BLUE</b>
<b>DELUXE</b> .....					
Front Seat .....	8703497	8703511	8703510	8703499	8703509
Rear Seat .....	8703583	8703597	8703596	8703585	8703595

**FOLDING TOP PARTS—INTERIOR TRIM**

**1970 CHEVELLE**

**SHOULDER STRAP UNITS**

	<b>BLACK</b>	<b>MEDIUM GOLD</b>	<b>DARK GREEN</b>	<b>DARK BLUE</b>				<b>DARK SANDAL-WOOD</b>	<b>DARK BLUE</b>
<b>STANDARD</b> .....									
Front Seat .....									
(Exc. Conv., El Camino) .	8703491	8703534	8701693	8703532					
El Camino .....	8705876	—	—	8705876					
	<b>BLACK</b>	<b>DARK TURQ.</b>	<b>MEDIUM GOLD</b>	<b>MEDIUM RED</b>	<b>MEDIUM SADDLE</b>	<b>DARK GREEN</b>	<b>DARK SANDAL-WOOD</b>	<b>DARK BLUE</b>	
<b>DELUXE</b> .....									
Front Seat .....									
(Exc. Conv., El Camino) .	8703497	—	8703511	8703514	8703512	8703510	8703499	8703509	
El Camino .....	8703542	—	—	—	8703544	—	—	8703543	
Front & Rear Seat Conv.	8703552	—	—	8703564	8703562	8703560	—	8703559	
Malibu (Sed.) .....	—	8703515	—	—	—	—	—	—	
Rear Seat .....									
(Exc. Conv., Sta. Wag.) .	8703583	—	8703597	—	—	8703596	8703585	8703595	
Malibu (Sed.) .....	—	8703601	—	—	—	—	—	—	
(Spt. Cpe.) .....	—	—	—	8703600	8703598	—	—	—	
2nd and 3rd Seat (Sta. Wag.) .....	8703620	—	—	—	8703626	—	—	8703623	

**1970 CAMARO**

**SHOULDER STRAP UNITS**

	<b>BLACK</b>	<b>DARK BLUE</b>	<b>DARK GREEN</b>		
<b>STANDARD</b> .....					
Front Seat .....	8704001	8704002	8704003		
	<b>BLACK</b>	<b>DARK GREEN</b>	<b>DARK BLUE</b>	<b>MED. SADDLE</b>	<b>SANDAL-WOOD</b>
<b>DELUXE</b> .....					
Front Seat .....	8704004	8704007	8704006	8704008	8704005
Rear Seat .....	8703583	8703596	8703595	8703598	8703585

**FOLDING TOP PARTS—INTERIOR TRIM**

**1971 PASSENGER**

**BELT UNITS**

	<b>BLACK</b>
STANDARD .....	
Front Seat (RH) .....	8705857
Front Seat (LH) .....	8705858
Front Seat Center .....	8705863
Rear Seat .....	8705867
Sta. Wag. (2nd Seat Outer) .....	8704585

	<b>BLACK</b>	<b>BLUE</b>	<b>SANDAL- WOOD</b>	<b>SADDLE</b>	<b>MAIZE</b>	<b>JADE</b>
DELUXE .....						
Front Seat (RH) .....	8704586	8705918	8705920	8705914	8705912	8704604
Front Seat (LH) .....	8704587	8705919	8705921	8705915	8705913	8704605
Front Seat Center .....	8705952	8705945	8705946	8705943	8705941	8704625
Rear Seat, .....						
Sta. Wag. (2nd & 3rd Seat Center) .....	8704631	8704791	8704793	8705956	8705955	8704792
Sta. Wag. (2nd Seat Outer) .....	8704864	8705542	—	8705978	8705540	8705543

**1971 NOVA**

**BELT UNITS**

	<b>BLACK</b>
STANDARD .....	
Front Seat .....	8705859
Rear Seat .....	8705867

	<b>BLACK</b>	<b>BLUE</b>	<b>SANDAL- WOOD</b>	<b>SADDLE</b>	<b>JADE</b>
DELUXE .....					
Front Seat (2-Dr.) (RH) ..	8705880	8705882	8704814	8704808	8704812
Front Seat (2-Dr.) (LH) ..	8705881	8705883	8704815	8704809	8704813
Front Seat Center .....	8705952	8705945	8705946	8705943	8704625
Front Seat (4-Dr.) (RH) ..	8705890	—	8704804	—	8704802
Front Seat (4-Dr.) (LH) ..	8704799	8704801	8704805	—	8704803
Front Seat Center .....	8705952	8705945	8705946	8705943	8704625
Rear Seat .....	8704631	8704791	8704793	8705956	8704792

**1971 CHEVELLE**

**BELT UNITS**

	<b>BLACK</b>
STANDARD .....	
Front Seat (RH) .....	8705857
Front Seat (LH) .....	8705858
Front Seat Center .....	8705863
Rear Seat, .....	
Sta. Wag. (2nd & 3rd Seat) .....	8705867

	<b>BLACK</b>	<b>BLUE</b>	<b>SANDAL- WOOD</b>	<b>SADDLE</b>	<b>JADE</b>
DELUXE .....					
Front Seat (RH) .....	8704586	8705918	8705920	8705914	8704604
Front Seat (LH) .....	8704587	8705919	8705921	8705915	8704605
Front Seat Center .....	8705952	8705945	8705946	8705943	8704625
Rear Seat .....	8704631	8704791	8704793	8705956	8704792
Sta. Wag. (2nd & 3rd Seat) .....	8704631	8704791	8705955	8705956	8704792

**FOLDING TOP PARTS—INTERIOR TRIM**

**1971 CAMARO**

**BELT UNITS**

	<b>BLACK</b>					
<b>STANDARD</b> .....						
Front Seat (RH) .....	8705855					
Front Seat (LH) .....	8705856					
Rear Seat .....	8705868					
	<b>BLACK</b>	<b>BLUE</b>	<b>JADE</b>	<b>SADDLE</b>	<b>SANDAL- WOOD</b>	
<b>DELUXE</b> .....						
Front Seat (RH) .....	8705898	8705902	8704822	8705900	8704824	
Front Seat (LH) .....	8704817	8705903	8704823	8705901	8704825	
Rear Seat .....	8705868	8705962	8704831	8705971	8704832	

**1971 PASSENGER**

**SHOULDER STRAP UNITS**

	<b>BLACK</b>					
<b>STANDARD</b> .....						
Front Seat .....						
Impala, Caprice (Spt. Cpe.) .....	8704575					
Passenger (exc. Spt. Cpe., Conv.) .....	8704576					
	<b>BLACK</b>	<b>BLUE</b>	<b>JADE</b>	<b>MAIZE</b>	<b>SADDLE</b>	<b>SANDAL- WOOD</b>
<b>DELUXE</b> .....						
Front Seat .....						
Impala, Caprice (Spt. Cpe.) .....	8704834	8704841	8704842	8704836	8704837	8704843
Passenger (exc. Spt. Cpe., Conv.) .....	8704848	8704856	8704857	8704851	8704852	8704858
Passenger (Conv.) .....	8706012	—	8705535	8706014	8706015	—
Rear Seat .....						
(Exc. Conv., Sta. Wag.) .....	8705473	8705481	8705482	8705476	8705477	8705483
Passenger (Conv.) (RH) ..	8705713	—	8705726	8705717	8705720	—
Passenger (Conv.) (LH) ..	8705714	—	8705727	8705718	8705721	—
Sta. Wag. (2nd and 3rd Seat) .....	8705492	8705495	8705496	8705493	8705494	—

**1971 NOVA**

**SHOULDER STRAP UNITS**

	<b>BLACK</b>					
<b>STANDARD</b> .....						
Front Seat .....	8704576					
	<b>BLACK</b>	<b>BLUE</b>	<b>JADE</b>	<b>SADDLE</b>	<b>SANDAL- WOOD</b>	
<b>DELUXE</b> .....						
Front Seat .....	8704848	8704856	8704857	8704852	8704858	
Rear Seat .....	8705473	8705481	8705482	8705477	8705483	

**FOLDING TOP PARTS—INTERIOR TRIM**

**1971 CHEVELLE**

**SHOULDER STRAP UNITS**

	<b>BLACK</b>					
<b>STANDARD</b> .....						
Front Seat (exc. Conv., ...)						
El Camino) .....	8704576					
El Camino .....	8705876					
	<b>BLACK</b>	<b>BLUE</b>	<b>JADE</b>	<b>SADDLE</b>	<b>SANDAL- WOOD</b>	
<b>DELUXE</b> .....						
Front Seat (exc. Conv., ...)						
El Camino) .....	8704848	8704856	8704857	8704852	8704858	
Front Seat (Conv.) .....	8705522	—	8705525	8705523	—	
El Camino .....	8705488	—	8705490	8705489	8705491	
Rear Seat (exc. Conv., ...)						
Sta. Wag.) .....	8705473	8705481	8705482	8705477	8705483	
(Conv.) .....	8705522	—	8705525	8705523	—	
(Sta. Wag.) (2nd & 3rd Seat) .....	8705492	8705495	8705496	8705494	8705497	

**1971 CAMARO**

**SHOULDER STRAP UNITS**

	<b>BLACK</b>					
<b>STANDARD</b> .....						
Front Seat .....	8704578					
	<b>BLACK</b>	<b>BLUE</b>	<b>JADE</b>	<b>SADDLE</b>	<b>SANDAL- WOOD</b>	
<b>DELUXE</b> .....						
Front Seat .....	8705516	8705518	8705519	8705517	8705520	
Rear Seat .....	8705473	8705481	8705482	8705477	8705483	

**1971 VEGA**

Vega .....	<b>8704183</b>	1	15.55	<b>BELT AND STRAP ASSY., driver seat</b> .....
Vega .....	<b>8704182</b>	1	15.55	<b>BELT AND STRAP ASSY., pass. seat</b> .....
Vega .....	<b>8704188</b>	2	13.00	<b>BELT ASSY., rear seat</b> .....

**1972 PASSENGER BELT UNITS**

**1ST DESIGN— 4-POINT SYSTEM**

**(NOT USED WITH SENSOR WARNING)**

	<b>BLACK</b>					
<b>STANDARD</b> .....						
Front Seat (RH) .....	8705857					
Front Seat (LH) .....	8705858					
Front Seat Center .....	8705863					
Rear Seat (exc. Sta. Wag.) .....	8705867					
Rear Seat Center (2-Dr.)	8707018					
Sta. Wag. (2nd Seat & 3rd Seat) .....	8705867					
Sta. Wag. (2nd Seat Outer) .....	8705862					
Sta. Wag. (2nd Seat Center) .....	8705872					
	<b>BLACK</b>	<b>BLUE</b>	<b>GREEN</b>	<b>COVERT</b>	<b>SADDLE</b>	<b>PEWTER</b>
<b>DELUXE</b> .....						
Front Seat (RH) .....	8705938	8705918	8705924	8705926	8705914	8705916
Front Seat (LH) .....	8705939	8705919	8705925	8705927	8705915	8705917
Front Seat Center .....	8705952	8705945	8705940	8705948	8705943	8705944
Rear Seat .....	8705953	8705959	8705964	8705966	8705956	8705957
2nd Seat Center .....	8705972	8705974	8705975	8705976	8705973	—
2nd Seat Outer .....	8705977	8705979	8705980	8705981	8705978	—



**FOLDING TOP PARTS—INTERIOR TRIM**

**1972 PASSENGER BELT UNITS**

**2ND DESIGN— 3-POINT SYSTEM**

**(USED WITH SENSOR WARNING)**

<b>BLACK</b>						
<b>STANDARD</b>						
Front Seat (RH) (Conv.) . . . . .	8706712*					
Front Seat (LH) (Conv.) . . . . .	8706669					
Front Seat Center . . . . .	8706805*					
Front Seat (RH) (Conv.) . . . . .	9630180#					
Front Seat (LH) (Conv.) . . . . .	9630181#					
Front Seat Center . . . . .	9630286#					
Rear Seat (2-Dr.) . . . . .	8706906*					
Rear Seat (4-Dr.) (exc. Sta. Wag.) (RH & LH) . . . . .	8706893*					
Rear Seat (2-Dr.) . . . . .	8707234#					
Rear Seat (4-Dr.) (exc. Sta. Wag.) . . . . .	9631494#					
Rear Seat Center (4-Dr.) (exc. Sta. Wag.) . . . . .	8707108*					
Rear Seat Center (Exc. Sta. Wag.) . . . . .	8707240#					
2nd Seat (6-Pass.) (RH) . . . . .	8707140*					
2nd Seat (6-Pass.) (LH) . . . . .	8707141*					
2nd Seat (9-Pass.) (RH) . . . . .	8706998*					
2nd Seat (9-Pass.) (LH) . . . . .	8706999*					
2nd Seat Center (6-Pass.) . . . . .	8707018*					
2nd Seat Center (9-Pass.) . . . . .	8707208*					
2nd Seat Center (6-Pass.) . . . . .	8707240#					
2nd Seat Center (9-Pass.) . . . . .	8707248#					
3rd Seat (9-Pass.) . . . . .	8707036*					
3rd Seat (9-Pass.) . . . . .	9631271#					
<b>BLACK</b>	<b>BLUE</b>	<b>GREEN</b>	<b>COVERT</b>	<b>SADDLE</b>	<b>PEWTER</b>	
<b>DELUXE</b>						
Front Seat (Conv.) (RH) . . . . .	8706704	—	—	8706710	8706706	—
Front Seat (Conv.) (LH) . . . . .	8706705	—	—	8706711	8706707	—
Front Seat Center . . . . .	8706818	8706823	8706826	8706827	8706821	8706822
Rear Seat (2-Dr.) . . . . .	8706894	8706899	8706902	8706903	8706897	8706898
Rear Seat (4-Dr.) (Exc. Sta. Wag.) . . . . .	8706881	8706886	8706889	8706890	9630384	8706885
Rear Seat Center (Exc. Sta. Wag.) . . . . .	8707013	8707015	—	8706962	—	8706947
2nd Seat (6-Pass.) (RH) . . . . .	—	8707148	8707150	—	8707146	—
2nd Seat (6-Pass.) (LH) . . . . .	—	8707149	8707151	—	—	—
2nd Seat (9-Pass.) (RH) . . . . .	—	8706992	8706994	—	—	—
2nd Seat (9-Pass.) (LH) . . . . .	9631525	8706993	8706995	9631539	—	—
2nd Seat Center (6-Pass.) . . . . .	8707013	8707015	8707016	8707017	8707014	—
2nd Seat Center (9-Pass.) . . . . .	8707202	8707204	8707205	8707206	8707203	—
3rd Seat (9-Pass.) . . . . .	1696343	8707033	8707034	8707035	9630250	—
	<i>*Plastic Buckle</i>					
	<i>#Die Cast Buckle</i>					

**FOLDING TOP PARTS—INTERIOR TRIM**

**1972 PASSENGER SHOULDER STRAP UNITS**

**1ST DESIGN— 4-POINT SYSTEM**

**(NOT USED WITH SENSOR WARNING)**

		<b>BLACK</b>					
STANDARD .....							
Front Seat (2-Dr.) .....	8705877						
Front Seat (4-Dr.) .....	8705874						
		<b>BLACK</b>	<b>BLUE</b>	<b>GREEN</b>	<b>COVERT</b>	<b>SADDLE</b>	<b>PEWTER</b>
DELUXE .....							
Front Seat (2-Dr.) .....							
(Exc. Conv.) .....	8706002	8706007	8706010	8706011	8706005	8706006	
Front Seat (Conv.) .....	8706012	—	—	8706020	8706015	—	
Front Seat (4-Dr.) .....	8705982	—	—	—	8705985	8705986	

**1972 PASSENGER BELT AND STRAP UNITS 2ND DESIGN**

**3-POINT SYSTEM (USED WITH SENSOR WARNING)**

		<b>BLACK</b>					
STANDARD .....							
Front Seat (RH) .....							
(Exc. Conv.) .....	8706668						
Front Seat (LH) .....							
(Exc. Conv.) .....	8706669						
Front Seat (RH) .....							
(Exc. Conv.) .....	8707228#						
Front Seat (LH) .....							
(Exc. Conv.) .....	9630181						
		<b>BLACK</b>	<b>BLUE</b>	<b>GREEN</b>	<b>COVERT</b>	<b>SADDLE</b>	<b>PEWTER</b>
DELUXE .....							
Front Seat (RH) .....							
(Exc. Conv.) .....	8706670	8706680	8706686	8706688	8706676	8706678	
Front Seat (LH) .....							
(Exc. Conv.) .....	8706671	8706681	8706687	8706689	8706677	8706679	
Front Seat (Conv.) (RH) ..	8706696	—	—	8706702	8706698	—	
Front Seat (Conv.) (LH) ..	8706697	—	—	8706703	8706699	—	

\*Plastic Buckle  
#Die Cast Buckle

**1972 NOVA BELT UNITS 1ST DESIGN**

**4-POINT SYSTEM (NOT USED WITH SENSOR WARNING)**

		<b>BLACK</b>				
STANDARD .....						
Front Seat .....	8705859					
Rear Seat .....	8705867					
		<b>BLACK</b>	<b>BLUE</b>	<b>GREEN</b>	<b>COVERT</b>	<b>TAN</b>
DELUXE .....						
Front Seat (RH) (2-Dr.) ..	8705880	8705882	8705884	8705886	8705888	
Front Seat (LH) (2-Dr.) ..	8705881	8705883	8705885	8705887	8705889	
Front Seat (RH) (4-Dr.) ..	8705890	8705892	8705894	8705896	—	
Front Seat (LH) (4-Dr.) ..	8705891	8705893	8705895	8705897	—	
Front Seat Center .....	8705952	8705945	8705940	8705948	—	
Rear Seat .....	8705953	8705959	8705964	8705966	8705970	

**FOLDING TOP PARTS—INTERIOR TRIM**

**1972 NOVA SHOULDER STRAP 1ST DESIGN**

**4-POINT SYSTEM (NOT USED WITH SENSOR WARNING)**

	<b>BLACK</b>				
STANDARD .....					
Front Seat .....	8705874				
	<b>BLACK</b>	<b>BLUE</b>	<b>GREEN</b>	<b>COVERT</b>	<b>TAN</b>
DELUXE .....					
Front Seat .....	8705982	8705987	8705990	8705991	8705993

**1972 NOVA BELT AND STRAP UNITS 2ND DESIGN**

**3-POINT SYSTEM (USED WITH SENSOR WARNING)**

	<b>BLACK</b>			
STANDARD .....				
Front Seat (RH) (2-Dr.) ..	8706538*			
Front Seat (LH) (2-Dr.) ..	8706539*			
Front Seat (RH) (2-Dr.) ..	8707256#			
Front Seat (LH) (2-Dr.) ..	8707257#			
Front Seat (RH) (4-Dr.) ..	8706554*			
Front Seat (LH) (4-Dr.) ..	8706555*			
Front Seat (RH) (4-Dr.) ..	8707264#			
Front Seat (LH) (4-Dr.) ..	8707265#			
Front Seat Center .....	8706817*			
Front Seat Center .....	8706842#			
Rear Seat (2-Dr.) .....	8706851*			
Rear Seat (2-Dr.) .....	8707285#			
Rear Seat (4-Dr.) .....	8706856*			
Rear Seat (4-Dr.) .....	8707289#			
Rear Seat Center (2-Dr.)	8707196*			
Rear Seat Center (2-Dr.)	8707195#			
Rear Seat Center (4-Dr.)	8707018*			
Rear Seat Center (4-Dr.)	8707013#			
	*Plastic Buckle			
	#Vinyl Spray Buckle			
	<b>BLACK</b>	<b>BLUE</b>	<b>GREEN</b>	<b>COVERT</b>
DELUXE .....				
Front Seat (RH) (2-Dr.) ..	8706538	8706544*	8706546*	8706548*
Front Seat (LH) (2-Dr.) ..	8706539	8706545*	8706547*	8706549*
Front Seat (RH) (2-Dr.) ..	—	—	—	—
Front Seat (LH) (2-Dr.) ..	—	—	—	—
Front Seat (RH) (4-Dr.) ..	8707264#	8706558*	8706560*	8706562*
Front Seat (LH) (4-Dr.) ..	8707265#	8706559*	8706561*	8706563*
Front Seat Center .....	8707131*	8707052*	8707053*	8707054*
Front Seat Center .....	8706842#	—	—	—
Rear Seat (2-Dr.) .....	8706851*	8706847*	8706848*	8706849*
Rear Seat (2-Dr.) .....	8707285#	—	—	—
Rear Seat (4-Dr.) .....	8706856*	8706853*	8706854*	8706855*
Rear Seat (4-Dr.) .....	8707289#	—	—	—
Rear Seat Center (2-Dr.)	8707196*	8706927*	8706928*	8706929*
Rear Seat Center (2-Dr.)	8707195#	—	—	—
Rear Seat Center (4-Dr.)	8707018*	8707055*	8707056*	8707057*
Rear Seat Center (4-Dr.)	8707013	—	—	—
	*Plastic Buckle			
	#Vinyl Spray Buckle			

**FOLDING TOP PARTS—INTERIOR TRIM**

**1972 CHEVELLE BELT UNITS**

**1ST DESIGN— 4-POINT SYSTEM**

**(NOT USED WITH SENSOR WARNING)**

	<b>BLACK</b>						
<b>STANDARD</b> .....							
Front Seat (RH) .....	8705857						
Front Seat (LH) .....	8705858						
Front Seat Center .....	8705863						
Rear Seat (exc. Sta. Wag.) .....	8705867						
Sta. Wag. (2nd & 3rd Seat) .....	8705867						
	<b>BLACK</b>	<b>BLUE</b>	<b>GREEN</b>	<b>COVERT</b>	<b>SADDLE</b>	<b>PEWTER</b>	<b>TAN</b>
<b>DELUXE</b> .....							
Front Seat (RH) .....	8705938	8705918	8705924	8705926	8705914	8705916	8705934
Front Seat (LH) .....	8705939	8705919	8705925	8705927	8705915	8705917	8705935
Front Seat Center .....	8705952	8705945	8705940	8705948	8705943	8705944	8705950
Rear Seat .....	8705953	8705959	8705964	8705966	8705956	8705957	8705970

**1972 CHEVELLE BELT UNITS**

**2ND DESIGN— 3-POINT SYSTEM**

**(USED WITH SENSOR WARNING)**

	<b>BLACK</b>
<b>STANDARD</b> .....	
Front Seat (Conv.) (Bench) (RH) .....	8706636*
Front Seat (Conv.) (Bench) (LH) .....	8706637*
Front Seat (Conv.) (Bench) (RH) .....	8707212#
Front Seat (Conv.) (Bench) (LH) .....	8707213#
Front Seat (Conv.) (Bucket) (RH) .....	8706628*
Front Seat (Conv.) (Bucket) (LH) .....	8706629*
Front Seat (Conv.) (Bucket) (LH) .....	8707223#
Front Seat Center (Bench) .....	
(Exc. Monte Carlo) .....	8706817*
Front Seat Center (Bench) .....	
(Exc. Monte Carlo) .....	8707218#
Front Seat Center (Bench) .....	
(Monte Carlo) .....	8707131*
Front Seat Center (Bench) .....	
(Monte Carlo) .....	8707243#
Rear Seat (2-Dr.) (RH & LH) .....	8706879*
Rear Seat (2-Dr.) (RH & LH) .....	8707232#
Rear Seat Center (2-Dr.) .....	8707196*
Rear Seat Center (2-Dr.) .....	9631222#
Rear Seat, 2nd Seat (4-Dr.) (RH & LH) .....	8706878*
Rear Seat, 2nd Seat (4-Dr.) (RH & LH) .....	8707221#
Rear Seat, 2nd Seat (4-Dr.) (Center) .....	8707018*
Rear Seat, 2nd Seat (4-Dr.) (Center) .....	8707240#
3rd Seat .....	8707030*
3rd Seat .....	8707241#

**FOLDING TOP PARTS—INTERIOR TRIM**

	BLACK	BLUE	GREEN	COVERT	SADDLE	PEWTER
DELUXE .....						
Front Seat (Conv.) .....						
(Bucket) (RH) .....	8707044	—	8707050	—	—	—
Front Seat (Conv.) .....	—	—	8706615	—	—	—
(Bucket) (LH) .....	8707045	—	—	—	—	—
Front Seat (Conv.) .....						
(Bench) (RH) .....	8706638	—	8706642	—	—	—
Front Seat (Conv.) .....						
(Bench) (LH) .....	9630561	—	8707097	—	—	—
Front Seat Center .....						
(Exc. Monte Carlo) .....	8706806	8706811	8706814	8706815	—	—
Front Seat Center .....						
(Monte Carlo) .....	8707133	8707136	8707138	8707139	8707134	8707135
Rear Seat (2-Dr.) .....	8706907	8706910	8706911	8706912	—	—
Rear Seat, 2nd Seat (4-Dr.) (RH & LH) .....	8706857	8706874	8706875	9631478	—	—
Rear Seat (RH & LH) .....						
(Monte Carlo) .....	—	—	—	—	8706908	8706909
Rear Seat, 2nd Seat .....						
(Center) (4-Dr.) .....	8707013	8707015	8707016	8707017	—	—
Rear Seat Center (2-Dr.) .....	1696337	8707021	8707022	1696342	9630659	8707190
3rd Seat .....	8707025	—	8707040	—	—	—

\*Plastic Buckle  
#Vinyl Spray Buckle

**1972 CHEVELLE SHOULDER STRAP UNITS**

**1ST DESIGN— 4-POINT SYSTEM**

**(NOT USED WITH SENSOR WARNING)**

	BLACK	BLUE	GREEN	COVERT	SADDLE	TAN
STANDARD .....						
Front Seat (4-Dr.) .....	8705874					
Front Seat (El Camino) .....	8705876					
DELUXE .....						
Front Seat (exc. Conv., El Camino) .....	8705982	—	8705990	—	—	8705993
Front Seat (Conv.) .....	8705998	—	8706001	—	8705985	8705986
Front Seat (El Camino) .....	8705995	—	—	8705996	—	8705997
Front Seat (exc. Conv., Sta. Wag.) .....	—	8705987	—	8705991	—	—

**FOLDING TOP PARTS—INTERIOR TRIM**

**1972 CHEVELLE BELT AND STRAP UNITS**

**2ND DESIGN— 3-POINT SYSTEM**

**(USED WITH SENSOR WARNING)**

**BLACK**

STANDARD .....  
Front Seat Malibu .....  
Spt. Cpe., El Camino  
(Bucket) (RH) ..... 8706604\*  
Front Seat Malibu .....  
Spt. Cpe., El Camino  
(Bucket) (LH) ..... 8706605\*  
Front Seat Malibu .....  
Spt. Cpe., Conv., El  
Camino (Bucket) (RH) .. 8707216#  
Front Seat Malibu .....  
Spt. Cpe., El Camino  
(Bucket) (LH) ..... 8707217#  
Front Seat Monte Carlo  
(RH) ..... 8706604\*  
Front Seat Monte Carlo  
(LH) ..... 8706605\*  
Front Seat Monte Carlo  
(RH) ..... 8707216#  
Front Seat Monte Carlo  
(LH) ..... 8707217#  
Front Seat (exc. Conv.),  
(Bench) (RH) ..... 8706594\*  
Front Seat (exc. Conv., El  
Camino), .....  
(Bench) (LH) ..... 8706595\*  
Front Seat Malibu Spt.  
Cpe. ....  
(Bench) (RH) ..... 8707212#  
Front Seat Malibu Spt.  
Cpe., El Camino, .....  
(Bench) (LH) ..... 8707213#  
Front Seat (4-Dr.) (RH) .. 8706594\*  
Front Seat (4-Dr.) (LH) .. 8706595\*  
Front Seat (4-Dr.) (RH) .. 8707212#  
Front Seat (4-Dr.) (LH) .. 8707213#  
Front Seat El Camino ..  
(Bench) (LH) ..... 8706597\*  
Front Seat El Camino ..  
(Bench) (RH) ..... 8707212#

**FOLDING TOP PARTS—INTERIOR TRIM**

	BLACK	BLUE	GREEN	COVERT	SADDLE	PEWTER
DELUXE .....						
Front Seat .....						
Spt. Cpe., El Camino						
(Bucket) (RH) .....	8706606	—	8706614	8706616	—	—
Front Seat Spt. Cpe., El						
Camino, .....						
(Bucket) (LH) .....	8706607	—	8706615	8706617	—	—
Front Seat Conv. ....						
(Bucket) (RH) .....	8706620	—	8706626	—	—	—
Front Seat Conv. ....						
(Bucket) (LH) .....	8706621	—	8706627	—	—	—
Front Seat (4-Dr.) (RH) ..	8706578	—	8706586	—	—	—
Front Seat (4-Dr.) (LH) ..	8706579	—	8706587	—	—	—
Front Seat Malibu Spt.						
Cpe. ....						
(Bench) (RH) .....	8706578	—	8706586	—	—	—
Front Seat Malibu Spt.						
Cpe. ....						
(Bench) (LH) .....	8706579	—	8706587	—	—	—
Front Seat Conv. ....						
(Bench) (RH) .....	8706630	—	8706634	—	—	—
Front Seat Conv. ....						
(Bench) (LH) .....	8706631	—	8706635	—	—	—
Front Seat El Camino ..						
(Bench) (RH) .....	9630560	—	—	9630782	—	—
Front Seat El Camino ..						
(Bench) (LH) .....	8706599	—	—	9630783"	—	—
Front Seat Spt. Cpe.,						
Sed. (RH) .....	—	8707094	—	8706588	—	—
Front Seat Spt. Cpe.,						
Sed. (LH) .....	—	8706585	—	8706589	—	—
Front Seat Malibu .....						
Spt. Cpe. (Bench) (RH) ..	—	8707094	—	8706588	—	—
Front Seat Malibu .....						
Spt. Cpe. (Bench) (LH) ..	—	8706585	—	8706589	—	—
Front Seat Monte Carlo						
(RH) .....	—	8706612	—	—	8706608	8706610
Front Seat Monte Carlo						
(LH) .....	—	8706613	—	—	8706609	8706611

\*Plastic Buckle  
 #Die Cast Buckle  
 "Neutral

**FOLDING TOP PARTS—INTERIOR TRIM**

**1972 CAMARO SEAT BELTS**

**1ST DESIGN— 4-POINT SYSTEM**

**(NOT USED WITH SENSOR WARNING)**

	<b>BLACK</b>				
<b>STANDARD</b> .....					
Front Seat (RH) .....	8705855				
Front Seat (LH) .....	8705856				
Rear Seat .....	8705868				
	<b>BLACK</b>	<b>BLUE</b>	<b>GREEN</b>	<b>COVERT</b>	<b>TAN</b>
<b>DELUXE</b> .....					
Front Seat (RH) .....	8705898	8705902	8705904	8705906	8705908
Front Seat (LH) .....	8705899	8705903	8705905	8705907	8705909
Rear Seat .....	8705958	8705962	8705963	8705965	8705967

**1972 CAMARO SEAT BELTS**

**2ND DESIGN— 3-POINT SYSTEM**

**(USED WITH SENSOR WARNING)**

	<b>BLACK</b>				
<b>STANDARD</b> .....					
Rear Seat (RH) .....	8706870*				
Rear Seat (LH) .....	8706871*				
Rear Seat (RH) .....	8707293#				
Rear Seat (LH) .....	8707294#				
	<b>BLACK</b>	<b>BLUE</b>	<b>GREEN</b>	<b>COVERT</b>	<b>TAN</b>
<b>DELUXE</b> .....					
Rear Seat (RH) .....	—	8706862	8706864	8706866	—
Rear Seat (LH) .....	—	8706863	8706865	8706867	—



**FOLDING TOP PARTS—INTERIOR TRIM**

**1972 CAMARO SHOULDER STRAPS**

**1ST DESIGN— 4-POINT SYSTEM**

**(NOT USED WITH SENSOR WARNING)**

	<b>BLACK</b>				
STANDARD .....					
Front Seat .....	8705875				
	<b>BLACK      BLUE      GREEN      COVERT      TAN</b>				
DELUXE .....					
Front Seat .....	8706029	8706031	8706032	8706033	8706034

**1972 CAMARO BELT AND STRAP**

**2ND DESIGN— 3-POINT SYSTEM**

**(USED WITH SENSOR WARNING)**

	<b>BLACK</b>		
STANDARD .....			
Front Seat (RH) .....	8706564*		
Front Seat (LH) .....	8706565*		
Front Seat (RH) .....	8707272#		
Front Seat (LH) .....	8707273#		
	<b>BLUE      GREEN      COVERT</b>		
DELUXE .....			
Front Seat (RH) .....	8706570	8706572	8706574
Front Seat (LH) .....	8706571	8706573	8706575

\*Plastic Buckle.

\*Vinyl Spray Buckle.

**1972 VEGA**

**FRONT SEAT BELTS AND SHOULDER HARNESS**

Vega .....	<b>8704183</b>	1	15.55	<b>BELT AND STRAP ASSY., driver seat (Note 1)</b>
Vega .....	<b>8704182</b>	1	15.55	<b>BELT AND STRAP ASSY., pass. seat (Note 1)</b>
Vega .....	<b>8705865</b>	1	20.85	<b>BELT AND STRAP ASSY., driver seat (Note 2)</b>
Vega .....	<b>8706653</b>	1	31.50	<b>BELT AND STRAP ASSY., driver seat (Note 3)</b>
Vega .....	<b>8705866</b>	1	20.85	<b>BELT AND STRAP ASSY., pass. seat (Note 2)</b>
Vega .....	<b>8706652</b>	1	31.50	<b>BELT AND STRAP ASSY., pass. seat (Note 3)</b>
Vega .....	<b>8706880</b>	2	19.65	<b>BELT ASSY., rear seat and fldg. 2nd (Note 2)</b>
Vega .....	<b>8704188</b>	2	13.00	<b>BELT ASSY., rear seat</b>
Vega .....	<b>8705869</b>	2	7.80	<b>BELT ASSY., rear seat</b>

*NOTE 1: For 1972 models use on jobs built before 9-1-71.*

*NOTE 2: For 1972 models use on jobs with 4-point system on models built after 9-1-71.*

*NOTE 3: For 1972 models use on jobs with 3-point system on models built after 9-1-71.*

*NOTE: All Seat Belt and Strap Unit Package's contain all necessary parts for installation exc. stowage provisions 1973 Only.*

*Standard Belts and shoulder strap are black with plastic buckles.*

*Deluxe Belts and shoulder strap are color-keyed to the interior with brushed metal buckles.*

**FOLDING TOP PARTS—INTERIOR TRIM**

**1973 PASSENGER**

**BELT UNITS**

STANDARD	BLACK
Front Seat (Conv.) (R.H.)	9630180
Front Seat (Conv.) (L.H.)	9630181
Front Seat Center	9630286
Rear Seat Center	9631261
Rear Seat (Sed.)	9630624
Rear Seat (2-Dr.)	9631495
Sta. Wag. (2nd St. Ctr.)	9631222
Sta. Wag. (2nd St.) (R.H.)	9631533
Sta. Wag. (2nd St.) (L.H.)	9631532
Sta. Wag. (3rd Seat)	9631271

DELUXE	BLACK	GREEN	SADDLE	FIRST DESIGN NEUTRAL	SECOND DESIGN NEUTRAL
Front St. (Conv.) (R.H.)	—	9630112	—	9630690	9630792
Front St. (Conv.) (L.H.)	—	9630113	—	9630691	9630793
Front St. Center	9630715	9630278	9630279	9631467	9631467
Front St. Center (Recl.)	9630589	9630766	—	9630590	9630590
Rear Seat (2-Dr.)	9631496	9630369	—	—	—
Rear Seat (4-Dr. Sed.)	9631489	9630381	9631492	9631492	—
Rear Seat Center	9630663	9630667	1695406	1695406	—
2nd Seat (R.H.)	9631525	9630643	9630647	9630645	9630779
2nd Seat (L.H.)	1695261	9630642	9630646	9630644	9630778
2nd Seat Center	1690337	9630657	9630659	1696342	1696342
3rd Seat	1696343	9630248	9630250	1696348	1696348

DELUXE (Cont.)	BLUE	OXBLOOD	MIDN. BLUE	WHITE
Front St. (Conv.) (R.H.)	—	—	—	9630685
Front St. (Conv.) (L.H.)	—	—	—	9630104
Front St. Center	—	9630283	9631466	—
Front St. Center (Recl.)	—	9630768	9630767	—
Rear Seat (2-Dr.)	—	9630376	9631498	—
Rear Seat (4-Dr. Sed.)	9631490	1695338	9631491	—
Rear Seat Center	9631511	1695408	9631512	—
2nd Seat (R.H.)	—	—	9630641	—
2nd Seat (L.H.)	—	—	9631526	—
2nd Seat Center	—	—	9631536	—
3rd Seat	—	—	9631542	—

**1973 PASSENGER**

**BELT AND SHOULDER STRAP UNITS**

STANDARD	BLACK
Front Seat (exc. Conv.) (R.H.)	9630180
Front Seat (exc. Conv.) (L.H.)	9630181

**FOLDING TOP PARTS—INTERIOR TRIM**

DELUXE .....	BLACK	GREEN	SADDLE	FIRST DESIGN NEUTRAL	SECOND DESIGN NEUTRAL
Front Seat (Bench) (exc. Conv.) (R.H.) .....	9630103	9630112	9630122	9630118	9630784
Front Seat (Bench) (exc. Conv.) (L.H.) .....	9630104	9630113	9630123	9630119	9630785
Front Seat (Recl.) (R.H.) ..	9630560	9630760	—	9630562	9630782
Front Seat (Recl.) (L.H.) ..	9630561	9630761	—	9630563	9630783

DELUXE (Cont.) .....	BLUE	OXBLOOD	MIDN. BLUE	WHITE
Front Seat (Bench) (exc. Conv.) (R.H.) .....	9630105	9630126	9630107	—
Front Seat (Bench) (exc. Conv.) (L.H.) .....	9630106	9630127	9630108	—
Front Seat (Recl.) (R.H.) ..	—	9630764	9630762	—
Front Seat (Recl.) (L.H.) ..	—	9630765	9630763	—

*NOTE: First Design Neutral-w/light retractor cover.  
NOTE: Second Design Neutral-w/dark retractor cover.*

**1973 CHEVELLE**

**BELT UNITS**

STANDARD	BLACK
Front Seat (6-way power) (Center)	1695302
Front Seat (exc. 6-way power) (Center)	9630286
Rear Seat (6-way power, Swivel) (2-Dr.)	1692957
Rear Seat (exc. 6-way power) (2-Dr.)	9631486
Rear Seat (6-way power) (4-Dr.)	9631487
Rear Seat (exc. 6-way power) (4-Dr.)	9631480
Rear Seat (6-way power, Swivel) (Ctr.) (2-Dr.)	1693004
Rear Seat (exc. 6-way power, Swivel) (Ctr.) (2-Dr.)	9631209
Rear Seat, 2nd St. (Ctr.) 3rd St. (w/6-way power)	9630676
Rear St., 2nd St. (Ctr.) 3rd St. (exc. 6-way power)	9631261

DELUXE .....	BLACK	GREEN	SADDLE	FIRST DESIGN NEUTRAL	SECOND DESIGN NEUTRAL
Front Seat Center .....	1695302	9630278	9630279	9631467	9631467
Rear Seat (2-Dr.) .....	9631481	9630394	9630397	1721235	9630773
Rear, 2nd Seat (4-Dr.) ...	9630401	9630404	9630406	9630405	9630774
Rear, Ctr. Seat (2-Dr.) ...	9630411	9630414	9630417	1695414	1695414
Rear, 2nd St. Ctr., 3rd Seat (4-Dr.) .....	9630663	9630667	9630672	1695406	1695406

DELUXE (Cont.) .....	BLUE	CHAMOIS	OXBLOOD	MIDN. BLUE
Front Seat Center .....	9630281	9630282	9630283	9631466
Rear Seat (2-Dr.) .....	9631482	9630395	9630398	9631483
Rear, 2nd Seat (4-Dr.) ...	9631476	9630408	1721230	—
Rear, Ctr. Seat (2-Dr.) ...	9631516	9630415	1695408	9631517
Rear, 2nd St. Ctr., 3rd Seat (4-Dr.) .....	9631511	9630669	1695408	—

**FOLDING TOP PARTS—INTERIOR TRIM**

**1973 CHEVELLE BELT AND SHOULDER STRAP UNITS**

Front Seat (6-way power) (2-Dr.) (R.H.)	9630320
Front Seat (6-way power) (2-Dr.) (L.H.)	9630321
Front Seat (exc. 6-way power) (2-Dr.) (R.H.)	9630306
Front Seat (exc. 6-way power) (2-Dr.) (L.H.)	9630307
Front Seat (6-way power) (4-Dr.) (R.H.)	9630526
Front Seat (6-way power) (4-Dr.) (L.H.)	9630527
Front Seat (exc. 6-way power) (4-Dr.) (R.H.)	9630104
Front Seat (exc. 6-way power) (4-Dr.) (L.H.)	9630307

DELUXE .....	BLACK	GREEN	SADDLE	FIRST DESIGN NEUTRAL	SECOND DESIGN NEUTRAL
Front Seat (exc. 6-way power) (2-Dr.) (R.H.) ...	9630287	9630294	9630300	9630298	9630797
Front Seat (exc. 6-way power) (2-Dr.) (L.H.) ...	9630288	9630295	9630301	9630299	9630798
Front Seat (6-way power) (2-Dr.) (R.H.) .....	9630320	9630326	9630332	9630330	9630800
Front Seat (6-way power) (2-Dr.) (L.H.) .....	9630321	9630327	9630333	9630331	9630801
Front Seat (Swivel) (R.H.)	9631458	9630352	9630358	9630356	9630818
Front Seat (Swivel) (L.H.)	9631459	9630353	9630359	9630357	9630819
Front Seat (exc. 6-way power) (4-Dr.) (R.H.) ...	9630480	—	9630492	9630490	9630807
Front Seat (exc. 6-way power) (4-Dr.) (L.H.) ...	—	9630295	9630493	9630491	9630808
Front Seat (6-way power) (4-Dr.) (R.H.) .....	9630510	9630326	9630522	9630520	9630810
Front Seat (6-way power) (4-Dr.) (L.H.) .....	9630511	—	9630523	9630521	9630811

DELUXE (Cont.) .....	BLUE	CHAMOIS	OXBLOOD	MIDN. BLUE
Front Seat (exc. 6-way power) (2-Dr.) (R.H.) ...	9630290	9630296	9630302	9630292
Front Seat (exc. 6-way power) (2-Dr.) (L.H.) ...	9630291	9630297	9630303	9630293
Front Seat (6-way power) (2-Dr.) (R.H.) .....	9630322	9630328	9630334	9630324
Front Seat (6-way power) (2-Dr.) (L.H.) .....	9630323	9630329	9630335	9630325
Front Seat (Swivel) (R.H.)	9630347	9630354	9630360	9630350
Front Seat (Swivel) (L.H.)	9630348	9630355	9630361	9631461
Front Seat (exc. 6-way power) (4-Dr.) (R.H.) ...	9630482	9630296	9630302	—
Front Seat (exc. 6-way power) (4-Dr.) (L.H.) ...	9630291	—	—	—
Front Seat (6-way power) (4-Dr.) (R.H.) .....	9630322	9630518	—	—
Front Seat (6-way power) (4-Dr.) (L.H.) .....	9630323	9630519	9630335	—

*NOTE: First Design Neutral-w/light retractor cover.  
NOTE: Second Design Neutral-w/dark retractor cover.*

**FOLDING TOP PARTS—INTERIOR TRIM**

**1973 CAMARO**

**BELT UNITS**

<b>DELUXE</b> .....	<b>GREEN</b>	<b>SADDLE</b>	<b>NEUTRAL</b>	<b>CHAMOIS</b>
Rear Seat (R.H.) .....	9630606	9630612	9630610	9630608
Rear Seat (L.H.) .....	9630607	9630613	9631475	9630609

**1973 CAMARO**

**BELT AND SHOULDER STRAP UNITS**

<b>STANDARD</b>	<b>BLACK</b>
Front Seat (R.H.)	9630593
Front Seat (L.H.)	9630594
Rear Seat (R.H.)	9631472
Rear Seat (L.H.)	9631473

<b>DELUXE</b> .....	<b>GREEN</b>	<b>SADDLE</b>	<b>NEUTRAL</b>	<b>CHAMOIS</b>
Front Seat (R.H.) .....	9630595	9630602	9630814	9630597
Front Seat (L.H.) .....	9630596	9630603	9630815	9630598

**1973 NOVA**

**BELT UNITS**

<b>STANDARD</b>	<b>BLACK</b>
Front Seat Center	9630253
Rear Seat	9631278
Rear Seat Center	9630756

<b>DELUXE</b> .....	<b>GREEN</b>	<b>NEUTRAL</b>	<b>BLUE</b>	<b>CHAMOIS</b>
Front Seat Center .....	9630255	9630257	9630254	9630256
Rear Seat .....	9630617	9630806	9631279	9630618
Rear Seat Center .....	9630679	9631290	9631288	9630680

**1973 NOVA**

**BELT AND SHOULDER STRAP UNITS**

<b>STANDARD</b>	<b>BLACK</b>
Front Seat Bucket (R.H.)	9630272
Front Seat Bucket (L.H.)	9630273
Front Seat Bench (R.H.)	9630260
Front Seat Bench (L.H.)	9630261
Rear Seat	9631146
Rear Seat Center	9631147

**FOLDING TOP PARTS—INTERIOR TRIM**

**1973 NOVA**

<b>DELUXE</b> .....	<b>GREEN</b>	<b>FIRST DESIGN NEUTRAL</b>	<b>SECOND DESIGN NEUTRAL</b>	<b>BLUE</b>	<b>CHAMOIS</b>
Front Seat (R.H.) .....	9630264	9630274	9630802	9630262	9630270
Front Seat (L.H.) .....	9630265	9630275	9630803	9630263	9630271
Front Seat (Custom) (R.H.) .....	—	9630266	9630804	—	—
Front Seat (Custom) (L.H.) .....	—	9630267	9630805	—	—

*NOTE: First Design Neutral-w/light retractor cover.*

*NOTE: Second Design Neutral-w/dark retractor cover.*

**1973-1975 ACCESSORY SEAT BELT AND SHOULDER HARNESS PACKAGES**



**BLACK**

<b>PASSENGER:</b> .....	
<b>73-75</b> Sta. Wag. (2nd Seat) ...	994808
<b>73-75</b> Conv. (Rr. Seat) .....	994807
<b>73-75</b> Spt. Cpe. (Rr. Seat) .....	994805
<b>73-75</b> Spt. Sed. (Rr. Seat) .....	994806
<b>74-75</b> Sta. Wag. (9-Pass.) .....	994809
<b>CHEVELLE:</b> .....	
<b>73-75</b> Sta. Wag. (2nd Seat) ...	994804
<b>73-75</b> Exc. Sta. Wag. (Rr. Seat) .	994803
<b>CAMARO:</b> .....	
<b>73-75</b> Rr. Seat .....	994810
<b>NOVA:</b> .....	
<b>73-75</b> 2nd Seat .....	994802

**1973 VEGA**

Vega .....	<b>9630592</b>	2	21.05	<b>BELT ASSY., rear seat and fldg. 2nd</b> .....
Vega (exc. Panel) .....	<b>9630536</b>	1	39.75	<b>BELT AND STRAP ASSY., driver seat</b> .....
Vega (Panel) .....	<b>9631469</b>	1	29.75	<b>BELT AND STRAP ASSY., driver seat</b> .....
Vega (exc. Panel) .....	<b>9630535</b>	1	39.75	<b>BELT AND STRAP ASSY., pass. seat</b> .....
Vega (Panel) .....	<b>9631470</b>	1	29.75	<b>BELT AND STRAP ASSY., pass. seat</b> .....

1974 SEAT BELT BUCKLES

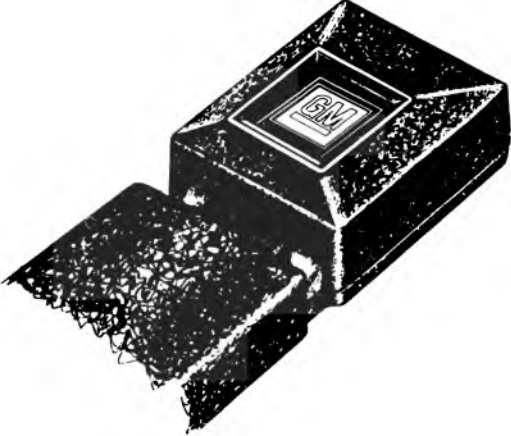
DELUXE (Chrome)	STANDARD (Vinyl Clad)
<p data-bbox="581 541 813 573">Bright Brushed Finish</p>  <p data-bbox="792 821 857 842">CHROME</p>	<p data-bbox="1154 541 1377 573">Black Vinyl Coated</p>  <p data-bbox="1409 793 1482 814">CHROME</p>
STANDARD (Diecast) (Black)	STANDARD (Plastic) (Black)
	

**FOLDING TOP PARTS—INTERIOR TRIM**

**1974 PASSENGER BELTS**

**Front Seat (Exc. Conv.)**

**BUCKLE SIDE-Black Only**

	<b>BLACK</b>
STANDARD (PLASTIC BUCKLE)	9736887
DELUXE (Brushed Metal Buckle)	9736877

**FRONT SEAT— RETRACTOR SIDE (Exc. Conv.)**

	<b>BLACK</b>	<b>GREEN</b>	<b>SADDLE</b>	<b>NEUTRAL</b>	<b>TAUPE</b>	<b>MID. BLUE</b>	<b>OXBLOOD</b>
STANDARD—							
(w/Plastic Buckles)							
R.H. ....	9727616						
L.H. ....	9727617						
DELUXE—							
(w/Brushed Metal Buckles)							
R.H. ....	1699610	1699618	9729662	9729656	9729670	9729654	1699614
L.H. ....	1699611	1699619	1699617	9729657	9729671	9729655	1699615
DELUXE—							
(w/Die-Cast Buckles)							
R.H. ....	9727616						
L.H. ....	9727617						



**FOLDING TOP PARTS—INTERIOR TRIM**

**BELT UNITS**

STANDARD	BLACK
Front Seat Center	9631149
Rear Seat Center	9631261
Rear Seat (Coupe)	9631495
Rear Seat (Sedan)	9631494
2nd Seat Center	9631222
2nd Seat (R.H.)	9631533
2nd Seat (L.H.)	9631532
3rd Seat	9631271

	BLACK	GREEN	SADDLE	NEUTRAL	TAUPE	MID. BLUE	OXBLOOD
DELUXE . . . . . (w/Brushed Metal Buckles) . . . . .							
Front Seat Center . . . . .	1695287	1695293	9631424	1695289	9631428	9631421	9631423
Rear Seat (Coupe) . . . . .	9631496	1695374	9631122	9631499	9631126	9631498	1695372
Rear Seat (Sedan) . . . . .	9631489	1695340	9631116	9631492	9631119	9631491	1695338
Rear Seat Center . . . . .	1695404	1695410	1695409	1695406	9631139	9631512	1695408
2nd Seat (R.H.) . . . . .	9631525	1695266	9631143	9631529	—	9631527	—
2nd Seat (L.H.) . . . . .	1695261	9631144	9631142	9631528	—	9631526	—
2nd Seat Center . . . . .	1696337	1696340	9631294	1696342	—	9631536	—
3rd Seat . . . . .	1696343	1696346	9631296	1696348	—	9631542	—

**BELT UNITS**

**CONVERTIBLE**

STANDARD	BLACK
Front Seat (R.H.)	9631164
Front Seat (L.H.)	9631165
Front Seat Center	9631149
Rear Seat	9631495
Rear Seat Center	9631261

	BLACK	GREEN	NEUTRAL
DELUXE . . . . . (w/Brushed Metal Buckles) . . . . .			
Front Seat (R.H.) . . . . .	9631166	9631176	9631170
Front Seat (L.H.) . . . . .	9631167	9631177	9631171
Front Seat Center . . . . .	1695287	1695293	1695289
Rear Seat . . . . .	9631496	1695374	9631499
Rear Seat Center . . . . .	1695404	1695410	1695406

**1974 CHEVELLE BELTS**

**Front Seat (exc. El Camino)**

**BUCKLE SIDE— Available in Black Only**

STANDARD	BLACK
w/6-Way Power	1695148
exc. 6-Way Power	9736887
DELUXE	9736877

**FOLDING TOP PARTS—INTERIOR TRIM**

**RETRACTOR SIDE— Front Seat (exc. El Camino)**

	<b>BLACK</b>	<b>GREEN</b>	<b>SADDLE</b>	<b>NEUTRAL</b>	<b>MID. BLUE</b>	<b>OXBLOOD</b>
<b>STANDARD</b> .....						
w/6-way power R.H. ....	9729618					
w/6-way power L.H. ....	9729619					
exc. 6-way power L.H. ....	9727589					
w/swivel bucket R.H. ....	9729634					
w/swivel bucket L.H. ....	9729635					
<b>DELUXE</b> .....						
w/6-way power R.H. ....		9729630	9729628	9729624	9729622	1699600
w/6-way power L.H. ....		9729631	9729629	9729625	9729623	9729627
exc. 6-way power R.H. ....	9729602	9729614	9729612	9729608	9729606	9729610
exc. 6-way power L.H. ....	9729603	9729615	9729613	9729609	9729607	9729611
w/swivel bucket R.H. ....		9729644	9729642	9729638	9729636	9729640
w/swivel bucket L.H. ....		9729645	9729643	9729639	9729637	9729641

**BELT UNITS**

**FRONT SEAT CENTER— REAR SEAT (exc. El Camino)**

<b>STANDARD</b>	<b>BLACK</b>
Front Seat Center (w/6-way power)	1692911
Front Seat Center (exc. 6-way power)	9631149
Rear Seat Center (2-Dr.) (swivel, 6-way power)	1693004
Rear Seat Center (2-Dr.) (exc. 6-way power)	9631209
Rear Seat (2-Dr.) (swivel, 6-way power)	1692957
Rear Seat (2-Dr.) (exc. 6-way power)	9631486
Rear Seat, 2nd Seat (4-Dr.) (exc. 6-way power)	9631480
Rear Seat, 2nd Seat (4-Dr.) (swivel, 6-way power)	9631487
Rear Seat Center, 2nd Seat Center, 3rd Seat (exc. 6-way power) (4-Dr.)	9631261
Rear Seat Center, 2nd Seat Center, 3rd Seat (swivel, 6-way power) (4-Dr.)	1693004

	<b>BLACK</b>	<b>GREEN</b>	<b>SADDLE</b>	<b>NEUTRAL</b>	<b>MID. BLUE</b>	<b>OXBLOOD</b>
<b>DELUXE</b> .....						
Front Seat Center .....	1695287	1695293	9631424	1695289	9631421	9631423
Rear Seat (Coupe) .....	9631481	1695329	9631112	1721235	9631483	9631485
Rear Seat Center (2-Dr.) ..	1695348	1695410	9631131	1695414	9631517	1695408
Rear Seat (Sedan) .....	9631471	1721231	9631129	9631478	9631477	1721230
Fldg. 2nd .....	9631471	1721231	9631129	9631522	9631477	—
Rear Seat Center, 2nd Seat Center, 3rd Seat (4-Dr.) .....	1695404	1695410	1695409	1695406	9631512	1695408

**EL CAMINO**

**BELT UNITS**

<b>STANDARD</b>	<b>BLACK</b>
Front Seat Center	1653200

	<b>BLACK</b>	<b>GREEN</b>	<b>SADDLE</b>	<b>NEUTRAL</b>	<b>MID. BLUE</b>
<b>DELUXE</b> .....					
Front Seat Center .....	1695302	1695305	9631151	9631467	9631466

**FOLDING TOP PARTS—INTERIOR TRIM**

**BELT AND STRAP UNITS**

STANDARD	BLACK
Front Seat Bench (R.H.)	9631456
Front Seat Bench (L.H.)	9631457
Front Seat Swivel (R.H.)	9631464
Front Seat Swivel (L.H.)	9631465

	BLACK	GREEN	SADDLE	NEUTRAL	MID. BLUE	WHITE
DELUXE .....						
Front Seat Bench (R.H.) .	9631450	9631157	9631155	9631454	9631452	9631460
Front Seat Bench (L.H.) .	1695077	9631158	9631156	9631455	9631453	9631461
Front Seat Swivel (R.H.) .	9631458	9631162	9631160	9631462	9631452	9631460
Front Seat Swivel (L.H.) .	9631459	9631163	9631161	9631463	9631453	9631461

**1974 CAMARO**

**FRONT SEAT BUCKLE SIDE— 1st DESIGN**

STANDARD	BLACK
Front Seat	9729107

	GREEN	SADDLE	NEUTRAL	TAUPE	RED
DELUXE .....					
Front Seat .....	9729111	9729110	9729109	9729112	9729113

**FRONT SEAT BUCKLE SIDE— 2ND DESIGN**

STANDARD	BLACK
Front Seat	9729107

	GREEN	SADDLE	NEUTRAL	TAUPE	RED
DELUXE .....					
Front Seat .....	1657044	1657043	1657042	1657045	1657046

*NOTE: 1st design with black wire. 2nd design with gray wire.*

**FRONT SEAT RETRACTOR SIDE**

STANDARD	BLACK
Front Seat (R.H.)	9729692
Front Seat (L.H.)	9729693

	GREEN	SADDLE	NEUTRAL	TAUPE	RED
DELUXE .....					
Front Seat (R.H.) .....	9731568	9729698	9729696	9731570	9731572
Front Seat (L.H.) .....	9731569	9729699	9729697	9731571	9731573

**FOLDING TOP PARTS—INTERIOR TRIM**

**BELT UNITS**

**Rear Seat**

STANDARD	BLACK
Rear Seat (R.H.)	9631472
Rear Seat (L.H.)	9631473

	GREEN	SADDLE	NEUTRAL	TAUPE	RED
DELUXE .....					
Rear Seat (R.H.) .....	9631106	9631104	9631474	9631108	9631110
Rear Seat (L.H.) .....	9631107	9631105	9631475	9631109	9631111

**1974 NOVA BELTS**

**Front Seat**

**BUCKLE SIDE**

STANDARD	BLACK
Front Seat (Bucket)	9736890-Plastic Buckle
Front Seat (Bench)	9737849-Plastic Buckle
Front Seat (Bucket)	1668340 (Die Cast Buckle)
Front Seat (Bench)	1668333 (Die Cast Buckle)

	GREEN	SADDLE	NEUTRAL	MID-BLUE	RED
DELUXE .....					
Plastic Buckle .....					
Front Seat (Bucket) .....	9736894	9736893	9736892	—	9736895
Front Seat (Bench) .....	9737854	9737853	9737852	9737851	—
DELUXE— .....					
Die Cast Buckle .....					
Front Seat (Bucket) .....	1668344	1668343	1668342	—	1668345
Front Seat (Bench) .....	1668338	1668337	1668336	1668335	—

**FRONT SEAT— RETRACTOR SIDE**

STANDARD	BLACK
Front Seat (R.H.)	9729678-Plastic Buckle
Front Seat (L.H.)	9729679-Plastic Buckle
Front Seat (R.H.)	1668346-Die Cast Buckle
Front Seat (L.H.)	1668347-Die Cast Buckle

	GREEN	SADDLE	NEUTRAL	MID-BLUE	RED
DELUXE— .....					
Plastic Buckle .....					
Front Seat (R.H.) .....	9729688	9729686	9729684	9729682	9729690
Front Seat (L.H.) .....	9729689	9729687	9729685	9729683	9729691
DELUXE— .....					
Die Cast Buckle .....					
Front Seat (R.H.) .....	1668356	1668354	1668352	1668350	1668358
Front Seat (L.H.) .....	1668357	1668355	1668353	1668351	1668359

**FOLDING TOP PARTS—INTERIOR TRIM**

**BELT UNITS**

**Front Seat Center— Rear Seat**

STANDARD	PLASTIC BUCKLE BLACK
Front Seat Center	9631298
Rear Seat	9631278 (9631146 Taxi Only)
Rear Seat Center	9631287 (9631147 Taxi Only)
<b>STANDARD</b>	<b>DIE-CAST BUCKLE BLACK</b>
Rear Seat	1668308 (1668316 Taxi Only)
Rear Seat Center	1668325 (1668332 Taxi Only)

	GREEN	SADDLE	NEUTRAL	MID-BLUE	RED
DELUXE— . . . . .					
Plastic Buckle . . . . .					
Front Seat Center . . . . .	9631303	9631302	9631301	9631300	—
Rear Seat . . . . .	9631283	9631282	9631281	9631280	9631284
Rear Seat Center . . . . .	9631292	9631291	9631290	9631289	9631293
DELUXE— . . . . .					
Die-Cast Buckle . . . . .					
Rear Seat . . . . .	1668313	1668312	1668311	1668310	1668314
Rear Seat Center . . . . .	1668330	1668329	1668328	1668327	1668331

**1974 VEGA**

**Front Seat**

**BUCKLE SIDE**

STANDARD	BLACK
Front Seat (R.H.) (exc. Panel)	9727612
Front Seat (L.H.) (exc. Panel)	9727613

**RETRACTOR SIDE**

STANDARD	BLACK
Front Seat (R.H.) (exc. Panel)	9727590
Front Seat (L.H.) (exc. Panel)	9727591

**BELT UNIT**

STANDARD	BLACK
Fldg. 2nd and Rear Seat (All)	9631148

**FOLDING TOP PARTS—INTERIOR TRIM**

**1974-75**

**BELT AND STRAP PACKAGE**

STANDARD	BLACK	
Pass. Seat (Panel)	9631470	
Driver Seat (Panel)	9631469	
Rear Seat (All)	994490	(Accessory Pkg.)
Rear Seat (exc. Panel)	994800	(Accessory Pkg.)
Rear Seat-HR-HM	994801	(Accessory Pkg.)

**1974**

**EXTRA LENGTH**

**BELT AND STRAP PACKAGE**

**Front Seat Installation**

*NOTE: These packages are complete for installation consisting of two retractor side belts, one for passenger and one for driver, two buckle side belts passenger and driver and all attaching parts and installation instructions.*

**PASSENGER (exc. Conv.)**

	BLACK
STANDARD DELUXE	1656218-(w/Plastic Buckle) 1656040-(w/Brushed Metal Buckle)

**CONVERTIBLE**

	BLACK
STANDARD DELUXE	1656217-(w/Plastic Buckle) 1656123-(w/Brushed Metal Buckle)

**CHEVELLE**

STANDARD	BLACK
Bench Seat (exc. 6-Way)	1656211
Bucket Seat	1656214
6-Way Seat	1656212
<b>DELUXE</b>	<b>BLACK</b>
Bench Seat (exc. 6-Way)	1656026
Bucket Seat	1656055

**NOVA**

STANDARD	BLACK
Bucket Seat	1656198

**CAMARO**

STANDARD	BLACK
Bucket Seat	1656191 (1st design)

*NOTE: 1st design with black wire. 2nd design with gray wire.*

1975 SEAT BELT BUCKLES

DELUXE

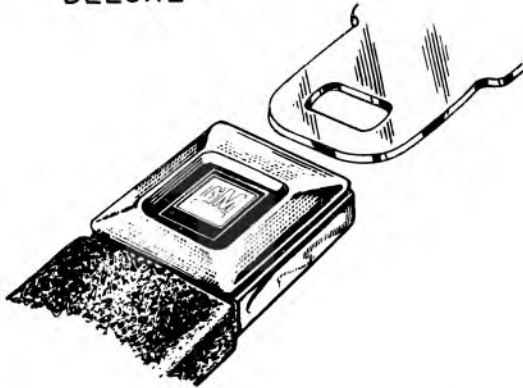

VINYL

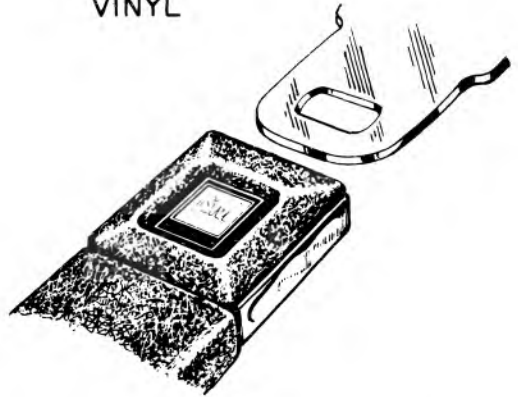

DIECAST

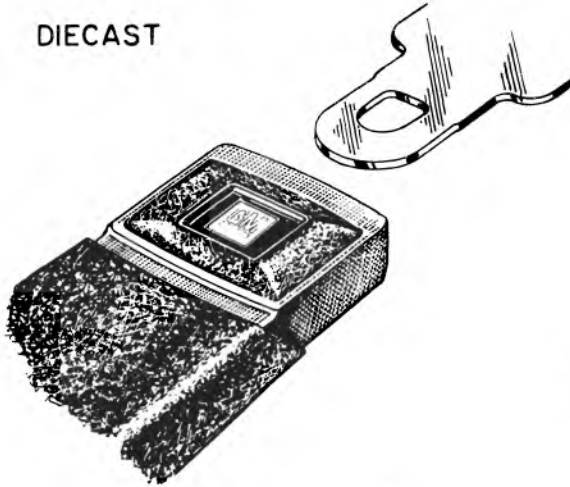

PLASTIC

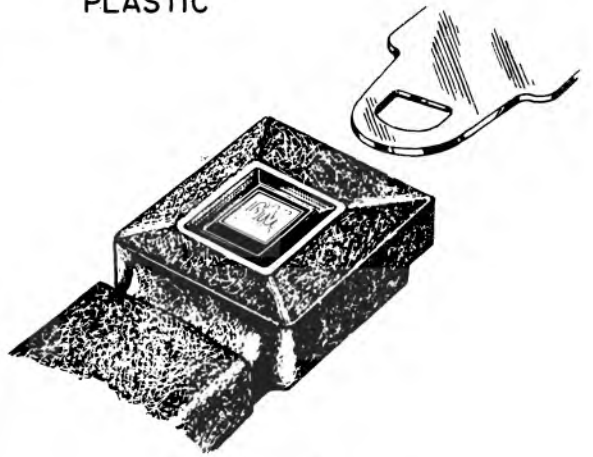

STANDARD II



STANDARD III

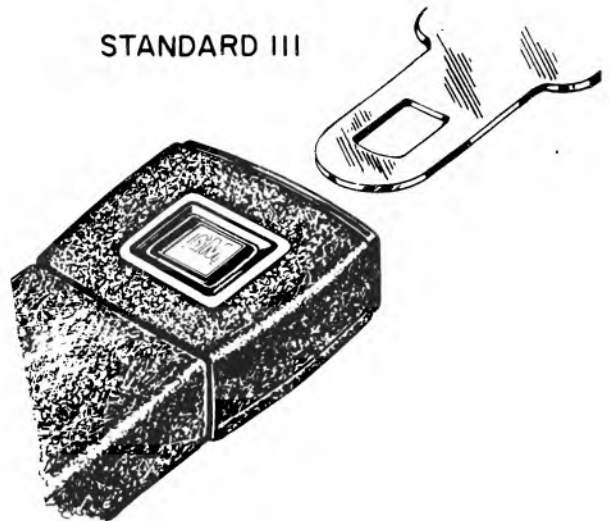

**FOLDING TOP PARTS—INTERIOR TRIM**

**1975 ACCESSORY REAR SHOULDER HARNESS PACKAGES**

75	Chevelle (Sta. Wag.)	994804	1	56.25	BELT & STRAP ASM. (rear seat shoulder pkg.)
75	Chevelle (exc. Sta. Wag.)	994803	1	59.25	BELT & STRAP ASM. (rear seat shoulder pkg.)
75	Pass. (Conv.)	994807	1	59.25	BELT & STRAP ASM. (rear seat shoulder pkg.)
75	Pass. (Sta. Wag.)	994808	1	59.25	BELT & STRAP ASM. (2nd/seat shoulder pkg.)
75	Pass. (Sta. Wag.) (exc. Conv.)	994805	1	59.25	BELT & STRAP ASM. (rear seat shoulder pkg.)
75	Pass. (4-Dr.) (exc. Sta. Wag.)	994806	1	59.25	BELT & STRAP ASM. (rear seat shoulder pkg.)
75	Pass. (Sta. Wag.) (3rd/seat shoulder pkg.)	994809	1	59.25	BELT & STRAP ASM. (3rd/seat shoulder pkg.)
75	Camaro	994810	1	59.25	BELT & STRAP ASM. (rear seat shoulder pkg.)
75	Vega (exc. Panel, Monza) (exc. Towne Cpe.)	994800	1	56.25	BELT & STRAP ASM. (rear seat shoulder pkg.)
75	Vega (Panel), Monza (Towne Cpe.)	994801	1	56.25	BELT & STRAP ASM. (rear seat shoulder pkg.)
75	Nova	994802	1	59.25	BELT & STRAP ASM. (rear seat shoulder pkg.)

**1975**

**EXTRA LENGTH**

**BELT AND STRAP PACKAGE**

**PASSENGER (EXC. CONV.)**

STANDARD 2	Black	1700050
STANDARD 3	Black	1700051
DELUXE	Black	1700053

**CONVERTIBLE**

STANDARD 2	Black	1700062
STANDARD 3	Black	1700063
DELUXE	Black	1700065

**CHEVELLE (EXC. EL CAMINO)**

Bench Seat (exc. 6-Way)	Standard 2	Black	1700031
Bench Seat (exc. 6-Way)	Standard 3	Black	1700032
Bench Seat (exc. 6-Way)	Deluxe	Black	1700034
w/6-Way	Vinyl	Black	1700037
w/6-Way	Deluxe	Black	1700038
(Monte Carlo) w/6-Way	Deluxe	Black	1700039
Bucket Seat	Vinyl	Black	1700046
Bucket Seat	Deluxe	Black	1700047



**FOLDING TOP PARTS—INTERIOR TRIM**

**1975 PASSENGER BELTS**

**FRONT SEAT (exc. CONV.)**

YEAR	BUCKLE TYPE/ BODY STYLE	SEAT	COLOR	RETRACTOR RH	SIDE LH	CENTER	BUCKLE SIDE
<i>NOTE: Seat Type A52-Bench, AT8-50/50 Reclining.</i>							
75	Std. 2	A52	black				1693058
75	Std. 3	A52	black				1693059
75	Deluxe	A52, AT8	black				1695144
75	Std. 2	A52	black	1693040	1693041	1692912	
75	Std. 3	A52	black	1693042	1693043	1692913	
75	Deluxe	A52, AT8	saddle	1696400	1696401	1695290	
75	Deluxe	A52, AT8	blue	1696406	1696407	1695296	
75	Deluxe	A52, AT8	graystone	1696404	1696405	1695295	
75	Deluxe	A52, AT8	sandstone	1696408	1696409	1695297	
75	Deluxe/Vinyl	A52, AT8	black	1699610	1699611	1695287	
75	Deluxe	A52, AT8	green	1699618	1699619	1695293	
75	Deluxe	A52, AT8	oxblood	1699614	1699615	1695291	
75	Die Cast (4-Dr.)	A52	black	1719212	1719213	1695287	

**FRONT SEAT (CONVERTIBLE)**

YEAR	BUCKLE TYPE/ BODY STYLE	SEAT	COLOR	RH	LH	CENTER
75	Std. 2	A52	black	1692878	1692879	1692912
75	Std. 3	A52	black	1692880	1692881	1692913
75	Deluxe	A52, AT8	black	1695126	1695127	1695287
75	Deluxe	A52, AT8	blue	1695132	1695133	1695296
75	Deluxe	A52, AT8	sandstone	1695134	1695135	1695297
75	Deluxe	A52, AT8	oxblood	1695130	1695131	1695291
75	Deluxe	A52, AT8	saddle	1695128	1695129	1695290
75	Deluxe	A52, AT8	green	1709547	1709548	1695293

**FOLDING TOP PARTS—INTERIOR TRIM**

**REAR SEAT (EXC. CONV.)**

75	2-Dr. (Std. 2)	rear	black	1692976	1692976	1693005
75	2-Dr. (Std. 3)	rear	black	1692977	1692977	1693006
75	4-Dr. (exc. S/W) (Std. 2)	rear	black	1692968	1692968	1693005
75	4-Dr. (exc. S/W) (Std. 3)	rear	black	1692969	1692969	1693006
75	2-Dr. (Deluxe)	rear	sandstone	1695378	1695378	1695414
75	2-Dr. (Deluxe)	rear	blue	1695377	1695377	1695413
75	2-Dr. (Deluxe)	rear	graystone	1695376	1695376	1695412
75	2-Dr. (Deluxe)	rear	green	1695374	1695374	1695410
75	2-Dr. (Deluxe)	rear	oxblood	1695372	1695372	1695408
75	2-Dr. (Deluxe)	rear	saddle	1695371	1695371	1695407
75	2-Dr. (Deluxe)	rear	black	1695368	1695368	1695404
75	4-Dr. (exc. S/W) (Deluxe)	rear	saddle	1695337	1695337	1695407
75	4-Dr. (exc. S/W) (Deluxe)	rear	oxblood	1695338	1695338	1695408
75	4-Dr. (exc. S/W) (Deluxe)	rear	green	1695340	1695340	1695410
75	4-Dr. (exc. S/W) (Deluxe)	rear	graystone	1695342	1695342	1695412
75	4-Dr. (exc. S/W) (Deluxe)	rear	blue	1695343	1695343	1695413
75	4-Dr. (exc. S/W) (Deluxe)	rear	sandstone	1695344	1695344	1695414
75	4-Dr. (exc. S/W) (Deluxe)	rear	black	1695334	1695334	1695404
75	4-Dr. (exc. S/W) Die-Cast	rear	black	—	—	1719237
75	(Sta. Wag.) (Std. 2)	fldg. 2nd	black	1692940	1692941	1693008
75	(Sta. Wag.) (Std. 3)	fldg. 2nd	black	1692942	1692943	1693011
75	(Sta. Wag.) (Std. 2)	fldg. 3rd	black	1693011	1693011	—
75	(Sta. Wag.) (Std. 3)	fldg. 3rd	black	1693012	1693012	—
75	(Sta. Wag.) (Deluxe)	fldg. 2nd	black	1695260	1695261	1696337
75	(Sta. Wag.) (Deluxe)	fldg. 2nd	saddle	1695262	1695263	1696338
75	(Sta. Wag.) (Deluxe)	fldg. 2nd	green	1695266	1695267	1696340
75	(Sta. Wag.) (Deluxe)	fldg. 2nd	blue	1695268	1695269	1696341
75	(Sta. Wag.) (Deluxe)	fldg. 2nd	sandstone	1695270	1695271	1696342
75	(Sta. Wag.) (Deluxe)	fldg. 3rd	black	1696343	1696343	—
75	(Sta. Wag.) (Deluxe)	fldg. 3rd	saddle	1696344	1696344	—
75	(Sta. Wag.) (Deluxe)	fldg. 3rd	green	1696346	1696346	—
75	(Sta. Wag.) (Deluxe)	fldg. 3rd	blue	1696347	1696347	—
75	(Sta. Wag.) (Deluxe)	fldg. 3rd	sandstone	1696348	1696348	—
75	(Sta. Wag.) (Die Cast)	fldg. 2nd	black	1719227	1719228	1719239
75	(Sta. Wag.) (Die Cast)	fldg. 3rd	black	1719240	1719240	—

**REAR SEAT (CONVERTIBLE)**

75	Std. 2	rear	black	1692976	1692976	1693005
75	Std. 3	rear	black	1692977	1692977	1693006
75	Deluxe	rear	black	1695368	1695368	1695404
75	Deluxe	rear	oxblood	1695372	1695372	1695408
75	Deluxe	rear	saddle	1695371	1695371	1695407
75	Deluxe	rear	sandstone	1695378	1695378	1695414

**FOLDING TOP PARTS—INTERIOR TRIM**

**1975 CHEVELLE BELT**

**FRONT SEAT (EXC. EL CAMINO)**

YEAR	BUCKLE TYPE/ BODY STYLE	SEAT	COLOR	RETRACTOR R.H.	SIDE L.H.	CENTER	BUCKLE SIDE
<i>NOTE: Seat Type A52-Bench, A65-Notchback, AT8-50/50 reclining, AN7-Swivel Bucket.</i>							
75	Std. 2	A52, A65	black	1693036	1693037	1692912	1693058
75	Std. 3	A52, A65	black	1693038	1693039	1692913	1693059
75	Std.-Vinyl (exc. AC-29)	A52, A65, AN7	black	1699604	1699605	1692911	1695148
75	Deluxe	A52, A65, AT8	black	1699592	1699593	1695287	1695144
75	Deluxe	A52, A65, AT8	oxblood	1699594	1699595	1695291	
75	Deluxe	A52, A65, AT8	graystone	1696420	1696421	1695295	
75	Deluxe	A52, A65, AT8	blue	1696422	1696423	1695296	
75	Deluxe	A52, A65, AT8	sandstone	1696424	1696425	1695297	
75	Deluxe	A52, A65, AT8	green	1699596	1699597	1695293	
75	Deluxe	A52, A65, AT8	saddle	1696416	1696417	1695290	
75	Deluxe/Vinyl	6-way	black	1699598	1699599	—	
75	Deluxe	6-way	oxblood	1699600	1699601	—	
75	Deluxe	6-way	graystone	1696430	1696431	—	
75	Deluxe	6-way	blue	1696432	1696433	—	
75	Deluxe	6-way	sandstone	1696434	1696435	—	
75	Deluxe	6-way	green	1699602	1699603	—	
75	Deluxe	6-way	saddle	1696426	1696427	—	
75	Deluxe/Vinyl	AN7	black	1699604	1699605	—	
75	Deluxe	AN7	blue	1696312	1696313	—	
75	Deluxe	AN7	saddle	1696310	1696311	—	
75	Deluxe	AN7	oxblood	1699606	1699607	—	
75	Deluxe	AN7	sandstone	1696314	1696315	—	
75	Deluxe	AN7	green	1699608	1699609	—	
75	Die Cast	A52	black	1719210	1719211	1719188	1719198

**1975 EL CAMINO BELT**

**FRONT SEAT— BELT AND STRAP PACKAGE**

**FRONT SEAT CENTER— BELT PACKAGE**

YEAR	BUCKLE TYPE/ BODY STYLE	SEAT	COLOR	R.H.	L.H.	CENTER
<i>NOTE: Seat Type A52-Bench, A65-Notchback, AN7-Swivel.</i>						
75	Std. 2	A52, A65	black	1692860	1692861	1692914
75	Std. 3	A52, A65	black	1692862	1692863	1692915
75	Std. (Vinyl)	AN7	black	1692858	1692859	—
75	Deluxe	A52, A65	black	1695076	1695077	1695302
75	Deluxe	A65	saddle	1695078	1695079	1695303
75	Deluxe	A65	oxblood	1695080	1695081	1695304
75	Deluxe	A52, A65	green	1695082	1695083	1695305
75	Deluxe	A65	graystone	1695084	1695085	1695306
75	Deluxe	A52, A65	blue	1695086	1695087	1695307
75	Deluxe	A52, A65	sandstone	1695088	1695089	1695308
75	Deluxe	AN7	black	1695090	1695091	—
75	Deluxe	AN7	saddle	1695092	1695093	—
75	Deluxe	AN7	oxblood	1695094	1695095	—
75	Deluxe	AN7	blue	1695096	1695097	—
75	Deluxe	AN7	sandstone	1695098	1695099	—
75	Die Cast	A52	black	1719183	1719184	1719189

**FOLDING TOP PARTS—INTERIOR TRIM**

**REAR SEAT (EXC. EL CAMINO)**

YEAR	BUCKLE TYPE/ BODY STYLE	SEAT	COLOR	R.H.	L.H.	CENTER
75	Coupe (Std. 2)	rear	black	1692958	1692958	1693005
75	Coupe (Std. 3)	rear	black	1692959	1692959	1693006
75	Coupe (Std.) (Vinyl)	rear	black	1692957	1692957	1693004
75	Coupe (Deluxe)	rear	black	1695326	1695326	1695348
75	Coupe (Deluxe)	rear	saddle	1721229	1721229	1695407
75	Coupe (Deluxe)	rear	oxblood	1721230	1721230	1695408
75	Coupe (Deluxe)	rear	green	1695329	1695329	1695410
75	Coupe (Deluxe)	rear	graystone	1695331	1695331	1695353
75	Coupe (Deluxe)	rear	blue	1721234	1721234	1695354
75	Coupe (Deluxe)	rear	sandstone	1721235	1721235	1695414
75	Sedan (Std. 2)	rear	black	1716515	1716515	1693005
75	Sedan (Std. 3)	rear	black	1716516	1716516	1693006
75	Sedan (Std.) (Vinyl)	rear	black	1716514	1716514	1693004
75	Sedan (Deluxe)	rear	black	1695309	1695309	1695404
75	Sedan (Deluxe)	rear	saddle	1721229	1721229	1695407
75	Sedan (Deluxe)	rear	oxblood	1721230	1721230	1695408
75	Sedan (Deluxe)	rear	green	1721231	1721231	1695410
75	Sedan (Deluxe)	rear	graystone	1695314	1695314	1695412
75	Sedan (Deluxe)	rear	blue	1721234	1721234	1695413
75	Sedan (Deluxe)	rear	sandstone	1721235	1721235	1695414
75	Sta. Wag. (Std. 2)	fldg. 2nd	black	1716515	1716515	1693005
75	Sta. Wag. (Std. 3)	fldg. 2nd	black	1692956	1692956	1693006
75	Sta. Wag. (Std.) (Vinyl)	fldg. 2nd	black	1692954	1692954	1693004
75	Sta. Wag. (Deluxe)	fldg. 2nd	black	1695309	1695309	1695404
75	Sta. Wag. (Deluxe)	fldg. 2nd	saddle	1721229	1721229	1695407
75	Sta. Wag. (Deluxe)	fldg. 2nd	blue	1721234	1721234	1695413
75	Sta. Wag. (Deluxe)	fldg. 2nd	sandstone	1721236	1696557	1695414
75	Sedan (Die Cast)	rear	black	1719225	1719225	1719237

**1975 CAMARO BELTS**

**FRONT SEAT**

YEAR	BUCKLE TYPE/ BODY STYLE	SEAT	COLOR	RETRACTOR R.H.	SIDE L.H.	BUCKLE R.H.	SIDE L.H.
<i>NOTE: Seat Type A51-Bucket Seat.</i>							
75	Std. 2	A51	black	1695356	1695357	1696369	1696369
75	Std. 2	A51	saddle	1695358	1695359	1696370	1696370
75	Std. 2	A51	oxblood	1695360	1695361	1696371	1696371
75	Std. 2	A51	graystone	1695362	1695363	1696372	1696372
75	Std. 2	A51	sandstone	1695366	1695367	1696374	1696374
75	Die Cast	—	black	1719868	1719869	1719846	—

**REAR SEAT**

YEAR	BUCKLE TYPE/ BODY STYLE	SEAT	COLOR	R.H.	L.H.
75	Std. 2	rear	black	1696298	1696299
75	Std. 2	rear	saddle	1696300	1696301
75	Std. 2	rear	oxblood	1696302	1696303
75	Std. 2	rear	graystone	1696304	1696305
75	Std. 2	rear	sandstone	1696308	1696309

**FOLDING TOP PARTS—INTERIOR TRIM**

**1975 NOVA BELT**

**FRONT SEAT**

YEAR	BUCKLE TYPE/ BODY STYLE	SEAT	COLOR	RETRACTOR R.H.	SIDE L.H.	CENTER	BUCKLE SIDE
<i>NOTE: Seat Type A52-Bench, A51-Bucket, AR9-European.</i>							
75	Std. 2	A52	black	1695390	1695391	1695317	1696316
75	Std. 2	A51	black	1695390	1695391	—	1696362
75	Std. 2	A52	saddle	1695392	1695393	1695318	1696317
75	Std. 2	A51	saddle	1695392	1695393	—	1696363
75	Std. 2	A52	oxblood	1695394	1695395	1695319	—
75	Std. 2	AR9	oxblood	1695394	1695395	—	1696364
75	Std. 2	A52	green	1695396	1695397	1695320	1696319
75	Std. 2	A51	green	1695396	1695397	—	1696365
75	Std. 2	A52	blue	1695400	1695401	1695321	1696320
75	Std. 2	AR9	blue	1695400	1695401	—	1696367
75	Std. 2	AR9	graystone	1695398	1695399	—	1696366
75	Std. 2	A52	sandstone	1695402	1695403	1695322	1696321
75	Std. 2	A51, AR9	sandstone	1695402	1695403	—	1696368
75	Die Cast	A52	black	1719858	1719859	1719894	1719836

YEAR	BUCKLE TYPE	SEAT	COLOR	R.H.	L.H.	CENTER	BUCKLE SIDE
75	Plastic	A52	black	1700624	1700625	1700648	1700608
75	Plastic	A51-AR9	black	1700624	1700625	—	1700601
75	Plastic	A52	dk. saddle	1700626	1700627	1700649	1700609
75	Plastic	A51-AR9	dk. saddle	1700626	1700627	—	1700602
75	Plastic	A52	dk. oxblood	1700628	1700629	1700650	1700610
75	Plastic	A51-AR9	dk. oxblood	1700628	1700629	—	1700603
75	Plastic	A52	med. green	1700630	1700631	1700651	1700611
75	Plastic	A51-AR9	med. green	1700630	1700631	—	1700604
75	Plastic	A52	dk. blue	1700634	1700635	1700652	1700612
75	Plastic	A51-AR9	dk. blue	1700634	1700635	—	1700606
75	Plastic	A52	med.	—	—	—	—
75	Plastic	A51-AR9	sandstone	1700636	1700637	1700653	1700613
75	Plastic	A51-AR9	med.	—	—	—	—
75	Plastic	A51-AR9	sandstone	1700636	1700637	—	1700607
75	Plastic	A51-AR9	med.	—	—	—	—
75	Plastic	A51-AR9	graystone	1700632	1700633	—	1700605

YEAR	BUCKLE	SEAT	COLOR	R.H.	L.H.	CENTER
75	Plastic	rear	black	1700654	1700654	1700666
75	Plastic	rear	dk. saddle	1700655	1700655	1700667
75	Plastic	rear	dk. oxblood	1700656	1700656	1700668
75	Plastic	rear	med. green	1700657	1700657	1700669
75	Plastic	rear	med. graystone	1700658	1700658	1700670
75	Plastic	rear	dk. blue	1700659	1700659	1700671
75	Plastic	rear	med. sandstone	1700660	1700660	1700672
75	Die Cast	rear	black	1719905	1719905	1719928

**FOLDING TOP PARTS—INTERIOR TRIM**

**REAR SEAT**

YEAR	BUCKLE TYPE/ BODY STYLE	SEAT	COLOR	R.H.	L.H.	CENTER
75	Std. 2	rear	black	1695383	1695383	1696330
75	Std. 2	rear	saddle	1695384	1695384	1696331
75	Std. 2	rear	oxblood	1695385	1695385	1696332
75	Std. 2	rear	green	1695386	1695386	1696333
75	Std. 2	rear	graystone	1695387	1695387	1696334
75	Std. 2	rear	blue	1695388	1695388	1696335
75	Std. 2	rear	sandstone	1695389	1695389	1696336

**1975 VEGA— MONZA SEAT BELTS**

BODY STYLE	BUCKLE TYPE	BUCKLE COLOR	BUCKLE R.H.	SIDE L.H.	RTCTR R.H.	SIDE L.H.	REAR R.H.	SEAT L.H.
HR-HM27	Std. 3	black	1696386	1696387	1696286	1696287	1696350	1696351
HR	Std. 3	saddle	1696388	1696389	1696288	1696289	1696352	1696353
HR	Std. 3	oxblood	1696390	1696391	1696290	1696291	1696354	1696355
HR	Std. 3	graystone	1696392	1696393	1696292	1696293	1696356	1696357
HR	Std. 3	blue	1696394	1696395	1696294	1696295	1696358	1696359
HR	Std. 3	sandstone	1696396	1696397	1696296	1696297	1696360	1696361
HM	Std. 3	buckskin	1708362	1708363	1721220	1721221	1708370	1708371
HM	Std. 3	firethorn	1708360	1708361	1708364	1708365	1708368	1708369
HM	Plastic	firethorn	1721212	1721213	1721218	1721219	—	—
HM	Plastic	black	1721210	1721211	1721216	1721217	1721222	1721223
HM	Plastic	buckskin	1721214	1721215	—	—	1721226	1721227
HV11-15-77	Plastic	black	1700614	1700615	1700638	1700639	—	—
HV11-77	Plastic	black	—	—	—	—	1700661	1700661
HV11-15-77	Plastic	saddle	1700616	1700617	1700640	1700641	—	—
HV11-77	Plastic	saddle	—	—	—	—	1700662	1700662
HV11-15-77	Plastic	oxblood	1700618	1700619	1700642	1700643	—	—
HV11-77	Plastic	oxblood	—	—	—	—	1700663	1700663
HV11-15-77	Plastic	blue	1700620	1700621	1700644	1700645	—	—
HV11-77	Plastic	blue	—	—	—	—	1700664	1700664
HV11-15-77	Plastic	sandstone	1700622	1700623	1700646	1700647	—	—
HV11-77	Plastic	sandstone	—	—	—	—	1700665	1700665

**14.875A BASE ASSY.— BOLT— BOOT— BUZZER— CONTAINER— COVER— CLIP— DOOR— ESCUTCHEON— EXTENSION— FASTENER— GUIDE— MOULDING— NUT— PLATE— PLUG— POCKET ASSY.— PROTECTOR— RETAINER— SCREW— STOP— SPACER— STRAP— SUPPORT, Belt Unit and Shoulder Strap Unit Components**

69-72	Chevelle, Pass. w/front and rear deluxe belts	8764090	2	2.10	front seat belt retainer
64-66	Chevy, Chevelle,				
65-68	Pass.	3841314	A.R.	.21	BOLT, seat belt to floor (7/16" — 20 x 1 3/8")
65-66	Pass. (Spt. Sed.)				BOLT, frt. and rear seat belt outer anchor,
65-66	All	7583221	A.R.	.53	fr. seat belt inr. anchor (7/16" — 20 x 1 7/16")
67-69	Camaro,				
67	Pass., Chevy,				
71	Impala (Conv.)	3985006	A.R.	.50	BOLT, frt. seat belt anchor, outer
67	All				BOLT, front seat belt inner anchor,
67	Camaro,				
70	Camaro	7700984	A.R.	.53	BOLT, front seat belt inner and outer anchor
67-70	Sta. Wag.				fldg. 2nd and 3rd seat belt anchor, inner, outer, 2nd and 3rd seat belt to anchor plate
67-70	Nova, Chevelle, Pass.,				
72	Nova, Chevelle (1st Design)				BOLT, front seat belt outer anchor, front seat shoulder strap to top support,
67-70	All (exc. Sta. Wag., El Camino),				
71-72	Vega	7668784	A.R.	.57	BOLT, rear seat belt anchor outer, rear seat shoulder strap to brace
68	Camaro (Spt. Cpe.),				
68	Pass., Chevelle (exc. Conv.),				
68-71	Chevy, Nova,				
69-72	Pass. (exc. Conv.),				
70-72	Chevelle				BOLT, front seat belt and shldr. strap inner,

FOLDING TOP PARTS—INTERIOR TRIM

**14.875A BASE ASSY.— BOLT— BOOT— BUZZER— CONTAINER— COVER— CLIP— DOOR— ESCUTCHEON— EXTENSION— FASTENER— GUIDE— MOULDING— NUT— PLATE— PLUG— POCKET ASSY.— PROTECTOR— RETAINER— SCREW— STOP— SPACER— STRAP— SUPPORT, Belt Unit and Shoulder Strap Unit Components (Con't)**

70-72	Pass. (Conv.),				
71	Sta. Wag.,				
71	Camaro,				
		7765672 A.R.	1.05	BOLT, front seat belt and shldr. strap inner	
71	Impala (Conv.)	9418994 A.R.	.11	BOLT, rear seat shldr. strp. outer hinge and panel	
72	Nova,				
72	Chevelle (2-Dr.)	7700984 A.R.	.53	BOLT, frt. st. belt & shldr. strp. inr.	
67-72	Nova, Chevelle (Pass.) Camaro	7668784 A.R.	.57	BOLT, frt. st. belt otr. anc.	
72-73	All	9639880 A.R.	.52	BOLT, seat belt to anchor pnl., front seat belt to anchor plt., outer, fldng. 2nd seat belt to plt., fldng. 3rd seat belt to plt. (repl. 9624614)	
72-73	Nova	9624611 A.R.	.52	BOLT, f/seat belt to anchor	
72-73	Nova, Vega	9885669 A.R.	.57	BOLT, front seat belt anchor plate outer (1/2" — 13)	
72	Nova	9603159 A.R.	1.05	BOLT, front seat belt anchor plate inner	
72-75	All	9658871 A.R.	.80	BOLT, frt. & rear st. belt to anc. plate inr.	
72-73	Pass. (Sta. Wag.)	9624616 A.R.	.91	BOLT, 2nd st. belt to plt. otr.	
72-73	Pass., Chevelle, Camaro (2nd design)	9886920 A.R.	1.55	BOLT, front seat belt anchor plate outer & inner (w/sensor warning system)	
73	All	9663143 A.R.	.53	BOLT, 3/8" — 16 x 1.500	
73-75	Pass., Chevelle (exc. Sta. Wag.)	9639880 A.R.	.52	BOLT, fldg. 2nd seat belt plate inner also front seat belt to anc. plate outer	
73-75	Pass., Chevelle, Nova, Vega	9658870 A.R.	1.00	BOLT, front seat belt to anc. plate inner	
73	Nova (2-Dr.) w/bucket seats	9648790 A.R.	.91	BOLT, frt. st. belt plt. inr.	
68	All (exc. Sta. Wag., El Camino)	8712918 2		BOOT, frt. seat belt anc. inner (gold) (repl. 7777218)	
68-72	All	9824426 2	.91	BOOT, seat belt anchor inner (black)	
72	Nova, Camaro, Chevelle (exc. Sta. Wag., Conv.) Pass.	9603232 2	.82	BOOT, front seat belt anchor plate inner (covert)	
72	Nova (2-Dr.) w/bucket seat	9648790 2	.91	BOOT, front seat belt anchor plate inner (black)	
73	Pass., Chevelle, Nova,				
74-75	Pass. (Sta. Wag.) (9-Pass.)	9824426 2	.91	BOOT, anc. plate inner (black)	
73	Malibu (Spt. Cpe., Sed.) Nova (Cpe.) (exc. Custom)	9656988 2	.82	BOOT, anc. plt. inner (chamois)	
73	Pass., Chevelle, Nova (exc. El Camino),				
74	Pass. (Sta. Wag.) (9-Pass.)	9656989 2	.82	BOOT, anchor plate inner (neutral)	
73	Impala (exc. 6-Pass. Sta. Wag.),				
73	Caprice (exc. Conv.),				
73	Monte Carlo,				
74	Impala, Caprice (Sta. Wag.) (9-Pass.)	9656984 2	.82	BOOT, anchor plate inner (mid. blue)	
73	Bel Air (Sed.) Nova (exc. Custom) Chevelle (exc. Deluxe)	9656983 2	.82	BOOT, anc. plate inner (blue)	
73	Impala, Caprice (Sta. Wag.) (9-Pass.),				
73	Impala (Custom) Monte Carlo	9656986 2	.82	BOOT, front seat belt anc. plate inner also 2nd 2/3 seat belt anc. inner (green)	
73	Malibu, Laguna (Spt. Cpe.),				
73	Deluxe, Malibu (Sta. Wag.),				
73	Pass. (Sta. Wag.) (9-Pass.),				
75	Pass. (Sta. Wag.) (9-Pass.)	9656992 2	.82	BOOT, 2nd 2/3 seat belt anc. plate inner (saddle)	
73	Caprice (Sed., Spt. Cpe.),				
73	Laguna (exc. Estate),				
73	Monte Carlo	9656993 2	.82	BOOT, anc. plate inner (oxblood)	
74	Impala, Caprice (Sta. Wag.) (9-Pass.)	9726738 R.H.	.82	BOOT, 2nd 2/3 seat belt anchor plate inner (saddle)	
74-75	Pass. (Sta. Wag.) (9-Pass.)	9726739 R.H.	.82	BOOT, 2nd 2/3 seat belt anchor plate inner (green)	
71	Bel Air (Sedan),				
71	Impala, Caprice	9854705 2	.78	BOOT ASSY., front seat belt anchor plate inner (maize)	
71	Nova (Spt. Cpe.),				

**FOLDING TOP PARTS—INTERIOR TRIM**

**14.875A BASE ASSY.— BOLT— BOOT— BUZZER— CONTAINER— COVER— CLIP— DOOR— ESCUTCHEON— EXTENSION— FASTENER— GUIDE— MOULDING— NUT— PLATE— PLUG— POCKET ASSY.— PROTECTOR— RETAINER— SCREW— STOP— SPACER— STRAP— SUPPORT, Belt Unit and Shoulder Strap Unit Components (Con't)**

71	Camaro,					
71	Malibu,					
71	Chevelle (Conv.),					
72	Pass. (Sta. Wag.),					
72	Impala (exc. Sta. Wag.),					
72	Monte Carlo	9854706	2	.78	<b>BOOT ASSY.</b> , front seat belt anchor plate inner (saddle) (repl. 9858475)	
71-72	Nova, Camaro,					
71-72	Chevelle (exc. Conv., El Camino),					
71-72	Pass. (exc. Conv.)	9854710	2	.78	<b>BOOT ASSY.</b> , front seat belt anchor plate inner (blue)	
71	Camaro, Nova,					
71	Chevelle (exc. Conv.),					
71	Biscayne, Bel Air (Sedan),					
71	Impala, Caprice (Spt. Sed., Spt. Cpe.)	9854712	2	.82	<b>BOOT ASSY.</b> , front seat belt anchorplate inner (sandalwood)	
72	Impala, Caprice, Monte Carlo	9854708	2	.91	<b>BOOT ASSY.</b> , f/st. belt anch. plt. (pewter)	
72	Nova, Camaro,					
72	Chevelle (exc. El Camino),					
72	Bel Air (Sedan),					
72	Impala, Caprice (exc. Conv.)	9603231	2	.78	<b>BOOT ASSY.</b> , front seat belt anchor plate inner (green)	
75	Pass. (Sta. Wag.) (9-Pass.)	1696976	2	.78	<b>BOOT ASSY.</b> , fldg. 2nd seat belt anchor (blue)	
75	Pass. (Sta. Wag.) (9-Pass.)	1696978	1	.78	<b>BOOT ASSY.</b> , fldg. 2nd seat belt anchor (sandstone)	
72	All	6262663	1	3.30	<b>BUZZER</b> , seat belt warning— (2.195)	
73	All	6270699	1	3.15	<b>BUZZER</b> , seat belt warning— (2.195)	
74-75	All	6258257	1	3.40	<b>BUZZER</b> , seat belt warning— (2.195)	
72	Camaro	3983960	1	.11	<b>CLIP</b> , seat belt warning wire— (2.408)	
74-75	All	9729050	2	.16	<b>CLIP</b> , front seat shoulder strap (plastic)	
74	Chevelle w/bench seat (exc. Laguna, El Camino)	1659546	R.H.	.48	<b>CLIP</b> , frt. seat shoulder strap routing	
74	Chevelle w/bench seat (exc. Laguna, El Camino)	1659547	L.H.	.48	<b>CLIP</b> , frt. seat shoulder strap routing	
75	Nova	1712170	2	.16	<b>CLIP</b> , shoulder strap retractor cover	
69	Pass. w/bucket seats,					
70-71	Chevelle w/bucket sts.	3983187	2	1.45	<b>CONTAINER</b> , buckle stowage (paint as reqd.)	
68	All	7799407	2	1.05	<b>COVER</b> , frt. seat shldr. strap anc. L/strap cutout (black)	
70-72	Nova,					
69-70	Camaro (Spt. Cpe.),					
69-72	Chevelle (exc. Conv.),					
69-72	Pass. (4-Dr.) (exc. Spt. Sed.)	8769516	4	.21	<b>COVER</b> , frt. seat shldr. strap stowage	
72	Camaro	3994593	1	.38	<b>COVER</b> , seat belt warning light	
71-73	Vega	8769516	2	.21	<b>COVER</b> , driver and pass. seat shoulder strap stowage retainer front	
71-75	Vega (Panel)	7799407	1	1.05	<b>COVER</b> , shoulder strap anchor rail pass. seat	
73-75	Camaro	3994593	1	.38	<b>COVER</b> , seat belt warning light	
74-75	Pass. (Sedan)	9685854	R.H.	.44	<b>COVER</b> , retractor shoulder strap (prime and paint as reqd.)	
74-75	Pass. (Sedan)	9685855	L.H.	.44	<b>COVER</b> , retractor shoulder strap (prime and paint as reqd.)	
74-75	Pass. (Spt. Cpe.)	9686002	R.H.	.91	<b>COVER</b> , retractor shoulder strap (prime and paint as reqd.)	
74-75	Pass. (Spt. Cpe.)	9686003	L.H.	.91	<b>COVER</b> , retractor shoulder strap (prime and paint as reqd.)	
74-75	Pass. (Sta. Wag.)	9685840	R.H.	.42	<b>COVER</b> , retractor shoulder strap (prime and paint as reqd.)	
74-75	Pass. (Sta. Wag.)	9685841	L.H.	.42	<b>COVER</b> , retractor shoulder strap (prime and paint as reqd.)	
74-75	Chevelle (Sedan)	9686020	R.H.	.44	<b>COVER</b> , retractor shoulder strap (prime and paint as reqd.)	
74-75	Chevelle (Sedan)	9686021	L.H.	.44	<b>COVER</b> , retractor shoulder strap (prime and paint as reqd.)	
74-75	Chevelle (Coupe) (1st design)	9686288	R.H.	.90	<b>COVER</b> , retractor shoulder strap (prime and paint as reqd.) (Note 3)	



**FOLDING TOP PARTS—INTERIOR TRIM**

**14.875A BASE ASSY.— BOLT— BOOT— BUZZER— CONTAINER— COVER— CLIP—  
DOOR— ESCUTCHEON— EXTENSION— FASTENER— GUIDE—  
MOULDING— NUT— PLATE— PLUG— POCKET ASSY.— PROTECTOR—  
RETAINER— SCREW— STOP— SPACER— STRAP— SUPPORT, Belt Unit  
and Shoulder Strap Unit Components (Con't)**

74-75	Chevelle (Coupe) (1st design) . . .	9686289	L.H.	.90	COVER, retractor shoulder strap (prime and paint as reqd.) (Note 3) . . . . .
74-75	Chevelle (Coupe) w/sun roof (1st design) . . . . .	9686304	R.H.	.35	COVER, retractor shoulder strap (prime and paint as reqd.) (Note 3) . . . . .
74-75	Chevelle (Coupe) w/sun roof (1st design) . . . . .	9686305	L.H.	.35	COVER, retractor shoulder strap (prime and paint as reqd.) (Note 3) . . . . .
74-75	Chevelle (Sta. Wag.) . . . . .	9686086	R.H.	1.25	COVER, retractor shoulder strap (prime and paint as reqd.) . . . . .
74-75	Chevelle (Sta. Wag.) . . . . .	9686087	L.H.	1.25	COVER, retractor shoulder strap (prime and paint as reqd.) . . . . .
74	Monte Carlo . . . . .	9688058	R.H.	.62	COVER, retractor shoulder strap (prime and paint as reqd.) . . . . .
74	Monte Carlo . . . . .	9688059	L.H.	.62	COVER, retractor shoulder strap (prime and paint as reqd.) . . . . .
74-75	Monte Carlo w/sun roof . . . . .	9688112	R.H.	.87	COVER, retractor shoulder strap (prime as reqd.) . . . . .
74-75	Monte Carlo w/sun roof . . . . .	9687471	L.H.	.71	COVER, retractor shoulder strap (prime and paint as reqd.) . . . . .
74	Camaro . . . . .	9685872	R.H.	.42	COVER, retractor shoulder strap (prime and paint as reqd.) . . . . .
74	Camaro . . . . .	9685873	L.H.	.42	COVER, retractor shoulder strap (prime and paint as reqd.) . . . . .
74	Nova (Sedan) . . . . .	9685960	R.H.	.37	COVER, retractor shoulder strap (prime and paint as reqd.) . . . . .
74	Nova (Sedan) . . . . .	9685961	L.H.	.37	COVER, retractor shoulder strap (prime and paint as reqd.) . . . . .
74	Nova (Coupe) . . . . .	9685944	R.H.	.52	COVER, retractor shoulder strap (prime and paint as reqd.) . . . . .
74	Nova (Coupe) . . . . .	9685945	L.H.	.52	COVER, retractor shoulder strap (prime and paint as reqd.) . . . . .
74-75	Vega (Notchback Cpe., Sta. Wag.) . . . . .	9685900	R.H.	.52	COVER, retainer shoulder strap (prime and paint as reqd.) . . . . .
74-75	Vega (Notchback Cpe., Sta. Wag.) . . . . .	9685901	L.H.	.52	COVER, retainer shoulder strap (prime and paint as reqd.) (repl. 9685891) . . . . .
74-75	Vega (Hatchback Cpe.) . . . . .	9685934	R.H.	.43	COVER, retainer shoulder strap (prime and paint as reqd.) . . . . .
74-75	Vega (Hatchback Cpe.) . . . . .	9685935	L.H.	.43	COVER, retainer shoulder strap (prime and paint as reqd.) . . . . .
74-75	Vega (Panel) . . . . .	9726728	2	1.25	COVER, shoulder mtg. plate (prime and paint as reqd.) . . . . .
75	Pass. (Spt. Sed.) . . . . .	1677784	R.H.	.46	COVER, retractor shoulder strap (prime and paint as reqd.) . . . . .
75	Pass. (Spt. Sed.) . . . . .	1677785	L.H.	.46	COVER, retractor shoulder strap (prime and paint as reqd.) . . . . .
75	Monte Carlo . . . . .	9688076	R.H.	.70	COVER, retractor shoulder strap (prime and paint as reqd.) . . . . .
75	Monte Carlo . . . . .	9688077	L.H.	.70	COVER, retractor shoulder strap (prime and paint as reqd.) . . . . .
75	Nova (Coupe) . . . . .	1689526	R.H.	.53	COVER, retractor shoulder strap (prime and paint as reqd.) . . . . .
75	Nova (Coupe) . . . . .	1689527	L.H.	.53	COVER, retractor shoulder strap (prime and paint as reqd.) . . . . .
75	Nova (Sedan) . . . . .	1689542	R.H.	.38	COVER, retractor shoulder strap (prime and paint as reqd.) . . . . .
75	Nova (Sedan) . . . . .	1689543	L.H.	.38	COVER, retractor shoulder strap (prime and paint as reqd.) . . . . .
75	Camaro . . . . .	1666976	R.H.	1.30	COVER, retractor shoulder strap (prime and paint as reqd.) . . . . .
75	Camaro . . . . .	1666977	L.H.	1.30	COVER, retractor shoulder strap (prime and paint as reqd.) . . . . .
75	Monza . . . . .	1698053	R.H.	.44	COVER, retainer shoulder strap (prime and paint as reqd.) . . . . .
75	Monza . . . . .	1698054	L.H.	.44	COVER, retainer shoulder strap (prime and paint as reqd.) . . . . .
75	Monza (Notchback) . . . . .	1707256	R.H.	.42	COVER, retainer shoulder strap (prime and paint as reqd.) . . . . .

**FOLDING TOP PARTS—INTERIOR TRIM**

**14.875A BASE ASSY.— BOLT— BOOT— BUZZER— CONTAINER— COVER— CLIP— DOOR— ESCUTCHEON— EXTENSION— FASTENER— GUIDE— MOULDING— NUT— PLATE— PLUG— POCKET ASSY.— PROTECTOR— RETAINER— SCREW— STOP— SPACER— STRAP— SUPPORT, Belt Unit and Shoulder Strap Unit Components (Con't)**

75	Monza (Notchback) . . . . .	1707257 L.H.	.42	COVER, retainer shoulder strap (prime and paint as reqd.) . . . . .
75	Vega (Hatchback Cpe.) w/roof intr. finish luxury design . . . . .	1701726 R.H.	.70	COVER, retractor shoulder strap (prime and paint as reqd.) . . . . .
75	Vega (Hatchback Cpe.) w/roof intr. finish luxury design . . . . .	1701727 L.H.	.70	COVER, retractor shoulder strap (prime and paint as reqd.) . . . . .
75	Vega (Sta. Wag.) w/roof intr. finish luxury design . . . . .	1701738 R.H.	.39	COVER, retractor shoulder strap (prime and paint as reqd.) . . . . .
75	Vega (Sta. Wag.) w/roof intr. finish luxury design . . . . .	1701739 L.H.	.39	COVER, retractor shoulder strap (prime and paint as reqd.) . . . . .
74-75	Chevelle (Coupe) (2nd design) . . . . .	1657308 R.H.	.92	COVER ASSY., retractor shoulder strap (paint as reqd.) (Note 3) . . . . .
74-75	Chevelle (Coupe) (2nd design) . . . . .	1657309 L.H.	.92	COVER ASSY., retractor shoulder strap (paint as reqd.) (Note 3) . . . . .
74-75	Chevelle (Coupe) w/sunroof (2nd design) . . . . .	1657276 R.H.	.71	COVER ASSY., retractor shoulder strap (paint as reqd.) (Note 3) . . . . .
74-75	Chevelle (Coupe) w/sunroof (2nd design) . . . . .	1657277 L.H.	.71	COVER ASSY., retractor shoulder strap (paint as reqd.) (Note 3) . . . . .
	<i>NOTE 3: To aid in identifying first design, a metal insert was required to fill void in quarter panel used for tear drop window design. Second design quarter panel will have added metal in sail area.</i>			
75	X . . . . .	1749600 2	.52	DOOR, p & d/seat retr. cover (type 2) (paint to match) . . . . .
75	X . . . . .	1749598 1	.52	DOOR, p/seat retr. cover (type 4) (paint to match) . . . . .
73	Monte Carlo . . . . .	9656338 R.H.	.12	ESCUTCHEON, shoulder strap upper (paint as reqd.) . . . . .
73	Monte Carlo . . . . .	9656339 L.H.	.12	ESCUTCHEON, shoulder strap upper (paint as reqd.) . . . . .
74-75	Pass., Chevelle, Nova, Camaro w/bench seat . . . . .	9691094 2	.23	ESCUTCHEON, shoulder strap pass. and driver seat back (black) (rectangular shape) (prime and paint as reqd.) . . . . .
74	Pass., Chevelle, Nova w/bench seat . . . . .	9691100 2	.23	ESCUTCHEON, shoulder strap pass. and driver seat back (mid. blue) (rectangular shape) . . . . .
74	Pass. w/bench seat . . . . .	9691106 2	.23	ESCUTCHEON, shoulder strap pass. and driver seat back (taupe) (rectangular shape) . . . . .
74	Chevelle w/notch back seat . . . . .	9691097 2	.23	ESCUTCHEON, shoulder strap pass. and driver seat back (white) (rectangular shape) . . . . .
74	Chevelle, Camaro, Nova w/bucket seat, . . . . .			
75	Chevelle w/bucket seat . . . . .	9732276 1	.22	ESCUTCHEON, shoulder strap pass. seat back (black) (triangular shape) . . . . .
74	Chevelle, Camaro, Nova w/bucket seat, . . . . .			
75	Chevelle w/bucket seat . . . . .	9732277 1	.22	ESCUTCHEON, shoulder strap driver seat back (black) (triangular shape) . . . . .
74	Chevelle, Nova w/bucket seat . . . . .	9732278 1	.20	ESCUTCHEON, shoulder strap pass. seat back (white) (triangular shape) . . . . .
74	Chevelle, Nova w/bucket seat . . . . .	9732279 1	.20	ESCUTCHEON, shoulder strap driver seat back (white) (triangular shape) . . . . .
74	Chevelle w/bucket seat . . . . .	9732282 1	.20	ESCUTCHEON, shoulder strap pass. seat back (mid. blue) (triangular shape) . . . . .
74	Chevelle w/bucket seat . . . . .	9732283 1	.20	ESCUTCHEON, shoulder strap driver seat back (mid. blue) (triangular shape) . . . . .
74	Chevelle, Camaro, Nova w/bucket seat . . . . .	9732284 1	.22	ESCUTCHEON, shoulder strap pass. seat back (neutral) (triangular shape) . . . . .
74	Chevelle, Camaro, Nova w/bucket seat . . . . .	9732285 1	.22	ESCUTCHEON, shoulder strap driver seat back (neutral) (triangular shape) . . . . .

**FOLDING TOP PARTS—INTERIOR TRIM**

**14.875A BASE ASSY.— BOLT— BOOT— BUZZER— CONTAINER— COVER— CLIP—  
DOOR— ESCUTCHEON— EXTENSION— FASTENER— GUIDE—  
MOULDING— NUT— PLATE— PLUG— POCKET ASSY.— PROTECTOR—  
RETAINER— SCREW— STOP— SPACER— STRAP— SUPPORT, Belt Unit  
and Shoulder Strap Unit Components (Con't)**

74-75	Chevelle w/bucket seat	9732286	1	.20	ESCUTCHEON, shoulder strap pass. seat back (oxblood) (triangular shape)
74-75	Chevelle w/bucket seat	9732287	1	.20	ESCUTCHEON, shoulder strap driver seat back (oxblood) (triangular shape)
74	Chevelle, Camaro, Nova w/bucket seat	9732288	1	.22	ESCUTCHEON, shoulder strap pass. seat back (saddle) (triangular shape)
74	Chevelle, Camaro, Nova w/bucket seat	9732289	1	.22	ESCUTCHEON, shoulder strap driver seat back (saddle) (triangular shape)
74	Chevelle, Camaro, Nova w/bucket seat,				
75	Monte Carlo w/bucket seat	9732290	1	.22	ESCUTCHEON, shoulder strap pass. seat back (green) (triangular shape)
74	Chevelle, Camaro, Nova w/bucket seat,				
75	Monte Carlo w/bucket seat	9732291	1	.22	ESCUTCHEON, shoulder strap driver seat back (green) (triangular shape)
74	Camaro	9732292	1	.20	ESCUTCHEON, shoulder strap pass. seat back (taupe) (triangular shape)
74	Camaro	9732293	1	.20	ESCUTCHEON, shoulder strap driver seat back (taupe) (triangular shape)
74	Camaro	9732294	1	.22	ESCUTCHEON, shoulder strap pass. seat back (red) (triangular shape)
74	Camaro	9732295	1	.22	ESCUTCHEON, shoulder strap driver seat back (red) (triangular shape)
74-75	Vega (Notchback, Hatchback Cpe.) (Sta. Wag.)	9732276	1	.22	ESCUTCHEON, shoulder strap pass. seat back (19J) (black) (triangular shape)
74-75	Vega (Notchback, Hatchback Cpe.) (Sta. Wag.)	9732277	1	.22	ESCUTCHEON, shoulder strap driver seat back (19J) (black) (triangular shape)
74	Vega (Notchback, Hatchback Cpe.) (Sta. Wag.)	9732284	1	.22	ESCUTCHEON, shoulder strap pass. seat back (neutral) (triangular shape)
74	Vega (Notchback, Hatchback Cpe.) (Sta. Wag.)	9732285	1	.22	ESCUTCHEON, shoulder strap driver seat back (neutral) (triangular shape)
74	Vega (Notchback, Hatchback Cpe.) (Sta. Wag.)	9732288	1	.22	ESCUTCHEON, shoulder strap pass. seat back (saddle) (triangular shape)
74	Vega (Notchback, Hatchback Cpe.) (Sta. Wag.)	9732289	1	.22	ESCUTCHEON, shoulder strap driver seat back (saddle) (triangular shape)
74	Vega (Notchback, Hatchback Cpe.) (Sta. Wag.)	9732290	1	.22	ESCUTCHEON, shoulder strap pass. seat back (green) (triangular shape)
74	Vega (Notchback, Hatchback Cpe.) (Sta. Wag.)	9732291	1	.22	ESCUTCHEON, shoulder strap driver seat back (green) (triangular shape)
74	Vega (Hatchback Cpe.)	9691094	1	.23	ESCUTCHEON, shoulder strap pass. & driver seat back (white) (repl. 1673282, 1673283)
74	Vega (Hatchback Cpe.) (Sta. Wag.)	9732294	1	.22	ESCUTCHEON, shoulder strap pass. seat back (red) (triangular shape)
74	Vega (Hatchback Cpe.) (Sta. Wag.)	9732295	1	.22	ESCUTCHEON, shoulder strap driver seat back (red) (triangular shape)
75	Chevelle w/bucket seat (exc. El Camino)	1674532	1	.23	ESCUTCHEON, seat belt pass. seat (blue)
75	Chevelle w/bucket seat (exc. El Camino)	1674533	1	.23	ESCUTCHEON, seat belt driver seat (blue)
75	Chevelle w/bucket seat (exc. El Camino)	1674534	1	.23	ESCUTCHEON, seat belt pass. seat (sandstone)
75	Chevelle w/bucket seat (exc. El Camino)	1674535	1	.23	ESCUTCHEON, seat belt driver seat (sandstone)

**FOLDING TOP PARTS—INTERIOR TRIM**

**14.875A BASE ASSY.— BOLT— BOOT— BUZZER— CONTAINER— COVER— CLIP— DOOR— ESCUTCHEON— EXTENSION— FASTENER— GUIDE— MOULDING— NUT— PLATE— PLUG— POCKET ASSY.— PROTECTOR— RETAINER— SCREW— STOP— SPACER— STRAP— SUPPORT, Belt Unit and Shoulder Strap Unit Components (Con't)**

75	Chevelle w/bucket seat (exc. El Camino) .....	1674528	1	.23	ESCUTCHEON, seat belt pass. seat (saddle) (63N) .....
75	Chevelle w/bucket seat (exc. El Camino) .....	1674529	1	.23	ESCUTCHEON, seat belt driver seat (saddle) (63N) .....
75	Monte Carlo w/bucket seat .....	9691094	1	.23	ESCUTCHEON, seat belt pass. & driver seat (white) (11J) (repl. 1673282, 1673283) ..
74-75	Chevelle (Coupe) w/sun roof (2nd design) .....	1657292	R.H.	.35	EXTENSION, cover retractor shoulder (prime and paint as reqd.) (used with second design covers only) .....
74-75	Chevelle (Coupe) w/sun roof (2nd design) .....	1657293	L.H.	.35	EXTENSION, cover retractor shoulder (prime and paint as reqd.) (used with second design covers only) .....
68	All (exc. Conv.) .....	7796712	2	.32	FASTENER, frt. seat shldr. strap ret. ....
75	All .....	8731909		.11	FASTENER, guide s/strap pass. and driver seat back .....
74-75	All .....	1708118	2	.50	GUIDE, shoulder strap pass. and driver seat back (black) (Note 3) .....
74	Pass., Chevelle, Nova w/bench seat, Malibu (Classic) (Sta. Wag.) w/bucket seat .....	9691907	2	.72	GUIDE, shoulder strap pass. and driver seat back (mid. blue) (Note 3) .....
74	All .....	9691908	2	.53	GUIDE, shoulder strap pass. and driver seat back (neutral) (Note 3) .....
74-75	Pass., Chevelle, Nova, Camaro w/bucket seat, European seat ..	9691909	2	.50	GUIDE, shoulder strap pass. and driver seat back (oxblood) (Note 3) .....
74	All .....	9691910	2	.53	GUIDE, shoulder strap pass. and driver seat back (saddle) (Note 3) .....
74-75	All .....	9691911	2	.53	GUIDE, shoulder strap pass. and driver seat back (green) (Note 3) .....
74	Pass. w/bench seat, Camaro w/bucket seat .....	9691913	2	.50	GUIDE, shoulder strap pass. and driver seat back (taupe) (Note 3) .....
74	Pass. w/bench seat, Vega (Hatchback Cpe.) .....	9691902	2	.50	GUIDE, shoulder strap pass. and driver seat back (white) .....
74	Chevelle w/notchback seat, Nova w/bucket seat, Chevelle w/bucket seat .....	9691904	2	.72	GUIDE, shoulder strap pass. and driver seat back (white) (Note 3) .....
74	Camaro w/bucket seat, Vega (Hatchback Cpe., Sta. Wag.) .....	9732268	2	.53	GUIDE, shoulder strap pass. and driver seat back (red) (Note 3) .....
75	Camaro, Nova w/bucket, European seats .....	1673404	2	.29	GUIDE, shoulder strap pass. and driver seat back (green) .....
75	All .....	1708118	2	.50	GUIDE, shoulder strap pass. and driver seat back (black) (Note 4) .....
75	All .....	1708119	2	.50	GUIDE, shoulder strap pass. and driver seat back (white) (Note 4) .....
75	All .....	1708123	2	.50	GUIDE, shoulder strap pass. and driver seat back (saddle) (Note 4) .....
75	All .....	1708124	2	.50	GUIDE, shoulder strap pass. and driver seat back (oxblood) (Note 4) .....
75	All .....	1708126	2	.50	GUIDE, shoulder strap pass. and driver seat back (green) (Note 4) .....
75	All .....	1708127	2	.50	GUIDE, shoulder strap pass. and driver seat back (graystone) (Note 4) .....
75	All .....	1685229	2	.53	GUIDE, shoulder strap pass. and driver seat back (dk. blue) .....
75	All .....	1708129	2	.50	GUIDE, shoulder strap pass. and driver seat back (sandstone) (Note 4) .....

**FOLDING TOP PARTS—INTERIOR TRIM**

**14.875A BASE ASSY.— BOLT— BOOT— BUZZER— CONTAINER— COVER— CLIP— DOOR— ESCUTCHEON— EXTENSION— FASTENER— GUIDE— MOULDING— NUT— PLATE— PLUG— POCKET ASSY.— PROTECTOR— RETAINER— SCREW— STOP— SPACER— STRAP— SUPPORT, Belt Unit and Shoulder Strap Unit Components (Con't)**

75	Vega, Monza	1673404	2	.29	GUIDE, shoulder strap pass. and driver seat back (graystone)
75	Vega, Monza	9691909	2	.50	GUIDE, shoulder strap pass. and driver seat back (oxblood)
75	Monza (Towne Cpe.)	1708137	2	.50	GUIDE, shoulder strap pass. and driver seat back (buckskin) (Note 2)
75	Monza (Towne Cpe.)	1708135	2	.50	GUIDE, shoulder strap pass. and driver seat back (firethorn) (Note 2)
75	Vega, Monza	1708118	2	.50	GUIDE, shoulder strap pass. and driver seat back (black) (Note 2)
75	Vega, Monza	1708119	2	.50	GUIDE, shoulder strap pass. and driver seat back (white) (Note 2)
75	Vega, Monza	1708123	2	.50	GUIDE, shoulder strap pass. and driver seat back (saddle) (Note 2)
75	Vega, Monza	1708124	2	.50	GUIDE, shoulder strap pass. and driver seat back (oxblood) (Note 2)
75	Vega, Monza	1708126	2	.50	GUIDE, shoulder strap pass. and driver seat back (green) (Note 2)
75	Vega, Monza	1708127	2	.50	GUIDE, shoulder strap pass. and driver seat back (graystone) (Note 2)
75	Vega, Monza	1708128	2	.50	GUIDE, shoulder strap pass. and driver seat back (dk. blue) (Note 2)
75	Vega, Monza	1708129	2	.50	GUIDE, shoulder strap pass. and driver seat back (sandstone) (Note 2)
<i>NOTE 1: 1st design-Low-Profile. 2nd design-Hi-Profile.</i>					
<i>NOTE 2: Hole added for fastener.</i>					
69	Pass. w/bucket seats,				
70-72	Chevelle (2-Dr.) w/floor console,				
72	Monte Carlo	3957379	2	.78	MOULDING, bkl. stowage container
74-75	Vega (Panel)	9695700	2	1.80	PLATE ASSY., shoulder strap mounting
75	All	1696436	1		PLUG, front seat belt sleeve
71-72	Nova (2-Dr.)				POCKET ASSY. (comb. 754),
71-72	Malibu (Spt. Cpe., Conv.) El Camino (Custom)				(comb. 706),
71-72	Monte Carlo	9873472	2	2.25	pass. and driver seat belt bkl. stowage (comb. 707, 710) (black)
71-72	Nova (2-Dr.)				POCKET ASSY. (comb. 767),
71-72	Malibu (Spt. Cpe., Conv.) El Camino (Custom)				(comb. 722),
71-72	Monte Carlo	9873473	2	2.25	pass. and driver seat belt bkl. stowage (comb. 723) (dk. saddle)
71	Monte Carlo	9873474	2	2.25	POCKET ASSY., pass. and driver seat belt bkl. stowage (comb. 727) (dk. blue)
71	Malibu (Spt. Cpe., Conv.) El Camino (Custom)				POCKET ASSY. (comb. 732),
71	Monte Carlo	9873475	2	2.25	pass. and driver seat belt bkl. stowage (comb. 729, 733) (dk. jade)
71	Malibu (Spt. Cpe.) El Camino (Custom)				POCKET ASSY. (comb. 715),
71	Monte Carlo	9873547	2	2.25	pass. and driver seat belt bkl. stowage (comb. 716) (lt. sandalwood)
72	Chevelle (Spt. Cpe. exc. Monte Carlo) (Conv.) (1st design) w/bucket seat console	9899075	2	2.95	POCKET ASSY., pass. & driver seat belt bucket stow. (comb. 743) (white)
72	Chevelle (Spt. Cpe., Conv.) (1st design)	9600196	2	1.95	POCKET ASSY., pass. and driver seat belt buckle stow. (comb. 713) (green)
72	Malibu (Spt. Cpe.), El Camino (Custom) (1st design)	9600197	2	1.90	POCKET ASSY., pass. and driver seat belt buckle stow. (comb. 732) (covert)
72	Nova, Malibu (Spt. Cpe.), El Camino (Custom) (1st design)	9600198	2	1.90	POCKET ASSY., pass. and driver seat belt buckle stow. (comb. 720, 766) (tan)
65-70	Pass., Chevy, Chevelle	4519465	2	.38	PROTECTOR, frt. seat, standard (black)
67-70	Pass., Chevelle, Camaro (Conv.) w/shldr. harness,				
71-72	Chevelle (Conv.)	7698556	2	.13	PROTECTOR, shldr. strap (clear)
68	Caprice, Impala (Spt. Cpe., Spt. Sed.) w/strato bench seat,				

**FOLDING TOP PARTS—INTERIOR TRIM**

**14.875A BASE ASSY.— BOLT— BOOT— BUZZER— CONTAINER— COVER— CLIP— DOOR— ESCUTCHEON— EXTENSION— FASTENER— GUIDE— MOULDING— NUT— PLATE— PLUG— POCKET ASSY.— PROTECTOR— RETAINER— SCREW— STOP— SPACER— STRAP— SUPPORT, Belt Unit and Shoulder Strap Unit Components (Con't)**

69	Caprice	8715238	2	.38	PROTECTOR, frt. st. belt trim (black)
71	Nova, Chevelle,				
72	Nova,				
72	Chevelle (2-Dr.) (Sta. Wag.)	9627402	2	.53	PROTECTOR, front seat belt
71-73	Pass.,				
73	Chevelle, Nova	9627404	2	.98	PROTECTOR, front seat belt trim
71-72	Pass. (Sta. Wag.) (9-Pass.)	9868853	R.H.	1.05	PROTECTOR, fldg. 2nd 2/3 seat belt trim (comb. 804, 806) (black)
71	Kingswood (9-Pass.)	9868854	R.H.	.98	PROTECTOR, fldg. 2nd 2/3 seat belt trim (comb. 827) (med. maize)
71-72	Pass. (Sta. Wag.) (9-Pass.)	9868855	R.H.	1.05	PROTECTOR, fldg. 2nd 2/3 seat belt trim (comb. 824, 825) (saddle)
71-72	Pass. (Sta. Wag.) (9-Pass.)	9868856	R.H.	1.05	PROTECTOR, fldg. 2nd 2/3 seat belt trim (comb. 812, 814) (dk. blue)
71	Kingswood (9-Pass.)	9868857	R.H.	1.05	PROTECTOR, fldg. 2nd 2/3 seat belt trim (comb. 835) (dk. jade)
72	Chevelle (Conv.) (1st design)				PROTECTOR, front seat shoulder strap clear
72	Kingswood (9-Pass.)	9600975	R.H.	1.15	PROTECTOR, fldg. 2nd 2/3 seat belt (comb. 818) (covert)
72	Kingswood (9-Pass.)	9600953	R.H.	1.15	PROTECTOR, fldg. 2nd 2/3 seat belt (comb. 830) (green)
73	Caprice (exc. Sta. Wag.)	9657737	1	.83	PROTECTOR, pass. & driver seat belt trim
67-69	Chevelle (2-Dr.),				
67-69	Nova (S.S.),				
67-68	Camaro w/floor console,				
67-69	Spt. Cpe., Conv.	3930150	2	1.20	RETAINER, seat belt buckle
67-68	Chevy,				
68	Pass. (exc. Conv.),				
68-69	Pass. (Sta. Wag.) w/rear seat shldr. harn. std.,				
68-69	All (Conv.) w/std. shldr. harn.,				
70-72	El Camino (exc. front seat shoulder harness)	7779994	A.R.	.71	RETAINER, strap stowage (black) (Note 1)
	<i>NOTE 1: Used with 1st design shldr. straps.</i>				
68-72	Impala, Caprice (Spt. Cpe., Spt. Sed.)	8717380	4	.71	RETAINER, frt. st. shldr. strap stow. (snap on type)
68	Chevelle (exc. Spt. Mdls.),				
68-70	Camaro (Spt. Cpe.), Nova,				
68-70	Pass. (exc. Spt. Mdls.),				
70	Chevelle	8769517	A.R.	1.10	RETAINER, front seat strap stow.
69	Camaro (Conv.) w/deluxe shldr. harn.	778007	2		RETAINER, frt. seat shldr. strap bkl. stowage (orange)
70-72	Camaro w/floor console	3975806	2	.71	RETAINER, seat belt buckle
70-72	Camaro	9825137	R.H.	.34	RETAINER, front seat shoulder strap stowage
70-72	Camaro	9825138	L.H.	.34	RETAINER, front seat shoulder strap stowage
71-72	Concours, Kingswood w/deluxe rear seat shoulder harness				RETAINER, 2nd and 3rd seat shoulder strap buckle stowage (comb. 721, 825)
71-72	Chevelle (exc. Conv.),				
71-75	Pass. (4-Dr.) (exc. Spt. Sed.),				
73-75	Vega	9845845	A.R.	.34	RETAINER, front seat, fldg. 2nd and 3rd seat shoulder strap stowage
72	El Camino,				
72	Pass., Chevelle (Conv.)	9611172	3	.78	RETAINER, front seat shoulder strap
71-72	Impala, Caprice (exc. Conv., Sta. Wag.)	9845844	4	.92	RETAINER, front seat shoulder strap stowage
72-73	Pass. (exc. Spt. Cpe., Spt. Sed.)	9613173		1.35	RETAINER, f/st. shldr. strp. L.H. (paint as reqd.)
72-73	Pass. (exc. Spt. Cpe., Spt. Sed.)	9613172		1.35	RETAINER, f/st. shldr. strp. L.H. (paint as reqd.)
71-72	Chevelle (Sta. Wag.)	9861392	1	1.70	2nd seat belt bkl. stowage (single)
71-73	Vega	9842027	1	.47	RETAINER, driver and pass. seat shoulder strap
72-73	Vega,				

**FOLDING TOP PARTS—INTERIOR TRIM**

**14.875A BASE ASSY.— BOLT— BOOT— BUZZER— CONTAINER— COVER— CLIP—  
DOOR— ESCUTCHEON— EXTENSION— FASTENER— GUIDE—  
MOULDING— NUT— PLATE— PLUG— POCKET ASSY.— PROTECTOR—  
RETAINER— SCREW— STOP— SPACER— STRAP— SUPPORT, Belt Unit  
and Shoulder Strap Unit Components (Con't)**

74-75	Vega (Panel) . . . . .	9607940	1	.47	RETAINER, pass. seat shoulder strap (paint as reqd.) . . . . .
72-73	Vega,				
74-75	Vega (Panel) . . . . .	9607941	1	.47	RETAINER, driver seat shoulder strap (paint as reqd.) . . . . .
72	Camaro,				
73	Pass. (Spt. Cpe., Spt. Sed.),				
73	Camaro (1st design) . . . . .	9607946	R.H.	1.35	RETAINER, front seat shoulder strap (prime and paint as reqd.) (Note 1) . . . . .
72	Camaro,				
73	Pass. (Spt. Cpe., Spt. Sed.),				
73	Camaro (1st design) . . . . .	9607947	L.H.	1.35	RETAINER, front seat shoulder strap (prime and paint as reqd.) (Note 1) . . . . .
73	Camaro (2nd design) . . . . .	9667040	R.H.	1.35	RETAINER, front seat shoulder strap (paint as reqd.) (Note 2) . . . . .
73	Camaro (2nd design) . . . . .	9667041	L.H.	1.35	RETAINER, front seat shoulder strap (paint as reqd.) (Note 2) . . . . .
74-75	Pass., Chevelle . . . . .	9686109	2	.08	RETAINER, shoulder strap retr. cover stab. . . . .
74-75	Pass., Chevelle, Nova, Camaro . . . . .	1668380	2	.12	RETAINER, frt. seat shldr. strap fr. clip . . . . .
74-75	Camaro . . . . .	1651650	2	.12	RETAINER, shoulder strap retr. cover stab. . . . .
74-75	Vega, Monza . . . . .	9686109	2	.08	RETAINER, shoulder strap retr. cover stab. . . . .
74-75	Vega (exc. Panel) . . . . .	1668380	2	.12	RETAINER, frt. seat shldr. strp. fr. clip . . . . .
68	Impala (2-Dr.) w/Deluxe shldr. strap,				
68	Camaro,				
68	Malibu, S.S. (Spt. Cpe., Conv.) w/front seat shldr. harn. (Deluxe),				
70-71	Conv., El Camino w/deluxe seat belts and front seat shoulder harness (exc. Custom) . . . . .				RETAINER ASSY., front seat shoulder strap buckle stowage, . . . . .
70-71	Conv., El Camino (Custom) w/deluxe seat belts and front seat shoulder harness,				
70-71	Pass. (Sta. Wag.) w/deluxe rear seat shoulder harness . . . . .	7780007	2	1.25	2nd and 3rd seat shoulder strap buckle (black) stowage (comb. 810, 812, 814) (dk. blue) . . . . .
70	Kingswood w/rear seat deluxe shoulder harness . . . . .				RETAINER ASSY., 2nd seat shldr. strap buckle stowage, . . . . .
70	Pass., Chevelle (Sta. Wag.) w/deluxe rear seat shoulder harness . . . . .				RETAINER ASSY., 2nd seat shoulder strap buckle stowage, . . . . .
70	Pass. (Sta. Wag.) w/deluxe seat belts and front shoulder harness . . . . .				RETAINER ASSY., 2nd seat belt buckle stowage single, . . . . .
70	Pass. (exc. Sta. Wag.) w/deluxe seat belts and front shoulder harness . . . . .	9823039	1	1.70	rear seat belt buckle stowage single . . . . .
71	Pass. . . . .	9858758	1	1.70	RETAINER ASSY., front seat belt bkl. stowage (single) . . . . .
71-72	Nova, Chevelle . . . . .	9858760	1	2.65	RETAINER ASSY., front seat belt bkl. stowage (double) . . . . .
71-72	Nova, Chevelle . . . . .	9858762	1	1.80	RETAINER ASSY., front seat belt bkl. stowage (single) . . . . .
71	Pass. (Sta. Wag.) . . . . .				RETAINER ASSY., 2nd seat belt bkl. stowage, . . . . .
71	Pass. (4-Dr.) (exc. Sta. Wag.) . . . . .	9858764	1	2.85	rear seat belt bkl. stowage (double) . . . . .
71	Pass. (Sta. Wag.) . . . . .				RETAINER ASSY., 2nd seat belt bkl. stowage, . . . . .
71	Pass. (4-Dr.) (exc. Sta. Wag.) . . . . .	9858766	1	2.85	rear seat belt bkl. stowage (single) . . . . .
71	Pass. . . . .	9860156	1	2.70	RETAINER ASSY., front seat belt bkl. stowage (double) . . . . .
71-72	Nova,				
71-72	Pass. (2-Dr.),				

**FOLDING TOP PARTS—INTERIOR TRIM**

**14.875A BASE ASSY.— BOLT— BOOT— BUZZER— CONTAINER— COVER— CLIP— DOOR— ESCUTCHEON— EXTENSION— FASTENER— GUIDE— MOULDING— NUT— PLATE— PLUG— POCKET ASSY.— PROTECTOR— RETAINER— SCREW— STOP— SPACER— STRAP— SUPPORT, Belt Unit and Shoulder Strap Unit Components (Con't)**

71-72	Chevelle (exc. Sta. Wag., El Camino) .....					RETAINER ASSY., rear seat belt bkl. stowage, .....
71-72	Chevelle (Sta. Wag.) .....	9861390	1	2.50		2nd seat belt bkl. stowage (double) .....
71	Nova, Pass. (2-Dr.),					
71	Chevelle (exc. Sta. Wag., El Camino) .....					RETAINER ASSY., rear seat belt bkl. stowage, .....
70	Pass. (exc. Sta. Wag.) w/deluxe seat belts and front shoulder harness .....	9823041	1	3.00		RETAINER ASSY., rear seat belt buckle stowage double .....
73	Chevelle (Sedan) .....	1658075 A.R.		1.20		RETAINER ASSY., front seat shoulder belt to cntr. pillar .....
69-70	Chevelle (Sta. Wag.) w/rear seat shoulder harness,					
All	All .....	8741422	4	.40		SCREW (5/16— 18 x 7/8) .....
71	Pass., Chevelle (Sta. Wag.) w/deluxe rear seat shoulder harness .....	8742389	4	.32		SPACER, 2nd seat shoulder strap anchor outer .....
74	All .....	9667498	4	.21		SCREW, front seat belt to roof inner panel .....
74-75	All .....	1705723	2	.12		SPACER, front seat belt anchor to floor .....
75	All .....	1705722	2	.27		SPACER, rear seat and fldg. 2nd, fldg. 2nd seat belt to anchor to fir. ....
71-72	Vega .....	8704191	2	11.20		STRAP ASSY., rear seat .....
70	Camaro .....	9825128	2	.19		STOP, front seat belt retainer .....
68	Pass., Spt. Sed. ....					SUPPORT, coat hook support, .....
68	Pass. (exc. Spt. Cpe., Conv.) .....	7778982	2	.12		frt. st. shldr. strap hook (Note 3) .....
74	Chevelle w/Swivel Bucket .....	9667742	2	.80		SUPPORT, pass. and driver seat back shoulder strap guide .....

NOTE 1: Soft.

NOTE 2: Hard.

NOTE 3: 1st design-Low-Profile. 2nd design-Hi-Profile.

NOTE 4: Hole added for fastener.

**14.875B SLEEVE, Seat Belt Deluxe**

**1974**

**PASSENGER**

**BUCKLE SIDE— Bench Seat (w/Brushed Metal Buckles)**

	BLACK	GREEN	SADDLE	OXBLOOD	NEUTRAL	MID. BLUE	TAUPE
Front Seat (R.H.) .....	9738610	9738626	1696480	9738622	9738620	9738618	9738632
Front Seat (L.H.) .....	9738611	9738627	9738625	1696479	9738621	9738619	9738633

**BUCKLE SIDE— Bench Seat (w/Die-Cast Buckles)**

	BLACK	MID.
Front Seat (R.H.) .....	9738560	
Front Seat (L.H.) .....	9738561	



**FOLDING TOP PARTS—INTERIOR TRIM**

**CHEVELLE**

**BUCKLE SIDE— Bench Seat**

	BLACK	GREEN	SADDLE	OXBLOOD	NEUTRAL	MID. BLUE	TAUPE
Front Seat (R.H.) . . . . .	9738610	9738626	1696480	9738622	9738620	9738618	—
Front Seat (L.H.) . . . . .	9738611	9738627	9738625	1696479	9738261	9738619	—

**BUCKLE SIDE— Bucket Seat**

Front Seat . . . . .	9738583	9738588	9738587	9738586	9738585	9738584	—
----------------------	---------	---------	---------	---------	---------	---------	---

**NOVA**

**BUCKLE SIDE— Bench Seat-Plastic Buckle**

	BLACK	GREEN	SADDLE	NEUTRAL	MID. BLUE	WHITE
Front Seat (R.H.) . . . . .	9738590	9738600	9738598	9738596	9738594	—
Front Seat (L.H.) . . . . .	9738591	9738601	9738599	9738597	9738595	—

**BUCKLE SIDE— Bench Seat— Die Cast Buckle**

	BLACK	GREEN	SADDLE	NEUTRAL	MID. BLUE
Front Seat (R.H.) . . . . .	1668360	1668370	1668368	1668366	1668364
Front Seat (L.H.) . . . . .	1668361	1668371	1668369	1668367	1668365

**BUCKLE SIDE— Bucket Seat— Plastic Buckle**

Front Seat . . . . .	9738589	9738607	9738606	9738605	9738608
----------------------	---------	---------	---------	---------	---------

**BUCKLE SIDE— Bucket Seat— Die Cast Buckle**

Front Seat . . . . .	1668374	1668378	1668377	1668376	1668379
----------------------	---------	---------	---------	---------	---------

*NOTE: For 1974-75 Vega and Camaro sleeve are not service order belt asm.*

**1975**

**PASSENGER**

**BUCKLE SIDE— BENCH SEAT**

	BLACK	SADDLE	OXBLOOD	GREEN	BLUE	SANDSTONE
Front Seat R.H. (Std. 2) . .	1696500	—	—	—	—	—
Front Seat L.H. (Std. 2) . .	1696501	—	—	—	—	—
Front Seat R.H. (Std. 3) . .	1696502	—	—	—	—	—
Front Seat L.H. (Std. 3) . .	1696503	—	—	—	—	—
Front Seat R.H. (Deluxe) . .	1696470	1696476	1696478	1696482	1696486	1696488
Front Seat L.H. (Deluxe) . .	1696471	1696477	1696479	1696483	1696487	1696489

**FOLDING TOP PARTS—INTERIOR TRIM**

**CHEVELLE**

**BUCKLE SIDE— BENCH SEAT**

	BLACK	SADDLE	OSBLOOD	GREEN	BLUE	SAND- STONE	GRAY- STONE
Front Seat R.H. (Std. 2) . .	1696500	—	—	—	—	—	—
Front Seat L.H. (Std. 2) . .	1696501	—	—	—	—	—	—
Front Seat R.H. (Std. 3) . .	1696502	—	—	—	—	—	—
Front Seat L.H. (Std. 3) . .	1696503	—	—	—	—	—	—
Front Seat R.H. (Deluxe) . .	1696470	1696476	1696478	1696482	1696486	1696488	1696484
Front Seat L.H. (Deluxe) . .	1696471	1696477	1696479	1696483	1696487	1696489	1696485

**BUCKLE SIDE— BUCKET SEAT**

Front Seat (Deluxe) . . . . .	1696504	1696505	1696506	1696507	1696508	1696509	—
-------------------------------	---------	---------	---------	---------	---------	---------	---

**NOVA**

**BUCKLE SIDE— BENCH SEAT— PLASTIC BUCKLE**

	BLACK	SADDLE	OSBLOOD	GREEN	BLUE	SANDSTONE
Front Seat R.H. . . . .	1700680	1700682	1700684	1700686	1700688	1700690
Front Seat L.H. . . . .	1700681	1700683	1700685	1700687	1700689	1700691

**BUCKLE SIDE— BENCH SEAT— STANDARD 2**

Front Seat R.H. . . . .	1696458	1696460	1696462	1696464	1696466	1696468
Front Seat L.H. . . . .	1696459	1696461	1696463	1696465	1696467	1696469

**BUCKLE SIDE— BUCKET SEAT— PLASTIC BUCKLE**

	BLACK	SADDLE	OSBLOOD	GREEN	BLUE	SAND- STONE	GRAY- STONE
Front Seat . . . . .	1700673	1700674	1700675	1700676	1700678	1700679	1700677

**BUCKLE SIDE— BUCKET SEAT— STANDARD 2**

Front Seat . . . . .	1696451	1696452	1696453	1696454	1696456	1696457	1696455
----------------------	---------	---------	---------	---------	---------	---------	---------

*NOTE: For 1974-75 Vega and Camaro car sleeve are not service order belt asm.*

**14.880 TRIM ASSY., Front Seat Bench Cushion Cover**

**PASSENGER**

<b>70</b>	Impala (Spt. Cpe., Conv.) . . . . .	<b>8808512</b>	1	113.00	(comb. 806) (black) . . . . .
<b>70</b>	Kingswood, Impala (4-Dr.) . . . . .	<b>8808500</b>	1	80.25	(comb. 806) (black) . . . . .
<b>70</b>	Impala, Kingswood (4-Dr.) . . . . .	<b>8808501</b>	1	80.25	(comb. 821) (med. blue) . . . . .
<b>73-74</b>	Impala (Spt. Cpe.) . . . . .	<b>9628268</b>	1	109.00	(comb. 802) (black) . . . . .
<b>73-74</b>	Impala (Spt. Cpe.),				
<b>74</b>	Pass. (Conv.) . . . . .	<b>9732438</b>	1	105.00	(comb. 806) (black) . . . . .
<b>73-74</b>	Impala (Spt. Cpe.) . . . . .	<b>9732440</b>	1	105.00	(comb. 813) (blue) . . . . .
<b>73-74</b>	Impala (Spt. Cpe.) Pass. (Conv.) . . . . .	<b>9732439</b>	1	105.00	(comb. 818, 819) (neutral) . . . . .
<b>73-74</b>	Impala (Sedan) . . . . .	<b>9735756</b>	1	85.75	(comb. 802) (black) (repl. 9628263) . . . . .
<b>73-74</b>	Impala (4-Dr.) Caprice (Sta.				
	Wag.) . . . . .	<b>9735753</b>	1	85.00	(comb. 813) (midnight blue) . . . . .
<b>73</b>	Impala (4-Dr.) Caprice (Sta.				
	Wag.) . . . . .	<b>9628260</b>	1		(comb. 818, 819) (neutral) . . . . .
<b>73</b>	Caprice (Spt. Cpe.) . . . . .	<b>9628286</b>	1	126.00	(comb. 843) (midnight blue) . . . . .
<b>73</b>	Caprice (Spt. Cpe.) . . . . .	<b>9628282</b>	1	126.00	(comb. 836) (oxblood) . . . . .
<b>73</b>	Caprice (Sedan) . . . . .	<b>9628281</b>	1	96.50	(comb. 843) (midnight blue) . . . . .
<b>73</b>	Caprice (Sedan) . . . . .	<b>9628280</b>	1	96.50	(comb. 842) (green) . . . . .
<b>73</b>	Caprice (Sedan) . . . . .	<b>9628277</b>	1	96.50	(comb. 836) (oxblood) . . . . .

FOLDING TOP PARTS—INTERIOR TRIM

14.880 TRIM ASSY., Front Seat Bench Cushion Cover (Con't)

73	Impala (4-Dr.) Caprice (Sta. Wag.)	9628258	1		(comb. 806) (black)
74	Bel Air	9675881	1	81.00	(comb. 817) (neutral)
74	Bel Air	9675882	1	81.00	(comb. 851) (green)
74	Bel Air (Sedan)	9675883	1	81.00	(comb. 803) (black)
74	Bel Air (Sedan)	9675884	1	81.00	(comb. 815) (neutral)
74	Bel Air (Sedan)	9675885	1	81.00	(comb. 852) (green)
74	Impala (Sedan)	9675617	1	85.00	(comb. 805) (black)
74	Impala (Sedan)	9675618	1	85.00	(comb. 821) (neutral)
74	Impala (Sedan)	9675619	1	85.00	(comb. 847) (midn. blue)
74	Impala (Sedan)	9675620	1	85.00	(comb. 853) (green)
74	Impala (Sedan), Impala, Caprice (Sta. Wag.)	9735756	1	85.75	(comb. 802) (black and white)
74	Impala (Spt. Cpe.)	9732436	1	109.00	(comb. 802) (black and white)
74	Impala (Spt. Cpe.)	9732441	1	105.00	(comb. 849) (saddle)
74	Impala (Spt. Cpe.)	9729454	1	104.00	(comb. 858) (saddle and black)
74	Impala (Spt. Cpe.)	9675626	1	109.00	(comb. 805) (black)
74	Impala (Spt. Cpe.)	9675627	1	109.00	(comb. 851) (green)
74	Impala (Spt. Cpe.)	9675628	1	109.00	(comb. 847) (midn. blue)
74	Impala (Spt. Cpe.)	9675629	1	109.00	(comb. 853) (green)
74	Impala (Spt. Cpe.) Pass. (Conv.) (exc. Custom)	1666302	1	111.00	(comb. 804, 809, 810) (white)
74	Impala (Spt. Cpe.) Pass. (Conv.)	9675635	1	105.00	(comb. 855) (green)
74	Impala (Spt. Cpe.), Pass. (Conv.)	9732438	1	105.00	(comb. 806) (black)
74	Impala (Spt. Cpe.), Pass. (Conv.)	9732439	1	105.00	(comb. 819) (neutral)
74	Impala (Sedan), Impala, Caprice (Sta. Wag.)	9675615	1	82.25	(comb. 849) (saddle)
74	Impala (Sedan), Impala, Caprice (Sta. Wag.)	9735752	1	85.00	(comb. 806) (black)
74	Impala (Sedan), Impala, Caprice (Sta. Wag.)	9735754	1	85.00	(comb. 819) (neutral)
74	Impala, Caprice (Sta. Wag.)	1690378	1	85.75	(comb. 858) (saddle and black)
74	Impala, Caprice (Sta. Wag.)	1690379	1	85.75	(comb. 859) (black and green)
74	Impala (4-Dr.) Caprice (Sta. Wag.)	9675616	1	82.25	(comb. 855) (green)
74	Caprice (Sedan)	9684083	1	96.50	(comb. 840) (black)
74	Caprice (Sedan)	9684084	1	96.50	(comb. 843) (midn. blue)
74	Caprice (Sedan)	9684085	1	96.50	(comb. 850) (green)
74	Caprice (Sedan)	9684086	1	96.50	(comb. 857) (oxblood)
74	Caprice (Sedan)	9684087	1	96.50	(comb. 896) (taupe)
74	Caprice (Sedan)	9684088	1	96.50	(comb. 808) (black)
74	Caprice (Sedan)	9684089	1	81.00	(comb. 841) (neutral)
74	Caprice (Spt. Cpe.)	9684134	1	126.00	(comb. 850) (green)
74	Caprice (Spt. Cpe.)	9684135	1	126.00	(comb. 857) (oxblood)
74	Caprice (Spt. Cpe.)	9684136	1	126.00	(comb. 896) (taupe)
74	Caprice (Spt. Cpe.)	9684132	1	126.00	(comb. 840) (black)
74	Caprice (Spt. Cpe.)	9684133	1	126.00	(comb. 843) (midn. blue)
74	Caprice (Spt. Cpe.)	9684137	1	112.00	(comb. 808) (black)
74	Caprice (Spt. Cpe.)	9684138	1	112.00	(comb. 841) (neutral)
74	Caprice w/reclining seat	9684118	1	63.50	pass. (comb. 840) (black)
74	Caprice w/reclining seat	9684125	1	63.50	driver (comb. 840) (black)
74	Caprice w/reclining seat	9684119	1	63.50	pass. (comb. 843) (midn. blue)
74	Caprice w/reclining seat	9684126	1	63.50	driver (comb. 843) (midn. blue)
74	Caprice w/reclining seat	9684120	1	63.50	pass. (comb. 850) (green)
74	Caprice w/reclining seat	9684127	1	63.50	driver (comb. 850) (green)
74	Caprice w/reclining seat	9684121	1	63.50	pass. (comb. 857) (oxblood)
74	Caprice w/reclining seat	9684128	1	63.50	driver (comb. 857) (oxblood)
74	Caprice w/reclining seat	9684122	1	63.50	pass. (comb. 896) (taupe)
74	Caprice w/reclining seat	9684129	1	63.50	driver (comb. 896) (taupe)
74	Caprice w/reclining seat	9684123	1	56.75	pass. (comb. 808) (black)
74	Caprice w/reclining seat	9684130	1	56.75	driver (comb. 808) (black)
74	Caprice w/reclining seat	9684124	1	56.75	pass. (comb. 841) (neutral)
74	Caprice w/reclining seat	9684131	1	56.75	driver (comb. 841) (neutral)
75	Bel Air (Sedan)	1662679	1	103.00	(comb. 19C) (black)
75	Bel Air (Sedan)	1662680	1	103.00	(comb. 26C) (blue)
75	Bel Air (Sedan)	1662681	1	103.00	(comb. 55C) (sandstone)
75	Bel Air	1658531	1	106.00	(comb. 55V) (sandstone)
75	Bel Air (Sta. Wag.)	1658529	1	106.00	(comb. 26V) (blue)
75	Pass. (2-Dr.)	1665214	1	141.00	(comb. 63E) (saddle)
75	Impala (Sedan)	1665195	1	116.00	(comb. 19D) (black)
75	Impala (Sedan)	1665196	1	116.00	(comb. 26D) (blue)
75	Impala (Sedan)	1665197	1	116.00	(comb. 44D) (green)
75	Impala (Sedan)	1665198	1	116.00	(comb. 55D) (sandstone)

**FOLDING TOP PARTS—INTERIOR TRIM**

**14.880 TRIM ASSY., Front Seat Bench Cushion Cover (Con't)**

75	Impala (Spt. Cpe.)	1665210	1	135.00	(comb. 44W) (green)
75	Impala (Spt. Cpe.)	1665208	1	135.00	(comb. 19W) (black)
75	Impala (Spt. Cpe.)	1665209	1	135.00	(comb. 26W) (blue)
75	Impala (Spt. Cpe.)	1665201	1	147.00	(comb. 19D) (black)
75	Impala (Spt. Cpe.)	1665202	1	147.00	(comb. 26D) (blue)
75	Impala (Spt. Cpe.)	1665203	1	147.00	(comb. 44D) (green)
75	Impala (Spt. Cpe.)	1665204	1	147.00	(comb. 55D) (sandstone)
75	Impala (Spt. Cpe.) Pass. (Conv.)	1665211	1	135.00	(comb. 55W) (sandstone)
75	Impala (Spt. Cpe.) Pass. (Conv.)	1665212	1	135.00	(comb. 63W) (saddle)
75	Impala (Spt. Cpe.) Pass. (Conv.)	1665207	1	135.00	(comb. 02W, 07W, 11W) (white)
75	Impala (4-Dr.) Caprice (Sta. Wag.)	1665191	1	104.00	(comb. 44W) (green)
75	Impala (4-Dr.) Caprice (Sta. Wag.)	1665192	1	104.00	(comb. 55W) (sandstone)
75	Impala (4-Dr.) Caprice (Sta. Wag.)	1665193	1	104.00	(comb. 63W) (saddle)
75	Impala (4-Dr.) Caprice (Sta. Wag.)	1665190	1	104.00	(comb. 26W) (blue)
75	Impala (4-Dr.) Caprice (Sta. Wag.)	1665189	1	104.00	(comb. 19W) (black)
75	Impala (4-Dr.) Caprice (Sta. Wag.)	1665213	1	113.00	(comb. 63E) (saddle)
75	Caprice (Sedan)	1663810	1	119.00	(comb. 19B) (black)
75	Caprice (Sedan)	1663811	1	119.00	(comb. 26B) (blue)
75	Caprice (Sedan)	1663812	1	119.00	(comb. 44B) (green)
75	Caprice (Sedan)	1663813	1	119.00	(comb. 55B) (sandstone)
75	Caprice (Sedan)	1663814	1	119.00	(comb. 73B) (oxblood)
75	Caprice (Sedan)	1663821	1	119.00	(comb. 19H) (black)
75	Caprice (Sedan)	1663822	1	119.00	(comb. 55H) (sandstone)
75	Caprice (Spt. Cpe.)	1663823	1	137.00	(comb. 19H) (black)
75	Caprice (Spt. Cpe.)	1663824	1	137.00	(comb. 55H) (sandstone)
75	Caprice (Spt. Cpe.)	1663816	1	150.00	(comb. 19B) (black)
75	Caprice (Spt. Cpe.)	1663817	1	150.00	(comb. 26B) (blue)
75	Caprice (Spt. Cpe.)	1663818	1	150.00	(comb. 44B) (green)
75	Caprice (Spt. Cpe.)	1663819	1	150.00	(comb. 55B) (sandstone)
75	Caprice (Spt. Cpe.)	1663820	1	150.00	(comb. 73B) (oxblood)
75	Pass. w/reclining seat	1666260	1	75.50	pass. (comb. 63E) (saddle)
75	Pass. w/reclining seat	1666261	1	75.50	driver (comb. 63E) (saddle)
75	Pass. w/reclining seat	1666264	1	71.75	pass. (comb. 26W) (blue)
75	Pass. w/reclining seat	1666265	1	71.75	driver (comb. 26W) (blue)
75	Pass. w/reclining seat	1666266	1	71.75	pass. (comb. 44W) (green)
75	Pass. w/reclining seat	1666267	1	71.75	driver (comb. 44W) (green)
75	Pass. w/reclining seat	1666268	1	71.75	pass. (comb. 55W) (sandstone)
75	Pass. w/reclining seat	1666269	1	71.75	driver (comb. 55W) (sandstone)
75	Pass. w/reclining seat	1666270	1	71.75	pass. (comb. 63W) (saddle)
75	Pass. w/reclining seat	1666271	1	71.75	driver (comb. 63W) (saddle)
75	Impala w/reclining seat (exc. Sta. Wag.)	1666252	1	79.25	pass. (comb. 19D) (black)
75	Impala w/reclining seat (exc. Sta. Wag.)	1666253	1	79.25	driver (comb. 19D) (black)
75	Impala w/reclining seat (exc. Sta. Wag.)	1666254	1	79.25	pass. (comb. 26D) (blue)
75	Impala w/reclining seat (exc. Sta. Wag.)	1666255	1	79.25	driver (comb. 26D) (blue)
75	Impala w/reclining seat (exc. Sta. Wag.)	1666256	1	79.25	pass. (comb. 44D) (green)
75	Impala w/reclining seat (exc. Sta. Wag.)	1666257	1	79.25	driver (comb. 44D) (green)
75	Impala w/reclining seat (exc. Sta. Wag.)	1666258	1	79.25	pass. (comb. 55D) (sandstone)
75	Impala w/reclining seat (exc. Sta. Wag.)	1666259	1	79.25	driver (comb. 55D) (sandstone)
75	Caprice w/reclining seat	1663866	1	82.25	pass. (comb. 19B) (black)
75	Caprice w/reclining seat	1663867	1	82.25	driver (comb. 19B) (black)
75	Caprice w/reclining seat	1663868	1	82.25	pass. (comb. 26B) (blue)
75	Caprice w/reclining seat	1663869	1	82.25	driver (comb. 26B) (blue)
75	Caprice w/reclining seat	1663870	1	82.25	pass. (comb. 44B) (green)
75	Caprice w/reclining seat	1663871	1	82.25	driver (comb. 44B) (green)
75	Caprice w/reclining seat	1663872	1	82.25	pass. (comb. 55B) (sandstone)
75	Caprice w/reclining seat	1663873	1	82.25	driver (comb. 55B) (sandstone)
75	Caprice w/reclining seat	1663874	1	82.25	pass. (comb. 73B) (oxblood)
75	Caprice w/reclining seat	1663875	1	82.25	driver (comb. 73B) (oxblood)
75	Caprice w/reclining seat	1663878	1	73.25	pass. (comb. 19H) (black)
75	Caprice w/reclining seat	1663879	1	73.25	driver (comb. 19H) (black)
75	Caprice w/reclining seat	1663880	1	73.25	pass. (comb. 55H) (sandstone)

FOLDING TOP PARTS—INTERIOR TRIM

14.880 TRIM ASSY., Front Seat Bench Cushion Cover (Con't)

75	Caprice w/reclining seat	1663881	1	73.25	driver (comb. 55H) (sandstone)
<b>CHEVY—NOVA</b>					
70	Nova (2-Dr.)	8795750	1	58.75	(comb. 732) (black)
71	Nova (2-Dr.)	8795750	1	58.75	(comb. 753) (black)
73	Nova (Cpe.) (exc. Custom)	9645997	1	86.25	(comb. 756) (blue)
73	Nova (Cpe.) (exc. Custom)	9645998	1	86.25	(comb. 759) (green)
73	Nova (Cpe.) (exc. Custom)	9646002	1	90.50	(comb. 767) (chamois)
73	Nova (Custom Cpe.)	9646014	1	88.25	(comb. 752) (black & white)
73	Nova (Custom Cpe.)	9646015	1	88.25	(comb. 761) (green)
73	Nova (Custom Cpe.)	9646016	1	88.25	(comb. 764) (neutral)
74	Nova (Sedan) (exc. Custom)	9692624	1	65.00	(comb. 750) (black and white)
74	Nova (Sedan) (exc. Custom)	9692625	1	65.00	(comb. 756) (green and black)
74	Nova (Sedan) (exc. Custom)	9692626	1	65.00	(comb. 764) (neutral and black)
74	Nova (Sedan) (exc. Custom)	9728251	1	71.50	(comb. 753) (black)
74	Nova (Sedan) (exc. Custom)	9728252	1	71.50	(comb. 772) (mid. blue)
74	Nova (Sedan) (exc. Custom)	9728253	1	71.50	(comb. 758) (green)
74	Nova (Sedan) (exc. Custom)	9728254	1	71.50	(comb. 765) (neutral)
74	Nova (Sedan) (exc. Custom)	9731352	1	64.00	(comb. 769) (black)
74	Nova (Sedan) (exc. Custom)	9731353	1	64.00	(comb. 768) (neutral)
74	Nova (Sedan) (exc. Custom)	1658323	1	69.25	(comb. 825) (black)
74	Nova (Sedan) (exc. Custom)	1658324	1	69.25	(comb. 826) (mid. blue)
74	Nova (Sedan) (exc. Custom)	1658325	1	69.25	(comb. 828) (green)
74	Nova (Sedan) (exc. Custom)	1658326	1	69.25	(comb. 829) (neutral)
74	Nova (Coupe) (exc. Custom)	9692616	1	88.00	(comb. 750) (black and white)
74	Nova (Coupe) (exc. Custom)	9692617	1	88.00	(comb. 756) (green and black)
74	Nova (Coupe) (exc. Custom)	9692618	1	88.00	(comb. 764) (neutral and black)
74	Nova (Coupe) (exc. Custom)	9692619	1	91.75	(comb. 753) (black)
74	Nova (Coupe) (exc. Custom)	9692620	1	91.75	(comb. 758) (green)
74	Nova (Coupe) (exc. Custom)	9692621	1	91.75	(comb. 765) (neutral)
74	Nova (Coupe) (exc. Custom)	9692622	1	91.75	(comb. 772) (midn. blue)
74	Nova (Coupe) (exc. Custom)	1658318	1	91.75	(comb. 825) (black)
74	Nova (Coupe) (exc. Custom)	1658319	1	91.75	(comb. 828) (green)
74	Nova (Coupe) (exc. Custom)	1658320	1	91.75	(comb. 829) (neutral)
74	Nova (Coupe) (exc. Custom)	1658321	1	91.75	(comb. 826) (mid. blue)
74	Nova (H.B.) (exc. Custom)	9692623	1	91.75	(comb. 773) (saddle)
74	Nova (H.B.) (exc. Custom)	1658322	1	91.75	(comb. 827) (saddle)
74	Nova (Custom) (Sedan)	9692627	1	80.00	(comb. 766) (neutral)
74	Nova (Custom) (Sedan)	9692628	1	87.75	(comb. 751) (black)
74	Nova (Custom) (Sedan)	9692629	1	87.75	(comb. 757) (green)
74	Nova (Custom) (Sedan)	9733035	1	80.00	(comb. 754) (black)
74	Nova (Custom) (Coupe)	9692613	1	108.00	(comb. 752) (black and white)
74	Nova (Custom) (Coupe)	9692614	1	108.00	(comb. 755) (green and black)
74	Nova (Custom) (Coupe)	9692615	1	108.00	(comb. 771) (midn. blue)
74	Nova (Custom) (Coupe)	9692611	1	97.75	(comb. 766) (neutral)
74	Nova (Custom) (Coupe)	9692612	1	108.00	(comb. 751) (black)
74	Nova (Custom) (Coupe)	9733034	1	97.75	(comb. 754) (black)
75	Nova (Sedan) (exc. Custom)	1652861	1	82.50	(comb. 19C) (black)
75	Nova (Sedan) (exc. Custom)	1743954	1	77.25	(comb. 19Z) (black)
75	Nova (Sedan) (exc. Custom)	1652862	1	82.50	(comb. 26C) (blue)
75	Nova (Sedan) (exc. Custom)	1652863	1	82.50	(comb. 55C) (sandstone)
75	Nova (Sedan) (exc. Custom)	1652865	1	77.75	(comb. 19V) (black)
75	Nova (Sedan) (exc. Custom)	1652866	1		(comb. 26V) (blue)
75	Nova (Sedan) (exc. Custom)	1652867	1	77.75	(comb. 55V) (sandstone)
75	Nova (Sedan) (exc. Custom)	1652868	1	77.75	(comb. 63V) (saddle)
75	Nova (Coupe) (exc. Custom)	1652852	1	113.00	(comb. 19C) (black)
75	Nova (Coupe) (exc. Custom)	1652853	1	113.00	(comb. 26C) (blue)
75	Nova (Coupe) (exc. Custom)	1652854	1	113.00	(comb. 55C) (sandstone)
75	Nova (Coupe) (exc. Custom)	1652856	1	107.00	(comb. 19V) (black)
75	Nova (Coupe) (exc. Custom)	1652857	1	107.00	(comb. 26V) (blue)
75	Nova (Coupe) (exc. Custom)	1652858	1	107.00	(comb. 55V) (sandstone)
75	Nova (Coupe) (exc. Custom)	1652859	1	107.00	(comb. 63V) (saddle)
75	Nova (Custom) (Sedan)	1657474	1	103.00	(comb. 19W) (black)
75	Nova (Custom) (Sedan)	1657475	1	103.00	(comb. 55W) (sandstone)
75	Nova (Custom) (Sedan)	1657465	1	112.00	(comb. 26D) (blue)
75	Nova (Custom) (Sedan)	1657466	1	112.00	(comb. 44D) (green)
75	Nova (Custom) (Sedan)	1657467	1	112.00	(comb. 55D) (sandstone)
75	Nova (Custom) (Coupe)	1657459	1	143.00	(comb. 19E) (black)
75	Nova (Custom) (Coupe)	1657460	1	143.00	(comb. 26D) (blue)
75	Nova (Custom) (Coupe)	1657461	1	143.00	(comb. 44D) (green)
75	Nova (Custom) (Coupe)	1657462	1	143.00	(comb. 55D) (sandstone)
75	Nova (Custom) (Coupe)	1657463	1	143.00	(comb. 63E) (saddle)
75	Nova (Custom) (Coupe)	1657469	1	131.00	(comb. 19W) (black)
75	Nova (Custom) (Coupe)	1657470	1	131.00	(comb. 55W) (sandstone)

**FOLDING TOP PARTS—INTERIOR TRIM**

**14.880 TRIM ASSY., Front Seat Bench Cushion Cover (Con't)**

75	Nova (Custom) (Coupe) . . . . .	1657471	1	131.00	(comb. 63W) (saddle) . . . . .
75	Nova (Custom) (Coupe) . . . . .	1657472	1	131.00	(comb. 73W) (oxblood) . . . . .
75	Nova (Custom) (Coupe) . . . . .	1693352	1	131.00	(comb. 02W, 04W, 07W, 11W) (white) . . . . .

**CHEVELLE**

39	El Camino (Custom),				
39	Malibu (Spt. Cpe., Conv.) . . . . .	8718105	1	71.75	(comb. 755) (black) . . . . .
70	Malibu (Spt. Cpe., Conv.),				
70	El Camino . . . . .	8795976	1	74.25	(comb. 770) (med. saddle) . . . . .
72	Malibu (Spt. Cpe., Conv.),				
72	Malibu (Spt. Cpe., Conv.),				
72	Malibu (Spt. Cpe., Conv.) . . . . .	9839333	2	53.25	(comb. 704, 706) (black) . . . . .
73	Deluxe (Cpe.) (El Camino) (exc. Custom) . . . . .	9626454	1	93.75	(comb. 733) (neutral) . . . . .
73	Malibu (Cpe.) El Camino (Custom) . . . . .	9626468	1	82.50	(comb. 705) (blue) . . . . .
73	Malibu (Cpe.) El Camino (Custom) . . . . .	9626467	1	82.50	(comb. 704) (black) . . . . .
73	Malibu (Cpe.) El Camino (Custom) . . . . .	9626472	1	82.50	(comb. 732) (neutral) . . . . .
73	Malibu (Sed.) . . . . .	9626456	1	68.25	(comb. 724) (blue) . . . . .
73	Malibu, Laguna (Cpe.),				
74	Laguna (2-Dr.) . . . . .	9627033	1	101.00	(comb. 707, 708) (black) . . . . .
73	Malibu, Laguna (Cpe.),				
74	Laguna (2-Dr.) . . . . .	9627038	1	101.00	(comb. 715, 734) (neutral) . . . . .
73	Malibu, Laguna (4-Dr.),				
74	Laguna (Sed.) . . . . .	9627026	1	80.50	(comb. 707, 708) (black) . . . . .
73	Malibu, Laguna (4-Dr.),				
74	Laguna (Sed.) . . . . .	9627028	1	80.50	(comb. 715, 734) (neutral) . . . . .
73	Monte Carlo . . . . .	9627039	1	114.00	(comb. 706) (black) . . . . .
73	Monte Carlo . . . . .	9627041	1	114.00	(comb. 725) (midnight blue) . . . . .
73	Monte Carlo . . . . .	9627042	1	114.00	(comb. 731) (neutral) . . . . .
73	Monte Carlo . . . . .	9627043	1	114.00	(comb. 740) (oxblood) . . . . .
73-74	Monte Carlo . . . . .	9732183	1	114.00	(comb. 708, 709) (black) . . . . .
74	Malibu (Sedan) (exc. Classic) . . . . .	9680603	1	75.25	(comb. 701) (black) . . . . .
74	Malibu (Sedan) (exc. Classic) . . . . .	9680604	1	75.25	(comb. 723) (green) . . . . .
74	Malibu (Sedan) (exc. Classic) . . . . .	9680614	1	73.75	(comb. 727, 738) (green) . . . . .
74	Malibu (Sedan) (exc. Classic) . . . . .	1658458	1	73.75	(comb. 893, 894) (green) . . . . .
74	Malibu (Sedan) El Camino (exc. Classic) . . . . .	9729946	1	96.50	(comb. 749) (mid. blue) . . . . .
74	Malibu (4-Dr.) (exc. Classic) . . . . .	9680612	1	73.75	(comb. 706) (black) . . . . .
74	Malibu (4-Dr.) (exc. Classic) . . . . .	9680613	1	73.75	(comb. 713, 745) (neutral) . . . . .
74	Malibu (4-Dr.) (exc. Classic) . . . . .	1658456	1	73.75	(comb. 891) (black) . . . . .
74	Malibu (4-Dr.) (exc. Classic) . . . . .	1658457	1	73.75	(comb. 830, 892) (neutral) . . . . .
74	Malibu (Coupe) (exc. Classic),				
74	El Camino (exc. Classic) . . . . .	9680751	1	95.75	(comb. 701) (black) . . . . .
74	Malibu (Coupe) (exc. Classic),				
74	El Camino (exc. Classic) . . . . .	9680752	1	95.75	(comb. 723) (green) . . . . .
74	Malibu (Coupe) (exc. Classic),				
74	El Camino (exc. Classic) . . . . .	9680763	1	96.50	(comb. 706) (black) . . . . .
74	Malibu (Coupe) (exc. Classic),				
74	El Camino (exc. Classic) . . . . .	9680764	1	96.50	(comb. 713, 745) (neutral) . . . . .
74	Malibu (Coupe) (exc. Classic),				
74	El Camino (exc. Classic) . . . . .	9680765	1	96.50	(comb. 727, 738) (green) . . . . .
74	Malibu (Coupe) (exc. Classic),				
74	El Camino (exc. Classic) . . . . .	1658460	1	96.50	(comb. 891) (black) . . . . .
74	Malibu (Coupe) (exc. Classic),				
74	El Camino (exc. Classic) . . . . .	1658461	1	96.50	(comb. 830, 892) (neutral) . . . . .
74	Malibu (Coupe) (exc. Classic),				
74	El Camino (exc. Classic) . . . . .	1658462	1	96.50	(comb. 893, 894) (green) . . . . .
74	Malibu (Coupe) (exc. Classic),				
74	El Camino (exc. Classic) . . . . .	1658463	1	96.50	(comb. 897) (mid. blue) . . . . .
74	Malibu (Classic) (Sedan, Coupe) . . . . .	9729750	1	126.00	(comb. 743) (oxblood) . . . . .
74	Malibu (Classic) (Sedan Coupe),				
74	El Camino (Classic) . . . . .	9680040	1	126.00	(comb. 722) (neutral) . . . . .
74	Malibu (Classic) (Sedan Coupe),				
74	El Camino (Classic) . . . . .	9680039	1	126.00	(comb. 724) (green) . . . . .
74	Malibu (Classic) (Sedan Coupe),				
74	El Camino (Classic) . . . . .	9680037	1	126.00	(comb. 702) (black) . . . . .
74	Malibu (Classic) (Sedan Coupe),				
74	El Camino (Classic) . . . . .	9680038	1	126.00	(comb. 732) (midn. blue) . . . . .
74	Malibu (Classic) El Camino (Classic) . . . . .	9729752	1	108.00	(comb. 707) (black) . . . . .
74	Malibu (Classic) El Camino (Classic) . . . . .	9729753	1	108.00	(comb. 714) (neutral) . . . . .

**FOLDING TOP PARTS—INTERIOR TRIM**

**14.880 TRIM ASSY., Front Seat Bench Cushion Cover (Con't)**

74	Malibu (Classic) El Camino (Classic) .....	9729754	1	108.00	(comb. 740) (saddle) .....
74	Malibu (Classic) El Camino (Classic) .....	9729755	1	108.00	(comb. 728) (green) .....
74	Malibu (Classic) (Coupe) El Camino (Classic) .....	9729794	1	108.00	(comb. 747, 785) (white) .....
74	Malibu (Classic) (Sta. Wag.) .....	9729756	1	108.00	(comb. 735) (mid. blue) .....
74	Laguna .....	1680108	1	116.00	(comb. 703) (black) .....
74	Laguna .....	1680109	1	116.00	(comb. 704) (black and white) .....
74	Laguna .....	1680110	1	116.00	(comb. 720) (oxblood) .....
74	Laguna .....	1680111	1	116.00	(comb. 731) (saddle) .....
74	Laguna .....	1680113	1	97.75	(comb. 708) (black) .....
74	Laguna .....	1680114	1	97.75	(comb. 718) (saddle) .....
74	Laguna .....	1680115	1	97.75	(comb. 719) (oxblood) .....
74	Monte Carlo .....	9679962	1	114.00	(comb. 730) (green) .....
74	Monte Carlo .....	9679963	1	114.00	(comb. 737) (midn. blue) .....
74	Monte Carlo .....	9679964	1	113.00	(comb. 716) (neutral) .....
74	Monte Carlo .....	9679584	1	113.00	(comb. 705) (black) .....
74	Monte Carlo .....	9679585	1	113.00	(comb. 726) (green) .....
74	Monte Carlo .....	9679586	1	113.00	(comb. 734) (midn. blue) .....
74	Monte Carlo .....	9679587	1	113.00	(comb. 744) (oxblood) .....
74	Monte Carlo .....	9732183	1	114.00	(comb. 709) (black) .....
75	Malibu (Sedan) (1st design) (exc. Classic) .....	1666066	1	103.00	(comb. 26V) (blue) (horizontal pattern) .....
75	Malibu (Sedan) (1st design) (exc. Classic) .....	1666067	1	103.00	(comb. 44V) (green) (horizontal pattern) .....
75	Malibu (Sedan) (exc. Classic) .....	1666070	1	105.00	(comb. 19C) (black) .....
75	Malibu (Sedan) (exc. Classic) .....	1666071	1	105.00	(comb. 26C) (blue) .....
75	Malibu (Sedan, Sta. Wag.) (1st design) (exc. Classic) .....	1666065	1	103.00	(comb. 19V) (black) (horizontal pattern) .....
75	Malibu (Sedan, Sta. Wag.) (1st design) (exc. Classic) .....	1666068	1	103.00	(comb. 55V) (sandstone) (horizontal pattern) .....
75	Malibu (Coupe) (exc. Classic), El Camino (exc. Classic) .....	1666078	1	124.00	(comb. 19C) (black) .....
75	Malibu (Coupe) (exc. Classic), El Camino (exc. Classic) .....	1666079	1	124.00	(comb. 26C) (blue) .....
75	Malibu (Coupe) (1st design) (exc. Classic), El Camino (1st design) (exc. Classic) .....	1666081	1	121.00	(comb. 19V) (black) (horizontal pattern) .....
75	Malibu (Coupe) (1st design) (exc. Classic), El Camino (1st design) (exc. Classic) .....	1666082	1	121.00	(comb. 26V) (blue) (horizontal pattern) .....
75	Malibu (Coupe) (1st design) (exc. Classic), El Camino (1st design) (exc. Classic) .....	1666083	1	121.00	(comb. 44V) (green) (horizontal pattern) .....
75	Malibu (Coupe) (1st design) (exc. Classic), El Camino (1st design) (exc. Classic) .....	1666084	1	121.00	(comb. 55V) (sandstone) (horizontal pattern) .....
75	Malibu (Sedan, Sta. Wag.) (2nd design) (exc. Classic) .....	1708630	1	99.25	(comb. 19V) (black) (vertical pattern) .....
75	Malibu (Sedan) (2nd design) (exc. Classic) .....	1708631	1	99.25	(comb. 26V) (blue) (vertical pattern) .....
75	Malibu (Sedan) (2nd design) (exc. Classic) .....	1708632	1	99.25	(comb. 44V) (green) (vertical pattern) .....
75	Malibu (Sedan, Sta. Wag.) (2nd design) .....	1708633	1	99.25	(comb. 55V) (sandstone) (vertical pattern) .....
75	Malibu (Coupe) El Camino (2nd design) (exc. Classic) .....	1708634	1	123.00	(comb. 19V) (black) (vertical pattern) .....
75	Malibu (Coupe) El Camino (2nd design) (exc. Classic) .....	1708635	1	123.00	(comb. 26V) (blue)(vertical pattern) .....
75	Malibu (Coupe) El Camino (2nd design) (exc. Classic) .....	1708636	1	123.00	(comb. 44V) (green)(vertical pattern) .....
75	Malibu (Coupe) El Camino (2nd design) (exc. Classic) .....	1708637	1	123.00	(comb. 55V) (sandstone) (vertical pattern) .....
75	Monte Carlo .....	1666104	1	133.00	(comb. 26H) (blue) .....
75	Monte Carlo .....	1666105	1	133.00	(comb. 55H) (sandstone) .....
75	Monte Carlo .....	1666103	1	133.00	(comb. 19H) (black) .....
75	Monte Carlo .....	1666106	1	115.00	(comb. 02H, 04H, 07H, 11H) (white) .....
75	Monte Carlo .....	1666108	1	146.00	(comb. 19B) (black) .....
75	Monte Carlo .....	1666109	1	146.00	(comb. 26B) (blue) .....
75	Monte Carlo .....	1666110	1	146.00	(comb. 55B) (sandstone) .....

**FOLDING TOP PARTS—INTERIOR TRIM**

**14.880 TRIM ASSY., Front Seat Bench Cushion Cover (Con't)**

75	Monte Carlo	1666111	1	146.00	(comb. 73B) (oxblood)
75	Monte Carlo w/reclining seat	1667174	1	94.75	pass. (comb. 19N) (black)
75	Monte Carlo w/reclining seat	1667169	1	94.75	driver (comb. 19N) (black)
75	Monte Carlo w/reclining seat	1667175	1	94.75	pass. (comb. 26N) (blue)
75	Monte Carlo w/reclining seat	1667170	1	94.75	driver (comb. 26N) (blue)
75	Monte Carlo w/reclining seat	1667176	1	94.75	pass. (comb. 44N) (green)
75	Monte Carlo w/reclining seat	1667171	1	94.75	driver (comb. 44N) (green)
75	Monte Carlo w/reclining seat	1667177	1	94.75	pass. (comb. 55N) (sandstone)
75	Monte Carlo w/reclining seat	1667172	1	94.75	driver (comb. 55N) (sandstone)
75	Monte Carlo w/reclining seat	1667178	1	94.75	pass. (comb. 73N) (oxblood)
75	Monte Carlo w/reclining seat	1667173	1	94.75	driver (comb. 73N) (oxblood)
75	Malibu (Classic) w/Notchback seat	1666098	1	137.00	(comb. 19W) (black)
75	Malibu (Classic) w/Notchback seat	1666099	1	137.00	(comb. 26W) (blue)
75	Malibu (Classic) w/Notchback seat	1666100	1	137.00	(comb. 55W) (sandstone)
75	Malibu (Classic) w/Notchback seat	1666101	1	137.00	(comb. 63W) (saddle)
75	Malibu (Classic), El Camino (Classic) w/Notchback seat	1666095	1	149.00	(comb. 44D) (green)
75	Malibu (Classic) (Sedan, Coupe), El Camino (Classic) w/Notchback seat	1666096	1	149.00	(comb. 73D) (oxblood)
75	Malibu (Classic) (Sedan, Coupe), El Camino (Classic) w/Notchback seat	1666092	1	149.00	(comb. 19D) (black)
75	Malibu (Classic) (Sedan, Coupe), El Camino (Classic) w/Notchback seat	1666093	1	149.00	(comb. 16D) (graystone)
75	Malibu (Classic) (Sedan, Coupe), El Camino (Classic) w/Notchback seat	1666094	1	149.00	(comb. 26D) (blue)
75	Monte Carlo	1666106	1	115.00	(comb. 02H, 04H, 07H, 11H) (white)
75	Laguna	1703302	1	140.00	(comb. 07E, 11E) (black)
75	Laguna	1703303	1	140.00	(comb. 19E) (black)
75	Laguna	1703304	1	140.00	(comb. 63E) (saddle)
75	Laguna	1703305	1	134.00	(comb. 73E) (oxblood)
75	Laguna	1703307	1	130.00	(comb. 07Z, 11Z) (white)
75	Laguna	1703308	1	130.00	(comb. 19Z) (black)
75	Laguna	1703309	1	130.00	(comb. 63Z) (saddle)
75	Laguna	1703310	1	130.00	(comb. 73Z) (oxblood)

NOTE 1 Production Deviation Trim Change.

**14.880A TRIM ASSY., Bucket Seats Cushion**

**PASS**

73	Caprice (Sed., Spt. Cpe.)	9665384	1	63.50	pass. seat (comb. 836) (oxblood)
----	---------------------------	---------	---	-------	----------------------------------

**CHEVELLE**

70	Malibu (Spt. Cpe., Conv.)	8795990	2	55.00	pass. and driver (comb. 791) (ivory)
71	Malibu (Spt. Cpe., Conv.)				
71-72	El Camino (Custom)	9839333	2	53.25	pass. and driver (comb. 706) (black)

NOTE: For Chevelle Trim Assy. 1973-1975 See Group 14.800A which are one piece-cushion and back.

**NOVA**

73-74	Nova (Custom Cpe.)	9646021	2	56.75	pass. and driver (comb. 766, 771) (neutral)
73-74	Nova (Custom Cpe.)	9646018	2	60.25	pass. and driver (comb. 752) (black)
73-74	Nova (Custom Cpe.)	9646020	2	56.75	pass. and driver (comb. 754) (black)
74	Nova (Coupe) (exc. Custom)	9693264	2	35.25	pass. and driver (comb. 753) (black)
74	Nova (Coupe) (exc. Custom)	9693265	2	35.25	pass. and driver (comb. 758) (green)
74	Nova (Coupe) (exc. Custom)	9693266	2	35.25	pass. and driver (comb. 765) (neutral)
74	Nova (Coupe) (exc. Custom)	9693267	2	35.25	pass. and driver (comb. 773) (saddle)
74	Nova (Coupe) (exc. Custom)	1658327	2	34.50	pass. and driver (comb. 825) (black)
74	Nova (Coupe) (exc. Custom)	1658328	2	34.50	pass. and driver (comb. 828) (green)
74	Nova (Coupe) (exc. Custom)	1658329	2	34.50	pass. and driver (comb. 829) (neutral)
74	Nova (H.B.) (exc. Custom)	1658330	2	34.50	pass. and driver (comb. 827) (saddle)
74	Nova (Custom) (Coupe)	9693268	2	56.75	pass. and driver (comb. 759) (green)
74	Nova (Custom) (H.B.)	9694201	2		pass. and driver (comb. 774) (white)
75	Nova (Coupe) (exc. Custom)	1654640	2	36.50	pass. and driver (comb. 19V) (black)
75	Nova (Coupe) (exc. Custom)	1654641	2	36.50	pass. and driver (comb. 55V) (sandstone)
75	Nova (Coupe) (exc. Custom)	1654642	2	36.50	pass. and driver (comb. 63V) (saddle)
75	Nova (Custom) (Coupe)	1657513	2	78.25	pass. and driver (comb. 19E) (black)



**FOLDING TOP PARTS—INTERIOR TRIM**

**14.880A TRIM ASSY., Bucket Seats Cushion (Con't)**

75	Nova (Custom) (Coupe) . . . . .	1657515	2	70.25	pass. and driver (comb. 19W) (black) . . . . .
75	Nova (Custom) (Coupe) . . . . .	1657516	2	70.25	pass. and driver (comb. 55W) (sandstone) . . . . .
75	Nova (Custom) (Coupe) . . . . .	1657517	2	70.25	pass. and driver (comb. 63W) (saddle) . . . . .
75	Nova (Custom) (Coupe) . . . . .	1693358	2	70.25	pass. and driver (comb. 02W, 04W, 07W, 11W) (white) . . . . .
75	Nova (Custom) w/European seat . . . . .	1659087	2	86.75	pass. and driver (comb. 16G) (graystone) . . . . .
75	Nova (Custom) w/European seat . . . . .	1659088	2	86.75	pass. and driver (comb. 26G) (blue) . . . . .
75	Nova (Custom) w/European seat . . . . .	1659089	2	86.75	pass. and driver (comb. 55G) (sandstone) . . . . .
75	Nova (Custom) w/European seat . . . . .	1659090	2	86.75	pass. and driver (comb. 73G) (oxblood) . . . . .

**CAMARO**

70	Camaro . . . . .	9818854	2	38.25	pass. and driver (comb. 711) (black) . . . . .
70	Camaro . . . . .	9818858	2	38.25	pass. and driver (comb. 726) (saddle) . . . . .
71-72	Camaro . . . . .	9893927	2	54.50	pass. and driver (comb. 775) (black) . . . . .
73	Camaro . . . . .	9661878	2	59.50	pass. and driver (comb. 785) (black & white) . . . . .
73	Camaro (exc. L.T.) . . . . .	9663026	2	49.00	pass. and driver (comb. 775) (black) . . . . .
73-74	Camaro (exc. L.T.) . . . . .	9645956	2	57.00	pass. and driver (comb. 776, 775) (black & white) . . . . .
73	Camaro (L.T.) . . . . .	9663027	2	55.00	pass. and driver (comb. 773) (black) . . . . .
74	Camaro (exc. L.T.) . . . . .	9686581	2	52.75	pass. and driver (comb. 796) (saddle and black) . . . . .
74	Camaro (exc. L.T.) . . . . .	9686582	2	52.75	pass. and driver (comb. 786) (green and black) . . . . .
74-75	Camaro (exc. L.T.) . . . . .	9686508	2	59.50	pass. and driver (comb. 777, 19V) (black) . . . . .
74	Camaro (exc. L.T.) . . . . .	9686509	2	59.50	pass. and driver (comb. 779) (black) . . . . .
74	Camaro (exc. L.T.) . . . . .	9686510	2	49.00	pass. and driver (comb. 781) (neutral) . . . . .
74	Camaro (exc. L.T.) . . . . .	9686511	2	49.00	pass. and driver (comb. 798) (saddle) . . . . .
74	Camaro (exc. L.T.) . . . . .	9686512	2	49.00	pass. and driver (comb. 787) (green) . . . . .
74	Camaro (exc. L.T.) . . . . .	9686513	2	49.00	pass. and driver (comb. 792) (red) . . . . .
74	Camaro (L.T.) . . . . .	9687264	2	57.00	pass. and driver (comb. 776) (black) . . . . .
74	Camaro (L.T.) . . . . .	9687265	2	57.00	pass. and driver (comb. 780) (neutral) . . . . .
74	Camaro (L.T.) . . . . .	9687266	2	57.00	pass. and driver (comb. 797) (saddle) . . . . .
74	Camaro (L.T.) . . . . .	9687267	2	57.00	pass. and driver (comb. 783) (taupe) . . . . .
74	Camaro (L.T.) (1st design) . . . . .	9686570	2	54.50	pass. and driver (comb. 778) (black) (Note 1) . . . . .
74	Camaro (L.T.) (1st design) . . . . .	9686571	2	54.50	pass. and driver (comb. 799) (saddle) (Note 1) . . . . .
74	Camaro (L.T.) (1st design) . . . . .	9686572	2	54.50	pass. and driver (comb. 784) (taupe) (Note 1) . . . . .
74	Camaro (L.T.) (2nd design) . . . . .	1654185	2	55.00	pass. and driver (comb. 778) (black) (Note 1) . . . . .
74	Camaro (L.T.) (2nd design) . . . . .	1654186	2	55.00	pass. and driver (comb. 799) (saddle) (Note 1) . . . . .
74	Camaro (L.T.) (2nd design) . . . . .	1654187	2	55.00	pass. and driver (comb. 784) (taupe) (Note 1) . . . . .
75	Camaro (exc. L.T.) . . . . .	1707456	2	62.50	pass. and driver (comb. 19C) (black) (repl. 1663505) . . . . .
75	Camaro (exc. L.T.) . . . . .	1663506	2	54.25	pass. and driver (comb. 55C) (sandstone) . . . . .
75	Camaro (exc. L.T.) . . . . .	1663507	2	56.75	pass. and driver (comb. 55V) (sandstone) . . . . .
75	Camaro (exc. L.T.) . . . . .	1663508	2	56.75	pass. and driver (comb. 63V) (saddle) . . . . .
75	Camaro (exc. L.T.) . . . . .	1663509	2	59.50	pass. and driver (comb. 91V) (white) . . . . .
75	Camaro (L.T.) . . . . .	1663522	2	63.25	pass. and driver (comb. 55W) (sandstone) . . . . .
75	Camaro (L.T.) . . . . .	1663523	2	63.25	pass. and driver (comb. 63W) (saddle) . . . . .
75	Camaro (L.T.) . . . . .	1663517	2	65.50	pass. and driver (comb. 16D) (graystone) . . . . .
75	Camaro (L.T.) . . . . .	1663518	2	65.50	pass. and driver (comb. 55D) (sandstone) . . . . .
75	Camaro (L.T.) . . . . .	1663519	2	65.50	pass. and driver (comb. 63D) (saddle) . . . . .
75	Camaro (L.T.) . . . . .	1663520	2	65.50	pass. and driver (comb. 73D) (oxblood) . . . . .
75	Camaro w/Custom Seat . . . . .	1698556	1	147.00	pass. and driver (comb. 732) (oxblood) . . . . .
75	Camaro . . . . .	1698555	1	147.00	pass. and driver (comb. 632) (saddle) . . . . .

*NOTE 1: First design vertical stitch line pattern dimension width is 7/16 inches, second design 5/16 inches.*

**VEGA—MONZA**

71	Vega (exc. Panel) . . . . .	9893665	2	30.50	driver and pass. (comb. 873) (black) . . . . .
71	Vega (exc. Panel) . . . . .				
72	Vega (Hatchback Cpe., Sta. Wag.) . . . . .	9893670	2	50.75	driver and pass. (comb. 861, 874) (black) . . . . .
72	Vega (exc. Panel) . . . . .	9893355	2	36.00	driver and pass. (comb. 866) (tan) . . . . .
72	Vega (exc. Panel) . . . . .	9893354	2	36.00	driver and pass. (comb. 863) (green) . . . . .
73	Vega (exc. Panel) . . . . .	9645967	2	31.75	driver and pass. (comb. 860) (black) . . . . .
73	Vega (exc. Panel) . . . . .	9645968	2	31.75	driver and pass. (comb. 863) (green) . . . . .
73	Vega (Hatchback Cpe.) . . . . .	9645969	2	31.75	driver and pass. (comb. 858) (oxblood) . . . . .
73	Vega (Sta. Wag.) . . . . .	9645970	2	31.75	driver and pass. (comb. 866) (saddle) . . . . .
73	Vega (exc. Panel) . . . . .	9645971	2	31.75	driver and pass. (comb. 868) (neutral) . . . . .
73	Vega (Hatchback Cpe.) . . . . .	9645972	2	31.75	driver and pass. (comb. 859) (chamois) . . . . .

**FOLDING TOP PARTS—INTERIOR TRIM**

**14.880A TRIM ASSY., Bucket Seats Cushion (Con't)**

73-75	Vega (exc. Panel)	9645951	2	65.75	driver and pass. (comb. 861, 884, 19Y) (black)
73	Vega (exc. Panel)	9645952	2	65.75	driver and pass. (comb. 874, 888) (neutral)
73	Vega (exc. Panel)	9661878	2	59.50	driver and pass. (comb. 871, 887) (black and white)
73-75	Vega (Panel)	6258182	2	31.00	pass. and driver (pearl)
74	Vega (exc. Panel)	9686544	2	31.75	driver and pass. (comb. 862) (black)
74	Vega (exc. Panel)	9686545	2	31.75	driver and pass. (comb. 870, 881) (neutral)
74	Vega (exc. Panel)	9733029	2	58.00	driver and pass. (comb. 863) (neutral)
74	Vega (exc. Panel)	9686546	2	31.75	driver and pass. (comb. 879) (green)
74	Vega (exc. Panel)	9686548	2	31.75	driver and pass. (comb. 888) (saddle)
74	Vega (exc. Panel)	9686506	2	58.00	driver and pass. (comb. 880) (green)
74	Vega (exc. Panel)	9686583	2	59.50	driver and pass. (comb. 871) (black and white)
74	Vega (exc. Panel)	9686584	2	59.50	driver and pass. (comb. 887) (green and black)
74	Vega (exc. Panel) (1st design)	9686593	2	31.75	driver and pass. (comb. 873) (black and white) (square pattern)
74	Vega (exc. Panel) (1st design)	9686594	2	31.75	driver and pass. (comb. 883) (green and black) (square pattern)
74	Vega (exc. Panel) (2nd design)	1694279	1	30.50	pass. (comb. 873, 883) (black) (stripe pattern)
74	Vega (exc. Panel) (2nd design)	1694280	1	30.50	driver (comb. 873, 883) (black) (stripe pattern)
74	Vega (Hatchback Cpe.)	1674343	2	55.00	pass. and driver (comb. 867) (white)
74	Vega (Hatchback Cpe., Sta. Wag.)	9686547	2	31.75	driver and pass. (comb. 884) (red)
74	Vega (Hatchback Cpe., Sta. Wag.)	9686505	2	58.00	driver and pass. (comb. 869) (black)
74	Vega (Hatchback Cpe., Sta. Wag.)	9686507	2	58.00	driver and pass. (comb. 890) (saddle)
75	Vega (exc. Panel)	1661567	2	35.00	pass. and driver (comb. 19D) (black)
75	Vega (exc. Panel)	1661568	2	49.00	pass. and driver (comb. 55D) (sandstone)
74-75	Vega (exc. Panel)	1661569	2	32.50	pass. and driver (comb. 862, 19W) (black) (Note 1)
75	Vega (exc. Panel) (1st design)	1661570	2	32.50	pass. and driver (comb. 26W) (blue) (Note 1)
75	Vega (exc. Panel) (1st design)	1661571	2	32.50	pass. and driver (comb. 55W) (sandstone) (Note 1)
75	Vega (exc. Panel) (1st design)	1661572	2	32.50	pass. and driver (comb. 63W) (saddle) (Note 1)
75	Vega (exc. Panel) (2nd design)	1708205	2	33.00	pass. and driver (comb. 19W) (black) (Note 1)
75	Vega (exc. Panel) (2nd design)	1708206	2	33.00	pass. and driver (comb. 26W) (blue) (Note 1)
75	Vega (exc. Panel) (2nd design)	1708207	2	33.00	pass. and driver (comb. 55W) (sandstone) (Note 1)
75	Vega (exc. Panel) (2nd design)	1708208	2	33.00	pass. and driver (comb. 63W) (saddle) (Note 1)
75	Vega (Hatchback Cpe., Sta. Wag.)	1694439	2	35.75	pass. and driver (comb. 02Y, 11Y) (white)
75	Vega (exc. Panel)	1697529	2	67.25	pass. and driver (comb. 73Y) (oxblood)
75	Vega (exc. Panel)	1661537	2	65.75	pass. and driver (comb. 55Y) (sandstone)
75	Vega (exc. Panel)	1661538	2	65.75	pass. and driver (comb. 63Y) (saddle)
75	Vega (exc. Panel)	1661533	2	65.25	pass. and driver (comb. 19E) (black)
75	Vega (exc. Panel)	1661534	2	65.25	pass. and driver (comb. 55E) (sandstone)
75	Vega (Hatchback Cpe., Sta. Wag.)	1694540	2	82.25	pass. and driver (comb. 26B) (blue)
75	Vega (Hatchback Cpe., Sta. Wag.)	1694541	2	82.25	pass. and driver (comb. 55B) (sandstone)
75	Vega (Hatchback Cpe., Sta. Wag.)	1694542	2	82.25	pass. and driver (comb. 73B) (oxblood)
75	Monza (exc. Towne Cpe.)	1661552	2	73.25	pass. and driver (comb. 16G) (graystone)
75	Vega (Panel)	358834	2	35.75	pass. and driver (gray)
75	Vega (Panel)	358835	2	35.75	pass. and driver (blue)
75	Vega (Panel)	358836	2	35.75	pass. and driver (saddle)
75	Monza (exc. Towne Cpe.)	1661553	2	73.25	pass. and driver (comb. 26G) (blue)
75	Monza (exc. Towne Cpe.)	1661554	2	73.25	pass. and driver (comb. 55G) (sandstone)
75	Monza (exc. Towne Cpe.)	1661555	2	73.25	pass. and driver (comb. 63G) (saddle)
75	Monza (exc. Towne Cpe.)	1661556	2	73.25	pass. and driver (comb. 73G) (oxblood)
75	Monza (exc. Towne Cpe.)	1661558	2	69.25	pass. and driver (comb. 16Z) (graystone)
75	Monza (exc. Towne Cpe.)	1661559	2	69.25	pass. and driver (comb. 26Z) (blue)
75	Monza (exc. Towne Cpe.)	1661560	2	69.25	pass. and driver (comb. 55Z) (sandstone)
75	Monza (exc. Towne Cpe.)	1661561	2	69.25	pass. and driver (comb. 63Z) (saddle)
75	Monza (exc. Towne Cpe.)	1661562	2	69.25	pass. and driver (comb. 73Z) (oxblood)

**FOLDING TOP PARTS—INTERIOR TRIM**

**14.880A TRIM ASSY., Bucket Seats Cushion (Con't)**

75	Monza (exc. Towne Cpe.)	1698555	2	147.00	pass. and driver (comb. 632) (saddle)
75	Monza (exc. Towne Cpe.)	1698556	2	147.00	pass. and driver (comb. 732) (oxblood)
75	Monza (exc. Towne Cpe.)	1700414	2	134.00	pass. and driver (comb. 192) (black)
75	Monza (exc. Towne Cpe.)	1700580	2	73.25	pass. and driver (comb. 19G) (black)
75	Monza (exc. Towne Cpe.)	1700581	2	68.75	pass. and driver (comb. 19Z-H) (black)
75	Monza (Towne Cpe.)	1706497	2	77.75	pass. and driver (comb. 19N) (black)
75	Monza (Towne Cpe.)	1706498	2	77.75	pass. and driver (comb. 64N) (buckskin)
75	Monza (Towne Cpe.)	1706499	2	77.75	pass. and driver (comb. 71N) (firethorn)
75	Monza (Towne Cpe.)	1706502	2	142.00	pass. and driver (comb. 643) (buckskin)
75	Monza (Towne Cpe.)	1706491	1	68.75	pass. and driver (comb. 07H, 11H) (white)
75	Monza (Towne Cpe.)	1706494	1	68.75	pass. and driver (comb. 64H) (buckskin)
75	Monza (Towne Cpe.)	1706492	1		pass. and driver (comb. 71H) (firethorn)
75	Monza (Towne Cpe.)	1706497	1	77.75	pass. and driver (comb. 19N) (black)
75	Monza (Towne Cpe.)	1706498	1	77.75	pass. and driver (comb. 64N) (buckskin)
75	Monza (Towne Cpe.)	1706499	1	77.75	pass. and driver (comb. 71N) (firethorn)
75	Monza (Towne Cpe.)	1706502	1	142.00	pass. and driver (comb. 643) (buckskin)
75	Monza (Towne Cpe.)	1706495	2	68.75	pass. and driver (comb. 71H) (firethorn)
75	Monza (Towne Cpe.)	1706493	2		pass. and driver (comb. 190) (black)
75	Monza (Notchback)	1706501	2		pass. and driver (comb. 193) (black)

*NOTE 1: For 1974 Black-White-Red Napachi Knit Vinyl material being changed to black Nike Knit Vinyl. For 1975 design change from vertical to horizontal by rotating pattern 90°.*

**14.890 PAD ASSY., Front Seat Cushion**

70-72	Chevelle	9678681	1	15.90	(foam rubber)
71-72	Pass. (exc. Caprice)	9639537	1	42.00	
71-72	Caprice	9640649	1	37.25	
72	Nova, Camaro	9818475	2	33.50	pass. & drv. st. bottom wire
71-72	Vega (exc. Panel) w/Custom Seat	9672365	2	60.75	seat back wire driver and pass. (repl. 9893404)
71-72	Vega (exc. Panel) w/Custom Seat	9818475	2	33.50	seat bottom wire pass. and driver
71-73	Vega (exc. Panel) (exc. Custom Seat)	9620697	2	24.60	seat bottom wire pass. and driver
73	Caprice (Sed., Spt. Cpe.)	9640649	1	37.25	bottom wire
73	Bel Air, Impala (exc. Police),				
73	Caprice (Sta. Wag., Conv.)	9639537	1	42.00	bottom wire
73	Caprice w/reclining seat	9678681	1	15.90	driver bottom wire (repl. 9653531)
73	Chevelle (2-Dr.) w/swivel Bucket Seat (exc. Deluxe)	9875146	2	31.00	pass. and driver seat bottom wire
73	Monte Carlo	9613062	1	46.00	seat bottom wire
73	Chevelle, Nova w/Bench Seat (exc. Monte Carlo, Taxi, Notchback Seat)	9613059	1	44.75	seat bottom wire
73-74	Nova w/Bucket Seat (exc. Custom),				
75	Vega (exc. panel) w/bucket seat	9620697	2	24.60	pass. and driver bottom wire
73	Bel Air, Impala (Police) (exc. Spt. Sed. Custom),				
74-75	Pass. (Taxi, Police) w/bench seat (exc. reclining seat)	9678667	1	58.25	bottom wire
74-75	Pass. w/bench seat (exc. reclining, Taxi, Police)	9678668	1	63.75	bottom wire
74	Bel Air, Impala w/bench seat (exc. reclining bench, Taxi, Police),				
74	Caprice (Sta. Wag., Conv.) w/bench seat (exc. reclining seat)	9678666	1	48.00	bottom wire
74	Caprice (Sedan, Spt. Cpe.) w/bench seat (exc. reclining seat)	9678669	1	55.00	bottom wire
74-75	Caprice w/reclining seat,				
74	Caprice w/reclining seat,				
75	Impala w/reclining seat	9678681	1	15.90	pass. driver bottom wire
74-75	Chevelle w/swivel bucket	9678648	2	40.50	pass. and driver bottom wire
74	Malibu, El Camino, Nova, Monte Carlo w/bench seat (exc. Notchback, Classic),				
74	Malibu, El Camino (Classic) w/Notchback Seat	9678645	1		bottom wire
73	Nova (Custom) Camaro w/bucket seat (exc. Sedan),				
74-75	Nova (Custom, Coupe) Camaro w/bucket seat	9730718	2	36.75	pass. and driver seat bottom wire

**FOLDING TOP PARTS—INTERIOR TRIM**

**14.890 PAD ASSY., Front Seat Cushion (Con't)**

73	Vega (exc. Panel) w/Custom Seat .....	9730718	2	36.75	seat bottom wire pass. and driver (repl. 9620698) .....
73	Vega (exc. Panel) (exc. Custom Seat) .....	9668348	2		seat back wire driver and pass. ....
73	Vega (Hatchback Cpe., Sta. Wag.) w/Custom Seat .....	9668358	2	67.00	seat back wire driver and pass. ....
74-75	Vega (exc. Panel) w/Custom Seat .....	9730718	2	36.75	seat back bottom wire pass. and driver .....
73-74	Nova (Taxi) w/bench seat (exc. Custom) .....	9681775	1		bottom wire .....
75	Nova (Taxi) w/bench seat (exc. Custom) .....	1741604	1		bottom wire .....
75	Chevelle w/bench seat (exc. Monte Carlo, Notchback seat, reclining seat),				
75	Nova w/bench seat (exc. Taxi) ..	9678645	1		bottom wire .....
75	Monte Carlo w/reclining seat ...	1661522	1	34.00	pass. bottom wire .....
75	Monte Carlo w/reclining seat ...	1661523	1	33.75	driver, bottom wire .....
75	Monza w/bucket seat .....	1660448	2	36.25	pass. and driver bottom wire .....

**14.896 SEAT ASSY, Front**

*"Bench Type" seat assemblies are available from production during the current model year only.*

*"Bucket Seat" only during current model year.*

*Orders for both types of seat assembly are to be submitted to dealers normal shipping PDC for forwarding to GMPD— Flint, Attn: Engineering— NPN Department.*

*When ordering it is necessary that the following information is included:*

1. Year and Model
2. Trim Combination Number
3. Seat RPO Number

*Front seat components can be found in the following Groups 11.373, 11.419.*

*Front trim covers can be found in Groups 14.800 and 14.880.*

71	Vega (Panel) .....	3978501	1	111.00	(comb. 873) (black) (driver or aux.) (Note 1)
71	Vega (Panel) .....	3978503	1	111.00	(comb. 878) (med. green) (driver or aux.) (Note 1) .....

*NOTE 1: Seat Assy. does not include attaching brackets, adjusters, or risers.*

72	Vega (Hatchback Cpe.) (exc. Custom Seat) .....	9726326	1	138.00	pass. (repl. 9606499) .....
72-73	Vega (Notchback Cpe.) (exc. seat adjuster) .....	9662438	1	136.00	pass. (standard trim) .....
72-73	Vega (Notchback Cpe.) (exc. seat adjuster) .....	9662432	1	158.00	pass. (custom trim) .....
72-73	Vega (Notchback Cpe., Sta. Wag.) w/seat adjuster .....	9662433	1	161.00	pass. (standard trim) .....
73	Vega (Notchback Cpe., Sta. Wag.) w/adjustable seat back ..	9662436	1	179.00	driver (standard trim) .....
72-73	Vega (Hatchback Cpe.) w/adjustable seat back .....	9662443	1	179.00	driver (standard trim) .....
72-73	Vega (Hatchback Cpe.) w/adjustable seat back .....	9662440	1	202.00	driver (custom trim) .....
72-73	Vega (Hatchback Cpe.) (exc. adjustable seat back) .....	9662444	1	161.00	driver (standard trim) .....
73	Camaro w/adjustable seat back ..	9662427	1	215.00	driver .....
74-75	Vega (Panel) .....	329502	1	114.00	pass. and driver (pearl) .....
75	Vega (Panel) .....	353102	2	87.50	pass. and driver (gray) .....
75	Vega (Panel) .....	353103	2	87.50	pass. and driver (blue) .....
75	Vega (Panel) .....	353104	2	87.50	pass. and driver (saddle) .....

**14.900 ARM REST ASSY.— COVER— CURTAIN— WIRE ASSY., Arm Rest Front Seat**

71-72	Chevelle (Sed.) w/bench seat ...	9828430	1	24.65	less cover .....
73	Caprice (Sed.) w/bench seat (exc. reclining) .....	9639896	1	24.65	less cover .....
74-75	Chevelle w/notchback seat,				
75	Caprice (Sedan) .....	9699639	1	24.65	less cover .....
66-67	Caprice, S.S. (Spt. Mdls.) w/Astro. bench seat,				
67-68	Impala (Spt. Cpe.),				
68-69	Caprice .....	7589536	R.H.	.67	COVER, center panel fin. (paint as reqd.) ..
66-67	Caprice, S.S. (Spt. Mdls.) w/Astro. bench seat,				
67-68	Impala (Spt. Cpe., Conv.),				
68-69	Caprice .....	7589537	L.H.	.67	COVER, center panel fin. (paint as reqd.) ..
66-67	Caprice, S.S. (Spt. Mdls.) w/Astro. bench seat,				

FOLDING TOP PARTS—INTERIOR TRIM

**14.900 ARM REST ASSY.— COVER— CURTAIN— WIRE ASSY., Arm Rest Front Seat (Con't)**

68	Impala (Spt. Cpe.), Caprice (exc. Sta. Wag.)				
69	Caprice	7589480	R.H.	63	COVER, trim panel fin. (paint as reqd.)
66-67	Caprice, S.S. (Spt. Mdls.) w/Astro. bench seat,				
68	Impala (Spt. Cpe.), Caprice (exc. Sta. Wag.)				
69	Caprice	7589481	L.H.	67	COVER, trim panel fin. (paint as reqd.)
74	Caprice (Sedan)	9731827	1	20.75	COVER (comb. 840) (black)
74	Caprice (Sedan)	9731828	1	20.75	COVER (comb. 843) (mid. blue)
74	Caprice (Sedan)	9731829	1	20.75	COVER (comb. 850) (green)
74	Caprice (Sedan)	9731830	1	20.75	COVER (comb. 857) (oxblood)
74	Caprice (Sedan)	9731831	1	20.95	COVER (comb. 896) (taupe)
74	Caprice (Sedan)	9682706	1	20.75	COVER (comb. 808) (black)
74	Caprice (Sedan)	9682707	1	20.75	COVER (comb. 841) (neutral)
75	Caprice (Sedan)	1672778	1	47.00	COVER (comb. 19B) (black)
75	Caprice (Sedan)	1672779	1	47.00	COVER (comb. 26B) (blue)
75	Caprice (Sedan)	1672780	1	40.75	COVER (comb. 44B) (green)
75	Caprice (Sedan)	1672781	1	40.75	COVER (comb. 55B) (sandstone)
75	Caprice (Sedan)	1672782	1	40.75	COVER (comb. 73B) (oxblood)
75	Caprice (Sedan)	1672784	1	35.25	COVER (comb. 19H) (black)
75	Caprice (Sedan)	1672785	1	35.25	COVER (comb. 55H) (sandstone)
74	Chevelle w/notchback seat	9731854	1	31.25	COVER (comb. 747, 785) (white)
74-75	Chevelle w/notchback seat	9731855	1	31.25	COVER (comb. 702, 707) (black)
74	Chevelle w/notchback seat	9731856	1	19.55	COVER (comb. 732, 735) (mid. blue)
74	Chevelle w/notchback seat	9731865	1	19.55	COVER (comb. 740) (saddle)
74	Chevelle w/notchback seat	9731867	1	19.55	COVER (comb. 714, 722) (neutral)
74-75	Chevelle w/notchback seat	9731866	1	25.50	COVER (comb. 728) (44D) (green)
74-75	Chevelle w/notchback seat	9731857	1	20.85	COVER (comb. 743) (73D) (oxblood)
75	Chevelle w/notchback seat	1676402	1	40.00	COVER (comb. 16D) (graystone)
75	Chevelle w/notchback seat	1676403	1	40.00	COVER (comb. 55W) (sandstone)
75	Chevelle w/notchback seat	1676404	1	43.75	COVER (comb. 63W) (saddle)
75	Chevelle w/Notchback	1676405	1	41.75	COVER (comb. 26D, 26E, 26G) (blue)
73-74	Caprice (Sed.)	9654782	1	8.85	CURTAIN ASSY. (comb. 843) (blue)
75	Caprice (Sedan)	9829719	1	1.70	WIRE ASSY., front seat center arm rest opg. fil.

NOTE 1: Production Deviation Trim Change.

**14.924 COVER ASSY.— PAD— HEAD RESTRAINT ASSY.— TRIM ASSY., Front Seat Back Head Restraint**

NOTE Head Restraint Assemblies listed in this group have a dual post. For single post head restraints use component parts listed in this group.

Parts needed for single post, pad w/panel assy., cover assy. For head restraint attaching parts see group 11.376.

69	All (exc. Camaro)	8771007	2	14.75	pass and driver (black)
69	Malibu (Sed., Spt. Cpe.),				
69	Chevy, Pass. (exc. Conv.)	8771008	2	20.35	pass. and driver (midnight green)
70	Nova, Monte Carlo,				
70	Malibu (exc. Conv.),				
70	Bel Air, Impala, Caprice	9805379	2	20.90	pass. and driver (dk. green)
70	Malibu (Spt. Cpe., Conv.)	9805382	2	20.90	pass. and driver (ivory)
71	Nova, Chevelle	9883029	2	10.25	pass. and driver (comb. 730, 731, 734, 735, 736, 759, 760, 761) (dk. jade)
71	Nova, Chevelle	9883028	2	10.25	pass. and driver (comb. 724, 725, 726, 728, 756, 757) (dk. blue)
71	Nova, Chevelle	9883030	2	10.25	pass. and driver (comb. 712, 713, 714, 717, 718, 763, 764) (sandalwood)
71	Concours, Malibu (exc. Spt. Sed.)	9883031	2	10.25	pass. and driver (comb. 721) (dk. saddle)
70	Sta. Wag.,				
70	Malibu, Impala (Spt. Cpe., Conv.),				
71	Nomad, Greenbrier,				
71	Chevelle (Deluxe),				
71	El Camino (exc. Custom)	9883032	2	11.35	pass. and driver (comb. 719, 720) (med. saddle)
71-72	Pass. (1st design)	9883037	2	10.25	pass. and driver (comb. 802, 803, 804, 805, 806, 807, 809) (black)
71-72	Pass. (New York Taxi) (2nd des.)	9644302	2	10.30	pass. and driver (comb. 802, 803, 804, 805, 806, 807, 809) (black)
71	Pass. (exc. Conv.)	9883038	2	11.35	pass. and driver (dk. blue)
71	Brookwood, Townsman	9853260	2	11.35	pass. and driver (comb. 823, 824) (med. saddle)

FOLDING TOP PARTS—INTERIOR TRIM

**14.924 COVER ASSY.— PAD— HEAD RESTRAINT ASSY.— TRIM ASSY., Front  
Seat Back Head Restraint (Con't)**

71	Biscayne, Bel Air,					
71	Impala, Caprice (Spt. Cpe., Spt. Sed.)	9883040	2	11.35	pass. and driver (sandalwood)	
71	Pass. (exc. Brookwood, Townsmen)	9883041	2	10.25	pass. and driver (dk. jade)	
71	Pass. (exc. Biscayne, Brookwood, Townsmen)	9853263	2	11.35	pass. and driver (med. maize)	
71-72	Impala, Kingswood, Estate Wagon (1st design)	9883043	2	11.35	pass. and driver (comb. 825) (dk. saddle)	
72	Impala, Kingswood, Estate Wagon (2nd design)	9645127	2	11.35	pass. and driver (comb. 825) (dk. saddle)	
70	Pass., Chevelle, Nova,					
71-72	Nova, Chevelle	9883027	2	11.35	pass. and driver (black)	
72	Pass. (exc. Conv.) 1st design	9893827	2	10.30	pass. & driver (comb. 809, 810, 811, 812, 813, 814) (blue)	
72	Pass. (exc. Conv.) (2nd design)	9645130	2	10.30	pass. & driver (comb. 809, 810, 811, 812, 813, 814) (blue)	
72	Nova, Chevelle (exc. Conv.)	9890895	2	7.20	pass. & driver (comb. 723, 724, 725, 756) (blue)	
72	Bel Air, Impala, Caprice (exc. Conv.) (1st design)	9893826	2	10.30	pass. & driver (comb. 828, 829, 830, 831) (green)	
72	Bel Air, Impala, Caprice (exc. Conv.) (2nd design)	9645129	2	10.30	pass. & driver (comb. 828, 829, 830, 831) (green)	
72	Nova (w/bench seats), Chevelle (exc. El Camino)	9890930	2	10.30	pass. & drv. seat back head rest (comb. 710-711-713-715-759-760-761) (green)	
72	Chevelle (Sta. Wag., El Camino), Malibu (Spt. Cpe., Sed.)	9896219	2	10.30	pass. & driver (comb. 719, 720, 721) (tan)	
72	Monte Carlo	9896220	2	10.30	pass. & driver (comb. 740) (pewter)	
72	Impala (Spt. Sed., Spt. Cpe.) Caprice (1st design)	9893231	2	10.30	pass. & driver (comb. 834, 835, 836) (pewter)	
72	Impala (Spt. Sed., Spt. Cpe.) Caprice (2nd design)	9645128	2	10.30	pass. & driver (comb. 834, 835, 836) (pewter)	
72	Biscayne, Bel Air (Sed.) Caprice, Impala (1st des.)	9893828	2	10.30	pass. & driver (comb. 816, 817, 818) (covert)	
72	Biscayne, Bel Air (Sed.) Caprice, Impala (2nd design)	9645131	2	10.30	pass. & driver (covert)	
72	Nova, Malibu (exc. Conv.) Monte Carlo	9890931	2	10.30	pass. & driver (comb. 730, 731, 732, 734, 763, 764, 765) (covert)	
72	Chevelle (exc. Sta. Wag., El Camino)	9893804	2	10.30	pass. and driver (white)	
72	Chevelle	9896219	2	10.30	pass. and driver (comb. 719, 761) (tan)	
73	Pass., Nova, Chevelle	9644303	2	10.30	pass. and driver (green)	
73	Caprice (Conv.)	9644310	2	10.30	pass. and driver (white)	
73	Pass., Nova, Chevelle	9644302	2	10.30	pass. and driver (black)	
73	Impala, Caprice, Monte Carlo (exc. Conv.)	9644305	2	10.30	pass. and driver (midnight blue)	
73	Malibu, Laguna, Bel Air (Sed.) Nova (exc. Custom)	9644304	2	10.30	pass. and driver (med. blue)	
73	Malibu (Spt. Sed., Spt. Cpe.), Nova (2-Dr.) (exc. Custom)	9644306	2	10.30	pass. and driver (chamois)	
73	Malibu (exc. Spt. Sed.) Laguna (Spt. Cpe.), Pass., Deluxe (Sta. Wag.)	9644308	2	10.30	pass. and driver (saddle)	
73	Laguna, Monte Carlo, Caprice (Spt. Cpe., Sed.)	9644309	2	10.30	pass. and driver (oxblood)	
73	Pass. (exc. Bel Air Sed., Conv.), Chevelle (exc. Deluxe 4-Dr.), Nova	9644307	2	10.30	pass. and driver (neutral)	
74	Caprice (Sedan, Coupe)	9687759	2	10.30	pass. and driver (taupe)	
74	Pass., Chevelle, Nova w/bench seat, reclining seat	9687755	2	10.30	pass. and driver (neutral)	
74	Impala (Spt. Cpe.) Pass. (Conv.) w/bench seat (exc. Custom, reclining seat),					

FOLDING TOP PARTS—INTERIOR TRIM

**14.924 COVER ASSY.— PAD— HEAD RESTRAINT ASSY.— TRIM ASSY., Front Seat Back Head Restraint (Con't)**

75	Pass. w/bench seat (exc. reclining),				
75	Chevelle w/bench seat (exc. notchback, reclining),				
75	Nova w/bench seat	1666311	2	10.25	pass. and driver (white)
74-75	Pass., Chevelle, Nova w/bench seat	9687757	2	10.30	pass. and driver (green)
74-75	Pass., Chevelle, Nova w/bench seat	9687751	2	10.30	pass. and driver (black)
74	Chevelle w/notchback seat	9687752	2	10.30	pass. and driver (white)
74	Pass., Chevelle, Nova w/bench seat, reclining seat	9687754	2	10.30	pass. and driver (midn. blue)
74	Pass., Chevelle, Nova w/bench seat	9687758	2	10.30	pass. and driver (saddle)
74-75	Pass., Chevelle, Nova w/bench seat	9687756	2	10.30	pass. and driver (oxblood)
75	Pass., Chevelle; Nova w/bench seat	1689483	2	10.90	pass. and driver (blue)
75	Pass., Chevelle, Nova w/bench seat	1689488	2	11.10	pass. and driver (sandstone)
75	Pass., Chevelle, Nova w/bench seat	1689492	2	11.10	pass. and driver (saddle)
75	Chevelle w/notchback seat	1689498	2	11.10	pass. and driver (graystone)
69-70	Pass., Chevy, Chevelle	8748950	2	24.00	PAD, w/panel assy., pass. and driver seat back
71-72	Nova, Chevelle	9874550	2	25.50	PAD ASSY. AND PANEL, pass. and driver
71-73	Pass., Chevelle, Nova	9874564	2	20.55	PAD and PANEL ASSY., pass. and driver seat back panel
74	Pass., Chevelle, Nova w/bench seat, reclining seat	9667735	1	20.20	PAD and PANEL ASSY., pass.
74	Pass., Chevelle, Nova w/bench seat, reclining seat	9667736	1	20.20	PAD and PANEL ASSY., driver
75	Pass., Chevelle, Nova	1674270	1	23.40	PAD and PANEL ASSY., pass.
75	Pass., Chevelle, Nova	1674271	1	23.40	PAD and PANEL ASSY., driver
69	Camaro (1st design)	8737455	2	45.50	HEAD RESTRAINT ASSY., pass. and driver (comb. 701, 711, 712, 713) (black) (Note 5)
9	Camaro (2nd design)	8787553	2	45.50	HEAD RESTRAINT ASSY., pass. and driver (black) (Note 6)
9	Camaro (2nd design)	8787554	2	45.50	HEAD RESTRAINT ASSY., pass. and driver (ivory) (Note 6)
69	Nova (2-Dr.),				
69	El Camino (Custom),				
69	Malibu, Impala (Spt. Cpe., Conv.),				
69	Caprice,				
69	Chevy, Malibu, Caprice (Spt. Cpe., Conv.),				
69	Impala	8737463	2	44.50	HEAD RESTRAINT ASSY., pass. and driver (black) (paint as reqd.)
70-72	Nova,				
70	Malibu (Spt. Cpe., Conv.), El Camino (Custom),				
70-72	Chevelle (2-Dr.) (exc. Monte Carlo Conv.)	8799215	2	47.00	HEAD RESTRAINT ASSY., pass. and driver (black) (paint as reqd.)
70	Camaro	9817854	2	47.00	HEAD RESTRAINT ASSY., pass. and driver (comb. 711, 712, 713, 725) (black) (repl. 9817857)
70	Malibu (Spt. Cpe., Conv.)	8799223	2	47.00	HEAD RESTRAINT ASSY., pass. and driver (comb. 791) (ivory)
70	Nova (2-Dr.)	8799216	2	47.00	HEAD RESTRAINT ASSY., pass. and driver (comb. 742) (med. gold)
70	Chevelle (Spt. Cpe.)	8799217	2	47.00	HEAD RESTRAINT ASSY., pass. and driver (comb. 796, 784, 854) (dk. green)
70	Camaro	9817854	2	47.00	HEAD RESTRAINT ASSY., pass. and driver (comb. 714, 715, 716) (med. brt. blue)
70	Nova (2-Dr.)	8799224	2	47.00	HEAD RESTRAINT ASSY., pass. and driver (comb. 746) (med. sandalwood)
70	Camaro	9817854	2	47.00	HEAD RESTRAINT ASSY., pass. and driver (black) (paint to match)
71	El Camino (Custom),				

**FOLDING TOP PARTS—INTERIOR TRIM**

**14.924 COVER ASSY.— PAD— HEAD RESTRAINT ASSY.— TRIM ASSY., Front  
Seat Back Head Restraint (Con't)**

<b>71</b>	Malibu, Monte Carlo (Spt. Cpe.) .	<b>9854692</b>	2	41.25	<b>HEAD RESTRAINT ASSY.,</b> pass. and driver (comb. 715, 716) (lt. sandalwood) . . . . .
<b>71</b>	Monte Carlo . . . . .	<b>9854694</b>	2	43.50	<b>HEAD RESTRAINT ASSY.,</b> pass. and driver (comb. 727) (dk. blue) . . . . .
<b>71</b>	El Camino (Custom),				
<b>71</b>	Malibu, Monte Carlo (Spt. Cpe., Conv.) . . . . .	<b>8799215</b>	2	47.00	<b>HEAD RESTRAINT ASSY.,</b> pass. and driver (dk. jade) . . . . .
<b>71-72</b>	Nova, Chevelle (2-Dr.) . . . . .	<b>9854693</b>	2	41.25	<b>HEAD RESTRAINT ASSY.,</b> pass. and driver (comb. 722, 723, 767) (dk. saddle) . . . . .
<b>2</b>	Monte Carlo,				
<b>2</b>	Chevelle (Conv.) . . . . .	<b>9899200</b>	2	44.00	<b>HEAD RESTRAINT ASSY.,</b> pass. & driver (comb. 740) (pewter) . . . . .
<b>2</b>	Monte Carlo . . . . .	<b>9899204</b>	2	44.00	<b>HEAD RESTRAINT ASSY.,</b> pass. & driver (comb. 743) (white) . . . . .
<b>72</b>	Chevelle (Spt. Cpe.) . . . . .	<b>9899208</b>	2	44.00	<b>HEAD RESTRAINT ASSY.,</b> pass. & driver (comb. 713, 717) (green) . . . . .
<b>72</b>	Malibu (Spt. Cpe.) El Camino (Custom) . . . . .	<b>9899212</b>	2	44.00	<b>HEAD RESTRAINT ASSY.,</b> pass. & driver (comb. 732) (covert) . . . . .
<b>72</b>	Malibu (Spt. Cpe.) El Camino (Custom) . . . . .	<b>9899216</b>	2	44.00	<b>HEAD RESTRAINT ASSY.,</b> pass. & driver (comb. 720) (tan) . . . . .
<b>72</b>	Monte Carlo . . . . .	<b>9854693</b>	2	41.25	<b>HEAD RESTRAINT ASSY.,</b> pass. and driver (comb. 735) (saddle) . . . . .
<b>72</b>	Nova, Chevelle . . . . .	<b>9883027</b>	2	11.35	<b>HEAD RESTRAINT ASSY.,</b> pass. and driver (comb. 701, 702, 703, 705, 708, 750, 751, 752) (black) . . . . .

- NOTE 1 Used on conventional bench seats.  
NOTE 2. Used on astro type seats.  
NOTE 3. Used on strato type seats.  
NOTE 4. Used w/shoulder harness.  
NOTE 5 Straight post.  
NOTE 6 Curved post.  
NOTE 7 Production Deviation Trim Change.*





# CHEVROLET BODY GROUP 15.000



## REAR SEAT TRIM — CARPETS — YARDAGE

### ALPHABETICAL INDEX

B		H	
BAG ASSY., Fldg. Top Compt.....	15.027	GROMMET, Front Floor.....	15.300
BASE, Rear Quarter Arm Trimmed.....	15.108		
BINDING, Floor Carpet.....	15.294		
C		I	
CAP, Rear Seat Back.....	15.011	HOOK ASSY., Coat.....	15.388
CARPET.....	15.286A	HOOK, Coat.....	15.388
CARPET ASSY., Front Floor.....	15.286		
CARPET ASSY., Load Floor.....	15.320		
CARPET ASSY., Rear Floor.....	15.306		
CARPET, Doors, Seats, Cowl and Load Floor.....	15.512		
CARPET, Front Floor.....	15.286		
CARPET MATERIAL, Load Floor.....	15.320		
CLIP, Rear Quarter.....	15.100A		
CLIP, Rear Seat Back Compartment Shelf			
Foundation.....	15.024		
COATED FABRIC.....	15.506		
COVER ASSY., Rear Quarter.....	15.100A		
COVER ASSY., Spare Tire Cover.....	15.100C		
COVER, Front Floor.....	15.300		
COVER, Rear Quarter Arm Trimmed.....	15.108		
D		L	
DEADENER, Floor Pan.....	15.492	LACE ASSY., Wheelhouse Cover.....	15.099
		LACE, Door (with filler).....	15.520
		LACE, Front Floor.....	15.286
		LINING, Top and Well.....	15.530
E		M	
ESCUTCHEON, Coat.....	15.388	MAT ASSY., Rear Floor.....	15.306A
EXTENSION, Spare Tire Cover.....	15.100C	MAT ASSY., Rear Floor.....	15.306
		MAT, Dash Panel.....	15.280
		MATERIAL, Top Covering.....	15.490
		MAT, Front Floor.....	15.286B
		MAT, Front Floor.....	15.286
		MAT, Rear Compartment.....	15.222
		MAT, Rear Floor.....	15.306A
		MAT, Rear Floor.....	15.306
		MAT UNIT.....	15.306B
		MAT UNIT, Front Floor.....	15.286B
		MAT UNIT (Rear Floor Contour Twin Type	
		Rubber).....	15.268
		MAT UNIT, Rear Floor.....	15.306
		MAT, Well Lining and Load Floor.....	15.311
		MOULDING ASSY., Rear Quarter Trim.....	15.101
		MOULDING ASSY., Rear Seat Back.....	15.011
		MOULDING, Rear Quarter Trim.....	15.101
		MOULDING, Rear Seat Back.....	15.011
F		N	
FABRIC, Top and Well.....	15.530	NUT, Rear Quarter Trim.....	15.101A
FASTENER, Rear and Center Seat Back		NUT, Rear Quarter Arm Trimmed.....	15.108
Cover.....	15.000		
FASTENER, Rear Compartment.....	15.222		
FASTENER, Rear Quarter.....	15.100A		
FOUNDATION, Rear Compartment.....	15.222		
FOUNDATION, Rear Seat Back			
Compartment Shelf Foundation.....	15.024		
G			
GENUINE LEATHER.....	15.504		

# ALPHABETICAL INDEX

## P

PAD ASSY., Rear Seat Back.....	15.002
PAD ASSY., Rear Seat Cushion.....	15.036
PAD, Front Floor.....	15.286
PAD, Rear Quarter Arm Trimmed.....	15.108
PANEL ASSY., Rear Quarter Trim.....	15.101
PANEL, Rear Compartment.....	15.222
PANEL, Rear Quarter Arm Trimmed.....	15.108
PANEL, Rear Quarter Trim.....	15.101
PANEL, Rear Quarter.....	15.100A
PANEL, Spare Tire Cover.....	15.100C
PANEL, Wheelhouse Cover.....	15.099
PLUG, Front Floor.....	15.300
PLUG, Rear Quarter.....	15.100A

## R

REINFORCEMENT, Rear Quarter.....	15.100A
REST ASSY., Rear Quarter Arm Trimmed.....	15.108
RETAINER, Dash Panel.....	15.280
RETAINER, Front Floor.....	15.300
RETAINER, Rear Quarter.....	15.100A
RETAINER, Rear Seat Back Compartment Shelf Foundation.....	15.024

## S

SCREW, Rear Quarter Arm Trimmed.....	15.108
SEAL, Dash Panel.....	15.280
SEAL, Front Floor.....	15.300
STRAP ASSY., Assist.....	15.390
SUPPORT, Coat.....	15.388
SUPPORT, Rear Quarter.....	15.100A

## T

TRIM ASSY.....	15.306B
TRIM ASSY., Rear and Center Seat Back Cover.....	15.000
TRIM ASSY., Rear and Center Seat Cushion Cover.....	15.035
TRIM ASSY., Rear Floor.....	15.306
TRIM ASSY., Rear Quarter Arm Trimmed.....	15.108
TRIM ASSY., Rear Quarter.....	15.100
TRIM ASSY., Rear Seat Back Compartment Shelf Foundation.....	15.024
TRIM ASSY., Spare Tire Cover.....	15.100C
TRIM ASSY., Top Compartment Side Trim Panel.....	15.100B
TRIM ASSY., Third Seat Back Cover.....	15.060
TRIM ASSY., Third Seat Cushion.....	15.070
TRIM ASSY., Wheelhouse Cover.....	15.099
TRIM, Rear Compartment.....	15.222
TRUNK LINING, Rear Compartment.....	15.222

## U

UPHOLSTERY CLOTH, Seat Cushion and Sidewall (See Yardage Code preceding group 15.500).....	15.500
--	--------

## W

WINDLACE, Door (with filler).....	15.520
-----------------------------------	--------

## Y

YARDAGE, Doors, Seats, Cowl and Load Floor.....	15.512
--	--------

**REAR TRIM—MATS—YARDAGE**

**15.000 TRIM ASSY.—FASTENER, Rear and Center Seat Back Cover**

**PASS.**

72	Caprice (Spt. Sed.)	9626076	1		(comb. 807) (black) (repl. 9895641)
72	Caprice (Spt. Sed.)	9626078	1	168.00	(comb. 831) (green)
72	Caprice (Spt. Cpe.)	9626089	1	163.00	(comb. 833) (green)
73-74	Impala (Spt. Cpe.)	9628392	1	99.25	(comb. 802) (black)
73-74	Impala (Spt. Cpe.),				
74	Pass. (Conv.)	9628397	1	93.00	(comb. 806) (black)
73-74	Impala (Spt. Cpe.)	9665297	1	93.00	(comb. 813) (midn. blue)
73-74	Impala (Spt. Cpe.) Caprice (Conv.)	9628399	1	93.00	(comb. 818) (neutral)
73-74	Impala (Sed.)	9628387	1	106.00	(comb. 802) (black)
73-74	Impala (Sed.)	9628384	1	99.00	(comb. 813) (midn. blue)
73-74	Impala (Sed.)	9628383	1	99.00	(comb. 806) (black)
73-74	Impala (Sed.)	9628385	1	99.00	(comb. 818) (neutral)
73	Impala, Caprice (Sta. Wag.) (9- Pass.)	9628438	1	87.75	fldg. 2nd— 2/3 (comb. 806) (black)
74	Bel Air (Sedan)	9675886	1	76.75	(comb. 817) (neutral)
74	Bel Air (Sedan)	9675887	1	76.75	(comb. 851) (green)
74	Bel Air (Sedan)	9675888	1	76.75	(comb. 803) (black)
74	Bel Air (Sedan)	9675889	1	76.75	(comb. 815) (neutral)
74	Bel Air (Sedan)	9675890	1	76.75	(comb. 852) (green)
74	Impala (Sedan)	9675666	1	106.00	(comb. 805) (black)
74	Impala (Sedan)	9675667	1	106.00	(comb. 821) (neutral)
74	Impala (Sedan)	9675668	1	106.00	(comb. 847) (midn. blue)
74	Impala (Sedan)	9675669	1	106.00	(comb. 853) (green)
74	Impala (Sedan)	9729460	1	99.00	(comb. 849) (saddle)
74	Impala (Sedan)	9675664	1	99.00	(comb. 855) (green)
74	Impala (Spt. Cpe.)	9675675	1	99.25	(comb. 805) (black)
74	Impala (Spt. Cpe.)	9675676	1	99.25	(comb. 821) (neutral)
74	Impala (Spt. Cpe.)	9675677	1	99.25	(comb. 847) (midn. blue)
74	Impala (Spt. Cpe.)	9675678	1	99.25	(comb. 853) (green)
74	Impala (Spt. Cpe.)	9729461	1	93.00	(comb. 849) (saddle)
74	Impala (Spt. Cpe.)	9729462	1	99.25	(comb. 858) (saddle and black)
74	Impala (Spt. Cpe.)	9675687	1	93.00	(comb. 855) (green)
74	Impala (Spt. Cpe.) Pass. (Conv.) (exc. Custom)	1666308	1	95.75	(comb. 804, 809, 810) (white)
74	Caprice (Sedan)	9684090	1	164.00	(comb. 840) (black)
74	Caprice (Sedan)	9684091	1	164.00	(comb. 843) (midn. blue)
74	Caprice (Sedan)	9684092	1	164.00	(comb. 850) (green)
74	Caprice (Sedan)	9684093	1	164.00	(comb. 857) (oxblood)
74	Caprice (Sedan)	9684094	1	164.00	(comb. 896) (taupe)
74	Caprice (Sedan)	9684095	1	164.00	(comb. 808) (black)
74	Caprice (Sedan)	9684096	1	164.00	(comb. 841) (neutral)
74	Caprice (Spt. Cpe.)	9684153	1	159.00	(comb. 840) (black)
74	Caprice (Spt. Cpe.)	9684154	1	159.00	(comb. 843) (midn. blue)
74	Caprice (Spt. Cpe.)	9684155	1	159.00	(comb. 850) (green)
74	Caprice (Spt. Cpe.)	9684156	1	159.00	(comb. 857) (oxblood)
74	Caprice (Spt. Cpe.)	9684157	1	159.00	(comb. 896) (taupe)
74	Caprice (Spt. Cpe.)	9684158	1	159.00	(comb. 808) (black)
74	Caprice (Spt. Cpe.)	9684159	1	159.00	(comb. 841) (neutral)
74	Bel Air (Sta. Wag.) (6-Pass.)	9675896	1	74.25	fldg. 2nd (comb. 817) (neutral)
74	Bel Air (Sta. Wag.) (6-Pass.)	9675897	1	74.25	fldg. 2nd (comb. 851) (green)
74	Impala, Caprice (Sta. Wag.) (6- Pass.)	9675712	1	104.00	fldg. 2nd (comb. 849) (saddle)
74	Impala, Caprice (Sta. Wag.) (6- Pass.)	9675713	1	104.00	fldg. 2nd (comb. 855) (green)
74	Impala, Caprice (Sta. Wag.) (6- Pass.)	9735978	1	104.00	fldg. 2nd (comb. 806) (black)
74	Impala, Caprice (Sta. Wag.) (6- Pass.)	9735979	1	104.00	fldg. 2nd (comb. 813) (mid. blue)
74	Impala, Caprice (Sta. Wag.) (6- Pass.)	9735980	1	104.00	fldg. 2nd (comb. 819) (neutral)
74	Impala, Caprice (Sta. Wag.) (6- Pass.)	1690381	1	102.00	fldg. 2nd (comb. 802) (black and white)
74	Impala, Caprice (Sta. Wag.) (6- Pass.)	1690382	1	102.00	fldg. 2nd (comb. 858) (saddle and black)
74	Impala, Caprice (Sta. Wag.) (6- Pass.)	1690383	1	102.00	fldg. 2nd (comb. 859) (black and green)
74	Bel Air (Sta. Wag.) (9-Pass.)	9675898	1	34.25	fldg. 2nd— 1/3 (comb. 817) (neutral)
74	Bel Air (Sta. Wag.) (9-Pass.)	9675899	1	34.25	fldg. 2nd— 1/3 (comb. 851) (green)
74	Impala, Caprice (Sta. Wag.) (9- Pass.)	9675717	1	50.00	fldg. 2nd— 1/3 (comb. 849) (saddle)

**REAR TRIM—MATS—YARDAGE**

**15.000 TRIM ASSY.—FASTENER, Rear and Center Seat Back Cover (Con't)**

74	Impala, Caprice (Sta. Wag.) (9-Pass.)	9675718	1	50.00	fldg. 2nd— 1/3 (comb. 855) (green)
74	Impala, Caprice (Sta. Wag.) (9-Pass.)	9735983	1	50.00	fldg. 2nd— 1/3 (comb. 806) (black)
74	Impala, Caprice (Sta. Wag.) (9-Pass.)	9735984	1	50.00	fldg. 2nd— 1/3 (comb. 813) (mid. blue)
74	Impala, Caprice (Sta. Wag.) (9-Pass.)	9735985	1	50.00	fldg. 2nd— 1/3 (comb. 819) (neutral)
74	Impala, Caprice (Sta. Wag.) (9-Pass.)	1690389	1	49.25	fldg. 2nd— 1/3 (comb. 802) (black and white)
74	Impala, Caprice (Sta. Wag.) (9-Pass.)	1690390	1	49.25	fldg. 2nd— 1/3 (comb. 858) (saddle and black)
74	Impala, Caprice (Sta. Wag.) (9-Pass.)	1690391	1	49.25	fldg. 2nd— 1/3 (comb. 859) (black and green)
74	Bel Air (Sta. Wag.) (9-Pass.)	9675900	1	56.25	fldg. 2nd— 2/3 (comb. 817) (neutral)
74	Bel Air (Sta. Wag.) (9-Pass.)	9675901	1	56.25	fldg. 2nd— 2/3 (comb. 851) (green)
74	Impala, Caprice (Sta. Wag.) (9-Pass.)	9675722	1	87.75	fldg. 2nd— 2/3 (comb. 849) (saddle)
74	Impala, Caprice (Sta. Wag.) (9-Pass.)	9675723	1	87.75	fldg. 2nd— 2/3 (comb. 855) (green)
74	Impala, Caprice (Sta. Wag.) (9-Pass.)	9735988	1	87.75	fldg. 2nd— 2/3 (comb. 806) (black)
74	Impala, Caprice (Sta. Wag.) (9-Pass.)	9735989	1	87.75	fldg. 2nd— 2/3 (comb. 813) (mid. blue)
74	Impala, Caprice (Sta. Wag.) (9-Pass.)	9735990	1	87.75	fldg. 2nd— 2/3 (comb. 819) (neutral)
74	Impala, Caprice (Sta. Wag.) (9-Pass.)	1690393	1	95.25	fldg. 2nd— 2/3 (comb. 802) (black and white)
74	Impala, Caprice (Sta. Wag.) (9-Pass.)	1690394	1	95.25	fldg. 2nd— 2/3 (comb. 858) (saddle and black)
74	Impala, Caprice (Sta. Wag.) (9-Pass.)	1690395	1	95.25	fldg. 2nd— 2/3 (comb. 859) (black and green)
75	Bel Air (Sedan)	1662682	1	83.50	(comb. 19C) (black)
75	Bel Air (Sedan)	1662683	1	83.50	(comb. 26C) (blue)
75	Bel Air (Sedan)	1662684	1	83.50	(comb. 55C) (sandstone)
75	Bel Air (Sedan)	1658534	1	83.50	(comb. 55V) (sandstone)
75	Impala (Sedan)	1665244	1	121.00	(comb. 19D) (black)
75	Impala (Sedan)	1665245	1	121.00	(comb. 26D) (blue)
75	Impala (Sedan)	1665246	1	121.00	(comb. 44D) (green)
75	Impala (Sedan)	1665247	1	121.00	(comb. 55D) (sandstone)
75	Impala (Sedan)	1665249	1	112.00	(comb. 63E) (saddle)
75	Impala (Sedan)	1665251	1	103.00	(comb. 19W) (black)
75	Impala (Sedan)	1665252	1	103.00	(comb. 26W) (blue)
75	Impala (Sedan)	1665253	1	103.00	(comb. 44W) (green)
75	Impala (Sedan)	1665254	1	103.00	(comb. 55W) (sandstone)
75	Impala (Sedan)	1665255	1	103.00	(comb. 63W) (saddle)
75	Impala (Spt. Cpe.)	1665265	1	96.50	(comb. 19W) (black)
75	Impala (Spt. Cpe.)	1665266	1	96.50	(comb. 02W, 11W) (white)
75	Impala (Spt. Cpe.)	1665267	1	96.50	(comb. 44W) (green)
75	Impala (Spt. Cpe.)	1665257	1	114.00	(comb. 19D) (black)
75	Impala (Spt. Cpe.)	1665258	1	114.00	(comb. 26D) (blue)
75	Impala (Spt. Cpe.)	1665259	1	114.00	(comb. 44D) (green)
75	Impala (Spt. Cpe.)	1665260	1	114.00	(comb. 55D) (sandstone)
75	Impala, Caprice (2-Dr.)	1665264	1	96.50	(comb. 02W, 04W, 07W, 11W) (white)
75	Impala, Caprice (2-Dr.)	1665268	1	96.50	(comb. 55W) (sandstone)
75	Impala, Caprice (2-Dr.)	1665269	1	96.50	(comb. 63W) (saddle)
75	Impala, Caprice (2-Dr.)	1665262	1	114.00	(comb. 63E) (saddle)
75	Caprice (Sedan)	1663893	1	158.00	(comb. 19H) (black)
75	Caprice (Sedan)	1663894	1	158.00	(comb. 55H) (sandstone)
75	Caprice (Sedan)	1663882	1	158.00	(comb. 19B) (black)
75	Caprice (Sedan)	1663883	1	158.00	(comb. 26B) (blue)
75	Caprice (Sedan)	1663884	1	158.00	(comb. 44B) (green)
75	Caprice (Sedan)	1663885	1	158.00	(comb. 55B) (sandstone)
75	Caprice (Sedan)	1663886	1	158.00	(comb. 73B) (oxblood)
75	Caprice (Spt. Cpe.)	1663895	1	152.00	(comb. 19H) (black)
75	Caprice (Spt. Cpe.)	1663896	1	152.00	(comb. 55H) (sandstone)
75	Caprice (Spt. Cpe.)	1663888	1	152.00	(comb. 19B) (black)
75	Caprice (Spt. Cpe.)	1663889	1	152.00	(comb. 26B) (blue)
75	Caprice (Spt. Cpe.)	1663890	1	152.00	(comb. 44B) (green)

**REAR TRIM—MATS—YARDAGE**

**15.000 TRIM ASSY.—FASTENER, Rear and Center Seat Back Cover (Con't)**

75	Caprice (Spt. Cpe.)	1663891	1	152.00	(comb. 55B) (sandstone)
75	Caprice (Spt. Cpe.)	1663892	1	152.00	(comb. 73B) (oxblood)
75	Bel Air (Sta. Wag.) (6-Pass.)	1658539	1	82.25	fldg. 2nd (comb. 26V) (blue)
75	Bel Air (Sta. Wag.) (6-Pass.)	1658540	1	82.25	fldg. 2nd (comb. 55V) (sandstone)
75	Impala, Caprice (Sta. Wag.) (6-Pass.)	1665496	1	109.00	fldg. 2nd (comb. 63E) (saddle)
75	Impala, Caprice (Sta. Wag.) (6-Pass.)	1665498	1	102.00	fldg. 2nd (comb. 19W) (black)
75	Impala, Caprice (Sta. Wag.) (6-Pass.)	1665499	1	102.00	fldg. 2nd (comb. 26W) (blue)
75	Impala, Caprice (Sta. Wag.) (6-Pass.)	1665500	1	102.00	fldg. 2nd (comb. 44W) (green)
75	Impala, Caprice (Sta. Wag.) (6-Pass.)	1665501	1	102.00	fldg. 2nd (comb. 55W) (sandstone)
75	Impala, Caprice (Sta. Wag.) (6-Pass.)	1665502	1	102.00	fldg. 2nd (comb. 63W) (saddle)
75	Bel Air (Sta. Wag.) (9-Pass.)	1658542	1	36.50	fldg. 2nd— 1/3 (comb. 26V) (blue)
75	Bel Air (Sta. Wag.) (9-Pass.)	1658543	1	36.50	fldg. 2nd— 1/3 (comb. 55V) (sandstone)
75	Impala, Caprice (Sta. Wag.) (9-Pass.)	1665506	1	49.25	fldg. 2nd— 1/3 (comb. 19W) (black)
75	Impala, Caprice (Sta. Wag.) (9-Pass.)	1665507	1	49.25	fldg. 2nd— 1/3 (comb. 26W) (blue)
75	Impala, Caprice (Sta. Wag.) (9-Pass.)	1665508	1	49.25	fldg. 2nd— 1/3 (comb. 44W) (green)
75	Impala, Caprice (Sta. Wag.) (9-Pass.)	1665509	1	49.25	fldg. 2nd— 1/3 (comb. 55W) (sandstone)
75	Impala, Caprice (Sta. Wag.) (9-Pass.)	1665504	1	49.25	fldg. 2nd— 1/3 (comb. 63E) (saddle)
75	Impala, Caprice (Sta. Wag.) (9-Pass.)	1665510	1	49.25	fldg. 2nd— 1/3 (comb. 63W) (saddle)
75	Bel Air (Sta. Wag.) (9-Pass.)	1658545	1	56.00	fldg. 2nd— 2/3 (comb. 26V) (blue)
75	Bel Air (Sta. Wag.) (9-Pass.)	1658546	1	56.00	fldg. 2nd— 2/3 (comb. 55V) (sandstone)
75	Impala, Caprice (Sta. Wag.) (9-Pass.)	1665512	1	84.75	fldg. 2nd— 2/3 (comb. 63E) (saddle)
75	Impala, Caprice (Sta. Wag.) (9-Pass.)	1665514	1	84.75	fldg. 2nd— 2/3 (comb. 19W) (black)
75	Impala, Caprice (Sta. Wag.) (9-Pass.)	1665515	1	84.75	fldg. 2nd— 2/3 (comb. 26W) (blue)
75	Impala, Caprice (Sta. Wag.) (9-Pass.)	1665516	1	84.75	fldg. 2nd— 2/3 (comb. 44W) (green)
75	Impala, Caprice (Sta. Wag.) (9-Pass.)	1665517	1	84.75	fldg. 2nd— 2/3 (comb. 55W) (sandstone)
75	Impala, Caprice (Sta. Wag.) (9-Pass.)	1665518	1	84.75	fldg. 2nd— 2/3 (comb. 63W) (saddle)

**NOVA**

72	Nova (4-Dr.)	9891105	1	54.25	(comb. 751) (black)
72	Nova (4-Dr.)	9891107	1	54.25	(comb. 760) (green)
72	Nova (4-Dr.)	9891111	1	61.00	(comb. 764) (covert)
72	Nova (4-Dr.)	9891103	1	55.25	(comb. 756) (blue)
73-74	Nova (Sed.) (exc. Custom)	9678803	1	99.00	(comb. 765, 769) (black)
73-74	Nova (Sed.) (exc. Custom)	9678802	1	99.00	(comb. 768) (neutral)
73	Nova (Custom Cpe.) (exc. H.B.)	9651789	1	76.50	(comb. 764) (neutral)
73	Nova (Custom H.B.)	9675181	1	72.25	fldg. rear seat (comb. 752) (black & white) (repl. 9651813)
73	Nova (Custom H.B.)	9675179	1	60.50	fldg. rear seat (comb. 771) (neutral) (repl. 9651811)
74	Nova (Sedan) (exc. Custom)	9692577	1	65.25	(comb. 753) (black)
74	Nova (Sedan) (exc. Custom)	9692578	1	65.25	(comb. 772) (midn. blue)
74	Nova (Sedan) (exc. Custom)	9692579	1	65.25	(comb. 758) (green)
74	Nova (Sedan) (exc. Custom)	9692580	1	65.25	(comb. 765) (neutral)
74	Nova (Sedan) (exc. Custom)	9692581	1	59.00	(comb. 750) (black and white)
74	Nova (Sedan) (exc. Custom)	9692582	1	59.00	(comb. 756) (green and black)
74	Nova (Sedan) (exc. Custom)	9692583	1	59.00	(comb. 764) (neutral and black)
74	Nova (Sedan) (exc. Custom)	1658335	1	65.25	(comb. 825) (black)
74	Nova (Sedan) (exc. Custom)	1658336	1	65.25	(comb. 826) (mid. blue)
74	Nova (Sedan) (exc. Custom)	1658337	1	65.25	(comb. 828) (green)
74	Nova (Sedan) (exc. Custom)	1658338	1	65.25	(comb. 829) (neutral)
74	Nova (Coupe) (exc. H.B., Custom)	9692313	1	63.75	(comb. 753) (black)
74	Nova (Coupe) (exc. H.B., Custom)	9692314	1	63.75	(comb. 772) (midn. blue)
74	Nova (Coupe) (exc. H.B., Custom)	9692315	1	63.75	(comb. 758) (green)
74	Nova (Coupe) (exc. H.B., Custom)	9692316	1	63.75	(comb. 765) (neutral)
74	Nova (Coupe) (exc. H.B., Custom)	9692317	1	57.25	(comb. 750) (black and white)
74	Nova (Coupe) (exc. H.B., Custom)	9692318	1	57.25	(comb. 756) (green and black)
74	Nova (Coupe) (exc. H.B., Custom)	9692319	1	57.25	(comb. 764) (neutral and black)

**REAR TRIM—MATS—YARDAGE**

**15.000 TRIM ASSY.—FASTENER, Rear and Center Seat Back Cover (Con't)**

74	Nova (Coupe) (exc. H.B., Custom)	1658331	1	63.75	(comb. 825) (black)
74	Nova (Coupe) (exc. H.B., Custom)	1658332	1	63.75	(comb. 826) (mid. blue)
74	Nova (Coupe) (exc. H.B., Custom)	1658333	1	63.75	(comb. 828) (green)
74	Nova (Coupe) (exc. H.B., Custom)	1658334	1	63.75	(comb. 829) (neutral)
74	Nova (Custom) (Sedan)	9692584	1	65.25	(comb. 766) (neutral)
74	Nova (Custom) (Sedan)	9692585	1	76.50	(comb. 751) (black)
74	Nova (Custom) (Sedan)	9692586	1	76.50	(comb. 757) (green)
74	Nova (Custom) (Sedan)	9735078	1	65.25	(comb. 754) (black)
74	Nova (Custom) (Coupe) (exc. H.B.)	9692320	1	65.75	(comb. 754) (black)
74	Nova (Custom) (Coupe) (exc. H.B.)	9692321	1	65.75	(comb. 759) (green)
74	Nova (Custom) (Coupe) (exc. H.B.)	9692322	1	65.75	(comb. 766) (neutral)
74	Nova (Custom) (Coupe) (exc. H.B.)	9692323	1	76.50	(comb. 751) (black)
74	Nova (Custom) (Coupe) (exc. H.B.)	9692324	1	76.50	(comb. 752) (black and white)
74	Nova (Custom) (Coupe) (exc. H.B.)	9692325	1	76.50	(comb. 755) (green and black)
74	Nova (Custom) (Coupe) (exc. H.B.)	9692576	1	76.50	(comb. 771) (midn. blue)
74	Nova (H.B.) (exc. Custom)	9692301	1	60.25	fldg. (comb. 753) (black)
74	Nova (H.B.) (exc. Custom)	9692302	1	60.25	fldg. (comb. 772) (midn. blue)
74	Nova (H.B.) (exc. Custom)	9692303	1	60.25	fldg. (comb. 773) (saddle)
74	Nova (H.B.) (exc. Custom)	9692304	1	60.25	fldg. (comb. 758) (green)
74	Nova (H.B.) (exc. Custom)	9692305	1	60.25	fldg. (comb. 765) (neutral)
74	Nova (H.B.) (exc. Custom)	9692306	1	55.25	fldg. (comb. 750) (black and white)
74	Nova (H.B.) (exc. Custom)	9692307	1	55.25	fldg. (comb. 756) (green and black)
74	Nova (H.B.) (exc. Custom)	9692308	1	55.25	fldg. (comb. 764) (neutral and black)
74	Nova (H.B.) (exc. Custom)	1658339	1	60.25	fldg. (comb. 825) (black)
74	Nova (H.B.) (exc. Custom)	1658340	1	60.25	fldg. (comb. 826) (mid. blue)
74	Nova (H.B.) (exc. Custom)	1658341	1	60.25	fldg. (comb. 827) (saddle)
74	Nova (H.B.) (exc. Custom)	1658342	1	60.25	fldg. (comb. 828) (green)
74	Nova (H.B.) (exc. Custom)	1658343	1	60.25	fldg. (comb. 829) (neutral)
74	Nova (Custom) (H.B.)	9692309	1	58.25	fldg. (comb. 759) (green)
74	Nova (Custom) (H.B.)	9692310	1	69.75	fldg. (comb. 751) (black)
74	Nova (Custom) (H.B.)	9692311	1	69.75	fldg. (comb. 755) (green and black)
74	Nova (Custom) (H.B.)	9692312	1	69.75	fldg. (comb. 771) (midn. blue)
73-74	Nova (Custom) (H.B.)	9675178	1	60.50	fldg. (comb. 754) (black)
74	Nova (Custom) (H.B.)	9675179	1	60.50	fldg. (comb. 766) (neutral)
74	Nova (Custom) (H.B.)	9675181	1	72.25	fldg. (comb. 752) (black and white)
74	Nova (Custom) (H.B.)	9692768	1	77.50	fldg. (comb. 774) (white)
75	Nova (Sedan) (exc. Custom)	1655184	1	67.75	(comb. 19V) (black)
75	Nova (Sedan) (exc. Custom)	1743956	1	67.75	(comb. 19Z) (black)
75	Nova (Sedan) (exc. Custom)	1655185	1	67.75	(comb. 26V) (blue)
75	Nova (Sedan) (exc. Custom)	1655186	1	67.75	(comb. 55V) (sandstone)
75	Nova (Sedan) (exc. Custom)	1655187	1	67.75	(comb. 63V) (saddle)
75	Nova (Sedan) (exc. Custom)	1653894	1	78.50	(comb. 19C) (black)
75	Nova (Sedan) (exc. Custom)	1653895	1	78.50	(comb. 26C) (blue)
75	Nova (Sedan) (exc. Custom)	1653896	1	78.50	(comb. 55C) (sandstone)
75	Nova (Coupe) (exc. H.B., Custom)	1653885	1	74.50	(comb. 19C) (black)
75	Nova (Coupe) (exc. H.B., Custom)	1653886	1	74.50	(comb. 26C) (blue)
75	Nova (Coupe) (exc. H.B., Custom)	1653887	1	74.50	(comb. 55C) (sandstone)
75	Nova (Coupe) (exc. H.B., Custom)	1653889	1	66.75	(comb. 19V) (black)
75	Nova (Coupe) (exc. H.B., Custom)	1653890	1	66.75	(comb. 26V) (blue)
75	Nova (Coupe) (exc. H.B., Custom)	1653891	1	66.75	(comb. 55V) (sandstone)
75	Nova (Coupe) (exc. H.B., Custom)	1653892	1	66.75	(comb. 63V) (saddle)
75	Nova (H.B.) (exc. Custom)	1653898	1	61.25	fldg. (comb. 19C) (black)
75	Nova (H.B.) (exc. Custom)	1653899	1	61.25	fldg. (comb. 26C) (blue)
75	Nova (H.B.) (exc. Custom)	1653900	1	61.25	fldg. (comb. 55C) (sandstone)
75	Nova (H.B.) (exc. Custom)	1654644	1	54.00	fldg. (comb. 19V) (black)
75	Nova (H.B.) (exc. Custom)	1654645	1	54.00	fldg. (comb. 26V) (blue)
75	Nova (H.B.) (exc. Custom)	1654646	1	54.00	fldg. (comb. 55V) (sandstone)
75	Nova (H.B.) (exc. Custom)	1654647	1	54.00	fldg. (comb. 63V) (saddle)
75	Nova (Custom) (Sedan)	1656529	1	174.00	(comb. 16G) (graystone)
75	Nova (Custom) (Sedan)	1656530	1	174.00	(comb. 26G) (blue)
75	Nova (Custom) (Sedan)	1656531	1	174.00	(comb. 55G) (sandstone)
75	Nova (Custom) (Sedan)	1656532	1	174.00	(comb. 73G) (oxblood)
75	Nova (Custom) (Sedan)	1656534	1	102.00	(comb. 26D) (blue)
75	Nova (Custom) (Sedan)	1656535	1	102.00	(comb. 44D) (green)
75	Nova (Custom) (Sedan)	1656536	1	102.00	(comb. 55D) (sandstone)
75	Nova (Custom) (Sedan)	1656538	1	87.50	(comb. 19W) (black)
75	Nova (Custom) (Sedan)	1656539	1	87.50	(comb. 55W) (sandstone)

**REAR TRIM—MATS—YARDAGE**

**15.000 TRIM ASSY.—FASTENER, Rear and Center Seat Back Cover (Con't)**

75	Nova (Custom) (Coupe) (exc. H.B.)	1656514	1	103.00	(comb. 26D) (blue)
75	Nova (Custom) (Coupe) (exc. H.B.)	1656515	1	103.00	(comb. 44D) (green)
75	Nova (Custom) (Coupe) (exc. H.B.)	1656516	1	103.00	(comb. 55D) (sandstone)
75	Nova (Custom) (Coupe) (exc. H.B.)	1656517	1	103.00	(comb. 63E) (saddle)
75	Nova (Custom) (Coupe) (exc. H.B.)	1656519	1	164.00	(comb. 16G) (graystone)
75	Nova (Custom) (Coupe) (exc. H.B.)	1656520	1	164.00	(comb. 26G) (blue)
75	Nova (Custom) (Coupe) (exc. H.B.)	1656521	1	164.00	(comb. 55G) (sandstone)
75	Nova (Custom) (Coupe) (exc. H.B.)	1656522	1	164.00	(comb. 73G) (oxblood)
75	Nova (Custom) (Coupe) (exc. H.B.)	1656524	1	89.25	(comb. 19W) (black)
75	Nova (Custom) (Coupe) (exc. H.B.)	1656525	1	89.25	(comb. 55W) (sandstone)
75	Nova (Custom) (Coupe) (exc. H.B.)	1656526	1	89.25	(comb. 63W) (saddle)
75	Nova (Custom) (Coupe) (exc. H.B.)	1656527	1	89.25	(comb. 73W) (oxblood)
75	Nova (Custom) (Coupe) (exc. H.B.)	1656513	1	103.00	(comb. 19E) (black)
75	Nova (Custom) (H.B.)	1656502	1	85.25	fldg. (comb. 19E) (black)
75	Nova (Custom) (H.B.)	1656503	1	85.25	fldg. (comb. 26D) (blue)
75	Nova (Custom) (H.B.)	1656504	1	85.25	fldg. (comb. 44D) (green)
75	Nova (Custom) (H.B.)	1656505	1	85.25	fldg. (comb. 55D) (sandstone)
75	Nova (Custom) (H.B.)	1656506	1	85.25	fldg. (comb. 63E) (saddle)
75	Nova (Custom) (H.B.)	1656508	1	75.25	fldg. (comb. 19W) (black)
75	Nova (Custom) (H.B.)	1656509	1	75.25	fldg. (comb. 55W) (sandstone)
75	Nova (Custom) (H.B.)	1656510	1	75.25	fldg. (comb. 63W) (saddle)
75	Nova (Custom) (H.B.)	1656511	1	75.25	fldg. (comb. 73W) (oxblood)

**CHEVELLE**

73	Malibu (Cpe.)				
74	Malibu (Classic) (Coupe)	9627658	1	71.75	(comb. 704, 707) (black)
73	Malibu (Cpe.)				
74	Malibu (Classic) (Coupe)	9627663	1	71.75	(comb. 714, 732) (neutral)
73	Malibu (Sed.)				
74	Malibu (Classic) (Sedan)	9627650	1	63.75	(comb. 704, 707) (black)
73	Malibu (Sed.)	9665208	1	63.75	(comb. 705) (blue)
73	Malibu (Sed.)				
74	Malibu (Classic) (Sedan)	9627653	1	63.75	(comb. 714, 732) (neutral)
73	Malibu (Sed.)	9627652	1	63.75	(comb. 721) (chamois)
73	Malibu, Laguna (Spt. Cpe.)				
74	Laguna (Cpe.)	9627674	1	89.00	(comb. 707, 708) (black)
73	Malibu, Laguna (Sed.)	9627667	1	90.75	(comb. 707) (black)
73	Malibu, Laguna (Sed.)	9627669	1	90.75	(comb. 734) (neutral)
73	Malibu (Sta. Wag.)	9665210	1	68.50	fldg. 2nd (comb. 705) (blue)
73	Malibu (Sta. Wag.)				
74	Malibu (Classic) (Sta. Wag.)	9627752	1	68.50	fldg. 2nd seat back (comb. 704, 707) (black)
73	Malibu (Sta. Wag.)				
74	Malibu (Classic) (Sta. Wag.)	9627755	1	68.50	fldg. 2nd seat back (comb. 714, 732) (neutral)
73	Malibu, Laguna (Sta. Wag.)	9666712	1	90.25	fldg. 2nd (comb. 734) (neutral)
73	Malibu, Laguna (Sta. Wag.)	9666708	1	90.25	fldg. 2nd (comb. 707) (black)
73-74	Monte Carlo	9627691	1	79.00	(comb. 708, 709) (black)
74	Malibu (Sedan) (exc. Classic)	9680605	1	68.75	(comb. 701) (black)
74	Malibu (Sedan) (exc. Classic)	9680606	1	68.75	(comb. 723) (green)
74	Malibu (Sedan) (exc. Classic)	9680615	1	67.25	(comb. 706) (black)
74	Malibu (Sedan) (exc. Classic)	9680616	1	67.25	(comb. 713, 745) (neutral)
74	Malibu (Sedan) (exc. Classic)	9680617	1	67.25	(comb. 727, 738) (green)
74	Malibu (Sedan) (exc. Classic)	1658481	1	67.25	(comb. 891) (black)
74	Malibu (Sedan) (exc. Classic)	1658482	1	67.25	(comb. 830, 892) (neutral)
74	Malibu (Sedan) (exc. Classic)	1658483	1	67.25	(comb. 893, 894) (green)
74	Malibu (Coupe) (exc. Classic)	9680753	1	67.00	(comb. 701) (black)
74	Malibu (Coupe) (exc. Classic)	9680754	1	67.00	(comb. 723) (green)
74	Malibu (Coupe) (exc. Classic)	9680766	1	71.25	(comb. 706) (black)
74	Malibu (Coupe) (exc. Classic)	9680767	1	71.25	(comb. 713, 745) (neutral)
74	Malibu (Coupe) (exc. Classic)	9680768	1	71.25	(comb. 727, 738) (green)
74	Malibu (Coupe) (exc. Classic)	9729948	1	71.25	(comb. 749) (mid. blue)
74	Malibu (Coupe) (exc. Classic)	1658485	1	71.25	(comb. 891) (black)

**REAR TRIM—MATS—YARDAGE**

**15.000 TRIM ASSY.—FASTENER, Rear and Center Seat Back Cover (Con't)**

74	Malibu (Coupe) (exc. Classic) . . .	1658486	1	71.25	(comb. 830, 892) (neutral) . . . . .
74	Malibu (Coupe) (exc. Classic) . . .	1658487	1	71.25	(comb. 893, 894) (green) . . . . .
74	Malibu (Coupe) (exc. Classic) . . .	1658488	1	71.25	(comb. 897) (mid. blue) . . . . .
74-75	Malibu (Classic) (Sedan) . . . . .	9680069	1	165.00	(comb. 702, 19D) (black) . . . . .
74	Malibu (Classic) (Sedan) . . . . .	9680070	1	165.00	(comb. 732) (midn. blue) . . . . .
74-75	Malibu (Classic) (Sedan) . . . . .	9680071	1	165.00	(comb. 724, 44D) (green) . . . . .
74	Malibu (Classic) (Sedan) . . . . .	9680072	1	165.00	(comb. 722) (neutral) . . . . .
74-75	Malibu (Classic) (Sedan) . . . . .	9729760	1	165.00	(comb. 743, 73D) (oxblood) . . . . .
74-75	Malibu (Classic) (Sedan) . . . . .	9729767	1	142.00	(comb. 707, 19W) (black) . . . . .
74	Malibu (Classic) (Sedan) . . . . .	9729768	1	142.00	(comb. 714) (neutral) . . . . .
74	Malibu (Classic) (Sedan) . . . . .	9729769	1	142.00	(comb. 740) (saddle) . . . . .
74	Malibu (Classic) (Sedan) . . . . .	9729770	1	142.00	(comb. 728) (green) . . . . .
74	Malibu (Classic) (Sedan) . . . . .	9736769	1	142.00	(comb. 747, 785) (white) . . . . .
74	Malibu (Classic) (Coupe) . . . . .	9680876	1	150.00	(comb. 722) (neutral) . . . . .
74	Malibu (Classic) (Coupe) . . . . .	9680877	1	115.00	(comb. 704) (black and white) . . . . .
74-75	Malibu (Classic) (Coupe) . . . . .	9680073	1	150.00	(comb. 702, 19D) (black) . . . . .
74	Malibu (Classic) (Coupe) . . . . .	9680074	1	150.00	(comb. 732) (midn. blue) . . . . .
74-75	Malibu (Classic) (Coupe) . . . . .	9680075	1	150.00	(comb. 724, 44D) (green) . . . . .
74	Malibu (Classic) (Coupe) . . . . .	9680076	1		(comb. 722) (neutral) . . . . .
74-75	Malibu (Classic) (Coupe) . . . . .	9729779	1	150.00	(comb. 743, 73D) (oxblood) . . . . .
74-75	Malibu (Classic) (Coupe) . . . . .	9729787	1	131.00	(comb. 707, 19W) (black) . . . . .
74	Malibu (Classic) (Coupe) . . . . .	9729788	1	131.00	(comb. 747, 785) (white) . . . . .
74	Malibu (Classic) (Coupe) . . . . .	9729789	1	131.00	(comb. 714) (neutral) . . . . .
74	Malibu (Classic) (Coupe) . . . . .	9729790	1	131.00	(comb. 740) (saddle) . . . . .
74	Malibu (Classic) (Coupe) . . . . .	9729791	1	131.00	(comb. 728) (green) . . . . .
74	Laguna (Coupe) . . . . .	9680943	1	115.00	(comb. 703) (black) . . . . .
74	Laguna . . . . .	9736772	1	89.00	(comb. 718) (saddle) . . . . .
74	Laguna . . . . .	9736774	1	115.00	(comb. 720) (oxblood) . . . . .
74	Laguna . . . . .	9736775	1	115.00	(comb. 731) (saddle) . . . . .
74	Monte Carlo . . . . .	9679951	1	97.75	(comb. 705) (black) . . . . .
74	Monte Carlo . . . . .	9679952	1	97.75	(comb. 726) (green) . . . . .
74	Monte Carlo . . . . .	9679953	1	97.75	(comb. 734) (midn. blue) . . . . .
74	Monte Carlo . . . . .	9679954	1	97.75	(comb. 744) (oxblood) . . . . .
74	Monte Carlo . . . . .	9680033	1	79.00	(comb. 730) (green) . . . . .
74	Monte Carlo . . . . .	9680034	1	79.00	(comb. 737) (midn. blue) . . . . .
74	Monte Carlo . . . . .	9680035	1	79.00	(comb. 716) (neutral) . . . . .
74	Monte Carlo . . . . .	9680036	1	79.00	(comb. 742) (saddle) . . . . .
74	Malibu (Sta. Wag.) (exc. Classic) . . .	9680772	1	66.25	fldg. 2nd (comb. 706) (black) . . . . .
74	Malibu (Sta. Wag.) (exc. Classic) . . .	9680773	1	66.25	fldg. 2nd (comb. 713, 745) (neutral) . . . . .
74	Malibu (Sta. Wag.) (exc. Classic) . . .	1658499	1	66.25	fldg. 2nd (comb. 891) (black) . . . . .
74	Malibu (Sta. Wag.) (exc. Classic) . . .	1658500	1	66.25	fldg. 2nd (comb. 830, 892) (neutral) . . . . .
74-75	Malibu (Classic) (Sta. Wag.) . . . . .	9729921	1	124.00	fldg. 2nd (comb. 707, 19W) (black) . . . . .
74	Malibu (Classic) (Sta. Wag.) . . . . .	9729922	1	124.00	fldg. 2nd (comb. 735) (mid. blue) . . . . .
74	Malibu (Classic) (Sta. Wag.) . . . . .	9729923	1	124.00	fldg. 2nd (comb. 714) (neutral) . . . . .
74	Malibu (Classic) (Sta. Wag.) . . . . .	9729924	1	124.00	fldg. 2nd (comb. 740) (saddle) . . . . .
74	Malibu (Classic) (Sta. Wag.) . . . . .	9729925	1	124.00	fldg. 2nd (comb. 728) (green) . . . . .
75	Malibu (Sedan) 1st design (exc. Classic) . . . . .	1667179	1	82.75	(comb. 19V) (black) (Note 1) . . . . .
75	Malibu (Sedan) 1st design (exc. Classic) . . . . .	1667180	1	82.75	(comb. 26V) (blue) (Note 1) . . . . .
75	Malibu (Sedan) 1st design (exc. Classic) . . . . .	1667181	1	82.75	(comb. 44V) (green) (Note 1) . . . . .
75	Malibu (Sedan) 1st design (exc. Classic) . . . . .	1667182	1	82.75	(comb. 55V) (sandstone) (Note 1) . . . . .
75	Malibu (Sedan) (2nd design) (exc. Classic) . . . . .	1708648	1	90.25	(comb. 19V) (black) (Note 1) . . . . .
75	Malibu (Sedan) (2nd design) (exc. Classic) . . . . .	1708649	1	90.25	(comb. 26V) (blue) (Note 1) . . . . .
75	Malibu (Sedan) (2nd design) (exc. Classic) . . . . .	1708650	1	90.25	(comb. 44V) (green) (Note 1) . . . . .
75	Malibu (Sedan) (2nd design) (exc. Classic) . . . . .	1708651	1	90.25	(comb. 55V) (sandstone) (Note 1) . . . . .
75	Malibu (Sedan) (exc. Classic) . . . . .	1667183	1	85.25	(comb. 19C) (black) . . . . .
75	Malibu (Sedan) (exc. Classic) . . . . .	1667184	1	85.25	(comb. 26C) (blue) . . . . .
75	Malibu (Coupe) (exc. Classic) . . . . .	1667185	1	80.25	(comb. 19C) (black) . . . . .
75	Malibu (Coupe) (exc. Classic) . . . . .	1667186	1	80.25	(comb. 26C) (blue) . . . . .
75	Malibu (Coupe) 1st design (exc. Classic) . . . . .	1667187	1	78.00	(comb. 19V) (black) (Note 1) . . . . .
75	Malibu (Coupe) 1st design (exc. Classic) . . . . .	1667188	1	78.00	(comb. 26V) (blue) (Note 1) . . . . .
75	Malibu (Coupe) 1st design (exc. Classic) . . . . .	1667189	1	78.00	(comb. 44V) (green) (Note 1) . . . . .
75	Malibu (Coupe) 1st design (exc. Classic) . . . . .	1667190	1	78.00	(comb. 55V) (sandstone) (Note 1) . . . . .



**REAR TRIM—MATS—YARDAGE**

**15.000 TRIM ASSY.—FASTENER, Rear and Center Seat Back Cover (Con't)**

75	Malibu (Coupe) (2nd design) (exc. Classic) . . . . .	1708652	1	88.25	(comb. 19V) (black) (Note 1) . . . . .
75	Malibu (Coupe) (2nd design) (exc. Classic) . . . . .	1708653	1	88.25	(comb. 26V) (blue) (Note 1) . . . . .
75	Malibu (Coupe) (2nd design) (exc. Classic) . . . . .	1708654	1	88.25	(comb. 44V) (green) (Note 1) . . . . .
75	Malibu (Coupe) (2nd design) (exc. Classic) . . . . .	1708655	1	88.25	(comb. 55V) (sandstone) (Note 1) . . . . .
75	Malibu (Classic) (Sedan) . . . . .	1667191	1	137.00	(comb. 26W) (blue) . . . . .
75	Malibu (Classic) (Sedan) . . . . .	1667192	1	137.00	(comb. 55W) (sandstone) . . . . .
75	Malibu (Classic) (Sedan) . . . . .	1667193	1	159.00	(comb. 16D) (graystone) . . . . .
75	Malibu (Classic) (Sedan) . . . . .	1667194	1	159.00	(comb. 26D) (blue) . . . . .
75	Malibu (Classic) (Coupe) . . . . .	1667195	1	126.00	(comb. 26W) (blue) . . . . .
75	Malibu (Classic) (Coupe) . . . . .	1667196	1	126.00	(comb. 55W) (sandstone) . . . . .
75	Malibu (Classic) (Coupe) . . . . .	1667197	1	126.00	(comb. 63W) (saddle) . . . . .
75	Malibu (Classic) (Coupe) . . . . .	1667198	1	145.00	(comb. 16D) (graystone) . . . . .
75	Malibu (Classic) (Coupe) . . . . .	1667199	1	145.00	(comb. 26D) (blue) . . . . .
75	Monte Carlo . . . . .	1667214	1	105.00	(comb. 19B) (black) . . . . .
75	Monte Carlo . . . . .	1667215	1	105.00	(comb. 26B) (blue) . . . . .
75	Monte Carlo . . . . .	1667216	1	105.00	(comb. 55B) (sandstone) . . . . .
75	Monte Carlo . . . . .	1667217	1	105.00	(comb. 73B) (oxblood) . . . . .
75	Monte Carlo . . . . .	1667219	1	90.50	(comb. 19H) (black) . . . . .
75	Monte Carlo . . . . .	1667220	1	90.50	(comb. 26H) (blue) . . . . .
75	Monte Carlo . . . . .	1667221	1	90.50	(comb. 55H) (sandstone) . . . . .
75	Monte Carlo . . . . .	1667222	1	90.50	(comb. 02H, 04H, 07H, 11H) (white) . . . . .
75	Monte Carlo . . . . .	1667532	1	159.00	(comb. 19N) (black) . . . . .
75	Monte Carlo . . . . .	1667533	1	159.00	(comb. 26N) (blue) . . . . .
75	Monte Carlo . . . . .	1667534	1	159.00	(comb. 44N) (green) . . . . .
75	Monte Carlo . . . . .	1667535	1	159.00	(comb. 55N) (sandstone) . . . . .
75	Monte Carlo . . . . .	1667536	1	159.00	(comb. 73N) (oxblood) . . . . .
75	Malibu (Sta. Wag.) 1st design (exc. Classic) . . . . .	1667546	1	84.00	fldg. 2nd (comb. 19V) (black) . . . . .
75	Malibu (Sta. Wag.) 1st design (exc. Classic) . . . . .	1667540	1	84.00	fldg. 2nd (comb. 55V) (sandstone) . . . . .
75	Malibu (Sta. Wag.) (2nd design) (exc. Classic) . . . . .	1708664	1	93.00	fldg. 2nd (comb. 19V) (black) (Note 1) . . . . .
75	Malibu (Sta. Wag.) (2nd design) (exc. Classic) . . . . .	1708665	1	93.00	fldg. 2nd (comb. 55V) (sandstone) (Note 1) . . . . .
75	Malibu (Classic) (Sta. Wag.) . . . . .	1667541	1	119.00	fldg. 2nd (comb. 26W) (blue) . . . . .
75	Malibu (Classic) (Sta. Wag.) . . . . .	1667542	1	119.00	fldg. 2nd (comb. 55W) (sandstone) . . . . .
75	Malibu (Classic) (Sta. Wag.) . . . . .	1667543	1	119.00	fldg. 2nd (comb. 63W) (saddle) . . . . .
75	Laguna . . . . .	1703338	1	108.00	(comb. 19Z) (black) . . . . .
75	Laguna . . . . .	1703334	1	130.00	(comb. 63E) (saddle) . . . . .
75	Laguna . . . . .	1703332	1	130.00	(comb. 07E, 11E) (black) . . . . .
75	Laguna . . . . .	1703337	1	108.00	(comb. 07Z, 11Z) (white) . . . . .
75	Laguna . . . . .	1703335	1	130.00	(comb. 73E) (oxblood) . . . . .
75	Laguna . . . . .	1703333	1	130.00	(comb. 19E) (black) . . . . .
75	Laguna . . . . .	1703339	1	108.00	(comb. 63Z) (saddle) . . . . .
75	Laguna . . . . .	1703340	1	108.00	(comb. 73Z) (oxblood) . . . . .

*NOTE 1: Seat back and cushion cover assemblies have been redesigned from horizontal to vertical pattern.*

**CAMARO**

74-75	Camaro (exc. L.T.) . . . . .	9686527	1	78.75	(comb. 777, 19V) (black) . . . . .
74	Camaro (exc. L.T.) . . . . .	9686528	1	78.75	(comb. 779) (black) . . . . .
74	Camaro (exc. L.T.) . . . . .	9686529	1	78.75	(comb. 781) (neutral) . . . . .
74	Camaro (exc. L.T.) . . . . .	9686530	1	78.75	(comb. 798) (saddle) . . . . .
74	Camaro (exc. L.T.) . . . . .	9686531	1	78.75	(comb. 787) (green) . . . . .
74	Camaro (exc. L.T.) . . . . .	9686532	1	78.75	(comb. 792) (red) . . . . .
74	Camaro (exc. L.T.) . . . . .	9687200	1	78.75	(comb. 775) (black and white) . . . . .
74	Camaro (exc. L.T.) . . . . .	9687258	1	78.75	(comb. 796) (saddle and black) . . . . .
74	Camaro (exc. L.T.) . . . . .	9687259	1	78.75	(comb. 786) (green and black) . . . . .
74	Camaro (exc. L.T.) (2nd design) . . . . .	1707457	1	99.25	(19C) (black) (Note 1) . . . . .
74	Camaro (L.T.) (1st design) . . . . .	9686576	1	98.25	(comb. 778) (black) (Note 1) . . . . .
74	Camaro (L.T.) (1st design) . . . . .	9686577	1	98.25	(comb. 799) (saddle) (Note 1) . . . . .
74	Camaro (L.T.) (1st design) . . . . .	9686578	1	98.25	(comb. 784) (taupe) (Note 1) . . . . .
74	Camaro (L.T.) (2nd design) . . . . .	1654191	1	98.25	(comb. 778) (black) (Note 1) . . . . .
74	Camaro (L.T.) (2nd design) . . . . .	1654192	1	98.25	(comb. 799) (saddle) (Note 1) . . . . .
74	Camaro (L.T.) (2nd design) . . . . .	1654193	1	98.25	(comb. 784) (taupe) (Note 1) . . . . .
74	Camaro (L.T.) . . . . .	9687268	1	98.25	(comb. 776) (black) . . . . .
74	Camaro (L.T.) . . . . .	9687269	1	89.25	(comb. 780) (neutral) . . . . .
74	Camaro (L.T.) . . . . .	9687270	1	98.25	(comb. 797) (saddle) . . . . .
74	Camaro (L.T.) . . . . .	9687271	1	98.25	(comb. 783) (taupe) . . . . .
75	Camaro (exc. L.T.) . . . . .	1663524	1	85.50	(comb. 19C) (black) . . . . .
75	Camaro (exc. L.T.) . . . . .	1663525	1	85.50	(comb. 55C) (sandstone) . . . . .
75	Camaro (exc. L.T.) . . . . .	1663527	1	81.00	(comb. 63V) (saddle) . . . . .

**REAR TRIM—MATS—YARDAGE**

**15.000 TRIM ASSY.—FASTENER, Rear and Center Seat Back Cover (Con't)**

75	Camaro (exc. L.T.)	1663528	1	81.00	(comb. 91V) (white)
75	Camaro (exc. L.T.)	1663526	1	81.00	(comb. 55V) (sandstone)
75	Camaro (L.T.)	1663529	1	113.00	(comb. 16D) (graystone)
75	Camaro (L.T.)	1663530	1	113.00	(comb. 55D) (sandstone)
75	Camaro (L.T.)	1663531	1	113.00	(comb. 63D) (saddle)
75	Camaro (L.T.)	1663532	1	113.00	(comb. 730) (oxblood)
75	Camaro (L.T.)	1663534	1	107.00	(comb. 55W) (sandstone)
75	Camaro (L.T.)	1663535	1	107.00	(comb. 63W) (saddle)
75	Camaro (L.T.) w/Custom Seat	1698558	1	271.00	(comb. 632) (saddle)
75	Camaro (L.T.) w/Custom Seat	1698559	1	271.00	(comb. 732) (oxblood) <sup>5</sup> / <sub>16</sub> inches

NOTE 1: 1st Design - Vertical Stitch Pattern <sup>1</sup>/<sub>16</sub>" width, 2nd Design - Vertical Stitch Pattern <sup>5</sup>/<sub>16</sub>" width.

**VEGA—MONZA**

73-74	Vega (H.B., Sta. Wag.)	9675162	1	102.00	folding (comb. 861, 884) (black)
73-74	Vega (N.B.)	9651845	1	117.00	(comb. 861, 884) (black)
74-75	Vega (N.B.)	9686549	1	60.25	(comb. 862, 19W) (black)
74	Vega (N.B.)	9686520	1	117.00	(comb. 880) (green)
74	Vega (N.B.)	9686550	1	60.25	(comb. 870, 881) (neutral)
74	Vega (N.B.)	9686551	1	60.25	(comb. 879) (green)
74	Vega (N.B.)	9686552	1	60.25	(comb. 888) (saddle)
74	Vega (N.B.)	9686585	1	138.00	(comb. 871) (black and white)
74	Vega (N.B.)	9686586	1	138.00	(comb. 887) (green and black)
74	Vega (N.B.)	9686595	1	58.25	(comb. 873) (black and white)
74	Vega (N.B.)	9686596	1	58.25	(comb. 883) (green and black)
74	Vega (N.B.)	9733032	1	117.00	(comb. 863) (neutral)
74	Vega (N.B.)	9733027	1	117.00	(comb. 890) (saddle)
74	Vega (H.B., Sta. Wag.)	9686598	1	51.50	(comb. 883) (green and black)
74-75	Vega (N.B.) w/Custom Trim	9732964	1	117.00	(comb. 861, 19Y) (black)
74	Vega (H.B.)	1674345	1	99.50	folding (comb. 867) (white)
74	Vega (H.B., Sta. Wag.)	9686521	1	102.00	folding (comb. 869) (black)
74	Vega (H.B., Sta. Wag.)	9686522	1	102.00	folding (comb. 880) (green)
74	Vega (H.B., Sta. Wag.)	9686523	1	102.00	folding (comb. 890) (saddle)
74	Vega (H.B., Sta. Wag.)	9686587	1	110.00	folding (comb. 871) (black and white)
74	Vega (H.B., Sta. Wag.)	9686588	1	110.00	folding (comb. 887) (green and black)
74	Vega (H.B., Sta. Wag.)	9686597	1	51.50	folding (comb. 873) (black and white)
74	Vega (H.B., Sta. Wag.)	9686553	1	48.75	folding (comb. 862) (black)
74	Vega (H.B., Sta. Wag.)	9686555	1	48.75	folding (comb. 879) (green)
74	Vega (H.B., Sta. Wag.)	9686556	1	48.75	folding (comb. 884) (red)
74	Vega (H.B., Sta. Wag.)	9686557	1	48.75	folding (comb. 888) (saddle)
74	Vega (H.B., Sta. Wag.)	9733033	1	102.00	folding (comb. 863) (neutral)
74-75	Vega (H.B., Sta. Wag.) w/Custom Trim	9732040	1	102.00	folding (comb. 861, 19Y) (black)
74	Vega (H.B., Sta. Wag.)	9731824	1	48.75	folding (comb. 881) (neutral)
75	Vega (N.B.)	1661592	1	58.00	(comb. 19D) (black)
75	Vega (N.B.)	1661593	1	58.00	(comb. 55D) (sandstone)
75	Vega (N.B.)	1661595	1	126.00	(comb. 19E) (black)
75	Vega (N.B.)	1661596	1	126.00	(comb. 55E) (sandstone)
75	Vega (N.B.) w/Custom Trim	1661621	1	107.00	(comb. 55Y) (sandstone)
75	Vega (N.B.) w/Custom Trim	1661622	1	107.00	(comb. 63Y) (saddle)
75	Vega (exc. Panel) (1st design)	1661599	1	63.75	(comb. 26W) (blue) (Note 2)
75	Vega (exc. Panel) (1st design)	1661600	1	63.75	(comb. 55W) (sandstone) (Note 1)
75	Vega (exc. Panel) (1st design)	1661601	1	63.75	(comb. 63W) (saddle) (Note 2)
75	Vega (exc. Panel) (2nd design)	1708209	1	60.75	(comb. 19W) (black) (Note 2)
75	Vega (exc. Panel) (2nd design)	1708210	1	60.75	(comb. 26W) (blue) (Note 2)
75	Vega (exc. Panel) (2nd design)	1708211	1	60.75	(comb. 55W) (sandstone) (Note 1)
75	Vega (exc. Panel) (2nd design)	1708212	1	60.75	(comb. 63W) (saddle) (Note 2)
75	Monza (Towne Cpe.)	1747152	1	142.00	(comb. 07H, 11H) (white) (repl. 1706505)
75	Monza (Towne Cpe.)	1747153	1	142.00	(comb. 19H) (black) (repl. 1706507)
75	Monza (Towne Cpe.)	1706508	1	127.00	(comb. 64H) (buckskin)
75	Monza (Towne Cpe.)	1706509	1	127.00	(comb. 71H) (firethorn)
75	Monza (Towne Cpe.)	1706511	1	135.00	(comb. 19N) (black)
75	Monza (Towne Cpe.)	1747158	1	133.00	(comb. 64N) (buckskin) (repl. 1706572)
75	Monza (Towne Cpe.)	1706513	1	135.00	(comb. 71N) (firethorn)
75	Monza (Towne Cpe.)	1706515	1	.70	(comb. 193) (black)
75	Monza (Towne Cpe.)	1706516	1	263.00	(comb. 643) (buckskin)
75	Vega (Sta. Wag.)	1661603	1	56.75	folding (comb. 19D) (black)
75	Vega (H.B., Sta. Wag.)	1661604	1	56.75	folding (comb. 55D) (sandstone)
75	Vega (H.B., Sta. Wag.)	1661606	1	112.00	folding (comb. 19E) (black)
75	Vega (H.B., Sta. Wag.)	1661607	1	112.00	folding (comb. 55E) (sandstone)
75	Vega (H.B., Sta. Wag.) w/Custom Trim	1661617	1	99.50	folding (comb. 55Y) (sandstone)
75	Vega (H.B., Sta. Wag.)	1661618	1	99.50	folding (comb. 63Y) (saddle)
75	Vega (Sta. Wag.)	1696769	1	99.50	folding (comb. 11Y) (white)
75	Vega (H.B., Sta. Wag.)	1694440	1	99.50	folding (comb. 02Y) (white)
75	Vega (H.B., Sta. Wag.)	1694544	1	133.00	folding (comb. 26B, 26W) (blue)

**REAR TRIM—MATS—YARDAGE**

**15.000 TRIM ASSY.—FASTENER, Rear and Center Seat Back Cover (Con't)**

75	Vega (H.B., Sta. Wag.)	1694545	1	133.00	folding (comb. 55B, 55Y) (sandstone)
75	Vega (H.B., Sta. Wag.)	1694546	1	133.00	folding (comb. 73B, 73Y) (oxblood)
75	Monza (exc. Towne Cpe.)	1700434	1		folding (comb. 02J) (white)
75	Monza (exc. Towne Cpe.)	1700436	1	157.00	folding (comb. 07J) (white)
75	Monza (exc. Towne Cpe.)	1700437	1	157.00	folding (comb. 11J) (white)
75	Monza (exc. Towne Cpe.)	1663478	1	166.00	folding (comb. 26G) (blue)
75	Monza (exc. Towne Cpe.)	1663479	1	166.00	folding (comb. 55G) (sandstone)
75	Monza (exc. Towne Cpe.)	1663480	1	166.00	folding (comb. 63G) (saddle)
75	Monza (exc. Towne Cpe.)	1663481	1	166.00	folding (comb. 73G) (oxblood)
75	Monza (exc. Towne Cpe.)	1663483	1	157.00	folding (comb. 16Z) (graystone)
75	Monza (exc. Towne Cpe.)	1663484	1	157.00	folding (comb. 26Z) (blue)
75	Monza (exc. Towne Cpe.)	1663485	1	157.00	folding (comb. 55Z) (sandstone)
75	Monza (exc. Towne Cpe.)	1663486	1	157.00	folding (comb. 63Z) (saddle)
75	Monza (exc. Towne Cpe.)	1663487	1	157.00	folding (comb. 73Z) (oxblood)
75	Monza (exc. Towne Cpe.)	1663477	1	166.00	folding (comb. 16G) (graystone)
75	Monza (exc. Towne Cpe.)	1700445	1	284.00	folding (comb. 732) (oxblood)
75	Monza (exc. Towne Cpe.)	1700444	1	284.00	folding (comb. 632) (saddle)
75	Monza (exc. Towne Cpe.)	1700443	1	284.00	folding (comb. 192) (black)
75	Monza (exc. Towne Cpe.)	1700582	1	166.00	folding (comb. 19G) (black)
75	Monza (exc. Towne Cpe.)	1700583	1	157.00	folding (comb. 19Z) (black)
75	Vega (H.B., Sta. Wag.) (1st design)	1661609	1	61.75	folding (comb. 19W) (black) (Note 2)
75	Vega (H.B., Sta. Wag.) (1st design)	1661610	1	61.75	folding (comb. 26W) (blue) (Note 2)
75	Vega (H.B., Sta. Wag.) (1st design)	1661612	1	61.75	folding (comb. 63W) (saddle) (Note 2)
75	Vega (H.B., Sta. Wag.) (1st design)	1661611	1	61.75	folding (comb. 55W) (sandstone) (Note 2)
75	Vega (H.B., Sta. Wag.) (2nd design)	1708213	1	71.25	folding (comb. 19W) (black) (Note 2)
75	Vega (H.B., Sta. Wag.) (2nd design)	1708214	1	71.25	folding (comb. 26W) (blue) (Note 2)
75	Vega (H.B., Sta. Wag.) (2nd design)	1708215	1	71.25	folding (comb. 55W) (sandstone) (Note 2)
75	Vega (H.B., Sta. Wag.) (2nd design)	1708216	1	71.25	folding (comb. 63W) (saddle) (Note 2)
<i>NOTE 2: Seat back and cushion assemblies design change from vertical to horizontal by rotating pattern 90°.</i>					
65-67	Chevelle (Conv.)	7631319	2	.24	<b>FASTENER</b> , w/screw, back of rr. back foundation— (13.384)

**15.002 PAD ASSY., Rear Seat Back**

71-74	Caprice (Spt. Cpe.)	9615746	1	37.75	
71-72	Caprice (Spt. Cpe.)				
75	Caprice (Sedan)	1654829	1	52.25	wire
71-74	Impala (Spt. Cpe.) Pass. (Conv.)	9639375	1	48.75	
71-75	Impala (Sed.), Bel Air (Sed.)	9644280	1	44.00	
71-75	Pass. (Sta. Wag.) (6-Pass.)	9638290	1	27.00	fldg. 2nd seat back
71-75	Pass. (Sta. Wag.) (6-Pass.)	9638567	1	4.95	fldg. 2nd seat back rear upper
71-75	Pass. (Sta. Wag.) (9-Pass.)	9638289	1	25.75	fldg. 2nd 2/3 seat back
71-75	Pass. (Sta. Wag.) (9-Pass.)	9638288	1	15.55	fldg. 2nd 1/3 seat back
71	Vega (N.B.)				
71-72	Vega (Sta. Wag., H.B.)	9821363	1	20.15	
71	Vega (N.B.)				
72-74	Vega (N.B.) (exc. Custom Seat)	9638594	1	24.15	
72	Impala (Sed.)	9837767	1	46.75	
73-74	Caprice (Sed.)	9620400	1	47.50	wire
73	Deluxe (Coupe)				
74-75	Chevelle (Coupe) (exc. Classic)	9613068	1	26.00	
73-74	Nova (H.B.)	9622100	1	24.75	
73-74	Nova (Cpe.) (exc. H.B.)	9613129	1	29.75	
73-75	Nova (Sed.)	9669747	1	37.50	
73-74	Nova (Sed.) (Taxi) (exc. Custom)	9658375	1	24.05	
73	Impala, Caprice (Sta. Wag.) (6-Pass.)				
73-74	Laguna (Spt. Sed.)				
74-75	Malibu (Sedan) (exc. Classic)	9613066	1	42.75	
74	Malibu (Classic) (Sedan)	9613067	1	33.75	
74-75	Malibu (Classic) (Sedan)	9685042	1	48.00	rr. st. bk. wire
74-75	Malibu (Classic) (Cpe.)	9651813	1		(repl. 9613069)
74-75	Monte Carlo	9728445	1	45.00	wire
74-75	Chevelle (Sta. Wag.)	9728997	1	24.15	fldg. 2nd
73-74	Chevelle (Sta. Wag.)	9644669	1	.43	fldg. 2nd upper
73-75	Chevelle (Sta. Wag.)	1669518	1	11.65	fldg. 3rd
73-74	Vega (Sta. Wag., H.B.)	9638565	1	26.00	
74-75	Vega (N.B.)	1689760	1	32.50	wire

**REAR TRIM—MATS—YARDAGE**

**15.002 PAD ASSY., Rear Seat Back (Con't)**

74-75	Vega (N.B.) w/Custom Seat . . . . .	1689761	1	50.00	
74-75	Vega (Sta. Wag., H.B.) . . . . .	9695841	1	39.25	folding . . . . .
74-75	Camaro . . . . .	9679612	1	43.25	
74-75	Pass. (Sta. Wag.) (9-Pass.) . . . . .	9675939	1	20.75	fldg. 3rd . . . . .
75	Monte Carlo . . . . .	1661524	1	44.75	wire . . . . .
75	Nova (H.B.) . . . . .	9677701	1	35.75	fldg. . . . .
75	Nova (Cpe. exc. H.B.) . . . . .	9669748	1	37.50	
75	Monza (Towne Cpe.) . . . . .	1698696	1	36.75	wire . . . . .
75	Vega, Monza . . . . .	1657569	1	21.60	folding . . . . .

**15.011 CAP— MOULDING— MOULDING ASSY., Rear Seat Back**

71-74	Vega (N.B., Sta. Wag.) . . . . .	9832706	1	2.15	finish side . . . . .
71-74	Vega (N.B., Sta. Wag.) . . . . .	9832705	2	4.25	finish corner . . . . .
71-73	Vega (N.B., Sta. Wag.) . . . . .	9832704	1	3.25	finish upper . . . . .
73-75	Nova (H.B.) . . . . .	9832705	2	4.25	finish fldg. cor. . . . .
73-75	Nova (H.B.) . . . . .	9832706	2	2.15	finish fldg. side . . . . .
73-75	Nova (H.B.) . . . . .	9638202	1	6.30	finish fldg. upper . . . . .

**15.024 TRIM ASSY.— FOUNDATION— CLIP— RETAINER, Rear Seat Back  
Compartment Shelf Foundation**

**PASS.**

65-66	Impala (Sed.) (exc. Spt. Sed.) . . . . .	7692855	1	9.90	(comb. 811) (black) . . . . .
65-66	Spt. Sed. (exc. Caprice) . . . . .	9643456	1	13.15	(comb. 811, 814) (black) . . . . .
65-66	Spt. Cpe. . . . .	7692867	1	9.90	(comb. 802, 811, 813, 814, 815, 885) (black) . . . . .
65-66	Spt. Cpe. . . . .	7692869	1	9.75	(comb. 831, 837, 842) (blue) . . . . .
67-68	Sed. (exc. Spt. Sed.) . . . . .	7662302	1	9.90	(comb. 802, 803, 805, 806, 811, 812, 819, 829) (black) . . . . .
67-68	Impala (Spt. Cpe.) (exc. Custom) . . . . .	7662307	1	10.80	(comb. 805, 806, 811, 812, 813, 814, 858, 859, 870, 874, 895, 898) (black) . . . . .
69	4-Dr. Sed. (exc. Spt. Sed.) . . . . .	8757796	1	10.70	(comb. 802, 810, 829, 803, 804, 805, 806) (black) . . . . .
69	4-Dr. Sed. (exc. Spt. Sed.) . . . . .	8757797	1	11.10	(comb. 816, 818, 819, 820, 821) . . . . .
69	4-Dr. Sed. (exc. Spt. Sed.) . . . . .	8757798	1	11.35	(comb. 849, 850, 852) . . . . .
69	Impala (Spt. Cpe.) (exc. Custom) . . . . .	8762248	1	20.10	(comb. 805, 806, 812, 858, 859) . . . . .
69	Impala (Custom), Caprice (Spt. Cpe.) . . . . .	8803787	1		(med. blue) . . . . .
69	Impala (Custom), Caprice (Spt. Cpe.) . . . . .	8803790	1		(dk. green) . . . . .
69-70	Impala (Spt. Sed.) . . . . .	9818773	1	11.90	(comb. 805, 806) (black) . . . . .
70	Biscayne, Bel Air, Impala (Sed.) (exc. Spt. Sed.) . . . . .	9818757	1	11.90	(comb. 802, 803, 804, 805, 806, 810, 829) (black) . . . . .
70	Impala (Spt. Cpe.) (exc. Custom) . . . . .	9816294	1	20.55	(comb. 805, 806) (black) . . . . .
70	Bel Air, Impala (Sed.) (exc. Spt. Sed.) . . . . .	9818760	1	11.90	(comb. 848, 860) (dk. green) . . . . .
70	Impala (Spt. Sed.) . . . . .	9818778	1	11.90	(comb. 860, 861) (dk. green) . . . . .
71-74	(Sed.) (exc. Spt. Sed.) . . . . .	9643456	1	13.15	(black) (repl. 9865633) . . . . .
71-72	Impala (Spt. Sed.) . . . . .	9865664	1	15.70	(black) . . . . .
71-72	Impala (Spt. Sed.) . . . . .	9893619	1	15.75	(dk. blue) (repl. 9865665) . . . . .
71-72	Impala (Spt. Sed.) . . . . .	9865667	1	15.70	(dk. saddle) . . . . .
71	Caprice (Sed.) . . . . .	9643426	1	28.00	(black) . . . . .
71-73	Impala (Custom) Caprice (Spt. Cpe.) . . . . .	9643471	1	23.90	(black) . . . . .
71-72	Impala (Spt. Cpe.) (exc. Custom) . . . . .	9865678	1	16.15	(black) . . . . .
71-72	Impala (Spt. Cpe.) (exc. Custom) . . . . .	9643446	1	16.20	(dk. saddle) (repl. 9865681) . . . . .
72-73	Impala (Spt. Cpe.) (exc. Custom) . . . . .	9643442	1	16.20	(covert-neutral) (repl. 9893622) . . . . .
72	(Sed.) (exc. Spt. Sed.) . . . . .	9643457	1	13.15	(covert) (comb. 815, 816, 817, 818) (repl. 9893608) . . . . .
72	(Sed.) (exc. Spt. Sed.) . . . . .	9893609	1	13.15	(green) . . . . .
72	Impala, Caprice (Spt. Sed.) . . . . .	9643436	1	15.85	(covert) (comb. 815, 818, 819) (repl. 9893611) . . . . .
72	Impala, Caprice (Spt. Sed.) . . . . .	9893613	1	15.75	(green) (comb. 829, 830, 831, 833) . . . . .
72	Impala (Spt. Cpe.) (exc. Custom) . . . . .	9893621	1	16.40	(dk. blue) . . . . .
73	Bel Air (Sed.) . . . . .	9643460	1	13.15	(comb. 810) (blue) . . . . .
73	Impala (Spt. Cpe.) (exc. Custom) . . . . .	9643441	1	16.20	(comb. 802, 805, 806) (black) . . . . .
73	Impala (Spt. Cpe.) (exc. Custom) . . . . .	9643443	1	16.20	(comb. 829, 830) (green) . . . . .
73	Impala (Spt. Cpe.) (exc. Custom) . . . . .	9643444	1	16.20	(comb. 812, 813) (midn. blue) . . . . .
73-74	Pass. (Spt. Sed.) . . . . .	9643435	1	15.85	(comb. 812, 813, 843, 847) (midn. blue) . . . . .
73	Pass. (Spt. Sed.) . . . . .	9643434	1	15.85	(comb. 829, 830, 842) (green) . . . . .
73-74	Pass. (Spt. Sed.) . . . . .	9643436	1	15.85	(comb. 815, 818, 819, 821, 841) (neutral) . . . . .
73-74	Pass. (Spt. Sed.) . . . . .	9643433	1	15.85	(comb. 802, 805, 806, 808, 840) (black) . . . . .
73-74	Caprice (Spt. Sed.) . . . . .	9643437	1	15.85	(comb. 836, 857) (oxblood) . . . . .

**REAR TRIM—MATS—YARDAGE**

**15.024 TRIM ASSY.— FOUNDATION— CLIP— RETAINER, Rear Seat Back  
Compartment Shelf Foundation (Con't)**

73-74	Caprice (Sed.) (exc. Spt. Sed.)	9643463	1	13.15	(comb. 836) (oxblood)
73-74	Impala, Caprice (Sed.) (exc. Spt. Sed.)	9643462	1	13.15	(comb. 812, 813, 843) (midn. blue)
73	Pass. (Sed.) (exc. Spt. Sed.)	9643459	1	13.15	(comb. 827, 828, 829, 830, 842) (green)
74	Pass. (Sed.) (exc. Spt. Sed.)	9685461	1	13.15	(comb. 850, 851, 852, 853, 855) (green)
74	Impala (Custom)	1667471	1	19.70	(comb. 849, 858) (saddle)
74-75	Impala (Custom), Caprice (Spt. Cpe.)	9685401	1	15.85	(comb. 802, 805, 806, 808, 840) 11W, 19 (black)
74	Impala (Custom)	9685402	1	15.85	(comb. 813, 843, 847) (mid. blue)
74	Impala (Custom), Caprice (Spt. Cpe.)	1667468	1	16.35	(comb. 819, 821, 841) (neutral)
74-75	Impala (Spt. Cpe.) (exc. Custom)	9691496	1	16.20	(comb. 802, 805, 806) 11W, 19W (black)
74	Impala (Spt. Cpe.) (exc. Custom)	9691497	1	16.20	(comb. 804, 813, 847) (mid. blue)
74	Impala (Spt. Cpe.) (exc. Custom)	9691498	1	16.20	(comb. 819) (neutral)
74	Impala (Spt. Cpe.) (exc. Custom)	9735052	1	16.20	(comb. 849, 858) (saddle)
74-75	Impala (Spt. Cpe.) (exc. Custom)	9691499	1	16.20	(comb. 853, 855) 04W, 44 (green)
74	Impala (Spt. Cpe.) (exc. Custom)	1667390	1	16.35	(comb. 809) (white)
74	Caprice (Sed.) (exc. Spt. Sed.)	9685460	1	13.15	(comb. 896) (taupe)
74	Caprice (Spt. Sed.)	9685417	1	15.85	(comb. 896) (taupe)
74	Caprice (Spt. Cpe.)	1667469	1	26.75	(comb. 896) (taupe)
74-75	Caprice (Spt. Cpe.), Impala (Custom)	9685405	1	15.85	(comb. 857) 07W, 73B (oxblood)
74	Caprice (Spt. Cpe.), Impala (Custom)	1667470	1	16.35	(comb. 850, 853, 855) (green)
74	Pass. (Spt. Sed.)	9685418	1	15.85	(comb. 850, 853, 855) (green)
74	Impala (Spt. Sed.)	9685416	1	15.85	(comb. 849) (saddle)
74	Impala (Sedan) (exc. Spt. Sed.)	9685459	1	13.15	(comb. 849) (saddle)
73	Impala, Caprice (Sed.) (exc. Spt. Sed.)	9643457	1	13.15	(comb. 815, 818, 841) (neutral)
75	Pass. (Spt. Sed.)	1677048	1	15.25	(comb. 55) (sandstone)
75	Pass. (Spt. Sed.)	1677050	1	15.25	(comb. 19) (black)
75	Pass. (Spt. Sed.)	1677047	1	15.25	(comb. 26) (blue)
75	Pass. (Sedan) (exc. Spt. Sed.)	1678347	1	13.45	(comb. 19) (black)
75	Pass. (Sedan) (exc. Spt. Sed.)	1678344	1	13.45	(comb. 26) (blue)
75	Pass. (Sedan) (exc. Spt. Sed.)	1678345	1	13.45	(comb. 55) (sandstone)
75	Impala (Custom), Caprice (Spt. Cpe.)	1731103	1	24.45	(comb. 02W, 26B, 26D, 26W) (blue) (repl. 1669222)
75	Impala (Custom), Caprice (Spt. Cpe.)	1669223	1	15.25	(comb. 55) (sandstone)
75	Impala (Custom), Caprice (Spt. Cpe.)	1667470	1	16.35	(comb. 04W, 44D, 44W, 44B) (green)
75	Impala (Spt. Sed.)	1677076	1	15.25	(comb. 63) (saddle)
75	Impala, Caprice (Spt. Sed.)	1677078	1	15.25	(comb. 44) (green)
75	Impala (4-Dr.)	1678348	1	13.45	(comb. 63) (saddle)
75	Impala (Custom)	1669225	1	15.25	(comb. 63E, 63W) (saddle)
75	Impala (Spt. Cpe.) (exc. Custom)	1668396	1	15.70	(comb. 55D, 55W) (sandstone)
75	Impala (Spt. Cpe.) (exc. Custom)	1668397	1	15.70	(comb. 63E, 63W) (saddle)
75	Impala (Spt. Cpe.) (exc. Custom)	1668394	1	15.70	(comb. 07W) (white)
75	Caprice (Sedan) (exc. Spt. Sed.)	1678346	1	13.45	(comb. 73) (oxblood)
75	Impala, Caprice (Sedan) (exc. Spt. Sed.)	1678349	1	13.45	(comb. 44) (green)
75	Caprice (Spt. Sed.)	1677049	1	15.25	(comb. 73B) (oxblood)

**CHEVY— NOVA**

68-69	Chevy (Spt. Cpe.)				(comb. 731, 732, 733, 734, 735), (black) (repl. 9849768) (Note 1)
68-69	Chevy (4-Dr.)	9644463		9.00	(comb. 731D, 733D, 735D) (Note 1)
68	Chevy (Spt. Cpe.)				(comb. 730, 731, 732, 733) (black)
69	Chevy (Spt. Cpe.)	7771785	1	8.45	(comb. 730, 731, 732, 733) (black)
70	Nova (2-Dr.)	7771785	1	8.45	(comb. 730, 731, 732, 733, 737) (black)
70-74	Nova (4-Dr.)	9644463	1	9.00	(black) (repl. 9849768) (Note 1)
71	Nova (2-Dr.)	9849724	1	10.15	(comb. 763, 764) (lt. sandalwood)
71-72	Nova (2-Dr.)				(comb. 750, 751, 752, 753, 767) (black)
73-74	Nova (Cpe.) (exc. H.B.)	9644457	1	9.90	(comb. 751, 752, 754, 755, 19X) (black)
72	Nova (2-Dr.)	9892701	1	9.60	(comb. 756) (blue)
72	Nova (2-Dr.)	9892702	1	9.60	(comb. 759, 760, 761) (green)
72	Nova (2-Dr.)	9892703	1	9.60	(comb. 763, 764, 765) (covert)
72	Nova (4-Dr.)				
73	Nova (Custom Sed.)				
74	Nova (Sedan)	9644465	1	9.00	(comb. 763, 764, 769, 60X) (neutral)
73	Nova (Cpe.) (exc. H.B.)	9644458	1	9.90	(comb. 759, 760, 761) (green)
73-74	Nova (Cpe.) (exc. H.B.)	9644461	1	9.90	(comb. 763, 764, 766, 771, 60X) (neutral)

**REAR TRIM—MATS—YARDAGE**

**15.024 TRIM ASSY.— FOUNDATION— CLIP— RETAINER, Rear Seat Back  
Compartment Shelf Foundation (Con't)**

73	Nova (Cpe.) (exc. Custom H.B.)	9644459	1	9.90	(comb. 767) (chamois)
73	Nova (Cpe.) (exc. Custom H.B.)	9644460	1	9.90	(comb. 756) (blue)
73	Nova (Sed.) (exc. Custom)	9644466	1	9.00	(comb. 772) (blue)
74	Nova (Sedan)	9685411	1	9.00	(comb. 756, 757, 758) (green)
74	Nova (Sedan) (exc. Custom)	9685412	1	9.00	(comb. 772) (mid. blue)
74	Nova (Coupe) (exc. H.B.)	9685407	1	9.90	(comb. 755, 759) (green)
74	Nova (Coupe) (exc. H.B.)	9685408	1	9.90	(comb. 772) (mid. blue)
75	Nova (Coupe) (exc. H.B.)	1668876	1	9.00	FOUNDATION (black) (paint)
75	Nova (Sedan)	1662993	1	9.60	FOUNDATION (black) (paint)
75	Nova (Sedan)	1662996	1	9.60	FOUNDATION (44D) (green)
75	Nova (Sedan)	1662997	1	9.60	FOUNDATION (16G) (graystone)
75	Nova (Coupe) (exc. H.B.)	1668877	1	9.60	FOUNDATION (63) (saddle)
75	Nova (Coupe) (exc. H.B.)	1668882	1	9.60	FOUNDATION (55) (sandstone)

**CHEVELLE**

68	Malibu (Spt. Sed.)	9849702	1		(black)
68-72	Chevelle (Spt. Cpe.)	9847251	1	10.50	(black) (repl. 8743566)
69-72	Chevelle (4-Dr. Sed.)	9847252	1	10.50	(comb. 701, 703, 704, 705, 751, 752, 753, 754, 755, 757, 797) (black)
69	Chevelle (2-Dr.)	8743568	1	9.75	(comb. 783, 784, 785, 786) (med. green)
70	Chevelle (Spt. Cpe.)	8803010	1	10.15	(comb. 758, 760, 762, 767) (med. blue)
70	Chevelle (Spt. Cpe.)	8803012	1	10.15	(comb. 780, 782, 784, 786, 795, 796) (dk. green)
70	Malibu, Monte Carlo (Spt. Cpe.)	8803011	1	10.15	(comb. 774, 775, 776) (med. gold)
71	Chevelle (Spt. Cpe.)	9844553	1	10.50	(comb. 714, 715, 716, 717, 718) (lt. sandalwood)
72	Chevelle (Spt. Cpe.)	9897595	1	10.50	(comb. 710, 711, 713, 715, 717) (green)
72	Monte Carlo	9897597	1	9.90	(comb. 732) (covert)
72	Malibu (Sed.)	9897600	1		(comb. 730, 732) (covert)
73-75	Chevelle (Coupe) (exc. Monte Carlo)	9662004	1	11.60	(black)
73	Chevelle (Coupe) (exc. Monte Carlo)	9662005	1	11.60	(comb. 710, 711, 713, 726, 727, 730) (green)
73	Chevelle (Coupe) (exc. Monte Carlo)				
74	Malibu (Coupe)	9662006	1	11.60	(comb. 713, 714, 722, 732, 733, 734, 892) (neutral)
73-75	Chevelle (Sedan)	9662031	1	9.90	(black)
73	Chevelle (Sedan)	9662032	1	9.90	(comb. 710, 711, 713, 726, 727, 730) (green)
73	Malibu (Coupe)	9662008	1	11.60	(comb. 716, 721) (chamois)
73	Malibu, Laguna (Sedan)				
74	Chevelle (Sedan)	9662035	1	9.90	(comb. 711, 713, 714, 715, 722, 732, 734, 892) (neutral)
73	Malibu, Laguna (Sedan)	9662034	1	9.90	(comb. 705, 719, 723, 724) (med. blue)
73	Malibu, Laguna (Coupe)	9662009	1	11.60	(comb. 717, 720) (saddle)
73	Malibu, Laguna (Coupe)	9662007	1	11.60	(comb. 705, 719, 723, 724) (med. blue)
73-75	Laguna (Coupe)				
74-75	Malibu (Classic) (Coupe)	9662010	1	11.60	(comb. 709, 714, 719, 720, 743) 07, 73 (oxblood)
73	Laguna (Sedan)				
74	Malibu (Classic) (Sedan)	9662037	1	9.90	(comb. 709, 714, 743) (oxblood)
74	Malibu (Classic) (Sedan)	9662038	1	9.90	(732, 785) (midnight blue)
74	Malibu (Coupe)	9662178	1	11.60	(732, 749, 785, 897) (midnight blue)
74-75	Chevelle (Sedan)	9685415	1	9.90	(comb. 723, 724, 727, 728, 745, 830, 893, 44) (green)
74	Malibu (Classic) (Sedan)	9685414	1	9.90	(comb. 740) (saddle)
74	Malibu, Laguna (Coupe)	9687374	1	11.60	(comb. 718, 731, 740) (saddle)
74	Malibu (Coupe)				
75	Chevelle (Coupe)	9685465	1	11.60	(comb. 723, 724, 727, 728, 745, 830, 893, 44) (green)
75	Chevelle (Sedan)	1672692	1	9.55	(comb. 55) (sandstone)
75	Chevelle (Coupe)	1672708	1	11.20	(comb. 26) (blue)
75	Malibu (Coupe)	1672710	1	11.20	(comb. 55) (sandstone)
75	Malibu (Classic) (Coupe)	1672711	1	11.20	(comb. 16D) (graystone)
75	Chevelle (Sedan)	1672693	1	11.20	(comb. 26) (blue)
75	Malibu (Classic) (Sedan)	1672690	1	11.20	(comb. 16D) (graystone)
73-75	Monte Carlo	9646576	1	9.25	FOUNDATION ASSY. (black) (paint)
73-74	Monte Carlo	9646578	1	9.55	FOUNDATION ASSY. (comb. 725, 734, 737) (mid. blue)
73	Monte Carlo	9646579	1	9.25	FOUNDATION ASSY. (comb. 715, 728) (green)

**REAR TRIM—MATS—YARDAGE**

**15.024 TRIM ASSY.— FOUNDATION— CLIP— RETAINER, Rear Seat Back  
Compartment Shelf Foundation (Con't)**

73-74	Monte Carlo	9646581	1	9.25	FOUNDATION ASSY. (comb. 716, 731, 735) (neutral)
74	Monte Carlo	9697453	1	10.15	FOUNDATION ASSY. (comb. 742) (saddle)
74-75	Monte Carlo	9697455	1	10.15	FOUNDATION ASSY. (comb. 726, 730, 04H, 44N) (green)

**CAMARO**

67-69	Camaro (Spt. Cpe.)	7666129	1	7.85	(comb. 706, 711, 712, 713, 714, 715, 716, 727, 729, 730, 749, 756, 760, 765, 767, 797) (black)
70	Camaro	9819403	1	7.80	(comb. 714, 715, 716) (blue)
70	Camaro	9819405	1	7.80	(comb. 720, 723, 724) (green)
70-72	Camaro	9644468	1	8.95	(comb. 775, 785, 789) (black)
71	Camaro	9849773	1	9.40	(comb. 776, 786) (dk. blue)
71	Camaro	9849776	1	9.40	(comb. 779, 792) (dk. saddle)
72	Camaro	9600339	1	8.95	(comb. 776, 786) (dk. blue)
72	Camaro	9600341	1	8.95	(comb. 779, 788) (covert)
73-74	Camaro	9644468	1	8.95	(comb. 773, 774, 775, 776, 777, 778, 779, 785, 786) (black)
73	Camaro	9644470	1	8.95	(comb. 777, 781) (green)
73-74	Camaro	9644469	1	8.95	(comb. 779, 780, 781, 788) (neutral)
73	Camaro (exc. L.T.),				
75	Camaro	9644471	1	8.95	(comb. 778) 63 (saddle)
74	Camaro	9688270	1	8.95	(comb. 796, 797, 798, 799) (saddle)
74	Camaro (exc. L.T.)	9688274	1	8.95	(comb. 792) (red)
74	Camaro (exc. L.T.)	9688273	1	8.95	(comb. 786, 787) (green)
74	Camaro (L.T.)	9688272	1	8.95	(comb. 783, 784) (taupe)
75	Camaro	1669542	1	8.65	(comb. 55C, 55V, 55D) (sandstone)
75	Camaro (L.T.)	9644473	1	8.95	(comb. 73D, 732) (oxblood)
75	Camaro (L.T.)	1669544	1	8.65	(comb. 16D) (graystone)
71-72	Vega (N.B.)	9843081	1	8.50	(paint as reqd.)
73-75	Vega (N.B.)	9650573	1	6.10	(black) (paint)
73	Vega (N.B.)	9650575	1	5.45	(comb. 863, 864) (green)
73-74	Vega (N.B.)	9650576	1	6.10	(comb. 863, 868, 870, 874, 888) (neutral)
74	Vega (N.B.)	9673548	1	7.55	(comb. 879, 880, 881, 883, 887) (green)
74	Vega (N.B.)	9673549	1	7.55	(comb. 888, 890) (saddle)
75	Monza (Towne Cpe.)	1707420	1	8.05	(comb. 19N) (paint)
61	Impala (exc. Conv.),				
67-68	Caprice (Spt. Mdls.) w/tape player, stereo radio, aux. speaker,				
69-70	Impala (Custom) Caprice w/tape player, stereo radio, aux. speaker	4749319 A.R.		.11	CLIP, front
75	Monza (Towne Cpe.)	1706697	1	4.65	RETAINER, fdtn. panel

NOTE 1: Production deviation trim change.

**15.027 BAG ASSY., Fldg. Top Compt.**

73-75	Pass. (Conv.)	9645099	1	45.50	
-------	---------------	---------	---	-------	--

**15.035 TRIM ASSY., Rear and Center Seat Cushion Cover**

NOTE. For passenger models TRIM ASSY. is rear. For station wagons TRIM ASSY. is center.

**PASS.**

73-74	Impala (Spt. Cpe.),				
74	Pass. (Conv.)	9628364	1	82.50	(comb. 806) (black)
73-74	Impala (Spt. Cpe.)	9628359	1	85.25	(comb. 802) (black)
73-74	Impala (Spt. Cpe.)	9665298	1	82.50	(comb. 813) (midn. blue)
73-74	Impala (Spt. Cpe.) Pass. (Conv.)	9628366	1	82.50	(comb. 818, 819) (neutral)
73-74	Impala (Sed.)	9628354	1	85.75	(comb. 802) (black)
73-74	Impala (Sed.)	9628351	1	77.75	(comb. 813) (midn. blue)
73-74	Impala (Sed.)	9628350	1	77.75	(comb. 806) (black)
73	Impala (Sed.)	9628353	1	77.75	(comb. 830) (green)
73-74	Impala (Sed.)	9628352	1	77.75	(comb. 818, 819) (neutral)
73	Caprice (Sed.)	9628372	1	95.50	(comb. 843) (midn. blue)
73	Caprice (Sed.)	9628371	1	95.50	(comb. 842) (green)
73-74	Impala, Caprice (Sta. Wag.) (6- Pass.)	9665305	1	79.25	fldg. 2nd (comb. 818, 819) (neutral)
73-74	Impala, Caprice (Sta. Wag.) (6- Pass.)	9628413	1	79.25	fldg. 2nd (comb. 806) (black)
73-74	Impala, Caprice (Sta. Wag.) (6- Pass.)	9665306	1	79.25	fldg. 2nd (comb. 813) (midn. blue)
73-74	Impala, Caprice (Sta. Wag.) (9- Pass.)	9628418	1	40.00	fldg. 2nd— 1/3 (comb. 806) (blue)

**REAR TRIM—MATS—YARDAGE**

**15.035 TRIM ASSY., Rear and Center Seat Cushion Cover (Con't)**

73-74	Impala, Caprice (Sta. Wag.) (9-Pass.)	9665308	1	40.00	fldg. 2nd— 1/3 (comb. 813) (midn. blue)
73-74	Impala, Caprice (Sta. Wag.) (9-Pass.)	9665307	1	40.00	fldg. 2nd— 1/3 (comb. 818, 819) (neutral)
73-74	Impala, Caprice (Sta. Wag.) (9-Pass.)	9665310	1	61.00	fldg. 2nd— 2/3 (comb. 813) (midn. blue)
73-74	Impala, Caprice (Sta. Wag.) (9-Pass.)	9665309	1	61.00	fldg. 2nd— 2/3 (comb. 818, 819) (neutral)
73-74	Impala, Caprice (Sta. Wag.) (9-Pass.)	9628423	1	61.00	fldg. 2nd— 2/3 (comb. 806) (black)
74	Bel Air (Sedan)	9675891	1	51.25	(comb. 817) (neutral)
74	Bel Air (Sedan)	9675892	1	51.25	(comb. 851) (green)
74	Bel Air (Sedan)	9675893	1	52.25	(comb. 803) (black)
74	Bel Air (Sedan)	9675894	1	52.25	(comb. 815) (neutral)
74	Bel Air (Sedan)	9675895	1	52.25	(comb. 852) (green)
74	Impala (Sedan)	9675689	1	77.75	(comb. 855) (green)
74	Impala (Sedan)	9675690	1	85.75	(comb. 805) (black)
74	Impala (Sedan)	9675691	1	85.75	(comb. 821) (neutral)
74	Impala (Sedan)	9675692	1	85.75	(comb. 847) (midn. blue)
74	Impala (Sedan)	9675693	1	85.75	(comb. 853) (green)
74	Impala (Sedan)	9729463	1	77.75	(comb. 849) (saddle)
74	Impala (Spt. Cpe.)	9675699	1	85.25	(comb. 805) (black)
74	Impala (Spt. Cpe.)	9675700	1	85.25	(comb. 821) (neutral)
74	Impala (Spt. Cpe.)	9675701	1	85.25	(comb. 847) (midn. blue)
74	Impala (Spt. Cpe.)	9675702	1	85.25	(comb. 853) (green)
74	Impala (Spt. Cpe.)	9729464	1	85.25	(comb. 858) (saddle and black)
74	Impala (Spt. Cpe.)	9729465	1	82.50	(comb. 849) (saddle)
74	Impala (Spt. Cpe.) Pass. (Conv.) (exc. Custom)	1666310	1	84.75	(comb. 804, 809, 810) (white)
74	Impala (Spt. Cpe.) Pass. (Conv.)	9675708	1	82.50	(comb. 855) (green)
74	Caprice (Sedan)	9684097	1	95.50	(comb. 840) (black)
74	Caprice (Sedan)	9684098	1	95.50	(comb. 843) (midn. blue)
74	Caprice (Sedan)	9684099	1	95.50	(comb. 850) (green)
74	Caprice (Sedan)	9684100	1	95.50	(comb. 857) (oxblood)
74	Caprice (Sedan)	9684101	1	95.50	(comb. 896) (taupe)
74	Caprice (Sedan)	9684102	1	95.50	(comb. 808) (black)
74	Caprice (Sedan)	9684103	1	95.50	(comb. 841) (neutral)
74	Caprice (Spt. Cpe.)	9684160	1	95.25	(comb. 840) (black)
74	Caprice (Spt. Cpe.)	9684161	1	95.25	(comb. 843) (midn. blue)
74	Caprice (Spt. Cpe.)	9684162	1	95.25	(comb. 850) (green)
74	Caprice (Spt. Cpe.)	9684163	1	95.25	(comb. 857) (oxblood)
74	Caprice (Spt. Cpe.)	9684164	1	95.25	(comb. 896) (taupe)
74	Caprice (Spt. Cpe.)	9684165	1	95.25	(comb. 808) (black)
74	Caprice (Spt. Cpe.)	9684166	1	95.25	(comb. 841) (neutral)
74	Bel Air (Sta. Wag.) (6-Pass.)	9675902	1	53.50	fldg. 2nd (comb. 817) (neutral)
74	Bel Air (Sta. Wag.) (6-Pass.)	9675903	1	53.50	fldg. 2nd (comb. 851) (green)
74	Impala, Caprice (Sta. Wag.) (6-Pass.)	9675724	1	79.25	fldg. 2nd (comb. 849) (saddle)
74	Impala, Caprice (Sta. Wag.) (6-Pass.)	9675725	1	79.25	fldg. 2nd (comb. 855) (green)
74	Impala, Caprice (Sta. Wag.) (6-Pass.)	1690385	1	80.50	2nd (comb. 802) (black and white)
74	Impala, Caprice (Sta. Wag.) (6-Pass.)	1690386	1	80.50	2nd (comb. 858) (saddle and black)
74	Impala, Caprice (Sta. Wag.) (6-Pass.)	1690387	1	80.50	2nd (comb. 859) (black and green)
74	Impala, Caprice (Sta. Wag.) (9-Pass.)	1690397	1	41.75	fldg. 2nd— 1/3 (comb. 802) (black and white)
74	Impala, Caprice (Sta. Wag.) (9-Pass.)	1690398	1	41.75	fldg. 2nd— 1/3 (comb. 858) (saddle and black)
74	Impala, Caprice (Sta. Wag.) (9-Pass.)	1690399	1	41.75	fldg. 2nd— 1/3 (comb. 859) (black and green)
74	Impala, Caprice (Sta. Wag.) (9-Pass.)	1690401	1	66.00	2nd— 2/3 (comb. 802) (black and white)
74	Impala, Caprice (Sta. Wag.) (9-Pass.)	1690402	1	66.00	2nd— 2/3 (comb. 858) (saddle and black)
74	Impala, Caprice (Sta. Wag.) (9-Pass.)	1690403	1	66.00	2nd— 2/3 (comb. 859) (black and green)
74	Bel Air (Sta. Wag.) (9-Pass.)	9675904	1	27.00	fldg. 2nd— 1/3 (comb. 817) (neutral)
74	Bel Air (Sta. Wag.) (9-Pass.)	9675905	1	27.00	fldg. 2nd— 1/3 (comb. 851) (green)
74	Impala, Caprice (Sta. Wag.) (9-Pass.)	9675726	1	40.00	fldg. 2nd— 1/3 (comb. 849) (saddle)



**REAR TRIM—MATS—YARDAGE**

**15.035 TRIM ASSY., Rear and Center Seat Cushion Cover (Con't)**

74	Impala, Caprice (Sta. Wag.) (9-Pass.)	9675727	1	40.00	fldg. 2nd— 1/3 (comb. 855) (green)
74	Bel Air (Sta. Wag.) (9-Pass.)	9675906	1	40.25	fldg. 2nd— 2/3 (comb. 817) (neutral)
74	Bel Air (Sta. Wag.) (9-Pass.)	9675907	1	40.25	fldg. 2nd— 2/3 (comb. 851) (green)
74	Impala, Caprice (Sta. Wag.) (9-Pass.)	9675728	1	96.00	fldg. 2nd— 2/3 (comb. 849) (saddle)
74	Impala, Caprice (Sta. Wag.) (9-Pass.)	9675729	1	96.00	fldg. 2nd— 2/3 (comb. 855) (green)
75	Bel Air	1662685	1	60.25	(comb. 19C) (black)
75	Bel Air	1658537	1	59.00	(comb. 55V) (sandstone)
75	Bel Air	1662686	1	60.25	(comb. 26C) (blue)
75	Bel Air	1662687	1	60.25	(comb. 55C) (sandstone)
75	Impala (Sedan)	1665477	1	88.00	(comb. 19W) (black)
75	Impala (Sedan)	1665478	1	88.00	(comb. 26W) (blue)
75	Impala (Sedan)	1665479	1	88.00	(comb. 44W) (green)
75	Impala (Sedan)	1665480	1	88.00	(comb. 55W) (sandstone)
75	Impala (Sedan)	1665481	1	88.00	(comb. 63W) (saddle)
75	Impala (Sedan)	1665271	1	103.00	(comb. 19D) (black)
75	Impala (Sedan)	1665272	1	103.00	(comb. 26D) (blue)
75	Impala (Sedan)	1665273	1	103.00	(comb. 44D) (green)
75	Impala (Sedan)	1665274	1	103.00	(comb. 55D) (sandstone)
75	Impala (4-Dr.)	1665275	1	103.00	(comb. 63E) (saddle)
75	Impala (Spt. Cpe.)	1665483	1	103.00	(comb. 19D) (black)
75	Impala (Spt. Cpe.)	1665484	1	103.00	(comb. 26D) (blue)
75	Impala (Spt. Cpe.)	1665485	1	103.00	(comb. 44D) (green)
75	Impala (Spt. Cpe.)	1665486	1	103.00	(comb. 55D) (sandstone)
75	Impala (Spt. Cpe.)	1665490	1	90.50	(comb. 19W) (black)
75	Impala (Spt. Cpe.)	1665491	1	90.50	(comb. 26W) (blue)
75	Impala (Spt. Cpe.)	1665492	1	90.50	(comb. 44W) (green)
75	Impala (Spt. Cpe.) Pass. (Conv.)	1665487	1	103.00	(comb. 63E) (saddle)
75	Impala (Spt. Cpe.) Pass. (Conv.)	1665489	1	90.50	(comb. 02W, 04W, 07W, 11W) (white)
75	Impala (Spt. Cpe.) Pass. (Conv.)	1665493	1	90.50	(comb. 55W) (sandstone)
75	Impala (Spt. Cpe.) Pass. (Conv.)	1665494	1	90.50	(comb. 63W) (saddle)
75	Caprice (Sedan)	1663899	1	111.00	(comb. 26B) (blue)
75	Caprice (Sedan)	1663900	1	111.00	(comb. 44B) (green)
75	Caprice (Sedan)	1663898	1	111.00	(comb. 19B) (black)
75	Caprice (Sedan)	1663926	1	111.00	(comb. 55B) (sandstone)
75	Caprice (Sedan)	1663927	1	111.00	(comb. 73B) (oxblood)
75	Caprice (Sedan)	1663934	1	92.00	(comb. 19H) (black)
75	Caprice (Sedan)	1663935	1	92.00	(comb. 55H) (sandstone)
75	Caprice (Spt. Cpe.)	1663936	1	92.00	(comb. 19H) (black)
75	Caprice (Spt. Cpe.)	1663937	1	92.00	(comb. 55H) (sandstone)
75	Caprice (Spt. Cpe.)	1663929	1	105.00	(comb. 19B) (black)
75	Caprice (Spt. Cpe.)	1663930	1	105.00	(comb. 26B) (blue)
75	Caprice (Spt. Cpe.)	1663931	1	105.00	(comb. 44B) (green)
75	Caprice (Spt. Cpe.)	1663932	1	105.00	(comb. 55B) (sandstone)
75	Caprice (Spt. Cpe.)	1663933	1	105.00	(comb. 73B) (oxblood)
75	Bel Air (Sta. Wag.) (6-Pass.)	1658547	1	61.00	2nd (comb. 26V) (blue)
75	Bel Air (Sta. Wag.) (6-Pass.)	1658548	1	61.00	2nd (comb. 55V) (sandstone)
75	Impala, Caprice (Sta. Wag.) (6-Pass.)	1665520	1	91.75	2nd (comb. 63E) (saddle)
75	Impala, Caprice (Sta. Wag.) (6-Pass.)	1665522	1	85.25	2nd (comb. 19W) (black)
75	Impala, Caprice (Sta. Wag.) (6-Pass.)	1665523	1	85.25	2nd (comb. 26W) (blue)
75	Impala, Caprice (Sta. Wag.) (6-Pass.)	1665524	1	85.25	2nd (comb. 44W) (green)
75	Impala, Caprice (Sta. Wag.) (6-Pass.)	1665525	1	85.25	2nd (comb. 55W) (sandstone)
75	Impala, Caprice (Sta. Wag.) (6-Pass.)	1665526	1	85.25	2nd (comb. 63W) (saddle)
75	Impala, Caprice (Sta. Wag.) (9-Pass.)	1665541	1	70.00	2nd (comb. 55W) (sandstone)
75	Bel Air (Sta. Wag.) (9-Pass.)	1658549	1	26.50	fldg. 2nd— 1/3 (comb. 26V) (blue)
75	Bel Air (Sta. Wag.) (9-Pass.)	1658550	1	26.50	fldg. 2nd— 1/3 (comb. 55V) (sandstone)
75	Impala, Caprice (Sta. Wag.) (9-Pass.)	1665528	1	41.75	fldg. 2nd— 1/3 (comb. 63E) (saddle)
75	Impala, Caprice (Sta. Wag.) (9-Pass.)	1665530	1	38.25	fldg. 2nd— 1/3 (comb. 19W) (black)
75	Impala, Caprice (Sta. Wag.) (9-Pass.)	1665531	1	38.25	fldg. 2nd— 1/3 (comb. 26W) (blue)
75	Impala, Caprice (Sta. Wag.) (9-Pass.)	1665532	1	38.25	fldg. 2nd— 1/3 (comb. 44W) (green)
75	Impala, Caprice (Sta. Wag.) (9-Pass.)	1665533	1	38.25	fldg. 2nd— 1/3 (comb. 55W) (sandstone)

**REAR TRIM—MATS—YARDAGE**

**15.035 TRIM ASSY., Rear and Center Seat Cushion Cover (Con't)**

75	Impala, Caprice (Sta. Wag.) (9-Pass.)	1665534	1	38.25	fldg. 2nd— 1/3 (comb. 63W) (saddle)
75	Bel Air (Sta. Wag.) (9-Pass.)	1658551	1	40.00	fldg. 2nd— 2/3 (comb. 26V) (blue)
75	Bel Air (Sta. Wag.) (9-Pass.)	1658552	1	40.00	fldg. 2nd— 2/3 (comb. 55V) (sandstone)
75	Impala, Caprice (Sta. Wag.) (9-Pass.)	1665536		73.75	fldg. 2nd— 2/3 (comb. 63E)
75	Impala, Caprice (Sta. Wag.) (9-Pass.)	1665538	1	70.00	fldg. 2nd— 2/3 (comb. 19W) (black)
75	Impala, Caprice (Sta. Wag.) (9-Pass.)	1665539	1	70.00	fldg. 2nd— 2/3 (comb. 26W) (blue)
75	Impala, Caprice (Sta. Wag.) (9-Pass.)	1665540	1	70.00	fldg. 2nd— 2/3 (comb. 44W) (green)
75	Impala, Caprice (Sta. Wag.) (9-Pass.)	1665542	1	70.00	fldg. 2nd— 2/3 (comb. 63W) (saddle)

**CHEVY—NOVA**

72	Nova (2-Dr.)	9891088	1	43.75	(comb. 750) (black)
73	Nova (Sed.) (exc. Custom)	9678803	1	99.00	(comb. 765) (black)— (15.000)
73	Nova (Sed.) (exc. Custom)	9651832	1	43.75	(comb. 772) (blue)
73	Nova (Sed.) (exc. Custom)	9678802	1	99.00	(comb. 768) (neutral)— (15.000)
73	Nova (Custom H.B.)	9651776	1	59.25	(comb. 754) (black)
73	Nova (Custom H.B.)	9651779	1	64.75	(comb. 752) (black & white)
74	Nova (Sedan) (exc. Custom)	9693297	1	50.00	(comb. 753) (black)
74	Nova (Sedan) (exc. Custom)	9693298	1	50.00	(comb. 772) (midn. blue)
74	Nova (Sedan) (exc. Custom)	9693299	1	50.00	(comb. 758) (green)
74	Nova (Sedan) (exc. Custom)	9693300	1	50.00	(comb. 765) (neutral)
74	Nova (Sedan) (exc. Custom)	9693303	1	43.75	(comb. 750) (black and white)
74	Nova (Sedan) (exc. Custom)	9693304	1	43.75	(comb. 756) (green and black)
74	Nova (Sedan) (exc. Custom)	9693305	1	43.75	(comb. 764) (neutral and black)
74	Nova (Sedan) (exc. Custom)	1658348	1	50.00	(comb. 825) (black)
74	Nova (Sedan) (exc. Custom)	1658349	1	50.00	(comb. 826) (mid. blue)
74	Nova (Sedan) (exc. Custom)	1658350	1	50.00	(comb. 828) (green)
74	Nova (Sedan) (exc. Custom)	1658351	1	50.00	(comb. 829) (neutral)
74	Nova (Coupe) (exc. H.B., Custom)	9693290	1	50.25	(comb. 753) (black)
74	Nova (Coupe) (exc. H.B., Custom)	9693291	1	50.25	(comb. 772) (midn. blue)
74	Nova (Coupe) (exc. H.B., Custom)	9693292	1	50.25	(comb. 758) (green)
74	Nova (Coupe) (exc. H.B., Custom)	9693293	1	50.25	(comb. 765) (neutral)
74	Nova (Coupe) (exc. H.B., Custom)	9693294	1	46.50	(comb. 750) (black and white)
74	Nova (Coupe) (exc. H.B., Custom)	9693295	1	46.50	(comb. 756) (green and black)
74	Nova (Coupe) (exc. H.B., Custom)	9693296	1	46.50	(comb. 764) (neutral and black)
74	Nova (Coupe) (exc. H.B., Custom)	1658344	1	50.25	(comb. 825) (black)
74	Nova (Coupe) (exc. H.B., Custom)	1658345	1	50.25	(comb. 826) (mid. blue)
74	Nova (Coupe) (exc. H.B., Custom)	1658346	1	50.25	(comb. 828) (green)
74	Nova (Coupe) (exc. H.B., Custom)	1658347	1	50.25	(comb. 829) (neutral)
74	Nova (H.B.) (exc. Custom)	9693306	1	52.50	(comb. 753) (black)
74	Nova (H.B.) (exc. Custom)	9693307	1	52.50	(comb. 758) (green)
74	Nova (H.B.) (exc. Custom)	9693308	1	52.50	(comb. 765) (neutral)
74	Nova (H.B.) (exc. Custom)	9693309	1	52.50	(comb. 772) (midn. blue)
74	Nova (H.B.) (exc. Custom)	9693310	1	52.50	(comb. 773) (saddle)
74	Nova (H.B.) (exc. Custom)	9693311	1	50.25	(comb. 750) (black and white)
74	Nova (H.B.) (exc. Custom)	9693312	1	50.25	(comb. 756) (green and black)
74	Nova (H.B.) (exc. Custom)	9693313	1	50.25	(comb. 764) (neutral and black)
74	Nova (H.B.) (exc. Custom)	1658352	1	52.50	(comb. 825) (black)
74	Nova (H.B.) (exc. Custom)	1658353	1	52.50	(comb. 828) (green)
74	Nova (H.B.) (exc. Custom)	1658354	1	52.50	(comb. 829) (neutral)
74	Nova (H.B.) (exc. Custom)	1658355	1	52.50	(comb. 826) (mid. blue)
74	Nova (H.B.) (exc. Custom)	1658356	1	52.50	(comb. 827) (saddle)
74	Nova (Custom) (Sedan)	9693301	1	62.50	(comb. 751) (black)
74	Nova (Custom) (Sedan)	9693302	1	62.50	(comb. 757) (green)
74	Nova (Custom) (Sedan)	9693314	1	55.25	(comb. 766) (neutral)
74	Nova (Custom) (Sedan)	9735079	1	55.25	(comb. 754) (black)
74	Nova (Custom) (Coupe) (exc. H.B.)	9693276	1	59.25	(comb. 751) (black)
74	Nova (Custom) (Coupe) (exc. H.B.)	9693277	1	59.25	(comb. 752) (black and white)
74	Nova (Custom) (Coupe) (exc. H.B.)	9693278	1	59.25	(comb. 755) (green and black)
74	Nova (Custom) (Coupe) (exc. H.B.)	9693279	1	59.25	(comb. 771) (midn. blue)
74	Nova (Custom) (Coupe) (exc. H.B.)	9693280	1	55.25	(comb. 754) (black)
74	Nova (Custom) (Coupe) (exc. H.B.)	9693281	1	55.25	(comb. 759) (green)
74	Nova (Custom) (Coupe) (exc. H.B.)	9693282	1	55.25	(comb. 766) (neutral)

**REAR TRIM—MATS—YARDAGE**

**15.035 TRIM ASSY., Rear and Center Seat Cushion Cover (Con't)**

74	Nova (Custom) (H.B.)	9693283	1	64.75	(comb. 751) (black)
74	Nova (Custom) (H.B.)	9693284	1	64.75	(comb. 752) (black and white)
74	Nova (Custom) (H.B.)	9693285	1	64.75	(comb. 755) (green and black)
74	Nova (Custom) (H.B.)	9693286	1	64.75	(comb. 771) (midn. blue)
74	Nova (Custom) (H.B.)	9693287	1	59.25	(comb. 754) (black)
74	Nova (Custom) (H.B.)	9693288	1	59.25	(comb. 759) (green)
74	Nova (Custom) (H.B.)	9693289	1	59.25	(comb. 766) (neutral)
74	Nova (Custom) (H.B.)	9693585	1	85.00	(comb. 774) (white)
75	Nova (Sedan) (exc. Custom)	1655320	1	58.25	(comb. 19C) (black)
75	Nova (Sedan) (exc. Custom)	1655321	1	58.25	(comb. 26C) (blue)
75	Nova (Sedan) (exc. Custom)	1655322	1	58.25	(comb. 55C) (sandstone)
75	Nova (Sedan) (exc. Custom)	1655324	1	50.50	(comb. 19V) (black)
75	Nova (Sedan) (exc. Custom)	1743958	1	50.50	(19Z) (black)
75	Nova (Sedan) (exc. Custom)	1655325	1	50.50	(comb. 26V) (blue)
75	Nova (Sedan) (exc. Custom)	1655326	1	50.50	(comb. 55V) (sandstone)
75	Nova (Sedan) (exc. Custom)	1655327	1	50.50	(comb. 63V) (saddle)
75	Nova (Coupe) (exc. H.B., Custom)	1655311	1	56.25	(comb. 19C) (black)
75	Nova (Coupe) (exc. H.B., Custom)	1655312	1	56.25	(comb. 26Z) (blue)
75	Nova (Coupe) (exc. H.B., Custom)	1655313	1	56.25	(comb. 55C) (sandstone)
75	Nova (Coupe) (exc. H.B., Custom)	1655315	1	51.75	(comb. 19V) (black)
75	Nova (Coupe) (exc. H.B., Custom)	1655316	1	51.75	(comb. 26V) (blue)
75	Nova (Coupe) (exc. H.B., Custom)	1655317	1	51.75	(comb. 55V) (sandstone)
75	Nova (Coupe) (exc. H.B., Custom)	1655318	1	51.75	(comb. 63V) (saddle)
75	Nova (H.B.) (exc. Custom)	1655304	1	62.25	(comb. 55C) (sandstone)
75	Nova (H.B.) (exc. Custom)	1655303	1	62.25	(comb. 26C) (blue)
75	Nova (H.B.) (exc. Custom)	1655302	1	62.25	(comb. 19C) (black)
75	Nova (H.B.) (exc. Custom)	1655306	1	56.75	(comb. 19V) (black)
75	Nova (H.B.) (exc. Custom)	1655307	1	56.75	(comb. 26V) (blue)
75	Nova (H.B.) (exc. Custom)	1655308	1	56.75	(comb. 55V) (sandstone)
75	Nova (H.B.) (exc. Custom)	1655309	1	56.75	(comb. 63V) (saddle)
75	Nova (Custom) (Sedan)	1657068	1	136.00	(comb. 16G) (graystone)
75	Nova (Custom) (Sedan)	1657069	1	136.00	(comb. 26G) (blue)
75	Nova (Custom) (Sedan)	1657070	1	136.00	(comb. 55G) (sandstone)
75	Nova (Custom) (Sedan)	1657071	1	136.00	(comb. 73G) (oxblood)
75	Nova (Custom) (Sedan)	1657073	1	86.00	(comb. 26D) (blue)
75	Nova (Custom) (Sedan)	1657074	1	86.00	(comb. 44D) (green)
75	Nova (Custom) (Sedan)	1657075	1	86.00	(comb. 55D) (sandstone)
75	Nova (Custom) (Sedan)	1657077	1	74.50	(comb. 19W) (black)
75	Nova (Custom) (Sedan)	1657078	1	74.50	(comb. 55W) (sandstone)
75	Nova (Custom) (Coupe) (exc. H.B.)	1693363	1	74.25	(comb. 02W, 04W, 07W, 11W) (white)
75	Nova (Custom) (Coupe) (exc. H.B.)	1657052	1	130.00	(comb. 19G) (black)
75	Nova (Custom) (Coupe) (exc. H.B.)	1657053	1	130.00	(comb. 26G) (blue)
75	Nova (Custom) (Coupe) (exc. H.B.)	1657054	1	130.00	(comb. 55G) (sandstone)
75	Nova (Custom) (Coupe) (exc. H.B.)	1657055	1	130.00	(comb. 73G) (oxblood)
75	Nova (Custom) (Coupe) (exc. H.B.)	1657057	1	83.25	(comb. 19E) (black)
75	Nova (Custom) (Coupe) (exc. H.B.)	1657058	1	83.25	(comb. 26D) (blue)
75	Nova (Custom) (Coupe) (exc. H.B.)	1657059	1	83.25	(comb. 44D) (green)
75	Nova (Custom) (Coupe) (exc. H.B.)	1657060	1	83.25	(comb. 55D) (sandstone)
75	Nova (Custom) (Coupe) (exc. H.B.)	1657061	1	83.25	(comb. 63E) (saddle)
75	Nova (Custom) (Coupe) (exc. H.B.)	1657063	1	74.25	(comb. 19W) (black)
75	Nova (Custom) (Coupe) (exc. H.B.)	1657064	1	74.25	(comb. 55W) (sandstone)
75	Nova (Custom) (Coupe) (exc. H.B.)	1657065	1	74.25	(comb. 63W) (saddle)
75	Nova (Custom) (Coupe) (exc. H.B.)	1657066	1	74.25	(comb. 73W) (oxblood)
75	Nova (Custom) (H.B.)	1656541	1	91.50	(comb. 19E) (black)
75	Nova (Custom) (H.B.)	1656542	1	91.50	(comb. 26D) (blue)
75	Nova (Custom) (H.B.)	1656543	1	91.50	(comb. 44D) (green)
75	Nova (Custom) (H.B.)	1656544	1	91.50	(comb. 55D) (sandstone)
75	Nova (Custom) (H.B.)	1656545	1	91.50	(comb. 63E) (saddle)
75	Nova (Custom) (H.B.)	1656547	1	82.25	(comb. 19W) (black)
75	Nova (Custom) (H.B.)	1656548	1	82.25	(comb. 55W) (sandstone)
75	Nova (Custom) (H.B.)	1656549	1	82.25	(comb. 63W) (saddle)

**REAR TRIM—MATS—YARDAGE**

**15.035 TRIM ASSY., Rear and Center Seat Cushion Cover (Con't)**

75	Nova (Custom) (H.B.)	1656550	1	82.25	(comb. 73W) (oxblood)
<b>CHEVELLE</b>					
73	Malibu (Cpe.)	9627158	1	57.25	(comb. 704) (black)
73	Malibu, Laguna (Cpe.)				
74-75	Laguna (Cpe.)	9627174	1	76.00	(comb. 707, 708) 19Z (black)
73	Malibu, Laguna (Sed.)	9627167	1	76.00	(comb. 707) (black)
73	Malibu, Laguna (Sed.)	9627169	1	76.00	(comb. 734) (neutral)
73	Malibu, Laguna (Sta. Wag.)	9666702	1	76.50	fldg. 2nd (comb. 707) (black)
73	Malibu, Laguna (Sta. Wag.)	9666706	1	76.50	fldg. 2nd (comb. 734) (neutral)
73	Monte Carlo	9627630	1	83.00	(comb. 706) (black)
73-74	Monte Carlo	9627635	1	69.75	(comb. 708, 709) (black)
73	Monte Carlo	9627632	1	83.00	(comb. 725) (midn. blue)
73	Monte Carlo	9627631	1	83.00	(comb. 715) (green)
73	Monte Carlo	9627637	1	69.75	(comb. 735) (neutral)
73	Monte Carlo	9627634	1	83.00	(comb. 740) (oxblood)
74	Malibu (Sedan) (exc. Classic)	9680607	1	56.00	(comb. 701) (black)
74	Malibu (Sedan) (exc. Classic)	9680608	1	56.00	(comb. 723) (green)
74	Malibu (Sedan) (exc. Classic)	9680618	1	56.00	(comb. 706) (black)
74	Malibu (Sedan) (exc. Classic)	9680619	1	56.00	(comb. 713, 745) (neutral)
74	Malibu (Sedan) (exc. Classic)	9680620	1	56.00	(comb. 727, 738) (green)
74	Malibu (Sedan) (exc. Classic)	1658490	1	56.00	(comb. 891) (black)
74	Malibu (Sedan) (exc. Classic)	1658491	1	56.00	(comb. 830, 892) (neutral)
74	Malibu (Sedan) (exc. Classic)	1658492	1	56.00	(comb. 893, 894) (green)
74	Malibu (Coupe) (exc. Classic)	9680755	1	51.50	(comb. 701) (black)
74	Malibu (Coupe) (exc. Classic)	9680756	1	51.50	(comb. 723) (green)
74	Malibu (Coupe) (exc. Classic)	9680769	1	56.00	(comb. 706) (black)
74	Malibu (Coupe) (exc. Classic)	9680770	1	56.00	(comb. 713, 745) (neutral)
74	Malibu (Coupe) (exc. Classic)	9680771	1	56.00	(comb. 727, 738) (green)
74	Malibu (Coupe) (exc. Classic)	9729947	1	56.00	(comb. 749) (mid. blue)
74	Malibu (Coupe) (exc. Classic)	1658494	1	56.00	(comb. 897) (mid. blue)
74	Malibu (Coupe) (exc. Classic)	1658495	1	56.00	(comb. 891) (black)
74	Malibu (Coupe) (exc. Classic)	1658496	1	56.00	(comb. 830, 892) (neutral)
74	Malibu (Coupe) (exc. Classic)	1658497	1	56.00	(comb. 893, 894) (green)
74	Malibu (Classic) (Sedan)	9680060	1	95.50	(comb. 702) (black)
74	Malibu (Classic) (Sedan)	9680061	1	95.50	(comb. 732) (midn. blue)
74	Malibu (Classic) (Sedan)	9680062	1	95.50	(comb. 724) (green)
74	Malibu (Classic) (Sedan)	9680063	1	95.50	(comb. 722) (neutral)
74	Malibu (Classic) (Sedan)	9729758	1	95.50	(comb. 743) (oxblood)
74	Malibu (Classic) (Sedan)	9729762	1	78.00	(comb. 707) (black)
74	Malibu (Classic) (Sedan)	9729763	1	78.00	(comb. 714) (neutral)
74	Malibu (Classic) (Sedan)	9729764	1	78.00	(comb. 740) (saddle)
74	Malibu (Classic) (Sedan)	9729765	1	78.00	(comb. 728) (green)
74	Malibu (Classic) (Sedan)	9736768	1	78.00	(comb. 747, 785) (white)
74-75	Malibu (Classic) (Coupe)	9680064	1	90.50	(comb. 702) 19D (black)
74	Malibu (Classic) (Coupe)	9680065	1	90.50	(comb. 732) (midn. blue)
74-75	Malibu (Classic) (Coupe)	9680066	1	90.50	(comb. 724) 44D (green)
74	Malibu (Classic) (Coupe)	9680067	1	90.50	(comb. 722) (neutral)
74	Malibu (Classic) (Coupe)	9680068	1	93.25	(comb. 704) (black and white)
74-75	Malibu (Classic) (Coupe)	9729777	1	90.50	(comb. 743) 73D (oxblood)
74-75	Malibu (Classic) (Coupe)	9729781	1	74.00	(comb. 707) 19W (black)
74	Malibu (Classic) (Coupe)	9729782	1	74.00	(comb. 747, 785) (white)
74	Malibu (Classic) (Coupe)	9729783	1	74.00	(comb. 714) (neutral)
74	Malibu (Classic) (Coupe)	9729784	1	74.00	(comb. 740) (saddle)
74	Malibu (Classic) (Coupe)	9729785	1	74.00	(comb. 728) (green)
74	Laguna (Coupe)	9680953	1	93.25	(comb. 703, 704) (black)
74	Laguna	9736770	1	93.25	(comb. 720) (oxblood)
74	Laguna	9736647	1	76.00	(comb. 718) (saddle)
74	Laguna	9736771	1	93.25	(comb. 731) (saddle)
74	Monte Carlo	9679596	1	83.00	(comb. 705) (black)
74	Monte Carlo	9679597	1	83.00	(comb. 726) (green)
74	Monte Carlo	9679598	1	83.00	(comb. 734) (midn. blue)
74	Monte Carlo	9679599	1	83.00	(comb. 744) (oxblood)
74	Monte Carlo	9680029	1	69.75	(comb. 730) (green)
74	Monte Carlo	9680030	1	79.00	(comb. 737) (midn. blue)
74	Monte Carlo	9680031	1	69.75	(comb. 716) (neutral)
74	Monte Carlo	9680032	1	69.75	(comb. 742) (saddle)
74-75	Malibu (Classic) (Sta. Wag.)	9729915	1	70.75	fldg. 2nd (comb. 707) 19W (black)
74	Malibu (Classic) (Sta. Wag.)	9729916	1	70.75	fldg. 2nd (comb. 735) (mid. blue)
74	Malibu (Classic) (Sta. Wag.)	9729917	1	70.75	fldg. 2nd (comb. 714) (neutral)
74	Malibu (Classic) (Sta. Wag.)	9729918	1	70.75	fldg. 2nd (comb. 740) (saddle)
74	Malibu (Classic) (Sta. Wag.)	9729919	1	70.75	fldg. 2nd (comb. 728) (green)
74	Malibu (Sta. Wag.) (exc. Classic)	9680774	1	52.25	fldg. 2nd (comb. 706) (black)
74	Malibu (Sta. Wag.) (exc. Classic)	9680775	1	52.25	fldg. 2nd (comb. 713, 745) (neutral)
74	Malibu (Sta. Wag.) (exc. Classic)	1658502	1	52.25	fldg. 2nd (comb. 891) (black)

**REAR TRIM—MATS—YARDAGE**

**15.035 TRIM ASSY., Rear and Center Seat Cushion Cover (Con't)**

74	Malibu (Sta. Wag.) (exc. Classic)	1658503	1	52.25	fldg. 2nd (comb. 83, 892) (neutral)
75	Malibu (Sedan) 1st design (exc. Classic)	1667223	1	68.00	(comb. 19V) (black) (Note 1)
75	Malibu (Sedan) 1st design (exc. Classic)	1667224	1	68.00	(comb. 26V) (blue) (Note 1)
75	Malibu (Sedan) 1st design (exc. Classic)	1667225	1	68.00	(comb. 44V) (green) (Note 1)
75	Malibu (Sedan) (exc. Classic)	1667477	1	70.75	(comb. 19C) (black)
75	Malibu (Sedan) 1st design (exc. Classic)	1667476	1	68.00	(comb. 55V) (sandstone) (Note 1)
75	Malibu (Sedan) (2nd design) (exc. Classic)	1667478	1	70.75	(comb. 26C) (blue)
75	Malibu (Sedan) (2nd design) (exc. Classic)	1708656	1	77.50	(comb. 19V) (black) (Note 1)
75	Malibu (Sedan) (2nd design) (exc. Classic)	1708657	1	77.50	(comb. 26V) (blue) (Note 1)
75	Malibu (Sedan) (2nd design) (exc. Classic)	1708658	1	77.50	(comb. 44V) (green) (Note 1)
75	Malibu (Sedan) (2nd design) (exc. Classic)	1708659	1	77.50	(comb. 55V) (sandstone) (Note 1)
75	Malibu (Coupe) (exc. Classic)	1667479	1	63.75	(comb. 19C) (black)
75	Malibu (Coupe) (exc. Classic)	1667480	1	63.75	(comb. 26C) (blue)
75	Malibu (Coupe) 1st design (exc. Classic)	1667481	1	63.25	(comb. 19V) (black) (Note 1)
75	Malibu (Coupe) 1st design (exc. Classic)	1667482	1	63.25	(comb. 26V) (blue) (Note 1)
75	Malibu (Coupe) 1st design (exc. Classic)	1667483	1	63.25	(comb. 44V) (green) (Note 1)
75	Malibu (Coupe) 1st design (exc. Classic)	1667484	1	63.25	(comb. 55V) (sandstone) (Note 1)
75	Malibu (Coupe) (2nd design) (exc. Classic)	1708660	1	75.00	(comb. 19V) (black) (Note 1)
75	Malibu (Coupe) (2nd design) (exc. Classic)	1708661	1	75.00	(comb. 26V) (blue) (Note 1)
75	Malibu (Coupe) (2nd design) (exc. Classic)	1708662	1	75.00	(comb. 44V) (green) (Note 1)
75	Malibu (Coupe) (2nd design) (exc. Classic)	1708663	1	75.00	(comb. 55V) (sandstone) (Note 1)
75	Malibu (Classic) (Sedan)	1681213	1	96.25	(comb. 19W) (black)
75	Malibu (Classic) (Sedan)	1682614	1	105.00	(comb. 19D) (black)
75	Malibu (Classic) (Sedan)	1688084	1	105.00	(comb. 44D) (green)
75	Malibu (Classic) (Sedan)	1688085	1	105.00	(comb. 73D) (oxblood)
75	Malibu (Classic) (Sedan)	1667485	1	96.25	(comb. 26W) (blue)
75	Malibu (Classic) (Sedan)	1667486	1	96.25	(comb. 55W) (sandstone)
75	Malibu (Classic) (Sedan)	1667487	1	105.00	(comb. 16D) (graystone)
75	Malibu (Classic) (Sedan)	1667488	1	105.00	(comb. 26D) (blue)
75	Malibu (Classic) (Coupe)	1700505	1	77.75	(comb. 19W) (black)
75	Malibu (Classic) (Coupe)	1667489	1	71.25	(comb. 26W) (blue)
75	Malibu (Classic) (Coupe)	1667490	1	71.25	(comb. 55W) (sandstone)
75	Malibu (Classic) (Coupe)	1667491	1	71.25	(comb. 63W) (saddle)
75	Malibu (Classic) (Coupe)	1667492	1	87.00	(comb. 16D) (graystone)
75	Malibu (Classic) (Coupe)	1667493	1	87.00	(comb. 26D) (blue)
75	Monte Carlo	1667516	1	77.75	(comb. 02H, 04H, 07H, 11H) (white)
75	Monte Carlo	1667508	1	88.50	(comb. 19B) (black)
75	Monte Carlo	1667509	1	88.50	(comb. 26B) (blue)
75	Monte Carlo	1667510	1	88.50	(comb. 55B) (sandstone)
75	Monte Carlo	1667511	1	88.50	(comb. 73B) (oxblood)
75	Monte Carlo	1667513	1	77.75	(comb. 19H) (black)
75	Monte Carlo	1667514	1	77.75	(comb. 26H) (blue)
75	Monte Carlo	1667515	1	77.75	(comb. 55H) (sandstone)
75	Monte Carlo	1667518	1	116.00	(comb. 19N) (black)
75	Monte Carlo	1667519	1	116.00	(comb. 26N) (blue)
75	Monte Carlo	1667520	1	116.00	(comb. 44N) (green)
75	Monte Carlo	1667521	1	116.00	(comb. 55N) (sandstone)
75	Monte Carlo	1667522	1	116.00	(comb. 73N) (oxblood)
75	Malibu (Sta. Wag.) 1st design (exc. Classic)	1667547	1	61.75	2nd (comb. 19V) (black) (Note 1)
75	Malibu (Sta. Wag.) 1st design (exc. Classic)	1667548	1	61.75	2nd (comb. 55V) (sandstone) (Note 1)
75	Malibu (Sta. Wag.) (2nd design) (exc. Classic)	1708666	1	70.75	(comb. 19V) (black) (Note 1)
75	Malibu (Sta. Wag.) (2nd design) (exc. Classic)	1708667	1	70.75	(comb. 55V) (sandstone) (Note 1)
75	Malibu (Classic) (Sta. Wag.)	1667549	1	68.25	2nd (comb. 26W) (blue)
75	Malibu (Classic) (Sta. Wag.)	1667550	1	68.25	2nd (comb. 55W) (sandstone)
75	Malibu (Classic) (Sta. Wag.)	1668408	1	68.25	2nd (comb. 63W) (saddle)

**REAR TRIM—MATS—YARDAGE**

**15.035 TRIM ASSY., Rear and Center Seat Cushion Cover (Con't)**

75	Laguna	1703299	1	105.00	(comb. 07Z, 11Z) (white)
75	Laguna	1703300	1	105.00	(comb. 63Z) (saddle)
75	Laguna	1703342	1	105.00	(comb. 07E, 11E) (black)
75	Laguna	1703345	1	105.00	(comb. 73E) (oxblood)
75	Laguna	1703344	1	105.00	(comb. 63E) (saddle)
75	Laguna	1703343	1	105.00	(comb. 19E) (black)

*NOTE 1: Seat back and cushion cover assemblies have been redesigned from horizontal to vertical pattern.*

**CAMARO**

73-74	Camaro (exc. L.T.)	9647931	2	38.25	(comb. 775, 776) (black & white)
74-75	Camaro (exc. L.T.)	9686533	2	38.25	(comb. 777) 19V (black)
74	Camaro (exc. L.T.)	9686534	2	38.25	(comb. 779) (black)
74	Camaro (exc. L.T.)	9686535	2	38.25	(comb. 781) (neutral)
74	Camaro (exc. L.T.)	9686536	2	38.25	(comb. 798) (saddle)
74	Camaro (exc. L.T.)	9686537	2	38.25	(comb. 787) (green)
74	Camaro (exc. L.T.)	9686538	2	38.25	(comb. 792) (red)
74	Camaro (exc. L.T.)	9687198	2	38.25	(comb. 796) (saddle and black)
74	Camaro (exc. L.T.)	9687199	2	38.25	(comb. 786) (green and black)
74-75	Camaro (exc. L.T.) (2nd design)	1707458	1	57.25	(775-19C) (black) (Note 1)
74	Camaro (L.T.) (1st design)	9686573	2	45.00	(comb. 778) (black) (Note 1)
74	Camaro (L.T.) (1st design)	9686574	2	45.00	(comb. 799) (saddle) (Note 1)
74	Camaro (L.T.) (1st design)	9686575	2	45.00	(comb. 784) (taupe) (Note 1)
74	Camaro (L.T.) (2nd design)	1654188	1	45.00	(comb. 778) (black) (Note 1)
74	Camaro (L.T.) (2nd design)	1654189	1	45.00	(comb. 799) (saddle) (Note 1)
74	Camaro (L.T.) (2nd design)	1654190	1	45.00	(comb. 784) (taupe) (Note 1)
74	Camaro (L.T.)	9687272	2	46.00	(comb. 776) (black)
74	Camaro (L.T.)	9687273	2	46.00	(comb. 780) (neutral)
74	Camaro (L.T.)	9687274	2	46.00	(comb. 797) (saddle)
74	Camaro (L.T.)	9687275	2	46.00	(comb. 783) (taupe)
75	Camaro (exc. L.T.)	1663537	1	40.25	(comb. 55C) (sandstone)
75	Camaro (exc. L.T.)	1663538	1	36.75	(comb. 55V) (sandstone)
75	Camaro (exc. L.T.)	1663539	1	36.75	(comb. 63V) (saddle)
75	Camaro (exc. L.T.)	1663540	1	36.75	(comb. 91V) (white)
75	Camaro (L.T.)	1698561	1	107.00	(comb. 632) (saddle)
75	Camaro (L.T.)	1698562	1	107.00	(comb. 732) (oxblood)
75	Camaro (L.T.)	1663541	1	46.50	(comb. 16D) (graystone)
75	Camaro (L.T.)	1663542	1	46.50	(comb. 55D) (sandstone)
75	Camaro (L.T.)	1663543	1	46.50	(comb. 63D) (saddle)
75	Camaro (L.T.)	1663544	1	46.50	(comb. 73D) (oxblood)
75	Camaro (L.T.)	1663546	1	46.25	(comb. 55W) (sandstone)
75	Camaro (L.T.)	1663547	1	46.25	(comb. 63W) (saddle)

*NOTE 1: 1st design vertical stitch line pattern dimension width is 7/16 inches, 2nd design 5/16 inches.*

**VEGA—MONZA**

73	Vega (Sta. Wag., H.B.)	9651867	1	53.25	(comb. 860) (black)
73	Vega (N.B.)	9651886	1	59.75	(comb. 860) (black)
74	Vega (exc. Panel)	9686589	1	115.00	(comb. 871) (black and white)
74	Vega (exc. Panel)	9686590	1	115.00	(comb. 887) (green and black)
74	Vega (exc. Panel)	9686525	1	101.00	(comb. 880) (green)
74	Vega (exc. Panel)	9686599	1	51.75	(comb. 873) (black and white)
74	Vega (exc. Panel)	9686600	1	51.75	(comb. 883) (green and black)
74	Vega (exc. Panel)	9686558	1	59.75	(comb. 862) (black)
74	Vega (exc. Panel)	9686560	1	59.75	(comb. 879) (green)
74	Vega (exc. Panel)	9686561	1	59.75	(comb. 888) (saddle)
74	Vega (exc. Panel)	9686526	1	101.00	(comb. 890) (saddle)
74-75	Vega (exc. Panel)	9732962	1	101.00	(comb. 861) (19Y) (black)
74	Vega (exc. Panel)	9733031	1	101.00	(comb. 863) (neutral)
74	Vega (H.B.)	1674346	1	92.25	(comb. 867) (white)
74	Vega (Sta. Wag., H.B.)	9686524	1	101.00	(comb. 869) (black)
74	Vega (Sta. Wag., H.B.)	9686565	1	53.25	(comb. 884) (red)
75	Vega (exc. Panel)	1687228	1	49.75	(comb. 19D) (black)
75	Vega (exc. Panel)	1687230	1	49.75	(comb. 55D) (sandstone)
75	Vega (exc. Panel)	1687242	1	105.00	(comb. 19E) (black)
75	Vega (exc. Panel)	1687244	1	105.00	(comb. 55E) (sandstone)
75	Vega (1st design) (exc. Panel)	1687248	1	54.25	(comb. 19W) (black) (Note 1)
75	Vega (1st design) (exc. Panel)	1687250	1	54.25	(comb. 26W) (blue) (Note 1)
75	Vega (1st design) (exc. Panel)	1687252	1	54.25	(comb. 55W) (sandstone) (Note 1)
75	Vega (1st design) (exc. Panel)	1687254	1	54.25	(comb. 63W) (saddle) (Note 1)
75	Vega (2nd design) (exc. Panel)	1708217	1	54.50	(comb. 19W) (black) (Note 1)
75	Vega (2nd design) (exc. Panel)	1708218	1	54.50	(comb. 26W) (blue) (Note 1)
75	Vega (2nd design) (exc. Panel)	1708219	1	54.50	(comb. 55W) (sandstone) (Note 1)
75	Vega (2nd design) (exc. Panel)	1708220	1	54.50	(comb. 63W) (saddle) (Note 1)
75	Vega (exc. Panel)	1687274	1	92.25	(comb. 55Y) (sandstone)
75	Vega (exc. Panel)	1687276	1	57.25	(comb. 63Y) (saddle)
75	Vega (Sta. Wag., H.B.)	1694441	1	92.25	(comb. 02Y, 11Y) (white)

**REAR TRIM—MATS—YARDAGE**

**15.035 TRIM ASSY., Rear and Center Seat Cushion Cover (Con't)**

75	Vega (Sta. Wag., H.B.)	1694548	1	103.00	(comb. 26B-W) (blue)
75	Vega (Sta. Wag., H.B.)	1694549	1	103.00	(comb. 55B-Y) (sandstone)
75	Vega (Sta. Wag., H.B.)	1694550	1	103.00	(comb. 73B-Y) (oxblood)
75	Monza	1702958	R.H.	52.50	(comb. 19H-N-O) (black)
75	Monza	1702959	L.H.	52.50	(comb. 19H-N-O) (black)
75	Monza	1702980	R.H.	90.25	(comb. 192, 193) (black)
75	Monza	1702981	L.H.	90.25	(comb. 192, 193) (black)
75	Monza (exc. Towne Cpe.)	1702968	R.H.	52.50	(comb. 02J, 07J, 11J) (white)
75	Monza (exc. Towne Cpe.)	1702969	L.H.	52.50	(comb. 02J, 07J, 11J) (white)
75	Monza (exc. Towne Cpe.)	1702982	R.H.	90.25	(comb. 632) (saddle)
75	Monza (exc. Towne Cpe.)	1702983	L.H.	90.25	(comb. 632) (saddle)
75	Monza (exc. Towne Cpe.)	1702984	R.H.	90.25	(comb. 732) (oxblood)
75	Monza (exc. Towne Cpe.)	1702985	L.H.	90.25	(comb. 732) (oxblood)
75	Monza (exc. Towne Cpe.)	1702930	R.H.	55.00	(comb. 19G) (black)
75	Monza (exc. Towne Cpe.)	1702931	L.H.	55.00	(comb. 19G) (black)
75	Monza (exc. Towne Cpe.)	1702928	R.H.	55.00	(comb. 16G) (graystone)
75	Monza (exc. Towne Cpe.)	1702929	L.H.	55.00	(comb. 16G) (graystone)
75	Monza (exc. Towne Cpe.)	1702964	R.H.	52.50	(comb. 63Z) (saddle)
75	Monza (exc. Towne Cpe.)	1702965	L.H.	52.50	(comb. 63Z) (saddle)
75	Monza (exc. Towne Cpe.)	1702962	R.H.	52.50	(comb. 55Z) (sandstone)
75	Monza (exc. Towne Cpe.)	1702963	L.H.	52.50	(comb. 55Z) (sandstone)
75	Monza (exc. Towne Cpe.)	1702960	R.H.	52.50	(comb. 26Z) (blue)
75	Monza (exc. Towne Cpe.)	1702961	L.H.	52.50	(comb. 26Z) (blue)
75	Monza (exc. Towne Cpe.)	1702956	R.H.	52.50	(comb. 16Z) (graystone)
75	Monza (exc. Towne Cpe.)	1702957	L.H.	52.50	(comb. 16Z) (graystone)
75	Monza (exc. Towne Cpe.)	1702938	R.H.	55.00	(comb. 73G) (oxblood)
75	Monza (exc. Towne Cpe.)	1702939	L.H.	55.00	(comb. 73G) (oxblood)
75	Monza (exc. Towne Cpe.)	1702936	R.H.	55.00	(comb. 63G) (saddle)
75	Monza (exc. Towne Cpe.)	1702937	L.H.	55.00	(comb. 63G) (saddle)
75	Monza (exc. Towne Cpe.)	1702934	R.H.	55.00	(comb. 55G) (sandstone)
75	Monza (exc. Towne Cpe.)	1702935	L.H.	55.00	(comb. 55G) (sandstone)
75	Monza (exc. Towne Cpe.)	1702932	R.H.	55.00	(comb. 26G) (blue)
75	Monza (exc. Towne Cpe.)	1702933	L.H.	55.00	(comb. 26G) (blue)
75	Monza (exc. Towne Cpe.)	1702966	R.H.	52.50	(comb. 73Z) (oxblood)
75	Monza (exc. Towne Cpe.)	1702967	L.H.	52.50	(comb. 73Z) (oxblood)
75	Monza (Towne Cpe.)	1713578	R.H.	61.25	(comb. 07H, 11H) (white)
75	Monza (Towne Cpe.)	1713579	L.H.	61.25	(comb. 07H, 11H) (white)
75	Monza (Towne Cpe.)	1713582	R.H.	61.25	(comb. 64H-N) (buckskin)
75	Monza (Towne Cpe.)	1713583	L.H.	61.25	(comb. 64H-N) (buckskin)
75	Monza (Towne Cpe.)	1713584	R.H.	61.25	(comb. 71H) (firethorn)
75	Monza (Towne Cpe.)	1713585	L.H.	61.25	(comb. 71H-N) (firethorn)
75	Monza (Towne Cpe.)	1713588	R.H.	64.00	(comb. 19N) (black)
75	Monza (Towne Cpe.)	1713589	L.H.	64.00	(comb. 19N) (black)
75	Monza (Towne Cpe.)	1713590	R.H.	64.00	(comb. 64N) (buckskin)
75	Monza (Towne Cpe.)	1713591	L.H.	64.00	(comb. 64N) (buckskin)
75	Monza (Towne Cpe.)	1713592	R.H.	64.00	(comb. 71N) (firethorn)
75	Monza (Towne Cpe.)	1713593	L.H.	64.00	(comb. 71N) (firethorn)
75	Monza (Towne Cpe.)	1713598	R.H.	98.25	(comb. 643) (buckskin)
75	Monza (Towne Cpe.)	1713599	L.H.	98.25	(comb. 64e) (buckskin)

*NOTE 1: Seat back and cushion assemblies design change from vertical to horizontal by rotating pattern 90°.*

**15.036 PAD ASSY., Rear Seat Cushion**

72-75	Pass. (4-Dr.) (exc. Sta. Wag.)	9622377	1	48.50	rr. st. cush. w/wire
72	Vega (N.B.) w/Sensor Warning System (exc. Custom Seat)				
72	Vega (N.B., Sta. Wag.) (exc. Custom Seat)		1		4 point seat belt system
73	Vega (N.B.),				
73-75	Vega (exc. Panel)	9638593	1	23.85	
72	Vega (H.B.) w/Sensor Warning System,				
73-74	Vega (exc. Panel) w/Custom Seat	9638592	1	31.00	
72	Vega (Sta. Wag.) (exc. Custom Seat)		1		3 point seat belt system
73-74	Vega (Sta. Wag.)	9638589	1	27.25	
73-75	Bel Air, Taxi	9668580	1	44.75	
73-75	Pass. (2-Dr.)	9672023	1	44.50	
73-75	Pass. (Sta. Wag.)	9622391	1	40.25	fldg. 2nd
73-75	Pass. (Sta. Wag.) (9-Pass.)	9622404	1	11.95	fldg. 2nd— 1/3
73-75	Pass. (Sta. Wag.) (9-Pass.)	9622400	1	29.25	fldg. 2nd— 2/3
74-75	Pass. (Sta. Wag.) (9-Pass.)	9675940	1	17.70	fldg. 3rd
73-75	Chevellé (Sedan)	9613071	1	34.75	
73-74	Chevellé (Sta. Wag.)	9613077	1	16.95	fldg. 2nd
73-74	Chevellé (Sta. Wag.)	9866972	1	11.60	fldg. 3rd

**REAR TRIM—MATS—YARDAGE**

**15.036 PAD ASSY., Rear Seat Cushion (Con't)**

73-75	Chevelle (Coupe) . . . . .	9613075	1	34.75	
73-75	Nova (Coupe) . . . . .	1659523	1	22.65	
73-74	Nova (Sedan) . . . . .	1659524	1	22.65	
73-74	Nova (Taxi) . . . . .	9677225	1	34.25	
74-75	Chevelle (Sedan) . . . . .	9685036	1	28.25	
74-75	Camaro . . . . .	9679613	2	18.15	
75	Chevelle (Sta. Wag.) . . . . .	9613079	1	26.00	fldg. 2nd . . . . .
75	Monte Carlo w/Custom Seat . . . . .	1661525	1	43.50	
75	Chevelle (Sta. Wag.) . . . . .	1672789	1	23.05	fldg. 3rd . . . . .
75	Nova (Sedan, Taxi) (exc. Custom) . . . . .	1733809	1	59.00	
75	Monza . . . . .	1660108 R.H.		21.60	w/wire . . . . .
75	Monza . . . . .	1660109 L.H.		21.60	w/wire . . . . .

**15.060 TRIM ASSY., Third Seat Back Cover**

**PASS.**

72	Townsmen . . . . .	9897043	1		(comb. 825) (saddle) . . . . .
74	Bel Air (Sta. Wag.) (9-Pass.) . . . . .	9675908	1	67.25	(comb. 817) (neutral) . . . . .
74	Bel Air (Sta. Wag.) (9-Pass.) . . . . .	9675909	1	67.25	(comb. 851) (green) . . . . .
74	Impala, Caprice (Sta. Wag.) (9-Pass.) . . . . .	9675730	1	94.25	(comb. 806) (black) . . . . .
74	Impala, Caprice (Sta. Wag.) (9-Pass.) . . . . .	9675731	1	94.25	(comb. 813) (midn. blue) . . . . .
74	Impala, Caprice (Sta. Wag.) (9-Pass.) . . . . .	9675732	1	94.25	(comb. 819) (neutral) . . . . .
74	Impala, Caprice (Sta. Wag.) (9-Pass.) . . . . .	9675733	1	94.25	(comb. 849) (saddle) . . . . .
74	Impala, Caprice (Sta. Wag.) (9-Pass.) . . . . .	9675734	1	94.25	(comb. 855) (green) . . . . .
74	Impala, Caprice (Sta. Wag.) (9-Pass.) . . . . .	1690405	1	99.75	fldg. (comb. 802) (black and white) . . . . .
74	Impala, Caprice (Sta. Wag.) (9-Pass.) . . . . .	1690406	1	99.75	fldg. (comb. 858) (saddle and black) . . . . .
74	Impala, Caprice (Sta. Wag.) (9-Pass.) . . . . .	1690407	1	99.75	fldg. (comb. 859) (black and green) . . . . .
75	Bel Air (Sta. Wag.) (9-Pass.) . . . . .	1658554	1	74.00	(comb. 55V) (sandstone) . . . . .
75	Bel Air (Sta. Wag.) (9-Pass.) . . . . .	1658553	1	74.00	(comb. 26V) (blue) . . . . .
75	Impala, Caprice (Sta. Wag.) (9-Pass.) . . . . .	1665544	1	108.00	(comb. 63E) (saddle) . . . . .
75	Impala, Caprice (Sta. Wag.) (9-Pass.) . . . . .	1665546	1	96.50	(comb. 19W) (black) . . . . .
75	Impala, Caprice (Sta. Wag.) (9-Pass.) . . . . .	1665547	1	96.50	(comb. 26W) (blue) . . . . .
75	Impala, Caprice (Sta. Wag.) (9-Pass.) . . . . .	1665548	1	96.50	(comb. 44W) (green) . . . . .
75	Impala, Caprice (Sta. Wag.) (9-Pass.) . . . . .	1665549	1	96.50	(comb. 55W) (sandstone) . . . . .
75	Impala, Caprice (Sta. Wag.) (9-Pass.) . . . . .	1665550	1	96.50	(comb. 63W) (saddle) . . . . .

**CHEVELLE**

72	Concours . . . . .	9839465	1		fldg. (comb. 704, 705) (black) . . . . .
73-75	Chevelle (Sta. Wag.) . . . . .	9627762	1	50.00	(comb. 701, 704, 706, 707, 708, 891, 19V, 19W) (black) . . . . .
73	Malibu, Laguna (Sta. Wag.),				
74	Chevelle (Sta. Wag.) . . . . .	9627767	1	38.00	(comb. 713, 714, 715, 732, 734, 745, 830, 892) (neutral) . . . . .
74	Malibu (Classic) (Sta. Wag.) . . . . .	9738706	1	42.25	(comb. 735) (midn. blue) . . . . .
74	Malibu (Classic) (Sta. Wag.) . . . . .	9738703	1	42.25	(comb. 728) (green) . . . . .
75	Malibu (Classic) (Sta. Wag.) . . . . .	1668413	1	46.75	(comb. 63W) (saddle) . . . . .
75	Malibu (Classic) (Sta. Wag.) . . . . .	1668411	1	46.75	(comb. 26W) (blue) . . . . .
75	Chevelle (Sta. Wag.) . . . . .	1668412	1	46.75	(comb. 55V, 55W) (sandstone) . . . . .

**15.070 TRIM ASSY., Third Seat Cushion**

**PASS.**

72	Townsmen (9-Pass.) . . . . .	9897041	1		fldg. (comb. 804) (black) . . . . .
72	Townsmen (9-Pass.) . . . . .	9897042	1		fldg. (comb. 811) (blue) . . . . .
74	Bel Air (Sta. Wag.) (9-Pass.) . . . . .	9675910	1	47.75	(comb. 817) (neutral) . . . . .
74	Bel Air (Sta. Wag.) (9-Pass.) . . . . .	9675911	1	47.75	(comb. 851) (green) . . . . .
74	Impala, Caprice (Sta. Wag.) (9-Pass.) . . . . .	9677271	1	68.00	(comb. 819) (neutral) . . . . .



**REAR TRIM—MATS—YARDAGE**

**15.070 TRIM ASSY., Third Seat Cushion (Con't)**

74	Impala, Caprice (Sta. Wag.) (9-Pass.)	9677272	1	68.00	(comb. 813) (midn. blue)
74	Impala, Caprice (Sta. Wag.) (9-Pass.)	9677273	1	68.00	(comb. 806) (black)
74	Impala, Caprice (Sta. Wag.) (9-Pass.)	9675735	1	68.00	(comb. 849) (saddle)
74	Impala, Caprice (Sta. Wag.) (9-Pass.)	9675736	1	68.00	(comb. 855) (green)
75	Bel Air (Sta. Wag.) (9-Pass.)	1658555	1	50.50	(comb. 26V) (blue)
75	Bel Air (Sta. Wag.) (9-Pass.)	1658556	1	50.50	(comb. 55V) (sandstone)
75	Impala, Caprice (Sta. Wag.) (9-Pass.)	1665558	1	70.00	(comb. 63W) (saddle)
75	Impala, Caprice (Sta. Wag.) (9-Pass.)	1665557	1	70.00	(comb. 55W) (sandstone)
75	Impala, Caprice (Sta. Wag.) (9-Pass.)	1665556	1	70.00	(comb. 44W) (green)
75	Impala, Caprice (Sta. Wag.) (9-Pass.)	1665555	1	70.00	(comb. 26W) (blue)
75	Impala, Caprice (Sta. Wag.) (9-Pass.)	1665554	1	70.00	(comb. 19W) (black)
75	Impala, Caprice (Sta. Wag.) (9-Pass.)	1665552	1	78.75	(comb. 63E) (saddle)

**CHEVELLE**

72	Greenbrier (9-Pass.)	9607248	1		fldg. (comb. 701) (black)
72	Greenbrier (9-Pass.)	9898721	1		fldg. (comb. 710) (green)
73-74	Chevelle (Sta. Wag.)	9627756	1	51.00	(comb. 701, 704, 706, 707, 708, 891) (black)
73	Malibu, Laguna (Sta. Wag.)	9665213	1	42.00	(comb. 705, 719) (blue)
73	Malibu, Laguna (Sta. Wag.)				
74	Chevelle (Sta. Wag.)	9627761	1	42.00	(comb. 713, 714, 715, 732, 734, 745, 830, 892) (neutral)
74	Malibu (Classic) (Sta. Wag.)	9738710	1	42.00	(comb. 740) (saddle)
74	Malibu (Classic) (Sta. Wag.)	9738709	1	42.00	(comb. 728) (green)
74	Malibu (Classic) (Sta. Wag.)	9738712	1	42.00	(comb. 735) (midn. blue)
75	Chevelle (Sta. Wag.)	1746642	1	51.50	(comb. 19V, 19W) (black)
75	Chevelle (Sta. Wag.)	1668416	1	48.00	(comb. 55V, 55W) (sandstone)
75	Chevelle (Sta. Wag.)	1668418	1	48.00	(comb. 63W) (saddle)
75	Malibu (Classic) (Sta. Wag.)	1668415	1	48.00	(comb. 26W) (blue)

**15.099 TRIM ASSY.—LACE ASSY.—PANEL, Wheelhouse Cover**

**PASS.**

71-72	Kingswood Estate,				
71-75	Caprice (Sta. Wag.) (1st design)	9646431	L.H.	13.95	front (comb. 802, 806) (19) (black) (Note 1)
71-73	Caprice (Sta. Wag.)	9646436	L.H.	13.00	rear (comb. 806) (black)
73-75	Caprice (Sta. Wag.) (1st design)	9646426	R.H.	14.20	(comb. 802, 806, 19) (black) (Note 1)
73-74	Caprice (Sta. Wag.)	9646430	R.H.	14.20	(comb. 818, 819) (neutral)
73-74	Caprice (Sta. Wag.)	9646429	R.H.	14.20	(comb. 813) (mid. blue)
73	Caprice (Sta. Wag.)	9646428	R.H.	14.25	(comb. 826) (63) (saddle) (Note 1)
75	Caprice (Sta. Wag.) (1st design)	9646428	R.H.	14.25	(comb. 826) (63) (saddle) (Note 1)
73	Caprice (Sta. Wag.)				
75	Caprice (Sta. Wag.) (1st design)	9646433	L.H.	13.95	front (comb. 826) (63) (saddle) (Note 1)
73-74	Caprice (Sta. Wag.)	9646434	L.H.	13.95	front (comb. 813) (mid. blue)
73-74	Caprice (Sta. Wag.)	9646435	L.H.	13.95	front (comb. 818) (neutral)
73	Caprice (Sta. Wag.)	9646440	L.H.	13.00	rear (comb. 818, 819) (neutral)
73	Caprice (Sta. Wag.)	9646439	L.H.	13.00	rear (comb. 813) (mid. blue)
73	Caprice (Sta. Wag.)	9646438	L.H.	13.00	rear (comb. 826) (saddle)
74-75	Caprice (Sta. Wag.) (1st design)	9678987	R.H.	14.20	(comb. 855, 859, 44) (green) (Note 1)
74	Caprice (Sta. Wag.)	9678988	R.H.	14.20	(comb. 849, 858) (saddle)
74-75	Caprice (Sta. Wag.) (1st design)	9678993	L.H.	13.95	front (comb. 855, 859, 44) (Note 1) (green)
74	Caprice (Sta. Wag.)	9678994	L.H.	13.95	front (comb. 849, 858) (saddle)
74-75	Caprice (Sta. Wag.) (1st design)	9678990	L.H.	13.00	rear (comb. 855, 859, 44) (green) (Note 1)
74	Caprice (Sta. Wag.)	9678991	L.H.	13.00	rear (comb. 849, 858) (saddle)
74-75	Caprice (Sta. Wag.) (1st design)	9694293	L.H.	13.95	rear (comb. 802, 806, 19) (black) (Note 1)
74	Caprice (Sta. Wag.)	9694294	L.H.	13.95	rear (comb. 813) (midnight blue)
74	Caprice (Sta. Wag.)	9694295	L.H.	13.95	rear (comb. 819) (neutral)
75	Caprice (Sta. Wag.) (1st design)	1675701	R.H.	13.40	front (comb. 26W) (blue) (Note 1)
75	Caprice (Sta. Wag.) (1st design)	1675703	L.H.	13.10	front (comb. 26W) (blue) (Note 1)
75	Caprice (Sta. Wag.) (1st design)	1675702	R.H.	13.40	front (comb. 55W) (sandstone) (Note 1)
75	Caprice (Sta. Wag.) (1st design)	1675704	L.H.	13.10	front (comb. 55W) (sandstone) (Note 1)
75	Caprice (Sta. Wag.) (1st design)	1675707	L.H.	13.10	rear (comb. 63) (saddle) (Note 1)
75	Caprice (Sta. Wag.) (1st design)	1675708	L.H.	13.10	rear (comb. 26W) (blue) (Note 1)
75	Caprice (Sta. Wag.) (1st design)	1675709	L.H.	13.10	rear (comb. 55W) (sandstone)

**REAR TRIM—MATS—YARDAGE**

**15.099 TRIM ASSY.— LACE ASSY.— PANEL, Wheelhouse Cover (Con't)**

74-75	Caprice (Sta. Wag.) (1st design)	9691293 L.H.	.70	LACE ASSY., rear (comb. 802, 806) 19 (black) (Note 1)
74	Caprice (Sta. Wag.)	9691294 L.H.	.70	LACE ASSY., rear (comb. 813) (midn. blue)
74	Caprice (Sta. Wag.)	9691295 L.H.	.70	LACE ASSY., rear (comb. 819) (neutral)
74	Caprice (Sta. Wag.)	9691297 L.H.	.70	LACE ASSY., rear (comb. 849, 858) (saddle)
74-75	Caprice (Sta. Wag.) (1st design)	9691298 L.H.	.70	LACE ASSY., rear (comb. 855, 859) 44 (green) (Note 1)
75	Caprice (Sta. Wag.) (1st design)	1674466 L.H.	1.40	LACE ASSY., rear (comb. 63) (saddle) (Note 1)
75	Caprice (Sta. Wag.) (1st design)	1674467 L.H.	1.40	LACE ASSY., rear (comb. 26) (blue) (Note 1)
75	Caprice (Sta. Wag.) (1st design)	1674468 L.H.	1.40	LACE ASSY., rear (comb. 55) (sandstone) (Note 1)
72	Brookwood, Townsman, Kingswood (exc. Estate) (2nd design),			
73	Bel Air, Impala (Sta. Wag.)	9896727 R.H.	16.10	PANEL, w/h cover (prime and paint as reqd.) (sensor warning)
72	Brookwood, Townsman, Kingswood (exc. Estate) (2nd design),			
73-75	Bel Air, Impala (Sta. Wag.) (2nd design)	9896722 L.H.	16.10	PANEL, w/h cover front (prime and paint as reqd.) (Note 1) (sensor warning)
74-75	Bel Air, Impala (Sta. Wag.)	9689689 R.H.	17.75	PANEL, w/h cover front (prime and paint as reqd.)
74-75	Bel Air, Impala (Sta. Wag.) (2nd design)	9688693 L.H.	19.90	PANEL, w/h cover rear (prime and paint as reqd.) (Note 1)

**CHEVELLE**

75	Chevelle (Sta. Wag.)	9627236 R.H.	13.85	PANEL, w/h cover (paint as reqd.)
75	Chevelle (Sta. Wag.)	9627215 L.H.	13.85	PANEL, w/h cover (paint as reqd.)
75	Chevelle (Sta. Wag.)	9627229 L.H.	10.10	PANEL, rr. w/h cover (paint as reqd.)

**CHEVY—NOVA**

73-74	Nova (Sed., Taxi) (exc. Custom)	9662046 R.H.	4.55	PANEL, w/h trim finish
73-74	Nova (Sed., Taxi) (exc. Custom)	9662047 L.H.	4.55	PANEL, w/h trim finish

NOTE 1: 1st design trim assy. are colored.

NOTE 2: 2nd design use panels and prime and paint as reqd.

**15.100 TRIM ASSY., Rear Quarter**

NOTE It may be necessary to punch holes in Trim Assembly to insure proper fit.

NOTE Spare tire trim assy. for pass. (Sta. Wag.) are located in group 12.579 as panel assy.

**PASS.**

73	Impala (Custom Cpe.)	9645651 L.H.	43.00	upper (comb. 812, 813) (midn. blue)
73	Impala (Custom Cpe.)	9645646 R.H.	43.00	upper (comb. 815, 818) (neutral)
73	Impala (Custom Cpe.)	9645647 L.H.	43.00	upper (comb. 815, 818) (neutral)
73	Impala (Spt. Cpe.) (exc. Custom)	9645642 R.H.	45.00	upper (comb. 812, 813) (midn. blue)
73	Caprice (Spt. Cpe.)	9645660 R.H.	51.25	upper (comb. 841) (neutral)
73	Caprice (Conv.)	9645654 R.H.	35.25	upper (comb. 830) (green)
73-74	Caprice (Conv.)	9645652 R.H.	35.25	upper (comb. 818, 819) (neutral)
73-74	Caprice (Conv.)	9645653 L.H.	35.25	upper (comb. 818, 819) (neutral)
74	Impala (Custom)	9691584 R.H.	23.50	upper (comb. 802, 805, 806) (black)
74	Impala (Custom)	9691585 L.H.	23.50	upper (comb. 802, 805, 806) (black)
74	Impala (Custom)	9691588 R.H.	23.50	upper (comb. 819, 821) (neutral)
74	Impala (Custom)	9691589 L.H.	23.50	upper (comb. 819, 821) (neutral)
74	Impala (Custom)	9691590 R.H.	23.50	upper (comb. 853, 855) (green)
74	Impala (Custom)	9691591 L.H.	23.50	upper (comb. 853, 855) (green)
74	Impala (Custom)	9691592 R.H.	23.50	upper (comb. 813, 847) (mid. blue)
74	Impala (Custom)	9691593 L.H.	23.50	upper (comb. 813, 847) (mid. blue)
74	Impala (Custom)	9732112 R.H.	23.50	upper (comb. 849, 858) (saddle)
74	Impala (Custom)	9732113 L.H.	23.50	upper (comb. 849, 858) (saddle)
74	Impala (Spt. Cpe.) (exc. Custom)	9691576 R.H.	45.00	upper (comb. 802, 805, 806) (black)
74	Impala (Spt. Cpe.) (exc. Custom)	9691577 L.H.	41.50	upper (comb. 802, 805, 806) (black)
74	Impala (Spt. Cpe.) (exc. Custom)	9691578 R.H.	41.50	upper (comb. 819, 821) (neutral)
74	Impala (Spt. Cpe.) (exc. Custom)	9691579 L.H.	41.50	upper (comb. 819, 821) (neutral)
74	Impala (Spt. Cpe.) (exc. Custom)	9691580 R.H.	41.50	upper (comb. 853, 855) (green)
74	Impala (Spt. Cpe.) (exc. Custom)	9691581 L.H.	45.00	upper (comb. 853, 855) (green)
74	Impala (Spt. Cpe.) (exc. Custom)	9691582 R.H.	41.50	upper (comb. 813, 847) (midn. blue)
74	Impala (Spt. Cpe.) (exc. Custom)	9691583 L.H.	45.00	upper (comb. 813, 847) (midn. blue)
74	Impala (Spt. Cpe.) (exc. Custom)	9732110 R.H.	41.50	upper (comb. 849, 858) (saddle)
74	Impala (Spt. Cpe.) (exc. Custom)	9732111 L.H.	41.50	upper (comb. 849, 858) (saddle)

**REAR TRIM—MATS—YARDAGE**

**15.100 TRIM ASSY., Rear Quarter (Con't)**

74	Impala (Spt. Cpe.) (exc. Custom)	1665364 R.H.	45.50	upper (comb. 804, 809) (white)
74	Impala (Spt. Cpe.) (exc. Custom)	1665365 L.H.	45.50	upper (comb. 804, 809) (white)
74	Caprice (Spt. Cpe.)	9691594 R.H.	29.25	upper (comb. 840) (black)
74	Caprice (Spt. Cpe.)	9691595 L.H.	29.25	upper (comb. 840) (black)
74	Caprice (Spt. Cpe.)	9691596 R.H.	29.25	upper (comb. 843) (midn. blue)
74	Caprice (Spt. Cpe.)	9691597 L.H.	29.25	upper (comb. 843) (midn. blue)
74	Caprice (Spt. Cpe.)	9691598 R.H.	29.25	upper (comb. 850) (green)
74	Caprice (Spt. Cpe.)	9691599 L.H.	29.25	upper (comb. 850) (green)
74	Caprice (Spt. Cpe.)	9691600 R.H.	29.25	upper (comb. 857) (oxblood)
74	Caprice (Spt. Cpe.)	9691601 L.H.	29.25	upper (comb. 857) (oxblood)
74	Caprice (Spt. Cpe.)	9691602 R.H.	29.25	upper (comb. 896) (taupe)
74	Caprice (Spt. Cpe.)	9691603 L.H.	29.25	upper (comb. 896) (taupe)
74	Caprice (Spt. Cpe.)	9691604 R.H.	27.25	upper (comb. 808) (black)
74	Caprice (Spt. Cpe.)	9691605 L.H.	27.25	upper (comb. 808) (black)
74	Caprice (Spt. Cpe.)	9691606 R.H.	27.25	upper (comb. 841) (neutral)
74	Caprice (Spt. Cpe.)	9691607 L.H.	27.25	upper (comb. 841) (neutral)
74	Pass. (Conv.)	9691608 R.H.	35.25	upper (comb. 855) (green)
74	Pass. (Conv.)	9691609 L.H.	35.25	upper (comb. 855) (green)
74	Pass. (Conv.)	9691610 R.H.	35.25	upper (comb. 806) (black)
74	Pass. (Conv.)	9691611 L.H.	35.25	upper (comb. 806) (black)
74	Pass. (Conv.)	1690512 R.H.	34.00	upper (comb. 810) (white)
74	Pass. (Conv.)	1690513 L.H.	34.00	upper (comb. 810) (white)
75	Impala (Spt. Cpe.) (exc. Custom)	1681530 R.H.	48.00	upper below belt (comb. 02W, 04W, 07W, 11W) (white)
75	Impala (Spt. Cpe.) (exc. Custom)	1681531 L.H.	48.00	upper below belt (comb. 02W, 04W, 07W, 11W) (white)
75	Impala (Spt. Cpe.) (exc. Custom)	1665310 R.H.	48.00	upper below belt (comb. 19) (black)
75	Impala (Spt. Cpe.) (exc. Custom)	1665311 L.H.	48.00	upper below belt (comb. 19) (black)
75	Impala (Spt. Cpe.) (exc. Custom)	1665312 R.H.	48.00	upper below belt (comb. 26) (blue)
75	Impala (Spt. Cpe.) (exc. Custom)	1665313 L.H.	48.00	upper below belt (comb. 26) (blue)
75	Impala (Spt. Cpe.) (exc. Custom)	1665314 R.H.	48.00	upper below belt (comb. 44) (green)
75	Impala (Spt. Cpe.) (exc. Custom)	1665315 L.H.	48.00	upper below belt (comb. 44) (green)
75	Impala (Spt. Cpe.) (exc. Custom)	1665316 R.H.	48.00	upper below belt (comb. 55) (sandstone)
75	Impala (Spt. Cpe.) (exc. Custom)	1665317 L.H.	48.00	upper below belt (comb. 55) (sandstone)
75	Impala (Spt. Cpe.) (exc. Custom)	1665318 R.H.	48.00	upper below belt (comb. 63) (saddle)
75	Impala (Spt. Cpe.) (exc. Custom)	1665319 L.H.	48.00	upper below belt (comb. 63) (saddle)
75	Impala (Custom)	1672726 R.H.	17.55	upper below belt (comb. 19) (black)
75	Impala (Custom)	1672727 L.H.	17.55	upper below belt (comb. 19) (black)
75	Impala (Custom)	1672728 R.H.	17.55	upper below belt (comb. 26) (blue)
75	Impala (Custom)	1672729 L.H.	17.55	upper below belt (comb. 26) (blue)
75	Impala (Custom)	1672730 R.H.	17.55	upper below belt (comb. 44) (green)
75	Impala (Custom)	1672731 L.H.	17.55	upper below belt (comb. 44) (green)
75	Impala (Custom)	1672732 R.H.	17.55	upper below belt (comb. 55) (sandstone)
75	Impala (Custom)	1672733 L.H.	17.55	upper below belt (comb. 55) (sandstone)
75	Impala (Custom)	1672734 R.H.	17.55	upper below belt (comb. 63) (saddle)
75	Impala (Custom)	1672735 L.H.	17.55	upper below belt (comb. 63) (saddle)
75	Impala (Custom)	1681528 R.H.	17.55	upper below belt (comb. 02W, 04W, 07W, 11W) (white)
75	Impala (Custom)	1681529 L.H.	17.55	upper below belt (comb. 02W, 04W, 07W, 11W) (white)
75	Caprice (Spt. Cpe.)	1658284 R.H.	32.75	upper below belt (comb. 19B) (black)
75	Caprice (Spt. Cpe.)	1658285 L.H.	32.75	upper below belt (comb. 19B) (black)
75	Caprice (Spt. Cpe.)	1658286 R.H.	32.75	upper below belt (comb. 26B) (blue)
75	Caprice (Spt. Cpe.)	1658287 L.H.	32.75	upper below belt (comb. 26B) (blue)
75	Caprice (Spt. Cpe.)	1658288 R.H.	32.75	upper below belt (comb. 44B) (green)
75	Caprice (Spt. Cpe.)	1658289 L.H.	32.75	upper below belt (comb. 44B) (green)
75	Caprice (Spt. Cpe.)	1658290 R.H.	32.75	upper below belt (comb. 55B) (sandstone)
75	Caprice (Spt. Cpe.)	1658291 L.H.	32.75	upper below belt (comb. 55B) (sandstone)
75	Caprice (Spt. Cpe.)	1658292 R.H.	32.75	upper below belt (comb. 73B) (oxblood)
75	Caprice (Spt. Cpe.)	1658293 L.H.	32.75	upper below belt (comb. 73B) (oxblood)
75	Caprice (Spt. Cpe.)	1658294 R.H.	30.25	upper below belt (comb. 19H) (black)
75	Caprice (Spt. Cpe.)	1658295 L.H.	30.25	upper below belt (comb. 19H) (black)
75	Caprice (Spt. Cpe.)	1658296 R.H.	30.25	upper below belt (comb. 55H) (sandstone)
75	Caprice (Spt. Cpe.)	1658297 L.H.	30.25	upper below belt (comb. 55H) (sandstone)
75	Pass. (Conv.)	1681532 R.H.	37.25	upper below belt (comb. 11W) (white)
75	Pass. (Conv.)	1681533 L.H.	37.25	upper below belt (comb. 11W) (white)
75	Pass. (Conv.)	1665328 R.H.	37.25	upper below belt (comb. 55W) (sandstone)
75	Pass. (Conv.)	1665329 L.H.	37.25	upper below belt (comb. 55W) (sandstone)
75	Pass. (Conv.)	1665330 R.H.	37.25	upper below belt (comb. 63E, W) (saddle)
75	Pass. (Conv.)	1665331 L.H.	37.25	upper below belt (comb. 63E, 63W) (saddle)

**CHEVY—NOVA**

68	Chevy (Spt. Cpe.)			(comb. 733)
69-70	Chevy (Spt. Cpe.)	7751362 R.H.	22.70	(comb. 730, 731) (black)
68-70	Chevy (Spt. Cpe.)	7751363 L.H.	22.70	(comb. 730, 731) (black)

**REAR TRIM—MATS—YARDAGE**

**15.100 TRIM ASSY., Rear Quarter (Con't)**

71-72	Nova (2-Dr.)	7751363 L.H.	22.70	(comb. 750, 751) (black)
71-72	Nova (2-Dr.)	7751362 R.H.	22.70	(comb. 750, 751) (black)
71-72	Nova (2-Dr.)	9848846 R.H.	32.75	(comb. 752, 753, 754) (black)
71	Nova (2-Dr.)	9848842 R.H.	29.50	(comb. 759, 760) (dk. jade)
72	Nova (2-Dr.)	9890909 L.H.	29.50	(comb. 756) (blue)
72	Nova (2-Dr.)	9890910 R.H.	29.50	(comb. 759, 760) (green)
72	Nova (2-Dr.)	9890912 R.H.	29.50	(comb. 763, 765) (covert)
72	Nova (2-Dr.)	9890913 L.H.	29.50	(comb. 763, 765) (covert)
75	Nova (Custom) (Coupe) (exc. H.B.)	1683776 R.H.	41.25	upper below belt (comb. 16G) (graystone)
75	Nova (Custom) (Coupe) (exc. H.B.)	1683777 L.H.	41.25	upper below belt (comb. 16G) (graystone)
75	Nova (Custom) (Coupe) (exc. H.B.)	1683778 R.H.	41.25	upper below belt (comb. 26G) (blue)
75	Nova (Custom) (Coupe) (exc. H.B.)	1683779 L.H.	41.25	upper below belt (comb. 26G) (blue)
75	Nova (Custom) (Coupe) (exc. H.B.)	1683780 R.H.	41.25	upper below belt (comb. 55G) (sandstone)
75	Nova (Custom) (Coupe) (exc. H.B.)	1683781 L.H.	41.25	upper below belt (comb. 55G) (sandstone)
75	Nova (Custom) (Coupe) (exc. H.B.)	1683782 R.H.	41.25	upper below belt (comb. 73G) (oxblood)
75	Nova (Custom) (Coupe) (exc. H.B.)	1683783 L.H.	41.25	upper below belt (comb. 73G) (oxblood)

**CHEVELLE**

70-72	Malibu (Spt. Cpe.)	8796510 R.H.	39.50	(comb. 704, 705, 706, 753, 755, 756) (black)
70-72	Malibu (Spt. Cpe.)	8796511 L.H.	39.50	(comb. 704, 705, 706, 753, 755, 756) (black)
73	Deluxe (Cpe.)	9643289 L.H.	11.25	upper (comb. 701, 702, 706, 738, 891, 894) (black)
73	Deluxe (Cpe.)	9643292 R.H.	11.25	upper (comb. 713, 733, 892) (neutral)
73	Deluxe (Cpe.)	9643293 L.H.	11.25	upper (comb. 713, 733, 892) (neutral)
73	Malibu (Coupe)	9643294 R.H.	9.10	upper (comb. 703, 704, 708, 748) (black)
73	Malibu (Coupe)	9643295 L.H.	9.10	upper (comb. 703, 704, 708, 748) (black)
73-74	Laguna (Cpe.)	9643306 R.H.	14.35	upper (comb. 703, 707, 708, 712) (black)
73-74	Laguna (Cpe.)	9643307 L.H.	14.35	upper (comb. 703, 707, 708, 712) (black)
73-74	Laguna (Cpe.)	9643314 R.H.	14.35	upper (comb. 711, 715, 734) (neutral)
73-74	Laguna (Cpe.)	9643315 L.H.	14.35	upper (comb. 711, 715, 734) (neutral)
73-74	Laguna (Cpe.)	9670860 R.H.	14.35	upper (comb. 707, 714, 743) (oxblood) (repl. 9643312)
73-74	Laguna (Cpe.)	9643313 L.H.	14.35	upper (comb. 707, 714, 743) (oxblood)
73-74	Monte Carlo	9643318 R.H.	20.70	upper (comb. 705, 706, 708, 709) (black)
73-74	Monte Carlo	9643319 L.H.	20.70	upper (comb. 705, 706, 708, 709) (black)
73-74	Monte Carlo	9643326 R.H.	20.70	upper (comb. 725, 734, 737) (midn. blue)
73-74	Monte Carlo	9643327 L.H.	20.70	upper (comb. 725, 734, 737) (midn. blue)
73-74	Monte Carlo	9643320 R.H.	20.70	upper (comb. 716, 731, 735) (neutral)
73-74	Monte Carlo	9643321 L.H.	20.70	upper (comb. 716, 731, 735) (neutral)
73-74	Monte Carlo	9643324 R.H.	20.70	upper (comb. 740, 744) (oxblood)
73-74	Monte Carlo	9643325 L.H.	20.70	upper (comb. 740, 744) (oxblood)
74	Malibu (Coupe) (exc. Classic)	9643288 R.H.	11.25	upper (comb. 701, 702, 706, 738, 891, 894) (black)
74	Malibu (Coupe) (exc. Classic)	9643289 L.H.	11.25	upper (comb. 701, 702, 706, 738, 891, 894) (black)
74	Malibu (Coupe) (exc. Classic)	9643292 R.H.	11.25	upper (comb. 713, 733, 892) (neutral)
74	Malibu (Coupe) (exc. Classic)	9643293 L.H.	11.25	upper (comb. 713, 733, 892) (neutral)
74	Laguna	9643294 R.H.	9.10	upper (comb. 703, 704, 708, 748) (black)
74	Laguna	9643295 L.H.	9.10	upper (comb. 703, 704, 708, 748) (black)
74	Malibu (Coupe) (exc. Classic)	9677000 R.H.	11.25	upper (comb. 723, 727, 745, 830, 893) (green)
74	Malibu (Coupe) (exc. Classic)	9677001 L.H.	11.25	upper (comb. 723, 727, 745, 830, 893) (green)
74	Malibu (Coupe) (exc. Classic)	9731230 R.H.	11.25	upper (comb. 749, 897) (mid. blue)
74	Malibu (Coupe) (exc. Classic)	9731231 L.H.	11.25	upper (comb. 749, 897) (mid. blue)
74-75	Malibu (Classic) (Coupe)	9732558 R.H.	26.25	upper (comb. 702, 19D) (black)
74-75	Malibu (Classic) (Coupe)	9732559 L.H.	26.25	upper (comb. 702, 19D) (black)
74	Malibu (Classic) (Coupe)	9732560 R.H.	26.25	upper (comb. 732) (mid. blue)
74	Malibu (Classic) (Coupe)	9732561 L.H.	26.25	upper (comb. 732) (mid. blue)
74-75	Malibu (Classic) (Coupe)	9732562 R.H.	26.25	upper (comb. 724, 44D) (green)
74-75	Malibu (Classic) (Coupe)	9732563 L.H.	26.25	upper (comb. 724, 44D) (green)
74	Malibu (Classic) (Coupe)	9732564 R.H.	26.25	upper (comb. 722) (neutral)
74	Malibu (Classic) (Coupe)	9732565 L.H.	26.25	upper (comb. 722) (neutral)
74	Malibu (Classic) (Coupe)	9731746 R.H.	24.50	upper (comb. 785) (white)

**REAR TRIM—MATS—YARDAGE**

**15.100 TRIM ASSY., Rear Quarter (Con't)**

74	Malibu (Classic) (Coupe)	9731747 L.H.	24.50	upper (comb. 785) (white)
74	Malibu (Classic) (Coupe)	9731748 R.H.	24.50	upper (comb. 728) (green)
74	Malibu (Classic) (Coupe)	9731749 L.H.	24.50	upper (comb. 728) (green)
74	Malibu (Classic) (Coupe)	9731750 R.H.	24.50	upper (comb. 740) (saddle)
74	Malibu (Classic) (Coupe)	9731751 L.H.	24.50	upper (comb. 740) (saddle)
74	Malibu (Classic) (Coupe)	9731752 R.H.	24.50	upper (comb. 707, 747) (black)
74	Malibu (Classic) (Coupe)	9731753 L.H.	24.50	upper (comb. 707, 747) (black)
74-75	Malibu (Classic) (Coupe)	9731754 R.H.	26.25	upper (comb. 743, 73D) (oxblood)
74-75	Malibu (Classic) (Coupe)	9731755 L.H.	26.25	upper (comb. 743, 73D) (oxblood)
74	Malibu (Classic) (Coupe)	9731756 R.H.	24.50	upper (comb. 714) (neutral)
74	Malibu (Classic) (Coupe)	9731757 L.H.	24.50	upper (comb. 714) (neutral)
74	Laguna	9736618 R.H.	9.10	upper (comb. 718, 731) (saddle)
74	Laguna	9736619 L.H.	9.10	upper (comb. 718, 731) (saddle)
74	Laguna	9736620 R.H.	9.10	upper (comb. 719, 720) (oxblood)
74	Laguna	9736621 L.H.	9.10	upper (comb. 719, 720) (oxblood)
74	Monte Carlo	9677012 R.H.	20.70	upper (comb. 726, 730) (green)
74	Monte Carlo	9677013 L.H.	20.70	upper (comb. 726, 730) (green)
74	Monte Carlo	9677014 R.H.	20.70	upper (comb. 742) (saddle)
74	Monte Carlo	9677015 L.H.	20.70	upper (comb. 742) (saddle)
75	Malibu (Classic) (Coupe)	1662464 R.H.	23.65	upper below belt (comb. 26W) (blue)
75	Malibu (Classic) (Coupe)	1662465 L.H.	23.65	upper below belt (comb. 26W) (blue)
75	Malibu (Classic) (Coupe)	1662466 R.H.	23.65	upper below belt (comb. 55W) (sandstone)
75	Malibu (Classic) (Coupe)	1662467 L.H.	23.65	upper below belt (comb. 55W) (sandstone)
75	Malibu (Classic) (Coupe)	1662468 R.H.	23.65	upper below belt (comb. 63W) (saddle)
75	Malibu (Classic) (Coupe)	1662469 L.H.	23.65	upper below belt (comb. 63W) (saddle)
75	Malibu (Classic) (Coupe)	1662484 R.H.	28.25	upper below belt (comb. 16D) (graystone)
75	Malibu (Classic) (Coupe)	1662485 L.H.	28.25	upper below belt (comb. 16D) (graystone)
75	Malibu (Classic) (Coupe)	1662486 R.H.	28.25	upper below belt (comb. 26D) (blue)
75	Malibu (Classic) (Coupe)	1662487 L.H.	28.25	upper below belt (comb. 26D) (blue)
75	Malibu (Coupe) (exc. Classic)	1659388 R.H.	12.70	upper below belt (19C, 19V) (black)
75	Malibu (Coupe) (exc. Classic)	1659389 L.H.	12.70	upper below belt (19C, 19V) (black)
75	Malibu (Coupe) (exc. Classic)	1659392 R.H.	12.70	upper below belt (26C, 26V) (blue)
75	Malibu (Coupe) (exc. Classic)	1659393 L.H.	12.70	upper below belt (26C, 26V) (blue)
75	Laguna	1666824 R.H.	10.75	upper below belt (07E-Z, 11E-Z) (white)
75	Laguna	1666825 L.H.	10.75	upper below belt (07E-Z, 11E-Z) (white)
75	Laguna	1667380 R.H.	10.75	upper below belt (comb. 73E-Z) (oxblood)
75	Laguna	1667381 L.H.	10.75	upper below belt (comb. 73E-Z) (oxblood)
75	Monte Carlo	1676954 R.H.	28.50	upper below belt (comb. 19N) (black)
75	Monte Carlo	1676955 L.H.	28.50	upper below belt (comb. 19N) (black)
75	Monte Carlo	1676956 R.H.	28.50	upper below belt (comb. 26N) (blue)
75	Monte Carlo	1676957 L.H.	28.50	upper below belt (comb. 26N) (blue)
75	Monte Carlo	1676958 R.H.	28.50	upper below belt (comb. 44N) (green)
75	Monte Carlo	1676959 L.H.	28.50	upper below belt (comb. 44N) (green)
75	Monte Carlo	1676960 R.H.	28.50	upper below belt (comb. 55N) (sandstone)
75	Monte Carlo	1676961 L.H.	28.50	upper below belt (comb. 55N) (sandstone)
75	Monte Carlo	1676962 R.H.	28.50	upper below belt (comb. 73N) (oxblood)
75	Monte Carlo	1676963 L.H.	28.50	upper below belt (comb. 73N) (oxblood)
75	Monte Carlo	1690504 R.H.	20.90	upper below belt (comb. 02H, 04H, 07H, 11H) (white)
75	Monte Carlo	1690505 L.H.	20.90	upper below belt (comb. 02H, 04H, 07H, 11H) (white)
75	Monte Carlo	1674040 R.H.	20.90	upper (comb. 19B, 19H) (black)
75	Monte Carlo	1674041 L.H.	20.90	upper (comb. 19B, 19H) (black)
75	Monte Carlo	1674046 R.H.	20.90	upper (comb. 73B) (oxblood)
75	Monte Carlo	1674047 L.H.	20.90	upper (comb. 73B) (oxblood)
75	Monte Carlo	1674044 R.H.	20.90	upper (comb. 55B, 55H) (sandstone)
75	Monte Carlo	1674045 L.H.	20.90	upper (comb. 55B, 55H) (sandstone)
75	Monte Carlo	1674042 R.H.	20.90	upper (comb. 26B, 26H) (blue)
75	Monte Carlo	1674043 L.H.	20.90	upper (comb. 26B, 26H) (blue)

**VEGA— MONZA**

71	Vega (exc. Panel)			
71	Vega (exc. Panel)	9667304 R.H.	12.30	qtr. trim front (Note 1)
72-73	Vega (Pnl.) w/Custom Build-up Door and Qtr.	9667305 L.H.	12.30	qtr. trim front (Note 1)
72-73	Vega (Pnl.) w/Custom Build-up Door and Qtr.	9667304 R.H.	12.30	qtr. trim front (Note 1)

**CAMARO**

**15.100A CLIP— COVER ASSY.— FASTENER— PANEL— PLUG— REINFORCEMENT— RETAINER— SUPPORT, Rear Quarter**

72	Impala, Caprice (Spt. Cpe.),
73	Pass. (Spt. Cpe.),

**REAR TRIM—MATS—YARDAGE**

**15.100A CLIP— COVER ASSY.— FASTENER— PANEL— PLUG—  
REINFORCEMENT— RETAINER— SUPPORT, Rear Quarter (Con't)**

74-75	Impala (Spt. Cpe.)	9883655	2	.16	qtr. belt trim supt. retainer rear
74-75	Chevelle (Coupe)	9617200	2	.16	qtr. stat. wdo. frt.— (14.651)
73	Nova (H.B.)	9660414	2	1.15	COVER, fin. comp. si. trm. pl. (prime and paint as reqd.)
74	Nova (H.B.)	9670176	R.H.	1.80	COVER ASSY., finish compt. side trim finish panel
74	Nova (H.B.)	9670177	L.H.	1.80	COVER ASSY., finish compt. side trim finish panel
62	Chevy	4851737	A.R.	.14	FASTENER, trim pad— (14.691)
64-65	Chevelle (Sed. Spt. Cpe.)	4870324	A.R.	.11	FASTENER, qtr. upper foundation to roof rail— (14.730)
64	Chevelle (2-Dr. Sta. Wag.)				FASTENER, qtr. foundation to inner pnl.,
64	Chevelle (4-Dr. Sta. Wag.)				FASTENER, qtr. foundation to inner pnl. frt.,
64-66	Malibu (Sta. Wag.)				FASTENER, qtr. foundation to inner pnl.,
65-67	Pass., Chevelle Deluxe (Sta. Wag.)				
65-67	Pass. (Spt. Cpe., Spt. Sed.)				
68	Chevelle (Sta. Wag.)				FASTENER, rear qtr. trim pad,
66-67	Chevelle (Spt. Cpe., Sed.)				
68	Chevy, Chevelle (exc. Sta. Wag.)				FASTENER, qtr. upper fdtn. to inner panel,
68-69	Pass.	4500027	A.R.	.11	
68-72	Chevelle (Conv.)				
69-72	Pass. (Conv.)	4866841	2	.12	FASTENER, top side qtr. ext. to panel
71	Chevelle (Spt. Cpe., Conv.)				
73-74	Pass., Chevelle (Spt. Cpe., Conv.)				FASTENER, qtr. upper foundation to roof rail,
74-75	Nova (Sedan)	4500027	A.R.	.11	FASTENER, frt. dr. trim pad to intr. panel— (14.683)
74-75	Chevelle (4-Dr.) (exc. Sta. Wag.)	9736462	4	.16	FASTENER, qtr. inner upper fin. pnl.— (14.645)
75	Monza (exc. Towne Cpe.)	1699250	4	.11	FASTENER, trim fin. qtr.
73-74	Nova (H.B.)	9652314	R.H.	20.50	PANEL, trim fin. compt. side (prime and paint as reqd.)
73-74	Nova (H.B.)	9652315	L.H.	20.50	PANEL, trim fin. compt. side (prime and paint as reqd.)
72-73	Vega (exc. Panel) w/Custom build-up door and qtr.,				
72-73	Vega (exc. Panel) w/Custom Build-up Door and Qtr.,				
74-75	Vega (N.B.)	9682976	R.H.	12.30	PANEL, qtr. trim front finish (Note 1)
74-75	Vega (N.B.)	9682977	L.H.	12.30	PANEL, qtr. trim front finish (Note 1)
75	Monza (exc. Towne Cpe.)	1697890	R.H.	24.75	PANEL, qtr. trim finish (prime and paint as reqd.)
75	Monza (exc. Towne Cpe.)	1697894	L.H.	24.75	PANEL, qtr. trim finish (prime and paint as reqd.)
75	Nova (H.B.)	1670110	R.H.	19.70	PANEL, trim finish compt. (prime and paint as reqd.)
75	Nova (H.B.)	1670111	L.H.	19.70	PANEL, trim finish compt. (prime and paint as reqd.)
71-72	Vega (exc. Panel) w/Custom build-up door and qtr.	9820131	L.H.	6.05	PANEL ASSY., qtr. frt. trim insert
71-72	Vega (exc. Panel) w/Custom build-up door and qtr.	9820130	R.H.	6.05	PANEL ASSY., qtr. frt. trim insert
71-73	Vega (exc. Panel),				
71-73	Vega (H.B.)	9839959	L.H.	11.20	PANEL ASSY., qtr. trim rear finish (Note 1)
71-73	Vega (H.B.)	9839958	R.H.	11.20	PANEL ASSY., qtr. trim rear finish (Note 1)
71-73	Vega (Sta. Wag.),				
72-73	Vega (Panel) w/Custom build-up door and qtr.	9839953	L.H.	11.20	PANEL ASSY., qtr. trim rear finish (Note 1)
71-73	Vega (Sta. Wag.),				
72-73	Vega (Panel) w/Custom build-up door and qtr.	9839952	R.H.	11.20	PANEL ASSY., qtr. trim rear finish (Note 1)
73	Vega (exc. Panel) w/Custom build-up door and qtr.	9647397	L.H.	7.65	PANEL ASSY., qtr. frt. trim insert
73	Vega (exc. Panel) w/Custom build-up door and qtr.	9647396	R.H.	7.65	PANEL ASSY., qtr. frt. trim insert
74-75	Vega (Panel) w/Custom build-up door and qtr.,				
74-75	Vega (Sta. Wag.)	9687068	R.H.	16.70	PANEL ASSY., qtr. trim finish (Note 1)
74-75	Vega (Pnl.) w/Custom build-up door and qtr.,				
74-75	Vega (Sta. Wag.)	9687069	L.H.	16.70	PANEL ASSY., qtr. trim finish (Note 1)
74-75	Vega (H.B.)	9687088	R.H.	16.70	PANEL ASSY., qtr. trim finish (Note 1)
74-75	Vega (H.B.)	9687089	L.H.	16.70	PANEL ASSY., qtr. trim finish (Note 1)

**REAR TRIM—MATS—YARDAGE**

**15.100A CLIP—COVER ASSY.—FASTENER—PANEL—PLUG—REINFORCEMENT—RETAINER—SUPPORT, Rear Quarter (Con't)**

75	Vega (H.B.), Monza (exc. Towne Cpe.)	1670884	1	14.85	PANEL ASSY., qtr. trim finish (Note 1)
75	Monza (Towne Cpe.)	1707272	R.H.	11.25	PANEL ASSY., qtr. trim fin. (repl. 1707264) (Note 1)
75	Monza (Towne Cpe.)	1707265	L.H.	11.05	PANEL ASSY., qtr. trim fin. (Note 1)
<i>NOTE 1: Prime and paint as required.</i>					
64-68	Chevelle (2-Dr. Sta. Wag.)				PLUG, trim pad sealing,
64-68	Chevelle (4-Dr. Sta. Wag.)				PLUG, trim pad sealing frt.,
64	Malibu (Sta. Wag.)				PLUG, qtr. foundation to inner pnl. rr.— (14.685)
70	Chevelle, Nova, Camaro				PLUG, door trim pad seal,
70-71	Pass., Chevelle (Spt. Cpe., Conv.)	4853962	A.R.	.11	PLUG, qtr. trim pad seal— (14.685)
75	Nova (Coupe) w/swing vent wind.	1726322	R.H.	2.75	REINFORCEMENT, qtr. upr. trim fin. pnl.
75	Nova (Coupe) w/swing vent wind.	1726323	L.H.	2.75	REINFORCEMENT, qtr. upr. trim fin. pnl.
71-73	Pass. (Sed.) (exc. Spt. Sed.)	8794563	2	.52	RETAINER, inner upper panel trim
71-74	Pass. (Spt. Sed.)	8794536	2	.63	RETAINER, inner upper panel trim
73	Camaro (2nd design)	9726688	2	1.20	RETAINER, inner upper panel trim
73-74	Nova (H.B.)	9667275	2	.22	RETAINER, qtr. inner trim panel
74	Pass. (Sedan) (exc. Spt. Sed.)	8794563	2	.52	RETAINER, inner upper panel trim
74-75	Impala (Spt. Cpe.)	9736611	R.H.	1.70	RETAINER, inner upper panel
74-75	Impala (Spt. Cpe.)	9736612	L.H.	1.70	RETAINER, inner upper panel
74	Camaro	9726688	2	1.20	RETAINER, inner upper panel
74	Impala (Custom) Caprice (Spt. Cpe.)	9680200	2	1.90	SUPPORT, inner upper panel
75	Camaro	9734925	2	1.15	RETAINER, inner upper panel trim
75	Nova (H.B.) w/swing qtr. vent window	1709949	2	3.55	SUPPORT, qtr. wind. trim fin. pnl.

*NOTE 1 Production Deviation Trim Change.*

*NOTE 2 Used with 2nd design headlining in Group 14.640.*

**15.100B TRIM ASSY., Top Compartment Side Trim Panel**

*NOTE. See group 12.989 for metal panel.*

**PASS.**

71-73	Kingswood	9646441	R.H.	15.05	(comb. 804, 806) (black) (repl. 9859651)
71	Kingswood	9859623	R.H.		(comb. 835) (dk. jade)

**CHEVELLE**

71	El Camino (Custom)	8809640	1	33.00	(comb. 706, 756) (black)
72	Chevelle (Conv.)	9893313	L.H.		f/top compt. side upper panel (comb. 743) (white)

*NOTE 1 Coated fabric.*

*NOTE 2 Production Deviation Trim Change.*

**15.100C TRIM ASSY.—PANEL—EXTENSION—COVER ASSY., Spare Tire Cover**

**PASS.**

73-75	Caprice (Sta. Wag.) (1st design)	9646441	R.H.	15.05	(comb. 802, 806) (19) (black) (Note 1)
73	Caprice (Sta. Wag.)				
75	Caprice (Sta. Wag.) (1st design)	9646443	R.H.	16.20	(comb. 826, 63E, 63W) (saddle) (Note 1)
73-74	Caprice (Sta. Wag.)	9646444	R.H.	16.20	(comb. 813) (mid. blue)
73-74	Caprice (Sta. Wag.)	9646445	R.H.	15.05	(comb. 818, 819) (neutral)
74-75	Caprice (Sta. Wag.) (1st design)	9679507	R.H.	15.05	(comb. 855, 859, 44) (green) (Note 1)
74	Caprice (Sta. Wag.)	9679508	R.H.	15.05	(comb. 849, 858) (saddle)
75	Caprice (Sta. Wag.) (1st design)	1675705	R.H.	14.90	(comb. 26W) (blue) (Note 1)
75	Caprice (Sta. Wag.) (1st design)	1675706	R.H.	14.90	(comb. 55W) (sandstone) (Note 1)
73-74	Bel Air, Impala (Sta. Wag.)				
75	Pass. (Sta. Wag.) (2nd design)	9865384	R.H.	16.45	PANEL, spare tire cover (prime and paint as reqd.) (Note 1)

**CHEVELLE**

70	Concours	9800770	1		(comb. 755) (black)
73-75	Chevelle (Sta. Wag.)	9627222	R.H.	18.55	PANEL ASSY., spare tire cover (prime and paint as reqd.)
74	Chevelle (Sta. Wag.)	9645418	1	4.80	EXTENSION (prime and paint as reqd.)
75	Monza (exc. Towne Cpe.)	1719628	1	25.50	COVER ASSY. (blue)
75	Monza (exc. Towne Cpe.)	1719627	1	22.60	COVER ASSY. (comb. 16) (graystone) (repl. 1695637)
75	Monza (exc. Towne Cpe.)	1719628	1	25.50	COVER ASSY. (comb. 26) (blue) (repl. 1695638)

**REAR TRIM—MATS—YARDAGE**

**15.100C TRIM ASSY.— PANEL— EXTENSION— COVER ASSY., Spare Tire Cover  
(Con't)**

75	Monza (exc. Towne Cpe.)	1719629	1	22.60	COVER ASSY. (comb. 55) (sandstone) (repl. 1695639)
75	Monza (exc. Towne Cpe.)	1719630	1	22.70	COVER ASSY. (comb. 63) (saddle)
75	Monza (exc. Towne Cpe.)	1719631	1	22.70	COVER ASSY. (oxblood)
75	Monza (exc. Towne Cpe.)	1698498	1	16.05	COVER ASSY. (comb. 19) (black)

NOTE 1: 1st design trim assy. are colored.

NOTE 2: 2nd design use panels and prime and paint as reqd.

**15.101 MOULDING— MOULDING ASSY.— PANEL— PANEL ASSY., Rear Quarter Trim**

**PASS.**

71-72	Impala (Conv.)	9600221	L.H.		quarter window inner at belt (repl. 9836993)
71-72	Impala (Conv.)	9600220	R.H.		quarter window inner at belt (repl. 9836992)
73	Impala (Custom) Caprice (Spt. Cpe.)				
74	Impala (Spt. Cpe.)	9647310	R.H.	1.55	MOULDING ASSY., qtr. wdo. inr. at belt
73	Impala (Custom) Caprice (Spt. Cpe.)				
74	Impala (Spt. Cpe.)	9647311	L.H.	1.55	MOULDING ASSY., qtr. wdo. inr. at belt
73-75	Pass. (Conv.)	9647365	R.H.	2.00	MOULDING ASSY., qtr. wdo. inr. at belt
73-75	Pass. (Conv.)	9647366	L.H.	2.00	MOULDING ASSY., qtr. wdo. inr. at belt

**CHEVELLE**

73	Chevelle (Sta. Wag.)	9672827	2	2.95	MOULDING ASSY., finish w/h cover panel
73-75	Chevelle (Sta. Wag.)	9672829	L.H.	2.10	MOULDING, finish w/h cover panel rear
74-75	Malibu (Classic) (Coupe)	9874871	R.H.	5.10	MOULDING ASSY., trim pad qtr.
74-75	Malibu (Classic) (Coupe)	9874872	L.H.	5.10	MOULDING ASSY., trim pad qtr.

**CHEVY— NOVA**

75	Nova (2-Dr.)	1719154	R.H.	3.55	trim fin. qtr. wind. rr.
75	Nova (2-Dr.)	1719155	L.H.	3.55	trim fin. qtr. wind. upr.
75	Nova (2-Dr.) w/Swing Qtr. Vent. Wind.	1721551	R.H.	3.55	trim fin. qtr. wind. upr. frt.
75	Nova (2-Dr.) w/Swing Qtr. Vent. Wind.	1721552	L.H.	3.55	trim fin. qtr. wind. upr. frt.
75	Nova (2-Dr.) w/swing qtr. vent wind.	1721553	R.H.	2.30	trim fin. qtr. wind. upr. rr.
75	Nova (2-Dr.) w/Swing Qtr. Vent. Wind.	1721554	L.H.	2.30	trim fin. qtr. wind. upr. rr.
75	Nova (2-Dr.)	1704613	R.H.	4.65	MOULDING ASSY., trim fin. qtr. wdo. (prime and paint)
75	Nova (2-Dr.)	1704614	L.H.	4.65	MOULDING ASSY., trim fin. qtr. wdo. (prime and paint)

**VEGA— MONZA**

71-73	Vega (N.B.)	9837687	L.H.	5.35	inner rear of qtr. window (Note 1)
71-73	Vega (N.B.)	9837686	R.H.	5.35	inner rear of qtr. window (Note 1)
71-73	Vega (H.B.)	9837697	L.H.	5.20	inner rear of qtr. window (Note 1)
71-73	Vega (H.B.)	9837696	R.H.	5.20	inner rear of qtr. window (Note 1)
74-75	Vega (H.B.)	9682326	R.H.	5.20	inner rear of qtr. window (Note 1)
74-75	Vega (H.B.)	9682327	L.H.	5.20	inner rear of qtr. window (Note 1)
74-75	Vega (N.B.)	9686992	R.H.	5.35	inner rear of qtr. window (Note 1)
74-75	Vega (N.B.)	9686993	L.H.	5.35	inner rear of qtr. window (Note 1)
75	Vega (H.B.), Monza (exc. Towne Cpe.)	1678501	R.H.	29.25	(comb. 16G, 16Z) (graystone)
75	Vega (H.B.), Monza (exc. Towne Cpe.)	1678506	L.H.	24.40	(comb. 16G, 16Z) (graystone)
75	Monza (exc. Towne Cpe.)	1678502	R.H.	22.60	(comb. 26G, 26Z) (blue)
75	Monza (exc. Towne Cpe.)	1678507	L.H.	22.60	(comb. 26G, 26Z) (blue)
75	Monza (exc. Towne Cpe.)	1678503	R.H.	22.60	(comb. 55G, 55Z) (sandstone)
75	Monza (exc. Towne Cpe.)	1678508	L.H.	22.60	(comb. 55G, 55Z) (sandstone)
75	Monza (exc. Towne Cpe.)	1678504	R.H.	22.60	MOULDING ASSY. (comb. 63G, 63Z, 632) (saddle)
75	Monza (exc. Towne Cpe.)	1678509	L.H.	24.40	MOULDING ASSY. (comb. 63G, 63Z, 632) (saddle)
75	Monza (exc. Towne Cpe.)	1678505	R.H.	22.60	MOULDING ASSY. (comb. 73G, 73Z, 732) (oxblood)
75	Monza (exc. Towne Cpe.)	1678510	L.H.	22.60	MOULDING ASSY. (comb. 73G, 73Z, 732) (oxblood)
75	Monza (exc. Towne Cpe.)	1698201	R.H.	3.85	MOULDING, finish qtr. wdo. front



**REAR TRIM—MATS—YARDAGE**

**15.101 MOULDING— MOULDING ASSY.— PANEL— PANEL ASSY., Rear Quarter Trim (Con't)**

75 Monza (exc. Towne Cpe.) ..... 1698202 L.H. 3.85 MOULDING, finish qtr. wdo. front .....  
*NOTE 1: Prime and paint as required.*

**PASS.**

71-74 Spt. Sed. .... 9852023 L.H. 4.10 PANEL, quarter inner finish, paint as reqd. .  
 71-74 Spt. Sed. .... 9852022 R.H. 4.10 PANEL, quarter inner finish, paint as reqd. .  
 72-74 Pass. (Sed., exc. Spt. Sed.) ..... 9610566 R.H. 5.60 PANEL (paint as reqd.) .....  
 72-74 Pass. (Sed., exc. Spt. Sed.) ..... 9610567 L.H. 5.60 PANEL (paint as required) .....  
 72 Kingswood Estate,  
 73-74 Caprice Estate ..... 9613236 R.H. 3.85 PANEL, qtr. inr. finish .....  
 72 Kingswood Estate,  
 73-74 Caprice Estate ..... 9613237 L.H. 3.85 PANEL, qtr. inr. finish .....  
 73-74 Impala (Spt. Cpe.) Caprice  
 (Conv.) ..... 9616589 1 9.30 PANEL ASSY. ....  
 74 Impala (Spt. Cpe.) (exc. Custom) 1665701 2 4.55 PANEL ASSY., trim finish qtr. ....  
 75 Pass. (Sedan) (exc. Spt. Sed.) ... 1670364 R.H. 5.60 PANEL ASSY. (prime and paint as reqd.) ..  
 75 Pass. (Sedan) (exc. Spt. Sed.) ... 1670365 L.H. 5.60 PANEL ASSY. (prime and paint as reqd.) ..  
 75 Pass. (Spt. Sed.) ..... 1670348 R.H. 4.20 PANEL ASSY. (prime and paint as reqd.) ..  
 75 Pass. (Spt. Sed.) ..... 1670349 L.H. 4.20 PANEL ASSY. (prime and paint as reqd.) ..

**CHEVY— NOVA**

73-74 Nova (Coupe) ..... 9652128 R.H. 15.70 PANEL (prime and paint as reqd.) .....  
 73-74 Nova (Coupe) ..... 9652129 L.H. 15.70 PANEL (prime and paint as reqd.) .....  
 73-75 Nova (Sedan) ..... 9652164 R.H. 3.85 PANEL (prime and paint as reqd.) .....  
 73-75 Nova (Sedan) ..... 9652165 L.H. 3.85 PANEL (prime and paint as reqd.) .....  
 75 Nova (Coupe) (exc. H.B.) ..... 1725802 R.H. 6.95 PANEL, qtr. wdo. trim fin. (paint) .....  
 75 Nova (Coupe) (exc. H.B.) ..... 1725803 L.H. 6.95 PANEL, qtr. wdo. trim fin. (paint) .....  
 75 Nova (Coupe) (exc. H.B.) ..... 1662910 R.H. 15.70 PANEL, qtr. wdo. trim fin. rear (prime and  
 paint as reqd.) .....  
 75 Nova (Coupe) (exc. H.B.)  
 w/Formal Qtr. Wdo. .... 1732868 R.H. 5.65 PANEL, qtr. wdo. trim fin. frt. (paint) .....  
 75 Nova (Coupe) (exc. H.B.)  
 w/Formal Qtr. Wdo. .... 1732869 R.H. 5.65 PANEL, qtr. wdo. trim fin. frt. (paint) .....  
 75 Nova (Coupe) ..... 1662876 R.H. 4.95 PANEL, qtr. wdo. trim fin. frt. (prime and  
 paint as reqd.) .....  
 75 Nova (Coupe) ..... 1662877 L.H. 4.95 PANEL, qtr. wdo. trim fin. frt. (prime and  
 paint as reqd.) .....  
 75 Nova (H.B.) ..... 1662894 R.H. 16.65 PANEL, qtr. wdo. trim fin. rear (prime and  
 paint as reqd.) .....  
 75 Nova (H.B.) ..... 1662895 L.H. 16.65 PANEL, qtr. wdo. trim fin. rear (prime and  
 paint as reqd.) .....  
 75 Nova (Coupe) (exc. Custom Up  
 Door and Quarter) ..... 1675428 R.H. 14.05 PANEL (prime and paint as reqd.) .....  
 75 Nova (Coupe) (exc. Custom Up  
 Door and Quarter) ..... 1675429 L.H. 14.05 PANEL (prime and paint as reqd.) .....  
 75 Nova (Custom Cpe.) (exc. H.B.)  
 w/Custom Door & Quarter .... 1675444 R.H. 5.80 PANEL, inr. lwr. trim (paint) .....  
 75 Nova (Custom Cpe.) (exc. H.B.)  
 w/Custom Door & Quarter .... 1675445 L.H. 5.80 PANEL, inr. lwr. trim (paint) .....  
 75 Nova (Coupe) (exc. H.B.) ..... 1677858 R.H. 4.40 PANEL (prime and paint as reqd.) .....  
 75 Nova (Coupe) (exc. H.B.) ..... 1677859 L.H. 4.40 PANEL (prime and paint as reqd.) .....

**CHEVELLE**

69-72 El Camino ..... 8767394 R.H. 9.10 PANEL, inner lower fin. (comb. 752, 755,  
 756, 761, 764) (black) .....  
 69-72 El Camino ..... 8767395 L.H. 9.10 PANEL, inner lower fin. (comb. 752, 755,  
 756) (black) .....  
 73-75 Chevelle (Sedan) ..... 9628890 R.H. 4.90 PANEL ASSY., upper (prime and paint as  
 reqd.) .....  
 73-75 Chevelle (Sedan) ..... 9628891 L.H. 4.90 PANEL ASSY., upper (prime and paint as  
 reqd.) .....

**CAMARO**

70-72 Camaro,  
 73 Camaro (1st design) ..... 9816928 R.H. 5.80 PANEL, qtr. inner finish, upper (black) (paint  
 as reqd.) (Note 1) .....  
 70-72 Camaro,  
 73 Camaro (1st design) ..... 9816929 L.H. 5.80 PANEL, qtr. inner finish, upper (black) (paint  
 as reqd.) (Note 1) .....  
 70-71 Camaro ..... 9875004 R.H. 12.50 PANEL, qtr. inner finish, lower (comb. 711,  
 712, 713, 725, 775, 785, 789) (black) ...  
 72-75 Camaro ..... 9606858 R.H. 11.85 PANEL, quarter inner finish lower (paint as  
 required) .....

**REAR TRIM—MATS—YARDAGE**

**15.101 MOULDING— MOULDING ASSY.— PANEL— PANEL ASSY., Rear Quarter Trim (Con't)**

72-75	Camaro	9606859	L.H.	11.85	PANEL, quarter inner finish lower (paint as required)
73	Camaro (2nd design)	9667612	R.H.	5.80	PANEL, upper (prime and paint as reqd.) (Note 2)
73	Camaro (2nd design)	9667613	L.H.	5.80	PANEL, upper (prime and paint as reqd.) (Note 2)
74	Camaro	9726744	R.H.	5.80	PANEL, upper (prime and paint as reqd.)
74	Camaro	9726745	L.H.	5.80	PANEL, upper (prime and paint as reqd.)
75	Camaro	1670180	R.H.	5.80	PANEL, upper (paint)
75	Camaro	1670181	L.H.	5.80	PANEL, upper (paint)

**VEGA— MONZA**

75	Monza (exc. Towne Cpe.)	1698071	R.H.	22.60	PANEL ASSY. (comb. 19) (black)
75	Monza (exc. Towne Cpe.)	1698073	L.H.	22.60	PANEL ASSY. (comb. 19) (black)

NOTE 1: Soft.  
NOTE 2: Hard.

**15.101A NUT, Rear Quarter Trim**

66	Malibu, S.S.	4450956	A.R.	.14	(14.691)
----	--------------	---------	------	-----	----------

**15.108 REST ASSY.— TRIM ASSY.— BASE— COVER— PAD— PANEL— SCREW— NUT, Rear Quarter Arm Trimmed**

NOTE. For Convertible Folding Top Compartment Side Panels, see group 12.989.

**PASS.**

67	Bel Air (2-Dr.)	7651237	L.H.		(comb. 839) (blue) (less tray)— (14.762)
71-73	Pass. (Spt. Cpe.)	9658602	R.H.	31.00	arm complete (black) (paint) (repl. 9865034)
72-73	Impala, Caprice (Spt. Cpe.)	9658603	L.H.	31.00	arm complete (comb. 829, 830, 831) (green) (repl. 9607593)
71-75	Pass. (Conv.)	9728631	L.H.	31.00	complete (paint)
73	Pass. (Spt. Cpe.)	9658609	L.H.	31.00	complete (comb. 829, 830, 842) (green)
73	Pass. (Spt. Cpe.)	9658606	R.H.	31.00	complete (comb. 815, 818, 841) (neutral)
73-75	Pass. (Conv.)	9728630	R.H.	31.00	complete (paint)
74-75	Pass. (Spt. Cpe.)	9728626	R.H.	31.00	complete (black) (paint)
74-75	Pass. (Spt. Cpe.)	9728627	L.H.	31.00	complete (black) (paint)
74	Pass. (Spt. Cpe.)	9728638	R.H.	31.00	complete (comb. 813, 843, 847) (mid. blue)
74	Pass. (Spt. Cpe.)	9728639	L.H.	31.00	complete (comb. 813, 843, 847) (mid. blue)
74	Pass. (Spt. Cpe.)	9728655	L.H.	31.00	complete (comb. 850, 853, 855) (green)
74	Impala (Custom) Caprice (Spt. Cpe.)	9728632	R.H.	31.00	complete (comb. 819, 821, 841) (neutral)
74	Impala (Custom) Caprice (Spt. Cpe.)	9728633	L.H.	31.00	complete (comb. 819, 821, 841) (neutral)
74	Impala (Spt. Cpe.)	9728646	R.H.	31.00	complete (comb. 849, 858) (saddle)
74	Impala (Spt. Cpe.)	9728647	L.H.	31.00	complete (comb. 849, 858) (saddle)
74	Impala (Spt. Cpe.) (exc. Custom)	9728660	R.H.		complete (comb. 804, 809) (white)
74	Impala (Spt. Cpe.) (exc. Custom)	9728661	L.H.		complete (comb. 804, 809) (white)
74	Caprice (Spt. Cpe.)	9728643	L.H.	31.00	complete (comb. 896) (taupe)
74	Caprice (Spt. Cpe.)	9728651	L.H.	31.00	complete (comb. 857) (oxblood)
74	Pass. (Conv.)	9728656	R.H.	31.00	complete (comb. 855) (green)
73	Pass. (2-Dr.)	9658609	L.H.	31.00	TRIM ASSY., quarter (comb. 829, 830, 842) (green)

**CHEVELLE**

65	Malibu (S.S.) (Spt. Cpe.),				
66-67	Chevelle (Spt. Cpe.)	4473160	R.H.	12.00	(comb. 712, 714, 759, 761, 763) (black) (less tray)
65	Malibu (S.S. Spt. Cpe.),				
66-67	Chevelle (Spt. Cpe.)	4473161	L.H.	12.00	(comb. 712, 714, 759, 761, 763) (black) (less tray)
67	Chevelle (Deluxe) (2-Dr.)	7651237	L.H.		(comb. 726) (blue) (less tray)— (14.762)
68	S.S. (Spt. Cpe.)				(comb. 765/158, 766/178)
70-72	Monte Carlo	9805204	R.H.	29.00	arm complete (black) (paint)

**PASS.**

68-69	2-Dr. Sedan	7759660	R.H.		BASE (black)
69	2-Dr. Sedan	7759661	L.H.		BASE (black)
70	Biscayne, Bel Air, Brookwood, Townsman	8769816	R.H.	3.75	BASE, quarter (comb. 836, 843) (med. gold)
69	Pass. (2-Dr. Sed.),				
70	Biscayne, Bel Air, Brookwood, Townsman	8769817	L.H.	3.75	BASE, quarter (comb. 836, 843) (med. gold)
68-69	Biscayne, Bel Air (2-Dr.)	7766564	R.H.	7.05	COVER (comb. 802, 803, 810, 811)

**REAR TRIM—MATS—YARDAGE**

**15.108 REST ASSY.— TRIM ASSY.— BASE— COVER— PAD— PANEL— SCREW— NUT, Rear Quarter Arm Trimmed (Con't)**

<b>68-69</b>	Biscayne, Bel Air (2-Dr.)	<b>7766565</b>	L.H.	7.05	<b>COVER</b> (comb. 802, 803, 810, 811)
<b>73-75</b>	Monte Carlo	<b>9655560</b>	R.H.	4.10	<b>PAD</b> , quarter trim finish panel (black) (paint)
<b>73-75</b>	Monte Carlo	<b>9655561</b>	L.H.	4.10	<b>PAD</b> , quarter trim finish panel (black) (paint)

**CHEVELLE**

*NOTE 3 Field fix item. Consists of rubber pad, plate and trim.*

<b>69</b>	Malibu (Spt. Cpe.)				
<b>69-70</b>	Chevelle (2-Dr. Sed.)	<b>8769817</b>	L.H.	3.75	<b>BASE</b> (comb. 762, 765) (dk. blue)
<b>68-69</b>	Chevelle (2-Dr.) (exc. Conv.)	<b>7766564</b>	R.H.	7.05	<b>COVER</b> (comb. 731, 731D, 732, 733, 734, 735, 735D, 751, 752, 753, 755, 756, 757, 760, 762, 764, 765, 766) (760/217, 765/118) (black) (Note 1)
<b>68-69</b>	Chevelle (2-Dr.) (exc. Conv.)	<b>7766565</b>	L.H.	7.05	<b>COVER</b> (comb. 731, 731D, 732, 733, 734, 735, 735D, 751, 752, 753, 755, 756, 757, 760, 762, 764, 765, 766) (760/217, 765/118) (black) (Note 1)

**CHEVY— NOVA**

<b>68-69</b>	Chevy (Spt. Cpe.)	<b>7759660</b>	R.H.		<b>BASE</b> (black) (custom trim) (paint)
<b>69</b>	Chevy (Spt. Cpe.)	<b>7759661</b>	L.H.		<b>BASE</b> (black) (custom trim)
<b>69-72</b>	Nova (2-Dr.)	<b>8769817</b>	L.H.	3.75	<b>BASE</b> , quarter (black) (paint as required)
<b>70-72</b>	Nova (2-Dr.)	<b>8769816</b>	R.H.	3.75	<b>BASE</b> , quarter (black) (paint as required)
<b>68-72</b>	Chevy (2-Dr.) (exc. Conv.)	<b>7766564</b>	R.H.	7.05	<b>COVER</b> (comb. 731, 731D, 732, 733, 734, 735, 735D, 751, 752, 753, 755, 756, 757, 760, 762, 764, 765, 766) (760/217, 765/118) (black) (Note 1)
<b>68-72</b>	Chevy (2-Dr.) (exc. Conv.)	<b>7766565</b>	L.H.	7.05	<b>COVER</b> (comb. 731, 731D, 732, 733, 734, 735, 735D, 751, 752, 753, 755, 756, 757, 760, 762, 764, 765, 766) (760/217, 765/118) (black) (Note 1)
<b>75</b>	Nova (Custom) (Coupe) (exc. H.B.)	<b>1682286</b>	R.H.	4.25	<b>PAD ASSY.</b> (comb. 16G) (graystone)
<b>75</b>	Nova (Custom) (Coupe) (exc. H.B.)	<b>1682287</b>	L.H.	4.25	<b>PAD ASSY.</b> (comb. 16G) (graystone)
<b>75</b>	Nova (Custom) (Coupe) (exc. H.B.)	<b>1682288</b>	R.H.	4.25	<b>PAD ASSY.</b> (comb. 26) (blue)
<b>75</b>	Nova (Custom) (Coupe) (exc. H.B.)	<b>1682289</b>	L.H.	4.25	<b>PAD ASSY.</b> (comb. 26) (blue)
<b>75</b>	Nova (Custom) (Coupe) (exc. H.B.)	<b>1682290</b>	R.H.	4.25	<b>PAD ASSY.</b> (comb. 55) (sandstone)
<b>75</b>	Nova (Custom) (Coupe) (exc. H.B.)	<b>1682291</b>	L.H.	4.25	<b>PAD ASSY.</b> (comb. 55) (sandstone)
<b>75</b>	Nova (Custom) (H.B.)	<b>1682282</b>	R.H.	4.25	<b>PAD ASSY.</b> (comb. 73) (saddle)
<b>75</b>	Nova (Custom) (H.B.)	<b>1682283</b>	L.H.	4.25	<b>PAD ASSY.</b> (comb. 73) (saddle)
<i>NOTE 1: Production deviation trim change.</i>					
<b>70-72</b>	Malibu (Spt. Cpe.)	<b>9806350</b>	R.H.	7.05	<b>PANEL</b> , quarter arm rest trim finish (paint as req.)
<b>70-72</b>	Malibu (Spt. Cpe.)	<b>9806351</b>	L.H.	7.05	<b>PANEL</b> , quarter arm rest trim finish (paint as req.)
<b>73-75</b>	Chevelle (Coupe)	<b>9655254</b>	R.H.	8.00	<b>PANEL</b> , quarter trim finish (prime and paint as reqd.)
<b>73-75</b>	Chevelle (Coupe)	<b>9655255</b>	L.H.	8.00	<b>PANEL</b> , quarter trim finish (prime and paint as reqd.)
<b>73-75</b>	Monte Carlo	<b>9655558</b>	R.H.	8.80	<b>PANEL</b> , quarter trim finish (prime and paint as reqd.)
<b>73-75</b>	Monte Carlo	<b>9655559</b>	L.H.	8.80	<b>PANEL</b> , quarter trim finish (prime and paint as reqd.)
<b>62-64</b>	Chevy Deluxe (2-Dr.) (exc. Conv.)	<b>161742</b>	1	.11	<b>SCREW</b> , rest to inner panel
<b>63</b>	Chevy Std. (2-Dr.)	<b>447124</b>	4	.18	<b>SCREW</b> , rest to inner panel (No. 14— 10 x 2)
<b>68</b>	Impala, Caprice (4-Dr.)	<b>7768480</b>	6	.18	<b>SCREW</b> , armrest to inner panel— (14.686)
<b>68-69</b>	Pass. (2-Dr. Sed.)				
<b>68-70</b>	Chevelle, Chevy (Spt. Cpe.)				
<b>69</b>	Chevelle (2-Dr. Plr. Cpe.)	<b>9824833</b>	4	.16	<b>SCREW</b> , armrest to inner panel (round head self drilling, 1/4"— 16 x 1 1/2")— (14.686)
<b>68-69</b>	Chevelle, Chevy (2-Dr. Plr. Cpe., Spt. Cpe.)	<b>7768479</b>	4	.22	<b>SCREW</b> , qtr. armrest to inner panel
<b>71-72</b>	Nova	<b>9824834</b>	4	.24	<b>SCREW</b> , qtr. arm to inner panel
<b>74-75</b>	Nova (Custom) (Coupe) (exc. H.B.)	<b>4895791</b>	2	.11	<b>NUT</b> , quarter arm rest trim finish panel

**REAR TRIM—MATS—YARDAGE**

**15.222 FOUNDATION— MAT— FASTENER— TRIM— PANEL— TRUNK LINING,  
Rear Compartment**

**PASS.**

67	Biscayne, Bel Air (Sed.),				
67	Impala, Caprice (exc. Sta. Wag.),				
71-72	Pass. (exc. Sta. Wag.)	9622995	L.H.	1.35	
71-72	Pass. (exc. Sta. Wag.)	9622994	R.H.	1.25	
74-75	Impala, Caprice (exc. Sta. Wag.)	9699466	R.H.	1.10	fil. compt. side
74-75	Impala, Caprice (exc. Sta. Wag.)	9699467	L.H.	1.10	fil. compt. side
74	Pass. w/Lug. Compt. Trim Deluxe	1656360	R.H.	4.75	rear end panel
74	Pass. w/Lug. Compt. Trim Deluxe	1656361	L.H.	4.75	rear end panel
74	Impala (Custom) Caprice (Spt. Cpe.) w/Lug. Compt. Trim Deluxe	1656362	R.H.	5.70	side
74	Impala (Custom) Caprice (Spt. Cpe.) w/Lug. Compt. Trim Deluxe	1656363	L.H.	5.70	side
74	Pass. (Sedan, Conv.) Impala (Spt. Cpe.) w/Lug. Compt. Trim Deluxe	1656364	R.H.	4.75	side
74	Pass. (Sedan, Conv.) Impala (Spt. Cpe.) w/Lug. Compt. Trim Deluxe	1656365	L.H.	4.75	side
74-75	Pass. (Sedan, Conv.) Impala (Spt. Cpe.) w/Lug. Compt. Trim Deluxe	1656367	R.H.	1.50	cover compt. hinge box
74-75	Pass. (Sedan, Conv.) Impala (Spt. Cpe.) w/Lug. Compt. Trim Deluxe	1656368	L.H.	1.50	cover compt. hinge box
75	Pass. (Sed.) Impala (Spt. Cpe.) w/Lug. Compt. Trim Deluxe (exc. Custom)	1697193	R.H.	4.75	compt. side (39"L x 27"W)
75	Pass. (Sed.) Impala (Spt. Cpe.) w/Lug. Compt. Trim Deluxe (exc. Custom)	1697194	L.H.	4.75	compt. side (39"L x 27"W)
75	Impala (Custom) Caprice (Spt. Cpe.) w/Lug. Compt. Trim Deluxe	1697195	R.H.	6.35	compt. side (50"L x 32"W)
75	Impala (Custom) Caprice (Spt. Cpe.) w/Lug. Compt. Trim Deluxe	1697196	L.H.	6.35	compt. side (50"L x 32"W)
75	Pass. w/Lug. Compt. Trim Deluxe (exc. Impala Custom Cpe. & Caprice Classic Sport Cpe.)	1718374	R.H.	6.25	compt. side (44"L x 33"W)
75	Pass. w/Lug. Compt. Trim Deluxe (exc. Impala Custom Cpe. & Caprice Classic Sport Cpe.)	1718375	L.H.	6.25	compt. side (44"L x 33"W)
75	Impala Custom (Cpe.), Caprice Classic (Sport Cpe.) w/Lug. Compt. Trim Deluxe	1719248	R.H.	7.90	compt. side (53"L x 32"W)
75	Impala Custom (Cpe.), Caprice Classic (Sport Cpe.) w/Lug. Compt. Trim Deluxe	1719249	L.H.	7.90	compt. side (53"L x 32"W)
75	Pass. (exc. S.W.)	1697192	R.H.	4.90	rear end panel
75	Pass. (exc. Sta. Wag.) w/Dlx. Lug. Compt.	1697192	R.H.	4.90	rr. end panel
75	Pass. (exc. Sta. Wag.) w/Dlx. Lug. Compt.	1697191	L.H.	2.75	rr. end panel
65	Bel Air, Impala (exc. Sta. Wag.)	4519787	1	14.85	<b>MAT</b> , compt. floor, rr. (gray and black)
66	Impala (exc. Sta. Wag.)	7634566	1	14.55	<b>MAT</b> , floor rear (gray and black)
67	Impala (Sedan, Spt. Cpe.), Caprice (Spt. Mdls.)	7669296	1	14.55	<b>MAT</b> , compt. floor rr. (gray and black)
65-66	Caprice (Spt. Sed.),				
74-75	Pass. w/Lug. Compt. Trim Deluxe (exc. Custom)	4824561	A.R.	.11	<b>FASTENER</b> , side fdtn. to w/h pinchweld
68	S.S. (Conv.)	7767372	1	7.35	<b>TRIM</b> , rr. compt. flr. ctr.
68	Impala, Caprice (exc. Conv.)	7767380	1	12.65	<b>TRIM</b> , floor center
69-70	Impala, Caprice (exc. Conv.)	8727547	1	12.55	<b>TRIM</b> , floor center
69-70	Impala (Custom), Caprice (Spt. Cpe.),				

**REAR TRIM—MATS—YARDAGE**

**15.222 FOUNDATION— MAT— FASTENER— TRIM— PANEL— TRUNK LINING,  
Rear Compartment (Con't)**

69-70	Impala w/rear window defogger	8767194	1	12.55	TRIM, floor center
71-73	Pass. (exc. Sta. Wag.)	8703312	1	FT/1.75	TRIM, trunk lining
73	Impala, Caprice (Sta. Wag.)	4228123	A.R.	FT/2.35	TRIM, trunk lining (gray and black)
74	Pass. w/Lug. Compt. Trim Deluxe	9699114	1	47.00	TRIM, front
74	Pass. w/Lug. Compt. Trim Deluxe (exc. Sta. Wag.)	1659508	1	62.00	TRIM, pan center
74	Pass. w/Lug. Compt. Trim Deluxe (exc. Sta. Wag., Conv.)	1688663	1		TRIM, spare tire (repl. 9862247)
74-75	Pass.	9630947	A.R.	FT/2.50	TRIM, trunk lining (turq. and black)
74-75	Bel Air (Sta. Wag.)	4228123	A.R.	FT/2.35	TRIM, trunk lining (gray and black)
75	Pass. w/Dlx. Lug. Compt.	1727977	1	70.50	TRIM, compt. pan center
75	Pass. (exc. Sta. Wag. & Conv.)	1707138	1	50.25	TRIM, spare tire (black)
75	Pass. (exc. S.W.)	9630974	A.R.	FT/4.45	TRUNK LINING, carpet (black) (1/4" pile)— (15.512)

**CHEVY— NOVA**

70	Nova	9809942	1	8.25	TRIM, floor center
71-72	Nova	9844447	1	3.50	
71-72	Nova	8703312	A.R.	FT/1.75	TRIM, lining, trunk
73-75	Nova (Taxi)	9657823	1	6.90	compt. frt.
73	Nova (Custom),				
73	Nova (H.B.) (exc. Custom),				
74	Nova (Custom) (exc. H.B.)	8703312	A.R.	FT/1.75	TRIM, lining, trunk
74-75	Nova (exc. H.B.)	9630947	A.R.	FT/2.50	TRIM, trk. lining (turq. and black)
74-75	Nova (exc. H.B.)	8703313	A.R.	FT/1.40	TRIM, trk. lining (turq. and gray)
75	Nova (Custom) (exc. H.B.)	4228123	A.R.	FT/2.35	TRIM, trunk lining (gray and black)
73-74	Nova	9652818	1	5.70	PANEL, compt. trim fin. (paint)— (12.975)
75	Nova	1670101	1	8.85	PANEL, compt. trim fin. (prime and paint as reqd.)

**CHEVELLE**

67	Malibu (exc. Sta. Wag., El Camino),				
67	Chevelle (S.S.)	7695825	1	8.30	MAT, rear
71-72	Chevelle (Sed., Spt. Cpe.) (exc. Monte Carlo)	9861574	1	2.85	
5	Monte Carlo	1711433	R.H.	.75	compt. pan to qtr. pnl. fil.
5	Monte Carlo	1711434	L.H.	.75	compt. pan to qtr. pnl. fil.
38-69	Malibu (exc. Sta. Wag.)	7767372	1	7.35	TRIM, rr. compt. flr. ctr.
70-72	Chevelle (exc. Sta. Wag.),				
73	Malibu (exc. Custom, Sta. Wag.),				
73	Monte Carlo (Custom),				
74	Malibu (Classic) Laguna (exc. Sta. Wag.)	8703312	A.R.	FT/1.75	TRIM, trk. lining
74-75	Monte Carlo, Chevelle (exc. Sta. Wag.)	8703313	A.R.	FT/1.40	TRIM, trk. lining (turq. and gray)
74-75	Chevelle (Sta. Wag.)	4228123	A.R.	FT/2.35	TRIM, trk. lining (gray and black)
75	Monte Carlo w/Lug. Compt. Trim Deluxe (exc. Space Saver Tire)	1707138	1	50.25	TRIM, spare tire (black)
75	Monte Carlo w/Dlx. Lug. Compt. & Space Saver Tire	1716978	1	18.20	TRIM, compt. spare tire outer

**CAMARO**

70	Camaro	9811340	1	20.15	MAT, rear compt. floor pan
71-72	Camaro	9864336	1	20.60	MAT, compt. floor pan
73-75	Camaro	9630947	A.R.	FT/2.50	TRIM, trk. lining (turq. and black)

**VEGA— MONZA**

71-73	Vega (H.B.)	9843091	L.H.	1.30	(Note 1)
71-73	Vega (H.B.)	9843086	R.H.	1.30	(Note 1)
<i>NOTE 1: Prime and paint as required.</i>					
75	Monza (exc. Towne Cpe.) w/Space Saver Tire	105506	1		FASTENER, eyelet load floor carpet— (14.804)
75	Monza (exc. Towne Cpe.)	1721540	1	41.25	TRIM ASSY., spare tire carpet cover (63G-Z, 632) (saddle)
75	Monza (exc. Towne Cpe.)	1721541	1	41.25	TRIM ASSY., spare tire carpet cover (73G-Z, 732) (oxblood)
75	Monza (exc. Towne Cpe.)	1721542	1	41.25	TRIM ASSY., spare tire carpet cover (16G-Z) (graystone)
75	Monza (exc. Towne Cpe.)	1721543	1	41.25	TRIM ASSY., spare tire carpet cover (26G-Z) (blue)

**REAR TRIM—MATS—YARDAGE**

**15.222 FOUNDATION— MAT— FASTENER— TRIM— PANEL— TRUNK LINING, Rear Compartment (Con't)**

75	Monza (exc. Towne Cpe.)	1721544	1	41.25	TRIM ASSY., spare tire carpet cover (55G-Z) (sandstone)
75	Monza (exc. Towne Cpe.)	1721545	1	41.25	TRIM ASSY., spare tire carpet cover (19G-Z, 192) (black)
74-75	Vega (H.B.)	9674640	1	8.70	PANEL, trim finish compt. r/end (Note 1)
75	Monza (exc. Towne Cpe.)	1698079	1	9.20	PANEL, rear end compt. trim finish (prime and paint as reqd.)
75	Monza (Towne Cpe.)	9630947	A.R.	FT/2.50	TRUNK LINING (turq. & black)
75	Monza (exc. Towne Cpe.)	141994	2		BUTTON, load floor carpet

**15.268 MAT UNIT (Rear Floor Contour Twin Type Rubber)**

73	Vega (exc. Panel)	989103	1	7.95	(comb. 860) (black)
73	Vega (H.B.)	989128	1		(comb. 858) (oxblood)
73	Vega (exc. Panel)	989130	1	7.95	(comb. 868) (neutral)
73	Vega (exc. Panel)	989125	1		(comb. 872) (blue and black)

**15.280 MAT— INSULATOR— SEAL— RETAINER, Dash Panel**

68-69	Chevy, Camaro w/C.A.C.,				
70-74	Nova	341051	1	7.30	
70-75	Camaro (exc. C.A.C.)	333705	1	7.65	
70-75	Camaro w/C.A.C.	333706	1	7.65	
75	Nova (exc. C.A.C.)	347574	1	7.90	
71-74	Vega	9600868	1	9.55	INSULATION
74	Vega	1664425	1		INSULATION
69-71	Chevelle (exc. C.A.C.)	9817605	1	10.10	INSULATION ASSY.
71-74	Pass.	9839086	1	11.55	INSULATION ASSY.
73	Chevelle w/C.A.C.	9871047	1	9.25	INSULATION ASSY.
74	Pass.	9697533	1	10.15	INSULATION ASSY.
74-75	Chevelle w/C.A.C.	1693810	1	13.75	INSULATION ASSY.
74-75	Chevelle (exc. C.A.C.)	1693809	1	13.75	INSULATION ASSY.
75	Pass.	1688096	1	10.15	INSULATION ASSY.
75	Vega	1690175	1	9.80	
75	Vega (H.B.), Monza (exc. Towne Cpe.)	346768	1	11.70	INSULATION
75	Monza (Towne Cpe.)	352369	1	17.25	INSULATION (acoustical pkg.)
75	Monza	1665825	1	9.80	
75	Vega (H.B.), Monza (exc. Towne Cpe.)	346769	1	.16	SEAL, insulation
75	Monza (Towne Cpe.)	458488	1		RETAINER, inst. panel insulation (part of 352369)

**15.286 CARPET— CARPET ASSY.— MAT— LACE— PAD, Front Floor**

**PASS.**

65-68	Impala, Caprice (exc. S.S.)	8756503	1	64.50	frt. (comb. 802, 803, 804, 805, 806, 807, 810, 811, 812, 813, 814, 817, 819, 820, 858, 894) (black)
66-67	Pass. (exc. S.S.)	7603103	1	60.25	(comb. 832, 833, 836, 839, 840, 842, 843, 845) (blue)
66-68	Caprice (Spt. Mdls.),				
67	S.S.				frt. (comb. 808, 810, 818, 821, 898)
67-68	Biscayne, Bel Air	8756503	1	64.50	frt. (comb. 802, 803, 804, 805, 806, 807, 810, 811, 812, 813, 814, 817, 819, 820, 858, 894) (black)
68	Impala (Spt. Cpe.)	7603151	1	59.25	(comb. 808, 813) (black)
68	Pass. (exc. Conv., Sta. Wag., 4-Spd.)	7729074	1	62.50	frt. (comb. 830, 831, 832, 834, 865) (gold)
68	Pass. (exc. Conv., 4-Spd.)	7729071	1	62.50	frt. (comb. 815, 816, 817, 818, 819, 820, 821, 822) (blue)
69	Pass. (exc. Conv.)	8756505	1	64.50	frt. (comb. 815, 816, 818, 819, 820, 821, 822, 826) (blue)
69	Pass. (exc. Brookwood, Kingswood, Estate Wag.)	8756507	1	64.50	frt. (comb. 849, 850, 851, 852, 853, 856) (med. green)
69	Pass.	8756503	1	64.50	frt. (comb. 802, 803, 804, 805, 806, 807, 810, 811, 812, 813, 814, 817, 819, 820, 858, 894) (black)
69	Spt. Sed., Spt. Cpe	8756509	1	65.75	frt. (med. gold)
70	Pass. (exc. Conv.)	9812940	1	68.25	(comb. 815, 818, 819) (dk. blue)
70	Impala (exc. Sed.),				
70	Brookwood, Townsman	9812942	1	69.50	(comb. 830, 831, 838) (dk. saddle)
70	Pass.	9812943	1	69.50	(comb. 848, 855, 860, 861) (dk. green)

**REAR TRIM—MATS—YARDAGE**

<b>15.286 CARPET— CARPET ASSY.— MAT— LACE— PAD, Front Floor (Con't)</b>					
70	Pass. (exc. Conv.)	9812944	1	68.25	(comb. 836, 837, 839, 840, 841, 843) (dk. gold)
71-73	Pass.	9871451	1	67.75	(comb. 802, 805, 806, 816) (black)
71-72	Pass.	9871452	1	67.75	(comb. 810, 811, 812, 813, 814, 815) (dk. blue)
71	Pass.	9871577	1	63.25	(comb. 832, 834, 835, 836) (dk. jade)
71	Pass.	9871579	1	63.25	(comb. 827, 828, 830) (med. maize)
71	Biscayne, Bel Air, Impala, Caprice (Spt. Sed., Spt. Cpe.)	9871454	1	67.75	(comb. 818, 819, 820, 821) (med. beige)
71-72	Pass.	9871456	1	67.75	(comb. 825) (dk. saddle)
72	Pass. (exc. Sta. Wag.), Kingswood	9887981	1	63.25	(comb. 815, 816, 817, 818, 819) (covert)
72	Bel Air, Impala, Caprice, Kingswood	9899325	1	67.50	(comb. 828, 829, 830, 831, 833) (green)
72	Impala, Caprice (Spt. Sed., Spt. Cpe.)	9899324	1	67.50	(comb. 834, 835, 836) (pewter)
73	Pass. (Sta. Wag.)	9654218	1	40.75	saddle carpet (w/interior trim comb. 825, 826)
73	Bel Air (Sed.)	9654213	1	35.75	blue carpet (w/interior trim comb. 810)
73	Impala (exc. 6-Pass. Sta. Wag.), Caprice (exc. Conv.)	9654214	1	40.75	midnight blue carpet (w/interior trim comb. 812, 813, 843)
73	Pass.	9654215	1	40.75	green carpet (w/interior trim comb. 827, 828, 829, 830, 842)
73	Bel Air (Sta. Wag.), Impala (exc. 6-Pass. Sta. Wag.), Caprice	9654217	1	40.75	neutral carpet (w/interior trim comb. 815, 817, 818, 841)
73	Caprice (Spt. Sed., Spt. Cpe.)	9654219	1	40.75	oxblood carpet (w/interior trim comb. 836)
73	Pass. (Conv.)	9658281	1	41.00	blue carpet (w/interior trim comb. 816)
74	Pass.	9681783	1	42.75	green carpet (w/interior trim comb. 850, 851, 852, 853, 855, 44X)
74	Pass.	9681780	1	42.75	neutral carpet (w/interior trim comb. 815, 817, 819, 821, 841)
74	Pass. (exc. Taxi, Police)	9737085	1	46.00	blue carpet (w/interior trim comb. 802, 803, 805, 806, 810, 24F)
74	Pass. (exc. Taxi, Police)	9737086	1	46.00	red carpet (w/interior trim comb. 802, 803, 805, 806, 808, 810, 840, 75F)
74	Pass. (exc. Taxi, Police)	9737087	1	46.00	gold carpet (w/interior trim comb. 802, 803, 805, 806, 53F)
74	Pass. (exc. Taxi, Police)	9737088	1	46.00	russet carpet (w/interior trim comb. 803, 805, 806, 66F)
74	Pass. (exc. Taxi, Police)	9681776	1	42.75	black carpet (w/interior trim comb. 802, 803, 805, 806, 808, 810, 840, 19F)
74	Impala (exc. Sta. Wag.), Impala, Caprice (Sta. Wag.)	9681777	1	42.75	saddle carpet (w/interior trim comb. 849, 858)
74	Impala, Caprice (exc. Conv.)	9681779	1	42.75	midnight blue carpet (w/interior trim comb. 813, 843, 847)
74	Caprice	9681781	1	42.75	taupe carpet (w/interior trim comb. 896)
74	Impala, Caprice (exc. Police)	9681782	1	42.75	oxblood carpet (w/interior trim comb. 802, 805, 806, 808, 840, 857, 73F)
75	Pass.	1662360	1	53.25	sandstone carpet (w/interior trim comb. 55)
75	Pass.	1662359	1	41.75	blue carpet (w/interior trim comb. 02, 26)
75	Pass. (exc. Conv.)	1662358	1	53.25	green carpet (w/interior trim comb. 44, 04)
75	Pass.	1662354	1	53.25	black carpet (w/interior trim comb. 19, 11)
75	Pass.	1662356	1	53.25	saddle carpet (w/interior trim comb. 63)
75	Pass.	1662357	1	53.25	oxblood carpet (w/interior trim comb. 73, 07W)
73-74	Caprice w/Reclining Seat	6258682	1	FT/.12	LACE, finish (comb. 808, 840) (black) (repl. 9662809)
73-74	Caprice w/Reclining Seat	6258684	1	FT/.12	LACE, finish (comb. 843) (mid. blue) (repl. 9662811)
74	Caprice w/Reclining Seat	9686347	1	.60	LACE, finish (comb. 850) (green)
75	Caprice w/Reclining Seat	9686348	1	.60	LACE, finish (comb. 896) (taupe)
75	Caprice (Sedan, Coupe) w/Bucket Seat (exc. Console)	1682156	1	.87	LACE, finish (comb. 26) (blue)
<b>CHEVY— NOVA</b>					
68-72	Nova		1		(comb. 750, 751, 752, 753, 766) (black)
73	Nova (Cpe.) w/Bucket Seat (exc. 4-Spd., Console)	9638245	1	42.25	black carpet (w/interior trim 751, 752, 754, 794)
73	Nova w/Bench Seat (exc. 4-Spd.)	9638220	1	40.00	black carpet (w/interior trim comb. 750, 751, 752, 755, 794)

**REAR TRIM—MATS—YARDAGE**

**15.286 CARPET— CARPET ASSY.— MAT— LACE— PAD, Front Floor (Con't)**

73	Nova (Cpe.) w/Bench Seat (exc. Custom) . . . . .	9638221	1	35.50	blue carpet (w/interior trim comb. 756) . . . . .
73	Nova (Cpe.) w/Bench Seat (exc. 4-Spd., Custom) . . . . .	9657645	1	35.50	chamois carpet (w/interior trim comb. 767) . . . . .
73	Nova (Custom) w/Bench Seat (exc. 4-Spd.) . . . . .	9638223	1	40.00	neutral carpet (w/interior trim comb. 764, 769) . . . . .
73	Nova (Cpe.) w/Bucket Seat (exc. 4-Spd., Console) . . . . .	9638246	1	37.75	neutral carpet (w/interior trim comb. 771) . . . . .
73	Nova (Cpe.) w/Bucket Seat, 4-Spd. . . . .	9654128	1	42.50	neutral carpet (w/interior trim 763, 771) . . . . .
73	Nova (Cpe.) w/Bucket Seat, 4-Spd. . . . .	9654127	1	42.50	black carpet (w/interior trim comb. 751, 752, 754, 794) . . . . .
74	Nova w/Bench Seat, 4-Spd. . . . .	9679764	1	41.75	midnight neutral carpet (w/interior trim comb. 766) . . . . .
74	Nova w/Bench Seat, 4-Spd. . . . .	9679765	1	41.75	green carpet (w/interior trim comb. 755) . . . . .
74	Nova w/Bench Seat, 4-Spd. . . . .	9679763	1	41.75	midnight blue carpet (w/interior trim comb. 771) . . . . .
74	Nova w/Bench Seat, 4-Spd. . . . .	9679760	1	41.75	black carpet (w/interior trim comb. 751, 752, 754) . . . . .
74	Nova w/Bucket Seat (exc. 4-Spd.) . . . . .	9680378	1	43.75	midnight neutral carpet (w/interior trim comb. 766) . . . . .
74	Nova w/Bucket Seat, 4-Spd. . . . .	9680328	1	44.00	midnight neutral carpet (w/interior trim comb. 766) . . . . .
74	Nova (Coupe) w/Bucket Seat (exc. 4-Spd.) . . . . .	1665067	1	48.75	green carpet (w/interior trim comb. 759) (repl. 9680379) . . . . .
74	Nova (Coupe) w/Bucket Seat, 4-Spd. . . . .	9680329	1	44.00	green carpet (w/interior trim comb. 759) . . . . .
74	Nova (Coupe) w/Bucket Seat . . . . .	9680375	1	43.75	black carpet (w/interior trim comb. 752, 754) . . . . .
74	Nova (H.B.) . . . . .	9680376	1	43.75	saddle carpet (w/interior trim comb. 773) . . . . .
74	Nova (Coupe) w/Bench Seat, 4-Spd. (exc. Custom) . . . . .	9693014	1	41.75	red carpet (w/interior trim comb. 751, 754) . . . . .
74	Nova (Coupe) w/Bucket Seat . . . . .	1665068	1	48.50	red carpet (w/interior trim comb. 752, 754) . . . . .
74	Nova (Coupe) w/Bench Seat, 4-Spd. (exc. Custom) . . . . .	9693013	1	41.75	blue carpet (w/interior trim comb. 751, 754) . . . . .
74	Nova (Coupe) (exc. 4-Spd., Custom) . . . . .	9693012	1	43.75	blue carpet (w/interior trim comb. 754) . . . . .
74	Nova (Coupe) w/Bucket Seat, 4-Spd. (exc. Custom) . . . . .	9693015	1	44.00	blue carpet (w/interior trim comb. 754) . . . . .
74	Nova (Coupe) (exc. Custom) . . . . .	9735832	1	38.00	midnight blue carpet (29X) . . . . .
74	Nova (Coupe) w/Bucket Seat, 4-Spd. (exc. Custom) . . . . .	9735833	1	38.25	midnight blue carpet (29X) . . . . .
74-75	Nova . . . . .	1665068	1	48.50	red carpet (w/interior trim comb. 19, 11) . . . . .
75	Nova . . . . .	1665066	1	54.50	oxblood carpet (w/interior trim comb. 73, 07W) . . . . .
75	Nova . . . . .	1665070	1	54.50	blue carpet (w/interior trim 26, 02W) . . . . .
75	Nova . . . . .	1665069	1	54.50	graystone carpet (w/interior trim 16, 55) . . . . .
75	Nova . . . . .	1746332	1	55.25	black carpet (w/interior trim 19, 91) (standard carpet) (repl. 1665064) . . . . .
75	Nova . . . . .	1665065	1	54.50	saddle carpet (w/interior trim 63) . . . . .
75	Nova . . . . .	1665071	1	54.50	sandstone carpet (w/interior trim 55) . . . . .
75	Nova . . . . .	1665067	1	48.75	green carpet (w/interior trim 04W, 44) . . . . .
75	Nova . . . . .	1726693	1	56.00	deluxe black carpet (trim 11, 19) . . . . .
75	Nova . . . . .	1748083	1	99.50	deluxe blue carpet (trim 02, 26) (repl. 1726697) . . . . .

**CHEVELLE**

66	El Camino (Custom) . . . . .	7599763	1	56.50	(comb. 762, 763, 797) (black) . . . . .
68	Malibu, S.S. Concours w/A.T. (exc. strato bucket seats) . . . . .	7752263	1	59.25	(comb. 764, 765, 768, 793) (black) . . . . .
68	Malibu, S.S. (2-Dr.) (exc. H.D. 3-Spd., 4-Spd.) . . . . .	7752274	1	59.25	(comb. 766, 794) (black) . . . . .
68	Chevelle (4-Dr.) (exc. Nomad), Malibu (Spt. Cpe.), . . . . .				
68	Chevelle (Sta. Wag., El Camino) (exc. Nomad) . . . . .	7752271	1	59.25	(comb. 782) (saddle) . . . . .



**REAR TRIM—MATS—YARDAGE**

**15.286 CARPET— CARPET ASSY.— MAT— LACE— PAD, Front Floor (Con't)**

<b>69-70</b>	Chevelle w/floor shift (exc. floor console, Deluxe, Nomad, Greenbrier) .....	<b>8736299</b>	1	61.75	(comb. 704, 705, 706, 707, 708, 709, 710, 714, 748, 749, 753, 754, 755, 756, 757, 790, 791) (black) (repl. 8736323) .....
<b>69</b>	Malibu (exc. Conv.),				
<b>69</b>	El Camino (Custom),				
<b>69</b>	Concours .....	<b>8736331</b>	1	62.00	(comb. 762, 763, 764) (dark blue) .....
<b>69-70</b>	Malibu (Conv.) El Camino (Custom) w/bucket seats (exc. 4-Spd.),				
<b>70</b>	Chevelle (Spt. Cpe.) (bucket seats w/floor console, column shift) .....	<b>8788898</b>	1	67.00	(comb. 784, 796) (dk. green) .....
<b>70</b>	Chevelle (bucket seats w/floor console, column shift) .....	<b>9840340</b>	1	83.50	(comb. 769, 771) (dk. saddle) .....
<b>73</b>	Malibu (exc. Sta. Wag.) .....	<b>9654522</b>	1	49.50	chamois carpet (w/interior trim comb. 716, 721) .....
<b>73</b>	Malibu, Laguna .....	<b>9654519</b>	1	49.50	blue carpet (w/interior trim comb. 705, 719, 723, 724) .....
<b>73</b>	Malibu, Laguna (exc. Sta. Wag., 4-Spd.) .....	<b>9665411</b>	1	38.75	red carpet (w/interior trim comb. 704, 707)
<b>73</b>	Malibu, Laguna, Monte Carlo, El Camino (Custom) .....	<b>9654521</b>	1	49.50	green carpet (w/interior trim comb. 713, 715, 726, 727, 728, 730) .....
<b>73</b>	Malibu, Laguna, Monte Carlo, El Camino (Custom) (exc. 4-Spd.) .....	<b>9654518</b>	1	44.75	black carpet (w/interior trim comb. 703, 704, 706, 707, 708, 712) .....
<b>73</b>	Malibu, Laguna, El Camino (Custom) Monte Carlo .....	<b>9654523</b>	1	44.75	neutral carpet (w/interior trim comb. 731, 732, 734, 735) .....
<b>73</b>	Malibu, Laguna, Monte Carlo (Cpe.) El Camino (Custom) w/4-Spd. ....	<b>9654904</b>	1	46.00	black carpet (w/interior trim comb. 703, 704, 706, 707, 712) .....
<b>73</b>	Malibu (Cpe.) w/4-Spd. ....	<b>9654910</b>	1	46.00	saddle carpet (w/interior trim comb. 720) ..
<b>73</b>	Malibu (Cpe., Sta. Wag.) Laguna (Cpe.) El Camino (Custom) (exc. 4-Spd.) .....	<b>9654524</b>	1	49.50	saddle carpet (w/interior trim comb. 717, 720) .....
<b>3</b>	Laguna, Monte Carlo (exc. 4-Spd.) .....	<b>9654525</b>	1	49.50	oxblood carpet (w/interior trim 709, 714, 740) .....
<b>3</b>	Monte Carlo .....	<b>9654520</b>	1	49.50	midnight blue carpet (w/interior trim comb. 725) .....
<b>4</b>	Chevelle .....	<b>9728511</b>	1	44.00	black carpet (w/interior trim comb. 701, 702, 703, 704, 705, 706, 707, 708, 709, 738, 747, 748, 891, 894) .....
<b>74</b>	Chevelle w/4-Spd. ....	<b>9728527</b>	1	44.00	neutral carpet (w/interior trim comb. 713, 714, 722, 892) .....
<b>74</b>	Chevelle (exc. 4-Spd.) .....	<b>9728515</b>	1	44.00	neutral carpet (w/interior trim comb. 713, 714, 716, 722, 892) .....
<b>74</b>	Chevelle .....	<b>9728518</b>	1	44.00	green carpet (w/interior trim comb. 723, 724, 726, 727, 728, 730, 745, 830, 893)
<b>74</b>	Chevelle w/4Spd. ....	<b>9728526</b>	1	44.00	mid. blue carpet (w/interior trim comb. 732, 749, 785, 897) .....
<b>74</b>	Chevelle (exc. 4-Spd.) .....	<b>9728514</b>	1	44.00	mid. blue carpet (w/interior trim comb. 732, 734, 735, 737, 749, 785, 897) .....
<b>74</b>	Chevelle .....	<b>9728512</b>	1	44.00	saddle carpet (w/interior trim comb. 718, 731, 740, 742) .....
<b>74</b>	Chevelle .....	<b>9728517</b>	1	44.00	oxblood carpet (w/interior trim comb. 719, 720, 743, 744) .....
<b>74</b>	Chevelle .....	<b>9728519</b>	1	44.00	russet carpet (w/interior trim comb. 701, 703, 706, 708, 891) .....
<b>74</b>	Chevelle (exc. 4-Spd.) .....	<b>9728520</b>	1	42.50	blue carpet (w/interior trim comb. 701, 706, 891) .....
<b>74</b>	Chevelle w/4-Spd. ....	<b>9728532</b>	1	44.00	red carpet (w/interior trim comb. 701, 702, 703, 706, 707, 708, 891) .....
<b>74</b>	Chevelle (exc. 4-Spd.) .....	<b>9728521</b>	1	44.00	red carpet (w/interior trim comb. 701, 702, 703, 706, 707, 708, 891) .....
<b>75</b>	Chevelle .....	<b>1662169</b>	1	48.75	sandstone carpet (w/interior trim comb. 55)
<b>75</b>	Chevelle .....	<b>1662168</b>	1	46.75	blue carpet (w/interior trim comb. 26, 02H)
<b>75</b>	Chevelle .....	<b>1662166</b>	1	46.75	green carpet (w/interior trim comb. 44, 04H) .....

**REAR TRIM—MATS—YARDAGE**

**15.286 CARPET— CARPET ASSY.— MAT— LACE— PAD, Front Floor (Con't)**

75	Chevelle	1662165	1	46.75	oxblood carpet (w/interior trim comb. 73, 07H)
75	Chevelle	1662164	1	46.75	saddle carpet (w/interior trim comb. 63)
75	Chevelle	1662162	1	46.75	black carpet (w/interior trim comb. 19, 11)
75	Chevelle	1662167	1	44.25	graystone carpet (comb. 16D, 16E)
73	Malibu, Laguna (Cpe.) El Camino (Custom) w/Swivel Bucket	9662810	1	.75	LACE, finish (comb. 705, 719) (blue)
73	Malibu, Laguna (Cpe.) w/Swivel Bucket (exc. Console),				
73	El Camino (Custom) w/Swivel Bucket	9662814	1	.75	LACE, finish (comb. 717, 720) (saddle)
73-74	Chevelle w/Swivel Bucket (exc. Console),				
75	Malibu (Classic) (Coupe),				
75	El Camino (Classic),				
75	Monte Carlo	1682156	1	.87	LACE, finish (comb. 26) (blue)
75	Monte Carlo	1664400	1	27.50	PAD, frt. floor mldg.

**CAMARO**

67	Camaro (Spt. Cpe.) w/floor console	7666912 R.H.		24.00	(comb. 760, 765, 797) (black)
69	Camaro (Spt. Cpe.)	8733532	1	51.50	(comb. 723, 725) (midnight green)
73	Camaro	9871257	1	58.00	black carpet (w/interior trim comb. 773, 774, 775, 776, 785, 786)
73	Camaro w/A.T.	9658275	1	38.75	blue carpet (w/interior trim comb. 773, 774, 775, 776, 785, 786)
73	Camaro w/A.T.	9638883	1	38.75	neutral carpet (w/interior trim comb. 779, 788)
73	Camaro w/A.T. (exc. L.T.)	9638884	1	38.75	saddle carpet (w/interior trim comb. 778)
74	Camaro w/A.T.	9679741	1	40.75	black carpet (w/interior trim comb. 775, 776, 777, 778)
74	Camaro w/A.T.	9679742	1	40.75	saddle carpet (w/interior trim comb. 796, 797, 798, 799)
74	Camaro (exc. A.T.)	9679767	1	40.25	saddle carpet (w/interior trim comb. 796, 797, 798, 799)
74	Camaro w/A.T.	9679744	1	40.75	neutral carpet (w/interior trim comb. 780, 781)
74	Camaro (exc. A.T.)	9679769	1	40.25	neutral carpet (w/interior trim comb. 780, 781)
74	Camaro w/A.T. (exc. L.T.)	9692841	1	40.75	blue carpet (w/interior trim comb. 775, 777)
74	Camaro (exc. L.T., A.T.)	9692842	1	40.25	blue carpet (w/interior trim comb. 775, 777)
74	Camaro w/A.T. (exc. L.T.)	9679746	1	40.75	green carpet (w/interior trim comb. 786, 787)
74	Camaro (exc. L.T., A.T.)	9679771	1	40.25	green carpet (w/interior trim comb. 786, 787)
74	Camaro w/A.T. (exc. L.T.)	9679747	1	40.75	red carpet (w/interior trim comb. 775, 779, 792)
74	Camaro (exc. L.T., A.T.)	9679772	1	40.25	red carpet (w/interior trim comb. 775, 779, 792)
74	Camaro (L.T.) w/A.T.	9679745	1	40.75	taupe carpet (w/interior trim comb. 783, 784)
74	Camaro (L.T.)	9679770	1	40.25	taupe carpet (w/interior trim comb. 783, 784)
75	Camaro	1664623	1	40.25	saddle carpet (w/interior trim 63, 632) (standard carpet)
75	Camaro	1703697	1	63.25	saddle carpet (trim 63, 632) (deluxe carpet)
75	Camaro	1703696	1	63.25	black carpet (w/interior trim 19) (deluxe carpet)
75	Camaro	1664624	1	45.50	oxblood carpet (w/interior trim 73, 732) (standard carpet)
75	Camaro	1703698	1	63.25	oxblood carpet (trim 73D, 732) (deluxe carpet)
75	Camaro w/column shift	1664626	1	45.50	graystone carpet (w/interior trim 16) (standard carpet)
75	Camaro	1703699	1	63.25	graystone carpet (trim 16D) (deluxe carpet)
75	Camaro w/column shift	1664628	1	45.50	sandstone carpet (w/interior trim 55) (standard carpet)
75	Camaro	1703700	1	63.25	sandstone carpet (trim 55) (deluxe carpet)
75	Camaro w/floor shift	1664622	1	45.50	black carpet (w/interior trim 19, 91) (standard carpet)
75	Camaro	1664625	1	45.25	red carpet
75	Camaro (exc. L.T.)	1718646	1	33.00	red carpet (deluxe frt. and rr. flr., w/interior trim 19C-V, 91V)

**REAR TRIM—MATS—YARDAGE**

**15.286 CARPET— CARPET ASSY.— MAT— LACE— PAD, Front Floor (Con't)**

**VEGA**

*NOTE: It may be necessary to punch holes in trim assy. to insure proper fit.*

71	Vega (N.B. & H.B.)	9831613	1	46.00	sandalwood carpet (w/interior trim comb. 888)
71-72	Vega (exc. Panel)	9618736	1	35.75	black carpet (w/interior trim comb. 860, 861, 862, 866, 867)
71	Vega (N.B. & H.B.)	9831611	1	46.00	blue carpet (w/interior trim comb. 879, 892)
72	Vega (exc. Panel)	9618738	1	35.75	covert carpet (w/interior trim comb. 868, 869, 874)
73	Vega (exc. Panel)	9638207	1	35.50	black carpet (w/interior trim comb. 860, 861, 871, 884, 887)
73	Vega (exc. Panel)	9638208	1	35.50	black and blue carpet (w/interior trim comb. 872)
73	Vega (exc. Panel)	9638209	1	35.50	green carpet (w/interior trim comb. 863, 864)
73	Vega (H.B.)	9638210	1	35.50	chamois carpet (w/interior trim comb. 859, 876)
73	Vega (exc. Panel)	9638211	1	35.50	neutral carpet (w/interior trim comb. 868, 874, 888)
73	Vega (Sta. Wag.)	9638212	1	35.50	saddle carpet (w/interior trim comb. 866, 867)
73	Vega (H.B.)	9638213	1	35.50	oxblood carpet (w/interior trim comb. 858, 875)
73	Vega (exc. Panel)	9658252	1	35.00	orange carpet (w/interior trim comb. 860, 861, 871, 884, 887)
73	Vega (exc. Panel)	9658253	1	35.00	red carpet (w/interior trim comb. 860, 861, 871, 884, 887)
74	Vega (exc. Panel)	9680435	1	58.25	black carpet (w/interior trim comb. 861, 862, 871, 873)
74	Vega (exc. Panel)	9680436	1	58.25	saddle carpet (w/interior trim comb. 888, 890)
74	Vega (exc. Panel)	9680437	1	58.25	midnight neutral carpet (w/interior trim comb. 863, 870)
74	Vega (exc. Panel)	9680438	1	58.25	green carpet (w/interior trim comb. 879, 880, 883, 887)
74	Vega (Sta. Wag., H.B.)	9680439	1	55.00	red carpet (w/interior trim comb. 861, 862, 869, 871, 873, 884)
74	Vega (N.B.)	9692778	1	58.25	red-blue carpet (w/interior trim comb. 861, 862, 871, 873)
74	Vega (N.B.)	9692779	1	58.25	gold carpet (w/interior trim comb. 861, 871)
74	Vega (N.B.)	9692780	1	70.75	russet carpet (w/interior trim comb. 861)
75	Vega (Sta. Wag., H.B.)	1709411	1	114.00	(73B) (oxblood)
75	Vega (Sta. Wag., H.B.)	1709412	1	116.00	(comb. 26B) (blue) (repl. 1700786)
75	Vega (Sta. Wag., H.B.)	1709413	1	114.00	(comb. 55B) (sandstone)
75	Vega (exc. Panel)	1689564	1	63.25	(comb. 63Y, 63W) (saddle)
75	Vega (exc. Panel)	1689565	1	63.25	red carpet (w/trim 19D, 19W, 19Y, 19E) (black)
75	Vega (exc. Panel)	1689566	1	63.25	blue carpet (w/trim 02Y white, 26W blue)
75	Vega (exc. Panel)	1689567	1	63.25	(comb. 55E, 55D, 55Y, 55W) (sandstone)
75	Vega (exc. Panel)	1689562	1	63.25	(w/trim 11Y, 19D-E-W-Y) (black)
75	Vega (exc. Panel)	1695602	1	59.00	(w/trim 73Y) (oxblood)
75	Vega (Sta. Wag., H.B.)	1661167	1		(comb. 75W) (red)
75	Monza	1735101	1	102.00	black carpet (w/interior trim comb. 19G, 11H, 11J, 19Z, 19H-N, 192, 193)
75	Monza (exc. Towne Cpe.)	1661165	1	63.00	(comb. 63G, 63Z, 632) (saddle)
75	Monza (exc. Towne Cpe.)	1661169	1	63.00	(comb. 26G, 26Z) (blue)
75	Monza (exc. Towne Cpe.)	1661168	1	63.00	(comb. 16G, 16Z) (graystone)
75	Monza (exc. Towne Cpe.)	1739502	1	63.75	(comb. 73G, 73Z, 732) (oxblood) (repl. 1661166)
75	Monza (exc. Towne Cpe.)	1744096	1	71.25	(blue) (repl. 1735105)
75	Monza (exc. Towne Cpe.)	1739501	1		less console cut-out (saddle)
75	Monza (exc. Towne Cpe.)	1739502	1	63.75	less console cut-out (oxblood)
75	Monza (exc. Towne Cpe.)	1739503	1		less console cut-out (graystone)
75	Monza (exc. Towne Cpe.)	1739504	1	63.75	less console cut-out (sandstone)
75	Monza (Towne Cpe.)	1735102	1	102.00	saddle carpet (w/interior trim 64H, 64N, 643)
75	Monza (Towne Cpe.)	1735103	1	102.00	firethorn carpet (w/interior trim 07H, 71H, 71N)

**REAR TRIM—MATS—YARDAGE**

**15.286A CARPET**

**1971 CHEVELLE**

**BENCH SEAT (Exc. Floor Shift)**

BLACK	DK. BLUE	DK. JADE	MED. BEIGE	DK. SADDLE
(comb. 704, 705, 708, 709) 8736299	(comb. 725, 726, 727, 707) 9840336	(comb. 730, 731, 734, 735) 9840337	(comb. 714, 718, 717) 9840338	(comb. 721) *9840340

**BENCH SEAT w/Floor Shift**

(comb. 704, 705, 706, 707, 708, 710, 714) 8736323	(comb. 725, 726, 727, 728) 9840336	(comb. 729, 730, 731, 732, 733, 734, 735) 9840337	(comb. 714, 715, 716, 717, 718) *9839929	(comb. 721, 722, 723) *9839930
--	---------------------------------------	--	---	-----------------------------------

**BUCKET SEATS**

(comb. 706, 707, 710) 8736299	(comb. 727) *9840336	(comb. 729, 732, 733) *9840337	(comb. 715, 716) *9840338	(comb. 722, 723) *9840340
----------------------------------	-------------------------	-----------------------------------	------------------------------	------------------------------

**1971 NOVA**

BLACK	DK. JADE	MED. BEIGE	DK. SADDLE	DK. BLUE
(comb. 752, 753) (comb. 754) 8771726	(comb. 759, 760, 761) 9832372	(comb. 763, 764) 9832373	(comb. 767) 9832234	(comb. 756, 757) 9875732

**1971 CAMARO**

	BLACK	DK. BLUE	DK. JADE	MED. BEIGE	DK. SADDLE
exc. A.T. w/A.T. w/A.T.	(comb. 775, 785, 789) 9871257	(comb. 776, 786) 9871252	(comb. 778, 787) 9871259	(comb. 777) 9871254 9871260	(comb. 779, 792) 9871256 9871262

**REAR TRIM—MATS—YARDAGE**

**1972 CHEVELLE**

**BENCH SEAT (exc. Floor Shift)**

Black	Covert	Dk. Blue	Dk. Jade	Med. Beige	Dk. Green	Dk. Saddle	Med. Pewter
(comb. 704, 705, 708, 709)	(comb. 730, 731, 732, 734)	(comb. 724, 725)	(comb. 721)	(comb. 713, 717, 718, 731, 734, 735)			(comb. 740)
8736299	9600051	9840336	*9840342	*9840344	9600050		9600039

**BENCH SEAT w/Floor Shift**

(comb. 704, 705, 706, 707, 708, 710, 714)	(comb. 730, 731, 732, 734)	(comb. 724, 725)	(comb. 729, 730, 731, 732, 733, 734, 735)	(comb. 714, 715, 716, 717, 718)		(comb. 721, 722, 723)	
8736323	9600051	*9839927	*9839928	*9839929	9600150	*9839930	

**BUCKET SEATS**

(comb. 706, 707, 710)	(comb. 730, 731, 732, 734)	(comb. 724, 725)	(comb. 729, 732, 733)	(comb. 715, 716)	(comb. 713, 715, 717)	(comb. 735)	
8736299	9600051	9839927	*9840337	*9840338	9600150 9600050	*9840340	

**1972 NOVA**

Black	Covert	Dk. Blue	Dk. Jade	Med. Beige	Dk. Green	Dk. Saddle	
(comb. 752, 753) 7741102 (comb. 754) 8771726 (comb. 751, 767) 9607909	(comb. 764, 765)  9899323	(comb. 756)  9875732	(comb. 761)  9832372	(comb. 764)  9832373	(comb. 761)  9899322	(comb. 767)  9832234	

**1972 CAMARO**

Black	Covert	Dk. Blue	Dk. Green
(comb. 775, 780, 785, 789) 9871257 exc. A.T. w/A.T.	(comb. 779, 788)  9899319	(comb. 776, 786)  9871258	(comb. 778, 787)  9899318

**15.286B MAT— MAT UNIT, Front Floor**

**PASS.**

68-69 Biscayne (2-Dr.) w/H.D. mat.

67-70 Bel Air, Brookwood, Townsman  
w/H.D. mat

65-70 Taxi w/H.D. mat ..... **8776806** 1 44.00 (black) .....

**REAR TRIM—MATS—YARDAGE**

**15.286B MAT— MAT UNIT, Front Floor (Con't)**

71-75	Taxi, Police	9866945	1	43.75	rubber
75	All	1242658	2		throw (rubber-oxblood)
72-75	Pass.	994298	1	13.95	<b>MAT UNIT, front floor (full width type)</b> (blue) (vinyl)
72-75	Pass.	994297	1	13.95	<b>MAT UNIT, front floor (full width type)</b> (black) (vinyl)
72-75	Pass.	994299	1	13.95	<b>MAT UNIT, front floor (full width type) (dk. green)</b> (vinyl)
73-75	Pass.	989226	1	9.50	<b>MAT UNIT, contour type (rubber) (black)</b>
73-75	Pass.	989120	1	9.50	<b>MAT UNIT, contour type (rubber) (blue)</b>
73-74	Pass.	989123	1	8.95	<b>MAT UNIT, contour type (rubber) (oxblood)</b>
74-75	Pass.	989124	1	8.95	<b>MAT UNIT, contour type (rubber) (midn. neutral)</b>
74	Pass.	989237	1	9.50	<b>MAT UNIT, contour type (rubber) (saddle)</b>
74-75	Pass.	994603	1	9.50	<b>MAT UNIT, full width (vinyl) (taupe)</b>
75	Pass.	994602	1	9.50	<b>MAT UNIT (full width type) (vinyl) (dark green)</b>

**CHEVY— NOVA**

63-67	Chevy (Std.)	4519783	1	27.75	(black)
68-72	Chevy	7731717	1	26.25	(black)
70	Nova	8798300	1	29.75	(blue and black) (rubber)
70	Nova	8800025	1	29.75	(comb. 745) (green and black) (rubber)
71-72	Nova	9838240	1	29.50	(comb. 756, 757) (dk. blue and black) (rubber)
71	Nova	9838241	1	27.25	(comb. 759, 760) (dk. jade and black) (rubber)
71	Nova	9838242	1	27.25	(comb. 763) (med. beige and black) (rubber)
72	Nova	9603213	1	27.25	(comb. 759, 760) (green)
73	Nova w/Bench Seat (exc. Custom, New York Taxi)	9651365	1	20.00	(green)
73	Nova w/Bench Seat (exc. Custom, New York Taxi)	9651367	1	20.00	(blue)
73-74	Nova (exc. Custom, Taxi)	9651497	1	20.35	(black)
73-74	Nova (Cpe.) (exc. Custom Console)				
74	Nova w/Bench Seat, 4-Spd. (exc. Custom, Taxi)	9651498	1	21.25	(neutral)
74	Nova (exc. Custom, Taxi)	9683854	1	23.80	green
74	Nova (Coupe) (exc. Custom)	1667893	1	23.80	midnight blue
74	Nova (H.B.) (exc. Custom)	9683856	1	23.80	saddle
73-74	Nova (Sed.) (Taxi)	9658203	1	43.75	
75	Nova (Sedan) (exc. Custom) w/spec. body-Taxi	1660250	1	58.25	(comb. 19Z, 64Z)
73	Nova	989226	1	9.50	<b>MAT UNIT, contour type (rubber) (black)</b>
74-75	Nova	981963	1	8.50	<b>MAT UNIT, contour type (rubber) (saddle)</b>
74-75	Nova	981863	1	8.20	<b>MAT UNIT, contour type (rubber) (mid. neutral)</b>
75	Nova	983407	1		<b>MAT UNIT, contour type (rubber) (dark blue)</b>
75	Nova	980037	1	8.65	<b>MAT UNIT, contour type (rubber) (medium gray)</b>
75	Nova	980035	1	8.65	<b>MAT UNIT, contour type (rubber) (sandstone)</b>

**CHEVELLE**

66-67	Chevelle (exc. Malibu, El Camino Custom)	7619132	1	33.50	(black)
68	Chevelle (Std.) Nomad (exc. floor shift)	7745139	1	33.50	(black)
68	Chevelle (Deluxe, Custom) (exc. floor shift)	7762317	1	33.50	(black)
69-72	Nomad	8744687	1	37.25	rubber (black)
69-72	Chevelle (Deluxe), Greenbrier, El Camino (exc. Custom)	8767113	1	37.25	(black)
69	Greenbrier, El Camino	8767114	1	36.25	(comb. 773) (med. saddle)
70	Nova	7731717	1	26.25	(black) (rubber)
71	Deluxe (exc. 4-Spd.)	9862049	1	36.75	(comb. 736) (dk. jade) (rubber)
71-72	Std. (Spt. Cpe., Sed.)	9862050	1	36.75	(comb. 723, 724) (blue)
73	Chevelle (Deluxe) El Camino (exc. Custom, 4-Spd.)	9651766	1	37.25	(black)
73	Chevelle (Deluxe) El Camino w/4-Spd. (exc. Custom)	9651770	1	37.25	(black)

**REAR TRIM—MATS—YARDAGE**

**15.286B MAT— MAT UNIT, Front Floor (Con't)**

<b>73</b>	Chevelle (Deluxe) El Camino (exc. Custom) .....	<b>9651769</b>	<b>1</b>	<b>37.25</b>	(neutral) .....
<b>74-75</b>	Chevelle .....	<b>981862</b>	<b>1</b>	<b>8.50</b>	<b>MAT UNIT, contour type (rubber) (black)</b> ..
<b>74-75</b>	Chevelle .....	<b>981963</b>	<b>1</b>	<b>8.50</b>	<b>MAT UNIT, contour type (rubber) (saddle)</b> ..
<b>74-75</b>	Chevelle .....	<b>981863</b>	<b>1</b>	<b>8.20</b>	<b>MAT UNIT, contour type (rubber) (mid. neutral)</b> .....
<b>75</b>	Chevelle .....	<b>983407</b>	<b>1</b>		<b>MAT UNIT, contour type (rubber) (dark blue)</b> .....
<b>75</b>	Chevelle .....	<b>980037</b>	<b>1</b>	<b>8.65</b>	<b>MAT UNIT, contour type (rubber) (medium gray)</b> .....
<b>75</b>	Chevelle .....	<b>980035</b>	<b>1</b>	<b>8.65</b>	<b>MAT UNIT, contour type (rubber) (sandstone)</b> .....

**CAMARO**

<b>73</b>	Camaro, .....				
<b>74-75</b>	Camaro .....	<b>981862</b>	<b>1</b>	<b>8.50</b>	<b>MAT UNIT, contour type (rubber) (black)</b> ..
<b>74-75</b>	Camaro .....	<b>981963</b>	<b>1</b>	<b>8.50</b>	<b>MAT UNIT, contour type (rubber) (saddle)</b> ..
<b>74-75</b>	Camaro .....	<b>981863</b>	<b>1</b>	<b>8.20</b>	<b>MAT UNIT, contour type (rubber) (mid. neutral)</b> .....
<b>75</b>	Camaro .....	<b>980037</b>	<b>1</b>	<b>8.65</b>	<b>MAT UNIT, contour type (rubber) (medium gray)</b> .....
<b>75</b>	Camaro .....	<b>980035</b>	<b>1</b>	<b>8.65</b>	<b>MAT UNIT, contour type (rubber) (sandstone)</b> .....

**VEGA— MONZA**

<b>71</b>	Vega (N.B.), .....				
<b>71-72</b>	Vega (Pnl.) .....	<b>9889630</b>	<b>1</b>	<b>25.50</b>	rubber (black) .....
<b>73-74</b>	Vega (Panel) .....	<b>9652242</b>	<b>1</b>	<b>21.80</b>	rubber (comb. 860, 862, 863, 879) (black) ..
<b>75</b>	Monza (Towne Cpe.) .....	<b>356660</b>	<b>R.H.</b>	<b>5.15</b>	rubber (firethorn) .....
<b>75</b>	Monza (Towne Cpe.) .....	<b>356659</b>	<b>L.H.</b>	<b>4.00</b>	rubber (firethorn) .....
<b>75</b>	Monza (Towne Cpe.) .....	<b>365296</b>	<b>R.H.</b>	<b>5.15</b>	rubber (dk. saddle) .....
<b>75</b>	Monza (Towne Cpe.) .....	<b>365295</b>	<b>L.H.</b>	<b>5.15</b>	rubber (dk. saddle) .....
<b>75</b>	Vega, Monza .....	<b>994718</b>	<b>1</b>	<b>8.50</b>	<b>MAT UNIT, contour twin rubber (black)</b> ..
<b>75</b>	Vega, Monza .....	<b>994719</b>	<b>1</b>	<b>8.50</b>	<b>MAT UNIT, contour twin rubber (blue)</b> ..
<b>75</b>	Vega, Monza .....	<b>994721</b>	<b>1</b>	<b>8.50</b>	<b>MAT UNIT, contour twin rubber (saddle)</b> ..
<b>75</b>	Vega, Monza .....	<b>994619</b>	<b>1</b>	<b>8.20</b>	<b>MAT UNIT, contour twin rubber (accent russet)</b> .....

**15.294 BINDING, Floor Carpet**

<b>73-75</b>	All .....	<b>6258685</b>	<b>A.R.</b>	<b>FT/.12</b>	(saddle) .....
<b>73-75</b>	All .....	<b>6258682</b>	<b>A.R.</b>	<b>FT/.12</b>	(black) .....
<b>73</b>	Vega .....	<b>9632397</b>	<b>A.R.</b>	<b>FT/.11</b>	(black) .....
<b>73</b>	Vega .....	<b>9632414</b>	<b>A.R.</b>	<b>FT/.11</b>	(dark green) .....
<b>73</b>	Vega .....	<b>9632416</b>	<b>A.R.</b>	<b>FT/.11</b>	(accent red) .....
<b>73-74</b>	All .....	<b>6260812</b>	<b>A.R.</b>	<b>FT/.11</b>	(neutral) .....
<b>73-75</b>	All .....	<b>6258683</b>	<b>A.R.</b>	<b>FT/.12</b>	(oxblood) .....
<b>74</b>	All .....	<b>9632397</b>	<b>A.R.</b>	<b>FT/.11</b>	(accent blue) .....
<b>74</b>	All .....	<b>9632400</b>	<b>A.R.</b>	<b>FT/.11</b>	(russet) .....
<b>74</b>	All .....	<b>9632399</b>	<b>A.R.</b>	<b>FT/.11</b>	(gold) .....
<b>74-75</b>	All .....	<b>9632932</b>	<b>A.R.</b>	<b>FT/.13</b>	(blue) .....
<b>74-75</b>	All .....	<b>9632396</b>	<b>A.R.</b>	<b>FT/.11</b>	(green) .....
<b>74-75</b>	All .....	<b>9632395</b>	<b>A.R.</b>	<b>FT/.11</b>	(med. saddle) .....
<b>74-75</b>	All .....	<b>6258684</b>	<b>A.R.</b>	<b>FT/.12</b>	(mid. blue) .....
<b>74-75</b>	All .....	<b>9632398</b>	<b>A.R.</b>	<b>FT/.11</b>	(red) .....
<b>75</b>	All .....	<b>9632934</b>	<b>A.R.</b>	<b>FT/.13</b>	(sandstone) .....
<b>75</b>	Monza (exc. Towne Cpe.) .....	<b>9632933</b>	<b>A.R.</b>	<b>FT/.13</b>	(graystone) .....

**15.300 GROMMET— COVER— PLUG— RETAINER— SEAL, Front Floor**

<b>68-75</b>	All .....	<b>4479999</b>	<b>1</b>	<b>.18</b>	at dimmer switch (1" I.D.) .....
<b>71-74</b>	Camaro .....	<b>9871100</b>	<b>2</b>	<b>1.60</b>	<b>COVER, finish carpet front at seat adjuster</b> ..
<b>73-75</b>	Chevelle w/6-way seat .....	<b>9676476</b>	<b>R.H.</b>	<b>.58</b>	<b>COVER, front seat adj. opg. (paint)</b> .....
<b>73-75</b>	Chevelle w/6-way seat .....	<b>9676477</b>	<b>L.H.</b>	<b>.58</b>	<b>COVER, front seat adj. opg. (paint)</b> .....
<b>75</b>	Camaro .....	<b>1652316</b>	<b>1</b>	<b>2.10</b>	<b>COVER, front finish carpet at pass./st. adj.</b> ..
<b>75</b>	Camaro .....	<b>1652317</b>	<b>1</b>	<b>2.10</b>	<b>COVER, front finish carpet at driver/st. adj.</b> ..
<b>75</b>	Vega (Panel) .....	<b>9836063</b>	<b>A.R.</b>	<b>.54</b>	<b>PLUG, frt. filler panel</b> .....
<b>64-68</b>	Chevelle w/elect. seat (exc. S.S., El Camino), .....				
<b>66-68</b>	Impala, Caprice (Spt. Cpe., Conv.), .....				
<b>70-71</b>	Monte Carlo .....	<b>4472223</b>	<b>1</b>	<b>1.65</b>	<b>RETAINER, driver st. carpet rr. retainer</b> .....
<b>71</b>	Camaro .....	<b>9827503</b>	<b>4</b>	<b>.96</b>	<b>RETAINER, carpet on adjuster</b> .....
<b>71-72</b>	Pass. w/6-way seat, .....				
<b>73-75</b>	Impala, Caprice w/6-way seat ..	<b>9856051</b>	<b>4</b>	<b>.61</b>	<b>RETAINER, carpet on adjuster</b> .....
<b>66</b>	Pass. w/4-Spd. (exc. B.S.) .....	<b>3860183</b>	<b>1</b>	<b>6.05</b>	<b>SEAL, trans. cont. curv. (dark fawn)— (4.015)</b> .....

**REAR TRIM—MATS—YARDAGE**

**15.306 CARPET ASSY.— MAT— MAT UNIT— MAT ASSY.— TRIM ASSY., Rear Floor**

**PASS.**

69	Impala, Caprice (2-Dr.)	8732313	1	67.50	(comb. 809, 812, 859) (black)
71-72	Impala (Spt. Cpe., Conv.)	9869985	1	62.00	(comb. 825) (dk. saddle)
71-72	Impala Caprice (Spt. Cpe., Conv.)	9869977	1	62.00	(comb. 805, 806, 807) (black)
71-72	Impala Caprice (Spt. Cpe., Conv.)	9869978	1	62.00	(comb. 813, 814, 815) (dk. blue)
71	Impala Caprice (Spt. Cpe., Conv.)	9869982	1	62.00	(comb. 820, 821) (lt. sandalwood)
71-72	Impala Caprice (Spt. Sed.)	9869515	1	62.50	(comb. 805, 806, 807) (black)
71	Impala Caprice (Spt. Sed.)	9869517	1	62.00	(comb. 834, 835, 836) (dk. jade)
71-72	Pass. (4-Dr. Sed.) (exc. Spt. Sed.)	9869986	1	55.25	(comb. 802, 803, 804, 805, 806) (black)
71-72	Pass. (Sed.) (exc. Spt. Sed.)	9869987	1	55.25	(comb. 809, 810, 811, 812, 813, 814) (dk. blue)
71	Bel Air, Impala (4-Dr. Sed.) (exc. Spt. Sed.)	9869988	1	59.00	(comb. 832, 834, 835) (dk. jade)
71-72	Impala (4-Dr. Sed.) (exc. Spt. Sed.)	9869993	1	55.25	(comb. 825) (dk. saddle)
71-72	Kingswood (9-Pass.)	9869926	1	66.25	(comb. 825) (dk. saddle)
72	Impala, Caprice (Spt. Cpe., Conv.)	9891270	1	54.25	(comb. 815, 816, 818, 819) (covert)
72	Pass. (Spt. Cpe.)	9891258	1	54.25	(comb. 829, 830, 831, 833) (green)
72	Impala, Caprice (Spt. Sed.)	9891017	1	62.50	(comb. 829, 830, 831, 833) (green)
72	Impala, Caprice (Spt. Sed.)	9891018	1	62.50	(comb. 815, 818, 819) (covert)
72	Pass. (4-Dr. Sed.) (exc. Spt. Sed.)	9891394	1	62.00	(comb. 829, 830, 831) (green)
72	Pass. (Sed.) (exc. Spt. Sed.)	9891395	1	62.50	(comb. 815, 817, 818, 819) (covert)
72	Sta. Wag. (6-Pass.)	9611445	1	66.25	(comb. 802, 804, 806, 808) (black)
72	Sta. Wag. (6-Pass.)	9611446	1	66.25	(comb. 824, 825, 826) (saddle)
72	Sta. Wag. (6-Pass.)	9611447	1	66.25	(comb. 809, 811, 813) (blue)
72	Kingswood (9-Pass.)	9891041	1	66.25	(830) (green)
72	Kingswood (9-Pass.)	9891042	1	66.25	(818) (covert)
73	Bel Air (Sedan)	9655275	1	37.75	blue carpet (w/interior trim comb. 810)
73	Pass. (Spt. Sed.)	9869515	1	62.50	black carpet (w/interior trim comb. 802, 805, 806, 840)
73	Pass. (Spt. Sed.)	9655283	1	37.75	midnight blue carpet (w/interior trim comb. 812, 813, 843)
73	Pass. (Spt. Sed.)	9655284	1	37.75	green carpet (w/interior trim comb. 829, 830, 842)
73	Pass. (Spt. Sed.)	9655286	1	37.75	neutral carpet (w/interior trim comb. 815, 818, 841)
73	Pass. (Sedan) (exc. Spt. Sed.)	9655277	1	37.75	green carpet (w/interior trim comb. 827, 828, 829, 830, 842)
73	Pass. (Sedan) (exc. Spt. Sed.)	9869986	1	55.25	black carpet (w/interior trim comb. 802, 803, 804, 805, 806)
73	Pass. (Spt. Cpe., Conv.)	9655272	1	33.50	neutral carpet (w/interior trim comb. 815, 818, 841)
73	Pass. (Spt. Cpe.)	9655269	1	33.50	midnight blue carpet (w/interior trim comb. 812, 813, 843)
73	Pass. (Spt. Cpe., Conv.)	9655270	1	33.50	green carpet (w/interior trim comb. 829, 830, 842)
73	Pass. (Spt. Cpe., Conv.)	9869977	1	62.00	black carpet (w/interior trim comb. 802, 805, 806, 816, 840)
73	Pass. (Sta. Wag.) (6-Pass.)	9650769	1	40.00	neutral carpet (w/interior trim comb. 817, 818)
73	Pass. (Sta. Wag.) (6-Pass.)	9650770	1	40.00	saddle carpet (w/interior trim comb. 825, 826)
73	Pass. (Sta. Wag.) (9-Pass.)	9650756	1	36.25	neutral carpet (w/interior trim comb. 817, 818)
73	Pass. (Sta. Wag.) (9-Pass.)	9650757	1	36.25	saddle carpet (w/interior trim comb. 825, 826)
73	Impala, Caprice (Sedan) (exc. Spt. Sed.)	9655276	1	37.75	midnight blue carpet (w/interior trim comb. 812, 813, 843)
73	Impala, Caprice (Sta. Wag.) (6-Pass.)	9611445	1	66.25	black carpet (w/interior trim comb. 806)
73	Impala, Caprice (Sta. Wag.) (6-Pass.)	9650768	1	40.00	green carpet (w/interior trim comb. 830)
73	Impala, Caprice (Sta. Wag.) (9-Pass.)	9650754	1	36.25	midnight blue carpet (w/interior trim comb. 813)
73	Impala, Caprice (Sta. Wag.) (9-Pass.)	9650755	1	36.25	green carpet (w/interior trim comb. 830)
73	Caprice (Spt. Cpe.)	9655274	1	33.50	oxblood carpet (w/interior trim comb. 836)
74-75	Pass. (Spt. Sed.)	9682309	1	39.75	oxblood carpet (w/interior trim comb. 802, 805, 806, 808, 840)



**REAR TRIM—MATS—YARDAGE**

**15.306 CARPET ASSY.— MAT— MAT UNIT— MAT ASSY.— TRIM ASSY., Rear Floor (Con't)**

74-75	Pass. (Sedan) (exc. Spt. Sed.) . . .	9682395	1	39.75	green carpet (w/interior trim comb. 850, 851, 852, 853, 854, 855, 44) . . . . .
74	Pass. (Sedan) (exc. Spt. Sed.) . . .	9682319	1	39.75	black carpet (w/interior trim comb. 802, 803, 805, 806, 807, 808, 840, 19) . . . . .
74	Pass. (Sedan) (exc. Spt. Sed.) . . .	9682323	1	39.75	midnight neutral carpet (w/interior trim comb. 815, 817, 819, 821, 822, 841) . . . . .
74	Pass. (Sedan) (exc. Spt. Sed., Taxi, Police) . . . . .	9737100	1	38.25	red carpet (w/interior trim comb. 802, 803, 805, 806, 808, 840) . . . . .
74	Pass. (Sedan) (exc. Spt. Sed., Police) . . . . .	9737151	1	38.25	gold carpet (w/interior trim comb. 802, 803, 805, 806) . . . . .
74	Pass. (Sedan) (exc. Spt. Sed., Taxi, Police) . . . . .	9737236	1	38.25	russet carpet (w/interior trim comb. 803, 805, 806) . . . . .
74	Pass. (Sedan) (exc. Spt. Sed., Police) . . . . .	9737099	1	40.00	blue carpet (w/interior trim comb. 802, 803, 805, 806) . . . . .
74-75	Pass. (Sedan) (exc. Spt. Sed., Police) . . . . .	9682325	1	39.75	oxblood carpet (w/interior trim comb. 802, 805, 806, 808, 857, 73) . . . . .
74-75	Pass. (2-Dr.) (exc. Police) . . . . .	9682311	1	34.50	black carpet (w/interior trim comb. 802, 805, 806, 807, 808, 840, 11, 19, 91) (repl. 1714475) . . . . .
74	Pass. (Spt. Cpe., Conv.) . . . . .	9682315	1	34.50	midnight neutral carpet (w/interior trim comb. 819, 821, 822, 841) . . . . .
74-75	Pass. (Spt. Cpe., Conv.) . . . . .	9682318	1	34.50	green carpet (w/interior trim comb. 850, 853, 854, 855, 04W, 44) . . . . .
74	Pass. (Spt. Cpe., Conv.) (exc. Police) . . . . .	9737242	1	34.25	red carpet (w/interior trim comb. 802, 805, 806, 808, 810, 840) . . . . .
74-75	Pass. (2-Dr.) (exc. Police) . . . . .	9682317	1	34.50	oxblood carpet (w/interior trim comb. 802, 805, 806, 808, 809, 840, 857, 07, 73) (repl. 1714477) . . . . .
74	Pass. (Spt. Cpe.) . . . . .	9682314	1	34.50	midnight blue carpet (w/interior trim comb. 804, 813, 843, 847, 848) . . . . .
74	Pass. (Sta. Wag.) (6-Pass.) . . . . .	9681879	1	41.00	midnight neutral carpet (w/interior trim comb. 817, 819) . . . . .
74-75	Pass. (Sta. Wag.) (6-Pass.) . . . . .	9681881	1	41.00	green carpet (w/interior trim comb. 851, 855, 859, 44) . . . . .
74	Pass. (Sta. Wag.) (9-Pass.) . . . . .	9681885	1	36.50	midnight neutral carpet (w/interior trim comb. 817, 819) . . . . .
74-75	Pass. (Sta. Wag.) (9-Pass.) . . . . .	9681887	1	36.50	green carpet (w/interior trim comb. 851, 855, 859, 44) . . . . .
74	Impala (Sedan) (exc. Spt. Sed.) . . . . .	9682320	1	39.75	saddle carpet (w/interior trim comb. 849) . . . . .
74	Impala, Caprice (Sedan) (exc. Spt. Sed.) . . . . .	9682322	1	39.75	midnight blue carpet (w/interior trim comb. 813, 843, 847, 848) . . . . .
74	Impala (Spt. Sed.) . . . . .	9737237	1	34.25	blue carpet (w/interior trim comb. 802, 805, 806) . . . . .
74	Impala (Spt. Sed.) . . . . .	9737239	1	34.25	gold carpet (w/interior trim comb. 802, 805, 806) . . . . .
74	Impala (Spt. Sed.) . . . . .	9737240	1	34.25	russet carpet (w/interior trim comb. 805, 806) . . . . .
74	Impala (Spt. Sed.) . . . . .	9682298	1	39.75	saddle carpet (w/interior trim comb. 849) . . . . .
74	Impala, Caprice (Spt. Sed.) . . . . .	9682297	1	39.75	black carpet (w/interior trim comb. 802, 805, 806, 807, 808, 840, 19) . . . . .
74	Impala, Caprice (Spt. Sed.) . . . . .	9682300	1	39.75	midnight blue carpet (w/interior trim comb. 813, 843, 847, 848) . . . . .
74	Impala, Caprice (Spt. Sed.) . . . . .	9682307	1	39.75	midnight neutral carpet (w/interior trim comb. 819, 821, 822, 841) . . . . .
74-75	Impala, Caprice (Spt. Sed.) . . . . .	9682310	1	39.75	green carpet (w/interior trim comb. 850, 853, 854, 855, 44) . . . . .
74	Impala, Caprice (Spt. Sed.) . . . . .	9737238	1	34.25	red carpet (w/interior trim comb. 802, 805, 806, 808, 840) . . . . .
74	Impala (Spt. Cpe.) . . . . .	9682312	1	34.50	saddle carpet (w/interior trim comb. 849, 858) . . . . .
74	Impala (Spt. Cpe.) Pass. (Conv.) (exc. Police) . . . . .	9737241	1	34.25	blue carpet (w/interior trim comb. 802, 805, 806, 810) . . . . .
74	Impala (Spt. Cpe.) Pass. (Conv.) (exc. Police) . . . . .	9737243	1	34.25	gold carpet (w/interior trim comb. 802, 805, 806) . . . . .

**REAR TRIM—MATS—YARDAGE**

**15.306 CARPET ASSY.— MAT— MAT UNIT— MAT ASSY.— TRIM ASSY., Rear Floor (Con't)**

74	Impala (Spt. Cpe.) Pass. (Conv.) (exc. Police)	9737244	1	34.25	russet carpet (w/interior trim comb. 805, 806)
74	Impala, Caprice (Sta. Wag.) (6-Pass.)	9737095	1	35.75	blue carpet (w/interior trim comb. 802, 806, 24F)
74	Impala, Caprice (Sta. Wag.) (6-Pass.)	9737096	1	35.75	red carpet (w/interior trim comb. 802, 806, 75F)
74	Impala, Caprice (Sta. Wag.) (6-Pass.)	9737097	1	35.75	gold carpet (w/interior trim comb. 802, 806, 53F)
74	Impala, Caprice (Sta. Wag.) (6-Pass.)	9737098	1	38.25	russet carpet (w/interior trim comb. 802, 806, 66F)
74	Impala, Caprice (Sta. Wag.) (6-Pass.)	9681876	1	41.00	black carpet (w/interior trim comb. 802, 806, 19F, 19W)
74	Impala, Caprice (Sta. Wag.) (6-Pass.)	9681877	1	41.00	saddle carpet (w/interior trim comb. 849, 858)
74	Impala, Caprice (Sta. Wag.) (6-Pass.)	9681878	1	41.00	midnight blue carpet (w/interior trim comb. 813)
74-75	Impala, Caprice (Sta. Wag.) (9-Pass.)	9681882	1	36.50	black carpet (w/interior trim comb. 802, 806, 19F, 19W)
74	Impala, Caprice (Sta. Wag.) (9-Pass.)	1744084	1	43.00	saddle carpet (w/interior trim comb. 849, 858) (repl. 9681883)
74	Impala, Caprice (Sta. Wag.) (9-Pass.)	9681884	1	36.50	midnight blue carpet (w/interior trim comb. 813)
74	Impala, Caprice (Sta. Wag.) (9-Pass.)	9737245	1	31.75	blue carpet (w/interior trim comb. 802, 8024F)
74	Impala, Caprice (Sta. Wag.) (9-Pass.)	9737246	1	31.75	red carpet (w/interior trim comb. 802, 806, 75F)
74	Impala, Caprice (Sta. Wag.) (9-Pass.)	9737247	1	31.75	gold carpet (w/interior trim comb. 802, 806, 53F)
74	Impala, Caprice (Sta. Wag.) (9-Pass.)	9737248	1	31.75	russet carpet (w/interior trim comb. 802, 806, 66F)
74	Impala, Caprice (Sta. Wag.) (9-Pass.)	9681886	1	36.50	oxblood carpet (w/interior trim comb. 802, 806, 73F)
74	Caprice (Sedan) (exc. Spt. Sed.)	9682324	1	39.75	taupe carpet (w/interior trim comb. 896)
74	Caprice (Sedan) (exc. Spt. Sed.)	9682325	1	39.75	oxblood carpet (w/interior trim comb. 856, 857)
74	Caprice (Spt. Sed.)	9682308	1	39.75	taupe carpet (w/interior trim comb. 896)
74-75	Caprice (Spt. Sed.)	9682309	1	39.75	oxblood carpet (w/interior trim comb. 856, 73)
74	Caprice (Spt. Cpe.)	9682316	1	34.50	taupe carpet (w/interior trim comb. 896)
74	Caprice (Spt. Cpe.)	9682317	1	34.50	oxblood carpet (w/interior trim comb. 809, 856, 857)
75	Pass. (Sedan) (exc. Spt. Sed.)	1683085	1	39.25	sandstone carpet (w/interior trim comb. 55)
75	Pass. (Sedan) (exc. Spt. Sed.)	1683082	1	39.25	saddle carpet (w/interior trim comb. 63)
75	Pass. (Sedan) (exc. Spt. Sed.)	1744808	1	51.24	blue carpet (w/interior trim comb. 26) (repl. 1683084)
75	Pass. (Sedan) (exc. Spt. Sed.)	1744805	1	51.24	black carpet
75	Pass. (Spt. Sed.)	1675512	1	48.75	saddle carpet (w/interior trim comb. 63)
75	Pass. (Spt. Sed.)	1744121	1	51.24	blue carpet (w/interior trim comb. 26) (repl. 1675513)
75	Pass. (Spt. Sed.)	1675514	1	48.75	sandstone carpet (w/interior trim comb. 55)
75	Pass. (Spt. Sed.)	1744118	1	51.24	black carpet
75	Pass. (2-Dr.)	1681166	1	35.00	saddle carpet (w/interior trim comb. 63)
75	Pass. (2-Dr.)	1681168	1	35.00	blue carpet (w/interior trim comb. 26, 02)
75	Pass. (2-Dr.)	1681169	1	35.00	sandstone carpet (w/interior trim comb. 55)
75	Pass. (2-Dr.)	9682318	1	34.50	green carpet (comb. 44)
75	Pass. (Sta. Wag.) (6-Pass.)	1675239	1	36.25	saddle carpet (w/interior trim comb. 63)
75	Pass. (Sta. Wag.) (6-Pass.)	1744090	1	48.00	blue carpet (w/interior trim comb. 26) (repl. 1675240)

**REAR TRIM—MATS—YARDAGE**

**15.306 CARPET ASSY.— MAT— MAT UNIT— MAT ASSY.— TRIM ASSY., Rear Floor (Con't)**

75	Pass. (Sta. Wag.) (6-Pass.)	1675241	1	40.75	sandstone carpet (w/interior trim comb. 55)
75	Pass. (Sta. Wag.) (6-Pass.)	1744088	1	48.00	black carpet
75	Pass. (Sta. Wag.) (9-Pass.)	1675236	1	36.25	saddle carpet (w/interior trim comb. 63)
75	Pass. (Sta. Wag.) (9-Pass.)	1744085	1	48.00	blue carpet (w/interior trim comb. 26) (repl. 1675237)
75	Pass. (Sta. Wag.) (9-Pass.)	1675238	1	36.25	sandstone carpet (w/interior trim comb. 55)

**CHEVY— NOVA**

70-72	Nova	9638246	1	37.75	(comb. 733, 750, 751, 753, 766, 767) (black)
73	Nova	9638227	1	30.75	green carpet (w/interior trim comb. 759, 760, 761, 770)
73	Nova w/Bucket Seat	9638248	1	31.50	black carpet (w/interior trim comb. 751, 752, 754, 794)
73	Nova (Coupe)	9638249	1	31.50	neutral carpet (w/interior trim comb. 763, 764, 769, 771)
73	Nova (Coupe) w/Bench Seat (exc. Custom)	9638226	1	30.75	blue carpet (w/interior trim comb. 756)
73	Nova (Coupe) w/Bench Seat (exc. Custom)	9657654	1	27.50	chamois carpet (w/interior trim comb. 767)
74	Nova w/Bench Seat	9680391	1	32.00	black carpet (w/interior trim comb. 751, 752, 754)
74	Nova w/Bench Seat	9680396	1	32.00	green carpet (w/interior trim comb. 755, 756, 757, 758)
74	Nova (Coupe) w/Bucket Seat,				
75	Nova	9681301	1	30.75	black carpet (w/interior trim comb. 752, 753, 754, 11, 19) (repl. 1716326)
74	Nova (Coupe) w/Bucket Seat,				
75	Nova (Coupe) (Custom)	9681305	1	32.50	green carpet (w/interior trim comb. 758, 759, 04W, 44)
74	Nova	9681304	1	32.50	midnight neutral carpet (w/interior trim comb. 765, 766)
74	Nova (Coupe)	9735834	1	28.00	midnight blue carpet
74	Nova (H.B.) w/Bucket Seat (exc. Custom)	9681302	1	32.50	saddle carpet (w/interior trim comb. 773)
74	Nova (Custom) (Coupe) w/Bucket Seat	9681306	1	29.00	red carpet (w/interior trim comb. 752, 754, 11, 19)
74	Nova (Custom) (Coupe) w/Bucket Seat	9693018	1	32.00	blue carpet (w/interior trim comb. 754)
75	Nova	9681306	1	29.00	red carpet (w/interior trim comb. 752, 754, 11, 19)
75	Nova	1666829	1	37.00	sandstone carpet (w/interior trim comb. 55)
75	Nova	1666826	1	37.00	saddle carpet (w/interior trim comb. 63)
75	Nova	1745714	1	33.50	blue carpet (w/interior trim comb. 26, 02W)
75	Nova	1666827	1	37.75	oxblood carpet (w/interior trim comb. 73, 07W)
75	Nova (Custom exc. H.B.)	1694592	1	32.25	graystone carpet (comb. 16G)

**CHEVELLE**

68-69	Chevelle (Spt. Cpe., Conv.) (exc. Deluxe)	7752334	1	53.75	(black)
69	Malibu (4-Dr. Sed.)				
70-72	Chevelle (Spt. Cpe., Conv.)	9813466	1	54.00	(comb. 704, 705, 706, 707, 708, 709, 710, 748, 749, 753, 754, 755, 756, 757, 790, 791) (black) (Note 3)
71-72	Malibu, Monte Carlo (Spt. Cpe.) Concours,	9839624	1	52.25	(comb. 725, 727, 728) (dk. blue)
72	Monte Carlo	9608333	1	52.25	(comb. 735) (saddle)
72	Malibu, Monte Carlo (Spt. Cpe., Conv.)	9608336	1	46.50	(comb. 713, 715, 717) (green)
72	Malibu, Monte Carlo (Spt. Cpe., Conv.)	9608337	1	52.25	(comb. 730, 731, 732, 734) (covert)
72	Malibu (Spt. Sed.)	9606898	1		(comb. 703, 704, 743) (black & white)
73	Malibu	9654551	1	37.50	chamois carpet (w/interior trim comb. 716, 721)
73	Malibu (Coupe) w/Swivel Bucket	9655231	1	33.25	blue carpet (w/interior trim comb. 705)
73	Malibu, Laguna (Sedan, Sta. Wag.), El Camino (Custom)	9654548	1	37.50	blue carpet (w/interior trim comb. 705, 719, 723, 724)
73	Malibu, Laguna (Sedan, Sta. Wag.)	9654547	1	37.50	black carpet (w/interior trim comb. 703, 704, 707, 712)

**REAR TRIM—MATS—YARDAGE**

**15.306 CARPET ASSY.— MAT— MAT UNIT— MAT ASSY.— TRIM ASSY., Rear Floor (Con't)**

73	Malibu, Laguna (Sedan, Sta. Wag.)	9654552	1	37.50	neutral carpet (w/interior trim comb. 732, 734)
73	Malibu, Laguna (Sedan, Sta. Wag.), El Camino (Custom)	9654550	1	37.50	green carpet (w/interior trim comb. 713, 726, 727, 730)
73	Malibu, Laguna (Coupe) w/Bench Seat	9655234	1	33.25	saddle carpet (w/interior trim comb. 717, 720)
73	Malibu, Laguna (Coupe)	9655231	1	33.25	blue carpet (w/interior trim comb. 705, 719, 723, 724)
73	Malibu, Laguna (Coupe) w/Swivel Bucket	9655234	1	33.25	saddle carpet (w/interior trim comb. 717, 720)
73	Malibu (Sta. Wag.) w/Bench Seat	9654553	1	37.50	saddle carpet (w/interior trim comb. 720)
73	Malibu, Laguna (Coupe) Monte Carlo	9655232	1	33.25	green carpet (w/interior trim comb. 713, 715, 726, 727, 730)
73	Malibu, Laguna (Coupe) Monte Carlo w/Bench Seat	9655230	1	33.25	black carpet (w/interior trim comb. 703, 704, 706, 707, 712)
73	Malibu, Laguna (Coupe) Monte Carlo w/Bench Seat	9655236	1	33.25	neutral carpet (w/interior trim comb. 731, 732, 734, 735)
73	Malibu, Laguna (Coupe) Monte Carlo w/Swivel Bucket	9655236	1	33.25	neutral carpet (w/interior trim comb. 731, 732, 734, 735)
73	Malibu, Laguna (Coupe) Monte Carlo w/Swivel Bucket	9655238	1	33.00	black carpet (w/interior trim comb. 704, 705, 706, 707, 708)
73	Laguna (Coupe) Monte Carlo		1		oxblood carpet (w/interior trim comb. 709, 714, 740) (repl. 9655235)
73	Laguna (Sedan, Sta. Wag.)	9654554	1	37.50	oxblood carpet (w/interior trim comb. 709, 714)
73	Monte Carlo	9655237	1	33.25	midnight blue carpet (w/interior trim comb. 725)
73	Monte Carlo w/Swivel Bucket, 6-way power seat	9655243	1	33.00	green carpet (w/interior trim comb. 715, 728)
73	Monte Carlo w/Swivel Bucket, 6-way power seat	9655244	1	33.00	oxblood carpet (w/interior trim comb. 740)
73	El Camino (Custom)	9665059	1	33.00	saddle carpet (w/interior trim comb. 720)
73	El Camino (Custom)	9654180	1	32.75	neutral carpet (w/interior trim comb. 732)
73	El Camino (Custom)	9654179	1	32.75	black carpet (w/interior trim comb. 704)
74-75	Chevelle (Sed., Sta. Wag.)	1740008	1	44.75	black carpet (w/interior trim comb. 701, 702, 706, 707, 738, 747, 891, 894, 19) (repl. 9681433)
74	Chevelle (Sed., Sta. Wag.)	9691307	1	36.75	russet carpet (w/interior trim comb. 701, 706, 891)
74	Chevelle (Sed., Sta. Wag.), El Camino	1740009	1	50.00	saddle carpet (w/interior trim comb. 740) (repl. 9681434)
74	Chevelle (Sed., Sta. Wag.)	9681437	1	40.00	midnight neutral carpet (w/interior trim comb. 711, 713, 714, 715, 722, 892)
74	Chevelle (Sed., Sta. Wag.)	9681436	1	40.00	midnight blue carpet (w/interior trim comb. 732, 735, 785)
74-75	Chevelle (Sed., Sta. Wag.)	9681439	1	40.00	green carpet (w/interior trim comb. 723, 724, 727, 728, 745, 830, 893, 44)
74	Chevelle	9737250	1	34.25	blue carpet (w/interior trim comb. 701)
74-75	Chevelle (Sedan), Malibu (Coupe), Chevelle (Sta. Wag.)	9692449	1	40.00	red carpet (w/interior trim comb. 701, 702, 706, 707, 891)
74	Chevelle (Coupe)	9681443	1	34.25	midnight blue carpet (w/interior trim comb. 732, 733, 734, 737, 749, 785, 897)
74	Chevelle (Coupe)	9681437	1	40.00	midnight neutral carpet (w/interior trim comb. 714, 716, 722, 892) (repl. 9681444)
74-75	Chevelle (Coupe)	9681440	1	34.25	black carpet (w/interior trim comb. 701, 702, 704, 706, 707, 738, 747, 891, 894, 19)

**REAR TRIM—MATS—YARDAGE**

<b>15.306 CARPET ASSY.— MAT— MAT UNIT— MAT ASSY.— TRIM ASSY., Rear</b>					
<b>Floor (Con't)</b>					
74-75	Chevelle (Coupe) . . . . .	9681447	1	34.25	green carpet (w/interior trim comb. 723, 724, 726, 727, 728, 729, 730, 745, 830, 893, 44, 04H) . . . . .
74	Chevelle (Coupe) . . . . .	9681441	1	34.25	saddle carpet (w/interior trim comb. 718, 731, 740, 742) . . . . .
74-75	Chevelle (Coupe) . . . . .	9691308	1	33.25	oxblood carpet (w/interior trim comb. 719, 720, 743, 744, 73) (repl. 9681446) . . . . .
75	El Camino (Classic) . . . . .	9681438	1	40.00	oxblood carpet (w/interior trim comb. 73D) . . . . .
74	Chevelle (Coupe) . . . . .	9691308	1	33.25	russet carpet (w/interior trim comb. 701) . . . . .
74-75	El Camino . . . . .	9681433	1		black carpet (w/interior trim comb. 701, 702, 706, 707, 738, 747, 891, 894, 19) (repl. 9681448) . . . . .
74	El Camino . . . . .	9681451	1	34.25	neutral carpet (w/interior trim comb. 713, 714, 722, 892) . . . . .
74	El Camino . . . . .	9681450	1	34.25	mid. blue carpet (w/interior trim comb. 732, 749, 785, 897) . . . . .
74-75	El Camino . . . . .	9681498	1	34.25	green carpet (w/interior trim comb. 723, 724, 727, 728, 745, 830, 893, 44) . . . . .
74	El Camino . . . . .	9692497	1	34.25	red carpet (w/interior trim comb. 701, 702, 706, 707, 891) . . . . .
74	El Camino . . . . .	9692499	1	32.75	russet carpet (w/interior trim comb. 701) . . . . .
75	Chevelle (4-Dr.), El Camino . . . . .	1680635	1	45.75	sandstone carpet (w/interior trim comb. 55) . . . . .
75	Chevelle, El Camino . . . . .	1680634	1	45.75	blue carpet (w/interior trim comb. 26) (repl. 1681117) . . . . .
75	Malibu (Classic) (4-Dr.) . . . . .	1680632	1	45.75	saddle carpet (w/interior trim comb. 63) . . . . .
75	Malibu (Classic) (Sedan) . . . . .	1680633	1	45.75	graystone carpet (w/interior trim comb. 16) . . . . .
75	Malibu (Classic) (Coupe) . . . . .	1681116	1	43.50	graystone carpet (w/interior trim comb. 16) . . . . .
75	Chevelle (2-Dr.) (exc. El Camino) . . . . .	1681118	1	43.50	sandstone carpet (w/interior trim comb. 55) . . . . .
75	Chevelle (2-Dr.) (exc. El Camino) . . . . .	1681115	1	43.50	saddle carpet (w/interior trim comb. 63) . . . . .
75	El Camino (Classic) . . . . .	1680633	1	45.75	graystone carpet (w/interior trim comb. 16D) (repl. 1675498) . . . . .
75	El Camino (Classic) . . . . .	1675496	1	42.00	saddle carpet (w/interior trim comb. 63W) . . . . .
<b>CAMARO</b>					
71-73	Camaro . . . . .	9871263	1	56.25	(black) . . . . .
71-72	Camaro . . . . .	9871264	1	56.25	(comb. 776, 786) (dk. blue) . . . . .
72	Camaro . . . . .	9899355	1	54.00	(comb. 779, 788) (covert) . . . . .
71	Camaro . . . . .	9871268	1	56.25	(comb. 779, 792) (dk. saddle) . . . . .
73	Camaro . . . . .	9658279	1	34.25	blue carpet (w/interior trim comb. 773, 774, 775, 776, 785, 786) . . . . .
73	Camaro (L.T.) . . . . .	9638891	1	34.25	green carpet (w/interior trim comb. 777, 781) . . . . .
73	Camaro . . . . .	9638893	1	34.25	neutral carpet (w/interior trim comb. 779, 788) . . . . .
73	Camaro (exc. L.T.) . . . . .	9638894	1	34.25	saddle carpet (w/interior trim comb. 778) . . . . .
74	Camaro . . . . .	9679748	1	36.25	black carpet (w/interior trim comb. 775, 776, 777, 778) . . . . .
74	Camaro . . . . .	9679749	1	36.25	saddle carpet (w/interior trim comb. 796, 797, 798, 799) . . . . .
74	Camaro . . . . .	9679755	1	36.25	neutral carpet (w/interior trim comb. 780, 781) . . . . .
74	Camaro (exc. L.T.) . . . . .	9679774	1	36.25	green carpet (w/interior trim comb. 786, 787) . . . . .
74-75	Camaro (exc. L.T.) . . . . .	1666889	1	40.00	red carpet (w/interior trim comb. 775, 779, 792, 19C-V, 91V) (opt. 75F) . . . . .
74	Camaro (exc. L.T.) . . . . .	9692840	1	36.25	blue carpet (w/interior trim comb. 775, 777) . . . . .
74	Camaro (L.T.) . . . . .	9679773	1	36.25	taupe carpet (w/interior trim comb. 783, 784) . . . . .
75	Camaro . . . . .	1666886	1	40.75	black carpet (w/interior trim comb. 19, 91) . . . . .
75	Camaro . . . . .	1703706	1	65.00	black accent carpet (w/interior trim comb. 19C-V, 91V) . . . . .
75	Camaro . . . . .	1666887	1	35.50	saddle carpet (w/interior trim comb. 63, 632) . . . . .
75	Camaro . . . . .	1666888	1	35.50	oxblood carpet (w/interior trim comb. 73D, 732) . . . . .
75	Camaro . . . . .	1666890	1	35.50	graystone carpet (w/interior trim comb. 16D) . . . . .
75	Camaro . . . . .	1666892	1	35.50	sandstone carpet (w/interior trim comb. 55) . . . . .
75	Camaro . . . . .	1703707	1	65.00	dlx. saddle carpet (63) . . . . .
75	Camaro . . . . .	1703710	1	65.00	dlx. sandstone carpet (55) . . . . .
75	Camaro (L.T.) . . . . .	1703708	1	65.00	dlx. oxblood carpet (73D, 732) . . . . .
75	Camaro (L.T.) . . . . .	1703709	1	65.00	dlx. graystone carpet (16D) . . . . .

**REAR TRIM—MATS—YARDAGE**

**15.306 CARPET ASSY.— MAT— MAT UNIT— MAT ASSY.— TRIM ASSY., Rear Floor (Con't)**

75	Camaro (exc. L.T.)	1718685	1	65.00	red carpet (w/interior trim comb. 19C) (deluxe frt. & rr.)
----	--------------------	---------	---	-------	--

**VEGA— MONZA**

71	Vega (N.B., Sta. Wag.) (2nd design)				
71	Vega (H.B.)	9831619	1	43.25	saddle carpet (w/interior trim comb. 883, 884)
71	Vega (N.B., Sta. Wag.) (1st design)				
72	Vega (H.B.)	9871934	1	49.75	black carpet (w/interior trim comb. 860, 861, 862, 866, 867, 873, 874) (Note 1)
71	Vega (N.B., Sta. Wag.) (2nd design)				
71	Vega (H.B.)				
72	Vega (N.B., Sta. Wag.)	9831615	1	43.25	black carpet (w/interior trim comb. 860, 861, 862, 866, 867, 873, 874)
71	Vega (N.B.)	9876541	1	1.20	blue carpet (w/interior trim comb. 892)
72	Vega (H.B.)	9888315	1	49.75	green carpet (w/interior trim comb. 863) (Note 1)
72-73	Vega (exc. Panel)	9897692	1	45.50	black carpet (w/interior trim comb. 860, 861, 862, 866, 867, 871, 884, 887)
73	Vega (exc. Panel)	9638215	1	35.50	green carpet (w/interior trim comb. 863, 864)
73	Vega (H.B.)	9638216	1	35.50	chamois carpet (w/interior trim comb. 859, 876)
73	Vega (exc. Panel)	9638217	1	35.50	neutral carpet (w/interior trim comb. 868, 874, 888)
73	Vega (exc. Panel)	9658254	1	35.50	blue carpet (w/interior trim comb. 860, 861, 871, 884, 887)
73	Vega (exc. Panel)	9658255	1	35.25	orange carpet (w/interior trim comb. 860, 861, 871, 884, 887)
73	Vega (exc. Panel)	9658256	1	35.25	red carpet (w/interior trim comb. 860, 861, 871, 884, 887)

**15.306A MAT— MAT ASSY., Rear Floor**

**PASS.**

71	Biscayne, Bel Air (Taxi, Police)	9866947	1	48.00	rubber
73-75	Pass. (Sed.) (Taxi, Police)	9866947	1	48.00	rubber
73-75	Impala (Spt. Cpe.) (Police)	9613647	1	48.00	rubber
74-75	Pass.	989240	1		(contour type) rubber (saddle)
74-75	Pass.	989241	1	7.95	(contour type) rubber (green)

**CHEVY— NOVA**

70-72	Nova	9614390	1	26.75	rubber (comb. 750, 751) (black)
71-72	Nova	9838243	1	27.00	rubber (comb. 756, 757) (dk. blue and black)
73-75	Nova (Taxi)	9658205	1	47.00	
74-75	Nova	989240	1		(contour type) rubber (saddle)
74-75	Nova	989241	1	7.95	(contour type) rubber (green)
74-75	Nova	989244	1	7.95	twin (accent red)
75	Nova (Sed. exc. Custom)	1740841	1	66.50	w/bench seat (comb. 19Z) (black)
73	Nova w/Bench Seat (exc. Custom, Taxi)	9651377	1	21.50	MAT ASSY. (comb. 756, 772) (blue)
73-74	Nova (2-Dr.) w/Bucket Seat (exc. Custom)	9651522	1	24.60	MAT ASSY. (comb. 751, 794, 19X) (black)
73	Nova w/Bench Seat (exc. Custom, Taxi)	9651375	1	17.50	MAT ASSY. (comb. 757, 758, 759, 760) (green)
73-74	Nova (2-Dr.) w/Bucket Seat (exc. Custom)	9651523	1	24.60	MAT ASSY. (comb. 763) (neutral)
74	Nova (Coupe) w/Bucket Seat (exc. Custom)	9683863	1	27.50	MAT ASSY. (green)
74	Nova (Coupe) w/Bucket Seat (exc. Custom)	9735836	1	23.80	MAT ASSY. (29X) (midnight blue)
74	Nova (H.B.) w/Bucket Seat (exc. Custom)	9683865	1	27.50	MAT ASSY. (saddle)
74	Nova w/Bench Seat (exc. Custom, Taxi)	9683023	1	20.35	MAT ASSY. (green)
74	Nova w/Bench Seat (exc. Custom, Taxi)	9683025	1	22.75	MAT ASSY. (midnight blue)

**REAR TRIM—MATS—YARDAGE**

**15.306A MAT— MAT ASSY., Rear Floor (Con't)**

74	Nova w/Bench Seat (exc. Custom, Taxi) .....	9651374	1	17.50	MAT ASSY. (comb. 764, 765) (midnight neutral) .....
74	Nova (H.B.) w/Bench Seat (exc. Custom) .....	9683024	1	22.75	MAT ASSY. (saddle) .....

**CHEVELLE**

73	Deluxe (Cpe.) Chevelle .....	9661965	1	37.25	rubber (comb. 710, 711) (green) .....
73	Deluxe (Sed.) Chevelle .....	9652250	1	35.25	rubber (comb. 710, 711) (green) .....
73	Deluxe (4-Dr.) Chevelle .....	9652249	1	35.25	rubber (comb. 701, 702) (black) .....
74-75	Chevelle .....	989240	1		(contour type) rubber (saddle) .....
74-75	Chevelle .....	989241	1	7.95	(contour type) rubber (green) .....

**CAMARO**

74-75	Camaro .....	989240	1		(contour type) rubber (saddle) .....
74-75	Camaro .....	989241	1	7.95	(contour type) rubber (green) .....
74-75	Camaro .....	989244	1	7.95	twin (accent red) .....

**15.306B MAT UNIT— TRIM ASSY.**

**PASS.**

65-75	Pass. (Sta. Wag.) .....	986245	1	11.50	MAT UNIT, contour type (rubber) .....
73-75	Pass. ....	989103	1	7.95	MAT UNIT, contour type (black) (rubber) ..
73-75	Pass. ....	989130	1	7.95	MAT UNIT, contour type (neutral) (rubber) ..
75	Pass. ....	994746	1	8.40	MAT UNIT, contour type (rubber) (medium gray) .....
75	Pass. ....	989298	1	7.95	MAT UNIT (sandstone) .....

**CHEVY— NOVA**

73-75	Nova .....	989103	1	7.95	MAT UNIT, contour type (black) (rubber) ..
73-75	Nova .....	989130	1	7.95	MAT UNIT, contour type (neutral) (rubber) ..
75	Nova .....	994746	1	8.40	MAT UNIT, contour type (rubber) (medium gray) .....
75	Nova .....	989298	1	7.95	MAT UNIT (sandstone) .....

**CHEVELLE**

73-75	Chevelle .....	989103	1	7.95	MAT UNIT, contour type (black) (rubber) ..
73-75	Chevelle .....	989130	1	7.95	MAT UNIT, contour type (neutral) (rubber) ..
75	Chevelle .....	994746	1	8.40	MAT UNIT, contour type (rubber) (medium gray) .....
75	Chevelle .....	989298	1	7.95	MAT UNIT (sandstone) .....

**CAMARO**

73-75	Camaro .....	989103	1	7.95	MAT UNIT, contour type (black) (rubber) ..
73-75	Camaro .....	989130	1	7.95	MAT UNIT, contour type (neutral) (rubber) ..
75	Camaro .....	994746	1	8.40	MAT UNIT, contour type (rubber) (medium gray) .....
75	Camaro .....	989298	1	7.95	MAT UNIT (sandstone) .....

**VEGA— MONZA**

72	Vega (N.B.) .....	9897699	1	25.50	MAT, rear floor (comb. 863) (green) ..
75	Vega .....	1704799	R.H.	13.45	MAT .....
75	Monza (Towne Cpe.) .....	365288	2	4.25	MAT, rubber (dk. saddle) .....
75	Monza (Towne Cpe.) .....	365294	2	4.25	MAT, rubber (firethorn) .....
73-75	Vega, Monza .....	994725	1	7.95	MAT UNIT, contour twin rubber (black) ..
75	Vega, Monza .....	994726	1	7.95	MAT UNIT, contour twin rubber (dark blue)
75	Vega, Monza .....	994728	1	7.95	MAT UNIT, contour twin rubber (dark saddle) .....
75	Vega, Monza .....	994656	1	7.95	MAT UNIT, contour twin (rubber) (russett) ..

NOTE 1: Used on models built before 9/1/71.  
NOTE 2: Used on models built after 9/1/71.

70-75	Camaro .....	9650144	1	9.75	TRIM ASSY., rear floor rear (black) (paint) ..
72	Camaro .....	9600338	1	9.40	TRIM ASSY. (comb. 780) (white) .....
73-74	Camaro .....	9650147	1	9.75	TRIM ASSY. (comb. 779, 780, 781, 788) (neutral) .....

**15.311 MAT, Well Lining and Load Floor**

68-72	Nomad .....	7752687	1	17.65	compt. load floor (vinyl-black) .....
71	Vega (Sta. Wag., H.B.) .....	9837531	1	13.70	compt. load floor (comb. 878) (med. saddle)
71	Vega (Sta. Wag., H.B.) .....	9837532	1	13.70	compt. load floor (comb. 878) (dk. green) ..
71	Vega (Sta. Wag., H.B.),				
72	Vega (H.B.) .....	9837533		13.70	compt. load floor (comb. 860, 866, 873), ..
72	Vega (H.B.) .....	9601770	1	13.70	compt. load floor (comb. 863) (green) .....
72-75	Vega (Panel) .....	9615213	1	16.00	compt. load floor .....

**REAR TRIM—MATS—YARDAGE**

**15.311 MAT, Well Lining and Load Floor (Con't)**

73	Vega (H.B.)	9837533	1	13.70	(comb. 860) (black)
73-74	Nova (H.B.) (exc. Custom)	1653501	1	13.55	(comb. 751, 755) (black)
73-74	Nova (H.B.) (exc. Custom)	1653504	1	13.55	(comb. 756) (blue)
73-74	Nova (H.B.) (exc. Custom)	1653505	1	13.55	(comb. 759, 760, 756, 758) (green)
73-74	Nova (H.B.) (exc. Custom)	1653502	1	13.00	(comb. 763) (neutral)
74	Nova (H.B.) (exc. Custom)	1653503	1	13.55	(comb. 773) (saddle)
74	Nova (H.B.) (exc. Custom)	9683867	1	27.50	(comb. 772) (midnight blue)
74-75	Vega (H.B.)	9688147	1	12.20	compt. load floor (black)
74	Vega (H.B.)	9688148	1	12.20	compt. load floor (saddle)
74	Vega (H.B.)	9688149	1	12.20	compt. load floor (midnight neutral)
74	Vega (H.B.)	9688150	1	12.20	compt. load floor (green)
74-75	Vega (H.B.)	9688151	1	12.20	compt. load floor (red)
75	Vega (H.B.)	1675993	1	12.60	compt. load floor (saddle)
75	Vega (H.B.)	1675994	1	12.60	compt. load floor (blue)
75	Vega (H.B.)	1675995	1	12.60	compt. load floor (sandstone)

**15.320 CARPET ASSY.— CARPET MATERIAL, Load Floor**

*NOTE: Specific Load Floor usage no longer found in this group. See Groups 15.294 Binding and 15.512 Carpet material.*

**PASS.**

73	Impala, Caprice (Sta. Wag.)	9609347	1	28.00	black carpet (w/interior trim comb. 806)
73	Pass. (Sta. Wag.) (9-Pass.)	9648504	R.H.	13.40	extension rear seat pan (saddle carpet) (w/interior trim comb. 825, 826)
73	Pass. (Sta. Wag.) (9-Pass.)	9648510	L.H.	13.40	extension rear seat pan (saddle carpet) (w/interior trim comb. 825, 826)
73	Impala, Caprice (Sta. Wag.) (9-Pass.)	9648501	R.H.	13.40	extension rear seat pan (midnight blue carpet) (w/interior trim comb. 813)
74	Pass. (Sta. Wag.)	9680335	1	46.75	midnight neutral (w/interior trim comb. 817, 819)
74	Pass. (Sta. Wag.)	9680336	1	46.75	green carpet (w/interior trim comb. 851, 855)
74	Impala, Caprice (Sta. Wag.)	9737557	1	46.75	red carpet (w/interior trim comb. 806)
74	Impala, Caprice (Sta. Wag.)	9737559	1	46.75	russet carpet (w/interior trim comb. 806)
74	Pass. (Sta. Wag.) (9-Pass.)	9691162	1	40.50	fldg. 2nd seat pan (midnight neutral carpet) (w/interior trim comb. 817, 819)
74-75	Pass. (Sta. Wag.) (9-Pass.)	9691164	1	40.50	fldg. 2nd seat pan (green carpet) (w/interior trim comb. 855, 851, 859, 44)
74	Impala, Caprice (Sta. Wag.) (9-Pass.)	9691160	1	40.50	fldg. 2nd seat pan (saddle carpet) (w/interior trim comb. 849)
74	Impala, Caprice (Sta. Wag.) (9-Pass.)	9691161	1	40.50	fldg. 2nd seat pan (midnight blue carpet) (w/interior trim comb. 813)
74	Impala, Caprice (Sta. Wag.) (9-Pass.)	9691163	1	40.50	fldg. 2nd seat pan (oxblood carpet) (w/interior trim comb. 806, 802, 73F)
74	Impala, Caprice (Sta. Wag.) (9-Pass.)	9737563	1	34.25	fldg. 2nd seat pan (russet carpet) (w/interior trim comb. 806, 802, 66F)
74	Pass. (Sta. Wag.) (9-Pass.)	9691168	R.H.	13.20	extension rear seat pan (midnight neutral carpet) (w/interior trim comb. 817, 819)
74	Pass. (Sta. Wag.) (9-Pass.)	9691174	L.H.	13.20	extension rear seat pan (midnight neutral carpet) (w/interior trim comb. 817, 819)
74-75	Pass. (Sta. Wag.) (9-Pass.)	9691170	R.H.	13.20	extension rear seat pan (green carpet) (w/interior trim comb. 851, 855, 859, 44)
74-75	Pass. (Sta. Wag.) (9-Pass.)	9691176	L.H.	13.20	extension rear seat pan (green carpet) (w/interior trim comb. 851, 855, 859, 44)
74-75	Impala, Caprice (Sta. Wag.) (9-Pass.)	9691165	R.H.	13.20	extension rear seat pan (black carpet) (w/interior trim comb. 806, 802, 19F)
74	Impala, Caprice (Sta. Wag.) (9-Pass.)	9691171	L.H.	13.20	extension rear seat pan (black carpet) (w/interior trim comb. 806, 802, 19F)
74	Impala, Caprice (Sta. Wag.) (9-Pass.)	9691166	R.H.	13.20	extension rear seat pan (saddle carpet) (w/interior trim comb. 849, 858)
74	Impala, Caprice (Sta. Wag.) (9-Pass.)	9691172	L.H.	13.20	extension rear seat pan (saddle carpet) (w/interior trim comb. 849, 858)
74	Impala, Caprice (Sta. Wag.) (9-Pass.)	9691167	R.H.	13.20	extension rear seat pan (midnight blue carpet) (w/interior trim comb. 813)



**REAR TRIM—MATS—YARDAGE**

**15.320 CARPET ASSY.— CARPET MATERIAL, Load Floor (Con't)**

<b>74</b>	Impala, Caprice (Sta. Wag.) (9-Pass.)	<b>9691173</b>	L.H.	13.20	extension rear seat pan (midnight blue carpet) (w/interior trim comb. 813)
<b>74</b>	Impala, Caprice (Sta. Wag.) (9-Pass.)	<b>9691169</b>	R.H.	13.20	extension rear seat pan (oxblood carpet) (w/interior trim comb. 806, 802, 73F)
<b>74</b>	Impala, Caprice (Sta. Wag.) (9-Pass.)	<b>9691175</b>	L.H.	13.20	extension rear seat pan (oxblood carpet) (w/interior trim comb. 806, 802, 73F)
<b>75</b>	Pass. (Sta. Wag.) (9-Pass.)	<b>1675244</b>	1	53.50	fldg. 2nd seat pan (sandstone) (w/interior trim comb. 55)
<b>75</b>	Pass. (Sta. Wag.) (9-Pass.)	<b>1675243</b>	1	53.50	fldg. 2nd seat pan (blue) (w/interior trim comb. 26)
<b>75</b>	Pass. (Sta. Wag.) (9-Pass.)	<b>1675242</b>	1	53.50	fldg. 2nd seat pan (saddle) (w/interior trim comb. 63)
<b>75</b>	Pass. (Sta. Wag.) (9-Pass.)	<b>1675245</b>	R.H.	16.15	extension rear seat pan (saddle) (w/interior trim comb. 63)
<b>75</b>	Pass. (Sta. Wag.) (9-Pass.)	<b>1675248</b>	L.H.	16.15	extension rear seat pan (saddle) (w/interior trim comb. 63)
<b>75</b>	Pass. (Sta. Wag.) (9-Pass.)	<b>1675246</b>	R.H.	16.15	extension rear seat pan (blue) (w/interior trim comb. 26)
<b>75</b>	Pass. (Sta. Wag.) (9-Pass.)	<b>1675249</b>	L.H.	16.15	extension rear seat pan (blue) (w/interior trim comb. 26)
<b>75</b>	Pass. (Sta. Wag.) (9-Pass.)	<b>1675247</b>	R.H.	16.15	extension rear seat pan (sandstone) (w/interior trim comb. 55)
<b>75</b>	Pass. (Sta. Wag.) (9-Pass.)	<b>1675250</b>	L.H.	16.15	extension rear seat pan (sandstone) (w/interior trim comb. 55)
<b>72</b>	Pass. (Sta. Wag.)	<b>9609347</b>	1	28.00	<b>CARPET MATERIAL</b> , load floor (comb. 802, 804, 806, 808) (black) loose
<b>72</b>	Pass. (Sta. Wag.)	<b>9609348</b>	1	31.50	<b>CARPET MATERIAL</b> , load floor (comb. 824, 825, 826) (saddle) loose
<b>72</b>	Kingswood	<b>8705345</b>	1		<b>CARPET MATERIAL</b> , load floor (comb. 818) (covert) loose flr. cpt. (repl. 9609351)

**CHEVY—NOVA**

<b>73</b>	Nova (H.B.) (Custom)	<b>9658274</b>	1	38.25	red carpet (w/interior trim comb. 752, 754)
<b>73</b>	Nova (H.B.)	<b>9654247</b>	1	38.00	green carpet (w/interior trim comb. 759, 760, 761)
<b>73</b>	Nova (H.B.)	<b>8704370</b>	1	FT/3.50	rear seat fldg. back (green carpet) (w/interior trim comb. 759, 760, 761) (repl. 9654257)
<b>73</b>	Nova (H.B.)	<b>8704371</b>	1	FT/3.50	rear seat fldg. back (neutral carpet) (w/interior trim comb. 763, 764, 771) (repl. 9654258)
<b>74</b>	Nova (H.B.)	<b>9681324</b>	1	35.50	midnight blue carpet (w/interior trim comb. 771)

**CHEVELLE**

<b>73</b>	Malibu, Laguna (Sta. Wag.)	<b>9626594</b>	1	14.65	bottom well (green carpet) (w/interior trim comb. 713, 727)
<b>74</b>	Chevelle (Sta. Wag.)	<b>9680256</b>	1	13.90	bottom well (black carpet) (w/interior trim comb. 706, 707)

**VEGA—MONZA**

<b>71</b>	Vega (Sta. Wag., H.B.)	<b>9837536</b>	1	12.20	rear seat fldg. filler panel (green carpet) (w/interior trim comb. 878, 879)
<b>72</b>	Vega (Sta. Wag., H.B.)	<b>9632189</b>	1	FT/4.45	rear seat folding back (covert carpet) (w/interior trim comb. 868, 869, 874) (repl. 8704394)
<b>73</b>	Vega (Sta. Wag., H.B.)	<b>9622337</b>	1	12.20	rear seat folding back filler panel (black carpet) (w/interior trim comb. 860, 861, 871, 884, 887)
<b>73</b>	Vega (Sta. Wag., H.B.)	<b>9837538</b>	1	12.20	rear seat folding back (black carpet) (w/interior trim comb. 860, 861, 871, 884, 887)
<b>73</b>	Vega (Sta. Wag., H.B.)	<b>9632351</b>	1	FT/10.30	rear seat folding back (blue carpet) (w/interior trim comb. 860, 861, 871, 884, 887) (repl. 9658257)
<b>73</b>	Vega (Sta. Wag., H.B.)	<b>9658264</b>	1	20.15	compt. load floor (orange carpet) (w/interior trim comb. 860, 861, 871, 884, 887)
<b>73</b>	Vega (Sta. Wag., H.B.)	<b>9651251</b>	1	20.15	compt. load floor (blue and black carpet) (w/interior trim comb. 872)
<b>73</b>	Vega (H.B.)	<b>9651333</b>	1	20.15	compt. load floor (chamois carpet) (w/interior trim comb. 876)

**REAR TRIM—MATS—YARDAGE**

**15.320 CARPET ASSY.— CARPET MATERIAL, Load Floor (Con't)**

NOTE 1 With skid strip holes.  
 NOTE 2 Without skid strip holes.  
 NOTE 3 For models built before 6-20-71.  
 NOTE 4 For models built after 6-20-71.

**15.388 HOOK ASSY.— HOOK— ESCUTCHEON— SUPPORT, Coat**

71-73	Vega (Sed., Sta. Wag., Cpe.)				
74-75	Vega (Sta. Wag.)	9867352	2	.43	(black)
73-75	Chevelle, Camaro, Nova, Vega (N.B. & H.B.), Monza	1673506	2	.44	HOOK, black
73-74	Monte Carlo, Camaro,				
75	Monte Carlo	9653915	2	.12	ESCUTCHEON (prime and paint as required)
68	Pass., Spt. Sed.	7778982	2	.12	SUPPORT, hook— (14.875)

**15.390 STRAP ASSY., Assist**

67-68	Biscayne (Taxi),				
69-72	Biscayne (4-Dr. Sed.)	7752484	1	5.20	STRAP ASSY., center pillar

**15.490 MATERIAL, Top Covering**

62-71	Conv.	4296133	A.R.	FT/8.70	black
65-69	All w/vinyl top,				
71	All w/vinyl top	4224270	A.R.	FT/9.90	black
71-72	Conv.	8705957	A.R.	10.10	white (repl. 8704871)
73-75	Pass. (Conv.)	8706063	A.R.	FT/12.25	(black)
73-75	Pass. (Conv.)	8706064	A.R.	FT/12.90	(white)
73-75	All	8706055	A.R.	FT/12.15	(black) (levant grain) (19T)
73	All	8706050	A.R.	FT/8.00	(neutral)
73-74	All	8706051	A.R.	FT/8.10	(blue)
73	All	8706052	A.R.	FT/7.55	(green)
73-75	All	8706053	A.R.	FT/9.55	(maroon)
73-75	All	8704359	A.R.	FT/10.55	(white) (levant grain) (11T)
74-75	All	9630984	A.R.	FT/10.95	(green)
74	All	9630985	A.R.	FT/9.40	(taupe)
74	All	9630986	A.R.	FT/10.00	(beige)
74	All	9630993	A.R.	FT/8.85	(russet)
74	All	9630994	A.R.	FT/9.90	(brown)
74	All	9630995	A.R.	FT/9.75	(saddle)
75	All	9633031	A.R.	FT/12.60	(silver met.) (levant grain) (13T)
75	Pass. (2 Dr.) (exc. Conv.)	9633024	A.R.	FT/11.55	(green)
75	Impala (Custom Cpe.) Caprice (Classic Sport Cpe.)	9633016	A.R.	FT/12.20	(silver met.) (elk grain) (13T)
75	Impala (Custom Cpe.) Caprice (Classic Sport Cpe.)	9632358	A.R.	FT/10.85	(black) (elk grain) (19T)
75	Impala (Custom Cpe.) Caprice (Classic Sport Cpe.)	9632359	A.R.	FT/10.85	(white) (elk grain) (11T)
75	Impala (Custom Cpe.) Caprice (Classic Sport Cpe.)	9633027	A.R.	FT/12.20	(red met.)
75	Pass., Chevelle, Nova, Camaro, Vega (H.B. & N.B.)	9633029	A.R.	FT/11.90	(sandstone)
75	Pass., Chevelle, Nova, Camaro, Vega (H.B. & N.B.)	9633030	A.R.	FT/11.90	(dark blue)
75	Pass., Chevelle, Nova, Camaro, Vega (H.B. & N.B.)	9633032	A.R.	FT/12.60	(red)
75	Pass., Chevelle, Nova, Camaro, Vega (H.B. & N.B.)	9633033	A.R.	FT/11.90	(cordovan)
75	Monza (Towne Cpe.)	9633267	A.R.	FT/16.20	(firethorn) (levant grain) (36T)
75	Monza (Towne Cpe.)	9633268	A.R.	FT/16.20	(mahogany) (levant grain) (37T)
75	Monza (Towne Cpe.)	9633269	A.R.	FT/12.05	(buckskin) (levant grain) (64T)

**15.492 DEADENER— INSULATOR, Floor Pan**

75	All	1721689	A.R.	20.65	(48 in. x 60 in.) (mastic & 3/8" amberlite)
75	All	1705370	A.R.	3.80	INSULATOR (12 in. x 18 in.) (phenolic bonded fiberglass)
75	Chevelle, Camaro, Nova, Vega, Monza	1721688	A.R.	FT/16.35	INSULATOR (48 in. x 25 ft. roll) (cerra blanket thermo)
75	All	1721690	A.R.	FT/1.90	INSULATOR (54 in. x 150 ft. roll) (3/8" amberlite)

**15.500 UPHOLSTERY CLOTH, Seat Cushion and Sidewall (See Yardage Code preceding group 15.500)**

NOTE To insure receipt of proper material, kindly submit sample and indicate model, description and trim combination number.

**REAR TRIM—MATS—YARDAGE**

**15.500 UPHOLSTERY CLOTH, Seat Cushion and Sidewall (See Yardage Code preceding group 15.500) (Con't)**

**PASS.**

72	Caprice, Kingswood (Est.)	8706221 A.R.	FT/12.50	body cloth (comb. 808, 807, 838) (black) (rochelle)
72	Caprice	8706223 A.R.	FT/12.50	body cloth (comb. 831) (green) (rochelle)
72	Caprice	8706204 A.R.	FT/14.00	body cloth (comb. 836) (pewter) (rochelle)
72	Caprice	8706203 A.R.	FT/13.75	body cloth (comb. 831) (green) (rochelle)
73	Impala (exc. Sta. Wag.)	8707474 A.R.	FT/12.50	body cloth (comb. 812) (mid. blue) (ridgecrest)
73	Impala (exc. Sta. Wag.)	8707473 A.R.	FT/12.50	body cloth (comb. 829) (green) (ridgecrest)
73	Impala (exc. Sta. Wag.)	8707472 A.R.	FT/12.50	body cloth (comb. 815) (neutral) (ridgecrest)
73	Impala (exc. Sta. Wag.)	8707471 A.R.	FT/12.50	body cloth (comb. 805) (black) (ridgecrest)
73-74	Impala (exc. Sta. Wag.)	8707489 A.R.	FT/15.70	body cloth (comb. 750, 752, 802) (black & white) (ranier)
73	Caprice (Sed.) (Spt. Cpe.)	8707480 A.R.	FT/15.15	body cloth (comb. 725, 843) (midn. blue) (regatta)
73	Caprice (Sed.) (Spt. Cpe.)	8707479 A.R.	FT/15.15	body cloth (comb. 740, 836) (oxblood) (regatta)
73	Caprice (Sed.) (Spt. Cpe.)	8707477 A.R.	FT/16.70	body cloth (comb. 706, 840) (black) (regatta)
74-75	Bel Air (Sed.)	9632006 A.R.	FT/11.25	(19C) (black-radiant)
74-75	Impala (exc. Sta. Wag.)	8707477 A.R.	FT/16.70	(19D) (black-regatta)
74-75	Impala (exc. Sta. Wag.)	9632051 A.R.	FT/16.70	(44D) (green-regatta)
75	Bel Air (Sed.)	9633134 A.R.	FT/13.95	(26C) (blue-radiant)
75	Bel Air (Sed.)	9633135 A.R.	FT/13.95	(55C) (sandstone-radiant)
75	Impala, Caprice (Sta. Wag. & Conv.)	9633151 A.R.	FT/18.55	(63E) (saddle-cavalier)
75	Impala (exc. Sta. Wag.)	9633156 A.R.	FT/35.25	(55D) (sandstone-regatta)
75	Impala (exc. Sta. Wag.)	9633155 A.R.	FT/35.25	(26D) (blue-regatta)
75	Caprice (exc. Sta. Wag. & Conv.)	9633146 A.R.	FT/15.80	(44B) (green-chelsea)
75	Caprice (exc. Sta. Wag. & Conv.)	9633145 A.R.	FT/15.80	(26B) (blue-chelsea)
75	Caprice (exc. Sta. Wag. & Conv.)	9633143 A.R.	FT/15.80	(19B-G) (black-chelsea)
75	Caprice (exc. Sta. Wag. & Conv.)	9633147 A.R.	FT/15.80	(73B-G) (oxblood-chelsea)
75	Caprice (exc. Sta. Wag. & Conv.)	9633148 A.R.	FT/15.80	(55B-G) (sandstone-chelsea)

**NOVA**

*NOTE 1 This part covers one linear foot.*

*NOTE 2: Parts also in Chevelle sub group.*

73-74	(Nova) (Custom)	9707489 A.R.		body cloth (comb. 750, 752, 802) (black & white) (ranier)
73	Nova (Custom)	8707488 A.R.	FT/12.30	body cloth (comb. 764, 769) (neutral) (pingree)
74-75	Nova Custom	9632051 A.R.	FT/16.70	(44D) (green-regatta)
74-75	Nova Custom (exc. H.B.)	9632013 A.R.	FT/14.55	(73G-N) (oxblood-repose)
74-75	Nova (exc. Custom)	9633125 A.R.	FT/11.10	(19C-D) (black-caballero)
75	Nova Custom (exc. Sed.)	9633151 A.R.	FT/18.55	(63E) (saddle-cavalier)
75	Nova Custom	9633156 A.R.	FT/35.25	(55D) (sandstone-regatta)
75	Nova Custom	9633155 A.R.	FT/35.25	(26D) (blue-regatta)
75	Nova Custom (exc. Sed.)	9633150 A.R.	FT/18.55	(07E, 11E, 19E) (black-cavalier)
75	Nova Custom (exc. H.B.)	9633120 A.R.	FT/19.45	(55B-G-N) (sandstone-repose)
75	Nova Custom (exc. H.B.)	9633118 A.R.	FT/14.90	(26G-N) (blue-repose)
75	Nova Custom (exc. H.B.)	9633130 A.R.	FT/14.90	(26G) (blue-cambridge)
75	Nova Custom (exc. H.B.)	9633131 A.R.	FT/14.90	(55G) (sandstone-cambridge)
75	Nova Custom (exc. H.B.)	9633132 A.R.	FT/18.05	(16G) (graystone-cambridge)
75	Nova Custom (exc. H.B.)	9633133 A.R.	FT/18.05	(73G) (oxblood-cambridge)
75	Nova Custom (exc. H.B.)	9633117 A.R.	FT/14.90	(16G) (graystone-cambridge)
75	Nova (exc. Custom)	9633127 A.R.	FT/11.10	(26C) (blue-caballero)
75	Nova (exc. Custom)	9633126 A.R.	FT/11.10	(55C-D) (sandstone-caballero)

**CHEVELLE**

*NOTE 1 This part covers one linear foot.*

*NOTE 2: Parts also in Nova sub group.*

73	Monte Carlo	8707480 A.R.	FT/15.15	body cloth (comb. 725, 843) (midn. blue) (regatta)
73	Monte Carlo	8707479 A.R.	FT/15.15	body cloth (comb. 740, 836) (oxblood) (regatta)
73	Monte Carlo	8707477 A.R.	FT/16.70	body cloth (comb. 706, 840) (black) (regatta)
74-75	Malibu Classic (exc. Sta. Wag.)	9632017 A.R.	FT/14.25	(73D) (oxblood-rhone)
74-75	Malibu Classic (exc. Sta. Wag.)	9632019 A.R.	FT/14.25	(44D) (green-rhone)
74-75	Malibu Classic (exc. Sta. Wag.) El Camino Classic	9632015 A.R.	FT/14.25	(19D) (black-rhone)
74-75	Monte Carlo	9632010 A.R.	FT/14.55	(19N) (black-repose)

**REAR TRIM—MATS—YARDAGE**

**15.500 UPHOLSTERY CLOTH, Seat Cushion and Sidewall (See Yardage Code preceding group 15.500) (Con't)**

74-75	Monte Carlo	9632011 A.R.	FT/14.55	(44N) (green-carousel)
74-75	Monte Carlo	9632013 A.R.	FT/14.55	(73G-N) (oxblood-repose)
75	Laguna	9633151 A.R.	FT/18.55	(63E) (saddle-cavalier)
75	Monte Carlo	9633145 A.R.	FT/15.80	(26B) (blue-chelsea)
75	Monte Carlo	9633143 A.R.	FT/15.80	(19B-G) (black-chelsea)
75	Monte Carlo	9633147 A.R.	FT/15.80	(73B-G) (oxblood-chelsea)
75	Monte Carlo	9633148 A.R.	FT/15.80	(55B-G) (sandstone-chelsea)
75	Malibu Classic (exc. Sta. Wag.)	9633153 A.R.	FT/18.05	(16D) (graystone-rhone)
75	Malibu Classic (exc. Sta. Wag.)	9633154 A.R.	FT/18.05	(26D) (blue-rhone)
75	Malibu (exc. Classic & Sta. Wag.)	9633129 A.R.		(26C) (blue-charade)
75	Malibu (exc. Classic & Sta. Wag.), El Camino (exc. Classic)	9633128 A.R.	FT/13.70	(19C) (black-charade)
75	Laguna	9633152 A.R.	FT/18.55	(73E) (oxblood-cavalier)
75	Laguna	9633150 A.R.	FT/18.55	(07E, 11E, 19E) (black-cavalier)
75	Monte Carlo	9633138 A.R.	FT/17.35	(26B-N) (blue-carousel)
75	Monte Carlo	9633139 A.R.	FT/17.35	(44N) (green-carousel)
75	Monte Carlo	9633136 A.R.	FT/17.35	(19N) (black-carousel)
75	Monte Carlo	9633120 A.R.	FT/19.45	(55B-G-N) (sandstone-repose)
75	Monte Carlo	9633118 A.R.	FT/14.90	(26G-N) (blue-repose)
75	Monte Carlo	9633140 A.R.	FT/17.35	(55B-D-N) (sandstone-carousel)
75	Monte Carlo	9633141 A.R.	FT/17.35	(73D-N) (oxblood-carousel)

**CAMARO**

71	Camaro	8704997 A.R.	FT/9.90	body cloth (raydo) (comb. 792) (saddle and black)
73	Camaro (L.T.)	8707482 A.R.	FT/14.80	body cloth (comb. 724, 786) (blue & black) (rally)
73-74	Camaro (exc. L.T.)	8707475 A.R.	FT/9.30	body cloth (comb. 776) (black & white) (randolph)
75	Camaro L.T.	9633140 A.R.	FT/17.35	(55B-D-N) (sandstone-carousel)
75	Camaro L.T.	9633141 A.R.	FT/17.35	(73D-N) (oxblood-carousel)
75	Camaro (exc. L.T.)	9633126 A.R.	FT/11.10	(55C-D) (sandstone-caballero)
75	Camaro L.T.	9633142 A.R.	FT/17.35	(63D) (saddle-carousel)
75	Camaro L.T.	9633137 A.R.	FT/17.35	(16D) (graystone-carousel)

**VEGA—MONZA**

73	Vega (exc. Panel)	8707482 A.R.	FT/14.80	(comb. 872) (blue and black)
74	Vega (exc. Panel)	9632445 A.R.	FT/7.85	(comb. 883) (green and black)
74-75	Vega (exc. Panel)	9633125 A.R.	FT/11.10	(19C-D, 873) (black-caballero)
75	Vega (exc. Panel)	9633126 A.R.	FT/11.10	(55C-D) (sandstone-caballero)
75	Vega (exc. Panel)	9633123 A.R.	FT/13.60	(19E) (black-calypto)
75	Vega (exc. Panel)	9633124 A.R.	FT/13.60	(55E) (sandstone-calypto)
75	Vega (Sta. Wag., H.B.)	9632013 A.R.	FT/14.55	(comb. 73B) (oxblood) (repose)
75	Vega (Sta. Wag., H.B.)	9633118 A.R.	FT/14.90	(26B) (blue-repose)
75	Vega (Sta. Wag., H.B.)	9633140 A.R.	FT/17.35	(55B) (sandstone-carousel)
75	Vega (Sta. Wag., H.B.)	9633120 A.R.	FT/19.45	(55B) (sandstone-repose)
75	Vega (Sta. Wag., H.B.)	9633138 A.R.	FT/17.35	(26B-N) (blue-carousel)
75	Vega (Sta. Wag., H.B.)	9633141 A.R.	FT/17.35	(73B) (oxblood-carousel)
75	Monza (exc. Towne Cpe.)	9633148 A.R.	FT/15.80	(55B-G) (sandstone-chelsea)
75	Monza (exc. Towne Cpe.)	9633147 A.R.	FT/15.80	(73B-G) (oxblood-chelsea)
75	Monza (exc. Towne Cpe.)	9633143 A.R.	FT/15.80	(19B-G) (black-chelsea)
75	Monza (exc. Towne Cpe.)	9633145 A.R.	FT/15.80	(26G) (blue-chelsea)
75	Monza (exc. Towne Cpe.)	9633149 A.R.	FT/15.80	(63G) (saddle-chelsea)
75	Monza (exc. Towne Cpe.)	9633144 A.R.	FT/15.80	(16G) (graystone-chelsea)
75	Monza (Towne Cpe.)	9633260 A.R.	FT/13.30	(19N) (black-cambridge)
75	Monza (Towne Cpe.)	9633261 A.R.	FT/15.75	(64N) (buckskin-cambridge)
75	Monza (Towne Cpe.)	9633262 A.R.	FT/15.75	(71N) (firethorn-cambridge)

**15.504 GENUINE LEATHER**

*NOTE: Specify in inches the length and width of leather required.*

75	Camaro (L.T.), Monza (exc. Towne Cpe.)	8706043 A.R.	SI/.05	LEATHER, saddle
75	Camaro (L.T.), Monza (exc. Towne Cpe.)	9632926 A.R.	SI/.05	LEATHER, dark oxblood
75	Monza (exc. Towne Cpe.)	8701810 A.R.	SI/.11	LEATHER, black
75	Monza (Towne Cpe.)	9633259 A.R.	SI/.05	LEATHER, buckskin

**15.506 COATED FABRIC**

*NOTE To insure receipt of proper material, kindly submit sample and indicate model, description and trim combination number.*

*SPECIAL NOTE. Embossed footage not sold separately— in assemblies only.*

64-65	Chevelle (exc. Conv., S.S.),
66	Malibu (exc. El Camino, S.S.),

**REAR TRIM—MATS—YARDAGE**

**15.506 COATED FABRIC (Con't)**

65-66	Impala, Caprice .....			cushions and backs, ends, facings, inserts, center arm rest curtain, centerers, back of frt. back (comb. 811, 813, 814, 815, 817, 818), .....
67-69	Impala, Caprice .....			cushions and backs, doors (comb. 805, 806, 807, 808, 809, 810, 811, 813, 8, 814, 817, 818, 821, 859, 868), .....
67-69	Bel Air .....			ends, facings, center (comb. 803, 804, 811, 819, 820), .....
67-69	Biscayne,			facings and center (comb. 802, 803, 804,
69	Pass. (Sta. Wag.) .....			810, 812, 829), .....
67	Camaro .....			cushions and backs, ends, facings (comb. 713, 758, 765), .....
65-66	Nova (S.S.),			ends, facings, inserts, cushions and backs
65	Malibu (S.S.) (2nd design) .....			(comb. 712, 714, 765), .....
66-67	Chevelle (exc. Std., Deluxe, 4-Dr. Sed.) .....			facings, inserts, end caps, ends, centers, cushion and backs (comb. 761, 762, 763), .....
68	Chevelle .....			cushions and backs (comb. 765), .....
68	Chevy, Camaro, Chevelle (Std., Nomad) (exc. Custom) .....			cushions and back (comb. 712, 713, 714, 715, 731, 733, 734, 735, 749, 761), .....
68	Chevelle (Spt. Sed., Deluxe, Nomad Custom) .....			cushions, backs, facings, center (comb. 760, 762, 763, 768) (black) .....
70	Camaro .....			(comb. 711, 712, 713, 725), .....
70	Nomad, Malibu (Spt. Cpe., Sed.)			facings (comb. 750, 753), .....
70	Greenbrier, Monte Carlo, Bel Air, Townsman .....			cushions and backs (comb. 751, 752, 748, 749, 757, 754, 803, 804), .....
70	Concours, Chevelle (2-Dr.) (exc. Monte Carlo) .....			cushions and backs, facings, inserts, embossing only (comb. 755, 756), .....
70	Biscayne, Brookwood .....			cushions and backs, ends, facings, centers (comb. 802, 810, 829), .....
70	Impala (Spt. Cpe., Sed.) .....			cushions and backs, door, embossing only (comb. 805, 806), .....
70	Caprice .....			facings, doors (comb. 813) (black) (Note 1)
71-72	Nova .....			facings, cushions and backs, ends, centers, doors (embossed) (comb. 750, 751, 752, 753, 754), .....
71-72	Vega (exc. Panel) .....			cushions and backs (comb. 860, 861, 862, 874), .....
71	Vega .....			facings (comb. 873, 874), .....
71	Vega .....			end cap (comb. 873), .....
71	Vega (exc. Panel) .....			back of frt. back (comb. 860, 861, 862) (black) (Note 1) .....
71-72	Camaro .....			facings (comb. 775, 785, 787), .....
71-72	Chevelle .....			facings, cushions and backs (comb. 701, 702, 703, 704, 706, 707, 708, 710), .....
71-72	Pass. ....	4225623 A.R.	FT/5.30	cushions and backs, doors, facings (embossed) (comb. 802, 803, 804, 805, 806, 807, 809) (black) (Note 1) .....
65	Nova (S.S.) .....			frt. back bottom facing (comb. 712, 713), ..
65	Malibu (S.S.) (2nd design) .....			frt. back bottom facing, fldg. top compt. sunshades, qtr. arm rest (comb. 714), ..
65	Malibu (S.S. Conv.) .....			qtr. arm rest lower (comb. 792), .....
66-67	Chevelle, Camaro (Conv.) .....			qtr. arm rest lower, sunshades, qtr. arm rest side, qtr. arm rest side up. (comb. 760, 761, 763, 765, 767, 797, 798), .....
67	Camaro (Deluxe) (Conv.) .....			(comb. 706, 797), .....
67	Malibu (exc. Sed., Sta. Wag.),			bk. of frt. bk. lwr. ext. (comb. 759, 761), ...
67	Chevelle S.S. ....			bk. of frt. bk. (comb. 751, 757, 764), .....
67	Chevelle (Std., Deluxe) .....			(766, 785, 786, 791), .....
67	Chevy (exc. S.S.) .....			bk. of frt. bk., bk. of frt. upr. (comb. 785, 786, 791), .....
67	Chevy (exc. Conv., S.S.) .....			frt. back bottom facing, conv. sunshades, sta. wag. center pillar, buttons, fldg. top compt. qtr. arm rest side and lower (comb. 806, 811, 814, 815, 817, 818) .....
65-69	Impala, Caprice-(D) .....			
67-69	Impala, Caprice (Sta. Wag.),			

**REAR TRIM—MATS—YARDAGE**

**15.506 COATED FABRIC (Con't)**

69	Townsmen, Brookwood, Kingswood .....			center pillar and qtr. front (comb. 806, 811, 814, 894), .....
67-69	Impala (Spt. Cpe., Conv.) .....			quarter armrest side (comb. 806, 810, 811, 812, 813, 814, 858, 8, 859, 894, 895, 898), .....
67-69	Bel Air, Impala (4-Dr. Sed.) .....			center pillar (comb. 811, 819), .....
67-69	Caprice (Sed., Spt. Cpe.) .....			quarter armrest side, buttons (comb. 815, 817, 818), .....
67-69	Caprice (Spt. Sed.) .....			buttons (comb. 807, 808, 821), .....
67-68	Bel Air (Sta. Wag.) .....			center pillar (comb. 820), .....
67-69	Biscayne (4-Dr. Sed.) .....			back of frt. back (comb. 802, 812, 829), ...
67-69	Bel Air (2-Dr. Sed.) .....			back of frt. bk. ext. (comb. 819), .....
67-69	Impala, S.S. (Conv.) .....			(comb. 814, 894, 895, 898), .....
68	Chevy, Chevelle (Std., Deluxe, Nomad) .....			bk. of frt. bk. (comb. 733, 760, 761, 762, 763), .....
68	Malibu, Concours, S.S. ....			buttons, sunshades (comb. 764, 765, 766, 768, 794), .....
68	Camaro (Conv.) .....			sunshades, qtr. a/rest side (comb. 712, 714, 730) (black) .....
70	Malibu (Conv.) .....			sunshades (comb. 790, 791), .....
70	Malibu (Conv.) .....			qtr. arm rest side, sunshades (comb. 755, 756), .....
70	Monte Carlo .....			qtr. arm rest side (comb. 748, 749, 757, 754), .....
70	Impala, Caprice (Spt. Cpe., Sed.), Kingswood .....			buttons (comb. 805, 806, 813), .....
70	Impala, Kingswood (exc. Estate Wagon) .....			sunshades, buttons (comb. 806) (black) (Note 1), .....
71	Chevelle .....			sunshades on conv., qtr. arm rest, buttons (comb. 703, 706, 707, 708, 710), .....
71	Pass. ....			sunshades on conv., qtr. arm rest (comb. 805, 806) (black) (Note 1) .....
72	Nova .....			doors (comb. 751, 753) (black), .....
72	Chevelle .....			buttons (comb. 704, 706, 708), .....
72	Impala, Caprice (Spt. Cpe., Conv.) .....	<b>8707522</b> A.R.	FT/4.35	buttons (comb. 805, 806, 807, 838) (black)
65-68	Chevy, Chevelle, Camaro (Conv.) .....			dust boot (comb. 704, 712, 713, 714, 758, 760, 761, 763, 7, 765, 766, 767), .....
65-69	Pass. (Conv.) .....			dust boots (comb. 806, 810, 812, 813, 814, 815) (black) .....
70	Chevelle, Pass. (Conv.) .....			used for dust boots (comb. 754, 755, 756, 757, 806) (black) (Note 1), .....
71-72	Pass., Chevelle .....	<b>4225632</b> A.R.	FT/5.50	dust boots (comb. 704, 705, 706, 709, 806) .....
73	Vega (exc. Panel) .....	<b>4225632</b> A.R.	FT/5.50	buttons (comb. 860, 861) (black) (Note 1) ..
66	Pass. (S.S.) .....			cush. and backs (comb. 844), .....
66-67	Chevy (S.S.),			cushions and bk. end caps, facings, cushion and bk. inserts (c (comb. 731), .....
66-67	Chevelle (Spt. Cpe., Conv.) .....			cushion and bk. centers (comb. 732) (med. brt. blue), .....
66-67	Chevelle (S.S.) .....			cushions and backs, doors (comb. 844, 845, 848), .....
67	Impala (Spt. Cpe., Conv.) .....			cushions and bks. (comb. 716, 732) (med. brt. blue) .....
67	Camaro Deluxe .....	<b>4226643</b> A.R.	FT/5.15	headlining (comb. 814, 815, 817, 818, 821), .....
67	Caprice .....			(comb. 768), .....
68	Malibu (Spt. Sed.) .....			(comb. 807, 808, 809, 814), .....
68-69	Caprice (exc. Sta. Wag.) .....			(comb. 805, 806, 812, 813, 858, 859)
68	Impala (Spt. Mdls.) (exc. Conv.),	<b>4228061</b> A.R.	FT/4.55	(black) (perforated type) .....
69	Kingswood .....			seat facing (comb. 731, 732, 733, 737, 749, 750, 751, 753, 755, 756, 757, 802, 803, 804, 805, 806, 813), .....
70	All (exc. Camaro, Kingswood Estate) .....			w/house and rear qtr. (comb. 755, 804, 806) .....
70	Sta. Wag. (exc. Nomad, Greenbrier, Brookwood) .....			back of front back (comb. 748, 797, 810, 829) (black) (Note 1) .....
70-72	Chevelle (Std.) Monte Carlo, Biscayne .....	<b>8707365</b> A.R.	FT/5.50	

**REAR TRIM—MATS—YARDAGE**

**15.506 COATED FABRIC (Con't)**

70	Camaro .....			headlining (comb. 711, 712, 713, 725), ...
70	Impala, Chevelle (Spt. Cpe., Sed.) .....			headlining (comb. 753, 790, 791, 748, 749, 757, 805), .....
70	El Camino (exc. Custom) .....			headlining (comb. 752), .....
70	Caprice, Biscayne, Bel Air .....			headlining (comb. 802, 803, 804, 810, 813, 829) (black) (Note 1), .....
71	Vega .....			seat facing and back of front back (comb. 873, 874), .....
71	Camaro .....			(comb. 775, 785, 789), .....
71	Chevelle (exc. Deluxe, Sta. Wag.) .....			(comb. 701, 703, 704, 705, 706, 707, 708, 710), .....
71	Pass. (exc. Brookwood, Townsman) .....			(comb. 802, 803, 804, 805, 806, 807) (black) .....
72	Nova .....			(comb. 750, 751, 752, 753, 766, 767), .....
72	Camaro .....			(comb. 775, 785, 789), .....
72	Chevelle (exc. Conv.) .....			(comb. 701, 703, 704, 719, 706, 707, 708, 720, 743) .....
72	Pass. (exc. Brookwood, Townsman) .....	<b>8707677</b> A.R.	FT/3.95	headlining (comb. 802, 803, 804, 805, 806, 807) (black) .....
70	Monte Carlo .....			quarter arm rest side (comb. 780, 784, 785), .....
70	Impala, Caprice (Spt. Cpe., Sed.) .....			buttons (comb. 860, 855), .....
70	Kingswood, Impala (Spt. Cpe., Conv., Spt. Sed.) .....	<b>8703824</b> A.R.	FT/4.20	sunshade covers (comb. 861) (dk. green) (Note 1) .....
70	Nova .....			(comb. 744), .....
70	Malibu (exc. Conv.) .....			(comb. 782, 795), .....
70	Bel Air, Impala, Caprice, Kingswood .....	<b>8704111</b> A.R.	FT/5.30	back of front back (comb. 848, 855, 860, 861) (dk. green) (Note 1) .....
70	Malibu (Sed.) .....			embossed, doors (comb. 779), .....
70	Impala, Caprice (Spt. Cpe.) .....	<b>8703799</b> A.R.	FT/5.30	windhose (comb. 844, 845) (med. turq.) (Note 1) .....
71	All (exc. Caprice) .....			seat facing (comb. 701, 702, 703, 704, 705, 706, 707, 708, 710, 754, 775, 785, 789, 802, 803, 804, 805, 806), .....
71	Sta. Wag. (exc. Nomad, Brookwood) .....			wheelhouse and rear qtr. (comb. 705, 804, 806), .....
71	Camaro .....			rear cushion back facing (comb. 775, 776, 777, 778, 779, 785, 786, 787, 789, 792), .....
71	Nova, Chevelle (Deluxe, Nomad, Monte Carlo), .....			
71	Biscayne, Brookwood .....	<b>8707365</b> A.R.	FT/5.50	back of front back (comb. 701, 702, 708, 758, 751, 752, 753, 802) (black) .....
71	Brookwood (6-Pass.), .....			
71	Impala (exc. Conv.), .....			
71-72	Caprice .....			facing, cushion & back, doors, embossing only (comb. 810, 813, 814, 815), .....
71	Vega (N.B. & H.B.) .....	<b>8706305</b> A.R.	FT/6.10	cushion and back facing (comb. 892) (dk. blue) (Note 1) .....
71	Vega .....	<b>8703963</b> A.R.	FT/4.70	seat facing, back of back (comb. 878, 879) (dk. green) (Note 2) .....
71	Vega .....			facing and end cap (comb. 878), .....
71	Vega (exc. Panel) .....	<b>8703967</b> A.R.	FT/5.40	cushion and back facing (comb. 879) (dk. green) (Note 2) .....
71	Nova .....			facing, cush. and bk. ctr., ends (comb. 759, 760, 761, 778, 787), .....
71	Camaro .....			facing (comb. 778m 787), .....
71	Chevelle (Deluxe), .....			
71	Malibu, Concours, El Camino Custom .....			cush. and bk. (comb. 730, 731, 732), .....
71	Monte Carlo .....			facing (comb. 729, 733, 734), .....
71	Bel Air .....			cush. and bk. (comb. 832), .....
71	Impala, Kingswood Estate .....			cush. and bk. embossing only (comb. 834, 835), .....
71	Caprice .....	<b>8705161</b> A.R.	FT/5.55	facing, doors (comb. 836) (dk. jade) .....
71	Camaro, .....			
71	Monte Carlo .....			qtr. arm rest side, buttons (comb. 707, 708, 710), .....
71	Biscayne, Bel Air, Brookwood ..			buttons (comb. 802), .....

**REAR TRIM—MATS—YARDAGE**

**15.506 COATED FABRIC (Con't)**

71	Pass. (Spt. Cpe.)	8707522 A.R.	FT/4.35	qtr. arm rest side (comb. 805, 806, 807) (black)
71	Pass., Chevelle (Conv.)	4225632 A.R.	FT/5.50	dust boots (comb. 705, 706, 709, 806) (black)
71	Malibu (exc. Spt. Sed.), El Camino Custom, Concours (exc. Estate)			cushion and back inserts (comb. 721, 722), doors (comb. 723) (dk. saddle)
71-72	Monte Carlo	8705318 A.R.	FT/5.50	embossing only, doors lower (comb. 767), (comb. 779, 792),
71-72	Nova			(comb. 721, 722, 723),
71	Camaro			valance (comb. 825) (dk. saddle)
71	Malibu (Spt. Cpe., Cpt. Sed.), Monte Carlo			buttons (comb. 818), (comb. 716, 717),
71	Impala (exc. Conv.)	8703293 A.R.	FT/3.10	buttons, qtr. arm rest side (comb. 820, 821) (sandalwood)
71	Biscayne			(comb. 775, 785, 789),
71	Monte Carlo			(comb. 701, 703, 704, 705, 706, 707, 708, 710),
71	Impala, Caprice (Spt. Cpe.)	8705105 A.R.	FT/4.60	
71-72	Camaro			
71-72	Chevelle (exc. Conv.)			
71-72	Pass. (exc. Brookwood, Townsmen)	8707659 A.R.	FT/3.40	buttons, qtr. a/rst. (comb. 727, 728), buttons (comb. 810), frt. back button facing (comb. 892) (dk. blue),
71	Monte Carlo			qtr. a/rst. side (comb. 813, 814, 815)
71	Biscayne, Brookwood			(comb. 779, 788),
71	Vega (N.B. & H.B.)			
71	Impala (2-Dr.) (exc. Conv.)	8706282 A.R.	FT/4.75	
72	Camaro			(comb. 816, 817),
72	Chevelle (Spt. Cpe., Sed., El Camino) (comb. 730, 731, 732),			
72	Biscayne, Bel Air			
72	Impala (exc. Conv.) Caprice, Kingswood	8706350 A.R.	FT/3.95	headlining (comb. 815, 818, 819) (covert) (premier perforated)
72	Camaro			(comb. 779, 788),
72	Monte Carlo			(comb. 731, 734),
72	Biscayne, Bel Air			(comb. 816),
72	Impala, Caprice (Spt. Cpe., Conv.)	8706284 A.R.	FT/4.75	buttons, welts (comb. 815, 818, 819) (covert)
72	Nova, Camaro, Chevelle, Biscayne, Bel Air			inserts, h/rest, cushions & backs, back of backs, facing, ends, pull straps & doors, qtr. arm/rest (comb. 751, 756, 776, 786, 723, 724, 725, 809, 810, 811, 812, 813, 814) (black)
72	Nova, Camaro, Chevelle (exc. El Camino), Bel Air			inserts, h/rest, cushions & backs, back of backs, facings, ends, doors, pull straps, qtr. arm/rest (comb. 759, 760, 761, 777, 787, 710, 711, 713, 715, 717, 828) (green)
72	Impala (exc. Conv.), Kingswood, Caprice	8706306 A.R.	FT/6.30	embossing only (comb. 829, 830, 831, 833) (green)
72	Monte Carlo			(comb. 740),
72	Camaro, Bel Air, Chevelle (exc. Conv., El Camino), Impala, Caprice (exc. Conv.)	8706349 A.R.	FT/3.60	headlining (comb. 713, 715, 717, 777, 787, 828, 829, 830, 831, 833) (green) (premier perforated)
72	Chevelle (Conv.)	8706089 A.R.	FT/6.05	dust boot (comb. 713) (green)
72	Monte Carlo, Caprice			facings, h/restraints, upper doors, pull straps and a/rest tops (comb. 740, 834, 835, 836),
72	Impala (Spt. Cpe., Spt. Sed.)	8706304 A.R.	FT/5.70	embossing only, facing, h/restraints, upper doors, pull straps and qtr. a/rest tops (comb. 834, 835, 836) (pewter)
72	Nova (2-Dr.), Nomad, Greenbrier, Chevelle (Std.), El Camino (exc. Custom)	8706354 A.R.	FT/6.55	cushs. and backs (comb. 719, 721) (tan)



**REAR TRIM—MATS—YARDAGE**

**15.506 COATED FABRIC (Con't)**

72	Camaro,				doors, embossed only (comb. 802, 775)
72	Biscayne, Brookwood, Camaro				(black)
72	Greenbrier, El Camino	4228130 A.R.	FT/3.10		door accent, embossed only (comb. 713)
					(black)
72	Nova,				inserts, h/restraints, cushions & backs, back
72	Chevelle,				of back facings, ends, doors, pull straps, &
72	Biscayne, Bel Air				qtr. a/rests (comb. 763, 764, 765, 730,
					731, 732, 734, 816, 817)
72	Impala, Caprice				embossing only inserts h/restraints,
					cushions & backs back of back facing
72	Kingswood	8706307 A.R.	FT/6.65		ends, doors, pulls straps, & qtr. a/rests,
72	Nova (2-Dr.) Camaro,				embossing only (comb. 815, 818, 819)
72	Chevelle (exc. Conv. & Monte Carlo)	8706309 A.R.	FT/6.10		inserts, h/rest, cushions & backs, back of
					backs, facing, ends & doors (comb. 766,
					778, 719, 720, 721, 743) (tan)
71	Nova (2-Dr.),				(comb. 767),
71	Camaro				(comb. 779, 792),
71	Malibu (Spt. Cpe., Spt. Sed.)				
	Monte Carlo				
71-72	Impala (exc. Conv.),				valance (comb. 825, 826) (saddle)
72	Monte Carlo	8703293 A.R.	FT/3.10		back of back (comb. 766, 778, 719, 70,
72	Nova, Camaro, Chevelle	8706126 A.R.	FT/6.25		721) (tan)
72	Nova (2-Dr.),				insert, h/restraints, cushs., and backs, back
72	Camaro,				of back, facing, ends, and doors (comb.
72	Chevelle (Spt. Cpe., Spt. Sed., Conv.) (exc. Monte Carlo)	8706303 A.R.	FT/5.50		767, 780, 743) (white)
72	Chevelle (Conv.) Monte Carlo,				buttons and welts (comb. 713, 715, 717,
72	Impala, Caprice (Spt. Cpe., Conv.)	8706283 A.R.	FT/4.50		777, 787, 829, 830, 831, 833) (green)
72	Vega (exc. Panel)	8706284 A.R.	FT/4.75		buttons and welts (comb. 868, 869, 874)
					(covert) (Note 1)
72	Vega (exc. Panel)	8706307 A.R.	FT/6.65		inserts, head restraints, cushions and backs,
					back of back facings, ends, doors, pulls
					straps, and qtr. arm rests (comb. 868,
					869, 874) (covert) (Note 1)
72	Vega (exc. Panel)	8706126 A.R.	FT/6.25		sunshade (comb. 866, 867) (med. tan) (Note
					1)
72	Vega (exc. Panel)	8706309 A.R.	FT/6.10		inserts, head restraints, cushions and backs,
					back of backs, facings, ends and doors
					(comb. 866, 867) (med. tan) (Note 1)
73	Chevelle (Spt. Cpe.) El Camino (Custom) (exc. Deluxe)	8706374 A.R.	FT/6.75		headrests, facings, map pockets (comb.
					704, 706, 707, 708) (black)
73	Malibu, Laguna (Cpe.)	8706376 A.R.	FT/7.10		headrests, facings, blind seams & map
					pockets (comb. 705, 719) (blue)
73	Monte Carlo	8706377 A.R.	FT/7.10		headrests, facings, map pockets (comb.
					725) (blue)
73	Pass. (Conv.),				headrests, dust boot, facings, map pockets
73	Pass. (Conv.),				(comb. 732, 734, 735, 818) (neutral)
73	Chevelle (Spt. Cpe.) El Camino (Custom) (exc. Deluxe)	8706380 A.R.	FT/6.85		headrests, facings, map pockets (comb.
					717, 720) (saddle)
73	Malibu, Laguna (Cpe.) El Camino (Custom)	8706381 A.R.	FT/7.55		headrests, facings, map pockets (comb.
					740) (oxblood)
73	Monte Carlo	8706382 A.R.	FT/7.95		headrests, facings, map pockets (comb.
					708) (black)
73	Monte Carlo	8707350 A.R.	FT/7.20		headrests, facings, map pockets (comb.
					735) (neutral)
73	Monte Carlo	8707354 A.R.	FT/6.85		back of back, back facings, sunshades
					(black)
73	All (exc. Sta. Wag.)	8707365 A.R.	FT/5.50		back of back (comb. 816) (white) (madrid)
73	Chevelle, Impala, Caprice (Sta. Wag.),				
73	Pass. (Conv.)	8707366 A.R.	FT/5.15		

**REAR TRIM—MATS—YARDAGE**

**15.506 COATED FABRIC (Con't)**

73	Malibu, Laguna,				
73	El Camino (Custom) .....				back of back, sunshades, .....
73	Bel Air (Sedan), Nova (exc. Custom) .....	8707367 A.R.	FT/5.55		back of back (comb. 705, 719, 723, 724, 756, 772, 810) (blue) .....
73	Impala, Caprice, Monte Carlo (exc. Conv.) .....	8707368 A.R.	FT/5.25		back of back (comb. 725, 812, 813, 843) (mid. blue) .....
73	Chevelle (exc. El Camino) Nova, El Camino (Custom) .....				back of back, sunshades, .....
73	Bel Air (Sed.) .....				back of back, .....
73	Impala, Caprice, Monte Carlo .....	8707369 A.R.	FT/5.75		back of back, sunshade (green) .....
73	Malibu (exc. Sta. Wag.) .....				back of back (comb. 716, 721) (chamois) ..
73	Chevelle (exc. Deluxe 4-Dr.), Bel Air (exc. Sedan), Monte Carlo,				
73	Impala, Caprice, Nova (Sed.) Nova (Custom) .....	8707371 A.R.	FT/6.15		back of back, sunshade (comb. 731, 732, 733, 734, 735, 764, 768, 769, 815, 817, 818, 841) (neutral) .....
73	Malibu (exc. Sed.) Laguna (exc. Sed., Sta. Wag.),				
73	El Camino (Custom),				
73	Pass. (Sta. Wag.) .....	8707372 A.R.	FT/6.15		back of back (comb. 717, 720, 825, 826) (saddle) .....
73	Laguna, Monte Carlo .....				back of back, .....
73	Caprice (exc. Sta. Wag., Conv.) .....	8707373 A.R.	FT/6.15		back of back blind seams (comb. 709, 714, 740, 836) (oxblood) .....
73	Malibu, El Camino (Custom) .....				back of back sunshades, .....
73	Nova (Custom),				
73	Bel Air (Sedan) .....				back of back, .....
73	Impala, Caprice (exc. Conv.) .....	9633891 A.R.	FT/5.30		back of back, sunshades (comb. 703, 704, 750, 752, 802, 803, 804, 805, 806, 840) (black) (repl. 8707374) .....
73	Pass. (Conv.) .....	8707375 A.R.	FT/5.15		dust boot (comb. 816) (white) (bedford) .....
73	Malibu,				
73	El Camino (Custom),				
73	Bel Air (Sedan) .....	8707376 A.R.	FT/5.75		back of back (comb. 705, 724, 810) (med. blue) .....
73	Impala, Caprice (exc. Conv.) .....	8707377 A.R.	FT/5.75		back of back (comb. 812, 813, 843) (mid. blue) .....
73	Malibu, El Camino (Custom),				
73	Bel Air (Sedan),				back of back, sunshades, .....
73	Malibu, El Camino (Custom) .....				back of back .....
73	Bel Air (Sta. Wag.) .....				back of back, sunshades (comb. 732, 764, 769, 815, 817, 818, 841) (neutral) .....
73	Impala, Caprice, Nova (Custom) .....	8707380 A.R.	FT/5.25		
73	Malibu (exc. Sed.) El Camino (Custom),				
73	Pass. (Sta. Wag.) .....	8707381 A.R.	FT/5.75		back of back (comb. 720, 825, 826) (saddle) .....
73	Caprice (exc. Conv.) .....	8707382 A.R.	FT/5.75		back of back (comb. 836) (oxblood) .....
73	Malibu, Laguna				cushions & backs, .....
73	Impala, Nova (Custom Cpe.) .....				cushions & backs facings, .....
73	Caprice (Sta. Wag.) .....	8707383 A.R.	FT/9.30		cushions & backs, facings, headrest back of back (comb. 707, 754, 806, 861) (black) ..
73	Caprice (Conv.) .....	8707384 A.R.	FT/8.80		cushions & backs (comb. 816) (white) (tetra)
73	Malibu, Laguna .....	8707385 A.R.	FT/8.25		cushions & backs (comb. 719) (med. blue) ..
73	Impala,				
73	Caprice (Sta. Wag.) .....	8707386 A.R.	FT/8.25		cushions & backs (comb. 813) (mid. blue) ..
73	Malibu, Laguna,				
73	Impala,				
73	Caprice (Sta. Wag., Conv.) .....	8707387 A.R.	FT/8.75		cushions & backs (comb. 727, 830) (green)
73	Malibu, Laguna,				
73	Impala, Nova (Custom Cpe.),				
73	Caprice (Sta. Wag., Conv.) .....	8707389 A.R.	FT/8.75		cushions & backs headrest facings, back of backs (comb. 734, 771, 818) (neutral) ...
73	Laguna,				
73	Impala (Sedan) (exc. Spt. Sed.) .....	8707391 A.R.	FT/9.95		cushions & backs (comb. 709, 830) (oxblood) .....
73	Chevelle,				
73	Impala, Caprice (exc. Sed.)				
73	Camaro, Nova .....	8707522 A.R.	FT/4.35		buttons welts fin. strips (black) .....
73	Caprice (Conv.) .....	8707523 A.R.	FT/4.05		cushions & back (comb. 816) (white) (madrid) .....

**REAR TRIM—MATS—YARDAGE**

**66 COATED FABRIC (Con't)**

73	Caprice (Conv.)	8706375	1	FT/6.90	dust boot (comb. 816) (white)
73	Malibu, Nova (exc. Custom)				buttons welts
73	Laguna	8707524	A.R.	FT/4.65	buttons welts (comb. 705, 719, 723, 724, 756, 772) (med. blue)
73	Impala, Caprice (exc. Sed., Conv.),				
73	Monte Carlo	8707525	A.R.	FT/4.40	buttons, fin. strips (comb. 725, 812, 813, 843) (mid. blue)
73	Impala, Nova				fin. strips, buttons,
73	Deluxe (exc. Sta. Wag.),				
73	Malibu, Camaro,				
73	Laguna, Caprice (exc. Sed.)				buttons welts,
73	Monte Carlo	8707526	A.R.	FT/4.40	buttons welts, fin. strips (green)
73	Malibu (exc. Sta. Wag.)				buttons welts,
73	Camaro, Nova (2-Dr.)				button,
73	Impala, Nova				buttons, fin. strips,
73	Caprice (exc. Sed.)				fin. strips,
73	Deluxe (Spt. Cpe.) Malibu,				
73	Laguna, El Camino, Camaro				buttons welts,
73	Monte Carlo	8707528	A.R.	FT/4.40	buttons welts, fin. strips (neutral)
73	Caprice (Conv.)	8707529	A.R.	FT/4.05	cushions and backs (comb. 818) (neutral)
73	Deluxe, Malibu (Sta. Wag.),				
73	Malibu, Laguna (Cpe.) El Camino (Custom)				buttons and welts,
73	Impala, Caprice (Sta. Wag.),				
73	Camaro	8707530	A.R.	FT/4.65	buttons (comb. 717, 720, 722, 778, 826) (saddle)
73	Malibu, Laguna				buttons, welts,
73	Monte Carlo				buttons,
73	Caprice (Spt. Cpe.)	8707531	A.R.	FT/4.85	buttons welts fin. strips (comb. 709, 714, 735, 740, 836)
73	Bel Air (Sta. Wag.),				
73	Nova (2-Dr.) (exc. Custom)	8707554	A.R.	FT/8.50	cushions & back inserts (comb. 763, 817) (neutral)
73	Chevelle, Nova,				
73	Bel Air (Sed.),				
73	Impala, Caprice (exc. Conv.),				
73	Camaro	8707610	A.R.	FT/6.15	facings headrest cushions & backs doors armrest blind seams stitches walls deck seams pull straps (black)
73	Caprice (Conv.)	8707611	A.R.	FT/6.15	facings headrest back of backs doors armrest sidewalls (comb. 816) (white)
73	Malibu,				
73	Laguna, El Camino (Custom),				
73	Bel Air (Sed.),				
73	Nova (exc. Custom)	8707612	A.R.	FT/6.80	facings, headrest cushions & backs doors stitches (comb. 705, 719, 723, 724, 756, 772, 810) (blue)
73	Impala, Monte Carlo,				
73	Caprice (exc. Conv.)	8707613	A.R.	FT/6.50	facings, headrest, doors, walls, pull straps armrest, stitches (comb. 725, 812, 813, 843) (mid. blue)
73	Deluxe (exc. Sta. Wag.) Monte Carlo				facings headrest,
73	Malibu, Laguna, El Camino (Custom)				facings headrest cushion & backs doors,
73	Bel Air (Sed.) Nova				facings headrest cushion & backs,
73	Impala, Caprice, Camaro,				
73	Monte Carlo	8707614	A.R.	FT/6.50	facings headrest cushion & backs doors armrest blind seams stitches walls deck seams pull straps (green)
73	Malibu (exc. Sta. Wag.),				
73	Nova (2-Dr.),				
73	Camaro (exc. L.T., Custom)	8707615	A.R.	FT/6.55	facings headrest, cushions & backs, stitches (comb. 716, 721, 767, 780) (chamois)
73	Deluxe (Spt. Cpe.) El Camino				facings, headrests,
73	Malibu, Laguna				facings, headrests, cushions & backs,
73	Bel Air (Sta. Wag.) Nova				facings, headrests, cushions & backs, door,
73	Impala, Caprice				facings, headrests, cushions, backs, doors, blind seams, stitches walls,
73	Monte Carlo, Camaro	8707616	A.R.	FT/6.50	facings, headrest, cushions & backs, doors, armrest, blind seams, stitches, walls, deck seams, pull straps (neutral)
73	Deluxe, Malibu (Sta. Wag.),				
73	Malibu, Laguna (Spt. Cpe.)				facings, headrest,

**REAR TRIM—MATS—YARDAGE**

**15.506 COATED FABRIC (Con't)**

73	Pass. (Sta. Wag.)			facings, headrest, armrest, . . . . .
73	Camaro (exc. L.T.)	8707617 A.R.	FT/6.50	facings, headrests, cushions & bac (saddle) . . . . .
73	Monte Carlo, Laguna			pull straps & walls, doors, . . . . .
73	Caprice (Sed., Spt. Cpe.)	8707618 A.R.	FT/7.20	facings, headrest, cushions & back pull straps, blind seams, stitches, walls (oxblood) . . . . .
73	Deluxe (Sta. Wag.),			
73	Malibu, El Camino (Custom),			
73	Laguna (Sta. Wag.)	8707631 A.R.	FT/6.15	facings, headrest, cushion & backs (comb. 701, 704, 707) (black) . . . . .
73	Malibu, El Camino (Custom),			
73	Laguna (Sta. Wag.)	8707633 A.R.	FT/5.85	facings, headrests, cushions, backs (comb. 705, 719) (blue) . . . . .
73	Malibu, El Camino (Custom),			
73	Laguna (Sta. Wag.)	8707635 A.R.	FT/6.50	facings, headrests, cushions, backs (comb. 713, 727) (green) . . . . .
73	Malibu, Laguna (Sta. Wag.) El Camino (Custom)	8707637 A.R.	FT/6.50	facings, headrests, cushions & backs (comb. 732, 734) (neutral). . . . .
73	Deluxe (Sta. Wag.),			
73	Malibu (Spt. Cpe., Sta. Wag.) El Camino (Custom),			
73	Laguna (Sta. Wag.)	8707638 A.R.	FT/6.35	facings, headrests, cushions backs (comb. 720, 722) (saddle) . . . . .
73	Laguna (Sta. Wag.)	8707639 A.R.	FT/6.80	facings, headrests, cushions, back of backs (comb. 709) (oxblood) . . . . .
73	Camaro (exc. L.T.)	8707640 A.R.	FT/5.55	facings, headrests, cushions, backs (comb. 775) (black) . . . . .
73	Camaro (exc. L.T.)	8707645 A.R.	FT/5.85	facings, headrests, cushions, backs (comb. 778) (saddle) . . . . .
73	Impala, Caprice (Spt. Cpe.)			valance, . . . . .
73	Impala, Chevelle, Camaro (exc. Sta. Wag.)			headlining, . . . . .
73	Bel Air (Sed.),			
73	Impala (exc. Sta. Wag.),			
73	Nova, Camaro (exc. H.B.)	8707659	FT/3.40	panel rear seat to back wdo. (black) . . . . .
73	Bel Air (Sedan),			
73	Nova (Cpe., Sed.) (exc. H.B.)			panel rear seat back to window, . . . . .
73	Malibu, Laguna (exc. Sta. Wag.)	8707660 A.R.	FT/3.40	headlining (med. blue) . . . . .
73	Monte Carlo			headlining, . . . . .
73	Impala, Caprice (Sed.)			panel r/seat to back wdo., headlining, . . . . .
73	Impala, Caprice (Cpe.)	8707661 A.R.	FT/3.75	foundation (comb. 725, 812, 813, 843) (mid. blue) . . . . .
73	Bel Air (Sed.) Nova (exc. H.B.)			panel r/seat to back window, . . . . .
73	Impala, Caprice (Sed.),			
73	Camaro			panel r/seat to back window headlining, . . . . .
73	Impala, Caprice (Cpe.)			panel r/seat to back window headlining foundation, . . . . .
73	Chevelle (Spt. Cpe., Spt. Sed.)	8707662 A.R.	FT/3.75	headlining (green) . . . . .
73	Nova (exc. H.B.)			panel r/seat to back window, . . . . .
73	Deluxe (Spt. Cpe.),			
73	Chevelle (exc. Sta. Wag., El Camino)			headlining, . . . . .
73	Impala, Caprice (Sed., Cpe.)			panel r/seat to back window, headlining, foundation, . . . . .
73	Camaro	8707664 A.R.	FT/3.40	panel r/seat to back window, headlining (neutral) . . . . .
73	Malibu, Laguna (Spt. Cpe.)			headlining (comb. 718, 720) (saddle), . . . . .
73	Camaro (exc. L.T.)	8707665 A.R.	FT/3.75	headlining, panel r/seat to back window (comb. 778) (saddle) . . . . .
73	Caprice (Spt. Cpe., Sed.)			panel r/seat to back wdo., headlining (comb. 836) (oxblood), . . . . .
73	Laguna (exc. Sta. Wag.),			
73	Monte Carlo	8707666 A.R.	FT/4.40	headlining (comb. 709, 714, 740, 836) (oxblood) . . . . .
73	Nova (Sed.) (exc. Cust.)	8707667 A.R.	FT/5.00	cushion & backs (comb. 768) (neutral) . . . . .
70-73	Deluxe	8707668 A.R.	FT/3.50	headlining (comb. 701, 702) (black) . . . . .
73	Deluxe (Cpe., Sed.)	8707672 A.R.	FT/3.50	headlining (comb. 710, 711) (green) . . . . .
73	Bel Air (Sta. Wag.),			
73	Deluxe (Cpe.)	8707674 A.R.	FT/3.35	headlining (comb. 733, 817) (neutral) . . . . .
73	Deluxe (Sta. Wag.),			
73	Bel Air (Sta. Wag.)	8707675 A.R.	FT/3.50	headlining (comb. 722, 825) (saddle) . . . . .
73	Malibu, Laguna,			
73	El Camino, Monte Carlo			headlining, . . . . .

**TRIM—MATS—YARDAGE**

**COATED FABRIC (Con't)**

	id.)				panel r/seat to back wdo.,
73	Impala, Caprice (exc. Conv.)				panel r/seat to back wdo., headlining,
73	Impala, Caprice (exc. Conv.)				foundation,
73	Camaro	8707677 A.R.	FT/3.95		panel r/seat to back wdo., headlining (black)
73	Malibu, Laguna				headlining,
73	Bel Air (Sed.)	8707679 A.R.	FT/3.95		panel r/seat to back wdo. (comb. 705, 719, 723, 724, 810) (med. blue)
73	Monte Carlo				headlining,
73	Impala, Caprice				panel r/seat to back wdo., headlining,
73	Impala, Caprice	8707680 A.R.	FT/3.95		foundation (midn. blue)
73	Malibu, Laguna,				
73	El Camino (Custom)				headlining,
73	Bel Air (Sed.) Monte Carlo				panel r/seat to back wdo.,
73	Impala, Caprice (exc. Sta. Wag.)				panel r/seat to back wdo., headlining,
73	Impala, Caprice (Sta. Wag.)				headlining,
73	Impala, Caprice (Spt. Cpe.)				foundation,
73	Camaro	8707681 A.R.	FT/3.95		panel r/seat to back wdo., headlining (green)
73	Malibu (exc. Sta. Wag.)				headlining (comb. 716, 721) (chamois),
73	Camaro (exc. L.T.)	8707682 A.R.	FT/3.75		panel r/seat to back wdo., headlining (comb. 716, 721, 780) (chamois)
73	Malibu, Laguna				headlining,
73	Impala, Caprice (exc. Sta. Wag.)				panel r/seat to back wdo., headlining,
73	El Camino				foundation,
73	Camaro	8707683 A.R.	FT/3.75		panel r/seat to back wdo., headlining (neutral)
73	Impala, Caprice (Sta. Wag.),				
73	Malibu, Laguna (exc. Spt. Sed.)				headlining (comb. 717, 720, 826) (saddle),
73	El Camino (Custom)				panel r/seat to back wdo., headlining (saddle)
73	Camaro (exc. L.T.)	8707684 A.R.	FT/3.95		headlining,
73	Laguna, Monte Carlo				panel r/seat to back wdo., headlining,
73	Caprice (Sed.)				panel r/seat to back wdo., headlining,
73	Caprice (Cpe.)	8707685 A.R.	FT/4.10		foundation (oxblood)
73	Vega (exc. Panel)	8707367 A.R.	FT/5.55		sunshade (comb. 872) (blue and black) (Note 1)
73	Vega (exc. Panel)	8707371 A.R.	FT/6.15		sunshade (comb. 868, 874) (neutral) (Note 1)
73	Vega (Sta. Wag.)	8707372 A.R.	FT/6.15		sunshade (comb. 866, 867) (saddle) (Note 1)
73	Vega (H.B.)	8707373 A.R.	FT/6.15		sunshade (comb. 858, 875) (oxblood) (Note 1)
73	Vega (exc. Panel)	8707383 A.R.	FT/9.30		cushions and backs (comb. 861) (black) (Note 1)
73	Vega (exc. Panel)	8707387 A.R.	FT/8.75		cushions and backs (comb. 864) (green) (Note 1)
73	Vega (exc. Panel)	8707389 A.R.	FT/8.75		cushions and backs (comb. 874) (neutral) (Note 1)
73	Vega (H.B.)	8707391 A.R.	FT/9.95		cushions and backs (comb. 875) (oxblood) (pattern) (Note 1)
73	Vega (exc. Panel)	8707524 A.R.	FT/4.65		buttons (comb. 872) (blue and black) (Note 1)
73	Vega (Sta. Wag.)	8707530 A.R.	FT/4.65		buttons (comb. 866, 867) (saddle) (Note 1)
73	Vega (H.B.)	8707531 A.R.	FT/4.85		buttons (comb. 858, 875) (oxblood) (Note 1)
73	Vega (exc. Panel)	8707612 A.R.	FT/6.80		facings, cushions and backs (comb. 872) (blue and black) (Note 1)
73	Vega (H.B.)	8707615 A.R.	FT/6.55		head restraints, cushion and backs (comb. 859, 876) (chamois) (plain) (Note 1)
73	Vega (H.B.)	8707618 A.R.	FT/7.20		facings, cushions and backs (comb. 858, 875) (oxblood) (plain) (Note 1)
73	Vega (exc. Panel)	9630932 A.R.	FT/6.80		facings, cushions and backs (comb. 863) (green) (Note 1)

NOTE 1 This part covers one linear foot.

NOTE 1 Used wherever cotton synthetic resin coated cloth except back window trim cover or seat back cushion facings.

NOTE 2 Rayon Vinyl Coated.

NOTE 3 Production deviation trim change.

**15.512 CARPET—YARDAGE, Doors, Seats, Cowl and Load Floor**

67-68	Camaro				folding rr. seat back (comb. 706, 711, 712, 713, 714, 715, 716, 730, 749, 756, 760, 765, 767, 797),
66-68	Impala, Caprice (Sta. Wag.),				

**REAR TRIM—MATS—YARDAGE**

**15.512 CARPET—YARDAGE, Doors, Seats, Cowl and Load Floor**

70-72	Kingswood	4226161 A.R.	FT/7.45	(comb. 806, 814) (black)
73	Nova (Custom) (H.B.),			
73	Caprice (Spt. Cpe., Sed.),			
73	Impala, Caprice (Sta. Wag.)			(comb. 806, 752, 754, 840) (black)
70	Monte Carlo (Spt. Cpe.),			
70	Monte Carlo (Spt. Cpe.)			(comb. 774),
70	Caprice	8703211 A.R.	FT/7.55	doors (comb. 840) (dk. gold) (Note 1)
70	Kingswood			load floor (comb. 830),
70	Caprice	8703202 A.R.	FT/8.95	doors (comb. 822) (dk. saddle) (Note 1)
70	Kingswood	8703211 A.R.	FT/7.55	load floor (comb. 841) (dk. gold) (Note 1)
71	Camaro			(comb. 786),
71-72	Monte Carlo			(comb. 727),
71	Caprice	8704900 A.R.	FT/7.60	doors (comb. 828) (med. maize) (Note 1)
71	Camaro			(comb. 787),
71-72	Kingswood	8704887 A.R.	FT/8.35	fldg. 2nd seat back panel outer (comb. 814)
				(dk. blue) also load floor (comb. 809, 811)
71	Kingswood	8704900 A.R.	FT/7.60	fldg. 2nd seat back panel outer (comb. 827)
				(med. maize)
71	Kingswood	8703390 A.R.	11.95	fldg. 2nd seat back filler panel outer (comb.
				824, 825) (dk. saddle)
71	Monte Carlo			(comb. 733),
71	Monte Carlo			(comb. 716),
71	Caprice	8704902 A.R.	FT/8.35	doors (comb. 821) (med. beige) (Note 1)
71-72	Camaro,			
72	Monte Carlo	8703309 A.R.	FT/7.50	doors (comb. 792) (dk. saddle) (repl.
				8704934)
	<i>NOTE 1 Part number covers one linear yard.</i>			
72	Monte Carlo			(comb. 740),
72	Monte Carlo			(comb. 731, 734),
72	Kingswood	8705344 A.R.	FT/8.95	load floor (comb. 830) (green) (loose)
72	Impala Custom, Caprice			doors (819) (covert),
72	Kingswood	A.R.		load floor (comb. 818) (repl. 8705345)
72-73	Nova (Custom) (H.B.),			
72-73	Pass. (Sta. Wag.)	8704371 A.R.	FT/3.50	(neutral)
71-72	Chevelle (Sta. Wag.)			(comb. 702, 703, 705),
71-72	Brookwood, Townsman	8703917 A.R.		headlining (comb. 802, 804) (black)
71	Camaro			(comb. 785, 789),
71	Malibu, Monte Carlo, El Camino			(comb. 703, 704, 705, 706, 707, 708, 710),
71	Pass. (exc. Conv.)	8707677 A.R.	FT/3.95	headlining (comb. 802, 803, 804, 805, 806,
				807) (black)
71-73	Vega,			
74-75	All	9630974 A.R.	FT/4.45	(black) (1/4" pile)
71-72	Vega	8705353 A.R.	FT/9.30	(dk. green)
72-73	Vega	A.R.		(covert) (repl. 8705359)
74	All	9632189 A.R.	FT/4.45	(neutral)
73	Caprice (Spt. Cpe., Sed.)	8704369 A.R.	FT/3.50	(midn. blue)
73	Caprice (Spt. Cpe., Spt. Sed.)	8704373 A.R.	FT/3.50	(oxblood)
73	Pass. (Sta. Wag.)	8704372 A.R.	FT/3.50	(saddle)
73	Impala, Caprice (Sta. Wag.),			
73	Nova (H.B.) (exc. Custom)	8704370 A.R.	FT/3.50	(dark green)
73	Nova (Custom H.B.)	9630070 A.R.	FT/3.90	(red)
73	Vega	9632187 A.R.	FT/10.30	(blue and black)
73	Vega	8704402 A.R.	FT/3.75	(dark green)
73	Vega	8704404 A.R.	FT/3.75	(saddle)
73	Vega,			
74-75	All	9632192 A.R.	FT/4.15	(oxblood) (1/4" pile)
75	Monza (exc. Towne Cpe.),			
73	Vega	8704406 A.R.	FT/3.75	(chamois)
73	Vega,			
74	All	9632351 A.R.	FT/10.30	(blue)
73	Vega	9630072 A.R.	FT/3.75	(orange)
73	Vega,			
74-75	All	9632198 A.R.	FT/10.90	(red)
74-75	All	9632185 A.R.	FT/4.45	(saddle) (1/4" cut pile)
74	All	9632188 A.R.	FT/4.15	(mid. blue)
74	All	9632191 A.R.	FT/4.15	(taupe)
74-75	All	9632195 A.R.	FT/4.45	(green) (1/4" pile)
74	All	9632352 A.R.	FT/10.90	(russet)
74	All	9632382 A.R.	FT/10.30	(gold)
75	All	9632944 A.R.	FT/6.50	(blue) (1/4" pile)
75	All	9632947 A.R.	FT/6.45	(sandstone) (1/4" pile)
75	All	9632946 A.R.	FT/6.50	(saddle)
75	All	9632952 A.R.	FT/10.65	(firethorn) (1/4" pile)
75	Nova (Custom exc. H.B.), Monza			
	(exc. Towne Cpe.)	9632945 A.R.	FT/6.50	(graystone) (1/4" pile)

**NEAR TRIM—MATS—YARDAGE**

**PET— YARDAGE, Doors, Seats, Cowl and Load Floor (Con't)**

		<b>9632936</b> A.R.	FT/7.80	(sandstone)
Sta. Wag., H.B.)		<b>9632937</b> A.R.	FT/15.95	(blue) (1/2" pile)
Sta. Wag., H.B.)		<b>9632939</b> A.R.	FT/7.80	(oxblood) (1/2" pile)

1: This part covers one linear foot.

**15.520 WINDLACE— LACE, Door (with filler)**

<b>71</b>	Pass., Chevelle (Conv.)	<b>4164686</b> A.R.	FT/2.50	top (black) (56" wide)
<b>68</b>	Pass. (Sta. Wag., Sed.) (exc. Spt. Sed.)	<b>7792257</b> A.R.	FT/.53	doors and qtrs. (comb. 816, 817, 818, 819, 820, 821) (dk. blue)
<b>68</b>	Pass. (Sed.) (exc. Spt. Sed.)	<b>7792258</b> A.R.	FT/.58	doors and qtrs. (comb. 831, 832, 833) (med. gold)
<b>62-64</b>	Chevy Deluxe (2nd type),			
<b>64</b>	Chevelle (exc. El Camino)	<b>4874823</b> A.R.	FT/1.10	doors, center pillars and lock pillars (comb. 731, 732, 735, 736, 738, 739, 740, 741, 742) (med. blue) (grained vinyl coated) (simulated type)
<b>63-64</b>	Nova (Spt. Cpe., Conv.),			
<b>64</b>	Malibu, S.S.	<b>4461397</b> A.R.	FT/.83	doors, center pillars and lock pillars (comb. 712, 715, 830, 869, 870, 878) (black) (grained vinyl coated) (simulated type)
<b>65</b>	Nova, Malibu,			
<b>66</b>	Chevy, Chevelle (exc. S.S.)	<b>4531278</b> A.R.	FT/1.10	doors, center pillars, and lock pillars (blue) (grained vinyl coated)
<b>65-66</b>	Nova, Malibu (S.S.),			
<b>66</b>	Malibu (Spt. Cpe., Conv.),			
<b>67</b>	Chevy, Chevelle, Camaro,			
<b>68</b>	Camaro	<b>4531284</b> A.R.	FT/1.10	doors, center pillars, and lock pillars (black) (grained vinyl coated)
<b>67</b>	Chevy, Chevelle, Camaro	<b>7696212</b> A.R.	FT/1.10	<b>LACE</b> , pinchweld (med. gold)

**15.530 LINING— FABRIC, Top and Well**

<b>65-70</b>	Conv.,			
<b>71</b>	Pass., Chevelle (Conv.)	<b>4164686</b> A.R.	FT/2.50	top (black) (56 wide)
<b>63</b>	Nova (Conv.),			
<b>64-70</b>	Malibu (Conv.),			
<b>65-70</b>	Pass. (Conv.),			
<b>67</b>	Camaro (Conv.),			
<b>71</b>	Pass., Chevelle (Conv.)	<b>4241739</b> A.R.	FT/4.35	<b>FABRIC</b> , well (black) (54" wide)
<b>73</b>	Pass. (Conv.)	<b>8706064</b> A.R.	FT/12.90	<b>FABRIC</b> , top lining (white)
<b>73-75</b>	Pass. (Conv.)	<b>8706065</b> A.R.	FT/3.75	<b>FABRIC</b> , top lining (black)
<b>73-75</b>	Pass. (Conv.)	<b>9630939</b> A.R.	FT/6.20	<b>FABRIC</b> , well lining (black)