

OLDSMOBILE ROCKETS AHEAD

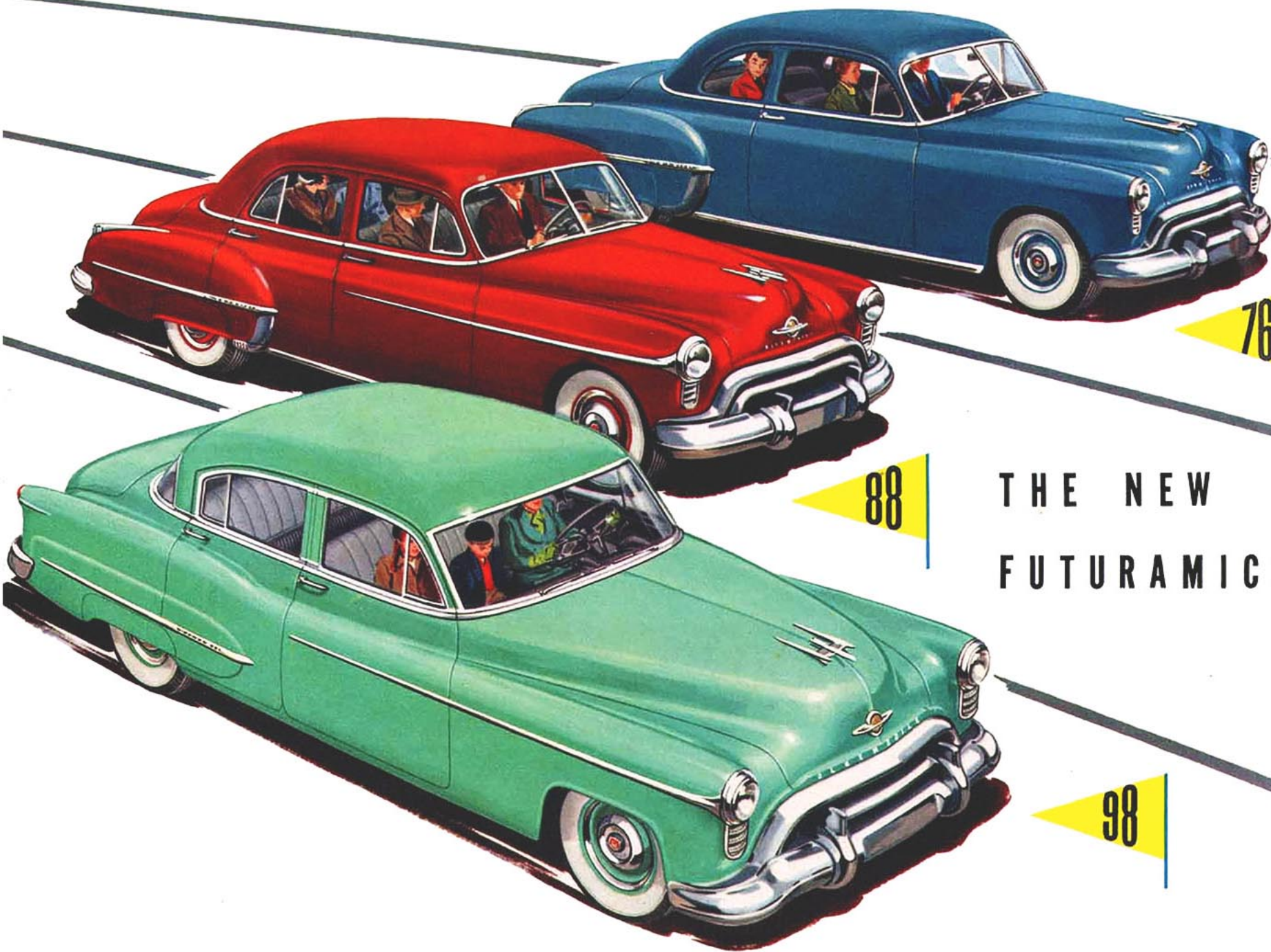

76

88

THE NEW  
FUTURAMICS

98

THE POWER SENSATION  
OF THE NATION

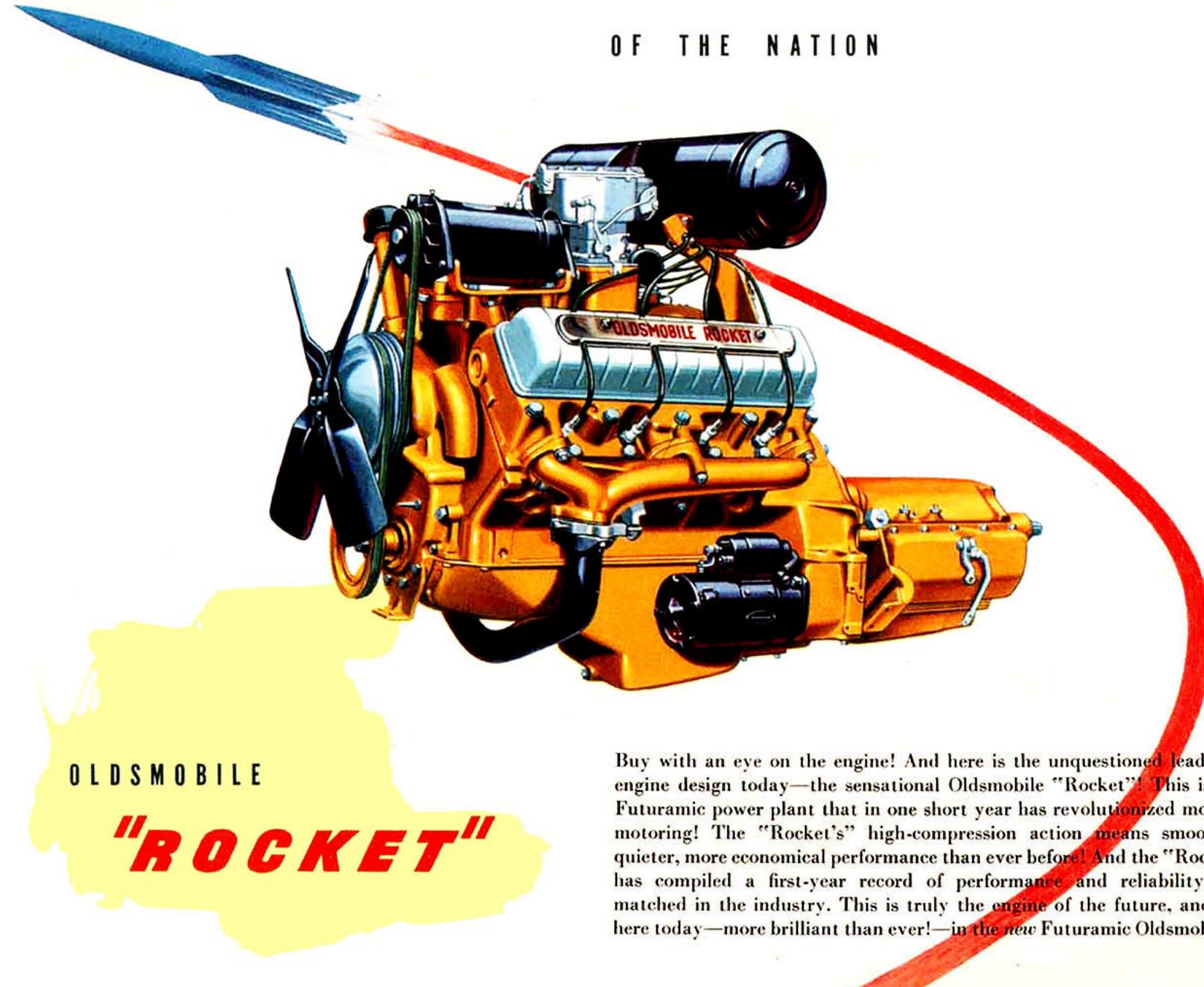

OLDSMOBILE

**"ROCKET"**

Buy with an eye on the engine! And here is the unquestioned leader in engine design today—the sensational Oldsmobile "Rocket"! This is the Futuramic power plant that in one short year has revolutionized modern motoring! The "Rocket's" high-compression action means smoother, quieter, more economical performance than ever before! And the "Rocket" has compiled a first-year record of performance and reliability unmatched in the industry. This is truly the engine of the future, and it's here today—more brilliant than ever!—in the *new* Futuramic Oldsmobiles!

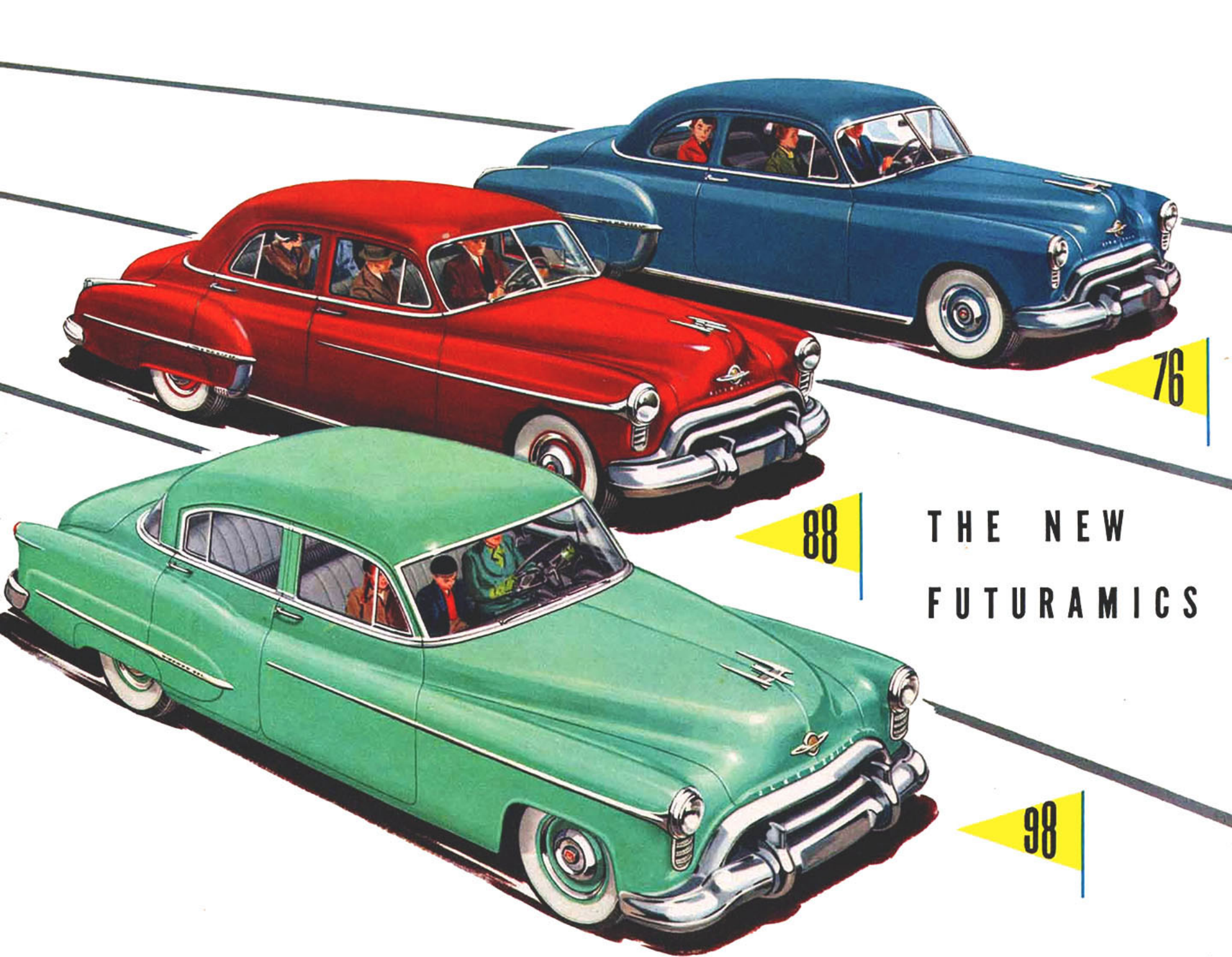

THE NEW  
FUTURAMICS

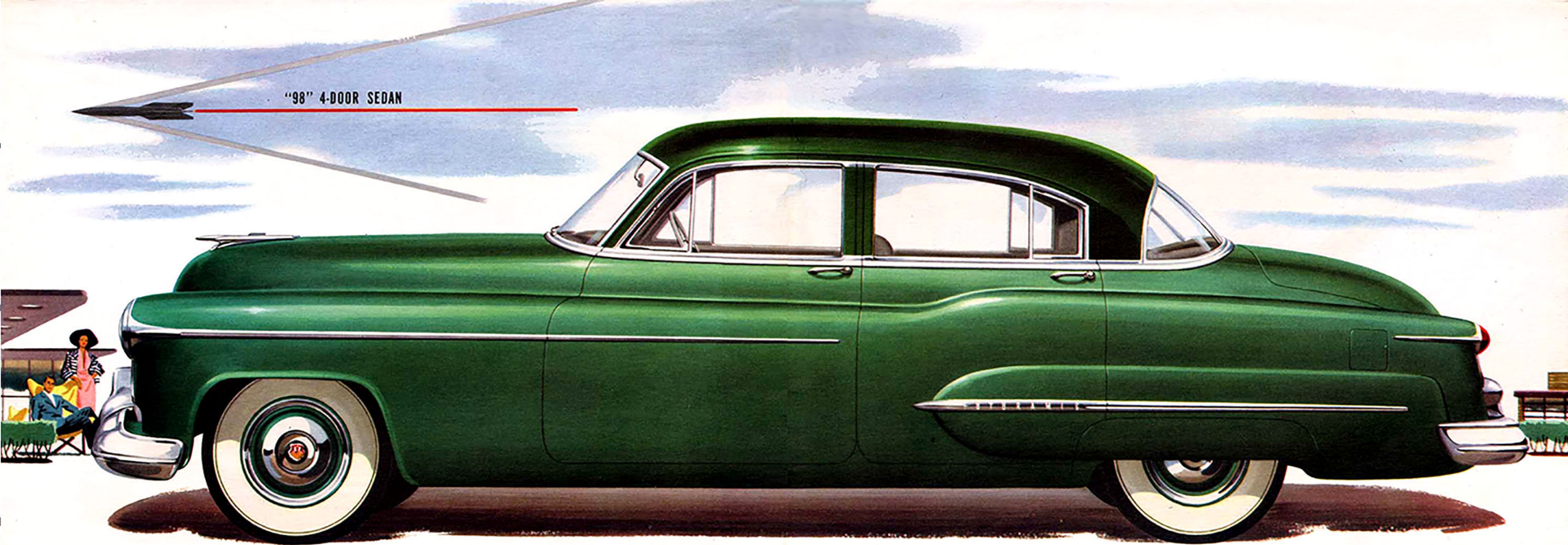

"98" 4-DOOR SEDAN

Here it is! Glamor leader of the Futuramic fleet—the luxurious new Oldsmobile "98"! A beautiful new Body by Fisher—the lowest and widest in Oldsmobile history. Dazzling new interiors—tailored and trimmed in new Futuramic fabrics and materials. Panoramic visibility in every direction! The windshield sweeps across in an

unbroken, one-piece arc of safety plate glass—the rear window curves all the way around to blend into the sides of the body. And for smooth-surging response and handling ease, this is the car that tops them all with Oldsmobile's Futuramic power package—the "Rocket" Engine and new Whirlaway Hydra-Matic Drive!

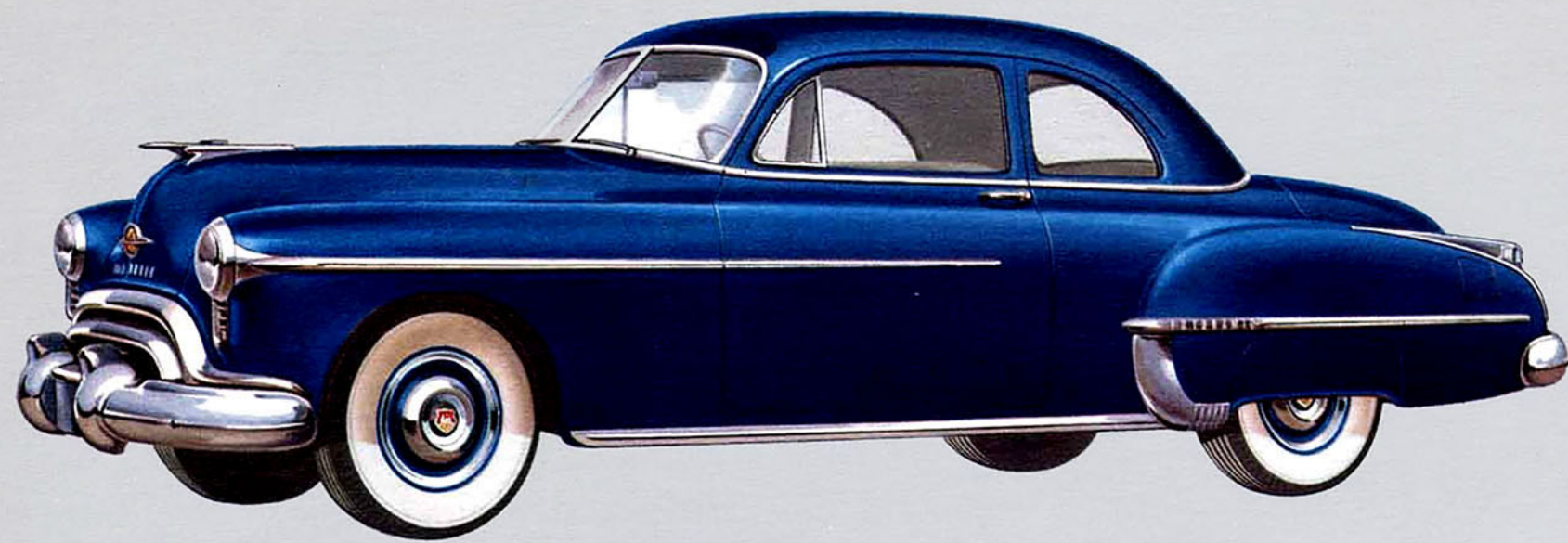

"88" CLUB COUPÉ

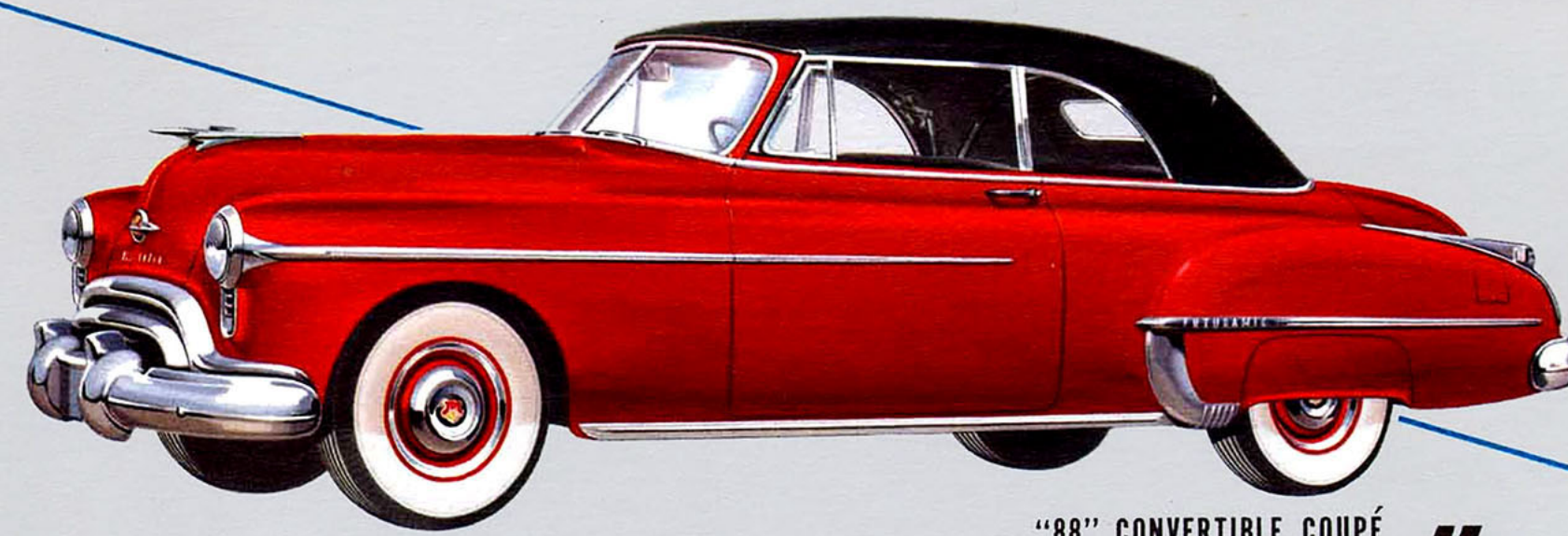

"88" CONVERTIBLE COUPÉ

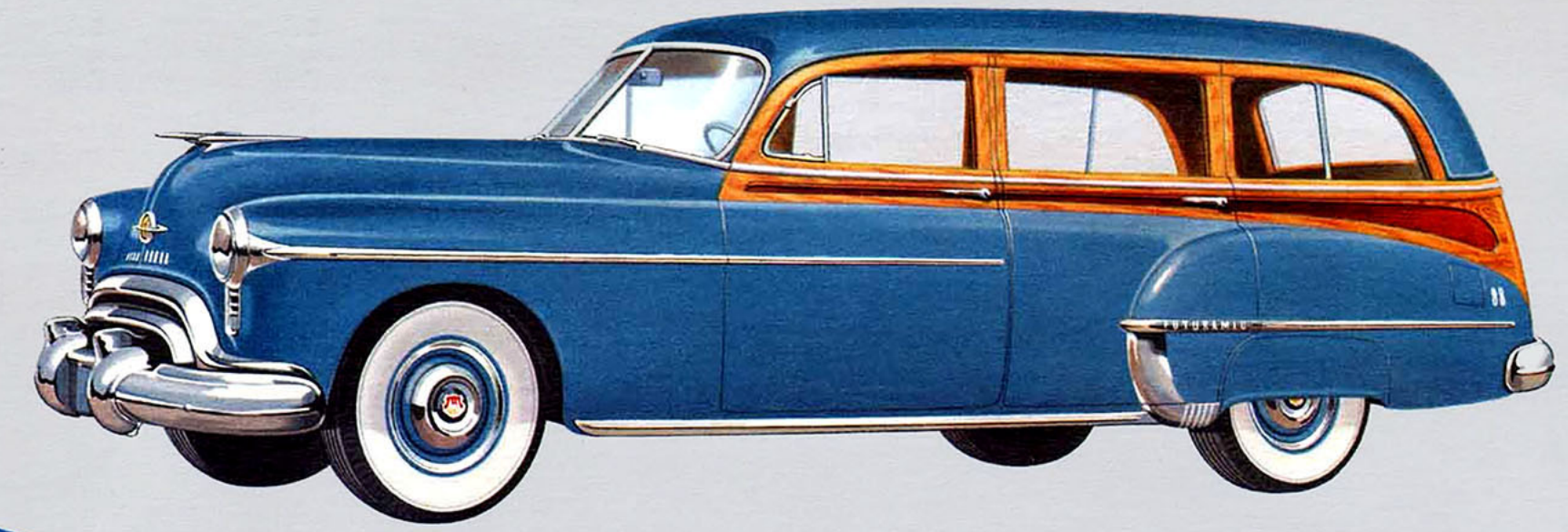

"88" STATION WAGON



"88" CLUB SEDAN

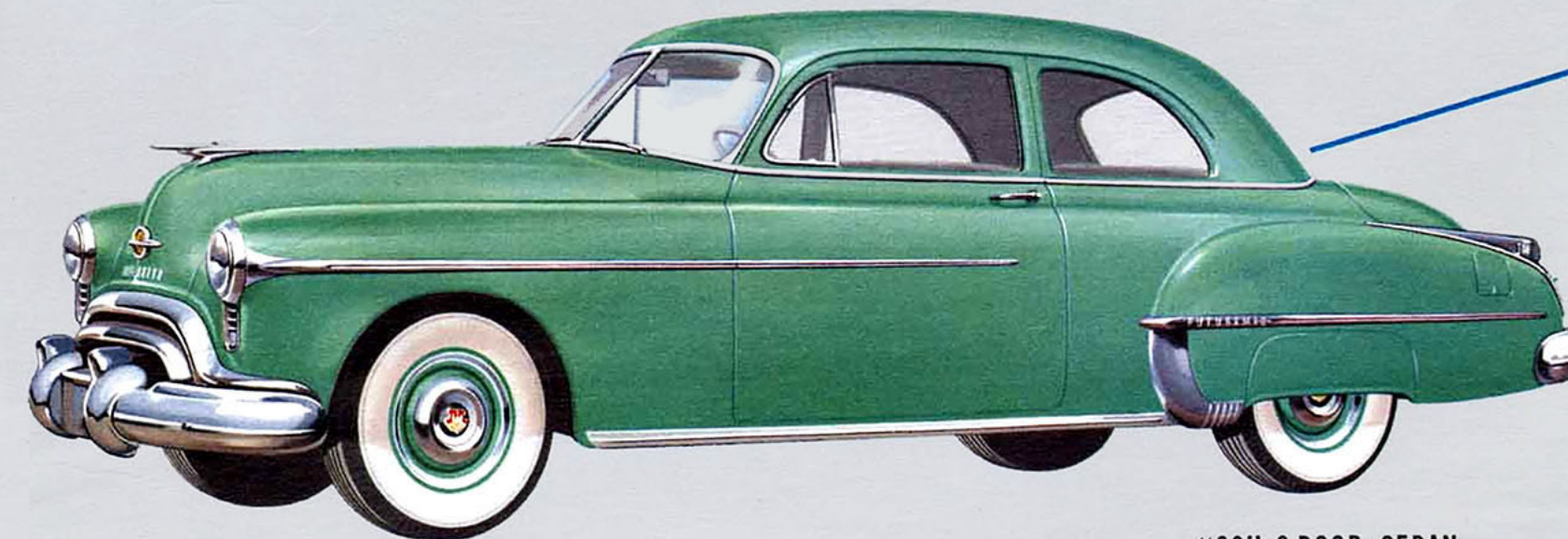

"88" 2-DOOR SEDAN

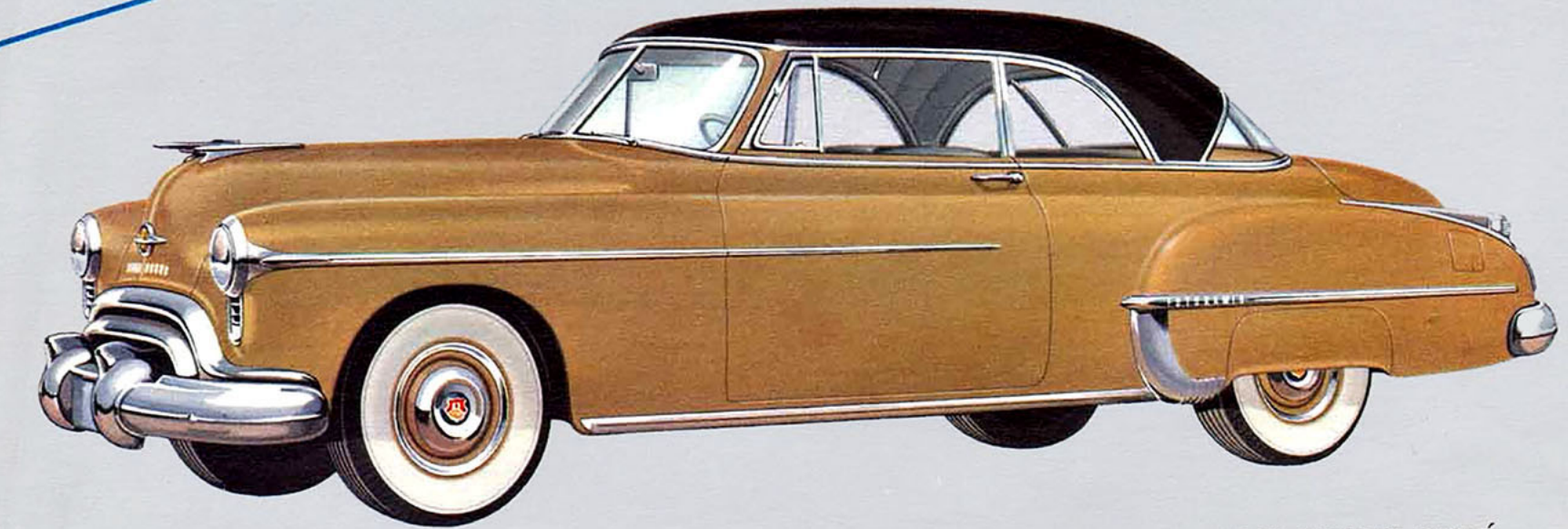

"88" HOLIDAY COUPÉ

FUTURAMIC OLDSMOBILE

"88"



NEW *Whirlaway* HYDRA-MATIC DRIVE  
MAKES "ROCKET" PERFORMANCE SMOOTHER THAN EVER



No gears to shift!  
Just sit and relax.  
Both hands are always  
free for steering—for  
signaling—for safety!

"Smooth—smoother than silk," you'll say when you experience the way new Whirlaway Hydra-Matic Drive pairs with the high-compression "Rocket" Engine. It's Oldsmobile's new "power package"—available in both the glamorous "98" and the famous "88" Oldsmobile! When you step down on the gas, you glide away on a magic carpet of smooth-going power. Saves on gas, too, as new Whirlaway Hydra-Matic is perfectly coordinated with the "Rocket" Engine for maximum efficiency from every ounce of fuel. It's another Oldsmobile first!

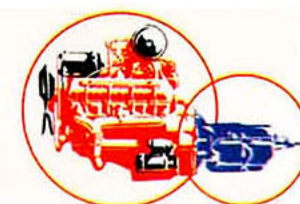

OLDSMOBILE'S FUTURAMIC POWER PACKAGE!

No clutch to push! It's the easiest car in the world to drive. Your left foot rests as you smoothly roll along.

A ROAD-HUGGING CHASSIS

FOR THAT WONDERFUL

*Air-Borne Ride*

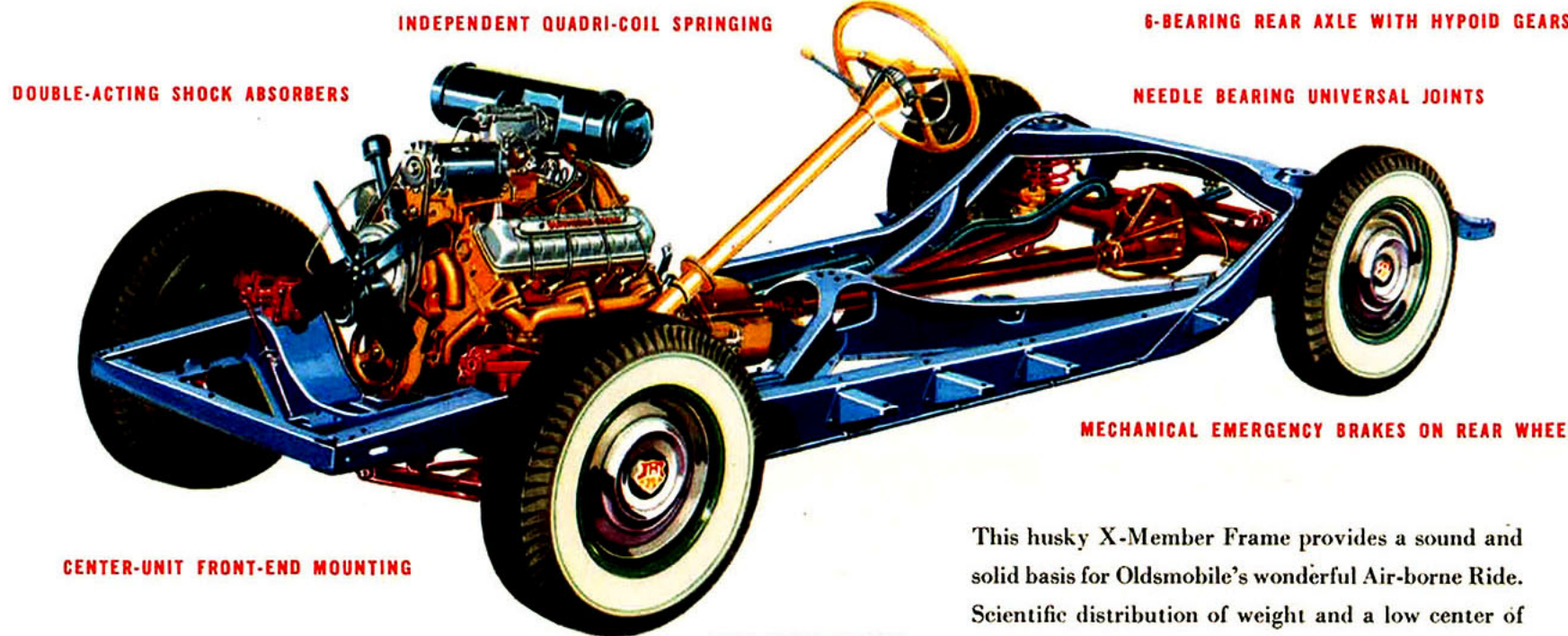

INDEPENDENT QUADRI-COIL SPRING

6-BEARING REAR AXLE WITH HYPOID GEARS

DOUBLE-ACTING SHOCK ABSORBERS

NEEDLE BEARING UNIVERSAL JOINTS

MECHANICAL EMERGENCY BRAKES ON REAR WHEELS

CENTER-UNIT FRONT-END MOUNTING

4-WAY STABILIZATION

SELF-ENERGIZING SUPER-HYDRAULIC BRAKES

This husky X-Member Frame provides a sound and solid basis for Oldsmobile's wonderful Air-borne Ride. Scientific distribution of weight and a low center of gravity mean more stability, more rugged roadability than ever! Every feature of the chassis assembly is tested and proven by the craftsmen of Oldsmobile. Every feature is designed with one thing in mind—to give you a safer, better ride on every kind of road.



Greater Vision  
and Luxury  
with Beautiful New  
Fisher Bodies



Luxurious new upholstery, including dazzling new nylon fabrics, highlights the interiors of the new Futuramics. Seats are broader, roomier, more comfortable—windows are wider, offering a new range of visibility. The inside trim is marked by a new and ultra-modern instrument cluster and a new steering wheel; in fact, every refinement for your motoring pleasure has been included.

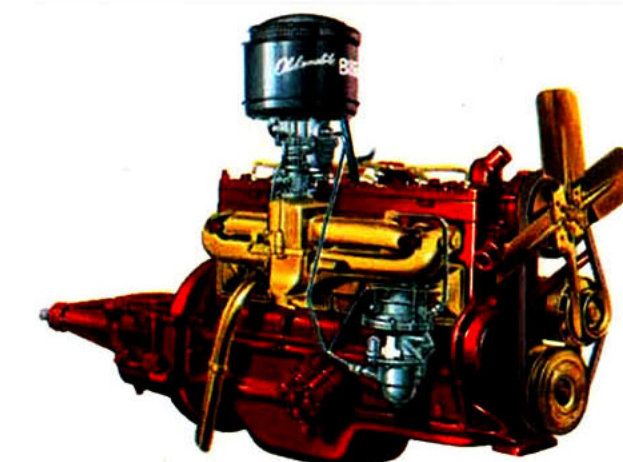

POWER-PACKED ECONOMICAL  
BIG SIX ENGINE

The Big Six Engine, powering the Futuramic Series "76" Oldsmobiles, more than matches many an eight in life and surging acceleration! 105 horsepower means plenty of "go!" And this rugged power plant has set an outstanding record for smooth, economical, trouble-free motoring.



"88" CLUB COUPÉ



"88" CONVERTIBLE COUPÉ

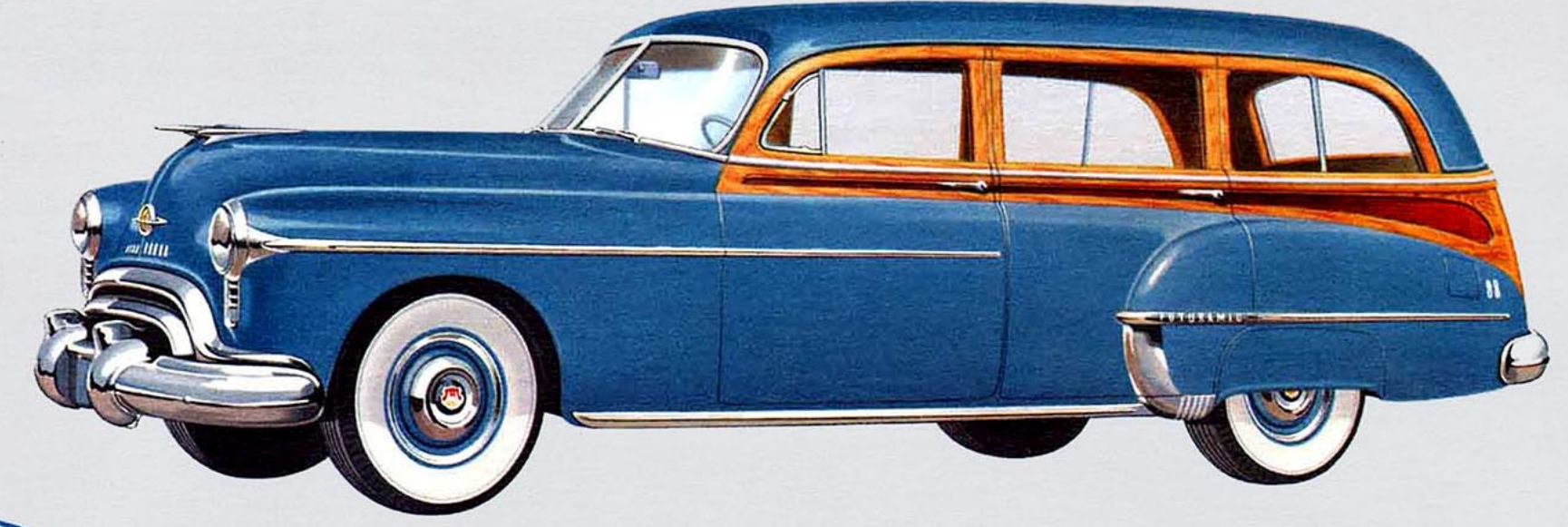

"88" STATION WAGON

FUTURAMIC OLDSMOBILE

"88"



"88" CLUB SEDAN

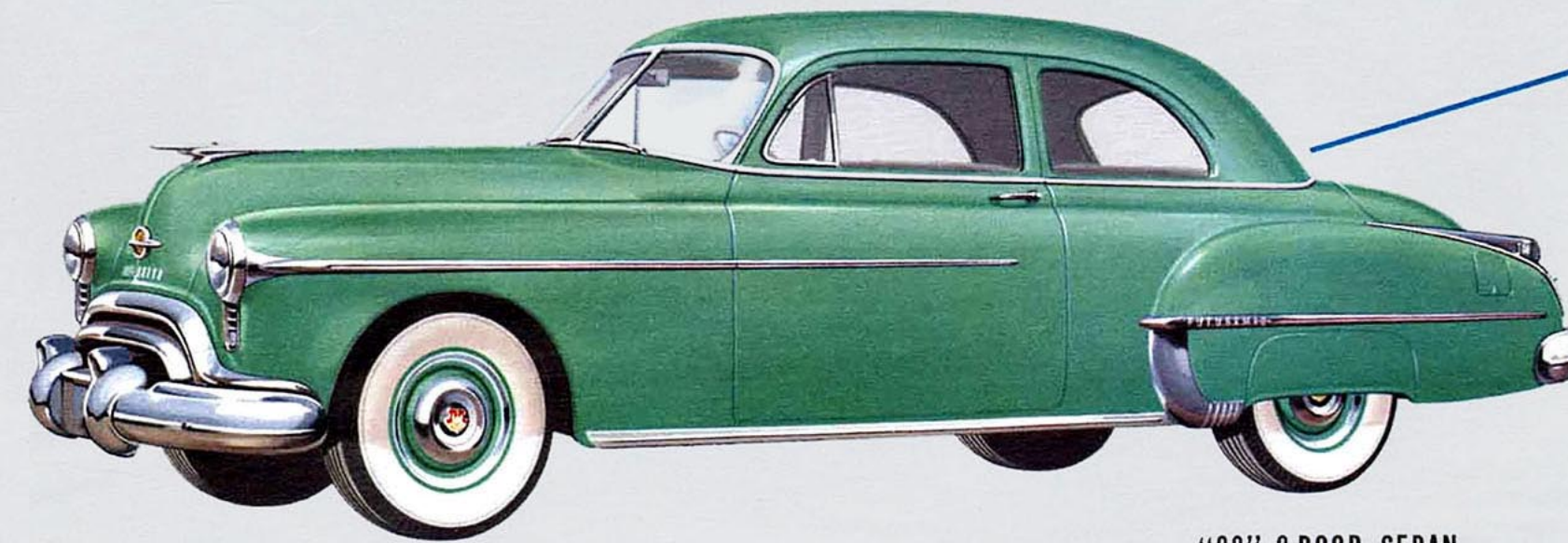

"88" 2-DOOR SEDAN

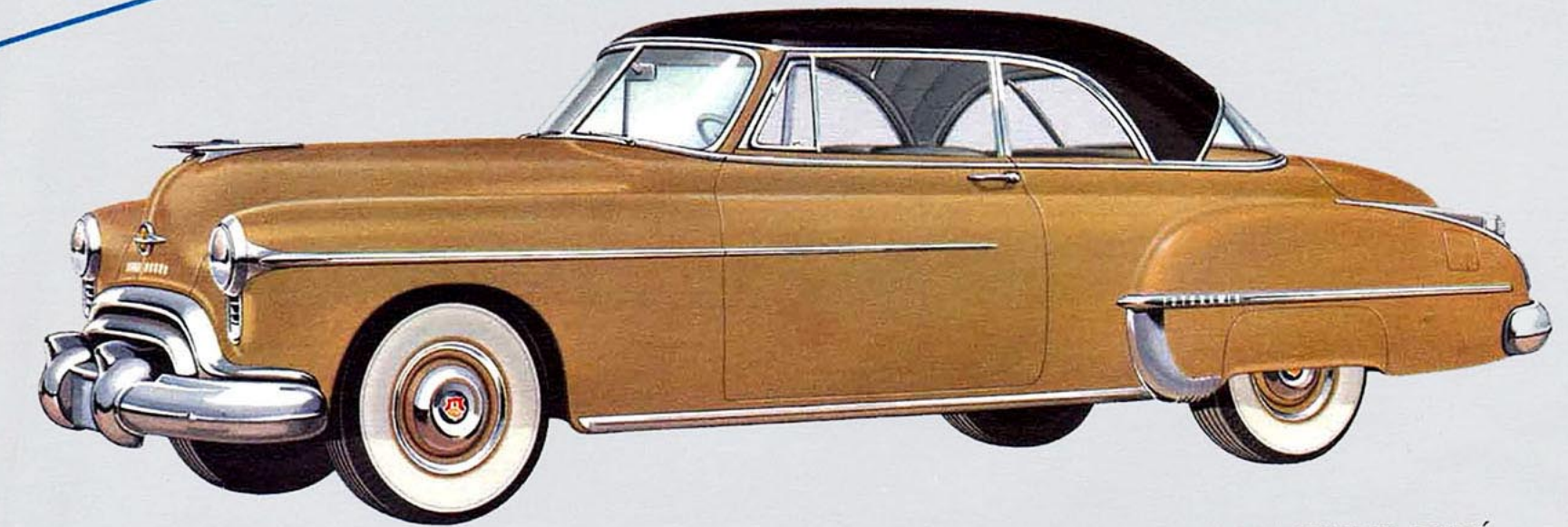

"88" HOLIDAY COUPÉ

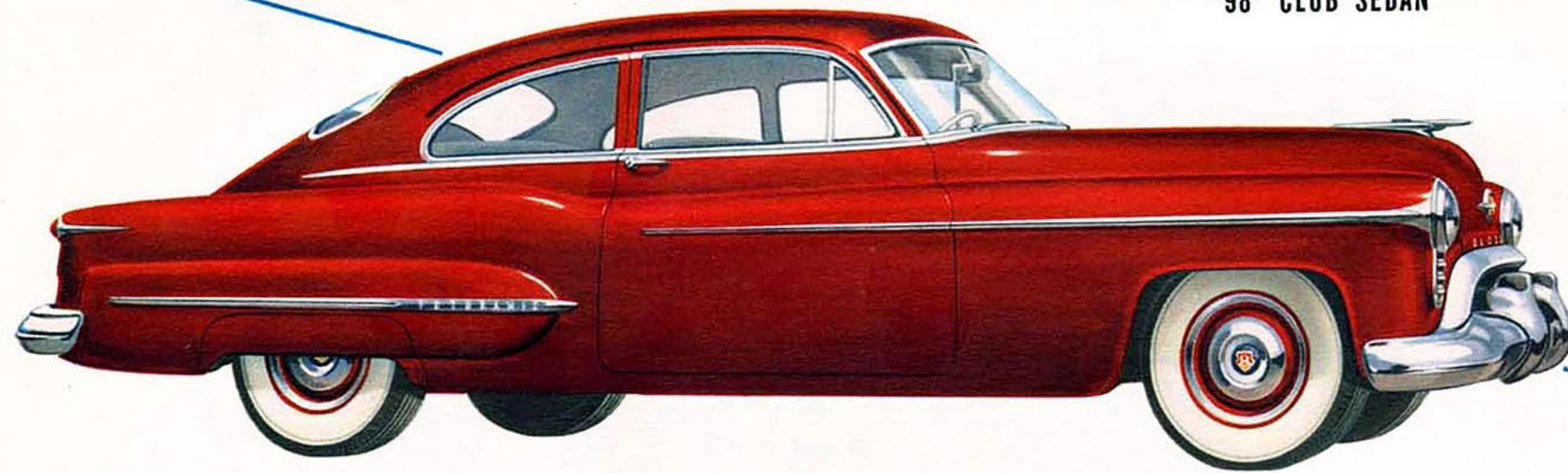

"98" CLUB SEDAN

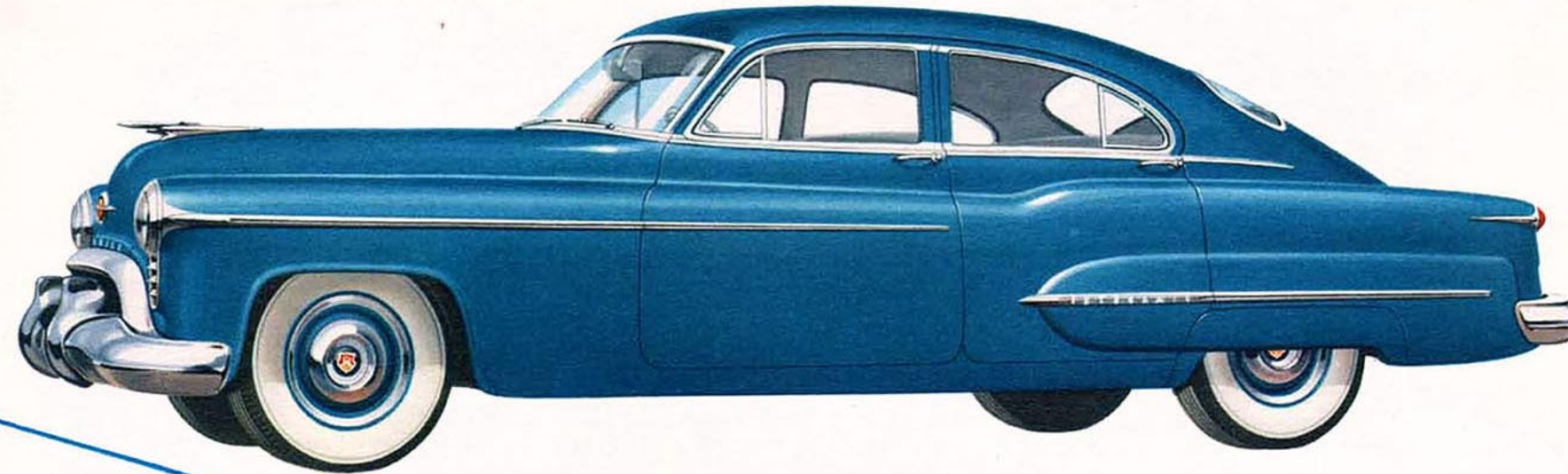

"98" 4-DOOR TOWN SEDAN



"88" 4-DOOR SEDAN

FUTURAMIC OLDSMOBILE

"98"

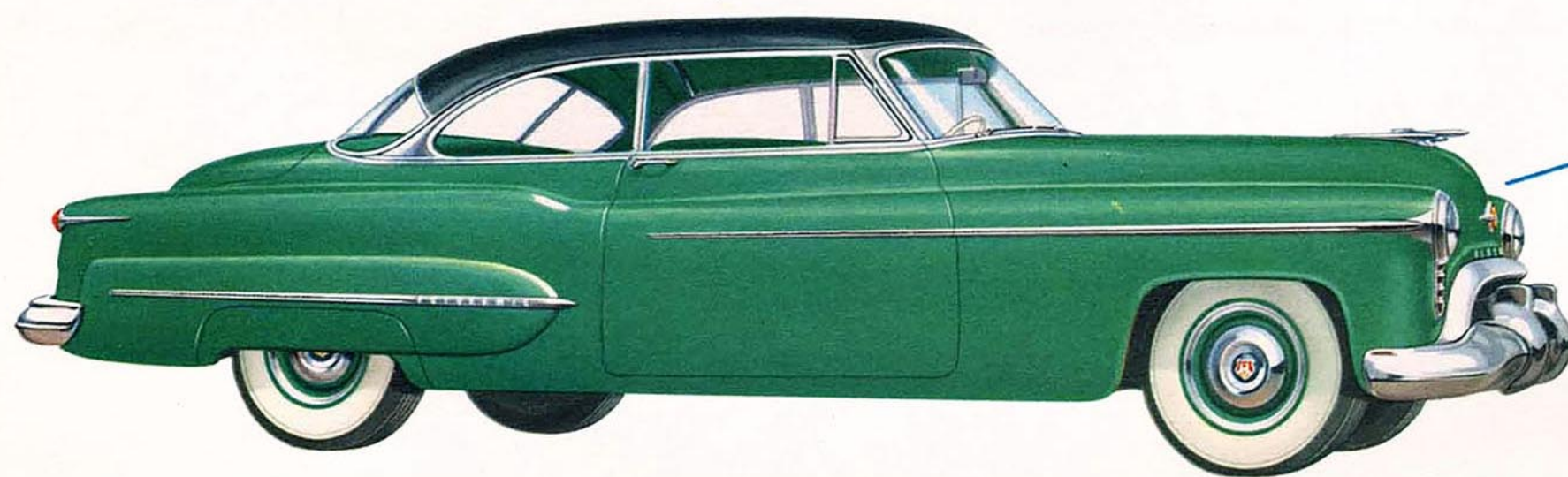

"98" HOLIDAY COUPÉ

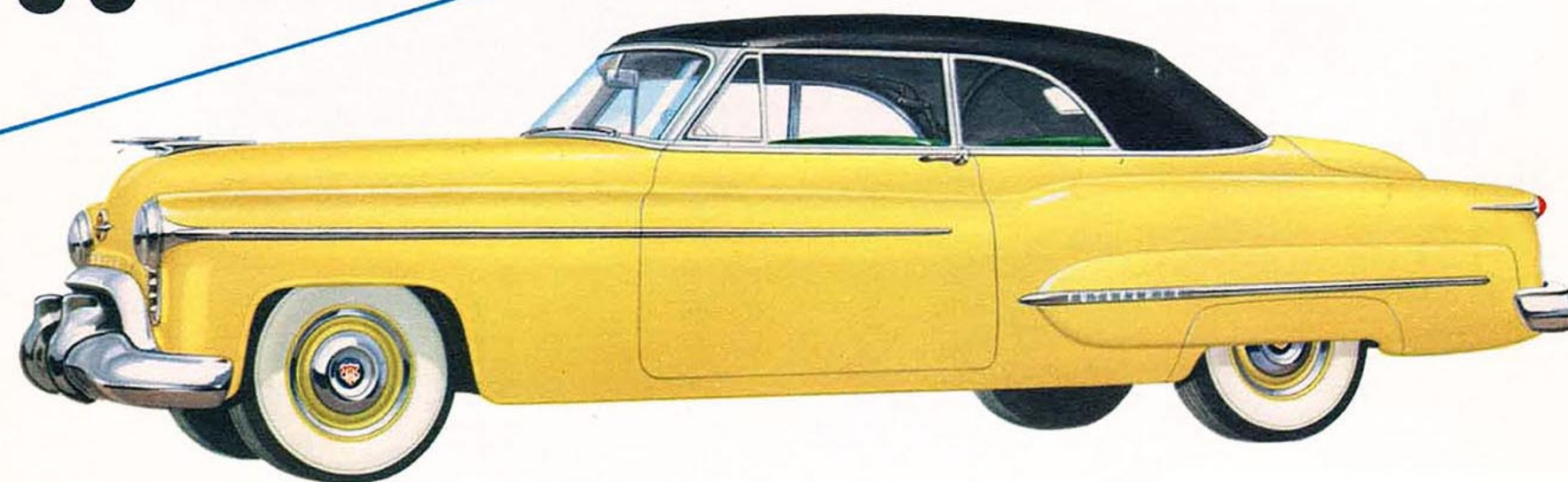

"98" CONVERTIBLE COUPÉ

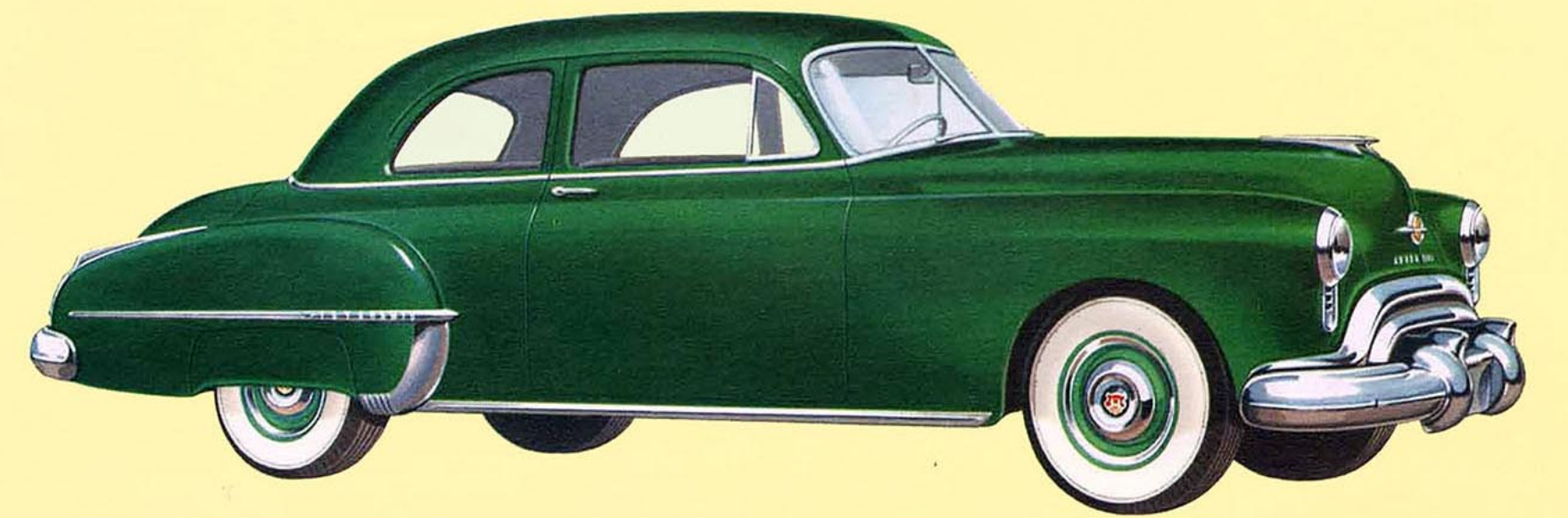

"76" 2-DOOR SEDAN



"76" CLUB COUPÉ

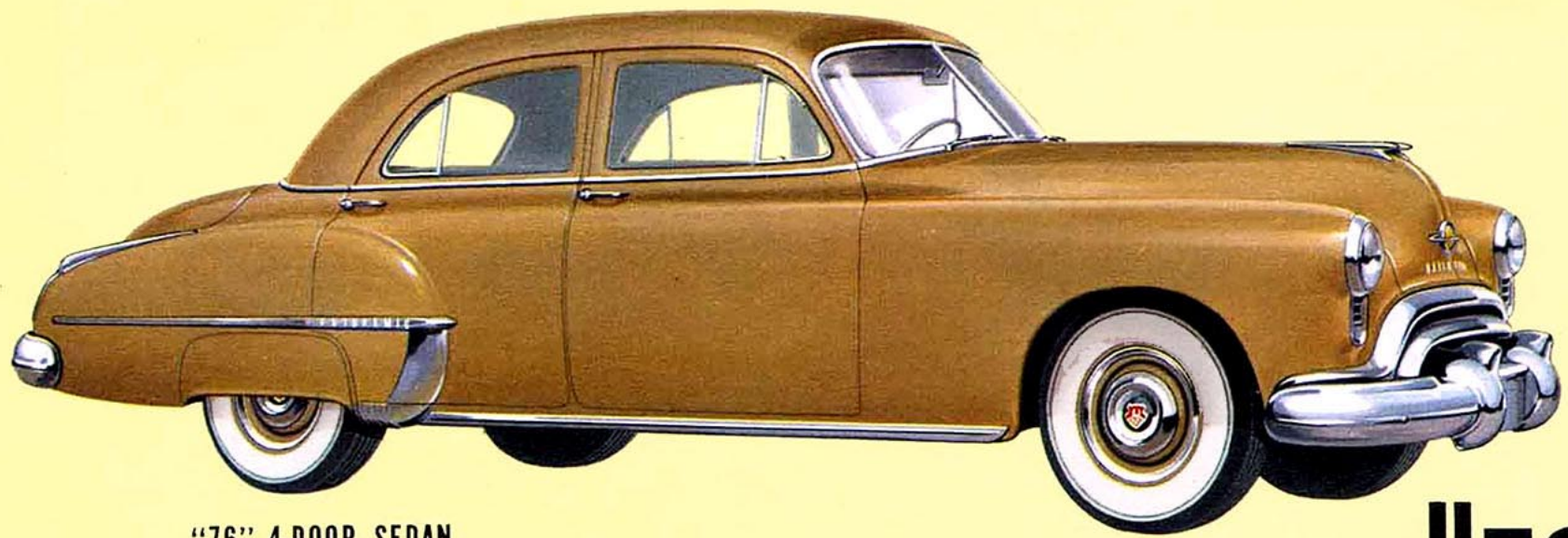

"76" 4-DOOR SEDAN

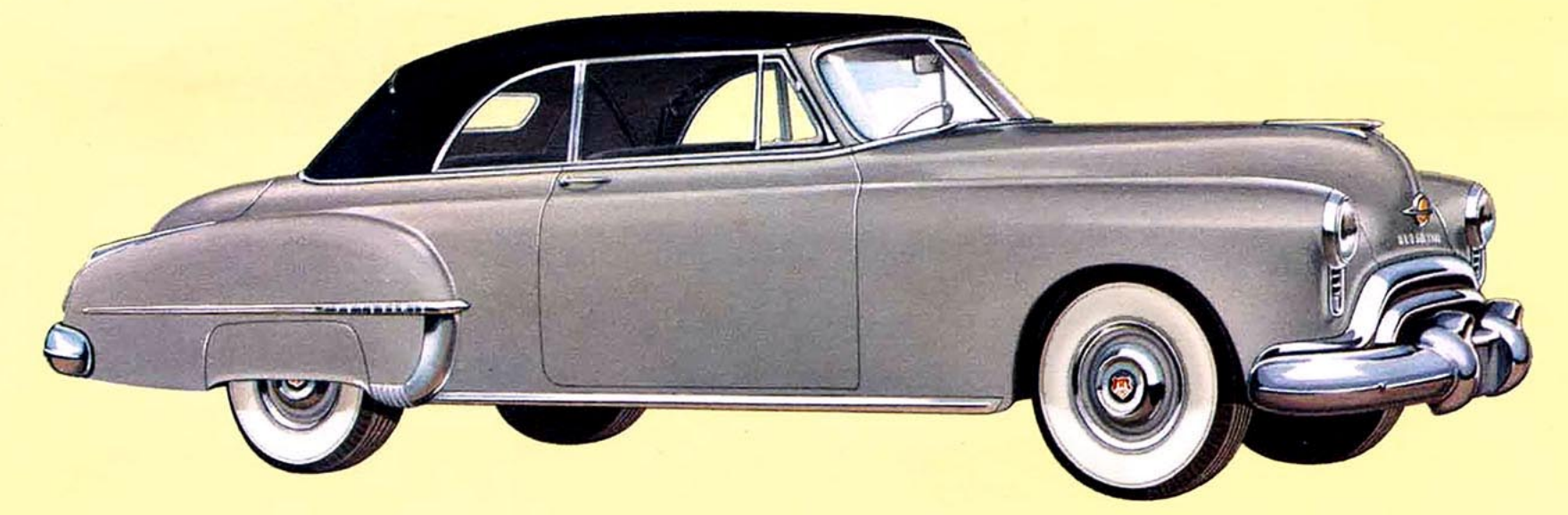

"76" CONVERTIBLE COUPÉ

FUTURAMIC OLDSMOBILE

"76"

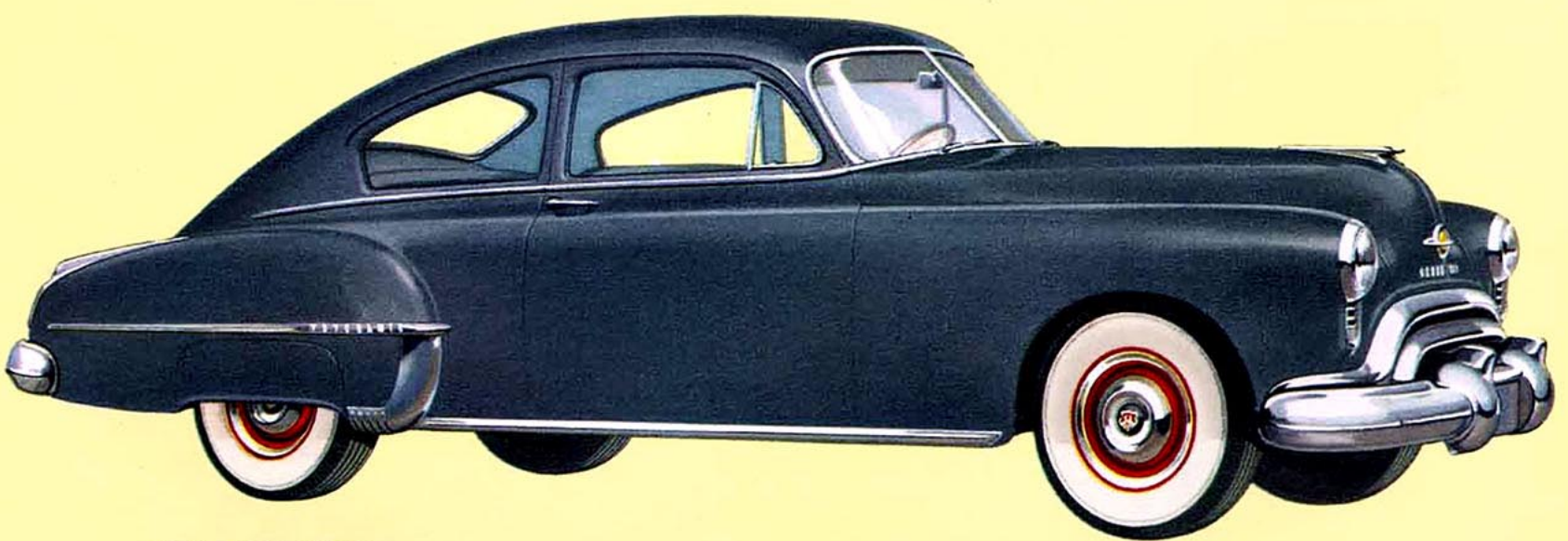

"76" CLUB SEDAN



"76" HOLIDAY COUPÉ



"76" STATION WAGON

All models shown carry deluxe trim. White sidewall tires and other accessories shown are optional at extra cost.

Here it is! Channor leader of the Futuramic Fleet—the luxurious new Oldsmobile Rocket. Panoramic visibility in every direction! The windshield sweeps across in an unbroken, one-piece arc of safety plate glass—the rear window curves all the way around to blend into the sides of the body. And for smooth-surfing response and handling ease, this is the car that tops them all with Oldsmobile's Futuramic power package—the "Rocket" Engine and new Whitway Hydra-Matic Drive!

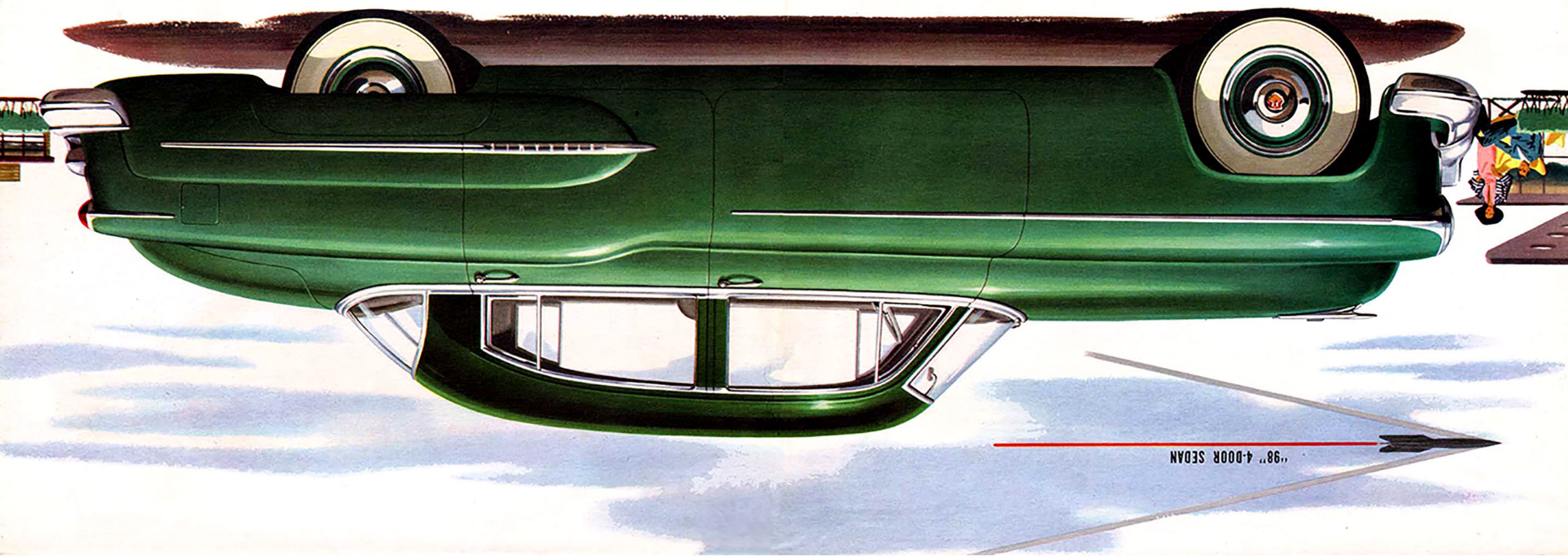

'49 4-DOOR SEDAN

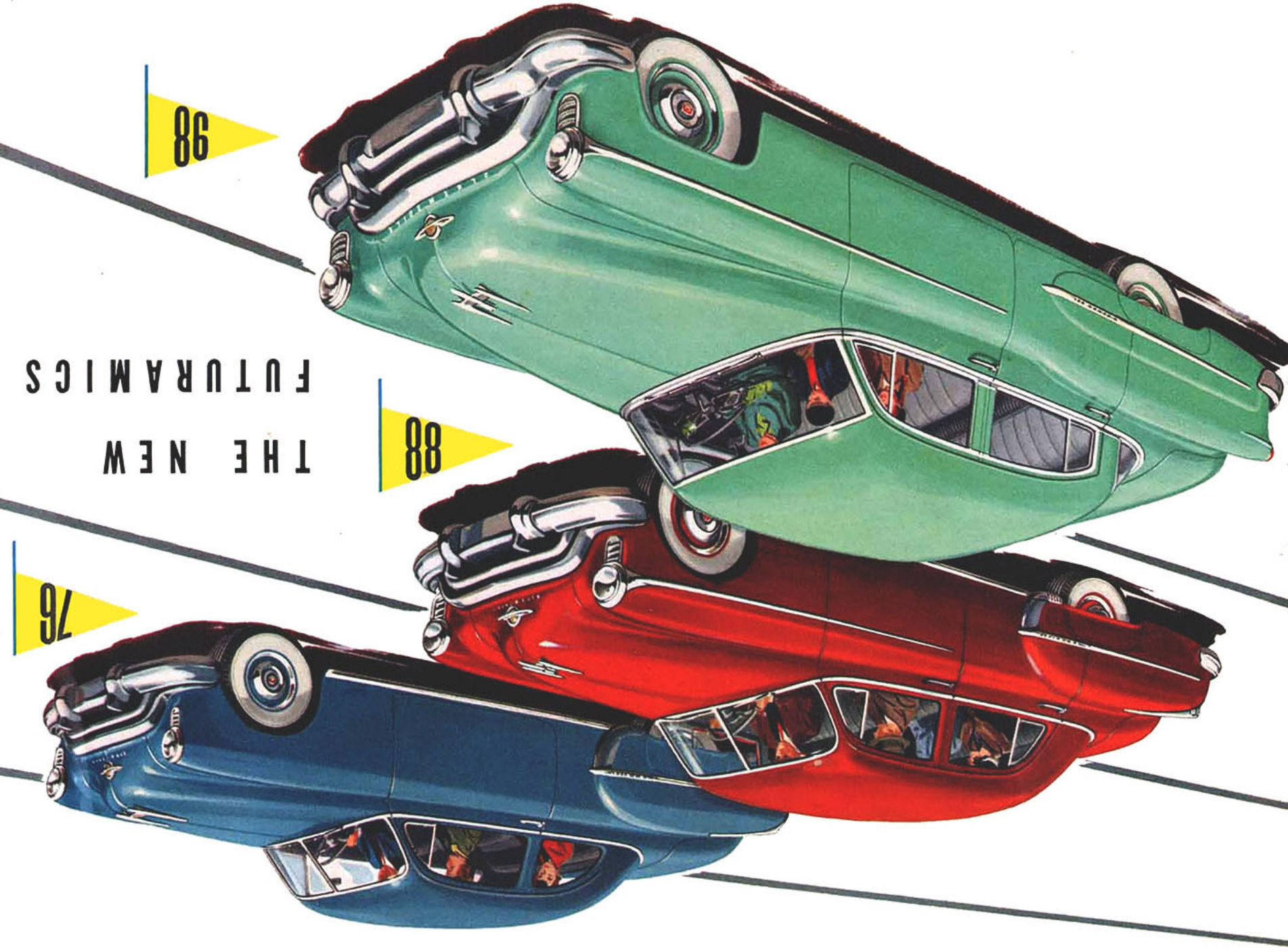

THE NEW  
FUTURAMICS

THE POWER SENSATION  
OF THE NATION

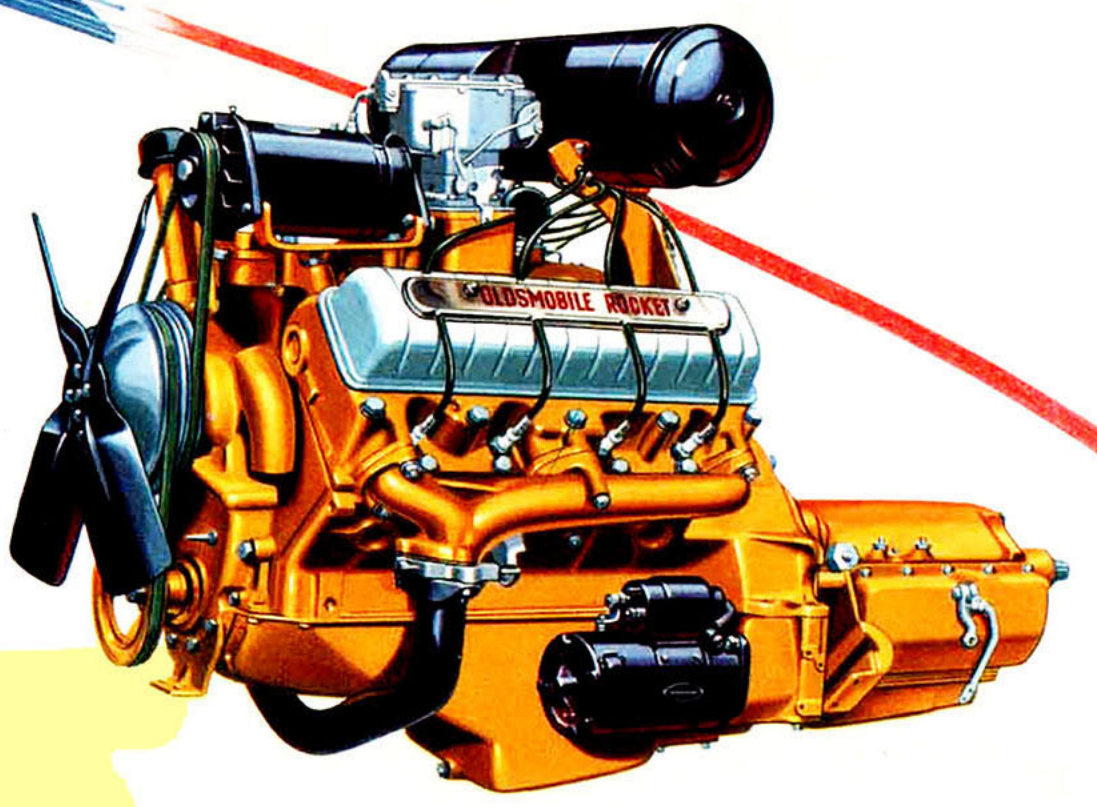

OLDSMOBILE  
"ROCKET"

Buy with an eye on the engine! And here is the unquestioned leader in engine design today—the sensational Oldsmobile "Rocket". This is the Futuramic power plant that in one short year has revolutionized modern motoring! The "Rocket's" high-compression action means smoother, quieter, more economical performance than ever before! And the "Rocket" has compiled a first-year record of performance and reliability unmatched in the industry. This is truly the engine of the future, and it's here today—more brilliant than ever!—in the new Futuramic Oldsmobiles!

SPECIFICATIONS

**"76"**  
SIX-CYLINDER ENGINE—The "BIG SIX"—Bore, 3 1/2 inches; stroke, 4 3/4 inches; displacement, 257 cubic inches. Taxable horsepower, 29.9. Brake horsepower, 105 at 3400 r.p.m. Electro-Hardened Aluminum Alloy Pistons fitted with two compression and two oil control rings. Full-pressure lubrication to all main, connecting rod, piston pin and camshaft bearings, timing chain, and cylinder walls.

FUEL AND COOLING SYSTEM—Down-draft carburetion with built-in automatic choke. Thermostatically controlled cooling and recirculation system. Ball-bearing, permanently lubricated water pump.

CLUTCH AND TRANSMISSION—Single plate, dry disc clutch. All-Silent Synco-Mesh Transmission.

HYDRA-MATIC DRIVE—Optional at extra cost.

ELECTRICAL SYSTEM—Under-hood battery, 15-plate, 100-ampere-hour capacity. Air-cooled generator with automatic charging control. Solenoid starter. Unit-type Sealed-Beam headlights with foot selector switch.

FRAME—Rigid-girder, channel X-Member construction.

SUSPENSION—Quadri-Coil Springing, with Knee-Action front suspension and heavy coil springs at rear. 4-Way Stabilization through dual stabilizing arms, front and rear ride stabilizers and lateral stabilizer at rear. Double-action hydraulic shock absorbers, front and rear.

STEERING—Dual Center-Control. Worm and double-roller design.

BRAKES—Super-Hydraulic, self-energizing type. Cast iron braking surfaces. Mechanical parking brake on rear wheels. All brakes completely sealed. Brake lining area, 159.8 square inches. Front lining, 11" x 2 1/2"; rear, 11" x 1 3/4".

TIRES—Low-pressure tires, 7.10 x 15. (Convertible and Station Wagon, 7.60 x 15.)

WHEELBASE—119 1/2 inches. TURNING CIRCLE DIAMETER—40 feet.

UNISTEEL TURRET-TOP BODIES BY FISHER, completely bodierized and finished with several coats of high grade lacquer.

BODY TYPES—Club Coupe, Convertible Coupe, Holiday Coupe, Club Sedan, 2-Door Sedan, 4-Door Sedan, Station Wagon. (Closed models, standard and de luxe equipment available, as ordered.)

ELECTRICAL SYSTEM—Under-hood battery, 17-plate, 115-ampere-hour capacity. Air-cooled generator with automatic charging control. Solenoid starter. Sealed-Beam headlights.

FRAME—Rigid-girder, channel X-Member type construction.

SUSPENSION—Knee-Action front suspension and heavy coil springs at rear. 4-Way Stabilization through dual stabilizing arms, front and rear ride stabilizers and lateral stabilizer at rear. Double-action hydraulic shock absorbers, front and rear.

STEERING—Dual Center-Control. Worm and double-roller.

BRAKES—Super-Hydraulic, self-energizing type. Cast iron braking surfaces. Mechanical parking brake on rear wheels. All brakes completely sealed. Brake lining area, 191.7 square inches. Front lining, 11" x 2 1/2"; rear lining, 11" x 2".

WHEELBASE—119 1/2 inches. TURNING CIRCLE DIAMETER—40 feet.

UNISTEEL TURRET-TOP BODIES BY FISHER, completely bodierized and finished with several coats of high grade lacquer.

BODY TYPES—Club Coupe, Convertible Coupe, Holiday Coupe, Club Sedan, 2-Door Sedan, 4-Door Sedan, Station Wagon. (Closed models, standard and de luxe equipment available, as ordered.)

HYDRA-MATIC DRIVE—Optional at extra cost.

ELECTRICAL SYSTEM—Under-hood battery, 17-plate, 115-ampere-hour capacity. Air-cooled generator with automatic charging control. Solenoid-type starter. Unit-type Sealed-Beam headlights with foot selector switch.

FRAME—Rigid-girder, channel X-Member construction.

SUSPENSION—Quadri-Coil Springing, with Knee-Action front suspension and heavy coil springs at rear. 4-Way Stabilization through dual stabilizing arms, front and rear ride stabilizers and lateral stabilizers at rear. Double-action hydraulic shock absorbers, front and rear.

STEERING—Dual Center-Control. Recirculating ball and nut.

TIRES—Low-pressure tires, 7.60 x 15 inches. (Convertible, 8.20 x 15.)

BRAKES—Super-Hydraulic, self-energizing type. Cast iron braking surfaces. Mechanical parking brake on rear wheels. All brakes completely sealed. Brake lining area, 191.7 square inches. Front lining, 11" x 2 1/2"; rear, 11" x 2".

WHEELBASE—122 inches. TURNING CIRCLE DIAMETER—42 feet.

UNISTEEL TURRET-TOP BODIES BY FISHER, completely bodierized and finished with several coats of high grade lacquer.

BODY TYPES—Convertible Coupe, Holiday Coupe, Club Sedan, 4-Door Town Sedan, 4-Door Sedan. (Closed models, standard and de luxe equipment available, as ordered.)

OLDSMOBILE RESERVES THE RIGHT TO MAKE CHANGES AT ANY TIME, WITHOUT NOTICE, IN PRICES, COLORS, MATERIALS, EQUIPMENT, SPECIFICATIONS AND MODELS, AND ALSO TO DISCONTINUE MODELS, WHITE SIDEWALL TIRES, AND OTHER ACCESSORIES AS ILLUSTRATED, OPTIONAL AT EXTRA COST. COPYRIGHT 1949, OLDSMOBILE DIVISION, GENERAL MOTORS CORP., LANSING, MICH., U.S.A.

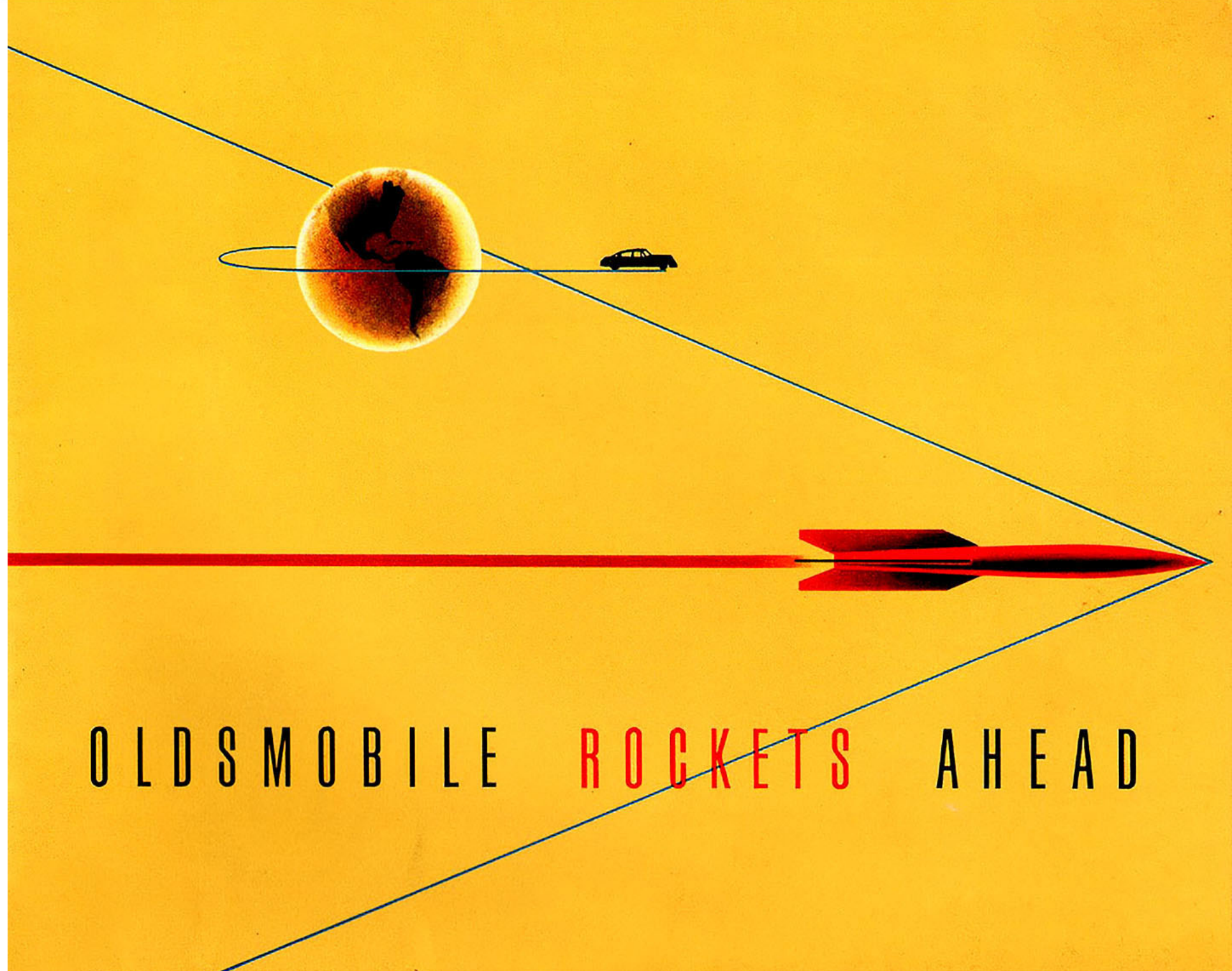

The Big Six engine, powering the Futuramic Series "76" Oldsmobiles, more than matches many an eight in life and surging acceleration! 105 horsepower means plenty of "go"! And this rugged power plant has set an outstanding record for smooth, economical, trouble-free motoring.

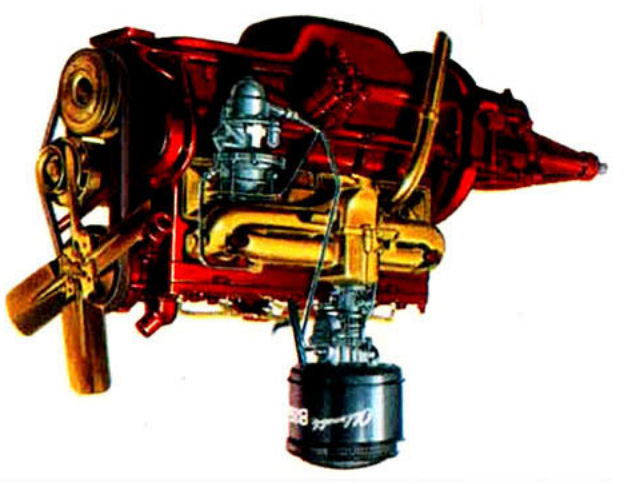

POWER-PACKED ECONOMICAL  
BIG SIX ENGINE

Luxurious new upholstery, including dazzling new nylon fabrics, highlights the interiors of the new Futuramic. Seats are broader, roomier, more comfortable—windows are wider, offering a new range of visibility. The inside trim is marked by a new and ultra-modern instrument cluster and a new steering wheel. In fact, every refinement for your motoring pleasure has been included.

Greater Vision and Luxury With Beautiful New Fisher Bodies



This husky X-Member Frame provides a sound and solid basis for Oldsmobile's wonderful Air-Borne Ride. Scientific distribution of weight and a low center of gravity mean more stability, more rugged roadability than ever! Every feature of the chassis assembly is tested and proven by the craftsmen of Oldsmobile. Every feature is designed with one thing in mind—to give you a safer, better ride on every kind of road.

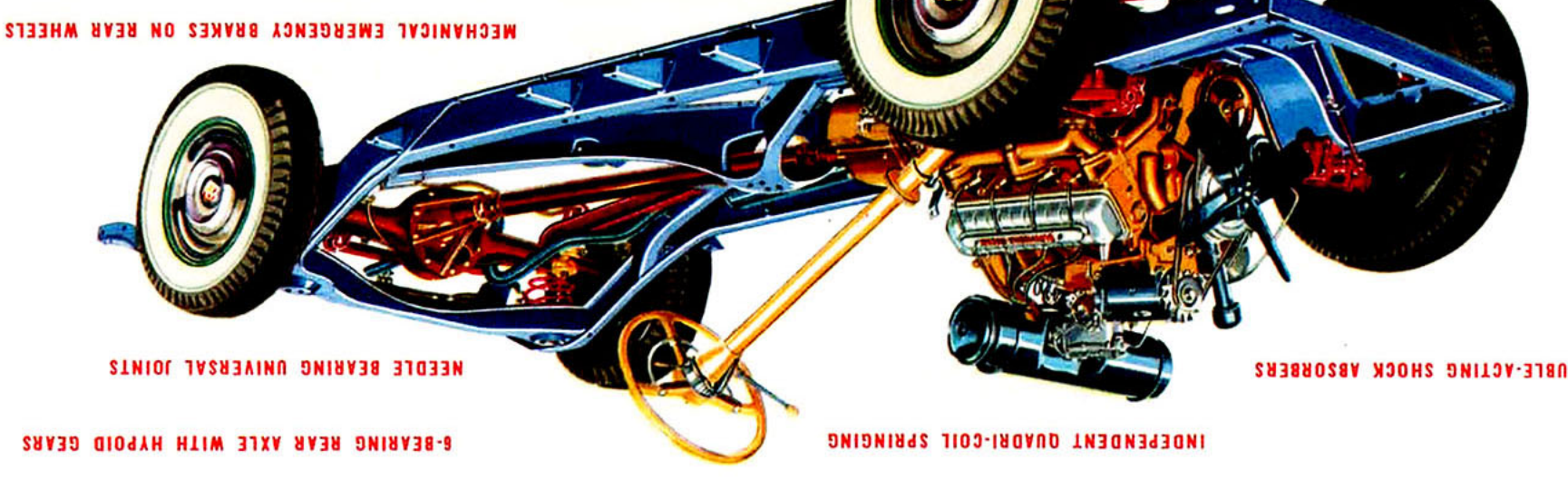

A ROAD-HUGGING CHASSIS FOR THAT WONDERFUL Air-Borne Ride

OSMOBILE'S FUTURAMIC POWER PACKAGE!

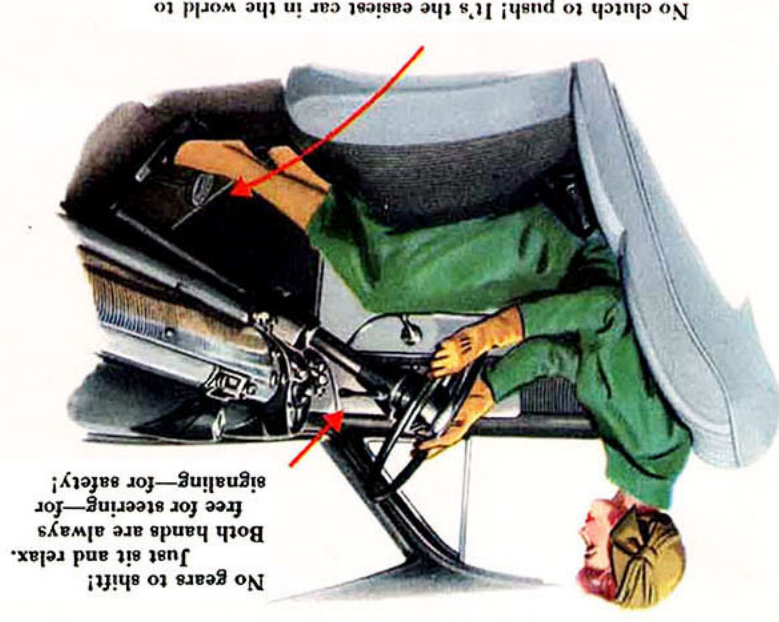

"Smooth—smoother than silk," you'll say when you experience the way new Whitway Hydra-Matic Drive pairs with the high-compression "Rocket" engine. It's Oldsmobile's new "power package"—available in both the glamorous "98" and the famous "88" Oldsmobile! When you step down on the gas, you glide away on a magic carpet of smooth-going power. Saves on gas, too, as new Whitway Hydra-Matic is perfectly coordinated with the "Rocket" Engine for maximum efficiency from every ounce of fuel. It's another Oldsmobile first!

No gears to shift! Just sit and relax. Both hands are always free for steering—for signaling—for safety!

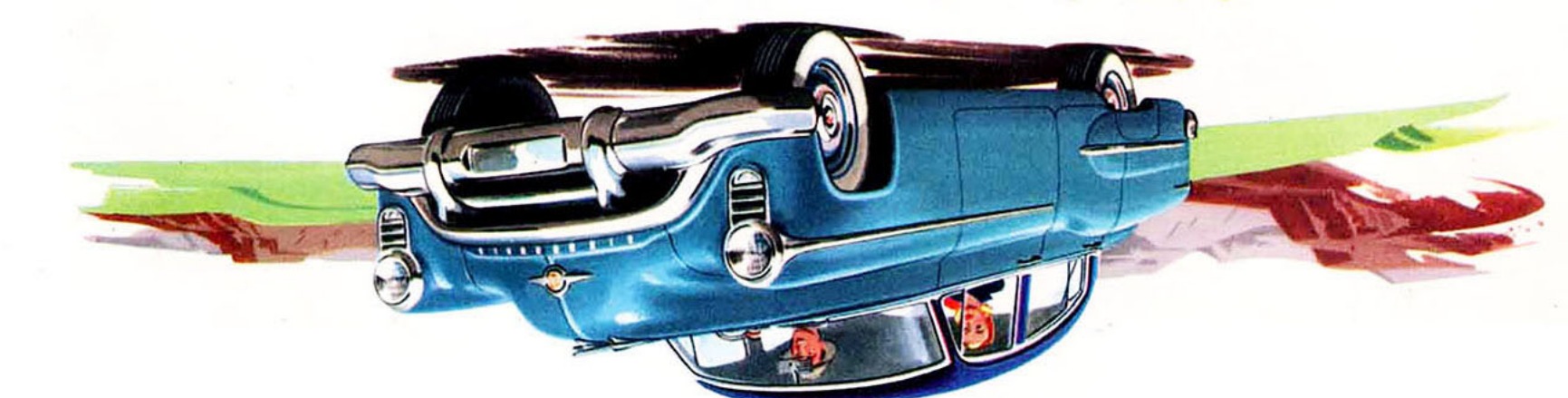

NEW Whitway HYDRA-MATIC DRIVE MAKES "ROCKET" PERFORMANCE SMOOTHER THAN EVER

# SPECIFICATIONS

## "76"

**SIX-CYLINDER ENGINE**—The "BIG SIX"—Bore,  $3\frac{1}{2}$  inches; stroke,  $4\frac{3}{8}$  inches; displacement, 257 cubic inches. Taxable horsepower, 29.9. Brake horsepower, 105 at 3400 r.p.m. Electro-Hardened Aluminum Alloy Pistons fitted with two compression and two oil control rings. Full-pressure lubrication to all main, connecting rod, piston pin and camshaft bearings, timing chain, and cylinder walls.

**FUEL AND COOLING SYSTEM**—Down-draft carburetion with built-in automatic choke. Thermostatically controlled cooling and recirculation system. Ball-bearing, permanently lubricated water pump.

**CLUTCH AND TRANSMISSION**—Single plate, dry disc clutch. All-Silent Synco-Mesh Transmission.

**HYDRA-MATIC DRIVE**—Optional at extra cost.

**ELECTRICAL SYSTEM**—Under-hood battery, 15-plate, 100-ampere-hour capacity. Air-cooled generator with automatic charging control. Solenoid starter. Unit-type Sealed-Beam headlights with foot selector switch.

**FRAME**—Rigid-girder, channel X-Member construction.

**SUSPENSION**—Quadri-Coil Springing, with Knee-Action front suspension and heavy coil springs at rear. 4-Way Stabilization through dual stabilizing arms, front and rear ride stabilizers and lateral stabilizer at rear. Double-action hydraulic shock absorbers, front and rear.

**STEERING**—Dual Center-Control. Worm and double-roller design.

**BRAKES**—Super-Hydraulic, self-energizing type. Cast iron braking surfaces. Mechanical parking brake on rear wheels. All brakes completely sealed. Brake lining area, 159.8 square inches. Front lining,  $11" \times 2"$ ; rear,  $11" \times 1\frac{3}{4}"$ .

**TIRES**—Low-pressure tires, 7.10 x 15. (Convertible and Station Wagon, 7.60 x 15.)

**WHEELBASE**—119½ inches. TURNING CIRCLE DIAMETER—40 feet.

**UNISTEEL TURRET-TOP BODIES BY FISHER**, completely bonderized and finished with several coats of high grade lacquer.

**BODY TYPES**—Club Coupe, Convertible Coupe, Holiday Coupe, Club Sedan, 2-Door Sedan, 4-Door Sedan, Station Wagon. (Closed models, standard and de luxe equipment available, as ordered.)

## "88"

**EIGHT-CYLINDER ENGINE**—The "ROCKET"—Bore,  $3\frac{3}{4}$  inches; stroke,  $3\frac{1}{8}$  inches; displacement, 303 cubic inches. Taxable horsepower, 45. Brake horsepower, 135 at 3600 r.p.m. Pistons are of the Auto-Thermic type reinforced with two steel struts—with two compression and one oil control rings. Full-pressure lubrication to all main, connecting rod, and camshaft bearings, distributor drive gear, timing chain, and cylinder walls.

**FUEL AND COOLING SYSTEM**—Down-draft carburetion with built-in automatic choke. Thermostatically controlled cooling and recirculation system. Ball-bearing, leakproof, permanently lubricated water pump.

**CLUTCH AND TRANSMISSION**—10½-inch single plate semi-centrifugal dry disc clutch, Synco-Mesh Transmission.

**HYDRA-MATIC DRIVE**—Optional at extra cost.

**ELECTRICAL SYSTEM**—Under-hood battery, 17-plate, 115-ampere-hour capacity. Air-cooled generator with automatic charging control. Solenoid starter. Sealed-Beam headlights.

**FRAME**—Rigid-girder, channel X-Member type construction.

**SUSPENSION**—Knee-Action front suspension and heavy coil springs at rear. 4-Way Stabilization through dual stabilizing arms, front and rear ride stabilizers and lateral stabilizer at rear. Double-action hydraulic shock absorbers, front and rear.

**STEERING**—Dual Center-Control. Worm and double-roller.

**TIRES**—7.60 x 15. Low-pressure tires.

**BRAKES**—Super-Hydraulic, self-energizing type. Cast iron braking surfaces. Mechanical parking brake on rear wheels. All brakes completely sealed. Brake lining area, 191.7 square inches. Front lining,  $11" \times 2\frac{1}{2}"$ ; rear lining,  $11" \times 2"$ .

**WHEELBASE**—119½ inches. TURNING CIRCLE DIAMETER—40 feet.

**UNISTEEL TURRET-TOP BODIES BY FISHER**, completely bonderized and finished with several coats of high grade lacquer.

**BODY TYPES**—Club Coupe, Convertible Coupe, Holiday Coupe, Club Sedan, 2-Door Sedan, 4-Door Sedan, Station Wagon. (Closed models, standard and de luxe equipment available, as ordered.)

## "98"

**EIGHT-CYLINDER ENGINE**—The "ROCKET"—Bore,  $3\frac{3}{4}$  inches; stroke,  $3\frac{1}{8}$  inches; displacement, 303 cubic inches. Taxable horsepower, 45. Brake horsepower, 135 at 3600 r.p.m. Pistons are of the Auto-Thermic type reinforced with two steel struts—with two compression and one oil control rings. Full-pressure lubrication to all main, connecting rod, and camshaft bearings, distributor drive gear, timing chain, and cylinder walls.

**FUEL AND COOLING SYSTEM**—Dual down-draft carburetion with automatic choke. Thermostatically controlled cooling and recirculation system. Ball-bearing, leakproof, permanently lubricated water pump.

**CLUTCH AND TRANSMISSION**—10½-inch single plate semi-centrifugal dry disc clutch, Synco-Mesh Transmission.

**HYDRA-MATIC DRIVE**—Optional at extra cost.

**ELECTRICAL SYSTEM**—Under-hood battery, 17-plate, 115-ampere-hour capacity. Air-cooled generator with automatic charging control. Solenoid-type starter. Unit-type Sealed-Beam headlights with foot selector switch.

**FRAME**—Rigid-girder, channel X-Member construction.

**SUSPENSION**—Quadri-Coil Springing, with Knee-Action front suspension and heavy coil springs at rear. 4-Way Stabilization through dual stabilizing arms, front and rear stabilizers and lateral stabilizers at rear. Double-action hydraulic shock absorbers, front and rear.

**STEERING**—Dual Center-Control. Recirculating ball and nut.

**TIRES**—Low-pressure tires, 7.60 x 15 inches. (Convertible, 8.20 x 15.)

**BRAKES**—Super-Hydraulic, self-energizing type. Cast iron braking surfaces. Mechanical parking brake on rear wheels. All brakes completely sealed. Brake lining area, 191.7 square inches. Front lining,  $11" \times 2\frac{1}{2}"$ ; rear,  $11" \times 2"$ .

**WHEELBASE**—122 inches. TURNING CIRCLE DIAMETER—42 feet.

**UNISTEEL TURRET-TOP BODIES BY FISHER**, completely bonderized and finished with several coats of high grade lacquer.

**BODY TYPES**—Convertible Coupe, Holiday Coupe, Club Sedan, 4-Door Town Sedan, 4-Door Sedan. (Closed models, standard and de luxe equipment available, as ordered.)

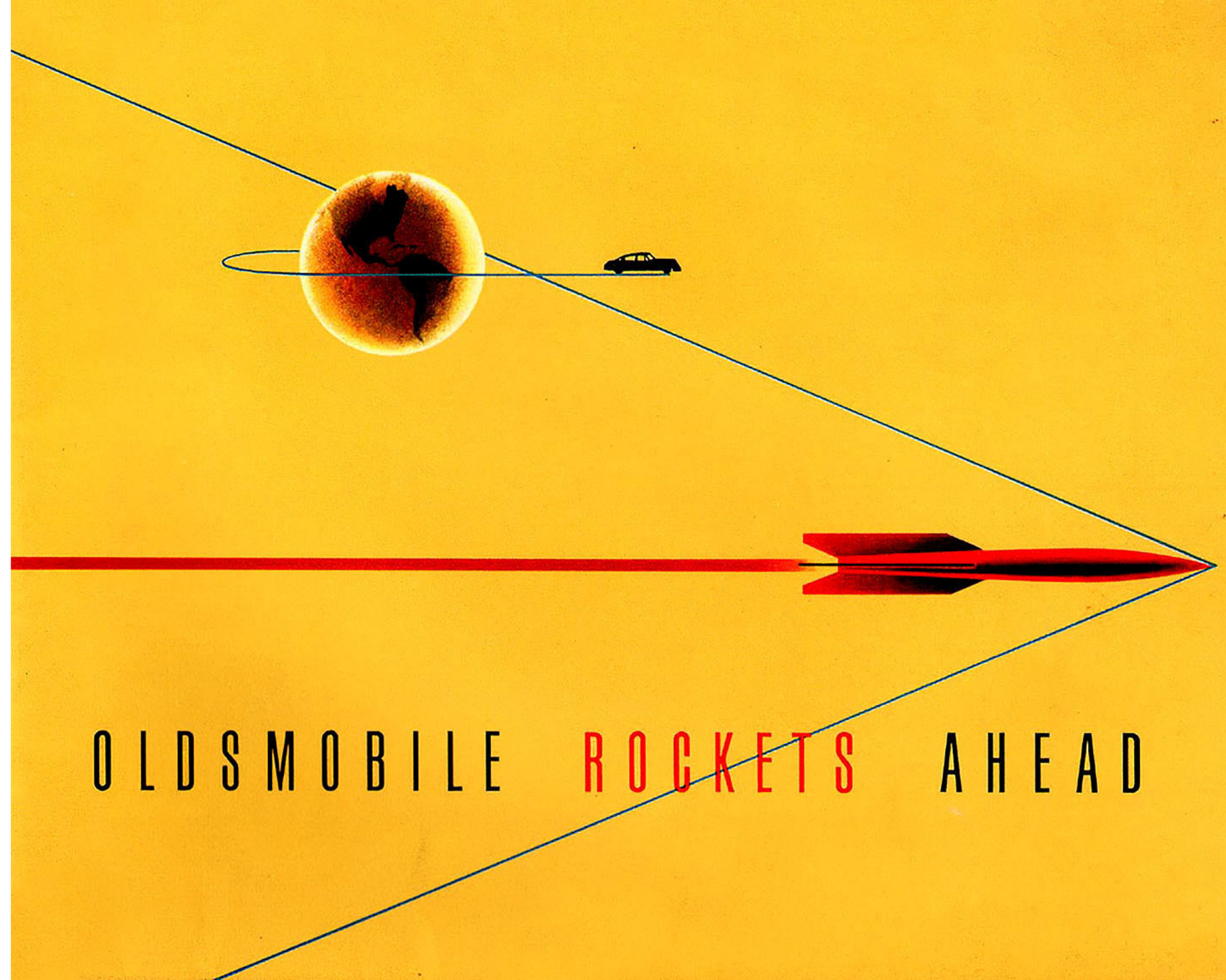

# OLDSMOBILE ROCKETS AHEAD