

AUTOMOBILE MANUFACTURERS ASSOCIATION CONSOLIDATED SPECIFICATION QUESTIONNAIRE

MAKE OF CAR: FORD COMPANY: FORD DIVISION FORD MOTOR COMPANY	MODEL NAME SYMBOL 6 CYLINDER ONLY MAINLINE CUSTOMLINE FAIRLANE
MODEL YEAR: 1956 DATE: SEPTEMBER 23, 1955	

TABLE OF CONTENTS

General Specifications.....	1	Frame.....	16
Engine.....	2	Front Suspension.....	16
Electrical.....	8	Steering.....	17
Drive Units.....	12	Rear Suspension.....	18
Brakes.....	15	Body.....	19
Index.....	24		

- NOTES: 1. The specifications set forth herein are those in effect at the date of compilation and are subject to change without notice.
 2. All specifications are standard for the models under which they are listed unless otherwise indicated.
 3. All dimensions are nominal engineering dimensions unless otherwise indicated.
 4. Unless otherwise indicated, specifications apply to 5 or 6 passenger, 4-door sedan or equivalent.

GENERAL SPECIFICATIONS

Model	6 CYLINDER	MAINLINE	CUSTOMLINE	FAIRLANE
Wheelbase			115.5	
Tread	Front		58.0	
	Rear		56.0	
Maximum Overall Dimensions	Length (L-103)		198.5	
	Width (W-103)		75.9	
	Height (H-101)		60.4	
Steering ratio—overall			25.3 TO 1	
Turning diameter (curb to curb)			41.18	
Shipping weight*				
Transmission— (Specify standard, optional, not avail.)	Conventional		STD.	
	Overdrive		OPT.	
	Automatic		OPT.	
Axle ratio	Conventional		3.89 STD.-4.11 OPT.	
	Overdrive		4.11 STD.-3.89 OPT.	
	Automatic		3.22 STD.-3.56 OPT.	
Tire size			6.70x15-4 PLY (TUBELESS)	
Engine	Type		IN-LINE	
	No. of cylinders		6	
	Valve arrangement		OVERHEAD	
	Bore and stroke		3.62 x 3.60	
	Piston displacement, cu. in.		223	
	Standard compression ratio		8.0:1	
	Maximum bhp at engine rpm		137 @ 4200	
Maximum torque at rpm		202 @ 2000 - 2400		

*Standard car weight, not including gas and water.

AMA Consolidated Specification Questionnaire

SEPTEMBER 23, 1955

MAKE OF CAR FORD **MODEL YEAR** 1956

MODEL 6 CYLINDER **MAINLINE** **CUSTOMLINE** **FAIRLANE**

ENGINE—GENERAL

Type	V, In-line, other Angle of V	IN-LINE NONE	
No. of cylinders		6	
Valve arrangement		OVERHEAD	
Bore and stroke		3.62 x 3.60	
Piston displacement, cu. in.		223	
Numbering system (front to rear)	L. Bank	1-2-3-4-5-6	
	R. Bank		
Firing order		1-5-3-6-2-4	
Compression ratio	Standard Head	8.0:1	
	Optional Head	NONE	
Cylinders	Head Material	CAST IRON	
	Standard Optional	NONE	
	Sleeve—Wet, dry, other, none	NONE	
Number of mounting points	Front	2	
	Rear	1	
Taxable horsepower	(Dia. ² x No. Cyl.) 2.5	31.54	
Advertised max. brake horsepower at engine RPM*	Standard head	137 @ 4200	
	Optional head	NONE	
	With fuel (Octane and method)	Standard Head	---
		Optional Head	NONE
Max. torque (lb. ft. @ RPM)	Standard head	202 @ 2000-2400	
	Optional head	NONE	
Recommended idle speed (neutral)		475-500 R.P.M.	

ENGINE—PISTONS

Material	ALUMINUM ALLOY		
Description and finish	AUTOTHERMIC, SOLID SKIRT CAM-GROUND, FLAT HEAD TIN PLATED		
Weight (piston only) oz.	19.3		
Clearance	Top land	.0210-.0264	
	Skirt	Top	.0010-.0024
		Bottom	.0006-.0012
Ring groove depth	No. 1 ring	.1926-.1940	
	No. 2 ring	.1926-.1940	
	No. 3 ring	.1735-.1802	
	No. 4 ring	NONE	

*Corrected as defined by SAE Engine Test Code, with the following standard power consuming accessories:

AMA Consolidated Specification Questionnaire

SEPTEMBER 23, 1955

MAKE OF CAR FORD **MODEL YEAR** 1956

MODEL 6 CYLINDER MAINLINE CUSTOMLINE FAIRLANE

ENGINE—RINGS

Type (top to bottom)	No. 1 oil or comp.	COMPRESSION	
	No. 2 oil or comp.	COMPRESSION	
	No. 3 oil or comp.	OIL CONTROL	
	No. 4 oil or comp.	NONE	
No. rings above piston pin		3	
Compression	Material	CAST IRON	
	Coating	NO. 1 RING CHROME-PLATED	NO. 2 RING PHOSPHATE COATED
	Width	.0930 - .0935	
	Gap	.010 - .020	
	Maximum wall thickness	TOP RING .187	SECOND RING .181
Oil	Material	STEEL	
	Coating	CHROME-PLATED RAILS, BLUED EXPANDER	
	Width	.183 (ASSEMBLY)	
	Gap	.015 - .055	
	Maximum wall thickness	.177	
Location of expanders		IN OIL RING ASSEMBLY	

ENGINE—PISTON PINS

Material		TUBULAR, ALLOY-STEEL
Length		3.016 - 3.030
Diameter		.9120 - .9123
Type	Locked in rod, in piston, floating, etc.	FULL-FLOATING
	Bushing	In rod or piston Material
		IN-ROD
		BRONZE
Clearance	In piston	.0001-.0003 SELECTIVE FIT
	In rod	.0001-.0003 SELECTIVE FIT
Direction offset in piston		RIGHT - .062

ENGINE—CONNECTING RODS

Material		FORGED STEEL
Weight (oz.)		29.63
Length (center to center)		6.258 - 6.262
Bearing	Material	BABBITT
	Type (cast-in or removable)	REPLACEABLE INSERT
	Effective length	1.034
	Clearance	.0004 - .0023
	End play	.0030 - .0090

ENGINE—CRANKSHAFT

Material	PRECISION-MOLDED, ALLOY IRON
Weight (lb.)	68.25

AMA Consolidated Specification Questionnaire

SEPTEMBER 23, 1955

MAKE OF CAR FORD **MODEL YEAR** 1956

MODEL 6 CYLINDER MAINLINE CUSTOMLINE FAIRLANE

ENGINE—CRANKSHAFT (cont.)

Vibration damper type		RUBBER-FLOATED	
End thrust taken by bearing (No.)		3	
Crankshaft end play		.004 - .008	
Main bearing	Material	BABBITT	
	Type (cast-in or removable)	REPLACEABLE INSERT	
	Clearance	.0005 - .0021	
	Journal dia. and bearing effective length	No. 1	2.4980 - 2.4988 x .954
		No. 2	2.4980 - 2.4988 x .954
		No. 3	2.4980 - 2.4988 x .895
		No. 4	2.4980 - 2.4988 x 1.179
		No. 5	NONE
No. 6		NONE	
No. 7		NONE	
Direction offset from cyl. bore			
Connecting rod crankpin journal diameter		2.2980 - 2.2988	

ENGINE—CAMSHAFT

Material		PRECISION-MOLDED, ALLOY IRON	
Bearings	Material	STEEL-BACKED BABBITT	
	Number	4	
Type of drive	Gear or chain		CHAIN
	Crankshaft gear or sprocket material		STEEL
	Camshaft gear or sprocket material		CAST IRON
	Timing chain	Make	----
		No. of links	56
		Width	.9375
Pitch		.375	

ENGINE—VALVE SYSTEM

Hydraulic lifters (yes, no)		NO
Special provision for valve rotation (intake, exhaust)		FREE-TURN, INTAKE AND EXHAUST VALVES
Rocker ratio		1.42:1
Operating tappet clearance (indicate hot or cold)	Intake	.019 HOT
	Exhaust	.019 HOT
Tappet clearance for timing	Intake	.019 HOT
	Exhaust	.019 HOT
Timing marks on fly-wheel, damper, other		VIBRATION DAMPER

AMA Consolidated Specification Questionnaire

SEPTEMBER 23, 1955

MAKE OF CAR FORD **MODEL YEAR** 1956

MODEL 6 CYLINDER **MAINLINE** **CUSTOMLINE** **FAIRLANE**

ENGINE—VALVE SYSTEM (cont.)

Timing	Intake	Opens (°BTC)	24°	
		Closes (°ABC)	46°	
	Exhaust	Opens (°BBC)	68°	
		Closes (°ATC)	20	
Intake	Material		CHROME STEEL	
	Overall length		5.11	
	Actual overall head dia.		1.775 - 1.785	
	Angle of seat		45°30' - 45°45'	
	Seat insert material		NONE	
	Stem diameter		.3415 - .3425	
	Stem to guide clearance		.001 - .002 SELECTIVE FIT	
	Lift		.370	
	Outer spring press. and length	Valve closed (lb. @ in.)	71 - 79 @ 1.78	
		Valve open (lb. @ in.)	161 - 177 @ 1.39	
	Inner spring press. and length	Valve closed (lb. @ in.)	NONE	
		Valve open (lb. @ in.)	NONE	
	Exhaust	Material		AUSTENITIC STEEL
		Overall length		5.09
Actual overall head dia.		1.505 - 1.515		
Angle of seat		45°30' - 45°45'		
Seat insert material		NONE		
Stem diameter		.3405 - .3415		
Stem to guide clearance		.002 - .003 SELECTIVE FIT		
Lift		.370		
Outer spring press. and length		Valve closed (lb. @ in.)	71 - 79 @ 1.78	
		Valve open (lb. @ in.)	161 - 171 @ 1.39	
Inner spring press. and length	Valve closed (lb. @ in.)	NONE		
	Valve open (lb. @ in.)	NONE		

ENGINE—LUBRICATION SYSTEM

Type of lubrication (splash, pressure, nozzle)	Main bearings	PRESSURE
	Connecting rods	PRESSURE
	Piston pins	OIL MIST
	Camshaft bearings	PRESSURE
	Tappets	GRAVITY
	Timing gear or chain	INDEXED PRESSURE
	Cylinder walls	PRESSURE STREAM

AMA Consolidated Specification Questionnaire

Page 6
Rev. 8-53

SEPTEMBER 23, 1955

MAKE OF CAR FORD MODEL YEAR 1956

MODEL 6 CYLINDER MAINLINE CUSTOMLINE FAIRLANE

ENGINE—LUBRICATION SYSTEM (cont.)

Oil pump type	GEAR
Normal oil pressure (lb. @ rpm)	45-50 @ 2000
Oil pressure gage type (electric or mechanical)	ELECTRIC
Type oil intake (floating, stationary)	STATIONARY
Oil filter type (full flow, partial flow)	FULL-FLOW
Capacity of crankcase, less filter—refill (qt.)	4
Oil grade recommended (SAE viscosity and temperature range)	NOT LOWER THAN +30°F - SAE 20 or 20W NOT LOWER THAN -10°F - SAE 10 or 10W LOWER THAN -10°F - SAE 5W
Oil type recommended	NORMAL SERVICE - ML - REGULAR (LOW DETERGENCY) HEAVY DUTY SERVICE-MM - PREMIUM (MILD DETERGENCY)

ENGINE—FUEL SYSTEM

Recommended fuel	Standard head	REGULAR	
	Optional head	NONE	
Fuel Tank	Capacity (gals.)	17.5	
	Filler Location	BACK OF REAR LICENSE PLATE	
Fuel Filter	Type	POROUS FIBER	
	Location	FUEL PUMP SEDIMENT BOWL	
Fuel pump	Type (elec. or mech.)	MECHANICAL DIAPHRAGM	
	Location	RIGHT FRONT	
	Pressure range	4 - 5 PSI @ IDLE	
	Vacuum booster (std., optl., none)	OPTIONAL	
Carburetor	Make	FORD	
	Model number		
	Number used	ONE	
	Type	Downdraft, side inlet, other	DOWNDRAFT
		Single or dual	SINGLE
	Intake manifold heat control (manual, auto., none)		AUTOMATIC
	Automatic choke type (integral, other)		NONE
	Air cleaner type	Standard	DRY
Optional		OIL BATH	

ENGINE—EXHAUST SYSTEM

Type (single, single with cross-over, dual, other)	SINGLE	
Muffler type (rev. flow, str. thru, sep. resonator)	THREE PASSAGE	
Exhaust pipe dia.	Branch	
	Main	2.00
Tail pipe diameter	1.75	

AMA Consolidated Specification Questionnaire

SEPTEMBER 23, 1955

MAKE OF CAR **FORD** MODEL YEAR **1956**

MODEL **6 CYLINDER** MAINLINE CUSTOMLINE FAIRLANE

ENGINE—COOLING SYSTEM

Type (pressure system, atmospheric, other)		PRESSURE	
Radiator cap relief valve press.		13 P.S.I.	
Circulation thermostat	Type (choke, bypass)	CHOKE, PELLET-OPERATED	
	Starts to open at	157 - 162°F	
Water pump	Type (centrifugal, other)	CENTRIFUGAL	
	Number of pumps	ONE	
	Drive (V-belt, other)	V BELT	
	Bearing type	DOUBLE ROW SEALED BALL	
By-pass recirculation type (internal, external)		INTERNAL	
Radiator core type (cellular, tube and fin)		CORRUGATED FIN AND TUBE OR FLAT FIN AND TUBE	
Cooling system capacity	With heater (qt.)	15.5	
	Without heater (qt.)	14.5	
Water jackets full length of cylinder (yes, no)		YES	
Water all around cylinder (yes, no)		YES	
Radiator hose	Lower	Number and type (molded, straight)	ONE MOLDED
		Inside diameter and length	1.75 x 17.2 (DEVELOPED)
	Upper	Number and type (molded, straight)	ONE MOLDED
		Inside diameter and length	1.50 x 8.2 (DEVELOPED)
	By-pass	Number and type (molded, straight)	NONE
		Inside diameter and length	NONE
Drive belts	Fan	Number used	ONE (TWO WITH OPTIONAL POWER STEERING) (a)
		Angle of V	38°
		Outside length	39.60 @ P.D.
		Width	.38
	Generator	Angle of V	SAME
		Outside length	BELT USED
		Width	ON FAN
Fan	Number of blades and spacing	3 UNEQUAL	
	Diameter	18	
	Ratio—fan to crankshaft revolutions	.97:1	
	Bearing type		

(a) POWER STRG. (OPT.)

DRIVE BELT

ANGLE OF V -38°

OUTSIDE LENGTH - 38.37 @ P.D.

WIDTH -.38

AMA Consolidated Specification Questionnaire

SEPTEMBER 23, 1955

MAKE OF CAR FORD

MODEL YEAR 1956

MODEL 6 CYLINDER MAINLINE CUSTOMLINE FAIRLANE

ELECTRICAL—SUPPLY SYSTEM

Battery	Make and Model		VARIOUS	
	Voltage Rtg. & Plates/cell		12 VOLTS 11 PLATES/CELL	
	SAE Designation & Amp Hr. Rtg		55	
	Location		ENGINE COMPARTMENT-RIGHT FRONT	
Generator	Terminal grounded		NEGATIVE	
	Make		FORD	
	Model		FAR-10000-B	
	Type		SHUNT	
Regulator	Ratio—Gen. to Cr/s rev.		2:1	
	Make		FORD OR AMERICAN BOSCH	
	Model		FAP-10505-B OR C	
	Type		3-COIL	
	Cutout relay	Closing voltage @ generator rpm		12.0-12.8
		Reverse current to open		2-6
	Regu-lated	Voltage		14.6-15.4 @ 75°F.
		Current		28 - 32
	Min. Gen. rpm required		3000	
	Voltage test con-ditions	Temperature		75°F.
Load		5 AMPS.		
Other				

ELECTRICAL—STARTING SYSTEM

Starting motor	Make		FORD	
	Model		FAR-11001-A	
	Rotation (drive end view)		CLOCKWISE	
	Engine cranking speed		150-180	
	Test conditions		85°F.	
	Lock test	Amps		550
		Volts		5
		Torque (lb. ft.)		15.5
	No load test	Amps		120
		Volts		12
RPM (min.)		4800		
Motor control	Switch (solenoid, manual)		SOLENOID	
	Starting procedure		TURN IGNITION KEY TO RIGHT BEYOND THE "ON" POSITION	

AMA Consolidated Specification Questionnaire

SEPTEMBER 23, 1955

MAKE OF CAR FORD MODEL YEAR 1956

MODEL 6 CYLINDER MAINLINE CUSTOMLINE FAIRLANE

ELECTRICAL—STARTING SYSTEM (cont.)

Motor drive	Engagement type		BENDIX FOLO-THRU
	Pinion meshes (front, rear)		REAR
	Number of teeth	Pinion	9
		Flywheel	146
	Flywheel tooth face width		3/8 IN.

ELECTRICAL—IGNITION SYSTEM

Coil	Make		FORD & ESSEX WIRE
	Model		FAC-12029-A
	Amps	Engine stopped	4.5
		Engine idling	2.5
Distributor	Make		HOLLEY
	Model		FDR-12127-A
	Spark advance data (at distributor shaft)	Centr. advance start (rpm)	NONE
		Centr. advance max. deg. @ rpm	NONE
		Vacuum advance start (in. Hg.)	.25
		Vac. adv. (max. deg. @ in. Hg.)	13.5 @ 6.0
	Breaker gap (in.)		.024 - .026
	Cam angle (deg.)		35° - 38°
	Breaker arm tension (oz.)		17 - 20
	Timing	C/S deg. @ rpm	
Mark location		VIBRATION DAMPER	
Cylinder numbering system (see page 2)		1-2-3-4-5-6	
Firing order (see page 2)		1-5-3-6-2-4	
Spark plug	Make and model		CHAMPION 870
	Thread (mm)		18
	Tightening torque (lb. ft.)		20-30 PROD. INST. ONLY
	Gap		.032 - .036
Cable	Conductor type		STRANDED STEEL
	Insulation type		NEOPRENE SHEATH
	Spark plug protector		NEOPRENE CAP

ELECTRICAL—SUPPRESSION

Description	
-------------	--

AMA Consolidated Specification Questionnaire

SEPTEMBER 23, 1955

MAKE OF CAR FORD **MODEL YEAR** 1956

MODEL 6 CYLINDER MAINLINE CUSTOMLINE FAIRLANE

ELECTRICAL—INSTRUMENTS AND SWITCHES

Speed-ometer	Make Trip odometer (yes, no)	KING SEELEY OR FORD NO
	Charge indicator—type	WARNING LAMP
	Temperature indicator—type	ELECTRIC GAGE
	Oil pressure indicator—type	WARNING LAMP
	Fuel indicator—type	ELECTRIC GAGE
Ignition switch	Identify positions in order and circuits controlled	TO LEFT - ACCESSORIES ON CENTER - ACCESSORIES AND ENGINE OFF TO RIGHT - 1ST POSITION: ACCESSORIES AND ENGINE ON 2ND POSITION: STARTER AND ENGINE ON
	Provision for illumination	LIGHTED WITH INSTRUMENT PANEL LIGHTS "ON"
	Location	LOWER LEFT SIDE OF INSTRUMENT PANEL
	Theft protection type	
Main lighting switch	Identify positions and lights controlled	PULL OUT - 1ST POSITION: PARKING, TAIL, LICENSE AND INSTRUMENT PANEL LIGHTS 2ND POSITION: HEAD, TAIL, LICENSE AND INSTRUMENT PANEL LIGHTS ROTATE KNOB CLOCKWISE TO DIM INSTRUMENT PANEL LIGHTS
Other light switches	Locations and lamps controlled	MAINLINE - SLIDE SW. ON DOME LAMP. CUSTOMLINE & FAIRLANE- SLIDE SW. ON DOME LAMP; FRONT DOOR SW. ALSO OPERATE DOME LAMP (MAP LIGHT ON CONVERTIBLE). TOE BOARD SW.-HEADLIGHT DIMMER. BRAKE MASTER CYLINDER SW. FOR STOP LIGHTS. TURN SIGNAL SW. ON STEERING COLUMN.
Other switches	Locations and devices controlled	AUTO. TRANS. NEUTRAL SW. & BACK-UP LAMP SW. ON STEER. COL. CONV. TOP CONTROL SW. UNDER L.H. SIDE OF INST. PANEL. O/D KICKDOWN SW. UNDER ACC. PEDAL. POWER WINDOW SW. ON DOOR & QUARTER PANELS. POWER SEAT SW. ON SEAT SIDE SHIELD. HEAT. BLOWER SW. ON HEAT. CONTROL.
Windshield wiper	Make	TRICO
	Type	VACUUM
	Vacuum booster provision	OPTIONAL
	Washer provision	OPTIONAL
Horn	Type	AIR-ELECTRIC
	Number used	TWO
	Amp draw (each)	9.5

AMA Consolidated Specification Questionnaire

SEPTEMBER 23, 1955

MAKE OF CAR FORD MODEL YEAR 1956

MODEL 6 CYLINDER MAINLINE CUSTOMLINE FAIRLANE

ELECTRICAL—LAMP BULBS

Give quantity used and trade number, e.g., Headlamp 2-4030. Indicate accessories which are not standard equipment by an asterisk following the numbers.

Headlamp		2-5400
Headlamp beam indicator		1-57
Parking light		2-1034
Tail light		2-1034
Stop light		SEE TAIL LIGHT
Direction indicator	Front	SEE PARKING LIGHT
	Rear	SEE TAIL LIGHT
	Tell-Tale	2-57*
License plate light		1-67
Instrument light	SPEEDOMETER 2-57; OIL & GENERATOR WARNING LAMPS 2-57	
Ignition lock light	1-57; ALSO ILLUMINATES LIGHT SWITCH	
Map light		1-67*
Dome light		1-1003
Clock light	1-57*; ALSO ILLUMINATES TEMPERATURE INDICATOR	
Radio dial light		1-57*
Glove compartment light		1-57*
Courtesy light		SEE MAP LIGHT
Trunk compartment light		1-89*
Other	FUEL GAGE 1-57; TURN INDICATORS 2-57*; HEATER CONTROLS 1-57* CIGAR LIGHTER & W/S WIPER 1-57; AUTO. TRANS. QUADRANT 1-67* BACK-UP LIGHTS 2-1073;* SPOTLIGHT 1-4405;* ENGINE COMP. LIGHT 1-93*	

ELECTRICAL—FUSE & CIRCUIT BREAKER DATA

Use trade number of fuse, e.g., SFE-10. Indicate circuit breaker by ampere capacity suffixed by letters "C.B.", e.g., 30 C.B. Where fuse or circuit breaker protects multiple circuits indicate first use by a letter and repeat the same letter for all units protected by the same fuse or circuit breaker, e.g., Parking light: SFE-10 (a), Direction indicator: same as (a).

Headlamp		12 C.B. (A)
Headlamp beam indicator		SAME AS (A)
Parking light		12 C.B. (B)
Tail light		SAME AS (B)
Stop light		SAME AS (B)
Direction indicator		SFE - 7.5
License plate light		SAME AS (B)
Instrument light		SAME AS (B)
Ignition light		SAME AS (B)
Map light		SFE - 7.5 (C)
Dome light		SAME AS (C)
Clock		1AG-1
Clock light		SAME AS (B)
Radio		6 TUBE 1AG-5; 9 TUBE SFE - 7.5
Glove compartment light		SAME AS (C)
Courtesy light		SAME AS (C)
Trunk compartment light		SAME AS (B)
Other	HEATER BLOWER SFE-14; CIGAR LIGHTER - THERMAL FUSE; OVERDRIVE 3AG-15 BACK-UP LIGHTS - SAME AS (B); SPOTLIGHT SFE-7.5; CONVERTIBLE TOP 30 C.B.; POWER SEAT AND WINDOWS AS FOLLOWS: ONE 30 C.B. (LINE PROTECTOR); ONE 15 C.B. (EACH WINDOW MOTOR); ONE 15 C.B. (COMMON TO BOTH SEAT MOTORS).	

AMA Consolidated Specification Questionnaire

SEPTEMBER 23, 1955

MAKE OF CAR **FORD**

MODEL YEAR **1956**

MODEL	6 CYLINDER	MAINLINE	CUSTOMLINE	FAIRLANE
--------------	-------------------	-----------------	-------------------	-----------------

DRIVE UNITS—CLUTCH (PEDAL OPERATED)

Make		LONG
Type (dry or wet plate)		DRY
In combination with fluid coupling (yes, no)		NO
Semi-centrifugal (yes, no)		YES
Type pressure plate springs		COIL
Total plate pressure (lb.)		1230
No. of clutch driven discs		ONE
Clutch facing	Material	WOVEN ASBESTOS
	Inside diameter	6.0"
	Outside diameter	9.5"
	Total eff. area (sq. in.)	85.22
	Thickness	.125
	Number required	TWO
	Engagement cushioning method	TORBEND DISC. WITH SPRING VIBRATION DAMPER
	Release bearing	BALL THRUST
	Torsional damping	PREPACKED
	Frict. mat.	STEEL

DRIVE UNITS—TRANSMISSIONS

Conventional (std. or opt.)	STD.
Conventional with overdrive (std. or opt.)	OPT.
Automatic (std. or opt.)	OPT.

DRIVE UNITS—CONVENTIONAL TRANSMISSION

Number of forward speeds	3 SPD. FORD	3 SPD. BORG-WARNER (a)	
Transmission ratios	In first	2.78:1	2.80:1
	In second	1.61:1	1.69:1
	In third	1.00:1	1.00:1
	In fourth	---	---
	In reverse	3.38:1	3.80
Constant mesh gears in 2nd (yes, no)	YES		
Spur gear used in (indicate speeds)	NONE		
Helical gears used in (indicate speeds)	ALL		
Synchronous meshing in 2nd and 3rd gears (yes, no)	YES		

(a) BORG-WARNER USED WITH "OVERDRIVE" ONLY.

AMA Consolidated Specification Questionnaire

SEPTEMBER 23, 1955

MAKE OF CAR FORD MODEL YEAR 1956

MODEL 6-CYLINDER MAINLINE CUSTOMLINE FAIRLANE

DRIVE UNITS—CONVENTIONAL TRANSMISSION (cont.)

		<u>FORD</u>	<u>BORG-WARNER</u>	
		<u>3 SPD-FORD - 3.0</u>	<u>3 SPD-WARNER - 3.0</u>	
Lubricant	Capacity (pt.)			
	Type recommended	<u>MILD EXTREME PRESSURE</u>		
	SAE viscosity number	Summer	<u>80</u>	
		Winter	<u>80</u>	
Extreme cold		<u>80</u>		

DRIVE UNITS—CONVENTIONAL TRANSMISSION WITH OVERDRIVE

For transmission data see conventional transmission section

Overdrive	Type (planetary or other)		<u>PLANETARY</u>		
	If planetary, No. of pinions		<u>3</u>		
	Manual lockout (yes, no)		<u>YES</u>		
	Downshift accelerator control (yes, no)		<u>YES</u>		
	Minimum cut-in speed		<u>27 M.P.H.</u>		
	Gear ratio		<u>0.70</u>		
	Lubricant	Capacity (O.D. only)	<u>FORD</u> <u>1.5</u>	<u>WARNER</u> <u>N.A.</u>	
		Separate filter (yes, no)	<u>NO</u>		
		Type recommended	<u>MILD EXTREME PRESSURE</u>		
		SAE viscosity number	Summer	<u>80</u>	
Winter	<u>80</u>				
Ext. cold	<u>80</u>				

DRIVE UNITS—AUTOMATIC TRANSMISSION

Trade name	<u>FORDOMATIC</u>				
Type (fluid coupling with gears, torque converter with gears, other)	<u>TORQUE CONVERTER WITH PLANETARY GEARS</u>				
Manual selector positions, left to right (show symbols and define, e.g., N- Neutral)	<u>P</u> <u>PARK</u>	<u>R</u> <u>REVERSE</u>	<u>N</u> <u>NEUTRAL</u>	<u>Dr</u> <u>DRIVE</u>	<u>Lo</u> <u>LOW RANGE</u>
List gear ratios in each drive position (range)	<u>DRIVE 1.47 or 1.00 to 1 - PLUS TORQUE CONVERTER *</u> <u>LOW 2.40 TO 1 - PLUS TORQUE CONVERTER</u> <u>REVERSE 2.00 TO 1 - PLUS TORQUE CONVERTER</u> <u>*2.40 TO 1 AT FULL THROTTLE THRU DETENT-PLUS TORQUE CONV.</u>				
Shifting within drive position range by accelerator control and speed limiting governor (yes, no)	<u>YES</u>				
By governor—forced shift (yes, no)	<u>YES</u>				
Downshift of gears in high range possible up to (mph)	<u>UP TO 62 M.P.H.</u>				

AMA Consolidated Specification Questionnaire

SEPTEMBER 23, 1955

MAKE OF CAR **FORD**

MODEL YEAR **1956**

MODEL 6 CYLINDER	MAINLINE	CUSTOMLINE	FAIRLANE
--------------------------------	-----------------	-------------------	-----------------

DRIVE UNITS—AUTOMATIC TRANSMISSION (cont.)

Torque convertor	Number of elements		3
	Max. ratio at stall at engine rpm		2.1 TO 1 @ 1380-1580
	Mechanical lockup	Provided (yes, no)	NO
		Speed range	---
		Releases at (speed range, mph)	---
	Type of cooling (forced air, oil cooler and type, other)		FORCED AIR
	Anti-creep device (yes, no)		NO
Capacity—refill (pt.)		18.7	
Lubricant	Type recommended		AUTOMATIC TRANSMISSION FLUID
	Grade	Summer	TYPE A
		Winter	TYPE A
		Extreme cold	TYPE A

DRIVE UNITS—PROPELLER SHAFT

Number used		ONE	
Type (exposed, torque tube)		EXPOSED	
Outer diameter x length* x wall thickness	Conventional trans.	2.75 x 53.06 x 0.065	
	Overdrive trans.	SAME	
	Automatic trans.	SAME	
Inter-mediate bearing	Type (plain, anti-friction)	NONE	
	Lubri. (fitting, prepack)	----	
Universal joints	Make		MECHANICS
	Number used		TWO
	Type (ball and trunion, cross, other)		CROSS SLIP JOINT IN FRONT SPLIT JOINT IN REAR & COMPANION FLANGE
	Bearing	Type (plain, anti-friction)	NEEDLE ROLLER
		Lubric. (fitting, prepack)	PREPACK
Drive taken through (torque tube or arms, spring)		REAR SPRINGS	
Torque taken through (torque tube or arms, springs)		REAR SPRINGS	

*Centerline to centerline of joints or centerline of rear attachment point.

AMA Consolidated Specification Questionnaire

SEPTEMBER 23, 1955

MAKE OF CAR FORD MODEL YEAR 1956

MODEL 6-CYLINDER MAINLINE CUSTOMLINE FAIRLANE

DRIVE UNITS—REAR AXLE

Type (semi-floating, other)		SEMI-FLOATING	
Gear type (hypoid, other)		HYPOID	
Gear ratio and No. of teeth	Conventional trans.	3.89 STD. - 4.11 OPT.	
	Overdrive trans.	4.11 STD. - 3.89 OPT.	
	Automatic trans.	3.22 STD. - 3.56 OPT.	
Pinion adjustment (shim, other)		SHIMS	
Pinion bearing adj. (shim, other)		COLLAPSIBLE SPACER	
Lubricant	Capacity (pt.)	3½	
	Type recommended	HYPOID-EXTREME PRESSURE	
	SAE viscosity number	Summer	SAE-90
		Winter	SAE-90
Extreme cold		SAE-90	

DRIVE UNITS—WHEELS

Type (disc, other)		DISC
Rim (size and flange type)		15 X 5K
Attachment	Type (bolt or stud)	STUD
	Circle diameter	4½
	Number and size	5 STUD - ½" - 20

DRIVE UNITS—TIRES

Size and ply rating	Standard	6.70 X 15 - 4 PLY (TUBELESS)
	Optional	6 PLY & W.S.W.
Rev/mile at 30 mph		753
Inflation press. (cold)	Front	26
	Rear	23

BRAKES—SERVICE

Type		HYDRAULIC, INTERNAL EXPANDING, DUO-SERVO, FIXED ANCHOR	
Booster type		VACUUM (ACCESSORY)	
Effective area (sq. in.)		180.16	
Percent brake effectiveness—rear		38	
Drum	Diameter	Front	11
		Rear	11
	Type and material		COMPOSIT; FRESSED STEEL DISC & CAST IRON DRUM.

AMA Consolidated Specification Questionnaire

SEPTEMBER 23, 1955

MAKE OF CAR **FORD** MODEL YEAR **1956**

MODEL **6-CYLINDER** MAINLINE CUSTOMLINE FAIRLANE

BRAKES—SERVICE (cont.)

Brake lining	Bonded or riveted				RIVETED	
	Pri- mary	Material				MOLDED ASBESTOS
		Size (length x width x thickness)			Front wheel	10.62 x 2.25 x 0.187
					Rear wheel	10.62 x 1.75 x 0.187
		Segments per shoe				ONE
	Second- ary	Material				MOLDED ASBESTOS
		Size (length width x thickness)			Front wheel	11.93 x 2.25 x 0.187
					Rear wheel	11.93 x 1.75 x 0.187
		Segments per shoe				ONE
	Wheel cy- linder bore	Front				1.125
Rear				0.875		
Master cylinder bore				1.00		
Available pedal travel				6.5		
Line pressure at 100 lb. pedal load				APPROX. 700 P.S.I.		
Shoe clearance adjustment				.010		

BRAKES—PARKING

Type of control		T HANDLE, FULL-TWIST RELEASE
Location of control		UNDER INSTRUMENT PANEL-L.H. SIDE
Operates on		REAR BRAKES
If sepa- rate from service brakes	Type (internal or external)	---
	Drum diameter	---
	Lining size (length x width x thickness)	---

FRAME

Type and description	LADDER TYPE, WITH BOX SECTION SIDE-RAILS, 5 CROSSMEMBERS AND "K" BRACING.
----------------------	---

FRONT SUSPENSION

Type and description	INDEPENDENT BALL JOINT, COIL SPRING SYSTEM, INCORPORATING TWO UNEQUAL LENGTH TRANSVERSE CONTROL ARMS.
----------------------	---

AMA Consolidated Specification Questionnaire

SEPTEMBER 23, 1955

MAKE OF CAR FORD

MODEL YEAR 1956

MODEL 6-CYLINDER MAINLINE CUSTOMLINE FAIRLANE

FRONT SUSPENSION (cont.)

Spring	Type			COIL
	Material			SAE 5160 OR 9260
	Size (length x width x No. leaves or coil I.D.)			15.24 x 4.03
	Spring rate (lb. per in.)			360
	Rate at wheel (lb. per in.)			
	Normal load (lb. @ rated length)			2000 @ 9.59
Shock absorbers	Manufacturer			HOUE, GABRIEL, MONROE
	Type (direct or lever)			DIRECT
	Piston diameter			1.0"
Stabilizer	Type (link, linkless, frameless)			LINK FRAME MOUNTED
	Material			SAE 1065 OR 1090

STEERING

Type used (Standard or optional)	Mechanical		STD.	
	Power		OPTIONAL	
Wheel diameter			18"	
Turning diameter	Outside front	Wall to wall (r. & l.)	N.A.	
		Curb to curb (r. & l.)	41.18 FT.	
	Inside rear	Wall to wall (r. & l.)	N.A.	
		Curb to curb (r. & l.)	N.A.	
Inside wheel angle with outside wheel at 20°			24°30'	
Mechanical	Gear	Type	WORM & TWO TOOTH ROLLER	
		Make	FORD	
		Ratios	Gear	20.1 TO 1
			Overall	25.3 TO 1
	No. wheel turns		4.75 APPROX. LOCK TO LOCK	
Power	Type		LINKAGE BOOSTER	
	Make		BENDIX	
	Trade name		MASTER GUIDE	
	Gear	Type	WORM & TWO TOOTH ROLLER	
		Ratios	Gear	20.1 TO 1
			Overall	25.3 TO 1
	Pump driven by		BELT TO CRANKSHAFT PULLEY	
	Overall torque ratio		25% STD. STEERING EFFORT	
	Number wheel turns		4.75 APPROX. LOCK TO LOCK	
	Linkage	Type		PARALLELOGRAM
Location (front or rear of wheels)		REAR OF WHEELS		
Drag link (trans. or long)		TRANSVERSE		
Tie rods (one or two)		TWO		

AMA Consolidated Specification Questionnaire

SEPTEMBER 23, 1955

MAKE OF CAR **FORD**

MODEL YEAR **1956**

MODEL 6 CYLINDER	MAINLINE	CUSTOMLINE	FAIRLANE
--------------------------------	-----------------	-------------------	-----------------

STEERING (cont.)

Kingpin	Inclination at camber (deg.)		7° 10' WITH 45° CAMBER (CURB WEIGHT)	
	Diameter		N.A.	
	Bearings (type)	Upper		BALL JOINT
		Lower		BALL JOINT
Thrust			BALL BEARING IN LOWER BALL JOINT	
Wheel alignment (range and preferred)	Caster (deg.)		0° TO +1° 30' (CURB WEIGHT) CASTER NOT TO VARY MORE THAN 3/4° FROM ONE SIDE TO OTHER	
	Camber (deg.)		0° 8' TO 1° 8' (CURB WEIGHT) CAMBER NOT TO VARY MORE THAN 1/4° FROM ONE SIDE TO OTHER	
	Toe-in (outside tread-inches)		1/16 - 1/8	
	Steering knuckle type		BALL SOCKET JOINTS	
Wheel spindle	Diameter	Inner bearing	1.2493-1.2498	
		Outer bearing	0.7493-0.7498	
	Thread size		3/4 - 16	
	Bearing type			

REAR SUSPENSION

Type		LONGITUDINAL LEAF		
Drive and torq. taken through (see page 14)		REAR SPRING		
Spring	Type		SEMI-ELLIPTIC	
	Material		SAE-5147 & 5160	
	Size (length x width x No. leaves or coil I.D.)		53.00 X 2.00-5	
	Spring rate (lb. per in.)		DESIGN LOAD X LB/IN. RATE 110	
	Rate at wheel (lb. per in.)			
	Normal load (lb. at rated length)		810	
	Mounting insulation type		RUBBER BUSHED SHACKLES AND RUBBER PAD AT AXLE	
	If leaf	No. of leaves		5
		Covers (yes, no)		NO
		Lubricated (yes, no)		NO
Inserts		Type and size		LEAF TIP INSERTS (ONE PIECE)
		Material		IMPREGNATED FABRIC
Shackle (comp. or tens.)		TENSION		
Shock absorbers	Manufacturer		HOUDS-GAGRIEL-MONROE	
	Type (direct or lever)		DIRECT	
	Piston diameter		1.0"	
Stabilizer	Type (link, linkless, frameless)		NONE	
	Material		---	
Track bar type			NONE	

AMA Consolidated Specification Questionnaire

Page 19
Rev. 8-53

SEPTEMBER 23, 1955

MAKE OF CAR FORD MODEL YEAR 1956

BODY—GENERAL DEFINITIONS

NOTE: Included in the dimension definitions listed on this and the following pages are those which have been proposed for adoption by the SAE. These are indicated by a number following the type of dimension, e.g., L 3. Additional dimensions have been added by the AMA Specifications Body Sub-Committee for inclusion in the Questionnaire. These are shown by an additional letter, e.g., HA. The dimensions are developed from the following basic points:

1. Front and rear seat "A" points are taken 5" forward of vertical tangent to seat back 15" from center of body.
2. Front seat is in the rear position.
3. Loaded position—5 passengers, front 300 lb., rear 450 lb., includes spare wheel, tire and tools, and full complement of gas, oil, water, etc. and tires to recommended pressure, etc.
4. C. L. (centerline).
5. D. L. O. (daylight opening, exposed glass dimension).
6. Ramp breakover angle (page 20-A) is the supplement of the included ramp angle (180° minus the included ramp angle) over which a car can pass without hanging up.

MODEL 6 CYLINDER	MAINLINE	CUSTOMLINE	FAIRLANE
------------------	----------	------------	----------

BODY—TRUNK OPENING DIMENSIONS

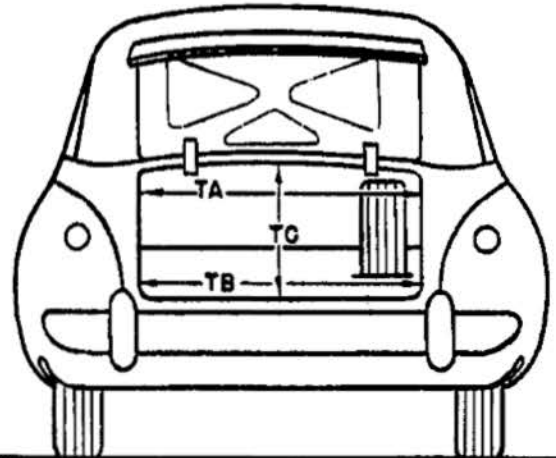
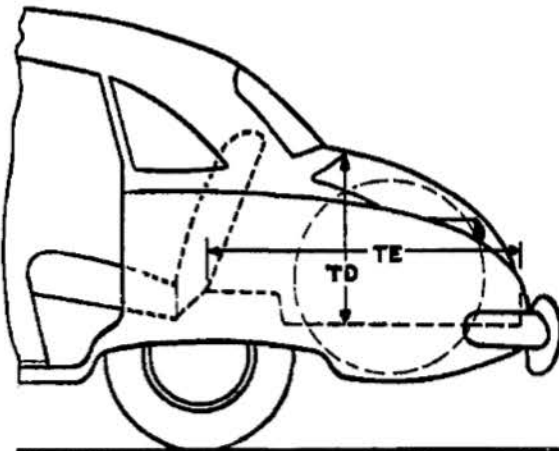

TA—Width across the top	49.1
TB—Width across the bottom	46.0
TC—Diagonal dimension at CL from top of opening to bottom	30.5
TD—Vertical height of opening (floor to top, inside edge of opening)	22.3
TE—Max. horizontal depth (forward from vertical projection of inside edge of opening)	48.9
Position of spare tire stowage	R.H. SIDE ON ANGLE
Method of holding lid open	SPRING COUNTER BALANCE

AMA Consolidated Specification Questionnaire

Page 20
Rev. 8-53

SEPTEMBER 23, 1955

MAKE OF CAR FORD MODEL YEAR 1956

MODEL 6 CYLINDER MAINLINE CUSTOMLINE FAIRLANE

BODY—HEIGHT DIMENSIONS—INTERIOR

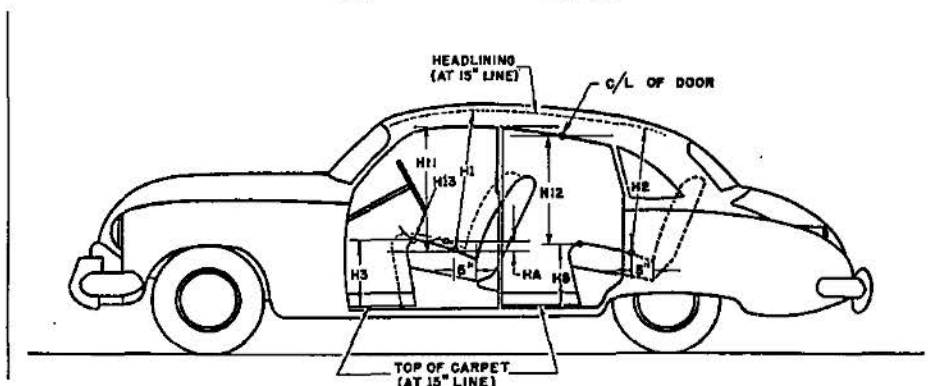

H1. Front headroom—from "A" pt. to headlining at 8° back of vertical on 15" line. (For "A" pt. see note 1, page 19)	34.9
H2. Rear headroom—from "A" pt. to headlining at 8° back of vertical on 15" line.	33.9
H3. Front seat height to floor carpet on 15" line (front edge of cushion).	12.6
H8. Rear seat height to floor carpet on 15" line (front edge of cushion).	13.1
H11. Entrance—front—cushion "A" point to bottom windcord vertical.	29.2
H12. Entrance—rear—top of cushion to bottom windcord vertical at C/L of rear door.	26.2
H13. Steering wheel clearance to seat cushion taken on arc.	5.4
HA. Front seat vertical rise at "A" pt. (inches.)	.5

AMA Consolidated Specification Questionnaire

Page 20-A
Rev. 8-53

SEPTEMBER 23, 1955

MAKE OF CAR FORD MODEL YEAR 1956

MODEL 6 CYLINDER MAINLINE CUSTOMLINE FAIRLANE

BODY—HEIGHT DIMENSIONS—EXTERIOR

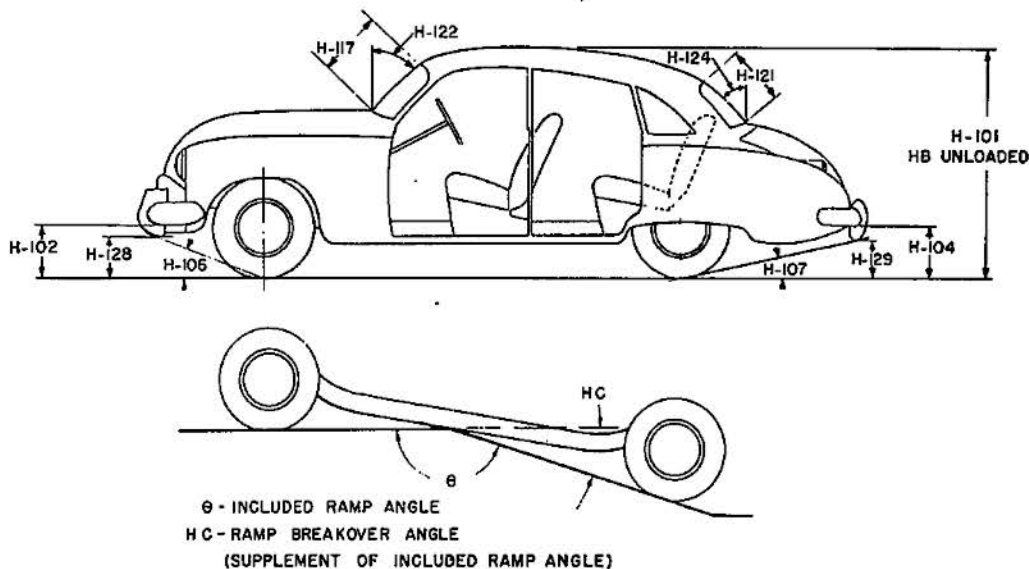

H101. Overall height.	60.4
HB. Overall height—unloaded.	62.1
H102. Front bumper bottom to ground at normal section.	14.1
H104. Rear bumper bottom to ground at normal section.	12.2
H106. Angle of approach—from the tire rolling radius to lowest point on front bumper or guard.	23°13'
H107. Angle of departure—from the tire rolling radius to lowest point on rear bumper or guard.	12°
HC. Ramp breakover angle.*	13°50'
H117. Windshield DLO-slant height.	16.7
H121. Backlight DLO*—Max., slant height.	16.3
H122. Windshield slope angle to vertical line on car axis.	44°
H124. Backlight slope angle to vertical line on car axis.	47°30'
H128. Ground to bottom of front bumper guard.	13.7
H129. Ground to bottom of rear bumper guard.	11.8
HD. Min. road clearance (location and dimension).	6.5 AT REAR SHOCK ABSORBER
HE. Min. road clearance at rear axle.	8.1

*See Notes, page 19.

AMA Consolidated Specification Questionnaire

SEPTEMBER 23, 1955

MAKE OF CAR FORD MODEL YEAR 1956

MODEL 6 CYLINDER MAINLINE CUSTOMLINE FAIRLANE

BODY—LENGTH DIMENSIONS

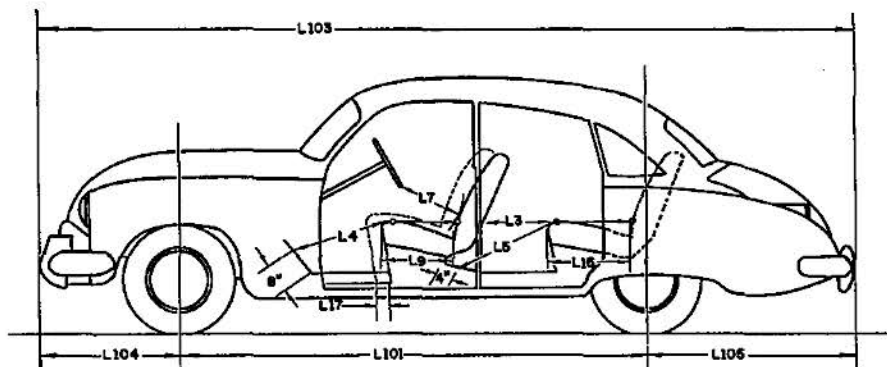

Interior	L3. Rear compartment back of front seat back to rear seat back.	29.5
	L4. Leg room—front—diagonal—ball of foot to top of seat to front seat back—15" line.	44.3
	L5. Leg room—rear—diagonal—from ball of foot to top of rear seat cushion and to seat back.	41.9
	L7. Steering wheel clearance to seat back taken on arc.	15.0
	L9. Front seat depth (front edge to vert. tan. to seat back on 15" line).	18.3
	L16. Depth of rear seat (front edge to seat back).	18.5
	L17. Total adjustment of front seat at floor.	4.9
Exterior	L101. Wheel base.	115.5
	L103. Overall length (bumper to bumper inc. guards).	198.5
	L104. Overhang—front including bumper guards.	33.9
	L105. Overhang—rear including bumper guards.	49.1

AMA Consolidated Specification Questionnaire

Page 22

SEPTEMBER 23, 1955

MAKE OF CAR FORD MODEL YEAR 1956

MODEL 6 CYLINDER MAINLINE CUSTOMLINE FAIRLANE

BODY—WIDTH DIMENSIONS

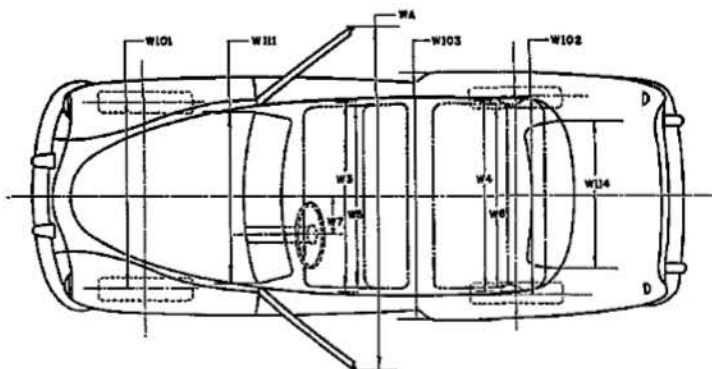

Interior	W3. Front shoulder room, at garnish moulding height or nearest interference 5" forward of seat back.	57.0
	W4. Rear shoulder room, at garnish moulding height or nearest interference 5" forward of seat back.	56.8
	W5. Front hip room, at top of seat 5" forward of vert. tan. to seat back.	60.5
	W6. Rear hip room, at top of seat 5" forward of vert. tan. to seat back.	60.3
	W7. Steering wheel center to center of body.	15.0
Exterior	W101. Front tread at ground.	58.0
	W102. Rear tread at ground.	56.0
	W103. Max. overall width of car including bumpers or mouldings.	75.9
	WA. Max. overall width of car with doors open.	148.9
	W111. Windshield DLO, max. width.	59.5
	W114. Back window DLO, max. width.	59.2

AMA Consolidated Specification Questionnaire

SEPTEMBER 23, 1955

MAKE OF CAR FORD **MODEL YEAR** 1956

MODEL 6 CYLINDER **MAINLINE** **CUSTOMLINE** **FAIRLANE**

BODY—MISCELLANEOUS INFORMATION

Doors hinged (front, rear)	Front	FRONT
	Rear	FRONT
Type of finish (lacquer, enamel)		ENAMEL
Hood opening (front, side; semi-full, full, half)		FRONT - FULL
Hood counterbalanced (yes, no)		YES
Hood release control (internal, external)		EXTERNAL
Vent window control method (crank, friction, pivot).		FRICTION
Windshjeld (one piece, two piece; curved, flat)		ONE PIECE - CURVED
Rear window type (one piece, two piece, three piece; curved, flat)		ONE PIECE - CURVED
Windshield glass area		1098.1
Backlight glass area		1030.0
Total glass area		3348.9

BODY—TYPES AND STYLE NAMES

Body type, number of passengers, and style names (use letter code shown below followed by passenger capacity and style name e.g., N-6 Ranchwagon)	MAINLINE	CUSTOMLINE	FAIRLANE	STATION WAGONS
	D-6	D-6	D-6 CLUB SEDAN	N-6 RANCH WAGON
	G-6	G-6	G-6 TOWN SEDAN	N-6 CUSTOM R. WAGON
	Q-3		J-6 VICTORIA	N-6 PARKLANE
			J-6 CROWN VICTORIA	P-6 COUNTRY SEDAN
			J-6 CR. VIC. SKYLINER	P-8 COUNTRY SEDAN
			K-6 FORDOR VICTORIA	P-8 COUNTRY SQUIRE
			L-6 SUNLINER	S-1 COURIER

Body type code

- | | |
|--|---|
| <ul style="list-style-type: none"> A—Coupe—2 door flatback B—Coupe—2 door notchback C—Sedan—2 door flatback D—Sedan—2 door notchback E—Sedan—4 door flatback (4 windows) F—Sedan—4 door flatback (6 windows) G—Sedan—4 door notchback (4 windows) H—Sedan—4 door notchback (6 windows) J—Hardtop—2 door K—Hardtop—4 door | <ul style="list-style-type: none"> L—Convertible—2 door M—Convertible—4 door N—Station wagon—2 door P—Station wagon—4 door Q—Combined passenger and utility—2 door R—Combined passenger and utility—4 door S—Sedan delivery T—Limousine |
|--|---|

AMA Consolidated Specification Questionnaire

Page 24

INDEX

SUBJECT	PAGE	SUBJECT	PAGE
Battery.....	8	Kingpin.....	18
Belts, drive.....	7	Lamp bulbs.....	11
Body		Linings—clutch, brake.....	12, 16
General Body Information.....	19, 23	Lubrication.....	5, 6, 13, 14, 15
Height dimensions.....	20	Muffler.....	6
Length dimensions.....	21	Overdrive.....	13
Overall dimensions.....	1	Piston pins.....	3
Trunk opening dimensions.....	19	Pistons.....	2
Width dimensions.....	22	Propeller shaft.....	14
Types.....	23	Radiator, radiator hoses.....	7
Brakes		Rear axle.....	1, 15
Parking.....	16	Rims.....	15
Service.....	15, 16	Rings.....	3
Camber.....	18	Shock absorbers	
Camshaft.....	4	Front.....	17
Capacities		Rear.....	18
Cooling system.....	7	Spark plugs.....	9
Fuel tank.....	6	Springs	
Lubricants		Front.....	17
Crankcase.....	6	Rear.....	18
Overdrive.....	13	Valve.....	5
Transmissions.....	13, 14	Stabilizer	
Rear axle.....	15	Front.....	17
Carburetor.....	6	Rear.....	18
Caster.....	18	Starting motor.....	8
Choke, automatic.....	6	Steering.....	1, 17, 18
Circuit breakers.....	11	Suppression.....	9
Clutch (pedal operated).....	12	Suspension	
Coil, ignition.....	9	Front.....	16, 17
Connecting rods.....	3	Rear.....	18
Cooling system.....	7	Switches.....	10
Crankshaft.....	3, 4	Tailpipe.....	6
Cylinders, cylinder head.....	2	Timing, engine.....	4, 5, 9
Distributor.....	9	Tires.....	1, 15
Electrical System.....	8, 9, 10, 11	Toe-in.....	18
Engine		Torque converter.....	14
Bore and stroke, displacement.....	1, 2	Torque, maximum.....	1, 2
Compression ratio.....	1, 2	Transmission	
Firing order, cylinder numbering.....	2, 9	Automatic.....	13, 14
General information.....	1, 2	Conventional.....	12, 13
Lubrication.....	5, 6	Conventional with overdrive.....	13
Type.....	1, 2	Ratios.....	12
Exhaust system.....	6	Types.....	1, 12, 13
Fan.....	7	Tread.....	1, 22
Frame.....	16	Turning diameter.....	1, 17
Fuel.....	6	Universal joints.....	14
Fuel pump.....	6	Valves, intake and exhaust.....	4, 5
Fuel system.....	6	Voltage regulator.....	8
Fuses.....	11	Water pump.....	7
Generator.....	8	Weight, shipping.....	1
Horns.....	10	Wheel alignment.....	18
Horsepower		Wheelbase.....	1, 21
Maximum brake.....	1, 2	Wheels.....	15
Taxable.....	2	Wheel spindle.....	18
Ignition system.....	9	Windshield wiper.....	10
Instruments.....	10		