

AMA Specifications – Passenger Car

Data prepared and distributed by American automobile manufacturers, using uniform questionnaire form developed by car manufacturers under auspices of the Automobile Manufacturers Association.

MAKE OF CAR DODGE **MODEL YEAR** 1958 **DATE: ISSUED** Sept. 1957 **REVISED** Jan. 1958 \emptyset

COMPANY DODGE DIVISION, CHRYSLER CORPORATION, DETROIT 31, MICHIGAN

MODEL NAME	SYMBOL	(6-Cyl only)	MODEL NAME	SYMBOL
Coronet Standard	LD2-L1	LD1-L1	Custom Royal	LD3-H
Coronet Custom	LD2-L2	LD1-L2	+Custom Sierra+	LD3-H
Royal	LD2-M	---	#D500	#LD2, LD3
+Suburban, Sierra+	LD3-L	---	(+Station Wagons)	

#Engine Package Only.

TABLE OF CONTENTS

General Specifications	1	Brakes	15	Station Wagon	24
Engine – Mechanical	2	Front Suspension & Steering	16	Body & Car – General	25
Electrical	8	Rear Suspension	18	Weights	26
Drive Units	12	Body Dimensions	19	Index	27

NOTES:

1. The specifications set forth herein are those in effect at the date of compilation and are subject to change without notice.

UNLESS OTHERWISE INDICATED:

- All specifications are standard for the models under which they are listed.
- Specifications apply basically to 4-door sedan or equivalent. Body dimensions shown on pages 19-24 include other body models available.
- All dimensions are nominal engineering dimensions.

GENERAL SPECIFICATIONS

MODEL	Additional Information Page No.:	LD1	LD2-L	LD2-M	LD3-H Except Suburban	LD3-L LD3-H Suburban	LD2 & LD3 D500 Package (a) (b) (c)	
Wheelbase (L-101)	22	122.0						
Tread	Front (W-101)	61.4(f)			60.9	Not applicable		
	Rear (W-102)	60.1	60.2(f)	59.8		" "		
Maximum Overall Dimensions	Length (L-103)	213.8			216.2		" "	
	Width (W-103)	78.3					" "	
	Height (H-101)	56.6	56.8		57.1	" "		
Transmission— (Specify trade name - opt., not available)	Manual	Standard					None	
	Overdrive	None						
	Automatic	*PF Optional	*PF or TF Opt	*TF Optional	*TF Standard			
Axle ratio	Manual	3.91	3.54		3.31	3.54	Not applicable	
	Overdrive	None						
	Automatic	3.73	(d)	3.15		Not applicable		
Tire size		7.50 x 14 (e)		8.00 x 14		" "		
	Type, no. cyl., valve arr.	In-Line 6, L-Hd.		90° V8, OHV In Line		90° V-8, OHV In Line		
Engine	Fuel system (Carb. or Inj.)	Carbureted						(a) (b) (c)
	Bore and stroke	3.25 x 4.63	3.69 x 3.80	4.06 x 3.38		4.12 x 3.38		
	Piston displ., cu. in.	230	325	350		361		
	Std. compression ratio	8.0	9.0		10.0			
	Max. bhp at engine rpm \emptyset	2	138 @ 4000	252 @ 4400	265 @ 4400	295 @ 4600	(a) (b) (c) \emptyset	
	Max. torque at rpm \emptyset	2	208 @ 1600	345 @ 2400	355 @ 2800	385 @ 2800	(a) (b) (c) \emptyset	

* PF-PowerFlite, TF-TorqueFlite

Rev. Form 6-57

- \emptyset (a) Single carburetor, available on all V-8 models; bhp 305 at 4600 rpm, torque 400 at 2800 rpm
- \emptyset (b) Two carburetors, available on all V-8 models; bhp 320 at 4800 rpm, torque 400 at 2800 rpm.
- \emptyset (c) Fuel injector, available on all V-8 models except Suburbans; bhp 333 at 4800 rpm, torque 400 at 3600 rpm.
- (d) 3.31 with PowerFlite; 3.15 with TorqueFlite. (e) Except 8.00 x 14 on LD2-L1 Convertible.
- (f) On LD2-L1 Convertible: Front 60.9, Rear 59.8.

AMA Specifications - Passenger Car

MAKE OF CAR	DODGE	MODEL YEAR	1958	DATE ISSUED	Sept. 1957	REVISED	Jan. 1958
MODEL	LD1	LD2-L (*1-2B)	LD2-M (*1-4B)	LD3		LD2 & LD3 D500 Package	

ENGINE-GENERAL

Type, no. cyls., valve arr.		In-Line 6, L-head	90° V-8 OHV Latrl	90° V-8, OHV In line		
Bore and stroke		3.25 x 4.63	3.69 x 3.80	4.06 x 3.38	4.12 x 3.38	
Piston displacement, cu. in.		230	325	350	361	
Bore spacing (C/L to C/L)		(a)	4.19	4.80		
No. system (front to rear)	L. Bank	Not applicable		1 - 3 - 5 - 7		
	R. Bank	Not applicable		2 - 4 - 6 - 8		
Firing order		1-5-3-6-2-4		1-8-4-3-6-5-7-2		
Compres. ratio (nominal)	Standard	8.0	9.0 ϕ	10.0		
	Optional	None				
Cylinder Head Material	Standard	Cast iron				
	Optional	None				
Cylinder Sleeve - Wet, dry, none		None				
Number of mounting points	Front	Two				
	Rear	One				
Taxable Dia.² x No. Cyl. horsepower 2.5		25.4	43.3	52.7	54.3	
Published max. bhp at engine RPM*	Standard ϕ	138 @ 4000	252 @ 4400	265 @ 4400	295 @ 4600	*1-4B 305 @ 4600
	Optional ϕ	None				*2-4B 320 @ 4800 *F.I. 333 @ 4800
Published max. torque* (lb. ft. @ RPM)	Standard ϕ	208 @ 1600	345 @ 2400	355 @ 2800	385 @ 2800	*1-4B 400 @ 2800
	Optional ϕ					*2-4B 400 @ 2800 *F.I. 400 @ 3600
Recommended fuel regular - premium	Standard	Regular		Premium		
	Optional	---				
Recommended idle speed (neutral)		450 - 500				

ENGINE-PISTONS

Material	Aluminum alloy					
Description and finish	U-slot, elliptically-turned, tin-plated	Thermally controlled by steel band, horizontal slot, elliptically-turned, tin-plated				
Weight (piston only) oz.	15.8	18.5	ϕ (b) 21.5	ϕ (c) 21.4		

* Max. bhp (brake horsepower) and max. torque corrected as defined by SAE Engine Test Code. (Continued) Rev. Form 6-57

- # Carburetors: 1-2B=one two-barrel, 1-4B=one 4-barrel, 2-4B=two 4-barrel, F.I.=fuel injector.
- (a) 3.5625 except 3.875 between 2-3 and 4-5.
- ϕ (b) Later models - 21.4 oz.
- ϕ (c) Later models - 21.3 oz.

AMA Specifications – Passenger Car

MAKE OF CAR	DODGE	MODEL YEAR	1958	DATE ISSUED	Sept. 1957	REVISED	Jan. 1958
MODEL	LD1	LD2	LD3	LD2 & LD3 D500 Package			

ENGINE PISTONS (Cont.)

Clearance (limits)	Top land	.030	.028 - .033	.042 - .047
	Skirt	Top	---	.00075 - .00125
		Bottom	.0007	---
Ring groove depth	No. 1 ring	.17	.19	.21
	No. 2 ring	.17	.19	.21
	No. 3 ring	.17	.19	.20
	No. 4 ring	.17	None	

ENGINE—RINGS

Function (top to bottom)	No. 1, oil or comp.	Compression		
	No. 2, oil or comp.	Compression		
	No. 3, oil or comp.	Oil		
	No. 4, oil or comp.	Oil	None	
Compression	Description - material, type, coating, etc.	Cast iron, std. type, #1 chrome plate, #2 tin plated	Cast iron, low taper and twist, tin plated	Cast iron, standard taper and twist, tin plated
	Width	.093	.078	
	Gap	.010 - .020		.013 - .025
Oil	Description - material, type, coating, etc.	Cast iron, single-piece unit		
	Width	.155	.186	.188
	Gap	.010 - .020		.013 - .025
Expanders	None	Low tension, hump	Standard tension, hump type	

ENGINE—PISTON PINS

Material	High-manganese steel			
Length	2.75	3.07	3.44	
Diameter	.859	.922	1.0935	
Type	Locked in rod, in piston, floating, etc.	Floating		Press-fit in rod
	Bushing	In rod or piston	Rod	
		Material	Bronze on steel	
Clearance	In piston	.0000 - .0005	.0000 - .0003	.00015 - .00065
	In rod	.0001 - .0002	.0001 - .0004	.0007 - .0012 Interference
Direction & amount offset in piston	None		.06 Right	

ENGINE—CONNECTING RODS

Material	High-manganese forging steel	Drop-forged steel		
Weight (oz.)	27.9	24.0	28.6	
Length (center to center)	7.81	6.62	6.36	
Bearing	Material & Type	Bi-metal grid		Lead-base babbitt on steel (a) ϕ
		Removeable, precision type		
	Overall length	1.00	.811	.927
	Clearance (limits)	.0005 - .0015		
End play	.006 - .011	.006 - .014 (2 rods)	.009 - .017 (2 rods)	

(a) On D-500 Special Police Cars only - bi-metal grid. ϕ

AMA Specifications – Passenger Car

MAKE OF CAR	DODGE	MODEL YEAR	1958	DATE ISSUED	Sept. 1957	REVISED	
MODEL	LD1		LD2		LD2&LD3 D500 Package; LD3		

ENGINE—CRANKSHAFT

Material		Drop-forged steel			
Vibration damper type		Rubber-dynamic	None	Rubber-dynamic	
End thrust taken by bearing (No.)		#4-Rear	#3-Center		
Crankshaft end play		.003 - .007	.002 - .007		
Main bearing	Material & type		Lead-base babbitt on steel. (a) Removable, precision type.		
	Clearance		.0005 - .0015		
	Journal dia. and bearing overall length	No. 1	2.50 x 1.24	2.50 x .842	2.63 x .94
		No. 2	2.50 x 1.03	2.50 x .842	2.63 x .94
		No. 3	2.50 x 1.03	2.50 x 1.09 (a)	2.63 x 1.22 (a)
		No. 4	2.50 x 1.87 (a)	2.50 x .842	2.63 x .94
		No. 5	None	2.50 x 1.56	2.63 x .94
		No. 6		None	
No. 7			None		
Dir. & amt. cyl. offset		Left 0.125	None		
Crankpin journal diameter		2.06	2.25	2.38	

ENGINE—CAMSHAFT

Location		Right side	Center of "V" above crankshaft		
Material		Hardenable cast iron, with cams and drive gear for distributor and oil pump cast integrally			
Bearings	Material	(b)	Lead-base babbitt on steel		
	Number	4	5		
Gear or chain		Chain			
Crankshaft gear or sprocket material		High-manganese steel			
Type of drive	Camshaft gear or sprocket material		Cast iron		
	Timing chain	No. of links	48	68	50
		Width?	1.02	1.12	.88
		Pitch	.50	.375	.50

ENGINE—VALVE SYSTEM

Hydraulic lifters (Std, opt, NA)		NA	Standard	
Special provision for valve rotation (Intake, exhaust)		None	Low-friction lock on exhaust	
Rocker ratio		Not applicable	1.50 to 1	
Operating tappet clearance (Indicate hot or cold)	Intake	.010 (Hot)	Not applicable	
	Exhaust	.010 (Hot)	Not applicable	
Timing marks on fly-wheel, damper, other		Vibration damper	Fan drive pulley	Vibration damper

(a) Thrust bearings are tin-base babbitt on steel.

(Continued)

Rev. Form 6-57

(b) #1, #2, #3 - Lead base babbitt on steel; #4 cast iron (bored in block).

AMA Specifications – Passenger Car

MAKE OF CAR DODGE **MODEL YEAR** 1958 **DATE ISSUED** Sept. 1957 **REVISED** Jan. 1958
MODEL LD1 LD2 LD3; D500 D500 W/two
W/One 4-bbl 4-bbl Carburetors
ENGINE--VALVE SYSTEM (cont.) Carburetor or Fuel Injection

		LD1	LD2	LD3; D500 W/One 4-bbl Carburetor	D500 W/two 4-bbl Carburetors or Fuel Injection	
Timing	Intake	Opens (°BTC)	12	10	15	20
		Closes (°ABC)	44	58	57	60
		Duration - deg.	236	248	252	260
	Exhaust	Opens (°BBC)	50	56	57	58
		Closes (°ATC)	6	16	15	22
		Duration - deg.	236	252	252	260
Valve opening overlap		18°	26°	30°	42°	
Material		silicon-chromium steel				
Overall length		4.84	4.31	4.78		
Actual overall head dia.		1.53	1.84	1.95		
Angle of seat		45°				
Seat insert material		None				
Stem diameter		.34	.37			
Stem to guide clearance		.002				
Intake	Lift		.365	.389	.390	
	Outer spring press. and length	Valve closed (lb. @ in.)	42 @ 1.75	72 @ 1.69	80 @ 1.86	100 @ 1.86
		Valve open (lb. @ in.)	115 @ 1.38	166 @ 1.31	180 @ 1.47	195 @ 1.47
	Inner spring press. and length	Valve closed (lb. @ in.)	None			
		Valve open (lb. @ in.)	None			
	Material		XCR Chr-Ni-Steel	21-4N Chromium steel		
Overall length		4.89	4.58	4.78		
Actual overall head dia.		1.41	1.56	1.60		
Angle of seat		45°				
Seat insert material		Alloy iron	None			
Stem diameter		.34	.37			
Stem to guide clearance		.004	.003			
Exhaust	Lift		.365	.389	.390	
	Outer spring press. and length	Valve closed (lb. @ in.)	42 @ 1.75	72 @ 1.69	80 @ 1.86	100 @ 1.86
		Valve open (lb. @ in.)	115 @ 1.38	166 @ 1.31	180 @ 1.47	195 @ 1.47
	Inner spring press. and length	Valve closed (lb. @ in.)	None			
		Valve open (lb. @ in.)	None			

ENGINE--LUBRICATION SYSTEM

Type of lubrication (splash, pressure, nozzle)	Main bearings	Pressure			
	Connecting rods	Pressure			
	Piston pins	Metered jet spray		Splash	
	Camshaft bearings	Pressure			
	Tappets	Jet spray	Pressure		
	Timing gear or chain	Metered flow			
	Cylinder walls	Metered jet spray			

(Continued)

Rev. Form 6-57

AMA Specifications – Passenger Car

Page 6

MAKE OF CAR	DODGE	MODEL YEAR	1958	DATE: ISSUED	Sept. 1957	REVISED	Jan. 1958
MODEL	LD1	LD2-L	LD2-M	LD3	LD2 & LD3 D500 Package		

ENGINE—LUBRICATION SYSTEM (cont.)

Oil pump type	Rotary		
Normal oil pressure (lb. @ engine rpm)	40-45 @ 1500	40-65 @ 2000	50-65 @ 1500
Oil pressure sending unit (electric or mechanical)	Mechanical		
Type oil intake (floating, stationary)	Stationary		
Oil filter system (full flow, partial, other)	Bypass	Shunt	Full flow
Filter replacement (element, complete)	Element	Element	Complete
Capacity of crankcase, less filter-refill (qt.)	5		4
Oil grade recommended (SAE viscosity and temperature range)	Above +32° F	SAE 30, SAE 20W-40, or SAE 10W-30	As low as +10° F
	As low as +10° F	SAE 20W, SAE 20W-40, or SAE 10W-30	As low as -10° F
	As low as -10° F	SAE 10W, SAE 10W-30, or SAE 5W-20	Below -10° F
	Below -10° F	SAE 5W, or SAE 5W-20	
Oil type recommended	API Classification MS		

ENGINE—EXHAUST SYSTEM

Type (single, single with cross-over, dual, other)	Single	Single with crossover(a)	Dual (b)	Dual
Muffler No. & type (reverse flow, straight thru, separate resonator)	One; Reverse flow		Two; Reverse flow	
Exhaust pipe dia. (O.D.)	None	1.88 x .083	None	
Branch wall thickness	2 x .083	2.25 x .083	2 x .083	2.25 x .083
Main wall thickness	1.75 x .048	2 x .048	1.75 x .048	2 x .048
Tail pipe diameter (O.D. & wall thickness)	1.75 x .048		1.75 x .048	2 x .048

ENGINE—FUEL SYSTEM

(See Supplement to Page 6 for Details of Fuel Injection, Supercharger, etc. if used)

Induction type: Carburetor, fuel injection, supercharger.	Carburetor			
Fuel Tank	All except Suburbans - 20; Suburbans - 22			
Capacity (gals.)	Left rear fender			
Filler location	Mechanical			
Fuel Pump	Right front of engine			
Type (elec. or mech.)	6 - 7 psi			
Locations	None			
Pressure range	Plastic			
Vacuum booster (std., optional, none)	Plastic and ceramic			
Fuel Filter	Fuel tank and carburetor		Fuel tank and fuel pump	
Type	(c)	(d)	(e)	(k) Carter AFB-261, 2S (f)
Locations	One dual		One 4-barrel (g)	
Make & Model No.	1.31		1.44 (h)	
Number & Type Downdraft	Integral			
Barrel size	Remote in manifold crossover (j)			
Choke type	Exhaust			
Intake manifold heat control (exhaust or water)	Paper element			
Air clnr. type	None			
Standard				
Optional				

- (a) Dual on LD2-L1-27 Convertible. (b) Single on LD3-L Suburbans. Rev. Form 6-57
 (c) Stromberg WW3-159; w/PowerFlite WW3-160. (d) Stromberg WW3-163; w/auto trans WW3-164.
 (e) Carter WCFB-2660S. (f) With 2 carburetors - Carter, Front AFB-2652S, Rear AFB-2653S.
 (g) One or two 4-barrel. (h) One carburetor - 1.44; two carburetors - Primary 1.44, Secondary 1.56 each carburetor. (j) With 2 carburetors: Integral on rear, none on front.
 (k) On LD3 with manual transmission - Carter AFB-2773-S.

AMA Specifications -- Passenger Car

Supplement
to Page 6

MAKE OF CAR DODGE **MODEL YEAR** 1958 **DATE ISSUED** Sept. 1957 **REVISED** _____
MODEL _____ LD2 and LD3 D500 Package

SUPPLEMENTARY INFORMATION

ENGINE--FUEL SYSTEM (cont.) - FUEL INJECTION

Injection System	Description		Speed-density system with electrically-operated injectors and electronically-controlled metering of fuel
	Trade Name		
	Make		Bendix
Fuel Recommended			Premium
Fuel Pump	Type		Fuel-Immersed Electric-Motor-Driven Vanes
	Location		Fuel Tank
	Pressure Range		25 to 33 psi
Pressure Regulator-Filter	Type		Fuel Filter, Constant-Pressure Regulator, and Vapor Return
	Filter Type & Size		Micronic; 5-micron
	Regulated Pressure		12.5 psi
	Vapor-air Trap and Bleed		Yes
Fuel Manifold	Type		Double-runner tubes with branches to each injector valve
	Type		Electric solenoid-operated disc valves
Injectors	Location		On intake manifold above each intake port
	Duration of Opening		1 to 4 milliseconds
	Control		Modulator electronic circuits vary duration of injector-operating electrical pulses, which are initiated by a trigger-selector
	Description		Filtered air through two throttle bodies
Air Induction	Air Cleaner	Number	Two
		Type	Dry - Elliptical
	Location		At each throttle body
	Control		Interconnected throttle blades
Modulator	Description and Function		Two-channel electronic circuit adjusted by engine operating and atmospheric sensor circuits. Regulates injected fuel by the duration of electric pulse.
	Location		Left front of radiator core
Sensor System	Description and Function		Resistance elements in the modulator external control circuit which are varied by the engine operating functions and atmospheric conditions.
	Types and Locations		Temperature - Rear throttle body Manifold vacuum - Altitude - At modulator -Rear throttle body Idle - Rear throttle body Cold start and warm-up - Acceleration- Rear throttle body - Rear throttle body
	Description and Function		Cam-operated breaker points for triggering modulator and commutator for distributing electrical pulses to injectors
Trigger Selector	Driven by		Integral with distributor
	Speed		One-half engine speed

AMA Specifications – Passenger Car

MAKE OF CAR	DODGE	MODEL YEAR	1958		DATE ISSUED	Sept. 1957		REVISED			
MODEL	LD1	LD2	LD3 and D500 Package								
	Std	PS	Std	PS	AC	PS&AC	Std	PS	AC	PS&AC	

ENGINE—COOLING SYSTEM

Type (pressure system, atmospheric, other)		Pressure-vent										
Radiator cap relief valve pressure		14 psi										
Circulation thermostat	Type (choke, bypass)	Pellet										
	Starts to open at (°F)	157 - 162										
Water pump	Type (centrifugal, other)	Centrifugal										
	Number of pumps	One										
	Drive (V-belt, other)	V-Belt										
	Bearing type	Sealed ball bearing										
By-pass recirculation type (internal, external)		Internal										
Radiator core type (cellular, tube and fin, other)		Cellular or fin-and-tube										
Cooling system capacity	With heater (qt.)	14			21			17				
	Without heater (qt.)	13			20			16				
	Opt. equipment-specify (qt.)	None										
Water jackets full length of cylinder (yes, no)		Yes					No					
Water all around cylinder (yes, no)		No					Yes					
Radiator hose	Lower	Number and type (molded, straight)	One, molded									
		Inside diameter	1.5									
	Upper	Number and type (molded, straight)	One, molded									
		Inside diameter	1.5									
	By-pass	Number and type (molded, straight)	None									
		Inside diameter	- - -									
Fan	Number of blades & Spacing	Four, 76-104°				Four, 76-104° (a)						
	Diameter	17" (sq tip)				18" (curved tip)						
	Ratio-fan to crankshaft rev.	0.95										
	Fan cutout type	None										
	Bearing type	See "Water Pump"										
*Drive belts (Indicate belt used by letter)	Fan	A	B	D	D	E	E	H	H	J	J	
	Generator	A	B	D	D	2F	2F	H	H	2K	2K	
	Water Pump	A	B	D	D	E	E	H	H	J	J	
	Power Steering		C			G		2F		L		L
	Air Conditioning						2F	2F			2K	2K

(a) With AC - Six, 45-75-60°

Rev. Form 6-57

*Drive Belt Dimensions	A	B	C	D	E	F	G	H	J	K	L
Angle of V	38 - 42°										
Nominal length (SAE)	40.0	38.63	40.0	57.38	37.25	*71.38	38.0	56.5	36.88	68.75	41.75
Width	.375	.375	.5	.375	.375	.375	.5	.375	.375	.375	.5

(PS=Power steering, AC=Air conditioning, PS&AC=Power steering and air conditioning)
 *With 40-amp generator 72.75.

AMA Specifications – Passenger Car

MAKE OF CAR	DODGE	MODEL YEAR	1958
		DATE ISSUED	Sept. 1957
MODEL	LD1	LD1 with PowerFlite	LD2
			LD3 and D500 Package

ELECTRICAL—SUPPLY SYSTEM

			A-L 11-HS-60 or Wil HO-11-60*	
Battery	Make and Model	*A-L 11-HS-50, Wil HO-11-50, or Gld 11-OE-53		
	Voltage Rtg. & Plates/cell	12V, 9		
	SAE Designation & Amp Hr. Rtg.	*A-L and Wil - None, 50; Gld - None, 53		
	Location	Under hood, left side		
	Terminal grounded	Negative		
Generator	Make	Auto-Lite		
	Model	GJC-7012-A		
	Type	Shunt wound		
	Ratio—Gen. to Cr/s rev.	2.12 : 1	2 : 1	
	Gen. cut-in—engine rpm	615	650	
Regulator	Make	Auto-Lite		
	Model	VRX-6201-A		
	Type	Current and voltage control		
	Cutout relay	Closing voltage @ generator rpm	13.0 - 13.8 @ 1300	
		Reverse current to open	Contacts open at 0 - 6-amp discharge at 8.2 - 9.3 volts after 10-amp discharge	
	Regulated	Voltage	14.28 - 14.88	
		Current	30 - 40	
	Voltage test conditions	Temperature	70° F	
Load		Run 15 min at 7.0 amp - Voltage regulator check		
Other		Additional 15 min at rated output - Current regulator check		

ELECTRICAL—STARTING SYSTEM

Starting motor	Make	Auto-Lite			
	Model	MDM-6001	MDL-6004	MDL-6003	MDT-6001
	Rotation (drive end view)	Clockwise			
	Engine cranking speed	Cold - 35 rpm; Hot - 150 rpm			
	Test conditions	Cold: SAE 5W at -20° F Hot: SAE 30 with completely-warmed engine			
	Lock test	Amps	210	225	350
		Volts	4	4	4
		Torque (lb. ft.)	5	6	8.5
	No load test	Amps	50	60	58
		Volts	11	11	11
RPM (min.)		3600	3400	3800	
Motor control	Switch (solenoid, manual)	Bendix (anti-kickout)			
	Starting procedure	<p>WITH MANUAL AND POWER-FLITE TRANSMISSIONS: Depress accelerator pedal about one-third and turn ignition key beyond "Ignition On" position.</p> <p>WITH TORQUE-FLITE TRANSMISSION: Depress accelerator pedal about one-third and press "N" (Neutral) transmission push button to "Extreme In" position.</p>			

A-L = Auto-Lite, Wil = Willard, Gld = Gould.

AMA Specifications – Passenger Car

Page 9

MAKE OF CAR DODGE **MODEL YEAR** 1958 **DATE: ISSUED** Sept. 1957 **REVISED** Jan. 1958 ϕ
MODEL LD1 Dual Carb LD2 2 or 4-Bbl LD3 One 4-Bbl LD2 & LD3 D500 Package One 4-Bbl Two 4-Bbl Fuel Injector

ELECTRICAL—STARTING SYSTEM (cont.)

Motor drive	Engagement type		Inertia follow-through drive
	Pinion meshes (front, rear)		Front
	Number of teeth	Pinion	9
		Flywheel	172
Flywheel tooth face width		.375	

ELECTRICAL—IGNITION SYSTEM

Coil	Make		Auto-Lite			
	Model		CAG-4001B	CAH-4001E	CAH-4001A	
	Amps	Engine stopped	2.4	3.1		
		Engine idling	1.8	2.5		
Distributor	Make		Auto-Lite			
	Model		IBR-4001	IBP-4002E	IBP-4005	IBS-4006B IBS-4009
	Spark adv. centrifugal (crankshaft degrees)	Start (rpm)	500-900	600-800	550-850	
		Intermediate points @ rpm	0-4 @ 900	0-4 @ 800	0-4 @ 850	
		Max. @ rpm	11-15 @ 2100	8-12 @ 1300	9-13 @ 1500	
	Spark adv. vacuum (crankshaft degrees)	Start (in. Hg)	0 @ 5.5-7	0 @ 6-7.5	0 @ 4.2-8	
		Intermediate points (in. Hg)	9 @ 8 - 11	10 @ 9-10	15 @ 10.5-13	
		Max. (in. Hg)	17-21 @ 16	20-24 @ 14	23-29 @ 16.5	
	Breaker gap (in.)		.018- .022	.015 - .018 ϕ		
	Cam angle (deg.)		39 + 3	27 - 32		36-40 (total; dbl breaker)
Breaker arm tension (oz.)		17 - 20				
Crankshaft deg. @ rpm.		2 BTC @ 500	6 BTC @ 500		8 BTC @ 500	
Timing	Mark location		(a)	(b)	Vibration damper	
	Cylinder numbering system (see page 2)		Left bank: 1 - 3 - 5 - 7			
			Right bank: 2 - 4 - 6 - 8			
Firing order (see page 2)		1-5-3-6-2-4	1-8-4-3-6-5-7-2			
Spark Plug	Make and model		Auto-Lite Resistor			
			AR-51	AGR-42	AR-42	AR-32
	Thread (mm)		14			
	Tightening torque (lb. ft.)		30-32			
	Gap		.035			
Cable	Conductor type		Stranded Copper			
	Insulation type		Rubber with neoprene jacket			
	Spark plug protector		Neoprene cover			

ELECTRICAL—SUPPRESSION

Description	Spark plugs: 10,000-ohm integral resistor
	Distributor: 10,000-ohm integral resistor

(a) Vibration damper.
 (b) Fan drive pulley.

AMA Specifications -- Passenger Car

Sept. 1957

MAKE OF CAR DODGE MODEL YEAR 1958 DATE ISSUED 1957 REVISED _____

MODEL _____ All Models - LD1, LD2 and LD3

ELECTRICAL—INSTRUMENTS AND SWITCHES

Speed-ometer	Make	Stewart Warner
	Trip odometer (yes, no)	No
Charge indicator-type		Ammeter
Temperature indicator-type		Electric, magnetic
Oil pressure indicator-type		Bourdon tube
Fuel indicator-type		Electric, magnetic
Other		None
Ignition switch	Identify positions in order and circuits controlled	Center Position - Off 1st Position Clockwise - Ignition and accessory circuit only 2nd Position Clockwise - Starter and ignition circuit only (a) 1st Position Counter-clockwise - Accessory circuit only
	Provision for illumination	None
	Location	Right of steering column
Main lighting switch	Identify positions and lights controlled	Left Position - Off 1st Position Clockwise - Instrument, tail, license plate, and parking lamps 2nd Position Clockwise - Instruments, head, tail, and license plate lamps
	Locations and lamps controlled	Instrument lamp switch - Left of steering column on instrument panel concentric with headlamp switch, variable all instruments; Stop lamp switch - In master cylinder; Dome lamp - Manual switch on instrument panel, automatic switches in front doors (on all doors of Custom Royals); Direction signal switch - Lever on steering column below wheel.
Other switches	Locations and devices controlled	Windshield wiper switch - One-speed, right of steering column (Variable speed special equipment). Heater switch - Two-speed, right of steering column Defroster control - Right of steering column Starter switch - Neutral push button (extreme in position) (b)
Windshield wiper	Make	Auto-Lite or (single speed only) General Industries
	Type	Electric
	Vacuum booster provision	None
	Washer provision	None
Horn	Type	Air note - Sea shell
	Number used	2
	Amp draw (each)	9 - 10

- (a) Models with PowerFlite or manual transmission only.
 (b) Models with TorqueFlite transmission only.

AMA Specifications – Passenger Car

MAKE OF CAR DODGE **MODEL YEAR** 1958 **DATE ISSUED** Sept. 1957 **REVISED** _____
MODEL _____ All Models – LD1, LD2, and LD3

ELECTRICAL—LAMP BULBS

Give quantity used and trade number, e.g., Headlamp 2-5400 S, dual headlight 2-4001, 2-4002. Indicate accessories which are not standard equipment by an asterisk following the numbers.

Headlamps & arrangement	Horizontal; 2-4001, 2-4002
Headlamp beam indicator	1-57
Parking light	2-1034 (a)
Tail light	2-1034 (b)
Stop light	2-1034 (b)
Direction signal	Front 2-1034 (a)
	Rear 2-1034 (b)
	Indicator 2-57
License plate light	1-67
Instrument light	2-57
Ignition lock light	None
Back up light	2-1073*
Dome light	1-1004 (c)
Clock light	1-1816*
Radio light	1-1816*
Glove compartment light	1-57
Speedometer	3-57
Transmission Control	1-57
Handbrake Indicator	1-68
Map Light	1-90*

ELECTRICAL—FUSE & CIRCUIT BREAKER DATA

Use trade number of fuse, e.g., SFE-10. Indicate circuit breaker by ampere capacity suffixed by letters "C.B." e.g., 30 C.B. Where fuse or circuit breaker protects multiple circuits indicate first use by a letter and repeat the same letter for all units protected by the same fuse or circuit breaker, e.g., Parking lights SFE-10 (a), Direction Indicator same as (a).

Headlamp	22.5 CB (A)
Headlamp beam indicator	Same as (A)
Parking light	Same as (A)
Tail light	15 CB (B)
Stop light	Same as (B)
Direction indicator	None
License plate light	Same as (B)
Instrument light	Same as (B)
Ignition light	None
Back up light	Same as (B)
Dome light	Same as (B)
Clock	SFE-2
Clock light	Same as (B)
Radio	SFE-7.5
Glove compartment light	Same as (B)
Map Light	Same as (B)
Windshield Wiper	5 CB (C); Variable Speed - 6 CB (D)
Window Lift	30 CB (E)
Seat Adjuster	40 CB (F)

(a) Integral units. (b) Integral units, dual-filament.
(c) 2 on Hardtops and 3-seat Suburbans.

AMA Specifications – Passenger Car

MAKE OF CAR	DODGE	MODEL YEAR	1958	DATE: ISSUED	Sept. 1957	REVISED	
MODEL	LD1	LD2	LD3	LD2 & LD3	D500 Package		

DRIVE UNITS—CLUTCH (Manual Transmission)

Make & type	Auburn (Opt) Dry plate	Borg & Beck, Dry plate			
Type pressure plate springs	Coil				
Total plate pressure (lb.)	1280	1206	1920	2013	2104
No. of clutch driven discs	One				
Clutch facing	Material	Molded woven asboestos			
	Outside & inside dia.	9.25 x 6.00	10.00 x 6.00	10.50 x 6.50	11.00 x 6.50
	Total eff. area (sq.in.)	77.8	100.5	106.8	123.7
	Thickness	.114	.125		
	Engagement cushioning method	Flat springs, crimped			
Release bearing	Type & method of lubrication	Sealed ball bearing, permanently lubricated			
Torsional damping	Methods: springs, friction material	Coil springs			

DRIVE UNITS—TRANSMISSIONS

Manual (std. or opt.)	Standard	None
Manual with overdrive (std. or opt.)	None	
Automatic (std. or opt.)	PowerFlite optional	TorqueFlite standard
	---	TorqueFlite optional

DRIVE UNITS—MANUAL TRANSMISSION

Number of forward speeds	3			
Transmission ratios	In first	2.50	2.31	
	In second	1.68	1.55	
	In third	1.00	1.00	
	In fourth	None		
	In reverse	3.20	2.96	
Synchronous meshing, specify gears	2nd and 3rd			
Lubricant	Capacity (pt.)	2.75		
	Type recommended	Multi-purpose gear oil, API classification GL-4		
	SAE viscosity number	Summer	SAE 80	
		Winter	Above -10° F, SAE 80	
Extreme cold		Below -10° F, SAE 75		

AMA Specifications – Passenger Car

MAKE OF CAR DODGE	MODEL YEAR 1958	DATE: ISSUED Sept. 1957	REVISED	
MODEL	LD1	LD2-L	LD2-M	LD3
				D500 Package

DRIVE UNITS—MANUAL TRANSMISSION WITH OVERDRIVE

For transmission data see manual transmission section

Overdrive	Type (planetary or other)		Not applicable		
	Manual lockout (yes, no)		---		
	Downshift accelerator control (yes, no)		---		
	Minimum cut-in speed		---		
	Gear ratio		---		
	Lu- bri- cant	Capacity (Overdrive only)		---	
		Separate filler (yes, no)		---	
		Type recommended		---	
		SAE vis- cosity number	Summer	---	
			Winter	---	
Ext. cold	---				

DRIVE UNITS—AUTOMATIC TRANSMISSION

Trade name	PowerFlite	(a)	TorqueFlite		
Type describe	Torque converter with gears				
Method of Selection (Lever, Push Button or other)	Pushbutton				
Selector Pattern	(PowerFlite) R N D L		R N D 1 2 (TorqueFlite)		
List gear ratios Selector Pattern and indicate which are used in each selector position	PowerFlite R 2.39:1 - Reverse D 1.00:1 - Drive L 1.72:1 - Drive & Low		TorqueFlite R 2.20:1 - Reverse D 1.00:1 - Drive 2 1.45:1 - Drive & 2 1 2.45:1 - Drive, 2, & 1		
Max. upshift speeds—drive range (b)	50-55 mph	(c)	74-78 mph		
Max. kickdown speeds—drive range (b)	43-47 mph	(d)	70-75 mph		
Torque converter	Number of elements		3		
	Max. ratio at stall at engine rpm	Early Cars	2.6 at 1330	(e)	(f)
		Later Cars			2.3 @ 1875
Type of cooling (air, water)		Air-cooled		2.2 @ 1775	(h)
Lubricant	Capacity—refill (pt.)	20	*PF - 20; TF - 18		21
	Type recommended	Automatic transmission fluid, Type A			
Special transmission features	Incorporates spring-loaded hydraulic valve to prevent accidental reverse engagement				

* PF = PowerFlite, TF = TorqueFlite

Rev. Form 6-57

- (a) PowerFlite and TorqueFlite optional only.
- (b) With standard axle ratios and tires.
- (c) With PowerFlite 57-62 mph, with TorqueFlite 74-78 mph.
- (d) With PowerFlite 50-54 mph, with TorqueFlite 70-75 mph.
- (e) With PowerFlite - 2.7 at 1855; with TorqueFlite - 2.7 at 1700.
- (f) With PowerFlite - 2.7 at 1710; with TorqueFlite - 2.7 at 1925.
- (g) One 4-bbl carb - 2.3 @ 1930; two 4-bbl carbs - 2.3 @ 1880.
- (h) One 4-bbl carb - 2.2 @ 1830; two 4-bbl carbs - 2.2 @ 1790.

AMA Specifications – Passenger Car

MAKE OF CAR DODGE	MODEL YEAR 1958	DATE ISSUED Sept. 1957	REVISED
MODEL	LD1	LD2-L	LD2-M
		LD3	D500 Package

DRIVE UNITS—PROPELLER SHAFT

Number used		One		
Type (exposed, torque tube)		Exposed		
Outer diameter x length* x wall thickness (a)	Manual transmission	3.0 x 58.81	3.5 x 59.02	3.5 x 59.03
	OverDrive transmission PowerFlite	3.0 x 58.81	3.5 x 59.02 3.25 x 59.02(b)	None
	Automatic transmission TorqueFlite	None	3.25 x 58.86	3.25 x 58.96 3.5 x 58.96(b)
Inter-mediate bearing	Type (plain, anti-friction)	None		
	Lubrication (fitting, prepack)	Not applicable		
Universal joints	Make	Own (Detroit)		
	Number used	Two		
	Type (ball and trunnion, cross, other)	Front: Ball and trunnion Rear: Cross		
	Bearing	Type (plain, anti-friction)	Anti-friction	
Lubric. (fitting, prepack)		Front: Clean and repack Rear: Prepack		
Drive taken through (torque tube or arms, springs)		Rear Springs		
Torque taken through (torque tube or arms, springs)		Rear Springs		

DRIVE UNITS—REAR AXLE (See Supplement to Page 14 for optional axles.)

Description - (incl. limited slip differential)		Conventional type: Semi-floating, hypoid, ¹ 2-pinion differential with single-piece case			
Drive Pinion Offset		1.5"			
No. of differential pinions		Conventional differential - 2			
Gear ratio and No. of teeth	Automatic transmission PowerFlite	3.73 (41-11)	3.31 (43-13)	None	
	OverDrive trans. TorqueFlite	None	3.15 (41-13)		
	Manual transmission	3.9 (43-11)	3.54 (39-11)	3.31 (43-13)(c)	
Ring gear pitch diameter & O.D.		8.25 and 8.25	8.75 and 8.75		
Pinion adjustment (shim, other)		Solid shim (washer)			
Pinion bearing adj. (shim, other)		Shims			
Wheel bearing type		Tapered roller bearing			
Lubricant	Capacity (pt.)	3.25	3.5		
	Type recommended	Multi-purpose gear lubricant, API Classification GL-4 (d)			
	SAE viscosity number	Summer	Above -10° F, SAE 90		
		Winter	Below -10° F, SAE 80		
	Extreme cold	Below -30° F, SAE 75			

*Center to center of universal joints, or to centerline of rear attachment.

- (a) Wall thickness .065 - all shafts. (b) Optional. (c) Suburbans - 3.54.
 (d) For "Sure-Grip" limited-slip type - Mopar Rear Axle Lubricant.

AMA Specifications -- Passenger Car

Supplement
to Page 14

MAKE OF CAR DODGE MODEL YEAR 1958 DATE ISSUED Sept. 1957 REVISED Jan. 1958 ϕ

SUPPLEMENTARY INFORMATION

OPTIONAL REAR AXLE RATIOS

MODEL	LD1	LD2-L	LD2-M	LD3 Except Sta. Wagons	LD3 Sta. Wagons	
CONVENTIONAL TYPE (Available in all ratios and applications listed.)						
Gear Ratio and No. of Teeth	PowerFlite Transmission ϕ	--	3.15 (41-13)	--	--	--
		3.54 (39-11)	3.54 (39-11)	--	--	--
		3.9 (43-11)	--	--	--	--
	TorqueFlite Transmission	--	2.93 (41-14)	2.93 (41-14)	2.93 (41-14)	2.93 (41-14)
		--	3.31 (43-13)	3.31 (43-13)	3.31 (43-13)	3.31 (43-13)
	Manual Transmission	--	--	--	3.15 (41-13)	--
		--	3.31 (43-13)	3.31 (43-13)	--	3.31 (43-13)
		--	--	--	3.54 (39-11)	--
		3.73 (41-11)	3.73 (41-11)	3.73 (41-11)	--	3.73 (41-11)
	4.1 (41-10)	--	--	--	--	

SURE-GRIP (LIMITED-SLIP) TYPE (Available in all ratios and applications listed above for V-8 models only.)

Description	Torque-bias type, with 4 pinions and 2 separate differential pinion shafts, cam-actuated friction clutches located back of each differential side gear
-------------	--

AMA Specifications – Passenger Car

MAKE OF CAR DODGE	MODEL YEAR 1958	DATE: ISSUED Sept. 1957	REVISED Jan. 1958
MODEL	LD1	LD2-L	LD2-M
		LD3 Except Sta. Wagons	LD3 Station Wagons

DRIVE UNITS—WHEELS

Type & material	Disc; pressed steel		
Rim (size and flange type)	14 x 5 K (a)	14 x 5.5 K	14 x 5.5 K(b)
Attachment	Type (bolt or stud) Stud		
	Circle diameter 4.5		
	Number and size Five, 1/2-20 N.F.		

DRIVE UNITS—TIRES (h) ϕ

Size (L-102) & ply rating	Standard Tubeless 4Ply	*BSW 7.50 x 14 (c)(d)	*BSW 8.00 x 14 (d)
	Optional Tubeless 4Ply	*B or WSW 8.00 x 14	*B or WSW 8.50 x 14
Type tires - nylon, etc.		Standard - Rayon; Optional - Rayon or Nylon, also 6-ply Rayon	
Rev/mile at 30 mph		776 with 7.50 x 14; 760 with 8.00 x 14; 746 with 8.50 x 14	
Inflation press. (cold)	Front (psi)	24	22
	Rear (psi)	22	24 (e)

BRAKES—SERVICE

Type	Hydraulic, internal expanding, calculated-contour variable-depth web, "Total-Contact" brake shoes		
Power brake type	Vacuum - optional		
Effective area (sq. in.) (g)	207	ϕ 207 (f)	230
Percent brake effectiveness—front 60			
Drum	Diameter	Front (g) 11"	
		Rear (g) 11"	
	Type and material Composite		
	Bonded or riveted Bonded		
Brake lining	Front Shoe	Material Molded asbestos	
		Size (length x width x thickness)	Front wheel 11.5 x 2.5 x 0.20
			Rear wheel 11.5 x 2.0 x 0.20 (f) 11.5 x 2.5 x 0.20
	Segments per shoe One		
	Rear Shoe	Material Molded asbestos	
		Size (length x width x thickness)	Front wheel 11.5 x 2.5 x 0.20
Rear wheel 11.5 x 2.0 x 0.20 (f) 11.5 x 2.5 x 0.20			
Segments per shoe One			
Wheel cylinder bore	Front 1.125		
	Rear 1.125		
Master cylinder bore 1.125			
Available pedal travel 6"; with optional power brakes - 4.63"			
Line pressure at 100 lb. pedal load 650 psi; with optional power brakes - 1150 psi			
Shoe clearance adjustment No major adjustment required			

- (a) Except 14 x 5.5 K on Convertible. (b) 14 x 6 K on 9-passenger models. Rev. Form 6-57
 (c) Except 8.00 x 14 on Convertible. (d) Whitewalls optional in all sizes.
 (e) Up to 28 psi under heavy loads. (f) On Convertibles and 4-door Hardtops, 11.5 x 2.5 x 0.20; effective area - 230 sq in.
 (g) 12 x 2.5 brakes optional on all models; effective area - 251 sq in. ϕ * BSW = Black Sidewall, WSW = White Sidewall
 (h) Captive-Air tires available on all models.

AMA Specifications – Passenger Car

Page 16

MAKE OF CAR <u>DODGE</u>	MODEL YEAR <u>1958</u>	DATE ISSUED <u>Sept. 1957</u>	REVISED <u>Jan. 1958</u> ϕ
MODEL		<u>LD1, LD2, and LD3 - All Models</u>	
	<u>Manual Transmission</u>	<u>Automatic Transmission</u>	

BRAKES—PARKING

Type of control	T-handle, multiple-pawl ratchet		
Location of control	Under instrument panel, left side of steering column		
Operates on	Transmission output shaft		
If separate from service brakes	Type (internal or external)	External	Internal
	Drum diameter	6"	7"
	Lining size (length x width x thickness)	ϕ 16.68 x 2 x 0.16	2 Shoe, ea 6.53 x 2 x 0.16 ϕ

FRAME or UNITIZED CONSTRUCTION

Type and description	Welded, double-channel box-section side rails; lateral crossmembers. X-type crossmember on Convertible
----------------------	--

SUSPENSION—GENERAL

Provision for car leveling (a)	Mechanical, by manual adjustment of torsion bar anchor bolt	
Provision for brake dip control	By inclined front upper control arms and unsymmetrical rear springs	
Provision for acc. squat control	By unsymmetrical rear springs	
Special provisions for car jacking	None	
Shock absorber front & rear	Type	Direct
	Make	Own
	Piston dia.	1 inch
Other special features	Front torsion bars are combined with outboard-mounted highly unsymmetrical semi-elliptical rear leaf springs	

SUSPENSION—FRONT

Type and description	Independent, lateral, non-parallel control arms with torsion bars
----------------------	---

(a) Front only.

(Continued)

Rev. Form 6-57

AMA Specifications – Passenger Car

MAKE OF CAR DODGE **MODEL YEAR** 1958 **DATE: ISSUED** Sept. 1957 **REVISED** Jan. 1958 \emptyset

MODEL LD1, LD2, and LD3

SUSPENSION FRONT (cont.)

Spring	Type	Torsion bar	
	Material	Chromium-alloy steel	
	Size (coil design height & I.D.; bar length x dia.)	44.6 x 1.04 (Suburbans 44.6 x 1.0)	
	Spring rate (lb. per in.)	Not applicable	
	Rate at wheel (lb. per in.) (a)	125 (Suburbans 105)	
	Design load (lb. @ design height)	Not applicable	
Stabilizer	Type (link, linkless, frameless)	None (Link on Suburbans)	
	Material & bar diameter	Not applicable (Suburbans: steel, .75)	

STEERING

Mechanical (std., opt., NA)			Standard	
Power (std., opt., NA)			Optional	
Wheel diameter			17"	
Turning diameter	Outside front	Wall to wall (l. & r.)	46'4" \emptyset	
		Curb to curb (l. & r.)	43'7"	
	Inside rear	Wall to wall (l. & r.)	\emptyset 27'8" (27'9" Suburban)	
		Curb to curb (l. & r.)	27'2" (27'1" Suburban)	
Outside wheel angle with inside wheel at 20°			18° 46'	
Mechanical	Gear	Type	Worm and three-tooth roller	
		Make	Own	
		Ratios	Gear 20.4 Overall 29.97	
	No. wheel turns		5.2	
Power	Type		Integral	
	Make		Own	
	Trade name		Constant Control	
	Gear	Type	Rack and sector	
		Ratios	Gear	15.7
			Overall	19.1
	Pump driven by		Belt from C/S pulley	
	Overall torque ratio		140:1 average (mean) \emptyset	
Number wheel turns		3.5		
Linkage	Type		Symmetrical idler arm, equal length tie rods	
	Location (front or rear of wheels, other)		Rear	
	Drag link (trans. or longit.)		Transverse	
	Tie rods (one or two)		Two	

(a) Without tires

(Continued)

Rev. Form 6-57

AMA Specifications – Passenger Car

MAKE OF CAR DODGE **MODEL YEAR** 1958 **DATE ISSUED** Sept. 1957 **REVISED** _____
MODEL LD1 LD2 & LD3

STEERING (cont.)

Steering Axis	Inclination at camber (deg.)		6½° at 0°
	Bearings (type)	Upper	Ball joint
		Lower	Ball joint
	Thrust	Oil-impregnated sintered metal	
Wheel alignment (range and preferred)	Caster (deg.)		Mechanical steering: +¼° ± ¼° Power steering: + 3/4° ± 3/4°
	Camber (deg.)		Left: +¼° ± ¼° (Prefer 3/8°) Right: 0° ± ¼° (Prefer 0°)
	Toe-in (outside tread-inches)		1/8" ± 1/32"
Steering spindle & joint type			Ball socket
Wheel spindle	Diameter	Inner bearing	1.25"
		Outer bearing	0.75"
	Thread size		3/4-16 N.F.
	Bearing type		Tapered roller

SUSPENSION—REAR

Type and description			Parallel, longitudinal leaf			
Drive and torq. taken through (see page 14)			Rear springs			
Spring	Type		Semi-elliptical			
	Material		Steel			
	Size (length x width, coil design height and I.D.; bar length & dia.)		57 x 2.5			
	Spring rate (lb. per in.)		95 (125 on Suburbans)			
	Rate at wheel (lb. per in.) (a)		130 (165 on Suburbans)			
	Design load (lb. at design height) (b)		RH-680at-.38; LH-720at-.38 RH-720at-.38; LH-760at-.38			
	Mounting insulation type		Rubber			
	If leaf	No. of leaves		4 (6 on Suburbans) 5 (6 on Suburbans)		
		Inserts	Type and size	2.5 x 2.5 front interliners; 2.5 x 3.5 rear interliners		
			Material	Wax impregnated fabric		
Shackle (comp. or tens.)		Compression				
Stabilizer	Type (link, linkless, frameless)		None			
	Material		Not applicable			
Track bar type			None			

- (a) Without tires
- (b) 2-Door Suburbans: RH 960 at -.38; LH-1000 at -.38
 4-Door Suburbans: RH 1000 at -.38; LH-1040 at -.38

AMA Specifications – Passenger Car

Page 19

MAKE OF CAR DODGE MODEL YEAR 1958 DATE ISSUED Sept. 1957 REVISED _____

BODY—GENERAL DEFINITIONS

NOTE: Included in the dimension definitions listed on this and the following pages are those which have been adopted by the S.A.E. These are indicated by a number following the type of dimension, e.g. L 3. Additional dimensions have been added by the AMA Specifications Body Subcommittee for inclusion in the Questionnaire. These are shown by an additional letter, e.g., HA. Symbol "a" added as suffix to SAE dimensions indicates an AMA modification. The dimensions are developed from the following basic points:

1. Front and rear seat free "A" points are taken 5" forward of vertical tangent to seat back 15" from center of body.
2. Front and rear seat "B" points are located on seat back 15" from center of body at height of horizontal tangent to top of seat cushion.
3. Front seat is in the full down and normal rearmost position.
4. Loaded position—5 passenger, front 300 lb., rear 450 lb.; includes spare wheel, tire and tools, and full complement of gas, oil, water, and tires to recommended pressure, etc.
5. C/L (centerline).
6. D. L. O. (daylight opening, exposed glass dimension - pages 21, 23 & 25).
7. Ramp breakover angle (page 21) is the supplement of the included ramp angle (180° minus the included ramp angle) over which a car can pass without hanging up.

MODEL	LD1-L 4-Door Sedan	LD2-L 4-Door Sedan	LD2-M, LD3-H 4-Door Sedan
-------	-----------------------	-----------------------	------------------------------

BODY—TRUNK DIMENSIONS

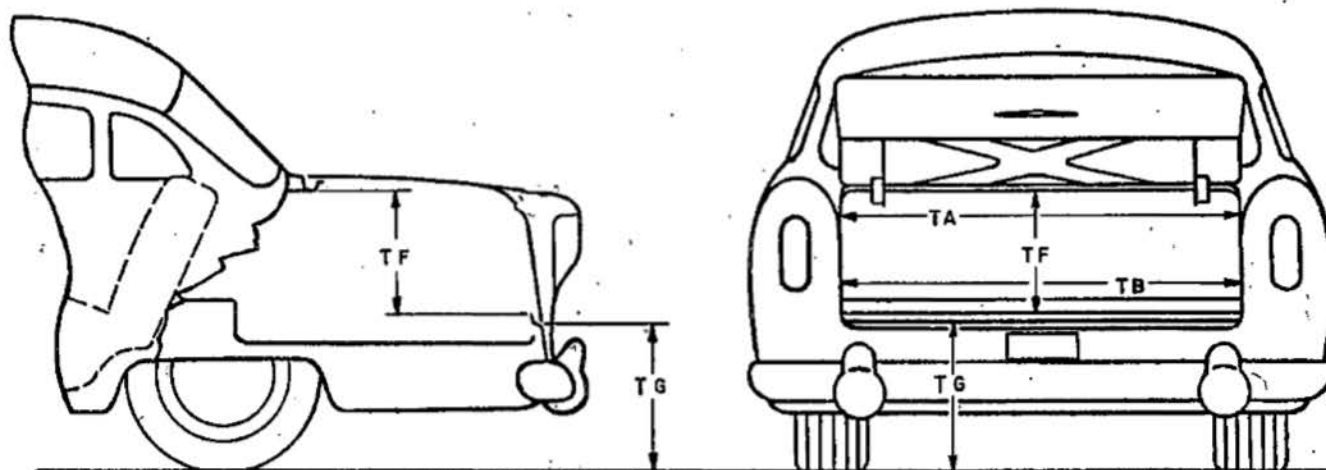

Usable trunk luggage capacity (see Section H1 of SAE Automotive Drafting Standards) (actual)	38.6 cu ft.		
TA—Width across the top	58.4		
TB—Width across the bottom	51.2		
TF—Vertical dimension at C/L from bottom to top of opening.	15.4		
TG—Vertical height from ground to trunk lower opening (normal surface of outside sheet metal - loaded)	20.3	19.3	19.7
Position of spare tire stowage	Horizontal on left side of trunk		
Method of holding lid open	Torsion bar		

AMA Specifications -- Passenger Car

Page 20

MAKE OF CAR DODGE **MODEL YEAR** 1958 **DATE ISSUED** Sept. 1957 **REVISED** Jan. 1958 ϕ
MODEL LD1, LD2, and LD3 - 4-Door Sedan

BODY--HEIGHT DIMENSIONS--INTERIOR

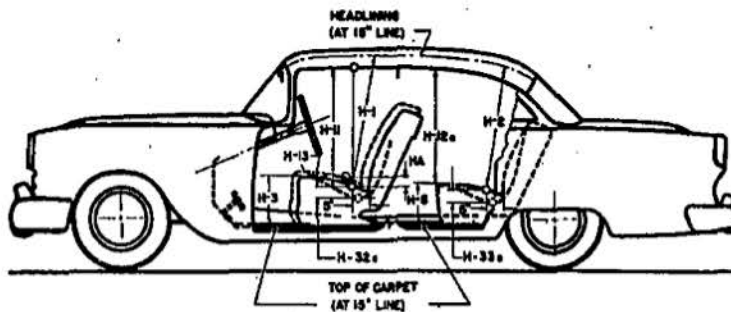

H1. Front headroom—from free "A" pt. to headlining at 8° back of vertical on 15" line. (For "A" pt. see note 1, page 19)	35.7
H2. Rear headroom—from free "A" pt. to headlining at 8° back of vertical on 15" line.	34.5
H3. Front cushion height above low point on floor carpet on 15" line (front edge of cushion).	10.8
H8. Rear cushion height above low point on floor carpet on 15" line (front edge of cushion).	12.0
H11. Entrance—front—cushion free "A" point to bottom windcord vertical.	31.2
H12a. Entrance—rear—top of cushion at vertical tangent to front of rear seat, to bottom of windcord in rear.	27.5
H13. Steering wheel clearance to seat cushion taken on arc (wheel turned for min. clearance).	6.0
HA. Front seat maximum vertical rise at free "A" point.	1.2 ϕ
HF. Front seat maximum vertical rise of free "A" point with multiple-position seat.	2.64 ϕ
H32a. Front seat depressed depth—vertical dimension from free "A" point to depressed "A" point.	4.0
H33a. Rear seat depressed depth—vertical dimension from free "A" point to depressed "A" point.	4.0

AMA Specifications – Passenger Car

MAKE OF CAR	DODGE	MODEL YEAR	1958	DATE: ISSUED	Sept. 1957	REVISED	Jan. 1958
MODEL	LD1-L	LD2-L	LD2-H, LD3-H	4-Door Sedan	4-Door Sedan	4-Door Sedan	

BODY—HEIGHT DIMENSIONS—EXTERIOR

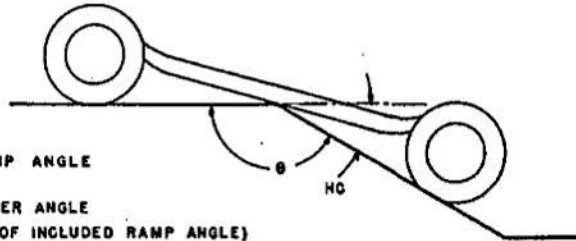
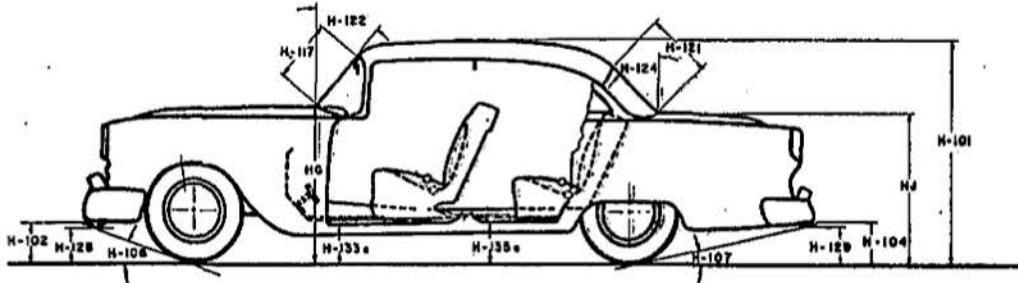

B - INCLUDED RAMP ANGLE
 HC - RAMP BREAKOVER ANGLE
 (SUPPLEMENT OF INCLUDED RAMP ANGLE)

H101. Overall height - loaded.	56.6		56.8
H101. Overall height - curb weight.	58.5	58.4	58.6
H102. Front bumper bottom to ground at normal section.	12.0 ϕ	11.9 ϕ	11.7 ϕ
H104. Rear bumper bottom to ground at normal section.	9.7		10.0
H106. Angle of appr.-fr. tire static loaded rad. to interfering pt. on fr. bumper, gd., other.	18.9° ϕ	18.7° ϕ	18.4° ϕ
H107. Angle of dep.-fr. tire static loaded rad. to interfering pt. on rr. bumper, gd., other.	9.8° ϕ		10.1° ϕ
HC. Ramp breakover angle.*	10.2°		10.4°
H117. Windshield DLO-slant height.	22.3		
H121. Backlight DLO*-max., slant height.	19.7		
H122. Windshield slope angle to vertical line on car axis.	50°		
H124. Backlight slope angle to vertical line on car axis.	53°		
H128. Ground to bottom of front bumper guard.	Not applicable		
H129. Ground to bottom of rear bumper guard.	15.3 ϕ	15.4 ϕ	15.7 ϕ
H133a. Bottom of front door to ground, min. dimension - car loaded.	11.1		11.3
H135a. Bottom of rear door to ground, min. dimension - car loaded.	10.8	10.7	11.0
HD. Min. road clear. (5 pass. load) & loc.	5.4 Frame side member		5.6 Frame side member
HE. Min. road clearance at rear axle.	7.4 ϕ	7.1 ϕ	7.4 ϕ
HG. Hood at rr. to grd.-vert. dim. excl. molding, fr. hood opening line at cowl (curb wt.)	40.4	40.3	40.5
HH. Max. ht., fr. grd. frt. of windshield (curb wt.)	40.9	40.8	41.0
HJ. Max. ht. fr. grd. back of r. window (curb wt.)	39.6	39.5	39.8

* See Notes, page 19.

AMA Specifications - Passenger Car

MAKE OF CAR DODGE **MODEL YEAR** 1958 **DATE ISSUED** Sept. 1957 **REVISED** Jan. 1958 ϕ
MODEL _____ LD1, LD2, and LD3 - All Models

BODY-LENGTH DIMENSIONS

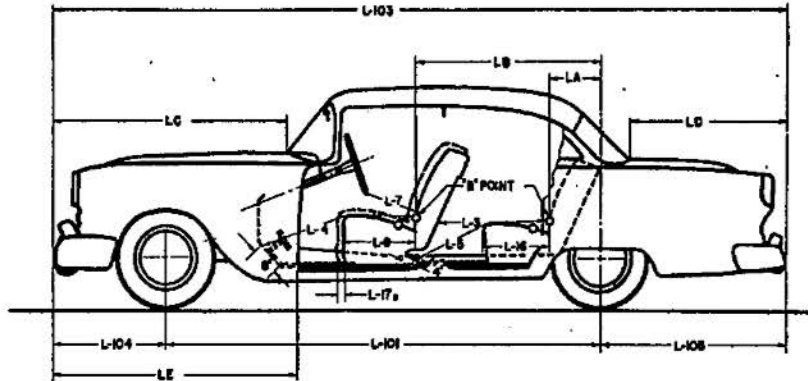

Interior	* L3. Rear compartment of front seat back to rear seat back.	31.0
	* L4. Leg room—front—ball of foot to top of seat to seat back—15" line.	45.5
	* L5. Leg room—rear—from ball of foot to top of seat cushion and to seat back†	42.5
	L7. Steering wheel clearance to seat back taken on arc.	15.0
	* L9. Front seat depth (front edge to vert. tan. to seat back on 15" line).	18.6
	* L16. Depth of rear seat (front edge to seat back).	18.6
	L17a. Total adjustment of front seat at front lower seat frame.	4.8 Manual; 5.0 Power ϕ
	LA. Rear seat "B" point to center line of rear axle.	20.2
	LB. Front seat "B" point to center line of rear axle.	57.8
	LC. Front of car to base of windshield.	58.8
LD. Rear of car to base of rear window or upper structure.	46.3	
LE. Front of car to front edge of front door.	64.1	
Exterior	L101. Wheelbase.	122.0
	L103. Overall length (bumper to bumper inc. guards).	213.8
	L104. Overhang—front including bumper guards	35.1
	L105. Overhang—rear including bumper guards.	56.7

* Dimension taken on 15" line—see notes 1 & 2, page 19.

AMA Specifications - Passenger Car

MAKE OF CAR DODGE MODEL YEAR 1958 DATE: ISSUED Sept. 1957 REVISED _____

MODEL _____ LD1, LD2, and LD3 - All Models

BODY—WIDTH DIMENSIONS

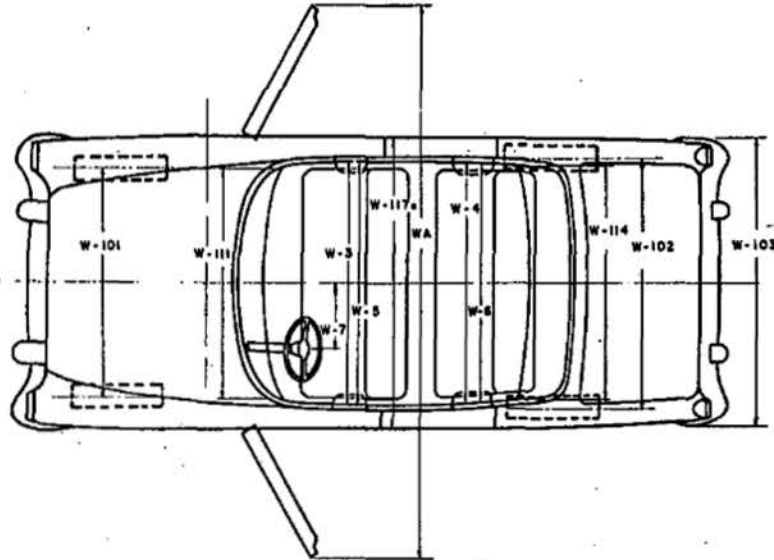

Interior	W3. Front shoulder room, at garnish moulding height or nearest interference 5" forward of seat back.	60.5
	W4. Rear shoulder room, at garnish moulding height or nearest interference 5" forward of seat back.	60.4
	W5. Front hip room, at top of seat 5" forward of vert. tan. to seat back.	63.0
	W6. Rear hip room, at top of seat 5" forward of vert. tan. to seat back.	62.7
	W7. Steering wheel center to center of body.	Manual steering 16.11; Power steering 16.25
Exterior	W101. Front tread at ground.	LD1, LD2 - 61.4; LD3 - 60.9
	W102. Rear tread at ground.	LD1-60.1; LD2-L - 60.2; LD2-M, LD3 - 59.8
	W103. Max. overall width of car including bumpers or mouldings.	78.3
	WA. Max. overall width of car with doors open.	156.8
	W111. Windshield DLO, max. width.	63.2
	W114. Back window DLO, max. width.	60.4
	W117a. Max. body width at center pillar, less hardware and applied moldings.	75.6

AMA Specifications – Passenger Car

MAKE OF CAR	DODGE	MODEL YEAR	1958
		DATE ISSUED	Sept. 1957
		REVISED	LD3-H
MODEL	LD3-L	Standard Station Wagon	Custom Station Wagon

STATION WAGON—CARGO SPACE DIMENSIONS

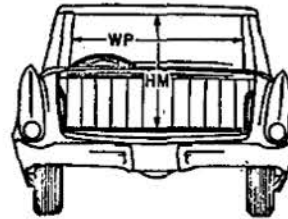
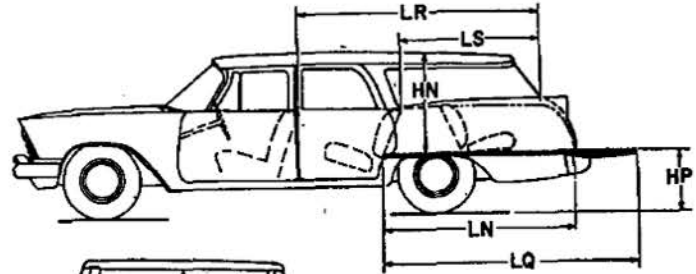
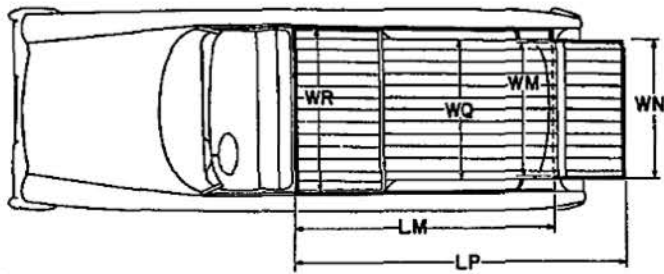

NOTE: Front seat in full down and rearmost position for all measurements.

LM Floor length from bottom of front seat to inside of tail gate in raised position.	98.6
LN Floor lgth. from bottom of second seat to inside of tail gate in raised position.	64.5
LP Floor lgth. from bottom of front seat to end of tail gate in lowered position.	119.7
LQ Floor lgth. from bottom of second seat to end of tail gate - tail gate lowered.	85.6
HM Maximum hght. of rear opening - tail gate lowered.	28.5
WM Rear end opening width at floor.	46.0
WN Rear end opening width at top of tail gate.	50.7
WQ Minimum distance between wheelhouses.	45.7
WP Maximum width of rear opening above raised tail gate.	48.0
WR Maximum width of cargo space at floor.	62.5
LR Cargo horizontal distance from top rear of front seat back to top of tail gate.	81.7
LS Cargo horizontal distance from top rear of second seat back to top of tail gate.	47.5
HN Maximum height of roof above floor at center line of car.	33.0
HP Platform height of end of lowered tail gate - curb weight.	27.5
Third Seat - facing direction.	Rearward

AMA Specifications - Passenger Car

MAKE OF CAR DODGE **MODEL YEAR** 1958 **DATE ISSUED** Sept. 1957 **REVISED** Jan. 1958 ϕ
MODEL LD1, LD2, and LD3 - All Models

BODY—MISCELLANEOUS INFORMATION

Drs. hinged (front, rear)	Front doors	Front
	Rear doors	Front
Type of finish (lacquer, enamel).		Synthetic enamel
Hood hinge location (front, rear).		Rear
Hood counterbalanced (yes, no).		Yes
Hood release control (internal, external).		External
Vehicle (Serial) No. Location		Bottom left front door hinge post
Engine No. location		Top of engine block - front
Theft protection - type		Ignition-key starting, ignition switch terminal barrier & door locks ϕ
Vent window control method (crank, friction pivot).		Friction pivot
Windshield type (single curved, compound curved, other)		Single curved
Rear window type (flat, curved, one piece, three piece)		One piece - curved
Side glass type (curved, flat)		Flat
Windshield glass area D.L.O.		1444
Backlight glass area D.L.O.		1173
Total glass area D.L.O.		4148

BODY—TYPES AND STYLE NAMES —

Body type, number of passengers & style names; use manufacturer's code for series & body style.

BODY STYLES:	CODES				
	LD1-L	LD2-L	LD2-M	LD3-H	LD3-L
4-Door Sedan		-41, 6-Pass.			---
2-Door Sedan	-21, 6-Pass.		---	---	---
4-Door Hardtop		-43, 6-Pass. Lancer			---
2-Door Hardtop		-23, 6-Pass. Lancer			---
Convertible Coupe	---	-27, 6-Pass. Lancer	---	-27, 6-Pass. Lancer	---
2-Door Station Wagon	---	ϕ	---	---	-25, 6-Pass. ϕ
4-Door Station Wagon	---	---	---	45A, 6-Pass. Custom Sierra	-45A, 6-Pass. Sierra
4-Door Station Wagon	---	---	---	-45B, 9-Pass. Cust. Sierra Spectator	-45B, 9-Pass. Sierra Spectator

AMA Specifications -- Passenger Car

MAKE OF CAR DODGE MODEL YEAR 1958 DATE ISSUED Jan. 1958 REVISED _____

MAJOR OPTIONAL ITEMS - WEIGHTS

	CURB - WEIGHT - POUNDS			% PASS. WEIGHT DISTRIBUTION				SHIPPING WEIGHT *
	Front	Rear	Total	Pass. In Front		Pass. In Rear		
				Front	Rear	Front	Rear	
Model CORONET STANDARD 6-Cyl.								
LD1-L1-21 2Dr Sedan								3360
-41 4Dr Sedan								3410
CORONET CUSTOM 6-Cyl.								
LD1-L2-21 2Dr Sedan								3360
-41 4Dr Sedan								3410
CORONET STANDARD V-8								
LD2-L1-21 2Dr Sedan	2005	1695	3700	57.5	42.5	22.0	78.0	3505
-23 2Dr Hardtop	2035	1710	3745	57.5	42.5	26.0	74.0	3540
-27 Conv Coupe	2110	1810	3920	57.5	42.5	26.0	74.0	3725
-41 4Dr Sedan	2030	1740	3770	57.5	42.5	22.0	78.0	3555
-43 4Dr Hardtop	2060	1765	3825	57.5	42.5	22.0	78.0	3605
CORONET CUSTOM V-8								
LD2-L2-21 2Dr Sedan	2005	1695	3700	57.5	42.5	22.0	78.0	3505
-23 2Dr Hardtop	2035	1710	3745	57.5	42.5	26.0	74.0	3540
-41 4Dr Sedan	2030	1740	3770	57.5	42.5	22.0	78.0	3555
-43 4Dr Hardtop	2060	1765	3825	57.5	42.5	22.0	78.0	3605
ROYAL V-8								
LD2-M-23 2Dr Hardtop	2050	1725	3775	57.5	42.5	26.0	74.0	3565
-41 4Dr Sedan	2045	1755	3800	57.5	42.5	22.0	78.0	3570
-43 4Dr Hardtop	2080	1775	3855	57.5	42.5	22.0	78.0	3640
Accessories & Equipment Weights								
	Differential Weights			Remarks				
PowerFlite Transmission	+15	+10	+25	LD1 and LD2 only				
TorqueFlite Transmission	+35	+15	+50	LD2 and LD3 only				
Radio and Heater	+25	+15	+40	All models				
Power Steering	+30	0	+30	All models, except those with manual trans.				
Power Brakes	+10	+5	+15	All models				
LD2-L1 D500 Package				Shipping Weight				+45
LD2-L2 D500 Package				Shipping Weight				+45
LD2-M D500 Package				Shipping Weight				+45

* These weights posted with State tax authorities for licensing purposes only.

AMA Specifications -- Passenger Car

Supplement to

Page 26

Jan.

MAKE OF CAR DODGE MODEL YEAR 1958 DATE ISSUED 1958 REVISED

MAJOR OPTIONAL ITEMS - WEIGHTS

Model	CURB - WEIGHT - POUNDS			% PASS. WEIGHT DISTRIBUTION				SHIPPING * WEIGHT
	Front	Rear	Total	Pass. In Front		Pass. In Rear		
				Front	Rear	Front	Rear	
STANDARD STATION WAGON								
LD3-L-25 2D Subr 2 Seat								3875
-45A 4D Sierra 2 Seat	2040	2090	4130	57.5	42.5	23.5	76.5	3930
-45B 4D Sierra 3 Seat	2040	2160	4200	57.5	42.5	23.5	76.5	3990
CUSTOM ROYAL								
LD3-H-23 2Dr Hardtop	2085	1750	3835	57.5	42.5	26.0	74.0	3610
-27 Conv Coupe	2160	1835	3995	57.5	42.5	26.0	74.0	3785
-41 4Dr Sedan	2080	1780	3860	57.5	42.5	22.0	78.0	3640
-43 4Dr Hardtop	2110	1805	3915	57.5	42.5	22.0	78.0	3670
LD3-H-45A 4Dr Custom								
Sierra 2 Seat	2045	2095	4140	57.5	42.5	23.5	76.5	3955
-45B 4Dr Custom								
Sierra 3 Seat	2045	2165	4210	57.5	42.5	23.5	76.5	4035
Accessories & Equipment Weights								
	Differential Weights			Remarks				
PowerFlite Transmission	+15	+10	+25	LD2 models only				
TorqueFlite Transmission	+30	+20	+50	LD2 and LD3 models				
Radio and Heater	+25	+15	+40	All models				
Power Steering	+30	0	+30	All models, except with manual transmissions				
Power Brakes	+10	+5	+15	All models				
LD3-L-25 D500 Package				Shipping Weight - +20				
-45 D500 Package				Shipping Weight - +5				
LD3-H-All D500 Package				Shipping Weight - +5				

* These weights posted with State tax authorities for licensing purposes only.

AMA Specifications -- Passenger Car

PAGE 27

INDEX

SUBJECT	PAGE NO.	SUBJECT	PAGE NO.
Air Suspension	16	Lamp Bulbs	11
Angles of Approach, Departure	21	Legroom	22
Automatic Transmission	1, 13	Lengths - Car, & Body Interior	1, 22
Axle, Rear	1, 14	Lifters, Valve	4
Battery	8	Linings - Clutch, Brake	12, 15
Bearings, Engine	3, 4, 7	Lubrication	5, 6, 12, 13, 14
Belts - Fan, Generator, Water Pump	7	Motor, Starting	8
Body - General Information, Types	19, 25	Muffler	6
Height Dimensions	21	Overdrive	13
Length Dimensions	22	Piston Pins & Rings	3
Overall Dimensions	1, 21, 22, 23	Pistons	2, 3
Trunk Capacities, Opening Dimensions	19	Power Brakes	15
Width Dimensions	23	Power Steering	17
Brakes - Parking, Service, Power	15, 16	Propeller Shaft, Universal Joints	14
Camber	18	Pumps - Oil, Fuel	6
Camshaft	4	Water	7
Capacities		Radiator, Hoses	7
Cooling System	7	Ramp Break-over Angle	21
Fuel Tank	6	Ratios - Axle	1, 14
Lubricants		Compression	1, 2
Engine Crankcase	6	Steering	17
Transmission and Overdrive	12, 13	Transmission	12, 13
Rear Axle	15	Rear Axle	1, 14
Carburetor	6	Regulator - Generator	8
Caster	18	Rims	15
Choke, Automatic	6	Rings, Piston	3
Circuit Breakers, Fuses	11	Rods - Connecting	3
Clearance, Ground	21	Shock Absorbers, Front & Rear	16
Clutch - Pedal Operated	12	Spark Plugs	9
Coil, Ignition	9	Speedometer	10
Connecting Rods	3	Springs - Front & Rear Suspension	17, 18
Cooling System	7	Valve, Engine	5
Crankshaft	4	Stabilizer (Sway Bar) - Front & Rear	17, 18
Cylinders and Cylinder Head	2	Starting Motor	8
Distributor - Ignition	9	Steering	17, 18
Electrical System	8, 9, 10, 11	Suppression - Ignition, Radio	9
Engine		Suspension - Front & Rear	16, 17, 18
Bore, Stroke, Displacement, Type	1, 2	Switches	10
Compression Ratio	1, 2	Tailpipe	6
Firing Order, Cylinder Numbering	2, 9	Thermostat, Cooling	7
General Information, H.P. & Torque	1, 2	Timing, Engine & Valve	4, 5, 9
Lubrication	5, 6	Tires	1, 15
Exhaust System	6	Toe in	18
Fan, Cooling	7	Torque Converter	13
Filters - Engine Oil, Fuel System	6	Torque - Engine, Rated	1, 2
Frame	16	Transmission - Types	1, 12, 13
Front Suspension	16, 17	Automatic	1, 13
Fuel, Fuel Pump, Fuel System	6	Manual & Overdrive	12, 13
Fuel Injection	1, 6	Ratios	12, 13
Fuses, Circuit Breakers	11	Tread	1, 23
Generator and Regulator	8	Turning Diameter	17
Glass	21, 23, 25	Universal Joints, Propeller Shaft	14
Headroom - Body	20	Valves - Intake & Exhaust	4, 5
Heights - Car & Body	1, 20, 21	Vibration Damper	4
Hood	25	Voltage Regulator	8
Horns	10	Water Pump	7
Horsepower - Brake, Rated, Taxable	1, 2	Weights - Shipping, Curb	26
Ignition System	9	Wheel Alignment	18
Inflation - Tires	15	Wheelbase	1, 22
Instruments	6, 10	Wheels & Tires	15
Kingpin	18	Wheel Spindle	18
		Widths - Car & Body	1, 23
		Windshield	21, 23, 25
		Windshield Wiper	10