

ANNOUNCING FOR 1960 . . . NEW FORD TRUCKS

New style! New models! New features! And never before could you be so *sure* of savings!

To give you this confidence, independent experts* tested the '60 Ford Trucks in the three major areas of operating economy. The result . . . Certified Economy!

Certified gas savings! Tests certified by America's foremost independent automotive research organization confirm the gas savings of the 1960 Ford 6-cylinder engine . . . the same engine that beat all competitive sixes in Economy Show-down U.S.A.!

Certified durability! Certified results on tests of key truck parts show definite durability benefits. For instance, half-ton pickup frames showed an increase of 23.6% in torsional rigidity; two-ton models showed an increase of 20% in brake-lining life.

Certified reliability! Typical of the many reliability tests was a "shake-test" on the wiring harness for heavy-duty engines. Certified results showed a threefold increase in Ford wiring reliability.

This is Certified Economy . . . and it adds new weight to the evidence

that Ford Trucks Cost Less!

But there's more . . . much more in 1960 Ford Trucks. New *toughness* with stronger frames . . . new *capacity* with huskier axles . . . new *brakes*, new *cab comfort*, new *riding smoothness*, new *handling ease!*

See your Ford Dealer. Check the facts in his "Certified Economy Book." Look into Ford's modern features. You'll discover that the things you want most in *your* new truck are in the 1960 Fords!

*Name on request. Send inquiry to Ford International Division, Ford Motor Company, Room 761, The American Road, Dearborn, Mich., U.S.A.

WITH *Certified Economy*

**CERTIFIED
GAS SAVINGS!
CERTIFIED
DURABILITY!
CERTIFIED
RELIABILITY!**

**NEW
FOR '60**

3 GREAT DIESEL ENGINES

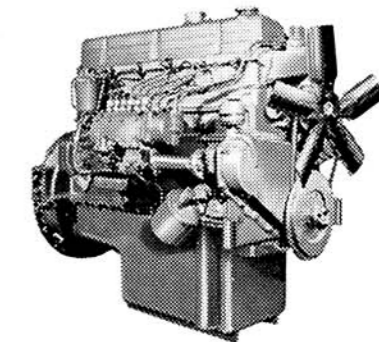

**DAGENHAM
330 DIESEL**
(By Ford of England)

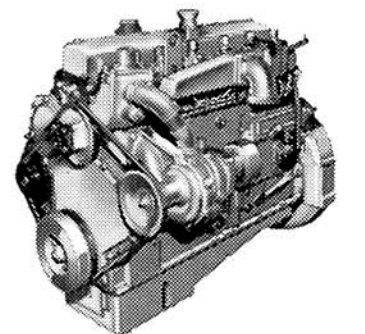

**PERKINS
F-340 DIESEL**

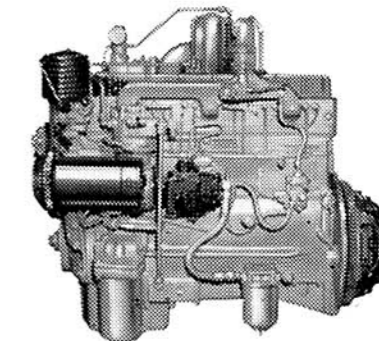

**CUMMINS
JT-175 DIESEL**

NEW FORD TRUCKS WITH 4-WHEEL DRIVE



New 4-wheel drive models. Here's new sure-footed power for hub-deep mud, sand, snow—wherever the going's the toughest! And the price is *Ford-low!* Half-ton or 3/4-ton sizes, with pickup, platform or stake bodies!

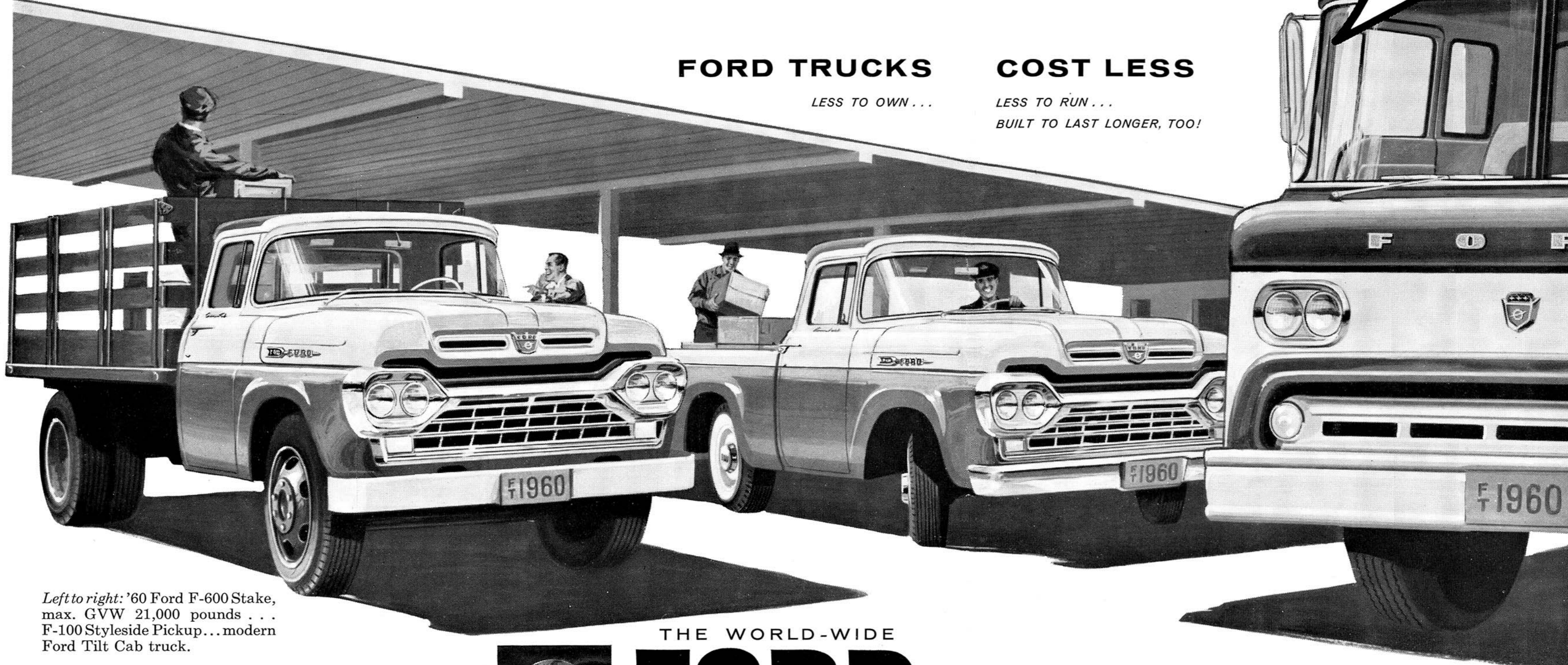

FORD TRUCKS

LESS TO OWN . . .

COST LESS

LESS TO RUN . . .

BUILT TO LAST LONGER, TOO!

Left to right: '60 Ford F-600 Stake, max. GVW 21,000 pounds . . . F-100 Styleside Pickup . . . modern Ford Tilt Cab truck.

**WHEREVER YOU LIVE . . . YOU GET MORE FOR
YOUR MONEY IN ANY FORD-BUILT PRODUCT**

THE WORLD-WIDE
FORD
COMPANIES

Ford-built products include cars, trucks, tractors, industrial engines, genuine replacement parts: Meteor • Monarch / Popular • Anglia • Prefect • Consul • Zephyr • Zodiac • Thames • Fordson Major and Dexta Tractors / Taunus • FK Truck / Continental • Mercury • Edsel • Lincoln • Ford • Falcon • Thunderbird • Ford Tractor and Implements