

1962

**P O N T I A C
T E M P E S T**

**BODY
SHOP MANUAL**

PONTIAC MOTOR DIVISION

1962

PONTIAC AND TEMPEST BODY SHOP MANUAL

GENERAL

This Body Manual contains the service procedures for all models of the 1962 Pontiac and Tempest Automobiles. Future changes and information will appear in the Service Craftsman News.

An alphabetical index is included in the back of this manual to supplement the table of contents on the edge of this page.

CONTENTS

Arrangement of the material is shown by the table of contents on the right-hand side of this page. Black tabs on the first page of each section can be seen on the edge of the book below the section title. More detailed table of contents precedes each section, and an index is included in the back of the manual.

PONTIAC MOTOR DIVISION
GENERAL MOTORS CORPORATION
PONTIAC 11, MICHIGAN

Table of Contents

SECTION	TITLE	PAGE
1	PONTIAC CHASSIS SHEET METAL	1-1
2	PONTIAC FRONT END	2-1
3	PONTIAC DOORS	3-1
4	PONTIAC REAR QUARTER	4-1
5	PONTIAC REAR END	5-1
6	PONTIAC EXTERIOR MOLDINGS	6-1
7	PONTIAC HEADLINING	7-1
8	PONTIAC SEATS	8-1
9	PONTIAC ELECTRICAL	9-1
10	PONTIAC LUBRICATION	10-1
11	TEMPEST CHASSIS SHEET METAL	11-1
12	TEMPEST FRONT END	12-1
13	TEMPEST DOORS	13-1
14	TEMPEST REAR QUARTER	14-1
15	TEMPEST REAR END	15-1
16	TEMPEST EXTERIOR MOLDINGS	16-1
17	TEMPEST HEADLINING	17-1
18	TEMPEST SEATS	18-1
19	TEMPEST ELECTRICAL	19-1
20	TEMPEST LUBRICATION	20-1
21	PONTIAC AND TEMPEST FABRIC CLEANING	21-1
22	PONTIAC AND TEMPEST FOLDING TOP	22-1
23	PONTIAC AND TEMPEST BUCKET SEATS	23-1

1962 BODY STYLES AND MODEL INFORMATION

Style, Paint and Trim identification can be obtained from the plate attached to the left side of the cowl under the rear edge of the hood.



The table below contains 1962 Pontiac and Tempest Body Styles and nomenclature. It may be used as reference in connection with this manual.

1962 BODY STYLES AND MODEL INFORMATION

Body Styles	Tempest	Catalina	Star Chief	Bonneville		Grand Prix
	Series 21	Series 23	Series 26	Series 27	Series 28	Series 29
Coupe - Convertible	2167	2367			2867	
Sport Coupe - 2 Door	2117 2127	2347*			2847*	2947*
Sport Sedan - 2 Door, 4 Window		2311				
Sedan - 4 Door, 4 Window		2369	2669			
Sedan - 4 Door, 6 Window	2119					
Vista - 4 Door, 4 Window		2339*	2639*		2839*	
Safari Station Wagon - 4 Door, 2 Seat; 2nd. Seat Folding	2135	2335		2735		
Safari Station Wagon - 4 Door, 3 Seat; 2nd. & 3rd. Seat Folding		2345				
Cowl & Underbody (HD Chassis)					2840 2890	
<p>WHEELBASE: - 21 Series - 112" 23 & 29 except Station Wagon - 120" 2335, 2345 and 2735 (Sta. Wgn.) - 119" 26 & 28 - 123"</p> <p style="text-align: right;">Pontiac Bodies - "B" Style Tempest Bodies - "Y" Style</p> <p style="text-align: center;">*Hardtop</p>						

PONTIAC

CHASSIS SHEET METAL

CONTENTS OF THIS SECTION

SUBJECT	PAGE	SUBJECT	PAGE
Bumpers	1-1	Hood Latch Bolt (Pilot Assembly)--Adjust	1-5
Radiator	1-1	Hood Hinges	1-6
Radiator Assembly--Removal and Installation	1-2	Sheet Metal	1-6
Chassis Sheet Metal Alignment	1-2	Front Fender--Removal and Installation	1-6
Fender,	1-2	Grille Assembly--Removal and Installation	1-6
Hood,	1-3	Hood Hinge Spring--Installation	1-7
Hood Latch	1-4	Hood Hinge--Removal and Installation	1-7
		Hood--Removal and Installation	1-8

BUMPERS

Front and rear bumpers (Figs. 1-1 and 1-2) are of one piece construction. Attachment of these bumpers is such that slotted holes are appropriately located in the frame, bumper to frame bars, and bumper to frame braces to provide fore and aft as well as lateral adjustment location of the bumper.

The front or rear bumper assembly may be adjusted as necessary by loosening the bracket to frame bolts and retightening after positioning the bumper. Front bumper height adjustment is controlled by eccentric bolts (one on each side at the front of the frame).

RADIATOR

The radiator assembly on all models is held secure by two cradle type brackets that fit into depressions in the radiator lower tank at the bottom

and one such "cradle" that holds the radiator top tank. The upper cradle is part of the engine fan top shield assembly which bolts to the fender to radiator support brace. On cars with air conditioning the engine fan top shield also attaches to the fan shroud.

Four radiator assemblies each with a frontal core area of approximately 439 sq. in. and a 2" thick core, are used as follows:

1. On all models equipped with synchro-mesh transmission (no oil cooler).
2. On 23 series cars equipped with Hydra-Matic transmission, air conditioning or used as police cars, (a one plate single center oil cooler).
3. On 24, 27 and 28 series cars equipped with Hydra-Matic transmission (a one plate single center oil cooler).

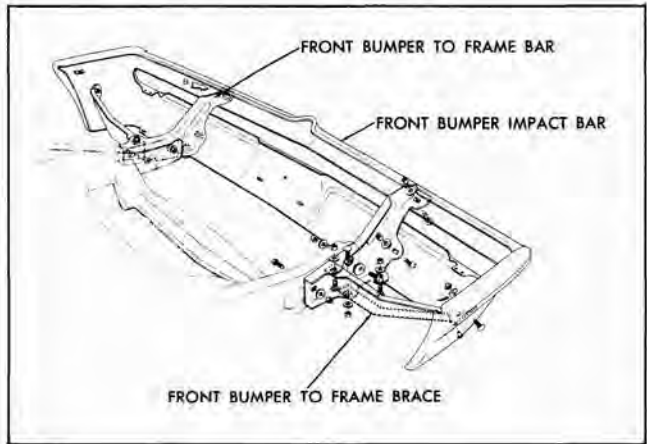

Fig. 1-1 Front Bumper Assembly

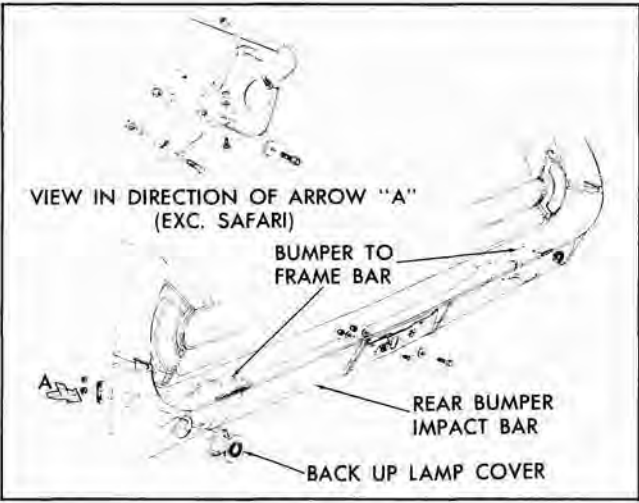

Fig. 1-2 Rear Bumper Assembly



Fig. 1-3 Engine Fan Top Shield (Underside)

4. For all heavy duty requirements (a two plate single center oil cooler).

The only difference in the radiator assemblies used for applications of 2 and 3 above is the heat constant of the core. A 13 lb. radiator pressure cap is used on all cars except those equipped with synchro-mesh transmission, 425E engine on air conditioning. All cars equipped with synchro-mesh transmission, 425E engine or air conditioning use a 15 lb. radiator pressure cap.

REMOVAL AND INSTALLATION

1. Drain radiator.
2. Remove engine fan top shield assembly. Note that the upper portion of the radiator is held by a "cradle" type bracket on the bottom side of the engine fan top shield assembly (Fig. 1-3).
3. Disconnect upper and lower engine coolant hoses.
4. On cars equipped with Hydra-Matic transmission, disconnect and plug transmission cooler lines.
5. On cars equipped with air conditioning remove the fan shroud.
6. Remove radiator assembly by pulling straight up. Note that the radiator assembly is held at the bottom by two "cradles" secured to the radiator shroud at bottom (Fig. 1-4).
7. Replace radiator assembly by reversing the above steps making sure radiator assembly lower cradles are located properly in the recess in the radiator lower tank.
8. Refill radiator.



Fig. 1-4 Radiator Lower Mounting Brackets

CHASSIS SHEET METAL ALIGNMENT

Proper alignment of the front end sheet metal will provide proper relationship of adjoining sheet metal parts, ease of hood operation, and eliminate squeaks rattles and vibration. (Figs. 10-5 through 10-8)

FENDER

Vertical and fore and aft adjustment is provided at rear of fenders by enlarged holes in the fender bracket at the attaching points.

Fenders can be moved closer to or farther from the cowl by shifting in the enlarged hole in the fender bolts and may be adjusted vertically by adding or removing shims.

1. Check the spaces between the front door to fender rear edge and adjust as necessary to obtain a parallel space.
2. Check to insure that all connections at the fender attaching bolts are tight.
3. Look between rubber mount and frame (minimum 1/16" shim is necessary).
 - a. If mount is loose tighten to correct.
 - b. If mount is loose and car feels harsh or sheet metal seems to vibrate then add shims and recheck for fender rear edge to door alignment.

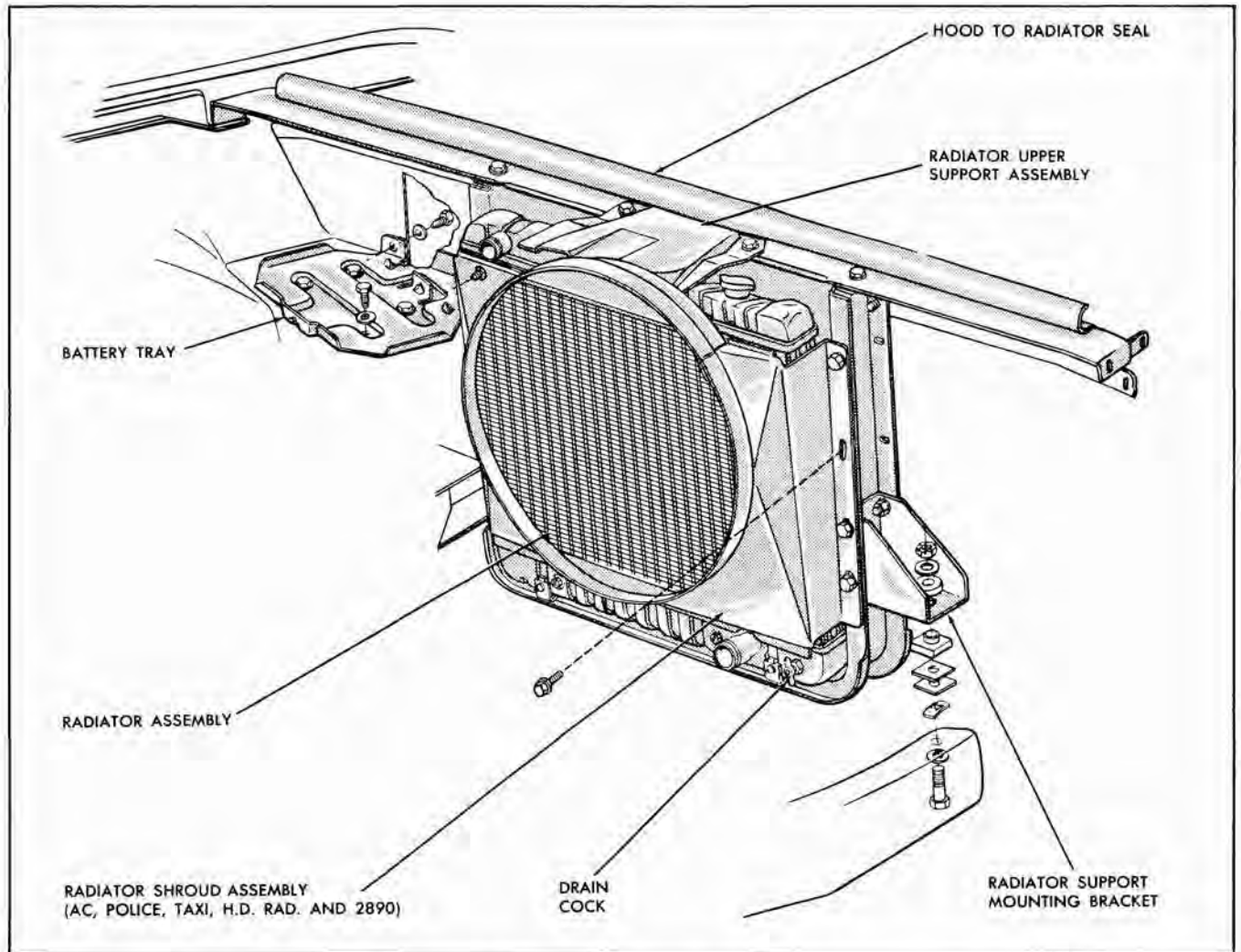

Fig. 1-5 Radiator Assembly Installation

HOOD

The hood is of rigid sheet metal construction with the outer panel of single sheet metal with a rugged inner panel reinforcement. Further rigidity is given the hood by reinforcement braces and brackets strategically located not to interfere with adjustments or service repair operations.

1. Slotted holes in the hinge brackets to hood are provided to align hood to obtain parallel space between hood sides and fender.

2. The rear corners of the hood should be held down against the rear bumpers to keep rear of hood from "dancing" or vibrating. Check for proper tightness and height of hood rear bumper (to hood) as follows:

a. Loosen front end of hinge mounting bracket to fender.

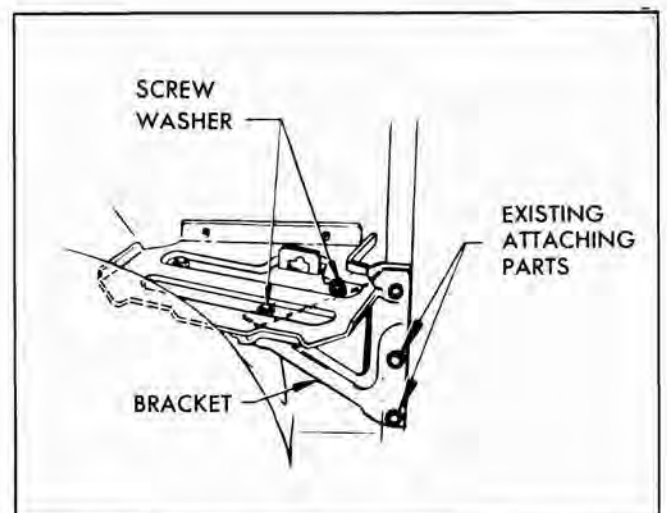

Fig. 1-6 Battery Tray Installation

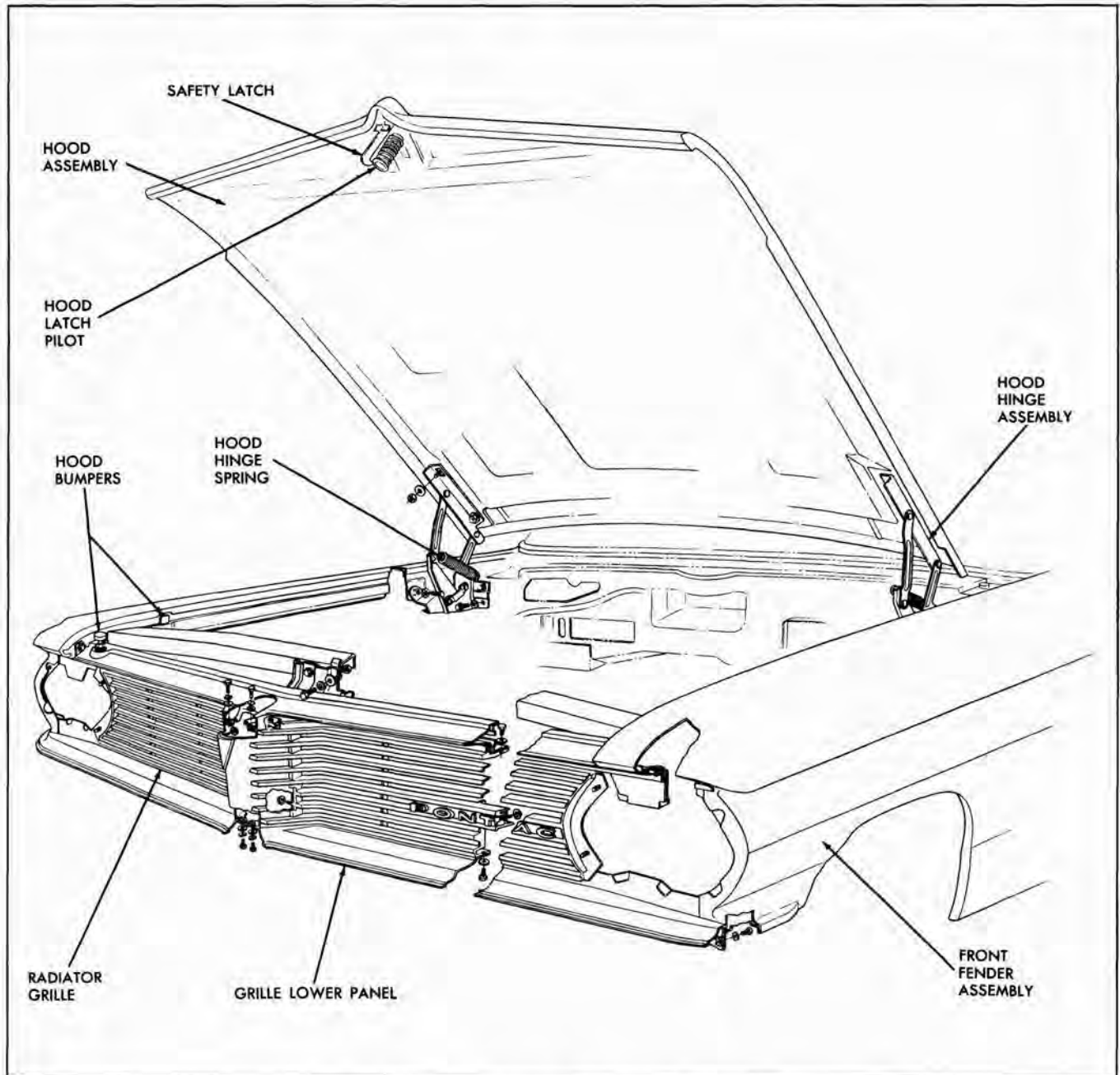

Fig. 1-7 Sheet Metal Parts - Installation

b. Hold hood open as high as possible and force front of hinge up as far as possible.

c. Tighten fender connection.

If this does not correct condition, raise entire hinge by loosening bolts to shroud and pulling up on hinge.

NOTE: The portion of the hood hinge that attaches to the shroud has elongated holes at the top and at the bottom to take care of any body variations (at the dash shroud).

HOOD LATCH

A positive locking hood latch is used consisting of three assemblies: a latch bolt assembly (that fastens to the hood), a safety hook, and a latch assembly that fastens to the grille lower panel and radiator support assembly (Fig. 1-7).

The hood is opened by lifting release handle under front bumper bar upper section (Fig. 1-9), which in turn opens the latch.

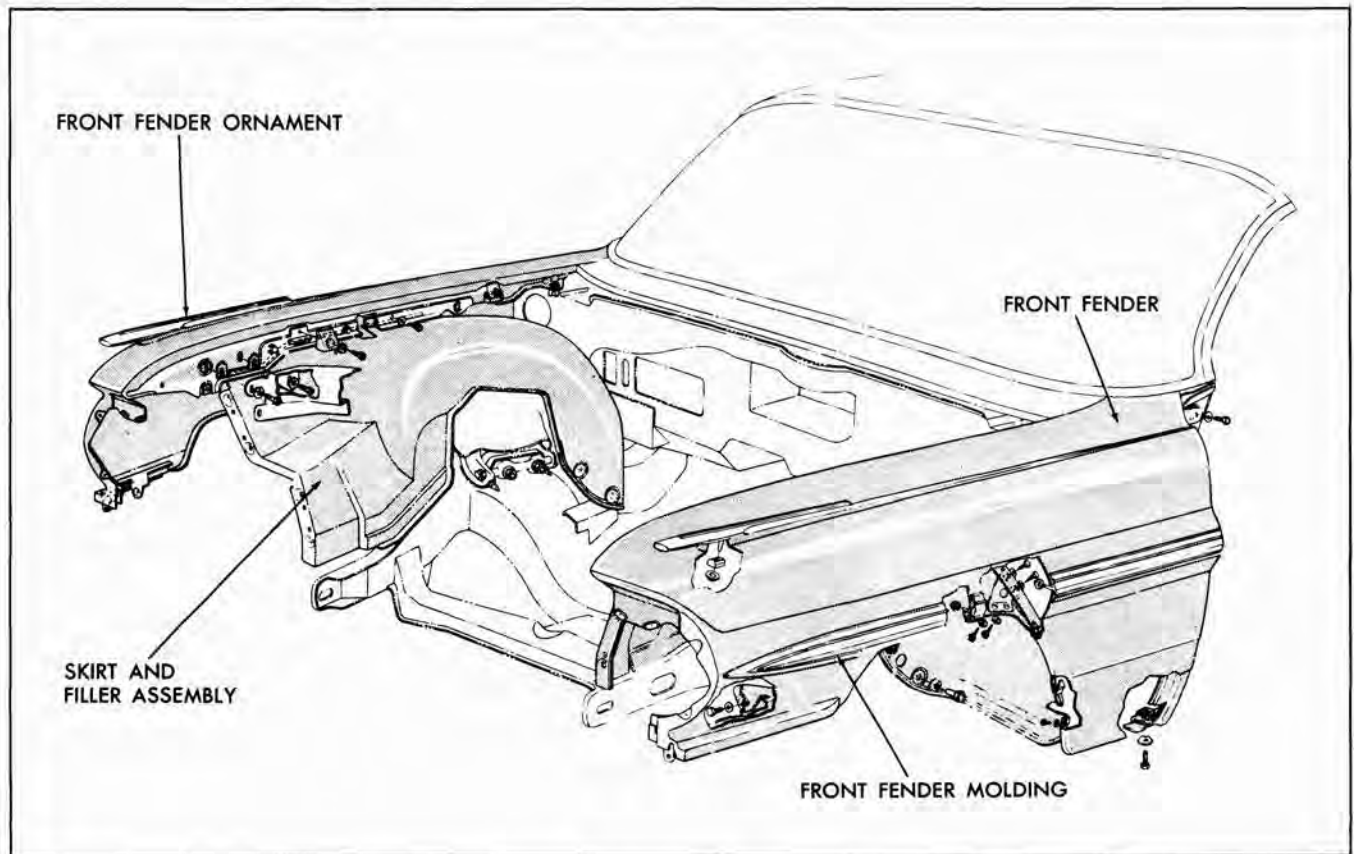

Fig. 1-8 Front Fenders Installation

The safety hook is released by pulling the handle directly under the front center of the hood.

The latch bolt in the pilot assembly (attached to the hood assembly) may be adjusted longitudinally for alignment purposes, and can be vertically adjusted to obtain a tight hood to fender relationship.

HOOD LATCH BOLT— (PILOT ASSEMBLY)—ADJUST

Should the hood release to safety latch position while driving on very bumpy or rough roads at high speed, loosen latch bolt assembly on hood (Fig. 1-10) and move rearward so that latch bolt spring retainer is $7/8$ " to rear of safety catch hole in front of hood latch support.

Proper adjustment of the hood latch bolt to provide for each hood closing is as follows:

1. Check tightness of bracket from radiator support to hood latch striker plate.

2. Raise hood bumpers to align front of hood with fenders.

3. Press down on center of hood just forward of the molding.

- a. If some "give" or looseness is noticed, hood is not tight and will vibrate and raise up on corners at high speeds. In this case shorten latch bolt and recheck.



Fig. 1-9 Location of Hood Release



Fig. 1-10 Pilot and Safety Latch

b. If hood is tight with no "give", then hood could be properly adjusted or could be too tight. Check as follows:

- (1) Close hood.
- (2) Release latch and raise hood 10"-12".
- (3) Let hood fall of own weight.
- (4) Adjust hood latch bolt to permit hood to close easily when hood drops of its own weight from 10"-12" from closed position.
- (5) Recheck 3 above.

HOOD HINGES

The hood is mounted on gear type hinges (Fig. 1-12), mounted on the front of the dash. Double assist overcenter springs are used, (one at each hood hinge) both ends of which are fastened to the arms of the hinge. This construction provides hold-open power.

A hood to hinge reinforcement bracket which has two points of attachment is used. Fore and aft adjustment of the hood is provided for by slotted holes in the bracket.

SHEET METAL

FRONT FENDER— REMOVAL AND INSTALLATION

NOTE: If the same fender is to be replaced, note position location and number of alignment shims used. (See Figs. 1-5 through 1-9).

1. Disconnect left and right parking lamp assemblies.



Fig. 1-11 Hood Hinge (Right Side)

2. Remove front bumper assembly by removing bumper to frame attaching bolts (two at each side). Pull bumper assembly straight out.

3. Disconnect headlamp assembly.

4. Disconnect fender from fender skirt and hood hinge.

5. Disconnect fender from radiator baffle and fender brace.

6. Disconnect fender from cowl at door opening and rocker panel area.

7. Install fender by reversing the above steps.

8. Align fender with other body and sheet metal parts.

GRILLE ASSEMBLY— REMOVAL AND INSTALLATION

This procedure is for removal of both the regular Pontiac grille assembly and the Grand Prix grille. The only difference between them is that the Grand Prix grille sections are composed of two parts, a casting and a stamping, which are bolted together. Other models have a one piece cast grille section.

1. Remove headlight doors and headlight assemblies.

2. Remove grille to center panel nuts (2 each side), grille to upper grille panel bolts (4 each side), and grille to lower panel bolts (4 each side). Remove grille sections.

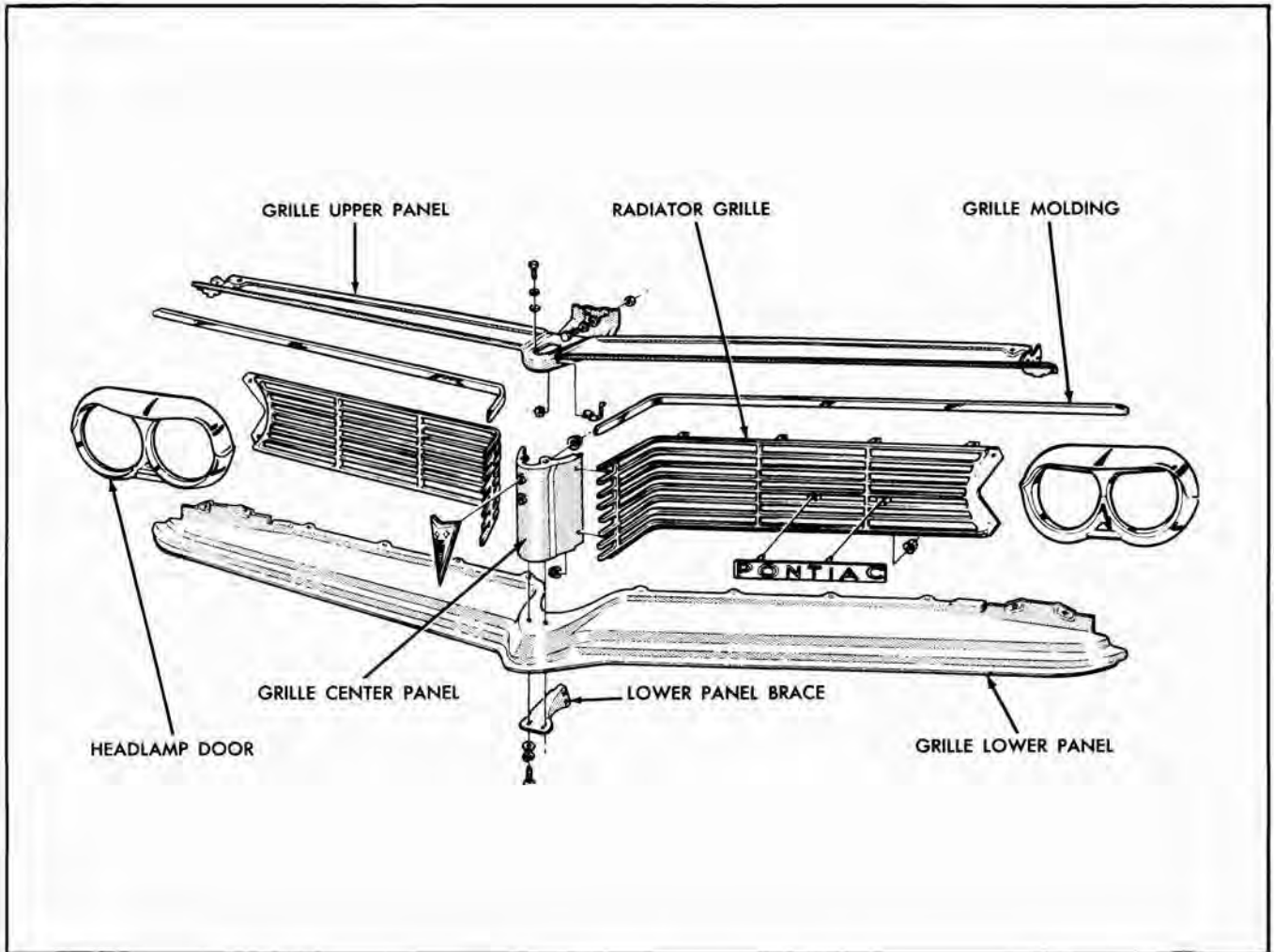

Fig. 1-12 Radiator Grille Assembly

3. Remove attaching bolts from upper grille panel to fenders (4 bolts, 2 screws), to grille center panel and hood latch (4 bolts), and to the radiator support (2 bolts). Remove the nuts from center emblem. Carefully remove upper grille panel. Remove decor strip attaching nuts and remove strip.

4. Remove center grille panel by removing 2 bolts attaching it to the lower grille panel.

5. Remove the hood latch assembly to radiator support bolt to remove hood latch assembly.

6. Remove the front bumper assembly by disconnecting the parking light wires and removing the bumper to frame attaching bolts—two at each side. Pull bumper assembly straight out.

7. Remove lower grille panel to fender attaching bolts and remove panel.

8. Replace by reversing above steps. Be sure to re-connect headlight ground wires.

HOOD HINGE SPRING— INSTALLATION

Hood hinge springs can be removed by propping hood open, and pulling front of spring off of hinge. When replacing the spring, hook the rear end on pin first, then stretch the spring out and hook it at front.

HOOD HINGE— REMOVAL AND INSTALLATION

1. Open hood.

2. While one man holds hood, remove spring, hinge to fender and cowl attaching screws, hinge to hood attaching nuts, and remove hinge.

3. Position new hinge to fender, install and tighten attaching screws.

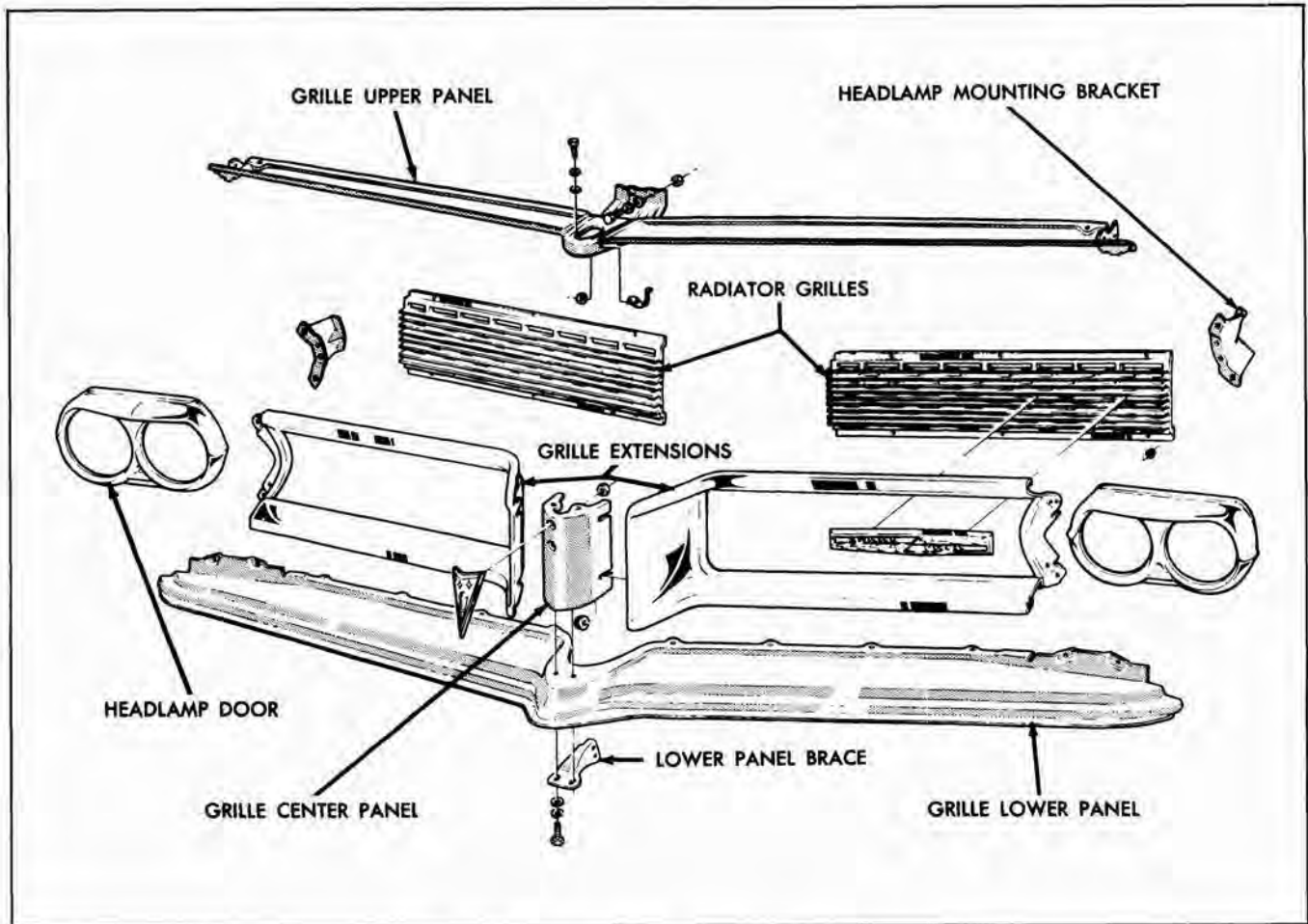

Fig. 1-13 Radiator Grille Assembly - Grand Prix

4. Position hinge to hood and install flat washers, lock nuts and tighten just snug.

5. Replace spring.

6. Close hood and check hood alignment.

7. If hood is misaligned, measure amount of misalignment.

a. Open hood, mark position of hinge relative to hood.

b. Loosen hinge at hood and move hinge the amount it was off.

c. Tighten securely and recheck alignment.

HOOD— REMOVAL AND INSTALLATION

The hood can be removed very quickly by disconnecting it from the hinges at the hood reinforcement.

When replacing the hood, adjust the alignment, one hinge at a time, as outlined in Steps 6 and 7 under HOOD HINGE--REMOVAL AND INSTALLATION

FRONT END

CONTENTS OF THIS SECTION

SUBJECT	PAGE	SUBJECT	PAGE
Windshield Assembly	2-1	Hinge Stop Assembly	2-6
Garnish Moldings	2-1	Knob Assembly	2-7
Rear View Mirror Support	2-1	Radio Speaker Grille	2-7
Sunshade Support	2-1		
Reveal Moldings	2-2	Body Ventilator System	2-7
Glass	2-3	Shroud Assembly	2-7
Checking Body Opening	2-4	Top Ventilator Grille	2-7
Glass Replacement	2-5	Side Foundation	2-7
Minor Water Leaks	2-6	Side Vent Duct Air Outlet	2-8
Instrument Panel Assembly		Side Duct Panel Air Outlet Door	2-8
Compartment Door	2-6		

WINDSHIELD ASSEMBLY

WINDSHIELD GARNISH MOLDINGS

DESCRIPTION

The windshield garnish moldings consist of an upper right and left, side right and left and lower right and left moldings. All moldings are secured by screws.



Fig. 2-1 Windshield Garnish Moldings

REMOVAL AND INSTALLATION

1. Place protective covering over front seat and instrument panel.
2. Remove moldings in following order: side, lower and upper moldings.

NOTE: On 67 styles remove windshield pillar weatherstrip retainers and side reveal moldings prior to removal of side garnish moldings. Remove sunshade supports prior to removal of upper garnish moldings.

3. To install, reverse removal procedure.

REAR VIEW MIRROR SUPPORT

REMOVAL AND INSTALLATION

1. Remove one side of upper windshield garnish moldings.
2. Remove support attaching screws and slide to one side and remove.
3. To install, reverse removal procedure (Figures 2-1 and 2-2).

SUNSHADE SUPPORT

REMOVAL AND INSTALLATION

1. Remove attaching screws and support.

NOTE: On 67 styles raise top before removing support.

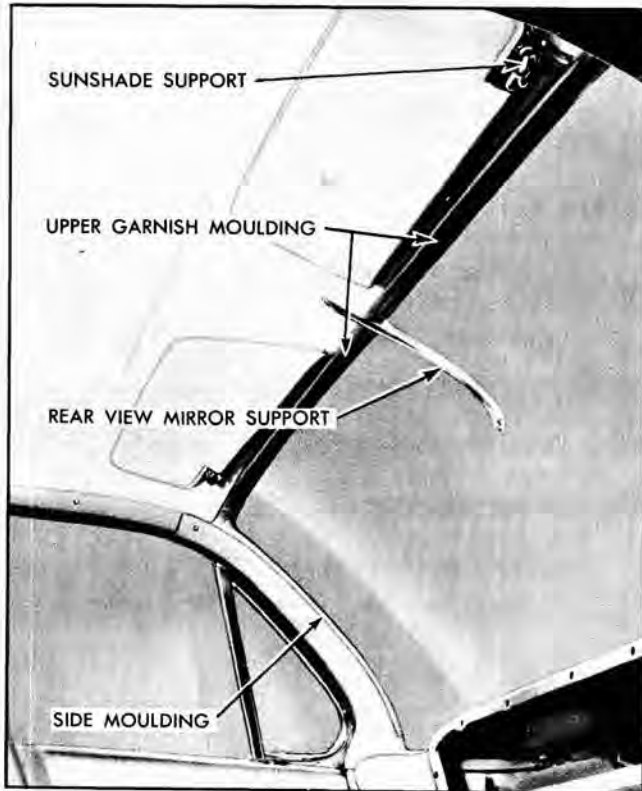

Fig. 2-2 Windshield Garnish Moldings

2. To install, reverse removal procedure.

WINDSHIELD REVEAL MOLDINGS

DESCRIPTION

The windshield reveal moldings consist of a one-piece upper, right and left side and right and left lower molding. On all styles except 67 styles

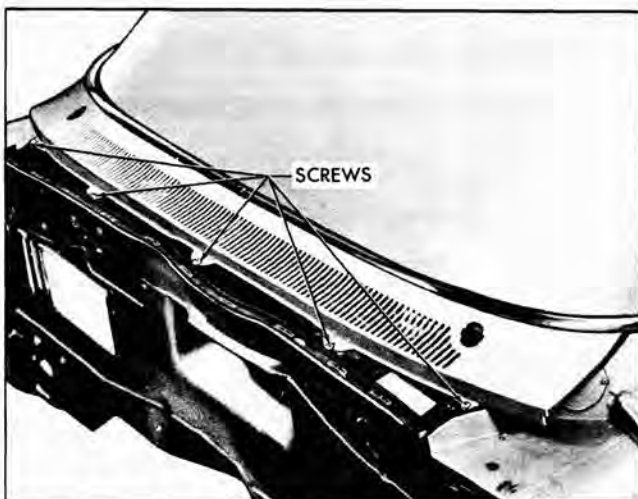

Fig. 2-3 Air Intake Grille

the upper reveal moldings are secured to the openings by clips. On 67 styles the upper reveal molding is secured to the upper windshield frame by screws at each end and studs and nuts in the center. The side reveal moldings are secured to the windshield opening by clips and a screw at the lower end of the molding located just below the lower reveal molding, and is accessible by opening the front door. On 67 styles the side reveal moldings are secured to the windshield pillar by screws. On all 39 and 47 styles the side reveal moldings are secured to the windshield pillars and the side roof rails by screws, which are hidden by the windshield pillar and side roof rail weatherstrip retainers. The lower reveal moldings on all styles are secured to the upper shroud assembly by screws through the molding clip tabs.

REMOVAL

1. Place protective covering over hood and front fenders.
2. Remove windshield wiper arms escutcheon nuts and escutcheons.
3. Remove air intake grille attaching screws (Fig. 2-3).
4. Lift up grille and slide forward to remove.

CAUTION: Care should be exercised to make certain grille does not contact hood, chipping paint.

5. Remove lower reveal molding attaching screws (Fig. 2-4) and remove the molding.
6. On all styles except 67 styles tool J-7898-01 may be used to remove the side and upper reveal moldings. When using reveal molding removing tool (J-7898-01) carefully lift up upper end of reveal molding sufficiently to engage point of tool between molding and molding clip as indicated in Fig. 2-5,

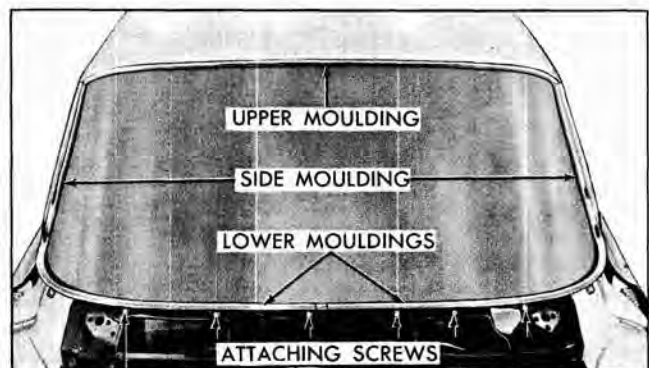

Fig. 2-4 Windshield Reveal Moldings

to disengage prongs of clip from molding and lift molding free of clip. Repeat this operation at each molding clip.

NOTE: In some instances a flat-bladed tool such as a putty knife or equivalent may be used to aid in removing the moldings from the opening. Care should be exercised when removing moldings to eliminate any damage to the moldings or body paint, etc.

7. On all 39 and 47 styles, the side reveal moldings are secured by screws at the windshield pillar and roof rail and it is necessary to loosen the windshield and side roof rail weatherstrip retainer to gain access to the attaching screws. Remove screws and carefully remove the molding from the opening. On 67 styles, the side reveal moldings are secured to the windshield pillar by screws. Raise top, loosen windshield pillar weatherstrip retainer, remove attaching screws and molding. The side reveal moldings are secured to the opening by clips and a screw through the lower end clip tab. Remove screw located at the lower end clip tab, and carefully remove molding from clips and opening.

8. On all styles except 67 styles, carefully remove the upper reveal molding with tool J-7898-01 (Fig. 2-5) or flat-bladed tool as required. On 67 styles remove screws at outer ends of molding; then, remove upper garnish molding to gain access to stud nuts. Remove nuts and molding.

INSTALLATION

Make certain there is sufficient sealer in cavity between windshield rubber channel and body. If sealer is required apply necessary medium-bodied sealer.

1. Upper Reveal Moldings: On all styles except 67 styles, snap upper reveal molding in place. On 67 styles, seal attaching studs and holes and install molding.

2. Side Reveal Molding: On 39 and 47 and all 67 styles, seal attaching screw holes and install moldings.

3. On 39 and 47 and all 67 styles, seal side roof rail and windshield pillar weatherstrips and retainers and install.

4. Install lower reveal molding and previously removed hardware parts.

WINDSHIELD GLASS

REMOVAL

1. Place protective covering over front seat and instrument panel.

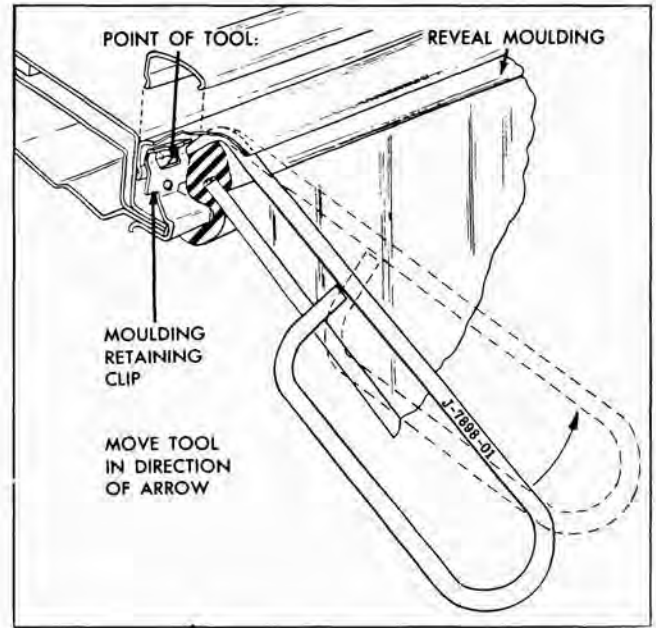

Fig. 2-5 Reveal Molding Removing Tool

2. Place protective covering over hood and front fenders.

3. Remove garnish moldings.

4. Remove windshield wiper arms, escutcheon nuts and escutcheons.

5. Remove shroud top ventilator grille.

6. Remove windshield reveal moldings.



Fig. 2-6 Windshield Glass Removal

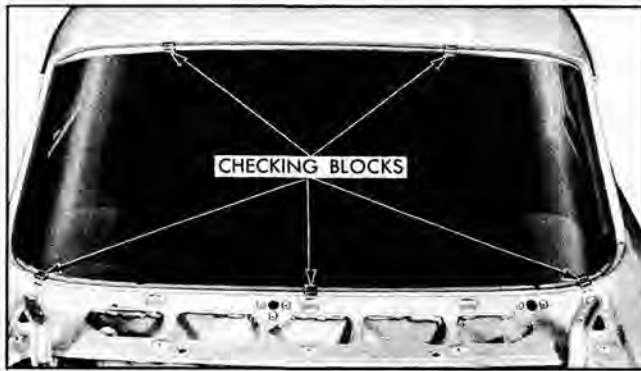

Fig. 2-7 Windshield Opening Check Blocks

NOTE: If glass is broken or cracked, mark centerline of glass and body so alignment of glass to body opening may be checked to locate cause of glass break (glass off center, strain break, etc.)

7. On inside of body loosen lip of rubber channel from pinchweld flange along top and sides of windshield as follows: with palm of hand, apply pressure to glass near edge (Fig. 2-6) at same time use a blunt putty knife or other suitable tool and carefully assist rubber channel over pinchweld flange.

8. After windshield channel is free from pinchweld flange, with aid of helper, carefully lift windshield assembly from opening and place on a protected bench.

CHECKING BODY WINDSHIELD OPENING

It is important that the body windshield opening be checked thoroughly before installation of a replacement windshield glass. The following procedure outlines the method which may be used to check the windshield opening.

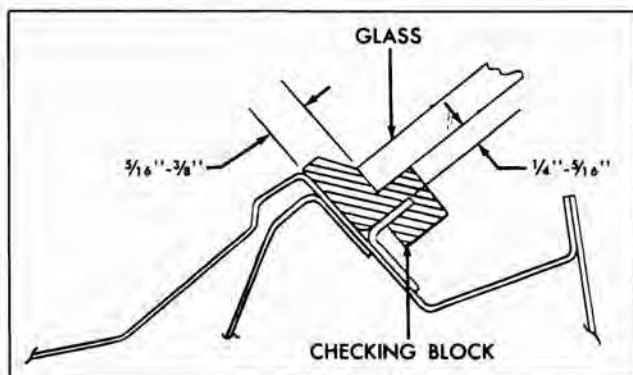

Fig. 2-8 Windshield Opening Checking Block

1. Remove the windshield from body.
2. Check windshield rubber channel for any irregularities.
3. Clean off old sealer around windshield opening and check entire body opening flange for any irregularities.
4. Install five (5) windshield checking blocks as follows: along lower retaining flange place one (1) block twelve inches (12") inboard of each lower corner and one (1) at center of windshield opening. Position one (1) block over upper pinchweld flange midway between center block and each outboard block on lower retaining flange.
5. With aid of helper, carefully position replacement glass on blocks in windshield opening.

CAUTION: Care should be exercised to make certain glass does not strike body metal during installation. Edge chips can lead to future breaks.

6. With windshield supported and centered in the body opening by checking blocks, Fig. 2-8, check relationship of glass to body opening around entire perimeter of glass. Check glass to body relationship as follows:

- a. The inside surface of glass should be a uniform distance from pinchweld flange. The dimension should be from 1/4" to 5/16".
- b. The outer edge of glass should be a uniform distance from body metal, measured in plane of the glass. This dimension should be from 5/16" to 3/8".

NOTE: Windshield checking blocks (J-8942) may be used as shown in Fig. 2-7.

7. Mark any sections of body to be re-formed, remove glass and re-form opening as required.
8. Recheck windshield opening as outlined above. Then mark the centerline on the glass and body so that glass can be accurately centered in the opening when installed.

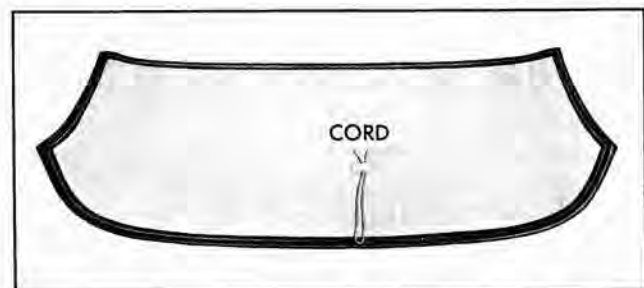

Fig. 2-9 Windshield Installation

INSTALLATION

1. Clean out old sealer in glass cavity of windshield, rubber channel and around base of rubber channel.

2. Install rubber channel to glass.

3. Install a strong cord in pinchweld cavity of rubber channel completely around windshield. Tie ends of cord and tape to inside surface of glass at bottom center of glass (Fig. 2-9).

4. Apply a ribbon of medium-bodied sealer completely around base of rubber channel (See #1 Fig. 2-10).

5. Inspect condition of each molding clip, install new clips where necessary, make certain clips are properly sealed to pinchweld and body (see #2 Fig. 2-10) except 67 styles.

6. Apply a 1/4" bead of medium-bodied sealer to the base of windshield opening flange at pillar areas and extending 4" inboard along top edge and approximately 8" inboard along lower edge of windshield opening.

7. With aid of helper, carefully position and center windshield assembly in windshield opening.

CAUTION: Do not position by tapping or hammering glass at any time.

8. When the glass and channel are properly positioned in the opening, slowly pull both ends of cord starting at lower center of windshield, to seat lip of rubber channel over pinchweld flange. Cord should be pulled first across bottom of windshield, then up each side and finally across top of windshield.

9. Using a pressure type applicator, seal inner and outer lips of rubber channel to glass with an approved weatherstrip adhesive (#4 Fig. 2-10). Seals are to extend completely around rubber channel.

10. Clean off excess sealer from windshield glass.

11. On outside of windshield apply medium-bodied sealer between windshield rubber channel and opening across top and sides (#5 Fig. 2-10).

12. Reinstall all previously removed parts and remove protective coverings.

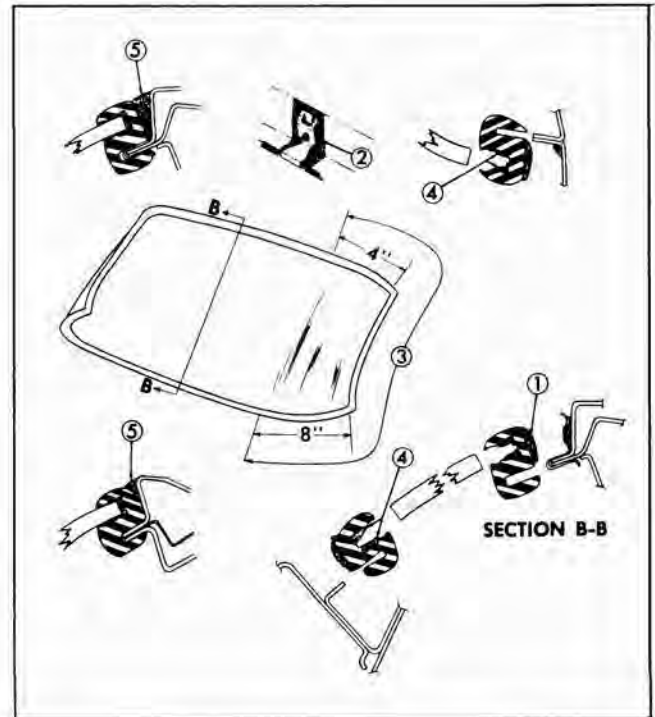

Fig. 2-10 Windshield Sealing

WINDSHIELD GLASS REPLACEMENT ONLY WHEN CHECKING OF OPENING IS NOT REQUIRED

REMOVAL

1. Place protective covering over front seat and instrument panel.

2. Place protective covering over hood and front fenders.

3. Remove upper and side garnish moldings and mirror support. On 67 styles, remove sunshade supports.

4. Remove upper and side reveal moldings.

5. Remove windshield wiper arms.

6. On inside of body loosen lip of rubber channel from pinchweld flange along top and sides of windshield as follows: with palm of hand apply pressure to glass near edge (Fig. 2-6) at same time use a blunt putty knife or other suitable tool and carefully assist rubber channel over pinchweld flange across top and sides only.

7. Tilt glass forward sufficiently to remove glass from channel and remove glass.

NOTE: Do not remove lower portion of rubber channel from pinchweld or break seal between rubber channel and lower pinchweld.

INSTALLATION

1. Clean out cavity of windshield rubber channel of all old sealer, etc.
2. Apply a mild soap solution to cavity and outer lip of rubber channel.
3. Place windshield glass in rubber channel.
4. Working from inside of body with a screw driver or other suitable tool, work the inner lip of the windshield channel over the pinchweld flange, up each side and across the top.

CAUTION: Do not attempt to position glass by tapping or hammering at any time.

5. Using a pressure type applicator, seal inner and outer lips of rubber channel to glass with an approved weatherstrip adhesive (#4 Fig. 2-10). Seals are to extend completely around rubber channel.
6. On outside of windshield, apply medium-bodied sealer between windshield rubber channel and opening across top and sides (#5 Fig. 2-10).
7. Clean off excess sealer.
8. Reinstall all previously removed parts and remove protective coverings.

MINOR WATERLEAKS AT WINDSHIELD

In many instances minor waterleaks around the windshield may be corrected by performing the following operations.

1. Leaks between rubber channel and glass
 - a. Working from outside of the body and using a pressure applicator (plews oiler or equivalent) with a narrow tip, apply an approved weatherstrip adhesive (black) between glass and rubber channel on the outside of the glass completely around perimeter of glass.
2. Leaks between rubber channel and body
 - a. Working from outside of the body along top and sides of body opening, remove side and/or upper reveal moldings. Apply sufficient amount of medium-bodied sealer to fill cavity between rubber channel and body opening.
 - b. Working from inside of body, remove inside garnish moldings, apply sufficient amount of medium-bodied sealer between inner lip of rubber channel and body opening. Water test and clean off excessive sealer.

INSTRUMENT PANEL ASSEMBLY**INSTRUMENT PANEL COMPARTMENT DOOR****REMOVAL AND INSTALLATION**

1. Mark location of compartment door hinge on door inner panel.
2. Remove attaching screws at door hinge and door stop from door inner panel and remove door (Fig. 2-11).

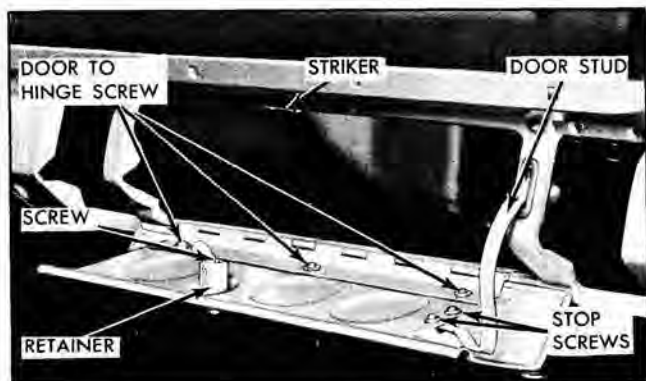

Fig. 2-11 Instrument Panel Compartment Door

3. To install, reverse removal procedure and align as necessary.

ADJUSTMENTS

1. To position compartment door up or down in its opening, loosen hinge and hinge stop screws at door inner panel and shift door to desired position.
2. To reposition door right or left, loosen hinge to instrument panel attaching screws and shift door to desired position. Adjust stop assembly as required.
3. The compartment door lock striker may be adjusted by loosening attaching screws and moving striker to desired position (Fig. 2-11).

INSTRUMENT PANEL COMPARTMENT DOOR HINGE STOP ASSEMBLY**REMOVAL AND INSTALLATION**

1. Remove hinge stop attaching screws, (Fig. 2-11), disengage stop assembly from instrument panel door and remove stop.

2. To install, reverse removal procedure. Check for proper alignment.

INSTRUMENT PANEL COMPARTMENT DOOR KNOB ASSEMBLY

REMOVAL AND INSTALLATION

1. Open compartment door, remove screw from retainer and remove knob assembly (Fig. 2-11).
2. To install, reverse removal procedure.

INSTRUMENT PANEL RADIO SPEAKER GRILLE

The radio speaker grille is attached to the upper instrument panel by studs and nuts.

REMOVAL AND INSTALLATION

1. Loosen lower garnish moldings.
2. From underside of instrument panel remove radio speaker grille attaching nuts and remove grille.
3. To install, reverse removal procedure.

BODY VENTILATING SYSTEM

The body ventilating system incorporates the use of an air intake grille located on top of the shroud panel. The air entering the shroud top ventilator grille flows through a duct which guides the air into the body through a shroud side duct panel air outlet assembly. The door in the outlet assembly regulates the flow of air and is adjusted by the use of a cable and knob control. Water entering the air inlet grille flows down the shroud side duct panel and is discharged through an opening in the shroud side panel.

SHROUD TOP VENTILATOR GRILLE

REMOVAL AND INSTALLATION

1. Place protective coverings over hood and fenders.
2. Remove windshield wiper arms, spanner nuts and escutcheons.

3. Raise hood, remove screws securing grille to shroud. (Fig. 2-3)
4. Carefully raise front edge of grille and slide grille forward and remove grille.
5. To install, reverse removal procedure.

NOTE: Exercise care so that grille does not contact hood.

SHROUD SIDE FOUNDATION

REMOVAL AND INSTALLATION

1. Remove screws securing upper and lower end of air inlet grille (Fig. 2-12).
2. Slide foundation forward to disengage rear edge of foundation from retainer and remove foundation.



Fig. 2-12 Air Outlet Grille

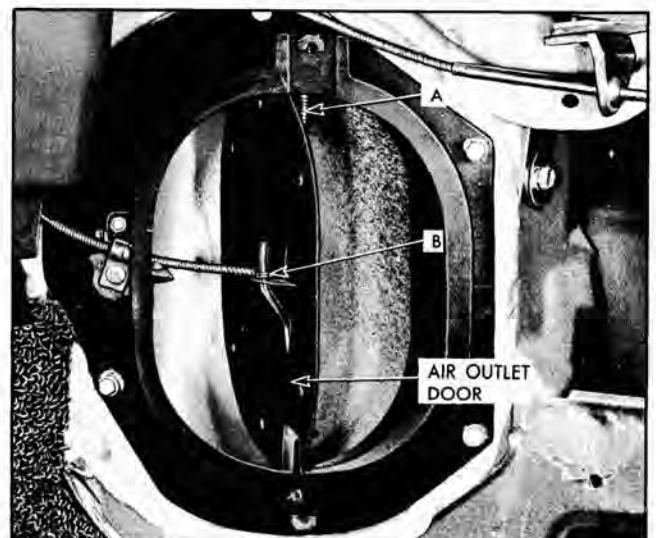

Fig. 2-13 Air Outlet Door

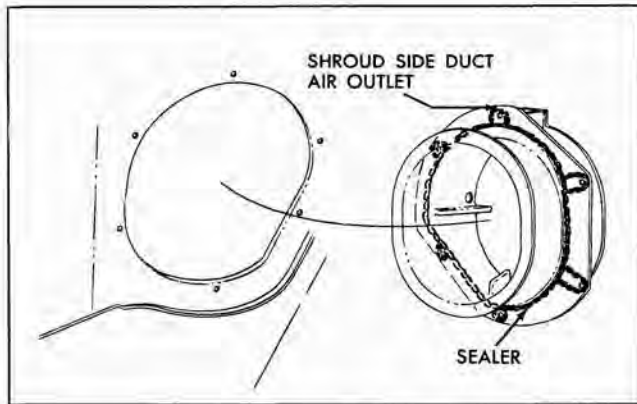

Fig. 2-14 Shroud Side Duct Air Outlet

3. To install, reverse removal procedure.

SHROUD SIDE VENT DUCT AIR OUTLET

REMOVAL AND INSTALLATION

1. Remove shroud side foundation.

2. Remove screws securing outlet to shroud panel, disengage cable from pin, on door, and remove outlet. (Fig. 2-13)

3. To install, apply a bead of medium-bodied sealer (Fig. 2-14) to shroud panel at perimeter of air outlet opening in shroud panel and reverse removal procedure.

SHROUD SIDE DUCT PANEL AIR OUTLET DOOR

REMOVAL AND INSTALLATION

1. Remove shroud side foundation.
2. Remove end control cable from pin.
3. Pry hinge pin downward and remove door.
4. To install, reverse removal procedure.

DOORS

CONTENTS OF THIS SECTION

SUBJECT	PAGE	SUBJECT	PAGE
Front and Rear Doors		Vent Regulator	3-16
Weatherstrip	3-1	Ventilator Adjustment	3-17
Drain Hole Sealing Strips	3-4	Glass Run Channel	3-20
Door Lock Spring Clips	3-4	Rear Doors	
Water Deflectors	3-4	Door Hinges	3-22
Inside Handles	3-7	Adjustments	3-24
Arm Rests	3-8	Lock	3-24
Trim Assemblies	3-8	Lock Striker	3-25
Outside Handle	3-8	Remote Control	3-26
Glass Run Channel	3-9	Window Regulator	3-27
Front Doors		Glass Run Channel	3-27
Door Assembly and Hinges	3-10	Lower Sash Channel Cam	3-28
Door Lock Striker	3-13	Window Assembly	3-28
Door Lock Cylinder	3-14	Side Roof Rail Weatherstrip	
Inner Panel Cam	3-14	Adjustments	3-31
Door Lock	3-14	Center Pillar Cap	3-32
Remote Control	3-15		

FRONT AND REAR DOORS

Service operations for doors are covered in the following sections:

Service operations which are the same or similar for both front and rear doors.

Service operations for front doors only.

Service operations for rear doors only.

Service operations for side roof rail weatherstrips.

Service operations for center pillars.

FRONT AND REAR DOOR WEATHERSTRIPS

39, 47 and 67 STYLES

The door weatherstrip is a one-piece mechanically retained type. On all styles, the weatherstrip is retained by a series of weatherstrip attaching clips which fit into weatherstrip attaching clip sealing

plugs. This feature eliminates the need of sealing weatherstrip clips along a substantial section of the door facing. Service procedures for front and rear door weatherstrips are similar and both are covered as follows:

REMOVAL

1. Remove snap fasteners securing front and rear ends of weatherstrip at belt line.

2. Insert tip of tool J-5757, or other suitable tool, at clip locations and carefully snap clips from retaining holes.

3. At upper rear section of front door weatherstrip on "39", "47" and "67" styles, carefully break cement bond securing weatherstrip to door inner panel (views "F" and "K" - Fig. 3-2).

NOTE: If necessary a flat-bodied tool such as a putty knife can be used to help break cement bond.



Fig. 3-1 Weatherstrip Clip Reformer

INSTALLATION

1. Check weatherstrip attaching clips for proper contour and reform, if necessary, using clip reforming tool J-5984 (Fig. 3-1).

2. Check all attaching hole sealing plugs. If sealing plugs are loose and will not remain engaged in door inner panel, install a 1/2" x 1" piece of cloth-backed waterproof body tape over sealing plug retaining hole as shown in Section "P-P" in Fig. 3-2. Make two (2) 5/16" slits in tape to form an "X" pattern. Install plugs and check for a snug fit. If plug is still loose, repeat above operation by installing a second piece of tape over existing repair. This procedure may also be used to repair waterleaks which may develop at sealing plug locations. If sealing plug becomes damaged, part must be replaced.

3. Clean off old cement from door to insure a clean cementing surface. On "47" and "67" styles, apply a nine (9) inch bead of an approved weatherstrip adhesive to lock pillar facing of front door (cove area) as illustrated in view "F" of Fig. 3-2. On "39" style, apply a nine (9) inch bead of an approved weatherstrip adhesive to lock pillar facing of rear doors as illustrated in view "K" of Fig. 3-2.

4. Install clips to door by placing notched end of weatherstrip inserting tool J-5757 in loop of clip and

pushing clip into attaching hole sealing plug. Repeat operation along both sides and bottom of door.

NOTE: Do not distort clips or unsatisfactory weatherstrip retention will result.

5. At front corner of rear doors (at belt), apply weatherstrip cement to facing of formed end of weatherstrip and corresponding surface of door inner panel and cement weatherstrip in place. Replace forward snap fastener only (Fig. 3-3).

6. Clean off all excessive weatherstrip adhesive and install snap fasteners.

7. On front doors, midway down from top of weatherstrip, fill area between weatherstrip and door inner panel with body caulking compound (view "K" in Fig. 3-2).

FRONT AND REAR DOOR WEATHERSTRIPS

11, 35, 45 and 69 STYLES

The door weatherstrip is a one-piece design, cemented into the door window frame channel and retained by clips inserted into attaching hole sealing plugs for the remainder of the door. Service procedures for front and rear door weatherstrips are similar and both are covered as follows:

REMOVAL

1. Insert tip of mechanically retained weatherstrip inserting tool J-5757, or other suitable tool, at clip locations and carefully snap clips from retaining holes.

2. On front doors, carefully break cement bond securing weatherstrip to door lock pillar facing of door. On rear doors, carefully break cement bond securing weatherstrip to door hinge pillar and lock pillar facings of door (views "B", "D" and "G" in Fig. 3-4). Remove weatherstrip from door.

INSTALLATION

1. Check weatherstrip clips for proper contour and reform, if necessary, using clip reforming tool J-5984 (Fig. 3-1).

2. Check all attaching hole sealing plugs. If sealing plugs are loose and will not remain engaged in door inner panel, install a 1/2" x 1" piece of cloth-backed waterproof body tape over sealing plug retaining hole,

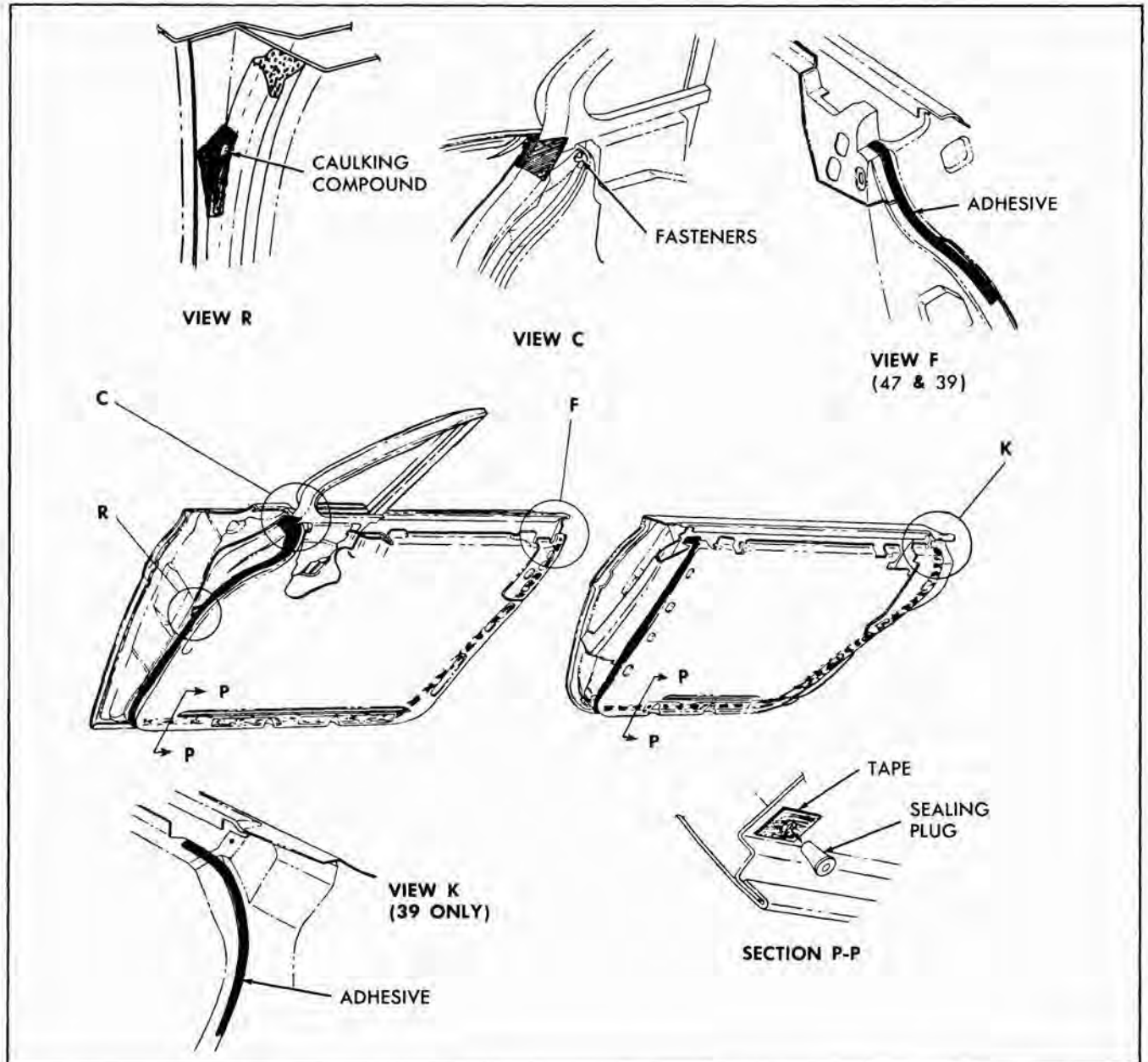

Fig. 3-2 Door Weatherstrip - 39, 47, 67 Styles

as shown in Section "P-P", Fig. 3-4. Make two (2) 5/16" slits in tape to form an "X". Install plugs and check for a snug fit. If plug is still loose, repeat above operation by installing a second piece of tape over existing repair. This procedure may also be used to repair waterleaks which develop at sealing plug locations.

3. If a new weatherstrip is being installed, clean old cement off door to insure a clean cementing surface and apply cement to the following locations:

a. Apply a bead of weatherstrip adhesive nine

(9) inches long to hinge pillar and lock pillar facings of front door at belt area (views "B" and "D" Fig. 3-4).

b. Apply a bead of weatherstrip adhesive nine (9) inches long to lock pillar facing of rear door at belt area (view "G" Fig. 3-4).

4. Position front door weatherstrip so that pre-formed section is at upper rear corner of door. Position rear door weatherstrip so that molded section is at upper front corner of door.

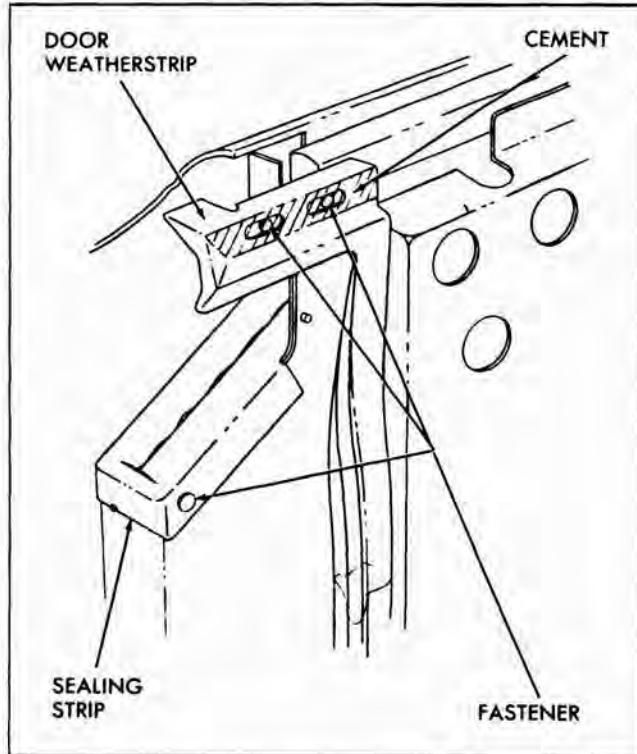

Fig. 3-3 Rear Door Hinge Pillar

5. Install clips to door by placing notched end of inserting tool J-5757 in loop of clip and pushing clip into attaching hole sealing plug.

NOTE: Do not distort clips or unsatisfactory weatherstrip retention will result.

6. Clean off all excessive weatherstrip adhesive.

FRONT DOOR LOCK PILLAR SEALING STRIP (AT BELT)

39 STYLE

The front door lock pillar sealing strip is installed at the belt line and is used as an aid in preventing entry into car of dust, water and cold air. This part is retained by four (4) snap fasteners and should receive proper lubrication to ease operating effort of front door window assembly.

REMOVAL AND INSTALLATION

1. Remove snap fasteners securing sealing strip to hinge pillar facing of front door and remove sealing strip (Fig. 3-5).

2. To install, reverse removal procedure.

REAR DOOR HINGE PILLAR SEALING STRIP (AT BELT)

39 STYLE

REMOVAL AND INSTALLATION

1. Remove snap fasteners securing sealing strip to hinge pillar facing of rear door and remove strip (Fig. 3-3).

2. To install, reverse removal procedure.

FRONT AND REAR DOOR BOTTOM DRAIN HOLE SEALING STRIPS

Door bottom drain hole sealing strips are attached to door inner panels over door bottom drain holes and are designed to prevent entry of dust at these areas. The sealing strips are of a new design and are retained by two (2) retaining plugs (carrots) which are an integral part of the sealing strip. These new sealing strips are of a vinyl construction and should not require lubrication.

REMOVAL AND INSTALLATION

1. With a putty knife, or other suitable flat-bladed tool, carefully pry out retaining carrots.

2. To install, insert tip of a blunt tool (such as a blunt ice pick) into carrot and push carrot into retaining holes (Fig. 3-6).

DOOR LOCK SPRING CLIP

A spring clip is used on the door lock levers to secure the remote control connecting rod and inside locking rod connecting link to the door levers. A slot in the spring clip provides for disengagement of the clip, thereby facilitating detachment of the connecting link from the lock lever.

To disengage spring clip, use a screw driver, or other suitable tool to slide the clip out of engagement (Fig. 3-7).

FRONT AND REAR DOOR WATER DEFLECTORS

A waterproof paper deflector is used to seal the door inner panel and prevent entry of water into the body. The polyethylene (black) side of the deflector is placed against the inner panel. The deflector fits into a retaining slot at the bottom of the door inner panel and deflects water to the bottom of the door

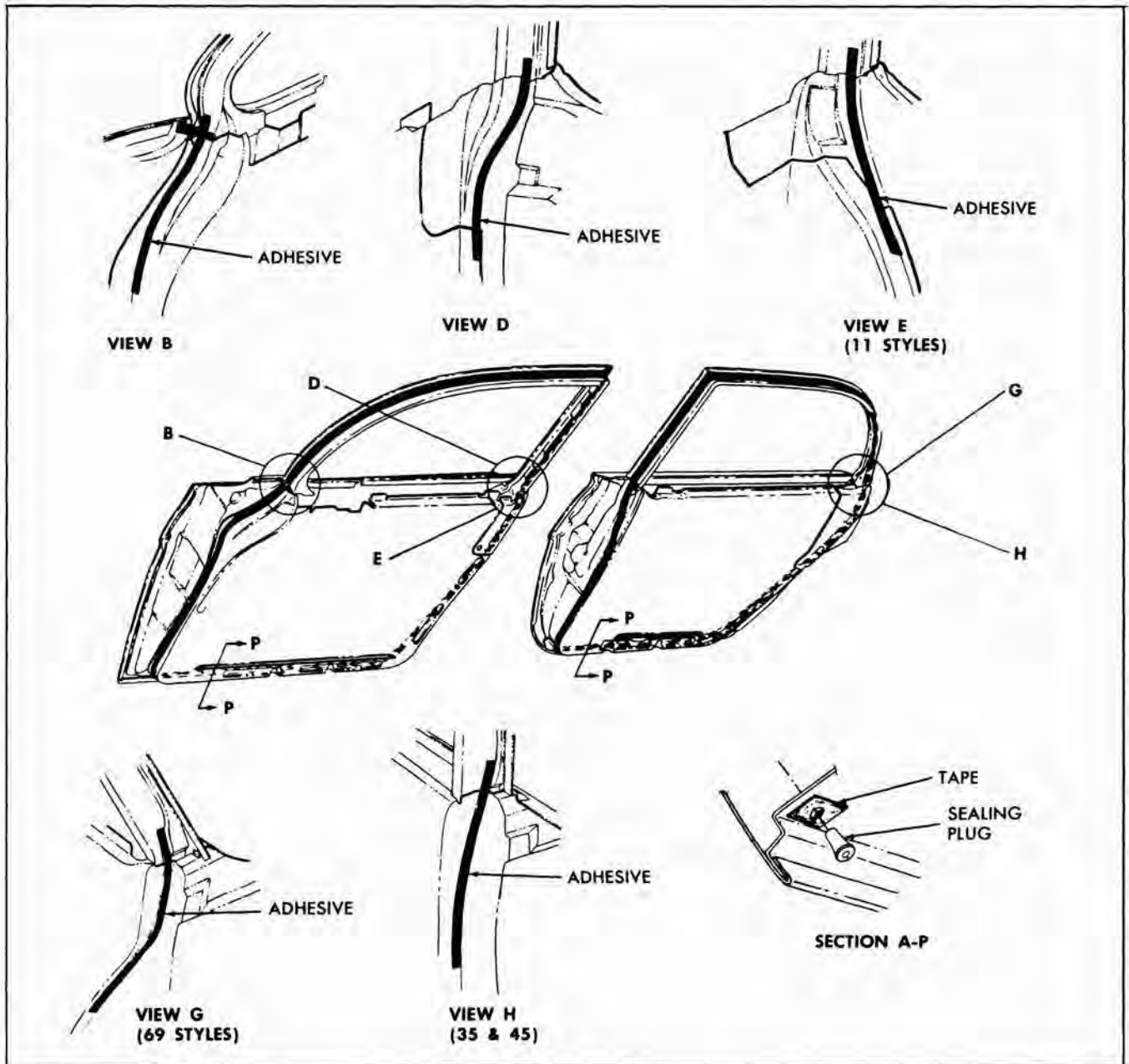

Fig. 3-4 Door Weatherstrips - 11, 35, 45, 69 Styles

and out the bottom drain holes. The deflector is further secured by a string loaded sealing material along both front and rear edges and by the application of waterproof sealing tape at front and rear lower corners.

Whenever work is performed on front or rear doors where the paper water deflector has been disturbed, the deflector must be properly sealed and taped to the inner panel to prevent serious water-leaks. It is important that all service personnel performing door hardware adjustments or sealing

operations are aware of the importance of using the specified material and recommended removal and installation or replacement procedures. For service sealing, body caulking compound is recommended if additional sealing material is required.

When access to the inner panel is required to perform service operations, the deflector may be completely or partially detached from the inner panel. If the existing water deflector is damaged so that it will not properly seal the door, replacement of the deflector is required.

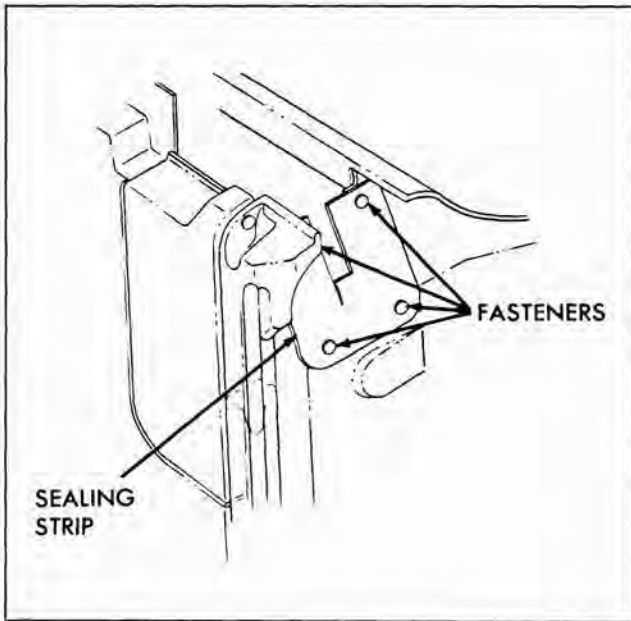

Fig. 3-5 Front Door Lock Pillar

The following procedure covers complete removal and installation of the water deflector. If only partial removal of the deflector is required, perform only those steps which are necessary to expose the required area of the door inner panel.

REMOVAL

1. Remove door trim assembly.

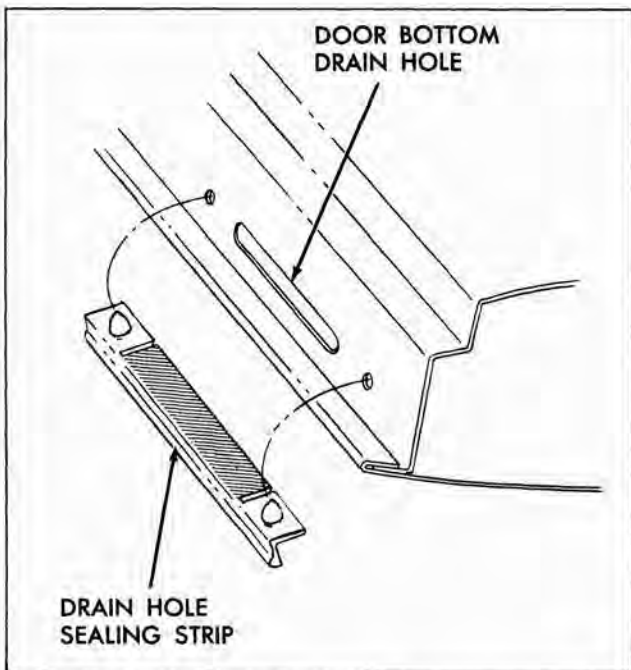

Fig. 3-6 Drain Hole Sealing Strip

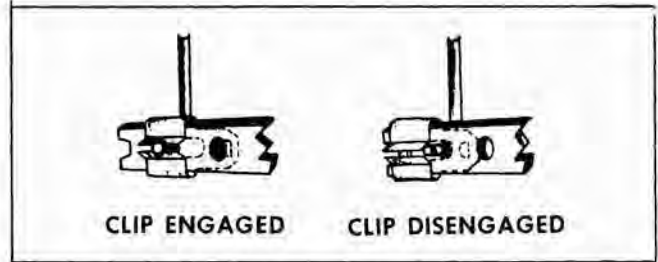

Fig. 3-7 Door Lock Spring Clip

2. Remove strips of waterproof body tape securing lower corners of water deflector (Fig. 3-8).
3. Carefully break cement bond securing upper corners of water deflector to door inner panel. While

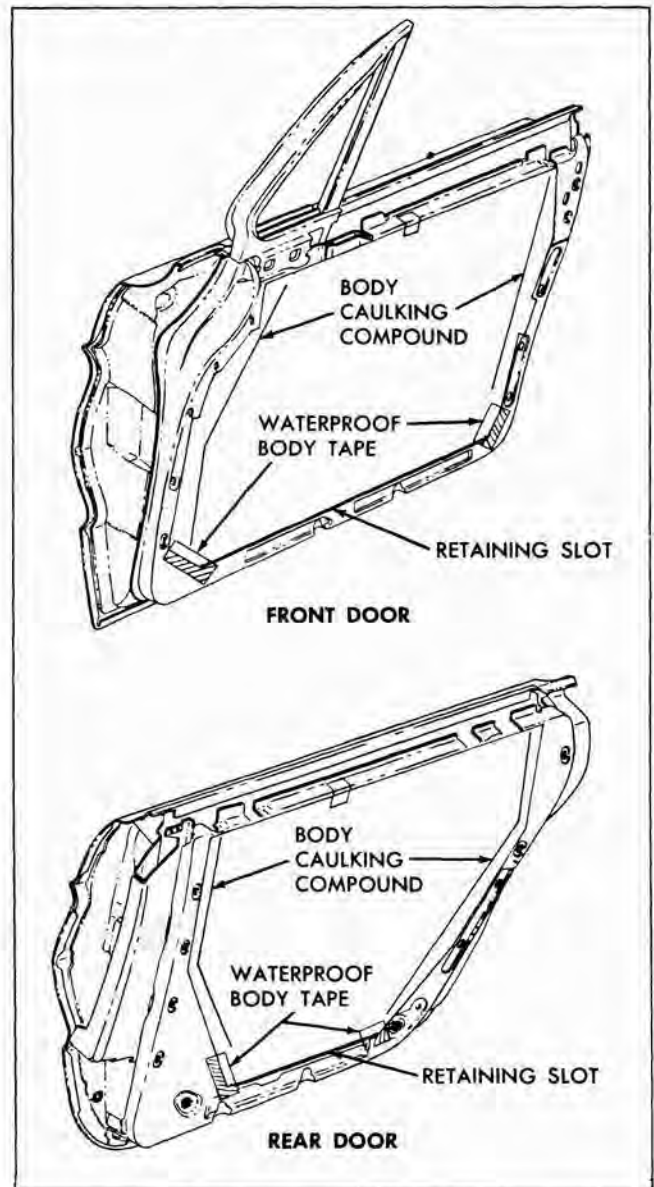

Fig. 3-8 Door Water Deflector Sealing

holding string, located within sealer, against water deflector, carefully disengage edges of deflector from door. Exercise care not to damage water deflector.

NOTE: If necessary, a flat-bladed tool such as a putty knife can be used to help break cement bond.

4. Disengage lower edge of water deflector from retaining slot in door inner panel and remove water deflector.

INSTALLATION

1. Inspect water deflector and, where necessary, repair any tears or holes with waterproof body tape applied to both sides of deflector. In addition, if bond between polyethylene and deflector paper has been torn, cut or damaged, apply waterproof body tape to both sides of deflector over damaged area to prevent water from wicking on uncoated side of deflector paper.

2. If new water deflector is to be installed, use old water deflector as a template, trim new deflector to proper size and cut holes for door inside hardware. If old sealer does not effect a satisfactory seal, clean off old cement from door inner panel and apply a continuous bead of body caulking compound (approximately 3/16" diameter) to door inner panel along line contacted by front and rear edges of water deflector (Fig. 3-8).

3. If necessary, seal all arm rest screw attaching holes with body caulking compound.

4. Position water deflector to door inner panel with polyethylene coated side (black) of deflector against inner panel. Insert lower edge of deflector in retaining slot. Firmly roll or press sealed areas to obtain a good bond between deflector and door inner panel.

5. Seal lower corners of deflector with 2 or 2-1/2" waterproof body sealing tape (Fig. 3-8).

6. Clean off all excessive cement or caulking compound and install previously removed door trim and inside hardware.

FRONT AND REAR DOOR INSIDE HANDLES

REMOVAL AND INSTALLATION

On styles equipped with door inside remote control "paddle" handles, proceed as follows:

1. Remove door arm rest as described under "Front and Rear Door Arm Rests".

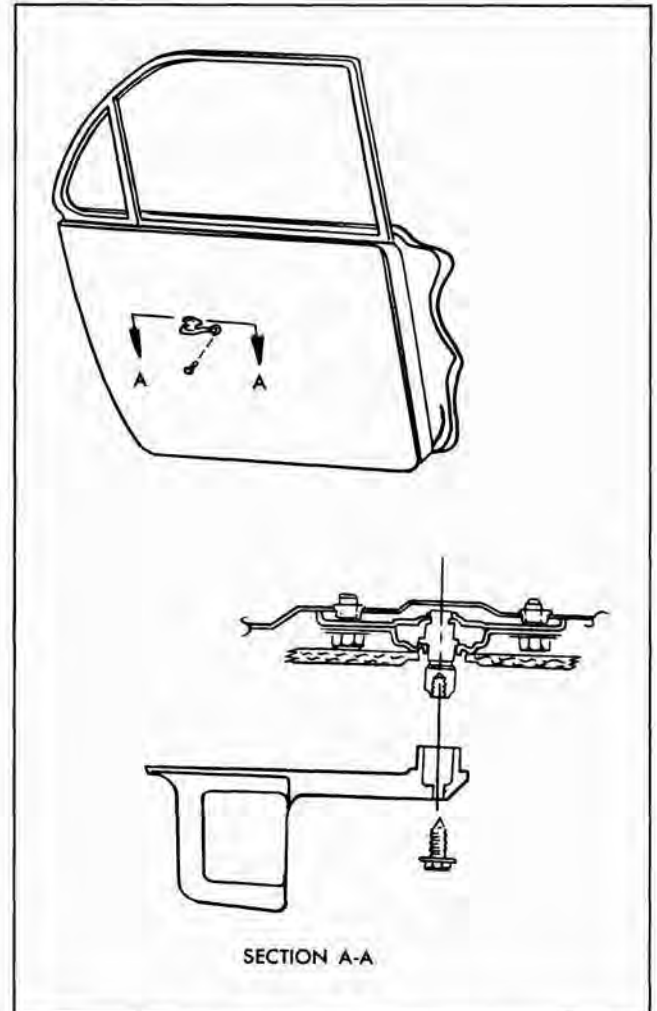

Fig. 3-9 Remote Control Handle

2. Remove handle-to-remote attaching bolt and remove handle from door (Fig. 3-9).

3. To install, reverse removal procedure.

On styles not equipped with paddle handles and for removal of manually operated door window and ventilator inside handles, proceed as follows:

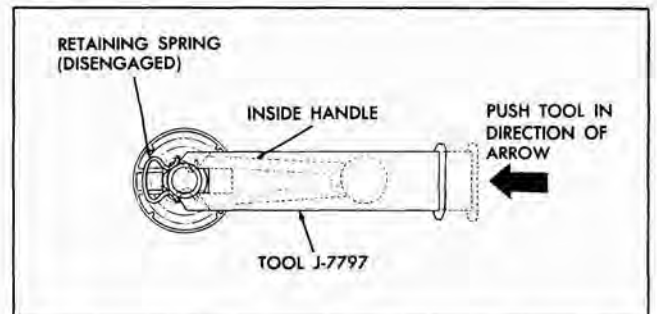

Fig. 3-10 Handle Retaining Spring

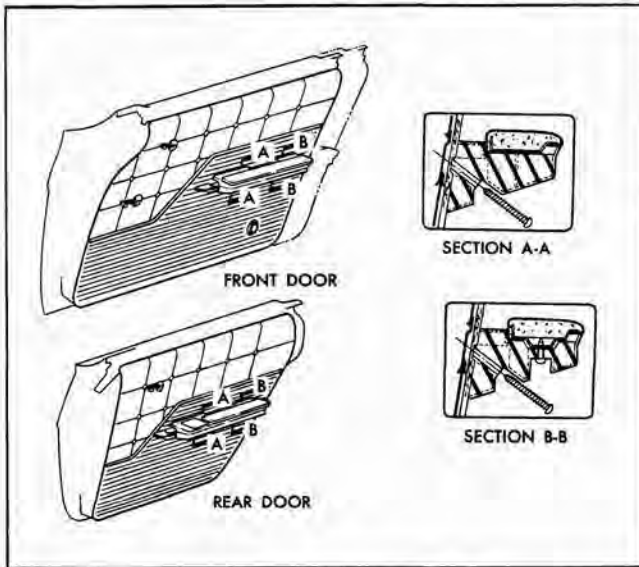

Fig. 3-11 Front and Rear Door Trim

1. Depress door trim assembly at handle sufficiently to install tool J-7797 between handle and bearing plate.

2. Push handle retaining spring out of engagement and remove handle and bearing plate from door (Fig. 3-10).

INSTALLATION

1. Install retaining spring on handle and bearing plate over regulator spindle.

2. Position handle on spindle at same angle as handle on opposite door and push handle until spring is engaged (Fig. 3-10).

NOTE: Handles are installed in a horizontal position with open end forward when glass is in full up position.

FRONT AND REAR DOOR ARM REST ASSEMBLIES

All arm rests are the applied type and are secured

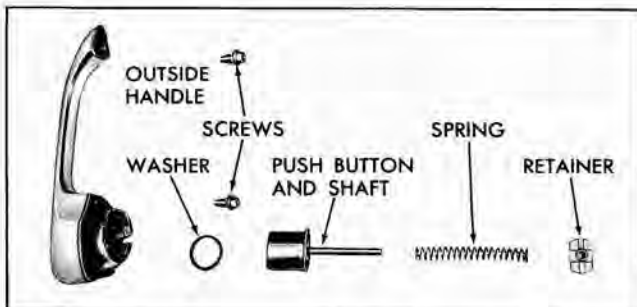

Fig. 3-12 Front Door Outside Handle

to the door inner panel by two (2) attaching screws. When a door arm rest is removed, it may be necessary to reseal the attaching screw holes with body caulking compound prior to installation.

REMOVAL AND INSTALLATION

1. Remove screws securing arm rest assembly to door inner panel and remove assembly (Fig. 3-11, typical of all "B" body door arm rest installations).

2. To install, reverse removal procedure.

FRONT AND REAR DOOR TRIM ASSEMBLIES

REMOVAL AND INSTALLATION

1. Remove door inside hardware, locking rod knob and arm rest assembly.

2. Remove screws securing trim assembly to door inner panel.

3. With a clean rubber mallet, tap trim assembly along front and rear edges to free trim assembly retaining nails in slots.

4. Place tool J-6335, or other suitable flat-bladed tool, between water deflector and door trim assembly at lower edge of trim assembly. Working upward, carefully loosen front and rear edges of door trim assembly from door inner panel.

NOTE: Exercise care not to disturb inner panel water deflector.

5. Lift trim assembly upwards and carefully disengage trim from top of door inner panel; then remove trim assembly from door.

NOTE: On styles equipped with electric window regulator, after trim assembly is disengaged from top of door inner panel, disconnect switch terminal block(s) from switch assembly(s).

6. To install, reverse removal procedure. Broken retaining nails should be replaced with repair tabs, which are available as service parts.

FRONT AND REAR DOOR OUTSIDE HANDLE ASSEMBLY

REMOVAL AND INSTALLATION

1. Raise door window. Remove door trim assembly and detach upper rear corner of inner panel water deflector sufficiently to gain access to door outside handle attaching screws.

2. Remove screws and door lock handle and gaskets from outside of body.

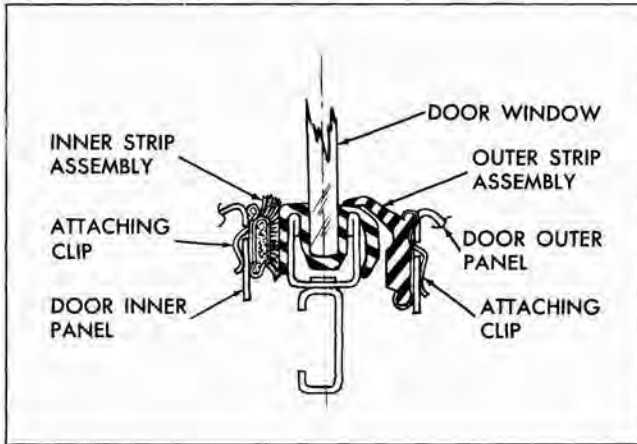

Fig. 3-13 Door Glass Channel

3. To install, reverse removal procedure.

ASSEMBLY AND DISASSEMBLY OF DOOR OUTSIDE HANDLE PUSH BUTTON

1. Remove door outside handle.
2. Depress retainer slightly and turn one quarter (1/4) turn. Remove retainer, spring, push button and shaft and sealing ring from handle.
3. To assemble, reverse disassembly procedure (see Fig. 3-12).

FRONT AND REAR DOOR WINDOW GLASS RUN CHANNEL INNER AND OUTER STRIP ASSEMBLIES

Glass run channel strip assemblies are used on all doors on all styles incorporating a dropping window and are designed to prevent cold air and water from entering the body between the door window lower sash channel and door inner and outer panels. The inner strip assembly is similar to that used on past models and is secured to the door inner panel by a series of attaching clips. The outer strip assembly is constructed of a molded rubber and is secured to a metal retainer by a series of staples. On styles equipped with a door window belt reveal molding, the metal retainer is an integral part of this molding.

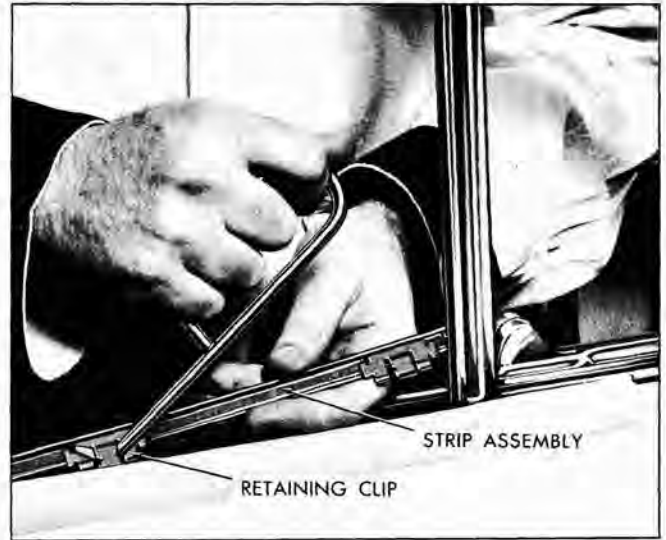

Fig. 3-14 Glass Run Channel Strip

In either case, the molding or retainer is secured to the door outer panel by a series of attaching clips. Moldings are further retained by two (2) attaching screws, one at each end. When the door window is raised, the top section of the outer strip assembly is lifted and held in position by the door window lower sash channel and/or filler (see Fig. 3-13).

REMOVAL AND INSTALLATION

1. Lower door window and apply masking tape over door panel adjacent to strip assembly to protect paint finish.
2. On styles equipped with a belt reveal molding, remove attaching screws.
3. With a hooked tool, carefully pry up inner edge of strip assembly at clip locations and remove assembly from door (Fig. 3-14).
4. To install, align clips with holes in door inner panel and press strip assembly into place.
5. On styles equipped with belt reveal molding, reinstall attaching screws and, if applicable, front door ventilator assembly.
6. Remove tape from door panel.

FRONT DOORS

11, 35, 45 and 69 STYLES

Fig. 3-15 is typical of sedan and station wagon style front doors with the trim assembly and inner panel water deflector removed. This illustration identifies the component parts of the front door assembly, their relationship and various attaching points.

39, 47 and 67 STYLES

Fig. 3-16 is typical of the hard top coupe and sedan style front doors with the trim assembly and inner panel water deflector removed. This illustration identifies the component parts of the front door assembly, their relationship and various attaching points.

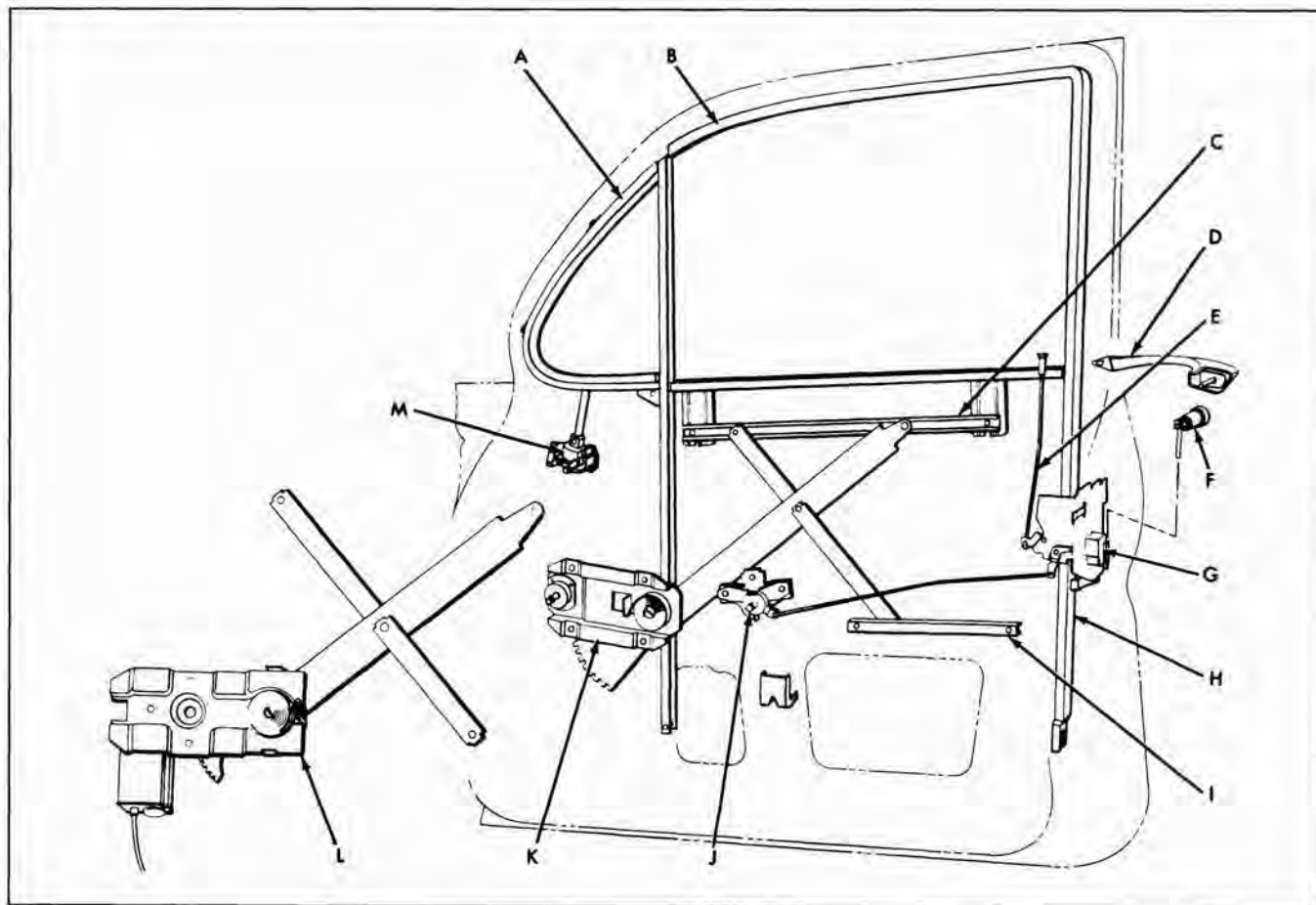

- | | | |
|-------------------------------------|-------------------------------|---|
| A. Ventilator Assembly | E. Inside Locking to Lock Rod | J. Lock Remote Control Assembly |
| B. Window Assembly | F. Lock Cylinder Assembly | K. Window Regulator-Manual |
| C. Window Lower Sash
Channel Cam | G. Lock Assembly | L. Window Electric Regulator
and Motor |
| D. Outside Handle Assembly | H. Window Glass Run Channel | M. Ventilator Regulator Assembly |
| | I. Inner Panel Cam Assembly | |

Fig. 3-15 Sedan and Station Wagon Front Door Assembly

11, 35, 45 and 69 STYLES

Fig. 3-17 is typical of all "B" body closed style front doors, illustrating the proper position of a fully lowered door window for maximum glass stability.

FRONT DOOR ASSEMBLY AND HINGES

The front door hinges are the swing-out type with an integral door check on top hinge assembly and a two position hold open on lower hinge assembly. The hinges are attached to the front body hinge pillar and to the door assembly with bolts and anchor plates. Either of two (2) methods may be used to remove the door from the body.

A. The door and hinges can be removed as an assembly from the body hinge pillar.

B. The door can be removed from the hinge straps.

REMOVAL

1. Place a protective covering over front fender at door opening to protect paint finish.

2. If door and hinges are to be removed from body pillar, additional access may be obtained at lower hinge by loosening front fender lower rear attaching bolt.

3. Mark hinge locations on door or hinge pillar depending on method of removal being used.

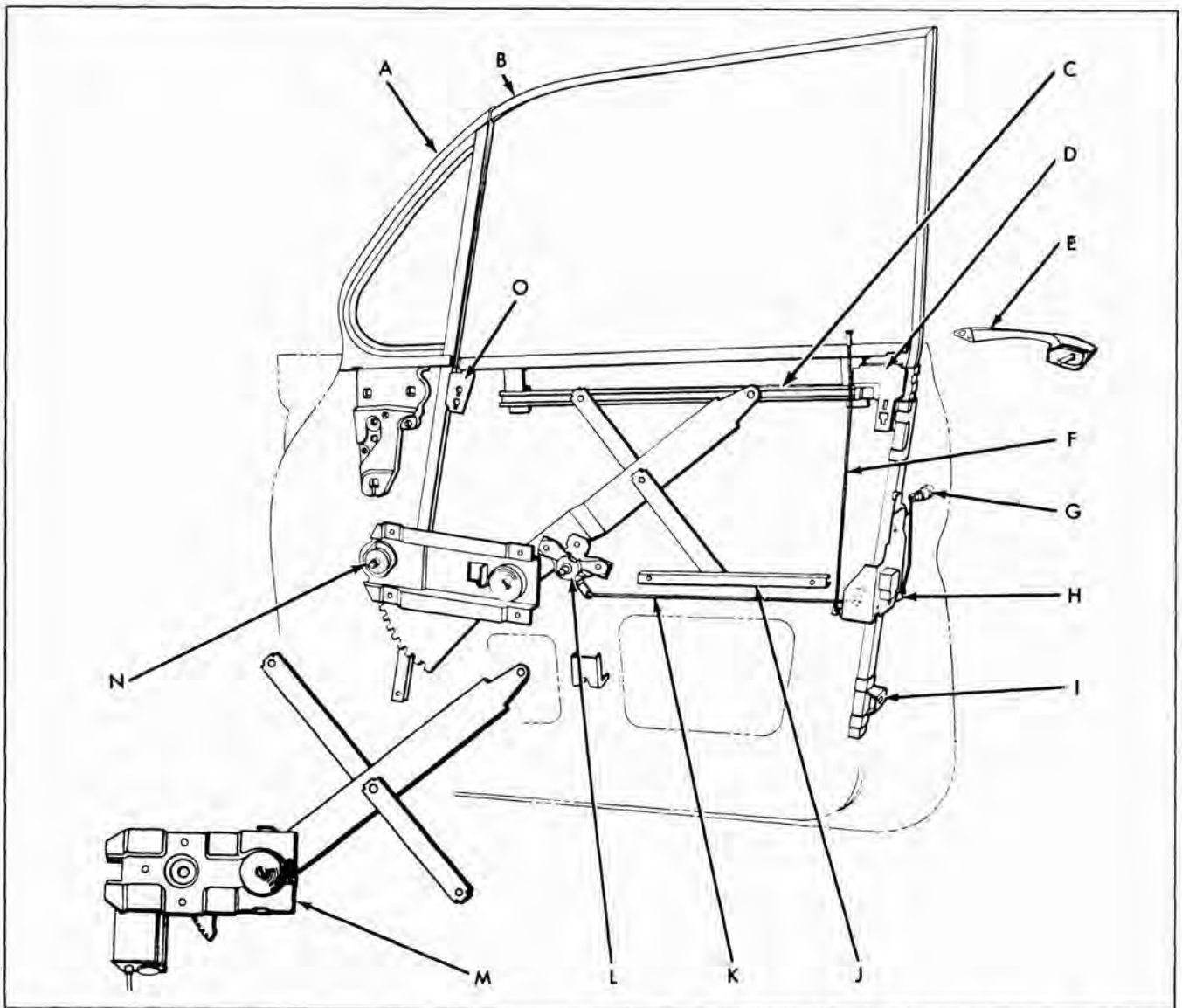

- | | | |
|----------------------------------|------------------------------------|--|
| A. Ventilator Assembly | F. Inside Locking to Lock Rod | L. Lock Remote Control Assembly |
| B. Window Assembly | G. Lock Cylinder Assembly | M. Window Electric Regulator and Motor |
| C. Window Lower Sash Channel Cam | H. Lock Assembly | N. Window Regulator-Manual |
| D. Window Rear Stop Assembly | I. Window Glass Run Channel | O. Window Front Stop Assembly |
| E. Outside Handle Assembly | J. Inner Panel Cam Assembly | |
| | K. Lock Remote Control to Lock Rod | |

Fig. 3-16 Hard Top Front Door Assembly

4. On bodies equipped with electrically powered window regulators proceed as follows:

a. Remove door trim assembly and detach inner panel water deflector sufficiently to gain access to wire connector(s) at motor(s).

b. Detach wire harness from inner panel as required and disconnect motor(s) from harness at connector(s).

c. Remove electric conduit from door and remove wire harness from between door panels through opening in door hinge pillar.

5. With door properly supported, remove bolts securing upper and lower hinges to front body hinge pillar or door hinge pillar. Then with aid of helper, remove door assembly from body (Fig. 3-18).

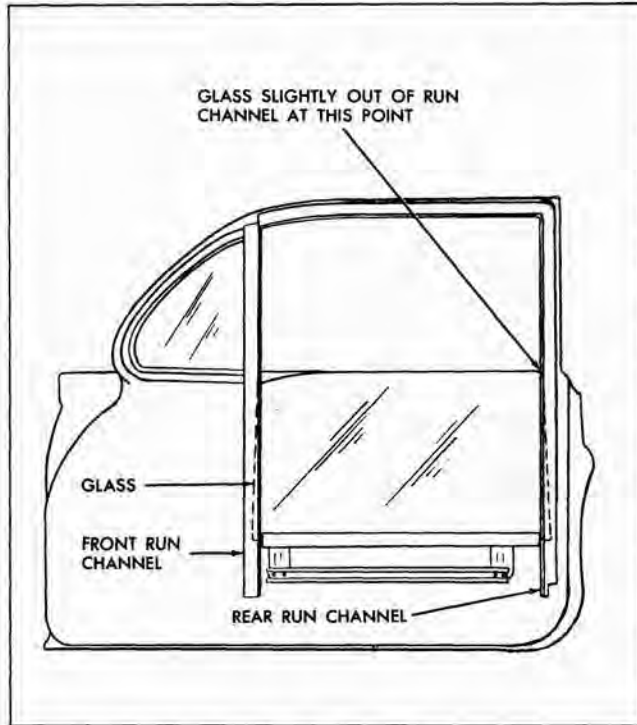

Fig. 3-17 Lowered Front Door Glass

INSTALLATION

1. As an anti-squeak precaution, before installing door, coat attaching surface of hinge with heavy-bodied sealer (Fig. 3-19).

2. With aid of helper, reinstall door to body opening, align hinges within marks and tighten bolts. Check door for proper alignment.

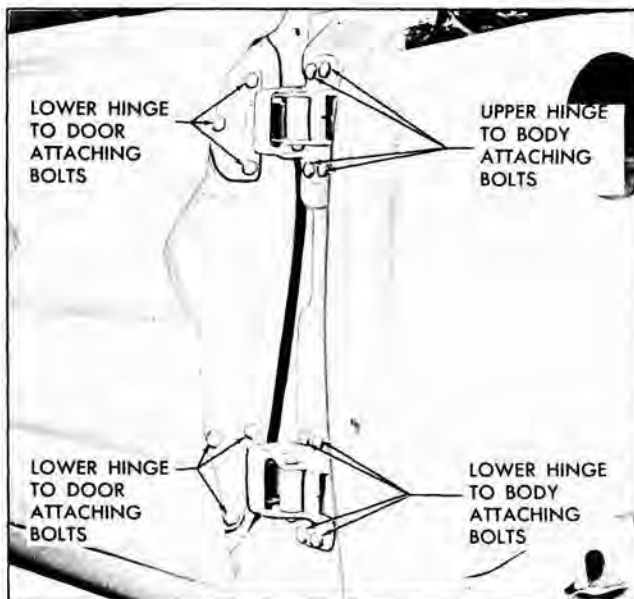

Fig. 3-18 Door Hinge Attachment

3. On bodies equipped with electrically-operated window regulator proceed as follows:

a. Install wire harness between door panels and reinstall harness to door inner panel. Connect regulator motor.

b. Install conduit to door inner panel. Check operation of electric window assembly.

4. Where required, seal door inner panel water deflector as specified in "DOOR INNER PANEL WATER DEFLECTOR" and reinstall previously removed parts.

5. For lubrication information see "LUBRICATION SECTION."

ADJUSTMENTS

In or out or up and down adjustments are provided at door hinge pillar. Fore and aft adjustments are provided at front body hinge pillar.

NOTE: After performing any door adjustments on "39", "47", or "67" styles, the front door ventilator and window should be checked for proper alignment with the side roof rail weatherstrip and adjusted, where required. In addition, the door lock extension-to-striker engagement should be checked, and, if necessary, adjusted as described under "DOOR LOCK STRIKER ADJUSTMENTS".

1. For in and out or up and down adjustments, loosen hinge to door pillar attaching bolts (see Fig. 3-18). Adjust door as required and tighten bolts.

NOTE: When performing in and out adjustments, adjust one (1) hinge at a time so as not to disturb up and down adjustment.

2. To adjust door fore or aft, loosen hinge to body pillar attaching bolts (see Fig. 3-18). Adjust door as required and tighten bolts.

NOTE: One (1) or more of the attaching bolts are not accessible due to inadequate wrench clearance. When fore and aft adjustments are performed, therefore, the recommended procedure is to remove the obstructing attaching bolt and perform adjustments with the remaining three (3) bolts. After satisfactory adjustments have been made, replace the previously removed bolt. The removal of the obstructing bolt and subsequent adjustments can best be accomplished with a ratcheting box socket wrench.

FRONT DOOR LOCK STRIKERS

REMOVAL AND INSTALLATION

1. With a pencil, mark position of striker on body pillar.

2. Remove three door lock striker attaching screws and remove striker and adjusting plates from pillar.

3. To install, seal all striker plate attaching screw clearance holes with body caulking compound.

4. Apply a 1/8" bead of body caulking compound around entire back surface of striker plate. No skips must exist in caulking compound. Place striker and adjusting plates within marks on pillar and install striker plate attaching screws.

IMPORTANT: Whenever a door has been removed and installed, or realigned, the door **SHOULD NOT** be closed completely until a visual check is made to determine if lock extension will engage in striker notch. Where required, door lock striker service spacers should be installed so that door can be closed and an accurate check made to determine spacer requirements.

5. Clean off all excess caulking compound.

ADJUSTMENTS

1. To adjust striker up or down or in or out, loosen striker plate attaching screws and shift striker and adjusting plates as required, then tighten screws.

DIMENSIONAL SPECIFICATIONS FOR USE OF DOOR LOCK STRIKER SERVICE SPACERS

1. Door should be properly aligned before checking door spacer requirements.

2. To determine if door lock striker emergency spacers are required, apply modeling clay or body caulking compound in door lock striker notch where lock extension engages and then close door to form measurable impression in clay or caulking compound (Figure 3-20).

When dimension "A" from rear face of striker teeth to rear edge of depression in clay is less than 11/32", install service spacers and proper length striker attaching screws as indicated.

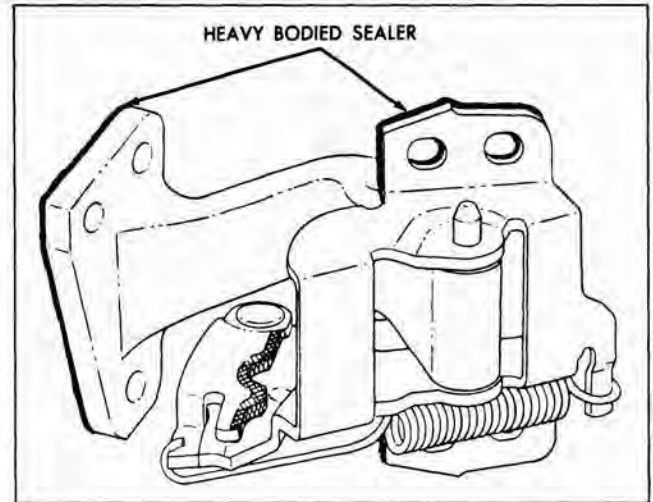

Fig. 3-19 Front Door Hinge Anti-Squeak

Dimension "A"	No. of Spacers Required	Spacer Thickness	Striker Attaching Screws*
11/32" to 9/32"	1	1/16"	Original
9/32" to 7/32"	1	1/8"	(1/8" longer)
7/32" to 5/32"	1-(1/16" Spacer) 1-(1/8" Spacer)	3/16"	(1/8" longer)
5/32" to 3/32"	2-(1/8" Spacer)	1/4"	(1/4" longer)

Note: Dimension "B" in the illustration should never be less than 1/8".

*Zinc or cadmium-plated flat-head cross recess screw with countersunk washer.



Fig. 3-20 Striker Engagement Check

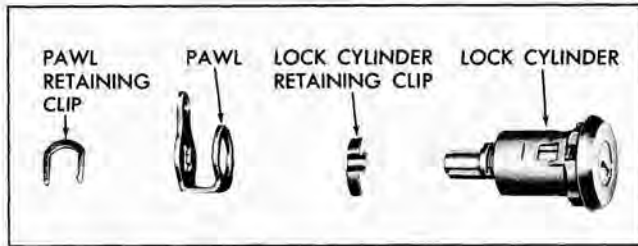

Fig. 3-21 Front Door Lock Cylinder

FRONT DOOR LOCK CYLINDER ASSEMBLY

REMOVAL AND INSTALLATION

1. Raise door window. Remove door trim assembly and detach inner panel water deflector sufficiently to expose large access hole.

2. Through access hole, with a screwdriver or other suitable tool, disengage door lock cylinder to lock connecting rod from door lock (see "DOOR LOCK SPRING CLIP").

3. On all except 39 models, with a suitable flat-bladed tool, slide lock cylinder retaining clip forward from door lock pillar facing sufficiently to permit removal of lock cylinder with attached connecting

rod from door. On 39 models, disengage spring clip from inside of door.

NOTE: Door lock cylinder connecting rod may be removed from lock cylinder as a bench operation or prior to removing cylinder.

4. To install, reverse removal procedure. Check operation of lock cylinder and lock prior to installing inner panel water deflector.

DISASSEMBLY AND ASSEMBLY

1. Remove lock cylinder assembly from door.

2. Remove pawl retaining clip, pawl and lock cylinder retaining clip (Figure 3-21).

3. To assemble, reverse disassembly procedure.

NOTE: The lock cylinder housing scalp used in production is usually damaged when removed and must be replaced by a new scalp which is available as a service part. The service lock cylinder housing scalp is secured by tabs.

FRONT DOOR INNER PANEL CAM ASSEMBLY

REMOVAL AND INSTALLATION

1. Raise door window. Remove door trim assembly and detach inner panel water deflector.

2. Remove screws securing door inner panel cam assembly, then disengage cam from window regulator balance arm and remove from door (Figure 3-22).

3. To install, reverse removal procedure. Prior to installation, lubricate entire length of cam with 630AAW Lubriplate or equivalent.

ADJUSTMENTS

1. To correct a condition where the glass is cocked in the glass run channels, loosen inner panel cam attaching screws, adjust either end of cam up or down as required and tighten screws.

FRONT DOOR LOCK ASSEMBLY

All locks are the rotary bolt type lock with the safety interlock feature. With the safety interlock feature it is important that the lock extension and housing engages properly in the door lock striker and that, where necessary, striker emergency spacers of the proper thickness are used to obtain proper engagement.

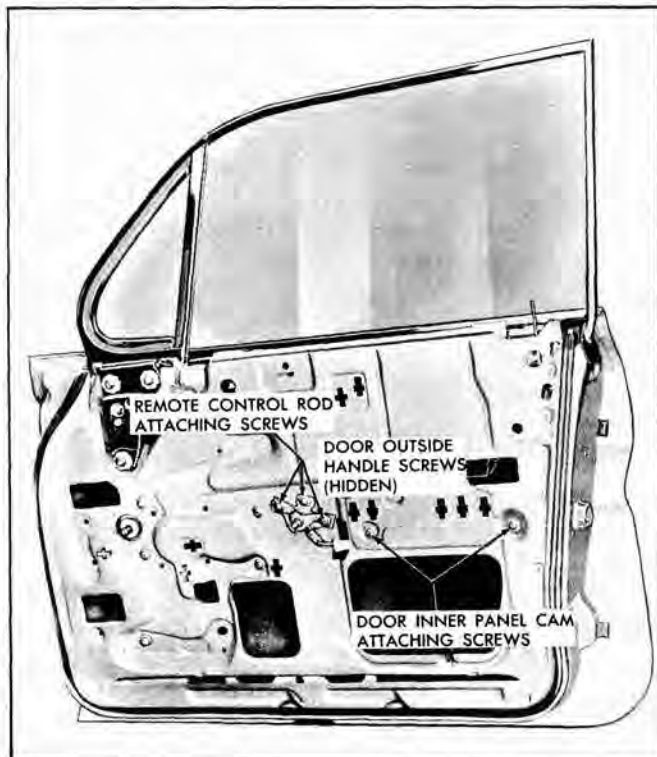

Fig. 3-22 Front Door Hardware

REMOVAL AND INSTALLATION

1. Raise door window. Remove door trim assembly and detach inner panel water deflector.

2. Through access hole, disengage spring clips securing lock cylinder rod, remote control connecting rod and inside locking rod to lock and disengage rods from lock (see "DOOR LOCK SPRING CLIPS").

3. On "39", "47" and "67" styles, remove door window rear glass run channel lower attaching screw and loosen upper attaching screws on lock pillar facing of door and at top of door inner panel to permit removal of lock. On 11, 35, and 69 models, from inside door, remove rear glass run channel lower attaching nut or screw and pull channel forward.

4. Remove door lock attaching screws from lock pillar facing of door and remove lock assembly from door (Fig. 3-23).

5. To install, reverse removal procedure. Prior to installation of lock assembly on 11, 47 and 67 models, apply a ribbon of medium bodied sealer (approximately 1/4" in diameter) across face of lock' frame. Check unit for proper operation and, if necessary, adjust glass run channel for proper alignment prior to installation of inner panel water deflector (Fig. 3-24).

FRONT DOOR REMOTE CONTROL ASSEMBLY AND CONNECTING ROD

REMOVAL AND INSTALLATION

1. Raise door window. Remove door trim assembly and detach inner panel water deflector.

2. Remove remote control attaching screws and disengage remote control from connecting rod (Fig. 3-22).

3. To remove remote control connecting rod, carefully disengage spring clip securing rod to lock and remove rod from lock. Disengage rod from spring clip on door inner panel where necessary, and remove rod.

4. To install, reverse removal procedure. Check door lock and remote control assemblies for proper operation prior to installing inner panel water deflector.

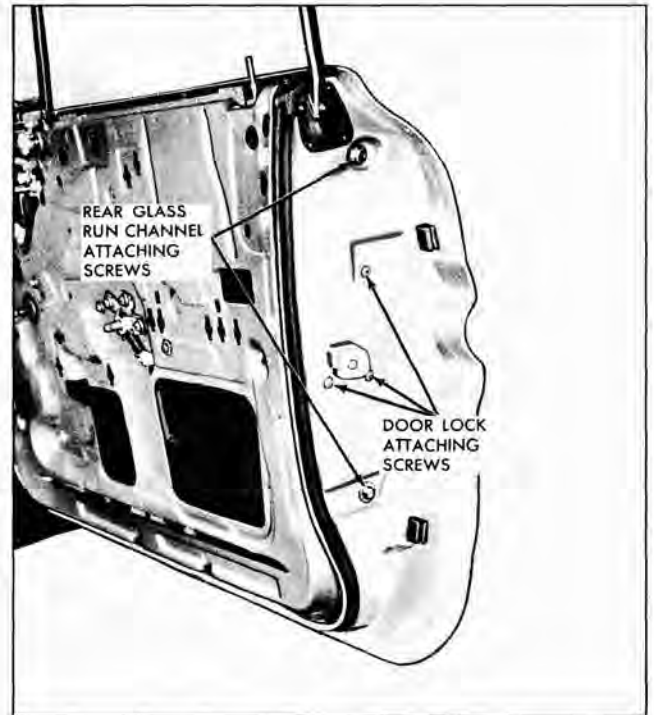

Fig. 3-23 Front Door Lock

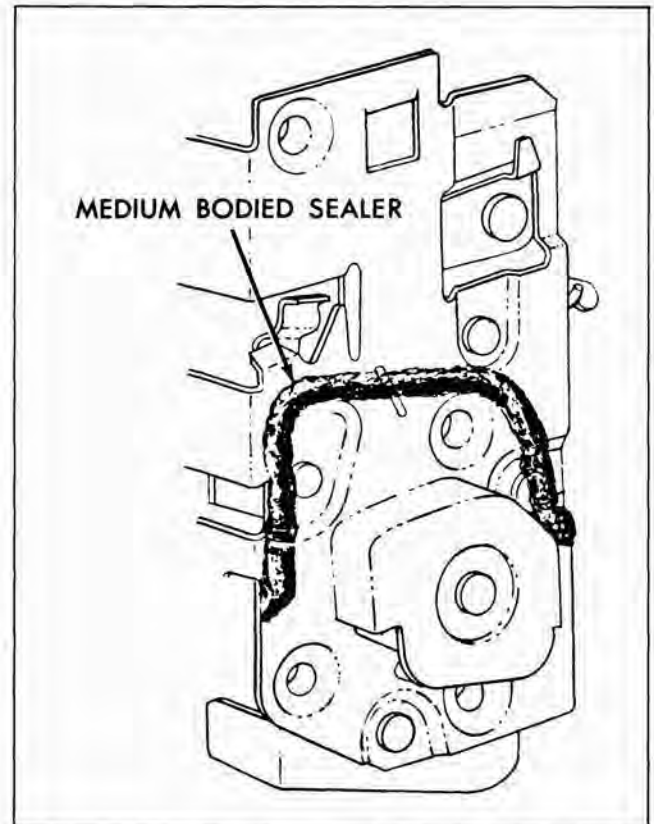

Fig. 3-24 Front Door Lock Sealing

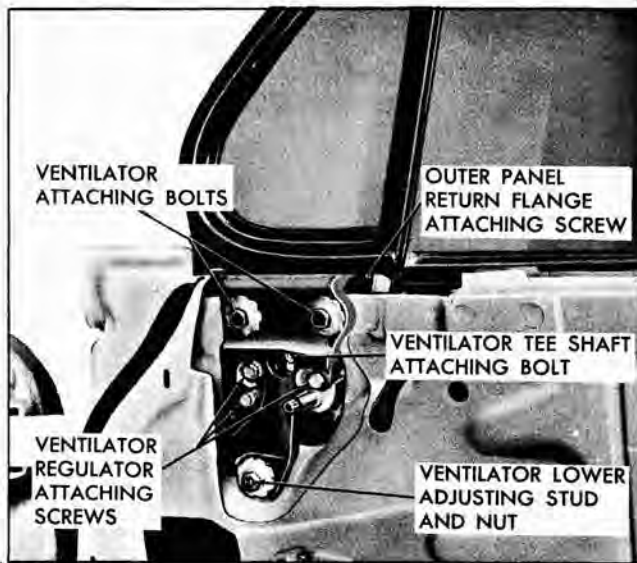

Fig. 3-25 Ventilator Regulator—Hard Tops

FRONT DOOR VENTILATOR REGULATOR

REMOVAL AND INSTALLATION

1. Raise door window. Remove door trim assembly and detach inner panel water deflector sufficiently to gain access to regulator attaching screws.

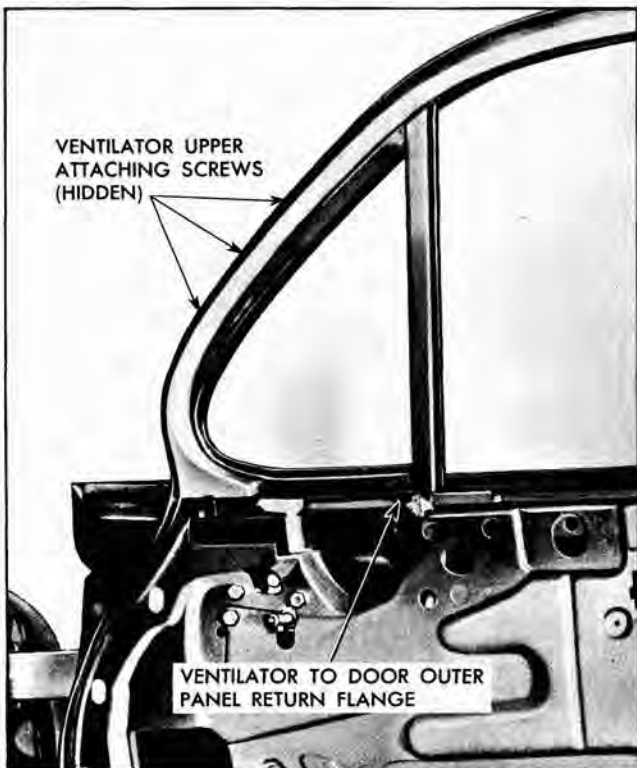

Fig. 3-26 Ventilator Regulator—Sedans

2. Remove ventilator tee shaft attaching bolt and ventilator regulator attaching screws (Fig. 3-25).

3. Disengage ventilator regulator shaft from ventilator tee shaft and remove regulator assembly from door through access hole.

4. To install, reverse removal procedure. Check operation of ventilator assembly prior to installing inner panel water deflector.

ADJUSTMENTS

1. Excessive "play" (flutter) of ventilator at pivot shaft when ventilator is in open position can be corrected by tightening ventilator tee shaft to regulator shaft attaching bolt (Fig. 3-25).

NOTE: Bolt should be tightened carefully to avoid stripping threads in regulator spiral gear shaft.

FRONT DOOR VENTILATOR ASSEMBLY

39, 47 and 67 STYLES

1. Remove door trim assembly and detach inner panel water deflector.

2. Lower door window. Remove ventilator to door outer panel return flange attaching screw (Fig. 3-25).

3. At front of ventilator assembly, break cement bond securing front door hinge pillar sealing strip (at belt) to ventilator assembly.

4. Remove ventilator division channel lower adjusting stud and nut (Fig. 3-25).

5. Loosen ventilator frame adjusting stud nut and remove ventilator attaching bolts (Fig. 3-25); then carefully lift ventilator assembly upward and rearward and remove from door.

6. To install, reverse removal procedure. Prior to installation of ventilator assembly, apply a bead of body caulking compound to door outer panel return flange along area contacted by ventilator assembly. Adjust ventilator assembly as described under "FRONT DOOR VENTILATOR ADJUSTMENTS."

FRONT DOOR VENTILATOR ADJUSTMENTS

39, 47 and 67 STYLES

The front door ventilator assembly can be adjusted up or down and in or out at the top for alignment in the door opening and proper weatherstrip

contact in the ventilator area. The lower portion of the ventilator division channel can be adjusted in or out and fore and aft for alignment with the door window glass. The ventilator assembly can also be adjusted fore or aft for alignment with the body windshield pillar.

To adjust the ventilator assembly, proceed as follows:

1. Remove door trim assembly and detach inner panel water deflector.
2. Remove ventilator frame to outer panel attaching screw.
3. Loosen ventilator division channel adjusting stud nut and ventilator frame adjusting stud nut.
4. Loosen ventilator frame attaching bolts.
5. a. To adjust upper portion of ventilator in or out, turn ventilator frame adjusting stud and ventilator division channel adjusting stud in or out as required, then tighten stud nuts and attaching bolts and install ventilator to outer panel return flange attaching screw.

b. To adjust ventilator assembly up or down or fore or aft, position entire ventilator assembly, as required, then tighten all attaching bolts, stud nuts and ventilator to outer panel return flange attaching screw. Check door window for proper alignment, and where required, adjust window as described under "FRONT DOOR WINDOW ADJUSTMENT."

NOTE: In some cases it may be necessary to relocate ventilator to outer panel attaching screw.

6. Seal water deflector to door inner panel and install door trim and inside hardware.

FRONT DOOR VENTILATOR ASSEMBLY

11, 35, 45 and 69 STYLES

REMOVAL AND INSTALLATION

1. Remove door trim assembly and detach inner panel water deflector.
2. Remove ventilator regulator assembly.
3. Lower door window. Remove ventilator to door outer panel return flange attaching screw (Fig. 3-26).
4. Remove ventilator division channel lower adjusting stud and nut.
5. Remove ventilator upper attaching screws along window frame (Fig. 3-27).

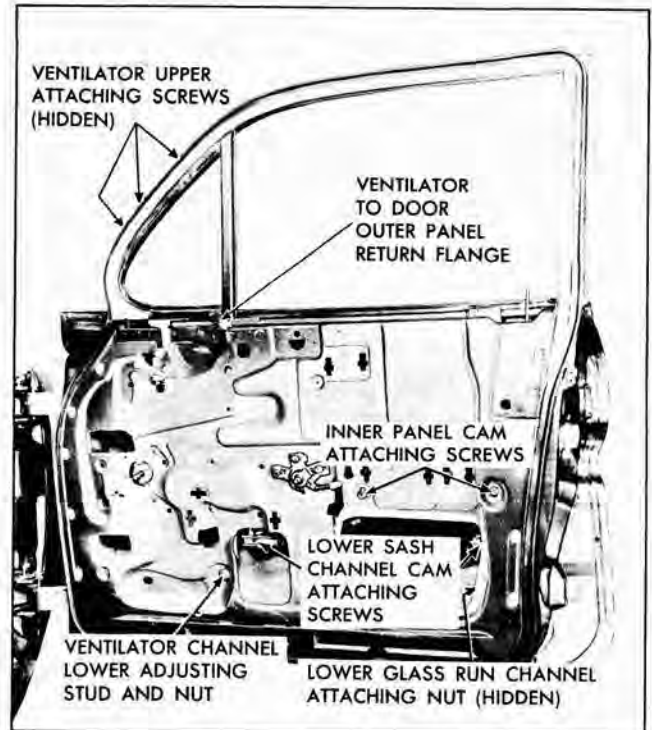

Fig. 3-27 Front Door Inner Panel

6. Lower ventilator assembly sufficiently to tilt assembly inward; then lift ventilator assembly upward and remove from door.

7. To install, reverse removal procedure.

ADJUSTMENTS

To adjust ventilator division channel in or out or fore or aft, remove door trim assembly and detach inner panel water deflector sufficiently to loosen

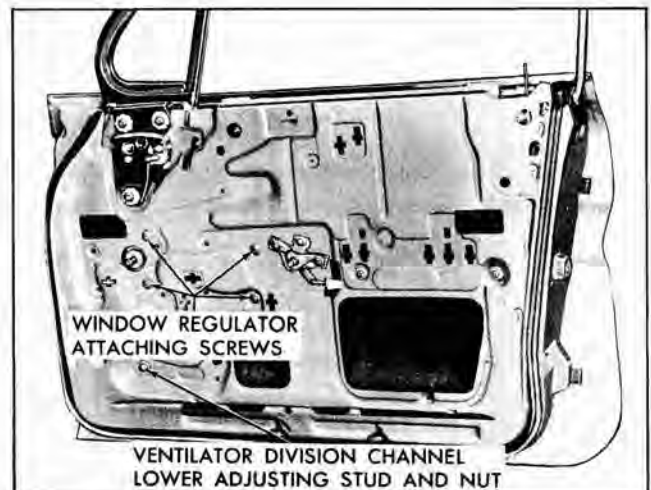

Fig. 3-28 Front Door Inner Panel - Hard Tops

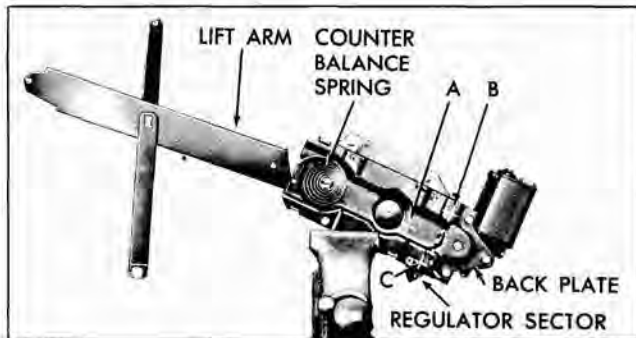

Fig. 3-29 Front Door Regulator - Electric

division channel lower adjusting stud nut. Adjust stud in or out as required or position channel fore or aft as required; then tighten stud nut.

FRONT DOOR WINDOW ASSEMBLY— MANUAL AND ELECTRIC 39, 47 and 67 STYLES

REMOVAL AND INSTALLATION

1. Raise door window. Remove door trim assembly and detach inner panel water deflector.

2. Through holes in inner panel, remove screw securing window assembly front and rear stops to lower window sash channel. Then lower window slightly and remove stops.

3. Lower door window to expose window lower sash channel cam attaching screws. Then on styles equipped with electric window regulators, disconnect wiring harness feed wires from regulator motor at connector.

NOTE: It may be necessary to loosen the ventilator frame and tilt it forward to facilitate removal of door window.

4. Remove window lower sash channel cam attaching screws and disengage cam from window sash channel. Then lift window assembly upward and remove from door.

CAUTION: Do not operate regulator motor after window assembly is disengaged from regulator. Operation of motor with load removed may damage unit.

5. To install, reverse removal procedure. Before installing window lower sash channel cam, lubricate entire length of cam with 630AAW Lubriplate or equivalent. Check window for proper operation prior to installing inner panel water deflector.

ADJUSTMENTS

The door window glass may be adjusted to provide proper contact with the side roof rail weatherstrip. Adjustments have also been provided to relieve a binding door glass due to misalignment of the glass run channels. To perform the following adjustments, remove door trim assembly and detach inner panel water deflector, where necessary, to gain access to hardware attaching points; then proceed as follows:

1. To correct a condition where glass is "cocked" in glass run channels, loosen inner panel cam attaching screws, adjust cam up or down as required and retighten screws.

2. To adjust upper front portion of window assembly in or out for proper contact with side roof rail weatherstrip, adjust ventilator assembly in or out as described under "FRONT DOOR VENTILATOR ADJUSTMENTS."

3. To adjust lower portion of ventilator division channel for alignment with window assembly, lower door window and loosen ventilator division channel adjusting stud nut. Turn adjusting stud in or out or position lower end of channel fore or aft, as required; then, retighten adjusting stud nut.

4. To adjust upper rear of window assembly in or out for proper contact with side roof rail weatherstrip, or to adjust rear of window assembly in or out at belt line, loosen rear glass run channel attaching screws at lock pillar facing of door and screw at top of door inner panel. Position channel in or out as required and tighten screws.

NOTE: Adjustments 2, 3 and 4 must be coordinated to provide a properly operating front door window.

5. To adjust limit of "up" travel of window assembly for proper contact with side roof rail weatherstrip, raise door window and through inner panel access holes loosen door window front and rear stop assembly attaching screws. Adjust stops up or down as required, then tighten attaching screws (Fig. 3-27).

FRONT DOOR WINDOW ASSEMBLY— MANUAL AND ELECTRIC 11, 35, 45 and 69 STYLES

REMOVAL AND INSTALLATION

1. Lower door window. Remove door trim assembly and detach inner panel water deflector.

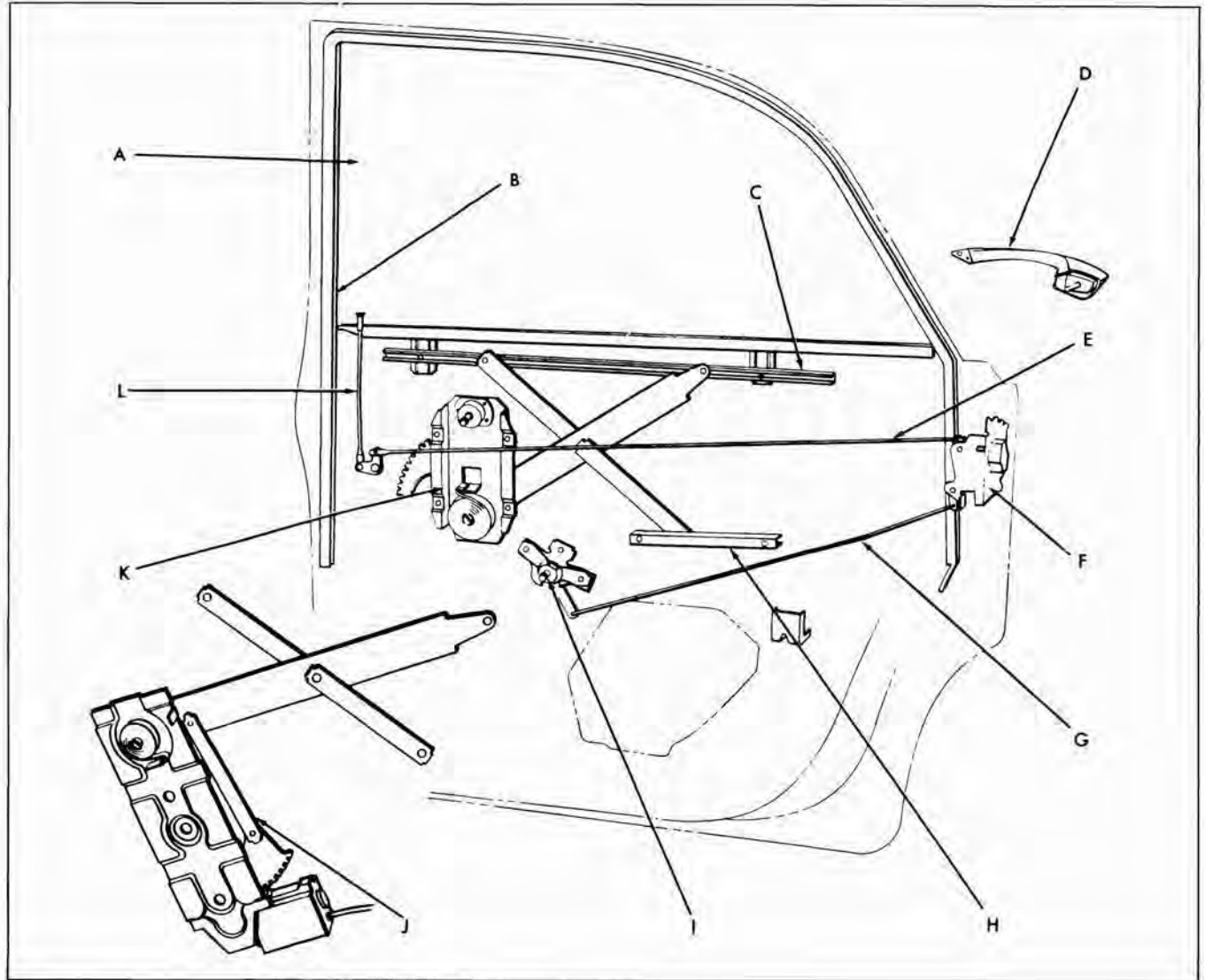

- | | | |
|----------------------------------|------------------------------------|--|
| A. Window Assembly | E. Inside Locking to Lock Rod | I. Lock Remote Control Assembly |
| B. Window Glass Run Channel | F. Lock Assembly | J. Window Electric Regulator and Motor |
| C. Window Lower Sash Channel Cam | G. Lock Remote Control to Lock Rod | K. Window Regulator |
| D. Outside Handle Assembly | H. Inner Panel Cam Assembly | L. Inside Locking Rod |

Fig. 3-30 Typical Sedan Rear Door

2. Remove door ventilator assembly as previously described under "FRONT DOOR VENTILATOR - REMOVAL AND INSTALLATION."

3. On styles equipped with electric window regulators, disconnect wiring harness feed wires from regulator motor at connector.

CAUTION: Do not operate regulator motor after window assembly is disengaged from regulator. Operation of motor with load removed may damage unit.

4. Remove screws securing window lower sash channel cam to window assembly and carefully disengage cam from window lower sash channel.

5. Rotate rear edge of window assembly upward and remove window assembly from between inner and outer panels.

6. To install, reverse removal procedure. Check window for proper operation before installing inner panel water deflector. Prior to installation, lubricate entire length of lower sash channel cam with 630AAW Lubriplate or equivalent.

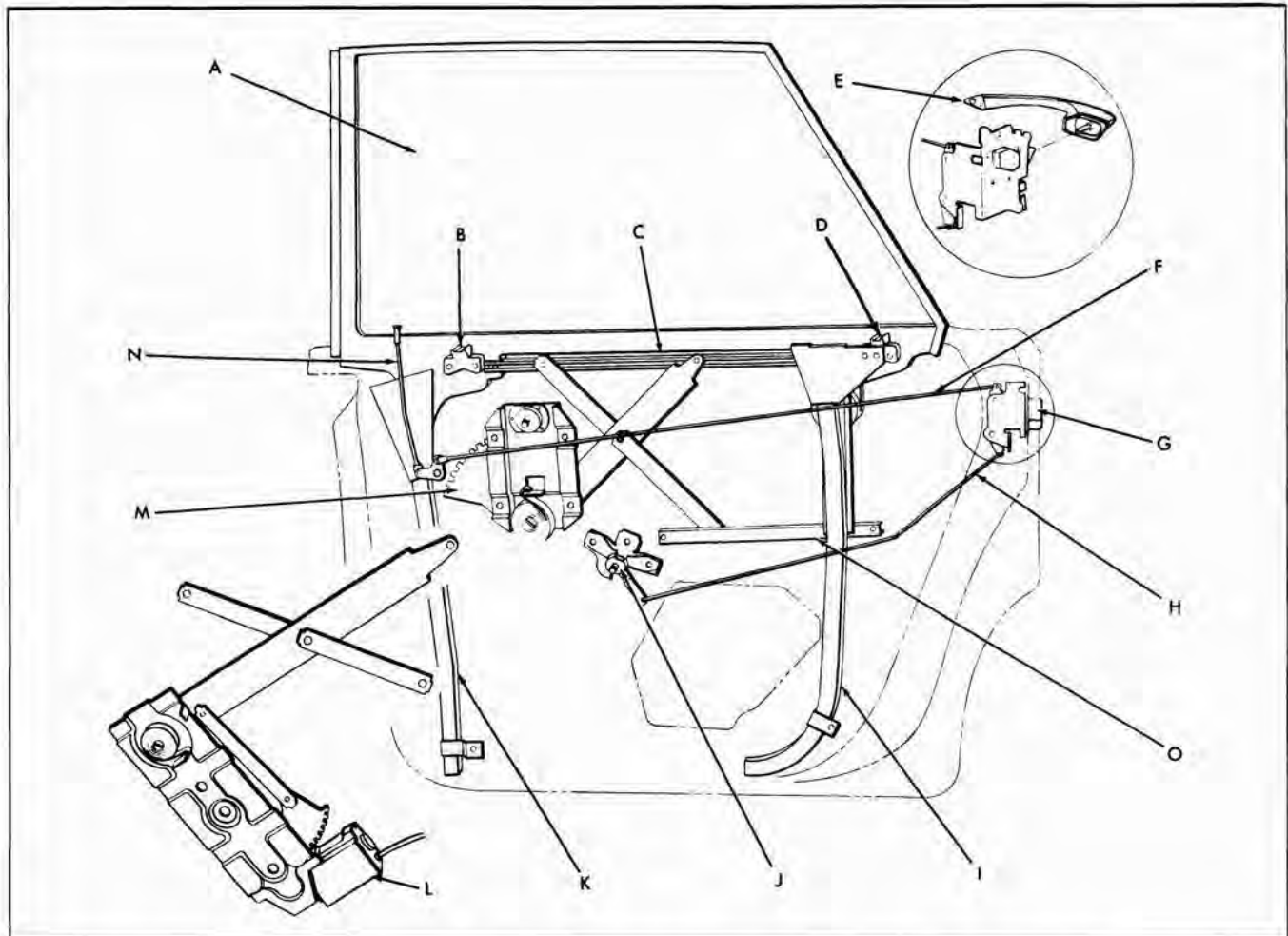

- | | | |
|------------------------------------|------------------------------------|--|
| A. Window Assembly | E. Outside Handle Assembly | K. Window Guide Front Cam |
| B. Window Front Female Wedge Plate | F. Lock to Locking Lever Rod | L. Window Electric Regulator and Motor |
| C. Window Lower Sash Channel Cam | G. Lock Assembly | M. Window Regulator—Manual |
| D. Window Rear Female Wedge Plate | H. Lock Remote Control to Lock Rod | N. Inside Locking Rod |
| | I. Window Rear Guide Cam | O. Window Inner Panel Cam |
| | J. Lock Remote Control Assembly | |

Fig. 3-31 Rear Door Assembly - 39 Style

ADJUSTMENTS

1. To correct a condition where glass is "cocked" in glass run channels, loosen inner panel attaching screws, adjust cam up or down as required and tighten screws.

2. To adjust lower portion of ventilator division channel for proper alignment with door window assembly, lower door window and loosen ventilator adjusting stud nut. Turn adjusting stud in or out or position lower end of channel fore or aft as required; then tighten adjusting stud nut.

3. To adjust lower portion of window glass run

channel in or out for proper alignment with door window, raise door window. From inside door, loosen glass run channel lower attaching nut or screw, adjust channel as required and tighten nut or screw.

FRONT DOOR WINDOW GLASS RUN CHANNEL ASSEMBLY

39, 47 and 67 STYLES

1. Remove door trim assembly and detach inner panel water deflector.

2. Remove ventilator division channel lower adjusting stud and nut (Fig. 3-28).

3. On styles equipped with manual window regulators, lower window. Remove window lower sash channel cam attaching screws and disengage sash channel cam from window lower sash channel; then raise window and prop in full up position. Disengage sash channel cam from window regulator arm rollers (Fig. 3-28).

4. On "39", "47" and "67" styles, equipped with electric window regulators, remove door ventilator assembly and door window, remove screws securing window lower sash channel cam to window sash channel and disengage cam from window sash channel and remove cam. On remaining styles prop window in up position.

5. On styles equipped with electric window regulators, disconnect wire harness feed wires from regulator motor at connector.

CAUTION: Do not operate regulator motor after window assembly is disengaged from regulator. Operation of motor with load removed may damage unit.

6. Remove window regulator attaching screws. Disengage regulator balance arm from inner panel cam and carefully remove regulator assembly from door.

NOTE: On some models only one end of inner panel cam is open sufficiently to permit removal of regulator arm roller.

7. To install, reverse removal procedure. Check window for proper operation prior to installing inner panel water deflector.

FRONT DOOR WINDOW REGULATOR ELECTRIC MOTOR ASSEMBLY

The electric motor assembly which powers the window regulator on electrically operated windows, is a twelve volt, reversible direction motor with a built-in circuit breaker and a self-locking gear drive. The motor is secured to the regulator assembly by screws.

REMOVAL AND INSTALLATION

1. Remove front door electric window regulator assembly from door as previously described and clamp it in a vise (Fig. 3-29).

NOTE: The position of regulator assembly in vise will vary with type of regulator and position of lift arm.

CAUTION: Be sure to perform steps 2 and 3 before attempting to remove motor from regulator. The regulator lift arm, which is under tension from the

counterbalance spring, can cause serious injury if motor assembly is removed without locking the sector in position with a nut and bolt.

2. Drill a 1/4" hole through back plate and sector at location indicated at either A, B, or C, depending on position of lift arm.

NOTE: Do not drill into motor housing, part of which is indicated by dotted line. In addition, locate hole a sufficient distance from edge of sector to insure proper retention of the sector.

3. Insert 3/16" bolt through hole in back plate and sector and install nut to bolt. Do not tighten nut.

4. Remove motor attaching bolts and remove motor assembly from regulator (Fig. 3-29).

NOTE: Clean off steel chips from regulator sector and motor pinion gear.

5. To install, reverse removal procedure. If difficulty is encountered when trying to line up motor attaching holes, the regulator lift arm may be moved up or down manually so that motor pinion gear will mesh with teeth on regulator sector and regulator attaching holes will line up.

NOTE: Be sure to remove temporary nut and bolt from regulator before installing it in door.

DOOR WINDOW LOWER SASH CHANNEL CAM

REMOVAL AND INSTALLATION

1. Remove door trim assembly and detach inner panel water deflector.

2. Lower door window to expose lower sash channel cam attaching screws and remove screws.

3. Disengage cam from window lower sash channel and prop window in up position.

4. Disengage cam from window regulator, lift and balance arm rollers and remove from door.

5. To install, reverse removal procedure. Prior to installation, lubricate entire length of lower sash channel cam with 630AAW Lubriplate or equivalent.

FRONT DOOR WINDOW GLASS RUN CHANNEL ASSEMBLY

11, 35, 45 and 69 STYLES

REMOVAL AND INSTALLATION

1. Lower door window. Remove door trim assembly and detach inner panel water deflector.

2. Remove front door ventilator assembly and slide window forward slightly to expose lock pillar portion of glass run channel.

NOTE: Exercise care so that exposed front edge of glass does not come in contact with body metal.

3. Through inner panel access hole loosen nut or

screw securing lower end of glass run channel.

4. Squeeze glass run channel together along upper and lock pillar sections of window frame and pull or carefully pry channel assembly from window frame. Remove channel assembly from door.

5. To install, reverse removal procedure.

REAR DOORS

Fig. 3-30 is typical of sedan and station wagon style rear doors with the trim pad and inner panel water deflector removed. This illustration identifies the component parts of the rear door assembly, their relationship and various attaching points.

Fig. 3-31 is typical of a hard top sedan "39" style rear door with the trim assembly and inner panel water deflector removed. This illustration identifies the component parts of the rear door assembly, their relationship and various attaching points.

Fig. 3-32 is typical of "69" style rear doors. This illustration indicates a fully lowered door window in proper position for maximum glass stability.

Fig. 3-33 is typical of "35" and "45" style rear

doors. This illustration indicates a fully lowered door window in proper position for maximum glass stability.

REAR DOOR HINGES

The rear door hinges are attached to the center pillar with two (2) butt-type hinges. The hinges are secured to the center pillar and door hinge pillar by screws and anchor plates. The lower hinge incorporates an integral door check and hold-open.

REMOVAL

The door and hinges can be removed as an assembly from the center pillar or the door can be removed from the hinge straps.

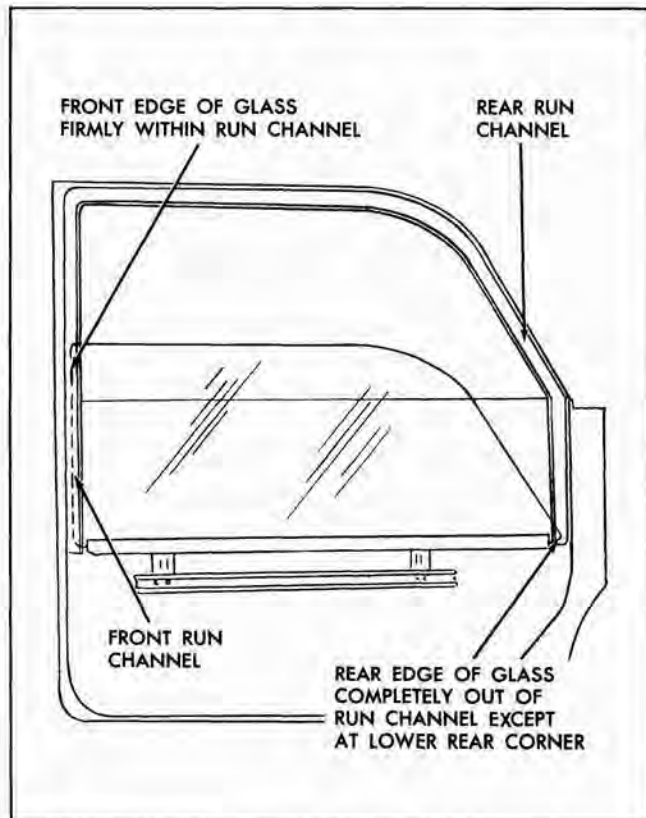

Fig. 3-32 Lowered Rear Door Glass

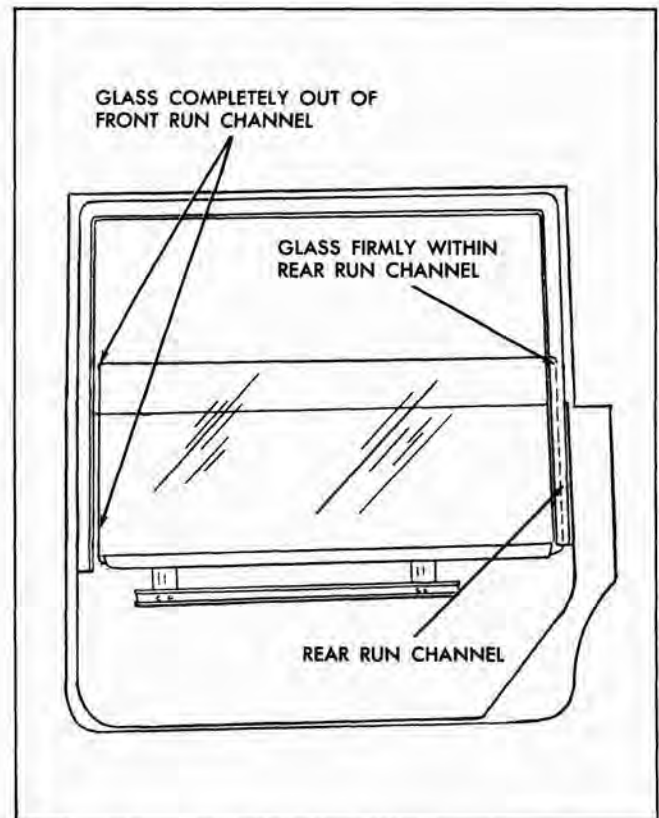

Fig. 3-33 Lowered Rear Door Glass (Sta. Wgn.)

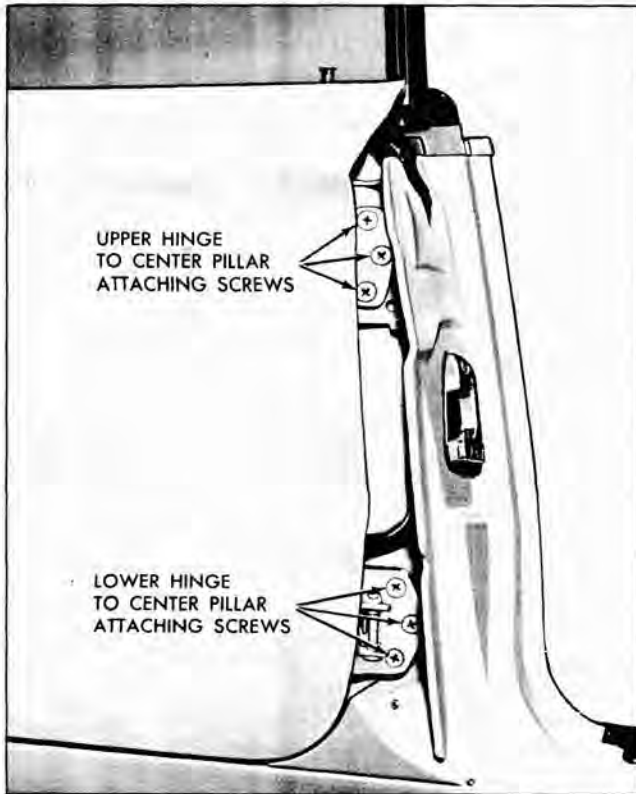

Fig. 3-34 Rear Door to Center Pillar Attachment

1. On "39" style, lower door window.
2. Clean off excess sealer around each hinge strap and mark location on door hinge pillar or center pillar, depending on method of removal being used.
3. On bodies equipped with electrically powered window regulators, proceed as follows:
 - a. Remove door trim assembly and detach inner panel water deflector sufficiently to gain access to wire connector at motor.
 - b. Detach wire harness from door inner panel and disconnect regulator motor from harness at connector.
 - c. Remove electrical conduit from door and remove wire harness from between door panels through opening in door hinge pillar.
4. With door properly supported, remove three (3) upper and three (3) lower hinge attaching screws at door hinge pillar or center pillar depending on method of removal (Fig. 3-34 and 3-35).
5. With aid of helper, remove door from body.

INSTALLATION

1. With scraper and mineral spirits, clean off old

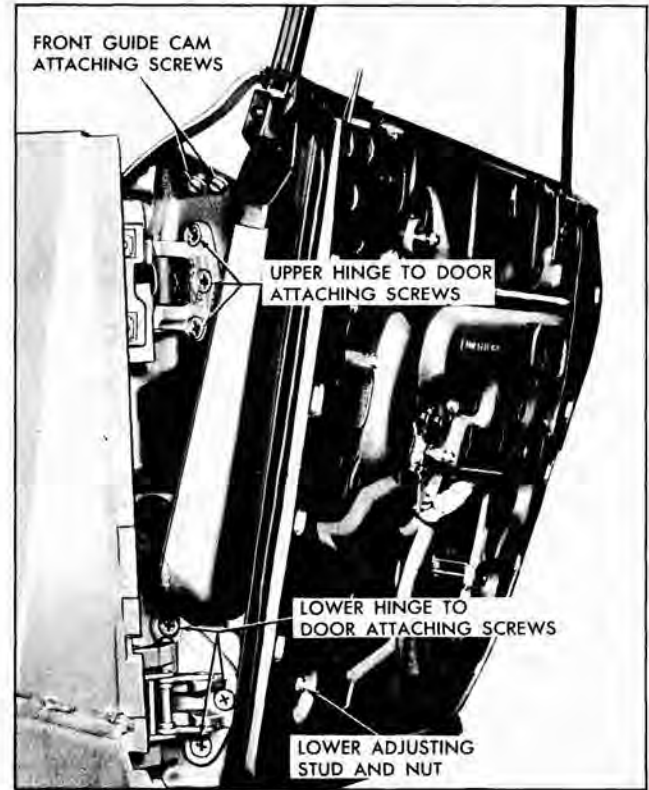

Fig. 3-35 Rear Door Hinge Attachment

sealing compound at hinge attaching areas. This operation should be performed carefully to avoid possibility of soiling adjacent trim material.

2. Apply a coat of heavy-bodied sealer to attaching surfaces of hinge straps or corresponding surfaces of door or body (Fig. 3-36).
3. With helper, lift door into position. Install screws loosely, align strap within scribe marks on pillar and tighten bolts. Check door for proper alignment.
4. On doors equipped with power operated windows, proceed as follows:

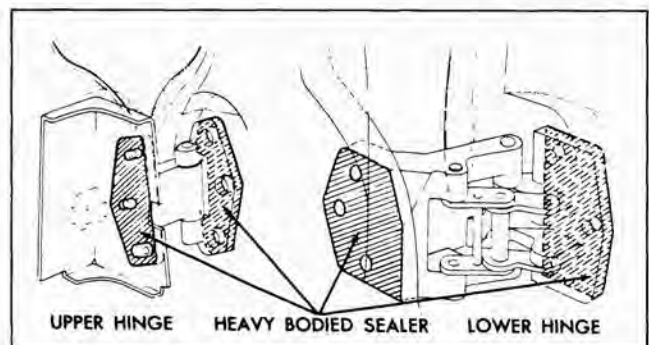

Fig. 3-36 Rear Door Hinge Sealer

- a. Install wiring harness inside of door. Connect regulator motor and install wiring harness to inner panel.
 - b. Install conduit to door hinge pillar. Check operation of electric window assembly.
5. Where required, seal door inner panel water deflector as specified in "DOOR INNER PANEL WATER DEFLECTOR" and reinstall all previously removed parts.
6. For lubrication information see "LUBRICATION" section.

ADJUSTMENTS

In and out or up and down adjustments are provided at door hinge pillar. Fore and aft and a slight up and down adjustment are provided at center pillar. When checking the door for alignment, remove door lock striker from body pillar to allow door to hang free on its hinges.

NOTE: After performing any adjustments, the rear door window on 39 models should be checked for proper alignment with side roof rail weatherstrip. In addition, door lock extension-to-striker engagement should be checked and adjusted if necessary.

1. For in and out or up and down adjustment, loosen hinge to door pillar attaching screws (Fig. 3-35). Adjust door as required and tighten screws.

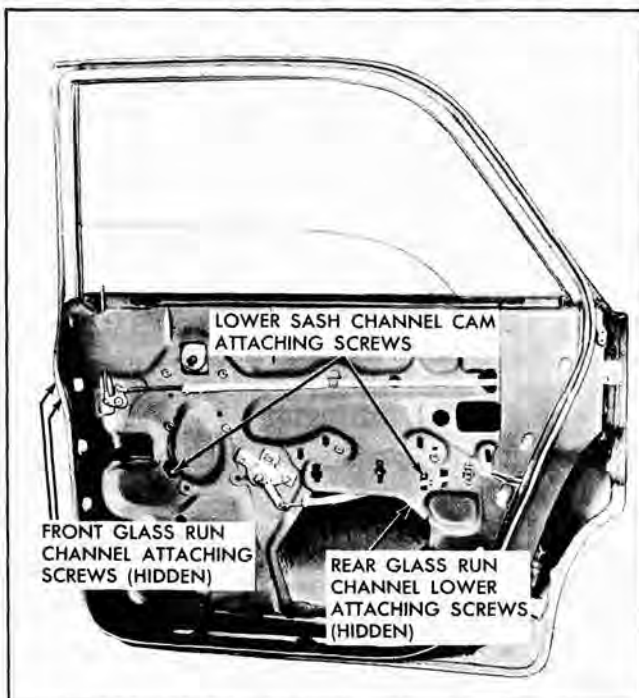

Fig. 3-37 Rear Door - "69" Style

NOTE: When performing in and out or fore and aft adjustments, adjust one hinge at a time so that "up and down" adjustment is maintained.

2. To adjust door fore or aft, loosen hinge to center pillar attaching screws (Fig. 3-34). Adjust door fore or aft as required and tighten screws and bolts.

CAUTION: The rear door upper hinge on "35", "45", and "69" styles is constructed of die cast aluminum which will break under strain of bending in an attempt to short cut adjustments. Use only the recommended procedures for adjusting rear doors.

REAR DOOR LOCK ASSEMBLY

REMOVAL AND INSTALLATION

1. Raise door window. Remove door trim assembly and detach inner panel water deflector.
2. On "35", "45" and "69" styles, through large access hole, remove screw securing lower end of glass run channel at door lock pillar and raise end of channel to expose lock assembly (Fig. 3-37).
3. Through access hole, disengage spring clips

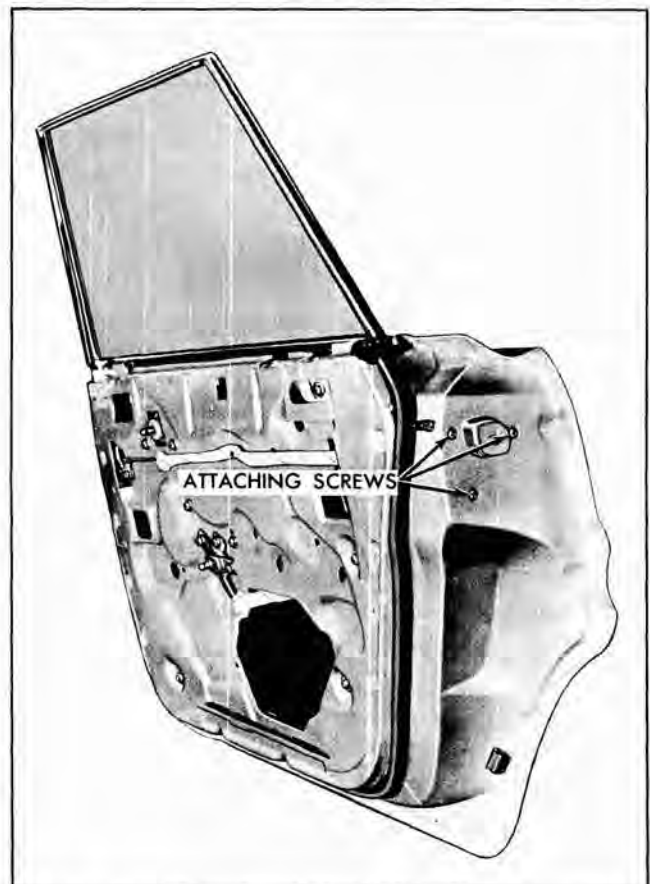

Fig. 3-38 Door Lock Attaching Screws

and detach inside lock connecting rod and remote control connecting rod from lock assembly (see "DOOR LOCK SPRING CLIPS").

4. At lock pillar facing, remove door lock attaching screws and remove lock assembly through access hole (Fig. 3-38).

5. To install door lock, reverse removal procedure. Check all operations of door lock before installing door trim and inside hardware.

REAR DOOR LOCK STRIKERS

REMOVAL AND INSTALLATION

1. With a pencil, mark position of striker on body pillar.

2. Remove three (3) door lock striker attaching screws and remove striker and adjusting plates from pillar.

3. To install, seal all striker plate attaching screw clearance holes with body caulking compound.

4. Apply a 1/8" bead of body caulking compound around entire back surface of striker plate; skips must not exist in caulking compound. Place striker and adjusting plates within marks on pillar and install striker plate attaching screws.

NOTE: Whenever a door has been removed and installed or realigned, the door SHOULD NOT be closed completely until a visual check is made to determine if lock extension will engage in striker notch. Where required, door lock striker service spacers should be installed so that door can be closed and an accurate check made to determine proper spacer requirements.

5. Clean off all excessive body caulking compounds.

ADJUSTMENTS

To adjust striker up or down or in or out, loosen striker plate attaching screws and shift striker and adjusting plates as required and tighten screws.

DIMENSIONAL SPECIFICATIONS FOR USE OF DOOR LOCK STRIKER SERVICE SPACERS

1. Door should be properly aligned before checking door spacer requirements.

2. To determine if door lock striker emergency spacers are required, apply modeling clay or body caulking compound in door lock striker notch where lock extension engages and close door to form a measurable impression in clay or caulking compound (Fig. 3-20).

When dimension "A" from rear face of striker teeth to rear edge of depression in clay is less than 11/32", install emergency spacers and proper length striker attaching screws as indicated.

NOTE: Dimension "B" in the illustration should never be less than 1/8".

Striker attaching screws should be zinc or cadmium-plated flat-head cross recess screw with countersunk washer.

Dimension "A"	No. of Spacers Required	Spacer Thickness	Striker Attaching Screws
11/32" to 9/32"	1	1/16"	Original
9/32" to 7/32"	1	1/8"	Emergency (1/8" longer)
7/32" to 5/32"	1 - (1/16" Spacer) 1 - (1/8" Spacer)	3/16"	Emergency (1/8" longer)
5/32" to 3/32"	2 - (1/8" Spacer)	1/4"	Emergency (1/4" longer)

REAR DOOR INNER PANEL CAM

REMOVAL AND INSTALLATION

1. Raise door window. Remove door trim assembly and detach inner panel water deflector suffi-

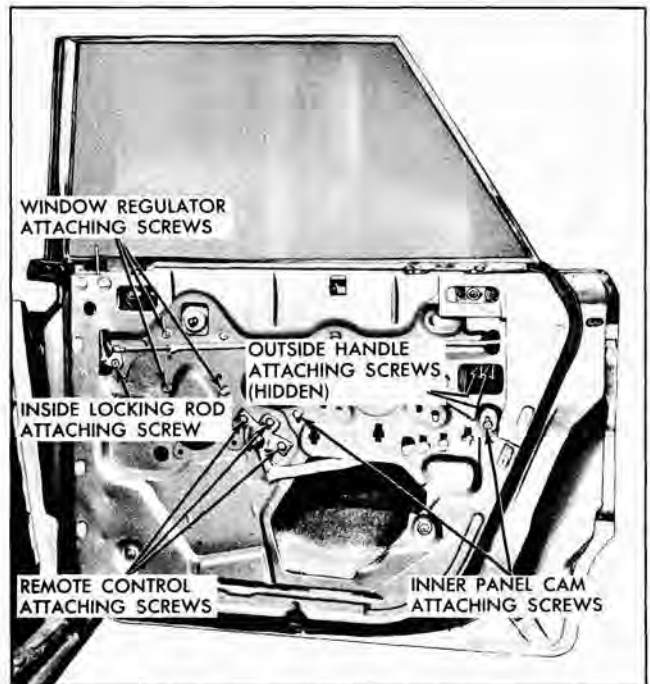

Fig. 3-39 Rear Door - "39" Style

ciently to expose inner panel cam attaching screws (Fig. 3-39).

2. Remove cam attaching screws and disengage cam from window regulator arm roller and remove from door.

3. To install, reverse removal procedure. Prior to installation of inner panel cam, lubricate entire length of cam with 630AAW Lubriplate or equivalent.

ADJUSTMENTS

1. To correct a condition where the window glass is cocked in glass run channels, loosen door inner panel cam attaching screws, adjust cam as required, and tighten screws (Fig. 3-39).

REAR DOOR LOCK TO LOCKING LEVER ROD

REMOVAL AND INSTALLATION

1. Raise door window. Remove door trim assembly and detach inner panel water deflector sufficiently to expose lock rod assembly and gain access to rear door lock assembly.

2. Remove inside locking rod knob from rod.

3. On "35", "45" and "69" styles, through large access hole, remove screw securing lower end of glass run channel at door lock pillar to gain access to spring clip securing rod to lock (Fig. 3-37).

4. Through access hole, disengage spring clip securing inside locking rod assembly to door lock and disengage rod from lock (see "DOOR LOCK SPRING CLIPS").

5. Disengage rod from spring clip on door inner panel. Remove inside locking rod assembly attaching screw, spring washer and washer cup and remove assembly from door (Fig. 3-39).

6. To install, reverse removal procedure. Check operation of inside locking rod assembly prior to installing water deflector.

REAR DOOR LOCK REMOTE CONTROL AND CONNECTING LINK ASSEMBLY

REMOVAL AND INSTALLATION

1. Raise door window. Remove door trim assembly and detach inner panel water deflector sufficiently to gain access to remote control attaching screws and door lock assembly.

2. Remove remote control attaching screws and remove remote control from connecting rod (Fig. 3-39).

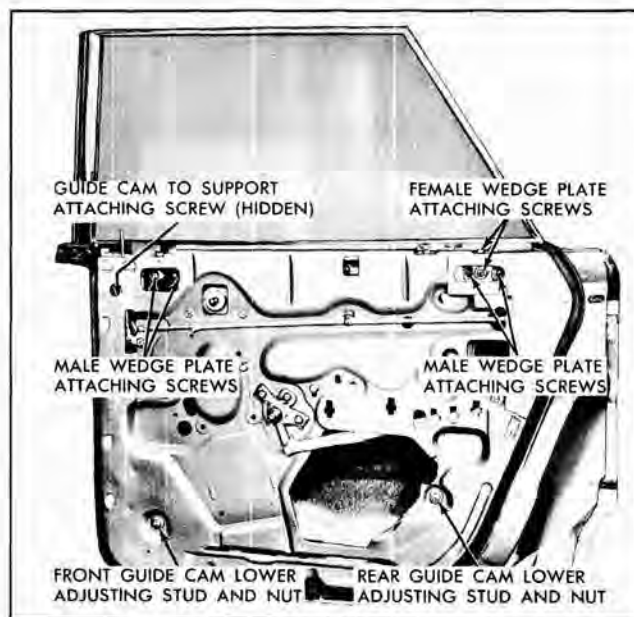

Fig. 3-40 Rear Door - "39" Style

3. On "35", "45" and "69" styles, through large access hole, remove glass run channel lower attaching screw at lock pillar to gain access to spring clip securing rod to lock (Fig. 3-37).

4. Through access hole, disengage remote control connecting rod spring clip and disengage rod from lock. Remove rod from door.

5. To install remote control and connecting rod, reverse removal procedure. Position remote control rearward sufficiently to take up slack in linkage so that all clearances are taken out of linkage in a rearward position. Check all operations of door lock before installing door inner panel water deflector.

REAR DOOR WINDOW REGULATOR ASSEMBLY MANUAL AND ELECTRIC

REMOVAL AND INSTALLATION

1. Lower door window. Remove door trim assembly and detach inner panel water deflector.

2. Remove door window lower sash channel cam. Then carefully raise window and prop in up position.

3. On styles equipped with electric window regulators, disconnect wiring harness feed wires from regulator motor at connector. On "39" style, loosen rear guide cam upper attaching screws and remove lower adjusting stud and nut to permit removal of electric window regulator.

CAUTION: Do not operate regulator motor after window assembly is disengaged from regulator. Operation of motor with load removed may damage unit.

4. Remove regulator attaching screws, disengage balance arm from inner panel cam and remove regulator assembly through access hole (Fig. 3-40).

5. To install, reverse removal procedure. Check operation of window before installing inner panel water deflector.

NOTE: To remove electric motor from regulator assembly, see WINDOW REGULATOR ELECTRIC MOTOR ASSEMBLY.

REAR DOOR WINDOW REGULATOR ELECTRIC MOTOR ASSEMBLY

The electric motor assembly which powers the window regulator on electrically-operated windows is a 12-volt reversible motor with a built-in type circuit breaker and a self-locking gear drive. The motor is attached to the regulator assembly with bolts.

REMOVAL AND INSTALLATION

1. Remove electric window regulator assembly from door and/or rear quarter and clamp securely in vise (Fig. 3-41).

NOTE: The position of the regulator clamped in the vise will vary with type of regulator and position of lift arm.

CAUTION: Be sure to perform steps 2 and 3 before attempting to remove motor from regulator. The regulator lift arm, which is under tension from the counterbalance spring, can cause serious injury if the motor is removed without locking the sector in position.

2. Drill a 1/4" hole through sector and back plate within area indicated by "A" (Fig. 3-41).

NOTE: Locate hole a sufficient distance from edge of sector to insure proper retention of the sector.

3. Insert a 3/16" bolt through hole in back plate and sector and install nut to bolt (do not tighten nut).

4. Remove motor attaching bolts and remove motor assembly from regulator (Fig. 3-41).

NOTE: Clean off steel chips from regulator sector and motor pinion gear after drilling operation.

5. To install, reverse removal procedure. If difficulty is encountered when trying to line up motor assembly attaching holes, the regulator lift arm may be moved up or down manually so that motor pinion gear will mesh with teeth on regulator sector, and regulator attaching holes will line up.

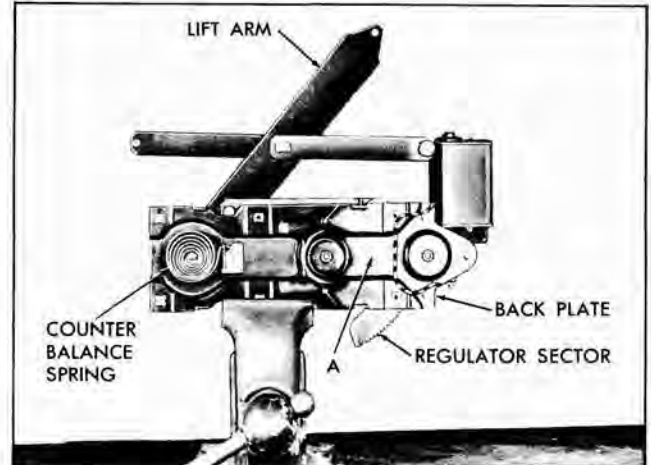

Fig. 3-41 Rear Door Window Regulator

NOTE: Be sure to remove temporary nut and bolt from regulator before installing it into door or rear quarter.

REAR DOOR WINDOW GLASS RUN CHANNEL ASSEMBLIES 69 STYLE

REMOVAL AND INSTALLATION

1. Remove door trim assembly and detach inner panel water deflector. Disengage lower sash channel cam from window sash channel (Fig. 3-42).

2. Remove door window assembly.

3. Remove front and rear attaching screws from hinge and lock pillar facing of door inner panel.

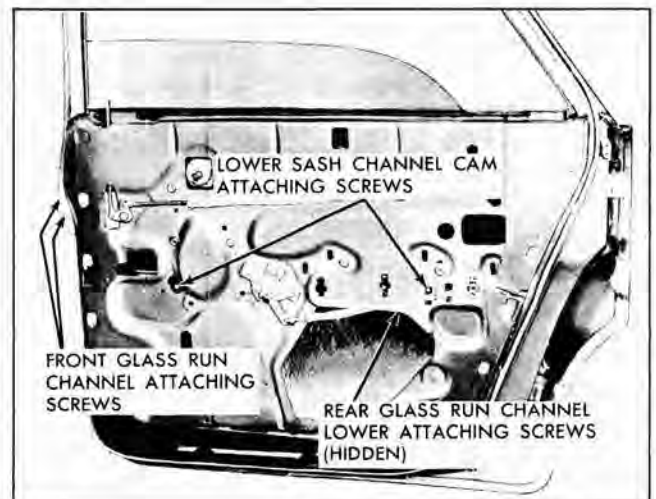

Fig. 3-42 Rear Door - "69" Style

4. Carefully disengage glass run channel attaching clips, beginning along front of door window frame. Pull glass run channel inboard and upward and remove channel from between inner and outer panels.

5. To install, reverse removal procedure. Check operation of rear door window and, where required, adjust glass run channel for proper operation of window assembly.

REAR DOOR WINDOW GLASS RUN CHANNEL ASSEMBLIES

35 and 45 STYLES

REAR GLASS RUN CHANNEL— REMOVAL AND INSTALLATION

1. Raise door window. Remove door trim assembly and detach inner panel water deflector.
2. From inside door, remove screw securing lower end of glass run channel at door lock pillar facing.
3. Remove screws securing door belt trim support rear finishing plate and remove plate.
4. Remove screws securing rear door window glass run channel rear retainer from rear of window frame assembly and remove retainer.
5. Lower door window. Disengage run channel attaching clips along lock pillar portion of window frame. Then carefully raise rear run channel and remove from door.
6. To install, reverse removal procedure. Check operation of rear door window and adjust rear glass run channel as required before installing water deflector.

FRONT GLASS RUN CHANNEL— REMOVAL AND INSTALLATION

1. Remove rear door window rear glass run channel and remove rear door window assembly.
2. Remove glass run channel lower attaching screws from hinge pillar facing of door.
3. Carefully disengage glass run channel attaching clips along top and hinge pillar portion of window frame. Then pull glass run channel inboard and upward and remove from door.
4. To install, reverse removal procedure. Check operation of rear door window and adjust channel as required.

ADJUSTMENTS (35, 45 and 69 STYLES)

1. To adjust either glass run channel in or out or

up or down, loosen channel attaching screw(s), adjust channel as required and tighten screws. After any adjustments, check window for proper operation.

NOTE: Adjustment of both channels must be coordinated to provide proper operation of the rear door window assembly.

REAR DOOR WINDOW LOWER SASH CHANNEL CAM

REMOVAL AND INSTALLATION

1. Remove door trim assembly and detach inner panel water deflector.
2. Lower door window sufficiently to gain access to lower sash channel cam attaching screws through access holes in door inner panel and remove screws (Fig. 3-42).
3. While supporting window by hand, carefully disengage cam from window lower sash channel and rollers on window regulator arms and remove from door. Carefully lower door window.
4. To install, reverse removal procedure. Prior to installation, lubricate entire length of sash channel cam with 630AAW Lubriplate or equivalent. Check operation of window assembly prior to installing inner panel water deflector.

REAR DOOR WINDOW ASSEMBLY

35, 45 and 69 STYLES

REMOVAL AND INSTALLATION

1. Lower door window. Remove door trim assembly and detach inner panel water deflector.
2. Remove lower sash channel cam attaching screws and disengage cam from sash channel.

NOTE: On styles equipped with electric window regulators, disconnect wiring harness electrical feed plug from regulator motor at connector.

CAUTION: Do not operate regulator motor after window assembly is disengaged from regulator. Operation of motor with load removed may damage unit.

3. Rotate rear edge of window assembly downward to remove assembly from door on "69" style.
4. To install, reverse removal procedure. Prior to installation of window lower sash channel cam, lubricate entire length of cam with 630AAW Lubriplate or equivalent. Check operation of window assembly and, where required, adjust window as described under "REAR DOOR WINDOW GLASS RUN CHANNEL ASSEMBLIES AND REAR DOOR INNER PANEL CAM".

REAR DOOR WINDOW GUIDE FRONT CAM ASSEMBLY

39 STYLE

The window guide front cam assembly incorporates an attaching support bracket at the upper edge of the guide cam which is attached to the door hinge pillar facing by two (2) screws. The front cam can be removed without removing this attaching bracket.

REMOVAL AND INSTALLATION

1. Raise door window. Remove door trim assembly and detach inner panel water deflector.
2. Through inner panel access hole remove front guide cam upper attaching screw(s) and front guide cam lower adjusting stud and nut (Fig. 3-40).
3. Carefully disengage guide cam from window lower sash channel roller and remove guide cam through access hole.
4. To install, reverse removal procedure. Prior to installation, lubricate entire length of guide cam with 630AAW Lubriplate or equivalent. Reseal front guide cam lower adjusting stud and nut with body caulking compound.
5. Check operation of window assembly and, where required, adjust window as described under "REAR DOOR WINDOW ADJUSTMENTS".

REAR DOOR WINDOW GUIDE FRONT CAM SUPPORT

39 STYLE

REMOVAL AND INSTALLATION

1. Remove door trim assembly and detach inner panel water deflector.
2. Raise door window. Through inner panel access hole remove front guide cam upper attaching screw (Fig. 3-40).
3. At door hinge pillar facing, remove two (2) screws securing guide cam support and remove support through access hole (Fig. 3-43).
4. To install, reverse removal procedure. Check operation of window assembly and, where required, adjust window as described under "REAR DOOR WINDOW ADJUSTMENTS".

REAR DOOR WINDOW GUIDE REAR CAM ASSEMBLY

39 STYLE

REMOVAL AND INSTALLATION

1. Raise door window. Remove door trim assembly and detach inner panel water deflector.



Fig. 3-43 Guide Cam Attaching Screws

ably and detach inner panel water deflector.

2. Remove rear cam upper attaching screws and lower adjusting stud and nut (Fig. 3-40).
3. Carefully disengage cam from roller on window guide assembly and remove rear cam through large access hole.
4. To install, reverse removal procedure. Prior to installation lubricate entire length of cam with 630AAW Lubriplate or equivalent. If exposed, seal cam lower adjusting stud and nut with body caulking compound.
5. Check operation of window assembly and, where required, adjust window as described under "REAR DOOR WINDOW ADJUSTMENTS".

REAR DOOR WINDOW ASSEMBLY— MANUAL AND ELECTRIC

39 STYLE

REMOVAL AND INSTALLATION

1. Raise door window. Remove door trim assembly and detach inner panel water deflector.
2. Through access holes in door inner panel remove screws securing rear door window front and

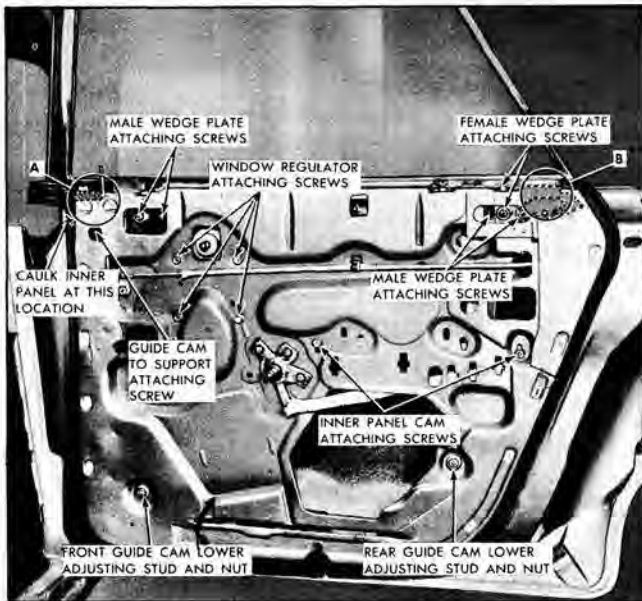

Fig. 3-44 Rear Door - "39" Style

rear male wedge plates to window lower sash channel and remove wedge plates (Fig. 3-44).

3. Lower door window and remove lower sash channel cam attaching screws (Fig. 3-44).

NOTE: On styles equipped with electric window regulators, disconnect wiring harness electrical feed plug from regulator motor at connector.

CAUTION: Do not operate regulator motor after window assembly is disengaged from regulator. Operation of motor with load removed may damage unit.

4. Carefully raise door window and remove from door.

5. To install, reverse removal procedure. Check window for proper alignment and, where necessary, align window as described under "REAR DOOR WINDOW ADJUSTMENTS". Prior to installation of window lower sash channel cam, lubricate entire length of cam with 630AAW Lubriplate or equivalent. Also lubricate lower sash channel cam rollers and pivot area of rear door window rear guide.

ADJUSTMENTS

CAUTION: The rear door assembly should be properly aligned in the body opening before adjusting the rear door window.

Adjustments have been provided to insure proper contact of the rear door window with the side roof rail weatherstrip and with the door glass run outer strip assembly; also, for proper contact of the rear door window front frame weatherstrip with the front

door window frame. Unless otherwise specified, the following window adjustments are for both manually and electrically-operated windows.

NOTE: To perform the following rear door window adjustments, remove door trim assembly and detach inner panel water deflector.

1. Up and down adjustment of door window assembly.

a. Through inner panel access holes, loosen screws securing front and rear male wedge plates to window lower sash channel.

b. Reposition window assembly as required, adjust front and rear male wedge plates up or down as required; then tighten wedge plate attaching screws. Check operation of window assembly.

CAUTION: The front or rear of window assembly may be adjusted up or down by adjusting either front or rear male wedge plate up or down as required. In cases of major adjustment, however, both wedge plates should be adjusted.

2. Fore or aft adjustment of rear door window assembly.

a. Loosen lower adjusting stud nut on both front and rear guide cams (Fig. 3-44).

b. Loosen screw(s) securing upper end of front and rear guide cams, position window fore or aft as required, then tighten screw(s) and lower stud nut on each cam.

c. Check window for proper operation and, if necessary, readjust rear door window front and/or rear male wedge plates fore or aft to insure proper contact with female wedge plates on door inner panel.

NOTE: On styles where lower adjusting stud and nut are not covered by water deflector, seal stud and nut with body caulking compound.

3. The in and out adjustment of the rear door window assembly can be obtained by adjusting the front and rear guide cams in or out as required. It is desirable, however, to adjust only one (1) guide cam at a time in order to maintain the fore and aft adjustment of the window assembly.

a. To adjust front of window assembly in or out proceed as follows:

(1) With window in full up position, loosen front guide cam adjusting stud nut (Fig. 3-40).

(2) Loosen front female wedge plate attaching screw (Fig. 3-40).

(3) Loosen two (2) front guide cam support attaching screws on door hinge pillar facing (Fig. 3-43).

(4) Position front of window assembly in or out as required and adjust front female wedge plate accordingly; then tighten wedge plate attaching screw.

(5) Adjust front guide cam lower adjusting stud in or out as required and tighten nut. Tighten front guide cam support attaching screws on door hinge pillar facing.

(6) Reseal lower adjusting stud and nut with body caulking compound.

(7) Position window assembly in or out as required; then tighten screws.

(8) Adjust lower adjusting stud in or out as required and tighten stud nut. Check window for proper operation.

NOTE: On styles where lower adjusting stud and nut are not covered by water deflector, seal stud and nut with body caulking compound.

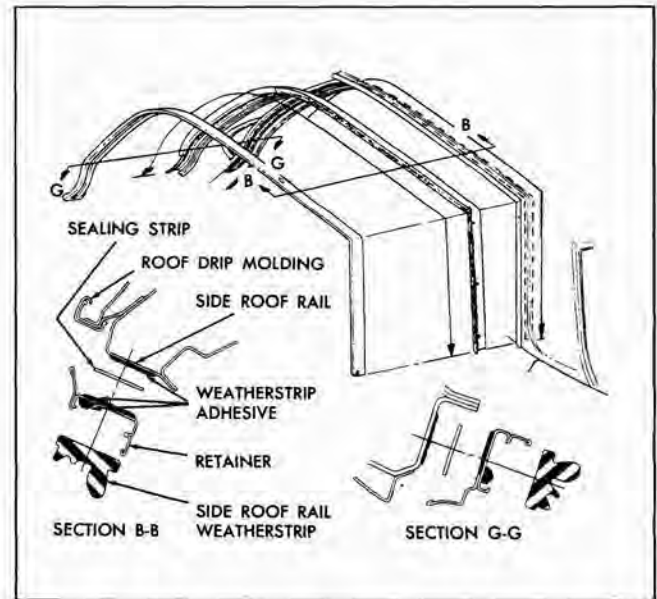

Fig. 3-45 Side Roof Rail Weatherstrip

SIDE ROOF RAIL WEATHERSTRIP

DESCRIPTION

The side roof rail weatherstrip assembly is a one-piece type which is secured to the front body hinge pillar with a snap fastener. The remainder of the weatherstrip is secured to the side roof rail by weatherstrip adhesive and a weatherstrip retainer and reveal molding assembly.

REMOVAL

1. Remove snap fastener securing weatherstrip at front body hinge pillar.

2. Carefully disengage inner lip of side roof rail weatherstrip from retainer. Using a flat-bladed tool, carefully break cement bond between weatherstrip and weatherstrip retainer and reveal molding assembly.

3. Remove side roof rail weatherstrip from body.

INSTALLATION

1. Clean off old cement from side roof rail weatherstrip and weatherstrip retainer to insure a clean cementing surface.

2. Apply a continuous bead (approximately 3/16" diameter) of weatherstrip adhesive along entire outboard surface of side roof rail weatherstrip retainer (section "B-B" in Fig. 3-45).

3. On "39" style, slide rear end of weatherstrip upward until weatherstrip retaining clip is engaged behind weatherstrip retainer.

4. With a flat-bladed tool, engage inboard edge of weatherstrip and then outboard edge of weatherstrip into weatherstrip retainer.

5. Install snap fastener at front body hinge pillar and clean off all excessive weatherstrip cement.

SIDE ROOF RAIL WEATHERSTRIP ADJUSTMENTS

39 and 43 STYLES

With doors and windows closed, front and/or rear door window upper frames should make an even continuous contact with the side roof rail weatherstrip. If necessary, adjust weatherstrip and/or ventilator or front or rear door windows to obtain proper weatherstrip contact.

The attaching holes in the side roof rail weatherstrip retainer are elongated allowing "in and out" adjustment of the side roof rail weatherstrip; however, the amount of adjustment is small and is not intended to correct improper ventilator or door window alignment. It is necessary to remove the weatherstrip to adjust the retainer.

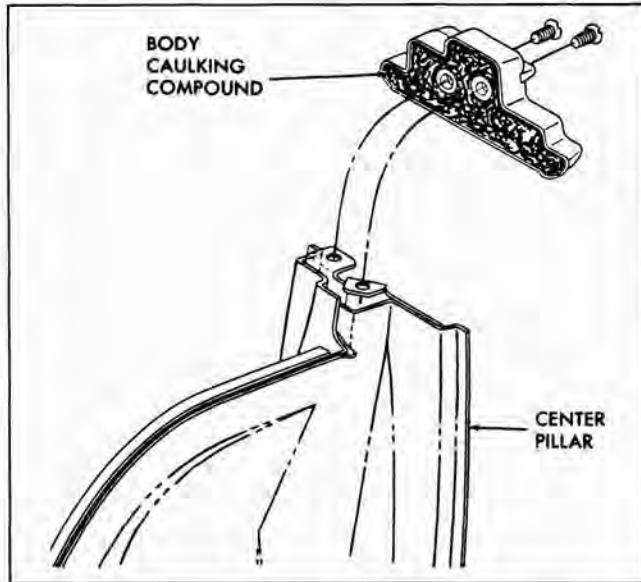

Fig. 3-46 Center Pillar Finishing Cap

CAUTION: Before attempting to adjust the side roof rail weatherstrip, first check that the ventilator and front and rear door windows are properly aligned and, where necessary, adjust for proper alignment as directed under adjustment of the ventilator and/or front or rear door window.

1. To adjust side roof rail weatherstrip "in or out" first determine and mark retainer at area or areas to be adjusted.
2. Remove side roof rail weatherstrip.

3. Loosen retainer attaching screws slightly in area to be adjusted and adjust retainer in or out as required.
4. Tighten retainer attaching screws and install side roof rail weatherstrip.

CENTER PILLAR FINISHING CAP

39 STYLE

REMOVAL AND INSTALLATION

1. Remove two (2) screws from top of cap and remove cap from center pillar.
2. To install, apply a bead of body caulking compound to underside of cap; then, position cap on center pillar and install attaching screws (Fig. 3-46).

CENTER PILLAR TRIM

39 STYLE

REMOVAL AND INSTALLATION

1. Remove center pillar finishing cap.
2. Carefully slide center pillar trim upward to disengage trim from pinchweld flanges and remove from body.
3. To install, reverse removal procedure.

REAR QUARTER

CONTENTS OF THIS SECTION

SUBJECT	PAGE	SUBJECT	PAGE
Two Door Sedans		Trim Assembly	4-7
Trim Assembly	4-1	Window Assembly	4-7
Glass Run Channel	4-2	Window Adjustments	4-8
Quarter Window	4-2	Window Regulator	4-8
Window Adjustment	4-3	Electric Motor	4-9
Channel Sealing Strip	4-3	Window Guide	4-9
Guide Assembly	4-3	Channel Sealing Strip	4-9
Regulator Assembly	4-4	Inner Panel Sealing	4-9
Two Door Coupes		Four Door Sedans	
Arm Rest	4-4	Trim Assembly	4-11
Trim Assembly	4-5	Station Wagons	
Window Assembly	4-5	Front Trim Panel	4-11
Window Adjustments	4-6	Rear Trim Panel	4-11
Regulator Assembly	4-6	Wheel House Cover	4-12
Electric Motor	4-6	Spare Tire Cover	4-12
Guide Assembly	4-6	Quarter Window Molding	4-12
Channel Sealing Strip	4-7	Window Assembly	4-12
Convertibles			
Top Compartment	4-7		

TRIM AND HARDWARE

The rear quarter section is divided according to body styles in the following sequence:

- Two Door Sedans ("11" Style)
- Two Door Coupes ("47" Style)
- Convertibles ("67" Style)
- Four Door Sedans ("39" and "69" Styles)
- Station Wagons ("35" and "45" Styles)

The service procedures for each style are arranged in the sequence that they normally would be performed, such as: removal, installation, adjustment and sealing.

Figures 4-1, 4-2 and 4-3 identify and show the relationship of major components of the rear quarter hardware of "11", "47" and "67" style bodies, which are the only styles incorporating a dropping rear quarter window. All rear quarter windows are made of solid tempered safety plate glass.

TRIM ASSEMBLY

11 STYLE

REMOVAL AND INSTALLATION

1. Remove rear seat cushion and seat back assemblies.

2. Remove rear quarter garnish molding and rear quarter arm rest assembly. On styles with manually operated windows, remove window regulator handle.

3. Using a trim panel removing tool J-6335, carefully pry rear quarter trim assembly retaining nails from tacking strip; then lift trim assembly upwards to disengage from retainers at top of rear quarter inner panel and remove assembly from quarter panel.

NOTE: On styles with electrically-operated windows disengage trim assembly from retainers at top of inner panel; then disconnect window switch junction block from switch and remove trim assembly.

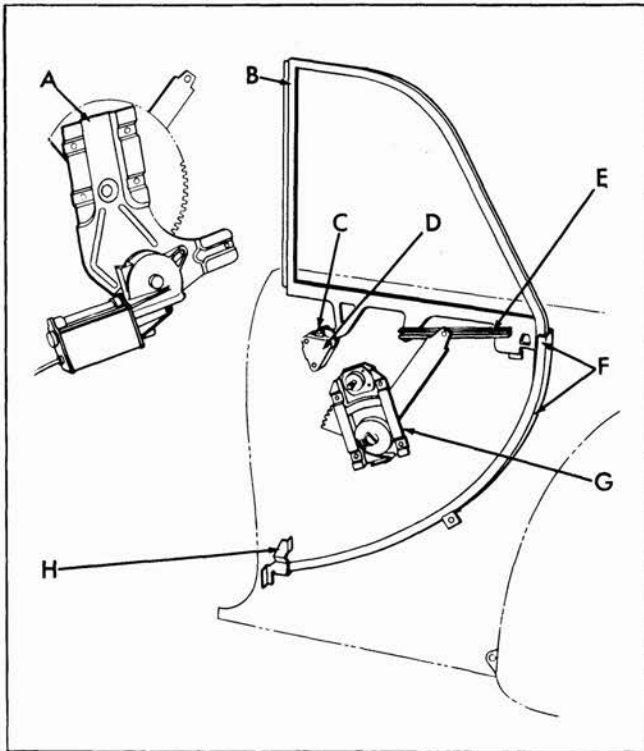

- A. Window Electric Motor and Regulator
- B. Window Assembly
- C. Window Hinge Bolt
- D. Window Hinge Adjusting Plate
- E. Window Lower Sash Channel Cam
- F. Window Guide - Includes Window Upper Stop
- G. Window Regulator - Manual
- H. Window Lower Stop

Fig. 4-1 Rear Quarter - "67" Style

4. To install rear quarter trim assembly, reverse removal procedure.

WINDOW GLASS RUN CHANNEL

11 STYLE

REMOVAL AND INSTALLATION

1. Lower rear quarter window. Remove rear quarter window garnish molding, rear quarter trim assembly.

2. Remove rear quarter window glass run channel attaching screw (Fig. 4-4). Carefully remove glass run channel from retainers in rear quarter pillar and side roof rail.

3. To install glass run channel, reverse removal procedure.

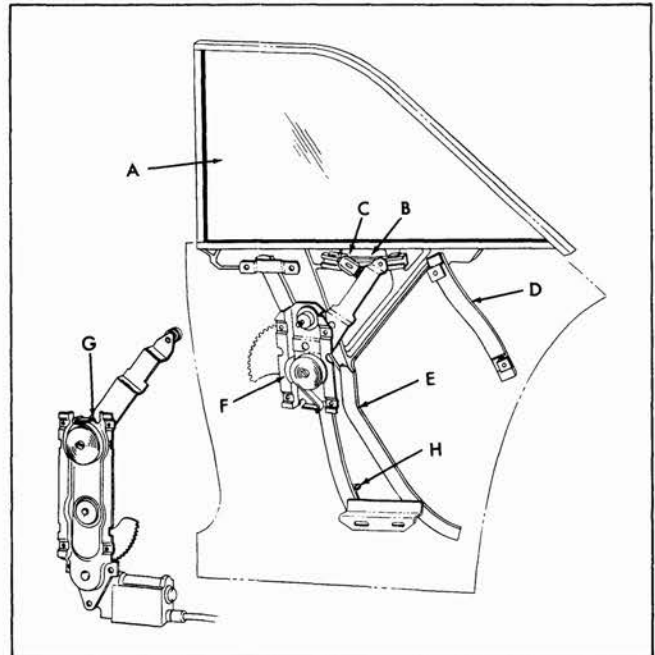

- A. Rear Quarter Window Assembly
- B. Rear Quarter Window Lower Sash Channel Cam
- C. Rear Quarter Window Upper Stop
- D. Rear Quarter Window Rear Guide
- E. Rear Quarter Window Front Guide
- F. Rear Quarter Window Regulator - Manual
- G. Rear Quarter Window Regulator - Electric
- H. Rear Quarter Window Lower Stop

Fig. 4-2 Rear Quarter - "47" Style

QUARTER WINDOW

11 STYLE

REMOVAL AND INSTALLATION

1. Lower rear quarter window. Remove rear quarter window garnish molding. Remove rear quarter arm rest and quarter trim assembly.

2. Remove access hole cover from inner panel. Loosen window front guide upper attaching screw. Remove window rear guide attaching screws and remove guide (Fig. 4-4).

3. Lift rear quarter window assembly upward and rearward and disengage window cam from regulator arm roller. Tilt window inward, disengage window from front guide and remove window from between rear quarter panels.

4. To install rear quarter window assembly, reverse removal procedure. Prior to installing the window lower sash channel cam, lubricate channel of cam with "Lubriplate" or its equivalent along length of channel.

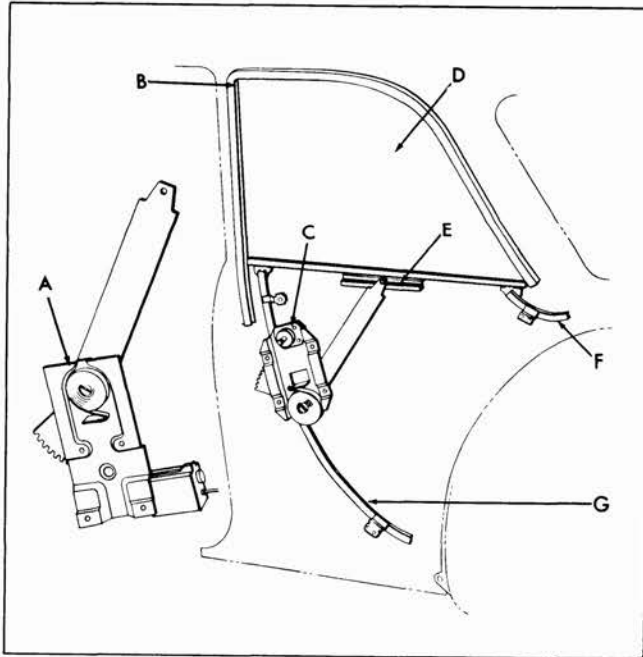

- A. Window Electric Motor and Regulator
- B. Window Glass Run Channel
- C. Window Regulator—Manual
- D. Window Assembly
- E. Window Lower Sash Channel Cam
- F. Window Rear Guide Assembly
- G. Window Front Guide Assembly

Fig. 4-3 Rear Quarter - "11" Style

Adjust rear quarter window for proper alignment and operation as described under "Rear Quarter Window Adjustment" for "11" style.

Seal large access hole cover and front guide upper attaching screw as specified under "Rear Quarter Inner Panel Sealing" for "11" style.

WINDOW ADJUSTMENT

11 STYLE

To adjust rear quarter window fore or aft, loosen front guide attaching screw (Fig. 4-4). Adjust window and guide fore or aft as required and tighten attaching screw.

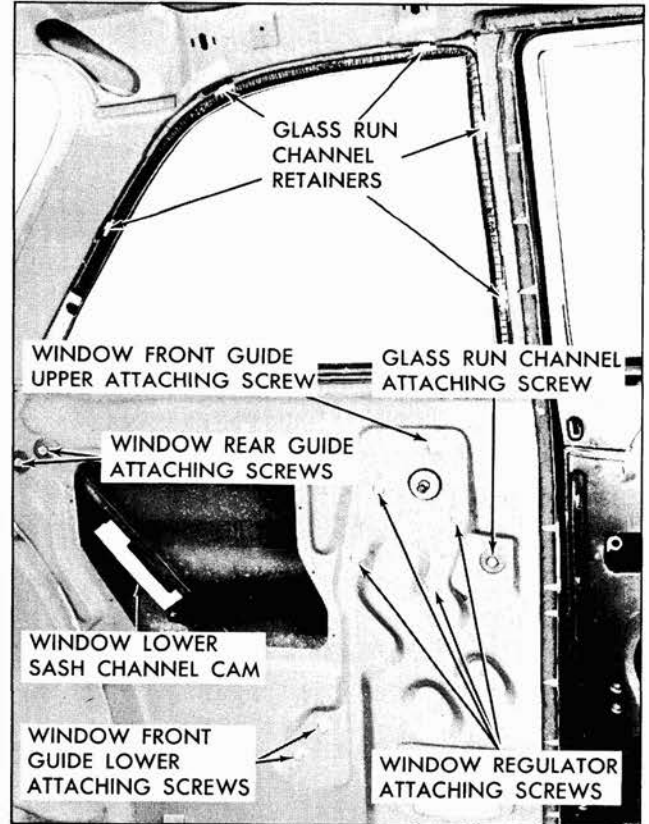

Fig. 4-4 Rear Quarter Hardware - "11" Style

WINDOW GLASS RUN OUTER SEALING STRIP

11 STYLE

REMOVAL AND INSTALLATION

1. Remove rear quarter trim assembly.
2. Remove screws securing sealing strip to return flange of rear quarter outer panel and remove sealing strip.
3. To install rear quarter window glass run outer sealing strip, reverse removal procedure.

WINDOW FRONT GUIDE ASSEMBLY

11 STYLE

REMOVAL AND INSTALLATION

1. Remove rear quarter trim assembly.
2. Remove access hole cover from inner panel.

3. Remove front guide upper and lower attaching screws (Fig. 4-4). Disengage guide from roller on window lower sash channel; move front guide assembly rearward between panels sufficiently to allow upper end of guide to be started out through large access hole; then remove guide assembly.

4. To install front guide assembly, reverse removal procedure. Prior to installing guide, lubricate channel of guide with "Lubriplate" or its equivalent along entire length of channel.

Adjust rear quarter guide for proper window alignment and operation as described under "Rear Quarter Window Adjustments" for "11" style. Seal inner panel hole cover and front guide attaching screws as specified under "Rear Quarter Inner Panel Sealing".

WINDOW REAR GUIDE ASSEMBLY

11 STYLE

REMOVAL AND INSTALLATION

1. Remove rear quarter trim assembly.
2. Remove large access hole cover from inner panel.
3. Remove rear guide attaching screws (Fig. 4-4).
4. Disengage rear guide from roller on window lower sash channel and remove rear guide from body.
5. To install rear guide assembly, reverse removal procedure. Prior to installation of guide, lubricate channel of guide with "Lubriplate" or its equivalent. Seal inner panel access hole cover and rear guide attaching screws as specified under "Rear Quarter Inner Panel Sealing".

WINDOW REGULATOR ASSEMBLY— MANUAL AND ELECTRIC

11 STYLE

REMOVAL AND INSTALLATION

1. Lower rear quarter window and remove rear quarter trim assembly.
2. Remove access hole cover from inner panel. Remove front guide upper attaching screw and glass run channel attaching screw. (Fig. 4-4).
3. On styles equipped with electric window regulators, disconnect feed wire plug from electric motor.

CAUTION: Do not operate regulator motor after the window assembly is disengaged from the regulator or after the regulator assembly is removed from the body. Operation of the motor with the load removed may damage the unit.

4. Remove window regulator attaching screws (Fig. 4-4), disengage regulator arm roller from window lower sash channel cam and remove regulator assembly through large access hole.

NOTE: The procedure for removing the electric motor from the rear quarter window regulator is described and illustrated under "Rear Door and/or Rear Quarter Window Regulator Electric Motor Assembly" in the Door Section.

5. To install window regulator assembly, reverse removal procedure. Prior to installing regulator, lubricate regulator and window guide cams as outlined in "Lubrications" section.

Seal access hole cover and any screws which have been disturbed as specified under "Rear Quarter Inner Panel Sealing".

Adjust window front guide as specified under "Rear Quarter Window Adjustments" for "11" style.

Check operation of window prior to installing rear quarter trim and inside hardware.

REAR QUARTER ARM REST ASSEMBLY

47 STYLE

REMOVAL AND INSTALLATION

1. Remove rear seat cushion, seat back, and filler panel.
2. Remove attaching screws at front and rear of arm rest.
3. On styles equipped with electrically-operated windows and/or rear quarter cigar lighter, carefully detach arm rest from rear quarter inner panel sufficiently to disconnect window switch junction block and/or cigar lighter wires.
4. Remove arm rest assembly from rear quarter panel.
5. To install arm rest assembly, reverse removal procedure.

Where present, check operation of power operated rear quarter window and/or rear quarter cigar lighter.

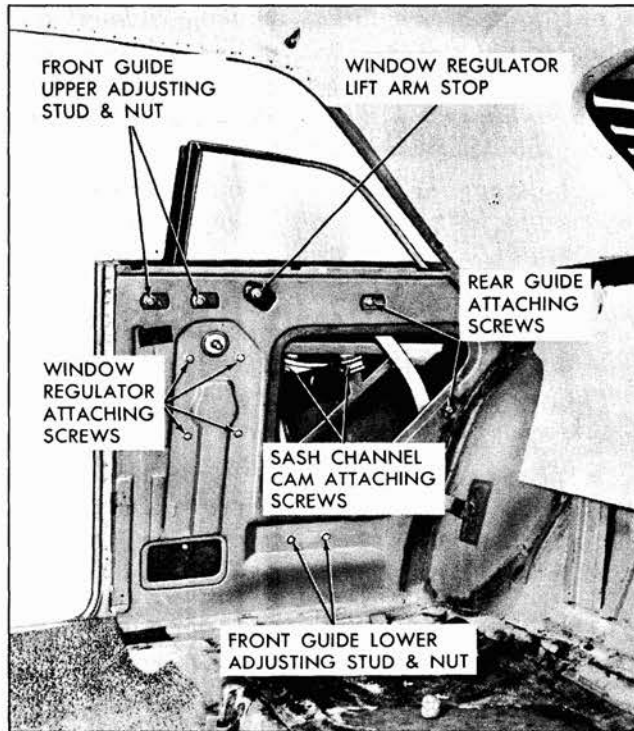

Fig. 4-5 Rear Quarter Hardware

TRIM ASSEMBLY

47 STYLE

REMOVAL AND INSTALLATION

1. Remove rear seat cushion and seat back assemblies.
2. Remove rear quarter arm rest assembly.
3. On styles with manually-operated windows, remove window regulator handle and anti-friction washer.
4. Remove three screws securing rear quarter panel filler to quarter panel and remove filler.
5. Using a trim panel removing tool J-6335, carefully pry trim assembly retaining nails from tacking strip; then lift trim assembly upward to disengage from retainers at top of rear quarter inner panel and remove assembly from body.
6. To install rear quarter trim assembly, reverse removal procedures.

NOTE: If any retaining nails are broken off, they can be replaced with door trim assembly nailing strip replacement tabs which are available as a service part.

WINDOW ASSEMBLY— MANUAL OR ELECTRIC

47 STYLE

REMOVAL AND INSTALLATION

1. Remove rear seat cushion and seat back assemblies and rear quarter arm rest and trim assemblies. Remove inner panel access hole cover.

NOTE: On models equipped with electric window regulators, disconnect feed wire connector from electric motor.

CAUTION: Do not operate regulator motor after the window assembly is disengaged from the regulator. Operation of the motor with the load removed may damage the unit.

2. Remove rear quarter window rear guide attaching screws (Fig. 4-5). Disengage rear guide from roller on window lower sash channel and remove guide.
3. With the rear quarter window in the half-down position, remove the lower sash channel cam attaching screws (Fig. 4-5). Detach cam from roller on regulator arm and remove cam.
4. Remove rear quarter window front guide adjusting stud nuts (Fig. 4-5).

5. With the rear quarter window in the half down position, disengage the front guide adjusting studs from the adjusting stud holes in the rear quarter inner panel, then disengage front guide from rollers on rear quarter window. Remove rear quarter window from between the panels by lifting upward and inward.

6. To install rear quarter window, insert the window between the panels and prop in the "up" position. Engage front guide channels to rollers on window lower sash channel frame. Allow window to drop to the half down position and insert front guide adjusting studs into the adjusting stud holes in the rear quarter inner panel. Install previously removed parts.

Prior to installation of window lower sash channel cam and the front and rear guides, lubricate the channels of the cam and guides with "Lubriplate" or its equivalent along the entire length of the channel.

Adjust rear quarter window for proper alignment and operation as described under "Rear Quarter Window Adjustments" for "47" style. Seal all hardware attachments that have been disturbed and the inner panel access hole cover, as specified under "Rear Quarter Inner Panel Sealing" for "47" style.

WINDOW ADJUSTMENTS

1. Remove rear seat cushion and seat back assemblies. Remove rear quarter arm rest and trim assemblies.

2. To adjust the window fore or aft, loosen the front and rear guide attaching stud nuts (Fig. 4-5). Position the window and guides fore or aft as required; then tighten the attaching stud nuts.

3. To adjust the rear quarter window in or out, loosen the front guide upper attaching stud nuts (Fig. 4-5). Adjust the studs in or out as required; then tighten the stud nuts.

4. To adjust the top of the rear quarter window in or out, loosen the front guide lower attaching stud nut (Fig. 4-5). Adjust the stud in or out as required then tighten the stud nut.

5. To relieve a binding condition between the channels of the front and rear guide, loosen the front and rear guide adjusting stud nuts (Fig. 4-5). Operate window to full up position and tighten upper stud nuts on the front guide and forward attaching screw on rear guide. Operate window to full down and tighten remaining nuts.

6. To limit the forward and upward travel of the rear quarter window, adjust the regulator lift arm stop as required (Fig. 4-5).

7. To limit the down travel of the rear quarter window, remove the inner panel large access hole cover, loosen the lower stop assembly attaching bolt (located at the lower end of the window front guide cam) and adjust stop up or down as required.

NOTE: After performing window adjustments, seal hardware attaching screws which have been disturbed, as specified under "Rear Quarter Inner Panel Sealing" for "47" style.

WINDOW REGULATOR ASSEMBLY— MANUAL OR ELECTRIC

47 STYLE

REMOVAL AND INSTALLATION

1. Remove rear quarter window as described under "Window Assembly - Manual or Electric - Removal".

NOTE: On styles equipped with electric window regulators, disconnect feed wire plug from electric motor.

CAUTION: Do not operate regulator motor after the window assembly is disengaged from the regulator or after the regulator assembly is removed from the body. Operation of the motor with the load removed may damage the unit.

2. Remove rear quarter window regulator attaching screws (Fig. 4-5); then remove regulator assembly through large access hole.

NOTE: The procedure for removing the electric motor from the rear quarter window regulator is described and illustrated under "Rear Door and/or Rear Quarter Window Regulator Electric Motor Assembly" in the Door Section.

3. To install, reverse removal procedure. Seal all hardware attaching locations that have been disturbed as specified under "Rear Quarter Inner Panel Sealing" for "47" style.

WINDOW REGULAR ELECTRIC MOTOR ASSEMBLY

47 STYLE

REMOVAL AND INSTALLATION

See "Rear Door and-or Rear Quarter Window Regulator Electric Motor Assembly" in the Door Section.

WINDOW FRONT GUIDE ASSEMBLY

47 STYLE

REMOVAL AND INSTALLATION

1. Remove rear seat cushion and seat back. Remove rear quarter arm rest and trim assemblies. Remove rear quarter inner panel large access hole cover.

2. With window in "up" position, remove the window front guide upper and lower attaching stud nuts (Fig. 4-5).

3. Maneuver guide assembly between rear quarter panels so that upper end can be started out of large access hole; then remove guide assembly.

4. To install rear quarter window front guide assembly, reverse removal procedure. Prior to installation of the front guide assembly, lubricate channels of guide with "Lubriplate" or its equivalent along full length of channels.

Adjust front guide assembly for proper window alignment and operation as described under "Rear Quarter Window Adjustments" for "47" style.

Seal front guide attaching screws as specified under "Rear Quarter Inner Panel Sealing" for "47" style.

WINDOW REAR GUIDE ASSEMBLY 47 STYLE

REMOVAL AND INSTALLATION

1. Remove rear seat cushion and back assemblies. Remove rear quarter arm rest and trim assemblies. Remove rear quarter inner panel large access hole cover.

2. With the window in the "up" position remove the window rear guide attaching screws (Fig. 4-5). Disengage guide from roller on window lower sash channel and remove guide through access hole.

3. To install, reverse removal procedure. Prior to installation of the rear guide lubricate the entire length of the channel with "Lubriplate" or its equivalent.

Adjust rear guide for proper window alignment and operation as described under "Rear Quarter Window Adjustments" for "47" style.

Seal rear guide attaching screws as specified under "Rear Quarter Inner Panel Sealing" for "47" style.

WINDOW GLASS RUN OUTER SEALING STRIP

47 STYLE

REMOVAL AND INSTALLATION

1. Remove rear seat cushion and back assemblies. Remove rear quarter arm rest and trim assemblies.

2. Remove rear quarter inner panel large access hole cover. Loosen window lower stop attaching screw located on lower end of window front guide assembly; then operate window to the extreme low position.

3. Remove screws at forward end of outer sealing strip securing nylon quarter-window-frame-channel-guide-plate and outer sealing strip to rear quarter outer panel return flange. Disengage outer sealing strip retaining clips from rear quarter outer panel return flange by pressing strip assembly downward.

NOTE: If necessary, use a screwdriver or other suitable tool to disengage retaining clips, however, use care not to damage painted surfaces or to distort shape of clips.

4. To install, reverse removal procedure.

FOLDING TOP COMPARTMENT SIDE TRIM PANEL ASSEMBLY 67 STYLE

REMOVAL AND INSTALLATION

1. Remove rear seat cushion and seat back.

2. Remove attaching screws securing front and rear of side trim panel.

3. Raise trim panel and move it inboard.

4. Disconnect electrical leads, where present, and remove side trim panel.

5. To install folding top compartment side trim panel, reverse removal procedure.

REAR QUARTER TRIM ASSEMBLY 67 STYLE

REMOVAL AND INSTALLATION

1. Remove folding top compartment side trim panel.

2. On styles with manually-operated windows, remove window regulator handle and anti-friction washer.

3. Using a trim panel removing tool J-6335 carefully pry trim assembly retaining nails from tacking strips; then lift assembly upward to disengage from retainers at top of rear quarter inner panel and remove assembly from body.

4. To install rear quarter trim assembly, reverse removal procedure.

NOTE: If any retaining nails are broken off, they can be replaced with door trim assembly nailing strip replacement tabs which are available as a service part.

QUARTER WINDOW ASSEMBLY— MANUAL OR ELECTRIC

67 STYLE

REMOVAL AND INSTALLATION

1. Lower folding top and operate rear quarter window to a half down position. Remove rear seat cushion and seat back. Remove folding top compartment side trim panel and rear quarter trim assembly.

2. On styles equipped with electric window regulators, remove access hole cover and disconnect the wiring harness electrical feed plug from the regulator motor.

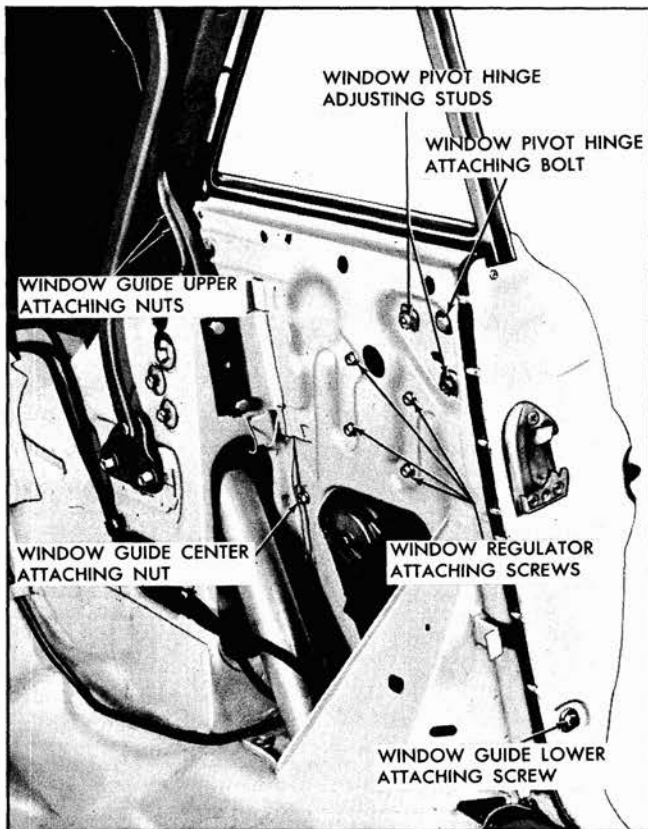

Fig. 4-6 Rear Quarter Hardware - "67" Style

CAUTION: Do not operate regulator motor after window is disengaged from regulator. Operation of motor with load removed may damage the unit.

3. Remove window pivot bolt (Fig. 4-6). Disengage window male hinge from female hinge plate; then raise window to disconnect window lower sash channel cam from roller on window regulator lift arm and remove window.

4. To install rear quarter window assembly, reverse removal procedure. Prior to installation, lubricate pivot hinge and window lower sash channel cam with Lubriplate or its equivalent.

Adjust rear quarter window for proper alignment and operation, as described under "REAR QUARTER WINDOW ADJUSTMENTS" for "67" style. Seal window pivot bolt and inner panel access hole cover as specified under "REAR QUARTER INNER PANEL SEALING" for "67" style.

QUARTER WINDOW ADJUSTMENTS

67 STYLE

1. To adjust the limit of the rear quarter window

up travel, loosen the window guide upper attaching screws (Fig. 4-6); then adjust upper stop to desired position and tighten guide attaching screws.

2. To adjust the rear quarter window up or down or fore or aft; or to adjust the top or the rear of the window in or out, the folding top compartment side trim panel and rear quarter trim assembly must be removed to gain access to the pivot bolt and adjusting studs.

a. Up or down or fore or aft window adjustment: Loosen pivot bolt and both adjusting stud nuts (Fig. 4-6). Position window as required; then tighten pivot bolt and stud nuts.

b. In or out adjustment of top of window: Loosen lower adjusting stud nuts and slightly loosen rear stud nut. Adjust lower stud in or out, as required; then tighten both stud nuts (Fig. 4-6).

c. In or out adjustment of rear window: Loosen pivot hinge rear adjusting stud nut and (slightly) lower adjusting stud nut. Loosen window guide upper attaching nuts and center stud nut (Fig. 4-6). Adjust rear adjusting stud in or out, as required, then tighten both stud nuts. Adjust window guide for proper alignment with window and tighten upper attaching nuts and center stud nut.

NOTE: After performing any rear quarter window adjustment, seal all attaching screws which have been disturbed as specified under "REAR QUARTER INNER PANEL SEALING" for "67" style.

QUARTER WINDOW REGULATOR— MANUAL OR ELECTRIC

67 STYLE

REMOVAL AND INSTALLATION

1. Remove rear seat cushion and back, folding top compartment side trim panel and rear quarter trim assembly.

2. Remove rear quarter inner panel access hole cover.

3. Operate window to full "up" position and prop in "up" position.

4. On styles equipped with electric window regulators, disconnect feed wire plug from electric motor.

CAUTION: Do not operate regulator motor after the regulator assembly is disengaged from the window assembly or after it is removed from the body. Operation of the motor with the load removed may damage the unit.

5. Remove regulator attaching screws (Fig. 4-6). Disengage regulator lift arm roller from window lower sash channel cam and remove regulator.

6. To install window regulator assembly, reverse removal procedure.

Lubricate regulator sector, window cams and pivot hinge as specified under "LUBRICATION" Section.

Seal regulator attaching screws and inner panel access hole cover as specified under "REAR QUARTER INNER PANEL SEALING" for "67" style.

**QUARTER WINDOW REGULATOR
ELECTRIC MOTOR ASSEMBLY**

67 STYLE

The procedure for removing the electric motor from the rear quarter window regulator assembly is similar to the procedure described under "REAR DOOR AND/OR REAR QUARTER WINDOW REGULATOR ELECTRIC MOTOR ASSEMBLY" in the Door Section.

QUARTER WINDOW GUIDE

67 STYLE

REMOVAL AND INSTALLATION

1. Remove rear seat cushion and seat back. Remove folding top compartment side trim panel, and rear quarter trim assembly.

2. Remove inner panel access hole cover and rear quarter window assembly. On styles equipped with electric window regulators, remove window regulator assembly.

3. Remove window guide upper and center attaching nuts and lower attaching screw (Fig. 4-6). Disengage window guide and remove guide through large access hole.

4. To install rear quarter window guide, reverse removal procedure. Adjust the window guide for proper window alignment and operation as described under "REAR QUARTER WINDOW ADJUSTMENTS" for "67" style.

Seal window guide attaching screws, access hole plug at lock pillar and inner panel access hole cover as specified under "REAR QUARTER INNER PANEL SEALING" for "67" style.

**QUARTER WINDOW GLASS RUN
OUTER SEALING STRIP**

67 STYLE

1. Remove rear quarter window assembly.

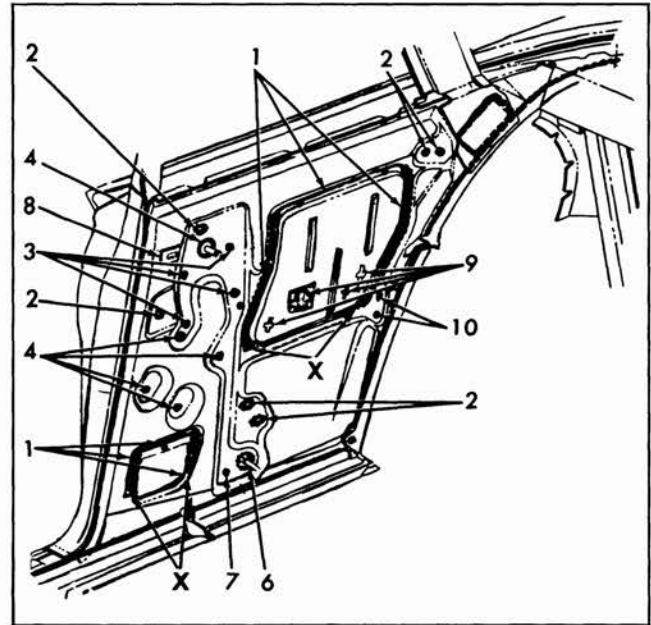

Fig. 4-7 Inner Panel Sealing - "11" Style

2. Remove screws securing sealing strip to outer panel and remove strip.

3. To install rear quarter window glass run outer sealing strip, reverse removal procedure.

QUARTER INNER PANEL SEALING

11, 47 and 67 STYLES

Whenever the rear quarter inner panel seals have been disturbed, the area must be resealed before the rear quarter trim is reinstalled. Following are the rear quarter inner panel openings and hardware attaching locations which must be sealed to prevent water leakage and possible trim damage.

NOTE: When body caulking compound is used, work compound firmly to metal surfaces and feather edges out to obtain good adhesion.

QUARTER INNER PANEL SEALING

For 11 Style - Fig. 4-7

For 47 Style - Fig. 4-8

For 67 Style - Fig. 4-9

The numbers on Figures 4-7, 4-8 and 4-9 correspond to the following item numbers:

1. Large and Small Access Hole Covers - Prior to installation of access hole cover, apply a continuous bead of body caulking compound (approximately 1/8" diameter) across top and down side of quarter inner panel along flange contacted by cover.

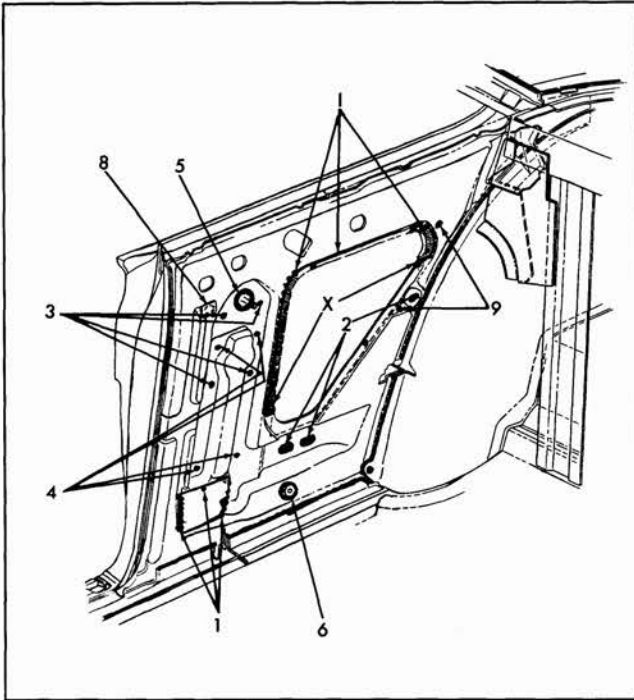

Fig. 4-8 Inner Panel Sealing - "47" Style

After installation of cover, apply body caulking compound at lower corners of cover, at locations "X", to seal openings where cover flange transition to inside of quarter panel occurs.

2. Window Guide Attaching Screws - Apply body caulking compound over window guide attaching screws and holes. Formly press caulking compound to assure a good bond and watertight seal.

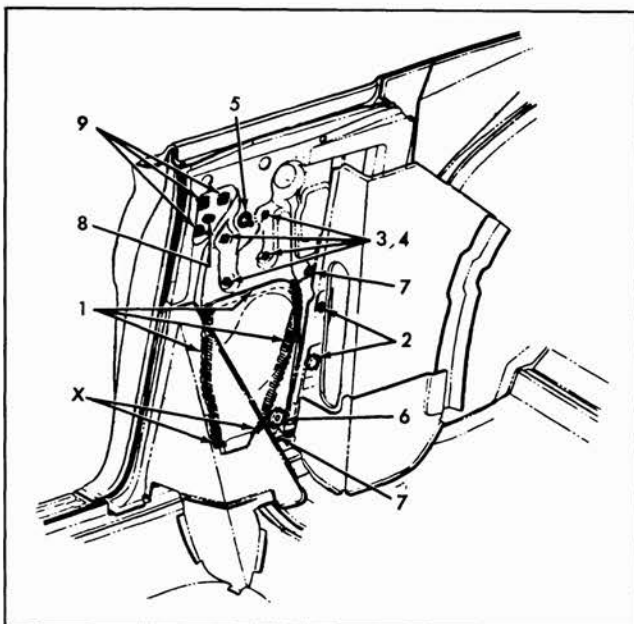

Fig. 4-9 Inner Panel Sealing - "67" Style

On convertible styles apply weatherstrip adhesive (black) around the window guide attaching hole plug to effect seal between inner panel and plug.

3. Manual Window Regulator Attaching Screws - Apply weatherstrip adhesive (black) over attaching screws.

4. Electric Window Regulator Attaching Screws - Apply weatherstrip adhesive (black) over attaching screws.

5. Window Regulator Spindle Hole Sealing Washer - Apply weatherstrip adhesive over exposed surface of washer to seal pores of sponge rubber and joint between inner panel and washer.

On convertible coupe styles with electrically operated windows apply weatherstrip adhesive (black) around the manual regulator spindle hole; then apply waterproof body tape over spindle hole.

6. Wire Harness and Grommet Hole (Styles with Electrically Operated Windows) - Apply weatherstrip adhesive (black) around the grommet and wire to effect a seal between wire and grommet and between grommet and inner panel.

7. Wire Harness Clip Hole (Styles with Electrically Operated Windows) - Apply weatherstrip adhesive over hole.

8. Gage Slot - Apply waterproof body tape over slot.

Items 9 and 10 for "11" style only (Fig. 4-7).

9. Arm Rest Anchor Nut ("11" style only) - Apply body caulking compound over anchor nut and hole to effect a seal around anchor nut, hole and attaching screw when arm rest is installed.

Arm Rest Anchor Nut Hole ("11" style only) - Where anchor nuts are not used, apply waterproof body tape over hole. Press tape firmly to effect a good bond.

10. Window Stop Attaching Screws ("11" style with electrically operated windows) - Apply weatherstrip adhesive (black) over stop attaching screws.

Item 9 for "47" style only (Fig. 4-7).

9. Seat Back to Quarter Panel Filler Panel Attaching Screw Holes ("47" style only) - Apply weatherstrip adhesive (black) over filler panel attaching holes.

Item 9 for "67" style only (Fig. 4-9).

9. Window Hinge Attaching Screws ("67" style only) - Apply body caulking compound over hinge attaching screws. Press compound firmly to assure a good bond and watertight seal.

REAR QUARTER LOWER TRIM ASSEMBLY

39 and 69 STYLES

REMOVAL AND INSTALLATION

1. Remove rear seat cushion and back assemblies. Remove back window side garnish molding.
2. Remove screw securing metal trim support in upper center of trim assembly ("69" style only).
3. Using a trim panel removing tool J-6335 carefully pry trim assembly retaining nails from tacking strip; then lift trim assembly upward to disengage from retainers at top of rear quarter inner panel and remove trim from quarter panel.
4. To install rear quarter trim assembly, reverse removal procedure.

REAR QUARTER UPPER TRIM ASSEMBLY

39 STYLE

REMOVAL AND INSTALLATION

1. Remove back window side garnish molding and side roof rail rear finishing molding.
2. Carefully break cement bond securing trim foundation to roof extension inner panel; then remove trim assembly.
3. To install, first apply trim cement to contacting surfaces of trim foundation and roof extension inner panel. Position trim and press or roll to assure a good cement bond. Install back window side garnish molding and side roof rail rear finishing molding.

REAR QUARTER UPPER TRIM ASSEMBLY

47 STYLE

REMOVAL AND INSTALLATION

1. Remove back window side garnish molding and side roof rail rear finishing molding. Remove na belt finishing molding, where present.
2. On styles with courtesy lamps in the upper trim assembly, remove courtesy lamp lens and two (2) screws securing reflector and remove lamp assembly.
3. Carefully insert a trim panel removing tool J-6335 or other suitable tool between headlining and upper edge of upper trim assembly. Disengage upper trim assembly retaining clips from roof extension inner panel by pulling inboard at clip locations. Remove trim assembly from body.
4. To install, reverse removal procedure.

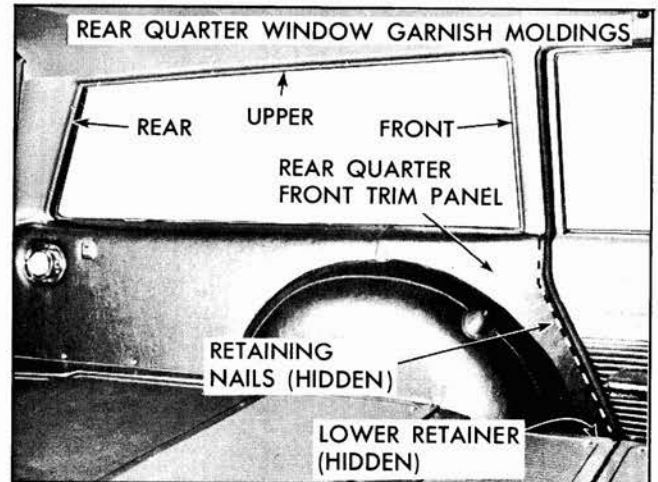

Fig. 4-10 Rear Quarter Trim - Station Wagon

REAR QUARTER FRONT TRIM PANEL

35 and 45 STYLES

REMOVAL AND INSTALLATION

1. Remove rear quarter stationary window front garnish molding.
2. Remove rear quarter front trim panel lower retainer.
3. Remove screws securing trim panel to body.
4. With a clean rubber mallet, tap trim assembly along front edge to free trim assembly retaining nails in slots.
5. With a suitable flat-bladed tool, carefully loosen trim assembly from inner panel.
6. Lift panel upwards to disengage from quarter inner panel, and remove assembly from body (Fig. 4-10).
7. To install, reverse removal procedure.

REAR QUARTER REAR TRIM PANEL (LEFT SIDE)

35 and 45 STYLES

REMOVAL AND INSTALLATION

1. On "45" style, remove screws securing courtesy lamp and switch assembly to trim panel and carefully remove assembly sufficiently to disengage wires at rear of lamp and switch. Remove rear finishing panel (Fig. 4-11).
2. Remove top screw in rear quarter front trim panel and all screws in rear quarter rear trim panel.

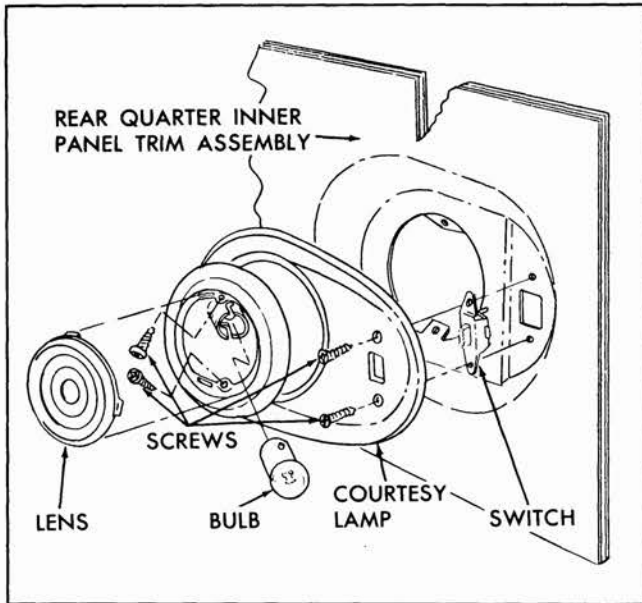

Fig. 4-11 Rear Quarter Courtesy Light

3. Lift panel slightly upward to disengage from quarter inner panel and rearward to disengage from rearward section of rear quarter front trim panel (Fig. 4-10).

4. To install, reverse removal procedure.

REAR QUARTER WHEELHOUSE PANEL COVER (RIGHT SIDE)

35 and 45 STYLES

REMOVAL AND INSTALLATION

1. Remove spare tire cover.

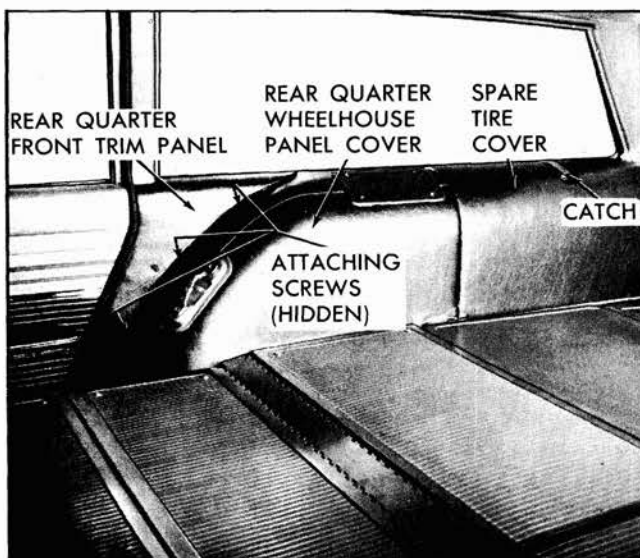

Fig. 4-12 Right Rear Quarter Trim - Station Wagon

2. Remove attaching screws securing trim panel to quarter inner panel and spare tire cover support (Fig. 4-12).

3. Remove rear quarter front trim panel.

4. Lift panel upward to disengage from quarter inner panel and remove panel from body.

5. To install, reverse removal procedure.

SPARE TIRE COVER PANEL

35 and 45 STYLES

The spare tire cover panel is secured to a retainer at the belt line by a folding catch type handle. To remove the panel disengage the catch and lift the panel upward. To install, reverse removal procedure.

The handle can be adjusted "in" or "out" to increase or decrease closing effort. To adjust, loosen the handle attaching screws; position the handle as desired and tighten the screws.

REAR QUARTER STATIONARY WINDOW GARNISH MOLDINGS AND FINISHING PANEL

35 and 45 STYLES

The rear quarter window front and upper garnish moldings and rear finishing panel are secured by screws. The upper garnish molding overlaps the front garnish molding and rear finishing panel (Fig. 4-10).

REAR QUARTER STATIONARY WINDOW ASSEMBLY

35 and 45 STYLES

REMOVAL

1. Remove rear quarter stationary window garnish moldings.

2. Remove rear quarter front trim panels, rear quarter rear trim panel, rear quarter wheelhouse panel cover, spare tire cover, and spare tire cover support (Fig. 4-13).

3. Remove rear quarter stationary window channel lower retainers (one (1) required for right side, two (2) required for left side), (Fig. 4-13).

4. Using a suitable tool, carefully break seal between rubber channel and body opening. With aid of helper, carefully push glass and rubber channel in-board and remove assembly from opening.

NOTE: Rubber channel may be removed from glass as a bench operation.

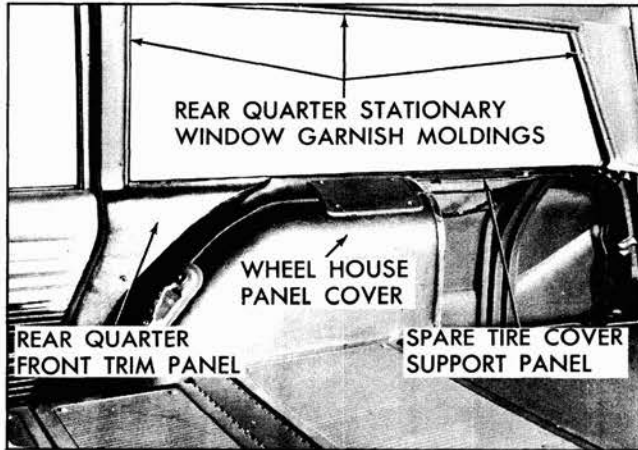

Fig. 4-13 Right Rear Quarter Trim

CAUTION: Care should be exercised to make certain glass does not strike body metal during installation. Edge chips can lead to future breaks. Do not attempt to grind glass.

INSTALLATION

1. Clean off old sealer from rubber channel and body opening to insure a smooth sealing surface.
2. Apply a ribbon of medium-bodied sealer com-

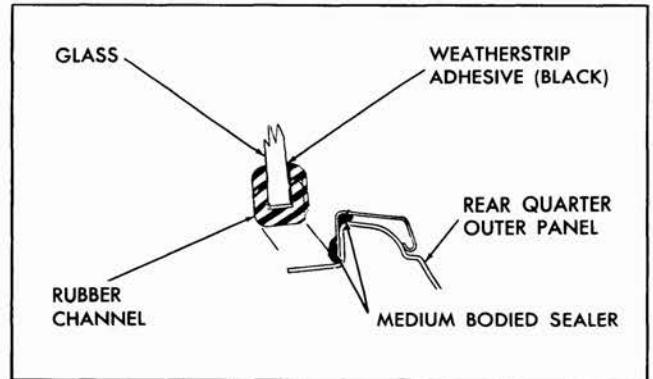

Fig. 4-14 Rear Quarter Stationary Window Sealing

pletely around window opening.

3. Install window assembly and window channel lower retainers.

4. Using a plews oiler or any other suitable applicator, apply an approved weatherstrip adhesive (black) between glass and outer wall of rubber channel completely around window. Clean off excess sealer (Fig. 4-14).

5. Replace all previously removed parts.

REAR END

CONTENTS OF THIS SECTION

SUBJECT	PAGE	SUBJECT	PAGE
Back Window Assembly		Hinge Assembly	5-10
Back Window - Sedans	5-2	Hinge Torque Strap	5-10
Back Window Moldings		Window Assembly	5-11
Retaining Clip	5-3	Window Adjustments	5-12
Reveal Moldings	5-4	Window Regulator	5-12
Rear Compartment		Regulator - Electric Motor	5-12
Lid	5-7	Outside Handle	5-13
Adjustments	5-7	Handle Lock Cylinder	5-13
Hinge	5-7	Switch and Escutcheon	5-14
Torque Rod Adjustment	5-8	Support Assembly	5-15
Lock Cylinder	5-8	Lock Assembly	5-16
Lid Lock	5-8	Lock Striker	5-16
Striker	5-8	Remote Control - Inside Handle	5-17
Striker Engagement	5-8	Water Deflector	5-18
Tail Gate		Weatherstrip	5-19
Adjustment	5-9	Drain Hole Sealing	5-20

BACK WINDOW ASSEMBLY

REMOVAL

1. Place protective coverings over rear seat cushion and back, over parcel shelf trim and over painted surfaces around back window.
2. Remove back window garnish moldings. On Oldsmobile Styles, remove back window sunshade and support, where present.
3. Remove back window reveal moldings.
4. From inside body carefully break seal between lip of rubber channel and pinchweld flange completely around back window.
5. Carefully push back window and rubber channel assembly outward until lip of rubber channel is disengaged from body pinchweld flange.
6. With the aid of a helper, lift complete assembly from body opening and place on a protected surface. Remove rubber channel from glass.

INSTALLATION

IMPORTANT: Care should be exercised to make certain glass does not strike body metal during installation as edge chips can cause solid tempered

safety plate glass to shatter. **DO NOT** attempt to grind glass.

1. Clean original sealer from back window body opening and rubber channel and install rubber channel to glass.

CAUTION: Before installing back window glass, check back window body opening and pinchweld flange for any irregularities and correct where necessary.

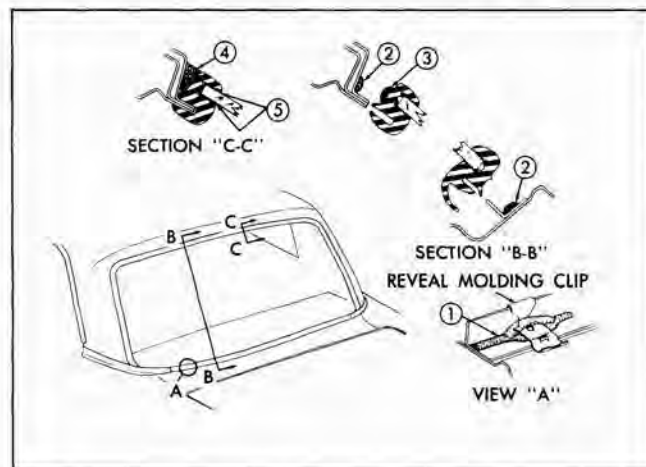

Fig. 5-1 Back Window Sealing

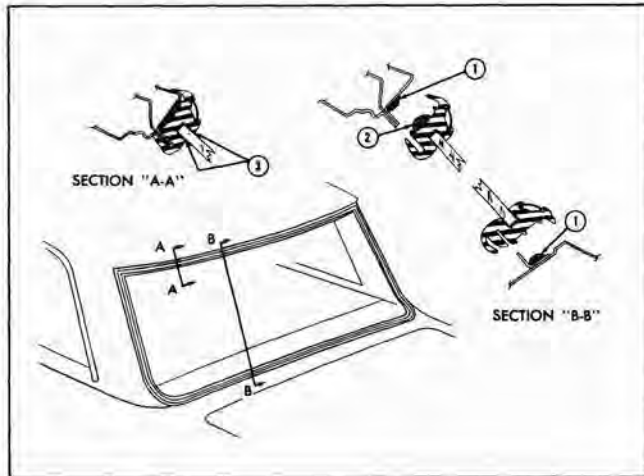

Fig. 5-2 Back Window Sealing

2. Check installation of reveal molding clips at pinchweld and retaining flanges and replace clips, where necessary. If replacing clips, apply medium-bodied sealer to opening rabbet, prior to installing clips. (See "1" in View "A" Fig. 5-1).

3. Apply a continuous ribbon of medium-bodied sealer (approximately 1/2 inch wide by 1/4 inch thick) on wall of rabbet, completely around opening. (See "2" in Section "B-B" Fig. 5-1).

4. Insert a strong cord into pinchweld cavity of rubber channel; tie ends together at bottom center and tape to inside surface of glass.

5. Apply a continuous ribbon of medium-bodied sealer (approximately 1/2 inch wide by 1/4 inch thick) to base of rubber channel across top and down sides at opening. (See "3" in Section "B-B" Fig. 5-1).

6. With aid of a helper, position back window assembly into body opening. While helper is applying hand pressure to outside surface of glass, use a hooked tool or other suitable tool to pull inner lip of rubber channel (located along lower portion of channel) over retaining flanges along bottom opening.

7. With aid of helper applying hand pressure to outside surface of glass, pull cords in rubber channel and, where necessary, use a hooked tool to seat lip of rubber channel over body flanges across bottom, up sides and across top of window opening.

NOTE: If, during the string-pulling operation, the rubber lip is not seating properly over the body flange, check for locations where rubber channel is tight against the body flange preventing forward movement of the glass and channel assembly into the opening. Using a hooked tool, seat the rubber lip over the body flange at any

tight locations before proceeding with the cord-pulling sequence.

8. Using a pressure-type applicator, apply sufficient medium-bodied sealer to completely fill any openings between rubber channel and body completely around rubber channel. (See "4" in Section "C-C" Fig. 5-1).

9. Using a pressure-type applicator (Pistol-type oiler) apply weatherstrip adhesive (black) between rubber channel and glass on inside and outside of glass around entire perimeter of glass (See "5" in Section "C-C" Fig. 5-1). Application of adhesive should be continuous with no skips.

10. Install back window moldings as described under "Back Window Reveal Moldings".

11. Clean off excess sealer and cement; install previously removed parts and remove protective coverings.

BACK WINDOW ASSEMBLY

11 and 69 STYLES

REMOVAL

1. Place protective covering over rear seat cushion and back, over parcel shelf trim, and over painted surfaces around back window.

2. Remove back window garnish moldings.

3. From inside body carefully break seal between lip of rubber channel and pinchweld flange completely around back window.

4. Carefully push back window and rubber channel assembly outward until lip of rubber channel is disengaged from body pinchweld flange.

5. With the aid of a helper, lift complete assembly from body opening and place on a protected surface.

6. Remove insert-type moldings from rubber channel and rubber channel from glass. (See "Back Window Reveal Moldings")

INSTALLATION

CAUTION: Care should be taken to make certain that glass does not strike body metal during installation as edge chips can cause solid tempered safety plate glass to shatter. Do not attempt to grind glass.

1. Clean original sealer from back window body opening and rubber channel and install rubber channel to glass. Insert moldings in rubber channel.

CAUTION: Before installing back window glass, check the back window body opening and pinchweld flange for any irregularities and correct, where necessary.

2. Apply a continuous ribbon of medium-bodied sealer (approximately 1/2 inch wide by 1/4 inch thick) on wall of rabbet completely around opening. (See "1" in Section "B-B", Fig. 5-2).

3. Insert a strong cord into pinchweld cavity of rubber channel; tie ends together at bottom center and tape to inside surface of glass.

4. Apply a continuous ribbon of medium-bodied sealer (approximately 1/2 inch wide by 1/4 inch thick) to base of rubber channel across the top and down both sides. (See "2" in Section "B-B", Fig. 5-2).

5. With the aid of a helper, position back window assembly in body opening. While helper is applying hand pressure to outside surface of glass, use a hooked tool or other suitable tool to pull inner lip of rubber channel (located along lower portion of channel) over retaining flange along bottom of opening.

6. With helper applying hand pressure to outside surface of glass pull cords in rubber channel to seat lip of rubber channel over body flanges across bottom, up sides, and across top of window opening.

NOTE: If, during cord pulling operation, the rubber lip is not seating properly over the body flange, check for locations where the rubber channel is tight against the body flange preventing movement of the glass into the opening. Using a hooked tool, seat the rubber lip over the body flange at any tight locations before proceeding with the cord pulling sequence.

7. Using a pressure type applicator (Pistol type oiler) apply weatherstrip adhesive (black) between rubber channel and glass on inside and outside of glass around entire perimeter of glass. (See "3" in Section "A-A" Fig. 5-2). Application should be continuous with no skips.

8. Clean off excess sealer and cement and remove protective coverings. Install previously removed parts.

REAR END MOLDINGS

DESCRIPTION

All back windows are made of solid tempered safety plate glass and are secured in the body openings by conventional rubber channels. All styles have reveal moldings that must be removed to remove the back window and rubber channel assembly.

BACK WINDOW REVEAL MOLDINGS

Back window reveal moldings are secured to the body by a combination of two or more of the following type attachments.

- A. Reveal Molding Retaining Clips
- B. Reveal Molding Bolt and Clip
- C. Reveal Molding Stud and Nut
- D. Reveal Molding Retaining Clip and Molding Clip

The location where the above type attachments are used are indicated on the illustrations for the various body styles. Also shown in the illustrations are sectional view of the attachments used.

REVEAL MOLDING RETAINING CLIP

NOTE: The reveal molding retaining clip attachment is used at various locations marked "A" on all body styles to secure the back window reveal moldings. Whenever this clip is called out in the procedure for removing back window reveal moldings, refer to the following procedure covering engagement and disengagement of reveal moldings from reveal molding retaining clips.

DISENGAGEMENT AND ENGAGEMENT OF REVEAL MOLDING FROM RETAINING CLIP

Reveal molding retaining clips are snapped over the back window pinchweld or retaining flange and secure the reveal molding by means of a barbed prong. To disengage the reveal molding from the clip requires the use of reveal molding removal tool J-7898-01. Insert end of tool between back window rubber channel and reveal molding. Engage point of

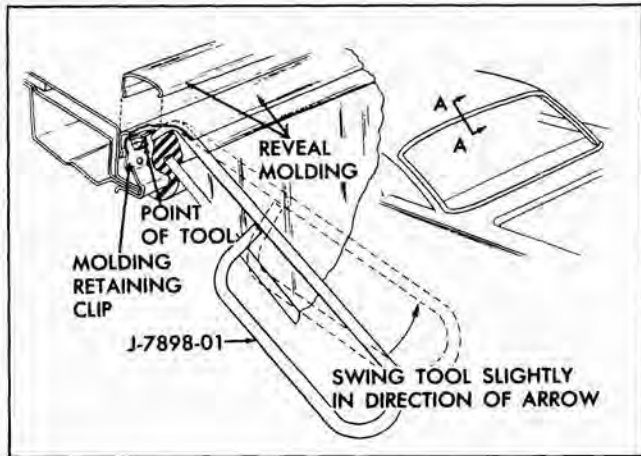

Fig. 5-3 Reveal Molding Removing Tool

tool between retaining clip and molding, then swing tool slightly (Fig. 5-3) to disengage prongs of clip from molding and lift molding free of clip.

NOTE: Do not lift excessively on molding - if clip is disengaged, molding will lift free of clip easily. If clip is not disengaged, any excessive "pull" on molding will cause prongs of clip to bite harder on molding, thereby, making it more difficult to disengage clip from molding. If difficulty is being experienced in disengaging clip, push molding at clip location to relieve pressure of clip prongs on molding while using tool to disengage clip.

An occasional application of silicone lubricant on end of tool will facilitate inserting tool between reveal molding and rubber channel and sliding tool to engage with clip.

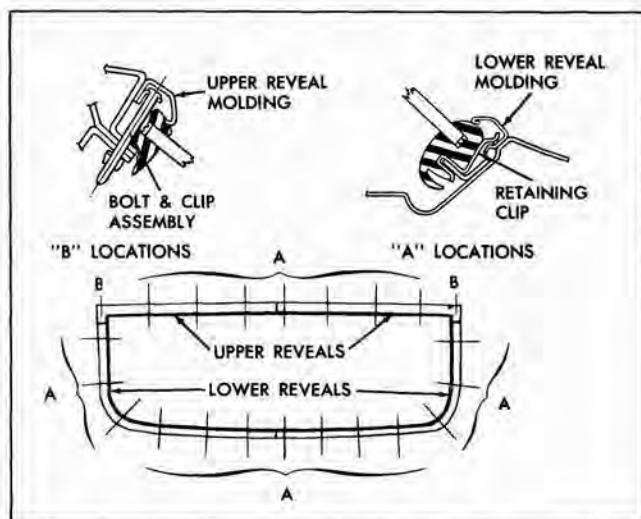

Fig. 5-4 Back Window Reveal Moldings

To install molding(s), position molding so that flange of molding is between body metal and retaining clip, then carefully push molding at retaining clip locations until molding is properly secured by retaining clips.

UPPER REVEAL MOLDING (FIG. 5-4)

11 and 69 STYLES

Remove both right and left back window side garnish moldings. Under inner lip of back window rubber channel, remove nut from both right and left bolt and clip assemblies at locations "B". From outside of body disengage both right and left upper reveal moldings from retaining clips "A" and remove moldings from body.

To install, reverse removal procedure.

LOWER REVEAL MOLDING (FIG. 5-4)

11 and 69 STYLES

Remove back window side garnish moldings. Under inner lip of back window rubber channel remove nuts from bolt and clip assemblies at locations "B". Disengage upper reveal molding sufficiently from retaining clips "A" to allow removal of lower reveal moldings.

Starting at upper end of lower reveal molding, disengage molding from first four or five retaining clips "A"; then slide molding off remaining clips by pulling molding towards side of body.

To install, reverse removal procedure.

LOWER REVEAL MOLDING (FIG. 5-5)

47 STYLE

From inside rear compartment under rear compartment front and shelf panel, remove nuts from both bolt and clip assemblies at "B". Remove belt reveal moldings as described in "Exterior Moldings". Using reveal molding tool J-7898-01 insert point of tool between molding and rubber channel and push or pull molding clip sideways to slide it out of engagement from molding retaining clip ("D", Fig. 5-6).

Perform this operation at each molding clip location "D" and remove molding from body.

To install, first slide molding clips in molding so they will be in position to engage retaining clips on body. Then position molding to body and engage clips.

UPPER REVEAL MOLDING (FIG. 5-5)**47 STYLE**

Starting at upper end of molding disengage molding from first three or four retaining clips "A". Remove nut from belt reveal molding bolt and clip assembly at locations "B". Slide molding off remaining clips "A" by pulling molding upwards.

When removing left upper molding only, disengage upper end of right molding sufficiently to allow removal of left molding, which it overlaps.

To install, reverse removal procedure.

SIDE REVEAL MOLDING (FIG. 5-6)**39 STYLE**

Remove back window side garnish molding. From inside body under lip of back window rubber channel, remove nuts from molding bolt and clip assemblies at locations "B". From outside body disengage retaining clips at locations "A" and remove molding from body.

To install, reverse removal procedure.

LOWER REVEAL MOLDING (FIG. 5-6)**39 STYLE**

From inside body under inner lip of back window rubber channel remove nut from right and left side reveal molding bolt and clip assemblies "B".

From outside body, disengage both right and left side reveal moldings from retaining clips "A". Pull both right and left side reveal moldings away from body sufficiently to allow removal of lower reveal molding. Disengage molding from retaining clips "A" and remove molding from body.

To install, reverse removal procedure.

UPPER REVEAL MOLDING (FIG. 5-6)**39 STYLE**

Remove both right and left back window side garnish moldings. From inside of body under inner lip of back window rubber channel, remove nut from both the right and left side reveal molding upper bolt and clip assemblies "B". From outside body disengage both right and left side reveal moldings from upper retaining clips "A". Pull side reveal moldings away from rubber channel sufficiently to disengage upper

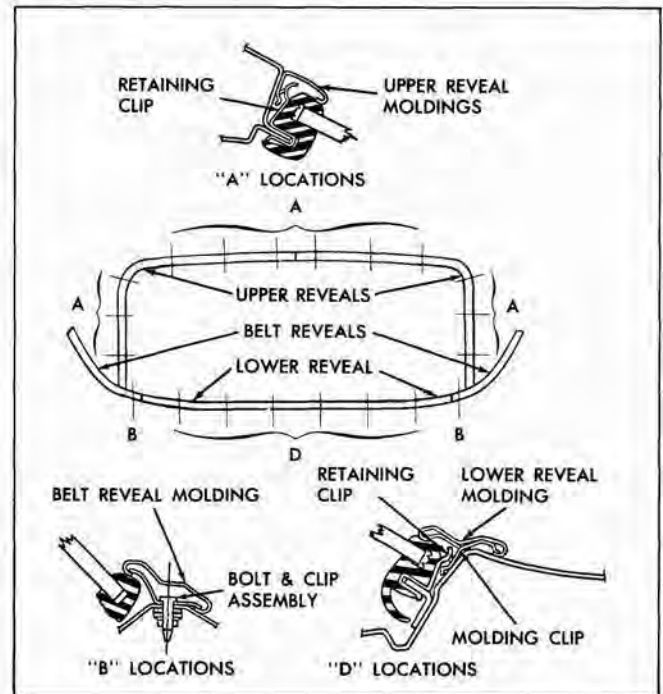

Fig. 5-5 Back Window Reveal Moldings

reveal molding retaining clips at locations "A", then remove upper reveal molding from body.

To install, reverse removal procedure.

LOWER REVEAL MOLDING (FIG. 5-6)**39 STYLE**

From inside body under inner lip of back window rubber channel, remove nuts from lower reveal molding bolt and clip assemblies at locations "B". Using a reveal molding removal tool J-7898-01 or other similar pointed tool, insert point of tool between molding and rubber channel and engage point of tool with molding clip as indicated in view "D", Fig. 5-6. Push or pull molding clip with tool until clip has moved sideways out of engagement with retaining clip on body. Perform this operation at each of the molding clip locations "D" and remove molding from body.

To install, first slide molding clips in molding so they will be in position to engage with retaining clips on body. Then, position molding to body and engage clips.

SIDE REVEAL MOLDING (FIG. 5-6)**39 STYLE**

From inside body under inner lip of back window

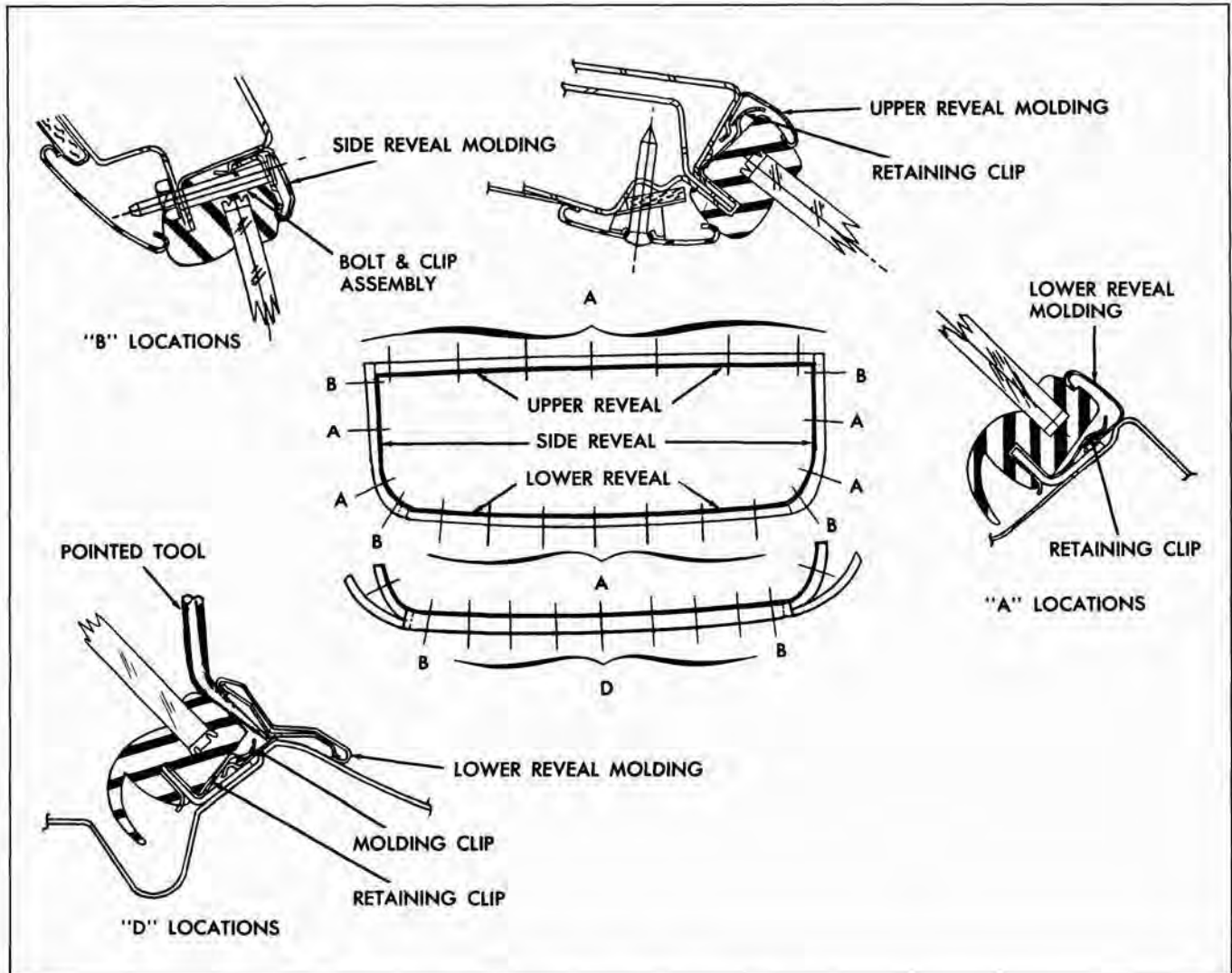

Fig. 5-6 Back Window Reveal Moldings

rubber channel, remove nuts from bolt and clip assemblies at locations "B". Using a reveal molding removal tool J-7898-01 or other similar pointed tool, disengage the first two molding clips "D" as follows: Insert point of tool between molding and rubber channel and engage point of tool with molding clip as indicated in View "D" Fig. 5-6; then, push or pull mold-

ing clip with tool until clip has moved sideways out of engagement with retaining clip on body. Disengage side reveal molding from retaining clips "A" and remove molding from body.

To install, reverse removal procedure.

REAR COMPARTMENT

DESCRIPTION

The rear compartment lid employs two (2) torsion rods between the hinge assemblies as a counterbalance and hold open for the lid. Notches are provided at the hinge assemblies for rod adjustment. The rear compartment lid lock employs

the use of a side action snap-bolt mechanism to conform to the thin section design of the rear compartment lid. The end of the lock assembly enters the striker when the lid is closed and acts as a guide. A single section cement-on type weatherstrip is used on all styles and is cemented to the rear compartment and gutter assembly.

REAR COMPARTMENT LID

REMOVAL AND INSTALLATION

1. Open lid and place protective covering along edges of rear compartment opening to prevent damage to painted surface.
2. Disengage wire harness from clips on hinge and rear compartment lid inner panel and remove wire harness from lid where necessary.
3. Mark location of hinge straps on lid inner panel.
4. With aid of helper, remove lid attaching bolts (Fig. 5-7) and remove rear compartment lid.
5. To install rear compartment lid reverse removal procedure. Align lid with scribe marks before tightening hinge attaching bolts.

REAR COMPARTMENT LID ADJUSTMENTS

1. To adjust compartment lid forward or rearward, or from side to side in body opening, loosen both hinge strap attaching bolts and adjust lid as required; then tighten bolts.
2. To adjust compartment lid at hinge area up or down install shims between lid inner panel and hinge straps as follows:
 - a. To raise front edge of lid at hinge area, place shim between lid inner panel and forward portion of one or both hinge straps at "B" (Fig. 5-7).
 - b. To lower front edge of lid at hinge area, place shim between lid inner panel and rearward portion of one or both hinge straps at "A" (Fig. 5-7).
3. To check lid lock bolt engagement with striker, see "REAR COMPARTMENT LID LOCK STRIKER ENGAGEMENT CHECK".

REAR COMPARTMENT LID HINGE

REMOVAL

1. Place protective covering over body around upper portion of rear compartment opening and pro-

vide support for lid on side where hinge is to be removed.

2. Remove rear compartment side trim foundation at hinge area if necessary. If left hinge is being removed, disengage wire harness from clip on left hinge. On Pontiac styles remove hinge torque rod covers.

3. Mark location of hinge strap on lid inner panel and remove bolts securing hinge strap to lid.

4. With a suitable tool disengage torque rod from notched retainer on inboard face of opposite hinge box (Fig. 5-7).

NOTE: Mark retainer notch before removing torque rod to insure that rod is installed in same position.

5. Disengage opposite end of torque rod from movable portion of hinge strap and remove rod.

6. Bend up hinge pin retaining tab on inboard face of hinge box (Fig. 5-7), remove hinge pin and then remove hinge from box.

INSTALLATION

1. Position hinge in hinge box and install hinge pin. Bend over retaining tab to secure hinge pin.
2. Position hinge strap within scribe marks on lid inner panel and install attaching bolts.

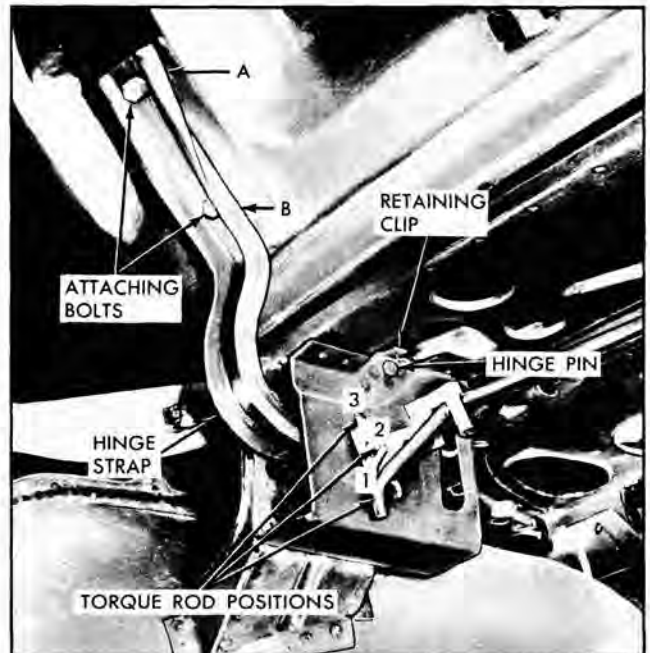

Fig. 5-7 Trunk Hinge and Torque Rod

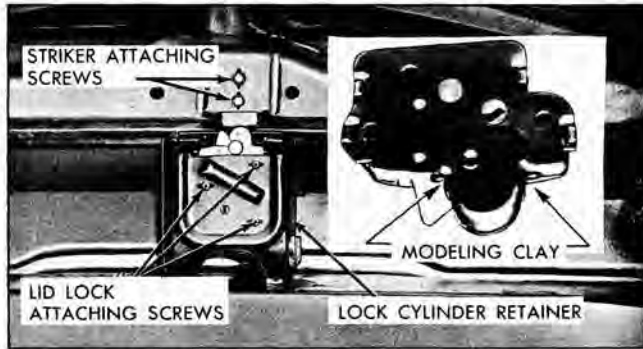

Fig. 5-8 Trunk Lock and Striker

3. Install "U" shaped end of torque rod to hinge box making certain outer end of rod is engaged in hole in outboard face of hinge box.
4. Engage torque rod to lower movable portion of hinge and engage other end of rod to correct retaining notch in inboard face of opposite hinge box.
5. Check alignment of rear compartment lid and make any necessary adjustments.
6. Replace wire harness if left hinge was removed.
7. Replace all previously removed trim.

REAR COMPARTMENT TORQUE ROD ADJUSTMENT

The amount of effort required to open and close the rear compartment lid is determined by the position of the torque rod in the notches on the inboard face of the hinge boxes. If the torque rod is located in the lowest most forward notch (position #1), the amount of effort required to open the lid is the greatest and the amount of effort required to close the lid is the least. If the torque rod is located in the top or most rearward notch (position #3), the amount of effort to open the lid is the least and the amount of effort to close the lid is the greatest. See (Fig. 5-7).

NOTE: It is not necessary to adjust the left and right hand torque rods at the same time or to the same final position (notch).

REAR COMPARTMENT LID LOCK CYLINDER

REMOVAL AND INSTALLATION

1. Open rear compartment. Remove slotted metal retainer securing lock cylinder to rear end panel (Fig. 5-7) and remove lock cylinder.

2. To install, reverse removal procedure. Make certain that lock cylinder gasket seals to rear end outer panel. Check lock cylinder for proper operation.

REAR COMPARTMENT LID LOCK

REMOVAL AND INSTALLATION

1. Open rear compartment. Remove lock cylinder retainer and lock cylinder (Fig. 5-8).
2. Remove lid lock attaching screws (Fig. 5-8) and remove lock.
3. To install, reverse removal procedure. Check lock and lock cylinder for proper operation.

REAR COMPARTMENT LID LOCK STRIKER

REMOVAL AND INSTALLATION

1. Open rear compartment. Mark vertical position of striker by scribing line at bottom of lid inner panel on striker. Mark horizontal position of striker on lid inner panel.
2. Remove striker attaching screws (Fig. 5-8) and remove striker.
3. To install position striker within scribed marks. Install attaching screws and check striker for proper alignment.

REAR COMPARTMENT LID LOCK STRIKER ENGAGEMENT

NOTE: Since the rear compartment lock frame acts as a guide when entering the striker, make sure rear compartment lid is properly positioned in body opening before performing striker engagement check. To check for proper engagement of rear compartment lid lock bolt with striker, use the following procedure:

- a. Insert a small quantity of modeling clay on frame of lock at both sides of the lock bolt (Fig. 5-8). Close lid with moderate force.
- b. Open lid and check amount of engagement of striker with lock frame as indicated by the compression of the clay. The striker bar impressions in the clay should be even on both sides of the lock frame. Where required, loosen striker attaching screws; adjust striker sideways or up or down to obtain proper engagement; then, tighten screws.

TAIL GATE**35 and 45 STYLES****DESCRIPTION**

All tail gates incorporate either a manually operated or electrically operated tail gate window which can be lowered into the tail gate or raised into the upper portion of the back body opening. The manually operated tail gate window is operated by means of a window regulator control handle (folding type) located in the tail gate outer panel. The electrically operated tail gate window can be operated from any one of two control switches: (1) control switch located on instrument panel; (2) lock cylinder control switch (key operated) located in tail gate outer panel. In addition, on nine passenger station wagon styles, the window can be operated by a control switch located in the upper portion of the left rear quarter trim assembly. A switch located at the right tail gate lock prevents the "up" cycle operation of the electrically operated tail gate window when the tail gate is not completely closed.

After lowering the tail gate window the tail gate can be opened by means of a tail gate lock remote control inside handle located at the tail gate belt finishing molding. On styles with the electrically operated tail gate window the tail gate lock remote control incorporates a safety feature which prevents operation of the inside handle unless the tail gate window is in the full "down" position.

The tail gate hinges are secured to the body rear cross bar and the tail gate inner panel by screws, which are accessible upon removal of the cross bar hinge cover plate and tail gate inner cover panel.

The tail gate is counterbalanced by four torque straps used in pairs. One end of each pair is retained in a stationary torque strap retainer located at the center of the body rear cross bar while the other ends are retained in slots in the pivoting part of the tail gate hinges.

When the tail gate is opened the ends of the torque straps retained in the tail gate hinges rotate with the gate while the ends secured at the retainer on the body rear cross bar remain stationary. This creates an assisting torque to hold the tail gate as the gate approaches and reaches the open position. This torque also assists in closing the tail gate. Fig. 5-9 is a phantom view which identifies the relationship of major component parts of the tail gate assembly.

TAIL GATE ADJUSTMENTS

To adjust the tail gate assembly "up or down" or "sideways" in the body opening loosen the tail gate hinge to inner panel, attaching screws. Shift tail gate to desired position and retighten screws.

To adjust the tail gate assembly forward or rearward in the body opening loosen the tail gate hinge to

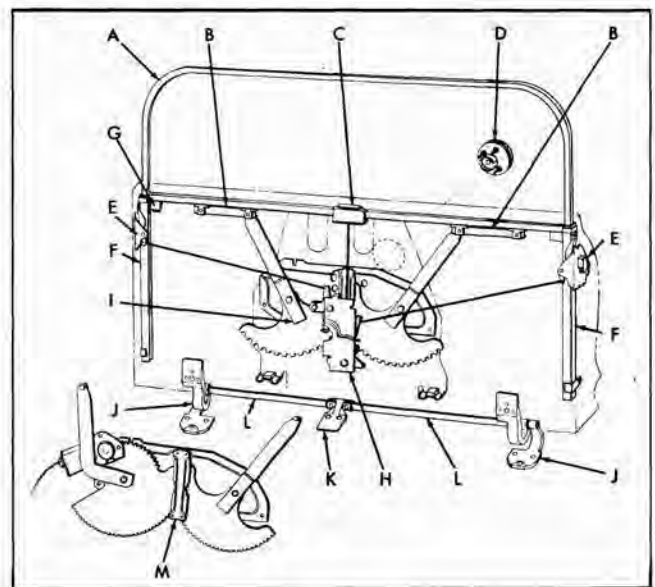

- A. Tail Gate Window Assembly
- B. Tail Gate Window Lower Sash Channel Cams
- C. Tail Gate Lock Remote Control Inside Handle
- D. Tail Gate Window Regulator Outside Handle or Lock Cylinder Switch and Escutcheon
- E. Tail Gate Lock Assembly
- F. Tail Gate Window Glass Side Run Channel
- G. Tail Gate Window Upper Stop
- H. Tail Gate Lock Remote Control
- I. Tail Gate Window Regulator - Manual
- J. Tail Gate Hinges
- K. Tail Gate Torque Strip Center Retainer
- L. Tail Gate Torque Straps
- M. Tail Gate Window Regulator - Electric

Fig. 5-9 Phantom View - Tail Gate

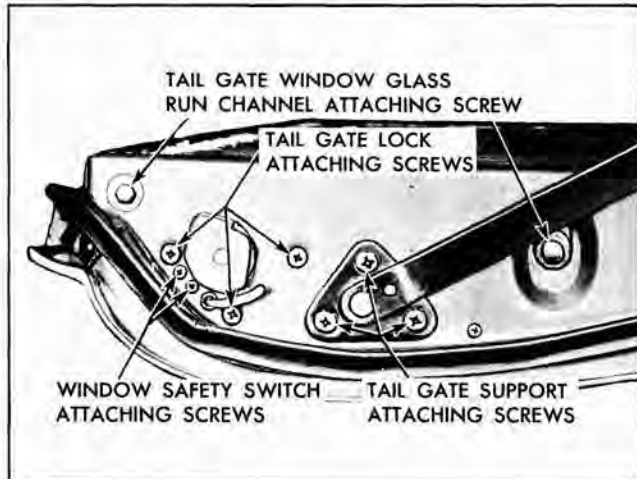

Fig. 5-10 Lock and Support

rear body cross bar attaching screws, shift tail gate assembly to the desired position and retighten the screws.

If "up or down" or "in or out" adjustment of tail gate has affected lock striker engagement, adjust strikers as described under "Tail Gate Lock Striker Adjustment".

REMOVAL AND INSTALLATION

1. Open tail gate. Raise floor-to-tail gate filler panel and prop in "up" position.
2. Remove tail gate inner cover panel lower retainer and inner cover panel. On "2735" Style, remove tail gate skid straps, tail gate inner cover panel finishing moldings and tail gate inner cover panel.
3. Carefully remove inner panel water deflector.
4. On styles equipped with electrically operated tail gate window remove window. Remove lock cyl-

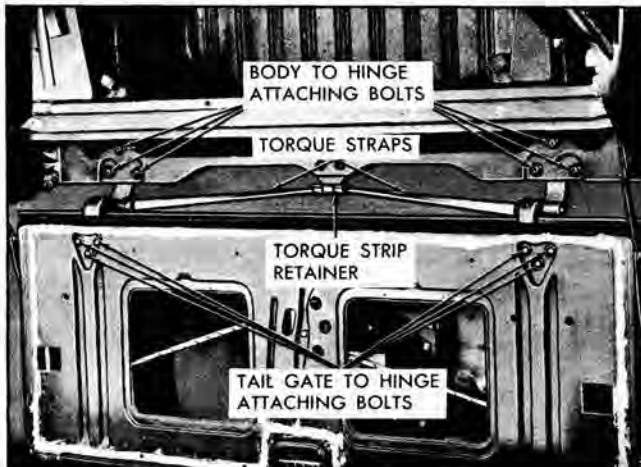

Fig. 5-11 Tail Gate Hinges

inder switch and escutcheon assembly as described under "Tail Gate Window Lock Cylinder Switch and Escutcheon Assembly". Disconnect harness connector from regulator motor, detach harness at clips inside tail gate and remove harness from tail gate.

5. Mark position of tail gate hinge (tail gate side) to facilitate installation in same position.
6. Suitably support tail gate to facilitate detachment of tail gate supports; then remove support attaching screws (Fig. 5-10) from both sides of tail gate and fold tail gate supports against body.
7. Raise tail gate and remove rear bumper. Disengage clips retaining torque straps to both hinges and center retainer and remove torque straps.

8. Remove tail gate to hinge attaching bolts (Fig. 5-11) and remove tail gate from body.

9. To install, reverse removal procedure. Prior to installation clean off old sealer from hinge straps and apply a coat of heavy bodied sealer to attaching surface of hinge straps (Fig. 5-12).

Apply body caulking compound between hinge strap and hinge strap opening in tail gate panels (Fig. 5-12) to effect a watertight seal.

Check alignment of tail gate assembly and, where necessary, adjust tail gate hinges for proper tail gate alignment as specified under "Tail Gate Adjustments".

TAIL GATE HINGE ASSEMBLY

REMOVAL AND INSTALLATION

1. Remove tail gate assembly, as previously described.
2. Scribe or mark position of hinge to facilitate installation in same position.
3. Remove hinge attaching bolts and remove hinge from body.
4. To install tail gate hinge assembly, reverse removal procedure. Prior to installing hinge, coat attaching surface of hinge with heavy-bodied sealer ("1" in Fig. 5-12). Install tail gate assembly as described under "Tail Gate Assembly - Installation".

TAIL GATE HINGE TORQUE STRAP

REMOVAL AND INSTALLATION

1. Remove rear bumper assembly from car.
2. Remove torque strap retainer clip from each

tail gate hinge and from torque strap center retainer (Fig. 5-11) and remove torque straps from body.

3. To install, reverse removal procedure.

TAIL GATE WINDOW ASSEMBLY— MANUAL AND ELECTRIC

REMOVAL AND INSTALLATION

1. Remove inner cover panel lower retainer and inner cover panel. On Pontiac "2735" style, remove tail gate skid strips, tail gate inner cover panel finishing moldings and tail gate inner cover panel.

2. Detach tail gate inner panel water deflector sufficiently to gain access to window lower sash channel cam attaching bolts (Fig. 5-13). Remove tail gate inner panel access hole covers.

3. Carefully operate window upward until the window lower sash right and left cam attaching bolts are accessible through access holes (Fig. 5-13).

4. Remove window lower sash channel right and left cam attaching bolts (Fig. 5-13) and disengage cams from window lower sash channel.

5. Remove tail gate window assembly by cocking glass so that left side of window assembly comes out of tail gate prior to right side. This is necessary to allow integral up travel stop on right side of lower sash channel to by-pass up travel stop engagement arm on glass run channel.

NOTE: To open the tail gate on styles with electric windows when window assembly is removed, depress tail gate lock remote control locking lever through access hole at location "A", (Fig. 5-13), and at the same time operate the tail gate remote control inside handle.

6. To install tail gate window assembly reverse removal procedure. Prior to installing window lower sash channel cams, lubricate channel portion of cams with "Lubriplate" or its equivalent. Prior to resealing tail gate inner panel water deflector, check operation of window and tail gate locking mechanisms. Where necessary, adjust tail gate window, tail gate lock strikers or tail gate lock remote control for proper operation. Reseal tail gate inner panel water deflector as specified under "Tail Gate Inner Panel Sealing".

In the event the tail gate cannot be opened due to the window becoming inoperative while in an "up" position, proceed as follows:

1. Using an offset screwdriver, remove tail gate

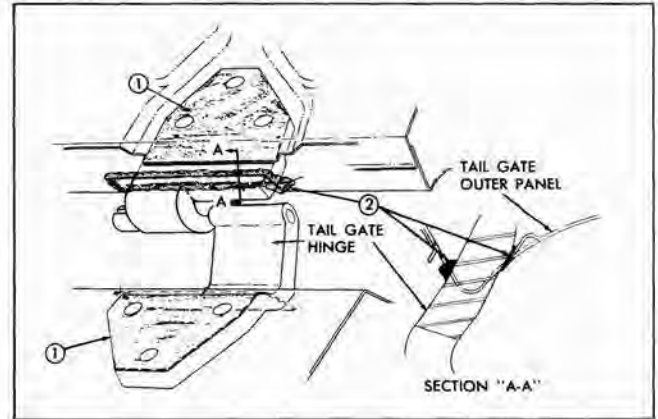

Fig. 5-12 Tail Gate Hinge

inner cover panel attaching screws. Lift panel upward to disengage it from lower retainer.

NOTE: Due to inaccessibility, it may be necessary to cut lower left cover panel attaching screws by chisel. To make chisel, taper one end of an 18" x 1" x 1/8" piece of steel. Cut lower screws by inserting chisel between tail gate inner panel and tail gate cover panel.

2. Remove inner panel access hole cover upper attaching screws. Loosen access hole cover lower attaching screws and remove cover by lifting it upward.

3. Remove lower sash channel cam attaching screws and lower window assembly into tail gate. Open tail gate.

In the event the window is inoperative in the full "up" position, the window regulator attaching screws can be removed and the window and regulator lowered sufficiently to allow removal of the window lower sash channel cam attaching screws.

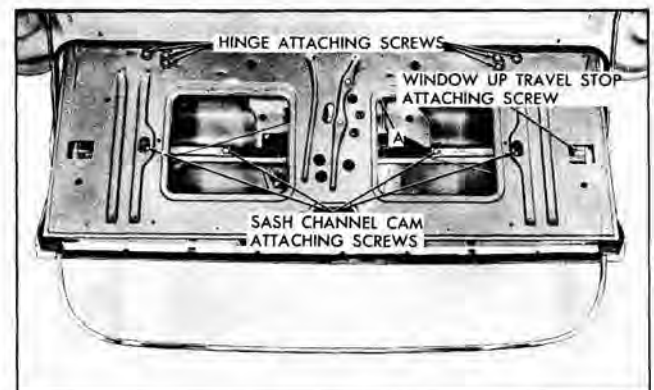

Fig. 5-13 Tail Gate Hardware

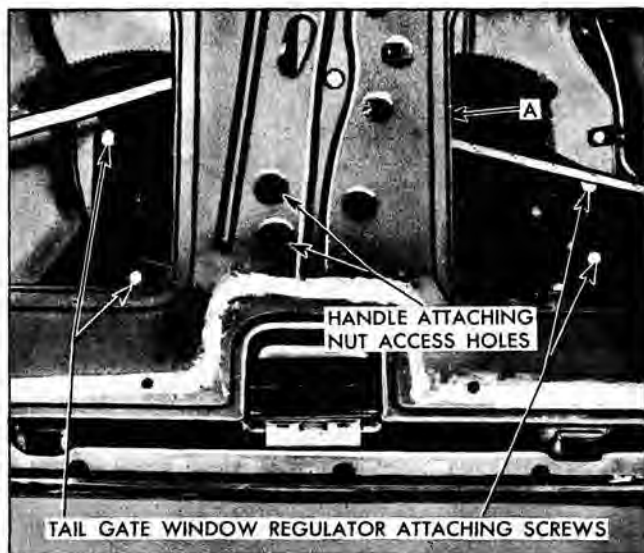

Fig. 5-14 Window Regulator

TAIL GATE WINDOW ADJUSTMENTS

1. To adjust the tail gate window forward or rearward for proper alignment with the window glass run channels on the body and/or to eliminate a binding condition of the window in the tail gate glass run side channel (s), loosen lower attaching bolt at tail gate lock pillar; move lower end of channel forward or rearward, as required, and tighten lower attaching bolt.

NOTE: The vertical portion of the tail gate window glass upper run channels are adjustable forward or rearward for proper alignment with the tail gate glass.

2. To correct a condition where the glass is "cocked" in the glass run channels, loosen window regulator attaching screws (Fig. 5-11), rotate regulator assembly clockwise or counterclockwise, as required, to eliminate "cocked" condition.

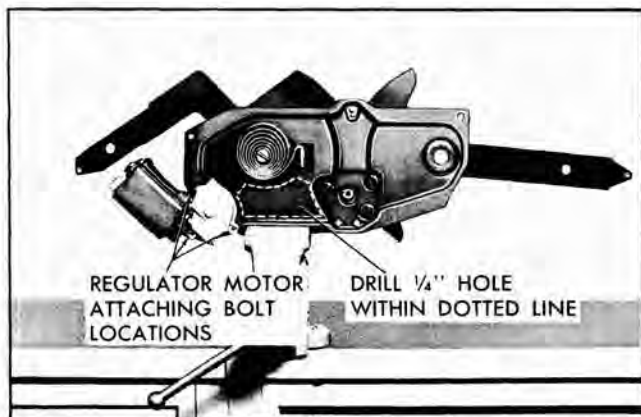

Fig. 5-15 Tail Gate Window Regulator

TAIL GATE WINDOW REGULATOR ASSEMBLY—MANUAL OR ELECTRIC

REMOVAL AND INSTALLATION

1. Remove tail gate window assembly, as described under "Tail Gate Window Assembly - Removal and Installation".

2. Detach tail gate lock remote control right connecting rod from remote control at "A" (Fig. 5-14).

3. On styles equipped with electrically operated tail gate window; disconnect tail gate harness connector from regulator motor.

CAUTION: Do not operate regulator motor after window assembly is disengaged from the regulator or after the regulator is removed from the tail gate. Operation of the motor with the load removed may damage the unit and make it inoperative.

4. Remove regulator attaching screws through access holes at locations shown in Fig. 5-14. Remove regulator assembly through large access hole.

NOTE: To remove electric motor from regulator assembly see "Tail Gate Window Regulator Electric Motor Assembly - Removal and Installation".

5. To install tail gate window regulator assembly, reverse removal procedure. Prior to installing regulator, lubricate the teeth on the regulator sectors with "Lubriplate" or its equivalent.

Prior to resealing tail gate inner panel water deflector, check operation of window and tail gate locking mechanism. Where necessary, adjust tail gate window, tail gate lock strikers or tail gate lock remote control for proper operation.

TAIL GATE WINDOW REGULATOR—ELECTRIC MOTOR ASSEMBLY

REMOVAL AND INSTALLATION

1. Remove tail gate window regulator and electric motor assembly as described under "Tail Gate Window Regulator Assembly - Removal and Installation".

2. Place regulator assembly in a vise as shown in Fig. 5-15.

CAUTION: Be sure to perform steps 3 and 4 before attempting to remove the motor from the regulator. The regulator lift arms which are under tension from the counterbalance spring can cause serious injury if the motor is removed without locking the sectors in position.

3. Drill a 1/4 inch hole through regulator backplate and main sector within area indicated by dotted lines (Fig. 5-15).

NOTE: Do not locate hole less than 1/2 inch away from edge of backplate, sector or holes in backplate and sector. Do not use holes in backplate or sector as they are too large and locking bolt can slip out.

4. Insert a 3/16 inch bolt through hole in backplate and sector and install nut to bolt. (Do not tighten nut)

5. Remove three (3) motor attaching bolts, at locations shown in Fig. 5-15 and remove motor assembly from regulator.

NOTE: Clean off steel chips from the regulator sectors and motor pinion gear after drilling operation.

6. To install regulator electric motor assembly, reverse removal procedure.

NOTE: Be sure to remove nut and bolt locking sector after motor is installed.

TAIL GATE WINDOW REGULATOR OUTSIDE HANDLE ASSEMBLY

REMOVAL AND INSTALLATION

1. Remove inner cover panel lower retainer and inner cover panel. On Pontiac "2735" style, remove tail gate skid strips, tail gate inner cover panel finishing moldings and tail gate inner cover panel.

2. Detach tail gate inner panel water deflector sufficiently to gain access to access holes, shown in Fig. 5-14, for removal of handle attaching nuts.

3. Carefully raise window until holes in window regulator are aligned with inner panel access holes, shown in Fig. 5-14, for removal and installation of outside handle attaching nuts.

CAUTION: Support portion of window assembly extending out of tail gate (Fig. 5-14).

4. Through access holes, shown in Fig. 5-14, remove tail gate handle attaching nuts and remove handle assembly and gasket from tail gate. To assemble tail gate handle assembly, see "Tail Gate Handle Assembly—Disassembly and Assembly".

5. To install tail gate handle assembly, reverse removal procedure. Make sure sealing gasket is installed between tail gate outer panel and handle escutcheon and make sure handle clutch is properly

engaged with window regulator clutch. Check operation of window prior to resealing water deflector. Reseal tail gate inner panel water deflector as specified under "Tail Gate Inner Panel Water Deflector".

TAIL GATE WINDOW REGULATOR OUTSIDE HANDLE LOCK CYLINDER AND CAP ASSEMBLY

REMOVAL AND INSTALLATION

1. Using an awl or suitable punch, carefully punch through webbed hole in face of lock cylinder cap (selector lever).

2. With key in lock cylinder and selector lever in "lock" position insert a piece of wire (paper clip) in hole on face of lock cylinder cap (selector lever) and depress plunger with wire sufficiently to allow key and selector lever to be turned counterclockwise approximately 1/8 turn; then, remove lock cylinder and cap assembly.

3. To install lock cylinder and cap assembly, reverse removal procedure. Prior to installation, lubricate frictional surfaces of lock cylinder and cap parts with "Lubriplate" or its equivalent.

TAIL GATE WINDOW REGULATOR OUTSIDE HANDLE ASSEMBLY

DISASSEMBLY AND ASSEMBLY

1. Remove window regulator handle assembly.

2. Using a hooked tool or other suitable tool, remove clutch spring retainer; then remove clutch washer and spring washer, and remove clutch and lock cylinder assembly from unit (Fig. 5-16).

3. Using snap ring pliers or other suitable tool remove housing spring retainer; then remove housing washer and spring washer, and remove back plate from handle and knob housing (Fig. 5-16).

NOTE: Plastic shoes can be removed from handle and knob housing by carefully prying shoes from housing (Fig. 5-16).

4. If replacing handle and knob assembly remove screws securing handle and knob retainers; then disengage handle and knob including handle pin from housing (Fig. 5-16).

5. To install handle assembly, reverse removal procedure. Prior to installation, lubricate frictional surfaces of parts with "Lubriplate" or its equivalent.

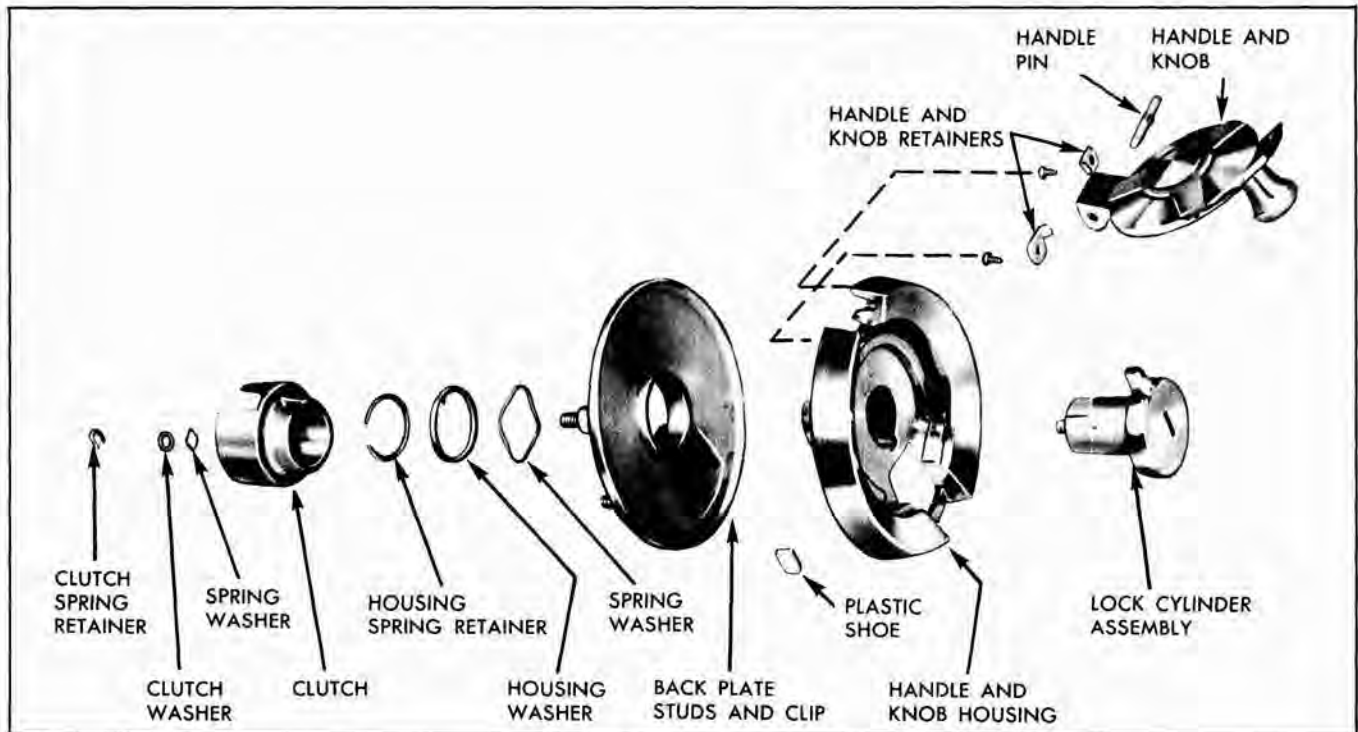

Fig. 5-16 Tail Gate Outside Handle Assembly

TAIL GATE WINDOW REGULATOR OUTSIDE HANDLE LOCK CYLINDER AND CASE ASSEMBLY

DISASSEMBLY AND ASSEMBLY

1. Using an awl or suitable punch, carefully punch through webbed hole in face of lock cylinder cap (selector lever). Remove window regulator handle assembly.

2. Using an awl or other suitable tool, remove clutch spring retainer; then remove clutch washer and spring washer and remove clutch and lock cylinder assembly from unit (Fig. 5-16).

3. Insert a piece of wire (paper clip) in hole on face of lock cylinder cap (selector lever). While holding lock cylinder case, depress plunger with wire sufficiently to allow key and selector lever to be turned counterclockwise approximately 1/8 turn; then, remove lock cylinder and cap (selector lever) assembly from handle assembly (Fig. 5-17).

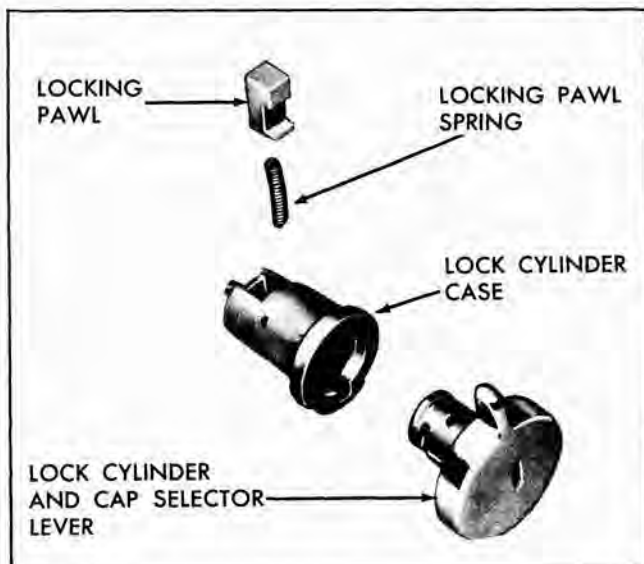

Fig. 5-17 Lock Cylinder - Manual

NOTE: When removing lock cylinder and cap assembly from case, place finger over locking pawl to prevent pawl and spring from popping out (Fig. 5-17).

4. Remove locking pawl and pawl spring from lock cylinder case.

5. To install lock cylinder and case assembly, reverse removal procedure. Prior to installation, lubricate frictional surfaces of parts with "Lubri-plate" or its equivalent.

TAIL GATE ELECTRIC WINDOW LOCK CYLINDER, SWITCH AND ESCUTCHEON ASSEMBLY

REMOVAL AND INSTALLATION

1. Remove inner cover panel lower retainer and inner cover panel. On Pontiac "2735" style, remove

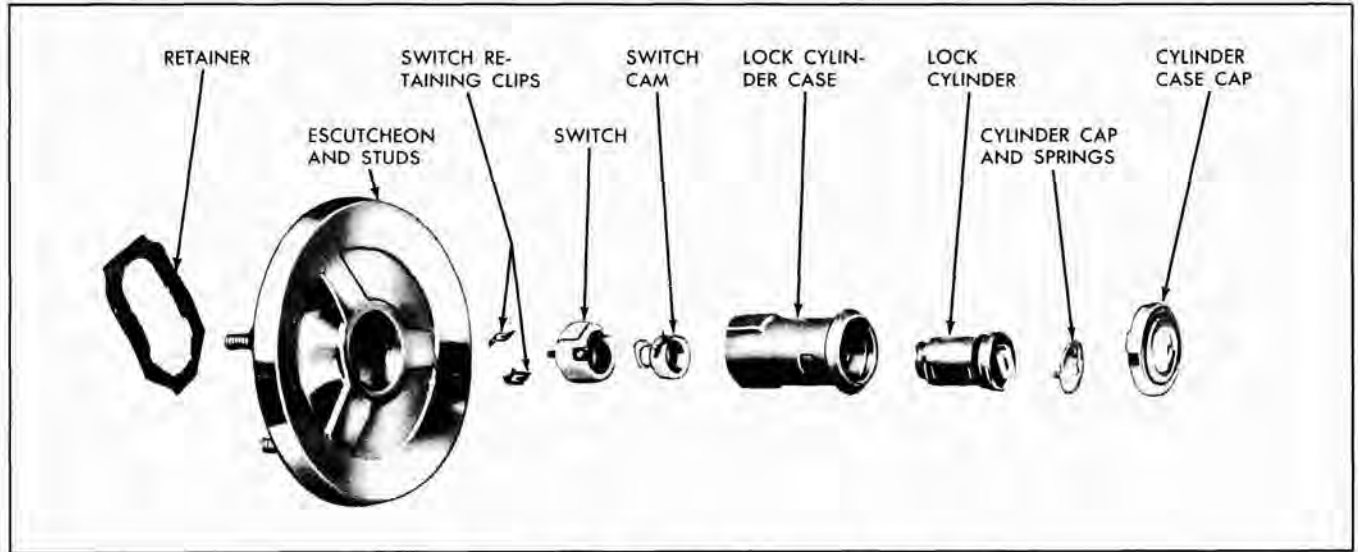

Fig. 5-18 Tail Gate Lock Cylinder and Switch

tail gate skid strips, tail gate inner cover panel finishing moldings and tail gate inner cover panel.

2. Detach tail gate inner panel water deflector sufficiently to gain access to access holes, shown in Fig. 5-14, for removal of assembly attaching nuts.

3. Carefully operate window upward until holes in window regulator assembly are aligned with inner panel access holes, shown in Fig. 5-14, for removal and installation of attaching nuts.

CAUTION: Support portion of window extending out of tail gate.

4. Through access holes, shown in Fig. 5-14, remove lock cylinder, switch and escutcheon assembly attaching nuts. Detach assembly from tail gate outer panel sufficiently to disconnect junction block from switch; then, remove assembly and gasket from tail gate.

To disassemble electric window lock cylinder, switch and escutcheon assembly see "Electric Window Lock Cylinder, Switch and Escutcheon Assembly-Disassembly and Assembly".

TAIL GATE ELECTRIC WINDOW LOCK CYLINDER AND SWITCH ASSEMBLY

REMOVAL AND INSTALLATION

1. Remove tail gate electric window lock cylinder, switch and escutcheon assembly.

2. Disengage lock cylinder and switch retainer (Fig. 5-18) and remove lock cylinder and switch assembly from escutcheon.

3. To install lock cylinder and switch assembly, reverse removal procedure.

DISASSEMBLY AND ASSEMBLY

1. Using a pointed tool inserted through holes in lock cylinder case, depress tab of switch clips and remove clips (Fig. 5-18).

2. Carefully pull switch and switch cam from lock cylinder case (Fig. 5-18).

3. Using a suitable tool, bend out crimped flange of lock cylinder case cap sufficiently to remove cap; then remove lock cylinder cap and springs.

NOTE: The crimped flange on production lock cylinder case caps necessitates damaging cap during removal from lock cylinder case; however, service replacement caps are available which have four (4) bend over tabs for installation.

4. To assemble lock cylinder and switch assembly, reverse removal procedure. Prior to installation, lubricate frictional surfaces of lock cylinder and switch parts with "Lubriplate" or its equivalent. Install a new service replacement lock cylinder case cap.

TAIL GATE SUPPORT ASSEMBLY

REMOVAL AND INSTALLATION

1. Lower tail gate.

2. Suitably support tail gate to prevent damage to tail gate outer panel.

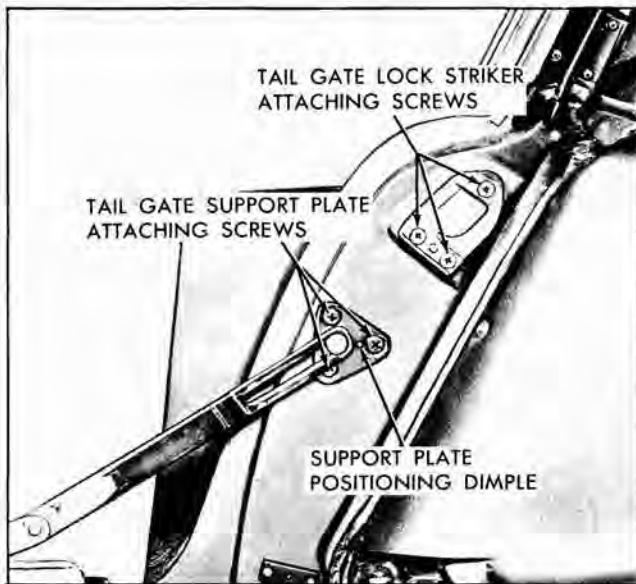

Fig. 5-19 Support and Lock Striker

3. Remove tail gate support attaching screws securing support plates to body and tail gate (Fig. 5-19) and remove support assembly.

4. To install tail gate support assembly, reverse removal procedure. Install support plate to body with positioning dimple towards front of body (Fig. 5-19).

TAIL GATE LOCK ASSEMBLY— RIGHT OR LEFT

REMOVAL AND INSTALLATION

1. Remove tail gate window assembly.

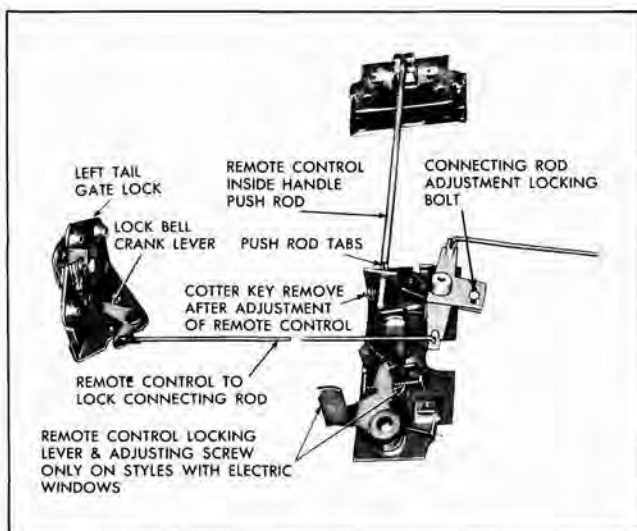

Fig. 5-20 Tail Gate Lock

2. Remove tail gate window glass run side channel attaching screws (Fig. 5-10) and remove channel from side of tail gate from which lock is being removed.

3. Disengage spring clip and detach lock remote control connecting rod from lock remote control (Fig. 5-20).

4. Remove tail gate lock attaching screws, (Fig. 5-10) and remove tail gate lock with attached connecting rod from tail gate; then detach connecting rod from lock.

5. To install tail gate lock assembly, reverse removal procedure. Prior to installing lock assembly into tail gate, apply a bead of body caulking compound to lock frame along the joint of the lock bolt housing ("1" in Fig. 5-21).

To attach lock connecting rod to remote control lever, first, loosen connecting rod adjustment locking bolt at remote control (Fig. 5-20); then, install rod to lever and tighten locking bolt.

NOTE: Check clips at ends of remote control levers for proper retention of connecting rods and replace if necessary.

Prior to resealing water deflector, check operation of tail gate locking mechanism.

TAIL GATE LOCK STRIKER

REMOVAL AND INSTALLATION

1. Open tail gate and with pencil, mark position of striker on body pillar.

2. Remove lock striker attaching screws and remove striker and adjusting plates from body pillar.

3. To install tail gate lock striker, place striker and adjusting plates within marks on body pillar and install striker attaching screws.

TAIL GATE LOCK STRIKER ADJUSTMENTS

1. To adjust the tail gate lock striker "up" or "down" or "forward" or "rearward", loosen striker attaching screws, shift striker and adjusting plates to desired position, then tighten striker attaching screws.

2. Dimensional specifications for use of door lock striker emergency spacers.

a. Tail gate should be properly aligned before checking spacer requirements.

b. To determine if tail gate lock striker emergency spacers are required, apply modeling clay or body caulking compound in the lock striker notch where the lock extension engages and then close the tail gate to form a measurable impression in the clay or caulking compound, as shown in (Fig. 5-22).

When dimension "A" from inside face of striker teeth to center of lock extension is less than 3/16" install emergency spacers and proper length striker attaching screws as directed.

Dimension "A"	No. of Spacers Required	Spacer Thickness	Striker Attaching Screws*
3/16" to 1/8"	1	1/16"	Original Screw
1/8" to 1/16"	1	1/8"	Emergency Screw (1/8" longer)
1/16" to 0	1 (1/8" Spacer) 1 (1/16" Spacer)	3/16" (Total)	Emergency Screw (1/4" longer)
0 to 1/16" Interference	2 (1/8" Spacers)	1/4" (Total)	Emergency Screw (1/4" longer)

* Zinc or cadmium-plated flat-head cross-recess screw with countersunk washer.

NOTE: Dimension "B" from center of lock extension to inside face of striker should never be less than 1/16".

TAIL GATE LOCK REMOTE CONTROL INSIDE HANDLE ASSEMBLY

REMOVAL AND INSTALLATION

1. Remove tail gate belt finishing molding and tail gate inner cover panel. Detach inner panel water deflector sufficiently to gain access to inner panel.

2. Loosen tail gate lock remote control attaching screws and move remote control towards bottom of tail gate sufficiently to disengage end of handle push rod from hole in remote control lever.

NOTE: In some instances it may be necessary to reach into tail gate and actuate remote control lever to disengage push rod from lever.

3. Remove handle attaching screws located under handle and remove handle assembly (includes push rod) from tail gate.

4. To install tail gate lock remote control handle assembly, reverse removal procedure. Lubricate frictional points of inside handle assembly with "Lubriplate" or its equivalent.

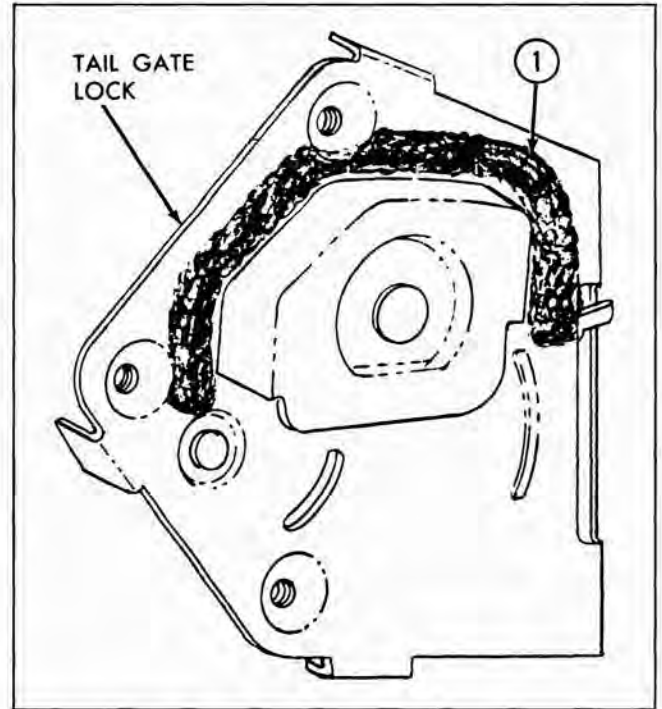

Fig. 5-21 Tail Gate Lock - Sealing

NOTE: To engage end of handle push rod into hole in remote control lever, it may be necessary to raise window in tail gate to gain access to lever. Adjust remote control upward until tabs on handle push rod (Fig. 5-20) just contact remote control lever.



Fig. 5-22 Striker Engagement Check

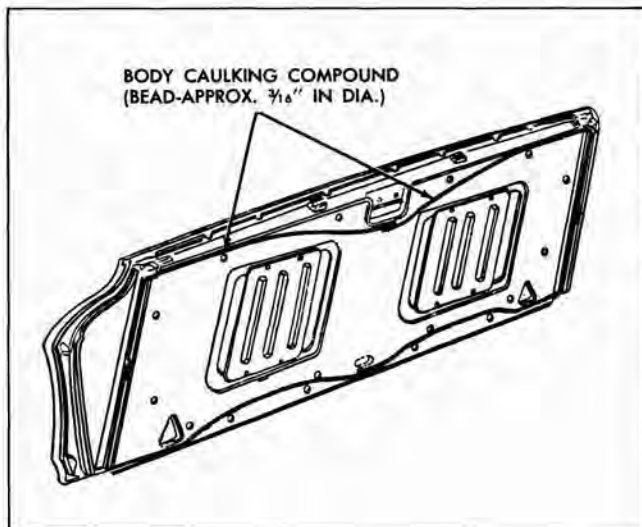

Fig. 5-23 Tail Gate Inner Panel

Prior to resealing tail gate inner panel water deflector check operation of tail gate lock mechanism and, where necessary, adjust door lock strikers or remote control for proper operation.

TAIL GATE LOCK REMOTE CONTROL ASSEMBLY

REMOVAL

1. Remove tail gate window assembly
2. Disengage clips securing lock connecting rods to remote control (Fig. 5-20) and detach connecting rods from remote control.
3. Remove tail gate lock remote control attaching



Fig. 5-24 Clip Reformer Tool

screws. Disengage remote control from inside handle push rod and remove remote control from tail gate.

INSTALLATION

1. Engage inside handle push rod into hole in remote control lever.
2. Adjust remote control assembly up or down until tabs on push rod (Fig. 5-20) just contact remote control lever.
3. To attach lock connecting rods to remote control lever, first, loosen connecting rod adjustment locking bolt (Fig. 5-20); then, install rods to levers and tighten locking bolt.

NOTE: Check clips at ends of remote control levers for proper retention of connecting rods and replace if necessary.

IMPORTANT: If installing new remote control assembly, remove cotter key (Fig. 5-20) after adjustment to free locking lever.

4. Check operation of tail gate locking mechanism. To open tail gate when window assembly is removed, depress tail gate lock remote control locking lever and at the same time operate the tail gate remote control inside handle.

5. Install tail gate window assembly as described under "Tail Gate Window Assembly - Installation".

6. Lower window to approximately 1/2 inch up from "full down" position; then adjust remote control locking lever adjusting screw (Fig. 5-20) so that lever is just contacting window lower sash channel frame. Check operation of remote control inside handle - handle should remain locked until window is lowered to within 1/4 inch of the "full-down" position.

TAIL GATE INNER PANEL WATER DEFLECTOR

On all station wagon styles a waterproof paper tail gate inner panel water deflector is sealed to the tail gate inner panel and deflects water into the bottom of the tail gate where it can drain out the bottom drain holes. The bottom of the water deflector is sealed to the inner panel in a manner that will deflect water towards designated access holes where the water can readily enter into the bottom of the tail gate.

It is important that whenever any work is performed on the tail gate where the water deflector has been disturbed, the deflector must be properly sealed to the tail gate inner panel.

REMOVAL AND INSTALLATION

1. Remove tail gate inner cover panel lower retainer and inner cover panel.

2. Using a sharp scraper or other suitable tool carefully lift up edge of deflector and detach sealer and water deflector as required.

NOTE: Do not tear water deflector.

INSTALLATION OR RESEALING PROCEDURE

1. If installing old deflector or resealing partially detached deflector first inspect water deflector for any tears or holes and, where necessary, repair any tears or holes with water proof body tape applied to both sides of deflector.

2. If installing new deflector use old deflector or tail gate inner panel to trim new deflector to proper size.

3. Apply a bead of body caulking compound (approximately 3/16" diameter) to tail gate inner panel. (Fig. 5-23)

NOTE: The body caulking compound should be applied along the lower portion of the tail gate exactly as shown in illustration to assure proper drainage of water through inner panel access holes into bottom of tail gate.

4. Position water deflector to tail gate inner panel with polyethylene coated side of deflector against inner panel. Firmly press or roll sealed areas to obtain a good bond between deflector and tail gate inner panel.

5. Clean off all excess caulking compound; then, install previously removed tail gate inner cover panel.

TAIL GATE WEATHERSTRIP

REMOVAL

1. Remove tail gate belt finishing molding.

At both sides of tail gate disengage snap fasteners securing upper ends of weatherstrip.

2. With a sharp scraper, carefully break cement bond securing weatherstrip along tail gate lock pillars.

3. Insert tip of mechanically-retained weatherstrip inserting tool J-5757, or any other suitable tool, at clip locations and carefully snap clips from retaining holes and remove weatherstrip from tail gate.

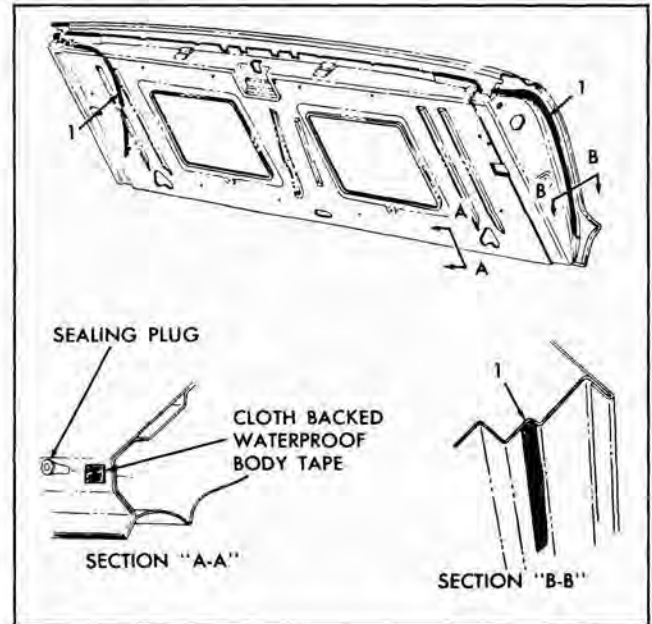

Fig. 5-25 Tail Gate Weatherstrip

INSTALLATION

1. Clean off old cement to insure a clean cementing surface.

2. Check weatherstrip clips for proper contour and reform clips, if necessary, using clip reforming tool J-5984 (Fig. 5-24).

3. Check weatherstrip clip hole sealing plugs along bottom of tail gate for cracks or damage and replace, where necessary.

NOTE: If sealing plugs are loose and will not remain engaged in panel, install a 1/2" x 1" piece of cloth backed waterproof body tape over sealing plug retaining hole, as shown in Section "A-A" (Fig. 5-25) then, slit tape over hole to form and "X" pattern. Check sealing plug for snug fit. If plug is still loose, repeat above operation by installing second piece of tape over existing repair.

4. Apply (brush coat) weatherstrip adhesive (neoprene type) on face of rabbet contacted by weatherstrip along full length of lock pillar as indicated at "1" in Section "B-B" (Fig. 5-25).

5. Properly position weatherstrip to tail gate. Install weatherstrip clips into retaining holes using Weatherstrip Inserting Tool J-5757. Press or roll cemented areas to assure a good cement bond.

TAIL GATE BOTTOM DRAIN HOLE SEALING STRIPS

REMOVAL AND INSTALLATION

1. With a flat-bladed tool carefully pry out snap-on fastener at each end of strip and remove sealing

strip from tail gate.

2. To install sealing strips, reverse removal procedure. To prevent strip from adhering to the tail gate panel and blocking the drain holes, apply a sparing amount of silicone rubber lubricant on the center section of the sealing strip.

EXTERIOR MOLDINGS

CONTENTS OF THIS SECTION

SUBJECT	PAGE	SUBJECT	PAGE
Windshield Drip Moldings	6-1	Rear Quarter Window Moldings	6-10
Roof Drip Moldings	6-1	Rear Fender Moldings	6-12
Front Door Window Moldings	6-8	Rear End Moldings	6-14
Rear Door Window Moldings	6-9	Tail Gate Moldings	6-14

BODY MOLDINGS

REMOVAL AND INSTALLATION

The exterior moldings are secured to the body by any one or a combination of the following: attaching screws, attaching nuts, snap retention on body parts, "bath-tub" snap-on clips of steel and plastic constructions, friction type snap-in clips, bolt and clip assemblies, and molding integral attaching studs. Fig. 6-1 depicts cross-section drawing which illustrate some of the typical methods used in attaching moldings to the body.

During removal and installation of body exterior moldings, certain precautions should be exercised. Adjacent paint finishes should be protected to avoid refinishing. Proper tools and methods should be employed to guard against molding damage, particularly if the part is to be reused. Whenever a sealing operation is disturbed, appropriate sealing materials and methods should be used to provide the required watertight seal. Every screw, nut or clip that secures a molding to a body outer panel, including the attaching hole, requires a specialized type of sealing operation. An approved grade of medium-bodied sealer and body caulking compound are the sealers used most generally in the effective sealing of these moldings. The exterior moldings are identified in Figs. 6-2, 6-3, 6-4 and 6-5.

Bath-tub type clips, of plastic construction, can be removed satisfactorily by cutting them part way through or all of the way through from the outer panel with a sharp, flat-bladed tool as shown in Fig. 6-6. In some cases it may be necessary to cut the clip from each end to remove it.

Fig. 6-7 shows the special tool, J-8954, which is required to install the narrow "bath-tub" type steel clips.

Plastic "bath-tub" type clips do not require the use of a special tool for their installation.

WINDSHIELD PILLAR DRIP MOLDING SCALP 35 AND 69 STYLES

The scalp is secured to the drip molding by snap retention.

To remove the scalp: use a suitable, pointed hook tool and by starting at the lower end under the drip molding, unsnap the scalp from the drip molding.

To install the scalp: position the scalp over the upper lip of the windshield pillar drip molding and over the roof drip molding scalp. Snap the lower rolled edge of the scalp under the drip molding.

WINDSHIELD PILLAR TO ROOF DRIP MOLDING ESCUTCHEON

11, 35, 45, 47 and 69 STYLES

The escutcheon is painted body color and is secured to both drip moldings by snap retention. The escutcheon is used only on those applicable styles that do not include the special order bright finish scalp moldings. On "47" styles, the windshield pillar weatherstrip retainer overlaps the escutcheon.

To remove the escutcheon: on "47" styles, remove the windshield pillar weatherstrip retainer. Use a suitable, pointed hook tool and unsnap the escutcheon by carefully prying outwardly under the drip moldings.

To install the escutcheon: position the escutcheon over the upper lip of the windshield pillar and roof drip moldings. Snap the lower rolled edge of the escutcheon under the drip moldings. Fit the escutcheon to the drip molding and touch up as required. Complete the installation of the windshield pillar weatherstrip.

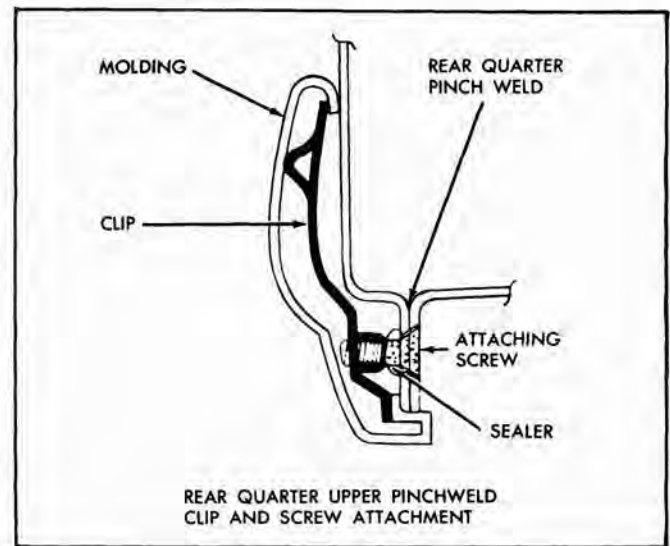
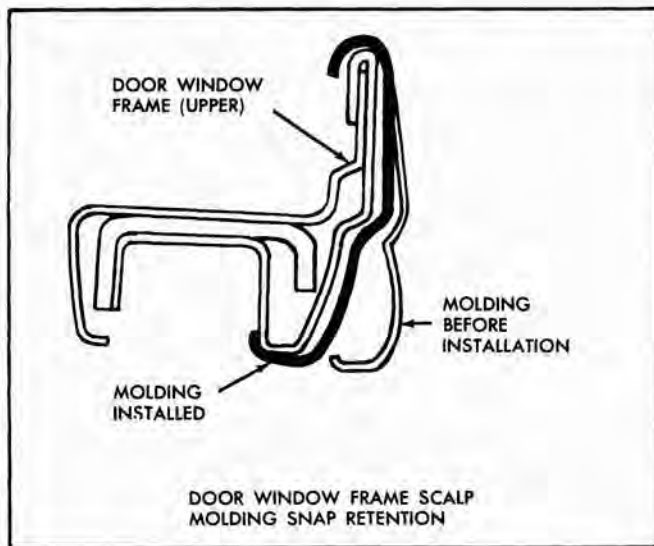
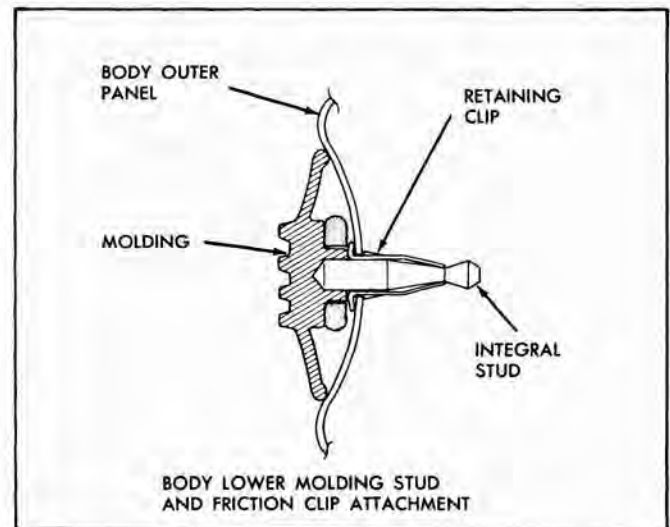
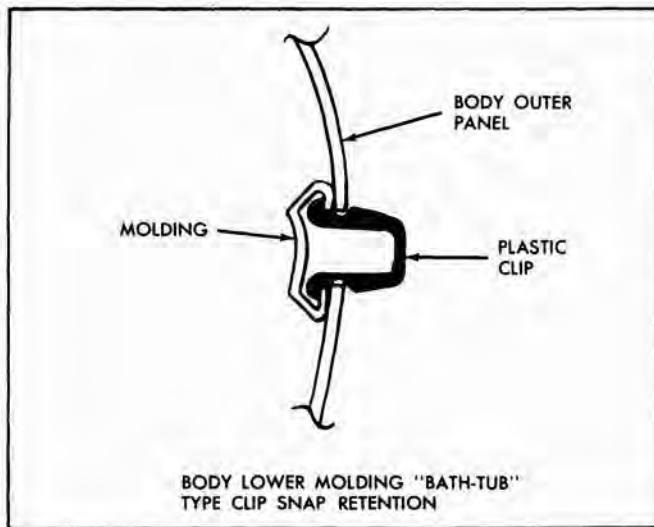
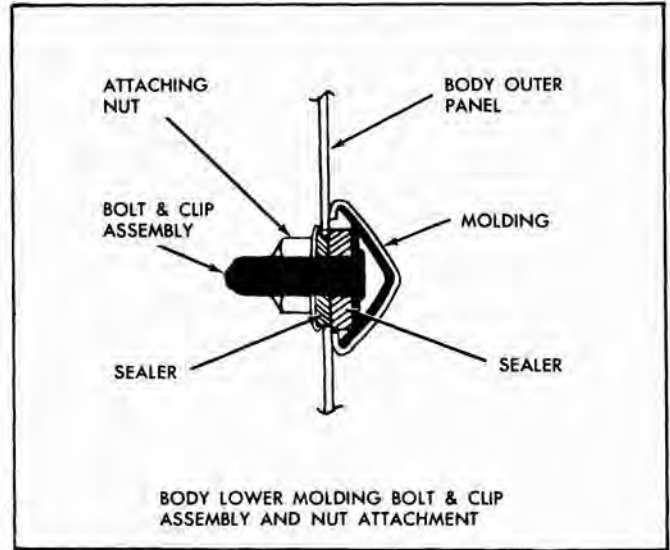
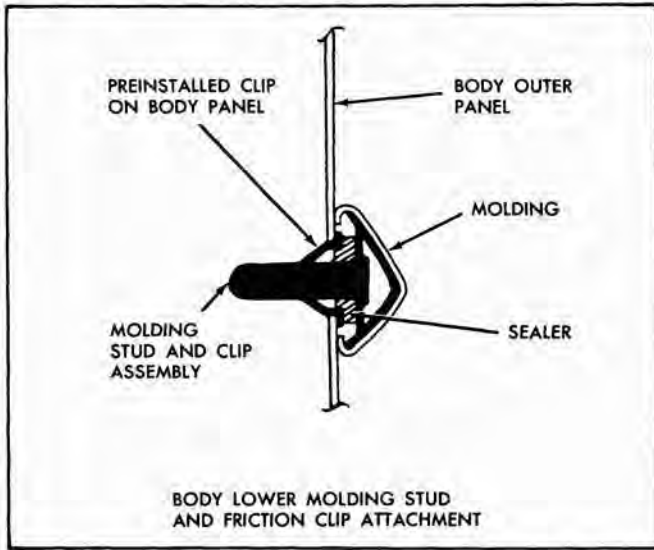
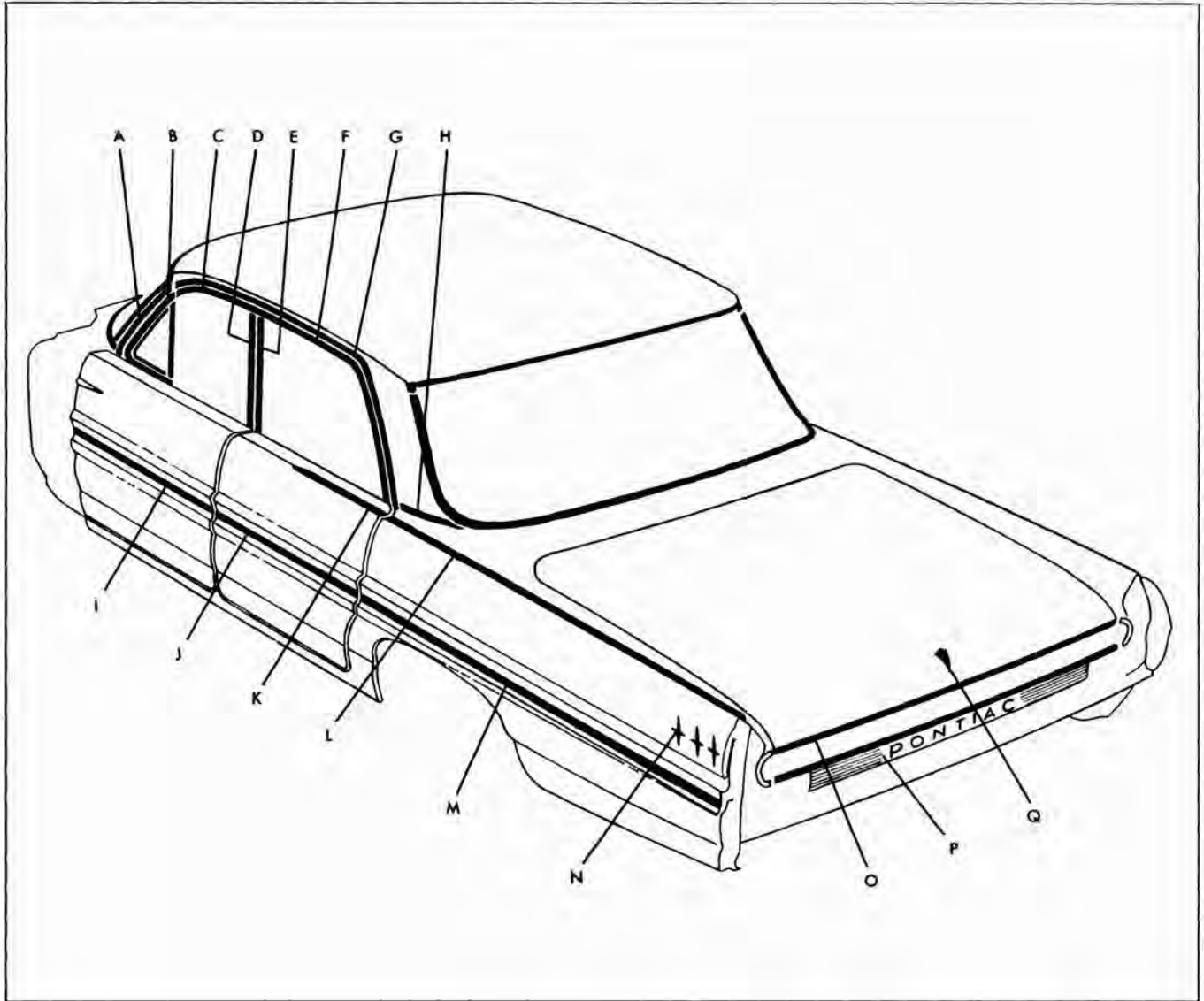
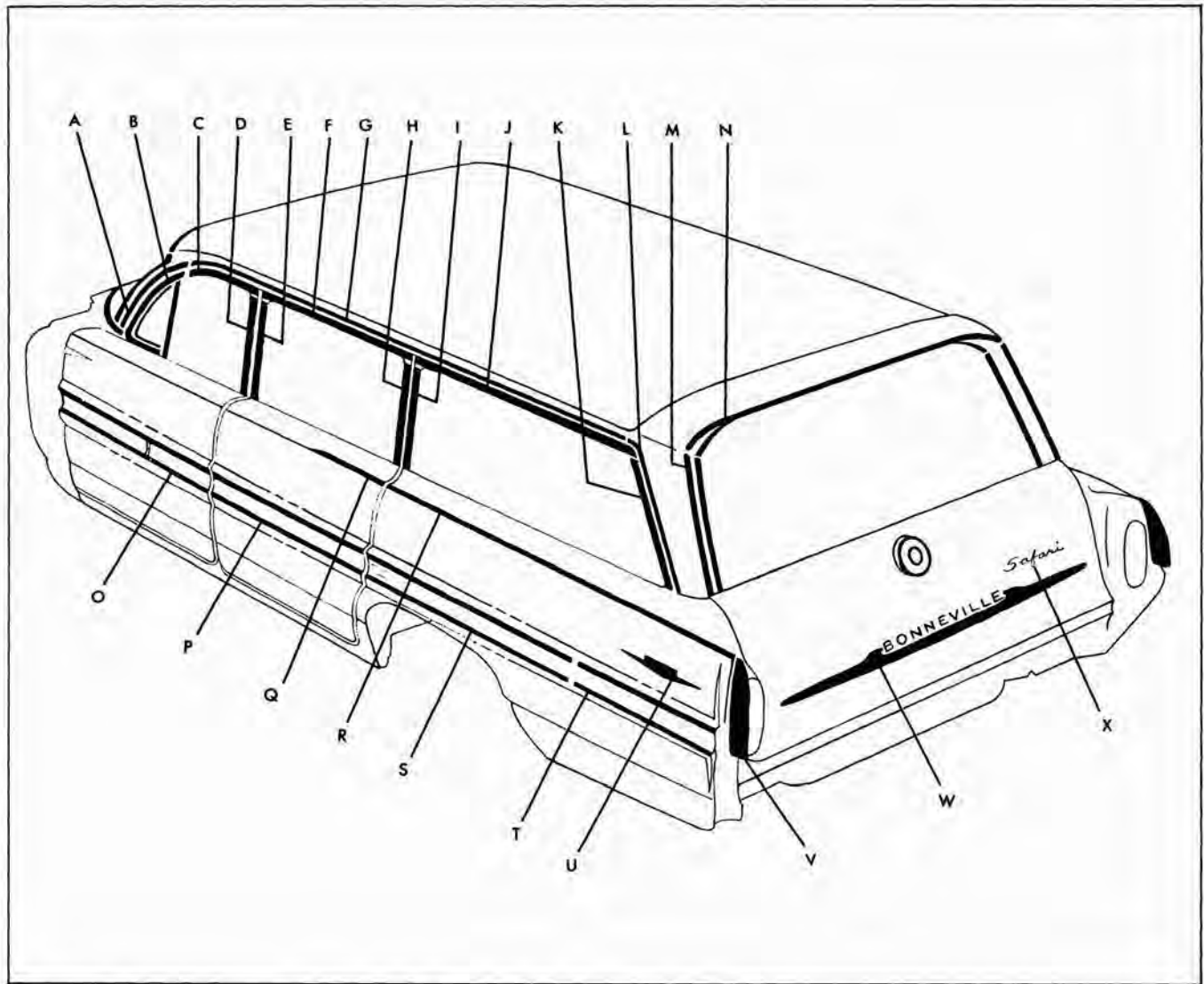

Fig. 6-1 Typical Methods of Molding Attachments



- | | |
|---|---|
| A. Windshield Pillar Drip Molding Scalp | H. Rear Quarter Belt Reveal Molding |
| B. Front Door Window Frame Front Vertical Scalp Molding | I. Front Door Outer Panel Lower Molding |
| C. Front Door Window Frame Upper Scalp Molding | J. Rear Door Outer Panel Lower Molding |
| D. Front Door Window Frame Rear Vertical Scalp Molding | K. Rear Door Outer Panel Upper Molding |
| E. Rear Door Window Frame Front Vertical Scalp Molding | L. Rear Fender Upper Molding |
| F. Rear Door Window Frame Upper Scalp Molding | M. Rear Fender Lower Molding |
| G. Roof Drip Molding Scalp | N. Rear Fender Ornament |
| | O. Rear Compartment Lid Outer Panel Molding |
| | P. Rear End Panel Molding Assembly |
| | Q. Rear Compartment Lid Emblem |

Fig. 6-2 Exterior Moldings - 2669 Style



- | | |
|---|--|
| A. Windshield Pillar Drip Molding Scalp | L. Roof Drip Molding Rear Scalp |
| B. Front Door Window Frame Front Vertical Scalp Molding | M. Back Body Opening Side Pinchweld Finishing Molding |
| C. Front Door Window Frame Upper Scalp Molding | N. Back Body Opening Upper Pinchweld Finishing Molding |
| D. Front Door Window Frame Rear Vertical Scalp Molding | O. Front Door Outer Panel Lower Molding |
| E. Rear Door Window Frame Front Vertical Scalp Molding | P. Rear Door Outer Panel Lower Molding |
| F. Rear Door Window Frame Upper Scalp | Q. Rear Door Outer Panel Upper Molding |
| G. Roof Drip Molding Front Scalp | R. Rear Fender Upper Molding |
| H. Rear Door Window Frame Rear Vertical Scalp Molding | S. Rear Fender Lower Front Molding |
| I. Rear Quarter Window Front Scalp Molding | T. Rear Fender Lower Rear Molding |
| J. Rear Quarter Window Upper Scalp Molding | U. Rear Fender Emblem |
| K. Rear Quarter Window Rear Scalp Molding | V. Rear of Rear Fender Molding |
| | W. Tail Gate Ornament |
| | X. Tail Gate Name Plate |

Fig. 6-3 Exterior Moldings - 2735 Style

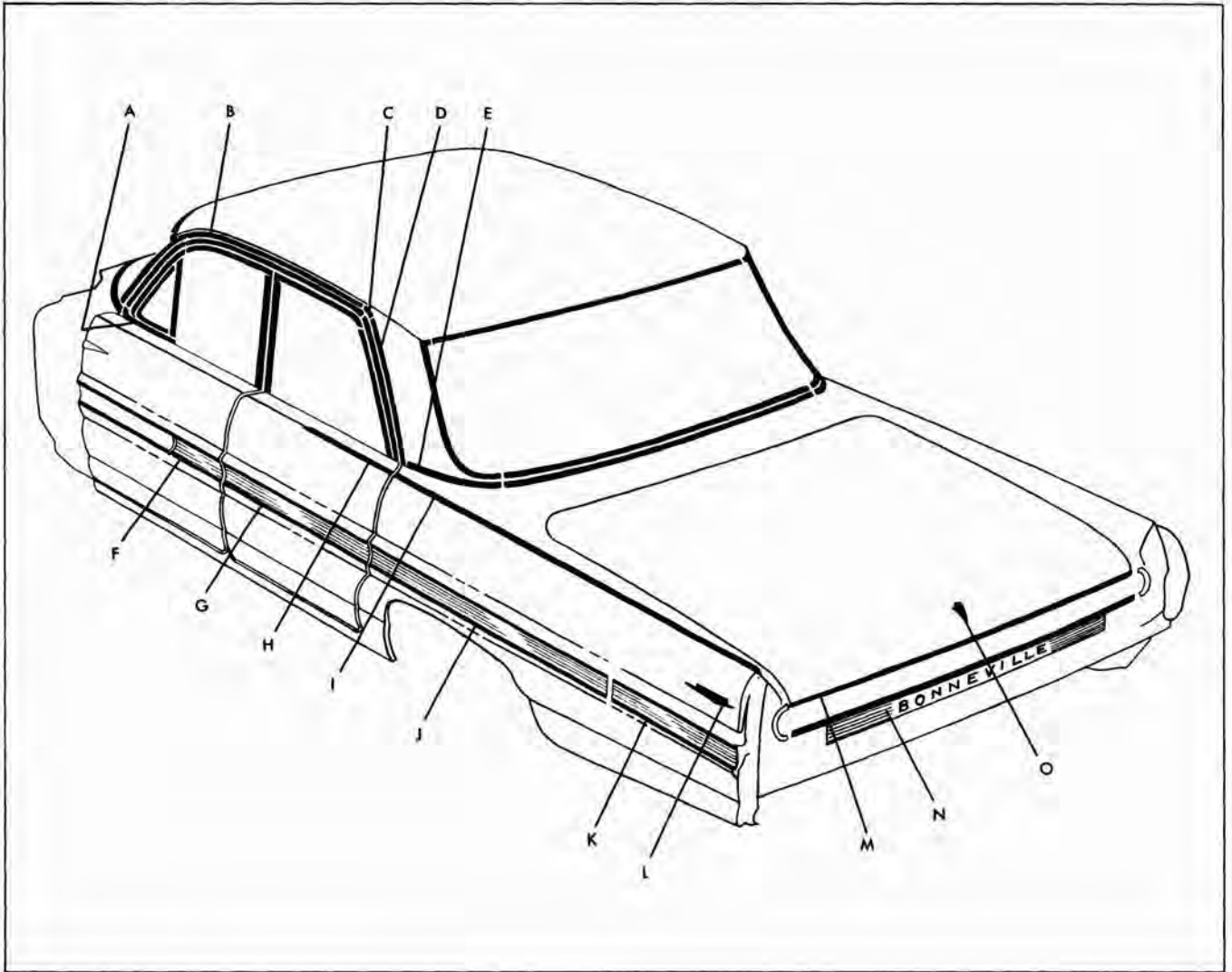

- | | |
|---|---|
| A. Front Door Window Reveal Molding (At Vent) | I. Rear Fender Upper Molding |
| B. Roof Drip Molding Front Scalp | J. Rear Fender Lower Front Molding |
| C. Roof Drip Molding Scalp Escutcheon | K. Rear Fender Lower Rear Molding |
| D. Roof Drip Molding Rear Scalp | L. Rear Fender Emblem |
| E. Rear Quarter Belt Reveal Molding | M. Rear Compartment Lid Outer Panel Molding |
| F. Front Door Outer Panel Lower Molding | N. Rear End Panel Molding Assembly |
| G. Rear Door Outer Panel Lower Molding | O. Rear Compartment Lid Emblem |
| H. Rear Door Outer Panel Upper Molding | |

Fig. 6-4 Exterior Moldings - 2839 Style

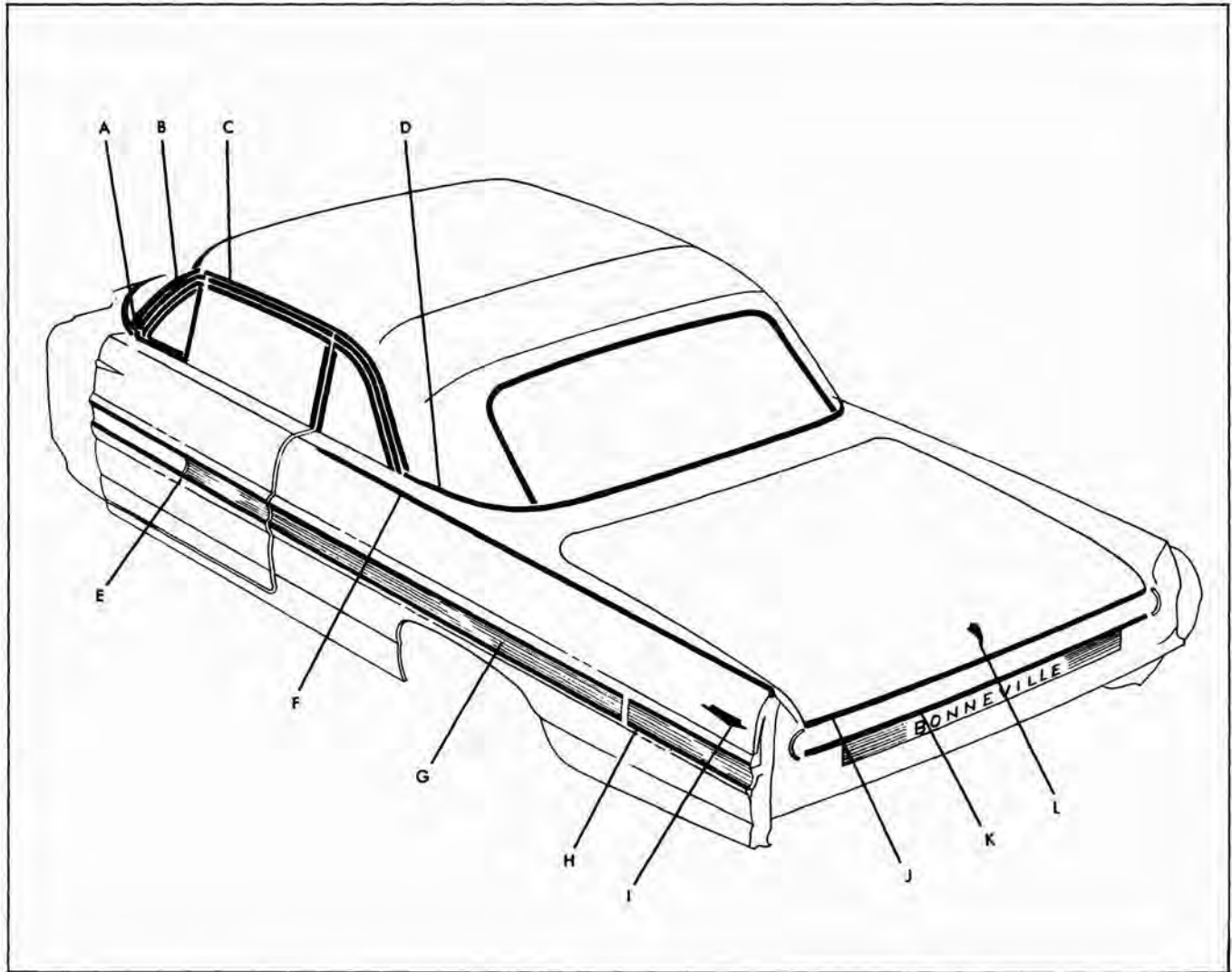

- | | |
|--|---|
| A. Door Window Reveal Molding (At Vent) | G. Rear Fender Lower Front Molding |
| B. Windshield Pillar Drip Molding Scalp | H. Rear Fender Lower Rear Molding |
| C. Roof Drip Molding Scalp | I. Rear Fender Emblem (Crest) |
| D. Rear Quarter Window Belt Reveal Molding | J. Rear Compartment Lid Outer Panel Molding |
| E. Front Door Outer Panel Lower Molding | K. Rear End Panel Molding |
| F. Rear Fender Upper Moldings | L. Rear Compartment Lid Outer Panel Emblem |

Fig. 6-5 Exterior Moldings - 2847 Style

ROOF DRIP MOLDING SCALP

47 and 69 STYLES

The scalp, of one-piece construction, is secured to the drip molding by snap retention. At the front, the scalp is overlapped by the windshield pillar drip molding scalp. On "47" style the scalp is overlapped by the side roof rail weatherstrip and reveal molding.

To remove the scalp: remove the windshield pillar drip molding scalp. On "47" style, remove the side roof rail weatherstrip retainer and reveal moldings. With a suitable, pointed, hook tool, unsnap the scalp from the drip molding. Start the removal on the under-side of the drip molding at either end.

To install the scalp: locate the scalp over the upper lip of the drip molding and snap the lower rolled edge of the scalp under the drip molding. Install the previously removed parts.

ROOF DRIP MOLDING FRONT SCALP AND ROOF DRIP MOLDING REAR SCALP

35 STYLE

The scalps are secured to the drip molding by snap retention. The front scalp is overlapped at the front by the windshield pillar drip molding scalp. The rear scalp is overlapped by the front scalp.

To remove the front scalp, first remove the windshield pillar drip molding scalp. To remove the rear scalp, detach only the required length of front scalp.

To remove either scalp, use a suitable, pointed hook tool and unsnap the scalp from the drip molding. Start the removal on the underside of the drip molding at either end of the scalp.

To install either scalp: locate the scalp over the upper lip of the drip molding and snap the lower rolled edge of the scalp under the drip molding. Install the previously removed parts.

ROOF DRIP MOLDING FRONT SCALP, ROOF DRIP MOLDING REAR SCALP AND ROOF DRIP MOLDING SCALP ESCUTCHEON

39 STYLE

The scalps, of three-piece construction, a front scalp, a rear scalp and a scalp escutcheon, are secured to the drip molding by snap retention. The scalp installation is overlapped by the windshield side reveal molding at the front and by corresponding sections of the side roof rail weatherstrip retainer and reveal moldings.

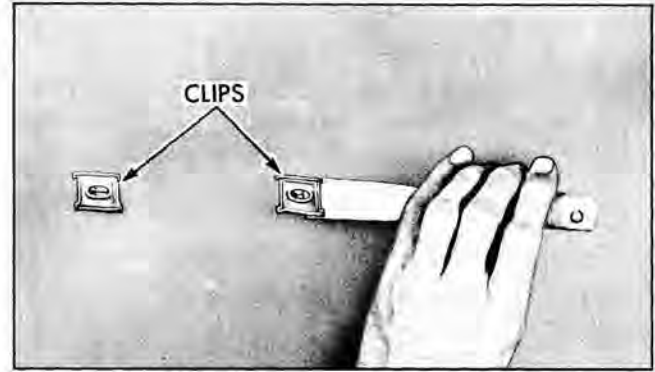

Fig. 6-6 Removing Bath-Tub Type Clip

To remove the front scalp remove the windshield side reveal molding and the side roof rail weatherstrip retainer and reveal molding.

To remove the rear scalp: remove the rear body lock pillar weatherstrip retainer and reveal molding.

After preliminary removal operations; remove the scalp escutcheon by unsnapping it from the drip molding. To remove either scalp, use a suitable, pointed hook-tool and unsnap the scalp from the drip molding. Start the removal on the underside of the drip molding at either end of the molding.

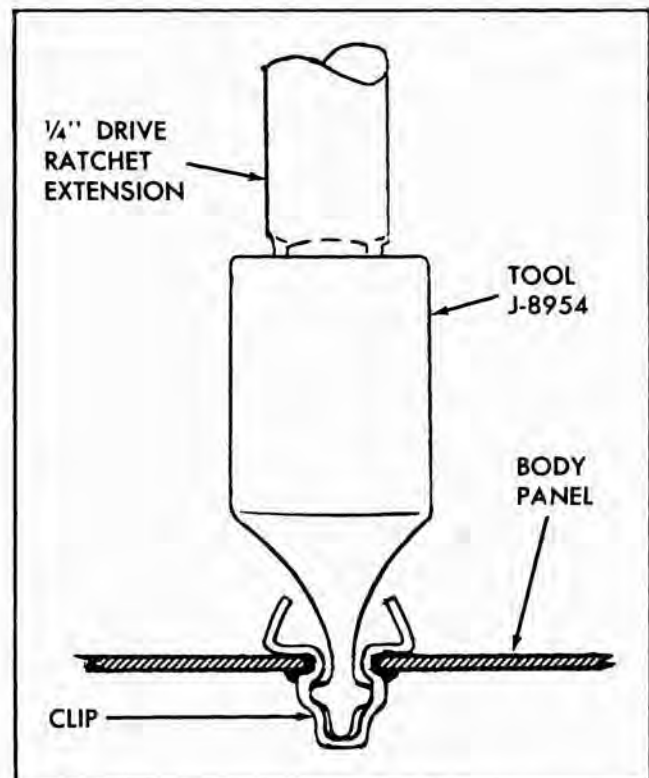

Fig. 6-7 Installing Narrow Bath-Tub Clip

To install either scalp: locate the scalp over the upper lip of the drip molding and snap the lower rolled edge of the scalp under the drip molding. Position the escutcheon and snap it into place. Seal and install the previously removed parts.

FRONT DOOR WINDOW REVEAL MOLDING (AT VENT)

39, 47 and 67 STYLES

The molding is secured to the return flange of the door by two attaching screws. The molding is overlapped by the door ventilator at the return flange.

To remove the molding remove the door trim assembly. Remove the attaching screws which are accessible on each side of the door ventilator. Loosen the ventilator to door upper attaching screws and remove the molding.

To install the molding position the molding to the door, align the attaching holes and install the attaching screws. Tighten the door ventilator to door upper attaching screws and install the door trim assembly.

FRONT DOOR WINDOW FRAME FRONT VERTICAL SCALP MOLDING

11, 35, 45 and 69 STYLES

The front vertical scalp molding is secured to the window frame by snap retention and by a metal tab which is retained by a screw behind the door ventilator.

To remove the molding remove the door ventilator. Remove the lower end attaching screw and unbend the metal tab. With a flat-bladed hook tool, unsnap the scalp molding from the window frame by working outwardly from the window opening.

To install the molding apply body caulking compound (1/8" x 1/4" x 1/4") at six inch intervals in the middle of the inner side of the molding. Position the molding to the outside edge of the window frame and to the window lower reveal line and snap it into place. Bend the molding tab at the lower end to the return flange of the door, drill the attaching hole as required on a replacement molding and install the attaching screw. Install the door ventilator and the previously removed parts.

FRONT DOOR WINDOW FRAME UPPER SCALP MOLDING

35, 45 and 69 STYLES

The upper scalp molding is secured to the window frame by snap retention and by a metal tab at the

rear. The upper scalp molding is overlapped at the front by the front vertical scalp molding.

To remove the molding: unbend the metal tab at the rear. With a flat-bladed hook tool, unsnap the scalp molding from the window frame by starting at the rear and by working outwardly from the window opening. Before unsnapping the front of the molding, slide it rearwardly to clear the front vertical scalp molding. Use care not to damage any door parts during this operation.

To install the molding: apply body caulking compound (1/8" x 1/4" x 1/4") at six inch intervals in the middle of the inner side of the molding. Position the molding to the outside of the window frame, engage the front end of the molding, and slide it under the rear edge of the vertical scalp molding. With the molding aligned at the upper rear corner, snap the molding on the window frame and secure the metal tab at the rear.

FRONT DOOR WINDOW FRAME REAR VERTICAL SCALP MOLDING

11, 35, 45 and 69 STYLES

The rear vertical scalp molding is secured to the door window frame by snap retention. The molding is overlapped at the top by the upper scalp molding.

To remove the molding: remove the upper scalp molding. With a flat-bladed hook tool, unsnap the scalp molding from the window frame by working outwardly from the window opening.

To install the molding: apply body caulking compound (1/8" x 1/4" x 1/4") at six inch intervals in the middle of the inner side of the molding. Position the molding to the outside edge of the window frame and to the lower reveal line and snap it into place. Install the upper scalp molding.

FRONT DOOR OUTER PANEL LOWER MOLDING

The molding is secured to the outer panel by snap-in type clip retainers and by screws at the front and rear hemming flanges.

To remove the molding: remove the front and rear hemming flange screws and, with a suitable flat-bladed tool, unsnap the molding from the door.

To install the molding: replace damaged clip retainers and seal as required. Position the molding to the door, and snap the molding on the retaining clips. Seal and install front and rear attaching screws.

FRONT DOOR OUTER PANEL LOWER MOLDING

2300 SERIES

The molding is secured to the door outer panel by snap-in type clips and by retaining screws at the rear hemming flanges.

To remove the molding: remove the retaining screw at the rear hemming flange. With a flat-bladed tool, engage each clip and squeeze the side with the tool and disengage it from the outer panel. Start at rear end of the molding. Position a small, insulated, wedge-shaped shim behind the molding during the removal to prevent the clips from re-engaging the outer panel.

To install the molding: replace damaged clips and seal as required. Apply body caulking compound to the edges of the attaching holes in the outer panel. Align the molding clips with the attaching holes and snap the molding onto the panel. Use care to apply a gradual, uniform pressure on a large area of the molding to prevent molding damage. Seal and install the rear attaching screw.

FRONT DOOR OUTER PANEL LOWER MOLDING

2600 SERIES

The molding is secured to the door outer panel by snap-in type clips and by retaining screws at the front and rear hemming flanges.

To remove the molding: remove the retaining screws at the front and rear hemming flanges. With a flat-bladed tool, engage each clip and squeeze the side with the tool and disengage it from the outer panel. Start at either end of the molding. Position a small, insulated, wedge-shaped shim behind the molding during the removal to prevent the clips from re-engaging the outer panel.

To install the molding: replace damaged clips and seal as required. Apply body caulking compound to the edges of the attaching holes in the outer panel. Align the molding clips with the attaching holes and snap the molding onto the panel. Use care to apply gradual, uniform pressure on a large area of the molding to prevent molding damage. Seal and install the front and rear attaching screws.

REAR DOOR WINDOW FRAME UPPER SCALP MOLDING

69 STYLE

The upper scalp molding is secured to the window

frame by snap retention and by a metal tab at the front end of the molding.

To remove the molding: unbend the metal tab at the front of the molding. Use a flat-bladed hook tool to unsnap the upper scalp molding from the window frame by working outwardly from the window opening.

To install the molding: apply body caulking compound (1/8" x 1/4" x 1/4") at six inch intervals in the middle of the inner side of the molding. Position the molding to the outside edge of the window frame and to the upper corner and snap it into place. Secure the front metal tab.

REAR DOOR WINDOW FRAME FRONT VERTICAL SCALP MOLDING AND REAR DOOR WINDOW FRAME REAR VERTICAL SCALP MOLDING

69 STYLE

Each vertical scalp molding is secured to the door window frame by snap retention. Each molding is overlapped at the top by the upper scalp molding.

To remove either molding: remove the upper scalp molding. With a flat-bladed hook tool, unsnap the molding from the window frame by working outwardly from the window opening.

To install either molding: apply body caulking compound (1/8" x 1/4" x 1/4") at six inch intervals in the middle of the inner side of the molding. Position the molding to the outside edge of the window frame and to the window lower reveal line and snap it into place. Install the upper scalp molding.

REAR DOOR WINDOW FRAME UPPER SCALP MOLDING

35 and 45 STYLES

The upper scalp molding is secured to the window frame by snap retention and by a metal tab at the rear.

To remove the molding: unbend the metal tab at the end of the molding. Use a flat-bladed hook tool to unsnap the upper scalp molding from the window frame by working outwardly from the window opening.

To install the molding: apply body caulking compound (1/8" x 1/4" x 1/4") at six inch intervals in the middle of the inner side of the molding. Position the molding to the outside edge of the window frame and to the upper corners and snap it into place. Secure the rear metal tab.

REAR DOOR OUTER PANEL LOWER MOLDING

35 and 39 STYLES

The molding is secured to the door outer panel by previously installed snap-in type clips, by a clip stud and nut at the front hemming flange, and by a screw at the rear hemming flange.

To remove the molding: open the front door and remove the attaching nut at the front of the molding. Remove the screw from the rear of the molding. With a flat-bladed tool, unsnap the molding from the retaining clips.

To install the molding: replace damaged clips and seal the replacement clips as required. Install washers over studs and guide the front clip stud through the pierced hole, position the molding over the snap-on clips and snap the molding into place. Seal and install the attaching nut at the front and the screw at the rear of the molding.

REAR DOOR OUTER PANEL LOWER MOLDING

35, 39, 45 and 69 STYLES

The molding is secured to the door outer panel by a clip bolt and nut at the front hemming flange, by snap-on clips, and by a screw at the rear hemming flange.

To remove the molding: remove the front attaching nut and the rear attaching screw. With a flat-bladed tool, unsnap the molding from each retaining clip by sliding the tool to the clip, squeezing one side in and disengage it from the door.

To install the molding: replace damaged clips and seal the replacement clips as required. Position the molding to the door and over the clips and snap it into place. Install the front attaching nut and the rear attaching screw.

REAR DOOR OUTER UPPER MOLDING

The molding is secured to the rear door by a snap-in type clip, a plastic "bath-tub" type snap-on clip and an attaching screw at the rear hemming flange.

To remove the molding: remove the attaching screw at the hemming flange. With a flat-bladed tool unsnap the molding from the door panel.

To install the molding: replace damaged clips and seal as necessary. Apply body caulking compound to the front attaching stud. Position the molding to the rear of the door and snap the molding to the panel. Secure the attaching screw through the hemming flange.

REAR QUARTER WINDOW UPPER SCALP MOLDING

2311 STYLE

The molding is secured to the roof rail pinchweld flange with attaching screws.

To remove the molding: remove the rear quarter window glass run channel and garnish molding. Remove the attaching screws and the molding.

To install the molding: apply body caulking compound to the attaching holes in the roof rail pinchweld flange. Assemble "U" spring nuts to the molding flange at the slot locations. Position the molding to the front reveal molding, align the "U" spring nuts with the body attaching holes and install the attaching screws. Install the previously removed parts.

REAR QUARTER WINDOW FRONT REVEAL MOLDING

2311 STYLE

The molding is secured to the rear body lock pillar by molding clips and attaching screws. The molding is overlapped by the upper scalp molding.

To remove the molding: remove the rear quarter window upper scalp molding. Remove the molding attaching screws and the molding.

To install the molding: apply body caulking compound to the attaching holes in the lock pillar. Position the molding to the lock pillar, align the clip holes with the attaching holes in the body and install the attaching screws. Install the upper scalp molding and the previously removed parts.

REAR QUARTER WINDOW UPPER, FRONT AND REAR REVEAL MOLDINGS

35 and 45 STYLES

The moldings, of bright finish on the 2735 style and of painted finish on the 2335 and 2345 styles, are secured to the body by means of molding clips and screws prior to the installation of the rear quarter window. Bright finish moldings are optional on the 2335 and 45 styles.

To remove the moldings: remove the rear quarter window and the applicable attaching screws. To remove the front or rear scalp molding, first remove the upper scalp molding.

To install the moldings: apply body caulking compound to the body attaching holes, to the clips and to the screws. Apply a bead of medium-bodied sealer to the entire length of the upper and rear scalp at the inner center off-set. Align the moldings with the

respective attaching holes on the body and install the screws to effect a watertight seal. Install the front and rear scalp moldings before installing the upper scalp molding. Seal and install the rear quarter window and the previously removed parts.

REAR QUARTER WINDOW REVEAL MOLDING

67 STYLE

The molding is secured to the rear quarter panel return flange by screws.

To remove the molding: remove the rear quarter window. Remove the attaching screws and the molding.

To install the molding: position the molding along the rear quarter panel return flange. Install the attaching screws and the previously removed parts.

REAR QUARTER BELT REVEAL MOLDING

39 STYLE

The molding is secured to the body by a screw at the front, and by two snap-in clips which are previously installed in the molding. At the rear, the molding is overlapped by the back window lower reveal molding which is secured to the back window lower pinchweld by a bolt and clip assembly.

To remove the molding: remove the front attaching screw and the bolt and clip assembly attaching nut of the back window lower reveal. With a flat-bladed tool, unsnap the molding clips from the body. Slide the molding down and forward to remove it.

To install the molding: replace damaged clips as required. Seal the molding clips and the attaching holes with body caulking compound to effect a watertight seal. Position the molding to the body and snap the clips into place. Seal and install the front attaching screws and the attaching nut of the back window lower reveal.

REAR QUARTER BELT REVEAL MOLDING

11 and 69 STYLES

The molding is secured to the roof extension panel by snap-in type clips. A retaining screw is also used on the "69" style at the lock pillar facing.

To remove the molding: remove the attaching screw on the "69" style. Protect the paint finish. Remove the molding with a thin, flat-bladed tool. Use the tool at the top of the molding to gain initial access to each clip. Engage and squeeze the side of each clip with the tool and disengage it from the outer panel. Start at front end of the molding. Position

a small, insulated, wedge-shaped shim behind the molding during the removal operation to prevent the clips from re-engaging the outer panel.

To install the molding: replace damaged clips as required. Apply body caulking compound to the panel attaching holes. Position the molding to the panel and snap-in all clips. Use care to apply a gradual, uniform pressure on a large area of the moldings to prevent damage. Seal and install the attaching screw on the "69" style.

REAR QUARTER BELT REVEAL

47 STYLE

The molding is secured to the extension panel by bolt and clip assemblies. The front of the molding is overlapped by the rear quarter window lower reveal molding.

To remove the molding: remove roof extension trim panel. Remove attaching nuts at roof extension panel. Remove the rear attaching nut at the rear compartment locations. Slide the molding rearward and lift at the rear until the molding is disengaged from the rear quarter window lower reveal.

To install the molding: apply body caulking compound around the molding studs. Position the molding and insert the front end of the molding under the quarter window lower reveal molding. Slide the molding forward until it fits the body contour. Secure the attaching nut at rear compartment. Secure the attaching nuts at roof extension panel. Install removed trim.

REAR QUARTER PINCHWELD FINISHING MOLDINGS

67 STYLE

The moldings are secured to the quarter pinchweld with snap-on clips which are previously installed on the pinchweld around the rear and side sections and with a screw at each forward end. The right molding overlaps the left molding.

To remove the moldings: remove the front attaching screws at the rear quarter window. Detach the front end of the folding top compartment bag from the rear seat back. Remove the attaching screws from the three back curtain trim retainers and pull them away from the body pinchweld. With a wood block and hammer or with a flat-bladed tool, carefully disengage the moldings from the clips. To remove the left molding, detach only a short section of the overlapping right molding.

To install the moldings: clean and seal the pinch-weld flange. Apply waterproof tape over the pinch-weld flange to seal it completely. Replace damaged clips as required. Position and locate the left molding to the body and snap it into place. Install the right molding. Install the previously removed parts.

REAR FENDER LOWER FRONT MOLDING AND REAR FENDER LOWER REAR MOLDING

35 AND 69 STYLES

The front molding is secured to the rear fender by snap-in type clips and is overlapped by the rear molding which is secured by integral studs with attaching nuts.

To remove the moldings: remove or loosen the rear compartment trim. On "35" style, remove the spare tire cover panel. Remove the attaching nuts. On the "35" style, one stud is retained by a snap-in type clip. With a flat-bladed tool unsnap the one stud on the rear molding and all studs on the front molding.

To install the moldings: replace damaged clip retainers and seal as required. Install washers over studs and position the molding to the fender. Snap the front then the rear molding to the fender. Secure attaching nuts to rear molding to effect a watertight seal. Install the removed parts.

REAR FENDER LOWER FRONT MOLDING LEFT SIDE AND REAR FENDER LOWER REAR MOLDING

2735 STYLE

The molding is secured to the left rear fender by snap-in friction type clips. The front molding is overlapped by the rear molding.

To remove the molding: with a flat-bladed tool unsnap the molding from the rear fender.

To install the moldings: replace and seal damaged retaining clips as required. Install washers over molding studs. Position the moldings to the fender and snap it into place inserting the front molding first.

REAR FENDER LOWER FRONT MOLDING AND REAR FENDER LOWER REAR MOLDING

47 and 67 STYLES

The moldings are secured to the rear fender by snap-in type clips and integral studs with attaching nuts.

To remove the moldings: remove the rear quarter trim assembly, the quarter inner panel access hole cover and remove or loosen the rear compartment side trim. Remove the front attaching nut through the access hole and the rear attaching nuts from the rear compartment. Then, with a flat-bladed tool, unsnap the remainder of the molding from each snap-in clip. The front molding is overlapped by the rear.

To install the moldings: replace damaged clips and seal as required. Attach washers over studs, position moldings and snap into place. Install front and rear molding attaching nuts to effect a watertight seal. Install the previously removed parts.

REAR FENDER UPPER MOLDING

35 and 45 STYLES

The molding is secured to the rear fender by plastic "bath tub" snap-on clips.

To remove the molding: with a flat-bladed tool unsnap the molding from the fender.

To install the molding: replace clips as necessary. Position the molding to the fender and over the upper edge of the clips and snap it in place.

REAR FENDER UPPER MOLDING

ALL STYLES (Except Station Wagons)

The molding is retained to the rear fender by plastic "bath-tub" type snap-on clips and a bolt and clip assembly at the rear.

To remove the molding: remove the attaching nut at the rear of the molding. With a suitable flat-bladed tool unsnap the molding from the fender.

To install the molding: replace damaged clips as necessary. Apply body caulking compound to rear attaching bolt. Position the molding to the fender and over the upper edge of the retaining clip and snap it into place. Secure attaching nut.

REAR FENDER STAR ORNAMENT
2600 SERIES

Each ornament is secured to the rear fender with sealed attaching nuts. In addition the rear most star is secured with a friction type retaining clip which was previously installed in the fender.

To remove the ornaments: remove or loosen the rear compartment side trim and remove the attaching nuts. With a flat-bladed tool carefully pry the lower stud of the rear star from the retaining clip.

To install the ornaments: replace damaged clip if required and seal with heavy-bodied sealer. Apply heavy-bodied sealer to ornament studs and attaching nuts. Position the ornament and press the rear star into the retaining clip in the fender and install attaching nuts. Install the rear compartment side trim.

REAR FENDER CREST EMBLEM
2800 SERIES

The emblem is secured to the rear fender with sealed attaching nuts.

To remove the emblem: remove or loosen the rear compartment side trim and remove the attaching nuts.

To install the emblem: assemble the washers to the emblem studs. Position the emblem to the fender and install the attaching nuts to effect a watertight seal. Install the rear compartment side trim.

GRAND PRIX EMBLEM
2900 SERIES

The name plate is secured to the rear fender by integral studs with attaching nuts.

To remove the name plate: remove or loosen the rear compartment trim. Remove the attaching nuts.

To install the name plate: apply caulking compound around the attaching holes and install the name plate. Install the attaching nuts to effect a watertight seal. Install the rear compartment side trim.

REAR FENDER EMBLEM (CREST)
LEFT SIDE
2735 STYLE

The emblem is secured to the fender by integral attaching studs and friction type retaining clips which are previously installed in the fender.

To remove the emblem: use a flat-bladed tool and pry each integral attaching stud from the retaining clip a relatively short distance at a time until the emblem is removed.

To install the emblem: replace damaged clips and seal the replacement clips as required. Assemble washers to the studs and position emblem studs to the retaining clips and with a gradual force, tap the emblem until it is flush to the fender panel.

REAR FENDER EMBLEM (CREST)
RIGHT SIDE
2735 STYLE

The emblem is secured to the fender by integral attaching studs and attaching nuts which are accessible inside of the body.

To remove the emblem: remove the spare tire cover panel and remove the attaching nuts.

To install the emblem: apply washer to the integral attaching studs. Position the emblem to the fender and install the attaching nuts to effect a watertight seal. Install the spare tire cover panel.

QUARTER PANEL REAR CORNER COVER
35 and 45 STYLES

The cover is secured to the rear quarter panel by attaching screws.

To remove the cover: remove the rear bumper. Remove the attaching screws.

To install the cover: position the cover to the rear quarter panel and secure with attaching screws. Replace the bumper.

REAR OF REAR FENDER MOLDING

35 and 45 STYLES

The molding is secured to the rear fender by an integral stud and attaching nut at the top and by an attaching screw at the bottom. The molding is overlapped by the rear fender upper molding.

To remove the molding: remove the rear bumper and quarter panel rear corner cover. Remove the left tail light assembly and left tail light mounting plate to remove the upper attaching nut on left side only. Remove the spare tire compartment panel cover to remove the attaching nut on the right side. Remove the attaching screw. Pry the rear fender upper molding up at the rear to disengage it from the rear of rear fender molding.

To install the molding: apply sealer to molding studs and attaching holes. Position the molding to the rear fender and secure the attaching nut and screw to effect a watertight seal. Install previously removed parts.

REAR COMPARTMENT LID OUTER PANEL MOLDING ASSEMBLY

ALL STYLES (Except Station Wagons)

The molding is secured to the rear compartment by attaching screws at the outer ends and metal "bath-tub" type snap-on clips.

To remove the molding: remove the attaching screws at each end. With a flat-bladed tool unsnap the molding from the rear compartment lid at each clip location.

To install the molding: replace damaged clips as necessary. Position the molding to the rear compartment lid and over the upper edge of the clip and snap it in place. Install the attaching screw at each end.

REAR END PANEL MOLDING ASSEMBLY

ALL 2300 SERIES (Except Station Wagons)

The molding is secured to the rear end panel by integral studs and attaching nuts and by metal "bath-tub" type snap-on clips.

To remove the molding: remove or loosen rear end panel trim. Remove the attaching nuts in rear compartment. With a flat-bladed tool unsnap the molding from the panel at each clip location.

To install the molding: replace damaged clips and seal as necessary. Apply caulking compound to the molding studs. Position the molding to the panel and over the edge of the clips. Snap the molding to the panel and install the attaching nuts insuring a watertight seal. Install removed trim.

REAR END PANEL MOLDING ASSEMBLY

ALL 2800 SERIES (Except Station Wagons)

The molding is secured to the rear end panel by attaching bolts.

To remove the molding: remove rear compartment end panel trim. Remove the attaching bolts.

To install the molding: install gasket to upper and lower edges of the molding. Apply caulking compound around attaching holes of the rear end panel. Install molding to the panel and secure attaching bolts. Install rear compartment end panel trim.

REAR COMPARTMENT LID OUTER PANEL EMBLEM

ALL STYLES (Except Station Wagons)

The emblem is secured to the rear compartment lid by integral attaching studs and sealed attaching nuts.

To remove the emblem: remove the attaching nuts.

To install the emblem: apply washers to the emblem studs. Position the emblem to the lid and install the attaching nuts to effect a watertight seal.

TAIL GATE OUTER PANEL NAME PLATE

2335 and 2345 STYLES

The name plate is comprised of individual letters each of which is secured to the outer panel by integral attaching studs and friction type clips which are previously installed in the outer panel.

To remove the name plate: use a flat-bladed tool and carefully pry the name plate letter studs from the retaining clips.

To install the name plate: secure replacement clips as required. Position the clips in the outer panel attaching slots. Seal each clip completely to provide a watertight seal. Align the name plate studs with the clips and tap the letter until it is flush to the outer panel.

TAIL GATE OUTER PANEL NAME PLATE

2735 STYLE

The name plate is secured to the outer panel by integral attaching studs and friction type clips which are previously installed in the outer panel.

To remove the name plate: use a flat-bladed tool and carefully pry the name plate studs from the retaining clips.

To install the name plate secure replacement clips as required. Position the clips in the outer panel attaching slots. Seal each clip completely to provide a watertight seal. Align the name plate studs with the clips and tap the plate until it is flush to the outer panel.

TAIL GATE ORNAMENT ASSEMBLY (BONNEVILLE)

2735 STYLE

The ornament assembly is secured to the outer panel by means of integral studs which are retained by attaching nuts.

To remove the ornament: remove the tail gate trim assembly, loosen the inner panel water deflector, and remove the inner panel loading hole covers. Remove the attaching nuts and the ornament.

To install the ornament: apply body caulking compound to the attaching studs and nuts. Position the ornament to the outer panel and install the attaching nuts to effect a watertight seal. Install the previously removed parts.

REAR END PANEL NAME PLATE (PONTIAC)

23 and 29 (Except Station Wagons)

The name plate is comprised of individual letters each of which is secured to the rear end panel by two integral attaching studs and sealed attaching nuts.

To remove the name plate: remove the attaching nuts.

To install the name plate: position each name plate letter to the rear end panel. Apply body caulking compound to the letter studs and attaching nuts. Install the attaching nuts to effect a watertight seal.

BACK BODY OPENING UPPER PINCHWELD FINISHING MOLDING

The molding is secured to the body by snap retention over special pinchweld clips. The molding is overlapped at each end by the side pinchweld finishing moldings.

To remove the molding: remove the back body opening side pinchweld finishing moldings. Then, with a flat-bladed tool, unsnap the molding at each clip location.

To install the molding: replace damaged clips and seal the replacement clips as necessary. Hook one edge of the molding over the clips and snap the opposite side over the clips to secure it. Install the previously removed parts.

BACK BODY OPENING SIDE PINCHWELD FINISHING MOLDING

ALL STATION WAGONS

The molding is secured to the body by snap retention over special pinchweld clips.

To remove the molding: use a flat-bladed tool and unsnap the molding at each clip location.

To install the molding: replace damaged clips and seal the replacement clips as necessary. Align the molding with the upper molding, hook one edge of the molding over the clips, and snap the opposite side over the clips to secure it.

HEADLINING

CONTENTS OF THIS SECTION

SUBJECT	PAGE	SUBJECT	PAGE
Headlining Assembly	7-1	Removal	7-1
Description	7-1	Installation	7-1

HEADLINING ASSEMBLY

DESCRIPTION

The headlining assembly is formed to the roof contour by concealed listing wires. Both ends of each listing wire are installed into holes in listing wire clips which are secured to the side roof inner rail assembly. The wires and listing pockets are secured to the roof bows on some styles by bend-over metal tabs. The headlining is secured at the windshield by cement and tacks or staples and along the side roof rail by tacks, staples or a pronged retainer. A pronged retainer is used where side roof rail finishing moldings are not used. The rear end of the headlining is secured at the back window by cement and tacks or staples.

CAUTION: Clean hands and tools are essential when working with headlining material.

REMOVAL

1. Place protective coverings over seat cushions and backs.
2. Prior to removing headlining, remove following hardware and trim assemblies if present.
 - a. Windshield side and upper garnish moldings.
 - b. Rear view mirror support.
 - c. Sunshade supports.
 - d. Dome or side roof rail lamps.
 - e. Coat hooks.
 - f. Rear quarter upper garnish moldings (2 door styles).
 - g. Side roof rail moldings.
 - h. Back window garnish moldings.
 - i. Rear quarter rear window front, rear and upper moldings (35 and 45 styles).
 - j. Back body window opening upper and side garnish moldings.

k. Center pillar finishing moldings.

l. Rear quarter trim, where necessary.

3. Carefully remove tacks or staples securing headlining at windshield opening, along side roof rails on bodies equipped with side roof rail finishing moldings, at rear quarter windows and at back window opening. Then carefully detach cemented edges of headlining.

4. On styles where headlining is secured to side roof rails by retainers, use headlining inserting tool J-2772 or similar wide bladed tool and carefully disengage headlining from retainer tabs (View A, Fig. 7-1).

5. Working from front to rear of body, disengage headlining listing wires from side roof rails, gathering or folding headlining with listing wires on outside to keep headlining clean. Bend down metal tabs at bows on bodies using tabs to support listing wire (View B, Fig. 7-1 and Fig. 7-2).

6. Disengage headlining on styles using foundation board from metal tabs or retainers at back window (see View D, Fig. 7-1) and remove headlining assembly from body.

CAUTION: Note into which hole the ends of the listing wires are installed to insure proper installation (see View "A", Fig. 7-1 and Fig. 7-2).

7. If necessary, listing wires may be removed from pockets.

INSTALLATION

1. Install listing wires into headlining listing pockets and lift entire headlining assembly into body.

2. Center and align rearward end of headlining and engage foundation board where used under metal retainer or metal tabs above back window (see View D, Fig. 7-1). Then working forward, install ends of listing wires into listing wire holes along side roof rail.

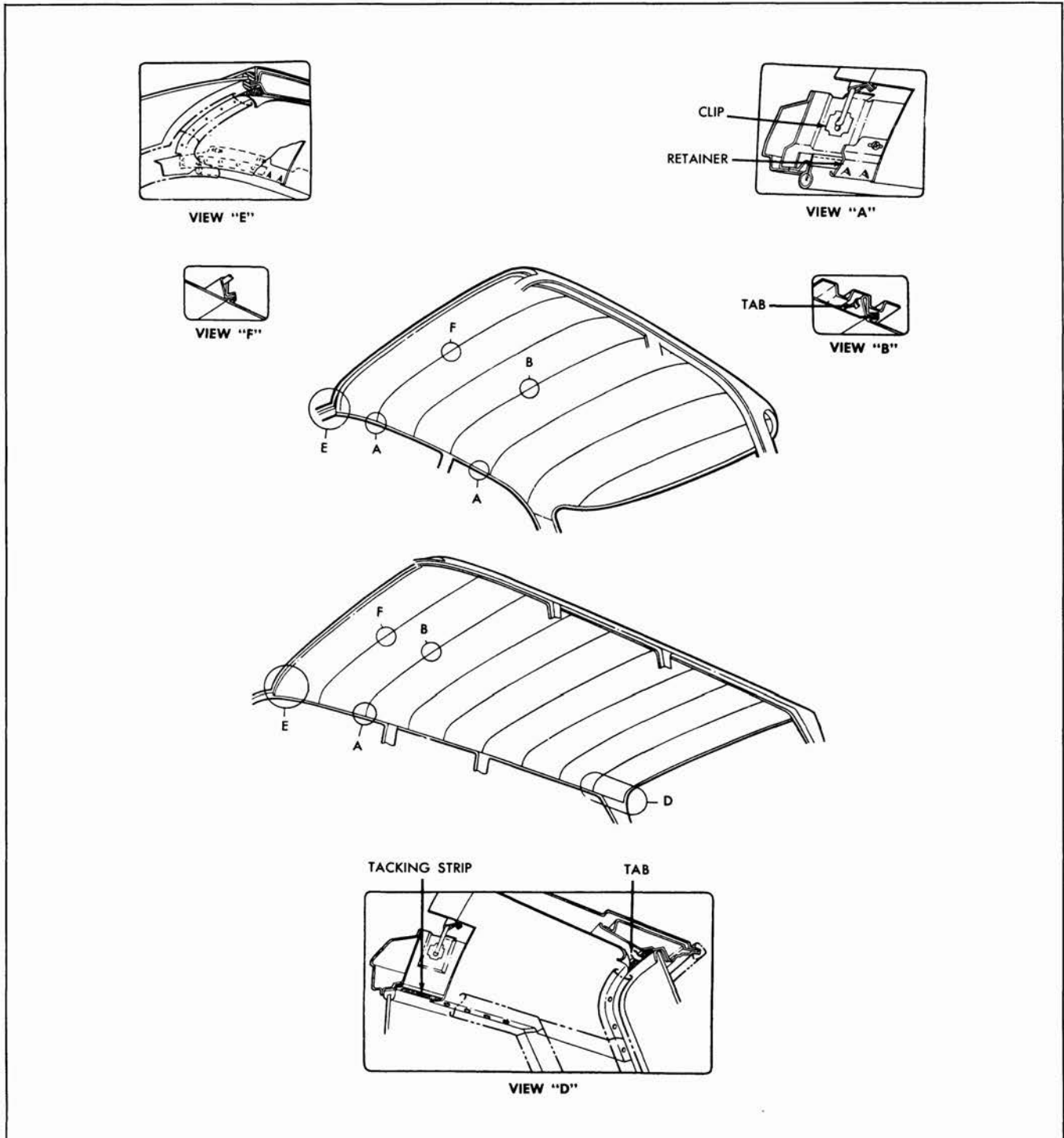

Fig. 7-1 Headlining Assembly

NOTE: Make certain listing wires are installed in correct hole in clips to insure proper contour of headlining. (View A, Fig. 7-1 and Fig. 7-2).

3. Install balance of listing wires into proper holes in listing wire clips (View A, Fig. 7-1 and Fig. 7-2). Install listing wire, where necessary,

to roof bow metal retaining tabs, center headlining and bend over retaining tabs.

4. Center and align headlining in relation to windshield opening, back window opening, coat hooks and sunshade support locations. Then apply trim cement to headlining tacking surfaces at windshield and back

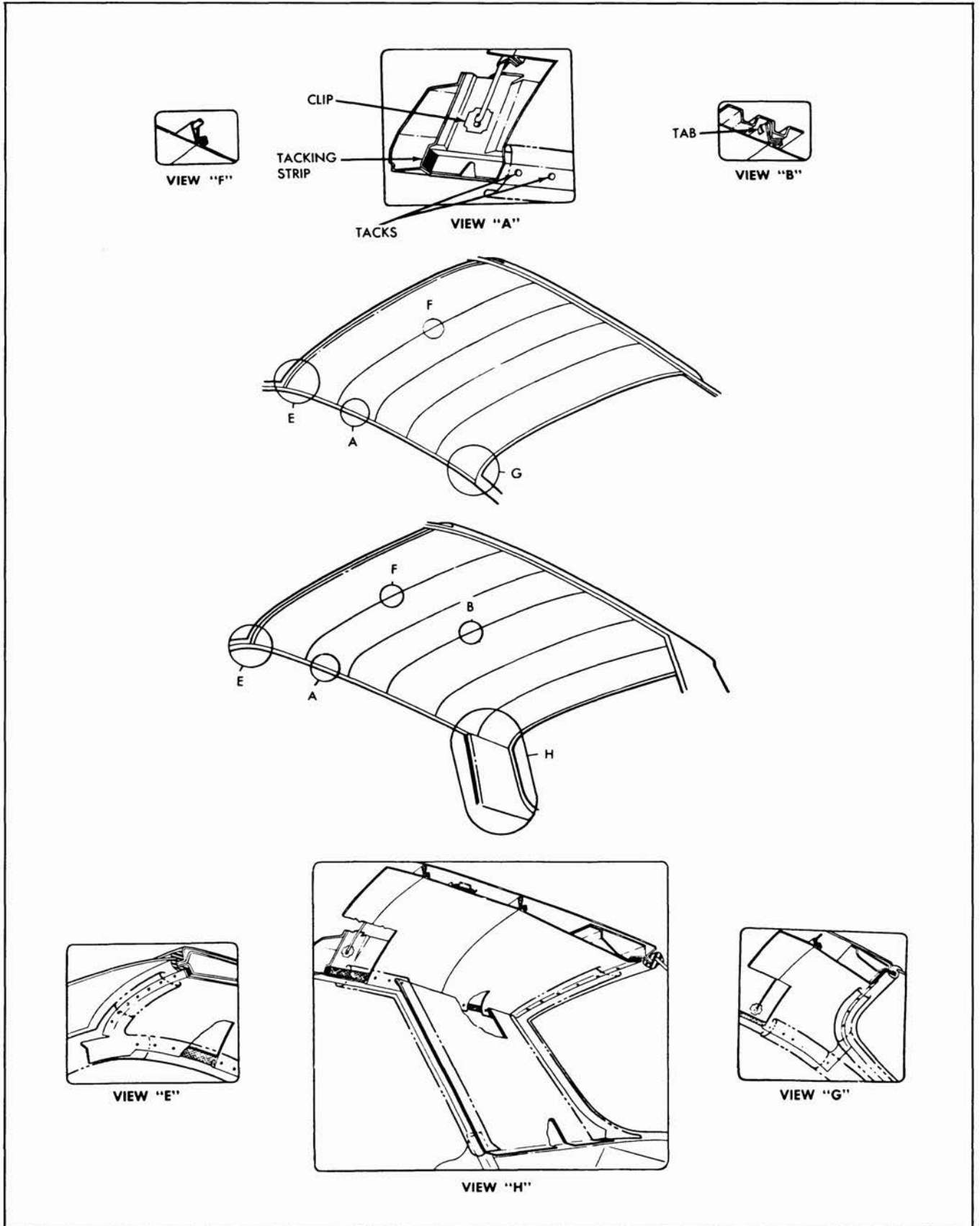

Fig. 7-2 Headlining Assembly

window openings, (Views D and E, Fig. 7-1 and Views E, G and H in Fig. 7-2) and stretch and stay tack headlining to windshield and back window openings and along side roof rails if tacks are used.

5. Remove all "fullness" and "draws" from headlining material and permanently tack headlining to tacking strips (View A, Fig. 7-2).

NOTE: On those styles where side roof rail moldings are not used, use headlining inserter tool J-2772 or similar wide-bladed tool and carefully tuck edges of headlining under metal retainer tabs along both side roof rails. (View A, Fig. 7-1).

6. Install all previously removed hardware and trim assemblies and remove protective coverings.

SEATS

CONTENTS OF THIS SECTION

SUBJECT	PAGE	SUBJECT	PAGE
Front Seat (Manual)		Filler Panel	8-4
Assembly	8-1	Luggage Compartment	8-4
Adjuster	8-1	Third Seat	8-5
Rear Seat		Electric Seat (Front)	
Cushion	8-2	Six-Way	8-7
Back	8-2	Adjuster	8-8
Center Arm Rest	8-3	Electric Motor	8-10
Folding Rear Seat		Drive	8-10
Floor Panels	8-3	Transmission	8-11

FRONT SEAT ASSEMBLY (MANUALLY OPERATED)

DESCRIPTION

Manually operated front seat adjusters provide fore and aft movement of the seat. When the knob at the left of the seat is pulled up, the seat adjusters unlock, permitting a horizontal travel of the seat. When the seat is in the desired position, the knob is released and the seat adjusters are locked.

3. Squeeze hooked end of seat adjuster locking wire together and slide retaining spring back over hump in locking wire, remove wire from retainer on seat bottom frame and disengage locking wire from seat adjuster.

FRONT SEAT ASSEMBLY (WITH ATTACHED SEAT ADJUSTERS)

REMOVAL AND INSTALLATION

1. Turn back floor covering. Remove four adjuster-to-floor pan attaching bolts from each adjuster.
2. With the aid of a helper, remove seat assembly from body.
3. To install, reverse removal procedure.

FRONT SEAT ADJUSTER (MANUAL)

REMOVAL AND INSTALLATION

1. Remove seat assembly with attached seat adjusters from body and place upside down on a clean protected surface.
2. When removing left adjuster, it is necessary to remove the seat adjuster control knob.

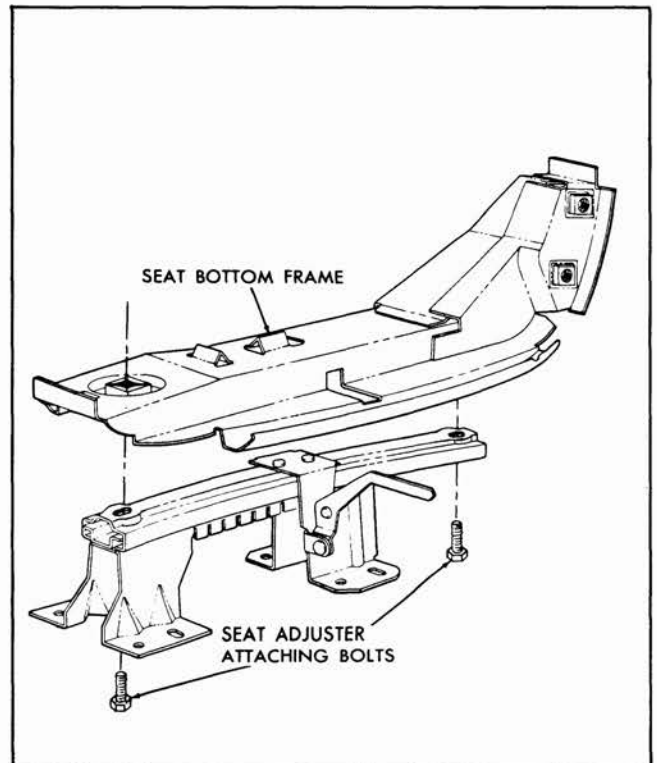

Fig. 8-1 Manual Seat Adjuster

4. Remove adjuster-to-seat bottom frame front and rear attaching bolts and remove seat adjuster from seat assembly (Fig. 8-1).

5. To install, reverse removal procedure.

6. Check operation of seat assembly. If right adjuster does not lock or unlock satisfactorily when control handle on left adjuster is operated, remove locking wire retainer from hole in seat bottom frame and adjust retainer by selecting another hole to obtain proper tension in locking wire.

REAR SEATS

REAR SEAT CUSHION ASSEMBLY

REMOVAL

1. Push lower forward edge of cushion rearward and pull cushion upward until protrusions on seat bottom frame disengage from floor pan stops.

2. Pull cushion forward and carefully remove from body.

INSTALLATION

1. Carefully lift cushion into body to avoid damaging adjacent trim.

2. Position rear edge of cushion under rear seat back assembly.

3. Center protrusions on seat bottom frame with stops on floor pan assembly.

IMPORTANT: If seat bottom frame protrusions are not properly centered in relation to floor pan stops, proper engagement and placement of cushion will be extremely difficult.

4. Push forward edge of cushion rearward and downward until protrusions are properly engaged behind floor pan stops.

REAR SEAT BACK ASSEMBLY

REMOVAL AND INSTALLATION

1. Remove rear seat cushion assembly.

2. On styles with rear seat center arm rest, lower arm rest, disengage upper end of arm rest trim panel from seat back assembly and lower trim panel; remove two bolts securing arm rest hanger plate to seat back support reinforcement.

3. At bottom of the seat back, bend the four (4) body tabs that secure the seat back to the floor panel and to the wheelhouse panel. On "47" style, the lower end of the seat back is retained by two body tabs at the floor panel only.

4. Pull seat back assembly out at bottom until seat back clears body tabs; then raise seat back upward until seat back disengages from hangers on the seat back panel support.

5. Remove seat back back assembly from body.

6. To install, reverse removal procedure, making certain that all attaching body tabs and hangers have industrial waterproof body tape applied to them to act as an anti-squeak.

REAR SEAT BACK ASSEMBLY

REMOVAL AND INSTALLATION

1. Remove rear seat cushion assembly.

2. Disconnect rear seat back speaker wire, if present.

3. Working over rear of rear seat back, remove screw securing rear end of folding top compartment side trim panel to rear of rear seat back frame.

4. At bottom of the seat back, remove two screws and washers which secure the seat back frame to the seat back support.

5. Raise seat back until seat back disengages from hangers on seat back panel and remove seat back assembly from body.

6. To install, reverse removal procedure.

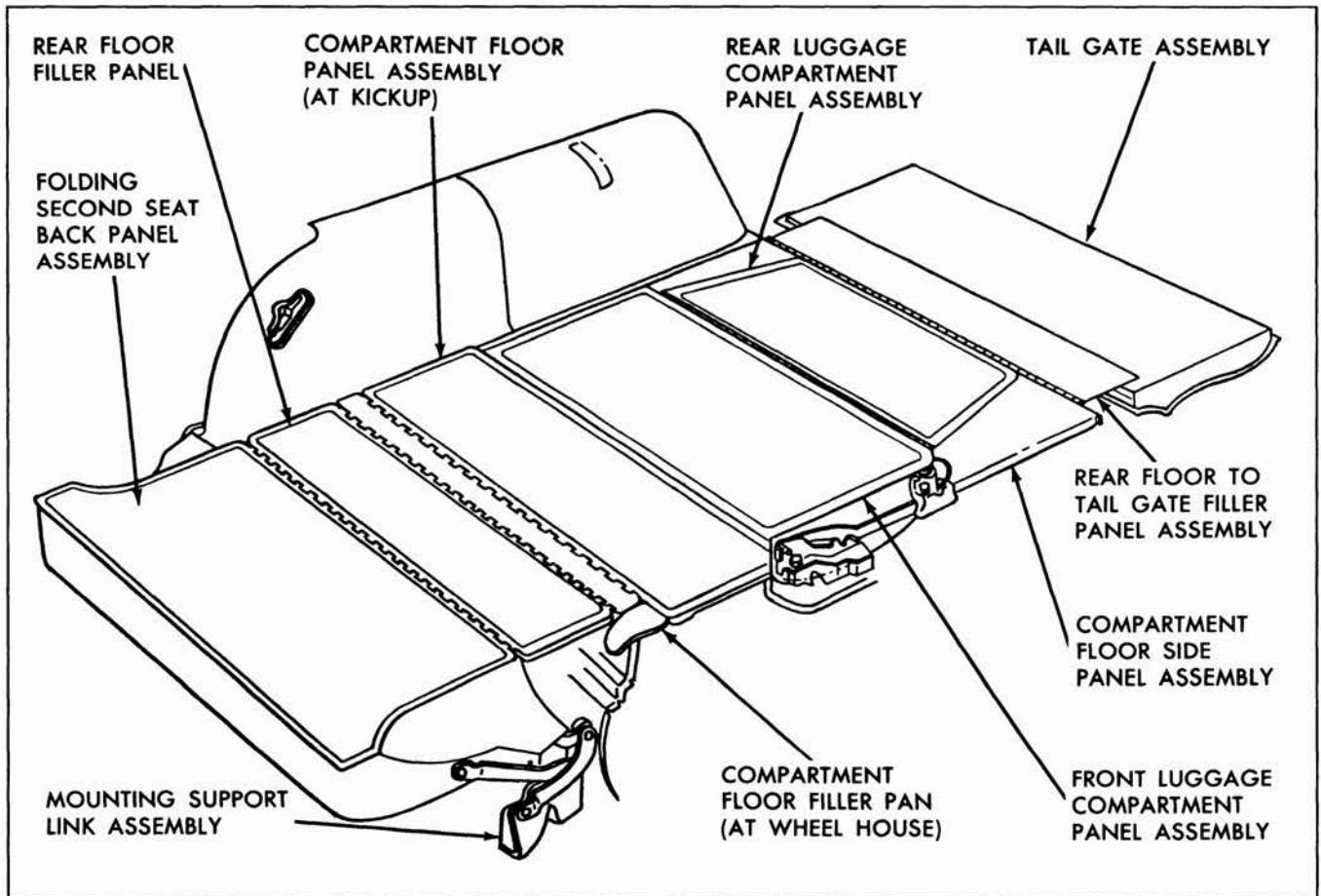

Fig. 8-2 Folding Seat and Rear Compartment Panels - 6 Passenger

REAR SEAT BACK CENTER ARM REST ASSEMBLY

REMOVAL AND INSTALLATION

1. Remove rear seat back assembly and place upside down on a clean protected surface.
2. Remove four bolts securing rear seat arm rest support plate to rear seat back spring assembly.
3. Lift up lower edge of seat back assembly and disengage arm rest with attached arm rest trim panel from seat back spring assembly and remove arm rest from assembly.
4. To install, reverse removal procedure.
5. Adjust support plate as required, so that arm rest, when in raised position, is centered in and flush to the seat back cushion.

FOLDING REAR SEAT AND REAR COMPARTMENT FLOOR PANELS

The following views are typical of the station wagon six and nine-passenger folding rear seat back and rear compartment floor panels. These illustrations identify the component parts of the rear compartment area and their relationship.

Fig. 8-2 is typical of Pontiac six-passenger station wagons.

Fig. 8-3 is typical of Pontiac nine-passenger station wagons.

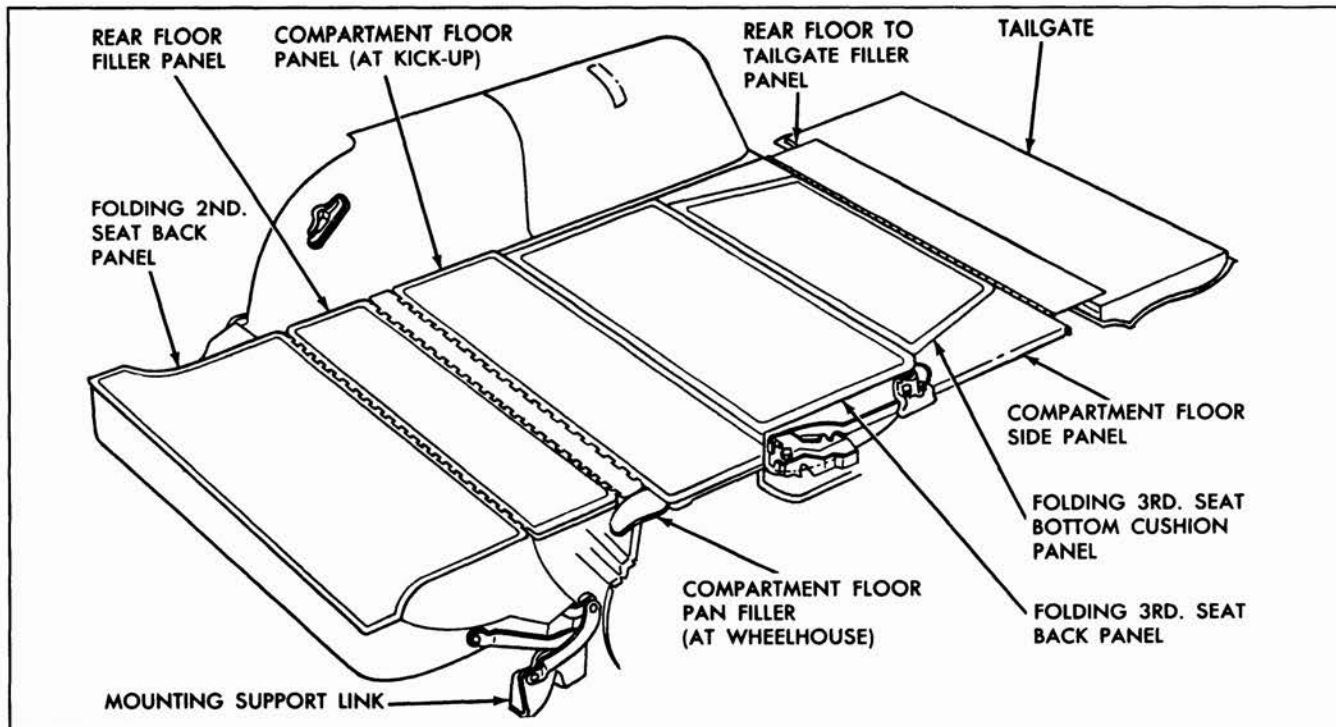

Fig. 8-3 Folding Seat and Rear Compartment Panels - 9 Passenger

REAR FLOOR TO TAIL GATE FILLER PANEL ASSEMBLY

35 and 45 STYLES

REMOVAL AND INSTALLATION

1. Lower tail gate assembly.
2. Lift up rear edge of filler panel assembly sufficiently to expose attaching screws along forward edge of panel.
3. Remove filler panel attaching screws and remove panel assembly from body opening.
4. To install, reverse removal procedure.

COMPARTMENT FLOOR SIDE PANEL ASSEMBLY (RIGHT OR LEFT SIDE)

35 and 45 STYLES

REMOVAL AND INSTALLATION

1. On "35" style, use handle and fold rear luggage compartment panel forward until it is resting entirely on front luggage compartment panel (Fig. 8-4).
2. On "45" style, raise folding 3rd seat back assembly to up position; then raise 3rd seat bottom cushion assembly to up or "sitting" position.

3. For right floor side panel, remove spare tire cover panel.

4. For left floor side panel, remove rear quarter inner trim rear panel assembly.

5. On left side, remove screw which secures floor side panel to panel support.

6. Along inboard and outboard side facing of right and/or left panel, remove screws which secure panel to panel supports and remove panel(s) from body.

7. To install, reverse removal procedure.

LUGGAGE COMPARTMENT FRONT AND REAR PANEL ASSEMBLIES

35 STYLE

REMOVAL AND INSTALLATION

1. Using handle, fold rear luggage compartment panel forward until it is resting entirely on front luggage compartment panel (Fig. 8-4).

2. Fold combined front and rear luggage compartment panels to "up" or half open position. (Panels should be approximately vertical to the floor pan assembly).

3. Lift left side of panel assembly upward to disengage panels from left floor pan support.

4. Move entire panel assembly approximately 1/2" to left side of body (outboard) to disengage right side of panel from right floor pan support and remove both front and rear luggage compartment panels from body.

5. To install, reverse removal procedure.

NOTE: When replacing front luggage compartment panel with new part, transfer rear luggage compartment panel with attached hinge to new part.

LUGGAGE COMPARTMENT REAR PANEL ASSEMBLY

35 STYLE

REMOVAL AND INSTALLATION

1. Using handle, fold rear luggage compartment panel forward until it is resting entirely on front luggage compartment panel (Fig. 8-4).

2. Remove screws securing hinge assembly to rear luggage compartment panel and remove panel assembly from body.

3. To install, reverse removal procedure.

LUGGAGE COMPARTMENT FRONT AND REAR PANEL HINGE ASSEMBLY

35 STYLE

REMOVAL AND INSTALLATION

1. Using handle, fold rear luggage compartment panel forward until it is resting entirely on front luggage compartment panel.

2. Remove screws securing hinge assembly to both front and rear panels and remove hinge from body (see view "A-A", Fig. 8-4).

3. To install, reverse removal procedure.

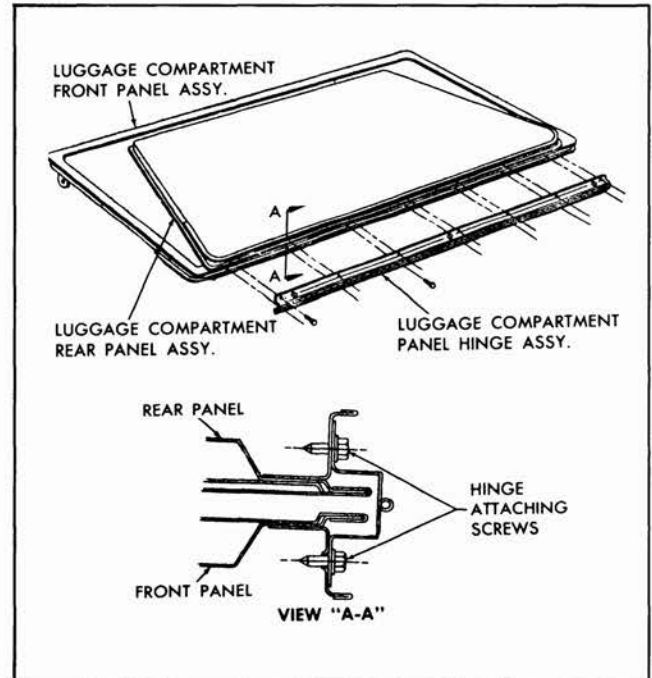

Fig. 8-4 Luggage Compartment Hinge Attachment

FOLDING 3RD SEAT BOTTOM CUSHION PANEL ASSEMBLY

45 STYLE

REMOVAL AND INSTALLATION

1. Using handle, lift cushion panel assembly to a half raised position or until cushion is approximately vertical to floor pan assembly.

2. Lift left side of cushion panel assembly upward to disengage panel from left floor pan support.

3. Move cushion panel assembly approximately 1/2" to left side of body (outboard) to disengage right side of cushion from right floor pan support and remove cushion panel assembly from body.

4. To install, reverse removal procedure.

FOLDING 3RD SEAT BACK PANEL ASSEMBLY

45 STYLE

REMOVAL AND INSTALLATION

1. Using handle, raise folding seat back until it is approximately vertical to floor pan assembly.

2. Disengage right and left folding 3rd seat back link assemblies from floor pan support.

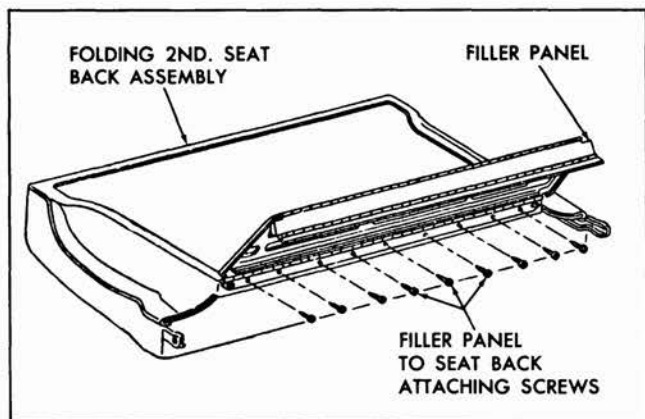

Fig. 8-5 Rear Door Filler Panel

3. Lift left side of seat back panel assembly upward to disengage panel from left floor pan support.

4. Move back cushion panel assembly approximately 1/2" to left side of body (outboard) to disengage right side of cushion from right floor pan support and remove back cushion panel assembly from body.

5. To install, reverse removal procedure.

COMPARTMENT FLOOR PANEL ASSEMBLY (AT KICK-UP)

35 and 45 STYLES

REMOVAL AND INSTALLATION

1. On "45" style, remove folding 3rd seat back assembly as previously described.

2. On "35" style, remove luggage compartment front and rear panel assemblies (complete) as previously described.

3. Remove screws which secure rear edge of compartment floor panel to floor pan assembly.

4. Lift up rear edge of panel sufficiently to firmly grasp panel; then pull panel rearward to disengage front edge of panel from retaining clips on floor pan and remove panel assembly from body.

5. To install, reverse removal procedure.

COMPARTMENT FLOOR PAN FILLER (AT WHEELHOUSE)

35 and 45 STYLES

REMOVAL AND INSTALLATION

1. Remove compartment floor panel assembly (at kick-up) as previously described.

2. Remove two screws securing floor pan filler (at wheelhouse) to floor pan assembly and remove filler from body.

3. To install, reverse removal procedure.

REAR FLOOR FILLER PANEL

35 and 45 STYLES

REMOVAL AND INSTALLATION

1. Remove compartment floor panel assembly (at kick-up) as previously described.

2. Along rear edge of filler panel, remove screws which secure panel to floor pan.

3. Fold filler panel forward sufficiently to remove screws which secure panel to folding 2nd seat back assembly and remove filler panel from body (Fig. 8-5).

4. To install, reverse removal procedure.

FOLDING REAR SEAT CUSHION

35 and 45 STYLES

REMOVAL AND INSTALLATION

1. Lift up front edge of folding rear seat cushion assembly to disengage protrusions in seat bottom frame from slots in rear seat support and remove cushion assembly.

2. To install, reverse removal procedure. Make certain that protrusions are fully engaged in rear seat support.

FOLDING 2ND SEAT BACK ASSEMBLY (WITH ATTACHED FILLER PANEL)

35 and 45 STYLES

REMOVAL AND INSTALLATION

1. Remove compartment floor panel assembly (at kick-up) as previously described.

2. Remove screws securing rear edge of rear floor filler panel assembly to floor pan.

3. With folding 2nd seat back assembly in down position, fold filler panel forward sufficiently to remove screws securing right and left lower corner moldings to 2nd seat back and remove moldings.

4. Remove bolts securing right and left mounting support link assemblies to seat back assembly (Fig. 8-6), and remove folding 2nd seat back assembly with attached filler panel from body.

5. To install, reverse removal procedure.

NOTE: When necessary to remove filler panel from seat back assembly, as a bench operation, fold filler panel as shown in Fig. 8-6 and remove screws which secure filler panel to seat back panel assembly.

FOLDING 2ND SEAT BACK MOUNTING SUPPORT LINK ASSEMBLY

35 and 45 STYLES

REMOVAL AND INSTALLATION

1. Release rear seat cushion and slide cushion forward.

2. Turn back floor carpet sufficiently to remove screws securing rear door opening carpet support filler to floor pan and remove support filler from body.

3. Remove bolts securing folding 2nd seat back mounting support link assembly to floor pan.

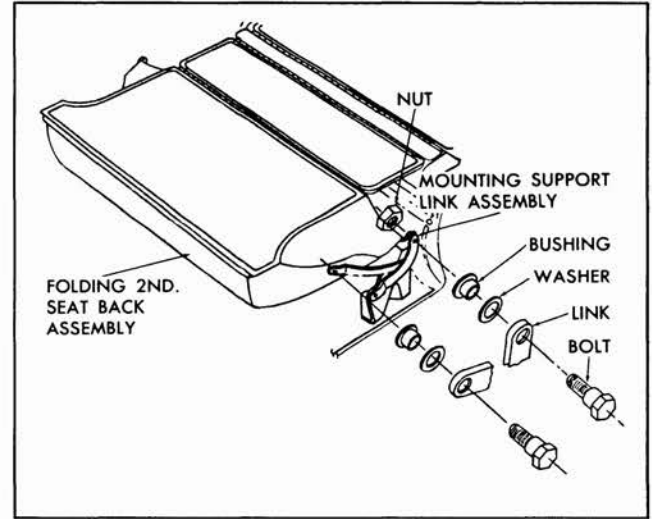

Fig. 8-6 Second Seat Mounting Support Link

4. Fold 2nd seat back assembly to down position.

5. Remove screws securing lower corner molding to 2nd seat back and remove molding from back.

6. Remove bolts securing support link to folding 2nd seat back assembly and remove support link from body (Fig. 8-6).

7. To install, reverse removal procedure.

FRONT SEATS ELECTRICALLY OPERATED (SIX WAY)

DESCRIPTION

The electrically-operated six-way front seat assembly can be moved forward, rearward, upward, downward or tilted by means of a manually-operated seat control switch. The large center control knob controls movement of the entire seat assembly horizontally. The smaller forward control knob controls the vertical movements of the front of the seat assembly causing the seat assembly to "tilt". In the same manner, the rear control knob controls vertical movement of the rear of the seat assembly. To obtain maximum vertical travel, it will be necessary to engage the center vertical control until the limit of travel is reached, then engage the smaller forward or rear control knob to complete the maximum travel. This is necessary due to the removal of the slip clutches in the seat transmission. This seat

adjuster operating mechanism incorporates a transmission assembly which includes three solenoids and six drive cables leading to the seat adjusters.

Solenoid #1 (Fig. 8-7) controls the vertical movement of the rear edge of the seat. Solenoid #2 controls the horizontal movement of the rear edge of the seat. Solenoid #3 controls the vertical movement of the front edge of the seat. In addition to the six seat adjuster drive cables at the transmission assembly, a motor drive cable is installed from the motor to the transmission assembly (Fig. 8-7). When one of the control switch buttons is actuated, the motor and one of the solenoids are energized simultaneously. The solenoid plunger engages the large gears with a driving gear. The driving gear rotates the large gears which rotates the drive cables and operates both adjusters. When the switch

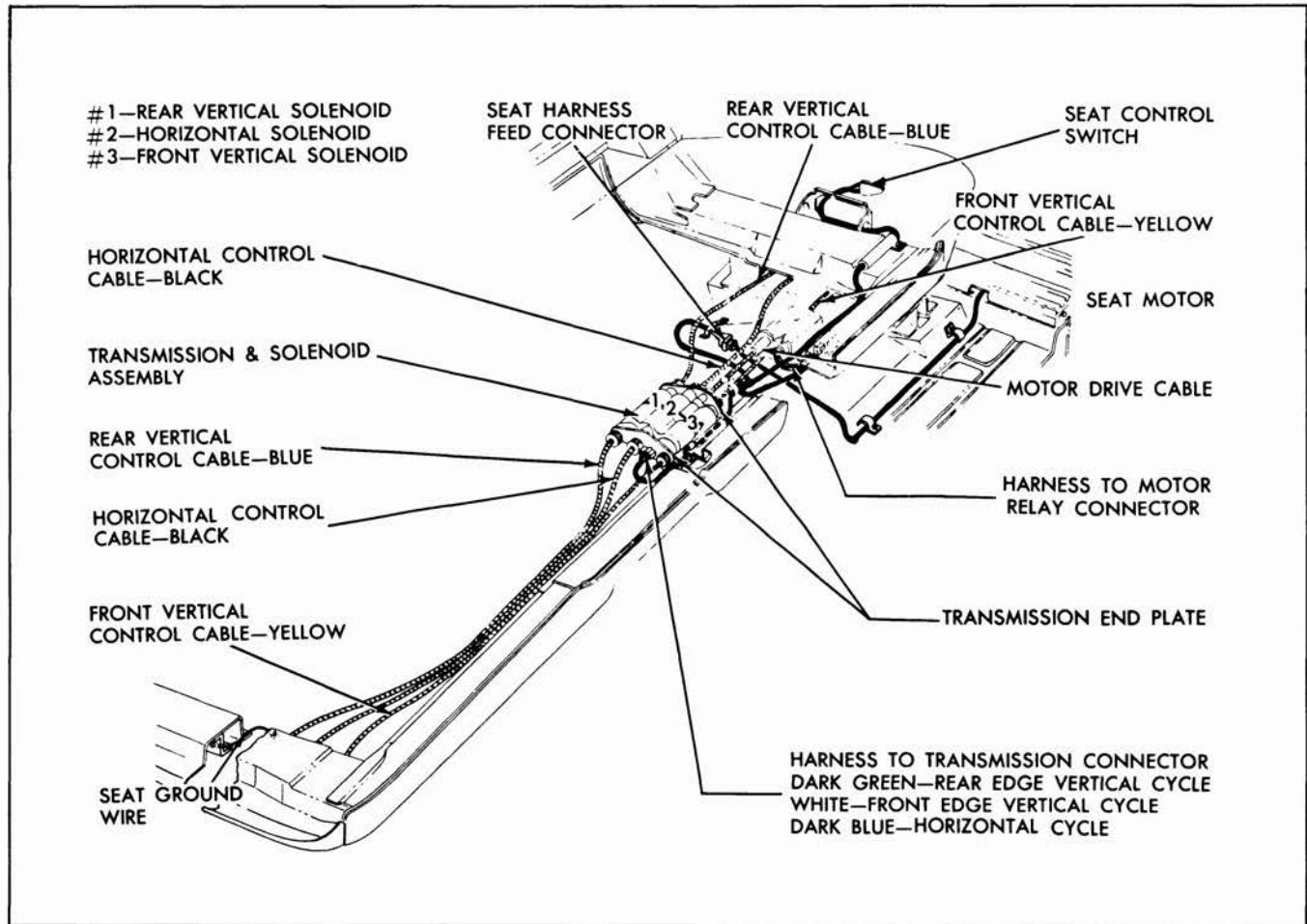

Fig. 8-7 Six-Way Installation

contacts are opened, a spring returns the solenoid plunger to its original position, disengaging the large gears from the driving gear.

FRONT SEAT ASSEMBLY

REMOVAL AND INSTALLATION

1. Under front of seat, disconnect seat wire harness from feed wire harness and detach control switch harness from clip on floor pan.
2. Turn back floor carpeting, remove both seat adjuster track covers and remove four seat adjuster-to-floor pan attaching bolts from each adjuster. Remove carpet retainers at front of seat adjusters.
3. With aid of a helper, remove seat assembly with attached adjusters, motor and transmission assembly from body.
4. To install seat assembly, reverse removal procedure. Make sure ground wire is securely

attached at right seat adjuster and under seat adjuster-to-floor pan attaching bolt.

FRONT SEAT ADJUSTER ASSEMBLY

REMOVAL AND INSTALLATION

1. Remove front seat assembly from body with attached adjusters, motor and transmission, and place upside down on a clean protected surface.
2. Detach the three power drive cables from adjuster to be removed.
3. Remove adjuster-to-seat bottom frame front and rear attaching bolts and remove adjuster from seat assembly.
4. To install seat adjuster assembly, reverse removal procedure. Black cable attaches to horizontal actuator; yellow cable to front vertical gear nut and blue cable to rear vertical gear nut.

CAUTION: When installing seat assembly in body, seat adjusters should be parallel and "in phase" with each other. In the event the adjusters are "out of phase" (that is, one adjuster reaches its maximum horizontal or vertical travel in a given direction before the other adjuster), proceed as follows:

a. Horizontal Travel - operate seat control switch until one adjuster reaches full forward position. Detach horizontal drive cable from adjuster which has reached full forward position. Operate seat forward until other adjuster reaches full forward position; then, connect horizontal drive cable and check horizontal travel of seat.

b. Front and Rear Vertical Travel - operate seat control switch until one adjuster reaches fully raised position. Disconnect vertical drive cable from adjuster which has reached the full up position. Operate seat upward until other adjuster has reached the full up position; then, connect the vertical drive cable and check vertical travel of seat.

FRONT SEAT ADJUSTER VERTICAL JACKSCREW GEAR NUTS AND SPRINGS

REMOVAL AND INSTALLATION

1. Remove seat assembly from body.
2. Remove seat adjuster from side on which jackscrew is to be removed.
3. Using clutch-type screwdriver or other suitable tool, remove shoulder screws securing linkages to vertical gear nuts (Fig. 8-8).
4. Insert a #1 crosshead screwdriver or other suitable tool into drive cable slot in rear vertical gear nut and actuate gear nut rearward. Actuate front vertical gear nut rearward to release tension from front assist spring.
5. Remove jackscrew front attaching nut.
6. Lift front end of jackscrew to disengage it from support and remove front assist spring and silencer.
7. Actuate front and rear gear nuts forward to release tension from rear assist spring.
8. Remove rear attaching nut from jackscrew.

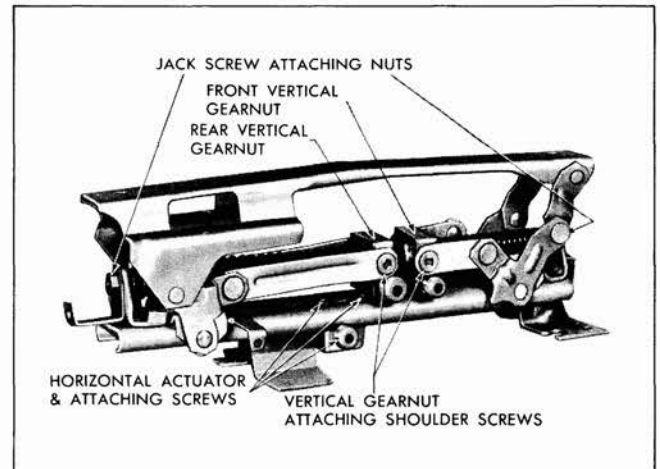

Fig. 8-8 Six Way Seat Adjuster

9. Disengage rear end of jackscrew from support and remove jackscrew with gear nuts and spring from adjuster. Rear assist spring and silencer may now be removed from jackscrew (Fig. 8-9).

10. To remove vertical gear nuts, turn or actuate gear nuts off jackscrew.

11. To install, reverse removal procedure making sure jackscrew is installed with unthreaded shoulder at rear of adjuster and with gear nuts installed. Rear vertical gear nut with larger diameter cable attachment is installed to rear; front vertical gear nut with smaller diameter cable attachment is installed at front. Both vertical gear nuts should have cable attachment at bottom of inner side of adjuster.

FRONT SEAT ADJUSTER HORIZONTAL ACTUATOR OR UPPER AND LOWER CHANNELS

REMOVAL AND INSTALLATION

1. Remove front seat adjuster.
2. Remove screws securing horizontal actuator and remove actuator from seat adjuster.
3. Slide seat adjuster lower channel from upper channel and, if required, remove plastic shoes from lower channel track.
4. To install, reverse removal procedure. If lower channel has been removed from upper channel, make sure all four plastic shoes are installed on lower track. Apply "Lubriplate" or equivalent to track portion of upper channel and to teeth on lower channel. When installing horizontal actuator, adjust

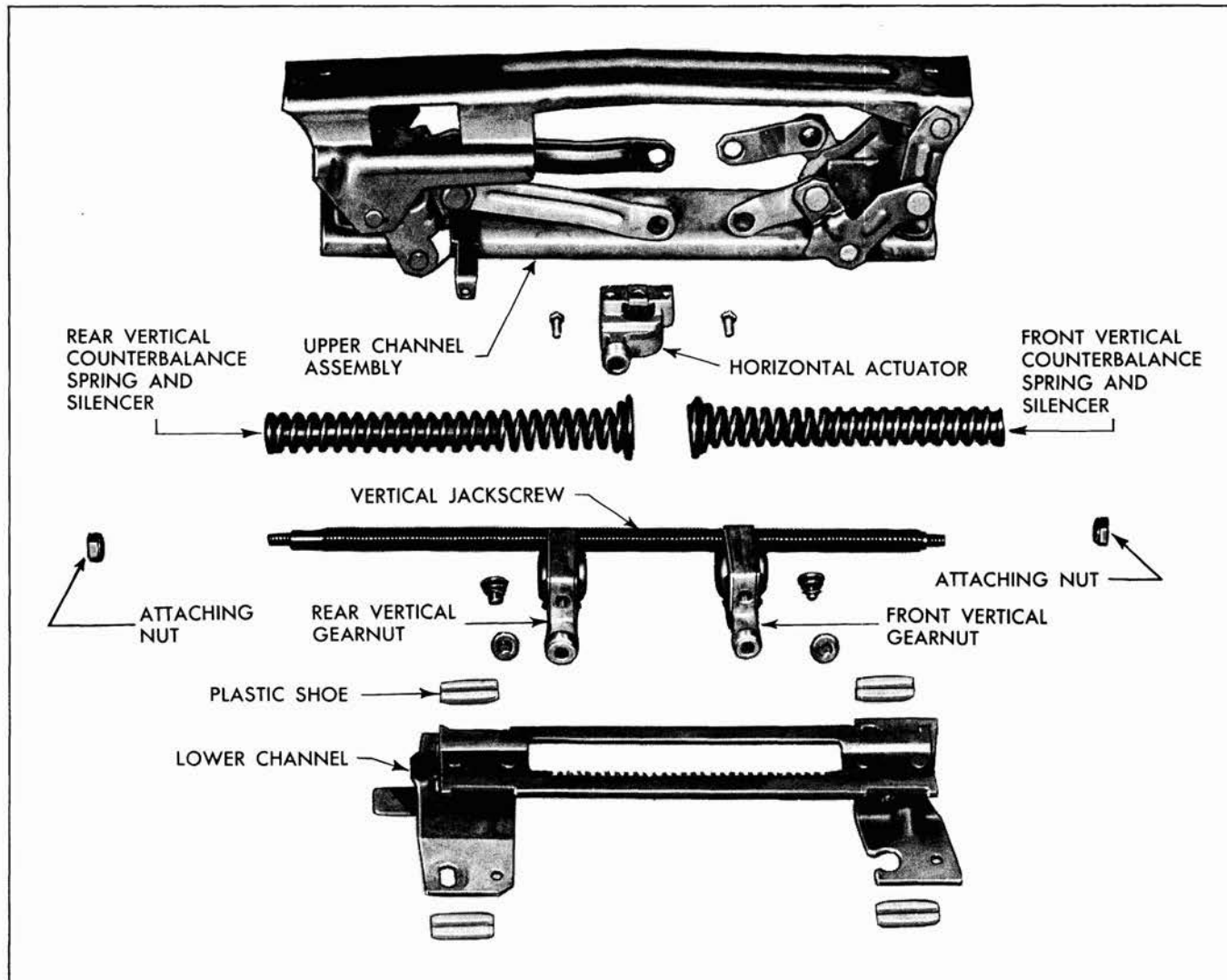

Fig. 8-9 Six Way Seat Adjuster

actuator so that drive gear is fully engaged with teeth on lower channel. When horizontal actuator screws are tightened, there should be no free motion between upper and lower channels.

FRONT SEAT ADJUSTER ELECTRIC MOTOR OR DRIVE CABLE

REMOVAL AND INSTALLATION

1. Remove front seat assembly as previously described.
2. Remove motor support-to-seat frame attaching bolts.
3. Move motor assembly towards left side of seat sufficiently to disengage motor drive cable; then,

remove motor from support assembly. Motor drive cable may be removed, if required, by removing cable end plate from transmission.

4. To install, reverse removal procedure making sure motor drive cable is properly engaged at both motor and transmission.

FRONT SEAT ADJUSTER HORIZONTAL AND VERTICAL DRIVE CABLES

REMOVAL AND INSTALLATION

1. Remove front seat assembly from body with attached adjusters, motor and transmission and place upside down on a clean protected surface.

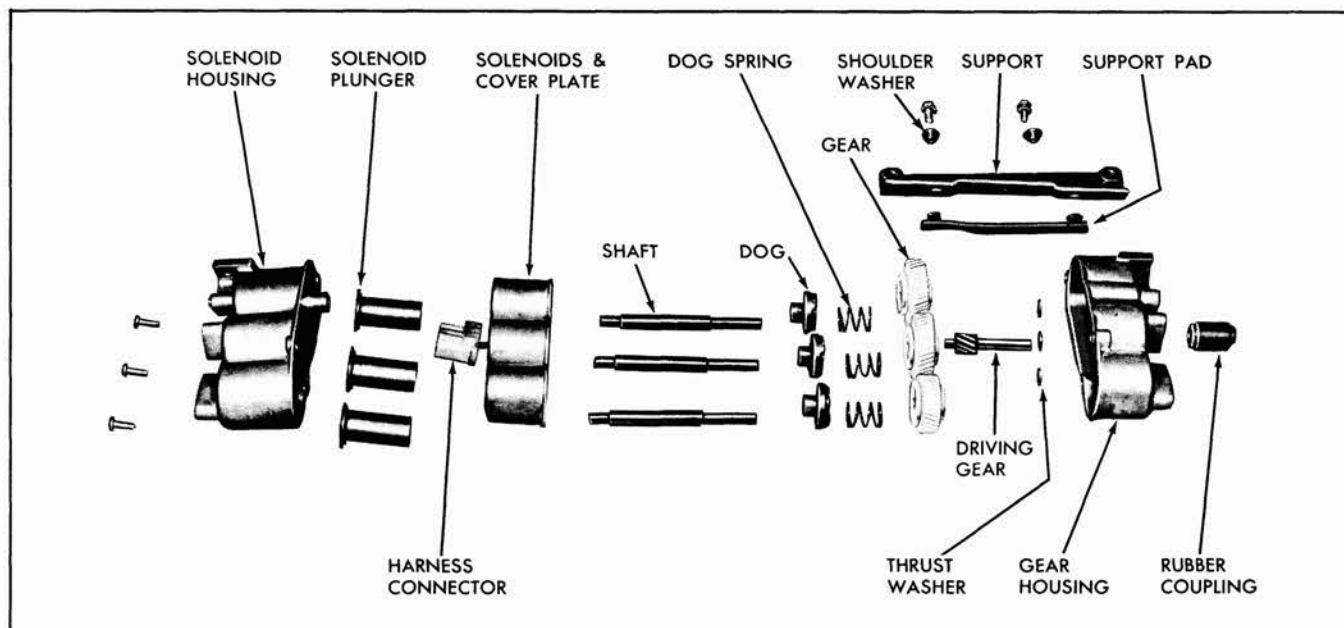

Fig. 8-10 Six-Way Seat Transmission

2. Detach both horizontal and vertical cables from seat adjuster.

3. Remove screws securing horizontal and vertical cable end plate on side of transmission from which cables are being removed and remove cables from seat assembly; then disengage cables from end plate.

4. To install horizontal and vertical cables, reverse removal procedure. Make sure cables are installed to correct gear nuts (Fig. 8-7).

FRONT SEAT ADJUSTER TRANSMISSION

REMOVAL AND INSTALLATION

1. Remove front seat assembly from body with attached adjusters, motor and transmission and place upside down on a clean protected surface.

2. Disconnect wire harness connector from transmission (Fig. 8-7).

3. Remove screws securing horizontal and vertical cable end plate on both sides of transmission and detach cables from transmission.

4. Remove transmission to support attaching bolts; then disengage transmission from motor drive cable and remove transmission from seat assembly.

5. To install, reverse removal procedure.

DISASSEMBLY AND ASSEMBLY

1. Remove front seat adjuster transmission from seat assembly.

2. Remove screw securing ground strap to solenoid housing and screws securing transmission support to gear and solenoid housings.

3. Remove screws securing gear housing to the solenoid housing; then, carefully separate housings and remove component parts of transmission assembly (Fig. 8-10).

4. To assemble transmission, reverse removal procedure.

IMPORTANT: Prior to or during installation, lubricate frictional surfaces of driving gear, thrust washer, large gears, dog washers, gear shaft and solenoid plungers with "Lubriplate" or equivalent.

ELECTRICAL

CONTENTS OF THIS SECTION

SUBJECT	PAGE	SUBJECT	PAGE
Power Operated Windows		Checking Procedures	9-7
Description	9-1	Checking Safety Switch	9-9
Crossover Harness	9-1	Six Way Seat	
Window Harness	9-1	Description	9-10
Checking Procedures	9-1	Checking Procedures	9-10
Electric Tail Gate Window		Seat Switch	9-13
Description	9-6	Wiring Diagrams	9-14

POWER OPERATED WINDOWS

DESCRIPTION

The wiring harness for the electrically operated windows consists of three (3) major sections.

FRONT CROSS-OVER HARNESS

This harness is installed beneath the instrument panel and completes the circuit from the right door to the left door windows. The front harness also includes the wiring for the front door windows. Fig. 9-1. The multiple connector located at the front harness is used only for manufacturing purposes and is not intended to be disengaged in service.

REAR DOOR OR REAR QUARTER WINDOW HARNESS

A separate harness controls the operation of the right and left rear door or quarter windows Fig. 9-2. The right and left harnesses are connected to the front crossover harness beneath the outer ends of the instrument panel.

The power windows are operated by a rectangular shaped 12 volt series wound motor with an internal circuit breaker and a self-locking rubber coupled gear drive. The harness to window motor connector is designed with a locking embossment to insure a

positive connection. When disengaging the harness connector from the motor, it is necessary to depress the thumb release. When installing the harness, the thumb release must be held depressed until the embossment on the female connector is locked in the hole of the motor connector.

The power window electrical circuit is protected by a 40 ampere circuit breaker. Circuit breaker located at left side of engine compartment.

POWER WINDOW CIRCUIT CHECKING PROCEDURES

Failures in a circuit are usually caused by short circuits or open circuits. Open circuits are usually caused by breaks in the wiring, faulty connection or mechanical failure in a component such as a switch or circuit breaker. Short circuits are usually caused by wires from different components of the current contacting one another or by a wire or component grounding to the metal of the body due to a screw through the wire, insulation cut through by sharp metal edge, etc.

It may be necessary to use only one or all of the procedures outlined to locate an electrical failure in the circuit. If the location of the failure is evident, follow only the steps required to check the affected wire or component. If the location of the failure is not evident, follow the procedure as outlined. Be

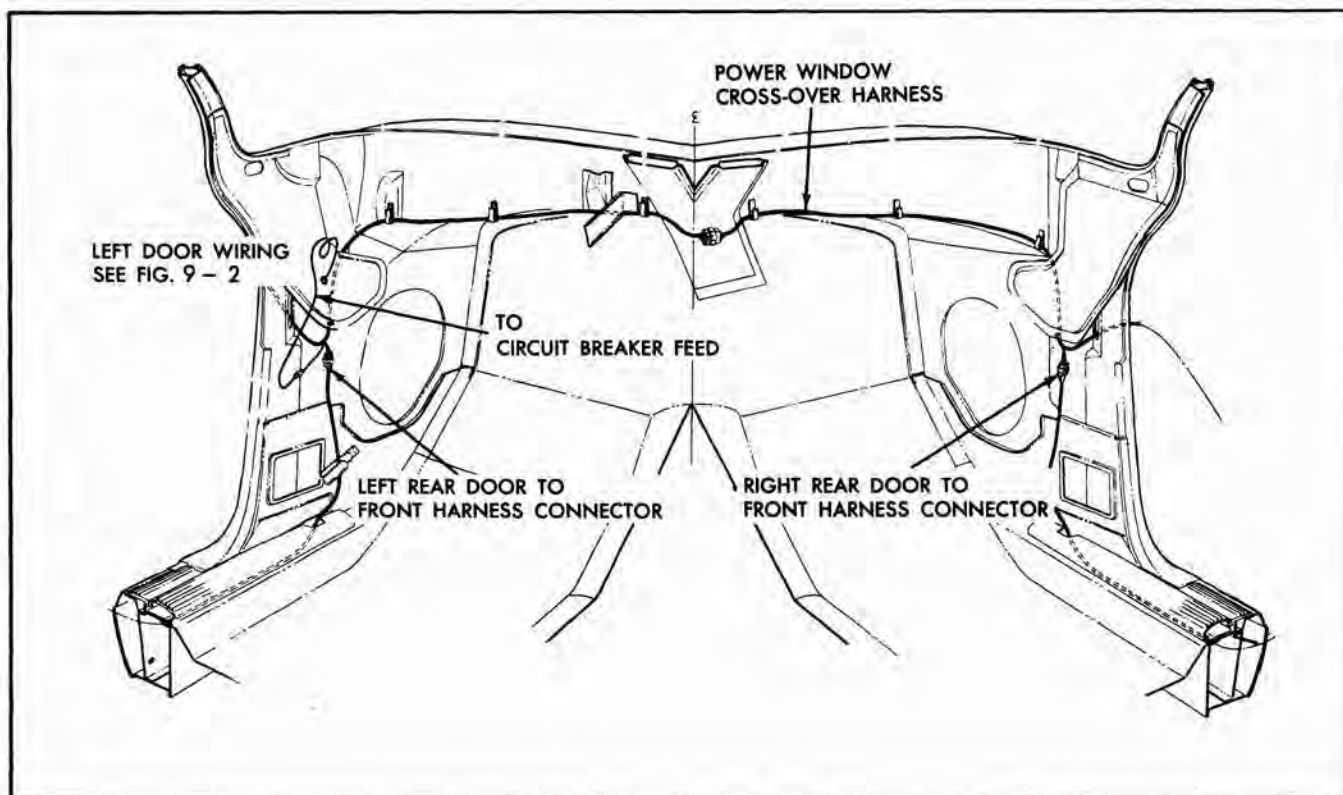

Fig. 9-1 Power Window Wiring Installation

sure to check the harness connectors beneath the outer ends of the instrument panel for proper engagement.

CHECKING FEED CIRCUIT CONTINUITY AT CIRCUIT BREAKER

1. Connect one light tester lead to battery side of circuit breaker and ground other lead. If tester does not light, there is an open or short circuit in feed circuit to breaker.

2. To check circuit breaker, disconnect the output feed wire (the wire opposite the power source feed to the breaker) from the breaker and with light tester, check terminal from which wire was disconnected. If tester does not light, circuit breaker is inoperative.

CHECKING FEED CIRCUIT CONTINUITY AT WINDOW CONTROL SWITCH

1. Connect one light tester lead to feed terminal of switch block and ground other tester lead to body metal Fig. 9-3.

2. If tester does not light, there is an open or short circuit between switch and power source.

CHECKING WINDOW CONTROL SWITCH

1. Insert one end of a #12 gauge jumper wire to the switch feed terminal and the other end to one of the motor lead terminals in the switch block. Repeat this check on the remaining motor lead terminal Fig. 9-4.

2. If the motor operates with the jumper wire, but does not operate with the switch, the switch is defective.

CHECKING WIRES BETWEEN DOOR WINDOW SWITCH AND DOOR WINDOW MOTOR

1. Disengage harness connector from window motor connector. The thumb release on the harness connector must be depressed before it can be disengaged from the motor.

2. Insert one end of a #12 gauge jumper wire to the switch feed terminal and the other end to one of the motor lead terminals in the switch block Fig. 9-4.

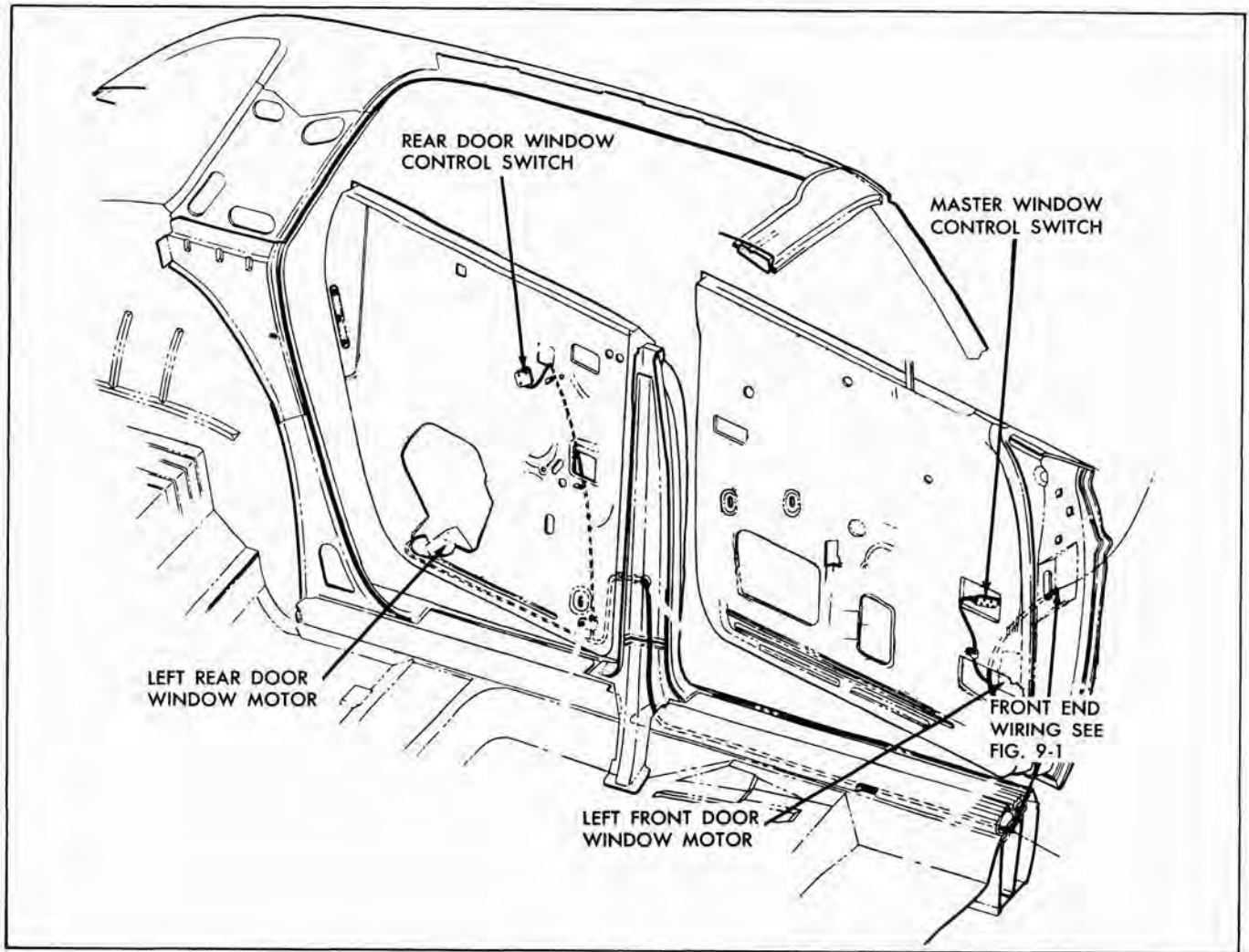

Fig. 9-2 Left Side Power Window Wiring Installation

3. With light tester check for current at terminal being checked. If tester does not light, there is an open or short circuit in the harness between the control switch and motor connector (see Fig. 9-5).

or replaced as required. Check the other motor lead in the same manner.

CHECKING DOOR WINDOW MOTOR

1. Check window regulator and channels for possible mechanical bind of window.

2. Check attachment of window motor to inner panel to insure an effective ground.

3. Connect one end of a #12 gauge jumper wire to the power source and the other end to one of the terminals on the window motor.

4. If the motor fails to operate with a jumper wire, the motor is defective and should be repaired

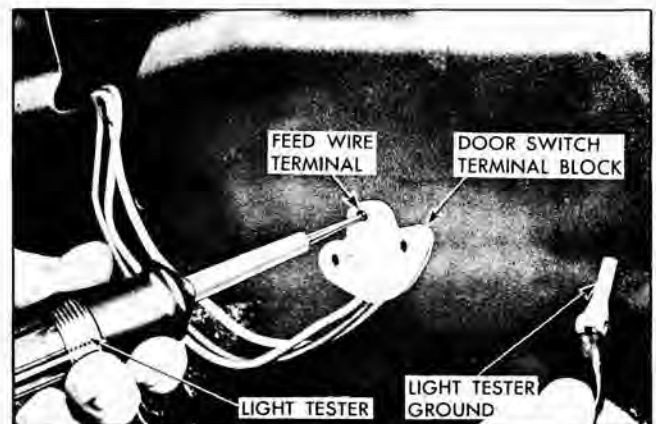

Fig. 9-3 Checking Feed Circuit

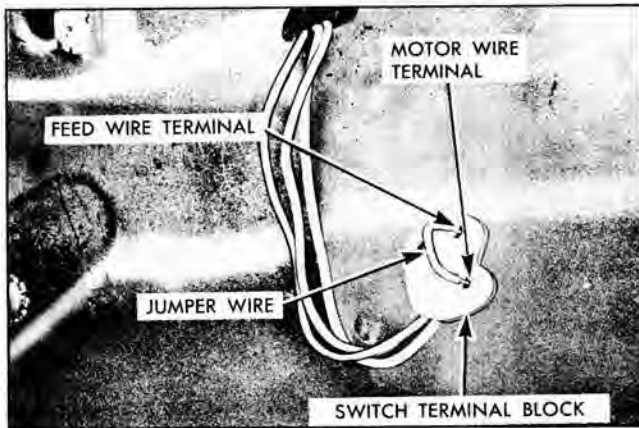

Fig. 9-4 Checking Window Control Switch

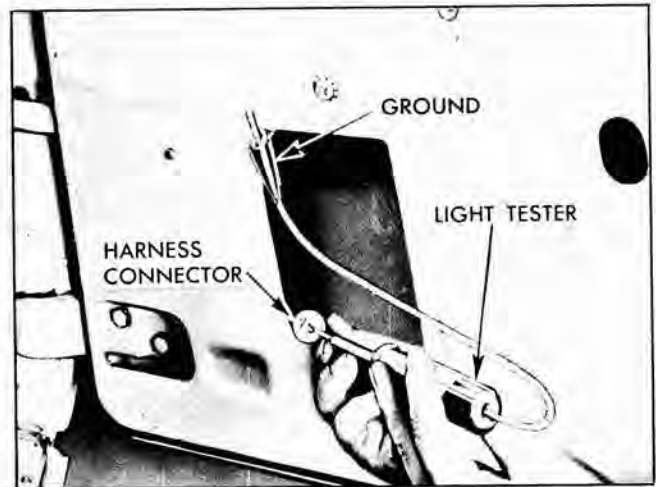

Fig. 9-5 Checking Circuit Between Switch and Motor

TYPICAL FAILURES OF POWER WINDOW

The following typical failures and corrections have been listed as an aid for eliminating electrical failures in the power window electrical circuit. It

should be noted that multiple failures in the circuit may lead to a combination of conditions, each of which must be checked separately. See circuit diagram shown in Fig. 9-6.

CONDITION	CAUSE	CORRECTION
1. None of the windows will operate.	Short or open circuit in power feed circuit.	<ol style="list-style-type: none"> 1. Check circuit breaker operation. 2. Check feed connector to power harness beneath instrument panel. 3. Check the feed circuit wires for possible short or open circuit.
2. Right rear door window does not operate from master control switch on left front door or from control switches on right rear door. Left door window operates.	<ol style="list-style-type: none"> 1. Short or open circuit between right rear door harness and power window front harness. 2. Short or open circuit in affected window control switch or window motor circuit. 3. Possible mechanical failure or bind in window channels. 4. Defective window motor. 	<ol style="list-style-type: none"> 1. Check harness connectors beneath outer ends of instrument panel for proper installation. 2. Check wires in power window front harness for possible short or open circuit. 3. Check operation of rear door window control switch. 4. Check circuit from window control switch to window motor for short or open circuit. 5. Check window regulator and channels for possible mechanical failure or bind. 6. Check operation of motor.
3. Right door windows will operate from left door master control switch but will not operate from right door control switches. Left door windows operate.	Open or short circuit in front harness feed wire circuit.	Follow up feed wire in front harness for possible short or open circuit.

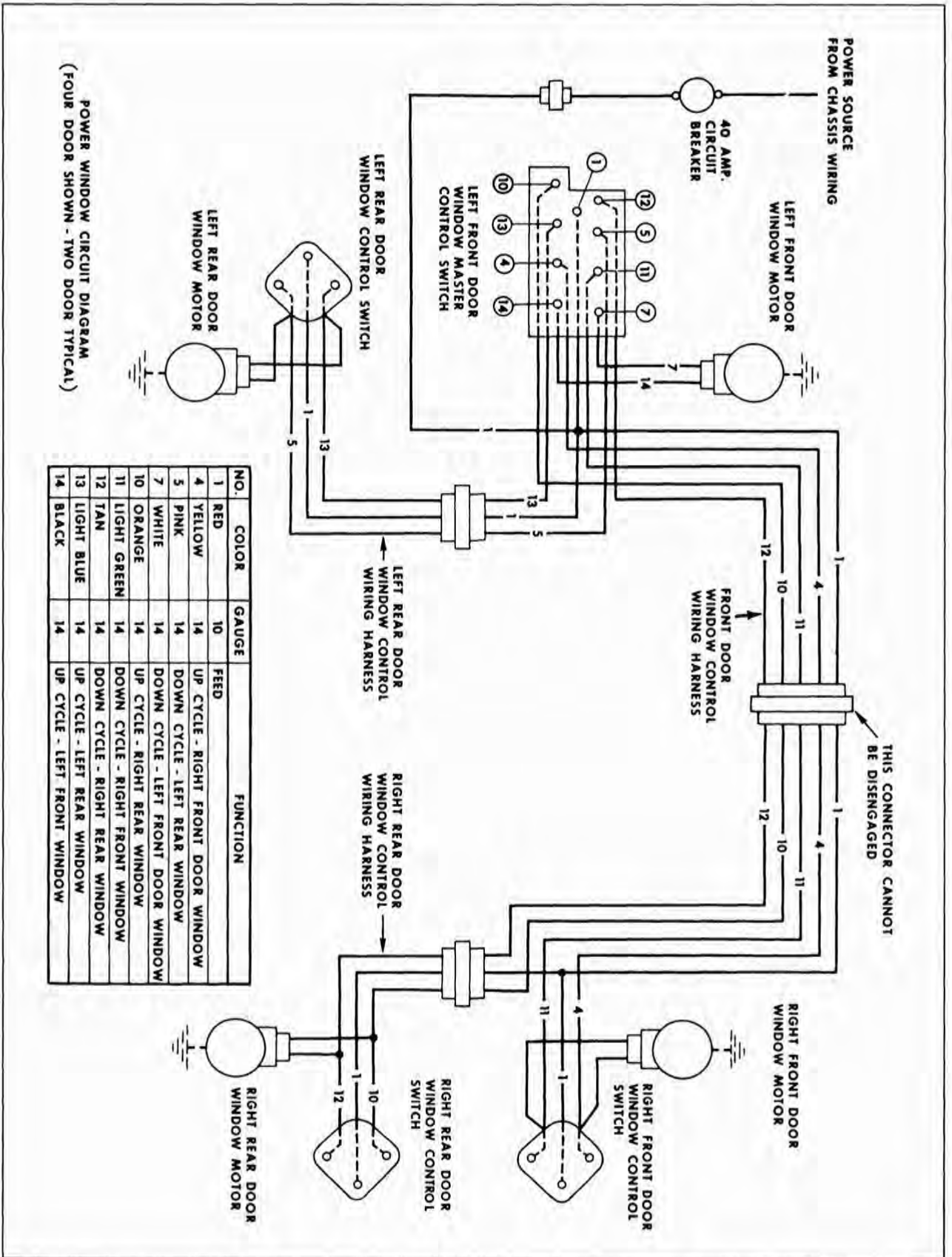

Fig. 9-6 Power Window Circuit Diagram

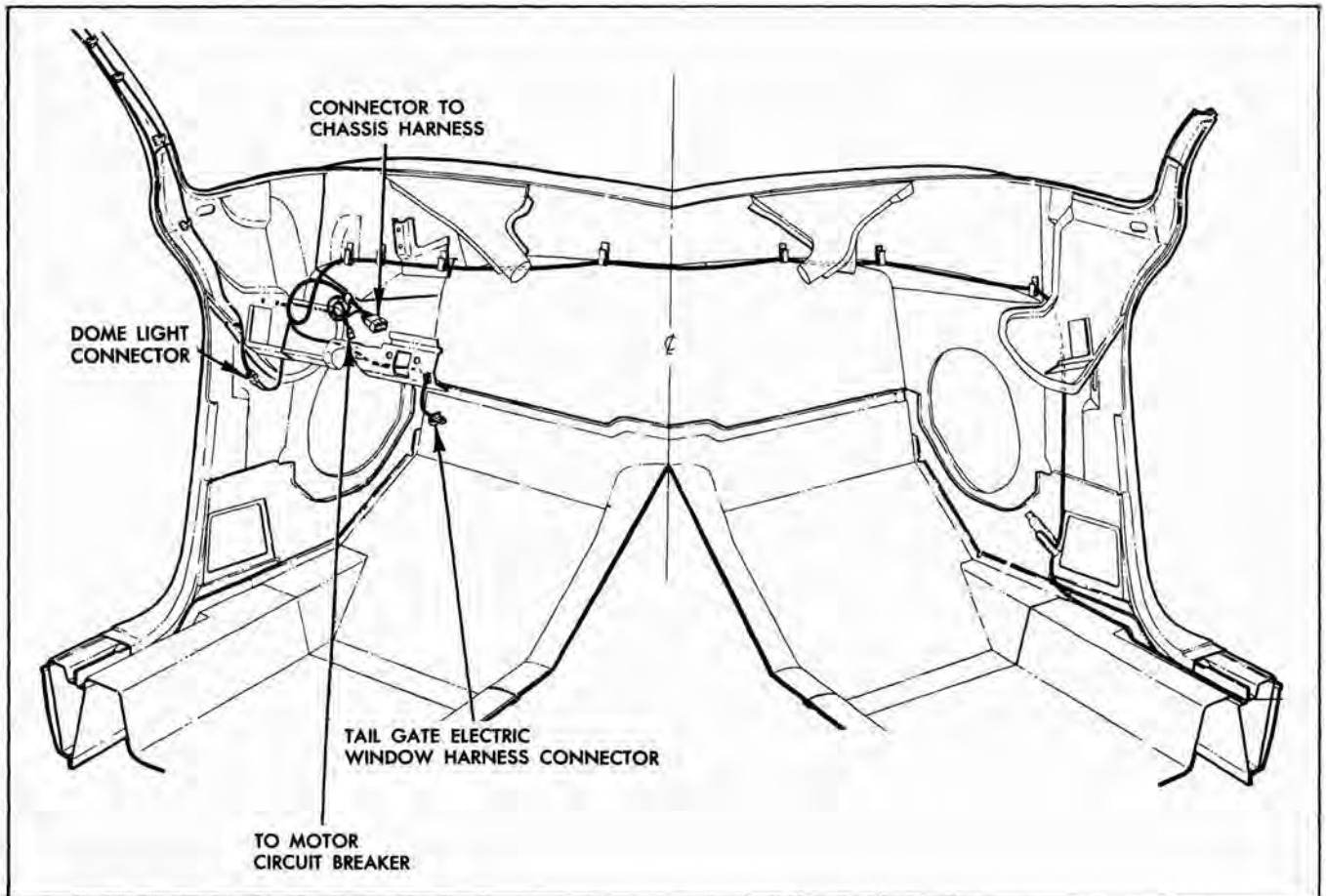

Fig. 9-7 Wiring For Tail Gate

ELECTRIC TAIL GATE WINDOW CIRCUIT

The 1962 station wagon style power operated tail gate dropping window is controlled by a window regulator equipped with a rectangular shaped, 12 volt D.C., reversible direction motor with an internal circuit breaker and a self-locking gear drive. The current for the motor is obtained through the circuit breaker located at the engine compartment.

The design of the tail gate requires the window to be lowered before the tail gate can be opened. A mechanical safety feature in the tail gate prevents the tail gate handle from being actuated before the window is in the fully lowered position. The window may be lowered from the instrument panel control switch located at the driver's side of the panel, or from the tail gate window lock cylinder switch. The lock cylinder switch is actuated when the key is in-

serted into the lock cylinder and rotated to open or lower the window. In addition, on the nine passenger station wagon styles, a tail gate window control switch is located at the rear of the left rear quarter inner panel trim.

The tail gate window harness is a component part of the body wiring harness which consists of a front and rear section connected together at the right rear quarter (Figs. 9-7, 9-8 and 9-9).

To prevent the window from being operated to the up position when the tail gate has been lowered, a safety switch is located adjacent to the right tail gate lock. The safety switch opens the ground circuit of the tail gate window motor, making it inoperative.

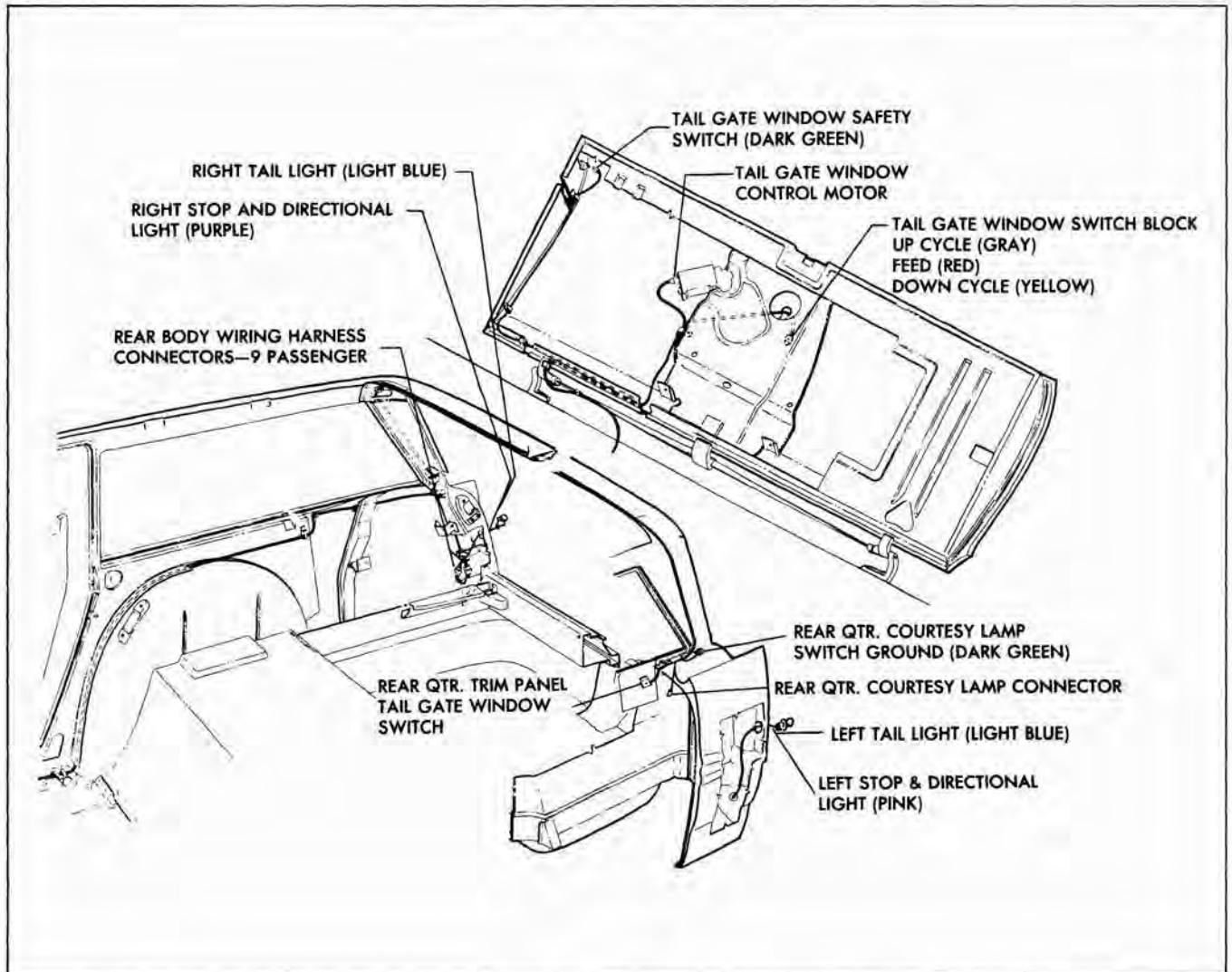

Fig. 9-8 Wiring For Tail Gate

CHECKING PROCEDURES

Before performing an intensive checking procedure to determine the failure in the circuit, be sure to check the connectors at the front and rear body wiring harness for proper installation. The checking procedures below may be used to check the operation of a switch or motor after the cause of the electrical failure has been isolated to a particular part of the circuit. Refer to Fig. 9-10 for the circuit diagram of the power window circuit.

CHECKING CIRCUIT BREAKER

This procedure is the same as "Checking the Circuit Breaker" for the power window circuit previously covered.

CHECKING FEED CIRCUIT CONTINUITY AT CONTROL SWITCH ON INSTRUMENT PANEL

1. Connect one light tester lead to feed terminal of switch block and ground other test lead to body metal.
2. If tester does not light, there is an open or short circuit between switch and power source.

CHECKING CONTROL SWITCH AT INSTRUMENT PANEL

1. Disengage harness connector from switch.
2. Use a #12 gauge jumper wire and insert one end into the red wire (feed) terminal and the other end into one of the other terminals. Tail gate window motor should operate.

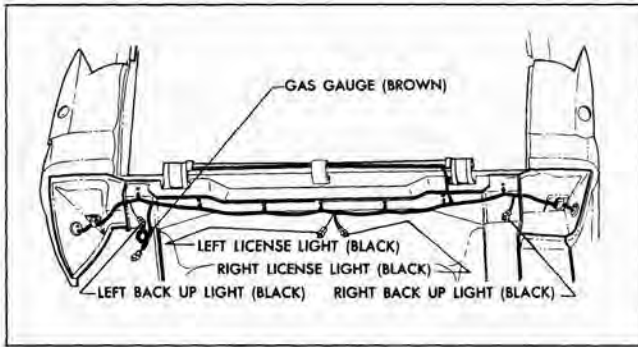

Fig. 9-9 Rear End Wiring (Sta. Wgn.)

3. Repeat procedure for the other terminals. If the tail gate window motor operates with the jumper wire but does not operate with the control switch, the switch is defective.

CHECKING CONTROL SWITCH AT REAR QUARTER OR TAIL GATE

First determine that there is current to the switch terminal block; then use a #12 gauge jumper and perform the same checking procedure as outlined for the door window motor control switch.

CHECKING CIRCUIT BETWEEN FRONT AND REAR HARNESS AT CONNECTOR

1. Remove right rear quarter trim to gain access to front and rear connector.
2. Check connector for proper engagement. If connector is engaged properly and motor does not operate, proceed as follows:

a. Disengage connector and check with test light for power (red). If tester does not light, there is a short or open circuit in the feed wire.

b. To check up and down cycle circuits, actuate window control switch at instrument panel or quarter trim panel. With test light, check continuity at wire terminal being energized.

CHECKING THE TAIL GATE WINDOW MOTOR

1. Disconnect harness connector from motor.
2. Connect the positive side of power source to the gray wire terminal on the motor connector and the negative lead to the dark green (ground) wire

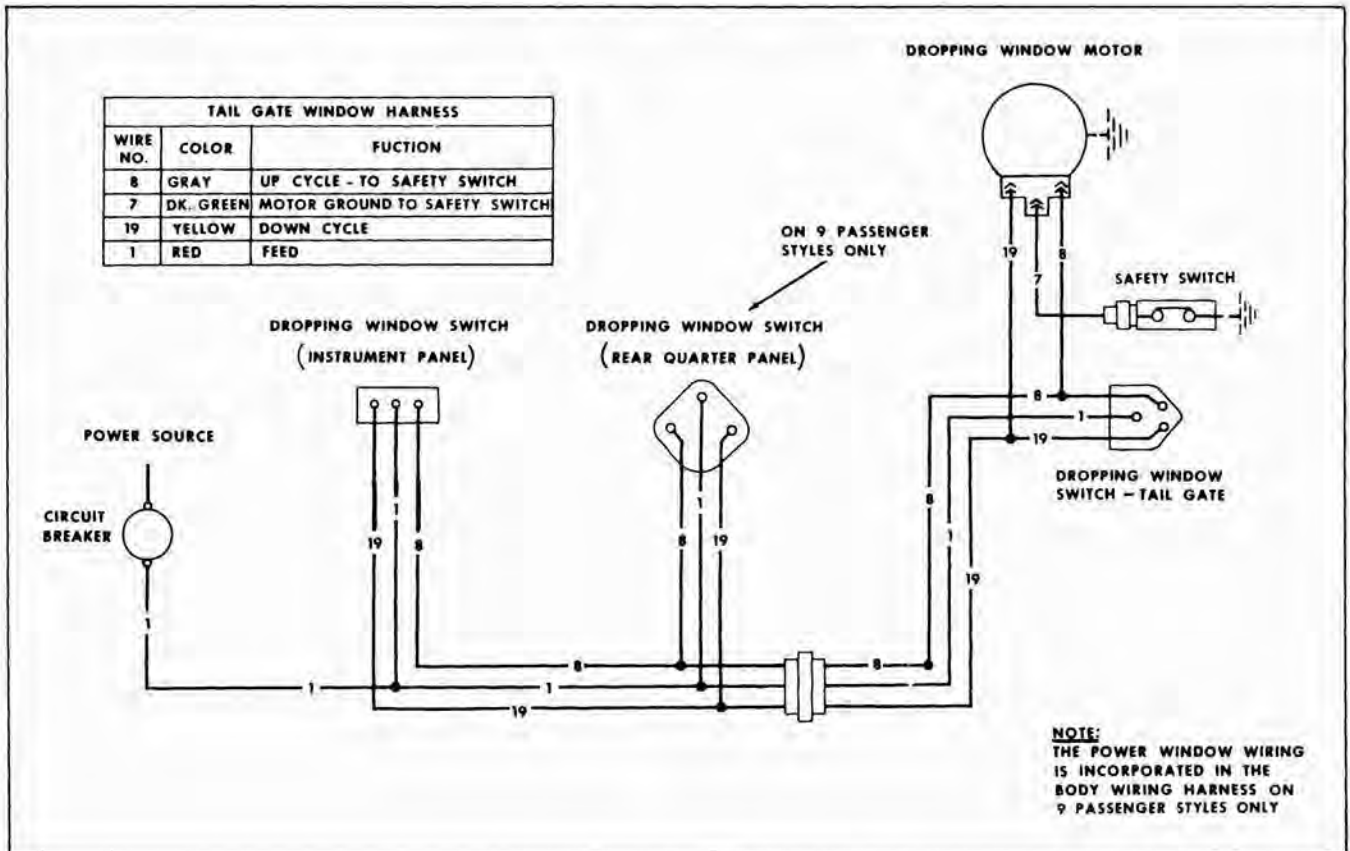

Fig. 9-10 Tail Gate Window Wiring - 9 Passenger

terminal. Motor should operate. To check the reverse operation of the motor, connect the power source to the yellow wire terminal.

CHECK OPERATION OF SAFETY SWITCH

1. With tail gate open, depress switch to simulate the tail gate being closed. If motor does not operate either switch is defective or the circuit is open from the motor to the switch.

2. To check for defective switch, connect one end of test light to a source of power and the other lead to the safety switch terminal. If the tester lights when the switch lever is actuated, the switch is operative.

NOTE: Safety switch completes the ground circuit from the motor.

TYPICAL FAILURES

CONDITION	CAUSE	CORRECTION
The tail gate window operates up and down from the tail gate switch, and the rear quarter switch (9-passenger style), but does not operate from the switch at the instrument panel.	<ol style="list-style-type: none"> 1. Open or short circuit from power source to control switch at instrument panel. 2. Defective or inoperative control switch. 	<ol style="list-style-type: none"> 1. Check affected wiring for open or short circuit and check connector at switch for proper installation. 2. Check operation of switch.
With the tail gate closed, the window operates downward but does not operate upward when the switch at the instrument panel, rear quarter or tail gate is actuated.	Open or short circuit in "up" cycle feed wire.	Check affected wiring for open or short circuit.
The window will not operate "up" or "down" from any of the control switches.	<ol style="list-style-type: none"> 1. Open or short circuit in circuit from power source to switches or motor. 2. Safety switch inoperative or poor ground. 3. Mechanical bind or failure in tail gate window regulator mechanism. 4. Defective tail gate window regulator motor. 	<ol style="list-style-type: none"> 1. Check operation of circuit breaker. 2. Check affected circuit for open or short circuit. (Check front and rear harness connections for proper engagement.) 3. Check connectors to safety switch and motor for proper engagement. 4. Check tail gate mechanical parts for bind or failure. 5. Check operation of tail gate motor.

SIX WAY SEAT

DESCRIPTION

The seat adjusters are actuated by a 12 volt motor installed at the left side of the seat assembly (Fig. 9-11). The motor is energized by a three (3) button-type control switch located in the left seat side panel.

THE ELECTRICAL PORTION OF THE SEAT OPERATES AS FOLLOWS

See circuit diagram Fig. 9-12. When one of the control switch buttons is actuated, current flows to the transmission solenoid which controls the desired seat movement. The energizing of the solenoid coil results in the solenoid plunger dog engaging the gear mechanism to rotate the control cable. The same switch action which energized the solenoid

produces a current flow through the motor control relay to one of the motor field coils. The current flows through the relay, closes the contacts between the relay power source and the armature motor lead wire, and results in the operation of the seat motor. When the control switch lever is released, the switch contacts open, a spring returns the shaft dog and solenoid plunger to their original position disengaging them from the gear dog.

CIRCUIT CHECKING PROCEDURES

It may be necessary to use only one or all of the procedures outlined to locate an electrical failure in the circuit. If the location of the failure is evident, follow only the steps required to check the affected wire or component. If the location of the failure is

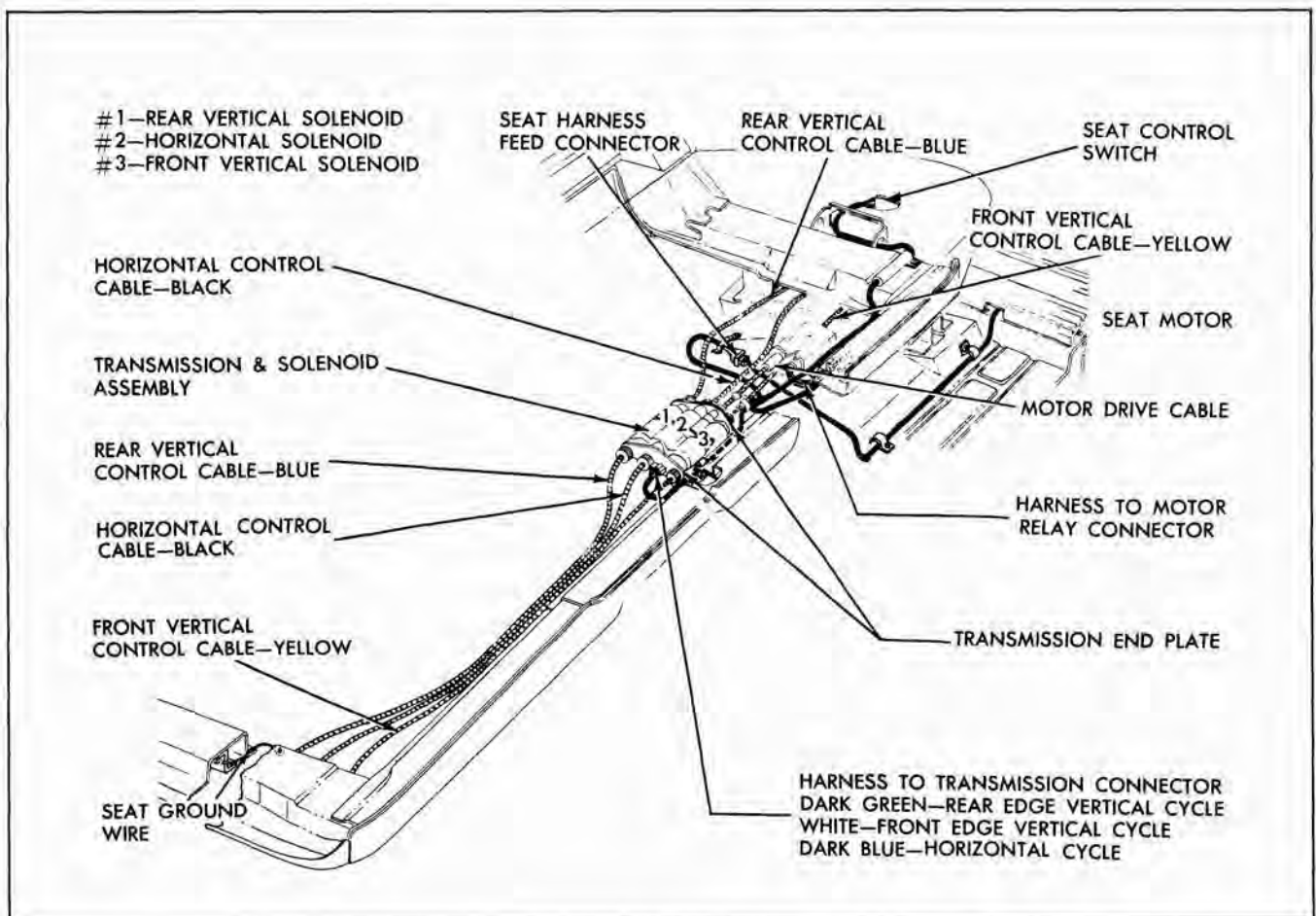

Fig. 9-11 Six-Way Seat Installation

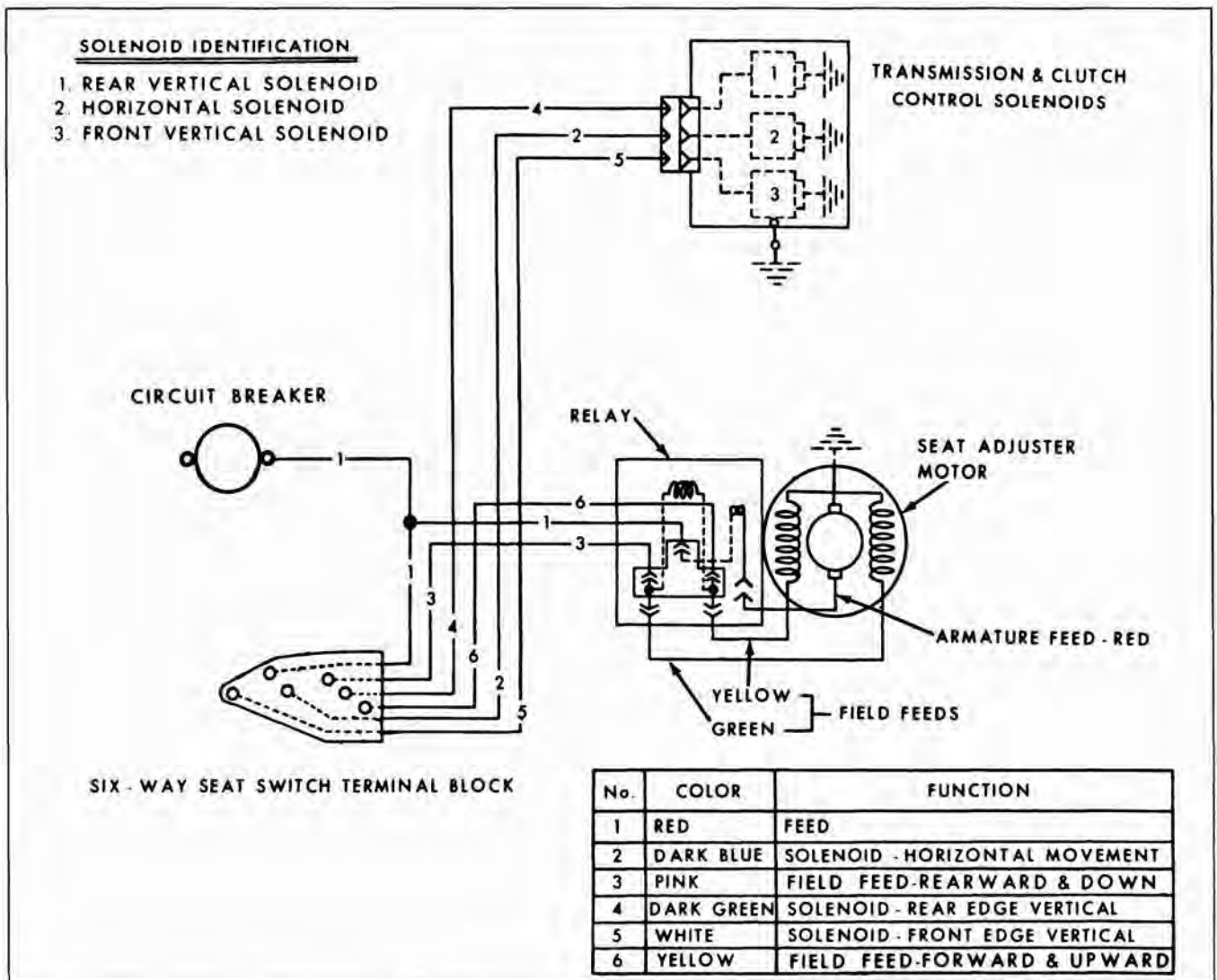

Fig. 9-12 Circuit Diagram - Six-Way Seat

not evident, follow the procedure as outlined. Before performing any extensive check procedures, check the seat adjuster drive cables for proper attachment. In addition, study the seat circuit diagrams to become familiar with the seat circuit.

CHECK FEED CIRCUIT CONTINUITY AT CIRCUIT BREAKER

1. Connect one light tester lead to battery side of circuit breaker and ground other lead. Circuit breaker is located in the engine compartment (Pontiac). If tester does not light, there is an open or short circuit in feed circuit to breaker.

2. To check circuit breaker, disconnect the output feed wire (the wire opposite the power source feed to the breaker) from the breaker and with light tester

check terminal from which wire was disconnected. If tester does not light, circuit breaker is inoperative.

CHECK FEED CIRCUIT CONTINUITY AT SEAT CONTROL SWITCH

1. Connect one light tester lead to feed terminal of switch block and ground other test lead to body metal Fig. 9-13.

2. If tester does not light, there is an open or short circuit between switch and power source.

CHECK FEED CIRCUIT CONTINUITY AT RELAY ON SEAT MOTOR

1. Disengage 3-wire connector body from the seat motor relay terminal.

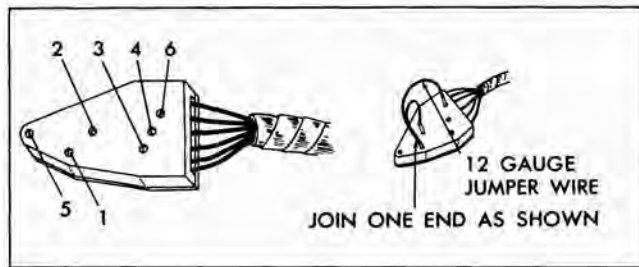

Wire Color	Function
1 Red	Switch Feed
2 Dark Blue	Solenoid-Horizontal Movement
3 Pink	Field Feed-Rearward & Down
4 Dark Green	Solenoid-Rear Edge Vertical
5 White	Solenoid-Front Edge Vertical
6 Yellow	Field Feed-Forward & Up

Fig. 9-13 Six-Way Seat Control Block Switch

2. Insert one light tester lead into the relay power feed (red wire) connector slot on the harness, and ground the other light tester lead.

3. If tester does not light, there is no current at end of feed wire. Failure is caused by an open or short in feed circuit.

NOTE: In the following operations which specify the seat control switch to be actuated, a switch that has been checked for proper operation may be connected to the switch block. If a switch is not available, a three-way jumper wire can be made to perform the switch function. The jumper wire and the switch locations to be connected to obtain a specific movement of the seat are shown in Fig. 9-13. If a jumper wire is used, number of locations on the switch block as indicated in the illustration. Details outlining the making, and use of the jumper wire follow the checking procedures.

CHECKING THE SEAT CONTROL SWITCH

1. Obtain switch or jumper wire and connect to switch block.

2. Operate switch. If adjusters operate with new switch or jumper wire, but did not operate with original switch, the original switch is defective.

3. Check all six movements of seat adjuster.

CHECKING WIRES BETWEEN CONTROL SWITCH AND MOTOR RELAY

1. Disengage 3-wire harness connector from relay at motor.

2. Insert one light tester lead into the motor field connector slot on harness and ground the other lead.

3. Actuate seat switch to energize field wire being tested.

4. If tester does not light, there is no current at end of wire. Failure is caused by an open or short circuit between end of wire and switch. Check other motor field wire in the same manner.

CHECK THE RELAY ASSEMBLY

1. Disconnect three (3) motor leads from relay assembly. These are the wires leading from the motor to the relay.

2. Connect one end of a jumper wire to one of the motor field feed studs on the relay and ground the other end of the jumper wire.

3. Connect one end of light tester to motor armature feed stud on relay and ground other light tester lead.

4. With a jumper wire, energize the field stud which is not grounded. If tester does not light the relay is defective.

CHECK THE MOTOR ASSEMBLY

1. Disconnect the motor armature feed lead and one of the motor field feeds from the relay assembly.

2. With a jumper wire, energize the armature feed and one of the field feeds.

3. If motor does not operate, it is defective. Check the other motor field feed in the same manner.

CHECKING THE WIRE BETWEEN THE SOLENOID AND SWITCH

1. Disengage harness connector from transmission.

2. Connect one light tester lead to end of harness wire being tested and ground other lead.

3. Operate switch to energize wire being tested. If tester does not light, there is no current at end of wire. Failure is caused by an open or short circuit between end of wire and switch.

CHECKING THE SOLENOID

1. Check solenoid ground strap attachment for proper ground.

2. Energize solenoid being checked with jumper wire.

NOTE: If solenoid is functioning, a "click" should be heard when solenoid plunger operates "in" and "out".

CAUTION: To prevent damaging the solenoid, do not energize solenoid for more than one minute.

3. With solenoid energized, actuate seat control switch to energize adjuster motor.

4. If adjusters do not operate, and there is no mechanical failure in the seat unit, the solenoid is defective.

THREE WAY JUMPER WIRE FOR CHECKING SEAT SWITCH

To make jumper wire, obtain two (2) pieces of #12 gauge wire, each 4-1/2" long, join one end of each wire as shown in Fig. 9-13. The joined end can be inserted in the feed location in the switch block; one

of the remaining ends can be inserted into one of the field locations in the switch block; the other end can be inserted into one of the solenoid locations.

CAUTION: To obtain a seat movement using a 3-way jumper wire at the switch block, the switch feed location, one of the motor field wire locations and one of the solenoid locations must be connected.

SEAT SIDE PANEL SWITCH

1. To raise front edge of seat, place jumper in locations 1, 6 and 5.

2. To lower front edge of seat, place jumper in locations 1, 3 and 5.

3. To raise rear edge of seat, place jumper in locations 1, 6 and 4.

4. To lower rear edge of seat, place jumper in locations 1, 3 and 4.

5. To move seat forward, place jumper in locations 1, 2 and 6.

6. To move seat rearward, place jumper in locations 1, 3 and 2.

TYPICAL ELECTRICAL FAILURES OF SIX-WAY SEAT CIRCUITS

CONDITION	CAUSE	CORRECTION
Seat adjuster motor does not operate.	1. Short or open circuit between power source or switch and motor.	1. Check circuit from power source and switch to motor to locate failure.
	2. Defective motor.	2. Check motor. If defective, repair or replace as required.

Seat adjuster motor operates, but seat adjusters are not actuated.

OR

Seat adjuster motor operates, front edge of seat moves up and down and seat moves forward and rearward. The rear edge of seat cannot be operated.

Seat adjuster motor operates and seat adjusters move front and rear edge of seat up and forward but will not move the seat down and rearward.

OR

Seat adjuster motor operates and seat adjusters move front and rear of seat down and rearward, but will not move the seat up and forward.

1. Short or open circuit between switch and affected solenoid.

2. Defective solenoid.

1. Short or open circuit between one of the motor field wires and seat control switch.

2. Defective field coil in motor.

1. Check circuit from switch to solenoid to locate failure.

2. Check solenoid. If defective, repair or replace as required.

1. Check circuit between affected motor field wire and seat switch.

2. Check motor. If defective, repair or replace as required.

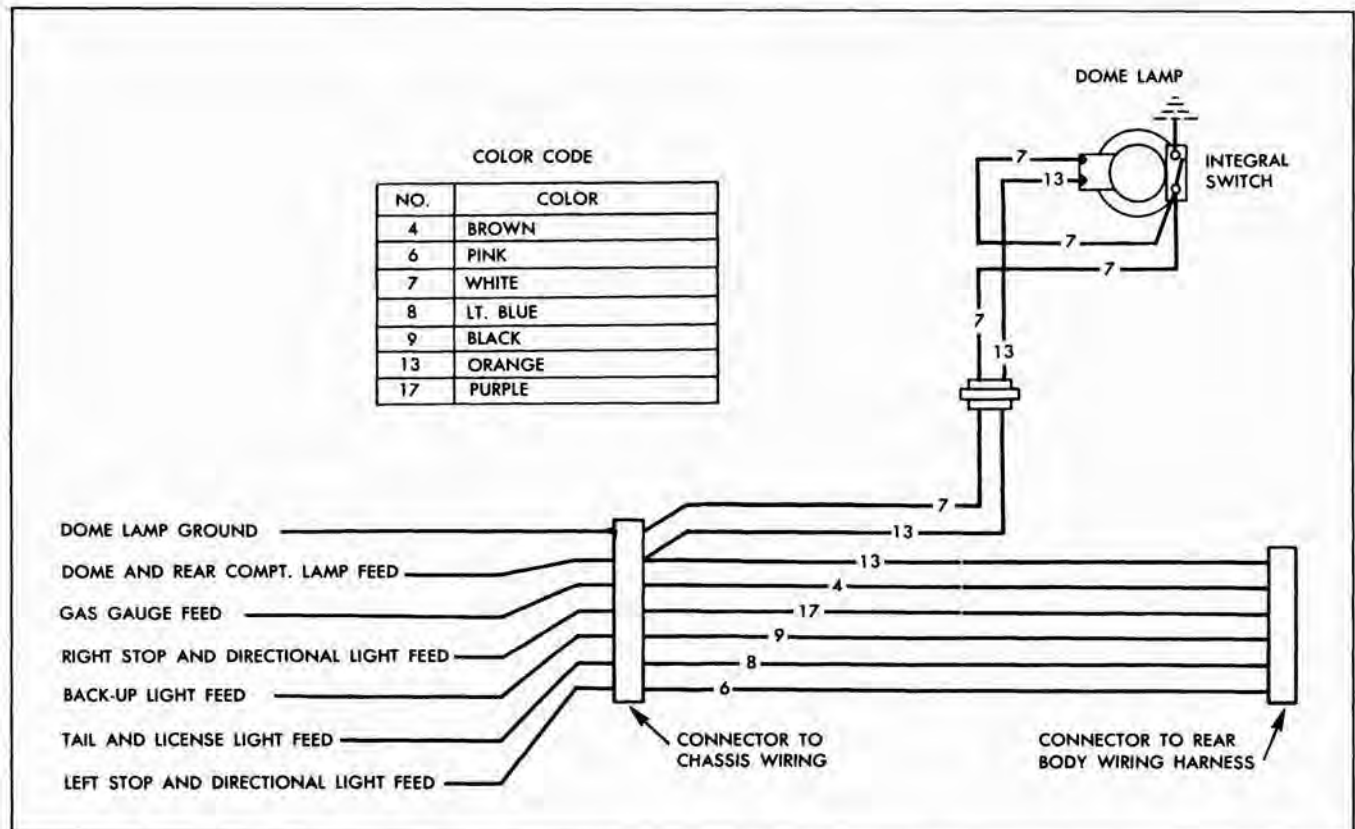

Fig. 9-14 Front Body Wiring Diagram - 2669, All 23 Series Except Wagons

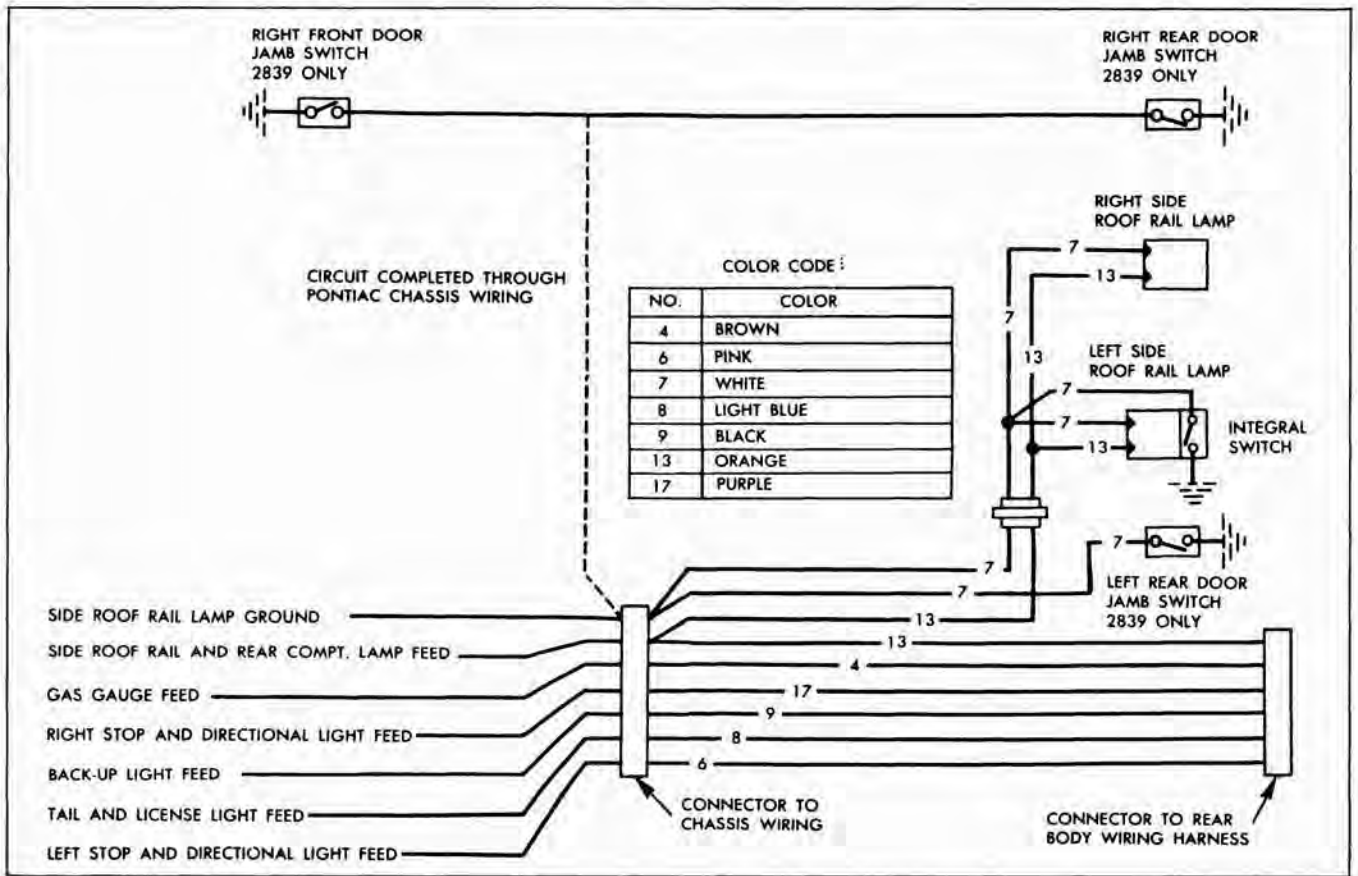

Fig. 9-15 Front Body Wiring Diagram - 2639, 2847, 2839

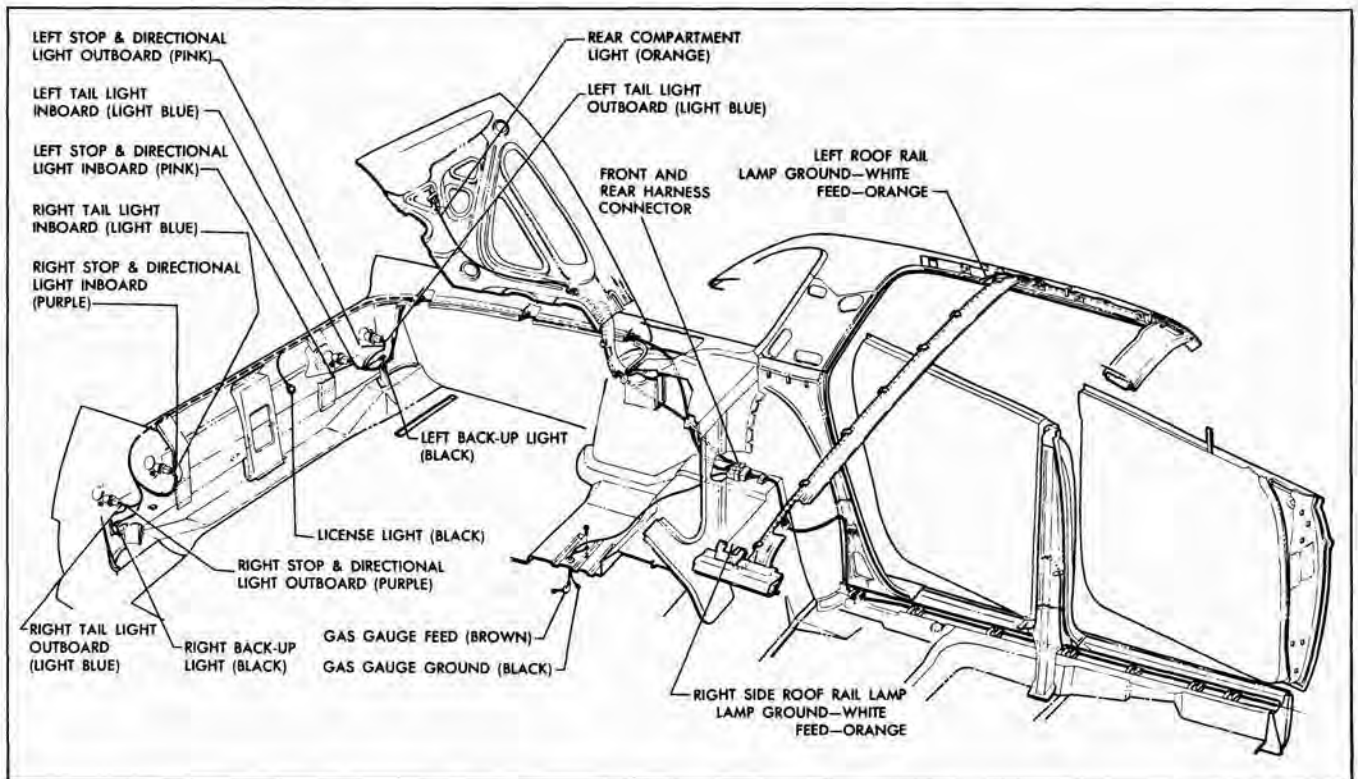

Fig. 9-16 Typical Body Wiring - 2639 Shown

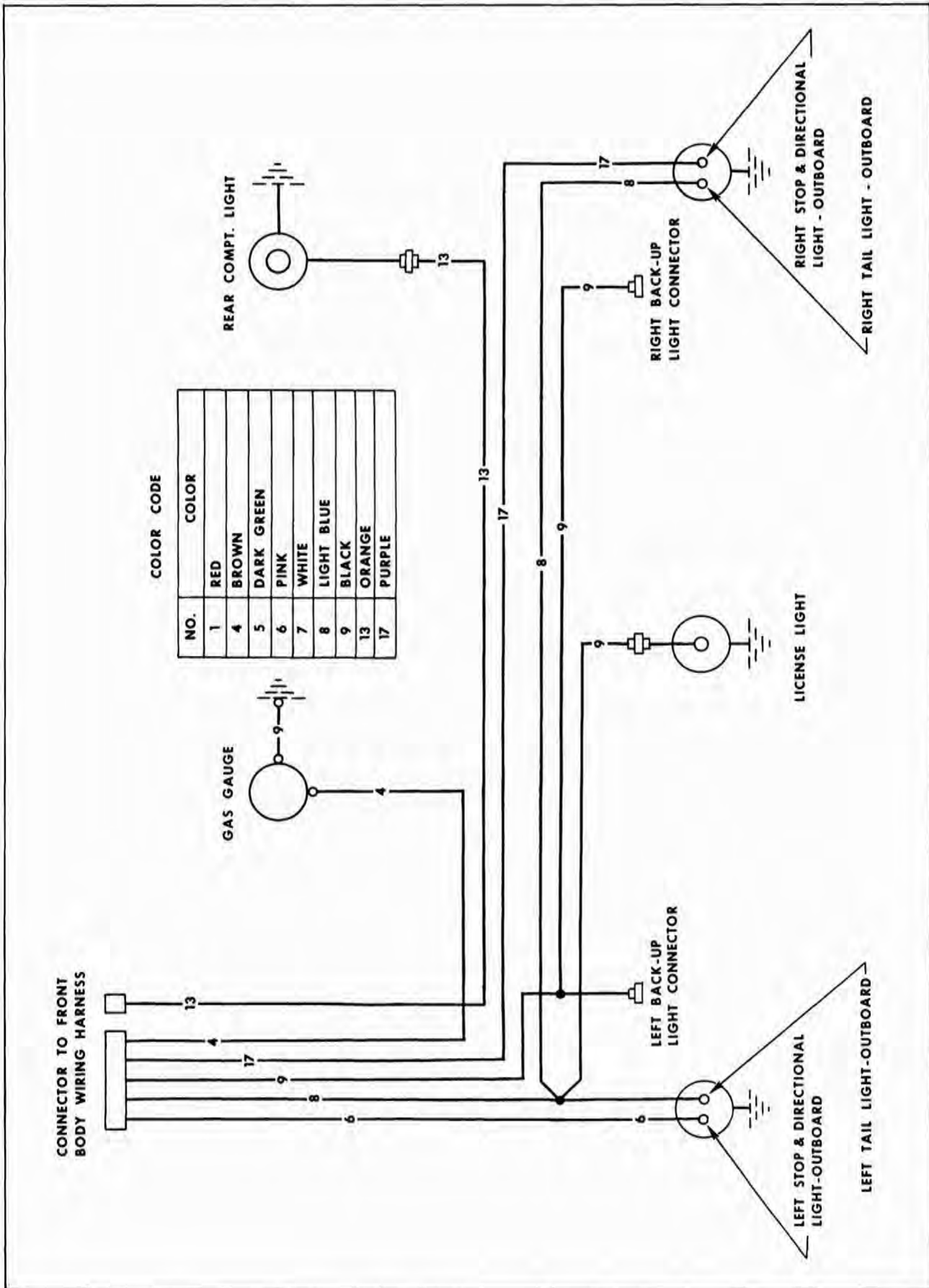

Fig. 9-17 Rear Body Wiring Circuit - 23 and 25 Series, Except Station Wagons

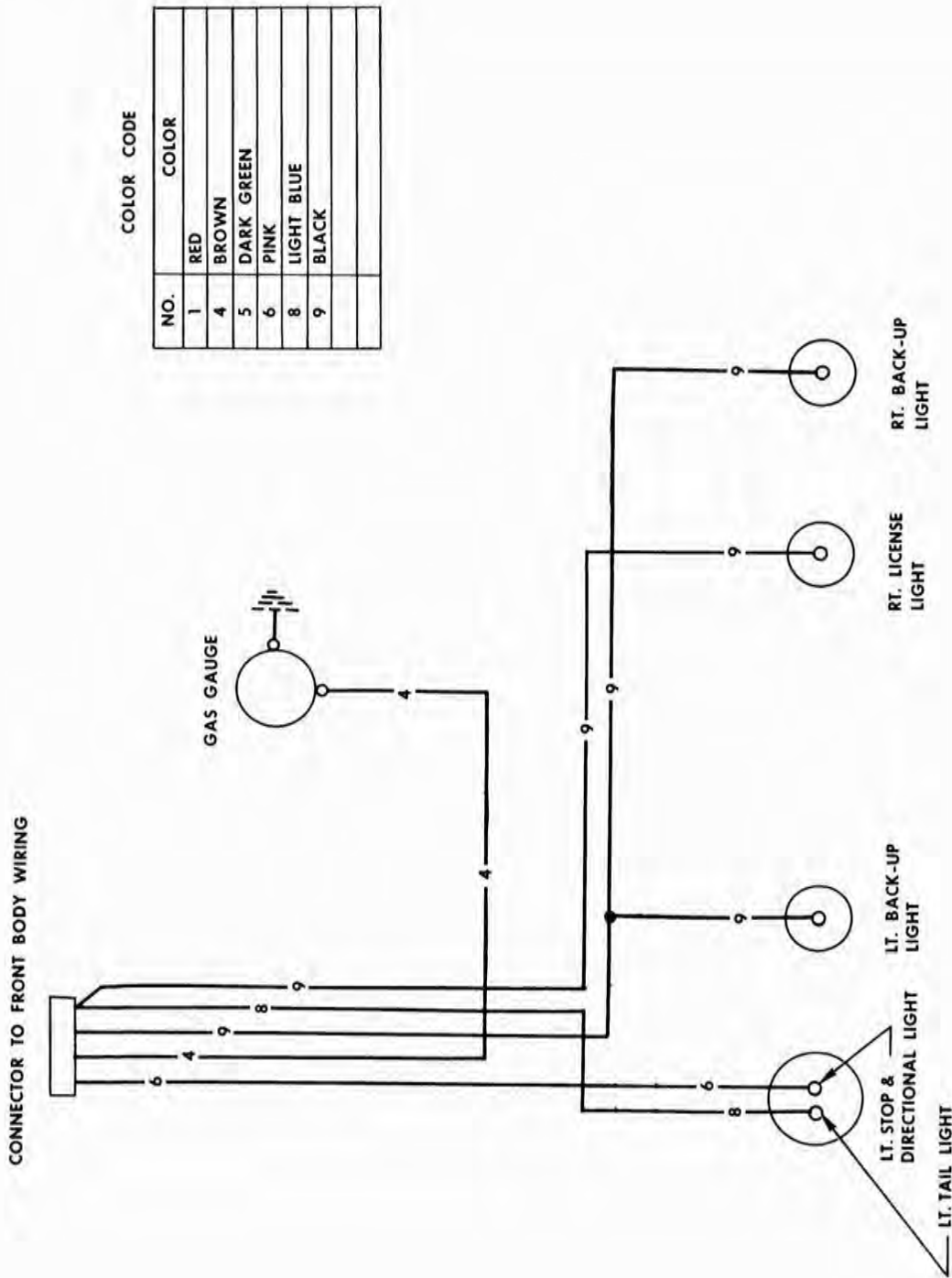

Fig. 9-18 Rear Body Wiring Circuit - Station Wagon

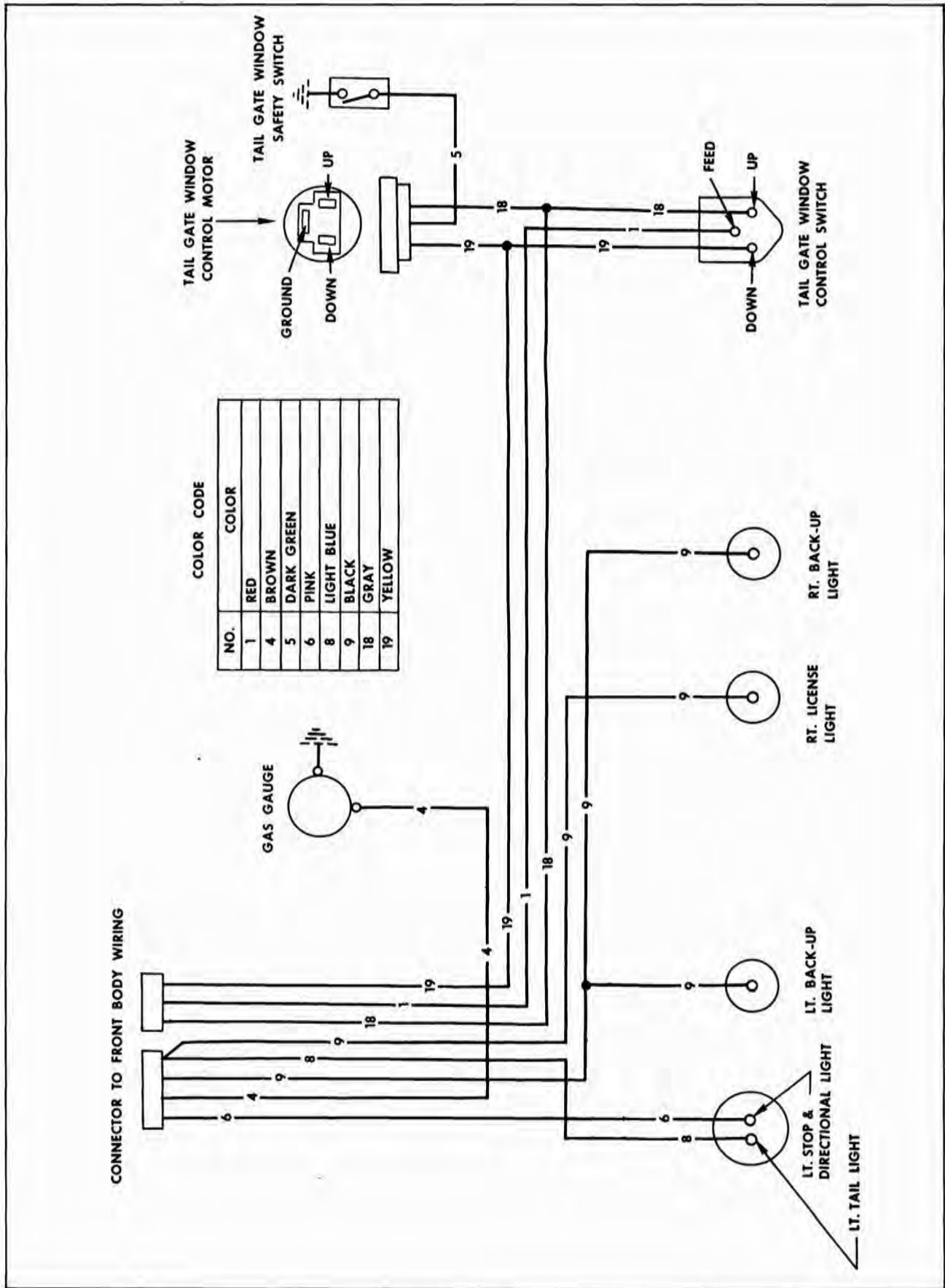

Fig. 9-19 Rear Body Wiring Circuit - 2345 Style

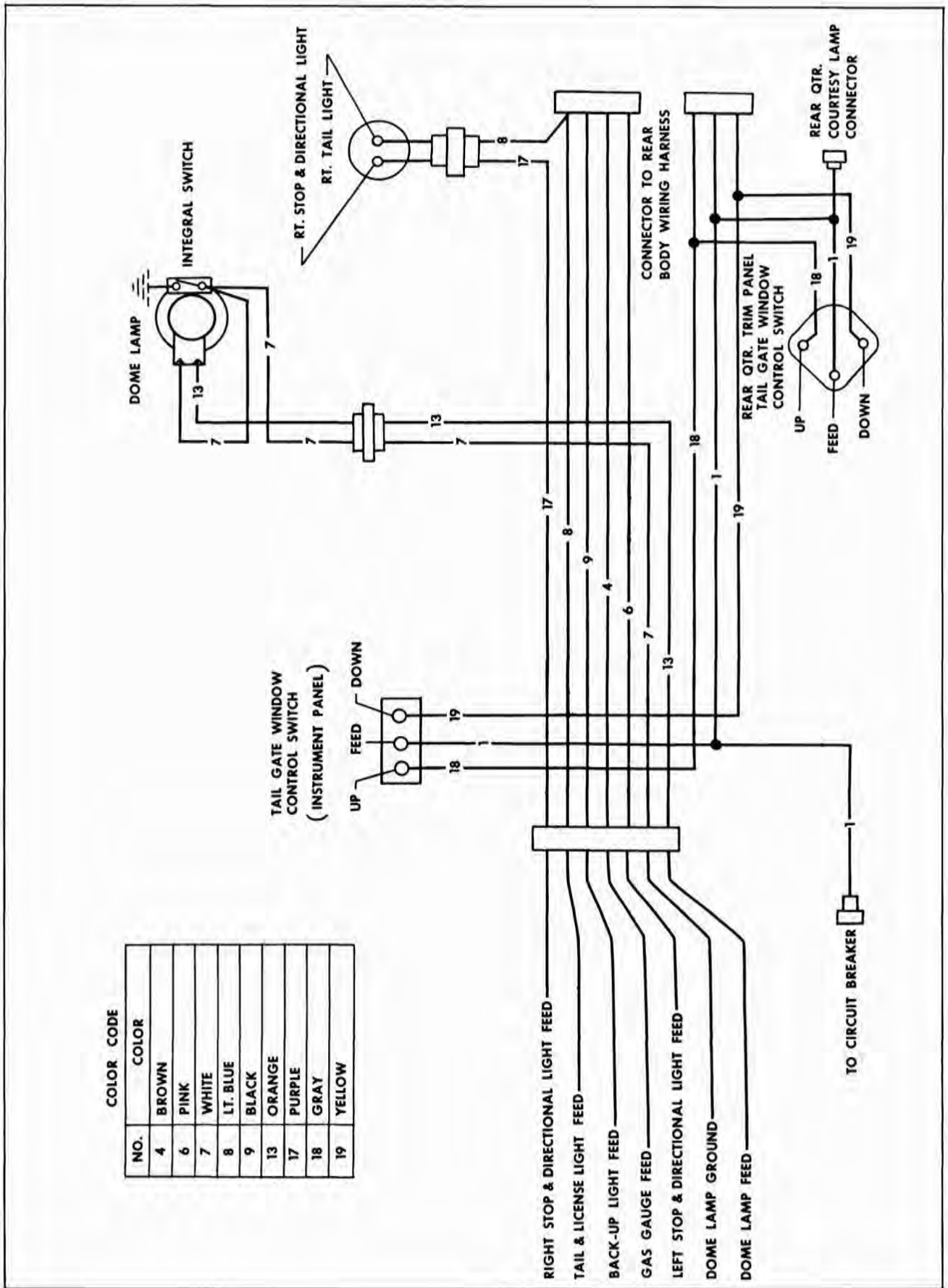

Fig. 9-20 Front Body Wiring Circuit - 2345 Style

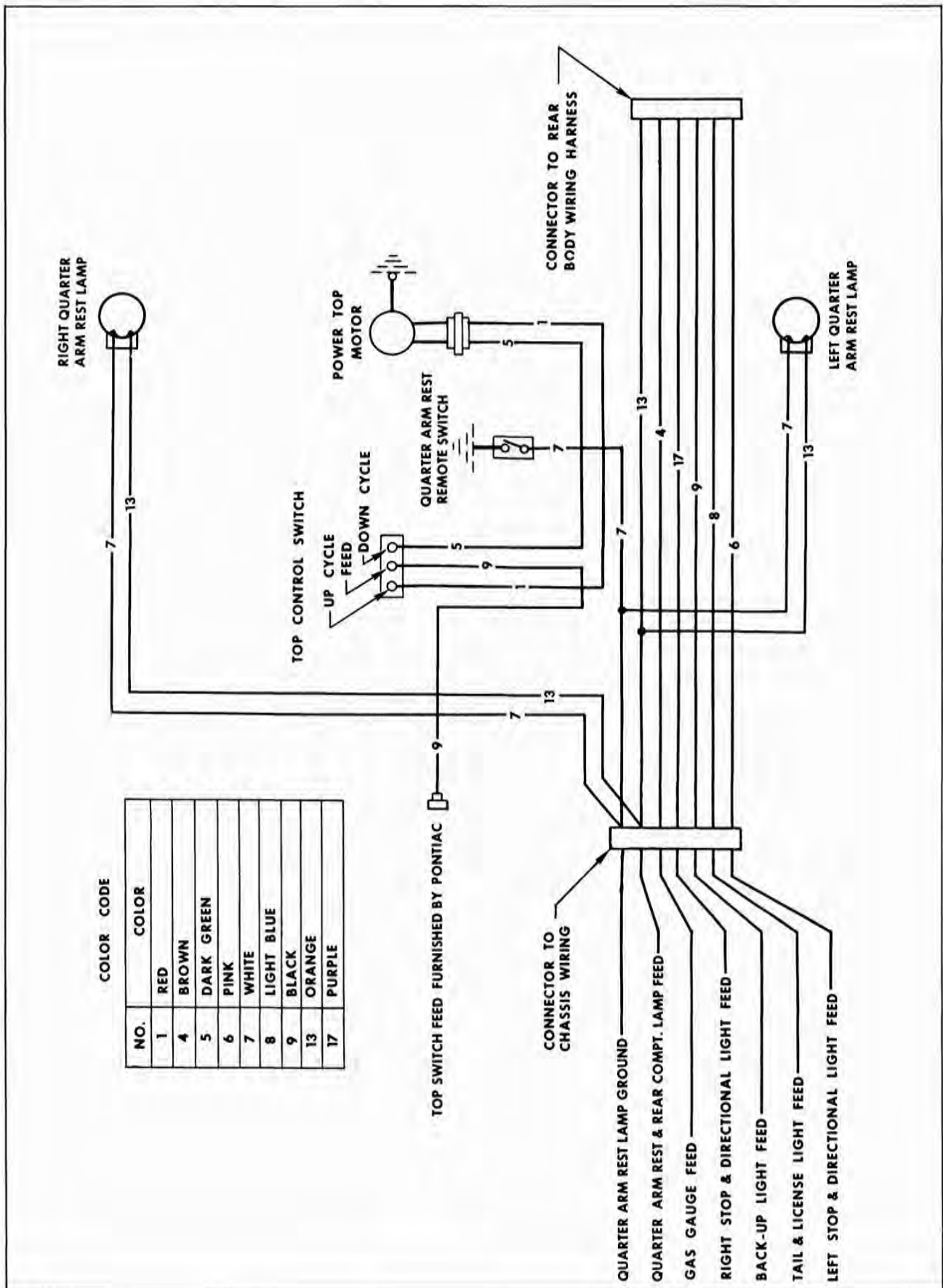
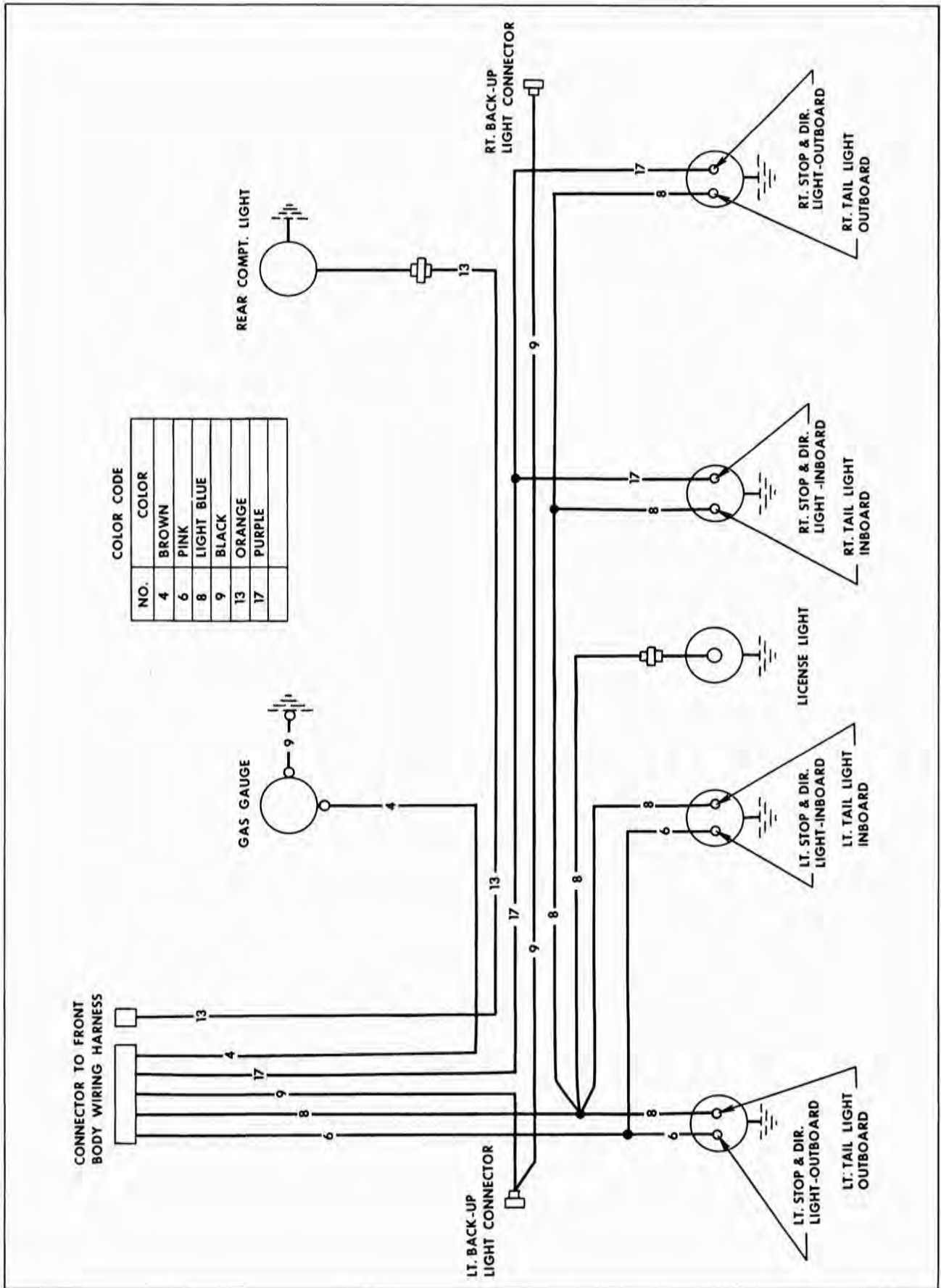

Fig. 9-21 Convertible Body Wiring



COLOR CODE	
NO.	COLOR
4	BROWN
6	PINK
8	LIGHT BLUE
9	BLACK
13	ORANGE
17	PURPLE

Fig. 9-22 Rear Body Wiring Circuit 26 and 28 Series

LUBRICATION

CONTENTS OF THIS SECTION

SUBJECT	PAGE	SUBJECT	PAGE
Lubrication - Bi-Yearly		Folding Top Linkage	10-3
Door Hinge Hold Open	10-1	Folding Top Piston Rods	10-3
Instrument Compartment Hinge	10-1	Sunshade Rod	10-3
Lock Striker	10-1	Lubrication - When Available	
Lock Rotary Bolt	10-1	Outside Handle	10-3
Rear Door Hinge	10-2	Window Regulator	10-4
Rear Compartment Lid and		Window Cams	10-4
Tail Gate Lock	10-2	Lock Parts	10-4
Door Jamb Switch	10-3	Locking Mechanism	10-5
Gas Tank Door	10-3	Seat Adjuster (Manual)	10-5
Tail Gate Hinge	10-3	Seat Adjuster (Electrical)	10-5
Folding Seat Linkage	10-3		
Door Lock Cylinders	10-3		

The movable mechanical hardware parts of the body are lubricated at the factory to insure proper and quiet operation. Because of frequent use of some parts, such as door locks and door lock strikers, it is important that the readily accessible parts be lubricated at least twice a year. Other body parts

should be lubricated whenever access to the parts is available.

Wipe off all lubrication points before applying new lubricant. Remove all excess lubricant where necessary to prevent staining of trim parts or clothing.

THE FOLLOWING PARTS SHOULD BE LUBRICATED TWICE EACH YEAR:

FRONT DOOR HINGE HOLD-OPEN ASSEMBLY

Wipe off dirt and apply a light coat of No. 630AAW Lubriplate or its equivalent at points indicated (Fig.

10-1). The hinge pins should be lubricated with engine oil.

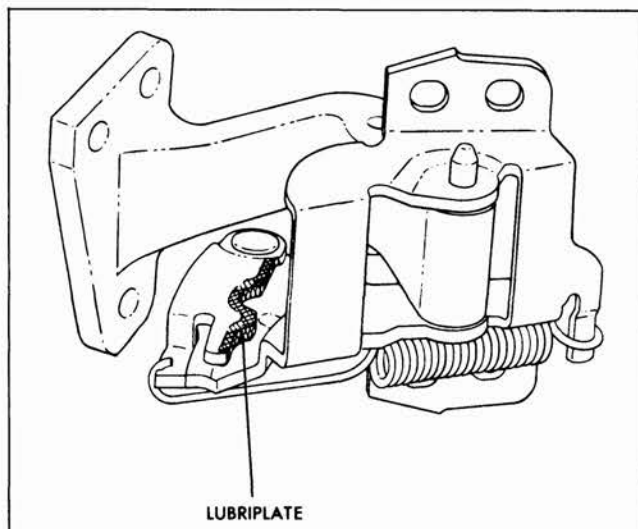

Fig. 10-1 Front Door Hinge and Hold Open

INSTRUMENT PANEL COMPARTMENT DOOR HINGE

Wipe off dirt and apply a sparing amount of drip-less oil to the hinge frictional points. Operate door and wipe off excess lubricant.

DOOR LOCK STRIKER

Wipe off dirt and apply a thin coat of stick-type lubricant to top surface of lock bolt striker teeth (Fig. 10-2). After lubrication, close door several times and remove excess lubricant along side edge of teeth.

DOOR LOCK ROTARY BOLT AND HOUSING

Wipe off dirt and apply a thin coat of stick-type lubricant and oil (Fig. 10-3).

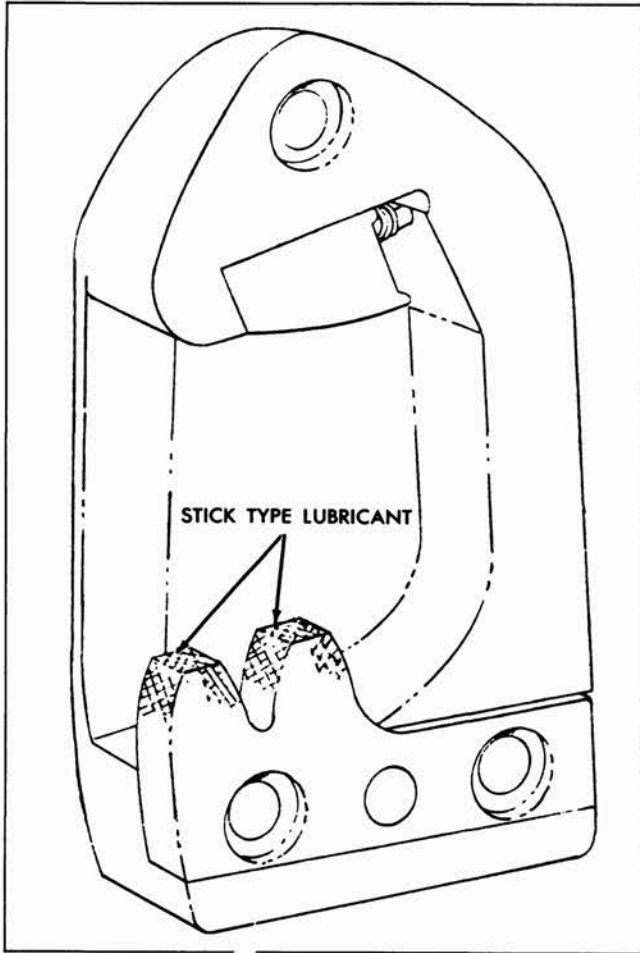

Fig. 10-2 Door Lock Striker

REAR DOOR HINGE AND HOLD-OPEN ASSEMBLY

Wipe off dirt and apply a light coat of No. 630

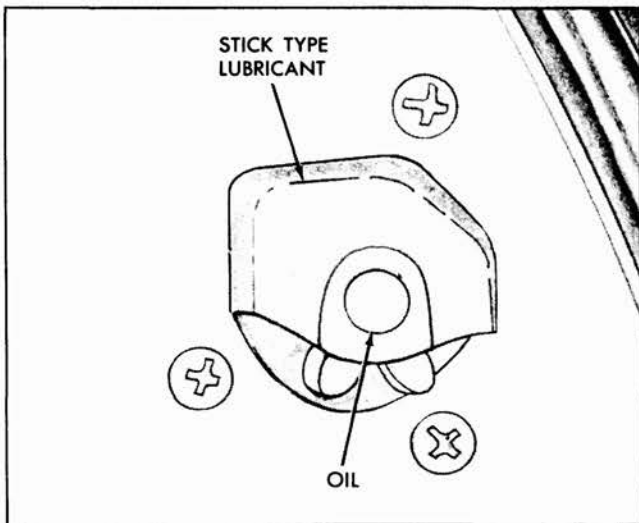

Fig. 10-3 Door Lock Rotary Bolt and Housing

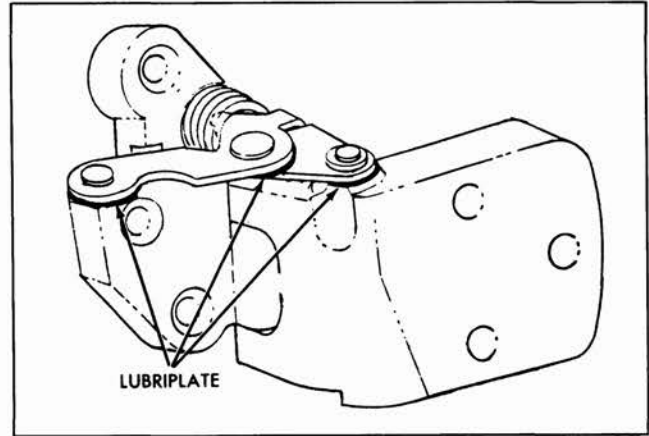

Fig. 10-4 Rear Door Hinge

AAW Lubriplate or equivalent, to frictional points (Fig. 10-4). Wipe off excess lubricant.

REAR COMPARTMENT LID AND TAIL GATE LOCKS

On rear compartment lid locks, apply a thin film of No. 630AAW Lubriplate or its equivalent (Fig. 10-5). On tail gate locks, apply a thin film of 630 AAW Lubriplate or its equivalent to the bolt at the striker contact areas.

DOOR WEATHERSTRIPS, SIDE ROOF RAIL WEATHERSTRIPS AND DOOR BUMPERS

A thin coat of Silicone lubricant should be used on weatherstrips and door bumpers to prevent squeaking.

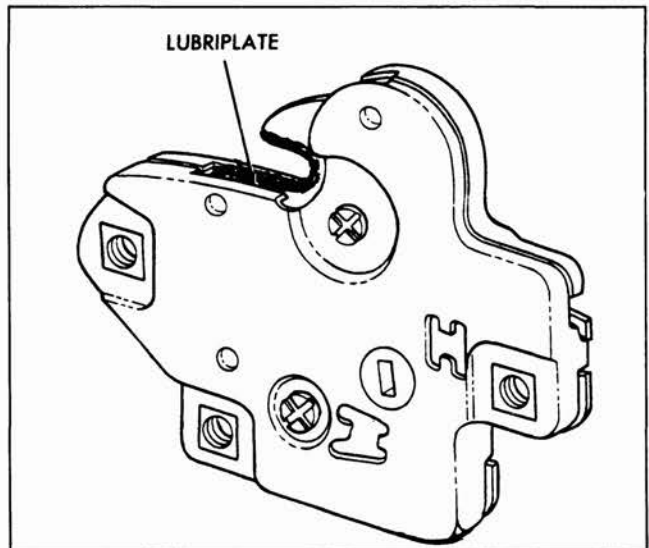

Fig. 10-5 Rear Compartment Lid Lock Bolt

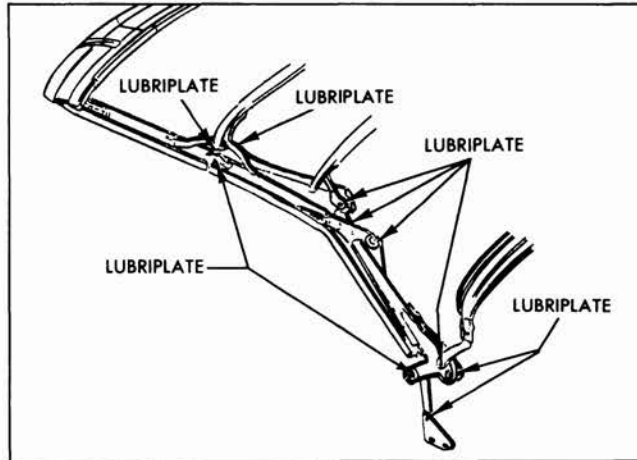

Fig. 10-6 Folding Top Linkage

DOOR JAMB SWITCH

Wipe off dirt and apply a thin coat of No. 630 AAW Lubriplate or equivalent to the end surface of switch plunger. Wipe off excess lubricant.

GAS TANK FILLER DOOR HINGE

Apply a few drops of dripless oil to frictional points of door hinge. Work door several times and wipe off excess lubricant.

TAIL GATE HINGE

Wipe off dirt and apply a small amount of dripless oil to frictional areas.

FOLDING SEAT LINKAGE

Wipe off dirt and apply a sparing amount of dripless oil to all frictional areas. Work linkage several times and wipe off excess lubricant.

DOOR AND REAR COMPARTMENT LOCK CYLINDERS

A small quantity of lock lubricant occasionally applied to the lock cylinders will prevent sticking.

THE FOLLOWING PARTS SHOULD BE LUBRICATED WHEN ACCESS TO PARTS IS AVAILABLE:

DOOR LOCK OUTSIDE HANDLE

Apply a light coat of No. 630AAW Lubriplate or

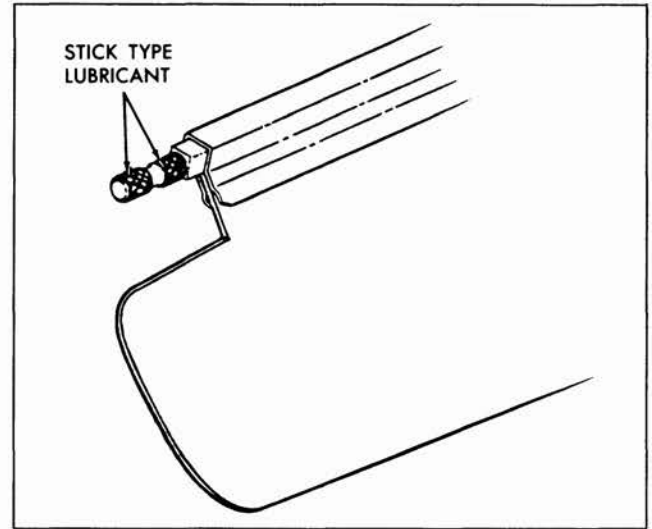

Fig. 10-7 Sunshade Rod

REAR COMPARTMENT LID HINGES AND TORQUE RODS

Apply Lubriplate No. 630AAW or equivalent, to hinge and torque rods at friction points.

FOLDING TOP LINKAGE

Apply a sparing amount of light oil to all bearing points (Fig. 10-6). Wipe off excess lubricant to prevent soiling trim.

FOLDING TOP LIFT CYLINDER PISTON RODS

Twice each year, with folding top in raised position, wipe exposed portion of each top lift cylinder piston rod with a cloth dampened with brake fluid to remove any oxidation or accumulated grime. With another clean cloth, apply a light film of brake fluid to the piston rods to act as a lubricant.

NOTE: Use caution so that brake fluid does not come in contact with any painted or trimmed parts of the body.

SUNSHADE ROD

Remove sunshade assembly from support and apply a thin film of stick-type lubricant to end of sunshade rod (Fig. 10-7). Wipe off all excess lubricant.

equivalent, to surface of lock cylinder shaft contacting bell crank (Fig. 10-8).

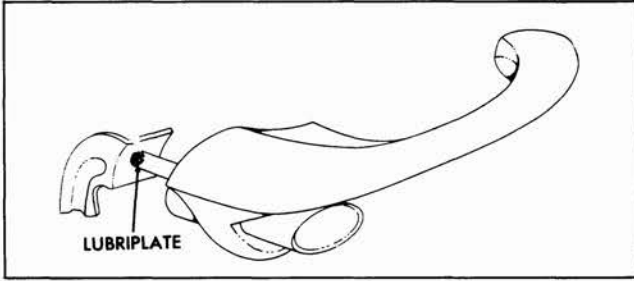

Fig. 10-8 Door Outside Handle

DOOR WINDOW REGULATOR

Apply a coat of No. 630AAW Lubriplate or equivalent to areas indicated in Fig. 10-9. Lubrication of front door window regulator is typical of lubrication of rear door and quarter regulators.

DOOR WINDOW CAMS

Apply a coat of No. 630AAW Lubriplate or equivalent to channel portions of cams (Fig. 10-10 and Fig. 10-11).

REAR QUARTER WINDOW CAMS

Apply a coat of No. 630AAW Lubriplate or equivalent to channel portion of cam and guide assemblies (Fig. 10-12).

DOOR LOCK PARTS

Lubricate moving parts of door lock with No. 630 AAW Lubriplate or equivalent.

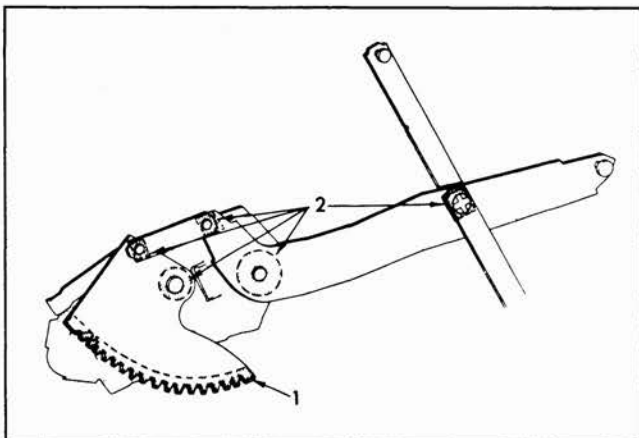

Fig. 10-9 Door Window Regulator

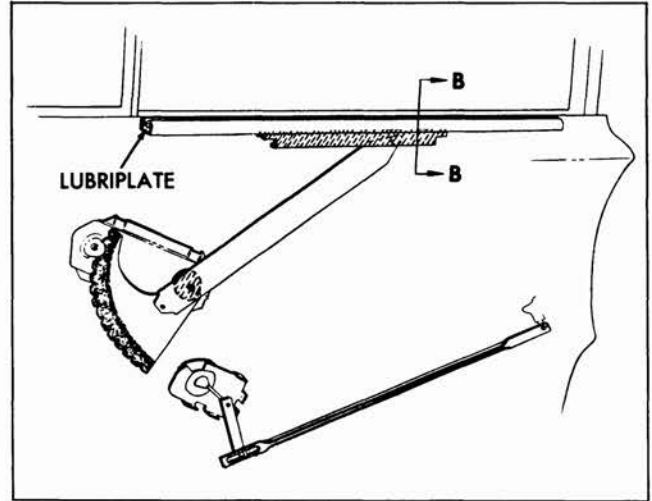

Fig. 10-10 Front Door Window Regulator Cams

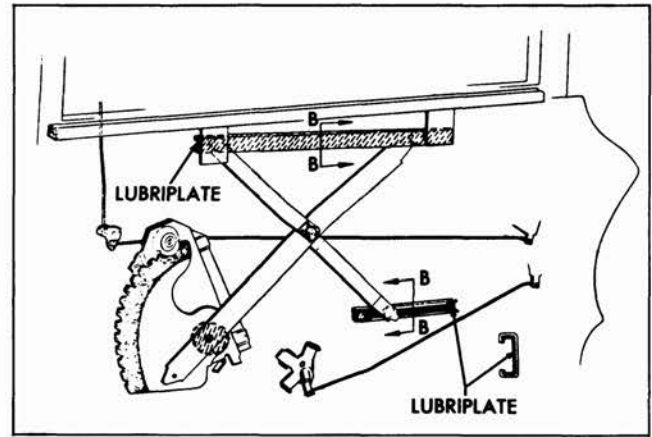

Fig. 10-11 Rear Door Window Regulator Cams

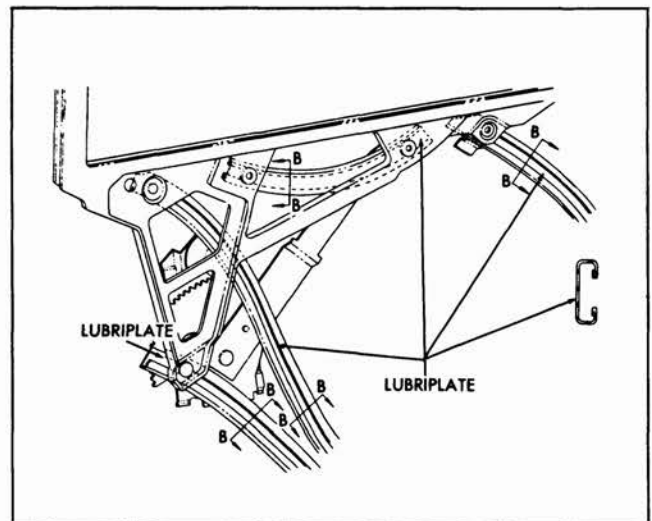

Fig. 10-12 Rear Quarter Window Cams

DOOR LOCKING MECHANISM

Apply No. 630AAW Lubriplate or equivalent to pivot points at ends of all connecting rods.

**FRONT SEAT ADJUSTER MECHANISM—
MANUALLY OPERATED**

A thin film of Lubriplate No. 630AAW or its equivalent should be applied to the seat tracks as needed or during repairs.

**FRONT SEAT ADJUSTER MECHANISM—
ELECTRICALLY OPERATED**

Thoroughly wipe off old lubricant from jackscrew. Apply a thin film of Lubriplate No. 630AAW or its equivalent to jackscrew, being careful not to soil seat trim. Operate the seat adjuster to limit of all positions. Apply a small amount of dripless oil to linkage and wipe off excess lubricant.

TEMPEST

CHASSIS SHEET METAL

CONTENTS OF THIS SECTION

SUBJECT	PAGE	SUBJECT	PAGE
Sheet Metal Alignment		Sheet Metal Replacement	
Front Fender	11-1	Front Fender	11-4
Hood	11-1	Grille Assembly	11-5
Hood Latch	11-2	Lower Grille Panel Assembly	11-6
Hood Latch Adjustment	11-2	Hood Spring	11-6
Hood Hinges	11-3	Hood Hinge	11-6
Bumper	11-3	Hood	11-6
		Front Fender Cross Brace Assembly	11-7

SHEET METAL ALIGNMENT

Proper alignment of the front end sheet metal will provide proper relationship of adjoining sheet metal parts, ease of hood operation and eliminate squeaks, rattles and vibration.

FRONT FENDER ALIGNMENT

Vertical and fore and aft adjustment is provided at rear of fenders by enlarged holes in the fender bracket or body at the attaching points (Figs. 11-1, 11-2).

Fenders can be moved closer to or farther from the cowl by adding or removing shims between fender and body. Fenders can also be adjusted vertically by shifting the fender on the enlarged bolt holes (Figs. 11-1, 11-2).

1. Check the space between the front door to fender rear edge and adjust as necessary to obtain a parallel space.

2. Check to insure that all connections at the fender attaching bolts are tight.

HOOD

The hood is of rigid sheet metal construction with the outer panel of single sheet metal with a rugged inner panel reinforcement frame. Further rigidity is given by reinforcement diagonal braces strategically located so as to give extra strength at stress points.

1. Slotted holes in the hinge bracket to hood are provided to align hood fore and aft (Fig. 11-3).

2. The parallel space between hood sides and fender is accomplished by the rubber wedges mounted to each fender.



Fig. 11-1 Upper Fender Adjusting Bolt

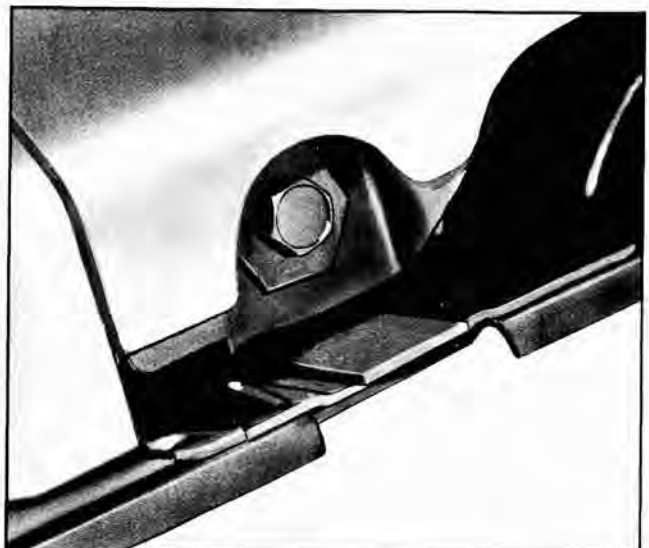

Fig. 11-2 Lower Fender Adjusting Bolt

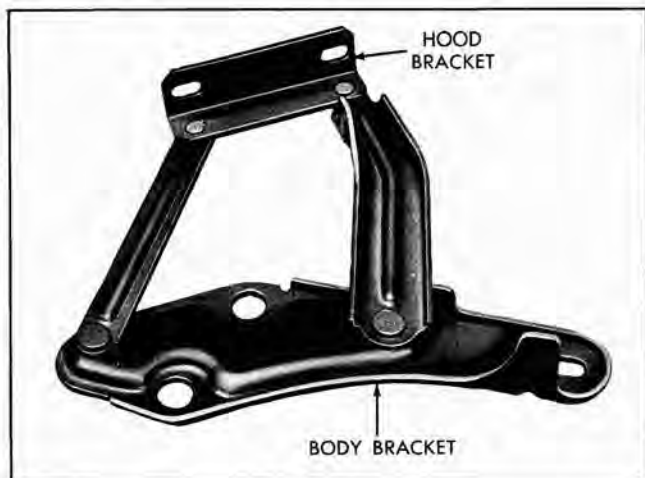

Fig. 11-3 Hood Hinge

3. The rear corners of the hood should be held down against the hood lacing to keep rear of hood from "dancing" or vibrating. The rear hood height is adjustable by moving hood hinge at body mount. The hinge bolt holes are enlarged giving room for adjustment.

HOOD LATCH

A positive locking hood latch is used consisting of two assemblies, a safety hood latch assembly (Fig. 11-5) that fastens to front fender cross brace and front frame crossmember and a pilot assembly that fastens to the hood (Fig. 11-4).

The hood is opened by pulling release handle under the bumper (Fig. 11-6) which in turn opens the latch. The safety hook is attached to the hood.



Fig. 11-4 Pilot Assembly



Fig. 11-5 Hood Latch Assembly

The pilot assembly attached to the hood assembly may be adjusted longitudinally for alignment purposes and can be vertically adjusted to obtain a tight hood to fender relationship.

HOOD LATCH ADJUSTMENT

Should the hood be difficult or even fail to release or close, there are 3 adjustments that can be made.

1. Move safety latch either fore or aft in elongated holes at fender cross brace.
2. Fore and aft adjustment of pilot assembly.

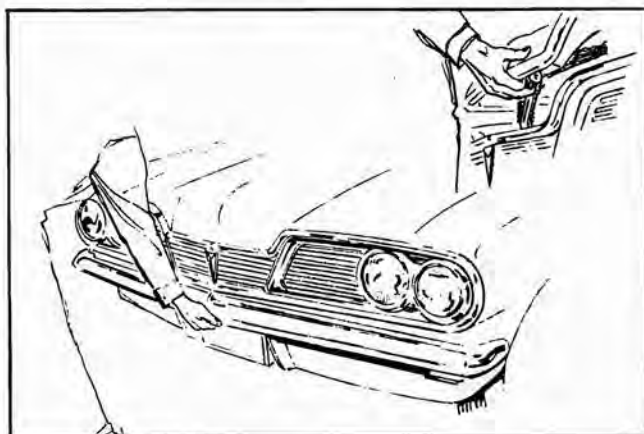

Fig. 11-6 Hood Release

3. Adjustment of pilot bolt.

Proper adjustment of hood latch to provide for easy hood closing is as follows:

1. Check tightness of hood latch bolts.
2. Raise or lower hood bumpers on front fender cross brace (Fig. 11-7).

3. Press down on nose of hood.

a. If some "give" or looseness is noticed, hood is not tight and will vibrate and raise up on corners at high speeds. In this case, shorten latch bolt and recheck.

b. If hood is tight with no "give", the hood could be properly adjusted or could be too tight.

CHECK AS FOLLOWS:

1. Close hood.
2. Release latch and raise hood 10"-12".
3. Let hood fall of own weight.
4. Adjust hood latch assembly and latch bolt to permit hood to close easily when it drops of its own weight from 10"-12" above closed position.

HOOD HINGES

The hood is mounted on hinges (Fig. 11-3) mounted to wheelhouse. Double assist over center springs are used (one at each hood hinge) both ends of which are fastened to the arms of the hinge. This construction provides hold-open power.

A hood to hinge reinforcement bracket which has two points of attachment is used. Fore and aft adjustment of the hood is provided for by slotted holes in the bracket.

BUMPER ALIGNMENT

FRONT

The bumper mounting bracket is the only adjusting point for the front bumper. This adjusting point is used for both fore and aft and vertical adjustments (Fig. 11-8).

REAR

The rear bumper may only be adjusted longitudinally through the use of the elongated holes in the bumper mounting bracket (Fig. 11-9).

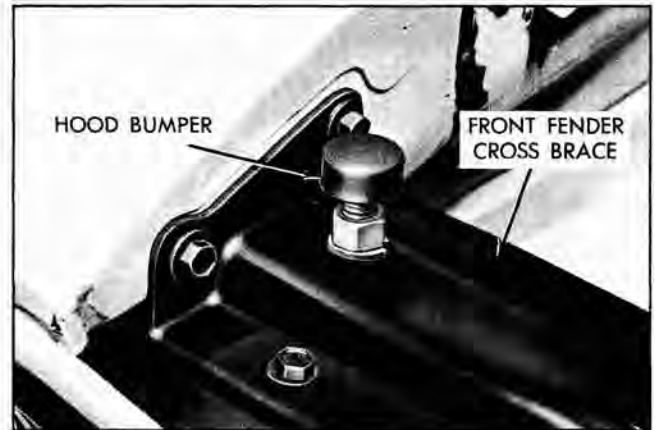

Fig. 11-7 Hood Bumper

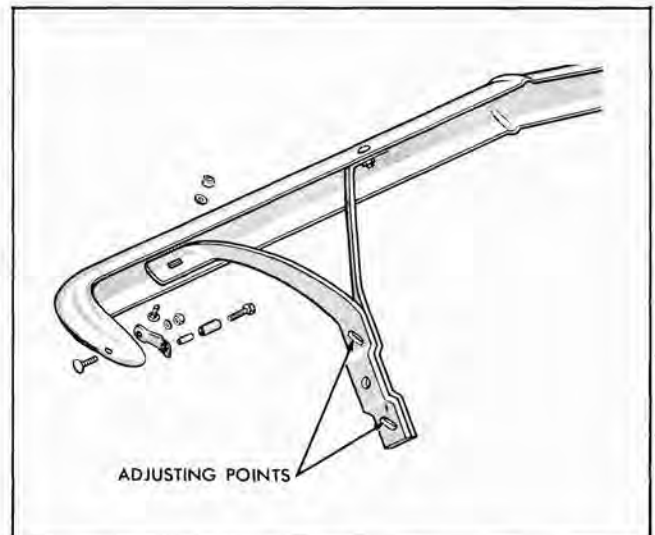

Fig. 11-8 Front Bumper

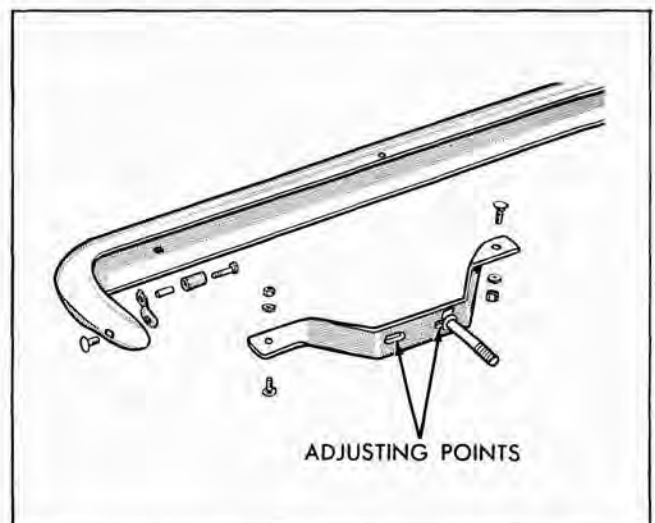
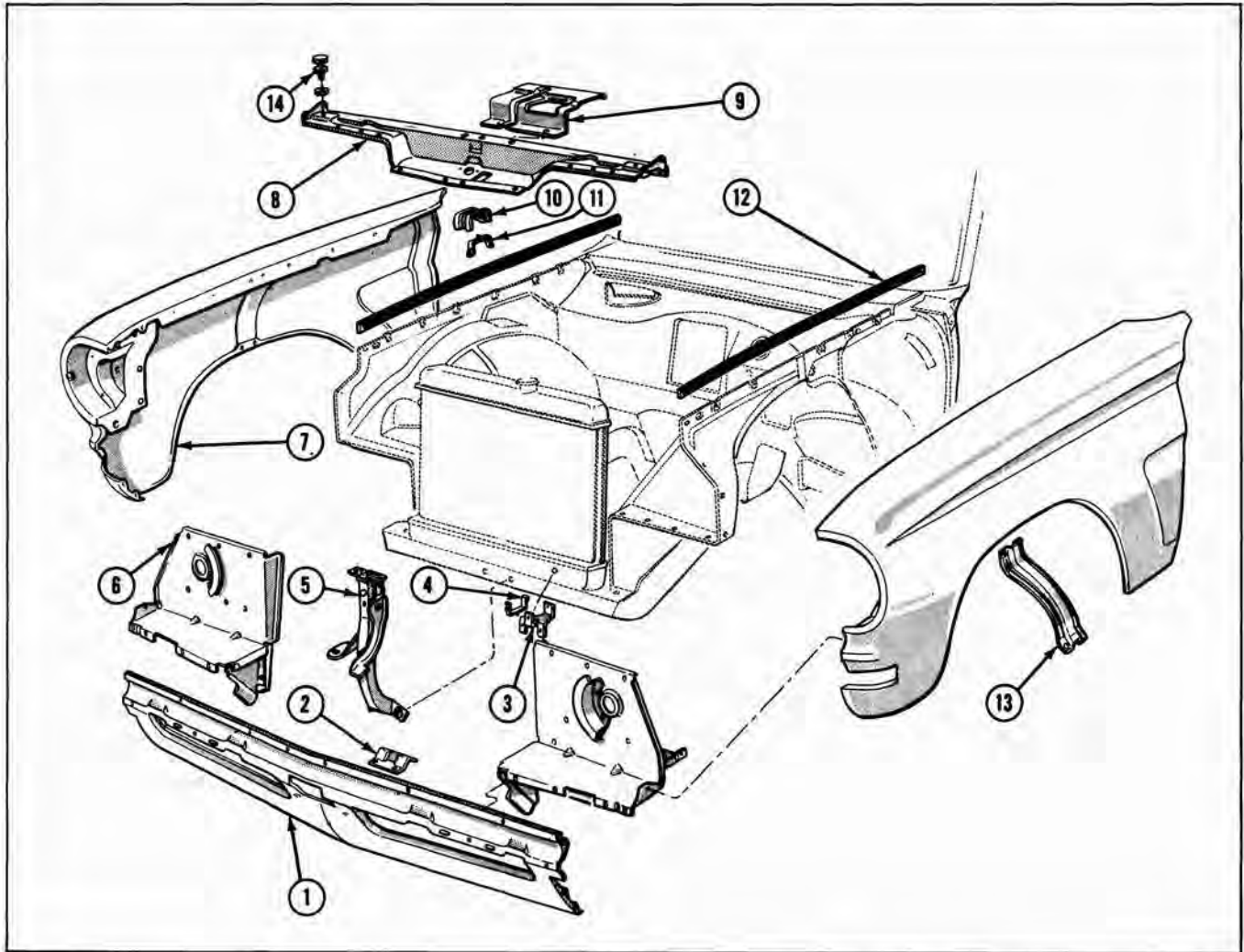

Fig. 11-9 Rear Bumper



- | | |
|---|--|
| 1 Panel, Radiator Grille-Lower | 8 Brace Ass'y. Front Fender Cross |
| 2 Bracket, Rad. Grille-Lower Panel Mounting | 9 Shield Ass'y. Radiator Fan |
| 3 Bracket, Radiator Support-Lower | 10 Bracket, Rad. Support-Upper-Part of Shield Ass'y. |
| 4 Insulator, Radiator Support Bracket-Lower | 11 Insulator, Rad. Support Bracket-Upper |
| 5 Hood Latch and Safety Catch-Ass'y. | 12 Strip, Front Fender to Body Sealing |
| 6 Baffle Ass'y. Radiator | 13 Brace, Front Fender to Wheel House Panel |
| 7 Fender Ass'y. Front | 14 Hood Bumper |

Fig. 11-10 Exploded View - Front End Sheet Metal

SHEET METAL REPLACEMENT

FRONT FENDER

REMOVAL

1. Remove front bumper.
2. Remove headlamp door and No. 2 seal

beam unit.

3. Remove screws between headlamp body and fender.

4. Remove four screws between fender and grille assembly.

5. Remove parking lamp assembly.
6. Remove upper and lower rear fender bolts.
NOTE: If same fender is to be replaced, note position, location and number of alignment shims used.
7. Remove hood spring, page 11-6.
8. Remove all screws holding fender to front wheelhouse.
9. Remove fender.

INSTALLATION

1. Replace all screws holding fender to front wheelhouse.
2. Replace front fender cross brace screws.
3. Replace headlamp body to fender screws.
4. Replace four screws between fender and grille assembly.
5. Replace seal beam unit and headlamp door.
6. Replace upper and lower rear fender bolts.
NOTE: Be sure fender is aligned with door.
7. Replace hood spring, page 11-6.
8. Replace parking lamp assembly.
9. Replace front bumper.

GRILLE ASSEMBLY (FIG. 11-11)

REMOVAL

1. Remove both headlamp bezel moldings.
2. Remove grille to fender screws at each end of grille.
3. Remove battery from car.
4. Remove four radiator to grille brackets.
5. Remove radiator fan shield assembly.
6. Remove front fender cross brace assembly.
NOTE: Disconnect horn while removing cross brace assembly.
7. Remove six nuts from lower clips on grille.
8. Remove grille from car (Fig. 11-12).

INSTALLATION

1. Install six clips in position on lower grille.
2. Install grille and secure with six nuts.

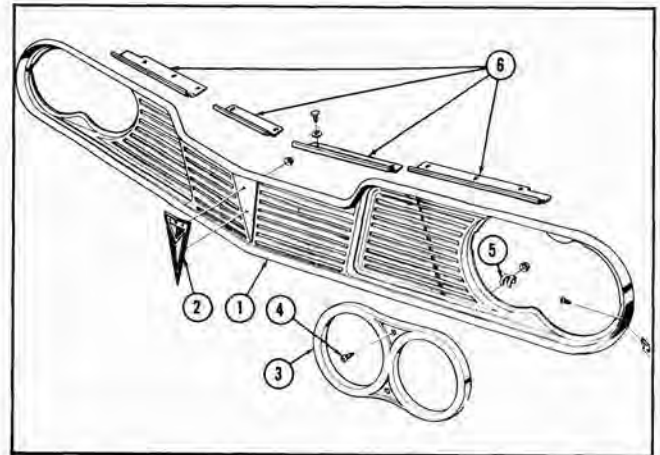

- 1 Grille
- 2 Emblem
- 3 Bezel, Headlamp
- 4 Screw, Headlamp Bezel Retainer
- 5 Clip, Grille to Lower Panel
- 6 Radiator Grille Bracket

Fig. 11-11 Grille Assembly

3. Install two screws securing grille to front fender.
4. Install front fender cross brace assembly in car.
NOTE: Connect horn wires while installing cross brace.
5. Install radiator fan shield assembly.
6. Install four radiator to grille brackets.
7. Install headlamp bezel moldings.



Fig. 11-12 Removing Grille Assembly



Fig. 11-13 Hood Spring Tool J-8923

8. Install battery in car.

LOWER GRILLE PANEL ASSEMBLY

REMOVAL AND INSTALLATION

1. Remove grille.
2. Remove front bumper and bracket.
3. Remove screws between lower grille and fenders.
4. Remove hood latch assembly.
5. Remove screws holding lower grille panel to radiator baffle assembly.
6. Remove lower grille panel.
7. To replace, reverse the above procedure.

HOOD SPRING

REMOVAL

1. Close hood a little to expand spring.
2. Insert tool J-8923 on spring (Fig. 11-13).
3. Open hood all the way so spring can be removed.

INSTALLATION

1. If new spring is to be installed, insert J-8923 in spring once it is expanded.
2. Open hood until spring can be put in place on hinge.
3. Close hood a little and remove J-8923.

HOOD HINGE

REMOVAL

1. Open hood.
2. Remove hood spring, page 11-6.
3. Remove screws holding hood to hinge.
4. Remove screws holding hinge to wheelhouse assembly.

INSTALLATION

1. Position hinge to wheelhouse assembly and tighten attaching screws.
2. Position hinge to hood and tighten attaching screws.
3. Replace hood hinge spring, page 11-6.
4. Close hood and check hood alignment.
5. If hood is misaligned, measure amount of misalignment.
 - a. Open hood, mark position of hinge relative to hood.
 - b. Loosen hinge and move hinge the amount it was off.
 - c. Tighten securely and recheck alignment.

NOTE: The hood may be aligned vertically and fore and aft. Vertical adjustment is made between hinge and wheelhouse assembly. Fore and aft adjustment between hood and hinge (Fig. 11-3).

HOOD REPLACEMENT

The hood can be removed by removing the attaching screws between hinges and hoods. When replacing the hood, adjust the alignment of one hinge at a time, as outlined in Steps 4 and 5 under Hood Hinge -- Removal and Installation

FRONT FENDER CROSS BRACE ASSEMBLY**REMOVAL AND INSTALLATION**

1. Remove battery.
2. Remove screws between front fender cross brace and fender.
3. Remove horns.
4. Remove screws between radiator baffle assemblies and front fender cross brace.
5. Remove front fender cross brace.
6. To replace, reverse the above procedure.

FRONT END

CONTENTS OF THIS SECTION

SUBJECT	PAGE	SUBJECT	PAGE
Body Shell		Windshield Glass	12-10
Description	12-1	Reveal Moldings	12-12
Underbody Assembly		Drip Moldings	12-13
Description	12-1	Instrument Panel	
Body Tram Gauge	12-6	Compartment Door	12-14
Underbody Alignment		Hinge Stop	12-15
Reference Points	12-6	Body Ventilating System	
Principles of Trammng	12-7	Shroud Top Ventilator Grille	12-16
Body Centering Gauges	12-9	Shroud Side Foundation	12-16
Windshield Assembly		Shroud Side Vent	12-16
Garnish Moldings	12-10	Air Outlet Door	12-17
Rear View Mirror Support	12-10		

BODY SHELL

DESCRIPTION

The over-all rigidity of the integral body construction is drawn from each of the individual metal components which, when welded together, comprise the body shell assembly. The floor pans and rail assemblies forming the underbody area incorporate attachment provisions for the power train and the suspension systems. The underbody, therefore, contributes the greatest amount of strength to the body assembly. This type of integral construction elimi-

nates the conventional independent chassis frame and has become known as the "unitized" type of body construction. The general body shell construction is illustrated in Figs. 12-1, 12-2, and 12-3.

Fig. 12-4 illustrates the major assemblies, sub-assemblies and various individual components that make up the underbody assembly. This illustration shows construction detail of the parts and is primarily intended as a guide to parts nomenclature. It does not necessarily reflect a breakdown of available service replacement parts.

UNDERBODY ASSEMBLY

DESCRIPTION

The underbody assembly is comprised of side rails, cross rails, floor pan cross bars, inner and outer rocker panels and other floor panel components. The underbody is of all-welded construction. Misalignment in the underbody can affect fit of doors and rear compartment lid. Most important, however, underbody misalignment can influence the suspension system, thereby causing many of the problems that arise from a suspension misalignment. Underbody alignment, therefore, should be exact to within plus or minus 1/16" of the specified dimensions.

In the event of extensive collision damage, major underbody repairs may be required to re-establish proper alignment. Extensive collision damage may include twist, side-sway, complicated sags or a combination of these conditions in the underbody area. In some cases it may be determined that the most practical method of repairing the damage is to employ a frame straightening machine and a qualified operator. A frame machine offers a variety of controlled pushing and pulling operations as well as accurate frame centering and leveling gages which are especially helpful in checking the conditions described above.

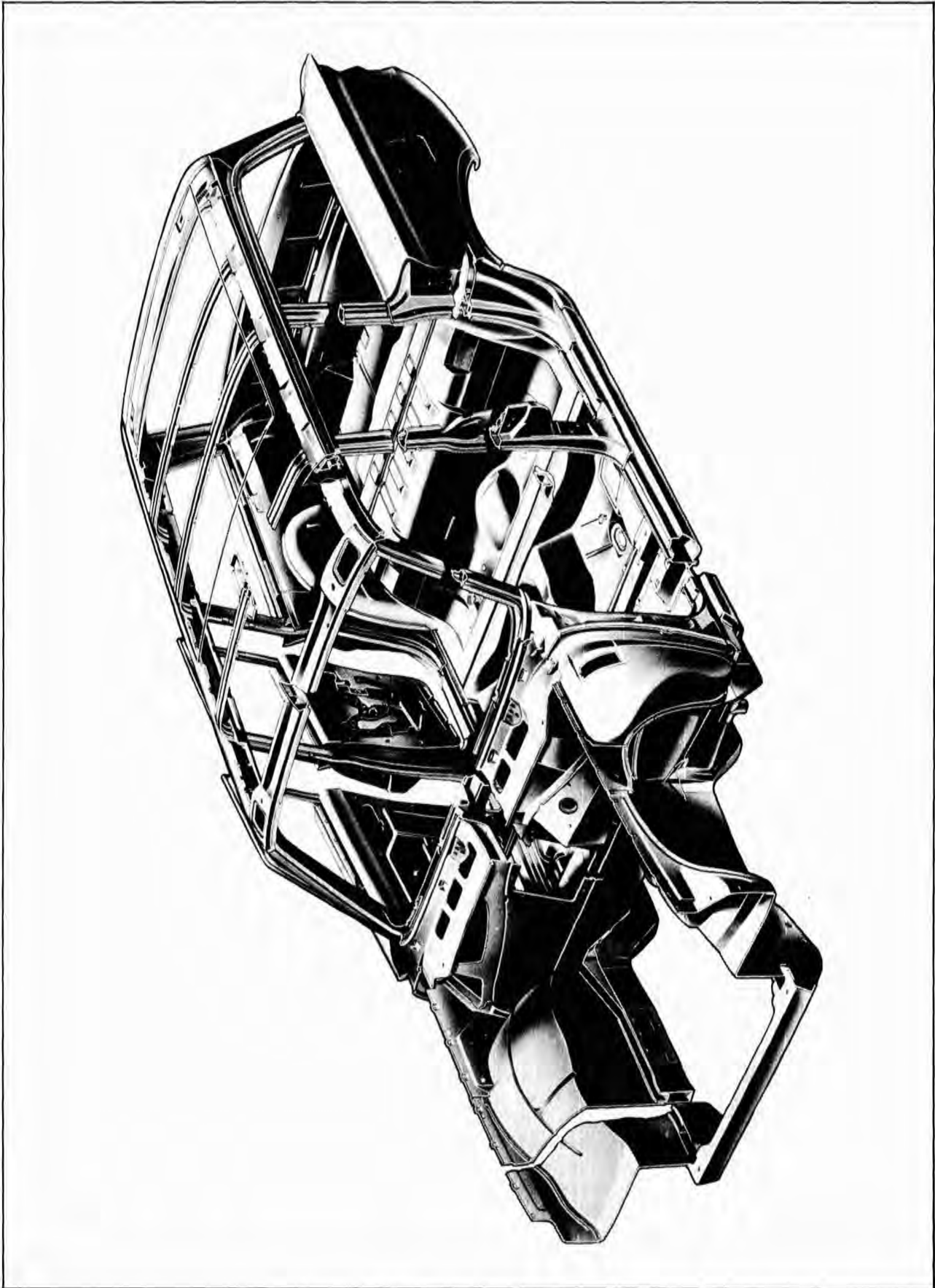

Fig. 12-1 2135 Body Shell Construction

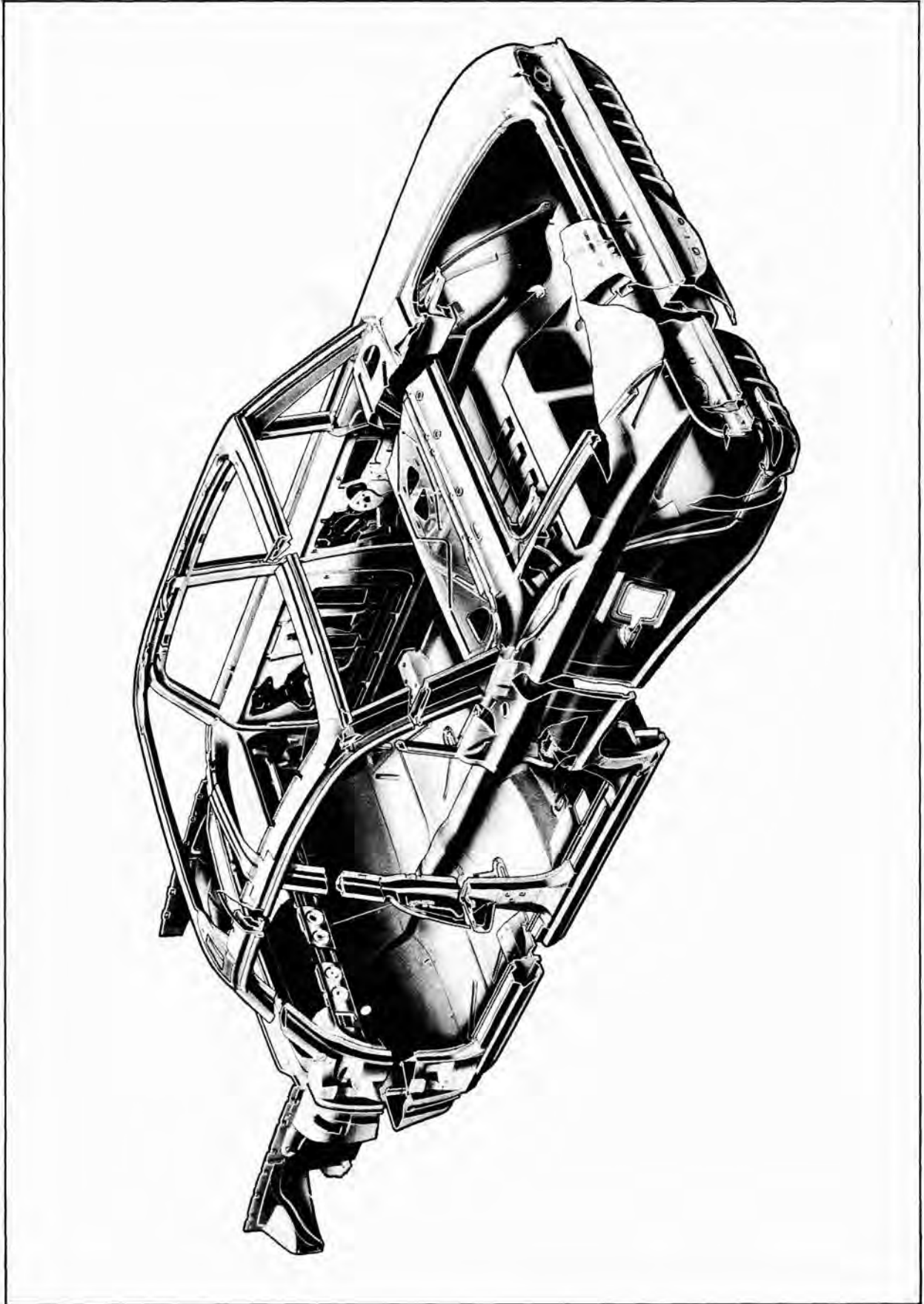
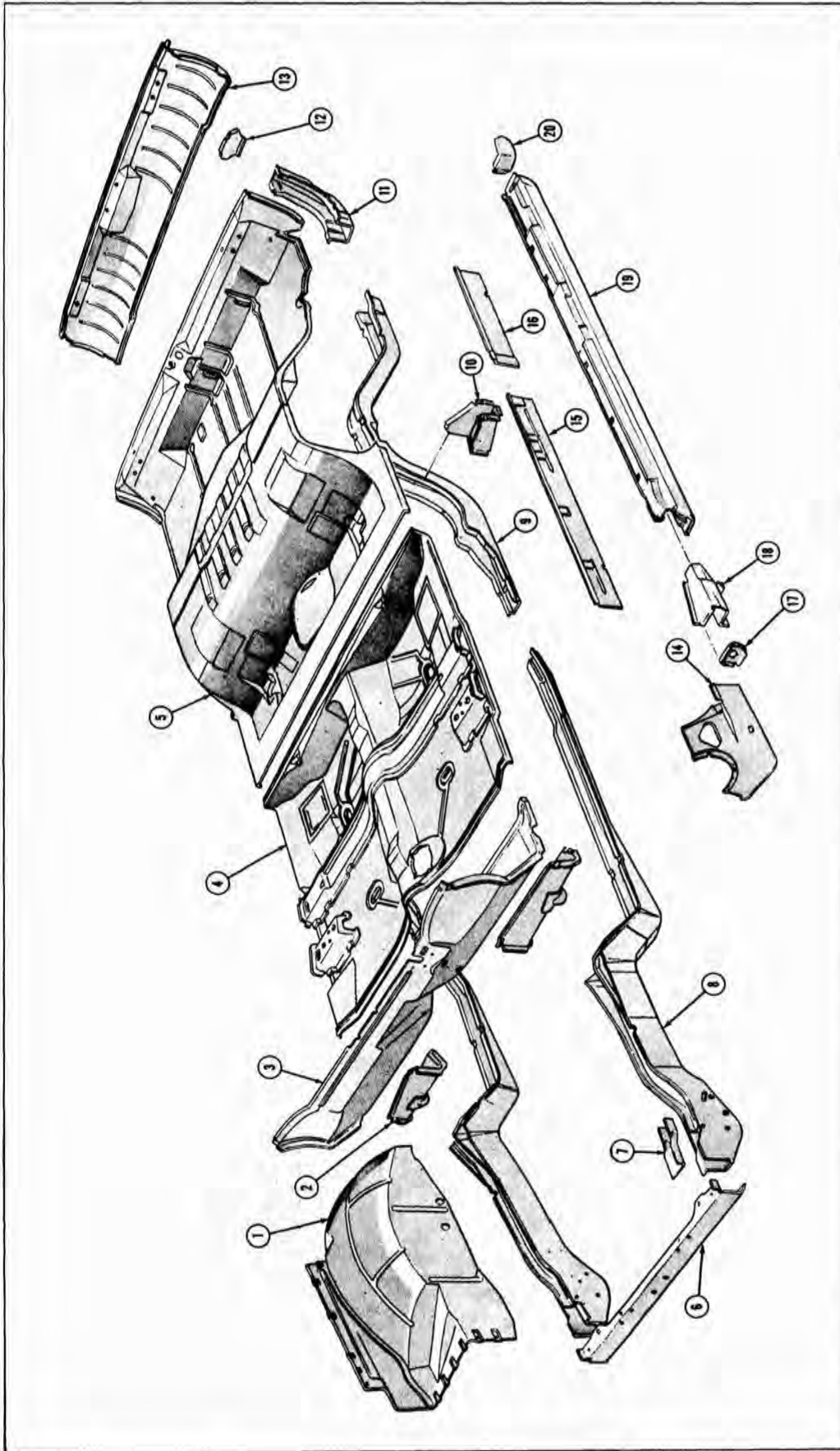

Fig. 12-2 2119 Body Shell Construction



Fig. 12-3 2167 Body Shell Construction



- | | | |
|---|--|--|
| <p>1. Panel, Front Wheel House
 2. Bar, Floor Pan No. 1
 3. Pan, Toe
 4. Pan, Floor (Consists of 2-3-4-6-8-15)
 5. Pan, Rear Compartment (Consists of 5-9-10-11-16)
 6. Rail, Front End Cross
 7. Rail, Engine Compartment Side - Upper Front</p> | <p>8. Rail, Floor Pan - Side
 9. Rail, Rear Compartment Side
 10. Brace, Rear Compartment Rail to Rocker - Inner
 11. Rail, Rear Compartment Pan Side - Rear
 12. Filler, Pan to Rear End Panel
 13. Panel, Rear End - Lower</p> | <p>14. Reinforcement, Front Body Hinge Pillar to Rocker
 15. Panel, Rocker Inner Front
 16. Panel, Rocker Inner Rear
 17. Filler, Rocker Outer Panel - Front
 18. Extension, Rocker Outer Panel - Front
 19. Panel, Rocker Outer (Consists of 17-18-19)
 20. Filler, Rocker Panel Rear</p> |
|---|--|--|

Fig. 12-4 Underbody Assembly

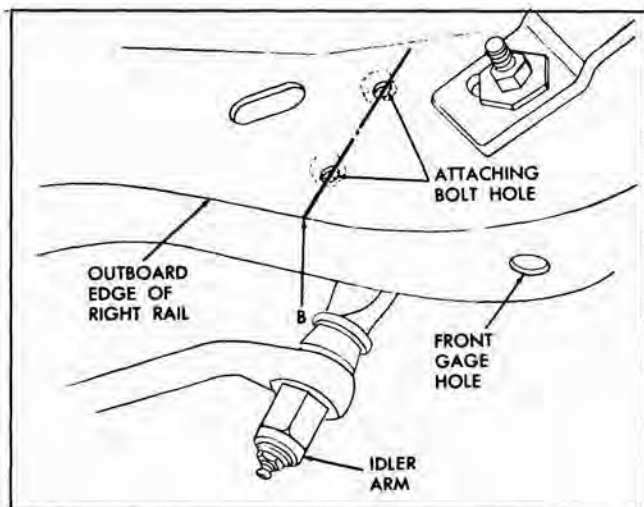

Fig. 12-5 Underbody Vertical Reference Point ("B")

To assist in checking alignment of the underbody components, repairing minor underbody damage or locating replacement parts, the following underbody dimension and alignment checking information is presented.

BODY TRAM GAGE

An accurate method of determining the alignment of the underbody utilizes a measuring tram gage. The tram gage required to perform all recommended measuring checks properly must be capable of extending from a length of approximately eighteen inches to a length of one hundred and six inches.

Dimensions shown in the upper portion of Fig. 12-8 are calculated on a horizontal plane parallel to the plane of the underbody. This can be controlled by setting the vertical pointers on the tram gage according to the dimensions shown in the lower portion of Fig. 12-8.

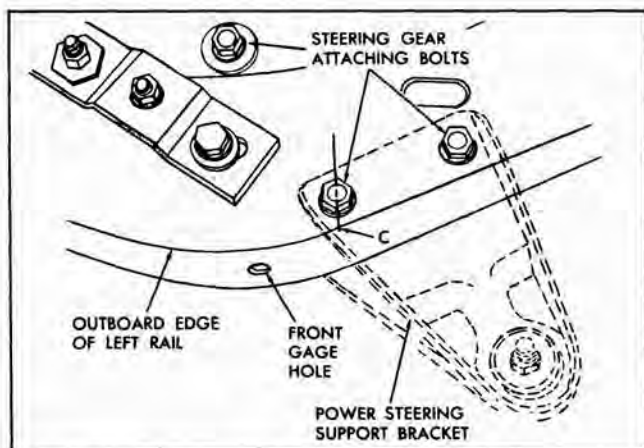

Fig. 12-6 Vertical Reference Point ("C")

At least one of the vertical pointers on the tram gage must have a minimum reach of seventeen inches.

A proper tramming tool is essential for analyzing and determining the extent of collision misalignment present in underbody construction.

UNDERBODY ALIGNMENT REFERENCE POINTS

Dimensions to gage holes and other unthreaded holes are measured to dead center of the holes and flush to the adjacent surface metal. Dimensions to bolt or bolt hole locations are measured to the dead center of the thread diameter of the bolt or bolt hole.

Following is a list of the specific underbody reference points used in making tram gage measurements. The reference points are identified by the same letters used to identify the vertical dimensions in the lower portion of Fig. 12-8.

- a. Front gage hole in lower surface of motor compartment side lower rail Fig. 12-5 and 12-6.
- b. Outboard lower edge of motor compartment right side rail on centerline drawn through idler arm attaching bolt holes Fig. 12-5.
- c. Outboard lower edge of motor compartment left side rail directly below front lower attaching bolt hole for the steering gear assembly Fig. 12-6.

NOTE: On power steering equipped cars it may be necessary to detach power steering support bracket from side rail to accommodate certain types of tram gages.

d. Front crossmember center attaching bolt hole in lower surface of motor compartment side lower rail (front suspension removed).

*d. Lower surface of front crossmember center attaching bolt (front suspension installed).

e. Gage hole (5/16 inch diameter) in floor pan side rail, located inboard and slightly rearward of front body hinge pillar.

f. Gage hole (5/16 inch diameter) in rear compartment pan side rail located inboard and slightly forward of rear body lock pillar.

g. Rear wheel suspension inner anchor nut located within the rear seat pan cross bar assembly at the "kick-up" area (rear suspension and drive system removed). This reference point used for vertical checks only.

*g. Lower surface of rear wheel suspension inner anchor attaching bolt head (rear suspension and drive system installed). This reference point used for vertical checks only.

h. Rear wheel suspension outer mounting support bolt hole (rear suspension and drive system removed).

*h. Lower surface of rear wheel suspension outer mounting attaching bolt head (rear suspension and drive system installed).

i. Center front edge of oblong hole in bottom surface of compartment pan side rear rail (located slightly forward of rear end lower panel) Fig. 12-7.

NOTE: Center of compartment pan left side rail assembly (gas tank filler neck side) is located 1-5/16 inches farther from body centerline than center of compartment pan right side rail assembly.

j. Inboard attaching bolt hole for rear bumper support (rear bumper and support brackets removed). This reference point used for vertical checks only.

PRINCIPLES OF TRAMMING

As indicated in the underbody dimension chart, diagonal dimensions "D", "I", "M", "N" and "Q" are of equal distance to the same matching reference points on the opposite side of the body. These are commonly referred to as crosscheck dimensions.

To measure the distance accurately between any two reference points on the underbody, two specifications are required:

a. The horizontal dimension between the two reference points to be trammed.

b. The vertical dimension from the datum line to the reference points to be trammed. As an example, diagonal measurement "M" (calculated on a horizontal plane) between vertical reference point "D" and vertical reference point "H" is 105-1/4 inches. With front and rear suspension systems removed, the specification chart shows a vertical height difference of 3-15/32 inches between vertical dimension "D" and vertical dimension "H". The rear vertical pointer used at reference point "H" should be adjusted so as to extend 3-15/32 inches farther from the tram bar than the forward pointer used at reference point "D".

With the proper settings the tram bar will be on

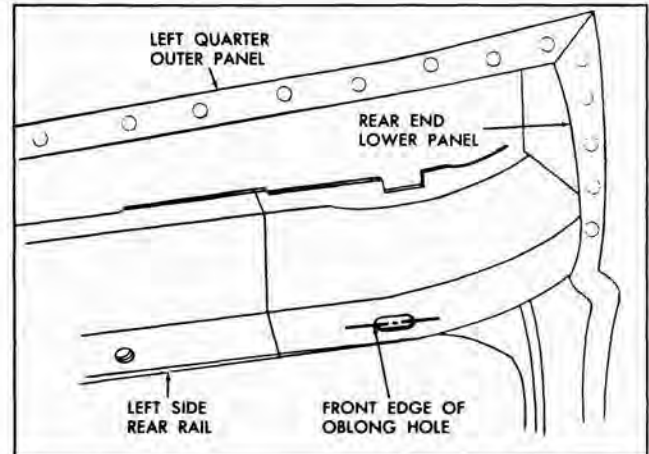

Fig. 12-7 Vertical Reference Point ("I")

a plane parallel to that of the body plane. The exception to this would be when one of the reference points is included in the misaligned area; then, the parallel plane between the body and the tram bar may not prevail. After completion of the repairs, the tram gage should be set at the specified dimensions to check the accuracy of the repair operation.

CAR PREPARATION

Preparing the car for the underbody alignment check involves the following:

1. Place the car on level surface.
2. The weight of the car should be supported at the wheel locations.
3. A visual damage inspection should be made to eliminate needless measuring. Obviously damaged or misaligned areas can often be located by sight.

TRAMMING SEQUENCE

The tramping sequence will vary depending upon the nature and location of the misaligned area. Basically there are five key reference points on each side of the body that should be utilized when making underbody alignment checks. These reference points are:

- a. Front gage hole in lower surface of motor compartment side lower rail.
- d and *d. Front crossmember center attaching bolt hole or attaching bolt.
- e. 5/16" diameter gage hole in forward portion of floor pan side rail.
- f. 5/16" diameter gage hole in forward portion of rear compartment pan side rail.

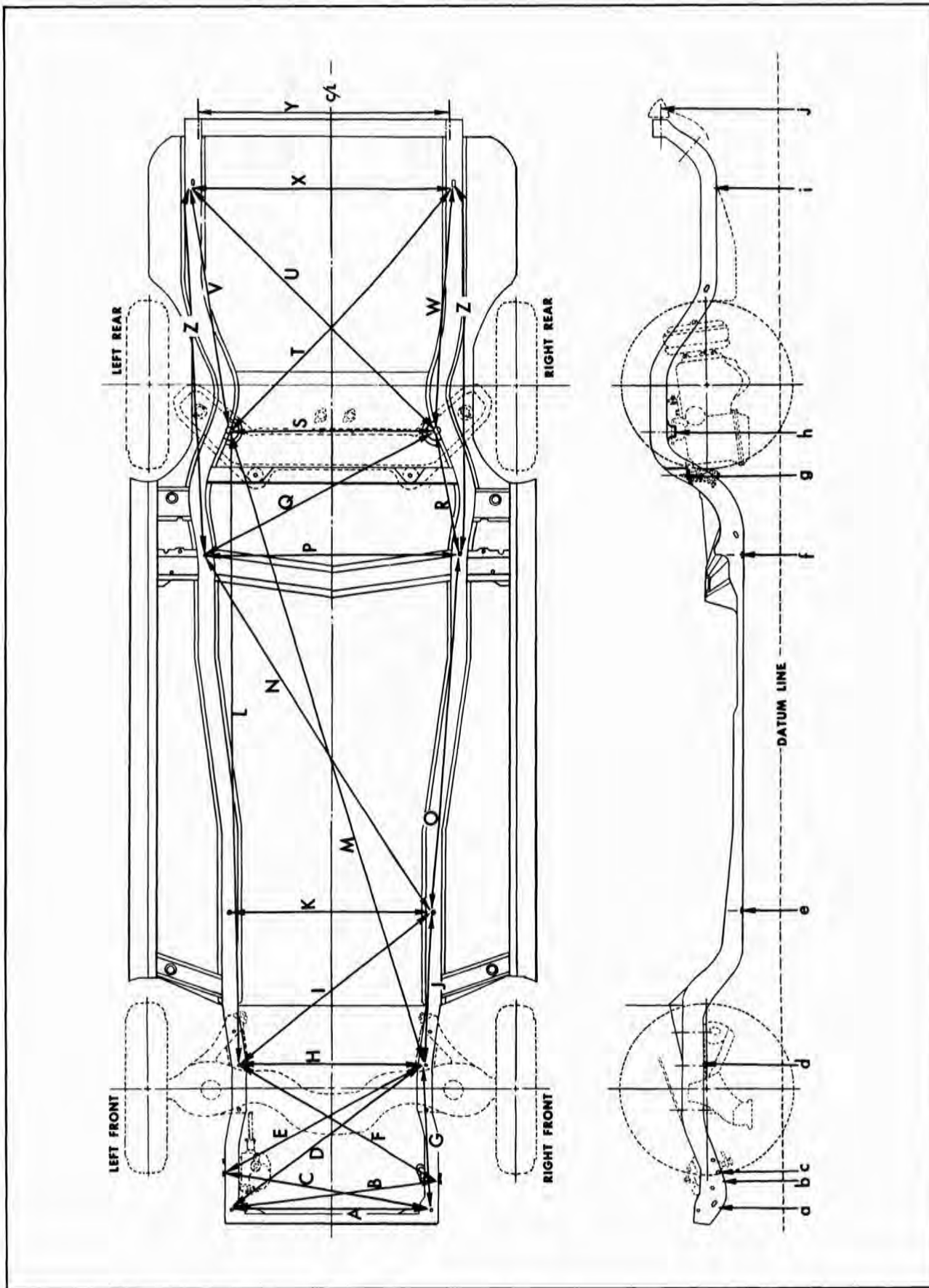

Fig. 12-8 Underbody Dimensions (*Not Symmetrical - See Note, Page 12-7)

UNDERBODY DIMENSION CHART

(Refer to Fig. 12-8)

HORIZONTAL

Fig. Ref.	Dimension	Vert. Ref. Point	to	Vert. Ref. Point
A	31-7/32	a		a
B	32-15/32	a (left side)		b
C	32-13/32	a (right side)		c
D	35-31/32	a		d (opp. side)
E	36-3/32	c		d (right side)
F	35-21/32	b		d (left side)
G	19-1/4	a		d (same side)
H	29-19/32	d		d
I	38-9/16	d		e (opp. side)
J	23-3/4	d		e (same side)
K	31-5/32	e		e
L	100-17/32	d		h (same side)
M	105-1/4	d		h (opp. side)
N	67-7/16	e		f (opp. side)
O	57-13/32	e		f (same side)
P	40-5/32	f		f
Q	41-1/4	f		h (opp. side)
R	19-15/16	f		h (same side)
S	32-17/32	h		h
T	53-11/32	h (left side)		i (right side)
U	54-1/4	h (right side)		i (left side)
V	39-3/16	h (left side)		i (left side)
W	39	h (right side)		i (right side)
X	42	i		i
Y	42	j		j
Z	58-3/8	f		i

VERTICAL

Fig. Ref.	Dimension to Datum Line
a	9-1/32
b	9-5/8
c	9-1/4
d	12-3/32
*d	11-19/32
e	6-1/16
f	6-1/16
g	13-15/16
*g	9-19/32
h	15-9/16
*h	13-3/4
i	10
j	18-15/16

* With suspension parts installed.

h and *h. Rear wheel suspension outer mounting support bolt hole or attaching bolt head.

Prior to performance of any tramming operation, the accuracy of reference points to be used must be determined. A measurement that originates from a reference point which is included in a damaged area will produce untrue results and confuse the evaluation of the underbody condition.

Unlike the conventional type of frame design, the unitized type of body construction seldom develops the two conditions of "twist" and "diamond" in the floor pan area as a result of front or rear end collisions. Therefore, underbody alignment checking can usually originate from the 5/16 inch diameter gage holes (locations "E" and "F") in the body side rails.

If inspection indicates that these locations have been disturbed and are not suitable for measuring, one of the undamaged suspension locations "D" or "H" should be used as a beginning reference point. If a rare situation should exist where all of the key locations are not suitable as reference points, repair operations should begin with the body floor pan area. All other underbody components should be aligned progressively from this area.

BODY CENTERING GAGES

Another tool that is extremely useful in repairing underbody collision damage is a body centering gage set. The centering gages automatically indicate the body centerline and the body level. Collision damage may result in twist, side-sway or sags to the underbody which may not be readily apparent to the naked eye. Sighting along the center vertical pointers and along the horizontal bars of the centering gages will make these conditions very apparent and will help to isolate the particular areas which are affected. A minimum of three centering gages must be used simultaneously.

The centering gages may be suspended or attached to the right and left motor compartment side rails or floor pan side rails at any matching points from the front of the car to the "kick-up" portion of the rear compartment pan side rails at the rear wheel area. From this point rearward, only the parallel portions of the rear compartment pan side rails may be used for centering gage attachment -- providing proper compensation is made for the dimensional differential between the side rails and the body centerline. The left side rail (gas tank filler neck side) is positioned 1-5/16 inches farther from the body centerline than the right side rail.

WINDSHIELD ASSEMBLY

WINDSHIELD GARNISH MOLDINGS

The windshield garnish moldings on all styles except convertible styles consist of upper right and left moldings, lower center molding and right and left lower outer moldings. On convertible styles the windshield header moldings consist of right and left end moldings and center molding. All moldings are secured by screws (Fig. 12-9, 12-10 and 12-11).

REMOVAL AND INSTALLATION

1. Place protective coverings over front seat and instrument panel.
2. Remove rear view mirror support; then remove upper moldings. On convertible styles raise top, remove sunshade supports; then remove end and center moldings.
3. Remove lower end moldings.
4. Remove lower center molding.
5. To install, on convertible styles, apply a 3/16" bead of medium-bodied sealer the entire length of the windshield header before installing the header moldings. Apply additional sealer to the underside

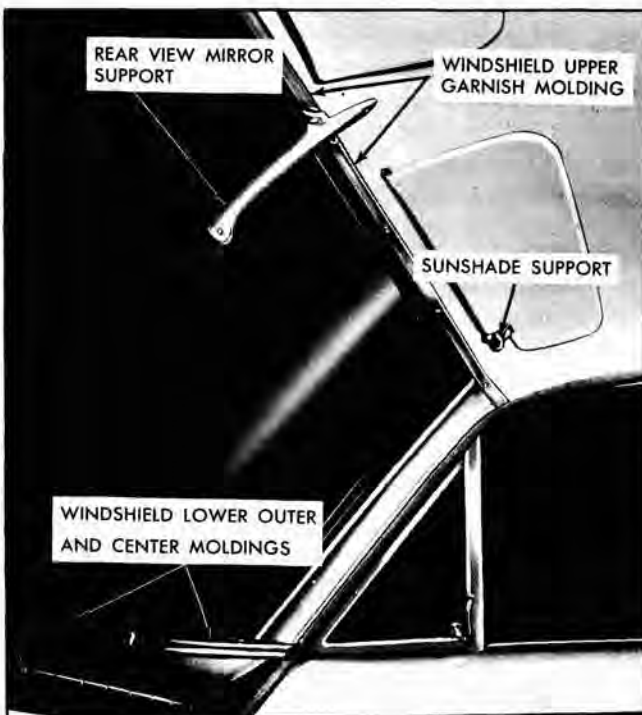

Fig. 12-9 Garnish Molding Attachment

of end moldings to insure watertight seal to the junction of the center molding (Fig. 12-10). Clean off excess sealer and reverse removal procedure.

REAR VIEW MIRROR SUPPORT

REMOVAL AND INSTALLATION

1. Remove screws securing mirror support and remove support.
2. To install, reverse removal procedure.

SUNSHADE SUPPORT ASSEMBLY

REMOVAL AND INSTALLATION

1. Remove screws securing assembly and remove assembly.
2. To install, reverse removal procedure.

WINDSHIELD GLASS

REMOVAL

1. Place protective covering over hood, front fenders, instrument panel and front seat assembly.
2. Remove rear view mirror support assembly.
3. Remove windshield garnish moldings.

NOTE: It is not necessary to remove upper header moldings on "67" style to remove windshield assembly.

4. Remove windshield wiper arms.
5. On inside of body loosen lip of rubber channel from pinchweld flange along top and sides of windshield as follows:

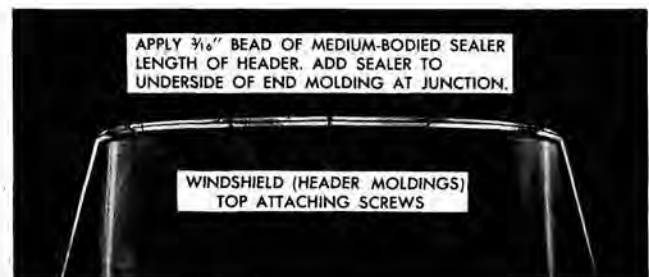

Fig. 12-10 Windshield Header Molding - "67" Style

With palm of hand, apply pressure to glass near edge (Fig. 12-12). At same time, use a blunt putty knife or other suitable tool and carefully assist rubber channel over pinchweld flange.

6. After windshield rubber channel is free from pinchweld flange, with aid of helper, carefully lift windshield assembly from body opening and place it on a protected bench.

7. Remove windshield reveal moldings from rubber channel on styles incorporating reveal moldings.

8. Remove rubber channel from glass.

CHECKING BODY WINDSHIELD OPENING

It is important that the body windshield opening be checked thoroughly before installation of a replacement windshield glass. The procedure below outlines the method which may be used to check the windshield opening.

1. Remove windshield from body.
2. Check windshield rubber channel for any irregularities.
3. Clean off old sealer around windshield opening and check entire body opening flange for any irregularities.
4. Install five (5) windshield checking blocks J-8942 to pinchweld flange (Fig. 12-13 and 12-14). Position one block over lower pinchweld flange on each side of body approximately twelve inches (12") inboard from the lower outer corner of the opening. Position final block on lower pinchweld flange in center of windshield opening. Position one block over upper pinchweld flange midway between center block and each outboard block on lower retaining flange.

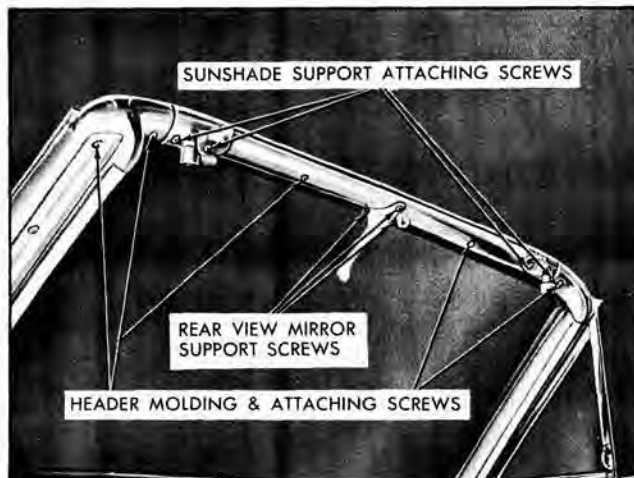

Fig. 12-11 Windshield Header - "67" Style



Fig. 12-12 Windshield Glass Removal

5. With aid of helper, carefully position replacement glass on blocks in windshield opening.

CAUTION: Care should be exercised to make certain glass does not strike body metal during installation. Edge chips can lead to future breaks.

6. With windshield glass supported and centered in the body opening by checking blocks, check relationship of glass to body opening around entire perimeter of glass. Check glass to body relationship as follows:

- a. The inside surface of the glass should be uniform distance from pinchweld flange. The dimension should be from 1/4" to 5/16".
- b. The outer edge of glass should be a uniform distance from body metal, measured in the plane of glass. This dimension should be from 5/16" to 3/8".

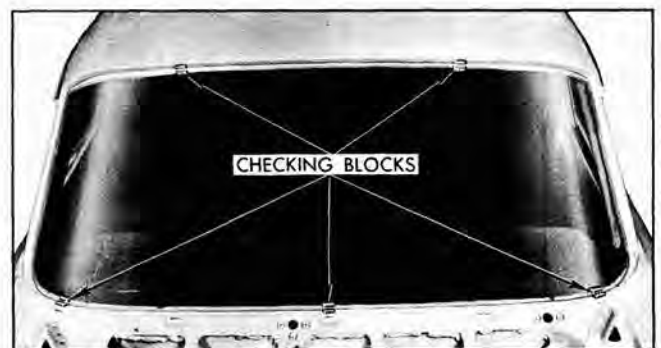

Fig. 12-13 Windshield and Opening Check

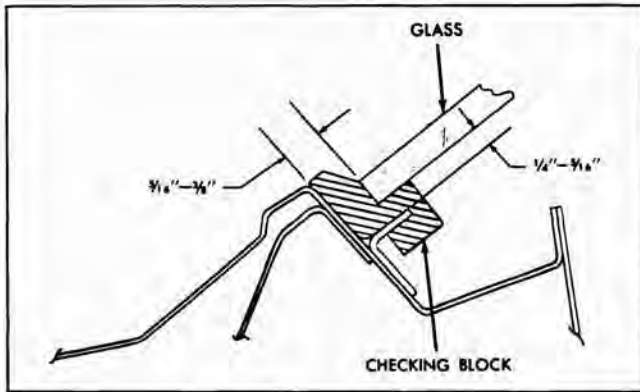

Fig. 12-14 Windshield Opening Check

7. Mark any sections of body to be re-formed, remove glass and re-form opening as required.

8. Recheck windshield opening as outlined above. Then mark the center line on the glass and body so that glass can be accurately centered in opening when installed.

INSTALLATION

1. Clean out old sealer in glass cavity of windshield rubber channel and around base of rubber channel.

2. Install rubber channel to glass.

3. Install reveal moldings in rubber channel on styles incorporating reveal moldings.

4. Insert a strong cord in pinchweld cavity of rubber channel completely around windshield. Tie ends of cord and tape to inside surface of glass at bottom center of glass. (Fig. 12-15).

5. Apply a ribbon of medium-bodied sealer completely around base of rubber channel as indicated by 1 (Fig. 12-16).

6. Apply a bead of medium-bodied sealer, approximately 1/4" in diameter to corner of windshield opening rabbet around each side of windshield for distance indicated by 3 (Fig. 12-16).

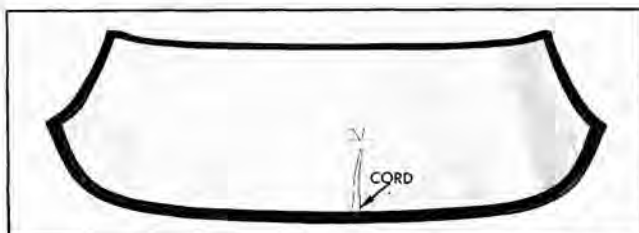

Fig. 12-15 Windshield Installation

7. With aid of helper, carefully position and center windshield assembly in windshield opening.

CAUTION: Do not position glass by tapping or hammering at any time.

8. When the glass and channel are properly positioned in opening, slowly pull ends of cord, starting at lower center of windshield, to seat lip of rubber channel over pinchweld flange. Cord should be pulled first across bottom of windshield, then up each side and finally across top of windshield.

9. Using a pressure type applicator, seal inner and outer lips of rubber channel to glass as indicated by 2 in (Fig. 12-16) with an approved weatherstrip adhesive. Seals are to extend completely around rubber channel.

10. Clean off excess sealer from windshield glass with mineral spirits.

11. Reinstall all previously removed parts and remove protective coverings.

WINDSHIELD REVEAL MOLDINGS

The windshield reveal moldings are secured in a cavity of the windshield rubber channel. The moldings consist of an upper and lower reveal molding and a right and left side reveal molding. The ends of the side reveal moldings overlap the upper and lower reveal moldings. (Fig. 12-17).

REMOVAL

1. Mark center line on glass and body, remove

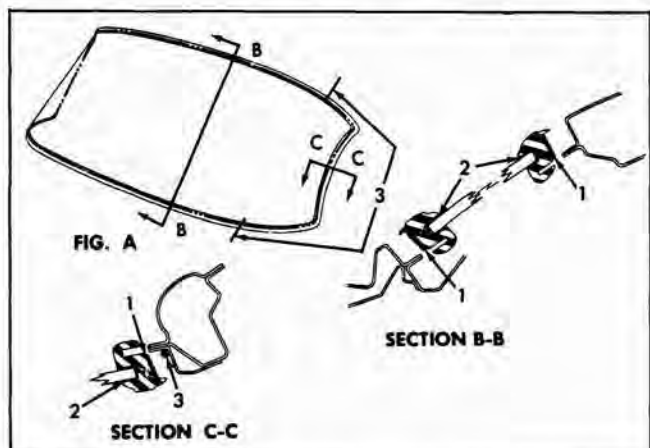

Fig. 12-16 Windshield Sealing

windshield assembly and place it on a protected bench.

2. Locate and mark center of upper and lower reveal moldings.

3. Carefully remove side reveal moldings from cavity of rubber channel; then, remove upper and lower reveal moldings.

INSTALLATION

1. Install and center upper and lower reveal moldings in cavity of rubber channel; then install side reveal moldings.

NOTE: To facilitate installation of the moldings, apply a mild soap solution to the cavity of the rubber channel prior to installing the moldings.

2. Install windshield assembly in body.

WINDSHIELD PILLAR DRIP MOLDING ALL EXCEPT 67 STYLE

REMOVAL AND INSTALLATION

1. On "17", "19", "27" and "35" styles remove screws securing drip molding (Fig. 12-18) and remove molding.

2. To install, apply medium-bodied sealer to screw attaching holes as indicated by #1 and to drip molding as indicated by #2 in (Fig. 12-19) and reverse removal procedure.

3. On station wagon styles it is necessary to remove the windshield pillar weatherstrip retainer, to gain access to the attaching screws. Remove attaching screws and molding.

4. To install, seal holes in pillar, install molding. Seal weatherstrip and retainer and install.

WINDSHIELD GLASS REPLACEMENT WHEN ALIGNMENT OF OPENING IS NOT REQUIRED

REMOVAL

1. Place protective covering over front seat and instrument panel.

2. Place protective covering over hood and front fenders.

3. Remove windshield wiper arms.

4. Remove rear view mirror support.

5. On inside of body loosen lip of rubber channel from pinchweld flange along top and sides of windshield as follows:

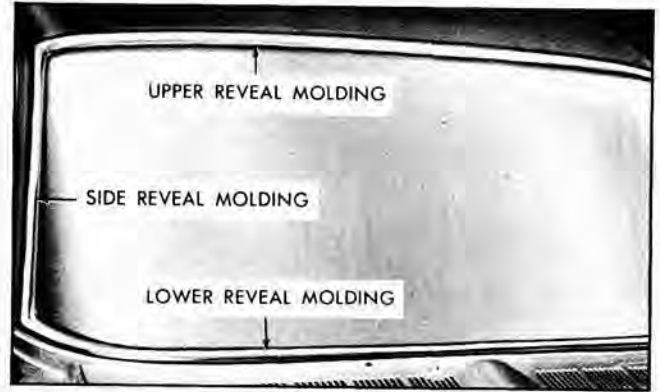

Fig. 12-17 Windshield Reveal Moldings

With palm of hand apply pressure to glass near edge (Fig. 12-12). At same time, use a blunt putty knife or other suitable tool and carefully assist rubber channel over pinchweld flange across top and sides only.

NOTE: Do not remove lower channel lip from pinchweld.

6. Tilt windshield forward at top.

7. Remove upper and side reveal moldings on bodies incorporating reveal moldings.

8. Carefully remove glass from rubber channel without breaking seal between rubber channel and lower pinchweld.

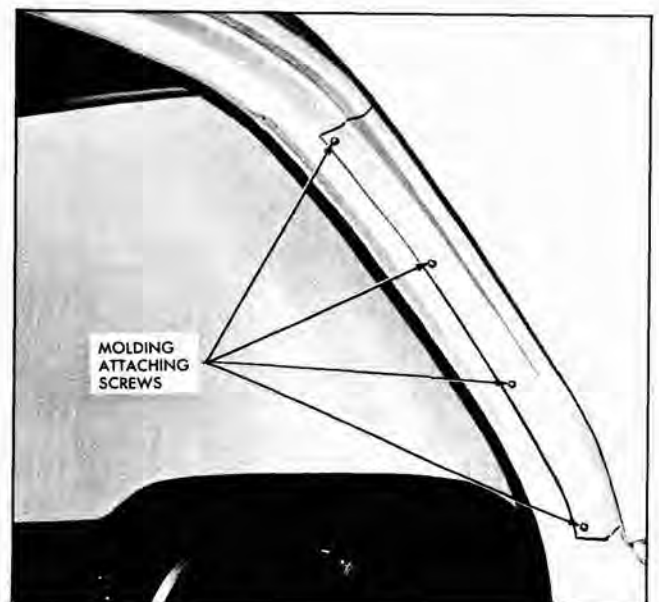

Fig. 12-18 Windshield Pillar Drip Moldings

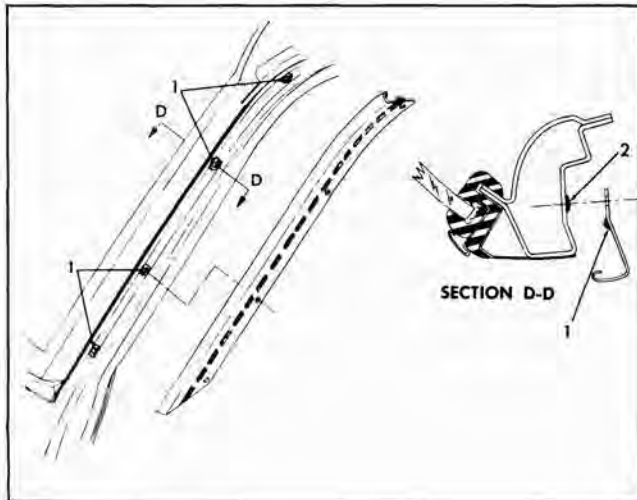

Fig. 12-19 Windshield Pillar Drip Moldings

INSTALLATION

1. Clean out cavity of windshield rubber channel of all old sealer, etc.
2. Apply a mild soap solution to cavity and outer lip of rubber channel.
3. Place windshield glass in rubber channel.
4. Install side and upper reveal moldings in rubber channel on bodies incorporating reveal moldings.
5. Apply medium bodied sealer around windshield opening rabbet area that is exposed.

6. Working from inside the body, with a screw driver or other suitable tool, work the inner lip of the windshield channel over the pinchweld flange, up each side and across the top.

CAUTION: Do not attempt to position glass by tapping or hammering at any time.

7. Using a pressure type applicator, seal inner and outer lips of rubber channel to glass with an approved weatherstrip adhesive #2 (Fig. 12-16).

8. Clean off excess sealer.

9. Reinstall all previously removed parts and remove protective coverings.

MINOR WATERLEAKS AT WINDSHIELD

In many instances minor waterleaks around the windshield may be corrected by performing the following operations.

1. Leaks between rubber channel and glass.

a. Using a pressure applicator (plews oiler or equivalent) with a narrow tip, apply an approved weatherstrip adhesive (black) between glass and rubber channel on the outside of the glass completely around perimeter of glass.

2. Leaks between rubber channel and body.

a. Use a pressure applicator with a narrow tip. Working from outside of the body, apply medium-bodied sealer under outer lip of rubber channel around entire perimeter of body opening.

INSTRUMENT PANEL ASSEMBLY

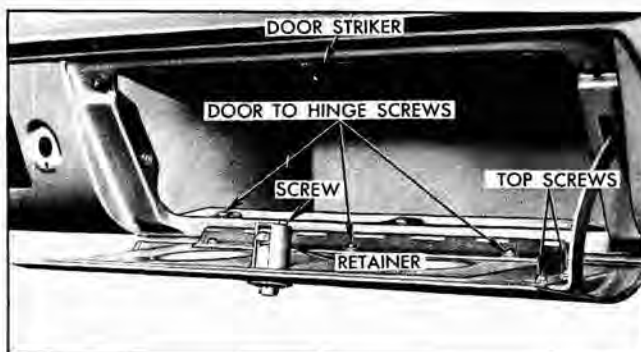

Fig. 12-20 Instrument Panel Compartment Door Assembly

INSTRUMENT PANEL COMPARTMENT DOOR

REMOVAL AND INSTALLATION

1. Mark location of compartment door hinge on door inner panel.

2. Remove hinge stop attaching screws from door inner panel (Fig. 12-20).

3. Remove door hinge attaching screws from door inner panel and remove door (Fig. 12-20).

4. To install, position door within locating lines and install attaching screws. Install hinge stop and adjust as necessary.

ADJUSTMENTS

1. To reposition compartment door up or down in its opening, loosen hinge and hinge stop attaching screws at door inner panel and shift door in desired direction.

NOTE: A slight up or down adjustment may also be obtained at hinge-to-instrument panel attachment.

2. To position the door right or left, loosen hinge-to-instrument panel attaching screws located on underside of instrument panel and shift door to desired position. Adjust stop assembly accordingly on door inner panel.

3. The door lock striker may be adjusted by loosening attaching screws and moving striker forward or rearward (Fig. 12-20).

INSTRUMENT PANEL COMPARTMENT DOOR HINGE STOP ASSEMBLY

REMOVAL AND INSTALLATION

1. Remove hinge stop attaching screws (Fig. 12-20) and remove from body.

2. To install, reverse removal procedure. Check for proper alignment of hinge stop to door inner panel.

INSTRUMENT PANEL COVER

The instrument panel cover is a one piece soft molded "Nose" design applied to the formed surface

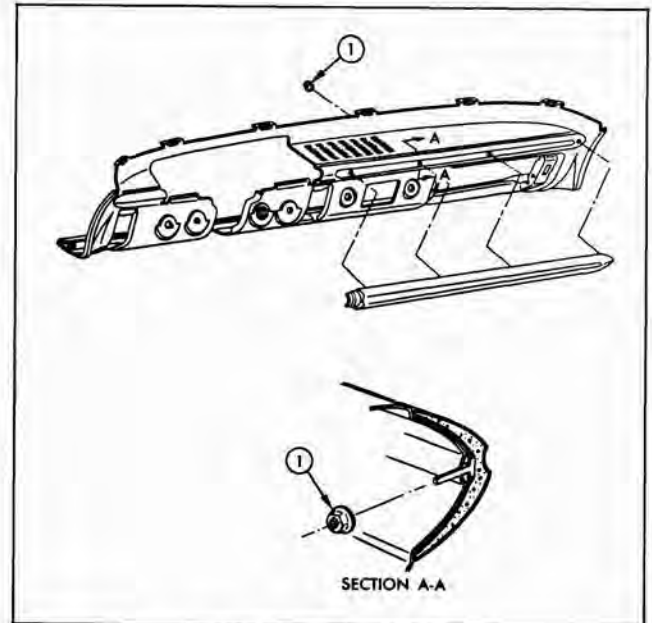

Fig. 12-21 Instrument Panel Cover

of the instrument panel and is attached by studs and nuts.

REMOVAL AND INSTALLATION

1. From underside of instrument panel remove attaching nuts indicated by #1 in Fig. 12-21 and remove cover assembly.

2. To install, reverse removal procedure.

BODY VENTILATING SYSTEM

The body ventilating system incorporates the use of an air intake grille located on top of the shroud panel.

The air entering the shroud top ventilator grille flows through a duct which guides the air into the body through a shroud side duct panel air outlet assembly.

The door in the outlet assembly regulates the flow of air and is adjusted by the use of a cable and knob control.

Water entering the air inlet grille flows down the shroud side duct panel and is discharged through an opening in the shroud side panel.



Fig. 12-22 Air Intake Grille



Fig. 12-23 Shroud Side Foundation

SHROUD TOP VENTILATOR GRILLE

REMOVAL AND INSTALLATION

1. Place protective coverings over hood and fenders.
2. Remove windshield wiper arms.
3. Raise hood, remove screws securing grille to shroud (Fig. 12-22).



Fig. 12-24 Air Outlet Door

4. Carefully raise front edge of grille and slide grille forward to disengage tabs along rear edge of grille from slots in shroud; then, remove grille.

5. To install, apply medium-bodied sealer around screw attaching holes and grille retaining slots (Fig. 12-22).

6. Insert retaining tabs along rear edge of grille in slots in shroud panel and reverse removal procedure.

NOTE: Exercise care so that grille does not contact hood.

SHROUD SIDE FOUNDATION

REMOVAL AND INSTALLATION

1. Remove screws (Fig. 12-23) securing upper and lower end of air inlet grille.
2. Slide foundation forward to disengage rear edge of foundation from retainer and remove foundation.

SHROUD SIDE VENT DUCT AIR OUTLET

REMOVAL AND INSTALLATION

1. Remove shroud side foundation.
2. Remove screws securing outlet to shroud panel, disengage cable from pin on door and remove outlet. (Fig. 12-24).
3. To install, apply a bead of medium-bodied sealer to shroud panel at areas indicated in Fig. 12-25 and reverse removal procedure.

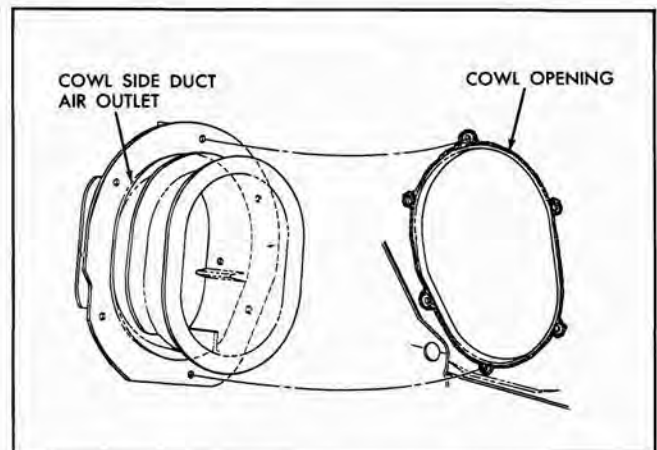

Fig. 12-25 Cowl Side Duct Air Outlet Sealing

**SHROUD SIDE DUCT PANEL
AIR OUTLET DOOR**

REMOVAL AND INSTALLATION

1. Remove shroud side foundation.
2. Remove end of control cable from door pin. (Fig. 12-24).
3. Pry upper hinge pin downward and remove door.
4. To install, reverse removal procedure.

DOORS

CONTENTS OF THIS SECTION

SUBJECT	PAGE	SUBJECT	PAGE
Doors - Front and Rear		Inner Panel Cam	13-13
Inside Handle	13-1	Window Assembly	13-13
Arm Rests	13-2	Adjustments	13-14
Trim Pads	13-2	Regulator Assembly	13-14
Water Deflectors	13-3	Door Lock	13-15
Lock Strikers	13-4	Door Lock Cylinder	13-15
Weatherstrips	13-5		
Glass Run Channel	13-7	Rear Doors	
Outside Handle	13-7	Hinges	13-16
Pinch Weld Finishing Strip	13-8	Adjustment	13-17
Lock Spring Clips	13-8	Lock Assembly	13-18
Front Doors		Remote Control Assembly	13-18
Hinges	13-9	Inner Panel Cam	13-18
Adjustments	13-10	Lower Sash Channel Cam	13-19
Lock Remote Control	13-10	Regulator Assembly	13-19
Ventilator Assembly	13-11	Window Adjustments	13-20
Ventilator Casting	13-11		
		Side Roof Rail Weatherstrip	13-20

DOORS—FRONT AND REAR

The entire door section has been divided into the following parts:

- A. Service operations which are the same or similar for both front and rear doors.
- B. Service operations for front doors only.
- C. Service operations for rear doors only.
- D. Service operations for side roof rail weatherstrips except convertible styles.

FRONT AND REAR DOOR INSIDE HANDLES

All door inside handles are attached to their respective spindles (window regulator or remote control) by a small retaining spring. The open end of this spring should face the unattached end of the inside handle.

REMOVAL

1. Depress door trim assembly at handle sufficiently to install tool J-7797 between handle and bearing plate.

2. Push handle retaining spring out of engagement and remove handle and bearing plate from door (Fig. 13-1).

INSTALLATION

1. Install retaining spring on handle and bearing plate over regulator spindle.
2. Position handle on spindle at same angle as handle on opposite door, and push handle until spring is engaged.

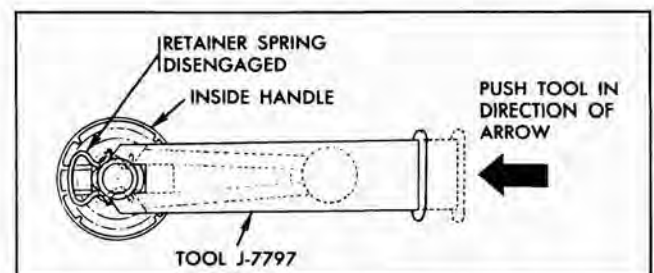

Fig. 13-1 Removing Retaining Spring

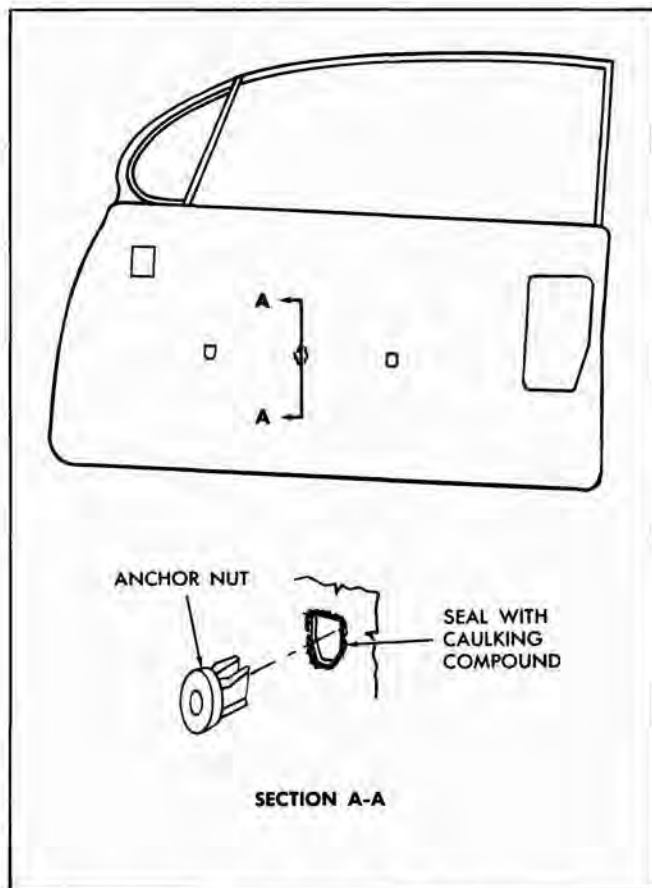

Fig. 13-2 Arm Rest Anchor Nut

NOTE: Handles are installed in a horizontal position with unattached end forward when glass is in full up position on all styles.

FRONT AND REAR DOOR ARM RESTS

All arm rests are the applied type and are secured to the door inner panel by two (2) attaching screws which fit into self-threading plastic anchor nuts which snap into the door inner panel. The anchor nuts are sealed to the door inner panel with body caulking compound and are replaceable as a service part (Fig. 13-2).

REMOVAL AND INSTALLATION

1. Remove screws securing arm rest to door inner panel and remove arm rest.
2. To install, reverse removal procedure.

FRONT AND REAR DOOR TRIM PADS

Both the front and rear door trim assemblies are secured to the door panel (inner) by a trim pad retainer and screws at the bottom of the door, and

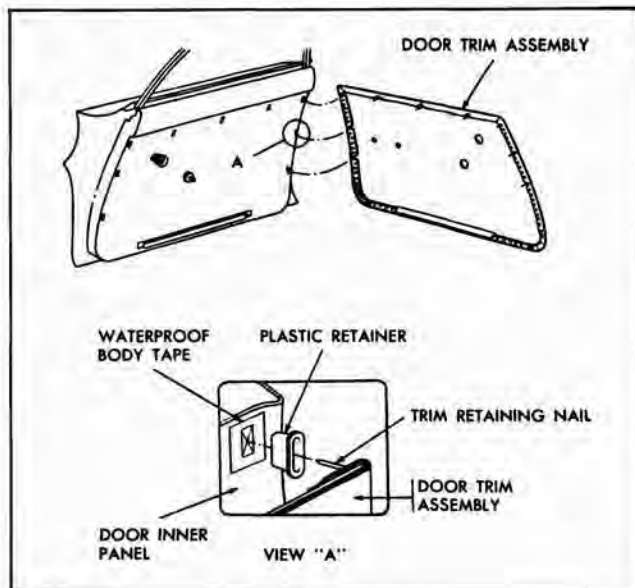

Fig. 13-3 Door Trim Installation

by retaining nails at the sides and top of the door. The nails are pressed or tapped into plastic retainers which fit into slots in the door inner panel.

REMOVAL AND INSTALLATION

1. Remove door inside handles and arm rest assembly.
2. At each lower corner of trim assembly remove screw securing assembly to door inner panel.
3. With a clean rubber mallet, tap along sides and top of trim assembly to free trim nails from door inner panel.
4. Starting at top of trim assembly, carefully insert tool J-6335, or a suitable flat-bladed tool, between door trim assembly and door inner panel at retaining nail locations and disengage nails from retainers (Fig. 13-3).

NOTE: Exercise care so as not to disturb inner panel water deflector.

5. Lift trim assembly upwards to disengage lower edge of assembly from door inner panel and remove trim assembly.
6. When installing, broken nails should be replaced with repair tabs which are available as a service part.

NOTE: Retaining nails must not pierce back of plastic retainers as waterleaks may develop. For this reason it is important that PROPER LENGTH repair tab nails (1/2") are used when replacing broken trim retaining nails.

7. If plastic retainers are loose and will not remain engaged in door inner panel, install a 1/2" x 3/4" piece of cloth-backed waterproof body tape over retaining hole in door inner panel. Make two (2) slits in tape to form an "X" pattern. Check retainer for snug fit. If retainer is still loose, repeat above operation by installing a second piece of tape over existing repair. This procedure may also be used to repair waterleaks which develop around perimeter of retainer.

FRONT AND REAR DOOR WATER DEFLECTORS

A waterproof paper deflector is used to seal the door inner panel and prevent entry of water into the body. The polyethylene (shiny or black) side of the deflector is placed against the inner panel. The deflector fits into a retaining slot at the bottom of the door inner panel and deflects the water to the bottom of the door and out the bottom drain holes. The deflector is further secured by a string loaded sealing material along both front and rear edges and by the application of waterproof sealing tape at front and rear lower corners. Whenever work is performed on front or rear doors where the paper water deflector has been disturbed, the deflector must be properly sealed and taped to the inner panel to prevent serious waterleaks. It is important that all service personnel performing door hardware adjustments or sealing operations are aware of the importance of using the specified material and recommended removal and installation or replacement procedures. For service sealing, body caulking compound is recommended if additional sealing material is required.

When access to the inner panel is required to perform service operations, the deflector may be completely or partially detached from the inner panel. If the existing water deflector is damaged, so that it will not properly seal the door, replacement of the deflector is required.

The following procedure covers complete removal and installation of the water deflector. If only partial removal of the deflector is required, perform only those steps which are necessary to expose the required area of the door inner panel.

REMOVAL

1. Remove door trim assembly.
2. Remove strips of waterproof body tape securing lower corners of water deflector (Fig. 13-4).

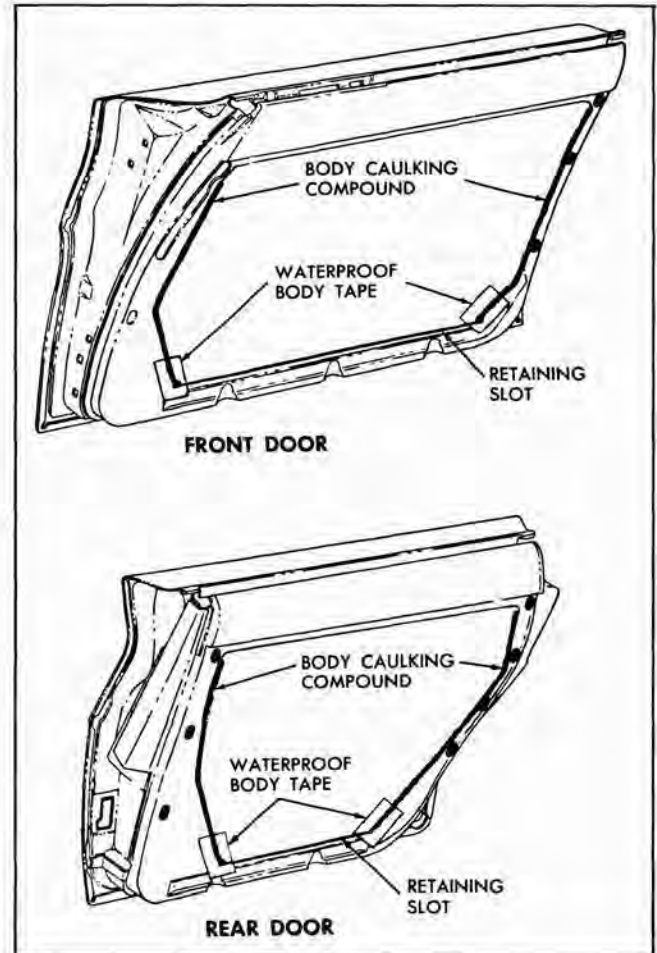

Fig. 13-4 Water Deflector Installation

3. Carefully break cement bond securing upper corners of water deflector to door inner panel. While holding string located within sealer against water deflector, carefully disengage edges of deflector from door. Exercise care so as not to tear water deflector.

NOTE: If necessary, a flat-bladed tool such as a putty knife can be used to help break cement bond.

4. Disengage lower edge of water deflector from retaining slot in door inner panel and remove water deflector.

INSTALLATION

1. Inspect water deflector and, where necessary, repair any tears or holes with waterproof body tape applied to both sides of deflector. In addition, if bond between polyethylene and deflector paper has been torn, cut or damaged, apply waterproof body tape to both sides of deflector over damaged area to prevent water from wicking on uncoated side of deflector.



Fig. 13-5 Door Lock Striker Engagement Check

2. If a new water deflector is to be installed, use old water deflector as a template, trim new deflector to proper size and cut holes for door inside hardware.

If old sealer does not effect a satisfactory seal, apply a bead of body caulking compound (approximately 3/16" diameter) to inner panel at unsealed areas (Fig. 13-4).

3. Position water deflector to door inner panel with polyethylene coated side of deflector against inner panel.

Insert lower edge of deflector in retaining slot. Then firmly roll or press sealed areas to obtain a good bond between deflector and door inner panel.

4. Seal lower corners of deflector with 2" or 2-1/2" waterproof body sealing tape (Fig. 13-4).

5. Clean off all excess cement or caulking compound and install previously removed door trim and inside hardware.

FRONT AND REAR DOOR LOCK STRIKERS

REMOVAL AND INSTALLATION

1. With a pencil, mark position of striker on body pillar.
2. Remove three (3) door lock striker attaching screws and remove striker and adjusting plates from pillar.
3. Prior to installation, seal all striker plate attaching screw clearance holes with body caulking compound.
4. Apply a 1/8" bead of body caulking compound around entire back surface of striker plate. No skips must exist in caulking compound. Place striker and adjusting plates within scribe marks on pillar and install striker plate attaching screws.

NOTE: Whenever a door has been removed and installed, or realigned, the door **SHOULD NOT** be closed completely until a visual check is made to determine if lock extension will engage in striker notch. Where required, door lock striker emergency spacers should be installed so that door can be closed and an accurate check made to determine emergency spacer requirements.

5. Clean off all excess caulking compound.

ADJUSTMENTS

1. To adjust striker up or down or in or out, loosen striker plate attaching screws and shift striker and adjusting plates as required, and tighten screws.

DIMENSIONAL SPECIFICATIONS FOR USE OF DOOR LOCK STRIKER EMERGENCY SPACERS

1. Door(s) should be properly aligned before checking door spacer requirements.
2. To determine if door lock striker emergency spacers are required, apply modeling clay or body caulking compound in door lock striker notch where lock extension engages, and then close door to form a measurable impression in clay or caulking compound as shown in Fig. 13-5.

When dimension "A" (Fig. 13-5) from rear face of striker teeth to rear edge of depression in clay is less than 11/32", install emergency spacers and proper length striker attaching screws as indicated.

Dimension "A"	No. of Required Spacers
11/32" to 9/32"	1
9/32" to 7/32"	1
7/32" to 5/32"	1 (1/16" Spacer)
	1 (1/8" Spacer)
5/32" to 3/32"	2 (1/8" Spacer)

Spacer Thickness	Striker Attaching Screws*
1/16"	Original
1/8"	Emergency (1/8" Longer)
3/16"	Emergency (1/8" Longer)
1/4"	Emergency (1/4" Longer)

NOTE: Dimension "B" in the illustration should never be less than 1/8".

*Zinc or cadmium plated flat-head cross-recess screw with countersunk washer.

FRONT AND REAR DOOR WEATHERSTRIPS

17, 19, 27 and 35 STYLES

The one-piece door weatherstrip is cemented into the door window frame assembly which forms a retainer type channel for retention of the weatherstrip assembly. The remainder of the door weatherstrip is retained by clips inserted into attaching hole sealing plugs. Service procedures for front and rear door weatherstrips are similar and both weatherstrips are covered as follows:

REMOVAL

1. With a flat-bladed tool, carefully break cement bond along door window frame assembly and at belt line.
2. Insert tip of tool J-5757 at clip location and carefully snap clips from retaining plugs and remove weatherstrip from door.

INSTALLATION

1. Clean off old cement from window frame and door inner panel to insure a clean cementing surface.
2. Check weatherstrip clips for proper contour and reform if necessary using tool J-5984 (Fig. 13-6).
3. Check all attaching hole sealing plugs. If sealing plugs are loose and will not remain engaged in door inner panel, install a 1/2" x 1" piece of cloth-



Fig. 13-6 Weatherstrip Clip Remover Tool

backed waterproof body tape over sealing plug retaining hole as shown in Section "G-G" of Fig. 13-7. Make two 5/16" slits in tape to form an "X". Install plug and check for a snug fit. If plug is still loose, repeat above operation by installing a second piece of tape over existing repair. This procedure may also be used to repair waterleaks which develop at sealing plug locations.

4. Prior to installation of weatherstrip on either door, apply a continuous bead of an approved weatherstrip cement extending from approximately one (1) inch below window frame at hinge pillar section (see view "B" or "D") along entire outboard portion of door weatherstrip retaining channel (see Section "F-F") to approximately one (1) inch below lock pillar section of window frame assembly as shown in view "C" (Fig. 13-7).

NOTE: When applying weatherstrip cement follow manufacturer's directions.

5. Starting at uppermost clip hole on either door pillar, install clips to door by placing notched end of tool J-5757 in loop of clip and pushing clip into attaching hole sealing plug. Repeat operation along both sides and bottom of door.

NOTE: Do not distort clips or unsatisfactory weatherstrip retention will result.

6. Using a putty knife, or other suitable flat-bladed tool, install door weatherstrip into door window frame assembly.
7. Clean off all excessive weatherstrip adhesive.

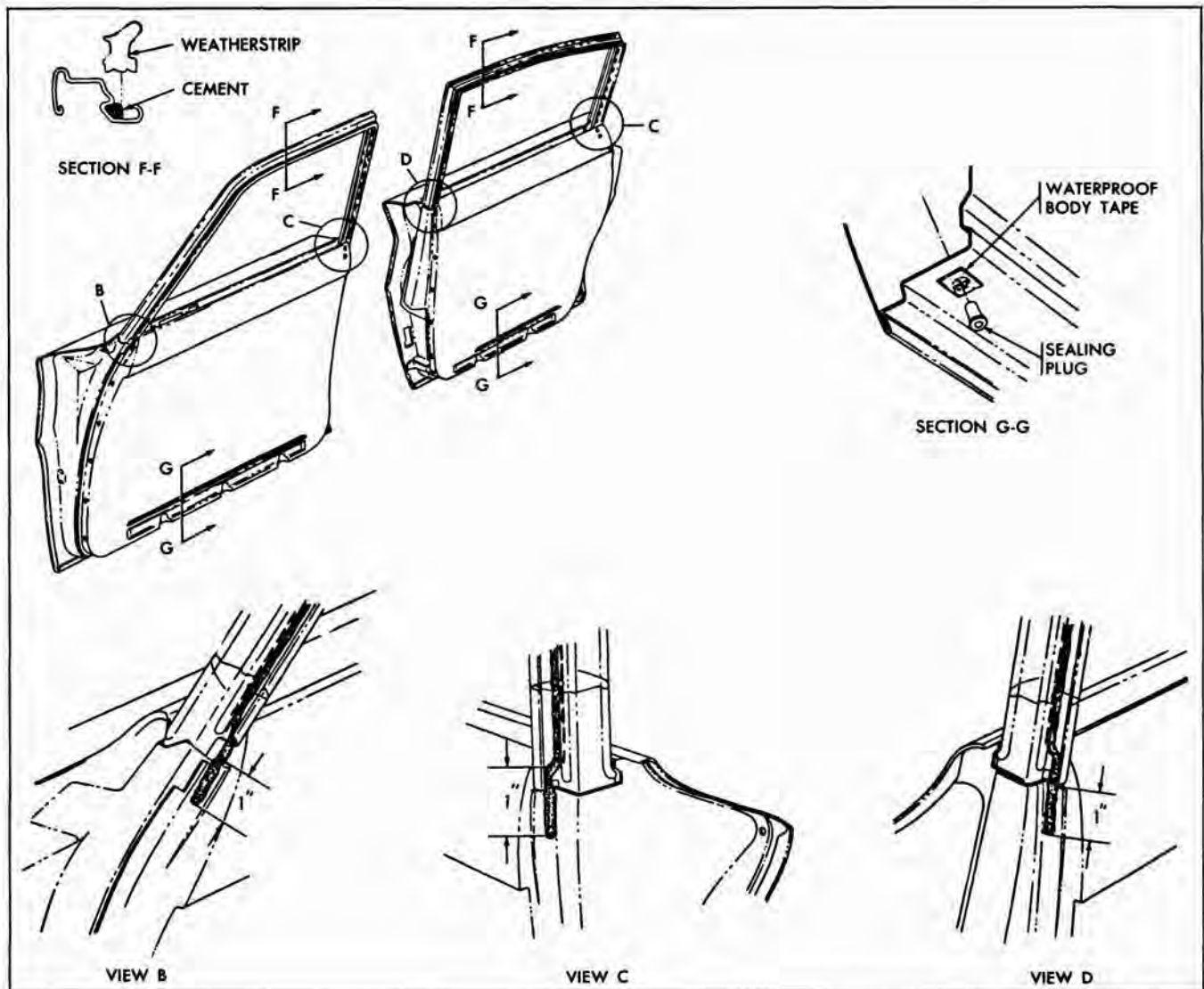

Fig. 13-7 Door Weatherstrips

FRONT DOOR WEATHERSTRIPS**67 STYLE**

The door weatherstrip is a one-piece design, retained by clips inserted into attaching hole sealing plugs for the entire door and by cement along the top four (4) inches of hinge and lock pillar panels.

REMOVAL

1. With a flat-bladed tool, carefully break cement bond at hinge and lock pillar panels.

2. Insert tip of tool J-5757 at clip locations and carefully snap clips from retaining plugs and remove weatherstrip from door.

INSTALLATION

1. Clean off old cement to insure a clean cementing surface.

2. Check weatherstrip attaching clips for proper contour and, if necessary, re-form using tool J-5984 (Fig. 13-6).

3. Check all attaching hole sealing plugs. If sealing plugs are loose and will not remain engaged in door inner panel, install a 1/2" x 1" piece of cloth-backed waterproof body tape over sealing plug retaining hole as shown in section "G-G" of Fig. 13-7. Make two (2) 5/16" slits in tape to form an "X" pattern. Install plug and check for a snug fit. If plug is still loose, repeat above operation by installing a second piece of tape over existing repair. This pro-

cedure may also be used to repair waterleaks that may develop at sealing plug locations.

4. Prior to installation of weatherstrip, apply a four (4) inch bead of an approved weatherstrip cement at top four (4) inches of hinge and lock pillar panels.

NOTE: When applying weatherstrip cement, follow manufacturer's directions.

5. Starting at uppermost clip hole on either door pillar, install clips to door by placing notched end of tool J-5757 in loop of clip and pushing clip into attaching hole sealing plug. Repeat operation along both sides and bottom of door.

NOTE: DO NOT distort clips or unsatisfactory weatherstrip retention will result.

6. Clean off all excessive weatherstrip adhesive.

FRONT AND REAR DOOR WINDOW GLASS RUN CHANNEL INNER AND OUTER STRIP ASSEMBLIES

Glass run channel strip assemblies are used on all doors on all styles incorporating a dropping window and are designed to prevent cold air and water from entering the body between the door window lower sash channel and door inner and outer panels. The inner strip assembly is secured to the door inner panel by a series of attaching clips. The outer strip assembly is constructed of a molded rubber and is secured to a metal retainer by a series of staples. On styles equipped with a door window belt reveal molding, the metal retainer is an integral part of this molding. In either case, the molding or retainer is secured to the door outer panel by a series of attaching clips. Moldings are further retained by two (2) attaching screws, one at each end. When the door window is raised, the top section of the outer strip assembly is lifted and held in position by the door window lower sash channel and/or filler (Fig. 13-8).

REMOVAL AND INSTALLATION

1. Lower door window and apply masking tape over door panel adjacent to strip assembly to protect paint finish.

2. On all styles equipped with a belt reveal molding, remove attaching screws.

NOTE: On rear doors, the belt reveal molding attaching screws are accessible; however, on front doors, the ventilator assembly must be removed to gain access to the forward attaching screw.

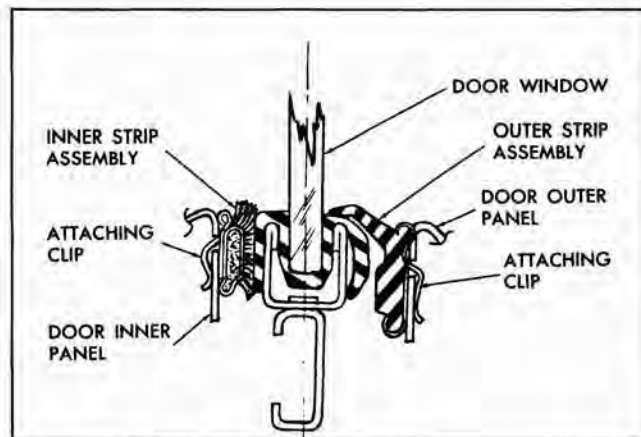

Fig. 13-8 Glass Run Channel

3. With a hooked tool, carefully lift up strip assembly at clip locations and remove assembly from door (Fig. 13-9).

4. To install, align clips with holes in door inner panel and press strip assembly into place.

5. On styles equipped with belt reveal molding, reinstall attaching screws and, if applicable, front door ventilator assembly.

6. Remove tape from door panel.

FRONT AND REAR DOOR OUTSIDE HANDLE ASSEMBLY

REMOVAL AND INSTALLATION

1. Raise door window. Remove trim assembly and detach upper rear corner of inner panel water de-



Fig. 13-9 Glass Run Channel

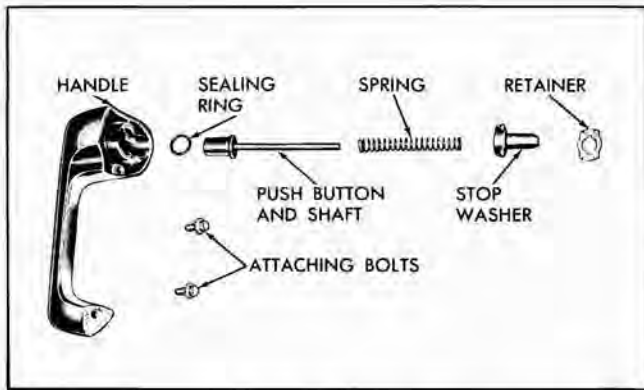

Fig. 13-10 Outside Handle

flector sufficiently to gain access to door outside handle attaching screws.

2. Remove screws through inner panel. Remove door handle and gaskets from outside of body.

3. To install, reverse removal procedure.

DISASSEMBLY AND ASSEMBLY OF DOOR OUTSIDE HANDLE

1. Remove door outside handle.

2. Firmly secure handle within protected vise jaws.

3. With a flat-bladed screwdriver and hammer, rotate sheet metal retainer 1/4 turn. Remove retainer, stop washer, spring, sealing ring and push button and shaft (Fig. 13-10).

4. To assemble, reverse disassembly procedure.

FRONT AND REAR DOOR WINDOW GLASS RUN CHANNELS

REMOVAL AND INSTALLATION

1. Remove door window.

2. Starting at either end of glass run channel, press sides of channel together and remove from window frame assembly.

3. To install, start at either upper corner of window frame assembly and reverse removal procedure.

FRONT AND REAR DOOR PINCHWELD FINISHING STRIPS

A new one-piece strip assembly of a woven cotton and vinyl construction is used.

REMOVAL AND INSTALLATION

1. Remove center pillar-to-roof rail finishing plate and door sill plate.

2. On station wagon styles, remove rear body lock pillar-to-roof rail finishing plate.

3. Carefully pull strip assembly loose from pinchweld.

4. To install, begin at front edge of sill plate and press strip over pinchweld.

FRONT AND REAR DOOR LOCK SPRING CLIPS

A spring clip is used on the door lock levers to secure the remote control connecting link and inside locking rod connecting link to the door levers. A slot in the spring clip provides for disengagement of the clip, thereby facilitating detachment of the connecting link from the lock lever.

To disengage the spring clip, use a screwdriver or other suitable tool to slide the clip out of engagement. Fig. 13-11 shows the door lock spring clip engaged and disengaged.

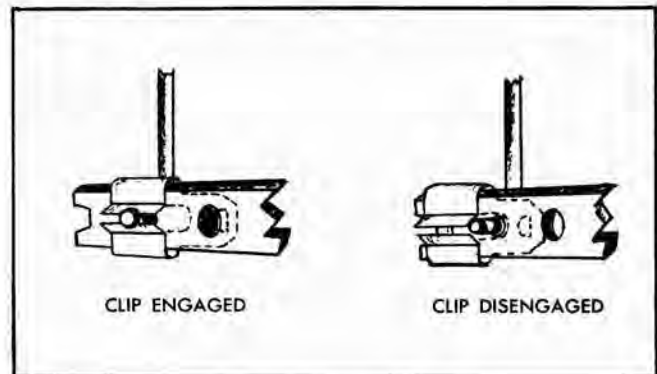

Fig. 13-11 Door Lock Spring Clip

FRONT DOORS

Fig. 13-12 is typical of hard top and convertible style front doors with the trim assembly and inner panel water deflector removed. This illustration

identifies the component parts of the front door assembly, their relationship and various attaching points.

FRONT DOOR ASSEMBLY AND HINGES

The front door assembly may be removed with or without the hinges attached.

To remove the front door assembly with hinges attached, proceed as follows:

REMOVAL

1. Place a suitable protective covering over front fender at door opening to protect finish.
2. Remove front fender opening filler panel.
3. Open door and mark hinge locations on front body hinge pillar.
4. If necessary, loosen lower rear fender attaching bolt at underside of body to gain additional access to lower hinge attaching bolts.
5. With aid of a helper, to properly support door, remove bolts securing upper and lower hinges to body and remove door assembly with attached hinges from body (Fig. 13-13).

INSTALLATION

1. As an anti-squeak precaution and to prevent entry of water into body at hinge attaching bolt locations, coat attaching surfaces of hinges with heavy-bodied sealer prior to installing door (Fig. 13-14).
2. With aid of a helper, reinstall door to body opening. Align hinges within scribe mark and tighten bolts
3. Check door for proper operation and alignment and, where required, adjust door as described under "Front Door Adjustments."
4. Install front fender opening filler panel and remove protective covering from front fender.

NOTE: For lubrication of hinges, see "Body Lubrication" section.

To remove the front door assembly from the hinges, proceed as outlined previously only remove the door to hinge bolts and it will not be necessary to remove the lower fender attaching bolt (Fig. 13-15).

When installing, as an anti-squeak precaution, coat attaching surfaces of hinges with heavy bodied sealer prior to installing door (Fig. 13-14).

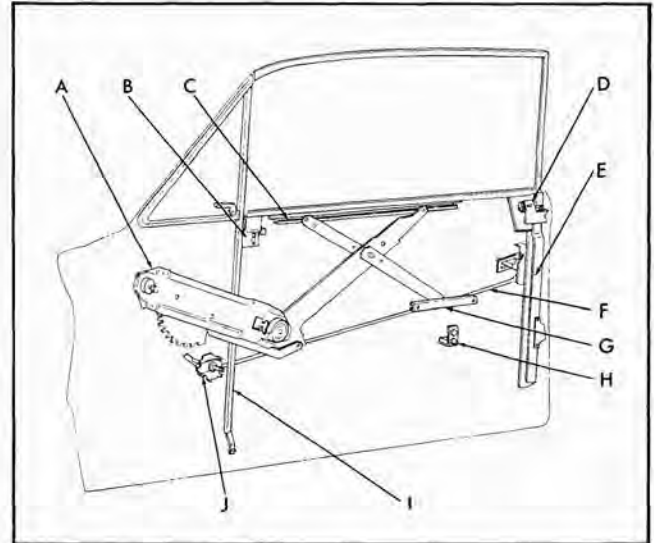

- A. Door Window Regulator Assembly
- B. Door Window Front Stop Assembly
- C. Door Window Lower Sash Channel Cam
- D. Door Window Rear Stop Assembly
- E. Door Window Glass Run Channel Assembly
- F. Door Lock Remote Control to Lock Rod Assembly
- G. Door Inner Panel Cam Assembly
- H. Door Window Lower Stop Assembly
- I. Ventilator Division Channel
- J. Door Lock Remote Control Assembly

Fig. 13-12 Door Window Assembly

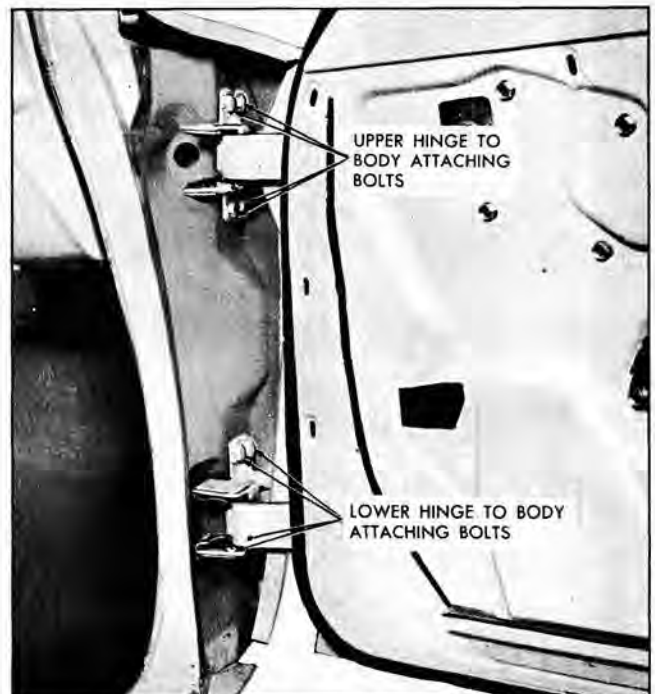

Fig. 13-13 Front Door Hinge Attachments

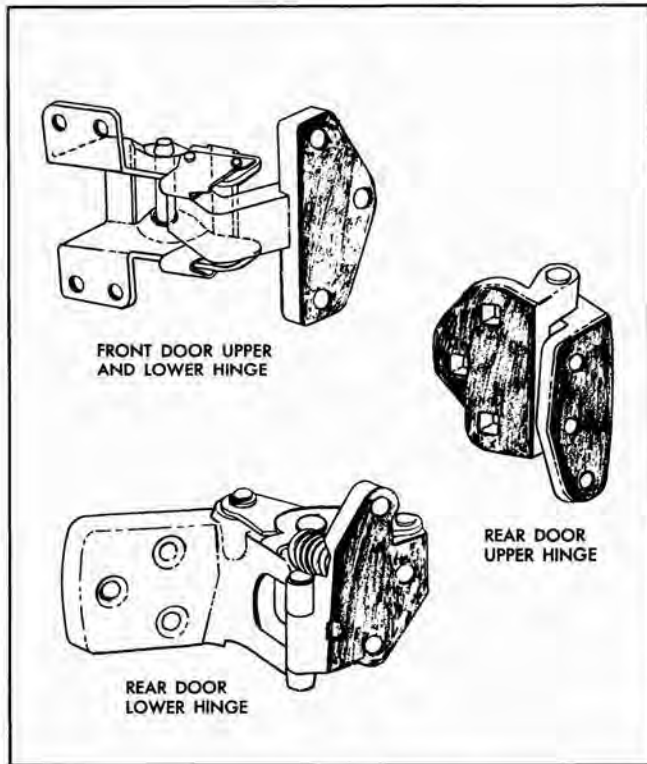

Fig. 13-14 Door Hinges

ADJUSTMENTS

Door adjustments are provided through the use of floating anchor plates at the door and body pillars.

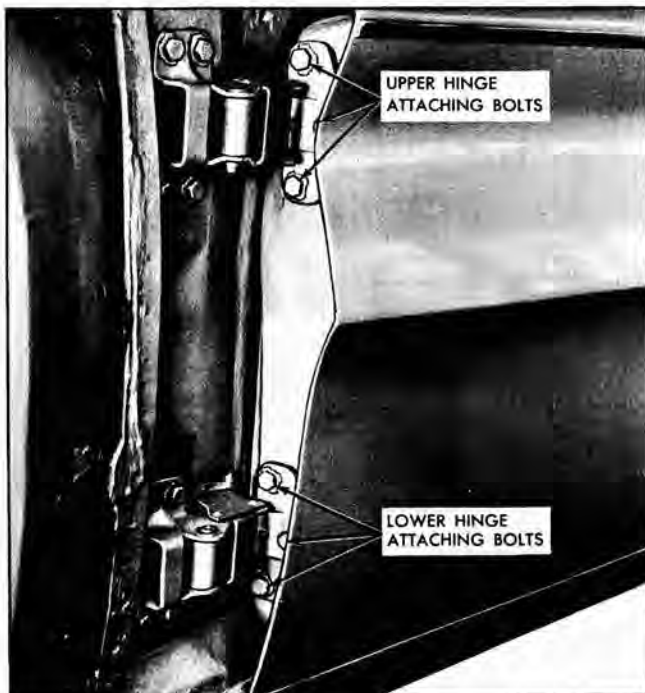

Fig. 13-15 Front Door Hinge Attachment

When checking the door for misalignment, remove the door lock striker from the body pillar to allow door to hang free on its hinges.

To adjust the door up or down and/or fore or aft at the front body hinge pillar, proceed as follows:

1. Remove front fender filler panel.
2. Mark location of hinges on front body hinge pillar.
3. Loosen hinge attaching bolts and shift door to desired position; then tighten hinge attaching bolts (Fig. 13-13).

NOTE: Loosen front fender lower rear attaching bolt, if necessary, to gain additional access to lower hinge attaching bolts.

4. Reinstall door lock striker and check lock extension-to-striker engagement as described under "Door Lock Striker - Adjustments."

To adjust door in or out and/or up or down at the door hinge pillar, proceed as follows:

1. Mark hinge locations on door.
2. Loosen hinge attaching bolts. Shift door to desired position, then tighten hinge attaching bolts (Fig. 13-15).
3. Check door for proper alignment and, where necessary, repeat steps 1 and 2 above until desired adjustment is obtained.

FRONT DOOR LOCK REMOTE CONTROL ASSEMBLY AND CONNECTING LINK

REMOVAL AND INSTALLATION

1. Raise door window. Remove door trim assembly and detach inner panel water deflector.
2. With aid of a screwdriver, or other suitable tool, disengage end of connecting link from lock assembly. See "Door Lock Spring Clip."
3. Remove screws securing remote control assembly to door inner panel. Pull remote control away from door inner panel; then rotate remote control assembly one quarter turn to disengage connecting link from remote control assembly. Remove control assembly and connecting link from door (Fig. 13-16).
4. To install, reverse removal procedure. Check operation of door lock before installing inner panel water deflector.

FRONT DOOR VENTILATOR ASSEMBLY

17, 19, 27 and 35 STYLES

REMOVAL AND INSTALLATION

1. Raise door window. Remove door trim assembly and detach inner panel water deflector.

2. Remove door lock remote control assembly and connecting link.

3. Remove door window lower stop and ventilator division channel lower adjusting stud and nut.

4. Carefully lower door window to extreme down position. Remove three door window frame to ventilator attaching screws and one inner panel to ventilator attaching screw (Fig. 13-17).

5. Disengage upper front corner of glass run channel from window frame assembly.

6. Carefully tilt ventilator assembly rearward until clear of window frame assembly; then lift ventilator inboard and upward and remove from door.

CAUTION: After ventilator has been removed, door glass should be held or otherwise suitably supported to prevent damage to door glass.

7. To install, reverse removal procedure. Check operation of ventilator and door window assembly and, where required, adjust ventilator assembly as described under "Front Door Ventilator Adjustments."

ADJUSTMENTS

1. To adjust ventilator division channel in or out or fore or aft, remove door trim assembly and detach inner panel water deflector sufficiently to loosen division channel lower adjusting stud nut. Adjust stud in or out as required or position channel fore or aft as required; then tighten stud nut. Seal water deflector and install door trim and inside hardware (Fig. 13-17).

2. The effort required to open or close the ventilator may be increased or decreased by straightening washer tab and tightening or loosening the adjusting nut (Fig. 13-18).

Tightening the adjusting nut will increase effort required to open and close ventilator, loosening adjusting nut will decrease opening and closing effort. When desired adjustment has been obtained, bend down washer tab to lock nut in position.

NOTE: This adjustment should be performed as a bench operation.

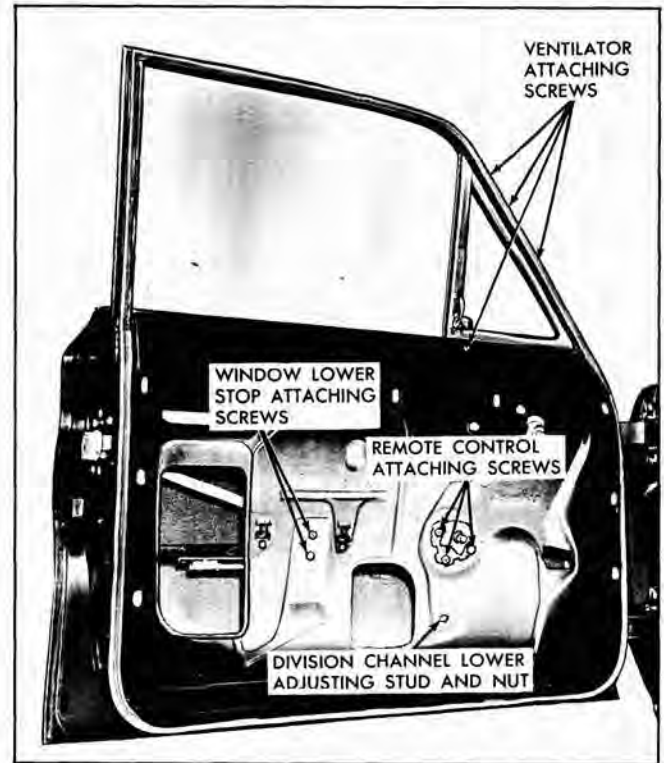

Fig. 13-16 Ventilator and Remote Control

FRONT DOOR VENTILATOR CASTING

67 STYLE

REMOVAL AND INSTALLATION

The front door ventilator casting is used on all "47" and "67" styles and is secured to the front

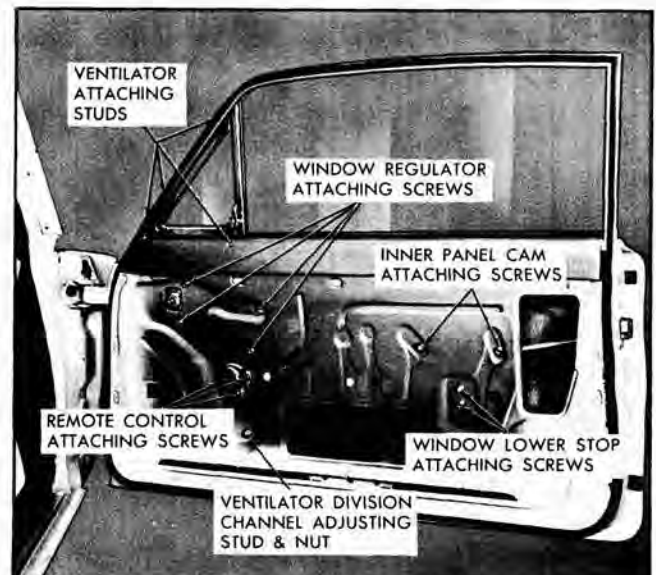

Fig. 13-17 Door Hardware Attachments

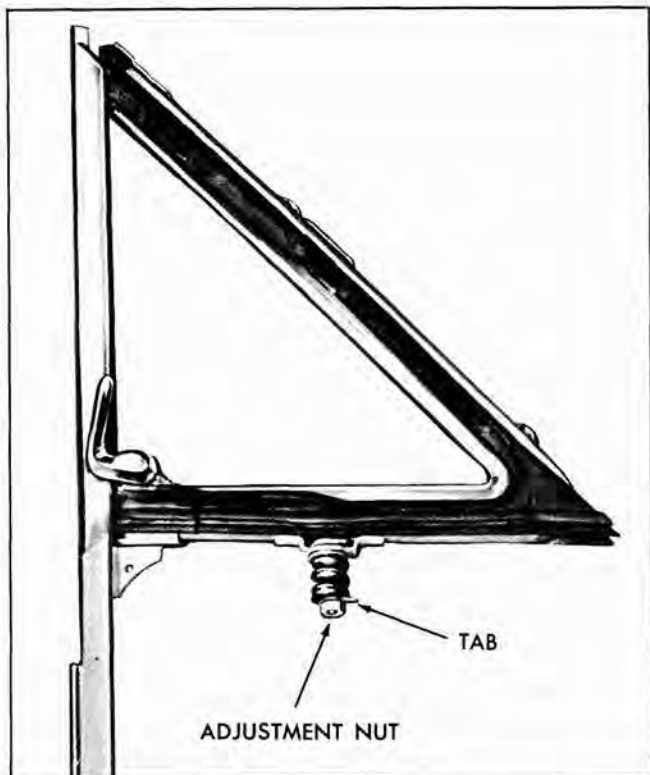

Fig. 13-18 Ventilator Friction Adjustment

door assembly by one (1) attaching bolt and one (1) adjusting stud and nut. The front facing of the ventilator frame is secured to the ventilator casting by three (3) attaching screws.

1. Remove ventilator casting to door hinge pillar panel attaching bolt and lower adjusting stud nut.

2. Remove three (3) ventilator casting to ventilator frame attaching screws and remove casting from door (Fig. 13-19).

3. A slight fore and aft adjustment of the ventilator casting can be obtained at the lower adjusting stud and nut.

FRONT DOOR VENTILATOR ASSEMBLY

67 STYLE

The front door ventilator assembly is a manually operated friction type unit on all styles.

REMOVAL AND INSTALLATION

1. Raise door window, remove door trim assembly and detach inner panel water deflector.

2. Remove ventilator division channel lower adjusting stud and nut (Fig. 13-20).

3. Remove front door ventilator casting.

4. Remove ventilator frame to door inner panel attaching screw (Fig. 13-20).

5. Tilt ventilator assembly until ventilator division channel is free from front edge of door window glass and remove ventilator assembly from door.

CAUTION: After ventilator has been removed, door glass should be held or otherwise suitably supported to prevent damage.

6. To install, reverse removal procedure. Check operation of ventilator and door window assembly and, where required, adjust ventilator assembly as described under "Front Door Ventilator - Adjustments."

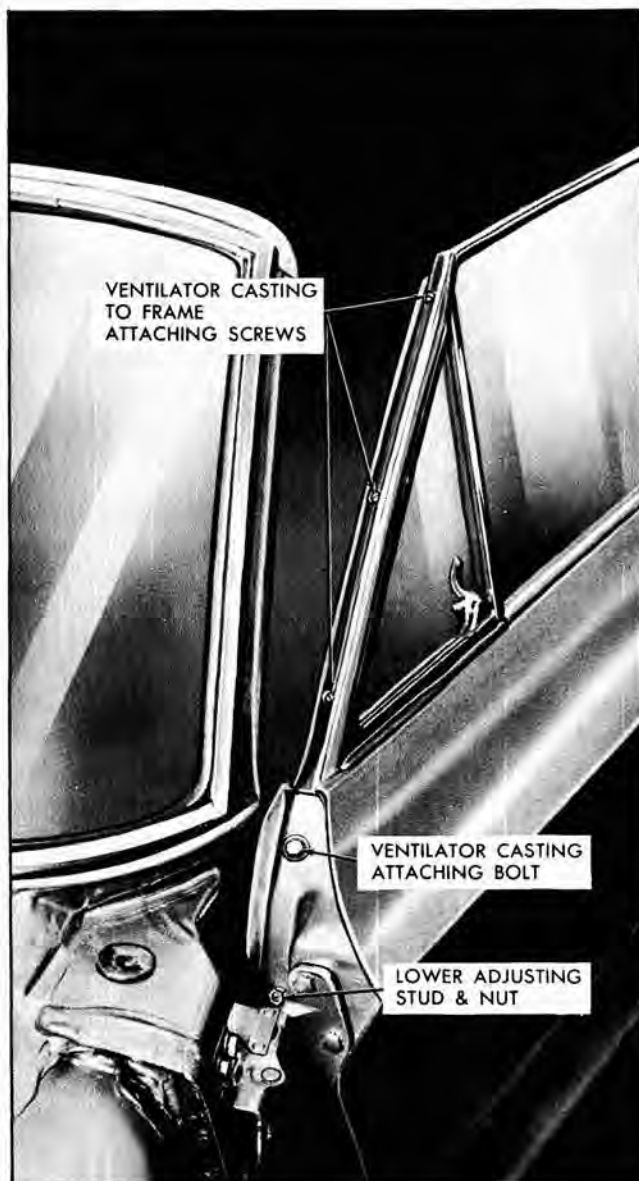

Fig. 13-19 Door Ventilator Casting

FRONT DOOR INNER PANEL CAM

17, 27 and 67 STYLES

REMOVAL AND INSTALLATION

1. Remove door trim assembly and detach inner panel water deflector sufficiently to gain access to inner panel cam attaching bolts.

2. Remove two (2) inner panel cam attaching bolts (Fig. 13-17).

3. Slide cam rearward to disengage nylon roller of window regulator balance arm and remove cam through large access hole in door inner panel.

4. To install, reverse removal procedure. Prior to installation, lubricate entire length of inner panel cam with 630AAW Lubriplate or equivalent.

FRONT DOOR WINDOW ASSEMBLY

17, 19, 27 and 35 STYLES

The front door glass is a solid tempered safety plate glass. The glass fits into a lower sash channel assembly which incorporates a welded-on lower sash channel cam.

With this type of design, the door glass, lower sash channel and sash channel cam are removed from the door as a unit.

CAUTION: Care should be exercised to make certain glass does not strike body metal during installation procedure as edge chips can cause solid tempered safety plate glass to shatter. DO NOT attempt to grind glass.

REMOVAL AND INSTALLATION

1. Remove door trim assembly and detach inner panel water deflector.

2. Remove front door ventilator assembly as previously described under "Front Door Ventilator - Removal and Installation."

CAUTION: After ventilator has been removed, door glass should be held or otherwise suitably supported to prevent damage to door glass.

3. On "17" and "27" styles, remove inner panel cam.

4. Carefully lift window assembly upward and forward to disengage regulator arm from door window lower sash channel cam and remove window assembly from between inner and outer panels.

5. To install, reverse removal procedure. After installation of window assembly, lubricate lower

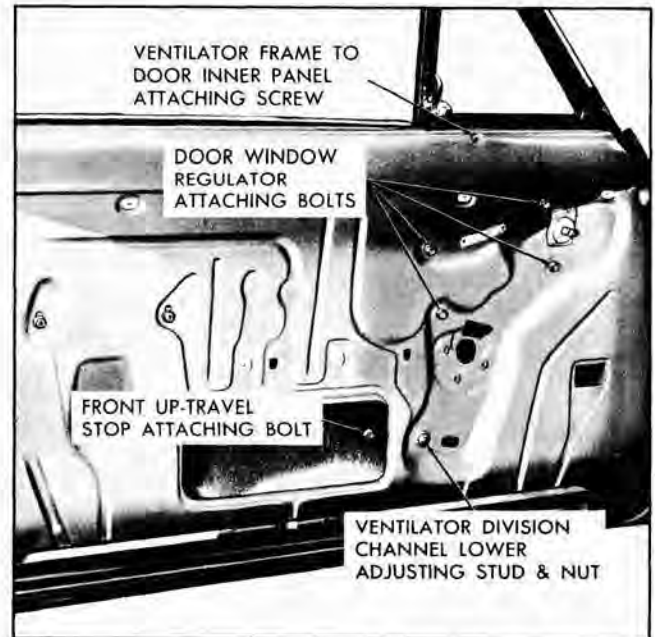

Fig. 13-20 Front Door Inner Panel

sash channel cam along entire length of cam with 630AAW Lubriplate or its equivalent.

ADJUSTMENTS

1. To adjust the lower portion of the ventilator division channel in or out or fore or aft, lower door window and loosen ventilator division channel adjusting stud nut (Fig. 13-16). Turn adjusting stud in or out or position lower end of channel fore or aft as required; then tighten stud nut.

2. A slight up or down adjustment of the door window, in the lowered position, can be obtained by adjusting the door window lower stop assembly.

FRONT DOOR WINDOW ASSEMBLY

67 STYLE

The front door glass is a solid tempered safety plate glass. The glass fits into a lower sash channel assembly which incorporates a welded-on lower sash channel cam. With this type of design, the door glass, lower sash channel and sash channel cam are removed from the door as a unit.

CAUTION: Care should be exercised to make certain glass does not strike body metal during installation procedure as edge chips can cause solid tempered safety plate glass to shatter. DO NOT attempt to grind glass.

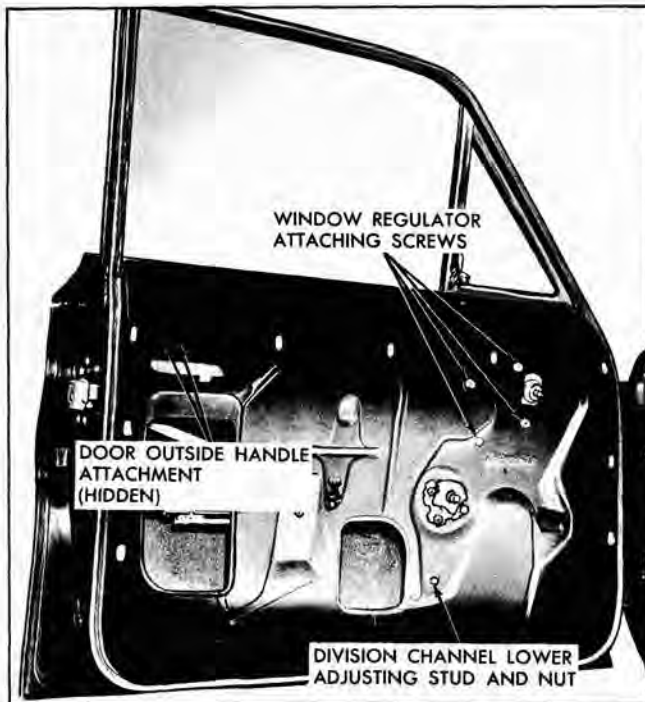

Fig. 13-21 Door Inner Panel

REMOVAL AND INSTALLATION

1. Remove door trim assembly and detach inner panel water deflector.
2. Lower door window and remove front up-travel stop (Fig. 13-20).
3. Remove front door ventilator casting and front door ventilator assembly.

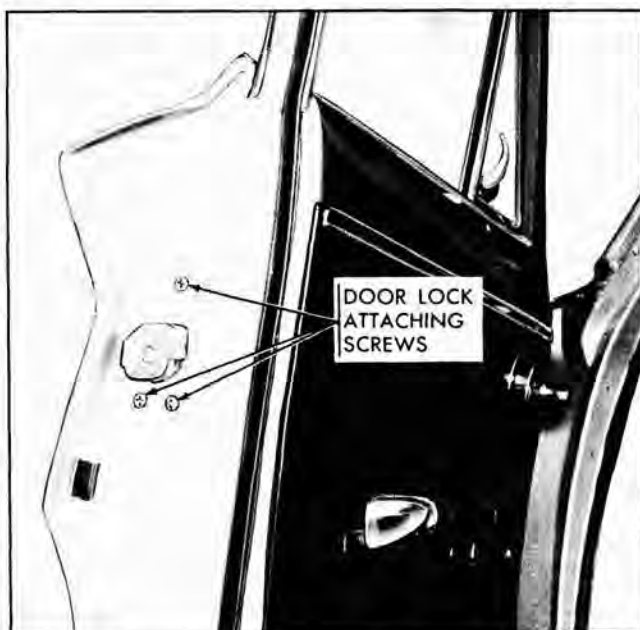

Fig. 13-22 Door Lock Attachment

4. With window in a fully lowered position, through large access hole, slide glass forward to disengage regulator lift arm from window lower sash channel cam.

5. Carefully raise window to full up position.

6. Tilt front edge of glass upward to disengage balance arm from window lower sash channel cam.

7. Lower regulator to avoid interference when removing window and remove window.

8. To install, reverse removal procedure.

FRONT DOOR WINDOW ADJUSTMENTS

67 STYLE

1. To adjust the window in or out or fore or aft at front section, lower door window and loosen ventilator division channel lower adjusting stud and nut. Turn adjusting stud in or out or position lower end of channel fore or aft as required and tighten stud nut.

2. To adjust the window in or out at rear section, loosen rear run channel lower attaching nut, adjust as required, and tighten nut (Fig. 13-25).

3. Up or down adjustment is available at the front up-travel stops.

4. A condition of a rotated (cocked) door window can be corrected by adjusting the inner panel cam and up stops.

FRONT DOOR WINDOW REGULATOR ASSEMBLY

17, 19, 27 and 35 STYLES

REMOVAL AND INSTALLATION

1. Remove door trim assembly and detach inner panel water deflector.

2. On "17" and "27" styles, remove inner panel cam.

3. Raise door window. Place a protective piece of paper over window frame assembly and door weatherstrip to protect paint and weatherstrip from damage; then secure window in full up position by installing a twelve to fifteen inch piece of body tape (2" or 2-1/2" in width) over window frame and

firmly pressing tape to both sides of glass. This is necessary to positively hold glass in the up position during removal of the window regulator.

4. Remove remote control assembly and ventilator division channel lower adjusting stud and nut.

5. Remove window regulator attaching screws and work window regulator rearward to disengage arm from window lower sash channel cam and remove regulator from door (Fig. 13-21).

6. To install, reverse removal procedure. Cycle window several times to insure proper operation before installing water deflector.

FRONT DOOR WINDOW REGULATOR ASSEMBLY

67 STYLE

REMOVAL AND INSTALLATION

1. Remove door trim assembly and detach inner panel water deflector.

2. Remove inner panel cam.

3. Remove remote control assembly.

4. Remove ventilator division channel lower adjusting stud and nut.

5. Prop window in full up position and remove all regulator attaching bolts.

6. Slide window forward to disengage regulator lift arm from window lower sash channel cam and then rearward to disengage regulator balance arm from window lower sash channel cam and remove assembly through large access hole.

7. To install, reverse removal procedure.

FRONT DOOR LOCK ASSEMBLY

All locks are the rotary bolt-type lock with safety interlock feature. With the safety interlock feature it is very important that the lock extension engages properly in the door lock striker notch and that, where necessary, striker emergency spacers of the proper thickness are used to obtain proper engagement.

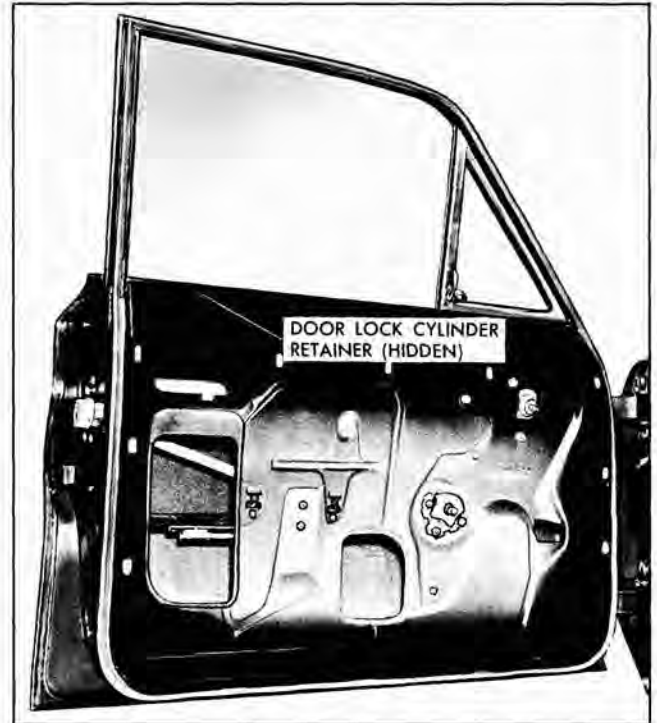

Fig. 13-23 Door Lock Cylinder Attachment

REMOVAL AND INSTALLATION

1. Raise door window. Remove door trim assembly and detach inner panel water deflector.

2. Remove lock cylinder assembly.

3. With a screwdriver, or other suitable pointed tool, disengage remote control connecting link from door lock assembly (see "Door Lock Spring Clip").

4. Remove door lock attaching screws and remove lock assembly through inner panel access hole (Fig. 13-22).

5. To install, reverse removal procedure. Check all operations of lock assembly before installing inner panel water deflector.

FRONT DOOR LOCK CYLINDER ASSEMBLY

REMOVAL AND INSTALLATION

1. Raise door window. Remove door trim assembly and detach inner panel water deflector.

2. With a suitable tool, through inner panel access hole slide lock cylinder retaining clip forward sufficiently to allow removal of cylinder, then remove cylinder and gasket (Fig. 13-23).

3. To install, reverse removal procedure. Using key, check operation of lock cylinder assembly.

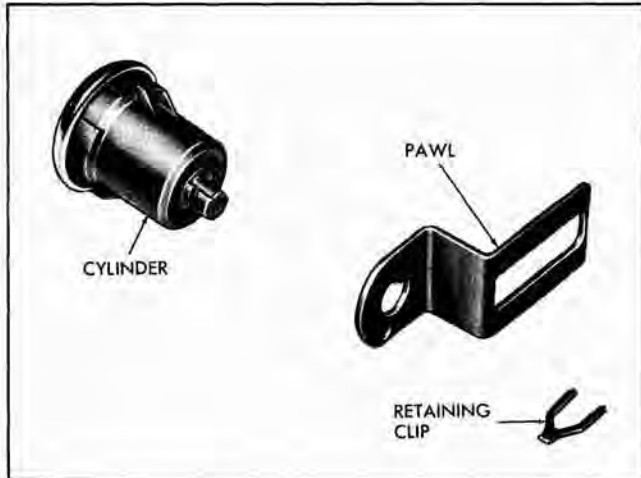

Fig. 13-24 Door Lock Cylinder

DISASSEMBLY AND ASSEMBLY

1. Remove cylinder assembly from door as previously described.
2. With a suitable tool, remove retainer and pawl (Fig. 13-24).
3. To assemble, reverse disassembly procedure.

NOTE: The lock cylinder housing scalp used in production is usually damaged when removed and must be replaced by a new scalp available as a service part. The service lock cylinder housing scalp is secured by tabs.

FRONT DOOR WINDOW REAR RUN CHANNEL 67 STYLE

REMOVAL AND INSTALLATION

1. Remove door trim assembly and detach inner

REAR DOOR ASSEMBLY AND HINGES

The rear door assembly is attached to the body center pillar with butt-type hinges. The upper hinge on all styles is secured with screws to an anchor plate at the door hinge pillar and bolts to an upper hinge support at the center pillar. The lower hinge on all styles incorporates an integral type door check and hold open and is secured with screws to an anchor plate at both the door hinge pillar and center pillar. The rear door assembly may be removed with or without the hinges attached.

REMOVAL

1. Clean off excess sealer from around each hinge

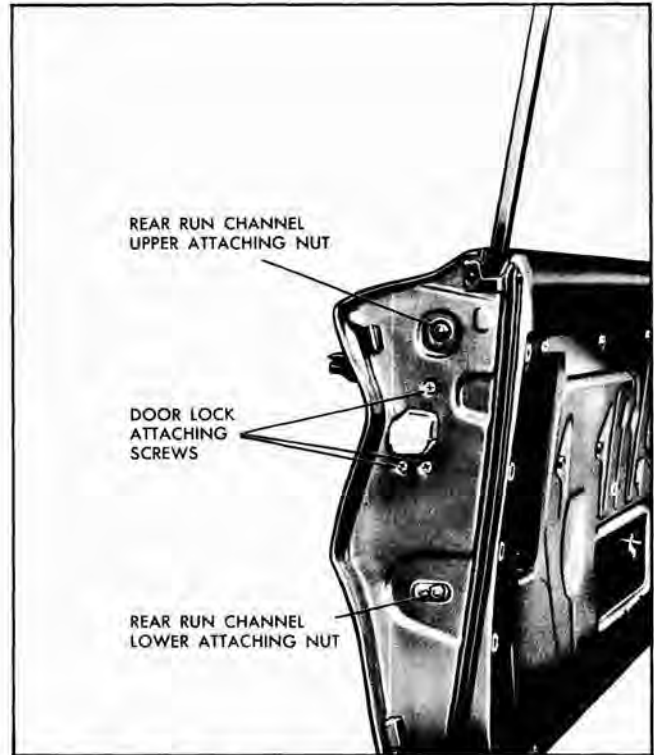

Fig. 13-25 Run Channel and Lock Attachments

panel water deflector.

2. Remove door ventilator casting and door ventilator assembly.
3. Remove inner panel cam and door window assembly.
4. Remove bolts securing run channel to lock pillar panel and remove run channel from door (Fig. 13-25).
5. To install, reverse removal procedure.

REAR DOORS

strap and mark hinge location on door hinge pillar or center pillar, depending on method of removal being used.

2. With door properly supported, remove upper and lower hinge attaching screws at door hinge pillar or screws and bolts at center pillar, depending on method of removal being used (Fig. 13-26).

3. With aid of a helper, remove door from body opening.

INSTALLATION

1. With scraper and mineral spirits, carefully clean off old sealing compound at hinge areas.

2. Apply a coat of heavy-bodied sealer to attaching surfaces of hinge straps or corresponding surfaces of door or body.

3. With helper, lift door into position, attach hinge loosely, then align straps within marks on pillar and tighten screws or screws and bolts. Check door for alignment.

ADJUSTMENTS

The in and out adjustments on the rear door are provided at the door hinge pillar while the up and down or fore and aft adjustments are provided at center pillar. When checking the door for alignment, remove the door lock striker from body pillar to allow door to hang free on its hinges.

1. For in and out adjustment, loosen hinge to door pillar attaching screws. Adjust door as required and tighten screws.

2. To adjust door up or down or fore or aft, loosen hinge to center pillar attaching bolts and screws. Adjust door up or down or fore or aft as required and tighten attaching bolts and screws.

NOTE: When performing fore or aft adjustments, adjust one (1) hinge at a time so that the up and down adjustment of door is maintained. After completing any fore or aft adjustments, the rear door upper hinge may have to be adjusted in or out due to the design of the center pillar hinge support.

CAUTION: Use only the recommended procedures for adjusting rear doors. The upper hinge is constructed of die cast aluminum which will break under strain of bending in an attempt to short-cut adjustments.

3. Reinstall door lock striker and check lock extension to striker engagement as described under "Door Lock Striker - Adjustments."

REAR DOOR GLASS RUN CHANNEL REAR RETAINER ASSEMBLY

19 and 35 STYLES

REMOVAL AND INSTALLATION

1. Raise rear door window. Remove door trim assembly and detach inner panel water deflector.

2. Remove rear door window glass run channel rear retainer assembly lower attaching bolt from lock pillar facing of door. (Fig. 13-27).

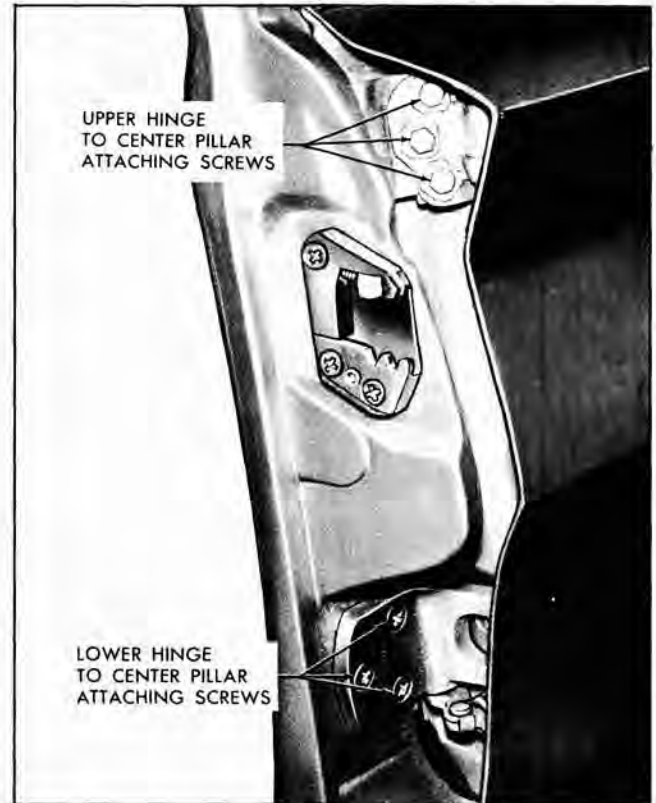

Fig. 13-26 Rear Door to Center Pillar Attachment

3. Inside of door, disengage end of window glass run channel from retainer. Then lower retainer to disengage upper end from rear door window frame and remove retainer from door.

4. To install, reverse removal procedure. Check operation of window assembly and, if required, adjust rear retainer as outlined under "Rear Door Window - Adjustments."

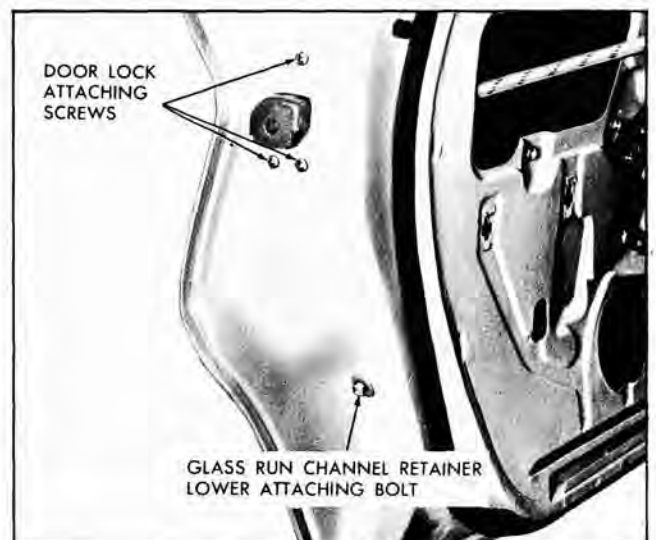

Fig. 13-27 Door Lock and Run Channel Attachments



Fig. 13-28 Rear Door Assembly

REAR DOOR LOCK ASSEMBLY

19 and 35 STYLES

Locks are the rotary bolt-type with the safety interlock feature. With the interlock feature it is very important that the lock extension engages properly in the door lock striker notch and that, where necessary, striker emergency spacers of the proper thickness be used to obtain proper engagement.

REMOVAL AND INSTALLATION

1. Raise rear door window. Remove door trim assembly and detach inner panel water deflector sufficiently to gain access to door lock.

2. Remove rear door window glass run channel retainer assembly.

3. With a screwdriver, or other suitable tool, disengage spring clips and detach inside lock connecting rod and remove control connecting rod from door lock; see "Door Lock Spring Clips."

4. At lock pillar facing, remove door lock attaching screws and remove lock assembly through access hole.

5. To install door lock, reverse removal procedure. Check all operations of door lock before installing door trim and inside hardware.

REAR DOOR REMOTE CONTROL ASSEMBLY AND CONNECTING ROD

19 and 35 STYLES

REMOVAL AND INSTALLATION

1. Remove door trim assembly and detach inner panel water deflector sufficiently to gain access to remote control attaching screws. (Fig. 13-28).

2. Remove screws securing remote control assembly to door inner panel and detach remote control from remote control-to-lock connecting rod.

3. Through access hole, disengage rod from lock, see "Door Lock Spring Clips."

4. To install remote control and connecting rod, reverse removal procedure. Position remote control rearward sufficiently to take up slack in linkage so that all clearances are taken out of linkage in a rearward position. Check lock for proper operation before installing inner panel water deflector.

REAR DOOR INSIDE LOCKING TO LOCK ROD ASSEMBLY

19 and 35 STYLES

REMOVAL AND INSTALLATION

1. Raise door window. Remove door trim assembly and detach inner panel water deflector.

2. Remove locking rod knob from rod.

3. Remove inside locking rod assembly attaching screw and washer and detach connecting rod from clip on inner panel (Fig. 13-28).

4. Through access hole, disengage spring clip securing inside lock connecting rod from door lock and disengage rod from lock, then remove inside locking rod assembly from door.

5. To install, reverse removal procedure. Check operation of inside locking rod assembly before installing door inner panel water deflector.

REAR DOOR INNER PANEL CAM

19 and 35 STYLES

REMOVAL AND INSTALLATION

1. Raise door window. Remove door trim assembly and detach inner panel water deflector sufficiently to expose inner panel cam attaching screws. (Fig. 13-29).

2. Remove cam attaching screws; then disengage cam from window regulator arm roller and remove

from door.

3. To install, reverse removal procedure. Prior to installation of inner panel cam, lubricate entire length of cam with 630AAW Lubriplate or equivalent.

REAR DOOR WINDOW LOWER SASH CHANNEL CAM

19 and 35 STYLES

REMOVAL AND INSTALLATION

1. Remove door trim assembly and detach inner panel water deflector.

2. Lower door window sufficiently to gain access to sash channel cam attaching screws through access holes in door inner panel and remove screws. (Fig. 13-29).

3. While supporting window by hand, carefully disengage cam from window lower sash channel and rollers on window regulator arms and remove from door. Then carefully lower window.

4. To install, reverse removal procedure. Prior to installation, lubricate entire length of window lower sash channel cam with 630AAW Lubriplate or equivalent. Check operation of window prior to installing inner panel water deflector.

REAR DOOR WINDOW REGULATOR ASSEMBLY

REMOVAL AND INSTALLATION

1. Remove door trim pad and detach inner panel water deflector.

2. Remove door window lower sash channel cam.

3. Carefully raise door window. Place a protective piece of paper over window frame assembly and door weatherstrip to protect paint and weatherstrip from damage and secure window in the full-up position by installing a twelve (12) to fifteen (15) inch piece of body tape (2" or 2-1/2" in width) over window frame and firmly pressing tape to both sides of glass. This is necessary to positively hold glass in the up position during removal of the window regulator.

4. Remove window regulator attaching screws. Carefully move regulator assembly rearward to disengage regulator arm roller from inner panel cam; then remove regulator from door.

5. To install, reverse removal procedure. Lubricate cams with 630AAW Lubriplate or equivalent and check window operation prior to installing water deflector.

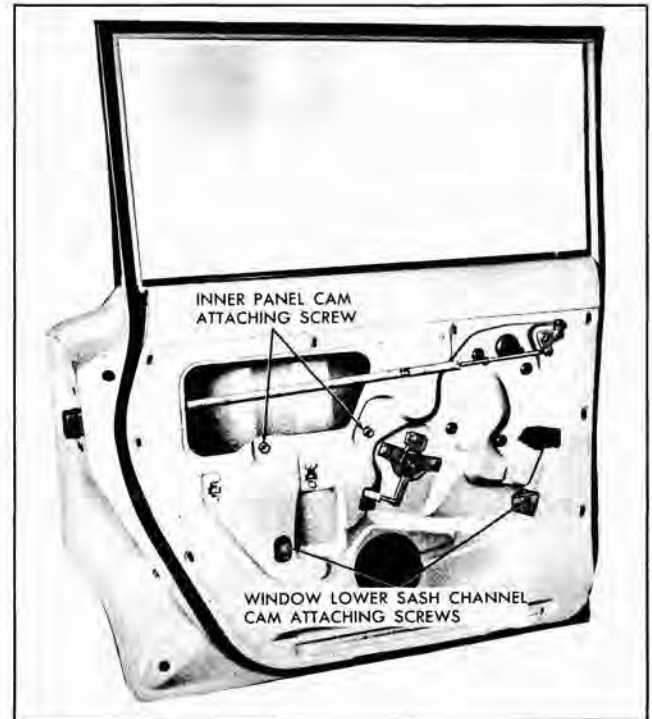

Fig. 13-29 Rear Door Assembly

REAR DOOR WINDOW ASSEMBLY

19 and 35 STYLES

The rear door glass is a solid tempered safety plate glass. The glass fits into a lower sash channel assembly which incorporates a screwed-on lower sash channel cam.

CAUTION: Care should be exercised to make certain glass does not strike body metal during installation procedure as edge chips can cause tempered plate glass to shatter. DO NOT attempt to grind glass.

REMOVAL AND INSTALLATION

1. Raise door window. Remove door trim assembly and detach inner panel water deflector.

2. Remove rear door window glass run channel rear retainer assembly.

3. Carefully lower door window and through access holes in door inner panel remove screws securing window lower sash channel cam to window lower sash channel (Fig. 13-29).

NOTE: Exercise care when lowering window since rear guide is not present.

4. While supporting window by hand, carefully disengage lower sash channel and window regulator arm rollers and remove cam from door. Disengage spring clips and detach inside lock connecting rod and remote control connecting rod from door lock.

5. Completely lower door window. Tilt front edge of glass upward and carefully lift window upward and outboard to clear window frame and remove from door.

NOTE: On station wagon styles, tilt rear edge of glass upward and lift window upward and outboard to remove from door.

6. To install, reverse removal procedure. Prior to installation of water deflector, lubricate lower sash channel cam and inner panel cam with 630

AAW Lubriplate or equivalent. Check operation of window and, where required, adjust window assembly as described under "Adjustments" below.

ADJUSTMENTS

1. To adjust rear door window in or out, lower door window. Loosen rear glass run channel retainer assembly attaching screw and adjust guide assembly as required and tighten screw (Fig. 13-29).

2. To correct a condition where the glass is cocked in the glass run channels, loosen door window inner panel cam front and/or rear attaching screw(s), adjust cam as required and tighten screws (Fig. 13-29).

SIDE ROOF RAIL WEATHERSTRIP ADJUSTMENTS

With doors and windows closed, front door window upper frame should make an even continuous contact with the side roof rail weatherstrip. If necessary, adjust weatherstrip, ventilator, front door or rear quarter windows to obtain proper weatherstrip contact.

The attaching holes in the side roof rail weatherstrip retainer are elongated allowing "in and out" adjustment of the side roof rail weatherstrip; however, the amount of adjustment is small and is not intended to correct improper ventilator or door window alignment. It is necessary to remove the weatherstrip to adjust the retainer.

NOTE: Before attempting to adjust the side roof rail weatherstrip, first check that the ventilator and front and rear quarter windows are properly

aligned and, where necessary, adjust for proper alignment as directed under ADJUSTMENT OF THE VENTILATOR AND FRONT DOOR WINDOW OR QUARTER WINDOW.

1. To adjust side roof rail weatherstrip "in or out" first determine and mark retainer at area or areas to be adjusted.

2. Remove side roof rail weatherstrip.

3. Loosen retainer attaching screws slightly in area to be adjusted and adjust retainer in or out as required.

4. Tighten retainer attaching screws and install side roof rail weatherstrip.

REAR QUARTER

CONTENTS OF THIS SECTION

SUBJECT	PAGE	SUBJECT	PAGE
Trim and Hardware	14-1	Window Adjustments	14-4
Trim Assembly	14-1	Window Regulator	14-6
Rear Quarter-"17" and "27" Styles		Window Guide	14-6
Rear Quarter Window	14-1	Outer Sealing Strip	14-7
Adjustments	14-2	Inner Panel Sealing	14-7
Window Regulator	14-3	Trim and Hardware-"19" and "35" Styles	
Rear Guide	14-3	Rear Quarter Window	14-8
Glass Run Channel	14-3	Trim Panels	14-8
Inner and Outer Sealing Strip	14-4	Wheelhouse Trim	14-8
Trim and Hardware-"67" Style			
Window Assembly	14-4		

TRIM AND HARDWARE

The rear quarter section is divided according to body styles as follows:

- "17"- "27" - Style Bodies
- "67" - Style Bodies
- "19" - Style Bodies
- "35" - Station Wagon Style Bodies

The service procedures for each style are arranged in the sequence that they normally would be performed; such as, removal, installation, adjustment and sealing. Figs. 14-1 and 14-2 identify and show the relationship of major components of the rear quarter hardware of "17"- "27" and "67" style bodies, which are the only styles incorporating a "dropping" rear quarter window.

TRIM ASSEMBLY

REMOVAL AND INSTALLATION

1. Remove rear seat cushion and back assemblies. Remove window regulator handle.

2. Remove (2) most rearward screws from rear section of door sill plate. Disengage pinchweld finishing strip from beneath door sill plate and pinchweld flange to a point above belt line (Fig. 14-3).

3. Using trim pad removing tool J-6335 disengage trim pad retaining nails from inner panel along upper edge of trim assembly.

NOTE: Protect paint on adjacent surfaces.

4. Pivot trim assembly forward using forward edge, which overlaps pinchweld flange and is cemented to pinchweld outboard face, as a hinge.

5. By carefully pressing outboard, break cement bond between trim assembly forward edge and pinchweld flange. Remove trim assembly and body.

6. To install, reverse removal procedure. Prior to installation of pinchweld finishing strip, recement overlapping forward edge of trim assembly to pinchweld flange outboard surface.

REAR QUARTER—17 and 27 STYLES

REAR QUARTER WINDOW 17 and 27 STYLES

REMOVAL AND INSTALLATION

1. Remove rear quarter trim assembly and inner

panel access hole cover. Remove rear quarter window inner sealing strip.

2. With window in "up" position remove rear quarter window rear guide attaching screws (Fig. 14-3) and remove rear guide.

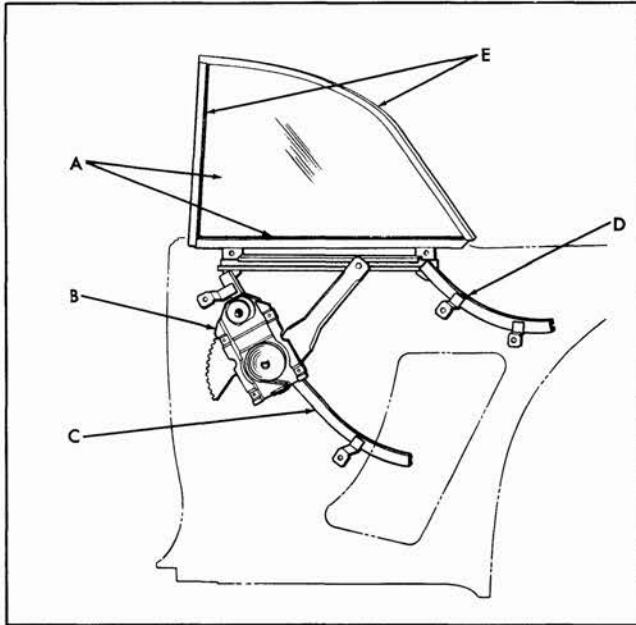

- A. Rear Quarter Window Assembly
(Includes Lower Sash Channel Cam)
- B. Rear Quarter Window Regulator
- C. Rear Quarter Window Front Guide
- D. Rear Quarter Window Rear Guide
- E. Rear Quarter Window Glass Run Channel

Fig. 14-1 Rear Quarter Hardware "17" and "27" Styles

3. Lower rear quarter window sufficiently to tilt window rearward to disengage roller on window regulator lift arm from lower sash channel cam.

4. Lift rear quarter window upward and inboard to disengage roller on window lower sash channel from front guide. Remove rear quarter window from body.

5. To install, reverse removal procedure. Prior to installation, lubricate channel of lower sash channel cam with "Lubriplate" or its equivalent.

Adjust rear quarter window for proper alignment as described under "Rear Quarter Window Adjustments" for "17" and "27" styles.

Seal large access hole and hardware attaching locations as specified under "Rear Quarter Inner Panel Sealing" for "17" and "27" styles.

REAR QUARTER WINDOW ADJUSTMENTS

17 and 27 STYLES

Both the rear quarter window front and rear guides are adjustable to provide proper seating of the window in the glass run channel and to provide proper operation of the window. When performing

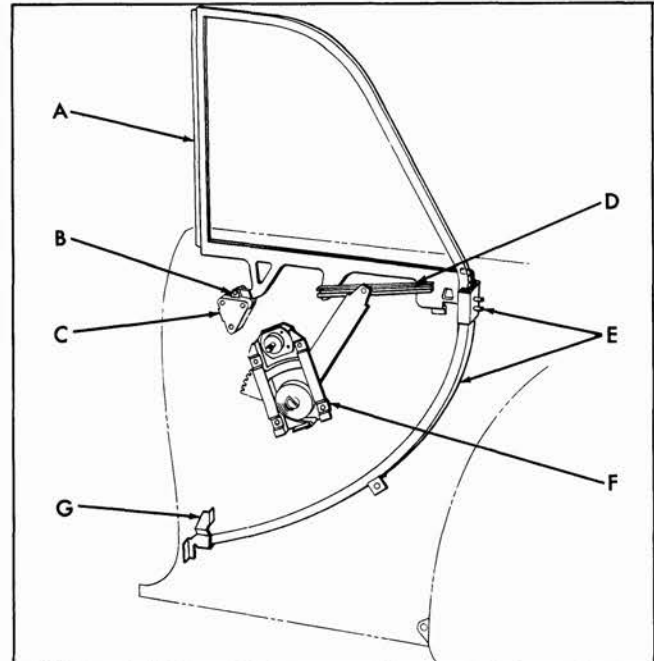

- A. Rear Quarter Window Assembly
- B. Rear Quarter Window Hinge Bolt
- C. Rear Quarter Window Hinge Adjusting Plate
- D. Rear Quarter Window Lower Sash Channel Cam
- E. Rear Quarter Window Guide
(Includes Window Upper Stop)
- F. Rear Quarter Window Regulator
- G. Rear Quarter Window Lower Stop

Fig. 14-2 Rear Quarter Hardware "67" Style

adjustments, make certain window and guides are as far forward and upward as possible to prevent front edge of window from coming out of run channel during "down" cycle.

To adjust rear quarter window, remove rear quarter trim assembly. Loosen both front and rear guide attaching screws (Fig. 14-3). Operate window to full "up" position, making sure window is all the way forward and up into the run channels. Install wrench on front guide upper attaching screw and tighten screw while forcing screw and guide as far forward as possible. Repeat procedure on lower attaching screw. Install wrench to forward attaching screw of rear guide and tighten screw while forcing screw and guide as far upward as possible. Lower window to full "down" position and tighten rear attaching screw.

NOTE: After performing window adjustments, seal all hardware attaching screw locations which have been disturbed, as specified under "Rear Quarter Inner Panel Sealing" for "17" and "27" styles.

REAR QUARTER WINDOW REGULATOR

REMOVAL AND INSTALLATION

1. Remove rear quarter window assembly.
2. Loosen rear quarter window front guide upper attaching bolt. Remove window regulator attaching bolts (Fig. 14-3) and remove regulator through access hole.

3. To install, reverse removal procedure.

Seal all hardware attaching locations, which have been disturbed, as specified under "Rear Quarter Inner Panel Sealing" for "17" and "27" styles.

REAR QUARTER WINDOW FRONT GUIDE

17 and 27 STYLES

REMOVAL AND INSTALLATION

1. Raise window to full "up" position. Remove rear quarter trim assembly and inner panel access hole cover.

2. Remove rear quarter window front guide attaching bolts (Fig. 14-3). Disengage guide from roller on window lower sash channel and remove guide through access hole.

3. To install, reverse removal procedure. Prior to installation, lubricate channel portion of guide with "Lubriplate" or its equivalent.

Seal all hardware attaching locations, which have been disturbed, as specified under "Rear Quarter Inner Panel Sealing" for "17" and "27" styles.

REAR QUARTER WINDOW REAR GUIDE

17 and 27 STYLES

REMOVAL AND INSTALLATION

1. Raise window to full "up" position. Remove rear quarter trim assembly and inner panel access hole cover.

2. Remove rear quarter window rear guide attaching bolts (Fig. 14-3). Disengage guide from roller on window lower sash channel cam and remove guide through access hole.

3. To install, reverse removal procedure. Prior to installation, lubricate channel portion of guide with "Lubriplate" or its equivalent.

Seal all hardware attaching locations, which have been disturbed, as specified under "Rear Quarter Inner Panel Sealing" for "17" and "27" styles.

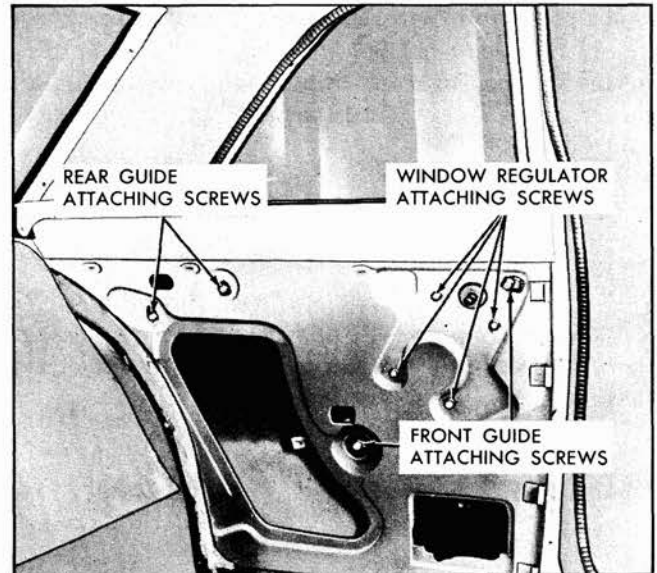

Fig. 14-3 Rear Quarter Hardware
"17" and "27" Styles

REAR QUARTER WINDOW GLASS RUN CHANNEL

17 and 27 STYLES

REMOVAL AND INSTALLATION

1. Lower rear quarter window. Remove rear quarter window front and upper garnish moldings.

2. Carefully pry glass run channel to disengage plastic snap-in-type fasteners from upper body lock pillar and inner side roof rail. Remove channel from window opening.



Fig. 14-4 Sealing Strip Removal

3. To install, reverse removal procedure. Prior to installation, apply a continuous bead of body caulking compound to rabbet of body lock pillar upper and side roof rail flanges to effect a weather-tight seal.

REAR QUARTER WINDOW INNER AND OUTER SEALING STRIPS

The rear quarter window sealing strips are secured by integral clips inserted in slots in the rear quarter inner and outer panel return flanges.

To remove either the inner or outer strip, insert a thin hooked tool (Reveal Molding Tool J-7898-01) between the rear quarter panel return flange and the sealing strip (Fig. 14-4). Engage point of tool with clip and lift upward to disengage clip from slot. Repeat procedure at each clip location and remove strip assembly.

To install, reverse removal procedure.

NOTE: Use care not to damage painted surfaces or rear quarter window glass. Prior to removal place protective covering over adjacent painted surfaces.

TRIM AND HARDWARE—67 STYLE

REAR QUARTER TRIM ASSEMBLY 67 STYLE

REMOVAL AND INSTALLATION

1. Remove rear seat cushion and back assemblies. Remove window regulator handle.

2. Remove screws securing folding top compartment side trim panel assembly (Fig. 14-5). Disengage side trim panel assembly retainer from folding top compartment brace ("C", Fig. 14-5). Disconnect electrical leads, where present, and remove side trim panel assembly.

3. Disengage pinchweld finishing strip from pinchweld flange immediately adjacent to trim assembly upper section. Using trim pad removing tool J-6335, disengage trim assembly retaining nails from inner panel along upper edge of trim assembly (View "B", Fig. 14-5).

4. Disengage forward edge of trim foundation from retainers on inner panel (View "A", Fig. 14-5). Pivot rear edge of trim assembly forward, using forward edge, which overlaps pinchweld and is cemented to pinchweld flange outboard surface, as a hinge (View "A", Fig. 14-5).

5. Carefully break cement bond between trim assembly forward edge and pinchweld flange by gently pressing trim assembly forward edge, outward. Remove trim assembly upper section from body.

6. To install, reverse removal procedure. Prior to installation of pinchweld finishing strip, recement overlapping forward edge of trim assembly to pinchweld flange outboard surface.

REAR QUARTER WINDOW ASSEMBLY 67 STYLE

REMOVAL AND INSTALLATION

1. Lower folding top and operate rear quarter window to half-down position. Remove rear seat cushion and back assemblies. Remove folding top compartment side trim panel and rear quarter trim assemblies.

2. Remove window pivot bolt (Fig. 14-6).

Disengage window male hinge from female hinge plate, then raise window to disengage lower sash channel cam from roller on window regulator lift arm and remove window.

3. To install, reverse removal procedure. Prior to installation, lubricate pivot hinge and lower sash channel cam, with "Lubriplate" or its equivalent.

REAR QUARTER WINDOW ADJUSTMENTS 67 STYLE

To adjust the forward travel and up travel of the rear quarter window, loosen the window guide upper attaching stud nuts (Fig. 14-6). Adjust upper stop to desired position and tighten guide attaching screws.

To adjust the rear quarter window "up or down", "fore or aft", or the top or the rear of the window "in or out", the rear quarter trim assemblies must be removed to gain access to the pivot bolt and adjusting studs.

a. "Up or down" or "fore or aft" adjustment: Loosen pivot bolt and both adjusting stud nuts (Fig. 14-6). Position window, as required, and tighten pivot bolt and stud nuts.

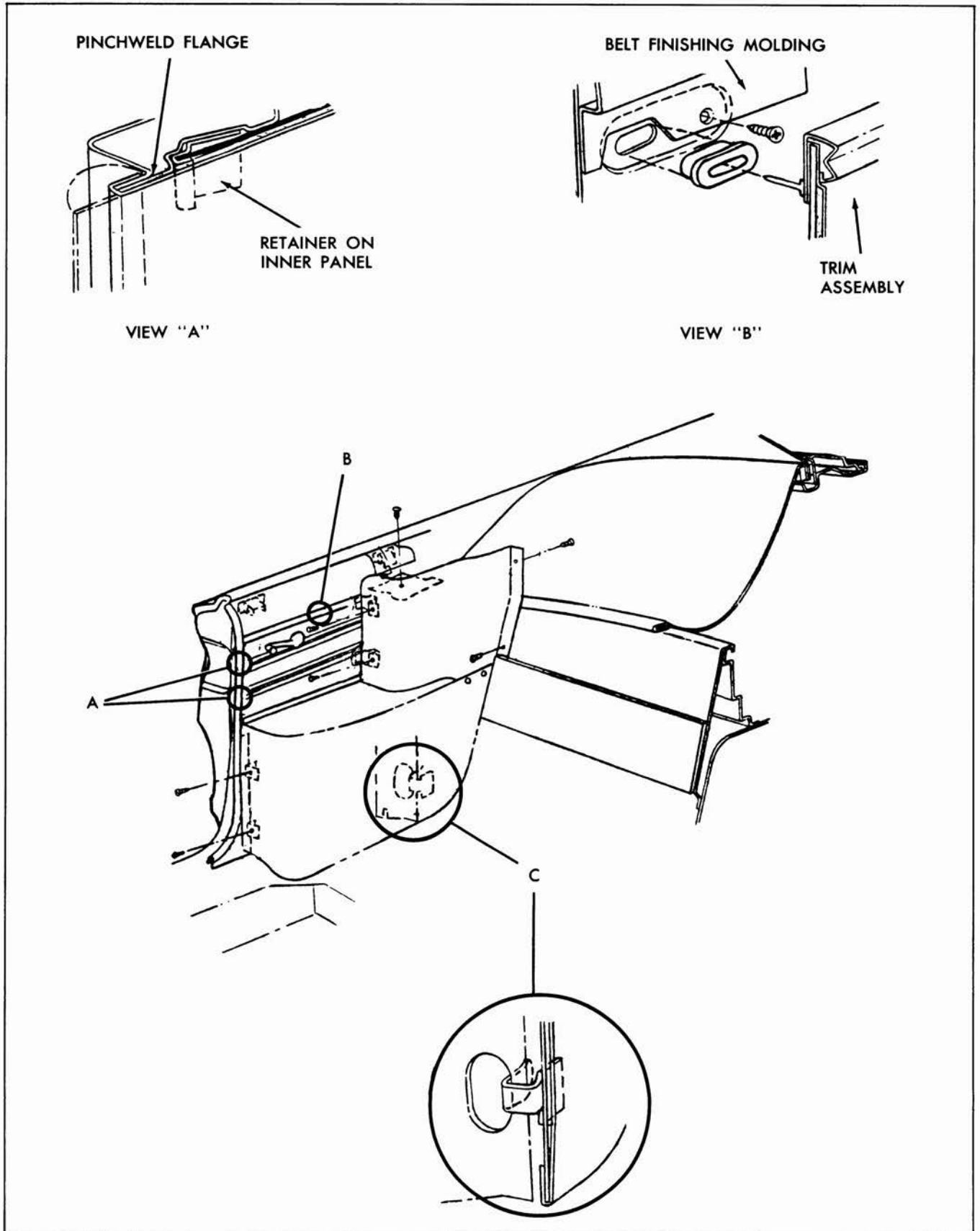

Fig. 14-5 Rear Quarter Trim Assembly

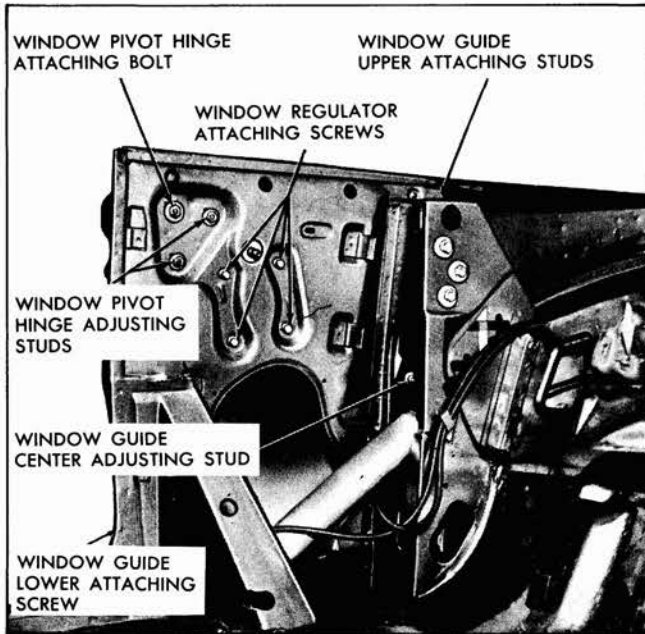

Fig. 14-6 Rear Quarter Hardware "67" Style

b. Top of window "in or out" adjustment: Loosen lower adjusting stud nut and slightly loosen rear stud nut (Fig. 14-6). Adjust lower stud "in or out", as required, then tighten both stud nuts.

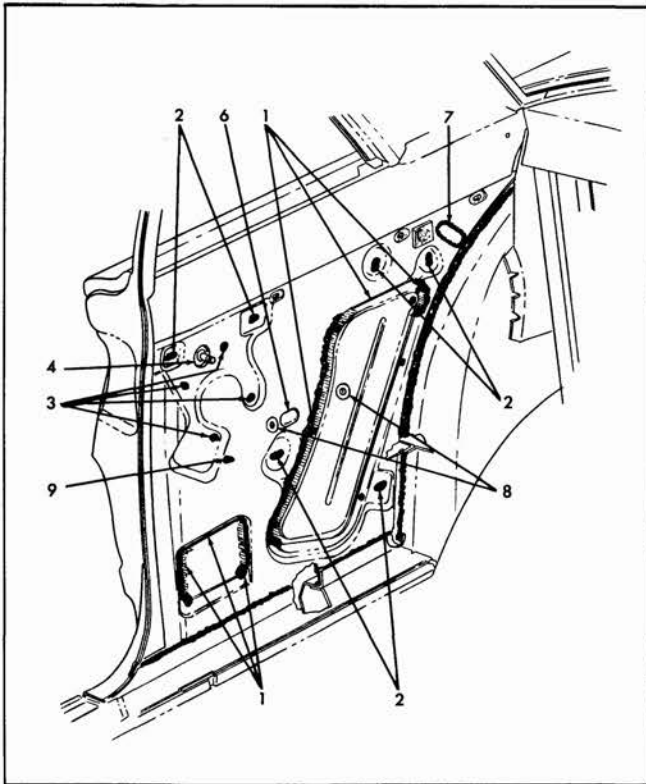

Fig. 14-7 Rear Quarter Sealing "17" and "27" Styles

c. Rear of window "in or out" adjustment: Loosen pivot hinge rear adjusting stud nut and slightly loosen lower adjusting stud nut (Fig. 14-6). Loosen window guide upper and center attaching screws (Fig. 14-6). Adjust rear adjusting stud "in or out", as required, then tighten both stud nuts. Adjust window guide for proper alignment with window and tighten guide upper and center attaching screws.

NOTE: After performing window adjustments, seal all hardware attaching locations that have been disturbed, as specified under "Rear Quarter Inner Panel Sealing" for "67" style.

REAR QUARTER WINDOW REGULATOR

67 STYLE

REMOVAL AND INSTALLATION

1. Remove rear seat cushion and back assemblies and rear quarter trim assemblies.

2. Remove rear quarter inner panel access hole cover. Operate window to "full up" and prop in that position.

3. Remove window regulator attaching screws (Fig. 14-6). Disengage roller on regulator lift arm from window lower sash channel cam and remove regulator through access hole.

4. To install, reverse removal procedure.

Lubricate regulator sector, window cam, and pivot hinge as specified in "Lubrication" section.

Seal all hardware attaching locations that have been disturbed, as specified under "Rear Quarter Inner Panel Sealing" for "67" style.

REAR QUARTER WINDOW GUIDE

REMOVAL AND INSTALLATION

1. Remove rear quarter trim assemblies and inner panel access hole cover. Remove rear quarter window assembly.

2. Remove window guide upper, center, and lower attaching stud nuts and screws (Fig. 14-6). Remove guide through large access hole.

3. To install, reverse removal procedure. Adjust window guide for proper window alignment as specified in "Rear Quarter Window Adjustments" for "67" style.

Seal all hardware attaching locations that have been disturbed, as specified under "Rear Quarter Inner Panel Sealing" for "67" style.

REAR QUARTER WINDOW OUTER SEALING STRIP

REMOVAL AND INSTALLATION

1. Remove rear quarter window assembly.
2. Remove screws securing outer sealing strip

to quarter outer panel return flange and remove strip.

3. To install, reverse removal procedure.

REAR QUARTER INNER PANEL SEALING

Whenever the rear quarter inner panel seals have been disturbed, the area must be resealed before the rear quarter trim is reinstalled. Following are the rear quarter inner panel openings and hardware attaching locations that must be sealed to prevent water leakage and possible trim damage.

NOTE: When body caulking compound is used, work compound firmly to metal surfaces and featheredge out to obtain good adhesion. (For "17" and "27" styles - Fig. 14-7; for "67" style - Fig. 14-8).

The number references in Figs. 14-7 and 14-8 correspond to the following item numbers:

1. Large and Small Access Hole Covers:

Prior to installation of access hole cover apply a bead of body caulking compound (approximately 1/8" diameter) across top and down sides of quarter inner panel along flange contacted by cover. After installation of cover, apply another bead of body caulking compound down the sides sealing cover to inner panel. Make certain to seal cover attaching screw locations and where cover flange transition to inside of quarter panel occurs.

2. Window Guide Attaching Screws:

Apply body caulking compound over window guide attaching screws and holes. Firmly press compound to assure a good bond and watertight seal.

3. Window Regulator Attaching Screws:

Apply neoprene type weatherstrip adhesive (yellow) over attaching screws.

4. Window Regulator Spindle Hole Sealing Washer:

Apply neoprene type weatherstrip adhesive over exposed surface of washer to seal pores of sponge rubber and joint between washer and inner panel.

5. Window Hinge Attaching Screws ("67" Style Only): Apply body caulking compound over hinge attaching screws. Press compound firmly to assure a good bond and watertight seal.

6. Sash Channel Cam Attaching Screw Access Hole: Apply 3" piece of waterproof body tape over hole. Pull or roll out tape to remove wrinkles and assure a good bond.

7. Welding Inspection Hole Sealing Plug:

Apply neoprene weatherstrip adhesive (yellow) around edges of sealing plug to effect a watertight seal.

8. Arm Rest Anchor Nut:

Apply body caulking compound over anchor nut and hole to effect a seal around anchor nut, hole, and attaching screw when arm rest is installed.

9. Window Regulator Lift Arm Up Travel Stop Attaching Screw:

Apply waterproof body tape over lower half of up travel stop to channel any moisture into drain slot directly below stop.

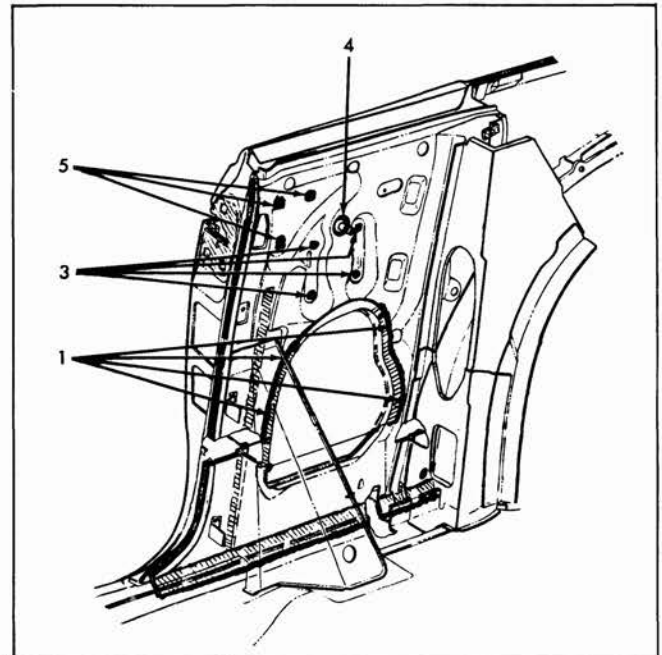

Fig. 14-8 Rear Quarter Sealing "67" Style

TRIM AND HARDWARE—19 and 35 STYLES

REAR QUARTER WINDOW

19 and 35 STYLES

REMOVAL AND INSTALLATION

1. On sedan styles remove rear seat cushion and back. On station wagon styles remove back body opening upper finishing panel. On all styles remove rear quarter window garnish moldings and belt finishing moldings.

2. Remove retainers securing glass and rubber channel, then from outside of body carefully push glass and rubber channel from body opening. Remove rubber channel from glass.

3. To install rear quarter window, first clean off all old sealer from rubber channel and window opening rabbet. Install rubber channel to window. Apply a bead of medium-bodied sealer to wall of window opening rabbet, completely around window opening to effect a seal between body and rubber channel ("1" in Fig. 14-9 for "19" style, and Fig. 14-10 for "35" style).

4. Position window assembly into opening and loosely install window retainers. Using a pressure type applicator, apply weatherstrip adhesive (black) between rubber channel and outside surface of glass ("2" in Fig. 14-9 for "19" style and Fig. 14-10 for "35" style).

5. Tighten retainers and clean off excess sealer. Install previously removed parts.

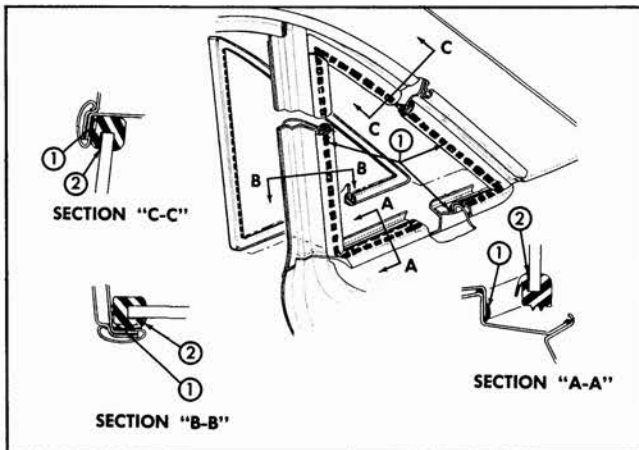

Fig. 14-9 Rear Quarter Window Sealing

QUARTER TRIM PANELS— FRONT AND REAR

REMOVAL AND INSTALLATION—FRONT

1. Remove rear quarter window front garnish molding and rear trim panel front attaching screw.

2. Remove front trim panel attaching screws and remove panel.

3. To install front trim panel, reverse removal procedure.

REMOVAL AND INSTALLATION—REAR

1. Loosen rear quarter window front garnish molding rear attaching screw and remove rear garnish molding.

2. Remove rear trim panel attaching screws and remove panel.

3. To install rear trim panel, reverse removal procedure.

REAR WHEELHOUSE TRIM

REMOVAL AND INSTALLATION

1. Remove rear quarter front and rear trim assemblies.

2. Remove screw securing rear floor filler panel to rear compartment floor panel and fold filler panel forward.

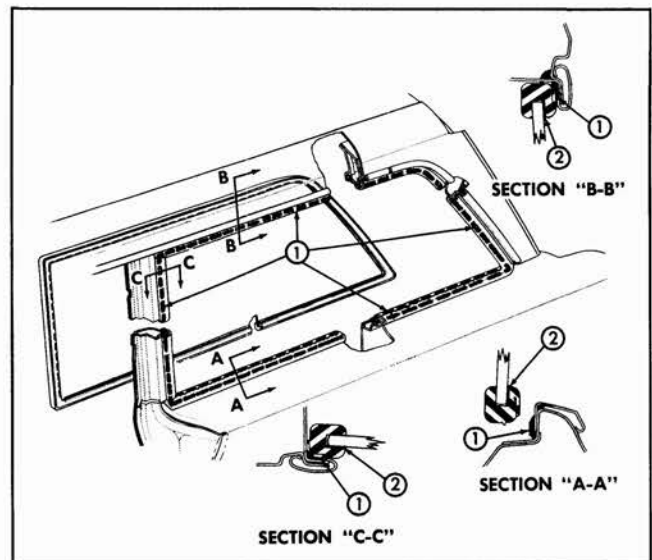

Fig. 14-10 Rear Quarter Window Sealing - Station Wagon

3. Remove rear compartment floor panel, spare tire cover panel, and floor compartment side panel (See "Folding Seat Back and Rear Compartment Floor Panels" in Seat Section).

4. Carefully detach wheelhouse trim from cemented areas of quarter panel, wheelhouse, and

floor pan; then remove trim.

5. To install rear wheelhouse trim, apply trim cement to contacting surfaces of trim and body panels; then install trim to wheelhouse, making sure trim is properly positioned and free of wrinkles. Install previously removed parts.

REAR END

CONTENTS OF THIS SECTION

SUBJECT	PAGE	SUBJECT	PAGE
Back Window Description	15-1	Back Door	15-8
Reveal Moldings	15-1	Adjustments	15-8
Rear Compartment	15-4	Hinge and Torque Rod	15-9
Deck Lid	15-4	Trim	15-10
Torque Rod	15-4	Lock Striker	15-11
Hinge	15-5	Outside Handle	15-12
Lock	15-7	Lock Cylinder	15-12
Lid Striker Check	15-7	Weatherstrip	15-12
Weatherstrip	15-7	Stationary Window	15-13
		Dropping Window	15-14
		Electric Window Motor	15-15
		Reveal Moldings	15-15

BACK WINDOW

DESCRIPTION

All 1962 back windows are retained in the body opening by conventional rubber channels. The rubber channel is designed with a cavity to hold the glass when the back window is installed and another cavity that overlaps the pinchweld flange of the body opening to retain the back window and rubber channel assembly in the opening. Some rubber channels incorporate a third cavity to retain the back window reveal moldings. On these styles, it is necessary to remove the back window and rubber channel assembly to remove the back window reveal moldings. Other styles use clip retained reveal moldings where it is necessary to remove the reveal moldings before the back window assembly can be removed.

Although the reveal moldings may vary, all back windows are solid tempered safety plate glass and are installed and sealed in basically the same manner.

Following are the procedures for servicing the reveal moldings and back window assembly:

BACK WINDOW REVEAL MOLDINGS 2119 and 2127 STYLES

The back window reveal moldings are equipped with an "L" shaped retaining flange that is secured in a similar shaped cavity in the back window rubber channel. To remove the reveal moldings it is necessary to first remove the back window and rubber channel assembly, then the moldings can be removed as a bench operation.

REVEAL MOLDING RETAINING CLIP 2117 STYLE

The reveal molding retaining clip is the most common type of back window reveal molding retention. Whenever it is necessary to remove or install a molding using this type of retention, refer to the following procedure covering the engagement and disengagement of reveal moldings from retaining clips.

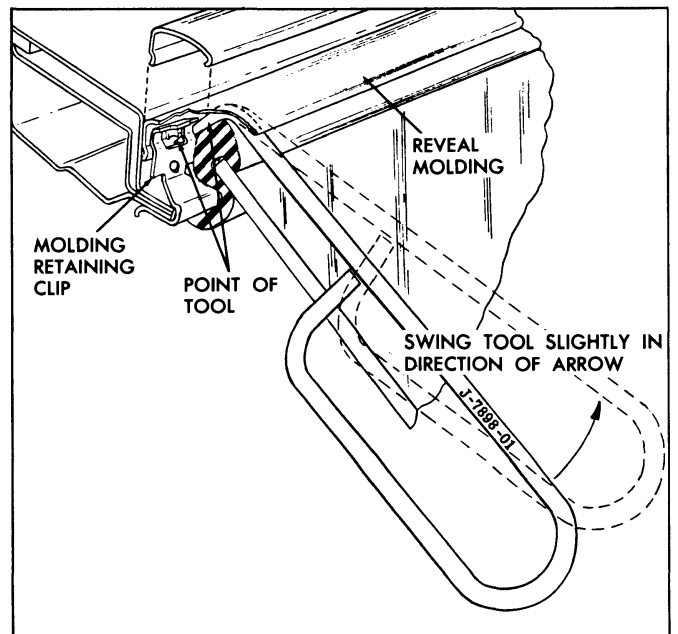

Fig. 15-1 Back Window Reveal Molding Removal Tool

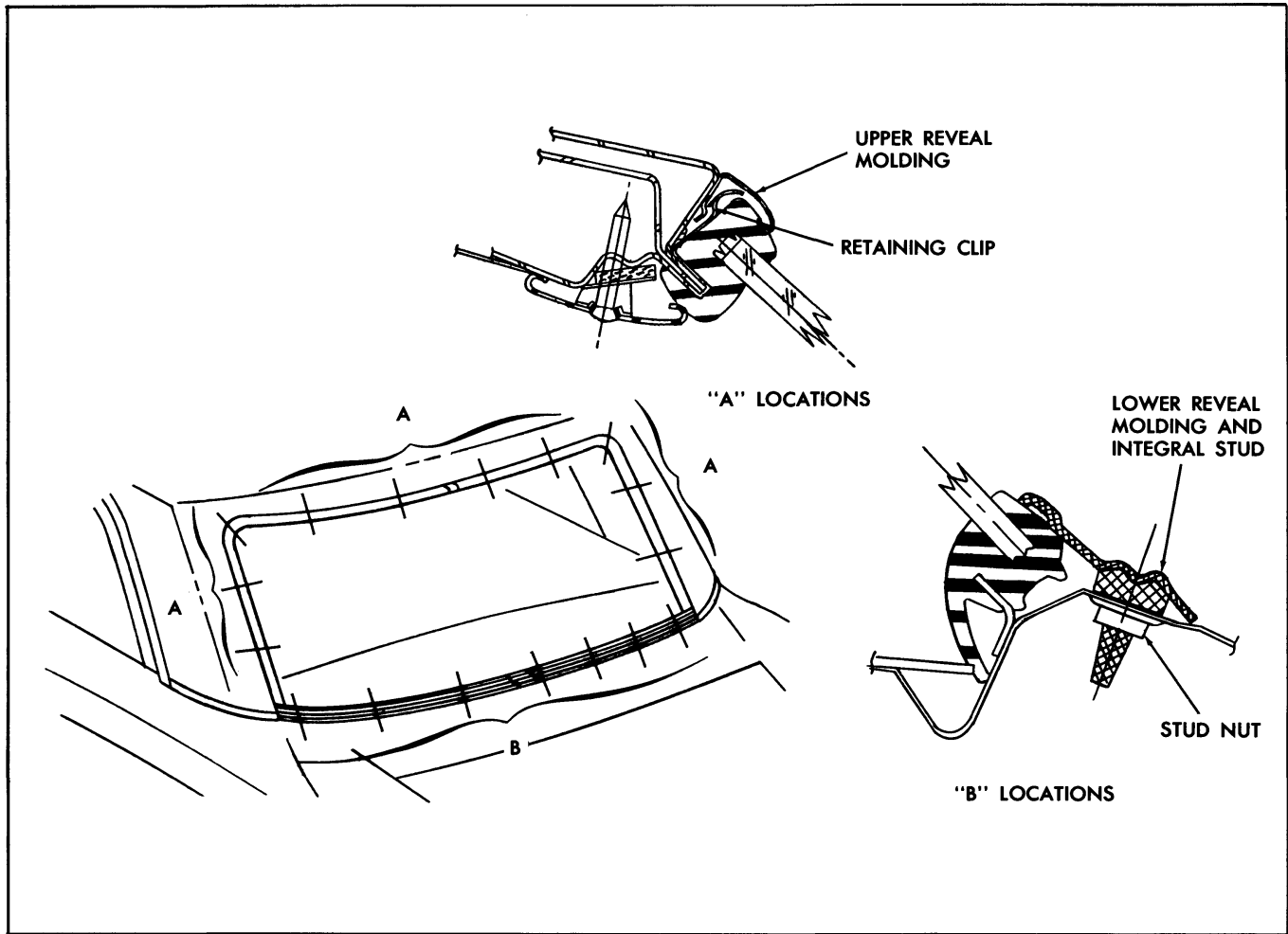

Fig. 15-2 Back Window Reveal Moldings (17 Style)

DISENGAGEMENT AND ENGAGEMENT OF REVEAL MOLDING FROM RETAINING CLIP

Reveal molding retaining clips are snapped over the back window pinchweld or retaining flange and secure the reveal molding by means of barbed prongs.

To disengage the reveal molding from the clip requires the use of reveal molding removal tool J-7898-01. Insert end of tool between back window rubber channel and reveal molding.

Engage point of tool between retaining clip and molding, then swing tool slightly (Fig. 15-1) to disengage prongs of clip from molding and lift molding free of clip.

NOTE: Do not lift excessively on molding. If clip is disengaged, molding will easily lift free of clip. If clip is not disengaged, any excessive pull on molding will cause prongs of clip to "bite" harder on molding; thereby making it more diffi-

cult to disengage clip from molding. If difficulty is being encountered in disengaging clip, push molding at clip location to relieve pressure of clip prongs on molding while using tool to disengage clip.

An occasional application of a silicone lubricant on end of tool will facilitate inserting tool between reveal molding and rubber channel and sliding tool to engage with clip.

To install moldings, position molding so that flange of molding is between body metal and clip, then carefully push molding at retaining clip locations until molding is properly secured by retaining clips.

BACK WINDOW LOWER REVEAL MOLDING 2117 STYLE

The back window lower reveal molding (Fig. 15-2) is retained by integral studs and sealing nuts.

To remove the molding, remove the sealing nuts from the molding studs under the rear compartment front and shelf panel. These are accessible through the rear compartment, then remove the molding.

To install, first replace any sealing nuts and washers which will not effect a good seal, then reverse removal procedure.

BACK WINDOW UPPER REVEAL MOLDING 2117 STYLE

When removing the right upper reveal molding (Fig. 15-2) disengage the molding from the retaining clips along the top. Remove the molding by sliding it upwards from under the lower reveal molding and off the remaining clips along the side of the molding.

Perform the same operation when removing the left molding except, disengage enough of the right upper reveal molding to allow removal of the left side molding.

To install, insert lower end of molding behind lower reveal molding. Then engage molding with retaining clips.

BACK WINDOW ASSEMBLY

REMOVAL

1. Place protective coverings over rear seat cushion and back assemblies, over parcel shelf trim, and over painted surfaces. On styles equipped with fabric roof cover place protective covering over roof cover adjacent to back window.

2. Remove back window garnish moldings and, where present, clip and stud retained back window reveal moldings.

3. From inside of body use a hooked or other suitable tool to carefully break seal between lip of rubber channel and pinchweld flange completely around perimeter of glass.

4. Carefully push back window and rubber channel assembly outward until lip of rubber channel is disengaged from pinchweld and retaining flange.

5. With the aid of a helper, lift complete assembly from body opening and place on a protected surface. On styles with reveal moldings secured in the rubber channel, remove moldings.

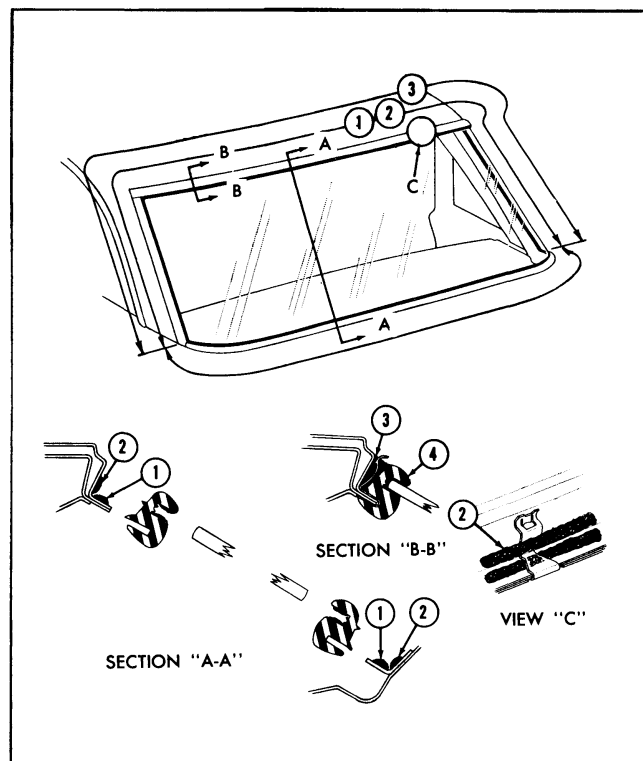

Fig. 15-3 Back Window Sealing

INSTALLATION

NOTE: Use care to make certain glass does not strike body metal during installation as edge chips can cause solid tempered safety plate glass to shatter. Do not attempt to grind glass.

1. Clean original sealer from back window body opening and rubber channel and install rubber channel to glass.

2. Check back window body opening and pinchweld flange for any irregularities and correct where necessary. Mark center of back window and body opening.

3. On styles using clip retained reveal moldings, check retaining clips and replace damaged or defective clips. Prior to installing clips, apply a continuous ribbon of medium-bodied sealer (approximately 1/4 inch thick) along the pinchweld and retaining flange (1 in Fig. 15-3) completely around the opening.

4. Apply a second continuous ribbon of medium-bodied sealer (approximately 1/4 inch thick) along outer wall of back window opening (2 in Fig. 15-3) completely around opening.

5. Install rubber channel to glass and insert a strong cord into pinchweld cavity of rubber channel. Tie ends of cord together at bottom center and tape

ends to inside surface of glass. On styles where the reveal moldings are retained in the rubber channel, install moldings and, where necessary, tie moldings to glass and rubber channel assembly. Make certain moldings are positioned properly as it is difficult to reposition them after installation of back window.

6. With the aid of a helper, position back window and rubber channel assembly into body opening. While helper is applying hand pressure to outside surface of glass, carefully pull ends of cord across bottom, up sides and across top of window opening to seat lip of rubber channel over pinchweld and retaining flange, completely around back window.

7. On styles with clip retained reveal moldings, apply sufficient medium-bodied sealer to fill void between rubber channel and body opening up sides and across top of window (3 in Fig. 15-3).

8. Using a pressure type applicator, apply an approved weatherstrip adhesive (black) between outer lip of rubber channel and glass (4 in Fig. 15-3) completely around rubber channel.

9. Install previously removed parts and clean off excess sealer and cement. Remove protective coverings.

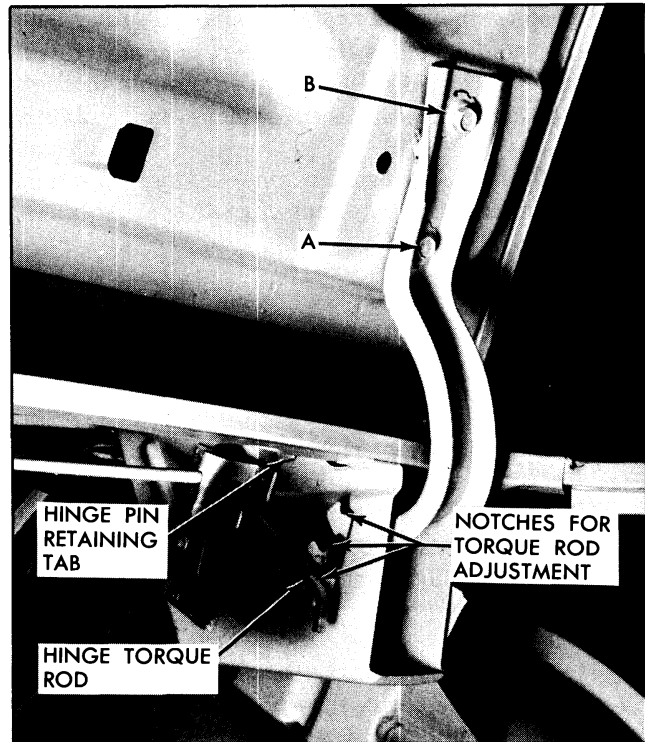

Fig. 15-4 Back Door Hinge and Torque Rod

REAR COMPARTMENT

REAR COMPARTMENT LID

REMOVAL AND INSTALLATION

1. Open lid and place protective covering along edges of rear compartment opening to prevent damage to painted surfaces.

2. Scribe location of hinge straps on lid inner panel.

3. With aid of a helper to hold lid, remove lid attaching bolts "A" and "B" (Fig. 15-4) at both hinge straps and remove rear compartment lid.

4. To install rear compartment lid, first, as an anti-squeak precaution, apply a coat of heavy-bodied sealer on the surface of the compartment lid hinge which contacts the rear compartment lid; then, reverse removal procedure.

REAR COMPARTMENT LID ADJUSTMENTS 17, 19 and 27 STYLES

1. To adjust compartment lid forward or rearward or from side to side in body opening, loosen hinge strap attaching bolts "A" and "B" (Fig. 15-4)

on both sides of lid, adjust lid as required, then tighten bolts.

2. To adjust front of compartment lid up or down, install shims between lid inner panel and hinge strap as follows:

a. To raise front edge of lid, place shim(s) between lid inner panel and forward portion of one or both hinge straps at "A" (Fig. 15-4).

b. To lower front edge of lid, place shim(s) between lid inner panel and rear portion of one or both hinge straps at "B" (Fig. 15-4).

3. To check lid lock bolt engagement with lock striker, see "Rear Compartment Lid Lock Striker Engagement Check".

TORQUE ROD ADJUSTMENTS 17, 19 and 27 STYLES

The amount of effort required to open and close the rear compartment lid is determined by the position of the torque rods in the notches on the in-board face of the hinge boxes (Fig. 15-4). If the torque rod is located in the lowest notch the effort

required to open the lid is the greatest and the amount of effort required to close the lid is the least. If the torque rod is located in the top notch, the amount of effort required to open the lid is the least and the amount of effort to close the lid is the greatest.

The torque rods can be disengaged and engaged in the notches by using a suitable length of pipe over the end of the torque rod.

NOTE: It is not necessary to adjust the left and right torque rods at the same time or to the same final position (notch).

REAR COMPARTMENT LID HINGE 17, 19 and 27 STYLES

REMOVAL

1. Open lid and place protective covering along edges of rear compartment opening to prevent damage to painted surfaces. Provide support for lid on side where hinge is to be removed.

2. Remove rear compartment side trim foundation at hinge area.

3. Scribe location of hinge strap on lid inner panel and remove bolts "A" and "B" (Fig. 15-4) securing hinge strap to lid.

4. With a suitable length of pipe, disengage torque rod from notched retainer on inboard face of opposite hinge boss.

5. Bend up hinge pin retaining tab on inboard face of hinge box and remove hinge pin, then remove hinge from box.

INSTALLATION

1. Position hinge in box and install hinge pin. Bend over retaining tab to secure hinge pin.

2. Install "U" shaped end of torque rod to hinge box making certain outer end of rod is engaged in hole in outboard face of hinge box.

3. Engage torque rod in notch of hinge strap lever; then, engage other end of rod to correct retaining notch on inboard face of opposite hinge box.

4. As an anti-squeak precaution, apply a coat of heavy-bodied sealer to surface of hinge strap which contacts the rear compartment lid.

5. Position hinge strap within scribe marks on lid inner panel and install attaching bolts.

6. Check alignment of rear compartment lid and make any necessary adjustments.

7. Replace all previously removed trim.

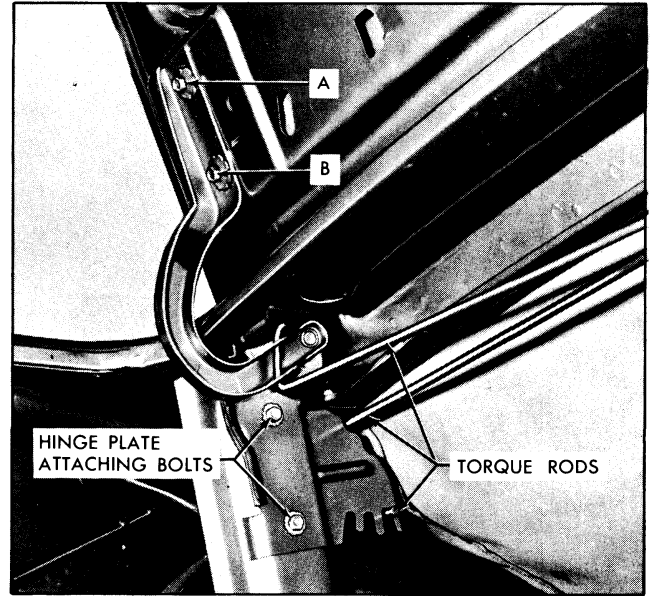

Fig. 15-5 Trunk Lid on 67 Style

REAR COMPARTMENT LID ADJUSTMENTS 67 STYLE

1. To adjust compartment lid forward or rearward, or from side to side in body opening, loosen hinge strap attaching bolts "A" and "B" (Fig. 15-5) on both sides of lid; adjust lid as desired, then tighten bolts.

2. To adjust front of compartment lid up or down loosen hinge plate attaching bolts (Fig. 15-5), adjust lid up or down as desired and tighten bolts.

3. To check lid lock bolt engagement with lock striker, see "Rear Compartment Lid Lock Striker Engagement Check".

TORQUE ROD ADJUSTMENTS 67 STYLE

The amount of effort required to open and close the rear compartment lid is determined by the position of the torque rods in the notches on the hinge mounting plate (Fig. 15-5). If the torque rod is located in the most forward notch, the effort required to open the lid is the greatest and the effort required to close the lid is the least. If the torque rod is located in the most rearward position, the effort required to open the lid is the least and the amount of effort required to close the lid is the greatest. Fig. 15-6 illustrates how to use tool J-9554 to perform these adjustments.

1. Open rear compartment lid and PROVIDE SUPPORT TO HOLD IT IN FULL OPEN POSITION.

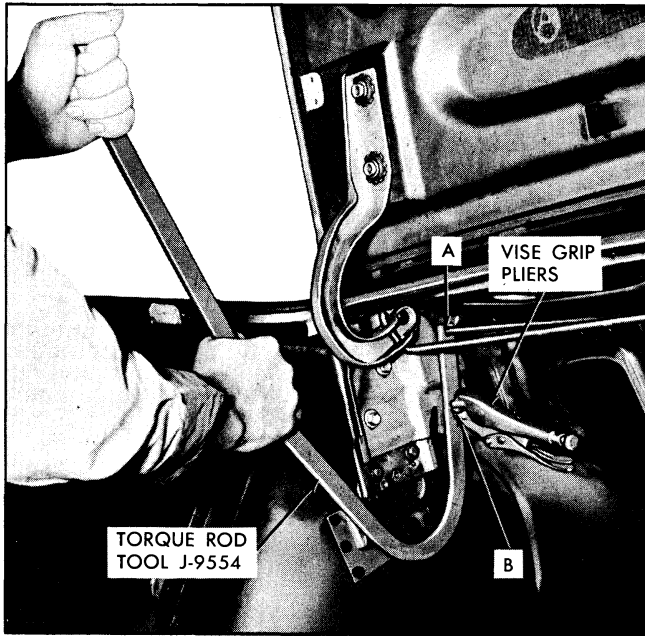

Fig. 15-6 Trunk Torque Rod Adjustment

2. Engage notch in end of tool J-9554 with torque rod to be adjusted ("A", Fig. 15-6). Engage hole in tool with "return crank end" of same torque rod ("B", Fig. 15-6).

3. Firmly clamp vise grip pliers to end of torque rod at point "B" to prevent tool from sliding off torque rod.

4. Disengage torque rod from hinge plate by raising tool with one hand and holding it firmly against hinge plate with other hand (Fig. 15-6). Adjust torque rod to desired position, or remove rod completely.

NOTE: Use extreme caution when disengaging torque rod from hinge plate. Torque rod is under

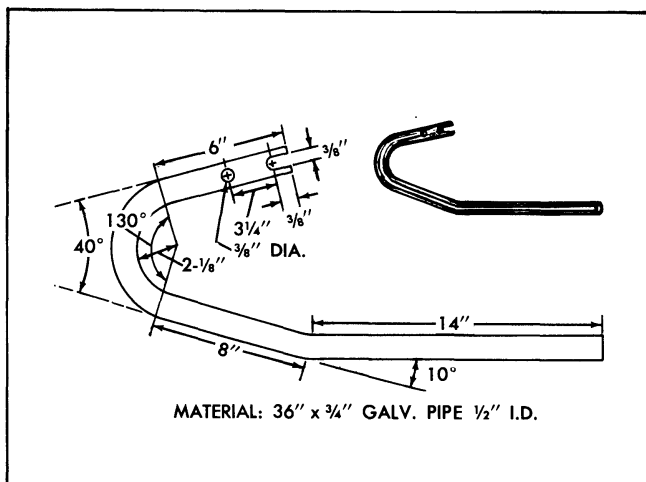

Fig. 15-7 Torque Rod Tool

great tension when it is engaged and careless handling of rod during disengagement can cause injury to operator.

A tool to make these torque rod adjustments can be made as shown in Fig. 15-7.

REAR COMPARTMENT LID HINGE 67 STYLE

REMOVAL AND INSTALLATION

1. Open rear compartment lid and place protective coverings along edges of lid opening to protect painted surfaces. Provide support for lid on side where hinge is to be removed.

2. Scribe location of hinge strap on lid inner panel and remove bolts "A" and "B" (Fig. 15-5) securing hinge strap to lid.

3. Disengage torque rods from hinge mounting plates using torque rod removing tool No. J-9554. Scribe location of hinge plate on hinge brace. Remove hinge plate attaching bolts (Fig. 15-5) and remove hinge from body.

4. To install, reverse removal procedure. Check for proper lid alignment and make any necessary adjustments.

NOTE: When installing torque rods, engage hinge strap end first, then engage other end in proper notch in hinge plate.

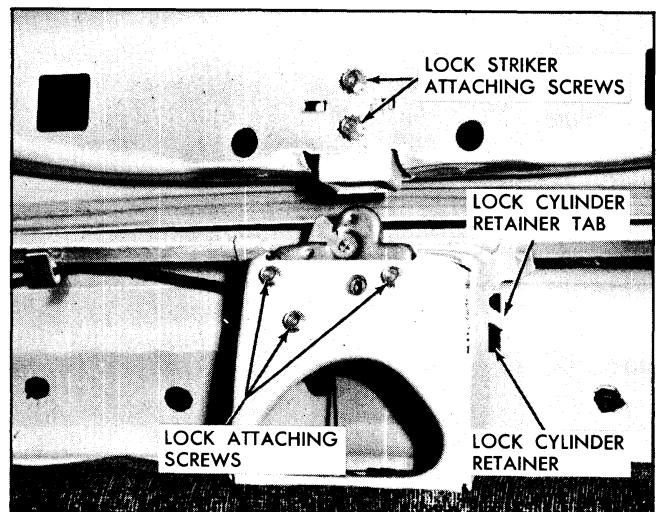

Fig. 15-8 Rear Compartment Lid Lock and Striker

REAR COMPARTMENT LID LOCK CYLINDER

REMOVAL AND INSTALLATION

1. Carefully bend lock cylinder retainer tab, (Fig. 15-8) forward to allow disengagement of retainer.
2. Using a suitable hooked tool, pull lock cylinder retainer, (Fig. 15-8) until retainer disengages from lock cylinder.
3. Remove lock cylinder and gasket from rear end panel.
4. To install rear compartment lid lock cylinder, replace gasket, if necessary, and reverse removal procedure.

REAR COMPARTMENT LID LOCK

REMOVAL AND INSTALLATION

1. Remove rear compartment lid lock cylinder.
2. Remove rear compartment lock attaching screws (Fig. 15-8) and remove lock.
3. To install rear compartment lid lock, reverse removal procedure.

LID LOCK STRIKER

REMOVAL AND INSTALLATION

1. Mark location of striker on compartment lid panel; then, remove striker attaching bolts and remove striker and retaining plate (Fig. 15-8).
2. To install striker, position striker and retaining plate within scribe marks and install attaching bolts and washers.

LID STRIKER ENGAGEMENT CHECK

NOTE: Make sure rear compartment lid is properly positioned to body opening before performing striker engagement check.

To check for proper engagement of rear compartment lid striker with lock frame, use the following procedure:

1. Place a small amount of modeling clay or body caulking compound on frame of lock at both sides of the lock bolt (Fig. 15-9). Close lid with moderate force.
2. Open lid and check amount of engagement of striker with lock frame, as indicated by the compression of the clay. The striker impressions in the clay should be even on both sides of the lock

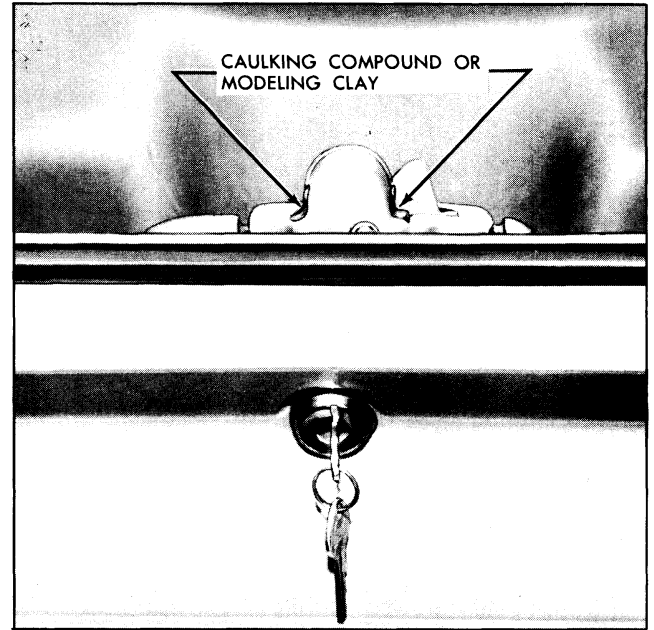

Fig. 15-9 Rear Compartment Lock Striker Engagement Check

frame (Fig. 15-9). Where required, loosen striker attaching screws: adjust striker sideways or up or down to obtain proper engagement, then tighten screws.

WEATHERSTRIP

REMOVAL

1. Separate “butt” ends of weatherstrip at rear of compartment opening.
2. Using a flat-bladed tool, carefully disengage weatherstrip from its cemented foundation in gutter around entire perimeter of rear compartment and remove weatherstrip.

INSTALLATION

1. Clean out gutter around entire rear compartment opening to provide a clean cementing surface.

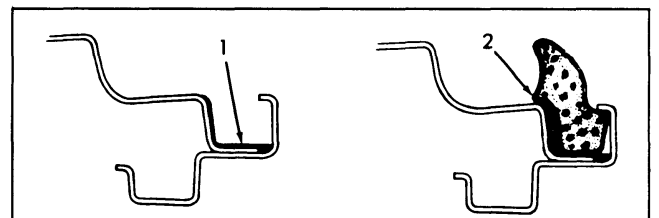

Fig. 15-10 Cross Section of Rear Compartment Gutter and Weatherstrip

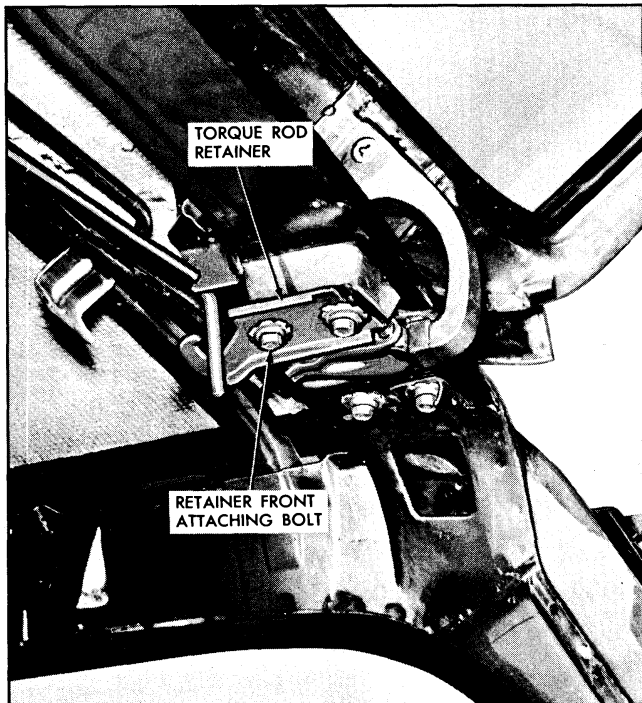

Fig. 15-11 Back Door Hinge and Torque Rod Retainer

2. Apply (brush) a continuous coat of weatherstrip cement (neoprene type) along the lower and outer surfaces of the rear compartment gutter (1 in Fig. 15-10) around full length of gutter.

3. Using a flat-bladed tool such as a putty knife, or headlining inserting tool, insert weatherstrip into gutter starting with one end of weatherstrip at rear

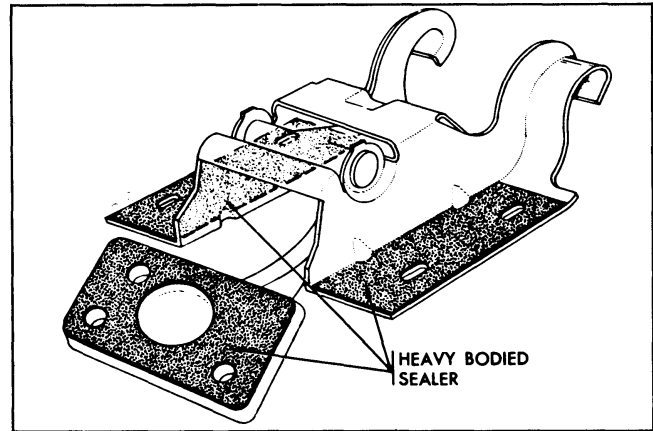

Fig. 15-12 Back Door Hinge - Anti-Squeak

center of gutter and working completely around gutter.

4. If installing new weatherstrip, trim end of weatherstrip to form a "butt" joint at rear center of opening. Brush weatherstrip adhesive (black) on both ends of weatherstrip and secure ends together to form a "butt" joint.

5. Using a pressure type applicator, apply weatherstrip cement (neoprene type) between weatherstrip and outer surface of gutter (2 in Fig. 15-10) completely around gutter to assure a watertight seal.

6. Roll or press weatherstrip to aid in obtaining a good cement bond and proper retention of the weatherstrip. Allow sufficient time for cement to set before closing rear compartment lid.

BACK DOOR

BACK DOOR ASSEMBLY

REMOVAL AND INSTALLATION

1. Open back door and mark location of hinge strap on back door inner panel to facilitate installation in same location.

2. With aid of a helper, to hold back door, remove hinge-to-back door attaching bolts. (Fig. 15-11).

3. To install back door assembly, first, as an anti-squeak precaution, apply a coat of heavy-bodied sealer to attaching surfaces of both hinges. (Fig. 15-12) then, reverse removal procedure. Align back door with previously made hinge marks.

4. Where required, adjust back door as described under "Back Door Adjustments".

BACK DOOR ADJUSTMENTS

1. To adjust the back door assembly up or down or sideways in the back body opening, remove back door lock striker and loosen both right and left hinge-to-back door attaching bolts. Shift door to desired position on hinges; then, tighten hinge attaching bolts and install back door lock striker.

2. To adjust the upper portion of the back door in or out proceed as follows:

a. Remove back door opening upper finishing panels.

b. Mark position of torque rod retainers, (Fig. 15-11), at both right and left hinges to facilitate repositioning of retainers in same fore and aft position.

c. Using a suitable length of pipe over end of torque rod, release tension of torque rod from retainer. While tension of torque rod is released from retainer, loosen retainer attaching bolts, (Fig. 15-11); then, release retainer. Loosen the two remaining hinge attaching bolts. Perform this operation at both right and left hinges.

d. Shift the hinges and back door assembly to desired position; then, tighten hinge attaching bolts making sure torque rod retainers are aligned with previously made marks. Install back door opening upper finishing panels.

3. To adjust the lower portion of the door in or out, see "Back Door Lock Striker Adjustments".

BACK DOOR HINGE AND TORQUE ROD ASSEMBLY

REMOVAL

1. Raise back door and remove both right and left back body opening upper finishing panels.

2. Prop the back door in the open position on the side from which hinge is being removed.

NOTE: If removing both hinges, remove the back door assembly from the hinges.

3. Mark position of torque rod retainer to facilitate installation in same fore and aft position.

4. Using a suitable length of pipe over end of torque rod, release tension of torque rod from retainer. While tension of torque rod is released from retainer, remove retainer front attaching bolt and loosen (no more than 2 turns) retainer rear attaching bolt; then, swing front end of retainer towards outside of body and release torque rod (Fig. 15-13).

5. If removing left torque rod, remove clip securing torque rod to body upper panel. Loosen anti-rattle clip attached to both torque rods; then, disengage torque rod from hinge and remove torque rod.

6. Remove hinge to back door attaching bolts; then, remove hinge to body attaching bolts and remove torque rod retainer and hinge from body.

INSTALLATION

1. Lubricate both right and left hinge pivot pins with an approved dripless oil (Fig. 15-14).

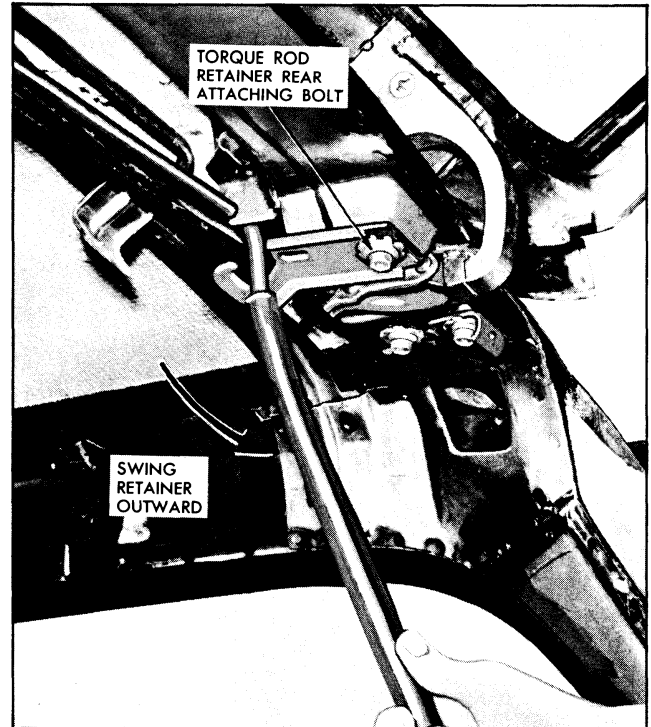

Fig. 15-13 Back Door Hinge and Torque Rod Removal

2. As an anti-squeak precaution, apply a coat of heavy-bodied sealer to surfaces of hinge which contact body and back door (Fig. 15-12).

3. To install back door hinge assembly, reverse steps 1 through 7 of the "Removal" procedure.

NOTE: When installing hinge torque rod make certain torque rod is properly engaged with hinge (Fig. 15-14) and align torque rod retainer with

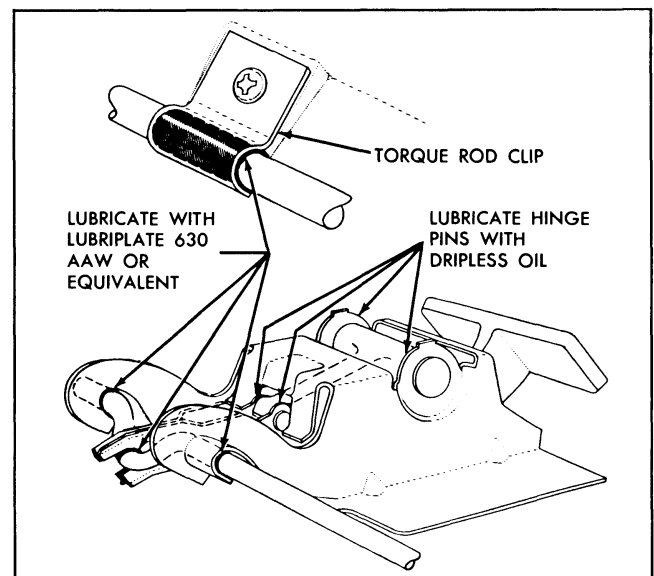

Fig. 15-14 Back Door Hinge and Torque Rod Lubrication

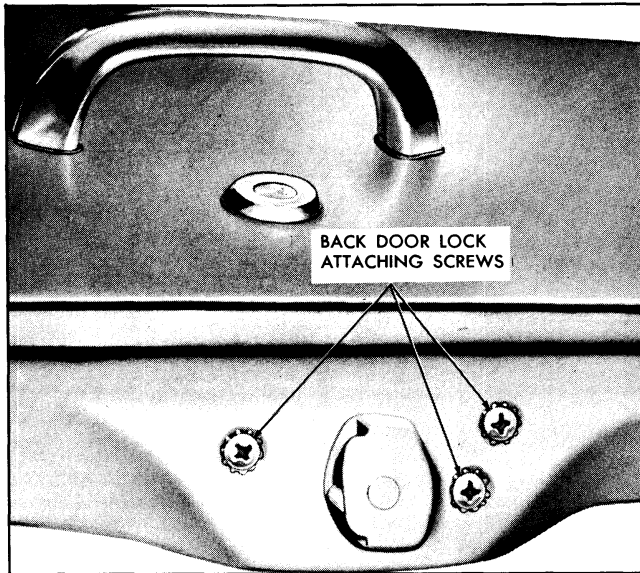

Fig. 15-15 Back Door Lock

previously made marks.

4. After installation of torque rods, lubricate torque rod frictional surfaces on both right and left hinges and frictional surfaces of both torque rod clips with "Lubriplate" No. 630AAW or equivalent (Fig. 15-14).

5. Where required, adjust back door as described under "Back Door Adjustments".

BACK DOOR TORQUE ROD TENSION ADJUSTMENT

The amount of effort required to open and close the back door is determined by the forward and rearward position of the right and left torque rod retainers. If both torque rod retainers are adjusted to the full forward position the amount of effort to

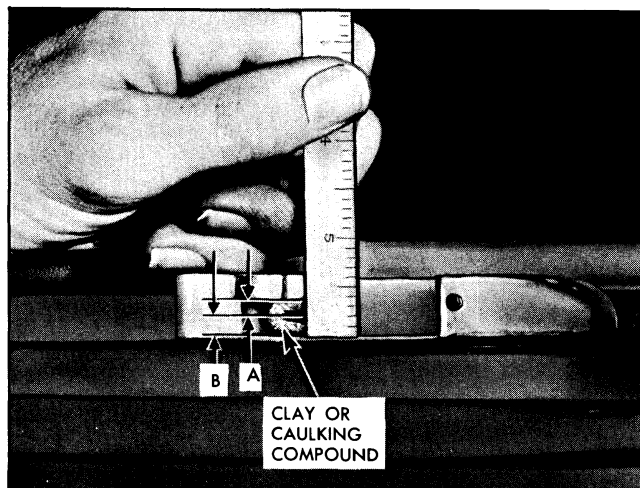

Fig. 15-16 Back Door Lock Striker Engagement Check

raise the lid is the greatest and the amount of effort to close the lid is the least. If both torque rod retainers are adjusted to the full rearward position, the amount of effort to raise the lid is the least and the amount of effort to close the lid is the greatest.

NOTE: It is not necessary to adjust both right and left torque rod retainers at the same time or to the same final position.

Adjust torque rod retainers as follows:

1. Raise back door and remove both right and left back body opening upper finishing panels.

2. Securely prop back door in the open position.

3. Mark location of retainer to facilitate adjustment from original position.

4. Using a suitable length of pipe over end of torque rod, remove tension of torque rod from retainer. While tension of torque rod is removed from retainer, loosen retainer attaching bolts (Fig. 15-14), adjust retainer forward or rearward, as required; then, tighten retainer attaching bolts.

5. Lubricate both right and left hinge pivot pins with an approved dripless oil (Fig. 15-14). Lubricate torque rod frictional surfaces on both hinges and frictional surfaces of both torque rod clips with "Lubriplate" No. 630AAW or equivalent (Fig. 15-14).

6. Install back body opening upper finishing panels.

BACK DOOR TRIM ASSEMBLY

REMOVAL AND INSTALLATION

1. Apply masking tape to back door inner panel adjacent to trim at retaining nail locations.

2. Using a clean rubber mallet, tap around edge of trim assembly to free trim nails in nail slots.

3. Insert a flat-bladed tool between inner panel and trim assembly at each retaining nail location; carefully disengage retaining nails from retaining slots in inner panel and remove trim from door.

4. To install, reverse removal procedure. Broken retaining nails should be replaced with repair tabs which are available as service parts.

BACK DOOR INNER COVER PANEL

REMOVAL AND INSTALLATION

1. On "35" style with electric window regulator, remove inner cover panel attaching screws and remove panel from door.

2. To install back door inner cover panel, reverse removal procedure.

**BACK DOOR LOCK ASSEMBLY
35 STYLE**

REMOVAL AND INSTALLATION

1. Operate back door window to full "up" position. Remove back door inner cover panel.
2. Remove remote control attaching screws (Fig. 15-18). Disengage locking rods from remote control and remove remote control from back door.
3. Remove remote control support plate attaching screws (Fig. 15-18). Move support plate towards right side of door to disengage inner panel cam from regulator arm roller and remove support plate.
4. Remove three back door lock attaching screws

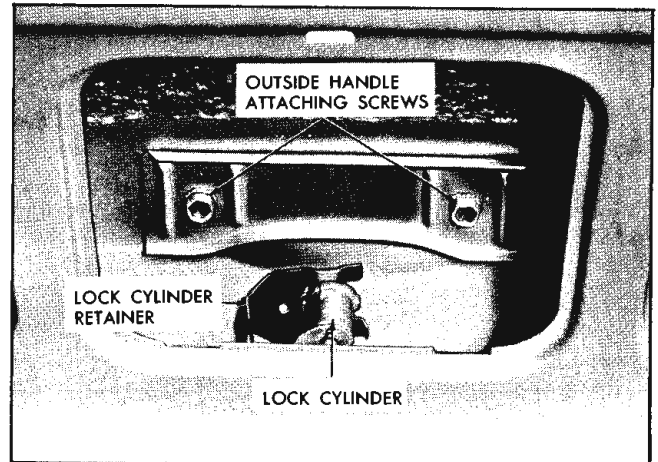

Fig. 15-17 Back Door Outside Handle and Lock Cylinder

from face of lock pillar (Fig. 15-15) and remove lock through hole in door inner panel.

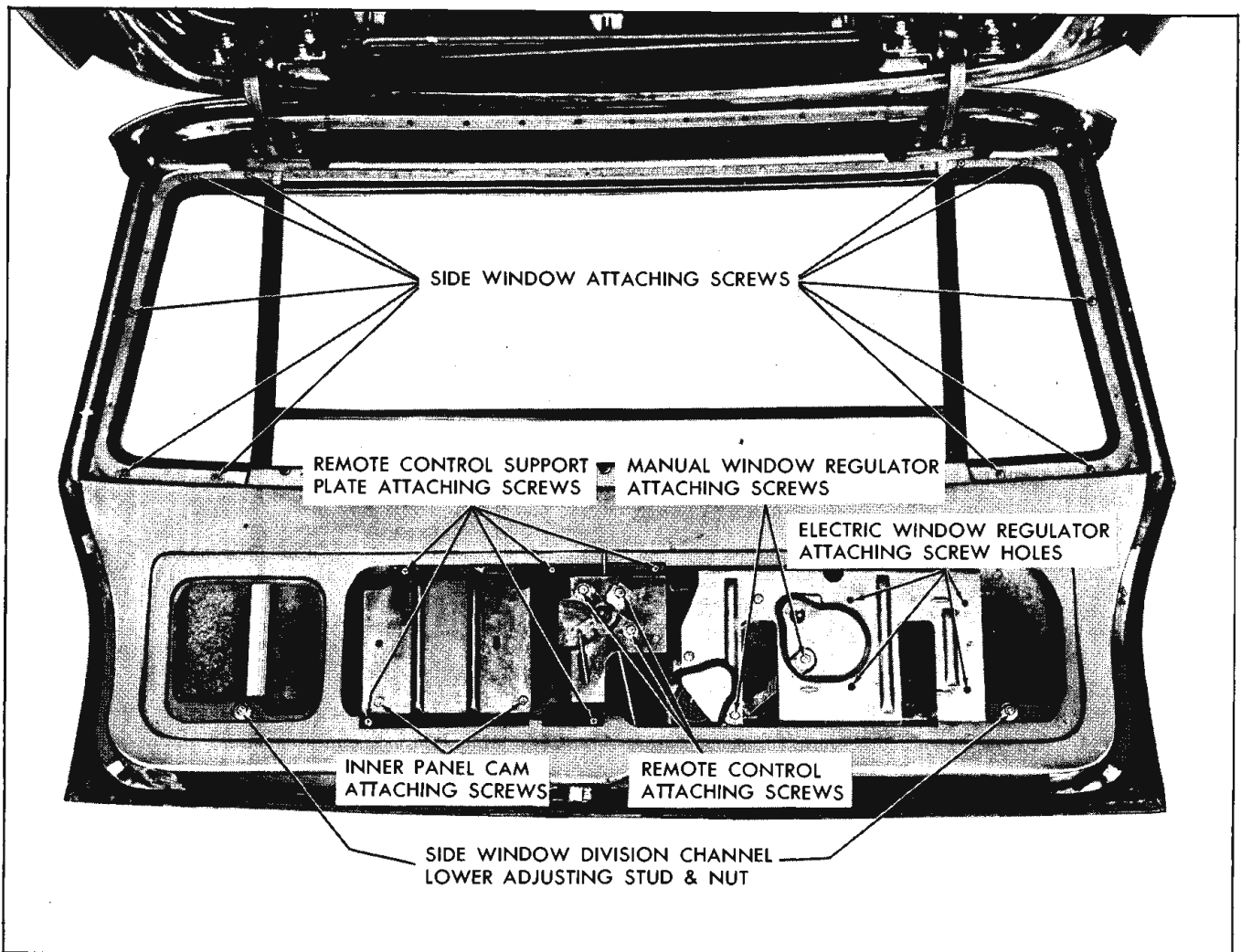

Fig. 15-18 Back Door Hardware

5. To install, reverse removal procedure.

BACK DOOR LOCK STRIKER ADJUSTMENTS 35 STYLE

1. To adjust the back door lock striker forward or rearward to obtain in or out adjustment of the lower portion of the door, or to adjust the striker sideways to obtain proper alignment with the back door lock rotary bolt, loosen striker attaching screws, shift striker to desired position and tighten screws.

2. Lock striker emergency spacer requirements.

a. The back door assembly should be properly aligned in the body opening before checking spacer requirements.

b. To determine if lock striker emergency spacers are required, apply modeling clay or body caulking compound in the lock striker notch where the lock extension engages; then, close the back door to form a measurable impression in the clay or caulking compound (Fig. 15-16).

When dimension "A" from inside face of striker teeth is less than 3/16", install one or more 1/16" emergency spacers (See Parts Book) to bring dimension "A" to the specified 3/16". If two or three spacers are required, install 1/8" longer striker attaching screws. If three or four spacers are required, install 1/4" longer striker attaching screws.

NOTE: Dimension "B" from center of lock extension to inside face of striker should never be less than 1/8".

BACK DOOR OUTSIDE HANDLE (STATIONARY WINDOW) 35 STYLE

REMOVAL AND INSTALLATION

1. Remove back door trim assembly as described under "Back Door Trim Assembly".
2. Remove two screws securing outside handle (Fig. 15-17), and remove handle and gaskets.
3. To install back door outside handle, first cement handle gaskets to handle with weatherstrip adhesive (black) and apply a coat of adhesive to surface of gaskets which contacts door outer panel (Fig. 15-17) then, reverse removal procedure.

BACK DOOR OUTSIDE HANDLE

REMOVAL AND INSTALLATION

1. Operate back door window to full "up" position. Remove back door inner cover panel.
2. Remove remote control attaching screws (Fig. 15-18). Disconnect remote control from connecting rod and remove remote control.
3. Remove remote control support plate attaching screws (Fig. 15-18). Move support plate towards right side of door to disengage inner panel cam from regulator arm roller and remove support plate.
4. Remove screws securing outside handle (Fig. 15-17) and remove handle and gaskets.
5. To install back door outside handle, first cement handle gaskets to handle with weatherstrip adhesive (black) and apply a coat of adhesive to surface of gaskets which contact door outer panel, then reverse removal procedure.

BACK DOOR LOCK CYLINDER ASSEMBLY 35 STYLE

REMOVAL AND INSTALLATION

1. Operate back door window to full "up" position. Remove back door inner cover panel.
2. Using a hooked tool or other suitable tool through access holes in door inner panel pry out lock cylinder retaining clip (Fig. 15-17) sufficiently to allow removal of lock cylinder and gasket from outer panel.
3. To install lock cylinder assembly, reverse removal procedure. Apply weatherstrip adhesive (black) on both contacting surfaces of lock cylinder gasket. Check operation of lock cylinder and lock before installing inside trim.

BACK DOOR WEATHERSTRIP 35 STYLE

REMOVAL

1. With a flat-bladed tool, carefully break cement bond securing butt ends of weatherstrip at bottom center of door and cement bond securing weatherstrip to door for a distance of approximately 2 inches on both sides of butt joint.
2. Starting at bottom center of door, insert tip of weatherstrip clip inserting tool J-5757 or other suitable tool at the first clip and carefully snap

clip from retaining hole. Then, using a flat-bladed tool, carefully break cement bond securing weatherstrip in corner of rabbet to the next clip. Perform the alternate operations of snapping clip out of retaining hole, and breaking cement bond to the next clip completely around door; then, remove weatherstrip.

INSTALLATION

1. Clean off old cement from back door to provide a clean cementing surface.
2. Check weatherstrip clips for proper contour and reform clips, where required, using clip reforming tool J-5984 (Fig. 15-19).
3. For distance of 2 inches on both sides of the butt joint location (bottom center of door), apply weatherstrip adhesive (neoprene type) to the door panel surface contacted by weatherstrip (See 1 in view "A", Fig. 15-20).
4. Apply a bead of weatherstrip adhesive (black) in the corner of the rabbet (2 in Sections "B-B" and "C-C" in Fig. 15-20) completely around door.
5. For a distance of 2 inches on both ends of weatherstrip, apply a coat of weatherstrip adhesive (neoprene type) to the weatherstrip surface which contacts the door panel (3 in view "A" Fig. 15-20).
6. Starting with end of weatherstrip at bottom center of door, install weatherstrip clips into retaining holes completely around door using weatherstrip clip inserting tool J-5757. Press or roll weatherstrip completely around door to assure a good cement bond.
7. Apply weatherstrip adhesive (neoprene type) to butt ends of weatherstrip and cement ends together to form an even butt joint. (See view "A", Fig. 15-20).

**BACK DOOR WINDOW ASSEMBLY—
STATIONARY
2135 STYLE**

REMOVAL

1. From inside body, carefully break seal between inside lip of rubber channel and pinchweld flange completely around rubber channel.
2. With aid of a helper to support glass on outside of body, carefully push lower edge of glass and rubber channel assembly outward until lip of rubber channel is disengaged from pinchweld flange; then, disengage remainder of rubber channel from pinchweld flange and remove rubber channel and glass from back door window opening.

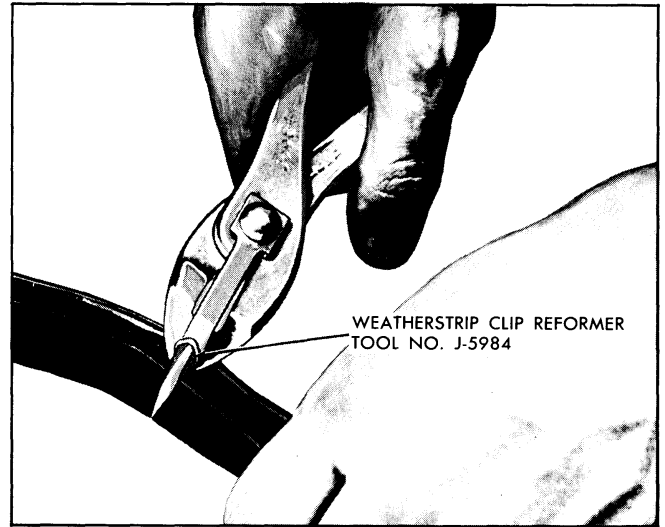

Fig. 15-19 Weatherstrip Clip Reformer Tool

3. Remove rubber channel and, where present, reveal moldings from glass.

INSTALLATION

NOTE: Care should be exercised to make certain glass does not strike body metal during installation as edge chips can cause tempered plate glass to shatter. **DO NOT** attempt to grind glass.

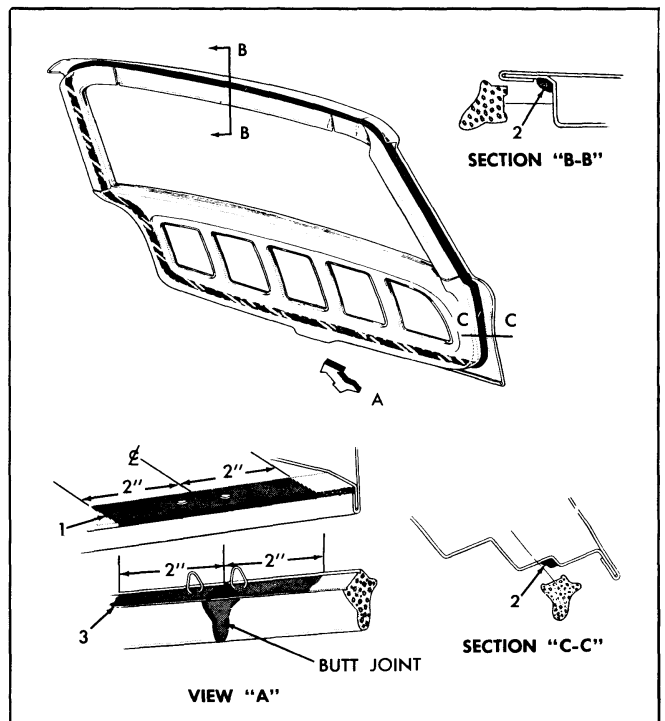

Fig. 15-20 Back Door Weatherstrip Installation

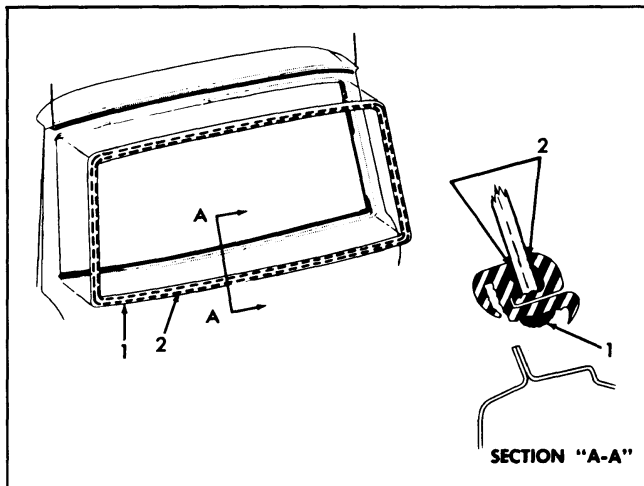

Fig. 15-21 Back Door Window Sealing

1. Clean off original sealer from rubber channel and back door window opening.

2. Check back door window opening pinchweld flange for any irregularities and correct, where required.

3. Install rubber channel to glass. Install reveal moldings in rubber channel. The side reveal moldings overlap the lower reveal molding.

4. Apply a continuous ribbon of medium-bodied sealer (Approximately 1/4" thick) to base of rubber channel, (1 in Section "A-A", Fig. 15-21), completely around rubber channel.

5. Insert a strong cord into pinchweld cavity of rubber channel so that ends of cord are at bottom center of glass. Tape ends of cord to inside surface of glass.

6. With aid of a helper, position glass and rubber channel assembly into door window opening. While a helper is applying hand pressure to outside surface of glass, use a hooked-tool to seat lip of rubber channel over pinchweld flange at sides of window opening; then, pull cords in rubber channel to seat lip over flange across bottom and across top of window opening.

7. Using a pressure type applicator, apply weather-strip adhesive (black) between rubber channel and glass on inside and outside of glass, (2 in Fig. 15-21) completely around glass and rubber channel. Application of adhesive should be continuous with no skips.

8. Clean off all excess sealer and adhesive.

BACK DOOR STATIONARY SIDE WINDOWS 35 STYLE

REMOVAL AND INSTALLATION

1. Lower dropping window. Remove garnish moldings and inner panel cover.

NOTE: To remove left stationary side window on styles with electric dropping window first remove right stationary side window and dropping window to facilitate removal.

2. Remove side window frame attaching screws; then, remove division channel lower adjusting stud (Fig. 15-18).

3. Carefully rotate side window inward to disengage division channel from dropping window; then, remove side window from door.

NOTE: Use care not to chip or scratch glass during removal as edge chips will cause solid tempered safety plate glass to shatter.

4. To install, reverse removal procedure. Adjust side window division channel lower adjusting stud for proper operation of dropping window.

BACK DOOR DROPPING WINDOW 35 STYLE

REMOVAL AND INSTALLATION

1. Remove right stationary window.

2. Rotate dropping window to almost full up position. From outside of body move dropping window to right to disengage rollers on regulator from window lower sash channel cams.

3. When rollers are free of cams, lift window assembly from between the panels and remove from body.

4. To install, reverse removal procedure. Prior to installation lubricate entire length of sash channel cams with "Lubriplate" or its equivalent.

BACK DOOR DROPPING WINDOW REGULATOR—(ELECTRIC) 35 STYLE

REMOVAL AND INSTALLATION

1. Remove right side stationary window, dropping window and left side stationary window. Disconnect wire harness connector from regulator.

NOTE: Do not operate regulator motor after window assembly is removed. Operation of motor with load removed may damage unit.

2. Remove back door lock inside handle remote control attaching screws (Fig. 15-18). Disconnect remote control from connecting rod and remove remote control.

3. Remove screws securing inside handle remote control support plate (Fig. 15-18); then, move support plate towards right side of door to disengage inner panel cam from regulator arm roller and remove support plate.

4. Remove regulator attaching screws (Fig. 15-18) and remove regulator.

NOTE: To remove motor from regulator assembly, see "Window Regulator Electric Motor Assembly".

5. To install, first lubricate window lower sash channel cams and inner panel cams with "Lubriplate" or its equivalent; then, reverse removal procedure.

BACK DOOR WINDOW REGULATOR ELECTRIC MOTOR

REMOVAL AND INSTALLATION

1. Remove window regulator as described under "Back Door Dropping Window Regulator (Electric)" - Removal and Installation.

NOTE: Be sure to perform steps 2 and 3 before attempting to remove motor from regulator. The regulator lift arm is under tension from the counter balance spring and can cause serious injury if the motor is removed without locking the sector in place with a nut and bolt.

2. Place regulator and motor assembly in a vise (Fig. 15-22). Drill a 1/4" hole through back plate and sector at location indicated at either "A", "B", or "C" (Fig. 15-22) depending on position of lift arm.

NOTE: Do not drill into motor housing, part of which is indicated by dotted line. Also, do not locate hole less than 1/2" from edge of back plate or sector.

3. Insert a 3/16" bolt through hole in back plate and sector and install nut to bolt. Do not tighten nut.

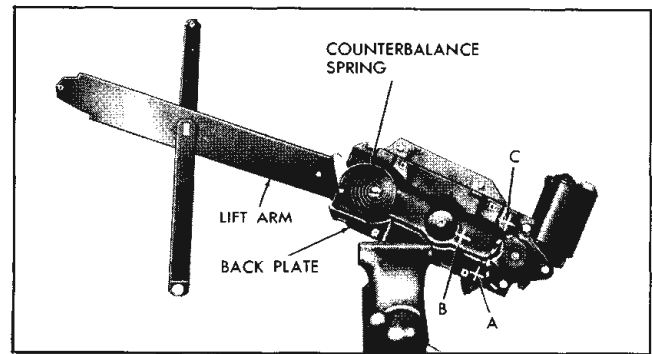

Fig. 15-22 Back Door Electric Window Regulator

4. Remove motor attaching bolts (Fig. 15-22) and remove motor from regulator.

NOTE: Clean off steel chips from regulator sector and motor pinion gear.

5. To install regulator motor, reverse removal procedure. If difficulty is encountered when trying to line up motor attaching holes, the regulator lift arm may be moved up or down manually so that motor pinion gear will mesh with teeth on regulator sector and regulator attaching holes will line up.

Lubricate regulator sector teeth and all frictional points with "Lubriplate" or equivalent.

NOTE: Be sure to remove temporary nut and bolt from regulator before installing regulator in door.

BACK DOOR WINDOW REVEAL MOLDINGS 35 STYLE

The back door window moldings, consisting of an upper, right, left and a lower molding, are secured to the back door by screws inserted through the window opening flanges.

UPPER REVEAL MOLDING REMOVAL AND INSTALLATION

Remove stationary side window frame attaching screws and the dropping window upper run channel screws; then, by moving the loosened stationary windows inward, remove the dropping window upper run channel. Remove the five upper reveal molding attaching screws, and remove the molding. To install, reverse removal procedure.

LOWER REVEAL MOLDING REMOVAL AND INSTALLATION

Remove stationary side window frame attaching

screws - both sides. Remove dropping window upper run channel. Raise dropping window so upper sash channel goes into opening between upper reveal molding and door pinchweld. Remove back door dropping window inner strip assembly and remove the three lower reveal molding attaching screws. Also, remove right and left end lower reveal molding screws by moving the stationary windows inward. Remove lower reveal molding. To install, reverse removal procedure.

**SIDE REVEAL MOLDING (RIGHT OR LEFT)
REMOVAL AND INSTALLATION**

Remove stationary side window frame attaching screws from side on which reveal molding is being removed. Push stationary side window inward and remove side reveal molding attaching screws. Remove lower reveal molding end attaching screw. Remove side reveal molding. To install, reverse removal procedure.

EXTERIOR MOLDINGS

CONTENTS OF THIS SECTION

SUBJECT	PAGE	SUBJECT	PAGE
Description	16-1	Rear Quarter Belt Reveal	16-6
Roof Drip Scalp Molding 2117	16-1	Rear Quarter Pinchweld Molding	16-7
Windshield Pillar Molding, 2167	16-1	Rear Fender Ornament	16-7
Windshield Pillar Molding, exc. 2167	16-3	Rear Fender Molding	16-7
Front Door Window Frame Molding	16-4	Back Door Molding	16-8
Center Pillar Scalp Molding	16-5	Deck Lid Emblem	16-8
Rear Door Window Frame Molding	16-5	Back Door Name Plate	16-8
Scalp Molding "19" and "35" Styles	16-5	Rear End Panel Molding	16-8
Rear Door Molding "19" and "35" Styles	16-6	Name Plate - LeMans	16-8
Rear Body Pillar Molding "35" Style	16-6	Pinchweld Finishing Molding	16-8
Rear Quarter Window Reveal	16-6		

DESCRIPTION

The exterior moldings are secured to the body by any one or a combination of the following: attaching screws, attaching nuts, snap retention on body parts, "bath-tub" type snap-on clips of steel or plastic construction, friction type snap-in clips, bolt and clip assemblies, joint plates and molding integral attaching studs. Fig. 16-1, depicts cross-section drawings which illustrate some of the typical methods used in attaching moldings to the body.

REMOVAL AND INSTALLATION

When removing and installing body exterior moldings, certain precautions should be exercised. Adjacent paint finishes should be protected to avoid refinishing. Proper tools and methods should be employed to guard against molding damage, particularly, if the part is to be reused. Whenever a sealing operation is disturbed, appropriate sealing materials and methods should be used to provide the required watertight seal. Every screw, nut or clip that secures a molding to a body outer panel, including the attaching hole, requires a specialized type of sealing operation. An approved grade of medium-bodied sealer and body caulking compound are the sealers used most generally in the effective sealing of these moldings. The exterior moldings are identified in Figs. 16-2 and 16-3.

If it is necessary to replace a "bath-tub" type clip as shown in Fig. 16-4, it may be removed with

a sharp flat bladed tool. Hammer the chisel until the base of the clip is cut approximately half-way through; then disengage the clip from the hole in the outer panel. In some cases, it may be necessary to cut the clip at the opposite side. To install a new steel clip, insert it in the hole in the outer panel and secure it to the panel, using Tool J-7160 as shown in Fig. 16-5.

ROOF DRIP SCALP MOLDING 2117 STYLE

The scalp, of one-piece construction, is secured to the drip molding by snap retention.

To remove the scalp: with a suitable pointed hook-tool unsnap the scalp from the drip molding. Start removal on the under side of the scalp at the front end.

To install the scalp: locate the scalp over the upper lip of the drip molding and snap the lower rolled edge over the drip molding.

WINDSHIELD PILLAR FINISHING MOLDING 2167 STYLE

The molding is secured to the windshield pillar by retaining screws in the windshield frame and by the windshield pillar weatherstrip retainer.

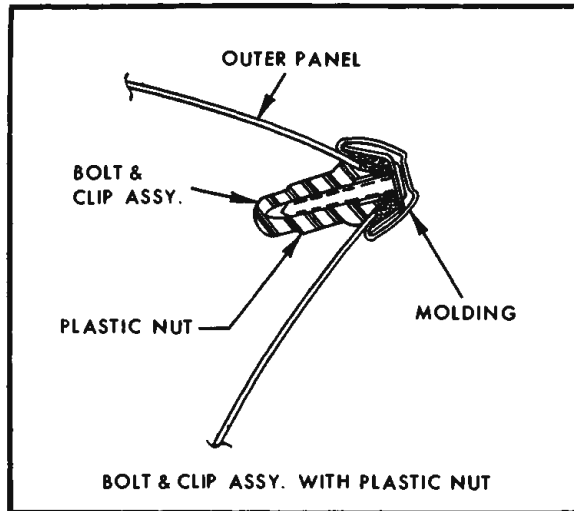
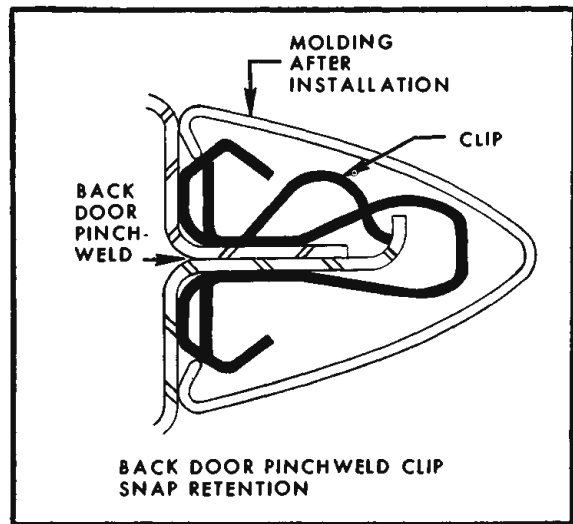
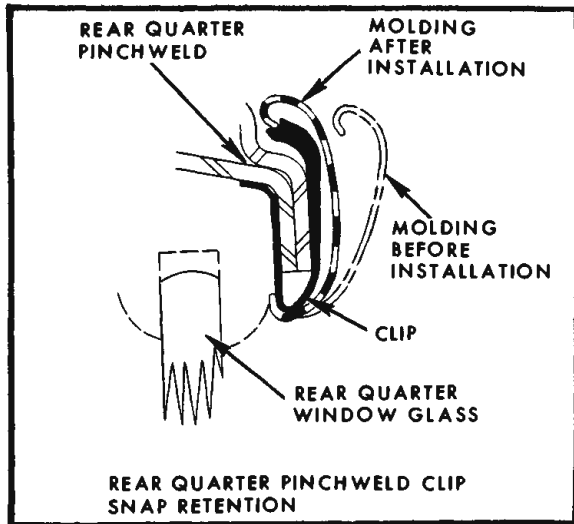
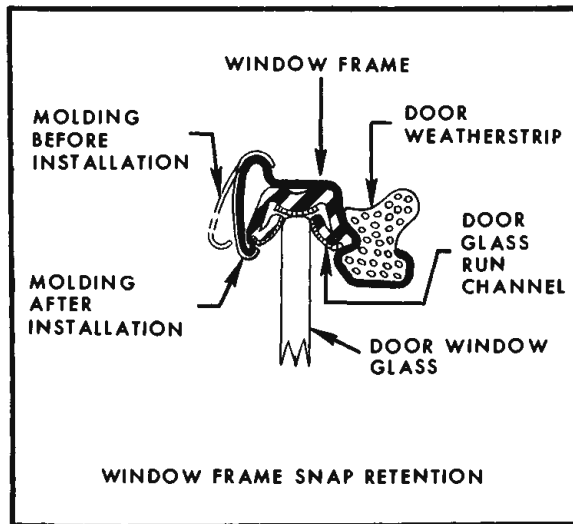
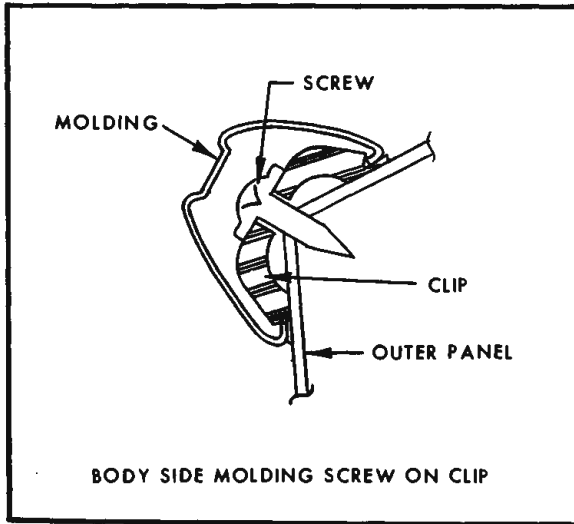
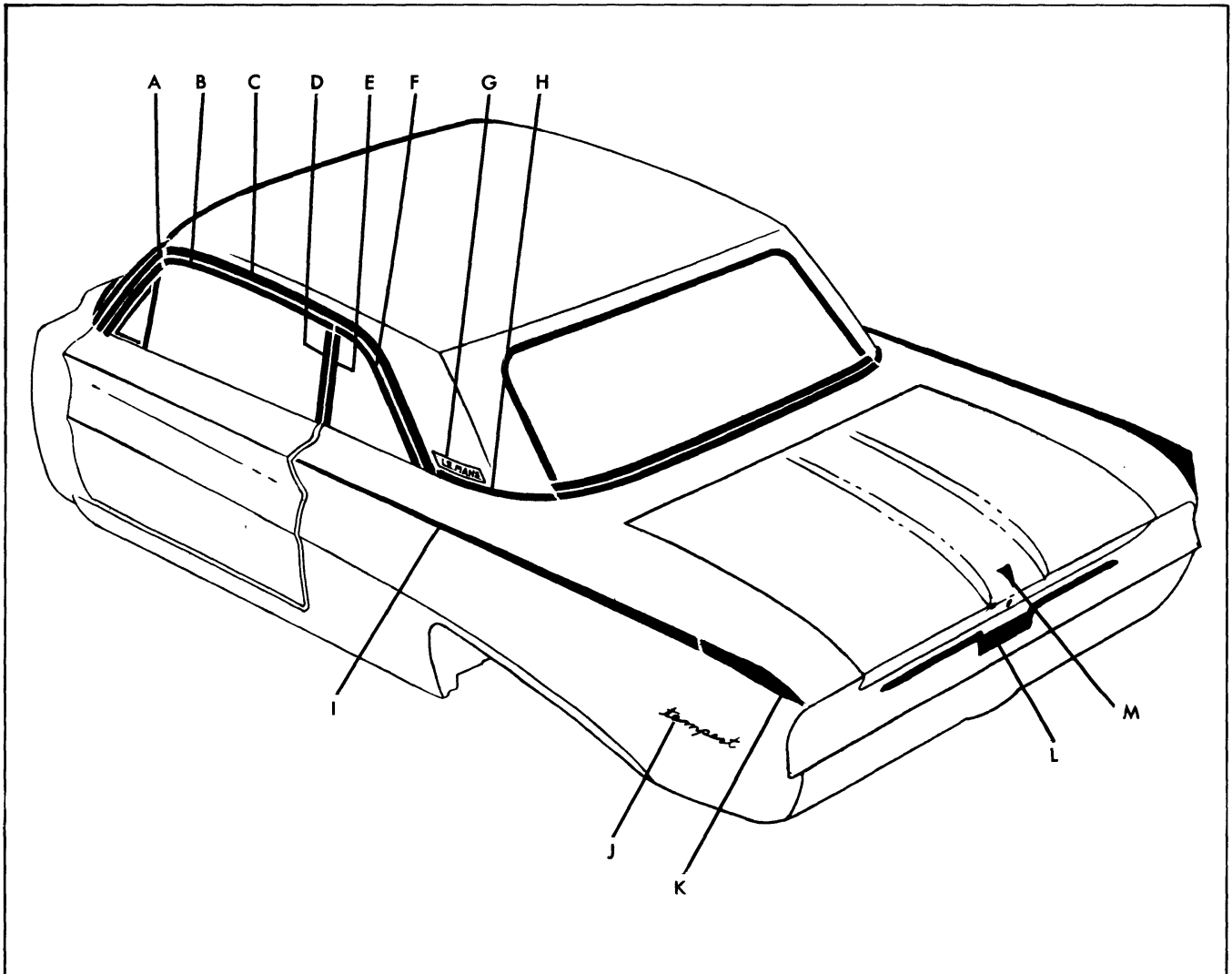

Fig. 16-1 Typical Method For Molding Attachment



- | | |
|---|--|
| A. Windshield Pillar Drip Molding | G. Roof Extension Panel Name Plate |
| B. Front Door Window Frame Upper Scalp Molding | H. Rear Quarter Belt Reveal Molding |
| C. Roof Drip Molding Scalp | I. Rear Fender Front Molding |
| D. Front Door Window Frame Vertical Scalp Molding | J. Rear Fender Name Plate |
| E. Rear Quarter Window Front Reveal Molding | K. Rear Fender Rear Molding |
| F. Rear Quarter Window Upper Reveal Molding | L. Rear End Panel Molding |
| | M. Rear Compartment Lid Outer Panel Emblem |

Fig. 16-2 Exterior Molding 2117 Style

To remove the molding: remove the windshield, windshield header and cap, windshield pillar weatherstrip and weatherstrip retainer and the molding retaining screws in the windshield frame.

To install the molding: apply a continuous strip of heavy-bodied sealer to the entire length of the molding attaching surface. Position the molding and attach screws to windshield frame. Install the previously removed parts.

WINDSHIELD PILLAR DRIP MOLDING ALL EXCEPT 67 STYLE

The molding extends from the front of the roof drip molding to the belt line, is secured to the pillar with screws, and requires sealing.

To remove the molding: remove the attaching screws, disengage the molding from the pillar and unhook it from the roof drip molding.

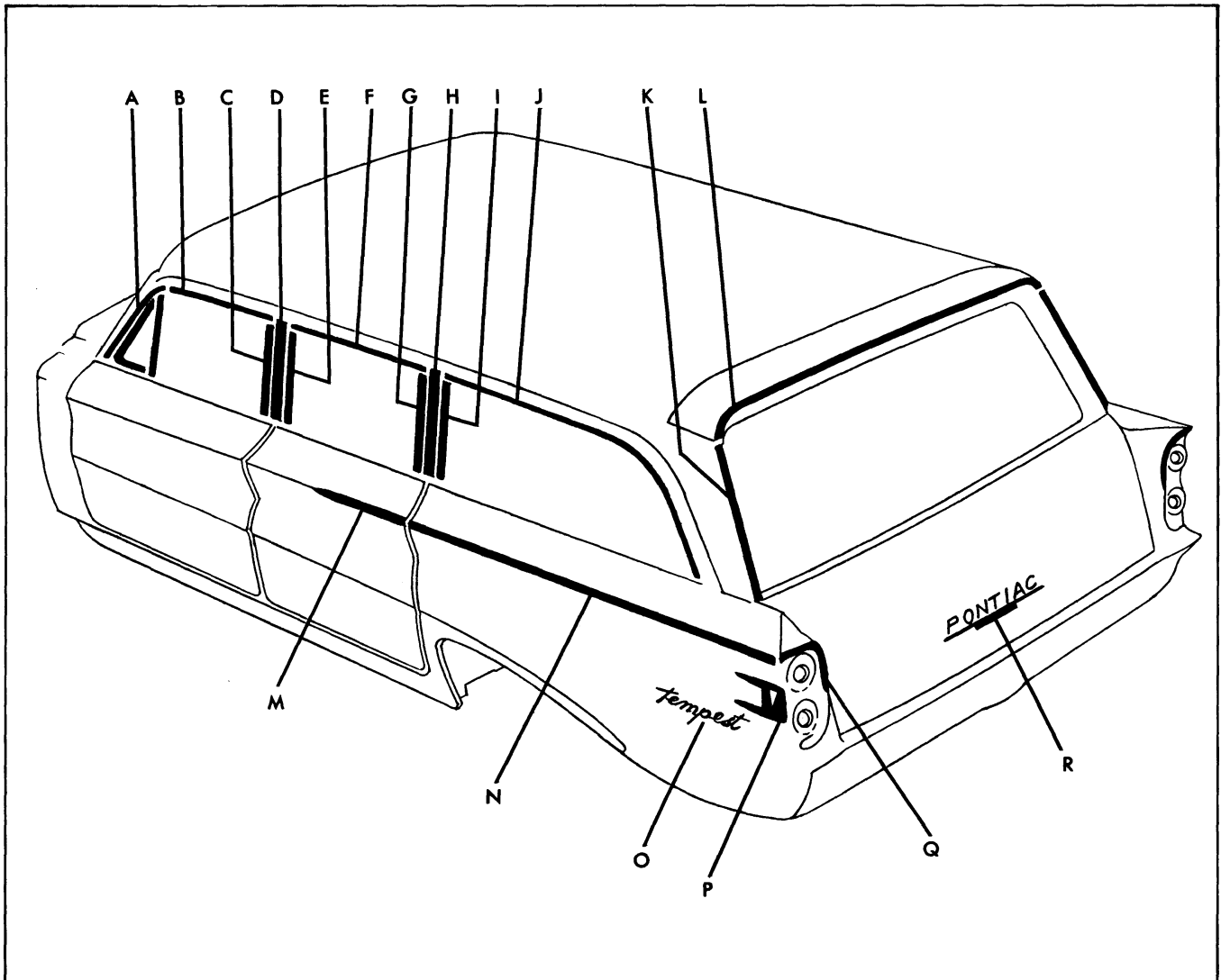

- A. Windshield Pillar Drip Molding
- B. Front Door Window Frame Upper Scalp Molding
- C. Front Door Window Frame Vertical Scalp Molding
- D. Center Pillar Vertical Scalp Molding
- E. Rear Door Window Frame Front Vertical Scalp Molding
- F. Rear Door Window Frame Upper Scalp Molding
- G. Rear Door Window Frame Rear Vertical Scalp Molding
- H. Body Lock Pillar Vertical Scalp Molding
- I. Rear Quarter Window Front Reveal Molding

- J. Rear Quarter Window Upper Reveal Molding
- K. Back Body Opening Side Upper Pinch Weld Finishing Molding
- L. Back Door Outer Panel Pinch Weld Finishing Molding
- M. Rear Door Outer Panel Lower Molding
- N. Rear Fender Lower Molding
- O. Rear Fender Name Plate
- P. Rear Fender Ornament
- Q. Rear of Rear Fender Molding
- R. Back Door Outer Panel Name Plate

Fig. 16-3 Exterior Moldings 2135 Style

To install the molding: clean the mating surfaces of the parts and apply a continuous ribbon of medium-bodied sealer along the center of the entire length of the molding attaching surface. Position the molding to the pillar and hook the upper edge over the front edge of the roof drip molding. Align and seal the

screw holes and install the attaching screws.

FRONT DOOR WINDOW FRAME UPPER SCALP MOLDING

The molding is secured to the window frame by snap retention.

To remove the molding: remove the door ventilator frame attaching screws, lower the door window and move the ventilator rearward slightly for access purposes.

With a suitable flat-bladed hook tool, unsnap the upper scalp molding from the window frame by working outwardly from the window opening. Start removal at the rear of the molding. Use care not to damage door parts during this operation.

To install the molding: apply body caulking compound (1/8" x 1/4" x 1/4") at six-inch intervals on the inner side of the molding. Engage the front end of the molding on the window frame. Position the molding to the rear corner of the window frame above the vertical molding and to the outside edge of the window frame and snap it into place. Install the door ventilator attaching screws.

FRONT DOOR WINDOW FRAME VERTICAL SCALP MOLDING

17, 19, 27 and 35 STYLES

The vertical scalp molding is overlapped by the upper scalp molding. The vertical scalp molding is secured to the door window frame by snap retention.

To remove the molding: loosen the upper scalp molding from the door rear edge to the ventilator division channel. With a flat-bladed hook tool, un-snap the vertical molding from the window frame by working outwardly from the window opening. Start the removal at the top. Use care not to damage any door parts during the operation.

To install the molding: apply body caulking compound (1/8" x 1/4" x 1/4") at six-inch intervals on the inner side of the molding. Position the molding to the outside edge of the window frame. Snap the upper portion of the molding into place.

CENTER PILLAR VERTICAL SCALP MOLDING

19 and 35 STYLES

The molding is secured to the center pillar with screws. To remove the molding: remove the attaching screws.

To install the molding: position the molding to the pillar, seal and install the attaching screws.

REAR DOOR WINDOW FRAME UPPER SCALP MOLDING

19 and 35 STYLES

The upper scalp molding is secured to the window frame by snap retention.

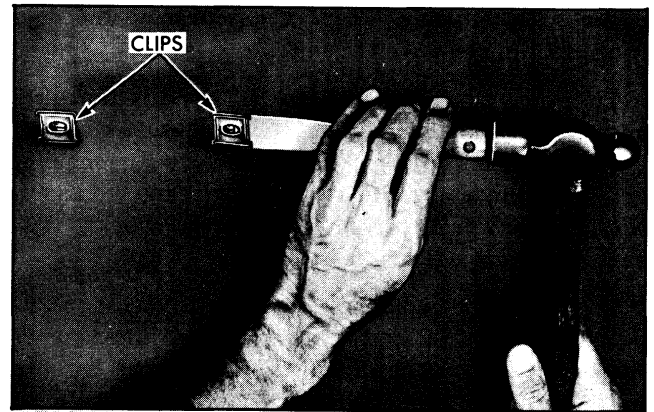

Fig. 16-4 Removing Clip

To remove the molding: use a suitable flat-bladed hook tool to un-snap the upper scalp molding from the window frame by working outwardly from the window opening. Use care not to damage any door parts.

To install the molding: apply body caulking compound (1/8" x 1/4" x 1/4") at six-inch intervals on the inner side of the molding. Position the molding to each corner of the window frame. Snap the molding inwardly over the window frame to secure it.

REAR DOOR WINDOW FRAME FRONT VERTICAL SCALP MOLDING AND REAR DOOR WINDOW FRAME REAR VERTICAL SCALP MOLDING

19 and 35 STYLES

The vertical scalp moldings are overlapped by the

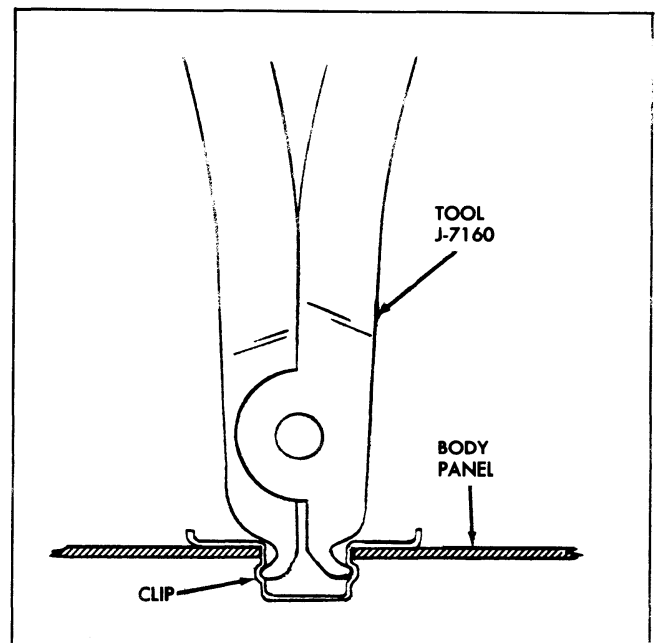

Fig. 16-5 Installing Clip

upper scalp molding. They are secured to the door window frame by snap retention.

To remove either molding: first, remove the upper scalp molding. Then, with a suitable flat-bladed hook tool, unsnap the vertical scalp molding from the window frame by starting at the top and by working outwardly from the window opening. Use care not to damage any door parts.

To install the molding: apply body caulking compound (1/8" x 1/4" x 1/4") at six-inch intervals on the inner side of the molding. Position the molding to the outside edge of the window frame, snap the lower end of the molding on the window frame. Snap the upper portion of the molding into place. Install the upper scalp molding.

REAR DOOR OUTER PANEL LOWER MOLDING

19 and 35 STYLES

The molding is secured to the door outer panel by a screw at the rear end and by "bath-tub" type snap-on clips which are previously installed on the door.

To remove the molding: remove rear attaching screw. With a flat-bladed tool, carefully unsnap the molding from the door at each clip location.

To install the molding: replace damaged clips as required. Place the molding upper return flange over the clips and snap the opposite flange over the clips. Seal and install the molding end attaching screw.

REAR BODY LOCK PILLAR SCALP MOLDING

35 STYLE

The front of the molding is secured to the lock pillar with screws. The rear of the molding is secured by the rear quarter window front reveal molding.

To remove the molding: remove the attaching screws. Swing the front of the molding outboard and release the rear edge from the quarter window front reveal molding.

To install the molding: apply body caulking compound at the upper and lower inner face of the molding (1/8" x 1/4" x 1/4"). Engage the rear edge of the molding under the quarter window front reveal molding and swing the molding into position. Install proper attaching screws.

REAR QUARTER WINDOW FRONT REVEAL MOLDING

ALL EXCEPT 67 STYLES

The molding, of bright or painted finish, is secured

by snap retention to special previously installed clips on the quarter window pinchweld. The molding is overlapped by the upper reveal molding.

To remove the molding: remove the upper reveal molding, except "35" style. On the "35" style, loosen the front half of the upper reveal molding. Using a suitable flat-bladed hook tool, unsnap the outer edge of the molding from the retaining clips located at the top and bottom of the molding.

To install the molding: replace molding retaining clips as required. Position the molding to the bottom of the window opening, engage the inner edge of the molding over the retaining clips, and with a pair of pliers, properly insulated, snap the molding into place. Install the upper reveal molding. Seal and complete the installation of the rear quarter window on "19" and "35" styles.

REAR QUARTER WINDOW UPPER REVEAL MOLDING

ALL EXCEPT 67 STYLE

The molding, of bright or painted finish is secured by snap retention to special, pre-installed clips on the quarter window pinchweld.

To remove the molding: remove the rear quarter window on "19" style. On "35" style, loosen the rear quarter window across the top. Protect the front reveal molding from damage, as required. With a flat-bladed hook tool, unsnap the outer edge of the molding from each retaining clip.

To install the molding: replace retaining clips as required. Align the molding with the front reveal molding and engage the inner edge of the molding with the retaining clips. Protect the front reveal molding from damage, as required. With a pair of pliers, properly insulated, snap the molding into position at each clip location. Seal and complete the installation of the rear quarter window on "19" and "35" styles.

REAR QUARTER BELT REVEAL MOLDING

17 STYLE

The molding is retained to roof extension panel by snap-in type clips.

To remove the molding: insert a flat-bladed tool at the top of the molding and carefully pry the molding from the roof extension panel.

To install the molding: replace damaged clips and apply heavy-bodied sealer to clips as required. Position the molding and the clips to the roof extension panel and snap it into place.

REAR QUARTER PINCHWELD FINISHING MOLDING

67 STYLE

The moldings are secured to the quarter pinchweld with snap-on clips which are previously installed on the pinchweld around the rear and side sections and with a screw at each forward end. The right molding overlaps the left molding.

REMOVAL

1. Remove the front attaching screws at the rear quarter windows.
2. Detach the front end of the folding top compartment bag from the rear seat back.
3. Remove the attaching screws from the back curtain trim retainers and pull them away from the body pinchweld.
4. With a wood block and hammer or with a flat-bladed tool, carefully disengage the moldings from the clips.
5. To remove the left molding, detach only a short section of the overlapping right molding.

INSTALLATION

1. Clean and seal the pinchweld flange.
2. Apply waterproof tape over the pinchweld flange to seal it completely.
3. Replace the damaged clips as required.
4. Position and locate the left molding to the body and snap it into place.
5. Install the right molding.
6. Install the previously removed parts.

REAR FENDER NAME PLATE

The name plate is sealed and is secured to the rear fender with attaching nuts.

To remove the name plate: on "35" style, remove the rear quarter rear trim assembly. On all styles, remove the attaching nut.

To install the name plate: apply body caulking compound to the name plate studs and to the attaching nuts. Position the name plate and install the attaching nut. On "35" style, install the rear quarter rear trim assembly.

REAR FENDER ORNAMENT

35 STYLE

The ornament is sealed and is secured to the rear fender with attaching nuts.

To remove the ornament: remove the rear quarter trim assembly and remove the four ornament attaching nuts, the two spacers and four sealing strips.

To install the ornament: apply body caulking compound to the four ornament studs before and after positioning it to the rear fender. Position the two spacers vertically over the four attaching studs and install the attaching nuts to effect a watertight seal. Install the trim assembly.

REAR FENDER LOWER MOLDING

The molding is of one-piece construction on "35" style and two-piece construction on all other styles. The body attachments of all styles are the same. The front molding is secured to the rear fender by snap-on type clips which have been previously installed on the fender. The rear molding is overlapped by the front molding and is secured by integral studs with attaching nuts.

To remove the molding: remove rear quarter trim on "35" style. With a flat-bladed tool, carefully unsnap the front molding from the fender at each clip location, starting at the front of the molding. Remove rear molding attaching nuts.

To install the molding: replace damaged clips as required. Insert washer over studs of rear molding. Telescope the rear end of the front molding into the front end of the rear molding. Insert the studs of the rear molding into locating holes. Place upper return flange of front molding over previously installed clips and snap the opposite flange over the clip. Install the attaching nuts. Install trim on "35" styles.

REAR OF REAR FENDER MOLDING

35 STYLE

The molding is sealed and is secured to the rear fender with attaching nuts.

To remove the molding: remove the rear quarter rear trim assembly and remove the molding attaching nuts.

To install the molding: install washer to molding studs. Position the molding to the fender and install the attaching nuts. Install the trim assembly.

BACK DOOR OUTER PANEL MOLDING

35 STYLE

The molding is secured to the back door by attaching nuts.

To remove the molding: remove the back door inner panel and remove the attaching nuts.

To install the molding: apply heavy-bodied sealer to the molding studs. Insert the studs into the holes and secure attaching nuts. Replace back door inner trim panel.

REAR COMPARTMENT LID OUTER PANEL EMBLEM

35 STYLE

The emblem is sealed and is secured to the lid outer panel with attaching nuts. To remove the emblem, simply remove the attaching nuts through the access holes in the lid inner panel.

To install the emblem: install sealing washer over emblem studs and position the emblem to the lid outer panel and install the attaching nuts.

BACK DOOR OUTER PANEL NAME PLATE

35 STYLE

The name plate is secured and sealed to the back door by special, previously installed "snap-in" type clips.

To remove the name plate: use a suitable flat-bladed tool and carefully pry the three integral attaching studs from the retaining clips.

To install the name plate: if necessary, secure replacement clips. Insert the clips into the back door attaching slots. Fill each clip with body caulking compound and apply compound around the clip edges to provide a watertight seal. Align the name plate studs with the clips and apply an even pressure on the entire plate until it is against the panel.

REAR END PANEL MOLDING

35 STYLE

The molding is secured to the rear end panel by attaching nuts.

To remove the molding: remove the attaching nuts.

To install the molding: install the washers over the studs on the molding. Insert the studs through the panel and install the sealing nuts to effect a watertight seal.

REAR END PANEL NAME PLATE (PONTIAC—"LEMANS")

The name plate is secured to the rear end outer panel by attaching nuts.

To remove the name plate: remove the attaching nuts.

To install the name plate: install the washers over the studs of the name plate. Insert the studs through the panel and attach the sealing nuts to effect a watertight seal.

BACK BODY OPENING SIDE UPPER PINCHWELD FINISHING MOLDING

35 STYLE

The molding is secured by snap retention over special pinchweld clips.

To remove the molding: use a suitable flat-bladed tool and unsnap the molding at each clip location.

To install the molding: replace and seal damaged clips as necessary. Before clip replacement, apply medium-bodied sealer to the pinchweld surfaces contacted by the clips. Hook one edge of the molding over the clips and snap the opposite side over the clips to secure it.

BACK DOOR OUTER PANEL PINCHWELD FINISHING MOLDING

35 STYLE

The molding is secured by a screw at each outer end and by snap retention over special pinchweld clips.

To remove the molding: remove the end attaching screws and, with a suitable flat-bladed tool, unsnap the molding at each clip location.

To install the molding: replace and seal damaged clips as necessary. Before clip replacement, apply medium-bodied sealer to the pinchweld surfaces by the clip. Hook one edge of the molding over the clips and snap the opposite side over the clips to secure it. Install and seal the end attaching screws.

HEADLINING

CONTENTS OF THIS SECTION

SUBJECT	PAGE	SUBJECT	PAGE
Description	17-1	Removal and Installation	17-1

HEADLINING ASSEMBLY

DESCRIPTION

The headlining assembly is formed to contour by concealed listing wires. Both ends of each listing wire are installed into holes in listing wire clips which are secured to the side roof inner rail assembly. The headlining assembly is secured at the windshield and back window by cement and tacks or staples. Along the side roof rail the headlining is cemented around the flange of the side roof inner rail assembly.

CAUTION: *Clean hands and tools are essential when working with headlining material.*

REMOVAL

1. Place protective coverings over seat cushions and backs.
2. Prior to removing headlining, remove following hardware and trim assemblies:
 - a. Sunshade support assembly(s)
 - b. Rear view mirror support
 - c. Windshield upper garnish moldings
 - d. Center pillar-to-roof rail finishing plates
 - e. Coat hooks (where present)
 - f. Back window upper garnish moldings, right, left and center
 - g. Dome lamp assembly
 - h. Front and rear door opening pinchweld finishing strip along top of each door opening sufficiently to expose edge of headlining
 - i. Body lock pillar to roof rail finishing plates (station wagon only)
 - j. Back body opening upper finishing panels (station wagon only)
 - k. Rear quarter upper pinchweld finishing strips (station wagon only)

3. Carefully detach cemented edge of headlining along each side roof inner rail including rear quarter windows on station wagon styles (see View "A", Fig. 17-1).

4. Carefully remove tacks or staples securing headlining at windshield opening as shown in View "A" and along back window or back body opening as shown in views "B" and "C", Fig. 17-1, then carefully detach cemented edges of headlining from openings.

5. Working from front to rear of body, disengage headlining #1 listing wire from clip on side roof inner rail. Gather or roll headlining with listing wires on outside to keep headlining clean.

6. At roof bow, bend down metal tabs shown in view "E", Fig. 17-1, and remove listing support wire from roof bow.

7. Disengage remaining listing wires from clips on side roof inner rail and remove headlining from body and place on clean protected surface.

NOTE: Note into which holes the ends of the listing wires are installed in side roof rail clips to insure proper installation (see view "B").

8. If replacing the headlining, remove listing wires from pockets of headlining.

INSTALLATION

1. If previously removed, install listing wires into pockets of new headlining assembly.

2. Apply approved trim cement to headlining attaching surfaces at windshield and back window openings. Also apply cement to headlining attaching surfaces along side roof inner rails.

3. Lift entire headlining assembly into body, then install rear listing wire. Center and align headlining in relation to back window opening and side roof rails. Working forward, install ends of listing wires into listing wire holes in side roof rails.

NOTE: The headlining listing wires are normally installed in center hole of clip as shown in view "B".

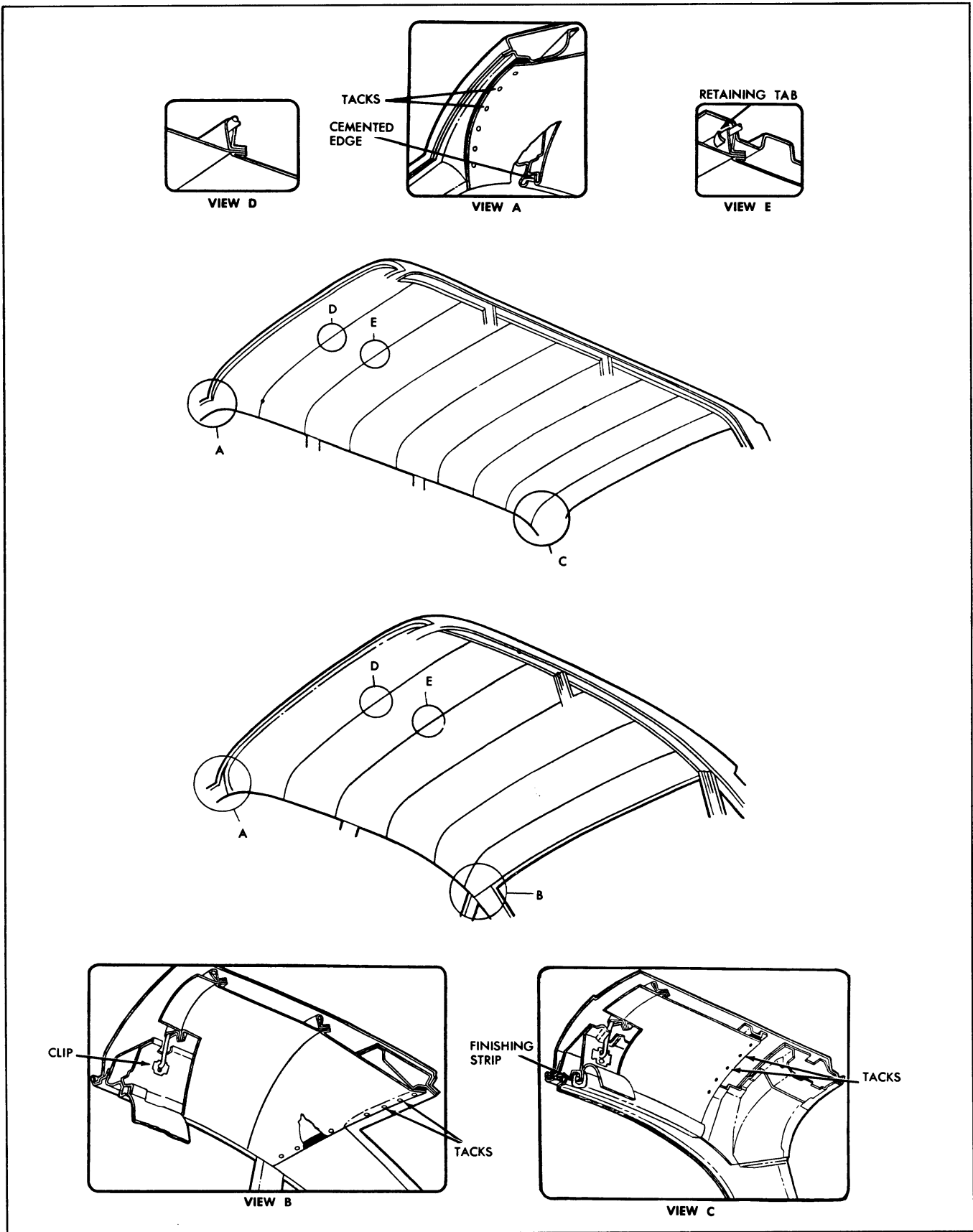

Fig. 17-1 Headlining Installation

4. Install headlining listing support wire over metal tabs on roof bow. Bend up metal tabs so that support wire is securely fastened to roof bow. (View "E", Fig. 17-1).

5. Install #1 listing wire into hole of clip on side roof inner rail.

NOTE: Headlining listing wires may be adjusted up or down in different clip holes as required to compensate for a headlining which may be too tight against the roof panel or too loose making it difficult to remove draws or wrinkles.

6. Stretch and stay tack headlining along entire windshield and back window openings.

7. Apply trim cement to side edges of headlining assembly.

8. Working toward front of body, install headlining to side roof inner rail, cutting headlining to shape at center pillar and upper rear body lock pillar. Remove all draws or wrinkles as required from headlining assembly.

9. Trim excess material from edges of headlining assembly.

10. Using a headlining inserting tool, install trimmed edges of headlining to outer surface of side roof inner rail to give headlining a finished appearance.

11. Inspect headlining along back window opening. Remove draws or wrinkles as required by stretching material and retacking. After all fullness has been removed, permanently tack headlining assembly across back window opening.

12. Trim away excess material across back window opening.

13. Inspect headlining along windshield opening. Remove draws or wrinkles as required by stretching material and retacking. After all fullness has been removed, permanently tack headlining assembly across windshield opening.

14. Trim away excess material across windshield opening.

15. Install door opening and/or rear quarter upper pinchweld finishing strips and all other previously removed inside hardware.

SEATS

CONTENTS OF THIS SECTION

SUBJECT	PAGE	SUBJECT	PAGE
Front and Rear Seat Assemblies		Folding Rear Floor Filler Panel	
Front Seat Assy. - Seat Adjusters Attached	18-1	Assembly	18-5
Removal and Installation	18-1	Removal and Installation	18-5
Front Seat Adjusters	18-1	Adjustment	18-6
Removal and Installation	18-1	Compartment Floor Panel Assembly	
Front Seat Back Assembly	18-2	(At Kick-up)	18-6
Removal and Installation	18-2	Removal and Installation	18-6
Front Seat Side Protector Cover	18-3	Spare Tire Cover Panel Assy.	18-6
Removal and Installation	18-3	Removal and Installation	18-6
Repositioning Front Seat Assy.	18-3	Compartment Floor Side Panel Assembly	
Rear Seat Cushion Assembly	18-3	(Right or Left Side)	18-6
Removal and Installation	18-3	Removal and Installation	18-6
Rear Seat Back Assembly.	18-3	Folding Rear Seat Back Bumper, Retainer	
Removal and Installation	18-3	and Support (Right or Left Side)	18-6
		Removal and Installation	18-6
Folding Rear Seat and Rear Compartment		Spare Tire Cover Handle Assy.	18-7
Floor Panels		Removal and Installation	18-7
Folding Rear Seat Cushion	18-4	Rear Seat Cushion Assembly	18-7
Removal and Installation	18-4	Removal and Installation	18-7
Folding Rear Seat Back Assembly	18-4	Folding 3rd Seat Back Panel Assy.	18-8
Removal and Installation	18-4	Removal and Installation	18-8
Folding Rear Seat Back Mounting		Folding 3rd Seat Bottom Cushion	
Support Link Assembly	18-5	Panel Assembly.	18-8
Removal and Installation	18-5	Removal and Installation	18-8

FRONT AND REAR SEAT ASSEMBLIES

Manually operated front seat adjusters provide fore and aft movement of the seat. When the lever at the left seat adjuster is raised the seat adjusters unlock, permitting horizontal travel of the seat. When the seat is in the desired position, the lever is released and the seat is locked.

The front seat adjusters may be reworked to reposition the front seat assembly one (1) inch rearward.

FRONT SEAT ASSEMBLY WITH SEAT ADJUSTERS ATTACHED

REMOVAL AND INSTALLATION

1. Turn back floor carpeting, where necessary, to expose seat adjuster-to-seat support attaching bolts.
2. Scribe location of rear end of adjuster on front seat rear support and remove adjuster rear attaching bolts.

3. With aid of helper, tilt seat assembly forward; then, slide seat assembly rearward to disengage front legs of adjusters from retainers. Remove seat assembly from body.

4. To install, reverse removal procedure.

NOTE: Make certain front legs of adjusters are completely engaged under retainers and adjusters are aligned within scribe marks before installing attaching bolts.

FRONT SEAT ADJUSTERS

REMOVAL AND INSTALLATION

1. Remove front seat assembly with adjusters attached from body and place it upside down on a clean, protected bench.
2. Remove seat adjuster counter balance spring attached to seat adjuster front support and seat bottom frame as shown in Fig. 18-1.

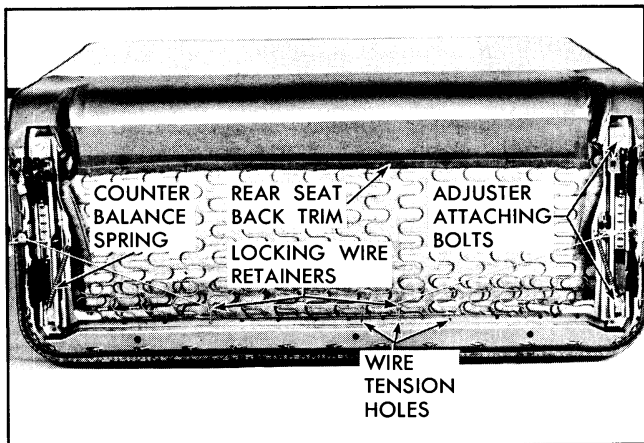

Fig. 18-1 Front Seat Adjuster Removal

3. Operate adjusters so that both front and rear attaching bolts are accessible.

4. Squeeze hooked end of seat adjuster locking wire together and slide retaining spring back over hump in locking wire and remove locking wire from adjuster.

5. Remove adjuster-to-seat bottom frame front and rear attaching bolts shown in Fig. 18-1 and remove seat adjuster from seat assembly.

6. To install, reverse removal procedure. Check seat assembly for proper operation prior to installing seat assembly.

NOTE: The right and left seat adjuster sliding mechanisms should be in same relative position when attaching adjuster to seat bottom frame.

7. If right adjuster does not lock or unlock satisfactorily when control handle on left adjuster is operated, disengage locking wire retainer on right side of seat from hole in seat bottom frame and engage retainer in one of adjacent holes to obtain proper tension in wire. (Fig. 18-1)

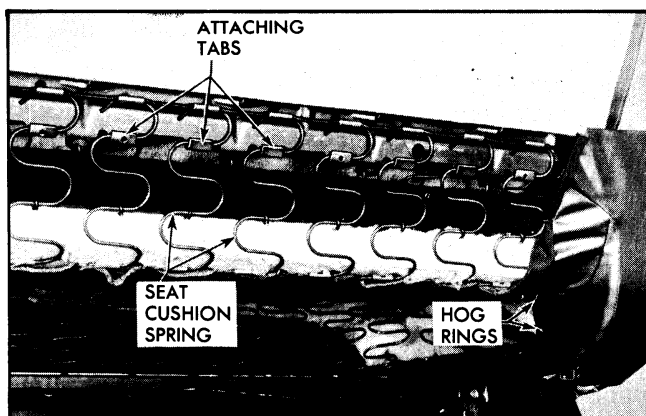

Fig. 18-2 Front Seat Cushion Spring Attachment

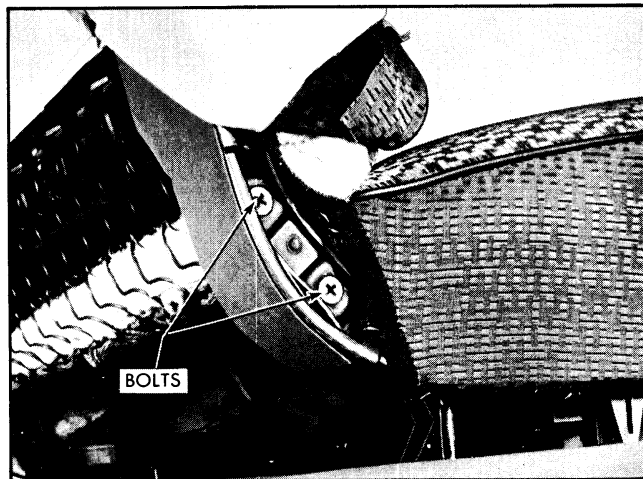

Fig. 18-3 Front Seat Back Attachment

FRONT SEAT BACK ASSEMBLY

REMOVAL AND INSTALLATION

1. Remove front seat assembly from body and place it upside down on a clean, protected bench.

2. Remove hog rings securing central portion of lower rear edge of seat back trim from front seat cushion spring assembly (Fig. 8-1).

3. Raise trim and remove cardboard breakover foundation to expose seat cushion spring attachment to seat back frame along rear of seat and hog rings securing ends of seat back trim to seat bottom frame (Fig. 18-2).

4. Bend open tabs securing seat cushion spring assembly to seat back frame and carefully disengage springs from tabs. (Fig. 18-2)

5. At each end of seat remove hog rings securing lower edge of seat back trim from seat bottom frame. Then raise seat back trim to expose bolts securing seat back reinforcement to seat bottom frame. (Fig. 18-3)

6. Place seat assembly in upright position. Then with a helper, holding seat back assembly, remove seat back reinforcement-to-seat bottom frame attaching bolts on each side of seat and remove seat back assembly.

7. To install, reverse removal procedure.

NOTE: Make certain rear edge of seat cushion spring assembly is properly engaged to seat back frame and cardboard breakover foundation is properly positioned prior to hog ringing central portion of trim in place.

FRONT SEAT SIDE PROTECTOR COVER

REMOVAL AND INSTALLATION

1. Turn back floor covering along outboard side at front seat adjuster sufficiently to expose protector cover.
2. Remove screws shown in Fig. 18-4 securing cover to floor pan and remove cover.
3. To install, reverse removal procedure.

REPOSITIONING FRONT SEAT ASSEMBLY

To reposition front seat assembly one (1) inch rearward, proceed as follows:

1. Remove front seat assembly from body and place it upside down on a clean, protected bench.
2. Remove seat adjuster retainers from front seat floor pan support.
3. Turn seat adjuster retainer 180° and install retainer.
4. Enlarge pilot holes in seat adjuster located one (1) inch forward of attaching holes at rear of each seat adjuster to 3/8" diameter. (Fig. 18-5)
5. Install front seat assembly. Check seat for proper operation.

REAR SEAT CUSHION ASSEMBLY

REMOVAL

1. Push lower forward edge of cushion rearward and pull cushion upward until protrusions on seat bottom frame disengage from floor pan stops.
2. Pull cushion forward and carefully remove from body.

INSTALLATION

1. Carefully lift cushion into body to avoid damaging adjacent trim.
2. Position rear edge of cushion under rear seat back assembly.
3. Center protrusions on seat bottom frame with stops on floor pan assembly.

NOTE: If seat bottom frame protrusions are not properly centered in relation to floor pan stops, proper engagement and placement of cushion will be extremely difficult.

4. Push forward edge of cushion rearward and downward until protrusions are properly engaged behind floorpan stops.

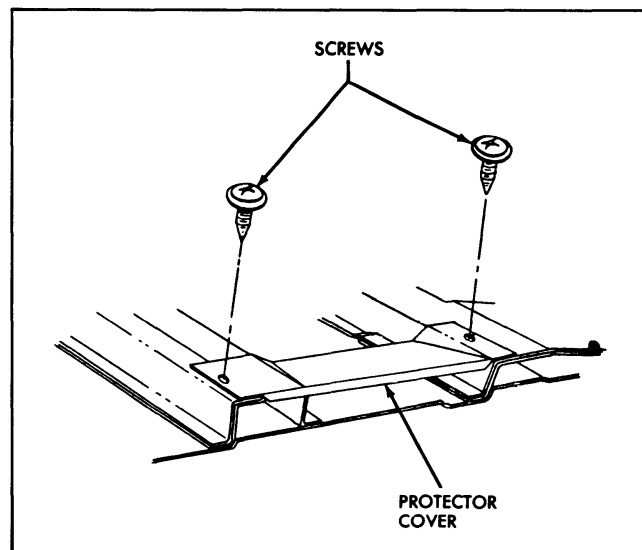

Fig. 18-4 Front Seat Side Protector Cover

REAR SEAT BACK ASSEMBLY

REMOVAL AND INSTALLATION

1. Remove rear seat cushion assembly.
2. At bottom of the seat back on all styles except convertibles, bend out the two (2) tabs that secure the seat back to the floor panel. On convertibles, remove the two (2) screws securing the seat back to the floor panel.
3. Pull seat back assembly out at bottom until seat back clears body tabs; then, raise seat back upward until disengaged from hangers on the seat back panel support.

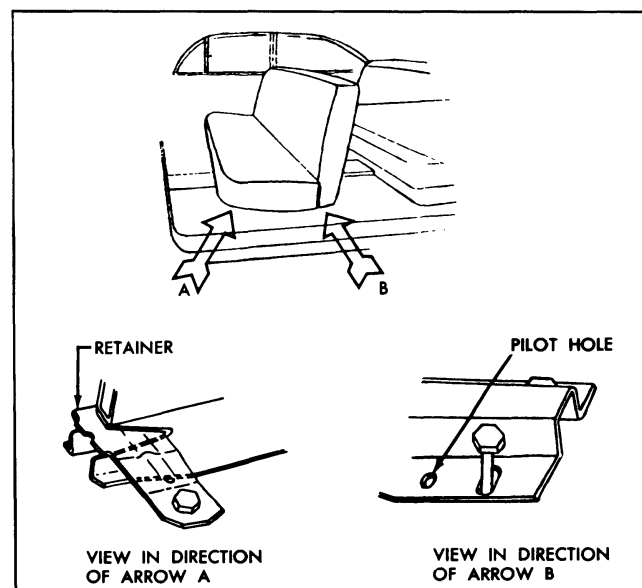

Fig. 18-5 Front Seat Repositioning

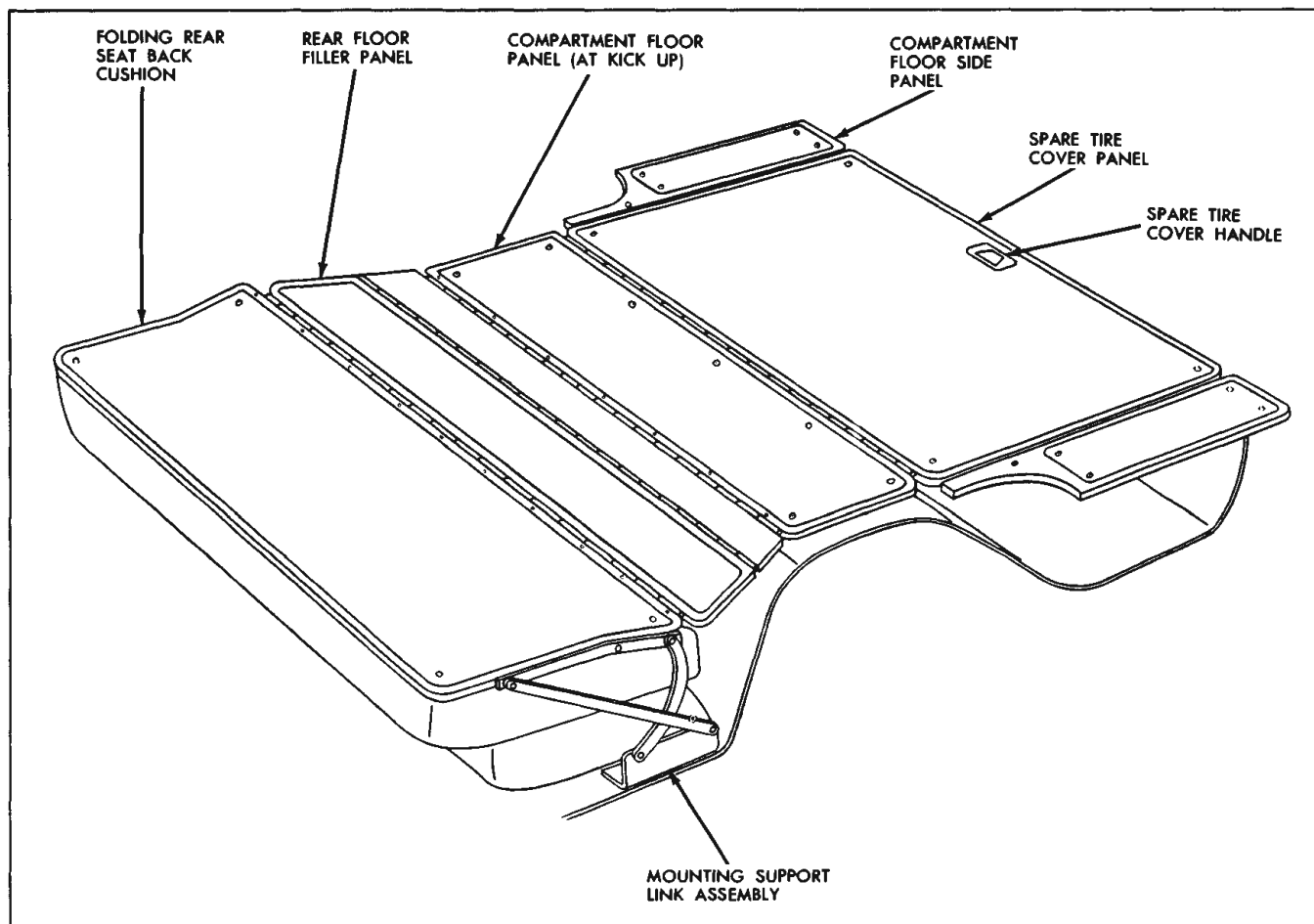

Fig. 18-6 Folding Rear Seat Back and Rear Compartment Floor Panels

4. Remove seat back assembly from body.
5. To install, reverse removal procedure, making

certain that all attaching body tabs and hangers have industrial body tape applied to them to act as an anti-squeak.

FOLDING REAR SEAT AND REAR COMPARTMENT FLOOR PANELS

The following view (Fig. 18-6) is typical of the Station Wagon folding rear seat back and rear compartment floor panels. This illustration identifies the component parts of the rear compartment area, their relationship and various attaching points.

FOLDING REAR SEAT CUSHION

REMOVAL AND INSTALLATION

1. Lift up front edge of folding rear seat cushion assembly to disengage protrusions in seat bottom frame from slots in rear seat support and remove cushion assembly.

2. To install, reverse removal procedure. Make certain that protrusions are fully engaged in rear seat support.

FOLDING REAR SEAT BACK ASSEMBLY

REMOVAL AND INSTALLATION

1. Fold rear seat back assembly to "down" position.
2. Remove rear floor filler panel to folding seat back panel attaching screws as shown in Fig. 18-7.
3. At each side of seat, remove screws securing mounting support link assembly to folding seat back assembly (Fig. 18-8).
4. With aid of helper, carefully remove folding seat back assembly from body and place it on a clean, protected bench.
5. To install, reverse removal procedure.

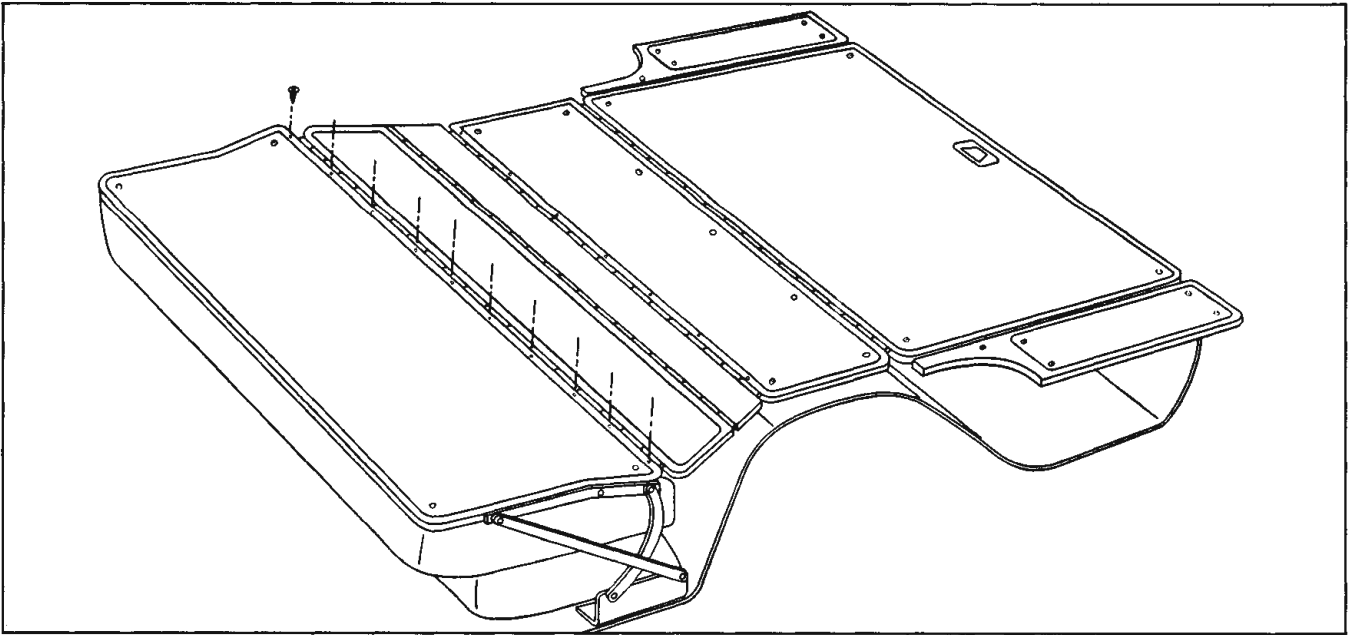

Fig. 18-7 Folding Rear Seat Back Assembly

FOLDING REAR SEAT BACK MOUNTING SUPPORT LINK ASSEMBLY

REMOVAL AND INSTALLATION

1. Release rear seat cushion and slide cushion forward.
2. Turn back rear floor carpet sufficiently to expose mounting support link to floor pan anchor plate attaching screws and remove screws.
3. Fold rear seat back assembly to "down" position.
4. Remove mounting support to folding seat back attaching screws as shown in Fig. 18-8 and remove mounting support link assembly from body.

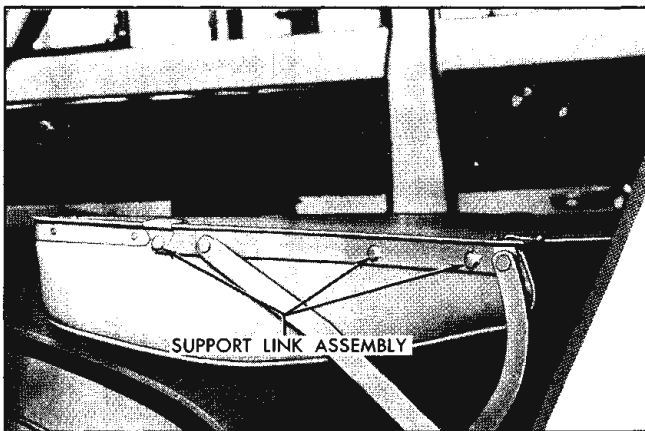

Fig. 18-8 Folding Seat Back Mounting Support Link Assembly

5. To install, reverse removal procedure. Check operation of folding rear seat back and filler panel assembly. Where required, loosen mounting support to anchor plate attaching screws. Adjust mounting support fore or aft as required for proper folding seat back operation.

FOLDING REAR FLOOR FILLER PANEL ASSEMBLY

REMOVAL AND INSTALLATION

1. Fold rear seat back assembly to "down" position.
2. Remove filler panel to folding seat back attaching screws and filler panel to rear seat pan attaching screws as shown in Fig. 18-9 and remove filler panel from body.
3. To install, reverse removal procedure.

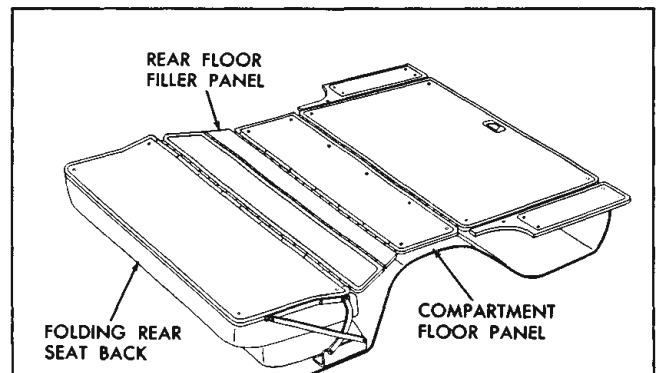

Fig. 18-9 Folding Rear Floor Filler Panel Assembly

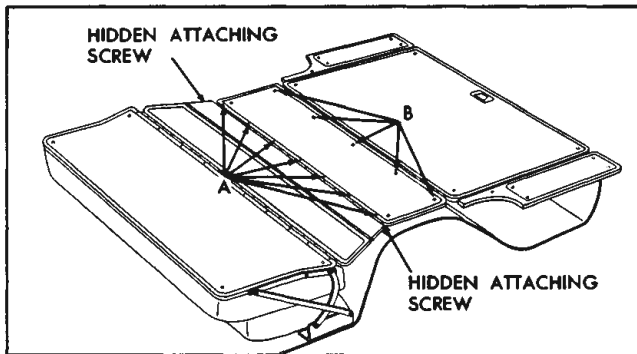

Fig. 18-10 Compartment Floor Panel Assembly

ADJUSTMENT

To adjust folding rear floor filler panel assembly, proceed as follows:

1. At each side of seat, loosen mounting support to floor pan anchor plate attaching screws.
2. Adjust mounting supports fore or aft as required and tighten screws.
3. Check operation of folding seat back and filler panel assembly. When the seat back is in the "down" or "folded" position, the back and rear floor filler panel should form a level floor surface. Where necessary, readjust mounting supports as required for proper seat back and filler panel operation.

COMPARTMENT FLOOR PANEL ASSEMBLY (AT KICK-UP)

REMOVAL AND INSTALLATION

1. Lower folding rear back assembly.
 2. Remove rear floor filler panel to rear seat pan attaching screws as shown at "A" in Fig. 18-10.
 3. Fold rear floor filler panel forward sufficiently to gain access to compartment floor panel to rear seat pan attaching screws and remove screws from panel.
- NOTE: Attaching screws are located at each end of panel (See Hidden Attaching Screw, Fig. 18-10).
4. Remove floor panel to spare tire cover hinge support panel attaching screws, shown at "B", Fig. 18-10 and remove compartment floor panel assembly from body.
 5. To install, reverse removal procedure.

SPARE TIRE COVER PANEL ASSEMBLY**REMOVAL AND INSTALLATION**

1. Remove compartment floor panel assembly as previously described.

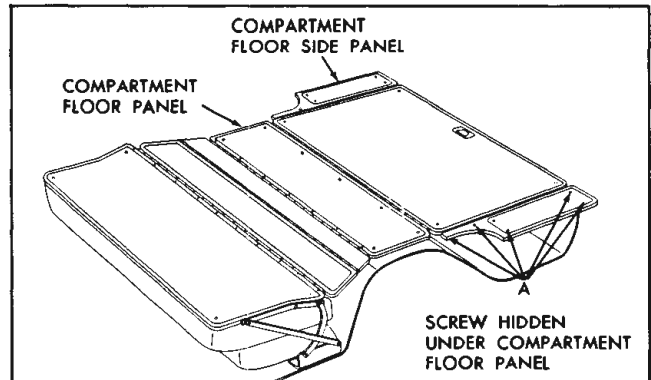

Fig. 18-11 Compartment Floor Side Panel Assembly (Right or Left)

2. Remove screws securing spare tire cover panel hinge to hinge support.
3. Using spare tire cover handle, lift panel upward and remove spare tire cover panel assembly from body.
4. To install, reverse removal procedure.

COMPARTMENT FLOOR SIDE PANEL ASSEMBLY (RIGHT OR LEFT SIDE)

REMOVAL AND INSTALLATION

1. Remove compartment floor panel assembly as previously described.
2. Remove screws securing compartment floor side panel to side panel support as shown at "A", Fig. 18-11 and remove panel assembly from body.
3. To install, reverse removal procedure.

FOLDING REAR SEAT BACK BUMPER, RETAINER AND SUPPORT (RIGHT OR LEFT SIDE)

REMOVAL AND INSTALLATION

1. With folding rear seat back in "down" position, remove screw shown in View "A", Fig. 18-12, and remove bumper and retainer from wheelhouse support.
2. Remove three (3) screws shown in View "A", Fig. 18-12 and remove support from wheelhouse assembly.
3. To install, reverse removal procedure.

NOTE: The folding rear seat back retainer is adjustable inboard or outboard (See Fig. 18-12). To adjust retainer, raise folding rear seat back to "up" position and check retainer tension. Lower

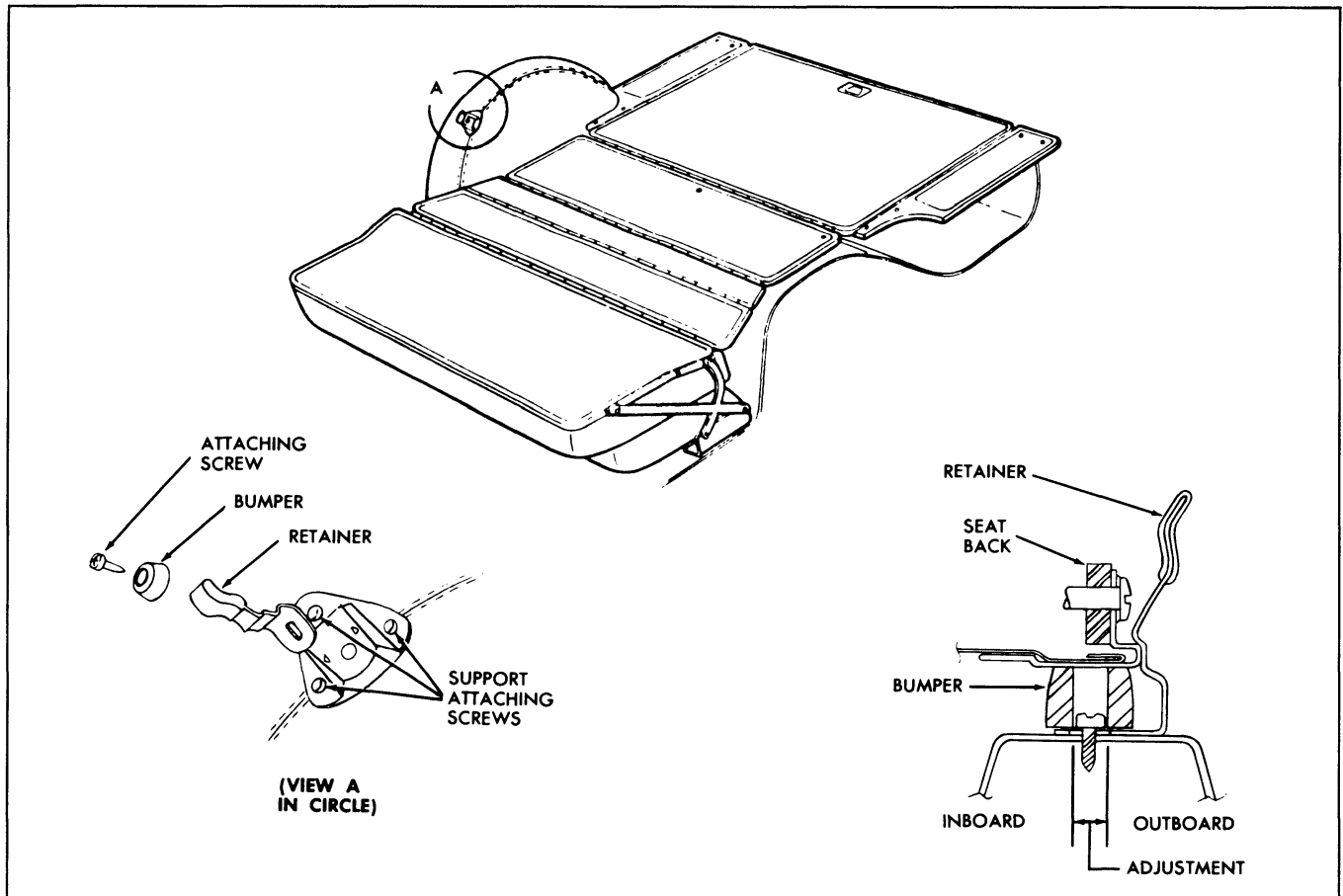

Fig. 18-12 Folding Rear Seat Back Bumper, Retainer and Support

folding seat back and loosen retainer attaching screw. Adjust retainer inboard or outboard as required then tighten attaching screw. Recheck folding seat back assembly. Where required, re-adjust retainer until desired seat back retention has been obtained.

SPARE TIRE COVER HANDLE ASSEMBLY

REMOVAL AND INSTALLATION

1. Remove four (4) screws securing handle to spare tire cover panel and remove handle assembly from panel.

2. To install, reverse removal procedure.

REAR SEAT CUSHION ASSEMBLY

REMOVAL

1. Push lower forward edge of cushion rearward and pull cushion upward until protrusions on seat

bottom frame disengage from floor pan stops.

2. Pull cushion forward and carefully remove from body.

INSTALLATION

1. Carefully lift cushion into body to avoid damaging adjacent trim.

2. Position rear edge of cushion under rear seat back assembly.

3. Center protrusions on seat bottom frame with stops on floor pan assembly.

NOTE: If seat bottom frame protrusions are not properly centered in relation to floor pan stops, proper engagement and placement of cushion will be extremely difficult.

4. Push forward edge of cushion rearward and downward until protrusions are properly engaged behind floor pan stops.

**FOLDING 3RD SEAT BACK
PANEL ASSEMBLY****REMOVAL AND INSTALLATION**

1. Remove compartment floor panel as previously described.
2. With folding 3rd seat back in "down" position, remove screws securing 3rd seat back hinge to hinge support.
3. Raise folding 3rd seat back and remove screws securing right and left link assembly from body.
4. To install, reverse removal procedure.

**FOLDING 3RD SEAT BOTTOM
CUSHION PANEL ASSEMBLY****REMOVAL AND INSTALLATION**

1. Raise folding 3rd seat back and cushion assembly to "up" or "sitting" position.
2. At right and left side of folding 3rd cushion, remove screws securing hinge to hinge support and remove folding 3rd cushion assembly from body.
3. To install, reverse removal procedure.

ELECTRICAL

CONTENTS OF THIS SECTION

SUBJECT	PAGE	SUBJECT	PAGE
Body Wiring	19-1	Back Door Dropping Window	19-3
		Checking Procedures	19-4

BODY WIRING

The current for all of the electrical circuits is provided by a twelve volt battery. The installation of the body wiring includes the dome lamp, stop and back-up lights, and tail lights (Fig. 19-1, 19-2, 19-3 19-4 and 19-5).

The body wiring consists of a front and rear harness which is joined by a multiple connector located at the left side of the rear compartment. The front end of the front harness is designed with a multiple connector which joins the chassis wiring at the left shroud.

The circuit diagram for typical body wiring circuits is illustrated in Figure 19-6.

Failures in a circuit are usually caused by short circuits or open circuits. Open circuits are usually caused by breaks in the wiring, faulty connections

or mechanical failure in a component such as a switch. Short circuits are usually caused by wires from different components of the circuit contacting one another or by a wire or component grounding to the metal of the body due to a screw driven through the wire, insulation cut through by sharp metal edge, etc.

If a failure is encountered in one of the body circuits, the circuit diagram should be thoroughly reviewed to become familiar with the circuit before performing an intensive checking procedure to determine the cause and location of the failure.

1. If a major portion of the electrical circuit becomes inoperative simultaneously, the failure may be due to improper connections between the front and rear harness, or between the front harness and the chassis wiring connector.

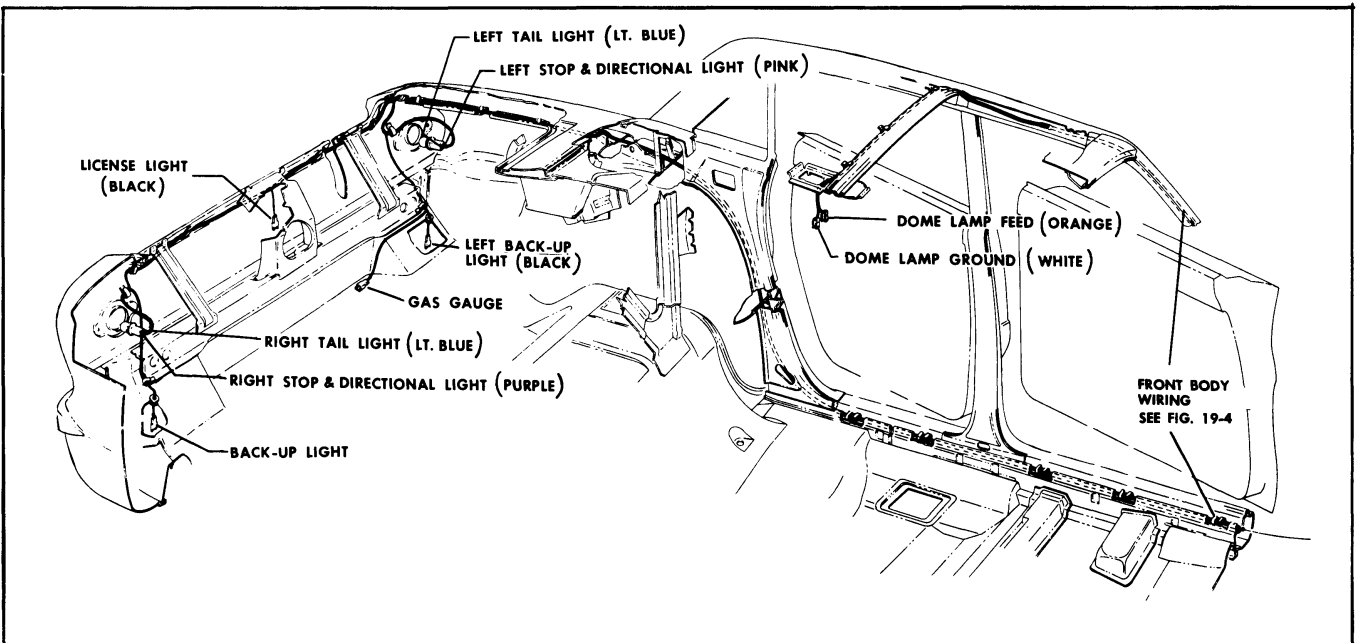

Fig. 19-1 Sedan Body Wire Installation

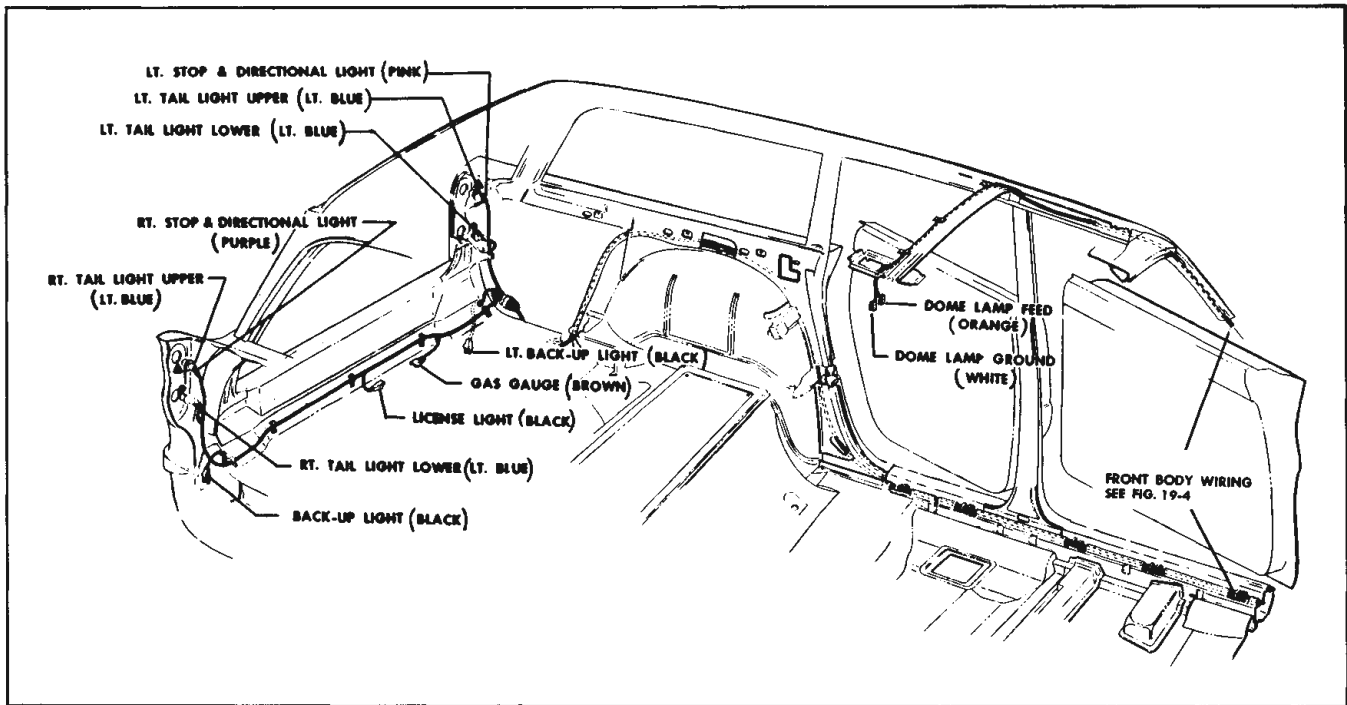

Fig. 19-2 Station Wagon Body Wire Installation

2. If only one of the circuits is inoperative, the failure is due to an open circuit or short in the affected circuit. Short circuits usually result in

blown fuses.

If the fuse is not blown and the circuit affected is a lamp circuit, check the bulb before proceeding with any checking procedures.

3. The dome lamp is designed so that the switches are in the "ground" side of the circuit. If a condition is encountered where the lamps remain "on"

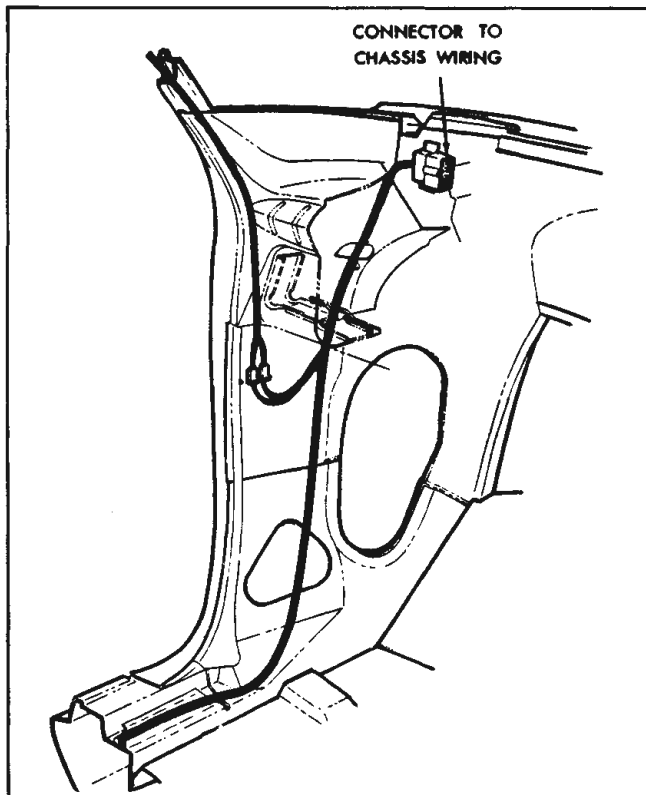

Fig. 19-3 Connector to Chassis Wiring

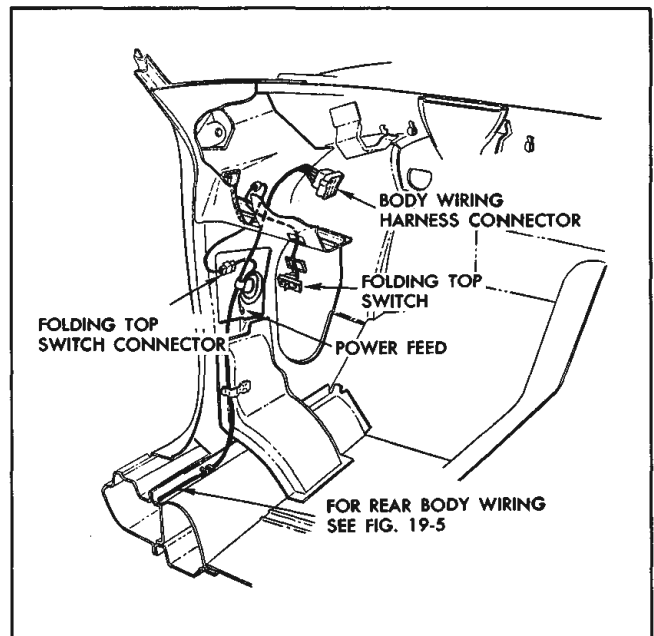

Fig. 19-4 Front End Wiring

even though the jamb switches are not actuated, the failure is probably due to defective switches, or to the wire leading to the switches being grounded.

ELECTRIC BACK DOOR DROPPING WINDOW

The 1962 "Y" body station wagon power operated back door dropping window is controlled by a 12 volt D.C. series wound reversible motor. This motor contains an internal circuit breaker and a self-locking gear drive. The current for the motor is obtained through a 40 amp circuit breaker located at left shroud (Fig. 19-7).

The back door window is lowered from a control switch located at the left side of the instrument panel.

The back door window harness is separate from the body wiring harness and runs along the left side of the body. Electrical contact between body wire

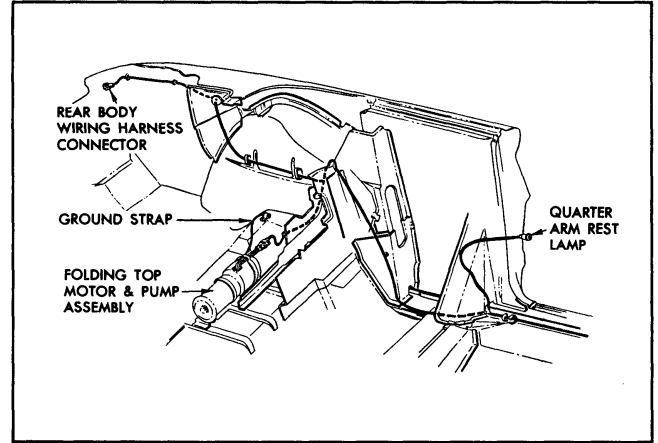

Fig. 19-5 Rear Body Wiring

harness and back door is made through open double contact plates located at the left back body opening side panel and mating surface on back door side facing (Fig. 19-8).

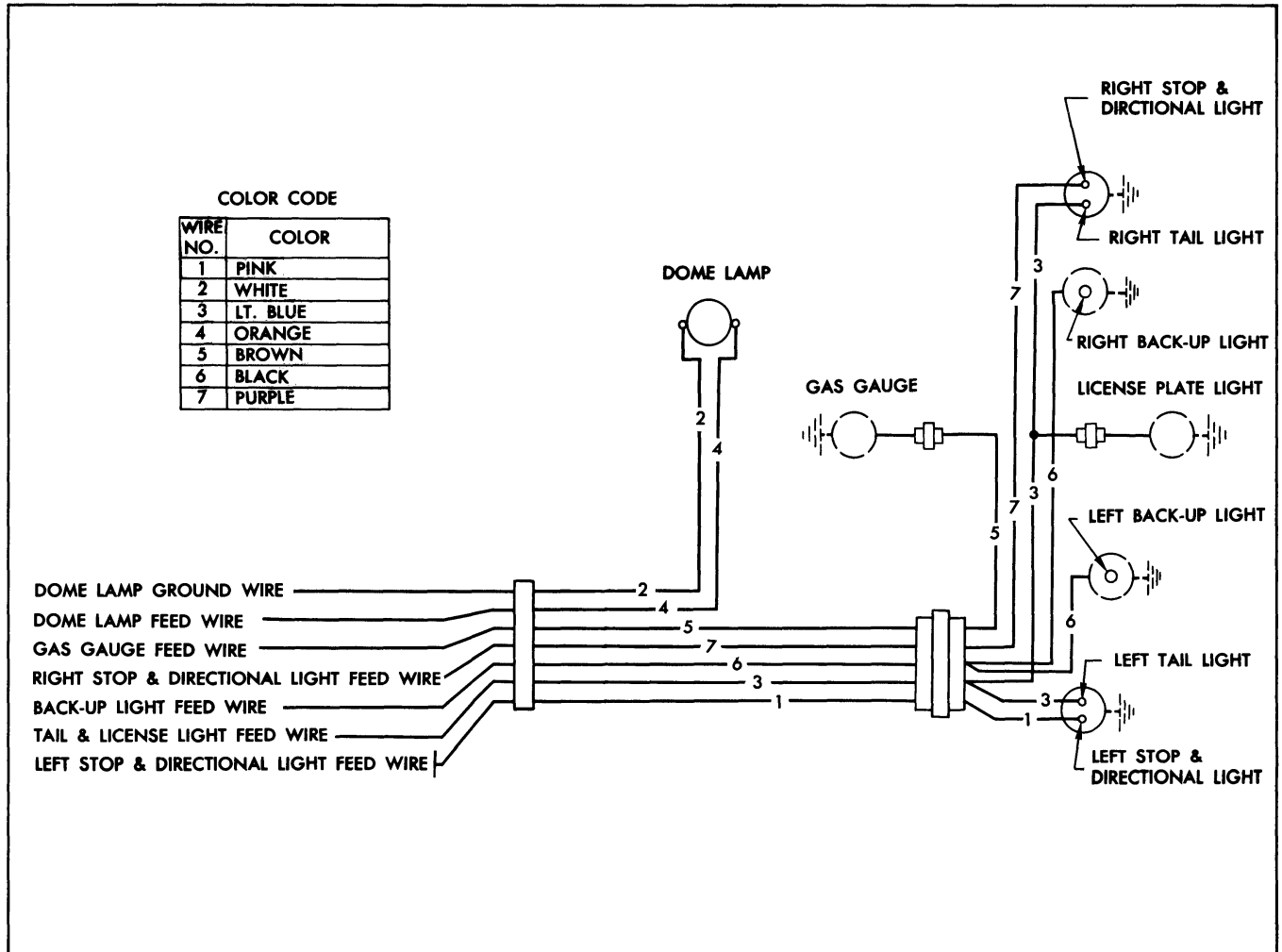

Fig. 19-6 Schematic Body Wiring Circuit Diagram

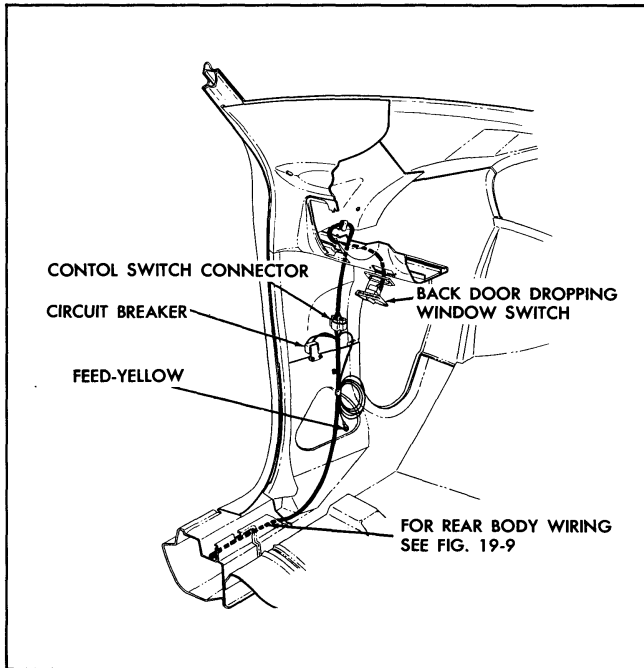

Fig. 19-7 Body Wiring - Electric Back Window

CHECKING PROCEDURE

Before performing an intensive checking procedure to determine the failure in the circuit, check all connections to insure proper installation and contact.

A. Check Feed Circuit Current at Circuit Breaker

1. Connect one light tester lead to battery side of circuit breaker and ground other lead. Circuit breaker is located at left shroud. If tester does not light there is an open or short circuit in feed circuit from battery to circuit breaker.

2. To check the circuit breaker, disconnect output side of circuit breaker. Connect one light tester

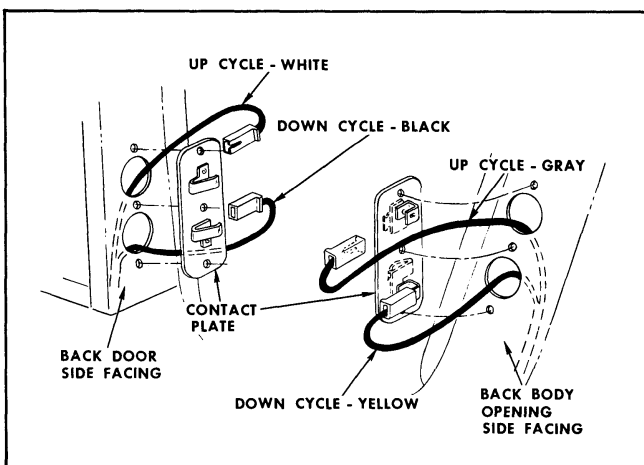

Fig. 19-8 Electric Window Connectors

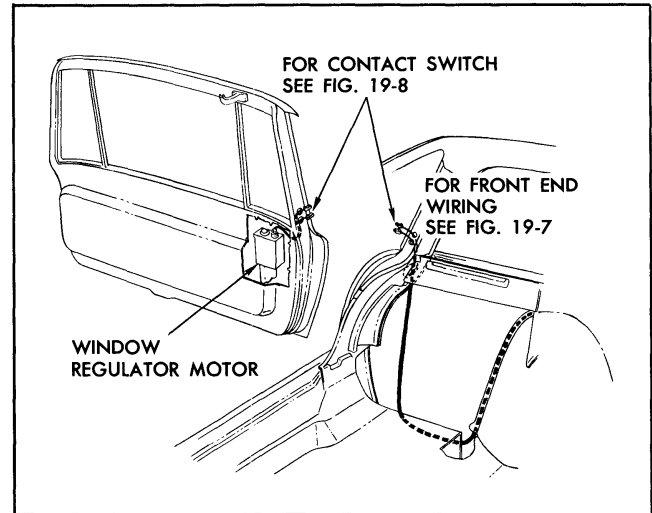

Fig. 19-9 Electric Window - Regulator Wiring

lead to the output side of circuit breaker and ground other lead. If tester does not light, the circuit breaker is inoperative.

B. Check Current of Feed Wire at Control Switch Connector

1. Disengage connector and place one light tester lead at feed terminal (red wire) of the feed.

2. With ignition switch on, disengage connector and place one light tester lead at the feed terminal (white wire) on the feed side of the connector and ground other lead. If tester does not light, there is an open or short circuit between the ignition switch fuse block and the switch connector.

C. Checking Instrument Panel Control Switch

1. Disengage harness connector from switch.

2. Using a #12 gauge jumper wire, insert one end into the feed terminal and the other end into one of the other terminals. Back door window should operate.

3. Repeat procedure for other terminal.

If the back door operates with the jumper wire but does not operate with control switch, the switch is defective.

D. Check Quarter Panel Control Switch

First determine if current is present at feed terminal and use same method as described for the instrument panel control switch.

E. Check Relay Assembly

1. Check current of feed wire at relays. Disengage relay connector at left shroud and connect one

light tester lead to feed terminal (red wire) and ground other lead. If tester does not light, there is an open or short circuit between the circuit breaker and relay terminal.

Repeat procedure with other relay.

2. Check switch terminal at relay. Connect one test lead to the yellow wire (up relay) and ground other lead. Turn ignition switch on and actuate the up cycle of the instrument panel switch. If test light does not light, there is an open or short between the control switch and relay.

3. Checking relay. Engage relay connector and connect light tester lead to motor terminal of relay (pink wire). Turn ignition switch on and actuate control switch to up cycle. If tester does not light, relay is defective.

Repeat check on down relay (brown wire).

F. Check Current at Rear Body Opening Side Facing Contact Plate

1. At battery side of window control switch connector place #12 gauge jumper wire from the feed terminal to the up cycle terminal. Turn ignition switch on.

2. With back door open, place one lead of the light tester on up terminal of the rear body opening con-

tact and ground other lead. If tester does not light there is an open or short circuit between switch connector and rear body opening contact plate.

3. Repeat steps 1 and 2 using down cycle terminal.

G. Check Current at Window Motor Harness Connector

NOTE: To perform the following check it will be necessary to remove sufficient parts to lower the regulator motor to gain access to motor connector. The proper sequence is described in the back door dropping window write-up.

1. Disengage window motor harness connector from motor.

2. Place #12 gauge jumper wire in the battery side of the window control switch connector from the feed terminal to the up cycle terminal.

3. From inside and with the back door closed, place one light tester lead on the up cycle terminal (white wire) and ground the other lead. If tester does not light there is an open or short circuit between the back door contact and the motor connector.

4. Repeat steps 3 and 4 changing connections to the down cycle wires. If motor does not operate at this point, it is defective and should be removed.

LUBRICATION

CONTENTS OF THIS SECTION

SUBJECT	PAGE	SUBJECT	PAGE
Lubrication Intervals	20-1	Sunshade Rod	20-3
Front Door Hinge Clips	20-2	Door Lock Outside Handle	20-3
Glove Box Door Hinge	20-2	Door Window Regulator	20-3
Door Lock Striker	20-2	Door Window Cams	20-4
Door Lock Rotary Bolt and Housing	20-2	Quarter Window Regulator	20-4
Rear Door Hinge and Hold Open Assembly	20-3	Rear Quarter Window	20-4
Rear Compartment Lid and Back Door Locks	20-3	Door Lock Parts	20-4
Door Weatherstrips and Bumpers	20-3	Door Lock Mechanism	20-4
Door Jamb Switch	20-3	Back Door Hinges and Torque Rod	20-5
Gas Tank Filler Door Hinge	20-3	Front Seat Adjuster Mechanism	20-5
Spare Tire Cover Hinge Assembly	20-3	Back Door Window Regulator	20-5
Door and Rear Compartment Locks	20-3	Convertible Top Linkage	20-5
		Folding Seat Linkage and Lock	20-5

The movable mechanical hardware parts of the body are lubricated at the factory to insure proper and quiet operation. Because of frequent use of some parts such as door locks and door lock strikers, it is important that the readily accessible parts be lubricated at least twice a year. Other body parts should be lubricated whenever access to the parts is available.

Wipe off all lubrication points before applying new lubricant. Remove all excess lubricant where necessary to prevent staining of trim parts or clothing.

LUBRICATION INTERVALS

The following parts should be lubricated twice each year.

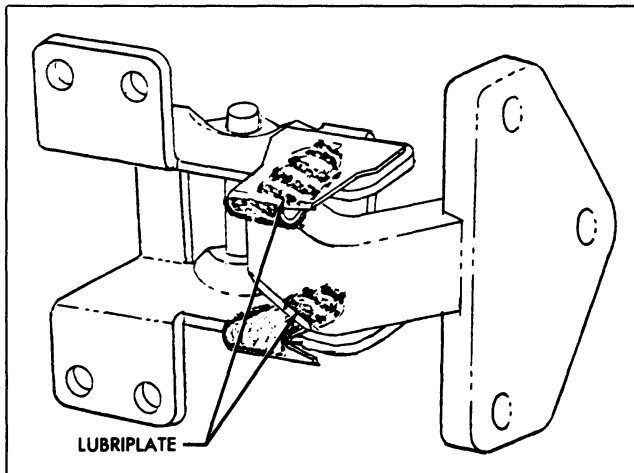

Fig. 20-1 Front Door Hinge and Hold Open

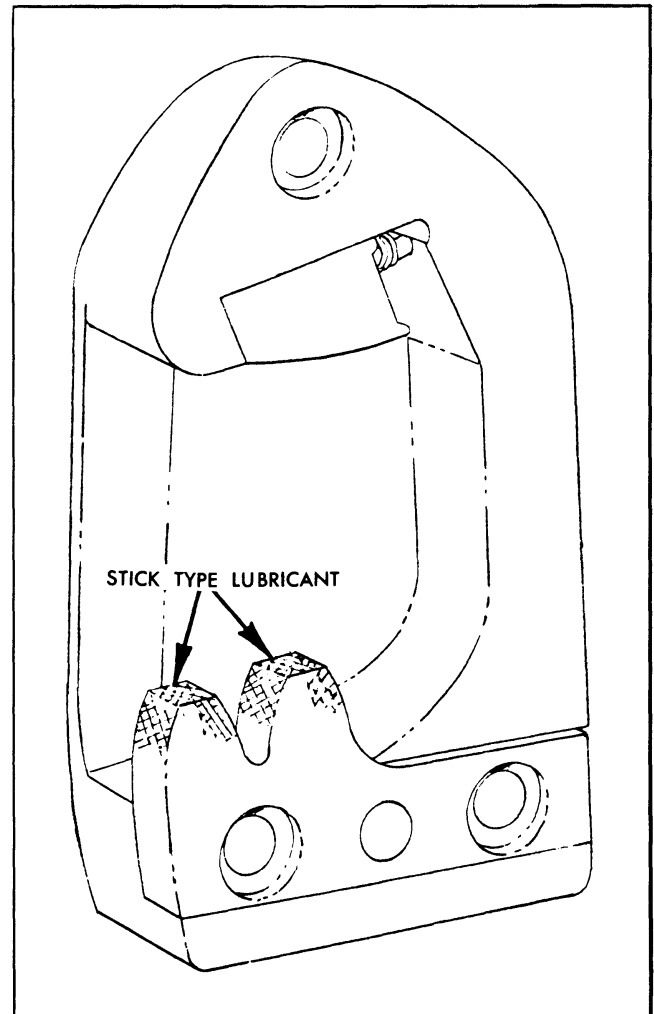

Fig. 20-2 Door Lock Striker

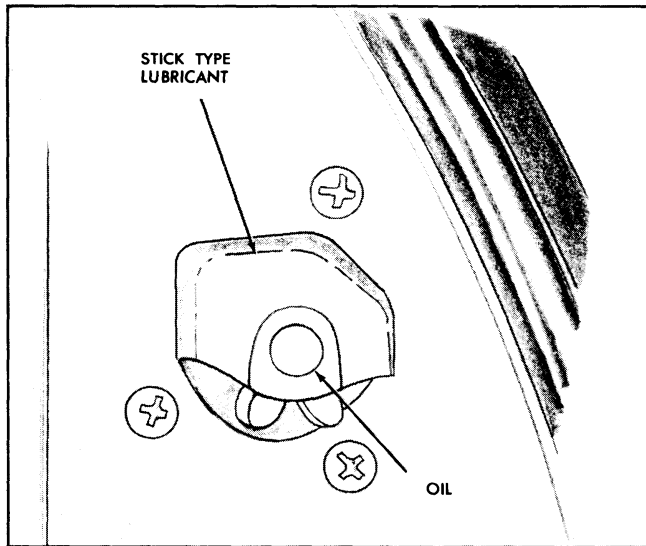

Fig. 20-3 Door Lock Rotary Bolt and Housing

FRONT DOOR HINGE HOLD OPEN CLIPS

Wipe off dirt and apply a light coat of No. 630 AAW Lubriplate or its equivalent to frictional points (Fig. 20-1). The hinge pins should be lubricated with engine oil.

INSTRUMENT PANEL COMPARTMENT DOOR HINGE

Wipe off dirt and apply a sparing amount of drip-less oil to the hinge frictional points. Operate door and wipe off excess lubricant.

DOOR LOCK STRIKER

Wipe off dirt and apply a thin coat of stick-type

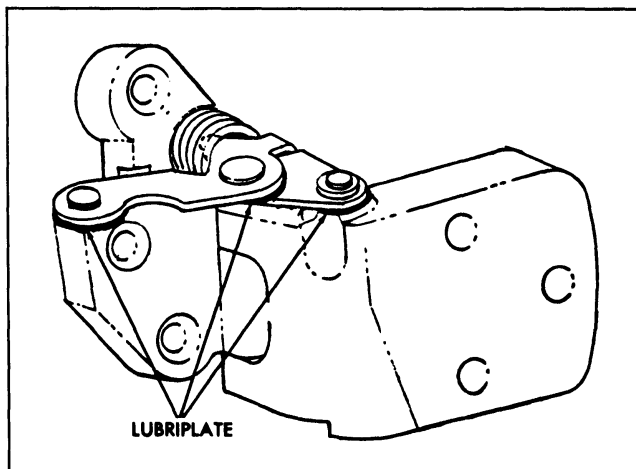

Fig. 20-4 Rear Door Hinge

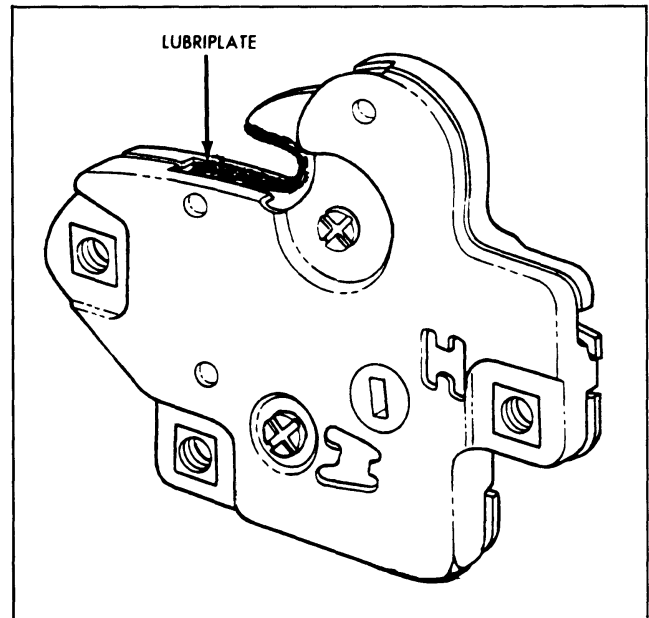

Fig. 20-5 Rear Compartment Lid Lock Bolt

lubricant to top surface of lock bolt striker teeth. (Fig. 20-2) After lubrication, close door several times and remove excess lubricant along side edge of teeth.

DOOR LOCK ROTARY BOLT AND HOUSING

Wipe off dirt and apply a thin coat of stick-type lubricant and oil (Fig. 20-3).

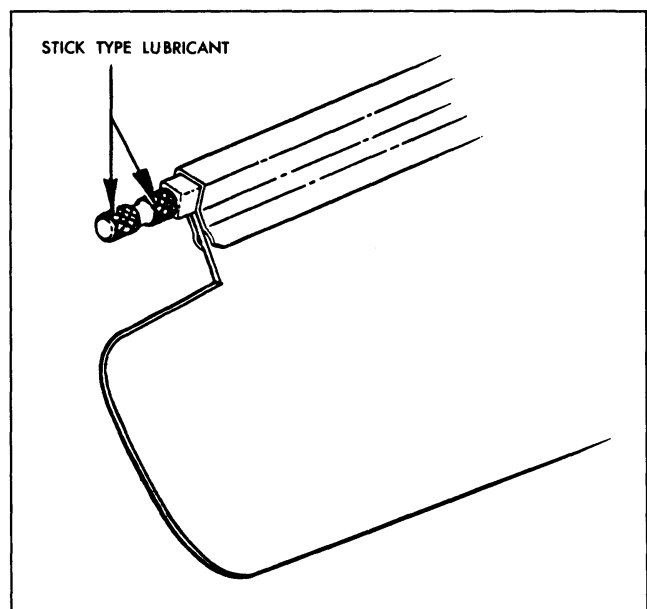

Fig. 20-6 Sunshade Rod

REAR DOOR HINGE AND HOLD OPEN ASSEMBLY

Wipe off dirt and apply a light coat of No. 630 AAW Lubriplate or equivalent to frictional points (Fig. 20-4). Wipe off excess lubricant.

REAR COMPARTMENT LID AND BACK DOOR LOCKS

On rear compartment lid locks, apply a thin film of No. 630AAW Lubriplate or its equivalent (Fig. 20-5). On back door locks, apply a thin film of No. 630AAW Lubriplate or its equivalent to the bolt at the striker contact areas.

DOOR WEATHERSTRIPS AND DOOR BUMPERS

A thin coat of silicone lubricant should be used on weatherstrips and door bumpers to prevent squeaking.

DOOR JAMB SWITCH

Wipe off dirt and apply a thin coat of No. 630AAW Lubriplate or equivalent to end surface of switch plunger. Wipe off excess lubricant.

GAS TANK FILLER DOOR HINGE

Apply a few drops of dripless oil to frictional points of door hinge. Work door several times and wipe off excess lubricant.

SPARE TIRE COVER HINGE ASSEMBLY

35 STYLE

Wipe off dirt and apply a few drops of dripless oil to frictional areas. Work cover several times and wipe off excess lubricant.

DOOR AND REAR COMPARTMENT LOCK CYLINDERS

A small quantity of lock lubricant occasionally applied to the lock cylinders will prevent sticking.

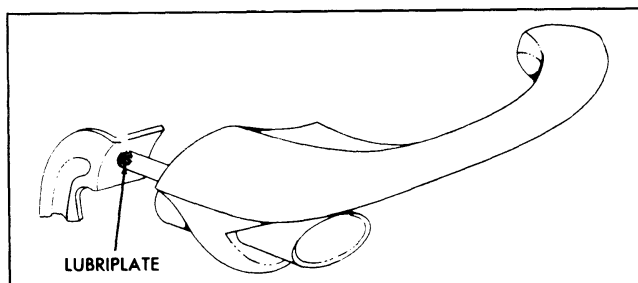

Fig. 20-7 Door Handle - Outside

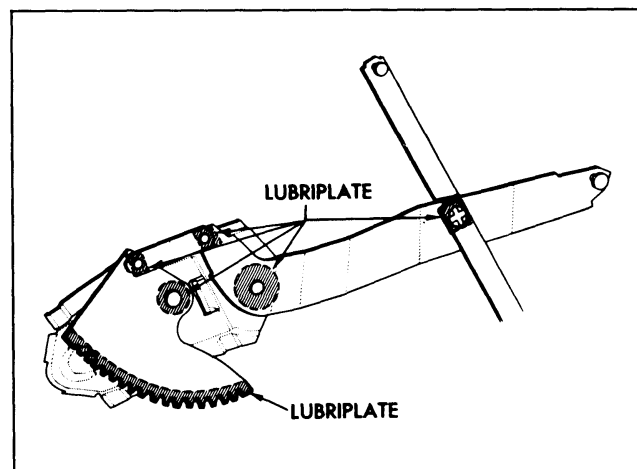

Fig. 20-8 Door Window Regulator

SUNSHADE ROD

Remove sunshade from support and apply a thin film of stick-type lubricant to end of sunshade rod (Fig. 20-6).

THE FOLLOWING PARTS SHOULD BE LUBRICATED WHEN ACCESS TO PARTS IS AVAILABLE:

DOOR LOCK OUTSIDE HANDLE

Apply a light coat of No. 630AAW Lubriplate or equivalent to surface of lock cylinder shaft contacting bell crank (Fig. 20-7).

DOOR WINDOW REGULATOR

Apply a coat of No. 630AAW Lubriplate or equivalent to areas indicated (Fig. 20-8). Lubrication of front door window regulator is typical of lubrication of rear door regulators.

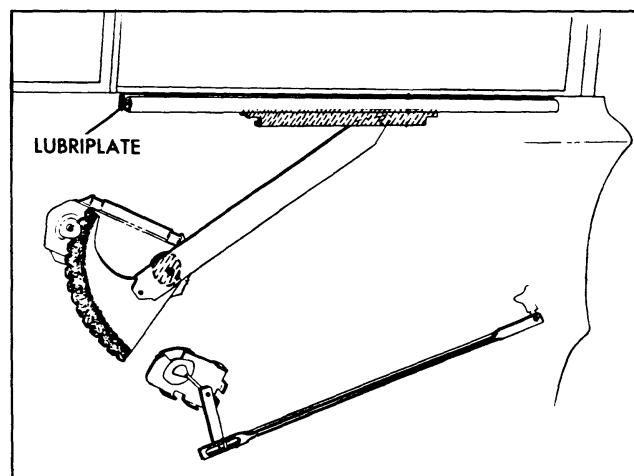

Fig. 20-9 Front Door Window Regulator Cams

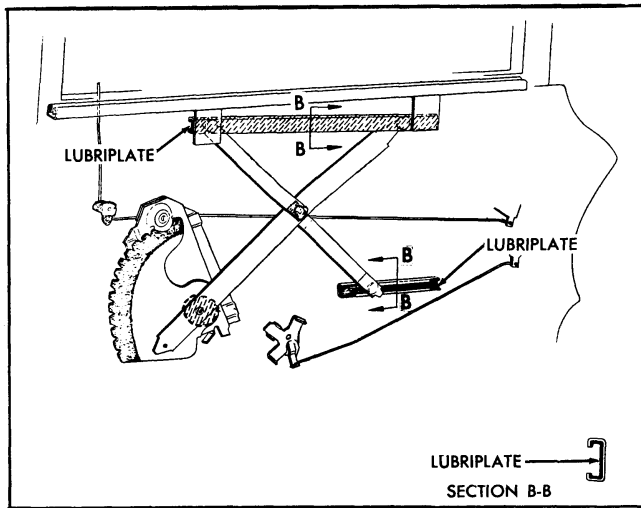

Fig. 20-10 Rear Door Window Regulator Cams

DOOR WINDOW CAMS

Apply a coat of No. 630AAW Lubriplate or equivalent to channel portions of cams (Fig. 20-9 and 20-10).

REAR QUARTER WINDOW REGULATOR, CAMS AND GUIDES

17, 27 37 and 47 STYLES

Apply a coat of No. 630AAW Lubriplate or equivalent to areas indicated by "1" and "2" (Fig. 20-11).

REAR QUARTER WINDOW

Apply a coat of No. 630AAW Lubriplate or equivalent to area "1" (Fig. 20-12).

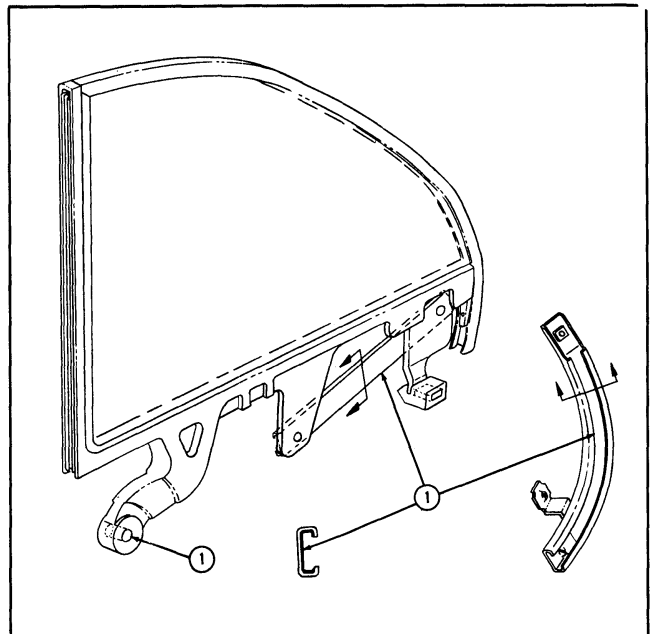

Fig. 20-12 Rear Quarter Window

DOOR LOCK PARTS

Lubricate moving parts of door lock with No. 630 AAW Lubriplate or equivalent.

DOOR LOCKING MECHANISM

Apply No. 630AAW Lubriplate or equivalent to pivot points at ends of all connecting rods.

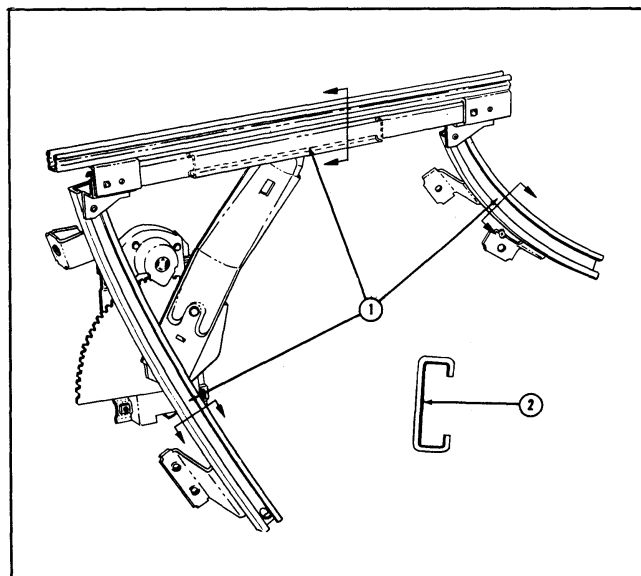

Fig. 20-11 Rear Quarter Window Regulator Cams

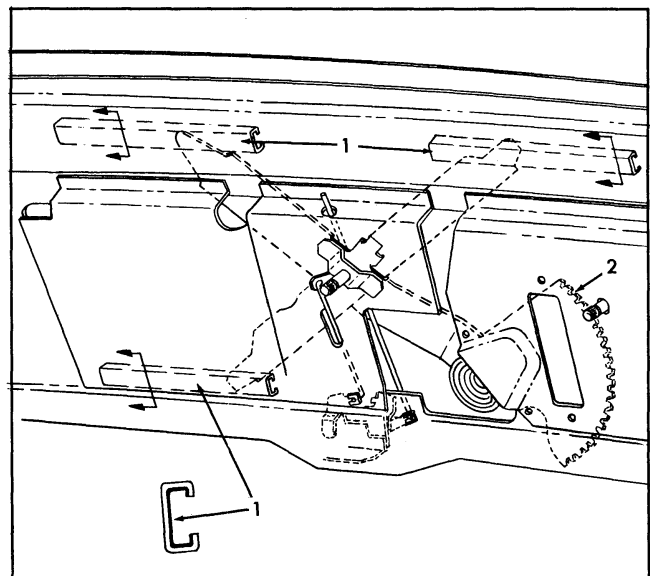

Fig. 20-13 Back Door Window Regulator Cams

BACK DOOR HINGES AND TORQUE RODS**35 and 45 STYLES**

Wipe off dirt and apply dripless oil to frictional points; work door several times and wipe off excess lubricant.

FRONT SEAT ADJUSTER MECHANISM

A thin film of No. 630AAW Lubriplate or its equivalent should be applied to the seat tracks as needed or during repairs.

BACK DOOR WINDOW REGULATOR, CAMS AND GUIDES**35 and 45 STYLES**

Apply a coat of No. 630AAW Lubriplate or equivalent to areas "1" and "2" (Fig. 20-13).

The following to be lubricated as required:

CONVERTIBLE TOP LINKAGE**67 STYLE**

Apply a sparing amount of dripless oil to areas "1" (Fig. 20-14). Wipe off excess lubricant.

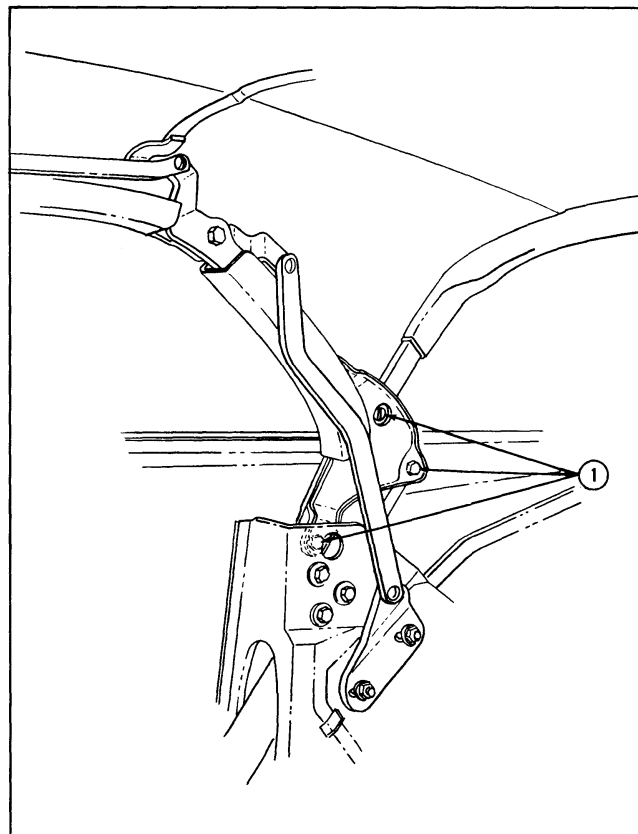

Fig. 20-14 Convertible Top Linkage

FOLDING SEAT LINKAGE AND LOCK**35 and 45 STYLES**

Apply a sparing amount of dripless oil to all frictional points, work folding seat as required, wipe off excess lubricant.

PONTIAC AND TEMPEST

FABRIC CLEANING

CONTENTS OF THIS SECTION

SUBJECT	PAGE	SUBJECT	PAGE
General Instructions	21-1	Candy	21-4
Cleaning with Volatile Cleaners	21-1	Chewing Gum	21-4
Cleaning with Synthetic Detergents	21-2	Fruit Stains, Liquor and Wine	21-4
Cleaning Precautions - Fabrics	21-2	Grease and Oil	21-4
Cleaning Leather and Coated Fabrics	21-2	Ice Cream	21-4
Cleaning Polyurethane Foam Material	21-3	Nausea	21-4
Cleaning Vicodec Folding Top Material	21-3	Shoe Polish and Dressings	21-4
Cleaning Carpets	21-3	Tar	21-5
Removal of Stains		Urine	21-5
Battery Acid	21-3	Lipstick	21-5
Blood	21-3		

GENERAL INSTRUCTIONS

There are four general types of trim materials used in automotive bodies:

1. Fabrics that may be either plain fabrics (broad-cloth, gabardine, etc.) or pattern fabrics which are manufactured with natural or synthetic (nylon, orlon, rayon, viscose, etc.) fabrics.
2. Genuine leather.
3. Coated fabrics (vinyl or mylar).
4. Polyurethane foam.

Dust and dirt particles that accumulate on the upholstery of a car should be removed every few weeks, or oftener if the car is given constant hard use. This is done with a whisk broom or vacuum cleaner.

CAUTION: Do not use a whisk broom on fabrics having raised tapestry patterns since damage to the fine threads may result. On polyurethane foam material use only a soft bristle brush—do not use a whisk broom or vacuum cleaner.

Before attempting to remove spots or stains from upholstery fabrics, determine as accurately as possible:

1. Nature and age of the spot or stain.
2. The affect of stain removing agents on the color structure and general appearance of the fabric.

For best results, stains should be removed from upholstery as soon as possible after they have been made. If they are allowed to stand for some time,

they often become set, and removal becomes more difficult - frequently, impossible.

There are three basic types of acceptable cleaners available to car owners:

1. Volatile cleaners (colorless liquids).
2. Synthetic detergents.
3. Neutral soap (nonalkaline).

The volatile cleaners are recommended since they have great solvent powers for grease, oils and general road grime. Synthetic detergents generally loosen up stains satisfactorily, however, the use of improper type detergents involves risk of damage to the color or finish of fabrics.

PROCEDURE FOR CLEANING FABRICS WITH VOLATILE CLEANERS

Care should be taken not to use too much solvent and to apply it only with clean cloths. It is the solvent that does the work - so only a minimum of pressure should be applied.

1. Brush away all loose particles of dirt and soil.
2. Dampen a clean cloth (cheese cloth may be used) with the volatile cleaner. Open the cloth and allow a portion of the cleaner to evaporate so that the cloth is just slightly damp.
3. Using very light pressure and circular lifting motion, rub the stained area, starting at the outer edge and working toward the center until the entire area has been covered. Change to a clean portion of the cloth every few strokes.

4. Before proceeding, wait several minutes to allow most of the volatile cleaner to evaporate. This will avoid the danger of the cleaner penetrating to the padding under the upholstery. Certain cleaners will deteriorate sponge rubber which is often used as padding.

5. It may be necessary to repeat Steps No. 2, 3, and 4 several times before the stain has been satisfactorily removed. Each time a clean cloth should be used.

6. If a ring should form on the fabric when removing a stain, the entire area of the trim assembly should be cleaned as described in the preceding steps.

7. The cleaned upholstery should be allowed to dry completely before using.

Some volatile cleaners are toxic and harmful; therefore, the following safety precautions should be used:

1. Always use in a well ventilated area. Car windows and garage doors must be open when such cleaners are used.

2. Avoid prolonged or repeated breathing of vapors from cleaner.

3. Avoid prolonged or repeated contact with the skin.

4. Keep away from eyes and mouth.

5. Some cleaners are flammable, and every precaution and care must be exercised in handling these cleaners.

PROCEDURE FOR CLEANING FABRICS WITH SYNTHETIC DETERGENTS

1. Make a solution of the synthetic detergent in lukewarm water, working up a thick, frothy suds.

2. With a clean cloth or sponge, dampened with lukewarm water, apply suds only to the surface of the upholstery using light to medium pressure, repeating several times, applying more suds with a clean portion of the cloth or sponge.

3. With a second clean cloth, dampened with lukewarm water, rub over the area with medium pressure to remove excess detergent and loose material.

4. With a clean dry cloth, wipe off all excess moisture. A vacuum cleaner may also be used.

5. Allow the upholstery to dry partially; then repeat the above treatment if necessary to remove stain.

6. When the upholstery is satisfactorily cleaned, allow to dry completely before using.

PRECAUTIONS FOR CLEANING FABRICS

1. Solutions containing water are not recommended for general cleaning of broadcloths. Water has great destructive powers on the high face or high gloss finish of broadcloths, causing the nap to curl and roughen to such an extent that the finish is destroyed or made very unsightly. However, in some cases where it is necessary to use a solution containing water to remove a stain, the resultant disturbance to the finish of the material may be preferable to the stain.

2. Do not use as a cleaning solvent any gasoline which is colored or which contains tetraethyl lead.

3. Do not use solvents such as acetone, lacquer thinners, enamel reducers and nail polish remover, as a cleaning solvent.

4. Do not use laundry soaps, bleaches or reducing agents, such as the following: chloride of lime, javelle water, hydrogen peroxide, sodium hydrosulphite, potassium permanganate, chlorine or chlorine water, sulphurous acid (sulphur dioxide), sodium thiosulphate (Photographers' hypo). The use of these agents tends to weaken fabric and to change its color.

5. Do not use too much cleaning fluid; some interior trim assemblies are padded with rubber, and volatile cleaners are generally solvents for rubber. The application of too much cleaner may destroy these rubber pads.

PROCEDURE FOR CLEANING GENUINE LEATHER AND COATED FABRICS

Care of genuine leather and coated fabrics (includes vinyl coated formed headlining) is a relatively simple but important matter. The surface should be wiped occasionally with a dry cloth, and whenever dirt accumulates, the following cleaning instructions should be used:

1. Lukewarm water and neutral soap should be used. Apply a thick suds, worked up on a piece of gauze or cheesecloth, to the surface.

2. The operation should be repeated, using only a damp cloth and no soap.

3. The surface should then be wiped dry with a soft cloth.

Polishes and cleaners used for auto body finishes, volatile cleaners, furniture polishes, oils, varnishes or household cleansing and bleaching agents should never be used.

PROCEDURE FOR CLEANING POLYURETHANE FOAM MATERIAL

Normal soilage such as dirt and finger prints can be removed with a cleaning solution of approximately two (2) ounces of white detergent powder mixed in a gallon of water. Immerse a clean cellulose sponge in cleaning solution. Wring the sponge out thoroughly leaving suds only; then clean soiled area carefully. Rinse off the cleaned area with sponge and clean water - DO NOT soak the cleaned area.

Soilage such as cements, sealers, and grease can be removed by first cleaning the soiled area with a detergent solution as described above - DO NOT RINSE. Leaving suds on the soiled area, clean area with a clean cloth that has been dipped in a good volatile upholstery cleaner and thoroughly wrung out. Then clean soiled area with detergent suds and rinse as described above.

PROCEDURE FOR CLEANING VICODEC FOLDING TOP MATERIAL

The top should be washed frequently with neutral soap suds, lukewarm water and a brush with soft bristles. Rinse top with sufficient quantities of clear water to remove all traces of soap.

If the top requires additional cleaning after using soap and water, a mild foaming cleanser can be used. Rinse the whole top with water; then apply a mild foaming type cleanser on an area of approximately two square feet. Scrub area with a small soft bristle hand brush, adding water as necessary until the cleanser foams to a soapy consistency. Remove the first accumulated soilage with a cloth or sponge before it can be ground into the top material. Apply additional cleanser to the area and scrub until the top is clean. Care must be exercised to keep the cleanser from running onto body finish as it may cause streaks if allowed to run down and dry. After the entire top has been cleaned, rinse the top generously with clear water to remove all traces of cleanser. If desired, the top can be supported from the underside during the scrubbing operations.

After cleaning always be sure the top is thoroughly dry before it is lowered. Lowering the top while it is still wet or damp may cause mildew and unsightly wrinkles.

Do not use volatile cleaners or household bleaching agents on the top material.

PROCEDURE FOR CLEANING FLOOR CARPETS

Thoroughly brush or vacuum the floor carpet.

In many instances the floor carpet may require no further cleaning. If carpet is extremely soiled remove carpet from car and thoroughly vacuum to remove loose dirt; then with a foaming type upholstery cleaner, clean approximately one (1) square foot of carpet at a time. After each area is cleaned, remove as much of the cleaner as possible with a vacuum cleaner. After cleaning the carpet use an air hose to "fluff" the carpet pile, then dry the carpet. After the carpet is completely dried, use an air hose to again "fluff" the carpet pile.

NOTE: If the carpet is not extremely soiled, the carpet may be cleaned in the car by applying a small amount of foaming type upholstery cleaner with a brush.

If oil or grease spots are still present on the carpet they may be removed by using a volatile cleaner.

INSTRUCTIONS FOR THE REMOVAL OF SPECIFIC STAINS FROM AUTOMOTIVE UPHOLSTERY MATERIALS

Some types of stains and soilage, including blood, ink, chewing gum, etc., require special consideration for most satisfactory results. For these, and other stains, specific instructions are outlined in succeeding paragraphs. It must be expected, particularly where water treatment is specified, that discoloration and finish disturbance may occur. In some cases fabric disturbance may be considered preferable to the stain itself. By following the procedures outlined with normal care and caution, reasonably satisfactory results can be expected.

BATTERY ACIDS

Apply ordinary household ammonia water with a brush or cloth to the affected area, saturating it thoroughly. Permit the ammonia water to remain on the spot about a minute, so that it will have ample time to neutralize the acid. Then rinse the spot by rubbing with a clean cloth saturated with cold water.

This treatment will suffice for both old and new stains. However, no type of treatment will repair damage to fibers resulting from the action of the acids on the fibers - particularly after the spot has dried.

BLOOD

Do not use hot water or soap and water on blood stains since they will set the stain, thereby making its removal practically impossible.

Rub the stain with a clean cloth saturated with cold water until no more of the stain will come out. Care must be taken so that clean portions of cloth are used for rubbing the stain.

This treatment should remove all of the stain. If it does not, apply a small amount of household ammonia water to the stain with a cloth or brush. After a lapse of about one minute, continue to rub the stain with a clean cloth dipped in clear water.

If the stain remains after the use of water and ammonia, a thick paste of corn starch and cold water may be applied to the stained area. Allow the paste to remain until it has dried and absorbed the stain. Then pick off the dry starch. Brush the surface to remove starch particles that remain. For bad stains, several applications of starch paste may be necessary.

CANDY

Candy stains, other than candy containing chocolate, can be removed by rubbing the affected area with a cloth soaked with very hot water. If the stain is not completely removed, rub area lightly (after drying) with a cloth wet with a volatile cleaner. This will usually remove the stain.

Candy stains resulting from cream and fruit-filled chocolates can be removed more easily by rubbing with a cloth soaked in lukewarm soap-suds (mild neutral soap) and scraping, while wet, with a dull knife. This treatment is followed with a rinsing by rubbing the spot with a cloth dipped in cold water.

Stains resulting from chocolate or milk chocolate can be removed by rubbing the stain with a cloth wet with lukewarm water. After the spot is dry, rub it lightly with a cloth dipped in a volatile cleaner.

CHEWING GUM

Harden the gum with an ice cube, and scrape off particles with a dull knife. If gum cannot be removed completely by this method, moisten it with a volatile cleaner and work it from the fabric with a dull knife, while gum is still moist.

FRUIT, FRUIT STAINS, LIQUOR AND WINE

Practically all fruit stains can be removed by treatment with very hot water. Wet the stain well by applying hot water to the spot with a clean cloth. Scrape all excess pulp, if present, off the fabric with a dull knife; then rub vigorously with a cloth wet with very hot water. If the stain is very old or deep, it may be necessary to pour very hot water directly

on the spot, following this treatment with the scraping and rubbing. Direct application of hot water to fabrics is not recommended for general use since discoloration usually results.

If the above treatments do not remove stain, allow fabric to dry thoroughly; then rub lightly with a clean cloth dipped in a volatile cleaner. This is the only further treatment recommended.

Soap and water are not recommended since they will probably set the stain and cause a permanent discoloration. Drying the fabric by means of heat (such as the use of an iron) is not recommended.

GREASE AND OIL

If grease has been spilled on the material, as much as possible should be removed by scraping with a dull knife or spatula before further treatment is attempted.

Grease and oil stains may be removed by rubbing lightly with a clean cloth saturated with a volatile cleaner. Be sure all motions are toward the center of the stained area to decrease the possibility of spreading the stain.

ICE CREAM

The same procedure is recommended for the removal of ice cream stains as that used in removing fruit stains.

If the stain is persistent, rubbing the spot with a cloth wet with warm soap suds (mild neutral soap) may be used to some advantage after the initial treatment with hot water. This soap treatment should be followed with a rinsing, by rubbing with a clean cloth wet with cold water. After this dries, rubbing lightly with a cloth wet with volatile cleaner will clear up the last of the stain, by removing fatty or oily matter.

NAUSEA

Sponge with a clean cloth, dipped in clear cold water. After most of the stain has been removed in this way, wash lightly with soap (mild neutral), using a clean cloth and lukewarm water. Then rub with another clean cloth dipped in cold water. If any of the stain remains after this treatment, gently rub clean with a cloth moistened with a volatile cleaner.

SHOE POLISH AND DRESSINGS

On types of shoe dressings which contain starch or dextrine or some water soluble vehicle, allow the polish to dry; then brush the spot vigorously with a brush. This will probably be all the treatment that

is necessary. If further treatment is required moisten the spot with cold water and after it has dried, repeat the brushing operation.

Paste or wax type shoe polishes may require using a volatile cleaner. Rub the stain gently with a cloth wet with a volatile cleaner until the polish is removed. Use a clean portion of the cloth for each rubbing operation and rub the stained area from outside to center.

TAR

Moisten the spot slightly with a volatile cleaner, and then remove as much of the tar as possible with a dull knife. Follow this operation by rubbing the spot lightly with a cloth wet with the cleaner until the stain is removed.

URINE

Sponge the stain with a clean cloth saturated with lukewarm soap suds (mild neutral soap) and then rinse well by rubbing the stain with a clean cloth dipped in cold water. Then saturate a clean cloth with a solution of one part household ammonia and five parts water. Apply the cloth to the stain and allow solution to remain on affected area for one minute; then rinse by rubbing with a clean wet cloth.

LIPSTICK

The compositions of different brands of lipsticks vary, making the stains very difficult to remove. In some instances a volatile cleaner may remove the stain. If some stain remains after repeated applications of the volatile cleaner, it is best to leave it rather than try other measures.

FOLDING TOP

CONTENTS OF THIS SECTION

SUBJECT	PAGE	SUBJECT	PAGE
Operation Of Folding Top		Installation of Folding Top and Back	
Description	22-1	Curtain Trim Assembly	22-16
Top Boot	22-2	Folding Top Assembly	22-23
Lowering The Top	22-2	Removal and Installation	22-23
Top Boot Installation	22-3	Back Curtain Assembly	22-23
Raising The Top	22-4	Removal	22-23
Lowering Rear Window	22-5	Installation	22-24
Raising Rear Window	22-5	Back Curtain Vinyl Replacement	22-24
General Information	22-5	Removal	22-24
Care of Rear Window	22-6	Installation	22-25
Cleaning The Top	22-7		
Folding Top Adjustments		Hydro-Lectric System	
Description	22-7	Motor and Pump Assembly	22-27
Misalignment Trouble Diagnosis		Removal	22-27
Description	22-10	Installation	22-27
Manually Operated Folding Top Hardware		Reservoir Tube	22-28
Folding Top Manual Lift Assembly		Disassembly from Motor and	
"67" Style	22-13	Pump Assembly	22-28
Description	22-13	Assembly to Motor and Pump Assembly	22-28
Removal and Installation	22-13	Operation of Folding Top	22-29
Folding Top Catch Clips	22-13	Operation of Pump Assembly	22-29
Description	22-13	Fluid Control Valve	22-29
Folding Top Trim Assembly		Mechanical Checking Procedure	22-30
Removal of Folding Top and Back		Electrical Checking Procedure	22-30
Curtain Trim Assembly	22-14	Hydraulic Checking Procedure	22-31
		Removal of Folding Top Lift Cylinder	22-32
		Filling of Hydro-Lectric Reservoir	22-32

OPERATION OF FOLDING TOP

DESCRIPTION

The convertible coupes use either a manual or Hydro-lectric system to operate the folding top. On the power operated top, after the top has been unlatched and raised above the windshield by hand, it can be lowered or raised, respectively, by actuating the power control switch. Hydraulic fluid from an electrically driven pump is forced through tubing to double-acting, piston-type cylinders located at each rear quarter section of the car. Pressurized fluid entering the top of the hydraulic lift cylinder forces the pistons down-thus lowering the top. Pressurized fluid entering the bottom of the hydraulic lift cylinders forces the piston upward-thus raising the top.

The convertible coupe with a manually operated folding top has two spring loaded manual lift as-

semblies which help compensate for the weight of the folding top mechanism when the top is near the full "up" or full "down" positions. The top assembly is retained in the folded or "stacked" position by two catch clip assemblies which are attached to the folding top compartment side braces. The clips snap over the center side roof rails when the top is fully depressed. Clips must be disengaged prior to raising top assembly.

CAUTION: When operating top, hands must be kept away from the folding portions of the top mechanism. Grasp top only in the areas illustrated and described in the following operational procedures. Do not touch or attempt to service spring loaded lift assemblies except as outlined in procedure for "Manually Operated Folding Top Hardware".

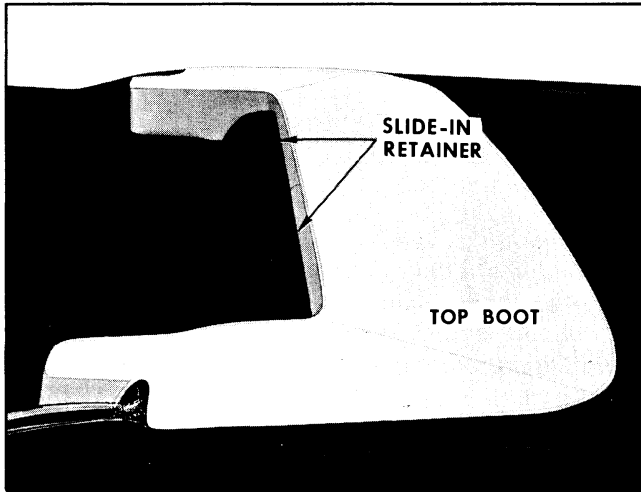

Fig. 22-1 Top Boot

TOP BOOT

The top boot is attached to the body with concealed "floating-type" snap fasteners along the side and rear edges and a "slide-in" retainer along the front edge as indicated in Fig. 22-1. When the folding top is raised, either of the following two methods may be used for storing the boot.

1. The boot may be stored in its protective case in rear compartment of car.
2. The boot may be left attached to the slide retainer and folded behind rear seat back.

The top compartment behind the rear seat back must be used only for storage of the top boot when it is attached to the slide retainer on the seat back. The storage of such items as golf clubs, luggage and miscellaneous objects in the compartment not only interferes with the proper operation of the top, but may damage the top or the plastic rear window.

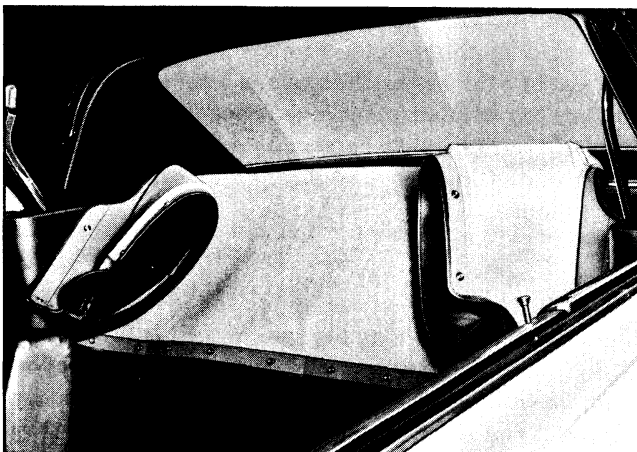

Fig. 22-2 Top Boot Turned Over Seat Back

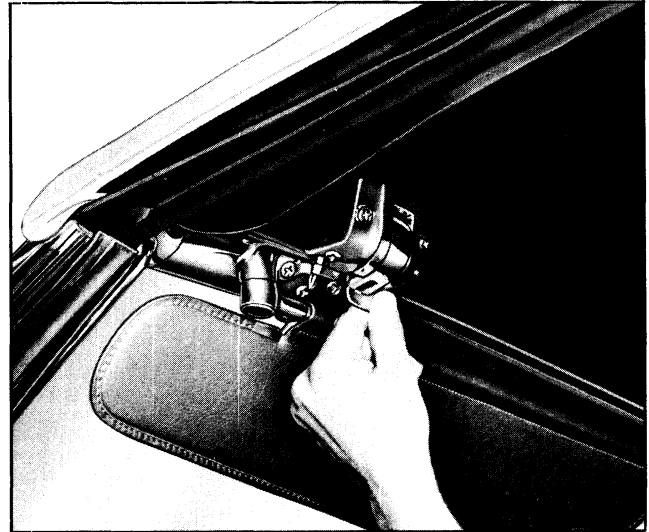

Fig. 22-3 Unlocking Top From Header

TO LOWER THE TOP

1. Stop the car. If top boot has been stored in its retainer behind rear seat, turn boot over seat back (Fig. 22-2). It is not necessary to lower rear window or rear quarter windows before lowering top.
2. Turn down both sun visors; then rotate each locking handle rearward then upward until it is disengaged from striker on windshield header (Fig. 22-3).
3. Raise front of top (Fig. 22-4) to disengage front roof rail from windshield header.

With power operated top proceed as follows:

- A. Actuate power top control switch until front top rail is approximately two feet from full down position (Fig. 22-5).

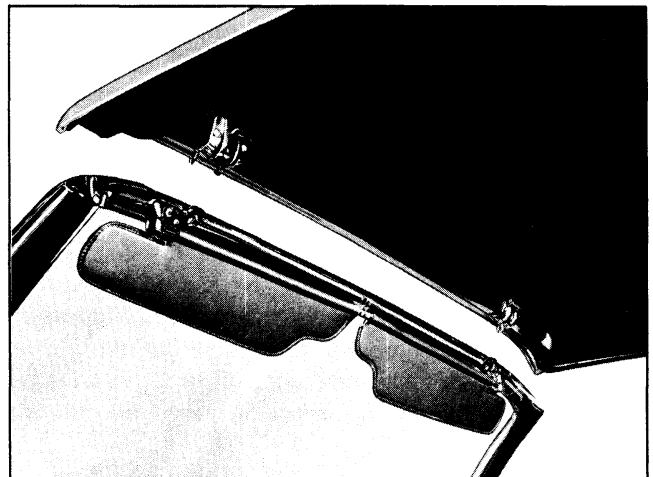

Fig. 22-4 Disengaging Top From Header

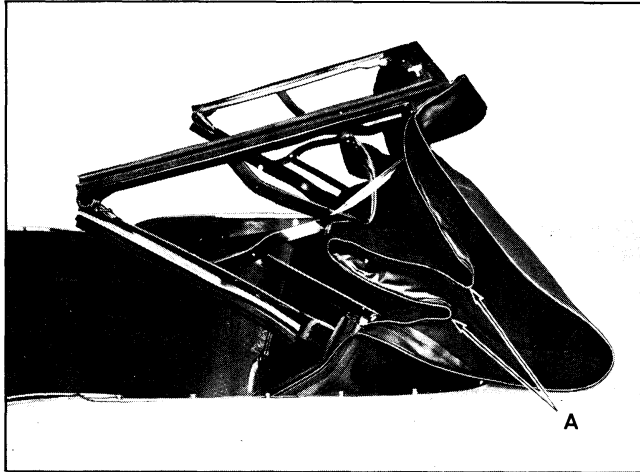

Fig. 22-5 Pull Padding from Between Arms

B. On right and left side of body, pull top material and padding "A" from between operating arms of top (Fig. 22-5).

C. Operate top control switch until top is approximately six (6) inches from full down position. Be sure padding "A" has been pulled rearward from between operating arms of top to insure proper fit of top boot (Fig. 22-6).

D. Operate top control switch until top is in fully lowered position. Smooth out top material on body panel (Fig. 22-7).

With manually operated top proceed as follows:

A. Standing along side of car, place palm of hand against middle of side roof rail front section. Lift up forward portion of top assembly and rotate top rearward (Fig. 22-8).

CAUTION: Keep hands away from hinged portion of side rails. Do not grasp upper portion of side rails or any of the top linkage.

B. As the top approaches mid-point of travel,

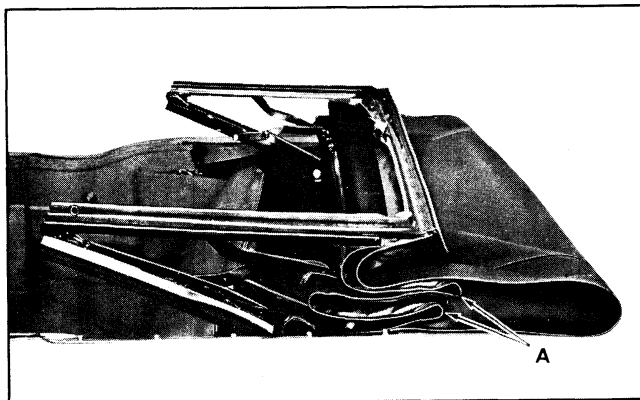

Fig. 22-6 Tuck Padding into Compartment

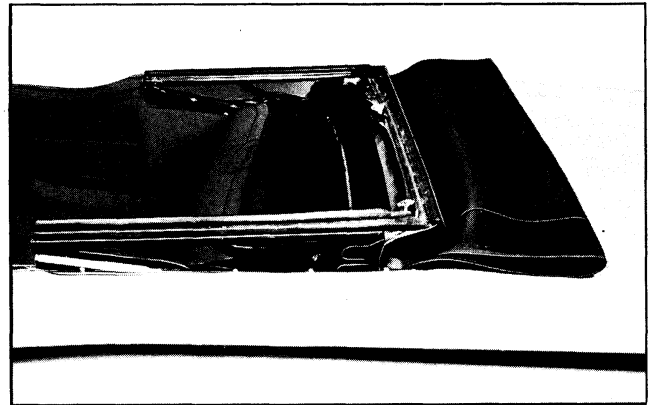

Fig. 22-7 Smooth Out Top Material

tension is relieved from the assist springs. Exert downward pressure on the exposed surface of the side rail front section until top is approximately 12 inches from full down position (Fig. 22-9).

C. Pull top material and padding "A" from between operating arms of top as shown in the illustration (Fig. 22-5).

D. Press down on side rail front section until catch clip snaps onto side rail center section. Repeat operation on opposite side of car (Fig. 22-10).

4. Fold over corners of top material (Fig. 22-11).

5. Fold top material forward over front roof rail (Fig. 22-12).

TOP BOOT INSTALLATION

1. Slide front edge of boot into retainer "A" along seat back (Fig. 22-13). Center boot for proper engagement of snap fasteners.

2. Place top boot in position over folded top and

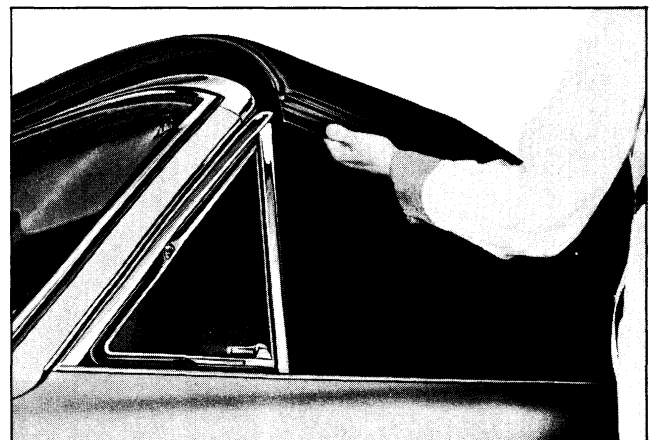

Fig. 22-8 Rotating Top Rearward

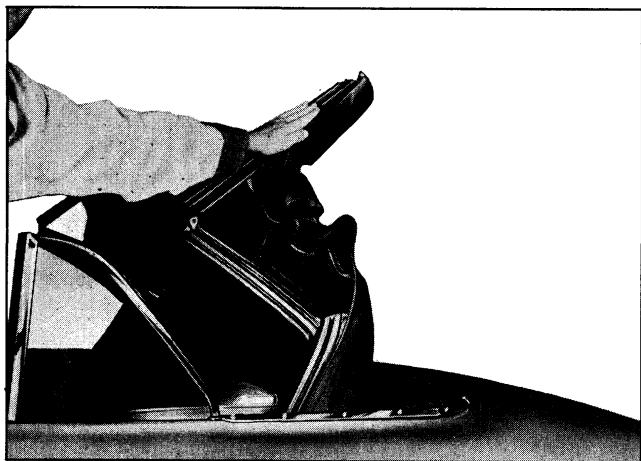

Fig. 22-9 Exerting Downward Pressure

engage several boot fasteners to studs along rear molding. Then adjust boot to remove wrinkles by sliding forward edge of boot to right or left in retainer (Fig. 22-14).

3. Engage remaining boot fasteners to studs on molding and rear quarter trim (Fig. 22-1).

TO RAISE THE TOP

1. Stop the car. Disengage all top boot snap fasteners from studs, turn boot over seat back and fold ends of boot toward center. If thoroughly dry, top boot may be removed from retainer, folded and placed in protective case (Fig. 22-2).

2. Smooth out top material on body panel (Fig. 22-7).

With power operated top proceed as follows:

A. Turn down sun visors and operate power top control switch until top is fully raised.

B. After top is raised, guide studs on lock assembly into striker holes; then engage each folding

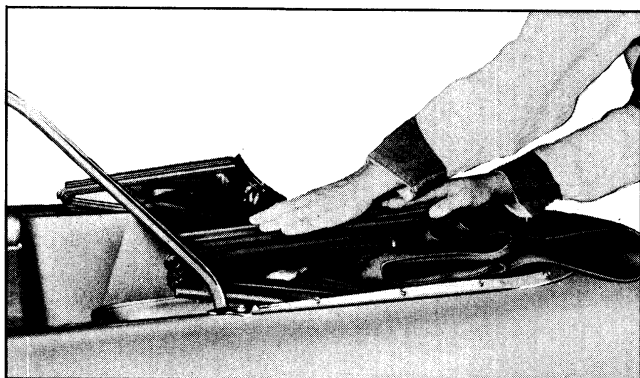

Fig. 22-10 Pressing Down on Side Rail

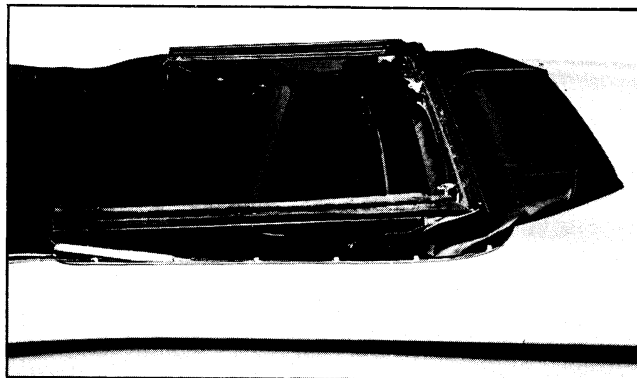

Fig. 22-11 Fold Corners of Top Material

top locking handle with striker on windshield header (Fig. 22-15).

With manually operated top proceed as follows:

A. At each side of car, move upper end of catch clip inboard to disengage top assembly (Fig. 22-16).

B. Standing along side of car, grasp front corner of folding top as shown in Fig. 22-17, lift and rotate top forward.

C. When top is approximately 12 inches away from windshield header, place hands on top assembly as shown in Fig. 22-18 and press down on top until guide studs on lock assembly engage striker holes.

D. Holding top down with one hand, reach into car and engage each folding top locking handle with striker on windshield header (Fig. 22-15).

3. Rotate each handle downward THEN forward until fully engaged with striker on windshield header; then turn up sun visors.

NOTE: Be sure top is securely locked to windshield header before starting car.

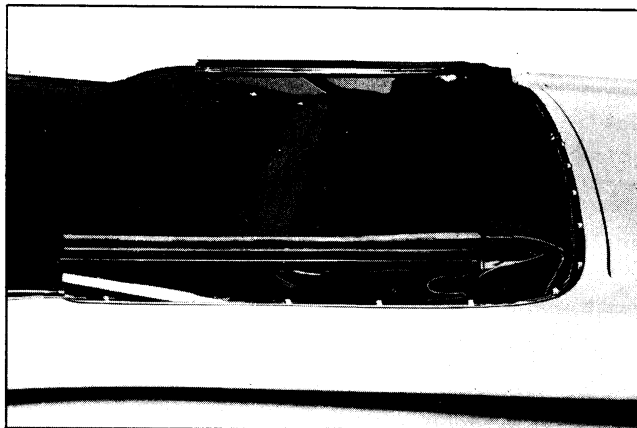

Fig. 22-12 Turn Top Material Forward

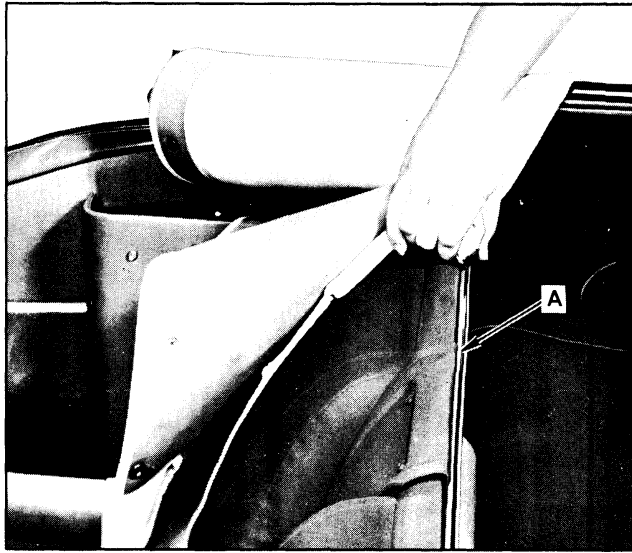

Fig. 22-13 Slide Boot into Retainer

TO LOWER REAR WINDOW

Slide zipper fastener indicated at "A" in Fig. 22-19 upward, across top to opposite side. Then carefully lower window into top compartment. To avoid damage, do not place miscellaneous objects on window.

TO RAISE REAR WINDOW

1. Hold window in its approximate closed position; then slide zipper along top of window and down side to its closed position as shown in Fig. 22-20.

NOTE: If the top has been released at the windshield header to relieve the tension on the zipper, be sure top is locked securely to header before moving car.

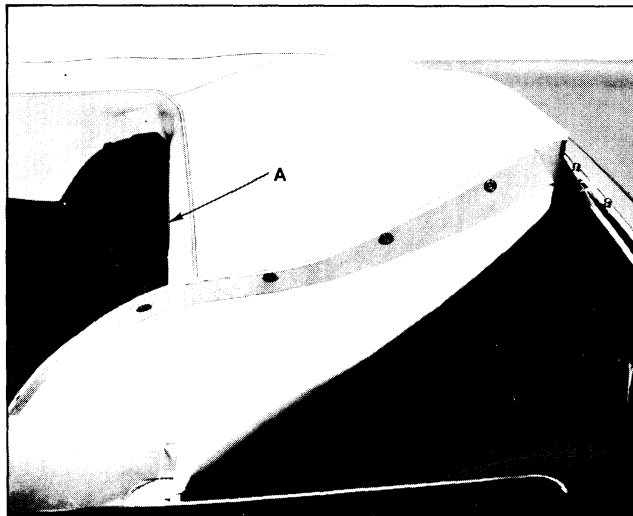

Fig. 22-14 Top Boot Partially Installed

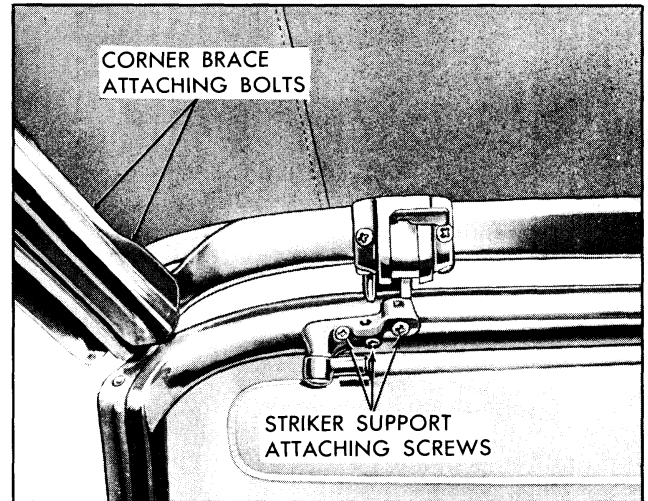

Fig. 22-15 Front Roof Rail Adjustment

GENERAL INFORMATION

1. Grasp top only at the specified areas when raising or lowering top. Do not place fingers into the open "U"-shaped upper portion of the side rails between the operating linkage arms of the folding top or on any portion of the side roof rail hinges.

2. Do not touch spring loaded manual lift assemblies located in rear quarter areas. Consult (a) the body shop service manual (b) the removal and installation procedure for the folding top assist arms before attempting any service operations.

3. As a safety precaution, do not operate top up or down while car is in motion. After raising top, make sure it is securely locked to the windshield header before starting car.

4. Do not obstruct the mechanical operation of top.

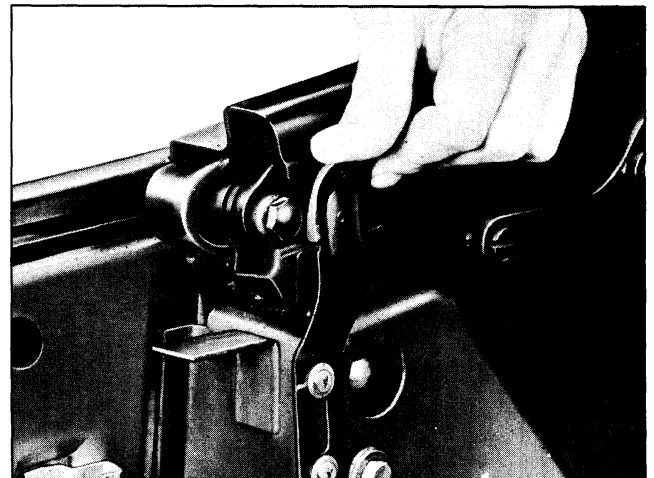

Fig. 22-16 Disengaging Top Assembly

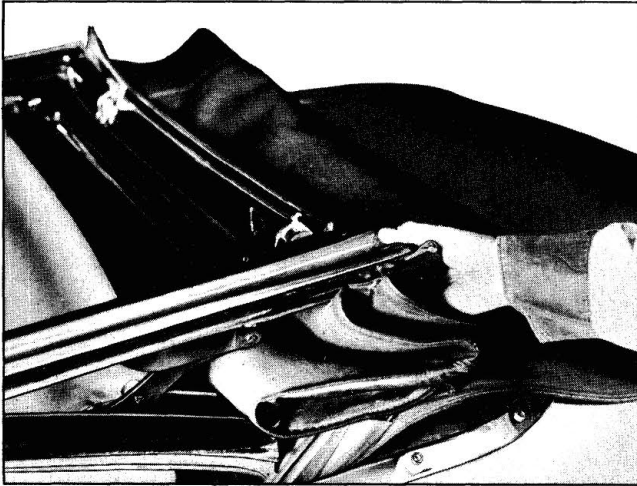

Fig. 22-17 Rotating Top Forward

5. Do not place miscellaneous objects such as golf clubs, luggage, etc., in the folding top compartment.

6. To prevent water stains, mildew or possible shrinkage of top material, do not keep top folded for a long period of time if it is damp or water-soaked.

7. Do not paste advertising stickers, gummed labels or masking tape on the plastic rear window. The adhesive used on such items is difficult to remove and may be injurious to the plastic composition of the window.

8. Allow plastic rear window and top material to become warm and pliable before attempting to operate top in temperatures below 50° Fahrenheit.

9. In some cases, the rear window can be lowered and raised much easier if the top is raised slightly above the windshield header to relieve the tension of the back curtain zipper.

10. Twice a year, lubricate the zipper with sili-

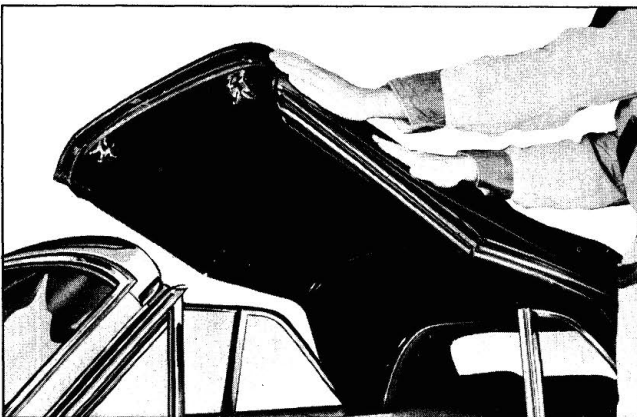

Fig. 22-18 Pressing Down on Top

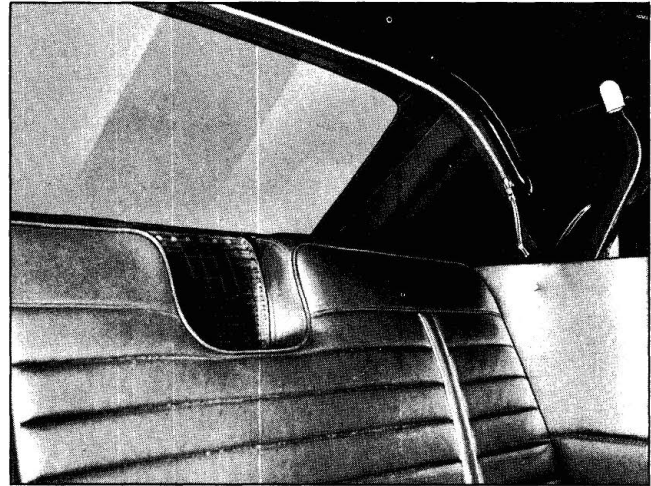

Fig. 22-19 Zipper Fastener on Rear Window

cone, beeswax or a non-staining type grease stick. The zipper should be cycled several times; then the excess lubricant wiped from the zipper assembly.

11. Twice a year with the top raised, clean exposed surface of hydraulic lift cylinder piston rods using a cloth dampened with brake fluid. Then apply a thin film of brake fluid to act as a lubricant.

CARE OF REAR WINDOW

The back curtain in the convertible coupe is provided with a large pliable plastic window. Due to the texture of the plastic window, it is susceptible to scratches and abrasions; therefore, when cleaning the window, follow the steps outlined below:

1. To remove superficial dust, do not use a dry cloth. Use a soft cotton cloth moistened with water and wipe crosswise of the window.

2. To wash the rear window, use cold or tepid



Fig. 22-20 Raising Rear Window

(not hot) water and a mild neutral soap suds. After the washing, rinse with clear water and wipe with a slightly moistened clean soft cloth.

CAUTION: *Never use solvents such as alcohol or volatile cleaning agents on the plastic window. These liquids may have a deteriorating effect on the plastic and, if spilled, may spot the painted finish on the body panels.*

3. When removing frost, snow or ice from the plastic window, do not use a scraper. In an emergency, warm water may be used. Use care that the warm water does not contact the glass windows or windshield.

CLEANING THE TOP

The top should be washed frequently with neutral soap suds, lukewarm water and a brush with soft bristles. Rinse top with sufficient quantities of clear water to remove all traces of soap.

If the top requires additional cleaning after using

soap and water, a mild foaming cleanser can be used. Rinse the whole top with water, then apply a mild foaming type cleanser on an area of approximately two square feet. Scrub area with a small soft bristle hand brush, adding water as necessary until the cleanser foams to a soapy consistency. Remove the first accumulated soilage with a cloth or sponge before it can be ground into the top material. Apply additional cleanser to the area and scrub until the top is clean. Care must be exercised to keep the cleanser from running onto body finish as it may cause streaks if allowed to run down and dry. After the entire top has been cleaned, rinse the top generously with clean water to remove all traces of cleanser. If desired, the top can be supported from the underside during the scrubbing operations.

After cleaning, always be sure the top is thoroughly dry before it is lowered. Lowering the top while it is still wet or damp may cause mildew and unsightly wrinkles.

Do not use volatile cleaners or household bleaching agents on the top material.

FOLDING TOP ADJUSTMENTS

DESCRIPTION

The folding top linkage consists of three sections of right and left side roof rails and a front roof rail connected by bolts, hinges, and a series of connecting links and bows. The top linkage is attached to the body at the rear quarter area by a male hinge. On Pontiac ("B") styles, the male hinge is bolted to an adjustable support. On Tempest ("Y") styles, the hinge is attached directly to the quarter panel brace. The front roof rail is locked at the windshield header by two hook type locks which are an integral part of the two locking handles.

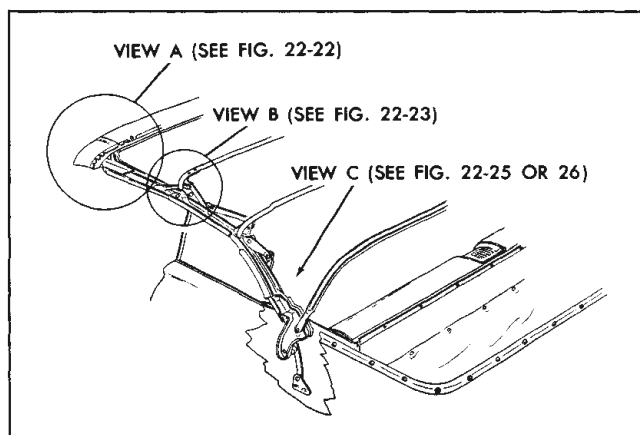

Fig. 22-21 Folding Top Adjustments

The following information outlines and illustrates procedures which may be used to correct misaligned folding top linkage. To correct some top variations, only a single adjustment is required; other top variations require a combination of adjustments. In conjunction with adjustment of the folding top, it may be necessary to adjust the door, door glass, rear quarter glass, trim sticks or side roof rail weatherstrips.

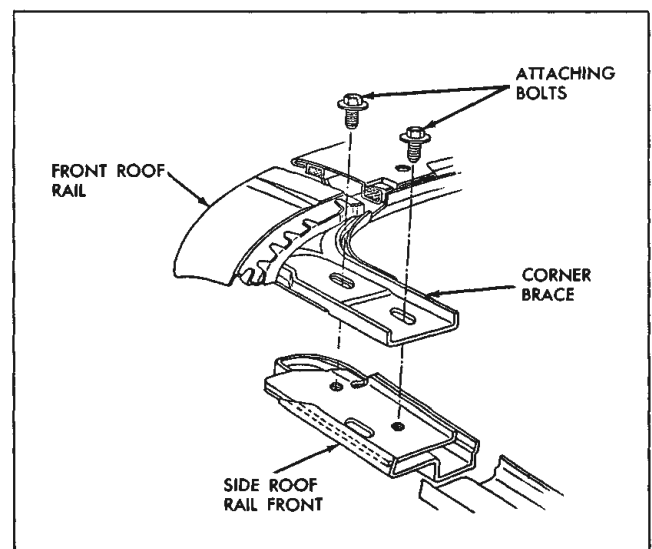

Fig. 22-22 View "A" in Fig. 22-21

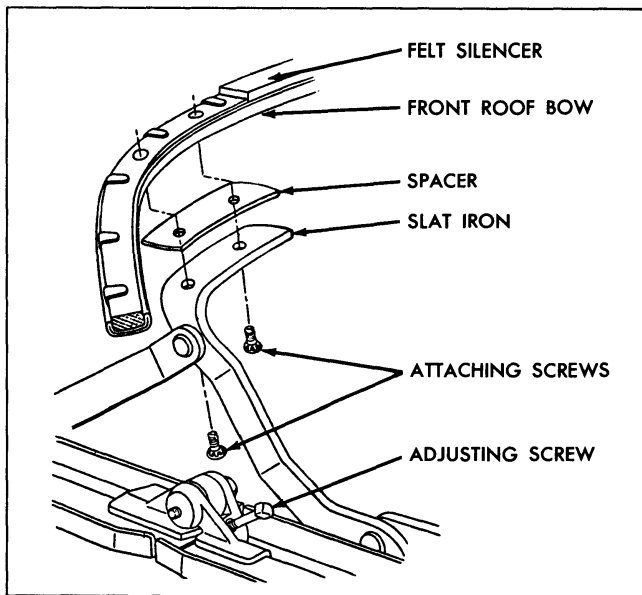

Fig. 22-23 View "B" in Fig. 22-21

CAUTION: When operating a manually operated folding top, hands must be kept clear of side roof rail hinges and connecting linkages.

ADJUSTMENT OF TOP AT FRONT ROOF RAIL CORNER BRACE

If the top, when in a raised position, is too far forward or does not move forward enough to allow the guide studs on the front roof rail to enter holes in the striker assemblies, proceed as follows: (Fig. 22-21).

1. Unlatch top and raise it above windshield header. Remove side roof rail weatherstrip front attaching screws.

2. Loosen corner brace attaching bolts and adjust front roof rail fore or aft as required. Repeat on opposite side if necessary (Fig. 22-22).

NOTE: This adjustment is limited. If additional adjustment is required, it can be made at the folding top male hinge.

3. When front roof rail corner brace is properly adjusted, tighten attaching bolts and reinstall side roof rail front weatherstrip attaching screws. Check forward section of weatherstrip and reseal if necessary.

ADJUSTMENT OF TOP AT SUNSHADE AND STRIKER SUPPORT ASSEMBLY

If a difficult locking action, caused by misalignment of the sunshade and striker support assembly

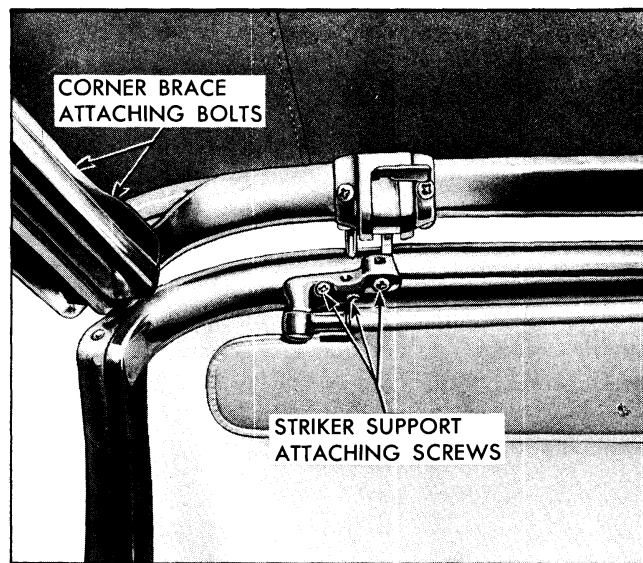

Fig. 22-24 Front Roof Rail Adjustment

is encountered at the front roof rail or if a closer fit of the front roof rail to windshield header is desired, proceed as follows: (Fig. 22-23).

1. Unlatch top and raise it above windshield header.

2. Loosen striker support attaching screws and adjust striker as required; then tighten attaching screws (Fig. 22-24).

If, after adjusting the striker support, the locking action of top is still unsatisfactory, the hook lever on the front roof rail lock assembly may be adjusted as follows:

1. To tighten locking action of top, turn hook lever clockwise.

2. To reduce locking action of top, turn hook lever counterclockwise.

NOTE: Hook lever may be adjusted with finger pressure, no tools are required.

ADJUSTMENT OF TOP CONTROL LINK ADJUSTING PLATE

1. With top in up position, if joint between front and center side roof rail is too high or too low, proceed as follows:

a. Remove folding top compartment side trim panel.

b. Scribe location of control link adjusting plate on folding top compartment brace.

c. Loosen two bolts securing control link adjusting plate sufficiently to permit adjustment of

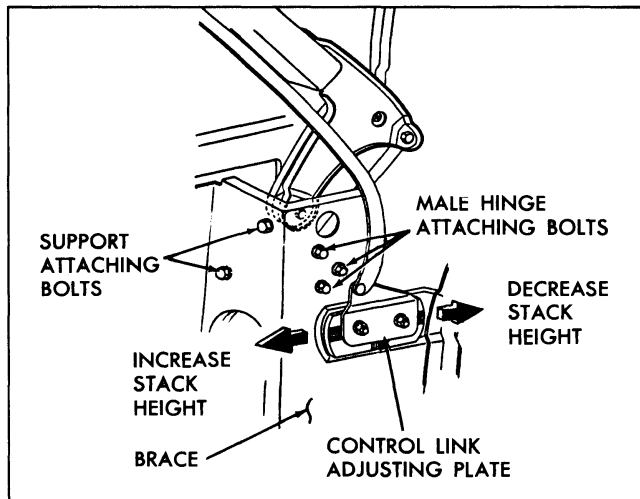

Fig. 22-25 View "C" in Fig. 22-21

plate. On "B" styles Fig. 22-25; on "Y" styles see Fig. 22-26.

d. Without changing fore and aft location of adjusting plate, adjust side roof rail up or down allowing adjusting plate to move up or down over serrations on support as required; then tighten bolts.

e. On "Y" styles equipped with manually operated folding tops, adjust both folding top catch clips as required. (See "Manually Operated Folding Top Hardware".)

2. If top assembly does not stack properly when top is in down position, proceed as follows:

a. Scribe location of control link adjusting plate on folding top compartment brace.

b. Loosen bolts securing control link adjusting plate sufficiently to permit adjustment of plate.

c. Without changing the up or down location of adjusting plate, move adjusting plate forward or rearward (horizontally) over serrations as required to obtain desired height; then tighten bolts.

d. On "Y" styles equipped with manually operated folding tops, adjust both folding top catch clips as required. (See "Manually Operated Folding Top Hardware".)

ADJUSTMENT OF TOP AT MALE HINGE SUPPORT

Prior to making any adjustment of top linkage at male hinge, loosen two bolts securing folding top rear quarter trim stick to rear quarter panel. This will prevent any possible damage to top when it is

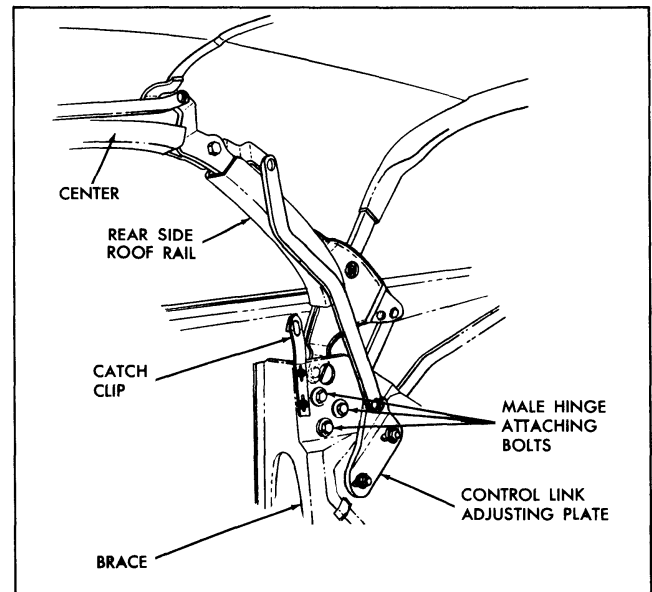

Fig. 22-26 View "C" in Fig. 22-21

raised after adjustment. After making an adjustment at male hinge, check folding top at rear quarter area for proper fit and, if necessary, adjust trim stick assembly.

1. If there is an excessive opening between side roof rail rear weatherstrip and rear of rear quarter window, or if front roof rail is too far forward or rearward, proceed as follows:

a. Scribe location of male hinge attaching bolt washers on folding top compartment brace.

b. Loosen three male hinge assembly attaching bolts. On "B" styles Fig. 22-25 on "Y" styles Fig. 22-26.

c. Move hinge fore or aft as required to obtain proper alignment between side roof rail rear weatherstrip and rear quarter window; then tighten bolts.

d. Lock front roof rail to windshield, (where required, adjust front roof rail corner brace as previously described), and check fit of top material at rear quarter trim stick area. If necessary, adjust trim stick; then tighten trim stick attaching bolts.

e. On "Y" styles equipped with manually operated folding tops adjust both folding top catch clips as required. (See "Manually Operated Folding Top Hardware".)

2. If side roof rail is too high or too low at rear quarter window area, proceed as follows:

a. On "Y" styles, scribe location of male

hinge attaching bolt washers on folding top compartment brace; on "B" styles scribe locating mark on top of male hinge and male hinge support to maintain proper fore and aft relation of the two parts.

b. Loosen male hinge assembly attaching bolts and, on "B" styles, loosen male hinge support front attaching bolts. On "B" styles see Fig. 22-25 on "Y" styles see Fig. 22-26.

c. Without changing fore and aft location of male hinge, on "Y" styles, adjust male hinge up or down; on "B" styles adjust hinge support up or down as required to obtain proper alignment

between side roof rails and rear quarter windows.

d. Tighten attaching bolts, while maintaining proper alignment of scribe marks.

e. Check fit of top material at rear quarter trim stick area and, if necessary, adjust trim stick. If adjustment is not necessary, tighten trim stick attaching bolts.

f. On "Y" styles equipped with manually operated folding tops, adjust both folding top catch clips as required. (See "Manually Operated Folding Top Hardware".)

MISALIGNMENT TROUBLE DIAGNOSIS

DESCRIPTION

The following procedure describes and illustrates

various types of folding top misalignment conditions, their apparent causes and the recommended procedure for their correction.

CONDITION	APPARENT CAUSE	CORRECTION
A. Difficult locking action at front roof rail.	1. Sunshade support misaligned.	Adjust sunshade support laterally.
	2. Lock hook lever improperly adjusted.	Adjust lock hook lever counterclockwise.
	3. Misaligned front roof rail front weatherstrip.	Loosen, realign and retack front roof rail front weatherstrip.
	4. Front roof rail misaligned.	Adjust front roof rail.
B. Top does not lock tight enough to windshield header.	1. Sunshade support misaligned.	Adjust sunshade support laterally.
	2. Lock hook lever improperly adjusted.	Adjust lock hook lever clockwise.
	3. Misaligned front roof rail front weatherstrip.	Loosen, realign and retack front roof rail front weatherstrip.
	4. Front roof rail misaligned.	Adjust front roof rail.
C. Top travels too far forward.	1. Front roof rail misaligned.	Adjust front roof rail rearward (Fig. 22-22).
	2. Male hinge assembly misaligned.	Adjust male hinge assembly rearward ("B" Fig. 22-25; "Y" Fig. 22-26).
D. Top does not travel forward far enough.	1. Front roof rail misaligned.	Adjust front roof rail forward (Fig. 22-22).
	2. Male hinge assembly misaligned.	Adjust male hinge assembly forward ("B" Fig. 22-25; "Y" Fig. 22-26).
	3. Improper spacing between rear trim stick and body metal.	Install an additional spacer between rear trim stick and body metal at each attaching bolt location.

CONDITION	APPARENT CAUSE	CORRECTION
E. Side roof rail rear weatherstrip too tight against rear of rear quarter window.	1. Male hinge assembly misaligned.	Adjust male hinge assembly rearward ("B" Fig. 22-25; "Y" Fig. 22-26).
F. Gap between side roof rail rear weatherstrip and rear of rear quarter window.	1. Male hinge assembly misaligned.	Adjust male hinge assembly forward (Fig. 22-25) and/or shim side roof rail rear weatherstrip forward as required.
G. Side roof rail rear weatherstrip too tight against top of rear quarter window.	1. Male hinge misaligned.	On "Y" styles, adjust male hinge upward; on "B" styles, adjust male hinge support upward ("B" Fig. 22-25; "Y" Fig. 22-26).
H. Gap between side roof rail rear weatherstrip and top of rear quarter window.	1. Male hinge misaligned.	On "Y" styles, adjust male hinge downward; on "B" styles, adjust male hinge support downward and/or shim side roof rail rear weatherstrip downward as required.
I. Sag at front to center side roof rail joint.	1. Control link adjusting plate misaligned.	Adjust control link adjusting plate downward ("B" Fig. 22-25; "Y" Fig. 22-26).
	2. Center side roof rail hinge adjusting screw improperly adjusted.	Adjust screw counterclockwise (Fig. 22-23).
J. Front and center side roof rails bow upward at hinge joint.	1. Control link adjusting plate misaligned.	Adjust control link adjusting plate upward ("B" Fig. 22-25; "Y" Fig. 22-26).
	2. Center side roof rail hinge adjusting screw improperly adjusted.	Adjust screw clockwise (Fig. 22-23).
K. Folding top dust boot is difficult to install.	1. Improper stack height due to misaligned control link adjusting plate.	Adjust control link plate rearward or forward as required ("B" Fig. 22-25; "Y" Fig. 22-26).
	2. Misaligned folding top dust boot female fastener.	Where possible, align female with male fastener.
	3. Rear seat back assembly is too far forward.	Relocate rear seat back panel rearward until dimension "Z" between upper rear edge of rear seat back to forward edge of pinchweld finishing molding on "B" styles is 19-1/2 inches \pm 1/16", and on "Y" styles is 17-1/8 inches \pm 1/16". The dimension is measured at approximate center line of body (Fig. 22-21).
	4. Excessive build-up of padding in side roof rail stay pads.	Repair side stay pads as required.
	5. On manual tops, due to improperly adjusted catch clips.	Adjust catch clips downward as required (Fig. 22-26).

CONDITION	APPARENT CAUSE	CORRECTION
L. Folding top dust boot fits too loosely.	1. Improper stack height due to misaligned control link adjusting plate.	Adjust control link plate forward ("B" Fig. 22-25; "Y" Fig. 22-26).
	2. Rear seat back assembly is too far rearward.	Relocate rear seat back panel forward until dimension "Z" between upper rear edge of rear seat back to forward edge of pinchweld finishing molding on "B" styles is 19-1/2 inches $\pm 1/16$ ", and on "Y" styles is 17-1/8 inches $\pm 1/16$ ". The dimension is measured at approximate center line of body (Fig. 22-21).
	3. On manual tops, due to improperly adjusted catch clips.	Adjust catch clips upward as required (Fig. 22-26).
M. Top material is too low over windows or side roof rails.	1. Front roof bow improperly shimmed.	*Install one or two 1/8" shims between front roof bow and slat iron (Fig. 22-23).
	2. Excessive width in top material.	If top is too large, detach binding along affected area, trim off excessive material along side binding as required; then hand sew binding to top material.
N. Top material is too high over windows or side roof rails.	1. Front roof bow improperly shimmed.	*Remove one or two 1/8" shims from between front roof bow and slat iron (Fig. 22-23).
	2. Front roof bow felt silencer too high.	Trim silencer to within 1/8" of top of front roof bow (Fig. 22-23).
O. Top material has wrinkles or draws.	1. Rear quarter trim stick improperly adjusted.	Adjust rear quarter trim stick on side affected.
	2. Top material improperly installed to center or rear quarter trim stick.	Retack top material as required.
P. Wind whistle or waterleak along front roof rail.	1. Top does not lock tight enough to windshield header.	Adjust sunshade support laterally and/or adjust lock hook lever clockwise.
	2. Misaligned front roof rail front weatherstrip.	Retack front weatherstrip to front roof rail.
	3. Front roof rail contour does not conform to windshield header.	Contour of front roof rail may be changed slightly by reforming rail.

*When no shims are required, use attaching screw part #4824789 (1/4-28x5/8" #12 oval head with external tooth lock washer, type "T" thread cutting, chrome finish).

When one shim is required, use attaching screw part #4837811 (1/4-28x3/4" #12 oval head with external tooth lock washer, type "T" thread cutting, chrome finish).

When two shims are required, use attaching screw part #4824257 (1/4-28x7/8" #12 oval head with external tooth lock washer type "T" thread cutting, chrome finish).

MANUALLY OPERATED FOLDING TOP HARDWARE

FOLDING TOP MANUAL LIFT ASSEMBLY 67 STYLE

DESCRIPTION

The manual lift assembly incorporates a dual-action heavy duty spring which helps compensate for the weight of the folding top mechanism when the top is at or near the full up or full folded positions. When the top is in the up position the spring is under compression; when it is in the folded or stacked position the spring is under tension.

CAUTION: Do not attempt to detach lift assembly when spring is under tension or compression.

REMOVAL AND INSTALLATION

1. Remove rear seat cushion and back and folding top compartment side trim panel assembly.
2. Move top to midway position to relieve the manual lift springs. If both lift assemblies are to be serviced, have helper support folding top or place supporting props under front roof rail.
3. Remove upper and lower attaching bolts. Raise upper end of lift assembly, then move lower end of lift assembly up and forward until lift assembly is clear of oblong hole in top compartment brace (Fig. 22-27).
4. To install manual lift assembly, reverse removal procedure making sure that upper end of lift is attached to the rearmost hole in the side roof rear rail assembly (Fig. 22-27).

FOLDING TOP FOR CATCH CLIPS

DESCRIPTION

The folding top catch clips snap over the folding

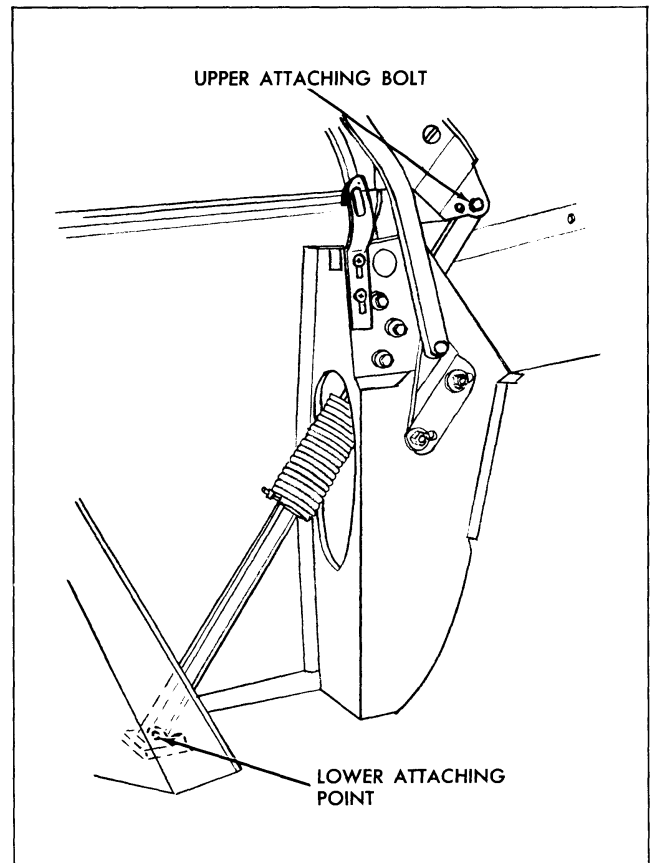

Fig. 22-27 Manual Lift Assembly

top side roof center rails when the top is being lowered to the folded or stacked position. The catch clips prevent the spring-loaded manual lift arms from raising the top from this position. In order to raise the top, both catch clips must be disengaged from the side roof center rails. Each catch clip is attached to the top compartment brace by two screws. Any adjustments made to change stack height of the folding top (See "Folding Top Adjustments") require corresponding adjustments to the catch clips.

FOLDING TOP TRIM ASSEMBLY

DESCRIPTION

Design changes have been made on the 1962 folding top and back curtain assembly. The most important of these changes include relocation of the back curtain zipper, extension of the back curtain vinyl to the rear trim stick and elimination of the vertical weather flaps on the folding top assembly and back curtain assembly. The back curtain assembly has also been extended around the rear quarter section

and is tacked to the rear and rear quarter trim sticks. In addition, all vertical portions of the back curtain assembly, which were formerly stitched, will be dielectrically sealed. The materials which are required for performing convertible top sealing operations are a neoprene-type weatherstrip adhesive for cementing vinyl surfaces and convertible top sealer (nitrile type) for sealing and cloth inner lining of the top material and back curtain assembly. The latter material may be obtained through G.M.P.D. Parts Channels.

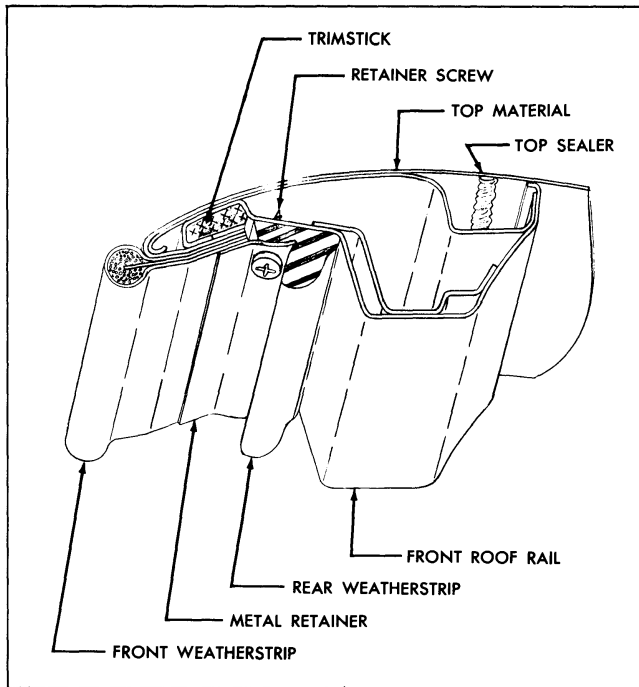

Fig. 22-28 Front Roof Rail

REMOVAL OF FOLDING TOP AND BACK CURTAIN TRIM ASSEMBLY

1. Place protective covers on all exposed panels which may be contacted during procedure.
2. Remove following trim and hardware items:
 - a. Rear seat cushion and back.

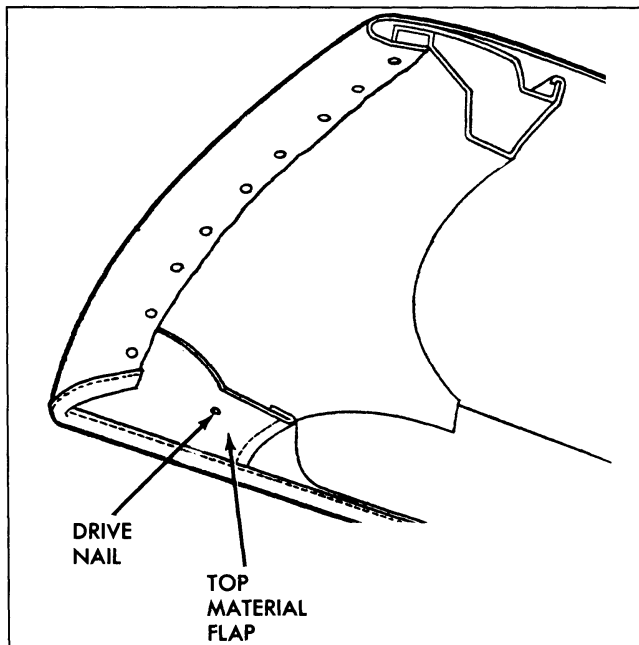

Fig. 22-29 Top Material at Front Rail

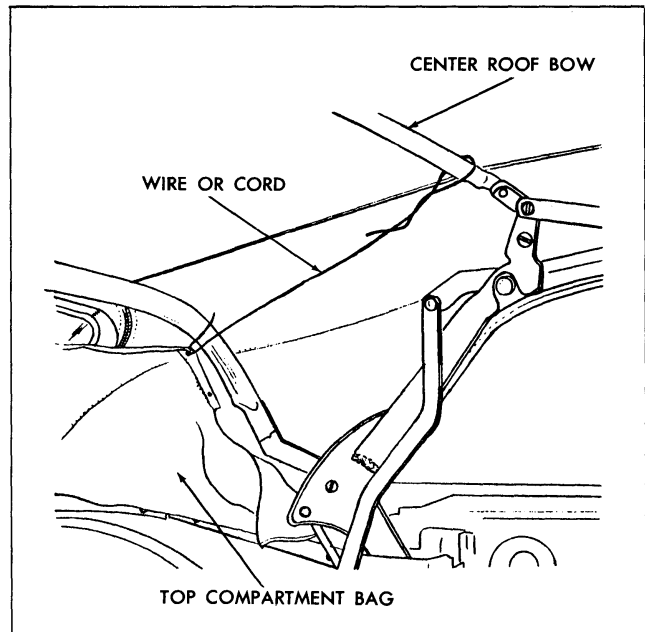

Fig. 22-30 Top Compartment Bag Tied

CAUTION: Disconnect rear seat speaker wire if present.

- b. Folding top compartment side trim panel assemblies.
 - c. Side roof rail rear weatherstrips; then loosen folding top quarter flaps from rails.
3. At the front of body, raise front roof rail, remove retainers and front weatherstrips, detach top material from front roof rail (Fig. 22-28).
 4. Loosen front end of each side roof rail front weatherstrip sufficiently to detach top material flaps which are nailed and cemented to rails (Fig. 22-29).
 5. Detach folding top compartment bag from rear seat back panel, thus exposing rear quarter and rear trim stick attaching bolts. Forward end of top compartment bag may be tied or wired to center roof bow to provide ready access to attaching bolts (Fig. 22-30).
 6. At each rear quarter area remove attaching bolts and washer securing rear quarter trim stick assembly to rear quarter inner panel (Fig. 22-31).
 7. Remove rear trim stick attaching bolts; then lift trim assembly with attached quarter and rear trim sticks on top of rear compartment front panel.
 8. To establish the relationship of right and left inner vertical edge of old top material to back curtain assembly at rear trim stick location, mark back curtain vinyl at both locations with a grease pencil (Fig. 22-32). Reference marks should be transferred to new back curtain when step 8 of

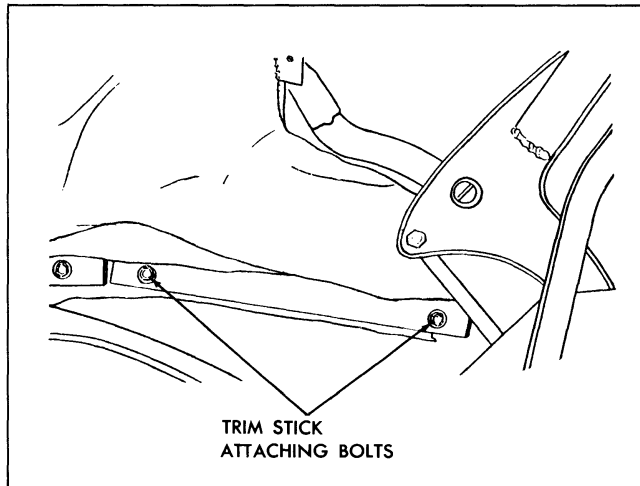

Fig. 22-31 Rear Quarter Trim Stick

installation procedure is performed.

NOTE: Reference marks must be made below upper edge of rear trim stick.

9. To establish the relationship of old top material to its position on rear trim sticks, cut selvage end of top material off flush with lower edge of trim sticks.

CAUTION: When cutting top material, be careful not to cut lower selvage edge of back curtain assembly.

10. Using a pencil, mark both ends of rear and rear quarter trim sticks on vinyl surface of top material. Reference marks for trim sticks should be transferred to new top material when step 31 of installation procedure is performed.

11. Remove screw securing escutcheon clip at each end of wire-on binding on rear bow. Remove wire-on binding from rear bow. Detach top material from rear roof bow and from trim sticks, then remove top cover assembly.

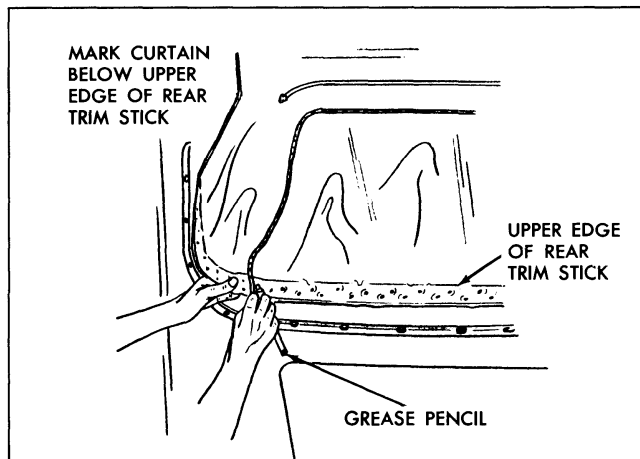

Fig. 22-32 Locating Edge of Top

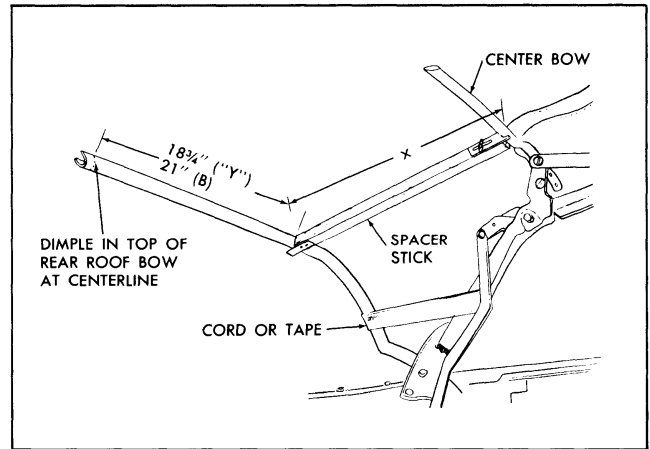

Fig. 22-33 Spacer Stick Installed

12. Lock top to windshield header. Install radius end of each adjustable spacer stick to fit against center roof bow. Install opposite end of spacer stick so that metal plate fits under rear roof bow (Fig. 22-33). Spacer stick should be installed along in-board edge of side stay pad or approximately 18-3/4" outboard from centerline dimple on "Y" body styles. While exerting rearward pressure on rear bow to draw side stay pads taut, extend spacer sticks until they fit snug between center bow and rear roof bow, then tighten wing nuts.

NOTE: Spacer stick may be made as shown in Fig. 22-34.

13. Temporarily tie or tape rear bow to rear side roof rails. Fig. 22-33. Detach nylon webbing, side stay pads and back curtain assembly from rear bow.

14. Remove rear trim stick with attached back curtain assembly and top compartment bag from body and place on a clean, protected surface.

15. Using chalk, or other suitable material, mark ends of rear and rear quarter trim sticks on vinyl

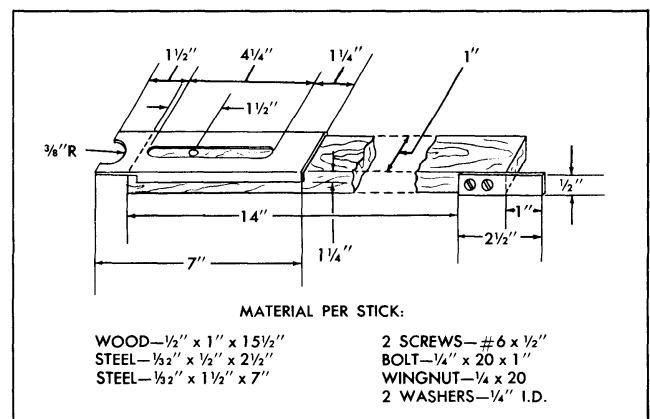

Fig. 22-34 Spacer Stick Dimensions

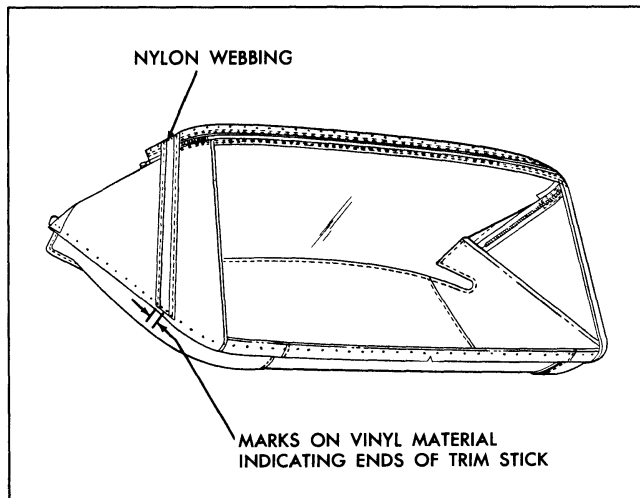

Fig. 22-35 Marking Back Curtain

surface of back curtain material (Fig. 22-35). Reference marks for trim sticks should be transferred to new back curtain material when step 8 of installation procedure is performed.

16. Remove right and left nylon webbing from rear trim stick (Fig. 22-35).

17. Remove back curtain assembly from rear and rear quarter trim sticks.

18. Remove side stay pads. Stay pads are attached to front roof rail and front and rear bows with tacks; to center bow, and side roof front rail with screws.

INSTALLATION OF FOLDING TOP AND BACK CURTAIN TRIM ASSEMBLY

1. If new top is being installed but it was impossible to perform step 12 of removal procedure, preset spacer sticks to shortest length and install between center and rear roof bow (Fig. 22-33). Adjust sticks so that dimension "X" in Fig. 22-33 (measured along spacer stick from front upper rolled edge of rear roof bow to center of center bow) is $17\text{-}3/4" \pm 1/4"$ on "Y" styles. Tie or tape rear bow to rear side roof rails.

2. In all cases, dimension "X", previously described, must be between $17\text{-}1/2"$ and $18"$ on "Y" styles and equal on both sides. This dimension may be changed slightly within tolerances to correspond with new top after tryout.

3. Tack side stay pads in conventional manner to rear roof bow and front roof rail. Make sure inboard edge of pad is properly aligned within depressions in bow and rail. Tack stay pad to front bow. Inboard edge of pad should be located within $1/4$ inch of outboard edge of front bow felt silencer.

Install pad to center bow with screws. Make sure inboard edge of pad is properly aligned within depression in bow. Install stay pad wadding in conventional manner using an approved trim cement. (Fig. 22-36 for "B" styles - Fig. 22-37 for "Y" styles).

4. Trim selvage end of side stay pads just forward of rear rolled edge of rear roof bow (Fig. 22-38).

5. Distance from center of center bow to rolled forward upper edge of rear roof bow is $17\text{-}3/4"$ ($\pm 1/4$) on "Y" styles. Re-adjust spacer sticks and side roof rail pads as required if rear bow does not come within this position range.

6. Place back curtain window assembly on clean covered work bench with exterior (vinyl) surface of back window valance facing down. (Large pliable back window must be handled carefully to avoid possible damage due to scratches, abrasions, etc.) Apply bead of convertible top sealer (nitrile) along lower edge of back curtain material in area which will be tacked to rear and rear quarter trim stick. (View "A-A" in Fig. 22-39).

7. Apply bead of convertible top sealer (nitrile) along lower selvage edge of back curtain material (Fig. 22-39).

8. After sealer has dried, carefully lay removed back curtain assembly over new back curtain assembly. Using a grease pencil, mark vinyl surface of new back curtain using marked edge of old curtain as guide. (See steps 8 and 15 of removal procedure.) In addition, mark trim stick bolt hole locations on new back curtain assembly.

NOTE: Where a grease pencil or similar material is used for marking back curtain vinyl, marks must be below trim stick so that they will not show after curtain is installed in body.

9. Center and position back curtain assembly to rear trim stick over attached compartment bag.

NOTE: Notch in back curtain vinyl at lower edge indicates centerline of back curtain assembly. (Fig. 22-40). In addition on all "Y" styles, back curtain lower edge should extend $1/2"$ below lower edge of trim sticks as shown in view "A-A", Fig. 22-39.

10. Tack curtain to rear and rear quarter trim sticks. On right side, tack zipper tape to forward edge of rear quarter trim stick. ("A" in direction of arrow in Fig. 22-40).

NOTE: Zipper stop should be above upper edge of rear quarter trim stick. Zipper tape should

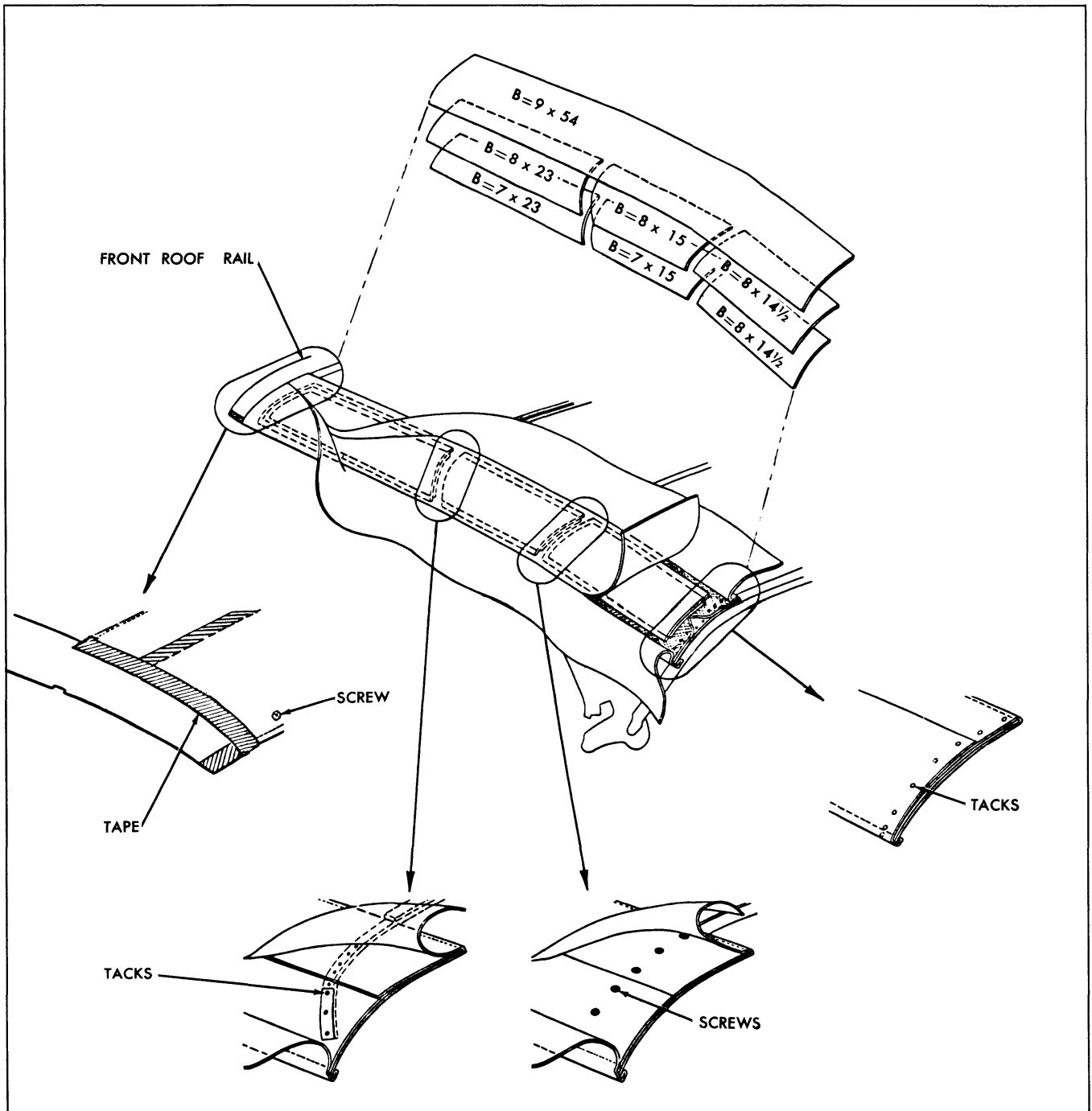

Fig. 22-36 Installation of Side Stay Pads ("B" Styles)

not be pulled taut after back curtain has been installed to rear roof bow as zipper assembly may show through top material after top has been properly installed.

11. Tack remainder of back curtain material to rear quarter trim stick, turning forward edge of material rearward to form a water barrier (Fig. 22-40).

12. Tacks securing back curtain assembly to trim

sticks should be placed close to each side of every bolt hole in trim sticks. Then pierce or punch back curtain assembly for each trim stick bolt.

13. Tack nylon webbing to rear trim stick. Forward edge of webbing should be even with edge of rear trim stick. New webbing may be cut from a piece of non-staining type webbing 2" x 19". Excess webbing should be trimmed off at rear trim stick, 1/2" above back curtain lower edge (see Fig. 22-40).

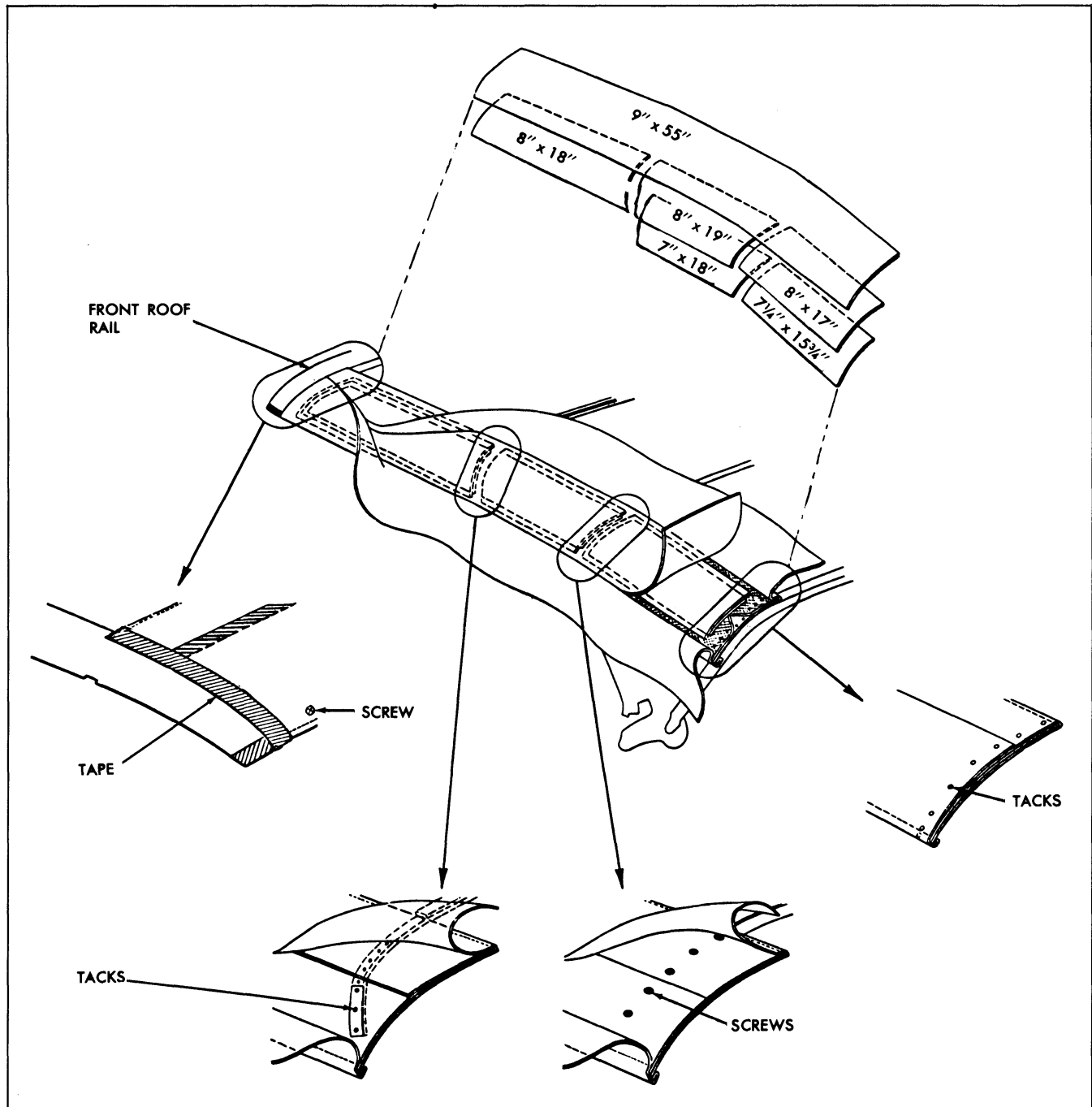

Fig. 22-37 Installation of Side Stay Pads ("Y" Styles)

NOTE: Webbing used in build-up of side roof rail stay pads is recommended for the above operation.

14. Inspect rubber trim stick fillers cemented to body below pinchweld. Recement if necessary (Fig. 22-41).

15. Install rear trim stick with attached back curtain assembly into body.

NOTE: Make sure that all trim stick bolts are driven completely in to represent finish condition.

16. Secure back curtain assembly with one tack to rear bow to prevent damage to plastic sheet (Fig. 22-42).

17. Working from body center progressively outboard to right and left sides, tack back curtain upper valance to rear bow. Make sure all fullness has been

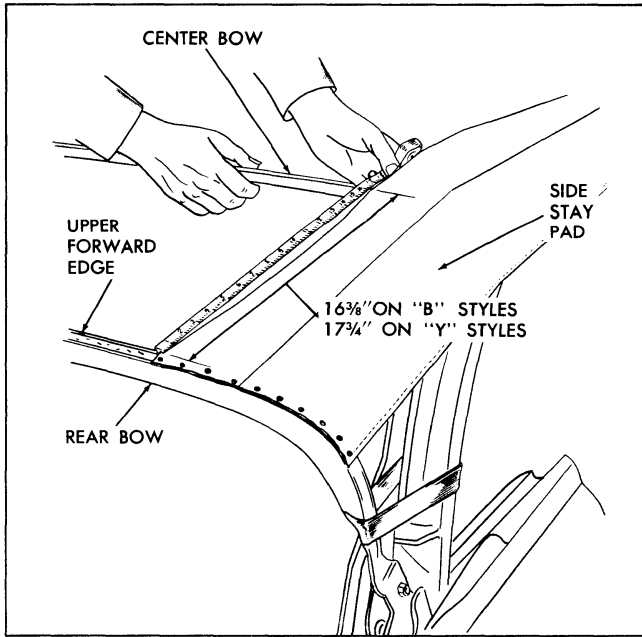

Fig. 22-38 Position of Rear Bow

drawn from back curtain assembly. Fold excess back curtain upper valance material rearward and tack to rear bow (Fig. 22-43).

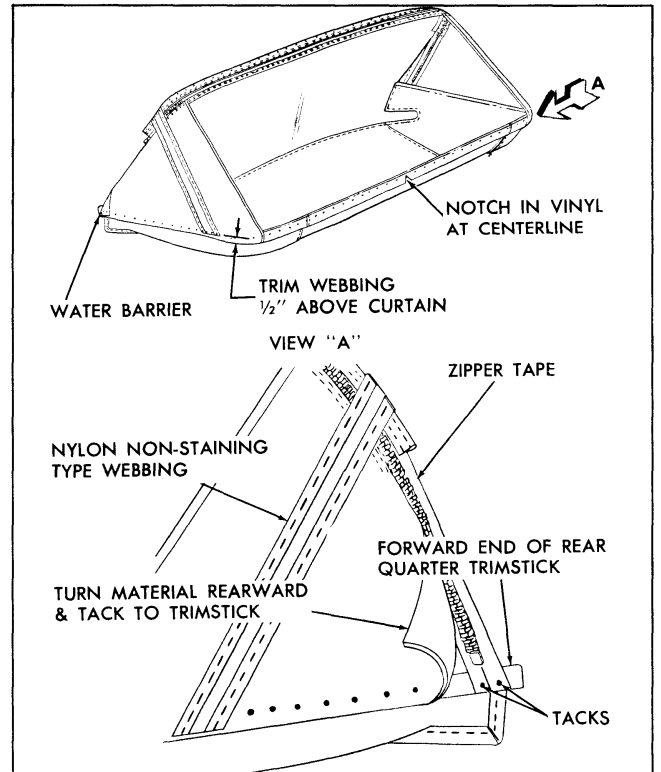

Fig. 22-40 Back Curtain Installation

CAUTION: Do not cut off excess upper valance material, as material may unravel.

18. Check contour of back curtain assembly at rear roof bow and at pinchweld molding.

19. Where required, place reference chalk mark on outer surface of back curtain along pinchweld finishing molding. Re-adjust back curtain assembly as required. (Fig. 22-44).

20. Where required, adjust side stay pads; then tack side stay pads to front roof rail and front bow. Attach side stay pads to center bow and side roof

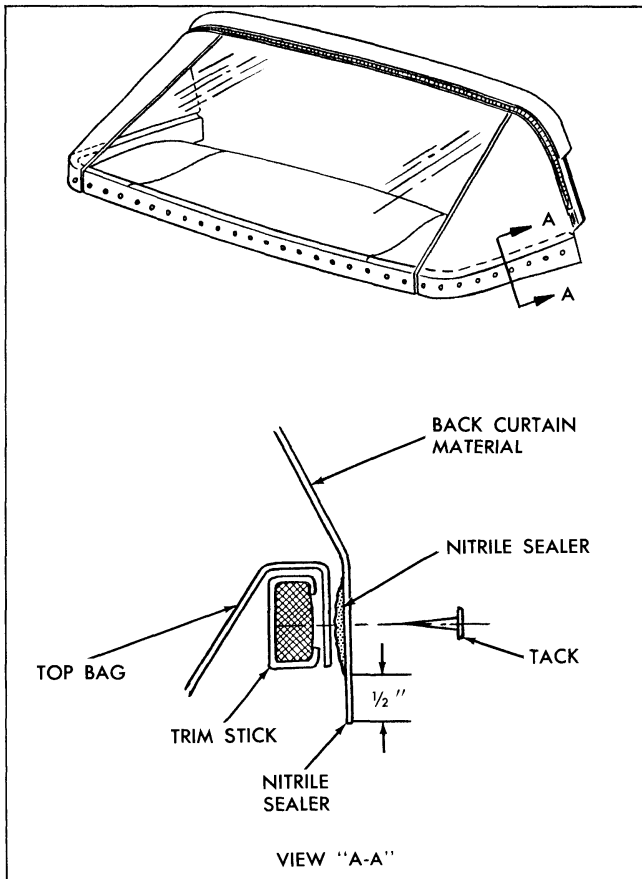

Fig. 22-39 Back Curtain Sealing

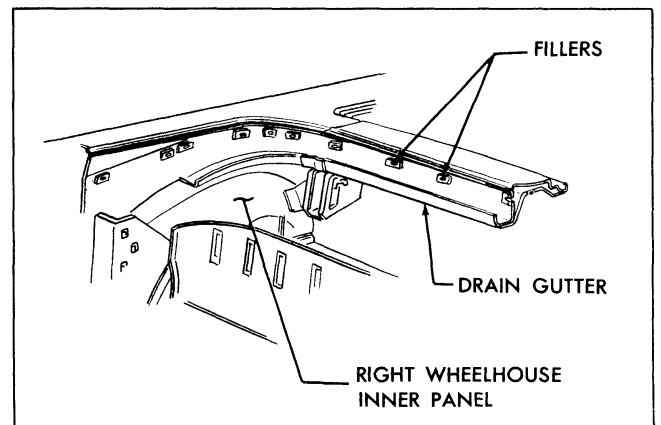

Fig. 22-41 Checking Trim Stick Fillers

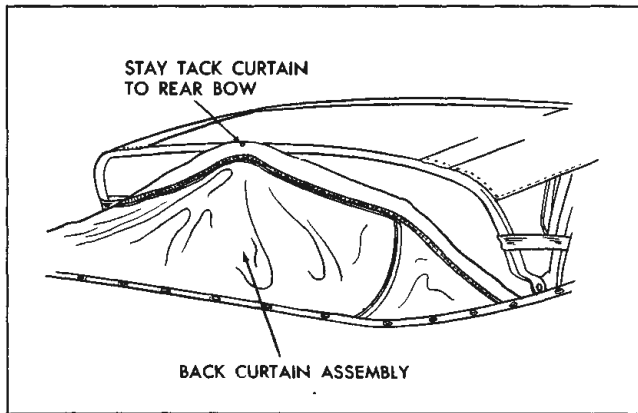

Fig. 22-42 Stay Tacking Back Curtain

front rail with screws. Trim selvage end of side stay pads at front roof rail. Install stay pad covering material in conventional manner using an approved trim cement.

21. Tack nylon webbing to rear roof bow. Outboard edge of webbing should be installed even with outboard edge of side roof rail pad. Remove excess by trimming webbing just rearward of front rolled edge of rear roof bow.

CAUTION: Do not cut back curtain or side stay pad material.

22. Detach rear trim stick with attached back curtain assembly from body.

23. Apply convertible top sealer (nitrile) around each tack head used to secure back curtain material and webbing to rear and/or rear quarter trim sticks (Fig. 22-45).

NOTE: It is not necessary to seal tacks which secure back curtain vinyl to rear trim stick.

24. Lay out new top material on clean protected surface with outer layer of material exposed.

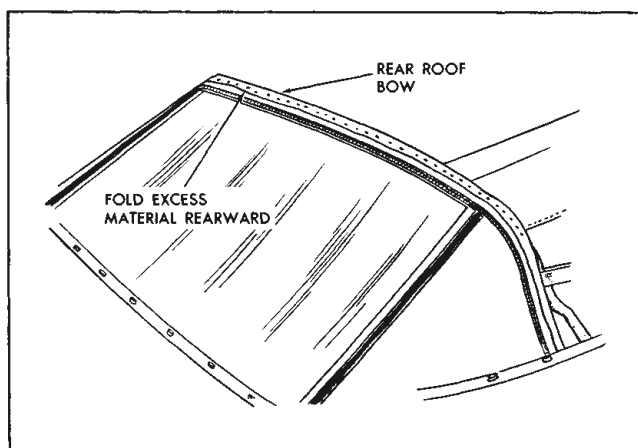

Fig. 22-43 Back Curtain Installation At Rear Roof Bow

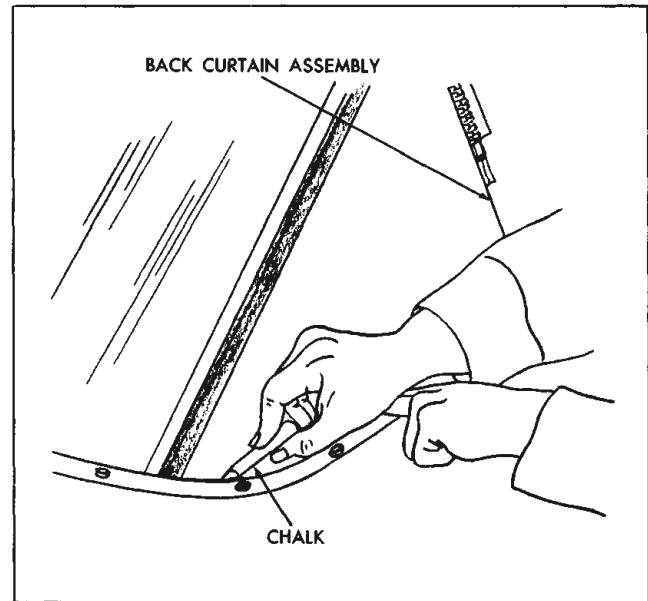

Fig. 22-44 Marking Back Curtain

25. Using a pencil, mark top material (mark should be approximately 1/2" in length) at deck seam 4-1/4" from edge of top material upper valance binding (Fig. 22-46).

26. Fold new top material in half so that inner lining of top material is exposed (Fig. 22-47). Install a 6" piece of tape on inner surface at centerline fold of new top material (Fig. 22-47). Using a pencil, mark the approximate centerline of new top material along entire length of tape.

CAUTION: Be sure mark will be visible inside of body after new top is installed on convertible top framework.

27. Along forward surface of rear roof bow install a 1" piece of tape at centerline dimple of rear roof

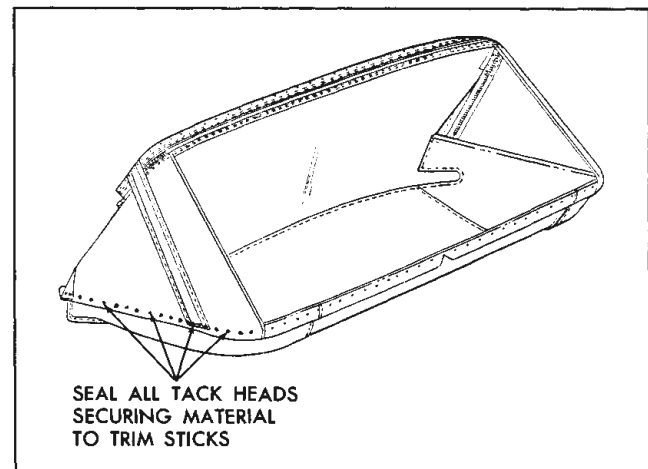

Fig. 22-45 Back Curtain Sealing

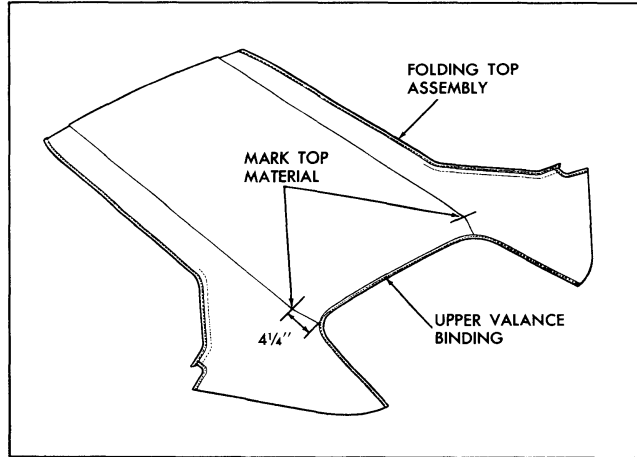

Fig. 22-46 Marking Top Material

bow. Using a pencil, mark centerline of rear bow on tape (Fig. 22-48).

28. Remove rear bow spacer sticks and positioning tape or cord.

29. Check position of rear roof bow in relation to new folding top trim assembly by placing new top trim over folding top framework. With quarter flaps properly folded over rear side roof rails (edge of rails should match stitch lines of quarter flap seams), marks on deck seam should be in center of rear roof bow.

NOTE: The deck seam mark will vary slightly ($\pm 1/4$ "') depending upon position of rear roof bow. Also check centerline mark on inner lining of top material. Mark should correspond to centerline mark on rear roof bow.

30. Remove top trim material.

31. Carefully lay removed top, which was marked at lower edge of trim stick prior to removal, over new top. Align old top with new top. Using a pencil,

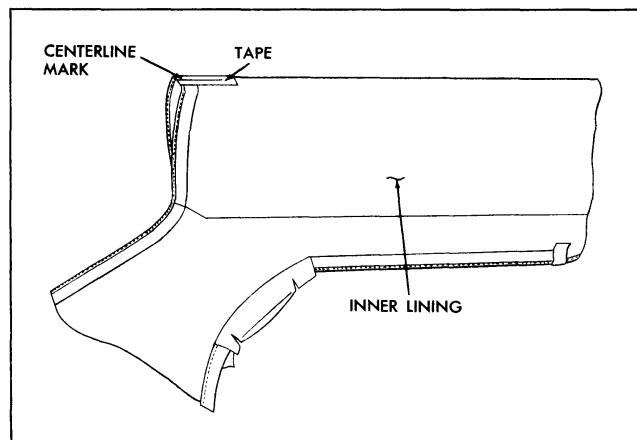

Fig. 22-47 Marking Top Assembly

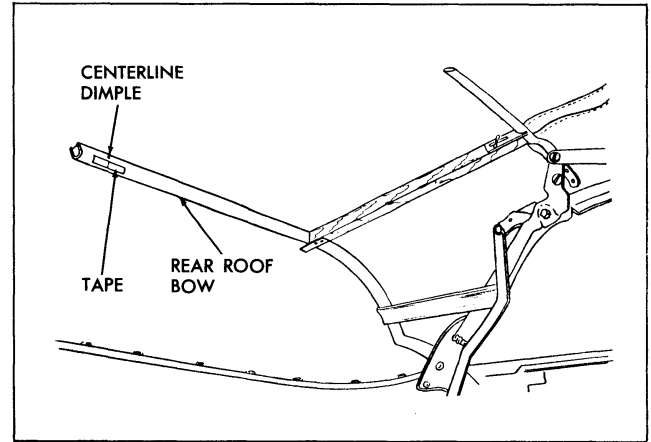

Fig. 22-48 Marking Rear Roof Bow

mark vinyl surface of new top using marked edge of old top as guide. Also mark edges of trim sticks on vinyl surface of new top material. (See steps 9 and 10 of removal procedure.)

32. Apply bead of convertible top sealer (nitrile) to inner lining of top material along front roof rail. Sealer bead should be roughly parallel with forward edge of top material and located so that sealer will be completely concealed by front roof rail when top is installed (Fig. 22-28).

33. After sealer has dried, position top trim on framework and center assembly both fore and aft and side to side.

34. Check position of top trim at rear roof bow and at side roof rear rails. With quarter flaps properly folded over rear side roof rails (edge of rails should match stitch lines of quarter flap seams), marks on deck seam should be in center of rear roof bow.

NOTE: The deck seam mark will vary slightly ($\pm 1/4$ "') depending upon position of rear roof bow. Also check centerline mark on inner lining of top material. Mark should correspond to centerline mark on rear roof bow (Fig. 22-48).

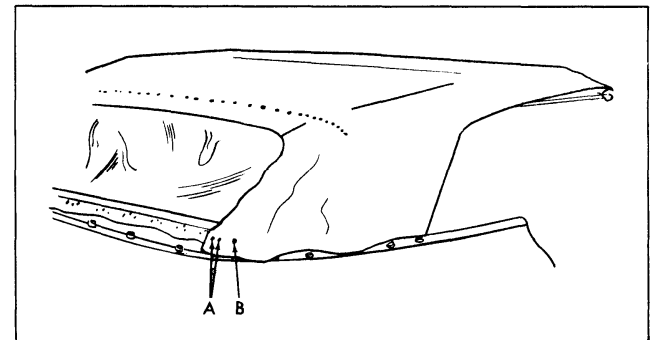

Fig. 22-49 Tacking Top Material

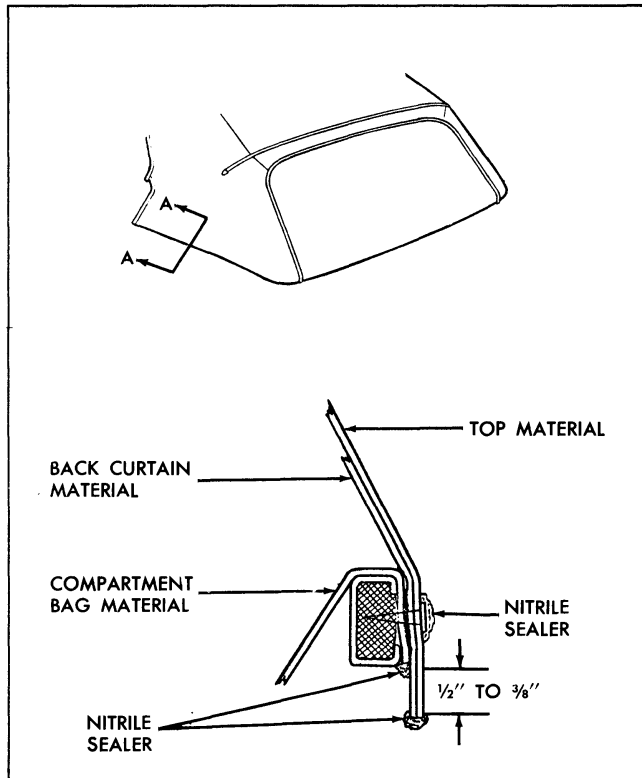

Fig. 22-50 Sealing At Trim Sticks

35. Using neoprene-type weatherstrip adhesive, fasten rear quarter flaps to side roof rear rails. Make sure that quarter flap seam breaks at forward edge of side roof rear rail.

NOTE: Material may have to be stretched from side to side to insure proper fit of top material flaps to side roof rear rails and to remove wrinkles from top material along rear roof bow.

36. Cut or pierce flaps for side roof rail rear weatherstrip attaching bolts. Install side roof rail rear weatherstrip to help maintain position of quarter flaps while adhesive is drying.

37. Using previously marked lines (ends of trim stick) as locating reference, tack top material to

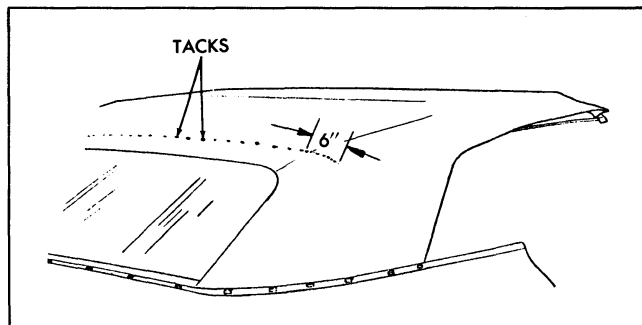

Fig. 22-51 Tacks Outboard of Seams

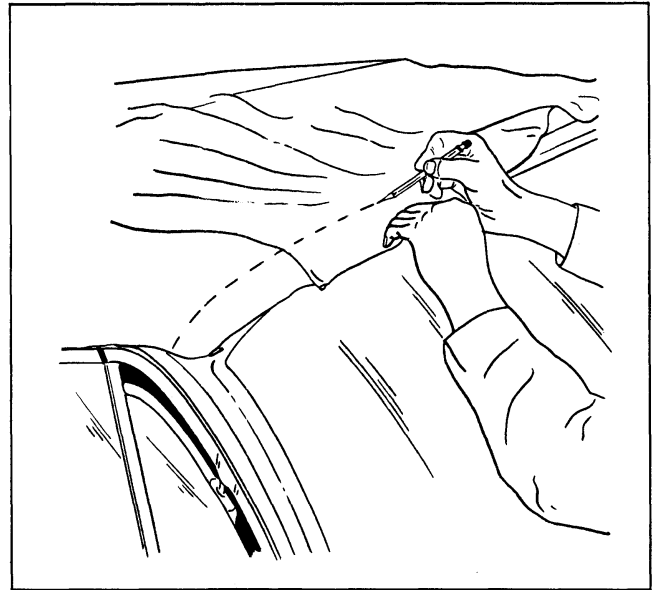

Fig. 22-52 Marking Top Material

rear and rear quarter trim sticks. "A" in Fig. 22-49 shows top material installed to rear trim stick at inboard edge.

38. Cut or punch hole in top material for each trim stick attaching bolt.

39. Install top material into body. Make sure rear and rear quarter trim stick attaching bolts are completely driven in to represent finished condition.

40. Check fit of top material. Rear quarter trim sticks may be adjusted downward to remove minor wrinkles in top material in rear quarter area.

41. Where required, re-mark top material; then make necessary adjustments to top material by re-positioning rear quarter trim sticks and/or by re-tacking top material to rear and/or rear quarter trim sticks.

NOTE: In extreme cases, adjustment of top material at rear or rear quarter trim sticks may have to be performed several times before desired fit of top material is obtained.

42. Remove trim sticks with attached top material from top compartment well. Back curtain should extend 1/2" below trim sticks on "Y" styles. (See step 9 of installation procedure.) In addition, top material must extend 1/2" to 5/8" below trim sticks on "Y" styles, to minimize water wicking on inner lining of back curtain material. (See view "A-A" in Fig. 22-50). Trim top material as required.

43. Apply convertible top sealer (nitrile) onto all trimmed edges, around each tack head and around

each trim stick attaching bolt hole. See view "A-A" in Fig. 22-50.

CAUTION: All painted surfaces adjacent to belt finishing molding should be adequately covered to prevent possible sealer damage.

44. Install trim sticks with attached top material into top compartment well and tighten side and rear trim stick attaching bolts.

45. Re-check side roof rail flaps. Make sure mark at deck seams is in center of rear bow. Also re-check centerline mark on inner surface of top material at rear bow.

46. Where required, remove side roof rail rear weatherstrips. Re-adjust top material at side roof rails and reinstall weatherstrips.

47. While pulling top material slightly rearward, stay tack top material along rear roof bow.

NOTE: Tacks must be installed along a straight line in center of rear bow. (Fig. 22-51). Tacks outboard of deck seams should be restricted to distance not to exceed six inches, which is length wire-on binding extends past seam (Fig. 22-51).

48. Unlock top from windshield header, apply neoprene-type weatherstrip adhesive to front flaps and to corresponding areas on side roof front rails. Fasten flaps to side roof front rails (Fig. 22-29). Lock top to windshield header.

49. At front roof rail, pull top trim material forward to desired tension. While maintaining tension on top trim, place a pencil mark on outer surface of trim material along forward edge of front roof rail (Fig. 22-52).

50. Unlock top from windshield header and apply neoprene-type weatherstrip adhesive to tacking area of front roof rail. Pull top trim material slightly forward so that pencil marks are forward on front edge of front roof rail. Fasten top trim to cemented area and stay tack trim to rail (Fig. 22-53).

51. Lock top to windshield header. Check appearance of top trim as well as operation and locking action of top. (If additional tension is desired in top trim, unlock top from header and reposition top trim so that pencil marks are further forward. Stay tack and re-check top appearance.)

52. Complete tacking of top trim to front roof rail and trim off excess material.

53. Permanently tack top material to rear roof bow. Apply bead of neoprene-type weatherstrip adhesive around each tack head, and into two holes pierced into top material for wire-on binding clip

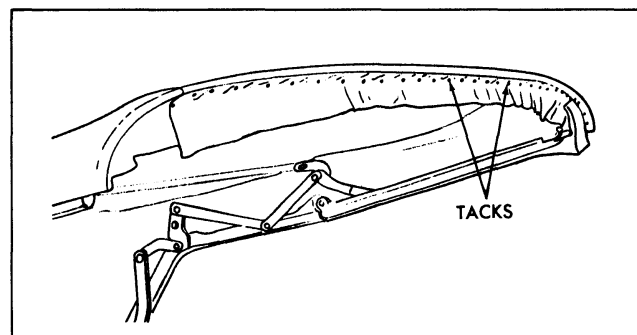

Fig. 22-53 Installation of Top Material

escutcheons.

54. When completed, folding top should be free from wrinkles and draws. Install all previously removed trim and hardware and clean any soil from top material, back curtain or pads.

FOLDING TOP TRIM

REMOVAL

1. Remove folding top trim as described in steps 1 through 11 of "Removal of Folding Top Trim Assembly (Complete)."

INSTALLATION

1. Prior to installation of new top trim material, check contour of back curtain and side stay pad assemblies. Where required, adjust back curtain and/or side stay pads as required.

2. Install new folding top trim as described in steps 24 through 27 and 29 through 54 of "Installation of Folding Top Trim Assembly (Complete)."

BACK CURTAIN TRIM

REMOVAL

1. Perform steps 1, 2, 5, 6, 7, 8, 10 as described in "Removal of Folding Top Trim Assembly (Complete)."

2. Remove wire-on binding and escutcheons from rear roof bow.

3. Detach folding top trim from rear roof bow and from rear and rear quarter trim sticks.

4. Carefully slide top trim forward exposing tacked edge of back curtain at rear roof bow.

5. Detach nylon webbing and back curtain from rear roof bow; then remove back curtain assembly

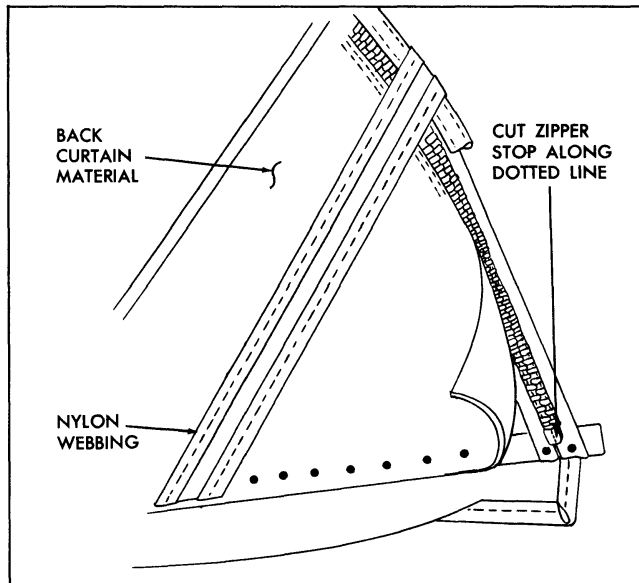

Fig. 22-54 Back Curtain Vinyl Replacement

with attached trim sticks and top compartment bag from body and place on a clean, protected surface.

6. Perform steps 15, 16 and 17 as described in "Removal of Folding Top Trim Assembly (Complete)."

INSTALLATION

1. Install spacer sticks as described in steps 1 and 2 of "Installation of Folding Top Trim Assembly (Complete)."

2. Seal and install back curtain assembly as described in steps 7 through 23 of "Installation of Folding Top Trim Assembly (Complete)."

NOTE: Extra care in positioning new curtain at same location on trim stick as old curtain and aligning of trim stick attaching bolt holes in top

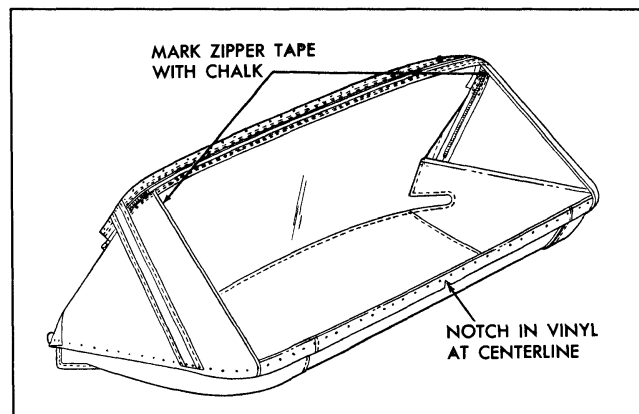

Fig. 22-55 Marking Zipper Tape

material with holes in trim stick will allow reinstallation of top material to its original position with a minimum of refitting.

BACK CURTAIN VINYL REPLACEMENT

REMOVAL

1. Place protective covers on all exposed panels which may be contacted during procedure.

2. Remove rear seat cushion and back.

CAUTION: Disconnect rear seat speaker wire if present.

3. Remove folding top compartment side trim panel assemblies and side roof rail rear weatherstrips; then detach folding top quarter flaps from side roof rear rails.

4. Detach top compartment bag from seat back panel and remove all trim stick attaching bolts.

5. To establish the relationship of right and left inner vertical edge of old top material to back curtain assembly at rear trim stick location, mark back curtain vinyl at both locations with a grease pencil (Fig. 22-32). Reference marks should be transferred to new back curtain when step 5 of installation procedure is performed.

6. Using a pencil, mark both ends of rear and rear quarter trim sticks on vinyl surface of top material. Reference marks should be used as a guide when installing top material to trim sticks after new back curtain has been installed.

7. Remove folding top material from rear and rear quarter trim sticks; then carefully slide top trim forward sufficiently to expose back curtain zipper.

8. Detach zipper tape from rear quarter trim stick.

9. Using a pair of wire cutting shears or other suitable tool, cut zipper stop along dotted line and remove both halves of stop from zipper (Fig. 22-54).

10. Operate slide fastener off of zipper assembly.

11. Detach nylon webbing from rear trim stick.

12. Remove rear and rear quarter trim sticks with attached back curtain and compartment bag material from body and place on a clean, protected surface.

13. Using chalk, or other suitable material, mark ends of rear and rear quarter trim sticks on vinyl surface of back curtain material (Fig. 22-35). Reference marks for trim sticks should be transferred

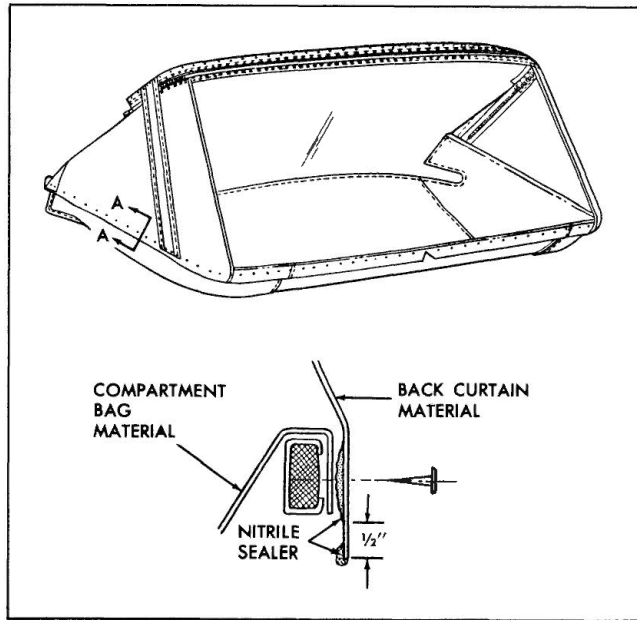

Fig. 22-56 Back Curtain Sealing

to new back curtain material when step 5 of installation procedure is performed.

14. Using chalk or similar material, mark zipper tape at upper edge of vinyl (Fig. 22-55).

15. Remove back curtain assembly from rear and rear quarter trim sticks.

16. As a bench operation, cut stitches securing half of zipper assembly to back curtain vinyl.

NOTE: Back curtain vinyl and extensions (less zipper) are available as a service part.

INSTALLATION

1. Using chalk mark as guide, locate rear half of zipper to new back curtain vinyl. Zipper tape may be stapled to new back curtain to aid in holding zipper in proper position during sewing operation.

2. Sew zipper to new back curtain assembly.

3. Place back curtain window assembly on clean covered work bench with exterior (vinyl) surface of back window valance facing down. (Large pliable back window must be handled carefully to avoid possible damage due to scratches, abrasions, etc.). Apply bead of convertible top sealer (nitrile) along lower edge of back curtain material in area which will be tacked to rear and rear quarter trim stick. (See view "A-A" in Fig. 22-56).

4. Apply bead of convertible top sealer (nitrile) along lower selvage edge of back curtain material (Fig. 22-56).

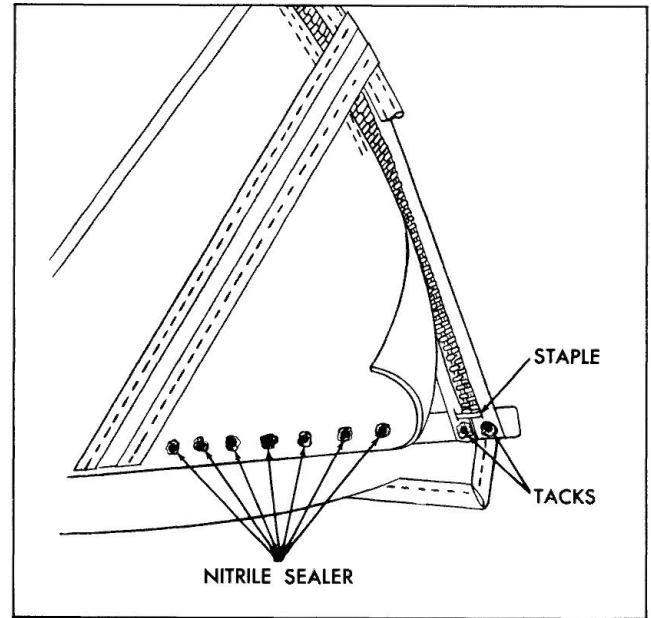

Fig. 22-57 Sealing At Trim Stick

5. After sealer has dried, transfer marks on old back curtain to new back curtain assembly. See steps 5 and 13 of removal procedure.

6. Center and position back curtain assembly to rear trim stick over attached compartment bag.

NOTE: Notch in back curtain vinyl at lower edge indicates centerline of back curtain assembly. (Fig. 22-56). In addition, back curtain lower edge should extend 1/2" below lower edge of trim sticks on "Y" styles.

7. Tack curtain to rear and rear quarter trim sticks. Turn forward edge of material rearward to form a water barrier (Fig. 22-56).

8. Tacks securing back curtain assembly to trim sticks should be placed close to each side of every bolt hole in trim sticks. Then pierce or punch curtain assembly for each trim stick bolt.

9. Tack nylon webbing to rear trim stick as previously described.

10. Inspect rubber trim stick fillers cemented to body below pinchweld. Recement if necessary.

11. Install slide fastener onto zipper assembly.

12. Staple both sections of zipper tape together. Staples will aid in preventing zipper scoops from disengaging and also serve as a stop for the slide fastener (Fig. 22-57).

13. Operate slide fastener to closed position.

14. Tack zipper tape to rear quarter trim stick

(Fig. 22-57). Zipper tape should not be pulled taut as zipper teeth may show through top material after top has been properly installed.

15. Install trim sticks with attached back curtain assembly into body.

NOTE: Make sure that all trim stick bolts are driven completely in to represent finished condition.

16. Check contour of back curtain assembly at pinchweld molding. Where required, place reference chalk mark on outer surface of back curtain along pinchweld finishing molding. Re-adjust back curtain assembly by retacking curtain to rear or rear quarter trim sticks as required.

17. Detach rear trim stick with attached back curtain assembly from body.

18. Apply convertible top sealer (nitrile) around each tack head used to secure back curtain material and webbing to rear and rear quarter trim sticks (Fig. 22-57).

NOTE: It is not necessary to seal tacks which secure back curtain vinyl to rear trim stock.

19. After sealer has dried, carefully replace top in position in rear quarter area.

20. Using neoprene-type weatherstrip adhesive, fasten rear quarter flaps to side roof rear rails. Make sure that rear quarter flap seam is even with forward edge of side roof rear rail. Install side roof rail rear weatherstrip to help maintain position of quarter flaps while adhesive is drying.

21. Using previously marked lines (end of trim sticks) and bolt hole locations in top material as a locating reference, tack top material to rear and rear

quarter trim sticks.

22. Install top material into body. Make sure rear and rear quarter trim stick attaching bolts are completely driven in to represent finished condition.

23. Check fit of top material. Rear quarter trim sticks may be adjusted downward to remove minor wrinkles in top material in rear quarter area.

24. Where required, re-mark top material; then make necessary adjustments to top material by re-positioning rear quarter trim sticks or by retacking top material to rear or rear quarter trim sticks.

25. After desired fit of top material has been obtained, remove trim sticks with attached top material from top compartment well. Back curtain should extend 1/2" below trim sticks "Y" styles.

26. Apply convertible top sealer (nitrile) onto all trimmed edges, around each tack head and around each trim stick attaching bolt hole (see view "A-A" in Fig. 22-50).

CAUTION: All painted surfaces adjacent to belt finishing molding should be adequately covered to prevent possible sealer damage.

27. Install trim sticks with attached top material into top compartment well and tighten side and rear trim stick attaching bolts.

28. Where required, remove side roof rail rear weatherstrips. Re-adjust top material at side roof rails and reinstall weatherstrips.

29. When completed, folding top and back curtain assembly should be free from all wrinkles and draws. Install all previously removed trim and hardware and clean any soil from top material or back curtain assembly.

HYDRO-LECTRIC SYSTEM

DESCRIPTION

The new high pressure Hydro-Lectric unit used in

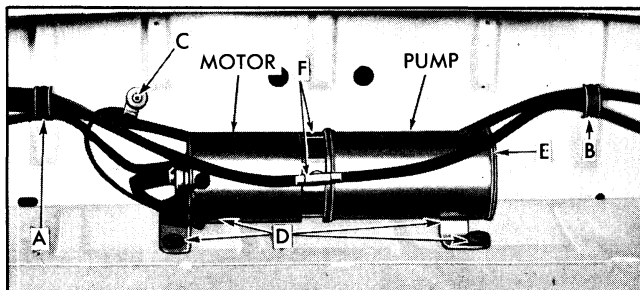

Fig. 22-58 Hydro-Lectric Motor and Pump Assy.

the Convertible bodies, consists of a 12 volt reversible type motor, a rotor-type pump, two hydraulic lift cylinders, and an upper and lower hydraulic hose assembly. The unit is installed in the body directly behind rear seat back Fig 22-58.

Fig. 22-59 illustrates and identifies the individual parts of the motor and pump assembly.

NOTE: When servicing the motor assembly or pump end plate assembly, it is extremely important that the small motor shaft "O" ring seal is properly installed over the motor armature shaft and into the pump end plate assembly prior to installing the pump rotors or the motor shaft drive ball.

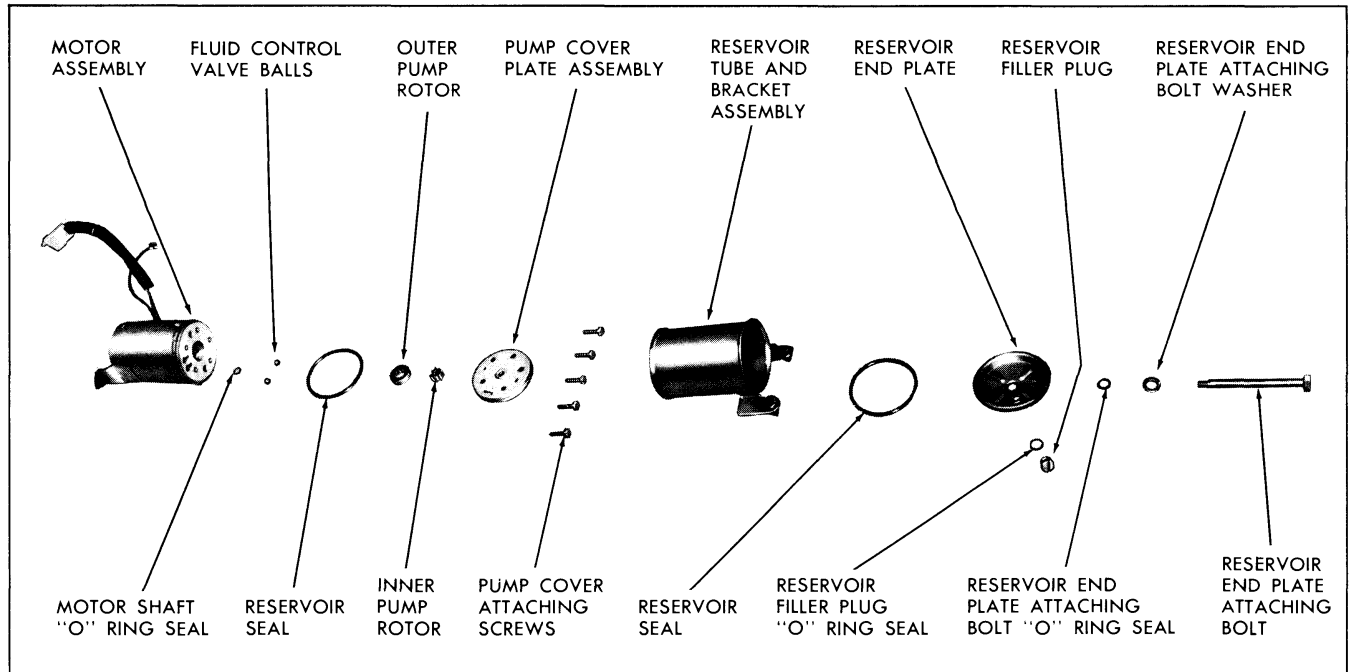

Fig. 22-59 Hydro-Lectric Motor and Pump Assembly-Exploded

MOTOR AND PUMP ASSEMBLY

REMOVAL

1. Operate folding top to full "up" position.
2. Disconnect battery cable.
3. Place protective covering over rear seat cushion and back.
4. Working inside body, detach front edge of folding top compartment bag from rear seat back panel.
5. Working on inside of body over rear seat back, remove pump and motor shield attaching screws and remove shield.
6. Remove clips securing wire harness and hydraulic hose to rear seat back panel. See "A" and "B" in Fig. 22-58.
7. Disconnect motor leads from wire harness and ground attaching screw. See "C" in Fig. 22-58.
8. To facilitate removal apply a rubber lubricant to pump attaching grommets; then carefully disengage grommets from floor pan. See "D" in Fig. 22-58.
9. Place absorbent rags below hose connections and end of reservoir.
10. With a straight-bladed screw driver, vent reservoir by removing filler plug; then reinstall plug. See "E" in Fig. 22-58.

NOTE: Venting reservoir is necessary in this

"sealed-in" unit to equalize air pressure in reservoir to that of the atmosphere. This operation prevents the possibility of hydraulic fluid being forced under pressure from disconnected lines and causing damage to trim or body finish.

11. Disconnect hydraulic lines and cap open fittings to prevent leakage of fluid. See "F" in Fig. 22-58. Use a cloth to absorb any leaking fluid, then remove unit from rear compartment.

INSTALLATION

1. If a replacement unit is being installed, fill reservoir unit with specified Delco No. 11 Hydraulic Fluid (G.M. Hydraulic Brake Fluid Super No. 11 or its equivalent). See "Filling of Hydro-Lectric Reservoir".

2. Connect hydraulic hoses, engage attaching

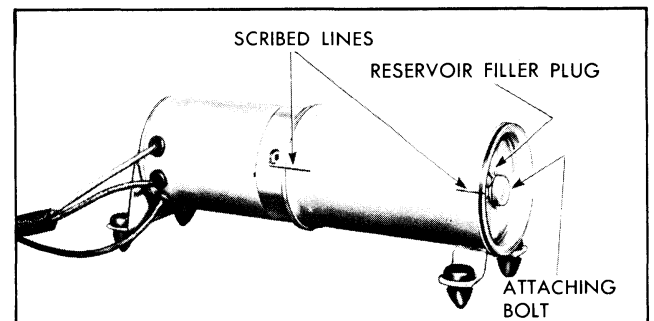

Fig. 22-60 Hydro-Lectric Assembly

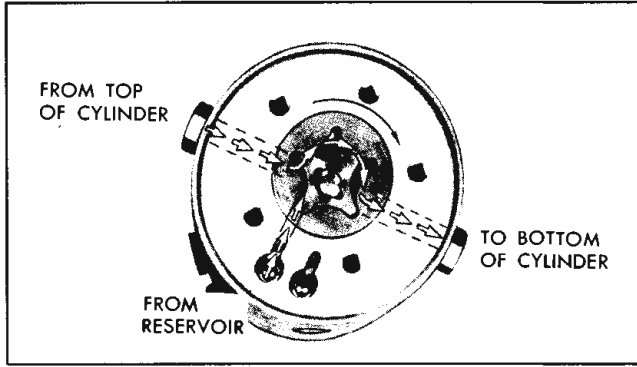

Fig. 22-61 Pump Operation-Raise Top

grommets in panel and connect wiring.

3. Connect battery and operate top through its up and down cycles until all air has been "bled" from hydraulic circuit. See "Filling of Hydro-Lectric Reservoir".

4. Check connections for leaks and recheck fluid level in reservoir.

5. Install previously removed parts.

RESERVOIR TUBE

DISASSEMBLY FROM MOTOR AND PUMP ASSEMBLY

1. Remove motor and pump assembly from body.
2. Scribe a line across pump end plate, reservoir tube and reservoir tube end plate to insure correct assembly of parts (Fig. 22-60).
3. With a straight-bladed screw driver, remove reservoir filler plug. Note sealing ring around plug.
4. Drain fluid from reservoir into a clean container.

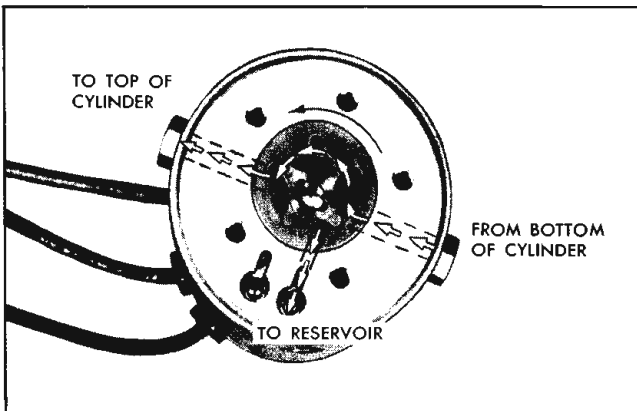

Fig. 22-62 Pump Operation-Lower Top

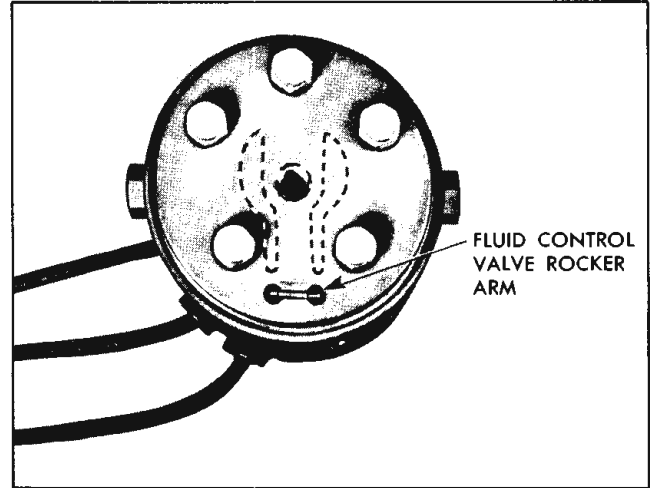

Fig. 22-63 Pump Cover Plate

5. With suitable tool remove bolt from end of assembly and remove reservoir end plate and tube. Note sealing rings around bolt, reservoir end plate, and between end of reservoir tube and pump cover plate assembly.

ASSEMBLY TO MOTOR AND PUMP ASSEMBLY

1. Position sealing ring on pump and assemble reservoir tube to pump according to scribe marks.

NOTE: Bracket assembly on tube should be located at outer end when tube is assembled to pump.

2. Position sealing ring on tube end plate and position end plate on reservoir tube, according to scribe marks. Install and tighten attaching bolt.

3. Place unit in horizontal position and fill with

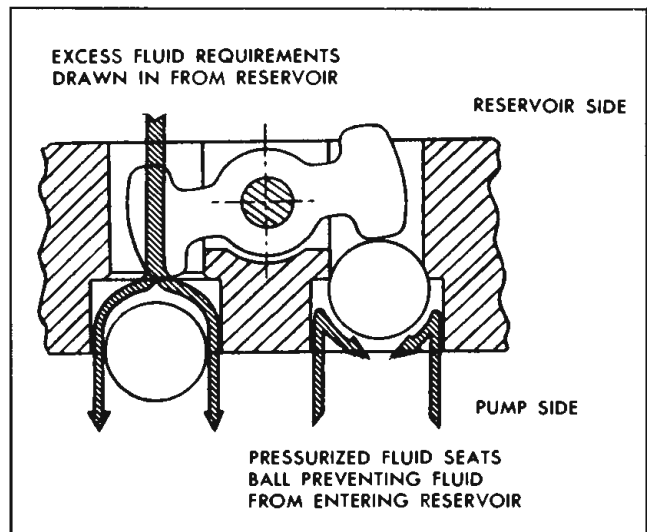

Fig. 22-64 Fluid Control Valve

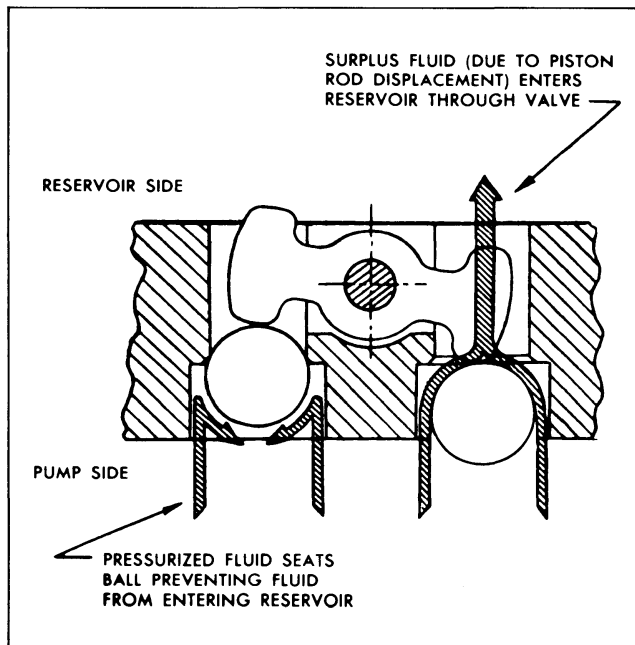

Fig. 22-65 Fluid Control Valve

fluid until fluid level is within 1/4 inch of lower edge of filler plug hole.

4. Make sure that sealing ring is on filler plug before installing filler plug.

OPERATION OF FOLDING TOP

When the control switch is actuated to the "up" position, the battery feed wire is connected to the red motor lead and the motor and pump assembly operate to force the hydraulic fluid through the hoses to the lower ends of the double-acting cylinders. The fluid forces the piston rods in the cylinders upward, thus raising the top. The fluid in the top of the cylinders returns to the pump for recirculation to the bottom of the cylinders. When the control switch knob is actuated to the "down" position, the feed wire is connected to the dark green motor lead and the motor and pump assembly operate in a reversed direction to force the hydraulic fluid through the hoses to the top of the cylinders. The fluid forces the piston rods in the cylinders downward, thus lowering the top. The fluid in the bottom of the cylinders returns to the pump for recirculation to the top of the cylinders.

OPERATION OF PUMP ASSEMBLY

The motor type pump assembly is designed to deliver a maximum pressure in the range of 340 psi to 380 psi. The operation of the pump assembly

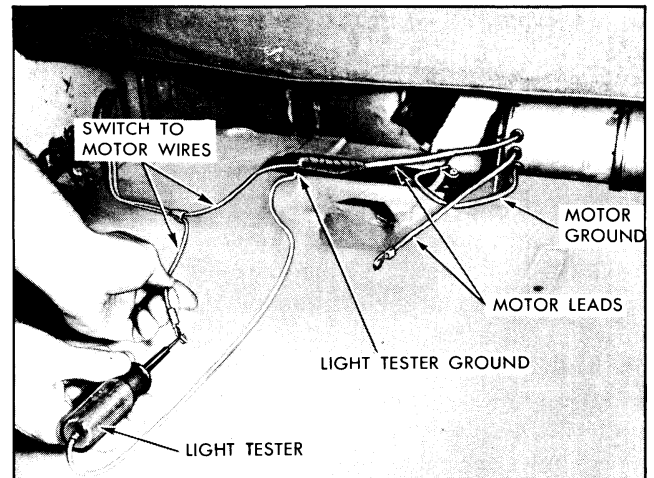

Fig. 22-66 Checking Motor Wiring

when raising the top is as follows:

1. Raising the Top. When the red motor lead is energized the motor drive shaft turns the rotors clockwise as indicated by the large arrow in Fig. 22-61. The action of the pump rotors forces the fluid under pressure to the bottom of each cylinder forcing the piston upward. This action causes the fluid above the piston in each cylinder to be forced into the pump, which recirculates the fluid to the bottom of the cylinders. The additional fluid required to fill the cylinder due to piston rod displacement is drawn from the reservoir.

2. Lowering the Top. When the green motor lead is energized the motor drive shaft turns the rotors counter-clockwise as indicated by the large arrow in Fig. 22-62. The action of the pump rotors forces the fluid under pressure to the top of each cylinder. This action causes the fluid below the piston in each cylinder to be forced into the pump which recirculates the fluid to the top of each cylinder. The surplus hydraulic fluid due to piston rod displacement flows into the reservoir.

FLUID CONTROL VALVE

The fluid control valve consists of a rocker arm installed in the pump cover plate, and two steel balls. Fig. 22-63 shows the top surface of the pump cover plate. The dotted lines indicate the cavities on the bottom side of the coverplate. The cavities are designed to permit fluid flow between pump rotors and the reservoir.

Fig. 22-64 and Fig. 22-65 illustrate the operation of the fluid control valve.

MECHANICAL CHECKING PROCEDURE

If there is a failure in the Hydro-Lectric system and the cause is not evident the mechanical operation of the top should first be checked. If the folding top assembly appears to have a binding action disconnect the top lift cylinder piston rods from the top linkage and then manually raise and lower the top. The top should travel through its up and down cycle without any evidence of a binding action. If a binding action is noted when the top is being locked at the header, check the alignment of the door windows, ventilators and rear quarter windows with relation to the side roof rail weatherstrips. Make all necessary adjustments for correct top alignment. See "Folding Top Adjustments". If a failure continues to exist after a check for mechanical failure has been completed, the Hydro-Lectric system should then be checked for electrical or hydraulic failures.

ELECTRICAL CHECKING PROCEDURE

If a failure in the Hydro-Lectric system continues to exist after the mechanical operation has been checked, the electrical system should then be checked. A failure in the electrical system may be caused by a low battery, breaks in wiring, faulty connections, mechanical failure of an electrical component, or wires or components shorting to one another or to body metal. Before beginning checking procedures, check battery according to recommended procedure.

1. Checking for Current at Folding Top Control Switch.

- a. Disengage terminal block from rear of switch.
- b. Connect light tester to central feed terminal of switch terminal block.
- c. Ground light tester ground lead to body metal.
- d. If light tester does not light there is an open or short circuit between power source and switch.

2. Checking the Folding Top Control Switch.

If there is current at the feed wire terminal of the terminal block, operation of switch can be checked as follows:

- a. Place a #12 jumper wire on switch terminal block between center terminal (feed) and one motor wire terminal. If motor operates with jumper wire but did not operate with switch, switch is defective.
- b. Connect jumper wire between center terminal and other motor wire terminal on switch terminal block. If motor operates with jumper wire, but did

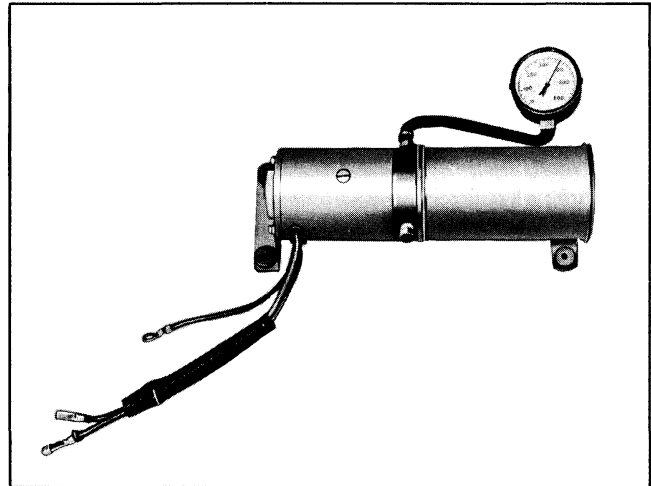

Fig. 22-67 Checking Pump Pressure

not operate with switch, switch is defective.

3. Checking Switch to Motor Lead Wires.

If switch is found to be operating properly, the switch to motor lead wires can be checked as follows: (Fig. 22-66).

- a. Disconnect green switch-to-motor wire from motor lead in rear compartment.
- b. Connect a light tester to green switch-to-motor wire terminal.
- c. Ground light tester ground lead to body metal.
- d. Actuate switch to "down" position. If tester does not light, there is an open or short circuit in wire.
- e. Disconnect red switch-to-motor wire from motor lead.
- f. Connect light tester to red switch-to-motor wire terminal.
- g. Actuate switch control knob to "up" position. If tester does not light, there is an open or short circuit in wire.

4. Checking the Motor Unit.

If a light tester indicates current at the motor-lead terminals of the switch-to-motor wires, but motor unit does not operate from switch, a final check of the motor unit can be made as follows:

- a. Check connection of motor ground wire to body metal. See "C" in Fig. 22-58.
- b. Connect a #12 jumper wire from battery positive pole to motor lead terminal that connects

to green switch-to-motor wire. The motor should operate to lower top.

c. Connect jumper wire to motor lead terminal that connects to red switch-to-motor wire. The motor should operate to raise top.

d. If motor fails to operate on either or both of these checks, it should be repaired or replaced.

e. If motor operates with jumper wire but will not operate from switch-to-motor wires, the trouble may be caused by reduced current resulting from damaged wiring or poor connections.

HYDRAULIC CHECKING PROCEDURE

Failures in the hydraulic system can be caused by lack of hydraulic fluid, leaks in hydraulic system, obstructions or kinks in hydraulic hoses or faulty operation of a cylinder or pump.

1. Checking Hydraulic Fluid Level in Reservoir.

- a. Operate top to raised position.
- b. At rear compartment, remove pump and motor shield.
- c. Place absorbent rags below reservoir at filler plug.
- d. With a straight-bladed screw driver, remove filler plug. Fluid level should be within 1/4 inch of lower edge of filler plug hole.
- e. If fluid is low, add Delco #11 Hydraulic Fluid (G.M. Hydraulic Brake Fluid Super #11 or its equivalent) to bring to specified level. See "Filling of Hydro-Lectric Reservoir".
- f. Reinstall filler plug and pump and motor shield.

2. Checking Operation of Lift Cylinders.

- a. Remove rear seat cushion and folding top compartment side panel assemblies.
- b. Operate folding top control switch and observe lift cylinders during "up" and "down" cycles for these conditions:

(1) If movement of cylinder is not coordinated or sluggish when the motor is actuated,

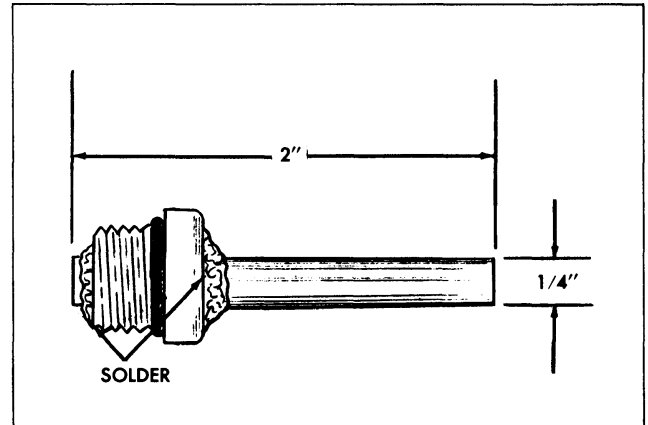

Fig. 22-68 Filler Plug Adapter

check hydraulic hoses from motor and pump to cylinder for kinks.

(2) If one cylinder rod moves slower than the other, cylinder having slower moving rod is defective and should be replaced.

(3) If both cylinder rods move slowly or do not move at all, check the pressure of the pump. See "Checking the Pressure of the Pump".

NOTE: To insure proper operation of the lift cylinders, the top lift cylinder rods should be cleaned and lubricated at least twice a year. To perform these operations, raise top to "up" position and wipe exposed portion of each top lift cylinder piston rod with a cloth dampened with brake fluid to remove any oxidation and/or accumulated grime. With another clean cloth apply a light film of brake fluid to the piston rods to act as a lubricant.

CAUTION: Exercise care so that brake fluid does not come in contact with any painted or trimmed parts of the body.

3. Checking Pressure at the Pump.

- a. Remove motor and pump assembly from rear compartment.
- b. Install plug in one port, and pressure gauge in port to be checked (Fig. 22-67).
- c. Actuate motor with applied terminal voltage within range of 9.5 volts to 11.0 volts. Pressure gauge should show a pressure between 340 psi and 380 psi.
- d. Check pressure in other port.

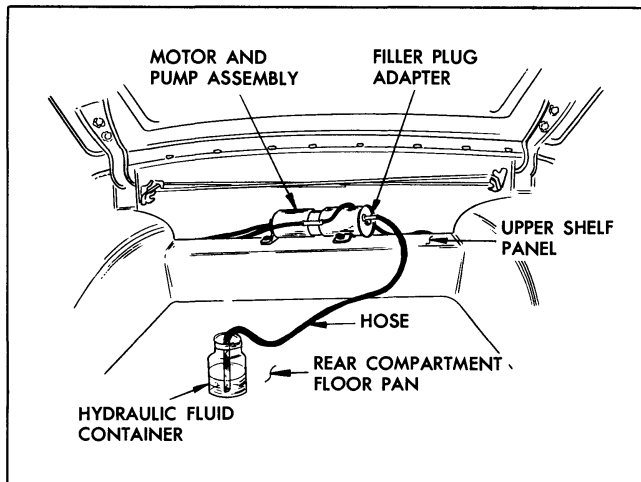

Fig. 22-69 Filling Hydro-Lectric Reservoir

NOTE: A difference in pressure readings may exist between the pressure port for top of cylinders and pressure port for bottom of cylinders. This condition is acceptable if both readings are within the limit of 340 psi and 380 psi.

e. If the pressure is not within specified limits, unit is defective and should be repaired or replaced, as required.

REMOVAL OF FOLDING TOP LIFT CYLINDER

1. Remove rear seat cushion and seat back.
2. Remove folding top compartment side trim panel assemblies.
3. With top in raised position, remove attaching nut, bolt, bushing and washer from upper end of cylinder.
4. Remove cotter pin, spacers and clevis pin securing lower end of cylinder to lift cylinder lower support.
5. Move cylinder to gain access to lower hydraulic hose connection.
6. Disconnect and cap hydraulic connections on cylinder and on each hose; remove cylinder.

CAUTION: Before disconnecting hydraulic connections, place suitable wiping rags under connections to absorb any drippage of hydraulic fluid. Also, dis-

connect battery cable to prevent accidental operation of motor and pump while hydraulic hoses are disconnected.

7. To install cylinder, reverse removal procedure with following exceptions: To aid in connection of cylinder piston rod to folding top linkage, use power to raise piston rod to extended position. Operate top down and up several times, then check and correct level of hydraulic fluid in reservoir. See "Filling of Hydro-Lectric Reservoir".

FILLING OF HYDRO-LECTRIC RESERVOIR

This procedure virtually eliminates discharge or spillage of hydraulic fluid and possible trim damage while filling and bleeding system.

1. Filler Plug Adapter
 - a. Drill 1/4 inch diameter hole through center of spare reservoir filler plug.
 - b. Install 2 inch length of metal tubing (1/4" O.D. x 3/16" I.D.) into center of filler plug and solder tubing on both sides of filler plug to form air tight connection (Fig. 22-68).
2. Filling and Bleeding of Reservoir.
 - a. With top in raised position, remove folding top compartment bag material from rear seat back panel. Remove pump and motor shield.
 - b. Place absorbent rags below reservoir at filler plug. Using a straight-bladed screw-driver, slowly remove filler plug from reservoir.

NOTE: When installing new or overhauled motor and pump assembly, as bench operation, fill reservoir to specified level with hydraulic fluid. This operation is necessary as pump must be primed prior to operation to avoid drawing excessive amount of air into hydraulic system.

c. Install filler plug adapter to reservoir and attach 4 or 5 foot length of 3/16 inch I.D. rubber tubing or hose to filler plug tubing.

d. Install opposite end of hose into a container of G.M. Hydraulic Brake Fluid Super #11 or equivalent (Fig. 22-69).

NOTE: Container should be placed in rear compartment area of body, below level of fluid in the reservoir. In addition, sufficient fluid must be available in container to avoid drawing air into hydraulic system.

e. Operate top to down or stacked position. After top is fully lowered continue to operate motor and pump assembly (approximately 15 to 20 seconds), or until noise level of pump is noticeably reduced. Reduction in pump noise level indicates that hydraulic system is filling with fluid.

f. Operate top several times or until operation of top is consistently smooth in both up and down cycles.

g. Remove hose from filler plug tubing and remove filler plug adapter from reservoir.

h. Check level of fluid in reservoir and re-install original filler hole plug.

NOTE: Fluid level should be within 1/4 inch of lower edge of filler plug hole.

BUCKET SEATS

CONTENTS OF THIS SECTION

SUBJECT	PAGE	SUBJECT	PAGE
Bucket Seats - Front		Front Seat Back Assembly	23-4
Description	23-1	Repositioning Front Seat -	
Assembly - Adjustable	23-1	Convertible	23-5
Assembly - Stationary	23-1	Repositioning Front Seat - 17	
Front Seat Adjusters	23-4	and 47 Styles	23-5
Front Seat Stationary			
Supports	23-4		

BUCKET TYPE FRONT SEATS

DESCRIPTION

The driver's seat assembly in Fig. 23-1 is typical of all "67" styles. The passenger's seat assembly in Fig. 23-1 is typical of all styles equipped with stationary seat supports.

Fig. 23-2 is typical of all driver and passenger seat assemblies equipped with manually operated seat adjusters.

Fig. 23-3 is typical of all driver and passenger seat assemblies equipped with power operated seat adjusters.

All seat adjusters and stationary supports are bolted to the seat bottom frame; however, a combination of bolts and/or nuts are used to retain the adjusters or stationary supports to the floor pan assembly (Figs. 23-1, 23-2 and 23-3).

All manually operated adjusters are equipped with assist springs. On the "17" and "47" styles, the assist spring is attached to the inboard adjuster. On all other styles, the assist spring is attached to the outboard adjuster.

BUCKET TYPE FRONT SEAT ASSEMBLY (DRIVER OR PASSENGER— MANUAL OR POWER OPERATED)

REMOVAL AND INSTALLATION

1. Turn back floor carpeting sufficiently to expose seat adjuster-to-floor pan attaching nuts or bolts.
2. Operate seat assembly to rearward position.

3. On all "Y" styles, loosen adjuster to floor pan attaching nuts or bolts. On "B" styles, remove attaching nuts.

4. Operate seat assembly to full forward position.

5. At rear of seat, remove adjuster to floor pan attaching nuts or bolts.

6. On "B" styles equipped with power operated seats, disconnect wiring harness from seat control switch and from actuator motor.

7. On "Y" styles, carefully slide seat assembly rearward until front adjusters are removed from under front attaching nuts or bolts.

8. With aid of helper, remove seat assembly with attached adjusters from body.

9. To install, reverse removal procedure. On "Y" styles, be sure adjusters are properly engaged under front attaching nuts or bolts prior to installing rear attaching bolts.

BUCKET TYPE FRONT SEAT (PASSENGER—STATIONARY)

REMOVAL AND INSTALLATION

1. Turn back floor carpeting sufficiently to expose stationary support-to-floor pan attaching nuts or bolts.

2. Scribe location of seat supports on floor pan assembly.

3. At front of seat, loosen seat support-to-floor pan attaching nuts or bolts.

4. At rear of seat, remove seat support-to-floor pan attaching nuts or bolts.

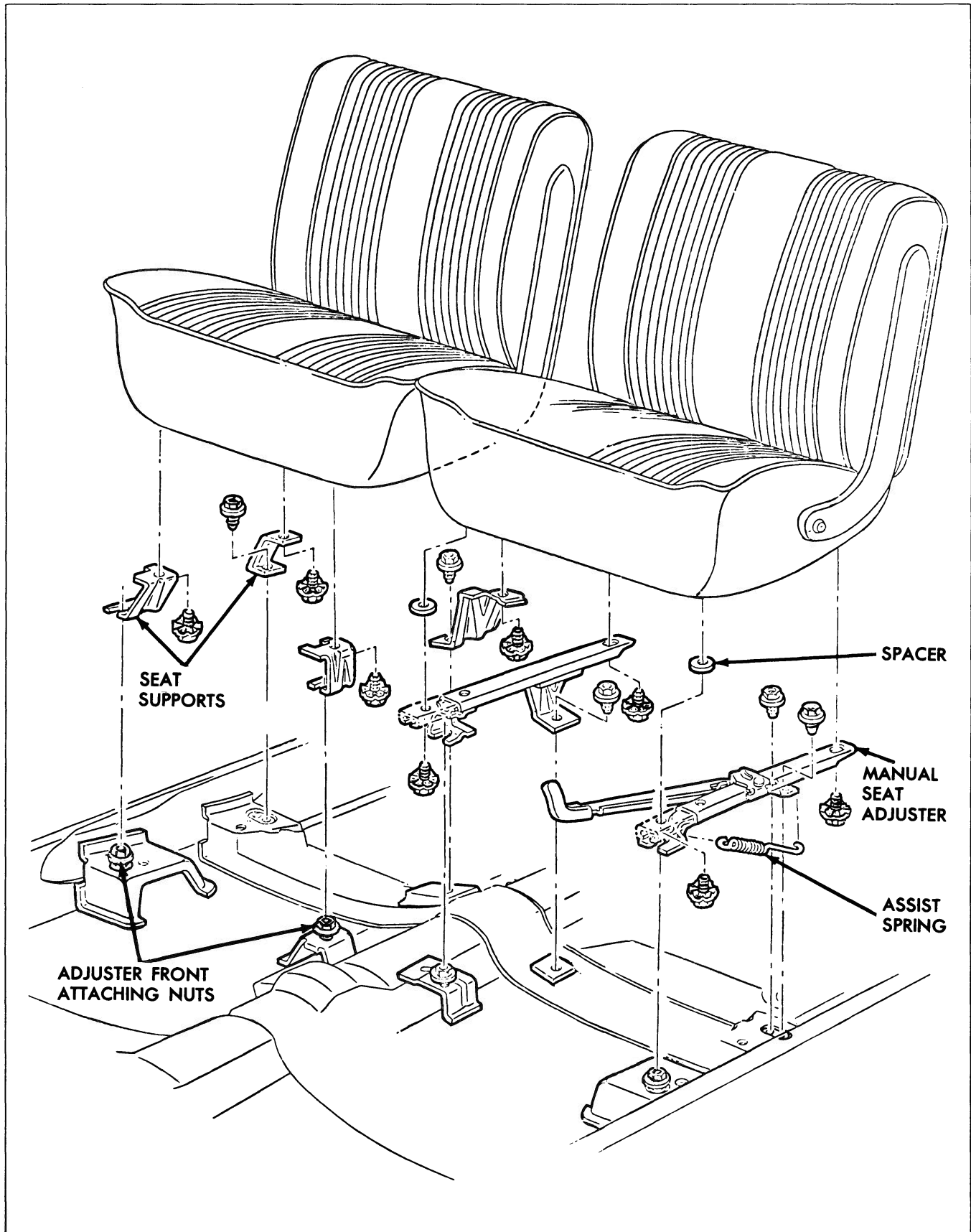

Fig. 23-1 Bucket Seat Assemblies - Typical "67" Style

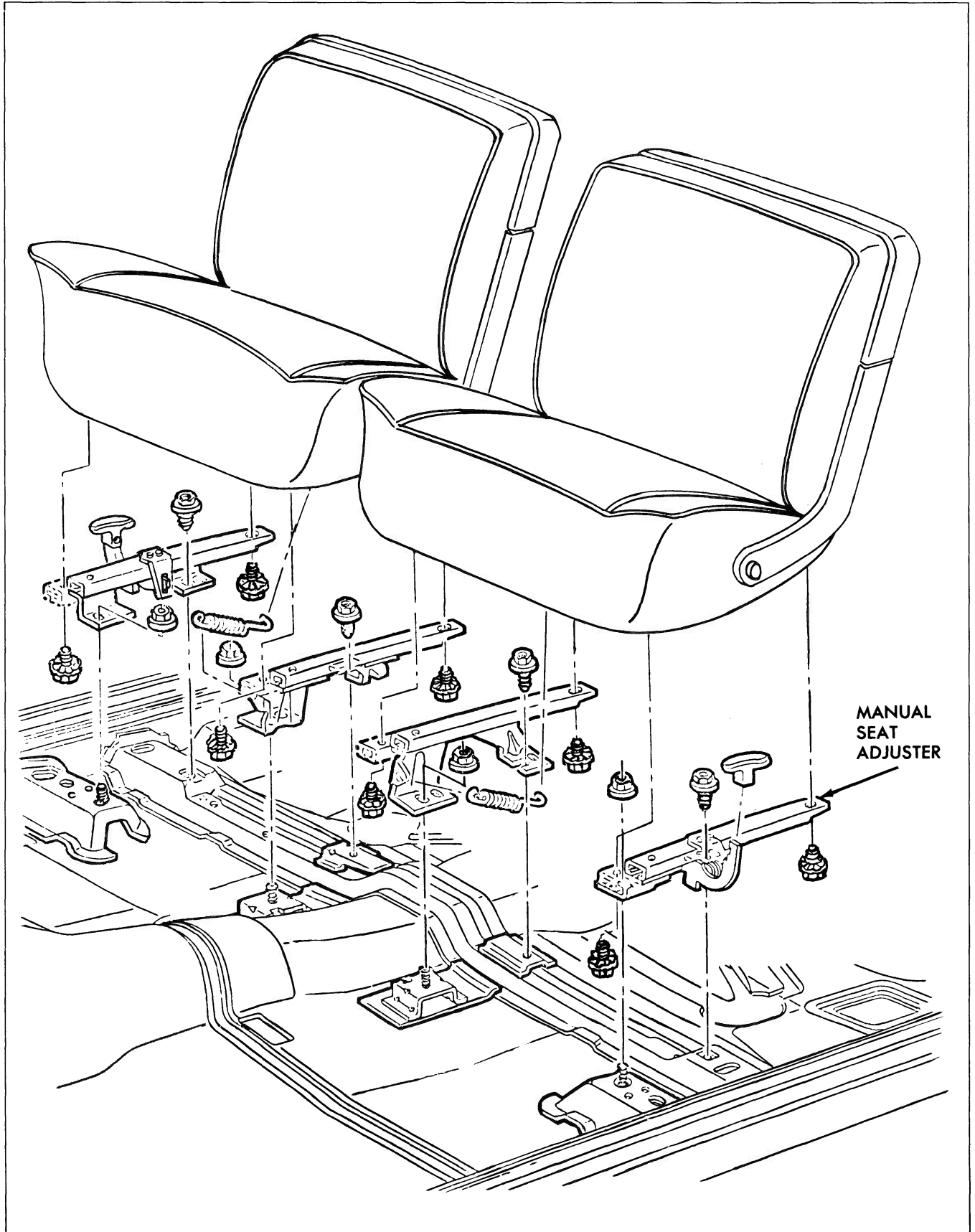

Fig. 23-2 Bucket Seat Assemblies - Typical all Adjustable Right Side

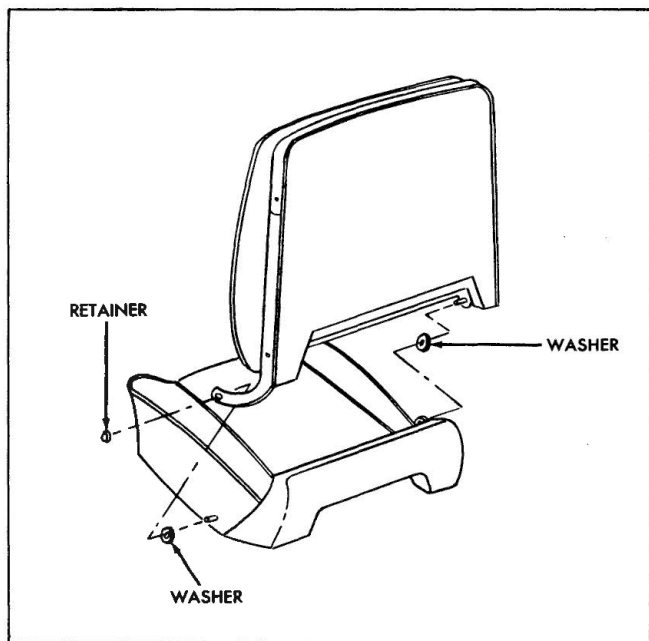

Fig. 23-3 Seat Back Removed

5. Carefully slide seat assembly rearward until front supports are removed from under front attaching nuts or bolts.

6. With aid of helper, remove seat assembly with attached supports from body.

7. To install, reverse removal procedure. Be sure supports are properly engaged under front attaching nuts or bolts and aligned within scribe marks prior to installing rear attaching bolts.

FRONT SEAT ADJUSTERS (DRIVER OR PASSENGER— MANUAL OR POWER OPERATED)

REMOVAL AND INSTALLATION

1. Remove front seat assembly as previously described and place upside down on a clean, protected surface.

2. If adjuster to be replaced is equipped with an assist spring, remove spring from adjuster.

3. Operate adjuster so that both front and rear attaching bolts are accessible.

4. If power operated outboard adjuster is being replaced, disconnect power drive cable from adjuster gear nut.

5. Remove adjuster-to-seat bottom frame front and rear attaching bolts and remove adjuster from seat assembly.

6. To install, reverse removal procedure.

FRONT SEAT STATIONARY SUPPORTS (PASSENGER SEAT ONLY) 17, 47 and 67 STYLES

REMOVAL AND INSTALLATION

1. Remove front seat assembly as previously described and place upside down on a clean protected surface.

2. Scribe location of support to be removed on seat bottom frame.

3. Remove bolt securing affected support to seat bottom frame (Fig. 23-1) and remove support from seat assembly.

4. To install, reverse removal procedure.

FRONT SEAT BACK ASSEMBLY

REMOVAL AND INSTALLATION

1. On "39" style, remove front seat assembly as previously described and place upside down on a clean protected surface.

2. On underside of seat cushion, on "39" style, loosen rear bar cover material sufficiently to expose seat cushion to seat back frame attaching bolts. Attaching bolts are located at right and left lower rear corners of seat cushion frame.

3. Remove bolts securing back assembly to seat cushion frame assembly.

4. On all "37" and "67" styles, tilt seat back forward and remove seat back stop cable from lower rear edge of back assembly.

5. On all styles, using a flat bladed tool, carefully remove retainer from outer hinge pin (Fig. 23-3).

6. On "27" and "69" styles, also remove retainer from inner hinge pin.

7. On all styles except "27" and "69" styles, carefully disengage front seat back outer hinge arm from pin.

8. Move entire seat back assembly inboard until inner hinge pin is disengaged from retainer on seat assembly; then remove seat back from body.

9. On "27" and "69" styles, carefully disengage inner and outer front seat back hinge arms from pins; then, remove seat back assembly from body.

10. To install, reverse removal procedure. Prior to installation of back assembly, be sure inner and outer washers are installed over the hinge pins. (Fig. 23-3).

**REPOSITIONING FRONT SEAT ASSEMBLY
67 STYLE**

The driver's seat assembly may be repositioned one inch forward as follows:

1. Remove seat assembly from body as previously described and turn upside down on a clean protected surface.
2. As a safety precaution, disengage assist spring from outboard adjuster.
3. Operate outboard adjuster lower track forward sufficiently to remove stop screw from rear of adjuster upper track.
4. Operate outboard adjuster lower track rearward sufficiently to install stop screw at front of adjuster upper track (Fig. 23-4).
5. Install assist spring and install seat assembly into body.
6. Operate seat assembly several times to full forward position. The cycling of the seat assembly will allow inboard adjuster upper track to skid over rollers between upper and lower track thus allowing both adjusters to become "in phase".

**REPOSITIONING FRONT SEAT ASSEMBLY
17 and 47 STYLES**

The driver's and passenger's seat assembly may be repositioned one inch forward as follows:

1. Remove adjuster-to-floor pan front and rear attaching nuts and bolts.

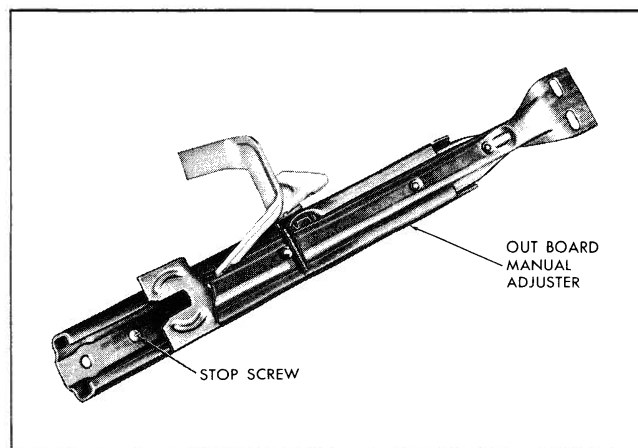

Fig. 23-4 Adjuster Mechanism

2. Reposition front seat assembly one inch forward. Align existing adjuster holes with floor pan attaching points; then, install attaching nuts and bolts.
3. Check seat for proper operation.
4. Operate outboard adjuster lower track forward sufficiently to install stop screw at rear of adjuster upper track (Fig. 23-4).
5. Operate lower track to full forward position and install assist spring.
6. Install seat assembly into body.
7. Operate seat assembly several times to full rearward position. The cycling of the seat assembly will allow inboard adjuster upper track to skid over rollers between upper and lower track thus allowing both adjusters to become "in phase".

PONTIAC SECTION

SUBJECT	PAGE	SUBJECT	PAGE
A			
Alignment		Hinges	3-22
Chassis Sheet Metal	1-2	Lock	3-24
Front Door	3-12	Lock Striker	3-25
Rear Door	3-24	Lower Sash Channel Cam	3-28
		Remote Control	3-26
		Window Assembly	3-28
		Window Regulator	3-27
		Side Roof Rail Weatherstrip	
		Adjustments	3-31
		Center Pillar Cap	3-32
B			
Bumpers	1-1		
C			
Chassis Sheet Metal Alignment			
Fender	1-2		
Hood	1-3		
Hood Hinges	1-6		
Hood Latch	1-4		
Hood Latch Bolt	1-5		
Chassis Steet Metal			
Removal and Installation Procedures	1-6		
D			
Doors			
Front and Rear			
Arm Rest	3-8		
Drain Hole Sealing Strips	3-4		
Door Lock Spring Clips	3-4		
Glass Run Channel	3-9		
Inside Handles	3-7		
Outside Handle	3-8		
Trim Assemblies	3-8		
Water Deflectors	3-4		
Weatherstrip	3-1		
Front			
Assembly and Hinges	3-10		
Glass Run Channel	3-20		
Inner Panel Cam	3-14		
Lock	3-14		
Lock Cylinder	3-14		
Lock Striker	3-13		
Remote Control	3-15		
Vent Regulator	3-16		
Ventilator Adjustment	3-17		
Rear			
Adjustments	3-24		
Glass Run Channel	3-27		
E			
		Electrical	
		Electric Tail Gate Window	
		Checking Procedures	9-7
		Checking Safety Switch	9-9
		Description	9-6
		Power Operated Windows	
		Checking Procedures	9-1
		Crossover Harness	9-1
		Description	9-1
		Window Harness	9-1
		Six Way Seat	
		Checking Procedures	9-10
		Description	9-10
		Seat Switch	9-13
		Wiring Diagrams	9-14
F			
		Fabric Cleaning	21-1
		Folding Top Servicing	22-1
G			
		Garnish Moldings	
		Windshield Assembly	2-1
H			
		Headlining	
		Description	7-1
		Installation	7-1
		Removal	7-1

SUBJECT	PAGE	SUBJECT	PAGE
I			
Instrument Panel Assembly		Regulators - Door Window	
Compartment Door	2-6	Front Door	3-20
Radio Speaker Grille	2-7	Rear Door	3-27
L			
Lubrication - Bi-Annually		Rear Quarter	
Door Hinge Hold Open	10-1	Convertibles	4-8
Door Jamb Switch	10-3	Tail Gate	5-12
Door Lock Cylinders	10-3	Two Door Coupes	4-6
Folding Seat Linkage	10-3	Two Door Sedans	4-4
Folding Top Linkage	10-3	Vent	3-16
Folding Top Piston Rods	10-3	Rear Quarter Assembly	
Gas Tank Door	10-3	Convertibles	
Instrument Compartment Hinge	10-1	Channel Sealing Strip	4-9
Lock Rotary Bolt	10-1	Electric Motor	4-9
Lock Striker	10-1	Inner Panel Sealing	4-9
Rear Compartment Lid and Tail Gate Lock	10-2	Top Compartment	4-7
Rear Door Hinge	10-2	Trim Assembly	4-7
Sunshade Rod	10-3	Window Adjustments	4-8
Tail Gate Hinge	10-3	Window Assembly	4-7
Lubrication - When Available		Window Guide	4-9
Lock Parts	10-4	Window Regulator	4-8
Locking Mechanism	10-5	Four Door Sedans	
Outside Handle	10-3	Trim Assembly	4-11
Seat Adjuster (Electric)	10-5	Station Wagons	
Seat Adjuster (Manual)	10-5	Front Trim Panel	4-11
Window Cams	10-4	Quarter Window Molding	4-12
Window Regulator	10-4	Rear Trim Panel	4-11
M			
Moldings		Spare Tire Cover	4-12
Exterior		Wheel House Cover	4-12
Front Door Window	6-8	Window Assembly	4-12
Rear Door Window	6-9	Two Door Coupes	
Rear End	6-14	Arm Rest	4-4
Rear Fender	6-12	Channel Sealing Strip	4-7
Rear Quarter Window	6-10	Electric Motor	4-6
Reveal Back Window	5-4	Guide Assembly	4-6
Reveal Windshield	2-2	Regulator Assembly	4-6
Roof Drip	6-1	Trim Assembly	4-5
Rail Gate	6-14	Window Adjustments	4-6
Windshield Drip	6-1	Window Assembly	4-5
Garnish - Windshield	2-1	Two Door Sedans	
R			
Radiator	1-1	Channel Sealing Strip	4-3
		Glass Run Channel	4-2
		Guide Assembly	4-3
		Quarter Window	4-2
		Regulator Assembly	4-4
		Trim Assembly	4-1
		Window Adjustments	4-3
		Rear End	
		Back Window Assembly	
		Back Window - Sedans	5-2

SUBJECT	PAGE	SUBJECT	PAGE
Back Window Molding		Front Seat (Manual)	
Retaining Clip	5-3	Adjuster	8-1
Reveal Molding	5-4	Assembly	8-1
Rear Compartment		Rear Seat	
Adjustments	5-7	Back	8-2
Hinge	5-7	Center Arm Rest	8-3
Lid	5-7	Cushion	8-2
Lid Lock	5-8	Six-Way Seat	
Striker	5-8	Checking Procedure	9-10
Striker Engagement	5-8	Servicing Procedure	8-7
Lock Cylinder	5-8		
Torque Rod Adjustment	5-8		
Tail Gate		T	
Adjustment	5-9	Top Compartment - Convertible	4-7
Drain Hole Sealing	5-20	Trim Assembly	
Handle Lock Cylinder	5-13	Front and Rear Doors	3-8
Hinge Assembly	5-10	Rear Quarter	
Hinge Torque Strap	5-10	Convertible	4-7
Lock Assembly	5-16	Four Door Sedans	4-11
Lock Striker	5-16	Station Wagons	4-11
Outside Handle	5-13	Two Door Coupes	4-5
Regulator - Electric Motor	5-12	Two Door Sedan	4-1
Remote Control - Inside Handle	5-17		
Support Assembly	5-15	V	
Switch and Escutcheon	5-14	Ventilator System	
Water Deflector	5-18	Shroud Assembly	2-7
Weatherstrip	5-19		
Window Adjustments	5-12		
Window Assembly	5-11	W	
Window Regulator	5-12	Weatherstrip	
		Front and Rear Doors	3-1
S		Side Roof Rail	3-31
Seats		Rail Gate	5-19
Bucket Front	23-1	Windshield Assembly	
Electric Seat (Front)		Checking Body Opening	2-4
Adjuster	8-8	Garnish Molding	2-1
Drive	8-10	Glass	2-3
Electric Motor	8-10	Glass Replacement	2-5
Six-Way	8-7	Minor Water Leaks	2-6
Transmission	8-11	Rear View Mirror Support	2-1
Folding Rear Seat		Reveal Moldings	2-2
Filler Panel	8-4	Sunshade Support	2-1
Floor Panels	8-3		
Luggage Compartment	8-4	Wiring Diagrams	9-14
Third Seat	8-5		

TEMPEST SECTION

SUBJECT	PAGE	SUBJECT	PAGE
A			
Alignment		Ventilator Casting	13-11
Chassis Sheet Metal	11-1	Window Assembly	13-13
		Adjustments	13-14
C			
Chassis Sheet Metal		Rear Doors	
Sheet Metal Alignment		Adjustment	13-17
Bumper	11-3	Hinges	13-16
Front Fender	11-1	Inner Panel Cam	13-18
Hood	11-1	Lock Assembly	13-18
Hood Hinges	11-3	Lower Sash Channel Cam	13-19
Hood Latch	11-2	Regulator Assembly	13-19
Hood Latch Adjustment	11-2	Remote Control Assembly	13-18
		Window Adjustments	13-20
Sheet Metal Replacement		Side Roof Rail Weatherstrip	13-20
Front Fender	11-4	E	
Front Fender Cross Brace Assembly	11-7	Electrical	
Grille Assembly	11-5	Back Door Dropping Window	19-3
Hood	11-6	Body Wiring	19-1
Hood Hinge	11-6	F	
Hood Spring	11-6	Fabric Cleaning	21-1
Lower Grille Panel Assembly	11-6	Folding Top Service	22-1
D			
Doors		Front End	
Front and Rear		Body Shell	
Arm Rests	13-2	Description	12-1
Glass Run Channel	13-7	Body Ventilating System	
Inside Handle	13-1	Air Outlet Door	12-17
Lock Spring Clips	13-8	Shroud Side Foundation	12-16
Lock Strikers	13-4	Shroud Side Vent	12-16
Outside Handle	13-7	Shroud Top Ventilator Grille	12-16
Pinchweld Finishing Strip	13-8	Instrument Panel	
Trim Pads	13-2	Compartment Door	12-14
Water Deflectors	13-3	Hinge Stop	12-15
Weatherstrips	13-5	Underbody Assembly	
Front Doors		Body Centering Gauges	12-9
Door Lock	13-15	Body Tram Gauge	12-6
Door Lock Cylinder	13-15	Description	12-1
Hinges	13-9	Principles of Tramming	12-7
Adjustments	13-10	Underbody Alignment Reference Points	12-6
Inner Panel Cam	13-13		
Lock Remote Control	13-10		
Regulator Assembly	13-14		
Ventilator Assembly	13-11		

SUBJECT	PAGE	SUBJECT	PAGE
Lid Striker Check	15-7	Folding Rear Floor Filler Panel	
Lock	15-7	Assembly	18-5
Torque Rod	15-4	Adjustment	18-6
Weatherstrip	15-7	Removal and Installation	18-5
Rear Quarter		Folding Rear Seat Back Assembly . . .	18-4
Inner Panel Sealing	14-7	Removal and Installation	18-4
Outer Sealing Strip	14-7	Folding Rear Seat Back Bumper Retainer	
Trim and Hardware	14-1	and Support (right or left side) . . .	18-6
Trim Assembly	14-1	Removal and Installation	18-6
Rear Quarter - "17" and "27" Styles		Folding Rear Seat Back Mounting	
Adjustments	14-2	Support Link Assembly	18-5
Glass Run Channel	14-3	Removal and Installation	18-5
Inner and Outer Sealing Strip	14-4	Folding Rear Seat Cushion	18-4
Rear Guide	14-3	Removal and Installation	18-4
Rear Quarter Window	14-1	Folding 3rd Seat Back Panel Assembly.	18-8
Window Regulator	14-3	Removal and Installation	18-8
Trim and Hardware - "67" Style		Folding 3rd Seat Bottom Cushion	
Window Adjustments	14-4	Panel Assembly	18-8
Window Assembly	14-4	Removal and Installation	18-8
Window Guide	14-6	Rear Seat Cushion Assembly	18-7
Window Regulator	14-6	Removal and Installation	18-7
Trim and Hardware - "19" and "35" Styles		Spare Tire Cover Handle Assembly . .	18-7
Rear Quarter Window	14-8	Removal and Installation	18-7
Trim Panels	14-8	Spare Tire Cover Panel Assembly . . .	18-6
Wheelhouse Trim	14-8	Removal and Installation	18-6
Regulator Assembly		Front and Rear Seat Assemblies	
Front Door	13-14	Front Seat Adjusters	18-1
Rear Door	13-19	Removal and Installation	18-1
Rear Quarter - "17" and "27"	14-3	Front Seat Assembly - Seat	
Rear Quarter - "67"	14-6	Adjusters Attached	18-1
		Removal and Installation	18-1
S		Front Seat Back Assembly	18-2
Seats		Removal and Installation	18-2
Bucket Front Seats	23-1	Front Seat Side Protector Cover . . .	18-3
Folding Rear Seat and Rear Compartment		Removal and Installation	18-3
Floor Panels		Rear Seat Back Assembly	18-3
Compartment Floor Panel Assembly -		Removal and Installation	18-3
(at kick-up)	18-6	Rear Seat Cushion Assembly	18-3
Removal and Installation	18-6	Removal and Installation	18-3
Compartment Floor Side Panel		Rear Seat Cushion Assembly	18-3
Assembly - (right or left side) . . .	18-6	Removal and Installation	18-3
Removal and Installation	18-6	Repositioning Front Seat Assembly . .	18-3

SUBJECT	PAGE	SUBJECT	PAGE
T		W	
Trim		Weatherstrip	
"19" - "35" Styles	14-8	Back Door	15-12
"67" Style	14-4	Front and Rear Doors	13-5
Back Door "2135"	15-10	Rear Compartment	15-7
Front and Rear Door	13-2	Side Roof Rail	13-20
Rear Quarter	14-1		

PONTIAC AND TEMPEST SECTION

SUBJECT	PAGE	SUBJECT	PAGE
B			
Bucket Seats - Front		Removal	22-24
Assembly - Adjustable	23-1	Folding Top Assembly	22-23
Assembly - Stationary	23-1	Removal and Installation	22-23
Description	23-1	Installation of Folding Top and Back	
Front Seat Adjusters	23-4	Curtain Trim Assembly	22-16
Front Seat Back Assembly	23-4	Removal of Folding Top and Back	
Front Seat Stationary Supports	23-4	Curtain Trim Assembly	22-14
Repositioning Front Seat - Convertible	23-5		
Repositioning Front Seat		Hydro-Lectric System	
"17" and "47" Styles	23-5	Electrical Checking - Procedure	22-30
		Filling of Hydro-Lectric Reservoir	22-32
		Fluid Control Valve	22-29
		Hydraulic Checking Procedure	22-31
		Mechanical Checking Procedure	22-30
		Motor and Pump Assembly	22-27
		Installation	22-27
		Removal	22-27
		Operation of Folding Top	22-29
		Operation of Pump Assembly	22-29
		Removal of Folding Top Lift Cylinder	22-32
		Reservoir Tube	22-28
		Assembly to Motor and	
		Pump Assembly	22-28
		Disassembly from Motor and	
		Pump Assembly	22-28
		Manually Operated Folding Top Hardware	
		Folding Top Catch Clips	22-13
		Description	22-13
		Folding Top Manual Lift Assembly -	
		"67" Styles	22-13
		Description	22-13
		Removal and Installation	22-13
		Misalignment Trouble Diagnosis	
		Description	22-10
		Operation of Folding Top	
		Care of Rear Window	22-6
		Cleaning the Top	22-7
		Description	22-1
		General Information	22-5
		Lowering Rear Window	22-4
		Lowering the Top	22-2
		Raising Rear Window	22-4
		Raising the Top	22-4
		Top Boot	22-2
		Top Boot Installation	22-3
Folding Top			
Folding Top Adjustments			
Description	22-7		
Folding Top Trim Assembly			
Back Curtain Assembly	22-23		
Installation	22-24		
Removal	22-23		
Back Curtain Vinyl Replacement	22-24		
Installation	22-25		