

444-SPEED FOR SPORTSMEN

Chrysler's all-new, full-synchro gearbox challenges the toughest 426 ever built, and those rodders who ask the perennial question: "What'll I use for a 4-speed?"

by BOB GREENE

Deep beneath the shining sheetmetal of Detroit's lineup for 'sixty-four is what could well be the story of the year, an engineering achievement of prime importance to performance enthusiasts in general and hot rodders in particular. Given the identification number A-833, the subject of our concern promises to be a boon to those who have watched

engine development zoom far ahead of its vital complement, the 4-speed manual transmission.

Realizing the desperate need for a really husky 4-speed box suitable for competition, the Chrysler Corporation dedicated a major section of their vast transmission facilities during the past year to the perfection of just such a compo-

As an engineer in the transmission department, Dale Reeker, right, helps design-in gearbox strength; as a member of the RamChargers, he has the ironical job of trying to prove himself wrong. When Dale throws a shift, everybody pays attention, including Engineer Dale Slaubaugh, left, HRM Editor Bob Greene. Test stand includes elaborate dyno, control panel.

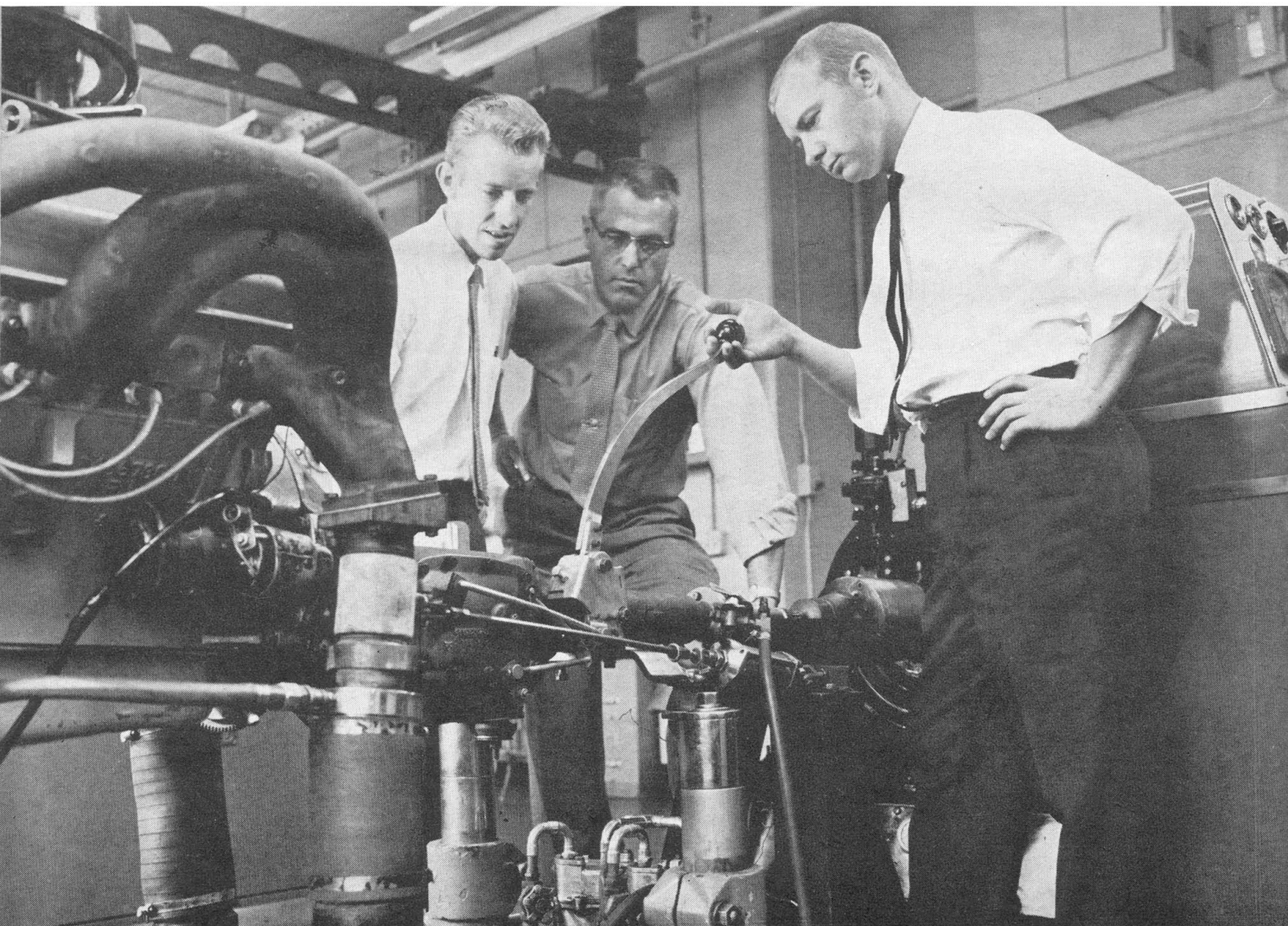

ment. We personally inspected every piece of it at their Central Engineering Staff laboratories in Detroit, from the smallest needle bearing to the massive cluster gear, then participated in brutal "shell 'em if you can" acceleration tests with Development Engineer Dale Reeker (member of the national champion RamChargers drag race team) — and, brother, this box is going to be around for a while!

Prior to 1961, when engine displacement and public opinion were not nearly so positive as they are today, the Borg-Warner 3-speed manual transmission, designated the T-85, was generally used by the industry to cover the needs of the growing group of sports-minded drivers who spearheaded the revival of the shift-for-yourself movement. Subsequent demands called for a 4-speed and, with the necessary orders in sight, B-W accommodated by making a very clever modification to their 3-speed, moving the reverse gear in their T-85 model outside the case proper and thereby making room for the necessary fourth gear inside. Known as the T-10, this is the 4-speed that Chrysler and others are currently using as an optional transmission for high performance application.

But with the rapid succession of bore and stroke increases that skyrocketed engine displacements from somewhat over 300 cubic inches to today's "hairy" 426's (NASCAR, USAC,

and NHRA limits), it became increasingly clear that a bigger box with more capacity was in order to withstand the extreme torque output of modern competition engines, especially at the drags.

Starting from scratch and designing toward a fully synchromesh 4-speed that could easily handle the full brunt of the hottest 426, Chrysler engineers realized that the gear case itself had to be physically larger for several reasons, most important of which concerned an engineering axiom that reads to this effect: Using the same gear ratio, doubling the center-to-center distance between the countershaft and the mainshaft increases by the square (4 times) the transmission's torque capacity. Obviously the larger diameter gears would be stronger; in the instance of the new A-833 gearbox, moving the center-to-center distance out from 3¼ to 3½ inches resulted in a 16% increase alone. Plus additional torque carrying capacity was gained by making all forward drive gears 15-30% wider. Further benefits from the larger gear case, and subsequently stronger gears, included the possibility now of using lower (numerically higher) starting ratios; low gear, for example, has been changed from the former 2.2:1 to 2.66:1 for the biggest Chrysler Corporation engines, while the smaller 6-cylinder

(Continued on following page)

The whole kit and caboodle spread out in pretty much the way it goes together. The A-833 was designed to withstand not only the wildest 426 but quite a bit more. Forward gears (1st through 4th) shown in center are all synchromesh; cluster has larger diameter, wider teeth. Box is available in all '64 Chrysler product cars except the New Yorker and Imperial.

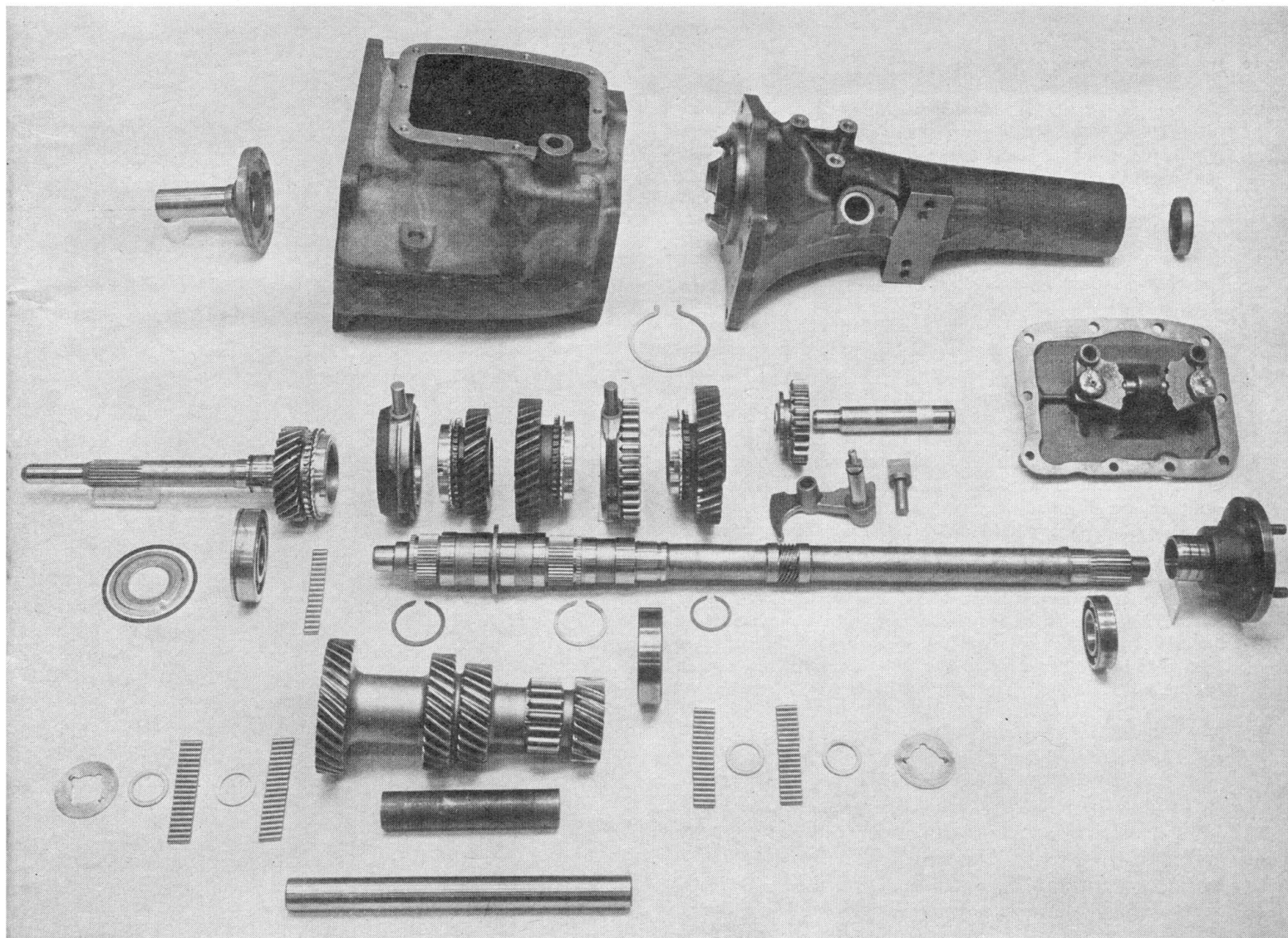

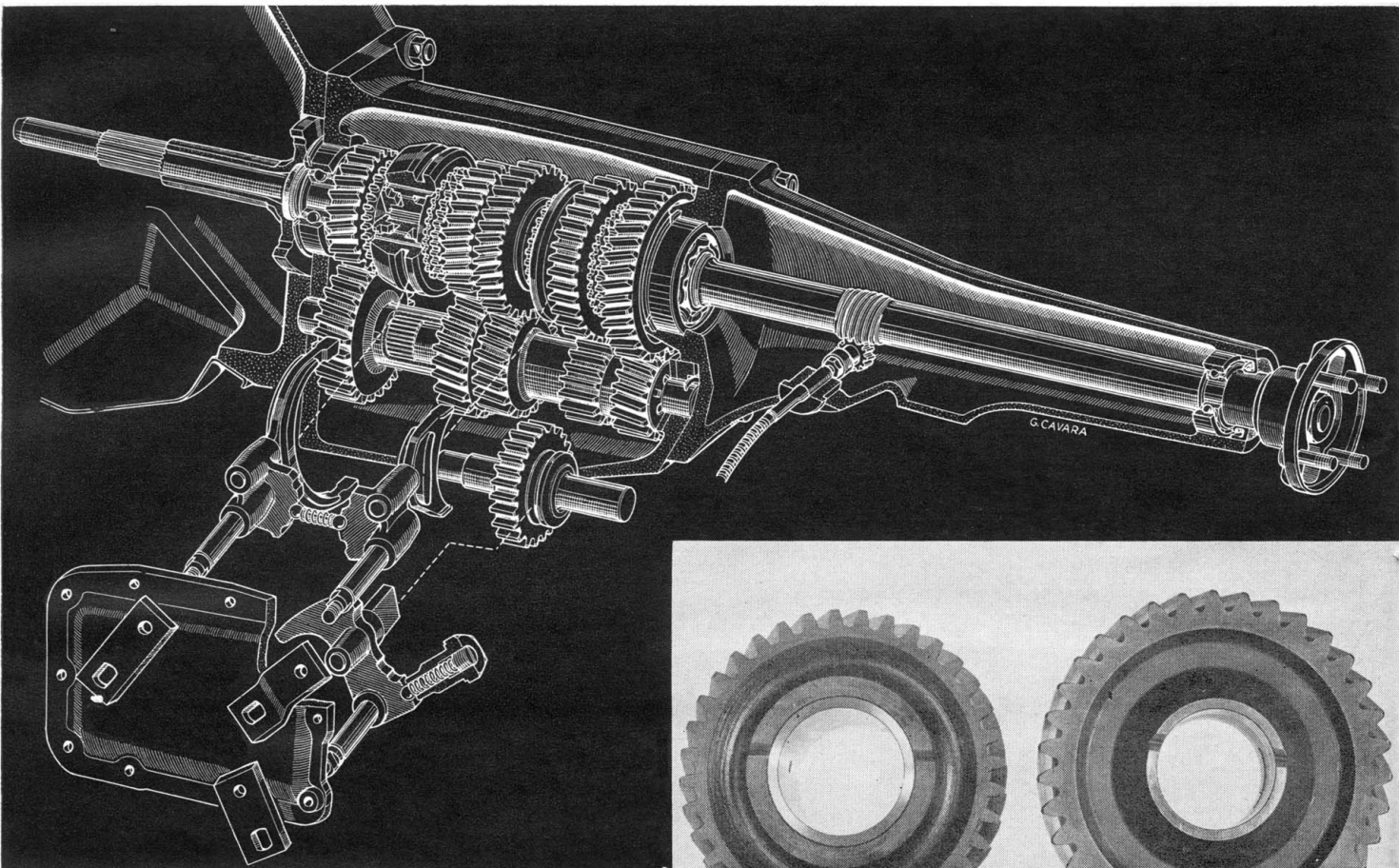

New optional 4-speed will undoubtedly be much in evidence in big Dodge, Plymouth drag machines. Note reverse gear is now incorporated inside case proper. All gears are helical cut (except for reverse) for quieter operation, more contact.

4-SPEED FOR SPORTSMEN *continued*

engine can take advantage of a 3.09:1 low. Before leaving the gear case, it is interesting to note that the housing itself, the tailshaft assembly, and the clutch housing have heavier walls and more gradual radii throughout to prevent breakage due to ever-present driveline vibrations encountered under maximum performance conditions. An additional bonus for the hot rodder is apparent when the A-833 4-speed or the still-popular T-85 3-speed are ordered with one of the maximum performance 426 SuperStock or RamCharger V8 versions for 1964; both come standard with an NHRA-approved cast steel clutch housing, thus eliminating the labor and expense of installing a separate shield. Considerable importance, too, is placed on the exterior fittings; Hurst shift linkage is standard equipment on the A-833 box!

Looking inside the gearbox, starting with the mainshaft, we find simplicity of construction has resulted in fewer parts. The clutch gears are now carried on the mainshaft by fine rolled splines (more contact area) rather than the big square splines often used in the past. You will see, too, in the included close-up photo, that the contact area on the

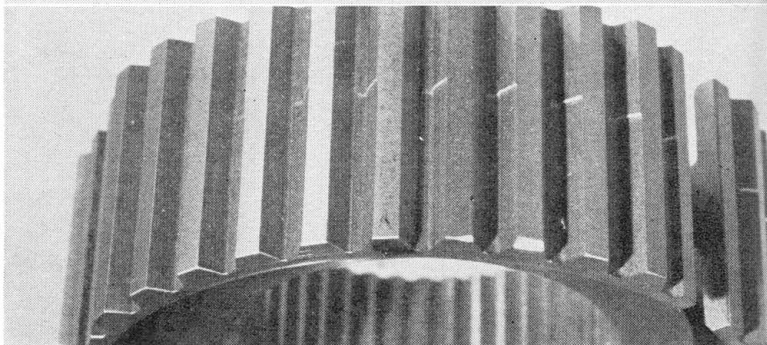
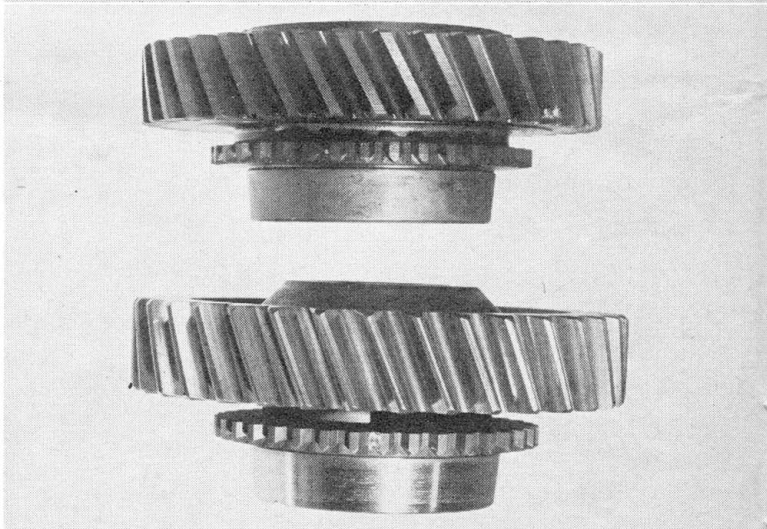
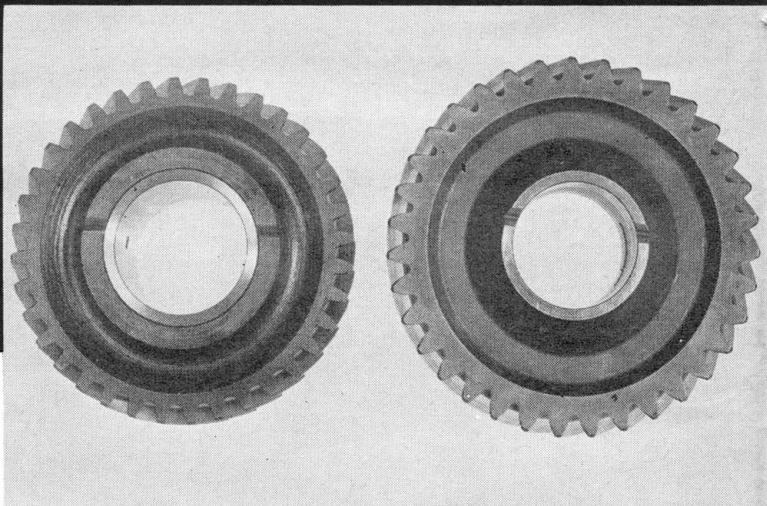

TOP RIGHT – This comparison view between A-833 (right) and T-10 low speed gears shows very noticeable increase in diameter as well as extra width at the base of gear teeth.

CENTER RIGHT—Another view of A-833 low gear (bottom) and T-10 counterpart. As evidenced here, all forward drive gears are 15-30% wider, increasing life span many times.

BOTTOM RIGHT—Extreme close-up of clutch gear shows partial relief or undercut (known as torquelock feature), prevents climbing out of gear when engine is decelerated.

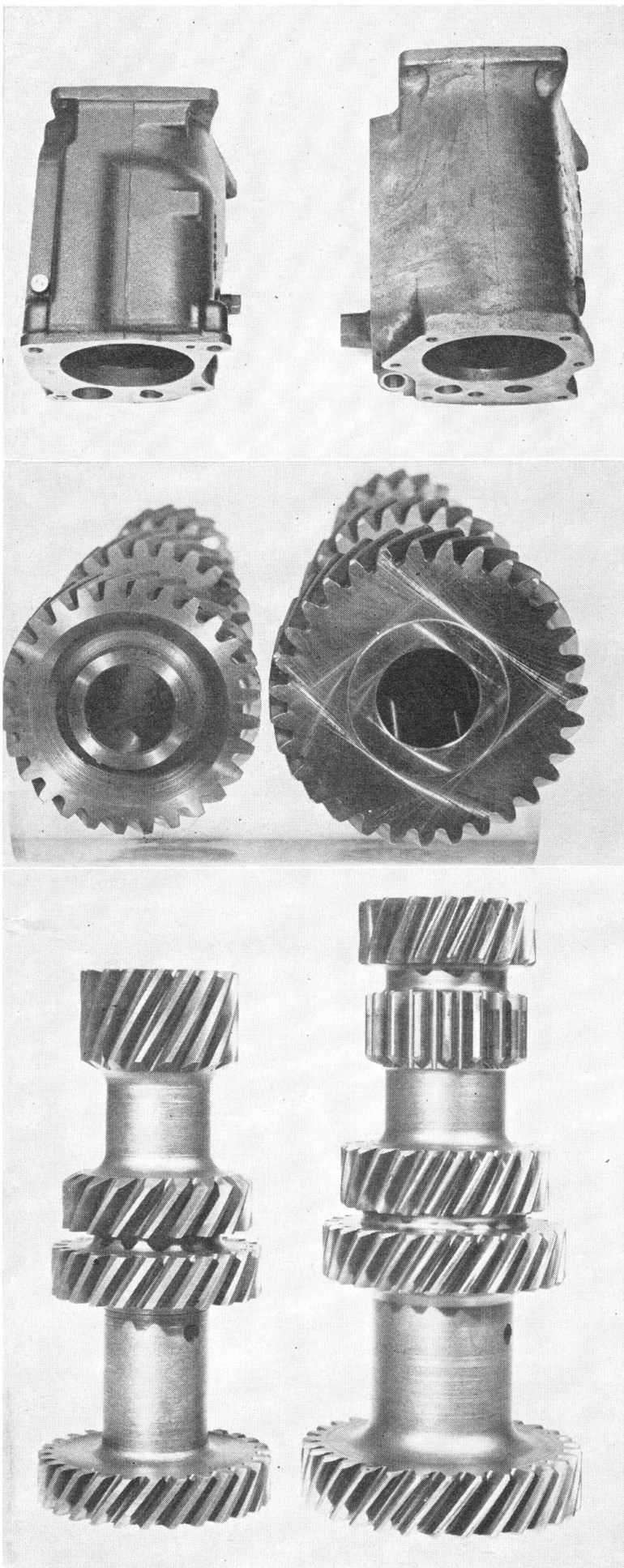

RATIO CHART FOR A-833 AND T-10 4-SPEEDS					
TRANS.	1st	2nd	3rd	4th	REV.
A-833 (6)	3.09	1.92	1.40	1.00	3.00
A-833 (V8)	2.66	1.91	1.39	1.00	2.58
T-10 (318 V8)	2.54	1.89	1.51	1.00	2.61
T-10 (361-838)	2.20	1.64	1.31	1.00	2.26

Chart indicates T-10 ratios currently used in Chrysler product cars compared to the new figures on the A-833 4-speeds. The B-W T-85 3-speed will again be the standard unit in '64.

clutch gear (the half on which the clutch sleeve rides during 1st and 3rd gear engagement) is undercut to prevent the possibility of gear jump-out during deceleration. For conversation sake, this is called the "torquelock" feature.

We attempted photographically to show the obvious size and beef of the backbone of the gearbox, the cluster gear. Improved tooth configuration is also evident, plus the fact that there are fewer teeth per inch due to larger gear diameter, permitting a more gradually radiused root to prevent stress concentrations and induced breakage. Cluster gear needle bearings are likewise 20% larger in diameter for increased capacity and durability. Final tests showed that the concentration on strength paid off — deflection of the cluster gear is less than .004 inch (the thickness of an average human hair) at full design torque load, 480 lb-ft-plus! How about ratios? Good news here, as you will notice by the included chart, with a perfectly even spread between all gears.

The bronze synchro rings have come in for their share of attention; metal has been added to the cross-section of the minimum areas of the rings for a 25% increase to reduce cracking. Whereas 50 to 75 torture shifts have been known to break the old synchros, the new ones have not even shown signs of failure after 100 cycles (complete shift sequences through all gears).

The testing of the transmissions, I might add, is one of the most fascinating phases of the entire development program. Besides enthusiastic in-the-field tests under the most strenuous competition circumstances by the RamChargers racing team, and around-the-clock grinds by test engineers at the Chelsea proving grounds, Chrysler has an equally torturous series of devices at their Central Engineering Staff laboratories. Approaching the transmission test room, your ears tell you that there just has to be a grand scale drag race going on inside — the roar of engines straining to peak, then a snap-shift to the next gear and roar again — but a look inside reveals a strange new automated drags, with row upon row of engines driving through transmissions under test, into huge dynamometers in an endless race to oblivion. Beside each test stand is a fully-instrumented control panel recording the number of cycles, torque load, rpm, and all pertinent data to tell the story on transmission durability. This is what it told: The new A-833 4-speed, when used behind the biggest and most powerful current production engines, has a gear and bearing life expectancy at least 15 times that of current available 4-speeds!

Even the RamChargers had to nod in concurrence. ■ ■

TOP LEFT—The A-833 case (right) beside T-10 model. Note more gradual radii around bolt holes, and larger exterior. New box, complete, is only 21 pounds heavier (dry) and will clear any floor pan that clears the T-10. The length of both is the same (28.7 inches from front of transmission case to face of prop shaft flange), except for 6-cylinder version of A-833 which is only 23 inches because of shorter tailshaft.

CENTER LEFT—End view of T-10 (left), A-833 clusters.

BOTTOM LEFT—Note larger body, radii of A-833 (right).