

PRELIMINARY

AMA Specifications – Passenger Car

The information contained herein is prepared, distributed by, and is solely the responsibility of the automobile manufacturing company to whose products it relates. Questions concerning these specifications should be directed to the manufacturer whose address is shown below. This uniform specification form was developed by the automobile manufacturing companies under the auspices of the Automobile Manufacturers Association.

MANUFACTURER	Buick Motor Division General Motors Corporation	CAR NAME	BUICK
MAILING ADDRESS	1051 E. Hamilton Avenue Flint 2, Michigan	MODEL YEAR	1963
		ISSUED:	1-25-62
		REVISED (e)	6-4-62

NOTES:

1. The Specifications herein are those in effect at date of compilation and are subject to change without notice by the manufacturer.
2. UNLESS OTHERWISE INDICATED:
 - a. Specifications apply to standard models without optional equipment. Significant deviations are noted.
 - b. Nominal design dimensions are used throughout these specifications.

TABLE OF CONTENTS

General Specifications 1	Drive Units 15	Rear Suspension 21	Body & Car - General 22
Engine - Mechanical 2	Brakes 18	Body Dimensions 22	Weights 33
Electrical 10	Front Suspension & Steering . . 19	Station Wagon 31	Index 37

BODY—TYPES AND STYLE NAMES—

Body type, number of passenger & style names; use manufacturer's code for series & body style.

Model

4747

Body Style

Riviera

2-Door 4-Window Pillarless Coupe

PRELIMINARY
AMA Specifications — Passenger Car

MAKE OF CAR BUICK MODEL YEAR 1963 DATE ISSUED 4-17-62 REVISED(6) 7-18-62

GENERAL SPECIFICATIONS

(All dimensions in inches unless otherwise indicated)

MODEL	Additional Information Page No.:	Series 4700
Wheelbase (L101)	23	117.0
Tread	Front (W101)	60.0
	Rear (W102)	59.0
Maximum Overall Dimensions	Length (L103)	208.0
	Width (W103)	74.6
	Height (H101)	53.2
Transmission— (Specify trade name - opt., not available)	Manual	Not Available
	Overdrive	Not Available
	Automatic	Turbine Drive (Standard)
Axle ratio	Manual	Not Available
	Overdrive	Not Available
	Automatic	3.23
Tire size	18	7.10-15
Engine	Type, no. cyl., valve arr.	2 V-8 in Head
	Fuel system (Carb., other)	8 Carburetor
	Bore and stroke	2 4.1875 x 3.64
	Piston displ., cu.in.	2 401
	Std. compression ratio	2 10.25
	Max. bhp at engine rpm	2 325 @ 4400
	Max. torque at rpm	2 445 @ 2800

PRELIMINARY
AMA Specifications—Passenger Car

MAKE OF CAR BUICK MODEL YEAR 1963 DATE ISSUED 1-25-62 REVISED (*)7-18-62
 Series
 4700

MODEL _____

ENGINE—GENERAL

Type, no. cyls., valve arr.	90° V-8 in Head	
Bore and stroke (nominal)	4.1875 x 3.64	
Piston displacement, c.u. in.	401	
Bore spacing (C/L to C/L)	4.750	
No. system (front to rear)	L. Bank	2-4-6-8
	R. Bank	1-3-5-7
Firing order	1-2-7-8-4-5-6-3	
Compres. ratio (nominal)	10.25	
Cylinder Head Material	Cast Iron	
Cylinder Block Material	Cast Iron	
Cylinder Sleeve—Wet, dry, none	None	
Number of mounting points	Front	Two
	Rear	One
Engine installation angle	6°5'	
Taxable horsepower	<u>Dia.² x No. Cyl.</u> 2.5	56.11
Published max. bhp* @ eng. RPM	325 @ 4400	
Published max. torque* (lb. ft. @ RPM)	445 @ 2800	
Recommended fuel regular - premium	Premium	
Idle speed (spec. neutral or drive)	Manual	Not Available
	Automatic	(a) 525 (Neutral)

ENGINE—PISTONS

Material	Cast Aluminum Alloy		
Description and finish	Cam Ground - Transverse Slot - Divorced Skirt		
Weight (piston only) oz.	24		
Clearance (limits)	Top land	.029 - .037	
	Skirt	Top	.001 - .0016
		Bottom	.002 - .0036
Ring groove depth	No. 1 ring	.211 - .219	
	No. 2 ring	.214 - .221	
	No. 3 ring	.214 - .221	
	No. 4 ring	None	

* Max. bhp (brake horsepower) and max. torque corrected as defined by SAE Engine Test Code.

(a) 575 in Neutral When Air Conditioning Equipped.

PRELIMINARY
AMA Specifications – Passenger Car

MAKE OF CAR BUICK **MODEL YEAR** 1963 **DATE ISSUED** 1-25-62 **REVISED** ^(a) 6-4-62

POWER TEAMS

(Indicate whether standard or optional)

MODEL AVAILABILITY	ENGINE					TRANSMISSION	AXLE RATIO (Std. first)
	Displ. cu. in.	Carburetor	Compr. Ratio	BHP @ RPM	Torque @ RPM		
*4700	425	4 bbl.	10.25	340 @ 4400	465 @ 2800	Turbine Drive	3.23

AMA Specifications - Passenger Car

MAKE OF CAR BUICK MODEL YEAR 1963 DATE ISSUED 1-25-62 REVISED (a) 7-18-62
 Series
 MODEL 4700

ENGINE-RINGS

Function (top to bottom)	No. 1, oil or comp.	Compression
	No. 2, oil or comp.	Compression
	No. 3, oil or comp.	Oil
	No. 4, oil or comp.	None
Compression	Description - material, type, coating, etc.	Cast Iron Lubrited
	Width	.077 - .078
	Gap	.015 - .025
Oil	Description - material, type, coating, etc.	Steel Uncoated
	Width	.181 - .187
	Gap	.015 - .025
Expanders		Steel Oil Ring - Hump Type

ENGINE-PISTON PINS

Material	SAE-1118 Steel		
Length	3.520		
Diameter	.9994 - .9997		
Type	Locked in rod, in piston, floating, etc.	Pressed in Rod	
	Bushing	In rod or piston	None
		Material	None
Clearance	In piston	.00005 - .0001 Select	
	In rod	.00075 - .00125 (Press.)	
Direction & amount offset in piston	None		

ENGINE-CONNECTING RODS

Material	Forged SAE-1141 Steel	
Weight (oz.)	24.384	
Length (center to center)	6.220	
Bearing	Material & Type	Steel Backed M/400 Aluminum - Removable
	Overall length	.820
	Clearance (Limits)	.0002 - .0023
	End play	(a) .005 - .012

(a) Total for both rods.

PRELIMINARY
AMA Specifications—Passenger Car

MAKE OF CAR BUICK **MODEL YEAR** 1963 **DATE ISSUED** 1-25-62 **REVISED** (*) 7-18-62

MODEL _____ **Series**
 _____ **4700**

ENGINE—CRANKSHAFT

Material		SAE 1145		
Vibration damper type		Rubber Absorption		
End thrust taken by bearing (No.)		Three		
Crankshaft end play		.004 - .008		
Main bearing	Material & type		Steel Backed - All Removable First Four M/400 - Rear Durex 100A	
	Clearance		.0005 - .0021	
	Journal dia. and bearing overall length	No. 1	2.4985 X .940	
		No. 2	2.4985 X .940	
		No. 3	2.4985 X .891	
		No. 4	2.4985 X .940	
		No. 5	2.4985 X 1.200	
		No. 6	None	
	No. 7	None		
Dir. & amt. cyl. offset		None		
Crankpin journal diameter		2.2495		

ENGINE—CAMSHAFT

Location		Above Crankshaft at Center of "Y"	
Material		Cast Alloy Iron	
Bearings	Material	Steel Backed Babbitt	
	Number	Five	
Gear or chain		Chain	
Crankshaft gear or sprocket material		Sintered Iron	
Type of Drive	Camshaft gear or sprocket material		Nylon on Cast Aluminum
	Timing chain	No. of links	52
		Width	.864
		Pitch	.500

ENGINE—VALVE SYSTEM

Hydraulic lifters (Std, opt, NA)		Standard	
Valve rotator, type (intake, exhaust)		None	
Rocker ratio		1.6	
Operating tappet clearance (indicate hot or cold)	Intake	None	
	Exhaust	None	
Timing marks on flywheel, damper, other		Harmonic Balancer	

(Continued)

PRELIMINARY
AMA Specifications—Passenger Car

MAKE OF CAR BUICK MODEL YEAR 1963 DATE ISSUED 1-25-62 REVISED ^(*)7-18-62
 MODEL _____ Series _____
 _____ 4700

ENGINE—VALVE SYSTEM (cont.)

Timing	Intake	Opens (°BTC)	28
		Closes (°ABC)	87
		Duration - deg.	295
	Exhaust	Opens (°BBC)	76
		Closes (°ATC)	46
		Duration - deg.	302
Valve opening overlap		74	
Intake	Material		SAE 1041 Steel
	Overall length		4.785
	Actual overall head dia.		1.875
	Angle of seat & face		45°
	Seat insert material		None
	Stem diameter		Tapered - .3730 ± .0005 to .3720 ± .0005
	Stem to guide clearance		Top - .001 to .003 - Bottom - .002 to .004
	Lift (@ zero lash)		.439
	Outer spring press. and length	Valve closed (lb. @ in.)	46 @ 1.600
		Valve open (lb. @ in.)	101 @ 1.160
	Inner spring press. and length	Valve closed (lb. @ in.)	25.5 @ 1.690
		Valve open (lb. @ in.)	76 @ 1.250
	Exhaust	Material	
Overall length		4.785	
Actual overall head dia.		1.500	
Angle of seat & face		45°	
Seat insert material		None	
Stem diameter		Tapered .3725 ± .0005 to .3715 ± .0005	
Stem to guide clearance		Top .0015 to .0035 Bottom .0025 to .0045	
Lift (@ zero lash)		.441	
Outer spring press. and length		Valve closed (lb. @ in.)	46 @ 1.600
		Valve open (lb. @ in.)	101 @ 1.160
Inner spring press. and length		Valve closed (lb. @ in.)	25.5 @ 1.690
		Valve open (lb. @ in.)	76 @ 1.250

ENGINE—LUBRICATION SYSTEM

Type of lubrication (splash, pressure, nozzle)	Main bearings	Pressure
	Connecting rods	Pressure
	Piston pins	Splash
	Camshaft bearings	Pressure
	Tappets	Pressure
	Timing gear or chain	Drip from Front Cam Bearing
	Cylinder walls	Splash & Nozzle

(Continued)

AMA Specifications – Passenger Car

MAKE OF CAR BUICK MODEL YEAR 1963 DATE ISSUED 1-25-62 REVISED (a) 7-18-62

MODEL _____ Series 4700

ENGINE—LUBRICATION SYSTEM (cont.)

Oil pump type	Gear	
Normal oil pressure (lb. @ engine rpm)	40 @ 2400	
Oil pressure sending unit (elect. or mech.)	Electrical	
Type oil intake (floating, stationary)	Stationary	
Oil filter system (full flow, partial, other)	Full-Flow	
Filter replacement (element, complete)	Element and Can	
Capacity of crankcase, less filter-refill (qt.)	Four	
Oil grade recommended (SAE viscosity and temperature range)	<u>Anticipated Lowest Temp.</u>	<u>Use S.A.E. Viscosity</u>
	Above Freezing (+32°F.)	10W-30, 20W, or 20
	Below Freezing (+32°F.)	5W-20, or 10W
	Below Zero Deg.F.	5W-20, or 5W
Engine Service Requirement (MM, MS, etc.)	Passing Car Makers Test GM-4745M	

ENGINE—EXHAUST SYSTEM

Type (single, single with cross-over, dual, other)	Dual	
Muffler No. & type (reverse flow, straight thru, separate resonator)	One Rev. Flow and Separate Resonator	
Exhaust pipe dia. (O.D. wall thickness)	Branch	Not Used
	Main	2.25 - .084 Laminated Tuning
Tail pipe diameter (O.D. & wall thickness)	2.0 - .084	

ENGINE—CRANKCASE VENTILATION SYSTEM

Type (ventilates to atmos., induction system, other)	Standard	
	Optional	
Control unit	Make and model	
	Location	
	Energy source (manifold vacuum, carburetor air stream, other)	
	Control method (variable orifice, fixed orifice, other)	
Complete system	Discharges (to intake manifold, carb. air intake, air cleaner intake, other)	
	Air inlet (breather cap, carburetor air cleaner, other)	
	Flame arrestor (screen, check valve, other)	

PRELIMINARY
AMA Specifications— Passenger Car

MAKE OF CAR BUICK MODEL YEAR 1963 DATE ISSUED 1-25-62 REVISED (*) 7-18-62

MODEL _____ Series 4700

ENGINE—FUEL SYSTEM

(See Supplement to Page 8 for Details of Fuel Injection, Supercharger, etc. if used)

Induction type: Carburetor, fuel injection, supercharger.		Carburetor
Fuel Tank	Capacity (gals.)	20
	Filler location	Behind Rear License Plate
Fuel Pump	Type (elec. or mech.)	Mechanical
	Locations	Engine
	Pressure range	5.25 - 6.50
Vacuum booster (std., optional, none)		None
Fuel Filter	Type	(a) Plastic
	Locations	Engine Tank
Carburetor	Choke type	Integral Automatic
	Intake manifold heat control (exhaust or water)	Exhaust
	Air clnr. type	Polyurethane None
	Standard	
	Optional	

CARBURETOR SUPPLEMENTARY INFORMATION

Model Usage	Engine Displ.	Transmission	Carburetors		No. Used and Type	Barrel Size
			Make	Model		
4700	401	Turbine Drive	Carter	AFB	One	1.5625 (Pri.) 1.6875 (Sec.)

(a) Replaceable Pleated Paper Type.

AMA Specifications – Passenger Car

MAKE OF CAR BUICK MODEL YEAR 1963 DATE ISSUED 5-17-62 REVISED(*) 7-18-62
 Series 4700
 MODEL _____

ENGINE—COOLING SYSTEM

Type system (pressure, pressure vented, atmospheric, other)			Pressure
Radiator cap relief valve pressure			15 P.S.I.
Circulation thermostat	Type (choke, bypass)	Choke	
	Starts to open at (°F)	180°F.	
Water pump	Type (centrifugal, other)	Centrifugal	
	GPM @ 1000 pump rpm		
	Number of pumps	One	
	Drive (V-belt, other)	V-Belt	
	Bearing type	Double Row Bearing	
By-pass recirculation type (internal, external)			Internal
Radiator core type (cellular, tube and fin, other)			Tube and Center
Cooling system capacity	With heater (qt.)	18.5	
	Without heater (qt.)		
	Opt. equipment—specify (qt.)		
Water jackets full length of cylinder (yes, no)			No
Water all around cylinder (yes, no)			Yes
Radiator hose	Lower	Number and type (molded, straight)	One-Molded
		Inside diameter	1.62
	Upper	Number and type (molded, straight)	One-Molded
		Inside diameter	1.50
	By-pass	Number and type (molded, straight)	None
		Inside diameter	
Fan	Number of blades & Spacing		Four-76°x104° (Five with A/C)
	Diameter		18.0 (20" with A/C)
	Ratio-fan to crankshaft rev.		.92 (1.30 with A/C)
	Fan cutout type		None (Eaton-Thermo Modulated with A/C)
	Bearing type		Single Row Ball Bearing
*Drive belts (indicate belt used by letter)	Fan		"A" Generator and Water Pump
	Generator		"A" Fan and Water Pump
	Water Pump		"A" Fan and Generator
	Power Steering		"B" Fan and Water Pump
	Air Conditioning		"C" Fan Generator & Water Pump (Matched Set)

* Drive Belt Dimensions	A	B	C
Angle of V	38°	38°	38°
Nominal length (SAE)	53.00	51.00	60.60
Width	.38	.47	(a) .38

(a) Four 76° x 104° (7-blade fan used with Air Conditioning)

MAKE OF CAR BUICK MODEL YEAR 1963 DATE ISSUED 1-25-62 REVISED (*)7-18-62
 MODEL _____ Series _____
 _____ 4700

ELECTRICAL—SUPPLY SYSTEM

Battery	Make and Model		Delco-Remy 570 (a)
	Voltage Rtg. & Total Plates		12-66
	SAE Designation & Amp Hr. Rtg		35M-70 Amp. Hour
	Location		Left Front Fender Skirt
	Terminal grounded		Negative
Generator	Make		Delco-Remy
	Model		1100623 (b)
	Type		Diode Rectified Alternator
	Ratio—Gen. to Cr/s rev.		2.51 (c)
	Gen. cut-in (hot)—engine rpm		17 Amps at Idle (d)
Regulator	Make		Delco-Remy
	Model		1119512
	Type		Voltage Control
	Cutout relay	Closing voltage @ generator rpm	None
		Reverse current to open	None
	Regulated	Voltage	13.6 to 14.4 at 125°F.
		Current	None
	Voltage test conditions	Temperature	
Load		Run 15 Min. at 10 Amps.	
Other		Battery Must Be in Circuit	

ELECTRICAL—STARTING SYSTEM

Starting motor	Make		Delco-Remy
	Model		1107221
	Rotation (drive end view)		Clockwise
	Engine cranking speed		160 RPM (Approximately)
	Test conditions		Engine at Operating Temp.
	Lock test	Amps	290-370
		Volts	2.0
		Torque (lb. ft.)	Not Available
	No load test	Amps	120
		Volts	10.6
RPM (min.)		4700	
Motor control	Switch (solenoid, manual)		Solenoid
	Starting procedure		Transmission in Neutral or Park, depress and release accelerator to set choke, turn ignition key to extreme right to engage starter, release when engine fires.

(Continued)

- (a) Wet Charge - Model 571 Dry Charge.
 (b) 1100622 for Air-Conditioned Cars.
 (c) 2.82 for Air-Conditioned Cars.
 (d) 24 Amps at Idle for Air-Conditioned Cars.

PRELIMINARY
AMA Specifications - Passenger Car

MAKE OF CAR BUICK MODEL YEAR 1963 DATE ISSUED 1-25-62 REVISED (*) 7-18-62

MODEL _____ Series
4700

ELECTRICAL—STARTING SYSTEM (cont.)

Motor Drive	Engagement type		Solenoid with Over-running Clutch
	Pinion meshes (front, rear)		Front
	Number of teeth	Pinion	9
		Flywheel	166
Flywheel tooth face width		.375	

ELECTRICAL—IGNITION SYSTEM

Coil	Make		Delco-Remy
	Model		1115100
	Amps	Engine stopped	3.8 @ 12.6 Volts
Engine idling		2.3 @ 12.6 Volts	
Distributor	Make		Delco-Remy
	Model		1110993
	Cent'fgal adv. in crankshaft degrees @ engine rpm (nominal)	Start (rpm)	550-900
		Intermediate points deg. @ rpm	0 to 4° @ 900
		Max deg. @ rpm	22° @ 3800
	Vacuum adv. in crankshaft degrees @ in. Hg. (nominal)	Start (in Hg)	8-10
		Intermediate points, deg @ in Hg	5.5° @ 12
		Max. deg. in. Hg.	17.5° @ 18
	Breaker gap (in.)		.013 - .019
	Cam angle (deg.)		30° ± 1°
Breaker arm tension (oz.)		19-23	
Timing	Crankshaft deg. @ rpm.		12° BTC @ 400
	Mark location		Harmonic Balancer
	Cylinder numbering system (see page 2)		Left Bank 2-4-6-8
			Right Bank 1-3-5-7
Firing order (see page 2)		1-2-7-8-4-5-6-3	
Spark Plug	Make and model		AC Type 44S
	Thread (mm)		14
	Tightening torque (lb. ft.)		25-30
	Gap		.030 - .035
Cable	Conductor type		4000 Ohms/Ft. Resistance Cable
	Insulation type		Neoprene
	Spark plug protector		Neoprene Boot

ELECTRICAL—SUPPRESSION

Locations & type	4000 Ohms/Ft. Spark Plug Wires and Coil to Distributor Wire
	Coil - .33 MFD Condenser
	Voltage Regulator - .50 MFD Condenser

PRELIMINARY
AMA Specifications - Passenger Car

MAKE OF CAR BUICK MODEL YEAR 1963 DATE ISSUED 1-25-62 REVISED (*)7-18-62
 Series
 4700

MODEL _____

ELECTRICAL—INSTRUMENTS AND SWITCHES

Speed-ometer	Make	A.C.
	Trip odometer (yes, no)	Yes
Charge indicator—type		Indicator Light
Temperature indicator—type		Thermal Switch - "Hot" & "Cold" Indicator Lights
Oil pressure indicator—type		Pressure Switch - Indicator Light
Fuel Indicator—type		Electrical
Other		
Ignition switch	Identify positions in order and circuits controlled	Starting with Switch in Full Counterclockwise Position. Accessory: (a) 1st Position Clockwise: "OFF" - Locked 2nd Position Clockwise: "OFF" - Unlocked 3rd Position Clockwise: "ON" - (b) 4th Position Clockwise: "START" - (Spring return to "ON")
	Provision for illumination	Yes
	Location	Lower Control Panel - Right of Steering Column
Main lighting switch	Identify positions and lamps controlled	1st Position Out - Park and Tail Lights 2nd Position Out - Headlamps and Tail Lights Rotating Switch Knob fully counterclockwise turns Dome Light on and Instrument Light on Bright. Rotating Clockwise turns Dome Light "Off" and dims Instrument Lights. Fully Clockwise turns Instrument Lights "Off".
Other light switches	Locations and lamps controlled Glove Comp't. Parking Brake Stop Light	Switch-Center Panel Below Instrument Panel Roll Mercury Switch in Lamp Mechanically Operated by Door On Parking Brake Release Bracket Hydraulic on Master Cylinder
Other switches	Locations and devices controlled Direction Signal	Console
	Back-up Lights	Console
Windshield wiper	Make	Delco Appliance
	Type	Electric
	Vacuum booster provision	None
	Washer provision	Yes
Horn	Type	Solenoid
	Number used	Two
	Amp draw (each)	(Both) 7 to 11 Amp.

(a) Radio, Back-up Lights, Heater Blower, Air-Conditioning Blower, Stop Lights, Direction Lights and Wiper.

(b) Ignition, Radio, Back-up Lights, Heater Blower, Air-Conditioning Blower, Stop Lights, Direction Signals, Wiper, Gas Gauge, Brake Warning, Oil Pressure, Water Temperature and Charge Indicator Lights. Form Rev. 3-62

PRELIMINARY
AMA Specifications - Passenger Car

MAKE OF CAR BUICK MODEL YEAR 1963 DATE ISSUED 1-25-62 REVISED (*) 6-4-62

MODEL Riviera
4747

ELECTRICAL—LAMP BULBS

Give quantity used and trade number, e.g., Headlamp 2-5400 S, dual headlight 2-4001, 2-4002.
 Indicate accessories which are not standard equipment by an asterisk following the numbers.

Headlamps & arrangement	4-4001, 2-4002, Dual Headlamps - Horizontal	
Headlamp beam indicator	158	
Parking	2-1034	
Tail	2-1034	
Stop	Same Bulb as Tail Light	
Direction signal	Front	Same Bulb as Parking Light
	Rear	Same Bulb as Tail Light
	Indicator	2-158
License plate	67	
Instrument	6-161	
Ignition lock	1-1445	
Back up	2-1073	
Dome	2-90	
Clock	1-1816	
Radio	1-1893	
Glove compartment	1-57	
Map	1-68	
Brake Indicator	1-1816	
Trans. Range	1-1816	
Oil - Water and		
Gen. Indicator	3-158	
Instr. Panel		
Control Hsg.	2-57	
Courtesy Light		
in Center		
Console	2-90, 1-68	
Ash Tray	1-53	

PRELIMINARY
AMA Specifications – Passenger Car

MAKE OF CAR BUICK MODEL YEAR 1963 DATE ISSUED 1-25-62 REVISED (a) 7-18-62

MODEL _____ Series
4700

ELECTRICAL—FUSE & CIRCUIT BREAKER DATA

Use trade number of fuse, e.g., SFE-10. Indicate circuit breaker by ampere capacity suffixed by letters "C.B.", e.g., 30 C.B. Where fuse or circuit breaker protects multiple circuits indicate first use by a letter and repeat the same letter for all units protected by the same fuse or circuit breaker, e.g., Parking lamp SFE-10 (a), Direction indicator same as (a).

Headlamp	15 CB (a)
Headlamp beam indicator	(a)
Parking lamp	(a)
Tail lamp	10 AGC (c)
Stop lamp	10 AGC (b)
Direction Indicator	(b)
License plate lamp	(c)
Instrument lamp	3 AGC (d)
Ignition lamp	(d)
Back up lamp	** 10 AGC (h)
Dome lamp	20 SFE (f)
Clock	***2 AGA
Clock lamp	(d)
Radio	**** Special 7.5 SFE (Wonder Bar)-Special 2.5 AGW (Sonomatic)
Glove compartment lamp	** 5 AGC (e)
Courtesy Light	(e)
Trunk Light	*** (f)
Blower-Heat.AC	****30 AGC
Cigar Lighter	Special
Antenna Motor	**** 15 AGC
Windows-Seat-Top	**** 40 CB
Safety Buzzer & Brake	**5 AGC (g)
Wiper	25 AGC
Ash Tray Light	(d)

ELECTRICAL—LOCATION OF OUTSIDE LAMPS

	Tail	Lowest	--	
		Highest	24.1	
Height above ground to center of bulb	Stop		24.1	
	Backup		19.5	
	License, rear		23.1	
	Directional	Front		14.7
		Rear		25.7
	Headlamp	Inside		25.2
		Outside*		25.1
	Distance from C/L of car to center of bulb	Tail	Inside	--
			Outside	20.9
		Stop		20.9
Backup			7.7	
License, rear			C/L	
Directional		Front		31.9
		Rear		23.3
Headlamp		Inside		15.7
	Outside*		22.8	

* If single headlamps are used enter here.

PRELIMINARY
AMA Specifications — Passenger Car

MAKE OF CAR BUICK MODEL YEAR 1963 DATE ISSUED 4-27-62 REVISED ^(a) 7-18-62
 Series
 MODEL 4700

DRIVE UNITS—CLUTCH (Manual Transmission)

Make & type		Not Available	
Type pressure plate springs		"	"
Effective plate pressure (lb.)		"	"
No. of clutch driven discs		"	"
Clutch facing	Material	"	"
	Outside & inside dia.	"	"
	Total eff. area (sq.in.)	"	"
	Thickness	"	"
	Engagement cushioning method	"	"
Release bearing	Type & method of lubrication	"	"
Torsional damping	Methods: springs, friction material	"	"

DRIVE UNITS—TRANSMISSIONS

Manual (std. or opt.)	Not Available
Manual with overdrive (std. or opt.)	" "
Automatic (std. or opt.)	" "

DRIVE UNITS—MANUAL TRANSMISSION

Number of forward speeds		Not Available		
Transmission ratios	In first	"	"	
	In second	"	"	
	In third	"	"	
	In fourth	"	"	
	In reverse	"	"	
Synchronous meshing, specify gears		"	"	
Shift lever location		"	"	
Lubricant	Capacity (pt.)	"	"	
	Type recommended	"	"	
	SAE viscosity number	Summer	"	"
		Winter	"	"
Extreme cold		"	"	

AMA Specifications - Passenger Car

MAKE OF CAR BUICK MODEL YEAR 1963 DATE ISSUED 4-27-62 REVISED (*) 7-18-62

MODEL _____ Series 4700

DRIVE UNITS—MANUAL TRANSMISSION WITH OVERDRIVE

For transmission data see manual transmission section

Overdrive	Type (planetary or other)		Not Available		
	Manual lockout (yes, no)		" "		
	Downshift accelerator control (yes, no)		" "		
	Minimum cut-in speed		" "		
	Gear ratio		" "		
	Lu- bri- cant	Capacity (pt.) (Overdrive only)		" "	
		Separate filler (yes, no)		" "	
		Type recommended		" "	
		SAE vis- cosity number	Summer	" "	
	Winter		" "		
Ext. cold	" "				

DRIVE UNITS—AUTOMATIC TRANSMISSION

Trade name	Turbine Drive		
Type describe	Torque Converter with Gears		
Method of Selection (Lever, Push Button or other)	Lever		
Selector Pattern	P-N-D-L-R		
List gear ratios Selector Pattern and indicate which are used in each selector position	D - - - 1 x converter ratio L - - - 1.82 x " " R - - - 1.82 x " "		
Max. upshift speeds—drive range	None		
Max. kickdown speeds—drive range	None		
Torque converter	Number of elements	5	
	Max. ratio at stall	3.4	
	Type of cooling (air, water)	Water	
Lubricant	Capacity—refill (pt.)	24	
	Type recommended	(a)	
Special transmission features	Two-position stator blade changes to high or performance angle at full throttle position.		

DRIVE UNITS—PROPELLER SHAFT

Number used	Two		
Type (exposed, torque tube)	Exposed		
Outer diameter x length* x wall thickness	Manual transmission	Not Available	
	Overdrive transmission	Not Available	
	Automatic transmission	Front - 2.250 x 31.35 x .095 Rear - 2.250 x 34.35 x .095	

*Center to center of universal joints, or to centerline of rear attachment.

(Continued)

(a) Automatic Transmission Fluid Type "A". Suffix "A" must be identified by "AQ-ATF" embossed in can, or, special Buick oil.

PRELIMINARY
AMA Specifications - Passenger Car

MAKE OF CAR BUICK MODEL YEAR 1963 DATE ISSUED 4-27-62 REVISED (*) 7-18-62
 Series
 4700

MODEL _____

DRIVE UNITS—PROPELLER SHAFT (cont.)

Inter-mediate bearing	Type (plain, anti-friction)	Ball
	Lubrication (fitting, prepack)	Packed for Life
Universal joints	Make	Saginaw
	Number used	Three
	Type (ball and trunion, cross, other)	Front & Rear - (Single Cardan Cross)
	Bearing	Type (plain, anti-friction)
Lubric. (fitting, prepack)		Packed for Life
Drive taken through (torque tube or arms, springs)		Arms
Torque taken through (torque tube or arms, springs)		Arms

DRIVE UNITS—REAR AXLE

Description (see instructions)		Banjo-Live Type	
Limited Slip differential, type		Positive Traction - Optional	
Drive Pinion Offset		1.75	
No. of differential pinions		(a) 2	
Gear ratios (Std. equip.)	Manual transmission	Not Available	
	Overdrive transmission	Not Available	
	Automatic transmission	3.23	
Ring gear O.D. (std. ratio)		9.375 - 9.375	
Pinion adjustment (shim, other)		Shim	
Pinion bearing adj. (shim, other)		Shim	
Wheel bearing type		Ball	
Lubricant	Capacity (pt.)	4.5	
	Type recommended	Hypoid GM 4655M (90)	
	SAE viscosity number	Summer	SAE-90 (GM4655M)
		Winter	SAE-90 (GM4655M)
		Extreme cold	SAE-90 (GM4655M)

REAR AXLE RATIO TOOTH COMBINATIONS

(See page 3 for axle ratio usage)

Axle ratio		3.23
No. of teeth	Pinion	14
	Ring gear	42

(a) Four Used with Optional Positive Traction Differential.

PRELIMINARY
AMA Specifications - Passenger Car

MAKE OF CAR BUICK MODEL YEAR 1963 DATE ISSUED 1-25-62 REVISED (*) 7-18-62

MODEL _____ Series
4700

DRIVE UNITS—WHEELS

Type & material		Disc - Steel
Rim (size and flange type)	Std.	15 - 5.50K
	Opt.	Not Available
Attachment	Type (bolt or stud)	Stud
	Circle diameter	5.00
	Number and size	Five (.500-20)

DRIVE UNITS—TIRES

Standard (List option below)	Size & ply	7.10-15 (4-Ply)
	Type - Nylon, etc.	Rayon
Rev/mile at 50 mph.		
Inflation press.(cold)	Front	24(a)
	Rear	24(a)
Optional tires - size and ply		Not Available

BRAKES—SERVICE

Type (duo-servo, disc, balanced, etc.)		Duo-Servo	
Self adjusting (std., opt., N.A.)		Not Available	
Hydraulic system type (single, dual, etc.)		Single	
Power brake make & type (remote, integral, etc.)		Moraine Integral Unit	
Effective area (sq. in.)*		156.90	
Gross lining area (sq. in.)**		197.32	
Swept drum area (sq. in.)***		320.49	
Percent brake effectiveness—front		55.9	
Drum	Diameter	Front	12.007/11.997
		Rear	12.007/11.997
	Type and material		(b)
Wheel cylinder bore	Front	1.125	
	Rear	1.00	
Master cylinder bore		1.00	
Available pedal travel		3.55	
Line pressure at 100 lb. pedal load		400# with 30# Pedal Load and 20" Hg. Vacuum	
Shoe clearance adjustment		.015	

(Continued)

* Excludes rivet holes, grooves, chamfers, etc.
 ** Includes rivet holes, grooves, chamfers, etc.
 *** Total swept areas for four brakes:
 Widest lining contact width for each brake x its drum circumference.

(a) Add 2# at Ambient Air 32°F. or less.

(b) Fronts are aluminum body with cast iron liners - rears are 60 fin cast iron.

PRELIMINARY
AMA Specifications—Passenger Car

MAKE OF CAR BUICK MODEL YEAR 1963 DATE ISSUED 1-25-62 REVISED (•) 7-18-62

MODEL _____ Series
4700

BRAKES—SERVICE (cont.)

Bonded or riveted			Riveted	
Brake lining	Front Shoe	Material	Primary - Molded Extruded	
		Size (length x width x thickness)	Front wheel	10.040 x 2.25 x .220
			Rear wheel	10.040 x 2.00 x .220
	Segments per shoe		One	
	Rear Shoe	Material	Secondary - Molded Extruded	
		Size (length x width x thickness)	Front wheel	12.959 x 2.25 x .220
Rear wheel			12.759 x 2.00 x .220	
Segments per shoe		One		

BRAKES—PARKING

Type of control	Step on	
Location of control	Left Side at Cowl Panel	
Operates on	Rear Shoes	
If separate from service brakes	Type (internal or external)	None
	Drum diameter	None
	Lining size (length x width x thickness)	None

FRAME or UNITIZED CONSTRUCTION

Type and description
Cruciform

SUSPENSION—GENERAL (See Supplemental page 19 for details on Air Suspension)*

Provision for car leveling	None	
Provision for brake dip control	Yes	
Provision for acc. squat control	Yes	
Special provisions for car jacking	Slot in Bumper Face Plates	
Shock absorber front & rear	Type	Direct
	Make	Delco
	Piston dia.	1"
Other special features	None	

SUSPENSION—FRONT

Type and description
Coil Spring and Ball Joint

* Air Suspension:
Air spring type
Compressor data
type
make
drive ratio

Normal operating pressures
spring rates
leveling data

(Continued)

PRELIMINARY
AMA Specifications - Passenger Cars

MAKE OF CAR BUICK MODEL YEAR 1963 DATE ISSUED 1-25-62 REVISED(*) 7-18-62

Series

4700

MODEL _____

SUSPENSION FRONT (cont.)

Spring	Type	Coil
	Material	SAE-9260 Steel
	Size (coil design height & I.D.; bar length x dia.)	11.00 - 4.05 154.76 - .700
	Spring rate (lb. per in.)	350
	Rate at wheel (lb. per in.)	90
	Design load (lb. @ design height)	2440
Stabilizer	Type (link, linkless, frameless)	Link
	Material & bar diameter	SAE-1084 - .812

STEERING

Mechanical (std., opt., NA)		Not Available
Power (std., opt., NA)		Standard
Wheel diameter		16"
Turning diameter	Outside front	Wall to wall (l. & r.)
		Curb to curb (l. & r.)
	Inside rear	Wall to wall (l. & r.)
		Curb to curb (l. & r.)
Outside wheel angle with inside wheel at 20°		17°55'
Mechanical	Gear	Type
		Make
		Ratios
No. wheel turns		
Power	Type (coaxial, linkage, etc.)	
	Make	
	Trade name	
	Gear	Type
		Ratios
		Gear
	Recirculating Ball Nut - Integral with Power Piston	
	Overall	
Pump driven by		
Number wheel turns		
Linkage	Type	
	Location (front or rear of wheels, other)	
	Drag link (trans. or longit.)	
	Tie rods (one or two)	

(Continued)

AMA Specifications – Passenger Car

MAKE OF CAR BUICK MODEL YEAR 1963 DATE ISSUED 1-25-62 REVISED (a) 7-18-62

Series
4700

MODEL _____

STEERING (cont)

Steering Axis	Inclination at camber (deg.)		9°52' @ 0°50' Camber
	Bearings (type)	Upper	Ball Joint Suspension Used
		Lower	Ball Joint Suspension Used
Thrust		Ball Joint Suspension Used	
Wheel alignment (range and preferred)	Caster (deg.)		1° Pos. + or - 1/2°
	Camber (deg.)		3/8° + or - 3/8°
	Toe-In (outside tread-inches)		3/16" to 9/32
Steering spindle & joint type			Ball Joint
Wheel spindle	Diameter	Inner bearing	1.3748
			1.3743
		Outer bearing	.8435
		.8430	
	Thread size		13/16 - 16 U.N.F.
Bearing type		Taper Roller Bearing	

SUSPENSION—REAR

Type and description			Coil Spring	
Drive and torq. taken through (see page 17)			Arms	
Spring	Type		Coil	
	Material		SAE 9260 Steel	
	Size (length x width, coil design height and I.D.; bar length & dia.)		11.50-4.38 151.76-.610	
	Spring rate (lb. per in.)		170	
	Rate at wheel (lb. per in.)		91	
	Design load (lb. at design height)		1200	
	Mounting insulation type		Laminated Rubber	
	If leaf	No. of leaves		None
		Inserts	Type and size	None
			Material	None
Shackle (comp. or tens.)		None		
Stabilizer	Type (link, linkless, frameless)		None	
	Material			
Track bar type			Tubular Steel Mounted in Rubber	

MAKE OF CAR BUICK MODEL YEAR 1963 DATE ISSUED 4-17-62 REVISED ^(*) 6-4-62

CAR AND BODY DIMENSIONS—GENERAL

NOTE: included in the dimension definitions listed on pages 34-36 are those which have been adopted by SAE. These are indicated by a number following the type of dimension, e.g., L3. Additional dimensions have been added by the AMA Specifications Review Committee. These are shown by an additional letter, e.g., H67a. The symbol "a" has been added as a suffix to denote a dimension adopted by the AMA and submitted to the SAE for approval. The dimensions are developed from the following basic points:

1. Body dimensions are for all body styles.
2. All interior dimensions are taken with manikin 15.0 inches outboard of car centerline unless otherwise stated.
3. All interior dimensions are measured with the front seat in the lowest and rearmost position.
4. Unless otherwise specified, all exterior height dimensions are taken with a full design load which consists of 5 passengers, 300 lbs. front, 450 lbs. rear; includes spare wheel, tire and tools, and full complement of gas, oil, water and tires to recommended pressure, etc.
5. The SAE manikin with 90th percentile leg length will be used for recording purposes.
6. The H Point is the pivot center of the manikin's torso and thigh.
7. The Torso Line is a line parallel to the small of manikin's back and extending through the H Point.

EXTERIOR WIDTH DIMENSIONS

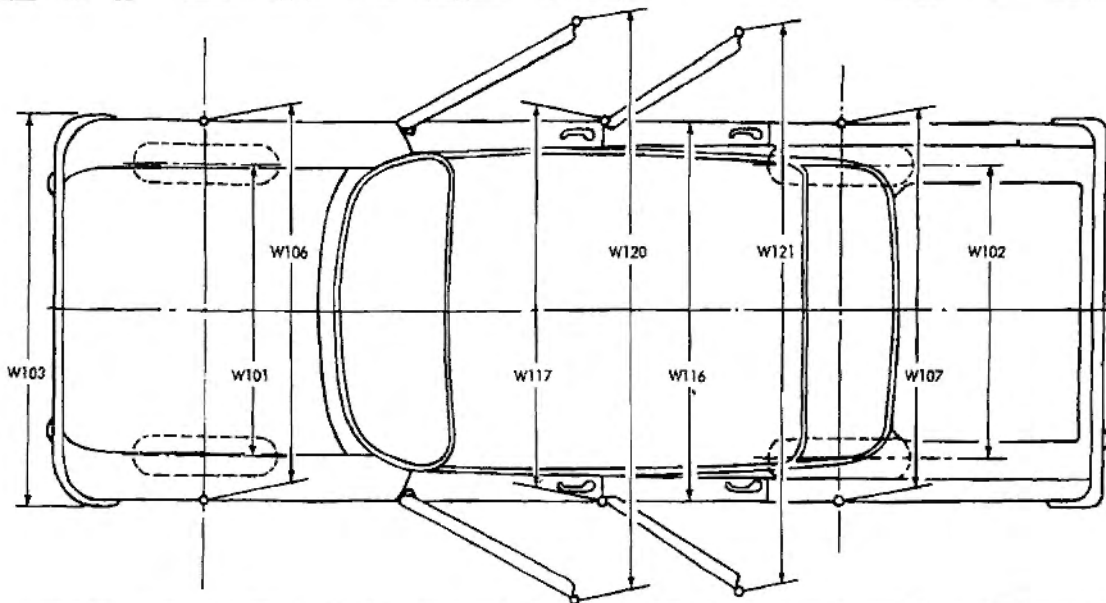

MODEL	Ref. No.	Riviera 4747
Tread - front	W101	60.0
Tread - rear	W102	59.0
Maximum overall car width	W103	76.6
Maximum overall body width	W116	75.4
Maximum body width at #2 pillar	W117	74.6
Front fender overall width	W106	76.6
Rear fender overall width	W107	
Maximum overall car width - front doors open	W120a	
Maximum overall car width - rear doors open	W121a	

PRELIMINARY
AMA Specifications – Passenger Car

MAKE OF CAR BUICK MODEL YEAR 1963 DATE ISSUED 4-17-62 REVISED(a) 6-4-62

EXTERIOR LENGTH DIMENSIONS

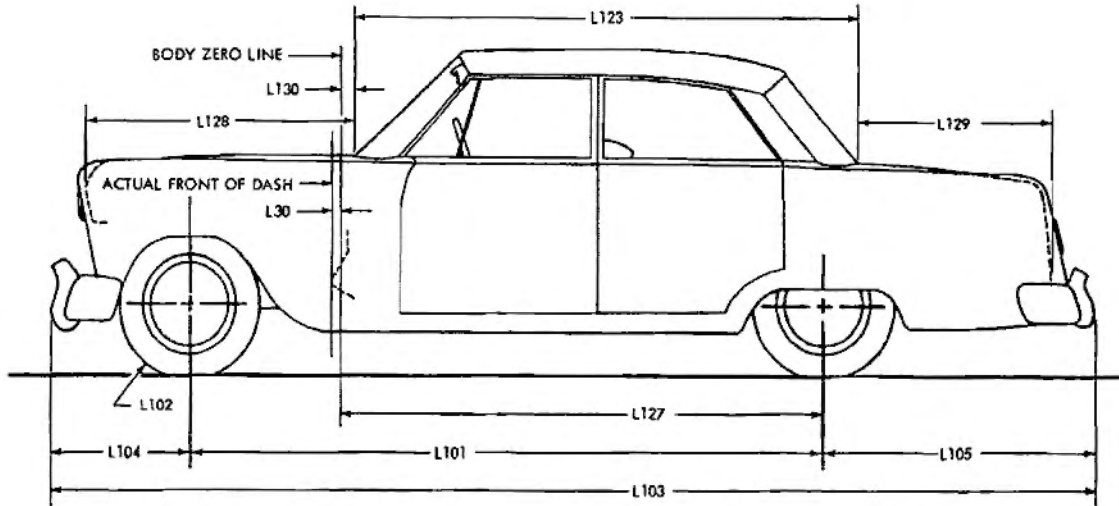

MODEL	Ref. No.	Riviera 4747
Body zero line to actual front of dash	L30	
Wheelbase	L101	117.0
Overhang - front	L104	36.7
Overhang - rear	L105	54.3
Overall length	L103	208.0
Hood length at car centerline	L128 _a	59.8
Body upper structure length at car centerline	L123	99.8
Deck length at car centerline	L129 _a	44.6
Body zero line to centerline of rear wheels	L127	
Body zero line to windshield cowl point	L130 _a	
Tire size	L102	7.10-15

PRELIMINARY
AMA Specifications— Passenger Car

MAKE OF CAR BUICK MODEL YEAR 1963 DATE ISSUED 4-17-62 REVISED (*) 6-4-62

EXTERIOR HEIGHT DIMENSIONS

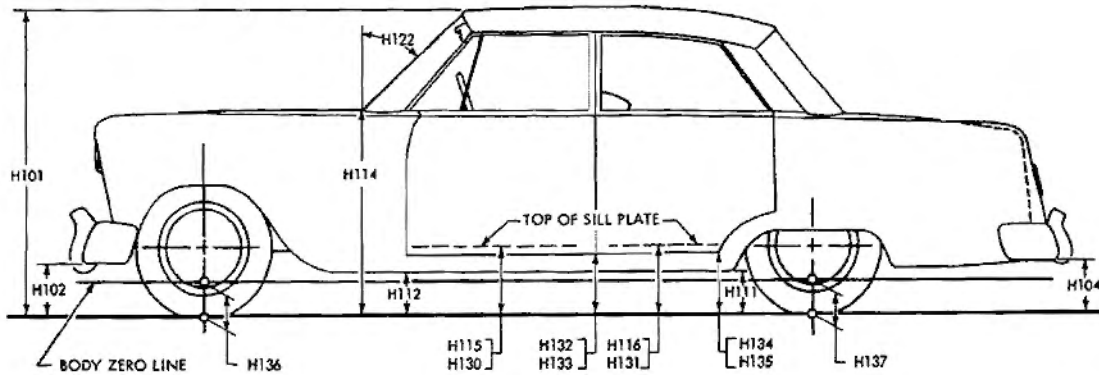

MODEL	Ref. No.	Riviera 4747
Overall height	H101	53.0
Hood at rear to ground	H114	
Rocker panel to ground - front	H112a	9.9
Rocker panel to ground - rear	H111	8.8
Step height - front (design load)	H115	
Step height - rear (design load)	H116	13.6
Step height - front (curb load)	H130	
Step height - rear (curb load)	H131	
Bottom of door to ground, open - front	H132	
Bottom of door to ground, closed - front	H133	11.67
Bottom of door to ground, open - rear	H134	
Bottom of door to ground, closed - rear	H135	----
Front bumper to ground	H102	11.1
Rear bumper to ground	H104	17.9
Windshield slope angle	H122	57.0
Body zero to ground - front	H136a	
Body zero to ground - rear	H137a	

PRELIMINARY
AMA Specifications—Passenger Car

MAKE OF CAR BUICK MODEL YEAR 1963 DATE ISSUED 4-17-62 REVISED(*) 6-4-62

GROUND CLEARANCE DIMENSIONS

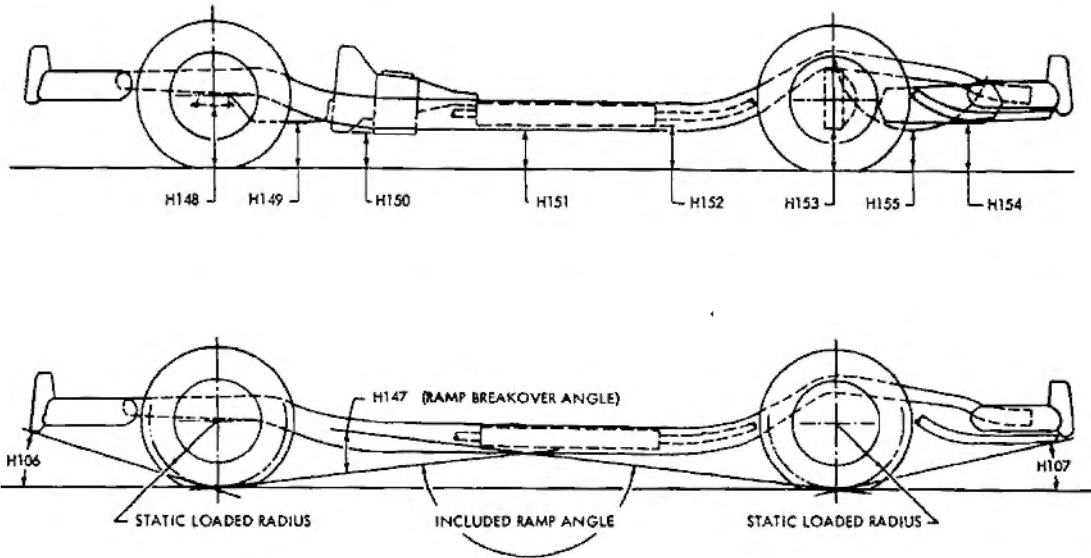

MODEL	Ref. No.	Riviera 4747
Angle of approach	H106	24.5°
Angle of departure	H107	15.75°
Ramp breakover angle	H147	12°
Front suspension to ground	H148	
Oil pan to ground	H149	
Flywheel housing to ground	H150	
Frame structure to ground	H151	
Exhaust system to ground	H152	
Rear axle differential to ground	H153	7.23
Fuel tank to ground	H154	
Spare tire well to ground	H155	
Minimum running ground clearance	H156	*5.5

*Frame Center Plate

PRELIMINARY
AMA Specifications—Passenger Car

MAKE OF CAR BUICK MODEL YEAR 1963 DATE ISSUED 1-25-62 REVISED (*) 6-4-62

FRONT COMPARTMENT DIMENSIONS

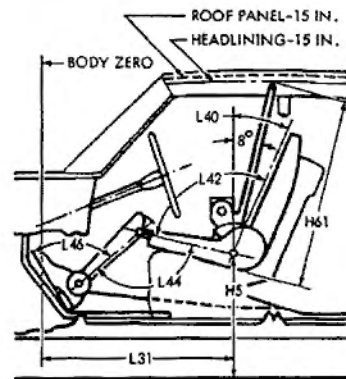
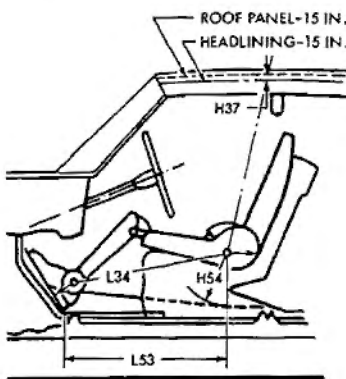
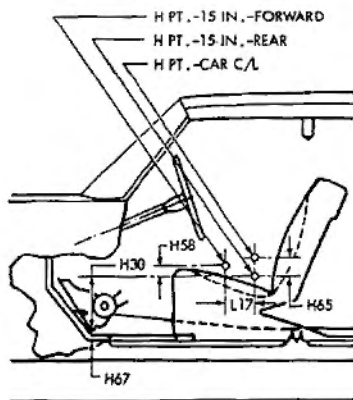

MODEL	Ref. No.	Riviera 4747
H Point to body zero line	L31a	
H Point to ground	H5a	
Effective head room	H61a	
Headlining to roof height	H37	
Maximum effective leg room - accelerator	L34a	40.9
H Point to heel point	H30a	9.3
Depressed floor covering thickness	H67a	
Back angle	L40a	22.0°
Hip angle	L42a	83.0°
Knee angle	L44a	92.5°
Foot angle	L46a	118.0°
H Point differential, side to center	H65a	
H Point to tunnel	H54a	
H Point to accelerator floor point	L53a	
H Point travel	L17a	
H Point rise	H58a	

AMA Specifications – Passenger Car

MAKE OF CAR BUICK MODEL YEAR 1963 DATE ISSUED 1-25-62 REVISED(•) 6-4-62

REAR COMPARTMENT DIMENSIONS

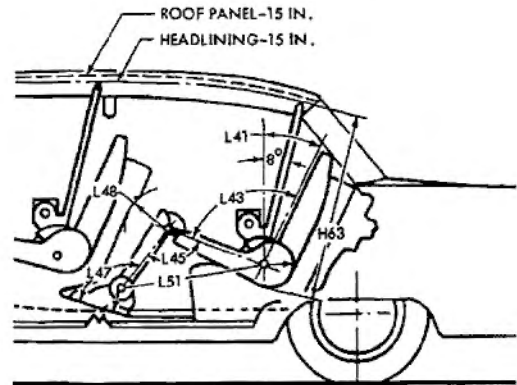
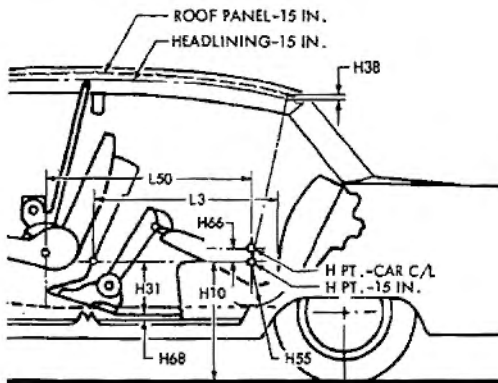

MODEL	Ref. No.	Riviera 4747
H Point couple distance	L50a	
H Point to ground	H10a	
Effective head room	H63a	
Headlining to roof height	H38	
Minimum effective leg room	L51a	
H Point to heel point	H31a	
Depressed floor covering thickness	H68a	
Minimum knee room	L48a	
Rear compartment room	L3	
Back angle	L41a	
Hip angle	L43a	
Knee angle	L45a	
Foot angle	L47a	
H Point differential, side to center	H66a	
H Point to tunnel	H55a	

PRELIMINARY
AMA Specifications – Passenger Car

MAKE OF CAR BUICK MODEL YEAR 1963 DATE ISSUED 1-25-62 REVISED(*) 6-4-62

SEAT AND ENTRANCE DIMENSIONS

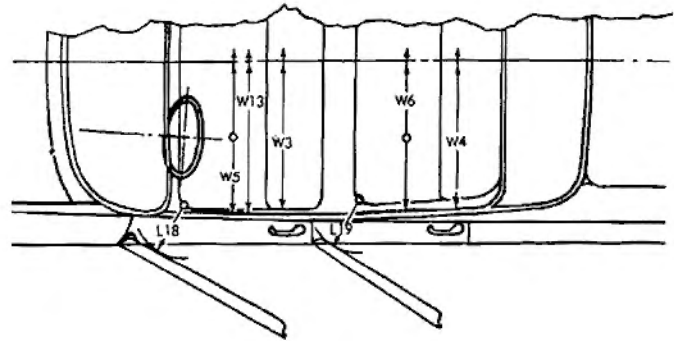
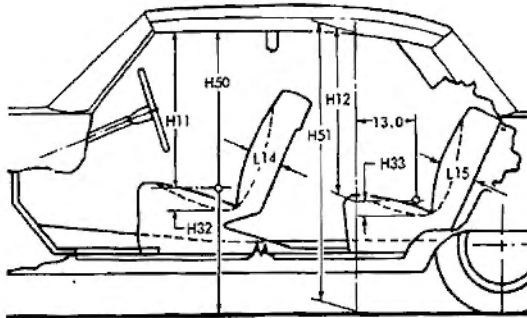

MODEL	Ref. No.	Riviera 4747
Shoulder room - front	W3a	56.5
Hip room - front	W5a	60.2
Seat width - front	W16a	
Upper body opening to ground - front	H50a	
Entrance height - front	H11a	30.5
Entrance foot clearance - front	L18	
Seat cushion deflection - front	H32a	
Seat back thickness - front	L14	
Shoulder room - rear	W4a	56.0
Hip room - rear	W6a	54.4
Upper body opening to ground - rear	H51a	
Entrance height - rear	H12a	---
Entrance foot clearance - rear	L19	---
Seat cushion deflection - rear	H33a	
Seat back thickness - rear	L15	

PRELIMINARY
AMA Specifications – Passenger Car

MAKE OF CAR BUICK MODEL YEAR 1963 DATE ISSUED 1-25-62 REVISED(●) 6-4-62

VISION AND CONTROL DIMENSIONS

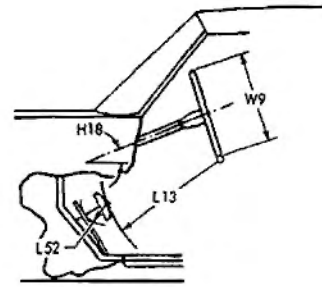
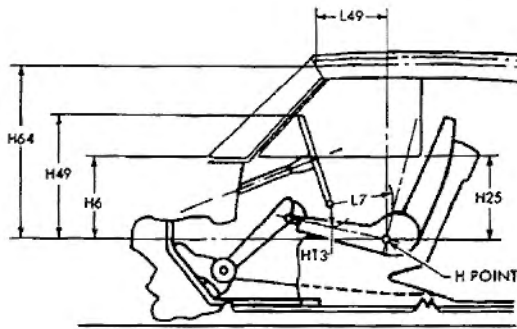

MODEL	Ref. No.	Riviera 4747
H Point to windshield bottom DLO	H6a	
H Point to windshield upper DLO	H64a	
H Point to windshield upper DLO	L49a	
Belt height - front	H25a	
Steering wheel center to centerline of car	W7	
Steering wheel maximum outside diameter	W9	
Steering column angle - horizontal	H18	
H Point to top of steering wheel	H49a	
Steering wheel torso clearance	L7a	
Steering wheel thigh clearance	H13a	
Brake pedal knee clearance	L13	
Brake pedal to accelerator	L52a	
Tumble-home	W122a	

AMA Specifications – Passenger Car

MAKE OF CAR BUICK MODEL YEAR 1963 DATE ISSUED 1-25-62 REVISED(*) 6-4-62

LUGGAGE COMPARTMENT

MODEL	Ref. No.	Riviera 4747
Usable luggage capacity (See instructions)		
Liftover height*	H301a	
Position of spare tire storage		
Method of holding lid open		Torsion Rods

THIRD SEAT DIMENSIONS

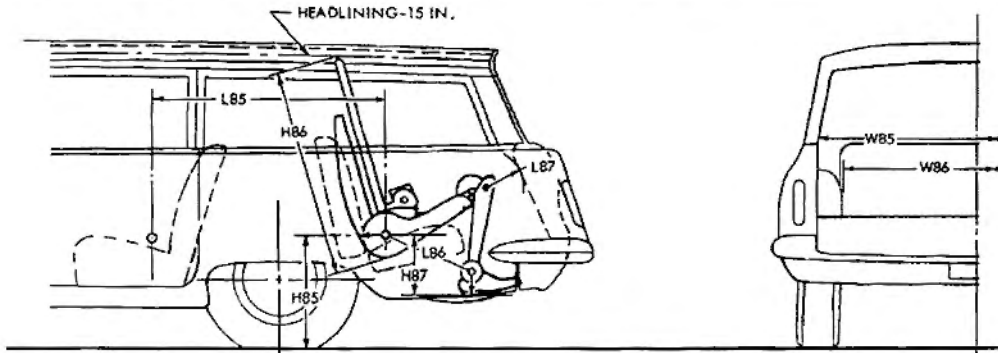

MODEL	Ref. No.	Riviera 4747
Seat facing direction		Estate Wagon Not Available
Shoulder room	W85a	
Hip room	W86a	
H Point couple distance	L85a	
H Point to ground	H85a	
Effective head room	H86a	
Effective leg room	L86a	
H Point to heel point	H87a	
Knee room	L87a	
Back angle	L88a	
Hip angle	L89a	
Knee angle	L90a	
Foot angle	L91a	

* Vertical dimension from luggage compartment lower opening to ground.

PRELIMINARY
AMA Specifications—Passenger Car

MAKE OF CAR BUICK MODEL YEAR 1963 DATE ISSUED 1-25-62 REVISED(*) 6-4-62

STATION WAGON—CARGO SPACE DIMENSIONS

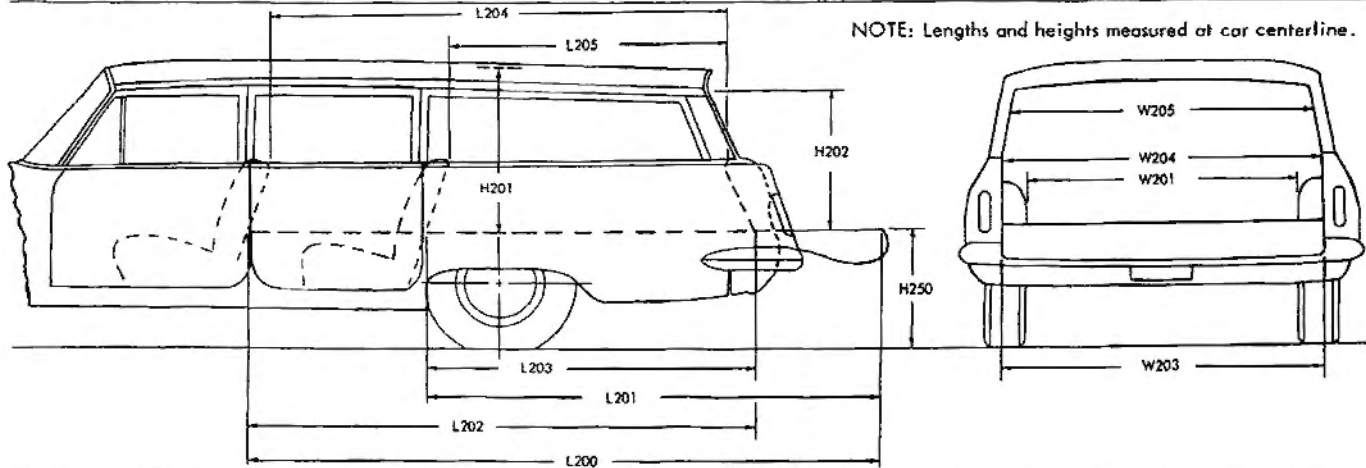

MODEL	Ref. No.	Riviera 4747
Floor length from back of front seat at floor level to end of lowered tail gate or floor	L200	Estate Wagon Style Not Available
Floor length from back of second seat at floor level to end of lowered tail gate or floor	L201	
Floor length from back of front seat at floor level to inside of closed tail gate	L202	
Floor length from back of second seat at floor level to inside of closed tail gate	L203	
Minimum horizontal distance from top rear of front seat back to inside of tail gate at belt	L204	
Minimum horizontal distance from top rear of second seat back to inside of tail gate at belt	L205	
Maximum width of cargo space at floor - specify location	W200a	
Minimum distance between wheel houses at floor level	W201	
Rear end opening width at floor	W203	
Rear end opening width at belt	W204	
Maximum width of rear opening above belt	W205	
Maximum height - floor covering to headlining at centerline of rear axle	H201	
Maximum height of rear opening - tail and lift gates open	H202	
Platform height from ground to top of tail gate floor covering at rear most edge of tail gate - curb weight	H250	
Rear end closure (e.g., one piece door, hinged left - sliding glass, drop tail gate)		
Cargo volume index (cu. ft.) W4 x L204 x H201		
1728		

INDEX

SUBJECT	PAGE NO.	SUBJECT	PAGE NO.
Angles of Approach, Departure	25	Lamp Bulbs	13
Automatic Transmission	1, 16	Lamp Height & Spacing	14
Axis, Steering	21	Legroom	26, 27, 30
Axle, Rear	1, 17	Lengths - Overall	1, 23
Battery	10	Lifters, Valve	5
Bearings, Engine	4, 5, 6	Linings - Clutch, Brake	15, 19
Belts - Fan, Generator, Water Pump	9	Lubrication	6, 7, 15, 16, 17
Body - General Information, types	Title, 1, 22, 32	Motor, Starting	10
Exterior Dimensions	1, 22, 23, 24	Muffler	7
Interior Dimensions	26, 27, 28, 29, 30	Overdrive	16
Clearance Dimensions	25	Piston Pins & Rings	2, 4
Brakes - Parking, Service, Power	18, 19	Pistons	2
Camber	21	Power Brakes	18
Camshaft	5	Power Steering	20
Capacities		Power Teams	3
Cooling System	9	Propeller Shaft, Universal Joints	16, 17
Fuel Tank	8	Pumps - Oil, Fuel	7, 8
Lubricants		Water	9
Engine Crankcase	7	Radiator, Hoses	9
Transmission and Overdrive	15, 16	Ramp Break-over Angle	25
Rear Axle	17	Ratios - Axle	1, 3, 17
Carburetor	3, 8	Compression	1, 2, 3
Caster	21	Steering	20
Choke, Automatic	8	Transmission	15, 16
Circuit Breakers, Fuses	14	Rear Axle	1, 3, 17
Clearance, Ground	25	Regulator - Generator	10
Clutch - Pedal Operated	15	Rims	18
Coil, Ignition	11	Rings, Piston	4
Connecting Rods	4	Rods - Connecting	4
Cooling System	9	Shock Absorbers, Front & Rear	19
Crankcase Ventilation	7	Spark Plugs	11
Crankshaft	5	Speedometer	12
Cylinders and Cylinder Head	2	Springs - Front & Rear Suspension	20, 21
Dimension Definitions	34, 35, 36	Valve, Engine	6
Distributor - Ignition	11	Stabilizer (Sway Bar) - Front & Rear	20, 21
Electrical System	10, 11, 12, 13, 14	Starting Motor	10
Engine		Steering	20, 21
Bore, Stroke, Displacement, Type	1, 2	Suppression - Ignition, Radio	11
Compression Ratio	1, 2	Suspension - Front & Rear	19, 20, 21
Firing Order, Cylinder Numbering	2, 11	Switches	12
General Information, H.P. & Torque	1, 2	Tailpipe	7
Lubrication	6, 7	Thermostat, Cooling	9
Power Teams	3	Timing, Engine & Valve	5, 6, 11
Exhaust System	7	Tires	1, 18
Fan, Cooling	9	Toe In	21
Filters - Engine Oil, Fuel System	7, 8	Torque Converter	16
Frame	19	Torque - Engine, Rated	1, 2, 3
Front Suspension	19, 20	Transmission - Types	1, 3, 8, 15, 16
Fuel, Fuel Pump, Fuel System	1, 2, 8	Automatic	1, 3, 8, 15, 16
Fuel Injection	1, 8	Manual & Overdrive	1, 3, 8, 15, 16
Fuses, Circuit Breakers	14	Ratios	15, 16
Generator and Regulator	10	Tread	1, 22
Glass	24, 32	Turning Diameter	20
Height (Lamps)	14	Unfitized Construction	19
Headroom - Body	26, 27, 30	Universal Joints, Propeller Shaft	16, 17
Heights - Overall	1, 24	Valves - Intake & Exhaust	5, 6
Hood	23	Vibration Damper	5
Horns	12	Voltage Regulator	10
Horsepower - Brake, Taxable	1, 2, 3	Water Pump	9
Ignition System	11	Weights - Shipping, Curb	33
Inflation - Tires	18	Wheel Alignment	21
Instruments	7, 12	Wheelbase	1, 23
Kingpin (Steering Axis)	21	Wheels & Tires	18
		Wheel Spindle	21
		Widths - Car & Body	1, 22
		Windshield	24, 32
		Windshield Wiper	12