



SERVICE BULLETIN



SERVICE DEPARTMENT... CHRYSLER-PLYMOUTH DIVISION
CHRYSLER MOTORS CORPORATION

TECHNICAL INFORMATION ON IMPERIAL CHRYSLER PLYMOUTH VALIANT

TO ALL IMPERIAL AND CHRYSLER DEALERS

The enclosed bulletin covers the general information and specifications of the 1963 Chrysler 300 J.

The information contained in this bulletin supplements the general service information in the 1963 Imperial and Chrysler Service Manual.

This bulletin covers specific data and specifications of the engine, carburetor and adjustments, special intake manifold, ignition system, new rear springs, special blue streak tubeless tires and other features exclusive with the 1963 Chrysler 300J vehicle. (Fig. 1).

J. W. Farley
Service Manager
CHRYSLER-PLYMOUTH DIVISION

December 26, 1962

No. 63-34

MISCELLANEOUS

DATA AND SPECIFICATIONS

CHRYSLER
ALL 1963
300J
MODELS

P-4950

Service Mgr.	
Shop Foreman	
Technicians	
Parts Mgr.	
Partsmen	



SERVICE BULLETIN



SERVICE DEPARTMENT... CHRYSLER-PLYMOUTH DIVISION
CHRYSLER MOTORS CORPORATION

TECHNICAL INFORMATION ON IMPERIAL CHRYSLER PLYMOUTH VALIANT

This bulletin supplements the Chrysler-Plymouth Service Bulletin No. 63-1, dated September 19, 1962.

Dec. 19, 1962

Attach this bulletin to your Service Bulletin No. 63-1 for complete information.

No. 63-1 A

The starting engine number for the 1963 Chrysler 300J should be corrected to read as follows:

MISCELLANEOUS

<u>MODEL</u>	<u>DESIGNATION</u>	<u>STARTING ENGINE NO.</u>
Chrysler 300J	TC-2 300J (Standard) 413 Cu. in.	C-300J-8-27-62

The 1963 Plymouth Super Stock Maximum Performance engines are identified as follows:

1963 IDENTIFICATION AND STARTING SERIAL NUMBERS "T" SERIES

<u>MODEL</u>	<u>DESIGNATION</u>	<u>STARTING ENGINE NO.</u>
PLYMOUTH Super Stock	TP-2 426 Cu. In. (11 to 1)	426-TMP-8-27-62
PLYMOUTH	TP-2 426 Cu. In. (13.5 to 1)	426-TMP-HC-9-12-62

1963 CHRYSLER 300J AND PLYMOUTH SUPER STOCK MODELS

POLICY: INFORMATION ONLY

J. W. Farley
J. W. FARLEY
Manager-Service
CHRYSLER-PLYMOUTH DIVISION

P-5227-C

Service Mgr.	
Shop Foreman	
Technicians	
Parts Mgr.	
Partsmen	



SERVICE BULLETIN



SERVICE DEPARTMENT... CHRYSLER-PLYMOUTH DIVISION
CHRYSLER MOTORS CORPORATION

TECHNICAL INFORMATION ON IMPERIAL CHRYSLER PLYMOUTH VALIANT

In order to insure against the possibility of objectional detonation in 1963 Chrysler 300J model engines, the basic ignition timing was changed to 12-1/2° B.T.C.

This change should be made on any C-300J models in dealer inventory and on any C-300J model brought in for service.

Please make notation of the new specification in your Chrysler-Plymouth Service Bulletin No. 63-34, dated December 26, 1962.

The new basic ignition timing of 12-1/2° B.T.C. began with engine date code 3-1-62. Refer to Chrysler-Plymouth Service Bulletin No. 63-1A, dated December 19, 1962.

POLICY: INFORMATION ONLY.

J. W. FARLEY
Manager-Service
CHRYSLER-PLYMOUTH DIVISION

March 29, 1963

No. 63-71

ELECTRICAL

BASIC
IGNITION
TIMING

1963
CHRYSLER
300J
MODELS

P-1298-C

Service Mgr.	
Shop Foreman	
Technicians	
Parts Mgr.	
Partsmen	

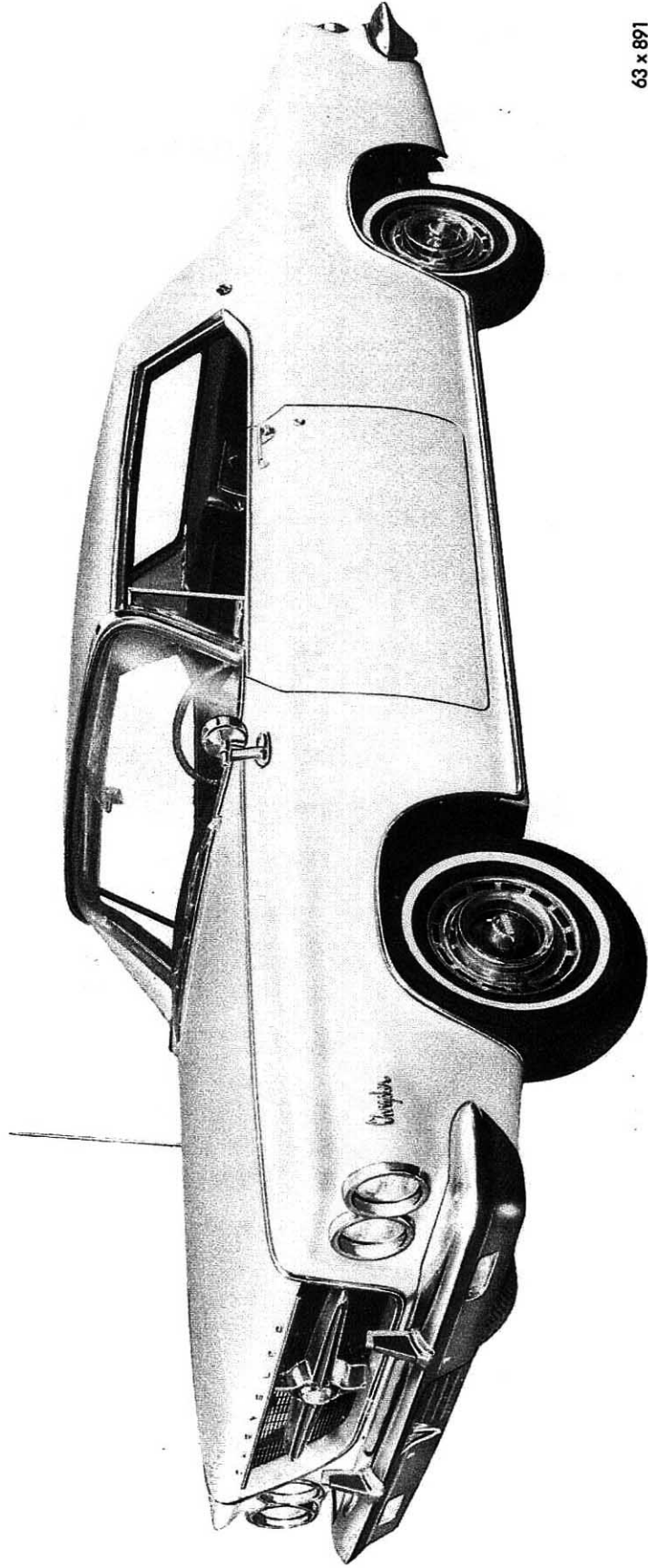

63 x 891

Fig. 1 - C300J Two Door Hardtop

1963 CHRYSLER - 300J

GENERAL DATA AND SPECIFICATIONS

TWO-DOOR HARDTOP

Wheelbase	122.0
Length with Bumper	215.5
Width with Bumper	79.0
Height	55.6
Rear Axle Ratio	
Manual Transmission	3.91
Automatic Transmission	3.23
Transmission	Manual TorqueFlite
Tire Size	7.60 x 15
Tread (Front)	61.1"
Tread (Rear).	60.0"
Fuel System	2-4 BBL. Carburetors
Engine Displacement	413
Compression Ratio	9.6 to 1
Recommended Fuel	Premium

GROUP 0 - LUBRICATION AND MAINTENANCE

Refer to the 1963 Imperial and Chrysler Service Manual for all service procedures. Lubrication and Maintenance service recommendations have been compiled therein to provide maximum protection for all types of driving conditions. Semi-annual lubrication and maintenance services have been prescribed for most items and exceptions to this are two month service intervals between engine oil changes not to exceed 4,000 miles, as compared to the front suspension lubrication which is every 32,000 miles.

GROUP 1 - ACCESSORIES (RADIO AND HEATERS)

A new transistorized 5 1/2 watt radio is available (as optional equipment) for the Chrysler 300J. Transistors have longer life and are less prone to damage. "Instant playing" and lower power consumption are features of the transistorized radio. An optional speaker is available in the middle of the rear seat back.

The hot water heating system for the 300J is controlled by four push buttons and a temperature control lever. A fifth push button independently controls the summer ventilating system.

All service procedures will remain the same as outlined in the 1963 Imperial and Chrysler Service Manual.

GROUP 2 - FRONT SUSPENSION

An improved steering linkage for the 300J has a new center link design with improved bushings. The new bushings provide longer life and reduce friction in the linkage. A permanently lubricated slip-type idler arm bushing is used to further reduce the steering effort and increase durability. The service procedures are the same as outlined in the 1963 Imperial and Chrysler Service Manual with the following exceptions:

FRONT SUSPENSION HEIGHT

The difference in the height between the floor and the measuring points on each lower control arm (lowest point on ball joint housing and underside of bushing housing between the flanges of arm) should be 1-3/4 inches. This height must be maintained + or - 1/8 inch with the maximum differential from the right to the left of 1/8 inch.

GROUP 3 - REAR AXLE

The rear axle ratio is 3.23 for cars equipped with an automatic transmission and 3.91 axle ratio for cars equipped with a manual shift transmission.

The service procedures are the same as outlined in the 1963 Imperial and Chrysler Service Manual.

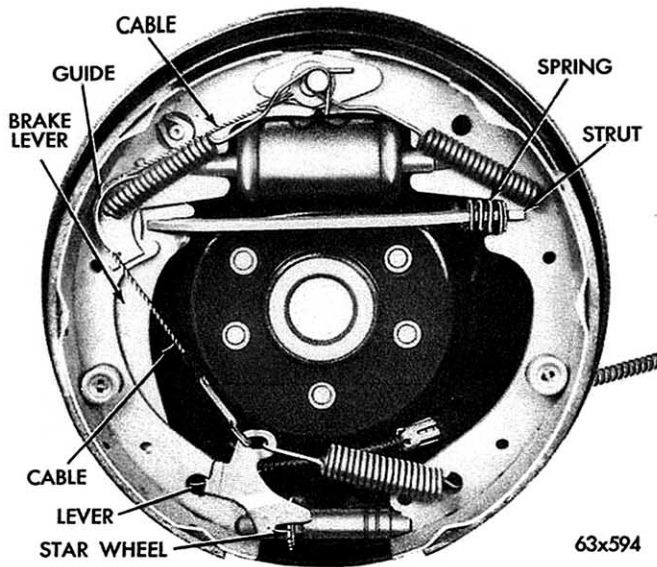

Fig. 2 - Duo Servo Brakes

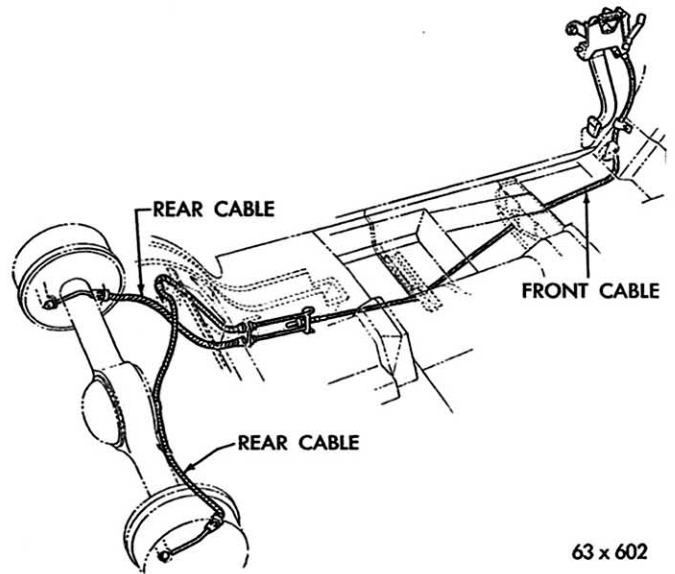

Fig. 3 - Rear Wheel Parking Brakes

GROUP 5 - BRAKES

New 11 inch Duo-Servo brakes are used in the 300J. The brakes are the self energizing type and a self adjusting mechanism is built into each wheel brake unit, therefore, the brakes need not be serviced to take up wear in the linings. The self adjusting mechanism consists of a simple cable and linkage device which indexes the star wheel, (Fig. 2) increasing the length of the floating link to maintain the correct shoe-to-drum clearance. The adjuster is designed so that it operates only during reverse stops.

Rear Wheel Parking Brakes

Parking brakes now operate on the rear wheels (Fig. 3). A foot pedal mechanism is used to apply the parking brakes. The parking brakes are released by a new pull-out type knob mounted on the instrument panel.

Remote Power Brake

The remote power brake system for the 300J Models is mounted on brackets under the left front fender, just back of the headlamp housing (Fig. 4). All the brake service procedures are the same as outlined in the 1963 Imperial and Chrysler Service Manual with the following exceptions:

Remote Power Brake Bleeding Procedures

With the engine shut off, exhaust all of the vacuum from the brake booster by applying the pedal several times. Make certain that the master cylinder is full of fluid before starting the bleeding procedure.

- (1) Attach the bleeder tank C-3496 to the master cylinder.

CAUTION: Do not apply more than 25 psi to the bleeder tank.

- (2) Open the inlet bleeder screw of the booster (closest to the master cylinder)

(Fig 4), and permit the fluid to run until free of air bubbles.

- (3) Open the outlet bleeder screw (Fig. 4) and allow the fluid to run until free of bubbles.

- (4) Bleed the wheel brake cylinder in the following sequence: Left front, right rear, right front and left rear. Repeat if necessary and inspect for leaks.

GROUP 7 - COOLING SYSTEM

The cooling system incorporates a tube and spacer type full flow radiator, a centrifugal water pump with a 180° thermostat and the Silent Flite Fan Drive (Fig. 5). All 300J Models have a 7 blade 18 inch diameter fan. The service procedures are the same as outlined in the 1963 Imperial and Chrysler Service Manual.

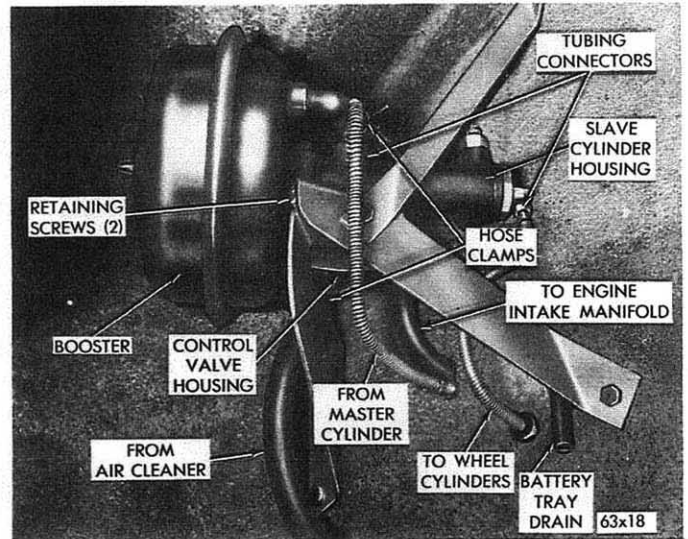

Fig. 4 - Remote Power Brake

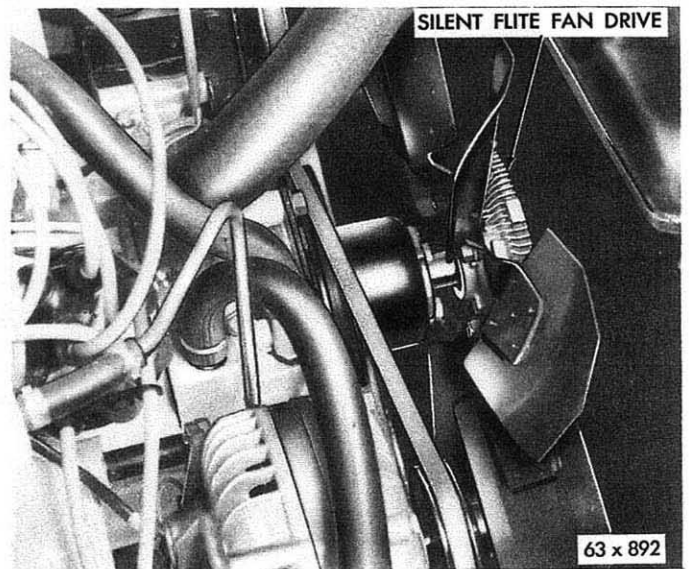

Fig. 5 - Silent Flite Fan Drive

GROUP 8 - ELECTRICAL SYSTEM

The service procedures are the same as outlined in the 1963 Imperial and Chrysler Service Manual, except for the following specifications:

IGNITION SYSTEM SPECIFICATIONS

Distributor Identification No. . . . Chrysler Auto-Lite	2098620 (Auto-Lite Built) IBS-4011B
Engine Displacement	413 Cubic Inch
Vehicle Model	TC2-300 J (with 2 - 4 bbl Carb.)
Advance - Automatic (Distributor Degrees at Distributor rpm)	0 ⁰ @ 525 to 675 0 to 3 ⁰ @ 675 4.5 to 6.5 @ 910
Advance - Vacuum (Distributor Degrees at inches of Mercury)	0 ⁰ @ 6" to 9" 4.5 to 7.5 ⁰ @ 12" 7.5 to 10.5 ⁰ @ 14.3"
Breaker Point Gap.014" to .019"
Dwell Angle	27 ⁰ to 32 ⁰ (one set points) 34 ⁰ to 40 ⁰ (both sets points)
Breaker Arm Spring Tension	17 to 21.5 oz.
Timing	15 ⁰ BTC
Condenser Capacity25 to .285 mfd.
Shaft Side Play.000" to .003"
Shaft End Play (After Assembly)003" to .010"
Rotation	Counter-Clockwise
Spark Plugs	J9Y Champion
Size.	14 MM -3/8" Reach
Gap035 inch
Firing Order.	1-8-4-3-6-5-7-2
Coil	Chrysler Auto-Lite Chrysler Essex 1688212 200567 2095223 62-160-2
Primary Resistance @ 70-80 ⁰ F.	1.65-1.79 ohms 1.41-1.55 ohms
Secondary Resistance @ 70-80 ⁰ F.	9400-11700 ohms 9200-10600 ohms
Ballast Resistor	2095501
Resistance @ 70-80 ⁰ F.	0.5-0.6 ohms

* Service wear tolerance should not exceed .006 inch.

IGNITION SYSTEM SPECIFICATIONS (Continued)

Current Draw (Coil and Ballast Resistor in Circuit)

Engine Stopped	3.0 Amperes
Engine Idling	1.9 Amperes

GROUP 9 - ENGINE

The Chrysler 300J is powered by a high performance version of the 413 cubic inch engine, (Fig. 6) using special ram intake manifolds of aluminum (Fig. 7) with two four-barrel carburetors and low restriction air cleaners (Fig. 8).

The service procedures are the same as outlined in the 1963 Imperial and Chrysler Service Manual with the following exceptions:

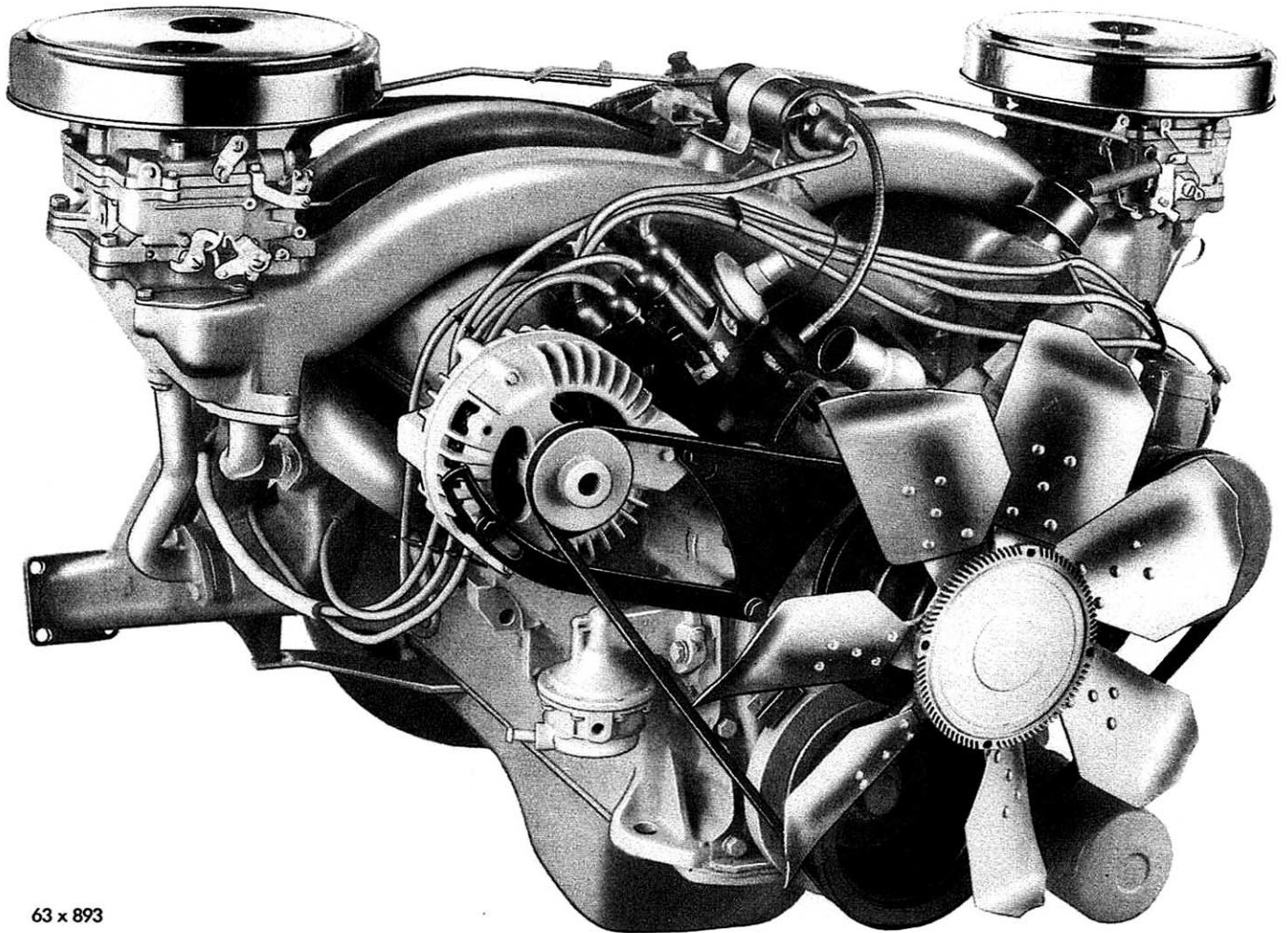

63 x 893

Fig. 6 - 413 Cubic Inch Chrysler 300 J Engine

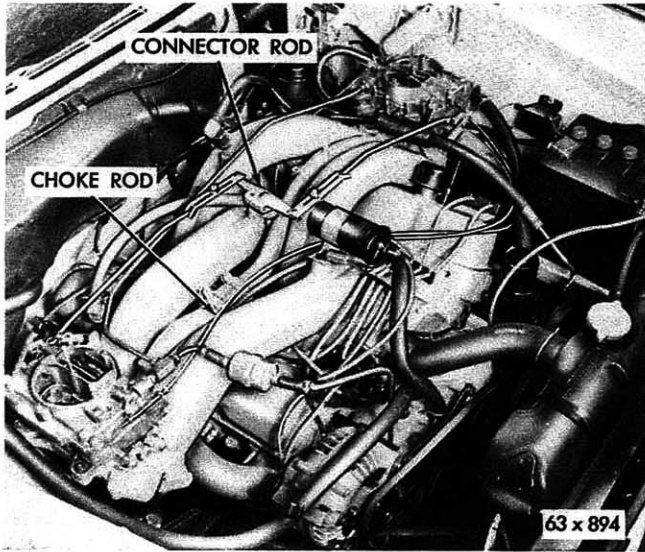

Fig. 7 - Right View 413 Cubic Inch Engine

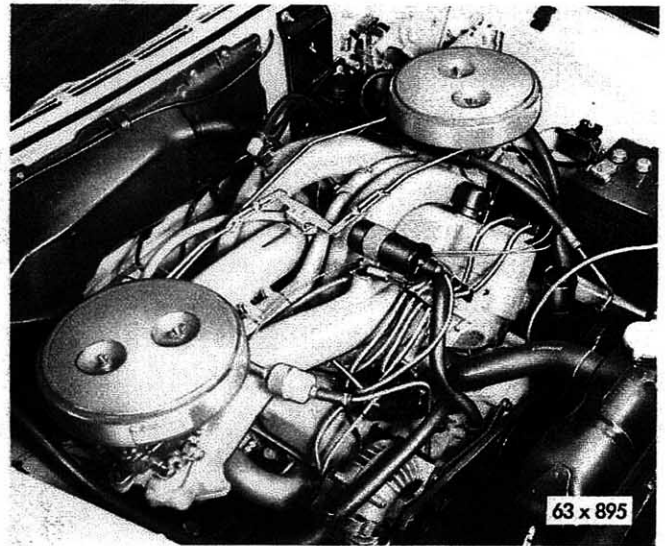

Fig. 8 - Carburetor Air Cleaner Installed

SPECIFICATIONS

ENGINE

Type	90°V
Number of Cylinders	8
Bore (413 Cubic Inch Displacement)	4.19 inch
Stroke	3.750 inch
Piston Displacement	413 Cubic Inch
Compression Ratio (Premium Fuel)	9.6 to 1
Compression Pressure with Engine warm, spark plugs removed, wide open throttle at a minimum cranking speed of 100 rpms with automatic transmission	130-165 psi.
120 rpms with standard transmission	125-155 psi.
Maximum variation between cylinders - any one engine with Standard Transmission	20 psi.
Automatic Transmission	25 psi.
Firing order	1-8-4-3-6-5-7-2

CYLINDER NUMBERING (FRONT TO REAR)

Left Bank	1-3-5-7
Right Bank	2-4-6-8

CYLINDER BLOCK

Cylinder Bore (Standard)	4.1870-4.1890
Cylinder Bore out-of-round (Maximum allowable before reconditioning)005"

CYLINDER BLOCK (Continued)

Cylinder Bore Taper (Maximum allowable before reconditioning010"
Reconditioning Working Limits (for taper and out-of-round)001 "
Maximum Allowable Oversize (Cylinder Bores)040"
Tappet Bore Diameter9050-.9058 "
Distributor Lower Drive Shaft Bushing (press fit in cylinder block)0005-.0040"
Ream to4865-.4880"
Shaft to Bushing Clearance0007-.0027"

CRANKSHAFT

Type	Fully Counter-Balanced
Bearings	Steel Backed Babbitt
Journal Diameter	2.7495-to 2.7505"
Crank Pin Diameter	2.374-to 2.375 "
Maximum Out-of-Round Permissible001 "
Number of Main Bearings	5
Clearance Desired (Bearing Installed I.D. Minus Journal O.D.)0005 to .0015 "
Maximum Clearance allowable Before Reconditioning End Play0025 "
.002 to .007 "
Thrust Taken By	No. 3 Main Bearing
Finish at Rear Seal Surface	Diagonal Knurling
Interchangeability of Bearings	Upper Nos. 2, 4, 5
	Lower Nos. 1, 2, 4, 5

MAIN BEARINGS (Service)

All available in standard and the following undersizes .001, .002, .003, .010, .012"

CONNECTING RODS AND BEARINGS

Type	Drop Forged "I" Beam
Length (Center to Center)	6.766 to 6.770"
Weight (less Bearing Shells).	846 ± 4 GMS
Bearings	Steel Backed Babbitt
Diameter and Length.	2.376 x .927 "
Clearance Desired (Bearing Installed I.D. Minus Journal O.D.)0005 to .0015 "
Maximum Allowable before Reconditioning0025 "
Side Clearance009 to .017 "
Bearings for Service	Standard .001, .002, .003, .010, .012 " Undersize
Piston Pin Bore Diameter	1.0925 to 1.0928 "

CAMSHAFT

Drive	Chain
Bearings	Steel Backed Babbitt
Number	5
Thrust Taken By	Cylinder Block
Clearance Desired (Bearing Installed I.D. Minus Journal O.D.)001 to .003 "
Maximum Allowable Before Reconditioning005 "

CAMSHAFT BEARING JOURNALS

Diameter	
No. 1	1.998-to 1.999 "
No. 2	1.982 to 1.983 "
No. 3	1.967 to 1.968 "
No. 4	1.951 to 1.952 "
No. 5	1.748 to 1.749 "

CAMSHAFT BEARINGS

Diameter (after reaming)	
No. 1	2.000 to 2.001 "
No. 2	1.984 to 1.985 "
No. 3	1.969 to 1.970 "
No. 4	1.953 to 1.954 "
No. 5	1.750 to 1.751 "

TIMING CHAIN

Adjustment	None
Number of Links	50
Pitch50 "
Width88 "

TAPPETS

Type	Mechanical
Clearance in Cylinder Block0005 to .0018 inch
Body Diameter9040 to .9045
Oversize Available for Service001, .008 inch
Valve Tappet Clearance - (Engine Cold)	
Intake017 "
Exhaust028 "

PISTONS

Type	Horizontal Slot w/Steel Struts
Material	Aluminum Alloy Tin Coated
Land Clearance032 " to .040 "
Clearance at Top of Skirt0003 " to .0013 "

PISTONS (Continued)

Weight (Standard Through .040" Oversize)	780 grms.
Piston Length (Overall)	3.96 in.
Ring Groove Depth	
No. 1216 in.
No. 2216 in.
No. 3206 in.
Pistons for Service	Standard, .005", .020", .040", Oversize

PISTON PINS

Type	Press Fit in Rod
Diameter	1.0935 to 1.0937"
Length	3.555 to 3.575"
Clearance in Piston00045 to .00075"
Interference in Rod0007 to .0012"
Piston Pins for Service	Standard Only
Direction Offset in Piston	Toward Right Side of Engine

PISTON RINGS

Number of Rings per Piston	3
Compression	2
Oil	1
Width of Rings	
(Compression)0775 to .0780"
(Oil)1860 to .1865"
Piston Ring Gap (all).013 to .025"

RING SIDE CLEARANCE

(Compression)	
Upper0015 to .0030"
Intermediate0015 to .0030"
(Oil)0010 to .0030"

VALVES - Intake

Material	SAE 1041 Steel
Head Diameter	2.08"
Stem Diameter372 to .373
Stem Oversizes Available for Service	Standard, .005, .015, .030"
Stem to Guide Clearance001 to .003
Maximum Allowable Before Reconditioning004"
Angle of Seat	45°
Adjustment017"
Lift444"

VALVES - Exhaust

Material	Nitrogen Treated Manganese Chromium Nickle Steel
Head Diameter	1.75
Steam Diameter371 to .372
Stem Oversize Available for Service	Standard, .005, .015, .030"
Stem to Guide Clearance.002 to .004
Maximum Allowable Before Reconditioning006"
Angle of Seat.	45 ^o
Adjustment.028"
Lift450"

VALVE SPRINGS

Number	16
Free Length	2.21 "
Load When Compressed to (Valve Closed)	85-95 lbs. @1.860"
Load When Compressed to (Valve Open).	216-234 lbs. @ 1.43"
Valve Springs I.D.	1.070 to 1.090"
Valve Spring Installed Height (Spring Seat to Retainer)	1.830 to 1.890 inch
Surge Damper	Spiral Type

VALVE TIMING

Intake - Opens	18 ^o BTC
Closes	70 ^o ABC
Duration	268 ^o
Exhaust - Opens	66 ^o BBC
Closes	22 ATC
Duration	268 ^o
Valve Opening Overlap.	40 ^o

VALVE GUIDES

Type	Cast in Head
Guide Bore Diameter374-.375" Std.

CYLINDER HEAD

Number Used	2
Combustion Chamber	Wedge Type
Valve Seat Runout (Maximum).002"
Intake Valve Seat Angle	45 ^o
Intake Seat Width.060 to .085"
Exhaust Valve Seat Angle	45
Exhaust Seat Width.040 to .060"
Cylinder Head Gasket Compressed (thickness)022"

ENGINE LUBRICATION

Pump Type	Rotor Full Pressure
Capacity (qts.)	5 *
Pump Drive	Camshaft
Operating Pressure at 40 to 50 mph	45 to 65 lbs.
Oil Filter Type.	Full Flow
Pressure Drop Resulting from Clogged Filter . . .	7 to 9 lbs.

* When Filter is Replaced, Add 1 Quart.

Valve Timing

- (1) Rotate the crankshaft until the No. 6 exhaust valve is closing and the No. 6 intake is opening. Turn the rocker arm adjusting screw down to zero clearance plus 1/2 turn on No. 1 intake valve. Install a dial indicator so that the indicator pointer contacts the retainer as near to the 90° angle as possible. Adjust the dial indicator to zero.
- (2) Turn the crankshaft clockwise (normal running direction) until the valve has opened .033 inch. The timing pointer should read 10° BTDC to 2° ATDC.
- (3) If the reading is not within the above specified limits: Note the sprocket index marks. Inspect the timing chain for wear. Determine the accuracy of the DC mark on the vibration damper.
- (4) Remove the dial indicator, back off the adjusting screw, adjust the valve clearance to specifications .017 inch intake, .028 inch exhaust cold.

GROUP 11 - EXHAUST SYSTEM

The exhaust system is of a very simple, but sturdy construction. (Fig. 9). The heat control valve has been eliminated by piping exhaust gases directly to the base of the carburetor (Fig. 10). The removal of the access panel from under the front fenders will permit easy removal and installation of the exhaust manifold. Balancing of the exhaust systems is done by a cross-over pipe placed in the center of the exhaust pipes (Fig. 9). Mufflers, tail pipes and brackets are serviced as outlined in the 1963 Imperial and Chrysler Service Manual.

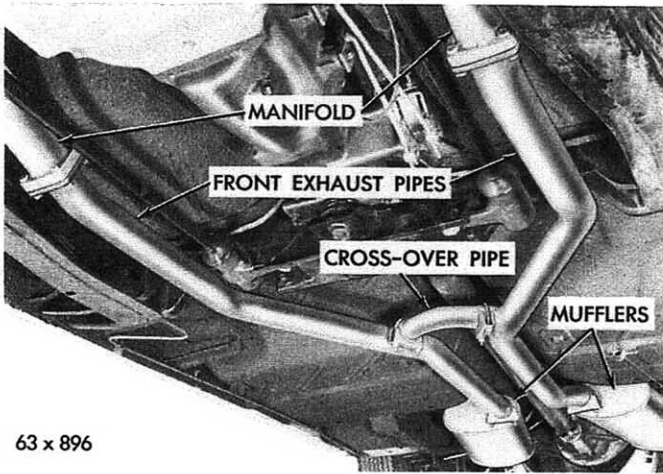

Fig. 9 - Exhaust System

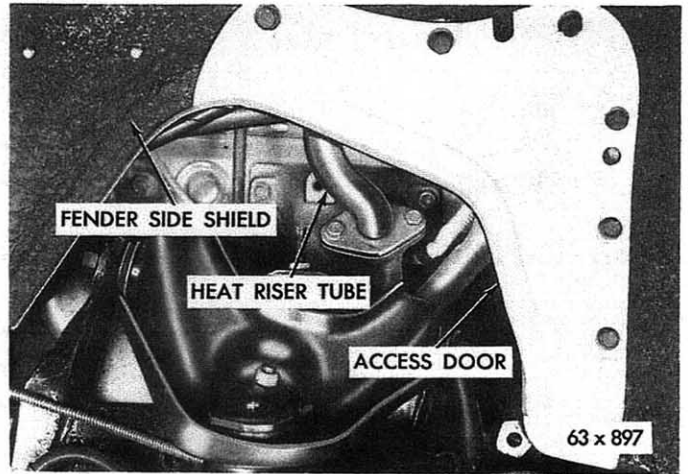

Fig. 10 - Exhaust Heat Riser

GROUP 14 - FUEL SYSTEM

FUEL AND INDUCTION SYSTEM

The new Chrysler 300J Engine, as shown in Figure 6 is equipped with twin air cleaners, twin AFB carburetors, hand type choke and two aluminum manifolds, containing eight sweeping passages (four in each manifold) all of which employs a new method of fuel induction.

The Service Procedures remain the same with the exception of the removal and disassembly of the intake manifolds, setting the throttle linkage and the carburetor adjustments which follows:

SPECIFICATIONS

AFB CARBURETOR

Make	Carter
<u>TYPE</u>	4 Barrel Downdraft
Model	AFB-3505S Twin
Carburetor Used On Chrysler Model	C-300J

BORE

Primary 1 7/16"
Secondary 1 11/16"

MAIN VENTURI

Primary 1 3/16"
Secondary 1 9/16"

MAIN METERING JET089"

MAIN JET (Secondary)082"

LOW SPEED JET (Primary) No. 65-.035"

STEP UP ROD (2 Stages)

Standard 16-118
(1 Size Lean) 16-119
(2 Sizes Lean) 16-50

ADJUSTMENTS

Accelerator Pump (Top of Plunger to Airhorn) 7/16"
Float Setting 9/32"
Float Drop 1/2"
Idle Mixture Screws (Turns Open) 1-2
Idle Speed RPM (Curb Idle) 700-750
(Air Conditioning on) RPM 750
Fast Idle Speed RPM 1400
Secondary Throttle Lever Adjustment 29/64"
Secondary Throttle Lockout Adjustment020"
Velocity Valve Free

CHOKE

Type Hand

FUEL PUMP

Make Carter
Model M-2769S
Type Diaphragm
Number of Valves 3
Driven by Camshaft
Pump Pressure 3 1/2 to 5 psi.

INTAKE MANIFOLDS

Removal (Fig. 11)

- (1) Drain the cooling system.
- (2) Remove the carburetor air cleaners.
- (3) Disconnect the fuel line between the fuel pump and the left hand carburetor.
- (4) Disconnect the fuel line between the left and right hand carburetor. Disconnect the choke controls from the carburetors and the cable clips.
- (5) Disconnect the vacuum line between the right hand carburetor and the distributor.
- (6) Remove the high tension coil wire.
- (7) Disconnect the throttle linkage at both carburetors and the bell crank, to the accelerator shaft.

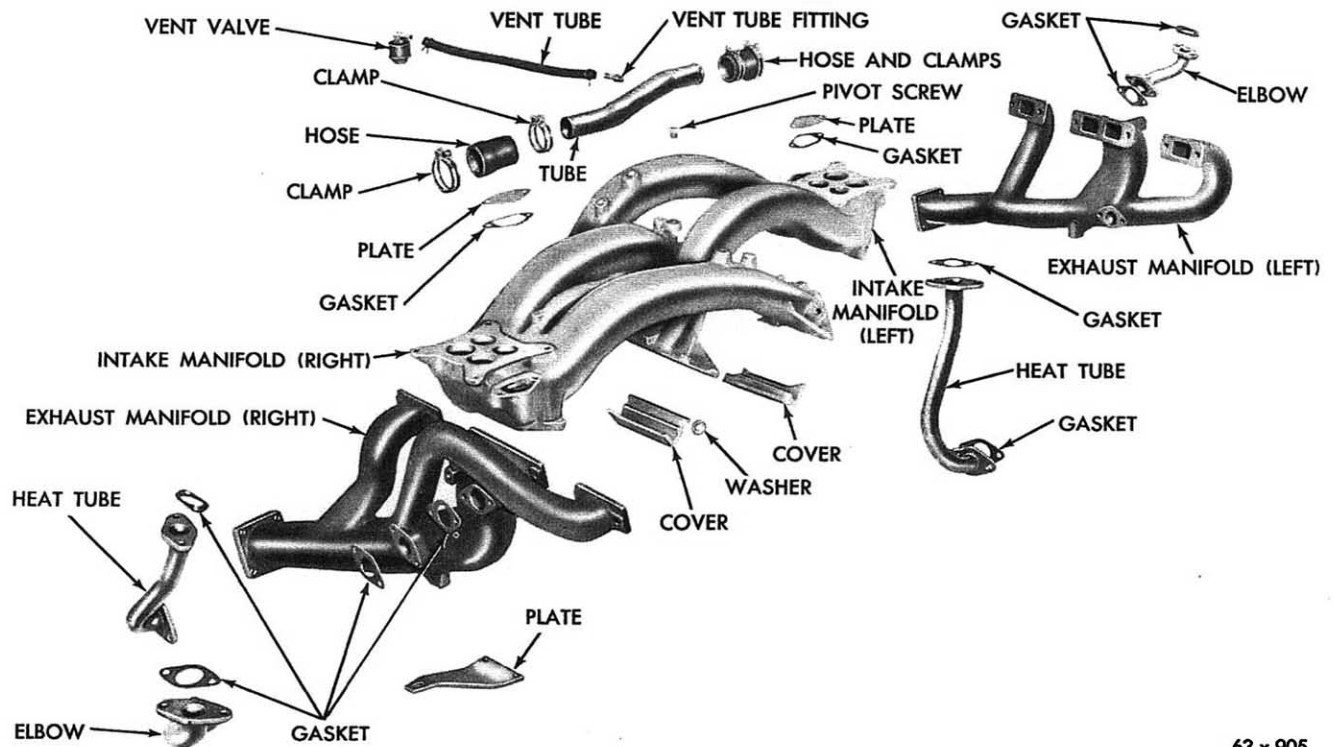

63 x 905

Fig. 11 - Ram Induction Manifold (Disassembled View)

(8) Loosen the clamps that attach the equalizer tube couplings to the manifolds, and to the equalizer tube. Slide either coupling inward on the tube far enough to clear the manifold tube opening. Lift the equalizer tube, couplings and clamps up and away from the engine.

(9) Disconnect the power steering hoses (if so equipped) at the pump and secure against the fire wall.

(10) Remove the air conditioning compressor and brackets, (if so equipped). (See Air Conditioning Group 24).

To remove the left hand ram manifold.

(11) Remove the eight attaching bolts that hold the left fender shield access plate to fender shield, then slide plate out of the engine compartment.

(12) Remove the bolts that attach the left hand by-pass pipes to the lower chamber.

(13) Remove the four bolts that attach the ram manifold to the right bank cylinder head. Remove the exhaust passage crossover cover.

(14) Lift the intake manifold and carburetor from the engine as an assembly.

(15) Remove the nuts that attach the carburetor to the intake manifold, then disconnect the automatic choke rod from the lever. Remove the carburetor.

To remove the right hand intake manifold, proceed as follows:

(16) Remove the eight attaching bolts that hold the right fender shield access plate to the fender shield, then slide plate out of the engine compartment.

(17) Remove the bolts that attach the right hand exhaust by-pass pipes to the lower chamber.

(18) Remove the four bolts that attach the intake manifold to the left hand bank cylinder head. Remove the exhaust passage crossover cover.

(19) Lift the manifold and carburetor from the engine as an assembly.

(20) Remove the nuts that attach the carburetor to the intake manifold, then disconnect the choke rod from the lever. Remove the carburetor.

Installation

When installing the intake manifold, be sure and use new gaskets and be sure all mating surfaces are smooth and clean.

To install the left hand intake manifold, refer to Figure 11.

- (1) Place the carburetor in position on the mounting pad of the intake manifold and engage the choke control. Install the carburetor mounting nuts and tighten.
- (2) Place the intake manifold assembly in position on the right hand bank cylinder head. Place the exhaust crossover passage cover over the passage, then install the manifold attaching bolts finger tight.
- (3) Slide new gaskets between the left hand exhaust by-pass pipes and the manifold lower chamber. Install the attaching bolts and tighten to 10 foot-pounds. Tighten the intake manifolds bolts to 50 foot-pounds.
- (4) Slide the left hand fender shield access plate into position against fender shield. Install bolts and tighten.

If both intake manifolds were removed, continue to install the right manifold as follows:

- (5) Place the carburetor in position on the mounting pad of the intake manifold and connect the choke control. Install the carburetor mounting nuts and tighten.
- (6) Place the intake manifold assembly in position on the left hand bank cylinder head. Place the exhaust crossover passage cover over the passage, then install the manifold attaching bolts finger tight.
- (7) Slide new gaskets between the right hand exhaust by-pass pipes and the lower chamber. Install attaching bolts and tighten to 10 foot-pounds. Tighten the intake manifold bolts to 50 foot-pounds.
- (8) Slide the right hand fender shield access plate into position against fender shield. Install bolts and tighten.
- (9) Place the air conditioning compressor and brackets in position (if so equipped) and install attaching bolts. Tighten securely. (Refer to the Air Conditioning Group 24 for method of recharging the system).

- (10) Reconnect the Power Steering hoses to the pump (if so equipped). (Refer to Power Steering, Group 19, for method of bleeding air out of the system).
- (11) Slide the equalizer tube, clamps and couplings over the manifold tubes. Slide either coupling outward far enough to firmly engage the manifold. Tighten clamps securely.
- (12) Reconnect the throttle linkage at both carburetors and bell-crank to accelerator shaft.
- (13) Reinstall the high tension coil wire.
- (14) Reconnect the vacuum line between the carburetor and distributor.
- (15) Reconnect the fuel line between the left and right hand carburetor.
- (16) Reconnect the fuel line between the fuel pump and the left hand carburetor.
- (17) Reinstall the right and left carburetor air cleaners. Install the choke control cables of each carburetor and the cable clips.
- (18) Refill the cooling system to required capacity.

After the manifolds have been installed it is very important that the next procedure of setting the throttle linkage be done in order to obtain peak engine performance.

SETTING THE THROTTLE LINKAGE

Setting the throttle linkage is a very important step. Various conditions affecting the performance can be encountered, such as, loss of performance, no wide open throttle response, delayed shifting of the transmission, no kickdown, delayed up shifts, etc.

Setting the throttle linkage is divided into three parts, namely: Positioning the accelerator shaft, positioning the accelerator pedal, setting the bellcrank and synchronizing each carburetor. It is very important that the throttle linkage be set in this order.

Positioning the Accelerator Shaft (with Automatic Transmission) (Fig. 12)

- (1) Loosen the adjusting nuts "A" and "B" (accelerator shaft to transmission rod and accelerator shaft to throttle shaft to throttle shaft lever rod).

- (2) Insert a piece of 3/16 inch welding rod, 10 inches long into the accelerator shaft bracket and through hole in lever.
- (3) Move the transmission throttle lever forward until it stops. Tighten the locknut "A" securely. This positions the accelerator shaft.

Positioning the Accelerator Pedal

- (1) Unsnap the accelerator pedal from the shaft rod.
- (2) Turn the threaded end of rod either in or out until a measurement of 114 degrees is obtained between the floor of car and the flat face of the accelerator pedal.
- (3) This measurement can be made with a spirit protractor.
- (4) After correct measurement has been obtained, reconnect the rod. Remove the pin from the accelerator shaft bracket.

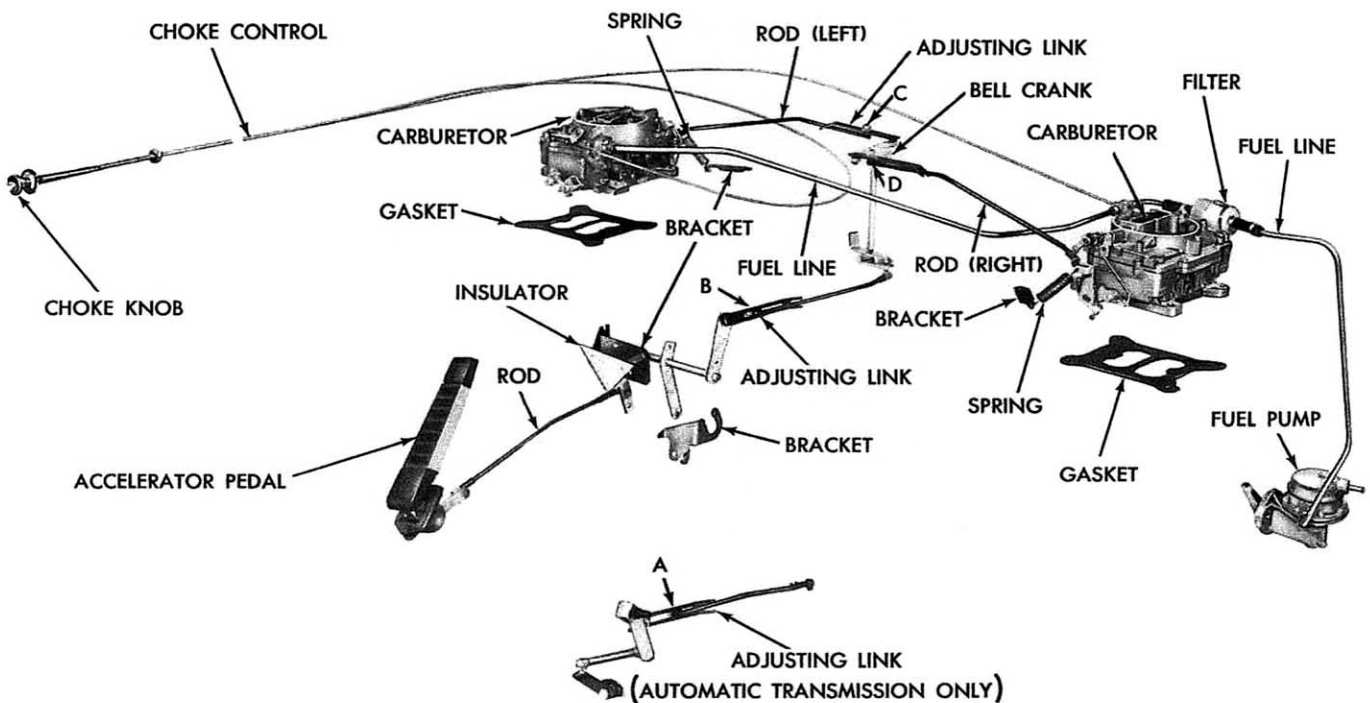

63 x 906

Fig. 12 - Throttle Linkage (Schematic View)

Setting the Bellcrank

- (1) Loosen locking nuts "C" and "D" (left and right bank carburetor rods).
- (2) Pivot the bellcrank until a 3/16 inch piece of welding rod 3 inches long can be inserted through the bellcrank hole and down into the locating hole in the intake manifold.
- (3) Test each carburetor to be sure the choke valves are open; that the fast idle cams are released and that the throttle valves are closed.
- (4) Tighten locking nuts "C" and "D" securely. Remove pin from the bellcrank.
- (5) Push rearward on the accelerator shaft to throttle shaft lever rod adjusting link, until stop is obtained. Tighten the locking nut securely.

Idle Speed and Mixture Adjustment

Connect a tachometer and warm-up the engine to normal operating temperature. Be sure the choke is fully off and that the engine is at curb idle.

- (1) Turn the idle mixture screws from 1 to 2 turns open.
- (2) Set the idle bypass air screws 2 turns open and adjust the idle speed to 700-750 rpm by opening or closing the by-pass screws, keeping the openings equal.

The idle bypass air screw is located at the front of each carburetor body flange, between the two idle mixture screws. Adjust the idle mixture screws on each carburetor for maximum rpm. Repeat on each carburetor.

During the adjustment period, should the idle speed exceed 700-750 rpm, the idle bypass screw should be readjusted to 700-750 rpm.

Before attaching the rod at each carburetor, inspect the transmission to throttle linkage adjustments, so that the idle position is not disturbed.

NOTE: Accurate carburetor synchronization or balance is extremely important and when performed should be rechecked and rebalanced in the outside ambient temperature after a five mile or more road test. This readjustment will prevent rough engine

idle performance and possible engine stalling when the vehicle is returned to the owner.

Fast Idle Adjustment (On Vehicle)

When making the fast idle adjustment on the vehicle, each AFB carburetor should be adjusted individually.

- (1) The engine should be at normal operating temperature and have a curb idle speed of 750 rpm with transmission in (N) and air conditioning compressor "ON" (if so equipped).
- (2) Turn air conditioning compressor "OFF" (if so equipped) before proceeding with the following adjustments:
- (3) Remove each air cleaner.
- (4) Disconnect each throttle rod at the bellcrank on the intake manifold.
- (5) Open the throttle valves of the left carburetor far enough to allow positioning of the fast idle cam to the fast idle index mark. The right carburetor should remain at the curb idle position.
- (6) Adjust fast idle screw until a fast idle speed of 1400 rpm is obtained.
- (7) After the desired engine speed has been obtained, open the throttle slightly to allow the fast idle cam to return to the open choke (or off fast idle) position.
- (8) Repeat steps 5, 6 and 7 in setting right carburetor fast idle speed as it is very important at the completion of this step (8), that each carburetor has identical fast idle speeds. There is no specification for engine rpm with both carburetors simultaneously set at the fast idle position.
- (9) Connect both carburetor throttle rods to the bell crank.

GROUP 16 - PROPELLER SHAFT AND UNIVERSAL JOINTS

The service procedures are the same as outlined in the 1963 Imperial and Chrysler Service Manual with the following exceptions:

The propeller shaft used with the 300J is held to a special tolerance for maximum performance. Since the universal joints are permanently lubricated it will not be necessary to relubricate them, however, if they are disassembled for any reason, they should be inspected and repacked with special Lubricant, Mopar Part Number 2298947.

GROUP 17 - SPRINGS AND SHOCK ABSORBERS

The rear springs are now 60 inches in length and have 7 leaves. The new springs give a smoother ride and extend spring life.

Shock Absorbers

The shock absorbers are the heavy-duty type. All service procedures are the same as those outlined in the 1963 Imperial and Chrysler Service Manual.

GROUP 19 - STEERING

The 1963 Chrysler 300J is equipped with the power steering pump belt self adjusting bracket. The service procedures for the steering gear and the power steering pump are the same as those outlined in the 1963 Imperial and Chrysler Service Manual with the exception of the power steering gear unit which follows:

Power Steering Gear Unit

Removal

- (1) Disconnect the negative (ground) cable from the battery.
- (2) Compress and turn the horn button 1/4 turn counterclockwise to release the horn button from the retainer.
- (3) Disconnect the horn wire at the horn blowing switch.
- (4) Remove the three (3) screws and insulators attaching the horn ring and horn blowing switch to the steering column. Remove the horn ring and switch.

- (5) Loosen the steering wheel nut several turns and install the steering wheel puller Tool C-3428 and remove the steering wheel nut and steering wheel.
- (6) Remove the two bolts attaching the steering jacket tube clamp at the instrument panel and remove the clamp.
- (7) Disconnect the directional switch wiring at the multiple connector below the instrument panel.
- (8) Remove the screws attaching the dust pad to the floor panel and slide the dust pad up on the jacket tube.
- (9) Loosen the jacket tube clamp at the steering gear housing.
- (10) Remove the retainer snap ring from the groove in the steering tube at the top of the bearing using Pliers Tool C-3128 (Fig. 13).
- (11) Reinstall the steering wheel nut on the upper steering tube to protect the threads. Then while pulling up on the jacket tube, tap the steering wheel nut with a fibre hammer. This action will force the bearing from the splines on the steering tube.
- (12) Pry between the jacket tube clamp and the steering gear housing to loosen the jacket tube from the column jacket support rubber insulator boot.
- (13) Slide the jacket tube assembly rearward and off the steering tube.

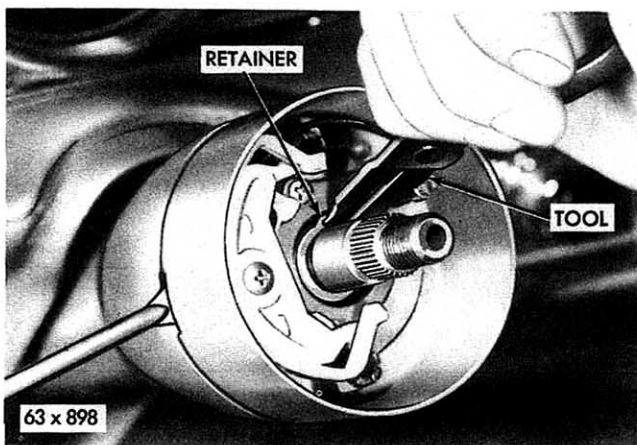

Fig. 13 - Removing Bearing Retainer Ring

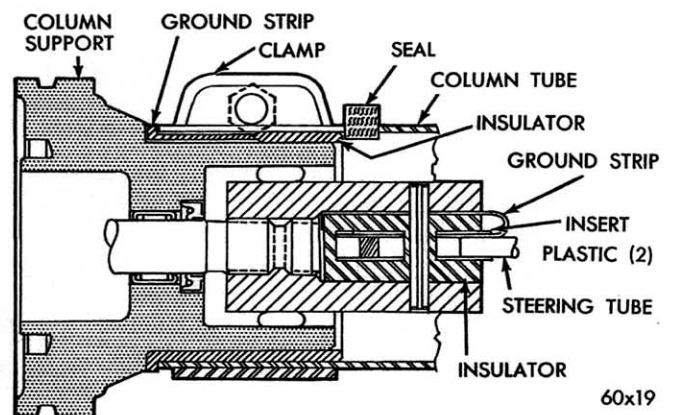

Fig. 14 - Jacket Tube Support and Steering Column Tube (Cross Section)

(14) Remove the steering column tube coupling pin, two plastic inserts, horn ground strap (Fig. 14) rubber insulator and the steering column tube.

(15) Remove the rubber insulator boot and the horn ground strap.

NOTE: The worm shaft coupling should not be removed at this time as the coupling will protect the worm shaft splines during removal.

(16) Remove the left air cleaner.

(17) Disconnect the hose at the crankcase vent (Fig. 15).

(18) Disconnect the throttle linkage at the throttle bell crank.

(19) Disconnect and remove the equalizer tube at the right hand intake manifold.

(20) Disconnect and remove the gas line from both carburetors.

(21) Disconnect the manual choke control from the left hand carburetor.

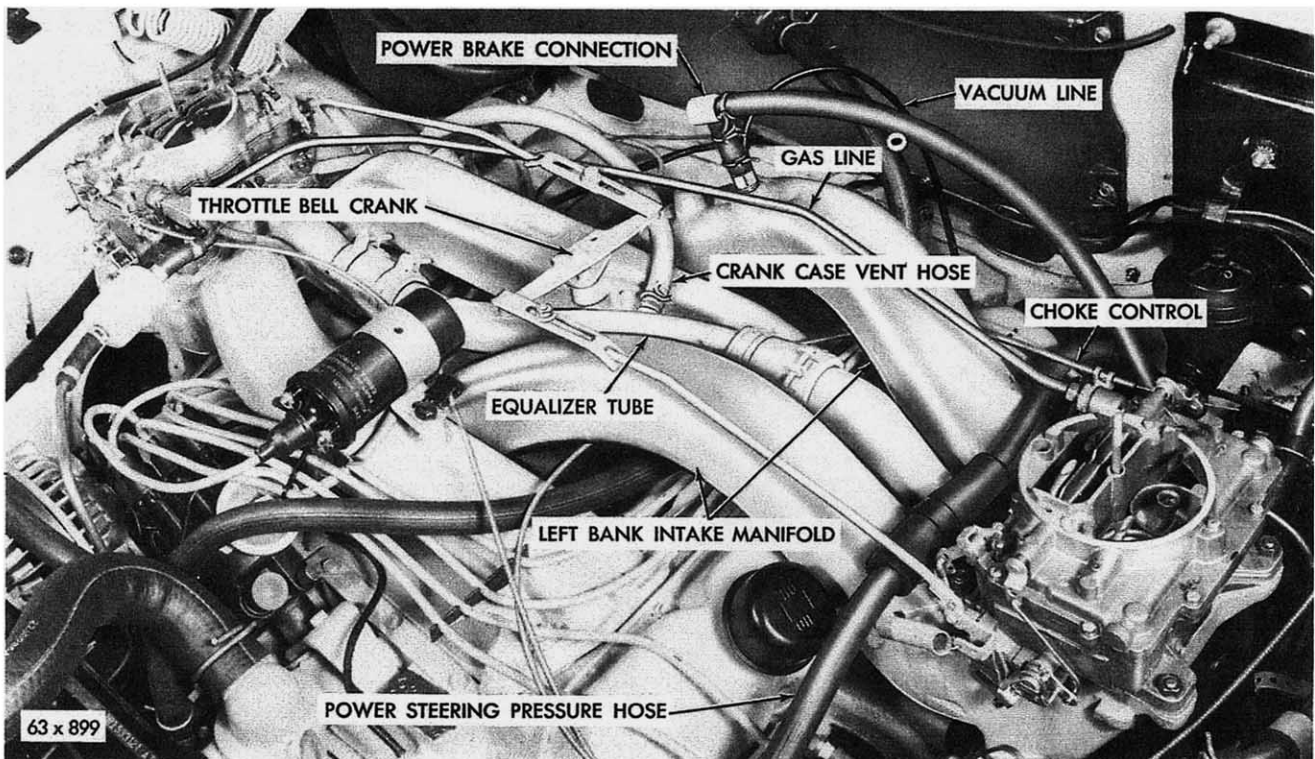

Fig. 15 - Fuel Induction Intake Manifolds

- (22) Remove the manifold heater tubes (Fig. 10) from the intake and exhaust manifolds. Do not damage the gaskets.
 - (23) Disconnect the power steering hoses at the steering gear valve. Fasten the ends of the hoses above the oil level in the pump reservoir. Cap hoses and valve housing fittings.
 - (24) Disconnect the power brake and vacuum source at the intake manifold.
 - (25) Remove the left intake manifold bolts and spacer.
 - (26) Carefully remove the left hand bank intake manifold and carburetor assembly.
 - (27) Raise the vehicle.
 - (28) Remove the left front wheel.
 - (29) Remove the cotter key and nut at the center link and disconnect the link from the arm.
 - (30) Remove the steering arm nut and washer.
 - (31) Slide Tool C-3646 upon the steering arm and place the shoe of the puller behind the steering arm. Tightening the tool center screw against the gear shaft will pull the steering arm from the gear shaft.
- CAUTION: Do not remove the steering arm by prying with a lever or striking with a hammer as serious steering gear internal damage will result.**
- (32) Remove the seven bolts attaching the dust shield (Fig. 10) to the fender sidepanel and remove the dust shield.
 - (33) Loosen the gear housing to frame bolts.
 - (34) Remove the gear housing to frame bolts, washers, and alignment wedge.
 - (35) Raise lower end of the steering gear housing in a clockwise motion towards the firewall until the cross shaft end of housing and shaft will clear the exhaust manifold. Tilt the complete assembly towards the engine slightly to allow swinging the steering gear assembly out through the opening of the fender side panel (cross shaft end first). This removal can be accomplished if the steering gear is rolled out end over end.

INSTALLING POWER STEERING UNIT

- (1) Enter the steering gear assembly into the engine compartment, position in place and install attaching bolts, flat washers, swivel washers and nuts, tighten finger tight.
- (2) Inspect the steering tube bearing for any damage incurred during removal from the steering tube.
- (3) Install the steering column tube, the two plastic inserts, rubber insulator, horn ground strap and coupling pin.
- (4) Assemble the horn ground strap (copper) to the jacket tube support rubber insulator boot and install this assembly into the jacket tube.
- (5) Lubricate (powder lubricant) the end of the steering gear column jacket support and insulator boot to facilitate installation and slide the jacket tube and insulator boot over the steering tube and down against the shoulder on the jacket tube support. Position the clamp and tighten clamp bolt securely.

NOTE: There must be at least 1/16 inch clearance between the bottom face of the jacket tube clamp and the column support spanner nut to avoid metal to metal contact.

- (6) Install the jacket tube support bracket clamp at the instrument panel. Tighten the clamp bolts to 50-inch-pounds torque.
- (7) Connect the directional signal wires and the horn wire at the connectors.
- (8) Install the directional switch lever.
- (9) Position the snap ring against the top of the bearing and place the installing Tool Sleeve C-3879, then a flat washer and the steering wheel nut on the top end of the steering shaft in that order (Fig. 16).
- (10) Turn the steering wheel retaining nut to exert pressure on the installing sleeve and upper snap ring and bearing, this action will press the bearing down onto the knurled section of the steering shaft and against the lower snap ring and flatten the upper snap ring so it can enter the groove in the steering shaft. Be sure the snap ring is firmly seated in the steering shaft groove. This lock ring places the upper column tube in the proper relation with the worm shaft coupling pin. Remove the steering wheel nut, washer and sleeve tool.

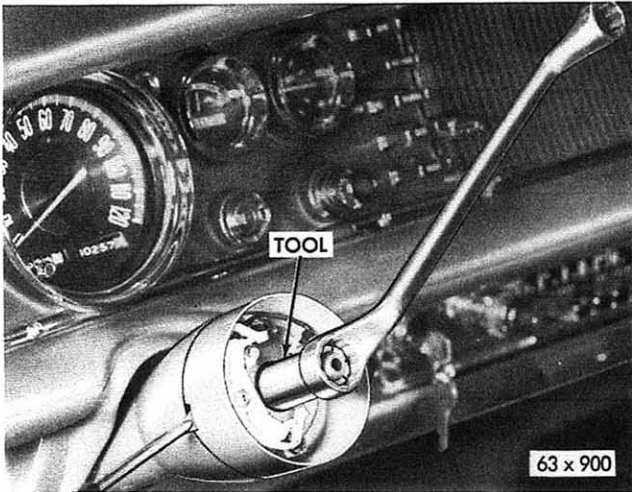

Fig. 16 - Installing Bearing and Retainer Ring

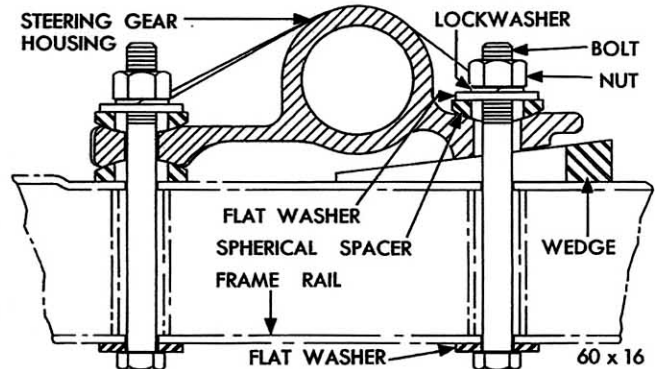

Fig. 17 - Steering Gear Mounting (Cross Section)

- (11) Install the steering wheel and steering wheel nut, tighten the nut to 40 foot-pounds torque.
- (12) Install the horn blowing switch, horn ring, the insulators and attaching screws. Connect the horn wire.
- (13) Compress and turn the horn button 1/4 turn clockwise to lock the horn button on the retainer.
- (14) Raise the vehicle.
- (15) Tighten the front upper and lower gear housing to the frame attaching bolts to 24 foot-pounds torque.
- (16) Install a wedge over the rear bolt (Fig. 17) between the housing and the frame so that the tapered surfaces match; wedge lightly into place and tighten the three attaching bolts to 50 foot-pounds torque.
- (17) Install the steering gear arm, washer and nut. Tighten nut to 120 foot-pounds torque.
- (18) Install the steering center link, nut and cotter pin.
- (19) Lower the vehicle.

(20) Carefully enter the left bank intake manifold and carburetor assembly into position.

NOTE: Make sure gasket surfaces are clean.

Connect the manifold equalizer tube at the right hand manifold.

(21) Install the manifold spacer, washers, spark plug wire holder and manifold attaching bolts and tighten securely.

(22) Connect the pressure and return hoses at the steering gear.

(23) Connect the hose at the crankcase vent.

(24) Connect the throttle linkage at the throttle bell crank.

(25) Connect the fuel line at both carburetors.

(26) Connect the manual choke at left hand carburetor.

(27) Connect power brake and vacuum lines at intake manifold.

(28) Raise the vehicle.

(29) Install the two manifold heater tubes to the exhaust and intake manifolds (Fig. 10).

(30) Install the dust shield to the fender side panel and tighten the seven bolts securely.

(31) Install left front wheel.

(32) Lower the vehicle. Refill the power steering pump reservoir as necessary.

(33) Expel all the air from the power steering system by turning the steering wheel several times to the full right and left.

(34) Connect the negative battery cable to the battery negative post.

GROUP 21 - TRANSMISSION (TorqueFlite):

The maximum performance TorqueFlite Transmission and a 3.23 axle ratio is standard equipment for the Chrysler 300J. There are a number of revisions for additional durability and an extra high speed governor (shift points as high as 5600 rpm). A parking sprag is incorporated in the transmission extension and is used to lock the output shaft to the housing. It provides a positive and convenient method of locking the drive train, and makes for additional parking security on steep hills. In

operation, the parking sprag is connected to a slide lever on the instrument panel through a flexible cable system. A mechanical interconnection with the transmission push button is designed to automatically select neutral when the parking lever is engaged, therefore, the parking sprag must be disengaged before the forward or reverse gears may be selected.

GOVERNOR PRESSURE CHART

<u>Vehicle Speed (3.23 to 1 Axle Ratio)</u>	<u>Pressure Limits-psi</u>
17-20	15
50-56	50
73-80	75

TRANSMISSION (Manual)

A Heavy Duty Three Speed Manual Transmission and a 3.91 axle ratio is optional equipment on the Chrysler 300J. The shift mechanism is a high performance type and is mounted on the transmission extension which protrudes up through the floor rather than being mounted on the floor. Adjust as follows:

Transmission Gearshift Lever Adjustment

Loosen the lever assembly pivot bolt and screw. Install a 1/4" diameter locking pin through the two lever aligning holes and bracket slots provided in the assembly.

Pre-set the length of the 1st-reverse shift rod to obtain the proper hand lever position. (The distance from the front of the knob to the closest point on the instrument panel in neutral is 5 to 6 inches).

Install the 1st-reverse rod by rotating the lever assembly in the adjusting slot until the 1st-reverse lever hole lines up with the re-set rod length, then tighten the lever assembly pivot bolt and screw.

Adjust the length of the 2nd-3rd rod to match the lever holes and install the rod.

Remove the locking pin.

Set the 2nd-3rd lever stop screws to provide .020 to .040" clearance between the lever and stops when the transmission is in 2nd or 3rd detent position.

Lock the stop screws in place by tightening the jam nuts. All service procedures are the same as outlined in the 1963 Imperial and Chrysler Service Manual.

MANUAL TRANSMISSION
SPECIFICATIONS

RATIO

First	2.17 to 1
Second	1.43 to 1
Direct	1.00 to 1
Reverse	2.84 to 1

LUBRICANT

Capacity	4 1/2 pints
Type	Auto. Trans. Fluid Type "A", Suffix "A", All Seasons
Gears	Helical

TOLERANCES

Clutch Housing006 inch Max.
Clutch Housing Bore Run-Out008 inch Max.
Countershaft End Play007 to .012 inch
Thrust Washers057 to .059 inch .062 to .064 inch
Second Speed Gear End Play002 to .011 inch

GROUP 22 - WHEELS BEARINGS AND TIRES

The 1963 Chrysler 300J is equipped with Hi-Speed Super Cushion Nylon Special Blue Streak tubeless tires, white sidewall 7.60 x 15, 4 ply and the wheel rim size is 15 x 6.0 K. The service procedures are the same as those outlined in the 1963 Imperial and Chrysler Service Manual.

GROUP 23 - BODY AND SHEET METAL

The 1963 Chrysler 300J continues the use of the unitized construction with the bolted-on-forestructure. The elimination of the transmission output shaft parking brake permits a new floor pan design that substantially lowers the transmission tunnel between

the front seats. The body has a wider C-pillar which provides additional support for the roof. The flatter rear window design keeps window light distortion to a minimum. The C-pillar emblem is a distinctive medallion. The body side molding is removed and replaced with a contrasting paint stripe. The rear deck is identified by a circular red, white and blue medallion concentric with an eight-inch diameter chromed ring.

The grille retains the customary massive crossed bars with a central 300J medallion over a fine mesh of black-textured stamped aluminum. The stainless molding framing the grille extends along the upper fender surfaces to meet the belt line moldings under the side windows. A thin rolled moulding is added to the forward edge of the hood.

The rubber cushioned bumper guards are high and well placed to provide maximum protection for the front headlamps and the body sheet metal. There are special chrome wheel covers, full wheel openings and chrome sill moldings.

The 300J interior (Fig. 18) has a genuine red leather trim with deeply pleated bucket seats and a central console containing a storage compartment, dual ash receivers, courtesy lights and a tachometer (Fig. 19). A medallion is added to the rear seat speaker grille in the notched area of the rear seat back. Special rubber foot pads

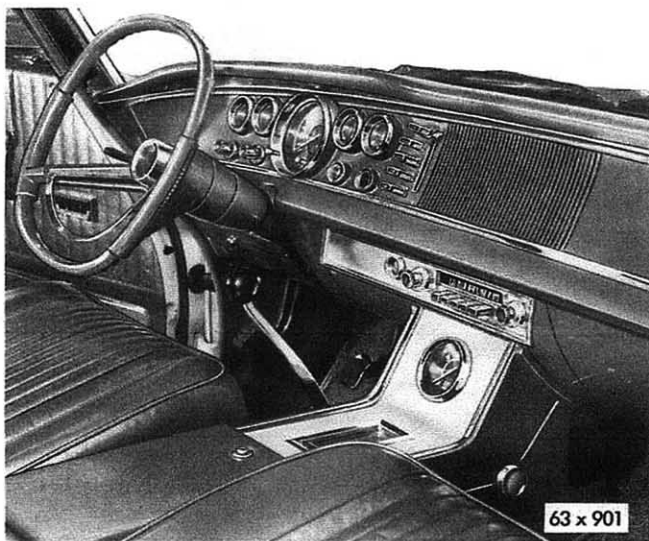

Fig. 18 - 300J Interior View

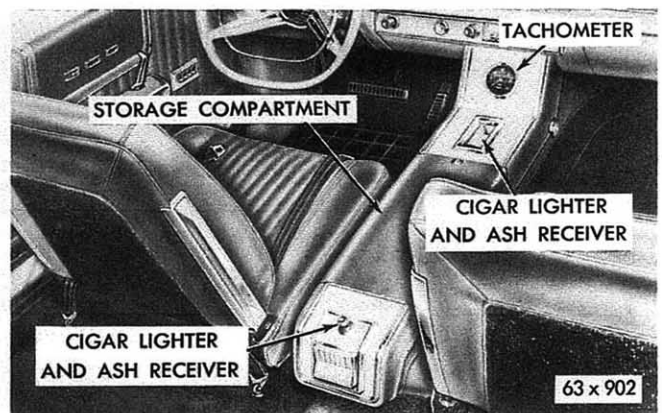

Fig. 19 - 300J Interior Front Seats and Console

are provided for the driver. A four way electric seat control is located on the left side of the driver's seat. The door panels are identical in color to those of the bucket seats. The steering wheel is oval and has a partial horn ring.

The instrument panel has a restyled appearance, a new layout, and superior instrument readability. Its design provides maximum knee room and creates a more spacious impression in the vehicle's interior.

All service procedures are the same as outlined in the 1963 Imperial and Chrysler Service Manual.

FOUR WAY ADJUSTABLE SINGLE SEAT

The electric single seat for the Chrysler 300J uses two electric motors (Fig. 20) to produce a front-back travel of 5 inches and an up-down travel of 1-1/2 inches. The control switch is a two button switch, the vertical button for front-back travel and the horizontal button for up-down travel. The switch is located on the bottom edge of the

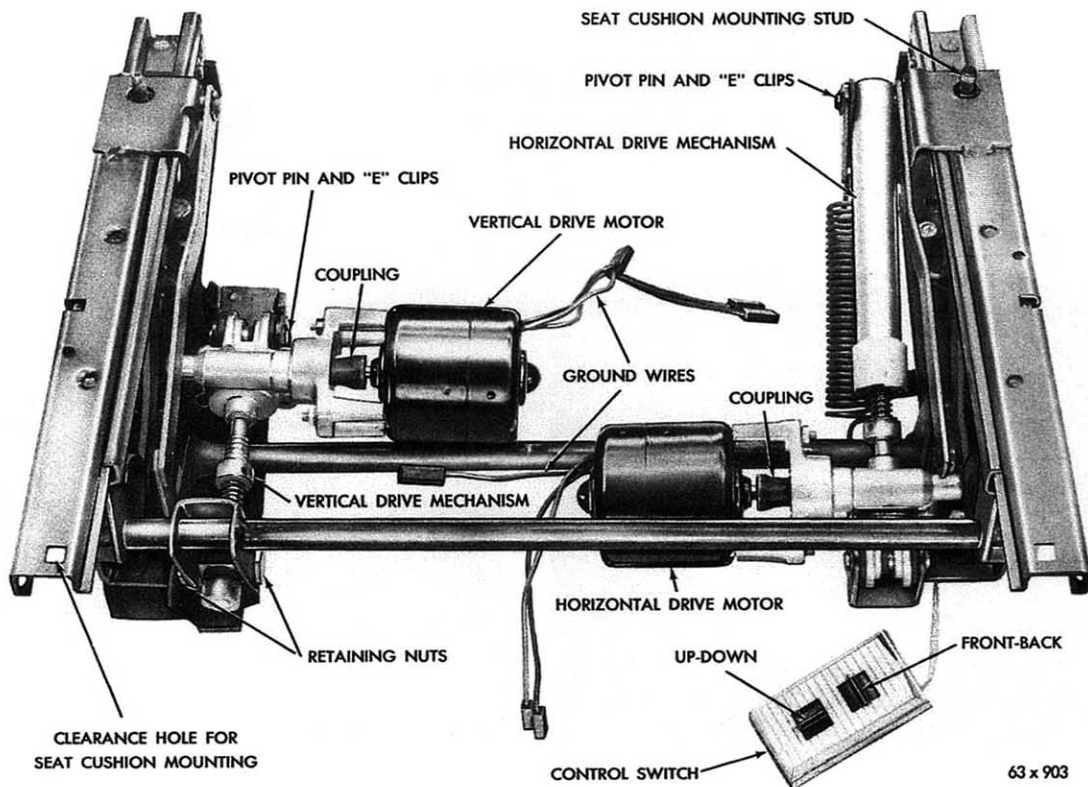

Fig. 20 - Seat Track and Rails Assembly

left side of the driver's seat. Power is supplied to the control switch from the 30 ampere circuit breaker mounted behind the left kick panel.

SEAT AND CUSHION ASSEMBLY

Removal

- (1) Remove the two nuts attaching the seat assembly to the seat track at the rear of the seat track rails.
- (2) Operate the seat to the extreme forward position to allow access to the two Phillips head screws attaching the seat assembly to the seat track at the front of the seat track rails.
- (3) Lift the seat assembly up off of the rear studs on the seat track rails and remove the seat and cushion assembly.

Installation

- (1) With the seat track in the extreme forward position, place the seat and cushion assembly on the seat track making certain the studs at the rear of the seat track protrude through the clearance holes at the rear of the seat assembly.
- (2) Install the two Phillips head screws that attach the seat and cushion assembly to the seat track at the front of the seat track and rails assembly.
- (3) Install the two nuts that mount the seat assembly to the seat track at the rear of the seat track. Tighten the nuts securely.

SEAT TRACK AND RAILS ASSEMBLY (Fig. 20)

Removal

- (1) Remove the seat and cushion assembly.
- (2) From underneath the vehicle, remove the four nuts attaching the seat track mounting studs to the floor pan of the vehicle.
- (3) Disconnect the wiring terminals from the lead wires of the two electric motors.

- (4) Lift the seat track and rails assembly up from the floor pan and remove from the vehicle.

Installation

- (1) Position the seat track and rails assembly in the vehicle making certain the four mounting studs protrude through the clearance holes in the floor pan.
- (2) From underneath the vehicle install the four nuts that attach the seat track and rails assembly to the floor pan. Tighten the nuts securely.
- (3) Install the seat and cushion assembly.

ELECTRIC DRIVE MOTORS (Fig. 20)

Service of the drive motors does not require removal of the seat and cushion assembly.

Service procedures for both the vertical and horizontal drive motors are identical.

See Wiring Diagram (Fig. 21) for complete electrical circuit.

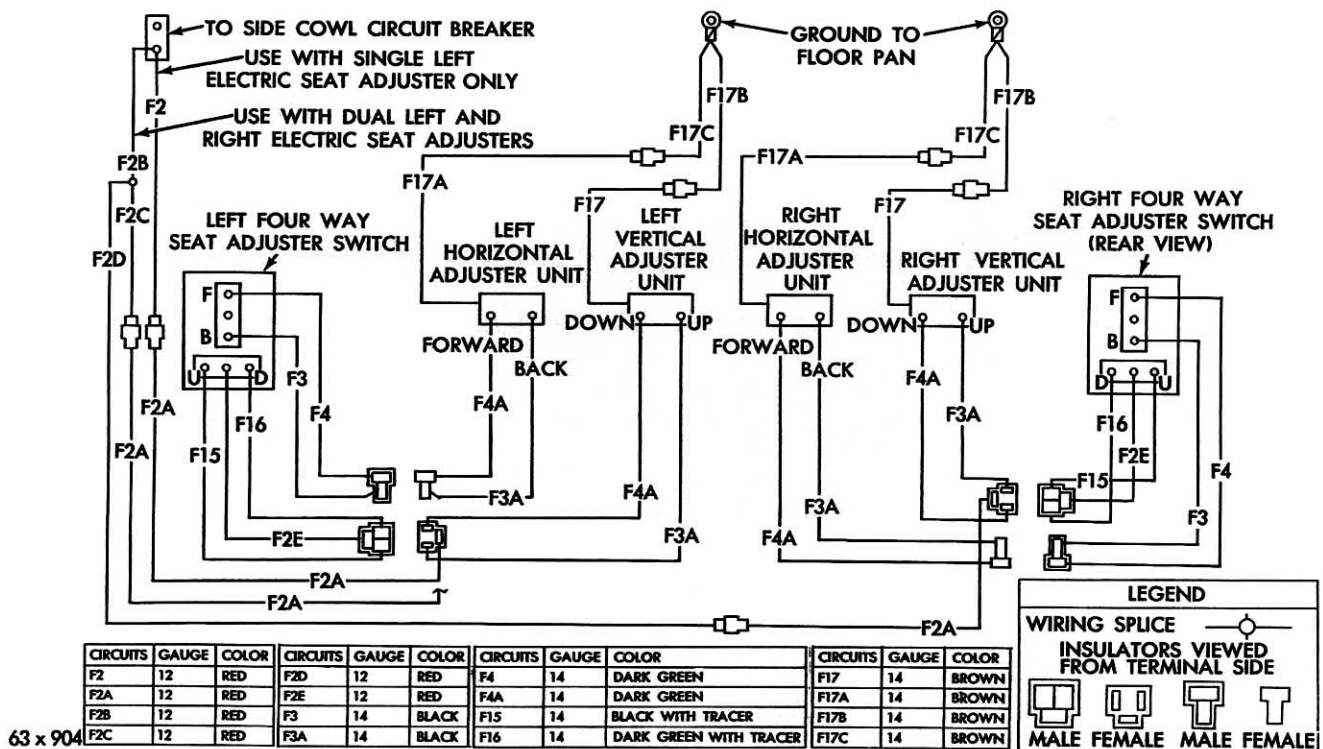

Fig. 21 - Wiring Diagram Four Way Adjustable Single Seat

Removal

- (1) Disconnect the wiring terminals at the motor lead wires.
- (2) Remove the two nuts attaching the motor to the gear housing.
- (3) Pull the motor out of the coupling between the motor and the gear housing and remove the motor.

Installation

- (1) Position the motor on the coupling on the gear housing making certain the studs on the motor protrude through the clearance holes in the gear housing.
- (2) Install the two nuts that attach the motor to the gear housing. Tighten the nuts securely.
- (3) Connect the wiring terminals to the lead wires on the motor. Make certain the ground lead from the motor (brown wire) has a good electrical connection.

CONTROL SWITCH

The control switch is retained to the seat assembly lower side panel by a spring clip. Insertion of a screwdriver on each side of the switch will release the spring clip and allow removal of the switch.

There are two terminals connected to the control switch. A two wire terminal and a three wire terminal. The circuits of the five wires are as follows:

Red Wire - 12 volt feed from the 30 ampere circuit breaker behind the left kick panel.

Dark Green Wire - "down" feed to the vertical drive motor.

Black Wire - "up" feed to the vertical drive motor.

Dark Green Wire - "forward" feed to the horizontal drive motor.

Black Wire - "back" feed to the horizontal drive motor.

Since the drive motors are interchangeable a duplication of wire colors occurs. The three wire terminal to the control switch (Dark Green, Black, Red) contains the feed wires for the vertical drive motor. The two wire terminal to the control switch (Dark Green, Black) contains the feed wires for the horizontal drive motor. (Fig. 21.)

COUPLING - MOTOR TO GEAR HOUSING (Fig. 20)

The coupling transmits the power from the drive motor to the gear housing. A coupling is used on both the horizontal and vertical drive mechanisms.

Removal of the motor allows the coupling to be serviced by pulling the coupling off the end of the drive shaft of the gear housing.

Service procedures are the same for the coupling on both the horizontal and vertical drive mechanisms.

HORIZONTAL DRIVE MECHANISM (Fig. 20)

Removal

- (1) Remove the seat and cushion assembly.
- (2) Remove the two "E" clips from the track bracket pivot pin at the rearward end of the horizontal worm gear.
- (3) Remove the pivot pin.
- (4) Remove the two "E" clips from the track, bracket pivot pin at the gear housing end of the horizontal worm gear.
- (5) Remove the pivot pin.
- (6) Disconnect the wiring terminals at the motor lead wire connectors.
- (7) Remove the motor from the gear housing and remove the motor. The drive mechanism can then be removed.

Installation

- (1) Position the horizontal drive mechanism and gear housing assembly into the track bracket.
- (2) Install the pivot pins and the two "E" clips at both ends of the drive mechanism.
- (3) Install the motor on the gear housing.

- (4) Connect the wiring terminals to the motor lead wire connectors.
- (5) Install the seat and cushion assembly.

VERTICAL DRIVE MECHANISM (Fig. 20)

Removal

- (1) Remove the seat and cushion assembly.
- (2) Remove the two nuts at the gear housing end of the vertical worm gear.
- (3) Remove the two "E" clips from the track bracket pivot pin at the rearward end of the vertical worm gear.
- (4) Remove the pivot pin.
- (5) Disconnect the wiring terminals at the motor lead wire connectors.
- (6) Remove the motor from the gear housing and remove the motor. The drive mechanism can then be removed.

Installation

- (1) Position the vertical drive mechanism and gear housing assembly into the track bracket.
- (2) Install the retaining nuts at the gear housing end of the drive mechanism and the pivot pin and the two "E" clips at the rearward end of the drive mechanism.
- (3) Install the motor on the gear housing.
- (4) Connect the wiring terminals to the motor lead wire connectors.
- (5) Install the seat and cushion assembly.

GROUP 24 - AIR CONDITIONING

The service procedures are the same as those outlined in the 1963 Imperial and Chrysler Service Manual with the following exceptions:

Due to the Ram Manifold Engine, it was necessary to reroute the suction and liquid lines and rotate the expansion valve 144 degrees counter-clockwise.