

*Displacement: 215.
Horsepower: DITTO!*

JETFIRE  *an exclusive from* **OLDSMOBILE**

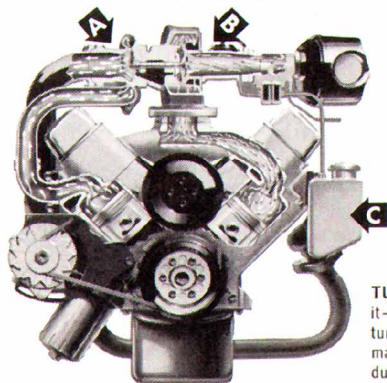

In simple arithmetic: one horsepower for every cubic inch displacement! And JETFIRE's got it. For up front is America's first fluid-injected, turbocharged production V-8—the power plant that's blowing up a storm in sports car circles everywhere. Put your foot down and the turbine revs up to 95,000—gives you a 5 psi boost with a whopping 10.25-to-1 compression ratio. More? Absolutely! Cat-quick handling, buckets, sports console . . . all wrapped up in a honey of a hardtop! Get the jump on the sports car crowd. Pilot a JETFIRE today! Oldsmobile Division, General Motors Corporation.

There's "Something Extra" about owning an OLDSMOBILE!

TURBO-ROCKET V-8 ENGINE. Power when you need it—economy when you want it! Waste exhaust gases turn turbine (A) which drives compressor (B) to boost manifold pressure. Tu.bo-Rocket Fluid (C) is injected during turbocharging, permits ultra-high compression.