



FALCON for '64  
The Total Performance Compact



## 1964 FALCON

The economy that made Falcon famous...*plus* new style, new comfort and the plushest ride ever built into a compact car!

Falcon retains the famous 6-cylinder engine that holds the all-time Mobil Economy Run record for 6's or 8's. All of Ford's famous service-saving features are built into the '64 Falcon, too. But everything else is changed.

The new styling needs no explanation—it speaks volumes for itself. In the driver's seat, you'll find new comfort and convenience; the seat, steering wheel and controls have been repositioned to give you a roomier feeling.

The smoothness of the '64 Falcon's new ride is something you'll have to *feel* to fully appreciate. Refinements in front and rear suspension, a wider rear tread . . . these plus other changes give the Falcon ride a quiet, solid smoothness no compact ever had before.

Variety? There are 17 new Falcon models. Spirit? The husky, hustling 164-hp Challenger 260 V-8\* leads a line-up of five engines, four transmissions. Price? Still pure Falcon. Samples? See your Ford Dealer for a test drive. Get reacquainted with Falcon today!

\*Optional

**Try Total Performance For a Change!**



Top left: Sprint Convertible Top right: One of five Sprint interiors

## FALCON SPRINT CONVERTIBLE & HARDTOP



Now . . . Sprint flair at a new lower Sprint price! Full-width 3-passenger front seat, sports-type steering wheel, all-vinyl trim, wire-style wheel covers are standard highlights. Sporty options include: bucket front seats, console, tachometer, rocker panel moldings. Standard as always is the lively Sprint 260 V-8, much like the one which helped Falcon capture the Manufacturer's Team Prize in the 4,000-mile Trans-Canada Rally last spring. Falcon roadability (termed "terrific" then by Rally drivers) is even more so now with a new wider rear tread. Underbody torque boxes, plus longer, wider rear springs and front suspension improvements give Falcon a road-leveling ride no compact ever had before. Take your pick: Sprint Hardtop or Convertible. Fully synchro 3-speed (std.) or 4-speed\* if you like to shift manually; Fordomatic\* if you like everything done for you. \*Optional

**STANDARD EQUIPMENT HIGHLIGHTS** □ 164-hp Sprint 260 V-8 (chromed engine dressup) □ Synchro-Smooth Drive (fully synchronized 3-spd. man. trans.) □ Wire-Style Wheel Covers □ "Bucket-Styled" Full-Width Seats, Front and Rear □ Color and Upholstery Choices: 12 Colors of Diamond Lustre Enamel, 5 Color-Keyed All-Vinyl Trims □ Sports-Type Steering Wheel, Full Carpeting, Thunderbird "Floating" Mirror, Padded Sun Visors (Convertible) □ Power Top (Convertible) in Black, White, Blue □ Ford's Twice-a-Year (or 6,000-mile) Maintenance Features (back cover). **POPULAR OPTIONS AND ACCESSORIES** □ Bucket Front Seats and Console □ Eye-Level Tachometer □ Bright-Metal Rocker Panel Moldings □ Black or White Vinyl Roof Covering (Hardtop) □ Power Steering □ Power Brakes (with Fordomatic) □ 4-Speed Manual Transmission □ Courtesy Light Group □ Radio □ Padded Instrument Panel □ Seat Belts\* □ Heater-Defroster\* □ Tonneau Cover (Convertible) □ White Sidewall Tires. **BASIC SPECIFICATIONS** □ Length 181.6" □ Width 71.6" □ Height—Hardtop 53.2", Convert. 53.8" □ Wheelbase 109.5" □ Curb Weight (approx.)—Hardtop 2935 lb., Convert. 3130 lb. □ Trunk Luggage Volume—Hardtop 12.2 cu. ft., Convert. 9.1 cu. ft.

\*See "Prices" on back cover

Left: Sprint Hardtop with optional vinyl roof covering

# FALCON FUTURA HARDTOPS & CONVERTIBLES

Good news for compact hardtop and convertible fans comes in packages marked "Falcon Futura." Sports Coupe and Sports Convertible with bucket seats, Futura Hardtop and Futura Convertible with full-width seats, as you please. They'll pamper you with leather-soft vinyl trim (10 color-keyed choices), full carpeting, Thunderbird "floating" mirror, courtesy-lighted interior . . . all the luxuries. Convertible tops are power-operated for ease; 5-ply design for durability; anchored at each roof bow for a sleek profile under way. True to the Falcon formula, Futura Hardtops and Convertibles have their thrifty, practical side, too. The Falcon Six (in hardtops) is a famous gas-saver. It set the all-time Mobil Economy Run record for 6's or 8's in 1961. The 170 Special Six (std. in convertibles; opt. in hardtops) packs a heftier power punch, is second in gas savings only to the Falcon Six. Add in Ford's renowned Twice-a-Year (or 6,000-mile) Maintenance features—every one from 36,000 miles or 3 years between major chassis lubes to self-adjusting brakes—and you can see how these Futuras can put a lot more fun in your kind of driving.

**STANDARD EQUIPMENT HIGHLIGHTS**

□ 101-hp 170 Special Six (Convertibles), 85-hp Falcon Six (Hardtops) □ 3-Speed Manual Transmission □ Bucket Front Seats and Console (Sports models) □ "Bucket-Styled" Full-Width Seats, Front (Futuras) and Rear (all models) □ 12 Colors of Diamond Lustre Enamel □ Power Top (Convertibles) in Black, White, Blue □ Color-Keyed 2-Spoke Safety-Type Steering Wheel with Chrome Horn Ring □ Twice-a-Year (or 6,000-mile) Maintenance Features (back cover). **POPULAR OPTIONS AND ACCESSORIES** □ Black or White Vinyl Roof Covering (Hardtops)

□ 116-hp 200 Special Six or 164-hp Challenger 260 V-8 □ Power Steering □ Deluxe or Wire-Style Wheel Covers □ Rocket Panel Moldings □ Fordomatic Drive (except with 85-hp Six) □ Ford Air Conditioner† □ Radio □ Electric Clock □ Padded Instrument Panel □ Seat Belts\* □ Heater-Defroster\* □ Tonneau Cover (Convertibles). **BASIC SPECIFICATIONS** □ Length 181.6" □ Width 71.6" □ Height—Hardtops 53.2", Convertibles 53.8" □ Wheelbase 109.5" □ Curb Weight (approx.)—Hardtops 2625 lb., Convert. 2820 lb. □ Trunk Luggage Vol.—Hardtops 12.2 cu. ft., Convert. 9.1 cu. ft.

†Unavailable with 4-speed transmission  
\*See "Prices" on back cover

Lush bucket-seat interior of Sports Futuras

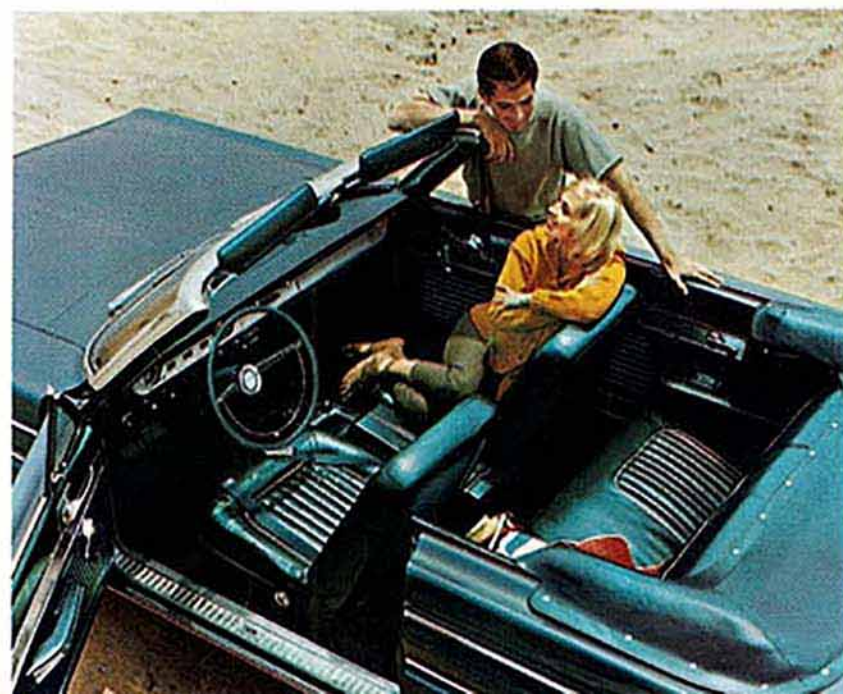

# FALCON FUTURA SEDANS

Good looking as these Futura Sedans are, their beauty is much more than what you see on the surface. Falcon quality goes deep and invites close inspection. Run your eye over the finish (it's Diamond Lustre Enamel, durable as it is brilliant). Check chrome and bright-metal trim. And don't stop there. Feel the richness of the upholstery, its precise cut and fit. Note the ease with which hood, doors and deck lid open and close. And *do* slam the doors. That solid sound as Ford's Safety-Yoke door latches engage tells you more than words of Falcon's solid quality. And you owe it to yourself to drive the new Falcon. Fifteen minutes behind the wheel will change all your ideas about compacts. Falcon's ride is that smooth, steady and quiet. Falcon's *total performance*—handling, roadability, acceleration and braking—is that *completely* rewarding. All this Falcon quality . . . built into every new Falcon . . . is backed by a remarkable long term, *total* car warranty (see page 16).

#### STANDARD EQUIPMENT HIGHLIGHTS

□ 85-hp Falcon Six □ 3-Speed Manual Transmission □ Full-Width, 3-Passenger Seats Front and Rear □ Color and Upholstery Choices: 11 Colors of Diamond Lustre Enamel, 4 Color-Keyed Cloth/Vinyl Trims □ Foam-Padded Front Seat Cushion, Full Carpeting, Arm Rests and Ash Trays, Front and Rear □ Courtesy-Lighted Interior, Dual Visors □ Cigarette Lighter □ Distinctive Futura Trim □ Ford's Twice-a-Year (or 6,000-mile) Maintenance Features (back cover).

#### POPULAR OPTIONS AND ACCESSORIES

□ Choice of 170 Special Six (101 hp), 200 Special Six (116 hp) or Challenger 260 V-8 (164 hp) □ Fordomatic Drive (except with 85-hp Six) □ Power Steering □ Ford Air Conditioner † □ Courtesy Light Group □ Radio □ Deluxe or Wire-Style Wheel Covers □ Seat Belts\* □ Heater-Defroster\*. **SPECIFICATIONS** □ Length 181.6" □ Width 71.6" □ Height 54.5" □ Wheelbase 109.5" □ Curb Weight (approx.)—2-Door 2485 lb., 4-Door 2520 lb. □ Trunk Luggage Volume—12.2 cu. ft. †Unavailable with 4-speed transmission \*See "Prices" on back cover

Big, handsome Futura Sedan interior

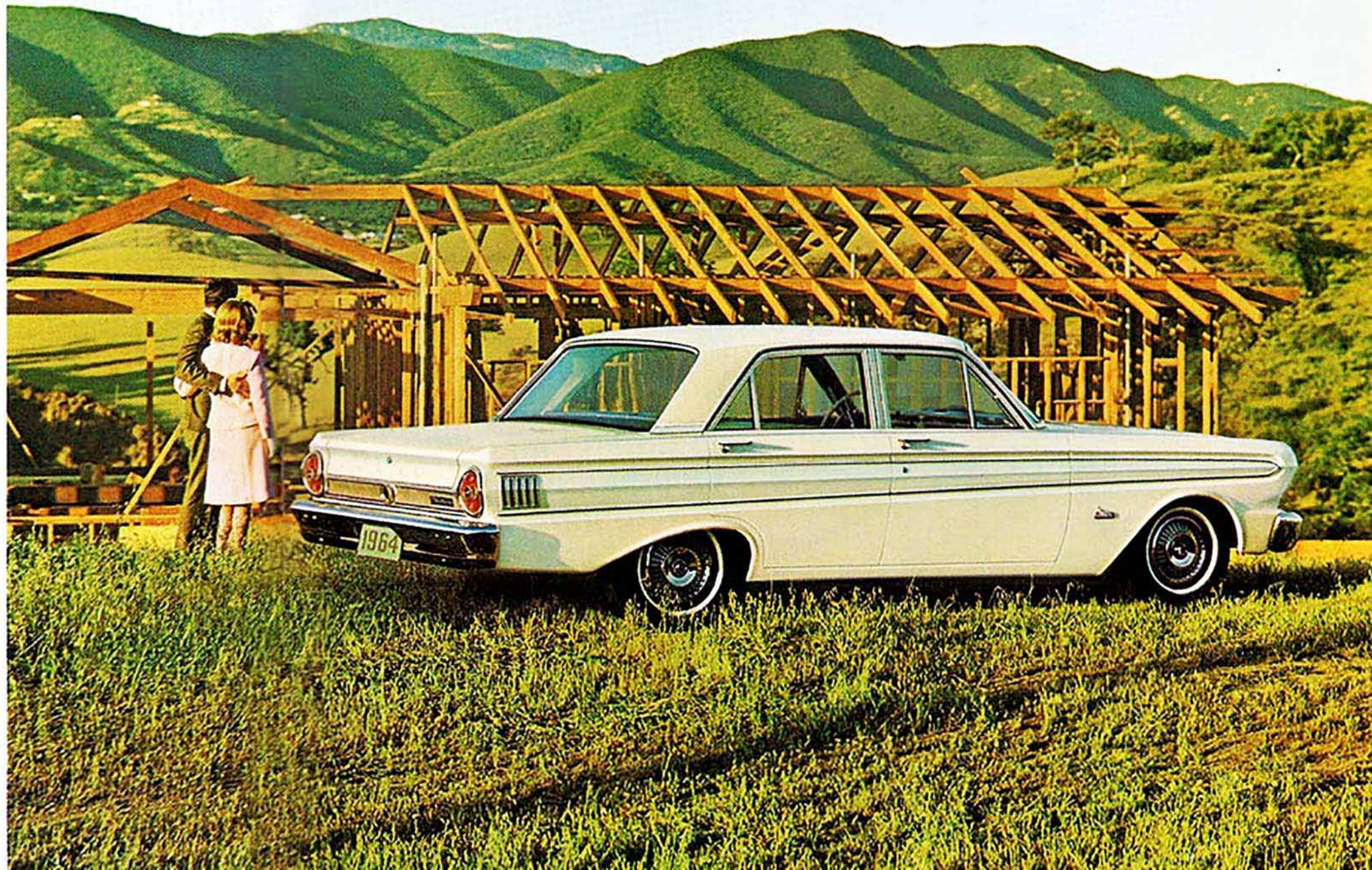

# FALCON SEDANS

In many ways these are the most remarkable Falcons of all. Falcon 2- and 4-door sedans are among America's lowest-priced 6-passenger sedans! Their standard Falcon Six engine holds the all-time Mobil Economy Run record for 6's or 8's. They're big in 6-passenger room and comfort. They're rich in standard features—foam-cushioned front seat, arm rests, sun visors, Ford's Twice-a-Year (or 6,000-mile) Maintenance features . . . many more. And their low prices even include front seat belts, heater and defroster!\* Take your pick of fine car options: 164-hp Challenger V-8, Falcon power steering, Ford air conditioner . . . to name a few. But you needn't pay more than the low prices of these thrifty Falcons to get the lush new Falcon ride or Falcon's total performance! \*See "Prices" on back cover

**STANDARD EQUIPMENT HIGHLIGHTS** □ 85-hp Falcon Six □ 3-Speed Manual Transmission □ Full-Width, 3-Passenger Seats Front and Rear □ Color and Upholstery Choices: 10 Colors of Diamond Lustre Enamel, Beige Cloth-Vinyl Trim □ Foam-Padded Front Seat Cushion, Vinyl-Rubber Floor Mats, Front Arm Rests and Ash Tray □ Dual Visors □ Ford's Twice-a-Year (or 6,000-mile) Maintenance Features. **CONVENIENCE PACKAGE** (Available, in addition to above, at moderate extra cost) □ Distinctive Body Trim, Bright Drip Moldings, Hood Ornament □ Choice of Beige, Red or Blue Cloth/Vinyl Trims □ Color-Keyed Floor Mats □ Rear Arm Rests and Ash Tray □ Cigarette Lighter □ Courtesy-Lighted Interior. **BASIC SPECIFICATIONS** □ Length 181.6" □ Width 71.6" □ Height 54.5" □ Wheelbase 109.5" □ Curb Weight (approx.)—2-Door 2475 lb., 4-Door 2510 lb. □ Trunk Luggage Volume—12.2 cu. ft.

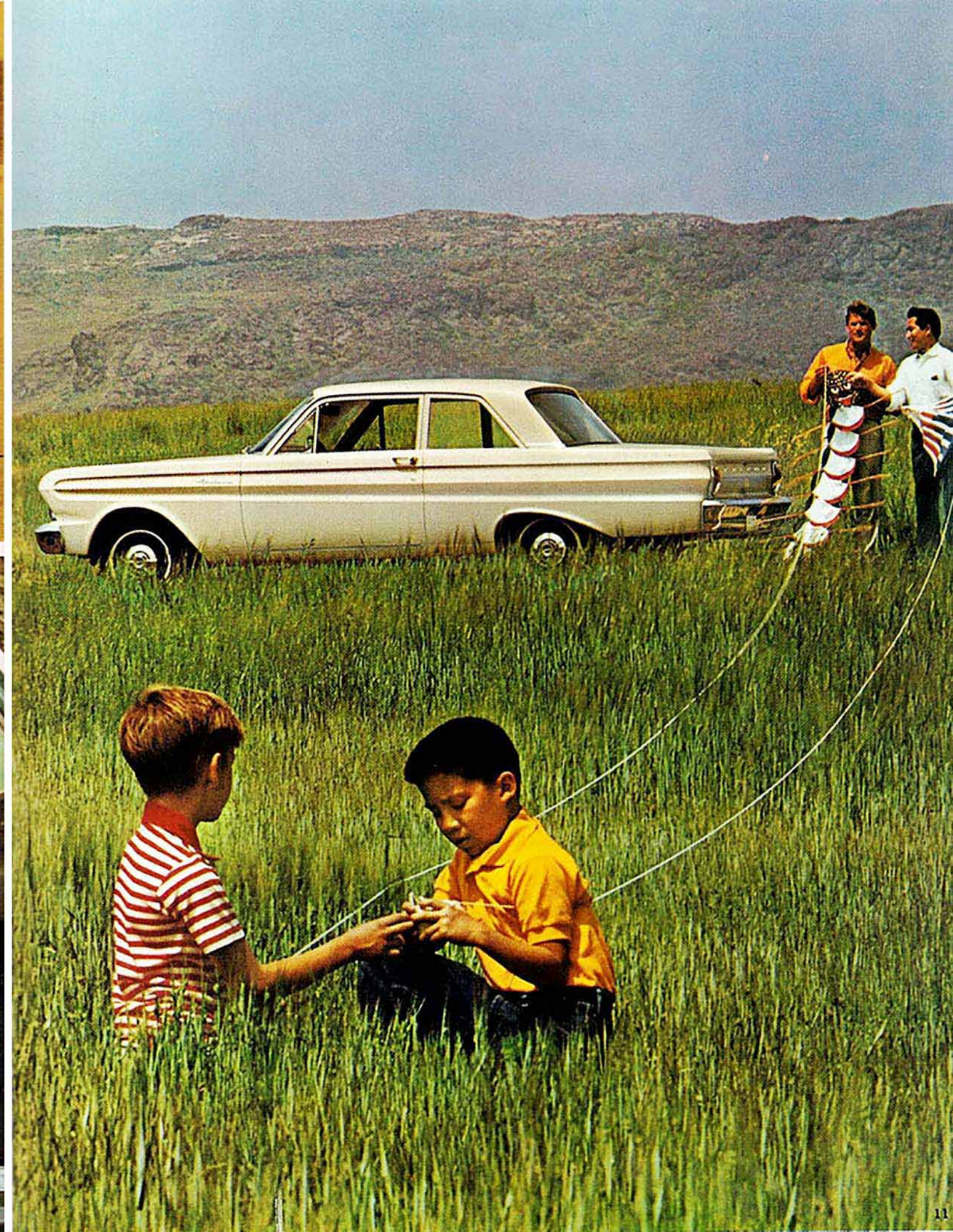



Top left: Squire conveniences—power tailgate window, four big doors  
Top right: Squire interior

## FALCON SQUIRE

Ford, America's wagon specialist, believes you can design a wagon to be a workhorse, but it doesn't have to look like one. The Falcon Squire is proof. Its distinctive woodlike body trim sets the Squire apart from other compact wagons. Inside, its "bucket-styled" vinyl seat trim, full carpeting and courtesy-lighted interior rival the big expensive wagons. Power tailgate window is standard; power steering available. Engine options range up to the 164-hp Challenger V-8. That part about being a workhorse? Just flip down Squire's second seat, lower the tailgate and you're ready to take aboard 78.5 cu. ft. of cargo.



**STANDARD EQUIPMENT HIGHLIGHTS** □ 101-hp 170 Special Six □ 3-Speed Manual Transmission □ "Bucket-Styled" Full-Width, 3-Passenger Seats Front and Rear □ Foam-Padded Cushions, Arm Rests, Ash Trays Front and Rear □ Color-Keyed, Wall-to-Wall Carpet (passenger area), Color-Keyed Vinyl-Rubber Mat (cargo area) □ Color and Upholstery Choices: 12 Colors of Diamond Lustre Enamel, 5 Color-Keyed Trims (4 all-vinyl, 1 cloth/vinyl) □ Automatic Dome Light □ Dual Visors □ Cigarette Lighter □ Distinctive Simulated Wood Body Trim □ Power Tailgate Window □ Ford's Twice-a-Year (or 6,000-mile) Maintenance Features.

**POPULAR OPTIONS AND ACCESSORIES** □ Engine choices: 116-hp 200 Special Six; 164-hp Challenger 200 V-8 □ Fordomatic Drive □ Power Steering □ Power Brakes (with Fordomatic) □ Ford Air Conditioner □ Deluxe or Wire-Style Wheel Covers □ Courtesy Light Group □ Radio □ Roof Rack □ Seat Belts\* □ Heater-Defroster\*, **BASIC SPECIFICATIONS** □ Length 190.0" □ Width 71.6" □ Height 54.9" □ Wheelbase 109.5" □ Curb Weight (approx.) 2830 lb. □ Cargo Vol. 78.5 cu. ft.

\*See "Prices" on back cover



Top left: Falcon Deluxe Club Wagon and Club Wagon  
 Top right: counterbalanced tailgate makes Falcon's 78½ cu. ft. cargo space easy to load



## FALCON WAGONS

One of the most popular of all compact wagons is the Falcon Deluxe 4-Door (left). It combines big cargo space (78½ cu. ft.) and low Falcon price with all the deluxe Falcon wagon features: Bright-metal body trim, side moldings and window frames. Foam-cushioned seats. Four pleated all-vinyl trims. Color-keyed, washable floor mats. Roll-down tailgate window. These are just off the top of the list. And, there are other Falcon wagons in different shapes and sizes to handle just about any hauling job you can name. Two of them (standard 2-door and 4-door) are among America's lowest-priced 6-passenger wagons. Three others (the extra-duty Falcons†, like the two at top opposite) carry up to 8 passengers or 194 cu. ft. of cargo! All Falcon wagons come "loaded" with Falcon conveniences and easy handling . . . are thrifty as only a Falcon can be.

†For details on these versatile Falcons, ask your Ford Dealer for the folder on Extra-Duty Wagons

**STANDARD EQUIPMENT HIGHLIGHTS** □ 101-hp 170 Special Six □ 3-Speed Manual Transmission □ Full-Width, 3-Passenger Seats Front and Rear □ Foam-Padded Cushions, Front Arm Rests and Ash Tray, Dual Visors □ Color-Keyed Vinyl-Rubber Mat, Rear Arm Rests (deluxe) □ Color and Upholstery Choices: 9 (standard), 12 (deluxe) Colors of Diamond Lustre Enamel; 5 All-Vinyl Trims (1 standard, 4 deluxe) □ Roll-Down Tailgate Window □ Distinctive Wagon Body Trim for Both Standard and Deluxe Models □ Ford's Twice-a-Year (or 6,000-mile) Maintenance Features. **POPULAR OPTIONS AND ACCESSORIES** □ Engine Choices: 116-hp 200 Special Six; 164-hp Challenger 260 V-8 □ Fordomatic Drive □ Power Steering □ Radio □ Power Tailgate Window □ Roof Rack □ Rear Window Screen □ Deluxe or Wire-Style Wheel Covers □ Seat Belts\* □ Heater-Defroster\*. **BASIC SPECIFICATIONS** □ Length 190.0" □ Width 71.6" □ Height 54.9" □ Wheelbase 109.5" □ Curb Weight (approx.)—Standard 2-Door 2770 lb., 4-Door 2805 lb.; Deluxe 4-Door 2825 lb. □ Cargo Vol. 78.5 cu. ft. \*See "Prices" on back cover



# FALCON TOTAL PERFORMANCE



With 1,500,000 Falcons already on the road, the '64 Falcon sets out to go the best one better. All-new styling. New comfort. New convenience. A lush new ride. But the biggest news is Falcon *total performance*. It's a combination no compact (and few big cars) ever had before. Much more than big power to go and big brakes to stop, *total performance* Falcon-style is quick-stepping action plus rock-solid roadability. It's handling, smooth and easy as a hot knife cleaving butter. It's a silent solidness under way that attests to hard-muscled durability. That's Falcon *total performance*. Try it—for a change!

FALCON IS THE QUALITY COMPACT, backed by this *total* car dealer warranty: Ford Dealers warrant to owners as follows: That for 24 months or for 24,000 miles, whichever comes first, free replacement, including related labor, will be made by dealers of any part with a defect in workmanship or materials. Tires are not covered by the warranty; appropriate adjustments will be made by tire companies. Owners will remain responsible for normal maintenance services, routine replacement of parts, such as filters, spark plugs, ignition points, wiper blades, brake or clutch linings, and normal deterioration of soft trim and appearance items. The warranties referred to herein are applicable to products sold in the U.S.A. and in certain neighboring areas.



**A MILLION DOLLARS' WORTH OF GOOD LOOKS...** Nothing "compact-looking" about the '64 Falcon. But then Falcon has always had a lot going for it in styling. (How could you miss with the big Fords for inspiration?) Clean, crisp lines and no nonsense in the chrome trim. New Falcon styling is extra big in "built-for-people" comfort, too. Yes indeed, the Falcon look is "very big" in the '64 fashion parade. How about trying one on for size?



**6-PASSENGER ROOM AND COMFORT...** Falcons have always been roomy, comfortable 6-passenger cars. (In '64, repositioned steering wheel, new accelerator position, new instrument panel arrangement provide even greater driver convenience.) Room for heads (with hats on), for shoulders, legs and knees. Room to get in and out with ease. Seats that cushion you gently. Falcon's trunk is big, too—12.2 cu. ft.—room for all your luggage!



**SMOOTH, QUIET RIDE...** Nothing "compact" about the new Falcon's ride, either. It's best compared to the ride in the big Fords. Torque boxes (to isolate vibration, harshness) are built into the underbody. Falcon's rear tread has been widened. Rear springs are longer, wider. These, with other suspension refinements, give Falcon a ride so smooth and quiet—so much like big, expensive cars—you'll just have to try it to believe it.



**CONVENIENCE—ANOTHER NAME FOR FALCON...** Falcons surround you with convenience. New Safety-Yoke door latches that open and close at little more than a touch. Dual sun visors and front arm rests. Center-fill fueling. On wagons, roll-down tailgate windows and quick-converting second seats. On convertibles, power-operated tops as *standard* equipment. Just highlights, but enough to show you why Falcons are so much fun to drive.

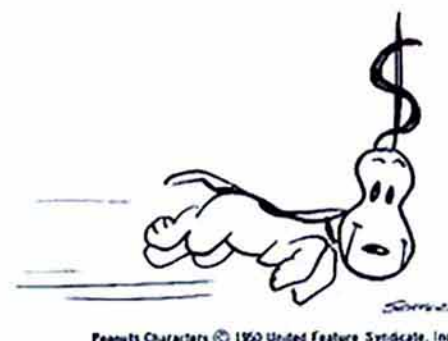

**ECONOMY—FALCON'S MIDDLE NAME...** Falcon is (and always has been) the compact it pays you to own. With Falcon you save in all these ways: low price (Falcon's among the lowest); gas savings (Falcon's the all-time Mobil Economy champ for 6's or 8's); low maintenance (self-adjusting brakes and engine valves, aluminized muffler, rust-resistant galvanized underbody parts... to name a few); higher resale (Falcon's among the highest).



**ON FALCONS, LUXURY IS STANDARD...** No need to pay more than the low Falcon price to get the best any compact has to offer. Bucket seats with console, for instance. They're standard on Sports Futuras. V-8's are standard on Sprints, power tops standard on convertibles; power tailgate window standard on Squires. Full carpeting, courtesy-lighted interiors are standard on many Falcons. The list goes on and on.



**TWICE-A-YEAR\* MAINTENANCE...** Ford introduced it—Falcon owners have been saving time and money ever since. Falcons go 36,000 miles (or 3 years whichever comes first) between major chassis lubes... 6,000 miles (or 6 months) between oil changes and minor lubes. Fuel filter and air cleaner last 36,000 miles (or 3 years). Engine coolant-antifreeze is good for 36,000 miles (or 2 years). Read complete list on the back cover.

\*Or 6,000 miles

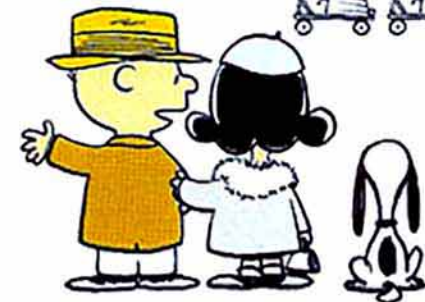

**17 FALCON MODELS TO CHOOSE FROM...** Big choice is also a Falcon bonus. Take your pick of 4 sedans (2-door & 4-door), 3 hardtops, 3 convertibles, 4 wagons (2-door & 4-door) and 3 extra-duty wagons (the extra-big, extra-versatile Falcons). For families (big or small), for business or fun... as the "one car" or second car... touring, camping, shopping or commuting... Falcon has so much *more* to offer in every way!

## TOTAL PERFORMANCE (Continued)

Of the 11 Falcon power teams, one is just right for *your* kind of driving. For top gas savings try the standard Falcon Six with 3-speed manual. For action, try the quick reflexes of the Sprint 260 V-8 and 4-speed stick. In between are options distinguished in their own right. The peppery 170 Special Six (std. in Futura convertibles and wagons), available with two manual drives, beautifully blends fuel economy with brisk motion. The fleet Challenger 260 V-8 with standard fully synchronized 3-speed Synchro-Smooth Drive is a great combination in wagons. Available with nearly all Falcon engines is famous Fordomatic, the quicker, smoother, more care-free automatic that lets you just sit there and steer.

11 TOTAL PERFORMANCE POWER TEAMS									
ENGINE	CU. IN. DISPL.	HP @ RPM	MAX. TORQUE @ RPM	BORE/STROKE	COMP. RATIO (to 1)	CARR. & FUEL	TRANSMISSION OPTIONS	AVAILABLE WITH MODELS	
1. FALCON SIX	144	85 @ 4200	134 @ 2000	3.50 x 2.50	8.7	1 bbl. Reg.	A	Std. all except Futura Convertibles, Sprints, Wagons	
2. 170 SPECIAL SIX	170	101 @ 4400	156 @ 2400	3.50 x 2.54	8.7	1 bbl. Reg.	A-B-C	Std. Futura Converts., Wagons, opt. others except Sprints	
3. 200 SPECIAL SIX	200	116 @ 4400	185 @ 2400	3.68 x 3.13	8.7	1 bbl. Reg.	B	Opt. all models except Sprints	
4. CHALLENGER 260 V-8	260	164 @ 4400	258 @ 2200	3.90 x 2.87	8.8	2 bbl. Reg.	B-C-D	Opt. all models except Sprints	
5. SPRINT 260 V-8	260	164 @ 4400	258 @ 2200	3.80 x 2.87	8.8	2 bbl. Reg.	B-C-D	Std. on Sprints	

Transmission Key:  
 A—3-Speed Manual  
 B—Fordomatic Drive  
 C—4-Speed Manual (all except wagons)  
 D—Synchro-Smooth Drive (fully synchronized 3-spd. man.)

## OPTIONS AND ACCESSORIES

Your Ford Dealer has over 50 separate options and accessories to help you *personalize* your new Falcon. He'll gladly explain in detail the many to be had with the '64 Falcon you select. Moreover, you can depend on your Ford Dealer's helpful guidance in selecting options which will multiply your Falcon's usefulness and enjoyment now as well as enhance its value later at trade-in. There are other benefits too. When you buy *genuine* Falcon options and accessories from your Ford Dealer you're getting the best, designed and engineered for your Falcon by Ford. What more could you ask in long-term satisfaction and pride of ownership?

**A. LIFE GUARD DESIGN OPTIONS:** padded instrument panel, cushioned visors (std. on convertibles) and metal-to-metal seat belts with retractor, in choice of seven colors. Lifeguard Design standard equipment on all '64 Falcons includes: safety-padded arm rests, deep-dish steering wheel, shatter-resistant mirror, Safety-Yoke door latches.  
**B. WAGON ROOF RACK:** greatly increases cargo capacity.  
**C. DELUXE WHEEL COVERS:** simulated wire wheel design, as shown, and full disc type.  
**D. REMOTE-CONTROL OUTSIDE MIRROR:** (one of several types of mirrors): permits quick, easy aiming without lowering window.  
**E. ELECTRIC CLOCK:** self-regulating, sweep second hand, illuminated dial for night driving.  
**F. FORD AIR CONDITIONER:** cool comfort for summer's hottest days. Three-speed blower, six adjustable outlets.  
**G. POWER STEERING:** extra-easy handling in any Falcon for parking, low-speed maneuvering.

**ALSO:**  
 • Power Brakes • Courtesy Light Group†  
 • All-Transistor Radio • Spotlight with Mirror  
 • StudioSonic Sound System  
 • Convertible Tonneau Cover

†Includes lights for ash tray, glove box, trunk (cargo area in wagons), map light, backup lights, front and rear courtesy switches. Items also available separately.

**PLUS:** Two-Tone Paint • Tinted Glass • White Sidewall Tires • Windshield Washer and 2-Speed Electric Wipers • Conventional Rear Seat Speaker • Vinyl Roof (hardtops) • Pleated Vinyl Trim (Futura sedans) • Inside Non-Glare Mirror • Parking Brake Warning Light • Glove Box Lock • Remote-Control Trunk Lid Release • Tachometer • Rocker Panel Molding • Door Edge Guards • Metal-to-Web Seat Belts\* • Fresh Air Heater-Defroster\* • Power Tailgate Window (std. on Squire) • Rear Window Screen (wagons) and many others. \*See "Prices" back cover

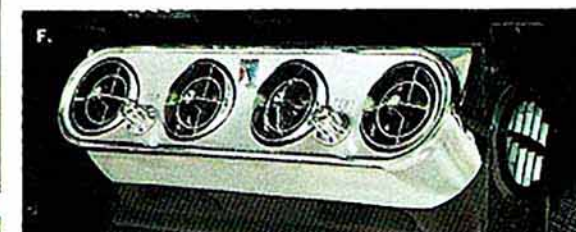
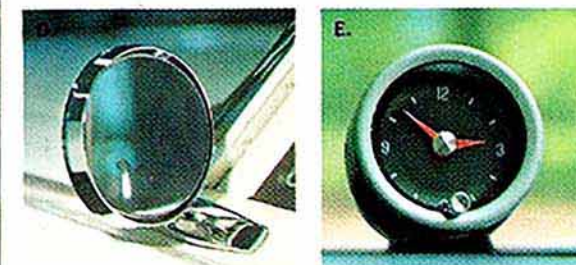
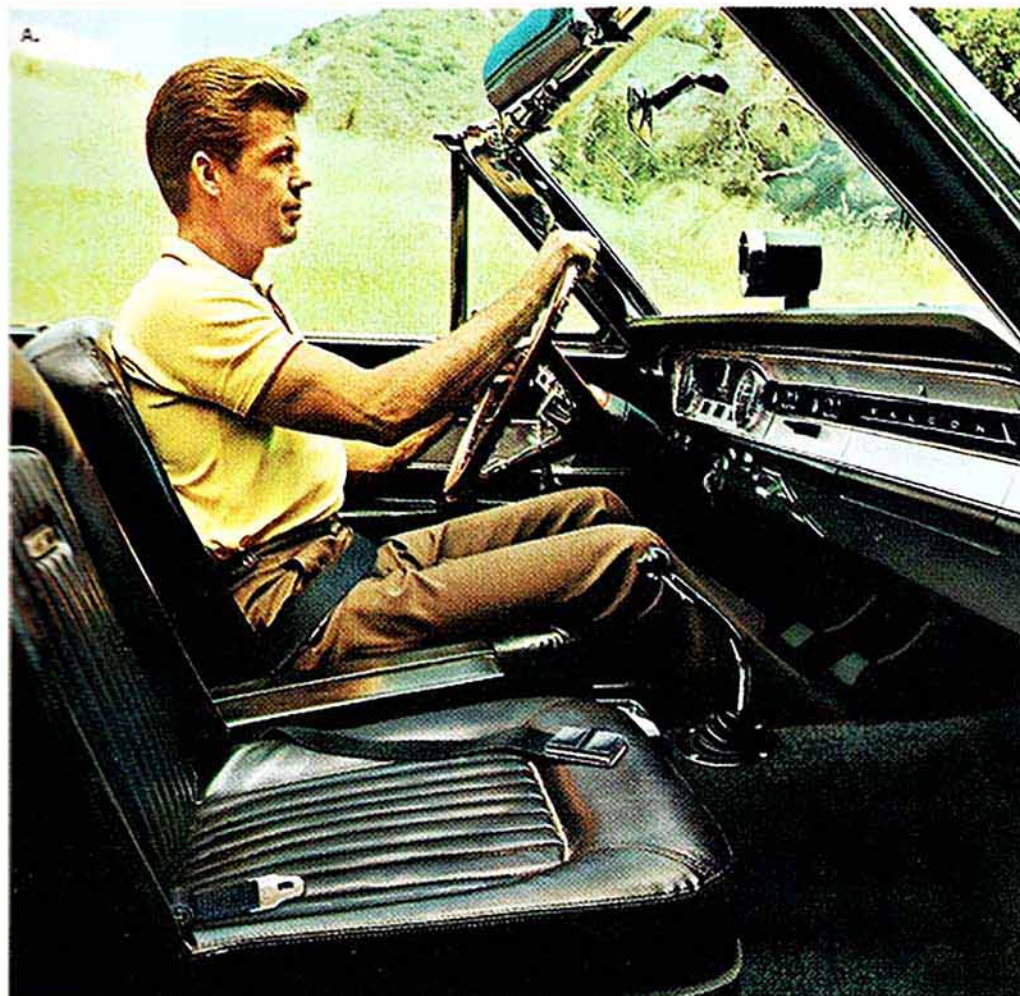

# 1964 FALCON SPECIFICATIONS\*

**COLOR AND UPHOLSTERY SELECTIONS:** You have a choice of 12 '64 Falcon single tone colors or 12 two-tone combinations in durable, brilliant Diamond Lustre Enamel. There are 27 upholstery choices; 8 cloth and vinyl combinations (6 std., 2 opt.), 16 all-vinyl trims in Wagons, Convertibles and Hardtops; plus 3 all-vinyl options in Futura Sedans. Your Ford Dealer will be happy to show you actual samples of '64 Falcon colors and upholstery.

**FALCON DESIGN:** Among many Falcon feature highlights are: Welded Integral Body and Frame (quietness, high strength-to-weight ratio); Body Fully Insulated and Weather-Sealed; Parallel Action Electric Windshield Wipers; Deep-Dish Steering Wheel; Dual Sun Visors with Retention Clips; Safety-Yoke Door Latches; Front Seat Belt Anchors; Center-Fill Fueling (sedans); Counterbalanced Hood and Deck Lid (sedans); Tailgate (wagons); Lined Trunk (sedans); Vinyl-Coated Rubber Cargo Mat (wagons); 20-Gal. Fuel Tank (V-8 wagons); 14-Gal. (all others); Roll-Down Tailgate Window (wagons); Quick-Converting Second Seat Providing Flat, Level Loadspace (wagons); Upright Spare Tire Stowage (wagons).

**TWICE-A-YEAR (OR 6,000-MILE) MAINTENANCE:** The 1964 Falcon goes 36,000 miles (or 3 years) between major chassis lube; 6,000 miles (or 6 months) between oil changes and minor lube. In fact, Falcon needs so little service it's just good sense to see that it gets the best—at your Ford Dealer's. His factory-trained mechanics and special tools add up to a great service combination you can get nowhere else! Other savings include: engine coolant-antifreeze, installed at the factory, good for 36,000 miles (or two years); self-adjusting brakes; aluminum muffler, and galvanized vital underbody parts to resist rust and corrosion.

**ENGINES: 85-hp Falcon Six** (std. on all except Futura Convertibles, Sprints and Wagons)—144 cu. in. displ.; 3.50" bore x 2.50" stroke; 8.7 to 1 comp. ratio; reg. fuel; single-barrel carb.; manual choke; self-adj. valves with hydraulic lifters; oil cap'y, with filter change, 4.5 qt.

**101-hp Falcon 170 Special Six** (std. on Futura Convertibles and Wagons, opt. on other models except Sprints)—170 cu. in. displ.; 3.50" bore x 2.94" stroke. Other specs. same as above.

**116-hp Falcon 200 Special Six** (opt. with Fordomatic on all except Sprints)—200 cu. in. displ.; 3.68" bore x 3.13" stroke. Other specifications same as Falcon Six above.

**164-hp Challenger 260 V-8** (opt. except Sprints)—260 cu. in. displ.; 3.80" bore x 2.87" stroke; 8.8 to 1 comp. ratio; reg. fuel; 2-barrel carb.; new vacuum-piston-operated automatic choke; self-adj. valves with hydraulic lifters; oil cap'y, with filter change, 5 qt.

**164-hp Sprint 260 V-8** (std. on Sprints)—same as Challenger 260 V-8 plus special trim items, power-vented air cleaner and muffler.

**ENGINE FEATURES:** For more economy and longer life Falcon engines have short-stroke, low-friction design; 6,000-mile (or 6-month) full-flow disposable-type oil filter; 36,000-mile (or 3-year) disposable-type fuel filter and replaceable dry-type element air cleaner; 190° thermostat; 12-volt electrical system; weatherproof ignition; battery 54-plate; 40 amp-hr (Sixes)—55 amp-hr (V-8's); fully aluminum muffler and tailpipe; crankcase emission control system (std. on all except Falcon Six, but available special order). All engines electronically mass-balanced for operating smoothness.

**CLUTCH AND MANUAL TRANSMISSIONS:** Non-

centrifugal clutch with Sixes; semi-centrifugal clutch with V-8's. Face diameter 8 1/2" with Sixes, 10" with V-8's.

**3-Speed Transmission** (std. on Sixes except 200 Special Six) has forged bronze synchronizers in 2nd and direct for smooth operation. Anti-friction bearings throughout. Standard "H" shift pattern with lever on steering column. **Synchro-Smooth Drive Transmission** (std. on V-8's) synchronized manual shifting in all three forward gears; cloth-free downshifting to low while under way. **4-Speed Transmission** (opt. on all models except Wagons) with floor-mounted stick shift. All forward gears synchronized for fast, smooth shifting.

**FORDOMATIC DRIVE** (opt. with all except Falcon Six): Features simplified design, lightweight cast-aluminum construction, vacuum-controlled throttle valve for greater smoothness, less servicing. Torque converter in combination with compound planetary gear set. In "D" range gives brisk, smooth starts in low. Effective engine braking in "L" position. Selector lever and quadrant on steering column, sequence P-R-N-D-L.

**REAR AXLE:** Semi-floating type with deep-offset hypoid gears. Induction-hardened forged shafts with permanently lubricated wheel bearings.

**FRONT SUSPENSION:** Angle-Poised Ball-Joint type with coil springs pivot-mounted on upper arms. 36,000-mile (or 3-year) lube intervals. Strut-stabilized lower arms with larger bushings. Threaded, permanently lubricated bushings in upper arms and low-friction rubber bushings in lower arms for softer, smoother ride. Link-type, rubber-bushed ride stabilizer. Built-in anti-dive control. Tapered roller wheel bearings. Double-acting shock absorbers with stable-viscosity fluid.

**REAR SUSPENSION:** Asymmetrical, variable-rate design with rear axle located forward from center of springs for anti-squat on take-off. Longer, wider leaf-type springs with lip inserts and wide spring base provide a softer, more stable, levelized ride. Diagonally mounted double-acting shock absorbers with stable-viscosity fluid.

**STEERING:** Recirculating-ball type steering gear provides easy handling. Anti-friction bearings throughout. Permanently lubricated steering linkage joints. Over-all steering ratio: 27 to 1. Turning diameter: 38.8 feet.

**BRAKES:** Self-adjusting, self-energizing design. Diameter, front and rear: 9 in. (Sixes), 10 in. (V-8's). Molded linings for longer life and fade resistance. Total lining area (sq. in.) (Sixes)—Sedans & Hardtops 131; Convertibles & Wagons 157. All V-8 models 154.

**TIRES:** Soft-Tread design, block, tubeless with Tyrex rayon cord. Safety-type rims. (Sixes); Sedans—6.00 x 13; other models—6.50 x 13. (V-8's); Sedans and Hardtops—6.50 x 13, others 7.00 x 13.

**PRICES:** Metal-to-web front seat belts, heater and defroster are installed in production on all Falcons unless otherwise specified. If deleted, an appropriate price reduction is made. All optional equipment and accessories, illustrated or referred to as options, optional or available are at extra cost. For the price of the Falcon with the equipment you desire, see your Ford Dealer.

*Comparative information in this catalog was obtained from authoritative sources, but is not guaranteed. The specifications contained herein were in effect at the time this catalog was approved for printing. Ford Division of Ford Motor Company reserves the right to discontinue models at any time, or change prices, specifications or design without notice and without incurring obligation.*

\*Except Falcon Station Bus and Club Wagons. For details on these models, including service intervals, ask your Ford Dealer for a copy of the extra-duty wagon folder.

## SEDAN AND WAGON DIMENSIONS†

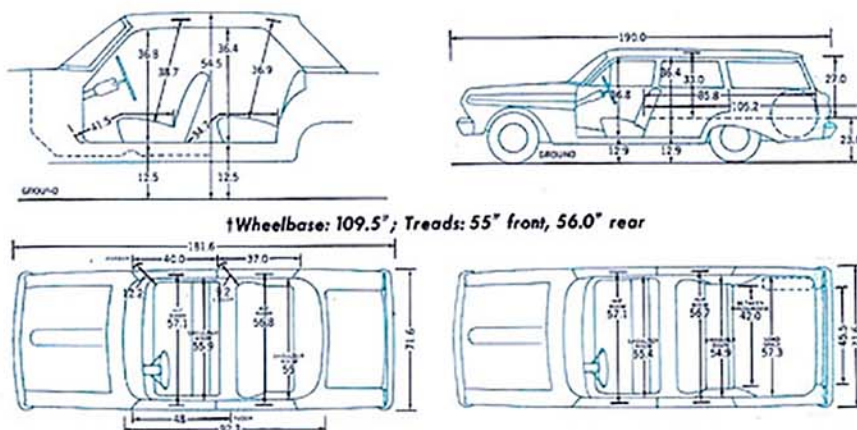

TRY TOTAL PERFORMANCE  
FOR A CHANGE!

# FORD

FALCON FAIRLANE FORD THUNDERBIRD

A PRODUCT OF  MOTOR COMPANY

# 1964 FALCON SPECIFICATIONS\*

**COLOR AND UPHOLSTERY SELECTIONS:** You have a choice of 11 '64 Falcon single tone colors or 12 two-tone combinations in durable, brilliant Diamond Lustre Enamel. There are 26 upholstery choices: 8 cloth and vinyl combinations (6 std., 2 opt.), 15 all-vinyl trims in Wagons, Convertibles and Hardtops; plus 3 all-vinyl options in Futura Sedans. Your Ford Dealer will be happy to show you actual samples of '64 Falcon colors and upholstery.

**FALCON DESIGN:** Among many Falcon feature highlights are: Welded Integral Body and Frame (quietness, high strength-to-weight ratio); Body Fully Insulated and Weather-Sealed; Parallel Action Electric Windshield Wipers; Deep-Dish Steering Wheel; Dual Sun Visors with Retention Clips; Safety-Yoke Door Latches; Front Seat Belt Anchors; Center-Fill Fueling (sedans); Counterbalanced Hood and Deck Lid (sedans); Tailgate (wagons); Lined Trunk (sedans); Vinyl-Coated Rubber Cargo Mat (wagons); 20-Gal. Fuel Tank (V-8 wagons), 14-Gal. (all others); Roll-Down Tailgate Window (wagons); Quick-Converter Second Seat Providing Flat, Level Loadspace (wagons); Upright Spare Tire Stowage (wagons).

**TWICE-A-YEAR (OR 6,000-MILE) MAINTENANCE:** The 1964 Falcon goes 36,000 miles (or 3 years) between major chassis lube; 6,000 miles (or 6 months) between oil changes and minor lube. In fact, Falcon needs so little service it's just good sense to see that it gets the best—at your Ford Dealer's. His factory-trained mechanics and special tools add up to a great service combination you can't find anywhere else! Other savings include: engine coolant-antifreeze, installed at the factory, good for 36,000 miles (or two years); self-adjusting brakes; aluminum muffler; and galvanized vital underbody parts to resist rust and corrosion.

**ENGINES: 85-hp Falcon Six** (std. on all except Futura Convertibles, Sprints and Wagons)—144 cu. in. displ.; 3.50" bore x 2.50" stroke; 8.7 to 1 comp. ratio; reg. fuel; single-barrel carb.; manual choke; self-adj. valves with hydraulic lifters; oil cap'y., with filter change, 4.5 qt.

**101-hp Falcon 170 Special Six** (std. on Futura Convertibles, opt. required installed in production on Wagons, opt. on other models except Sprints)—170 cu. in. displ.; 3.50" bore x 2.94" stroke. Other specs. same as above.

**116-hp Falcon 200 Special Six** (opt. on Wagons)—200 cu. in. displ.; 3.68" bore x 3.13" stroke. Other specifications same as Falcon Six above.

**164-hp Challenger 260 V-8** (opt. except Sprints)—260 cu. in. displ.; 3.80" bore x 2.87" stroke; 8.8 to 1 comp. ratio; reg. fuel; 2-barrel carb.; new vacuum-piston-operated automatic choke; self-adj. valves with hydraulic lifters; oil cap'y., with filter change, 5 qt.

**164-hp Sprint 260 V-8** (std. on Sprints)—same as Challenger 260 V-8 plus special trim items, power-toned air cleaner and muffler.

**ENGINE FEATURES:** For more economy and longer life Falcon engines have short-stroke, low-friction design; 6,000-mile (or 6-month) full-flow disposable-type oil filter; 36,000-mile (or 3-year) disposable-type fuel filter and replaceable dry-type element air cleaner; 190° thermostat; 12-volt electrical system; weatherproof ignition; battery 54-plate; 40 amp-hr (Sixes)—55 amp-hr (V-8's); fully aluminum muffler and tailpipe; crankcase emission control system. All engines electronically mass-balanced for operating smoothness.

**CLUTCH AND MANUAL TRANSMISSIONS:** Non-centrifugal clutch with Sixes; semi-centrifugal clutch with V-8's. Face diameter 8 1/2" with Sixes, 10" with V-8's.

**3-Speed Transmission** (std. on Sixes except 200 Special Six) has forged bronze synchronizers in 2nd and direct for smooth operation. Anti-friction bearings throughout. Standard "H" shift pattern with lever on steering column. **Synchro-Smooth Drive Transmission** (std. on V-8's) synchronized manual shifting in all three forward gears; clutch-free downshifting to low while under way. **4-Speed Transmission** (opt. on all models except Wagons) with floor-mounted stick shift. All forward gears synchronized for fast, smooth shifting.

**FORDOMATIC DRIVE** (opt. on all engines): Features simplified design, lightweight cast-aluminum construction, vacuum-controlled throttle valve for greater smoothness, less servicing. Torque converter in combination with compound planetary gear set. In "D" range gives brisk, smooth starts in low. Effective engine braking in "L" position. Selector lever and quadrant on steering column, sequence P-R-N-D-L.

**REAR AXLE:** Semi-floating type with deep-offset hypoid gears. Induction-hardened forged shafts with permanently lubricated wheel bearings.

**FRONT SUSPENSION:** Angle-Poised Ball-Joint type with coil springs pivot-mounted on upper arms. 36,000-mile (or 3-year) lube intervals. Strut-stabilized lower arms with larger bushings. Threaded, permanently lubricated bushings in upper arms and low-friction rubber bushings in lower arms for softer, smoother ride. Link-type, rubber bushing ride stabilizer. Built-in anti-dive control. Tapered roller wheel bearings. Double-acting shock absorbers with stable-viscosity fluid.

**REAR SUSPENSION:** Asymmetrical, variable-rate design with rear axle located forward from center of springs for anti-squat on take-off. Longer, wider leaf-type springs with tip inserts and wide spring base provide a softer, more stable, levelized ride. Diagonal y-mounted double-acting shock absorbers with stable-viscosity fluid.

**STEERING:** Recirculating-ball type steering gear provides easy handling. Anti-friction bearings throughout. Permanently lubricated steering linkage joints. Over-all steering ratio: 27 to 1. Turning diameter: 28.8 feet.

**BRAKES:** Self-adjusting, self-energizing design. Diameter, front and rear: 9 in. (Sixes), 10 in. (V-8's). Molded linings for longer life and fade resistance. Total lining area (sq. in.) (Sixes)—Sedans & Hardtops 131; Convertibles & Wagons 157. All V-8 models 154.

**TIRES:** Soft-Tread design, black, tubeless with Tyrex rayon cord. Safety-type rims. (Sixes): Sedans—6.00 x 13; other models—6.50 x 13. (V-8's): Sedans and Hardtops—6.50 x 13, others 7.00 x 13.

**PRICES:** All optional equipment and accessories, illustrated or referred to as options, optional or available are at extra cost. For the price of the Falcon with the equipment you desire, see your Ford Dealer.

\*Except Falcon Station Bus and Club Wagons. For details on these models, including service intervals, ask your Ford Dealer for a copy of the extra-duty wagon folder.

Comparative information in this catalog was obtained from authoritative sources, but is not guaranteed. The specifications contained herein were in effect at the time this catalog was approved for printing. Ford Division of Ford Motor Company reserves the right to discontinue models at any time, or change prices, specifications or design without notice and without incurring obligation.

## SEDAN AND WAGON DIMENSIONS†

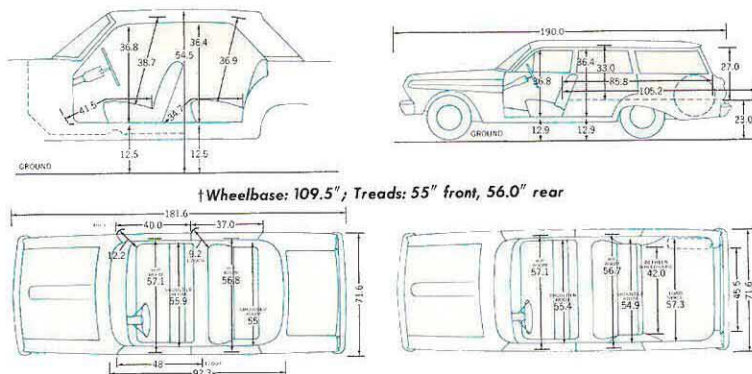

TRY TOTAL PERFORMANCE

FOR A CHANGE!

# FORD

FALCON FAIRLANE FORD THUNDERBIRD

A PRODUCT OF



MOTOR COMPANY

# FALCON for '64

The Total Performance Compact

