

BY ERIC DAHLQUIST □

Top rung or also-ran! Super-setup procedures on the 401/425

Buicks can make the difference

BUICK

Wildcat 465

VIEW HALF SIZE

MONOGRAM  
4 - MONOGRAM  
3 - CEMENT

1375118 ASM

# BLUEPRINTING BUICKS FOR ACTION

Of all the cars in the hot-compact field, the most underrated and most misunderstood is Buick's Gran Sport Skylark. This is true partly because, although it is entered in the Youth Market Sweepstakes, it comes from a stable recognized more for traditional bloodlines than spirit. Another thing is that it brings a slightly dearer price than the other "A"-bodied cars on the GM high-performance track, chiefly because the G. S. Skylark's heavy-duty frame and suspension are standard items, not options like the others. In the end, the "hot compact" price and performance fields are pretty competitive on comparable models, but that this notion hasn't gained wide knowledge is evident by our first statement.

So where are we? Quite a good way along the road to a champion as it turns out because, while nobody was paying much attention, a dedicated group of Gran Sport owners has been grinding up its rivals on the drag strips. This is true, of course, when the time has been taken to properly prepare the cars — which is what this story is all about. We noted last year when we checked out the Skylark that it was making a good account of itself in competition but, other than passing along a few tips, time and space were too short for much detailed information. We didn't forget the subject though and kept collecting bits and pieces, artifacts from Buick agency people and Buick campaigners like Lennie "Pop" Kennedy, who is current NHRA and AHRA champion, and now we're ready to publish the fruits of the research.

The basic Buick engine design is fairly straightforward, and we'll start the discussion by giving a few observations on general advantages and disadvantages of the powerplant. Although the current Buick engine range consists of the 425 and 401, most of what we have to say will be applicable to models as far back as 1957. Interestingly enough, the only major difference between the '57 and the 401 design which debuted in '59 is a .060-inch less bore. For example, speaking in broad terms, the Buick engine is lighter and narrower than most contemporary designs

(289 Ford and 273 Chrysler engines would be exceptions), incorporating a big bottom end that is reinforced with struts in high load areas. You will notice on Buick air cleaners this year that instead of cubic inch displacement or horsepower they have distinguished one model from another by noting its peak torque-output. And while you might think that they're just trying to be different, they realize that torque is really more important than horsepower because it's what makes the car go.

For a lot of years, Buicks have been synonymous with the phrase "nail-valve" because of their rather small diameter intake and exhaust valves, which this year are 1 7/8 and 1 1/2 inches respectively. While the engineers in Flint know that small valves restrict breathing, they also realize that small valves dissipate heat faster and, consequently, don't tend to burn as rapidly as others. Along with this dedication to long life (a goal reflected throughout the machine), they also aim for quiet operation, which means strict silencing of the exhaust. These two things, small valves and restricted exhaust, don't spell spectacular high speed (above the century mark) operation, although the engine will wind up to 6000 rpm in stock shape.

On another front, since the decree was issued, Buick has probably adhered to GM's non-racing policy more strictly than some Divisions that come to mind, (not to mention Ford and Chrysler, that are in high gear by comparison), so there has been little or no selection of power equipment from which enthusiasts might choose. And despite the fact that many devotees of the Flint Flyer would like to see this situation dramatically reversed, the policy is virtually unchanged in '66 except for two areas. For one thing, this year's differential selection spans ratios from 2.56 to 4.30, plus, of course, Positraction. More important, there have been built a limited number of so-called "police specials," Gran Sports with 11:1 pistons, high lift cams and Quadrajet carburetion, that will be available through Buick agencies. How much effect these "Specials" will have on Buick's image is ques-

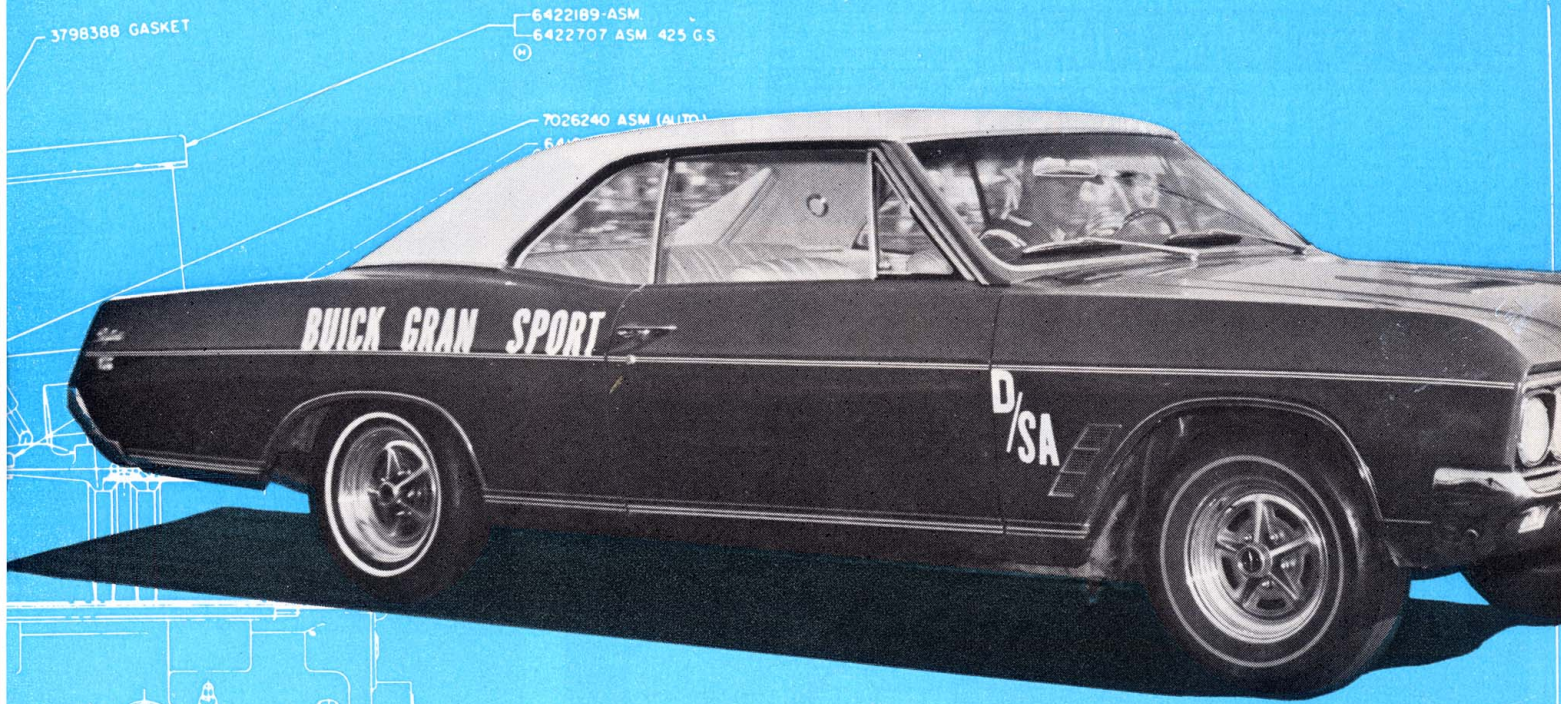

tionable because, if the dealer loads the cars down with accessories as some are prone to do, the youngsters they're trying to attract will shun them like the plague. The idea is on the right track, so let's hope it doesn't get switched onto a siding to rot.

But suppose a fellow has an ordinary G. S. Skylark, as most will, and wants to make it a legal D/Stocker or what have you, depending on the car's weight and horsepower. What modifications will make the mill turn on? Where should the initial steps be taken and will it cost a bundle? And what's this blueprinting business all about, anyway? OK, let's look at the questions in terms of a rising scale by starting at the easy side and then considering more complex things. And when we're done, it will be obvious that you don't merely blueprint the engine: it's a much broader problem than that.

The one thing the cars in the G. S. Skylark category suffer from most in drag-strip competition is lack of traction. Since the Positraction is available, the logical thing is to include it in the package. If you've already got a machine without it, better latch onto a limited slip before doing much else. There is a question, of course, as to which ratio is "ideal" but the answer depends on where your tolerance point is for everyday street use, if the vehicle is to be used for transportation at all. Most of the dragging Buicks have 4.30 gears, but this might be too severe for some. Next on the list is a good set of cheater slicks; a 14-inch tire, 27 inches in diameter, 7 inches wide, mounted on 6-inch rims. This is the hot setup for the 4.30 gear. In conjunction with the tires, it is also desirable that the chassis have the capability of being loaded to put more weight to the right rear as the car accelerates. Fortunately, Buick offers a set of Super-lift air shocks which were designed for quite a different purpose but work admirably well when inflated to 35 psi on the right and 7 psi on the left. Now the car no longer sits level, so two rubber spacers are inserted between the coils in each front spring, and caster, camber and toe-in are reset. The last thing, as far as the chassis is concerned, is that you drive four 1/8-to-1/16-inch

diameter pins into the rubber bushings on the rear-axle control arms. This will help stiffen the suspension. 1376817

Unlikely as it may seem, the standard Buick exhaust manifolds can be used for headers if they are ground to match the exhaust port perimeter and extensions added. Also, the heat valve should be removed and the shaft holes plugged. A better solution to the problem of exiting gases efficiently, though more costly, is a well-designed collector system using 4-foot-long, 1 1/2-inch-diameter tubing that meets in a 2 1/2-to-3-inch diameter, 10-to-12-inch long collector. Many of the Buicks in Southern California use the Hooker Header Company offerings because they originally researched out the design with week-by-week competition testing, but other brands of comparable dimensions will work.

In the ignition field, the Buick distributor should be set up along these lines: The breaker points must have a spring tension of 24 ounces so no point bounce will occur over 6000 rpm. Additionally, the cam lobe should be lubed with silicone 4X type compound to ensure the breaker block doesn't wear rapidly, changing the dwell angle of 28 degrees. The ignition curve depends mostly on the size of the tires to be used. With less than 7-inch tires, it should begin at 400 rpm and reach maximum at 2000. With 7-inch skins, since the car can use more low speed torque, the curve begins once more at 400 rpm but peaks earlier at 1400 rpm (distributor rpm).

Total maximum centrifugal advance is 15 degrees on the "lab" (testing machine) or 30 degrees on the crank (because lab speeds are 1/2 actual engine speeds). Initial advance is set at 2 1/2 crank degrees and should never exceed 5. A total advance of 35 degrees is too much for the engine, so if the initial, centrifugal and vacuum advance are added, their sum should not exceed 55 degrees. We have not mentioned vacuum directly here because under hard acceleration it doesn't play an important role in performance but on highway applications it should be 20 degrees maximum (10 distributor degrees).

(Continued on following page)

# BLUEPRINTING BUICKS FOR ACTION

**B**



photography: Eric Rickman

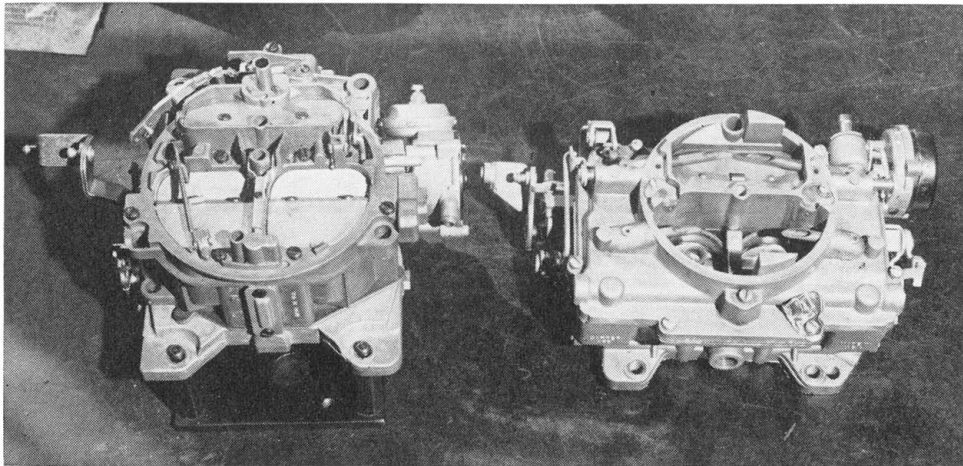

**A**

**C**

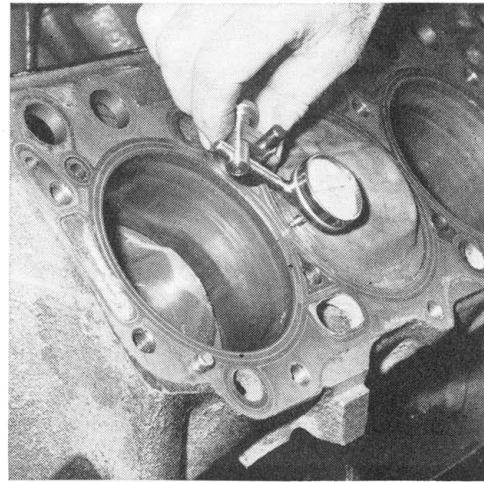

**A.** Quadrajets carburetor on left needs virtually no work for use on "stock" Buick prepared for drags. AFB Carter can use .086-inch jets on power step of primary metering rods, Rochester needle seat. **B.** 6-penny nails driven into control arm bushing will stiffen up suspension action. Other tricks utilize pumped-up air shocks and wedged front coils. **C.** Piston deck height is checked on center cylinders over piston pin in parallel plane with crank. Figure should be .010-inch. **D.** Exploded view of Super Turbine 300 shows where governor and valve body plate modifications should be made for quicker, more positive shifts. Four .250-in. holes on governor flyweights, removal of 1 spring, enlargement of shift plate hole from .090- to .125-inch are hot tips. **E.** Allan Brimhall, mechanic at Teryll Buick in Flagstaff, Ariz., shows correct method of cc check. **F.** Measuring distance from valves to piston top is easily done by subtracting difference between valve in seat position and valve touching piston. **G.** Good valve job uses 70-degree relief stone, 15-degree approach angle and 46-degree seat. **H.** Head heat-passages can be blocked with tinfoil. Valve guides are lubricated with a graphite mixture.

SUPER TURBINE 300

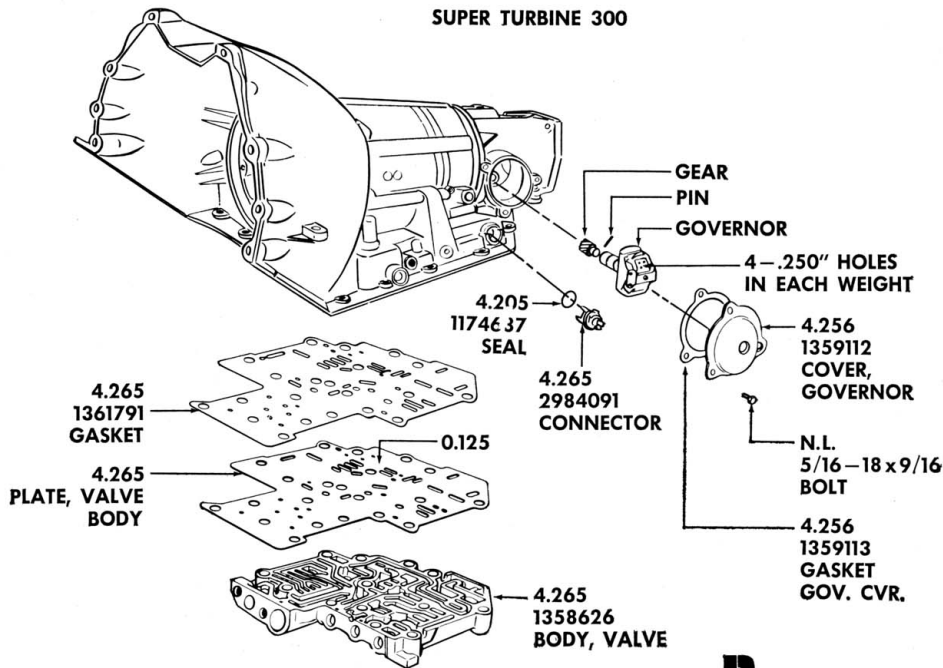

**D**



**E**

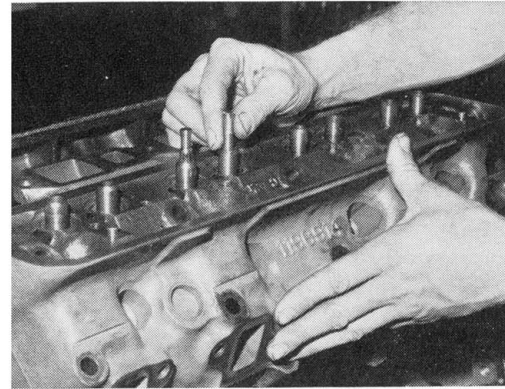

**F**

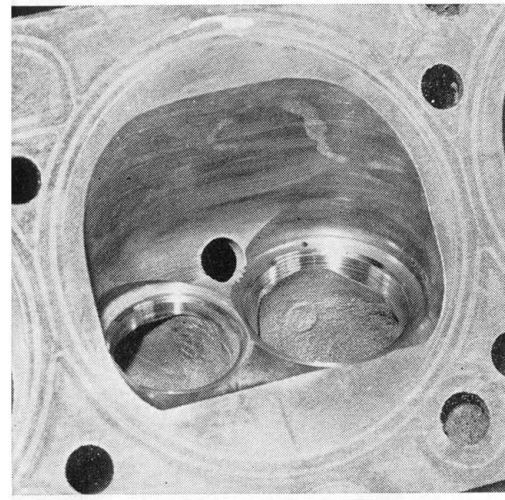

**G**

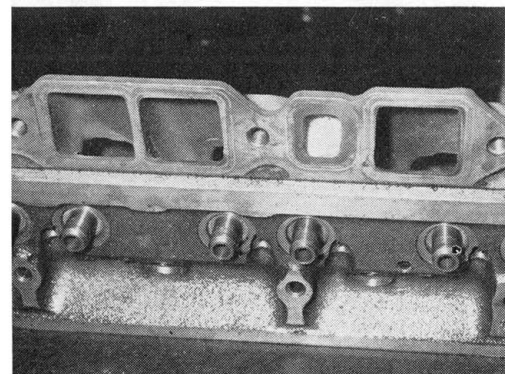

**H**

A great deal has been written concerning the subject of ignition cable, most of it generally supporting wire-center cable at the expense of the carbon-center, resistor-type. Now, despite the almost overwhelming majority against the performance capability of carbon-center cable, it turns out that the black stuff wins out over the wire. Here's why, and actually it's very simple. As the field in the coil collapses and pulses its voltage through the ignition cable to the plugs, there is an intermediate time section that follows the plug firing section, recorded on the oscilloscope as gradually diminishing oscillations, that disappears at the beginning of the dwell section when the points are closed. The wire-center-type cable tends to stretch the intermediate section and overlap into the dwell section when the points contact. At best, this means that there is unwanted voltage when the points are closing, creating a split-second arc with a temperature in the neighborhood of 6000 degrees F. This is what causes that Crater Lake landscape on the contacts. Also, since the field is not completely collapsed between each sequence, it does not belt out its maximum voltage when the points open next time. This situation doesn't mean much in normal operational scales but at 6 grand, grabbing for every 10th-second, sub par voltage causes plug misfire.

With the carbon-center cable and its built-in resistance, the intermediate section shortens up and the field collapses properly, even at high rpm. The only drawback of carbon cable is that with heat and age it hardens and becomes somewhat stiff, and doesn't stand up well to handling. As a consequence, it is recommended to use a wire-center cable from the coil to the distributor because of the increased use it usually sees.

Now that we have spent all this time on the ignition and its peculiarities, we'll balance it with only a few words on the carburetor. If you've had the luck to get a Quadrajets 4-barrel (7026242), then no modifications to the unit are necessary; it works that well — even in competition. If you have the AFB Carter, for a sea level elevation, 80-degree temperature, install .052-inch tips on the power step of the primary metering rods (.056- or .058-inch tips can be used during warmer weather and higher elevations). Also, the needle seats can be changed to .125-inch Rochester if two gaskets are used on each seat and the floats recalibrated to Buick factory Carter recommendation.

One of the reasons the Buick G.S. is such good drag strip bait is that keen little automatic transmission with variable pitch stator that allows almost a three-car-length jump right out of the gate. It requires no great amount of insight to forecast that the Buick driver has an almost insurmountable advantage

if his machine is in a good state of tune and he leaves at the same time as the opposition. To increase this advantage, making the overall potential of the car even more potent, two modifications to the automatic are desirable. First, it will be necessary to remove one governor spring (there are two in the governor assembly) and drill four 1/4-inch holes in the two large governor flyweights, in order to have a shift point out of low at 5500 rpm. Secondly, in order to improve the quality of the shifts, their rapid and positive character, the high-clutch feed passage in the valve body plate must be drilled out to .125-inch from .090-inch stock. Finally, there is one little tip that every Buick owner should know in order to check the operation of the electric switches in his automatic. The engineers have thoughtfully put the transmission kickdown on the same circuit as the windshield wipers, so all you have to do is switch on the wipers. If they work, then the fuse is okay. And if the stator and kickdown switches are adjusted, they should function.

On many of today's good automatics, the driver has the option of shifting for himself to attain a better maximum rpm in each gear. Although the Buick has this select-it-yourself feature, the transmission will actually shift quicker by itself because the oil pressure remains more within the functional limits of the design. For example, if the box does its own work, required pressure for each shift is 135 psi — manually held in gear it builds to 225 psi. This pressure differential is reflected by the fact that the transmission doesn't shift as precisely due to the greater force it has to overcome between gears, not to mention excess oil discharge.

One of the consequences of having a good transmission to match the rest of a properly set-up car is that as the vehicle accelerates, it creates quite a good deal of inertia on the fuel that has to be overcome before being pumped from the tank. Considering that the ordinary mechanical fuel pump creates 14 inches of vacuum or 7 pounds pressure to draw the gasoline through a 3/8-inch diameter line, it is apparent that there is the distinct possibility that the pump may not be able to cope with the situation. So the obvious answer is to augment the mechanical pump with an electric one, an accessory, we might add, that you see under the rear of every successful competition Buick.

The product of a G. S. Skylark that has had these modifications performed would generally fall into a range of 102 mph with an accompanying e.t. of 13.80 seconds. Not bad, all things considered. But to get the most out of the car, we have to plunge into the block itself, dismantle it to its essentials, and then fit

(Continued on page 123)

# BLUEPRINT FOR BUICKS

continued from page 43

it together as one would a fine watch. The process is not one which should throw pains into the heart of the tuner for, armed with basic information, even a novice can turn out a first-rate job provided he follows the plan carefully and uses an undeterminable amount of horse sense.

First off, the block has to be machined somewhere in the neighborhood of .020-.030-inch to bring the deck height (distance piston is below the surface of the block) to .010. The normal piston is usually found .030-.055-inch below the surface. It is important when establishing deck heights that the reading be taken (with a dial indicator surface gauge) on the center two cylinders above the piston pin, in line with the crank. Additionally, if the block has been milled, it is a good idea to check the deck height on all four corner pistons, too, because there is always the chance that the block surface has not been machined properly in relation to the crank.

A Buick block may be bored to a maximum of .030-inch and remain legal but this really doesn't accomplish much. In any case, the cylinders are to be honed .002-inch to allow a total skirt clearance of .004-inch for the cam-ground aluminum pistons. It goes without saying that no aluminum piston should be slipped into a cylinder bore that has not been properly cleansed of Carborundum grit. Stock rings are appropriate for drag strip competition, set with an end gap of .018-inch, plus or minus .001-inch. Piston side clearance is .0018-inch and piston pins are installed to a "slip-fit"; that is, so they have little or no drag. Reconditioning of the crankshaft demands that the throws be micro-finished .0005, undersized. Connecting rod bearing and main bearing inserts are Moraine 400 powdered aluminum, low-friction surface type that are clearanced at .002 and .0025-inch respectively. Side clearance on the connecting rods is maintained at .005-inch to prevent the collection of any excessive oil and in a measure discount "windage." Thus far, none of the Buicks have utilized a dropped oil sump with matching pickup, but it may be a thought for the future to yield 15 horsepower more.

Lubrication specs for this engine are not exotic so any good grade heavy-duty 20W HD may be used. Under no circumstances should you use more than 30W oil because its viscosity is such that it will take up the tolerances in the hydraulic lifters, causing them to pump

(Continued on following page)

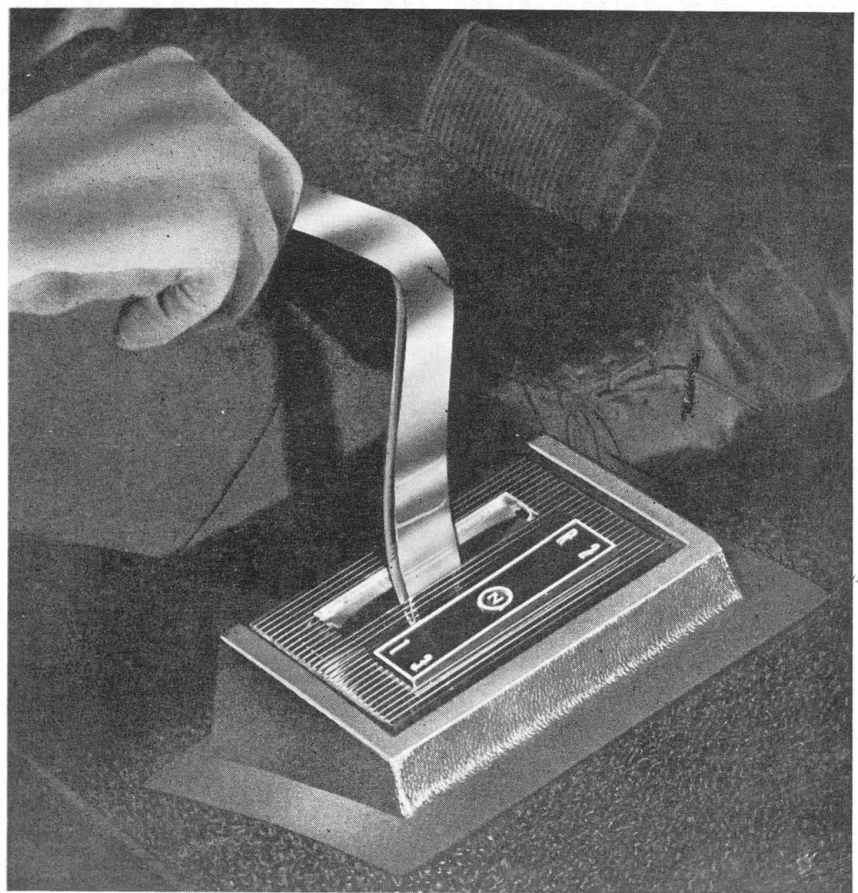

## CAUTION: DYNAMITE for use in blasting-off any starting line!

Ask for the Sparkomatic Triple Pattern Shift by name. It's available at most automotive chain stores, discount centers and speed shops throughout the country. Or write to Sparkomatic Corp., Milford, Pa. 18337.

If you want to be "boss" when it comes to scorching acceleration through the gears, Sparkomatic's big, beefy Triple Pattern Shift is a must. It's adjustable, too, to any one of three patterns: A conventional "H"; a narrow "H"; and a hairy "straight-line" that's just plain mean. Above the floor, nothing comes close to the Triple Pattern for looks. It's sheer luxury from the solid walnut barrel knob and flat racing-style chrome handle right down to the chrome inlaid Floor Console. Put one in now... and shake-up the competition.

### SUPER-H



NHRA APPROVED

## TRIPLE PATTERN FLOOR SHIFT

### SPARKOMATIC

CORPORATION  
MILFORD, PA. 18337

## EELCO wood-rimmed wheel

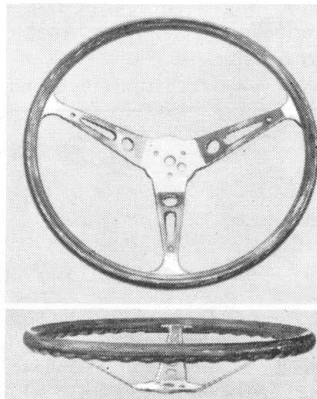

High Strength beautiful Danish Ash bonded to chrome-plated chrome moly steel under steam pressure. Steel seam along edge of wheel is concealed, permitting the rich full grain to show. Full 16" diameter, dished 3/2" deep. Strikingly flame treated to enhance and accent the beautiful and attractive hand-rubbed wood grain finish.

Do not confuse this handsome wheel with the usual heavy and thick competitive wood wheels. Eelco's functionally slim and strong wheel is identical to the thin lightweight European competition wheels that have been used for years in Grand Prix racing. Fits standard 3 bolt hub kits.

#4435 Racing Wood Rim Wheel.....\$42.50

EELCO . BOX 4095H . INGLEWOOD, CALIF.

## SPEED BOOSTS from McGURK



### Oldsmobile Adjustable Rocker Arms

The unchallenged choice from the standpoint of material; design, efficiency and performance.

49-58 Models — 1.5 to 1, or 1.8 to 1 comp. ratio. (Specify year and ratio required)

Set of 16.....\$29.95

59-65 Models — Cat. No. DL 200. Set of 16.....\$35.95

CHEVY II 6 CYLINDER 230 AND 292 CU. IN. CIRCULAR TRACK CAMS — ROLLER OR FLAT TAPPET



### CHEVY V8 OVERSIZE VALVES

#### THE VERY BEST

McGurk pioneered the use of Oversize Valves in Chevy V8 engines, and has been the prime supplier to the racing industry ever since. Volume production has kept the cost of McGurk products down, while quality has remained the highest. Complete coverage on oversizes.

INTAKE VALVES	EXHAUST VALVES
1 7/8" Size \$2.50 ea.	1 5/8" Size \$3.00 ea.
2" Size \$3.00 ea.	1 1/2" Size \$3.70 ea.

Reworking the Chev 6 and GM 3.....only 50¢  
Reworking the late Model Chev OHV.....50¢

## McGURK ENGINEERING

13226 Halldale Ave., Gardena, Calif. 90249  
Phones (213) 324-7226 321-3747



GIVE YOUR CAR THAT

# NEW LOOK!

... AND HAVE FUN DOING IT

- Easy on! Easy off!
- No hard rubbing necessary
- Not a wax—but a surface protector concentrate
- Forms hard protective shield That lasts... And lasts...
- Excellent for new Acrylic and Lacquer car finishes

## 25¢ VALUABLE COUPON—SAVE—USE 25¢

CLIP THIS VALUABLE COUPON. Present to your neighborhood service station and save 25¢ on the purchase of your next can of Custom Gloss Cream.

Use space below if your neighborhood service station is out of Custom Gloss Cream.

NAME \_\_\_\_\_  
ADDRESS \_\_\_\_\_  
CITY \_\_\_\_\_ STATE \_\_\_\_\_

Mail To:  
CUSTOM CREST CAR PRODUCTS, INC., Syracuse, Indiana

Enclose \$2.25 Check  Money Order  Cash   
Offer expires December 31, 1966 Midnight

HR

# BLUEPRINT FOR BUICKS

continued

up. Heavy oil for stocker-type drag racing is rather a moot point in any case, for the lubricant doesn't get hot enough in the quarter to worry about. One thing that is a problem, a big one at that, is getting the oil down the push rods due to air pressure buildup within the engine. One solution that works is the fitting of breathers, the type used on rocker arm covers, on the tappet galley cover.

For the best possible top end in a stock Buick, the 1368091 camshaft with a 2 1/2-degree offset key (available from Reynolds Buick in Covina, California) is suggested. This cam allows a .461-inch lift at the valve instead of the normal .441-inch. On the lifter situation, Buick is standing pat because their hydraulics will go 6000. We had already uncovered some pretty interesting footnotes to this story when we got the scoop on camshafts; not so much the "right" part number, but rather their care and feeding. For instance, no camshaft should be installed without first checking to see that it's straight. The method of doing this is to simply rotate the cam on a steady fixture and use a dial indicator to check variation on the center journal. Run-out must not exceed .002-inch or the camshaft will tend to "screw" itself in and out of the cam bearings, creating knock, wear and, more disastrous, erratic timing.

But how do cams get unstraight? It turns out that most often a cam that is exposed to sun for long periods will heat up unequally and distort. You might think this farfetched, but consider a camshaft left on a garage bench for a couple of days where the room temperature may be 40 degrees, but the hot sun streaming through the panes heats the top half of the billet cast iron unit while the bottom half stays cold. It's a point well worth remembering. Another one is not to lean a camshaft in a corner somewhere because this too will distort it. These items may seem trivial but it's all the overlooked trivial things that put you with the also-rans.

Now we've arrived at the stage of the

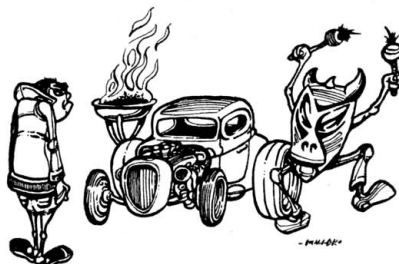

"Come off it man, it's just a bad plug!"

## CHEVY POWER REBUILD KIT

Choice of Complete Balanced 272, 292 or 301 C.I. Crank Assembly with High Comp. F.I. Pistons, New Billet Cam (316 degrees duration .486 lift), Solid Lifters, High Rev Springs, Aluminum Retainers, Mallory 9000 RPM Dual Point Distr., Carter 409 A.F.B. Carb., Manifold Adaptor, New Cam & Crank Sprockets, New Chain, New Cam Bearings. Complete, ready to install in your rebored block. FULL PRICE: \$299.95 F.O.B. No. Hollywood. 50% deposit on C.O.D. Give year of engine, heads, type of manifold (2 or 4 barrel).

Write for prices of individual parts.

## C-T AUTOMOTIVE, INC.

7259 Lankershim Blvd., North Hollywood, Calif.  
213 877-0347

**WHEELS** ✪ **WHEELS** ✪ **WHEELS** ✪

## \$SAVE

AT SPEEDWAY YOU SAVE ON ALL YOUR WHEEL AND SPEED EQUIPMENT NEEDS EVERYTIME!

CHROME WHEELS .....	\$55.00
Set of 4	
CRAGAR MAGS .....	\$109.00
Set of 4	
T.E. MAGS .....	\$129.00
Set of 4	
HURST MAGS .....	\$159.00
Set of 4	

Send 25c for Big Wheel Catalog  
ALL ORDERS SHIPPED SAME DAY!

**1719 N ST. LINCOLN, NEBR.**

## SWA-BAR

Ferraris & Police Specials, Avantis & stockers, sports cars & dragsters; the hot cars have rear stabilizer bars for handling & traction. Roger Huntington recommends 'em. Eliminate body roll, plowing, understeer, tire hop, spin & wear! Go flat with SWA-BAR! Satisfaction or refund! Specify any model & yr. Drill & wrench installs. \$19.95 Ppd. Dealer inquiries invited. Write Swa-Bar, HR-10, 704 N. State St., Chicago, Ill. 60610

# ATTENTION CAR CLUBS!

## SPECIAL SUBSCRIPTION RATE

A special low rate is available to members of your club on group subscription orders—with magazine delivery to be made direct to each member's home address!

### LET US TELL YOU ABOUT IT!

---

HR-466

**HOT ROD MAGAZINE**  
5959 Hollywood Blvd., Los Angeles, Calif. 90028  
Please send us, without obligation, complete details regarding the special low subscription rate that is available to members of our club.

Club Name \_\_\_\_\_ No. of Members \_\_\_\_\_

Street \_\_\_\_\_

City \_\_\_\_\_

State \_\_\_\_\_ Zip \_\_\_\_\_

Signed \_\_\_\_\_

game that can make or break an otherwise well set-up engine: The correct cylinder-head preparation. Each combustion chamber displaces a volume from 123 to 130cc and will require .004-inch of material off the head to reduce the volume 1cc. An average head will take about .017-inch of milling to bring the volume to 123cc minimum spec. One little pointer that may get you out of trouble someday is that Buick makes two types of identical-sized valves, flat and tuliped head. Often by juggling the two designs, flat for less volume and tuliped for more, you gain or lose just enough for the specified cc number.

The fine art of a super Buick valve job seems to lie in a kind of port blending that we have run into previously. In sequence, the methods run something like this: A 70-degree relief stone is used to raise the valve seat as well as improve flow characteristics. The seat approach angle is 15 degrees with a 46-degree seat 1/16-inch wide. (.060), plus or minus 1/64-inch. Valve facing seats are trimmed at a 44-degree angle. The 2 degrees difference between the valve and seat is to permit instant sealing, even in competition. Although no porting or polishing is permitted, it is an excellent idea to check for burrs or sharp corners and remove them. **Do not** remove those little dime-sized nodules you see in the ports for they are turbulence controls. Knock these out and you knock your performance.

To ensure that the valve stems do not gall in the guide, it is prudent to graphite the guides. This is easily accomplished by mixing up a compound of graphite and alcohol to be worked into the pores of the guide with the valve stem. The mixture functions a lot like heat-trap lubricant, where the alcohol acts as an agent to deposit the graphite and then evaporates, leaving the lubricant. Oils will not work because they burn away rapidly, creating gums that will stick the valve. One final touch for good intake valve stem sealing is a set of those fine P.C. Teflon valve seals ('66 Buicks have them).

Any time an engine block is blue-printed, it is imperative, due to variances in manufacturing tolerances, to check very carefully the installation of the heads, for there is always the possibility that a piston may contact the cylinder head or the carbon on the cylinder head or a valve, perish the thought. When a head is installed for checking, it is suggested that the valves have a minimum of 3/16-inch clearance without the head gasket. And try it on all eight pistons prior to installing head or valve springs permanently. And never have a piston at TDC when installing a head on a hydraulic lifter engine as the lifter could force the rocker to open a valve, striking the piston top.

*(Continued on following page)*

## SS POWER SHIFT FLOOR SHIFT CONVERSION FOR AUTOMATICS . . .

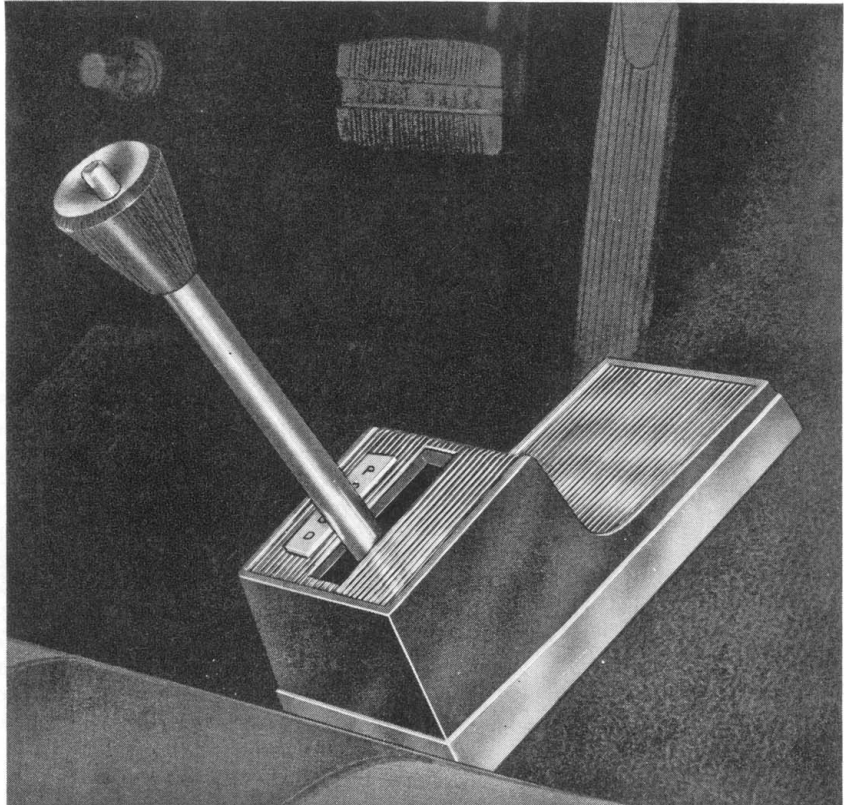

**the single most important modification you can make on your automatic to achieve maximum performance on street or strip!**

Your automatic can be a big wheel on or off the strip with a rugged Power Shift Floor Conversion by Sparkomatic. It doesn't matter what you've got going for it — a big mill, hot ignition, even an exotic cam — it still boils down to how fast you can shift. And, the fact is, you can't shift faster, safer or more accurately than with a Power Shift! Add to this push button lock-outs for reverse and park, heavy duty life-of-car construction, a magnificent cast aluminum and chrome console and a host of other exclusive features . . . and you're talking a winner in looks and performance. But don't take our word for it. Install one in your car and we guarantee it will forget it's supposed to be an automatic!

*The Sparkomatic Power Shift is on sale at all leading automotive chain stores, discount centers and speed shops throughout the country. Ask for it by name. If your dealer does not have it, write to Sparkomatic Corp., Milford, Pa. 18337.*

**SPARKOMATIC**

**CORPORATION  
MILFORD, PA. 18337**

## GOLDENROD SETS WORLD SPEED RECORD USING HOOKER HEADERS

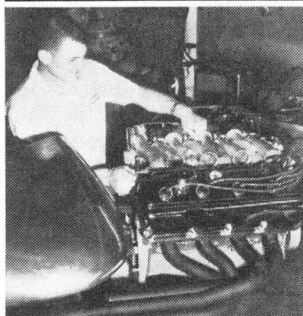

Bob Summers world land speed record holder . . . 409 MPH.

### MINIMUM EXTERIOR WELDS!

All Hooker Headers have been completely redesigned for 1966. We now offer new production techniques of mandrell bent 4 tube Headers for all late model cars.

For additional information send 25c for catalogue and free decals.

Dealer inquiries invited.

**PHONE (714) 984-8201**

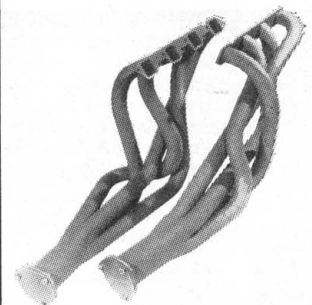

Hooker . . . world's fastest headers

**Hooker Headers, 415 W. Main St., Ontario, California**

**NEW!**

# GUMOUT PCV Valve Cleaner

**Heads off engine trouble fast!**

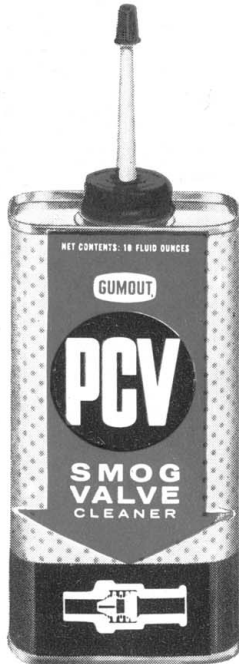

Positive Crankcase Ventilation valves, now standard on most cars and trucks, must be cleaned regularly to maintain proper idling, acceleration, fuel economy. Without cleaning, gas consumption soars, oil is contaminated, engine parts rust and corrode.

Just a few squirts of GUMOUT PCV VALVE CLEANER flush out the crankcase ventilation valve quickly and thoroughly. Exclusive probe applicator gets right into the valve—gets dirt out. Regular use prevents trouble, keeps engines running smoothly.

Buy GUMOUT PCV VALVE CLEANER at your auto supply store. Price is \$1.49. If your store doesn't have it, order directly from:

## GUMOUT DIVISION

Pennsylvania Refining Company,  
Cleveland, Ohio 44104

**EASY TO USE!** Disconnect crankcase side of PCV Valve. Insert probe applicator, squirt a little cleaner into the valve while working plunger back and forth. Let soak for a few minutes, then start the engine and flush valve with a few more squirts of PCV Valve Cleaner.



# BLUEPRINT FOR BUICKS

*continued*

Should there be a conflict between the valves and pistons in any particular cylinder, tools are available to cut "eyelids" in the piston top. If this is a bucks-down operation, the builder can fabricate his own tool by using an old valve with some coarse emery cloth glued backside to the valve head. It may take a little while longer the homemade way, but the job is comparable. Buick uses a standard inner and outer valve spring setup and these are plenty good for use with the stock cam. The recommended installed height is 1.60-inch outer, and 1.690-inch inner, and there is one thing to keep in mind. Since the valve springs tend to set at 6-8 pounds less than the desired pressures of 46 to 51 pounds outer and 26 to 31 pounds inner, it will be necessary to install .060 shims under the springs. It would be an excellent idea after the engine is broken in to remove the springs and shims and check their actual pressures at the proper installed height in a valve spring tester to see if everything's in the ballpark.

The last thing to go on the engine is the intake manifold, and since this is a racing engine, and since the volumetric efficiency of a unit is higher with a cooler charge, the heat riser in the manifold should be plugged. If you want, there is a blank Buick manifold gasket (1173705) that will get this very job done. Another method is to pack the heat passages in the heads with wads of tinfoil that are jammed up inside. For some reason, blocking the heat source in this fashion doesn't create as much turbulence in the exhaust ports.

Well, that's about the whole ball of wax as it looks from here. That's how Lennie Kennedy, Ralph Bergeron, Russ Mathews and Willard Bennett, classed from C, D and H/Stock, get the job done on their competitors. Kennedy's tudor, running out of Reynolds Buick in Covina, California, has popped 108.27 in 12.90 seconds in C/SA and has been beaten few times for the gold. Whether the rest of the "Hot Compact" youth market field knows it or not, Buick has added a new dimension to its famous slogan: "When better . . . er faster . . . cars are built, Buick will build them." ■ ■



## SUPERIOR CAMSHAFTS

Write Dept. A for latest Grinds and Prices  
Crankshafts Roto-Krome Plated

**CLEVELAND HONE & MFG. CO.**

8816 HARKNESS RD., CLEVELAND 6, OHIO

Now there's a set of **Jahns**   
**QUALITY PISTONS**  
**FOR ALMOST EVERY APPLICATION!**  
... from the mild street engine to the high RPM, high performance competition engine.

**CAST**  
Special low expansion aluminum alloy is used to insure light weight, with superior performance and dependability. Features strut-type piston pin bosses. Available for most engines through 1966, including the very popular Chevrolet 283 and Dodge "Hemi" in flat top and high compression, standard and oversize bores.

**FORGED**  
For high RPM Competition engines only. Forgings of the finest Alcoa aluminum alloy are precision machined to meet Jahns renowned standards. Engineered by our staff to withstand the extreme stresses of today's high RPM. High performance competition engines. Available for most engines in bore sizes 3 7/8 to 4 1/4 in flat top, high compression and strokers.

Write for **FREE ILLUSTRATED INFORMATIVE LITERATURE**

**Jahns QUALITY PISTONS, Inc.**  
Dept. HR-4 2662 Lacy St. Los Angeles, Calif. 90031

**COOL THE NOISE MAN** **PROTECT YOUR HEARING**



wear **Lee Sonic EAR-VALVS**



Lee Sonic EAR-VALVS let you hear everything normally while they eliminate the harmful effects of noise. A precision engineered, patented mechanical hearing protector. These are NOT EAR PLUGS. Only \$3.95 a pr. with money back guarantee. ORDER TODAY or write for FREE Medical Proof and literature.

► **SIGMA ENGINEERING CO., DEPT. HR**  
1608 Hillhurst Ave., Los Angeles, 27, Calif.

BUILDING A FUNNY CAR? GASSER??



Al offers a complete line of **LIGHTWEIGHT BODY & CHASSIS COMPONENTS** for  
Anglia ★ Austin ★ Barracuda ★ Chevrolet  
37-57 Chev. ★ Chevy II ★ 23-40 Ford  
Mustang ★ Willys ★ Many Others  
65; CATALOG ONLY \$1.00

HI-RISER HOOD SCOOP \$27.50 with wire mesh grille

**Anderson Industries / FIBERGLASS**  
5820 VILONA AVE. • ELKRIDGE 21227, MARYLAND (301) 355-6320

**DA-NITE SAFETY REFLECTOR**



**ONLY \$1.95**

- Be safe! Be seen! Travel safely!
- Helps prevent accidents on hills, in traffic
- Glows in all directions
- Glows day & night, rain or snow
- Raise height of your car—be seen
- Unbreakable
- No screws, permanent suction grip
- Money back guarantee

**DA-NITE SAFETY REFLECTOR, INC.**  
20024 EDMUNTON DRIVE  
PAT. PEND. ST. CLAIR SHORES, MICHIGAN 48080

**NEW Ford PARTS**  
1928 to 1948

Largest stock of new original parts and duplicate reproduction parts for the restorer. Send \$1 for 1928-1948 catalog listing over 2000 items.

**SPECIALIZED AUTO PARTS**  
301 ADAMS, HOUSTON, TEXAS 77011

**THUNDERBIRDS**  
1955-56-57

Fiberglass Hardtop \$189  
Soft top Assembly with bows & clamps \$175



Anything for 'Birds. Upholstery, Carpets, Dogr Trim Panels, Hoods, fenders, doors in fiberglass or steel. One piece front end weighs 40 pounds. Any Part or Accessory. Send 50c for complete new catalog.

**TEE-BOYD PRODUCTS** Decals 25c ea. WILDWOOD, N.J.