

INSTALLATION INSTRUCTIONS

INSTALL INTAKE MANIFOLD, CARBURETORS AND OLD WATER OUTLET USING NEW GASKETS AND SEALS PROVIDED. A NEW OIL FILLER TUBE AND RADIATOR INLET HOSE MUST ALSO BE USED.

CARBURETION:

TYPE OF LINKAGE (PROGRESSIVE):
THE 3-2 BBL CARBURETION SYSTEM IS DESIGNED SUCH THAT ALL DRIVING IS DONE WITH THE CENTER CARBURETOR ONLY. THE FRONT AND REAR CARBURETORS ARE PICKED UP A 1/2 THROTTLE.

LINKAGE ADJUSTMENT: (SEE SHEETS 1 & 2)

FOR PROPER IDLE, IT IS NECESSARY THAT THE REAR END OF THE ROD CONNECTING FRONT AND REAR CARBURETORS, ON RIGHT HAND SIDE, IS POSITIONED IN THE CENTER OF THE SLOT IN THE REAR CARBURETOR LEVER. IF ROD IS NOT CENTERED, ADJUST BY BENDING ROD AS SHOWN ON SHEET 2.

CHOKE ADJUSTMENT:

THE CHOKE HAS BEEN PRE-SET AT THE FACTORY AND SHOULD NEED NO ADJUSTMENT; HOWEVER, CHOKE SETTING MAY BE CHECKED AFTER TIGHTENING CHOKE HOUSING AND CARBURETOR IN POSITION BY THE FOLLOWING PROCEDURE: WITH CHOKE BLADE HELD CLOSED, PULL CHOKE ROD UP UNTIL FULLY EXTENDED OUT OF HOUSING. TOP END OF ROD SHOULD THEN BE TWO (2) ROD DIAMETERS ABOVE HOLE IN CARBURETOR CHOKE LEVER. (SEE VIEW B, SHEET 2) IF REQUIRED, BEND CHOKE ROD AS SHOWN TO MEET THIS CONDITION. THIS INSURES PROPER CHOKE SPRING TENSION WHEN ROD IS INSTALLED IN CHOKE LEVER HOLE AND RETAINED WITH CLIP PROVIDED.

FUEL LINE INSTALLATION

1. CAREFULLY INSTALL, TIGHTEN AND INDEX ALL FUEL FITTINGS IN THE CARBURETORS, FUEL FILTER AND FUEL PUMP.
2. INSTALL FUEL FILTER, BRACKET AND CLAMP, BUT DO NOT TIGHTEN.
3. INSTALL ALL FUEL PIPES LOOSELY BEFORE TIGHTENING ANY SINGLE PIPE. THEN GO BACK THROUGH SYSTEM AND CAREFULLY TIGHTEN ALL FUEL PIPES, FILTER BOLT AND BRACKET.

VACUUM FITTINGS AND HOSES

1. FRONT CARBURETOR (SEE SHEET 1 VIEW A)

INSTALL ELBOW AND PLUG ON CARS EQUIPPED WITH MANUAL BRAKES.

INSTALL ELBOW AND CONNECTOR ON CARS EQUIPPED WITH POWER BRAKES. (SEE SHEET 5)

2. CENTER CARBURETOR

INSTALL CRANKCASE VENTILATION CONNECTOR AND HOSE AS SHOWN ON SHEET 1, VIEW B AND SHEET 4.

3. REAR CARBURETOR

IF CAR ORIGINALLY HAD AIR CONDITIONING AND/OR VACUUM TRUNK RELEASE, REINSTALL VACUUM HOSE WHICH WAS CONNECTED TO ELBOW IN REAR OF 4 BBL INTAKE MANIFOLD TO ELBOW PROVIDED FOR BACK OF REAR CARBURETOR. IF NO VACUUM IS REQUIRED, INSTALL PIPE PLUG PROVIDED. (SEE SHEET 1, VIEW C)

4. HEATER HOSE

INSTALL HEATER HOSE AND WATER BY-PASS HOSE REVERSED AS SHOWN IN VIEW A, SHEET 4. POSITION SPACER ALONG HEATER HOSE AND ROUTE HOSE SO THAT IT DOES NOT TOUCH FUEL LINES OR CARBURETOR.

EXHAUST CROSSOVER VALVES

OPENINGS IN THE INTAKE MANIFOLD HAVE BEEN PROVIDED ON BOTH SIDES OF THE CENTER CARBURETOR FOR EXHAUST CROSSOVER VALVES. THIS SYSTEM ALLOWS THE EXHAUST CROSSOVER HEAT TO BE ELIMINATED FOR HIGH PERFORMANCE OPERATION ONLY. THIS IS ACCOMPLISHED BY POSITIONING THE VANE ON BOTH VALVES PARALLEL WITH THE ENGINE FOR BLOCKING THE HEAT OR CROSSWAYS TO THE ENGINE FOR NORMAL OPERATION.

IT IS RECOMMENDED THAT HEAT NOT BE BLOCKED FOR NORMAL OPERATION OR DURING COLD WEATHER AS IDLE, CHOKE OPERATION AND LOW SPEED DRIVING WILL BE AFFECTED.

WHEN BLOCKING HEAT, IT IS SUGGESTED THAT THE HEAT VALVE SPRING ON LEFT HAND EXHAUST MANIFOLD BE DISCONNECTED. THE CHOKE ROD MAY HAVE TO BE DISCONNECTED IF THE CHOKE IS NOT FULLY OPEN AFTER ENGINE HAS WARMED UP.

CARBURETION FLOAT LEVEL

ON CARS EQUIPPED WITH FUEL PUMP 644023, THE CARBURETOR FLOAT LEVELS WILL HAVE TO BE CHANGED FROM 5/8 INCH TO 1/2 INCH. (SEE SERVICE MANUAL FOR METHOD OF ADJUSTMENT.) CARS WITH FUEL PUMP 6440262 WILL NEED NO CARBURETOR CHANGE.

NOTE FUEL PUMP CAN BE IDENTIFIED BY THE LAST DIGITS OF THE PART NUMBER STAMPED ON THE TOP OF THE PUMP MOUNTING FLANGE. IF THE PUMP HAS NO IDENTIFICATION, IT IS A 6440262 AND NO CHANGE IS NECESSARY.

TIMING

DISTRIBUTOR TIMING IS TO BE SET AT 7.5° B.T.C. @ 850 RPM WITH VACUUM ADVANCE DISCONNECTED.

IDLE

IDLE SPEED TO BE 600 RPM ON STANDARD CARS AND 700 RPM ON CARS EQUIPPED WITH AIR CONDITIONING.

INSTALLATION OF OLDSMOBILE 3-2BBL CARBURETORS (FOR 442 SERIES WITH SYNCROMESH TRANSMISSION)

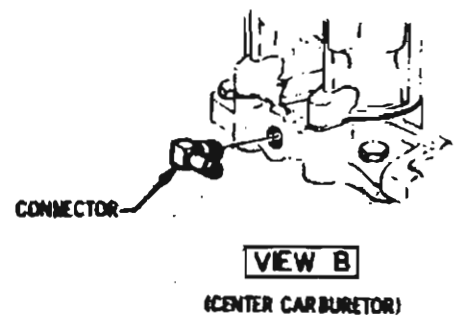
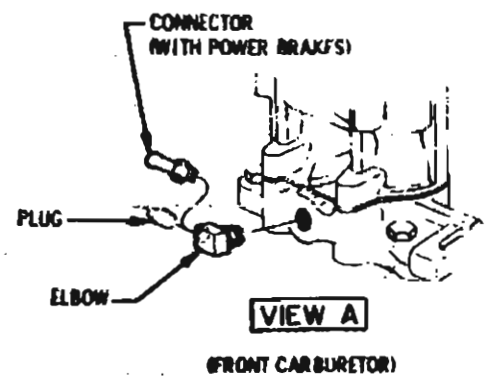
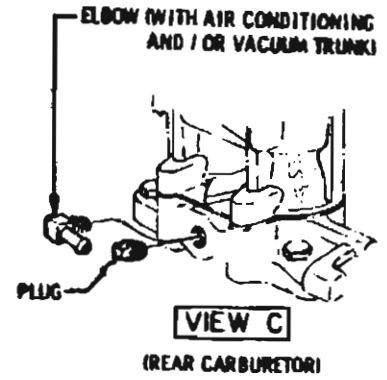
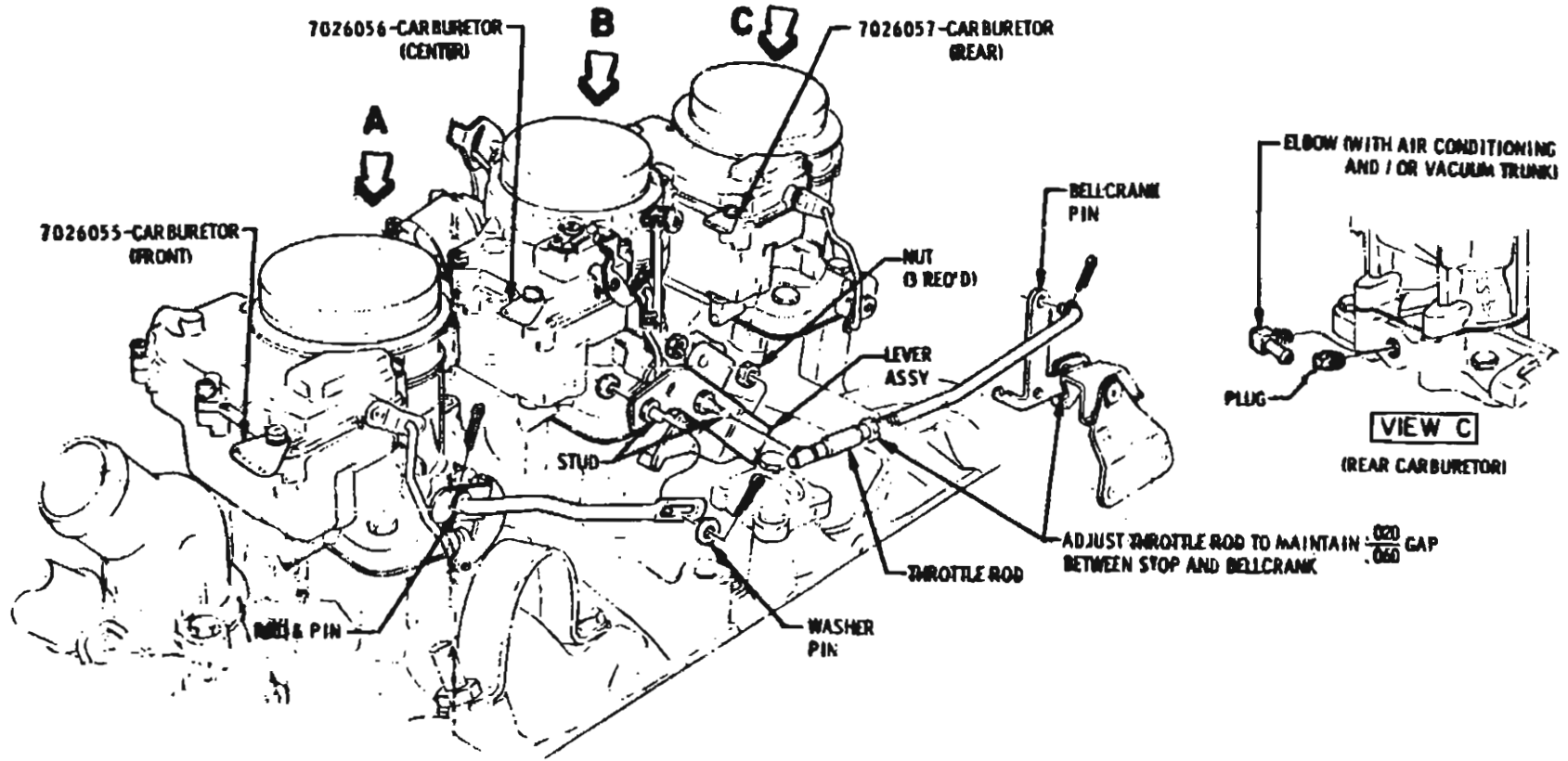

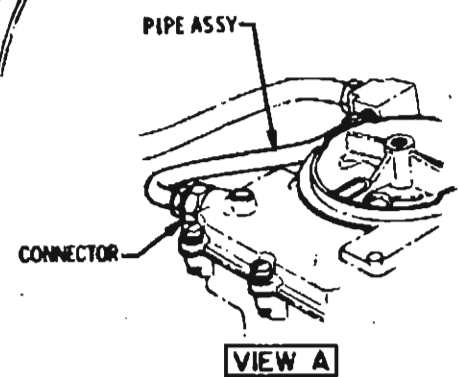
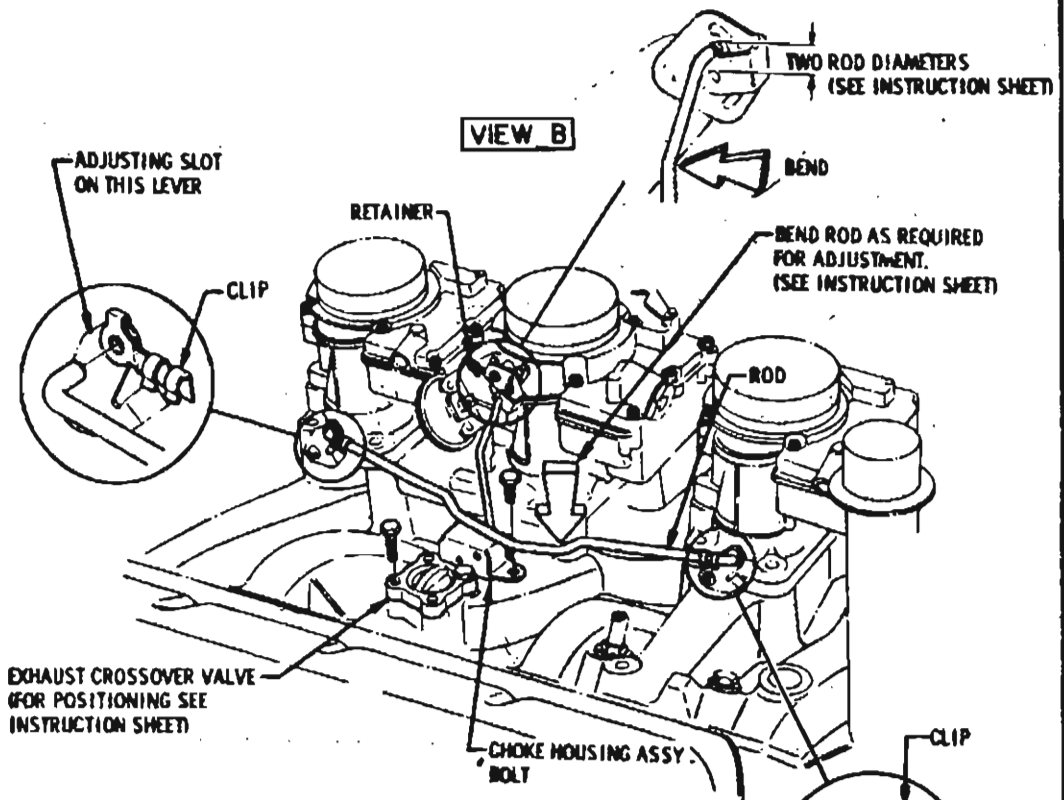
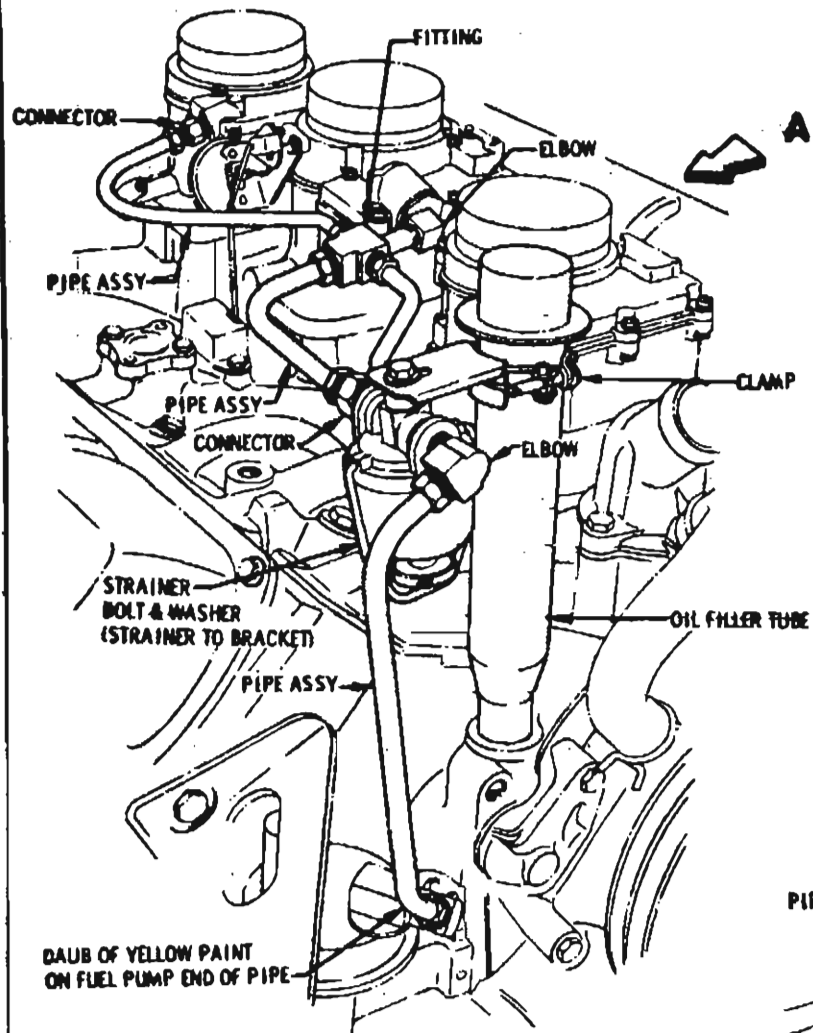

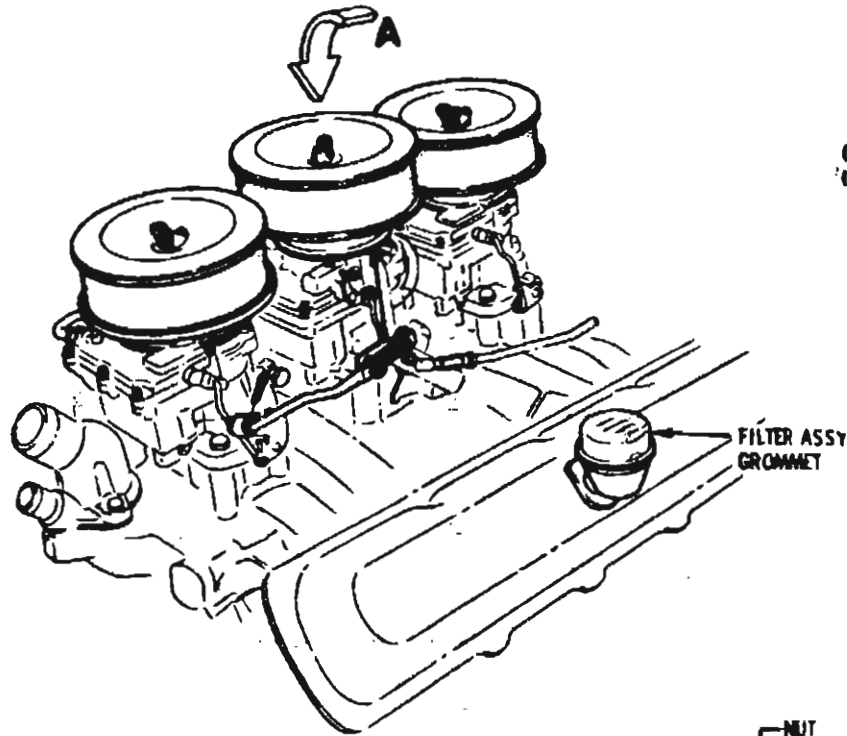

CRANKCASE VENTILATION
NON-CALIFORNIA

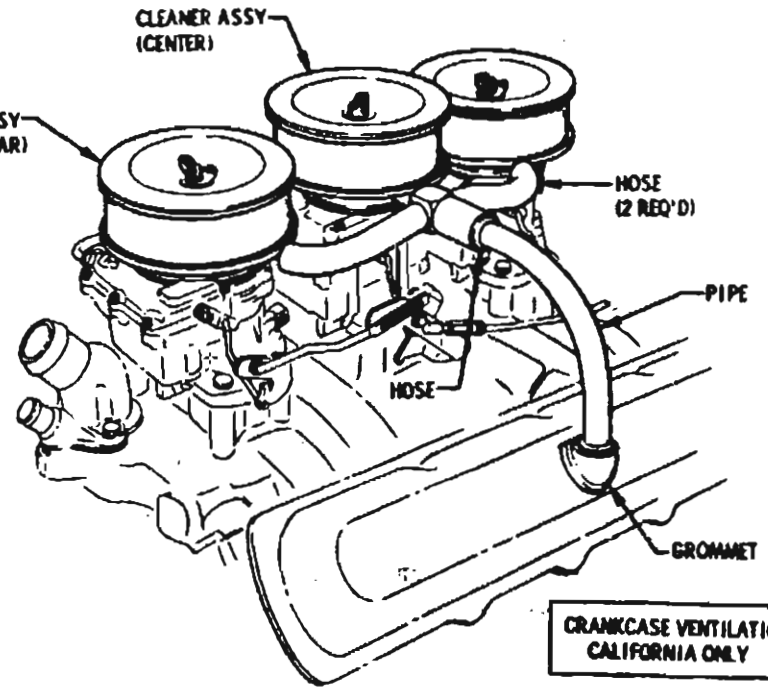

CRANKCASE VENTILATION
CALIFORNIA ONLY

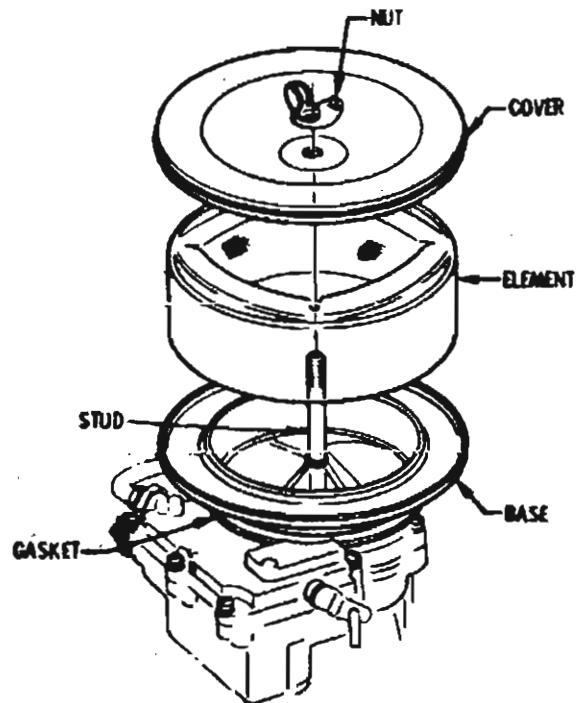

TYPICAL CLEANER INSTALLATION

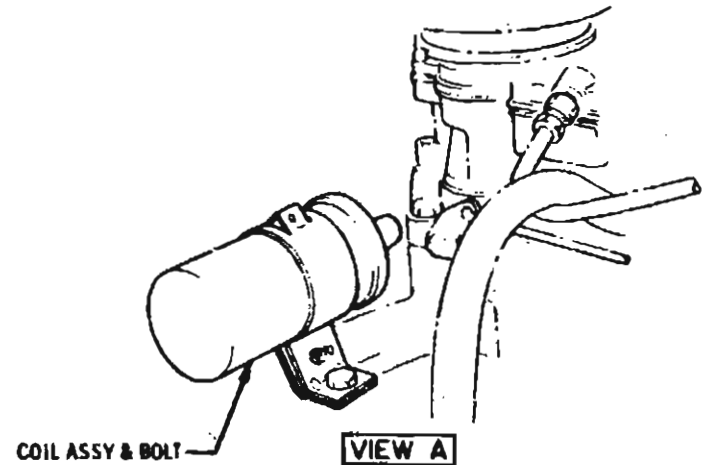

VIEW A

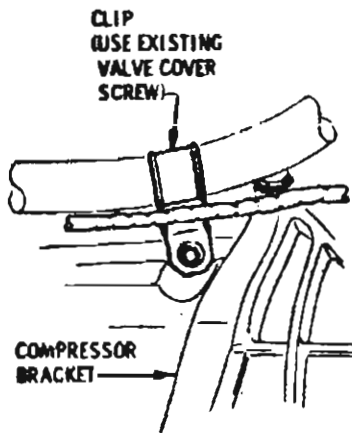
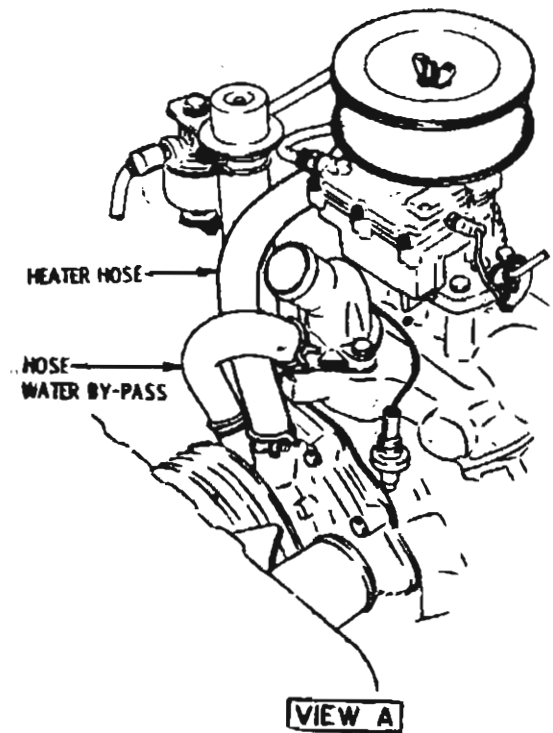
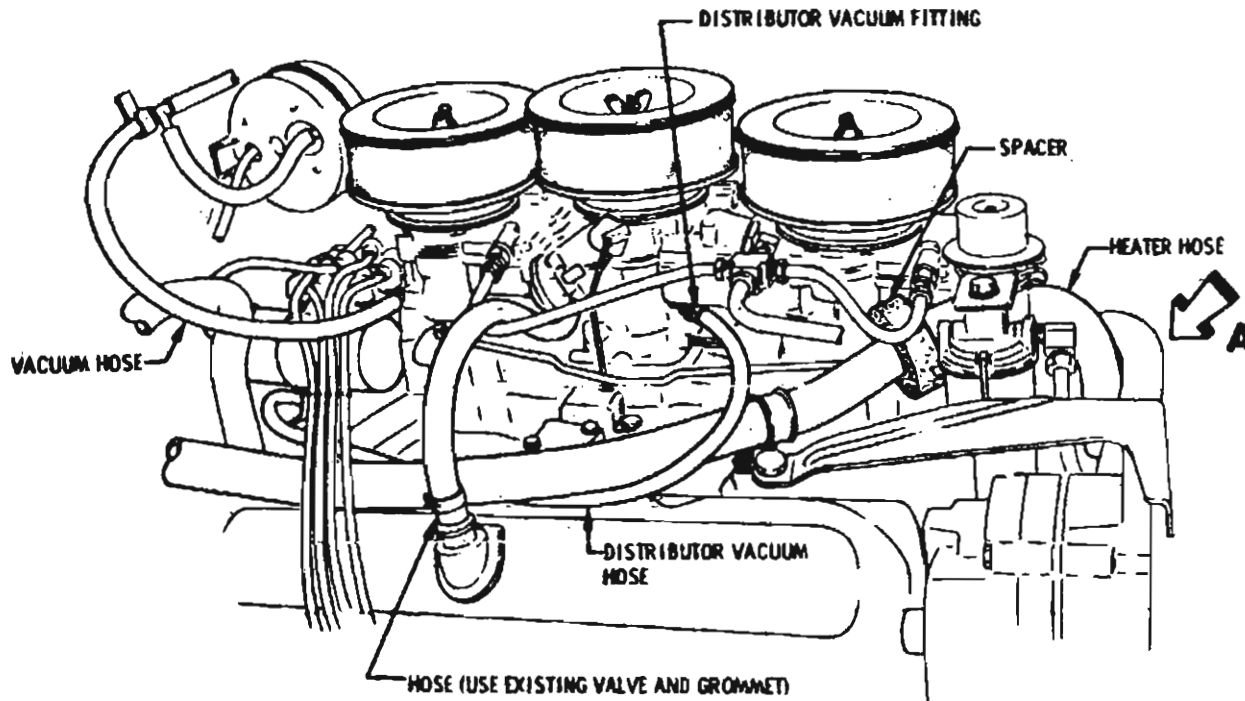

CLIP FASTENING WITH AIR CONDITIONING

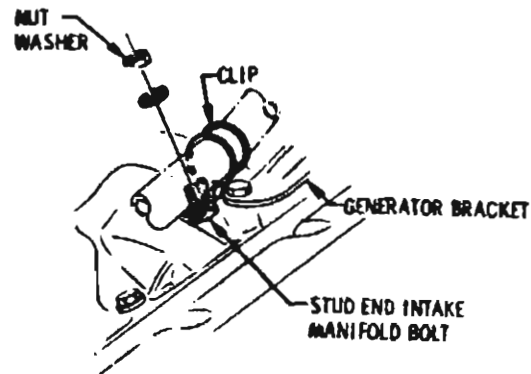

CLIP FASTENING WITHOUT AIR CONDITIONING

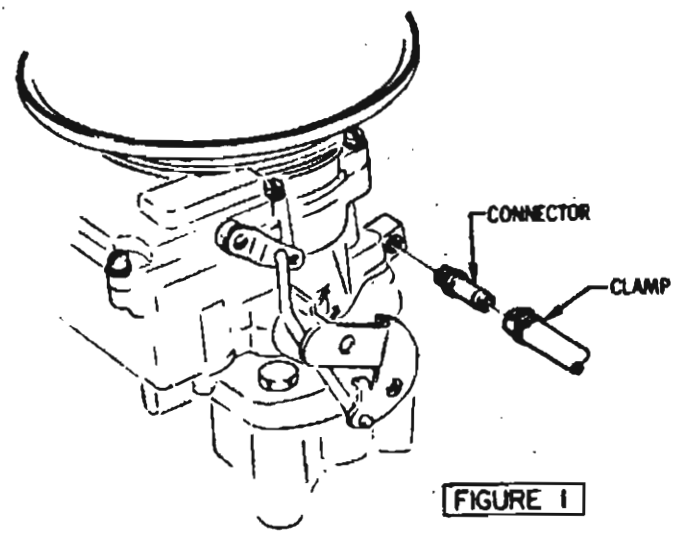
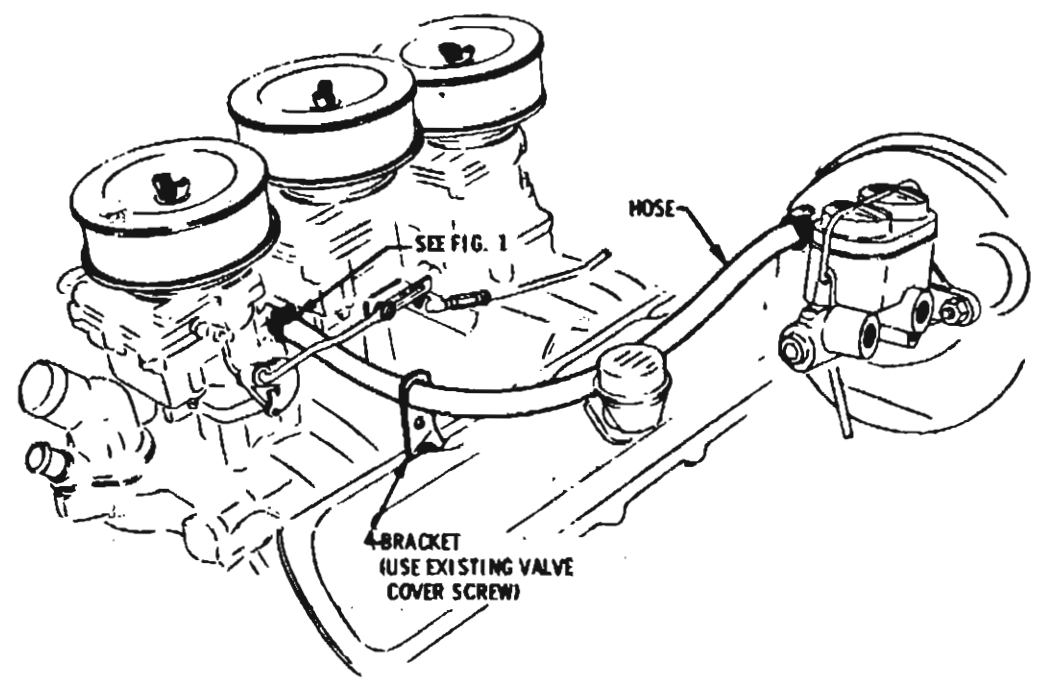
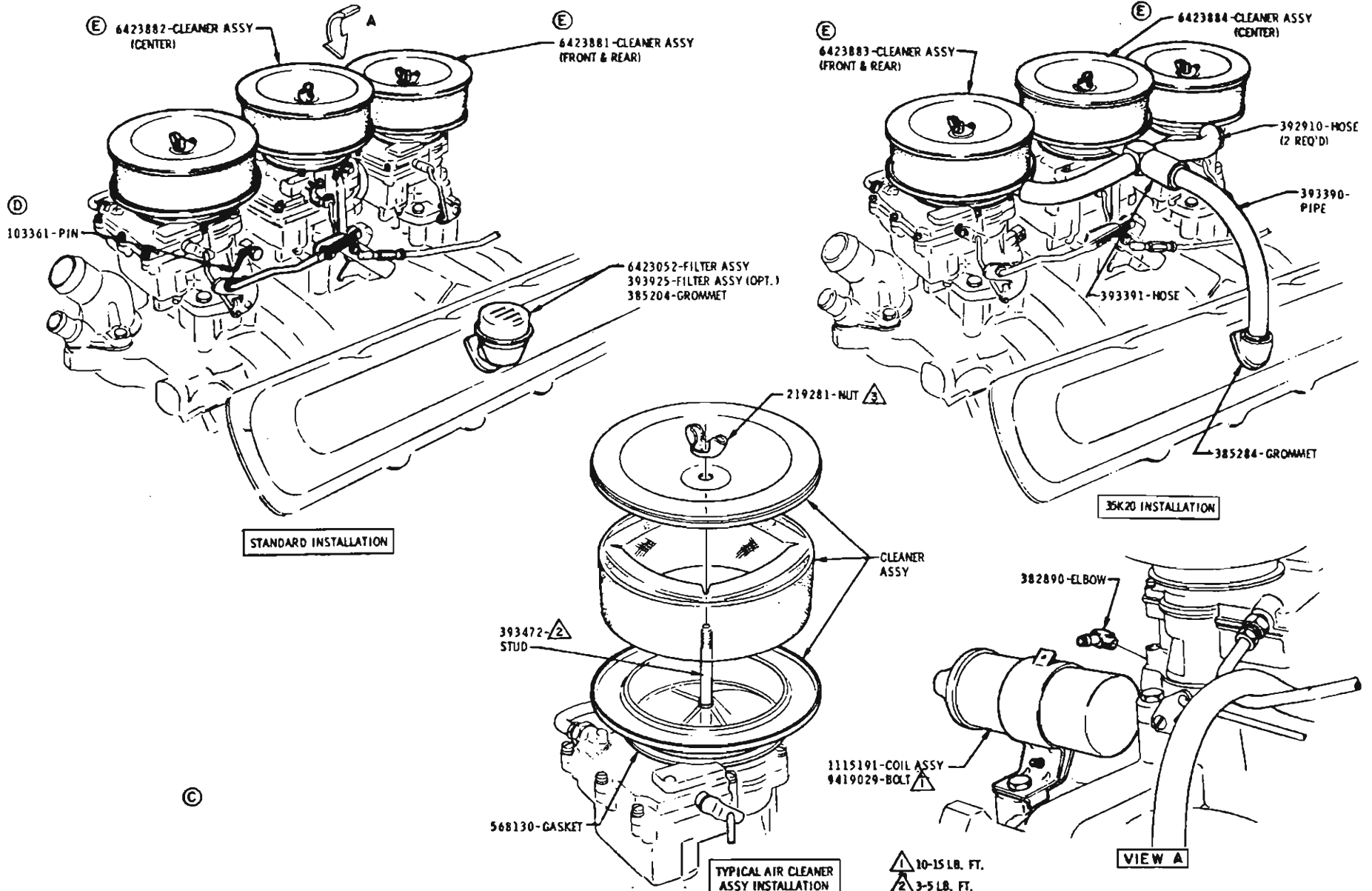

FIGURE 1

POWER BRAKE VACUUM HOSE INSTALLATION



DATE	SYN	REVISION	DR.	CK.	DATE	SYN	REVISION	DR.	CK.	DATE	SYN	REVISION	DR.	CK.	APPR.																																																																																						
					2-2-66	E	PART NUMBERS REVISED																																																																																														
					12-5-65	D	PART NUMBER ADDED																																																																																														
					12-5-65	C	VIEW REMOVED																																																																																														
					2-13-66	B	TORQUE ADDED																																																																																														
					2-13-66	A	NOTES ADDED																																																																																														
<table border="1" style="width:100%; border-collapse: collapse;"> <tr> <td style="width:15%;"></td> <td style="width:15%;"></td> <td style="width:15%;"></td> <td style="width:15%;"></td> <td style="width:15%;"></td> <td style="width:15%;"></td> <td style="width:15%;"></td> <td style="width:15%;"></td> <td style="width:15%;"></td> <td style="width:15%;"></td> <td style="width:15%;"></td> <td style="width:15%;"></td> <td style="width:15%;"></td> <td style="width:15%;"></td> <td style="width:15%;"></td> <td style="width:15%;"></td> </tr> <tr> <td colspan="10"></td> <td colspan="3" style="text-align: center;">INSTALLATION ENGINE DRESS</td> <td colspan="3"></td> </tr> <tr> <td colspan="10"></td> <td colspan="3" style="text-align: center;">DATE NOV. 18, 1965</td> <td colspan="3" style="text-align: center;">PART USED 1966</td> <td colspan="3" style="text-align: center;">PAGE 6-2.20</td> </tr> <tr> <td colspan="10"></td> <td colspan="3" style="text-align: center;">DR. BY D.C. LINDENBAUM</td> <td colspan="3" style="text-align: center;">CHECKED SLM</td> <td colspan="3" style="text-align: center;">APPR. LLP</td> </tr> <tr> <td colspan="10"></td> <td colspan="3" style="text-align: center;">SERIES A</td> <td colspan="3" style="text-align: center;">PART NO. 589998</td> </tr> </table>																																										INSTALLATION ENGINE DRESS																DATE NOV. 18, 1965			PART USED 1966			PAGE 6-2.20													DR. BY D.C. LINDENBAUM			CHECKED SLM			APPR. LLP													SERIES A			PART NO. 589998		
										INSTALLATION ENGINE DRESS																																																																																											
										DATE NOV. 18, 1965			PART USED 1966			PAGE 6-2.20																																																																																					
										DR. BY D.C. LINDENBAUM			CHECKED SLM			APPR. LLP																																																																																					
										SERIES A			PART NO. 589998																																																																																								