

AMA Specifications—Passenger Car

The information contained herein is prepared, distributed by, and is solely the responsibility of the automobile manufacturing company to whose products it relates. Questions concerning these specifications should be directed to the manufacturer whose address is shown below. This uniform specification form was developed by the automobile manufacturing companies under the auspices of the Automobile Manufacturers Association.

MANUFACTURER AMERICAN MOTORS CORPORATION	CAR NAME Rebel AMX Hornet Ambassador Javelin Gremlin
MAILING ADDRESS 14250 Plymouth Rd., Detroit, Michigan 48232	MODEL YEAR 1970
	ISSUED: Sept. 25, 1969 REVISED (●) Apr. 1, 1970

- NOTES: C. Chakmakian, Manager - Product Information Dept., Phone 493-2557 (AC 313)
- The General Specifications herein are those in effect at date of compilation and are subject to change without notice by the manufacturer.
 - UNLESS OTHERWISE INDICATED:
 - Specifications apply to standard models without optional equipment. Significant deviations are noted.
 - Nominal design dimensions are used throughout these specifications.

TABLE OF CONTENTS

Car & Body Dimensions	1,2	Drive Units	14	Suspensions	21
Engine - Mechanical	4	Brakes	18, 19	Weights	24
Electrical	12	Steering	20	Index	27

BODY - TYPES AND STYLE NAMES -

Body type, style names; use manufacturer's code for series & body style.

	2-DOOR SEDAN	4-DOOR SEDAN	4-DOOR WAGON	2-DOOR HARDTOP
<u>7001: HORNET</u> ; BASE (Six) SST (Six & V-8)	7006-0 7006-7	7005-5 7005-7	- - - - - -	- - - - - -
(●) <u>7040: GREMLIN</u> (Six); 2-Passenger 4-Passenger	7046-0 7046-5	- - - - - -	- - - - - -	- - - - - -
<u>7030: AMX</u> (V-8)	- - -	- - -	- - -	7039-7
<u>7070: JAVELIN</u> (Six & V-8); BASE SST	- - - - - -	- - - - - -	- - - - - -	7079-5 7079-7
<u>7010: REBEL</u> (Six & V-8); BASE SST	- - - - - -	7015-0 7015-7	7018-0 7018-7	7019-0 (& Machine) 7019-7
<u>7080: AMBASSADOR</u> ; BASE (Six & V-8) DPL (V-8) SST (V-8)	- - - - - - - - -	7085-2 7085-5 7085-7	- - - 7088-5 7088-7	- - - 7089-5 7089-7

All Hornet Models have 5-Passenger room. Gremlin is 2- or 4-passenger.
 All Javelin Models have 4-Passenger room. AMX Sports Coupe has 2-Passenger room.
 All Rebel & Ambassador Models have 6-Passenger room except:
 8-Pass. for Rebel SST, & Ambassador DPL & SST 3-Seat Wagon Option.
 5-Pass. for Rebel SST, & Ambassador SST Hardtops with Opt. Bucket Seats(Std. on Machine)
 Bucket Seats with Fold-Down Armrest & Center Cushion (or Console) opt. on Rebel SST
 Hardtop & Ambassador SST Hardtop (Std. on Rebel "Machine", less Armrest & Cushion).
 Bucket Seats with Fold-Down Armrest & Center Cushion Std. on Javelin SST (Console Opt.).
 Bucket Seats Standard on Javelin & AMX (Console or Center Armrest & Cushion, Opt.).
 Bucket Seats Optional on Gremlin 4-Passenger Model.
 Individually-Adjustable Reclining Seats Standard on Ambassador SST Models, Optional on
 Ambassador Base & DPL, all Rebels (except "Machine") & Hornet SST.
 All Rebel & Ambassador Wagons have Dual-Hinged Tailgate as Standard.
 Gremlin 4-Passenger Model has Fold-Down Rear Seat & Liftgate Window.
 Roof Rack Standard on Rebel SST & All Ambassador Wagons (Optional on Gremlins).

AMA Specifications—Passenger Car

MAKE OF CAR AMERICAN MOTORS MODEL YEAR 1970 DATE ISSUED 9-25-69 REVISED ^(*)4-1-70

CAR AND BODY DIMENSIONS

See Pages 25, 27 & 30 for SAE Dimension Definitions
(All dimensions in inches unless otherwise indicated)

See Pages 26, 28 & 29
for complete dimensions
on all body styles.

All dimensions to ground are for comparative purposes only. Dimensions are to be shown for:
4-Dr. Sedan, 2-Dr. H.T., 4-Dr. H.T., Convertible and Station Wagon.

MODEL	SAE Ref. No.	HORNET 7001		GREMLIN 7040		REBEL 7010			AMBASSADOR 7080			JAVELIN 7070		AMX 7030
		6	V-8	Sedan	Sedan	Hardtop	Wagon	Sedan	Hardtop	Wagon	6	V-8	V-8	
WIDTH														
Track - Front	W101	57.46	57.24	57.46		60.00			60.00			59.30	59.70	59.70
Track - Rear	W102	57.00		57.00		60.00			60.00				57.00	57.00
Maximum overall car width	W103	70.58		70.58		77.24			77.24				71.89	71.57
Body width at No. 2 pillar	W117	67.88		67.88		75.46			75.46				69.71	69.71
LENGTH														
Body "O" to front of dash	L 30	1.50		1.50		1.50			1.50				1.50	1.50
Wheelbase	L101	108.00		96.00		114.00			122.00				109.00	97.00
Overall car length	L103	179.26		161.25	199.00	199.00	198.00	208.00	208.00	207.00			191.04	179.04
Overhang - front	L104	33.25		33.25		31.90			32.90				41.52	41.52
Overhang - rear	L105	38.01		32.00	53.10	53.10	52.10	53.10	53.10	52.10			40.52	40.52
Body upper structure length	L123	96.10		91.37	104.70	109.64	135.86	104.37	110.23	135.86			102.03	90.03
Body "O" line to ϵ of rear wheel	L127	96.00		84.00		100.00			100.00				95.00	83.00
Body "O" line to w/s cowl point	L130	9.12		9.12		7.50			7.23				7.95	7.95
HEIGHT														
Passenger Distribution (front & rear)		3-2		2-2	2-3 (capacity 3-3)	2-3 (capacity 3-3)		2-3 (capacity 3-3)		2-2			2-0	
Trunk/Cargo load (lbs.)		175		175	200	200	300	200	200	300			200	200
Overall height	H101	52.25		51.80	55.03	54.41	56.69	55.21	54.61	56.88			51.53	51.40
Cowl height	H114	36.54		35.83	38.47	38.47	39.21	38.71	38.71	39.56			36.57	36.50
Deck height	H138	- - -		- - -	- - -	- - -	- - -	- - -	- - -	- - -			- - -	- - -
Rocker panel - front	To ground	8.20		7.60	9.10	9.10	10.00	9.32	9.32	10.31			8.90	8.66
	From front wheel ϵ	- - -		- - -	- - -	- - -	- - -	- - -	- - -	- - -			- - -	- - -
Rocker panel - rear	To ground	6.90		6.41	8.16	8.16	9.86	8.33	8.33	9.97			8.27	8.15
	From rear wheel ϵ	- - -		- - -	- - -	- - -	- - -	- - -	- - -	- - -			- - -	- - -
Windshield slope angle	H122	57°30'		57°30'		54°6'			54°6'				59°7'	59°7'
GROUND CLEARANCE														
Bumper to ground - front	H102	17.35		16.70	12.67	12.67	12.84	12.86	12.86	13.33			12.72	12.51
Bumper to ground - rear	H104	15.30		14.70	15.60	15.60	12.79	15.70	15.70	12.71			15.22	15.55
Angle of approach	H106	26°56'		27°41'	27°46'	27°37'	28°33'	25°27'	25°21'	26°31'			24°45'	23°05'
Angle of departure	H107	19°0'		23°0'	13°59'	11°05'	14°28'	11°11'	11°13'	11°17'			23°18'	25°0'
Ramp breakover angle	H147	16°20'		17°0'	16°59'	17°01'	18°18'	14°35'	15°49'	16°51'			16°55'	19°24'
Min. running clearance (Specify)	H156	5.21		5.01	6.08	6.08	6.60	6.45	6.45	7.00			5.11	5.30
Location		Exhaust		R.Axle	Front Suspension	Front Suspension		Rear Axle Diff.	F.Susp.	F.Susp.			Exhaust	Exhaust

AMA Specifications—Passenger Car

MAKE OF CAR AMERICAN MOTORS MODEL YEAR 1970 DATE ISSUED 9-25-69 REVISED (●) 4-1-70

CAR AND BODY DIMENSIONS

See Pages 25, 27 & 30 for SAE Dimension Definitions

See Pages 26, 28 & 29 for complete dimensions on all body styles.

(All dimensions in inches unless otherwise indicated)

MODEL	SAE Ref. No.	HORNET 7001	(●) GREMLIN 7040	REBEL & AMBASSADOR 7010 & 7080			JAVELIN 7070	AMX 7030	
FRONT COMPARTMENT		2 & 4-Door Sedan		2-Door Sedan	4-Door Sedan	2-Door Hardtop	4-Door Wagon	2-Door Hardtop	2-Door Hardtop
Effective head room	H61	38.00	37.90	39.60	38.95	39.88	37.50	37.20	
Max. eff. leg room - accelerator	L34	41.05	40.05		42.45		43.05	43.05	
H Point to Heel point	H30	8.72	8.82		9.64		8.07	8.07	
H Point travel	L17	4.93	4.93		4.93		4.93	4.93	
Shoulder room	W 3	54.88	54.88		60.00		55.00	55.00	
Hip room	W 5	54.88	54.88		60.30		57.60	57.60	
Upper body opening to ground	H50	48.45	47.40	50.13	49.66	50.95	47.13	47.16	
REAR COMPARTMENT									
H Point couple distance	L50	32.20	25.60	34.77	31.69	34.77	27.75	- - -	
Effective head room	H63	37.00	36.40	37.47	36.60	38.71	36.00	- - -	
Min. effective leg room	L51	36.75	29.45	38.60	35.50	38.60	30.80	- - -	
H Point to Heel point	H31	11.05	12.15	10.82	10.10	10.82	10.25	- - -	
Min. knee room	L48	3.65	1.50	5.70	3.30	5.70	1.25	- - -	
Rear Compartment room	L 3	26.07	20.90	29.60	26.26	29.60	21.90	- - -	
Shoulder room	W 4	53.32(1)	52.96	60.00	59.00	60.00	53.20	- - -	
Hip room	W 6	53.32(1)	52.96	60.40	59.50	60.40	56.38	- - -	
Upper body opening to ground	H51	48.12	- - -	49.06	- - -	50.64	- - -	- - -	
LUGGAGE COMPARTMENT									
Not Wagons									
Usable luggage capacity	V 1	11.20	6.0(2)	18.20	18.20	- - -	10.20(2)	9.60	
Liftover height	H195	29.54	33.90	28.91	28.91	- - -	27.39	27.82	
Position of spare tire storage	Tilted, Center, Front (5)			Tilted, Center, Front (3)			(4)		
Method of holding lid open	Counterbalanced			C'balanced		Counterbalanced, Flat Wound Spring			
STATION WAGON - THIRD SEAT		Torsion Bar		Two Spring Cylinders					
Shoulder Room	W85	- - -	- - -		59.25		- - -	- - -	
Hip room	W86	- - -	- - -		38.12		- - -	- - -	
Effective leg room	L86	- - -	- - -		30.75		- - -	- - -	
Effective head room	H86	- - -	- - -		36.00		- - -	- - -	
Seat facing direction		- - -	- - -		REAR		- - -	- - -	
STATION WAGON - CARGO SPACE									
Cargo length at floor - front seat	L202	- - -	- - -		92.63		- - -	- - -	
Cargo length at belt - front seat	L204	- - -	- - -		82.73		- - -	- - -	
Cargo width - Wheelhouse	W201	- - -	- - -		45.08		- - -	- - -	
Opening width at belt	W204	- - -	- - -		53.60		- - -	- - -	
Maximum cargo height	H201	- - -	- - -		31.72		- - -	- - -	
Rear opening height	H202	- - -	- - -		27.84		- - -	- - -	
Cargo volume index (cu. ft.)	V2	- - -	- - -		91.12		- - -	- - -	
W4 x L204 x H201	1728				(99.12 incl. under-floor storage space)				

(1) 4-Door Sedan = 54.40

(2) Plus 2 Cubic Feet with optional "Space-Saver" Spare.

(3) Javelin: Tilted, Right, Front (with optional "Space-Saver" Spare, located "Flat, Right, Rear").

(4) AMX: Flat, Right, Rear ("Space-Saver" Spare).

(●) (5) Gremlin: Flat, Left, Rear.

AMA Specifications—Passenger Car

MAKE OF CAR AMERICAN MOTORS MODEL YEAR 1970 DATE ISSUED 9-25-69 REVISED ^(*) 1-1-70

POWER TEAMS

(Indicate whether standard or optional)

ENGINE				
Displ. cu. in.	Carburetor	Compr. Ratio	BHP @ RPM	Torque @ RPM
199 Six	1-Barrel (Regular Fuel)	8.5	128@4400	182@1600
232 Six	1-Barrel (Regular Fuel)	8.5	145@4300	215@1600
232 Six	2-Barrel (Regular Fuel)	8.5	155@4400	222@1600
304 V-8	2-Barrel (Regular Fuel)	9.0	210@4400	305@2800
360 V-8	2-Barrel (Regular Fuel)	9.0	245@4400	365@2400
360 V-8	4-Barrel (Premium Fuel)	10.0	290@4800	395@3200
390 V-8	4-Barrel (Premium Fuel)	10.0	325@5000	420@3200
390 V-8	4-Barrel (Premium Fuel)	10.0	340@5100	430@3600

Optional Axle Ratios listed are available at extra cost. Less or with Twin-Grip &/or AC (except noted).

* For Javelin & AMX: with 360 or 390 opt. "Go Package" & Shift-Command; 3.15 Std., 2.87 & 3.15 Opt.

(●) ** With Air Conditioning: 2.73 Standard, 3.08 Optional

③ 3.91 available only with Twin-Grip Differential

Dealer Kit Extra-Cost Ratios: 3.73, 3.91 (& factory), 4.10, 4.44 & 5.00

Form Rev. 3-67

1970	Engine, Transmission, & Axle Ratio Combinations	3-Speed Manual Column Shift Standard (Floor Shift for Javelin & Gremlin 232)	Shift-Command Column Shift Opt. (Std. Amb. DPL & SST with 304 V-8)	Shift-Command Console Shift Optional	4-Speed Manual Floor Shift Opt. (Std. AMX & "Machine")
HORNET	128 H. P. - 199 CID, 1-Bbl. Standard on Basic	3.08 Std. 3.31 Opt.		N.A.	N.A.
	145 H. P. - 232 CID, 1-Bbl. Std. on SST, Opt. on Basic	3.08 Std. 3.31 Opt.	** 2.37 Std. ** 2.73 Opt.		
	155 H. P. - 232 CID, 2-Bbl. Optional on Basic & SST	N.A.	3.08 Std. 3.31 Opt.		
	210 H. P. - 304 CID, 2-Bbl. Standard V-8 on SST	N.A.	2.87 Std. 3.15 Opt.		
GREMLIN	128 H. P. - 199 CID, 1-Bbl. Standard	2.73 Std. 3.08 Opt.		N.A.	N.A.
	145 H. P. - 232 CID, 1-Bbl. Optional	3.08 Std. 3.31 Opt.	** 2.37 Std. ** 2.73 Opt.		
AMX	290 H. P. - 360 CID, 4-Bbl. Standard	N.A.		*2.87 Std. 3.15 Opt. 3.54 Opt.	3.54 Std. 3.15 Opt. @ 3.91 Opt.
	325 H. P. - 390 CID, 4-Bbl. Optional	N.A.			
JAVELIN	145 H. P. - 232 CID, 1-Bbl. Standard 6	3.08 Std. 3.31 Opt.		N.A.	
	210 H. P. - 304 CID, 2-Bbl. Standard V-8	3.15 Std. 3.54 Opt.	2.87 Std. 3.15 Opt.		N.A.
	245 H. P. - 360 CID, 2-Bbl. Optional	N.A.	N.A.		
	290 H. P. - 360 CID, 4-Bbl. Optional		*2.87 Std. 3.15 Opt. 3.54 Opt.		3.54 Std. 3.15 Opt. @ 3.91 Opt.
	325 H. P. - 390 CID, 4-Bbl. Optional		N.A.		
REBEL	145 H. P. - 232 CID, 1-Bbl. Standard 6	3.15 Std. 3.54 Opt.	3.15 Std.	N.A.	N.A.
	155 H. P. - 232 CID, 2-Bbl. Optional 6	N.A.	2.87 Std. 3.15 Opt.		
	210 H. P. - 304 CID, 2-Bbl. Standard V-8		2.87 Std. 3.15 Opt.		
	245 H. P. - 360 CID, 2-Bbl. Optional		2.87 Std. 3.15 Opt. 3.54 Opt.		
	290 H. P. - 360 CID, 4-Bbl. Optional		2.87 Std. 3.15 Opt. 3.54 Opt.		
	325 H. P. - 390 CID, 4-Bbl. Optional on SST		2.87 Std. 3.15 Opt. 3.54 Opt.		
340 H. P. - 390 CID, 4-Bbl. Standard on "Machine"	N.A.		3.54 Std. 3.15 Opt.	3.54 Std. @ 3.91 Opt.	
AMBASSADOR	155 H. P. - CID, 2-Bbl. Standard on Basic	3.15 Std. 3.54 Opt.	3.15 Std.	N.A.	N.A.
	210 H. P. - 304 CID, 2-Bbl. Std. on DPL & SST, Opt. on Basic	N.A.	2.87 Std. 3.15 Opt.		
	245 H. P. - 360 CID, 2-Bbl. Optional				
	290 H. P. - 360 CID, 4-Bbl. Optional				
325 H. P. - 390 CID, 4-Bbl. Opt. on DPL & SST					

AMA Specifications—Passenger Car

MAKE OF CAR		AMERICAN MOTORS		MODEL YEAR		1970		DATE ISSUED		9-25-69		REVISED (*)	
MODEL	Availability On Page 3	199 CID SIX 1-B. Carb.	232 CID SIX 1 & 2-B. Carb.	304 CID V-8 2-B. Carb.	360 CID V-8 2 & 4-B. Carb.	390 CID V-8 4-B. Carb.							
ENGINE - GENERAL													
Type, no. cyls., valve arr.		In-Line 6 OHV				90° V-8 OHV							
Bore and stroke (nominal)		3.75 x 3.00	3.75 x 3.50	3.75 x 3.44	4.08 x 3.44	4.165 x 3.574							
Piston displacement, cu. in.		199	232	304	360	390							
Bore spacing (C to C)		4.38				4.75							
No. system (front to rear)		L. Bank				R. Bank							
		1-2-3-4-5-6				1-3-5-7							
Firing order		1-5-3-6-2-4				2-4-6-8							
Compress. ratio (nominal)		8.5				9.0				9.0 (10.0 4-B.)			
Cylinder Head Material		Cast Iron											
Cylinder Block Material		Cast Iron											
Cyl. Sleeve-Wet, dry, none		None											
Number of mtg. points		Front				Rear							
		Two				One							
Engine installation angle		Vertical											
Taxable horsepower		Dia ² xNo. Cyl. 2.5		33.75		45.00		53.27		55.51			
Publishing max. bhp* @ eng. RPM		128 @4400	1-B., 145 @4300 2-B., 155 @4400	210 @4400	2-B., 245 @4400 4-B., 290 @4800	4-B., 325 @5000 4-B., 340 @5100(1)							
Publishing max. torque* (lb. ft. @ RPM)		182 @1600	1-B., 215 @1600 2-B., 222 @1600	305 @2800	2-B., 365 @2400 4-B., 395 @3200	4-B., 420 @3200 4-B., 430 @3600(1)							
Recommended fuel regular - premium		Regular				Regular				2-B., Regular 4-B., Premium			
ENGINE - PISTONS													
Material		Aluminum Alloy with Steel Insert											
Description and finish		"Conformatic", 199=Flat-Top, 232=Flat with Dished Top, Solid Skirt Tin Plate, Steel-Ring Insert				"Autothermic", Flat-Top with Valve Pockets, Slipper Skirt, Tin Plate, Steel-Strut Inserts.							
Weight (piston only) oz.		18.30	17.53	17.92	21.27	21.94							
Clearance (limits)		Skirt		---		---		---		---		---	
		.0005 - .0013 (2)		.0010 - .0018 (2)		.0012 - .0020 (2)		.0010 - .0018 (2)					
Ring groove Diameter		No. 1 ring		3.328 - 3.333		3.328 - 3.333		3.624 - 3.629		3.723 - 3.733			
		No. 2 ring		3.328 - 3.333		3.328 - 3.333		3.624 - 3.629		3.705 - 3.715			
Diameter		No. 3 ring		3.329 - 3.339		3.329 - 3.339		3.625 - 3.635		3.710 - 3.720			
		No. 4 ring		None									

* Max. bhp (brake horsepower) and max. torque corrected to 60° F and 29.92 in. Hg atmospheric pressure.

(1) Rebel "Machine" version uses Modified Intake & Exhaust Manifolds.

NOTE ... Special High-Performance V-8 Induction Systems available as Dealer Kits:

1. High-Riser Aluminum Intake Manifold with Holley 3-Barrel Carburetor (also 4-Barrel).
2. Cross-Ram Aluminum Intake Manifold for Dual Holley 4-Barrel Carburetors.

(2) Clearance measured at 2.31" below top of block at centerline of piston pin.

AMA Specifications—Passenger Car

MAKE OF CAR AMERICAN MOTORS MODEL YEAR 1970 DATE ISSUED 9-25-69 REVISSED ^(*)

Availability on Page 3	199 & 232 CID SIXES	304, 360 & 390 CID V-8's
---------------------------	------------------------	-----------------------------

ENGINE - RINGS

Function (top to bottom)	No. 1, oil or comp.	Compression
	No. 2, oil or comp.	Compression
	No. 3, oil or comp.	Oil
	No. 4, oil or comp.	None
Compres- sion #1 & #2	Description - material, coating etc.	Cast-Iron Alloy Phosphate-Coated, Parco Lubrite, or Granoseal Molybdenum-Filled Face for #1 Ring
	Width	.0775
	Gap	.010 - .020
Oil #3	Description - material, coating etc.	Three Piece, Steel Rail Type Rail Faces Chrome Plated
	Width	.0245 Each Rail (.1880 with Expander)
	Gap	.015 - .055
Expanders		Combination Expander - Spacer Located Between Oil Ring Rails.

ENGINE - PISTON PINS

Material	SAE #1016 Steel	
Length	3.187	304 & 360; 3.187 (390; 2.94)
Diameter	.93	304 & 360; .931 (390; 1.00)
Type	Locked in rod, in piston, floating, etc.	
	Locked-In-Rod (Press Fit)	
	Bush- ing	None
	In rod or piston Material	None
Clearance	In piston	.0003 - .0005
	In rod	Press Fit (Locked)
Direction & amount offset in piston		.0625 Toward Major Thrust Side

ENGINE - CONNECTING RODS

Material	Cast Nodular Iron	304 & 360, Cast Nodular Iron (1) 390; SAE 1042 Mod., Forged Steel
Weight (oz.)	199; 22.96 (232; 24.65)	304 & 360; 24.16 (390; 28.15)
Length (center to center)	199; 6.125 (232; 5.875)	304 & 360; 5.875 (390; 5.858)
Steel-Backed, Alloy Lining Removable	Det. Alum./Brass D52 or Fed. Mogul H-35LT	
	304 & 360; Clevite F-77 or Federaloy H-24 390; Clevite F-77	
Bearing	Overall length	.860 304 & 360; .832 (390; .800)
	Clearance (limits)	.001 - .002 .001 - .002
	End play	.008 - .010 .009 - .015 (Two Rods)

(1) Special Service Rods for 304 & 360; SAE 4340 Forged Steel (Dealer Kit).

AMA Specifications—Passenger Car

MAKE OF CAR AMERICAN MOTORS MODEL YEAR 1970 DATE ISSUED 9-25-69 REVISED ^(*)

Availability On Page 3	199 & 232 CID SIXES	304, 360 & 390 CID V-8's
---------------------------	------------------------	-----------------------------

ENGINE - CRANKSHAFT

Material	Cast Nodular Iron (SAE 1046 Forged Steel in 390 V-8) (1)	
----------	--	--

Vibration damper type	Dynamic-Tuned, Rubber-Suspended, Inertia Member	
-----------------------	---	--

End thrust taken by bearing (No.)	#3	
-----------------------------------	----	--

Crankshaft end play	.0015 - .007	.003 - .008
---------------------	--------------	-------------

Steel-Backed, Removable	Material & type	SAE-15 Micro-Babbitt (Clevite or McQuay Norris)	304&360; Clevite F-500 or Federaloy H-35LT 390; Clevite F-77	
	Clearance	.001 - .002	.001 - .002 (.002 - .003 Rear Main)	
Main bearing	Journal dia. and bearing overall length	No. 1	2.4986 - 2.5001 x .981	2.7474 - 2.7489 x .923 (x .9385 in 390 V-8)
		No. 2	2.4986 - 2.5001 x .981	2.7474 - 2.7489 x .923 (x .9385 in 390 V-8)
		No. 3	2.4986 - 2.5001 x 1.2685	2.7474 - 2.7489 x 1.2685
		No. 4	2.4986 - 2.5001 x .981	2.7474 - 2.7489 x .923 (x .9385 in 390 V-8)
		No. 5	2.4986 - 2.5001 x .981	2.7464 - 2.7479 x .923 (x .9385 in 390 V-8)
		No. 6	2.4986 - 2.5001 x .981	- - -
		No. 7	2.4986 - 2.5001 x .981	- - -
Dir. & amt. cyl. offset		None		

Crankpin journal diameter	2.0934 - 2.0955	2.0934 - 2.0955 (2.2471 - 2.2492 in 390 V-8)
---------------------------	-----------------	--

ENGINE - CAMSHAFT

Location	Right Side	Center Between Cylinder Banks
----------	------------	-------------------------------

Material	Special Cast-Iron Alloy	
----------	-------------------------	--

Bearings	Material	Steel-Backed, Micro-Babbitt Alloy, SAE-15 (Clevite or Fed. Mogul)	
	Number	Four	Five

Type of Drive	Gear or chain		Chain	
	Crankshaft gear or sprocket material		SAE 1117 Steel (Sintered Iron, Opt.)	
	Camshaft gear or sprocket material		Die-Cast Aluminum with Molded Nylon Teeth	
	Timing chain	No. of links	48	62
		Width	.69	.875
Pitch		.50	.375	

ENGINE - VALVE SYSTEM

Hydraulic lifters (Std., opt., NA)	Yes	
------------------------------------	-----	--

Valve rotator, type (intake, exhaust)	Yes, Free Valve Type	
--	----------------------	--

Rocker ratio	1.5	1.6
--------------	-----	-----

Operating tappet clearance (indicate hot or cold)	Intake	Zero Lash
	Exhaust	Zero Lash

(Continued)

(1) Special Service Crankshaft for 304 & 360; SAE 1046 Forged Steel (Dealer Kit).

AMA Specifications—Passenger Car

MAKE OF CAR AMERICAN MOTORS MODEL YEAR 1970 DATE ISSUED 9-25-69 REVISED (*)

MODEL		Availability On Page 3	199 & 232 CID SIXES	304 CID V-8	360 CID V-8	390 CID V-8	ALL V-8'S
ENGINE - VALVE SYSTEM (cont.)							
Dealer Hi-Perf. Cam Kit							
Timing (based on top of ramp points)	Intake	Opens (°BTC)	12° - 30'	18°30'		18°	46°
		Closes (°ABC)	51° - 30'	67°30'		68°	76°
		Duration - deg.	244°	266°		266°	302°
	Exhaust	Opens (°BBC)	53° - 30'	60°30'		66°	70°
		Closes (°ATC)	10° - 30'	25°30'		20°	52°
		Duration - deg.	244°	266°		266°	302°
Valve opening overlap			23°	44°		38°	98°
Material		Silichrome #1 or XB					
Overall length		4.899					
Actual overall head dia.		1.787	1.787	2.025	2.025		
Angle of seat & face		Head 30°, Valve 29°					
Seat insert material		None					
Stem diameter		.3715 - .3725					
Stem to guide clearance		.0010 - .0030					
Intake	Lift (@ zero lash)		.381	.425	.457	.477	
	Outer spring press. & length	Valve closed (lb.@ in.)	95 to 105 @1.812	85 to 93 @1.812	90 to 98 @1.812	95 to 103 @1.812	
		Valve open (lb.@ in.)	188 to 202 @1.437	193 to 207 @1.387	183 to 195 @1.365	240 to 260 @1.329	
	Inner spring press. & length	Valve closed (lb.@ in.)	None				---
		Valve open (lb.@ in.)	None				TOTAL 265 to 285 @1.329
	Material		SAE 21-LN				
Overall length		4.892	4.892	4.907	4.907		
Actual overall head dia.		1.406	1.406	1.625	1.625		
Angle of seat & face		Head 45°, Valve 44°					
Seat insert material		None					
Stem diameter		.3718 - .3725		.3715 - .3725			
Stem to guide clearance		.0010 - .0027		.0010 - .0030			
Exhaust	Lift (@ zero lash)		.381	.425	.457	.477	
	Outer spring press. & length	Valve closed (lb.@ in.)	95 to 105 @1.812	85 to 93 @1.812	90 to 98 @1.812	95 to 103 @1.812	
		Valve open (lb.@ in.)	188 to 202 @1.437	193 to 207 @1.387	183 to 195 @1.365	240 to 260 @1.329	
	Inner spring press. & length	Valve closed (lb.@ in.)	None				---
		Valve open (lb.@ in.)	None				TOTAL 265 to 285 @1.329

ENGINE - LUBRICATION SYSTEM

Type of lubrica- tion (splash, pressure, nozzle)	Main bearings	Pressure
	Connecting rods	Pressure
	Piston pins	Splash
	Camshaft bearings	Pressure
	Tappets	Pressure
	Timing gear or chain	Pressure Jet
	Cylinder walls	Oil Groove in Mating Surface Between Conn. Rod and Cap

(Continued)

AMA Specifications—Passenger Car

MAKE OF CAR AMERICAN MOTORS MODEL YEAR 1970 DATE ISSUED 9-25-69 REVISED (●) 4-1-70

Availability On Page 3	199 & 232 CID SIXES	304, 360 & 390 CID V-8's
---------------------------	------------------------	-----------------------------

ENGINE – LUBRICATION SYSTEM (cont.)

Oil pump type	Gear
Normal oil pressure (lb. @ engine rpm)	13#min.@600rpm, 21#min.@1100, 46#min.@2050&over(75#max.@all rpm)
Oil press. sending unit (elect. or mech.)	Electric
Type oil intake (floating, stationary)	Stationary
Oil filter system (full flow, part., other)	Full-Flow, Standard
Filter replacement (element, complete)	Complete
Capacity of c/case, less filter-refill (qt.)	4 (5 with Filter)
Oil grade recommended (SAE viscosity and temperature range)	Above 32°F. . .SAE 20W-20 (or SAE 10W-30 or 10W-40) Above 0°F. . .SAE 10W (or SAE 10W-30 or 10W-40) Below 0°F. . .SAE 10W (or SAE 5W-20 or 5W-30)

Engine Service Reqmt. (MM, MS, etc.) GREMLIN & MS (Certified Sequence Tested)

(●) ENGINE – EXHAUST SYSTEM	HORNET 6	HORNET V-8	REBEL & AMB. 6	REBEL & AMB. V-8	JAVELIN 6	JAV.&AMX V-8
Type (single, single with cross-over, dual, other)	Single	Single w/Y-Pipe	Single	S. w/Y-Pipe or Dual	Single	S. w/Y-Pipe or Dual
Muffler No. & type (reverse flow, straight thru, separate resonator)	One, Reverse Flow		One, Reverse Flow	One, RevFlo or Two	One, Reverse Flow	One, RevFlo or Two
Exhaust pipe dia. (O.D., wall thick.)	1.88x.083 Front 1.88x.075 Rear	1.88x.083	1.88x.083	1.88x.083	1.88x.083	1.88x.083
Tail pipe dia. (O.D. & wall thickness)	1.75x.048	2.00x.048	1.75x.048	2.00x.060	1.75x.060	2.00x.074

ENGINE – CRANKCASE VENTILATION SYSTEM

Type (ventilates to atmos., induction system, other)	Standard	Closed Induction System
	Optional	None
Make and model		Chicago Screw Co. & Novo Ind. Corp.
Location		In-Line Between Intake Manifold & Crankcase
Control Unit		Manifold Vacuum
Energy source (manifold vacuum, carburetor air stream, other)		Variable Orifice
Control method (variable orifice, fixed orifice, other)		Intake Manifold (Carb. Base or Carb. Spacer Plate)
Discharges (to intake manifold, carb. air intake, air cleaner intake, other)		Carburetor Air Cleaner
Complete system		Check Valve function designed into PCV Valve.
Air inlet (breather cap, carburetor air cleaner, other)		
Flame arrestor (screen, check valve, other)		

(1) 1.75 x .060 Tailpipe for Rebel-6 Wagon

(2) Dual Exhausts Opt. With 360 4-B V-8. Exh. Front.....2.00 x .083 2.25 O.D. for
Dual Exhausts Std. With 390 V-8. Exh. Rear.....2.00 x .083 Rebel "Machine"
Tailpipe.....2.00 x .060

(3) Javelin; Dual Exhausts Opt. With 360 4-B V-8. Exh. Front.....2.00 x .083
Javelin; Dual Exhausts Std. With 390 V-8. Exh. Rear.....2.00 x .083
AMX; Dual Exhausts Std. With 360 & 390 V-8's. Tailpipe.....2.00 x .074

AMA Specifications—Passenger Car

MAKE OF CAR AMERICAN MOTORS MODEL YEAR 1970 DATE ISSUED 9-25-69 REVISED ^(*) 4-1-70

Availability MODEL On Page 3		ALL 6's. V-8's W/AUTO. TRANS.	V-8's EQUIPPED WITH MANUAL TRANSMISSION	
ENGINE - EXHAUST EMISSION CONTROL				
Type (Air injection, engine modifications, other)		"Engine-Mod" System	Air Injection ("Air-Guard" System)	
Air Injection Pump	Type	- - -	Eccentric Vane (Saginaw Steering Gear)	
	Displacement	- - -	19.3 cu.in./rev.	
	Drive ratio	- - -	1.25:1	
	Drive type	- - -	Belt	
	Relief valve (type)	- - -	Integral	
	Filter (describe)	- - -	Centrifugal Separator (non-replaceable)	
Air Injection System	Air distribution (head, manifold, etc.)	- - -	Separate Header Manifold	
	Point of entry	- - -	Thru Exhaust Port	
	Injection tube I.D.	- - -	.285	
	Check valve type	- - -	Spring-Loaded Steel Plunger w/Asbestos Seat	
	Backfire protection (type)	- - -	Diverter Type (Rochester)	
Carburetor	Make		↑ See Page 10 ↓	
	Model			
	Barrel size			
	Idle speed	Drive Neutral		
	Idle A/F mixture			
Distributor	Aux. Adv. Systems (type)		↑ See Page 13 ↓	
	Make			
	Model			
	Cent'fgal adv. in crank degrees @ eng. rpm	Start (rpm)		
		Intermed. points deg. @ rpm		
		Max. deg. @ rpm		
Vacuum adv. in crank degrees @ eng. rpm	Start (in Hg)			
	Intermed. points deg. @ in. Hg Max. deg. @ in.			
Vacuum Source	Manifold Vacuum (Ported Above Throttle Plate)			
Timing - Crank degrees @ rpm	See Page 13			
Cooling System	None			
Exhaust System	None			
Fuel Tank Vapor Emission Control System	For All California Vehicles			
Storage Reservoir	Engine Crankcase			
Restriction Size & Location	.040" Dia. @ Crankcase			
(*) Fuel Expansion Protection	Expansion Tank within Fuel Tank (except Gremlin)			
(*) Liquid Fuel Transfer Protection	Check Valve Located @ Rear Axle Kick-Up Area (except Gremlin)			
Fuel Tank Cap	Non-Vented with Relief Protection for Pressure & Vacuum			

AMA Specifications—Passenger Car

MAKE OF CAR AMERICAN MOTORS MODEL YEAR 1970 DATE ISSUED 9-25-69 REVISED (•) 4-1-70

Availability On Page <u>3</u>	199 & 232 CID SIXES	304, 360 & 390 CID V-8's
----------------------------------	------------------------	-----------------------------

ENGINE— FUEL SYSTEM

(See supplemental page for Details of Fuel Injection, Supercharger, etc. if used)

Induction type: Carburetor, fuel injection, supercharger.		Gremlin 21 Carburetor (Downdraft)		
Fuel Tank	Refill capacity (U.S. gals.)	Hornet/Jav/AMX 19; Rebel 21.5 (3-seat wag 19); Amb. 21.5 (wag 19)		
	Filler location (1) Cal. Gals.	Hornet/Jav/AMX 16; Rebel 19.5 (3-seat wag 17); Amb. 19.5 (wag 17)		
Fuel Pump	Type (elec. or mech.)	Gremlin 21 Mechanical		
	Locations	Right Side, Center	Left Side, Front	
	Pressure range	4 to 5.5 P.S.I.		
Vacuum booster (std., optional, none)		Standard (less booster with opt. electric wipers)		
Fuel Filter	Type	A. Saran Plastic Spool. B. 15 Micron Paper Element		
	Locations	A. Gas Tank Pick-Up Tube B. Carburetor Inlet Side		
Carburetor	Choke type	Automatic		
	Intake manifold heat control (exhaust or water)	Exhaust		
	Air cleaner type	Standard	Cellulose Fiber Element	
		Optional	None	
Idle speed (spec. neutral or drive)	Manual	600 RPM	650 RPM	
	Automatic	550 RPM	600 RPM	
	Idle A/F mix.	14.0:1 ± .2A.F.R.	14.0:1 ± .2A.F.R. ("Air-Guard", 13.0:1)	

CARBURETOR SUPPLEMENTARY INFORMATION

Model Usage	Engine Displ.	Transmission	Carburetors		No. Used and Type	Barrel Size
			Make	Model		
(•) 199 CID SIX 128 HP, HORNET & GREMLIN	199	Manual	Carter YF	4768S	1,1-BBL.	1.69
		Automatic	Carter YF	4767S	1,1-BBL.	1.69
(•) 232 CID SIX 145 HP, HORNET & GREMLIN	232	Manual	Carter YF	4768S	1,1-BBL.	1.69
		Automatic	Carter YF	4767S (2)	1,1-BBL.	1.69
232 CID SIX 145 HP, REB.&JAV.	232	Manual	Carter YF	4770S	1,1-BBL.	1.69
		Automatic	Carter YF	4769S	1,1-BBL.	1.69
232 CID SIX 155 HP	232	Manual	Carter WCD	4817S	1,2-BBL.	1.44
		Automatic	Carter WCD	4816S	1,2-BBL.	1.44
304 CID V-8 210 HP	304	Manual	AM(FAL)2100D	ODM2	1,2-BBL.	1.56
		Automatic	AM(FAL)2100D	ODA2	1,2-BBL.	1.56
360 CID V-8 245 HP	360	Automatic	AM(FAL)2100D	ORA2	1,2-BBL.	1.69
360 CID V-8 290 HP	360	Manual	AM(FAL)4300	OWM4	1,4-BBL.	1.56 pri.
		Automatic	AM(FAL)4300	OWA4	1,4-BBL.	1.69 sec.
390 CID V-8 325 & 340 HP	390	Manual	AM(FAL)4300	OWM4	1,4-BBL.	1.56 pri.
		Automatic	AM(FAL)4300	OWA4	1,4-BBL.	1.69 sec.

(•) (1) Hornet & Gremlin: Center Rear Panel.

Rebel & Ambassador: Left Rear Fender

Javelin & AMX: Center Rear Bumper.

(•) (2) 4978S used from mid-Sept. to mid-Dec. 1969.

AMA Specifications—Passenger Car

MAKE OF CAR AMERICAN MOTORS MODEL YEAR 1970 DATE ISSUED 9-25-69 REVISED (*) 4-1-70

Availability On Page 3	199 & 232 CID SIXES	304, 360 & 390 CID V-8's
---------------------------	------------------------	-----------------------------

ENGINE—COOLING SYSTEM

Type system (pressure, pressure vented, atmospheric, other)	Pressure	
Radiator cap relief valve pressure	14 P.S.I.	
Circulation thermostat	Type (choke, bypass)	Choke
	Starts to open at (°F)	205 (202 to 209) 195 (192 to 199)
Water pump	Type (centrifugal, other)	Centrifugal
	GPM @ 1000 pump rpm	55 GPM @ 1400 RPM
	Number of pumps	One
	Drive (V-belt, other)	V-Belt
	Bearing type	Double Row Ball
By-pass recirculation type (inter., ext.)	Internal	External
Radiator core type (cellular, tube and fin, other)	Tube & Fin	
Cooling system capacity	With heater (qt.)	10.5 304;14 (360 & 390;13)
	Without heater (qt.)	9.5 304;13 (360 & 390;12)
	Opt. equipment-specify (qt.)	Same
Water jackets full length of cyl. (yes, no)	Yes	
Water all around cylinder (yes, no)	Yes	

Radiator hose	Lower	Number and type (molded, straight)	One, Molded, Curved	
		Inside diameter	1.50 Body & Rad. End 1.78 Water Pump End	1.50 Body & Rad. End 1.70 Water Pump End
	Upper	Number and type (molded, straight)	One, Molded, Curved	
		Inside diameter	1.50 Body & Rad. End 1.75 Thermostat End	1.50 Both Ends
	By-pass	Number and type (molded, straight)	None	One, Molded, Curved
		Inside diameter	- - -	.75

Fan	Number of blades & spacing	4 Std. (5 AC & HD)	6 Std. (7 AC & HD)
	Diameter	15.62 (17.25 AC & HD)	17 (18.38 AC & HD) (●)
	Ratio-fan to crankshaft rev.	1.20:1	1.06:1
	Fan cutout type	Power-Flex Fan (Std. with AC, Opt. HD)	
	Bearing type	Ball (All Engines)	

*Drive belts (indicate belt used by letter)	Fan	A	F
	Alternator alternator	A	F
	Water Pump	A	F
	Power Steering	B	G
	Air Conditioning with PS	C & D	F & H
" " less PS	D & E	F & I	

* Drive Belt Dimensions	A	B	C	D	E	F	G	H	I	J	K
Angle of V	38°	38°	38°	38°	38°	38°	38°	38°	38°		
Nominal length (SAE)	36.00	45.28	45.50	35.75	43.75	43.00	50.50	62.50	61.45		
Width	3/8	17/32	1/2	1/2	1/2	3/8	1/2	1/2	1/2		

AMA Specifications—Passenger Car

MAKE OF CAR AMERICAN MOTORS **MODEL YEAR** 1970 **DATE ISSUED** 9-25-69 **REVISED** (●)4-1-70

MODEL	Availability On Page 3	199 & 232 CID SIXES & 304 CID V-8	360 & 390 CID V-8's	
ELECTRICAL – SUPPLY SYSTEM				
Battery	Make and Model	Globe-Union 2SM-50 (1)	Globe-Union 2SM-60 (1)	
	Voltage Rtg. & Total Plates	12 Volts, 54 Plates (1)	12 Volts, 66 Plates (1)	
	SAE Designation & Amp. Hr. Rtg.	2SM-50 A.H.@20 HRS. (1)	2SM-60 A.H.@20 HRS. (1)	
	Location	Engine Compartment, Forward		
	Terminal grounded	199 & 232 CID SIXES	304, 360 & 390 CID V-8's	Negative
Generator or Alternator	Make	Motorola	American Motors	
	Model	35 Amp: A12NAM456(7)..(2)	35 Amp: 319534(5)..(2)	
	Type and rating	Alternator with Silicon Diodes & Isolation Diode (35&55 Amp.)		
	Output at engine idle (neutral)	N.A.		
	Ratio-Gen. to Cr/s rev.	2.41:1		
Regulator	Make	Motorola (or American Motors)		
	Model	R2AM4 (AM: 3195003)		
	Type	Solid State		
	Cutout relay	Closing voltage @ generator rpm	N.A.	
		Reverse current to open	N.A.	
	Regulated	Voltage	15	
		Current	35 AMPS (55 Opt., Std. with A.C.)	
	Voltage test conditions	Temperature	Hot	
		Load	10 AMPS	
		Other	- - -	

ELECTRICAL – STARTING SYSTEM				199 & 232 CID SIXES	304, 360 & 390 CID V-8's	
Starting Motor	Make	FOMOCO				
	Model	C9FF-11001-A	C7FF-11001-B			
	Rotation (drive end view)	Clockwise				
Motor control	Switch (solenoid, manual)	Solenoid				
	Starting procedure	Turn ignition key to extreme clockwise position. Automatic transmission lever must be in neutral or park position.				
Motor Drive	Engagement type	Solenoid Actuated				
	Pinion meshes (front, rear)	Front				
	Number of teeth	Pinion	9			
		Flywheel	Manual	153	164	164
	Auto.		153	164	164	
Flywheel tooth face width	Manual	.43				
	Auto.	.38				

- (1) Opt. Heavy Duty: Globe-Union 2SH-70, 12 V, 66 Plates, 70 A.H. @20 Hrs.
All Batteries are identified: "American Motors Clear Power".
- (●)(2) Opt. 55 Amp.
(Std. with Air Cond., "Command-Air" High-Level Vent or Rear Window Defogger)
...A12NAM606(2).

AMA Specifications—Passenger Car

MAKE OF CAR AMERICAN MOTORS MODEL YEAR 1970 DATE ISSUED 9-25-69 REVISED ^(*) 4-1-70

MODEL	Availability On Page 3	199 & 232 CID SIXES	304, 360 & 390 CID V-8's
-------	---------------------------	------------------------	-----------------------------

ELECTRICAL - IGNITION SYSTEM

Type	Conventional - Std., Opt., N.A.	Standard						
	Transistorized - Std., Opt., N.A.	N.A.		"Delcotronic" Capacitor Discharge (Dealer Kit)				
	Other (specify)	N.A.		"Mallory" High-Perf. (Dealer Kit)				
Coil	Make	Delco-Remy or American Motors						
	Model	D-R:1115294 (AM:3191922)			D-R:1115266 (AM:3182864)			
Amps	Engine stoppage	3.5/1.6						
	Dist. Diaphragm	Dual	Single	Dual	Dual	Dual	Single	
Distributor	Make	199 & 232 SIX	232 SIX (1)	304 2-B.(2)	360 2-B.(3)	360 4-B.	390 4-B.	
	Model	1110481	1110444	1112018	1111988	1111987	1111473(4)	
	Cent'gal adv. in c/shaft degrees @ engine rpm (nominal)	Start (rpm)	500-800	600-800	800-1000	800-1000	700-900	800-900
		Intermediate points deg. @ rpm	14°-18°@2100	16°-20°@2000	10°-14°@1650	10°-14°@1650	12°-16°@1600	16.5°-21°@1600
		Max. deg. @ rpm	22°-26°@4500	24°-28°@4000	24°-28°@4200	24°-28°@4200	22°-26°@4000	28°-32°@4400
	Vacuum adv. in c/shaft degrees @ in. Hg. (nominal)	Start (in. Hg.)	5" to 7"	5" to 7"	- - - -	5" to 7"	5" to 7"	8" to 10"
		Intermediate points, deg. @ in. Hg.	9° @ 9"	11° @ 10"	- - - -	9° @ 9.5"	9° @ 9.5"	12° @ 14"
		Max. deg. in. Hg.	18° @ 14"	22° @ 16.5"	- - - -	18° @ 14.5"	18° @ 14.5"	24° @ 19.5"
	Breaker gap (in.)	.016						
	Cam angle (deg.)	31 to 34			29 to 31			
Breaker arm tension (oz.)	17 to 21							
Timing	Crankshaft deg. @ rpm	3° BTDC (± 1°)			5° BTDC (± 1°)		TDC (± 1°)	
	Mark location	Vibration Dampener						
Spark Plug	Make	Champion						
	Model	N-14Y			N-12Y		N-12Y (5)	
	Thread (mm)	14						
	Tightening torque (lb. ft.)	25 to 30						
Cable	Gap	.033 to .037						
	Conductor type	Carbon Core Wire						
	Insulation type	Neoprene						
	Spark plug protector	Hypalon						

ELECTRICAL - SUPPRESSION

Locations & type	Carbon Core Ignition Wires
------------------	----------------------------

- (*) (1) For Hornet & Gremlin 145 HP/232 CID with Automatic Transmission.
- (2) For 304-2B. V-8 with Automatic Transmission (no vacuum advance).
- (3) For 304-2B. V-8 with Manual Trans., 360-2B. V-8 with Automatic Transmission.
- (4) Replaced by 1111948 as Early-Production Running Change.
 - Vacuum Start. . . . 4" to 6"
 - Inter. 12° @ 11"
 - Max. 24° @ 18.5"
- (5) N-10Y for 340 HP/390 CID Rebel "Machine" Engine.

AMA Specifications—Passenger Car

MAKE OF CAR AMERICAN MOTORS MODEL YEAR 1970 DATE ISSUED 9-25-69 REVISED ^(*)4-1-70

Availability MODEL On Page 3	199 & 232 CID SIXES	304, 360 & 390 CID V-8's
---------------------------------	------------------------	-----------------------------

ELECTRICAL – INSTRUMENTS AND EQUIPMENT

(●) Speed-ometer	Type	King-Seeley (Stewart-Warner for Hornet & Gremlin)
	Trip odometer (yes,no)	No
Charge indicator – type		Warning Light
Temperature indicator – type		Electrical Gauge
Oil pressure indicator – type		Warning Light
Fuel indicator – type		Electrical Gauge (plus Optional Low-Fuel-Warning Light)
Other		Dual Hydraulic Brake System Warning Light Parking Brake Warning Light
(●) Wind-shield wiper	Type – Standard	Vacuum, Variable-Speed
	Type – Optional	Electric, Variable-Speed, Hornet, Gremlin, Jav.&AMX (3-Speed Rebel & Amb.)
Wind-shield washer	Type – Standard	Manual Pump (Panel Switch)
	Type – Optional	Electric Powered Pump (Panel Switch)
(●) Horn	Type	Vibrator
	Number used	2(1 for all Hornets, all Gremlins & Rebel Base, 2nd. Horn Dealer Accessory)
	Amp draw (each)	8.5

(●) DRIVE UNITS – CLUTCH (Manual Transmission)	199 CID Hornet & Gremlin	232 CID Hornet, Gremlin & Javelin 232 CID Rebel & Ambassador
--	-----------------------------	---

6-CYL. ENGINES		
Make & type		Borg & Beck, Dry Type
Type pressure plate springs		9 Coils
Total spring load (lb.)		1176 1627(1730 for Rebel & Amb.)
No. of clutch driven discs		One
Clutch facing	Material	AMCO 157-80 Front, US 5935 Rear US 6384 Front, US 5935 Rear
	Outside & inside dia.	9.13 x 6.13
	Total eff. area (sq.in.)	71.88
	Thickness	.125
	Engagement cushioning method	Crimped Flat Springs
Release bearing	Type & method of lubrication	Ball, Pre-Lubricated
Torsional damping	Methods: springs, friction material	Springs, Steel-on-Steel

DRIVE UNITS – CLUTCH (Manual Transmission)		304 CID 3-Speed	360 CID 4-Speed	390 CID 4-Speed
V-8 ENGINES				
Make & type		Borg & Beck, Dry Type	Borg & Beck, Semi-Centrifugal, Dry Type	
Type pressure plate springs		9 Coils	12 Coils & 3 Rollers	12 Coils & 6 Rollers
Total spring load (lb.)		2028	2187	2133
No. of clutch driven discs		One		
Clutch facing	Material	AMCO 327LF	JM5003-8DL	
	Outside & inside dia.	10 x 6.5	10.5 x 6.5	
	Total eff. area (sq.in.)	90.72	106.82	
	Thickness	.125		
	Engagement cushioning method	Crimped Flat Springs		
Release bearing	Type & method of lubrication	Ball, Pre-Lubricated		
Torsional damping	Methods: springs, friction material	Springs, Steel-On-Steel		

AMA Specifications—Passenger Car

MAKE OF CAR AMERICAN MOTORS **MODEL YEAR** 1970 **DATE ISSUED** 9-25-69 **REVISED** ^(*)4-1-70

MODEL <u>Availability On Page 3</u>	199 & 232 CID SIXES	304, 360 & 390 CID V-8's
--	------------------------	-----------------------------

DRIVE UNITS – TRANSMISSIONS

Manual 3-speed (std. or opt.)	Standard	Std. for 304 V-8, Javelin only
Manual 4-speed (std. or opt.)	NA	Opt. (NA 304 & 360 2-Bbl.) Std.
Manual with overdrive (std. or opt.)	NA	NA on AMX & Machine
Automatic (std. or opt.)	Optional	Optional (NA AMX)
Column Shift	Optional	Optional (NA AMX)
Console Shift	NA	Optional (NA Hornet & Gremlin)

DRIVE UNITS – MANUAL TRANS.

(•)	199 SIX 232 SIX (Hornet & Gremlin)	232 SIX (Javelin, Rebel & Ambassador)	304 V-8 (Javelin)	360 V-8 390 V-8 (Javelin, AMX & Rebel Machine)
Number of forward speeds	3	3	3	4
Transmission ratios	In first	2.61	2.64	2.55
	In second	1.63	1.61	1.56
	In third	1.00	1.00	1.00
	In fourth	- - -	- - -	- - -
	In reverse	3.54	2.64	2.55
Synchronous meshing, specify gears	2 & 3	1, 2 & 3	1, 2 & 3	1, 2, 3 & 4
Shift lever location	Column (Floor for 232 Gremlin)	Column (Floor for Javelin)	Floor	Floor
Lubricant	Capacity (pt.)	1.5	2.5	3.5
	Type recommended	Mineral Gear Lubricant		
	SAE viscosity number	80		
		80		
	80			

DRIVE UNITS – MANUAL TRANS. W/OVERDRIVE

(For transmission data see manual transmission section)		- - -
Type (planetary or other)		- - -
Manual lockout (yes, no)		- - -
Downshift accelerator control (yes, no)		- - -
Minimum cut-in speed		- - -
Gear ratio		- - -
Lubricant	Capacity (pt.) (Overdrive only)	- - -
	Separate filler (yes, no)	- - -
	Type recommended	- - -
	SAE viscosity number	- - -
		- - -

AMA Specifications—Passenger Car

MAKE OF CAR AMERICAN MOTORS MODEL YEAR 1970 DATE ISSUED 9-25-69 REVISED ^(*) 4-1-70

Availability On Page 3	199 & 232 CID SIXES	304, 360 & 390 CID V-8's
---------------------------	------------------------	-----------------------------

DRIVE UNITS — AUTOMATIC TRANSMISSION

Trade name	Shift-Command			
Type describe	Borg & Beck/Long Torque Converter with Planetary Gears			
Selector location	Column		Column or Console	
	Operation	6&V-8 Col.	V-8 Con.	6 & 304 V-8
List gear ratios Selector Pattern and indicate which are used in each selector position	Park	P	PRK	- - -
	Reverse	R	REV	2.09:1
	Neutral	N	NTL	- - -
	1,2&3 Gears	D	DRV	1.00:1
	2 Gear	2	2ND	1.45:1
1 Gear	1	1ST	2.39:1	

- (●) Max. upshift speed—drive range 55 to 72 mph (65-87 Hornet & Gremlin 232 | 60 to 75 mph
- (●) Max. kickdown speed—drive range 50 to 65 mph (50-70 Hornet & Gremlin 232 | 55 to 70 mph

(●) Torque convertor	Number of elements	Three		
	Max. ratio at stall	2.00	304=2.00, 360 & 390 = 2.18 (1)	
	Type of cooling (air, liquid)	Air (Water, Opt.)	Air & Water (Auxiliary Cooler, Opt.)	
	Nominal diameter	11	304=11", 360 & 390 = 12" (1)	
Lubricant	Capacity—refill 6 Qts. Dry	9.5	(2)	
	Type recommended	"DEXRON" Auto. Trans. Fluid (Type A, AQ-ATF, Suffix "A")		
Special transmission features	Vacuum-Modulated Control Between Trans. & Engine. Electric "Kick-Down" Solenoid System			

DRIVE UNITS — PROPELLER SHAFT

		HORNET		GREMLIN		REBEL		AMBASSADOR		JAVELIN		AMX		
		SIX	V-8	SIX	SIX & V-8	SIX & V-8	SIX & V-8	SIX	V-8	V-8				
Number used		(●) One												
Type (straight tube, tube-in-tube, internal-external damper, etc.)		(●) Straight Tube (with tube-in-tube ends)												
Outer diam. x length* x wall thickness	Manual 3-speed trans.	52.500	- - -	40.720	54.940	58.900	51.690	47.220	- - -					
		2.500	- - -	2.000	2.750	3.000	2.500	2.500	- - -					
		.065	- - -	.083	.083	.083	.065	.083	- - -					
	Manual 4-speed trans.	- - -	- - -	- - -	54.940	- - -	- - -	50.170	38.180					
		- - -	- - -	- - -	3.000	- - -	- - -	2.500	2.500					
		- - -	- - -	- - -	.083	- - -	.083	.083	- - -					
Overdrive transmission		- - -	- - -	- - -	- - -	- - -	- - -	- - -						
Automatic transmission		47.940	46.830	36.150	50.340(3)	54.370(4)	47.220	47.220	38.180					
		2.500	2.500	2.000	2.500	3.000	2.500	2.500	2.500					
		.065	.065	.083	.065	.083	.083	.083	.083					

- * Center to center of universal joints, or to centerline of rear attachment. (Continued)
- (1) Early-Production Running Change for 390 V-8 to 2.00 Ratio with 11" Converter.
 - (2) 304 V-8 ... 9.5 Qts.
360 & 390 V-8 ... 10 Qts.
 - (3) 304 V-8 ... 51.970 x 3.000 x .083
360 & 390 V-8 ... 54.940 x 3.000 x .083
 - (4) 304 V-8 ... 55.940 x 2.750 x .083
360 V-8 ... 58.900 x 3.250 x .065
390 V-8 ... 58.900 x 3.250 x .065
 - (5) 360 & 390 V-8 ... 50.170 x 2.500 x .083

AMA Specifications—Passenger Car

MAKE OF CAR AMERICAN MOTORS MODEL YEAR 1970 DATE ISSUED 9-25-69 REVISED (*) 4-1-70

	HORNET, GREMLIN, JAVELIN & AMX	REBEL & AMBASSADOR
--	-----------------------------------	-----------------------

MODEL _____
DRIVE UNITS – PROPELLER SHAFT (cont.)

Intermediate bearing	Type (plain, anti-friction)	None		
	Lubrication (fitting, prepack)	- - -		
Slip Yoke	Type	Involute		
	Number of teeth	Six & 30 $\frac{1}{4}$ V-8 16	360 V-8 28	390 V-8 Auto. Trans. 16 Auto. (28 $\frac{1}{2}$ -Speed)
	Spline O.D.	1.170	1.207	1.375 Auto. Trans. 1.207 $\frac{1}{2}$ -Speed Trans.
Universal joints	Make and Mfg. No.	#1280	#1280 DANA	#1310 Auto. & $\frac{1}{2}$ -Speed
	Number used	Two		
	Type (ball and trunnion, cross)	Single-Pivot, Cross		
	Rear attach. (u-bolt, clamp, etc.)	U-Bolt		
	Bearing	Type (plain, anti-friction)	Anti-Friction	
Lubric. (fitting, prepack)		Prepack		
Drive taken through (torque tube or arms, springs)		Rear Springs	$\frac{1}{2}$ -Link Trailing Arms	
Torque taken through (torque tube or arms, springs)		Rear Springs (1)	$\frac{1}{2}$ -Link Trailing Arms	

DRIVE UNITS – AXLE

Type (front, rear)		Front				
Description		1 Piece Housing with Inserted Tubes. Live Axle (Conventional)				
(*) Limited Slip differential, type "Twin-Grip" Opt., Dana (Warner Gear, Hornet-6, Gremlin-6 & Javelin-6) (2)						
Drive Pinion Offset		1-1/2				
No. of differential pinions		Two (Four with V-8 Twin-Grip)		Two (Four with Twin-Grip)		
Pinion adjustment (shim, other)		Shim				
Pinion bearing adj. (shim, other)		Shim				
Wheel bearing type		Conic & Roller				
Lubricant	Capacity (pt.)	3 for Six, $\frac{1}{2}$ for V-8		4		
	Type recommended	Hypoid, or Multi-Purpose Gear Lube, API, GL-5 (3)				
	SAE viscosity number	Summer	80			
		Winter	80			
Extreme cold		80				

AXLE RATIO TOOTH COMBINATIONS

(See page 3 for axle ratio usage)

Axle ratio	Factory Installed								Both	Dealer Kits			
	2.37	2.73	2.87	3.08	3.15	3.31	3.54	3.91		3.73	4.10	4.44	5.00
No. of teeth	Pinion	19	15	15	13	13	13	11	11	11	10	9	9
	Ring gear	45	41	43	40	41	43	39	43	41	41	40	45
Ring Gear O.D.	7.56	7.5	8.75	7.5	8.75	7.6	8.75	8.88	8.88	8.88	8.88	8.88	8.88

- (1) Plus Torque Links, Standard on AMX (Dealer Kit for Javelin).
- (2) Positive-Locking Type available as Dealer Kit ("Detroit Locker" by Det. Auto. Products).
- (3) Special lube for opt. "Twin-Grip" differential (API, GL-5 Quality).

AMA Specifications—Passenger Car

MAKE OF CAR AMERICAN MOTORS MODEL YEAR 1970 DATE ISSUED 9-25-69 REVISED (*) 4-1-70

MODEL	HORNET		GREMLIN (*)		REBEL		AMBASSADOR		AMX	JAVELIN		
	SIX	V-8	SIX	SIX & V-8	V-8	SIX & V-8	V-8	SIX	V-8			
DRIVE UNITS - WHEELS	All	All	All	Except Wagon	Wagon	Machine	Except Wagon	Wagon	All	All	All	
Type & material	Pressed Steel Disc & Safety Rim											
Rim (size & flange type)	Std.	See "TIRES" Below										
	Opt.	See "TIRES" Below										
Attachment	Type (bolt or stud)	STUD										
	Circle diameter	4.50										
	Number and size	FIVE, 1/2 x 20, 3/4 HEX										
DRIVE UNITS - TIRES (1)					8.25x14 6JK (Base)							
Standard	Size, ply rating, & ply Rim Size	6.45x14 4 1/2 J	C78x14 5J(2)	6.00x13 4 1/2 J	E78x14 5 1/2 J	G78x14 6JK(SST)	E60x15 7JJ	F78x14 5 1/2 JK	H78x14 6JK	E78x14 6JK	C78x14 5J	D78x14 5J(2)
	Type (bias, radial, etc.)	Bias, 4-Ply Rating, 2-Ply Polyester plus 2-Ply Fiberglass-Belted Tread (6.00, 6.45 & 8.25 less Fiberglass-Belt)										
	Full rated Inflation Press.	Front	28	28	24 (28 V-8)	20	24	24	20	24	24	24
	Rear	28	28	28	28	28	28	28	28	24	24	24
Rev./Mile at 50 MPH (3)	835	812	874	798	764	807	784	749	798	812	811	
Optional	See "Type" Above	B78x14 4 1/2 J (4)	D78x14 5J(2)	6.45x14 4 1/2 J	F78x14 5 1/2 JK	G78x14 6JK (Base)	- - -	G78x14 6JK	- - -	E70x14 6JK	D78x14 5J	E78x14 5 1/2 JK
	Size, ply rating, & ply Rim Size	C78x14 5J	D70x14 6JK	B78x14 4 1/2 J (4)	- - -	H78x14 6JK (Base & SST)	- - -	- - -	- - -	F70x14 6JK	E78x14 5 1/2 J	E70x14 6JK
	(plus special fleet options on certain models)	- - -	- - -	- - -	- - -	- - -	- - -	- - -	- - -	E60x15 7JJ	E70x14 6JK	F70x14 6JK
BRAKES - PARKING											E60x15 7JJ	
Type of control	Foot Pedal, Hand Release											
Location of control	Left Side, Under Instrument Panel											
Operates on	Rear Service Brakes											
If separate from service brakes	Type (internal or external)	- - -										
	Drum diameter	- - -										
	Lining size (length x width x thickness)	- - -										

(1) "Space-Saver" Spare Tire (7.35x14 mounted on 14x5 1/2 JK wheel) Standard on AMX & Rebel "Machine".

Optional on Gremlin & Javelin, & included with set of 4 Styled-Steel Wheels.

(2) C78 & D78 use 5 1/2 JK Rim Wheels with Disc Brake Option.

(3) B78x14 = 838 Rev./Mile. D70x14 = 819. E70x14 = 813. F70x14 = 790. (4) Included with Air Conditioning.

AMA Specifications—Passenger Car

MAKE OF CAR AMERICAN MOTORS MODEL YEAR 1970 DATE ISSUED 9-25-69 REVISED (e) 4-1-70

MODEL		Hornet 6 Gremlin 6(●) Javelin 6	Hornet V8, Javelin V8, AMX V8, Rebel 6,	Rebel 360 & 390 V8 Sedan & Hardtop, Rebel V8 Wagon,	Opt. on all V-8's (Std. on "Machine") Opt. on 6's for Export & Fleet Sales Only	
BRAKES - SERVICE			Ambassador 6, Rebel 304 V8 Sed & HT	Ambassador V8	Disc/Drum (Power) (1)	
Type (drum) or (disc & no. of pistons)		Drum		Drum	Bendix (1)	
Self adjusting (std., opt., N.A.)	Std.	Bendix		Bendix (or Wagner)	Bendix (1)	
Special Valving	Type (proportion, delay, metering, other)	None		None	Proportioning Valve	
Power brake make & type (remote, int., etc.)	Std. Size	7.75 Dia.		7.75 Dia. Hornet, Javelin & AMX		
	Opt. Bendix	Integral, Vacuum-Suspended, Single Diaphragm		9.50 Dia. Rebel & Ambassador	7.75 Dia. Tandem Diaphragm (Single Hornet)	
Effective area (sq. in.) *		153.49		167.54	F37.2+R67.7=104.9	
Gross lining area (sq. in.) **		153.49		167.54	F37.2+R67.7=104.9	
Swept area (sq. in.) ***		254.47		267.04	F261+R110=371	
Front to Rear Effectiveness Relationship	Front	62.2%	64.6%	57.3%	61.6%	Variable
	Rear	37.8%	35.4%	42.7%	38.4%	
Drum	Diameter (nominal)	Front	9.00	10.00		
	Rear	9.00		10.00		10.00
	Type and material	Cast Iron Plain, Steel Center	Cast-Iron, Steel Flare & Center	Cast-Iron w/Cross Ribs, Steel Flare & Center		Cast-Iron, Steel Flare & Center
Rotor	Outer working diameter					11.14 (11.19 Rotor)
	Inner working diameter					6.30
	Working width		Hornet V8	Rebel & Ambassador		2.42
	Material & type (vented/solid)		Jav & AMX V8	6-Cyl.	V-8	Cast-Iron/Solid
Wheel cylinder bore	Front	1.13	1.19	1.09	1.19	2.00
	Rear	.88	.88	.94	.94	(2)
Master Cylinder	Bore			1.00		
	displacement distribution	Front %	60.4% (.487 Cu.In. Primary Section)			68% (.673 Cu.In.)
	Rear %	39.6% (.319 Cu.In. Secondary Section)			32% (.317 Cu.In.)	
Pedal arc ratio		5.61 to 1				
Line pressure at 100 lb. pedal load		640 psi min. with Manual Brakes (3)				1400 psi approx.
Shoe Clearance	Front	.004 to .010 @ high point on horizontal axis				0 Front Disc
	Rear	.004 to .010 @ high point on horizontal axis				
Brake lining	Bonded or riveted		Bonded			Bonded (4)
	Front Wheel	Material	Molded Asbestos Compound, Marshall-Eclipse			Mintex M-33
		Size (length x width x thickness)	Prim. or out-board	7.66x2.25x.19	8.91x2.50x.19	4.89x2.31x.44
		Second. or in-board				(.38 usable thick.)
		Segments per shoe				One ea. side of disc
	Rear Wheel	Material	Molded Asbestos Compound, Marshall-Eclipse			
		Size (length x width x thickness)	Prim. or out-board	7.66x2.00x.19	8.46x1.75x.19	8.46x1.75x.19
		Second. or in-board				
Segments per shoe					One	

* Excludes rivet holes, grooves, chamfers, etc. ** Includes rivet holes, grooves, chamfers, etc.
 *** Total swept area for four brakes. (Widest lining contact width for each brake x its contact circumference.)

- (1) Four-Wheel, Ventilated-Rotor Disc Brakes (Kelsey-Hayes) available as Dealer Kit.
- (2) Hornet, Javelin & AMX = .88" Dia.
 Rebel & Ambassador Sedan = .94" Dia.
 Rebel & Ambassador Wagon = 1.00" Dia.
- (3) Power Brakes Rebel & Amb. = 1100 psi approx. Power Brakes Hornet, Javelin & AMX = 800 psi approx.
- (4) Hornet, Javelin & AMX use Riveted Rear-Brake Linings (with Front Disc Brakes).

AMA Specifications—Passenger Car

MAKE OF CAR AMERICAN MOTORS MODEL YEAR 1970 DATE ISSUED 9-25-69 REVISED (•) 4-1-70

MODEL	(•) HORNET	GREMLIN	REBEL	AMBASSADOR	JAVELIN	AMX
--------------	---------------	---------	-------	------------	---------	-----

STEERING

Manual (std., opt., NA)		Standard						
Power (std., opt., NA)		Optional						
Adjustable steering wheel (tilt, swing, other)	Type and description	N.A.		7-Position, Vertical-Arc Adjustment for Steering Column ("Adjust-O-Tilt")				
	(std., opt., NA)	- - -		Opt.(N.A. with column-shift 3-speed manual)				
Wheel diameter	Manual	16"						
	Power	16"						
Turning diameter (feet)	Outside front	Wall to wall (l. & r.)	38'	34'8"	39'9"	42'5"	38'3"	34'10"
		Curb to curb (l. & r.)	36'	32'8"	37'9"	40'5"	36'3"	32'10"
	Inside rear	Wall to wall (l. & r.)	19'11"	- -	20'3"	22'4"	20'4"	18'3"
		Curb to curb (l. & r.)	20'4"	- -	21'	23'2"	20'7"	18'8"
Manual	Gear	Type	Recirculating Ball					
		Make	Saginaw					
	Ratios	Gear	24.0:1				20.0:1 (1)	
		Overall	31.8:1				27.1:1 (1)	
	No. wheel turns (stop to stop)		5.9				5.1 (1)	
Power	Type (coaxial, linkage, etc.)	Integral Rotary Valve with Variable-Ratio Gear Box						
	Make	Saginaw Box, Thompson Pump						
	Gear	Type	Recirculating Ball					
		Ratios	16.0:1 to 12.2:1					
	Overall		21.7:1 to 16.5:1					
		Pump driven by	Belt to Crankshaft Pulley					
No. wheel turns (stop to stop)		3.2						
Linkage	Type	Ball & Socket						
	Location (front or rear of wheels, other)	Front						
	Drag link (trans. or longit.)	Transverse						
	Tie rods (one or two)	Two						
Steering Axis	Inclination at camber (deg.)	7°45' @30'						
	Bearings (type)	Upper	Ball Joint					
		Lower	Ball Joint					
		Thrust	Ball Joint					
Whl. Align. (range at curb wt. & preferred)	Caster (deg.)	+½° to +1½° (+1° Desired)						
	Camber (deg.)	-3/8° to +3/8° (0° Desired)						
	Toe-in (outside track inches)	1/16" to 3/16" (1/8" Desired)						
Steering spindle & joint type	Integral Knuckle-Pin with Upper & Lower Ball Joints							
Wheel Spindle	Diameter	Inner bearing	1.25					
		Outer bearing	.75					
	Thread size	.75 x 16						
	Bearing type	Tapered Roller						

(1) Optional Quick-Ratio Manual Steering for Javelin & AMX ... Gear Box ... 16.0:1
 Overall 21.7:1
 Turns 4.0

AMA Specifications—Passenger Car

MAKE OF CAR AMERICAN MOTORS MODEL YEAR 1970 DATE ISSUED 9-25-69 REVISED (a) 4-1-70

MODEL	HORNET			JAVELIN			AMX			REBEL			AMBASSADOR			GREMLIN										
SUSPENSION - GENERAL																										
Provision for car leveling	None																									
Provision for brake dip control	Front Susp. plus Asymmetrical Rear Springs									Front Susp. plus 4-Link Rear Geometry						same as Hornet										
Provision for acc. squat control	Asymmetrical Rear Springs									4-Link Rear Geometry						same as Hornet										
Special provisions for car jacking	Side Scissors Jack									Bumper Jack						Side Scissors Jack										
Shock absorber front & rear	Type	Direct-Acting, Telescopic																								
	Make	Gabriel & Monroe																								
	Piston dia.	1.00 (1.19 Heavy Duty)																								
Other special features	---																									
SUSPENSION - FRONT																										
Type and description	HORNET 6 & V-8			JAVELIN 6 & V-8			AMX V-8			REBEL SEDAN & HT 6 & V-8			REBEL WAGON 6 & V-8			AMBASSADOR SEDAN & HT 6 & V-8			AMBASSADOR WAGON V-8			GREMLIN 6				
INDEPENDENT, TWIN BALL JOINT, COIL SPRINGS	STD	AC	HD	STD	AC	HD	STD	AC	HD	STD	AC	HD (& Machine)	STD	AC	HD	STD	AC	HD	STD	AC	HD	STD	AC	HD		
Spring	Coil																									
	SAE 5160																									
Material	9.75 x 5.05																									
Size (coil design height & I.D., bar length x dia.)																										
Spring rate (lb. per in.)	STX	218	233	285	233	248	285	--	--	--	240	257	304	233	248	295	213	227	304	--	--	--	211	225	285	
Rate at wheel (lb. per in.)	STX	97	103	122	103	109	122	--	--	--	105	111	129	103	109	125	95	100	129	--	--	--	94	100	122	
Spring Rate (lb./in.)	V-8	248	265	314	265	285	314	276	294	322	235	251	335	220	235	335	235	251	335	235	251	335	--	--	--	
Rate @ WH (lb./in.)	V-8	108	115	133	115	121	133	119	125	136	103	109	141	98	103	141	103	109	141	103	109	141	--	--	--	
Stabilizer	Standard for V-8 In Opt. Handling Pkg. for 6						Standard			Standard			Standard			Standard			In Optional Handling Package							
Type (link, linkless, frameless) Link Sway Bar																										
Material & bar diameter	SAE 1090, .94 Dia.																									
SUSPENSION - REAR																										
Type and description	HORNET			JAVELIN			AMX			REBEL & AMBASSADOR SEDAN & HARDTOP (less "Machine")						REBEL & AMBASSADOR STATION WAGON (& "MACHINE")						GREMLIN				
Hotchkiss	Rear Spring			Rear Spring (1)			Rear Spring (1)			4-Link with Coil Springs						4-Link Trailing Arms						Hotchkiss				
Drive and torque taken through	Rear Spring			Rear Spring (1)			Rear Spring (1)			4-Link with Coil Springs						4-Link Trailing Arms						Rear Spring				
Spring	Coil																									
	SAE 5155																									
Material	10.5 x 5.25																									
Size (length x width, coil design height & I.D., bar length & dia.)	10.0 x 5.25																									
Spring rate (lb. per in.)	ST 6	ST 8	HD 6	HD 8	ST 6	ST 8	HD 6	HD 8	STD	HD	STANDARD	HEAVY-DUTY	STD. (& "MACHINE")	HEAVY-DUTY	STD	HD	ST 6	ST 8	HD 6	HD 8	ST 6	ST 8	HD 6	HD 8		
Rate at wheel (lb. per in.)	82	87	95	100	86	87	106	102	102	120	115	135	160	200	87	105	100	105	115	120	104	105	130	125	135	155
Mounting insulation type	Rubber Bushing, "Silentbloc"						Front, CP Rear			Rubber, "Silentbloc"						Same as Hornet										
If leaf	---																									
No. of leaves	---																									
Shackle (comp. or tens.)	Compression																									
Stabilizer	None						None			In Opt. Handling Package, Frameless						None										
Material	SAE 1090, .95 Dia.																									
Track bar type	None																									

"HANDLING PACKAGE" OPTIONS: Gremlin, Hornet-6 & Javelin-6; Hornet V-8, Javelin V-8 & AMX; Front Sway Bar Heavy-Duty Springs & Shocks

Rebel & Ambassador (Std. on Rebel "Machine"); Heavy-Duty Springs & Shocks Rear Sway Bar

Note: Rebel "Machine" Hardtop uses Std. Wagon Rear Springs

(1) Rear Torque Links Standard on AMX, Dealer Kit for Javelin.

AMA Specifications—Passenger Car

MAKE OF CAR AMERICAN MOTORS MODEL YEAR 1970 DATE ISSUED 9-25-69 REVISED (*) 4-1-70

MODEL	HORNET & (*)		HORNET	REBEL & AMBASSADOR		JAVELIN	AMX
	GREMLIN		4-Dr Sed.	Sedan	Wagon	Hardtop	Coupe
FRAME	BASE	SST	BASE & SST	ALL	ALL	ALL	ALL
Type and description (Separate frame, unitized frame, partially - unitized frame)	Single-Unit, Body-And-Frame. One-Piece Uniside, Inner & Outer (Rebel & Amb. Wagon). Outer Front Fenders Bolted On.						

BODY – MISCELLANEOUS INFORMATION

Drs. hinged (front, rr.)	Front doors	Front						
	Rear doors	Front						
Type of finish (lacquer, enamel, other)	Acrylic Enamel							
Hood counterbalanced (yes, no)	Yes							
Hood release control (internal, external)	External							
Vehicle Ident. No. location	Plate on Left Door. Plate on Top Surface, Left-Side of Instrument Panel at Base of Windshield.							
Engine No. location	6-Cyl. . . .Block, Upper Right Center V-8. . . .Front of Right-Hand Valve Cover							
Theft protection - type	Key Lock on Steering Column Locks Ignition, Transmission & Steering Wheel. Warning Buzzer Included.							
Vent window control method (crank, friction pivot)	Front	None		Friction Pivot		None		
	Rear	None		None		None		
Seat cushion type	Front	Formed Wire		Coil (Formed Wire, Buckets)		Form. Wire		
	Rear	Formed Wire		Coil		Form. Wire None		
	3rd seat	Solid Polyurethane Foam for Rebel & Ambassador					3-Seat Wagon	
Seat back type	Front	Formed Wire		Coil (Formed Wire, Buckets)		Form. Wire		
	Rear	Formed Wire		Coil		Form. Wire None		
	3rd seat	Solid Polyurethane Foam for Rebel & Ambassador					3-Seat Wagon	
Windshield glass type (i.e., single curved - laminated plate)	Single, Curved Laminated Safety Plate ("Chemcor" type for Javelin & AMX)							
Side glass type (i.e., curved - tempered plate)	Curved, Tempered Safety Glass							
Backlight glass type (i.e., compound curved - tempered plate, three piece)	One-Piece Curved, Tempered Safety Plate on all Sedans & Hardtops. Curved, Tempered Safety Glass on Wagons.							
Windshield glass exposed surface area	1264	1264	1264	1313	1313	1313	1235	1235
Side glass exposed surface area	1416	1362	1328	1416	2496	1332	1321	1112
Backlight glass exposed surface area	787	787	787	1006	776	1215	1225	1225
Total glass exposed surface area	3467	3413	3379	3735	4585	3860	3781	3572

(*) GREMLIN:

Windshield Glass Area	1264
Side Glass Area	1186
Backlight Glass Area	889
Total Glass Area	3339

(1) Difference in 2-door sedan side-glass area (and total) due to fixed rear window on Hornet Base model vs flip-open window on Hornet SST model.

AMA Specifications—Passenger Car

MAKE OF CAR AMERICAN MOTORS MODEL YEAR 1970 DATE ISSUED 9-25-69 REVISED (●) 1-1-70

MODEL	(●)	HORNET & GREMLIN	REBEL & AMBASSADOR	JAVELIN & AMX

CONVENIENCE EQUIPMENT

(Indicate whether standard, optional or NA on each series)

Power windows	Side windows	N.A.	Opt. AMB. DPL & SST	N.A.
	Vent windows	N.A.		
	Rear door or tailgate	- - -	Opt. (Std. on 3-Seat)	- - -
Power seats (specify type as well as availability)		N.A.		
Reclining front seat back (R-L or both)		Opt. on Hornet SST	Opt. (Std. on Amb. SST)	N.A.
Front seat head restrainer (R-L or both)		Standard		
Radios (specify type as well as availability) Opt. All-Transistor		Push-Button AM	Push-Button AM or AM/FM	Push-Button AM or AM/FM. Manual AM with Tape Player.
Rear seat speaker		N.A.	Optional (1)	Optional (1)
Power antenna		N.A.		
Clock		Opt. on Hornet	Opt. (Std. Amb. SST)	Optional
Air conditioner (specify type and availability) Opt. (Std. Amb.)		Front Type Recirculating, Ported Air Discharge, Adjustable Thermostat, Engine Belt Driven 2-Cyl. Alum. Compressor.		
Speed warning device		N.A.		
Speed control device Cruise-Command		N.A.	Opt. V-8 Auto. Trans.	N.A.
Ignition lock lamp		N.A.		
Dome lamp Standard		Ceiling type for Sedans & Wagons (2)		Rear Pillars (NA AMX)
Glove compartment lamp		Optional	Opt. (Std. Amb. SST)	Optional
Luggage compartment lamp		Opt. on Hornet	Opt. (Std. Amb. SST)	Optional
Underhood lamp		N.A.		
Courtesy lamp		Optional	Opt. (Std. Amb. SST)	Opt. (Std. AMX)
Map lamp		N.A.	N.A.	Optional
Auto. trans. quad. lamp		Standard		
Cornering light lamp		N.A.		
Emergency flasher lamp		Standard (4-Way Hazard Warning Signal)		
Back-up lamp		Standard		
Tachometer		N.A.	Std. on Rebel "Machine"	Optional (Std. AMX)
Wagon Roof Rack		Opt. on Gremlin	Std., N.A. Base Rebel	Opt. Trunk Lid Rack
"Command-Air" High-Level Vent		Std. on Hornet	Opt. on cars less Air Cond.	

LAMP HEIGHT AND SPACING

			HORNET	GREMLIN	REBEL		AMBASSADOR		JAVELIN	AMX
			2 & 4 Dr. Sed	2dr. Sed	Sed & HT	Wagon	Sed & HT	Wagon	Hardtop	Coupe
Height above ground to center of bulb or marker	Headlamp	Highest *	25.62	25.02	27.11	27.16	27.35	27.68	26.26	26.05
		Lowest	- - -	- - -	- - -	- - -	- - -	- - -	- - -	- - -
	Tail	Highest	24.67	23.62	23.33	30.55	23.40	30.43	24.31	24.74
		Lowest	- - -	- - -	- - -	- - -	- - -	- - -	- - -	- - -
Distance from C/L of car to center of bulb	Sidemarkers	Front	24.52	23.92	30.90	31.10	23.00	23.34	24.15	23.95
		Rear	24.67	23.60	20.55	30.55	20.69	30.43	21.70	22.07
	Headlamp	Inside	- - -	- - -	20.70	20.70	22.56	22.56	- - -	- - -
		Outside *	24.70	24.70	29.42	29.42	29.20	29.20	27.25	27.25
Tail	Inside	- - -	- - -	16.66	- - -	7.32	- - -	12.51	12.51	
	Outside	26.80	24.00	28.34	34.24	26.22	34.24	24.76	24.76	
Directional	Front	17.15	15.00	24.56	24.56	25.68	25.68	26.85	18.00	
	Rear	26.80	24.00	28.34	34.24	26.22	34.24	24.76	24.76	

* If single headlamps are used enter here.

- Included with 8-Track Stereo Tape Player for Ambassadors (except wagon), Javelin & AMX.
- Rear Side Pillars (both) on Hardtops (except Rebel Base).

AMA Specifications—Passenger Car

MAKE OF CAR AMERICAN MOTORS MODEL YEAR 1970 DATE ISSUED 2-25-69 REVISED (4-1-70)

OFFICIAL SHIPPING WEIGHTS FILED

BASE ENGINE	MODEL	CURB WEIGHT * POUNDS			% PASS. WEIGHT DISTRIBUTION				LIQUID WEIGHT		W/STATE LICENSE BUREAUS	
		Front	Rear	Total	Pass. in Front	Pass. in Rear	Front	Rear	Fuel	Coolant		
HORNET:												
199 Six	4-Dr. Sedan	7005-0 Base	1597	1217	2814	49	51	19	81			2748
232 Six	4-Dr. Sedan	7005-7 SST	1601	1230	2831	49	51	19	81			2765
199 Six	2-Dr. Sedan	7006-0 Base	1566	1177	2743	49	51	19	81			2677
232 Six	2-Dr. Sedan	7006-7 SST	1580	1191	2771	49	51	19	81			2705
GREMLIN:												
199 Six	2-Dr. Sedan	7016-0 2-Pass	1506	1069	2575	43	57	-	-			2497
199 Six	2-Dr. Sedan	7016-5 4-Pass	1515	1120	2635	43	57	17	83			2557
REBEL:												
232 Six	4-Dr. Sedan	7015-0 Base	1686	1524	3210	49	51	19	81			3129
232 Six	4-Dr. Sedan	7015-7 SST	1697	1539	3236			19	81			3155
232 Six	4-Dr. Wagon	7018-0 Base	1605	1832	3437			19	81			3356
232 Six	4-Dr. Wagon	7018-7 SST	1617	1839	3456			19	81			3375
232 Six	2-Dr. Hardtop	7019-0 Base	1690	1539	3229			21	79			3118
232 Six	2-Dr. Hardtop	7019-7 SST	1726	1561	3287			21	79			3206
390 V-8	2-Dr. Hardtop	7019-0 Machine	2064	1667	3731	49	51	21	79			3650
AMBASSADOR:												
232 Six	4-Dr. Sedan	7085-2 Base	1822	1587	3409	47	53	18	82			3328
304 V-8	4-Dr. Sedan	7085-5 DPL	1975	1629	3604			18	82			3523
304 V-8	4-Dr. Sedan	7085-7 SST	1994	1644	3638			18	82			3557
304 V-8	4-Dr. Wagon	7088-5 DPL	1932	1951	3883			18	82			3817
304 V-8	4-Dr. Wagon	7088-7 SST	1962	1956	3918			18	82			3852
304 V-8	2-Dr. Hardtop	7089-5 DPL	1986	1650	3636			20	80			3555
304 V-8	2-Dr. Hardtop	7089-7 SST	2019	1668	3687	47	53	20	80			3606
JAVELIN:												
232 Six	2-Dr. Hardtop	7079-5 Base	1625	1286	2911	46	54	20	80			2845
232 Six	2-Dr. Hardtop	7079-7 SST	1630	1299	2929	46	54	20	80			2863
AMX:												
360 V-8	2-Dr. HT Coupe	7039-7 Base	1808	1384	3192	39	61	-	-			3126
Accessories & Equipment Differential												
			Front	Rear	Total			Front	Rear	Total		
			0	9	9	Cent. Cush. & Armrest, AMX, Jav (Std. SST)			5	6	11	
			5	25	30	Console (no shift lever), Javelin			5	4	9	
			5	23	28	Vinyl Covered Roof, Hornet/Javelin			2/1	4/4	6/5	
			35	-4	31	, Rebel & Amb.			3	4	7	
			9	1	10	Bumper Guards, Front & Rear			4	4	8	
			25	2	27	, Front Wagon			4	0	4	
			7	-7	0	, Rear Javelin & AMX			0	4	4	
			26	1	27	Wire Wheel Covers, 4			8	8	16	
			8	-8	0	Turbo-Cast Wheel Covers, 4			10	10	20	
			73/65	-7/-5	66/60	Handling Pkg., Hornet 6/V8			17/1	2/9	19/20	
			78	-5	73	, Gremlin 6			18	6	24	
			78/73	-3/-2	75/71	, Rebel (Std. Machine)			2	14	16	
			68/75	-3/-4	65/71	, Ambassador			2	14	16	
			66/64	2/2	64/62	, Javelin 6/V8 & AMX			17/1	4/4	21/5	
			9	2	11	Heavy-Duty Cooling (Std. W/AC)			8	-2	7	
			6	1	7	70-Amp. Battery			8	-1	7	
			5	1	6	Undercoat & Hood Insulation			10	10	20	
			5	2	7	Undercoat only			9	10	19	
			5	3	8	Hornet, 6.45x14 to B78x14 Tires			7	11	18	
			6	5	11	, 6.45x14 to C78 (5 to 6 rim)			11	17	28	
			7	5	12	, C78x14 to D78 (5 to 5 1/2 rim)			5	8	13	
			7	7	14	, C78x14 to D70 (5 to 6 rim)			15	23	38	
			-2	8	6	Rebel, E78x14 to F78x14			3	5	8	
			-4/-4	35/25	31/21	, C78x14 to H78x14			3	5	8	
			2	8	10	Amb., F78x14 to C78 (5 to 6 rim)			8	11	19	
			7	0	7	, H78 "B" to H78 "D" Rating			8	12	20	
			8/12	9/12	17/24	Javelin, C78x14 to D78x14			5	8	13	
			10/13	11/13	21/26	, C78x14 to E70 (5 to 6 rim)			16	25	41	
			9/12	12/14	21/26	, D78x14 to E70 (5 to 6 rim)			12	17	29	
			12	13	25	, D78x14 to F70 (5 to 6 rim)			22	13	35	
			16	17	33	AMX, E78x14 to E70x14			4	4	8	
			2	3	5	, E78x14 to F70x14			8	8	16	
			6	6	12	Gremlin, 6.00x13 to 6.45x14			7	11	18	
			11	11	25	, 6.00x13 to B78x14			13	20	33	
			4	2	6	Styled Wheels w/Space-Saver Spare			7	-5	2	

* Reference - SAE Aerospace-Automotive drawing standards, Section E 1.02 (d). (Std. on AMX & Machine)

OFFICIAL SHIPPING WEIGHT includes heater (plus air conditioning on Ambassador), two head-restraints, spare wheel & tire, tire jack with wrench, oil, coolant, plus 8 gallons fuel.
CURB WEIGHT equals shipping weight plus fuel to fill tank (see chart below).

FUEL TO FILL TO CURB WEIGHT:	FRONT	REAR	TOTAL
Hornet..... 8 to 19 gal.	-11	77	66
Javelin..... 8 to 19 gal.	-11	77	66
AMX..... 8 to 19 gal.	-12	78	66
Rebel..... 8 to 21.5 gal.	-16	97	81
Ambassador..... 8 to 21.5 gal.	-15	96	81
All 3-Seat Wagons.. 8 to 19 gal.	- 8	74	66
(*) Gremlin..... 8 to 21 gal.	-11	89	78

HORNET ENGINE/TRANS. COMBINATIONS:

199-1B 3-Speed to 199-1B Auto	13	5	18
199-1B 3-Speed to 232-1B 3-Speed	4	0	4
199-1B 3-Speed to 232-1B Auto	17	5	22
199-1B 3-Speed to 232-2B Auto	21	5	26
232-1B 3-Speed to 232-1B Auto	13	5	18
232-1B 3-Speed to 232-2B Auto	17	5	22
232-1B 3-Speed to 304-2B Auto	170	67	237

REBEL ENGINE/TRANS. COMBINATIONS:

232-1B 3-Speed to 232-1B Auto	7	3	10
232-1B 3-Speed to 232-2B Auto	11	3	14
232-1B 3-Speed to 304-2B Auto, Sed&HT	153	8	161
232-1B 3-Speed to 304-2B Auto, Wagon	169	20	189
232-1B 3-Speed to 360-2B Auto	224	25	249
232-1B 3-Speed to 360-LB Auto	231	25	256
232-1B 3-Speed to 390-LB Auto	260	52	312

AMBASSADOR ENGINE/TRANS. COMBINATIONS:

232-2B 3-Speed to 232-2B Auto	7	3	10
232-2B 3-Speed to 304-2B Auto	119	30	149
232-2B 3-Speed to 360-2B Auto	200	39	239
232-2B 3-Speed to 360-LB Auto	207	39	246
SST 304-2B Auto. to 360-2B Auto	51	9	60
& 304-2B Auto. to 360-LB Auto	58	9	67
DPL 304-2B Auto. to 390-LB Auto	88	35	123

JAVELIN ENGINE/TRANS. COMBINATIONS:

232-1B 3-Speed to 232-1B Auto	6	2	8
232-1B 3-Speed to 304-2B 3-Speed	199	68	267
232-1B 3-Speed to 304-2B Auto Column	171	64	235
Base 232-1B 3-Speed to 304-2B Auto Console	176	68	244
SST 232-1B 3-Speed to 304-2B Auto Console	171	62	233
232-1B 3-Speed to 360-2B Auto Column	229	78	307
Base 232-1B 3-Speed to 360-2B Auto Console	234	82	316
SST 232-1B 3-Speed to 360-2B Auto Console	229	66	295
232-1B 3-Speed to 360-LB Auto Column	236	78	314
Base 232-1B 3-Speed to 360-LB Auto Console	241	82	323
SST 232-1B 3-Speed to 360-LB Auto Console	236	66	302
232-1B 3-Speed to 360-LB 4-Speed	230	71	301
Base 232-1B 3-Speed to 390-LB Auto Console	274	109	383
SST 232-1B 3-Speed to 390-LB Auto Console	269	103	372
232-1B 3-Speed to 390-LB 4-Speed	256	91	347

AMX ENGINE/TRANS. COMBINATIONS:

360-LB 4-Speed to 390-LB 4-Speed	24	0	24
360-LB 4-Speed to 360-LB Auto Console	11	11	22
360-LB 4-Speed to 390-LB Auto Console	13	12	25

GREMLIN ENGINE/TRANS. COMBINATIONS:

199-1B 3-Speed to 199-1B Auto	13	6	19
199-1B 3-Speed to 232-1B 3-Speed Floor	6	1	7
199-1B 3-Speed to 232-1B Auto	17	6	23

	Front	Rear	Total
(*) Deck Luggage Rack, Gremlin	3	6	9
(*) Roof Luggage Rack, Javelin & AMX	-1	8	7

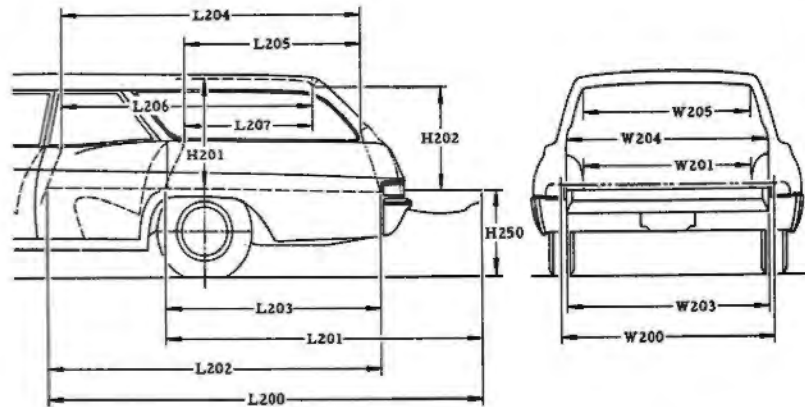
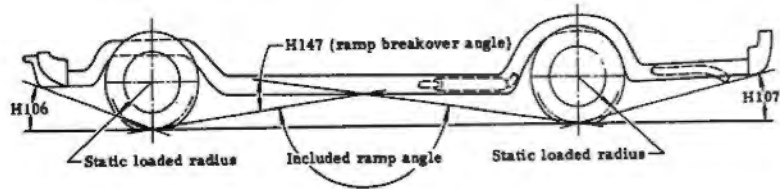
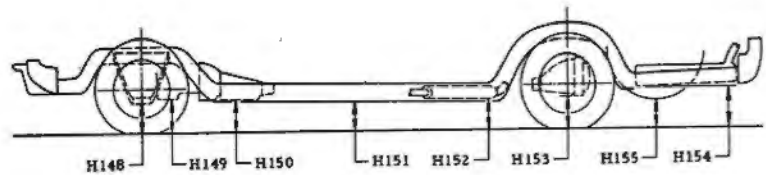
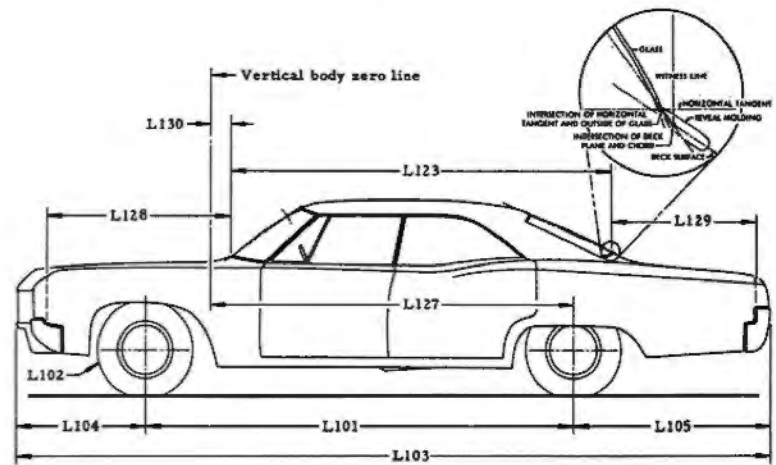
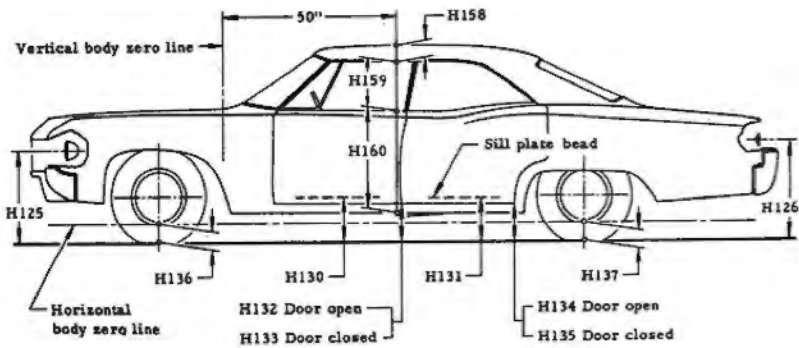
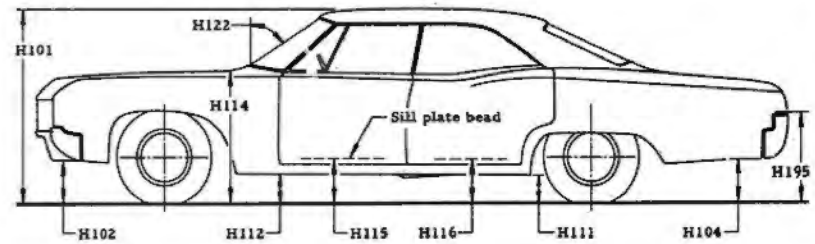
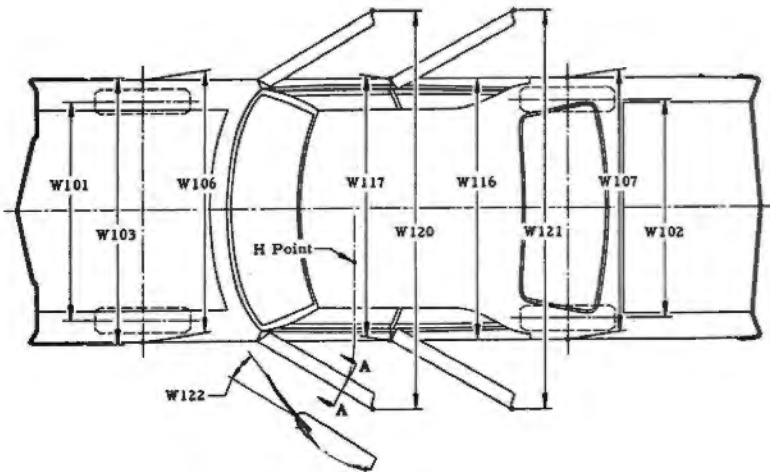

CAR AND BODY DIMENSIONS *
 AMA SPECIFICATIONS SUPPLEMENT

EXTERIOR

CODE NO	DESCRIPTION	CORNET		GREMLIN		REBEL		AMBASSADOR		JAVELIN		AMX
		2-Door Sedan 7006-0 7006-7	4-Door Sedan 7005-0 7005-7	2-Door Sedan 7006-0 2-Pass.	2-Door Sedan 7006-5 4-Pass.	4-Door Sedan 7005-0 7005-7	2-Door Hardtop 7009-0 7009-7	4-Door Wagon 7008-0 7008-7	4-Door Sedan 7008-2 7008-5 7008-7	2-Door Hardtop 7009-5 7009-7	4-Door Wagon 7008-5 7008-7	2-Door Hardtop 7009-5 7009-7
W101	TREAD - FRONT	57.46	57.46	57.46	57.46	60.00	60.00	60.00	60.00	60.00	59.30	59.70
W102	TREAD - REAR	57.00	57.00	57.00	57.00	60.00	60.00	60.00	60.00	60.00	57.00	57.00
W103	MAXIMUM OVERALL WIDTH OF CAR	70.58	70.58	70.58	70.58	77.24	77.24	77.24	77.24	77.24	71.89	71.57
W116	MAXIMUM OVERALL WIDTH OF BODY	70.58	70.58	70.58	70.58	77.24	77.24	77.24	77.24	77.24	71.89	71.57
W117	MAXIMUM BODY WIDTH AT #2 PILLAR	67.88	67.88	67.88	67.88	75.46	75.46	75.46	75.46	75.46	69.71	69.71
W106	FRONT FENDER OVERALL WIDTH	69.08	69.08	69.08	69.08	77.24	77.24	77.24	77.24	77.24	70.69	70.69
W107	REAR FENDER OVERALL WIDTH	70.58	70.58	70.58	70.58	76.76	76.76	76.76	76.76	76.76	71.89	71.57
W120	MAXIMUM OVERALL CAR WIDTH, FRONT DOORS OPEN	156.40	141.72	156.40	156.40	143.14	165.86	143.14	143.14	166.86	143.14	152.90
W121	MAXIMUM OVERALL CAR WIDTH, REAR DOORS OPEN	---	122.62	---	---	140.60	---	140.60	---	140.60	---	---
L30	BODY ZERO LINE TO ACTUAL FRONT OF DASH	1.50	1.50	1.50	1.50	1.50	1.50	1.50	1.50	1.50	1.50	1.50
L101	WHEELBASE	108.00	108.00	96.00	96.00	114.00	114.00	114.00	122.00	122.00	122.00	97.00
L104	OVERHANG, FRONT	33.25	33.25	33.25	33.25	31.90	31.90	31.90	32.90	32.90	41.52	41.52
L105	OVERHANG, REAR	38.01	38.01	32.00	32.00	53.10	53.10	52.10	53.10	52.10	40.52	40.52
L103	OVERALL LENGTH	179.26	179.26	161.25	161.25	199.00	199.00	198.00	208.00	208.00	207.00	179.04
L128	HOOD LENGTH AT CENTERLINE	52.93	52.93	52.93	52.93	52.07	52.07	52.07	61.75	61.75	61.31	61.31
L123	BODY UPPER STRUCTURE LENGTH AT CAR CENTERLINE	96.10	96.10	94.37	94.37	104.70	109.64	135.86	104.37	110.23	135.86	102.03
L129	DECK LENGTH AT CENTERLINE	27.22	27.22	---	---	39.86	36.26	---	39.86	36.26	---	23.30
L127	BODY ZERO LINE TO CENTERLINE OF REAR WHEELS	96.00	96.00	84.00	84.00	100.00	100.00	100.00	100.00	100.00	100.00	83.00
L130	BODY ZERO LINE TO WINDSHIELD COWL POINT	9.12	9.12	9.12	9.12	7.50	7.50	7.50	7.23	7.23	7.23	7.95
L102	TIRE SIZE	6.45x14	6.45x14	6.00x13	6.00x13	E78x14	E78x14	G78x14	F78x14	F78x14	H78x14	C78x14
	DESIGN LOAD (PASS. DISTR.)	3 - 2	3 - 2	2 - 0	2 - 2	2 - 3	2 - 3	2 - 3	2 - 3	2 - 3	2 - 3	2 - 0
H101	OVERALL HEIGHT	52.25	52.25	51.80	51.80	55.03	54.41	56.69	55.21	54.61	56.88	51.53
H114	COWL TO GROUND	36.54	36.54	35.83	35.83	38.47	38.47	39.21	38.71	38.71	39.56	36.50
H112	ROCKER PANEL TO GROUND - FRONT	8.20	8.20	7.60	7.60	9.10	9.10	10.00	9.32	9.32	10.31	8.90
H111	ROCKER PANEL TO GROUND - REAR	6.90	6.90	6.44	6.44	8.16	8.16	9.86	8.33	8.33	9.97	8.27
H132	BOTTOM OF DOOR TO GROUND, OPEN - FRONT	11.90	11.95	11.28	11.28	12.75	12.84	13.86	12.96	13.05	14.12	12.86
H134	BOTTOM OF DOOR TO GROUND, OPEN - REAR	---	10.45	---	---	11.98	---	13.52	12.10	---	13.68	---
H122	WINDSHIELD SLOPE ANGLE	57°30'	57°30'	57°30'	57°30'	54°06'	54°06'	54°06'	54°06'	54°06'	54°06'	59°07'
H125	HEADLAMP TO GROUND	25.74	25.74	25.20	25.20	27.11	27.11	27.16	27.35	27.35	27.68	26.05
H126	TAILLAMP TO GROUND	23.53	23.53	23.62	23.62	23.33	23.33	30.55	23.40	23.40	30.43	24.74
H136	BODY ZERO TO GROUND - FRONT	7.48	7.48	6.78	6.78	7.76	7.76	8.28	8.10	8.10	8.68	7.61
H137	BODY ZERO TO GROUND - REAR	6.10	6.10	5.64	5.64	6.63	6.63	8.65	6.77	6.77	8.68	6.37
H133	BOTTOM OF DOOR TO GROUND, CLOSED - FRONT	10.55	10.65	9.94	9.94	11.67	11.58	13.05	11.85	11.74	13.24	11.62
H135	BOTTOM OF DOOR TO GROUND, CLOSED - REAR	---	10.40	---	---	11.42	---	13.19	11.59	---	13.29	---
H158	ROOF THICKNESS	4.15	4.15	4.15	4.15	4.46	3.84	4.72	4.46	3.84	4.72	5.20
H159	D/O HEIGHT	13.90	13.90	13.90	13.90	14.10	14.06	14.10	14.10	14.06	14.10	12.25
H160	BODY THICKNESS	27.20	27.20	27.20	27.20	28.10	28.10	28.10	28.10	28.10	28.10	27.02
H195	LIFTOVER HEIGHT	28.75	28.75	---	33.90	28.91	28.91	---	29.00	29.00	---	27.39

GROUND CLEARANCE

H102	FRONT BUMPER TO GROUND	17.35	17.35	16.70	16.70	12.67	12.67	12.84	12.86	12.86	13.33	12.72
H104	REAR BUMPER TO GROUND	15.30	15.30	14.70	14.70	15.60	15.60	12.79	15.70	15.70	12.71	15.55
H106	ANGLE OF APPROACH	26°56'	26°56'	27°41'	27°41'	27°46'	27°37'	28°33'	25°27'	25°21'	26°34'	23°51'
H107	ANGLE OF DEPARTURE	19°01'	19°01'	23°01'	23°01'	13°59'	14°05'	14°28'	14°14'	14°13'	14°17'	23°18'
H147	RAMP BREAKOVER ANGLE	16°20'	16°20'	17°01'	17°01'	16°59'	17°01'	18°48'	14°35'	15°49'	16°54'	16°55'
H148	FRONT SUSPENSION TO GROUND	6.08	6.08	5.32	5.32	6.08	6.08	6.60	9.78	9.78	7.00	6.25
H149	OIL PAN TO GROUND	5.96	5.96	5.17	5.17	6.27	6.27	6.95	6.53	6.53	7.31	6.28
H150	FLYWHEEL HOUSING/TRANS. ASSY. TO GROUND	5.92	5.92	5.12	5.12	6.21	6.21	6.95	6.49	6.49	7.30	6.21
H151	FRAME TO GROUND	6.95	6.95	6.04	6.04	7.88	7.88	9.14	8.07	8.07	9.36	6.18
H152	EXHAUST SYSTEM TO GROUND	5.21	5.21	7.53	7.53	6.30	6.30	7.88	6.47	6.47	8.02	5.11
H153	REAR AXLE DIFFERENTIAL SYSTEM TO GROUND	7.11	7.11	5.01	5.01	6.31	6.31	8.33	6.45	6.45	8.36	6.19
H154	FUEL TANK TO GROUND	7.68	7.68	5.12	5.12	7.23	7.23	9.48	7.44	7.44	9.48	7.15
H155	TIRE WELL TO GROUND	12.22	12.22	11.17	11.17	---	---	10.97	---	---	10.93	---
H156	MINIMUM RUNNING GROUND CLEARANCE POSITION ON CAR	5.21	5.21	5.01	5.01	6.08	6.08	6.60	6.45	6.45	7.00	5.11

* For Dimension Definitions See Section E I, SAE Aerospace - Automotive Drawing Standards

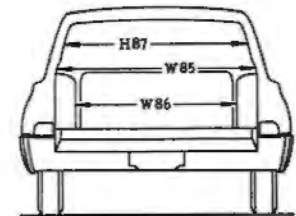
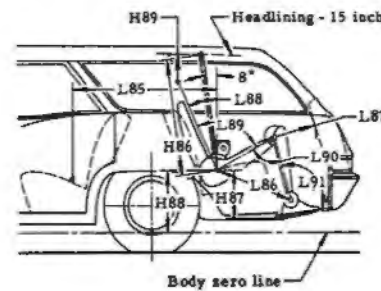
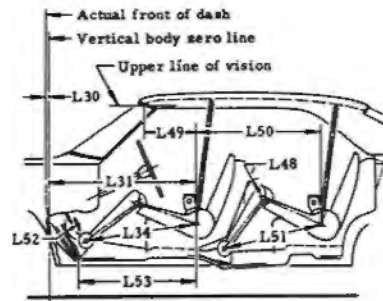
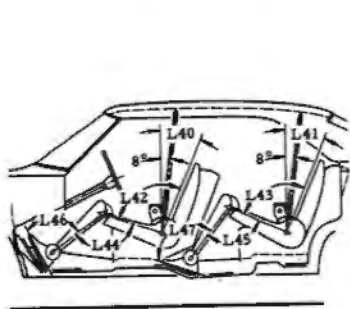
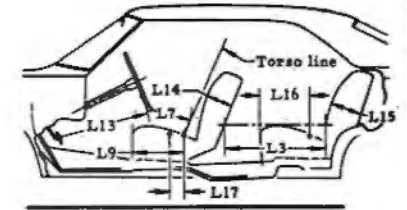
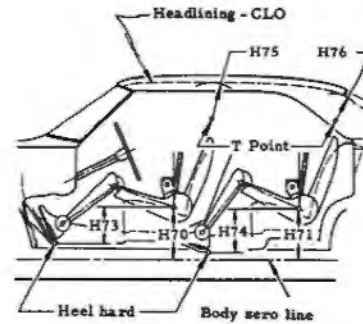
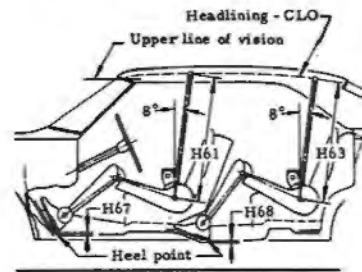
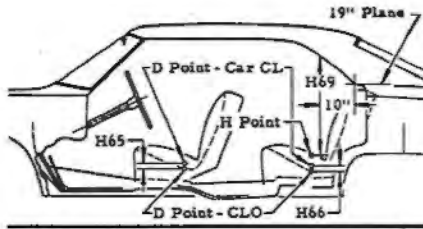
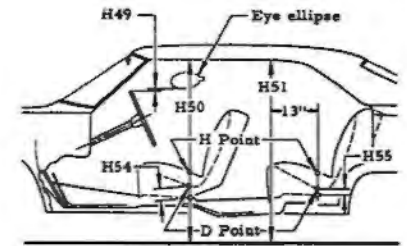
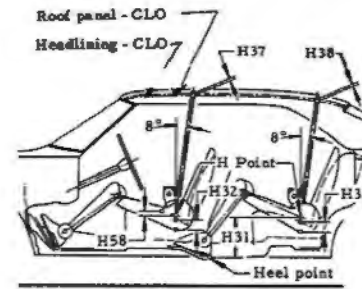
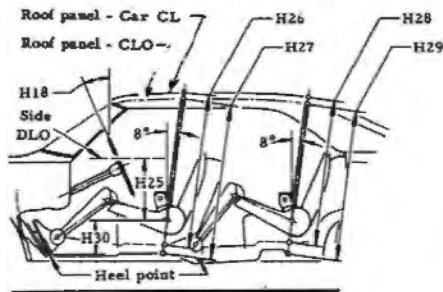
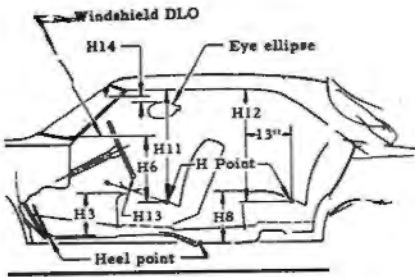
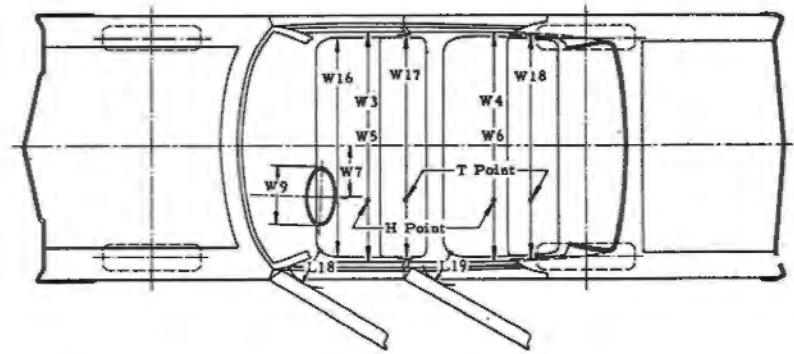
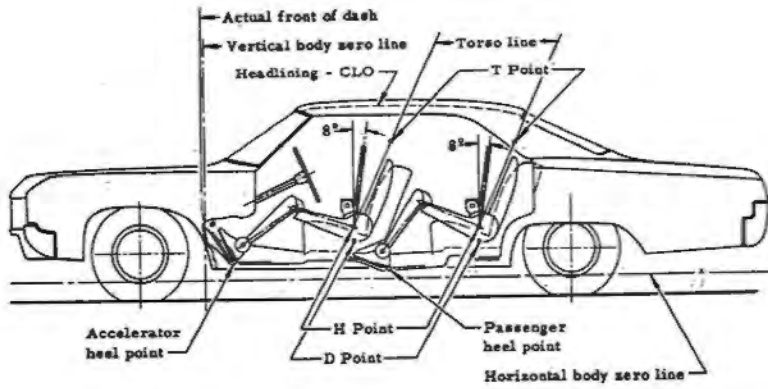

(*)

INTERIOR	CODE NO	DESCRIPTION	HORNET		GRANT		REBEL		AMBASSADOR		JAVELIN	AMC		
			2-Door Sedan 7005-0 7006-7	4-Door Sedan 7005-0 7005-7	2-Door Sedan 7016-0 2-Pass.	2-Door Sedan 7016-5 4-Pass.	4-Door Sedan 7015-0 7017-7	2-Door Hardtop 7019-0 7019-7	4-Door Wagon 7018-0 7018-7	4-Door Sedan 7005-2 7005-7	2-Door Hardtop 7009-5 7009-7	4-Door Wagon 7008-5 7008-7	2-Door Hardtop 7019-5 7019-7	2-Door Sports Coupe 7019-7
FRONT COMPARTMENT	L31	BODY ZERO LINE TO H POINT	43.44	43.44	42.44	42.44	43.97	43.97	43.97	43.97	43.97	43.97	45.00	45.00
	H70	H POINT TO BODY ZERO	10.85	10.85	10.98	10.98	11.84	11.84	11.84	11.84	11.84	11.84	10.20	10.20
	H61	EFFECTIVE HEAD ROOM	38.00	38.00	37.90	37.90	39.60	39.60	39.88	39.60	39.88	37.50	37.20	37.20
	H37	HEADLINING TO ROOF HEIGHT	.50	.50	.50	.50	.50	.50	.50	.50	.50	.50	.59	.59
	L34	MAXIMUM EFFECTIVE LEG ROOM - ACCELERATOR	41.05	41.05	40.05	40.05	42.45	42.45	42.45	42.45	42.45	43.05	43.05	43.05
	H30	H POINT TO HEEL POINT	8.72	8.72	8.82	8.82	9.64	9.64	9.64	9.64	9.64	8.07	8.07	8.07
	H67	DEPRESSED FLOOR COVERING THICKNESS	.35	.35	.35	.35	.45	.45	.45	.45	.45	.45	.45	.45
	L40	BACK ANGLE	21°	21°	21°	21°	24°	24°	24°	24°	24°	24°	24°	24°
	L42	HIP ANGLE	91°	91°	91°	91°	100°20'	100°20'	100°20'	100°20'	100°20'	100°20'	102°	102°
	L44	KNEE ANGLE	123°	123°	116°	116°	131°10'	131°10'	131°10'	131°10'	131°10'	131°10'	131°50'	131°50'
	L46	FOOT ANGLE	70°	70°	74°	74°	81°	81°	81°	81°	81°	81°	93°30'	93°30'
	H65	D POINT DIFFERENTIAL, SIDE TO CENTER	.30	.30	.30	.30	0	0	0	0	0	0	0	0
	H54	D POINT TO TUNNEL	.50	.50	.65	.65	1.42	1.42	1.42	1.42	1.42	1.42	.36	.36
	L53	H POINT TO ACCELERATOR FLOOR POINT	33.62	33.62	32.62	32.62	35.12	35.12	35.12	35.12	35.12	35.12	36.23	36.23
	L17	H POINT TRAVEL	4.93	4.93	4.93	4.93	4.93	4.93	4.93	4.93	4.93	4.93	4.93	4.93
H58	H POINT RISE	.81	.81	.81	.81	.86	.86	.86	.86	.86	.86	.86	.86	
H75	EFFECTIVE T POINT HEADROOM - FRONT	---	---	---	---	---	---	---	---	---	---	---	---	
REAR COMPARTMENT	L50	H POINT COUPLE DISTANCE	32.20	32.20	---	25.60	34.77	34.69	34.77	34.77	34.69	34.77	27.25	---
	H71	H POINT TO BODY ZERO	10.85	10.85	---	11.95	12.54	12.54	12.54	12.54	11.84	12.54	10.00	---
	H63	EFFECTIVE HEAD ROOM	37.00	37.00	---	36.40	37.47	36.60	38.71	37.47	36.60	38.71	36.00	---
	H38	HEADLINING TO ROOF HEIGHT	.50	.50	---	.50	.50	.50	.50	.50	.50	.50	.50	---
	L51	MINIMUM EFFECTIVE LEG ROOM	36.75	36.75	---	29.45	38.60	35.50	38.60	38.60	35.50	38.60	30.80	---
	H31	H POINT TO HEEL POINT	11.05	11.05	---	12.15	10.82	10.82	10.82	10.82	10.10	10.82	10.25	---
	H68	DEPRESSED FLOOR COVERING THICKNESS	.35	.35	---	.35	.45	.45	.45	.45	.45	.45	.45	---
	L48	KNEE CLEARANCE	3.65	3.65	---	1.50	5.70	3.30	5.70	5.70	5.70	3.30	5.70	---
	L3	REAR COMPARTMENT ROOM	26.07	26.07	---	20.90	29.60	26.26	29.60	29.60	26.26	29.60	21.90	---
	L41	BACK ANGLE	21°	21°	---	21°	18°	18°	18°	18°	18°	18°	20°	---
	L43	HIP ANGLE	85°	85°	---	85°	85°40'	78°	85°40'	85°40'	78°	85°40'	75°30'	---
	L45	KNEE ANGLE	99°	99°	---	67°	108°	92°	108°	108°	92°	108°	79°	---
	L47	FOOT ANGLE	108°	108°	---	83°	134°	126°	134°	134°	126°	134°	111°	---
	H66	D POINT DIFFERENTIAL, SIDE TO CENTER	---	---	---	0	0	0	0	0	0	0	0	---
	H55	D POINT TO TUNNEL	1.66	1.66	---	.35	1.01	.60	1.01	1.01	.60	1.01	---	---
H76	EFFECTIVE T POINT HEADROOM - REAR	---	---	---	---	---	---	---	---	---	---	---	---	
SEAT & ENTRANCE - FRONT	W3	SHOULDER ROOM	51.88	51.88	51.88	51.88	60.00	60.00	60.00	60.00	60.00	60.00	55.00	55.00
	W5	HIP ROOM	54.88	54.88	54.88	54.88	60.30	60.30	60.30	60.30	60.30	60.30	57.60	57.60
	W16	SEAT WIDTH	47.34	47.34	47.34	47.34	53.60	53.60	53.60	53.60	53.60	53.60	54.00	54.00
	H50	UPPER BODY OPENING TO GROUND	48.45	48.45	47.40	47.40	50.13	49.66	50.95	49.66	50.33	51.16	47.13	47.16
	H11	ENTRANCE HEIGHT	30.33	30.33	30.18	30.18	30.80	31.30	30.80	30.80	31.30	30.80	29.89	29.82
	H115	STEP HEIGHT - FRONT (DESIGN LOAD)	14.06	14.06	13.18	13.18	13.79	13.72	14.89	14.00	13.93	15.15	13.51	13.49
	H130	STEP HEIGHT - FRONT (CURB LOAD)	14.90	14.90	14.84	14.84	15.45	15.44	16.85	15.66	15.65	N/A	14.81	14.72
	L18	ENTRANCE - FOOT CLEARANCE	17.65	17.65	16.60	16.60	15.33	15.33	15.33	15.33	15.33	15.33	16.60	16.60
	H32	SEAT CUSHION DEFLECTION	4.34	4.34	4.34	4.34	3.77	3.77	3.77	3.77	3.77	3.77	3.60	3.60
	L14	THICKEST POINT OF SEAT BACK, AT C/L O	5.50	5.50	4.50	4.50	5.45	5.45	5.45	5.45	5.45	5.45	5.20	5.20
	W17	HAT ROOM	---	---	---	---	---	---	---	---	---	---	---	---
	H3	SEAT CHAIR HEIGHT	11.00	11.00	11.00	11.00	12.00	12.00	12.00	12.00	12.00	12.00	10.10	10.10
	H73	H POINT TO HEEL HARD - FRONT	8.72	8.72	8.82	8.82	---	---	---	---	---	---	---	---
	L9	SEAT DEPTH - FRONT	20.36	20.36	20.36	20.36	---	---	---	---	---	---	---	---
	H26	INTERIOR BODY HEIGHT - METAL TO METAL AT CAR C/L	39.00	39.00	38.75	38.75	42.00	42.30	42.20	42.00	42.30	42.20	38.89	37.86
H27	INTERIOR BODY HEIGHT - METAL TO METAL AT C/L O	44.50	44.50	44.00	44.00	46.00	45.30	46.25	46.00	46.30	46.25	44.39	43.92	
SEAT & ENTRANCE - REAR	W4	SHOULDER ROOM	53.32	54.40	---	52.96	60.00	59.00	60.00	60.00	59.00	60.00	53.20	---
	W6	HIP ROOM	53.32	54.40	---	52.96	60.40	59.50	60.40	60.40	59.50	60.40	56.38	---
	H51	UPPER BODY OPENING TO GROUND	---	48.12	---	---	49.00	---	50.64	49.24	---	50.78	---	---
	H12	ENTRANCE HEIGHT	---	30.27	---	---	29.60	---	29.60	29.60	---	29.60	---	---
	H116	STEP HEIGHT - REAR (DESIGN LOAD)	---	13.27	---	---	13.30	---	14.88	13.47	---	15.02	---	---
	H131	STEP HEIGHT - REAR (CURB LOAD)	---	14.90	---	---	15.32	---	16.94	15.53	---	N/A	---	---
	H69	EXIT HEIGHT	---	28.82	---	---	29.26	---	29.26	29.26	---	29.26	---	---
	L19	ENTRANCE - FOOT CLEARANCE	---	10.60	---	---	13.04	---	13.04	13.04	---	13.04	---	---
	H33	SEAT CUSHION DEFLECTION	4.80	4.80	---	5.20	4.00	3.82	3.70	4.00	3.82	3.70	4.75	---
	L15	THICKEST POINT OF SEAT BACK, AT C/L O	6.80	6.80	---	2.75	6.45	7.40	6.24	7.50	7.40	6.24	6.20	---
	W18	HAT ROOM	---	---	---	---	---	---	---	---	---	---	---	---
	H8	SEAT CHAIR HEIGHT	11.04	11.04	---	11.16	12.50	12.31	12.50	12.50	12.31	12.50	12.50	---
	H74	H POINT TO HEEL HARD - REAR	11.03	11.03	---	12.34	---	---	---	---	---	---	---	---
	L16	SEAT DEPTH - REAR	19.50	19.50	---	17.00	---	---	---	---	---	---	---	---
	H28	INTERIOR BODY HEIGHT - METAL TO METAL AT CAR C/L	36.90	36.90	---	37.80	39.75	38.20	40.80	39.75	38.20	40.80	35.16	---
H29	INTERIOR BODY HEIGHT - METAL TO METAL AT C/L O	40.50	40.50	---	41.00	41.50	40.10	42.75	41.50	40.10	41.50	38.79	---	
VISION & CONTROL	H6	H POINT TO WINDSHIELD BOTTOM DLO	19.09	19.09	18.96	18.96	19.29	19.29	19.29	19.29	19.29	19.29	19.76	19.76
	H64	H POINT TO WINDSHIELD UPPER DLO	32.12	32.12	32.00	32.00	32.23	32.23	32.23	32.23	32.23	32.23	31.03	31.03
	L49	H POINT TO WINDSHIELD UPPER DLO	11.38	11.38	10.38	10.38	15.00	15.00	15.00	15.00	15.00	15.00	13.78	13.78
	H25	BELT HEIGHT - FRONT	17.02	17.02	16.89	16.89	17.52	17.52	17.52	17.52	17.52	17.52	17.10	17.10
	W7	STEERING WHEEL CENTER TO CENTERLINE OF CAR	13.67	13.67	13.67	13.67	15.08	15.08	15.05	15.05	15.05	15.05	13.67	13.67
	H19	STEERING WHEEL OUTSIDE DIAMETER	16.00	16.00	16.00	16.00	16.00	16.00	16.00	16.00	16.00	16.00	16.00	16.00
	H18	STEERING WHEEL ANGLE - VERTICAL	19°23'	19°23'	19°23'	19°23'	20°4'	20°4'	20°4'	20°4'	20°4'	20°4'	17°50'	17°50'
	H49	H POINT TO TOP OF STEERING WHEEL	22.81	22.81	22.68	22.68	22.95	22.95	22.95	22.95	22.95	22.95	22.82	22.82
	L7	STEERING WHEEL TORSO CLEARANCE	12.25	12.25	11.25	11.25	12.64	12.64	12.64	12.64	12.64	12.64	11.86	11.86
	H13	STEERING WHEEL THIGH CLEARANCE	3.32	3.32	2.98	2.98	5.20	5.20	5.20	5.20	5.20	5.20	4.91	4.91
	L13	BRAKE PEDAL KNEE CLEARANCE	---	23.38 Manual	26.10 Power	---	---	24.50 Manual	26.88 Power	---	---	---	23.60 a	23.60 a
	L52	BRAKE PEDAL TO ACCELERATOR	---	3.65 Manual	.95 Power	---	---	4.38 Manual	1.96 Power	---	---	---	3.70 b	3.70 b
	W122	TUMBLE-HOME	25°	25°	---	---	21°6'	21°6'	21°6'	21°6'	21°6'	21°6'	23°50'	23°50'

* For Dimension Definitions See Section E1, SAE Aerospace - Automotive Drawing Standards

(a) Power 26.32 (b) Power 1.00

STATION WAGON THIRD SEAT DIMENSIONS *
AMA SPECIFICATIONS SUPPLEMENT

CODE NO	DESCRIPTION	REBEL	AMBASSADOR	
		4-Door Wagon 7018-7	4-Door Wagon 7088-5	7088-7
	SEAT FACING DIRECTION	Rear	Rear	
W85	SHOULDER ROOM	59.25	59.25	
W86	HIP ROOM	38.12	38.12	
L85	H POINT COUPLE DISTANCE	35.66	35.66	
H86	EFFECTIVE HEAD ROOM	36.00	36.00	
L86	EFFECTIVE LEG ROOM	30.75	30.75	
H87	H POINT TO HEEL POINT	12.58	12.58	
H88	H POINT TO BODY ZERO	14.25	14.25	
L87	KNEE ROOM	12.66	12.66	
L88	BACK ANGLE	14°	14°	
L89	HIP ANGLE	73°	73°	
L90	KNEE ANGLE	72°	72°	
L91	FOOT ANGLE	91°	91°	
W87	HAT ROOM	- -	- -	
H89	EFFECTIVE T POINT HEADROOM	- -	- -	
H90	H POINT TO HEEL HARD	11.55	11.55	

STATION WAGON CARGO SPACE DIMENSIONS *
(FOR 2- & 3-SEAT MODELS)

		REBEL	AMBASSADOR	
		4-Door Wagon 7018-0	4-Door Wagon 7088-5	7088-7
L200	MAXIMUM CARGO LENGTH - FRONT SEAT	114.90	114.90	
L201	MAXIMUM CARGO LENGTH - SECOND SEAT	78.83	78.83	
L202	CARGO LENGTH AT FLOOR - FRONT SEAT	92.63	92.63	
L203	CARGO LENGTH AT FLOOR - SECOND SEAT	56.53	56.53	
L204	CARGO LENGTH AT BELT - FRONT SEAT	82.73	82.73	
L205	CARGO LENGTH AT BELT - SECOND SEAT	46.74	46.74	
L206	CARGO LENGTH AT ROOF - FRONT SEAT	75.33	75.33	
L207	CARGO LENGTH AT ROOF - SECOND SEAT	39.36	39.36	
W200	CARGO WIDTH - FRONT	(1)	(1)	
W201	CARGO WIDTH - WHEELHOUSE	45.08	45.08	
W203	REAR OPENING WIDTH AT FLOOR	53.66	53.66	
W204	OPENING WIDTH AT BELT	53.60	53.60	
W205	MAXIMUM REAR OPENING WIDTH ABOVE BELT	45.60	45.60	
H201	MAXIMUM CARGO HEIGHT	31.72	31.72	
H202	REAR OPENING HEIGHT	27.84	27.84	
H250	TAILGATE TO GROUND HEIGHT	25.58	25.48	
V2	CARGO VOLUME	91.12(2)	91.12(2)	

* For Dimension Definitions See Section E1, SAE Aerospace - Automotive Drawing Standards,

(1) 2-Seat: 57.12 (1" Forward of Tailgate Pillar)
3-Seat: 53.86 (8" Forward of Tailgate Pillar)

(2) 99.12 including under-floor storage space.

CAR AND BODY DIMENSIONS

KEY SHEET

DIMENSION DEFINITIONS

EXTERIOR WIDTH DIMENSIONS

- W101 WHEEL TREAD — FRONT. Measured at centerline of tires, with nominal camber, at ground.
- W102 WHEEL TREAD — REAR. Measured at centerline of tires at ground.
- W103 MAXIMUM OVERALL CAR WIDTH. Include bumpers, moldings, or sheet metal protrusions. Measured to outside of metal.
- W117 MAXIMUM BODY WIDTH AT #2 PILLAR. Measured across body at #2 pillar, excluding hardware and applied moldings.

EXTERIOR LENGTH DIMENSIONS

- L 30 VERTICAL ZERO LINE TO ACTUAL FRONT OF DASH. If actual Front of Dash is to the rear of Body Zero Line, it is identified by a minus (-) sign.
- L101 WHEELBASE.
- L103 OVERALL LENGTH. Include bumper guards if standard equipment.
- L104 OVERHANG — FRONT. Measured from C/L of front wheels to front of car, including bumper guards if standard equipment.
- L105 OVERHANG — REAR. Measured from C/L of rear wheels to rear of car, including bumper guards if standard equipment.
- L123 BODY UPPER STRUCTURE LENGTH AT CAR CENTERLINE. The horizontal dimension from the Cowl Point to the Deck Point.
- L127 VERTICAL ZERO LINE TO CENTERLINE OF REAR WHEELS. A horizontal dimension.
- L130 VERTICAL ZERO LINE TO WINDSHIELD COWL POINT. The horizontal dimension from the vertical zero line to the theoretical intersection of extended windshield glass plane and normal cowl surface.

EXTERIOR HEIGHT DIMENSIONS

- H101 OVERALL HEIGHT — DESIGN. Measured with the vehicle in Manufacturer's Design Weight attitude.
- H114 COWL POINT TO GROUND. Measured at vehicle centerline.
- H138 DECK POINT TO GROUND. Measured at vehicle centerline.
- H112 ROCKER PANEL TO GROUND — FRONT. The vertical dimension from ground to bottom of rocker panel, excluding flanges. Measured to the outside of sheet metal at foremost point of rocker panel.
- H111 ROCKER PANEL TO GROUND — REAR. The vertical dimension from ground to bottom of rocker panel, excluding flanges. Measured to the outside of sheet metal at front of rear wheel opening.
- H122 WINDSHIELD SLOPE ANGLE. The angle between a vertical line and the windshield surface at car centerline. On compound-curved windshields the chord of the arc is used and limited to that section of the windshield comprehended by an 18-inch chord.

GROUND CLEARANCE DIMENSIONS

- H102 BUMPER TO GROUND — FRONT. Minimum dimension, includes bumper guards.
- H104 BUMPER TO GROUND — REAR. Minimum dimension, includes bumper guards.
- H106 ANGLE OF APPROACH. The angle between ground and a line tangent to the front tire static loaded radius arc and the first point of interference, i.e., bumper, guard, gravel deflector, fender or other component, excluding license plate. This dimension may be determined graphically for reporting purposes.
- H107 ANGLE OF DEPARTURE. The angle between ground and a line tangent to the rear tire static loaded radius arc and the first point of interference, i.e., bumper, guard, gravel deflector, tail pipe, fender or other component, excluding license plate. This dimension may be determined graphically for reporting purposes.
- H147 RAMP BREAKOVER ANGLE. The supplement of included ramp angle (180° minus included ramp angle) over which car can pass without interference; measured with car sitting on a level surface, using lines tangent to arcs of front and rear static loaded radii and intersecting at point on underside of car which defines the smallest angle.
- H156 MINIMUM RUNNING GROUND CLEARANCE. Location of measurement on the car is to be clearly recorded.

FRONT COMPARTMENT DIMENSIONS

- H 61 EFFECTIVE HEAD ROOM — FRONT. The dimension from H Point to the headlining, plus a constant of 4.0 inches, measured along a line 8° to rear of vertical.
- L 34 MAXIMUM EFFECTIVE LEG ROOM — ACCELERATOR. Measured along a diagonal line from the Manikin ankle pivot center to the H Point plus a constant of 10.0 inches. For treadle type accelerator pedals, the leg room is measured with the Manikin's right foot on the accelerator pedal and the Manikin Heel Point at Accelerator Heel Point. All other types of accelerator pedals will be measured with the Manikin foot angle set at 87° and the shoe touching the pedal.
- H 30 H POINT TO HEEL POINT — FRONT. The vertical dimension from the H Point to the Accelerator Heel Point.
- L 17 H POINT TRAVEL. The horizontal dimension between the H Point in the most forward and rearward seat positions.

FRONT COMPARTMENT DIMENSIONS (Cont.)

- W 3 SHOULDER ROOM — FRONT. The minimum lateral dimensions between the door garnish moldings or nearest interference, measured at the H Point station.
- W 5 HIP ROOM — FRONT. The lateral dimension through the H Point to trimmed body surfaces. Depress loose side wall cloth to trim foundation or other obstruction if such construction exists.
- H 50 UPPER BODY OPENING TO GROUND — FRONT. The vertical dimension from a point on the trimmed body opening to the ground, measured at the H Point station.

REAR COMPARTMENT DIMENSIONS

- L 50 H POINT COUPLE DISTANCE. The horizontal dimension from the front seat H Point to the rear seat H Point.
- H 63 EFFECTIVE HEAD ROOM — REAR. The dimension from the H Point to the headlining, plus a constant of 4.0 inches, measured along a line 8° to rear of vertical.
- L 51 MINIMUM EFFECTIVE LEG ROOM — REAR. Measured along a diagonal line from the ankle pivot center to the H Point plus a constant of 10.0 inches, with the foot positioned to the nearest interference between the seat structure and toe, instep or lower leg.
- H 31 H POINT TO HEEL POINT — REAR. The vertical dimension from the H Point to the Manikin Heel Point on the depressed floor covering.
- L 48 MINIMUM KNEE ROOM — REAR. The minimum dimension from the Manikin knee pivot center to the back of the front seat back.
- L 3 REAR COMPARTMENT ROOM. The horizontal dimension from the back of front seat to front of rear seat back at height tangent to the top of rear seat cushion.
- W 4 SHOULDER ROOM — REAR. The minimum lateral dimension between the door garnish molding or nearest interference. Measured at H Point station.
- W 6 HIP ROOM — REAR. The lateral dimension through H Point to trimmed body surfaces. Depress loose side wall cloth to trim foundation or other obstruction when such construction exists.
- H 51 UPPER BODY OPENING TO GROUND — REAR. The vertical dimension from a point on the trimmed body opening to the ground, measured 13.0 inches forward of the H Point.

LUGGAGE COMPARTMENT DIMENSIONS

- V 1 LUGGAGE CAPACITY — USABLE. The total luggage compartment luggage capacity in cubic feet with the tire and tools in place.
- H195 LIFTOVER HEIGHT. Vertical dimension from the highest point on the luggage compartment lower opening to ground, excluding corner radii.

STATION WAGON — THIRD SEAT DIMENSIONS

- W 85 SHOULDER ROOM — THIRD SEAT. The minimum lateral dimension between the door garnish moldings or nearest interference. Measured at H Point station.
- W 86 HIP ROOM — THIRD SEAT. The lateral dimension through H Point to trimmed surfaces.
- L 86 EFFECTIVE LEG ROOM — THIRD SEAT. Measured along a diagonal line from ankle pivot center to H Point plus a constant of 10.0 inches. With rear-facing third seat, foot is positioned in foot well or to nearest interference with rear end or rear closure.
- H 86 EFFECTIVE HEAD ROOM — THIRD SEAT. The dimension from H Point to the headlining, plus a constant of 4.0 inches. Measured along a line 8° to rear of vertical.

STATION WAGON — CARGO SPACE DIMENSIONS

- L202 CARGO LENGTH AT FLOOR — FRONT SEAT. The horizontal dimension, measured at the floor level from the rear of the front seat back to the normal inside limiting interference on the tailgate, on the car centerline.
- L204 CARGO LENGTH AT BELT — FRONT SEAT. The horizontal dimension measured from the top rear of front seat back to a vertical extension line from the normal inside limiting interference at the top of the tailgate, on the car centerline.
- W201 CARGO WIDTH — WHEELHOUSE. The minimum horizontal dimension, measured between wheelhousings at floor level.
- W204 OPENING WIDTH AT BELT. The minimum horizontal dimension, measured between the nearest normal inside limiting interferences of the rear opening at the top of the tailgate.
- H201 MAXIMUM CARGO HEIGHT. The maximum vertical dimension, measured from the top of the floor covering to the headlining, on the car centerline.
- H202 REAR OPENING HEIGHT. The vertical dimension measured from the top of the floor covering to the normal inside limiting interference at the top of the rear opening, on the car centerline, with both tail-and-liftgates fully open.
- V 2 CARGO VOLUME INDEX BEHIND FRONT SEAT. The total volume in cubic feet above the normal load floor and behind the front seat with the liftgate and tailgate closed.

W4xL204xH201

1728

AMA Specifications—Passenger Car

INDEX

SUBJECT	PAGE NO.	SUBJECT	PAGE NO.
Automatic Transmission.....	16	Kingpin (Steering Axis)	20
Axis, Steering	20	Lamp height and spacing	23
Axle, Rear	17	Legroom	2
Battery	12	Lengths - Car and Body.....	1
Bearings, Engine	5, 6, 7	Lifters, valve	6
Belts - Fan, Generator, Water Pump	11	Linings - Clutch, Brake	14, 19
Brakes - Parking, Service Power	18, 19	Lubrication	7, 8, 14, 15, 16, 17
Camber	20	Luggage Compartment	2
Camshaft	6	Motor, Starting	12
Capacities		Muffler	8
Cooling System	11	Overdrive	15
Fuel Tank	10	Piston Pins & Rings	4, 5
Lubricants		Pistons	4, 5
Engine Crankcase	8	Power Brakes	19
Transmission and Overdrive	15, 16	Power Steering	20
Rear Axle	17	Power Teams	3
Car and Body Dimensions		Propeller Shaft, Universal Joints	16, 17
Width	1	Pumps - Oil, Fuel	8, 10
Length	1	Water	11
Height	1	Radiator, Hoses	11
Ground Clearance	1	Ratios - Axle	3, 17
Front Compartment	2	Compression	3, 4
Rear Compartment	2	Steering	20
Luggage Compartment	2	Transmission	15, 16
Station Wagon - Third Seat	2	Rear Axle	3, 17
Station Wagon - Cargo Space	2	Regulator - Generator	12
Carburetor	3, 9, 10	Rims	18
Caster	20	Rings, Piston	5
Choke, Automatic	10	Rods - Connecting	5
Clutch - Pedal Operated	14	Shock Absorbers, Front & Rear.....	21
Coil, Ignition	13	Spark Plugs	13
Connecting Rods	5	Speedometer	14
Convenience Equipment	23	Springs - Front & Rear Suspension	21
Cooling System	11	Valve, Engine	6
Crankcase Ventilation System.....	8	Stabilizer (Sway Bar) - Front & Rear	21
Crankshaft	6	Starting System	12
Cylinders and Cylinder Head	4	Steering	20
Dimension Definitions		Supply System	12
Key Sheet	25, 27	Suppression - Ignition, Radio	13
Exterior & Interior	30	Suspension - Front & Rear	21
Distributor - Ignition	13	Tail Pipe	8
Electrical System	12, 13, 14	Thermostat, Cooling	11
Engine		Timing, Engine & Valve	6, 7, 13
Bore, Stroke, Displacement, Type	4	Tires	18
Compression Ratio	4	Toe in	20
Firing Order, Cylinder Numbering	4	Torque Converter	16
General Information, H.P. & Torque	4	Torque - Engine, Rated	3, 4
Lubrication	7, 8	Transmission - Types	3, 10, 15, 16
Power Teams	3	Automatic	3, 10, 15, 16
Exhaust Emission Control	9	Manual & Overdrive	3, 10, 15
Exhaust System	8	Ratios	15, 16
Equipment Availability	22	Track	1
Fan, Cooling	11	Trunk Luggage Capacity	2
Filters - Engine Oil, Fuel System.....	8, 10	Turning Diameter	20
Frame	22	Unitized Construction.....	22
Front Suspension	21	Universal Joints, Propeller Shaft.....	16, 17
Fuel, Fuel Pump, Fuel System	4, 10	Valves - Intake & Exhaust	6, 7
Fuel Injection	10	Vibration Damper	6
Generator and Regulator	12	Voltage Regulator	12
Glass	22	Water Pump.....	11
Height (Lamps)	14	Weights	24
Headroom - Body	2	Wheel Alignment	20
Heights - Car and Body	1	Wheelbase	1
Horns	14	Wheels & Tires	18
Horsepower - Brake	3, 4	Wheel Spindle	20
Ignition System	13	Widths - Car and Body	1
Inflation - Tires	18	Windshield	22
Instruments	14	Windshield Wiper	14