

AMA Specifications—Passenger Car

The information contained herein is prepared, distributed by, and is solely the responsibility of the automobile manufacturing company to whose products it relates. Questions concerning these specifications should be directed to the manufacturer whose address is shown below. This uniform specification form was developed by the automobile manufacturing companies under the auspices of the Automobile Manufacturers Association.

MANUFACTURER	BUICK MOTOR DIVISION GENERAL MOTORS CORPORATION	CAR NAME	BUICK GS "350" - GS "400"
MAILING ADDRESS	1051 E. HAMILTON AVENUE FLINT, MICHIGAN 48550	MODEL YEAR	1969
		ISSUED:	
		REVISED (a)	

NOTES:

1. The General Specifications herein are those in effect at date of compilation and are subject to change without notice by the manufacturer.
2. UNLESS OTHERWISE INDICATED:
 - a. Specifications apply to standard models without optional equipment. Significant deviations are noted.
 - b. Nominal design dimensions are used throughout these specifications.

TABLE OF CONTENTS

Car & Body Dimensions	1,2	Drive Units	14	Suspensions	21
Engine - Mechanical	4	Brakes.....	18, 19	Weights	24
Electrical	12	Steering	20	Index	27

BODY - TYPES AND STYLE NAMES -		Body type, style names; use manufacturer's code for series & body style.
<u>SERIES</u>	<u>BODY STYLE</u>	<u>MODEL DESIGNATION</u>
GS "350"	2 Door Hardtop Coupe	43437
GS "400"	2 Door Hardtop Coupe	44637
	2 Door Convertible	44667

AMA Specifications—Passenger Car

MAKE OF CAR BUICK MODEL YEAR 1969 DATE ISSUED _____ REVISED (a) _____

CAR AND BODY DIMENSIONS

See Pages 25, 26 for SAE Dimension Definitions

(All dimensions in inches unless otherwise indicated)

All dimensions to ground are for comparative purposes only. Dimensions are to be shown for:

4-Dr. Sedan, 2-Dr. H.T., 4-Dr. H.T., Convertible and Station Wagon.

MODEL	SAE Ref. No.	G.S.	
		"350"	"400"
		43437	44637 44667
WIDTH			
Track - Front	W101	59.0	59.4
Track - Rear	W102		59.0
Maximum overall car width	W103		75.6
Body width at No. 2 pillar	W117		----
LENGTH			
Body "O" to front of dash	L 30		0"
Wheelbase	L101		112.0
Overall car length	L103		202.0
Overhang - front	L104		37.2
Overhang - rear	L105		52.8
Body upper structure length	L123		
Body "O" line to ϕ of rear wheel	L127		
Body "O" line to w/s cowl point	L130		
HEIGHT			
Passenger Distribution (front & rear)			
Trunk/Cargo load (lbs.)			
Overall height	H101	53.5	53.0
Cowl height	H114		
Deck height	H138		
Rocker panel - front	To ground	8.76	8.43
	From front wheel ϕ		
Rocker panel - rear	To ground	8.18	7.63
	From rear wheel ϕ		
Windshield slope angle	H122		
GROUND CLEARANCE			
Bumper to ground - front	H102		
Bumper to ground - rear	H104		
Angle of approach	H106		
Angle of departure	H107		
Ramp breakover angle	H147		
Min. running clearance (Specify)	H156		

AMA Specifications—Passenger Car

MAKE OF CAR BUICK MODEL YEAR 1969 DATE ISSUED _____ REVISED (•) _____

CAR AND BODY DIMENSIONS

See Pages 25, 26 for SAE Dimension Definitions
(All dimensions in inches unless otherwise indicated)

MODEL	SAE Ref. No.	G.S.	
		"350"	"400"
	43437	44637	44667
FRONT COMPARTMENT			
Effective head room	H61		
Max. eff. leg room - accelerator	L34		
H Point to Heel point	H30		
H Point travel	L17		
Shoulder room	W 3		
Hip room	W 5		
Upper body opening to ground	H50		
REAR COMPARTMENT			
H Point couple distance	L50		
Effective head room	H63		
Min. effective leg room	L51		
H Point to Heel point	H31		
Min. knee room	L48		
Rear Compartment room	L 3		
Shoulder room	W 4		
Hip room	W 6		
Upper body opening to ground	H51		
LUGGAGE COMPARTMENT			
Usable luggage capacity	V 1		
Liftover height	H195		
Position of spare tire storage		Horizontal	
Method of holding lid open		Torsion Bar	
STATION WAGON - THIRD SEAT			
Shoulder Room	W85	No Wagons - This Series	
Hip room	W86		
Effective leg room	L86		
Effective head room	H86		
Seat facing direction			
STATION WAGON - CARGO SPACE			
Cargo length at floor - front seat	L202	No Wagons - This Series	
Cargo length at belt - front seat	L204		
Cargo width - Wheelhouse	W201		
Opening width at belt	W204		
Maximum cargo height	H201		
Rear opening height	H202		
Cargo volume index (cu. ft.) W4 x L204 x H201 1728	V2		

AMA Specifications—Passenger Car

MAKE OF CAR BUICK MODEL YEAR 1969 DATE ISSUED _____ REVISED ^(e) _____

POWER TEAMS

(Indicate whether standard or optional)

MODEL AVAILABILITY	ENGINE					TRANSMISSION	AXLE RATIO (Std. first) (Indicate A/C ratio)
	Displ. cu. in.	Carburetor	Compr. Ratio	BHP @ RPM	Torque @ RPM		
GS "350"	350	1-4 Bbl	10.25	280 @ 4600	375 @ 3200	Manual (3 & 4)	3.23 (Std) No Perf. or Economy - No S.C.O.
	350	1-4 Bbl	10.25	280 @ 4600	375 @ 3200	Automatic	3.23 (Std) No Perf. or Economy - No S.C.O.
GS "400"	400	1-4 Bbl	10.25	340 @ 5000	440 @ 3200	Manual (3&4)	3.42 (Std) 3.64 (Perf) 3.91 (S.C.O.)
	400	1-4 Bbl	10.25	340 @ 5000	440 @ 3200	Automatic	2.93 (Std) 3.42 (Perf) 3.64 (S.C.O.) 3.91 (S.C.O.)

AMA Specifications—Passenger Car

MAKE OF CAR BUICK MODEL YEAR 1969 DATE ISSUED GS REVISED *

MODEL "350" 43437 "400" 44637

ENGINE - GENERAL

Type, no. cyls., valve arr.	V8 - Valve-In-Head	
Bore and stroke (nominal)	3.800 x 3.850	4.040 x 3.900
Piston displacement, cu. in.	350	400
Bore spacing (C to C)	4.240	4.750
No. system	1-3-5-7	
(front to rear)	2-4-6-8	
Firing order	1-8-4-3-6-5-7-2	
Compres. ratio (nominal)	10.25	
Cylinder Head Material	Cast Iron	
Cylinder Block Material	Cast Iron	
Cyl. Sleeve-Wet, dry, none	None	
Number of mtg. points	Front	Two
	Rear	One
Engine installation angle	4° 37'	
Taxable horsepower	$\frac{\text{Dia}^2 \times \text{No. Cyl.}}{2.5}$ 46.2	52.23
Publishing max. bhp* @ eng. RPM	280 @ 4600	340 @ 5000
Publishing max. torque* (lb. ft. @ RPM)	375 @ 3200	440 @ 3200
Recommended fuel regular - premium	Premium	

ENGINE - PISTONS

Material	Cast Aluminum Alloy		
Description and finish	Cam Ground - Transverse Slot - Divorced Skirt .		
Weight (piston only) oz.	23.152 ± .064		
Clearance (limits)	Top land	.027 - .036	
	Skirt	Top	.0008 - .0014
		Bottom	.0013 - .0029
Ring groove depth	No. 1 ring	.1930 - .1855	
	No. 2 ring	.1955 - .1880	
	No. 3 ring	.1955 - .1880	
	No. 4 ring	Not Used	

* Max. bhp (brake horsepower) and max. torque corrected to 60° F and 29.92 in. Hg atmospheric pressure.

AMA Specifications—Passenger Car

MAKE OF CAR	BUICK	MODEL YEAR	1969	DATE ISSUED	REVISED (*)
				GS	
MODEL	"350" 43437			"400" 44637	

ENGINE - RINGS

Function (top to bottom)	No. 1, oil or comp.	Compression	
	No. 2, oil or comp.	Compression	
	No. 3, oil or comp.	Oil	
	No. 4, oil or comp.	None	
Compression	Description - material, coating, etc.	#1 - Cast Iron - Molybdenum Coated #2 - Cast Iron - Lubrited	
	Width	.077 - .078	
	Gap	.010 - .020	.013 - .023
Oil	Description - material, coating, etc.	SAE - 1070 Steel No Chrome Chrome Plated	
	Width	.0235 - .0245	.023 - .025
	Gap	.015 - .035	.015 - .055
Expanders	Hump Type		Steel Oil Ring (Abut. Type)

ENGINE - PISTON PINS

Material	Extruded SAE - 1018		
Length	3.060	3.520	
Diameter	.9394 - .9397	.9994 - .9997	
Type	Locked in rod, in piston, floating, etc.	Pressed-In Rod	
	Bush- ing	In rod or piston	None
		Material	None
Clearance	In piston	.0001 - .0004 (Selected)	
	In rod	.00075 - .00125 (Select Press)	
Direction & amount offset in piston	.040 (b)	.060 (b)	

ENGINE - CONNECTING RODS

Material	Pearlitic Malleable Iron	Forged SAE - 1141 Steel	
Weight (oz.)	22.800	24.384	
Length (center to center)	6.385	6.598 - 6.602	
Bearing	Material & Type	(a)	
	Overall length	.737	.816 - .826
	Clearance (limits)	.0002 - .0023	
	End play	.006 - .014	.005 - .012

(a) Steel Backed - M/400 Aluminum - Removable

(b) Major Thrust Side

AMA Specifications—Passenger Car

MAKE OF CAR	BUICK		MODEL YEAR	1969	DATE ISSUED	REVISED (a)
			GS			
MODEL	"350" 43437				"400" 44637	
ENGINE – CRANKSHAFT						
Material			Nodular Iron			
Vibration damper type			Rubber Absorption			
End thrust taken by bearing (No.)			Three			
Crankshaft end play			.004 - .008		.003 - .009	
Main bearing	Material & type		(a)			
	Clearance		.0004 - .0015		.0007 - .0018	
	Journal dia. and bearing overall length	No. 1	2.9995 x .864		3.250 x .865	
		No. 2	2.9995 x .864		3.250 x .865	
		No. 3	2.9995 x 1.057		3.250 x 1.057	
		No. 4	2.9995 x .864		3.250 x .865	
		No. 5	2.9995 x .864		3.250 x 1.143	
		No. 6	None			
	No. 7	None				
Dir. & amt. cyl. offset			None			
Crankpin journal diameter			2.000		2.249 - 2.250	
ENGINE – CAMSHAFT						
Location			Above Crankshaft at Center of "V"			
Material			Cast Iron Alloy			
Bearings	Material		Steel Backed Babbitt			
	Number		Five			
Type of Drive	Gear or chain		Chain			
	Crankshaft gear or sprocket material		Sintered Iron			
	Camshaft gear or sprocket material		Nylon Coated Aluminum			
	Timing chain	No. of links	54		48	
		Width	.875		.739	
Pitch		.375		.500		
ENGINE – VALVE SYSTEM						
Hydraulic lifters (Std., opt., NA)			Standard			
Valve rotator, type (intake, exhaust)			None			
Rocker ratio			1.55		1.59	
Operating tappet clearance (indicate hot or cold)	Intake		None			
	Exhaust		None			

(Continued)

(a) Steel Backed - M/400 Aluminum Except #5 is Durex M/100.

AMA Specifications—Passenger Car

MAKE OF CAR	BUICK	MODEL YEAR	1969	DATE ISSUED	REVISED (e)
		"350"		"400"	
		43437		44637	

ENGINE - VALVE SYSTEM (cont.)

Timing (based on top of ramp points)	Intake	Opens (°BTC)	24	14	
		Closes (°ABC)	78	104	
		Duration - deg.	282	298	
	Exhaust	Opens (°BBC)	70	88	
		Closes (°ATC)	38	47	
		Duration - deg.	288	315	
	Valve opening overlap		62	61	
Intake	Material		SAE - 1041 (c)		
	Overall length		5.024 - 4.994	5.155 - 5.125	
	Actual overall head dia.		1.880 - 1.870	2.005 - 1.995	
	Angle of seat & face		45°		
	Seat insert material		None		
	Stem diameter		(a)		
	Stem to guide clearance		.0015 - .0035 (.0003 Max. Taper)		
	Lift (@ zero lash)		.3766	.4187	
	Outer spring press. & length	Valve closed (lb.@in.)	75 ± 5 @ 1.727	72 ± 5 @ 1.890	
		Valve open (lb.@in.)	180 ± 7 @ 1.340	177 ± 7 @ 1.450	
	Inner spring press. & length	Valve closed (lb.@in.)	Not Used		
		Valve open (lb.@in.)	Not Used		
	Exhaust	Material		21 - 2 (c)	N82152 - (21-4N) (c)
		Overall length		5.044 - 5.014	5.175 - 5.145
		Actual overall head dia.		1.505 - 1.495	1.630 - 1.620
Angle of seat & face		45°			
Seat insert material		None			
Stem diameter		(b)			
Stem to guide clearance		.0015 - .0035 (Top) - .0025 - .0045 (Bottom)			
Lift (@ zero lash)		.3840	.4482		
Outer spring press. & length		Valve closed (lb.@in.)	75 ± 5 @ 1.727	72 ± 5 @ 1.890	
		Valve open (lb.@in.)	180 ± 7 @ 1.340	177 ± 7 @ 1.450	
Inner spring press. & length		Valve closed (lb.@in.)	Not Used		
		Valve open (lb.@in.)	Not Used		

ENGINE - LUBRICATION SYSTEM

Type of lubrica- tion (splash, pressure, nozzle)	Main bearings	Pressure		
	Connecting rods	Pressure		
	Piston pins	Splash		
	Camshaft bearings	Pressure		
	Tappets	Pressure		
	Timing gear or chain	Splash & Nozzle	Drip From Front Cam Bearing	
	Cylinder walls	Splash & Nozzle		

(Continued)

- (a) .3725 ± .0005, Max. Allowable taper to be .003 with smallest dia. @ Valve Head end.
- (b) .3725 ± .0005 Top --- .3715 ± .0005 Bottom.
- (c) Aluminized face and chrome flashed stem.

AMA Specifications—Passenger Car

MAKE OF CAR	BUICK	MODEL YEAR	1969	DATE ISSUED	REVISED (*)
				GS	
MODEL	"350" 43437				"400" 44637

ENGINE – LUBRICATION SYSTEM (cont.)

Oil pump type	Gear	
Normal oil pressure (lb. engine rpm)	37 @ 2400	40 @ 2400
Oil press. sending unit (elect. or mech.)	Electrical	
Type oil intake (floating, stationary)	Stationary	
Oil filter system (full flow, part., other)	Full Flow	
Filter replacement (element, complete)	Element & Can	
Capacity of c/case, less filter-refill (qt.)	Four	
	<u>Anticipated Lowest Temp.</u>	<u>Use SAE Viscosity</u>
Oil grade recommended (SAE viscosity and temperature range)	Above 32°F	10W-30; 20W or 20
	Below 32°F to Zero F	10W-30; 10W-40; 10W
	Below Zero F	5W-20; 5W-30, 5W
Engine Service Reqmt. (MM, MS, etc.)	Passing Car Makers Test - G.M. 6041M.	

ENGINE – EXHAUST SYSTEM

Type (single, single with cross-over, dual, other)	Dual	
Muffler No. & type (reverse flow, straight thru, separate resonator)	Two Reverse Flow	
Exhaust pipe dia. (O.D., wall thick.)	Branch	2.25 - .084 (Laminated Tubing)
	Main	- - - - -
Tail pipe dia. (O.D. & wall thickness)	2.00 - .060	

ENGINE – CRANKCASE VENTILATION SYSTEM

Type (ventilates to atmos., induction system, other)	Standard	Closed Induction System
	Optional	None
Control Unit	Make and model	A.C.
	Location	Intake Manifold (Lifter Cavity) Rear
	Energy source (manifold vacuum, carburetor air stream, other)	Manifold Vacuum
	Control method (variable orifice, fixed orifice, other)	Variable Orifice
Complete system	Discharges (to intake manifold, carb. air intake, air cleaner intake, other)	Intake Manifold Normally with Additional Discharge into Air Cleaner under Excessive Blow-By Condition
	Air inlet (breather cap, carburetor air cleaner, other)	Carburetor Air Cleaner
	Flame arrestor (screen, check valve, other)	Check Valve and Screen

AMA Specifications—Passenger Car

MAKE OF CAR	BUICK	MODEL YEAR	1969	DATE ISSUED	REVISED (*)
				G.S.	
		"350"			"400"
MODEL		43437			44637

ENGINE - EXHAUST EMISSION CONTROL

Type (Air injection, engine modifications, other)		Combustion Control		
Air Injection Pump	Type	Not Used		
	Displacement			
	Drive ratio			
	Drive type			
	Relief valve (type)			
	Filter (describe)			
Air Injection System	Air distribution (head, manifold, etc.)			
	Point of entry			
	Injection tube I.D.			
	Check valve type			
	Backfire protection (type)			
Carburetor	Make	Rochester		
	Model	4MV		
	Barrel size			
	Idle speed	Drive	600	
		Neutral	700 (Manual Transmission)	
Idle A/F mixture				
Distributor	Aux. Adv. Systems (type)	None		
	Make	Delco - Remy		
	Model	1111334	1111335	
	Cent'fgal adv. in crank degrees @ eng. rpm	Start (rpm)	1100	
		Intermed. points deg. @ rpm	19° @ 1750	21° @ 1800
		Max. deg. @ rpm	28° @ 4600	32° @ 4600
	Vacuum adv. in crank degrees @ eng. rpm	Start (in Hg) 7"	
		Intermed. points deg. @ in. Hg 16" @ 15	
Max. deg. @ in.	 19.5 @ 25		
Vacuum Source	Intake Manifold Ported to Atmosphere at Idle			
Timing - Crank degrees @ rpm	0° BTC @ 550			
Cooling System	T.V.S. Switch - (Automatic Transmission Only) To Advance Timing When Coolant Becomes Hot.			
Exhaust System				

AMA Specifications—Passenger Car

MAKE OF CAR BUICK MODEL YEAR 1969 DATE ISSUED GS REVISED (a)

	"350" 43437	"400" 44637
--	----------------	----------------

ENGINE – FUEL SYSTEM

(See supplemental page for Details of Fuel Injection, Supercharger, etc. if used)

Induction type: Carburetor, fuel injection, supercharger.		Carburetor
Fuel Tank	Refill capacity (U.S. gals.)	20 (Approx.)
	Filler location	Rear
Fuel Pump	Type (elec. or mech.)	Mechanical
	Locations	Engine
	Pressure range	4.25 - 5.75 at Outlet (a) 5.5 - 7.0 @ Pump Outlet (b)
Vacuum booster (std., optional, none)		None
Fuel Filter	Type	Pleated Paper Woven Plastic
	Locations	Carb. Inlet Fuel Tank
Choke type		Remote (Manifold) - Auto
Intake manifold heat control (exhaust or water)		Exhaust
Carburetor	Air cleaner type	Oiled Paper Element
		Heavy Duty Dual Stage Element
	Idle speed (spec. neutral or drive)	700 (Neutral) - A/C Same with A/C "Off"
		600 (Drive) - A/C Same with A/C "Off"
	Idle A/F mix.	14.5 14.6

CARBURETOR SUPPLEMENTARY INFORMATION

Model Usage	Engine Displ.	Transmission	Carburetors		No. Used and Type	Barrel Size
			Make	Model		
<u>GS "350"</u>	350	Manual (3)	Rochester	4 MV	1-4 Bbl.	Primary 1.3750 Secondary 2.250
	350	Automatic	Rochester	4 MV	1-4 Bbl.	Primary 1.3750 Secondary 2.250
<u>GS "400"</u>	400	Manual (3or4)	Rochester	4 MV	1-4 Bbl.	Primary 1.375 Secondary 2.250
	400	Automatic	Rochester	4 MV	1-4 Bbl.	Primary 1.375 Secondary 2.250

- (a) 5.5 - 7.0 @ Outlet with V.R. Lines Blocked
- (b) With Vapor Return Lines Blocked

AMA Specifications—Passenger Car

MAKE OF CAR BUICK MODEL YEAR 1969 DATE ISSUED G.S. REVISED (•)
 MODEL "350" "400"
43437 44637

ENGINE - COOLING SYSTEM

Type system (pressure, pressure vented, atmospheric, other)		Pressure	
Radiator cap relief valve pressure		15 psi	
Circulation thermostat	Type (choke, bypass)	Choke	
	Starts to open at (°F)	190	
Water pump	Type (centrifugal, other)	Centrifugal	
	GPM @ 1000 pump rpm	10	15
	Number of pumps	One	
	Drive (V-belt, other)	V-Belt	
Bearing type		Double Row	
By-pass recirculation type (inter., ext.)		External	
Radiator core type (cellular, tube and fin, other)		Cross-Flow	
Cooling system capacity	With heater (qt.)	13.45	16.17 (Std.)
	Without heater (qt.)	12.62	15.34
	Opt. equipment-specify (qt.)	13.52 (A.G.)	16.67 (A.G.)
Water jackets full length of cyl. (yes, no)		No	
Water all around cylinder (yes, no)		Yes	
Radiator hose	Lower	Number and type (molded, straight)	One Molded
		Inside diameter	1.50
	Upper	Number and type (molded, straight)	One Molded
		Inside diameter	1.50
	By-pass	Number and type (molded, straight)	One Molded
		Inside diameter	.62
Fan	Number of blades & spacing	4-(65 - 115°) 7 AC	4-(65 - 115°) 5 AC
	Diameter	18"	
	Ratio-fan to crankshaft rev.	.85 (1.15 A/C)	.92 (1.30 A/C)
	Fan cutout type	None - (Thermo - Clutch with A/C)	
Bearing type		Single Row Ball	
* Drive belts (indicate belt used by letter)	Fan	A	D (A/C)
	Generator or alternator	A	D (A/C)
	Water Pump	A	D (A/C)
	Power Steering	B	F
Air Conditioning	C	G	

* Drive Belt Dimensions	A	B	C	D	E	F	G	H	I	J	K
Angle of V	38°	38°	38°	38°	38°	38°	38°				
Nominal length (SAE)	45.5	52.5	61.50	46.0	48.9	50.96	65.00				
Width	.38	.47	.47	.38	.38	.47	.47				

AMA Specifications—Passenger Car

MAKE OF CAR	BUICK	MODEL YEAR	1969	DATE ISSUED	GS	REVISED (a)
MODEL	"350" 43437					"400" 44637

ELECTRICAL – SUPPLY SYSTEM

Battery	Make and Model	Delco #R-58	Delco #R-68	
	Voltage Rtg. & Total Plates	12-66		
	SAE Designation & Amp. Hr. Rtg.	9MJ3F-61	9TJ3-70	
	Location	Right Front Fender Skirt		
	Terminal grounded	Negative		
Generator or Alternator	Make	Delco - Remy		
	Model	1100761 (a)		
	Type and rating	Diode Rectified Alternator (b) (e)		
	Output at engine idle (neutral)	15 amp Min. (c)		
	Ratio—Gen. to Cr/s rev.	2.29 (f)	2.47 (d)	
Regulator	Make	Delco - Remy		
	Model	1119515		
	Type	Voltage Control		
	Cutout relay	Closing voltage - generator rpm	None	
		Reverse current to open	None	
	Regulated	Voltage	13.6 to 14.4 @ 125°	
		Current	None	
	Voltage test conditions	Temperature	None	
		Load	Run 15 Minutes at 10 Amps (Max.)	
		Other	Battery Must Be In Circuit	

ELECTRICAL – STARTING SYSTEM

Starting Motor	Make	Delco - Remy		
	Model	1108391	1108392	
	Rotation (drive end view)	Clockwise		
Motor control	Switch (solenoid, manual)	Solenoid		
	Starting procedure	Manual - Place selector lever in neutral and depress clutch pedal. Auto - Place selector lever in neutral or park. NOTE - Turn ignition switch key clockwise.		
Motor Drive	Engagement type	Solenoid with Over-Running Clutch		
	Pinion meshes (front, rear)	Front		
	Number of teeth	Pinion	9	
		Flywheel	Manual	160
	Auto.		160	166
	Flywheel tooth face width	Manual	.375	
Auto.		.375		

- (a) 1100774 with A/C
- (b) 42 amps on "350"
37 amps on "400"

- (c) 20 amps with A/C
- (d) 2.93 with A/C
- (e) 55 amps with A/C
- (f) 2.66 with A/C

AMA Specifications—Passenger Car

MAKE OF CAR	BUICK		MODEL YEAR	1969	DATE ISSUED	REVISED (a)
			GS			
MODEL			"350" 43437		"400" 44637	
ELECTRICAL – IGNITION SYSTEM						
Type	Conventional – Std., Opt., N.A.			Standard		
	Transistorized – Std., Opt., N.A.			Not Available		
	Other (specify)			None		
Coil	Make			Delco - Remy		
	Model			1115247		
	Amps	Engine stopped		3.8 @ 12.6 V		
Engine idling		2.3 @ 12.6 V				
Distributor	Make			Delco - Remy		
	Model			1111334		1111335
	Cent'fgal adv. in c/shaft degrees@ engine rpm (nominal)	Start (rpm)		1100		
		Intermediate points deg.@rpm		19° @ 1750		21° @ 1800
		Max. deg.@rpm		28° @ 4600		32° @ 4600
	Vacuum adv. in c/shaft degrees@ in. Hg. (nominal)	Start (in. Hg.)		6-8		
		Intermediate points, deg.@in. Hg.		16.0 @ 15		
		Max. deg. in. Hg.		19.5 @ 25		
	Breaker gap (in.)			.013 - .019		
	Cam angle (deg.)			30 ± 1		
Breaker arm tension (oz.)			19 - 23			
Timing	Crankshaft deg.@rpm			0° @ 550		
	Mark location			Crankshaft Flange		Harmonic Damper
Spark Plug	Make			AC		
	Model			R 45TS		R 44TS
	Thread (mm)			14		
	Tightening torque (lb. ft.)			15		
	Gap			.030		
Cable	Conductor type			2000 ohms per foot (Resistance Cable)		
	Insulation type			Neoprene (With Inner Braid)		
	Spark plug protector					
ELECTRICAL – SUPPRESSION						
Locations & type			(a)			

- (a) TVRS Cable - Spark Plugs & Coil to Distributor
 Ground Strap - Engine to Dash
 By-Pass Capacitors on Delcotron, Coil & Regulator
 Resistor Spark Plugs

AMA Specifications—Passenger Car

MAKE OF CAR BUICK MODEL YEAR 1969 DATE ISSUED GS REVISED (e)MODEL "350" 43437 "400" 44637

ELECTRICAL – INSTRUMENTS AND EQUIPMENT

Speed-ometer	Type	Mechanical (Eddy Current)	
	Trip odometer (yes,no)	No	
Charge indicator – type		Indicator Light	
Temperature indicator – type		"Hot" Indicator Light Only	
Oil pressure indicator – type		Indicator Light - Pressure Switch	
Fuel indicator – type		Electrical	
Other			
Wind-shield wiper	Type – Standard	Electric - Dual Speed	
	Type – Optional	None	
Wind-shield washer	Type – Standard	Electric Engagement Mech. Piston Pump	
	Type – Optional	None	
Horn	Type	Solenoid	
	Number used	Two	
	Amp draw (each)	4.5/5.5	

DRIVE UNITS – CLUTCH (Manual Transmission)

Make & type	Borg & Beck (Dry)		
Type pressure plate springs	Belleville		
Total spring load (lb.)	1900 - 2100	2450 - 2750	
No. of clutch driven discs	One		
Clutch facing	Material	Woven	
	Outside & inside dia.	10.4 - 6.5	11.0 - 6.5
	Total eff. area (sq.in.)	103.5	123.7
	Thickness	.135	.140
	Engagement cushioning method	Springs	
Release bearing	Type & method of lubrication	Ball Sealed	
Torsional damping	Methods: springs, friction material	Springs	

AMA Specifications—Passenger Car

MAKE OF CAR BUICK MODEL YEAR 1969 DATE ISSUED GS REVISED ^(e)
 MODEL "350" "400"
43437 44637

DRIVE UNITS – TRANSMISSIONS

Manual 3-speed (std. or opt.)	Standard
Manual 4-speed (std. or opt.)	Optional
Manual with overdrive (std. or opt.)	Not Available
Automatic (std. or opt.)	Optional

DRIVE UNITS – MANUAL TRANS.

Number of forward speeds.		Three (b) (c)		
Transmission ratios	In first	2.54 (a)	2.42 (a)	
	In second	1.50 (a)	1.61 (a)	
	In third	(a)	(a)	
	In fourth	(a)	(a)	
	In reverse	2.63 (a)	2.33 (a)	
Synchronous meshing, specify gears		All Forward Gears		
Shift lever location		Steering Column (b) (c)	Floor	
Lubricant	Capacity (pt.)	3.4	3.5	
	Type recommended	Multi-Purpose Gear Lubricant (MTL-L-2105B)		
	SAE viscosity number	Summer	SAE 80	
		Winter	SAE 80	
		Extreme cold	SAE 80	

DRIVE UNITS – MANUAL TRANS. W/OVERDRIVE

For transmission data see manual transmission section)

Type (planetary or other)		Not Available		
Manual lockout (yes, no)				
Downshift accelerator control (yes, no)				
Minimum cut-in speed				
Gear ratio				
Lubricant	Capacity (pt.) (Overdrive only)			
	Separate filler (yes, no)			
	Type recommended			
	SAE viscosity number	Summer		
		Winter		
Extreme cold				

(a) Optional 4-Speed Transmission Ratios Are:

1 - 2.20 3 - 1.28 Rev. - 2.27
 2 - 1.64 4 - 1.00

(b) Heavy Duty 3-Speed Manual Transmission with Floor Shift - Optional on GS 350 - (Ratios Same as G. S. 400).

(c) 4-Speed Manual Transmission Available on All Styles - Optional on GS 350 - (Floor Shift).

AMA Specifications—Passenger Car

MAKE OF CAR	BUICK	MODEL YEAR	1969	DATE ISSUED	REVISED (e)
		GS			
MODEL	"350" 43437				"400" 44637

DRIVE UNITS – AUTOMATIC TRANSMISSION

Trade name		Super Turbine (Optional)									
Type describe		Two Speed with Torque Converter				Three Speed with Torque Converter					
Selector location		Lever - Steering Column Mounted (b)									
List gear ratios Selector Pattern and indicate which are used in each selector position		<u>Drive</u>	<u>L²</u>	<u>L¹</u>	<u>Rev.</u>	<u>Drive</u>	<u>L²</u>	<u>L¹</u>	<u>Rev.</u>		
		1st	2.52	2.52	2.52	1.93	1st	2.48	2.48	2.48	2.08
		2nd	1.52	1.52	----	----	2nd	1.48	1.48	----	----
		3rd	1.00	----	----	----	3rd	1.00	----	----	----
Max. upshift speed-drive range		(c)47 (d)80				1-2 = 43 2-3 = 80					
Max. kickdown speed-drive range		(e)38 (f)70				2-1 = 24 3-2 = 74					
Torque converter	Number of elements	Three									
	Max. ratio at stall	2.05									
	Type of cooling (air, liquid)	Water									
	Nominal diameter	11.75									
Lubricant	Capacity-refill (pt.)	20 Total - 6.0 Drain				23.0 Total - 7.0 Drain					
	Type recommended	"DEXRON" (R) Automatic Transmission Fluid									
Special transmission features											

DRIVE UNITS – PROPELLER SHAFT

Number used		One	
Type (straight tube, tube-in-tube, internal-external damper, etc.)		Exposed	
Outer diam. x length* x wall thickness	Manual 3-speed trans.	3.00 x 56.00 x .065	
	Manual 4-speed trans.	Not Available	
	Overdrive transmission	Not Available	
	Automatic transmission	3.00 x 56.00 x .065 (a)	3.24 x 55.10 x .065 (a)

* Center to center of universal joints, or to centerline of rear attachment.

- (a) With Rubber Biscuit Drive.
 (b) Console Lever - Optional.
 (c) 1-2 Shift

(Continued)

- (d) 2-3 Shift
 (e) 2-1 Shift
 (f) 3-2 Shift

AMA Specifications—Passenger Car

MAKE OF CAR BUICK MODEL YEAR 1969 DATE ISSUED GS REVISED ^(a)MODEL "350" 43437 "400" 44637

DRIVE UNITS – PROPELLER SHAFT (cont.)

Inter- mediate bearing	Type (plain, anti-friction)	None	
	Lubrication (fitting, prepack)	None	
Slip Yoke	Type	Male Slip Yoke at Transmission Where Primary Slip Is Taken	
	Number of teeth	27 O.D. Fit-(Man. Trans.) 27 P.D. Fit-(Auto. Trans.)	28 O.D. Fit-(Man. Trans.) 32 P.D. Fit-(Auto. Trans.)
	Spline O.D.	1.1750 - 1.1745 (Manual) 1.166 - 1.150 (Automatic)	1.373 - 1.357 (Auto.)
Universal joints	Make and Mfg. No.	Saginaw	
	Number used	Two	
	Type (ball and trunnion, cross)	Cross	
	Rear attach. (u-bolt, clamp, etc.)	U-Bolt	
	Bearing	Type (plain, anti-friction)	Nylon Injected Composite
Lubric. (fitting, prepack)			
Drive taken through (torque tube or arms, springs)		Arms	
Torque taken through (torque tube or arms, springs)		Arms	

DRIVE UNITS – AXLE

Type (front, rear)		Rear		
Description		Salisbury Hypoid - Semi-Floating		
Limited Slip differential, type		Positive Traction (Optional)		
Drive Pinion Offset		1.750		
No. of differential pinions		2		
Pinion adjustment (shim, other)		Shim		
Pinion bearing adj. (shim, other)		Collapsible Spacer		
Wheel bearing type		Tapered Roller		
Lubricant	Capacity (pt.)	2.90		
	Type recommended	MIL-L-2105B		
	SAE vis- cosity number	Summer	80	
		Winter	80	
		Extreme cold	80	

AXLE RATIO TOOTH COMBINATIONS

(See page 3 for axle ratio usage)

Axle ratio		(a)	(b)	(c)	(d)	(e)
		3.23	3.42	3.64	3.91	2.93
No. of teeth	Pinion	13	12	11	11	14
	Ring gear	42	41	40	43	41
Ring Gear O.D.		8.500				

- (a) Std. - Manual (3) & Automatic (GS 350)
 (b) Std. - Manual (3 & 4) - (GS 400) - Also Perf. Ratio - Automatic Asm.
 (c) Perf. Ratio - Manual 3 & 4 (GS 400)
 (d) S.C.O. - Manual 3 & 4 and Automatic (GS 400)
 (e) Std. - Automatic (GS 400)

AMA Specifications—Passenger Car

MAKE OF CAR BUICK MODEL YEAR 1969 DATE ISSUED G.S. REVISED ^(a)

MODEL "350" "400"

43437 44637

DRIVE UNITS - WHEELS

Type & material		Disc Steel	
Rim (size & flange type)	Std.	14 x 6.00 "JK"	
	Opt.	None	
Attachment	Type (bolt or stud)	Stud	
	Circle diameter	4.750	
	Number and size	Five - .4375 - 20	
MODEL		"350"	"400"
		43437	44637

DRIVE UNITS - TIRES

Standard	Size, ply rating, & ply	7.75 - 14 (Two-Ply with 4-Ply Rating)	7.75 - 14 Whitewall	
	Type (bias, radial, etc.)	Bias Angle		
	Full rated Inflation Press.	Front	24	26
		Rear	26	28
Rev./Mile at 50 MPH				
Optional	Size, ply rating, & ply	8.25 - 14 (Two-Ply with 4-Ply Rating) 205R-14 Radial or F70-14 Wide Oval Opt. 7.75-14 4-Ply Nylon (Export)	8.25 - 14 and F70-14 Wide Oval 7.75-14 4-Ply Nylon (Export)	

BRAKES - PARKING

Type of control		Step-On (Hand Release)
Location of control		Left Side at Cowl Panel
Operates on		Rear Shoes
If separate from service brakes	Type (internal or external)	None
	Drum diameter	None
	Lining size (length x width x thickness)	None

AMA Specifications—Passenger Car

MAKE OF CAR	BUICK	MODEL YEAR	1969	DATE ISSUED	REVISED (e)
				G.S.	
MODEL	"350" 43437			"400" 44637	44667

BRAKES - SERVICE

Type (drum) or (disc & no. of pistons)		Drum (a)	
Self adjusting (std., opt., N.A.)		Standard	
Special Valving	Type (proportion, delay, metering, other)		
Power brake make & type (remote, int., etc.)	Std.	No	
	Opt.	Delco - Moraine - (Int. Vac. Susp.)	
Effective area (sq. in.) *		152.0	
Gross lining area (sq. in.) **		158.1	
Swept area (sq. in.) ***		268.6	
Front to Rear Effectiveness Relationship		62.4 - (Fronts) - (b)	
Drum	Diameter (nominal)	Front	9.495 - 9.505
		Rear	9.495 - 9.505
	Type and material	Composite Cast Iron	(c)
Rotor	Outer working diameter		
	Inner working diameter		
	Working width		
	Material & type (vented/solid)		
Wheel cylinder bore	Front		1.125
	Rear		.875
Master Cylinder	Bore		
	1.000		
	displacement	Front %	59.0
	distribution	Rear %	41.0
Pedal arc ratio		6.46 (d)	
Line pressure at 100 lb. pedal load		830 psi (e)	
Shoe Clearance	Front		.015
	Rear		.015
Brake lining	Banded or riveted		Riveted
	Front Wheel	Material	Extruded Molded
		Size (length x width x thickness)	7.57 x 2.50 x .196 (Gross) - .096 (Net)
		Prim. or out-board	
		Second. or in-board	9.83 x 2.50 x .265 (Gross) - .165 (Net)
	Segments per shoe		One
	Rear Wheel	Material	Extruded Molded
		Size (length x width x thickness)	7.57 x 2.00 x .196 (Gross) - .096 (Net)
Prim. or out-board			
Second. or in-board		9.83 x 2.00 x .265 (Gross) - .165 (Net)	
Segments per shoe		One	

* Excludes rivet holes, grooves, chamfers, etc. ** Includes rivet holes, grooves, chamfers, etc.

*** Total swept area for four brakes. (Widest lining contact width for each brake x its contact circumference.)

(a) Power Disc Fronts, Optional

(b) Based on Wheel Cyl. Size Only

(c) Fronts - Finned Aluminum with Cast Iron Liners. Rears - Composite C.I.

(d) 3.44 when Optional Power Brake Equipped

(e) 1130 psi with 30# Pedal Load when Power Brake Equipped.

AMA Specifications—Passenger Car

MAKE OF CAR BUICK MODEL YEAR 1969 DATE ISSUED _____ REVISED ^(a)

	G.S.	
MODEL	"350" 43437	"400" 46637

STEERING

Manual (std., opt., NA)		Standard		
Power (std., opt., NA)		Optional		
Adjustable steering wheel (tilt, swing, other)	Type and description (std., opt., NA)	Tilt (a)		
		Optional (a)	Optional	
Wheel diameter	Manual	16.00"		
	Power	16.00"		
Turning diameter (feet)	Outside front	Wall to wall (l. & r.)	41.55 - 42.20	
		Curb to curb (l. & r.)	38.38 - 38.96	
	Inside rear	Wall to wall (l. & r.)	21.44 - 22.48	
		Curb to curb (l. & r.)	22.12 - 23.12	
Manual	Gear	Type	Recirculating Ball Nut	
		Make	Saginaw	
		Ratios	Gear	24.0
			Overall	28.6
	No. wheel turns (stop to stop)	5.56		
Power	Type (coaxial, linkage, etc.)		In-Line Rotary Valve	
	Make		Saginaw	
	Gear	Type	Recirculating Ball-Nut (Integral with Power Piston)	
		Ratios	Gear	17.5
		Overall	20.9 (b)	
	Pump driven by		Belt	
No. wheel turns (stop to stop)		4.06		
Linkage	Type		Parallelogram	
	Location (front or rear of wheels, other)		Front of Wheels	
	Drag link (trans. or longit.)		Transverse	
	Tie rods (one or two)		Two	
Steering Axis	Inclination of camber (deg.)		8° 0' @ 1° 0'	
	Bearings (type)	Upper	Ball Joint Suspension Used	
		Lower	Ball Joint Suspension Used	
		Thrust	Ball Joint Suspension Used	
Whl. Align. (range at curb wt. & preferred)	Caster (deg.)		- 1/2° ± 30' (Curb Height)	
	Camber (deg.)		+ 1/2° ± 30' (Curb Height)	
	Toe-in (outside track inches)		.12 to .25 (Curb Height)	
Steering spindle & joint type		Ball		
Wheel Spindle	Diameter	Inner bearing	1.3748/1.3743	
		Outer bearing	.8435/ .8430	
	Thread size		.750 - 20 UNF	
	Bearing type		Tapered Roller	

(a) Not available with manual transmission with column shift,

(b) 17.9 with Optional 15-1 Gear.

AMA Specifications—Passenger Car

MAKE OF CAR BUICK	MODEL YEAR 1969	DATE ISSUED GS	REVISED (•)
MODEL	"350" 43437	"400" 44637	

FRAME

Type and description (Separate frame, unitized frame, partially - unitized frame)	Perimeter (Separate Frame)
---	----------------------------

BODY – MISCELLANEOUS INFORMATION

Drs. hinged (front, rr.)	Front doors	Front
	Rear doors	Front
Type of finish (lacquer, enamel, other)		Acrylic Lacquer
Hood counterbalanced (yes, no)		Yes
Hood release control (internal, external)		External
Vehicle Ident. No. location		Left Side of Upper Instrument Panel
Engine No. location	Left Cylinder Block at Front Below Head	Right Cylinder Head at Rear on Boss
Theft protection - type		Ignition - Steering Integral Lock
Vent window control method (crank, friction pivot)	Front	Crank
	Rear	- - -
Seat cushion type	Front	Zig - Zag
	Rear	Zig - Zag
	3rd seat	- - - -
Seat back type	Front	Zig - Zag
	Rear	Zig - Zag
	3rd seat	- - - -
Windshield glass type (i.e., single curved - laminated plate)		Compound Curved (Laminated Type)
Side glass type (i.e., curved - tempered plate)		Curved (Tempered Plate)
Backlight glass type (i.e., compound curved - tempered plate, three piece)		Single Curved (Tempered Plate)
Windshield glass exposed surface area		1208.7
Side glass exposed surface area		1300.2
Backlight glass exposed surface area		895.1
Total glass exposed surface area		3404.0

AMA Specifications—Passenger Car

CAR AND BODY DIMENSIONS

KEY SHEET

EXTERIOR CAR AND BODY DIMENSIONS

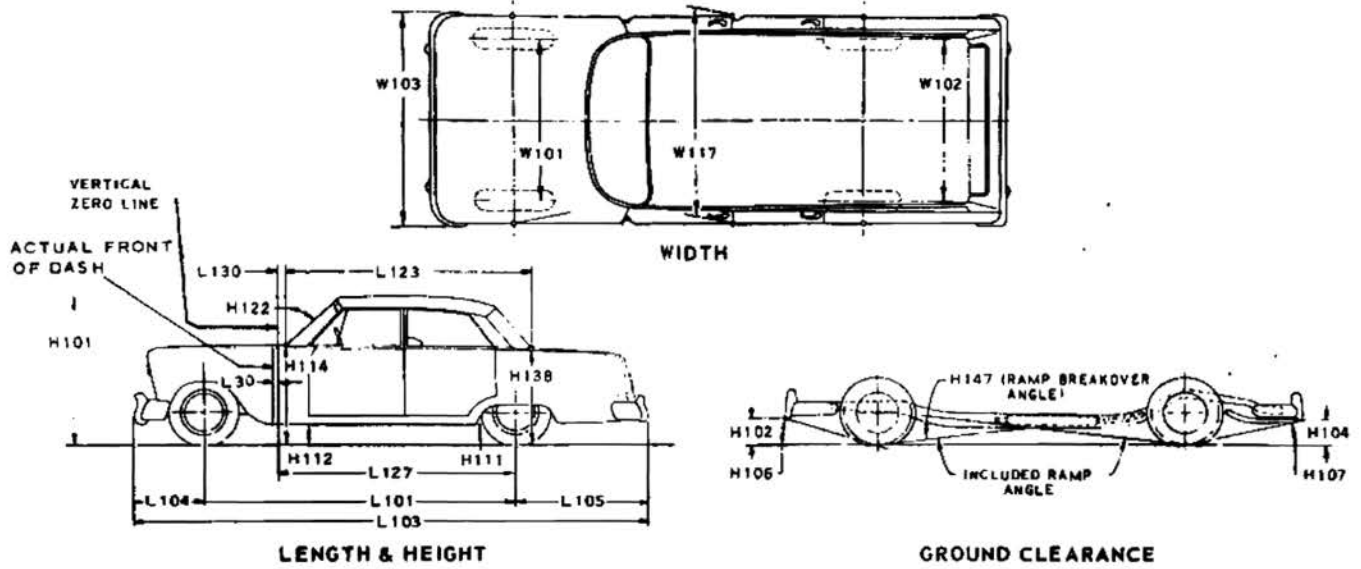

LENGTH & HEIGHT

GROUND CLEARANCE

INTERIOR CAR AND BODY DIMENSIONS

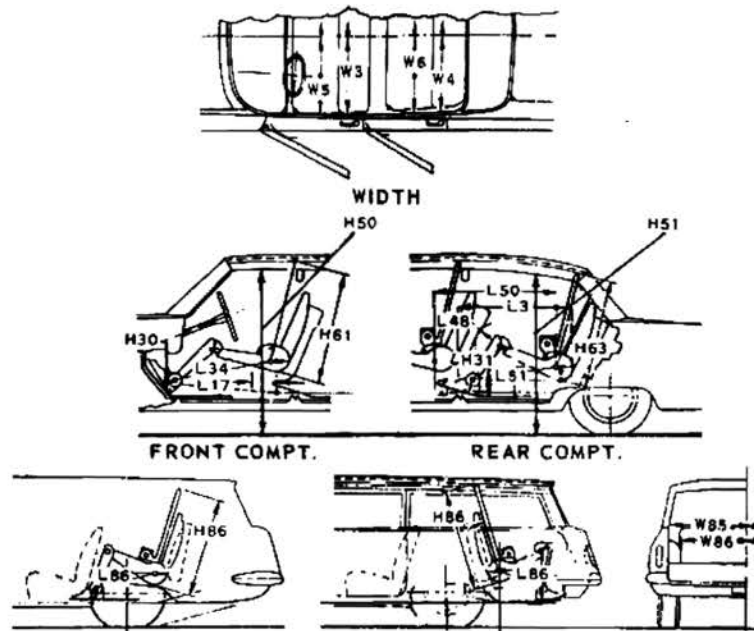

FRONT COMPT.

REAR COMPT.

THIRD SEAT

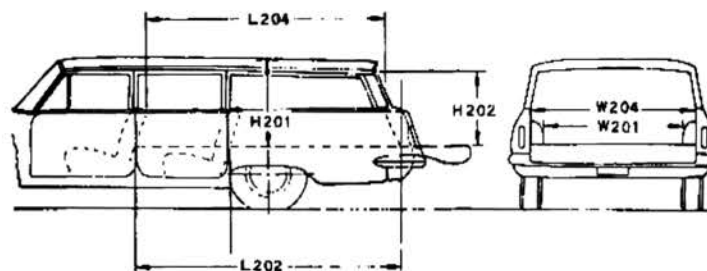

CARGO SPACE

CAR AND BODY DIMENSIONS

KEY SHEET

DIMENSION DEFINITIONS

EXTERIOR WIDTH DIMENSIONS

- W101 WHEEL TREAD - FRONT. Measured at centerline of tires, with nominal camber, at ground.
 W102 WHEEL TREAD - REAR. Measured at centerline of tires at ground.
 W103 MAXIMUM OVERALL CAR WIDTH. Include bumpers, moldings, or sheet metal protrusions. Measured to outside of metal.
 W117 MAXIMUM BODY WIDTH AT #2 PILLAR. Measured across body at #2 pillar, excluding hardware and applied moldings.

EXTERIOR LENGTH DIMENSIONS

- L 30 VERTICAL ZERO LINE TO ACTUAL FRONT OF DASH. If actual Front of Dash is to the rear of Body Zero Line, it is identified by a minus (-) sign.
 L101 WHEELBASE.
 L103 OVERALL LENGTH. Include bumper guards if standard equipment.
 L104 OVERHANG - FRONT. Measured from C/L of front wheels to front of car, including bumper guards if standard equipment.
 L105 OVERHANG - REAR. Measured from C/L of rear wheels to rear of car, including bumper guards if standard equipment.
 L123 BODY UPPER STRUCTURE LENGTH AT CAR CENTERLINE. The horizontal dimension from the Cowl Point to the Deck Point.
 L127 VERTICAL ZERO LINE TO CENTERLINE OF REAR WHEELS. A horizontal dimension.
 L130 VERTICAL ZERO LINE TO WINDSHIELD COWL POINT. The horizontal dimension from the vertical zero line to the theoretical intersection of extended windshield glass plane and normal cowl surface.

EXTERIOR HEIGHT DIMENSIONS

- H101 OVERALL HEIGHT - DESIGN. Measured with the vehicle in Manufacturer's Design Weight attitude.
 H114 COWL POINT TO GROUND. Measured at vehicle centerline.
 H138 DECK POINT TO GROUND. Measured at vehicle centerline.
 H112 ROCKER PANEL TO GROUND - FRONT. The vertical dimension from ground to bottom of rocker panel, excluding flanges. Measured to the outside of sheet metal at foremost point of rocker panel.
 H111 ROCKER PANEL TO GROUND - REAR. The vertical dimension from ground to bottom of rocker panel, excluding flanges. Measured to the outside of sheet metal at front of rear wheel opening.
 H122 WINDSHIELD SLOPE ANGLE. The angle between a vertical line and the windshield surface at car centerline. On compound-curved windshields the chord of the arc is used and limited to that section of the windshield comprehended by an 18-inch chord.

GROUND CLEARANCE DIMENSIONS

- H102 BUMPER TO GROUND - FRONT. Minimum dimension, includes bumper guards.
 H104 BUMPER TO GROUND - REAR. Minimum dimension, includes bumper guards.
 H106 ANGLE OF APPROACH. The angle between ground and a line tangent to the front tire static loaded radius arc and the first point of interference, i.e., bumper, guard, gravel deflector, fender or other component, excluding license plate. This dimension may be determined graphically for reporting purposes.
 H107 ANGLE OF DEPARTURE. The angle between ground and a line tangent to the rear tire static loaded radius arc and the first point of interference, i.e., bumper, guard, gravel deflector, tail pipe, fender or other component, excluding license plate. This dimension may be determined graphically for reporting purposes.
 H147 RAMP BREAKOVER ANGLE. The supplement of included ramp angle (180° minus included ramp angle) over which car can pass without interference; measured with car sitting on a level surface, using lines tangent to arcs of front and rear static loaded radii and intersecting at point on underside of car which defines the smallest angle.
 H156 MINIMUM RUNNING GROUND CLEARANCE. Location of measurement on the car is to be clearly recorded.

FRONT COMPARTMENT DIMENSIONS

- H 61 EFFECTIVE HEAD ROOM - FRONT. The dimension from H Point to the headlining, plus a constant of 4.0 inches, measured along a line 8° to rear of vertical.
 L 34 MAXIMUM EFFECTIVE LEG ROOM - ACCELERATOR. Measured along a diagonal line from the Manikin ankle pivot center to the H Point plus a constant of 10.0 inches. For treadle type accelerator pedals, the leg room is measured with the Manikin's right foot on the accelerator pedal and the Manikin Heel Point at Accelerator Heel Point. All other types of accelerator pedals will be measured with the Manikin foot angle set at 87° and the shoe touching the pedal.
 H 30 H POINT TO HEEL POINT - FRONT. The vertical dimension from the H Point to the Accelerator Heel Point.
 L 17 H POINT TRAVEL. The horizontal dimension between the H Point in the most forward and rearward seat positions.

FRONT COMPARTMENT DIMENSIONS (Cont.)

- W 3 SHOULDER ROOM - FRONT. The minimum lateral dimensions between the door garnish moldings or nearest interference, measured at the H Point station.
 W 5 HIP ROOM - FRONT. The lateral dimension through the H Point to trimmed body surfaces. Depress loose side wall cloth to trim foundation or other obstruction if such construction exists.
 H 50 UPPER BODY OPENING TO GROUND - FRONT. The vertical dimension from a point on the trimmed body opening to the ground, measured at the H Point station.

REAR COMPARTMENT DIMENSIONS

- L 50 H POINT COUPLE DISTANCE. The horizontal dimension from the front seat H Point to the rear seat H Point.
 H 63 EFFECTIVE HEAD ROOM - REAR. The dimension from the H Point to the headlining, plus a constant of 4.0 inches, measured along a line 8° to rear of vertical.
 L 51 MINIMUM EFFECTIVE LEG ROOM - REAR. Measured along a diagonal line from the ankle pivot center to the H Point plus a constant of 10.0 inches, with the foot positioned to the nearest interference between the seat structure and toe, instep or lower leg.
 H 31 H POINT TO HEEL POINT - REAR. The vertical dimension from the H Point to the Manikin Heel Point on the depressed floor covering.
 L 48 MINIMUM KNEE ROOM - REAR. The minimum dimension from the Manikin knee pivot center to the back of the front seat back.
 L 3 REAR COMPARTMENT ROOM. The horizontal dimension from the back of front seat to front of rear seat back at height tangent to the top of rear seat cushion.
 W 4 SHOULDER ROOM - REAR. The minimum lateral dimension between the door garnish molding or nearest interference. Measured at H Point station.
 W 6 HIP ROOM - REAR. The lateral dimension through H Point to trimmed body surfaces. Depress loose side wall cloth to trim foundation or other obstruction when such construction exists.
 H 51 UPPER BODY OPENING TO GROUND - REAR. The vertical dimension from a point on the trimmed body opening to the ground, measured 13.0 inches forward of the H Point.

LUGGAGE COMPARTMENT DIMENSIONS

- V 1 LUGGAGE CAPACITY - USABLE. The total luggage compartment luggage capacity in cubic feet with the tire and tools in place.
 H195 LIFTOVER HEIGHT. Vertical dimension from the highest point on the luggage compartment lower opening to ground, excluding corner radii.

STATION WAGON - THIRD SEAT DIMENSIONS

- W 85 SHOULDER ROOM - THIRD SEAT. The minimum lateral dimension between the door garnish moldings or nearest interference. Measured at H Point station.
 W 86 HIP ROOM - THIRD SEAT. The lateral dimension through H Point to trimmed surfaces.
 L 86 EFFECTIVE LEG ROOM - THIRD SEAT. Measured along a diagonal line from ankle pivot center to H Point plus a constant of 10.0 inches. With rear-facing third seat, foot is positioned in foot well or to nearest interference with rear end or rear closure.
 H 86 EFFECTIVE HEAD ROOM - THIRD SEAT. The dimension from H Point to the headlining, plus a constant of 4.0 inches. Measured along a line 8° to rear of vertical.

STATION WAGON - CARGO SPACE DIMENSIONS

- L202 CARGO LENGTH AT FLOOR - FRONT SEAT. The horizontal dimension, measured at the floor level from the rear of the front seat back to the normal inside limiting interference on the tailgate, on the car centerline.
 L204 CARGO LENGTH AT BELT - FRONT SEAT. The horizontal dimension measured from the top rear of front seat back to a vertical extension line from the normal inside limiting interference at the top of the tailgate, on the car centerline.
 W201 CARGO WIDTH - WHEELHOUSE. The minimum horizontal dimension, measured between wheelhouseings at floor level.
 W204 OPENING WIDTH AT BELT. The minimum horizontal dimension, measured between the nearest normal inside limiting interferences of the rear opening at the top of the tailgate.
 H201 MAXIMUM CARGO HEIGHT. The maximum vertical dimension, measured from the top of the floor covering to the headlining, on the car centerline.
 H202 REAR OPENING HEIGHT. The vertical dimension measured from the top of the floor covering to the normal inside limiting interference at the top of the rear opening, on the car centerline, with both tail-and-liftgates fully open.
 V 2 CARGO VOLUME INDEX BEHIND FRONT SEAT. The total volume in cubic feet above the normal load floor and behind the front seat with the liftgate and tailgate closed.

W4xL204xH201

1728

INDEX

SUBJECT	PAGE NO.	SUBJECT	PAGE NO.
Automatic Transmission.....	16	Kingpin (Steering Axis).....	20
Axis, Steering.....	20	Lamp height and spacing.....	23
Axle, Rear.....	17	Legroom.....	2
Battery.....	12	Lengths - Car and Body.....	1
Bearings, Engine.....	5, 6, 7	Lifters, valve.....	6
Belts - Fan, Generator, Water Pump.....	11	Linings - Clutch, Brake.....	14, 19
Brakes - Parking, Service Power.....	18, 19	Lubrication.....	7, 8, 14, 15, 16, 17
Camber.....	20	Luggage Compartment.....	2
Camshaft.....	6	Motor, Starting.....	12
Capacities.....		Muffler.....	8
Cooling System.....	11	Overdrive.....	15
Fuel Tank.....	10	Piston Pins & Rings.....	4, 5
Lubricants.....		Pistons.....	4, 5
Engine Crankcase.....	8	Power Brakes.....	19
Transmission and Overdrive.....	15, 16	Power Steering.....	20
Rear Axle.....	17	Power Teams.....	3
Car and Body Dimensions.....		Propeller Shaft, Universal Joints.....	16, 17
Width.....	1	Pumps - Oil, Fuel.....	8, 10
Length.....	1	Water.....	11
Height.....	1	Radiator, Hoses.....	11
Ground Clearance.....	1	Ratios - Axle.....	3, 17
Front Compartment.....	2	Compression.....	3, 4
Rear Compartment.....	2	Steering.....	20
Luggage Compartment.....	2	Transmission.....	15, 16
Station Wagon - Third Seat.....	2	Rear Axle.....	3, 17
Station Wagon - Cargo Space.....	2	Regulator - Generator.....	12
Carburetor.....	3, 9, 10	Rims.....	18
Caster.....	20	Rings, Piston.....	5
Choke, Automatic.....	10	Rods - Connecting.....	5
Clutch - Pedal Operated.....	14	Shock Absorbers, Front & Rear.....	21
Coil, Ignition.....	13	Spark Plugs.....	13
Connecting Rods.....	5	Speedometer.....	14
Convenience Equipment.....	23	Springs - Front & Rear Suspension.....	21
Cooling System.....	11	Valve, Engine.....	6
Crankcase Ventilation System.....	8	Stabilizer (Sway Bar) - Front & Rear.....	21
Crankshaft.....	6	Starting System.....	12
Cylinders and Cylinder Head.....	4	Steering.....	20
Dimension Definitions.....		Supply System.....	12
Key Sheet.....	25	Suppression - Ignition, Radio.....	13
Exterior & Interior.....	26	Suspension - Front & Rear.....	21
Distributor - Ignition.....	13	Tail Pipe.....	8
Electrical System.....	12, 13, 14	Thermostat, Cooling.....	11
Engine.....		Timing, Engine & Valve.....	6, 7, 13
Bore, Stroke, Displacement, Type.....	4	Tires.....	18
Compression Ratio.....	4	Toe in.....	20
Firing Order, Cylinder Numbering.....	4	Torque Converter.....	16
General Information, H.P. & Torque.....	4	Torque - Engine, Rated.....	3, 4
Lubrication.....	7, 8	Transmission - Types.....	3, 10, 15, 16
Power Teams.....	3	Automatic.....	3, 10, 15, 16
Exhaust Emission Control.....	9	Manual & Overdrive.....	3, 10, 15
Exhaust System.....	8	Ratios.....	15, 16
Equipment Availability.....	22	Track.....	1
Fan, Cooling.....	11	Trunk Luggage Capacity.....	2
Filters - Engine Oil, Fuel System.....	8, 10	Turning Diameter.....	20
Frame.....	22	Unitized Construction.....	22
Front Suspension.....	21	Universal Joints, Propeller Shaft.....	16, 17
Fuel, Fuel Pump, Fuel System.....	4, 10	Valves - Intake & Exhaust.....	6, 7
Fuel Injection.....	10	Vibration Damper.....	6
Generator and Regulator.....	12	Voltage Regulator.....	12
Glass.....	22	Water Pump.....	11
Height (Lamps).....	14	Weights.....	24
Headroom - Body.....	2	Wheel Alignment.....	20
Heights - Car and Body.....	1	Wheelbase.....	1
Horns.....	14	Wheels & Tires.....	18
Horsepower - Brake.....	3, 4	Wheel Spindle.....	20
Ignition System.....	13	Widths - Car and Body.....	1
Inflation - Tires.....	18	Windshield.....	22
Instruments.....	14	Windshield Wiper.....	14