

AMA Specifications—Passenger Car

The information contained herein is prepared, distributed by, and is solely the responsibility of the automobile manufacturing company to whose products it relates. Questions concerning these specifications should be directed to the manufacturer whose address is shown below. This uniform specification form was developed by the automobile manufacturing companies under the auspices of the Automobile Manufacturers Association.

MANUFACTURER	BUICK MOTOR DIVISION GENERAL MOTORS CORPORATION	CAR NAME	BUICK SPECIAL DELUXE - SKYLARK (6CYL.)
MAILING ADDRESS	1051 E. HAMILTON AVENUE FLINT, MICHIGAN 48550	MODEL YEAR	1969
		ISSUED:	Sept. 4, 1968
		REVISED (a)	12-2-68

NOTES:

1. The General Specifications herein are those in effect at date of compilation and are subject to change without notice by the manufacturer.
2. UNLESS OTHERWISE INDICATED:
 - a. Specifications apply to standard models without optional equipment. Significant deviations are noted.
 - b. Nominal design dimensions are used throughout these specifications.

TABLE OF CONTENTS

Car & Body Dimensions	1,2	Drive Units	14	Suspensions	21
Engine - Mechanical	4	Brakes.....	18, 19	Weights	24
Electrical	12	Steering	20	Index	27

BODY - TYPES AND STYLE NAMES -

Body type, style names; use manufacturer's code for series & body style.

<u>SERIES</u>	<u>BODY STYLE</u>	<u>MODEL DESIGNATION</u>
Special Deluxe	2 Door Thin Pillar Coupe	43327
	4 Door Thin Pillar Sedan	43369
Skylark	2 Door Hardtop Coupe	43537
	4 Door Thin Pillar Sedan	43569

AMA Specifications—Passenger Car

MAKE OF CAR BUICK MODEL YEAR 1969 DATE ISSUED 9-4-68 REVISED (e)

CAR AND BODY DIMENSIONS

See Pages 25, 26 for SAE Dimension Definitions

(All dimensions in inches unless otherwise indicated)

All dimensions to ground are for comparative purposes only. Dimensions are to be shown for:

4-Dr. Sedan, 2-Dr. H.T., 4-Dr. H.T., Convertible and Station Wagon.

MODEL	SAE Ref. No.	SPECIAL DELUXE		SKYLARK	
		43327	43369	43537	43569
WIDTH					
Track - Front	W101	59.0			
Track - Rear	W102	59.0			
Maximum overall car width	W103	75.6			
Body width at No. 2 pillar	W117	74.5			
LENGTH					
Body "O" to front of dash	L 30				
Wheelbase	L101	112.0	116.0	112.0	116.0
Overall car length	L103	200.7	204.7	200.7	204.7
Overhang - front	L104	37.5			
Overhang - rear	L105	51.2			
Body upper structure length	L123				
Body "O" line to \ominus of rear wheel	L127	95.5	99.5	95.5	99.5
Body "O" line to w/s cowl point	L130				
HEIGHT					
Passenger Distribution (front & rear)		2-2			
Trunk/Cargo load (lbs.)		200			
Overall height	H101	53.4	54.1	53.4	54.1
Cowl height	H114	38.3			
Deck height	H138				
Rocker panel - front	To ground	8.6			
	From front wheel \ominus	27.2			
Rocker panel - rear	To ground	8.4			
	From rear wheel \ominus	25.8			
Windshield slope angle	H122	53.1			
GROUND CLEARANCE					
Bumper to ground - front	H102	12.4			
Bumper to ground - rear	H104	11.9			
Angle of approach	H106	25.5°			
Angle of departure	H107	17.2°	17.8°	17.2°	17.8°
Ramp breakover angle	H147	12.3°	15.2°	12.3°	12.3°
Min. running clearance (Specify)(a)	H156	5.5	5.4	5.5	5.4

(a) Front Suspension to Ground.

AMA Specifications—Passenger Car

MAKE OF CAR BUICK MODEL YEAR 1969 DATE ISSUED 9-4-68 REVISED (#) 9-30-68

CAR AND BODY DIMENSIONS

See Pages 25, 26 for SAE Dimension Definitions
(All dimensions in inches unless otherwise indicated)

MODEL	SAE Ref. No.	SPECIAL DELUXE		SKYLARK	
		43327	43369	43537	43569
FRONT COMPARTMENT					
Effective head room	H61	37.9	38.6	37.9	38.6
Max. eff. leg room - accelerator	L34	41.3		41.6	
H Point to Heel point	H30	8.2		7.7	
H Point travel	L17	4.7			
Shoulder room	W 3	58.3			
Hip room	W 5	59.7		59.6	
Upper body opening to ground	H50	48.1	49.0	48.7	49.0
REAR COMPARTMENT					
H Point couple distance	L50	30.6	32.8	30.6	32.8
Effective head room	H63	36.3	37.3	36.3	37.3
Min. effective leg room	L51	32.4	35.0	32.2	34.8
H Point to Heel point	H31	10.0	10.6	10.0	10.6
Min. knee room	L48	0.7	2.3	0.7	2.3
Rear Compartment room	L 3	24.0	25.9	24.0	25.9
Shoulder room	W 4	57.1	57.3	57.1	57.3
Hip room	W 6	58.3	59.4	58.3	59.4
Upper body opening to ground	H51	-----	48.5	-----	48.5
LUGGAGE COMPARTMENT					
Usable luggage capacity	V 1	14.6			
Liftover height	H195	28.6			
Position of spare tire storage		Horizontal			
Method of holding lid open		Torsion Rods			
STATION WAGON - THIRD SEAT					
Shoulder Room	W85	No Wagons - This Series			
Hip room	W86				
Effective leg room	L86				
Effective head room	H86				
Seat facing direction					
STATION WAGON - CARGO SPACE					
Cargo length at floor - front seat	L202	No Wagons - This Series			
Cargo length at belt - front seat	L204				
Cargo width - Wheelhouse	W201				
Opening width at belt	W204				
Maximum cargo height	H201				
Rear opening height	H202				
Cargo volume index (cu. ft.) W4 x L204 x H201 1728	V2				

AMA Specifications—Passenger Car

MAKE OF CAR BUICK MODEL YEAR 1969 DATE ISSUED 9-4-68 REVISED (*)

POWER TEAMS

(Indicate whether standard or optional)

MODEL AVAILABILITY	ENGINE					TRANSMISSION	AXLE RATIO (Std. first) (Indicate A/C ratio)
	Displ. cu. in.	Carburetor	Compr. Ratio	BHP RPM	Torque RPM		
SPECIAL DELUXE & SKYLARK	250	1-bb1	8.5	155 @ 4200	235 @ 1600	Manual (3)	3.23 - (Std) N.A. - (Economy) N.A. - (Perf) 3.42 or 3.91 (S.C.O.)
	250	1-bb1	8.5	155 @ 4200	235 @ 1600	Automatic	2.93 - (Std) 3.23(a) - (Perf) 3.91 or 3.42 - (S.C.O.) 3.23(a) - Std. with A/C No A/C (Economy) 3.42 Perf. with A/C

(a) Canadian Built Car Axle Ratios.

Manual
3.31 (Std)

Automatic
3.07 (Std)
No Perf.

3.31 (Std with A/C)

AMA Specifications—Passenger Car

MAKE OF CAR BUICK MODEL YEAR 1969 DATE ISSUED 9-4-68 REVISED (a)

MODEL	SPECIAL DELUXE	SKYLARK
	43369	43569

ENGINE - GENERAL

Type, no. cyls., valve arr.	"In - Line" 6 Valve-In-Head
Bore and stroke (nominal)	3.875 x 3.530
Piston displacement, cu. in.	250
Bore spacing (C to C)	4.4
No. system (front to rear)	L. Bank R. Bank
Firing order	1-2-3-4-5-6 (In-Line)
Compress. ratio (nominal)	8.5
Cylinder Head Material	Cast Alloy Iron
Cylinder Block Material	Cast Alloy Iron
Cyl. Sleeve-Wet, dry, none	None
Number of mtg. points	Front Rear
Engine installation angle	4° 37'
Taxable horsepower	$\frac{\text{Dia}^2 \times \text{No. Cyl.}}{2.5}$ 2.5
Publishing max. bhp* @ eng. RPM	36.0 155 @ 4200
Publishing max. torque* (lb. ft. @ RPM)	235 @ 1600
Recommended fuel regular - premium	Regular

ENGINE - PISTONS

Material	Cast Aluminum Alloy		
Description and finish	Flat-Notched Head - Slipper Skirt		
Weight (piston only) oz.	24.16		
Clearance (limits)	Top land	.0345 - .0435	
	Skirt	Top	.0005 - .0011 (a)
		Bottom	- - - - -
Ring groove depth	No. 1 ring	.2153 - .2218	
	No. 2 ring	.2153 - .2218	
	No. 3 ring	.2093 - .2158	
	No. 4 ring	- - - - -	

* Max. bhp (brake horsepower) and max. torque corrected to 60° F and 29.92 in. Hg atmospheric pressure.

(a) Measured 2.44" from Top of Piston.

AMA Specifications—Passenger Car

MAKE OF CAR BUICK MODEL YEAR 1969 DATE ISSUED 9-4-68 REVISED (*)

MODEL	SPECIAL DELUXE	SKYLARK
	43369	43569

ENGINE - RINGS

Function (top to bottom)	No. 1, oil or comp.	Compression
	No. 2, oil or comp.	Compression
	No. 3, oil or comp.	Oil
	No. 4, oil or comp.	None
Compression	Description - material, coating, etc.	#1 - Cast Alloy Iron - Chrome Plated #2 - Cast Alloy Iron - Wear Resistant Coating
	Width	#1 - .0628 - .0633 -- #2 - .0623 - .0625
	Gap	.010 - .020
Oil	Description - material, coating, etc.	#3 - Multi-Piece (Two Rails and One Spacer Expander) Rails (Chrome Plated Steel) - Expander (Stainless Steel)
	Width	.1870 - .1890 (Assembled)
	Gap	.015 - .025
Expanders		In Oil Ring

ENGINE - PISTON PINS

Material	Chromium Steel		
Length	2.990 - 3.010		
Diameter	.9270 - .9273		
Type	Locked in rod, in piston, floating, etc.	Locked in Rod	
	Bush- ing	In rod or piston	None
		Material	None
Clearance	In piston	.00015 - .00025	
	In rod	None	
Direction & amount offset in piston	Major Thrust Side (.060)		

ENGINE - CONNECTING RODS

Material	Drop Forged Steel	
Weight (oz.)	12.5	
Length (center to center)	5.699 - 5.701	
Bearing	Material & Type	Copper Lead Alloy or Sintered Copper Nickel Backed Babbitt on Steel
	Overall length	.807
	Clearance (limits)	.0007 - .0027
	End play	.009 - .013

AMA Specifications—Passenger Car

MAKE OF CAR BUICK MODEL YEAR 1969 DATE ISSUED 9-4-68 REVISED ^(a)

MODEL	<u>SPECIAL DELUXE</u> <u>43369</u>	<u>SKYLARK</u> <u>43569</u>
-------	---------------------------------------	--------------------------------

ENGINE - CRANKSHAFT

Material	Nodular Iron		
Vibration damper type	Inertia (Rubber Mounted)		
End thrust taken by bearing (No.)	7		
Crankshaft end play	.002 - .006		
Main bearing	Material & type	Steel with Backed Insert (Copper Lead Alloy or Premium Aluminum)	
	Clearance	.0003 - .0029	
	Journal dia. and bearing overall length	No. 1	2.3004 - .752
		No. 2	2.3004 - .752
		No. 3	2.3004 - .752
		No. 4	2.3004 - .752
		No. 5	2.3004 - .752
		No. 6	2.3004 - .752
No. 7		2.3004 - .760	
Dir. & amt. cyl. offset	None		
Crankpin journal diameter	1.999 - 2.000		

ENGINE - CAMSHAFT

Location	Above and to Right of Crankshaft		
Material	Cast Iron Alloy		
Bearings	Material	Steel Backed Babbitt	
	Number	Four	
Type of Drive	Gear or chain	Gear	
	Crankshaft gear or sprocket material	Steel	
	Camshaft gear or sprocket material	Bakelite and Fabric with Steel Hub	
	Timing chain	No. of links	None
		Width	None
		Pitch	None

ENGINE - VALVE SYSTEM

Hydraulic lifters (Std., opt., NA)	Standard	
Valve rotator, type (intake, exhaust)	None	
Rocker ratio	1.75	
Operating tappet clearance (indicate hot or cold)	Intake	Zero
	Exhaust	Zero

(Continued)

AMA Specifications—Passenger Car

MAKE OF CAR BUICK MODEL YEAR 1969 DATE ISSUED 9-4-68 REVISED ^(*)MODEL SPECIAL DELUXE SKYLARK
43369 43569

ENGINE—VALVE SYSTEM (cont.)

Timing (based on top of ramp points)	Intake	Opens (°BTC)	62	
		Closes (°ABC)	94	
		Duration - deg.	336	
	Exhaust	Opens (°BBC)	92° 30'	
		Closes (°ATC)	63° 30'	
		Duration - deg.	330	
Valve opening overlap		125° 30'		
Intake	Material		Alloy Steel	
	Overall length		4.902 - 4.922	
	Actual overall head dia.		1.715 - 1.725	
	Angle of seat & face		46° Seat - 45° Face	
	Seat insert material		None	
	Stem diameter		.3410 - .3417	
	Stem to guide clearance		.0010 - .0027	
	Lift (@ zero lash)		.3880	
	Outer spring press. & length	Valve closed (lb.@ in.)	56-64 @ 1.66	
		Valve open (lb.@ in.)	180-192 @ 1.27	
	Inner spring press. & length	Valve closed (lb.@ in.)	None	
		Valve open (lb.@ in.)	None	
	Exhaust	Material		High Alloy Steel
		Overall length		4.913 - 4.933
Actual overall head dia.		1.495 - 1.505		
Angle of seat & face		46° Seat - 45° Face		
Seat insert material		None		
Stem diameter		.3410 - .3417		
Stem to guide clearance		.0010 - .0027		
Lift (@ zero lash)		.3880		
Outer spring press. & length		Valve closed (lb.@ in.)	56-64 @ 1.66	
		Valve open (lb.@ in.)	180-192 @ 1.27	
Inner spring press. & length		Valve closed (lb.@ in.)	None	
		Valve open (lb.@ in.)	None	

ENGINE—LUBRICATION SYSTEM

Type of lubrica- tion (splash, pressure, nozzle)	Main bearings	Pressure
	Connecting rods	Pressure
	Piston pins	Splash
	Camshaft bearings	Pressure
	Tappets	Pressure
	Timing gear or chain	Nozzle
	Cylinder walls	Connecting Rod Bearing Throw - Off

(Continued)

AMA Specifications—Passenger Car

MAKE OF CAR BUICK MODEL YEAR 1969 DATE ISSUED 9-4-68 REVISED (*)MODEL SPECIAL DELUXE SKYLARK
43369 43569

ENGINE - LUBRICATION SYSTEM (cont.)

Oil pump type	Gear	
Normal oil pressure (lb. engine rpm)	30 - 45 @ 1500	
Oil press. sending unit (elect. or mech.)	Electrical	
Type oil intake (floating, stationary)	Stationary	
Oil filter system (full flow, part., other)	Full Flow	
Filter replacement (element, complete)	Complete	
Capacity of c. case, less filter-refill (qt.)	4.0	
Oil grade recommended (SAE viscosity and temperature range)	<u>Anticipated Lowest Temp.</u>	<u>Use SAE Viscosity</u>
	Above 32° F	10W-30, 20W or 20
	Below 32° F to Zero F	10W-30, 10W-40, 10W
Engine Service Reqmt. (MM, MS, etc.)	5W-20, 5W-30, 5W	
	Passing Car Makers Test GM 6041M	

ENGINE - EXHAUST SYSTEM

Type (single, single with cross-over, dual, other)	Single
Muffler No. & type (reverse flow, straight thru, separate resonator)	Reverse Flow
Exhaust pipe dia. (O.D., wall thick.)	Branch
	Main
Tail pipe dia. (O.D. & wall thickness)	2.00 - .060
	1.75 - .060

ENGINE - CRANKCASE VENTILATION SYSTEM

Type (ventilates to atmos., induction system, other)	Standard	Closed Induction System
	Optional	None
Control Unit	Make and model	A.C.
	Location	Top Rear of Rocker Cover
	Energy source (manifold vacuum, carburetor air stream, other)	Manifold Vacuum
	Control method (variable orifice, fixed orifice, other)	Variable Orifice
Complete system	Discharges (to intake manifold, carb. air intake, air cleaner intake, other)	Intake Manifold Normally with Additional Discharge into Air Cleaner Under Excessive Blow-By Conditions
	Air inlet (breather cap, carburetor air cleaner, other)	Carburetor Air Cleaner
	Flame arrestor (screen, check valve, other)	Check Valve and Screen

AMA Specifications—Passenger Car

MAKE OF CAR BUICK MODEL YEAR 1969 DATE ISSUED 9-4-68 REVISED ^(*)

MODEL	SPECIAL DELUXE	SKYLARK
	43369	43569

ENGINE - EXHAUST EMISSION CONTROL

Type (Air injection, engine modifications, other)		Combustion Control	
Air Injection Pump	Type #	Not Used	
	Displacement		
	Drive ratio		
	Drive type		
	Relief valve (type)		
	Filter (describe)		
Air Injection System	Air distribution (head, manifold, etc.)		
	Point of entry		
	Injection tube I.D.		
	Check valve type		
	Backfire protection (type)		
Carburetor	Make	Rochester	
	Model	MV	
	Barrel size	1.560	
	Idle speed	Drive	500
		Neutral	700
	Idle A/F mixture		
Distributor	Aux. Adv. Systems (type)	None	
	Make	Delco - Remy	
	Model	1110439	
	Cent'fgal adv. in crank degrees @ eng. rpm	Start (rpm)	900
		Intermed. points deg. @ rpm	21 @ 1950
		Max. deg. @ rpm	32 @ 4100
	Vacuum adv. in crank degrees @ eng. rpm	Start (in Hg) 7
		Intermed. points deg. @ in. Hg 23 @ 16
Max. deg. @ in.	 25.5 @ 25	
	Vacuum Source	Carburetor	
Timing - Crank degrees @ rpm		0° BTC (Idle)	
Cooling System		Same As Standard	
Exhaust System		None	

AMA Specifications—Passenger Car

MAKE OF CAR BUICK MODEL YEAR 1969 DATE ISSUED 9-4-68 REVISED (*)

MODEL	SPECIAL DELUXE 43369	SKYLARK 43569
--------------	--------------------------------	-------------------------

ENGINE - FUEL SYSTEM (See supplemental page for Details of Fuel Injection, Supercharger, etc. if used)

Induction type: Carburetor, fuel injection, supercharger.		Carburetor	
Fuel Tank	Refill capacity (U.S. gals.)	20 (Approx.)	
	Filler location	Rear	
Fuel Pump	Type (elec. or mech.)	Mechanical	
	Locations	Lower Right Front of Engine	
	Pressure range	4.0 - 5.0 psi @ Pump Outlet	
Vacuum booster (std., optional, none)		None	
Fuel Filter	Type	Fine Mesh Plastic 1" Long Paper	
	Locations	Fuel Tank Carb, Inlet	
Carburetor	Choke type	Automatic (Remote)	
	Intake manifold heat control (exhaust or water)	Exhaust	
	Air cleaner type	Standard	Oiled Paper Element
		Optional	Heavy Duty Dual Stage Element
	Idle speed (spec. neutral or drive)	Manual	700 in Neutral (A/C Same with A/C off)
Automatic		500 in Drive (A/C Same with A/C on)	
Idle A/F mix.			

CARBURETOR SUPPLEMENTARY INFORMATION

Model Usage	Engine Displ.	Transmission	Carburetors		No. Used and Type	Barrel Size
			Make	Model		
Special Deluxe and Skylark	250	Manual (3)	Rochester	MV	1-1 bbl	1.560
	250	Automatic	Rochester	MV	1-1 bbl	1.560

AMA Specifications—Passenger Car

MAKE OF CAR BUICK MODEL YEAR 1969 DATE ISSUED 9-4-68 REVISED (a)

MODEL	SPECIAL DELUXE	SKYLARK
	43369	43569

ENGINE - COOLING SYSTEM

Type system (pressure, pressure vented, atmospheric, other)		Pressure	
Radiator cap relief valve pressure		15 psi	
Circulation thermostat	Type (choke, bypass)	Choke	
	Starts to open at (°F)	192 - 198	
Water pump	Type (centrifugal, other)	Centrifugal	
	GPM ± 1000 pump rpm	60 @ 4400	
	Number of pumps	One	
	Drive (V-belt, other)	V-Belt	
	Bearing type	Double Row	
By-pass recirculation type (inter., ext.)		Internal	
Radiator core type (cellular, tube and fin, other)		Cross Flow	
Cooling system capacity	With heater (qt.)	11.3 (Std.)	
	Without heater (qt.)	10.0	
	Opt. equipment-specify (qt.)	13.04 (A/C)	
Water jackets full length of cyl. (yes, no)		Yes	
Water all around cylinder (yes, no)		Yes	
Radiator hose	Lower	Number and type (molded, straight)	One Molded
		Inside diameter	1.50
	Upper	Number and type (molded, straight)	One Molded
		Inside diameter	1.50
	By-pass	Number and type (molded, straight)	None
		Inside diameter	None
Fan	Number of blades & spacing		4 (76° - 104°) Std. (a)
	Diameter		18" (Std.) 18" (A/C)
	Ratio-fan to crankshaft rev.		.95 (Std.) 1.16 (A/C)
	Fan cutout type		None (A.C. Thermo Clutch with A/C)
	Bearing type		Double Row
* Drive belts (indicate belt used by letter)	Fan		"A" - ("D" With A/C)
	Generator or alternator		"A"
	Water Pump		"A"
	Power Steering		"B"
	Air Conditioning		"C"

* Drive Belt Dimensions	A	B	C	D	E	F	G	H	I	J	K
Angle of V	38°	38°	38°	38°							
Nominal length (SAE)	39.0	49.5	54.75	31.50							
Width	.38	.38	.47	.38							

(a) A/C-7 Blades (45°-50°-54°-47°-59°-45°-60°)

AMA Specifications—Passenger Car

MAKE OF CAR BUICK MODEL YEAR 1969 DATE ISSUED 9-4-68 REVISED (a)

MODEL	SPECIAL DELUXE	SKYLARK
	43369	43569

ELECTRICAL — SUPPLY SYSTEM

Battery	Make and Model		Delco #Y54
	Voltage Rtg. & Total Plates		12 - 54
	SAE Designation & Amp. Hr. Rtg.		17MJ1B-45
	Location		Right Front Engine Compartment
	Terminal grounded		Negative
Generator or Alternator	Make		Delco - Remy
	Model		1100761 (a)
	Type and rating		Diode Rectified Alternator (37 amp) (b)
	Output at engine idle (neutral)		15 amp Min. (c)
	Ratio—Gen. to Cr.'s rev.		2.67 (d)
Regulator	Make		Delco - Remy
	Model		1119515
	Type		Voltage Control
	Cutout relay	Closing voltage generator rpm	None
		Reverse current to open	None
	Regu- lated	Voltage	13.6 to 14.4 @ 125°
		Current	None
	Voltage test conditions	Temperature	Operating
		Load	Run 15 Minutes @ 10 amp Max.
		Other	Battery Must Be In Circuit

ELECTRICAL — STARTING SYSTEM

Starting Motor	Make		Delco - Remy
	Model		1107399
	Rotation (drive end view)		Clockwise (rear)
Motor control	Switch (solenoid, manual)		Solenoid
	Starting procedure		(e)
Motor Drive	Engagement type		Solenoid
	Pinion meshes (front, rear)		Rear
	Number of teeth	Pinion	9
		Flywheel	Manual
	Auto.		153
	Flywheel tooth face width	Manual	.4010 - .4130
Auto.		.4010 - .4130	

(a) 1100802 with A/C

(b) 55 amps with A/C

(c) 20 amps with A/C

(d) 2.89 with A/C

(e) Manual (3) - Place Shift Lever in Neutral and Depress Clutch Pedal
Auto. - Place Shift Lever in Neutral or Park

Note: Turn Ignition Key Clockwise - Release When Engine Starts

AMA Specifications—Passenger Car

MAKE OF CAR BUICK MODEL YEAR 1969 DATE ISSUED 9-4-68 REVISED ^(a)

MODEL	SPECIAL DELUXE	SKYLARK
	43369	43569

ELECTRICAL - IGNITION SYSTEM

Type	Conventional - Std., Opt., N.A.		Standard
	Transistorized - Std., Opt., N.A.		Not Available
	Other (specify)		Not Available
Coil	Make #		Delco - Remy
	Model		1115208
	Amps	Engine stopped	4.0
		Engine idling	1.8
Distributor	Make		Delco - Remy
	Model		1110439
	Cent'fgal adv. in c/shaft degrees@ engine rpm (nominal)	Start (rpm)	900
		Intermediate points deg.@rpm	21 @ 1950
		Max. deg.@rpm	32 @ 4200
	Vacuum adv. in c/shaft degrees@ in. Hg. (nominal)	Start (in. Hg.)	7.00
		Intermediate points, deg.@in. Hg.	23 @ 16.0
		Max. deg. in. Hg.	25.5 @ 25
	Breaker gap (in.)		.019
	Cam angle (deg.)		31° - 34°
Breaker arm tension (oz.)		19 - 23	
Timing	Crankshaft deg.@rpm		0° BTC @ 500
	Mark location		Torsional Damper
Spark Plug	Make		A.C.
	Model		46N
	Thread (mm)		14
	Tightening torque (lb. ft.)		25
	Gap		.033 - .038
Cable	Conductor type		(a)
	Insulation type		Rubber with Neoprene Jacket
	Spark plug protector		Neoprene

ELECTRICAL - SUPPRESSION

Locations & type	Non-Metallic Ignition Cables
------------------	------------------------------

(a) Linen Core Impregnated with Electrical Conducting Material.

AMA Specifications—Passenger Car

MAKE OF CAR BUICK MODEL YEAR 1969 DATE ISSUED 9-4-68 REVISED (e)

MODEL	SPECIAL DELUXE	SKYLARK
	43369	43569

ELECTRICAL - INSTRUMENTS AND EQUIPMENT

Speed-ometer	Type	Mechanical - (Eddy Current)	
	Trip odometer (yes,no)	No	
Charge indicator - type		Indicator Light	
Temperature indicator - type		"Hot" Only	
Oil pressure indicator - type		Pressure Switch - Indicator Type	
Fuel indicator - type		Electrical	
Other			
Wind-shield wiper	Type - Standard	Electrical - Two Speed	
	Type - Optional	None	
Wind-shield washer	Type - Standard	Electrical Engagement - Mech. Piston Pump	
	Type - Optional	None	
Horn	Type	Solenoid	
	Number used	One	Two
	Amp draw (each)	4.5/5.5	

DRIVE UNITS - CLUTCH (Manual Transmission)

Make & type		Dry
Type pressure plate springs		Belleville
Total spring load (lb.)		1650 - 1850
No. of clutch driven discs		One
Clutch facing	Material	Woven
	Outside & inside dia.	9.12 - 6.12
	Total eff. area (sq.in.)	71.88
	Thickness	.135
	Engagement cushioning method	Spring
Release bearing	Type & method of lubrication	Single Row Ball - (Packed and Sealed)
Torsional damping	Methods: springs, friction material	Springs

AMA Specifications—Passenger Car

MAKE OF CAR <u>BUICK</u>	MODEL YEAR <u>1969</u>	DATE ISSUED <u>9-4-68</u>	REVISED <u>(*)</u>
MODEL	SPECIAL DELUXE 43369	SKYLARK 43569	

DRIVE UNITS – TRANSMISSIONS

Manual 3-speed (std. or opt.)	Standard
Manual 4-speed (std. or opt.)	Not Available
Manual with overdrive (std. or opt.)	Not Available
Automatic (std. or opt.)	Optional

DRIVE UNITS – MANUAL TRANS.

Number of forward speeds		Three	
Transmission ratios	In first	2.84	
	In second	1.68	
	In third	1.00	
	In fourth	- - -	
	In reverse	2.94	
Synchronous meshing, specify gears		All Forward Speeds	
Shift lever location		Steering Column	
Lubricant	Capacity (pt.)	3.375	
	Type recommended	Multi-Purpose Gear Lubricant (MIL-L-2105B)	
	SAE viscosity number	Summer	SAE 80
		Winter	SAE 80
		Extreme cold	SAE 80

DRIVE UNITS – MANUAL TRANS. W/OVERDRIVE

(For transmission data see manual transmission section)

Type (planetary or other)		Not Available	
Manual lockout (yes, no)			
Downshift accelerator control (yes, no)			
Minimum cut-in speed			
Gear ratio			
Lubricant	Capacity (pt.) (Overdrive only)		
	Separate filler (yes, no)		
	Type recommended		
	SAE viscosity number	Summer	
		Winter	
Extreme cold			

AMA Specifications—Passenger Car

MAKE OF CAR BUICK MODEL YEAR 1969 DATE ISSUED 9-4-68 REVISED ^(*)

MODEL	SPECIAL DELUXE 43369	SKYLARK 43569
--------------	--------------------------------	-------------------------

DRIVE UNITS – AUTOMATIC TRANSMISSION

Trade name	Super Turbine "300" (Optional)		
Type describe	Two-Speed with Torque Converter		
Selector location	Steering Column		
List gear ratios Selector Pattern and indicate which are used in each selector position	<u>Drive</u>	<u>Low</u>	<u>Reverse</u>
	1st Gear	1.765	1.765
	2nd Gear	1.000	- - -
Max. upshift speed—drive range	61		
Max. kickdown speed—drive range	57		
Torque converter	Number of elements	Three	
	Max. ratio at stall	2.55	
	Type of cooling (air, liquid)	Water	
	Nominal diameter		
Lubricant	Capacity—refill (pt.)	19.0 Total - 5.0 Drain	
	Type recommended	"DEXRON" R Automatic Transmission Fluid	
Special transmission features			

DRIVE UNITS – PROPELLER SHAFT

Number used	One		
Type (straight tube, tube-in-tube, internal-external damper, etc.)	Exposed		
Outer diam. x length* x wall thickness	Manual 3-speed trans.	3.25 x 60.00 x .065	
	Manual 4-speed trans.	Not Available	
	Overdrive transmission	Not Available	
	Automatic transmission	(a) 3.25 x 60.00 x .065	

* Center to center of universal joints, or to centerline of rear attachment.

(Continued)

(a) Rubber Biscuit Drive

AMA Specifications—Passenger Car

MAKE OF CAR	BUICK	MODEL YEAR	1969	DATE ISSUED	9-4-68	REVISED (e)
MODEL	SPECIAL DELUXE 43369		SKYLARK 43569			

DRIVE UNITS — PROPELLER SHAFT (cont.)

Inter-mediate bearing	Type (plain, anti-friction)	None
	Lubrication (fitting, prepack)	None
Slip Yoke	Type	Male Slip Yoke at Transmission Where Primary Slip is Taken
	Number of teeth	27 - O.D. Fit - 27 P.D. Fit
	Spline O.D.	1.750 - 1.745 - Manual Trans. 1.166 - 1.150 - Automatic Trans.
Universal joints	Make and Mfg. No.	Saginaw
	Number used	2
	Type (ball and trunion, cross)	Cross
	Rear attach. (u-bolt, clamp, etc.)	U-Bolt
	Bearing	Type (plain, anti-friction)
Lubric. (fitting, prepack)		
Drive taken through (torque tube or arms, springs)		Arms
Torque taken through (torque tube or arms, springs)		Arms

DRIVE UNITS — AXLE

Type (front, rear)	Rear		
Description	Salisbury Hypoid - Semi-Floating		
Limited Slip differential, type	Optional		
Drive Pinion Offset	1.750		
No. of differential pinions	2		
Pinion adjustment (shim, other)	Shim		
Pinion bearing adj. (shim, other)	Collapsible Spacer		
Wheel bearing type	Roller		
Lubricant	Capacity (pt.)	2.90	
	Type recommended	MIL-L-2105B	
	SAE viscosity number	Summer	80
		Winter	80
Extreme cold		80	

AXLE RATIO TOOTH COMBINATIONS

(See page 3 for axle ratio usage)

Axle ratio	Manual		Automatic				Canadian		
	3.23	3.91	2.93	3.42	3.23	3.91	Man.	Auto.	
No. of teeth	13	11	14	12	13	11	13	14	13
Ring gear	42	43	41	41	42	43	43	43	43
Ring Gear O.D.									

Usage	Std.	SCO	Std.	SCO	Perf.	SCO	Std.	Std.	Perf.
					(Perf. with A/C)				

AMA Specifications—Passenger Car

MAKE OF CAR	BUICK	MODEL YEAR	1969	DATE ISSUED	9-4-68	REVISED (a)
MODEL	SPECIAL DELUXE 43369		SKYLARK 43569			

DRIVE UNITS - WHEELS

Type & material		Disc - Steel
Rim (size & flange type)	Std.	14 x 5.00 "J"
	Opt.	14 x 6.00 JK (a)
Attachment	Type (bolt or stud)	Stud
	Circle diameter	4.75
	Number and size	Five - .4375-20

MODEL	SPECIAL DELUXE 43369	SKYLARK 43569
-------	-------------------------	------------------

DRIVE UNITS - TIRES

Standard	Size, ply rating, & ply	7.75 - 14 (2-Ply with 4-Ply Rating)	
	Type (bias, radial, etc.)	Bias Angle	
	Full rated Inflation Press.	Front	26
		Rear	28
	Rev./Mile at 50 MPH	785	
Optional	Size, ply rating, & ply	8.25 - 14 Two-Ply with 4-Ply Rating F70-14 Wide Oval (Export) 205R14 Radial Ply 7.75-14-4-Ply Nylon - (Export)	

BRAKES - PARKING

Type of control		Step - On (Hand Release)
Location of control		Left Side at Cowl Panel
Operates on		Rear Shoes
If separate from service brakes	Type (internal or external)	None
	Drum diameter	None
	Lining size (length x width x thickness)	None

(a) With Oversize Tire Option, Disc Brakes or Radial Ply Tires.

AMA Specifications—Passenger Car

MAKE OF CAR BUICK MODEL YEAR 1969 DATE ISSUED 9-4-68 REVISED (a) 9-30-68

	SPECIAL DELUXE 43369	SKYLARK 43569
--	-------------------------	------------------

MODEL _____

BRAKES—SERVICE

Type (drum) or (disc & no. of pistons)		Drum (c)			
Self adjusting (std., opt., N.A.)		Standard			
Special Valving	Type (proportion, delay, metering, other)	None			
Power brake make & type (remote, int., etc.)	Std.	No			
	Opt.	Delco - Moraine (Int. Vac. Susp.)			
Effective area (sq. in.) *		152.0			
Gross lining area (sq. in.) **		158.1			
Swept area (sq. in.) ***		268.6			
Front to Rear Effectiveness Relationship		62.4 Front (Based on Wheel Cyl. Size Only)			
Drum	Diameter (nominal)	Front	9.495 - 9.505		
		Rear	9.495 - 9.505		
	Type and material		Composite Cast Iron		
Rotor	Outer working diameter				
	Inner working diameter				
	Working width				
	Material & type (vented/solid)				
Wheel cylinder bore	Front		1.125		
	Rear		.875		
Master Cylinder	Bore		1.000		
	displacement	Front	% 59		
		Rear	% 41		
	distribution	Front	%		
Rear		%			
Pedal arc ratio		6.46 (a)			
Line pressure at 100 lb. pedal load		830 psi (b)			
Shoe Clearance	Front				
	Rear				
Brake lining	Bonded or riveted		Riveted		
	Front Wheel	Material		Extruded Molded	
		Size (length x width x thickness)	Prim. or out-board	7.57 x 2.50 x .196 (Gross) - .096 (Net)	
			Second. or in-board	9.83 x 2.50 x .265 (Gross) - .165 (Net)	
		Segments per shoe		One	
		Rear Wheel	Material		Extruded Molded
			Size (length x width x thickness)	Prim. or out-board	7.57 x 2.00 x .196 (Gross) - .096 (Net)
	Second. or in-board			9.83 x 2.00 x .265 (Gross) - .165 (Net)	
	Segments per shoe		One		

* Excludes rivet holes, grooves, chamfers, etc. ** Includes rivet holes, grooves, chamfers, etc.
 *** Total swept area for four brakes. (Widest lining contact width for each brake x its contact circumference.)

- (a) 3.44 with Optional Power Brakes
- (b) 1130 psi with 30# Pedal Load with Opt. Power Brakes
- (c) Power Disc Fronts - Optional

AMA Specifications—Passenger Car

MAKE OF CAR	BUICK	MODEL YEAR	1969	DATE ISSUED	9-4-68	REVISED (a) 12-2-68
MODEL	SPECIAL DELUXE		SKYLARK			
	43369		43569			

STEERING

Manual (std., opt., NA)		Standard								
Power (std., opt., NA)		Optional								
Adjustable steering wheel (tilt, swing, other)	Type and description	Tilt (a)								
	(std., opt., NA)	Optional								
Wheel diameter	Manual	16.0"								
	Power	16.0"								
Turning diameter (feet)	Outside front	Wall to wall (l. & r.)	43.8 (b)							
		Curb to curb (l. & r.)	40.6 (c)							
	Inside rear	Wall to wall (l. & r.)	21.44 - 22.48							
		Curb to curb (l. & r.)	22.12 - 23.12							
Manual	Gear	Type	Recirculating Ball - Nut							
		Make	Saginaw							
		<table border="1"> <tr> <td>Ratios</td> <td>Gear</td> <td>24.0</td> </tr> <tr> <td></td> <td>Overall</td> <td>28.6</td> </tr> </table>	Ratios	Gear	24.0		Overall	28.6		
	Ratios	Gear	24.0							
		Overall	28.6							
No. wheel turns (stop to stop)	5.56									
Power	Type (coaxial, linkage, etc.)		In - Line Rotary Valve							
	Make		Saginaw							
	Gear	Type	Recirculating Ball-Nut - (Integral with Power Piston)							
		<table border="1"> <tr> <td>Ratios</td> <td>Gear</td> <td>17.5</td> </tr> <tr> <td></td> <td>Overall</td> <td>20.9</td> </tr> </table>	Ratios	Gear	17.5		Overall	20.9		
		Ratios	Gear	17.5						
		Overall	20.9							
Pump driven by	Belt									
No. wheel turns (stop to stop)	4.06									
Linkage	Type		Parallelogram							
	Location (front or rear of wheels, other)		Front							
	Drag link (trans. or longit.)		Transverse							
	Tie rods (one or two)		Two							
Steering Axis	Inclination at camber (deg.)		8° 0' @ 1° 0'							
	Bearings (type)	Upper	Ball Joint Suspension Used							
		Lower	Ball Joint Suspension Used							
		Thrust	Ball Joint Suspension Used							
	Whl. Align. (range at curb wt. & preferred)	Caster (deg.)		- 1/2° ± 1/2° (Curb Height)						
Camber (deg.)		+ 1/2° ± 1/2° (Curb Height)								
Toe-in (outside track inches)		.12 to .25 (Curb Height)								
Steering spindle & joint type		Ball Joint								
Wheel Spindle	Diameter	Inner bearing	1.2498/1.2493							
		Outer bearing	.7498/ .7493							
	Thread size		.75-20 UNF							
	Bearing type		Tapered Roller							

(a) Not available with manual transmission with column shift.

(b) 43.0 (112.00" W.B.)

(c) 39.9 (112.00" W.B.)

MAKE OF CAR BUICK MODEL YEAR 1969 DATE ISSUED 9-4-68 REVISED (a)

MODEL	SPECIAL DELUXE	SKYLARK
	43369	43569

SUSPENSION – GENERAL

(See Supplement page for details on Air Suspension)

Provision for car leveling	None	
Provision for brake dip control	Yes	
Provision for acc. squat control	Yes	
Special provisions for car jacking	No	
Shock absorber front & rear	Type	Direct
	Make	Delco
	Piston dia.	1.00
Other special features	None	

SUSPENSION – FRONT

Type and description		Coil Spring and Ball Joint
Spring	Type	Coil
	Material	SAE 9260 Steel
	Size (coil design height & I.D. bar length x dia.)	11.31 Design Ht. - 3.60 I.D. 124 X .582
	Spring rate (lb. per in.)	280
	Rate at wheel (lb. per in.)	103
Stabilizer	Type (link, linkless, frameless)	Link
	Material & bar diameter	1070 Steel - .812

SUSPENSION – REAR

Type and description		Coil Springs	
Drive and torque taken through		Control Arms	
Spring	Type	Coil	
	Material	SAE - 9260	
	Size (length x width, coil design height & I.D.; bar length & dia.)	7.62 Design Ht. - 5.50 I.D. 104 x .530	
	Spring rate (lb. per in.)	106	
	Rate at wheel (lb. per in.)	101	
	Mounting insulation type	Rubber	
	If leaf	No. of leaves	Not Used
		Shackle (comp. or tens.)	Not Used
Stabilizer	Type (link, linkless, frameless)	Not Used	
	Material	Not Used	
Track bar type		Not Used	

AMA Specifications—Passenger Car

MAKE OF CAR	BUICK	MODEL YEAR	1969	DATE ISSUED	9-4-68	REVISED (e)
MODEL	SPECIAL DELUXE		SKYLARK			
FRAME	43369		43569			

Type and description (Separate frame, unitized frame, partially - unitized frame)	Perimeter Type (Separate Frame)
--	---------------------------------

BODY - MISCELLANEOUS INFORMATION

Drs. hinged (front, rr.)	Front doors	Front
	Rear doors	Front
Type of finish (lacquer, enamel, other)		Acrylic Lacquer
Hood counterbalanced (yes, no)		Yes
Hood release control (internal, external)		External
Vehicle Ident. No. location		Left Side of Upper Instrument Panel
Engine No. location		Pad on Right Front Cylinder Block
Theft protection - type		Ignition Switch Locks Steering Shaft
Vent window control method (crank, friction pivot)	Front	Crank
	Rear	- - -
Seat cushion type	Front	Zig - Zag
	Rear	Zig - Zag
	3rd seat	None
Seat back type	Front	Zig - Zag
	Rear	Zig - Zag
	3rd seat	None
Windshield glass type (i.e., single curved - laminated plate)		Compound Curved (Laminated Type)
Side glass type (i.e., curved - tempered plate)		Curved (Tempered Plate)
Backlight glass type (i.e., compound curved - tempered plate, three piece)		Single Curved (Tempered Plate)
Windshield glass exposed surface area		1249.6
Side glass exposed surface area		1181.4
Backlight glass exposed surface area		895.1
Total glass exposed surface area		3326.1

AMA Specifications—Passenger Car

MAKE OF CAR BUICK MODEL YEAR 1969 DATE ISSUED 9-4-68 REVISED ^(a)9-30-68

MODEL	SPECIAL DELUXE 43369	SKYLARK 43569
--------------	--------------------------------	-------------------------

CONVENIENCE EQUIPMENT

(Indicate whether standard, optional or NA on each series)

Power windows	Side windows	Not Available	Optional
	Vent windows	Not Available	
	Backlight or tailgate	Not Available	
Power seats (specify type as well as availability)		Not Available	4Way - Optional
Reclining front seat back (R-L or both)		Not Available	
Front seat head restrainer (R-L or both)		Standard	
Radios (specify type as well as availability)		Sonomatic or AM/FM - (Optional)	
Rear seat speaker		Optional	
Power antenna		(a) Optional (Excl. Convertible)	
Clock		Optional	
Air conditioner (specify type and availability)		Optional	
Speed warning device		Optional	
Speed control device		Optional (With Automatic Transmission Only)	
Ignition lock lamp		Not Available	
Dome lamp		Standard	
Glove compartment lamp		Optional	
Luggage compartment lamp		Optional	
Underhood lamp		Dealer Installed	
Courtesy lamp		Optional	
Map lamp		Not Available	
Auto. trans. quad. lamp		Included-with Optional Transmission	
Cornering light lamp		Not Available	
		Standard	
		Optional	

LAMP HEIGHT AND SPACING

Height above ground to center of bulb or marker	Headlamp	Highest *	26.47
		Lowest	-----
	Tail	Highest	20.94
		Lowest	-----
Sidemarkers	Front	22.31	
	Rear	20.61	
Distance from C'L of car to center of bulb	Headlamp	Inside	25.73
		Outside *	32.11
	Tail	Inside	20.78
		Outside	27.96
	Directional	Front	29.42
		Rear	14.18

* If single headlamps are used enter here.

(a) Included with AM/FM Radio

AMA Specifications—Passenger Car

MAKE OF CAR BUICK MODEL YEAR 1969 DATE ISSUED 9-4-68 REVISED (a) 12-2-68

WEIGHTS

Model	CURB WEIGHT * POUNDS			% PASS. WEIGHT DISTRIBUTION				LIQUID WEIGHT	
	Front	Rear	Total	Pass. In Front		Pass. In Rear		Fuel	Coolant
				Front	Rear	Front	Rear		
SPECIAL DELUXE									
43327	1683	1565	3248	50.65	49.35	19.74	80.26	122	24
43369	1721	1583	3304	50.91	49.09	19.64	80.36	122	24
SKYLARK-STANDARD									
43537	1715	1586	3301	50.79	49.21	19.69	80.31	122	24
43569	1738	1593	3331	50.99	49.01	19.61	80.39	122	24
Accessories & Equipment Differential Weights									
Engine, V8 - (2bbl)	143.91	-3.09	140.82	Remarks					
Engine, V8 - (2bbl)	148.01	-3.19	144.82						
Transmission - Auto	8.26	2.91	11.17						
Power Steering	32.79	-----	32.79						
Disc Brakes, Front	39.56	11.79	51.35						
Power Brakes	10.83	-----	10.83						
Radio, Sonomatic	6.00	2.30	8.30						
Radio, AM/FM	6.50	2.50	9.00						
Tires, Whitewall	2.36	3.54	5.90						
Tires, O.S. Whitewall	4.61	6.91	11.52						
Air Conditioner	122.96	-2.51	120.45						
Power Seat, 4-Way	10.00	9.50	19.50						
Cushions, Custom Padded	-.56	-3.76	-4.32						
Rallye Wheels	9.13	13.18	22.31						
Custom Mouldings	2.10	2.60	4.70	Special Deluxe					
Appearance Group	-3.42	-4.18	-7.60	Special Deluxe					
Tilt Steering Wheel	1.68	1.03	2.71						
Convenience Group	1.81	.86	2.67						
Pressure Relief System	NO INCREASE								
Ventilation, Upper Level	NO INCREASE			Skylark Standard					
Deluxe Steering Wheel	.22	.34	.56						

* Reference - SAE Aerospace-Automotive drawing standards, Section E 1.02 (d).

Door Locks, Vacuum 5.00 3.00 8.00 2 Doors
 Door Locks, Vacuum 6.00 7.00 13.00 4 Doors

CAR AND BODY DIMENSIONS

KEY SHEET

EXTERIOR CAR AND BODY DIMENSIONS

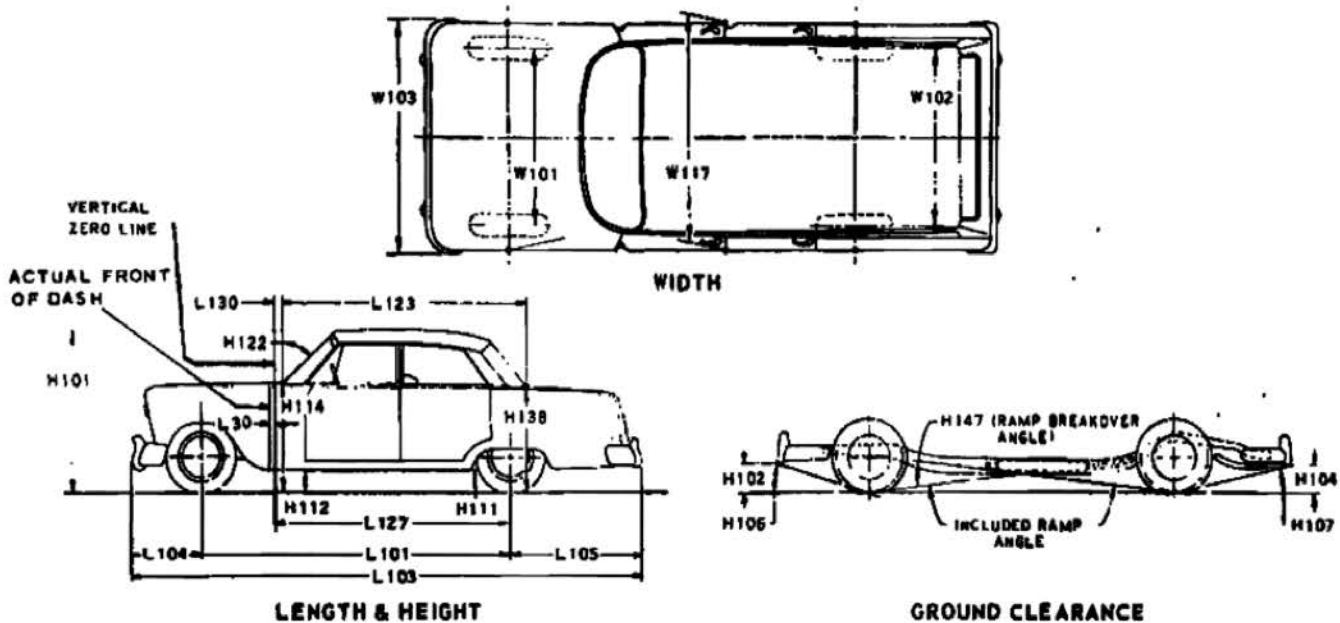

INTERIOR CAR AND BODY DIMENSIONS

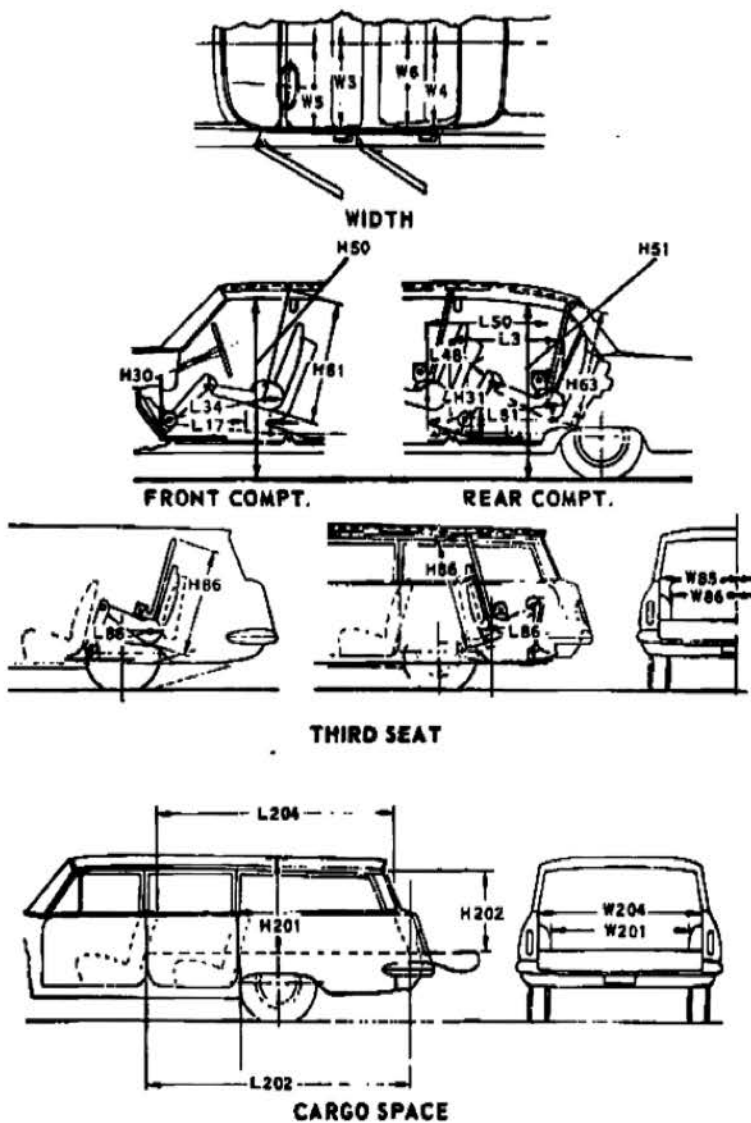

CAR AND BODY DIMENSIONS

KEY SHEET

DIMENSION DEFINITIONS

EXTERIOR WIDTH DIMENSIONS

W101 WHEEL TREAD - FRONT. Measured at centerline of tires, with nominal camber, at ground.

W102 WHEEL TREAD - REAR. Measured at centerline of tires at ground.

W103 MAXIMUM OVERALL CAR WIDTH. Include bumpers, moldings, or sheet metal protrusions. Measured to outside of metal.

W117 MAXIMUM BODY WIDTH AT #2 PILLAR. Measured across a body at #2 pillar, excluding hardware and applied moldings.

EXTERIOR LENGTH DIMENSIONS

L 30 VERTICAL ZERO LINE TO ACTUAL FRONT OF DASH. If actual Front of Dash is to the rear of Body Zero Line, it is identified by a minus (-) sign.

L101 WHEELBASE.

L103 OVERALL LENGTH. Include bumper guards if standard equipment.

L104 OVERHANG - FRONT. Measured from C/L of front wheels to front of car, including bumper guards if standard equipment.

L105 OVERHANG - REAR. Measured from C/L of rear wheels to rear of car, including bumper guards if standard equipment.

L123 BODY UPPER STRUCTURE LENGTH AT CAR CENTERLINE. The horizontal dimension from the Cowl Point to the Deck Point.

L127 VERTICAL ZERO LINE TO CENTERLINE OF REAR WHEELS. A horizontal dimension.

L130 VERTICAL ZERO LINE TO WINDSHIELD COWL POINT. The horizontal dimension from the vertical zero line to the theoretical intersection of extended windshield glass plane and normal cowl surface.

EXTERIOR HEIGHT DIMENSIONS

H101 OVERALL HEIGHT - DESIGN. Measured with the vehicle in Manufacturer's Design Weight attitude.

H114 COWL POINT TO GROUND. Measured at vehicle centerline.

H138 DECK POINT TO GROUND. Measured at vehicle centerline.

H112 ROCKER PANEL TO GROUND - FRONT. The vertical dimension from ground to bottom of rocker panel, excluding flanges. Measured to the outside of sheet metal at foremost point of rocker panel.

H111 ROCKER PANEL TO GROUND - REAR. The vertical dimension from ground to bottom of rocker panel, excluding flanges. Measured to the outside of sheet metal at front of rear wheel opening.

H122 WINDSHIELD SLOPE ANGLE. The angle between a vertical line and the windshield surface at car centerline. On compound-curved windshields the chord of the arc is used and limited to that section of the windshield comprehended by an 18-inch chord.

GROUND CLEARANCE DIMENSIONS

H102 BUMPER TO GROUND - FRONT. Minimum dimension, includes bumper guards.

H104 BUMPER TO GROUND - REAR. Minimum dimension, includes bumper guards.

H106 ANGLE OF APPROACH. The angle between ground and a line tangent to the front tire static loaded radius arc and the first point of interference, i.e., bumper, guard, gravel deflector, fender or other component, excluding license plate. This dimension may be determined graphically for reporting purposes.

H107 ANGLE OF DEPARTURE. The angle between ground and a line tangent to the rear tire static loaded radius arc and the first point of interference, i.e., bumper, guard, gravel deflector, tail pipe, fender or other component, excluding license plate. This dimension may be determined graphically for reporting purposes.

H147 RAMP BREAKOVER ANGLE. The supplement of included ramp angle (180° minus included ramp angle) over which car can pass without interference; measured with car sitting on a level surface, using lines tangent to arcs of front and rear static loaded radii and intersecting at point on underside of car which defines the smallest angle.

H156 MINIMUM RUNNING GROUND CLEARANCE. Location of measurement on the car is to be clearly recorded.

FRONT COMPARTMENT DIMENSIONS

H 61 EFFECTIVE HEAD ROOM - FRONT. The dimension from H Point to the headlining, plus a constant of 4.0 inches, measured along a line 8° to rear of vertical.

L 34 MAXIMUM EFFECTIVE LEG ROOM - ACCELERATOR. Measured along a diagonal line from the Manikin ankle pivot center to the H Point plus a constant of 10.0 inches. For treadle type accelerator pedals, the leg room is measured with the Manikin's right foot on the accelerator pedal and the Manikin Heel Point at Accelerator Heel Point. All other types of accelerator pedals will be measured with the Manikin foot angle set at 87° and the shoe touching the pedal.

H 30 H POINT TO HEEL POINT - FRONT. The vertical dimension from the H Point to the Accelerator Heel Point.

L 17 H POINT TRAVEL. The horizontal dimension between the H Point in the most forward and rearward seat positions.

FRONT COMPARTMENT DIMENSIONS (Cont.)

W 3 SHOULDER ROOM - FRONT. The minimum lateral dimensions between the door garnish moldings or nearest interference, measured at the H Point station.

W 5 HIP ROOM - FRONT. The lateral dimension through the H Point to trimmed body surfaces. Depress loose side wall cloth to trim foundation or other obstruction if such construction exists.

H 50 UPPER BODY OPENING TO GROUND - FRONT. The vertical dimension from a point on the trimmed body opening to the ground, measured at the H Point station.

REAR COMPARTMENT DIMENSIONS

L 50 H POINT COUPLE DISTANCE. The horizontal dimension from the front seat H Point to the rear seat H Point.

H 63 EFFECTIVE HEAD ROOM - REAR. The dimension from the H Point to the headlining, plus a constant of 4.0 inches, measured along a line 8° to rear of vertical.

L 51 MINIMUM EFFECTIVE LEG ROOM - REAR. Measured along a diagonal line from the ankle pivot center to the H Point plus a constant of 10.0 inches, with the foot positioned to the nearest interference between the seat structure and toe, instep or lower leg.

H 31 H POINT TO HEEL POINT - REAR. The vertical dimension from the H Point to the Manikin Heel Point on the depressed floor covering.

L 48 MINIMUM KNEE ROOM - REAR. The minimum dimension from the Manikin knee pivot center to the back of the front seat back.

L 3 REAR COMPARTMENT ROOM. The horizontal dimension from the back of front seat to front of rear seat back at height tangent to the top of rear seat cushion.

W 4 SHOULDER ROOM - REAR. The minimum lateral dimension between the door garnish molding or nearest interference. Measured at H Point station.

W 6 HIP ROOM - REAR. The lateral dimension through H Point to trimmed body surfaces. Depress loose side wall cloth to trim foundation or other obstruction when such construction exists.

H 51 UPPER BODY OPENING TO GROUND - REAR. The vertical dimension from a point on the trimmed body opening to the ground, measured 13.0 inches forward of the H Point.

LUGGAGE COMPARTMENT DIMENSIONS

V 1 LUGGAGE CAPACITY - USABLE. The total luggage compartment luggage capacity in cubic feet with the tire and tools in place.

H195 LIFTOVER HEIGHT. Vertical dimension from the highest point on the luggage compartment lower opening to ground, excluding corner radii.

STATION WAGON - THIRD SEAT DIMENSIONS

W 85 SHOULDER ROOM - THIRD SEAT. The minimum lateral dimension between the door garnish moldings or nearest interference. Measured at H Point station.

W 86 HIP ROOM - THIRD SEAT. The lateral dimension through H Point to trimmed surfaces.

L 86 EFFECTIVE LEG ROOM - THIRD SEAT. Measured along a diagonal line from ankle pivot center to H Point plus a constant of 10.0 inches. With rear-facing third seat, foot is positioned in foot well or to nearest interference with rear end or rear closure.

H 86 EFFECTIVE HEAD ROOM - THIRD SEAT. The dimension from H Point to the headlining, plus a constant of 4.0 inches. Measured along a line 8° to rear of vertical.

STATION WAGON - CARGO SPACE DIMENSIONS

L202 CARGO LENGTH AT FLOOR - FRONT SEAT. The horizontal dimension, measured at the floor level from the rear of the front seat back to the normal inside limiting interference on the tailgate, on the car centerline.

L204 CARGO LENGTH AT BELT - FRONT SEAT. The horizontal dimension measured from the top rear of front seat back to a vertical extension line from the normal inside limiting interference at the top of the tailgate, on the car centerline.

W201 CARGO WIDTH - WHEELHOUSE. The minimum horizontal dimension, measured between wheelhousings at floor level.

W204 OPENING WIDTH AT BELT. The minimum horizontal dimension, measured between the nearest normal inside limiting interferences of the rear opening at the top of the tailgate.

H201 MAXIMUM CARGO HEIGHT. The maximum vertical dimension, measured from the top of the floor covering to the headlining, on the car centerline.

H202 REAR OPENING HEIGHT. The vertical dimension measured from the top of the floor covering to the normal inside limiting interference at the top of the rear opening, on the car centerline, with both tail- and liftgates fully open.

V 2 CARGO VOLUME INDEX BEHIND FRONT SEAT. The total volume in cubic feet above the normal load floor and behind the front seat with the liftgate and tailgate closed.

W4xL204xH201

1728

INDEX

SUBJECT	PAGE NO.	SUBJECT	PAGE NO.
Automatic Transmission.....	16	Kingpin (Steering Axis).....	20
Axis, Steering.....	20	Lamp height and spacing.....	23
Axle, Rear.....	17	Legroom.....	2
Battery.....	12	Lengths - Car and Body.....	1
Bearings, Engine.....	5, 6, 7	Lifters, valve.....	6
Belts - Fan, Generator, Water Pump.....	11	Linings - Clutch, Brake.....	14, 19
Brakes - Parking, Service Power.....	18, 19	Lubrication.....	7, 8, 14, 15, 16, 17
Camber.....	20	Luggage Compartment.....	2
Camshaft.....	6	Motor, Starting.....	12
Capacities.....		Muffler.....	8
Cooling System.....	11	Overdrive.....	15
Fuel Tank.....	10	Piston Pins & Rings.....	4, 5
Lubricants.....		Pistons.....	4, 5
Engine Crankcase.....	8	Power Brakes.....	19
Transmission and Overdrive.....	15, 16	Power Steering.....	20
Rear Axle.....	17	Power Teams.....	3
Car and Body Dimensions.....		Propeller Shaft, Universal Joints.....	16, 17
Width.....	1	Pumps - Oil, Fuel.....	8, 10
Length.....	1	Water.....	11
Height.....	1	Radiator, Hoses.....	11
Ground Clearance.....	1	Ratios - Axle.....	3, 17
Front Compartment.....	2	Compression.....	3, 4
Rear Compartment.....	2	Steering.....	20
Luggage Compartment.....	2	Transmission.....	15, 16
Station Wagon - Third Seat.....	2	Rear Axle.....	3, 17
Station Wagon - Cargo Space.....	2	Regulator - Generator.....	12
Carburetor.....	3, 9, 10	Rims.....	18
Caster.....	20	Rings, Piston.....	5
Choke, Automatic.....	10	Rods - Connecting.....	5
Clutch - Pedal Operated.....	14	Shack Absorbers, Front & Rear.....	21
Coil, Ignition.....	13	Spark Plugs.....	13
Connecting Rods.....	5	Speedometer.....	14
Convenience Equipment.....	23	Springs - Front & Rear Suspension.....	21
Cooling System.....	11	Valve, Engine.....	6
Crankcase Ventilation System.....	8	Stabilizer (Sway Bar) - Front & Rear.....	21
Crankshaft.....	6	Starting System.....	12
Cylinders and Cylinder Head.....	4	Steering.....	20
Dimension Definitions.....		Supply System.....	12
Key Sheet.....	25	Suppression - Ignition, Radio.....	13
Exterior & Interior.....	26	Suspension - Front & Rear.....	21
Distributor - Ignition.....	13	Tail Pipe.....	8
Electrical System.....	12, 13, 14	Thermostat, Cooling.....	11
Engine.....		Timing, Engine & Valve.....	6, 7, 13
Bore, Stroke, Displacement, Type.....	4	Tires.....	18
Compression Ratio.....	4	Toe in.....	20
Firing Order, Cylinder Numbering.....	4	Torque Converter.....	16
General Information, H.P. & Torque.....	4	Torque - Engine, Rated.....	3, 4
Lubrication.....	7, 8	Transmission - Types.....	3, 10, 15, 16
Power Teams.....	3	Automatic.....	3, 10, 15, 16
Exhaust Emission Control.....	9	Manual & Overdrive.....	3, 10, 15
Exhaust System.....	8	Ratios.....	15, 16
Equipment Availability.....	22	Track.....	1
Fan, Cooling.....	11	Trunk Luggage Capacity.....	2
Filters - Engine Oil, Fuel System.....	8, 10	Turning Diameter.....	20
Frame.....	22	Unitized Construction.....	22
Front Suspension.....	21	Universal Joints, Propeller Shaft.....	16, 17
Fuel, Fuel Pump, Fuel System.....	4, 10	Valves - Intake & Exhaust.....	6, 7
Fuel Injection.....	10	Vibration Damper.....	6
Generator and Regulator.....	12	Voltage Regulator.....	12
Glass.....	22	Water Pump.....	11
Height (Lamps).....	14	Weights.....	24
Headroom - Body.....	2	Wheel Alignment.....	20
Heights - Car and Body.....	1	Wheelbase.....	1
Horns.....	14	Wheels & Tires.....	18
Horsepower - Brake.....	3, 4	Wheel Spindle.....	20
Ignition System.....	13	Widths - Car and Body.....	1
Inflation - Tires.....	18	Windshield.....	22
Instruments.....	14	Windshield Wiper.....	14