

AMA Specifications—Passenger Car

The information contained herein is prepared, distributed by, and is solely the responsibility of the automobile manufacturing company to whose products it relates. Questions concerning these specifications should be directed to the manufacturer whose address is shown below. This uniform specification form was developed by the automobile manufacturing companies under the auspices of the Automobile Manufacturers Association.

MANUFACTURER	Chevrolet Motor Division General Motors Corporation	CAR NAME	CAMARO	
MAILING ADDRESS	Chevrolet Engineering Center 30003 Van Dyke, Warren, Michigan 48090	MODEL YEAR	1969	ISSUED 10-15-68 REVISED (®) 2-14-69

NOTES:

1. The General Specifications herein are those in effect at date of completion and are subject to change without notice by the manufacturer.
2. UNLESS OTHERWISE INDICATED:
 - a. Specifications apply to standard models without optional equipment. Significant deviations are noted.
 - b. Nominal design dimensions are used throughout these specifications.

TABLE OF CONTENTS

Car & Body Dimensions	1,2	Drive Units	14	Suspensions	21
Engine - Mechanical	4	Brakes	18, 19	Weights	24
Electrical	12	Steering	20	Index	27

BODY - TYPES AND STYLE NAMES -	Body type, style names; use manufacturer's code for series & body style.	
	<u>L-6 Engine</u>	<u>V-8 Engine</u>
2-Door Sport Coupe, 4-Passenger	12337	12437
2-Door Convertible, 4-Passenger	12367	12467

MAKE OF CAR CAMARO MODEL YEAR 1969 DATE ISSUED 10-15-68 REVISED (*)

CAR AND BODY DIMENSIONS

See Pages 25, 26 for SAE Dimension Definitions

(All dimensions in inches unless otherwise indicated)

All dimensions to ground are for comparative purposes only. Dimensions are to be shown for:

4-Dr. Sedan, 2-Dr. H.T., 4-Dr. H.T., Convertible and Station Wagon.

MODEL	SAE Ref. No.	2-Door Coupe	Convertible
-------	--------------	--------------	-------------

WIDTH

Track - Front	W101	59.6	
Track - Rear	W102	59.5	
Maximum overall car width	W103	74.0	
Body width at No. 2 pillar	W117		

LENGTH

Body "O" to front of dash	L 30	0.5	
Wheelbase	L101	108.0	
Overall car length	L103	186.0	
Overhang - front	L104	37.1	
Overhang - rear	L105	40.9	
Body upper structure length	L123		
Body "O" line to ϵ of rear wheel	L127	90.0	
Body "O" line to w/s cowl point	L130		

HEIGHT

Passenger Distribution (front & rear)		2-2	
Trunk/Cargo load (lbs.)			
Overall height	H101	51.1	50.9
Cowl height	H114	36.4	36.3
Deck height	H138		
Rocker panel - front	To ground	8.1	8.0
	From front wheel ϵ		
Rocker panel - rear	To ground	6.8	6.7
	From rear wheel ϵ		
Windshield slope angle	H122	52.4	

GROUND CLEARANCE

Bumper to ground - front	H102	23.0	22.9
Bumper to ground - rear	H104	21.2	20.8
Angle of approach	H106	25.2	
Angle of departure	H107	18.5	18.3
Ramp breakover angle	H147	12.4	12.3
Min. running clearance (Specify)	H156 (H152)	5.1	4.9

AMA Specifications—Passenger Car

MAKE OF CAR CAMARO MODEL YEAR 1969 DATE ISSUED 10-15-68 REVISION (#)

CAR AND BODY DIMENSIONS

See Pages 25, 26 for SAE Dimension Definitions
(All dimensions in inches unless otherwise indicated)

MODEL	SAE Ref. No.	2-Door Coupe	Convertible
-------	--------------	--------------	-------------

FRONT COMPARTMENT

Effective head room	H61	37.1	37.5
Max. eff. leg room - accelerator	L34	42.5	
H Point to Heel point	H30	7.7	
H Point travel	L17	4.0	
Shoulder room	W 3	56.5	
Hip room	W 5	56.3	
Upper body opening to ground	H50	47.0	47.2

REAR COMPARTMENT

H Point couple distance	L50	27.0	27.3
Effective head room	H63	36.7	36.8
Min. effective leg room	L51	29.2	29.5
H Point to Heel point	H31	9.4	
Min. knee room	L48	+0.8	+0.5
Rear Compartment room	L 3	22.5	22.3
Shoulder room	W 4	53.6	47.3
Hip room	W 6	54.6	47.5
Upper body opening to ground	H51	--	--

LUGGAGE COMPARTMENT

Usable luggage capacity	V 1	8.5	6.1
Liftover height	H195	28.1	27.9
Position of spare tire storage		Right side trunk on floor	
Method of holding lid open		Actuating torsion rods & spring loaded hinges	

STATION WAGON - THIRD SEAT

Shoulder Room	W85	
Hip room	W86	NOT
Effective leg room	L86	
Effective head room	H86	AVAILABLE
Seat facing direction		

STATION WAGON - CARGO SPACE

Cargo length at floor - front seat	L202	
Cargo length at belt - front seat	L204	NOT
Cargo width - Wheelhouse	W201	
Opening width at belt	W204	AVAILABLE
Maximum cargo height	H201	
Rear opening height	H202	
Cargo volume index (cu. ft.) H3 L489 + H891 1728	V2	

AMA Specifications—Passenger Car

MAKE OF CAR CAMARO MODEL YEAR 1969 DATE ISSUED 10-15-68 REVISED (*)2-14-69

POWER TEAMS

(Indicate whether standard or optional)

MODEL AVAILABILITY	ENGINE					TRANSMISSION		AXLE RATIO (Std. first) (Indicate A/C ratio)				
	Displ. cu. in.	Carburetor	Compr. Ratio	BHP RPM	Torque RPM			A	B	C	D	
All Models	230 Standard	One; 1-bbl. Down-draft	8.5:1	140 @ 4400	220 @ 1600	3-Speed (2.85:1 low) and 4-Speed* (2.85:1 low)	Base	3.08	2.73	3.36	--	
							A/C	3.08	2.73	3.36	--	
						Powerglide* and Torq-Drive*	Base	2.73	2.56	3.08	3.36	
							A/C	3.08	2.73	3.36	--	
						Turbo* Hydra-Matic*	Base	2.56	--	2.73	3.08 3.36	
							A/C	2.73	2.56	3.08	3.36	
	307 Standard	One; 2-bbl. Down-draft	9.0:1	200 @ 4600	300 @ 2400	3-Speed (2.85:1 low) and 4-Speed* (2.85:1 low)	Base	3.08	2.73	3.36	--	
							A/C	3.08	--	3.36	--	
						Powerglide*	Base	2.73	2.56	3.08	--	
							A/C	2.73	--	--	3.36	
						Turbo* Hydra-Matic	Base	2.56	--	2.73	3.08	
							A/C	2.73	--	3.08	--	
	250 Standard	One; 1-bbl. Down-draft	8.5:1	155 @ 4200	235 @ 1600	3-Speed (2.85:1 low) and 4-Speed* (2.85:1 low)	Base	3.08	2.73	3.36	--	
							A/C	3.08	2.73	3.36	--	
						Powerglide* and Torq-Drive*	Base	2.73	2.56	3.08	3.36	
							A/C	3.08	2.73	3.36	--	
						Turbo* Hydra-Matic	Base	2.56	2.73	--	3.08 3.36	
							A/C	2.73	2.56	3.08	3.36	
	* - Optional ** - Positraction optional for all ratios								A - Standard B - Economy C - Performance D - Special			

AMA Specifications—Passenger Car

MAKE OF CAR CAMARO MODEL YEAR 1969 DATE ISSUED 10-15-68 REVISED (*)2-14-69

POWER TEAMS

(Indicate whether standard or optional)

MODEL AVAILABILITY	ENGINE					TRANSMISSION	AXLE RATIO (Std. first) (Indicate A/C ratio)				
	Displ. cu. in.	Carburetor	Compr. Ratio	BHP RPM	Torque RPM		A	B	C	D	
All Models	350 Option (L65)	One; 2-Bbl Down-draft	9.0:1	250 @ 4800	345 @ 2800	3-Spd* (2.54:1 low) & 4-Spd* (2.54:1 low)	Base & A/C	3.08	2.73	3.36	----
						Pwrglide* and Turbo Hydra-Matic*	Base & A/C	2.56	----	3.08	----
	350 Option (L48)	One; 4-Bbl Down-draft	10.25:1	300 @ 4800	380 @ 3200	HD 3-Spd* (2.42:1 low)	Base & A/C	3.31	3.07	3.55	3.73
						4-Spd* (2.52:1 low)	Base	3.31	3.07	3.55	3.73
							AC	3.31	3.07	3.55	3.73
						Pwrglide*	Base & A/C	3.08	----	3.36	----
						Turbo Hydra-Matic*	Base & A/C	3.07	2.73	3.31	3.55
	396 Option (L35)	One; 4-Bbl Down-draft	10.25:1	325 @ 4800	410 @ 3200	HD 3-Spd* (2.42:1 low) & 4-Spd* (2.52:1 low)	Base & A/C	3.07	2.73	3.31	----
						Turbo Hydra-Matic*	Base & A/C	3.07	2.73	----	2.56
	* Option ** Positraction required for 3.73, 4.10; Optional for all others.							A - Standard B - Economy C - Performance D - Special			

AMA Specifications—Passenger Car

MAKE OF CAR	CAMARO	MODEL YEAR	1969	DATE ISSUED	10-15-68	REVISED	(*)2-14-6
MODEL	L6 - 230 Cu. In. 140 HP - Std.	L6 - 250 Cu. In. 155 HP - Opt. L22	V8 - 307 Cu. In. 200 HP - Std.				

ENGINE - GENERAL

Type, no. cyls., valve arr.	In line - 6 OHV		90° V-8 OHV
Bore and stroke (nominal)	3.875 X 3.25	3.875 X 3.53	3.875 X 3.25
Piston displacement, cu. in.	230	250	307
Bore spacing (C to C)	4.40		
No. system (front to rear)	L. Bank	1-2-3-4-5-6	1-3-5-7
	R. Bank	In-Line	2-4-6-8
Firing order	1-5-3-6-2-4		1-8-4-3-6-5-7-2
Compress. ratio (nominal)	8.5:1		9.00:1
Cylinder Head Material	Cast Alloy Iron		
Cylinder Block Material	Cast Alloy Iron		
Cyl. Sleeve-Wet, dry, none	None		
Number of mg. points	Front	Two	
	Rear	One	
Engine installation angle	3°55'		
Taxable horsepower	Dia ² xNo. Cyl. 2.5	36.0	48.0
Publishing max. bhp* @ eng. RPM	140 @ 4400	155 @ 4200	200 @ 4600
Publishing max. torque* (lb. ft. @ RPM)	220 @ 1600	235 @ 1600	300 @ 2400
Recommended fuel regular - premium	Regular		

ENGINE - PISTONS

Material	Cast Aluminum Alloy		
Description and finish	Flat, notched head, slipper skirt		
Weight (piston only) oz.	20.32	24.16	21.60
Clearance (limits)	Top land	.0345 - .0435	.0235 - .0325
	Skirt	Top	.0005 - .0011 (a)
		Bottom	
Ring groove depth	No. 1 ring	.2153 - .2218	.2113 - .2178
	No. 2 ring	.2153 - .2218	.2113 - .2178
	No. 3 ring	.2093 - .2158	.2053 - .2118
	No. 4 ring	None	

* Max. bhp (brake horsepower) and max. torque corrected to 60° F and 29.92 in. Hg atmospheric pressure.

(a) - Measured 2.44 from top of piston.

(b) - Measured 1.675 from top of piston.

AMA Specifications—Passenger Car

MAKE OF CAR CAMARO MODEL YEAR 1969 DATE ISSUED 10-15-68 REVISED 02-14-69

MODEL	V8 - 350 Cu. In.		V8 - 396 Cu. In.
	250 HP - Opt. L65	300 HP - Opt. L48	325 HP - Opt. L35

ENGINE—GENERAL

Type, no. cyls., valve arr.	90° V8 OHV		
Bore and stroke (nominal)	4.00 X 3.48		4.094 X 3.76
Piston displacement, cu. in.	350		396
Bore spacing (C to C)	4.4		4.84
No. system (front to rear)	L. Bank	1-3-5-7	
	R. Bank	2-4-6-8	
Firing order	1-8-4-3-6-5-7-2		
Compress. ratio (nominal)	9.00:1	10.25:1	10.25:1
Cylinder Head Material	Cast Alloy Iron		
Cylinder Block Material	Cast Alloy Iron		
Cyl. Sleeve-Wet, dry, none	None		
Number of mtg. points	Front	Two	
	Rear	One	
Engine installation angle	3°55'		
Taxable horsepower	51.2		53.6
Di ² xNo. Cyl. 2.5			
Publishing max. bhp* @ eng. RPM	250 @ 4800	300 @ 4800	325 @ 4800
Publishing max. torque* (lb. ft. @ RPM)	345 @ 2800	380 @ 3200	410 @ 3200
Recommended fuel regular - premium	Regular	Premium	

ENGINE—PISTONS

Material	Cast Aluminum Alloy		
Description and finish	Flat, notched head, slipper skirt		Domed head, slipper skirt
Weight (piston only) oz.	20.91		24.80
Clearance (limits)	Top land	.0235 - .0325	
	Skirt	Top	.0007 - .0013 (a)
		Bottom	.0011 - .0018 (b)
Ring groove depth	No. 1 ring	.2218 - .2283	
	No. 2 ring	.2218 - .2283	
	No. 3 ring	.2038 - .2103	
	No. 4 ring	None	

* Max. bhp (brake horsepower) and max. torque corrected to 60° F and 29.92 in. Hg atmospheric pressure.

(a) - Measured 1.56 from top of piston.

(b) - Measured 1.955 from top of piston.

AMA Specifications—Passenger Car

MAKE OF CAR	CAMARO		MODEL YEAR	1969	DATE ISSUED	10-15-68	REVISED	(12-14-69)
MODEL	L6	L6	V8	V8	V8			
	230 Cu. In.	250 Cu. In.	307 Cu. In.	350 Cu. In.	396 Cu. In.			
	140 HP	155 HP	200 HP	250&300HP	325 HP			

ENGINE - RINGS

Function (top to bottom)	No. 1, oil or comp.	Compression				
	No. 2, oil or comp.	Compression				
	No. 3, oil or comp.	Oil				
	No. 4, oil or comp.	None				
Compression	Description - Upper material, coating, etc.	(a)	Cast Alloy Iron; Barrel face (b)			
	Lower	Cast Alloy Iron; Inside bevel; tapered face (c)				
	Width	(d)	(e)	(d)	(f)	(g)
	Gap	.010 - .020		(h)	.010 - .020	
Oil	Description - material, coating, etc.	Multi-piece (2 rails and 1 spacer expander) Rails - steel, chrome plated OD; expander - stainless steel				
	Width	.1870 - .1890 (assembled)				
	Gap	.015 - .055				
Expanders	In Oil Ring Assembly					

ENGINE - PISTON PINS

Material	Chromium steel		
Length	2.990 - 3.010		2.930 - 2.950
Diameter	.9270 - .9273		.9895 - .9898
Type	Locked in rod, in piston, floating, etc.	Locked in rod	
	Bush- ing	In rod or piston	None
Clearance	In piston	.00015 - .00025	.00025 - .00035
	In rod	None	
Direction & amount offset in piston	Major thrust side .060		

ENGINE - CONNECTING RODS

Material	Drop forged steel		
Weight (oz.)	12.50	20.80	27.84
Length (center to center)	5.695 - 5.705		6.130 - 6.140
Bearing	Material & Type	Copper lead alloy (sintered) steel backed material	Premium Aluminum
	Overall length	.807	.857
	Clearance (limits)	.0007 - .0027	.0009 - .0029
	End play	.009 - .013	.017 - .021

- (a) - Cast alloy iron; inside bevel and tapered face; chrome plated.
 (b) - Chrome plated on L6 - 250, V8 - 350 cu. in., Molybdenum inlay on V8 - 396 cu. in.
 (c) - Wear resistant coating on L6 - 230 & 250, V8 - 307 & 350, chrome plated on V8 - 396.
 (d) - Upper .0775-.0780; lower .0770 - .0780
 (e) - Upper .0628-.0633; lower .0623 - .0633
 (f) - Upper .0775-.0780; lower .0770 - .0775
 (g) - Upper & lower .0770-.0775
 (h) - Upper .010-.020; lower .013-.025

AMA Specifications—Passenger Car

MAKE OF CAR CAMARO MODEL YEAR 1969 DATE ISSUED 10-15-68 REVISED (a) 2-14-69

	L6 230 Cu. In.	L6 250 Cu. In.	V8 307 Cu. In.	V8 350 Cu. In.	V8 396 Cu. In.
MODEL	140 HP	155 HP	200 HP	250 & 300 HP	350 HP

ENGINE - CRANKSHAFT

Material	Cast nodular iron				
Vibration damper type	Rubber mounted inertia				
End thrust taken by bearing (No.)	7	5			
Crankshaft end play	.002 - .006		.006 - .010		
Main bearing	Material & type	Steel with backed insert (selected bearing material - copper lead alloy or premium aluminum - for intended operation or application)			
	Clearance	.0003 - .0029		(a) (b)	
	Journal dia. and bearing overall length	No. 1	2.3004 X .752	2.4502 X .752	2.7507 X .992
		No. 2	2.3004 X .752	2.4505 X .752	2.7507 X .992
		No. 3	2.3004 X .752	2.4505 X .752	2.7505 X .992
		No. 4	2.3004 X .752	2.4505 X .752	2.7505 X .992
		No. 5	2.3004 X .752	2.4507 X 1.177	2.7506 X 1.2525
No. 6		2.3004 X .752	None		
Dir. & amt. cyl. offset	None				
Crankpin journal diameter	1.999 - 2.000	2.099 - 2.100	2.199 - 2.200		

ENGINE - CAMSHAFT

Location	Above and to right of crankshaft	In block above crankshaft		
Material	Cast Alloy Iron			
Bearings	Material	Steel backed babbitt		
	Number	4	5	
Type of Drive	Gear or chain	Gear	Chain	
	Crankshaft gear or sprocket material	Steel	Steel sprocket	
	Camshaft gear or sprocket material	(c)	Nylon teeth with aluminum hub	
	Timing chain	No. of links	None	46
Width		None	.740	.740
Pitch		None	.500	.500

ENGINE - VALVE SYSTEM

Hydraulic lifters (Std., opt., NA)	Standard		
Valve rotator, type (intake, exhaust)	None		
Rocker ratio	1.75:1	1.50:1	1.70:1
Operating approx clearance (indicate hot or cold)	Intake	Zero	
	Exhaust	Zero	

(Continued)

(a) - No. 1 - .0008-.0020
 No. 2, 3, 4, - .0008-.0024
 No. 5 - .0015-.0031

(c) - Bakelite and fabric composition
 with steel hub

(b) - No. 1 & 2 - .0010-.0020
 No. 3 & 4 - .0013-.0025
 No. 5 - .0015-.0031

AMA Specifications—Passenger Car

MAKE OF CAR CAMARO MODEL YEAR 1969 DATE ISSUED 10-15-68 REVISED (*)2-14-69

MODEL	230 Cu. In. 140 HP	250 Cu. In. 155 HP	307 Cu. In. 200 HP	350 Cu. In. 250&300HP	396 Cu. In. 325 HP
-------	-----------------------	-----------------------	-----------------------	--------------------------	-----------------------

ENGINE—VALVE SYSTEM (cont.)

Timing (based on top of ramp points)	Intake	Opens (°BTC)	16°		28°	28°
		Closes (°ABC)	48°		72°	78°
		Duration - deg.	244°		280°	286°
Exhaust		Opens (°BBC)	46°30'		78°	75°
		Closes (°ATC)	17°30'		30°	31°
		Duration - deg.	244°		288°	286°
Valve opening overlap			33°30'		58°	59°
Material		Alloy steel, face aluminized on 230, 250 and 396 cu. in.				
Overall length		4.902 - 4.922		4.870-4.889		5.215-5.23
Actual overall head dia.		1.715 - 1.725		1.935-1.945		2.060-2.071
Angle of seat & face		46° (seat) 45° (face)				
Seat insert material		None				
Stem diameter		.3410 - .3417			.3715-.3722	
Stem to guide clearance		.0010 - .0027				
Intake	Lift (± zero lash)		.3317	.3880	.3900	.3983
	Outer spring press. & length	Valve closed (lb.@in.)	56-64 @ 1.66		76-84 @ 1.70	
Valve open (lb.@in.)		180-192 @ 1.27		194-206 @ 1.25		228-252@1.38
Inner spring press. & length	Valve closed (lb.@in.)	None		Spring Damper		26-34@1.78
	Valve open (lb.@in.)	None		Spring Damper		81-99@1.28
Material		High alloy steel, aluminized face (a)				
Overall length		4.913 - 4.933		5.345-5.365		
Actual overall head dia.		1.495 - 1.505		1.715-1.725		
Angle of seat & face		46° (seat) 45° (face)				
Seat insert material		None				
Stem diameter		.3410 - .3417			.3715-.3722	
Stem to guide clearance		.0010 - .0027				
Exhaust	Lift (± zero lash)		.3317	.3880	.4100	.3983
	Outer spring press. & length	Valve closed (lb.@in.)	56-64 @ 1.66		76 - 84 @ 1.70	
Valve open (lb.@in.)		180-192 @ 1.27		194-206 @ 1.25		228-252@1.38
Inner spring press. & length	Valve closed (lb.@in.)	None		Spring Damper		26-34@1.78
	Valve open (lb.@in.)	None		Spring Damper		81-99@1.28

ENGINE—LUBRICATION SYSTEM

Type of lubrication (splash, pressure, nozzle)		
Main bearings		Pressure
Connecting rods		Pressure
Piston pins		Splash
Camshaft bearings		Pressure
Tappets		Pressure
Timing gear or chain	Nozzle	Centrifugally oiled from camshaft bearing
Cylinder walls	Splash	Pressure jet cross sprayed

(Continued)

(a) - Head also aluminized on 396 engines

AMA Specifications—Passenger Car

MAKE OF CAR	CAMARO	MODEL YEAR	1969	DATE ISSUED	10-15-68	REVISED (*)	2-14-69
MODEL	230 Cu. In. 140 HP	250 Cu. In. 155 HP	307 Cu. In. 200 HP	350 Cu. In. 250 HP	350 Cu. In., 300 HP & 396 Cu. In.		

ENGINE – LUBRICATION SYSTEM (cont.)

Oil pump type	Gear
Normal oil pressure (lb. engine rpm)	50-65 PSI @ 2000 (a) 50-75 PSI @ 2000 (a)
Oil press. sending unit (elect. or mech.)	Electric
Type oil intake (floating, stationary)	Stationary
Oil filter system (full flow, part., other)	Full Flow
Filter replacement (element, complete)	Complete
Capacity of oil case, less filter-refill (qt.)	4
Oil grade recommended (SAE viscosity and temperature range)	32° and above - SAE 20W or SAE 10W-30 0°F to 32°F* - SAE 10W or SAE 10W-30 Below 0°F - SAE 5W or SAE 5W-20 * - (SAE 5W-30 can be used at temperatures below freezing)
Engine Service Reqmt. (MM, MS, etc.)	MS or DG

ENGINE – EXHAUST SYSTEM

Type (single, single with cross-over, dual, other)	Single	Single with crossover	Dual exhaust w/single mflr
Muffler No. & type (reverse flow, straight thru, separate resonator)	One; reverse flow		
Exhaust pipe dia. (O.D., wall thick.)	Branch	None	2.00 X .072-.091 (b) 2.25 X .073-.091 (b)
	Main	2.00 X .057-.071	2.00 X .073-.091 (b) 2.25 X .075-.091
Tail pipe dia. (O.D. & wall thickness)	1.88 X .062-.076	2.00 X .062-.076	2.25 X .062-.076

ENGINE – CRANKCASE VENTILATION SYSTEM

Type (ventilates to atmos., induction system, other)	Standard	Ventilates to induction system
	Optional	None
Control Unit	Make and model	AC Spark Plug
	Location	Top rear rocker cover Left front rocker cover
	Energy source (manifold vacuum, carburetor air stream, other)	Manifold vacuum
	Control method (variable orifice, fixed orifice, other)	Variable orifice
Complete system	Discharges (to intake manifold, carb. air intake, air cleaner intake, other)	Intake manifold
	Air inlet (breather cap, carburetor air cleaner, other)	Carburetor air cleaner
	Flame arrester (screen, check valve, other)	Screen

(a) - Bench test - no flow conditions

(b) - Laminated

AMA Specifications—Passenger Car

MAKE OF CAR CAMARO MODEL YEAR 1969 DATE ISSUED 10-15-68 REVISED 02-14-69

MODEL	L6 - 230 140 HP	L6 - 250 155 HP	V8 - 307 200 HP	V8 - 350 250 HP/300 HP	V8 - 396 325 HP
-------	--------------------	--------------------	--------------------	---------------------------	--------------------

ENGINE - EXHAUST EMISSION CONTROL

MANUAL TRANSMISSIONS

Type (Air injection, engine modifications, other)		Air injection reactor equipment								
Air Injection Pump	Type	Semi-articulated vane type								
	Displacement	19.3								
	Drive ratio	1.15:1								
	Drive type	Crankshaft pulley								
	Relief valve (type)	Diverter valve - separate from pump								
Filter (describe)		Centrifugal air cleaner								
Air Injection System	Air distribution (head, manifold, etc.)	Cylinder Head			Manifold					
	Point of entry	Exhaust ports								
	Injection tube I.D.	.2565								
	Check valve type	Pressure (plate type)								
Backfire protection (type)		Diverter valve								
Carburetor	Make									
	Model									
	Barrel size									
	Idle speed	Drive	REFER TO PAGE 10				Neutral			
Idle A/F mixture		Not Specified								
Aux. Adv. Systems (type)		None								
Make		Delco-Remy								
Model		1110459	1110463	1111481	1111486	1111488	1111497			
Distributor	Centrifugal adv. in crank degrees @ eng. rpm	Start (rpm)	1000	900	1000	800	950	900		
		Intermed. points deg. @ rpm								
		Max. deg. @ rpm	36@4600	32@4200	28@4200	36@4100	30@4700	32@5000		
Vacuum adv. in crank degrees @ eng. rpm	Start (in Hg)	7.00		6.00		7.00		8.00		
	Intermed. points deg. @ in. Hg									
	Max. deg. @ in.	23 @ 16		15 @ 12		24 @ 17.5		20 @ 17		15 @ 15.5
Vacuum Source		Carburetor								
Timing - Crank degrees @ rpm		TDC @ 700		2BTC@700		TDC @ 700		4BTC@700		
Cooling System										
Exhaust System										

AMA Specifications—Passenger Car

MAKE OF CAR CAMARO MODEL YEAR 1969 DATE ISSUED 10-15-68 REVISED 12-14-69

MODEL	L6 - 230 140 HP	L6 - 250 155 HP	V8 - 307 200 HP	V8 - 350 250 HP 300 HP	V8 - 396 325 HP
-------	--------------------	--------------------	--------------------	---------------------------	--------------------

ENGINE - EXHAUST EMISSION CONTROL

AUTOMATIC TRANSMISSION

Type (Air injection, engine modifications, other)	Engine modifications						SAME	
Air Injection Pump	Type							
	Displacement	NOT						AS
	Drive ratio							
	Drive type	USED						MAN-
	Relief valve (type)							
Filter (describe)							UAL	
Air Injection System	Air distribution (head, manifold, etc.)	NOT						SEE
	Point of entry							
	Injection tube I.D.	USED						PAGE
	Check valve type							
Backfire protection (type)							9A	
Carburetor	Make							
	Model	REFER						
	Barral size							
	Idle speed	Drive	TO					
		Neutral						
Idle A/F mixture	PAGE 10							
Aux. Adv. Systems (type)	None							
Make	Delco-Remy							
Model	1110460	1110464	1111481	1111487	1111489	1111497		
Cent'gal adv. in crank degrees @ eng. rpm	Start (rpm)	1000	900	1000	900	900	900	
	Intermed. points deg. @ rpm							
	Max. deg. @ rpm	32@4600	28@4200	28@4200	32 @ 4200	26@4700	32@5000	
Vacuum adv. in crank degrees @ eng. rpm	Start (in Hg)	7.00		6.00	7.00	8.00	8.00	
	Intermed. points deg. @ in. Hg							
	Max. deg. @ in.	23 @ 16		15 @ 12	24 @ 17.5	20 @ 17	15 @ 15.5	
Vacuum Source	Carburetor							
Timing - Crank degrees @ rpm	4BTC@550		2BTC@700	4BTC@600		4BTC@800		
Cooling System								
Exhaust System								

AMA Specifications—Passenger Car

MAKE OF CAR CAMARO MODEL YEAR 1969 DATE ISSUED 10-15-68 REVISED 10-2-14-69

MODEL	L6-230 140 HP	L6-250 155 HP	V8-307 200 HP	V8-350 250 & 300 HP	V8-396 325 HP
-------	------------------	------------------	------------------	------------------------	------------------

ENGINE - FUEL SYSTEM

(See supplemental page for Details of Fuel Injection, Supercharger, etc. if used)

Induction type: Carburetor, fuel injection, supercharger.		Carburetor			
Fuel Tank	Refill capacity (U.S. gals.)	18 (approximately)			
	Filler location	Behind hinged rear license plate			
Fuel Pump	Type (elec. or mech.)	Mechanical			
	Locations	Lower right front of engine			
	Pressure range *	4.00-5.00 PSI	5.00-7.50 PSI	7.50-9.00 PSI	5.50-7.00 PSI
Vacuum booster (std., optional, none)		None			
Fuel Filter	Type	Fine mesh plastic strainer in gasoline tank			
	Locations	and plastic filter in carburetor inlet F			
Carburetor	Choke type	Automatic			
	Intake manifold heat control (exhaust or water)	Exhaust			
	Air cleaner type	Standard	Oil-wetted paper element		
		Optional	None		
Idle speed (spec. neutral or drive)	Manual (N)	700		800	
	Automatic (D)	550	600		
	Idle A/F mix.	Not specified			

CARBURETOR SUPPLEMENTARY INFORMATION

Model Usage	Engine Displ.	Transmission	Carburetors		No. Used and Type	Barrel Size
			Make	Model		
12300	230	Manual	Rochester	7029017(a)	One; Single Barrel	1.69
		Automatic		7029014		
	250	Manual	Rochester	7029017(a)		
		Automatic		7029014		
12400	307	Manual	Rochester	7029101(b)	One; 2-Barrel	1.44
		Automatic		7029110(c)		
	350	Manual	Rochester	7029113(d)	One; 2-Barrel	1.69
		Automatic		7029114 (e)		
	350hp	Manual	Rochester	7029203	One; 4-Barrel	1.38 Prim 2.25 Sec
		Automatic		7029202		
	396hp	Manual	Rochester	7029215	One; 4-Barrel	1.38 Prim 2.25 Sec
Automatic		7029204				

(a) - 7029015 with air conditioning

(b) - 7029103 with air conditioning

(c) - 7029112 with air conditioning

* Shut off pressure - 1800 RPM at pump outlet

(d) - 7029115 with air conditioning

(e) - 7029116 with air conditioning

(f) - Additional in-line paper element with 396 cu. in. engine

AMA Specifications—Passenger Car

MAKE OF CAR CAMARO MODEL YEAR 1969 DATE ISSUED 10-15-68 REVISED (*)2-14-69

MODEL	230 Cu. In. 140 HP	250 Cu. In. 155 HP	307 Cu. In. 200 HP	350 Cu. In. 250 & 300HP	396 Cu. In. 325 HP
--------------	-----------------------	-----------------------	-----------------------	----------------------------	-----------------------

ENGINE - COOLING SYSTEM

Type system (pressure, pressure vented, atmospheric, other)		Pressure				
Radiator cap relief valve pressure		15 ± 1 PSI				
Circulation thermostat	Type (choke, bypass)	Choke				
	Starts to open at (°F)	192°-198°				
Water pump	Type (centrifugal, other)	Centrifugal				
	GPM ≥ 1000 pump rpm	60 @ 4400	54 @ 4400	57 @ 4400		
	Number of pumps	One				
	Drive (V-belt, other)	V-belt				
	Bearing type	Permanently lubricated double row ball				
By-pass recirculation type (inter., ext.)		Internal		External		
Radiator core type (cellular, tube and fin, other)		Tube and center				
Cooling system capacity	With heater (qt.)	13	17	16	23	
	Without heater (qt.)	11	16	15	22	
	Opt. equipment-specify (qt.)	13	18	17	24	
Water jackets full length of cyl (yes, no)		Yes				
Water all around cylinder (yes, no)		Yes				
Radiator hose	Lower	Number and type (molded, straight)	One, molded			
		Inside diameter	1.75			
	Upper	Number and type (molded, straight)	One, molded			
		Inside diameter	1.50			
	By-pass	Number and type (molded, straight)	None		One molded	
		Inside diameter	None		.725-.765	
Fan	Number of blades & spacing		4-staggered			
	Diameter		17.62			
	Ratio-fan to crankshaft rev.		.949:1			
	Fan cutout type		None			
	Bearing type		Double row ball			
* Drive belts (indicate belt used by letter)	Fan	A	D	E	H	I
	Generator or alternator	A	D	E	H	I
	Water Pump	A	D	E	H	I
	Power Steering	B	F			
	Air Conditioning	C	G			
	Air Injection	B	D & H-Manual Transmissions F & I - Automatic Transmissions			

* Drive Belt Dimensions	A	B	C	D	E	F	G	H	I	J	K
Angle of V	←				38°-42°	→					
Nominal length (SAE)	39.00	50.00	54.00	47.50	44.25	36.00	54.33	49.50	45.75	41.00	57.00
Width	←				.380	→					

AMA Specifications—Passenger Car

MAKE OF CAR	CAMARO	MODEL YEAR	1969	DATE ISSUED	10-15-68	REVISED (*)	2-14-69
MODEL	230 Cu. In. 140 HP	250 Cu. In. 155 HP	307 Cu. In. 200 HP	350 Cu. In. 250 & 300 HP	396 Cu. In. 325 HP		

ELECTRICAL – SUPPLY SYSTEM

Battery	Make and Model		Delco-Remy 1980032		1980030		
	Voltage Rtg. & Total Plates		12 volts - 54 plates		12 volts - 66 plates		
	SAE Designation & Amp. Hr. Rtg.		45 amp hr @ 20 hr rate		61 amp hr @ 20 hr rate		
	Location		Right side front of engine compartment				
	Terminal grounded		Negative				
Generator or Alternator	Make		Delco-Remy				
	Model		1100836 (a)		1100834		
	Type and rating		Diode rectified 37 amps				
	Output at engine idle (neutral)		13 amps		15 amps		
	Ratio-Gen. to Cr. s rev.		2.46:1				
Regulator	Make		Delco-Remy				
	Model		1119515				
	Type		Vibrator				
	Cutout relay	Closing voltage generator rpm		None			
		Reverse current to open		None			
	Regulated	Voltage		13.8 - 14.8 @ 85°F			
		Current		--			
Voltage test conditions	Temperature		Operating				
	Load		3-8 amperes				
	Other		None				

ELECTRICAL – STARTING SYSTEM

Starting Motor	Make		Delco-Remy			
	Model		1108365		1108367 1108361(b) 1108418	
	Rotation (drive end view)		Clockwise			
Motor control	Switch (solenoid, manual)		Solenoid			
	Starting procedure		3 & 4-SPD - Place gearshift lever in neutral & depress clutch AUTOMATIC - Place gearshift lever in N or P position INITIAL START - Press accelerator to floor & release. Turn ignition to START, release as soon as engine starts.			
Motor Drive	Engagement type		Positive shift solenoid			
	Pinion meshes (front, rear)		Rear			
	Number of teeth	Pinion		9		9
		Flywheel	Manual	153		168
			Auto.	153		168
Flywheel tooth face width		Manual	.4010-.4130		.4100-.4220	
		Auto.	.4010-.4130		.4100-.4220	

(a) 1100834 used when automatic transmission is specified.

(b) 1108338 when used with Powerglide and 300 HP engine.

1108420 when used with Turbo Hydra-Matic and 300 HP engine.

AMA Specifications—Passenger Car

MAKE OF CAR	CAMARO		MODEL YEAR	1969	DATE ISSUED	10-15-68	REVISED (a)	2-14-69
MODEL	L6-230	L6-250	V8-307	V8-350	V8-396 Cu. In.			
	140 HP	155 HP	200 HP	250 & 300 HP	325 HP			

ELECTRICAL - IGNITION SYSTEM

Type	Conventional - Std., Opt., N.A.		Standard			
	Transistorized - Std., Opt., N.A.		Not available			
	Other (specify)		None			
Coil	Make		Delco-Remy			
	Model		1115208	1115293		
	Amps	Engine stopped	4.0			
		Engine idling	1.8			
Distributor	Make		REFER			
	Model		REFER			
	Cent'fgal adv. in c/shaft degrees @ engine rpm (nominal)	Start (rpm)		TO		
		Intermediate points deg. @ rpm		TO		
		Max. deg. @ rpm		TO		
	Vacuum adv. in c/shaft degrees @ in. Hg. (nominal)	Start (in. Hg.)		PAGE		
		Intermediate points, deg. @ in. Hg.		NINE		
Max. deg. in. Hg.		NINE				
Breaker gap (in.)		.019				
Cam angle (deg.)		31 - 34	29-31	28-30		
Breaker arm tension (oz.)		19-23		28-32		
Timing	Crankshaft deg. @ rpm		Refer to page nine			
	Mark location		Torsional damper			
Spark Plug	Make		AC Spark Plug			
	Model		ACR46N	ACR45S	ACR44S ACR44N	
	Thread (mm)		14			
	Tightening torque (lb. ft.)		25			
	Gap		.033-.038			
Cable	Conductor type		Linen core impregnated with electrical conducting material			
	Insulation type		Rubber with Neoprene jacket			
	Spark plug protector		Neoprene			

ELECTRICAL - SUPPRESSION

Locations & type	Non-metallic high ignition cable
------------------	----------------------------------

AMA Specifications—Passenger Car

MAKE OF CAR	CAMARO		MODEL YEAR	1969	DATE ISSUED	10-15-68	REVISED	6-2-14-69
MODEL	L6-230 140 HP	L6-250 155 HP	V8-307 200 HP	V8-350 250 HP	V8-350 300 HP	V8-396 325 HP		

ELECTRICAL — INSTRUMENTS AND EQUIPMENT

Speed-ometer	Type	Dial
	Trip odometer (yes, no)	No
Charge indicator — type		Tell-Tale
Temperature indicator — type		Tell-Tale
Oil pressure indicator — type		Tell-Tale
Fuel indicator — type		Electric gauge
Other		Refer to page 23
Wind-shield wiper	Type — Standard	Electric Two-speed
	Type — Optional	None
Wind-shield washer	Type — Standard	Push-button
	Type — Optional	None
Horn	Type	Vibrator
	Number used	Two
	Amp draw (each)	4.5 - 6.5 @ 12.5V (Low note) 4.2 - 6.2 @ 12.5V (Hi-note)

DRIVE UNITS — CLUTCH (Manual Transmission)

Make & type	Chevrolet; single dry disc		Chevrolet; single dry disc centrifugal
Type pressure plate springs	Diaphragm		Diaphragm, bent finger design
Total spring load (lb.)	1650-1850	2100-2300 (a)	2450-2750
Na. of clutch driven discs	One		
Clutch facing	Material	Woven type asbestos	
	Outside & inside dia.	9.12 x 6.12	10.34 x 6.50
	Total eff. area (sq. in.)	71.82	101.54
	Thickness	.135	.140
Engagement cushioning method	Flat spring steel between facings		
Release bearing	Type & method of lubrication	Single row ball, packed and sealed	
Torsional damping	Methods: springs, friction material	Coil springs	

(a) 1900-2200 lbs. with V8-307 & 3-Spd. Trans.

AMA Specifications—Passenger Car

MAKE OF CAR CAMARO	MODEL YEAR 1969	DATE ISSUED 10-15-68	REVISED (12-14-69)
MODEL	L-6 230, L-6 250 307 V-8	350 V-8	396 V-8

DRIVE UNITS – TRANSMISSIONS

Manual 3-speed (std. or opt.)	Standard
Manual 4-speed (std. or opt.)	Optional
Manual with overdrive (std. or opt.)	Not Available
Automatic (std. or opt.)	Optional

DRIVE UNITS – MANUAL TRANS.

		3-Spd.	4-Spd.	HD 3-Spd	4-Spd
Number of forward speeds		3	4	3	4
Transmission ratios	In first	2.85	2.85	2.42	2.52
	In second	1.68	2.02	1.58	1.88
	In third	1.00	1.35	1.00	1.46
	In fourth	--	1.00	--	1.00
	In reverse	2.95	2.85	2.41	2.59
Synchronous meshing, specify gears		All forward speeds			
Shift lever location		Steering column 3-speed Floor mounted HD 3-speed and 4-speed			
Lubricant	Capacity (pt.)	3	3.5	3	
	Type recommended	Meeting Military Specs MIL-L-2105B			
	SAE viscosity number	Summer	SAE 80		
		Winter	SAE 80		
Extreme cold		SAE 80			

DRIVE UNITS – MANUAL TRANS. W/OVERDRIVE

(For transmission data see manual transmission section)

Type (planetary or other)	
Manual lockout (yes, no)	NOT
Downshift accelerator control (yes, no)	
Minimum cut-in speed	
Gear ratio	AVAILABLE
Lubricant	Capacity (pt.) (Overdrive only)
	Separate filler (yes, no)
	Type recommended
	SAE viscosity number
Winter	
Extreme cold	

AMA Specifications—Passenger Car

MAKE OF CAR CAMARO MODEL YEAR 1969 DATE ISSUED 10-15-68 REVISED (*)2-14-69

MODEL	Powerglide	Torque-Drive	Turbo Hydra-Matic
	L6-230	L6-230	L6-230&250 V8 - 396
	L6-250 V8-350	L6-250	V8-307&350
	V8-307		

DRIVE UNITS – AUTOMATIC TRANSMISSION

Trade name	Powerglide	Torque-Drive	Turbo Hydra-Matic		
Type describe	Torque converter with planetary gears				
Selector location	Steering column, floor mounted with console available optionally				
List gear ratios Selector Pattern and indicate which are used in each selector position	P-Park R-1.82 N-Ntrl. D-1.82-1.00 L-1.82	P-Park R-1.76 N-Ntrl. D-1.76-1.00 L-1.76	P-Park R-1.82 N-Neutral Hi-1.82-1.00 1st-1.82	P-Park R-1.93 N-Neutral D-2.52-1.52-1.00 L ₂ -2.52-1.52 L ₁ -2.52	P-Park R-2.00 N-Neutral D-2.48-1.48-1.00 L ₂ -2.48-1.48 L ₁ -2.48
P/Gld. Max. upshift speed—drive range	63(L6 230&250); 68(V8-307); 81(V8-350 L65); 73(V8-350 L48)				
* Max. kickdown speed—drive range	59(L6 230&250); 65(V8-307); 76(V8-350 L65); 69(V8-350 L48)				
Torque converter	Number of elements				
	3				
	Max. ratio at stall				
2.10		2.10		2.10	
Type of cooling (air, liquid)				Air	
Nominal diameter				11.75	
11.75		11.75		12.20	
Lubricant	Capacity—refill (pt.)				
	6		6.5		8
Type recommended				A suffix A	
Special transmission features					

DRIVE UNITS – PROPELLER SHAFT

Number used	One	
Type (straight tube, tube-in-tube, internal-external damper, etc.)	Straight tube	
Outer diam. x length* x wall thickness	Manual 3-speed trans.	2.75 x 49.56 x .065
	Manual 4-speed trans.	Same as 3-speed
	Overdrive transmission	Not available
	Automatic transmission	Same as 3-speed

* Center to center of universal joints, or to centerline of rear attachment.

(Continued)

* Turbo Hydra-Matic

Upshift - L6 230 & 250 (1-2 33-52; 2-3 68-82) V8-307 (1-2 38-56; 2-3 71-86)
 V8-350 L65 (1-2 44-63; 2-3 81-97) V8-350 L48 (1-2 37-53; 2-3 67-81)
 V8-396 (1-2 41-56; 2-3 80-99)

Kickdown - L6 230 & 250 (2-1 44-23; 3-2 79-64) V8-307 (2-1 48-25; 3-2 83-67)
 V8-350 L65 (2-1 52-28; 3-2 94-77) V8-350 L48 (2-1 43-23; 3-2 78-64)
 V8-396 (2-1 43-21; 92-72)

AMA Specifications—Passenger Car

MAKE OF CAR CAMARO MODEL YEAR 1969 DATE ISSUED 10-15-68 REVISED (*)

MODEL _____

DRIVE UNITS – PROPELLER SHAFT (cont.)

Inter-mediate bearing	Type (plain, anti-friction)	None
	Lubrication (fitting, prepack)	--
Slip Yoke	Type	Yoke
	Number of teeth	27
	Spline O.D.	1.502-1.503
Universal joints	Make and Mfg. No.	Chevrolet 3841935
	Number used	Two
	Type (ball and trunnion, cross)	Cross
	Rear attach. (u-bolt, clamp, etc.)	U-bolt
	Bearing	Type (plain, anti-friction)
Lubric. (fitting, prepack)		Prepack
Drive taken through (torque tube or arms, springs)		Springs
Torque taken through (torque tube or arms, springs)		Springs

DRIVE UNITS – AXLE

Type (front, rear)		Rear	
Description		Semi-floating, overhung pinion gear	
Limited Slip differential, type		Dual disc clutches	
Drive Pinion Offset		1.50	
No. of differential pinions		Two	
Pinion adjustment (shim, other)		None	
Pinion bearing adj. (shim, other)		Shim	
Wheel bearing type		Single row cylindrical roller	
Lubricant	Capacity (pt)	3.5	
	Type recommended	Meeting Military Specs. MIL-2105B	
	SAE viscosity number	Summer	SAE 80
		Winter	SAE 80
		Extreme cold	SAE 80

AXLE RATIO TOOTH COMBINATIONS

(See page 3 for axle ratio usage)

Axle ratio	2.56	2.73	3.08	3.36	2.73	3.07	3.31	3.55	3.73	4.10
No. of teeth	Pinion	16	15	12	11	15	14	13	11	10
	Ring gear	41	41	37	37	41	43	43	39	41
Ring Gear O.D.	8.125				8.875					

AMA Specifications—Passenger Car

MAKE OF CAR CAMARO MODEL YEAR 1969 DATE ISSUED 10/15/67 REVISED (*)2-14-69

MODEL _____

DRIVE UNITS—WHEELS

Type & material		Short spoke disc, steel	
Rim (size & flange type)	Std.	14 x 6	
	Opt.	14 x 7	
Attachment	Type (bolt or stud)	Stud	
	Circle diameter	4.75	
	Number and size	5 hex nuts, 7/16-20 UNF-2B	

MODEL _____

DRIVE UNITS—TIRES

Standard	Size, ply rating, & ply		E78-14-B (2x2) - L6-230, 250, V8-307 & 350 (L65) F70 x 14-B (2 x 2) V8-350 (L48) & 396	
	Type (bias, radial, etc.)		Bias	
	Full rated Inflation * Press.	Front	E78-14 Cold 26, Hot 32, F70-14 Cold 26, Hot 32	
		Rear	E78-14 Cold 28, Hot 34; F70-14 Cold 26, Hot 32	
Rev./Mile at 50 MPH		802-E78-14; 791-F70 x 14		
Optional	Size, ply rating, & ply		E70 x 14-B (2 x 2) E70 x 15-B (2 x 2)	

BRAKES—PARKING

Type of control		Foot pedal apply; 'T' handle release	
Location of control		Left of steering column under instrument panel	
Operates on		Rear service brakes	
If separate from service brakes	Type (internal or external)	--	
	Drum diameter	--	
	Lining size (length x width x thickness)	--	

* Pressures shown are up to base vehicle load limit (5-passengers plus 200 lbs)
Optional load (1 to 5 passengers) for E78-14, Front-26 cold, 32 hot; Rear 24 cold,
30 hot.

AMA Specifications—Passenger Car

MAKE OF CAR CAMARO MODEL YEAR 1969 DATE ISSUED 10-15-68 REVISID (*)

MODEL _____

BRAKES—SERVICE

				STANDARD	FRONT DISC (Opt)		
Type (drum) or (disc & no. of pistons)				Drum (front-finned)	Disc		
Self adjusting (std., opt., N.A.)				Standard			
Special Valving	Type (proportion, delay, metering, other)			Metering			
Power brake make & type (remote, int., etc.)	Std.			--	(a)		
	Opt.			(a)	--		
Effective area (sq. in.) *				155.2	114.0		
Gross lining area (sq. in.) **				168.9	118.1		
Swept area (sq. in.) ***				268.8	332.4		
Front to Rear Effectiveness Relationship				64	64		
Drum	Diameter (nominal)	Front			9.5	--	
		Rear			9.5		
Type and material		Composite, cast iron; steel web			Cast iron		
Rotor	Outer working diameter			--	11.00		
	Inner working diameter			--	7.18		
	Working width			--	1.00		
	Material & type (vented/solid)			--	Cast iron vented		
Wheel cylinder bore	Front		1.125		2.9375		
	Rear		.875		.875		
Master Cylinder	Bore		1.00		1.125		
	displacement distribution	Front	%	62		70	
		Rear	%	38		30	
Pedal arc ratio				6.20	3.82		
Line pressure at 100 lb. pedal load				790			
Shoe Clearance	Front			Self adjusting			
	Rear			Self adjusting			
Brake lining	Banded or riveted			Bonded	Riveted		
	Front Wheel	Material		Molded asbestos			
		Size (length x width x thickness)	Prim. or out-board	9.01 x 2.5 x .17		5.96 x 2.21 x .41	
			Second. or in-board	9.75 x 2.5 x .20		5.96 x 2.21 x .41	
		Segments per shoe			One		
	Rear Wheel	Material		Molded asbestos			
Size (length x width x thickness)		Prim. or out-board	9.01 x 2.0 x .17		9.01 x 2.0 x .17		
		Second. or in-board	9.75 x 2.0 x .20		9.75 x 2.0 x .20		
Segments per shoe			One				

* Excludes rivet holes, grooves, chamfers, etc. ** Includes rivet holes, grooves, chamfers, etc.

*** Total swept area for four brakes. (Widest lining contact width for each brake x its contact circumference.)

(a) Delco Moraine vacuum power unit; integral

AMA Specifications—Passenger Car

MAKE OF CAR CAMARO MODEL YEAR 1969 DATE ISSUED 10-15-68 REVISED (*)2-14-69

MODEL _____

STEERING

Manual (std., opt., NA)		Standard energy absorbing steering column	
Power (std., opt., NA)		Optional	
Adjustable steering wheel (tilt, swing, other)	Type and description	TILT: Tilt achieved with universally-jointed steering shaft at base of steering wheel	
	(std., opt., NA)	Optional	
Wheel diameter	Manual	Oval 16.25 x 15.50	
	Power	Oval 16.25 x 15.50	
Turning diameter (feet)	Outside front	Wall to wall (l. & r.)	39.9
		Curb to curb (l. & r.)	37.5
	Inside rear	Wall to wall (l. & r.)	NA
		Curb to curb (l. & r.)	NA
Manual	Gear	Type	Semi-reversible, recirculating ball nut
		Make	Saginaw
		Ratios	Gear 24:1
	Overall	28.3:1	
	No. wheel turns (stop to stop)	4.8	
Power	Type (coaxial, linkage, etc.)		Integral, with vane type pump
	Make		Saginaw
	Gear	Type	Same as manual
		Ratios	Gear 16.0:1-12.4:1
		Overall	15.5:1-11.8:1
	Pump driven by		Crankshaft pulley
No. wheel turns (stop to stop)		2.2	
Linkage	Type		Parallelogram
	Location (front or rear of wheels, other)		Rear
	Drag link (trans. or longit.)		None
	Tie rods (one or two)		Two
Steering Axis	Inclination at camber (deg.)		8 1/4 to 9 1/4
	Bearings (type)	Upper	Ball stud with non-metallic bearings
		Lower	Ball stud with non-metallic bearings
		Thrust	None
Whl. Align. (range of curb wt. & preferred)	Caster (deg.)		0 to P-1
	Camber (deg.)		N-1/4 to P-3/4
	Toe-in (outside track inches)		1/8 to 1/4
Steering spindle & joint type		Steering Knuckle	
Wheel Spindle	Diameter	Inner bearing	1.2493 - 1.2498
		Outer bearing	.7491 - .7497
	Thread size		3/4-20 NEF - 3 (modified)
	Bearing type		Taper roller

AMA Specifications—Passenger Car

MAKE OF CAR CAMARO MODEL YEAR 1969 DATE ISSUED 10-15-68 REVISED (*)2-14-69

MODEL _____

SUSPENSION – GENERAL

(See Supplement page for details on Air Suspension)

Provision for car leveling	Front stabilizer bar	
Provision for brake dip control	Front suspension geometry	
Provision for acc. squat control	Rear suspension geometry	
Special provisions for car jacking	Front: 3-3/4 in. inboard of bumper bolt Rear: 2-1/2 in. inboard of bumper bolt	
Shock absorber front & rear	Type	Direct, double acting, hydraulic
	Make	Delco
	Piston dia.	1.00
Other special features		

SUSPENSION – FRONT

Type and description	Independent SLA type with coil springs and concentric shock absorber and spherically jointed steering knuckle for each wheel	
Spring	Type	Coil right hand helix
	Material	Steel alloy
	Size (coil design height & I.D. bar length x dia.)	11.09 x 3.63; 121.76 x .592
	Spring rate (lb. per in.)	280
	Rate at wheel (lb. per in.)	99 (L6-Engines) 111 (V8-Engines)
Stabilizer	Type (link, linkless, frameless)	Link
	Material & bar diameter	Steel .687

SUSPENSION – REAR

Type and description	Salisbury rear axle with leaf springs (a)	
Drive and torque taken through	Rear springs	
Spring	Type	Single leaf (a)
	Material	Chrome carbon steel
	Size (length x width, coil design height & I.D.; bar length & dia.)	56.0 x 2.80 (at center)
	Spring rate (lb. per in.)	115 (Single leaf) 100 (Multiple leaf)
	Rate at wheel (lb. per in.)	
	Mounting insulation type	Rubber bushed at shackle and hanger
If leaf	No. of leaves	One (a)
	Shackle (comp. or tens.)	Compression
Stabilizer	Type (link, linkless, frameless)	None
	Material	--
Track bar type	None	

(a) Multiple leaf springs with V8-350 & 396 engine transmission combinations.

AMA Specifications—Passenger Car

MAKE OF CAR CAMARO MODEL YEAR 1969 DATE ISSUED 10-15-68 REVISED (*)2-14-69

MODEL _____

FRAME _____

Type and description (Separate frame, unitized frame, partially - unitized frame)	Combination body-frame integral with separate forward ladder frame
---	--

BODY - MISCELLANEOUS INFORMATION **2-Door Sport Coupe** **Convertible**

Drs. hinged (front, rr.)	Front doors	Front
	Rear doors	--
Type of finish (lacquer, enamel, other)		Acrylic lacquer
Hood counterbalanced (yes, no)		Yes
Hood release control (internal, external)		External
Vehicle indent. No. location		Top left hand of instrument panel pad
Engine No. location		6 Cyl.-Right side of cylinder block, rear of distributor 8 Cyl.-Front right side of cylinder block and case.
Theft protection - type		Lock, mounted on steering column; locks steering wheel, transmission shift levers and ignition
Vent window control method (crank, friction pivot)	Front	Friction pivot
	Rear	None
Seat cushion type	Front	Formed wire and foam pad
	Rear	Formed wire and cotton
	3rd seat	None
Seat back type	Front	Formed wire and cotton
	Rear	Formed wire and cotton
	3rd seat	None
Windshield glass type (i.e., single curved - laminated plate)		Curved-laminated plate
Side glass type (i.e., curved tempered plate)		Curved-tempered plate
Backlight glass type (i.e., compound curved - tempered plate, three piece)		Curved-tempered plate Plastic
Windshield glass exposed surface area	1032.6	990.5
Side glass exposed surface area	1128.6	1199.0
Backlight glass exposed surface area	819.2	834.0
Total glass exposed surface area	2980.4	3023.5

AMA Specifications—Passenger Car

CAR AND BODY DIMENSIONS

KEY SHEET

EXTERIOR CAR AND BODY DIMENSIONS

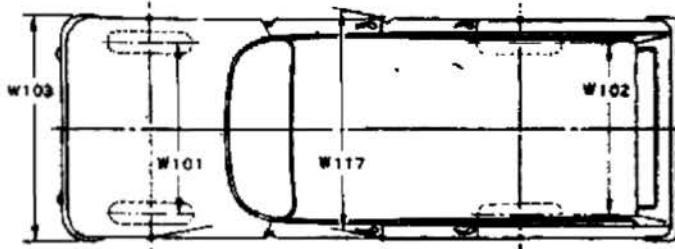

WIDTH

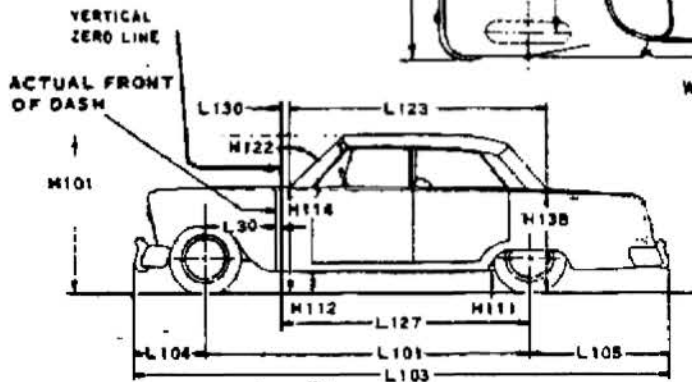

LENGTH & HEIGHT

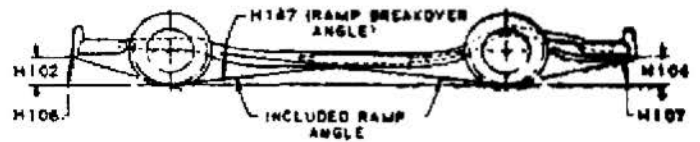

GROUND CLEARANCE

INTERIOR CAR AND BODY DIMENSIONS

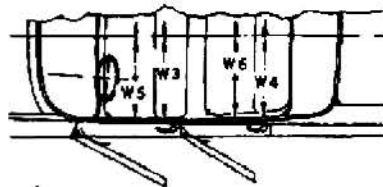

WIDTH

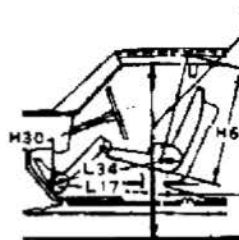

FRONT COMPT.

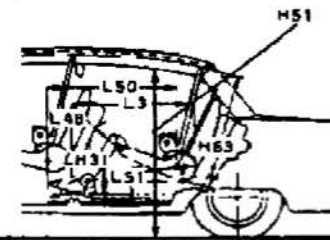

REAR COMPT.

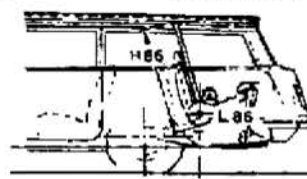
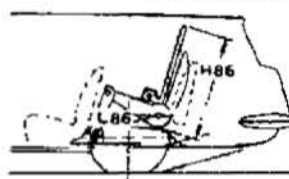

THIRD SEAT

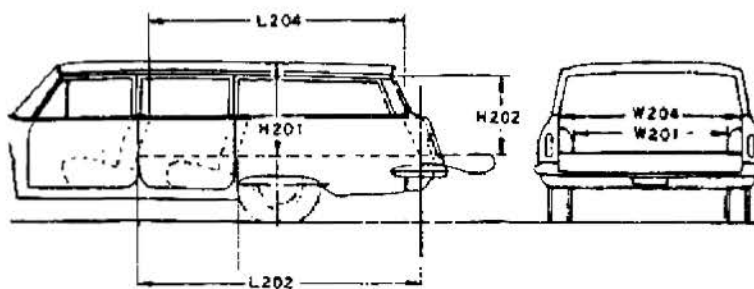

CARGO SPACE

CAR AND BODY DIMENSIONS

KEY SHEET

DIMENSION DEFINITIONS

EXTERIOR WIDTH DIMENSIONS

- W101 WHEEL TREAD - FRONT. Measured at centerline of tires, with nominal camber, at ground.
 W102 WHEEL TREAD - REAR. Measured at centerline of tires at ground.
 W103 MAXIMUM OVERALL CAR WIDTH. Include bumpers, moldings, or sheet metal protrusions. Measured to outside of metal.
 W117 MAXIMUM BODY WIDTH AT #2 PILLAR. Measured across body at #2 pillar, excluding hardware and applied moldings.

EXTERIOR LENGTH DIMENSIONS

- L 30 VERTICAL ZERO LINE TO ACTUAL FRONT OF DASH. If actual front of dash is to the rear of Body Zero Line, it is identified by a minus (-) sign.
 L101 WHEELBASE.
 L103 OVERALL LENGTH. Include bumper guards if standard equipment.
 L104 OVERHANG - FRONT. Measured from C/L of front wheels to front of car, including bumper guards if standard equipment.
 L105 OVERHANG - REAR. Measured from C/L of rear wheels to rear of car, including bumper guards if standard equipment.
 L123 BODY UPPER STRUCTURE LENGTH AT CAR CENTERLINE. The horizontal dimension from the Cowl Point to the Deck Point.
 L127 VERTICAL ZERO LINE TO CENTERLINE OF REAR WHEELS. A horizontal dimension.
 L130 VERTICAL ZERO LINE TO WINDSHIELD COWL POINT. The horizontal dimension from the vertical zero line to the theoretical intersection of extended windshield glass plane and normal cowl surface.

EXTERIOR HEIGHT DIMENSIONS

- H101 OVERALL HEIGHT - DESIGN. Measured with the vehicle in Manufacturer's Design Weight attitude.
 H114 COWL POINT TO GROUND. Measured at vehicle centerline.
 H138 DECK POINT TO GROUND. Measured at vehicle centerline.
 H112 ROCKER PANEL TO GROUND - FRONT. The vertical dimension from ground to bottom of rocker panel, excluding flanges. Measured to the outside of sheet metal at foremost point of rocker panel.
 H111 ROCKER PANEL TO GROUND - REAR. The vertical dimension from ground to bottom of rocker panel, excluding flanges. Measured to the outside of sheet metal at front of rear wheel opening.
 H122 WINDSHIELD SLOPE ANGLE. The angle between a vertical line and the windshield surface at car centerline. On compound-curved windshields the chord of the arc is used and limited to that section of the windshield comprehended by an 18-inch chord.

GROUND CLEARANCE DIMENSIONS

- H102 BUMPER TO GROUND - FRONT. Minimum dimension, includes bumper guards.
 H104 BUMPER TO GROUND - REAR. Minimum dimension, includes bumper guards.
 H106 ANGLE OF APPROACH. The angle between ground and a line tangent to the front tire static loaded radius arc and the first point of interference, i.e., bumper, guard, gravel deflector, fender or other component, excluding license plate. This dimension may be determined graphically for reporting purposes.
 H107 ANGLE OF DEPARTURE. The angle between ground and a line tangent to the rear tire static loaded radius arc and the first point of interference, i.e., bumper, guard, gravel deflector, tail pipe, fender or other component, excluding license plate. This dimension may be determined graphically for reporting purposes.
 H147 RAMP BRAKOVER ANGLE. The supplement of included ramp angle (180° minus included ramp angle) over which car can pass without interference; measured with car sitting on a level surface, using lines tangent to arcs of front and rear static loaded radii and intersecting at point on underside of car which defines the smallest angle.

- H156 MINIMUM RUNNING GROUND CLEARANCE. Location of measurement on the car is to be clearly recorded.

FRONT COMPARTMENT DIMENSIONS

- H 61 EFFECTIVE HEAD ROOM - FRONT. The dimension from H Point to the headlining, plus a constant of 4.0 inches, measured along a line 8° to rear of vertical.
 L 34 MAXIMUM EFFECTIVE LEG ROOM - ACCELERATOR. Measured along a diagonal line from the Manikin ankle pivot center to the H Point plus a constant of 10.0 inches. For treadle type accelerator pedals, the leg room is measured with the Manikin's right foot on the accelerator pedal and the Manikin Heel Point at Accelerator Heel Point. All other types of accelerator pedals will be measured with the Manikin foot angle set at 87° and the shoe touching the pedal.
 H 30 H POINT TO HEEL POINT - FRONT. The vertical dimension from the H Point to the Accelerator Heel Point.
 L 17 H POINT TRAVEL. The horizontal dimension between the H Point in the most forward and rearward seat positions.

FRONT COMPARTMENT DIMENSIONS (Cont.)

- W 3 SHOULDER ROOM - FRONT. The minimum lateral dimensions between the door garnish moldings or nearest interference, measured at the H Point station.
 W 5 HIP ROOM - FRONT. The lateral dimension through the H Point to trimmed body surfaces. Depress loose side wall cloth to trim foundation or other obstruction if such construction exists.
 H 50 UPPER BODY OPENING TO GROUND - FRONT. The vertical dimension from a point on the trimmed body opening to the ground, measured at the H Point station.

REAR COMPARTMENT DIMENSIONS

- L 50 H POINT COUPLE DISTANCE. The horizontal dimension from the front seat H Point to the rear seat H Point.
 H 63 EFFECTIVE HEAD ROOM - REAR. The dimension from the H Point to the headlining, plus a constant of 4.0 inches, measured along a line 8° to rear of vertical.
 L 51 MINIMUM EFFECTIVE LEG ROOM - REAR. Measured along a diagonal line from the ankle pivot center to the H Point plus a constant of 10.0 inches, with the foot positioned to the nearest interference between the seat structure and toe, instep or lower leg.
 H 31 H POINT TO HEEL POINT - REAR. The vertical dimension from the H Point to the Manikin Heel Point on the depressed floor covering.
 L 48 MINIMUM KNEE ROOM - REAR. The minimum dimension from the Manikin knee pivot center to the back of the front seat back.
 L 3 REAR COMPARTMENT ROOM. The horizontal dimension from the back of front seat to front of rear seat back at height tangent to the top of rear seat cushion.
 W 4 SHOULDER ROOM - REAR. The minimum lateral dimension between the door garnish molding or nearest interference. Measured at H Point station.
 W 6 HIP ROOM - REAR. The lateral dimension through H Point to trimmed body surfaces. Depress loose side wall cloth to trim foundation or other obstruction when such construction exists.
 H 51 UPPER BODY OPENING TO GROUND - REAR. The vertical dimension from a point on the trimmed body opening to the ground, measured 13.0 inches forward of the H Point.

LUGGAGE COMPARTMENT DIMENSIONS

- V 1 LUGGAGE CAPACITY - USABLE. The total luggage compartment luggage capacity in cubic feet with the tire and tools in place.
 H195 LIFT-OVER HEIGHT. Vertical dimension from the highest point on the luggage compartment lower opening to ground, excluding corner radii.

STATION WAGON - THIRD SEAT DIMENSIONS

- W 85 SHOULDER ROOM - THIRD SEAT. The minimum lateral dimension between the door garnish moldings or nearest interference. Measured at H Point station.
 W 86 HIP ROOM - THIRD SEAT. The lateral dimension through H Point to trimmed surfaces.
 L 86 EFFECTIVE LEG ROOM - THIRD SEAT. Measured along a diagonal line from ankle pivot center to H Point plus a constant of 10.0 inches. With rear-facing third seat, foot is positioned in foot well or to nearest interference with rear end or rear closure.
 H 86 EFFECTIVE HEAD ROOM - THIRD SEAT. The dimension from H Point to the headlining, plus a constant of 4.0 inches. Measured along a line 8° to rear of vertical.

STATION WAGON - CARGO SPACE DIMENSIONS

- L202 CARGO LENGTH AT FLOOR - FRONT SEAT. The horizontal dimension, measured at the floor level from the rear of the front seat back to the normal inside limiting interference on the tailgate, on the car centerline.
 L204 CARGO LENGTH AT BELT - FRONT SEAT. The horizontal dimension measured from the top rear of front seat back to a vertical extension line from the normal inside limiting interference at the top of the tailgate, on the car centerline.
 W201 CARGO WIDTH - WHEELHOUSE. The minimum horizontal dimension, measured between wheelhousings at floor level.
 W204 OPENING WIDTH AT BELT. The minimum horizontal dimension, measured between the nearest normal inside limiting interferences of the rear opening at the top of the tailgate.
 H201 MAXIMUM CARGO HEIGHT. The maximum vertical dimension, measured from the top of the floor covering to the headlining, on the car centerline.
 H202 REAR OPENING HEIGHT. The vertical dimension measured from the top of the floor covering to the normal inside limiting interference at the top of the rear opening, on the car centerline, with both tail-and-liftgates fully open.
 V 2 CARGO VOLUME INDEX BEHIND FRONT SEAT. The total volume in cubic feet above the normal load floor and behind the front seat with the liftgate and tailgate closed.

W4xL204xH201
1728

INDEX

SUBJECT	PAGE NO.	SUBJECT	PAGE NO.
Automatic Transmission	16	Kingpin (Steering Axis)	20
Axis, Steering	20	Lamp height and spacing	23
Axle, Rear	17	Legroom	2
Battery	12	Lengths - Car and Body	1
Bearings, Engine	5, 6, 7	Lifters, valve	6
Belts - Fan, Generator, Water Pump	11	Linings - Clutch, Brake	14, 19
Brakes - Parking, Service Power	18, 19	Lubrication	7, 8, 14, 15, 16, 17
Camber	20	Luggage Compartment	2
Camshaft	6	Motor, Starting	12
Capacities		Muffler	8
Cooling System	11	Overdrive	15
Fuel Tank	10	Piston Pins & Rings	4, 5
Lubricants		Pistons	4, 5
Engine Crankcase	8	Power Brakes	19
Transmission and Overdrive	15, 16	Power Steering	20
Rear Axle	17	Power Teams	3
Car and Body Dimensions		Propeller Shaft, Universal Joints	16, 17
Width	1	Pumps - Oil, Fuel	8, 10
Length	1	Water	11
Height	1	Radiator, Hoses	11
Ground Clearance	1	Ratios - Axle	3, 17
Front Compartment	2	Compression	3, 4
Rear Compartment	2	Steering	20
Luggage Compartment	2	Transmission	15, 16
Station Wagon - Third Seat	2	Rear Axle	3, 17
Station Wagon - Cargo Space	2	Regulator - Generator	12
Carburetor	3, 9, 10	Rims	18
Caster	20	Rings, Piston	5
Choke, Automatic	10	Rods - Connecting	5
Clutch - Pedal Operated	14	Shock Absorbers, Front & Rear	21
Coil, Ignition	13	Spark Plugs	13
Connecting Rods	5	Speedometer	14
Convenience Equipment	23	Springs - Front & Rear Suspension	21
Cooling System	11	Valve, Engine	6
Crankcase Ventilation System	8	Stabilizer (Sway Bar) - Front & Rear	21
Crankshaft	6	Starting System	12
Cylinders and Cylinder Head	4	Steering	20
Dimension Definitions		Supply System	12
Key Sheet	25	Suppression - Ignition, Radio	13
Exterior & Interior	26	Suspension - Front & Rear	21
Distributor - Ignition	13	Tail Pipe	8
Electrical System	12, 13, 14	Thermostat, Cooling	11
Engine		Timing, Engine & Valve	6, 7, 13
Bore, Stroke, Displacement, Type	4	Tires	18
Compression Ratio	4	Toe in	20
Firing Order, Cylinder Numbering	4	Torque Converter	16
General Information, H.P. & Torque	4	Torque - Engine, Rated	3, 4
Lubrication	7, 8	Transmission - Types	3, 10, 15, 16
Power Teams	3	Automatic	3, 10, 15, 16
Exhaust Emission Control	9	Manual & Overdrive	3, 10, 15
Exhaust System	8	Ratios	15, 16
Equipment Availability	22	Track	1
Fan, Cooling	11	Trunk Luggage Capacity	2
Filters - Engine Oil, Fuel System	8, 10	Turning Diameter	20
Frame	22	Unitized Construction	22
Front Suspension	21	Universal Joints, Propeller Shaft	16, 17
Fuel, Fuel Pump, Fuel System	4, 10	Valves - Intake & Exhaust	6, 7
Fuel Injection	10	Vibration Damper	6
Generator and Regulator	12	Voltage Regulator	12
Glass	22	Water Pump	11
Height (Lamps)	14	Weights	24
Headroom - Body	2	Wheel Alignment	20
Heights - Car and Body	1	Wheelbase	1
Horns	14	Wheels & Tires	18
Horsepower - Brake	3, 4	Wheel Spindle	20
Ignition System	13	Widths - Car and Body	1
Inflation - Tires	18	Windshield	22
Instruments	14	Windshield Wiper	14