

1969 CORVETTE

Putting you first, keeps us first 



No need to beware of substitutes. There aren't any.



There's no mistaking a Corvette for anything but a Corvette.

The aerodynamic lines of America's original sports car make it the one automobile nobody mistakes for anything else. In Coupe or Convertible this is the genuine article,

designed and engineered without compromise. Corvette stands proudly alone, because nobody but Chevrolet can turn out a car like this on a production line.

And it's as honest as it is beautiful. As you've learned to expect, Corvette goes, stops and handles like nothing else. The basic engine this year is a very healthy 350 CID 300-hp

V8 (plenty enough for most, but if you like, you can order one with up to 435-hp). Of course, Corvette is still the stopper, too, with disc brakes at all four wheels. Road-

grabbing 15-inch wide ovals plus new 8-inch wide wheels and wider tread give Stingray a better grip . . . and an even bolder appearance. Other subtle but significant refine-

ments include a stronger, more rigid frame for improved ride and handling, new maximum security 3-way locking system on the steering column and unique headlight

washers that even clean in motion with jets of water. Shown here are the ways you can get it: Coupe with removable hardtop sections; Convertible with soft top or

removable hardtop. For a more complete list of Corvette extra-cost Options and Custom Features illustrated or described throughout this book, see Page 11.

Corvette Stingray Coupe.



Coupe with roof sections removed.



Convertible with top down.

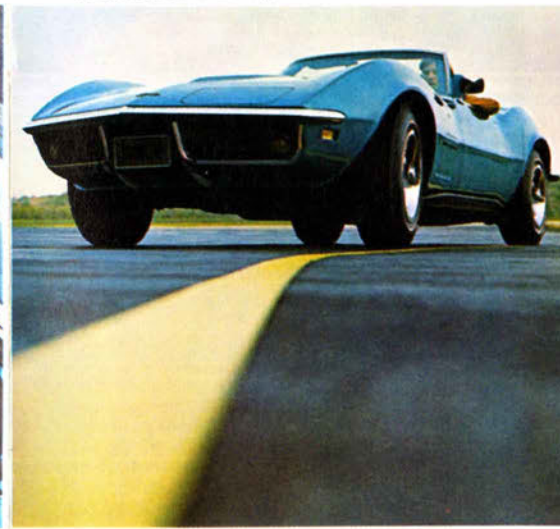

Vinyl-covered removable hardtop.



Headlight washers.

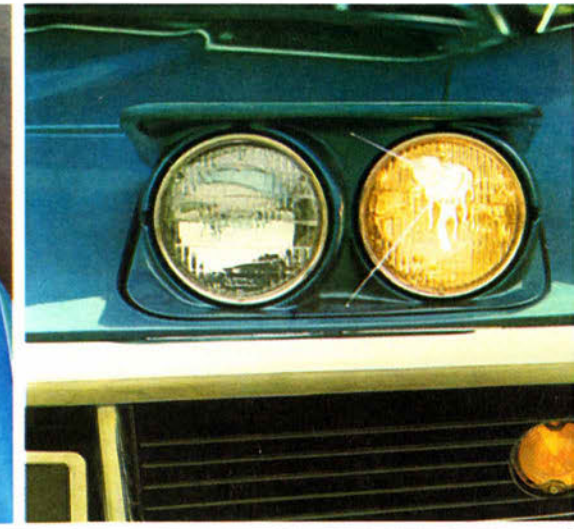

Corvette Stingray with removable hardtop in place.

If it has anything to do with the engine, there's a gauge for it.

The man that drives this kind of car likes to know what's happening...so Corvette has a gauge for everything but your blood pressure. Tachometer, ammeter, oil pressure, sweep second rally clock, fuel gauge,

mileage and trip odometer, warning lights for seat belts, headlight position and door ajar. The center console houses fingertip controls for the heater, defroster, radio, vents, ashtray, cigarette

lighter, shift lever and parking brake, plus an engine rating plate and softly glowing space-age fiber optics that monitor outside running lights. Color-keyed deluxe pushbutton seat belts and

inertia action shoulder belts, on the Coupe, retract out of the way when not in use. Now settle down into that remarkably comfortable contoured slimline bucket seat and enjoy the just right feel of

the new competition steering wheel with the resilient rim. Notice that the windshield wipers and their new integral washers are completely hidden from view when not in use. After you get roll-

ing, advanced Astro Ventilation provides noiseless, draft-free outside air. Color-keyed comfort extends to the use of deep, soft carpeting that stretches back across the luggage area. Under that

carpeting behind the seats you'll find stowage areas housing the battery, another for the jack and tools and a third for valuables (with a pushbutton key lock). More inside news includes door

assist grips, armrests designed to shield door handles and lock buttons, rear compartment courtesy light and built-in head restraints. Nice touches. That's how it's been for 17 years of refining one great idea.

Corvette Stingray Coupe with Turbo Hydra-Matic Transmission you can order.

Center, top to bottom: Standard fully synchronized 3-Speed Transmission. 4-Speed Transmission is available. A center console is standard.

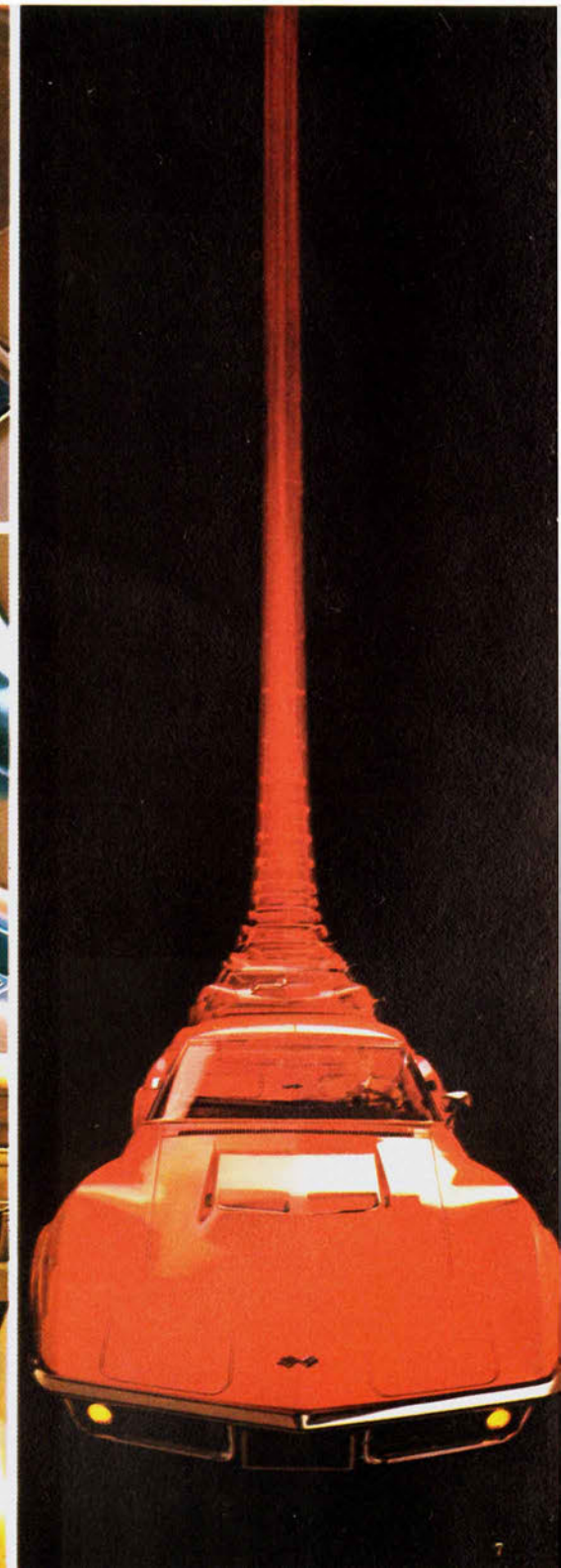
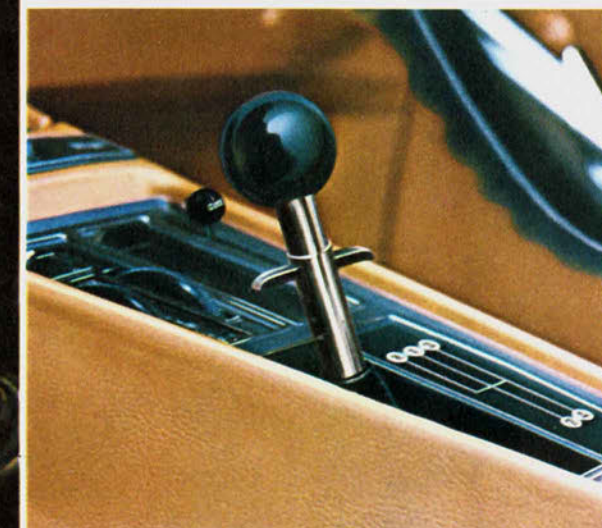

300-hp, 350-hp, 390-hp, 400-hp, 435-hp. Say when.

To propel your Stingray you can choose this 427 CID powerplant with a special high domed hood—or any one of its spirited brothers. The choice you make depends

primarily on what kind of spirited performance suits you best. Check the specifications and pick the transmission and rear axle ratio that fit your idea of sports car

capability and you'll have a tailor-made package. How about triple 2-barrel carburetion? You get it with the 435-hp and the 400-hp 427 CID engines. Want Turbo

Hydra-matic? It's available with all three Turbo-Jet 427 V8's in addition to the standard 300-hp V8. Prefer 4-Speed? With all engines except the 300-hp and the

435-hp, you have a choice of gear ratios. Depending on engine, axle ratios range from 3.08 to 4.11. If your choice is the Turbo Hydra-matic, you still get up to 3 choices.

New Corvette power team features for '69 include new, larger 350 CID 300-hp engine as standard, or a 350-hp version is available.

More new features include sturdier engine construction on the 350 CID, thicker bulkheads and main bearing caps, firmer crankshaft clamping with longer washer head bolts, extra-firm 4-bolt main bearing cap attachment and improved cooling system.

We even have a special engine (L-88) that we don't recommend for street use.

Transmissions: Standard 3-Speed fully synchronized; 4-Speed fully synchronized (wide-range or close-ratio); Turbo Hydra-matic shifts automatically unless you want to shift it—through three forward ranges.

Four-wheel disc brakes are still standard on Corvette—and in stopping ability, fade resistance and modulation they're very much appreciated by just about anybody interested in sports cars. Other Corvette features include a new anti-interference ignition system, a high-output Delcotron generator, new high-capacity energizer-type side terminal battery, rust-proof fiber glass body—and a thoroughness and attention to detail that Corvette owners fully understand.

Standard equipment safety and security features on the 1969 Corvette include: energy-

- absorbing steering column
- seat belts with pushbutton buckles
- shoulder belts with inertia retractors (Coupe only)
- head restraints
- passenger-guard door locks
- safety door latches and hinges
- four-way hazard warning flasher
- dual master cylinder brake system with warning light and corrosion-resistant brake lines
- tire safety rims
- folding seat back latches
- dual-speed windshield wipers and washer
- dual-action safety hood latch
- outside rearview mirror
- back-up lights
- side marker lights and parking lights that illuminate with headlights
- energy-absorbing instrument panel
- padded sun visors
- reduced-glare instrument panel top, inside windshield moldings, steering wheel hub and windshield wiper arms and blades
- wide inside day-night mirror with deflecting base
- lane-change feature in direction signal control
- safety armrests
- thick-laminate windshield
- soft, low-profile window control knobs
- smooth contoured door and window regulator handles
- anti-theft ignition key warning buzzer
- starter safety switch (to prevent engine starting when in gear) with all transmissions
- snag-resistant steering wheel hardware
- non-projecting wheel trim
- improved fuel tank retention
- headlight aiming access provision
- fail-safe concealed headlights
- anti-theft ignition, steering wheel and transmission selector lock.

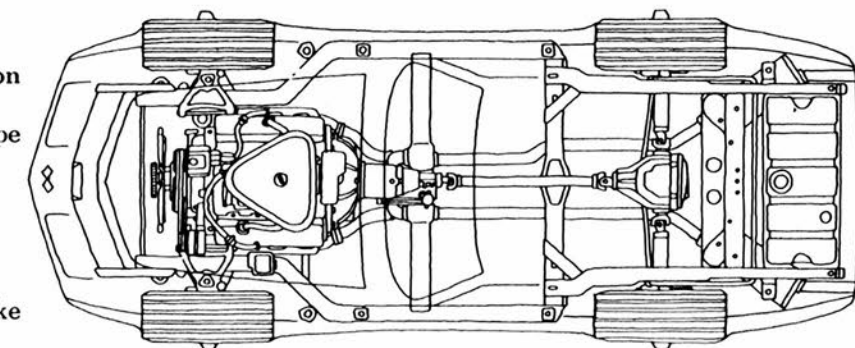

Top view of chassis.

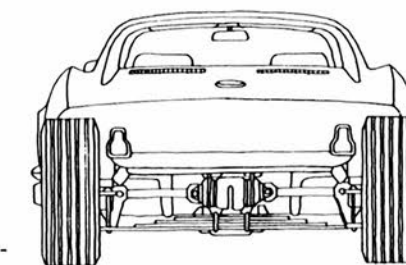

Fully independent rear suspension.

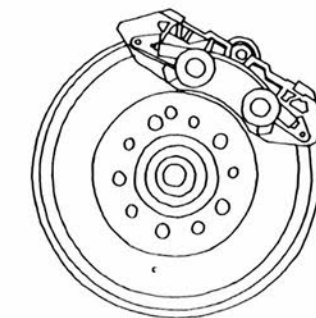

Advanced design disc brakes.

Engine	Transmission	Rear Axle Ratio (:1)							
		Without Air Cond.				With Air Cond.			
		Std	Optional		Spcl	Std	Optional		Spcl
BASE ENGINE									
300 HP Turbo-Fire 350 350-Cu.-In. V8	3-Speed (2.54:1 Low)	3.36	3.08			3.36	3.08		
	4-Speed (2.52:1 Low)								
	Turbo Hydra-matic	3.08				3.08			
OPTIONAL ENGINES									
350 HP Turbo-Fire 350 350-Cu.-In. V8 RPO L46	4-Speed (2.52:1 Low)	3.36		3.55		3.36		3.55	
	4-Speed (2.20:1 Low)	3.70		4.11		3.70		4.11	
390 HP Turbo-Jet 427 427-Cu.-In. V8 RPO L36	4-Speed (2.52:1 Low)	3.08		3.36		3.08			
	4-Speed (2.20:1 Low)	3.36	3.08	3.55	3.70	Air Conditioning Not Available			
	Turbo Hydra-matic	3.08	2.73			Air Conditioning Not Available			
400 HP Turbo-Jet 427 427-Cu.-In. V8 RPO L68	4-Speed (2.52:1 Low)	3.08		3.36		3.08			
	4-Speed (2.20:1 Low)	3.36	3.08	3.55	3.70	Air Conditioning Not Available			
	Turbo Hydra-matic	3.08	2.73			Air Conditioning Not Available			
435 HP Turbo-Jet 427 427-Cu.-In. V8 RPO L71	4-Speed (2.20:1 Low)	3.55	3.36	3.70	4.11	Air Conditioning Not Available			
	Turbo Hydra-matic	2.73		3.08	3.36	Air Conditioning Not Available			
SPECIAL HIGH PERFORMANCE ENGINE (OFF-ROAD APPLICATION ONLY)									
430 HP Turbo-Jet 427 427-Cu.-In. V8 RPO L88	Special 4-Speed (2.20:1 Low)	3.36	3.08	3.55	3.70	Air Conditioning Not Available			
	Turbo Hydra-matic	2.73		3.08	3.36	Air Conditioning Not Available			

*Positraction available. **Positraction required. † Heavy-duty clutch required.

435-hp Turbo-Jet 427 V8.

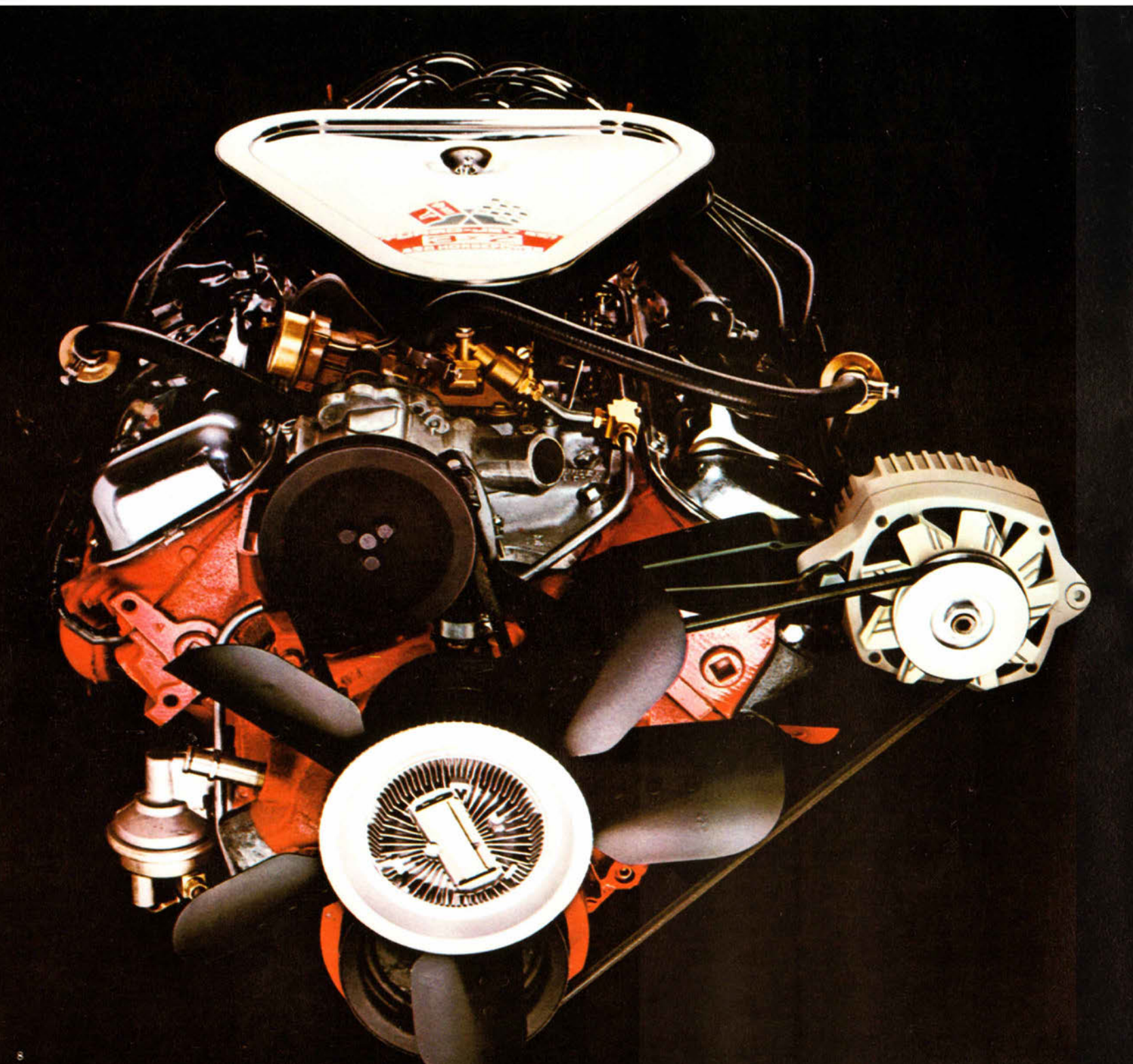

Why shouldn't you have air conditioning if you want it?

No good reason. It's just a useless old idea about sports cars being generally uncomfortable. Corvette buried all that nonsense with a lot of modern ideas that make driving more fun and a whole lot more comfortable.

Air-conditioned comfort is

just the beginning. A steering wheel that telescopes *and* tilts up and down adds another large degree of pleasure to any driving situation. For winter weather add a rear window defroster for Convertible or Coupe.

Handsome bits of dash

include wheel covers and bright trim for the front fender louvers. There are six new colors for '69, total of ten: Tuxedo Black Can-Am White Monza Red LeMans Blue Fathom Green Daytona Yellow Cortez Silver

Monaco Orange Burgundy Riverside Gold. Order interior trim in coordinated standard all-vinyl or extra-cost genuine leather in: Black Saddle Red Bright Blue Gunmetal Green. Convertible top colors are

black, white or beige. A black vinyl roof cover for the removable hardtop can be ordered.

Other extras for your consideration: Aluminum cylinder heads for the 435-hp engine Compass Deck lid luggage carrier Emergency road kit Clear vinyl floor

mats Full-transistor ignition system (not available with 300-hp Turbo-Fire 350 V8) Gas cap lock Hand portable spotlight Side-mounted exhaust system Positraction rear axle Power brakes Power steering Heavy-

duty dual disc clutch (435-hp only) Special brake system Engine block heater Power windows Push-button AM/FM radio with twin speakers FM Stereo multiplex Rear window defroster Removable hardtop for Convertible

(may be specified as standard in lieu of folding convertible top) Special-purpose front and rear suspension with 435-hp engine Speed warning indicator Tilt-telescopic steering wheel Audio alarm system Red or white stripe tires.

Deluxe wheel covers.



Four-Season air conditioning.

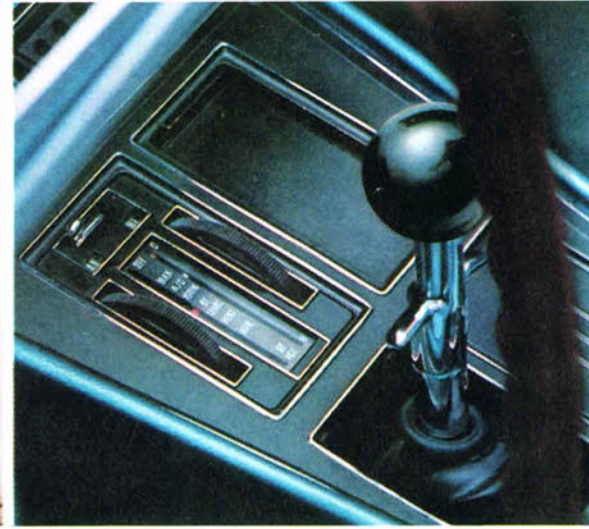

Positraction.



Luggage rack.



Side-mounted exhaust system.



Front fender louver trim.



Corvette Stingray Coupe

All illustrations and specifications in this literature are based on the latest product information available at the time of publication approval. The right is reserved to make changes at any time without notice in prices, colors, equipment, specifications and models, and also to discontinue models. Chevrolet Motor Division, General Motors Corporation, Detroit, Mich. 48202.

Corvette Stingray Coupe

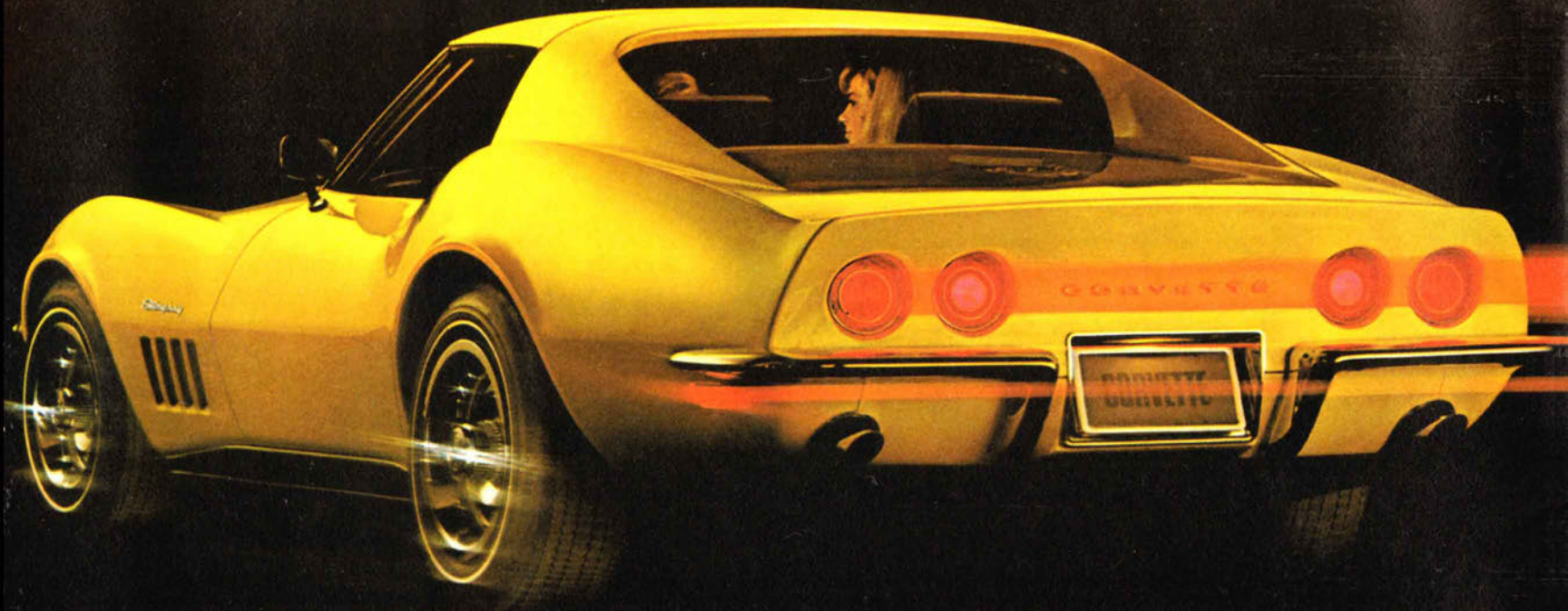

Litho in U.S.A.—D-67141—R1

