

# *Fisher Body*



**1969  
SERVICE  
MANUAL**

# 1969 FISHER BODY SERVICE MANUAL

FOR ALL  
BODY STYLES

This publication contains the essential removal, installation, adjustment and maintenance procedures for servicing all U.S. and Canadian built 1969 Fisher Body Styles. All information, illustrations, and specifications contained in this publication are based on the latest product information available at the time of publication approval. The right is reserved to make changes at any time without notice.

Arrangement of the material is shown by the table of contents on the right-hand side of this page. Black tabs on the first page of each section can be seen on the edge of the book below section title. A more detailed table of contents precedes each section, and an alphabetical index is included in the back of the manual.

## TABLE OF CONTENTS

SECTION	TITLE
1	GENERAL INFORMATION
2	LUBRICATION
3	UNDERBODY
4	STATIONARY GLASS
5	FRONT END
6	DOORS
7	REAR QUARTERS
8	REAR COMPARTMENT LID
9	TAIL GATE
10	TRIM CLEANING
11	HEADLINING
12	ROOF COVER
13	FOLDING TOP
14	DOOR, QUARTER AND SHELF TRIM
15	SEATS
16	ELECTRICAL
17	EXTERIOR MOLDINGS
18	INDEX

# SECTION 1

## GENERAL INFORMATION

### INDEX

Subject	Page	Subject	Page
Manual Description . . . . .	1-1	Removal . . . . .	1-10
Introduction . . . . .	1-1	Installation . . . . .	1-10
Index . . . . .	1-1	Paint Conditions . . . . .	1-11
Page and Figure Numbers . . . . .	1-1	Introduction . . . . .	1-11
Reference Tabs . . . . .	1-1	Blistering . . . . .	1-11
Text . . . . .	1-1	Blushing . . . . .	1-11
Illustrations . . . . .	1-1	Bull's-Eye . . . . .	1-11
Model Identification Chart . . . . .	1-2	Line-Checking . . . . .	1-12
Model Identification . . . . .	1-3	Chemical Discoloration . . . . .	1-12
Introduction . . . . .	1-3	Crazing . . . . .	1-12
Body Series Number . . . . .	1-3	Dirt in Paint . . . . .	1-13
Body Style Identification . . . . .	1-3	Dry Spray . . . . .	1-13
Body Style Name . . . . .	1-3	Etching . . . . .	1-13
Body Number Plate . . . . .	1-4	Fish-Eyes . . . . .	1-13
Vehicle Identification Number . . . . .	1-4	Mottling . . . . .	1-14
Lock Cylinder Coding . . . . .	1-5	Off-Color . . . . .	1-14
Five Bitting Level Lock Cylinder and Key . . . . .	1-5	Excessive Orange Peel . . . . .	1-14
Cutting Keys . . . . .	1-6	Overspray . . . . .	1-14
Replacement Lock Cylinders . . . . .	1-6	Pin-Holing . . . . .	1-15
Assembly and Coding Lock Cylinders . . . . .	1-6	Rust Spots . . . . .	1-15
Assembly and Coding Glove and Console Compartment Lock Cylinders . . . . .	1-7	Sand or File Marks . . . . .	1-15
Glass Polishing . . . . .	1-8	Sand Scratch Swelling . . . . .	1-16
Description . . . . .	1-8	Sweat Out or Bloom . . . . .	1-16
Glass Polishing Procedure . . . . .	1-8	Thin Paint . . . . .	1-16
Wood Grain Transfer . . . . .	1-9	Water Spotting . . . . .	1-16
Description . . . . .	1-9	Wheel Burn . . . . .	1-16
		Special Body Service Tools . . . . .	1-16

## MANUAL DESCRIPTION

### INTRODUCTION

This publication contains the essential removal, installation, adjustment and maintenance procedures for servicing all 1969 Fisher Body Styles. This information is current as of time of publication approval.

### INDEX

The preceding page contains a "Table of Contents" which lists the section number and subject title of each main body area section. The first page in each main body area section has an index to the subjects included in that section. An alphabetic index covering the entire manual is located in section 18.

### PAGE AND FIGURE NUMBERS

All page numbers and figure numbers consist of two sets of digits separated by a dash. The digits preceding the dash identify the main body area section. The digits following the dash represent the

consecutive page number or figure number within the particular body area section.

### REFERENCE TABS

The first page of each section is marked with a ready-reference black tab corresponding with the table of contents page.

### TEXT

Unless otherwise specified, each service procedure covers all body styles. Procedures covering specific styles are identified by the style number, body series number, body type letter or similar designation. A description of these designations is covered in this section under "Model Identification".

### ILLUSTRATIONS

Where possible, illustrations are placed in close proximity to the accompanying text and should be used as part of the text.

### MODEL IDENTIFICATION CHART

Division	Sales Name	Body Type	Series	Styles
Chevrolet	Chevelle Nomad	A	13200	35-36
	Chevelle "300" Deluxe	A	13400	27-35-36-37-45-46-69-80
	Chevelle Malibu	A	13600	35-36-37-39-45-46-67-69-80
	Chevelle - Concours Estate	A	13800	35-36-45-46
	Biscayne	B	15400	11-36-69
	Bel Air	B	15600	11-36-46-69
	Impala	B	16400	36-37-39-46-47-67-69
	Caprice	B	16600	36-39-46-47
	Camaro	F	12400	37-67
	Chevy Nova	X	11400	27-69
Corvair "500"	Corvair	Z	10100	37
	Corvair Monza	Z	10500	37-67
Pontiac	Tempest	A	23300	27-69
	Tempest Custom	A	23500	27-35-36-37-39-67-69
	Tempest LeMans	A	23700	27-37-39-67
	Tempest Safari	A	23900	36
	Tempest GTO	A	24200	37-67
	Catalina	B	25200	36-37-39-46-67-69
	Executive	B	25600	37-39-36-46-69
	Bonneville	B	26200	37-39-46-67-69
	Firebird	F	22300	37-67
	Grand Prix	G	27600	57
Oldsmobile	F-85	A	33200	77
	Cutlass	A	33600	35-36-39-67-69-77-87
	Cutlass Supreme	A	34200	39-69-87
	442	A	34400	67-77-87
	Custom Vista-Cruiser	A	34800	55-56-65-66
	Delta 88	B	35400	37-39-67-69
	Delta Custom 88	B	36400	37-39-69
	Delta Royale 88	B	36600	47
	Ninety Eight	C	38400	39-57-67-69
	Ninety Eight Luxury	C	38600	39-69
	Toronado	E	39400	87
	Toronado Deluxe	E	39600	87
	Buick	Special Deluxe	A	43300
Special Deluxe		A	43400	35-36-37
Skylark		A	43500	37-69
Skylark Custom		A	44400	37-39-67-69
Sport Wagon		A	44400	56-66
GS 400		A	44600	37-67
LeSabre		B	45200	37-39-69
LeSabre Custom		B	45400	37-39-67-69
Wildcat		B	46400	37-39-69
Wildcat Custom		B	46600	37-39-67
Electra "225"		C	48200	39-57-69
Electra "225" Custom		C	48400	39-57-67-69
Riviera		E	49400	87

**MODEL IDENTIFICATION CHART (Cont'd.)**

Division	Sales Name	Body Type	Series	Styles
Cadillac	Fleetwood Sixty Special	C	68000	69
	Fleetwood Brougham Sedan	C	68100	69
	Calais	C	68200	47-49
	DeVille	C	68300	47-49-67-69
	Fleetwood Seventy-Five	D	69700	23-33
	Eldorado	E	69300	47
GM of Canada Acadian and Beaumont	Acadian	X	71400	27-69
	Beaumont	A	73200	35-36
	Deluxe	A	73400	27-37-69
	Custom	A	73600	35-36-37-39-67-69
GM of Canada Pontiac	Strato Chief	B	75400	36-37-69
	Laurentian	B	75600	36-37-46-69
	Parisienne	B	76400	36-37-39-46-67-69
	2 + 2	B	76800	37-67
	Grande Parisienne	B	76600	36-37-39-46

**MODEL IDENTIFICATION**

**INTRODUCTION**

Due to the variety of body styles available, certain body styles have been grouped in this publication as an aid to identification. These group designations may be used individually or in various combinations. In addition to the model identification chart, an explanation of the principal categories follows:

**BODY SERIES NUMBER**

The body series number may be used to indicate three possibilities:

- Division - first digit and four zeros (ex. 10000 Chevrolet; 20000 Pontiac).
- Division and Car Line - first two digits and three zeros (ex. 33000 Oldsmobile F-85; 45000 Buick LeSabre).
- Division, Car Line and Style Group - First three digits and two zeros (ex. 25200 Catalina; 25600 Executive).

**BODY STYLE IDENTIFICATION**

The last two digits of the body series number indicate body style type as follows:

<u>STYLE</u>	<u>DESCRIPTION</u>
11	2-Door - Notch Back - Pillar Sedan
23	4-Door - Limousine with Auxiliary Seat
27	2-Door - Notch Back - Pillar Coupe

33	4-Door - Limousine with Auxiliary Seat and Center Partition Window
35	4-Door - Station - 2 Seat - Single Acting Tailgate
36	4-Door - Station Wagon - 2 Seat - Dual Acting Tailgate
37	2-Door - Notch Back - Hardtop Coupe
39	4-Door - Notch Back - Hardtop (4 Window) Sedan
45	4-Door - Station Wagon - 3 Seat - Single Acting Tailgate
46	4-Door - Station Wagon - 3 Seat - Dual Acting Tailgate
47	2-Door - Notch Back - Hardtop Coupe
49	4-Door - Notch Back - Hardtop (4 Window) Sedan
55	4-Door - Station Wagon - 2 Seat - Single Acting Tailgate
56	4-Door - Station Wagon - 2 Seat - Dual Acting Tailgate
57	2-Door - Notch Back - Hardtop Coupe
65	4-Door - Station Wagon - 3 Seat - Single Acting Tailgate
66	4-Door - Station Wagon - 3 Seat - Dual Acting Tailgate
67	2-Door - Convertible Coupe
69	4-Door - Notch Back - Pillar (4 Window) Sedan
77	2-Door - Plain Back Pillar Coupe
87	2-Door - Plain Back - Hardtop Coupe
80	2-Door - Pick-Up Delivery

**BODY STYLE NAME**

Body style names are used for group classification

as follows (style numbers suffix shown in brackets):

**Closed Style**

- Two-door sedan (11)
- Two-door coupe (27,77)
- Four-door sedan (69)
- Limousine (23,33)

**Hardtop**

- Sport coupe hardtop (37, 47, 57, 87)
- Sedan hardtop (39, 49)

**Station Wagon**

- Station wagon two seat (35-36, less skylight; 55-56 with skylight)
- Station wagon three seat (45-46 less skylight; 65-66 with skylight)

**Convertible Coupe (67)**

**Sedan Delivery (80)**

## BODY NUMBER PLATE

The body number plate identifies the model year, car division, series, style, body assembly plant, body number, trim combination, paint code and date build code (Figs. 1-1 and 1-2). On Corvair styles the body number plate is attached to the left side of the motor compartment cross rail. On Cadillac

“C & D” styles, the plate is located on the left upper portion of the horizontal surface of the shroud. On all other cars, the plate is located on the left upper portion of the vertical surface of the shroud.

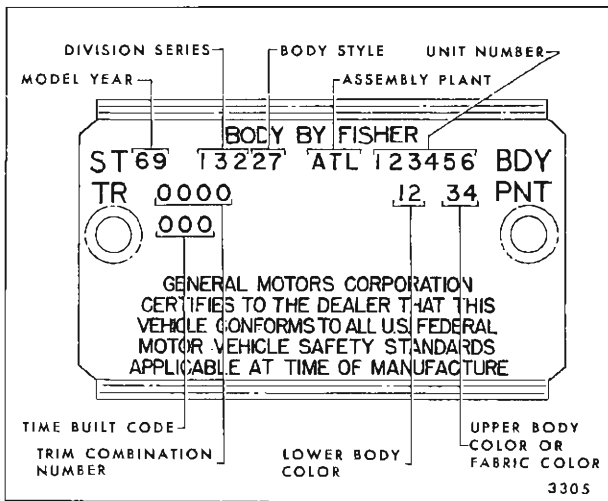

Fig. 1-1—Body Number Plate - U.S. Models

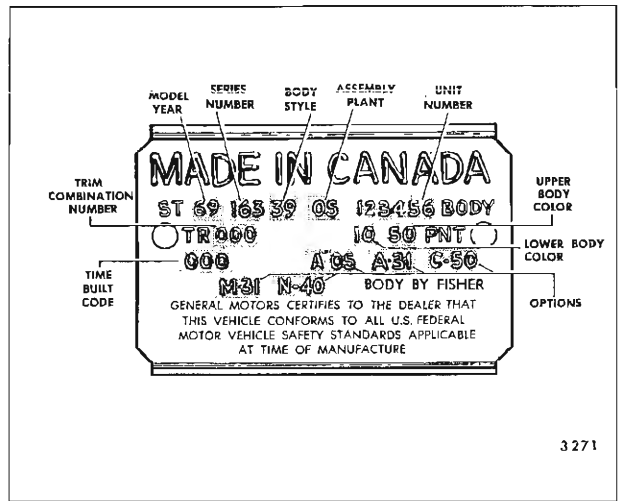

Fig. 1-2—Body Number Plate - Canadian Models

## VEHICLE IDENTIFICATION NUMBER

The Vehicle Identification Number (serial number) is located on the left horizontal surface of the instrument panel which is visible from outside the car. Figure 1-3 shows a typical installation.



Fig. 1-3—Typical Vehicle Identification Number

## LOCK CYLINDER CODING

### FIVE BITTING LEVEL LOCK CYLINDER AND KEY

All 1969 style cars are equipped with new lock cylinders and keys. The keyway has been revised so that prior model keys will not enter current model lock cylinders.

Two non-interchangeable keyways are used on 1969 model cars. One keyway, known as type "E", is used in all ignition, front door and station wagon tail gate lock cylinders. Type "E" keys will have a square head and be marked similar to keys used for 1968 styles, except that a capital letter "E" will be located on the shank just below the coining on the head, in place of capital letter "C". In addition, a code number within the series 0J00 to 9J99, or 0K00 to 9K99 will be stamped on the knock-out portion on the keyhead. This number identifies the lock combination and is used when ordering or making new keys.

The second keyway, known as type "H", is used in the instrument panel compartment, console compartment, rear compartment, front compartment

and station wagon rear floor compartment lock cylinders. Type "H" keys will have oval heads and will be similar to keys used for 1968 styles, except that a capital letter "H" will be stamped on the shank just below the coining on the head, in place of capital letter "D". In addition, a code number within the series 0L00 to 9L99, or 0M00 to 9M99 will be stamped on the knock-out portion of the key head. This number identifies the lock combination and is used when ordering or making new keys.

Key code numbers are stamped on the "knockout" plug in the key head and on the lock cylinder housing (to facilitate replacement or duplication of key). After the code number has been recorded by the owner, the plugs should be knocked out of the key head. From these numbers, the lock combination can be determined by use of a code list (available to owners of key cutting equipment from equipment suppliers). If key code numbers are not available from records or from the "knock-out" plug, lock combination (tumbler numbers and position arrangement) can be determined by laying the key on the diagram in Figure 1-4.

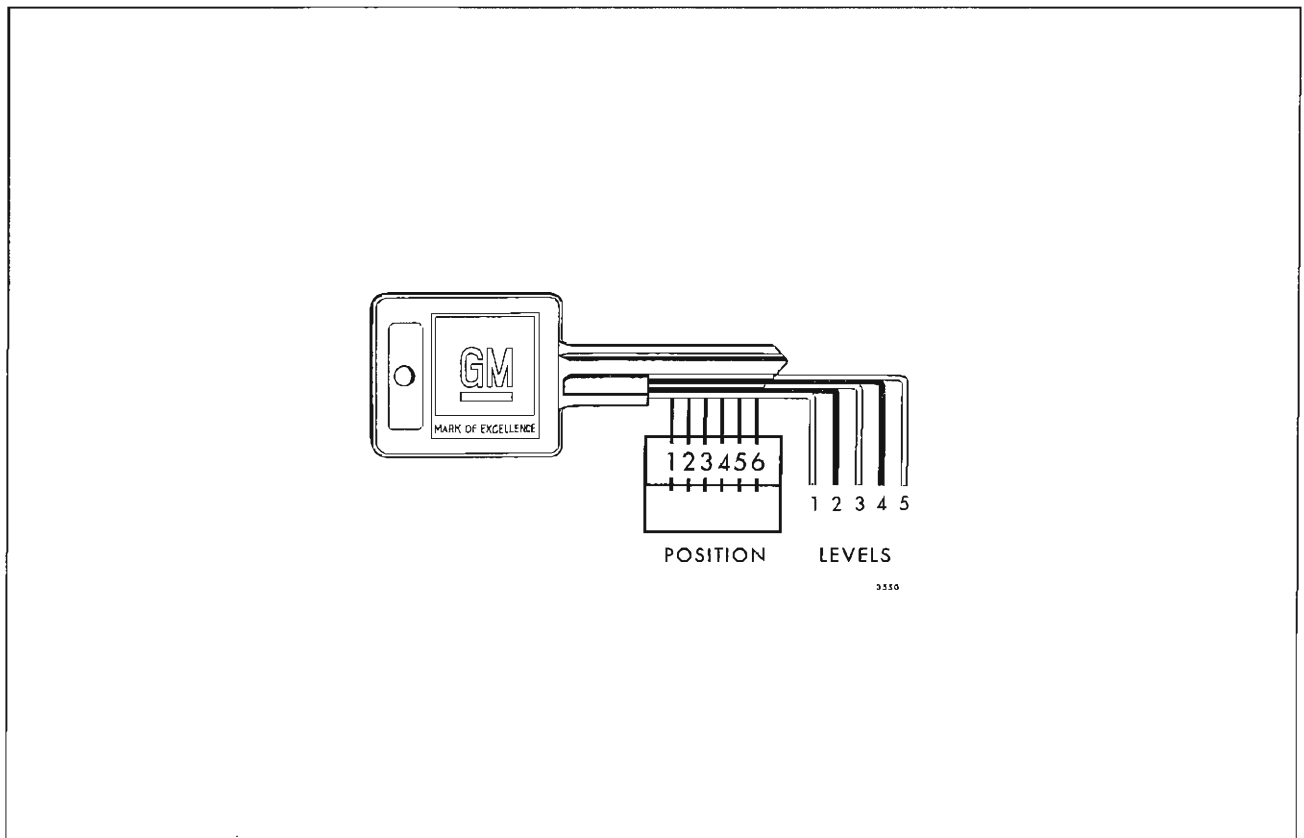

Fig. 1-4—Key Code Diagram

## CUTTING KEYS

After the special code has been determined, either from the code list or the Key Code Diagram (Figure 1-4) cut a blank key to the proper level for each of the six tumbler positions, and check the key in the lock cylinder. The new key should agree with the combination opposite the code number in the code list.

## REPLACEMENT LOCK CYLINDERS

New lock cylinders are available from the servicing Parts Warehouse with the new lock cylinder locking bar staked in place. Tumblers are also available and must be assembled into the cylinder according to the procedure outlined below.

## ASSEMBLY AND CODING LOCK CYLINDERS—

### ALL LOCK CYLINDERS EXCEPT GLOVE AND CONSOLE COMPARTMENTS

Tumblers for all locks except the glove and console compartments are shaped exactly alike, with the exception of the position of a notch on one side. As the key is inserted in the lock cylinder, the tumblers are raised to the correct height so that the notches on each tumbler are on the same level. When the notches on all six tumblers line up, the locking bar is pushed into the notches by two small springs, allowing the cylinder to turn in its bore. Five types of tumblers are used to make all the various lock tumbler combinations and each is coded according to a number, 1 through 5, stamped on its side.

1. Determine lock cylinder tumbler numbers and tumbler arrangement by use of a numerical key code lock cylinder code list. Code lists are made available to owners of key cutting equipment by equipment suppliers.

**NOTE:** To determine which tumblers should be installed in what position for a given key, when a code list is not available, proceed as follows:

- a. Lay the key on the Key Code Diagram (Figure 1-4) with the key outlined by the diagram as accurately as possible.
  - b. Starting at the head of the key blade, determine and record the lowest level (tumbler number) that is visible in position #1 and subsequent position numbers 2 through 6. After tumbler numbers and arrangement have been determined, assemble as follows:
2. Starting at the open end (head) of the cylinder, insert the tumblers in their proper slots in the

order called for by the code, as shown in Figure 1-5.

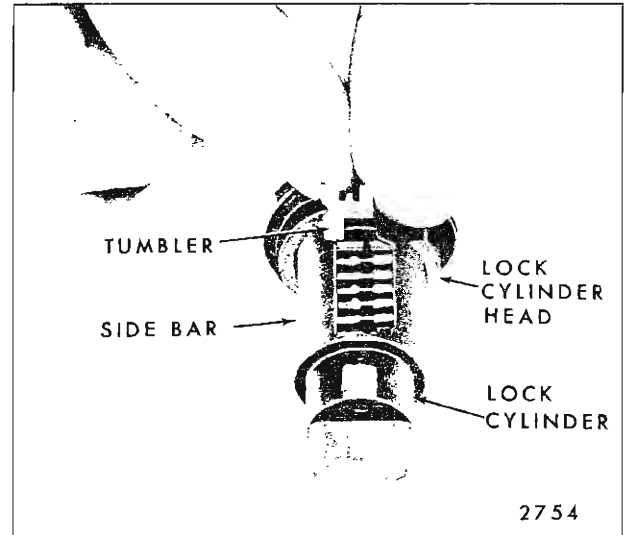

Fig. 1-5—Installing Tumblers

3. Pull out side bar with fingers so that tumblers will drop completely into place (Fig. 1-5). Insert one tumbler spring in the space provided above each tumbler.

**NOTE:** If the springs become tangled, do not pull them apart - unscrew them.

4. Insert the spring retainer so that the two end prongs slide into the slots at either end of the cylinder. Press the retainer down. (See Figure 1-6).

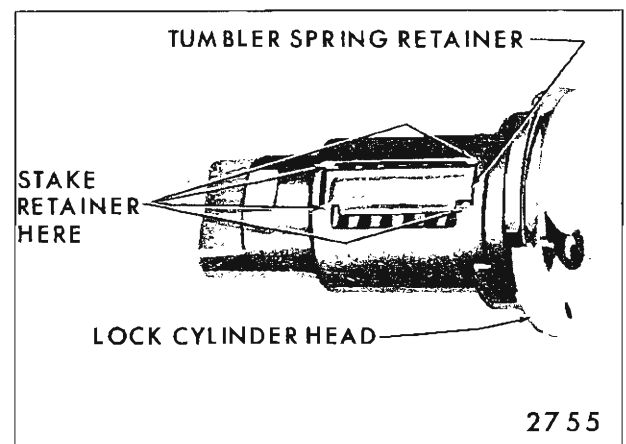

Fig. 1-6—Installing Spring Retainer

5. To determine if tumblers have been properly installed, insert key into lock cylinder. If tumblers are installed properly the side bar will drop down. If bar does not drop down,



remove the key, spring retainer, springs and tumblers and reassemble correctly.

**NOTE:** If the tumblers have not been assembled correctly, they can be removed from the cylinder by holding cylinder with the tumbler slots down, pulling the side bar out with the fingers and jarring the cylinder to shake the tumblers out. This procedure is necessary because once the tumblers have been pressed down into the cylinder they are held in their slots by the side bar.

6. If, after checking, it is found that the lock cylinder is assembled properly, remove key and secure cylinder in a vise with spring retainer exposed.

**NOTE:** Use leather or wood at each vise jaw to prevent damage to the cylinder.

7. Using a suitable staking tool, stake the spring retainer securely in place by staking the cylinder metal over the retainer at each end. Refer to Figure 1-6.

## ASSEMBLING AND CODING GLOVE AND CONSOLE COMPARTMENT LOCK CYLINDERS

Only one type of tumbler is used to make the various lock tumbler combinations for glove and console compartment locks. Tumblers for these two lock cylinders are pre-assembled in the service replacement lock cylinder and require that a correctly coded key be inserted in the cylinder before and during cylinder coding.

As the key is inserted in the coded lock cylinder, each tumbler is depressed so that no part of any tumbler is exposed above the level of the lock cylinder thereby allowing the cylinder to turn in its bore.

**NOTE:** These two lock assemblies are equipped with four or five tumblers rather than six as used in other locks. Tumblers are used in positions 3-4-5-6 or 2-3-4-5-6 only. Tumblers which correspond to positions 1 and/or 2 on the key are not used. The non-brass, black "tumbler" that is closest to the head of the four tumbler lock cylinder is a locking device and must **NOT** be removed or filed. See Figure 1-7.

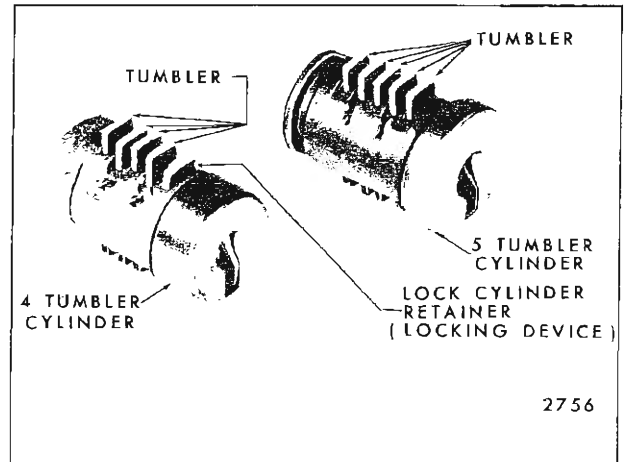

Fig. 1-7—Glove Compartment Lock Cylinder

1. Insert properly coded key in cylinder.
2. Place cylinder in a vise, bottom side up, using leather or wood at each vise jaw to prevent damage to the cylinder.
3. File tumblers down so that no part of any tumbler extends above the lock cylinder.

**NOTE:** Do not file any part of the non-brass, black "tumbler" (retainer) on four tumbler lock cylinders. This is a locking bar and should not be altered.

4. Reverse lock cylinder position in vise and repeat step #3 for top of tumblers. See Figure 1-8.

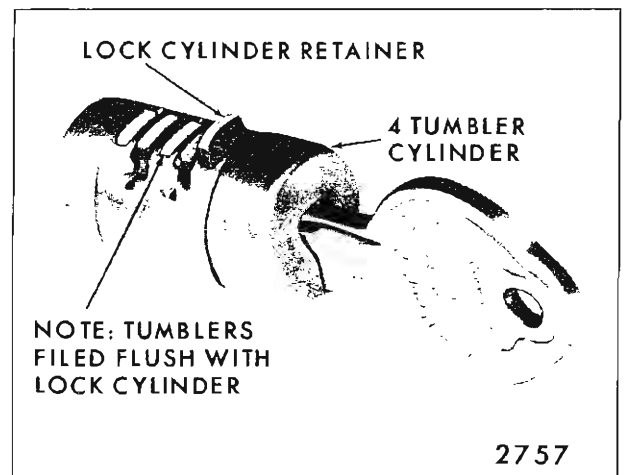

Fig. 1-8—Coded Glove Compartment Cylinder

## GLASS POLISHING

### REMOVAL OF MINOR SCRATCHES AND ABRASIONS—

#### Description

Minor glass scratches and abrasions can be effectively removed or substantially reduced by utilizing the procedure and precautions presented in this section. The phases of glass polishing discussed in this section include the equipment required, the recommended procedure and the precautions necessary.

There are two basic types of automotive glass: (1) laminated safety plate (all windshield and skylight glass) and (2) solid tempered safety plate (all side windows and back glass, except skylight).

A major concern in glass polishing is preventing double vision from developing in areas that will distort driver's vision. For this reason, less polishing can be done on the windshield in the driver's line of vision than in other areas. Distortion is most likely to result when attempting to remove deep scratches.

Glass polishing is an operation that must be performed with reasonable care.

The equipment and procedures recommended here were developed using cerium oxide compound (Glass-Nu or equivalent). Follow the manufacturer's directions if other materials are used.

The following equipment is recommended for glass polishing:

1. A low speed (600-1300 RPM) rotary polisher (Ski Model #570 or equivalent).
2. A wool felt rotary-type polishing pad, approximately three inches in diameter and two inches thick.
3. Powdered cerium oxide (Glass-Nu or equivalent) mixed with water as the abrasive compound.
4. A wide mouth container to hold the polish.

#### Glass Polishing Procedure

1. Mix at least three heaping tablespoons of cerium oxide (Glass-Nu or equivalent) with sufficient water to obtain a creamy consistency.

**NOTE:** If a larger proportion of cerium oxide (Glass-Nu or equivalent) is used, the com-

pound cakes on the felt pad faster. If a small proportion is used the polishing time required will increase.

2. Agitate the mixture occasionally to maintain a creamy consistency. The powdered cerium oxide is insoluble in water and tends to separate.
3. Draw a circle around the scratches on the inside of the windshield with a marking crayon or equivalent. Draw other lines directly behind scratches to serve as guides in locating the scratch during polishing (Fig. 1-9).

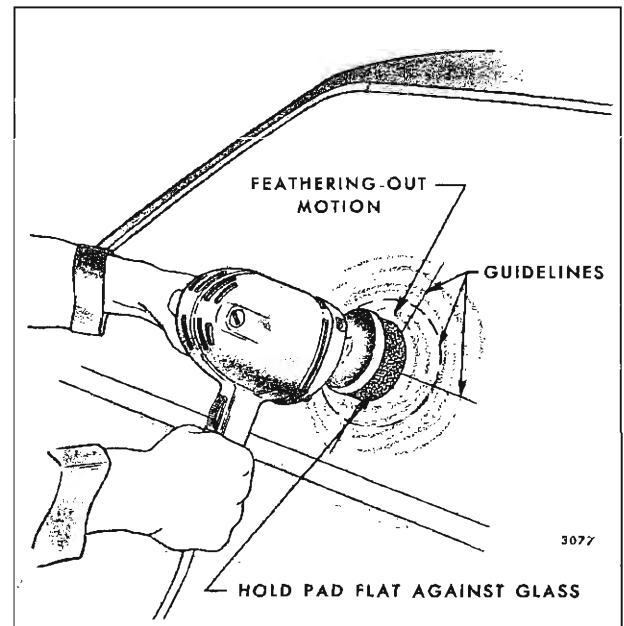

Fig. 1-9—Minor Glass Scratch Removal

4. Use masking paper where needed to catch drippings or spattered polish.
  5. Dip the felt pad attached to the polisher into the mixture several times to insure that the pad is well saturated.
- NOTE:** Never submerge or allow the pad to stay in the mixture as it may loosen the bond between the pad and the metal plate.
6. Using moderate, but steady, pressure, hold the pad flat against the scratched area of the glass, and with a feathering-out motion, polish the affected area as shown in Figure 1-9.

**NOTE:** Avoid excessive pressure which does not speed-up the operation and may cause overheating of the glass.

7. Cover a sufficient area around the scratch with a feathering-out motion as shown in Figure 1-9, to eliminate any possibility of a "bulls-eye".

**NOTE:** Never hold the tool in one spot or operate the tool on the glass any longer than 30 to 45 seconds at a time. If the glass becomes hot to touch, let it air cool before proceeding further. Cooling with cold water may crack the heated glass.

8. Dip the pad into the mixture about every fif-

teen seconds to insure that the wheel and the glass are always wet during the polishing operation. A dry pad causes excessive heat to develop.

9. After removing the scratch or abrasion, wipe the body clean of any polish.

10. Clean the polishing pad.

**NOTE:** Care should be taken during polishing and storage to keep the pad free of foreign material such as dirt, metal filings, etc.

## WOOD GRAIN TRANSFER (Station Wagon Styles)

### DESCRIPTION AND GENERAL INFORMATION

Two types of vinyl wood grain transfers are used on 1969 model station wagons. Both types incorporate a pressure sensitive adhesive. In addition, both transfers are designed with the same Burgundy Walnut wood grain pattern, the same colors, and the same 50° or semi-gloss finish. One transfer is of all-vinyl construction. The other transfer is a heavier gauge material and is also of vinyl construction, but is top coated with a clear acrylic containing a flattening agent. Due to the difference in construction, the two types of transfers are not to be inter-mixed on the same car.

Both types of transfers are available through the service parts department. When placing orders for transfers, carefully observe "Division", "Model Year" and "body style" identification to determine the correct part number.

The following general information and procedures apply to both types of transfers.

For quality installation of service replacement transfers, the temperature of the transfer, the panel surface and the work room should be between 65°F. and 90°F. Transfers should not be replaced in temperatures below 65°F.

Prepare a supply of wetting solution, as called out in the procedure, by adding 1/4 ounce of detergent ("Joy", "Vel", or equivalent) to one gallon of clean water.

Use of a wetting solution, as specified, insures a better bond between the transfer and the painted surface. Deviating from specifications, such as using too much detergent or using a soap solution, is detrimental to the bond of the transfer.

Transfer replacement involving collision damage,

or damage to the underlying acrylic paint finish requires that the metal repair and/or refinish operations be carried to completion before a transfer is installed.

The purpose of squeegeeing with a proper tool, using progressive, overlapping strokes and working from the center outwardly, is to drive out all the water and air. At the same time, proper squeegeeing provides the required pressure per square inch for proper bonding of pressure sensitive adhesive to painted surfaces.

Scuff-sanding an acrylic finish before transfer installation with #360 or #400 sandpaper promotes better adhesion, and removes dirt nibs and high spots.

The following equipment and materials are necessary in making a quality transfer installation. Equivalent products can be used.

1. Liquid detergent: "Joy", "Vel" or equivalent
2. Wax and Silicone Remover: "Prep-Sol", "Pre-Kleano", or "Acryli Clean"
3. 3-M Vinyl Trim Adhesive or equivalent; brush or spray-can
4. Squeegee: 3" to 5" wide; plastic or hard rubber
5. Water bucket and sponge
6. Sandpaper, #360 or #400, Wet-or-Dry Type
7. Infra-red heat bulb and extension cord
8. Clean wiping rags or paper towels
9. Sharp knife
10. Scissors
11. Fine pin or needle

**Removal**

1. Wash and clean repair surfaces and adjacent panels and openings as required.
2. Remove transfer finishing moldings, handles, side marker lamps, and/or other transfer overlapping parts.
3. Remove affected transfer by starting at one edge and by peeling transfer as sheet from surface. Application of heat to affected transfer at point of removal aids removal operation.

**CAUTION:** Avoid using pointed or sharp instruments during transfer removal as they may damage paint finish.

**Installation**

1. Scuff-sand acrylic painted surface with #360 or #400 sandpaper by dry sanding. Freshly painted surfaces must be thoroughly dry. Residual solvents in fresh paint may lead to subsequent blistering problems.
2. Clean acrylic painted surface with wax and silicone remover, such as: Prep-Sol; Pre-Kleano; Acryli-Clean; or equivalent. Wipe surface dry with clean cloth. Use compressed air to blow away loose dirt from area of repair.
3. Apply vinyl trim adhesive to door hem flanges and to rear body lock pillar facing that will be covered by transfer.
4. Peel paper backing from transfer and lay transfer, face down, on clean table.
5. Using clean sponge, apply ample wetting solution to transfer adhesive and to repair panel surface.
6. Align upper edge and ends of transfer with panel surface and press down lightly across top.
7. Squeegee outboard from middle to edges of transfer removing all air bubbles and wetting solution to assure bonding of film to painted surface. On large transfers, the following sequence of operations will simplify transfer installation.
  - a. Squeegee a short, 4 to 6 inch, horizontal section of transfer at center of panel. Lift right or left side of transfer, position it straight and close to panel, and squeegee toward lifted edge. Avoid stretching transfer at lifted end. Squeegee progressively from middle with firm, overlapping strokes.
  - b. Lift upper area of transfer (up to bonded area of step "a" above) and, working upward from bonded section at middle, squeegee transfer into place.
  - c. Lift lower area of transfer (up to bonded area) and, working downward from bonded section at middle, squeegee transfer into place.
  - d. Secure opposite half of transfer to surface as described in steps "a", "b" and "c", above.
8. Notch out peak or curved edges of transfer where necessary. In some cases it may be necessary to trim off excess material at edges.
9. Heat inboard side of door hem flanges (or body lock pillar facing, etc.) and edges of transfer film (to approximately 90°F.).
10. Fold ends of transfer over door hem flanges (or over corners at panel ends) and press to secure edges of transfer to panel surfaces. Avoid undue pulling or stretching at ends as tearing could result.
11. Apply heat to transfer at door handle holes, side marker lamps and other depressions. Press transfer uniformly into depressions to obtain formed bond.
12. Carefully cut out transfer at side marker lamps, door handle holes, and other openings in panel.
13. Inspect transfer installation from critical angle using adequate light reflection to detect any irregularities that may have developed during installation. Remove all air or moisture bubbles by piercing each at an acute angle with a fine pin or needle and by pressing the bubble down.
14. Install previously removed parts and clean up car as required.

## PAIN T CONDITIONS

### INTRODUCTION

Painters should be able to recognize paint conditions that occur on acrylics in order to be able to repair the conditions properly and thereby produce quality work. Understanding the cause and severity of a given condition is an aid to the painter in determining the best repair procedure. Many of the paint conditions that may be encountered are described and illustrated alphabetically in the following:

### BLISTERING

Blistering is the bubbling or raising of the paint surface. When dry and rubbed or sanded, blisters may give a pitted appearance down to the undercoat or even to the bare metal.

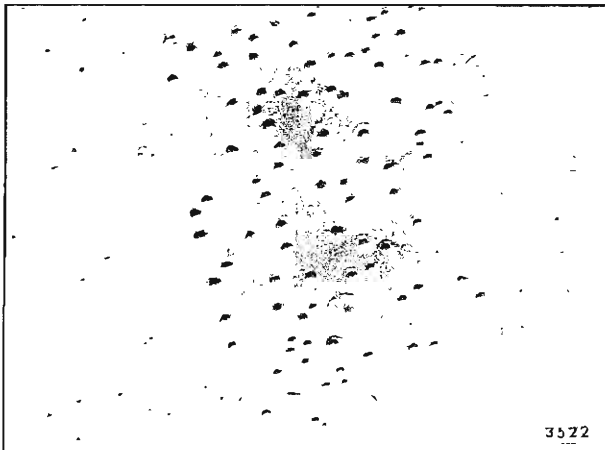

Fig. 1-10—Blistering

**Cause:** This condition is usually caused by moisture becoming trapped between metal and undercoat or between undercoat and color coat, expanding and forming small or large rounded blisters.

**Correction:** In minor cases the blister may be sanded out, resurfaced, sanded, and refinished. In severe cases however, the finish must be removed down to the metal before refinishing.

### BLUSHING

A milky or dull mist formation on the surface.

**Cause:** Blushing is caused by precipitation of the acrylic finish, due to condensation of moisture on the applied wet acrylic film. Rainy or humid weather at refinishing time is the usual cause of this condition.

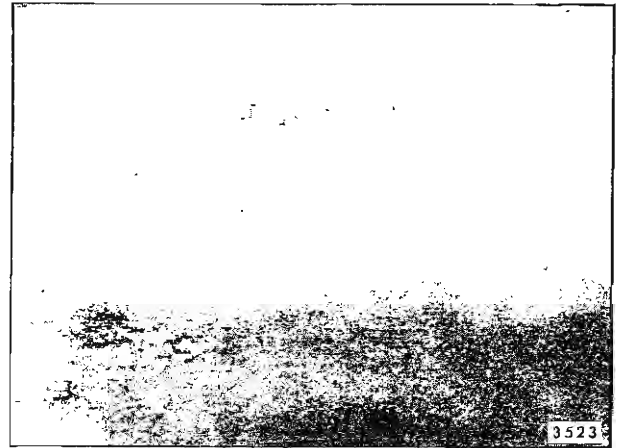

Fig. 1-11—Blushing

**Correction:** In most cases, spraying a coat of high grade thinner with 10% to 20% retarder immediately over affected area will dissolve the blushed acrylic and restore normal appearance of the finish. If blushed color dries, add retarder to reduced material and color coat as required.

### BULL'S-EYE

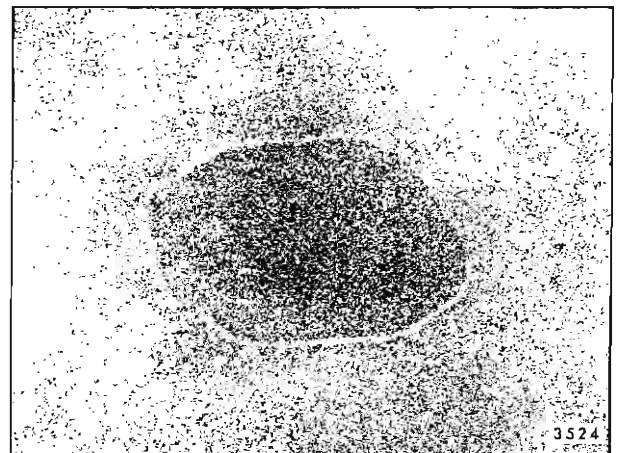

Fig. 1-12—Bull's-Eye

A spotted, ringed, outline or low area in the color coat. It often gives the illusion of a different color, depending upon the peculiarities of light and shadows in the area. Primer might show.

**Cause:** A bull's-eye is the result of undercoat shrinkage; incomplete spot repair; or poor technique.

**Correction:** In minor cases, sand with No. 600 sandpaper and polish. In extreme cases, sand and featheredge the area correctly, build up the paint surface with undercoat, then color coat as required.

## LINE—CHECKING

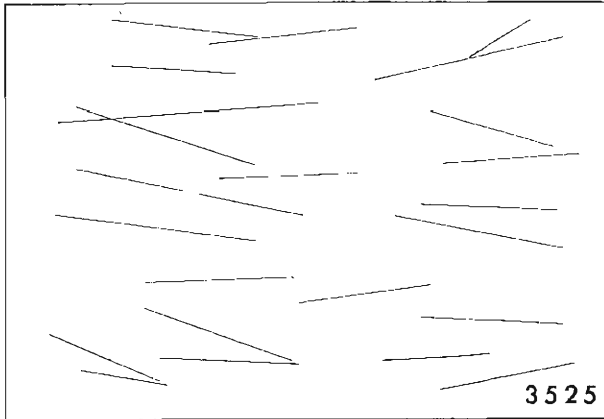

Fig. 1-13—Line-Checking

This appears as a series of straight lines of various configurations. Depending on the thickness of the color and the severity of the condition, the checking lines may be quite short or as long as 18 inches.

**Cause:** This may be due to excessively thick color coats; or application of new color over old color which checked before and was not removed completely.

**Correction:** Remove the checked color coat in the affected area to the undercoat and recolor coat as required. Original undercoats are not affected by line-checking.

## CHEMICAL DISCOLORATION

This is a condition that can occur on solid or metallic colors and is evidenced by contrasting color spots appearing mostly on flat or horizontal surfaces. On red metallics, the spots are darker red;



Fig. 1-14—Chemical Discoloration

on blue metallics, the spots are darker blue; etc. On solid colors, the discoloration spots may be of any color depending upon specific conditions.

**Cause:** On metallic colors the condition apparently is caused by fall-out or moisture in the form of rain water containing acid or alkaline materials which attack the aluminum flake. On solid colors, specific pigments may be affected by specific materials from fall-out.

**Correction:** In mild cases, rub out and polish. In severe cases, sand to remove the condition and color coat as required. The best prevention against this condition is to keep the paint finish clean and polished.

## CRAZING

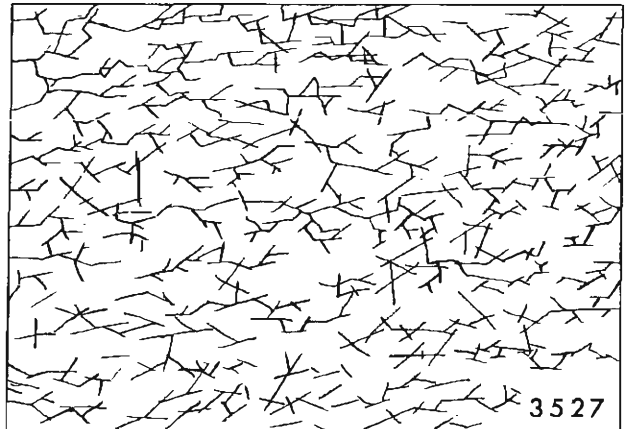

Fig. 1-15—Crazing

Crazing usually appears as a fine spider-web type of cracking in the color coat. The cracks may vary from very fine (requiring a magnifying glass) to relatively coarse.

The crack lines connect to one another. Crazing occurs immediately after repairs are attempted.

**Cause:** Crazing occurs when excessive stresses, which occasionally may be set up in an acrylic color film during the time it cures, are suddenly released.

**Prevention:** Before repairs are attempted, test color to be repaired as follows: (1) Apply a drop of thinner to color in a most inconspicuous spot; (2) Allow thinner to evaporate and inspect color within thinner ring for crazing. A lack of crazing indicates that the color can be color coated or blended into normally. The appearance of crazing within the thinner ring indicates that the color must be removed down to the undercoat before repairs. Original factory undercoats are not affected by the crazing condition.

**Correction:** If a panel surface to be repaired already has the crazing condition, remove the complete affected color coat down to the factory undercoat and color coat as required.

## DIRT IN PAINT

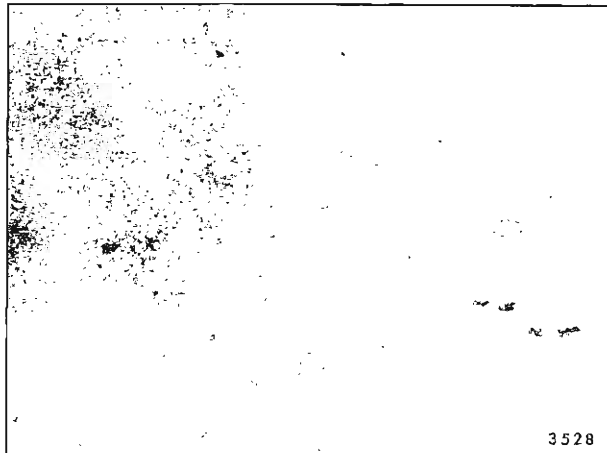

Fig. 1-16—Dirt in Paint

Surfaces with this condition have an uneven grittiness from lint, dirt, or sand-like particles.

**Cause:** Particles flying about and settling on wet paint film are the usual cause of this condition. In addition, surface edges and crevices that are not properly cleaned, blown out, or tacked off immediately before spraying will usually promote a dirt condition.

**Correction:** Rub or polish out with rubbing compound; or, in extreme cases, wet sand with No. 500 or No. 600 paper and rub out and polish.

## DRY SPRAY

This can easily be distinguished by a certain uni-

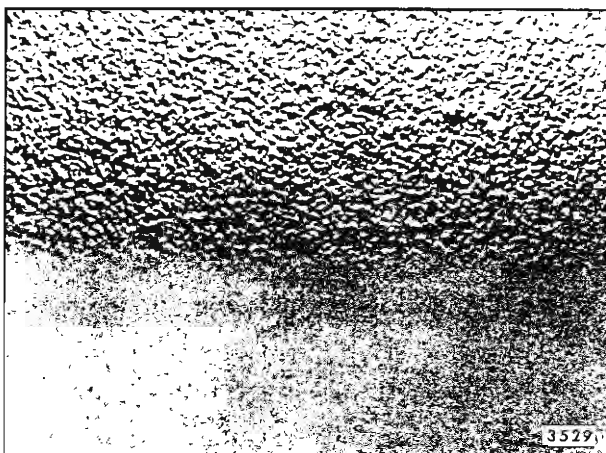

Fig. 1-17—Dry Spray

form, fine grittiness and dullness: It is usually in a linear pattern or a pattern of spray gun travel.

**Cause:** The condition is usually caused by holding the spray gun on an angle or too far from the surface. Insufficient thinner, excessive air pressure, dirty spray gun, or spraying in a draft can also cause dry spray conditions.

**Correction:** Minor cases of dry spray can usually be polished out. Major cases of dry spray must be sanded out and, if necessary, the surface color coated.

## ETCHING

Etching is a very severe form of water spotting in which the entire paint surface within the periphery of each spot is etched or eaten away. The condition may appear as small or large water spotted areas and usually appears on the flat or horizontal surfaces. Etching penetrates much more deeply into the finish than water spotting.

**Cause:** The condition may be caused by bird droppings, insects, etc., in which case a strong chemical deposit is allowed to react with the finish for a prolonged period of time.

**Correction:** If the condition is "mild", sand to remove the condition and color coat as required. If the condition is "severe", sand to remove the condition; apply undercoats and color coats as required. The best prevention against this condition is to keep the paint surface clean and polished.

## FISH-EYES

The appearance of small, crater-like openings in the finish after it has been applied.

**Cause:** Application of color coats over a surface contaminated with silicones.

### Prevention:

1. Clean surface with wax and silicone removing agent such as Prep-Sol, Pre-Kleano, Acrylic-Clean or equivalent.
2. Sand surface as required.
3. Re-clean surface with silicone removing agent.
4. Proceed with color coat application.
5. If above prevention steps are not successful and fish-eyes appear upon application of first coat, add "Fish-Eye Eliminator", "Fish-Eye

Preventor", or equivalent to reduced color and continue color coating immediately.

**Correction:** To repair a paint surface with the dried fish-eye condition, sand the surface smooth and color coat as required incorporating the above prevention steps.

## MOTTLING

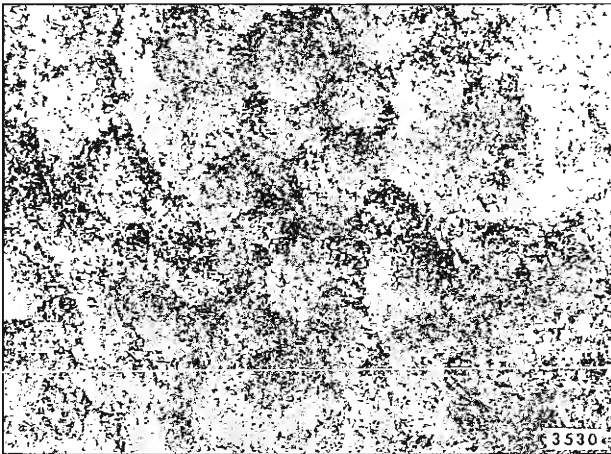

Fig. 1-18—Mottling

Mottling is a paint condition which appears as dark, shaded, or off-color spots and streaks in the paint finish. It is especially evident in metallic paints. A moderate amount of mottling is to be expected in metallic finishes.

**Cause:** Most colors are made from a combination of different pigments and metallic flakes which have varying densities and particle sizes, giving them a natural tendency to separate and float into groups when the film is in a liquid state. Under normal conditions, this tendency is small in magnitude and cannot be seen by the naked eye.

Certain conditions aggravate this to a point where the separation of the pigments and metallic flakes become visible, due to use of thinner which dries too slowly, allowing the pigment particles to migrate; or applying the color on a cold surface or in a cold room; or applying too heavy color coat.

**Correction:** In minor cases, no correction is required. In severe cases, clean and re-spray with color coat.

## OFF-COLOR

The color is off-shade or does not match.

**Cause:** The main cause of off-color conditions is not keeping the color coat thoroughly mixed.

Wrong thinner mixtures, air pressures, spraying distance, film thickness, or spraying too wet or dry will also affect the color match, especially with metallic colors. The use of compounds too soon or burning the color coat by hard wheel polishing will also affect the color's appearance. Old, waxed or polished areas will often appear different in color than areas with new color.

**Correction:** Sand only if necessary. Color coat with proper technique to nearest natural break line.

## EXCESSIVE ORANGE PEEL

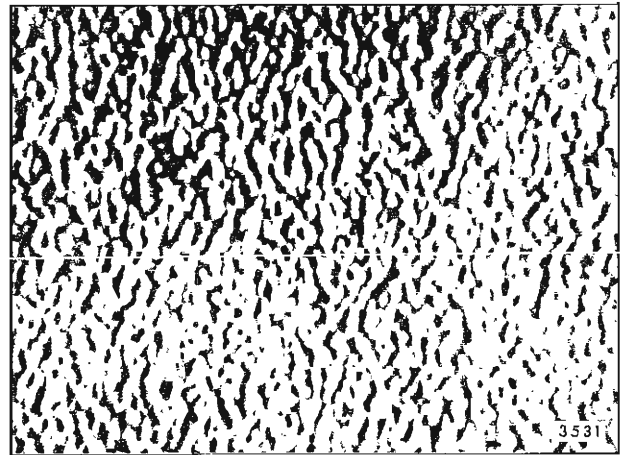

Fig. 1-19—Excessive Orange Peel

Orange peel is a natural occurrence in refinishing in which the resultant finish has uneven formations on the surface similar to that of an orange. A certain amount of orange peel occurs in normal refinishing and is acceptable.

**Cause:** Excessive orange peel is actually a defect of flow or leveling. Some of the causes are: using wrong type or a poor grade of thinner, using too high an air pressure, improper adjustment of spray gun, holding gun too far from surface or too close to surface, abnormal shop or metal temperatures, spraying in a draft, and coats applied too dry.

**Correction:** If condition is slight, no remedy is necessary. If condition is excessive, clean, compound, and polish affected area.

## OVERSPRAY

The appearance of a rough or dull paint finish, similar to dry spray.

**Cause:** Overspray is caused by the settling of semi-dry paint particles on an adjacent finished surface during spraying operations.

**Correction:** If the condition involves the same



color, compound and polish the affected area. If the condition involves two colors, but is slight, compounding and polishing the affected area may eliminate the condition. If the condition is severe, sand and color coat as required.

### PIN-HOLING

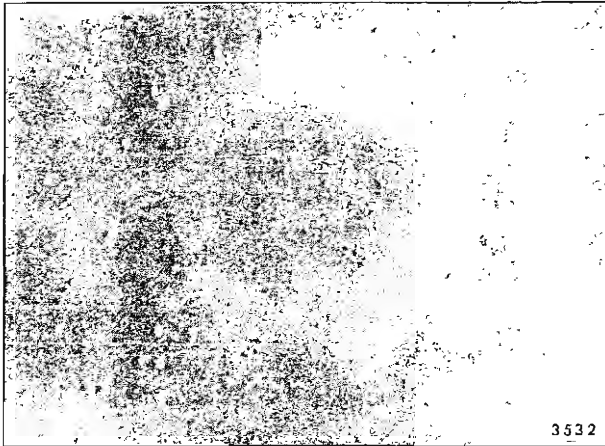

Fig. 1-20—Pinholing

Pin-holing is a series of tiny, fine holes or pits that give the surface a spotty, dull, or off-shade appearance.

**Cause:** This condition is usually caused by solvent or air trapped in the paint film, plus heat.

**Correction:** Sand down the surface until it is smooth, and then color coat as required.

### RUST SPOTS

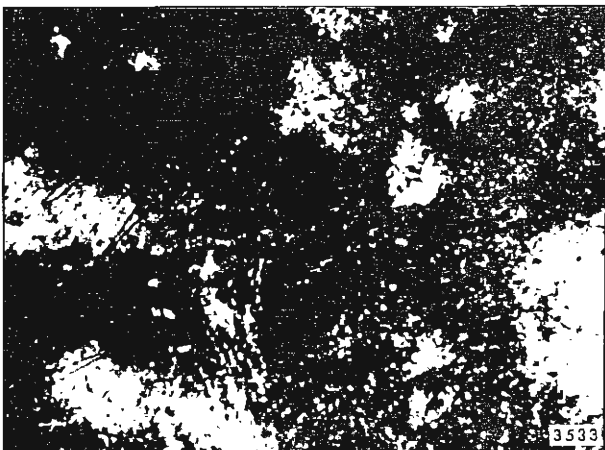

Fig. 1-21—Rust Spots

Rust spots are usually accentuated by a rust colored ring that forms at the affected area. Rusting beneath the film is usually made apparent by a raised section of film or a blister. After the film

or blister has broken, the rust begins to work back under the edges of the film. Since many primers are similar to rust in color, careful examination is necessary to identify the minor rust conditions accurately.

**Cause:** Moisture and chemicals attack the metal through either visible or microscopic breaks in the paint film, which usually result in blistering and peeling. Another cause is painting a metal surface containing rust that was not completely removed, or painting over metal touched by bare hands or chemical deposits from sanding water.

**Correction:** In minor cases, where the paint is not blistered, wash panel and clean rust stain off with body polish or a mild rubbing compound, hand-applied, then protect the finish with application of wax.

In severe cases the paint should be removed down to metal before cleaning the stains, so that no spots will be overlooked. Sand metal thoroughly to remove all traces of rust, treat surface with metal conditioner, dry and prime the areas as soon as possible to prevent the start of new rust formations. Refinish according to usual methods.

### SAND OR FILE MARKS

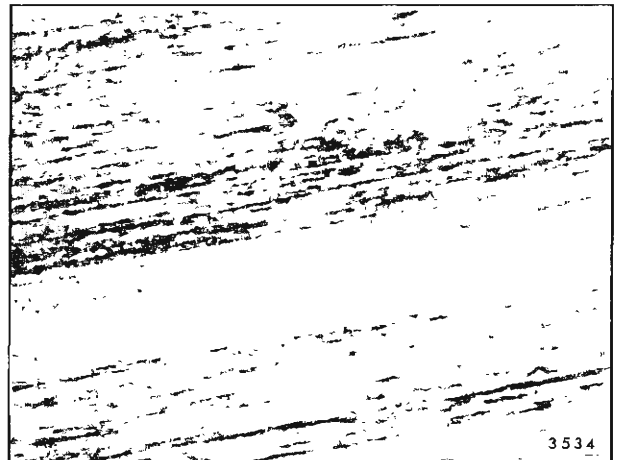

Fig. 1-22—Sand or File Marks

The surface is grained or scratched.

**Cause:** File or disc marks were left in the metal, or the grit of the sandpaper used to sand the undercoat was too coarse.

**Correction:** Minor sand marks or scratches on the color coat may be lightly sanded and polished. In severe cases, sand and refinish as required.

## SAND SCRATCH SWELLING

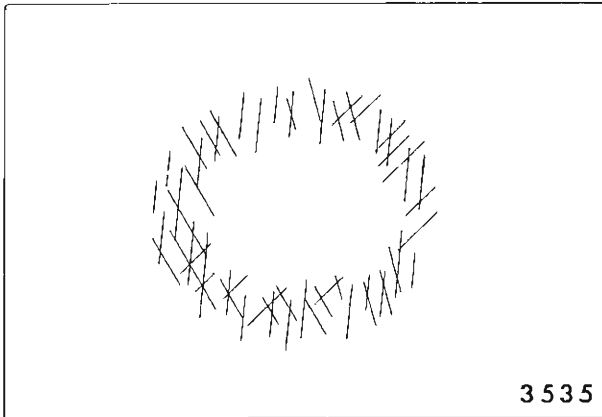

Fig. 1-23—Sand Scratch Swelling

Sand scratch swelling appears as exaggerated sandpaper scratches and occurs mostly after spot repairs or panel refinishing are done over sanded original acrylic finishes. The condition is most apparent on dark colors.

**Cause:** The condition is caused by sanding acrylic surfaces with coarse sandpaper preparatory to color coating. The thinner of fresh color coats swells the scratches to an enlarged size.

**Prevention:** Do not sand acrylics unless required. When sanding with coarse sandpaper is required, follow with extra-fine (No. 500 or No. 600) sandpaper. Then remove sand scratches by rubbing; or apply an approved sealer according to label directions before color coating.

**Correction:** Remove minor sand scratches by rubbing and polishing. In certain instances, water sanding with No. 500 or No. 600 sandpaper may be necessary before final rubbing and polishing. Remove severe sand scratches by employing steps outlined in "Prevention", above, and then color coat as required.

## SWEAT OUT OR BLOOM

Usually characterized by a dull appearance along with some sand scratches.

**Cause:** Due to film shrinkage because of evaporation.

**Correction:** Polishing is usually sufficient to bring the gloss to an acceptable level. In severe cases where some film shrinkage has occurred that results in a slight wrinkled or orange peel appearance, sanding with No. 600 sandpaper and polishing may be required.

## THIN PAINT

Severe thin paint conditions are easily identified by the undercoat showing through the top surface, or by light bright areas in the finish.

**Cause:** The usual cause of a thin paint condition is excessive rubbing or polishing that removes the paint film. This is usually due to improper use of power polishing equipment, or not enough color coat application.

**Correction:** For panels, this paint condition can be corrected by cleaning the affected areas and color coating the surface. If edges are thin, touch up with brush as required.

## WATER SPOTTING

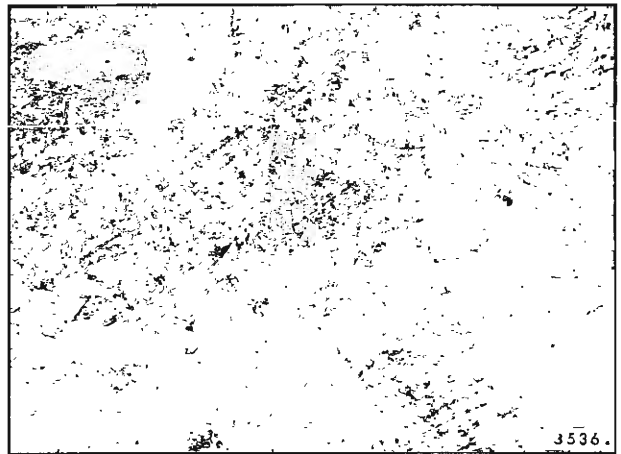

Fig. 1-24—Water Spotting

The condition is evidenced by tiny or small rings which surround each spot from which water has evaporated. These rings appear to be etched into the paint finish and cannot be removed by normal washing or polishing.

**Cause:** The condition is caused by the evaporation of droplets of water from an acrylic finish, particularly at temperatures over 150°F. The condition becomes more severe as the chemical content of the water and the temperature are increased. A chemical reaction is believed caused by the evaporating water and the paint finish, resulting in the ring.

**Correction:** Rub out and then polish as required. Use GM Acrylic Finish Conditioner, or equivalent.

## WHEEL BURN

A dark, often rough, smear on a panel surface.

**Cause:** Holding the polisher too long in one spot.

**Correction:** Rub out with cloth treated with paint finish cleaning solvent and hand polish.

In severe cases, water sand with No. 600 sandpaper, and then rub out and polish.

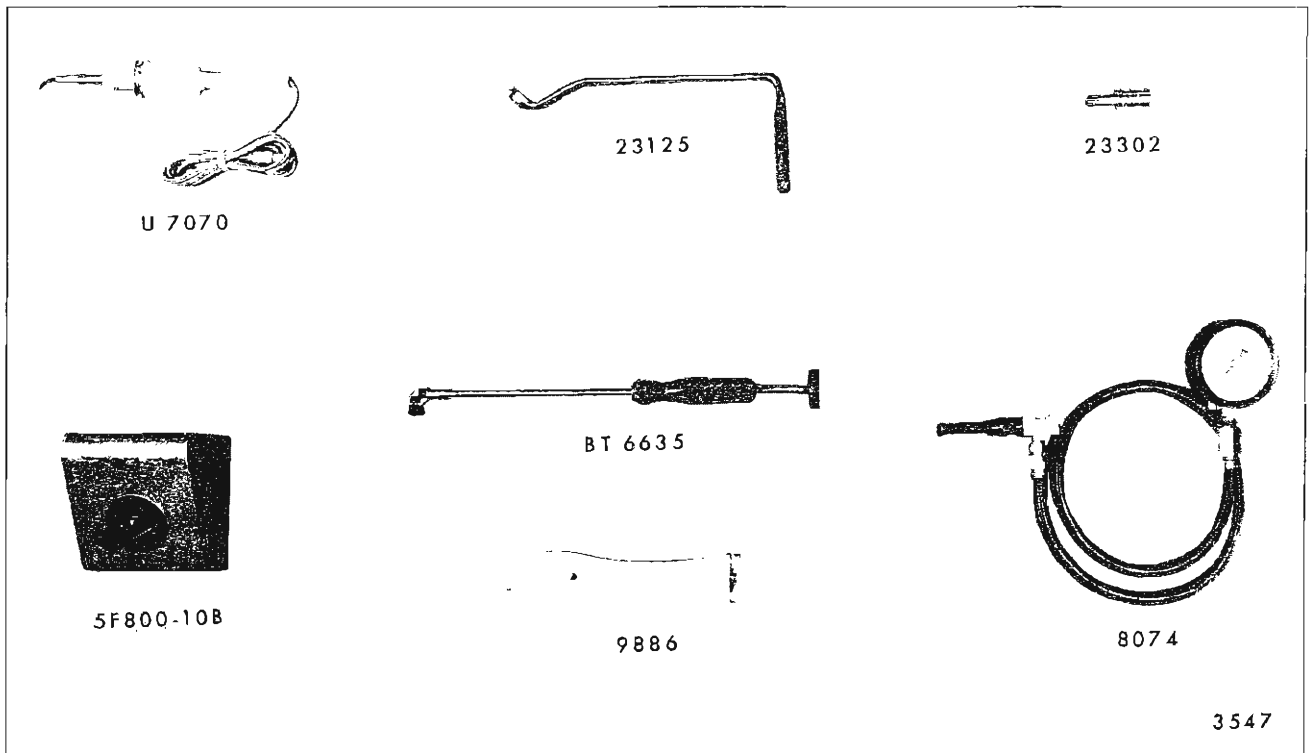

Fig. 1-25—Special Body Service Tools

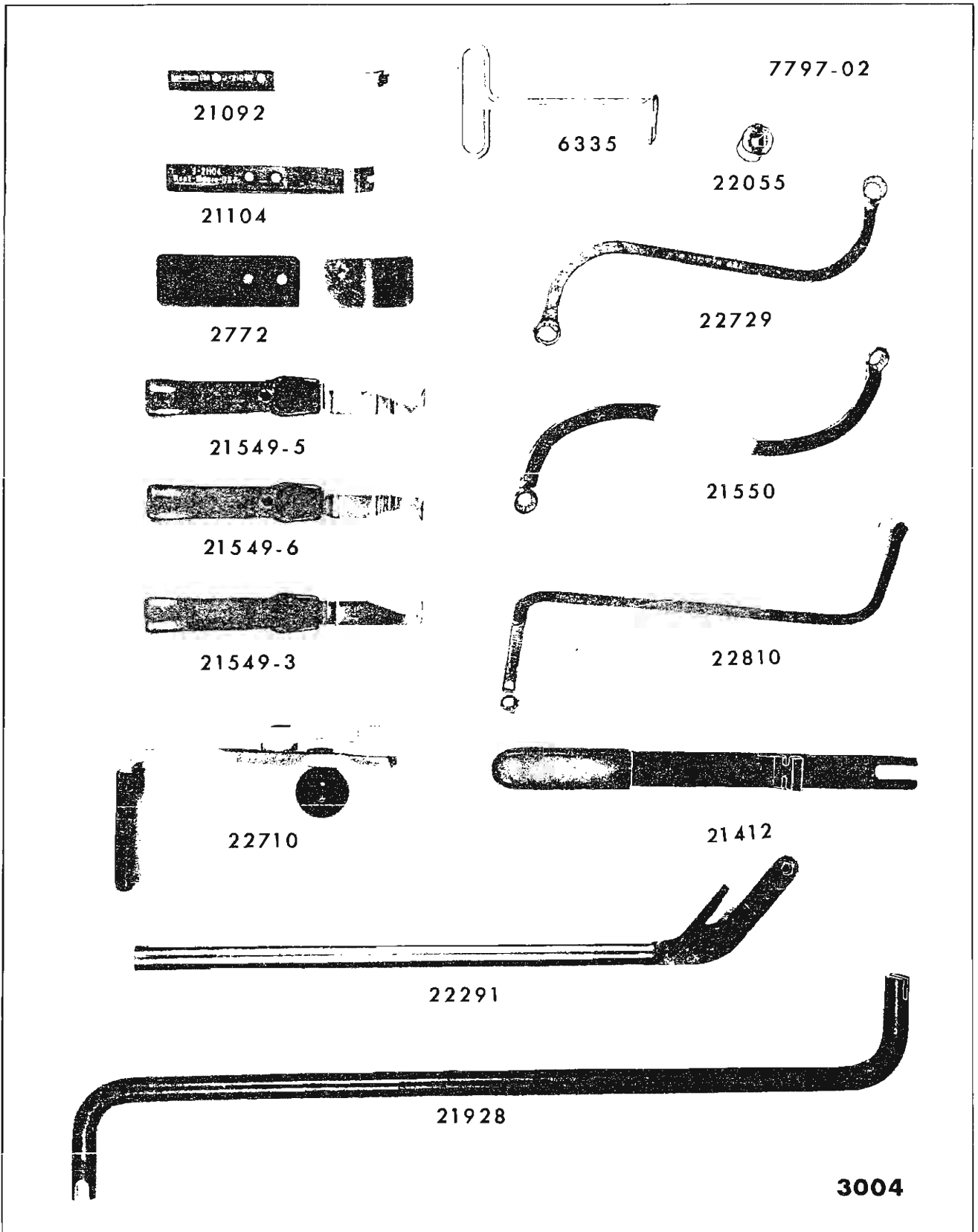

Fig. 1-26—Special Body Service Tools

## SECTION 2

# LUBRICATION

### INDEX

Subject	Page	Subject	Page
<b>Description</b>			
Front Compartment Lid Lock . . . . .	2-1	Tailgate Lock Fork Bolt (Right and Left)-(Station wagon Styles with Dual Acting Tailgate) . . . . .	2-5
Front Compartment Lid Hinges and Torque Rod . . . . .	2-1	Tailgate Lock Striker . . . . .	2-5
Instrument Panel Compartment Door Hinge . . . . .	2-2	Tailgate Torque Rod (All Station Wagons) . . . . .	2-6
Front Door Hinge Assembly . . . . .	2-2	Tailgate Hinge (All Station Wagons) . . . . .	2-6
Rear Door Hinge Assembly . . . . .	2-2	Tailgate Window Regulator, Cams, and Sector Gears (All Station Wagons) . . . . .	2-6
Door Lock Fork Bolt . . . . .	2-3	Gas Tank Filler Door Hinge . . . . .	2-7
Door Jamb Switch . . . . .	2-3	Folding Seat Linkage . . . . .	2-7
Door Locking Mechanism and Lock Parts . . . . .	2-3	Front Seat Adjuster Mechanism . . . . .	2-7
Door Window Regulator and Cams on Styles with Door Upper Frames . . . . .	2-3	Convertible Top Hinge Mechanism . . . . .	2-7
Door Window Regulator Cams and Guides on Styles without Upper Frames . . . . .	2-4	Rear Compartment Hinges . . . . .	2-8
Rear Quarter Window Regulator Cams and Guides . . . . .	2-5	Engine Compartment Lid Support . . . . .	2-8
		Rear Compartment Lid Lock . . . . .	2-8

### DESCRIPTION

The mechanical parts of the body with contacting surfaces that have relative motion with other parts are lubricated during assembly. If additional lubrication is required, the procedures and specified materials or their equivalents presented in this section should be used.

The illustrations in this section serve as typical views of the subject areas. The procedures described are similar for all styles.

#### FRONT COMPARTMENT LID LOCK— Corvair

1. Clean lock bolt surface.
2. Apply a thin coat of white lithium soap grease (Auto-Lube "A", Part No. 1050110, or Spray-Lube "A", Part No. 1050520 or equivalent) to the contact surface of the fork bolt (Fig. 2-1).
3. Actuate the lock mechanism several times.
4. Remove excess lubricant.

#### FRONT COMPARTMENT LID HINGES AND TORQUE ROD

1. Remove dirt and old lubricant.
2. Apply white lithium soap grease (Auto-Lube

"A", Part No. 1050110, or Spray-Lube "A", Part No. 1050520 or equivalent) to the frictional areas indicated 1 in Figure 2-2.

3. Open and close compartment lid to assure smooth operation.
4. Wipe off excess lubricant.

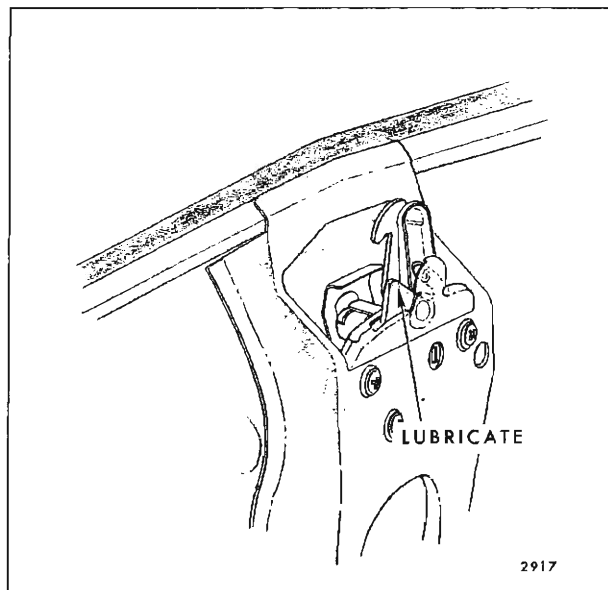

Fig. 2-1—Front Compartment Lid Lock Lubrication

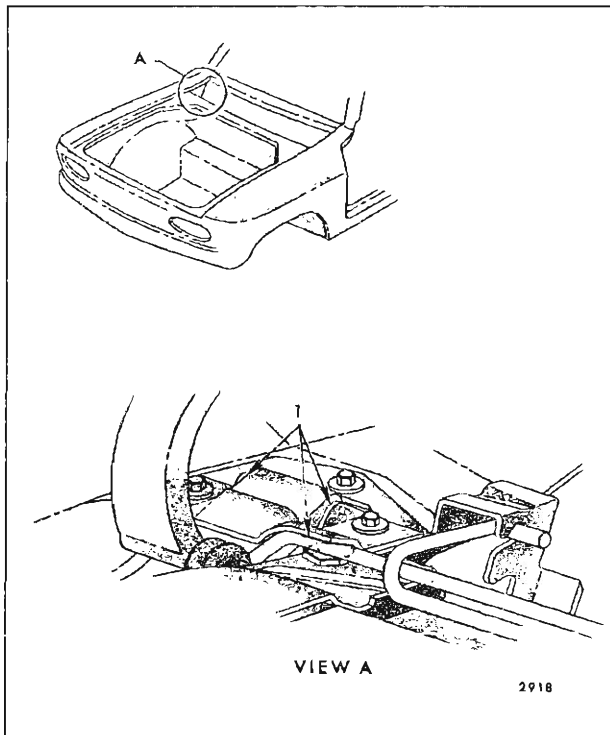

Fig. 2-2—Front Compartment Hinge and Torque Rod

### INSTRUMENT PANEL COMPARTMENT DOOR HINGE

1. Wipe off the dirt and old lubricant.
2. Apply a low temperature lubricant (Dripless oil or equivalent) sparingly to the friction areas.
3. Operate the hinge mechanism several times to be certain that the lubricant has worked in effectively.
4. Remove excess lubricant.

### FRONT DOOR HINGE ASSEMBLY

1. Clean dirt and old lubricant from subject area.
2. Apply a thin coat of white lithium soap grease (Auto-Lube "A", Part No. 1050110, or Spray-Lube "A", Part No. 1050520 or equivalent) to the friction areas of the front door hinge at the points indicated, except detent roller pin which should be lubricated with SAE 30 Motor Oil (Fig. 2-3).

**NOTE:** It is imperative that the contact surfaces of the detent roller and detent lever remain free of lubricant. Lubrication at these points indicated

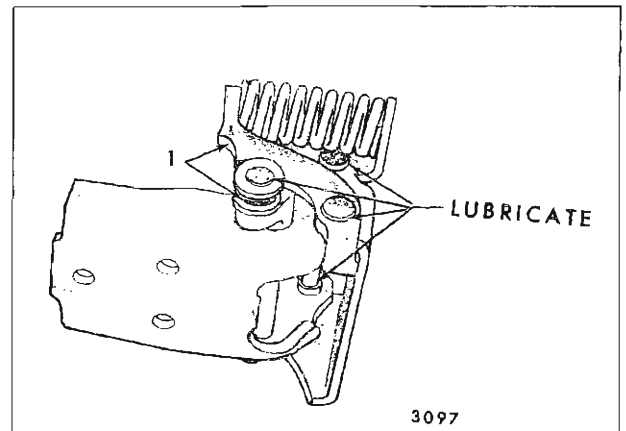

Fig. 2-3—"A-B & C" Styles Front Door Hinge Lubrication

1 in Figure 2-3, would result in a sliding action instead of the desired rolling action.

3. Lubricate the torque rod on the "E" series lower hinge assembly with molybdenum disulphide (Fiske Bros. 475-10DS or equivalent) at the points indicated (Fig. 2-4).
4. Open and close door several times to insure that the lubricant has worked in effectively.

### REAR DOOR HINGE ASSEMBLY

1. Clean surface of dirt and old lubricant.
2. Apply a thin coat of white lithium soap grease lubricant (Auto-Lube "A", Part No. 1050110, or Spray-Lube "A", Part No. 1050520 or equivalent) to the friction areas of the rear door hinge at the points indicated except detent roller pin which should be lubricated with SAE 30 Motor Oil (Fig. 2-3).

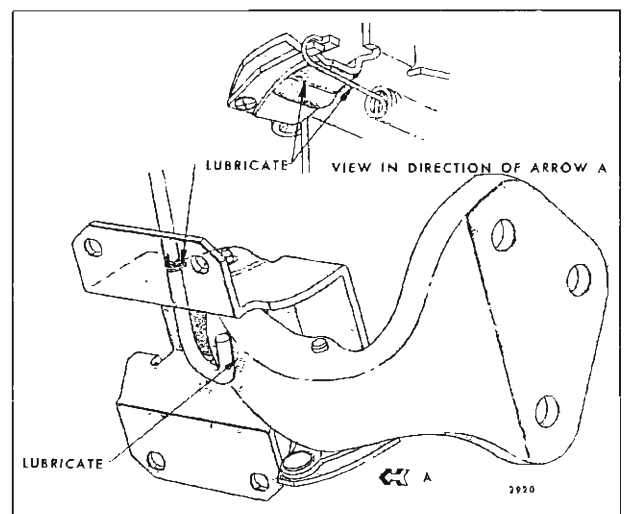

Fig. 2-4—"E" Body Front Door Hinge Lubrication

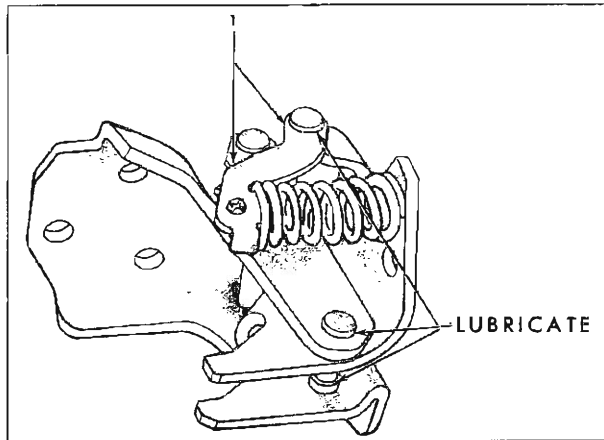

Fig. 2-5—Rear Door Hinge Lubrication

**NOTE:** It is imperative that the contact surfaces of the detent roller and detent lever remain free of lubricant. Lubrication at these points indicated 1 in Figure 2-5, would result in a sliding action instead of the desired rolling action.

3. Open and close door several times to insure that the lubricant has worked in effectively.

### DOOR LOCK FORK BOLT

1. Clean the fork bolt surface.
2. Apply a thin coat of grease stick lubricant (Dorease or equivalent) to the areas indicated (Fig. 2-6).
3. Operate the lock mechanism several times.

### DOOR JAMB SWITCH

1. Wipe off dirt.
2. Apply a thin coat of white lithium soap grease (Auto-Lube "A", Part No. 1050110, or Spray-Lube "A", Part No. 1050520 or equivalent) to the circumference and end surface of the switch plunger.
3. Operate the plunger several times to insure that the lubricant has been worked in effectively.
4. Remove excess lubricant.

### DOOR LOCKING MECHANISM AND LOCK PARTS

1. Apply white lithium soap grease lubricant (Fiske Bros. Lo-Temp. Lubriplate #777 or equivalent) to the pivot points, ends of connecting rods, and other movable parts of the lock.

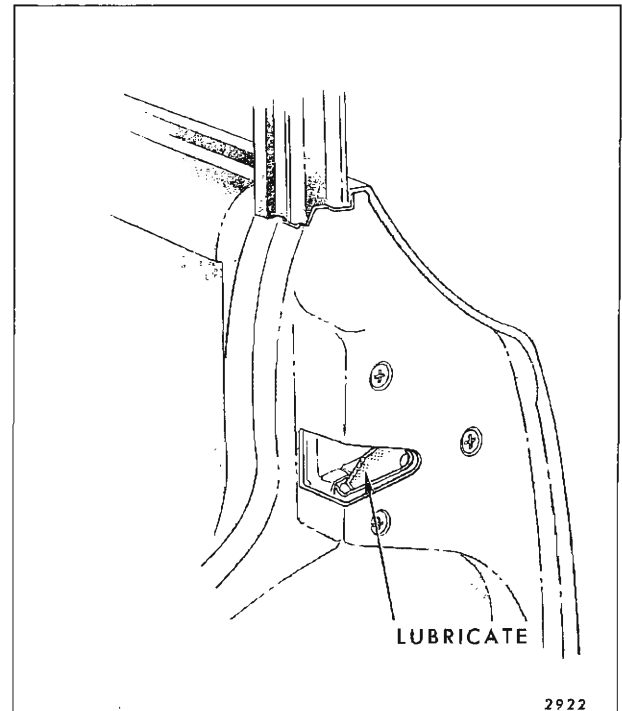

Fig. 2-6—Door Lock Fork Bolt Lubrication

2. Actuate the lock mechanism to insure smooth operation.

### DOOR WINDOW REGULATOR AND CAMS ON STYLES WITH DOOR UPPER FRAMES

1. Applying a thin coat of white lithium soap grease (Fiske Bros. Lo-Temp. Lubriplate #777 equivalent) cover the entire length of the lower sash channel cam and inner panel cam as shown in Section "A-A", Figure 2-7.

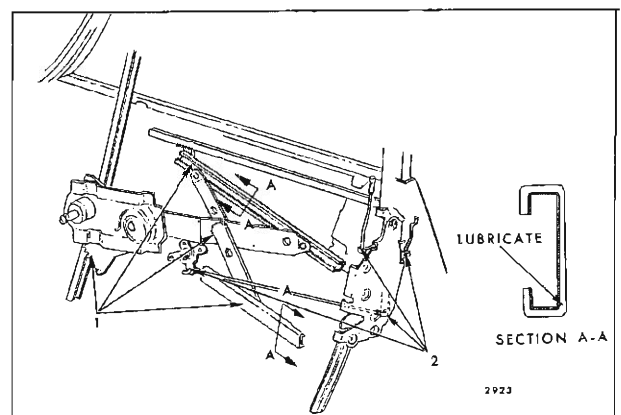

Fig. 2-7—Door Window Regulator and Cam Lubrication - Closed Styles

2. Lubricate all connecting rod pivot points with Auto-Lube "A", Part No. 1050110 or Spray-Lube "A", Part No. 1050520 or equivalent, at the points indicated in Figure 2-7.
3. Apply a thin coat of Auto-Lube "A", Part No. 1050110 or Spray-Lube "A", Part No. 1050520 or equivalent, to the teeth of the sector gear and the pivot point of the balance arm and lift arm as indicated at points 1 in Figure 2-7.
4. Operate the glass, remote control, and lock to assure smooth operation.

**NOTE:** Rear door lubrication is similar.

**DOOR WINDOW REGULATOR CAMS AND GUIDES ON STYLES WITHOUT UPPER FRAMES**

1. Applying a thin coat of white lithium soap

grease (Fiske Bros. Lo-Temp. Lubriplate #777 or equivalent), cover the entire length of the front guide, rear guide, the lower sash channel cam, and the inner panel cam as shown in the cross section "A-A", Figure 2-8.

2. Lubricate all connecting rod pivot points with Auto-Lube "A", Part No. 1050110 or Spray-Lube "A", Part No. 1050520 or equivalent at the points indicated 1 in Figure 2-8.
3. Apply a thin coat of Auto-Lube "A", Part No. 1050110 or Spray-Lube "A", Part No. 1050520 or equivalent to the teeth of the sector gear and the pivot point of the balance arm and lift arm as indicated at points 2 in Figure 2-8.
4. Operate the window, remote control, and lock to assure smooth operation.

**NOTE:** Front door lubrication is similar.

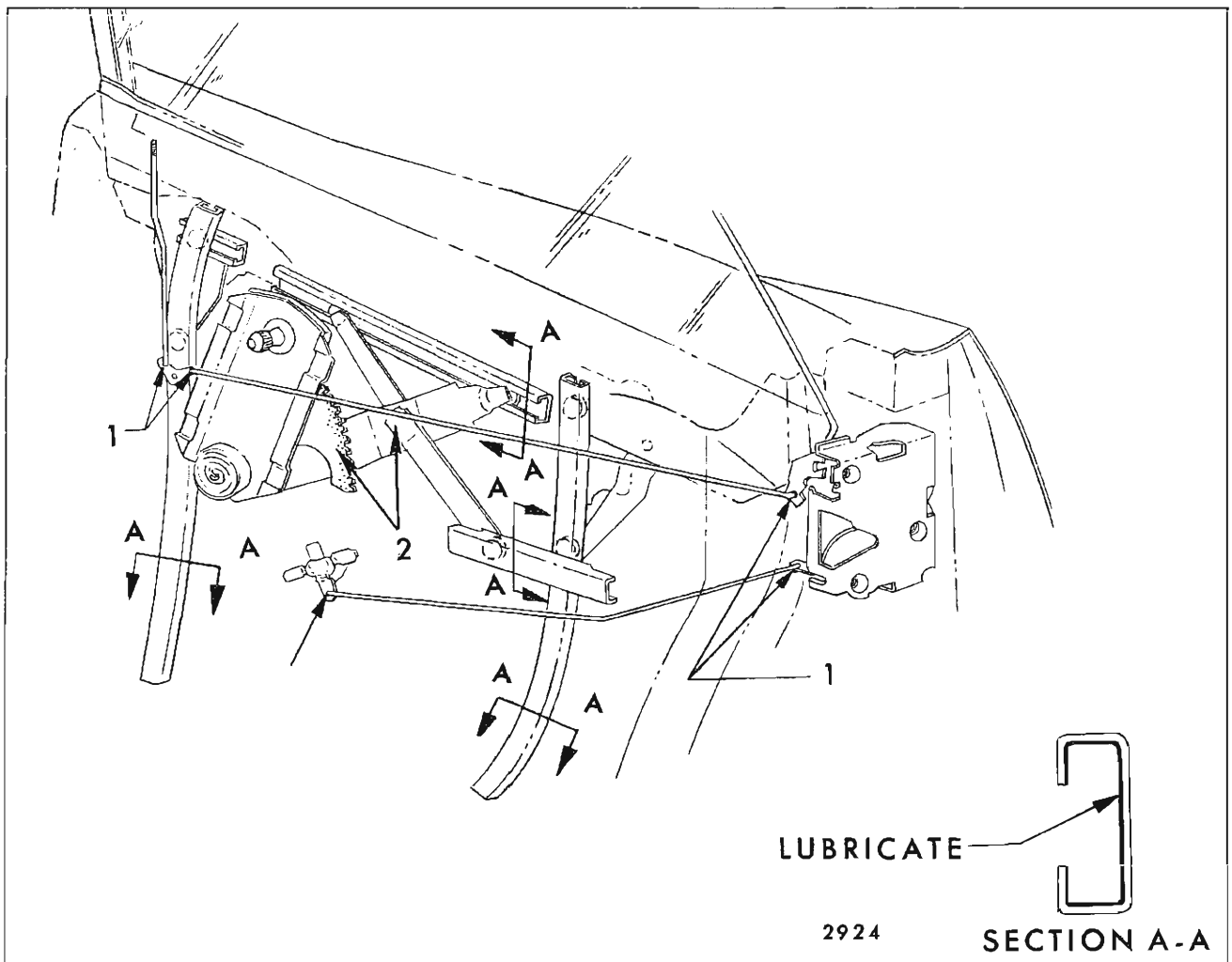

Fig. 2-8—Door Window Regulator and Cam Lubrication - Hardtop



## REAR QUARTER WINDOW REGULATOR CAMS AND GUIDES

1. Apply a thin coat of white lithium soap grease lubricant (Fiske Bros. Lo-Temp. Lubriplate #777 or equivalent) to the friction areas indicated (Figs. 2-9 & 2-10).
2. Cover the entire length of the inner surface of all guides with Fiske Bros. Lo-Temp. Lubriplate #777 or equivalent as shown in the cross sections (Fig. 2-9 & 2-10).
3. Operate glass to insure smooth operation.

## TAILGATE LOCK FORK BOLT (Right and Left) — (Station Wagon Styles with Dual Acting Tailgate)

1. With tailgate in gate position, clean surface of right and left fork bolt.
2. Apply a thin coat of grease stick lubricant (Doorease or equivalent) to the areas indicated by Point 1, Figure 2-11 (Right Side Shown, and Figure 2-12 Left Side Similar).
3. Open and close tailgate (in gate position) several times.

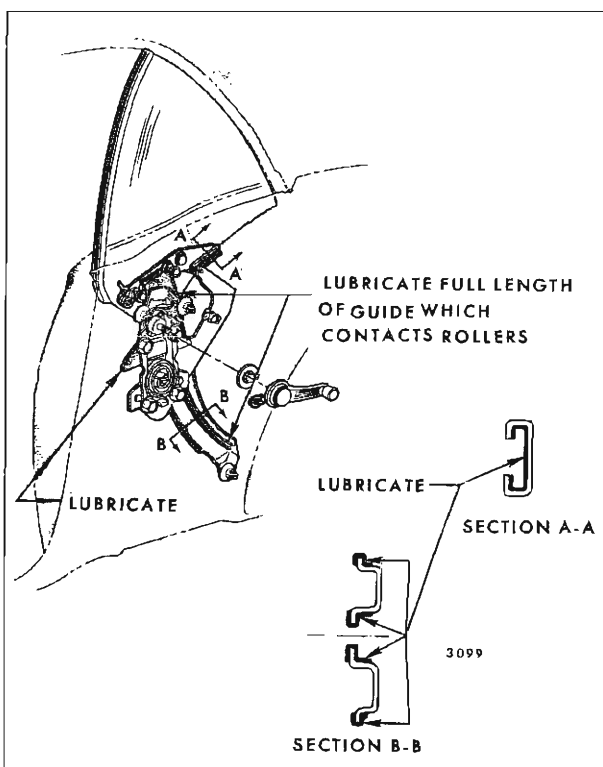

Fig. 2-9—"A-B-C-F" Styles - Quarter Window Regulator Lubrication

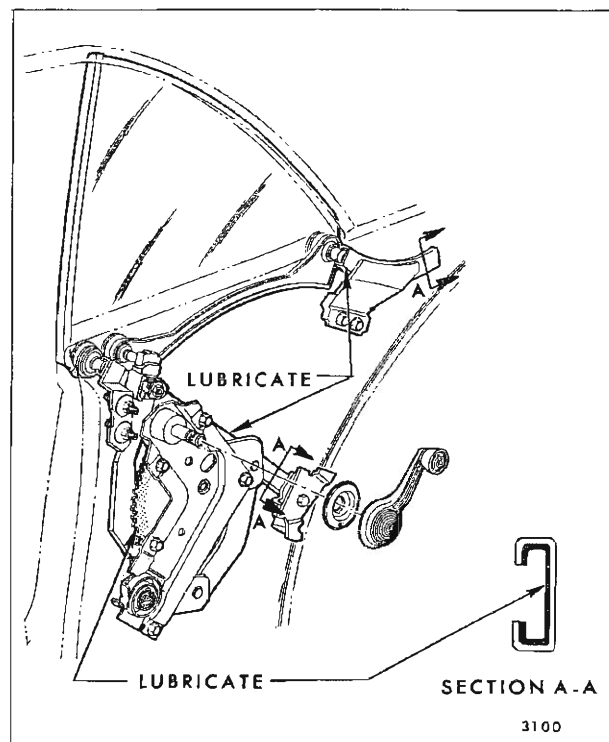

Fig. 2-10—"E" Styles - Quarter Window Regulator Lubrication

## TAIL GATE LOCK STRIKER

### (Station Wagon with Conventional Tailgate)

1. Wipe off dirt and old lubricant.
2. Apply a thin coat of grease stick lubricant (Doorease or equivalent) to the contact surfaces of the striker teeth (Fig. 2-13).
3. Open and close tail gate several times.
4. Remove excess lubricant.

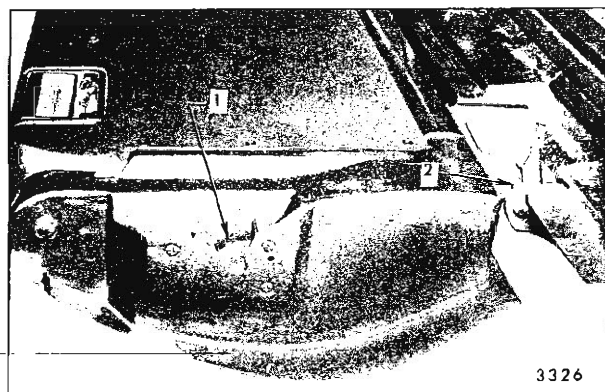

Fig. 2-11—Dual Acting Tailgate Lubrication - Right Side

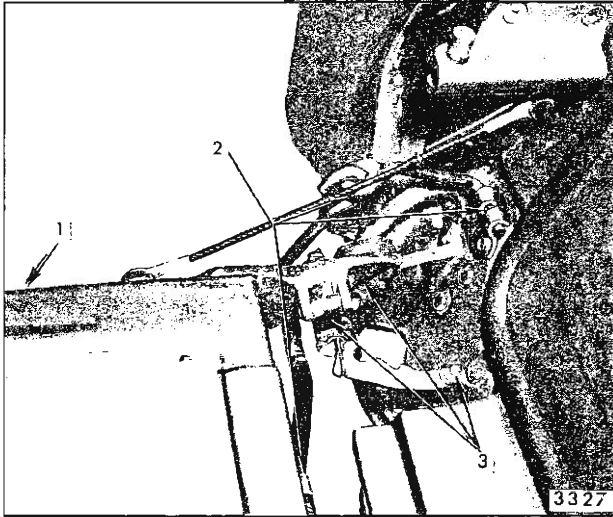

Fig. 2-12—Dual Acting Tailgate Lubrication - Left Side

### TAIL GATE TORQUE ROD (All Station Wagons)

1. a. Apply white lithium soap grease (Auto-Lube "A", Part No. 1050110 or Spray-Lube "A", Part No. 1050520 or equivalent) to the circumference of the tail gate torque rod which passes through the nylon guide of the torque rod retainer as indicated in Figure 2-13, for conventional tailgates.
- b. For dual acting tailgate, open in gate position, and apply white lithium soap grease (auto-lube "A", Part No. 1050110 or spray-

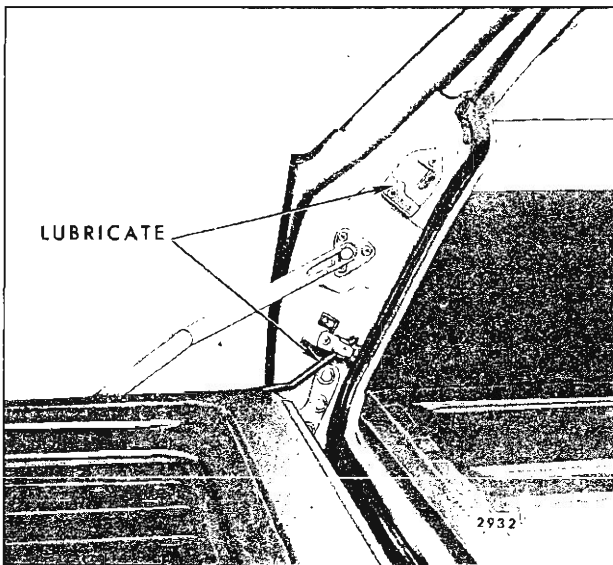

Fig. 2-13—Tailgate Lock Striker and Torque Rod - Conventional Tailgate

lube "A", Part No. 1050520 or equivalent) to contact surfaces of the torque rod to torque rod retainer (on bottom of tailgate), torque rod to torque rod assist link, and torque rod assist link to assist link retainer (on back body pillar), as indicated by Point 2, Figure 2-12.

2. Open and close tailgate several times to assure smooth operation.
3. Remove excess lubricant.

### TAIL GATE HINGE (All Station Wagon Styles)

1. a. Apply a minute amount of low temperature lubricant (dripless oil or equivalent) to the frictional surfaces of right and left hinge on styles with conventional tailgate.
- b. With dual-acting tailgate in gate position, apply a low temperature lubricant (dripless oil or equivalent) sparingly through the two oil holes provided, and onto the pivot pin for the hold-open feature on the left hinge assembly (Point 3, Figure 2-12, and apply a coating of wheel bearing lubricant or equivalent to the striker pin (Point 2, Figure 2-11 on the right hinge assembly.
2. Open and close tailgate several times.
3. Remove excess lubricant.

### TAIL GATE WINDOW REGULATOR, CAMS, AND SECTOR GEARS (All Station Wagons)

1. Apply white lithium soap grease lubricant (Auto-Lube "A", Part No. 1050110 or Spray-Lube "A", Part No. 1050520 or equivalent) to the pivot points of the connecting rods indicated 1 in Figure 2-14).

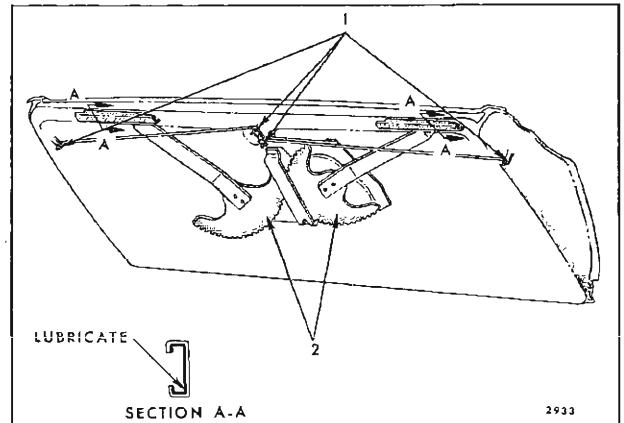

Fig. 2-14—Tailgate Window Regulator, Cams, etc. - All Tailgates

2. Coat the entire length of the inner surface of all cams with Fiske Bros. Lo-Temp Lubriplate #777 or equivalent as shown in the cross section "A-A" in Figure 2-14.
3. Apply Auto-Lube "A", Part No. 1050110 or Spray-Lube "A", Part No. 1050520 or equivalent to the teeth of the sector gears at points 2 as shown in Figure 2-14.
4. Operate the glass to assure smooth operation.

### GAS TANK FILLER DOOR HINGE

1. Clean area of dirt and old lubricant.
2. Apply a low temperature lubricant (Driplless oil or equivalent) sparingly to the friction areas.
3. Operate the door several times.
4. Remove excess lubricant.

### FOLDING SEAT LINKAGE

1. Clean surface of dirt and old lubricant.
2. Apply a low temperature lubricant (Driplless oil or equivalent) sparingly to the frictional areas.
3. Operate the linkage several times.
4. Remove excess lubricant to prevent soiling trim.

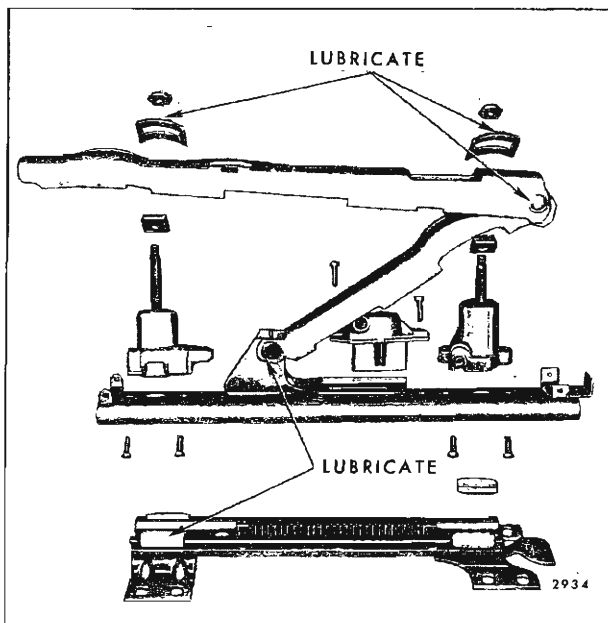

Fig. 2-15—Front Seat Adjuster Lubrication

### FRONT SEAT ADJUSTER MECHANISM (Manual or Electrical)

1. Wipe off old lubricant.
2. Apply a thin coat of white lithium soap grease (Auto-Lube "A", Part No. 1050110 or Spray-Lube "A", Part No. 1050520 or equivalent) to the pivot pins, upper surface of the gearnut tension springs and upper channel track nylon bushings as illustrated (Fig. 2-15).
3. Operate seat to the limit of all positions.
4. Remove excess lubricant.

### CONVERTIBLE TOP HINGE MECHANISM

1. Apply a limited amount of low temperature lubricant (Driplless oil or equivalent) to all friction surfaces.
2. The friction surfaces lubricated should include all washers, bushings, and other contact surfaces at the points indicated by the arrows (Figure 2-16, Figure 2-17, and Figure 2-18).
3. To prevent soiling trim, wipe off excess lubricant.

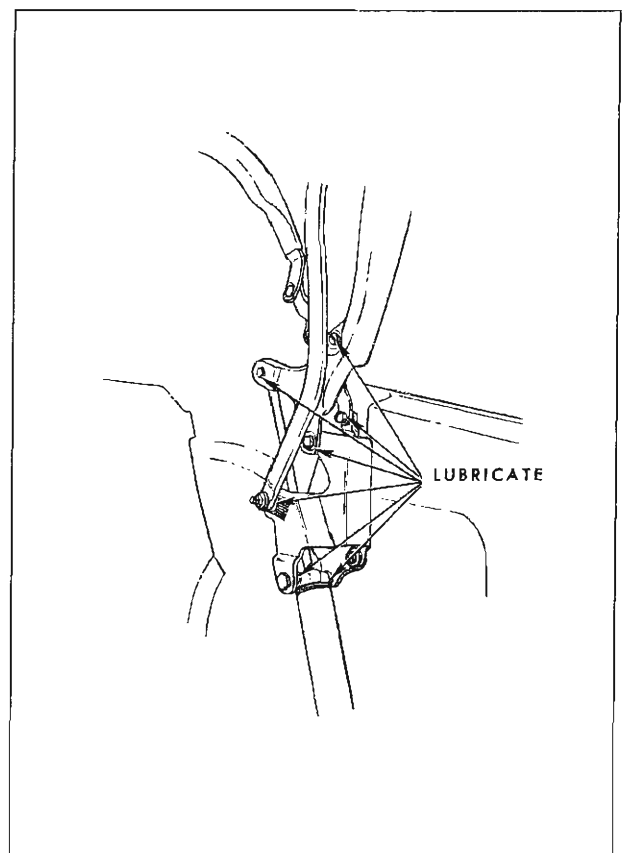

Fig. 2-16—"B" Convertible Hinge Lubrication

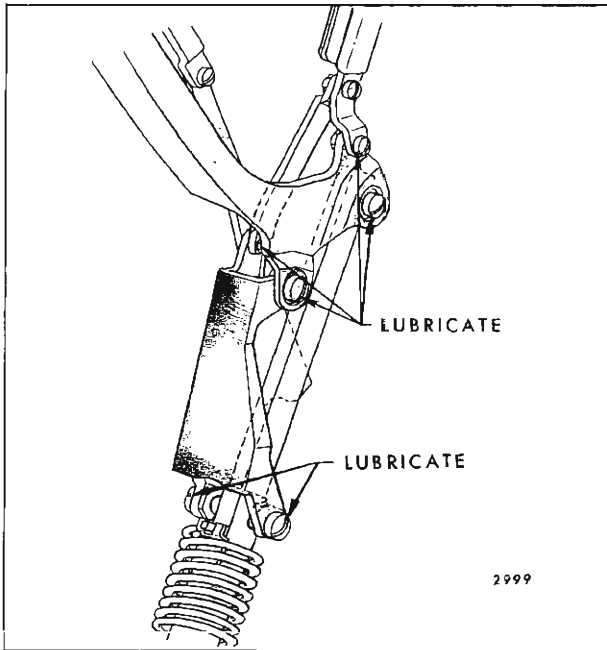

Fig. 2-17—"A" Convertible Hinge Lubrication

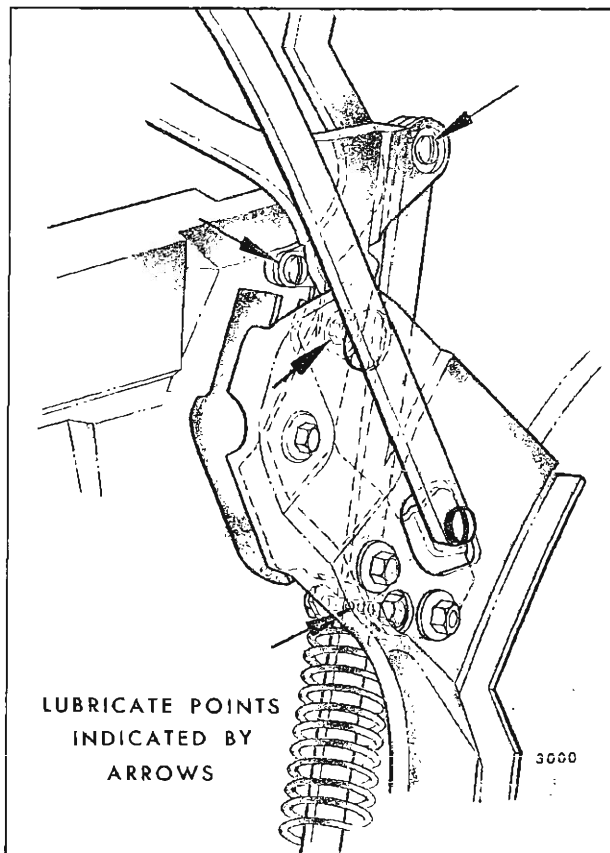

Fig. 2-18—"F" Convertible Hinge Lubrication

### REAR COMPARTMENT HINGES

1. Apply white lithium soap grease lubricant (Auto-Lube "A", Part No. 1050110 or Spray-Lube "A", Part No. 1050520 or equivalent) to the friction areas of the rear compartment lid hinge.
2. Open and close rear compartment lid several times.
3. Remove excess lubricant.

### ENGINE COMPARTMENT LID SUPPORT

1. Apply a thin coat of white lithium soap grease (Fiske Bros. Lo-Temp. Lubriplate #777 or equivalent) to the inner surface telescoping channel of the compartment lid support (Fig. 2-19).
2. Open and close the lid several times.
3. Remove excess lubricant.

### REAR COMPARTMENT LID LOCK

1. Clean the lock bolt surface.

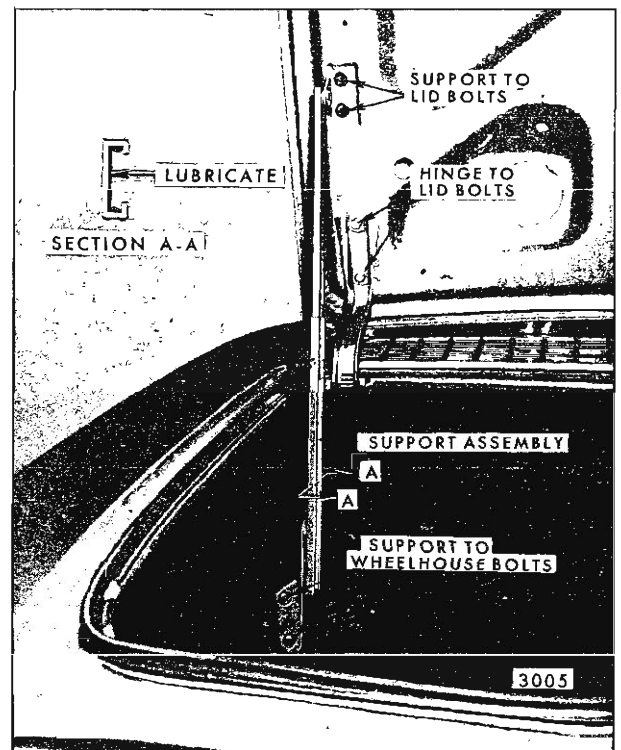

Fig. 2-19—Engine Compartment Lid Lubrication

2. Apply a thin coat of white lithium soap grease (Auto-Lube "A", Part No. 1050110 or Spray-Lube "A", Part No. 1050520 or equivalent) to the contact surface of the lock bolt (Fig. 2-20).
3. Actuate the lock mechanism several times.
4. Remove excess lubricant.

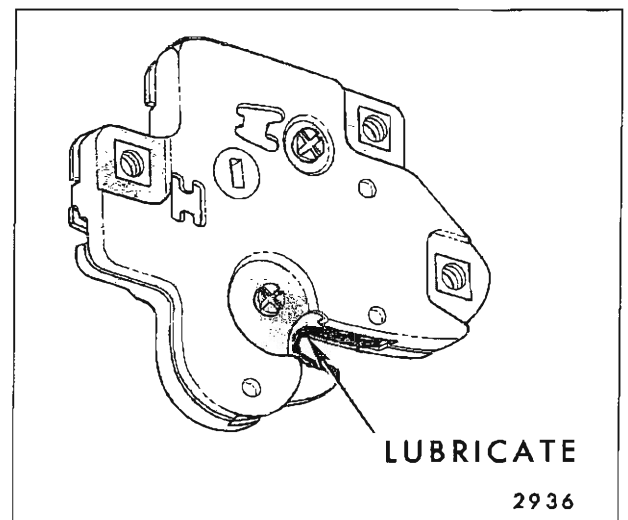

Fig. 2-20—Rear Compartment Lid Lock Lubrication

## SECTION 3

# UNDERBODY

### INDEX

Subject	Page	Subject	Page
Underbody Alignment - Corvaire "Z" Bodies . . . . .	3-1	General Construction . . . . .	3-5
General Construction . . . . .	3-1	Alignment Checking . . . . .	3-6
Underbody General Service . . . . .	3-1	Reference Point Dimensions . . . . .	3-6
Alignment Checking . . . . .	3-2	Horizontal Dimensions - Chevy Nova and Acadian	
Body Tram Gage . . . . .	3-2	"X" Bodies . . . . .	3-6
Reference Point Dimensions . . . . .	3-2	Vertical Dimensions - Chevy Nova and Acadian	
Horizontal Dimensions . . . . .	3-3	"X" Bodies . . . . .	3-7
Vertical Dimensions . . . . .	3-5	Horizontal Dimensions - Camaro and Firebird "F"	
Underbody Alignment . . . . .	3-5	Bodies . . . . .	3-7
Camaro and Firebird "F" Bodies . . . . .	3-5	Vertical Dimensions - Camaro and Firebird "F"	
Chevy Nova and Acadian "X" Bodies . . . . .	3-5	Bodies . . . . .	3-8

## UNDERBODY ALIGNMENT ALL CORVAIR STYLES

### GENERAL BODY CONSTRUCTION

The body design used on the 10000 series is of an integral, all steel, welded construction, commonly known as "unitized" body construction. The overall rigidity of the body is drawn from each of the individual metal components which, when welded together, comprise the body shell assembly. Panels forming the underbody area incorporate attachment provisions for the power train and the suspension systems. These panels, therefore, contribute the greatest amount of strength to the body assembly.

### UNDERBODY GENERAL SERVICE INFORMATION

The underbody assembly is comprised of frame side rails, frame cross rails, floor pan cross bars, inner and outer rocker panels and other floor panel components. The underbody is of all-welded construction. The slightest misalignment in the underbody can affect door, front compartment lid, and engine compartment lid fits. Most important, however, underbody misalignment can influence the suspension system, thereby causing many of the problems that arise from a suspension misalignment. It is essential, therefore, that underbody alignment be exact to within 1/16" of the specified dimensions.

In the event of collision damage it is important that underbody alignment be thoroughly checked and, if necessary, realigned in order to accurately establish suspension, steering and engine mounting lo-

cations. There are many classifications of tools that may be employed to correct the average collision damage situation including frame straightening machines, lighter external pulling equipment and standard body jacks.

Frame tools are not considered as essential equipment for average collision repair operations; however, there will be many situations with this unitized type of construction as with other types of frame construction, where frame equipment will be required. There are also areas of repair where, even though not essential, frame equipment may prove beneficial.

**IMPORTANT:** Since each individual underbody component contributes directly to the over-all strength of the body, it is essential that proper welding, sealing and rust proofing techniques be observed during service operations. Underbody components should be rust-proofed whenever body repair operations, which destroy or damage the original rust-proofing, are completed. Particularly critical are the enclosed box areas. When rust-proofing critical under body components, it is essential that a good quality type of air dry primer be used (such as corrosion resistant zinc chromate). It is not advisable to use combination type of primer surfacers.

To assist in checking alignment of the underbody components, repairing minor underbody damage or locating replacement parts, the following underbody dimensions and alignment checking information is presented.

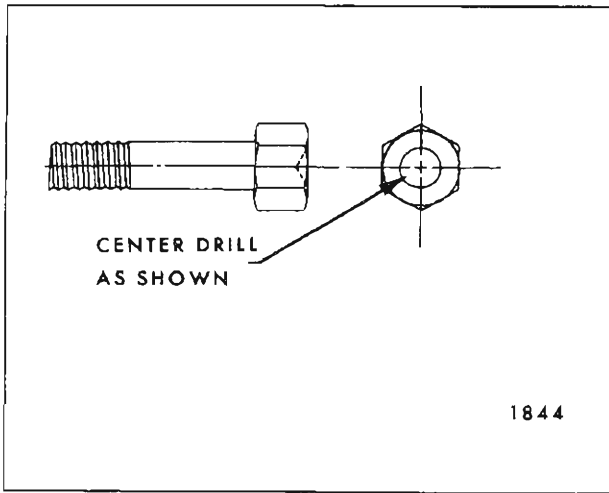

Fig. 3-1—Tram Gage Centering Bolt

**ALIGNMENT CHECKING INFORMATION**  
**Body Tram Gage**

An accurate method of determining the alignment of the underbody utilizes a measuring tram gage. The tram gage required to perform all recommended measuring checks properly must be capable of extending to a length of 102". At least one of the

vertical pointers must be capable of a maximum reach of 18"

Dimensional checks indicated in the upper portion of Figure 3-2 are calculated on a horizontal plane parallel to the plane of the underbody. Precision measurements can be made only if the tram gage is also parallel to the plane of the underbody. This can be controlled by setting the vertical pointers on the tram gage according to the dimensional checks shown in the lower portion of Figure 3-2. For actual dimensions, see charts in text.

A proper tramming tool is essential for analyzing and determining the extent of collision misalignment present in underbody construction.

To facilitate centering the tram gage pointers at the suspension locations, special centering bolts (same size and thread as original attaching bolts) may be prepared as shown in Figure 3-1. Use center of bolt thread diameter for centering drill point. Depth of drilled-out cone should be the same for all centering bolts being used as a "set".

**Underbody Alignment Reference**  
**Point Dimensions—(Fig. 3-2)**

Dimensions to gage holes and other unthreaded holes are measured to dead center of the holes and

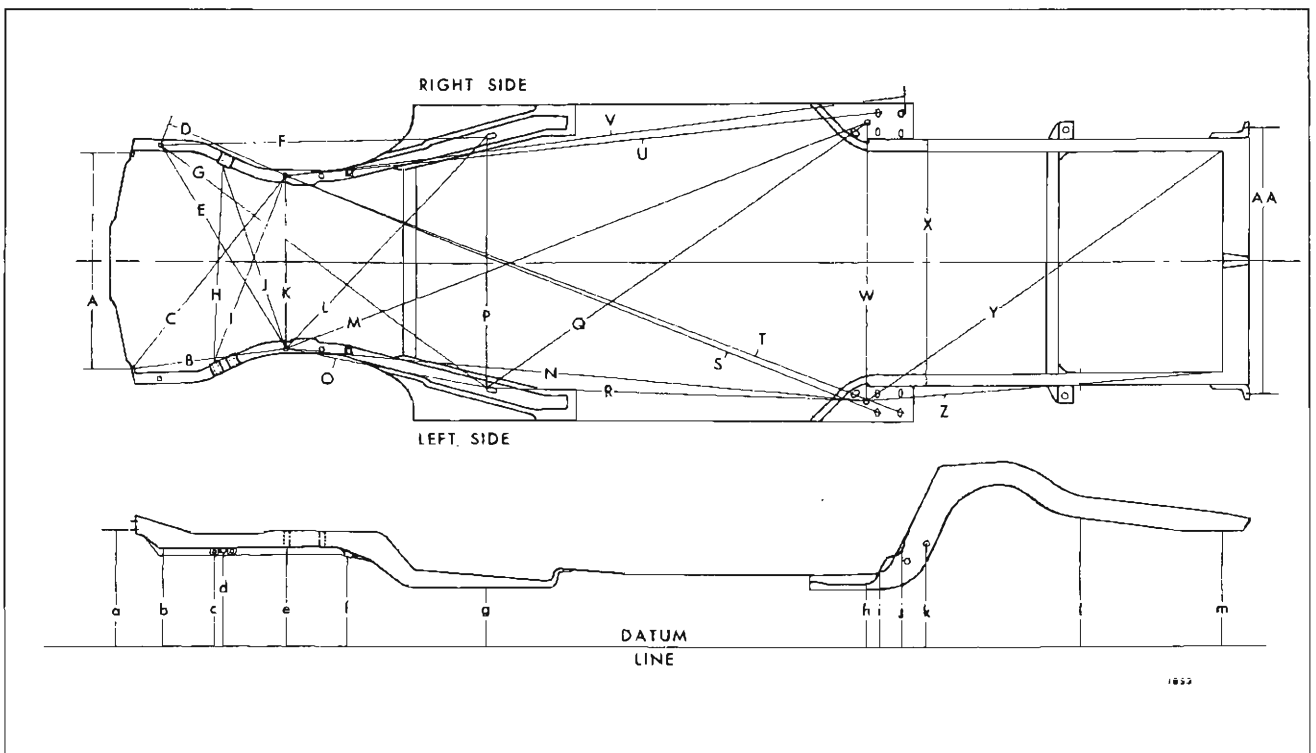

Fig. 3-2—Underbody Vertical Alignment Reference Points .

flush to the adjacent surface metal. Dimensions to body front tie down slots are measured to the front centerline edge of the slot (see Fig. 3-3). Dimensions to bolt or bolt hole locations are measured to the dead center of the thread diameter of the bolt or bolt hole, unless specified otherwise.

The following reference points are key locations and should be used wherever possible as a basis for checking other reference points:

1. Front suspension front attaching bolt holes or bolt heads.
2. 3/4 inch master gage hole in motor compartment side rail-to-rocker-panel brace.
3. Rear suspension control arm lower and upper outer attaching bolt holes (upper edge of holes).

**Horizontal Dimensions (Fig. 3-2)**

Fig. Ref.	Dimension	Location
A	33-7/8	Center of front bumper lower attaching bolt holes.
B	24-3/8	Directly below center of front bumper lower attaching bolt hole and front suspension front attaching bolt head or bolt hole on same side of body.
C	39-1/16	Directly below center of front bumper lower attaching bolt hole and front suspension front attaching bolt hole or bolt head on opposite side of body.
D	15-7/8	3/4" hole in front compartment side rail and front suspension front attaching bolt hole or bolt head on same side of body.
E	35-9/16	3/4" hole in front compartment side rail and front suspension front attaching bolt hole or bolt head on opposite side of body.
F	46	3/4" hole in front compartment side rail and body tie down slot on same side of body (use front center of slot of side rail metal - See Fig. 3-3).
G	59-29/32	3/4" hole in front compartment side rail and body tie down slot on opposite side of body (use front center of slot of side rail metal - See Fig. 3-3).

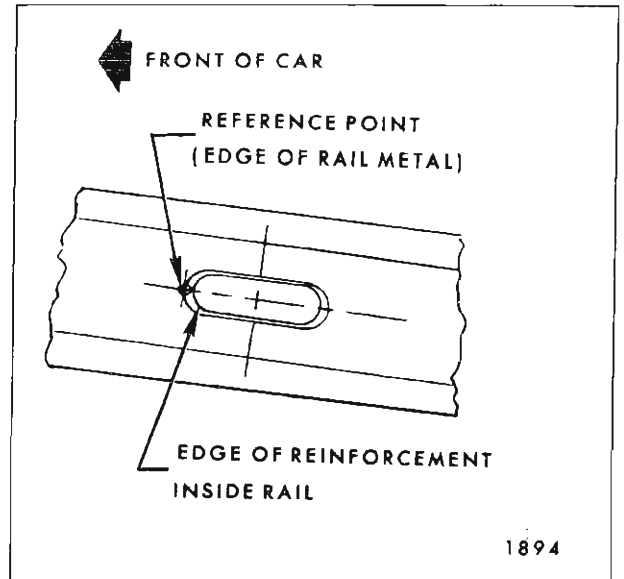

Fig. 3-3—Front Body Tie-Down Slot

- |   |        |  |
|---|--------|--|
| H | 31-7/8 | Lower inner edge of steering gear reinforcement directly below center of steering gear front attaching bolt hole (Fig. 3-4) and lower inner edge of front compartment right side rail directly below center of steering gear idler arm support lower attaching bolt hole (Fig. 3-5). |
|---|--------|--|

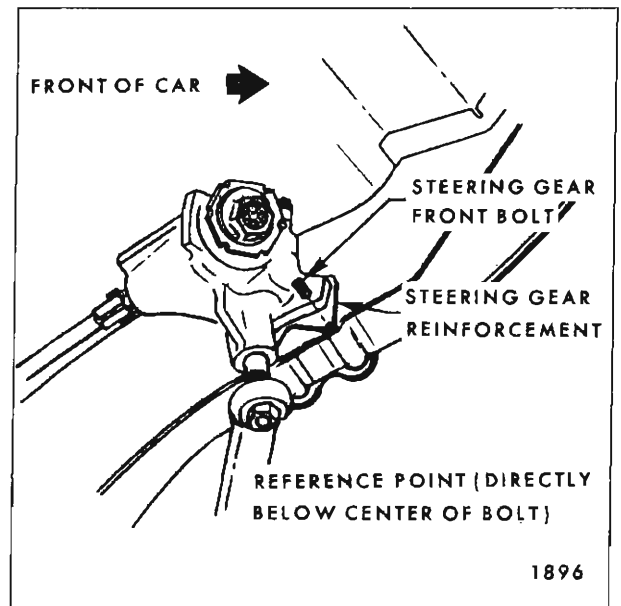

Fig. 3-4—Reference Point at Steering Gear Reinforcement



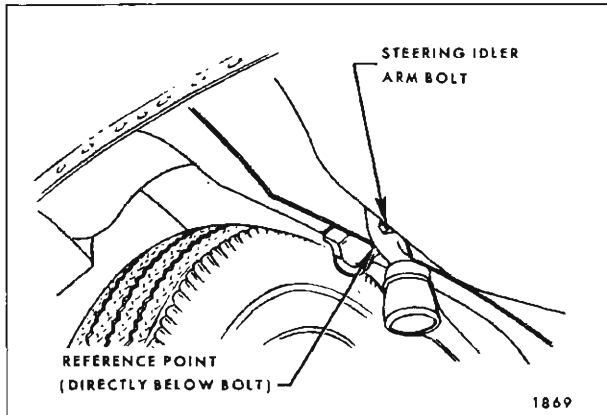

Fig. 3-5—Reference Point at Steering Idler Arm

Fig. Ref.	Dimension	Location
O	31-3/8	Front suspension front attaching bolt hole or bolt head and body front tie down slot on same side of body (use front center of slot of side rail metal - See Fig. 3-3).
P	40-3/16	Body front tie down slot (use front center of slot of side rail metal - See Fig. 3-3).
Q	72	Body front tie down slot (use front center of slot of side rail metal - See Fig. 3-3) and 3/4" master gage hole in motor compartment side rail-to-rocker panel brace on opposite side of body.
R	58-13/32	Body front tie down slot (use front center of slot of side rail metal - See Fig. 3-3) and 3/4" master gage hole in motor compartment side rail-to-rocker panel brace on same side of body.
S	98-1/8	Front suspension front attaching bolt hole or bolt head and rear suspension control arm lower outer attaching bolt hole (upper edge of hole) on opposite side of body.
T	101-3/8	Front suspension front attaching bolt hole or bolt head and rear suspension control arm upper outer attaching bolt hole (upper edge of hole) on opposite side of body.
U	91-3/8	Front suspension front attaching bolt hole or bolt head and rear suspension control arm lower outer attaching bolt hole (upper edge of hole) on same side of body.
V	94-7/8	Front suspension front attaching bolt hole or bolt head and rear suspension control arm upper outer attaching bolt hole (upper edge of hole) on same side of body.
W	44	3/4" master gage hole in motor compartment side rail-to-rocker panel brace.
I	31-15/16	Lower inner edge of steering gear reinforcement directly below center of steering gear front attaching bolt hole (Fig. 3-4) and front suspension front attaching bolt hole or bolt head on opposite side of body.
J	31-1/32	Lower inner edge of front compartment right side rail directly below center of steering gear idler arm support lower attaching bolt hole (Fig. 3-5) and front suspension front attaching bolt hole or bolt head on opposite side of body.
K	27-9/16	Front suspension front attaching bolt hole or bolt head.
L	45-23/32	Front suspension front attaching bolt hole or bolt head and body front tie down slot on opposite side of body (use front center of slot of side rail metal - See Fig. 3-3).
M	96-1/8	Front suspension front attaching bolt hole or bolt head on opposite side of body and 3/4" master gage hole in motor compartment side rail-to-rocker panel brace.
N	89-9/16	Front suspension front attaching bolt hole or bolt head and 3/4" master gage hole in motor compartment side rail-to-rocker panel brace on same side of body.

Fig. Ref.	Dimension	Location	Fig. Ref.	Dimension	Location
X	38-15/16	Outside edge of motor compartment side rail directly below transmission support upper attaching bolt.	d	11-17/32	Lower inner edge of front compartment right side rail directly below center of steering idler arm support lower attaching bolt hole (Fig. 3-5).
		<b>NOTE:</b> This dimension is constant rearward to motor compartment rear cross rail.	e	12-13/32	Front suspension front attaching hole (front suspension removed).
Y	67-1/2	3/4" master gage hole in motor compartment side rail-to-rocker panel brace and lower edge of joint of motor compartment side rail and motor compartment rear cross rail on opposite side of body.		11-13/16	Front suspension front attaching bolt (suspension installed).
			f	10-1/4	Front suspension rear attaching hole (front suspension removed).
				9-3/4	Front suspension rear attaching bolt (suspension installed).
Z	55-1/32	3/4" master gage hole in motor compartment side rail-to-rocker panel brace and lower edge of joint of motor compartment side rail and motor compartment rear cross rail on same side of body.	g	6	Lower surface of front compartment side rail at body front tie down slot (front center of slot). Fig. 3-3.
AA	41-5/32	Rear bumper lower attaching holes.	h	6-13/16	3/4" master gage hole in motor compartment side rail-to-rocker panel brace.
			i	8-3/4	Rear suspension control arm lower outer attaching bolt hole (upper edge of hole).
<b>Vertical Dimensions (Fig. 3-2)</b>			j	12-3/4	Rear suspension control arm upper outer attaching bolt hole (upper edge of hole).
Fig. Ref.	Dimension	Location	k	13-13/32	Transmission support upper attaching bolt hole or bolt head.
a	15-3/16	Center of front bumper lower attaching bolt holes.	l	18	Lower surface of motor compartment side rail at a point 1 inch rearward of rear edge of motor compartment corner reinforcement.
b	12-9/32	Front edge of 3/4" diameter paint hole.			
c	11-19/32	Lower inner edge of steering gear reinforcement directly below center of front attaching bolt hole (Fig. 3-4).	m	15-3/32	Lower surface of motor compartment side rail adjacent to front edge of motor compartment rear cross rail.

## UNDERBODY ALIGNMENT

### CAMARO AND FIREBIRD "F" BODIES

### CHEVY NOVA AND ACADIAN "X" BODIES

#### GENERAL BODY CONSTRUCTION

The "F" and "X" series bodies are of unitized construction. A stub frame supports the front end

sheet metal, front suspension, engine and other mechanical components. Unitized construction demands that underbody components be properly

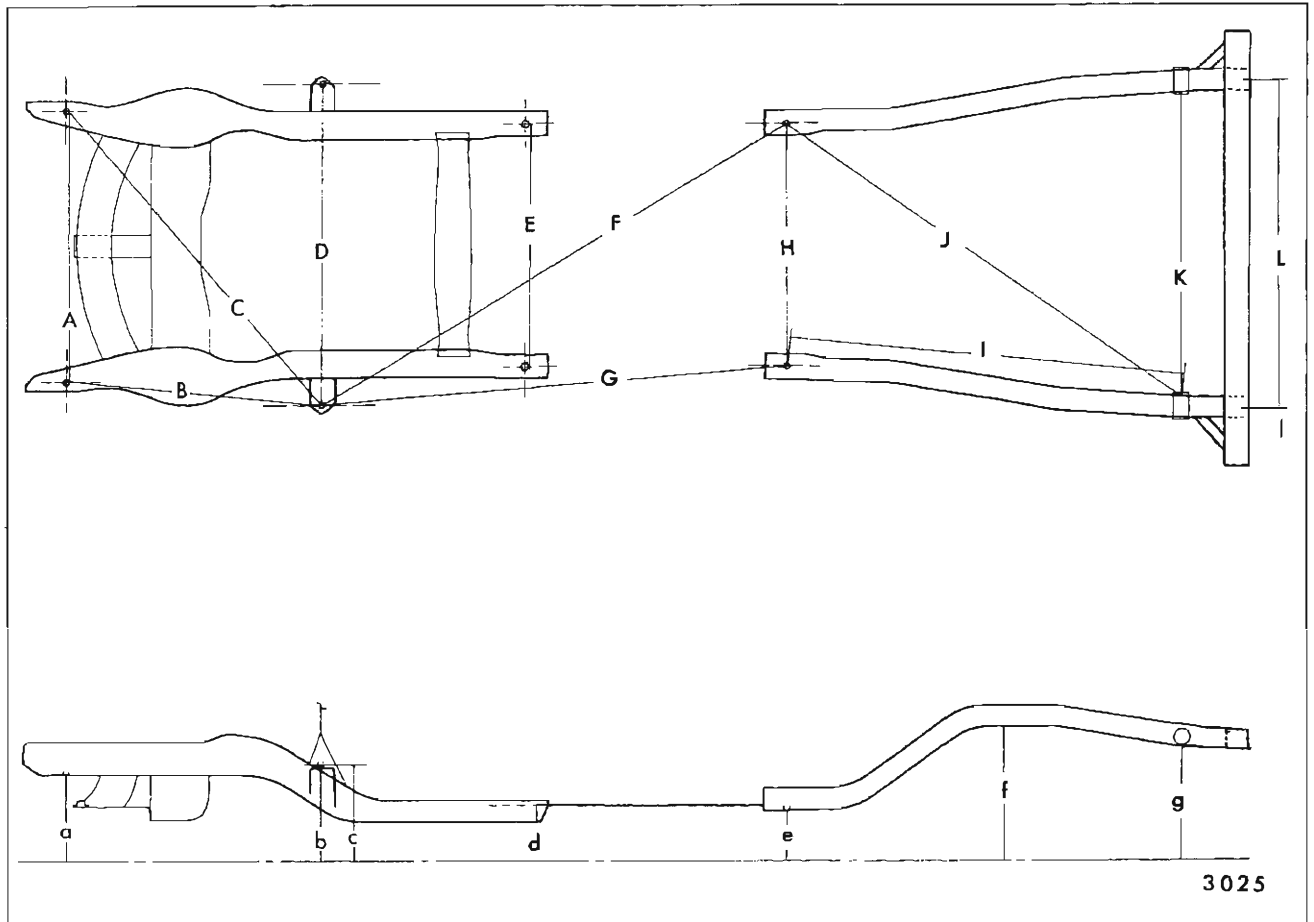

Fig. 3-6—Horizontal & Vertical Checking Dimensions (Chevy Nova & Acadian "X" Bodies)

aligned to assure correct suspension location. In the event of collision damage, it is important that the underbody be thoroughly checked and, if necessary, realigned in order to accurately establish proper dimensions.

Since each individual underbody component contributes directly to the over-all strength of the body, it is essential that proper welding, sealing and rust-proofing techniques be observed during service operations. Underbody components should be rust-proofed whenever body repair operations, which destroy or damage the original rust-proofing, are completed. When rust-proofing critical underbody components, it is essential that a good quality type of air dry primer be used (such as corrosion resistant zinc chromate). It is not advisable to use combination type primer-surfacers.

The tools and materials needed to check alignment and repair collision damage are described in the preceding Corvair Underbody Alignment section.

To assist in checking alignment of the underbody components, repairing minor underbody damage or

locating replacement parts, the following underbody dimensions and alignment checking information is presented.

**Underbody Alignment Reference Point Dimensions—(Fig. 3-6 for Chevy Nova and Acadian "X" Bodies)**

**(Fig. 3-8 for Camaro & Firebird "F" Bodies)**

Dimensions to gage holes are measured to dead center of the holes and flush to adjacent surface metal unless otherwise specified. The master gage holes, adjacent to the #1 body mount and in the side rails near the rear spring front attachment, are key locations and should be used wherever possible as a basis for checking other reference points.

**Horizontal Dimensions—Chevy Nova & Acadian "X" Bodies (Fig. 3-6)**

Ref.	Dimension	Location
A	38-1/4	Rear edge at centerline of 7/8" hole in lower surface of rail approximately 2" rearward of lower front edge of rail.

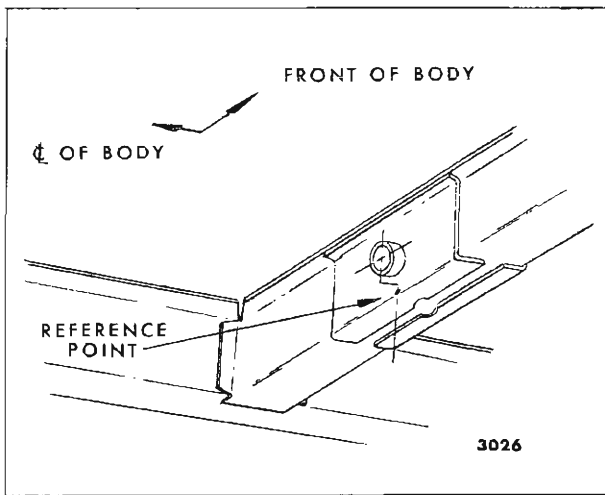

Fig. 3-7—Side Rail at Rear Spring Rear Shackle Bushing (Chevy Nova & Acadian "X" Bodies)

Fig. Ref.	Dimension	Location
B	35-1/4	Rear edge at centerline of 7/8" hole in lower surface of rail approximately 2" rearward of lower front edge of rail and center of master gage hole adjacent to #1 body mount on same side of body.
C	54-3/16	Rear edge at centerline of 7/8" hole in lower surface of rail approximately 2" rearward of lower front edge of rail and center of master gage hole adjacent to #1 body mount on opposite side of body.
D	44-9/16	Center of master gage hole adjacent to #1 body mount.
E	33-3/4	Rear edge at centerline of #2 body mount bolt hole.
F	79-1/16	Center of master gage hole adjacent to #1 body mount and center of master gage hole in side rail on opposite side of body.
G	69	Center of master gage hole adjacent to #1 body mount and center of master gage hole in side rail on same side of body.
H	33-3/16	Center of master gage hole in side rail.
I	54-11/16	Center of master gage hole in side rail and a point at inboard

Fig. Ref.	Dimensions	Location
		edge of same side rail at centerline of shackle bolt hole (See Fig. 3-7).
J	66-3/8	Center of master gage hole in side rail and a point at inboard edge of opposite side rail at centerline of shackle bolt hole (See Fig. 3-7).
K	42-5/8	Inboard edge of side rail at centerline of shackle bolt hole (See Fig. 3-7).
L	41-15/16	Center of rear bumper lower attaching bolts.

**Vertical Dimensions—  
Chevy Nova & Acadian "X" Bodies (Fig. 3-6)**

Fig. Ref.	Dimension	Location
a	10-1/8	7/8" hole in lower surface of rail approximately 2" rearward of lower front edge of rail.
b	10-15/16	Master gage hole adjacent to #1 body mount in frame.
c	11-13/16	Master gage hole adjacent to #1 body mount on body.
d	6-21/32	Floor pan adjacent to #2 body mount bolt cage nut.
e	6-7/16	Master gage hole in side rail.
f	12-7/32	Lower surface of side rail at kick up either side of rear axle housing.
g	10-5/16	Lower surface of side rail at centerline of shackle bolt hole.

**Horizontal Dimensions—  
Camaro & Firebird "F" Bodies (Fig. 3-8)**

Fig. Ref.	Dimension	Location
A	38-1/4	Rear edge at centerline of 7/8" hole in lower surface of rail approximately 2" rearward of lower front edge of rail.
B	35-1/4	Rear edge at centerline of 7/8" hole in lower surface of rail approximately 2" rearward of lower front edge of rail and

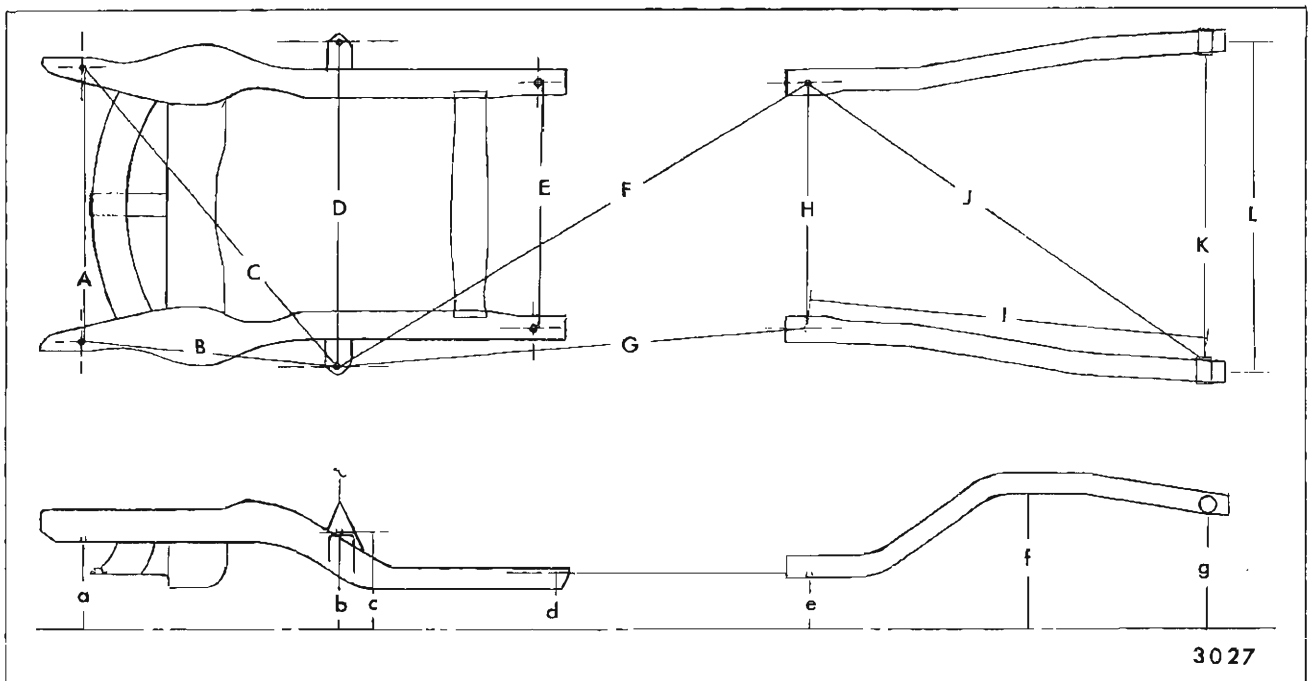

Fig. 3-8—Horizontal & Vertical Checking Dimensions (Camaro & Firebird "F" Bodies)

Fig. Ref.	Dimension	Location	Fig. Ref.	Dimension	Location
		center at master gage hole adjacent to #1 body mount on same side of body.	I	55-3/16	Center of master gage hole in side rail and a point at inboard edge of same side rail at centerline of shackle bolt hole (See Fig. 3-7).
C	54-3/16	Rear edge at centerline of 7/8" hole in lower surface of rail approximately 2" rearward of lower front edge of rail and center of master gage hole adjacent to #1 body mount on opposite side of body.	J	66-11/16	Center of master gage hole in side rail and a point at inboard edge of opposite side rail at centerline of shackle bolt hole (See Fig. 3-7).
D	44-9/16	Center of master gage hole adjacent to #1 body mount.	K	42-7/8	Inboard edge of side rail at centerline of shackle bolt hole (See Fig. 3-7).
E	33-3/4	Rear edge at centerline of #2 body mount bolt hole.	L	44-7/8	Center of rear bumper lower attaching bolts.
F	76"	Center of master gage hole adjacent to #1 body mount and center of master gage hole in side rail on opposite side of body.	<b>Vertical Dimensions— Camaro &amp; Firebird "F" Bodies (Fig. 3-8)</b>		
G	65-1/4	Center of master gage hole adjacent to #1 body mount and center of master gage hole in side rail on same side of body.	Fig. Ref.	Dimension	Location
H	33-1/2	Center of master gage hole in side rail.	a	11-15/16	7/8" hole in lower surface of rail approximately 2" rearward of lower front edge of rail.
			b	12-9/16	Master gage hole adjacent to #1 body mount in frame.

---

Fig. Ref.	Dimension	Location	Fig. Ref.	Dimension	Location
c	13-13/16	Master gage hole adjacent to #1 body mount on body.	f	18-7/16	Lower surface of side rail at kick up either side of rear axle housing.
d	9-1/8	Floor pan adjacent to #2 body mount bolt cage nut.	g	15-11/16	Lower surface of side rail at centerline of shackle bolt hole.
e	6-15/16	Master gage hole in side rail.			

## SECTION 4

# STATIONARY GLASS

### INDEX

Subject	Page	Subject	Page
Adhesive Caulked Glass - All Styles . . . . .	4-1	Installation (Short Method) . . . . .	4-3
Description . . . . .	4-1	Installation (Extended Method) . . . . .	4-4
Removal . . . . .	4-1	Waterleak Correction . . . . .	4-6

## ADHESIVE CAULKED GLASS

### ALL STYLES

#### DESCRIPTION

The stationary windows on all 1969 model passenger vehicles, excluding the Cadillac Limousine Landau option back window, are bonded to the body opening with a synthetic, self-curing, rubber adhesive caulking compound.

To replace a window installed with this material requires either partial or complete replacement of the caulking compound. Partial replacement of the material is referred to as the "short method". Complete material replacement is known as the "extended method".

The "short method" can be used in those situations where the original adhesive caulk material remaining on the window opening pinchweld flanges after glass removal can serve as a base for the new glass. This method would be applicable in cases of cracked windshields or the removal of windows that are still intact. In these situations, the amount of adhesive that is left in the window opening can be controlled during glass removal.

The "extended method" is required when the original adhesive caulking compound remaining in the window opening after glass removal cannot serve as a base for the replacement glass. Examples of this latter situation would be in cases requiring metal work or paint refinishing in the opening, or where there is a considerable loss of adhesion between the original caulk and the body metal. In these cases, the original caulk is removed and replaced with fresh material during window installation.

Adhesive Caulking Kit #4226000 contains some of the materials needed to remove and replace an adhesive caulked glass. This kit can be obtained through regular service parts channels. Other materials that may be required are available as service parts or can be readily obtained through local supply shops.

The components of adhesive caulking kit #4226000 are as follows:

- a. One tube of Adhesive Caulking material.

- b. One dispensing nozzle (cut for "short method" but can be notched-out for "extended method").
- c. Steel music wire (.020 diameter).
- d. Adhesive Caulking Primer (for priming original adhesive material in window opening).

Additional materials required:

- a. Caulking gun - standard household cartridge type reworked as follows:
  1. Widen end-slot to accept dispensing end of adhesive caulking tube.
  2. Reduce diameter of plunger disc on rod so that disc can enter large end of adhesive caulking tube.
- b. Two pieces of wood for wire handles.
- c. Black weatherstrip adhesive.
- d. Paint Finish Primer - available as service part #4226001 or equivalent - use only with "extended method".
- e. Rubber glass spacers - for "extended method".

**NOTE:** When the glass is originally installed, a rubber sealing strip "dam" is used around the edges of the window to prevent excessive squeeze-out of the adhesive caulk material. Service installations do not utilize this part. By applying masking tape around the inner perimeter of the glass prior to window installation, excess squeeze-out material is picked-up and removed with the tape.

#### ADHESIVE CAULKED WINDOW REMOVAL

The window removal procedure is the same for both the "short" and "extended" installation methods with one exception. If the "short method" installation is to be used, more care must be used during removal to make certain that an even, uniform bead of adhesive caulk material remains on the window opening to serve as a base for the replacement glass. Also, make certain that the glass lower support spacers are not disturbed.

4-2 STATIONARY GLASS

1. Place protective coverings around area where glass is being removed.
2. Remove all trim and hardware immediately adjacent to glass being removed. Depending on the area of the body, this could involve window reveal moldings, garnish moldings or finishing lace, rear view mirror support, windshield wiper arms and front fender mounted antenna.

**NOTE:** Reveal molding removal is covered in the Exterior Molding Section 17.

3. On styles equipped with rear window electric grid defogger (heating elements in glass), disconnect wire harness connectors located at right and left upper inside corners of glass from connectors located behind quarter upper trim panels. On Pontiac "G" and Oldsmobile "E" styles, also disconnect wire connectors at lower left inside corner of glass. If glass is to be reinstalled, tape leads to inside surface of glass to protect them during handling (See Figure 4-1).

**NOTE:** For quarter upper trim removal, refer to "Rear Quarter Trim", Section 14.

4. On styles equipped with radio antenna built into windshield glass, disconnect antenna lead at lower center of windshield. If glass is to be reinstalled, fold and tape lead wire back onto outer surface of windshield to protect it during glass removal and installation.
5. Secure one end of steel music wire to a piece of wood that can serve as a handle (Fig. 4-2). Using long nose pliers, insert other end of wire through caulk material at edge of glass; then, secure that end of wire to another wood handle.

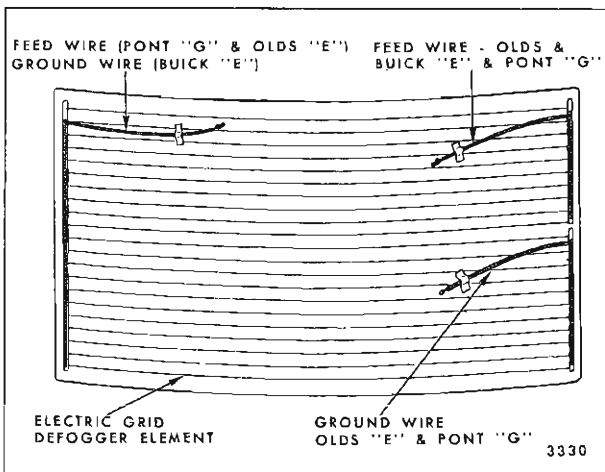

Fig. 4-1—Back Window Electric Grid Defogger (View From Inside Looking Rearward).

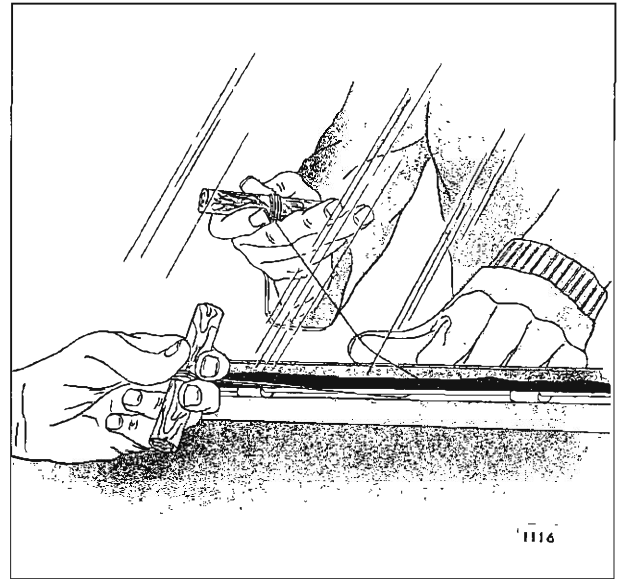

Fig. 4-2—Cutting Adhesive Caulk Material

6. With the aid of a helper, carefully cut (pull wire) through caulk material around entire perimeter of window (Fig. 4-2). If "short method" will be used to install new glass, hold wire close to inside plane of glass to prevent cutting an excessive amount of adhesive caulking from the window opening. Keep tension on wire throughout cutting operation to prevent wire from kinking and breaking.

**NOTE:** Optional methods of glass removal which require only one man are: (1) the electric hot-knife (Fig. 4-3) and (2) pulling the cutting wire through upper and lower edges of glass simultaneously (Fig. 4-4). For the latter

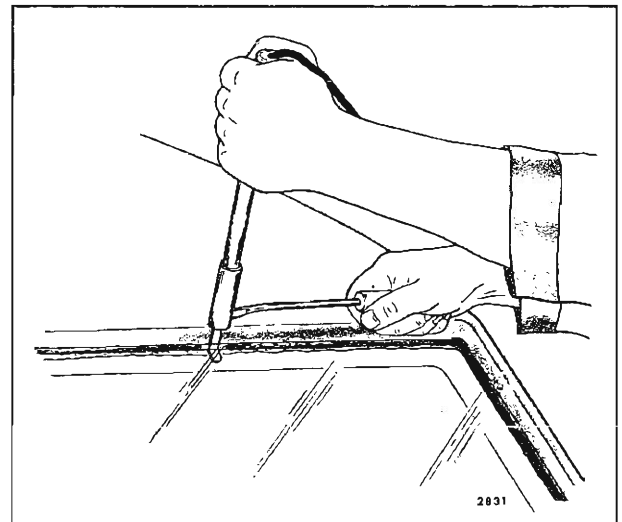

Fig. 4-3—Electric Hot-Knife Removal Method



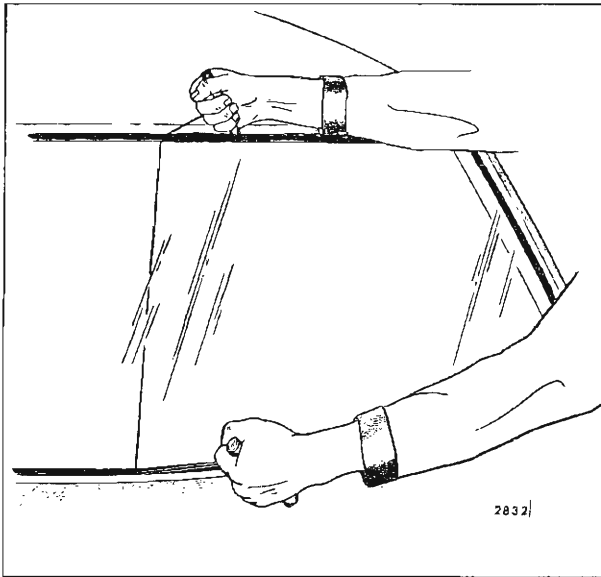

Fig. 4-4—One Man Wire Removal Method

optional method, insert one end of wire through caulking material at inner upper edge of glass and the other end of wire through caulking material at inner lower edge. Attach handles to both wire ends outside of body.

7. If the glass being removed is to be re-installed, place it on a protected bench or holding fixture; remove old caulking material using a razor blade or sharp scraper. Any remaining traces of caulk can be removed with a toluene or thinner dampened cloth.

**CAUTION:** When cleaning laminated glass, avoid contacting edge of plastic laminate material (on edge of glass) with a volatile cleaner. Contact may cause discoloration and deterioration of plastic laminate by "wicking" action.

**IMPORTANT:** DO NOT use a petroleum base solvent such as kerosene or gasoline. The presence of oil will prevent adhesion of new caulking material.

### ADHESIVE CAULKED GLASS INSTALLATION—"Short" Method

The "short" method of glass installation can be used if the original adhesive caulk material remaining on the window opening flanges after glass removal can serve as a base for the replacement glass. If there is substantial loss of adhesion between adhesive caulk material and body metal, or the window opening must be reworked or refinished, the "extended" method of replacement will be required.

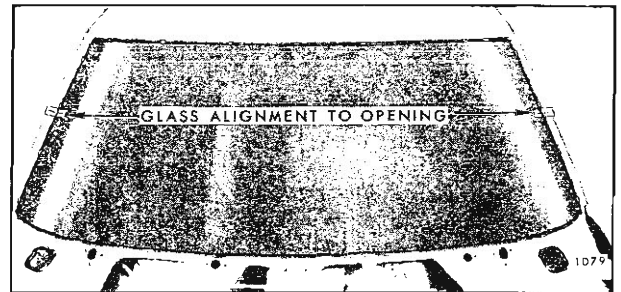

Fig. 4-5—Aligning Glass in Opening

### Installation—"Short" Method

1. Inspect reveal molding retaining clips. Replace or re-shape clips which are bent away from body metal  $1/32$ " or more. Where clips are retained by screws, make certain screws are sealed against waterleaks.
2. Position glass in the window opening. If new glass is being installed, check relationship of glass to adhesive caulk material on pinch-weld flange. Gaps in excess of  $1/8$ " must be corrected by shimming or by applying more adhesive caulk material than specified in Step 7.
3. When glass is in proper position in the opening, apply a piece of masking tape over each side edge of glass and adjacent body pillar (Fig. 4-5). Slit tape vertically at edge of glass. During installation, tape on glass can be aligned with tape on body to guide window into desired position.
4. Using a clean lint-free cloth liberally dampened with Adhesive Caulking Primer (furnished in Kit #4226000) or equivalent, briskly rub Primer over original adhesive material remaining on pinchweld flange. Perform the following steps while allowing Primer to dry for 5 to 10 minutes.
 

**CAUTION:** Use care so as not to spill or drip Primer on painted or trimmed surfaces.
5. Apply 1" wide masking tape to inside of windshield glass  $1/4$ " inboard from edge of glass, across the top and down each side, to facilitate clean-up after installation.
6. Wipe surface of glass to which adhesive caulking material will be applied (around edge of inside surface) with a clean, water-dampened cloth. Dry glass with a clean cloth.
7. Apply a smooth continuous bead of adhesive caulking material around entire inside edge of glass as shown in Figure 4-6. Material should be  $1/8$ " to  $3/16$ " in diameter.

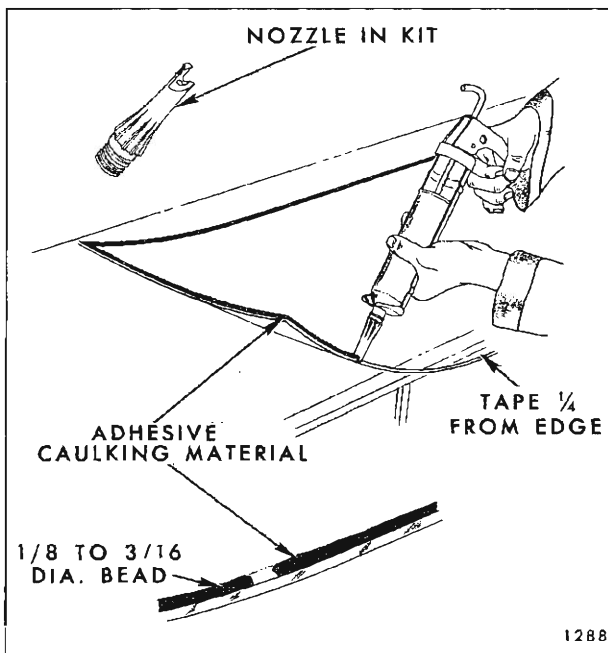

Fig. 4-6—Adhesive Material Application - Short Method

**IMPORTANT:** Due to the fast curing characteristics of adhesive caulk material, glass installation should be completed within 15 minutes from start of application of material to glass.

8. With the aid of a helper, lift glass into window opening. On back window installations it will be necessary to use suction cups to position glass in opening. On windows with narrow body pillars at the side edges of glass, the glass can be positioned without the aid of carrying devices. As shown in Figure 4-7, carry glass with one hand on inside of glass and one hand on outside. At the window opening, put glass in horizontal position. While one man holds glass in this position, the second man can reach one arm around the body pillar and support the glass while the other man assumes the same position.

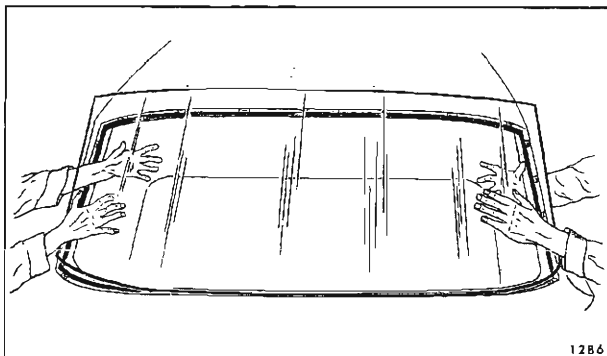

Fig. 4-7—Glass Installation

9. Using the tape guides applied in Step 3, carefully position glass in window opening making certain glass is properly centered and positioned on lower supports (metal or rubber).
10. Press glass firmly to "wet-out" and "set" caulking material. Use care to avoid excessive squeeze-out which would cause an appearance problem.
11. Watertest car immediately using a cold water spray. Do not direct a hard stream of water at fresh adhesive material. If any leaks are encountered, paddle-in extra adhesive material at leak point using a stick or flat-blade tool.
12. Install window reveal moldings. Remove clean-up masking tape from inner surface of glass and install remaining parts.

### ADHESIVE CAULKED GLASS INSTALLATION—"Extended" Method

If the adhesive caulk material remaining in the window opening after window removal is damaged, or must be removed to permit refinishing of the window opening, or has insufficient adhesion to body metal to serve as a base for the replacement glass, it will be necessary to use the "extended" installation method.

#### Installation—"Extended" Method

1. On styles using screw-retained lower glass supports, remove supports.
2. Using a sharp scraper or chisel, remove major portion of old caulking material from window opening flanges around entire opening. It is not necessary that all traces of the material be removed, but there should not be any mounds or loose pieces left.
3. Inspect reveal molding retaining clips. If upper end of a clip is bent away from body metal more than  $1/32$ ", replace or reform clip. Tighten all loose clip screws and reseal as required.
4. Using black weatherstrip adhesive or adhesive caulk material, cement flat rubber spacers #4459429 or equivalent to window opening pinchweld flanges. As shown in Figure 4-8, location "B", spacers should be positioned to provide equal support around entire perimeter of glass.

**NOTE:** If weatherstrip adhesive is used, apply sufficient material to obtain a watertight seal beneath spacer, however, do not allow excessive squeeze-out. Weatherstrip adhesive is not compatible with the replacement adhesive

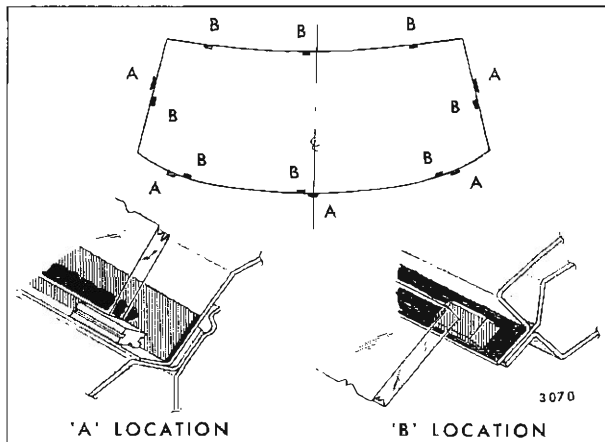

Fig. 4-8—Glass Spacer Installation

caulking material and waterleaks may develop at locations where these two materials are used together to form a seal.

5. Using black weatherstrip adhesive or adhesive caulking material, cement rectangular spacers #4871330 (.34 x .44 x 1.0) or equivalent to window opening rabbet to support lower edge of glass and restrict lateral movement. Figure 4-8, location "A", illustrates rectangular spacers positioned in a typical windshield installation. On smaller glasses, only 2 rectangular support spacers are required across the bottom.
6. With the aid of a helper, lift glass into window opening. On back window installations it will be necessary to use suction cups to position glass in opening. On windows with narrow body pillars at the sides, the glass can be positioned without the aid of carrying devices as described in step 7 and shown in Figure 4-7.
7. With one hand on each side of glass, put window in vertical position and support it on lower center glass support spacer. While one man holds glass in this position, the second man can reach one arm around the body pillar and support the glass while the other man assumes the same position.
8. With glass positioned in the opening, check relationship of glass to pinchweld flange around entire perimeter. Overlap of pinchweld flange should be equal with a minimum overlap of 3/16". Overlap across top may be varied by changing lower glass support spacers. Both thinner (#4404196 or equivalent) and thicker (#4534314 or equivalent) rectangular spacers are available as service parts.
9. Check relationship of glass contour to body

opening. Gap space between glass and pinchweld flange should be no less than 1/8" nor more than 1/4". If difficulty is encountered staying between these limits, correction can be made by any one of the following methods:

- a. Reposition flat spacers.
  - b. Apply more caulking material than is specified at excessive gap areas. Material can be applied to pinchweld flange or by allowing bead on glass to exceed 3/8" height at gap areas.
  - c. Change glasses - another glass may fit opening better.
  - d. Rework pinchweld flange.
10. After final adjustments have been made and glass is in proper position, apply pieces of masking tape over edges of glass and body (Fig. 4-5 or 4-9), depending on window being installed). Tape on glass can be aligned with tape on body to guide glass into opening during installation.
  11. Remove glass from opening and apply one-inch masking tape around inner surface of glass 1/4" inboard from outer edge (Fig. 4-10). On windshield installations, apply tape to top and sides only. Do not use tape across bottom. Removal of tape after glass installation will aid in clean-up and give a smooth, even edge to adhesive material.
  12. Using a clean lint-free cloth liberally dampened with Adhesive Caulking Primer or equivalent (supplied in Kit #4226000), briskly rub primer over original adhesive material remaining on pinchweld flange. Perform the following steps while allowing primer to dry for 5 to 10 minutes.

**NOTE:** If the pinchweld flange has been repainted, prime pinchweld flange with Paint

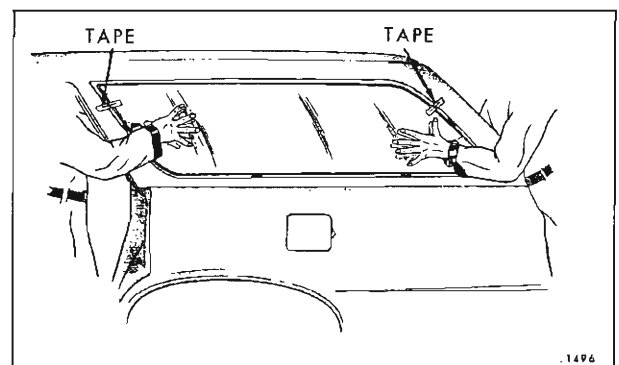

Fig. 4-9—Stationary Quarter Window Installation

Finish Primer #4226001 or equivalent. Paint Finish Primer is available as a service part.

**CAUTION:** Use extreme care to avoid spilling either primer solution on trim or painted surfaces. Wipe any spills immediately as primers will etch trim or painted surfaces on prolonged contact.

13. Nozzle furnished in kit is designed for "short" method. For the "extended" method, enlarge nozzle opening by removing material within score lines.
14. Wipe surface of glass to which bead of adhesive caulking material will be applied (between masking tape and edge of glass) with a clean water-dampened rag. Dry glass with a clean cloth.
15. With caulking gun and nozzle positioned as illustrated in Figure 4-10, carefully apply a smooth continuous bead of caulking material  $3/8$ " high by  $3/16$ " wide at base completely around inside edge of glass.

**NOTE:** Adhesive caulk material begins to cure after fifteen minute exposure to air; therefore, install glass in the opening as quickly as possible.

16. Install glass in opening as described in steps 6

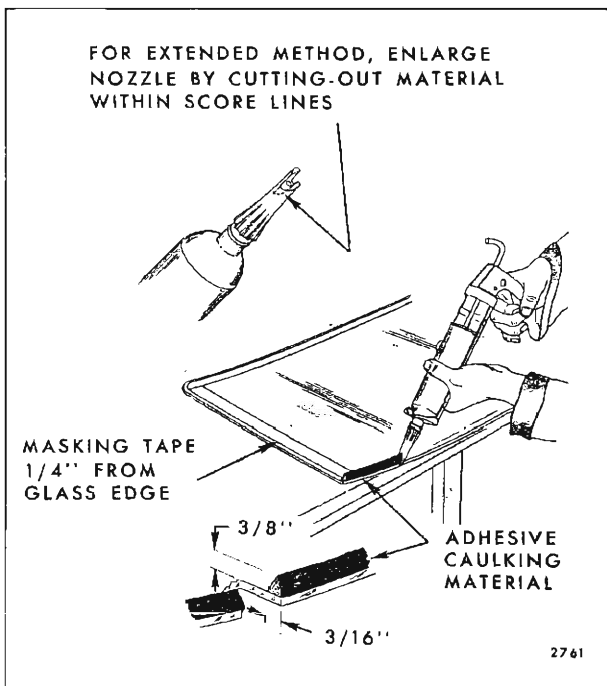

Fig. 4-10—Adhesive Material Application - Extended Method

and 7. Apply light hand pressure to "wet-out" adhesive material and obtain a bond to body opening.

17. Watertest immediately using a cold water spray. Do not direct stream of water at fresh adhesive material. Allow water to spill over edges of glass. If waterleak is encountered, use a flat-blade tool to work-in additional caulking material at leak point.
18. Install window reveal moldings. Then, carefully remove masking tape from around inner periphery of window. Pull tape toward center of glass to give a clean-cut edge to adhesive caulk, and to prevent excess squeeze-out material on tape from creating an additional clean-up problem.
19. Install all other previously removed parts and clean-up.

### WATERLEAK CORRECTION OF ADHESIVE CAULKED GLASS

Adhesive caulked glass installation waterleaks can be corrected in the following manner without removing and reinstalling the glass.

**NOTE:** The following procedure is applicable only with the use of adhesive caulking material

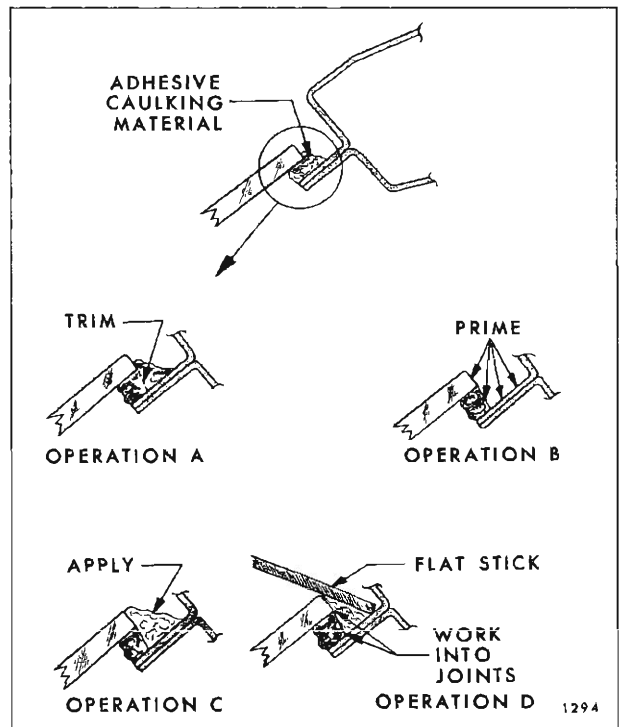

Fig. 4-11—Adhesive Caulked Glass Waterleak Correction

and primer furnished in Kit Part #4226000 or equivalent.

1. Remove reveal moldings in area of leak. In some cases, it may become necessary to remove garnish moldings or finishing lace to locate the source of a leak.

2. Mark location of leak(s).

**IMPORTANT:** If leak is between adhesive caulking material and body or between material and glass, carefully push outward on glass in area of leak to determine extent of leak. This operation should be performed while water is being applied to leak area. Mark extent of leak area.

3. From outside body clean any dirt or foreign material from leak area with water; then dry area with air hose.
4. Using a sharp knife, trim off uneven edge of adhesive caulking material (see Operation "A" Fig. 4-11) at leak point and 3 to 4 inches on

both sides of leak point or beyond limits of leak area.

5. Using a small brush, apply adhesive caulking material primer over trimmed edge of adhesive caulking material and over adjacent painted surface (see Operation "B" Fig. 4-11).
6. Apply adhesive caulking material, as shown in Operation "C" (Fig. 4-11), at leak point and 3 to 4 inches on both sides of leak point or beyond limits of leak area.
7. Immediately after performing step 6, use flat stick or other suitable flat-bladed tool to work adhesive caulking material well into leak point and into joint of original material and body to effect a watertight seal along entire length of material application (See Operation "D" Fig. 4-11).
8. Spray watertest to assure that leak has been corrected. DO NOT run a heavy stream of water directly on freshly applied adhesive caulking material.

## SECTION 5 FRONT END

### INDEX

Subject	Page	Subject	Page
BODY VENTILATION . . . . .	5-1	Pressure Relief Valve ("A, B, C, E, F, & G" Styles) . . . . .	5-8
Ventilation System Components - Non-Air Conditioning . . . . .	5-1	INSTRUMENT PANEL . . . . .	5-9
Description - Non-Air Conditioning . . . . .	5-1	Instrument Panel Compartment Door (Buick "A & E" Styles) . . . . .	5-9
Shroud Center Duct Upper Air Outlet and Door ("B & C" Styles) . . . . .	5-4	Instrument Panel Compartment Door Lock Cylinder and Lock (Buick "A & E" Styles, Chevrolet - All Styles) . . . . .	5-9
Shroud Center Duct Upper Air Outlet and Door ("A & G" Styles) . . . . .	5-4	Instrument Panel Covers (Chevrolet "A, X & Z" Styles and Pontiac "F" Styles) . . . . .	5-10
Shroud Center Duct Upper Air Outlet and Door ("F" Styles) . . . . .	5-4	FRONT COMPARTMENT - CORVAIR . . . . .	5-11
Shroud Side Finishing Panel ("A, G, B, C, X" and "Z-37" Styles) . . . . .	5-4	Description . . . . .	5-11
Shroud Side Finishing Panel ("F" Styles) . . . . .	5-6	Front Compartment Lid . . . . .	5-11
Shroud Side Finishing Panel and Air Duct Outlet ("Z-67" Styles) . . . . .	5-6	Front Compartment Lid Torque Rods . . . . .	5-12
Shroud Side Air Duct Outlet and Door (Buick and Cadillac "E" Styles) . . . . .	5-7	Front Compartment Lid Lock Cylinder Assembly . . . . .	5-13
Shroud Side Air Duct Outlet and Door (Oldsmobile "E" Styles) . . . . .	5-7	Front Compartment Lid Lock Assembly . . . . .	5-13
		Front Compartment Lid Lock Striker . . . . .	5-13
		Front Compartment Lid Gutter Weatherstrip . . . . .	5-14

## BODY VENTILATION

### VENTILATION SYSTEM COMPONENTS (Non-Air Conditioned)

(The following applies only to non-air conditioned styles) Body ventilation systems vary from one body style to another. Each ventilation system is comprised of a combination of components depending upon body style, as described in the following:

1. Air intake at front plenum chamber (all styles).
2. High level air outlets at instrument panel sides (all styles with vent-less front door windows; Buick and Oldsmobile "E" styles include a high level air outlet at the center of the instrument panel; high level ventilation system is optional on Buick and Oldsmobile "A-27, 77, 39 & 69" Styles).
3. Low level air outlets in shroud side panels (all styles).
4. Door ventilators ("A" and "X" Closed Styles; "A-39" and All "Z" Styles).
5. Pressure relief valves (air exhaust outlets) on body lock pillars (all styles with high level ventilation system except Oldsmobile & Buick "E", station wagons and Cadillac "C" air conditioned styles).

6. Pressure relief valve and air exhaust outlet at rear plenum chamber (Buick and Oldsmobile "E" styles).

### DESCRIPTION (Non-Air Conditioning Styles)

Ventilating air enters the front plenum chamber through an air intake grille and/or screen. Air is directed through the plenum chamber to the high level air outlet doors at the shroud center panel and/or to the low level air outlet doors at the shroud side panels. When ventilation controls are operated, air enters past the respective doors and into the body (Fig. 5-1).

Water entering the plenum chamber is channeled to the base of the shroud side panels where it is drained through openings provided for that purpose.

On all styles with high level ventilation, except "E" and all station wagons, air passes through the body, under the rear seat, into the rear compartment and into both rear quarters. The air then leaves the body by passing through pressure relief valves located on the rear lock pillars (Fig. 5-1).

**NOTE:** Cadillac "C" styles with air conditioning do not use pressure relief valves at rear lock pillars.

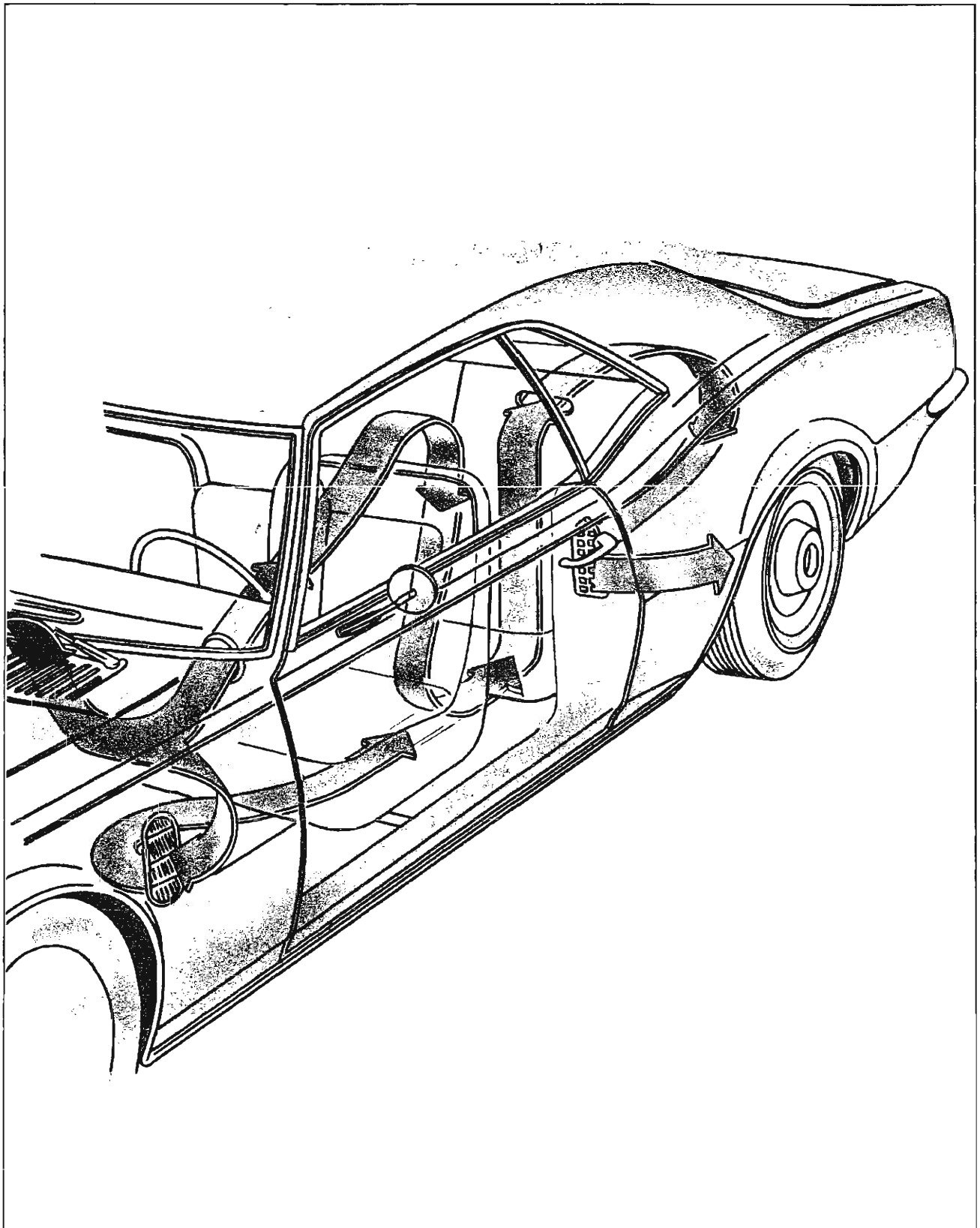

Fig. 5-1—High and Low Level Body Ventilation - "F" Styles Shown, "A, G, B, C" & Cadillac "E" Styles Similar-

On Buick "E" styles, air exhausts from the body by passing through a louvered grille in the rear shelf finishing panel, through a pressure relief valve,

through the rear plenum chamber and through the rear exhaust grille (Fig. 5-2).

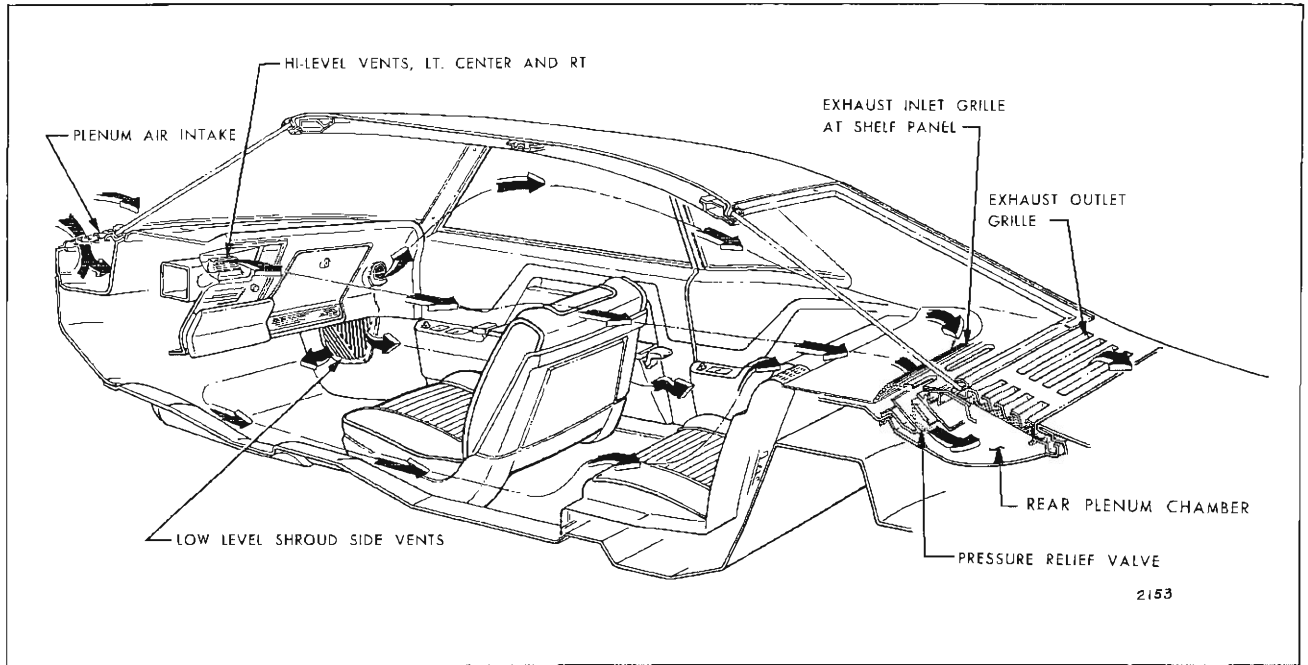

Fig. 5-2—Body Ventilation - Buick "E" Styles

On Oldsmobile "E" styles, air exhausts from the body by passing under the rear seat, through openings in the rear shelf panel, through a pressure

relief valve, through the rear plenum chamber, and through the rear exhaust grille (Fig. 5-3).

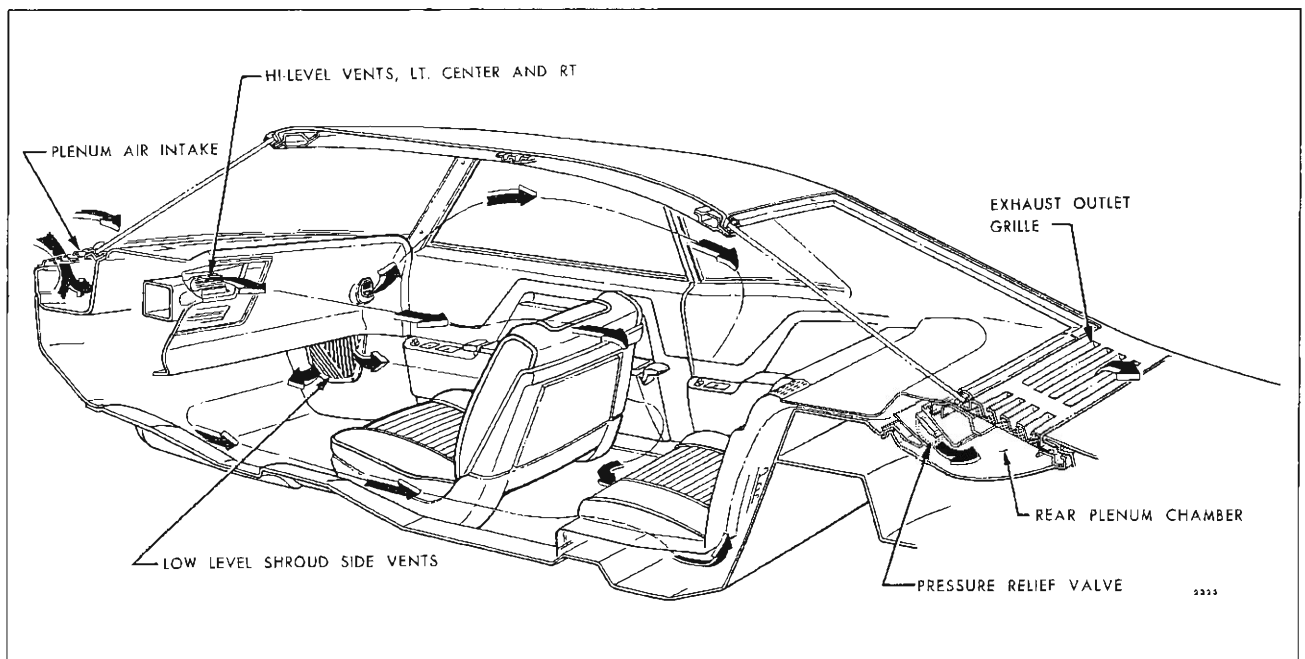

Fig. 5-3—Body Ventilation - Oldsmobile "E" Styles



Water entering the rear plenum chamber is channeled to drain hoses at the sides which drain the water at a location below the floor pan.

### SHROUD CENTER DUCT UPPER AIR OUTLET AND DOOR—"B and C" Styles

The outlet, door and control cable attachment are shown in Figure 5-4.

Door removal requires removal of the door retaining clip and control cable attaching screw before the door can be disconnected from the control cable. Removal of the shroud side finishing panel requires removal of the door.

As shown, the duct outlet is sealed with a gasket at the attaching flanges and is secured to the center duct panel with screws.

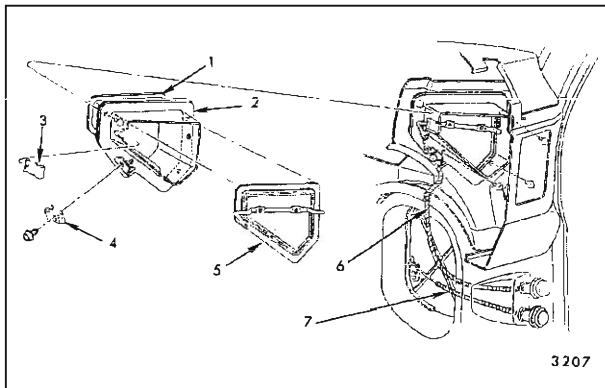

Fig. 5-4—Shroud Center Duct Upper Air Outlet and Door - "B & C" Styles

- |                         |                                   |
|-------------------------|-----------------------------------|
| 1. Gasket               | 5. Door                           |
| 2. Outlet               | 6. Upper Vent Control Cable       |
| 3. Door Retaining Clip  | 7. Shroud Side Vent Control Cable |
| 4. Cable Retaining Clip |                                   |

### SHROUD CENTER DUCT UPPER AIR OUTLET DOOR—"A and G" Styles

The door and control cable attachment are illustrated in Figure 5-5.

Door removal requires the removal of the retaining clip before the door can be disconnected from the control cable. Removal of the shroud side finishing panel requires removal of the door and cable retaining clips. The duct outlet is welded to the center duct panel.

### SHROUD CENTER DUCT UPPER AIR OUTLET AND DOOR—"F" Styles

As shown in Figure 5-6, the door is sub-assembled to the outlet before the assembly is sealed with a gasket and attached to the center duct panel with

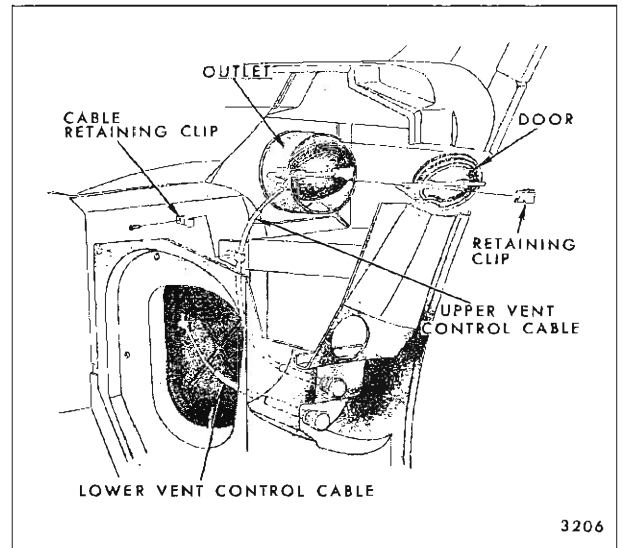

Fig. 5-5—Shroud Center Duct Upper Air Outlet Door - "A & G" Styles

screws. The door is secured to the outlet by a door hinge rod. The hinge rod is secured by a push-on retainer ring.

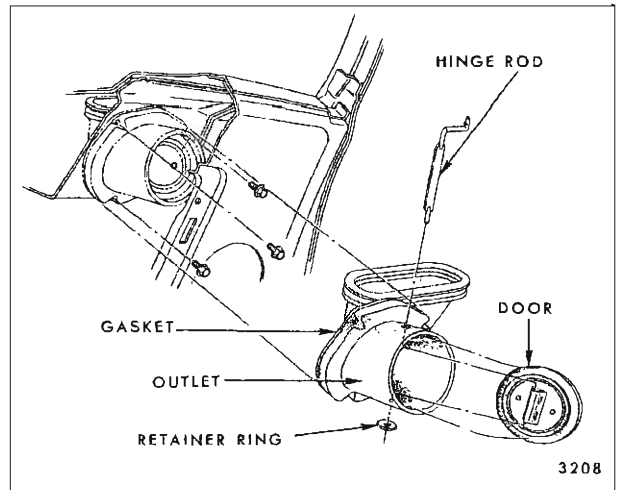

Fig. 5-6—Shroud Center Duct Upper Air Outlet and Door - "F" Styles

### SHROUD SIDE FINISHING PANEL "A-G-B-C-X & Z-37" Styles

The shroud side finishing panel is designed with an integral air duct outlet and hinge pillar pinchweld finishing lace. The following are added to the finishing panel before installation: air outlet door; upper and/or lower vent control cables; and medium-bodied sealer (on attaching flanges). The finishing panel is secured by screws at the side panel and by one screw at the hinge pillar. A snap-in type grille completes the installation.

Removal of the door and/or lower vent control cable requires removal of the finishing panel. Removal of the upper vent control cable requires re-

moval of the finishing panel and upper air duct outlet door (Figures 5-7, 5-8 and 5-9 depict types of finishing panels and their installation).

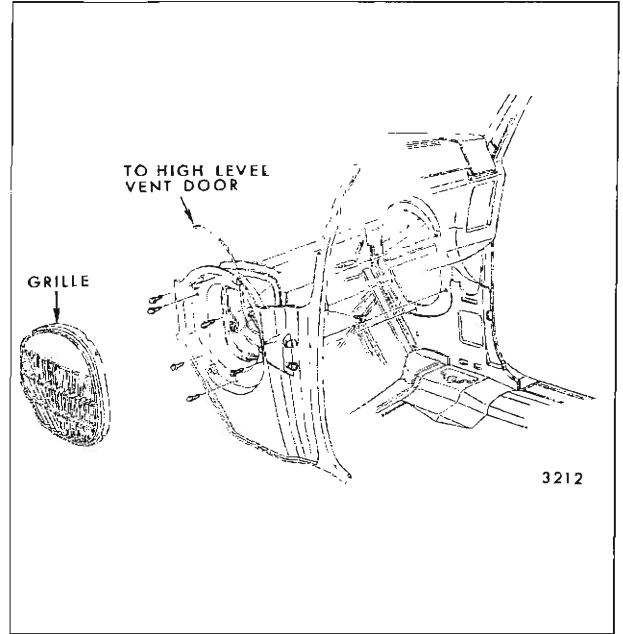
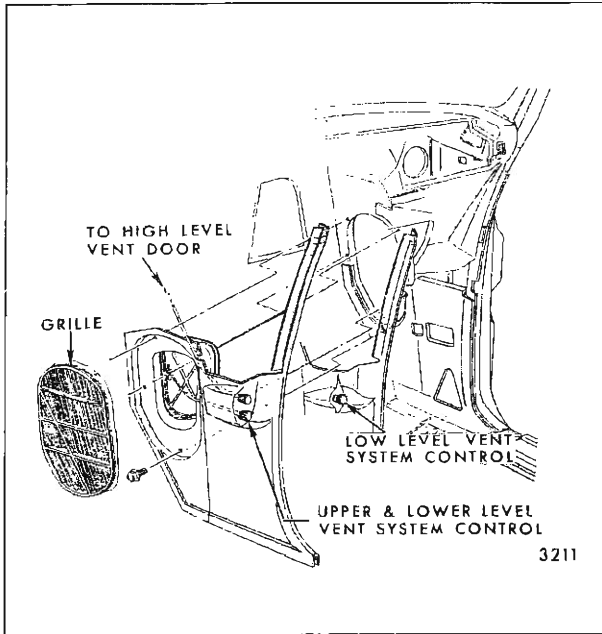

Fig. 5-7—Shroud Side Finishing Panel - "A, G, B, C, X" and "Z-37" Styles

Fig. 5-8—Shroud Side Finishing Panel - "B & C" Styles

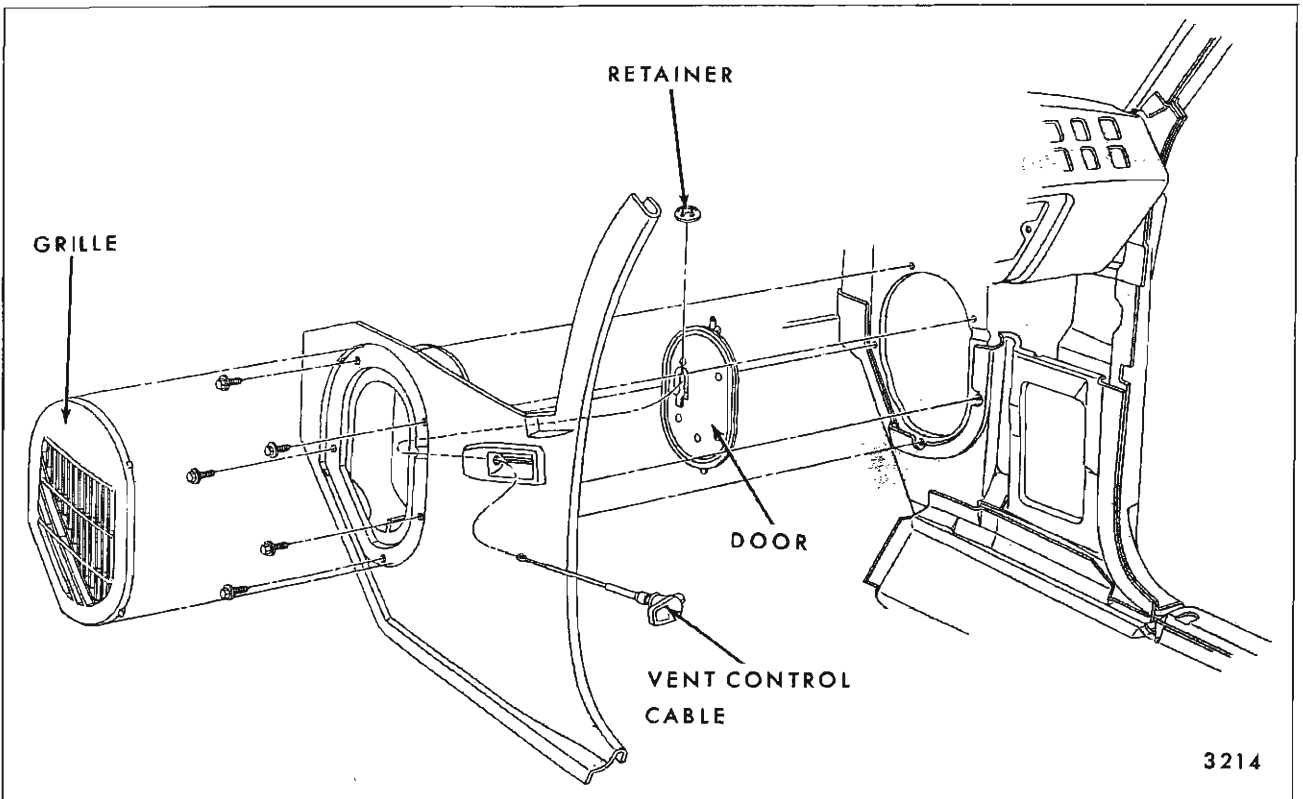

Fig. 5-9—Shroud Side Finishing Panel - "X" Styles

### SHROUD SIDE FINISHING PANEL—"F" Styles

Figure 5-10 illustrates that, in addition to an integral air duct outlet and hinge pillar pinchweld finishing lace, the shroud side finishing panel consists of an integral air outlet grille. Attachment and sealing are typical of other styles (Fig. 5-11).

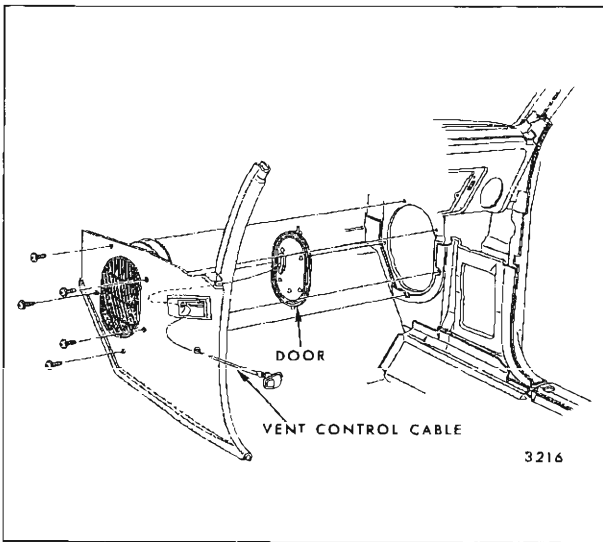

Fig. 5-10—Shroud Side Finishing Panel - "F" Styles

Figure 5-11 illustrates typical sealing of shroud side finishing panels prior to installation. When installing, apply a generous bead of medium-bodied sealer to attaching flanges of finishing panel as shown.

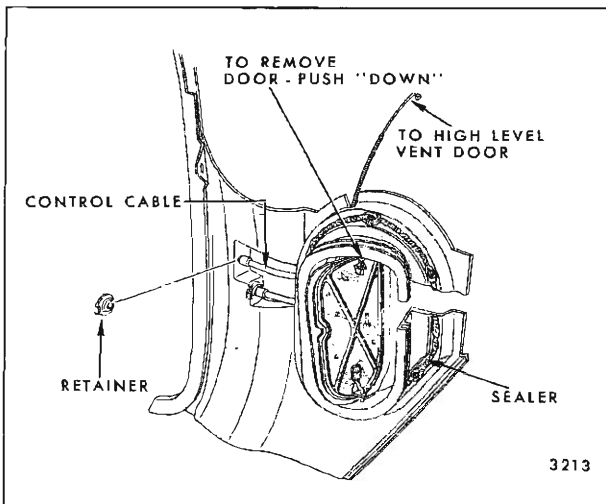

Fig. 5-11—Shroud Side Finishing Panel Sealing - All Styles Except "E" and "Z-67"

### SHROUD SIDE FINISHING PANEL AND AIR DUCT OUTLET—"Z-67" Styles

Figure 5-12 illustrates the components and installation of the finishing panel and separate air duct outlet. Figure 5-13 further illustrates the attachment of components. When installing, apply a generous bead of medium-bodied sealer to attaching flanges of the finishing panel and duct outlet as shown (Fig. 5-13).

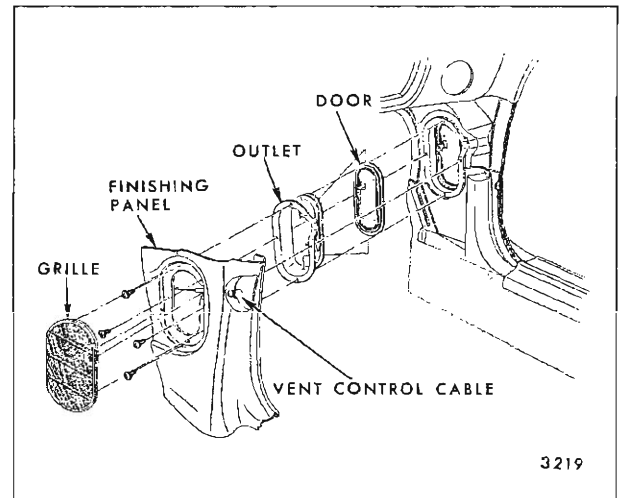

Fig. 5-12—Shroud Side Finishing Panel and Air Duct Outlet - "Z-67" Style

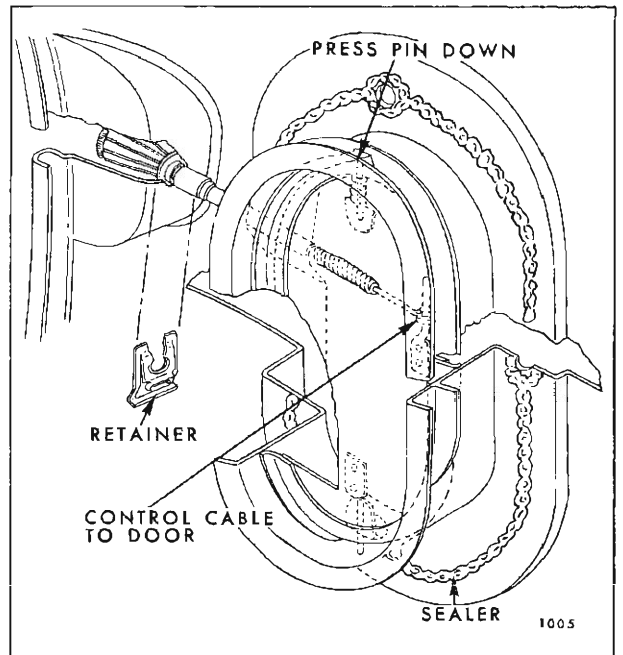

Fig. 5-13—Shroud Side Finishing Panel and Air Outlet - "Z-37" Styles

### SHROUD SIDE AIR DUCT OUTLET AND DOOR—Buick and Cadillac “E” Styles

Figure 5-14 illustrates the components and installation of the air duct outlet and door. The door is secured to the outlet by a retainer, and the manual control cable is secured to the instrument panel.

### SHROUD SIDE AIR DUCT OUTLET AND DOOR—Oldsmobile “E” Styles

Figure 5-15 illustrates the components and installation of the air outlet and door. The door is controlled by a vacuum actuator and link as shown.

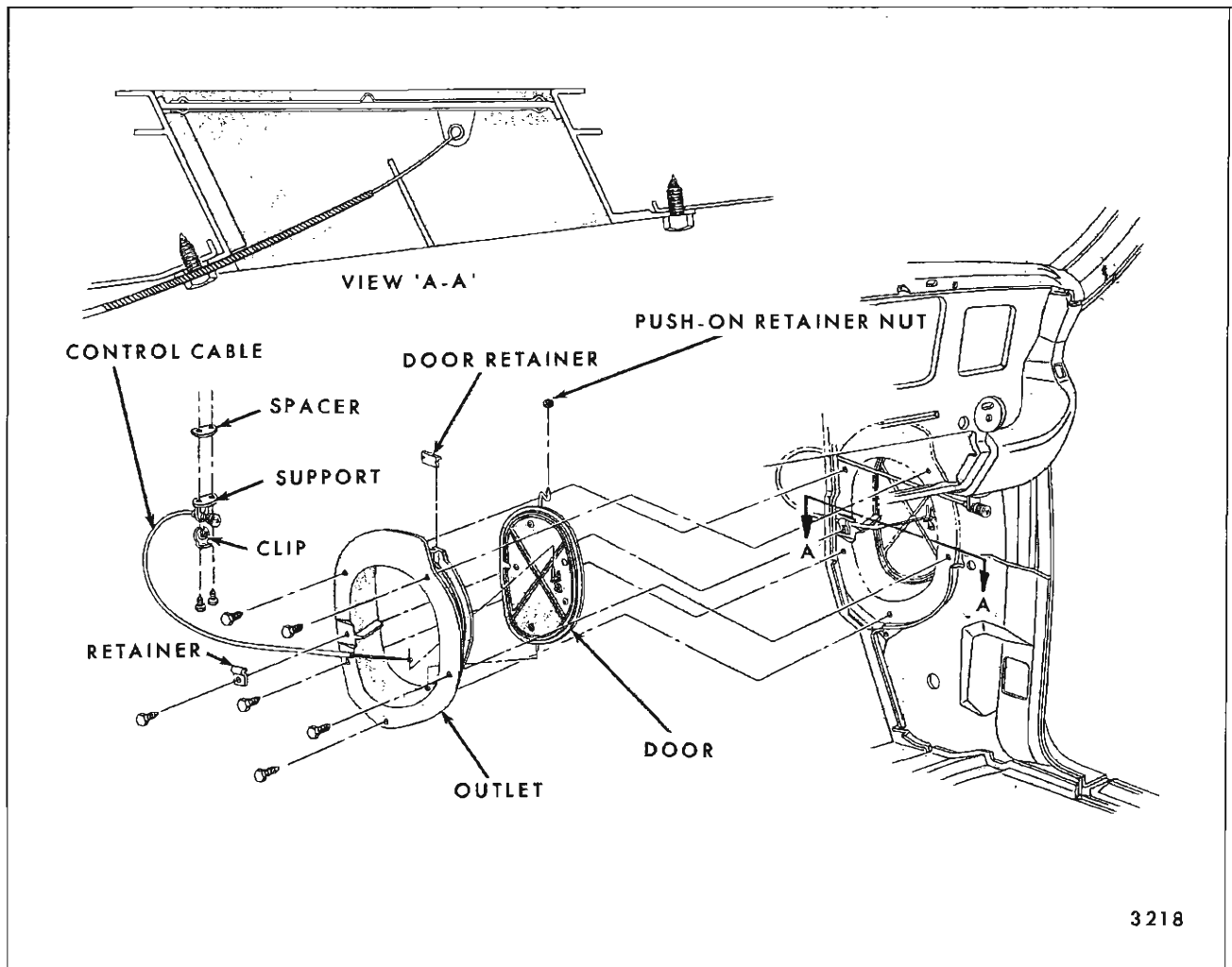

Fig. 5-14—Shroud Side Air Duct Outlet and Door - Buick & Cadillac "E" Styles

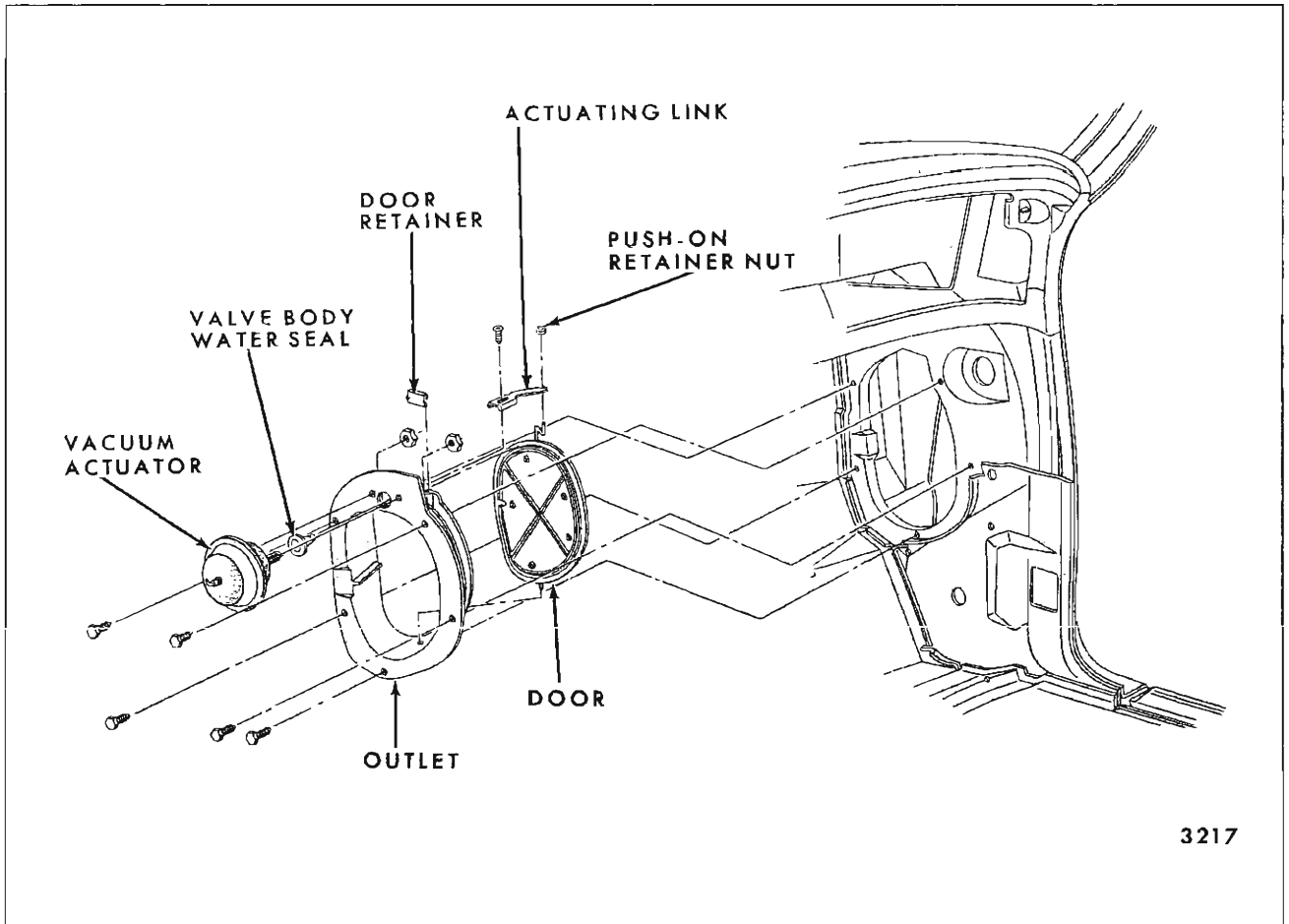

Fig. 5-15—Shroud Side Air Duct Outlet and Door - Oldsmobile "E"

**PRESSURE RELIEF VALVE—  
"A-B-C-E-F and G" Styles**

Used with high-level ventilation systems, pressure relief valves are attached to rear lock pillars

with screws. Figure 5-16 shows the "A and G" style pressure relief valve installation. Figure 5-17 shows the "B and C" style pressure relief valve installation.

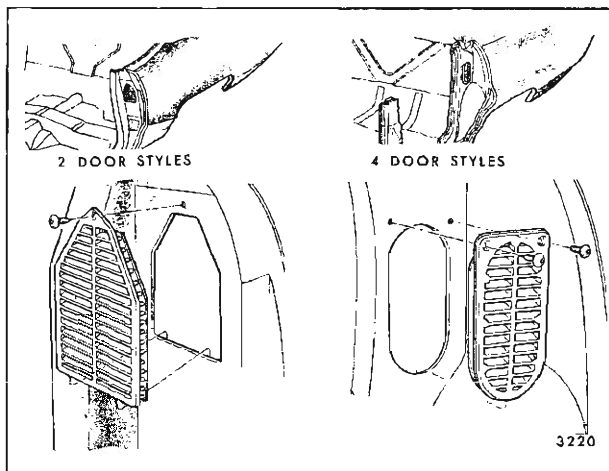

Fig. 5-16—Pressure Relief Valve - "A" Styles Shown

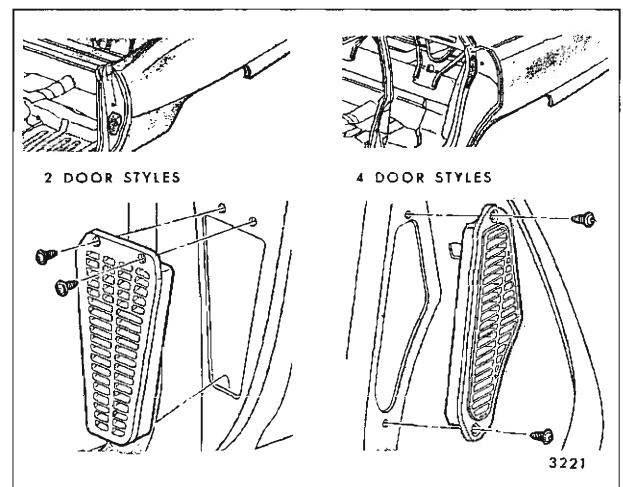

Fig. 5-17—Pressure Relief Valve - "B & C" Styles Shown

## INSTRUMENT PANEL

### INSTRUMENT PANEL COMPARTMENT DOOR—Buick “A & E” Styles

The instrument panel compartment door is secured to the instrument panel by a screw-attached hinge. A door stop holds the door in the open position (Figure 5-18).

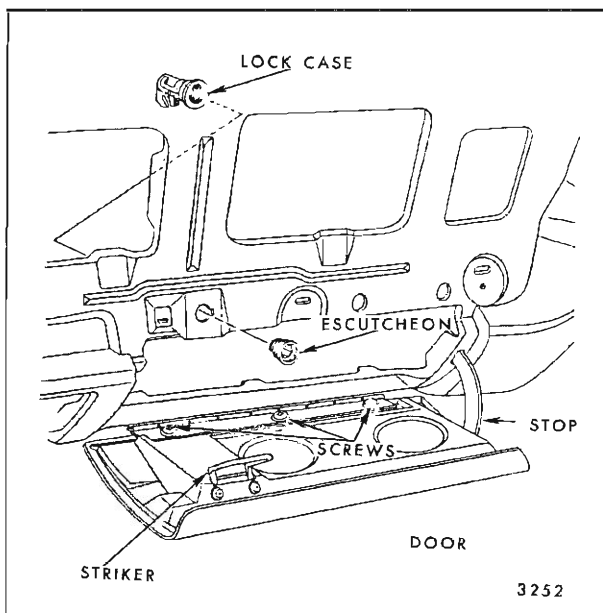

Fig. 5-18—Instrument Panel Compartment Door - Buick “A & E” Styles

### Removal and Installation

To remove door, open door and remove attaching screws from door or from instrument panel. Rotate door stop counter-clockwise to disengage it from the instrument panel opening, and remove door. To install, reverse removal operations.

### Adjustments

Provisions in door, hinge and instrument panel allow “Up and Down”, “Lateral” and “Fore and Aft” adjustment of door. Adjustments can be made by loosening necessary hinge attaching screws. The lock striker (Fig. 5-18) is secured by screws. Adjustment of striker to desired position can be made by loosening attaching screws.

### INSTRUMENT PANEL COMPARTMENT DOOR LOCK CYLINDER AND LOCK— Buick “A & E” Styles, Chevrolet—All Styles

#### Removal

1. With door open, set fork bolt in latched position.
2. Insert round head key into lock cylinder and turn to locked position. Cylinder retainer will come into view in lock case view slot (Fig. 5-19).
3. Withdraw key from cylinder.
4. Depress retainer with paperclip and reinsert key to hold retainer in retracted position (Fig. 5-19).
5. Squeeze latched fork bolt firmly to relieve pressure from lock cylinder and remove cylinder, with key inserted, from lock case.
6. Insert octagonal bar wrench, wide blade screwdriver or other suitable tool into lock escutcheon, unscrew and lift off case assembly.

#### Installation

1. Install case assembly with locating tang aligned with notch in opening.
2. Slide plastic washer over escutcheon and screw escutcheon into case firmly.
3. Depress cylinder retainer and insert key.
4. Push lock fork bolt to latched position. Align cylinder assembly with tumblers in lock case view slot. Slip cylinder assembly, key installed, into lock case assembly.
5. Remove and reinsert key into installed lock cylinder. This action locks retainer to lock case.
6. Before closing door, release latched fork bolt by turning key full right.

**CAUTION:** Failure to unlatch fork bolt could result in damage to striker and lock if door is closed.

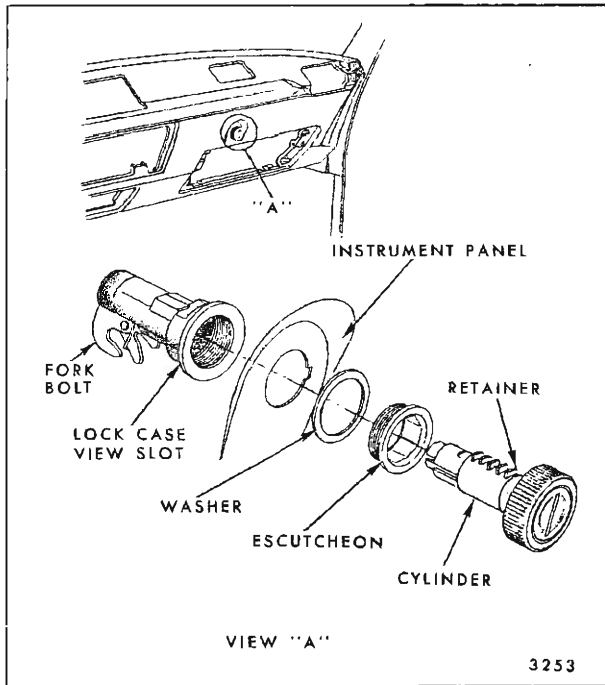

Fig. 5-19—Instrument Panel Compartment Door Lock and Cylinder - Buick "A & E" Styles, Chevrolet Typical

### INSTRUMENT PANEL COVERS— Chevrolet "A-X & Z" Styles and Pontiac "F" Styles

The instrument panel cover is secured to the instrument panel by a combination of screws, stud and clip assemblies, clips, and stud and nut assemblies. The cover attachment locations are shown in Figures 5-20, 5-21, 5-22 and 5-23.

**NOTE:** For instrument panel covers of all other series and body styles, refer to the chassis service manuals.

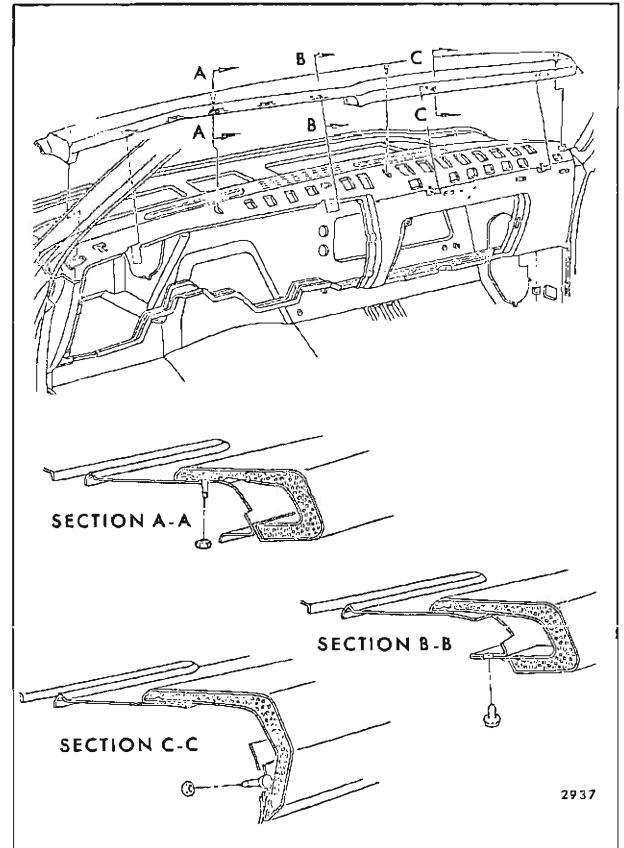

Fig. 5-20—Instrument Panel Cover - Chevrolet "A" Styles

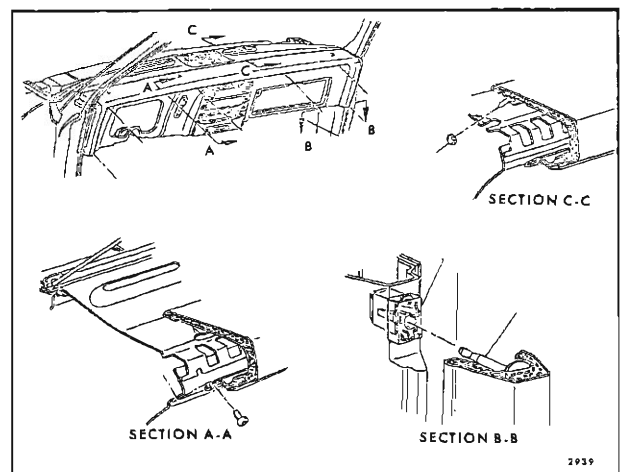

Fig. 5-21—Instrument Panel Cover - Pontiac "F" Styles

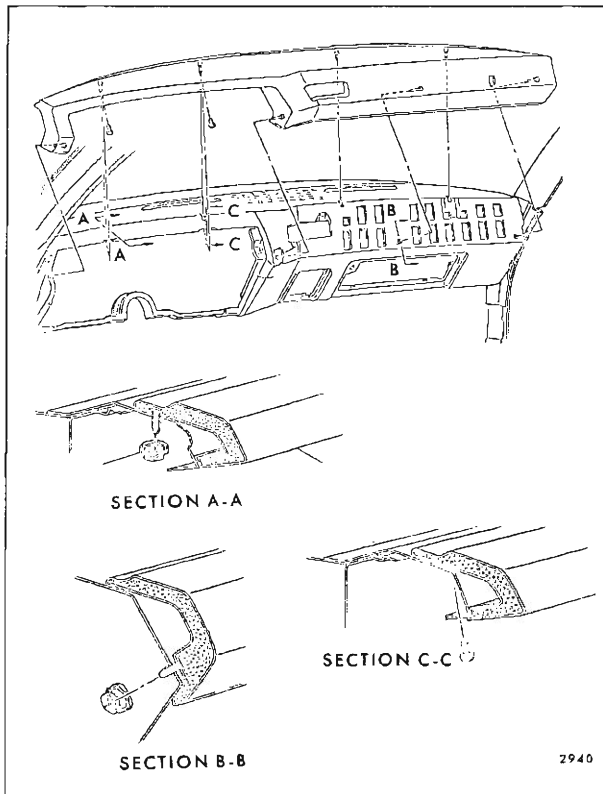

Fig. 5-22—Instrument Panel Cover - Chevrolet "X" Styles

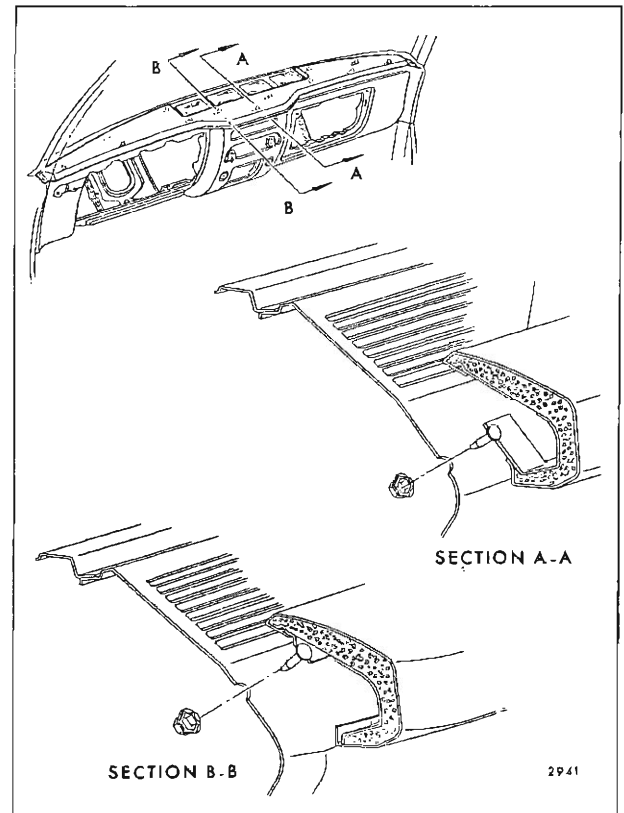

Fig. 5-23—Instrument Panel Cover - Chevrolet "Z" Styles

## FRONT COMPARTMENT—CORVAIR

### DESCRIPTION

Each front compartment lid hinge assembly employs the use of an individual torque rod which acts as a counterbalance and hold-open for the lid. Notches are provided in the torque rod retainer for adjustment of the rods.

The front compartment lid lock assembly consists of a side action snap-bolt mechanism equipped with a safety latch and is secured to a support on the front end panel. The end of the lock assembly acts as a guide by entering the striker when the lid is in a closed position.

A single section cement-on type front compartment weatherstrip is used on all styles.

### FRONT COMPARTMENT LID

#### Removal and Installation

1. Open lid and place a protective cover over surfaces adjacent to front compartment opening to prevent damage to painted areas.

2. Mark (pencil) location of hinge straps on inner panel.
3. With the aid of a helper, remove hinge to lid attaching bolts from each hinge and remove lid. (See Fig. 5-24).

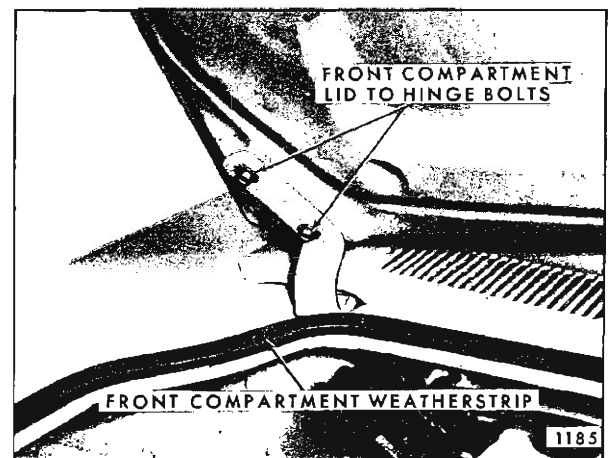

Fig. 5-24—Front Compartment Weather Strip and Lid to Hinge Bolts



4. To install, align lid to hinges within locating marks and reverse removal procedure.

### Adjustments

1. The front compartment lid may be adjusted forward or rearward and side to side in body opening by loosening hinge to upper shroud attaching bolts at each hinge. Adjust hinge as required and secure bolts (See Fig. 5-25).

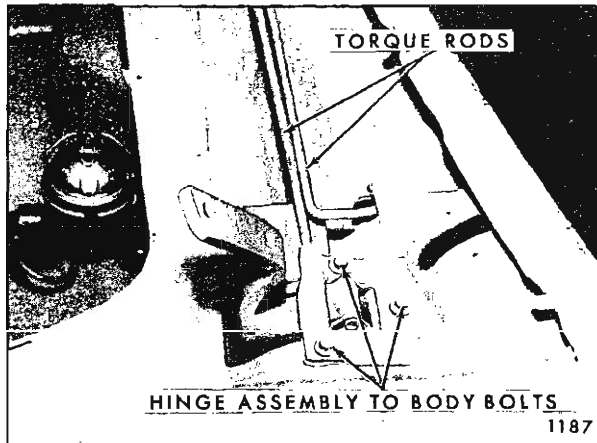

Fig. 5-25—Front Compartment Lid Hinge Removal

2. To adjust the lid up or down at one or both sides, install shims between the hinge strap and lid as follows:
  - a. To raise rear edge of lid at hinge area, place shim between hinge strap and lid inner panel at rear attaching bolt (Fig. 5-24).
  - b. To lower rear edge of lid at hinge area, place shim between hinge strap and lid inner panel at front attaching bolt (Fig. 5-24).
3. Check front compartment lid lock to insure proper engagement with striker.

### FRONT COMPARTMENT LID TORQUE RODS

Tool J 21928 is designed to remove, install or re-set tension for one or both rods without removal of the front compartment lid. The tool has a different design on each end for use on either the right or left side of the body.

#### Removal and Installation

1. Remove windshield wiper arms.

2. Open compartment lid and prop same in a full open position.
3. Remove shroud top air intake grille.
4. Install protective covering over compartment lid and lower part of windshield.
5. Remove torque rod clamp to shroud, located right of center of shroud (Fig. 5-26).
6. Install tool J 21928 (Fig. 5-26) to lid torque rod on right side of body. Securely grasp tool and move it toward windshield to disengage rod from retaining notch. Carefully disengage tool from rod.

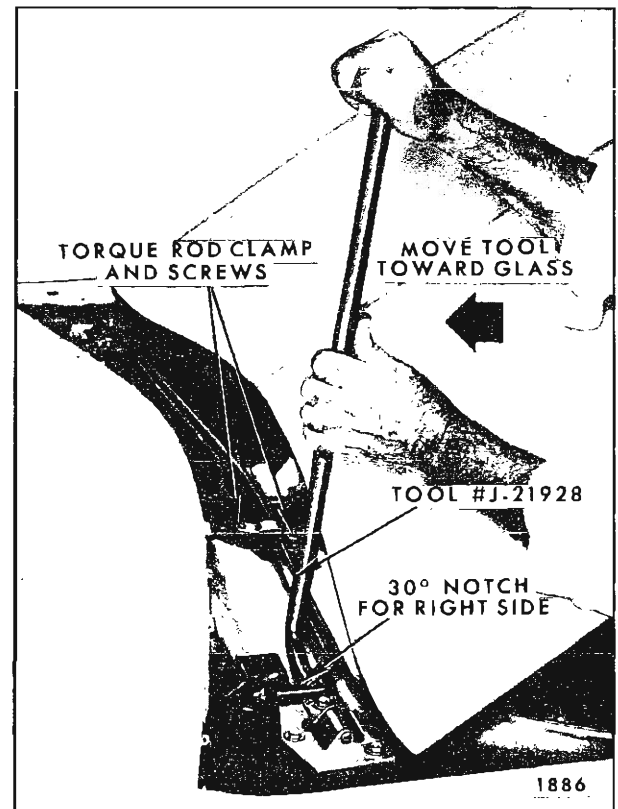

Fig. 5-26—Torque Rod Removal - Right Side

7. In like manner remove rod on left side of body (Fig. 5-27).

**NOTE:** It is necessary to remove torque rods prior to removal of front compartment lid hinge assemblies.

8. To install, apply an approved lubricant to

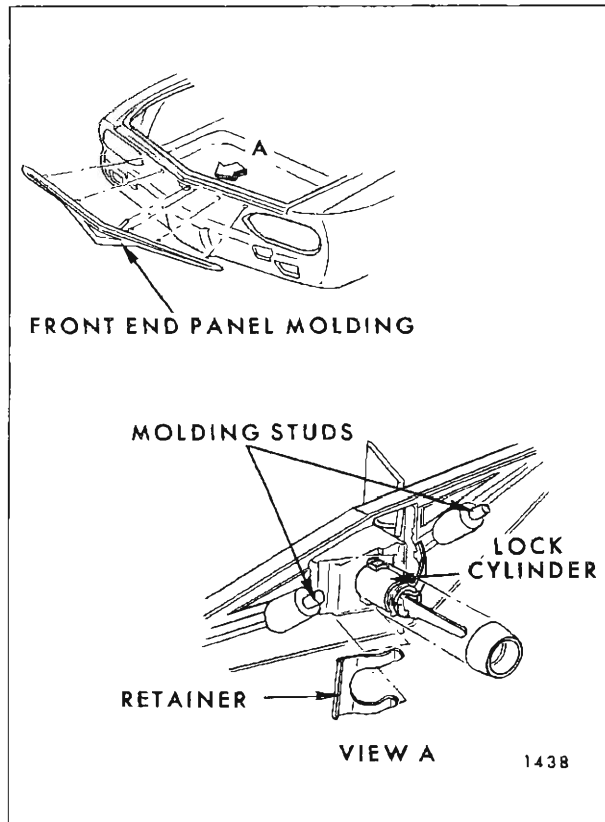

Fig. 5-27—Torque Rod Removal - Left Side

torque rod ends which contact hinge roller (see "Lubrication" section). Reverse removal procedure, placing torque rods in the same retainer notch as they were prior to removal. Check operating effort of compartment lid. Should operating effort be increased or decreased, relocate torque rods for proper operation.

### FRONT COMPARTMENT LID LOCK CYLINDER ASSEMBLY

The front compartment lid lock cylinder is attached to the front end panel molding which is secured to the front end panel by studs and nuts. (See Fig. 5-28).

#### Removal and Installation

1. Remove front end panel molding assembly as explained in the "Exterior Molding" section of this manual (See Index).
2. Remove lock cylinder retainer and remove lock cylinder from molding.

3. To install, reverse removal procedure. Make certain that molding is properly sealed to front end panel.

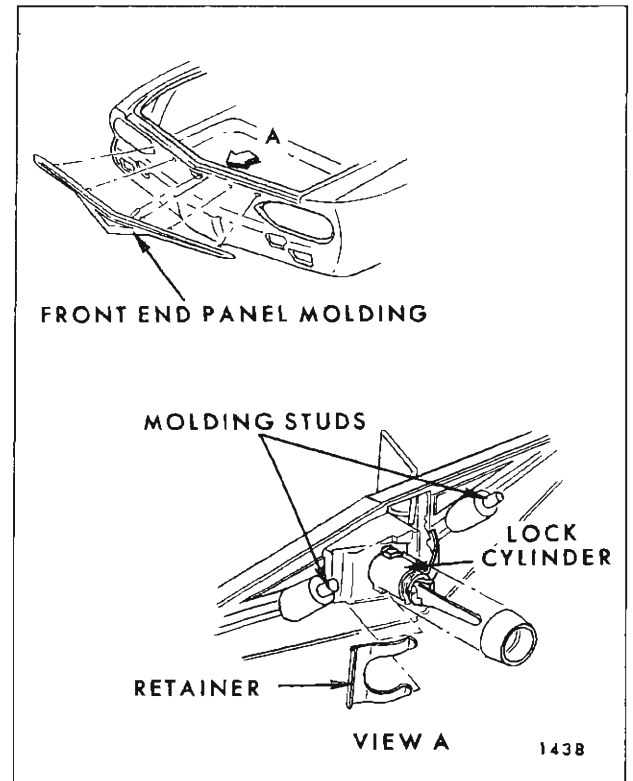

Fig. 5-28—Front Compartment Lid Lock Removal

### FRONT COMPARTMENT LID LOCK ASSEMBLY

#### Removal and Installation

1. Remove front end panel molding and lid lock cylinder assembly.
2. Remove bolts (Fig. 5-29) securing lock to lid lock support and remove lock assembly.
3. To install, reverse removal procedure.

**NOTE:** If lock does not properly engage in striker opening, the lock may be adjusted forward by installing emergency spacer(s) between lock and support.

### FRONT COMPARTMENT LID LOCK STRIKER

#### Removal and Installation

1. Mark (pencil) location of front compartment lid lock striker on striker support.

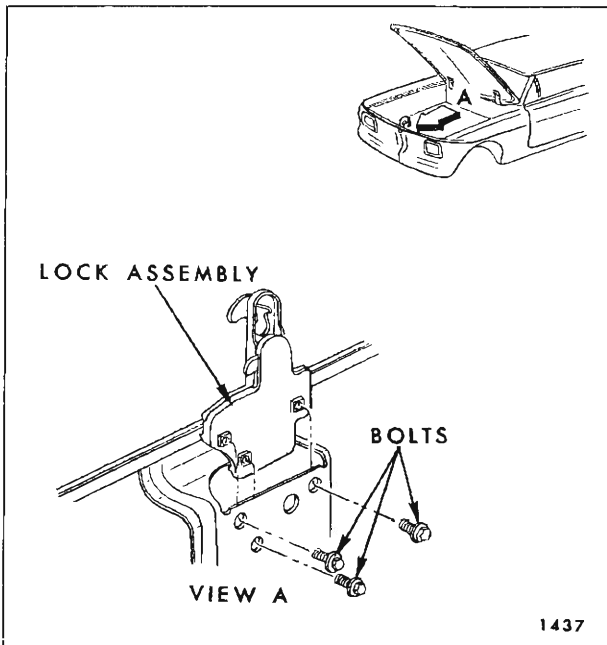

Fig. 5-29—Front Compartment Lid Lock

2. Remove striker retainer plate attaching screws and remove retainer plate and striker (Fig. 5-30).

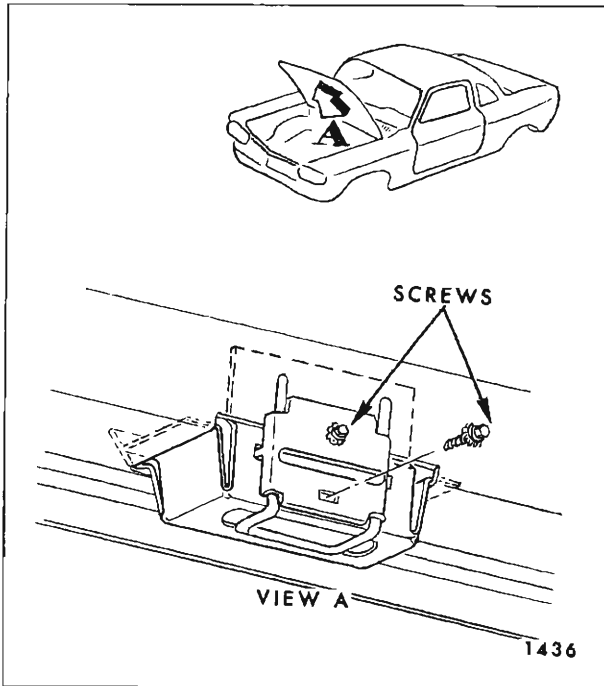

Fig. 5-30—Front Compartment Lid Lock Striker

3. To install, position striker within scribe marks and reverse removal procedure. Insure proper engagement of striker to lock.

### Adjustments

1. To adjust striker up, down, right or left, loosen retainer plate attaching bolts (while holding plate in position). Adjust striker as required and tighten bolts.

**NOTE:** Since the upper end of the lid lock acts as a guide by entering the striker when the lid is closed, align the front compartment lid properly in the body opening prior to making any striker adjustments.

### FRONT COMPARTMENT LID GUTTER WEATHERSTRIP

#### Removal

1. Separate "butt" ends of weatherstrip at front of compartment opening.
2. With a flat-bladed tool, carefully disengage weatherstrip from its cemented foundation in gutter around entire perimeter of front compartment and remove weatherstrip.

#### Installation

1. Remove excess cement from gutter around entire front compartment opening to insure a smooth cementing surface.
2. Using a brush, apply approved sealer along the base and around the entire perimeter of gutter.

**NOTE:** Apply a sufficient amount of weatherstrip cement along lower inboard corner of gutter so that after installation of weatherstrip, cement will spread and fill complete area.

3. Center weatherstrip at area between lid hinges using color or tape identification mark at center of weatherstrip as guide.
4. Using a flat-bladed tool, such as a putty knife with rounded corners, insert weatherstrip into gutter across top, down sides and across top front of compartment opening in that order. Roll or press weatherstrip to insure a good seal and proper retention of weatherstrip.
5. When a new weatherstrip is required, trim the ends to form a "butt" joint at front of opening. Using a brush, apply weatherstrip cement on both ends of new weatherstrip and secure ends together to form a matching joint.
6. Allow sufficient time for cement to set before closing front compartment lid.

## SECTION 6

# DOORS

### INDEX

Subject	Page	Subject	Page
<b>FRONT AND REAR DOORS</b>			
Introduction . . . . .	6-1	Window Regulator-Manual-"A and X" Closed Styles . . . . .	6-74
Weatherstrips . . . . .	6-1	Window Regulator-Electric-"A" Closed Styles . . . . .	6-74
Door Bottom Drain Hole Sealing Strip . . . . .	6-4	Window Regulator-Manual and Electric-"A-39" Styles . . . . .	6-74
Door Bottom Auxiliary Sealing Strip . . . . .	6-4	Window Regulator-Manual-"A-37, 67 and 87", "G-57" All "B and C" Styles . . . . .	6-75
Inner Panel Water Deflectors . . . . .	6-4	Window Regulator-Electric-"A-37, 67 and 87", "G-57" and All "B and C" Styles . . . . .	6-75
Glass Run Channel Sealing Strip Assemblies . . . . .	6-4	Window Regulator-Manual and Electric-"F" Styles . . . . .	6-75
Side Roof Rail Weatherstrip and Retainer . . . . .	6-6	Window Regulator-Manual and Electric-"E" Styles . . . . .	6-75
Side Roof Rail Weatherstrip Adjustment . . . . .	6-9	Window Regulator-Manual-"Z" Styles . . . . .	6-75
Center Pillar Weatherstrips-"C-69" Styles . . . . .	6-9	Window Rear Guide-"A-39" Styles . . . . .	6-75
Specified Body Opening Clearance Tolerances . . . . .	6-10	Window Front Guide-"A-37, 67 and 87" Styles and "G-57" Styles . . . . .	6-76
Spring Clips . . . . .	6-10	Window Rear Guide-"A-37, 67 and 87" Styles and "G-57" Styles . . . . .	6-76
Outside Handles - Removal . . . . .	6-10	Window Front Guide-"B and C" Hardtop & Convertible Styles . . . . .	6-76
Outside Handles - Disassembly . . . . .	6-10	Window Rear Guide-"B and C" Hardtop and Convertible Styles . . . . .	6-76
Lock Strikers - All Styles . . . . .	6-10	Window Rear Guide-"B-36, 46 and 69" Styles . . . . .	6-76
Vacuum Door Lock System . . . . .	6-16	Window Front Guide-"E" Styles . . . . .	6-77
Vacuum Lock Selector Valves . . . . .	6-17	Window Rear Guide-"E" Styles . . . . .	6-77
Vacuum Lock Actuator or Electric Solenoid . . . . .	6-17	Window Front Guide-"F" Styles . . . . .	6-77
Vacuum Lock Remote Control Assembly . . . . .	6-19	Window Rear Guide-"F" Styles . . . . .	6-77
Vacuum Lock Storage Tank . . . . .	6-19	Window Rear Glass Run Channel-"Z" Styles . . . . .	6-77
Vacuum Lock Trouble Diagnosis Procedure . . . . .	6-20	Window Glass Run Channel-"A" and "X" Closed Styles . . . . .	6-77
Window Regulator Electric Motor - Removal - All Styles Except "E" Styles . . . . .	6-24	Window Glass Run Channel-"B" Closed Styles . . . . .	6-77
Window Regulator Electric Motor - Removal - "E" Styles . . . . .	6-30	Door Wedge Plates-"67" Styles . . . . .	6-79
<b>FRONT DOORS</b>			
Description - All Styles . . . . .	6-30	<b>REAR DOORS</b>	
Front Door Hinges - All Styles . . . . .	6-53	Description - All Styles . . . . .	6-80
Door Removal and Installation - All Styles . . . . .	6-53	Rear Door Hinges - All Styles . . . . .	6-80
Hinge - Removal - All Styles . . . . .	6-54	Hinges - Removal - All Styles . . . . .	6-82
Hinge - Adjustment - All Styles . . . . .	6-54	Hinges - Installation - All Styles . . . . .	6-84
Inside Locking Rod - Coupe Styles . . . . .	6-54	Hinges - Adjustment - All Styles . . . . .	6-84
Lock Remote Control and Connecting Rod-All Styles . . . . .	6-55	Lock Remote Control - All Styles . . . . .	6-86
Lock Assembly - All Styles . . . . .	6-56	Lock Assembly - All Styles . . . . .	6-86
Lock Cylinder Assembly - All Styles . . . . .	6-56	Inner Panel Cam - All Except "A and X-69" Styles . . . . .	6-88
Mirror, Door Outside Remote Control-All Styles without Door Ventilators . . . . .	6-58	Window Assembly - "A" Closed Styles . . . . .	6-88
Inner Panel Cam-All except "A and X-69" Styles . . . . .	6-58	Window Adjustments - "A" Closed Styles . . . . .	6-90
Ventilator Regulator - "A" Styles . . . . .	6-58	Window Assembly - "A-39" Styles . . . . .	6-90
Ventilator Assembly - "A" Closed Styles . . . . .	6-58	Window Adjustments - "A-39" Styles . . . . .	6-90
Ventilator Disassembly and Assembly-"A" Closed Styles . . . . .	6-59	Window Assembly - "B" Closed Styles . . . . .	6-93
Ventilator Assembly - "A-39" Styles . . . . .	6-59	Window Adjustments - "B" Closed Styles . . . . .	6-93
Ventilator Disassembly and Assembly - "A-39" Styles . . . . .	6-60	Window Assembly - "B-39" and "C-39, 49 & 69" Styles . . . . .	6-94
Ventilator Assembly - "X" Styles . . . . .	6-61	Window Adjustments - "B-39" and "C-39, 49 & 69" Styles . . . . .	6-94
Ventilator Assembly - "Z" Styles . . . . .	6-61	Window Stationary Ventilator Division Channel - "X-69" Styles . . . . .	6-95
Ventilator Assembly Weatherstrip-"Z" Styles . . . . .	6-62	Window Stationary Ventilator Assembly - "X-69" Styles . . . . .	6-95
Window Assembly - "A" and "X" Closed Styles . . . . .	6-62	Window Assembly - "X-69" Styles . . . . .	6-96
Window Assembly - "A-39" Styles . . . . .	6-62	Window Regulator-Manual-"A-39 & 69" Styles . . . . .	6-96
Window Assembly - "A-37, 67 and 87 Styles and "G-57" Styles . . . . .	6-64	Window Regulator-Electric-"A, B and C" Styles . . . . .	6-96
Window Assembly - "B-11" Styles . . . . .	6-66	Window Regulator-Manual-"B and C" Styles . . . . .	6-96
Window Assembly - "B-36, 46 and 69" Styles . . . . .	6-66	Window Regulator Electric Motor Removal-All Styles . . . . .	6-96
Window Assembly - "B and C-37, 47, 57 and 67" Styles . . . . .	6-67	Window Regulator - "X-69" Styles . . . . .	6-97
Window Assembly - "B-39" and "C-39, 49 and 69" Styles . . . . .	6-68		
Window Assembly - "E" Styles . . . . .	6-70		
Window Assembly - "F" Styles . . . . .	6-71		
Window Assembly - "Z" Styles . . . . .	6-72		

Subject	Page	Subject	Page
Window Front Guide and Bracket Assembly - "A-39" Styles . . . . .	6-97	Window Rear Guide - "B-39" & "C-39, 49 & 69" Styles . . . . .	6-97
Window Rear Guide - "A-39" Styles . . . . .	6-97	Window Glass Run Channel-All "A & X" Closed Styles . . . . .	6-97
Window Front Guide - "B-39 and C-39, 49 & 69" Styles . . . . .	6-97	Window Glass Run Channel-All "B" Closed Styles . . . . .	6-98

## FRONT AND REAR DOORS

### INTRODUCTION

This section of the manual contains the service operations that are necessary for the removal, installation, adjustment and sealing of door assemblies and individual door hardware components. The procedures are arranged in the sequence that they would be performed when servicing a door. To locate specific procedures, refer to the "Door Index".

Hardware items are divided into three categories. Those which are common to all doors are found under "Front and Rear Doors", which also includes door and side roof rail weatherstrips. Items which are peculiar to front or rear doors are found under "Front Doors" or "Rear Doors" respectively.

Door trim service procedures are covered in Section 14 of this manual (See Index).

Body series or style references in the procedures are explained under "General Information" in Section 1 of this manual.

### FRONT AND REAR DOOR WEATHERSTRIPS—

Both the front and rear doors use nylon fasteners to retain the door weatherstrips. The fasteners are a component part of the weatherstrip and secure the weatherstrip to the door by engaging piercings in the door panels. The serrations of the fastener retain the fastener in the piercing and also seal the openings from water entry (Fig. 6-1).

On "B" Body Sedan Styles, nylon fasteners are used around the entire perimeter of the door. On "A & X" Closed Styles, nylon fasteners are used below the beltline only. Weatherstrip adhesive retains the weatherstrip around the door upper frame above the beltline (Fig. 6-2).

In addition to the nylon fastener, "B" Body Sedan Styles use weatherstrip adhesive at the beltline and down the front door hinge pillar. All styles other than closed styles use plastic fasteners at the belt.

To disengage nylon fasteners from door panel piercings use tool J-21104 or equivalent (Fig. 6-1).

This tool permits removal of the weatherstrip without damaging the serrations on the fasteners so that the weatherstrip can be reinstalled if desired.

Although a replacement door weatherstrip will include the nylon fasteners, individual fasteners are available as service parts.

### Removal

1. On all hardtop and convertible styles, remove door trim pad to gain access to weatherstrip fasteners hidden under trim assembly and remove fasteners (Fig. 6-3).

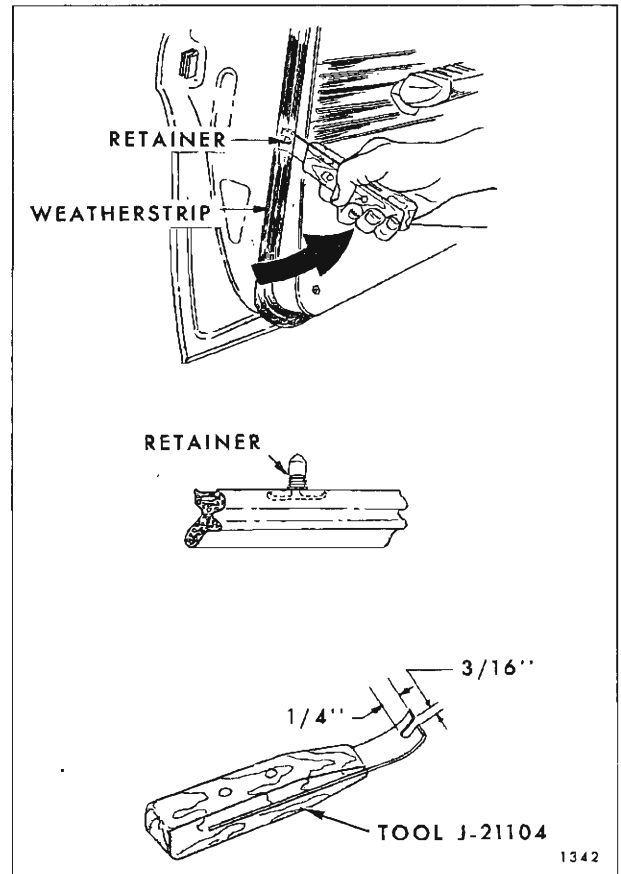

Fig. 6-1—Door Weatherstrip Removal

2. On sedan styles, use a flat-bladed tool to break cement bond between door and weatherstrip. On "B" Body Sedan Styles, weatherstrip adhesive is used for a distance of 9" on door lock pillar and the entire length of the front door hinge pillar ("D", Fig. 6-4). On "A & X" sedan styles, weatherstrip is retained by weatherstrip adhesive completely around door upper frame (Fig. 6-2).
3. On all styles, use tool J-21104 or equivalent to disengage weatherstrip from door where weatherstrip is retained by nylon fasteners. Nylon fastener usage is below the beltline on all styles, and above the belt only on "B" Body Sedan Styles.

### Installation

1. If previously removed weatherstrip is to be reinstalled, inspect nylon fasteners and replace those that are damaged.
2. Clean off old weatherstrip adhesive from door.
3. On sedan styles, apply black weatherstrip adhesive to door surface contacted by weatherstrip (Circle "C", Fig. 6-4) to effect a positive seal at point where door upper frame enters door.
4. On styles without door upper frames, position weatherstrip to door and install plastic fasteners at front and rear ends of weatherstrip.
5. On styles with door upper frames, position weatherstrip to door as follows:

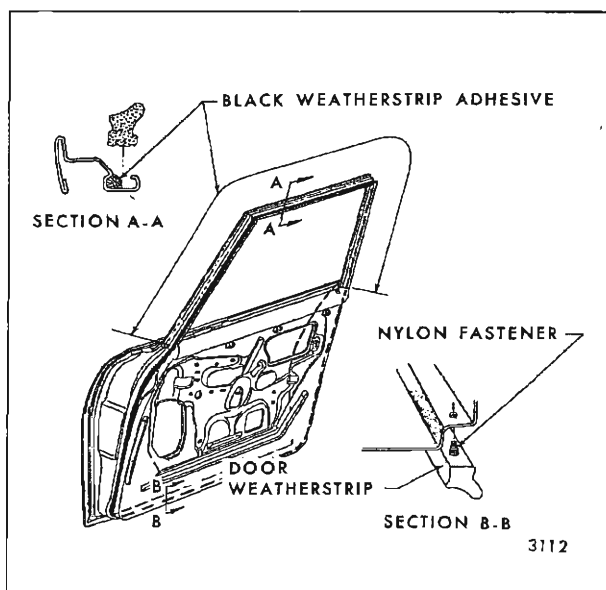

Fig. 6-2—Door Weatherstrip - "A & X" Closed Styles

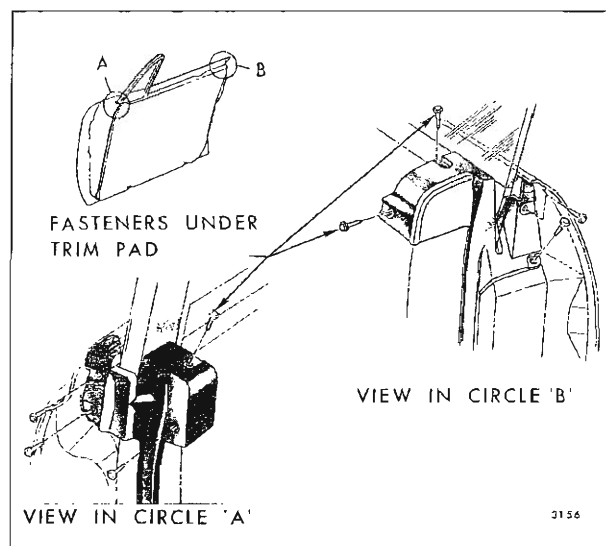

Fig. 6-3—Door Weatherstrip - Hardtop Styles

- a. On front doors, locate weatherstrip from rear upper corner which is color-coded (Fig. 6-4).
- b. On rear doors, locate weatherstrip from molded front upper corner.
6. Tap nylon fasteners into door piercing using a hammer and blunt caulking tool.
7. On "A & X" Sedan Styles, apply a bead of black weatherstrip adhesive to gutter of door upper frame as shown in section "A-A", Fig. 6-2, then, install weatherstrip.
8. After all fasteners have been installed on sedan styles, apply weatherstrip adhesive between door and weatherstrip outboard surface at the following locations:

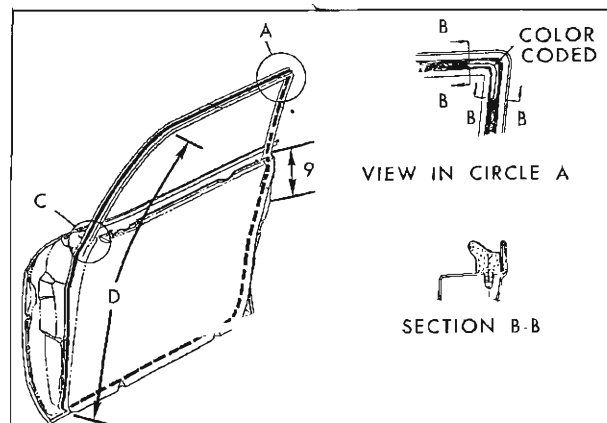

Fig. 6-4—Door Weatherstrip - "B" Closed Styles

- a. For 5" around rear upper corner of front door upper frame (Circle "A", Fig. 6-4), 9" down door lock pillar starting at beltline and down entire hinge pillar facing indicated "D".
- b. On sedan rear doors, 9" down both door lock pillar and door hinge pillars starting at beltline.
- c. On hardtop style front and/or rear doors starting at beltline and extending 9" down both door lock and door hinge pillars.

**NOTE:** . If weatherstrip becomes damaged at fastener location and will not retain fastener, remove fastener and secure weatherstrip to door with weatherstrip adhesive. If more than two consecutive fastener locations become damaged, replace weatherstrip.

Although weatherstrip adhesive is specified only at specific locations, it can be used at any point where additional retention or sealing is required.

### DOOR BOTTOM DRAIN HOLE SEALING STRIPS

Door bottom drain slot sealing strips are attached to door inner panels over door bottom drain slots to prevent entry of roadnoise, dust and cold air at these locations (Fig. 6-5).

To remove sealing strips, use a flat-bladed tool to pry retaining plugs from door inner panel piercings.

To install, insert a blunt pointed tool such as dull ice pick or scratch awl into strip retaining plugs and push plugs into door panel piercings.

### DOOR BOTTOM AUXILIARY SEALING STRIP—Chev. 16600 Styles, Pontiac 26000 Series Except "67" Styles, All Cadillac Styles and All "E" Body Styles Except Buick

The door bottom auxiliary sealing strip is secured to the door inner panel with weatherstrip adhesive. The strip is installed after water deflector installation and prior to trim installation. As shown in section "A", Figure 6-6, the upper edge of the strip is aligned with the water deflector drain slot. The rolled, semi-bulbular section of the sealing strip extends down below the door trim pad when the trim is installed and fills the opening between the door and door sill plate.

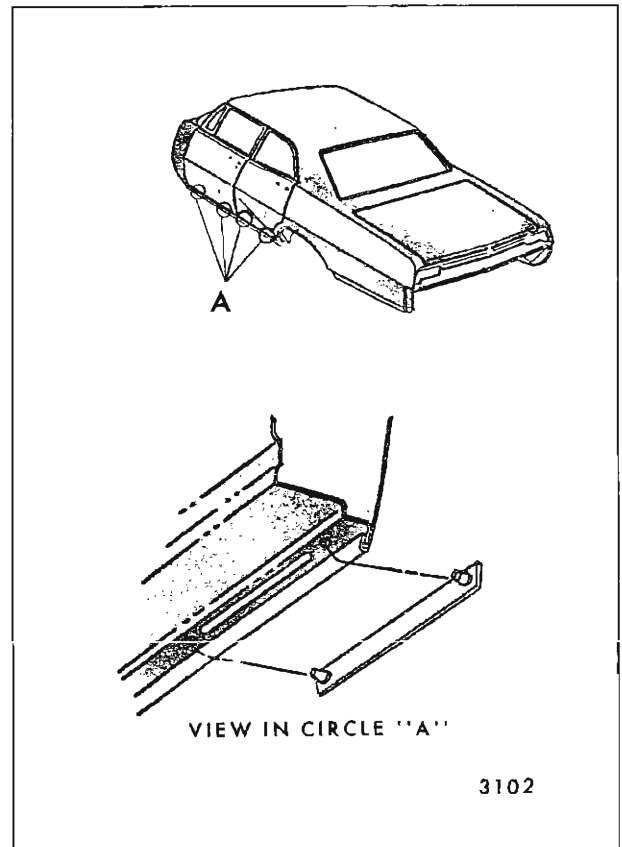

Fig. 6-5—Door Bottom Drain Hole Sealing Strips

### FRONT AND REAR DOOR INNER PANEL WATER DEFLECTOR

A waterproof deflector is used to seal the door inner panel and prevent entry of water into body. The deflector is secured by a string-loaded sealing material along both front and rear edges and by the

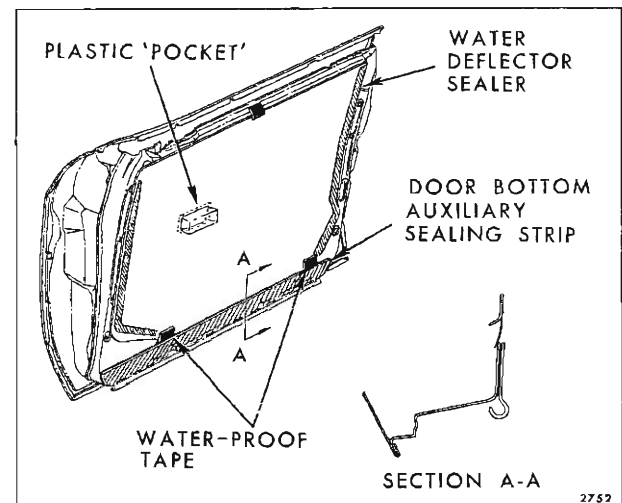

Fig. 6-6—Door Inner Panel Sealing

application of waterproof sealing tape at front and rear lower corners. Whenever work is performed on front or rear doors where the water deflector has been disturbed, the deflector must be properly sealed and taped to the inner panel to prevent waterleaks (Fig. 6-6). For service sealing, body caulking compound is recommended if additional sealing material is required.

When access to the inner panel is required to perform service operations, the deflector may be completely or partially detached from the inner panel. If the existing water deflector is damaged so that it will not properly seal the door, replacement of the deflector is required.

The following procedure covers complete removal and installation of the water deflector. If only partial removal of the deflector is required, perform only those steps which are necessary to expose the required area of the door inner panel.

#### Removal

1. Remove the door trim assembly.
2. Remove waterproof body tape securing top of water deflector to door inner panel.
3. Using a flat-bladed tool such as a putty knife, carefully break cement bond between water deflector and door inner panel down both sides of deflector. Make certain tool blade is between inner panel and string that is embedded in sealer.
4. When seal has been broken down both sides of deflector, carefully remove tape from inner panel at lower corners of water deflector (Fig. 6-6). Disengage water deflector from inner panel drain slot and remove deflector. On styles so equipped, it will be necessary to partially remove door bottom auxiliary sealing strip to permit removal of tape at bottom of deflector (Fig. 6-6).

#### Installation

1. Inspect water deflector and, where necessary, repair any tears or holes with waterproof body tape applied to both sides of deflector.
2. If a new deflector is to be installed, use old deflector as a template. On styles where deflector has small individual plastic "pockets", transfer "pockets" from old to new deflector (Fig. 6-6). Use waterproof body tape or black weatherstrip adhesive to form a watertight seal completely around "pocket". Seal on opposite side from which "pocket" deflector protrudes (dotted line, Fig. 6-6).

**NOTE:** If "pocket" deflector is damaged beyond repair, replace with new part which is available as service part.

3. Position water deflector to door inner panel and insert lower edge of deflector in retaining slot. Then, firmly roll or press edges of deflector to obtain a good bond between deflector and door inner panel.

If old sealer does not effect a satisfactory seal, apply additional body caulking compound to inner panel at unsealed areas.

4. Seal lower corners of deflector by re-applying previously removed tape or new pieces of 2" or 2-1/2" waterproof body tape.
5. On styles with door inner panel hardware attachments that are outboard of water deflector, seal attaching bolt head and panel piercing with body caulking compound.

#### DOOR WINDOW GLASS RUN CHANNEL SEALING STRIP ASSEMBLIES (At Belt)

Glass run channel sealing strips are used to form a seal between the door inner and outer panels and the window at the beltline. The construction and attachment of these strips vary with the body style involved.

On styles with a door window lower reveal molding, the outer strip assembly is clipped to the molding and, therefore, removed with the molding (See "Exterior Moldings"). The entire assembly is available as a service part, as is the strip assembly itself. The molding is not serviced independent of the strip assembly.

On styles without a door window lower reveal molding, the outer strip assembly is an independent part that is secured to the door outer panel return flange by clips or screws, or a combination thereof. The following procedures pertain to this type of construction.



Fig. 6-7—Clip Retained Glass Run Channel Strip Assembly Removal



On all except "Z" body styles, the inner strip assembly is attached to the door trim pad and is removed from the door with the trim pad. The "Z" style strip assembly is secured to the door inner panel with clips and must be removed to permit removal of the door window assembly.

**NOTE:** To remove either the clip or screw retained strip assembly, the glass must be low enough to gain access to the attachments. In most cases this will require removal of the window lower stop bumpers to permit further lowering of window assembly.

### Removal and Installation

1. On styles with screw retained strip assemblies, remove strip assembly by removing attaching screws.
2. On styles with clip retained inner or outer strip assemblies, remove strip assembly as follows:
  - a. Apply cloth-backed tape as a protective cover over painted surface of door panel adjacent to strip assembly.
  - b. Using a flat-bladed tool that is slotted to fit over tang of clip, disengage clips from slots in door panel return flange as shown in Figure 6-7.
- c. To install strip assembly, position strip so that each clip tang starts into slot in door panel; then, engage clips by pressing downward. Prior to installation, re-form clip tangs to assure positive retention when installed.

**NOTE:** To fabricate strip assembly removal tool, make a 1/4" wide by 3/8" deep slot in a flat-bladed tool similar to the J-2772 headlining inserting tool.

### SIDE ROOF RAIL WEATHERSTRIP AND RETAINER

The side roof rail weatherstrip is cemented to a side roof rail weatherstrip retainer, which in turn is secured with screws to the side roof rail. The adhesive that retains the weatherstrip also protects against water entry between the retainer and weatherstrip. A saturated polyurethane foam sealing strip prevents water entry between the retainer and side roof rail.

#### Removal—All Hardtop Styles Except "E" Body

1. Remove plastic fasteners at front of side roof rail weatherstrip (Fig. 6-8 is typical of all styles at front hinge pillar).
2. While carefully pulling weatherstrip out of retainer, simultaneously break cement bond

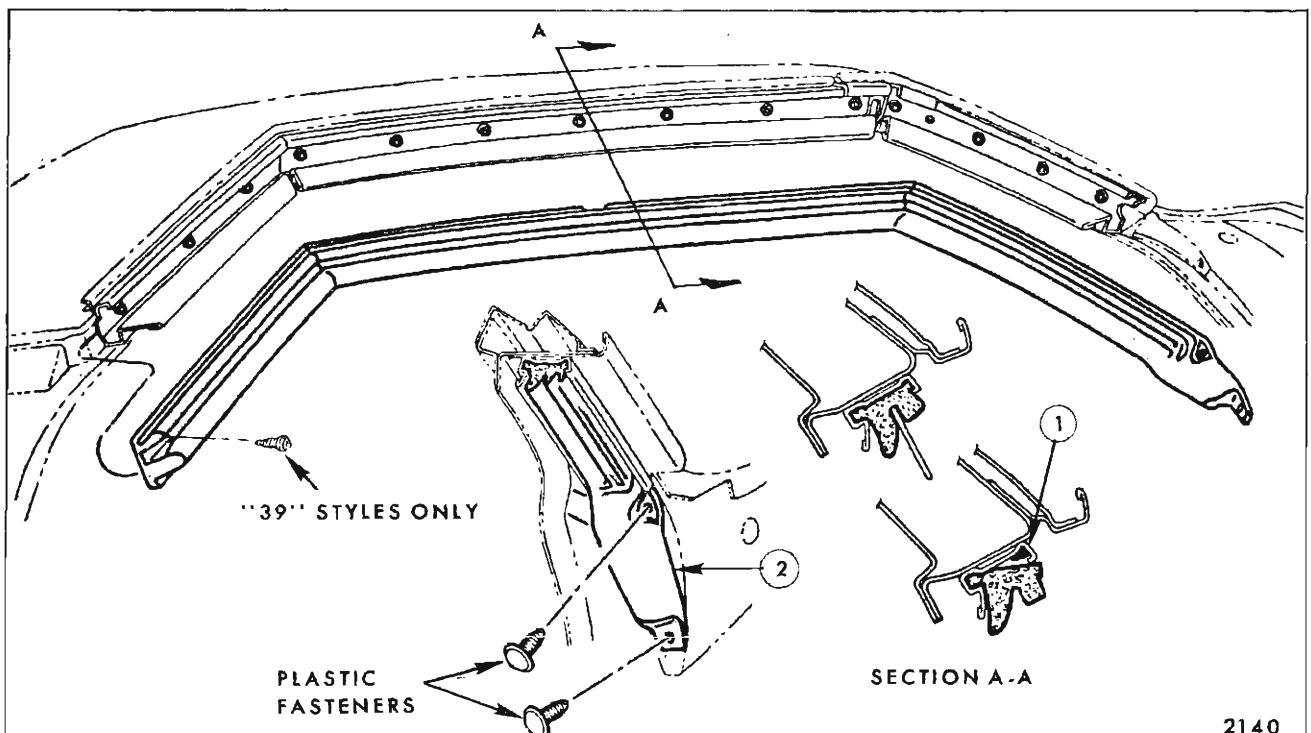

Fig. 6-8—Side Roof Rail Weatherstrip

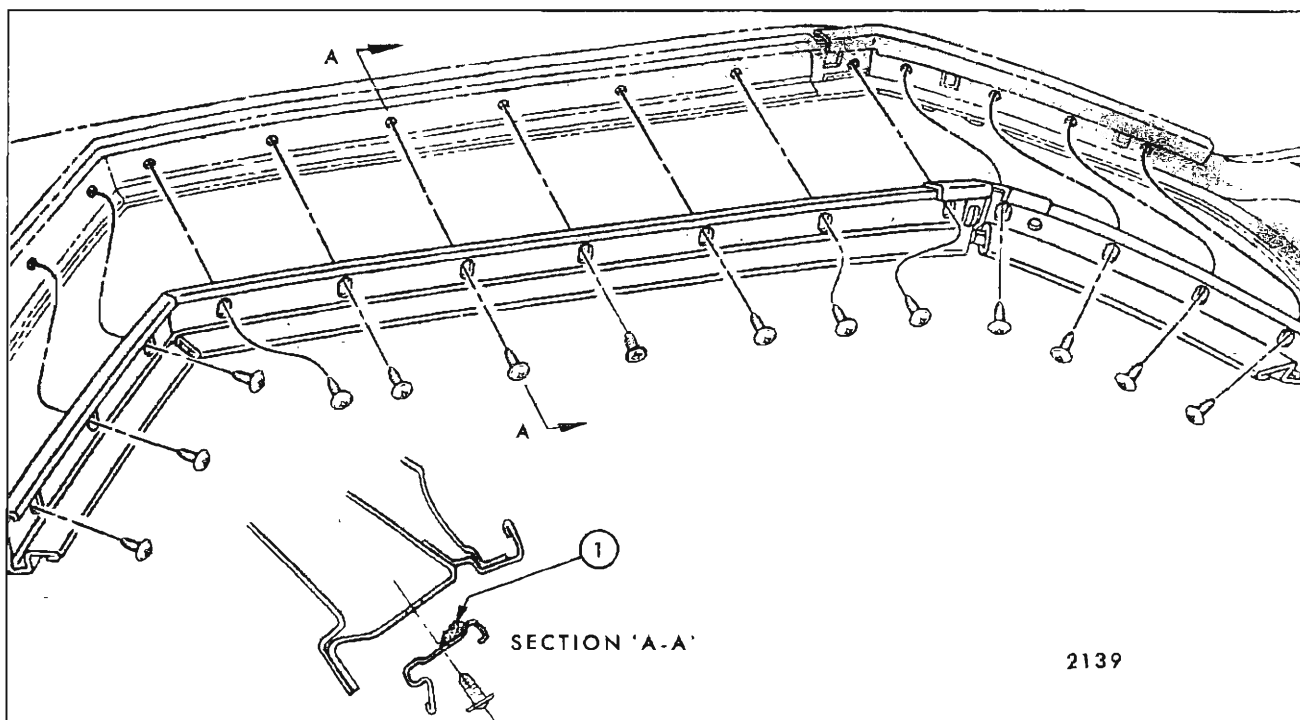

Fig. 6-9—Side Roof Rail Weatherstrip Retainer

between weatherstrip and weatherstrip retainer using a flat-bladed tool.

3. With weatherstrip removed, screws securing weatherstrip retainer to side roof rail are exposed. Remove screws to remove retainer (Figs. 6-9 and 6-10).

#### Removal—(Buick and Oldsmobile "E-87" Styles)

1. Remove plastic fasteners at front of weatherstrip similar to those shown in Figure 6-8.
2. Remove rear seat cushion, rear seat back and rear quarter upper trim assembly (See Trim Index).
3. Remove screw(s) securing side roof rail weatherstrip (rear section) to side roof rail (Fig. 6-11), and rear quarter panel.
4. While carefully pulling weatherstrip out of retainer, simultaneously break cement bond between weatherstrip and retainer using a flat-bladed tool.
5. With weatherstrip removed, screws securing weatherstrip retainer to side roof rail are exposed. Remove screws to remove side roof rail weatherstrip retainer.

**NOTE:** The following procedure outlines the recommended process of servicing side roof rail weatherstrips on "E-87" styles when only that portion over the door glass requires replacement.

The side roof rail weatherstrip consists of two sections connected by a vulcanized joint. The front section (over door glass) can be serviced separately from the rear section (over rear quarter window). Replacement of the rear section requires replacement of the entire side roof rail weatherstrip. Replacement of front section, however, can be accomplished individually by utilizing the following procedure.

1. With a sharp implement, sever the vulcanized joint and remove front section of side roof rail weatherstrip as outlined in the preceding procedure. The service weatherstrip is equipped with a nylon patch, half of which is cemented in place (Fig. 6-12). The other half is to be cemented over the rear section of side roof rail weatherstrip (over quarter window) as directed in Step #3.
2. Install replacement weatherstrip in the normal manner and form a butt joint to quarter run channel (see illustration). Use an approved weatherstrip adhesive (preferably black) to form butt joint.

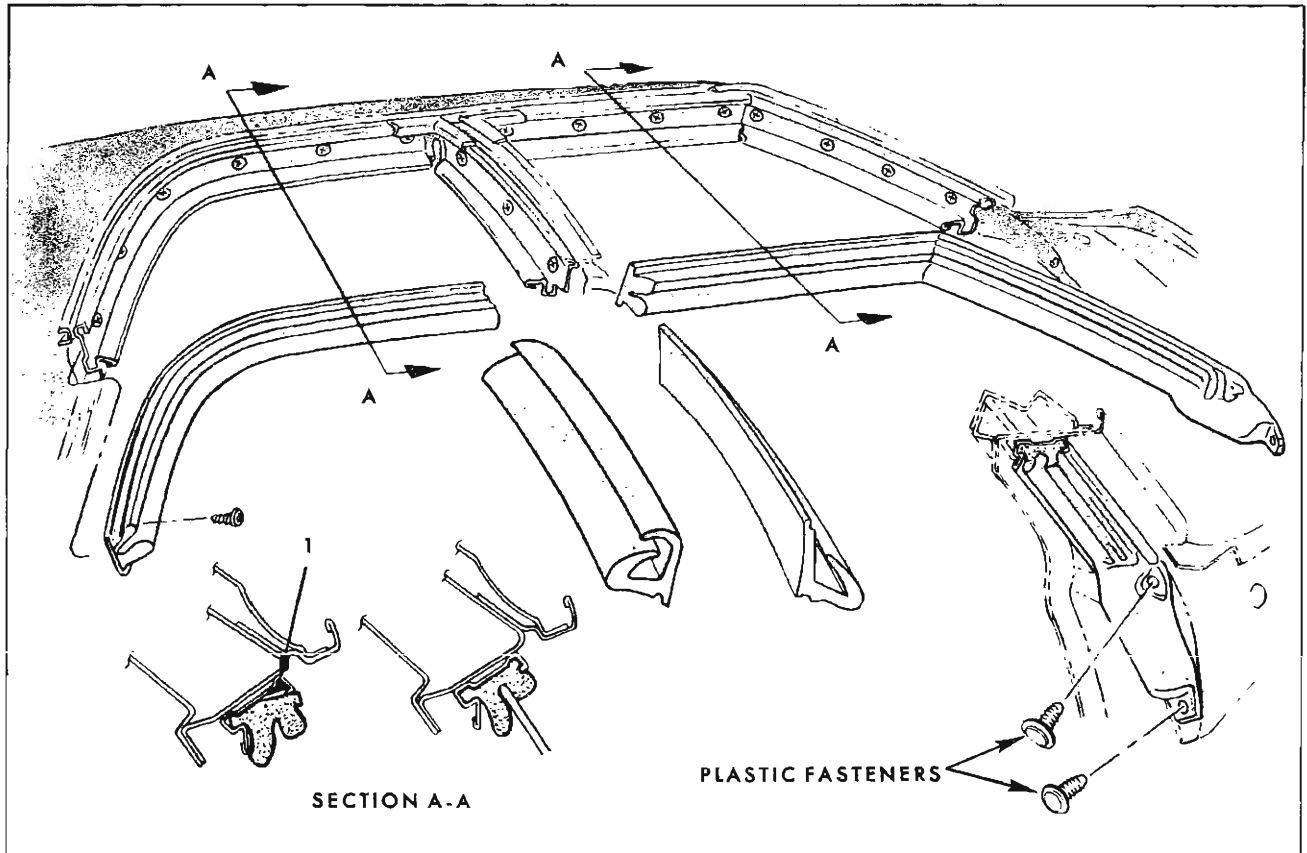

Fig. 6-10—Side Roof Rail and Center Pillar Weatherstrip  
"C-69" Styles

3. With an approved neoprene cement, install remainder of nylon patch (Fig. 6-12) to cover butt joint.

#### Removal—(Cadillac "E-47" Styles)

1. At front of weatherstrip, disengage plastic fasteners from front body hinge pillar similar to those shown in Figure 6-8.
2. Lower rear quarter window and remove screw at rear of side roof rail weatherstrip (Fig. 6-13).
3. While carefully pulling weatherstrip out of retainer, simultaneously break cement bond between weatherstrip and retainer, using a flat-bladed tool.
4. With weatherstrip removed, screws securing weatherstrip retainer to side roof rail are exposed. Remove screws to remove side roof rail weatherstrip retainer (similar to Fig. 6-9).

#### Installation (All Styles)

1. If retainer has been removed, remove and

discard saturated polyurethane foam sealing strip from side roof rail weatherstrip retainer and/or side roof rail (Sec. 'B-B', Fig. 6-11).

2. Scrape off any excess black weatherstrip adhesive from weatherstrip retainer.
3. Apply a continuous bead of a "pumpable" type body caulking compound to surface of retainer that mates with side roof rail ("1", Fig. 6-9). Apply bead outboard of attaching screw holes.
4. Position retainer to body and install attaching screws.
5. Apply a bead of black weatherstrip adhesive to outboard flange of weatherstrip retainer ("1", Figs. 6-8 and 6-10). Extend adhesive down front body hinge pillar to seal lower front end of weatherstrip that is retained with plastic fasteners.

**NOTE:** For Steps 5 & 6, Figures 6-8 and 6-10 are to be considered as typical for all hardtop styles.

6. Position front end of weatherstrip to body and

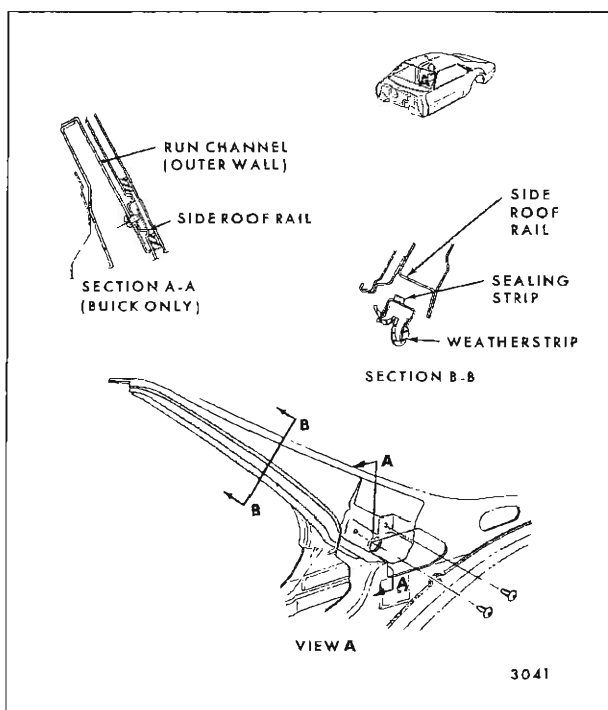

Fig. 6-11—Rear Quarter Glass Run Channel  
(Above Belt) "E-87" Styles

install plastic fasteners. Then, using a flat-bladed tool, begin engaging weatherstrip with retainer as shown in Section "A-A", Figs. 6-8 and 6-10. Engage inboard lip of weatherstrip first, then, outboard lip.

- After weatherstrip has been installed along length of retainer, install screw at rear end of weatherstrip where so equipped.

### SIDE ROOF RAIL WEATHERSTRIP ADJUSTMENT

The side roof rail weatherstrip can be adjusted either inboard or outboard to obtain a better seal with the door or quarter window.

To reposition the weatherstrip, disengage the inboard edge of weatherstrip from retainer and remove retainer attaching screws. Using a flat-bladed tool, carefully break the adhesive bond formed by the saturated polyurethane sealing strip between retainer and body. Adjust retainer as required and replace screws. Reinstall weatherstrip using black weatherstrip adhesive to seal weatherstrip to retainer.

For proper relationship of weatherstrip to door window, refer to "Front Door Window Adjustments".

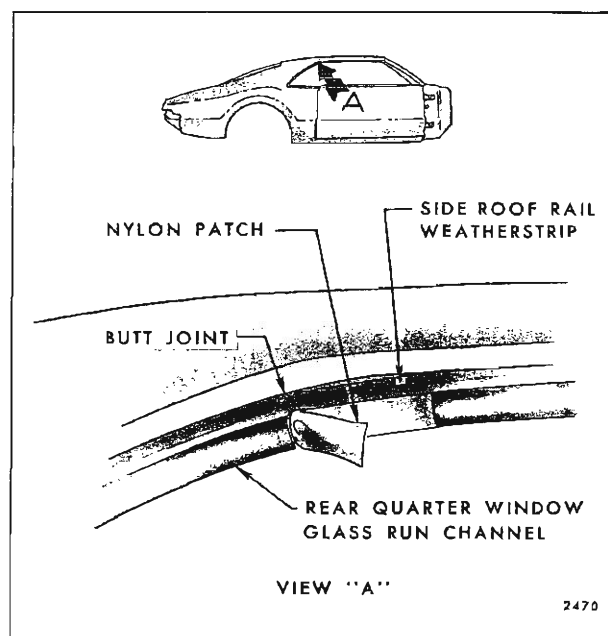

Fig. 6-12—Side Roof Rail Weatherstrip Replacement -  
"E-87" Styles

**NOTE:** Major retainer adjustments will require resealing retainer to body using body caulking compound.

### CENTER PILLAR WEATHERSTRIPS— "C-69" Styles

The center pillar weatherstrips are retained with adhesive in retainers that are screwed to the center pillar (Fig. 6-10). In addition, the weatherstrips are retained at the top by a barb in the retainer that engages the weatherstrip. Due to the

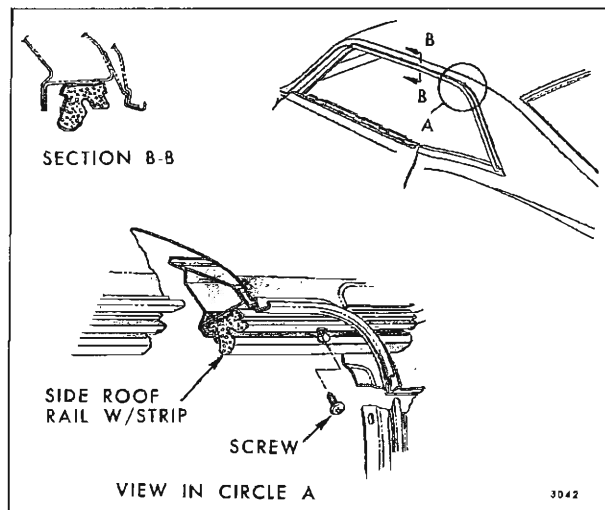

Fig. 6-13—Side Roof Rail Weatherstrip - "47-57" Styles

presence of the barb, a center pillar weatherstrip cannot be removed by sliding it out at the bottom of the retainer. Instead, it must be worked out of the retainer with a flat-bladed tool. Starting at the lower end and working upward, disengage weatherstrip from retainer outboard flange.

Although the weatherstrip cannot be slid out of the retainer, it is installed by engaging the upper end of the strip with the lower end of the retainer and sliding the strip upward. Prior to installing weatherstrip, apply a bead of black weatherstrip adhesive to outboard flange of retainer to secure weatherstrip when it is installed.

**NOTE:** The center pillar weatherstrips can be adjusted inboard or outboard to achieve a better seal with the door window. To reposition the weatherstrip, remove weatherstrip from retainer and adjust retainer in or out as required.

### **SPECIFIED BODY OPENING CLEARANCE TOLERANCES—All Styles**

Figures 6-14 through 6-18 show specified body opening gap spacing tolerances and deviations from flush alignment permissible between fender and front door and front to rear door on all 1969 body styles.

Deviations from flush alignment are required at those locations where a swing-in type hinge is used and the leading edge of the door swings inboard of adjacent body metal.

### **SPRING CLIPS**

A spring clip is used to secure remote control connecting rods and inside locking rod connecting links to door lock levers. A slot in the clip provides for disengagement of the clips, thereby facilitating detachment of linkage.

To disengage a spring clip, use a screwdriver, or other suitable tool, to slide clip out of engagement (See Fig. 6-19).

### **FRONT AND REAR DOOR OUTSIDE HANDLE ASSEMBLY—All Styles**

#### **Removal and Installation**

1. Raise door window. Remove door trim assembly and detach upper rear corner of inner panel water deflector sufficiently to gain access to door outside handle attaching screws (Refer to Fig. 6-20 for "G" styles and Fig. 6-21 for all other styles).
2. Remove screws through access hole and remove door handle and gaskets from outside of body.

3. To install, reverse removal procedure.

### **DOOR OUTSIDE HANDLE DISASSEMBLY AND ASSEMBLY—All Styles Except "G" Styles**

1. Remove door outside handle as previously described.
2. Depress retainer slightly and rotate 1/4 turn in either direction. Remove retainer, spring, push button and shaft and sealing washer from handle (See Fig. 6-22 for front door handles and Fig. 6-23 for rear door handles).

**NOTE:** Parts are serviced as shown in the illustrations; separate components for the front door handle, and a push button, spring, and retainer assembly for the rear door handle except on "E & G" Body Styles. On "E" Styles the front door push button, spring, and retainer are serviced as an assembly. "G" style front door handles are serviced as an assembly only.

3. To assemble, reverse disassembly procedure.

### **FRONT AND REAR DOOR LOCK STRIKERS—All Styles**

The front and rear door lock striker consists of a single metal bolt and washer assembly that is threaded into a tapped, floating cage plate located in the body lock pillar. With this design, the door is secured in the closed position when the door lock fork-bolt snaps-over and engages the striker bolt.

#### **Removal and Installation**

1. Mark position of striker on body lock pillar using a pencil.
2. Insert a 5/16" wrench into hex-head fitting in head of striker bolt and remove striker (Fig. 6-24). On bodies equipped with a star shaped tool fitting in the head of striker bolt (Fig. 6-24), use tool J-23302.
3. To install, reverse removal procedure. Make certain striker is positioned within pencil mark.

**NOTE:** When replacing striker, touch-up any exposed unpainted surface on lock pillar adjacent to striker assembly.

**IMPORTANT:** Whenever a door has been removed and reinstalled or realigned, the door should not be closed completely until a visual check is made to determine if lock fork-bolt will correctly engage with striker.

SPECIFIED BODY OPENING CLEARANCES

"A" Body Styles

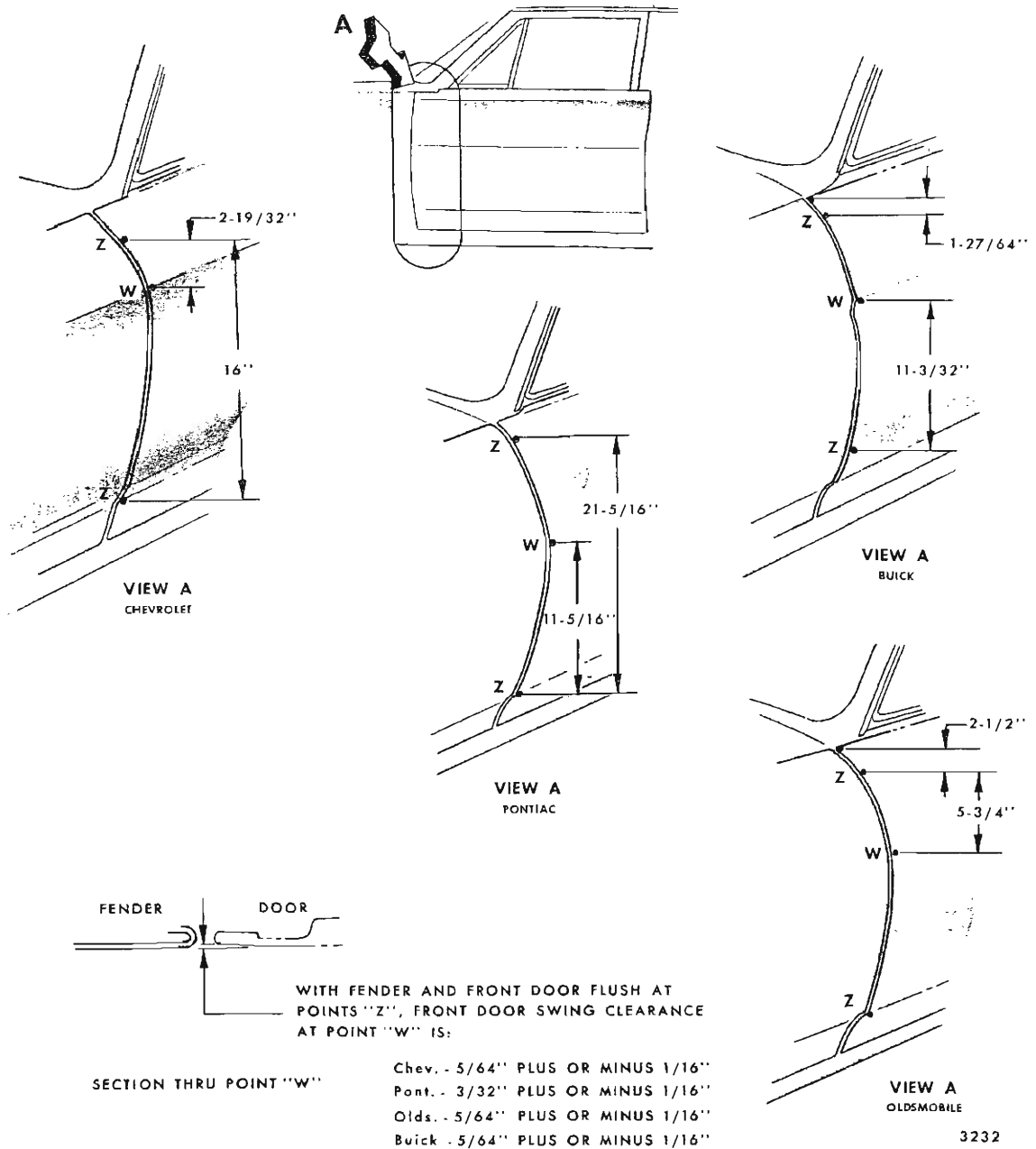

Fig. 6-14—Specified Body Opening Clearance Tolerances - "A" Styles

SPECIFIED BODY OPENING CLEARANCE TOLERANCES  
"A, B and C" Body 4 Door Styles

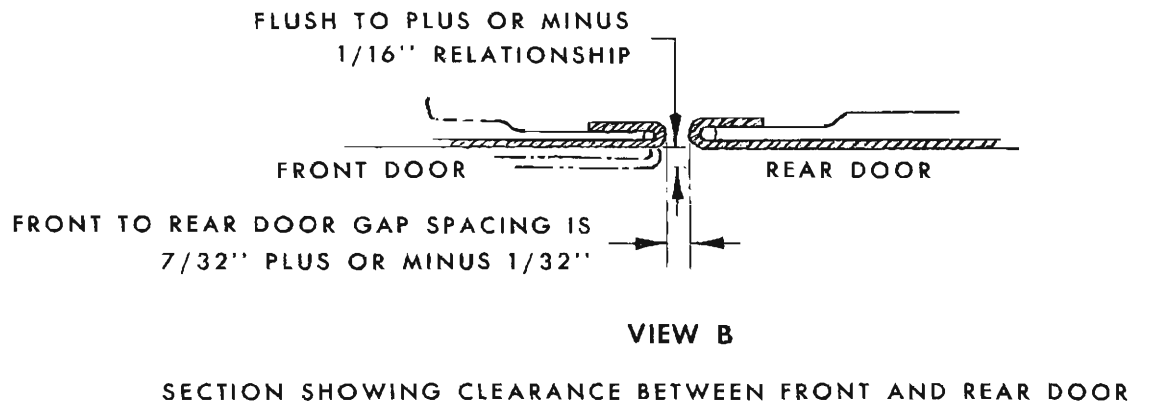
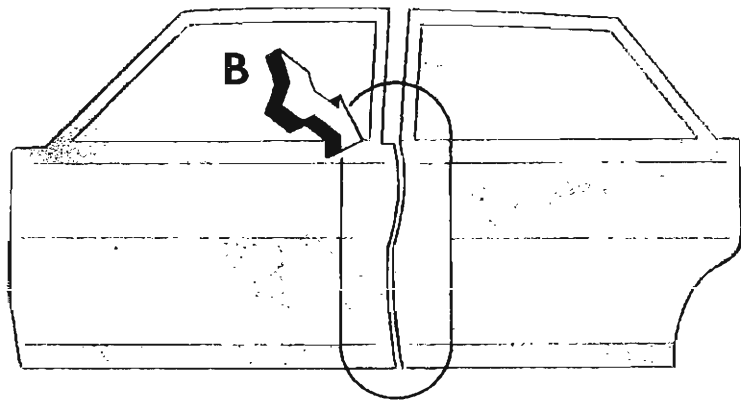
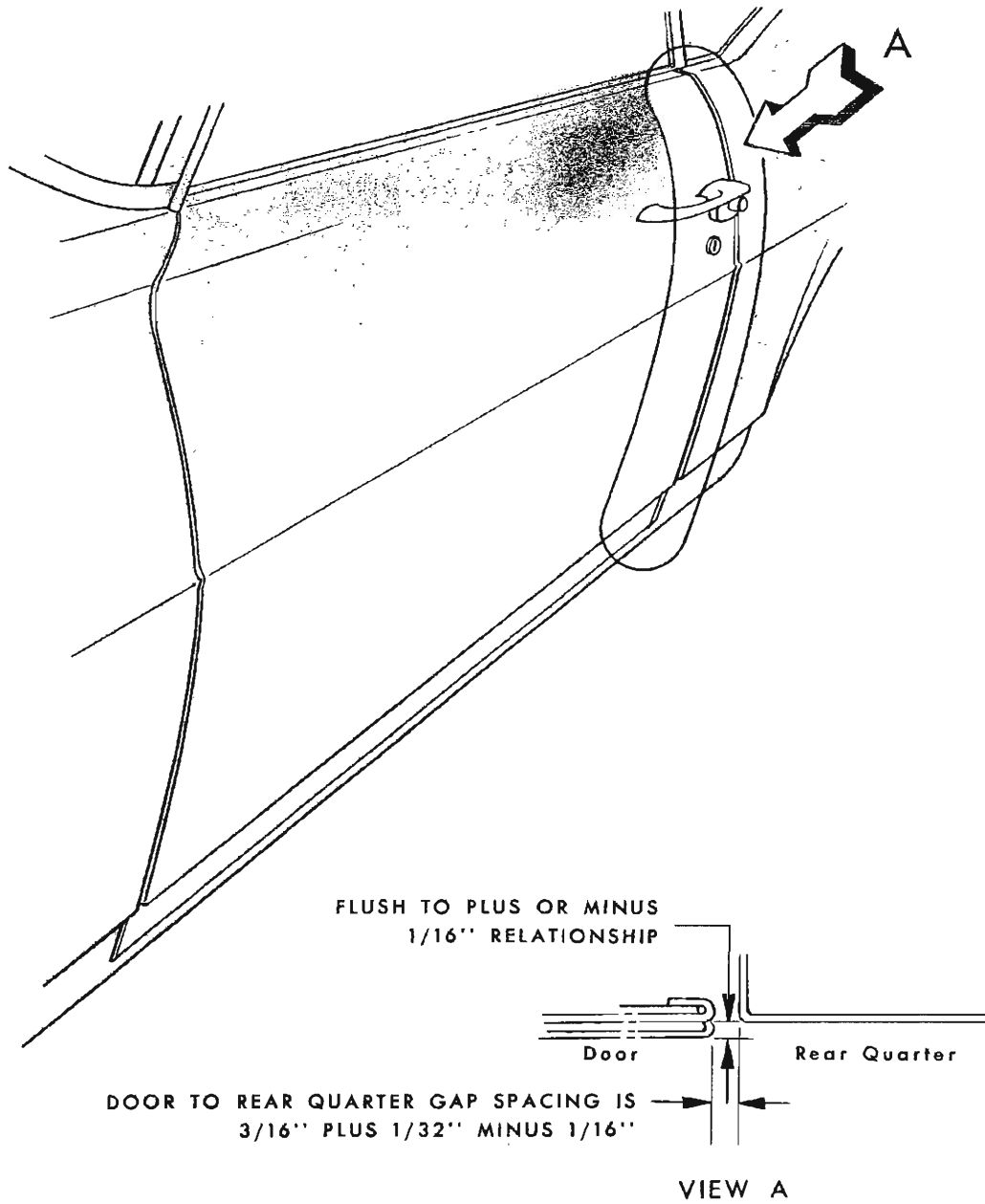

Fig. 6-15—Specified Body Opening Clearance Tolerances - "A, B and C" Body Four Door Styles

SPECIFIED BODY OPENING CLEARANCE TOLERANCES

"F" Body



SECTION SHOWING CLEARANCE BETWEEN DOOR-REAR QUARTER

3158

Fig. 6-16—Specified Body Opening Clearance Tolerances - "F" Styles



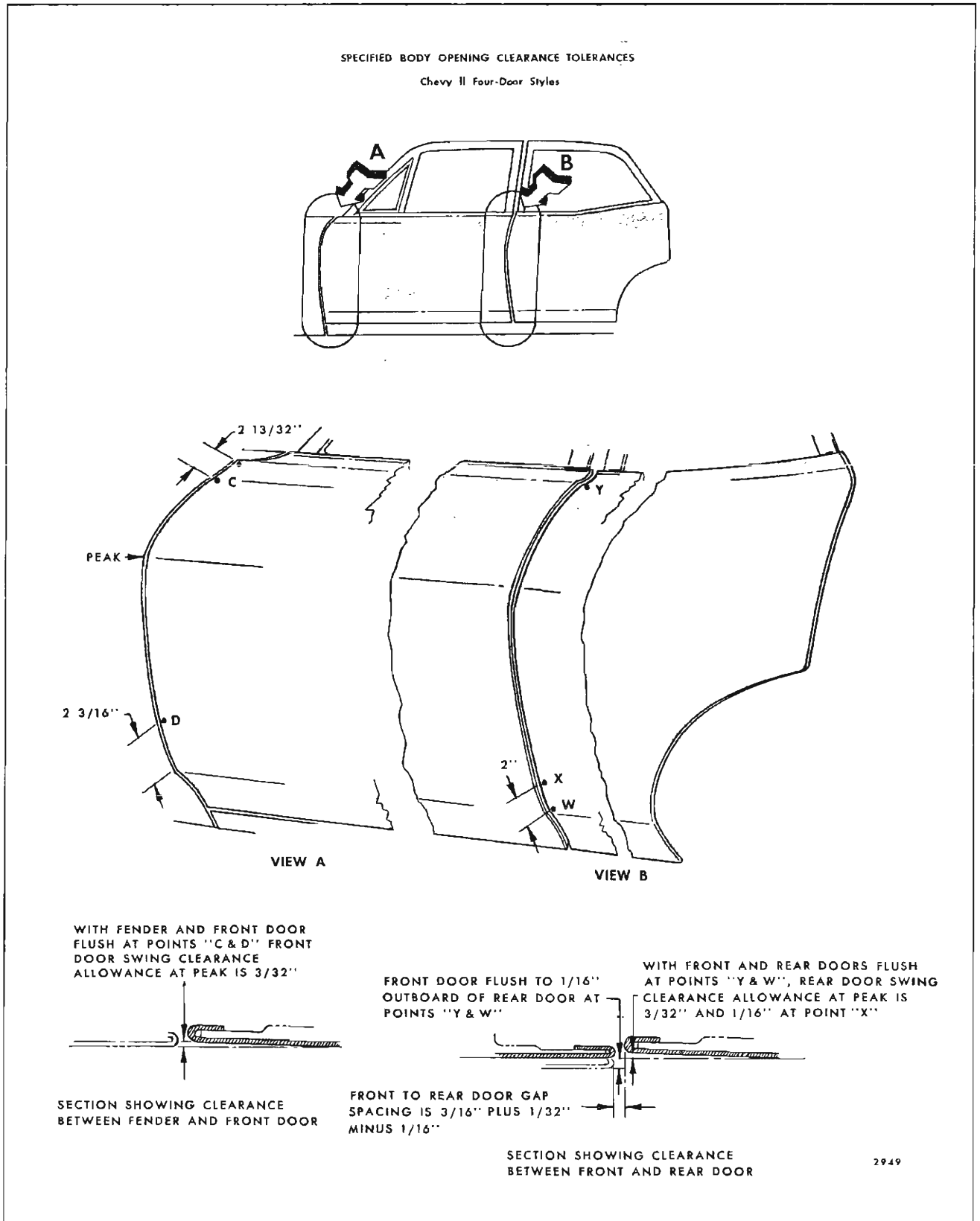
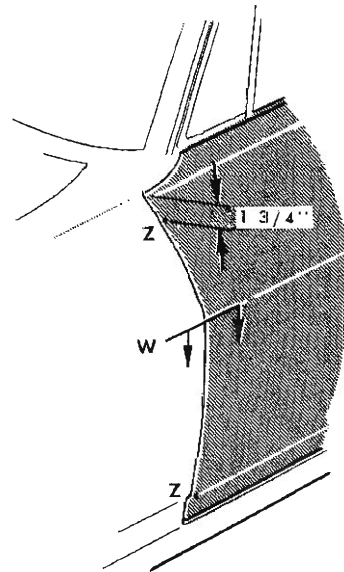

Fig. 6-17—Specified Body Opening Clearance Tolerances - "X" Styles

## SPECIFIED BODY OPENING CLEARANCE TOLERANCES

Corvair Body Styles



VIEW A

WITH FENDER AND DOOR FLUSH AT POINTS "Z",  
FRONT DOOR SWING CLEARANCE ALLOWANCE AT  
POINT "W" IS  $3/32''$  PLUS  $1/16''$  MINUS NOTHING

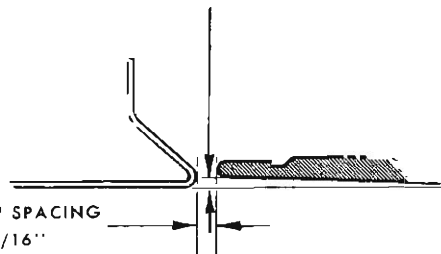

FENDER TO FRONT DOOR GAP SPACING  
IS  $3/16''$  PLUS  $1/32''$  MINUS  $1/16''$

Section "W" of View A

3043

Fig. 6-18—Specified Body Opening Clearance Tolerances - "Z" Styles

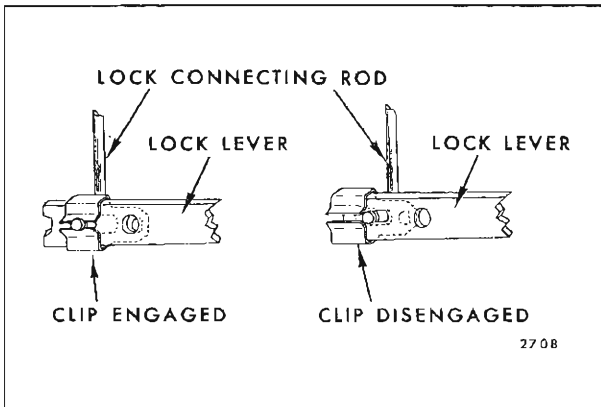

Fig. 6-19—Door Lock Spring Clip

**Adjustments**

1. To adjust striker up or down, or in or out, loosen striker bolt and shift striker as required, then tighten striker.
2. To determine if striker fore or aft adjustment is required, proceed as follows:
  - a. Make certain door is properly aligned.
  - b. Apply modeling clay or body caulking compound to lock bolt opening as shown in Figure 6-25.

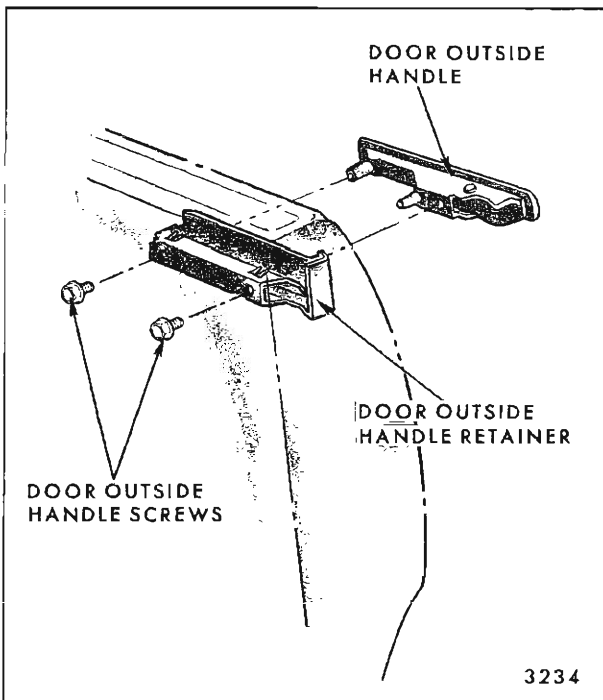

Fig. 6-20—Door Outside Handle Removal - "G" Styles

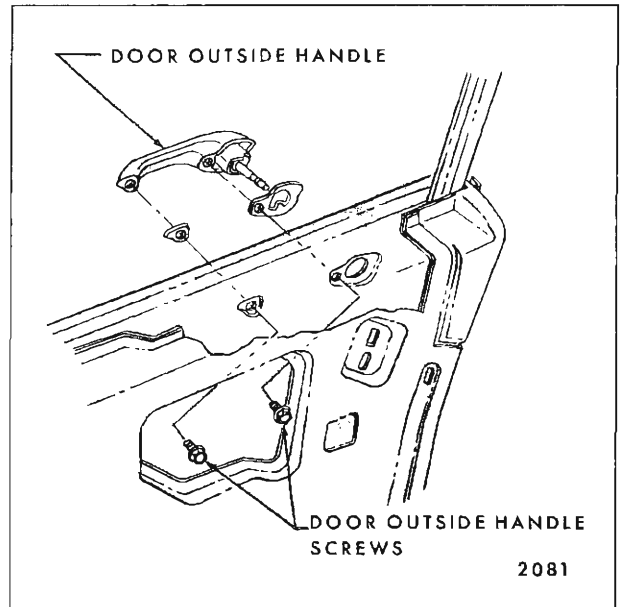

Fig. 6-21—Door Outside Handle Removal - All Styles Except "G" Styles

- c. Close door only as far as necessary for striker bolt to form an impression in clay or caulking compound as shown in Figure 6-25.

**CAUTION:** Do not close door completely. Complete door closing will make clay removal very difficult.

- d. Measure striker impressions as follows: Striker head should be centered fore and aft as shown, however, some tolerances are allowed. In any alignment, it is important that minimum dimensions, as outlined in Figure 6-25 be strictly maintained. The following spacers are available as service parts and can be used individually or in combination to achieve the desired alignment.

- 5/64" spacer - Part #4469196
- 5/32" spacer - Part #4469197
- 1/4" spacer - Part #4469194
- 5/16" spacer - Part #4469195

**VACUUM DOOR LOCK SYSTEM**

The vacuum door lock system is operated by selector valves located in the front door trim assemblies. When either valve is actuated upward, all door locks simultaneously unlock. When either valve is actuated downward, all door locks lock. Vacuum is supplied to the selector valve in the red color-coded hose and is present at all times at both valves. Only when the selector valve is

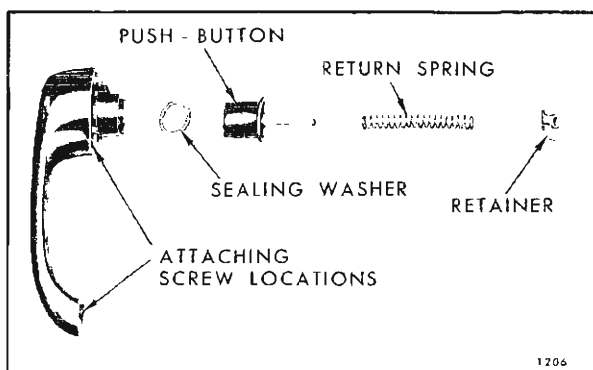

Fig. 6-22—Front Door Outside Handle - All Styles Except "G" Styles

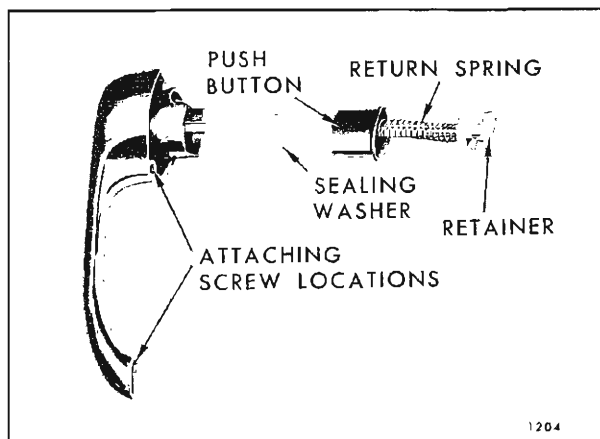

Fig. 6-23—Rear Door Outside Handle - All Styles

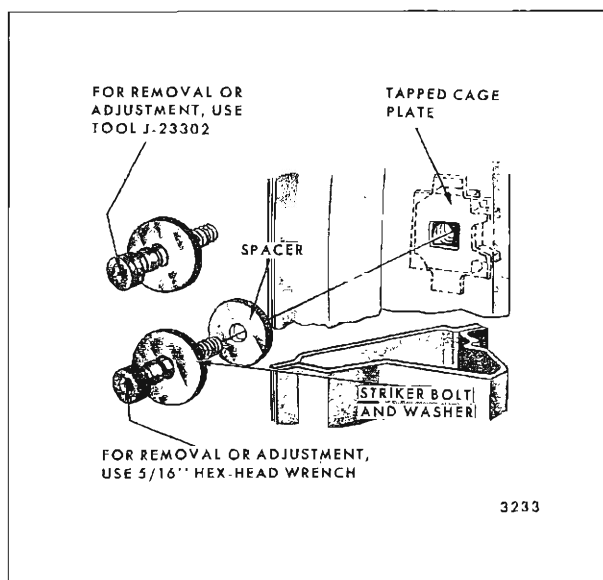

Fig. 6-24—Door Lock Striker Installation

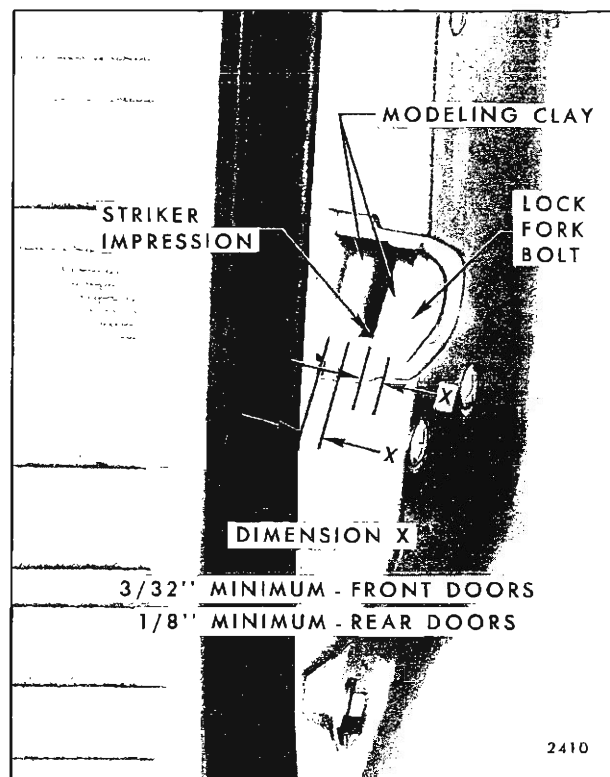

Fig. 6-25—Lock to Striker Engagement actuated is vacuum supplied to the balance of the system (Fig. 6-26).

## FRONT DOOR VACUUM LOCK SELECTOR VALVES

### Removal and Installation

1. Remove door trim pad and carefully disconnect vacuum hose from selector valve.
2. Carefully disengage valve assembly from door trim assembly.
3. To install, reverse removal procedure. When installing vacuum hoses to selector valve, install color-coded hoses to corresponding color-coded connections on the selector valve for proper valve operation. Check all operations of door lock vacuum system prior to installing door trim and inside hardware.

## VACUUM DOOR LOCK ACTUATOR AND ELECTRIC DOOR LOCK SOLENOID

### Removal and Installation

1. Raise door window, remove trim pad and detach inner panel water deflector.
2. Disconnect vacuum hoses from actuator or

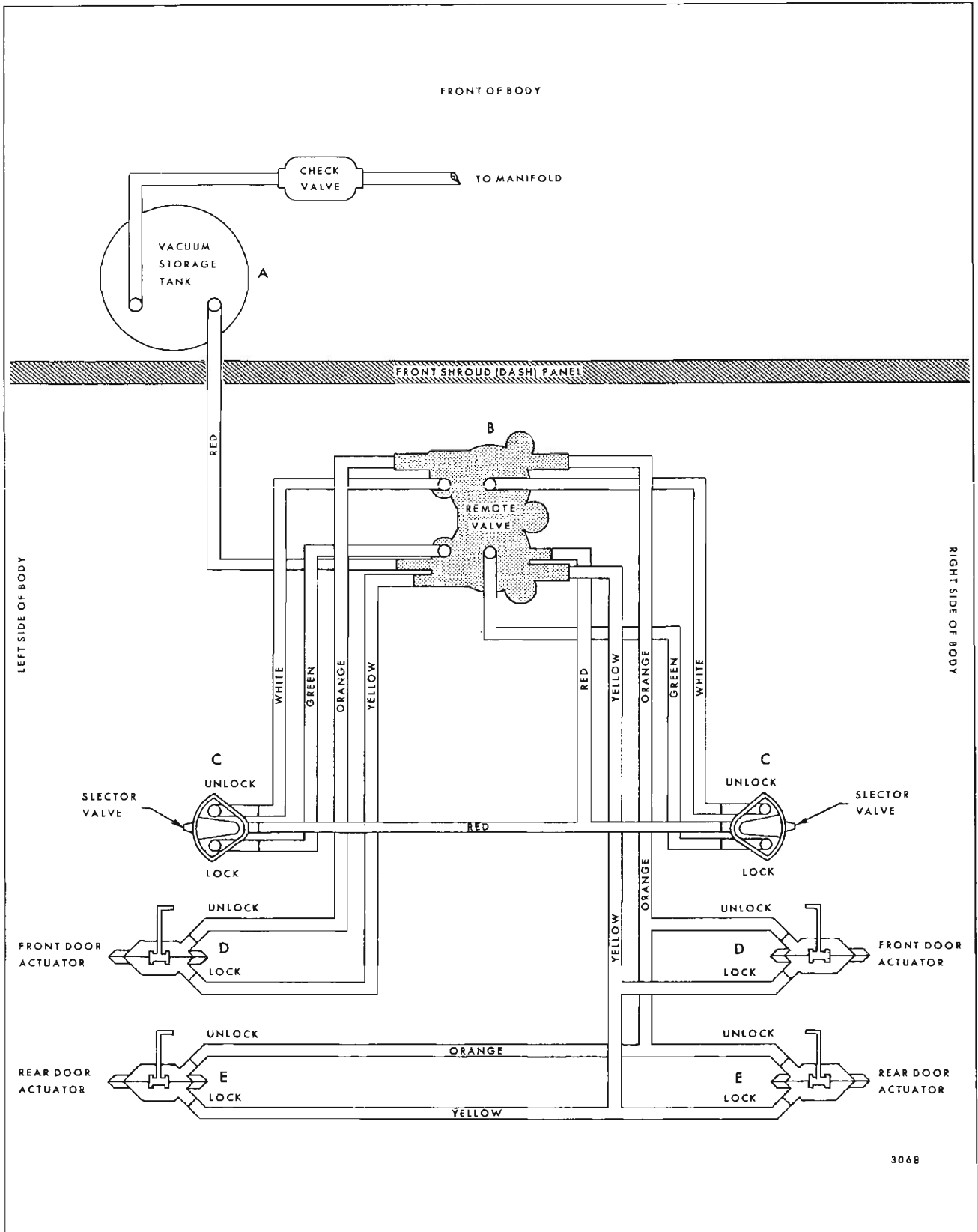

3068

Fig. 6-26—Vacuum Door Lock System

wire harness from solenoid.

3. On front doors, remove vacuum actuator or electric solenoid to door lock pillar attaching screws, disconnect rod and remove through access hole (Fig. 6-27).
4. On rear doors, remove vacuum actuator or electric solenoid to door inner panel attaching screws and connecting rod to door inside locking rod connecting link attaching clip. Remove through access hole (Fig. 6-28).
5. To install, reverse removal procedure.

### VACUUM DOOR LOCK REMOTE CONTROL ASSEMBLY—All Styles with Vacuum Door Locks

The function of the remote control assembly is to momentarily release the interrupted main vacuum in the red hose into the entire system upon receipt of the vacuum signal from the selector valve. A lock signal received from the selector valve through the green hose will open the ports to momentarily introduce vacuum into the yellow (lock) hoses. Conversely, an unlock signal received through the white hose will introduce vacuum into the orange (unlock) hoses.

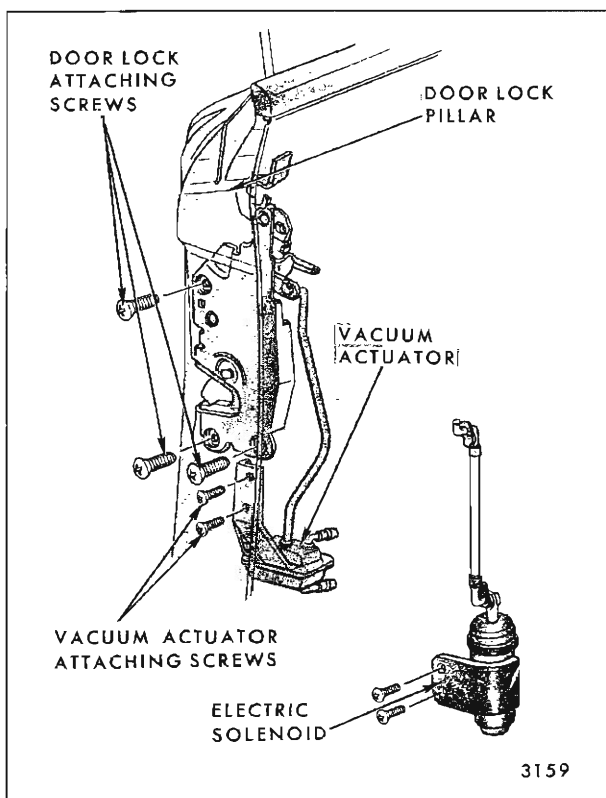

Fig. 6-27—Front Door Lock Vacuum Actuator or Electric Solenoid Installation

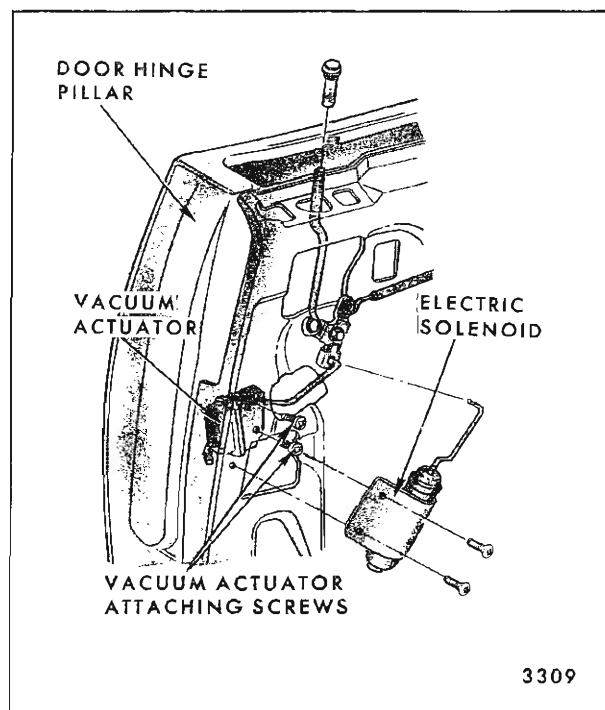

Fig. 6-28—Rear Door Lock Vacuum Actuator or Electric Solenoid Installation

The remote control valve is located under the instrument panel on the right or left side. All ports and hoses are color-coded for ease of hose installation (Fig. 6-29).

### DOOR LOCK VACUUM STORAGE TANK

The door lock vacuum storage tank is mounted in the engine compartment and is connected to the engine manifold by a hose (Fig. 6-26). A check valve at the tank connector maintains the vacuum in the tank. The storage tank supplies vacuum at

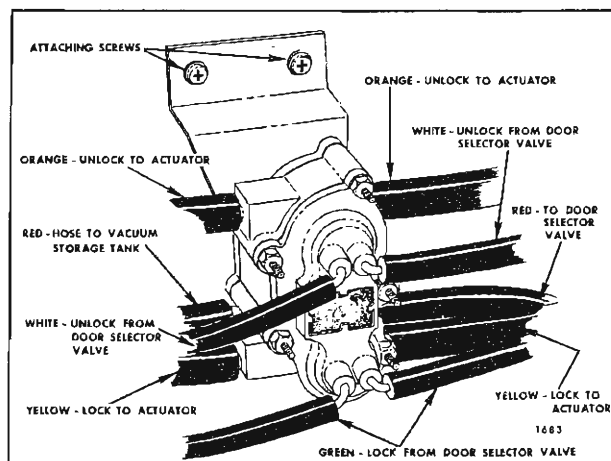

Fig. 6-29—Vacuum Lock Remote Control Valve

all times to the remote valve and door lock selector valves. The tank should provide a minimum of three complete cycles of operation (lock and unlock) immediately after the engine has been shut off.

### VACUUM DOOR LOCK TROUBLE DIAGNOSIS PROCEDURE

When an external air leak in the vacuum locking system is not severe enough to be heard, the leak-down testing device shown in Figure 6-30 will aid in determining which part is leaking. This device can be easily constructed from common items that are normally available. The following chart lists the necessary components. The item numbers are referenced to Figure 6-30.

Although several transparent glass containers may be satisfactory for use as a testing device, a quart jar with a metal cap that can be sealed is recommended.

Item	Description	ID	OD	Length	Quan.
1	Quart Glass Container				1
2	Metal Cap				1
3	Cap Sealing Ring				1
4	Cap Ports	3/16"	1/4"	2-1/2"	2
5	Hose Port	3/16"	1/4"	2-1/2"	1
6	Hose	7/32"	3/8"	2"	2
7	Hose	5/32"	5/16"	1"	1
8	Glass Tube	1/8"	5/16" to 3/8"	4"	1

Install ports in cap by drilling 2 holes and inserting ports half-way through cap. Solder ports to cap to make an air-tight seal.

**NOTE:** There cannot be any air leaks in leak-down testing device to check a vacuum system. The lower end of the glass tube in the jar should be cut on a 45° angle. If glass tubing is not available, plastic tubing may be substituted provided it has the specified inside diameter.

#### a. Installation of Testing Device Into Vacuum System:

The testing device is installed between the vacuum storage tank and the remote control valve. To install testing device, proceed as follows:

1. Add water to jar until level is approximately 1" above lower end of tube.
2. Raise hood and remove storage tank to remote control valve hose (red) from storage tank check valve.

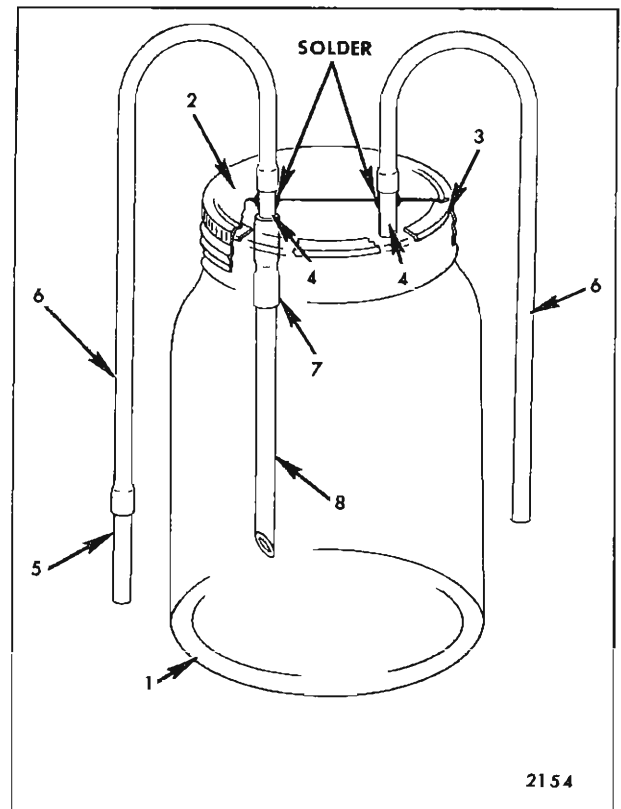

Fig. 6-30—Leak-Down Testing Device (See Text for Specifications of Components)

3. Install hose from testing device (hose without port) to bottom of check valve on storage tank.
4. Install other hose (with attached port) on testing device to hose leading to remote control valve.
5. Set testing device in an upright position.

#### b. Recharging Vacuum Storage Tank

Vacuum will usually have been depleted after four or five cycles of lock operation, or after testing device has been installed. To recharge storage tank to normal vacuum (22-24 inches of mercury), proceed as follows:

1. Turn testing device on its side until glass tube is out of water.
2. Start engine and run for approximately one minute.
3. Turn engine off and return testing device to a normal upright position.

**NOTE:** If water rises in glass tube, quickly pinch-off hose leading from testing device to

remote control valve. If hose is not pinched, and then disconnected, water rising up tube will enter vacuum lock system components. Condition is the result of a defective storage tank which must be replaced, provided hose connections check out satisfactorily.

4. Allow 15 to 30 seconds for water in testing device to stop bubbling. The waiting period is necessary due to different pressures in the system on both sides of testing device. The bubbling is the result of these pressures trying to equalize themselves. The storage tank may be recharged as often as required when checking vacuum system for an external air leak.

**CAUTION:** Be certain to turn testing device on its side each time system is recharged. If this is not done, water in jar may be drawn up into vacuum system components.

#### c. Determining Size of Air Leak from Bubbles in Testing Device:

If bubbles appear in water at a rate of approximately one every fifteen seconds or faster, an air leak is present at either the remote control valve or door selector valve. This assumes, of course, that the hoses are properly connected and free of defects. The faster bubbles appear in the water, the more severe is the air leak. In most cases, where the air leak rate is slower than one bubble every fifteen seconds, the vacuum loss is usually insufficient to affect the operation of the vacuum locking system.

#### d. Isolating a Leaking Vacuum Part (External Leak) Using the Leak-Down Testing Device:

After a specific part has been isolated as a leaking component, first check the hose color-coded red that attaches to that part. Make sure hose is properly installed to the port and that hose is not split.

When the testing device has been properly installed and storage tank recharged, watch glass tube in testing device and proceed as follows:

1. If water rises in glass tube, storage tank is leaking. Replace vacuum storage tank.
2. If bubbles appear in water, an air leak is present in either the remote control valve or in one of the door lock selector valves.
3. Remove right and left front door hinge pillar conduits.
4. Pinch right and left, vacuum hose color-coded red.

**NOTE:** This has eliminated the right and left door lock selector valves from vacuum system.

5. Check testing device. If bubbles continue to appear in water, the remote control valve is leaking. (If bubbles stop, See Step 6).
6. If bubbles stop forming in testing device, air leak is at either door valve. Discontinue pinching left valve hose at hinge pillar.
7. Check testing device. If bubbles appear in water, left door valve is leaking. (If no bubbles appear, See Step 8).

**NOTE:** Before replacing a door lock selector valve, tighten screws on back of valve, then recheck valve. If valve continues to leak, replace left door lock selector valve assembly.

8. If no bubbles appear in testing device after discontinuing pinching of left valve hose, then air leak is at right door valve. This may be shown by discontinuing pinching of right valve hose at hinge pillar. Bubbles will appear immediately in water of testing device.

### VACUUM DOOR LOCK DIAGNOSIS CHART (Ref. Fig. 6-26)

CONDITION	APPARENT CAUSE	REPAIR
A. System inoperative.	1. Hoses crossed at vacuum supply tank.	Reverse hoses at vacuum supply tank.
	2. Vacuum supply hose pinched at remote valve.	Straighten hose at "B" (Red).
	3. Door valve supply hose pinched at remote valve.	Straighten hose at "B" (Red).



CONDITION	APPARENT CAUSE	REPAIR
A. System inoperative—Cont'd.	<ol style="list-style-type: none"> <li>4. Vacuum supply hose disconnected at tank, remote valve, or engine.</li> <li>5. Remote valve diaphragm leaking.</li> </ol>	<p>Install hose at "A or B" (Red).</p> <p>Replace remote valve at "B".</p>
B. All doors can be locked but not unlocked.	<ol style="list-style-type: none"> <li>1. Main supply hose crossed lock supply hose at remote valve.</li> <li>2. Unlock selector hose or supply hose disconnected at remote valve.</li> </ol>	<p>Reverse hoses at remote "B" (Red and Green).</p> <p>Hook up hose at remote "B" (White).</p>
C. All doors can be unlocked but not locked.	<ol style="list-style-type: none"> <li>1. Main supply hose crossed with unlock supply hose on remote valve.</li> <li>2. Lock selector hose or supply hose disconnected at remote.</li> </ol>	<p>Reverse hoses at remote "B" (Red and White).</p> <p>Hook up hose at remote "B" (Green).</p>
D. Moving either door valve to lock or unlock produces the opposite action of all locks.	<ol style="list-style-type: none"> <li>1. Door lock selector valve hoses (small) crossed at remote valve.</li> <li>2. Actuator supply hoses (large) crossed at remote valve.</li> </ol>	<p>Reverse selector hoses at remote valve "B" (White and Green), or reverse selector hoses at each door lock selector valve "C" (White and Green).</p> <p>Reverse hoses at remote "B" (Orange and Yellow).</p>
E. Moving one of the door valves to lock or unlock produces the opposite action of the lock.	<ol style="list-style-type: none"> <li>1. Valve selector hoses crossed at one door valve.</li> <li>2. Door selector valve reversed in trim assembly.</li> </ol>	<p>Reverse small hoses at affected door valve "C" (White and Green).</p> <p>Reverse affected door selector valve in trim assembly "C".</p>
F. System inoperative from one door valve.	<p>Vacuum supply hose pinched or disconnected at affected door valve.</p>	<p>Connect hose or check for pinching at:</p> <ol style="list-style-type: none"> <li>1. Affected door valve "C".</li> <li>2. Front door conduit on side affected "E".</li> </ol>
G. System will not lock from one door valve, or system will not unlock from one door valve.	<p>Lock or unlock selector valve hose pinched or disconnected from affected door valve.</p>	<p>Connect hose or check for pinching at:</p> <ol style="list-style-type: none"> <li>1. Affected door valve "C" (White or Green).</li> <li>2. Front door conduit on that side "E".</li> </ol>
H. Lock movement on any one door not synchronized with other door(s).	<p>Hoses crossed at affected door lock actuator.</p>	<p>At Front Door Reverse hoses at lock actuator "D" (Orange and Yellow).</p> <p>At Rear Door Reverse hoses at lock actuator in door "F" (Orange and Yellow). Or reverse hoses at tubing center pillar "G".</p>

CONDITION	APPARENT CAUSE	REPAIR
I. One door lock lags behind others when locked or unlocked.	Lock or linkage binding.	<p>Front Door</p> <ol style="list-style-type: none"> <li>1. Lubricate lock and check inside locking control rod for freedom of movement.</li> <li>2. Check drive link for freedom of movement in lock trip lever.</li> </ol> <p>Rear Door</p> <ol style="list-style-type: none"> <li>1. Lubricate lock and check inside locking control rod and linkage for freedom of movement.</li> <li>2. Check clearance of lock and actuator to door hardware.</li> </ol> <p>Coupe</p> <ol style="list-style-type: none"> <li>1. Lubricate lock and check inside locking control rod for freedom of movement.</li> <li>2. Check freedom of movement of actuator and lock.</li> </ol>
J. One door lock will not lock or unlock.	Actuator hoses pinched or disconnected.	<p>Front Door</p> <ol style="list-style-type: none"> <li>1. Check for pinched hoses at front door, conduit on side affected.</li> <li>2. Check for hose disconnected at affected actuator. (Orange or Yellow).</li> </ol> <p>Rear Door</p> <ol style="list-style-type: none"> <li>1. Check for pinched hose at rear door conduit and at center pillar.</li> <li>2. Check for kinked or flattened hoses under front door carpet support plate.</li> <li>3. Check for disconnected hose at metal tubing or at actuator (Orange or Yellow).</li> </ol>
K. System will not hold vacuum for 48 hours.	<ol style="list-style-type: none"> <li>1. Excessive leakage in any one of the following units can be the cause: <ol style="list-style-type: none"> <li>a. Remote valve</li> <li>b. Door valves (2)</li> <li>c. Storage tank and check valve.</li> <li>d. That part of the harness assembly that contacts these components.</li> </ol> </li> </ol>	<ol style="list-style-type: none"> <li>1. Actuate system through several lock and unlock cycles, and recheck leakage.</li> <li>2. Isolate leaking component and replace.</li> </ol> <p><b>IMPORTANT:</b> If a door valve is found to be leaking, tighten screws on back of valve, then recheck valve. If valve continues to leak, replace valve.</p>
L. Lock(s) inoperative with front door closed but operates with door open.	Door valve vacuum supply hose pinched at front body hinge pillar on side affected.	Check for pinched hose of affected door at conduit.

CONDITION	APPARENT CAUSE	REPAIR
M. Door selector valve leaks.	Pinch vacuum supply hose (Red) at affected valve. If air leak stops, valve is defective.	Replace affected selector valve.  <b>IMPORTANT:</b> If selector valve leaks, first tighten screws on back of valve, then recheck valve. If valve continues to leak, replace valve assembly.
N. Storage tank leaks.	Turn engine off and disconnect manifold to storage tank supply hose at tank check valve; then pinch storage tank to remote valve supply hose. Actuate either door lock selector to equalize pressure in balance of system. If air continues to leak, tank is defective.	Replace vacuum storage tank.
O. Actuator assembly inoperative.	Connect hose or check for pinched hose at front door hinge pillar conduit "E", at rear door hinge pillar conduit "H" or at remote control valve "B", then actuate door lock selector valve. If actuator does not operate, actuator is defective.	Replace actuator assembly.
P. Remote valve leaks.	Check remote valve for pinched or disconnected hose(s). If balance of system is checked and found to be in satisfactory condition, replace remote valve with new part. If system then operates properly, original remote valve was defective.	Replace remote control valve assembly.

## DOOR WINDOW REGULATOR ELECTRIC MOTOR

The electric motor assembly which powers the electrically operated window regulators is a twelve volt, reversible direction motor with an internal circuit breaker and a self-locking gear drive. The motor is secured to the regulator assembly with bolts.

### Removal and Installation—All Styles Except "E" Styles

1. Remove door trim assembly and inner panel

water deflector. Disconnect harness connector at motor.

2. Refer to Figures 6-31 through 6-35 and select the appropriate template for locating window motor to regulator attaching bolts by using window regulator to door inner panel attaching bolts as reference points.
3. Align regulator bolt locations specified on template with appropriate regulator attaching bolts on door. Secure template in place with a piece of tape.

ALIGN TEMPLATE WITH APPROPRIATE UPPER AND LOWER LEFT REGULATOR ATTACHING BOLTS ON DOOR

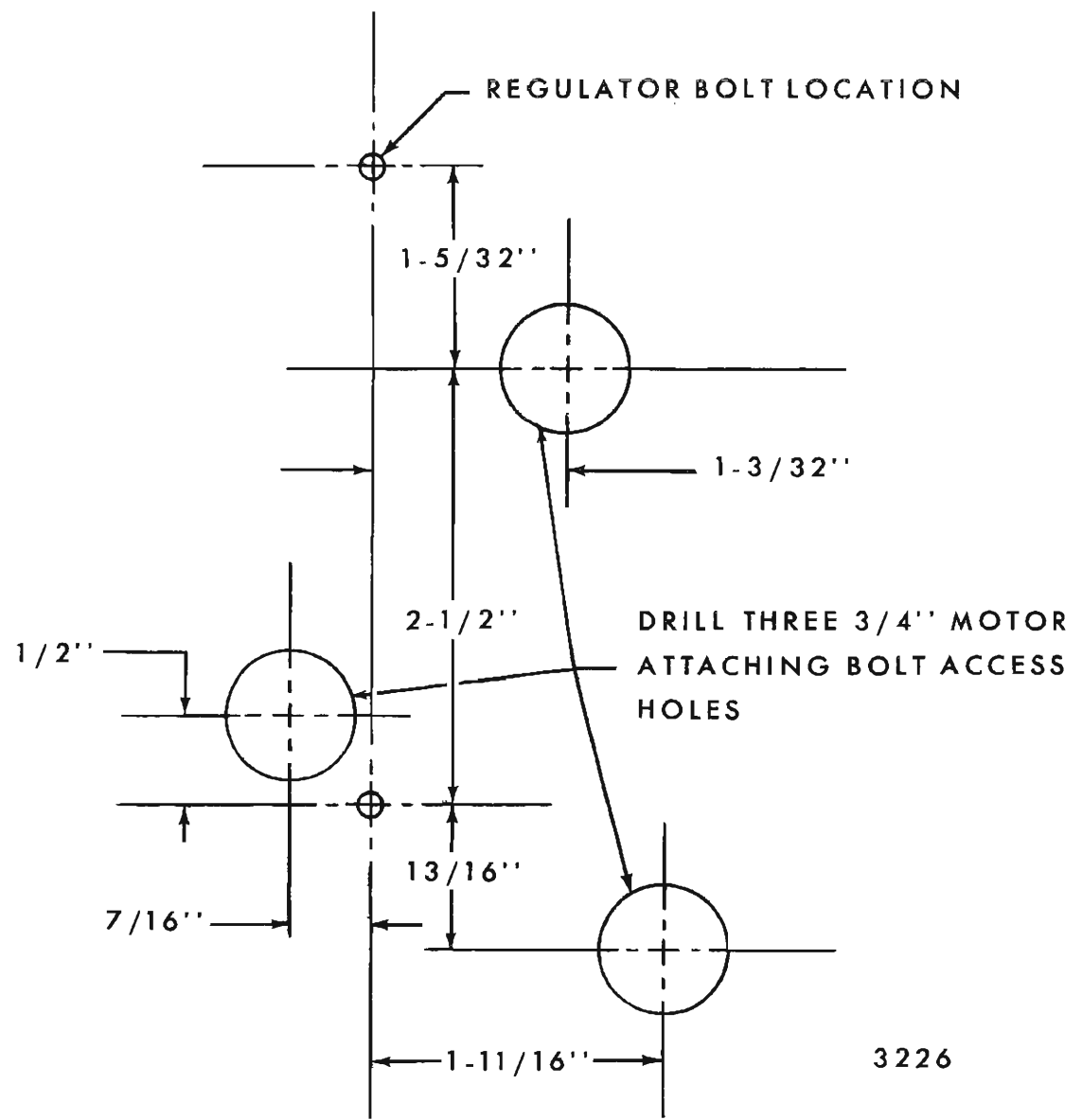

3226

Fig. 6-31—Window Regulator Upper and Lower Left Attaching Bolt Reference Points for Locating Window Motor to Regulator Attaching Bolts - "A-27 and 77" Styles

ALIGN TEMPLATE WITH UPPER AND LOWER LEFT  
REGULATOR ATTACHING BOLTS ON DOOR

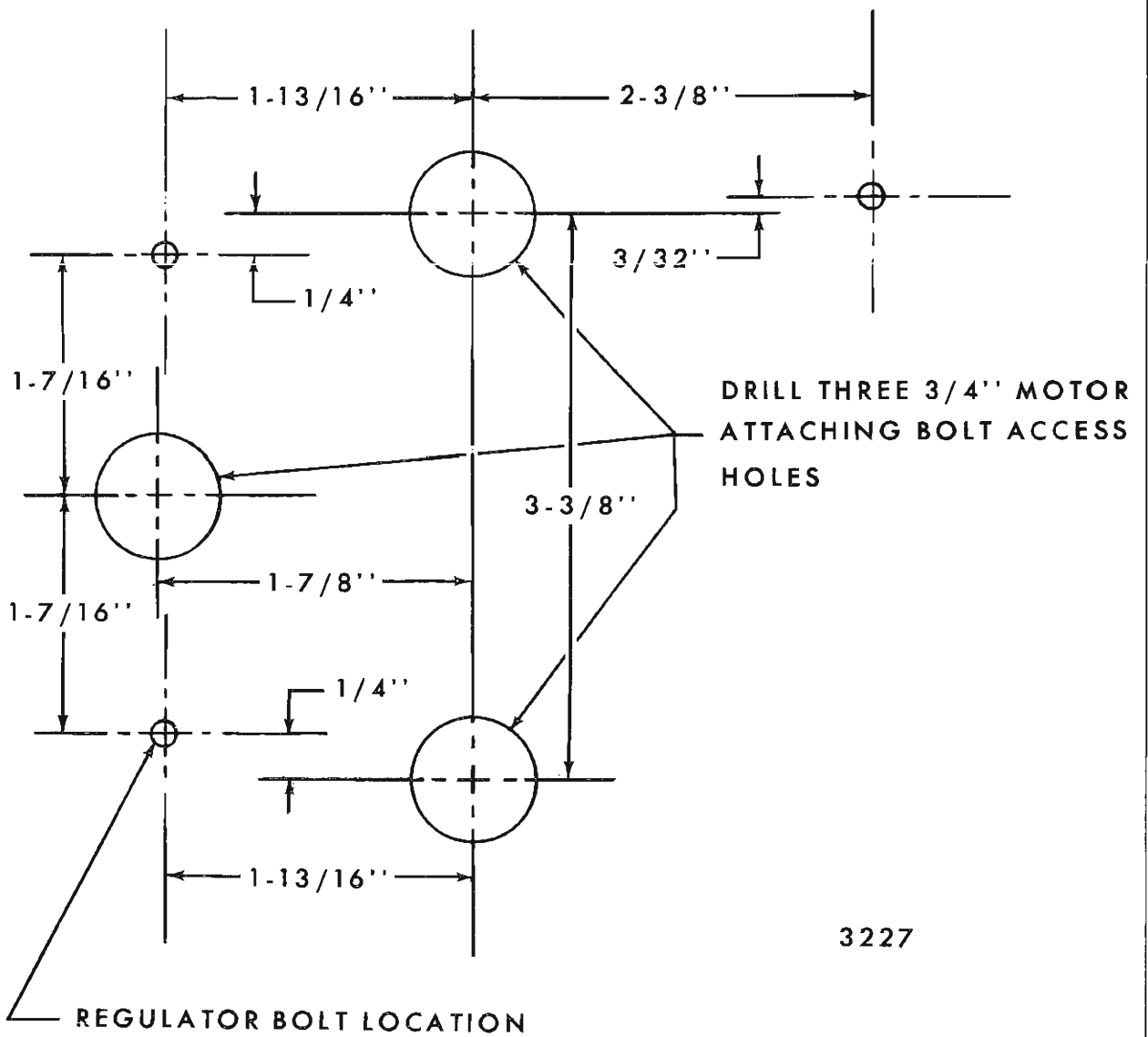

Fig. 6-32—Window Regulator Upper and Lower Left Attaching Bolt Reference Points for Locating Window Motor to Regulator Attaching Bolts - "A-35, 39, 45, 55, 69" Style Front Doors

ALIGN TEMPLATE USING REFERENCE POINTS "I OR II"  
WITH APPROPRIATE REGULATOR LOWER ATTACHING BOLTS ON DOOR

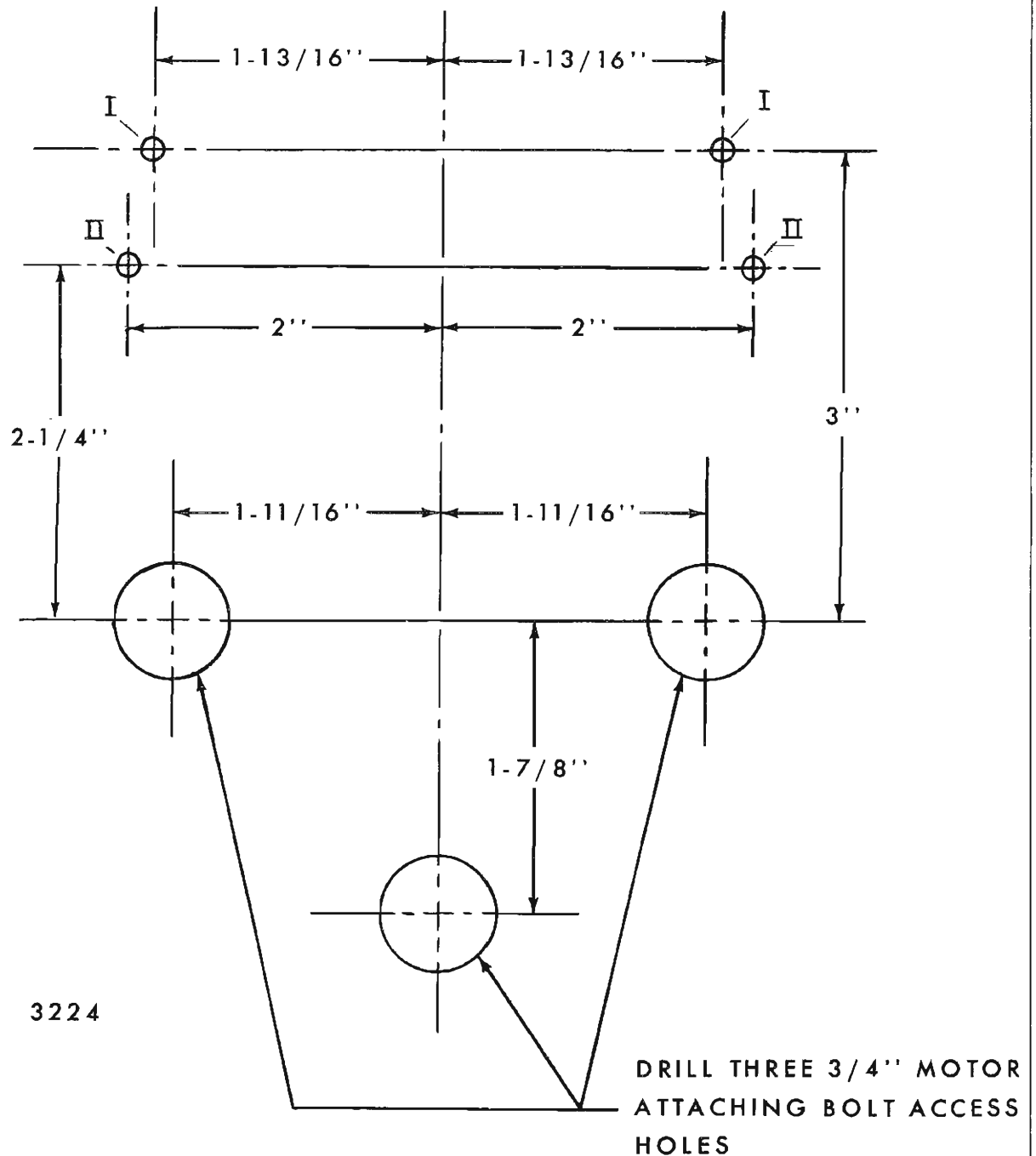

Fig. 6-33—Window Regulator Lower Attaching Bolt Reference Points for Locating Window Motor to Regulator Attaching Bolts: "I" for "A-35, 45, 39 and 69" Style Rear Doors; "II" for "A-37, 67 and 87" and "G-57" Style Front Doors

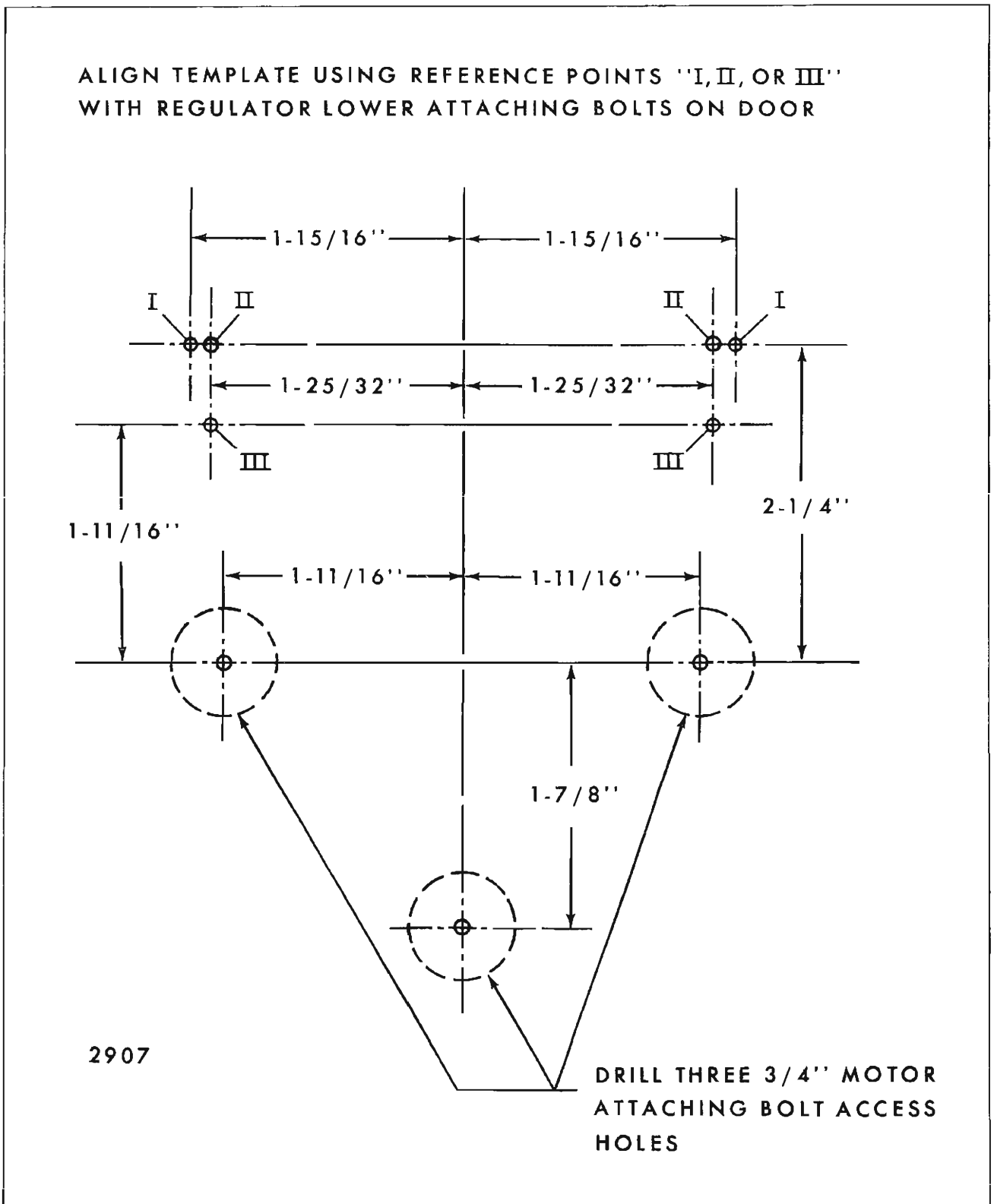

Fig. 6-34—Window Regulator Lower Attaching Bolts Reference Points for Locating Window Motor to Regulator Attaching Bolts: "I" for "B and C-11, 37, 47, 57 and 67" Style Front Doors; "II" for "C-69" Style Rear Doors; "III" for "B-36, 39, 46 and 69" and "C-49 and 69" Style Front and Rear Doors, Except "C-69" Style Rear Doors

ALIGN TEMPLATE WITH APPROPRIATE REGULATOR  
LOWER ATTACHING BOLTS ON DOOR

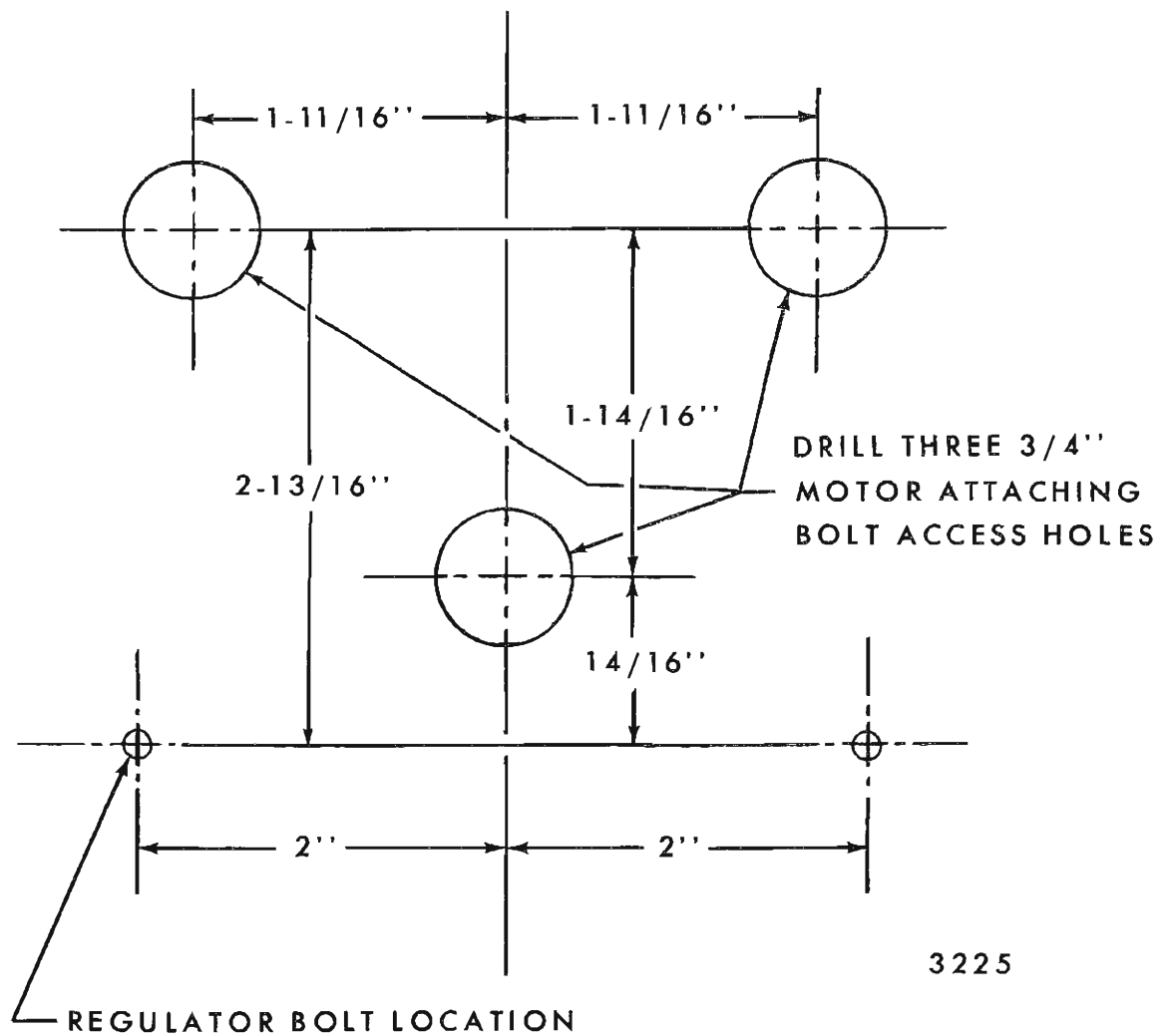
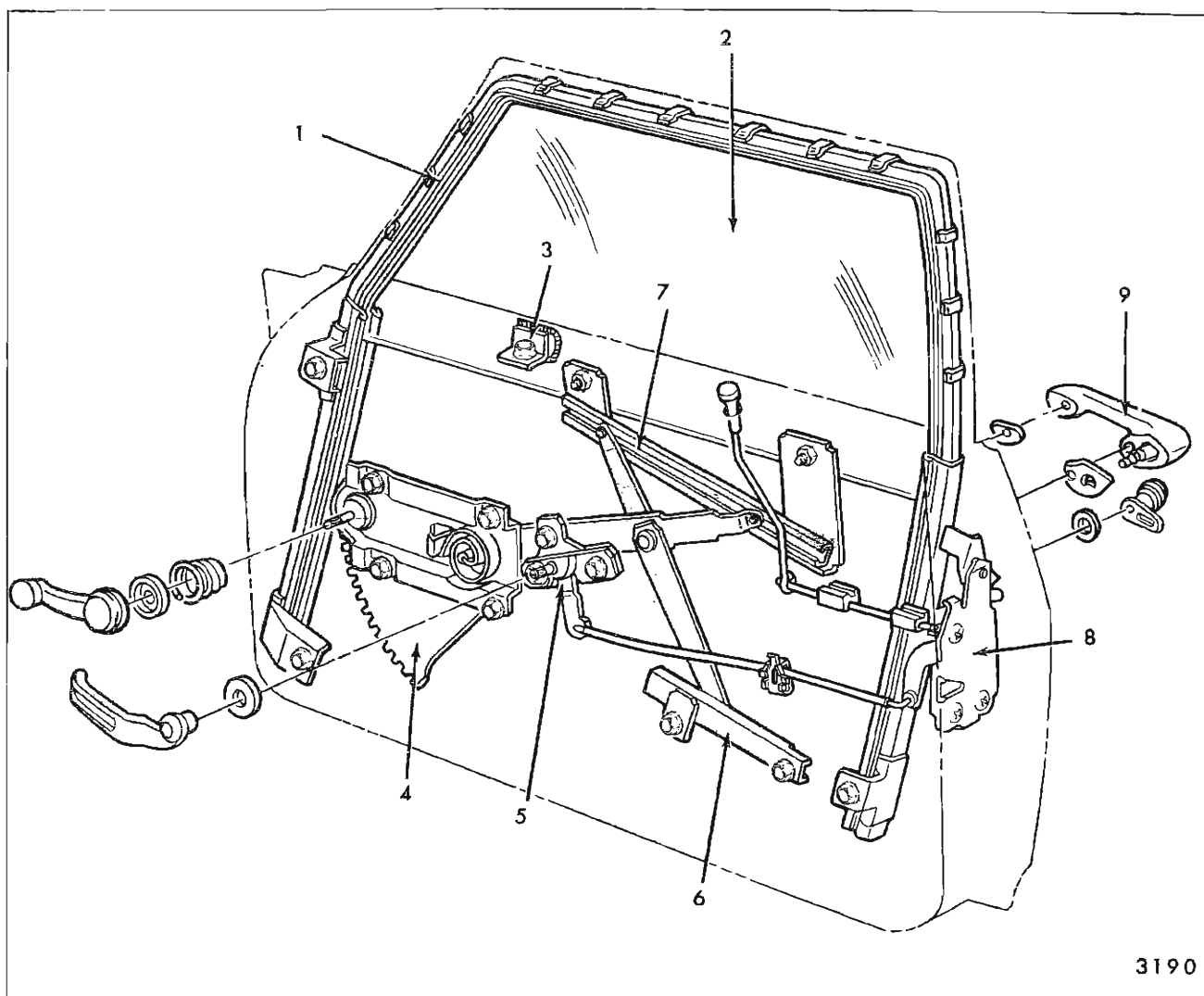

Fig. 6-35—Window Regulator Lower Attaching Bolt Reference Points for Locating Window Motor to Regulator Attaching Bolts - "F" Styles





3190

Fig. 6-43—Front Door Hardware - "B-11" Styles

1. Window Glass Run Channel
2. Window Assembly
3. Stabilizer Strip
4. Window Regulator
5. Door Lock Remote Control
6. Inner Panel Cam
7. Lower Sash Channel Cam
8. Door Lock
9. Door Outside Handle

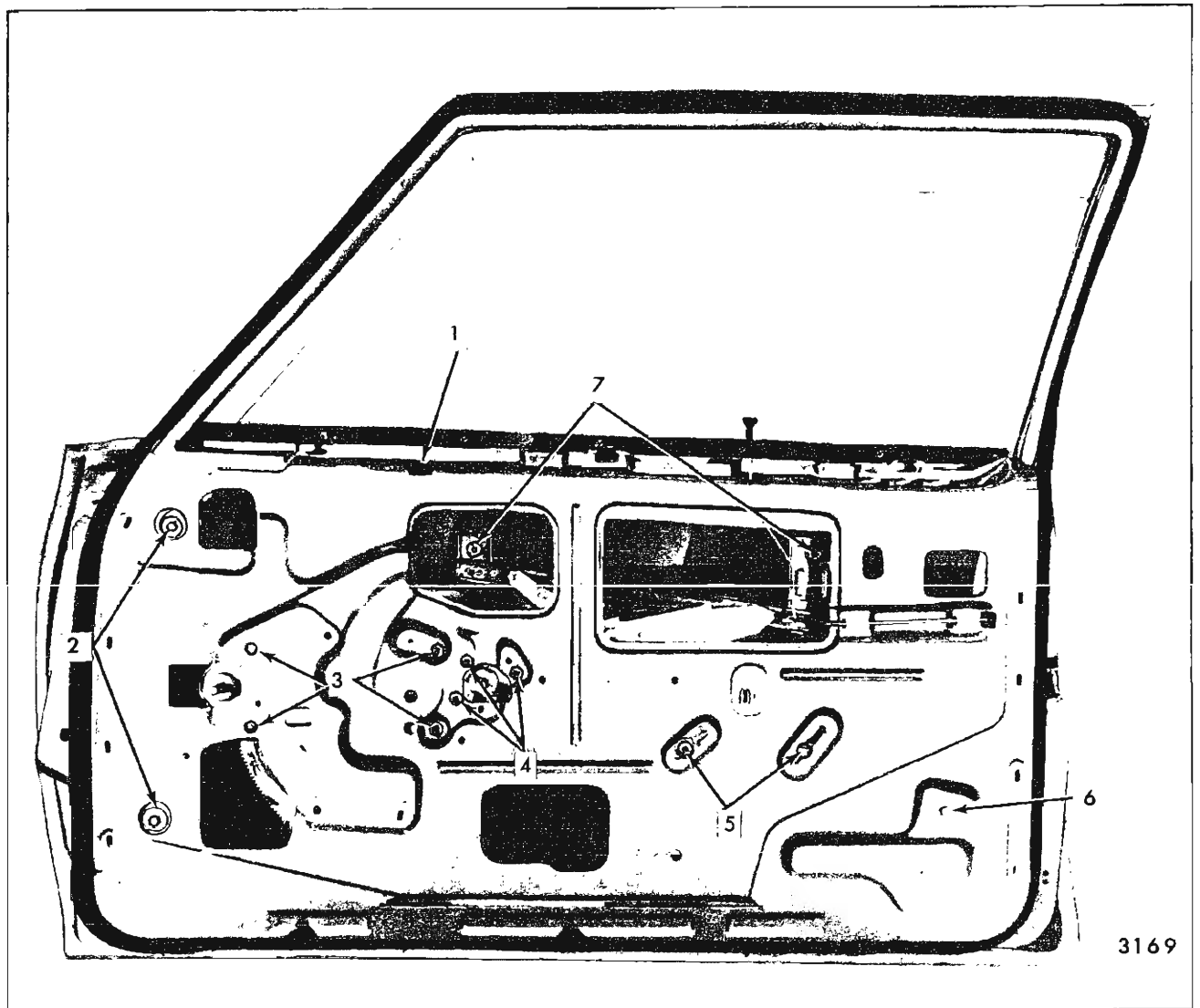
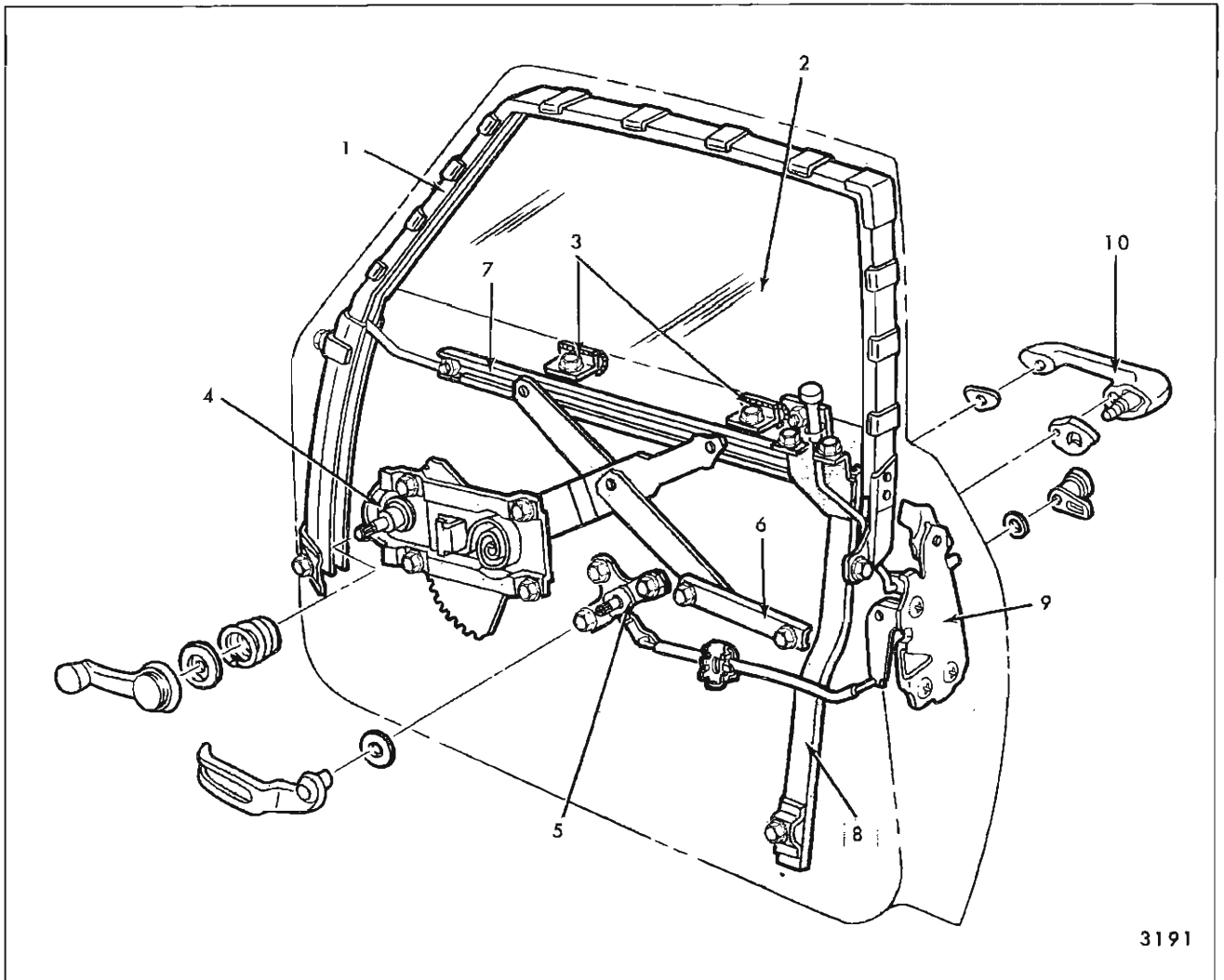

Fig. 6-44—Front Door Hardware - "B-11" Styles

1. Window Stabilizer Strip Bolt
2. Glass Run Channel Front Upper and Lower Attaching Bolts
3. Window Regulator Attaching Bolts
4. Door Lock Remote Control Attaching Bolts
5. Inner Panel Cam Attaching Bolts
6. Glass Run Channel Rear Attaching Bolt
7. Lower Sash Channel Cam to Glass Nuts



3191

Fig. 6-45—Front Door Hardware - "B-69" Styles

1. Window Glass Run Channel
2. Window Assembly
3. Stabilizer Strips
4. Window Regulator
5. Door Lock Remote Control
6. Inner Panel Cam
7. Lower Sash Channel Cam
8. Rear Guide
9. Door Lock
10. Door Outside Handle

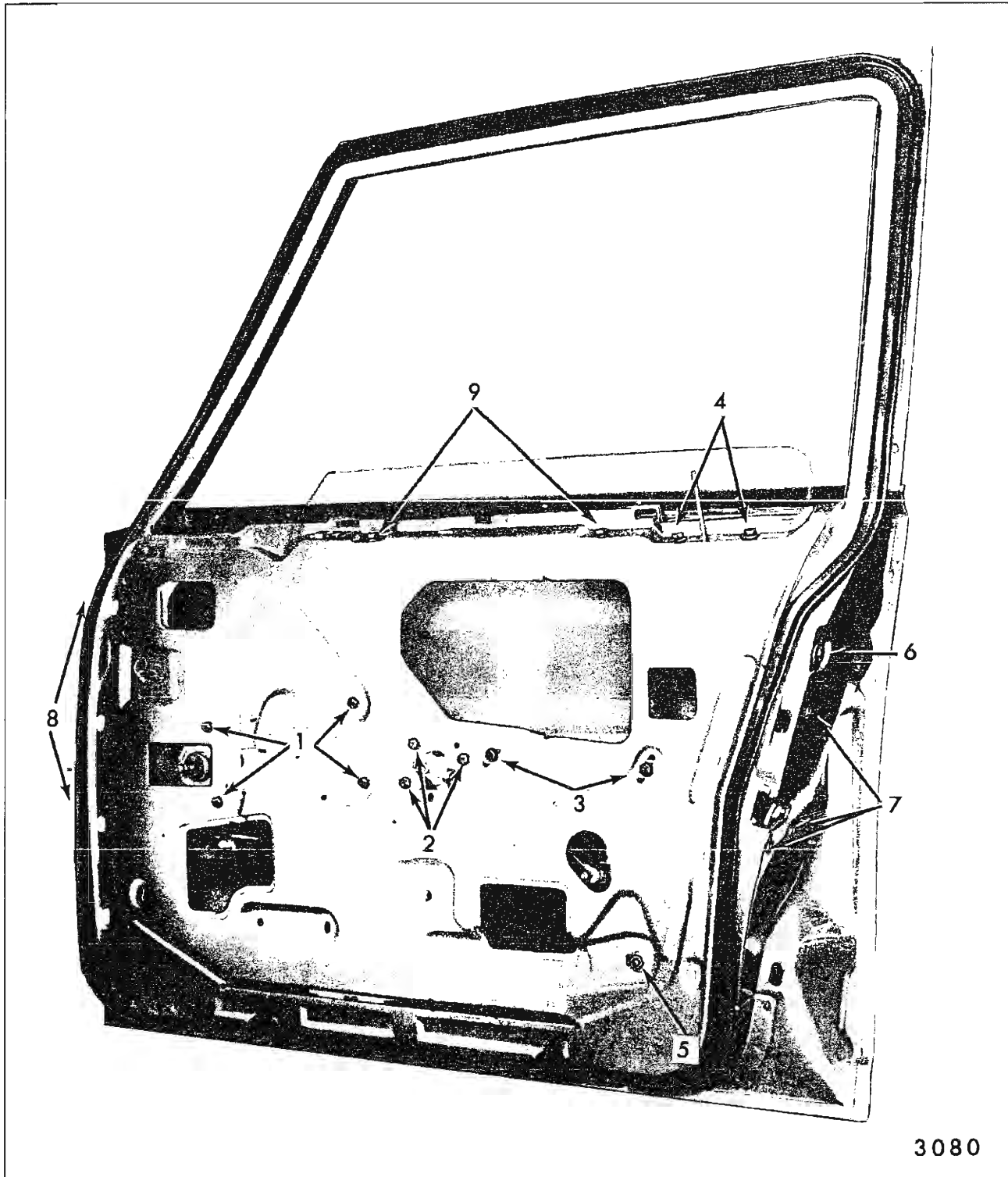
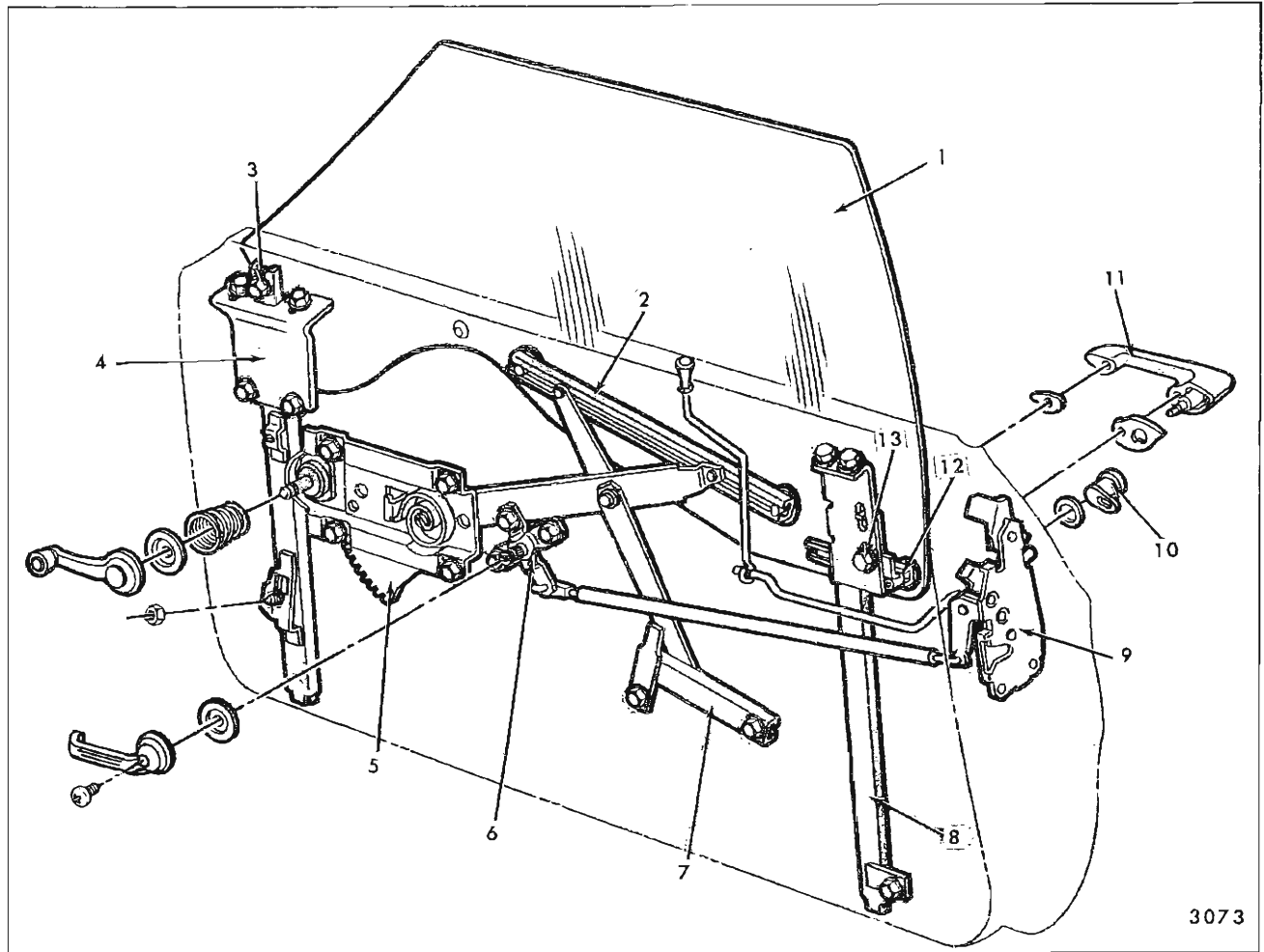

Fig. 6-46—Front Door Hardware - "B" Four Door Closed Styles

- |   |  |  |
|---|--|--|
| 1. Window Regulator Attaching Bolts         | 4. Rear Guide Upper Attaching Bolts      | 7. Door Lock Attaching Screws                              |
| 2. Door Lock Remote Control Attaching Bolts | 5. Rear Guide Lower Attaching Bolt       | 8. Glass Run Channel Front Upper and Lower Attaching Bolts |
| 3. Inner Panel Cam Attaching Bolts          | 6. Glass Run Channel Rear Attaching Bolt | 9. Window Stabilizer Strip Attaching Bolts                 |



3073

Fig. 6-47—Front Door Hardware - "B and C" Coupe Hardtop and Convertible Styles

1. Front Door Window Assembly
2. Lower Sash Channel Cam
3. Window Front Upper Stop
4. Front Guide
5. Window Regulator - Manual
6. Door Lock Remote Control
7. Inner Panel Cam
8. Rear Guide
9. Door Lock
10. Door Lock Cylinder
11. Door Outside Handle
12. Window Rear Upper Stop (on Window)
13. Window Rear Upper Stop (on Guide)

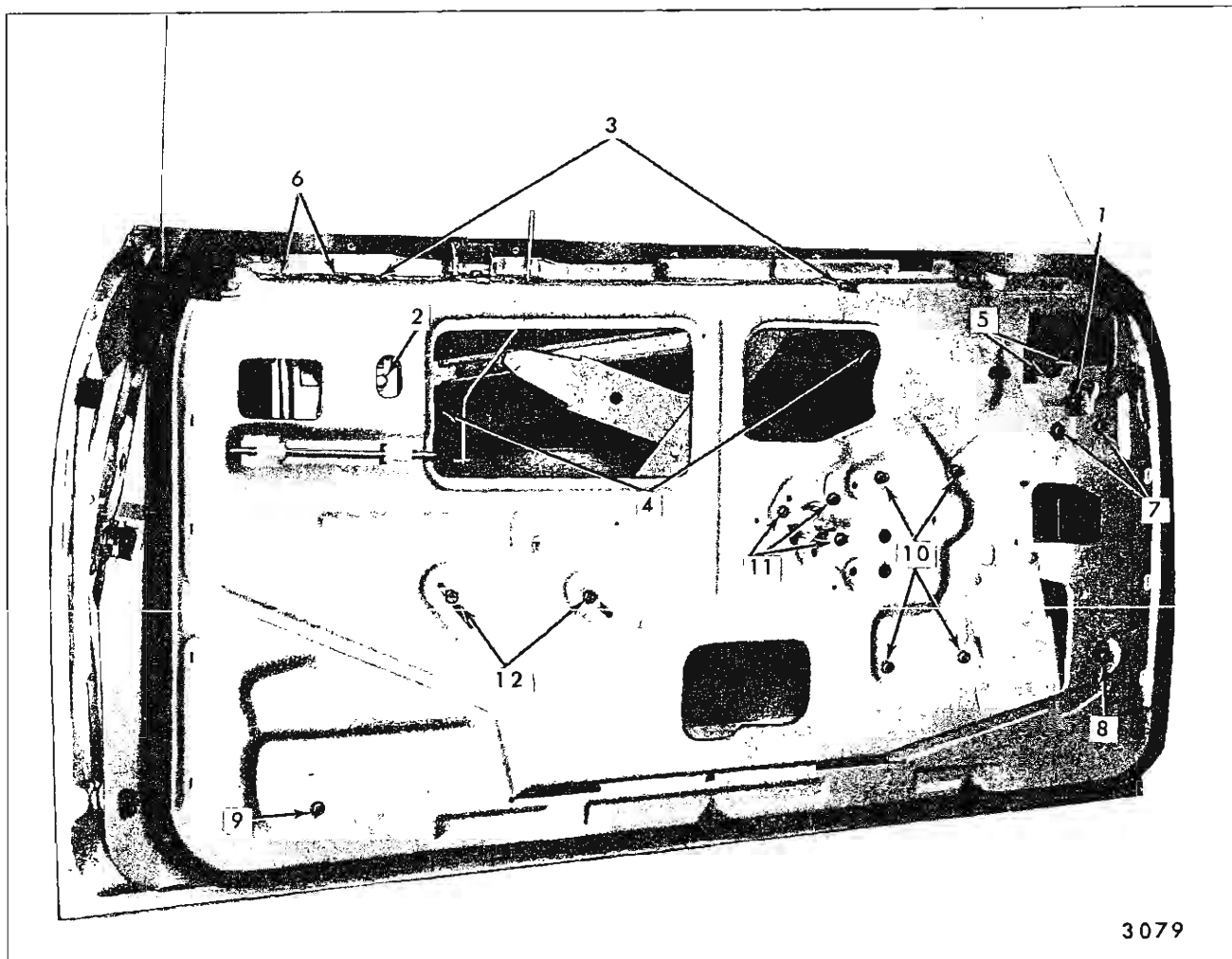

3079

Fig. 6-48—Front Door Hardware - "B and C" Coupe Hardtop and Convertible Styles

1. Window Front Upper Stop Attaching Bolt
2. Window Rear Upper Stop Attaching Bolt
3. Window Stabilizer Strip Assembly Attaching Bolts
4. Window Lower Sash Channel Cam Stud Nut Access Holes
5. Front Guide Upper Support Bracket Attaching Bolts
6. Rear Guide Upper Attaching Bolts
7. Front Guide to Upper Support Bracket Attaching Bolts
8. Front Guide Lower Attaching Bolt
9. Rear Guide Lower Attaching Bolt
10. Window Regulator Attaching Bolts
11. Door Lock Remote Control Attaching Bolts
12. Inner Panel Cam Attaching Bolts

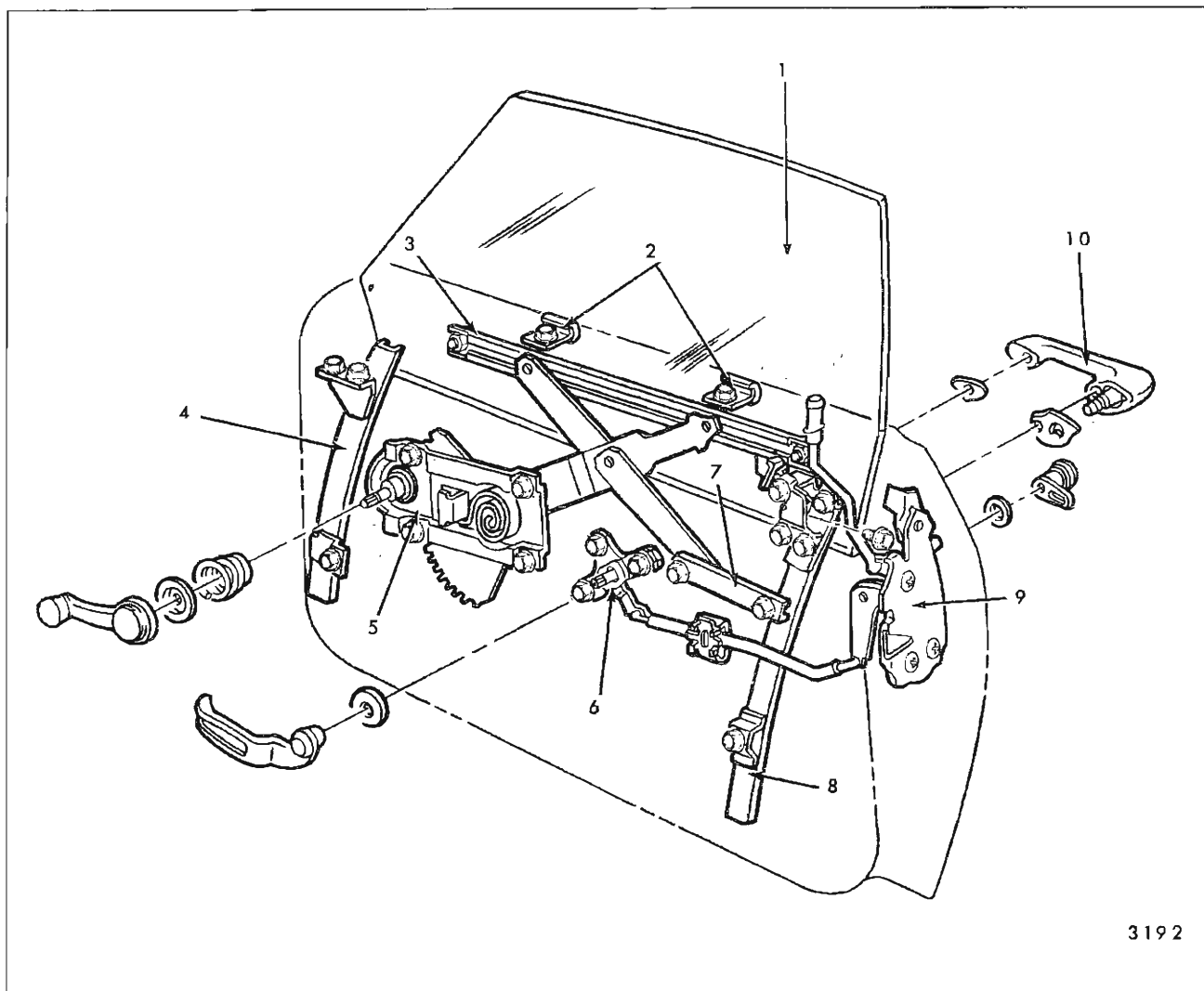

3192

Fig. 6-49—Front Door Hardware - "B-39" and "C-39, 49 and 69" Styles

1. Window Assembly
2. Stabilizer Strips
3. Lower Sash Channel Cam
4. Front Guide
5. Window Regulator
6. Door Lock Remote Control
7. Inner Panel Cam
8. Rear Guide
9. Door Lock
10. Door Outside Handle

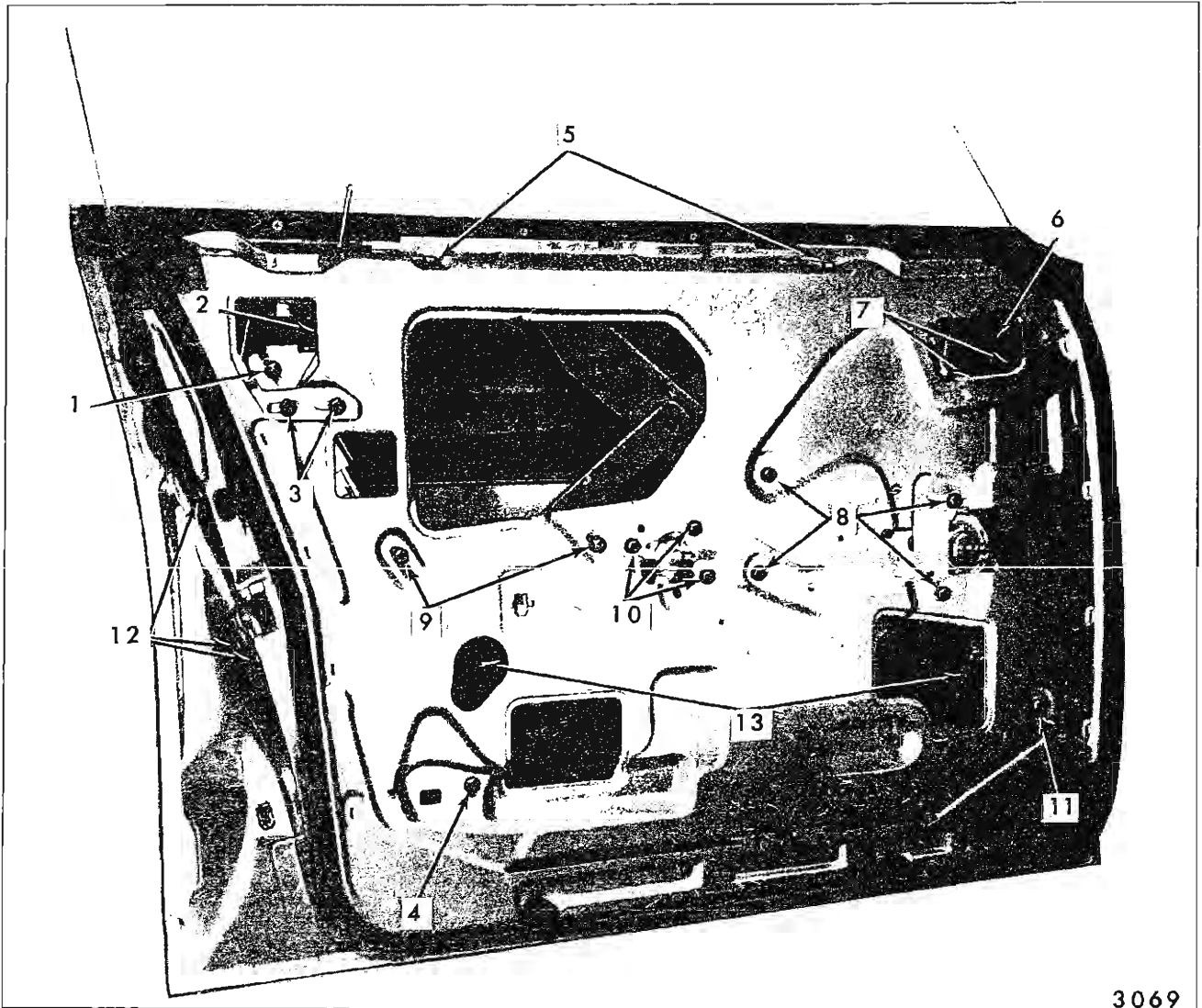

Fig. 6-50—Front Door Hardware - "B-39" and "C-39, 49 and 69" Styles

1. Window Rear Upper Stop Attaching Bolt
2. Rear Guide Upper Bracket Attaching Bolts
3. Rear Guide to Upper Bracket Attaching Bolts
4. Rear Guide Lower Attaching Bolt
5. Window Stabilizer Strip Attaching Bolts
6. Window Front Upper Stop Attaching Bolt
7. Front Guide Upper Attaching Bolts
8. Window Regulator Attaching Bolts
9. Inner Panel Cam Attaching Bolts
10. Door Lock Remote Control Attaching Bolts
11. Front Guide Lower Attaching Bolt
12. Door Lock Attaching Screws
13. Window Lower Sash Channel Cam Stud Nuts Access Holes



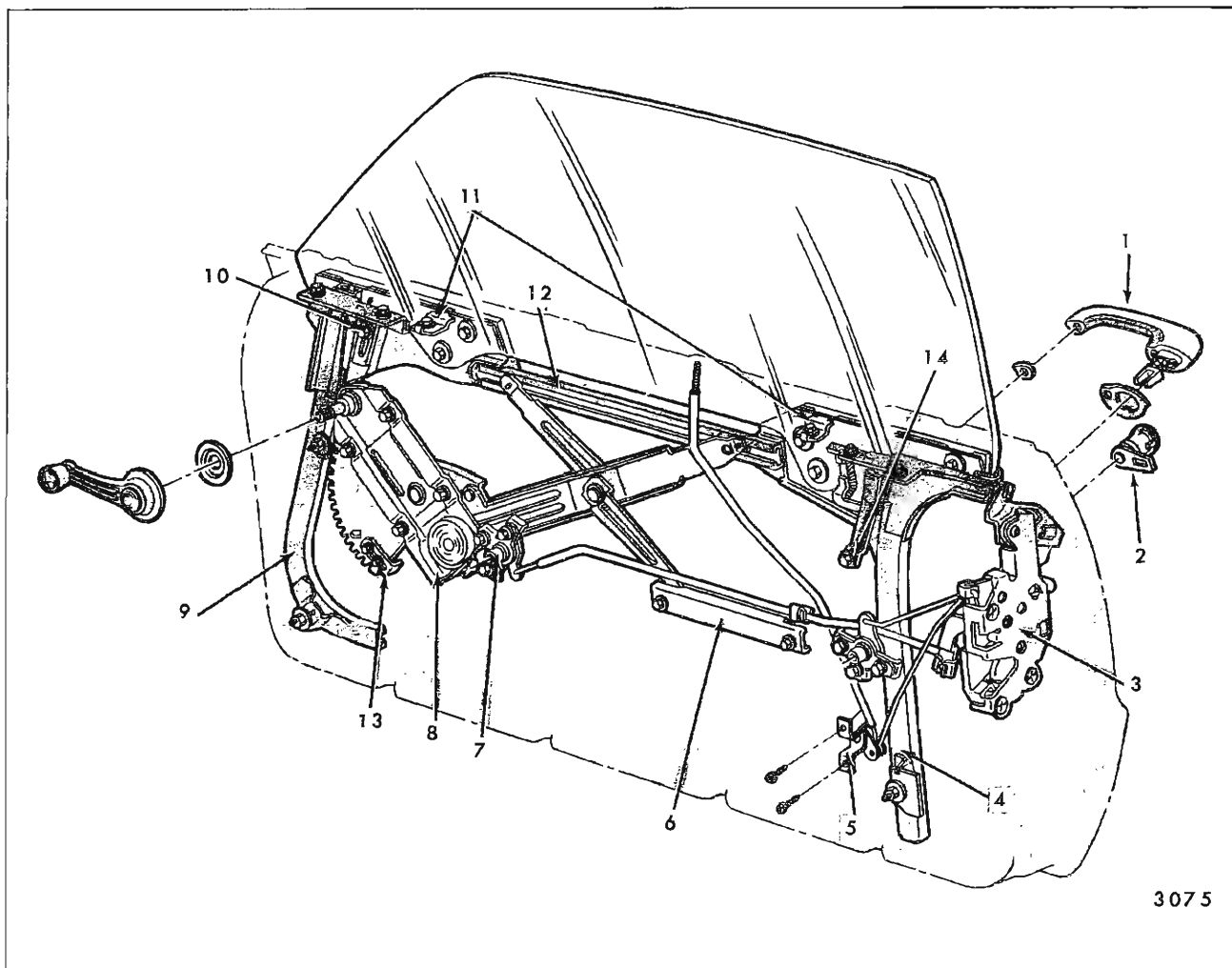
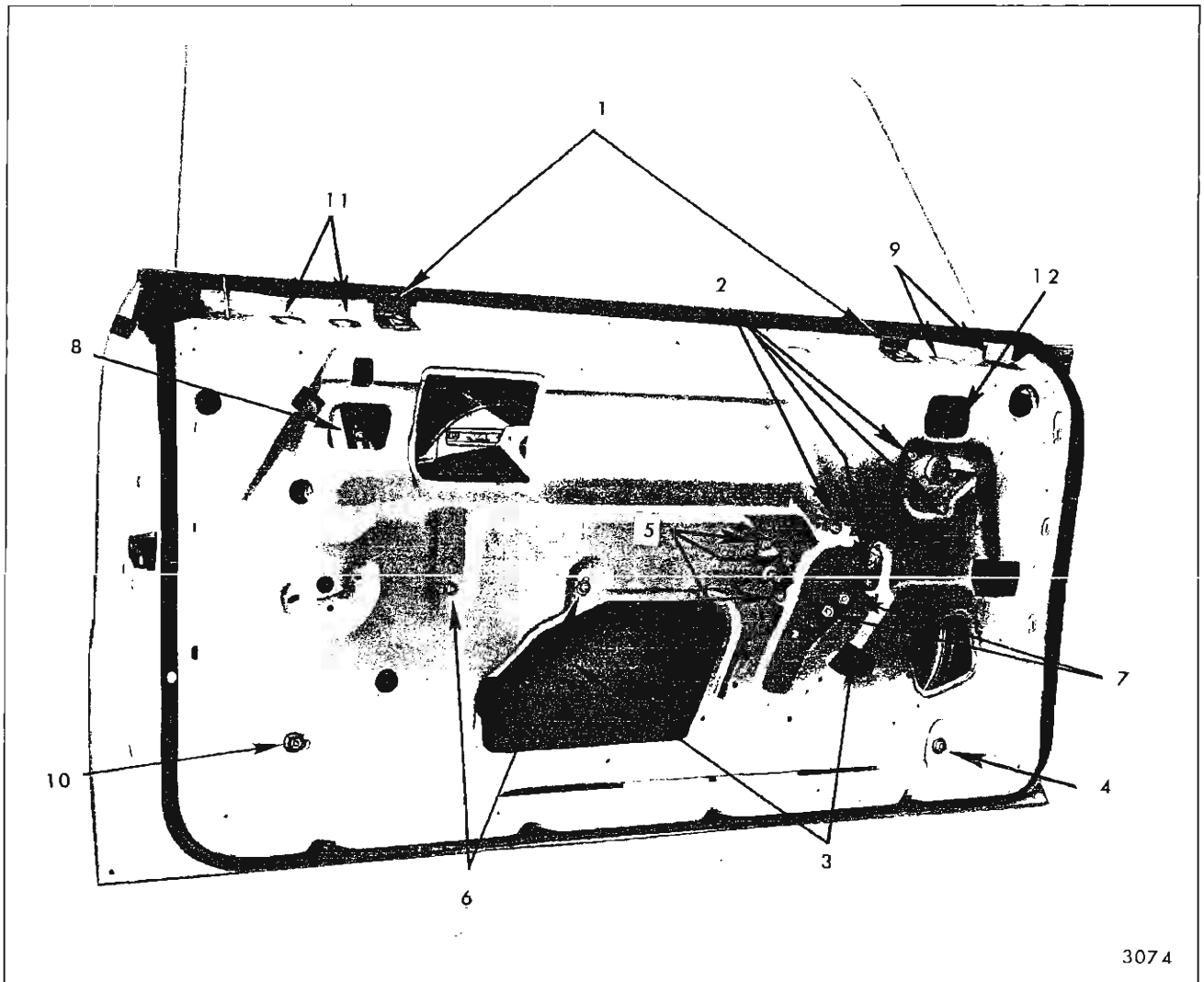

Fig. 6-51—Front Door Hardware - "E" Styles

1. Door Outside Handle
2. Lock Cylinder
3. Door Lock
4. Rear Guide
5. Inside Locking Rod to Lock Connecting Link
6. Inner Panel Cam
7. Door Lock Remote Control
8. Window Regulator
9. Front Guide
10. Window Front Up-Stop
11. Trim Pad Adjusting Plates
12. Lower Sash Channel Cam
13. Window Regulator Sector Stop (Manual)
14. Window Rear Up-Stop



3074

Fig. 6-52—Front Door Hardware - "E" Styles

1. Trim Pad Adjusting Plates
2. Window Regulator Attaching Bolts
3. Glass Sash Channel Attaching Screws Access Holes
4. Front Guide Lower Adjusting Stud and Nut
5. Remote Control (Standard) Attaching Bolts
6. Inner Panel Cam Attaching Bolts
7. Sector Gear Stop Bolts (manual only)
8. Window Rear Up-Travel Stop
9. Window Front Guide Upper Bolts
10. Rear Guide Lower Adjusting Stud and Nut
11. Window Rear Guide Upper Bolts
12. Window Front Up-Travel Stop

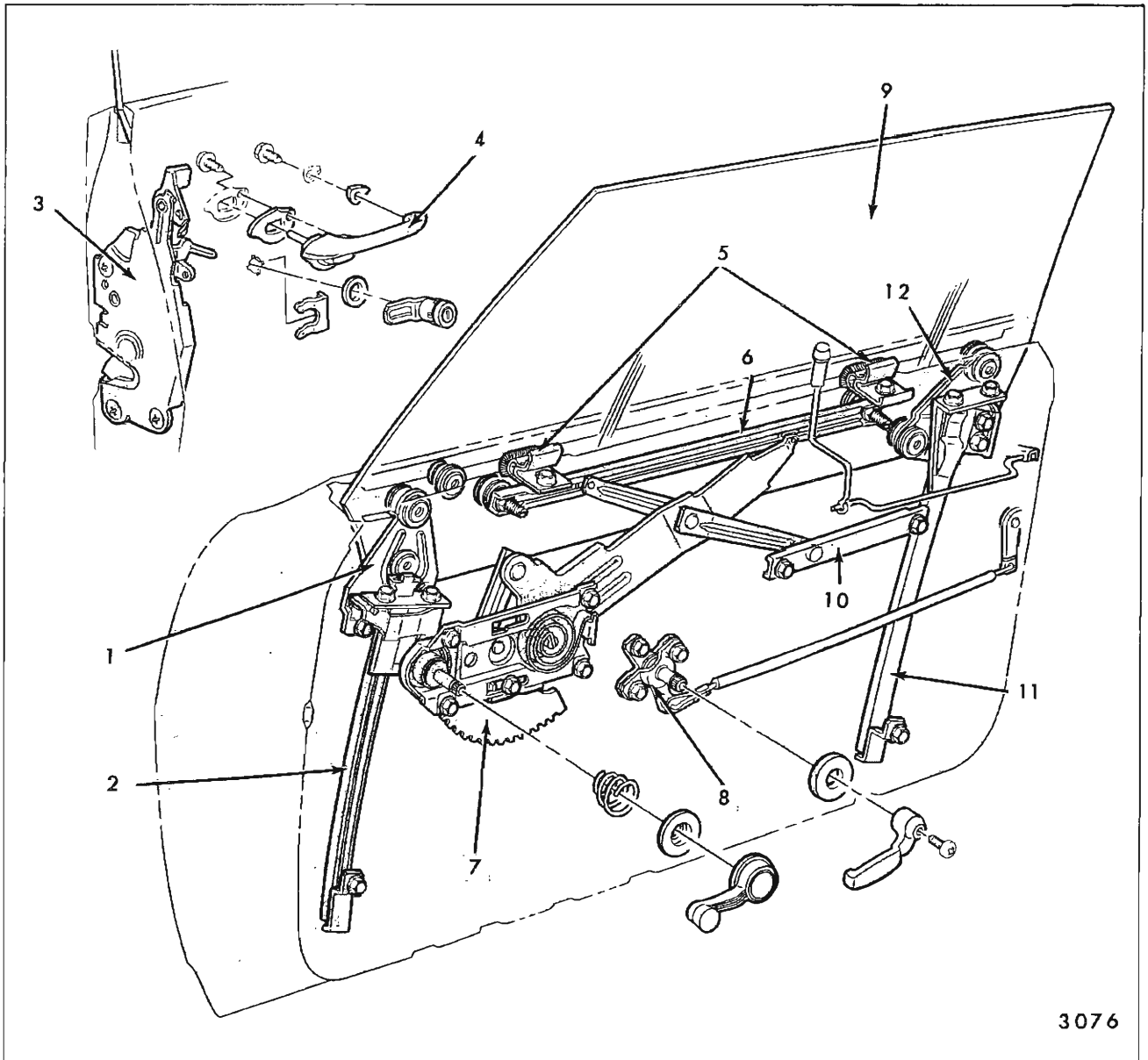

3076

Fig. 6-53—Front Door Hardware - "F" Styles

1. Front Lower Sash Channel and Window Roller Cam Assembly
2. Front Guide
3. Door Lock
4. Door Outside Handle
5. Stabilizer Strips
6. Lower Sash Channel Cam
7. Window Regulator
8. Door Lock Remote Control
9. Front Door Window Assembly
10. Inner Panel Cam
11. Rear Guide
12. Rear Lower Sash Channel and Window Roller Assembly

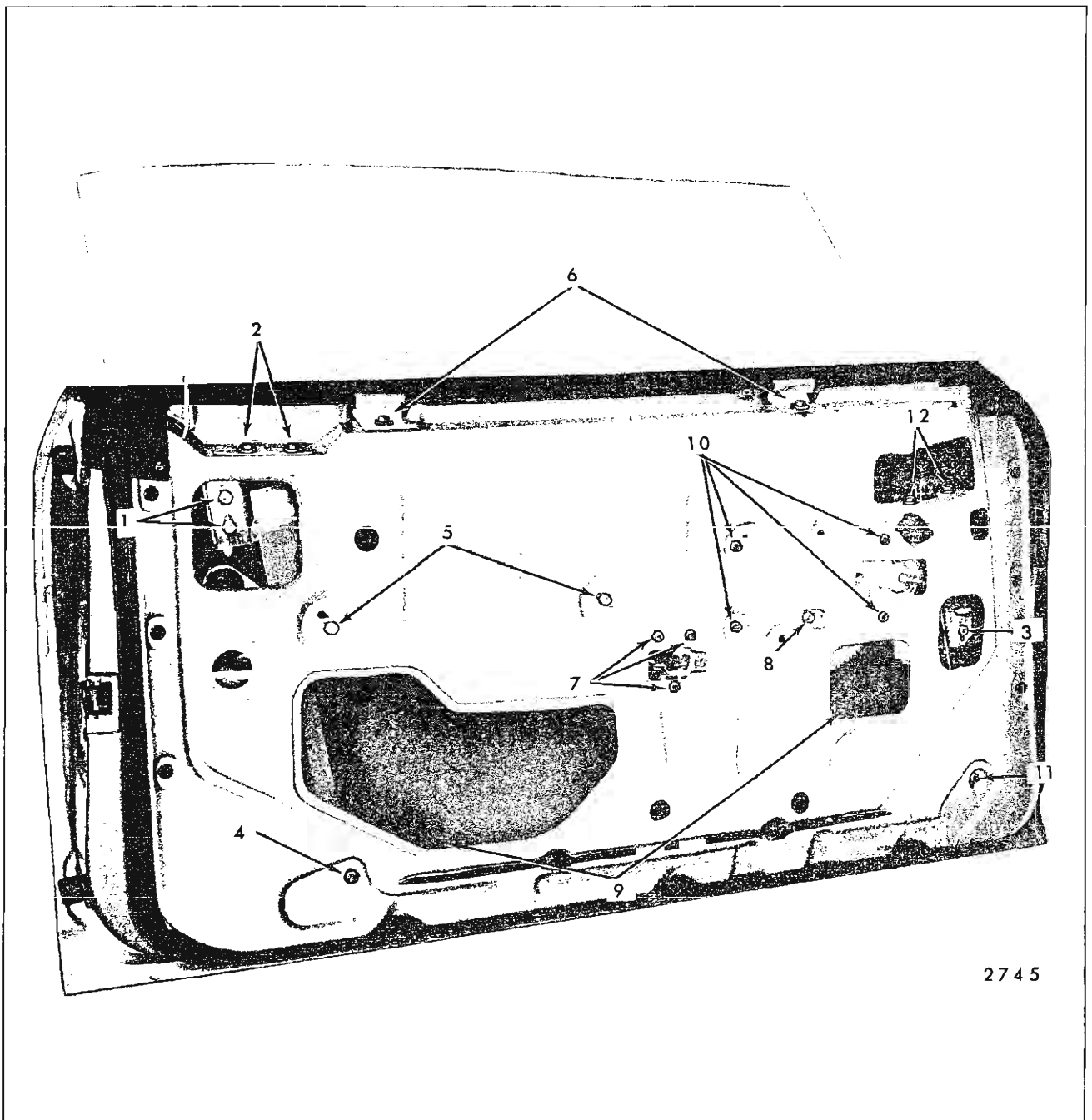

2745

Fig. 6-54—Front Door Hardware - "F" Styles

- |                                     |   |  |
|-------------------------------------|---|--|
| 1. Window Rear Up-Travel Stop       | 6. Window Front and Rear Stabilizer Strips  | 9. Window Lower Sash Channel Cam Stud Nut Access Holes |
| 2. Rear Guide Upper Attaching Bolts | 7. Door Lock Remote Control Attaching Bolts | 10. Window Regulator Attaching Bolts                   |
| 3. Window Front Up-Travel Stop      | 8. Sector Gear Stop Bolt                    | 11. Front Guide Lower Attaching Bolt                   |
| 4. Rear Guide Lower Attaching Bolt  |   | 12. Front Guide Upper Attaching Bolts                  |
| 5. Inner Panel Cam Attaching Bolts  |   |  |

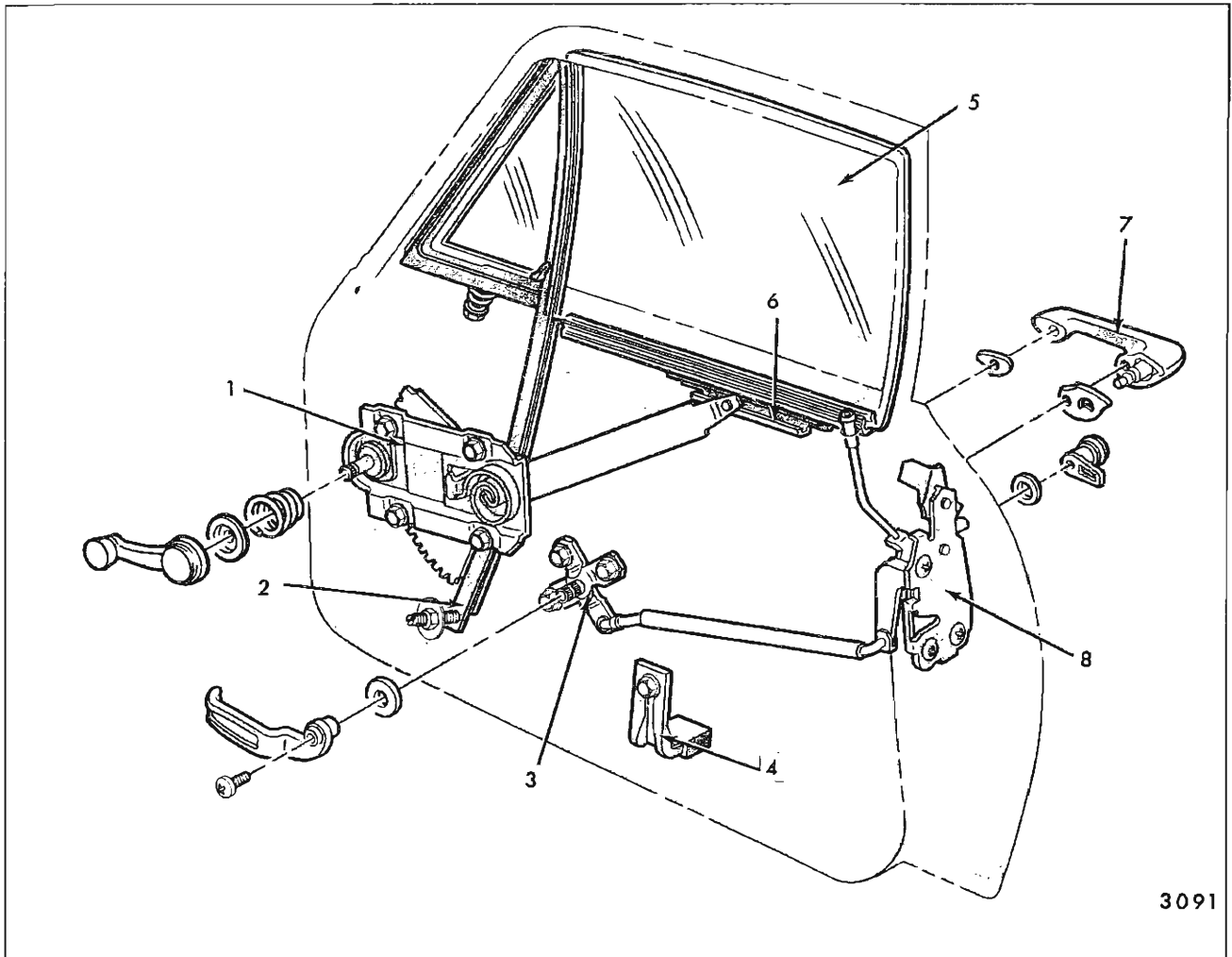
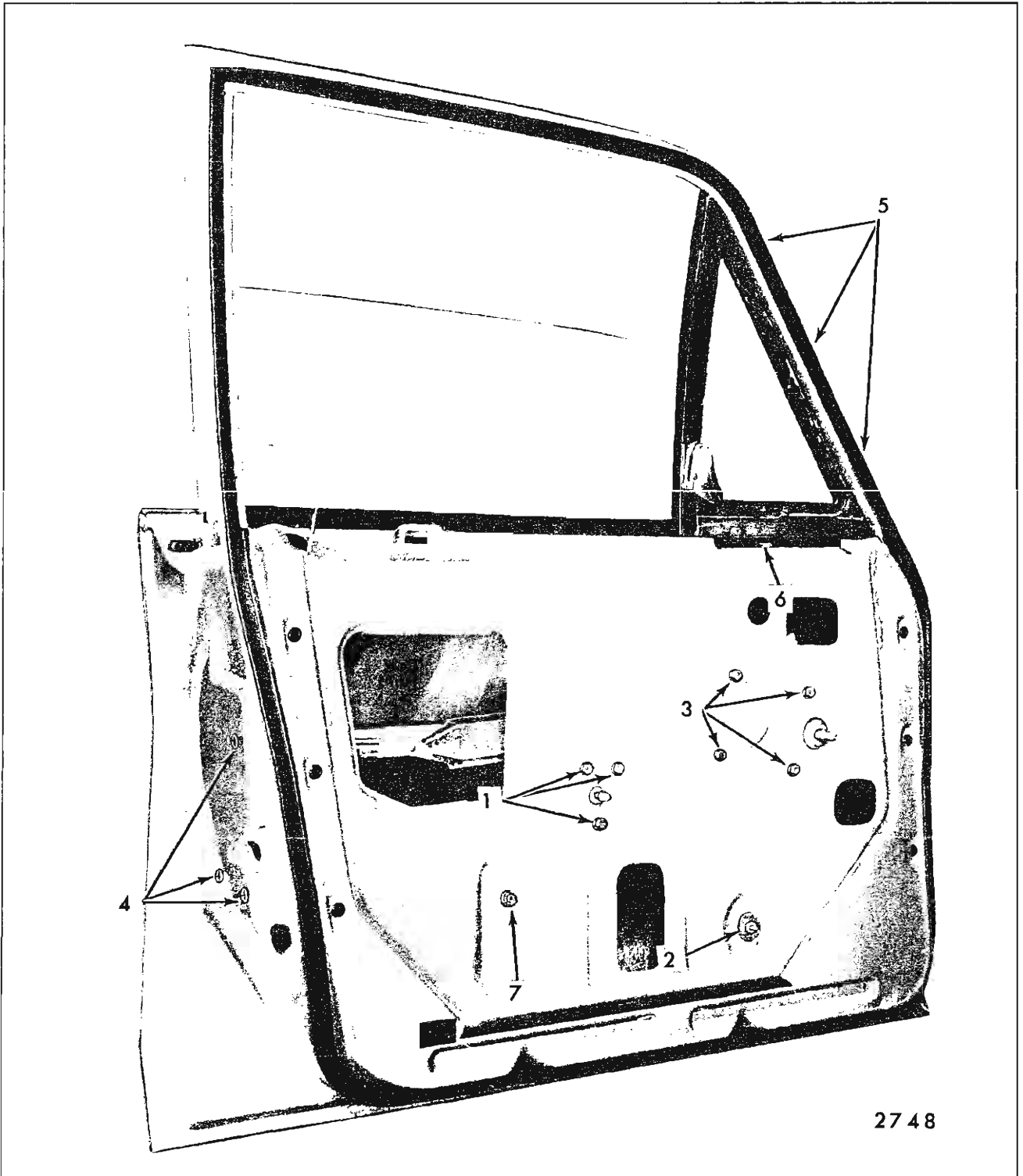

Fig. 6-55—Front Door Hardware - "X-69" Style Shown, "X-27" Style Similar

1. Window Regulator
2. Ventilator Division Channel
3. Door Lock Remote Control
4. Window Down-Travel Stop Support
5. Front Door Window Assembly
6. Lower Sash Channel Cam
7. Door Outside Handle
8. Door Lock



27 48

Fig. 6-56—Front Door Hardware - "X-69" Style Shown, "X-27" Style Similar

- |   |  |  |
|---|--|--|
| 1. Door Lock Remote Control Attaching Bolts         | 3. Window Regulator Attaching Bolts                      | 6. Ventilator Frame to Door Outer Panel Attaching Bolt |
| 2. Ventilator Division Channel Lower Adjusting Stud | 4. Door Lock Attaching Screws                            | 7. Window Down Stop Support Attaching Bolt             |
|   | 5. Door Upper Frame to Ventilator Frame Attaching Screws |  |

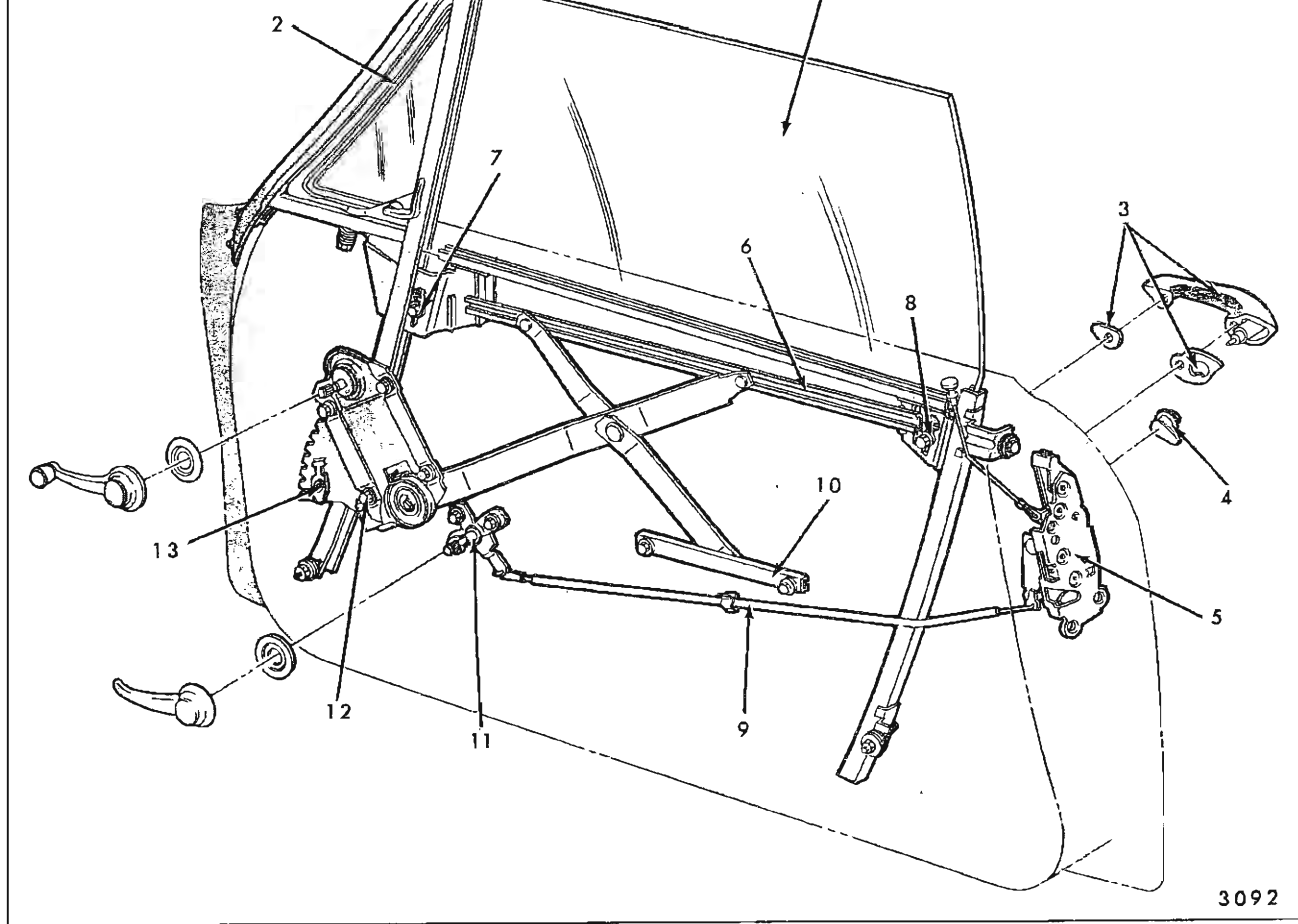

3092

Fig. 6-57—Front Door Hardware - "Z" Styles

1. Window Assembly
2. Ventilator Assembly
3. Outside Handle and Sealing Gaskets
4. Lock Cylinder
5. Lock
6. Sash Channel Cam
7. Window Front Up-Travel Stop
8. Window Rear Up-Travel Stop
9. Remote Control Connecting Rod
10. Inner Panel Cam
11. Remote Control
12. Window Regulator
13. Sector Gear Up-Stop

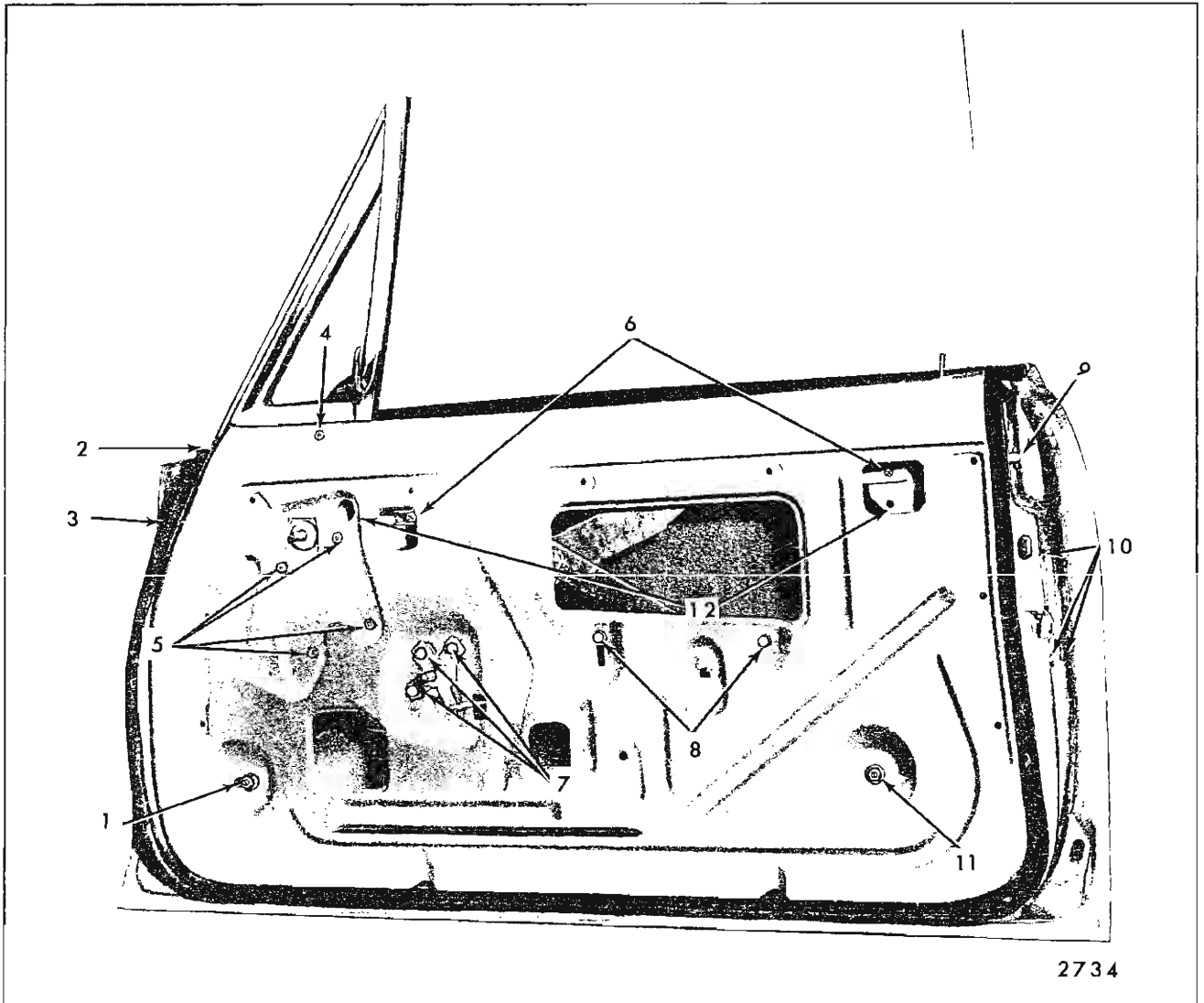

2734

Fig. 6-58—Front Door Hardware - "Z" Styles

- |   |   |   |
|---|---|---|
| 1. Ventilator Division Channel Lower Adjusting Stud     | 5. Window Regulator Attaching Bolts               | 9. Rear Glass Run Channel Upper Attaching Bolt          |
| 2. Ventilator Frame Attaching Bolt                      | 6. Window Lower Sash Channel Cam Attaching Screws | 10. Door Lock Attaching Screws                          |
| 3. Ventilator Frame Lower Adjusting Stud                | 7. Door Lock Remote Control Attaching Bolts       | 11. Rear Glass Run Channel Lower Adjusting Stud and Nut |
| 4. Door Inner Panel to Ventilator Frame Attaching Screw | 8. Inner Panel Cam Attaching Bolts                | 12. Window Front and Rear Upper Stops Access Holes      |



## FRONT DOOR HINGES

All hinges are constructed of steel, except the "Z" style lower hinge door-side strap which is constructed of malleable iron. A two stage hold-open feature is incorporated in all lower hinges, except on "B and C" styles. On "B and C" styles, the two stage hold-open feature is incorporated into the upper hinge.

The front door is mounted to the front body hinge pillar with an upper and lower hinge. Figure 6-59 illustrates typical front door hinge installation. On "E" styles, the hinges are the "swing-out" type, which means that the leading edge of the door swings outboard of the front fender when the door is opened. All other styles use "swing-in" type hinges, which means the leading edge of the door swings inboard of the front fender when opened.

Although the door can be removed from the body with or without the hinges attached to the door, it is recommended that when removing the door only, remove the door from the hinges. Accessibility to the door side hinge bolts is better than to the body side bolts.

When servicing both door hinges, remove the door from the hinges, then the hinges from the body. When servicing only one hinge, however, make replacement while supporting the door in the open position.

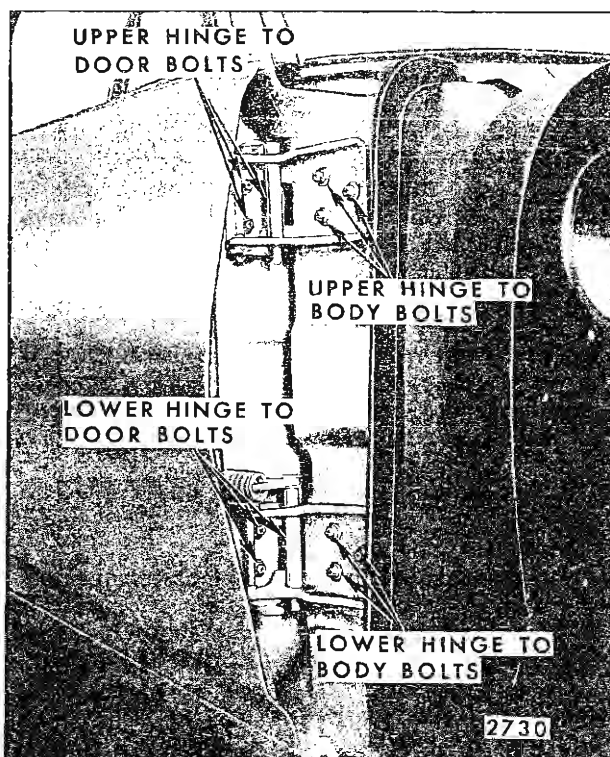

Fig. 6-59—Typical Front Door Hinge Attachment

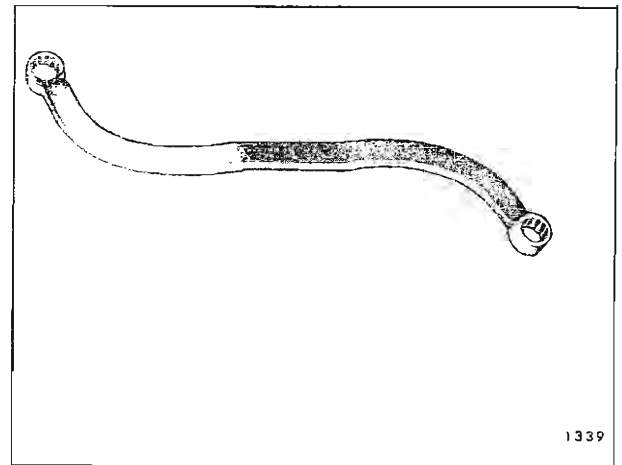

Fig. 6-60—Front Door Hinge Tool J-21550 (1/2" Box) - "F, X & Z" Styles

## Door Removal and Installation

1. Prior to loosening any hinge bolts, mark position of hinge on door to facilitate adjustment when reinstalling door on hinge.
2. For removal or adjustment of front door hinge to body attaching bolts, use tools outlined below:
  - a. On "F, X & Z" body styles, use tool J-21550 - 1/2" wrench (Figure 6-60).
  - b. On "A, B & C" body styles, use tool J-22810 - 1/2" wrench (Figure 6-61).
  - c. On "E" body styles, use tool J-22729 - 9/16" wrench (Figure 6-62).

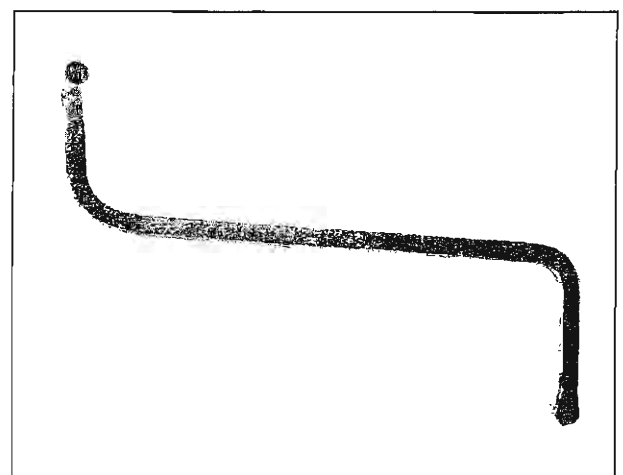

Fig. 6-61—Front Door Hinge Tool J-22810 - "A, B & C" Styles

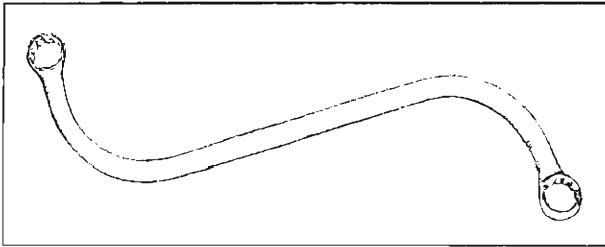

Fig. 6-62—Front Door Hinge Tool J-22729  
(9/16" Box) - "E" Styles

- On doors equipped with power operated windows and/or door locks, remove trim pad and detach inner panel water deflector sufficiently to disconnect harness assembly(ies) and remove same from door.

### Hinge Removal

- If both hinges are to be removed, remove front door as previously described. Mark position of hinge on body hinge pillar and remove hinge to body hinge pillar attaching bolts (Figure 6-59).

**NOTE:** On "E" body styles, loosen front fender lower attaching bolts as required to permit usage of a wrench when removing lower hinge lower attaching bolts (Fig. 6-63). Car Division Publications should, however, be referenced prior to any movement of front end sheet metal.

**NOTE:** All "E" body doors are equipped with a torque rod to ease door opening effort (Figure 6-64). This torque rod is secured under the upper hinge lower rearward bolt, body side, on right and left front doors. The lower end of rod is retained by the lower hinge box. Removal and installation of this rod usually requires loosening of front fenders. Remove rod with door fully opened, when tension on rod is relieved.

- With the aid of a helper to support door, remove upper and lower hinge to door attaching bolts (Figure 6-59) and remove door from body.

**NOTE:** On all styles except "E" body, removal of door from body with or without hinges attached can be accomplished without loosening front fender. On "E" body styles, removal of lower hinge from body hinge pillar necessitates loosening fender along lower edge (Figure 6-63).

- To install door, reverse removal procedure. Prior to installation, apply a coat of heavy body sealer to surface of hinge that contacts door for protection against corrosion.

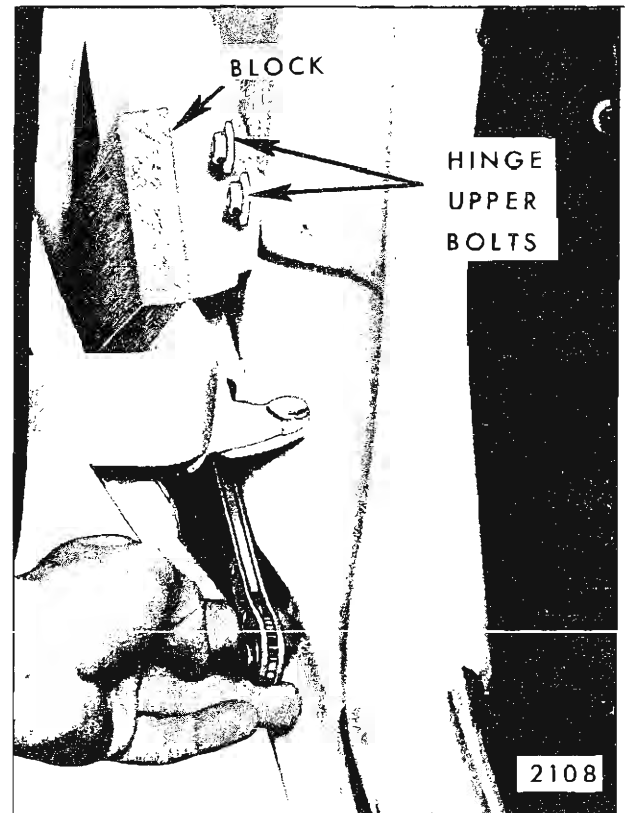

Fig. 6-63—Front Door Hinge Removal - "E" Styles

### Front Door Hinge Adjustment

Door adjustments are provided through the use of floating anchor plates in the door and front hinge pillars. When checking the door for alignment, and prior to making any adjustments, remove door lock striker from body to allow door to hang freely on its hinges. Loosen front fender where required.

**NOTE:** When making door adjustments, refer to the door gap spacing and lock striker engagement specifications in the "Front and Rear Door" section of this manual.

- Adjustments provided at body hinge pillars - up and down and fore and aft on all body styles.
- Adjustments provided at door hinge pillars - in and out on all body styles.

### INSIDE LOCKING ROD—Coupe Styles

#### Removal and Installation

- Remove door trim assembly and inner panel water deflector.

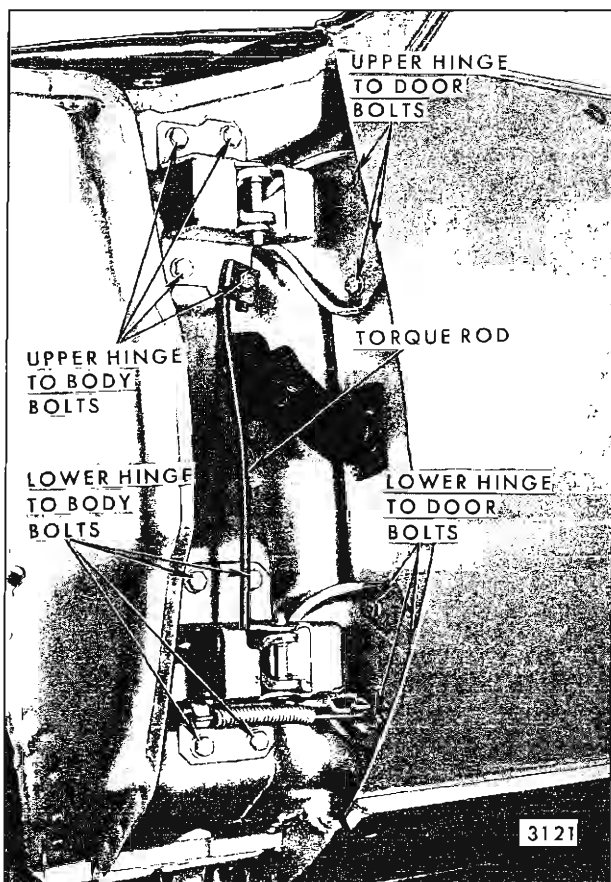

Fig. 6-64—Front Door Hinge and Torque Rod Installation - "E" Styles

2. Slide inside locking rod to door inner panel plastic retainers in direction of arrows shown in Figure 6-65.
3. Disengage rod from lock and lower locking rod through belt line to remove.
4. To install, reverse removal procedure.

### FRONT DOOR LOCK REMOTE CONTROL AND CONNECTING ROD

There are three basic types of remote controls; spindle type (Figure 6-50), inward acting type (Figure 6-54) and squeeze type ("G" Body only, Figure 6-42).

All remote controls are secured to the door inner panel by three attaching bolts. On some styles, the remote is attached to the inboard surface of the inner panel and on other styles to the outboard surface. The removal and installation is similar, however, for either method of attachment.

### Removal and Installation

1. Raise door window, remove door trim pad and detach inner panel water deflector.

**NOTE:** Some "E" body styles are equipped with two remote controls, one front and one rear. Attachment of both is the same; however, removal procedures differ in that the forward remote (standard equipment) is located in such close proximity to the window regulator that regulator must first be loosened. This can be accomplished by removing three of the four regulator to inner panel attaching bolts and pivoting regulator to a position that remote can be removed (See Figure 6-38). On "B & C" hardtop and convertible styles, remove window regulator two rear attaching bolts and loosen front attaching bolts (Figure 6-50).

2. Remove bolts securing remote control to door inner panel (Figure 6-50).
3. Inside of door, pivot remote control to disengage lock connecting rod and remove remote through access hole.

**NOTE:** On "B" closed styles, remove rubber bumper from down stop support bracket and remote control to lock rod anti-rattle clip.

4. If remote control to lock connecting rod is to

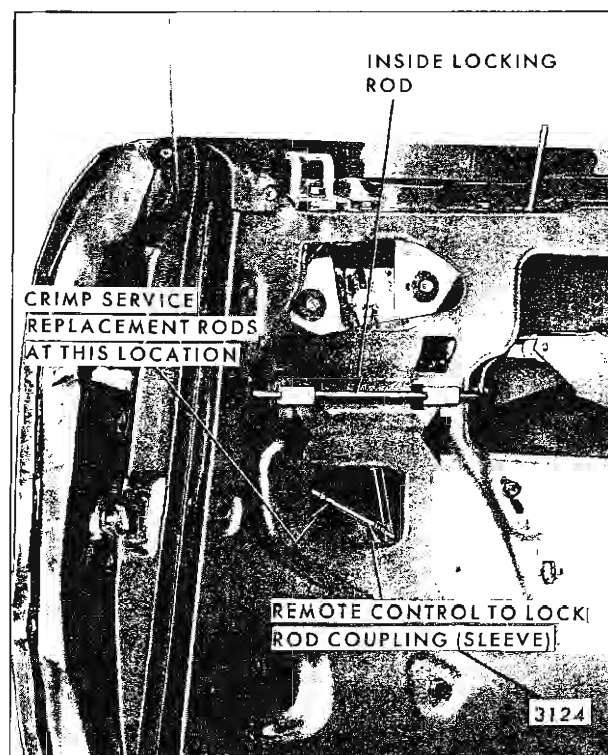

Fig. 6-65—Front Door Inside Locking Rod - Coupe Styles

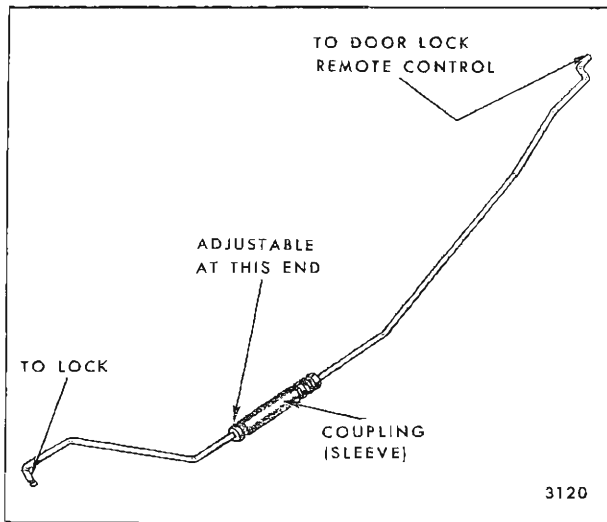

Fig. 6-66—Door Lock Remote Control to Lock Connecting Rod - "G" Styles

be removed, refer to "Front and Rear Door" section for method of disengaging spring clip at lock end of rod.

**NOTE:** Due to the limited operating travel of the squeeze type remote control handle on "G" styles, an adjustable remote control to lock rod coupling (sleeve, Figure 6-65) is utilized to insure proper locking operation.

The overall length of the "G" body remote control to lock rod can be reduced, to correct insufficient travel of the remote handle to unlock the door, by removing the rod assembly and turning the portion of the rod between the coupling and lock assembly clockwise (Refer to Figure 6-66). To increase the rod assembly length, turn counterclockwise. Proper rod length is determined to be correct when the connecting rod assembly aligns with the attaching holes in the door lock remote control and lock assembly.

Service Replacement "G" body remote control to lock rods are uncrimped at the adjustable end of the coupling (Figure 6-66). This permits the rod to telescope to the desired length when installing, but necessitates crimping of the coupling after installation. Crimping can be done with a pair of diagonal cutters or comparable tool to insure proper locking operation (Refer to Figure 6-65 for crimping location).

5. To install, reverse removal procedure.

## FRONT DOOR LOCK ASSEMBLY

All styles use the fork bolt lock design which includes a safety interlock feature. Where necessary, striker spacers should be used to insure

satisfactory lock and striker engagement. Refer to "Front and Rear Door" section for spacer usage.

**NOTE:** Figure 6-67 depicts a typical front door lock assembly which can be used for identifying locking problems. Do not attempt repairs to correct lock discrepancies. Make corrections through replacement of lock assembly.

### Removal and Installation

1. Raise door window, remove trim pad and detach inner panel water deflector.
2. Working through large access hole, disengage remote control to lock connecting rod at lock as specified under "Door Lock Spring Clips" in the preceding "Front and Rear Door" section.

**NOTE:** On coupe styles, it may be necessary to remove the inside locking rod.

3. On styles equipped with vacuum or electric door locks, remove the vacuum actuator or electric solenoid as described in the "Front and Rear Door" section.
4. Remove three screws securing lock to door lock pillar ("1", Figure 6-40) and remove lock assembly from door.

**NOTE:** On four-door styles, the design of the lock to inside locking rod attaching clip does not allow disengagement of rod from lock with lock in an installed position. This rod can be removed from lock in a bench operation after removal of lock assembly.

5. To install, reverse removal procedure.

## FRONT DOOR LOCK CYLINDER ASSEMBLY

### Removal and Installation

1. Remove door trim assembly and partially detach inner panel water deflector. Raise door window.
2. With a screwdriver or other comparable tool, slide lock cylinder retaining clip (on door outer panel) out of engagement and remove lock cylinder from door (Figure 6-68).
3. To install, reverse removal procedure.

### Disassembly and Assembly

1. Remove lock cylinder from door as previously described.

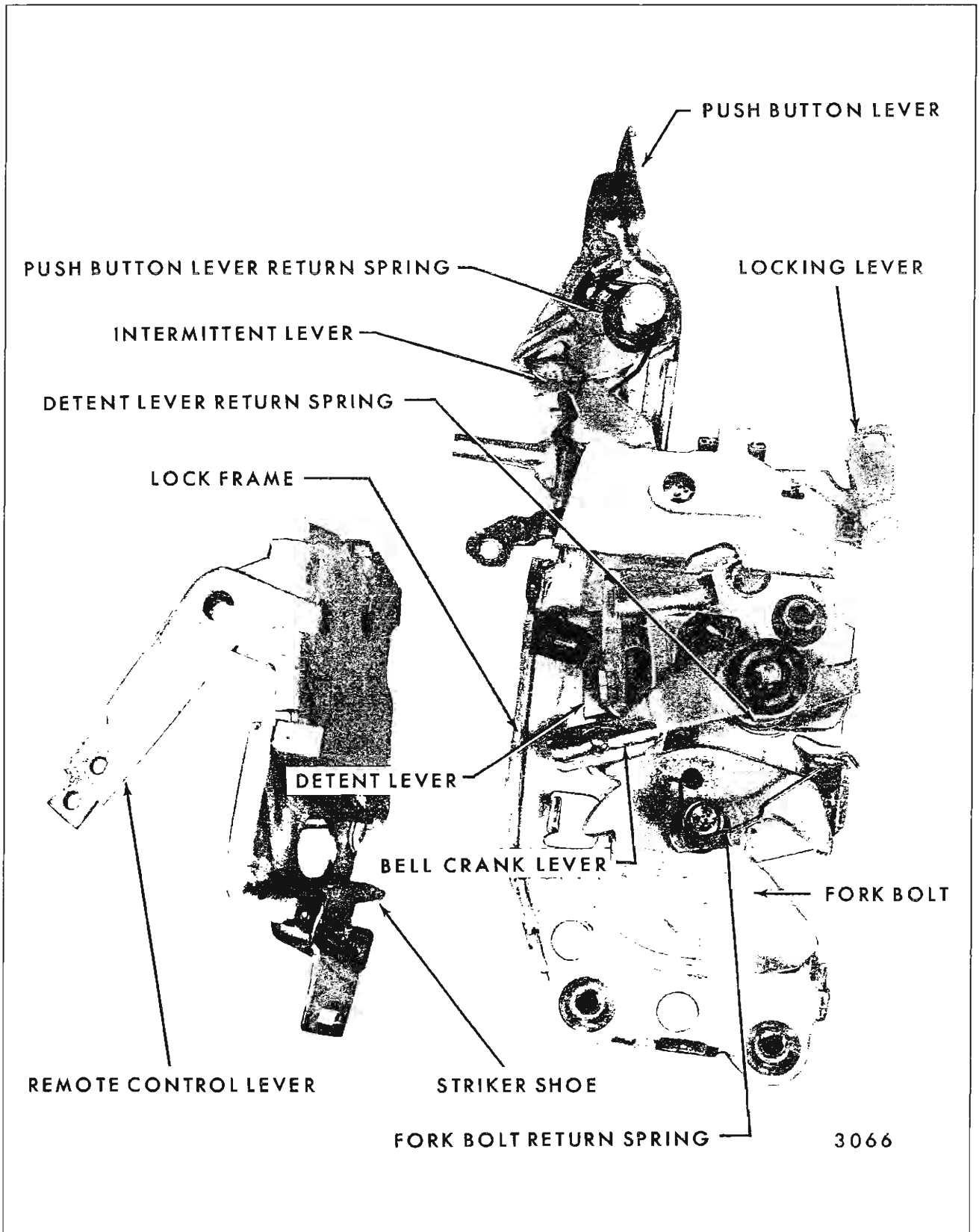

Fig. 6-67—Front Door Lock Assembly - All Styles

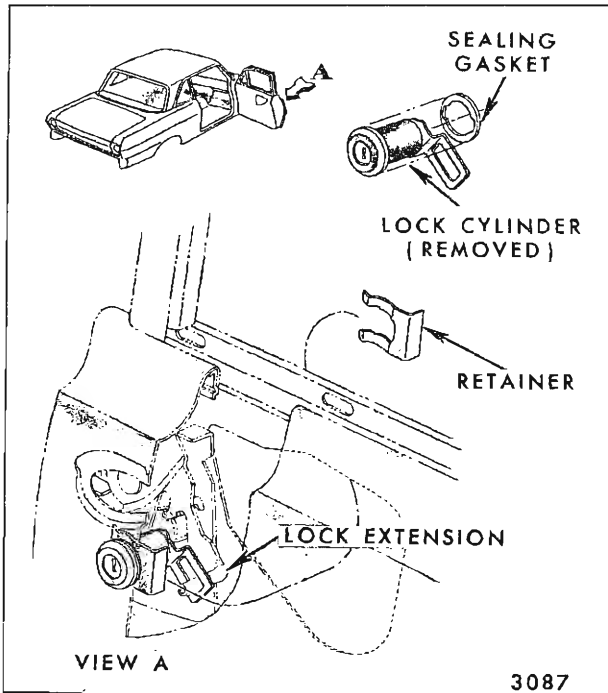

Fig. 6-68—Front Door Lock Cylinder Removal - All Styles

2. With a pointed tool, disengage pawl retaining clip and remove pawl (Figure 6-69).
3. With a flat-bladed tool, straighten out crimped-over edges of lock cylinder housing scalp and remove scalp and lock cylinder from housing.

**NOTE:** Refer to General Information Index (Section 1 of this manual) for lock cylinder coding.

4. To install, reverse removal procedure.

**NOTE:** The lock cylinder housing scalp is usually damaged in the removal procedure and, therefore, must be replaced. Replacement scalps are available as service parts.

### DOOR OUTSIDE REMOTE CONTROL MIRROR—All Styles Without Door Ventilators

#### Removal and Installation

1. Remove door trim assembly and detach inner

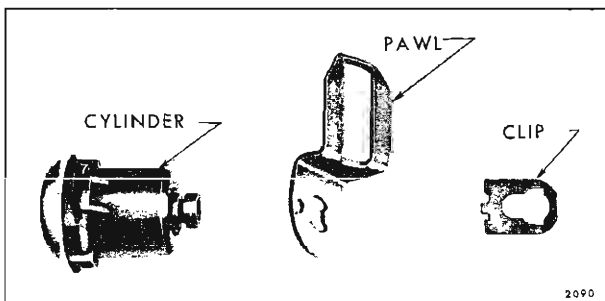

Fig. 6-69—Door Lock Cylinder Assembly

panel water deflector sufficiently to gain access to remote control mirror cable.

2. On all styles except Cadillac and Pontiac styles remove remote control mirror to door outer panel attaching screw(s) in base of mirror. On Cadillac and Pontiac styles, remove remote control mirror to door outer panel stud nuts from inside door.
3. Detach mirror cable from retaining tabs or hog rings where used and remove mirror and cable assembly from door.
4. To install, reverse removal procedure.

### FRONT DOOR INNER PANEL CAM—All Except "A & X-69" Styles

#### Removal and Installation

1. Remove door trim assembly and detach inner panel water deflector.
2. With window in raised position, remove cam attaching bolts (Figure 6-50) and slide cam off regulator balance arm roller.

**NOTE:** Figure 6-50 depicts "B & C" styles - other styles similar.

3. To install, reverse removal procedure.

**NOTE:** One end of the cam has provisions for up and down adjustment to correct a "cocked" window (not parallel with top of door upper frame or side roof rail weatherstrips).

### FRONT DOOR VENTILATOR REGULATOR—"A" Styles

#### Removal and Installation

1. With front door window in full-up position, remove door trim assembly and partially detach inner panel water deflector.
2. Remove ventilator T-shaft bolt ("6", Figure 6-70) and ventilator regulator to inner panel attaching bolts ("4", Figure 6-70).
3. Pull regulator down to disengage from ventilator T-shaft and remove regulator through access hole.
4. To install, reverse removal procedure.

### FRONT DOOR VENTILATOR ASSEMBLY—"A" Closed Styles

#### Removal and Installation

1. Remove door trim assembly and inner panel water deflector.

2. With window in up position, loosen down stop support attaching bolts and remove support ("2", Figure 6-70).
3. Remove ventilator regulator as previously described.
4. Lower window to full down position and remove bolt securing ventilator lower frame to door outer panel ("4", Figure 6-70).
5. Remove division channel lower adjusting stud nut ("1", Figure 6-70).
6. Remove ventilator to door upper frame attaching screws ("3", Figure 6-70). Disengage upper front end of glass run channel from door upper frame to permit rearward movement and removal of vent from door upper frame (refer to glass run channel removal procedure).
7. Tilt vent assembly rearward and remove vent inboard of door upper frame.

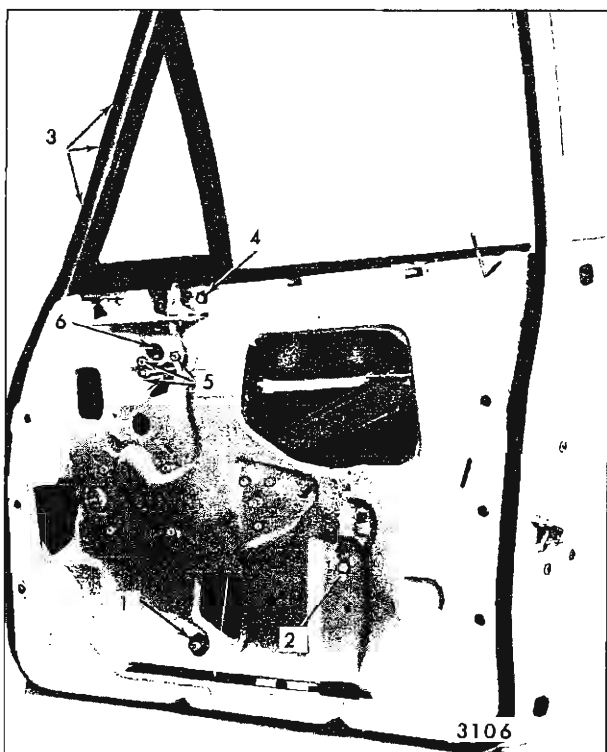

Fig. 6-70—Front Door Ventilator and Window Removal and Adjustments - "A" Closed Styles

1. Ventilator Division Channel Lower Adjusting Stud
2. Window Down Stop Support Attaching Bolt
3. Ventilator to Door Upper Frame Attaching Screws
4. Ventilator Frame to Door Outer Panel Attaching Bolt
5. Ventilator Regulator Attaching Bolts
6. Ventilator Regulator to "T-Shaft" Attaching Bolt Access Hole

8. To install, reverse removal procedure.

### Adjustments

Some in-and-out, or fore-and-aft adjustment of the ventilator division channel is available at the lower adjusting stud ("1", Figure 6-70). Adjustment at this location is required only to eliminate any misalignment between the ventilator division channel and window glass run channel.

### VENTILATOR DISASSEMBLY AND ASSEMBLY—"A" Closed Styles

The ventilator front frame is attached to the division channel with rivets at the bottom and a screw at the top (Figure 6-71).

The parts that can be replaced are the division channel strip assembly, ventilator weatherstrip (on division channel) and the vent glass.

### FRONT DOOR VENTILATOR ASSEMBLY—"A-39" Styles

#### Removal and Installation

1. Remove door window and ventilator regulator (see index for removal procedures).
2. Remove ventilator frame to door panel bolts

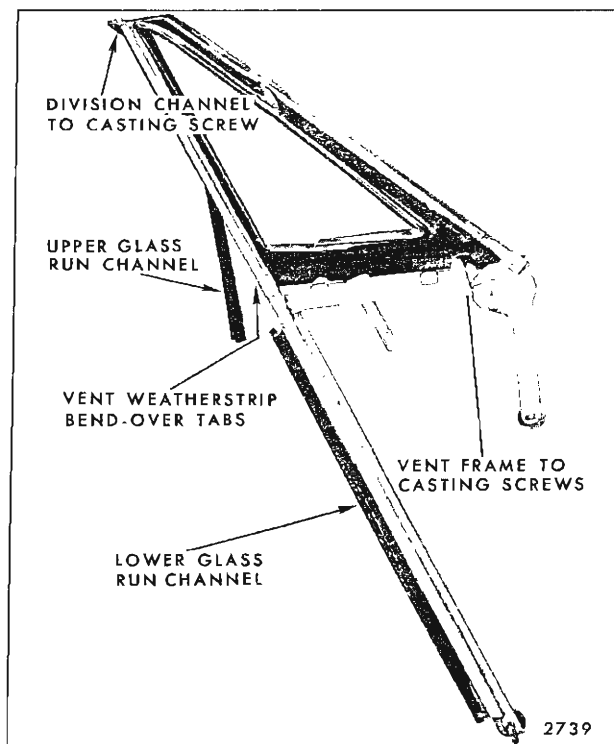

Fig. 6-71—Front Door Ventilator Assembly - "A" Closed Styles

("1", Figure 6-72) and trim pad hanger plate retained by rear bolt.

3. Remove ventilator lower frame adjusting stud ("2", Figure 6-72).
4. Remove division channel lower adjusting stud ("3", Figure 6-72).
5. Lift the ventilator upward, then rotate it so that division channel lower attaching bracket can clear the beltline adjacent to rear guide.
6. To install, reverse removal procedure. Adjust ventilator for proper operation and alignment as described below.

### Ventilator Adjustments

The ventilator assembly can be positioned up or down and fore or aft. In addition, the top of the vent can be adjusted in or out in relation to the side roof rail.

To reposition the ventilator assembly up or down or fore or aft, it is necessary to have the vent completely loose at all attaching locations, including the ventilator regulator attaching bolts ("4", Figure 6-72).

To adjust the top of the ventilator in or out, loosen only the adjusting stud nuts ("2" and "3", Figure 6-72) and adjust the studs in or out as required.

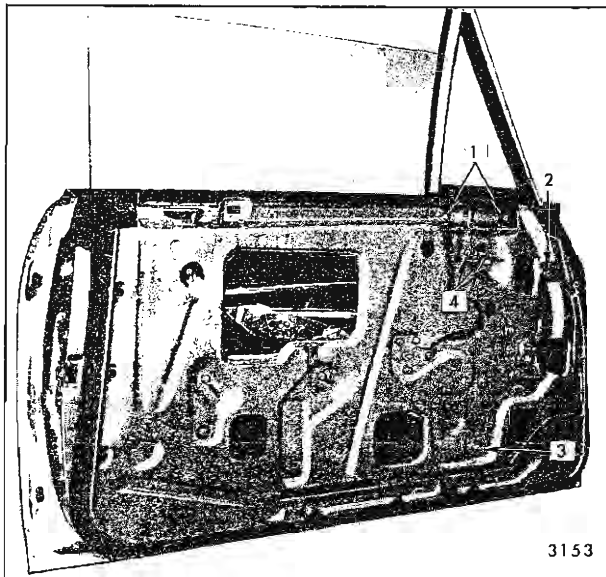

Fig. 6-72—Front Door Ventilator Assembly Removal and Adjustment "A-39" Styles

1. Ventilator Frame to Door Panel Bolts
2. Ventilator Lower Frame Adjusting Stud
3. Division Channel Lower Adjusting Stud
4. Ventilator Regulator Attaching Bolts

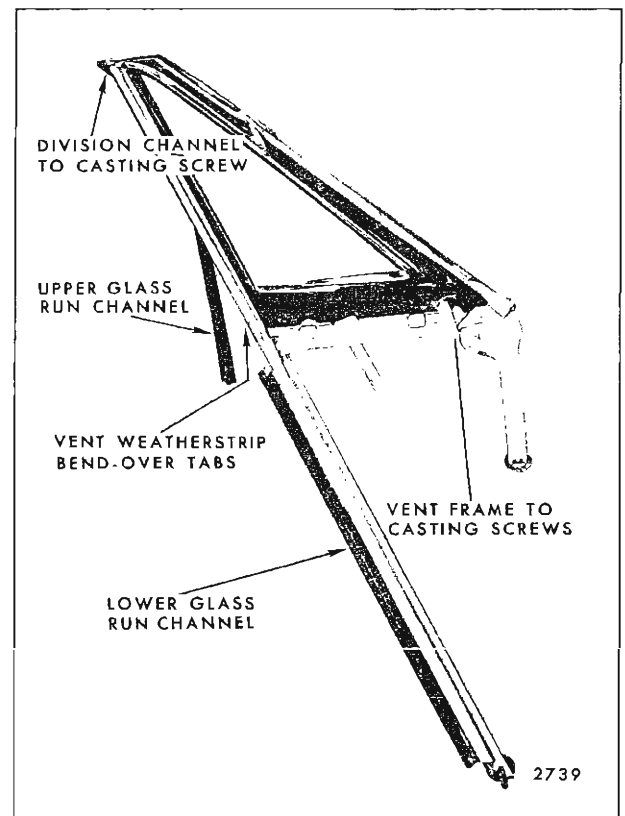

Fig. 6-73—Front Door Ventilator Assembly - "A-39" Styles

It is not necessary to loosen the vent to outer panel bolts ("3", Figure 6-72).

### Ventilator Disassembly and Assembly "A-39" Styles

The "hardtop" style ventilator permits more disassembly than does the "closed" style vent. The parts that can be removed and replaced are as follows: upper glass run channel; division channel and component lower glass run channel and vent lower frame; ventilator casting; ventilator window assembly; ventilator weatherstrip (on casting); ventilator rear weatherstrips (on division channel).

As shown in Figure 6-73, it is necessary to remove the vent from the door to gain access to the vent casting to vent frame screws.

The vent window and sash channel assembly can be removed without removing the vent from the door; however, the vent regulator must be removed (see preceding removal procedure). With the regulator out, open the vent window to align the bosses on the T-shaft with the slots in the vent lower frame. Then, press the vent window downward to disengage the vent upper pivot from the vent casting. Remove the vent window by lifting upward.



The division channel to casting screw (Figure 6-73), also retains the top of the division channel strip assembly. To remove the strip assembly, or to gain access to the vent weatherstrip bend-over tabs (weatherstrip on division channel), remove the screw and pull the strip assembly out of the division channel.

### FRONT DOOR VENTILATOR ASSEMBLY— “X” Styles

The front door ventilator is a manually operated friction type unit on all styles.

#### Removal and Installation

1. Remove door trim assembly and inner panel water deflector.
2. With window in “full-up” position loosen down stop support attaching bolt, remove support (“7”, Figure 6-56).
3. Lower door window and remove ventilator division channel lower adjusting stud nut and ventilator to door outer panel attaching screw (View “A” in Figure 6-74).
4. Remove ventilator to door upper frame attaching screws (View “A”, in Figure 6-74).
5. Lift ventilator rearward and upward until lower forward corner of assembly is free of door upper frame (View “B” in Figure 6-74).
6. Rotate ventilator assembly in an outboard movement and remove unit outboard of door upper frame (View “C” in Figure 6-74).
7. To install, reverse removal procedure.

#### Adjustment

A slight fore and aft adjustment of the ventilator

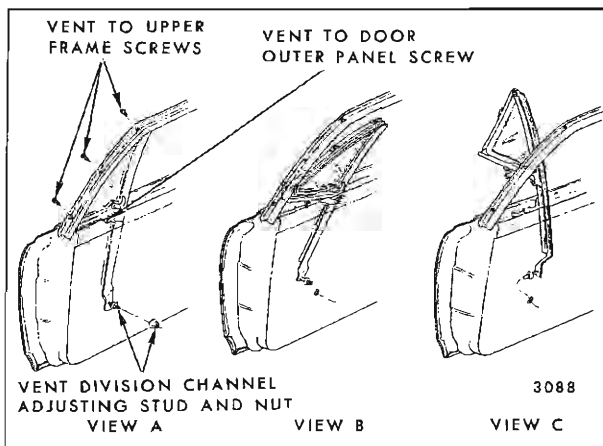

Fig. 6-74—Front Door Ventilator Removal

division channel is available at the lower adjusting stud by loosening attaching nut and sliding stud in slot provided. The division channel can also be positioned in or out by loosening nut and turning stud in or out as required.

### FRONT DOOR VENTILATOR ASSEMBLY— “Z” Styles

The front door ventilator assembly is a manually operated friction type unit.

#### Removal and Installation

1. Remove door trim assembly and detach inner panel water deflector.
2. Remove ventilator division channel lower adjusting stud nut and ventilator to door inner panel attaching screw (See Figure 6-75). Turn stud as far as possible out of contact with door inner panel.
3. On door hinge pillar, remove ventilator frame attaching bolt and ventilator frame lower adjusting stud nut (See Figure 6-75).
4. Loosen rear glass run channel upper attaching screw (“9”, Figure 6-58) and remove run channel lower adjusting stud nut (“11”, Figure 6-58). Move door glass as far rearward as possible.

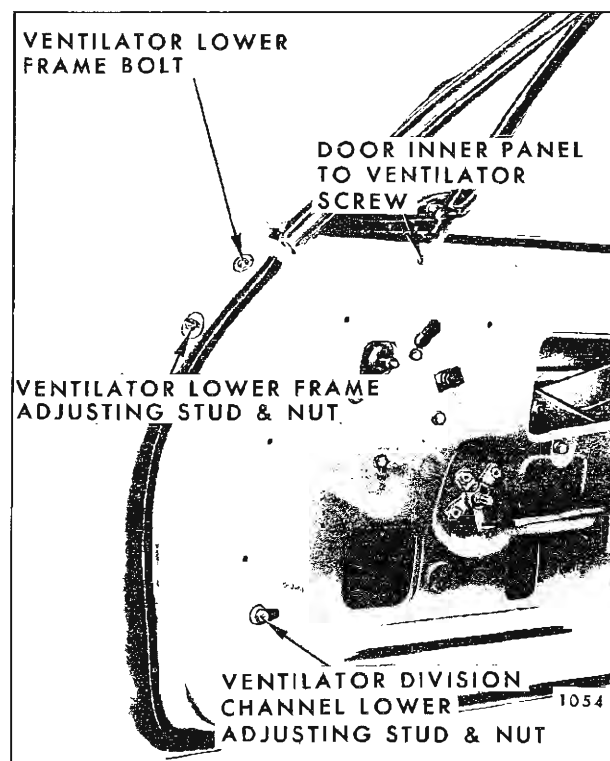

Fig. 6-75—Front Door Ventilator Attachments - “Z” Styles

5. Push ventilator lower adjusting stud free of inner panel and move ventilator rearward until front frame clears hinge pillar (See Figure 6-76).
6. Turn ventilator 90 degrees, as shown in Figure 6-76, and remove assembly from body.
7. To install, reverse removal procedure.

### Adjustments

It will generally be necessary to remove door trim pad and detach inner panel water deflector (as required) prior to ventilator assembly adjustments. In addition, removal of ventilator to door inner panel and ventilator front frame to door hinge pillar panel attaching screws is usually required.

1. A slight fore and aft adjustment of ventilator division channel is available at lower adjusting stud and nut (Figure 6-75) by loosening attaching nut and sliding stud in slot provided. The division channel can also be positioned in or out by loosening nut and turning stud in or out as required and tightening nut.
2. The ventilator frame lower adjusting stud and nut provides in or out adjustment by use of an oversize attaching hole and fore or aft adjustment by turning stud in or out as required.

**NOTE:** Adjustment No. 2 first requires loosening of ventilator front frame lower attaching bolt (See Figure 6-75).

3. The effort required to open or close the ventilator can be set by straightening retaining washer tab and tightening or loosening the adjusting nut. Tightening increases effort and

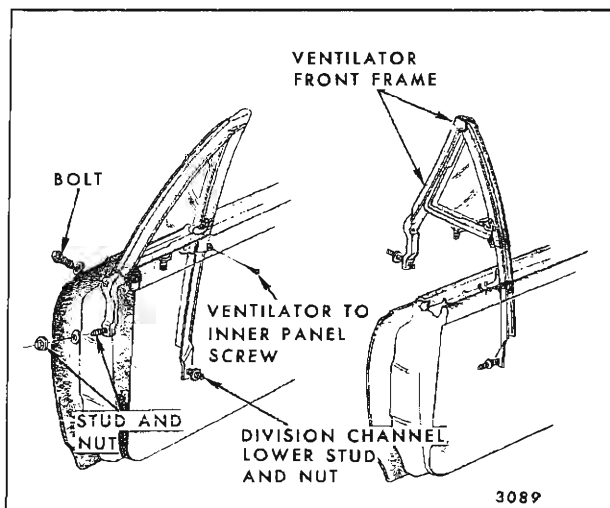

Fig. 6-76—Front Door Ventilator Removal - "Z" Styles

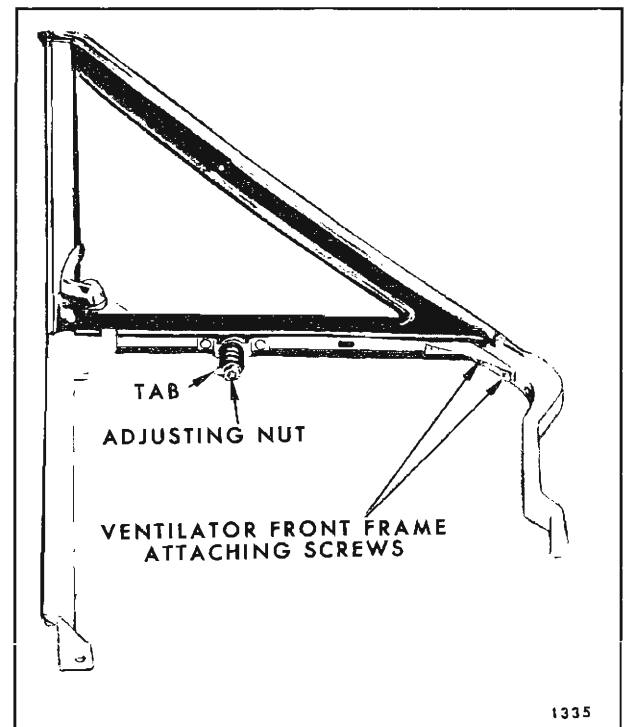

Fig. 6-77—Front Door Ventilator Assembly "X & Z" Styles

loosening decreases effort. When desired adjustment has been obtained, bend down washer tab to lock nut in position (See Figure 6-77).

**NOTE:** This adjustment should be performed as a bench operation.

### FRONT DOOR VENTILATOR ASSEMBLY WEATHERSTRIP—"Z" Styles

#### Removal and Installation

1. Remove front door ventilator assembly.
2. Remove ventilator division channel upper rubber bumper attaching screw.
3. Remove two attaching screws securing ventilator casting to frame and separate ventilator casting from frame so that the ventilator weatherstrips can be removed (Fig. 6-77).
4. To install, reverse removal procedure. Prior to installation, apply a ribbon of medium bodied sealer between ventilator weatherstrip and casting.

### FRONT DOOR WINDOW ASSEMBLY—"A & X" Closed Styles

The front door window assembly consists of a frameless piece of solid tempered safety plate

glass pressed into a thin section lower sash channel. When cycled, the glass operates within the ventilator division channel and window glass run channel.

### Removal and Installation

1. Remove front door ventilator assembly as previously described.
2. Slide window lower sash channel cam off window regulator lift arm and balance arm rollers on two door styles and off lift arm roller on four door styles. Remove window inboard of door upper frame.
3. To install, reverse removal procedure. Adjust window for proper alignment as described in the following procedure.

### Adjustments

1. To adjust lower portion of ventilator division channel for proper alignment with door window assembly, lower door window and loosen ventilator adjusting stud nut (Figure 6-78). Turn adjusting stud in or out or position lower end of channel fore or aft as required; then, tighten adjusting stud nut.
2. On two-door styles, the door window inner panel cam is adjustable at the front and can correct a rotated (cocked) front door window

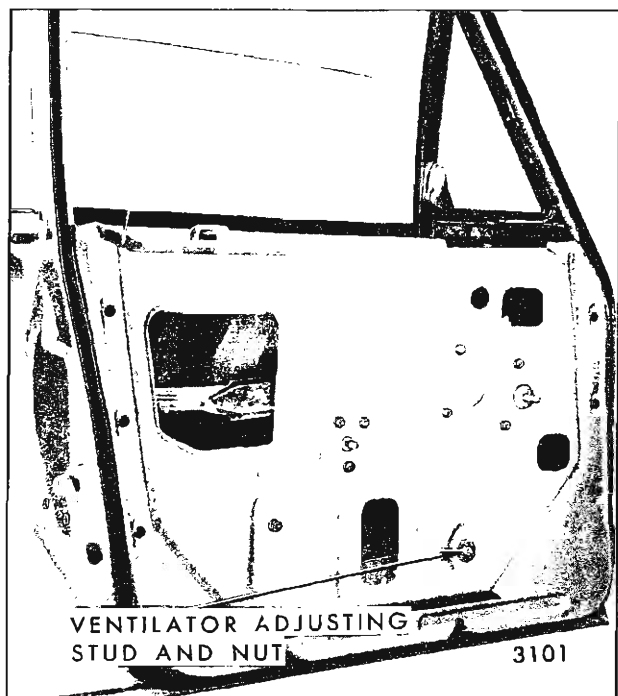

Fig. 6-78—Front Door Window Removal and Adjustment - "A and X" Closed Styles

(Refer to index for inner panel cam adjustment).

### FRONT DOOR WINDOW ASSEMBLY— "A-39" Styles

The front door window assembly consists of a solid tempered safety plate window and a combination pressed-on and bolt-on lower sash channel assembly which includes a screw-on lower sash channel cam. With this design, the door glass and sash channel are removed from the door as a unit and replacement glasses installed in bench operations.

Figure 6-79 is an exploded view of the front door window assembly and identifies the various components and their assembly sequence.

**CAUTION:** When installing the glass to sash channel bolts, torque nuts to 72 inch pounds (6 foot pounds). Also, when replacing door glass, replace glass spacers.

### Removal and Installation

1. Remove door trim assembly and inner panel water deflector.
2. Operate window to a one-quarter down position; remove front up travel stop from lower

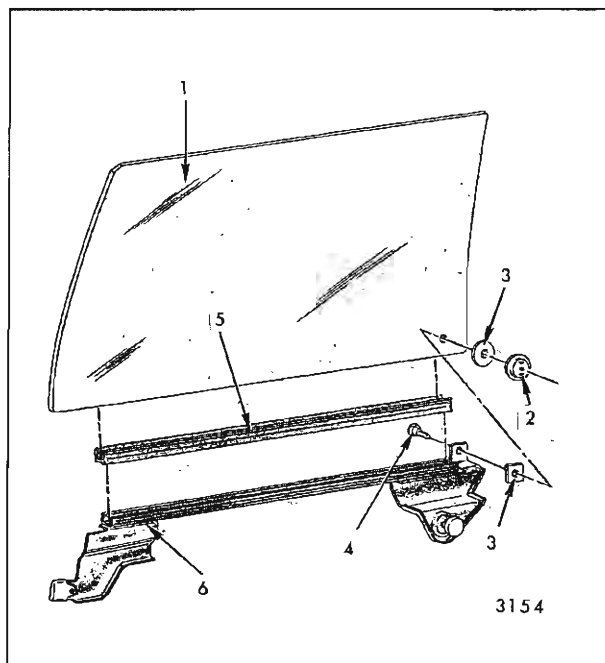

Fig. 6-79—Front Door Window Assembly - "A-39" Styles

- |                                       |  |
|---------------------------------------|--|
| 1. Front Door Window                  | 4. Glass to Sash Channel Bolt            |
| 2. Glass to Sash Channel Bolt Nut     | 5. Glass to Sash Channel Filler          |
| 3. Glass to Sash Channel Bolt Spacers | 6. Glass Lower Sash Channel Bolt Spacers |

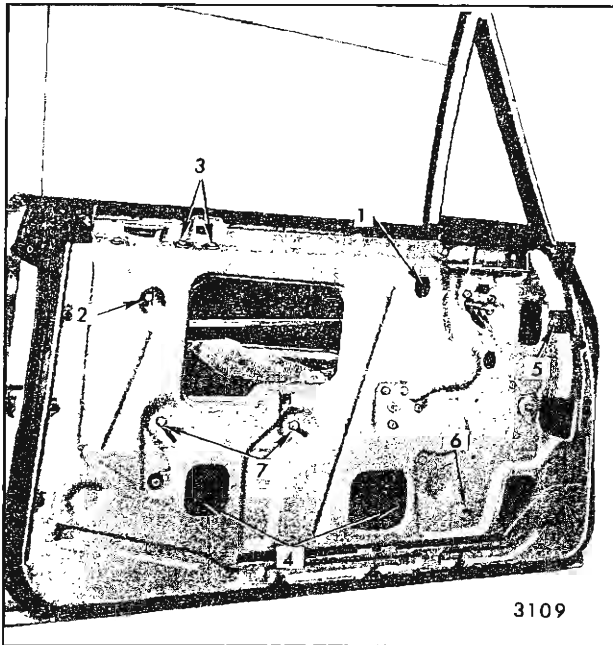

Fig. 6-80—Front Door Window Removal and Adjustments - "A-39" Styles

- |   |   |
|---|---|
| 1. Window Front Upper Stop Access Hole                  | 5. Ventilator Lower Frame Adjusting Stud and Nut            |
| 2. Window Rear Upper Stop Bolt                          | 6. Ventilator Division Channel Lower Adjusting Stud and Nut |
| 3. Rear Guide Upper Attaching Bolts                     | 7. Inner Panel Cam Attaching Bolts                          |
| 4. Lower Sash Channel Cam Attaching Screws Access Holes |   |

sash channel and rear up stop from rear guide ("1" and "2", Figure 6-80).

3. Loosen rear guide to door inner panel attaching bolts ("3", Figure 6-80).
4. With window in a three quarter down position, remove screws securing lower sash channel cam to lower sash channel ("4", Figure 6-80).
5. Support window and disengage lower sash channel cam from regulator lift and balance arm rollers.
6. Push regulator lift arm inboard, to clear glass sash channel; remove window by lifting straight-up.
7. To install, reverse removal procedure. Adjust window for proper alignment as described in the following procedure.

### Adjustments

1. A rotated window condition (glass cocked in opening) may be caused by any one or a combination of the following (Reference: Figure 6-80).

- a. Improperly adjusted inner panel cam ("7").
- b. Front or rear upper stop improperly adjusted ("1 or 2").

2. To adjust upper rear corner of window in or out in relation to side roof rail weatherstrip, loosen rear guide upper attaching bolts ("3", Figure 6-80) and position guide further inboard or outboard.

Outboard adjustment at this location tends to move the door window upper rear corner inboard. Conversely, inboard adjustment moves the top of the glass outboard.

If this adjustment proves inadequate, obtain additional adjustment at the ventilator front frame adjusting stud ("5", Figure 6-80).

3. To adjust window up-travel, operate window to "full-up" position and loosen front and rear upper stops ("1 and 2", Figure 6-80). Operate window to desired up position (Figure 6-81) and tighten stop bolts.
4. Adjustment has been provided to relieve a binding door glass due to a misaligned ventilator division channel ("6", Figure 6-80).

### FRONT DOOR WINDOW ASSEMBLY— "A-37, 67 and 87" Styles and "G-57" Styles

The front door window assembly consists of a solid tempered safety plate glass window and an individually bolted-on roller at the rear and window roller cam assembly at the front. The lower sash channel cam is bolted to the glass, but is removed in the process of removing the window.

Figure 6-82 is an exploded view of the window assembly and identifies the various components and their assembly sequence.

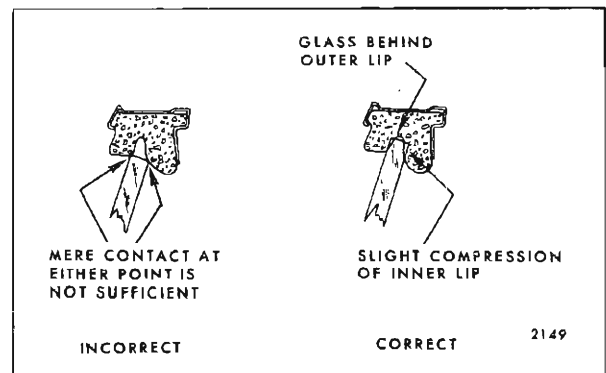

Fig. 6-81—Window to Side Roof Rail Weatherstrip Alignment

4. Using a center punch, dimple the door inner panel at the center of each of the 3/4" holes to be drilled as indicated on the template.
5. Using a 3/4" hole saw, drill three 3/4" motor to regulator attaching bolt access holes as indicated.
6. Remove motor attaching bolts and remove motor through access hole.

**NOTE:** Although window regulator lift arm is under tension of counterbalance spring, weight of window assembly prevents lift arm from moving. If necessary, window can be moved manually to clear access holes.

7. After replacing motor and prior to trim installation, apply waterproof tape to seal any motor bolt access hole that is outside of the sealing area of the water deflector.

#### Removal and Installation—"E" Styles

1. Remove front door window electric regulator and clamp assembly in a vise (Fig. 6-36).

**NOTE:** The position of regulator assembly in vise will vary with type of regulator and position of lift arm.

2. Drill a 1/4" hole through regulator back plate and sector gear. The exact point of this hole will be dependent on the position of the regulator lift arm.

**IMPORTANT:** DO NOT drill into the motor housing, part of which is indicated by the dotted line illustrated in Figure 6-36. In addition, locate hole sufficient distance from edge of sector gear to insure proper retention of sector gear to back plate.

3. Install a 3/16" bolt through hole in regulator back plate and sector gear and install a nut on the bolt. DO NOT tighten nut.

**CAUTION:** Be sure to perform steps 2 and 3 before attempting to remove motor from reg-

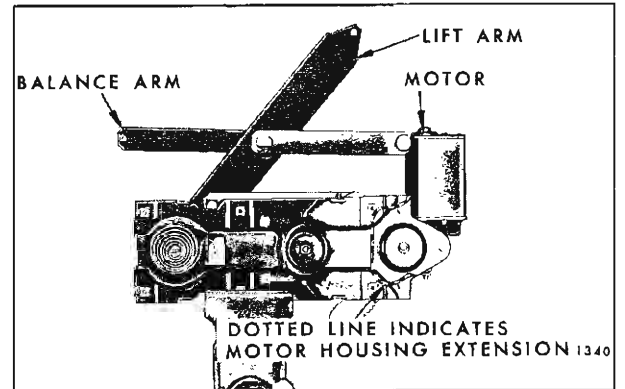

Fig. 6-36—Door Window Regulator and Electric Motor Assembly

ulator assembly. The regulator lift arm is under tension from the regulator counterbalance spring and can cause **SERIOUS INJURY** if motor is removed from regulator without locking the sector gear in position with a nut and bolt.

4. Remove regulator motor attaching bolts and remove motor from regulator assembly (Fig. 6-36).

**NOTE:** Clean off any steel chips from regulator sector gear and motor pinion gear.

5. To install, reverse removal procedure. If difficulty is encountered in lining up motor attaching holes with regulator assembly, the regulator lift arm may be moved into position manually so that motor pinion gear will mesh with teeth on regulator sector gear. After installation of front door window assembly, cycle electric regulator several times before installing inner panel water deflector and door trim pad.

**NOTE:** Be sure to remove temporary nut and bolt securing regulator back plate to regulator sector gear before installing assembly into door.

## FRONT DOORS

### DESCRIPTION

All doors fall into two basic categories, closed styles (those with door upper frames) and hard top or convertible styles (those without door upper frames). Although both types of front doors utilize similar hardware, the presence or lack of a door upper frame usually determines the removal or installation sequence of any particular part.

Any work performed on door hardware usually requires removal of trim pad and inner panel water deflector. The procedures for water deflectors are covered in the preceding "Front and Rear Doors" section. Trim procedures are in Section 14 (see index).

Unless otherwise stated, the front door service procedures listed here pertain to all body styles.

Figures 6-37 through 6-58 are typical of front doors with the trim assembly and inner panel water deflector removed. These figures identify the com-

ponent parts of the front door assembly (by style), their relationship and various attaching points.

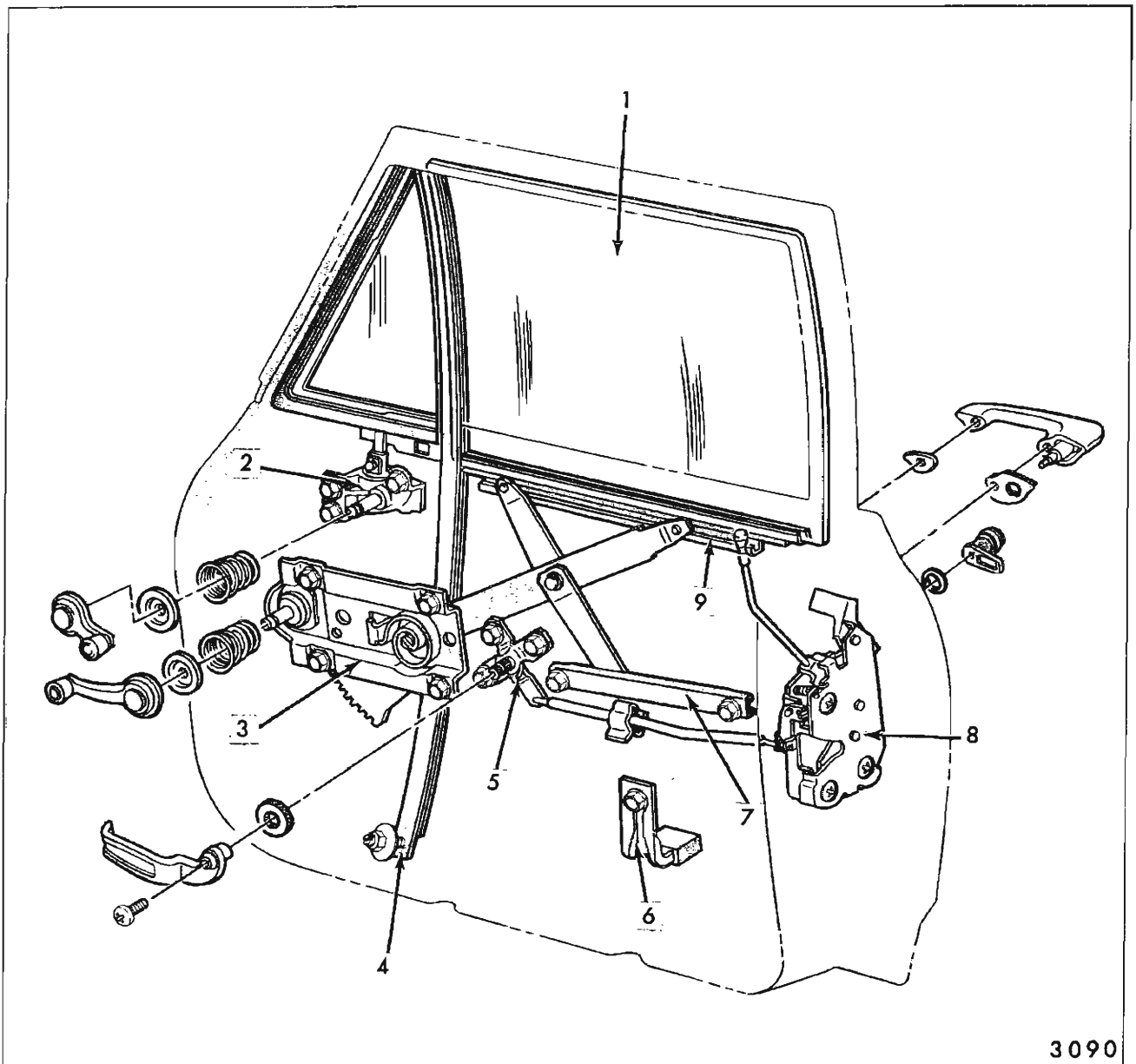

3090

Fig. 6-37—Front Door Hardware - "A" Closed Styles

- |                                |                             |
|--------------------------------|-----------------------------|
| 1. Front Door Window Assembly  | 6. Window Down Stop Support |
| 2. Ventilator Regulator        | 7. Inner Panel Cam          |
| 3. Window Regulator            | 8. Door Lock                |
| 4. Ventilator Division Channel | 9. Lower Sash Channel Cam   |
| 5. Door Lock Remote Control    |                             |

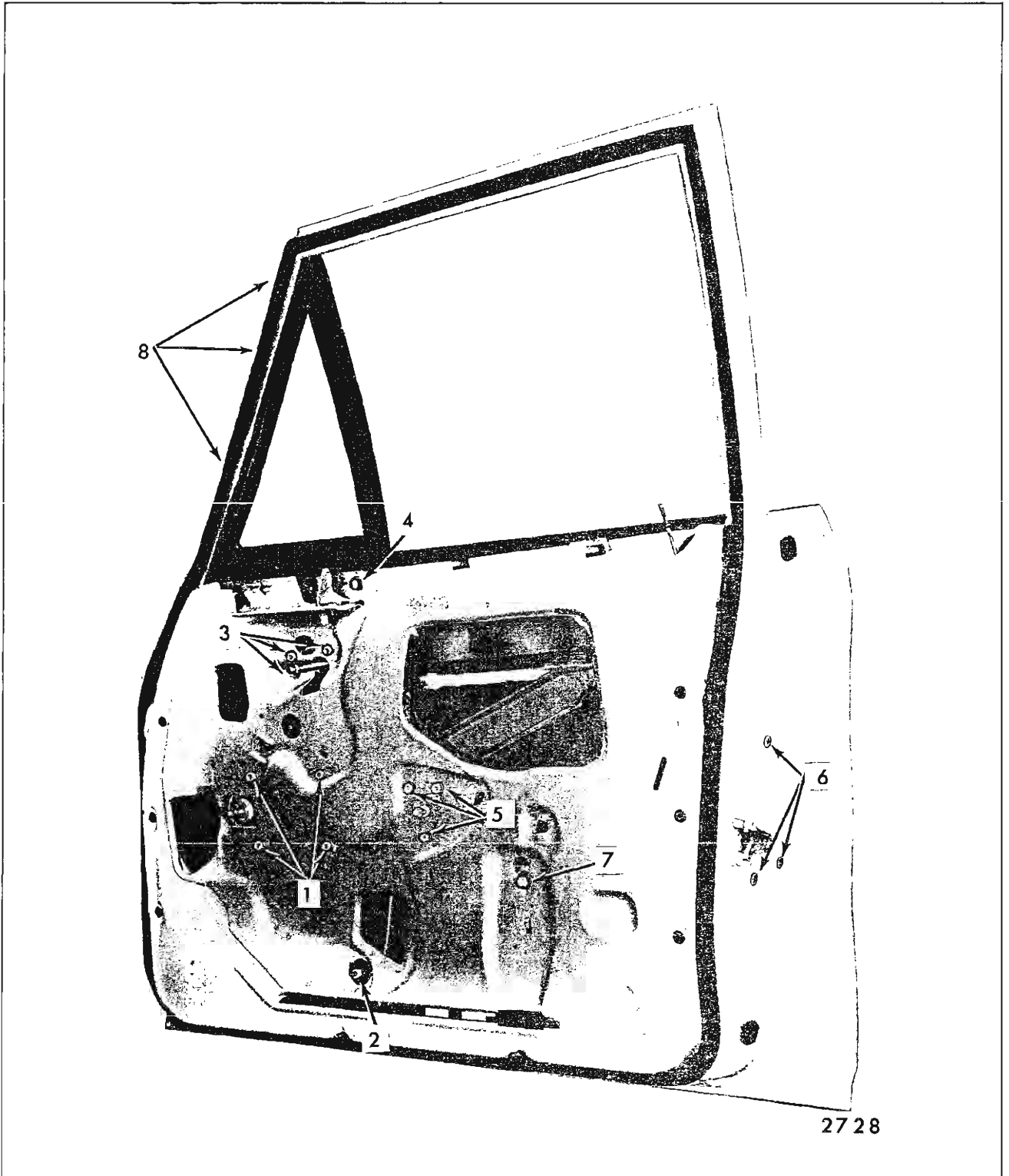
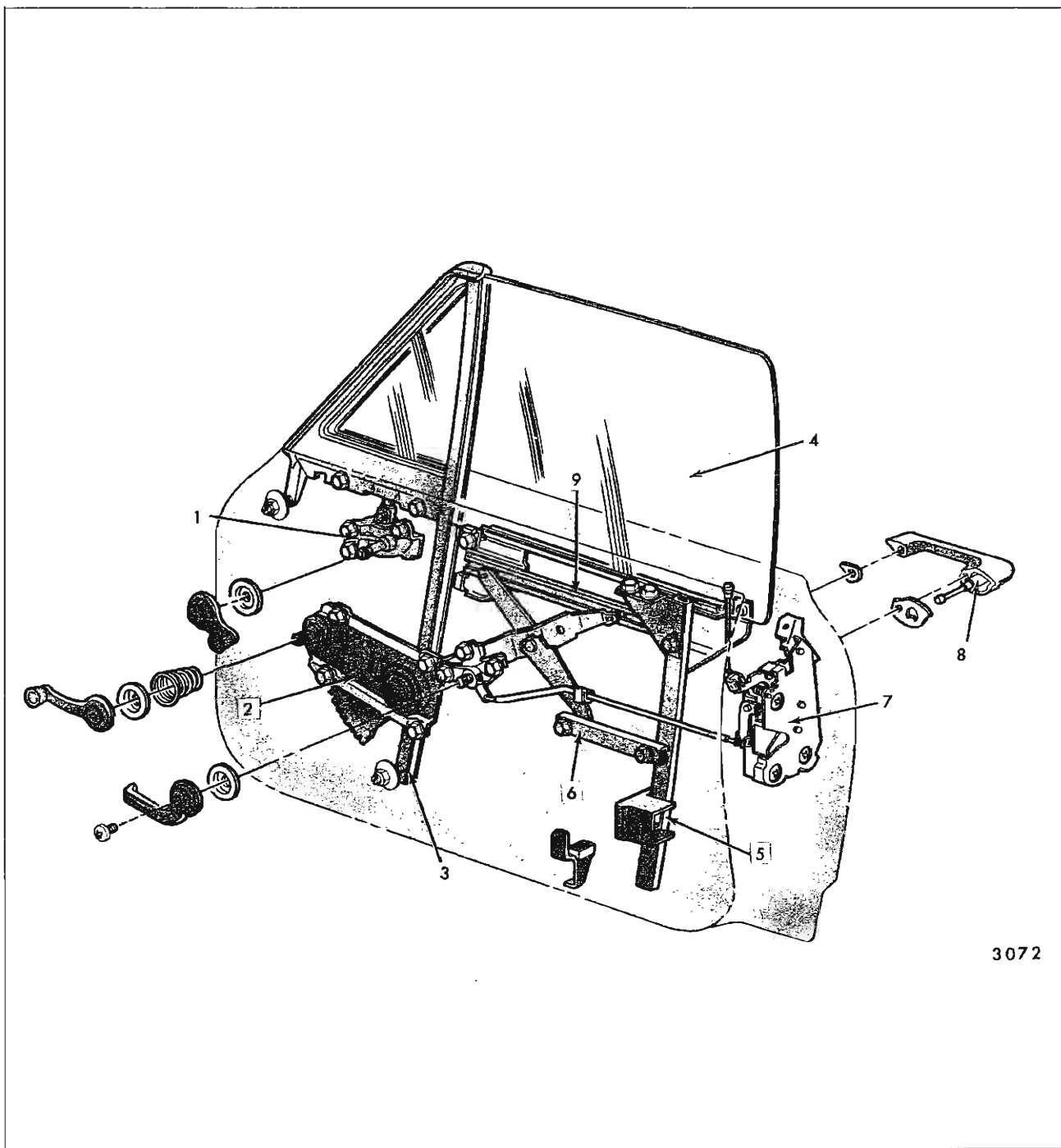

Fig. 6-38—Front Door Hardware—"A" Closed Styles

- 1. Window Regulator Attaching Bolts
- 2. Ventilator Division Channel Lower Adjusting Stud
- 3. Ventilator Regulator Attaching Bolts
- 4. Ventilator Frame to Outer Panel Attaching Bolt

- 5. Door Lock Remote Control Attaching Bolts
- 6. Door Lock Attaching Screws
- 7. Down Stop Support Attaching Bolt
- 8. Ventilator to Door Upper Frame Attaching Screws



3072

Fig. 6-39—Front Door Hardware - "A-39" Styles

1. Ventilator Regulator
2. Window Regulator
3. Ventilator Division Channel
4. Front Door Window Assembly
5. Rear Guide
6. Inner Panel Cam
7. Door Lock
8. Door Outside Handle
9. Lower Sash Channel Cam



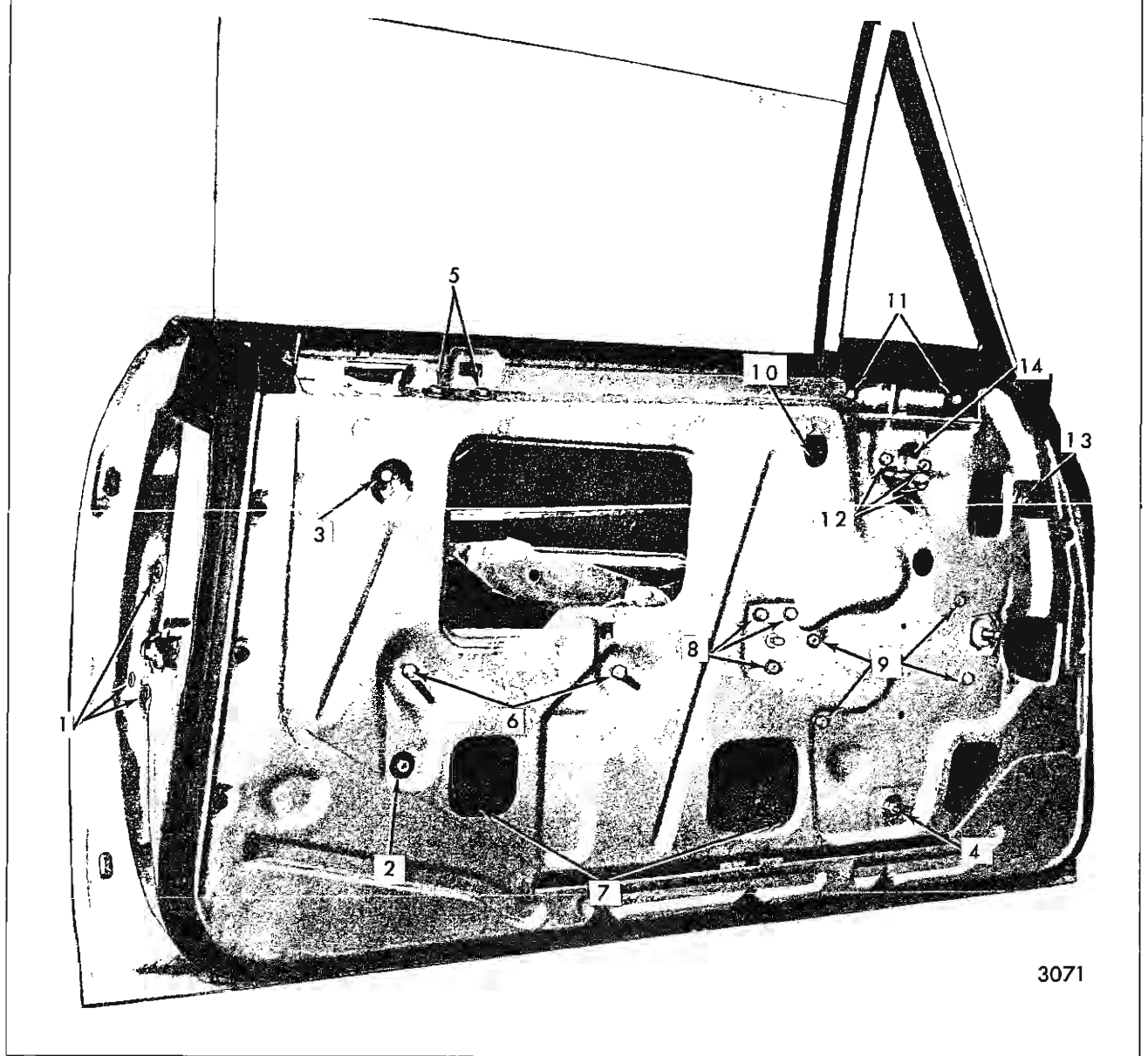

3071

Fig. 6-40—Front Door Hardware - "A-39"

1. Door Lock Attaching Screws
2. Rear Guide Lower Attaching Bolt
3. Window Rear Upper Stop Bolt
4. Ventilator Division Channel Lower Adjusting Stud and Nut
5. Rear Guide Upper Attaching Bolts
6. Inner Panel Cam Attaching Bolts
7. Lower Sash Channel Cam Attaching Screws Access Holes
8. Door Lock Remote Control Attaching Bolts
9. Window Regulator Attaching Bolts
10. Window Front Upper Stop Access Hole
11. Ventilator Frame to Door Outer Panel Attaching Bolts
12. Ventilator Regulator Attaching Bolts
13. Ventilator Lower Frame Adjusting Stud and Nut
14. Ventilator "T" Shaft to Regulator Screw Access Hole

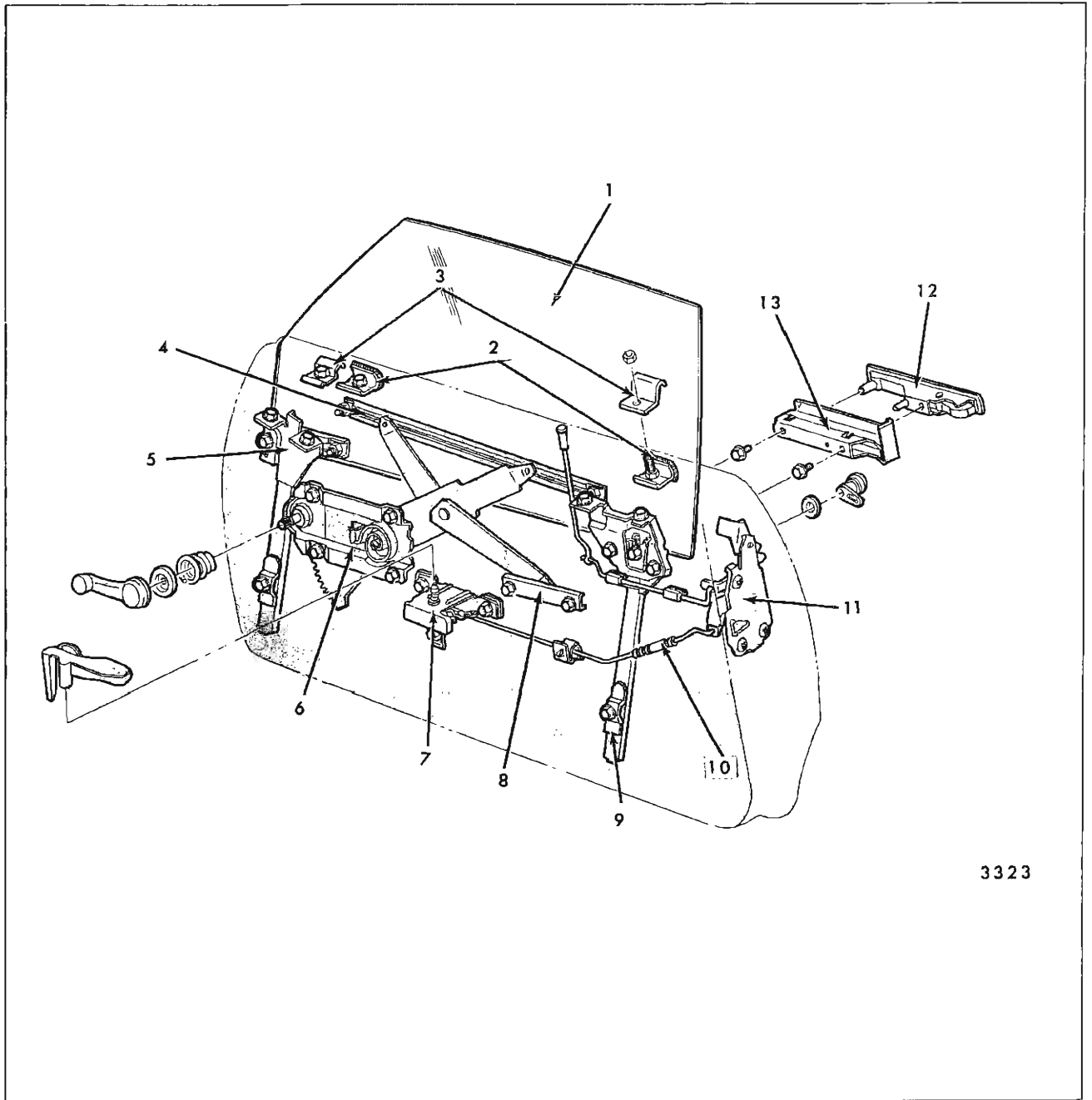

3323

Fig. 6-41—Front Door Hardware - "G-57" Style Shown, "A-37, 67 and 87" Style Similar

1. Window Assembly
2. Stabilizer Strips
3. Trim Pad Adjusting Plates
4. Lower Sash Channel Cam
5. Front Guide
6. Window Regulator
7. Door Lock Remote Control (Squeeze Type)
8. Inner Panel Cam
9. Rear Guide
10. Adjustable Remote Control to Lock Rod
11. Door Lock
12. Door Outside Handle (Pull Type)
13. Door Outside Handle Retainer

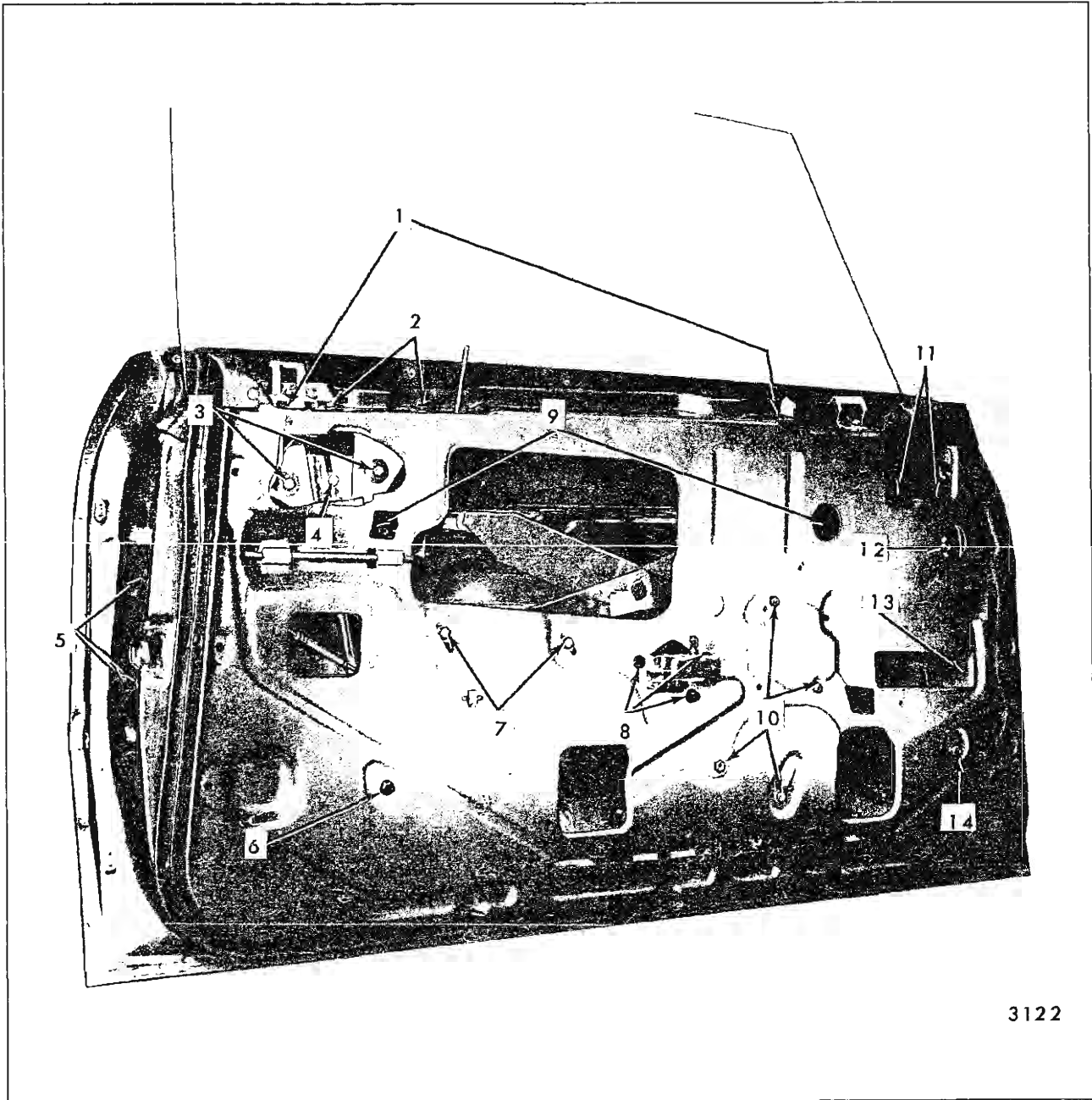

3122

Fig. 6-42—Front Door Hardware - "G-57" Style Shown, "A-37, 67 and 87" Style Similar

1. Window Stabilizer Strips
2. Rear Guide Upper Bracket Attaching Bolts
3. Rear Guide Upper Bracket to Guide Attaching Bolts
4. Window Rear Up - Travel Stop Bolt
5. Door Lock Attaching Screws
6. Rear Guide Lower Attaching Bolt
7. Inner Panel Cam Attaching Bolts
8. Door Lock Remote Control Attaching Bolts
9. Window Lower Sash Channel Cam Stud Nut Access Holes
10. Window Regulator Attaching Bolts
11. Front Guide Upper Attaching Bolts
12. Window Front Up - Travel Stop Bolt (on Guide)
13. Window Front Up - Travel Stop Nut (on Window)
14. Front Guide Lower Attaching Bolt

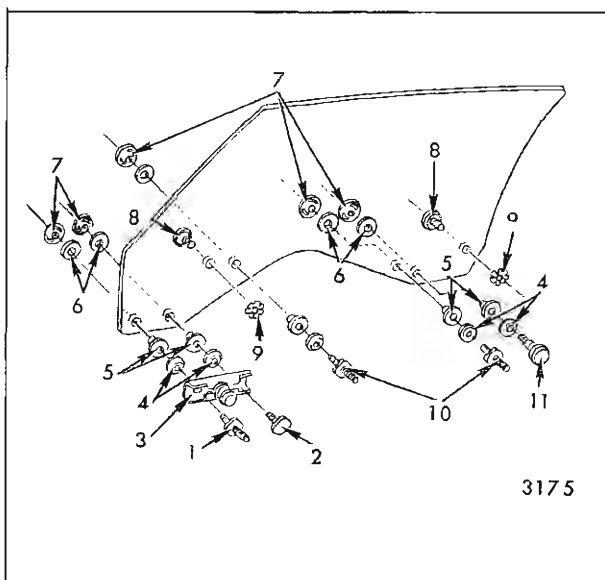

Fig. 6-82—Front Door Window Assembly "A-37, 67 and 87" Styles and "G-57" Styles

- |   |                                   |
|---|-----------------------------------|
| 1. Stud, Front Guide Cam<br>(Stud Portion for Up-<br>Stop Attachment) | 6. Washer                         |
| 2. Bolt, Guide Cam Assembly   | 7. Nut                            |
| 3. Front Guide Cam Assembly   | 8. Fastener, Glass<br>Bearing     |
| 4. Spacer   | 9. Cap, Glass Bearing<br>Fastener |
| 5. Bushing  | 10. Stud, Inner Panel Cam         |

### Removal and Installation

1. Remove door trim assembly and inner panel water deflector.
2. Loosen window rear up travel stop bolt ("1", Figure 6-83) and remove stop from rear guide.
3. Using a 1/4" hex-head wrench, remove front up-stop from window front roller cam ("2", Figure 6-83).
4. Remove window stabilizer strip assembly bolts ("3", Figure 6-83) and remove stabilizer strips.
5. Remove window lower sash channel cam to glass attaching stud nuts ("4", Figure 6-83). Tilt top edge of glass inboard and disengage window (with studs intact) from lower sash channel cam.
6. Raise window and disengage rear roller from rear guide, then front roller cam assembly from front guide. Remove window by aligning rollers with notches provided in door inner panel.
7. To install, reverse removal procedure. Adjust

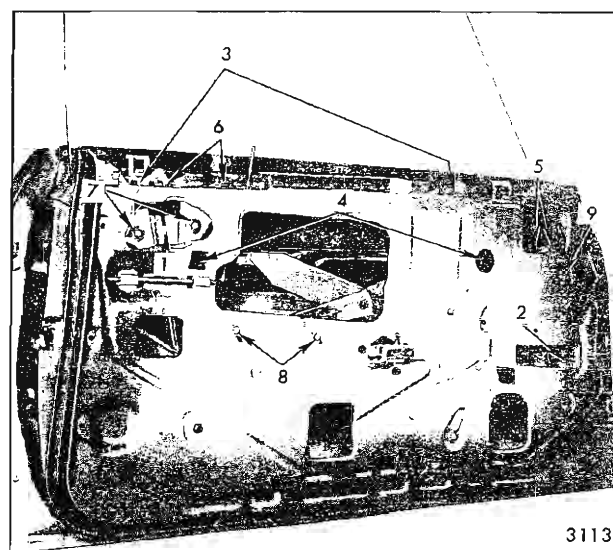

Fig. 6-83—Front Door Window Removal and Adjustment - "A-37, 67 and 87" Styles and "G-57" Styles

- |  |   |
|--|---|
| 1. Window Rear Up-Travel<br>Stop                             | 5. Front Guide Upper<br>Attaching Bolts                 |
| 2. Window Front Up-Travel<br>Stop (On Window)<br>Access Hole | 6. Rear Guide Upper Bracket<br>Attaching Bolts          |
| 3. Stabilizer Strips   | 7. Rear Guide Upper Bracket<br>to Guide Attaching Bolts |
| 4. Window Lower Sash<br>Channel Cam Access<br>Holes          | 8. Inner Panel Cam                                      |
|  | 9. Window Front Up-Travel<br>Stop (On Guide)            |

Window for proper alignment and operation as described in the following adjustment procedure.

### Adjustments

1. In and out adjustment of the glass is controlled by the in and out adjustment available at the top of the front and rear guides ("5" and "6", Figure 6-83) and the in and out position of the glass stabilizer strip assemblies ("3").
2. Fore and aft adjustment of the window assembly is controlled by the position of the rear guide. The upper guide bracket to guide attaching locations ("7", Figure 6-83) are slotted to permit fore and aft adjustment of the guide. Because of the free floating roller in the window front sash channel cam (Figure 6-82), the front guide does not have to be adjusted during fore or aft window alignment.
3. Ease of window operation and window stability depend to a great extent on the adjustment of the window stabilizer strip assemblies at the beltline ("3", Figure 6-83). The stabilizing strips ("3") should contact the glass throughout the full cycle of the window. Due to slight variations in glass contour, however, in some

cases the strip may lose contact with the glass halfway through the cycle. This is permissible provided it does not result in loose glass. Contact should be sufficient to stabilize glass, but not restrict ease of window operation.

4. A window that is rotated (cocked) in the window opening may be the result of an improperly adjusted inner panel cam ("8", Figure 6-83) or poorly adjusted up-travel stops ("1" or "9", Figure 6-83).

Control up-travel at front or rear of window through up or down adjustment of either front or rear up-travel stop.

Correct a poorly adjusted inner panel cam by loosening cam attaching bolts ("8", Figure 6-83) and adjusting front end of cam up or down as required. Adjustment of cam repositions front edge of glass up or down in relation to rear edge of glass.

5. The up-travel of the window is determined by the adjustment of the front and rear window up-travel stops ("1" and "9", Figure 6-83). To adjust window up-travel, loosen front and rear up-stops and operate window to desired position to establish proper glass to side roof rail weatherstrip contact (Figure 6-84).

### FRONT DOOR WINDOW ASSEMBLY— "B-11" Styles

The front door window assembly consists of a solid tempered safety plate glass window and a bolt-on lower sash channel cam.

#### Removal and Installation

1. Remove door trim assembly and inner panel water deflector.
2. Loosen window anti-rattle strip ("1", Figure 6-85).

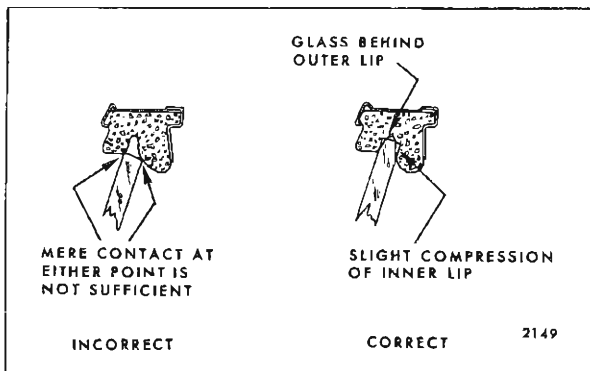

Fig. 6-84—Window to Side Roof Rail Weatherstrip Alignment

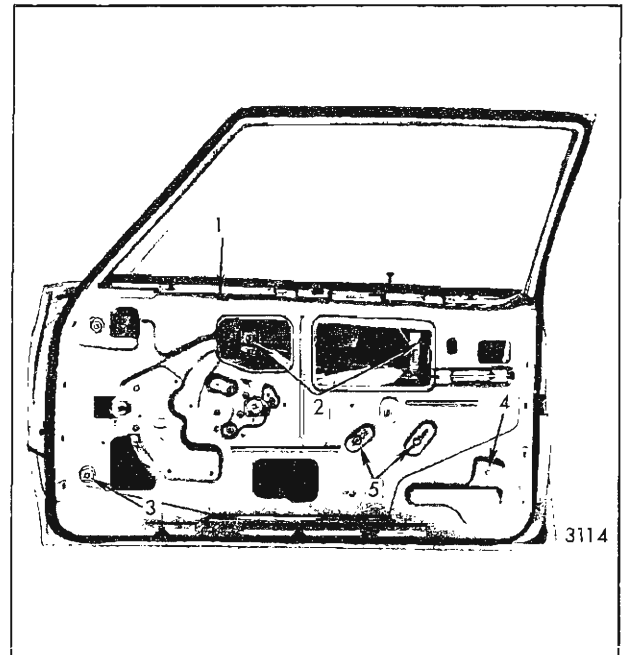

Fig. 6-85—Front Door Window Removal and Adjustment - "B-11" Styles

- |  |   |
|--|---|
| 1. Window Anti-Rattle Strip                                      | 3. Front Glass Run Channel Attaching Bolt |
| 2. Window to Lower Sash Channel Cam to Glass Attaching Stud Nuts | 4. Rear Glass Run Channel Attaching Bolt  |
|  | 5. Inner Panel Cam Bolts                  |

3. Partially lower front door window and remove window lower sash channel cam to glass attaching stud nuts ("2", Figure 6-85). Disengage lower sash channel cam from attaching studs by pressing cam inboard.
4. Tilt front edge of glass downward to disengage glass from run channel, remove window outboard of door upper frame, rear edge first, then front edge.
5. To install, reverse removal procedure. Adjust glass for proper alignment and operation by performing the following procedure.

#### Adjustments

Adjustments have been provided to relieve a binding front door glass due to misaligned glass run channels ("3" and "4", Figure 6-85). In addition, the door window inner panel cam is adjustable which can correct a rotated (cocked) front door window ("5", Figure 6-85).

### FRONT DOOR WINDOW ASSEMBLY— "B-36, 46 and 69" Styles

The front door window assembly consists of a solid

tempered safety plate glass window and an individually bolted-on roller at the rear. The lower sash channel cam is bolted to the glass, but is removed in the process of removing the window. When cycled, the glass operates within the glass run channel at the front and guide at the rear.

### Removal and Installation

1. Remove door trim assembly and inner panel water deflector.
2. Loosen window stabilizer strips ("1", Figure 6-86).
3. Operate window to a three-quarter-down position, remove window lower sash channel cam to glass attaching stud nuts ("2", Figure 6-86). Tilt front edge of glass down and remove window inboard of door upper frame.
4. To install, reverse removal procedure. Adjust glass for proper alignment and operation by performing the following procedure.

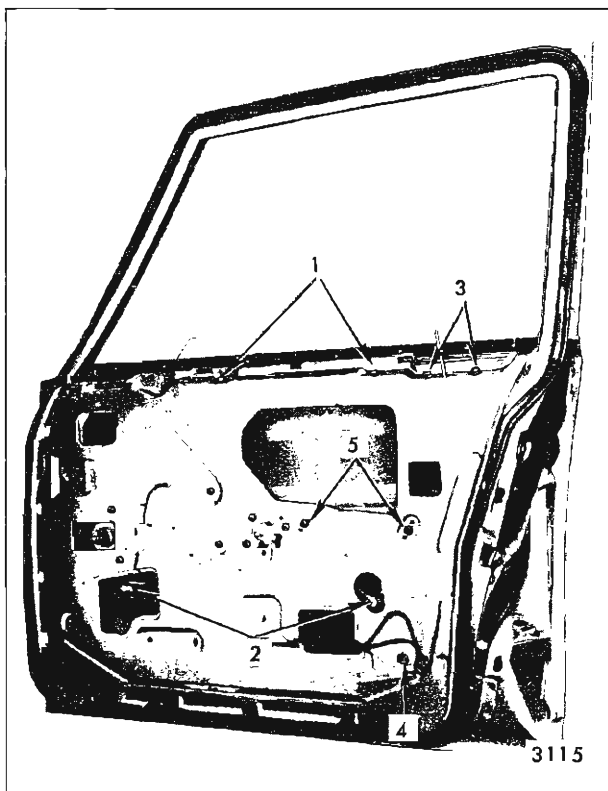

Fig. 6-86—Window Removal and Adjustment - "B-69" Styles

- |  |                                  |
|--|----------------------------------|
| 1. Window Stabilizer Strip Bolts                                 | 3. Window Rear Guide Upper Bolts |
| 2. Window Lower Sash Channel Cam Attaching Stud Nut Access Holes | 4. Window Rear Guide Lower Bolt  |
|  | 5. Inner Panel Cam Bolts         |

### Adjustments

1. The rear guide is adjustable in and out and fore and aft at the upper and lower attaching locations ("3" and "4", Figure 6-86) to relieve a binding door glass.
2. The door window inner panel cam ("5", Figure 6-86) is adjustable at the front and rear to correct a rotated (cocked) window.

### FRONT DOOR WINDOW ASSEMBLY— "B and C-37, 47, 57 and 67" Styles

The front door window assembly consists of a solid tempered safety plate glass window and an individually bolted-on roller at the front and window roller cam at the rear. The lower sash channel cam is bolted to the glass, but is removed in the process of removing the window.

Figure 6-87 is an exploded view of the window assembly and identifies the various components and their assembly sequence.

### Removal and Installation

1. Remove door trim pad and inner panel water deflector. Remove outer strip assembly or window lower reveal molding.

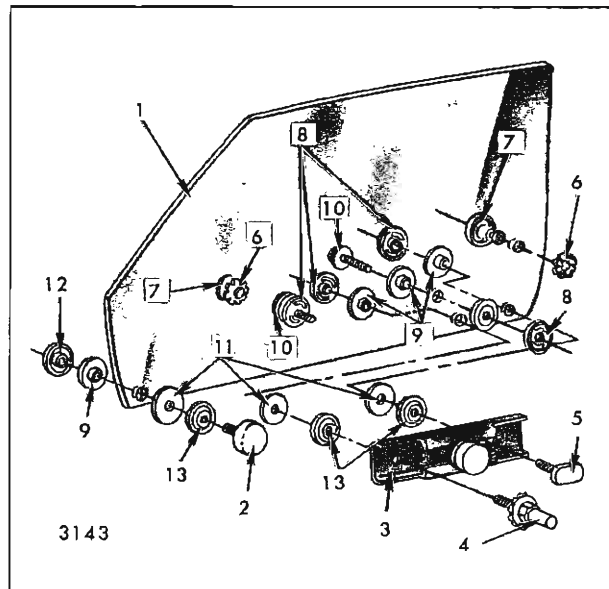

Fig. 6-87—Front Door Window Assembly - "B and C-37, 47, 57, and 67" Styles

- |   |                           |
|---|---------------------------|
| 1. Window Glass                                   | 7. Glass Bearing Fastener |
| 2. Roller Assembly                                | 8. Nut                    |
| 3. Rear Guide Cam Assembly                        | 9. Bushing                |
| 4. Stud, Rear Guide Cam and Window Up-Travel Stop | 10. Bolt, Inner Panel Cam |
| 5. Bolt, Rear Guide Cam                           | 11. Washer                |
| 6. Glass Bearing Fastener Cap                     | 12. Nut, Roller Assembly  |
|   | 13. Spacer                |

2. Loosen front up-stop bolt ("1", Figure 6-88) and remove stop from front guide.
3. Remove rear up-stop from rear guide ("2", Figure 6-88).
4. Remove window stabilizer strip assembly bolts ("3", Figure 6-88) and remove stabilizer strips.
5. Remove window lower sash channel cam to glass attaching stud nuts ("4", Figure 6-88).
6. Tilt top edge of glass inboard and disengage window (with studs intact) from lower sash channel cam.
7. Raise window and disengage front roller from front guide, then rear roller from rear guide.
8. Remove window from door by aligning rollers with notches provided in inner panel. Remove front end of window first, then rear end.
9. To install, reverse removal procedure. Adjust window for proper alignment and operation as described in the following adjustment procedure.

### Adjustments

1. In and out adjustment of the glass is controlled

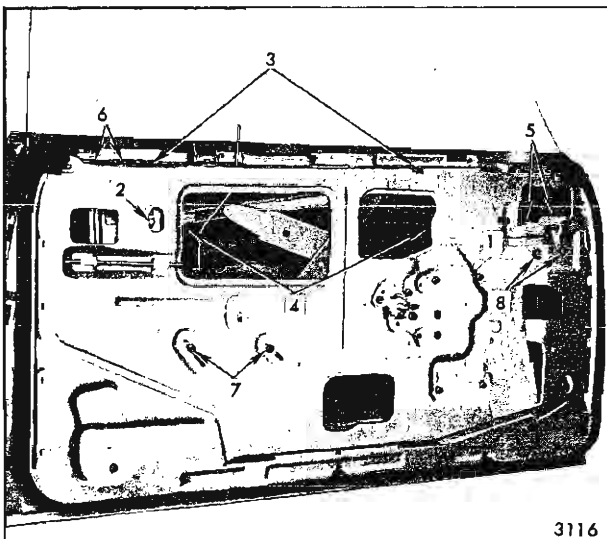

Fig. 6-88—Window Removal and Adjustments - "B and C-37, 47, 57 and 67" Styles

- |  |                                       |
|--|---------------------------------------|
| 1. Window Front Up-Travel Stop Bolt                    | 5. Front Guide Bracket Upper Bolts    |
| 2. Window Rear Up-Travel Stop Bolt                     | 6. Rear Guide Upper Bolts             |
| 3. Window Stabilizer Strip Bolts                       | 7. Inner Panel Cam Bolts              |
| 4. Window Lower Sash Channel Cam Stud Nut Access Holes | 8. Front Guide to Guide Upper Bracket |

by the in and out adjustment available at the top of the front and rear guides ("5", and "6", Figure 6-88) and the in and out position of the glass stabilizer strip assemblies "3".

2. Fore and aft adjustment of the window assembly is controlled by the position of the front guide. The upper attaching locations in the inner panel ("8", Figure 6-88) are slotted to permit fore and aft adjustment of the guide. Because of the free floating roller in the window rear sash channel cam (Figure 6-87), the rear guide does not have to be adjusted during fore or aft window alignment.
3. Ease of window operation and window stability depend to a great extent on the adjustment of the window stabilizer strip assemblies at the beltline ("3", Figure 6-88). The stabilizing strips "3" should contact the glass throughout the full cycle of the window. Due to slight variations in glass contour, however, in some cases the strip may lose contact with the glass halfway through the cycle. This is permissible provided it does not result in loose glass. Contact should be sufficient to stabilize glass, but not restrict ease of window operation.
4. A window that is rotated (cocked) in the window opening may be the result of an improperly adjusted inner panel cam ("7", Figure 6-88) or poorly adjusted up-travel stops ("1" or "2", Figure 6-88).

Control up-travel at front or rear of window through up or down adjustment of either front or rear up-travel stop.

Correct a poorly adjusted inner panel cam by loosening cam attaching bolts ("7", Figure 6-88), and adjusting front end of cam up or down as required. Adjustment of cam repositions front edge of glass up or down in relation to rear edge of glass.

5. The up-travel of the window is determined by the adjustment of the front and rear up-stop ("1" and "2", Figure 6-88). To adjust window up-travel, loosen front and rear up-stops and operate window to desired position to establish proper glass to side roof rail weatherstrip contact (Figure 6-89).

### FRONT DOOR WINDOW ASSEMBLY— "B-39" and "C-39, 49 and 69" Styles

The front door window assembly consists of a solid tempered safety plate glass window and an individually bolted-on roller at the rear and a roller assembly (bell-crank) at the front. The lower sash channel cam is bolted to the glass, but is removed in the process of removing the window.

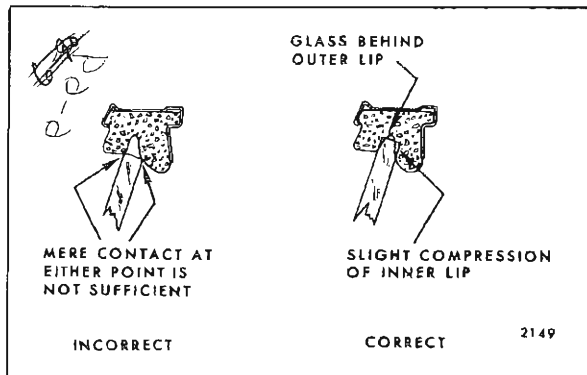

Fig. 6-89—Window to Side Roof Rail Weatherstrip Alignment

Figure 6-90 is an exploded view of the window assembly and identifies the various components and their assembly sequence.

### Removal and Installation

1. Remove door trim assembly and inner panel water deflector.
2. Remove front and rear window up-travel stops ("1" and "2", Figure 6-91).
3. Loosen front and rear window stabilizer strips ("3", Figure 6-91).
4. With window in three-quarter-down position, remove lower sash channel cam to glass attaching nuts ("4", Figure 6-91). Remove window by lifting straight up and aligning rollers

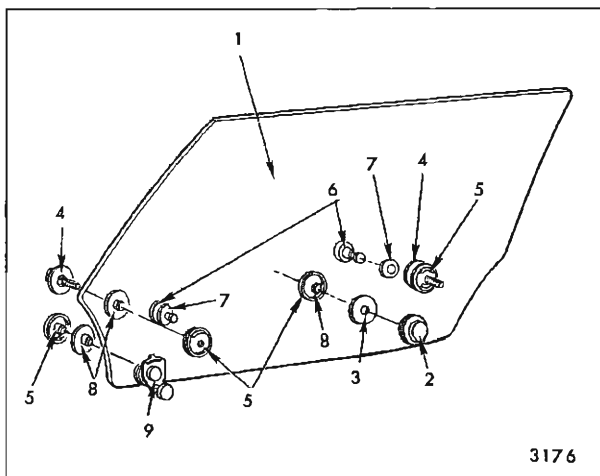

Fig. 6-90—Front Door Window Assembly - "B-39" and "C-39, 49 and 69" Styles

- |                         |                                 |
|-------------------------|---------------------------------|
| 1. Window Assembly      | 6. Glass Bearing Fastener       |
| 2. Window Roller        | 7. Glass Bearing Fastener Cap   |
| 3. Washer               | 8. Bushing                      |
| 4. Bolt Inner Panel Cam | 9. Roller Assembly (Bell Crank) |
| 5. Nut                  |                                 |

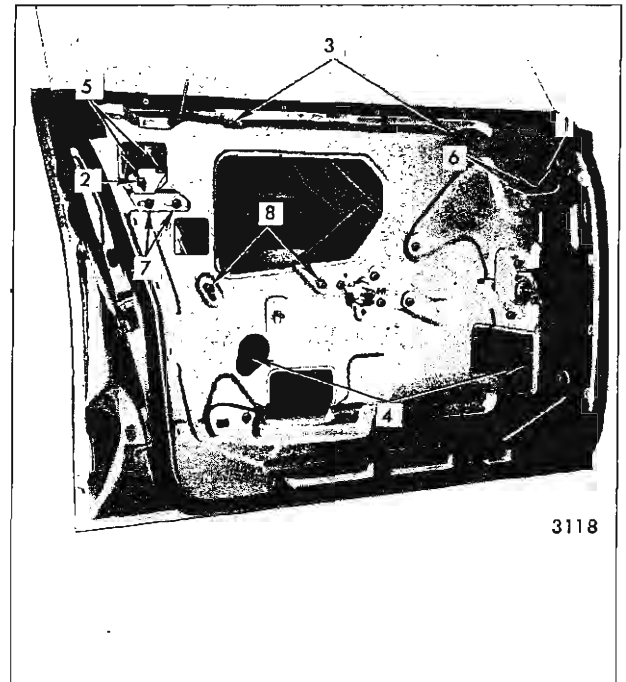

Fig. 6-91—Window Removal and Adjustment - "B-39" and "C-39, 49 and 69" Styles

- |  |  |
|--|--|
| 1. Window Front Up-Travel Stop Bolt                | 5. Rear Guide Upper Bracket Bolts          |
| 2. Window Rear Up-Travel Stop Bolt                 | 6. Front Guide Upper Bolts                 |
| 3. Window Stabilizer Strip Bolts                   | 7. Rear Guide to Guide Upper Bracket Bolts |
| 4. Window Lower Sash Channel Cam Nuts Access Holes | 8. Inner Panel Cam Bolts                   |
- with notches provided in the door inner panel. Remove front end of window first, then rear end.

5. To install, reverse removal procedure. Adjust window for proper alignment and operation as described in the following adjustment procedure.

### Adjustments

1. In and out adjustment of the glass is controlled by the in and out adjustment available at the top of the front and rear guides ("5" and "6", Figure 6-91) and the in and out position of the glass stabilizer strip assemblies ("3", Figure 6-91).
2. Fore and aft adjustment of the window assembly is controlled by the position of the rear guide. The upper attaching locations in the inner panel ("7", Figure 6-91) are slotted to permit fore and aft adjustment of the guide. Because the roller assembly (bell-crank) which attaches to the glass at the front pivots, the front guide does not have to be adjusted during fore or aft window alignment.



3. Ease of window operation and window stability depends a great extent on the adjustment of the window stabilizer strip assemblies at the belt-line ("3", Figure 6-91). The stabilizing strips "3" should contact the glass throughout the full cycle of the window. However, in some cases due to the slight variations in glass contour, the strip may loose contact with the glass halfway through the cycle. This is permissible provided it does not result in loose glass or restrict ease of window operation.
4. A window that is rotated (cocked) in the window opening may be the result of an improperly adjusted inner panel cam ("8", Figure 6-91) or poorly adjusted up-travel stops ("1" or "2", Figure 6-91).

Correct a poorly adjusted inner panel cam by loosening cam attaching bolts ("8", Figure 6-91) and adjusting front end of cam up or down as required. Adjustment of cam repositions front edge of glass up or down in relation to rear edge of glass.

5. The up-travel of the window is determined by the adjustment of the front and rear up-stop ("1" and "2", Figure 6-91). To adjust window up-travel, loosen front and rear up-stops and operate window to desired position to establish proper glass to side roof rail weatherstrip contact (Figure 6-92).

### FRONT DOOR WINDOW ASSEMBLY— "E" Body Styles

The front door window assembly consists of a frameless piece of solid tempered safety plate glass and bolt-on front and rear lower sash channel assemblies. With this design the window is removed from the door as an assembly and glass replacements made as bench operations. Figure 6-93 identifies the components of the door window assembly.

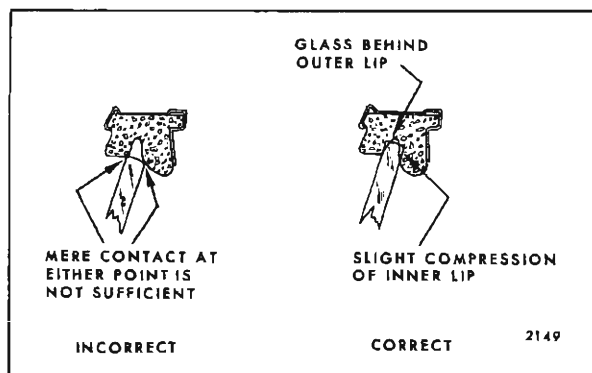

Fig. 6-92—Window to Side Roof Rail Weatherstrip Alignment

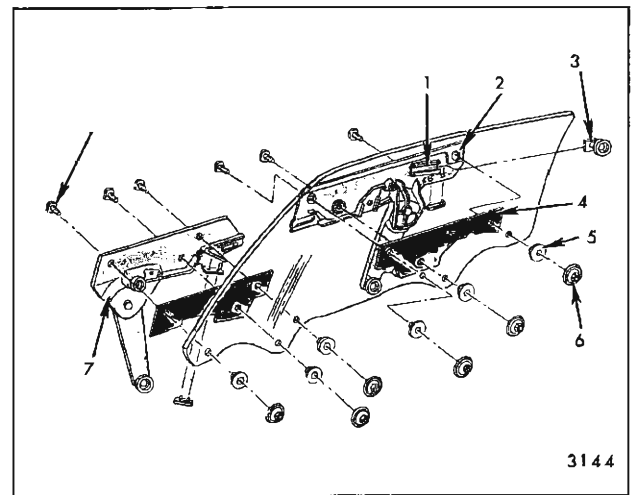

Fig. 6-93—Front Door Window Assembly - "E" Styles

- |                                |                       |
|--------------------------------|-----------------------|
| 1. Sash Channel Plate Rear Cam | 5. Spacer             |
| 2. Rear Sash Channel           | 6. Nut                |
| 3. Cam Roller                  | 7. Front Sash Channel |
| 4. Glass Filler                | 8. Bolt               |

**CAUTION:** Solid tempered safety plate glass will shatter if it is ground, drilled, chipped or scratched. When installing glass to sash channel nuts and washers, torque to 72 inch pounds (6 foot pounds).

### Removal and Installation

1. Remove door trim assembly, inner panel water deflector and glass run channel outer strip assembly or window lower reveal molding (Refer to Index for removal instructions).
2. With the window in the full-up position, remove front and rear up-travel stops ("1" and "2", Figure 6-94).
3. Lower window to a three-quarter-down position; remove lower sash channel cam attaching screws ("3", Figure 6-94). Remove window from door by lifting straight-up.

**NOTE:** If necessary, loosen front and rear guide upper attaching bolts.

4. To install, reverse removal procedure. Adjust window for proper alignment and operation as described in the following adjustment procedure.

### Adjustments

A rotated glass can be corrected by adjustment of inner panel cam ("4", Figure 6-94). Up or down adjustment is available at front and rear up-travel

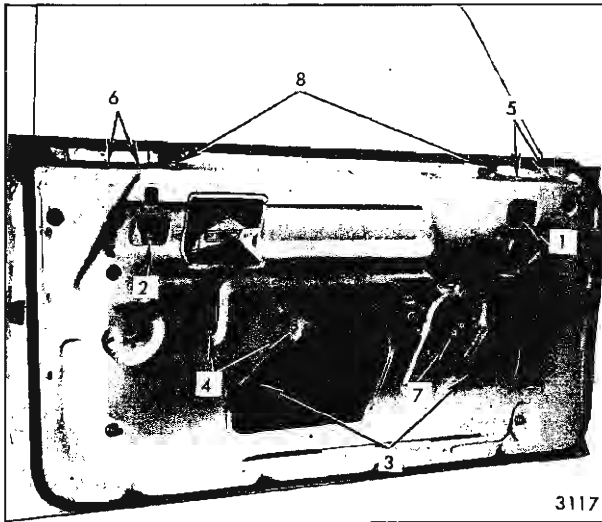

Fig. 6-94—Front Door Window Removal and Adjustment  
"E" Styles

- |  |                                      |
|--|--------------------------------------|
| 1. Window Front Up-Travel Stop                         | 4. Inner Panel Cam Bolts             |
| 2. Window Rear Up-Travel Stop                          | 5. Front Guide Upper Attaching Bolts |
| 3. Lower Sash Channel Cam Attaching Screw Access Holes | 6. Rear Guide Upper Attaching Bolts  |
|  | 7. Sector Gear Stop                  |
|  | 8. Window Stabilizer Strips          |

stops. In or out adjustment is available at front and rear guides. In addition, the regulator, on manually operated units, is equipped with a single up-travel sector gear stop. This stop is bolted to the inner panel and is adjustable up or down (See Figure 6-94).

The recommended sequence of total glass adjustment is as follows:

- Adjust rear guide upper attachments ("6", Figure 6-94) for proper fore or aft position of glass.
- Adjust upper attachments of front and rear guides ("5" and "6", Figure 6-94) for proper glass to side roof rail weatherstrip relationship.
- Adjust window up-travel stops ("1" and "2", Figure 6-94) for proper glass to side roof rail weatherstrip contact (See Figure 6-95).

**NOTE:** On manually operated windows, adjust sector gear stop ("7", Figure 6-94) after adjusting up-stops "1" and "2".

- Adjust window stabilizer strips ("8", Figure 6-94) for proper glass contact and ease of window operation. The strips should

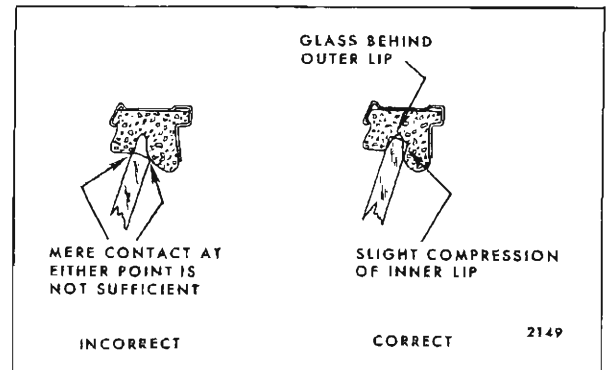

Fig. 6-95—Window to Side Roof Rail Weatherstrip Alignment

contact the glass throughout the full cycle of the window. However, in some cases due to the slight variation in the glass contour, the strip may loose contact with the glass halfway through the cycle. This is permissible provided it does not result in loose glass or restrict ease of window operation.

## FRONT DOOR WINDOW ASSEMBLY— "F" Styles

The front door window assembly consists of a solid tempered safety plate glass window, an individually bolted-on sash channel and roller assembly at the rear and a sash channel and window roller cam assembly at the front. The lower sash channel cam

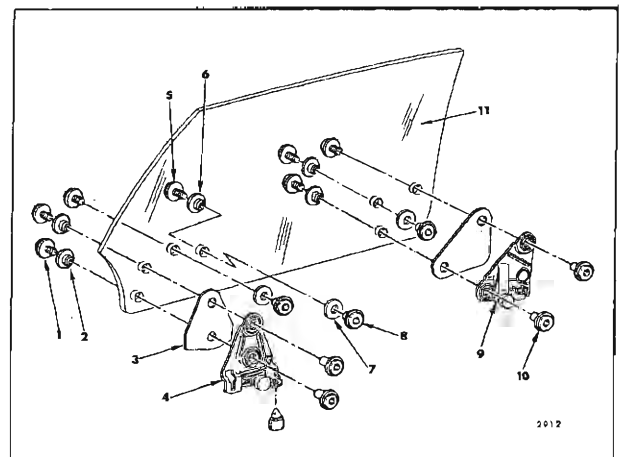

Fig. 6-96—Front Door Window Assembly - "F" Styles

- |  |                                    |
|--|------------------------------------|
| 1. Glass to Sash Channel Bolt                              | 5. Glass Bearing Fastener Bolt     |
| 2. Glass to Sash Channel Bolt Spacer                       | 6. Glass Bearing Spacer            |
| 3. Lower Sash Channel Filler                               | 7. Washer                          |
| 4. Front Lower Sash Channel and Window Roller Cam Assembly | 8. Glass Bearing Fastener          |
|  | 9. Rear Lower Sash Channel         |
|  | 10. Glass to Sash Channel Bolt Nut |
|  | 11. Front Door Window              |

is bolted to the glass, but is removed in the process of removing the window.

Figure 6-96 is an exploded view of the window assembly and identifies the various components and their assembly sequence.

### Removal and Installation

1. Remove door trim pad, inner panel water deflector and outer strip assembly.
2. With window in full-up position, remove rear up-stop from rear guide ("1", Figure 6-97) and front up-stop from front lower sash channel ("2", Figure 6-97).
3. Loosen front and rear stabilizer strips ("3", Figure 6-97) and front and rear guide upper bolts ("5" and "6", Figure 6-97).
4. Lower window to full down position, remove lower sash channel cam to glass attaching nuts ("4", Figure 6-97). Remove window by lifting straight-up, tilting slightly inboard to disengage rollers from guides. Slide window forward and remove rear roller forward of stabilizer strip.
5. To install, reverse removal procedure. Adjust

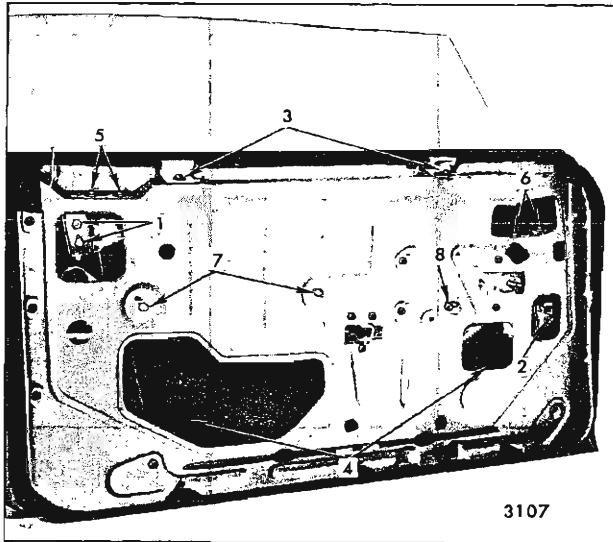

Fig. 6-97—Door Window Removal and Adjustment - "F" Styles

- |  |                                      |
|--|--------------------------------------|
| 1. Window Rear Up-Travel Stop                          | 5. Rear Guide Upper Attaching Bolts  |
| 2. Window Front Up-Travel Stop                         | 6. Front Guide Upper Attaching Bolts |
| 3. Window Front and Rear Stabilizer Strips             | 7. Inner Panel Cam Attaching Bolts   |
| 4. Window Lower Sash Channel Cam Stud Nut Access Holes | 8. Sector Gear Stop Bolt             |

window for proper alignment and operation as described in the following adjustment procedure.

### Adjustments

1. In and out adjustment of the glass is controlled by the in and out adjustment available at the top of the front and rear guide ("6" and "5", Figure 6-97) and the in and out position of the glass stabilizer strip assemblies "3".
2. Fore and aft adjustment of the window assembly is controlled by the position of the rear guide. The upper attaching locations in the inner panel ("5", Figure 6-97) are slotted to permit fore and aft adjustment of the guide. Because of the free floating roller in the window front sash channel cam (Figure 6-96), the front guide does not have to be adjusted during fore or aft window alignment.
3. Ease of window operation and window stability depend to a great extent on the adjustment of the window stabilizer strip assemblies at the beltline ("3", Figure 6-97). The stabilizing strips should contact the glass throughout the full cycle of the window. Due to slight variations in glass contour, however, in some cases the strip may lose contact with the glass halfway through the cycle. This is permissible provided it does not result in loose glass. Contact should be sufficient to stabilize glass, but not restrict ease of window operation.
4. A window that is rotated (cocked) in the window opening may be the result of an improperly adjusted inner panel cam ("7", Figure 6-97) or poorly adjusted up-travel stops ("1" or "2", Figure 6-97).
5. The up-travel of the window is determined by the adjustment of the front up-stop "2", rear up-stop "1" and window regulator sector gear stop ("8", Figure 6-97).

The sequence of stop adjustment is:

- a. Loosen sector gear stop "8".
- b. Adjust stops "1" and "2" up or down for proper glass to side roof rail weatherstrip contact (Figure 6-98).
- c. Adjust stop "8" against sector gear (press stop forward) and tighten stop bolt.

### FRONT DOOR WINDOW ASSEMBLY— "Z" Styles

The front door window assembly consists of a frameless piece of solid tempered safety plate

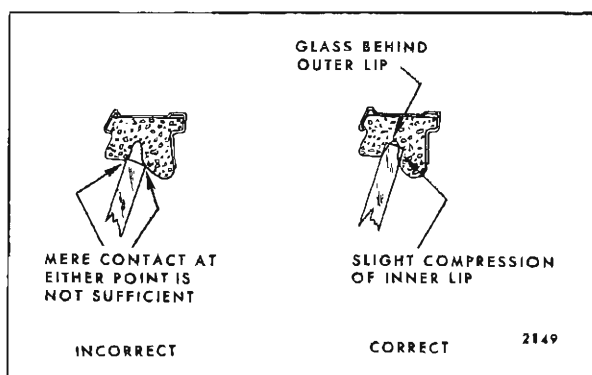

Fig. 6-98—Window to Side Roof Rail Weatherstrip Alignment

glass pressed into a thin-section lower sash channel. When cycled, the glass operates within the ventilator division run channel and the window rear run channel. Guide plates welded to the front and rear of the sash channel also operate in the run channels and give stability to the glass in the full-up position.

**NOTE:** Because these guide plates are not adjustable, it is imperative that replacement door glasses be installed flush with the guide plates at the front and rear of the glass. If glass is too far forward or rearward in relation to guide plates, window assembly will be tight within the run channels.

**CAUTION:** Handle glass with care. Edge chips can cause solid tempered safety plate glass to shatter. **DO NOT** attempt to grind glass.

### Removal and Installation

1. Remove door trim assembly and detach inner panel water deflector. Operate window to an almost full-up position.
2. Working through front and rear upper access holes, remove bolts securing front and rear up-travel stops to lower sash channel and remove stops ("1", Figure 6-99).
3. Lower glass to approximately 3" down from full-up position and remove lower sash channel cam attaching screws ("2", Figure 6-99).
4. Supporting glass with one hand, disengage cam from regulator rollers and remove cam. Lower glass to door bottom.
5. Remove both inner and outer strip assemblies at belt as described under "Glass Run Channel Inner and Outer Strip Assemblies".
6. Loosen ventilator attaching screw and adjusting

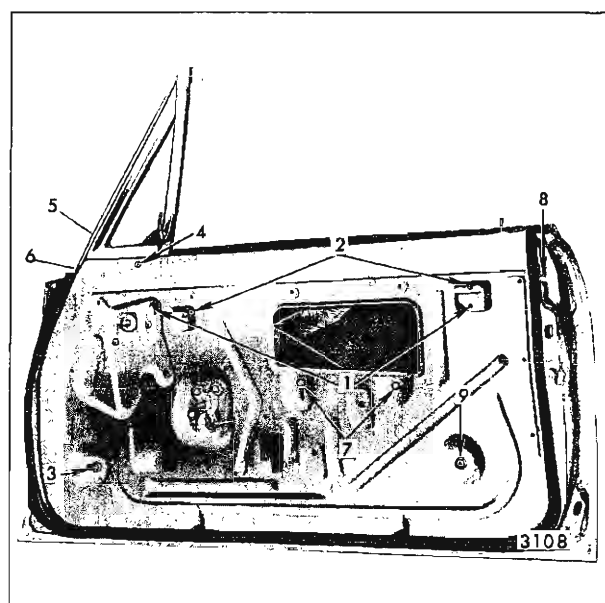

Fig. 6-99—Door Window Removal and Adjustment - "Z" Styles

- |   |  |
|---|--|
| 1. Window Front and Rear Upper Stop Access Holes        | 5. Ventilator Frame Upper Attaching Bolt       |
| 2. Window Lower Sash Channel Cam Attaching Screws       | 6. Ventilator Frame Lower Attaching Stud       |
| 3. Ventilator Division Channel Lower Adjusting Stud     | 7. Inner Panel Cam Attaching Bolts             |
| 4. Door Inner Panel to Ventilator Frame Attaching Screw | 8. Rear Glass Run Channel Upper Attaching Bolt |
|   | 9. Rear Glass Run Channel Lower Adjusting Stud |

stud nuts at points described below and illustrated in Figure 6-99.

- a. Ventilator division channel lower adjusting stud nut "3".
  - b. Door inner panel to ventilator attaching screw "4".
  - c. Ventilator adjusting stud nut and ventilator attaching bolt located on door hinge pillar "6" and "5".
7. Lift window assembly and remove it from between door panels at beltline.
  8. To install, reverse removal procedure. Adjust window as described below. Adjust ventilator as described under "Front Door Ventilator Adjustments".

### Adjustments

1. To adjust the front door window up or down, loosen the front and rear up-travel stops ("1", Figure 6-99), and operate window to desired position. Then, position and tighten adjustable stops on sash channel against welded-on stops on front and rear run channels.

2. To rotate the glass in the opening (lower or raise front edge of glass), loosen the inner panel cam attaching screws ("7", Figure 6-99). Raise or lower adjustable end of cam as required and tighten cam screws.
3. To adjust rear edge of glass in or out at the belt line, loosen the rear glass run channel upper attaching bolt ("8", Figure 6-99) and adjust the run channel in or out as required.
4. To adjust the top edge of glass in or out in relation to side roof rail, loosen lower adjusting stud nut of vent division channel and rear glass run channel ("3" and "9", Figure 6-99). Adjust studs in or out as required, then tighten stud nuts.
5. Slight fore and aft adjustment is available at the vent division channel and rear glass run channel lower adjusting stud locations ("3" and "9", Figure 6-99).

### FRONT DOOR WINDOW REGULATOR— Manual—"A & X" Closed Styles

#### Removal and Installation

1. Remove front door trim assembly and inner panel water deflector.

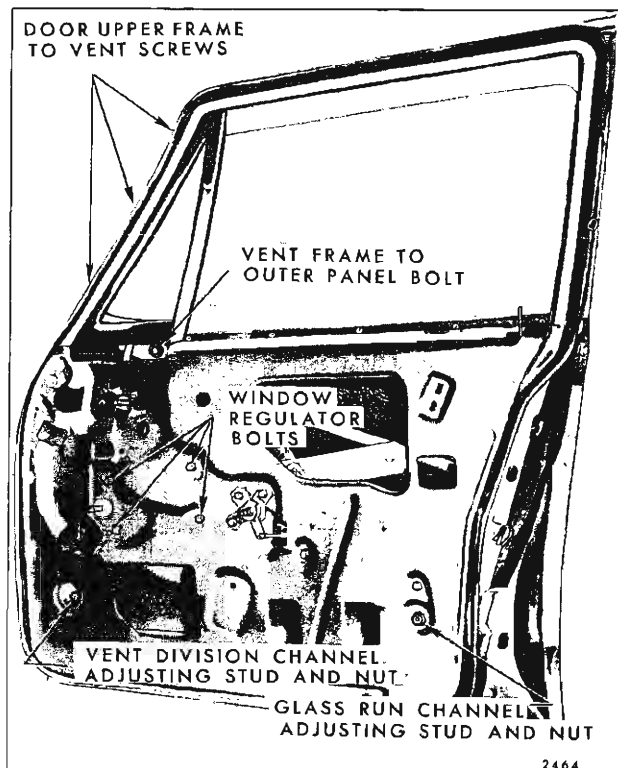

Fig. 6-100—Door Ventilator and Regulator Attachment - "A" Styles

2. Operate window to "full-up" position and secure in place with pieces of cloth-backed body tape applied over door frame.
3. On Two Door Styles, remove inner panel cam as previously described.
4. Remove ventilator division channel lower adjusting stud and nut and window regulator attaching bolts (Figure 6-100).
5. Press ventilator division channel outboard to permit disengagement of regulator spindle from inner panel, then run regulator balance arm roller and lift arm roller out of lower sash channel cam at front. Remove regulator through large access hole.
6. To install, reverse removal procedure.

### FRONT DOOR WINDOW REGULATOR— Electric—"A" Closed Styles

#### Removal and Installation

1. Remove front door trim assembly, inner panel water deflector, window and ventilator as previously described.
2. Disconnect wire harness connector at window regulator motor.
3. Remove window regulator attaching bolts ("1", Figure 6-38) and remove regulator through access hole.
4. To install, reverse removal procedure.

### FRONT DOOR WINDOW REGULATOR— Manual and Electric—"A-39" Styles

#### Removal and Installation

1. Remove door trim assembly and detach inner panel water deflector.
2. On manually operated regulators, prop window in full-up position and remove inner panel cam attaching bolts ("6", Figure 6-40). Remove regulator attaching bolts ("9", Figure 6-40) and remove regulator through large access hole.
3. On electrically operated regulators, remove door window as previously described and disconnect wire harness connector at window regulator motor. Remove the regulator attaching bolts ("9", Figure 6-40). Raise the regulator lift arm up through the beltline and rotate the regulator clockwise so that the regulator can be removed through the large access hole, motor coming out first.

4. To install, reverse removal procedure.

### **FRONT DOOR WINDOW REGULATOR— Manual—“A-37, 67 and 87”, “G-57” and All “B and C” Styles**

#### **Removal and Installation (Refer to Figure 6-42 for “A and G” Styles and Figure 6-50 for “B and C” Styles)**

1. Remove door trim assembly and inner panel water deflector.
2. Lower window and remove lower sash channel cam attaching stud nuts, except on “B” closed styles. On “B” closed styles, the regulator lift and balance arms can be disengaged from lower sash channel cam without removal of cam from glass.

**NOTE:** On “B” closed styles, raise window to full-up position and secure in place with pieces of cloth-backed body tape applied over door upper frame.

On Hardtop and Convertible Styles, prop the window in the full-up position.

3. Remove inner panel cam attaching bolts.
4. Loosen window regulator attaching bolts, remove regulator through large access hole.
5. To install, reverse removal procedure.

### **FRONT DOOR WINDOW REGULATOR— Electric—“A-37, 67 and 87”, “G-57” and All “B and C” Styles**

#### **Removal and Installation**

1. Remove door trim assembly and detach inner panel water deflector.
2. Remove door window and inner panel cam as previously described.
3. Disconnect wire harness connector at regulator motor.
4. Remove window regulator attaching bolts (“8”, Figure 6-50), remove regulator through large access hole.
5. To install, reverse removal procedure.

### **FRONT DOOR WINDOW REGULATOR— Manual and Electric—“F” Styles**

#### **Removal and Installation**

1. Remove door trim assembly and inner panel water deflector.

2. Operate window to a three-quarter down position and remove lower sash channel cam attaching stud nut (“9”, Figure 6-54).
3. Prop window in a full-up position, remove inner panel cam (“5”, Figure 6-54).
4. On styles equipped with electric window regulators, disconnect wire harness connector at window regulator motor.
5. Remove window regulator attaching bolts (“10”, Figure 6-54), remove regulator through large access hole.
6. To install, reverse removal procedure.

### **FRONT DOOR WINDOW REGULATOR— Manual and Electric—“E” Styles**

#### **Removal and Installation**

1. Remove door trim, inner panel water deflector and window as previously described.
2. Remove inner panel cam (“6”, Figure 6-52).
3. On styles equipped with electric window regulators, disconnect wire harness connector at window regulator motor.
4. Remove window regulator attaching bolts (“2”, Figure 6-52) and remove regulator through large access hole.
5. To install, reverse removal procedure.

### **FRONT DOOR WINDOW REGULATOR— Manual—“Z” Styles**

#### **Removal and Installation**

1. Remove door trim assembly, inner panel water deflector, window and ventilator assembly as previously described.
2. Remove inner panel cam (“8”, Figure 6-58).
3. Remove window regulator attaching bolts (“5”, Figure 6-58) and remove regulator through large access hole.
4. To install, reverse removal procedure.

### **FRONT DOOR WINDOW REAR GUIDE— “A-39” Styles**

#### **Removal and Installation**

1. Remove front door trim assembly and inner panel water deflector.

2. With window in full-up position, loosen rear guide window up-travel stop attaching bolt ("3", Figure 6-40), remove stop from guide.
3. Remove rear guide lower attaching bracket to door inner panel attaching bolt ("2", Figure 6-40).
4. Remove rear guide upper attaching bolts ("5", Figure 6-40).
5. Work lower edge of guide past bumper bracket and disengage from roller. Remove guide through access hole.
6. To install reverse removal procedure. For adjustment, refer to door window adjustments.

### **FRONT DOOR WINDOW FRONT GUIDE— "A-37, 67 and 87" Styles and "G-57" Styles**

#### **Removal and Installation**

1. Remove door trim assembly and inner panel water deflector as previously described.
2. Using a 1/4" hex-head wrench, remove front up-travel stop from window front sash channel cam ("13", Figure 6-42).
3. Remove window front guide upper and lower attaching bolts ("11" and "14", Figure 6-42). Pull guide down and rearward to disengage from window front roller and remove guide through access hole.
4. To install, reverse removal procedure. For adjustment, refer to door window adjustments.

### **FRONT DOOR WINDOW REAR GUIDE— "A-37, 67 and 87" Styles and "G-57" Styles**

#### **Removal and Installation**

1. Remove door trim assembly and inner panel water deflector as previously described.
2. With window in a full-up position, remove window rear up-travel stop ("4", Figure 6-42).
3. Remove window rear guide upper and lower attaching bolts ("3" and "6", Figure 6-42). Pull guide down and forward to disengage from window rear roller. Remove guide through access hole.
4. To install, reverse removal procedure. For adjustment, refer to door window adjustments.

### **FRONT DOOR WINDOW FRONT GUIDE— "B and C" Hardtop and Convertible Styles**

#### **Removal and Installation**

1. Remove front door trim assembly and inner panel water deflector.
2. With window in full-up position, remove front up-stop from guide (Refer to Figure 6-48) for two door styles and Figure 6-50) for four door styles).
3. Remove front guide upper and lower attaching bolts. Refer to Figure 6-48 for two door styles and Figure 6-50 for four door styles.
4. Pull guide down and rearward to disengage from window front roller, remove guide through large access hole.
5. To install, reverse removal procedure. For adjustment, refer to door window adjustments.

### **FRONT DOOR WINDOW REAR GUIDE— "B and C" Hardtop and Convertible Styles**

#### **Removal and Installation**

1. Remove front door trim assembly and inner panel water deflector.
2. With window in full-up position, remove rear up-stop from guide (Refer to Figure 6-48 for two door styles and Figure 6-50 for four door styles).
3. Refer to Figure 6-48 for two door styles and Figure 6-50 for four door styles and remove rear guide upper and lower attaching bolts.
4. Pull guide down and forward to disengage from window rear roller, remove guide through large access hole.
5. To install, reverse removal procedure. For adjustment, refer to door window adjustments.

### **FRONT DOOR WINDOW REAR GUIDE— "B-36, 46 and 69" Styles**

#### **Removal and Installation**

1. Remove front door trim assembly and inner panel water deflector.
2. With window in full-up position, remove rear guide upper attaching bolts ("4", Figure 6-46)

and lower adjusting stud nut ("5", Figure 6-46).

3. Pull guide down and forward to disengage from window roller, remove from door through large access hole.
4. To install, reverse removal procedure. For adjustment, refer to door window adjustments.

### **FRONT DOOR WINDOW FRONT GUIDE— "E" Styles**

#### **Removal and Installation**

1. Raise door window. Remove trim pad and detach inner panel water deflector.
2. Remove front door window assembly.
3. Remove front guide lower adjusting stud nut and upper two attaching bolts, remove guide assembly ("4 and 9" Figure 6-52).
4. To install, reverse removal procedure. For adjustment, refer to door window adjustments.

### **FRONT DOOR WINDOW REAR GUIDE— "E" Styles**

#### **Removal and Installation**

1. Raise door window. Remove trim pad and detach inner panel water deflector.
2. Remove front door window assembly.
3. Remove rear guide lower adjusting stud nut and upper two attaching bolts, remove guide assembly ("10 and 11", Figure 6-52).
4. To install, reverse removal procedure. For adjustment, refer to door window adjustments.

### **FRONT DOOR WINDOW FRONT GUIDE— "F" Styles**

#### **Removal and Installation**

1. Remove door trim assembly and inner panel water deflector.
2. With window in half-down position, remove front guide upper and lower attaching bolts ("11, and 12", Figure 6-54).
3. Disengage guide from window roller and remove through large access hole.
4. To install, reverse removal procedure. For adjustment, refer to door window adjustments.

### **FRONT DOOR WINDOW REAR GUIDE— "F" Styles**

#### **Removal and Installation**

1. Remove door trim assembly and inner panel water deflector.
2. Remove rear guide upper and lower attaching bolts ("2 and 4", Figure 6-54).
3. Pull guide down and forward to disengage from window roller and remove guide from door.
4. To install, reverse removal procedure. For adjustment, refer to door window adjustments.

### **FRONT DOOR WINDOW REAR GLASS RUN CHANNEL—"Z" Styles**

#### **Removal and Installation**

1. Lower door window and remove door trim pad and inner panel water deflector.
2. Remove glass run channel upper attaching bolt and lower adjusting stud nut ("9 and 11", Figure 6-58).
3. Disengage run channel from rear edge of glass and remove run channel through large access hole.
4. To install, reverse removal procedure. For adjustment, refer to door window adjustments.

### **FRONT DOOR WINDOW GLASS RUN CHANNEL—"A and X" Closed Styles**

#### **Removal and Installation**

1. Remove front door window as previously described.
2. Starting at the upper front corner of the door upper frame, press (Finger pressure) sides of run channel together and pull channel from frame.
3. To install, reverse removal procedure.

### **FRONT DOOR WINDOW GLASS RUN CHANNEL—"B" Closed Styles**

#### **Removal and Installation**

1. Remove door window as previously described.
2. On "B-11" styles, remove front and rear glass run channel attaching bolts (Figure 6-101). On "B-36, 46 and 69" styles, remove glass run channel rear bolt (Figure 6-101).



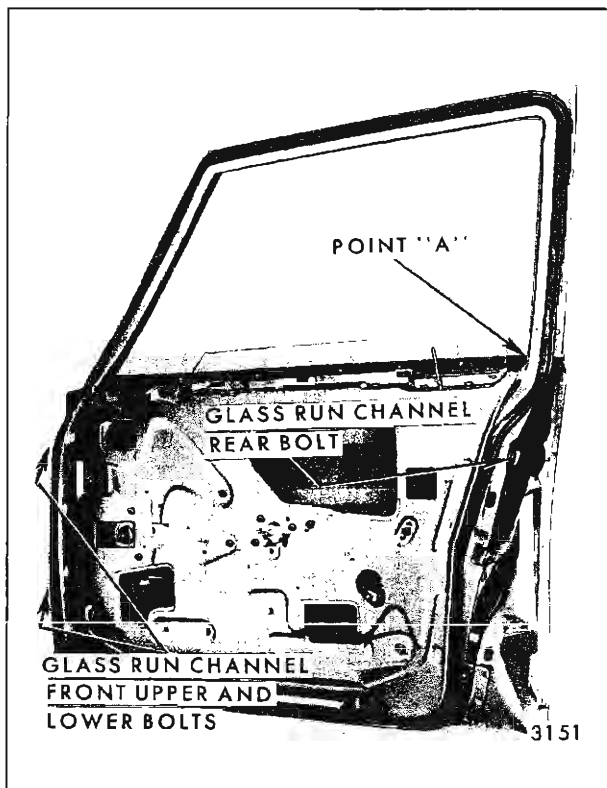

Fig. 6-101—Glass Run Channel Installation "B" Closed Styles

**NOTE:** "B-36, 46 and 69" styles utilize a two piece upper and lower glass run channel at the front. For removal of front lower glass run channel, remove glass run channel front

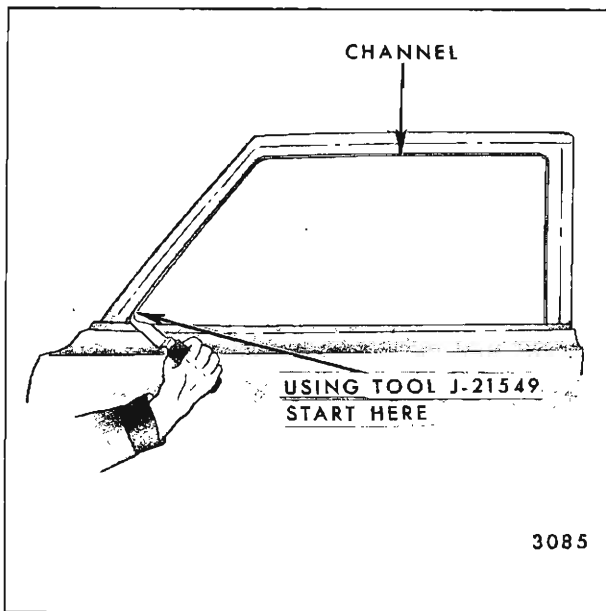

Fig. 6-102—Door Window Glass Run Channel Removal

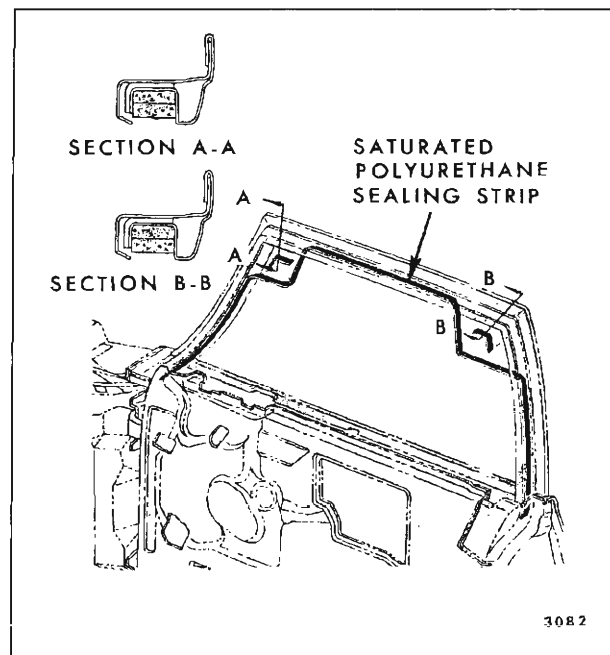

Fig. 6-103—Front Door Window Glass Run Channel Sealing - "B" Closed Styles

- upper and lower bolts. Remove through access hole, Figure 6-101.
3. From outside door, insert a sharp pointed right angle tool (reveal molding clip disengaging tool J-21549 or equivalent) between outer edge of glass run channel and door upper frame as shown in Figure 6-102. Slide the tool rearward until a clip is contacted, then engage point of tool under clip and carefully pry inboard to release clip tangs from door frame.
  4. Repeat Step 3 at each clip location until run channel is completely disengaged from door frame.
  5. Remove glass run channel from door through window opening at beltline.
  6. To install, reverse removal procedure. Begin installation by installing glass run channel rear attaching bolt (Figure 6-101). Starting at Point "A", Figure 6-101, engage run channel attaching clips into door upper frame making certain that run channel is fully seated, particularly at upper corners.

**NOTE:** Prior to installation, inspect run channel clips and saturated polyurethane foam sealing strips in door upper frame (Figure 6-103). Reform distorted clips to insure adequate retention.

Replace damaged sealing strips with service part which is available in five foot lengths (Part #4480378 or equivalent).

### DOOR WEDGE PLATES—"67" Styles

Door wedge plates are used on convertible styles to give additional support to the door when it is

in the closed position. One plate is installed to the body lock pillar and the other to the door lock pillar (Figure 6-104). The plates should contact each other to the extent of a  $1/32$ " interference when the door is closed. Body side wedge plate shims are available as a service part so that this interference can be obtained.

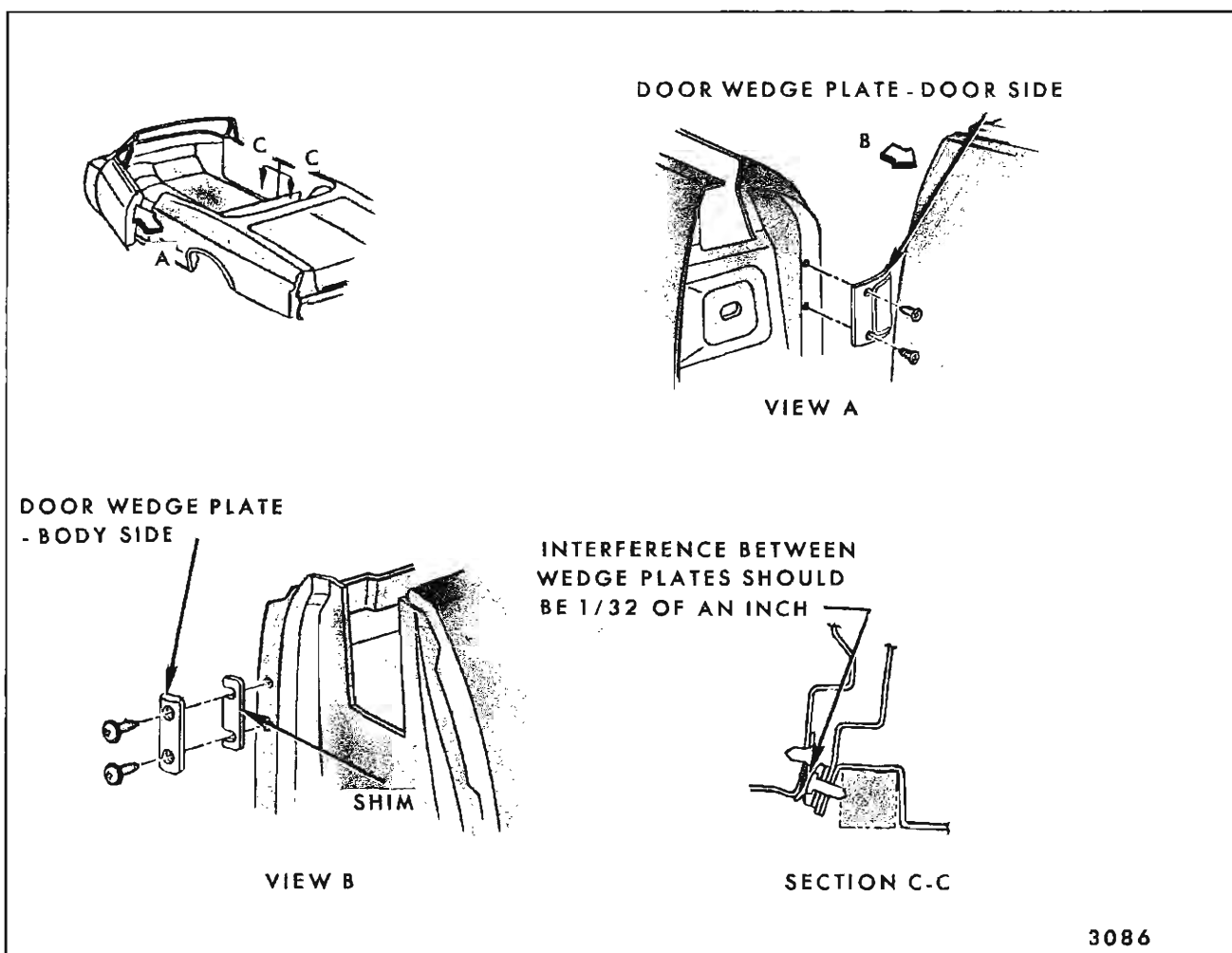

Fig. 6-104—Door Wedge Plates "67" Styles

## REAR DOORS

### DESCRIPTION

Information in this section concerns operations applicable to rear doors only. Procedures for removal of water deflectors, door handles and weatherstrips are outlined in the "Front and Rear Door" section of this manual - see index. Door trim assemblies are covered in Section 14 - see index

Illustrations 6-105 through 6-114 are typical of rear doors with the trim assembly and inner panel water deflector removed. These figures identify

the component parts of the rear door assembly (by style), their relationship and various attaching points.

### REAR DOOR HINGES—All Styles

All rear door hinges are constructed of steel or a combination of steel and malleable iron. A one stage hold-open feature is incorporated in all lower hinges, except on a "A" styles which have a two stage hold-open feature and "X" styles which do not have a hold-open feature.

Doors can be removed by either removing the door

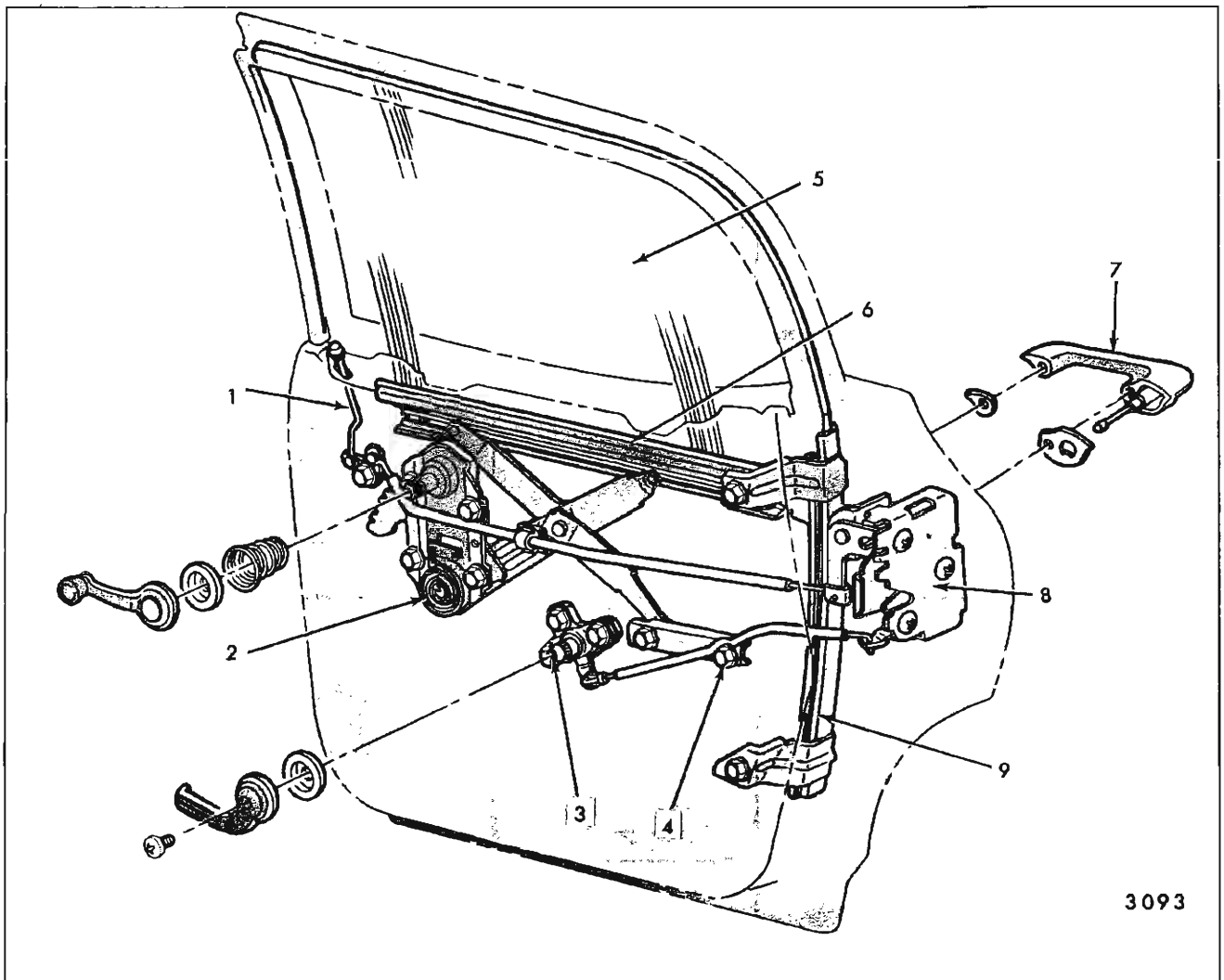
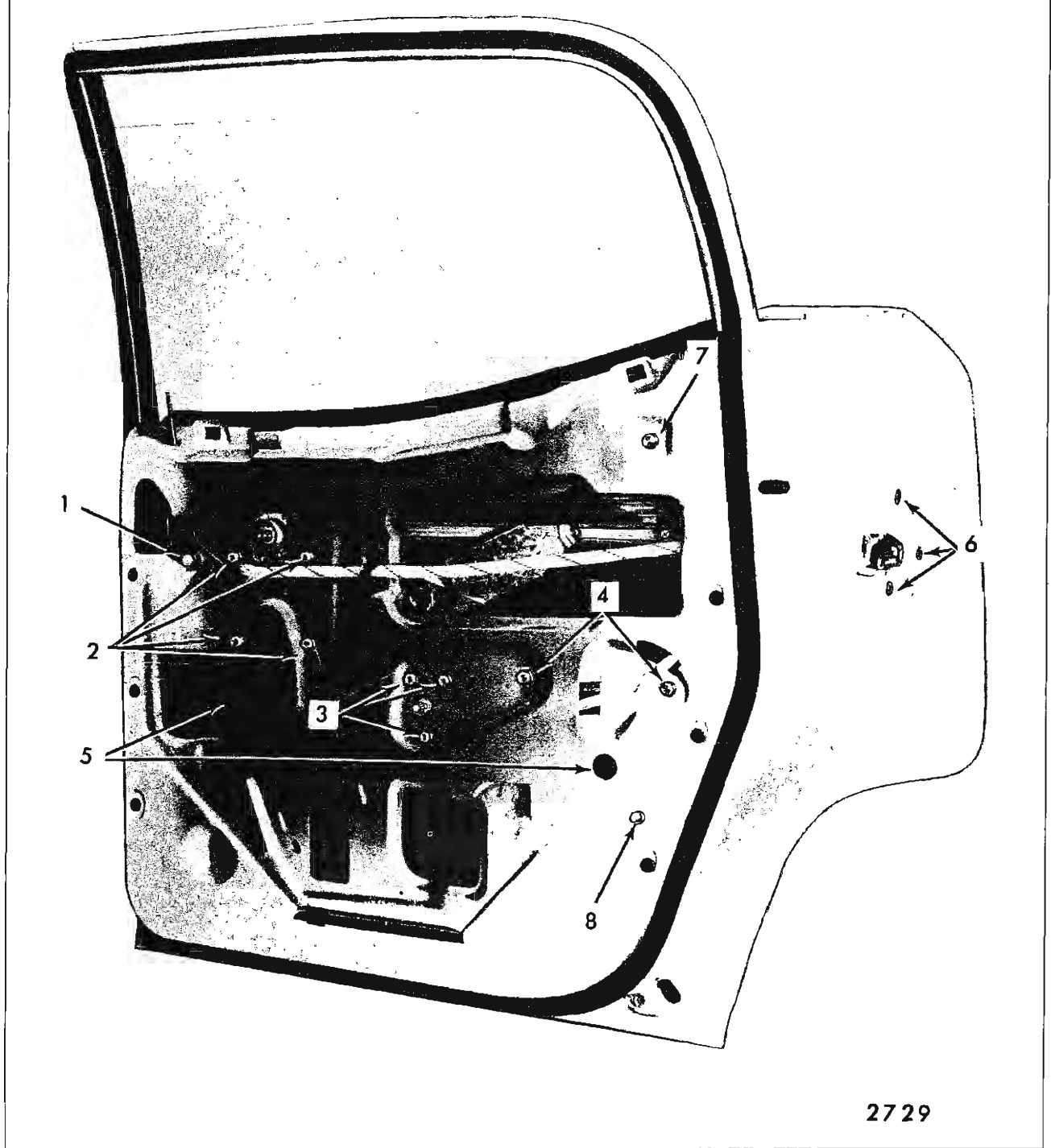

Fig. 6-105—Rear Door Hardware - "A" Closed Styles

1. Inside Locking Rod
2. Window Regulator - Manual
3. Door Lock Remote Control

4. Inner Panel Cam
5. Rear Door Window
6. Lower Sash Channel Cam

7. Door Outside Handle
8. Door Lock
9. Glass Run Channel



2729

Fig. 6-106—Rear Door Hardware - "A" Closed Styles

- 1. Inside Locking Rod to Lock Connecting Link Attaching Bolt
- 2. Window Regulator Attaching Bolts
- 3. Door Lock Remote Control Attaching Bolts

- 4. Inner Panel Cam Attaching Bolts
- 5. Lower Sash Channel Cam Attaching Screws Access Holes
- 6. Door Lock Attaching Screws

- 7. Glass Run Channel Upper Attaching Bolt
- 8. Glass Run Channel Lower Attaching Bolt

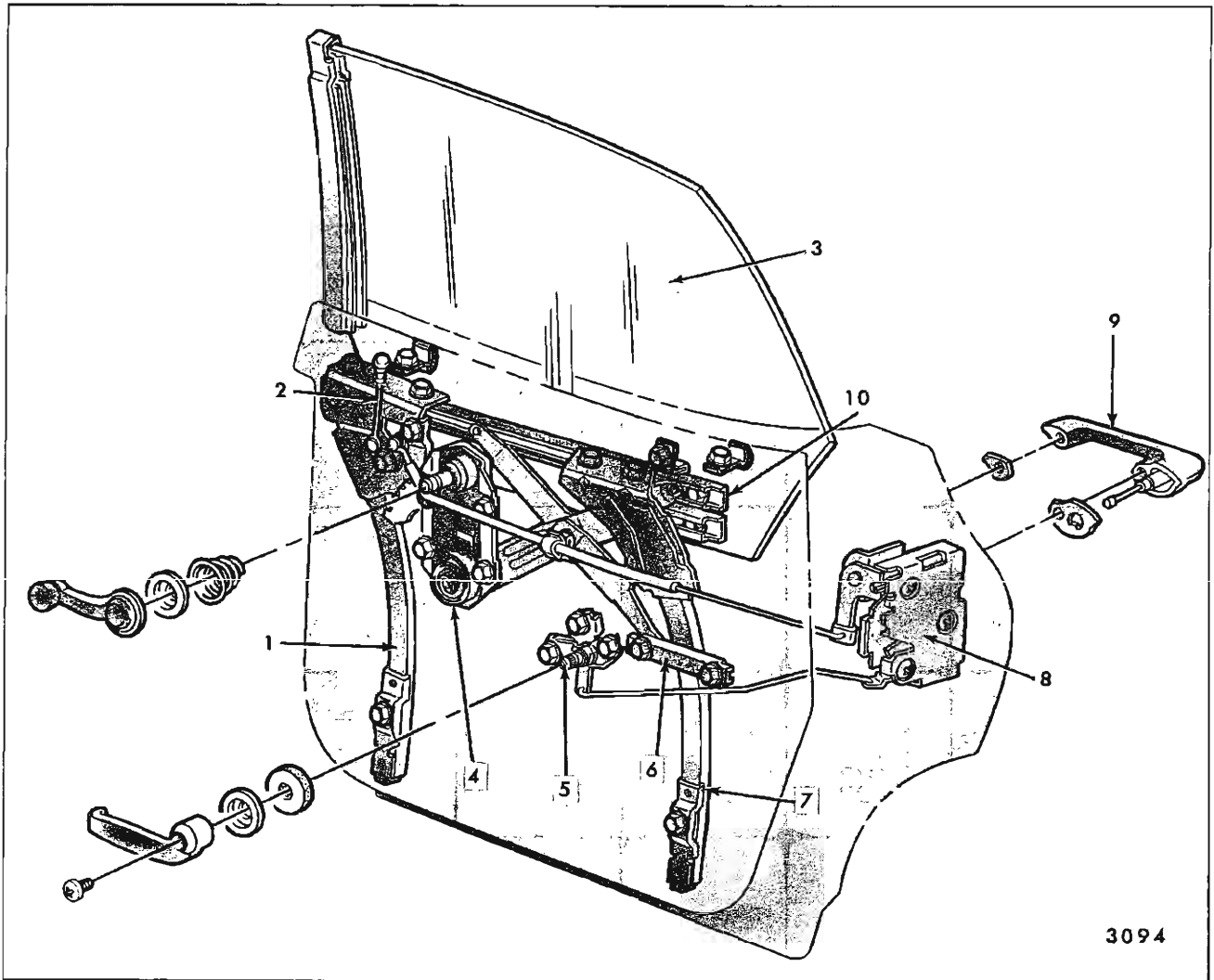

Fig. 6-107—Rear Door Hardware - "A-39" Styles

- |                              |                            |
|------------------------------|----------------------------|
| 1. Front Guide               | 6. Inner Panel Cam         |
| 2. Inside Locking Rod        | 7. Rear Guide              |
| 3. Rear Door Window          | 8. Door Lock               |
| 4. Window Regulator - Manual | 9. Door Outside Handle     |
| 5. Door Lock Remote Control  | 10. Lower Sash Channel Cam |

from the hinges or by removing the door and hinges as an assembly from the center pillar.

### Removal

1. With a pencil, mark location of hinges on door or center pillar, depending on removal method being used.
2. On styles equipped with electric window regulators or power operated locks, proceed as follows:
  - a. Remove door trim assembly and inner panel water deflector.
  - b. Disconnect wire harness connector from regulator motor, vacuum hoses from lock actuator and/or wire harness connector from electric lock solenoid.
  - c. Remove electric conduit from door, then remove wire harness and/or vacuum hoses from door through conduit access hole.
3. With door properly supported, loosen upper and lower hinge attaching screws or bolts from door or center pillar and remove door from body. Figure 6-115 is typical of rear door hinge attachment.

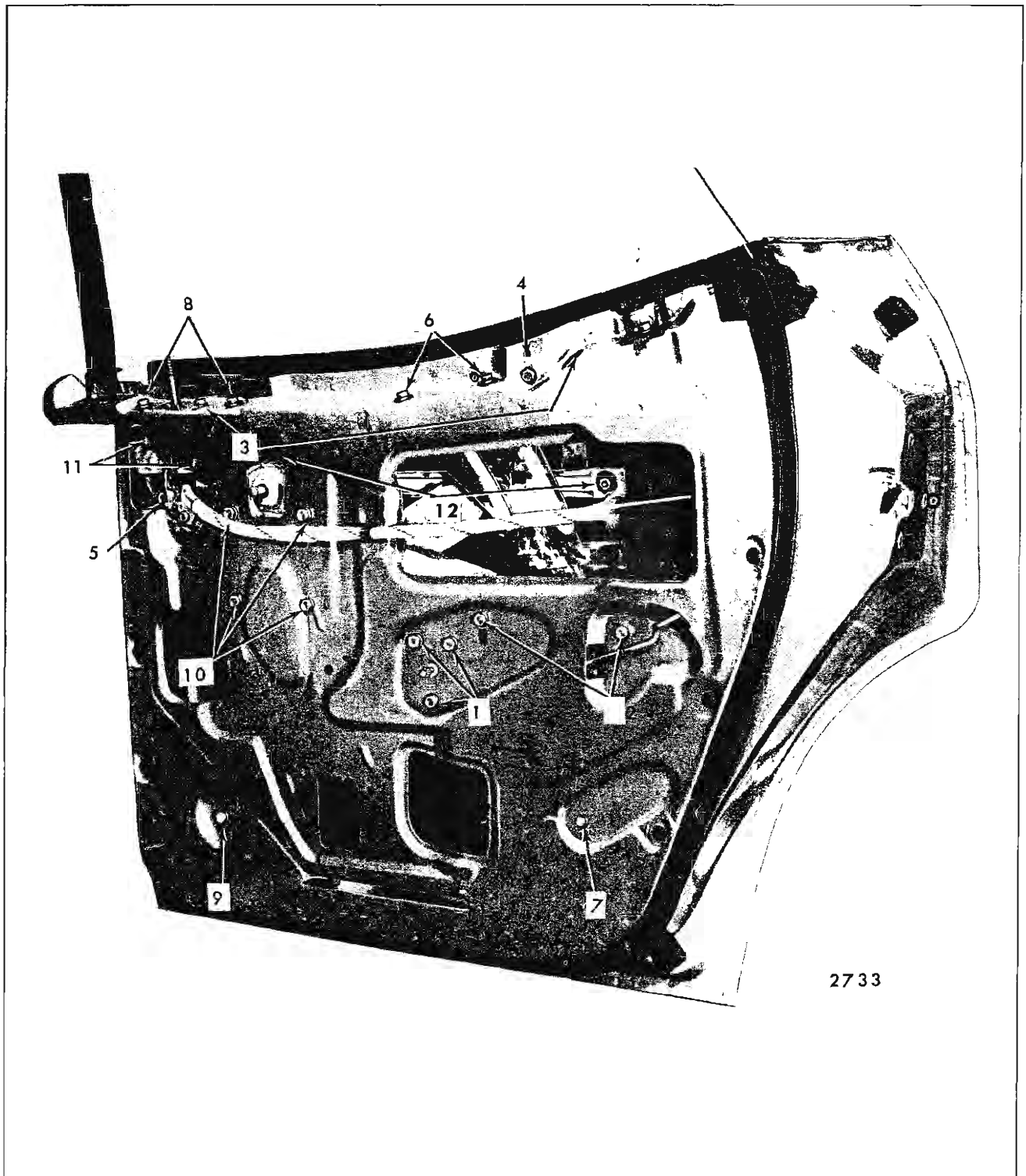

Fig. 6-108—Rear Door Hardware - "A-39" Styles

- |   |  |  |
|---|--|--|
| 1. Door Lock Remote Control Attaching Bolts | 6. Rear Guide Upper Attaching Bolts          | 10. Window Regulator Attaching Bolts             |
| 2. Inner Panel Cam Attaching Bolts          | 7. Rear Guide Lower Attaching Bolts          | 11. Front Guide to Upper Support Attaching Bolts |
| 3. Window Stabilizer Strip                  | 8. Front Guide Upper Support Attaching Bolts | 12. Window Lower Sash Channel Cam Stud Nuts      |
| 4. Window Rear Up-Travel Stop               |  |  |
| 5. Window Front Up-Travel Stop              |  |  |
|   | 9. Front Guide Lower Attaching Bolt          |  |

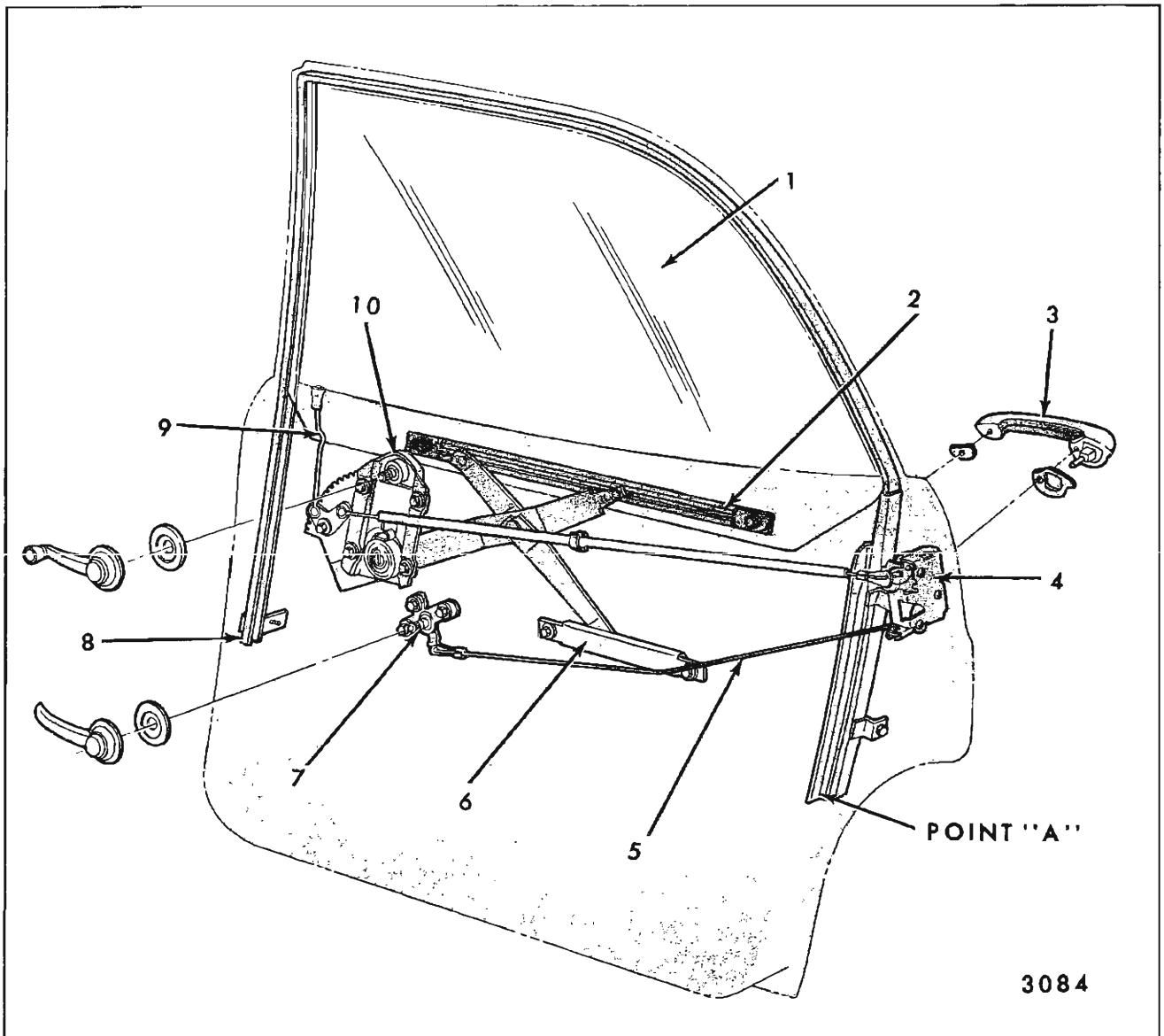

Fig. 6-109—Rear Door Hardware - "B" Closed Styles

- |                                       |                                  |  |
|---------------------------------------|----------------------------------|--|
| 1. Window Assembly                    | 4. Door Lock                     | 8. Glass Run Channel (Extends Completely Around Window to Point "A") |
| 2. Lower Sash Channel Cam             | 5. Remote Control Connecting Rod | 9. Inside Locking Rod  |
| 3. Outside Handle and Sealing Gaskets | 6. Inner Panel Cam               | 10. Window Regulator   |
|                                       | 7. Remote Control                |  |

### Installation

1. Clean off old sealer at hinge attaching areas.
2. Apply a coat of heavy-bodied sealer to surface of hinge that mates with door or center pillar to prevent corrosion.
3. With aid of a helper, lift door into position and loosely install hinge screws. Align hinges within pencil marks previously made and tighten hinge screws.

4. Install all previously removed parts and check door for proper alignment.

**NOTE:** When replacing or adjusting door hinges, torque bolts to 14 to 18 foot pounds.

### Adjustments

In-or-out and up-or-down adjustment is available at the door side hinge attaching screws. Fore-or-aft and a slight up-or-down adjustment is available at the body side (center pillar) hinge attaching screws.

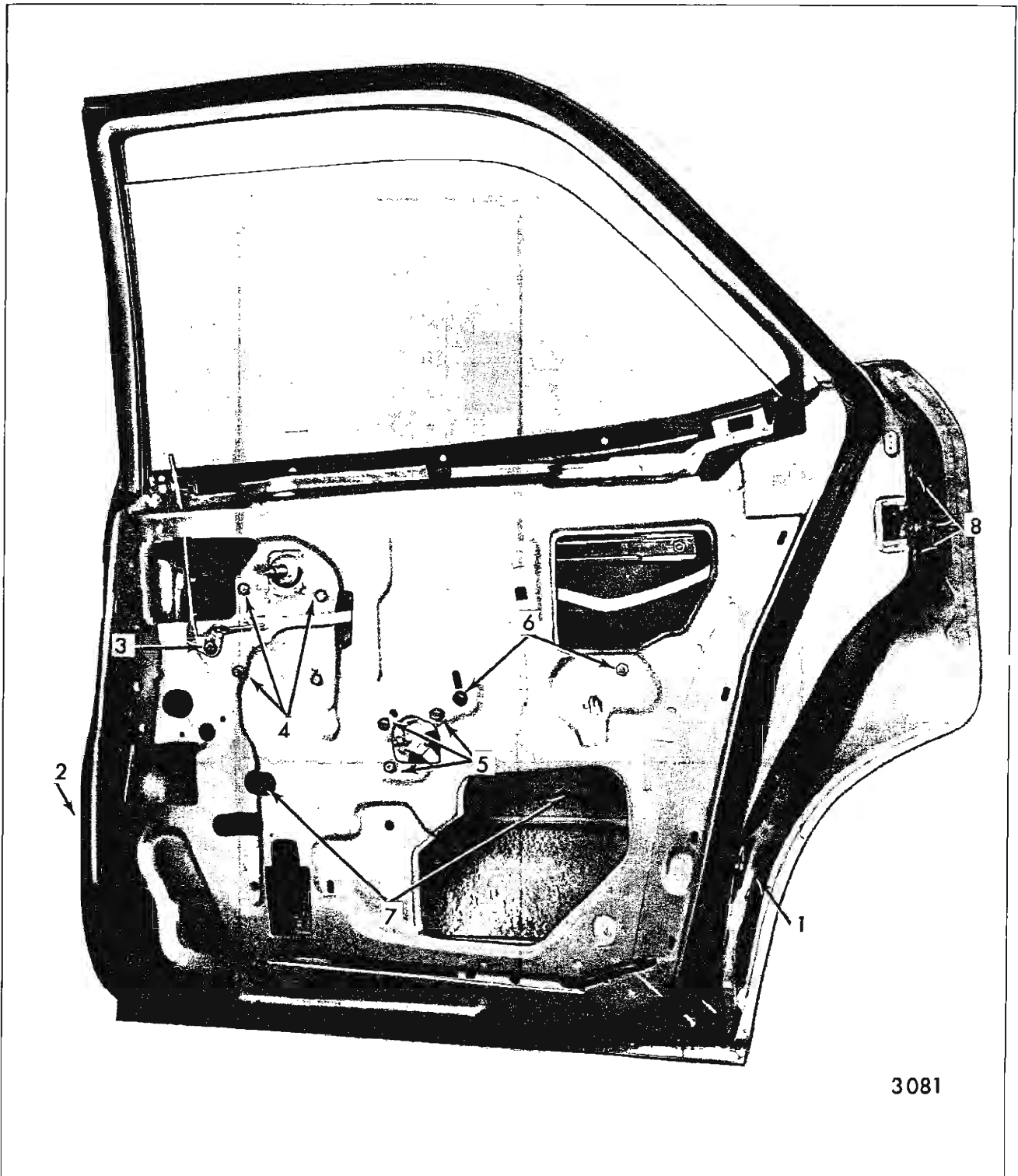
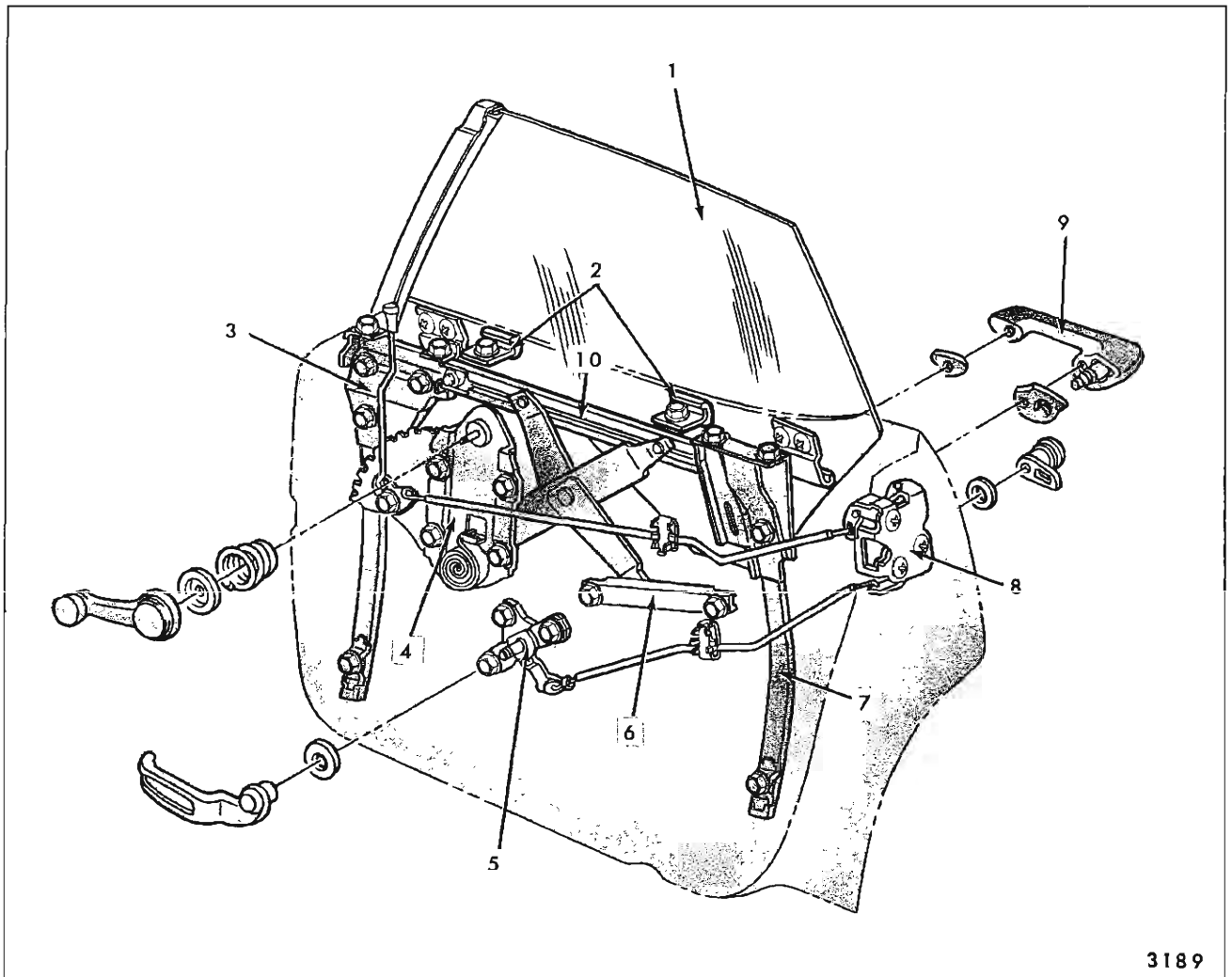

Fig. 6-110—Rear Door Hardware - "B" Closed Styles

- |  |   |   |
|--|---|---|
| 1. Glass Run Channel Rear Attaching Bolt   | 4. Window Regulator Attaching Bolts         | 7. Window Lower Sash Channel Cam Stud Nuts Access Holes |
| 2. Glass Run Channel Front Attaching Bolt  | 5. Door Lock Remote Control Attaching Bolts | 8. Door Lock Attaching Screws                           |
| 3. Inside Locking Rod Connecting Link Bolt | 6. Inner Panel Cam Attaching Bolts          |   |





3189

Fig. 6-111—Rear Door Hardware - "B-39" and "C-39, 49 and 69" Styles

- |                              |                             |                            |
|------------------------------|-----------------------------|----------------------------|
| 1. Rear Door Window          | 5. Door Lock Remote Control | 9. Door Outside Handle     |
| 2. Stabilizer Strips         | 6. Inner Panel Cam          | 10. Lower Sash Channel Cam |
| 3. Front Guide               | 7. Rear Guide               |                            |
| 4. Window Regulator - Manual | 8. Door Lock                |                            |

### REAR DOOR LOCK REMOTE CONTROL

There are two basic types of door lock remote controls; the "spindle" type which rotates upward when actuated and the "inward" acting type. Both type remote controls are secured to the door inner panel by three attaching bolts. On some styles it is mounted on the inboard surface of the door inner panel, and on others, on the outboard surface. Figure 6-106 illustrates the spindle type door lock remote control installation. The inward acting type is similar.

#### Removal and Installation

1. Remove rear door trim assembly and inner panel water deflector.

2. Remove remote control attaching bolts ("3", Figure 6-106).
3. Pivot remote to disengage it from remote control to lock connecting rod and remove remote control from door.
4. To install, reverse removal procedure. Make certain anti-rattle clip on lock connecting rod is properly positioned.

### REAR DOOR LOCK ASSEMBLY— All Styles

All styles use the fork bolt lock design which includes a safety interlock feature. Where necessary, striker spacers should be used to insure

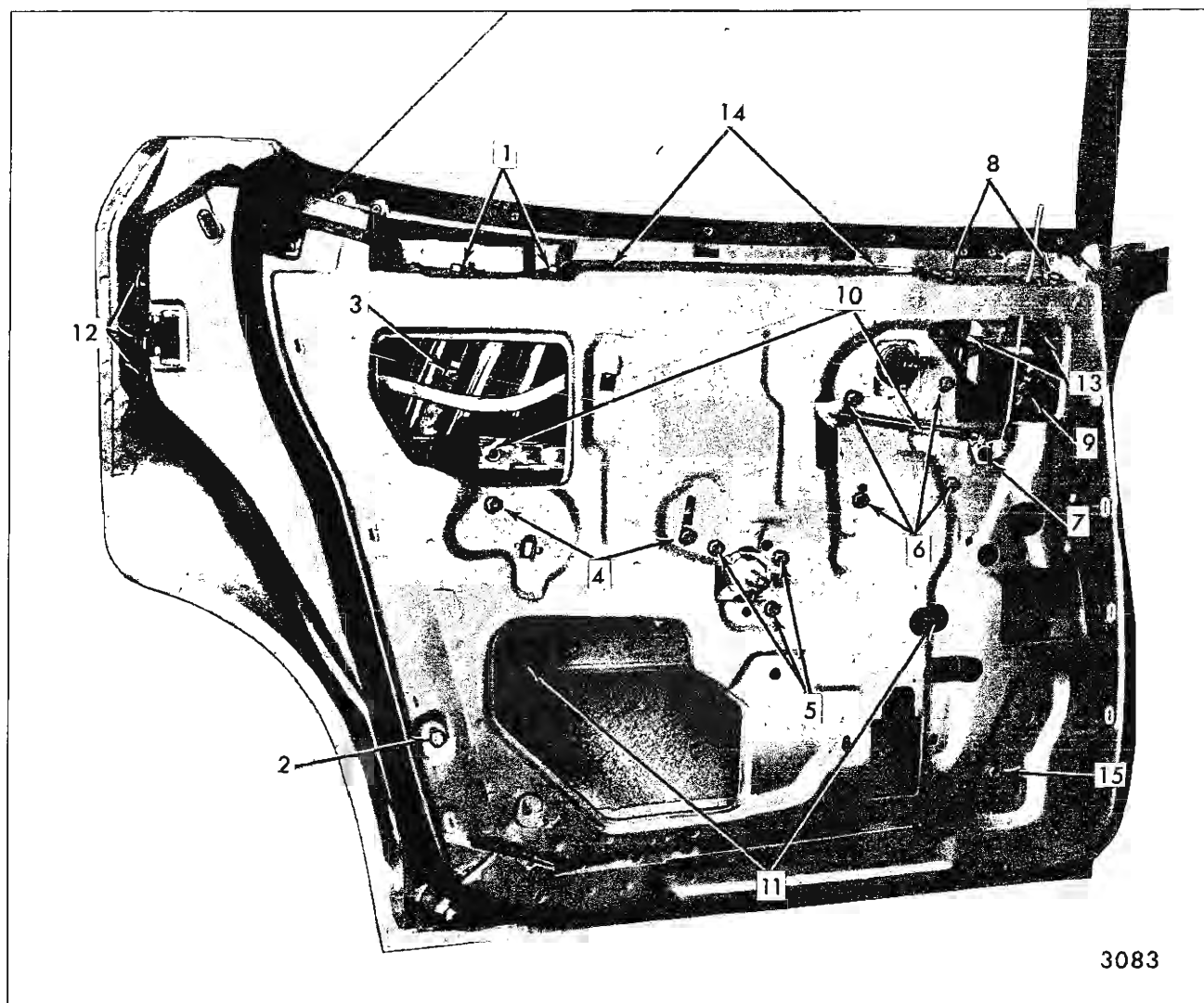

Fig. 6-112—Rear Door Hardware - "B-39" and "C-39, 49 and 69" Styles

- |  |   |   |
|--|---|---|
| 1. Rear Guide Upper Attaching Bolts          | 7. Inside Locking Rod to Lock Connecting Link Attaching Bolt                              | 11. Window Lower Sash Channel Cam Stud Nuts Access Holes (with Manual Window Regulator) |
| 2. Rear Guide Lower Attaching Bolt           | 8. Front Guide Support Bracket Attaching Bolts  | 12. Door Lock Attaching Screws  |
| 3. Window Rear Up-Travel Stop Attaching Bolt | 9. Window Front Up-Travel Stop  | 13. Front Guide to Upper Support Bracket Attaching Bolts                                |
| 4. Inner Panel Cam Attaching Bolts           | 10. Window Lower Sash Channel Cam Stud Nuts Access Holes (with Electric Window Regulator) | 14. Window Stabilizer Strips  |
| 5. Door Lock Remote Control Attaching Bolts  |   | 15. Front Guide Lower Attaching Bolt  |
| 6. Window Regulator Attaching Bolts          |   |   |

satisfactory lock striker engagement. Refer to "Front and Rear Door" section for spacer usage.

**NOTE:** Figure 6-116 depicts a typical front door lock assembly which can be used for identifying locking problems. **DO NOT ALTER OR REPAIR LOCK ASSEMBLIES.** Replace a defective lock with a new lock assembly.

#### Removal and Installation

1. Remove door trim assembly and inner panel water deflector.

2. Operate glass to full-up position.

3. Working through access hole, disengage lock connecting rods from spring clips on door lock (for clip disengagement refer to "Door Lock Spring Clips" in Front and Rear Door Section).

4. Remove door lock attaching screws ("6", Figure 6-106) and remove lock from door.

5. To install, reverse removal procedure.

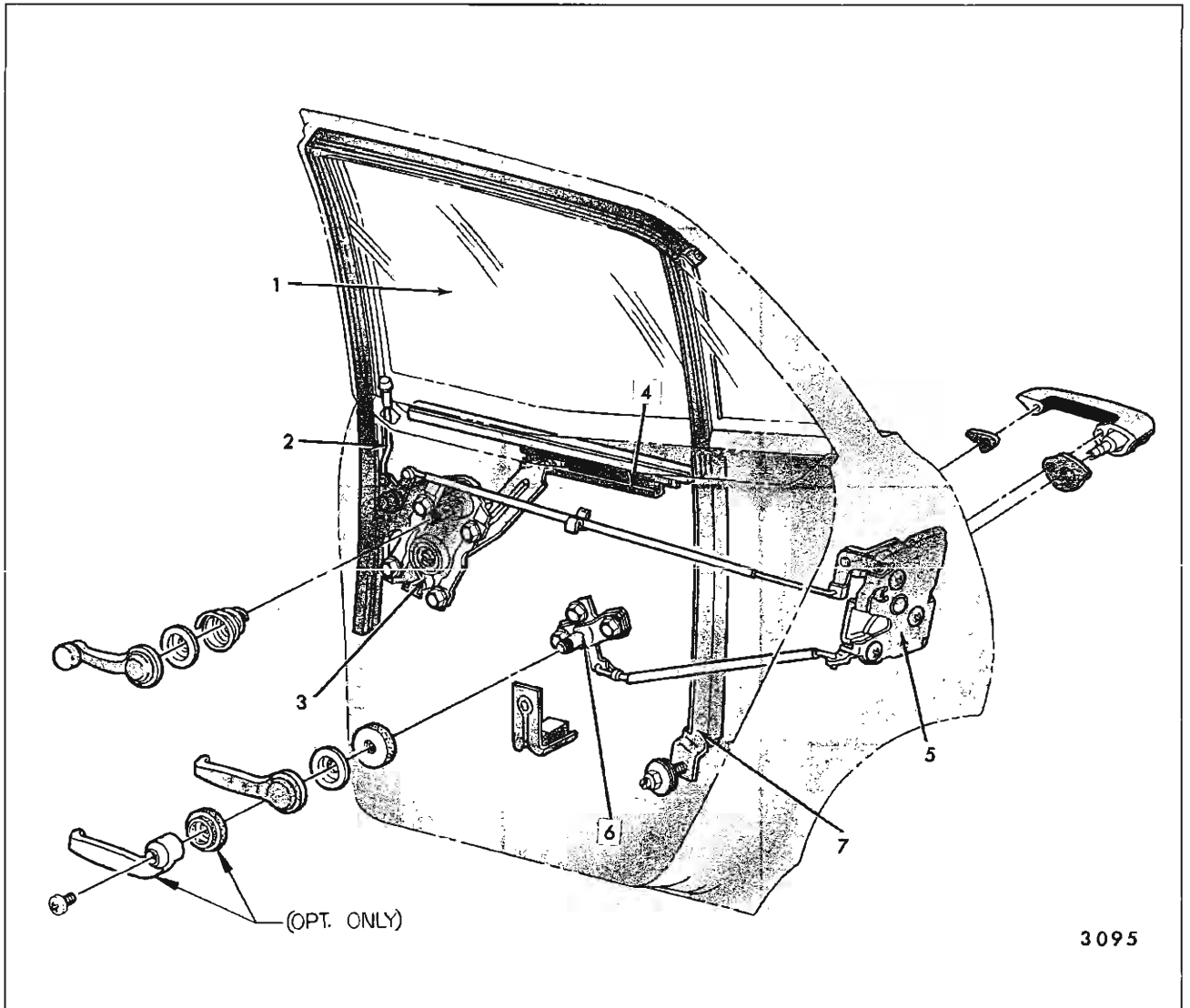

Fig. 6-113—Rear Door Hardware - "X" Style

- 1. Rear Door Window
- 2. Inside Locking Rod
- 3. Window Regulator

- 4. Lower Sash Channel  
Cam
- 5. Door Lock

- 6. Door Lock Remote Control
- 7. Ventilator Division  
Channel

**REAR DOOR INNER PANEL CAM—  
All Except "A & X-69" Styles**

front end of cam for proper window operation. Correct adjustment of cam will prevent a rotated (cocked) door window.

**Removal and Installation**

1. Remove door trim assembly and inner panel water deflector.
2. Remove inner panel cam attaching bolts ("4", Figure 6-106). Disengage cam from regulator balance arm roller and remove cam from door.
3. To install, reverse removal procedure. Adjust

**REAR DOOR WINDOW ASSEMBLY—  
"A" Closed Styles**

The rear door window assembly consists of a frameless solid tempered safety plate glass window and a pressed-on lower sash channel assembly. When handling window, make certain glass does not develop edge chips or deep scratches which could cause glass to shatter.

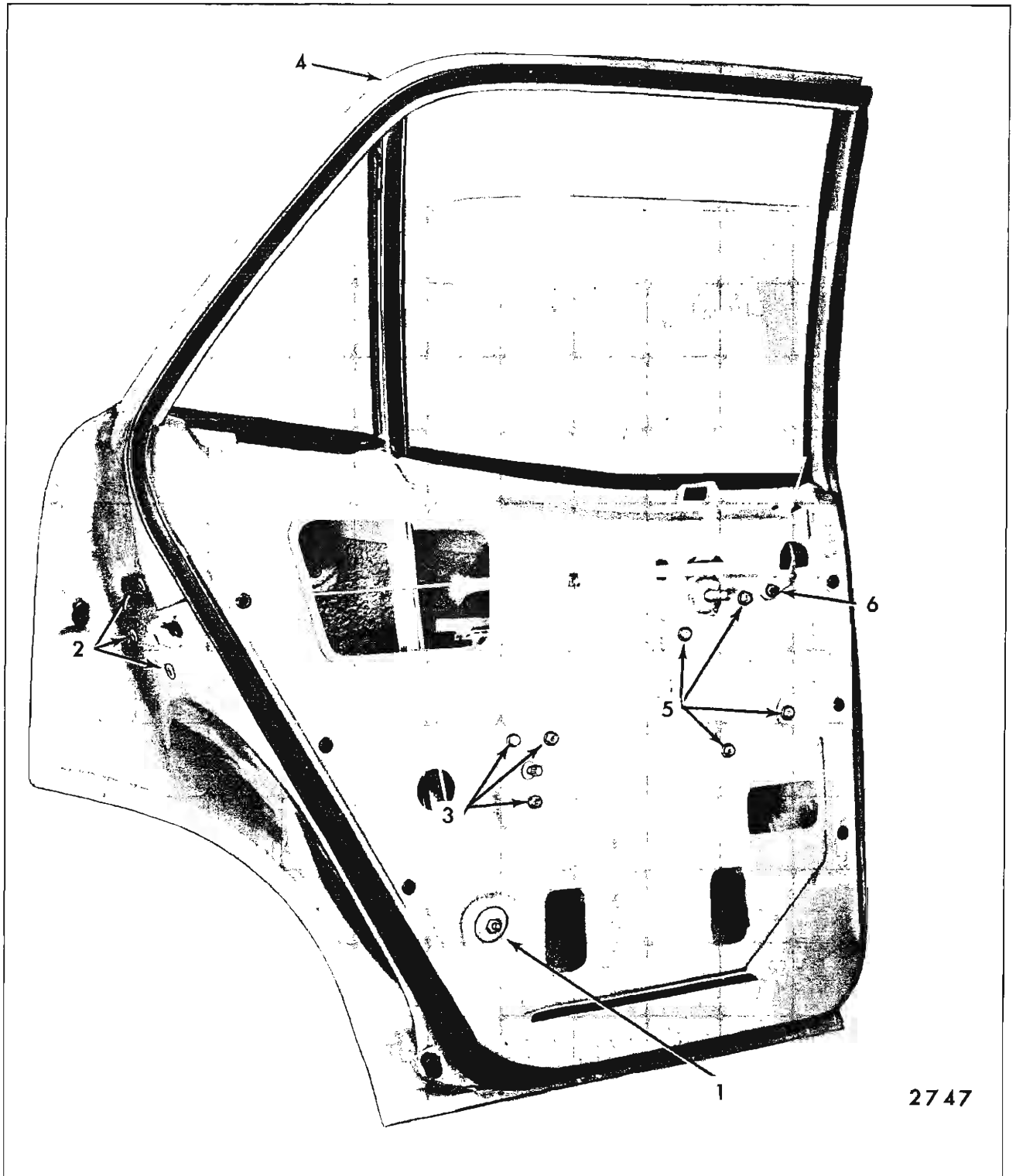

Fig. 6-114—Rear Door Hardware - "X" Style

1. Ventilator Division Channel Lower  
Adjusting Stud  
2. Door Lock Attaching Screws

3. Door Lock Remote Control  
Attaching Bolts  
4. Ventilator Division Channel  
Upper Attaching Screw

5. Window Regulator Attaching Bolts  
6. Inside Locking Rod to Lock  
Connecting Link Attaching Bolt

2747

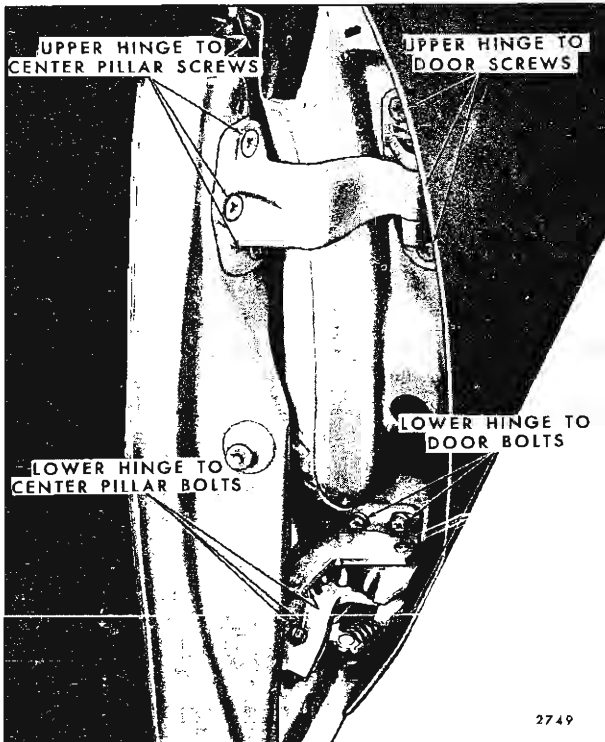

Fig. 6-115—Typical Rear Door Hinge Installation

### Removal and Installation

1. Remove door trim assembly and inner panel water deflector.
2. With window in a three-quarter lowered position, remove window lower sash channel cam attaching screws ("1", Figure 6-117).
3. Loosen rear glass run channel upper and lower attaching screws ("2", Figure 6-117).
4. Rotate rear edge of glass downward and remove window by lifting front edge of glass upward outboard of door upper frame.
5. To install, reverse removal procedure. Adjust window for proper operation and alignment as described in the following adjustment procedure.

### Adjustments

Adjustments have been provided to relieve a binding door glass due to misalignment of the glass run channel ("2", Figure 6-117). In addition, the door window inner panel cam ("3", Figure 6-117) is adjustable which can correct a rotated (cocked) front door window.

### REAR DOOR WINDOW ASSEMBLY— "A-39"

The rear door window assembly consists of a solid tempered safety plate glass window and an individually bolted-on roller at the front and window roller cam assembly at the rear. The lower sash channel cam is bolted to the glass, but is removed in the process of removing the window.

Figure 6-118 is an exploded view of the window assembly and identifies the various components and their assembly sequence.

### Removal and Installation

1. Remove door trim pad and inner panel water deflector.
2. Remove window front up-stop from guide ("1", Figure 6-119) and rear up-stop from door inner panel ("2", Figure 6-119).
3. Loosen front and rear window stabilizer strip assembly bolts ("3", Figure 6-119) and remove stabilizer strips.
4. With window in full-up position, remove lower sash channel cam to glass attaching stud nuts ("4", Figure 6-119).
5. Disengage front roller from front guide, then rear roller from rear guide.
6. Remove window from door by aligning rollers with notches provided in inner panel. Remove rear end of window first, then front end.
7. To install, reverse removal procedure. Adjust window for proper alignment and operation as described in the following adjustment procedure.

### Adjustments

1. In-and-out adjustment of the glass is controlled by the in-and-out adjustment available at the top of the front and rear guides ("5" and "6", Figure 6-119) and the in-and-out position of the glass stabilizer strip assemblies ("3", Figure 6-119).
2. Fore-and-aft adjustment of the window assembly is controlled by the position of the front guide. The upper attaching locations in the front guide upper support ("7", Figure 6-119) are slotted to permit fore-and-aft adjustment of the guide. Because of the free floating roller in the window rear sash channel cam (Figure 6-118) the rear guide does not have to be adjusted during fore-or-aft window alignment.

# REAR DOOR LOCK

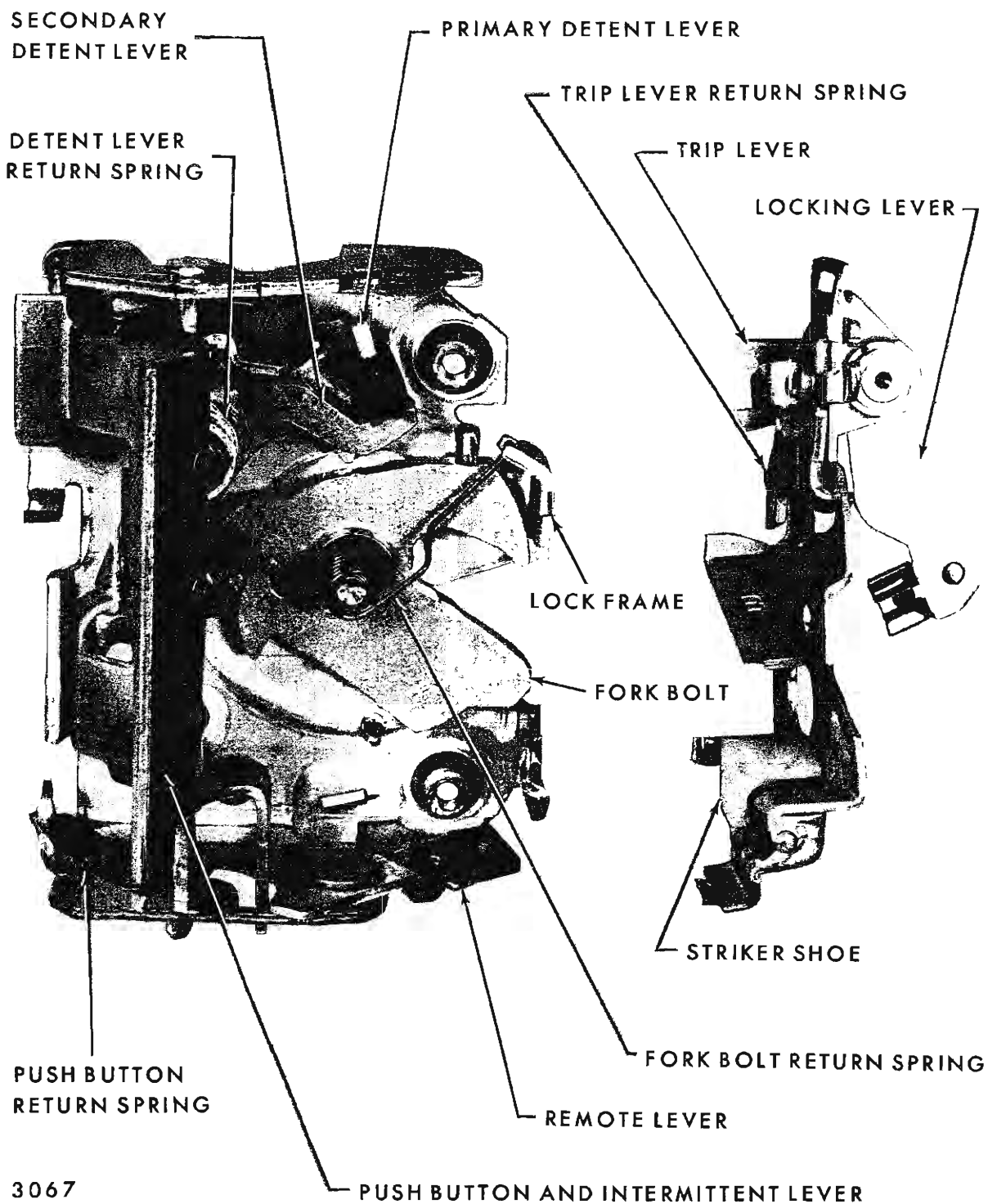

Fig. 6-116—Rear Door Lock Assembly - All Styles

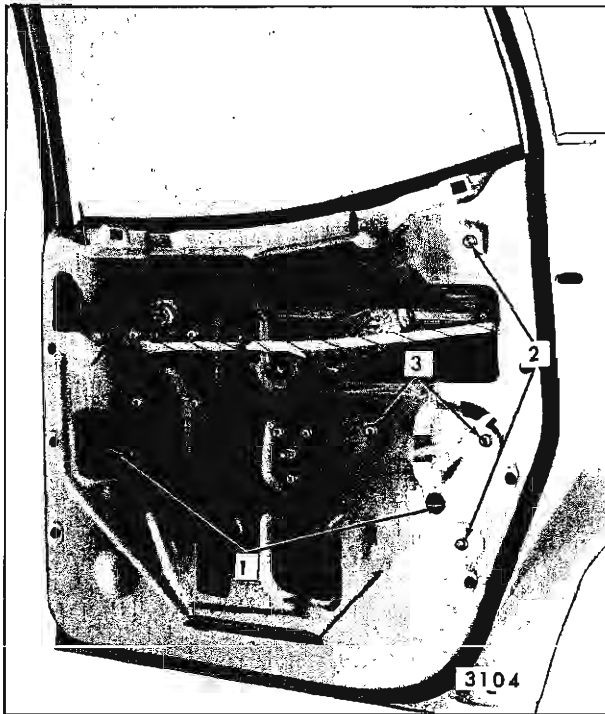

Fig. 6-117—Rear Door Window Removal and Adjustments - "A" Closed Styles

1. Lower Sash Channel Cam Attaching Screw Access Holes
2. Rear Glass Run Channel Upper and Lower Attaching Bolts
3. Inner Panel Cam Attaching Bolts

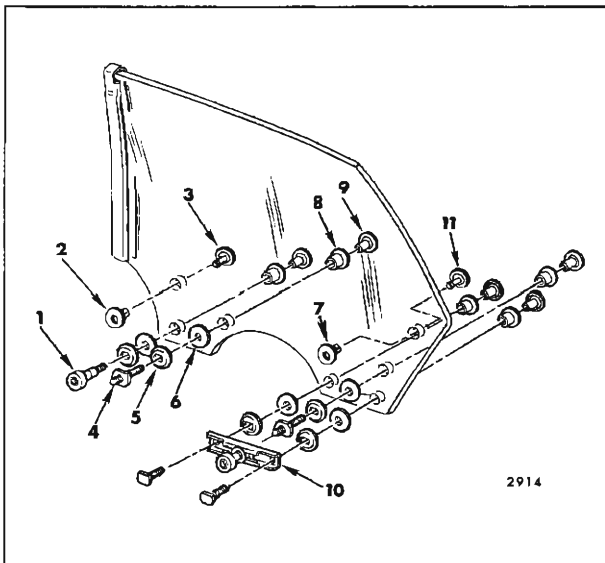

Fig. 6-118—Rear Door Window Assembly - "A-39" Styles

- |                               |                               |
|-------------------------------|-------------------------------|
| 1. Roller Assembly            | 7. Glass Bearing Fastener Cap |
| 2. Glass Bearing Fastener Cap | 8. Bushing                    |
| 3. Glass Bearing Fastener     | 9. Nut                        |
| 4. Stud Inner Panel Cam       | 10. Rear Guide Cam Assembly   |
| 5. Washer (Metal)             | 11. Glass Bearing Fastener    |
| 6. Washer                     |                               |

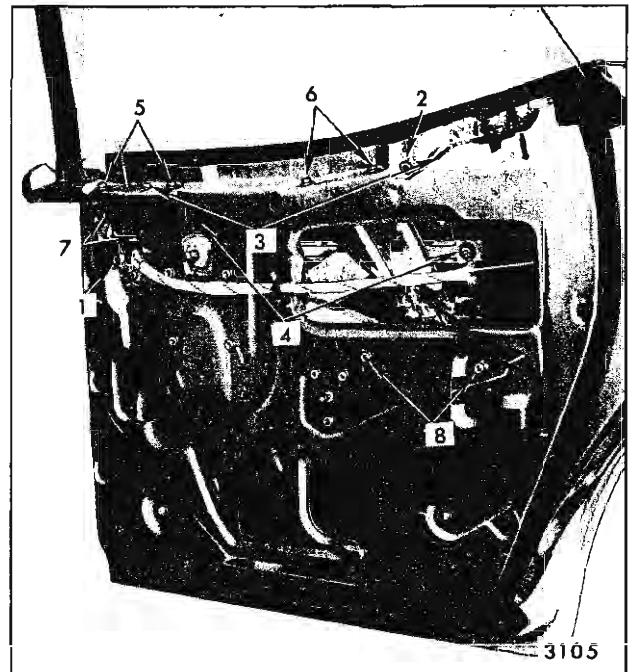

Fig. 6-119—Rear Door Window Removal and Adjustments - "A-39" Styles

- |  |   |
|--|---|
| 1. Window Front Up-Travel Stop             | 5. Front Guide Upper Support Attaching Bolts            |
| 2. Window Rear Up-Travel Stop              | 6. Rear Guide Upper Attaching Bolts                     |
| 3. Window Front and Rear Stabilizer Strips | 7. Front Guide to Upper Support Bracket Attaching Bolts |
| 4. Window Lower Sash Channel Cam Stud Nuts | 8. Inner Panel Cam Attaching Bolts                      |

3. Ease of window operation and window stability depend to a great extent on the adjustment of the window stabilizer strip assemblies at the beltline ("3", Figure 6-119).

The stabilizing strips should contact the glass throughout the full cycle of the window. Due to slight variations in glass contour, however, in some cases the strip may lose contact with the glass half-way through the cycle. This is permissible provided it does not result in loose glass. Contact should be sufficient to stabilize glass, but not restrict ease of window operation.

4. A window that is rotated (cocked) in the window opening may be the result of an improperly adjusted inner panel cam ("8", Figure 6-119) or poorly adjusted up-travel stops ("1" or "2", Figure 6-119).

5. The up-travel of the window is determined by the adjustment of the front and rear up-stop ("1" or "2", Figure 6-119). To adjust window up-travel, loosen front and rear up-stops and

operate window to desired position to establish proper glass to side roof rail weatherstrip contact (Figure 6-120). Tighten up-stop attaching bolts.

## REAR DOOR WINDOW ASSEMBLY "B" Closed Styles

The rear door window assembly consists of a frameless solid tempered safety plate glass window and a bolt-on lower sash channel cam. When handling window, make certain glass does not develop edge chips or deep scratches which could cause glass to shatter.

### Removal and Installation

1. Remove door trim assembly and inner panel water deflector.
2. Remove glass run channel attaching bolts (Arrows "A" & "B" Figure 6-122).
3. Partially lower rear door window, remove lower sash channel cam to glass attaching stud nuts ("2", Figure 6-121). Press lower sash channel cam inboard to disengage from attaching studs and lower window regulator to full-down position.
4. Tilt front edge of glass downward and remove outboard of door upper frame, rear edge first, then front edge.

**NOTE:** Apply protective tape on door upper frame along front and rear edges to protect painted surface when removing glass.

5. To install, reverse removal procedure. Adjust window for proper operation as described in the following procedure.

### Adjustments

Adjustments have been provided to relieve a binding

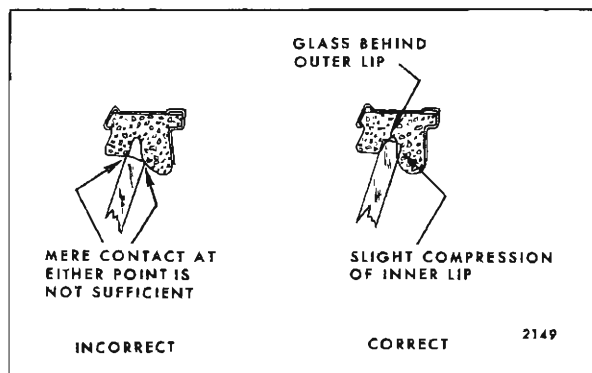

Fig. 6-120—Window to Side Roof Rail Weatherstrip Alignment

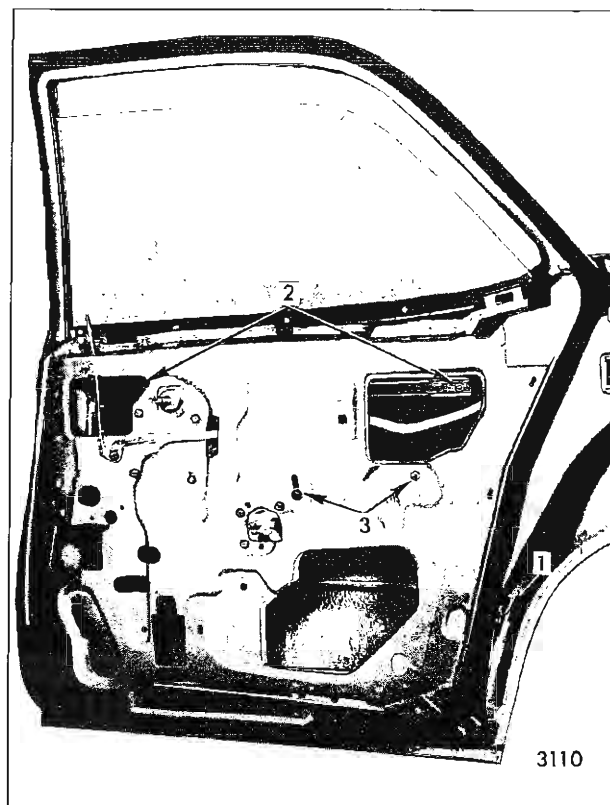

Fig. 6-121—Rear Door Window Removal and Adjustments - "B" Closed Styles

1. Glass Run Channel Rear Attaching Bolt
2. Window Lower Sash Channel Cam Stud Nuts Access Holes
3. Inner Panel Cam Bolts

door glass due to misalignment of the glass run channel (Arrow "A" and "B", Figure 6-122). In addition, the door window inner panel cam is adjustable which can correct a rotated (cocked) front door window ("3", Figure 6-121).

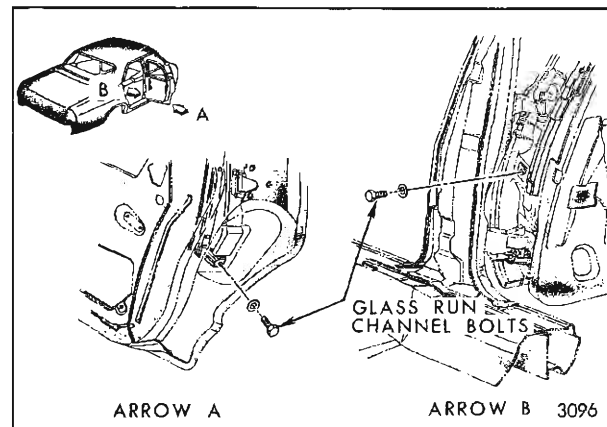

Fig. 6-122—Glass Run Channel Retention "B" Closed Styles



## REAR DOOR WINDOW ASSEMBLY— “B-39” and “C-39, 49 and 69” Styles

The rear door window assembly consists of a solid tempered safety plate glass window and an individually bolted-on roller at the front and roller assembly (bell-crank) at the rear. The lower sash channel cam is bolted to the glass, but is removed in the process of removing the window.

Figure 6-123 is an exploded view of the window assembly and identifies the various components and their assembly sequence.

### Removal and Installation

1. Remove door trim assembly and inner panel water deflector.
2. Remove front and rear window stabilizer strips (“1”, Figure 6-124).
3. Remove front and rear window up-travel stops (“2”, and “3”, Figure 6-124).
4. With window in a three-quarter-down position, remove lower sash channel cam to glass attaching stud nuts (“4”, Figure 6-124). Lift window upward and remove from door.
5. To install, reverse removal procedure. Adjust for proper window alignment and operation as described below.

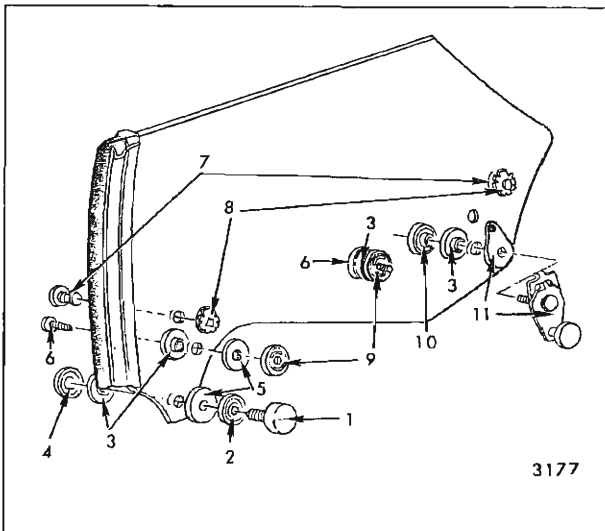

Fig. 6-123—Rear Door Window Assembly - “B-39” and “C-39, 49 and 69” Styles

- |                          |                                 |
|--------------------------|---------------------------------|
| 1. Roller Assembly       | 7. Fastener, Glass Bearing      |
| 2. Spacer                | 8. Cap, Glass Bearing Fastener  |
| 3. Bushing               | 9. Nut, Inner Panel Cam         |
| 4. Nut, Roller Assembly  | 10. Nut, Roller Assembly        |
| 5. Washer                | 11. Roller Assembly (Bellcrank) |
| 6. Bolt, Inner Panel Cam |                                 |

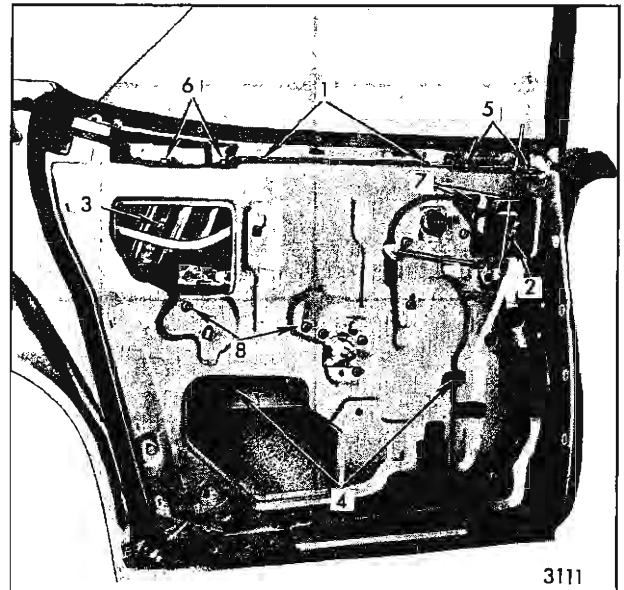

Fig. 6-124—Rear Door Removal and Adjustments - “B-39” and “C-39, 49, and 69” Styles

- |   |   |
|---|---|
| 1. Window Stabilizer Strip Bolts                        | 5. Front Guide Upper Support Bracket Bolts    |
| 2. Window Front Up-Travel Stop Bolt                     | 6. Rear Guide Upper Bolts                     |
| 3. Window Rear Up-Travel Stop Bolt                      | 7. Front Guide to Upper Support Bracket Bolts |
| 4. Window Lower Sash Channel Cam Stud Nuts Access Holes | 8. Inner Panel Cam Bolts                      |

### Adjustments

1. In-and-out adjustment of the glass is controlled by the in-and-out adjustment available at the top of the front and rear guides (“5” and “6”, Figure 6-123) and the in-and-out position of the glass stabilizer strips (“1”, Figure 6-123).
2. Fore-and-aft adjustment of the window assembly is controlled by the position of the front guide. The upper attaching locations in the front guide upper support (“7”, Figure 6-124) are slotted to permit fore-and-aft adjustment of the guide. Because the roller assembly (bell-crank, Figure 6-123) which attaches to the glass at the rear pivots, the rear guide does not have to be adjusted during fore-or-aft window alignment.
3. Ease of window operation and window stability depends to a great extent on the adjustment of the window stabilizer strip assemblies (“1”, Figure 6-124).

The stabilizer strips should contact the glass throughout the full cycle of the window. Due to slight variations in glass contour, however, in some cases the strip may lose contact with the glass half-way through the cycle. This

is permissible provided it does not result in loose glass. Contact should be sufficient to stabilize glass, but not restrict ease of window operation.

4. A window that is rotated (cocked) in the window opening may be the result of an improperly adjusted inner panel cam ("8", Figure 6-124) or poorly adjusted up-travel stops ("2" or "3", Figure 6-124).
5. The up-travel of the window is determined by the adjustment of the front and rear up-stops "2" and "3", Figure 6-124). To adjust window up-travel, loosen front and rear up-stops and operate window to desired position to establish proper glass to side roof rail weatherstrip contact (Figure 6-125). Tighten up-stop attaching bolts.

### REAR DOOR WINDOW STATIONARY VENTILATOR DIVISION CHANNEL— "X-69" Style

The stationary ventilator division channel is held into place by one division channel to door upper frame attaching screw and one lower adjusting stud and nut. This assembly acts as a rear door window rear glass run channel and also holds the stationary ventilator window in proper position.

#### Removal and Installation

1. Remove door trim assembly and detach inner panel water deflector sufficiently to gain access to the lower adjusting stud and nut ("1", Figure 6-126).
2. Remove door window lower stop (rubber bumper) from down stop support bracket on door inner panel.
3. Remove ventilator division channel lower adjusting stud and nut ("1", Figure 6-126).

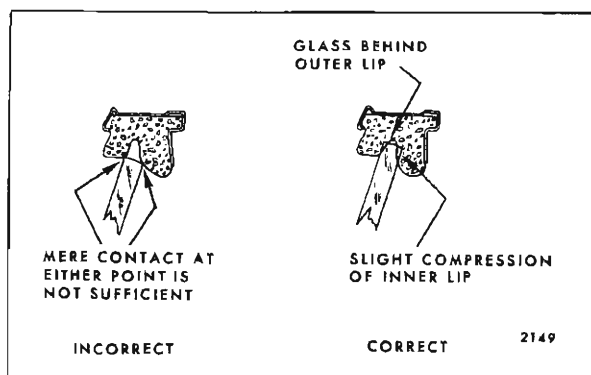

Fig. 6-125—Window to Side Roof Rail Weatherstrip Alignment

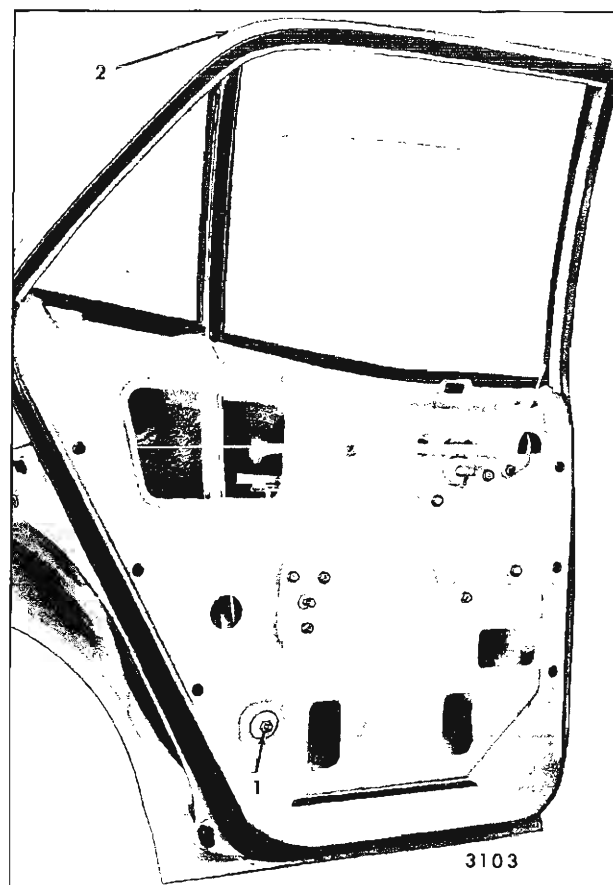

Fig. 6-126—Rear Door Window Removal and Adjustments - "X-69" Styles

1. Ventilator Division Channel Lower Adjusting Stud
2. Ventilator Division Channel Upper Attaching Screw
4. Carefully lower door window and remove division channel to door upper frame attaching screw ("2", Figure 6-126).
5. Rotate upper section of division channel forward and inboard and remove assembly from door.
6. To install, reverse removal procedure. In-out and fore-or-aft adjustment of this part is available at the lower adjusting stud and nut only.

### REAR DOOR WINDOW STATIONARY VENTILATOR ASSEMBLY— "X-69" Style

The rear door stationary ventilator assembly is set within a rubber channel and held into place by pressure of the ventilator division channel.

**Removal and Installation**

1. Remove door trim assembly and detach inner panel water deflector.
2. Remove stationary ventilator division channel as previously described.
3. Pull stationary ventilator window forward and remove from door.
4. To install, reverse removal procedure.

**REAR DOOR WINDOW ASSEMBLY  
"X-69" Style**

The rear door window assembly consists of a frameless solid tempered safety plate glass window and a pressed-on lower sash channel assembly.

**Removal and Installation**

1. Remove door trim assembly and inner panel water deflector.
2. Remove rear door window stationary ventilator assembly as previously described.
3. Slide window regulator lift arm roller out of window lower sash channel cam and remove glass inboard of door upper frame.
4. To install, reverse removal procedure. Adjust window for proper operation as described in the following procedure.

**Adjustments**

Adjustment has been provided to relieve a binding door glass due to misalignment of the ventilator division channel ("1", Figure 6-126).

**REAR DOOR WINDOW REGULATOR—  
Manual—All "A" Styles**

**Removal and Installation—Refer to Figure 6-106 for "Closed" Styles and Figure 6-108 for "A-39" Styles**

1. Remove door trim assembly and inner panel water deflector.
2. Lower window and remove lower glass sash channel cam attaching screws. While supporting glass, disengage cam from rollers on regulator lift and balance arms and remove cam.

**NOTE:** On Closed styles, raise window to a full-up position and secure in place with pieces of cloth-backed body tape applied over door frame. On Hardtop styles, prop the window in a full-up position.

3. Remove inner panel cam attaching bolts.
4. Loosen window regulator attaching bolts and remove window regulator through large access hole.
5. To install, reverse removal procedure.

**REAR DOOR WINDOW REGULATOR—  
Electric—All "A, B and C" Styles**

**Removal and Installation—Refer to Fig. 6-108**

1. Remove door window as previously described.
2. Remove inner panel cam attaching bolts.
3. Disconnect body wire harness from window regulator at regulator motor.
4. On "A-39" styles, remove the window rear guide as subsequently described.
5. Remove window regulator attaching bolts and remove regulator through large access hole.
6. To install, reverse removal procedure.

**REAR DOOR WINDOW REGULATOR—  
Manual—"B and C" Styles**

**Removal and Installation—Refer to Figure 6-110 for "B" Closed Styles and Figure 6-112 for "B and C" Hardtop Styles**

1. Remove door trim assembly and inner panel water deflector.
2. Lower window to a three-quarter-down position, remove lower sash channel cam to glass attaching stud nuts. While supporting glass, disengage cam from rollers on regulator lift and balance arms and remove cam.

**NOTE:** On closed styles, raise window to full-up position and secure in place with pieces of cloth-backed body type applied over door upper frame. On Hardtop Styles, prop the window in a full-up position.

3. Remove inner panel cam attaching bolts.
4. Loosen window regulator attaching bolts and remove window regulator through access hole.
5. To install, reverse removal procedure.

**REAR DOOR WINDOW REGULATOR  
ELECTRIC MOTOR REMOVAL—All Styles.**

If it is necessary to remove the electric motor

from the regulator, refer to "Front & Rear Door" section for the proper procedure. The tension on the lift arm assist spring can cause serious injury if the motor is removed without use of the cautionary measures described in the procedure.

### **REAR DOOR WINDOW REGULATOR— "X-69" Style**

#### **Removal and Installation**

1. Remove door trim assembly and inner panel water deflector.
2. Remove inside locking rod to lock connecting link bolt ("6", Figure 6-114) and disconnect locking rod at lock.
3. Operate window to full-up position and secure in place with pieces of cloth-backed body tape applied over door frame.
4. Remove regulator attaching bolts ("5", Figure 6-114). Slide regulator lift arm roller out of lower sash channel cam and remove regulator through large access hole.
5. To install, reverse removal procedure.

### **REAR DOOR WINDOW FRONT GUIDE AND BRACKET ASSEMBLY—"A-39" Styles**

#### **Removal and Installation**

1. Remove door trim assembly and inner panel water deflector.
2. Remove window front up-travel stop from guide ("5", Figure 6-108).
3. Remove inside locking rod to lock connecting link bolt ("15", Figure 6-100). Pull locking rod assembly downward through guide bracket.
4. With window in full-up position, loosen front guide upper and lower attaching bolts ("8" and "9", Figure 6-108), remove guide through access hole.
5. To install, reverse removal procedure. Adjust guide for proper window operation as described in door window adjustment procedure.

### **REAR DOOR WINDOW REAR GUIDE "A-39" Styles**

#### **Removal and Installation**

1. Remove door trim assembly and inner panel water deflector.
2. With window in full-up position, remove rear

guide upper and lower attaching bolts ("6" and "7", Figure 6-108). Remove guide through access hole.

3. To install, reverse removal procedure. Adjust guide for proper window operation as described in door window adjustment procedure.

### **REAR DOOR WINDOW FRONT GUIDE— "B-39" and "C-39, 49 and 69" Styles**

#### **Removal and Installation**

1. Remove door trim assembly and inner panel water deflector.
2. With window in full-up position, remove front up-stop ("9", Figure 6-112) from guide.
3. Remove front guide upper and lower attaching bolts ("8" and "15", Figure 6-112).
4. Pull guide down and rearward to disengage from window roller assembly; remove guide through access hole.
5. To install, reverse removal procedure. Adjust guide for proper window operation as described in door window adjustment procedure.

### **REAR DOOR WINDOW REAR GUIDE— "B-39" and "C-39, 49 and 69" Styles**

#### **Removal and Installation**

1. Removal door trim assembly and inner panel water deflector.
2. With window in full-up position, remove rear up-stop ("3", Figure 6-112) from guide.
3. Remove rear guide upper and lower attaching bolts ("1" and "2", Figure 6-112).
4. Pull guide down and forward to disengage from window roller, remove guide through access hole.
5. To install, reverse removal procedure. Adjust guide for proper window operation as described in door window adjustments.

### **REAR DOOR WINDOW GLASS RUN CHANNEL—All "A&X" Closed Styles**

#### **Removal and Installation**

1. Remove door window as previously described.
2. With finger pressure, squeeze run channel together and gently pull run channel out of rear door upper frame.

3. To install, reverse removal procedure.

### **REAR DOOR WINDOW GLASS RUN CHANNEL—All "B" Closed Styles**

#### **Removal and Installation**

1. Remove rear door window assembly as previously described.
2. Pull run channel into window opening to disen-

gage run channel clips from door upper frame and remove run channel from door.

3. To install, reverse removal procedure. Prior to installation, apply a continuous bead of caulking compound to door upper frame from beltline to beltline to effect a weathertight seal between door frame and run channel. If preferred, sealer can be applied to run channel rather than door upper frame.

## SECTION 7 REAR QUARTER

### INDEX

Subject	Page	Subject	Page
Description . . . . .	7-1	Window Assembly - "F-37 and 67" Styles . . . . .	7-21
Inner Panel Sealing . . . . .	7-1	Removal and Installation . . . . .	7-21
Window Rear Vertical Inner Sealing Strip - "B-37, 47", "C-47, 57" and "G-57" Styles . . . . .	7-2	Adjustments . . . . .	7-21
Window Rear Vertical Outer Sealing Strip - "B-47", "C-47, 57" and Pontiac, Oldsmobile and Buick "B-37" Styles . . . . .	7-3	Window Assembly - "Z-37 & 67" Styles . . . . .	7-21
Window Assembly - "A-27 & 77", "B-11" and "X-27" Styles . . . . .	7-3	Removal and Installation . . . . .	7-23
Removal and Installation . . . . .	7-3	Adjustments . . . . .	7-24
Window Rear Run Channel - All Closed Styles . . . . .	7-3	Window Regulator (Manual or Electric) - "A-27 & 77", "B-11 and "X-27" Styles . . . . .	7-24
Removal and Installation . . . . .	7-3	Removal and Installation . . . . .	7-24
Window Front Run Channel - All Closed Styles . . . . .	7-7	Window Regulator (Manual or Electric) - "A, E, F, G & Z" Hardtop and Convertible Styles . . . . .	7-28
Removal and Installation . . . . .	7-7	Removal and Installation . . . . .	7-28
Window Inner and Outer Strip Assemblies - All Styles . . . . .	7-7	Window Regulator (Manual or Electric) - "B-C" Hardtop and Convertible Styles . . . . .	7-29
Window Assembly - "A-37, 87 & 67" and "G-57" Styles . . . . .	7-7	Removal and Installation . . . . .	7-29
Description . . . . .	7-7	Window Motor - "A-27, 37, 77 & 87" and "G-57" and "F-37, 67" Styles . . . . .	7-29
Removal and Installation . . . . .	7-7	Removal and Installation . . . . .	7-29
Adjustments . . . . .	7-7	Window Guide Assembly - "A, G, B & C" Hardtop and Convertibles . . . . .	7-33
Window Assembly - "B & C-37, 47, 57 & 67" Styles . . . . .	7-14	Removal and Installation . . . . .	7-33
Description . . . . .	7-14	Window Guide Assembly - All "F" Styles . . . . .	7-33
Removal and Installation . . . . .	7-14	Removal and Installation . . . . .	7-33
Adjustments . . . . .	7-15	Window Front Guide Assembly - "Z-37 & 67" and "E-87" Styles . . . . .	7-33
Window Assembly - "E-87" Styles . . . . .	7-17	Removal and Installation . . . . .	7-33
Description . . . . .	7-17	Window Rear Guide Assembly - "Z-37 & 67" and "E-87" Styles . . . . .	7-34
Removal and Installation . . . . .	7-17	Removal and Installation . . . . .	7-34
Adjustments . . . . .	7-18	Window Run Channel - "E-47" Styles . . . . .	7-34
Window Assembly - "E-47" Styles . . . . .	7-19	Removal and Installation . . . . .	7-34
Removal and Installation . . . . .	7-20		
Adjustments . . . . .	7-20		

### DESCRIPTION

Closed style rear quarter windows operate within glass run channels. Hardtop and convertible styles employ nylon rollers that are component parts of the lower sash or bolt directly to the glass. These rollers primarily operate within or against a center guide that may vary somewhat, dependant on the style involved.

All quarter glass is constructed of solid tempered safety plate. Caution must be applied when handling glass, as glass may shatter if it is chipped or scratched. Do Not attempt to grind or drill glass.

When performing any service operations to the rear quarter window hardware, it is necessary to remove the rear quarter trim assembly (see Section 14).

### REAR QUARTER INNER PANEL SEALING

All rear quarter inner panels are sealed with one or a combination of water deflectors, access hole covers, sealing plugs (or grommets) and body

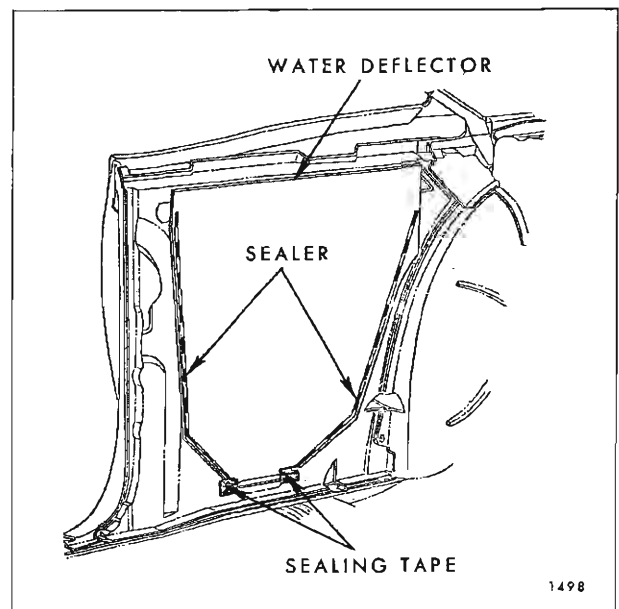

Fig. 7-1—Rear Quarter Inner Panel Sealing - Typical of Water Deflector Installation

sealer. Service procedures for inner panel water deflectors are outlined in the "Front and Rear

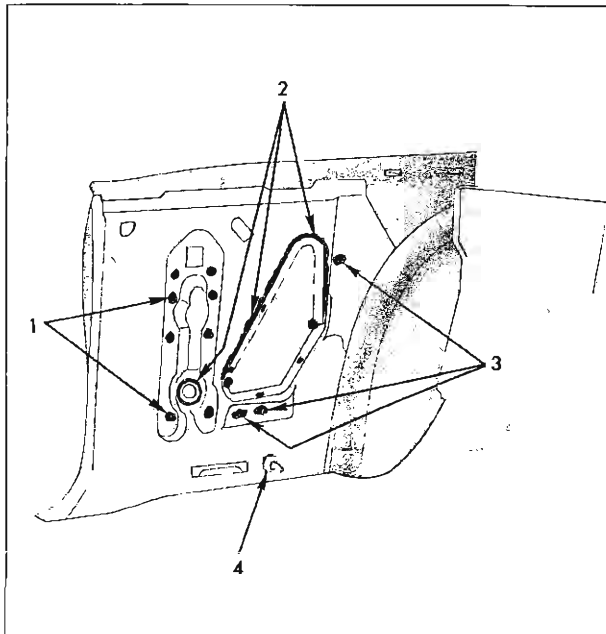

Fig. 7-2—Rear Quarter Typical Inner Panel Sealing - "67" Styles

1. Regulator Attaching Bolt Slots
2. Access Hole Covers
3. Window Guide Adjusting Stud Slots
4. Electrical Harness Grommet

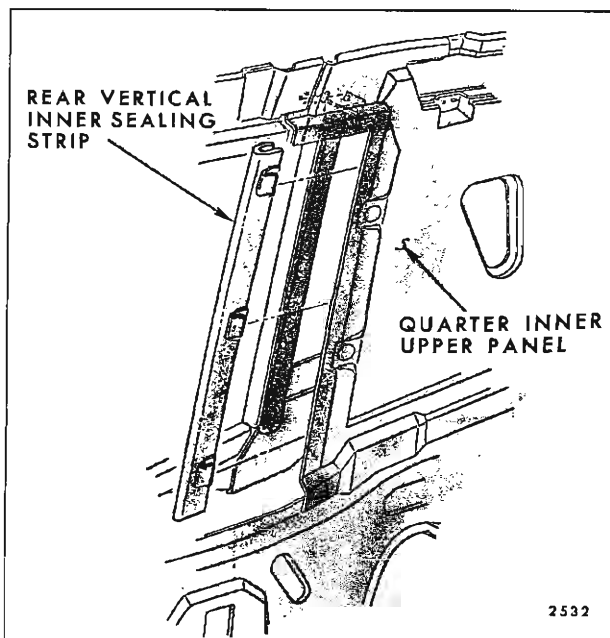

Fig. 7-3—Rear Quarter Window Rear Vertical Inner Sealing Strip Assembly

Door" section of this manual (see index). Figure 7-1 is typical of a water deflector installation.

Inner panel access hole covers are retained by screws and sealed with a non-hardening body sealer. Usually, removal of either the water deflector or access hole cover will provide the clearance required for service procedures of rear quarter hardware. Whenever any seal has been disturbed, however, the area must be carefully resealed to prevent waterleaks. Body caulking compound is recommended for service sealing. Figure 7-2 illustrates quarter inner panel sealing on styles which use individual seals at all hardware attaching locations.

### QUARTER WINDOW REAR VERTICAL INNER SEALING STRIP—"B-37-47-C-47-57 & G-57" Styles

The rear vertical inner sealing strip is attached to the quarter inner upper panel with clips that are an integral part of the sealing strip (Figure 7-3).

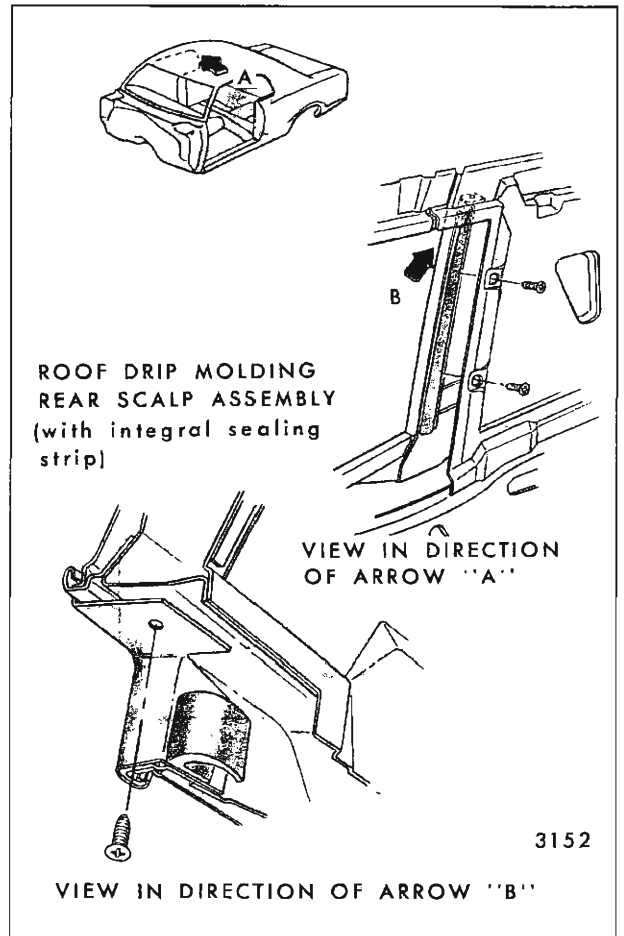

Fig. 7-4—Quarter Window Rear Vertical Outer Sealing Strip - "B-47, C-47, 57" and "B-37" Styles

To remove the strip assembly, lower quarter window and disengage side roof rail finishing molding adjacent to sealing strip. Slide strip assembly forward to disengage clips and remove sealing strip from window opening.

**QUARTER WINDOW REAR VERTICAL OUTER SEALING STRIP—"B-47"- "C-47-57" and Pontiac, Oldsmobile and Buick "B-37" Styles**

On all of the above styles except "B-37", the rear vertical outer sealing strip is an integral part of the drip scalp molding and, as such, is removed with the molding.

To remove the molding and sealing strip assembly, remove the quarter upper trim assembly to gain access to the attaching screws illustrated in Figure 7-4.

**REAR QUARTER WINDOW—"A-27 & 77"- "B-11" & "X-27" Styles**

**Removal and Installation**

1. Remove rear quarter trim assembly and inner panel water deflector.
2. Operate quarter window to the position illustrated in Figure 7-5.

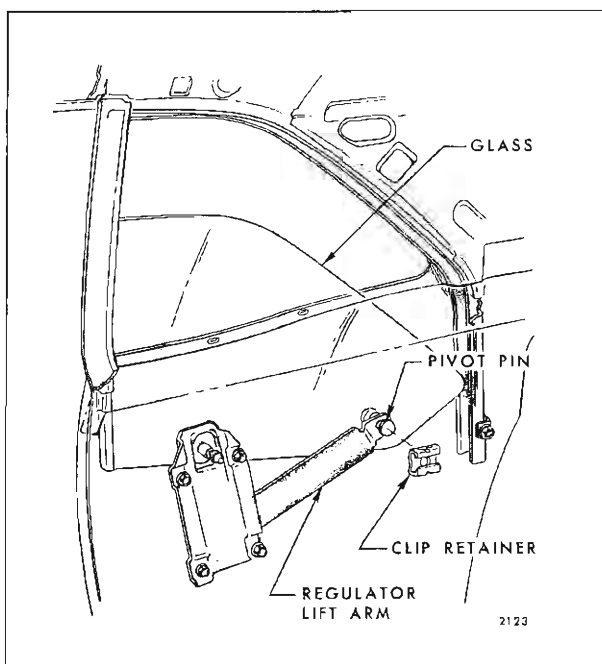

Fig. 7-5—Rear Quarter Window Attachment - Typical "A" Closed Styles

**NOTE:** Figures 7-5, 7-6 and 7-7 are typical of rear quarters with the inner panels removed. These figures identify the component parts of the rear quarter hardware (by style), their relationship and various attaching points.

3. While supporting glass, disengage clip retainer securing regulator lift arm to glass.
4. Manually lower glass until both front and rear bottom edges are sufficiently free of their respective run channels to rotate front edge of window down between rear quarter inner and outer panels. Remove window, rear edge up, inboard of side roof rail.
5. To install, reverse removal procedure.

**Adjustments**

All window assembly adjustments are provided at the window regulator attaching screws.

1. To obtain proper seating of the glass in the upper glass run channels, or proper contact between belt sealing strips and lower sash channel, loosen regulator attaching screws and adjust window as required.
2. To eliminate a fore and aft bind between the glass run channels (hard operating window), or a condition where window will not stay in rear run channel, loosen rear run channel attaching bolt and adjust run channel fore or aft as required.

**REAR QUARTER WINDOW REAR RUN CHANNEL—All Closed Styles**

**Removal and Installation**

1. Remove rear quarter window as previously described.
2. Remove run channel to inner panel attaching bolt (Fig. 7-8).
3. Remove screws securing run channel to side roof rail along length of run channel.
4. Using a flat-bladed tool, carefully pry run channel retaining clips (rosebud fasteners) from piercings in side roof rail.

**NOTE:** If difficulty is encountered disengaging run channel, inspect inside of channel for the presence of screws.



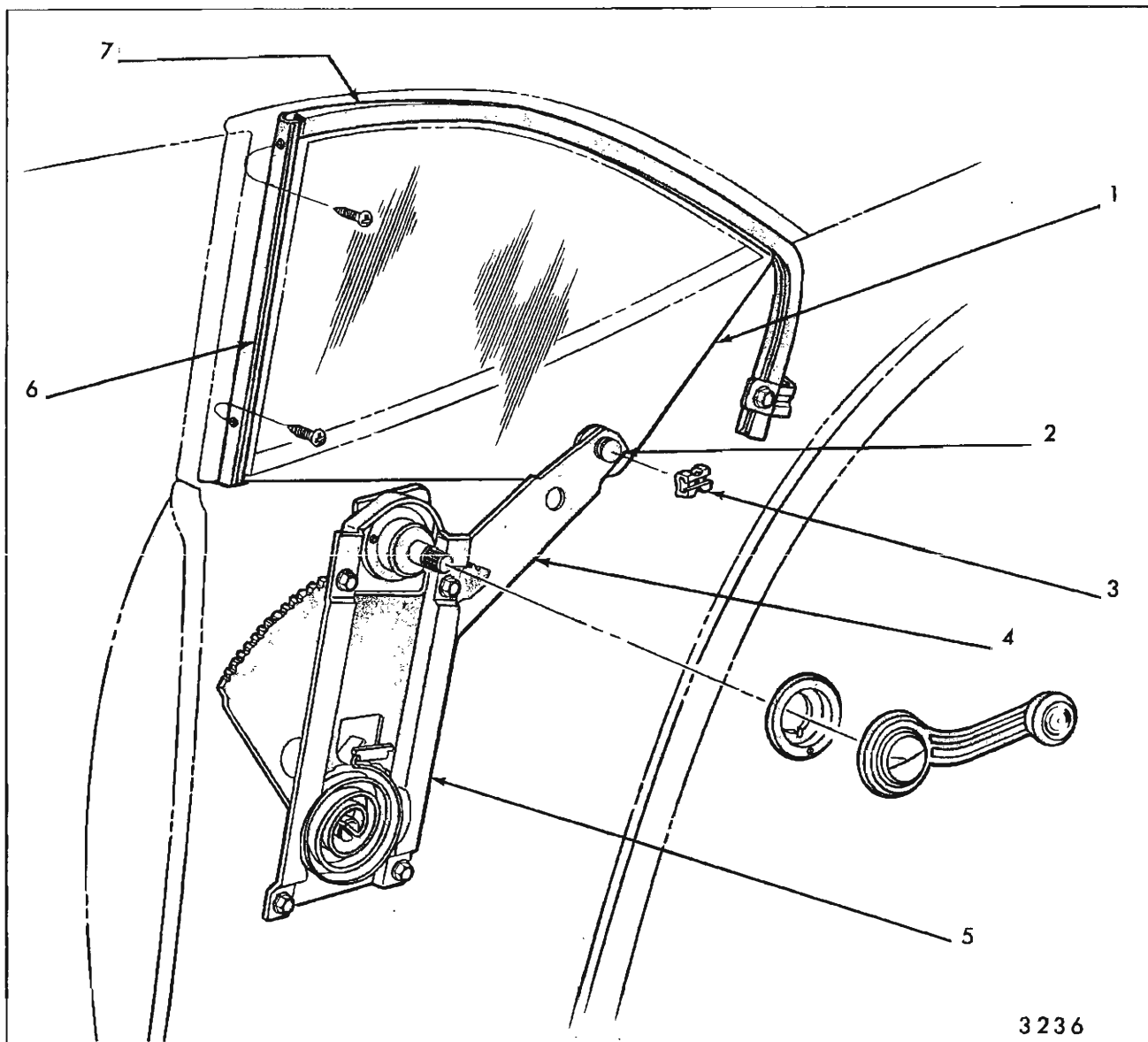
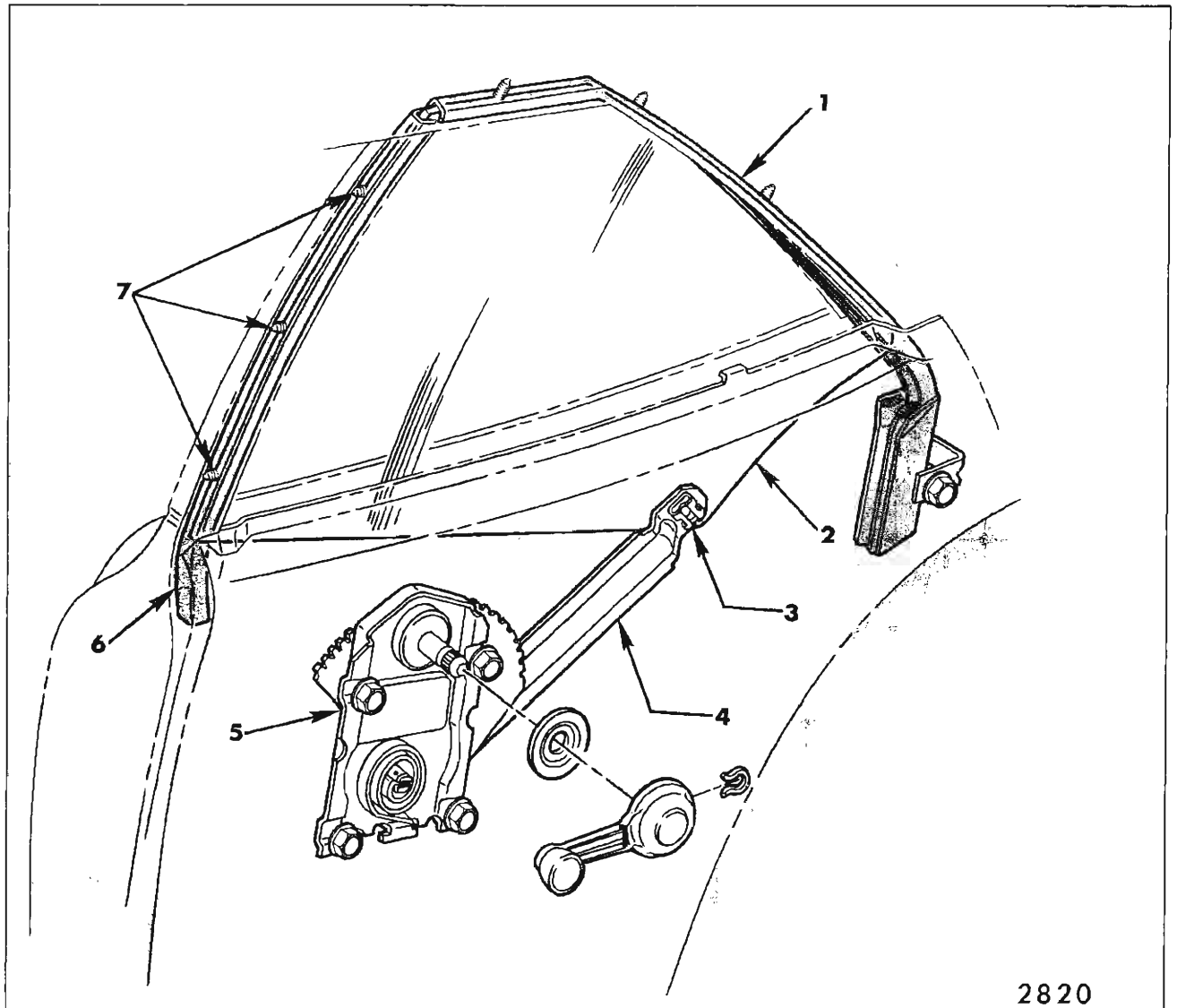

Fig. 7-6—Rear Quarter Hardware - "B-11" Styles

1. Glass
2. Pivot Pin
3. Clip Retainer
4. Regulator Lift Arm
5. Regulator Assembly
6. Garnish Molding
7. Glass Run Channel



2820

Fig. 7-7—Rear Quarter Hardware - "X-27" Styles

1. Rear Glass Run Channel
2. Rear Window Glass
3. Retainer and Pivot Pin
4. Regulator Lift Arm
5. Regulator Assembly
6. Front Glass Run Channel
7. Front Run Channel Retaining Screws

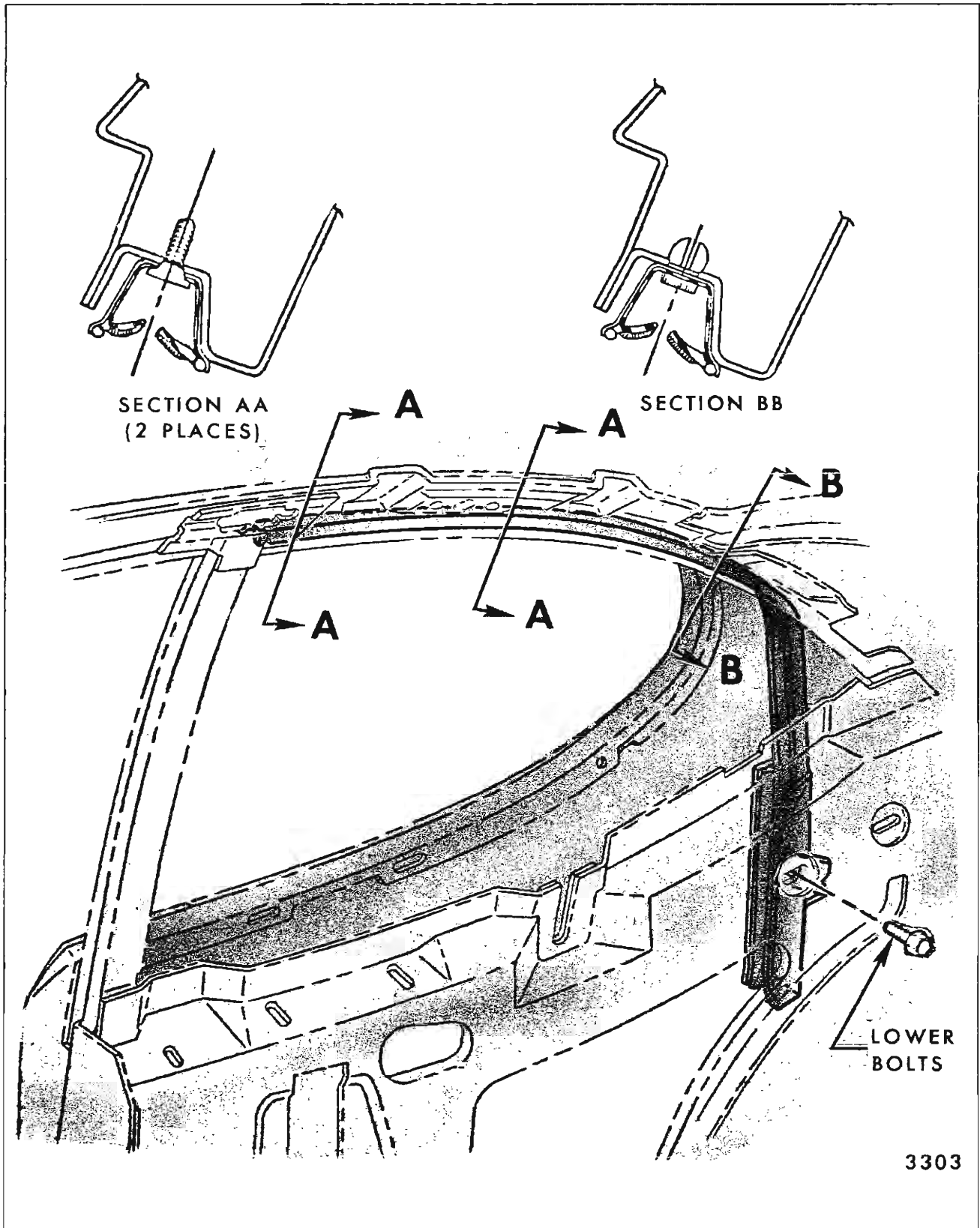

Fig. 7-8—Rear Quarter Window Glass Run Channels - Typical of All Closed Styles

5. Prior to installation, inspect foam sealing material for any damage that would result in waterleaks, and replace as necessary.
6. To install, reverse removal procedure.

## REAR QUARTER WINDOW FRONT RUN CHANNEL—All Closed Styles

### Removal and Installation

1. Remove rear quarter window as previously described.
2. Remove screws along length of run channel securing channel to body (Fig. 7-9).

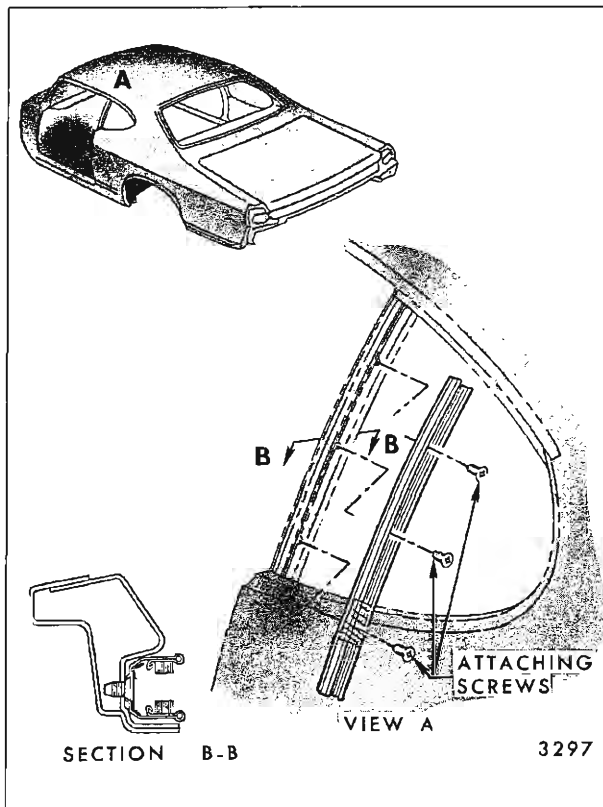

Fig. 7-9—Rear Quarter Window Front Glass Run Channel - Typical of All Closed Styles

3. On all styles, using a flat-bladed tool, pry run channel from body pillar and remove run channel.
4. To install, reverse removal procedure. Prior to installation inspect sealing material on body pillar or run channel and replace or add to as required.

## REAR QUARTER WINDOW INNER AND OUTER STRIP ASSEMBLIES—All Styles

On styles equipped with a full (hang-on) rear quarter trim assembly, the inner strip is attached to top of trim pad. On other styles, and for all outer strip assemblies, retention is achieved by a series of clips or screws. In some cases it will be necessary to remove quarter window to achieve access. For complete removal and installation procedures, refer to the "Door" section of this manual.

## REAR QUARTER WINDOW ASSEMBLY—"A-37-87 & 67" & "G-57" Styles

### Description

All "A & G" body rear quarter hardware is similar in design, as shown in Figures 7-10, 7-11 and 7-12. These illustrations identify the component parts of the rear quarter hardware (by style), their relationship and various attaching points.

### Removal and Installation

1. Remove rear seat cushion, seat back, rear quarter trim and inner panel water deflector and/or loading hole cover. On "67" Styles, lower folding top.
2. Remove rear up-travel stop.
3. Remove window guide to upper support attaching bolts.
4. Loosen window guide lower attaching bolt and tilt glass to enable disengagement of lift arm roller from sash channel cam.
5. Lift glass straight up for disengagement from guide and remove window outboard of side roof rail.
6. To install, reverse removal procedure. It may be necessary to remove the window guide lower attaching bolts to permit greater movement of the guide when loading window assembly.

### Adjustments

The rear quarter window guide is secured to the quarter inner panel at the bottom and top with support brackets. These support brackets provide both in and out and fore or aft adjustment of the glass. One down-stop and two up-stops are provided for alignment operations.

Figure 7-13 is typical of most hardtop or convertible styles utilizing a single window guide.

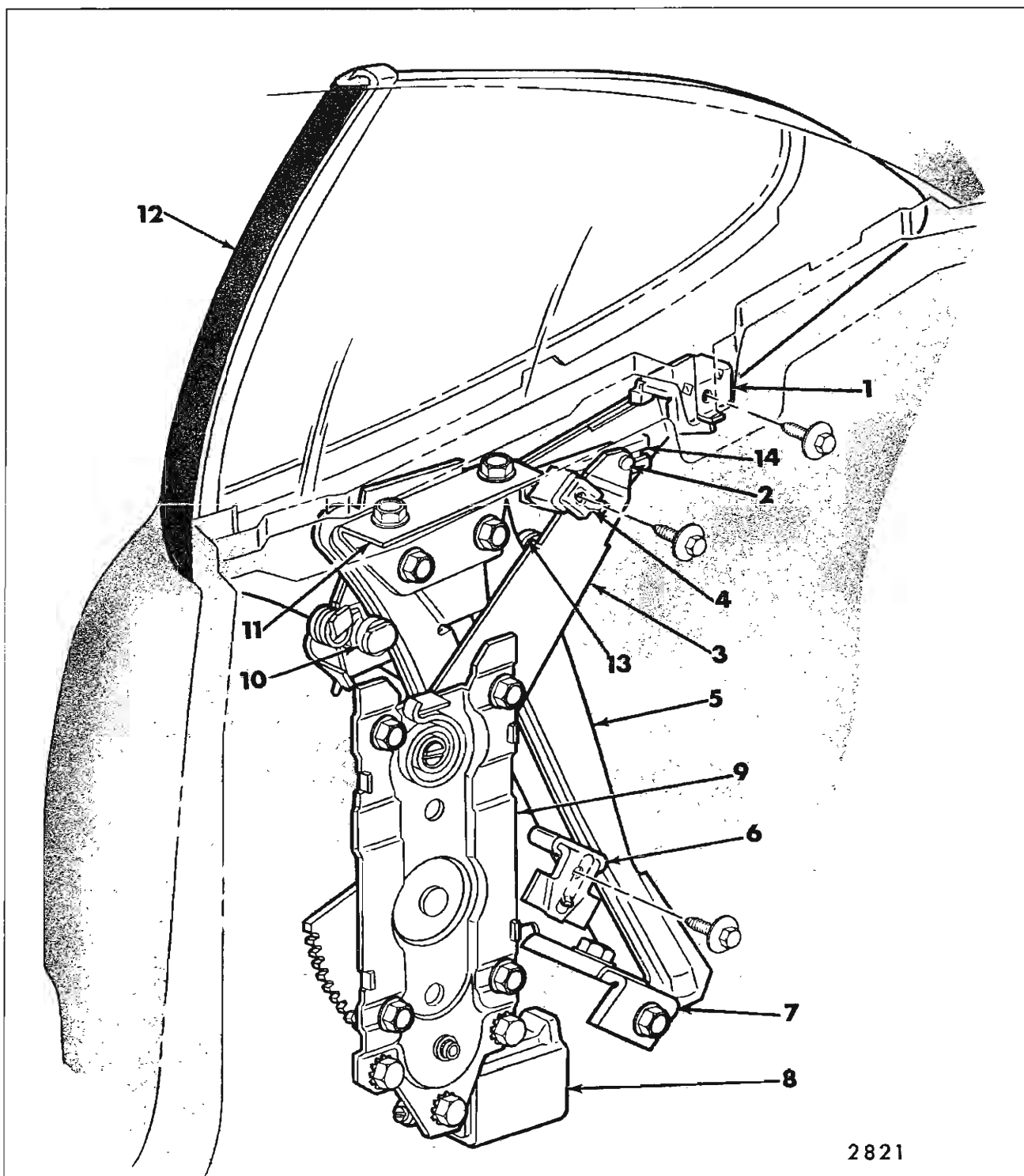

2821

Fig. 7-10—Rear Quarter Hardware - "A-37 & 87" Styles

- |                              |                                |                                 |
|------------------------------|--------------------------------|---------------------------------|
| 1. Rear Up-Stop              | 6. Down Stop                   | 11. Upper Guide Support Bracket |
| 2. Regulator Lift Arm Roller | 7. Lower Guide Support Bracket | 12. Front Vertical Weatherstrip |
| 3. Regulator Lift Arm        | 8. Electric Motor              | 13. Rear Roller                 |
| 4. Front Up-Stop             | 9. Regulator Assembly          | 14. Sash Channel Cam            |
| 5. Window Guide              | 10. Front Roller               |                                 |

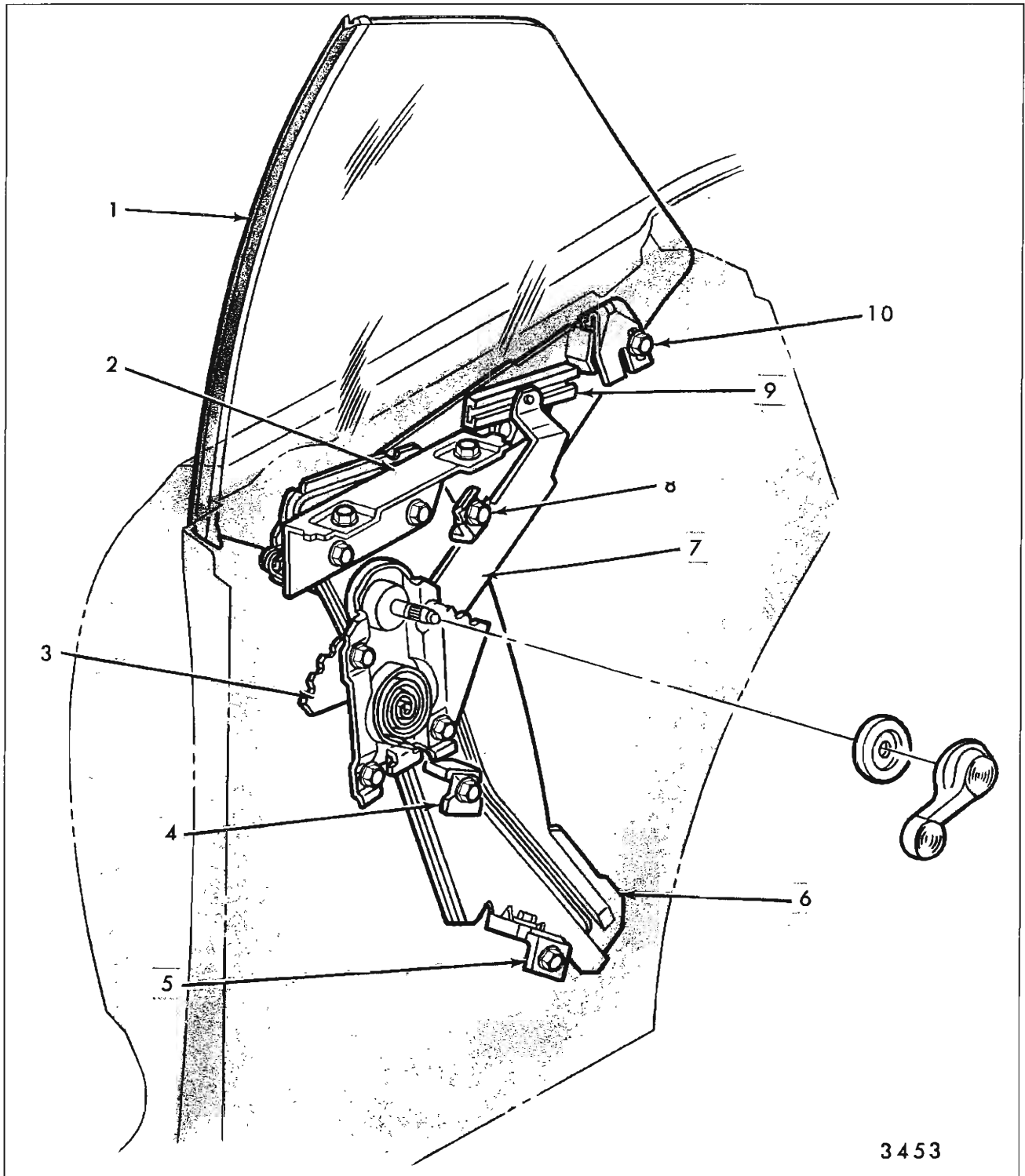

3453

Fig. 7-11—Quarter Hardware - "A-67"

- 1. Front Vertical Weatherstrip
- 2. Upper Guide Support Bracket
- 3. Regulator
- 4. Lower Stop

- 5. Lower Guide Support
- 6. Guide
- 7. Regulator Lift Arm

- 8. Guide Assembly
- 9. Sash Channel Cam
- 10. Rear Up-Stop

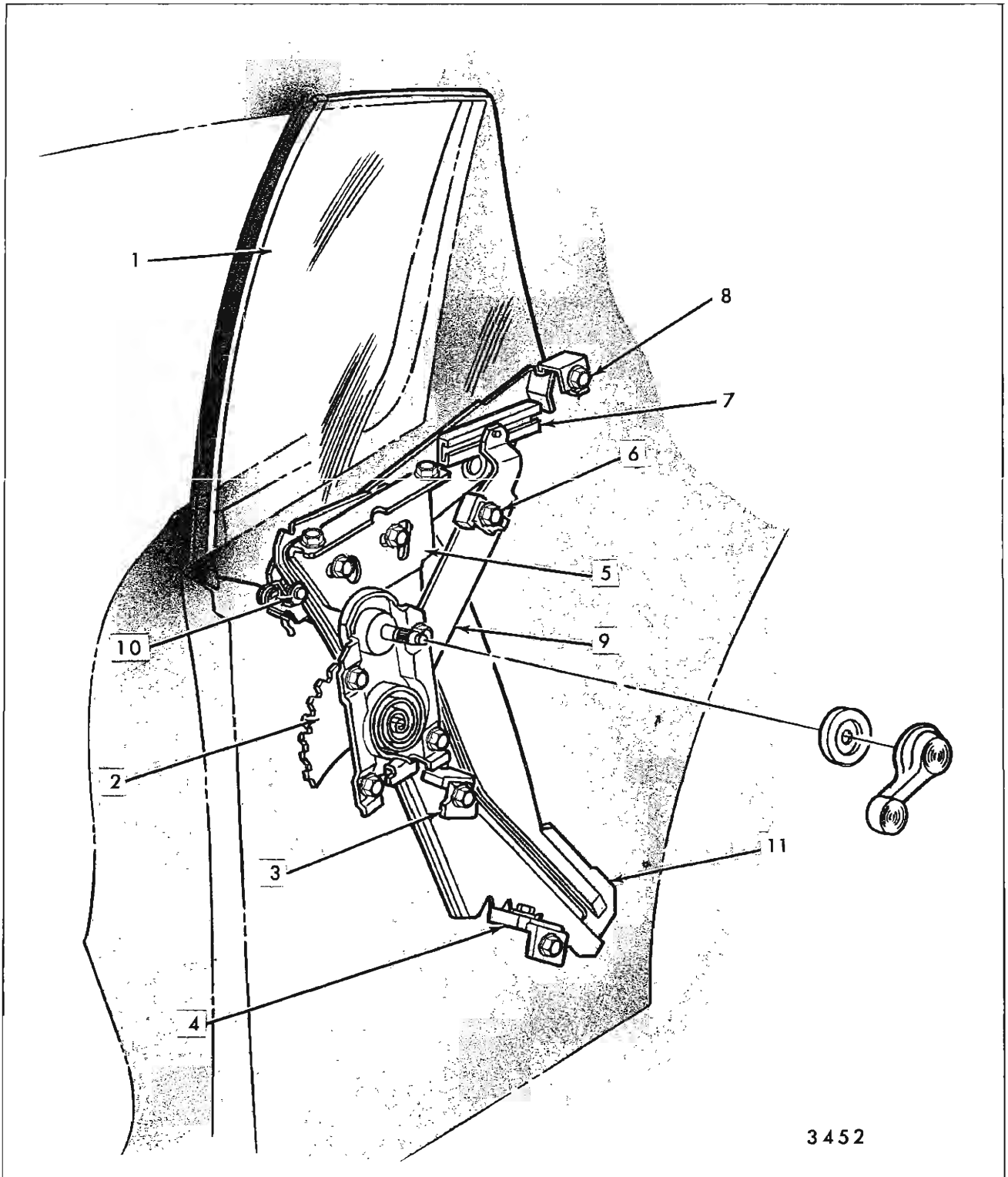

3452

Fig. 7-12—Quarter Hardware - "G-57"

1. Window Glass  
2. Regulator  
3. Lower Stop

4. Support Guide Lower  
5. Support Guide Upper  
6. Front Upper Stop

7. Sash Channel Cam  
8. Rear Upper Stop  
9. Regulator Lift Arm

10. Front Roller  
11. Guide

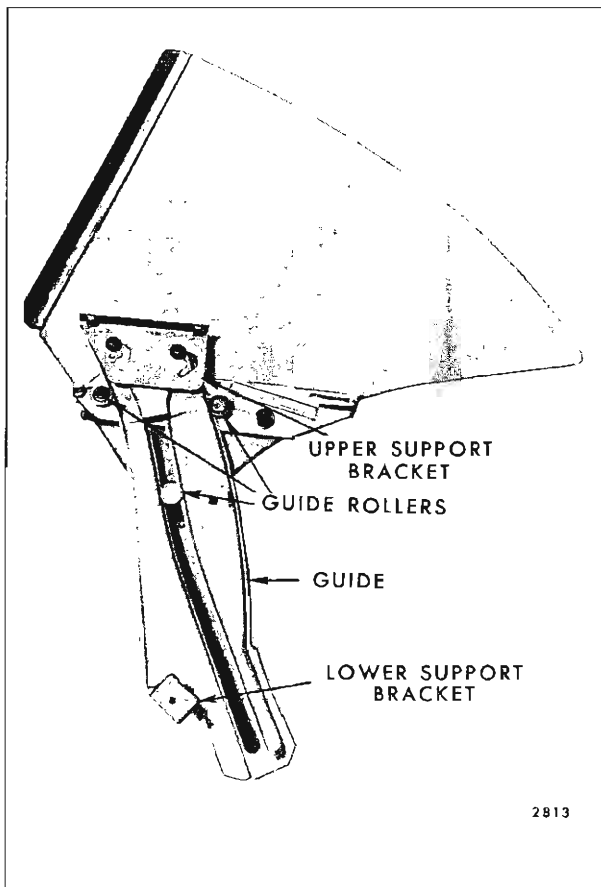

Fig. 7-13—Rear Quarter Window and Guide Assembly - "A-37, 67, 87" Styles

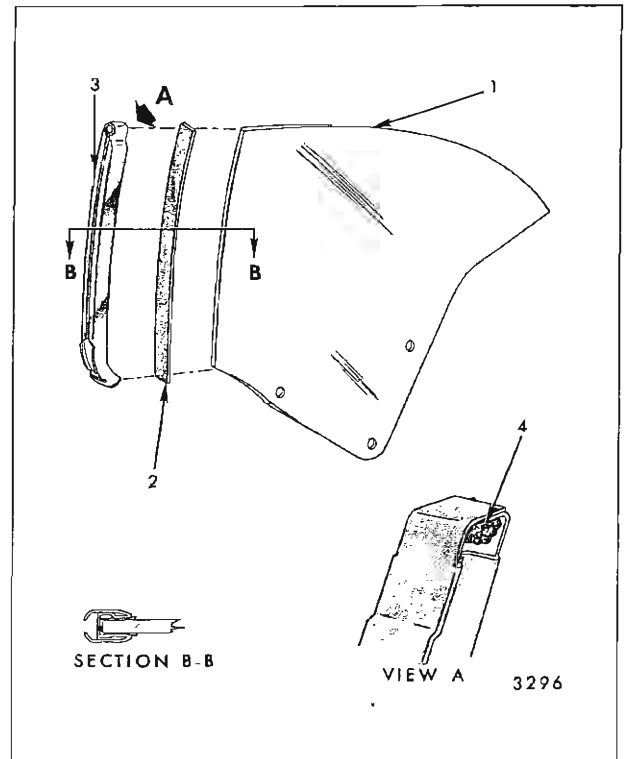

Fig. 7-14—Rear Quarter Window - "A-37, 87" Styles, "G-57" Style Typical

- |                         |            |
|-------------------------|------------|
| 1. Quarter Window Glass | 3. Channel |
| 2. Filler               | 4. Sealer  |

Figures 7-14 and 7-15 illustrate "A" and "G" body rear quarter window glass and hardware components that make up the window assembly.

**NOTE:** When reinstalling glass to sash channel bolts, or nylon roller nuts, torque to 72 inch pounds (6 foot pounds). The rear quarter window is constructed of solid tempered safety plate glass and cannot be drilled or ground.

Fig. 7-15—Rear Quarter Window Assembly - "A-37, 87" Styles Shown, "G-57" Style Typical

- |                              |                                 |
|------------------------------|---------------------------------|
| 1. Glass                     | 7. Guide Roller Spring          |
| 2. Lower Sash Channel Filler | 8. Guide Lower Roller           |
| 3. Lower Sash Channel        | 9. Guide Roller Washer Rubber   |
| 4. Lower Sash Channel Cam    | 10. Washer - Rubber             |
| 5. Glass to Sash Bolt        | 11. Glass to Sash Bushing       |
| 6. Guide Front Roller        | 12. Glass to Sash Nut           |
|                              | 13. Front Vertical Weatherstrip |

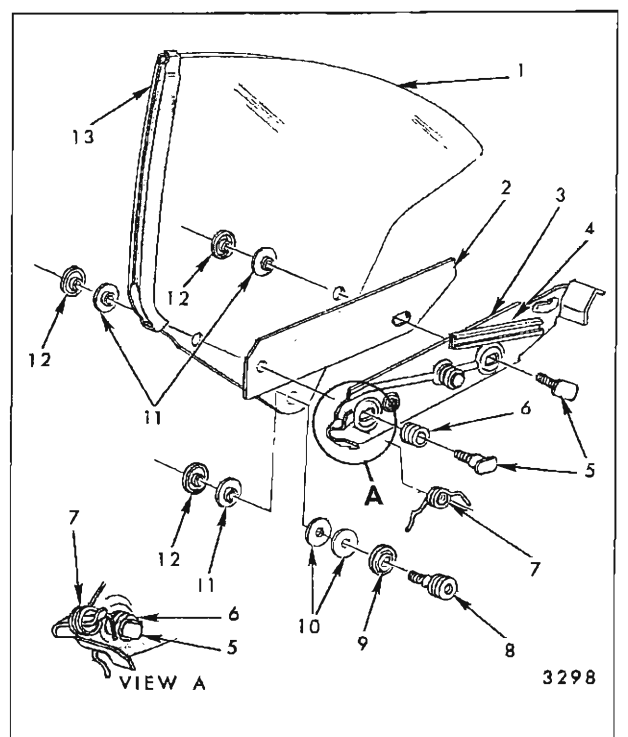



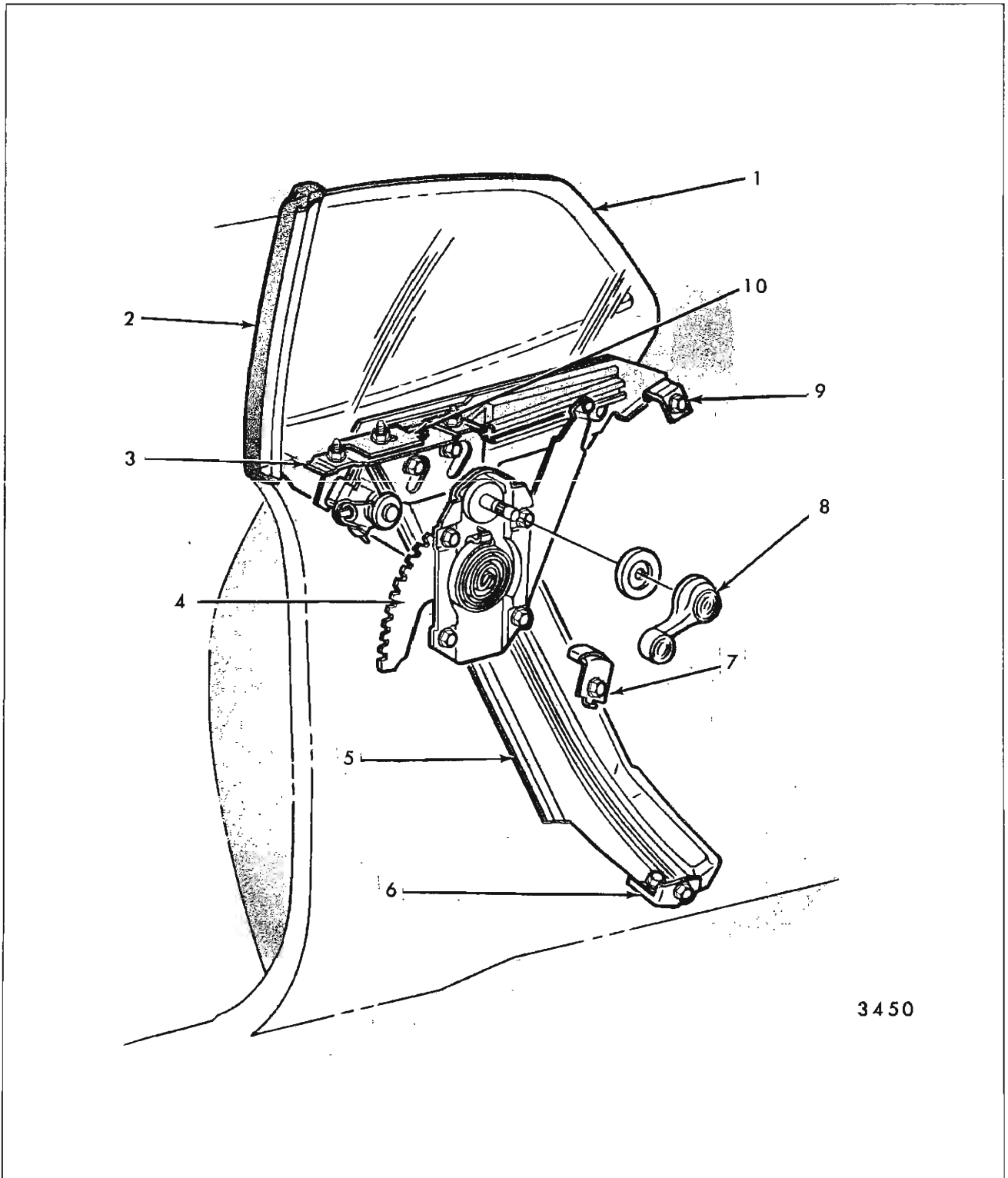

3450

Fig. 7-16—Quarter Window Hardware - "B & C" Body

1. Quarter Window Glass	5. Guide	8. Handle
2. Sash Channel	6. Lower Guide Support Assembly	9. Upper Rear Stop Assembly
3. Support Assembly	7. Lower Stop Assembly	10. Upper Front Stop Assembly
4. Regulator Assembly		

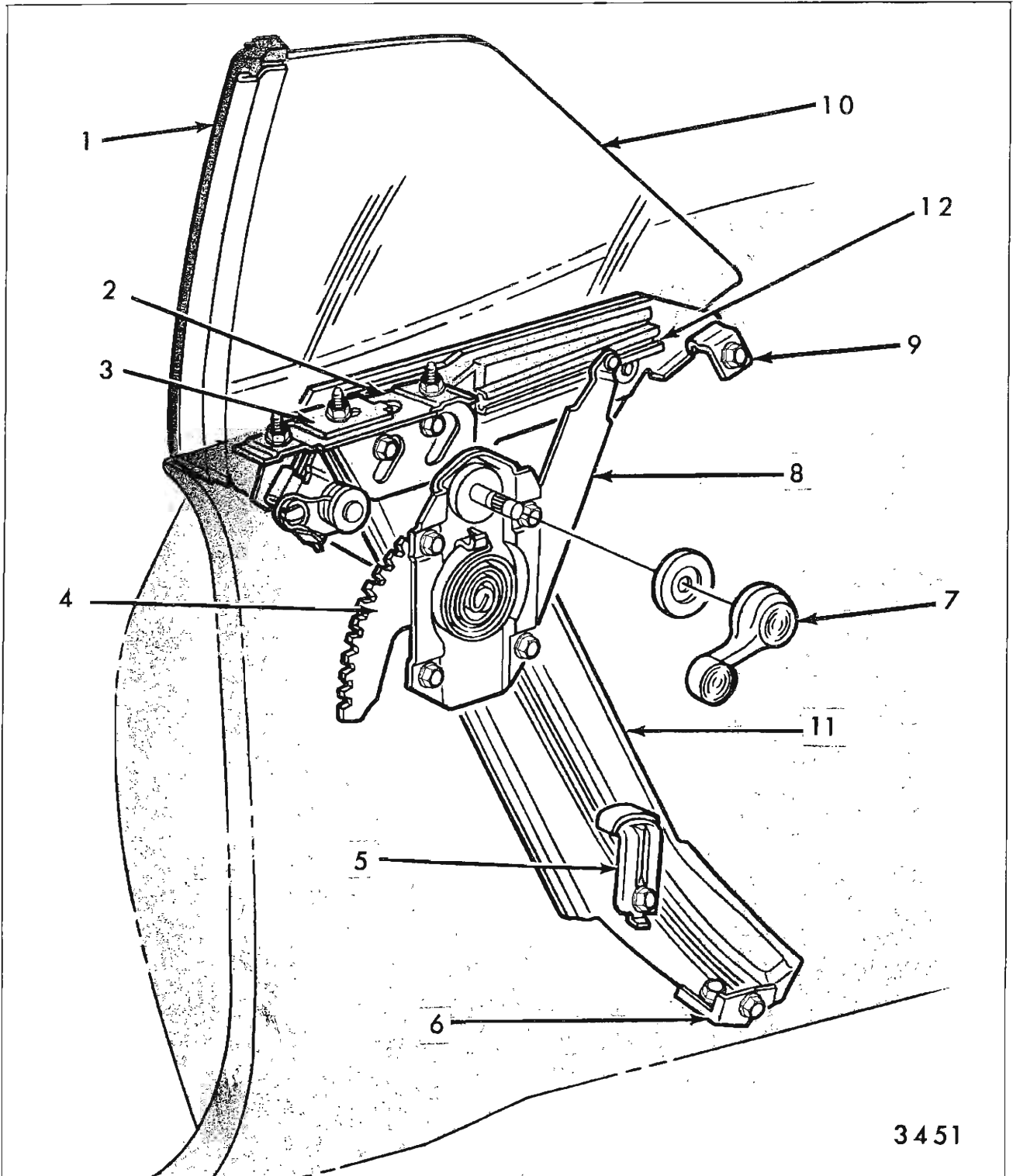

3451

Fig. 7-17—Quarter Window Hardware - "B-C 67" Styles

- |                              |                                 |                             |
|------------------------------|---------------------------------|-----------------------------|
| 1. Vertical Weatherstrip     | 5. Lower Stop Assembly          | 9. Upper Rear Stop Assembly |
| 2. Support Assembly          | 6. Support Assembly Guide Lower | 10. Glass                   |
| 3. Front Upper Stop Assembly | 7. Handle                       | 11. Guide                   |
| 4. Regulator Assembly        | 8. Regulator Lift Arm           | 12. Sash Channel Cam        |

**REAR QUARTER WINDOW ASSEMBLY—  
“B & C-37”-47-57 & 67” Styles**

**Description**

All “B & C” body rear quarter hardware is similar in design, as shown in Figures 7-16 and 7-17. These illustrations identify the component parts of the rear quarter hardware (by style), their relationship and various attaching points.

**Removal and Installation**

1. Remove rear seat cushion, seat back, rear quarter trim and inner panel water deflector or loading hole cover. On “67” styles, lower folding top.
2. Remove rear up-travel stop (See Figs. 7-18 and 7-19).
3. Remove front up-travel stop.



Fig. 7-18—Rear Quarter Hardware - “B-37, 47, 57” Styles

- |  |   |   |   |
|--|---|---|---|
| <p>1. Rear Up Travel Stop</p> <p>2. Front Up Travel Stop</p> | <p>3. Window Guide to Upper Support Upper Attaching Bolts</p> | <p>4. Window Guide to Upper Support Lower Attaching Bolts</p> | <p>5. Window Regulator Attaching Bolts</p> <p>6. Window Guide Lower Support to Inner Panel Attaching Bolt</p> |
|--|---|---|---|

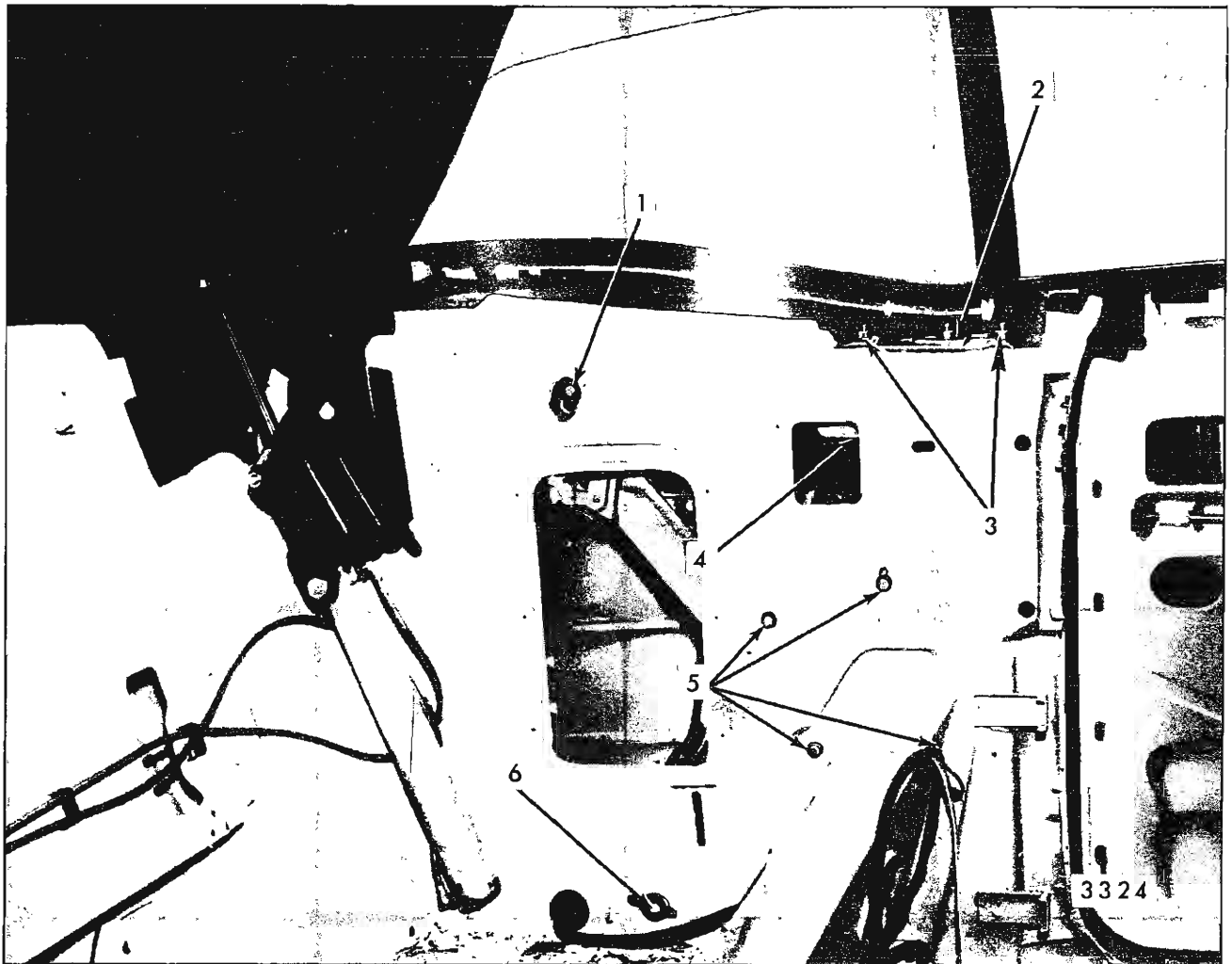

Fig. 7-19—Rear Quarter Hardware - "B-67" Styles

- |   |   |  |
|---|---|--|
| <p>1. Rear Up Travel Stop<br/>2. Front Up Travel Stop</p> | <p>3. Window Guide to Upper Support<br/>Upper Attaching Bolts<br/>4. Window Guide to Upper Support<br/>Lower Attaching Bolts (Hidden)</p> | <p>5. Window Regulator Attaching Bolts<br/>6. Window Guide Lower Support to<br/>Inner Panel Attaching Bolt</p> |
|---|---|--|

4. Loosen window guide to upper support lower attaching bolts.
5. Remove window guide lower support to inner panel attaching bolt and slide guide downward. Tilt glass to enable disengagement of lift arm roller from sash channel cam.
6. Lift glass to disengage from guide and remove window inboard of side roof rail.
7. To install, reverse removal procedure.

### Adjustments

The rear quarter window guide is secured to the

quarter inner panel at top and bottom by supports. These supports provide in or out, fore or aft and up or down adjustment. One down-stop and two up-stops are provided for alignment operations.

Figure 7-20 illustrates "B & C" body style rear quarter window glass and hardware components that make up the window assembly.

**NOTE:** When reinstalling glass to sash channel bolts, or nylon roller nuts, torque to 72 inch pounds (6 foot pounds). The rear quarter window is constructed of solid tempered safety plate glass and cannot be drilled or ground.

Figure 7-21 illustrates usage of tool J-22055 for removal of quarter window glass roller nuts.

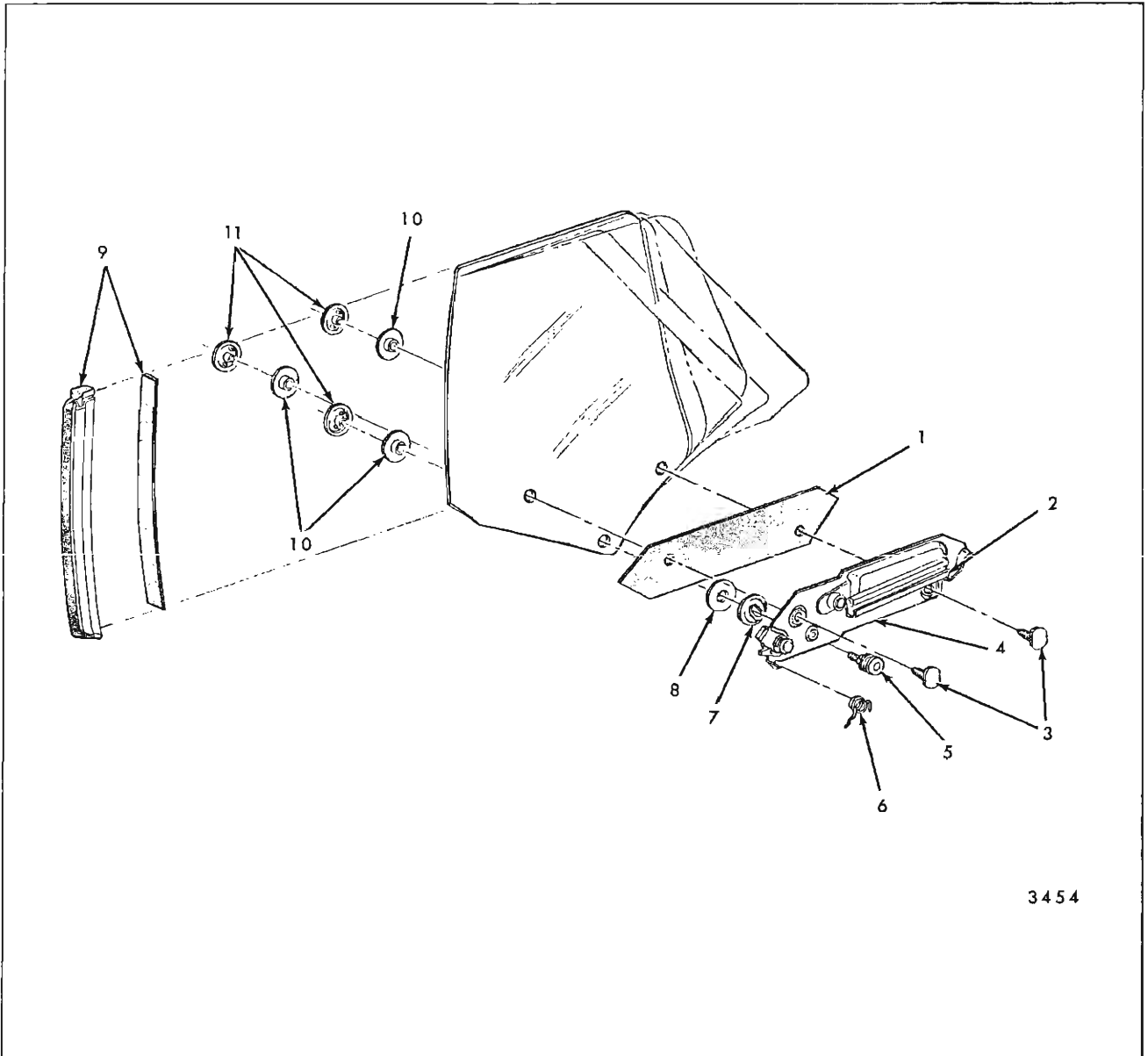

3454

Fig. 7-20--Rear Quarter Window Assembly - "B-C 37, 47, 57, 67" Styles

- |                              |                                |
|------------------------------|--------------------------------|
| 1. Lower Sash Channel Filler | 7. Guide Roller Washer Rubber  |
| 2. Lower Sash Channel Cam    | 8. Guide Roller Washer         |
| 3. Glass to Sash Bolt        | 9. Front Vertical Weatherstrip |
| 4. Lower Sash Channel        | 10. Glass to Sash Bushing      |
| 5. Guide Lower Roller        | 11. Glass to Sash Nut          |
| 6. Guide Roller Spring       |                                |

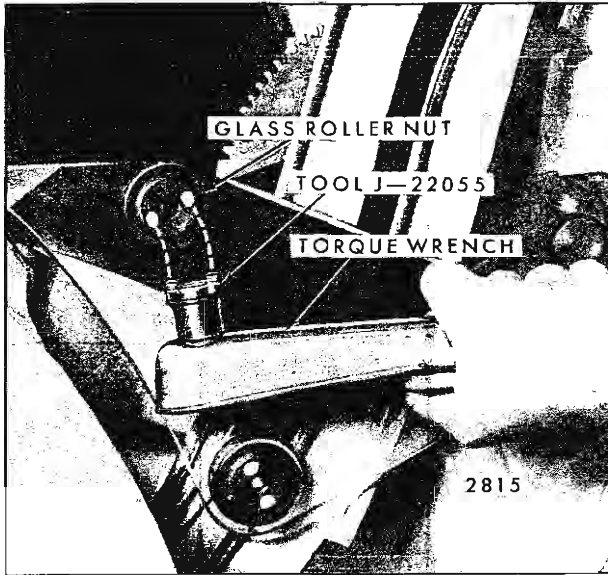

Fig. 7-21—Quarter Window Roller

## REAR QUARTER WINDOW ASSEMBLY— “E-87” Styles

### Description

“E-87” Style rear quarter hardware is similar for both Buick and Oldsmobile Styles, as shown in Figures 7-22 and 7-23. These illustrations identify the component parts of the rear quarter hardware (by style), their relationship and various attaching points.

### Removal and Installation

1. Remove necessary trim and sealing components. With window in a full-up position, remove rear guide upper and lower attaching bolts. Disengage guide from roller on window assembly and remove guide through access hole (see Fig. 7-24).
2. With quarter window partially lowered, remove

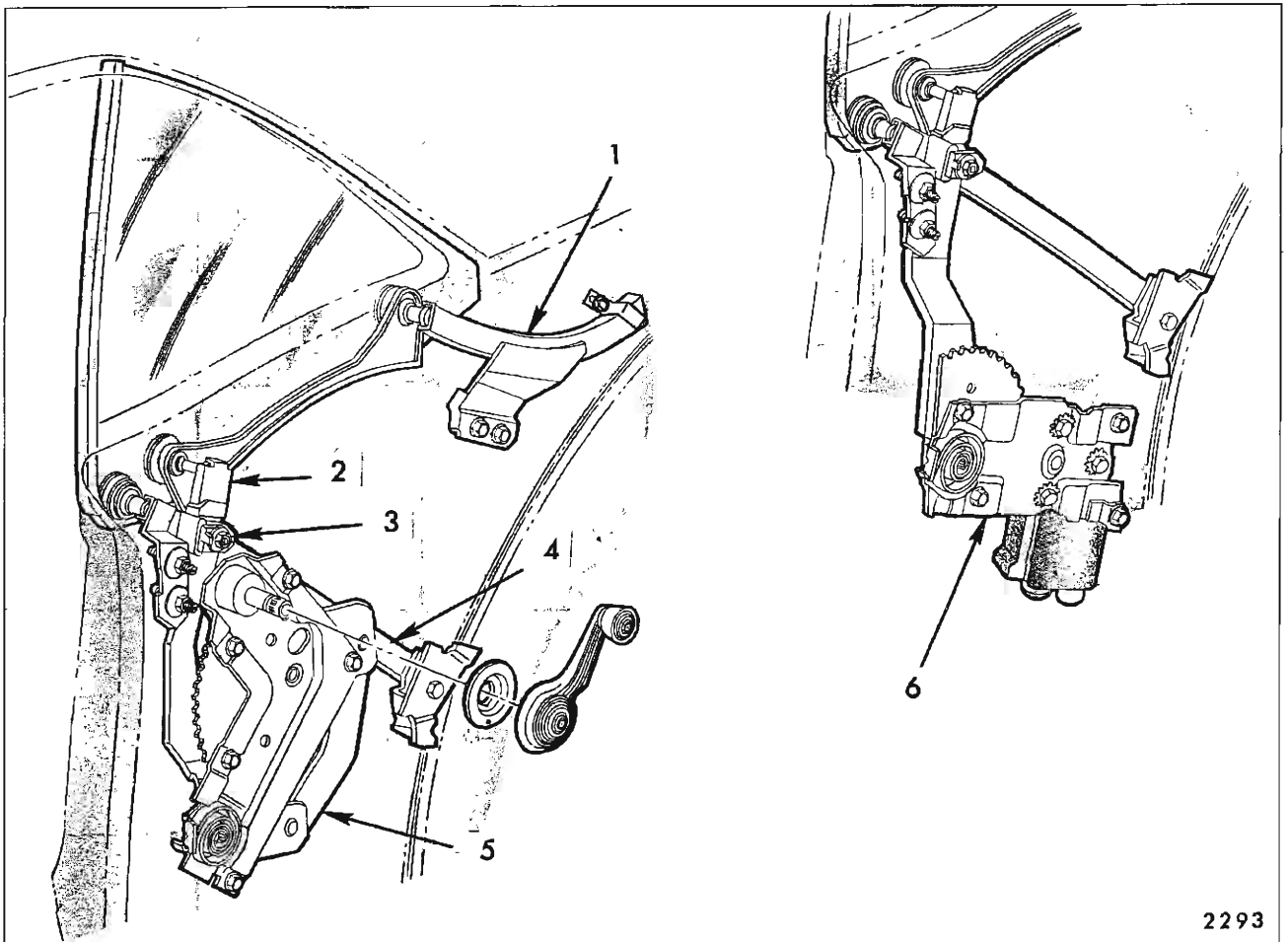

Fig. 7-22—Rear Quarter Hardware - Buick “E” Styles

1. Rear Guide
2. Regulator Lift Arm Cam

3. Up-Stop
4. Front Guide

5. Regulator (Manual)
6. Regulator (Electrical)

nuts securing regulator lift arm cam to regulator lift arm and remove cam.

**NOTE:** Lift arm must be pushed inboard slightly to remove cam.

3. While supporting glass, remove quarter window front guide attaching bolts and lower guide to bottom of rear quarter.
4. Remove quarter window inboard of roof panel.
5. To install, reverse removal procedure.

**Adjustments**

Fore and aft alignment is determined by positioning front guide. Adjusting rear guide will provide parallel condition of quarter window to door for constant seal. In or out alignment is determined

by upper two adjusting studs and nuts at front guide. The adjustable up-stop will provide up or down alignment and partially fore and aft alignments by controlling window travel.

**NOTE:** Adjustments on regulator lift arm cam are provided to permit maximum travel but caution must be observed so as not to interfere with quarter trim assembly at belt.

Figure 7-25 illustrates "E-87" style rear quarter window glass and hardware components that make up the window assembly.

**NOTE:** When reinstalling glass to sash channel bolts, or nylon roller nuts, torque to 72 inch pounds (6 foot pounds). The rear quarter window is constructed of solid tempered safety plate glass and cannot be drilled or ground.

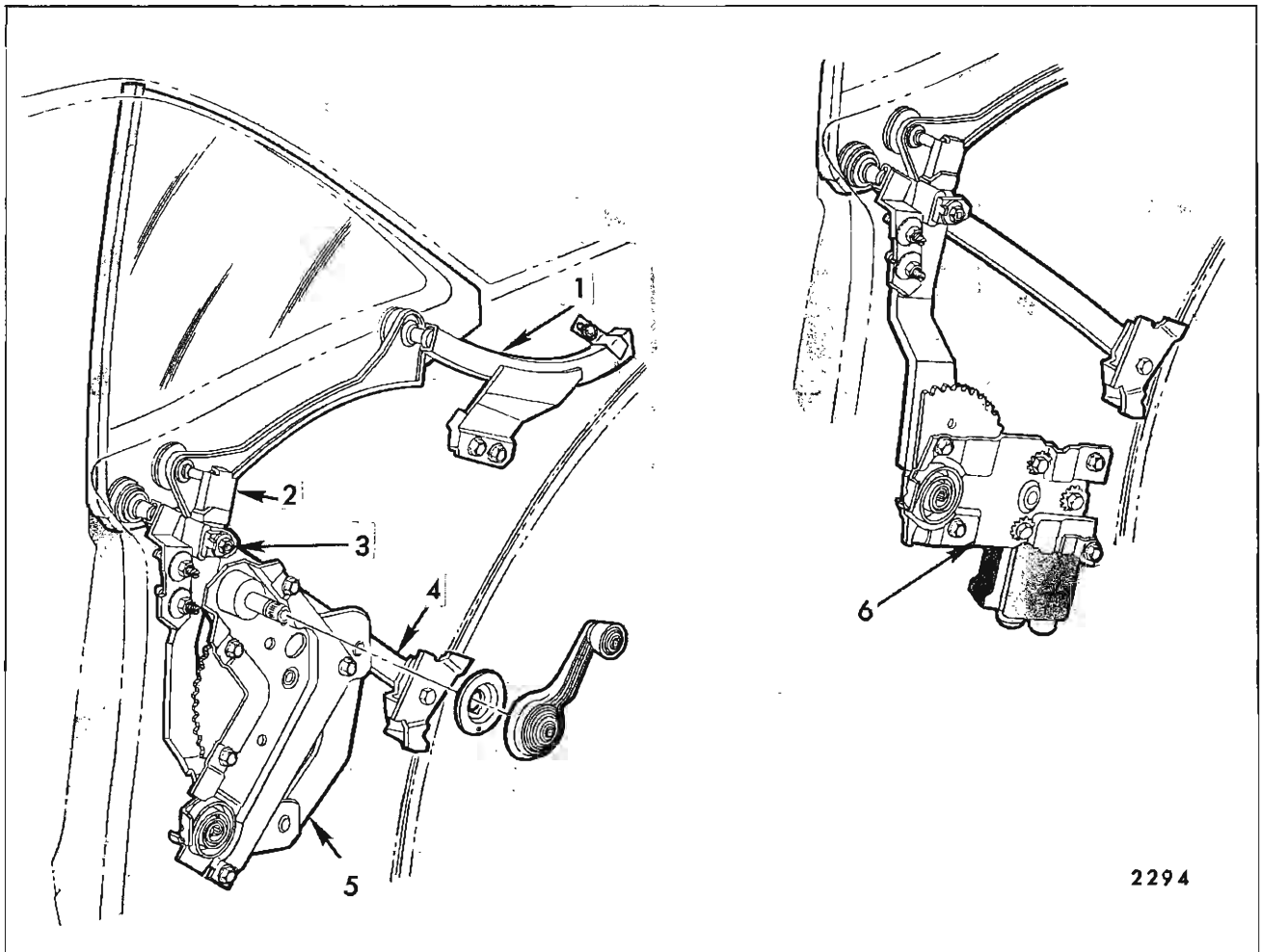

Fig. 7-23—Rear Quarter Hardware - Oldsmobile "E" Body

1. Rear Guide  
2. Regulator Lift Arm Cam

3. Up Stop  
4. Front Guide

5. Regulator (Manual)  
6. Regulator (Electrical)

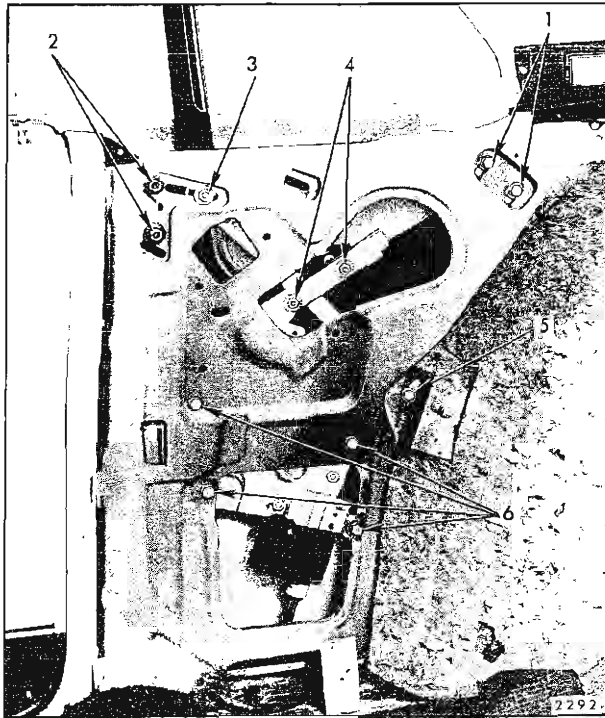

Fig. 7-24—Rear Quarter Hardware - "E" Body

- |   |   |
|---|---|
| 1. Rear Guide Attaching Bolts                 | 5. Front Guide Lower Attaching Bolt                         |
| 2. Front Guide Upper Adjusting Studs and Nuts | 6. Regulator Attaching Bolts (4 for Electric, 5 for Manual) |
| 3. Up-Stop Attaching Bolt                     |   |
| 4. Regulator Lift Arm Cam Attaching Nuts      |   |

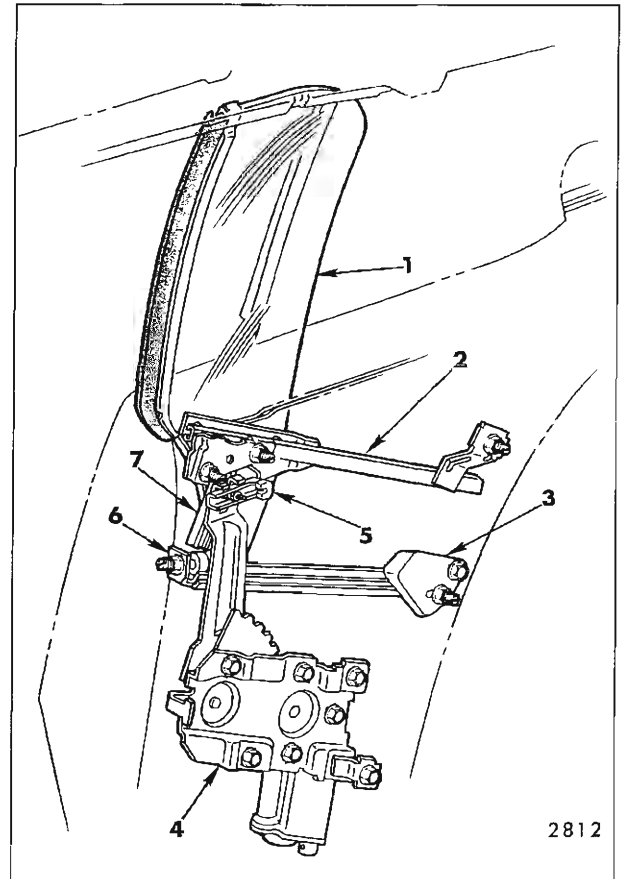

Fig. 7-26—Rear Quarter Hardware - Cadillac "E" Body

- |                            |                        |
|----------------------------|------------------------|
| 1. Glass                   | 5. Rearward Glass Stop |
| 2. Sash Channel Cam        | 6. Front Stop          |
| 3. Down Stop               | 7. Vertical Cam        |
| 4. Electric Motor Assembly |                        |

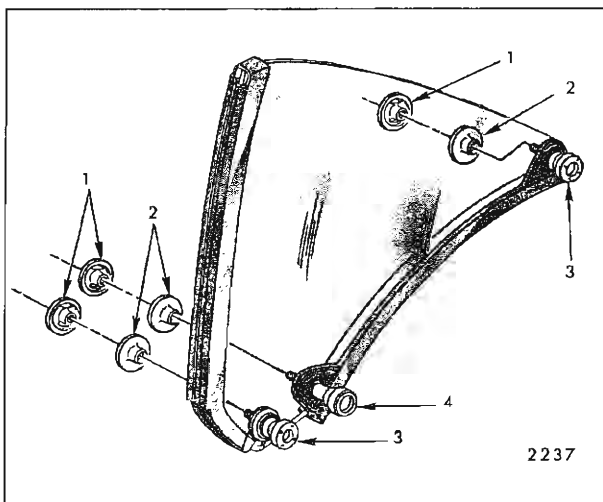

Fig. 7-25—Rear Quarter Window Assembly - "E-87" Style

- |           |                         |
|-----------|-------------------------|
| 1. Nut    | 3. Roller               |
| 2. Spacer | 4. Roller Bolt Assembly |

### REAR QUARTER WINDOW ASSEMBLY— "E-47" Styles

Figure 7-26 identifies the component parts of the "E-87" rear quarter hardware, their relationship and various attaching points.

#### Removal and Installation

1. Remove necessary trim, inner panel water deflector, body lock pillar pressure relief valve grille and body lock pillar upper sealing strip.
2. Lower quarter window to gain access to nut securing regulator lift arm and stop to lower sash channel roller and remove nut (Item 4 in figure 7-27). Disconnect lift arm from sash channel cam.



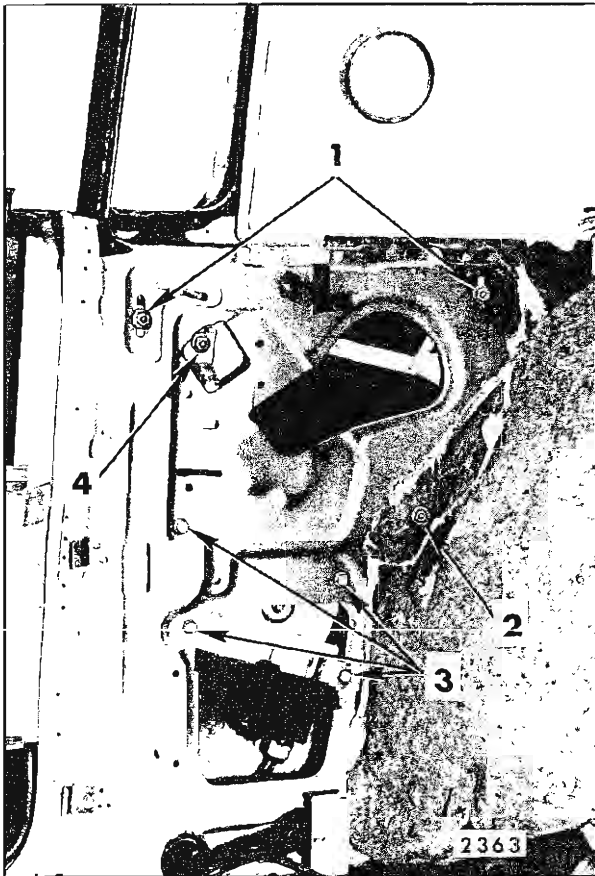

Fig. 7-27—Rear Quarter Hardware - "E-47" Style

- |  |   |
|--|---|
| 1. Inner Panel Cam Adjusting Studs and Nuts      | 3. Regulator Attaching Bolts                            |
| 2. Glass Run Channel Rear Adjusting Stud and Nut | 4. Regulator Lift Arm to Cam Glass Roller Attaching Nut |
3. Remove two nuts securing inner panel cam to inner panel (Item 1 in Figure 7-27).
  4. Remove adjusting studs from inner panel cam.
  5. Remove inner panel cam through lock pillar pressure relief valve opening.
  6. Pull quarter glass forward. Remove glass in-board of side roof rail. Figure 7-28 shows quarter glass after removal.
  7. To install, reverse removal procedure.

### Adjustments

Critical rear quarter window adjustments can be achieved at the lock pillar and DO NOT require seat and side wall trim removal (see Fig. 7-29).

1. Remove lock pillar grille.

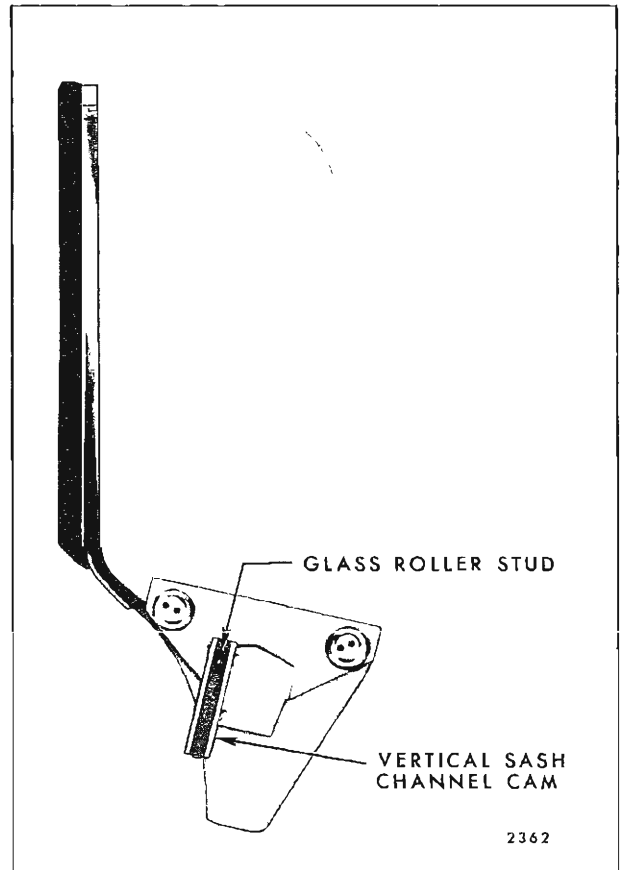

Fig. 7-28—Rear Quarter Window Assembly - "E-47" Styles

2. The forward glass stop can be adjusted fore and aft by loosening lock nut and turning stud in or out (see Fig. 7-29).

**NOTE:** Stop bolt also retains forward attachment of glass run channel.

3. A slight amount of in or out adjustment of glass is provided by an elongated slot at glass run channel forward attachment (see Fig. 7-29).
4. A secondary glass stop is located in the vertical sash channel cam (Fig. 7-26). This stop is retained by a single bolt and is accessible through lock pillar opening (see Fig. 7-29).

**NOTE:** Major glass adjustment is available at inner panel cam adjusting studs and nuts (see Fig. 7-27). In addition, the glass run channel rear attachment provides in or out and up or down adjustment. Also, a glass lower stop is attached to the rear plate of the glass run channel. This stop is adjustable fore and aft.

Figure 7-30 illustrates "E-47" style rear

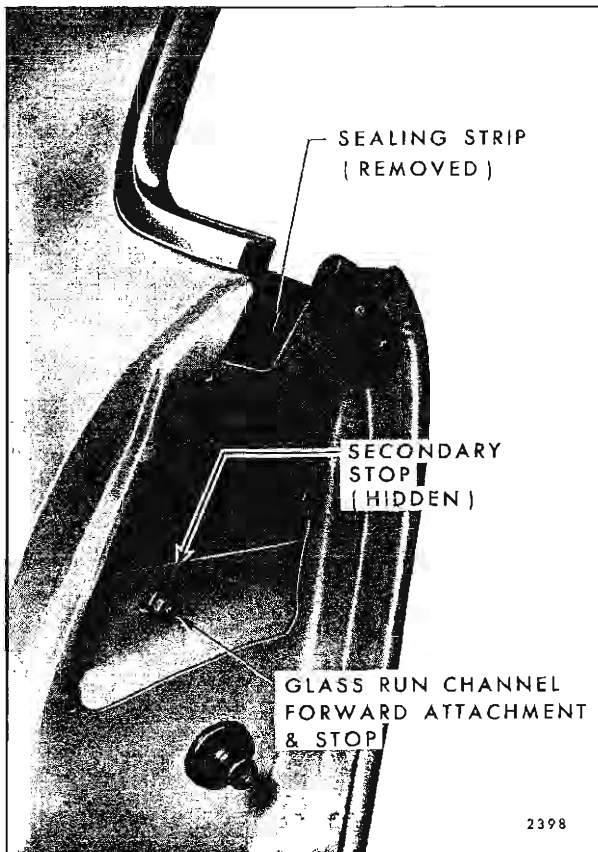

Fig. 7-29—Rear Quarter Window Hardware Attachments on Lock Pillar

quarter window glass and hardware components that make up the window assembly.

**NOTE:** When reinstalling glass to sash channel bolts, or nylon roller nuts, torque to 72 inch pounds (6 foot pounds). The rear quarter window is constructed of solid tempered safety plate glass and cannot be drilled or ground.

### REAR QUARTER WINDOW ASSEMBLY— “F-37 and 67” Styles

All rear quarter hardware on “F” body styles is similar as shown in Figure 7-31. This illustration identifies the component parts of the rear quarter hardware, their relationship and various attaching points.

#### Removal and Installation

1. Remove rear quarter trim assembly and inner panel water deflector or loading hole covers.
2. On convertible styles, lower folding top.

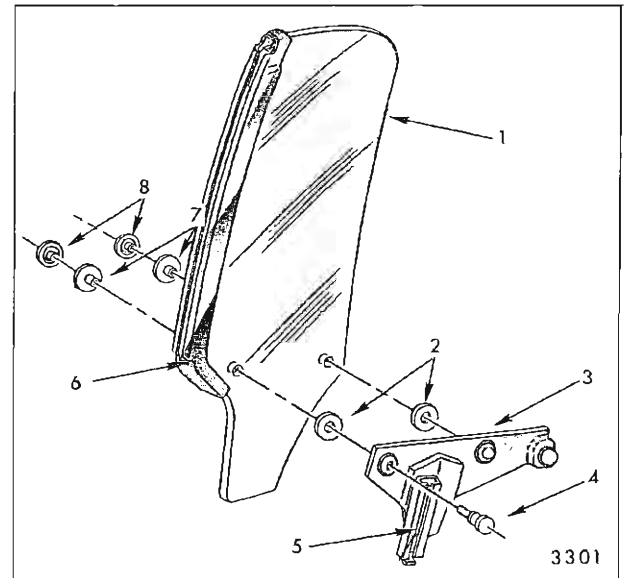

Fig. 7-30—Rear Quarter Window Assembly - “E-47” Styles

- |                       |                                 |
|-----------------------|---------------------------------|
| 1. Glass              | 5. Sash Channel Cam             |
| 2. Washer Rubber      | 6. Vertical Weatherstrip        |
| 3. Sash Channel       | 7. Glass to Sash Bushing Rubber |
| 4. Glass to Sash Bolt | 8. Glass to Sash Nut            |

3. Remove glass inner and outer strip assembly.
4. Remove window guide upper and lower attaching nuts (Fig. 7-32).
5. Support glass with one hand and position to enable disengagement of lift arm roller from sash channel cam.
6. Remove glass straight up and outboard of side roof rail on hardtop styles (Fig. 7-33).
7. To install, reverse removal procedure.

#### Adjustments

In or out and fore or aft adjustment is provided by inner panel slots and adjusting studs of the window guide. Up-travel of the glass is controlled by a stop located on the regulator assembly (Fig. 7-32).

Figure 7-34 illustrates relationship of window assembly to guide. Figure 7-35 illustrates “F” body style rear quarter window glass and hardware components that makeup the window assembly.

### REAR QUARTER WINDOW ASSEMBLY— “Z-37 and 67” Styles

All rear quarter hardware on “Z” body styles is similar as shown in Figures 7-36 and 7-37. These

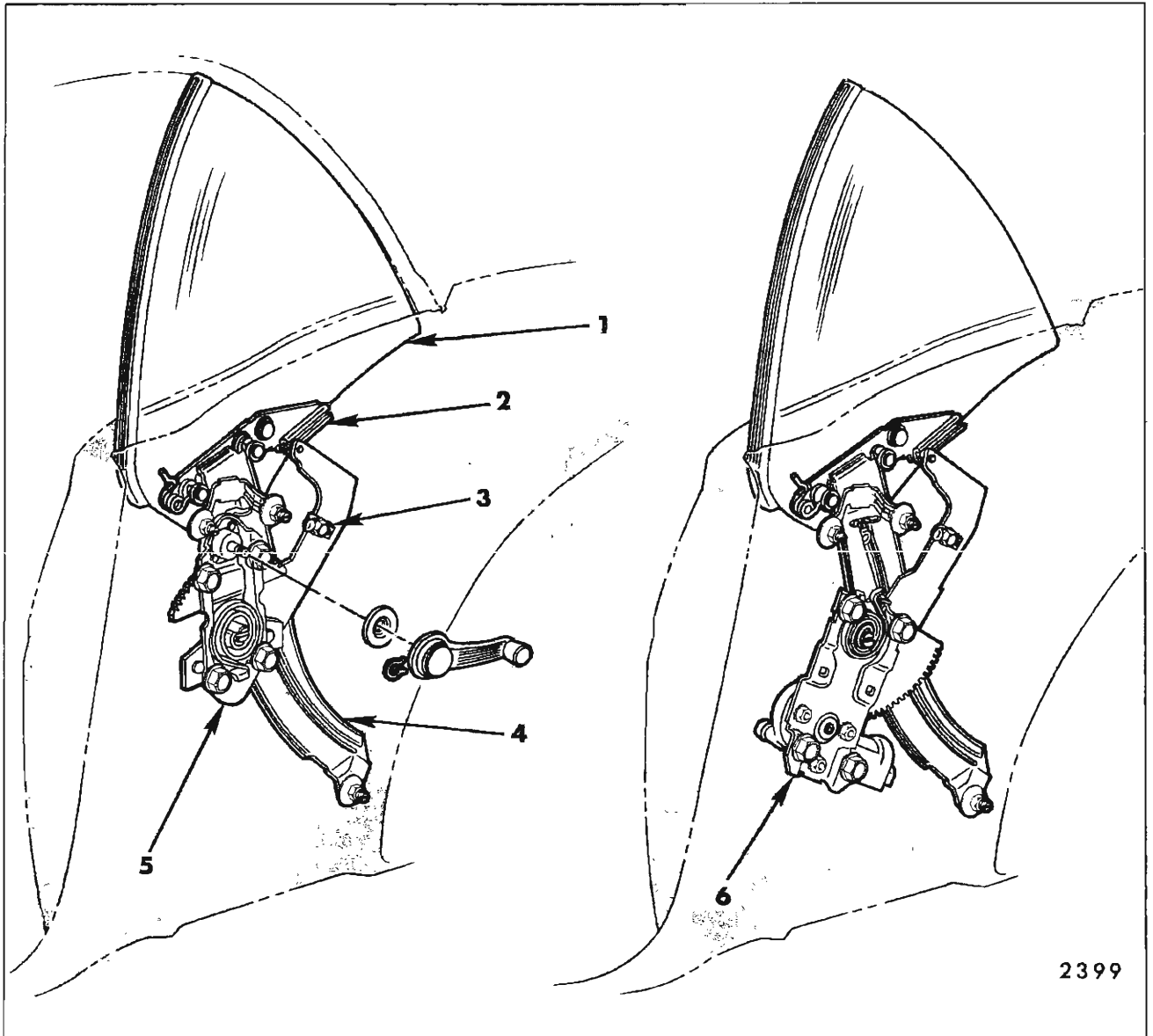

Fig. 7-31—Rear Quarter Hardware - "F" Body Style

1. Rear Quarter Window
2. Sash Channel Cam
3. Window Up-Stop
4. Window Guide
5. Regulator (Manual)
6. Regulator (Electrical)

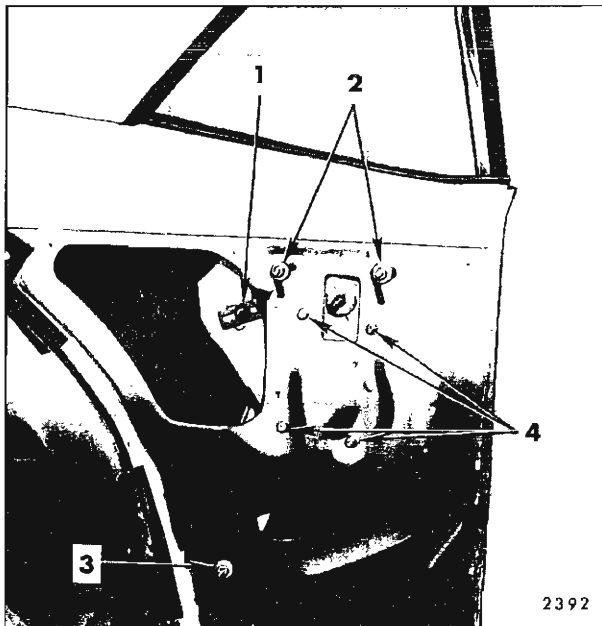

Fig. 7-32—Rear Quarter Window Hardware - "F" Styles

- |                   |                           |
|-------------------|---------------------------|
| 1. Window Up-Stop | 3. Window Guide           |
| 2. Window Guide   | Lower Adjusting           |
| Upper Adjusting   | Stud and Nut              |
| Stud and Nuts     | 4. Window Regulator Bolts |

**Removal and Installation**

1. With window in full-up position, remove rear guide upper and lower attaching bolts (Fig. 7-38). Disengage guide from roller on window assembly and remove guide.
2. Remove regulator as described in a following procedure (see index).
3. Slide rear quarter window upward and forward and pivot top rear corner of glass to a point outboard of side roof rail. Continue movement of glass upward and forward to disengage front glass rollers from front guide assembly and remove rear quarter window from body.
4. To install, reverse removal procedure.

illustrations identify (by style), the component parts of the rear quarter hardware, their relationship and various attaching points.

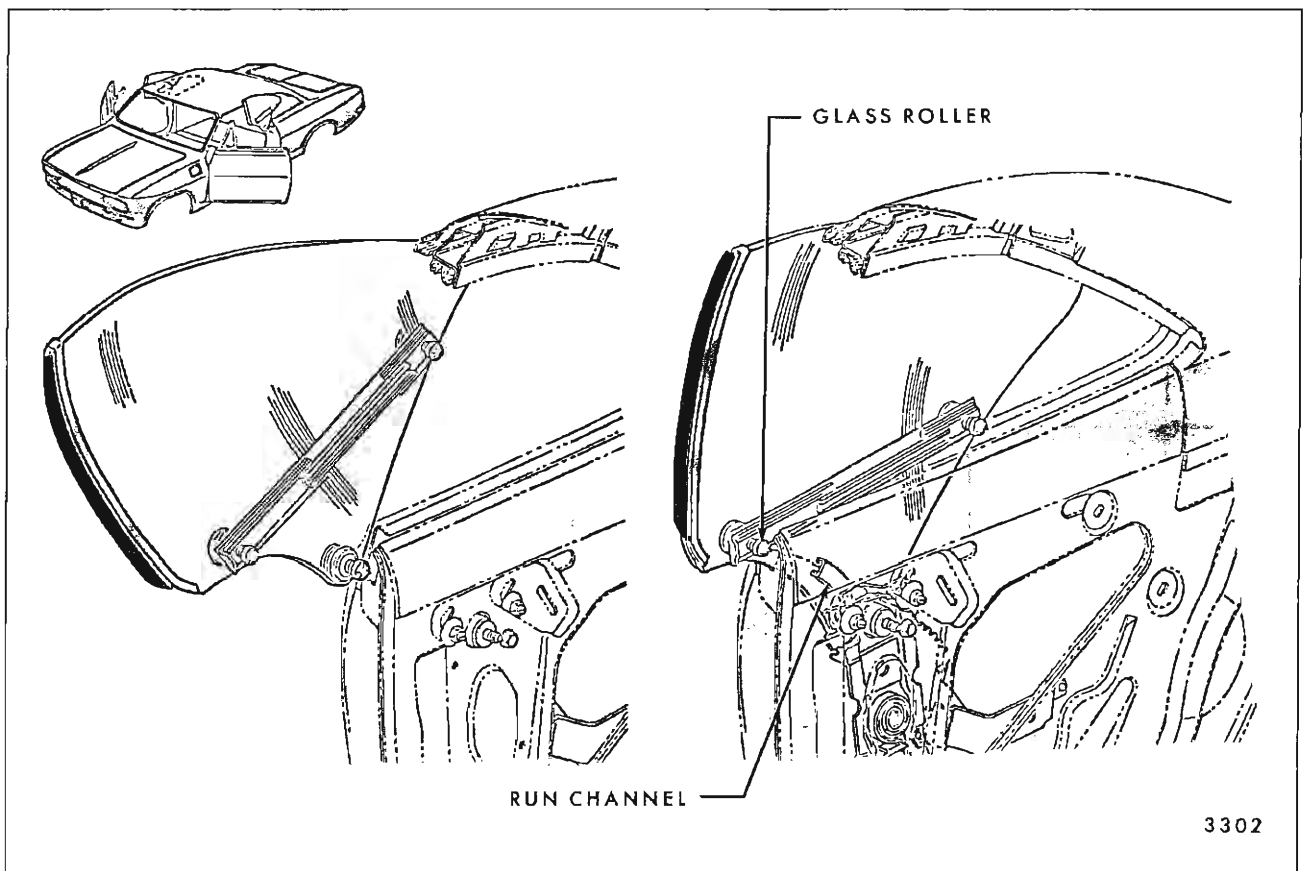

Fig. 7-33—Rear Quarter Window Removal - "Z-37" Style

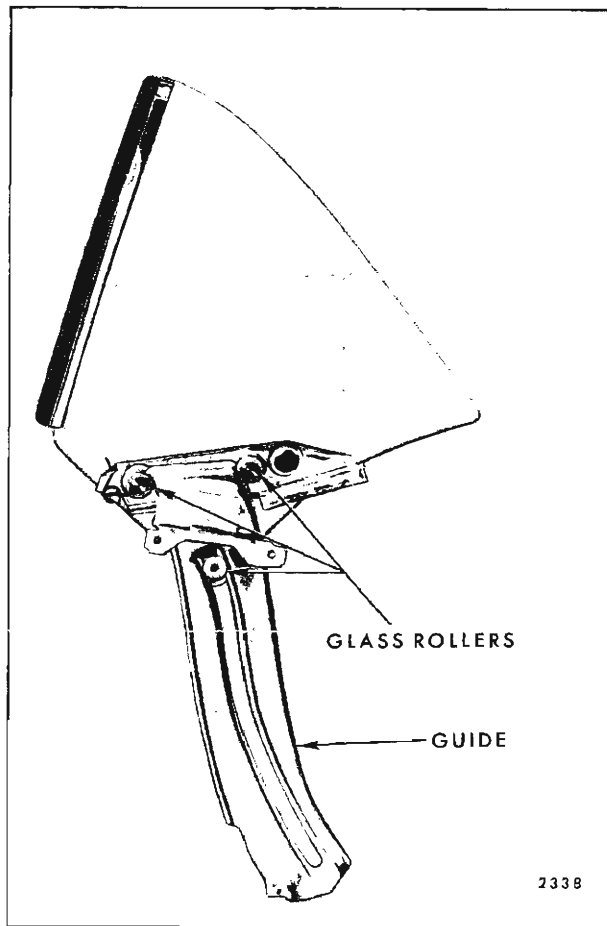

Fig. 7-34—Rear Quarter Window and Guide Assembly - "F" Styles

### Adjustments

1. The quarter window up-stop can be utilized for adjustments of glass to side roof rail weatherstrip (see Section "A-A" in Fig. 7-39).
2. The rear guide can be adjusted to gain proper fore and aft contact of rear quarter window vertical weatherstrip to rear edge of front door window (see section "C-C" and "F-F" in Fig. 7-39).

Figures 7-40 and 7-41 illustrate "Z" body (by style) rear quarter window glass and hardware components that make-up the window assembly.

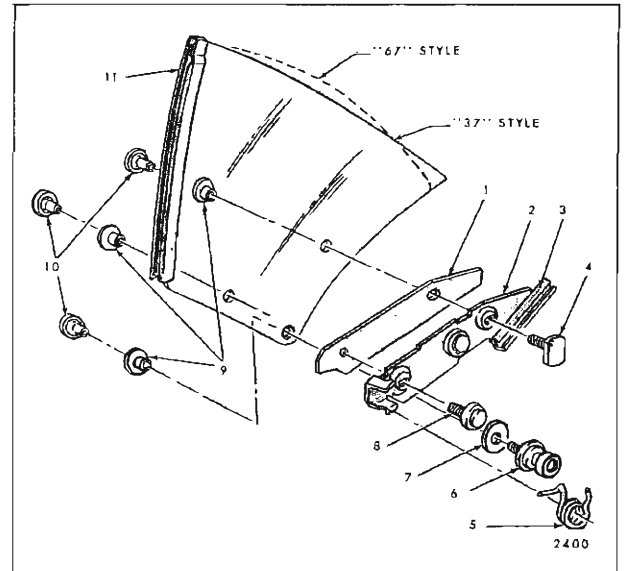

Fig. 7-35—Rear Quarter Window Assembly - "F" Style

1. Lower Sash Channel Filler
2. Lower Sash Channel
3. Lower Sash Channel Cam
4. Glass to Sash Channel Bolt
5. Guide Roller Spring
6. Guide Lower Roller
7. Guide Roller Washer (Rubber)
8. Lower Sash Channel Front Bolt
9. Glass to Sash Channel Bushing (Rubber)
10. Glass to Sash Channel Nut
11. Vertical Weatherstrip

### REAR QUARTER WINDOW REGULATOR (Manual or Electric)—"A-27 and 77"- "B-11" and "X-27" Styles

#### Removal and Installation

1. Remove necessary trim and water deflector or access hole cover.
2. On all electric styles, disconnect wire harness at motor.
3. While supporting window, disengage clip retainer securing regulator lift arm to glass and prop window in a full up position.

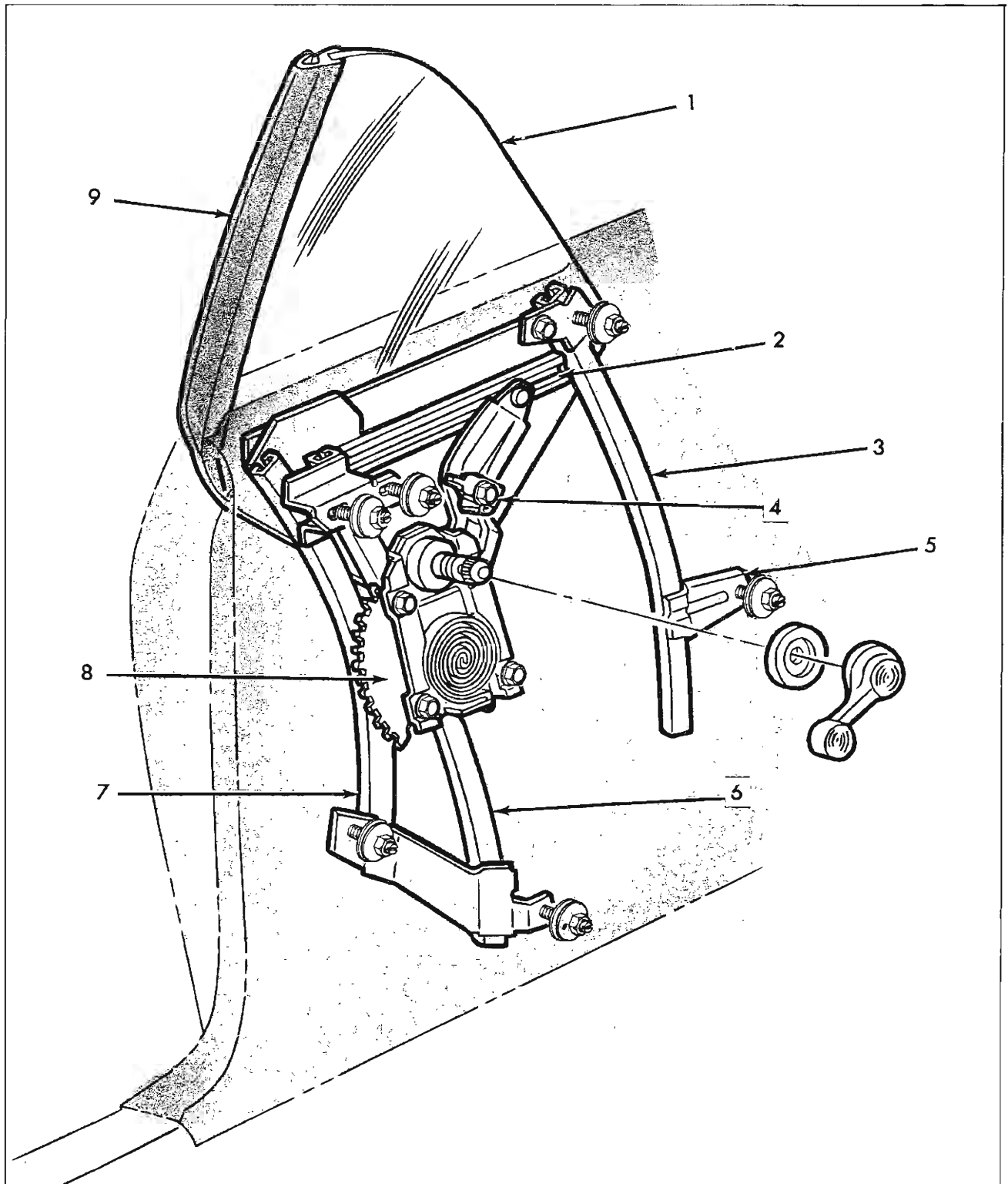
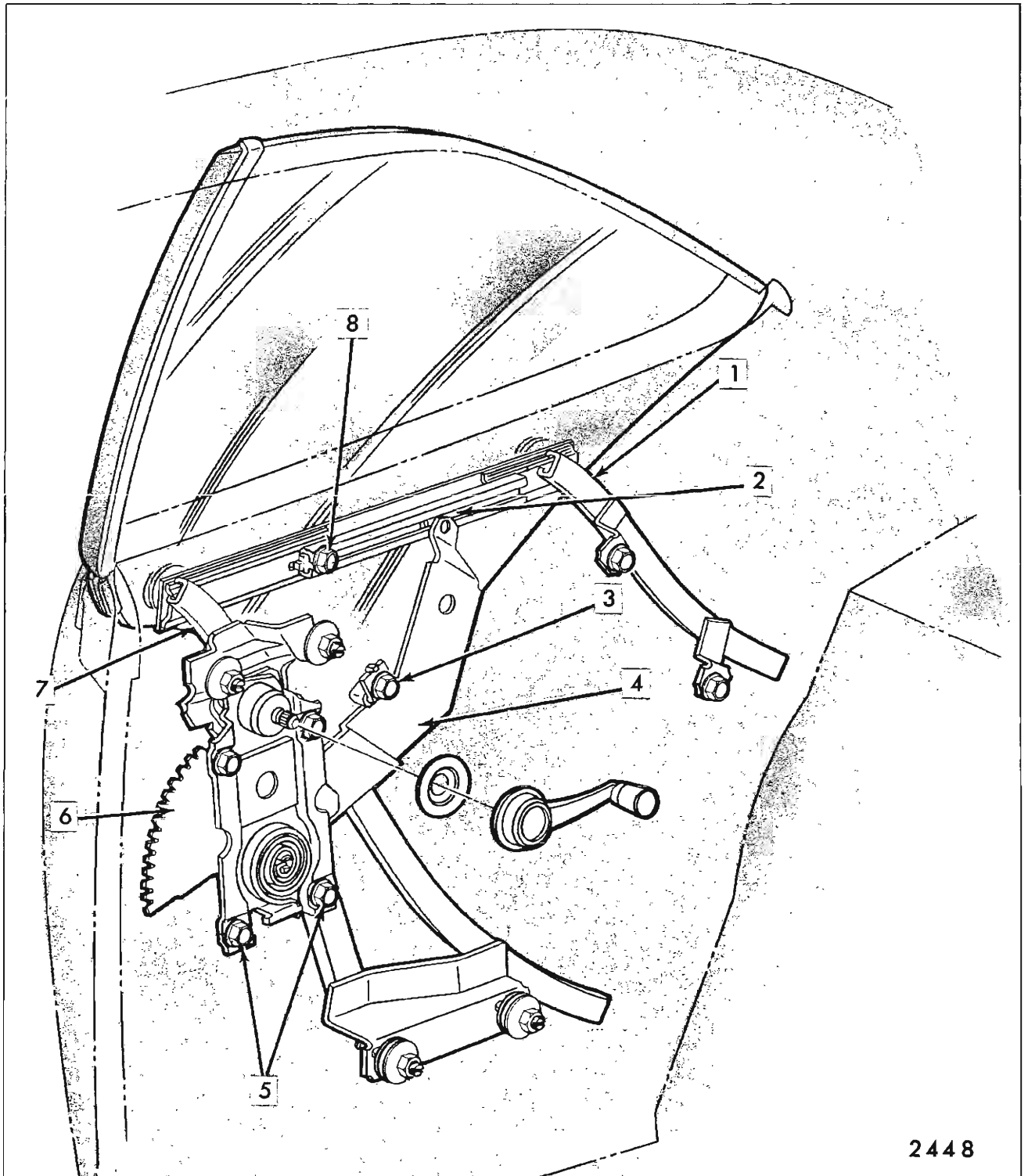

Fig. 7-36—Rear Quarter Window Hardware - "Z-67" Styles

1. Window Glass  
 2. Sash Channel Cam  
 3. Rear Guide

4. Window Upper Stop  
 5. Window Rear Stop  
 6. Run Channel Rear

7. Run Channel Front  
 8. Regulator  
 9. Vertical Weatherstrip



2448

Fig. 7-37—Rear Quarter Hardware - "Z-37" Style

- |                           |                             |
|---------------------------|-----------------------------|
| 1. Rear Guide             | 5. Regulator Attaching Bolt |
| 2. Lower Sash Channel Cam | 6. Regulator                |
| 3. Window Up-Stop         | 7. Front Guide              |
| 4. Lift Arm               | 8. Window Down Stop         |

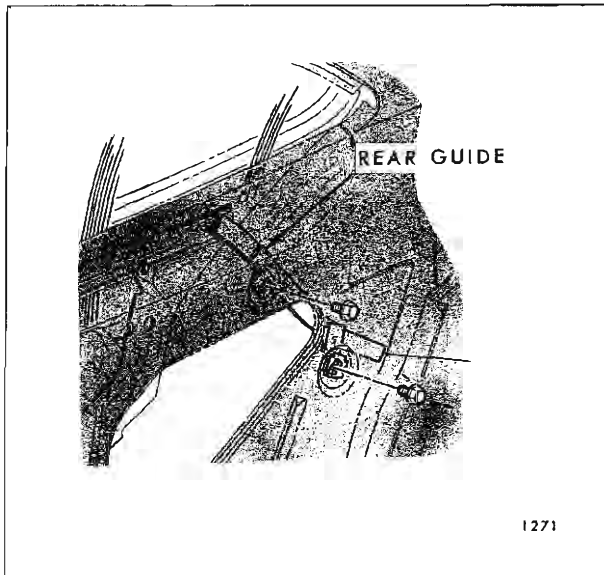

1271

Fig. 7-38—Rear Quarter Window Rear Guide Assembly - "Z-37" Styles

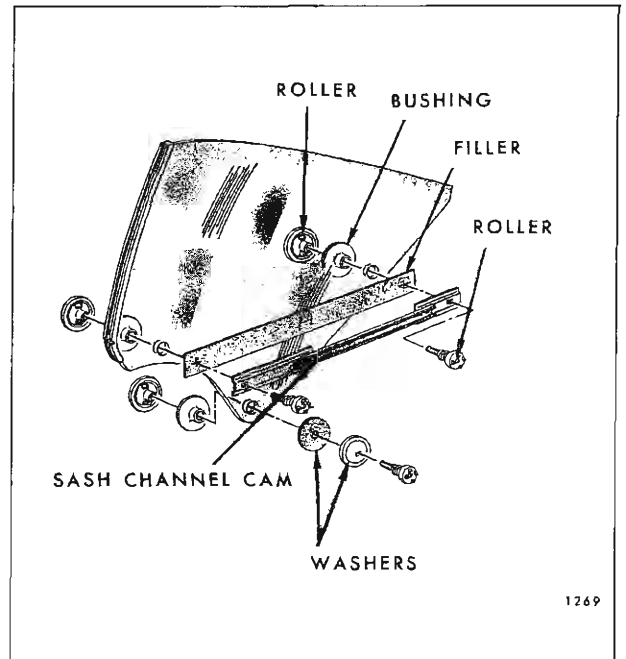

1269

Fig. 7-40—Rear Quarter Window Assembly - "Z-37" Styles

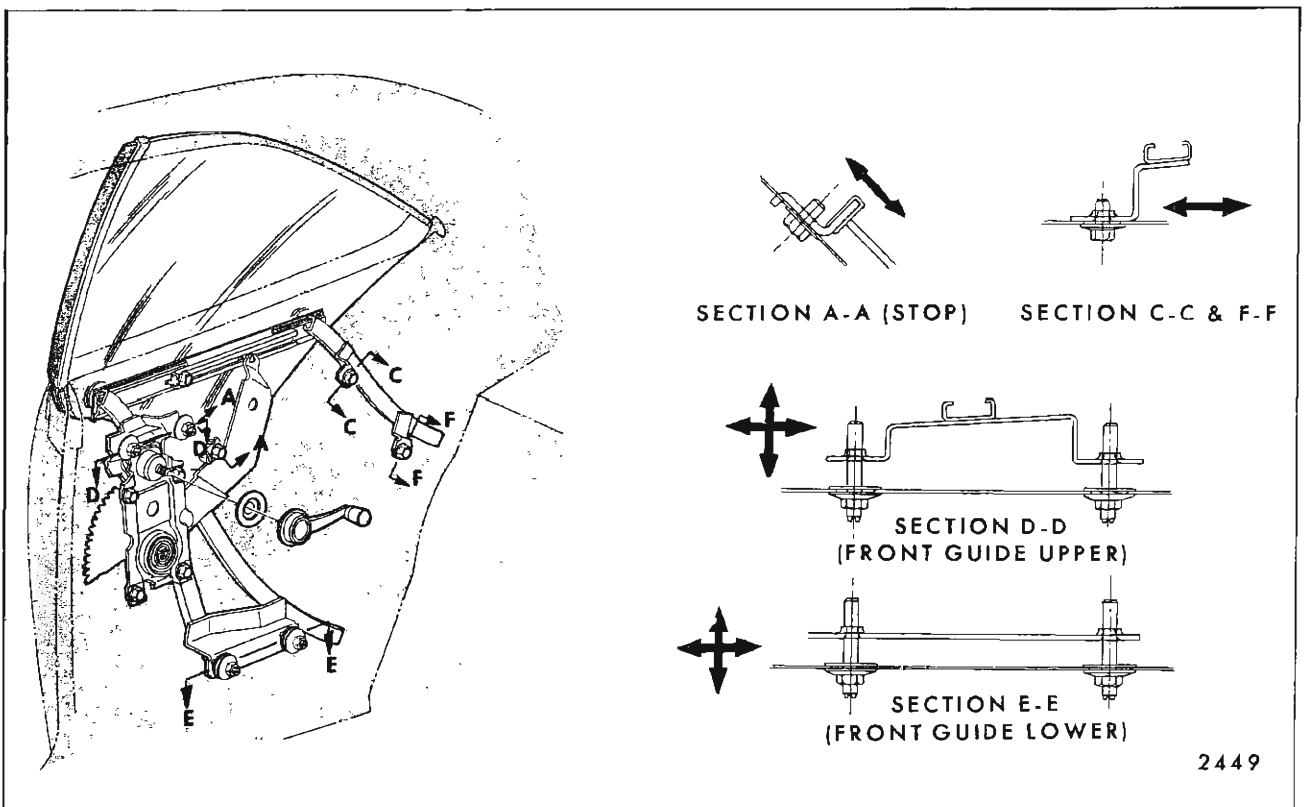

2449

Fig. 7-39—Rear Quarter Window Adjustments - "Z-37" (Arrows Indicate Adjustment Direction Available)



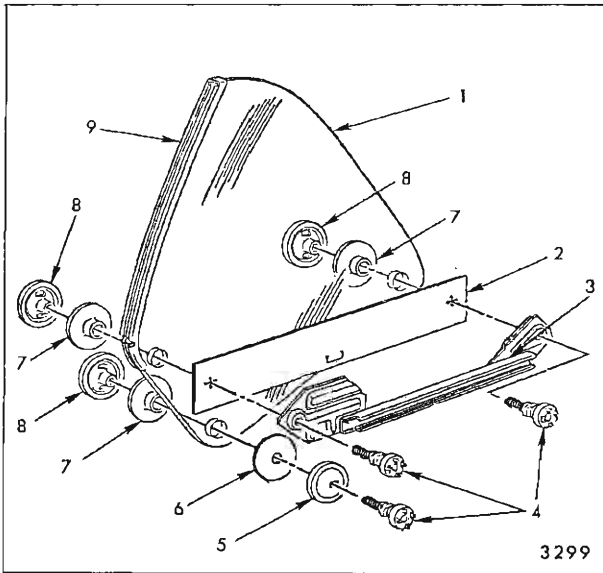

Fig. 7-41—Rear Quarter Window Assembly - "Z-67" Style

- |                     |                          |
|---------------------|--------------------------|
| 1. Glass            | 6. Washer Rubber         |
| 2. Filler           | 7. Bushing Rubber        |
| 3. Sash Channel Cam | 8. Glass to Sash Nut     |
| 4. Roller           | 9. Vertical Weatherstrip |
| 5. Washer Metal     |                          |

4. Remove regulator attaching bolts. Figure 7-42 is typical of closed style regulator attachment.
5. Remove regulator through large access hole.
6. To install, reverse removal procedure.

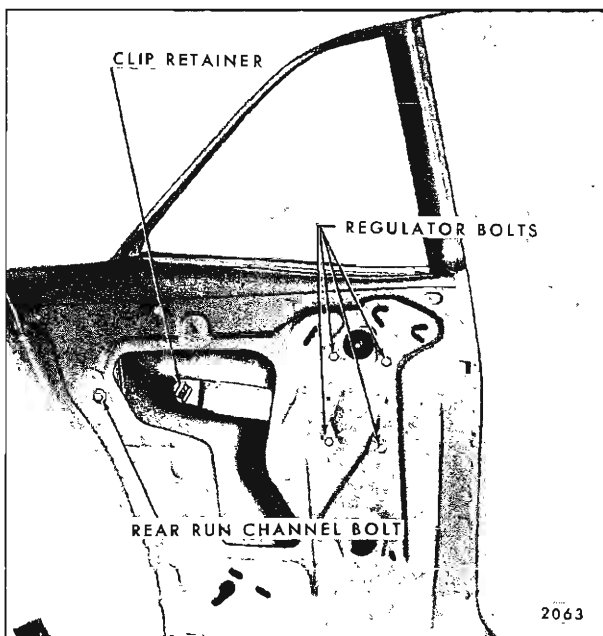

Fig. 7-42—Rear Quarter Hardware Attachment - "A, B, & X" Closed Styles

## REAR QUARTER WINDOW REGULATOR ASSEMBLY (Manual or Electric)— "A-E-F-G & Z" Hardtop and Convertible Styles

### Removal and Installation

1. Remove rear quarter trim assembly and inner panel access hole cover (or water deflector). On electric styles, disconnect feed wire at motor.
2. On "E-87" styles, remove rear quarter window. On "A & Z-37" styles, prop window in a full-up position (see Fig. 7-43).

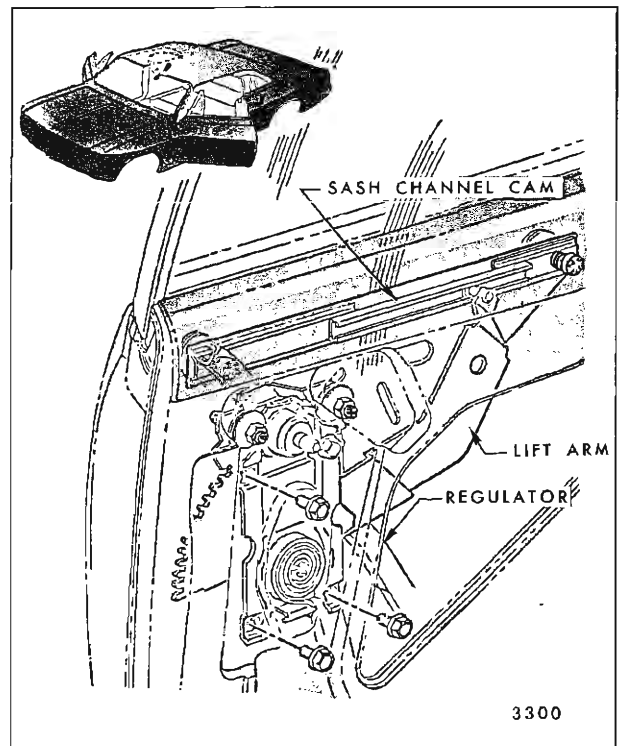

Fig. 7-43—Rear Quarter Window Regulator Removal - "Z-37" Style

3. On "Z-37" styles, remove rear quarter window rear guide assembly.
4. On "E-47" styles, disconnect regulator lift arm from quarter window as described in "Rear Quarter Window Assembly" (see index).
5. Remove regulator to quarter inner panel attaching bolts, disengage lift arm roller from sash channel cam and remove regulator.

**NOTE:** If necessary, loosen upper attaching points of front guide to gain additional clearance.

6. To install, reverse removal procedure.

**REAR QUARTER WINDOW REGULATOR  
(Manual or Electric)—“B & C” Hardtop  
and Convertible Styles**

**Removal and Installation**

1. Remove necessary trim, water deflector or access hole cover.
2. On electric styles, disconnect wire at motor.
3. Remove quarter window rear up-stop.

**NOTE:** On electric styles, it may be necessary to remove quarter window down-stop.

4. Remove regulator attaching bolts and slide lift arm rearward to disengage lift arm roller from window lower sash channel cam. Remove regulator through access hole (see Figs. 7-44 and 7-45).

5. To install, reverse removal procedure.

**REAR QUARTER WINDOW MOTOR—  
“A-27-37-77-87” Styles  
“G-57” and “F-37-67” Styles**

**Removal and Installation**

1. Remove rear seat cushion, seat back, rear quarter trim, and inner panel water deflector

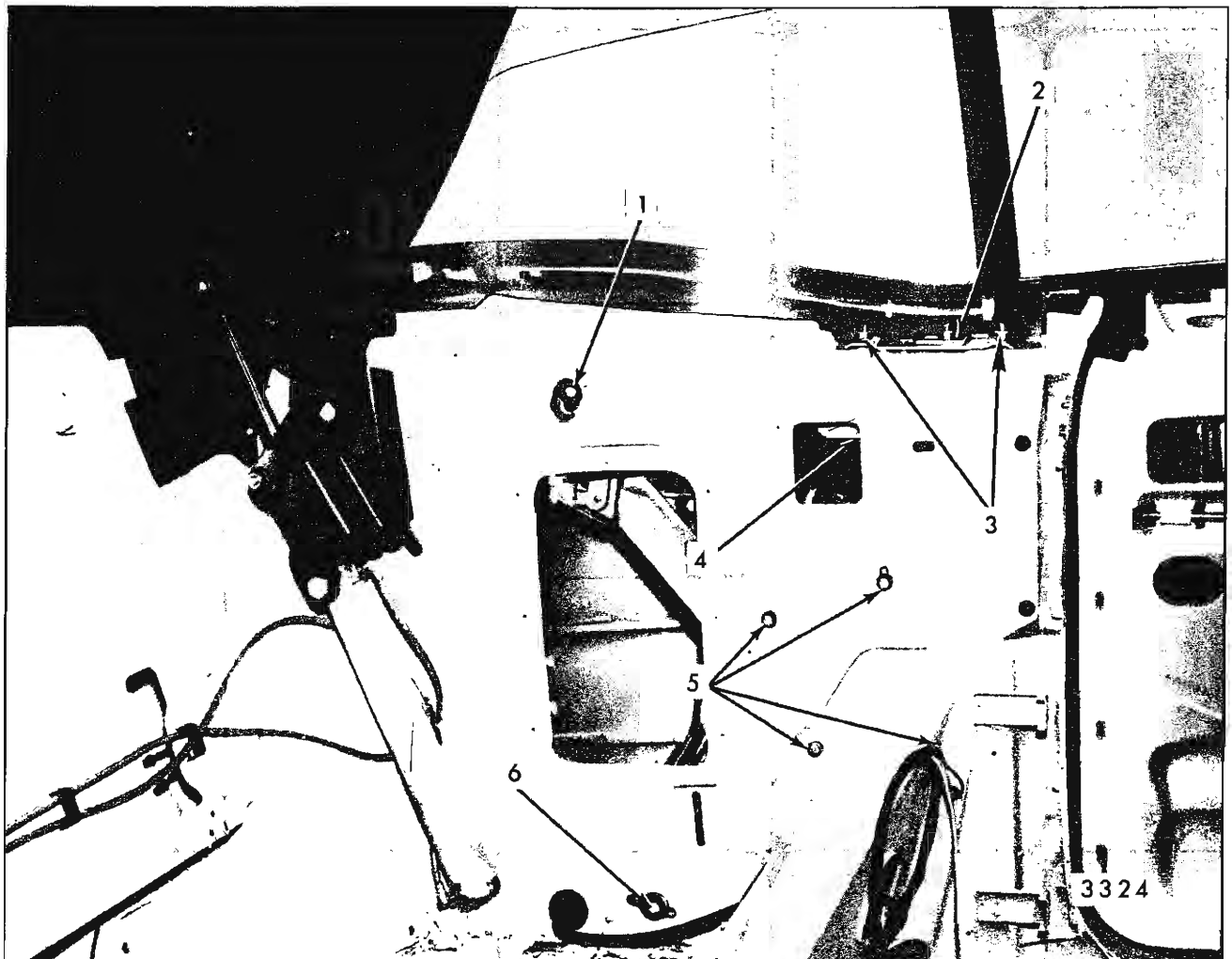

Fig. 7-44—Rear Quarter Hardware - “B-67” Styles

1. Rear Up Travel Stop
2. Front Up Travel Stop
3. Window Guide to Upper Support  
Upper Attaching Bolts

4. Window Guide to Upper Support  
Lower Attaching Bolts (Hidden)
5. Window Regulator Attaching Bolts
6. Window Guide Lower Support to  
Inner Panel Attaching Bolt

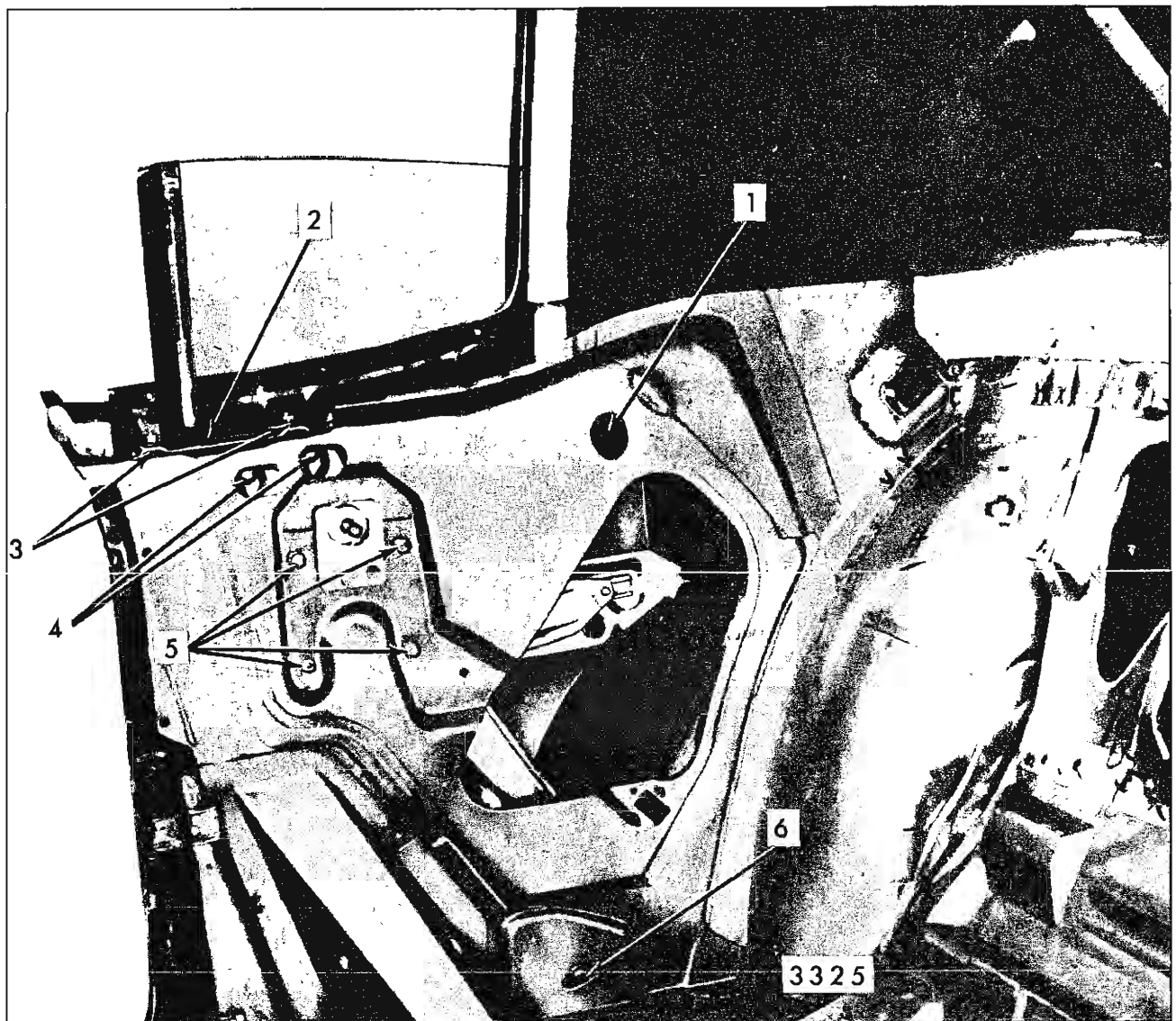

Fig. 7-45—Rear Quarter Hardware - "B-37, 47, 67" Styles

- 1. Rear Up Travel Stop
- 2. Front Up Travel Stop
- 3. Window Guide to Upper Support Upper Attaching Bolts

- 4. Window Guide to Upper Support Lower Attaching Bolts
- 5. Window Regulator Attaching Bolts
- 6. Window Guide Lower Support to Inner Panel Attaching Bolt

or loading hole cover. Window should be in a full up position.

- 2. Remove wiring harness clips.

**NOTE:** Wiring harness and switch assembly should be placed in an out of the way area to prevent damage.

- 3. Referring to Fig. 7-46 for "A" and "G" body

styles, Fig. 7-47 for "F" styles, make a template for locating window motor to regulator attaching bolts.

- 4. Align regulator bolt locations on template with regulator lower attaching bolts on quarter panel. Secure template in place with a piece of tape.

**CAUTION:** Do Not loosen regulator attaching bolts.

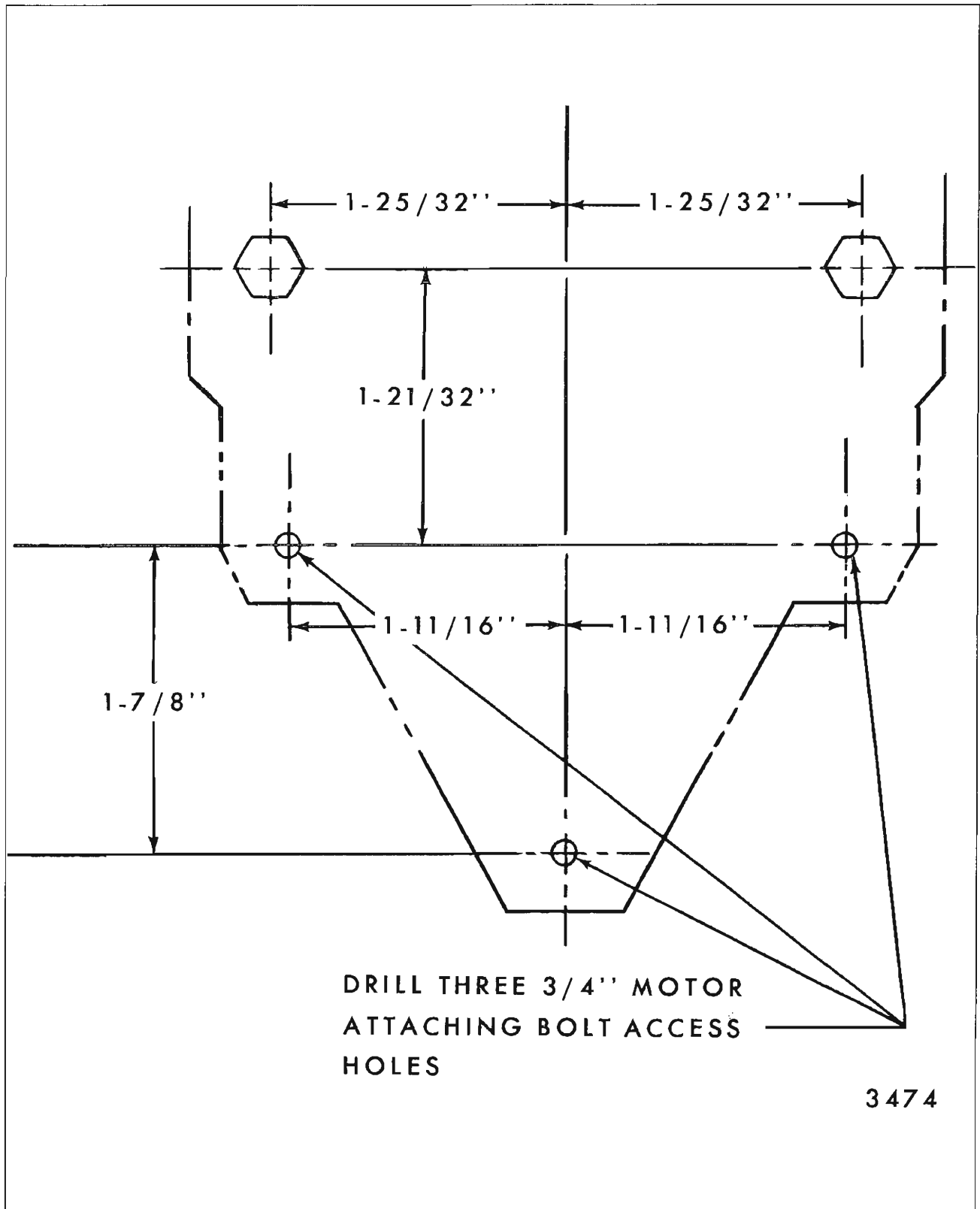

Fig. 7-46—Window Regulator Lower Attaching Bolts (Reference Points for Locating Window Motor to Regulator Attaching Bolts) - "A-27, 37, 77 & 87" and "G-57" Styles

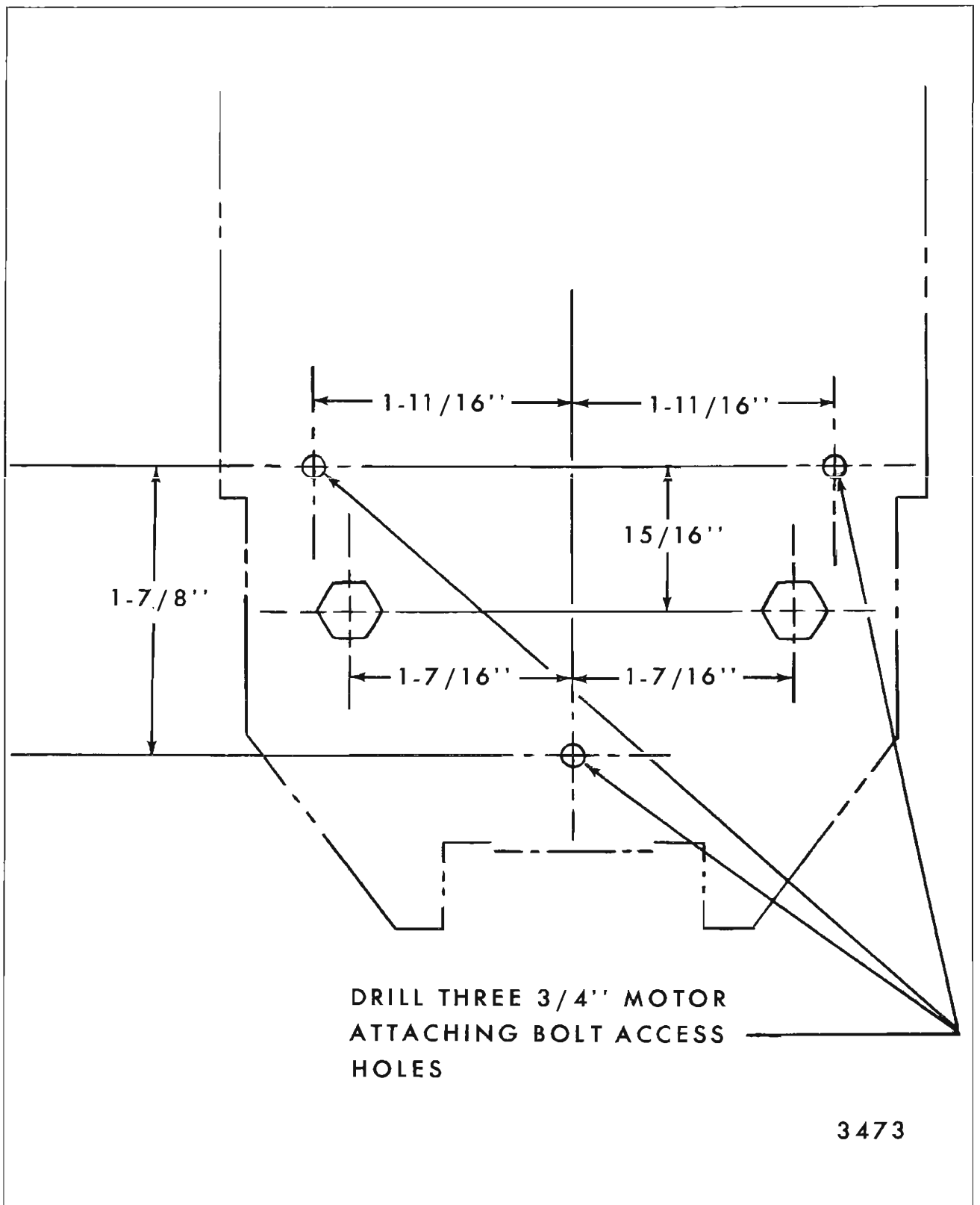

Fig. 7-47—Window Regulator Lower Attaching Bolts (Reference Points for Locating Window Motor to Regulator Attaching Bolts) - "F-37, 67" Styles

5. Using a center punch, dimple the quarter inner panel at the center of the 3/4" holes to be drilled as indicated on the template.
6. Using a 3/4" hole saw, drill three motor to regulator attaching bolt access holes as indicated.
7. Remove motor attaching bolts and remove motor through access hole.

**NOTE:** Although window regulator lift arm is under tension of counterbalance spring, weight of window assembly prevents lift arm from moving.

8. After replacing motor and prior to trim installation, apply waterproof tape to seal any motor bolt access hole that is outside of the sealing area of the water deflector.

**NOTE:** The procedure for removing the electric motor from the regulator as a bench operation is described in the "Door" section of this manual - see index. On styles indicated, removal of motor can be accomplished without removal of regulator, as outlined in the preceding procedure:

### REAR QUARTER WINDOW GUIDE ASSEMBLY—"A-G-B & C" Hardtop and Convertible Styles

#### Removal and Installation

1. Remove rear quarter window.
2. Remove rear quarter window regulator assembly.
3. Remove guide lower support to guide attaching bolt and guide upper support to inner panel (at belt line) attaching bolts (see Figs. 7-44 and 7-45).
4. Remove guide (with upper support attached) through top-between rear quarter inner and outer panels.
5. To install, reverse removal procedure. Adjust guide as required for proper window operation.

### REAR QUARTER WINDOW GUIDE ASSEMBLY—All "F" Styles

#### Removal and Installation

1. Remove rear quarter window regulator assembly.
2. Remove rear quarter window assembly.

3. Remove guide attaching nuts (3) and remove guide through large access hole (see Fig. 7-32).
4. To install, reverse removal procedure.

### REAR QUARTER WINDOW FRONT GUIDE ASSEMBLY—"Z-37 & 67" and "E-87" Styles

#### Removal and Installation

1. Remove rear quarter window assembly.
2. On "Z" styles, remove front guide upper and lower adjusting stud nuts (see Figs. 7-48 and 7-49, which are typical of "Z-37, 67" and "E-87" styles).

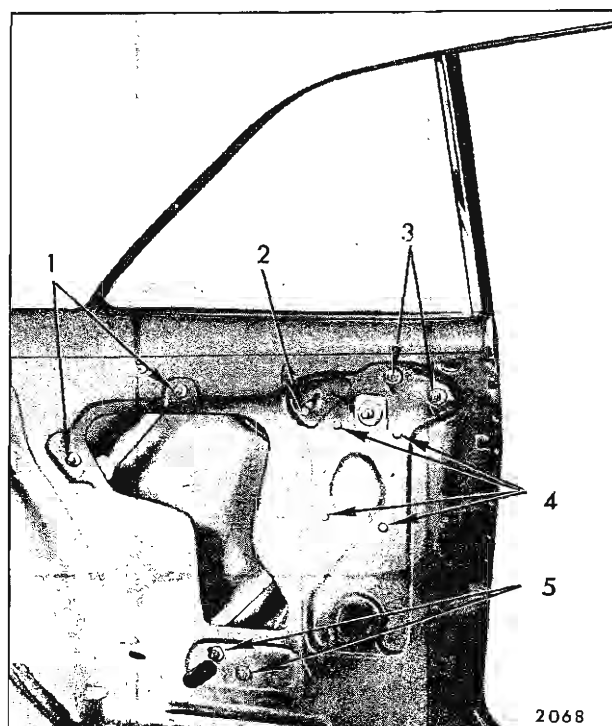

Fig. 7-48—Rear Quarter Hardware - "Z" Styles

1. Rear Guide Adjusting Studs and Nuts
2. Up-Stop Bolts
3. Front Guide Upper Adjusting Studs and Nuts
4. Regulator Bolts
5. Front Guide Lower Adjusting Studs and Nuts

**NOTE:** As explained under "Rear Quarter Window Assembly" - Removal and Installation for "E" bodies, the front guide attachments must be removed and guide lowered prior to removal of window assembly.

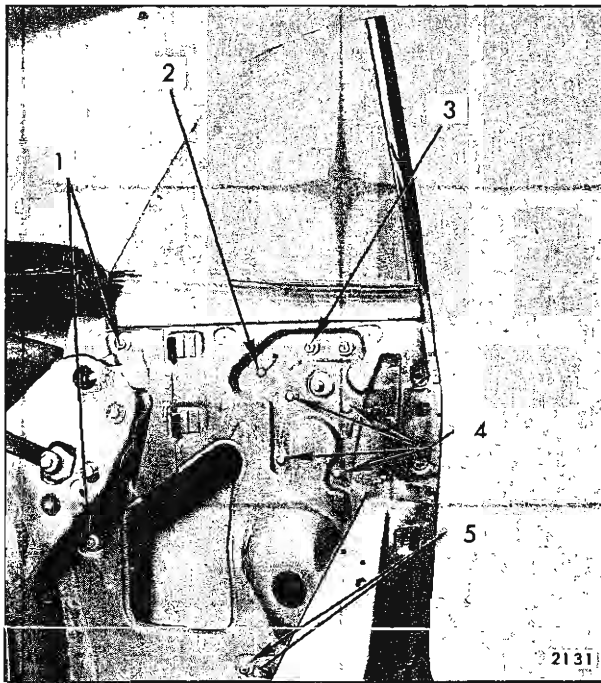

Fig. 7-49—Rear Quarter Hardware - "Z-67" Styles

1. Rear Guide Adjusting Studs and Nuts
  2. Up-Stop Bolt
  3. Front Guide Upper Adjusting Studs and Nuts
  4. Regulator Bolts
  5. Front Guide Lower Adjusting Studs and Nuts
3. Disengage guide adjusting studs from slots in quarter inner panel and remove guide through access hole on all except "E" styles. On "E" bodies, remove front guide between rear quarter inner and outer panels at belt.
  4. To install, reverse removal procedure. Adjust guide for proper window operation as specified under "Rear Quarter Window Adjustments".

**NOTE:** The rear channel of the front guide of most styles is equipped with an adjustable lower stop to control height of quarter window in the lowered position (see Fig. 7-50).

### REAR QUARTER WINDOW REAR GUIDE ASSEMBLY—"Z-37 & 67" and "E-87" Styles

#### Removal and Installation

1. Remove rear quarter trim assembly and inner panel water deflector (or access hole cover).

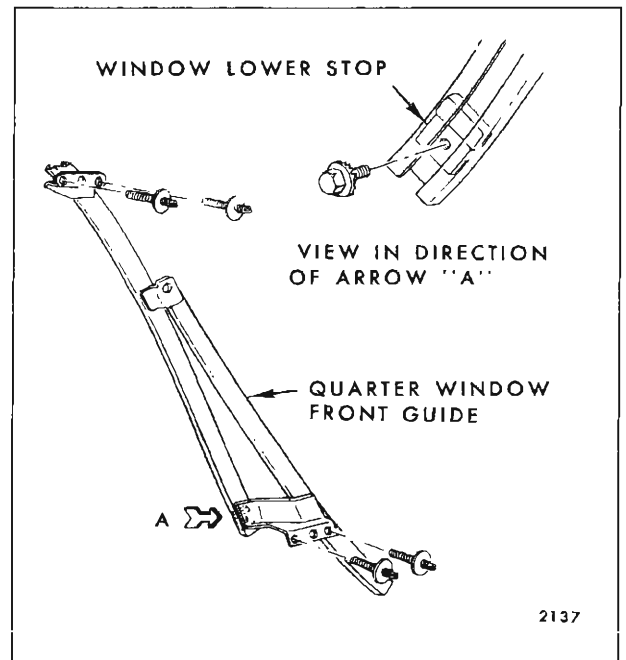

Fig. 7-50—Rear Quarter Window Lower Stop Adjustment - Styles so Equipped

2. As shown in Figures 7-48 and 7-49 and all phantom views, rear guides are retained by two bolts or adjusting studs. By providing a minimum of support for rear quarter window, these bolts or stud nuts can be removed and the guide disengaged from glass roller.
3. To install, reverse removal procedure. Adjust guide for proper window operation as specified under "Rear Quarter Window Adjustments".

### REAR QUARTER WINDOW RUN CHANNEL—"E-47" Styles

#### Removal and Installation

1. Remove rear quarter trim assembly and inner panel water deflector.
2. Remove lock pillar grille (see Fig. 7-51).
3. Remove run channel rear attachment (on inner panel (see Fig. 7-52) and forward attachment, under lock pillar grille).
4. With rear quarter window fully forward, remove glass run channel in a rearward motion.
5. To install, reverse removal procedure.

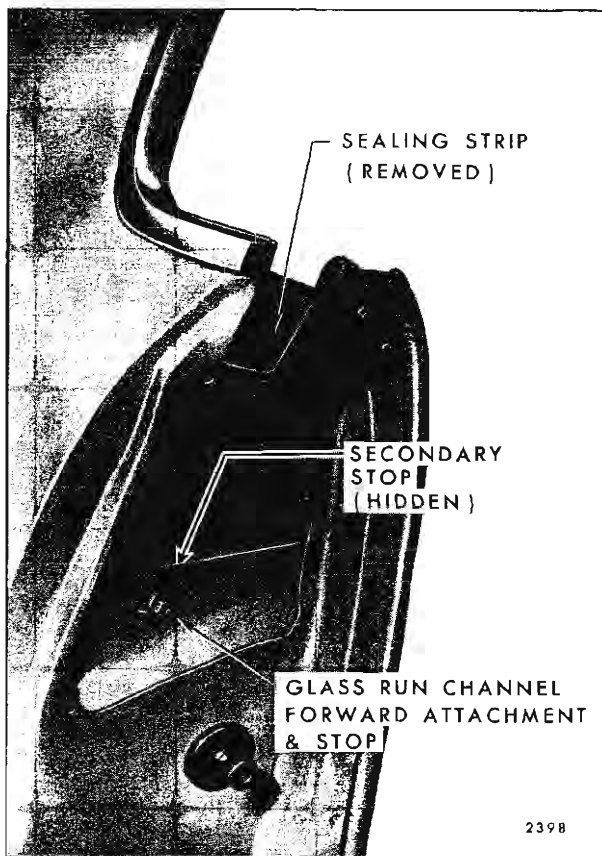

Fig. 7-51—Rear Quarter Window Hardware Attachments on Lock Pillar

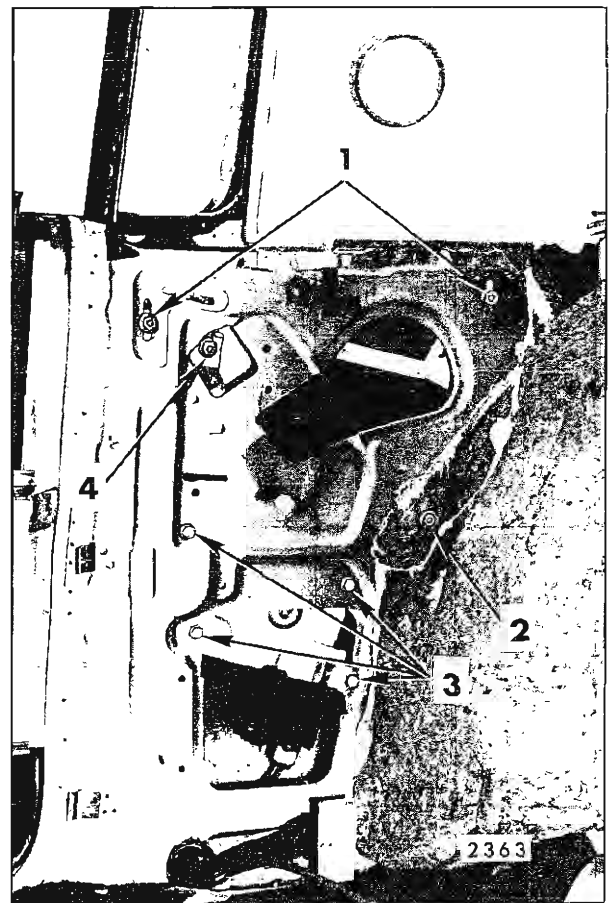

Fig. 7-52—Rear Quarter Hardware - "E-47" Style

1. Inner Panel Cam Adjusting Studs and Nuts
2. Glass Run Channel Rear Adjusting Stud and Nut
3. Regulator Attaching Bolts
4. Regulator Lift Arm to Cam Glass Roller Attaching Nut



# SECTION 8

## REAR COMPARTMENT LID

### INDEX

Subject	Page	Subject	Page
Rear Compartment Lid - All Styles		Rear Compartment Lid Mechanical Pull-Down	
Except Corvair . . . . .	8-1	Unit Cable - All Cadillac Styles . . . . .	8-11
Description . . . . .	8-1	Rear Compartment Lid Mechanical Pull-Down	
Lid - Corvair Styles . . . . .	8-2	Unit Hydraulic Cylinder - All Cadillac Styles . . . . .	8-12
Rear Compartment Front Panel - Buick & Olds		Rear Compartment Lid Mechanical Pull-Down	
"E" Styles . . . . .	8-3	Unit Adjustments - All Cadillac Styles . . . . .	8-12
Rear Compartment Torque Rod Adjustment . . . . .	8-3	Rear Compartment Lid Vacuum Release System -	
Engine Compartment Lid Support - Corvair Styles . . . . .	8-4	Styles Equipped with Option . . . . .	8-13
Engine Compartment Lid Latch - Corvair Styles . . . . .	8-4	Rear Compartment Lid Lock Electric Release	
Engine Compartment Latch Striker - Corvair Styles . . . . .	8-7	Unit - Styles Equipped with Option . . . . .	8-14
Rear Compartment Lid Lock Cylinder Assy -		Rear Compartment Lid Lock Striker . . . . .	8-15
All Styles . . . . .	8-7	Rear Compartment Lid Lock Striker Engagement -	
Rear Compartment Lid Mechanical Pull-Down		All Styles Except Corvair and Cadillac Styles	
Unit - All Cadillac Styles . . . . .	8-11	with Mechanical Closing Unit Option . . . . .	8-15
		Rear Compartment Weatherstrip - All Styles . . . . .	8-16

## REAR COMPARTMENT LID— ALL STYLES EXCEPT CORVAIR

### DESCRIPTION

Each rear compartment lid employs two torque rods which are mounted between the hinge assemblies to act as a counterbalance and hold-open for the lid. Notches in the hinge rod support plate allow for the adjustment of the rods to increase or decrease lid operating effort.

The rear compartment lid lock employs a side-action snap-bolt mechanism that has provisions at the attaching locations for lateral adjustment. Up and down adjustment, to correct lid locking effort, is available at the striker attaching locations.

All styles use a single section cement-on type weatherstrip which is cemented to the rear compartment gutter completely around the lid opening.

### Removal and Installation

1. Open lid and place protective covering along edges of rear compartment opening to prevent damage to painted surfaces.
2. Where necessary, disengage wire harness from clips on hinge and rear compartment lid inner panel and remove wire harness.
3. On styles with rear compartment lid lock vacuum release option in compartment lid, discon-

nect vacuum hose from vacuum release unit and remove hose from lid.

4. Mark location of hinge straps on rear compartment lid inner panel.
5. With the aid of a helper, remove strap to lid attaching bolts and remove lid (Fig. 8-1 is typical of all styles except "E" body; Fig. 8-2 for "E" body styles).
6. To install, align compartment lid within scribe marks and reverse removal procedure.

### Adjustments

1. Forward, rearward and side-to-side adjustments of lid are provided at hinge strap attaching locations. The lid can be raised at the hinge attaching locations with the use of shims placed between hinge strap and lid inner panel at the forward attaching bolt locations. To lower the lid, place shims as required between the hinge strap and lid inner panel at the rear attaching bolt locations.
2. The lock assembly is adjustable up or down and the lock striker is adjustable side-to-side to provide proper engagement.

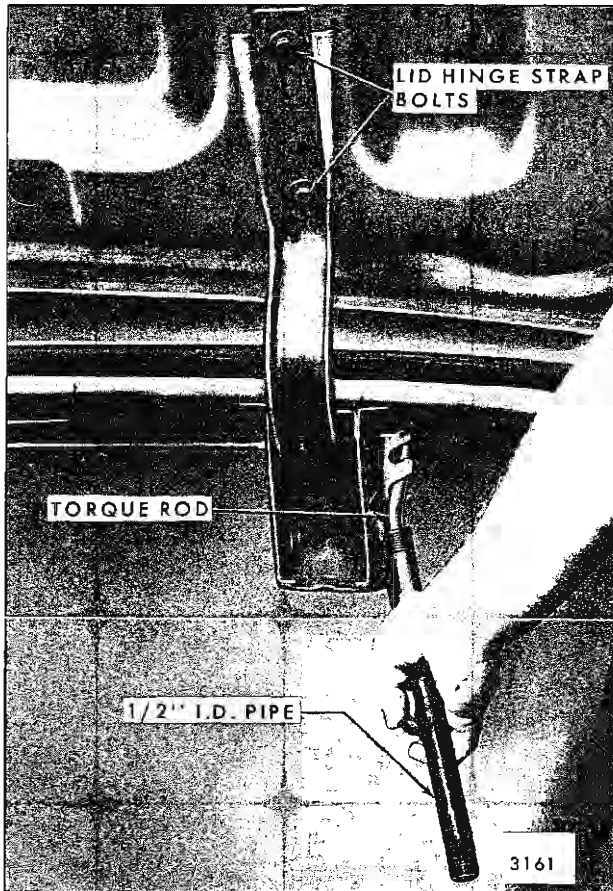

Fig. 8-1—Rear Compartment Lid Attachments - All "A, B, C, X" and Cadillac "E" Styles

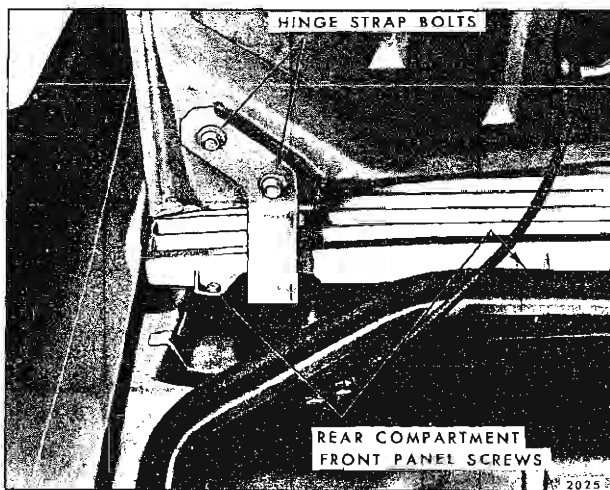

Fig. 8-2—Rear Compartment Lid Attachments - Oldsmobile and Buick "E" Styles

### ENGINE COMPARTMENT LID— Corvair Styles

#### Removal and Installation

1. Raise lid and place protective covering over adjacent paint finish.

2. Mark position of hinge straps on lid inner panel.
3. With the aid of a helper, holding lid in open position, remove lid support attaching bolts from lid (see Fig. 8-3).

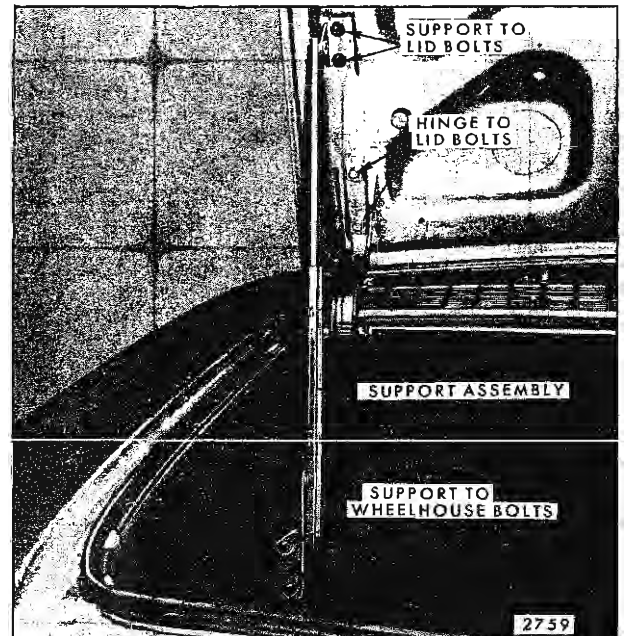

Fig. 8-3—Engine Compartment Lid Attachments - All "Z" Styles

4. With lid properly supported, remove hinge strap to lid attaching bolts and remove engine compartment lid from body.

#### Adjustments

1. To adjust the engine compartment lid forward, rearward or sideways in body opening, loosen hinge strap attaching bolts and shift lid to required position, then tighten bolts.
2. Up or down adjustment may be obtained at the hinge to lid attaching locations. To raise the lid, install shims as required between the hinge strap and inner panel at the forward bolt locations. To lower the lid, place shims as required between the hinge and inner panel at the rear.
3. The lid latch and striker are adjustable side-to-side or up-or-down to permit proper engagement when opening or closing lid.

### REAR COMPARTMENT FRONT PANEL— Buick and Oldsmobile "E" Styles

#### Removal and Installation

1. Raise rear compartment lid and remove lower screws of panel (Refer to Fig. 8-2).

2. Remove back window lower reveal molding (Refer to "Exterior Moldings", Section 17).
3. Remove upper screws of rear compartment front panel and remove panel.
4. To install, reverse removal procedure.

### REAR COMPARTMENT TORQUE ROD ADJUSTMENT

The amount of effort required to open and close the rear compartment lid is determined by the position of the torque rods in the hinge box adjusting plate notches. If the torque rod is located in the lowest notch, the amount of effort required to open the lid is the greatest and the amount of effort required to close the lid is the least. If the torque rod is located in the top notch, the amount of effort to open the lid is the least and the amount of effort to close the lid is the greatest.

**NOTE:** It is not necessary to adjust the left and right hand torque rods at the same time or to the same final position (notch).

On "A" hardtop and convertible, and all "B, C" and Cadillac "E" styles, adjust torque rod with a length of 1/2" I.D. pipe. On "A" closed styles and all "X" styles, use tool J-21412 as shown in Fig. 8-4. If tool is not available, fabricate equivalent as shown in Figure 8-5.

On Oldsmobile and Buick "E" styles, use tool J-22291 as shown in Figure 8-6. If tool is not available, fabricate equivalent as shown in Figure 8-7. On all "F" Styles, use 1/4" I.D. pipe as shown in Figure 8-8.

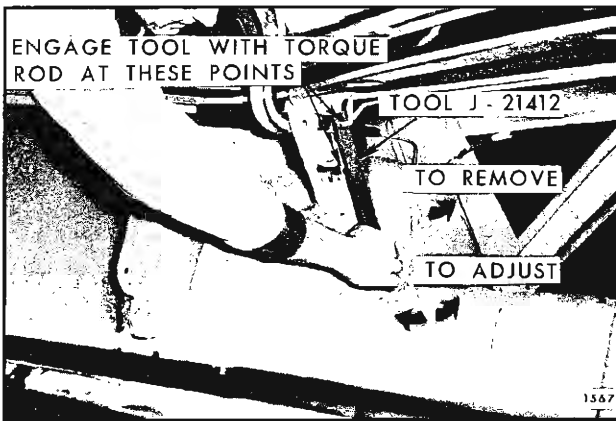

Fig. 8-4—Rear Compartment Torque Rod Adjustments - "X" Styles and "A" Closed Styles

**NOTE:** Each style utilizes a right and a left rear compartment torque rod. Although these torque rods are similar in design they are not interchangeable, and care must be taken during removal and installation so that the right and left rods do not become transposed. To make identification easy, most torque rods are color-coded on one end. The color and side should be

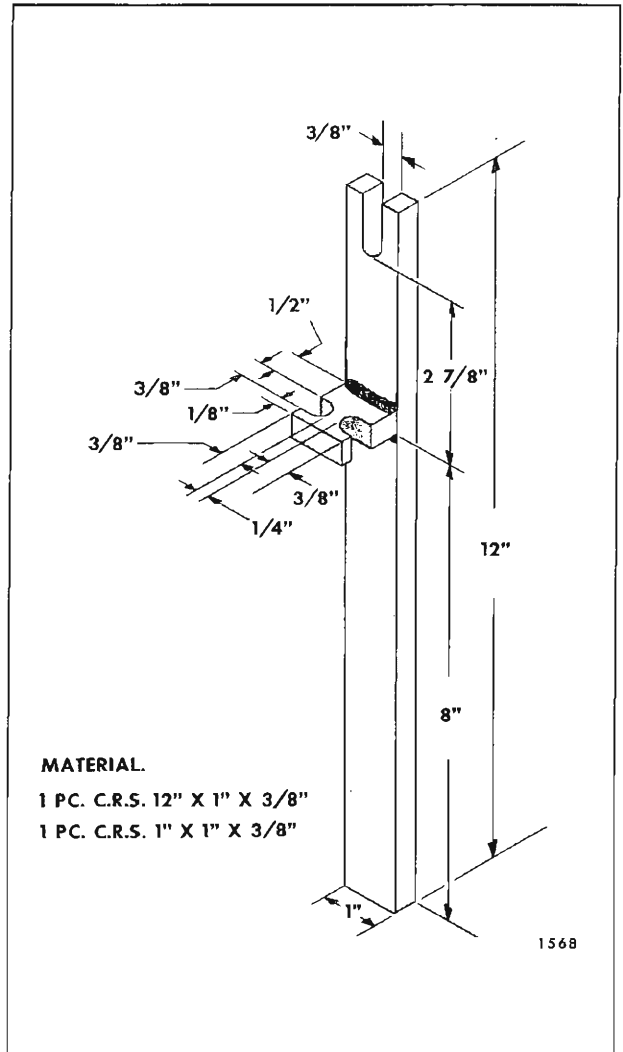

Fig. 8-5—Torque Rod Adjusting Tool

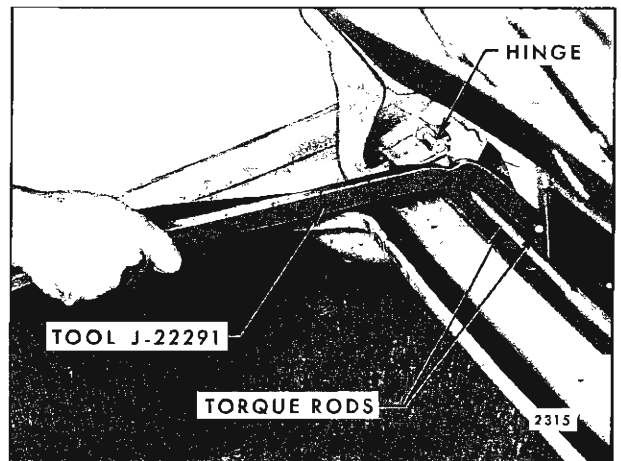

Fig. 8-6—Usage of Tool J-22291 on - Oldsmobile and Buick "E" Styles

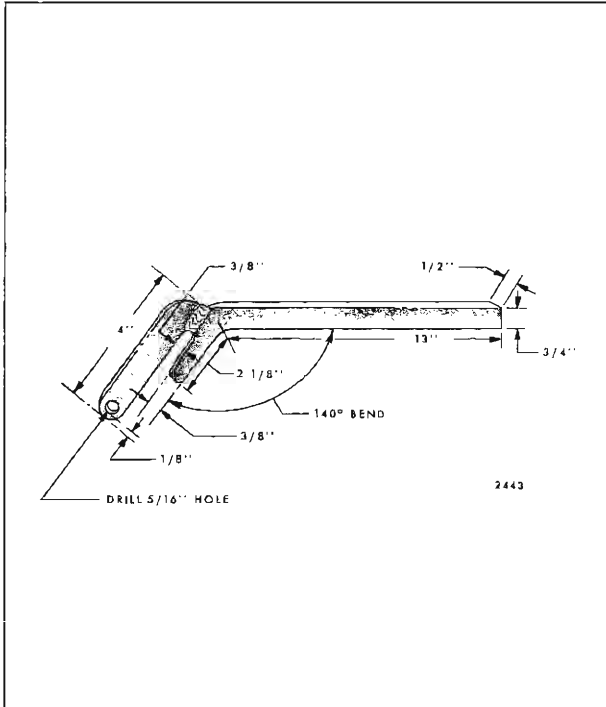

Fig. 8-7—Tool J-22291 Dimension Specifications noted for proper installation. In addition, inspect the end portion of the torque rod which engages the notched retainer on both right and left hinge. If the end portion of torque rod(s) point forward, rod(s) are correctly installed. If, however, torque

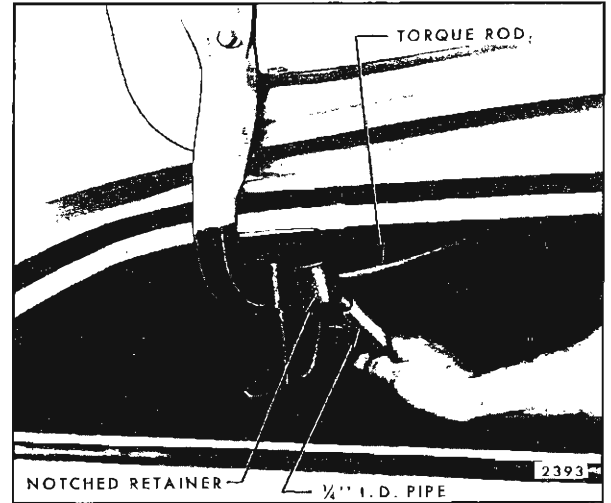

Fig. 8-8—Rear Compartment Lid Attachments - All "F" Styles

rod end(s) point rearward, rods are incorrectly installed and must be reversed (See Fig. 8-9 and torque rod color identification chart).

Figure 8-10 illustrates a typical torque rod installation. As shown, the torque rod side (right or left) is determined by the fixed (not adjustable) end installed in the body, when viewed from the rear compartment, facing forward. The torque rod with the fixed end attached to the right hinge is the right torque rod and the torque rod with the fixed end attached to the left hinge is the left torque rod.

REAR COMPARTMENT LID TORQUE RODS COLOR IDENTIFICATION

Styles	Side	Color	Styles	Side	Color
<u>"A" BODY CONVERTIBLE STYLES</u>			<u>"B, C &amp; D" BODIES EXCEPT "C" BODY CONVERTIBLE STYLES</u>		
Chevrolet . . . . .	Right	Silver	Chevrolet (Except "47" Styles)	Right	Purple
	Left	Light Green		Left	Light Green
Pontiac . . . . .	Right	Orange	Chevrolet "47" Styles . . . . .	Right	No Color
	Left	Pink		Left	No Color
Oldsmobile . . . . .	Right	Maroon	Pontiac (Except Extended Styles)	Right	Yellow
	Left	Blue		Left	Brown
Buick . . . . .	Right	Orange	Pontiac Extended Styles . . . . .	Right	Maroon
	Left	Blue		Left	Pink
<u>"A &amp; G" BODIES EXCEPT CONVERTIBLE STYLES</u>			Oldsmobile "B" Body Styles. . . . .	Right	Maroon
	Left	Pink		Left	Pink
Chevrolet . . . . .	Right	Red	Oldsmobile "C" Body Styles. . . . .	Right	Green
	Left	White		Left	White
Pontiac . . . . .	Right	Yellow	Buick "B" Body Styles . . . . .	Right	Purple
	Left	Pink		Left	Light Green
Oldsmobile			Buick "C" Body Styles . . . . .	Right	Red
(Except "77 & 87" Styles) . . . . .	Right	Green		Left	Blue
	Left	Silver	Cadillac "C & D" Body Styles . . . . .	Right	Green
Oldsmobile "77 & 87" Styles . . . . .	Right	Brown		Left	Gray
	Left	Silver	<u>"C" BODY CONVERTIBLE STYLES</u>		
Buick . . . . .	Right	Yellow	Oldsmobile . . . . .	Right	Green
	Left	Pink		Left	White
<u>"X" BODY STYLES</u>			Buick . . . . .	Right	Red
				Left	Blue
Chevrolet and Acadian . . . . .	Right	Orange	Cadillac . . . . .	Right	Green
	Left	Silver		Left	Gray
			All "F" & "E" Body Styles. . . . .	Right	No Color
				Left	No Color

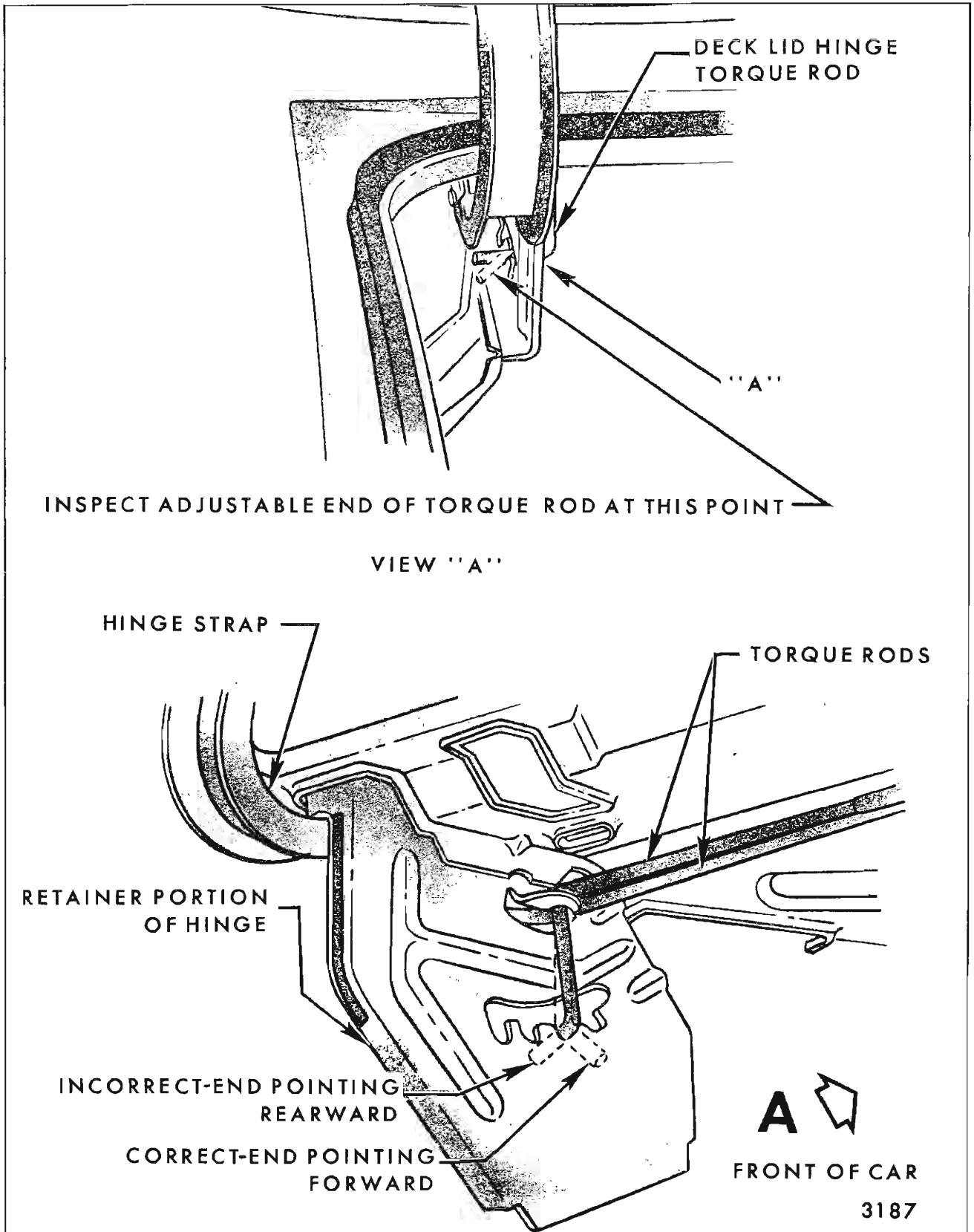

Fig. 8-9—Proper Torque Rod Positioning

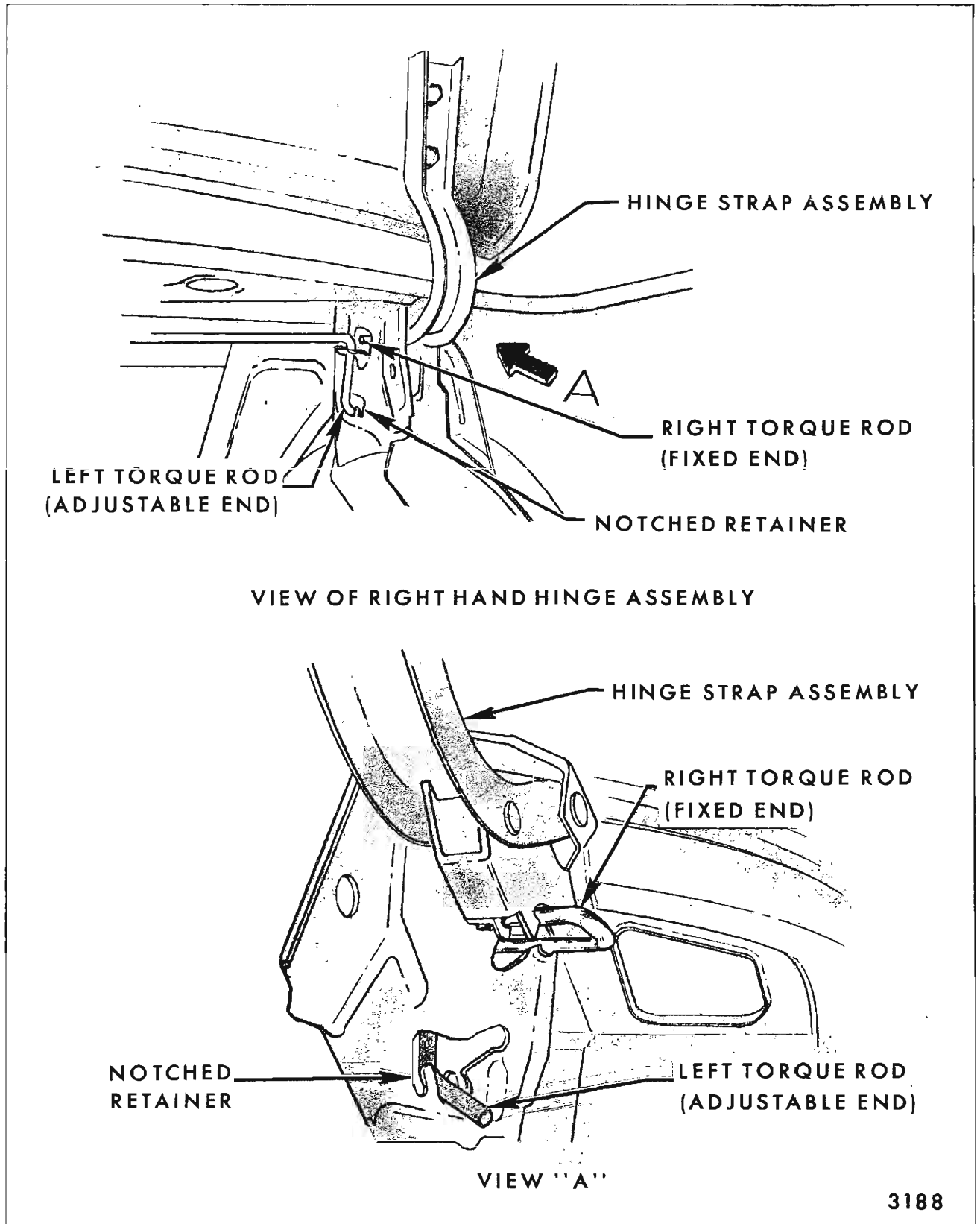

Fig. 8-10—Typical Torque Rod Adjustment

### ENGINE COMPARTMENT LID SUPPORT— Corvair Styles

#### Removal and Installation

1. Prop engine compartment lid in a full open position.
2. Remove two attaching bolts securing support to lid and two bolts securing support to wheelhouse and remove support from body (see Fig. 8-11).
3. To install, reverse removal procedure. To insure proper operation, lubricate telescoping channels of support.

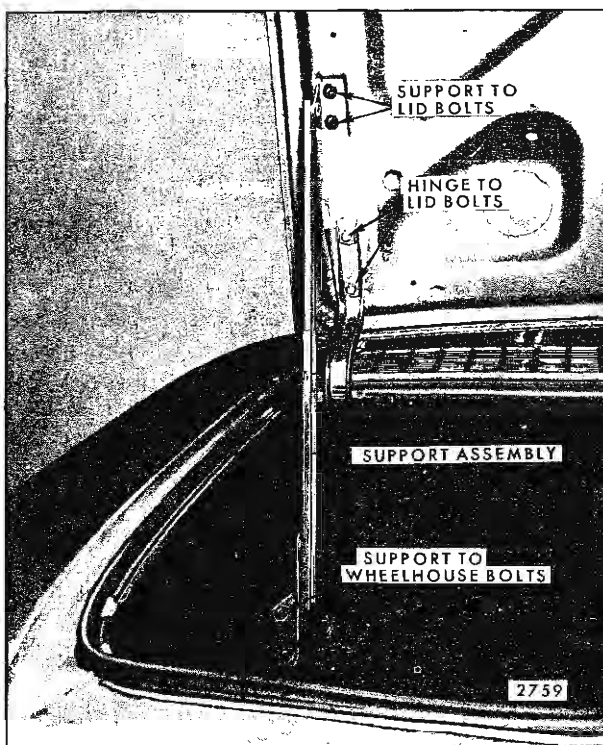

Fig. 8-11—Engine Compartment Lid Support - "Z" Styles

### ENGINE COMPARTMENT LID LATCH— All Corvair Styles

#### Removal and Installation

1. Raise engine compartment lid and mark position of latch.
2. Remove two bolts securing latch to engine compartment inner panel and remove assembly from body (see Fig. 8-12).
3. To install, align latch assembly within locating marks and install attaching bolts. Check engagements of latch with striker and perform any adjustments that may be required.

### ENGINE COMPARTMENT LATCH STRIKER—Corvair

#### Removal and Installation

1. Raise engine compartment lid and mark position of striker on rear end panel.
2. Remove attaching bolts and remove striker from body (see Fig. 8-13).
3. To install, align striker within locating marks and install attaching bolts. Check engagement of latch within striker and perform any adjustments that may be required.

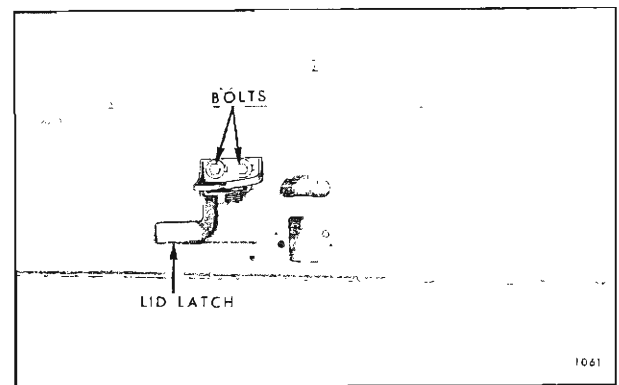

Fig. 8-12—Engine Compartment Lid Latch Assembly - "Z" Styles

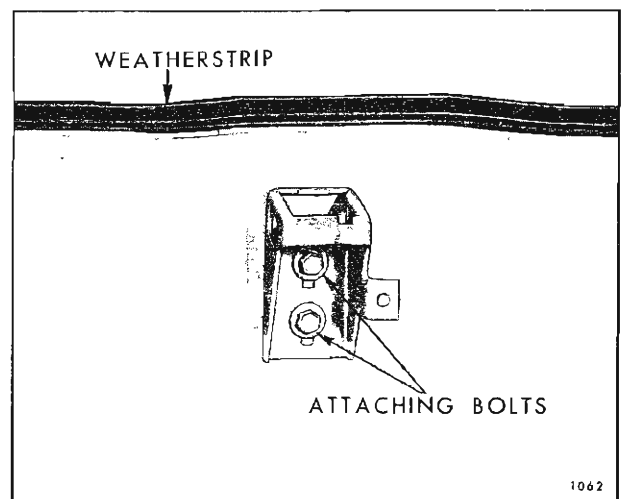

Fig. 8-13—Engine Compartment Lid Latch Striker - "Z" Styles

### REAR COMPARTMENT LID LOCK CYLINDER ASSEMBLY— All Styles

#### Description

The lock cylinder assembly for the rear compartment lid is similar in design on all styles; however, the method of retention may vary dependent

upon location of the lock assembly. Some styles have the lock cylinder attached to the deck lid, while on other styles, the lock cylinder is secured to the rear end panel.

On most styles, the lock cylinder is secured with a retainer which is attached to the deck lid inner panel or rear end panel. On these styles, it is necessary to disengage the retainer in removal of the lock cylinder assembly. On those styles, however, equipped with a rear compartment lid emblem, the lock cylinder is retained by a combination of studs and nuts or by a standard retainer and pop-rivets.

**A. Removal and Installation on Styles Not Equipped With Lock Cylinder Emblems**

1. Open rear compartment lid and remove retainer screw(s).
2. Pull retainer down or away from lock cylinder and remove cylinder from body.
3. To install, reverse removal procedure. Insure that lock cylinder shaft engages with lock and gasket mates properly with outer panel to form a watertight seal. Check lock cylinder for proper operation (see Figs. 8-14 & 8-15).

**B. Removal and Installation on Styles Equipped With Lock Cylinder Emblems**

On the following styles, access to the rear compartment lid lock cylinders is not available until

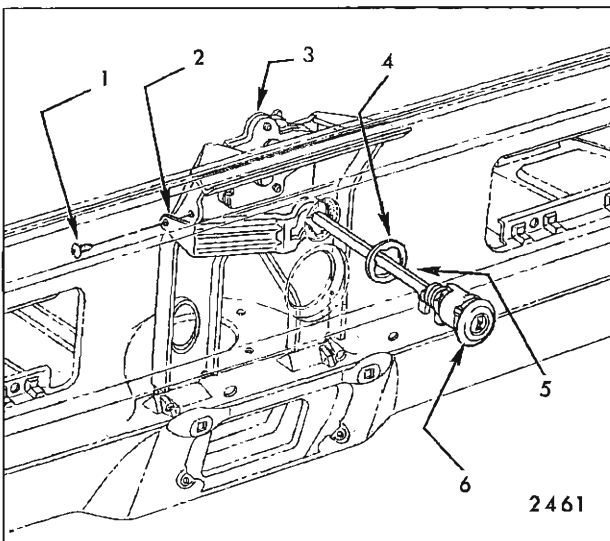

Fig. 8-14—Typical Rear Compartment Lid Lock Cylinder Installation (Side Load)

- |                             |                  |
|-----------------------------|------------------|
| 1. Retainer Attaching Screw | 4. Gasket        |
| 2. Retainer                 | 5. Shaft         |
| 3. Lock                     | 6. Lock Cylinder |

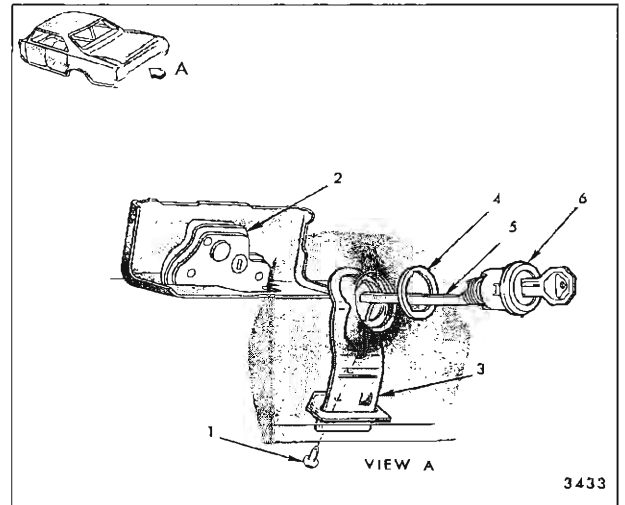

Fig. 8-15—Rear Compartment Lid Lock Cylinder Assy. - Typical Deck Lid Attachment (Bottom Load)

- |                             |             |
|-----------------------------|-------------|
| 1. Retainer Attaching Screw | 4. Gasket   |
| 2. Lock                     | 5. Shaft    |
| 3. Retainer                 | 6. Cylinder |

either a molding or emblem assembly is first removed. Figures 8-16 through 8-22 depict the entire cylinder and emblem (or molding) assemblies and the attachments on the specific styles so equipped.

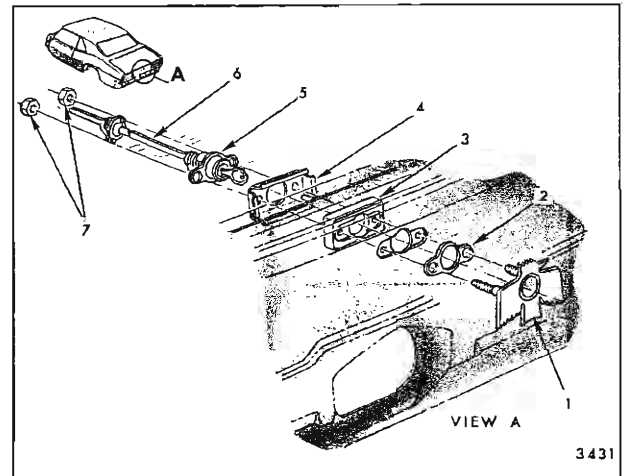

Fig. 8-16—Pontiac "F" Body Styles

- |                         |                  |
|-------------------------|------------------|
| 1. Lock Cylinder Emblem | 4. Retainer      |
| 2. Gasket               | 5. Lock Cylinder |
| 3. Anchor Plate         | 6. Shaft         |
|                         | 7. Retaining Nut |

**NOTE:** Coding of lock cylinders is described in General Information (Section one).

1. Open rear compartment lid. Remove access hole covers and trim as required.
2. On Pontiac "F", Oldsmobile "C" and Buick



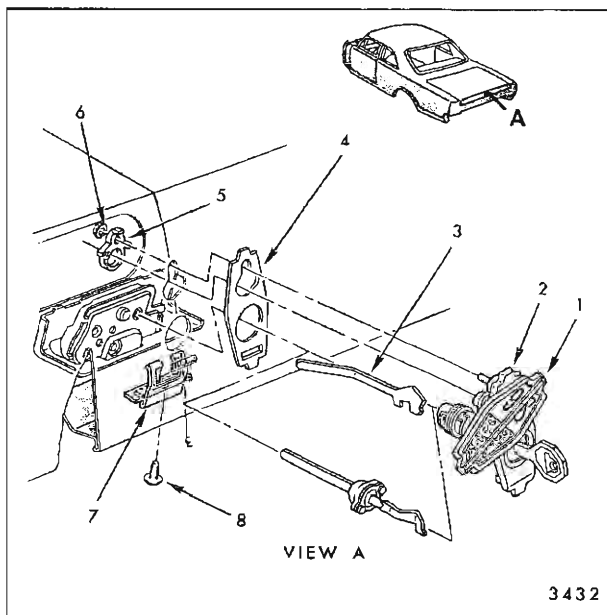

Fig. 8-17—Oldsmobile "C" Body Styles

- |                                      |                           |
|--------------------------------------|---------------------------|
| 1. Lock Cylinder Emblem              | 5. Guard                  |
| 2. Lock Cylinder and Emblem Assembly | 6. Nut                    |
| 3. Shaft                             | 7. Lock Cylinder Retainer |
| 4. Gasket                            | 8. Retainer Screw         |

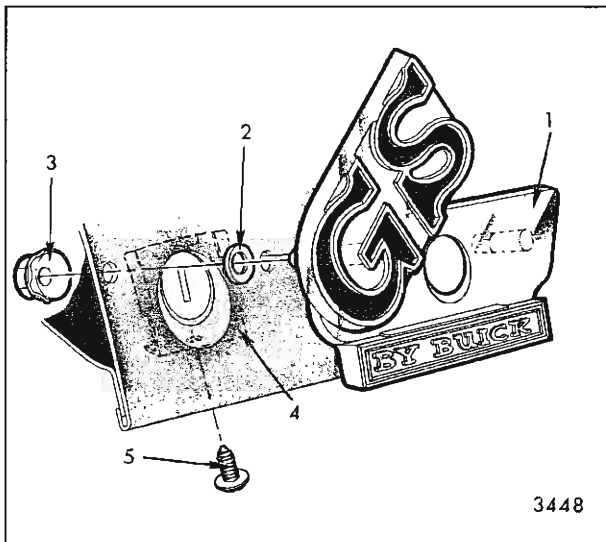

Fig. 8-18—Lock Cylinder Emblem - Buick 43437, 44637 and 44667 Styles

- |                         |                             |
|-------------------------|-----------------------------|
| 1. Lock Cylinder Emblem | 4. Retainer - Lock Cylinder |
| 2. Gasket               | 5. Retainer Attaching Screw |
| 3. Retainer Nut         |                             |

43437, 44637 and 44667 styles, remove stud nuts securing rear compartment lid emblem, lock cylinder and retainer assembly (See Fig. 8-16, 8-17 and 8-18). On styles so equipped, remove retainer screw and retainer.

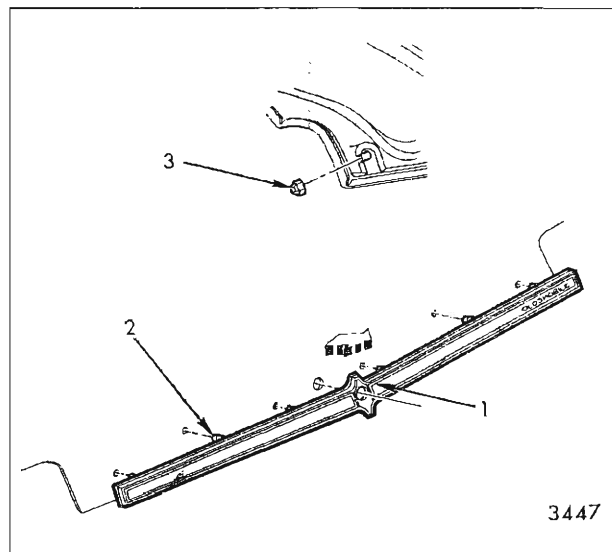

Fig. 8-19—Rear Compartment Lower Moldings

- |                                   |                   |
|-----------------------------------|-------------------|
| 1. Rear Compartment Lower Molding | 2. Attaching Stud |
|                                   | 3. Stud Nut       |

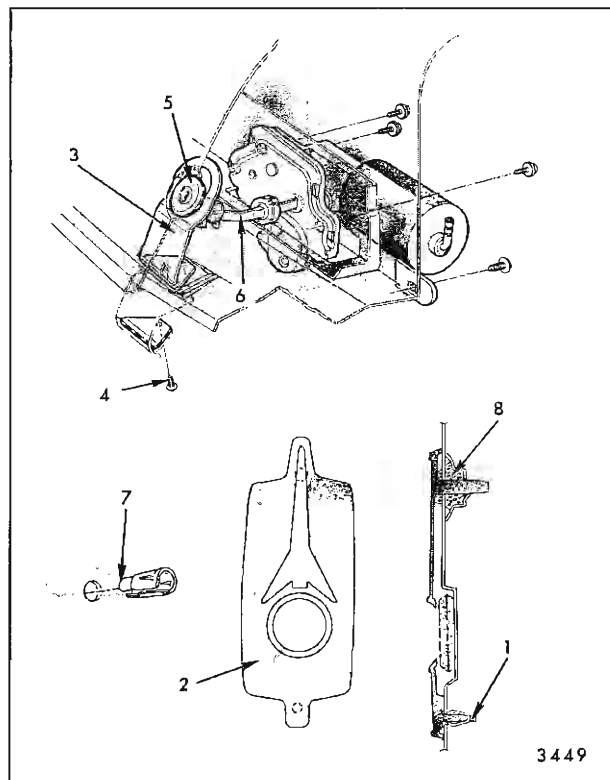

Fig. 8-20—Rear Compartment Lock Cylinder and Emblem Assembly - Oldsmobile "B" Styles

- |                             |                                    |
|-----------------------------|------------------------------------|
| 1. Emblem Stud Clips        | 5. Lock Cylinder                   |
| 2. Lock Cylinder Emblem     | 6. Shaft                           |
| 3. Lock Cylinder Retainer   | 7. Clip (Used for Lower Stud Only) |
| 4. Retainer Attaching Screw | 8. Sealer                          |

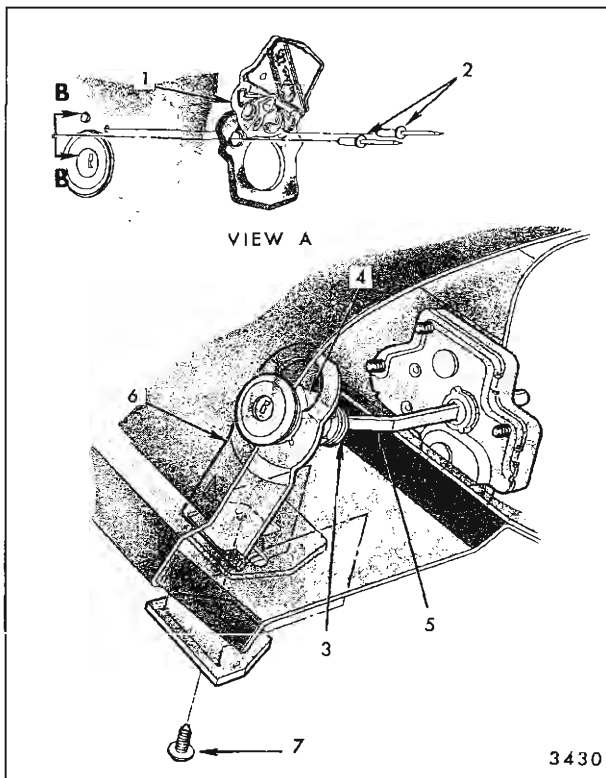

Fig. 8-21—Buick "C" Body Styles

- |                         |                             |
|-------------------------|-----------------------------|
| 1. Lock Cylinder Emblem | 4. Gasket                   |
| 2. Attaching Pop Rivets | 5. Shaft                    |
| 3. Lock Cylinder        | 6. Retainer - Lock Cylinder |
|                         | 7. Attaching Screw          |

3. On Oldsmobile "A" styles, remove stud nuts securing rear compartment lid lower molding (Fig. 8-19). The lock cylinder can now be removed as shown in Figure 8-15.

4. On Oldsmobile "B" styles, remove emblem stud clips illustrated in Section "B-B" of Figure 8-20. Remove emblem and then lock cylinder retainer. As shown, a service clip is available for repair of broken stud clips. This clip is available as a service part. Prior to reinstallation of emblem stud clips, medium-bodied sealer must be applied around lock stud to prevent waterleaks.

5. On Buick "C" styles, the rear compartment lid emblem is attached with pop-rivets that are of standard size and available as Service Parts. The rivets must be drilled out to remove emblem. After removal of emblem, the lock cylinder retainer can be removed as shown in Figure 8-21.

6. On Cadillac "C & E" styles, the emblem is retained by stud nuts. Following removal of emblem, lock cylinder can be removed. (Refer to Fig. 8-22).

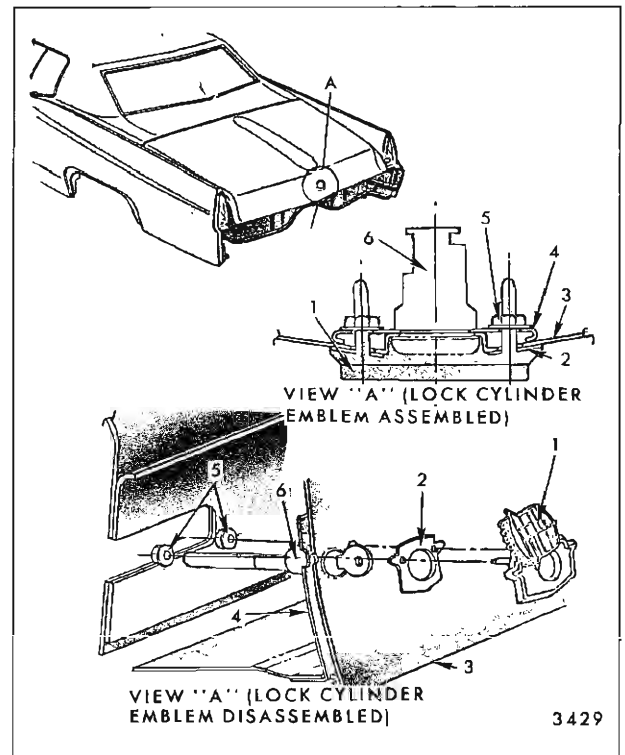

Fig. 8-22—Lock Cylinder Removal - Cadillac "C and E" Styles

- |                         |                           |
|-------------------------|---------------------------|
| 1. Lock Cylinder Emblem | 4. Lock Cylinder Retainer |
| 2. Gasket               | 5. Nuts                   |
| 3. Deck Lid Outer Panel | 6. Lock Cylinder          |

7. To install, reverse removal procedure. Make certain that emblem gasket mates properly outer panel and that emblem stud holes are sealed to protect against waterleaks.

### REAR COMPARTMENT LID MECHANICAL PULL-DOWN UNIT—All Cadillac Styles

The rear compartment lid mechanical pull-down unit is used in conjunction with the opening unit. When the rear compartment lid is lowered to a point where the lid lock engages with striker, the mechanical closing unit pulls the lid the remaining distance (7/8") to the fully closed position.

A hydraulic cylinder is incorporated in the mechanism to achieve a slow, uniform closing action. The cylinder is attached to a bell crank at the right rear compartment lid hinge and to the closing unit by a cable. As the lid is lowered and the lock latches to the striker, but before the mechanical closing feature is tripped, the piston extends to a "full-out" position. Then, as the lid is lowered to actuate the mechanical closing feature, the piston forces the fluid through an orifice retarding the closing action of the spring in the hydraulic cylinder.

**Removal and Installation**

1. Open rear compartment lid. Remove mechanical pull-down unit cover panel. Depress striker

slightly to relieve tension from cable and disengage clip securing cable to pull-down control arm (Fig. 8-23).

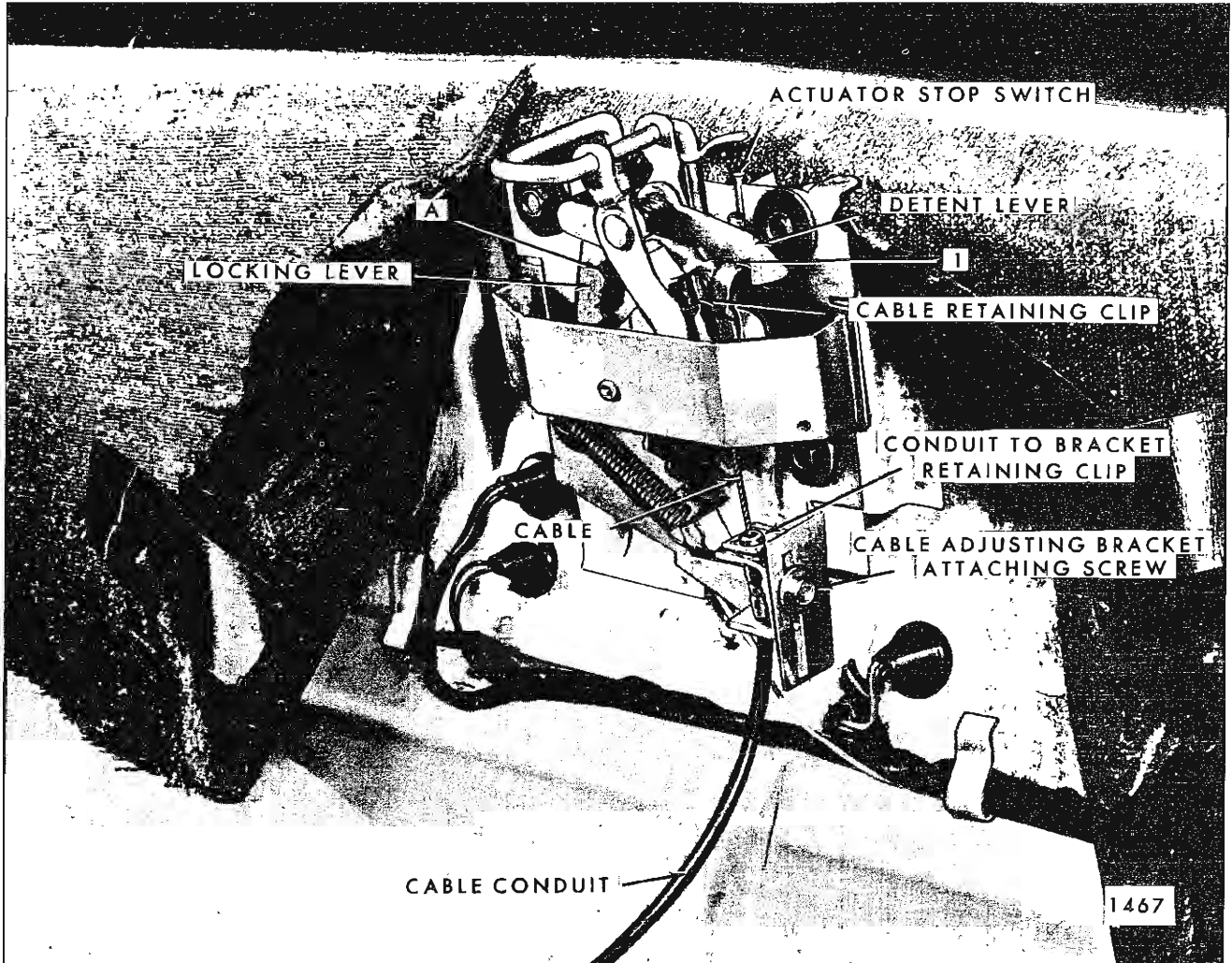

Fig. 8-23—Rear Compartment Mechanical Pull-Down Unit - Cadillac Styles with Option

2. Disengage clip securing cable conduit to cable adjusting bracket and disengage cable and cable conduit from pull-down unit.
3. Scribe (mark) position of pull-down unit on rear end panel and supports to facilitate reinstalling units in same position. Remove pull-down unit attaching bolts and remove unit from body (Fig. 8-24).
4. To install, reverse removal procedures.

away from hooked end of pull-down unit cable. Disengage cable from slot in cylinder. Disengage cable conduit retaining clip from support on wheelhouse and remove cable and conduit from support (Fig. 8-25).

2. Repeat this procedure at other end of cable, disengaging clips securing cable to pull-down unit and cable conduit to adjusting bracket (Fig. 8-23), and remove cable from body.
3. To install, reverse removal procedure.

**REAR COMPARTMENT LID MECHANICAL PULL-DOWN UNIT CABLE—  
All Cadillac Styles**

**Removal and Installation**

1. On lower end of hydraulic cylinder, pull clip

**REAR COMPARTMENT LID MECHANICAL PULL-DOWN UNIT HYDRAULIC CYLINDER—All Cadillac Styles**

**Removal and Installation**

1. Disengage cable from lower end of hydraulic

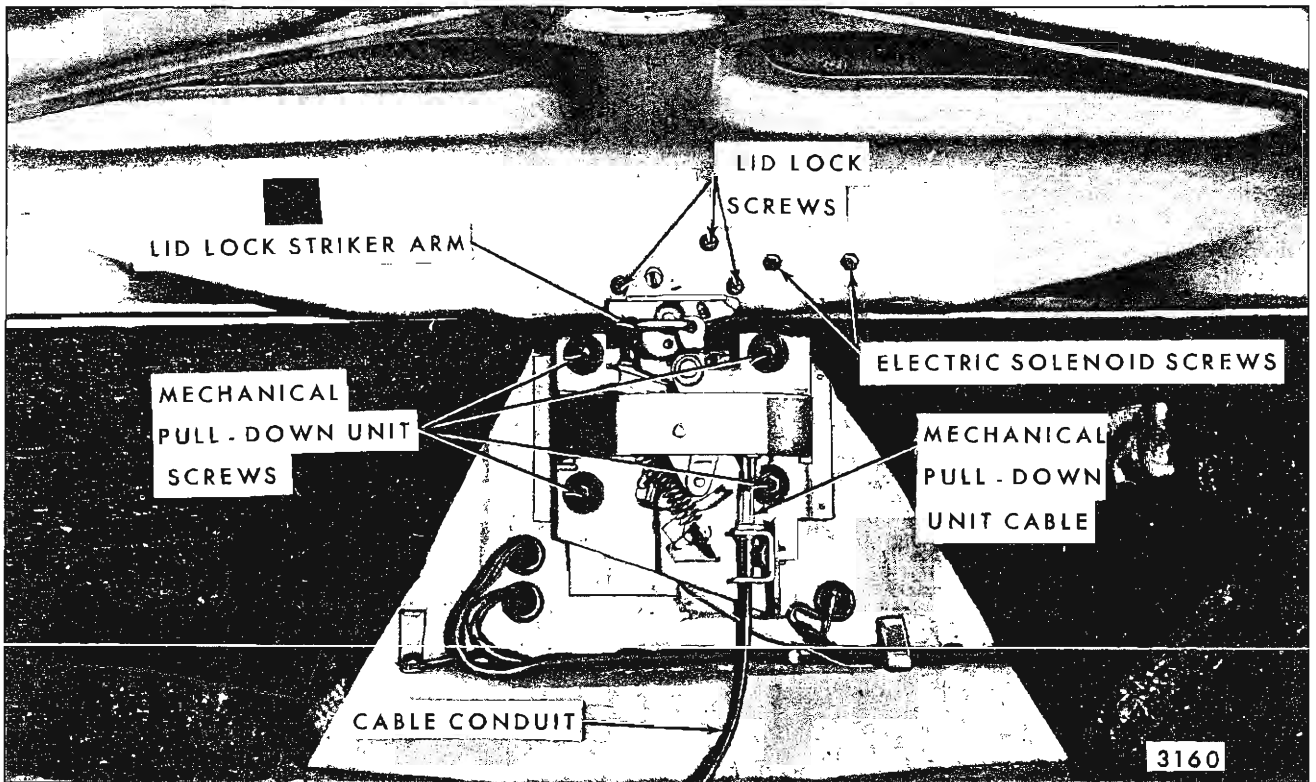

Fig. 8-24—Rear Compartment Lid Mechanical Pull-Down Unit

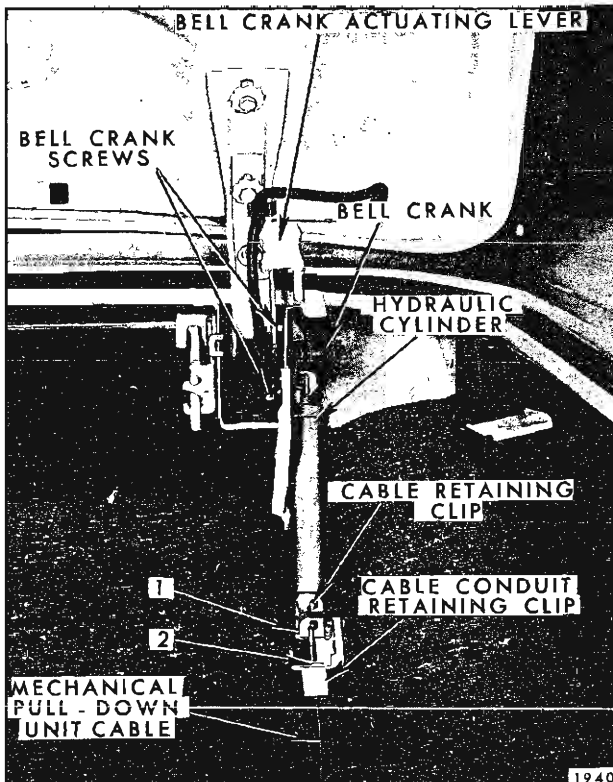

Fig. 8-25—Mechanical Pull-Down Unit Hydraulic Assembly - Cadillac Styles with Option

cylinder as described under "Rear Compartment Lid Mechanical Pull-Down Unit Cable Removal".

2. Lift cylinder to disengage upper end from shoulder to shaft on linkage portion of hinge assembly.
3. To install, reverse removal procedure.

### REAR COMPARTMENT LID MECHANICAL PULL-DOWN UNIT ADJUSTMENTS— All Cadillac Styles

To actuate the mechanical pull-down unit, the rear compartment lid lock must properly engage the striker arm and depress the detent lever of the pull-down unit. This engagement can be checked by lowering the lid and visually checking lock and striker alignment. If adjustment is necessary, obtain lateral adjustment at lock attaching screw locations and "up or down" adjustments at pull-down unit attaching screw locations.

For proper operation of the pull-down unit, the pull-down unit cable must be adjusted to the proper tension. If the cable has too much tension it will not allow the pull-down unit to return to its full-up position and "cock". This is apparent when as the lid begins to lower, so does the pull-down unit.

Too little tension in the cable results in a lessening of pull-down effort in the unit and consequently, a misaligned (high) rear compartment lid.

To increase cable tension, position hydraulic cylinder end of cable in the upper slot on the lower end of the cylinder ("1", in Figure 8-25). If more tension, or finer adjustment, is required, loosen cable adjusting bracket attaching screw (Fig. 8-23). Adjust bracket downward (to increase cable travel) and tighten attaching screw.

**IMPORTANT:** The lack of lubrication between the toggle and the detent lever ("1", Figure 8-23) can greatly increase the effort required to trip (unlock) the pull-down unit. Therefore, make certain point of contact between these two levers is lubricated with 630 AAW Lubriplate or its equivalent.

### REAR COMPARTMENT LID VACUUM RELEASE SYSTEM—Styles Equipped with Option

The rear compartment lid lock vacuum release system is a side-action snap-bolt type lock with a vacuum release unit attached that unlocks the lock upon the introduction of vacuum in the unit. The vacuum is stored in a storage tank located in the engine compartment and is controlled by a switch located in the instrument panel compartment box. By actuating the switch, vacuum enters into the line extending from the storage tank to the vacuum release unit, thereby unlocking the lid lock. As this is only an unlocking feature, the rear compartment lid must be closed manually.

#### Removal and Installation

1. Remove rear compartment lid lock cylinder as previously described.
2. Disconnect vacuum hose from vacuum release unit. Remove attaching bolts shown in illustration and remove vacuum unit (Figs. 8-26 and 8-27 for typical illustrations).
3. To install, reverse removal procedure. Check unit for proper operation.

### REAR COMPARTMENT LID LOCK ELECTRIC RELEASE UNIT—Styles Equipped with Option

The rear compartment lid lock electric release unit which is attached to the lock assembly is controlled by a switch located in the instrument panel compartment box. This option is only an unlocking feature; therefore, the rear compartment lid must be closed manually.

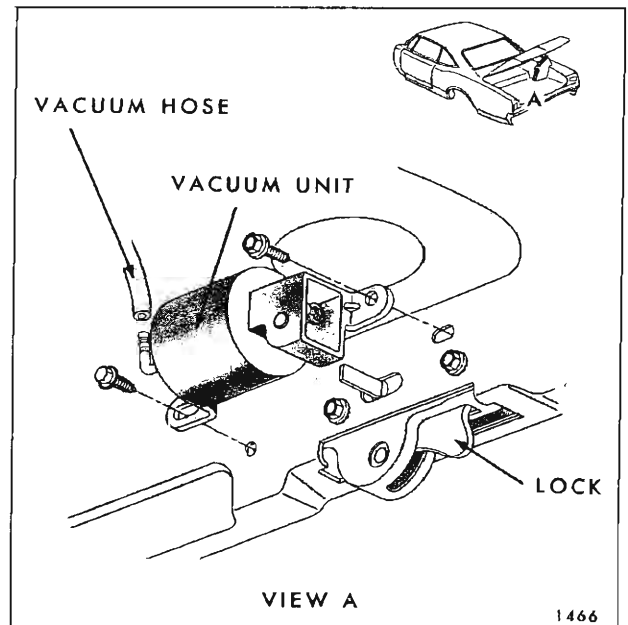

Fig. 8-26—Rear Compartment Lid Vacuum Release Unit - Exposed Type

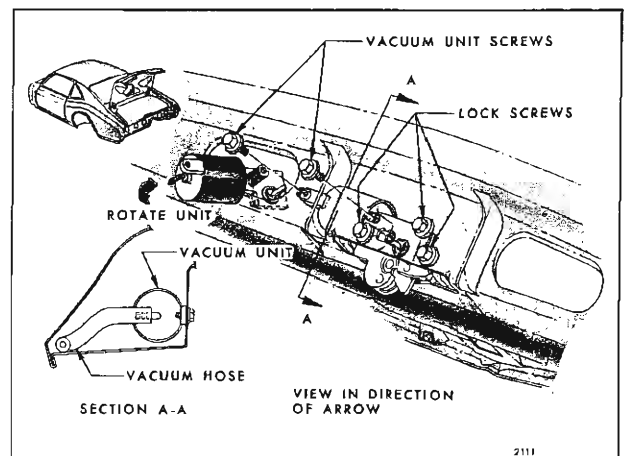

Fig. 8-27—Rear Compartment Lid Vacuum Release Unit - Concealed Type

#### Removal and Installation

1. Open rear compartment lid. Remove rear compartment lid lock cylinder and shaft as previously described.
2. Remove bolts securing rear compartment lid lock assembly to rear compartment lid anchor plate (Fig. 8-28).
3. Disconnect electric feed wire at connector.
4. Remove lock and electric release unit assembly. To separate release unit from lock, remove attaching screws.

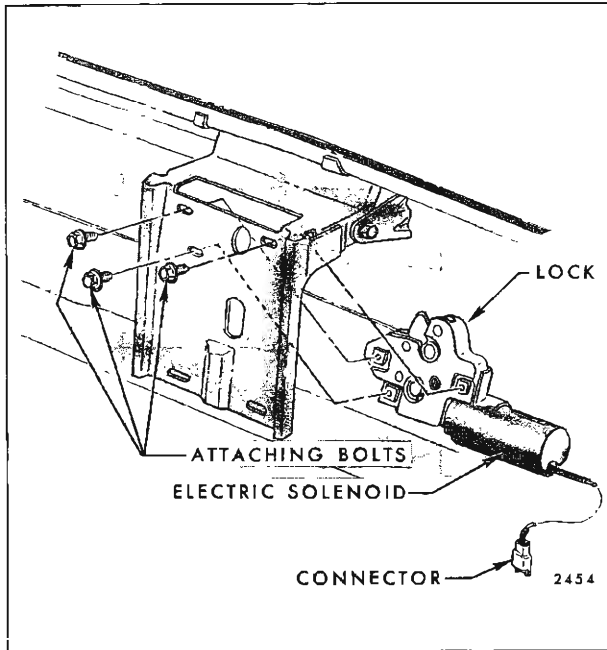

Fig. 8-28—Rear Compartment Lid Lock Electric Release Unit

5. To install, reverse removal procedure.

### REAR COMPARTMENT LID LOCK— All Styles

#### Removal and Installation

1. Remove rear compartment lid lock cylinder as previously described.
2. On styles so equipped, remove rear compartment lid vacuum release unit.
3. Remove rear compartment lid lock attaching bolts and remove lock from lid (Figs. 8-29 and 8-30).
4. To install, reverse removal procedure. Check lock engagement with striker and make necessary lateral adjustments before securing attaching bolts.

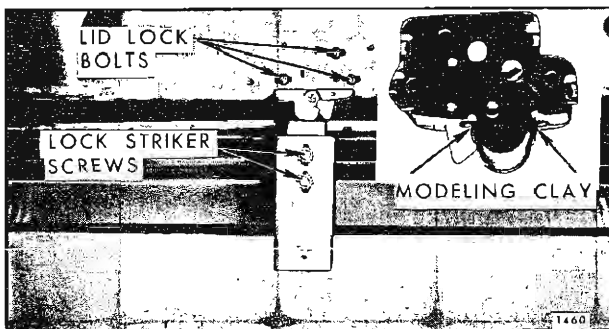

Fig. 8-29—Rear Compartment Lid Lock Assembly -  
Mounted in Rear Compartment Lid

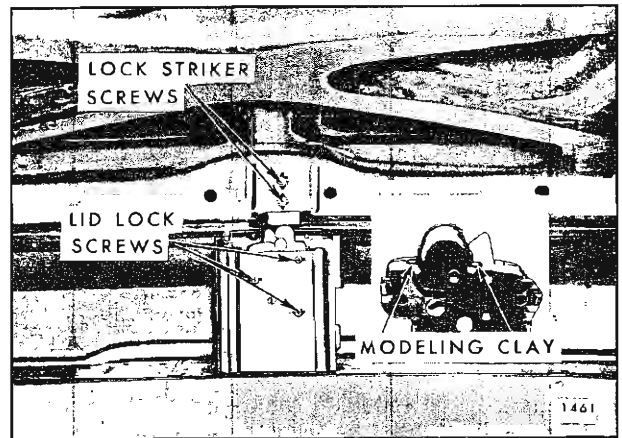

Fig. 8-30—Rear Compartment Lid Lock Assembly -  
Mounted in Rear End Panel

### REAR COMPARTMENT LID LOCK STRIKER

#### Removal and Installation

1. Open rear compartment lid. Mark vertical position of striker by scribing a line at top of striker support or at base of lid inner panel.
2. Remove striker attaching screws and remove striker (Fig. 8-29 and 8-30).
3. To install, reverse removal procedure. Close lid to check lock to striker engagement and make any necessary vertical adjustments before tightening striker screws.

### REAR COMPARTMENT LID LOCK STRIKER ENGAGEMENT—All Styles Except Corvair and Cadillac Styles with Mechanical Closing Unit Option

**IMPORTANT:** Since the rear compartment lock frame acts as a guide when entering the striker, make sure rear compartment lid is properly positioned in body opening before performing striker engagement check.

1. Insert a small quantity of modeling clay on frame of lock at both sides of the lock bolt (Figs. 8-29 and 8-30). Close lid with moderate force.
2. Open lid and check amount of engagement of striker with lock frame as indicated by the compression of the clay. The striker bar impressions in the clay should be even on both sides of the lock frame. Where required, loosen striker or lock attaching screws; adjust lock sideways or, striker up or down to obtain proper engagement; then, tighten screws.

## REAR COMPARTMENT WEATHERSTRIP— All Styles

### Removal

1. Separate "butt" ends of weatherstrip at rear compartment opening (Fig. 8-31).

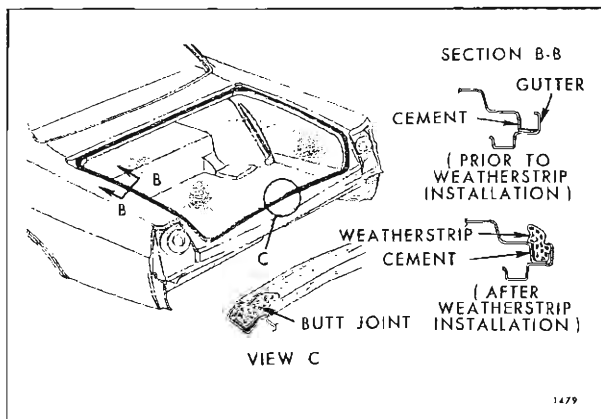

Fig. 8-31—Rear Compartment Weatherstrip Assembly

2. Using a flat-bladed tool, carefully disengage weatherstrip from its cemented foundation in gutter completely around opening and remove weatherstrip from body.

### Installation

1. Clean out gutter around entire rear compartment opening to provide a clean cementing surface.
2. Apply (brush) a continuous coat of black weatherstrip adhesive to surfaces of the rear compartment gutter.
3. Using a flat-bladed tool, such as a putty knife, insert weatherstrip into gutter while cement is still wet starting with one end of weatherstrip at rear center of gutter and working completely around gutter.
4. If a new weatherstrip is being installed, trim end to form a butt joint at rear center of opening. Brush weatherstrip adhesive (black) on both ends of weatherstrip and secure ends together to form a butt joint.
5. Using a pressure type applicator, apply weatherstrip adhesive (neoprene type) between weatherstrip and outer surface of gutter completely around opening to assure a watertight seal.
6. Roll or press weatherstrip to aid in obtaining a good cement bond. Allow sufficient time for cement to set before closing rear compartment lid.

## SECTION 9

# TAIL GATE

### INDEX

Subject	Page	Subject	Page
Introduction . . . . .	9-1	Weatherstrips . . . . .	9-21
Dual Acting Tail Gate . . . . .	9-1	Window Upper Glass Run Channel . . . . .	9-24
Inner Panel Water Deflector . . . . .	9-3	Servicing Procedures Chart . . . . .	9-24
Inner Panel Access Hole Covers . . . . .	9-4	Lock Synchronization Check . . . . .	9-28
Window Assembly - Manual or Electric . . . . .	9-5	Single Acting Tail Gate . . . . .	9-28
Torque Rod . . . . .	9-6	Inner Panel Cover . . . . .	9-28
Tail Gate Assembly . . . . .	9-8	Inner Panel Water Deflector . . . . .	9-31
Tail Gate Adjustments . . . . .	9-9	Inner Panel Access Hole Cover . . . . .	9-31
Hinge Assembly . . . . .	9-9	Hinge Assembly . . . . .	9-32
Window Regulator - Manual or Electric . . . . .	9-9	Support Assemblies . . . . .	9-33
Window Electric Regulator Motor Assembly . . . . .	9-9	Tail Gate Assembly . . . . .	9-33
Tail Gate Safety Switch . . . . .	9-11	Window Assembly - Manual or Electric . . . . .	9-35
Window Regulator Outside Handle - Manual . . . . .	9-13	Window Regulator - Manual or Electric . . . . .	9-36
Window Regulator Outside Electric Key Switch . . . . .	9-13	Window Electric Regulator Motor Assembly . . . . .	9-36
Window Lower Run Channels . . . . .	9-14	Window Regulator Outside Handle - Manual and Electric . . . . .	9-37
Remote Control Inside Handle - Gate Operation (Center) . . . . .	9-14	Lower Glass Run Channels . . . . .	9-37
Remote Control Inside Handle - Door Operation - Right Side . . . . .	9-15	Jamb Switch - Electric Option . . . . .	9-37
Lock Remote Control Assembly - Gate Operation (Center) . . . . .	9-15	Lock Remote Control Assembly . . . . .	9-38
Upper Lock Assembly - Right Side . . . . .	9-15	Lock Assembly - Right or Left Side . . . . .	9-38
Left Lock Assembly . . . . .	9-18	Lock Striker Assembly - Right or Left . . . . .	9-38
Upper Hinge and Striker Assembly . . . . .	9-21	Lock Striker Adjustments . . . . .	9-38
Lower Lock Assembly - Right Side . . . . .	9-21	Torque Rod . . . . .	9-39
Lower Striker and Support Assembly - Right Side . . . . .	9-21	Window Inner and Outer Strip Assemblies . . . . .	9-39
Drain Hole Sealing Strips . . . . .	9-21	Drain Hole Sealing Strips . . . . .	9-40
		Weatherstrip . . . . .	9-40
		Upper Glass Run Channel . . . . .	9-40

## INTRODUCTION

For purposes of clarity, the SINGLE acting and DUAL acting tail gates, comprising this section, are covered as complete and separate entities.

**IMPORTANT:** FOLLOWING ANY REPLACEMENT OR REALIGNMENT OF THE TAIL GATE, OR COMPONENT HARDWARE, ALL LOCKS

MUST BE CHECKED FOR SYNCHRONIZATION AND CORRECTED AS OUTLINED IN EACH SPECIFIC LOCK WRITE-UP. IT IS IMPERATIVE THAT ALL LOCKS ARE FULLY ENGAGED (LOCKED) DURING SYNCHRONIZATION. REFER TO THE SERVICING PROCEDURES CHART RELATING TO DUAL ACTING TAIL GATES.

## DUAL ACTING TAIL GATES

The dual-acting tail gate incorporates a unique hinge and locking arrangement that allows the tail gate to be operated in the conventional manner and, additionally, as a door. All wagons utilize either a manually or electrically operated window that can be lowered into the gate or raised into the back body opening. The manual window is operated by a regulator control handle located in the tail gate outer panel. The power window can be operated by any one of three control switches; one on the instrument panel, one at the lock cylinder on tail

gate outer panel (key operated) and one on the wheelhouse cover panel (optional - down only). All styles using a power tail gate window are equipped with an electrical switch that prevents movement of the window with gate in any position other than fully closed.

The tail gate is unlocked to "gate position" by means of a remote control inside handle located in the top center of gate inner panel. Unlocking to "door position" is accomplished with a remote



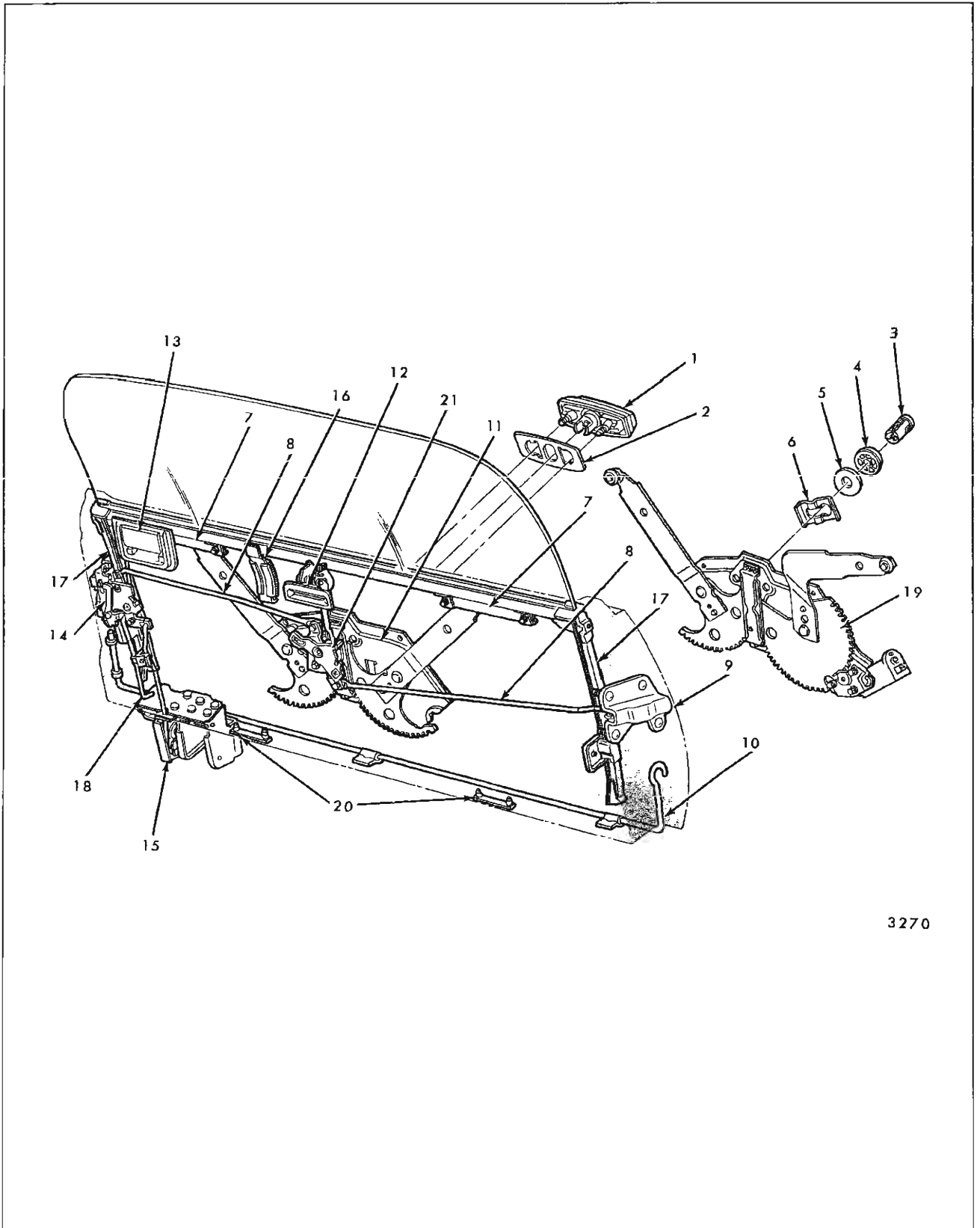

3270

Fig. 9-1—Dual Acting Tail Gate

Fig. 9-1—Dual Acting Tail Gate



- |                                  |   |
|----------------------------------|---|
| 1. Outside Handle (Manual)       | 12. Remote Gate Handle                  |
| 2. Gasket                        | 13. Remote Door Handle                  |
| 3. Lock Cylinder                 | 14. Right Upper Lock                    |
| 4. Electrical Feed Block         | 15. Right Lower Lock and Cover Assembly |
| 5. Gasket                        | 16. Glass Stabilizer                    |
| 6. Lock Cylinder Retainer        | 17. Lower Glass Run Channels            |
| 7. Sash Channel Cam              | 18. Glass Block-Out Rod                 |
| 8. Remote Control Connecting Rod | 19. Regulator Electrical                |
| 9. Left Lock Assembly            | 20. Sealing Strip                       |
| 10. Torque Rod                   | 21. Remote Control Assembly             |
| 11. Regulator - Manual           |   |

control inside handle located at top right side of inner panel. Tail gate cannot be opened in either direction, however, until window has been fully lowered. All tail gates are counter-balanced by a torque rod that assists in reducing the effort required to open or close the tail gate.

Unless otherwise stated, the tail gate service procedures outlined in this manual pertain to all station wagon styles.

All dual-acting tail gates employ a "hang-on" type inner panel cover that attaches over the top of the tail gate inner panel and is further secured by a series of screws. This cover can be readily removed with gate in either the open or closed position.

## TAIL GATE INNER PANEL WATER DEFLECTOR

A waterproof paper deflector is sealed against the tail gate inner panel to deflect water toward the bottom of the gate and out the drain holes.

**IMPORTANT:** When work is performed on the tail gate that requires any detachment of the

water deflector, it must be properly resealed to the inner panel.

### Removal

1. Remove tail gate inner panel cover.
2. Using a flat-bladed tool, carefully break bond securing water deflector to inner panel. Make sure string, located within sealer, is against water deflector and carefully slide tool between sealer and inner panel along both sides, top and bottom to disengage deflector from inner panel. If the entire deflector need not be removed, detach only that portion necessary.

### Installation

1. Inspect deflector and repair any damage noted with waterproof body tape applied to both sides.
2. If a new deflector is to be installed, use old deflector as a template.
3. If needed, apply a bead of body caulking compound (approximately 3/16" diameter) to tail gate inner panel (See Fig. 9-2). The inner panel cover attaching screw holes should also be sealed with body caulking compound.

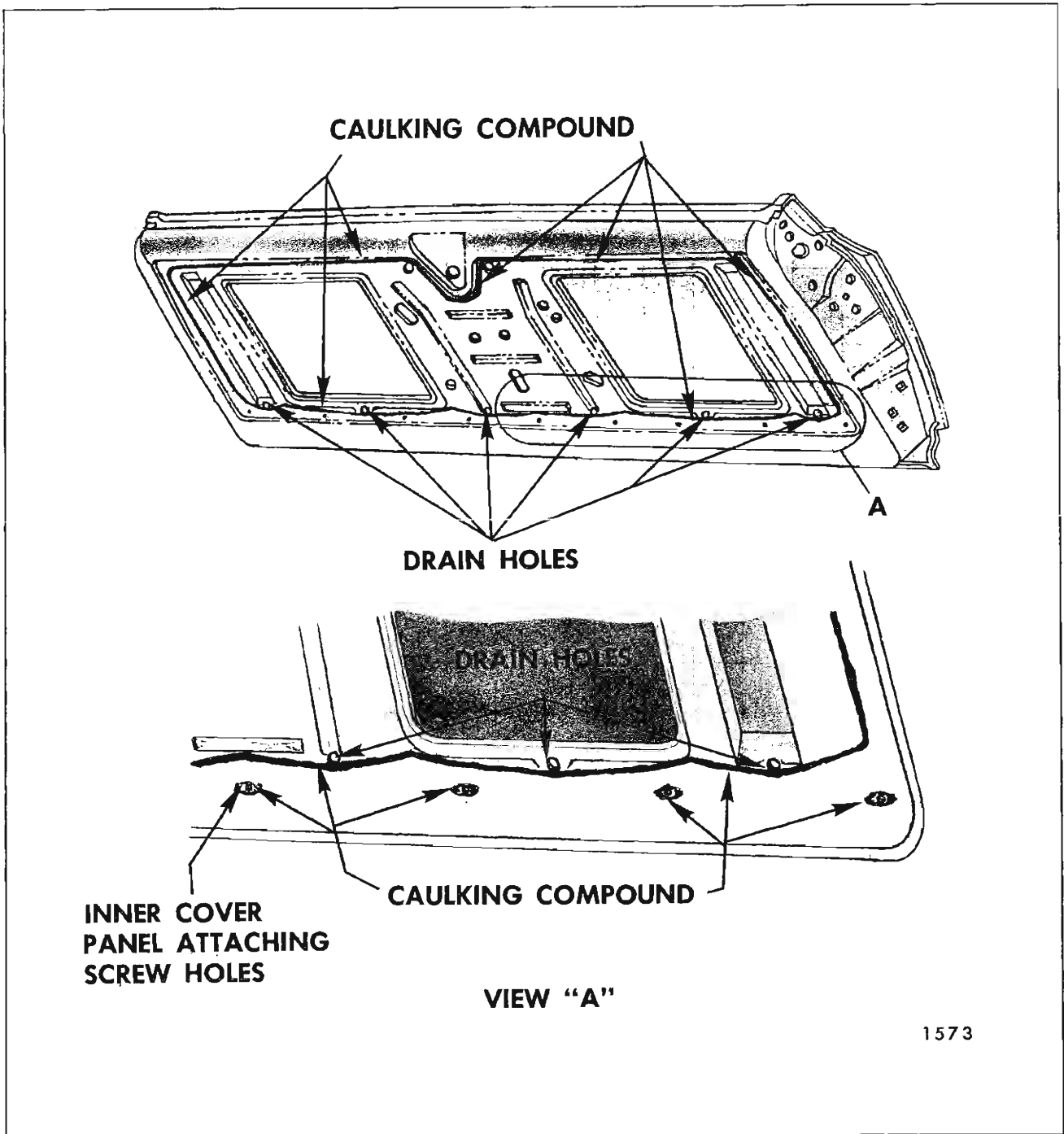

Fig. 9-2—Tail Gate Sealing

4. Position water deflector to tail gate with polyethylene coated side (black) against inner panel. Firmly press sealed areas to obtain a good bond between deflector and inner panel.

**TAIL GATE INNER PANEL  
ACCESS HOLE COVERS**

**Removal and Installation**

1. Remove tail gate inner panel cover and water deflector.

2. Remove upper screws securing right and left access hole covers to tail gate inner panel and remove covers by sliding upward. (See Fig. 9-3).

## TAIL GATE WINDOW ASSEMBLY— MANUAL OR ELECTRIC

### Removal and Installation

1. Open tail gate to gate position.
2. Remove tail gate inner panel cover, water deflector and both access hole covers.
3. Operate tail gate window to a point that sash channel cam attaching bolts are accessible through inner panel (Fig. 9-4) - See "NOTE" and "CAUTION".

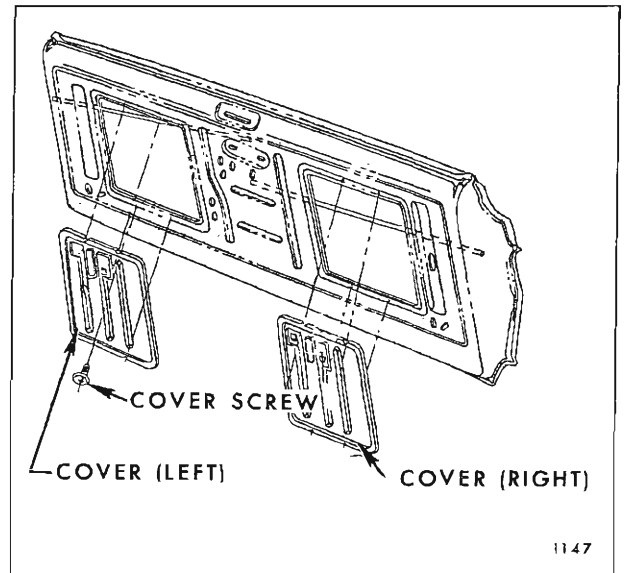

Fig. 9-3—Tail Gate Inner Panel Access Hole Cover

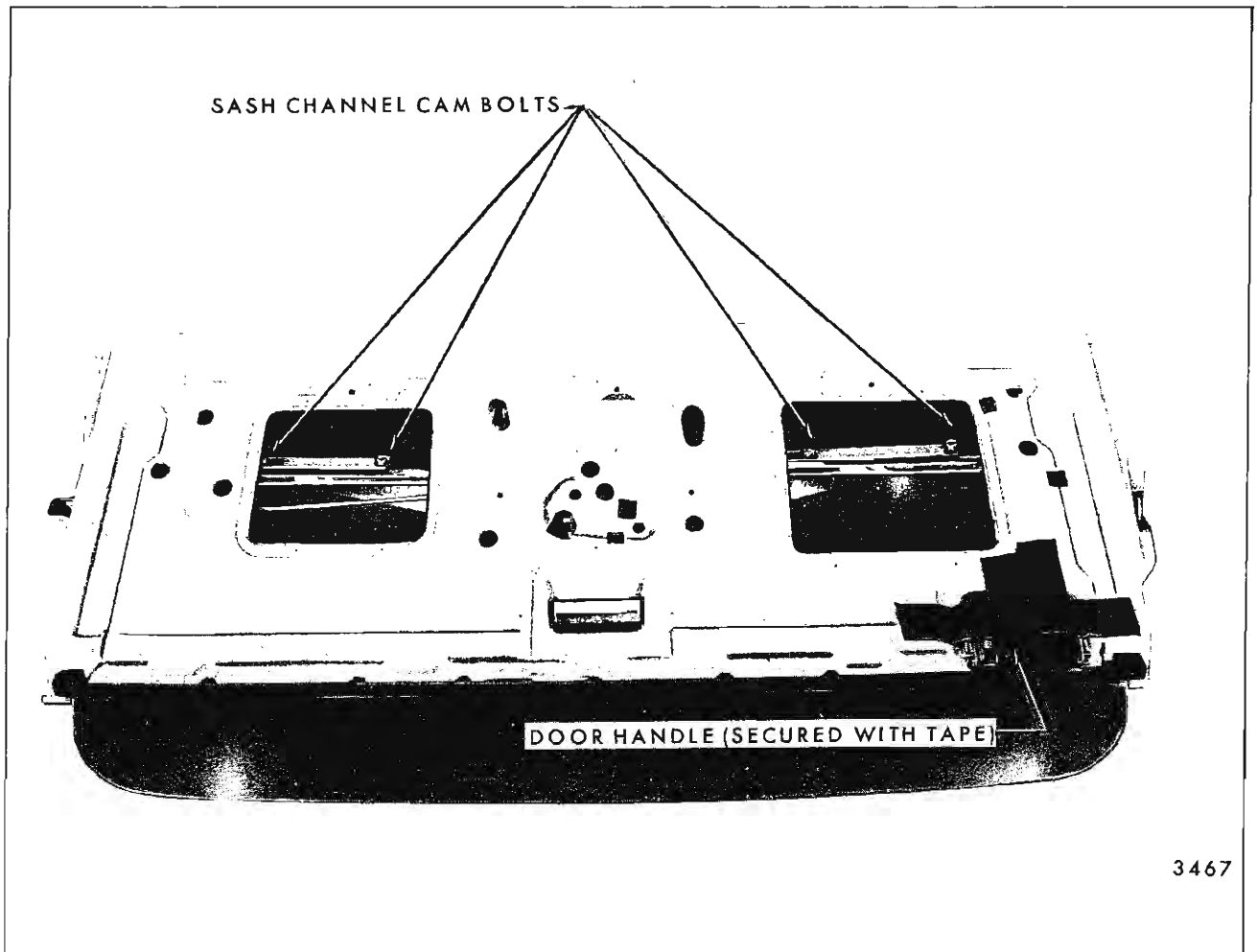

Fig. 9-4—Dual Tail Gate Glass Removal

**NOTE:** On manually operated tail gate windows, the glass can be raised by simply operating the outside handle. On electrically operated units, however, a switch mounted on the upper right lock assembly prevents window operation with any lock in an open position. To operate window, it is first necessary to manually lock both upper locks as follows:

- A. The right upper lock is engaged by pivoting fork bolt to its full clockwise limits (arrow "A", Fig. 9-5).

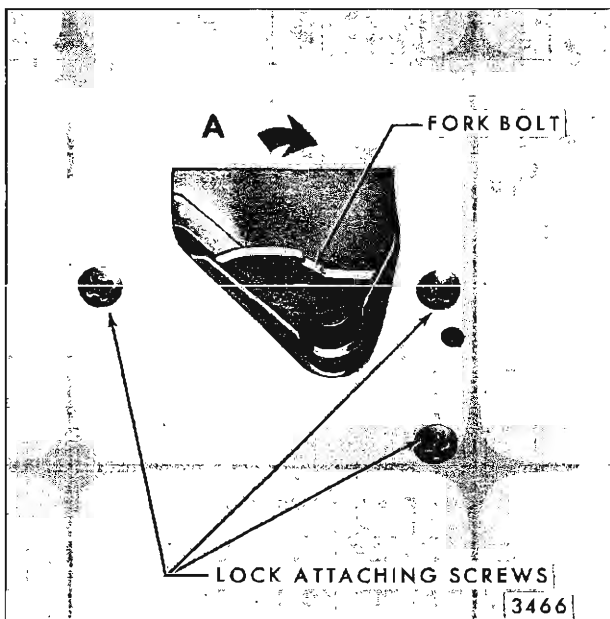

Fig. 9-5—Dual Tail Gate Right Upper Lock Engagement

- B. The left upper lock is engaged by depressing (with a screwdriver, or other suitable tool) the locking lever to full engagement (Fig. 9-6).

**CAUTION:** With tail gate open and locks engaged (as explained in preceding note), the tail gate has been placed in a vulnerable position and could drop from the right lower lock if inside door remote handle were actuated. As a safety precaution, prior to manually locking either right or left upper locks, firmly apply body tape over inside door remote handle to render same inoperable (Fig. 9-4).

4. Remove right and left cam attaching bolts (Fig. 9-4). Slide cams free of regulator lift arm rollers and remove cams from tail gate.
5. Pull window straight out to remove from tail gate.
6. To install, reverse removal procedure.



Fig. 9-6—Dual Tail Gate Left Lock Engagement

7. Right and left upper locks can be unlocked by actuating tail gate inside remote handle.

### Adjustments

The tail gate glass run channels can be adjusted to relieve a binding glass. To correct a rotated glass condition, loosen window regulator attaching screws and rotate regulator clockwise or counter clockwise as required.

### TAIL GATE TORQUE ROD

#### Removal and installation

1. Open tail gate slightly to gate position and remove two torque rod to body retainer attaching bolts (Fig. 9-7). Disconnect torque rod assist link from torque rod and close tail gate.

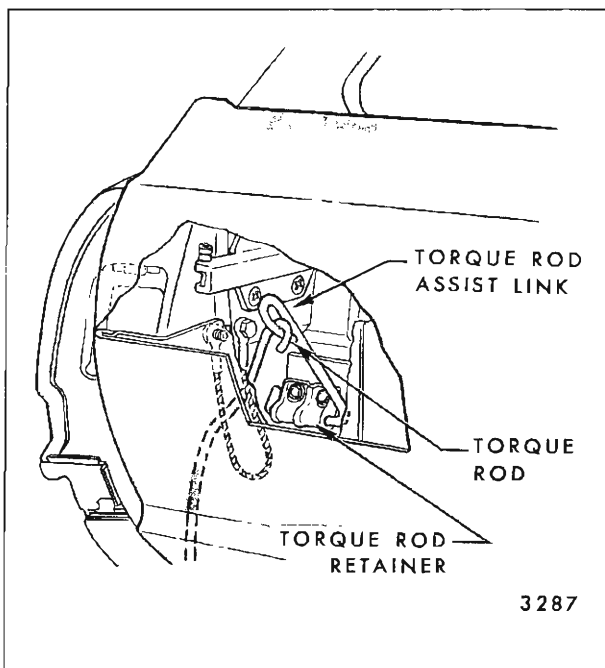

Fig. 9-7—Dual Gate - Torque Rod to Body Attachment

**CAUTION:** DO NOT attempt to remove torque rod or assist link unless tail gate is in a neutral position or these two parts have been disengaged.

2. Lower rear bumper as explained in "Tail Gate Assembly".
3. Lower tail gate to gate position and remove torque rod to gate retainers (Fig. 9-8).
4. Raise tail gate window sufficiently to be free of torque rod welded-in retainers on right side of tail gate.

**NOTE:** To raise window on electrically operated styles, refer to "Tail Gate Window Assembly", observing and adhering to the caution notes outlined therein.

5. With a suitable tool, disengage torque rod from welded-in retainers and remove rod.
6. To install, reverse removal procedure.

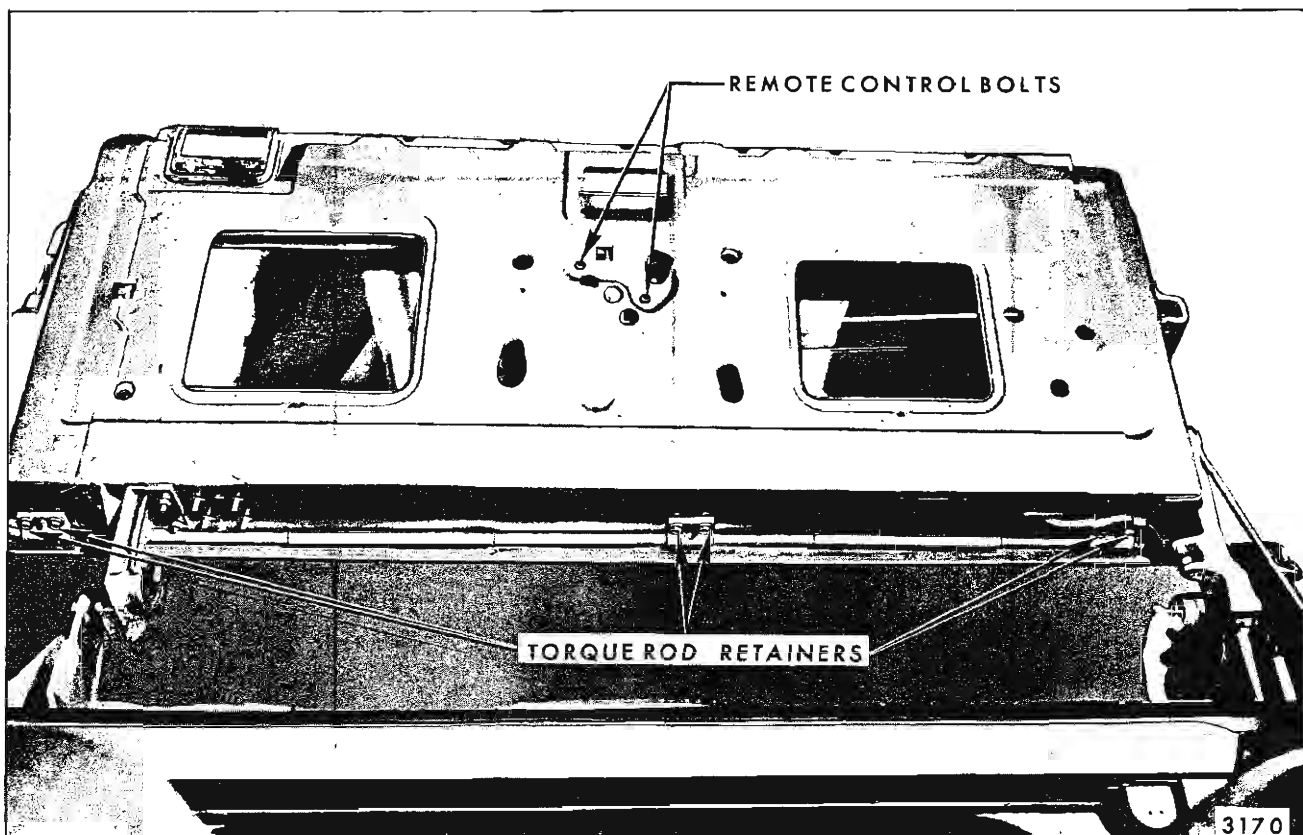

Fig. 9-8—Dual Gate Torque Rod Retention

## TAIL GATE ASSEMBLY

### Removal and Installation

1. Remove tail gate window as previously described.
2. On styles so equipped, disconnect electrical leads inside gate and pull main conduit free of tail gate. Close tail gate.
3. Remove two rearward chassis frame to bumper attaching bolts and loosen forward two bolts.

Remove center bumper to frame bolt (under license housing) and lower bumper (Fig. 9-9).

4. Remove torque rod assist link. (Refer to Fig. 9-7).
5. Open tail gate to door position and support free end of gate (Fig. 9-10).

**NOTE:** For purposes of illustration, Figure 9-11 shows tail gate open in the gate position.

**CAUTION:** A loaded tail gate weighs in excess of 140 pounds and must be handled by two men.

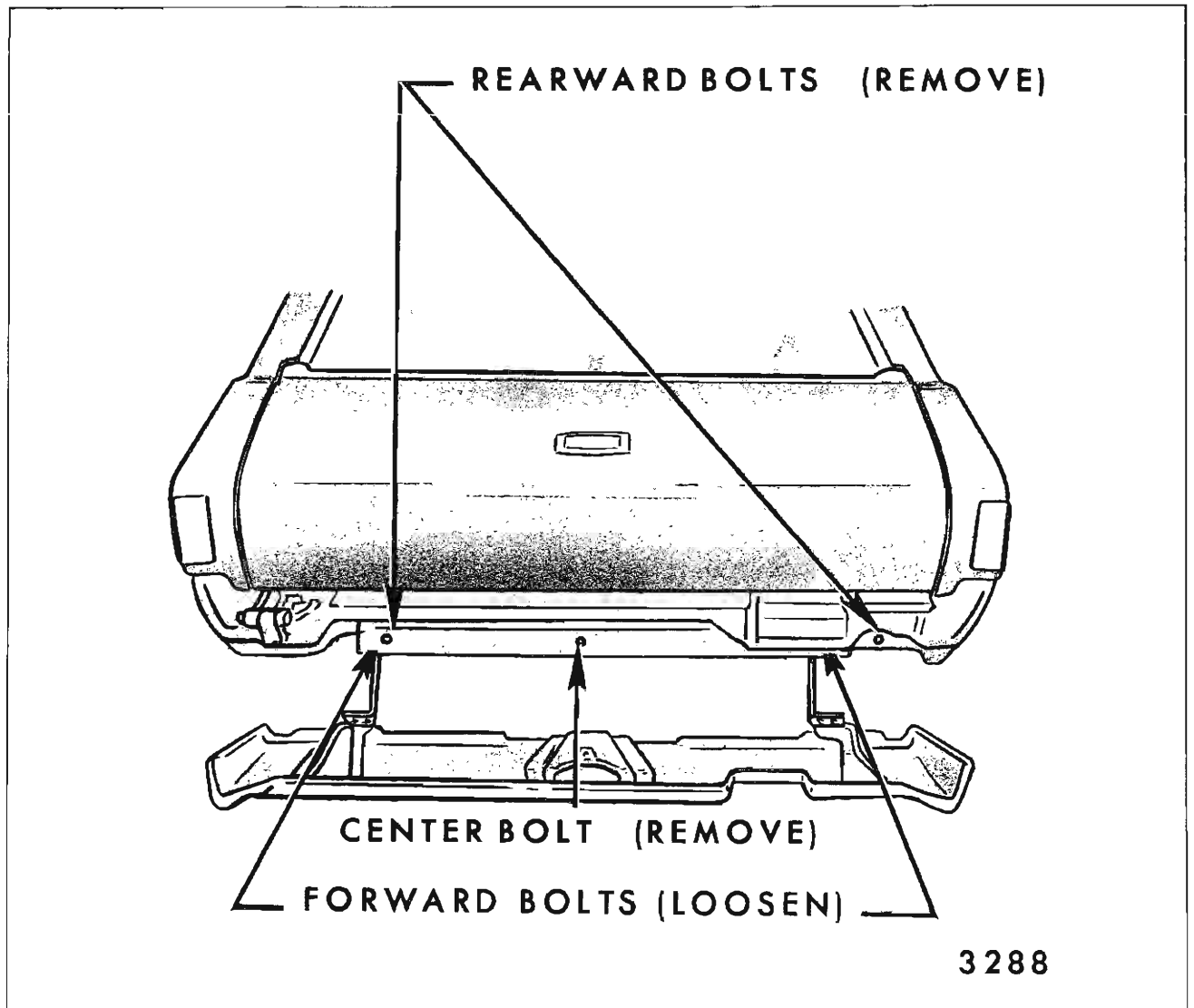

Fig. 9-9—Bumper Removal - "A" Body Shown - "B" Body Similar

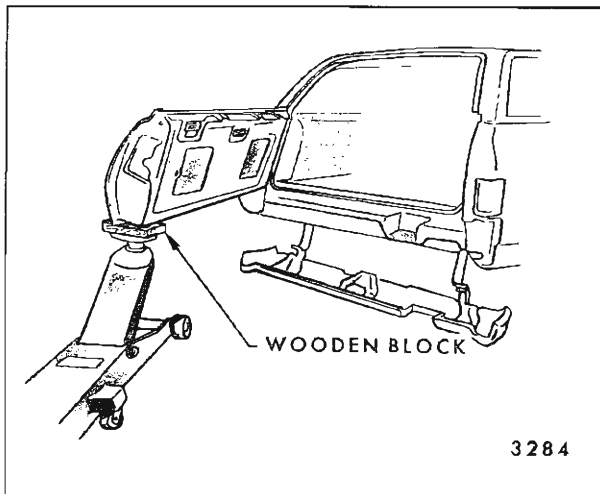

Fig. 9-10—Tail Gate Removal

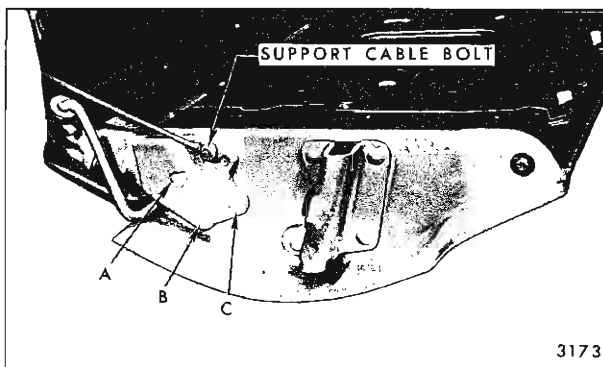

Fig. 9-11—Tail Gate Left Hinge Assembly - "B" Body Shown - "A" Body Typical

6. With the aid of a helper, remove hinge to gate attaching bolts, as follows:
  - A. On "A" body styles, the support cable bolt is retained with a nut. On "B" body styles, this bolt fits into a tapping plate (Fig. 9-11).
  - B. On "A" body styles, bolt A, Figure 9-11, fits into a tapping plate. Bolts B & C, Figure 9-11, are pressed into the hinge assembly and retained to the tail gate by nuts. The pressed bolts are removed with the hinge assembly - not separately.
  - C. On "B" body styles, bolts A" B & C, Figure 9-11, are pressed into the hinge assembly and retained to the tail gate by nuts. The pressed bolts are removed with the hinge - not separately.

7. With all hinge to gate attaching bolts removed, remove tail gate (with aid of helper) by lifting straight upward until left lock slides free of hinge and striker assembly.
8. To install, reverse removal procedure.

**IMPORTANT:** All nut retained bolts must be torqued to a minimum of forty (40) foot pounds to inhibit hinge slippage.

## TAIL GATE ADJUSTMENTS

The left hinge to body attaching bolts provide side to side adjustments (See Fig. 9-12).

The left hinge to tail gate bolts are loaded into oversized holes that allow up or down and fore or aft adjustment (Fig. 9-11). The right striker support to body bolts are loaded into floating tapping plates that provide side to side and up or down adjustment. The lower striker is adjustable fore or aft and the upper striker fore or aft and up or down (Fig. 9-13).

## TAIL GATE HINGE—Left Side

### Removal and Installation

1. Scribe location of hinge on tail gate and back body pillar, then remove tail gate as previously described.
2. Remove hinge to body attaching bolts and remove hinge (Fig. 9-12).
3. To install, reverse removal procedure.

## TAIL GATE WINDOW REGULATOR—Manual and Electric

### Removal and Installation

1. Remove tail gate window assembly.
2. On styles equipped with a power operated tail gate window assembly, disconnect electric harness at regulator motor connector.
3. Remove bolts securing regulator to support and remove regulator, with motor attached, from tail gate. (Refer to Fig. 9-1).
4. To install, reverse removal procedure.

## TAIL GATE WINDOW ELECTRIC REGULATOR MOTOR ASSEMBLY

### Removal

1. Open tail gate and remove tail gate inner cover



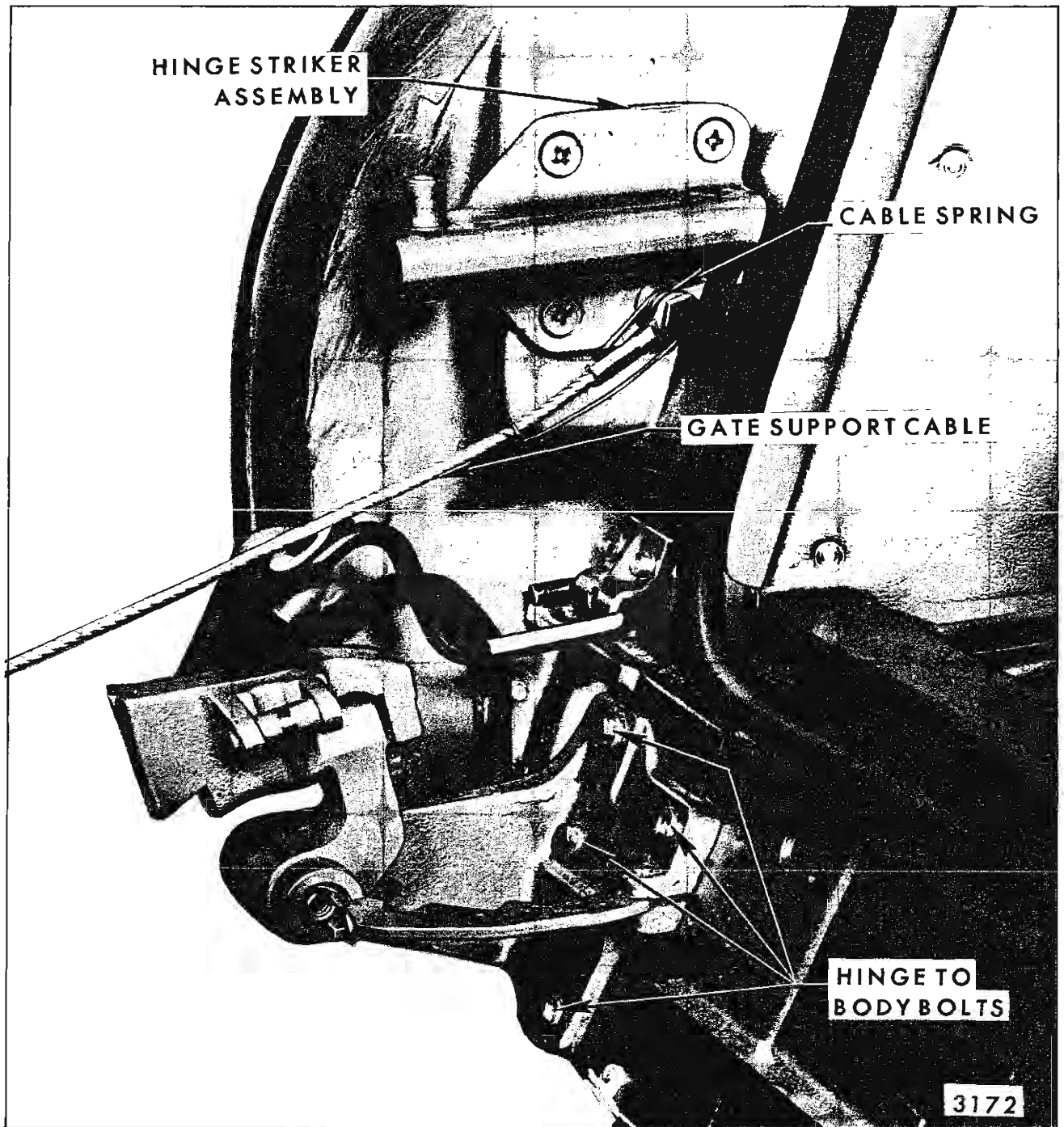

Fig. 9-12—Tail Gate Adjustments - "B" Body Shown - "A" Body Typical

panel. If necessary, cover can be removed with gate in the closed position.

2. Detach inner panel water deflector and remove left access hole cover.
3. Disconnect wire harness connector from motor.

**NOTE:** In the event a power operated window motor fails with tail gate closed and glass in the closed (up) position, remove window sash channel cams and manually lower glass to bottom of gate.

**IMPORTANT:** Step 4 must be performed if the window is removed or disengaged from

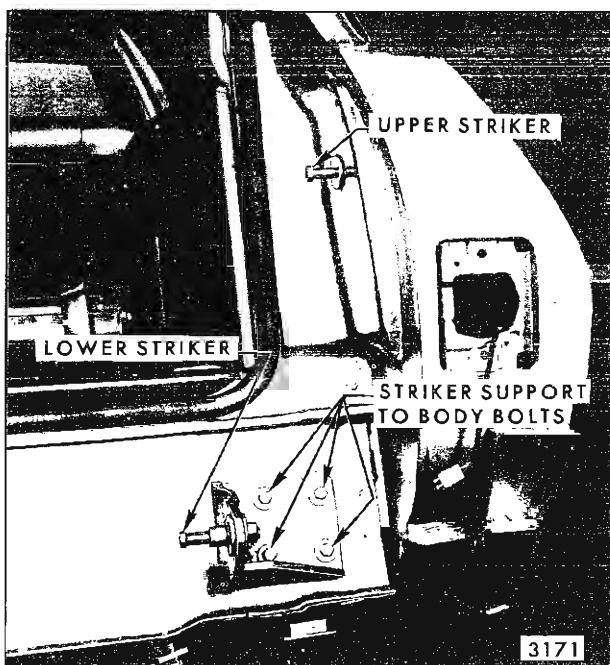

Fig. 9-13—Tail Gate Adjustments - "B" Body Shown - "A" Body Typical

the regulator lift arms. The regulator lift arms, which are under tension from the counter-balance spring, can cause serious injury if the motor is removed without locking the sector gears in position.

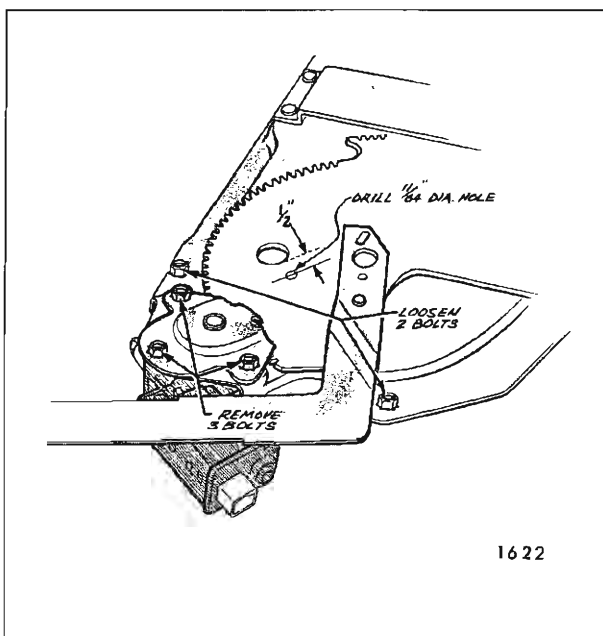

Fig. 9-14—Tail Gate Regulator Motor Assembly

4. Drill a 1/8" hole through regulator sector gear and back plate (Fig. 9-14). Do **NOT** drill hole closer than 1/2" to edge of sector gear or back plate. Install a pan head sheet metal tapping screw (#10-12 x 5/8) in drilled hole to lock sector gears in position.
5. Remove regulator motor attaching screws and remove motor assembly from regulator and tail gate.

### Installation

1. Lubricate the motor drive gear and regulator sector teeth.

**NOTE:** The lubrication used must be cold weather approved to a minimum of -20 degrees fahrenheit.

2. With tail gate in an open position, install regulator motor to regulator. Make sure the motor pinion gear teeth mesh properly with the sector gear teeth before installing the three motor attaching screws.
3. Remove screw locking sector gears into a fixed position.
4. Connect wire harness to motor and cycle tail gate window prior to installation of inner panel access hole cover, water deflector and cover panel.

## TAIL GATE SAFETY SWITCH

### Description

The tail gate safety switch is standard equipment on all station wagon styles equipped with a power operated tail gate window. This switch is mounted on the right upper lock and is designed to prevent upward movement of glass with tail gate in any position other than fully closed.

**NOTE:** In the event the tail gate safety switch fails with gate closed and glass in the fully lowered (open) position, refer to Dual Acting Tail Gate Servicing Procedures Chart for procedures to raise glass.

### Removal

1. With glass in up position, remove tail gate

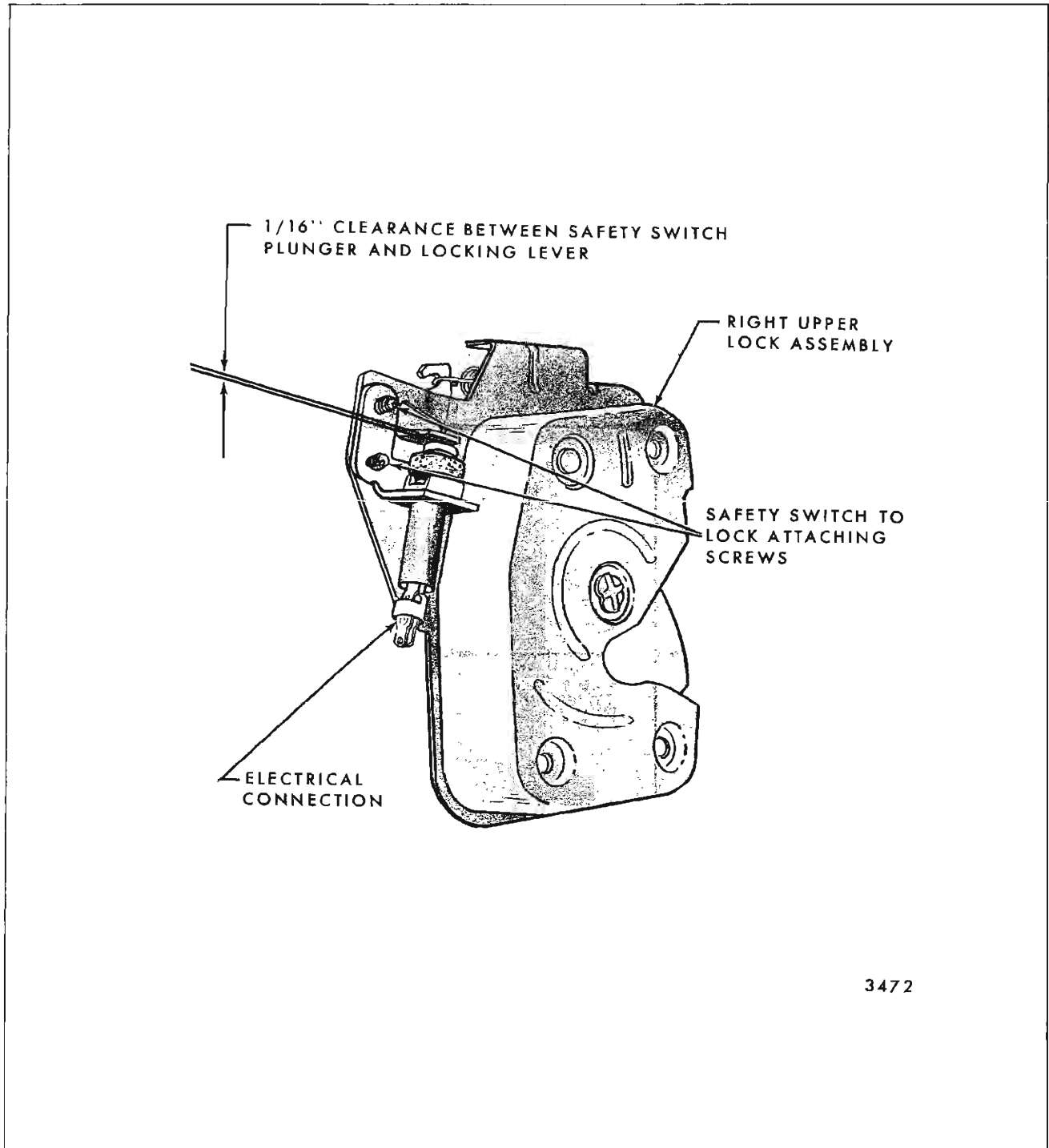

Fig. 9-15—Dual Tail Gate Electrical Safety Switch

inner panel cover, water deflector and right access hole cover.

2. Remove screws (2) securing switch to right upper lock, disconnect electrical conduit and remove switch (See Fig. 9-15).

#### Installation

1. Connect electrical conduit and loosely attach switch to lock assembly.
2. With tail gate closed, adjust switch to achieve

a 1/16" clearance between safety switch plunger and lock locking lever (See Fig. 9-15).

**IMPORTANT:** The adjustment specified in Step #2 is absolutely necessary to insure proper operation of switch.

3. Following proper adjustment of safety switch, secure attaching screws and cycle tail gate window and gate to insure proper operation prior to installation of cover panel, water deflector and trim pad.
2. Remove inner panel cover, water deflector and one access hole cover.
3. Position tail gate window so that outside handle (manual) attaching nuts are accessible through gate inner panel and window regulator access holes (Fig. 9-16).
4. Remove nuts securing handle to tail gate and remove handle and sealing gasket.
5. To install, reverse removal procedure.

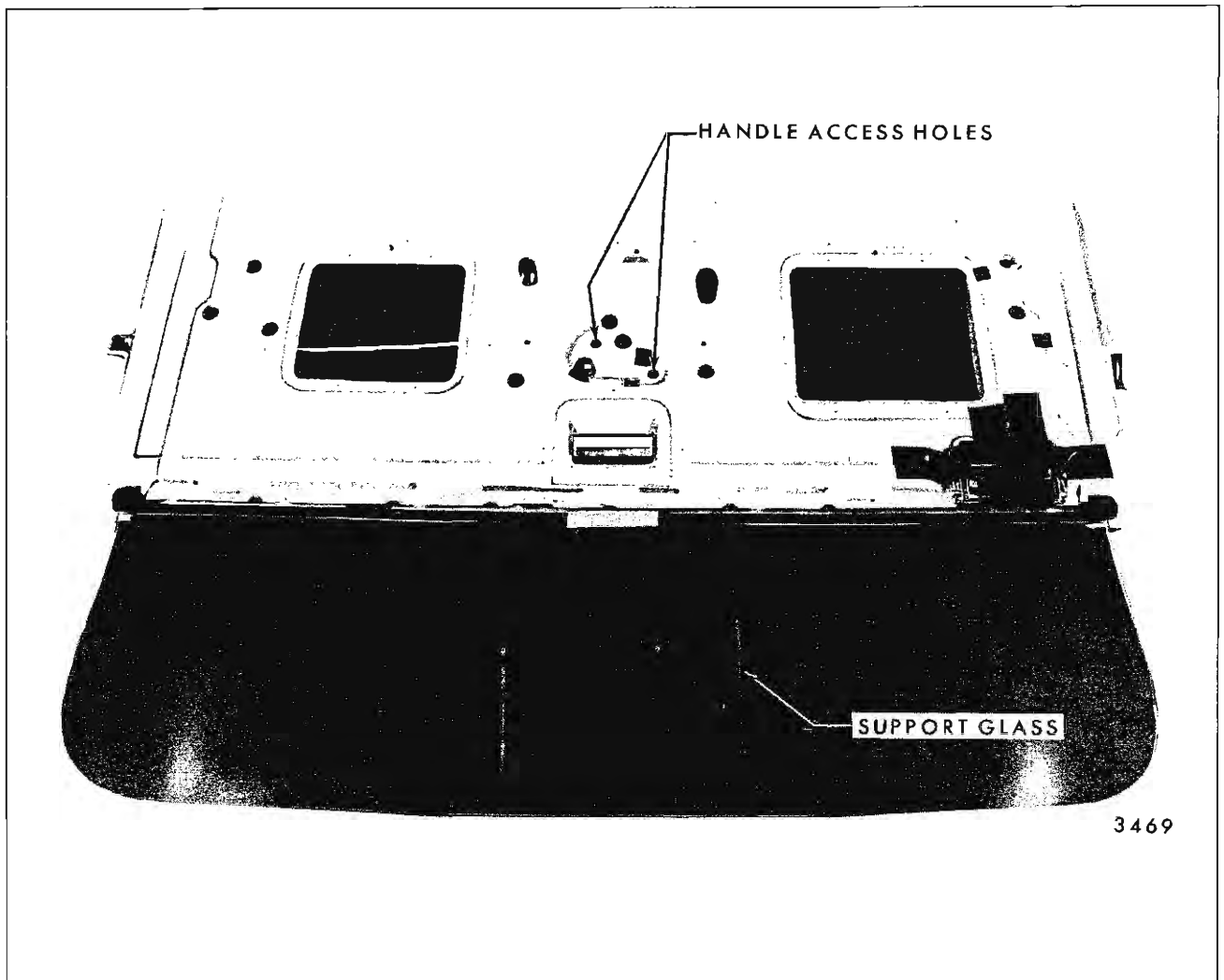

Fig. 9-16—Tail Gate Window Manual Outside Handle Removal

### TAIL GATE WINDOW REGULATOR MANUAL OUTSIDE HANDLE

#### Removal and Installation

1. Open tail gate in door position.

### TAIL GATE WINDOW REGULATOR OUTSIDE ELECTRIC KEY SWITCH

#### Removal and Installation

1. Open tail gate in door position.

2. Remove inner panel cover, water deflector and access hole covers.
3. Remove tail gate window assembly and loosen tail gate window regulator so that key switch retainer is accessible through tail gate inner panel.

**NOTE:** To remove a power operated tail gate window, refer to "Tail Gate Window" in this section. Carefully read the CAUTION note.

4. Slide retainer free of key switch and remove switch (See Figure 9-17 for "A" body styles and Figure 9-18 for "B" body styles.)

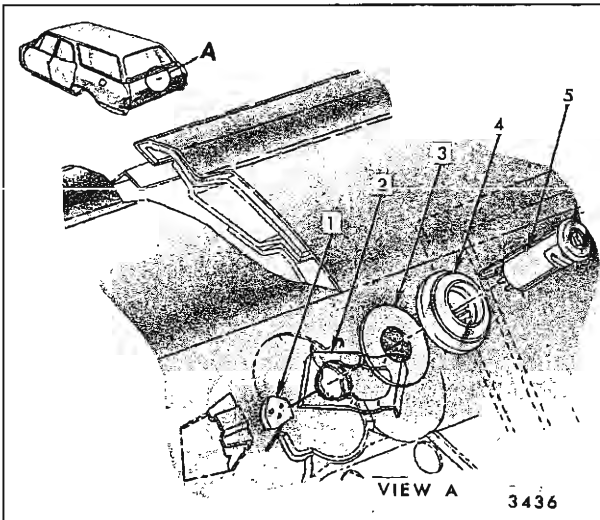

Fig. 9-17—Dual Gate Electric Key Switch and Cylinder Removal - "A" Body

- |               |                                     |
|---------------|-------------------------------------|
| 1. Feed Block | 4. Escutcheon                       |
| 2. Retainer   | 5. Key Switch and Cylinder Assembly |
| 3. Gasket     |                                     |

5. To install, reverse removal procedure.

### TAIL GATE WINDOW LOWER GLASS RUN CHANNELS

#### Removal and Installation

1. Remove tail gate window assembly.
2. Remove upper attaching bolt - accessible at lock pillar outer panel.
3. Remove lower attaching bolt - accessible through inner panel access hole (Fig. 9-19).
4. Turn run channel 90° and pull run channel(s) down into tail gate and remove through glass opening.

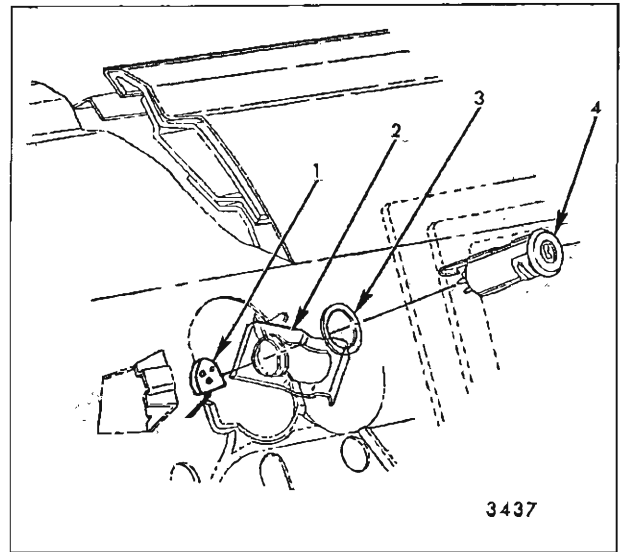

Fig. 9-18—Dual Gate Electric Key Switch and Cylinder Removal

- |               |                                     |
|---------------|-------------------------------------|
| 1. Feed Block | 4. Key Switch and Cylinder Assembly |
| 2. Retainer   |                                     |
| 3. Gasket     |                                     |

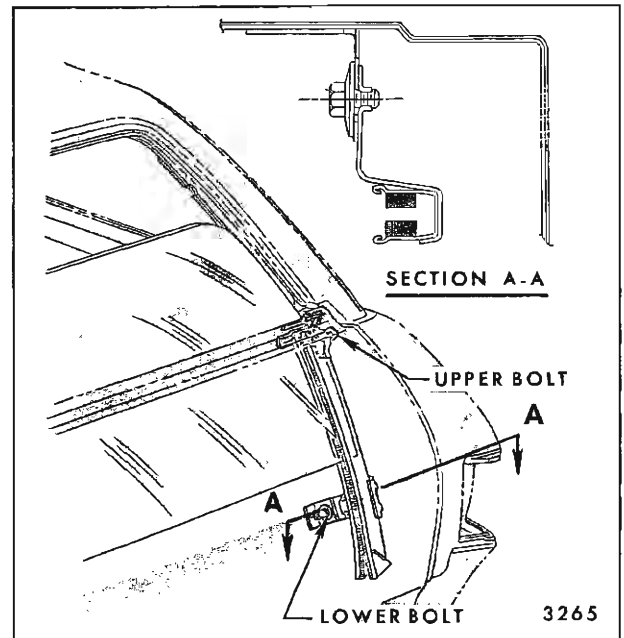

Fig. 9-19—Tail Gate Lower Glass Run Channel Attachment

5. To install, reverse removal procedure.

### TAIL GATE REMOTE CONTROL INSIDE HANDLE—Gate Operation (Center)

#### Removal and Installation

1. Raise inside handle and disengage remote push rod from spring clip (See Fig. 9-20).

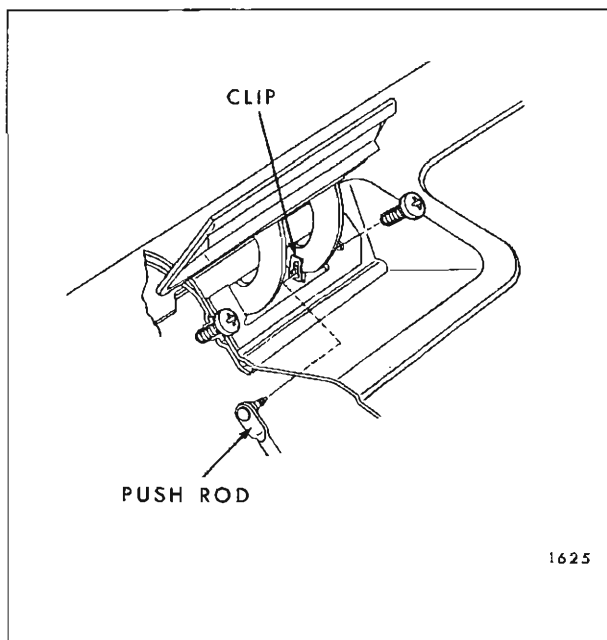

Fig. 9-20—Tail Gate Inside Handle Attachment

2. Remove screws securing handle to inner panel and remove handle.
3. To install, reverse removal procedure.

### TAIL GATE REMOTE CONTROL INSIDE HANDLE—Door Operation (Right Side)

#### Removal and Installation

1. Open tail gate in door position.
2. Remove inner panel cover, water deflector and left access hole cover.
3. Disengage handle cable at upper lock clip (Fig. 9-21).
4. Raise inside handle and remove screws securing handle to inner panel and remove handle.
5. To install, reverse removal procedure.

**NOTE:** This handle is equipped with a sealing strip (Part No. 8744881). Should this sealing strip become damaged, it should be replaced with a new piece, available as a service part.

### TAIL GATE LOCK REMOTE CONTROL ASSEMBLY—Gate Operation (Center)

#### Removal

1. Open tail gate to gate position.

2. Remove inner panel cover, water deflector and access hole covers.
3. Disconnect remote control to lock connecting rods at remote assembly by sliding clips out of engagement.
4. Remove remote control to tail gate inner panel attaching bolts (Fig. 9-22).
5. Disengage remote control center handle from push rod and remove remote control and rod assembly (Fig. 9-23).

#### Installation

1. Install remote control (two bolts) to inner panel.
2. Install a small nail or cotter pin in hole provided in remote control (Fig. 9-24).
3. Loosen remote adjusting screw.

**NOTE:** The remote control adjusting screw is used to insure that right and left locks and gate control push rod are synchronized. This screw is left hand thread.

4. Connect all remote rods and close tail gate.
5. Working through inner panel, tighten adjusting screw.
6. Remove cotter pin or nail (Fig. 9-24).

**NOTE:** Use of the cotter pin (supplied with replacement part) insures that remote is not installed in a position that would hold any lock in a partially open attitude. This pin holds all levers in position until final adjustment has been achieved.

7. Open tail gate and reinstall access hole covers, water deflector and inner panel cover.

### TAIL GATE UPPER LOCK ASSEMBLY—Right Side

#### Removal

1. Remove tail gate window assembly.
2. Remove tail gate window right lower glass run channel. Close tail gate and re-open in door position.
3. Remove three screws securing lock to tail gate lock pillar panel (Fig. 9-25).
4. Disengage inside handle cable (Fig. 9-21).
5. With gate open in door position, disengage

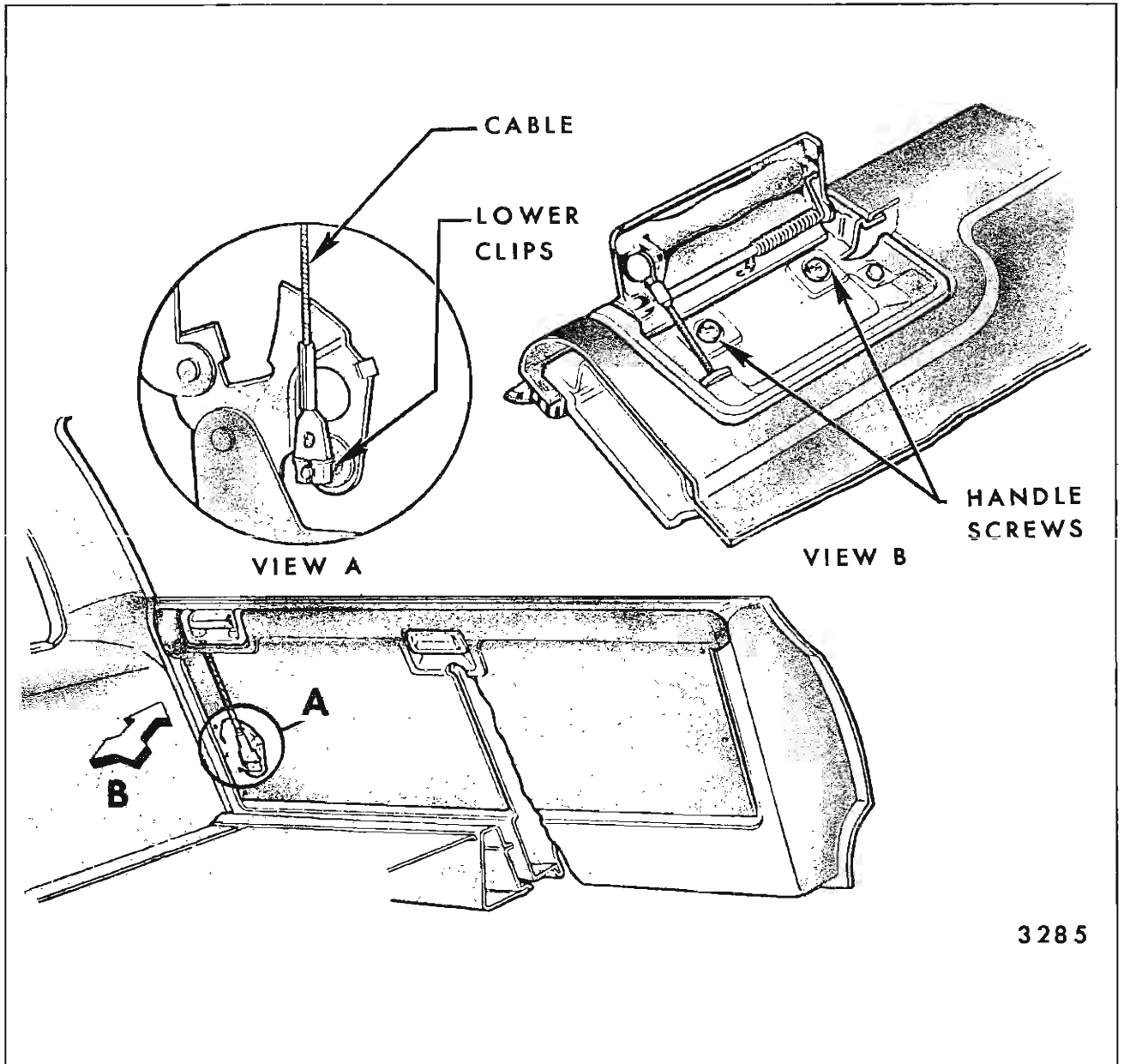

3285

Fig. 9-21—Tail Gate Remote Control Inside Handle - Door Operation

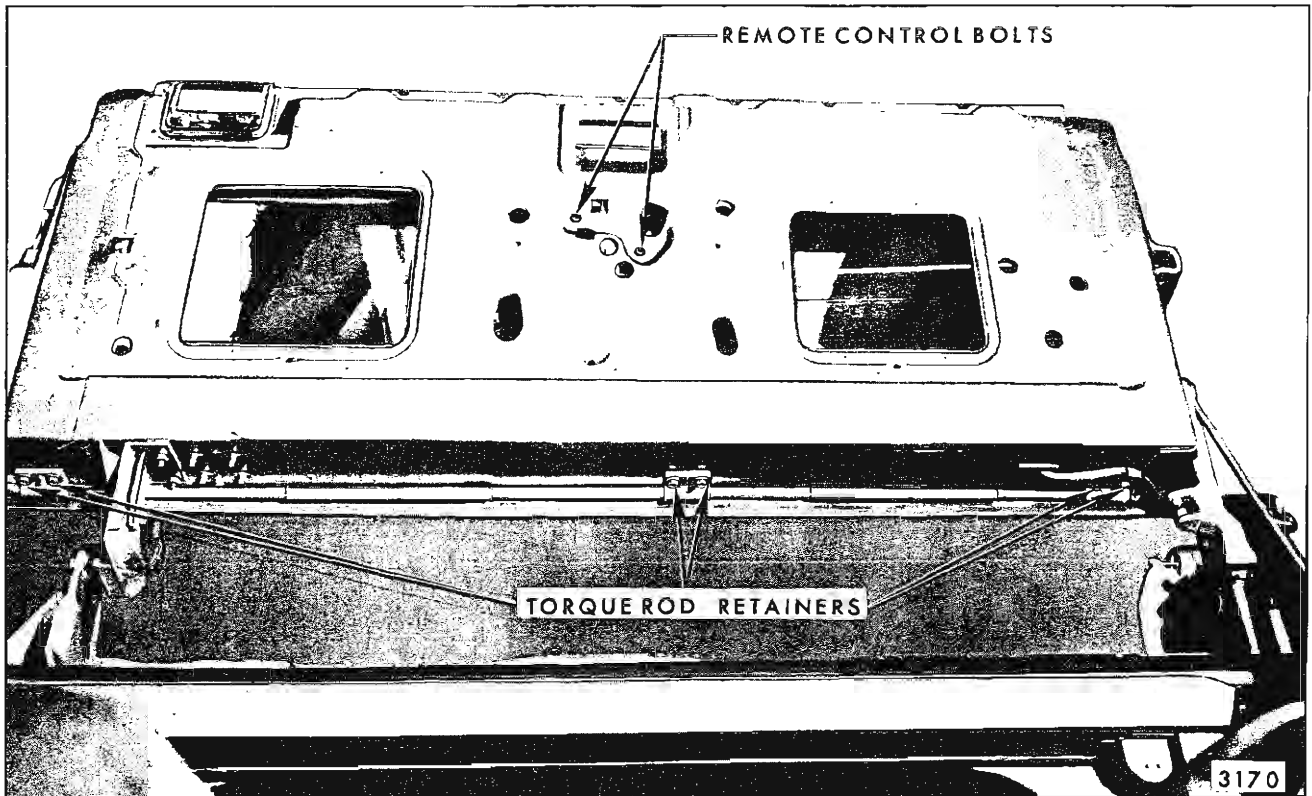

Fig. 9-22—Dual Gate Torque Rod Retention

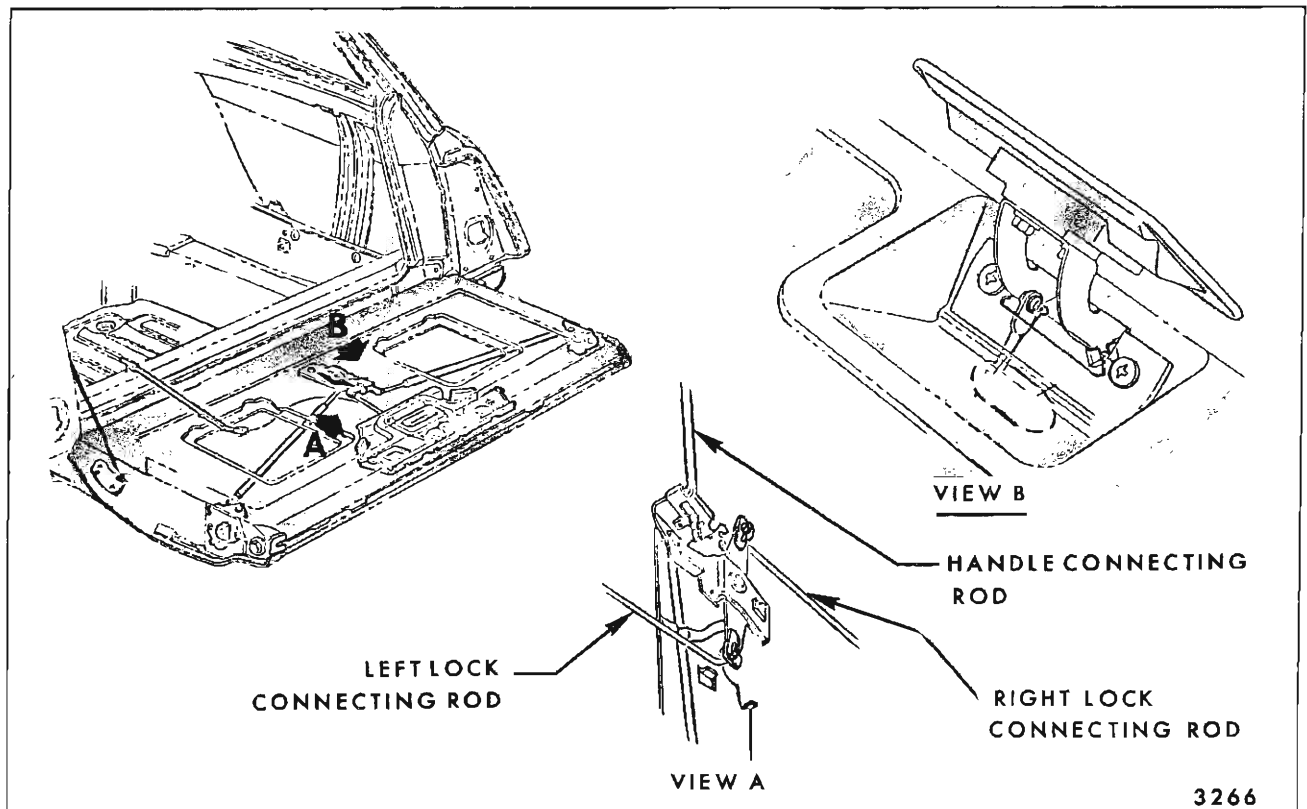

Fig. 9-23—Tail Gate Lock Remote Control Assembly - Gate Operation (Center)



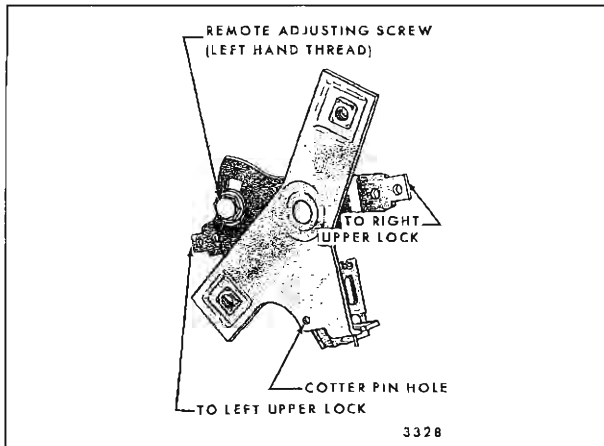

Fig. 9-24—Tail Gate Lock Remote Control - Gate Operation

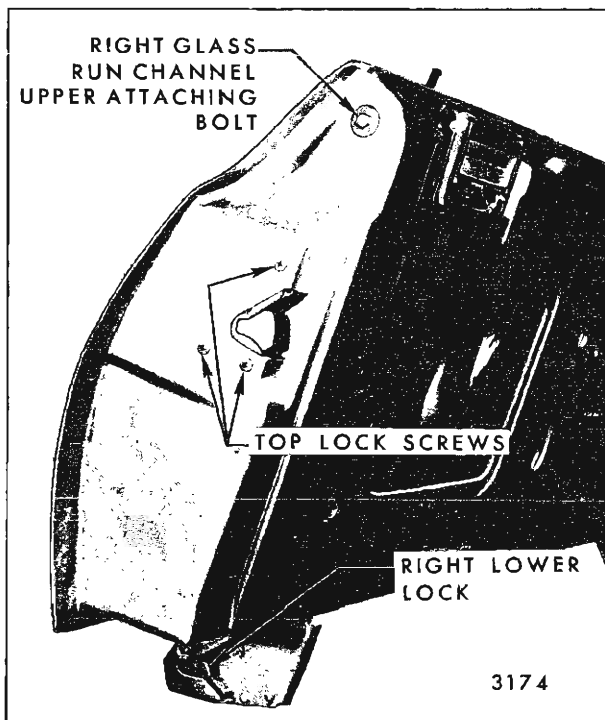

Fig. 9-25—Dual Tail Gate Lock Attachments - Right Side

clips securing lower lock connecting rod, remote control to lock connecting rod and tail gate window "block-out" rod (Fig. 9-26).

**CAUTION:** DO NOT pull remote control rod. Excessive movement of this rod could unlock upper left lock assembly.

6. On electric styles, disconnect safety switch and remove lock assembly (Fig. 9-27).

**Installation**

1. Install screws (three) securing lock to tail gate lock pillar panel (Fig. 9-25).
2. Loosen lower lock connecting rod to upper lock adjusting screw (10 in Fig. 9-26).
3. Connect lower lock, remote control connecting rod and block-out rod.

**NOTE:** When installing upper to lower connecting rod, move locking lever of upper lock to meet rod.

4. Engage inside handle cable and close tail gate.
5. Working through inner panel, tighten adjusting screw.

**NOTE:** The lower lock connecting rod to top lock linkage adjusting screw is utilized in synchronizing upper and lower lock operation. This adjusting screw is RIGHT HAND thread. Synchronization with left hand lock must also be checked as covered on page 9-28.

6. Open gate and reinstall all previously removed components.

**NOTE:** Service shims are available for tail gate striker assemblies. These shims are the same parts used in body side doors. If installing new lock, rubber dust seal must be transferred from removed lock.

Fig. 9-26—Dual Tail Gate Lock and Remote Control Linkage

- |  |  |  |
|--|--|--|
| 1. Left Lock Assembly                    | 6. Remote Control Assembly                         | 11. Tail Gate Window "Lock-out" Rod          |
| 2. Remote to Left Lock Connecting Rod    | 7. Remote (Door Operation) Inside Handle           | 12. Lock-Out Rod Adjusting Bolt              |
| 3. Remote (Gate Operation) Inside Handle | 8. Door Inside Handle to Right Lock Connecting Rod | 13. Right Lower Lock                         |
| 4. Remote to Inside Handle Push Rod      | 9. Right Upper Lock Assembly                       | 14. Right Upper to Lower Lock Connecting Rod |
| 5. Remote to Right Lock Connecting Rod   | 10. Right Locks Synchronizing Adjusting Screw      |  |



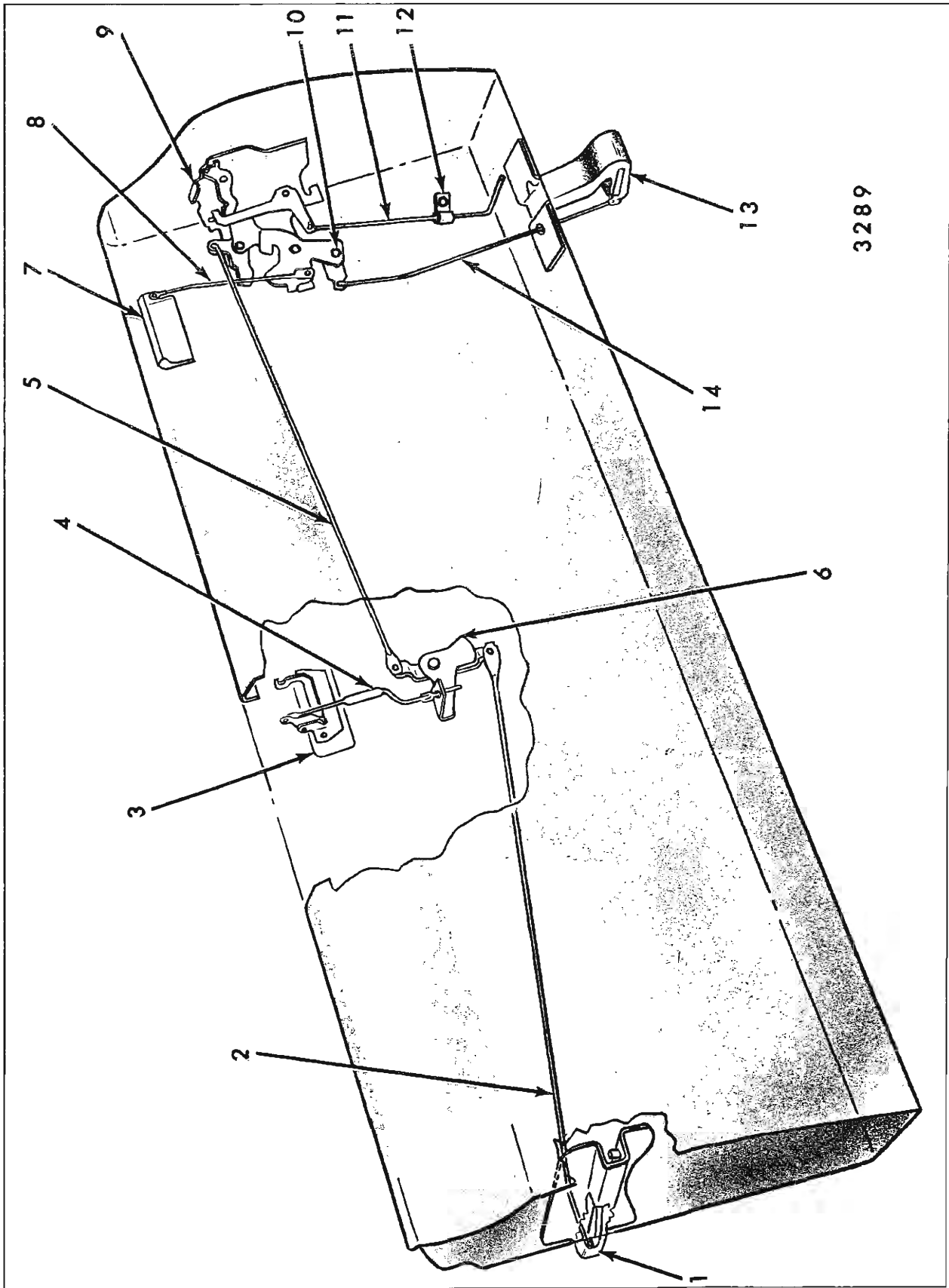

3289

Fig. 9-26—Dual Tail Gate Lock and Remote Control Linkage

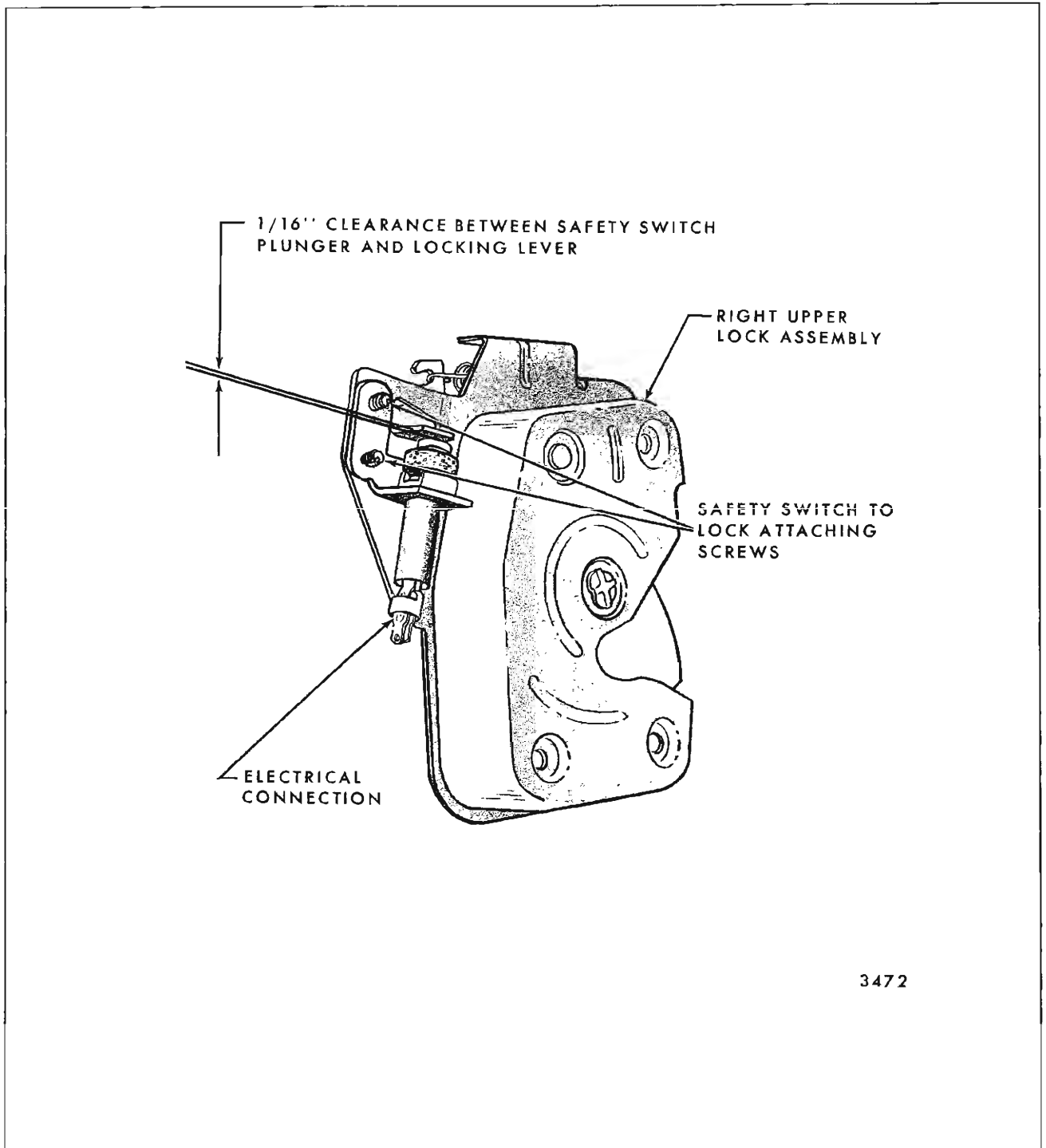

Fig. 9-27—Dual Tail Gate Electrical Safety Switch

### TAIL GATE LEFT LOCK ASSEMBLY

#### Removal and Installation

1. Remove tail gate window. Scribe (mark) position of lock on tail gate.

2. On "B" body styles, bolts A, B, C & D (Fig. 9-28) are all retained by nuts accessible through tail gate inner panel. On "A" body styles, bolts A & B fit into a tapping plate and bolts C & D are retained by nuts. In either

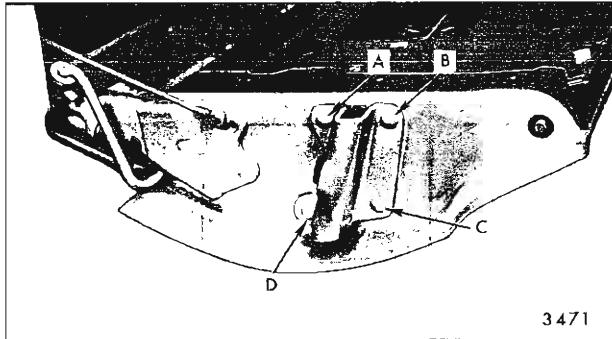

Fig. 9-28—Tail Gate Left Lock Assembly - "B" Body Shown - "A" Body Typical

case and on both style series, all bolts are pressed into the lock assembly and removed as a unit - not separately.

3. Disengage clip securing remote control assembly rod and remove lock assembly (Fig. 9-26).
4. To install, align lock assembly within scribe marks and reverse removal procedure. All nuts must be torqued to a minimum of forty (40) foot pounds. Close tail gate and synchronize all locks.

**NOTE:** This lock is equipped with a dust cover (available as a service part (Part No. 8717579)).

## TAIL GATE UPPER HINGE AND STRIKER ASSEMBLY

### Removal and Installation

1. Open tail gate to gate position.
2. With gate properly supported, remove hinge and striker attaching screws and remove assembly from left body hinge pillar.

**NOTE:** The support cable spring, shown in Figure 9-29, must be reinstalled in depicted position to insure proper movement of cable during gate operation.

3. To install, reverse removal procedure.

**NOTE:** Shims of 1/4" and 5/16" are available as service parts.

## TAIL GATE RIGHT LOWER LOCK ASSEMBLY

### Removal and Installation

1. Open tail gate to door position.

2. Remove lower lock cover and disengage upper to lower lock connecting rod at lower lock (Fig. 9-26).

**CAUTION:** Step No. 2 can be performed only when gate is open in door position.

3. Scribe (mark) lower lock position on tail gate. From underside of tail gate, remove lower lock attaching nuts and screws and remove assembly from tail gate (Fig. 9-30).
4. To install, reverse removal procedure. When installing new lock, transfer dust seal from removed lock.

**IMPORTANT:** Reinstall lock in the closed (locked) position. DO NOT pull lower lock connecting link up to connecting rod (14 in Fig. 9-26). Following installation, open lock using door handle, close tail gate and synchronize all locks.

**NOTE:** The bumperette covering outside surface of lower lock assembly is also adjustable.

## TAIL GATE RIGHT LOWER STRIKER AND SUPPORT ASSEMBLY

### Removal and Installation

1. Open tail gate and remove striker cover plate (top).
2. Scribe (mark) position of striker support on body and remove support (Fig. 9-31).
3. To install, reverse removal procedure.

### Adjustments

The striker support is adjustable up or down and side to side. The lower striker is adjustable fore or aft and side to side with usage of service shims (Fig. 9-31).

## TAIL GATE BOTTOM DRAIN HOLE SEALING STRIPS

### Removal and Installation

1. With a flat-bladed tool carefully pry out snap-on fastener at each end of strip and remove sealing strip from tail gate.
2. To install sealing strips, reverse removal procedure. To prevent strip from adhering

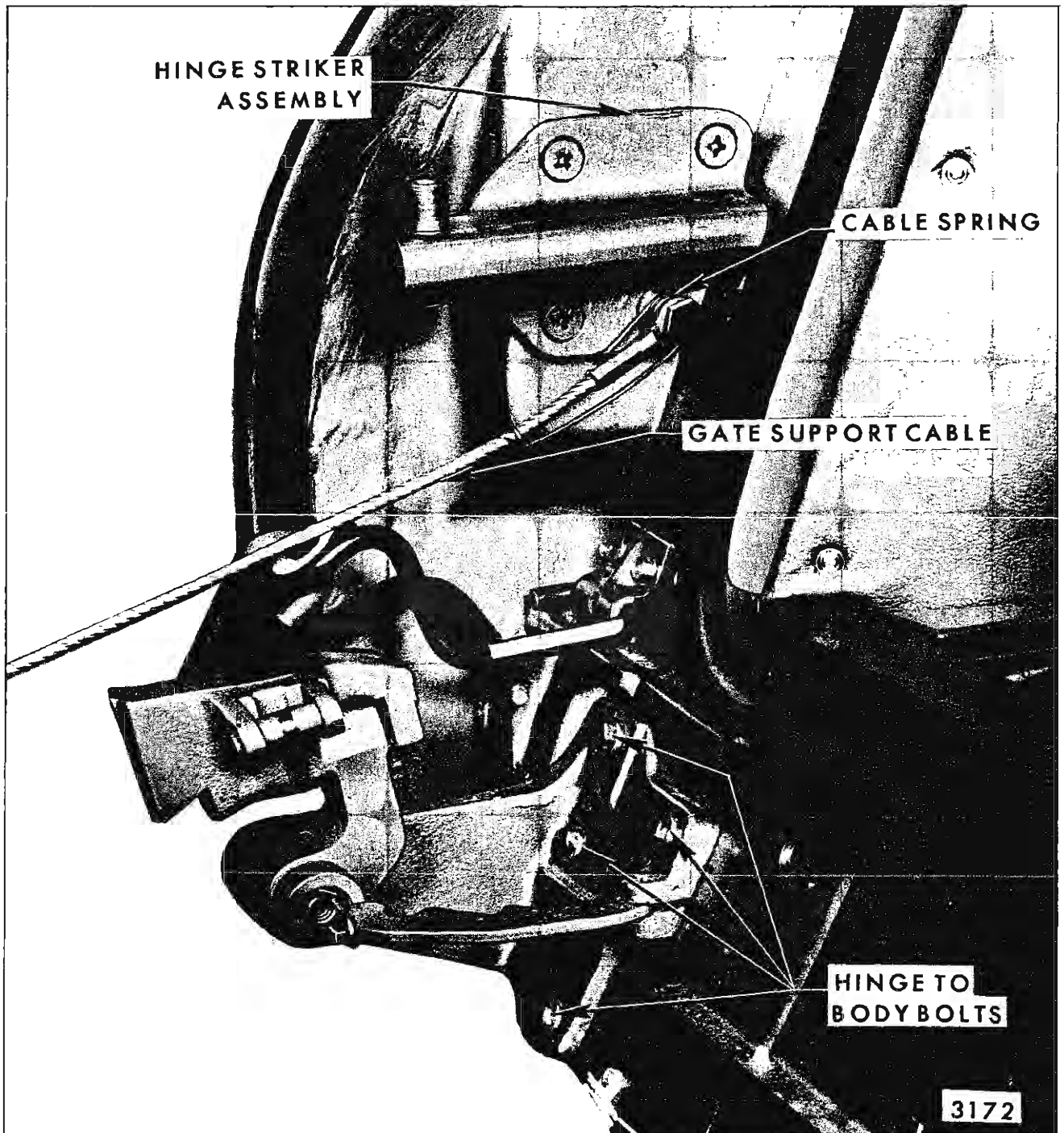

Fig. 9-29—Tail Gate Adjustments - "B" Body Shown - "A" Body Typical

to the tail gate panel and blocking the drain holes, apply a sparing amount of silicone rubber lubricant on the center section of the sealing strip (See Illustration under "Front and Rear Door Bottom Drain Hole Sealing Strips").

### **TAIL GATE OPENING WEATHERSTRIP**

#### **Removal and Installation**

1. Open tail gate and remove fasteners and/or screws securing weatherstrip to right and left body pillars (at belt) (Fig. 9-32).

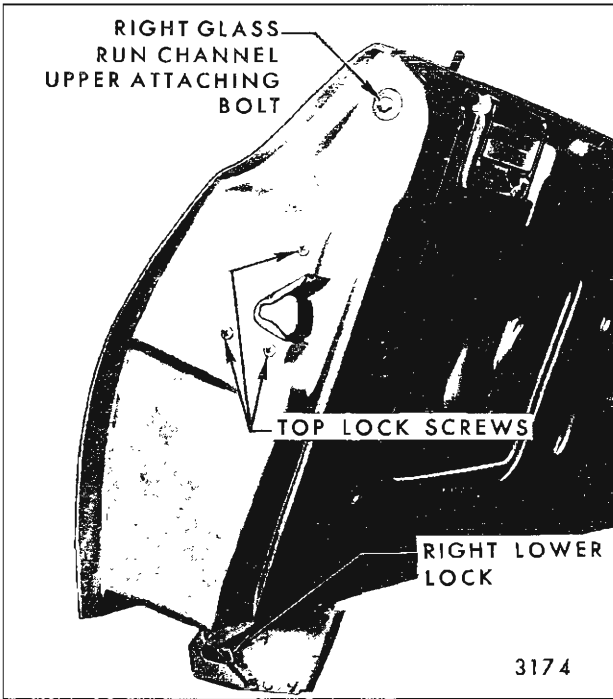

Fig. 9-30—Dual Tail Gate Lock Attachments - Right Side

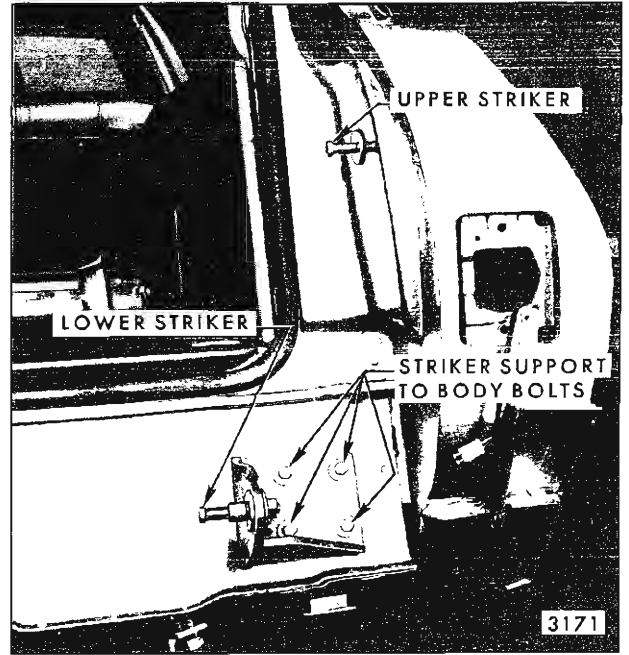

Fig. 9-31—Tail Gate Adjustments - "B" Body Shown  
"A" Body Typical

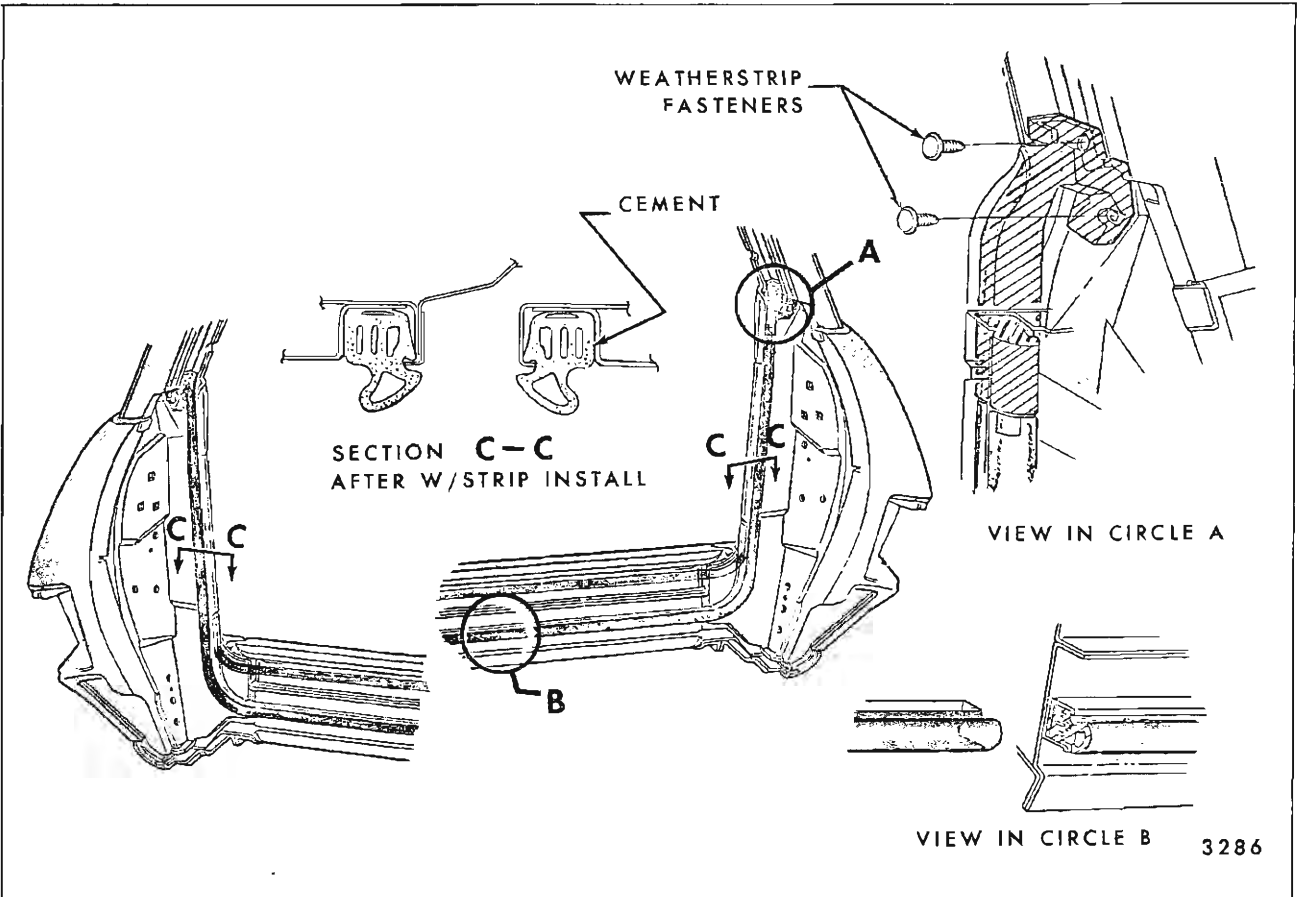

Fig. 9-32—Tail Gate Weatherstrip Installation

2. With a flat-bladed tool, carefully remove weatherstrip along entire tail gate opening.
3. To install original part, apply a bead of black weatherstrip cement into retainer along entire opening and reverse removal procedure. Replacement parts are serviced in two separate pieces, right and left. When installing a new weatherstrip, begin at belt line (on both side) and work to bottom center. Cut off excess weatherstrip and form a butt joint.

### TAIL GATE WINDOW UPPER GLASS RUN CHANNEL

#### Removal and Installation

1. Open tail gate and disengage clip at bottom of run channel on side to be removed. With finger pressure only, squeeze run channel at one end and pull channel out of retainer.
2. Once run channel has been removed, the retainer attaching screws are exposed. (See Fig. 9-33). The retainer can be adjusted by loosening attaching screws, shifting retainer to desired position and tightening screws. If

retainer is removed, seal retainer with medium bodied sealer prior to installation.

3. To install, reverse removal procedure.

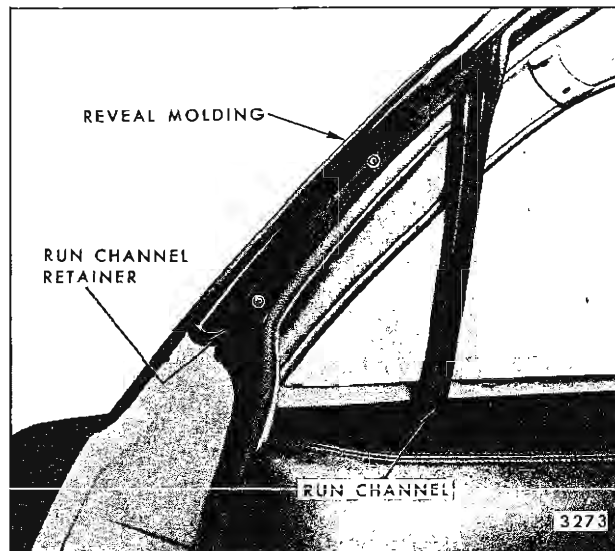

Fig. 9-33—Tail Gate Upper Glass Run Channel Retention

### DUAL ACTING TAIL GATE SERVICING PROCEDURES CHART

CONDITION	CAUSE	SOLUTION
1. Gate does not open as a gate.	<ol style="list-style-type: none"> <li>1. Glass blockout lever of upper right hand lock not actuated. <b>NOTE:</b> This condition prevents tail gate from operating either way</li> <li>2. Lower right hand lock not locked.</li> <li>3. Set screw of the remote control loose (located at center of tail gate).</li> </ol>	<ol style="list-style-type: none"> <li>(A) Check to see if the glass blockout rod is installed and attached to the lever of the upper right hand lock.</li> <li>(B) Check if the glass is in the full down position.</li> <li>(A) Check if the lower right hand lock is locked by visually inspecting the fork bolt of the lower lock. If the fork is visible and approximately flush with the rear of the lock housing, the lock is locked. If the fork bolt is considerably forward or not visible, the lock is unlocked.</li> <li>(B) Open the door and slam it to lock.</li> <li>(C) If the lock still is unlocked, the lower striker should be adjusted aft.</li> </ol> <p><b>NOTE:</b> This condition can be determined by trying to unlock the upper locks. Only the upper left hand hinge lock will unlock.</p>

## DUAL ACTING TAIL GATE SERVICING PROCEDURES CHART (CONT'D)

CONDITION	CAUSE	SOLUTION
<p>1. Gate does not open as a gate (cont'd.).</p>	<p>3. Set screw of the remote control loose (located at center of tail gate) (cont'd.).</p> <p>4. Horizontal lock rods and/or vertical rod from center handle to remote control not installed and/or attached.</p>	<p>(A) Removal of the tail gate inner panel cover, water deflector and right hand access hole cover, will be necessary.</p> <p>(B) After removing these parts, reach through the access hole and carefully, so as not to bend, pull the upper right horizontal lock rod towards the centerline of the body to unlock the upper right hand lock.</p> <p>(C) Open the tail gate and slam to lock all the locks.</p> <p>(D) Open as a door.</p> <p>(E) 1. Align two small holes in the remote control (located at the center of the gate). Place a cotter pin or other suitable tool through them.</p> <p>2. Check the upper left hand hinge lock by visually inspecting forward open end of the lock to see if the lock lever is in the full outboard position, indicating the lock is locked. If the lever is next to the inner panel extension (inboard) pull or push the upper left hand corner of the tail gate forward to lock the lock.</p> <p>3. Tighten the set screw (left hand thread).</p> <p>4. Remove the cotter pin.</p> <p>5. Close the door and open as a tail gate.</p> <p>(F) Make lock synchronization check.</p> <p>(A) This condition is characterized by the failure of the upper right hand lock and/or left hand lock to unlock. Check for unattached or missing rods. If either of the upper horizontal lock rods is unattached or missing, attach or replace and then follow the upper lock synchronization procedure outlined in 1-3 (C) thru (F).</p>



## DUAL ACTING TAIL GATE SERVICING PROCEDURES CHART (CONT'D)

CONDITION	CAUSE	SOLUTION
2. Gate does not open as a door.	<ol style="list-style-type: none"> <li>1. Glass blockout lever of upper right hand lock not activated, <b>NOTE:</b> This condition prevents tail gate from operating either way.</li> <li>2. Upper right hand striker too far rearward.</li> <li>3. Upper left hand hinge lock not locked.</li> <li>4. Cable from door handle to upper right hand lock detached.</li> <li>5. Rod from upper right hand lock to lower right hand lock detached.</li> </ol>	<p>(A) Follow procedure outlined in 1-1 (A) and (B).</p> <p>(A) This condition can prevent the upper left hand hinge lock from locking. Readjustment of the right hand upper striker forward is necessary to allow both upper locks to lock.</p> <p>(A) Check for unlocked upper left hand lock by pulling on corner of gate (gate will chuck if unlocked).</p> <p>(B) Open gate and slam hard to lock.</p> <p>(C) If the lock is still unlocked, the gate side upper left hinge lock will have to be adjusted forward.</p> <p>(A) Check for loose cable by opening the gate and pulling on door handle. If the handle opens easily to approximately 90° to the inner panel surface and by pulling on the cable it readily pulls out, the cable is loose and must be attached to the stud of the upper right hand lock.</p> <p>(A) Determine if rod is detached by visual inspection. If unattached:</p> <ol style="list-style-type: none"> <li>1. Open tail gate as a gate.</li> <li>2. Attach rod by moving the lever of the upper lock to the position of the rod.</li> </ol> <p><b>NOTE:</b> DO NOT PULL UP ON THE LOCK ROD AS THIS WILL UNLOCK THE LOWER LOCK.</p> <ol style="list-style-type: none"> <li>3. Be sure the lower lock is fully locked by pulling it against the striker.</li> <li>4. Tighten the set screw in the upper lock (right hand thread).</li> <li>5. Make lock synchronization check.</li> </ol>

## DUAL ACTING TAIL GATE SERVICING PROCEDURES CHART (CONT'D)

CONDITION	CAUSE	SOLUTION
3. With door open and center handle is pulled, gate unlocks (upper left hand hinge lock).	<ol style="list-style-type: none"> <li>1. Right hand lock set screw loose.</li> <li>2. Improper synchronization of upper locks.</li> <li>3. Bent upper horizontal lock rods (caused by using rods to unlock gate).</li> </ol>	<p>(A) Check by opening as a door.</p> <ol style="list-style-type: none"> <li>1. Actuate lower lock by pushing upon its lever to see if the lever of the upper lock moves without the set screw moving.</li> <li>2. If loose, follow procedure outlined above in 2-5 (A).</li> </ol> <p>(A) Synchronize locks by following procedure outlined in 1-3 (D) and (E).</p> <p>(A) Replace rod and re-synchronize locks by following procedure outlined in 1-3 (D) and (E).</p>
4. With gate open and door handle is pulled, lower right handle lock unlocks.	<ol style="list-style-type: none"> <li>1. Improper synchronization of upper locks (loose screw set).</li> <li>2. Bent vertical lock rod (caused by using rod to unlock door).</li> <li>3. Improper synchronization of right hand locks (caused by pulling on lock rod).</li> </ol>	<p>(A) Synchronize locks by following procedure outlined in 1-3 (D) and (E).</p> <p>(A) Replace rod and re-synchronize locks by following procedure outlined in 2-5 (A).</p> <p>(A) Open tail gate as a gate.</p> <ol style="list-style-type: none"> <li>1. Support gate while loosening the set screw in the upper lock.</li> <li>2. Synchronize locks by following procedure outlined in 2-5 (A).</li> </ol>
5. Tail gate window will not raise.	<ol style="list-style-type: none"> <li>1. Tail gate window safety switch inoperative.</li> <li>2. Window regulator motor inoperative.</li> </ol>	<ol style="list-style-type: none"> <li>1. Open tail gate as a gate. Remove inner cover panel and water deflector.</li> <li>2. Insert bare end of a tape insulated welding rod through belt glass opening into <u>blue wire</u> connector on regulator motor.</li> <li>3. Ground negative pole of 12V battery to tail gate.</li> <li>4. Raise glass by connecting other end of welding rod to positive pole of battery.</li> <li>5. Replace safety switch as specified on page 9-12.</li> </ol> <p>1. Refer to "Tail Gate Window Electric Regulator Motor Assembly - Removal" on page 9-9.</p>

## LOCK SYNCHRONIZATION CHECK

1. Visually check the lower right hand lock to determine if it is locked by the following conditions.
  - A. Locked - fork bolt is rear and up approximately flush with the rear of the lock housing.
  - B. Partly locked fork bolt is considerably forward of the locked position and is approximately vertical.
  - C. Unlocked fork bolt is in its full forward position and may not be visible from rear of body.
2. Visually check the upper left hand hinge lock by opening the gate as a door and checking to see if the hinge lock is locked by the following conditions.
  - A. Locked - the forward most part of the detent lever will be in an outboard position against the lock frame (away from the tail gate inner panel side extension).
  - B. Partly locked (due to improper synchronization) - the lever will be approximately centered between the outboard side of the lock frame and the tail gate inner panel side extension.
  - C. Unlocked - the lever will be against the tail gate inner panel side extension.
3. Functionally check the locking system by -
  - A. Open the gate as a door, support it in case of a malfunction, try to activate the upper left hand hinge lock by pulling the center handle. If the hinge unlocks, check under "door open and center handle is pulled, gate unlocks." If it remains locked, proceed with step B.
  - B. Close the door and reopen as a gate, support it in case of a malfunction, try to activate the lower right hand lock by pulling the right hand door handle. If the lower lock unlocks, check under "gate open and door handle is pulled, lower right hand lock unlocks." If it remains locked, the synchronization check is complete.

## SINGLE ACTING TAIL GATES

All single acting tail gates incorporate either a manually or electrically operated window that can be lowered into the gate or raised into the back body opening. The manual window is operated by a regulator control handle located in the tail gate outer panel. The power window can be operated by any one of three control switches; one on the instrument panel, one at lock cylinder on tail gate outer panel (key operated) and one on the wheelhouse cover panel (optional-down only). All styles using a power tail gate window are equipped with an electrical switch that prevents movement of the window with gate in any position other than fully closed.

The tail gate is unlocked by means of a remote control handle that should not be actuated with glass in any position other than fully lowered into tail gate. All gates are counter-balanced by a torque rod that assists in reducing the effort required to open or close the tail gate.

The pick-up delivery style tail gate employs locks, striker, hinges and support cables similar to "A" body station wagon styles.

### TAIL GATE INNER PANEL COVER

All single acting tail gates use a "hang-on" inner

panel cover which attaches over the top of inner panel and is secured at sides and bottom by a series of screws. On pick-up delivery styles, the inner panel cover is attached at the recessed portion of the tail gate inner panel and is also secured by a series of screws.

On all single acting gates, the inner panel cover can be readily removed with gate in the open position. In cases where the gate cannot be opened, as would occur if a power operated window motor failed with tail gate window in the up (closed) position, the cover attaching screws are still accessible on all station wagons except those styles equipped with a rear floor-to-tail gate filler panel. On styles so equipped, the following procedure should be performed:

Fabricate a special "pry tool", as depicted in Fig. 9-34.

### Service Procedure

1. Working from inside car, remove spare tire cover panel, tail gate lock handle and rubber grommet. Remove all exposed tail gate inner cover panel attaching screws; all screws should be removed except the lower row of screws which are inaccessible behind the rear floor-to-tail gate filler panel.

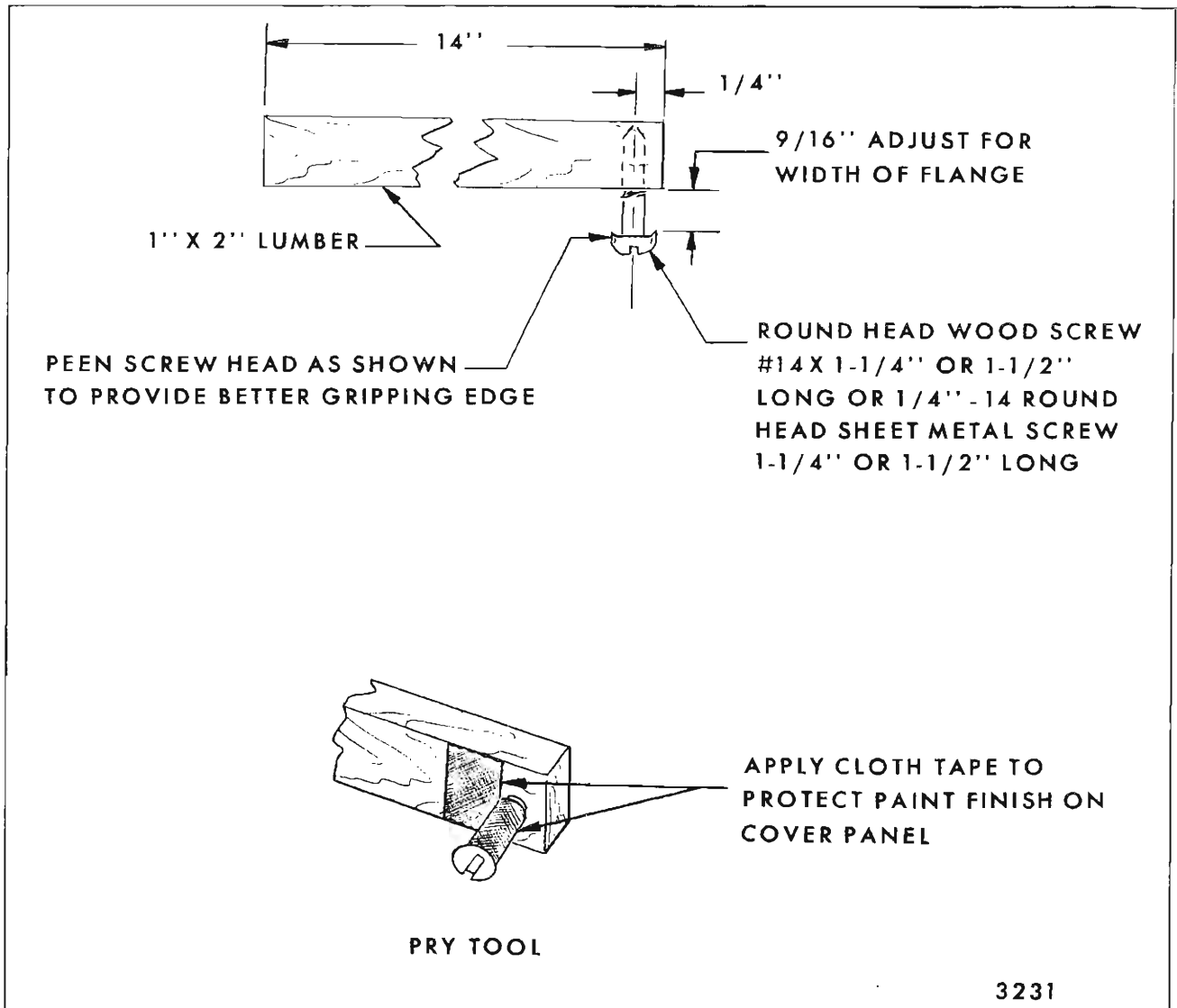

Fig. 9-34—Pry Tool Fabrication

**IMPORTANT:** On bodies equipped with carpeting and tail gate skid strips, carefully pivot skid strips downward towards right (passenger) side of car, as indicated by dotted lines in Figure 9-35. Do not overlap skid strips.

2. On left side of body remove the rear quarter window lower, front and rear garnish moldings. Remove the rear quarter front upper trim panel attaching screws and loosen the rear quarter lower front trim foundation.

**NOTE:** Prior to performing steps 3 through 9 make sure that tools are readily available in the body, as it will be difficult to exit from body. Tools required are: pry tool (See Fig. 9-34), #2 cross-recess screw driver, #2 cross

recess miniature ratchet or off-set screw driver, #2 cross recess "shorty" screw driver, sharp knife, ball-peen hammer and 1/4" drive ratchet with 7/16" socket.

3. On left side of body remove all screws securing the rear quarter wheelhouse trim panel assembly (use a #2 cross-recess miniature ratchet or an off-set screw driver on the two rear-most screws). Rotate rear of wheelhouse trim panel assembly inward sufficiently to allow upper left portion of tail gate inner cover panel to be moved forward.
4. Using "pry tool", as shown in Figure 9-35, start at right side (passenger's side) of tail gate inner cover panel and carefully pry upper

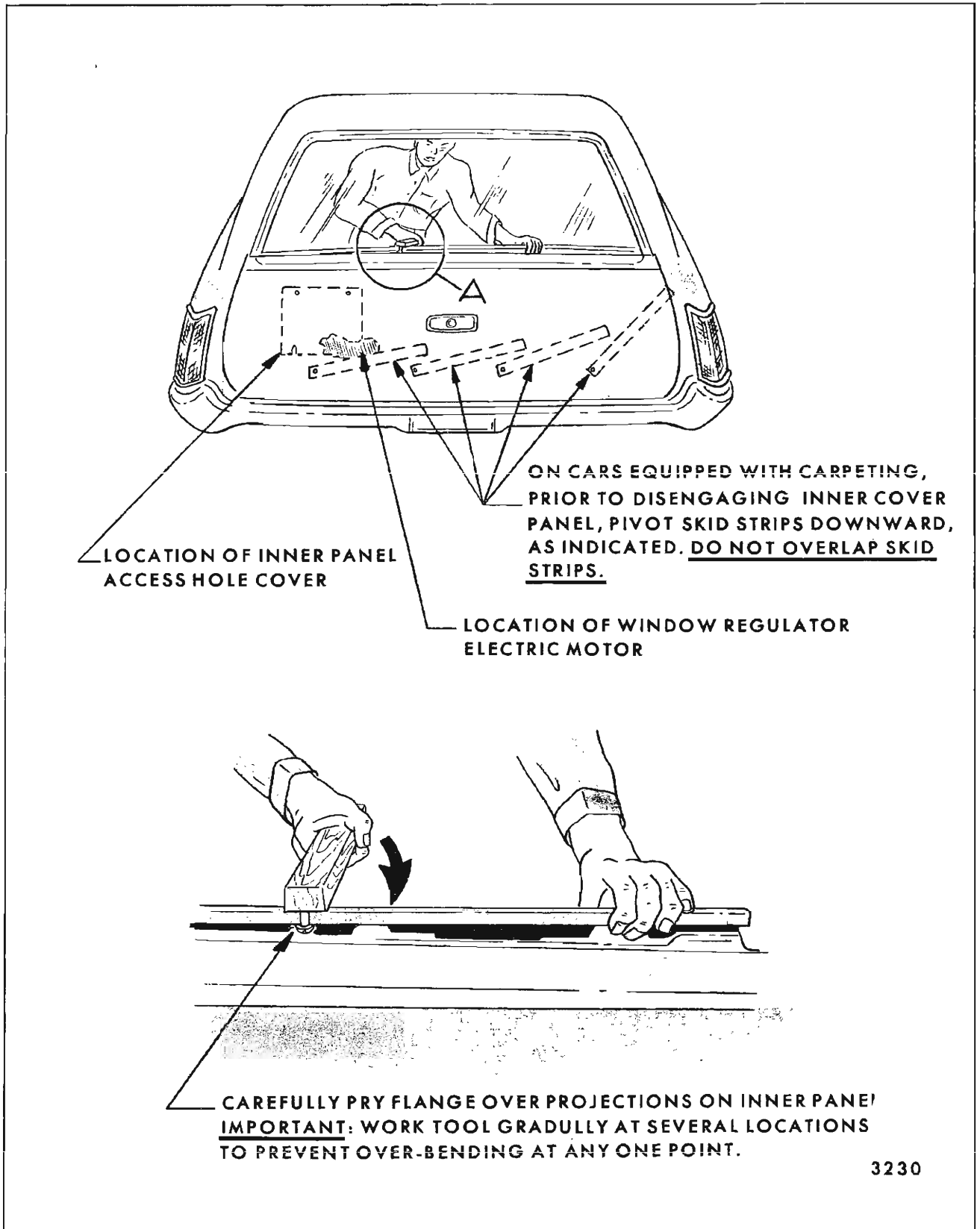

Fig. 9-35—Inner Panel Cover Removal

flange of inner cover panel up and forward of projections on tail gate inner panel.

**IMPORTANT:** To prevent excessive bending of inner cover panel flange at any one point, work tool gradually at several locations where panel is being pried over inner panel projections.

5. After the upper flange of the inner cover panel is completely disengaged from the tail gate inner panel, carefully pull upper left (driver's side) portion of cover panel forward sufficiently to cut the inner panel water deflector across the top and down the sides of the inner panel left access hole cover.
6. Remove the tail gate inner panel access hole cover upper attaching screws; then pull access hole cover upward to disengage slotted holes in cover from under lower attaching screws. It may be necessary to tap sides of cover to loosen.
7. Working through access hole, remove three screws securing window regulator motor to regulator assembly, then, disengage motor from regulator.
8. With tail gate window regulator motor disengaged from window regulator assembly, the tail gate window can be manually lowered and the tail gate opened. If window is in the full "up" position, it may be necessary to have a helper on outside of tail gate to assist in starting the window down.
9. With the tail gate open, remove the remaining inner cover panel attaching screws and remove the cover panel from the tail gate.
10. The tail gate window regulator motor may now be removed from the tail gate and a new motor installed on the window regulator.

**NOTE:** Prior to tightening regulator motor attaching screws, check that motor gear teeth are meshing properly with regulator sector gear teeth by holding jamb switch at left lock and energizing motor momentarily by turning key in tail gate switch on and off. Then tighten motor attaching screws.

11. Prior to installing tail gate inner cover panel, seal cuts in water deflector with waterproof body tape. Place inner cover panel on a protected surface with return flange "up" and straighten return flange with a body spoon (protected with tape) or other suitable tool.

## TAIL GATE INNER PANEL WATER DEFLECTOR

A waterproof paper deflector is sealed against the tail gate inner panel to deflector water toward the bottom of the gate and out the drain holes.

**IMPORTANT:** When work is performed on the tail gate that requires any detachment of the water deflector, it must be properly resealed to the inner panel.

### Removal

1. Remove tail gate inner panel cover.
2. Using a flat-bladed tool, carefully break cement bond securing water deflector to inner panel. Make sure string, located within sealer, is against water deflector and carefully slide tool between sealer and inner panel along both sides and top to disengage deflector from inner panel. If the entire deflector need not be removed, detach only that portion necessary.

### Installation

1. Inspect deflector and repair any damage noted with body waterproof tape applied to both sides.
2. If a new deflector is to be installed, use old deflector as a template.
3. If needed, apply a bead of body caulking compound (approximately 3/16" diameter) to tail gate inner panel (See Fig. 9-36). The inner panel cover attaching screw holes should also be sealed with body caulking compound.
4. Position water deflector to tail gate with polyethylene coated side (black) against inner panel. Firmly press sealed areas to obtain a good bond between deflector and inner panel.

## TAIL GATE INNER PANEL ACCESS HOLE COVERS

### Removal and Installation

1. Remove tail gate inner panel cover and water deflector.
2. Remove screws securing right and left access hole covers to tail gate inner panel and remove covers (See Fig. 9-37).
3. To install, reverse removal procedure.

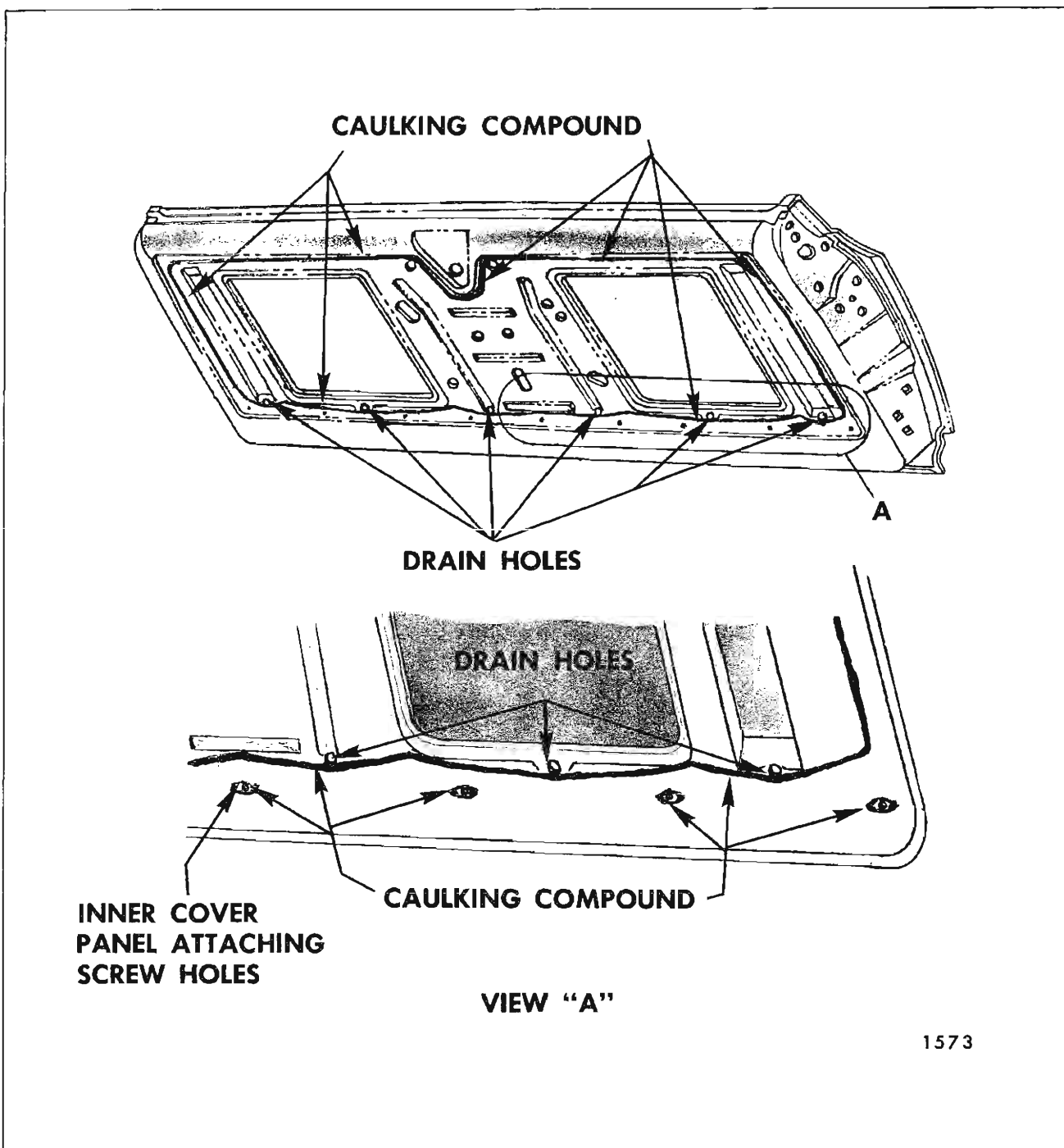

Fig. 9-36—Tail Gate Sealing

## TAIL GATE HINGE ASSEMBLY

### Removal and Installation

1. Open tail gate to vertical position and remove torque rod retainer attaching screws at the lock pillar. Provide support on side from which hinge is to be removed.
2. Remove tail gate hinge attaching bolts from both gate and body (Figs. 9-38 and 9-39).
3. To install, reverse removal procedure. Prior to installation, apply a coat of heavy-bodied sealer to surface of hinge that contacts body.
4. Check alignment of tail gate in opening and adjust as required.

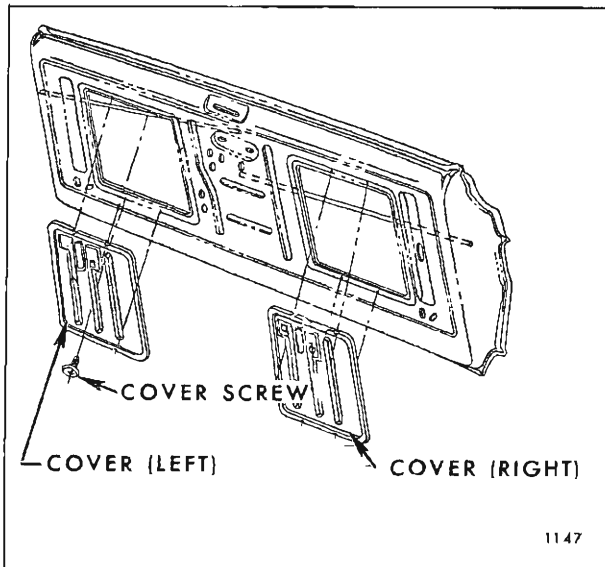

Fig. 9-37—Tail Gate Inner Panel Access Hole Cover

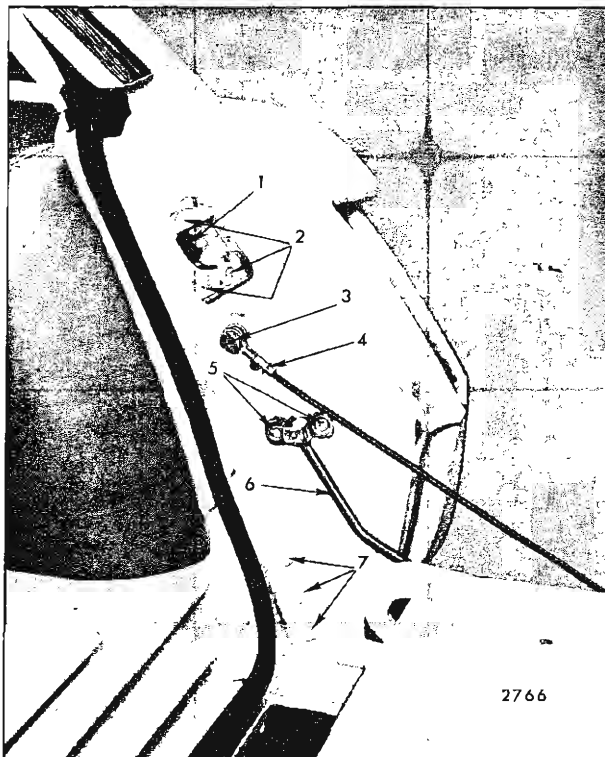

Fig. 9-38—Tail Gate Torque Rod, Hinge and Support Attachments

- |                                     |  |
|-------------------------------------|--|
| 1. Lock Striker Bumper              | 5. Torque Rod Retainer Attaching Screws    |
| 2. Lock Striker Attaching Screws    | 6. Tail Gate Torque Rod                    |
| 3. Tail Gate Support Attaching Bolt | 7. Tail Gate Hinge to Body Attaching Bolts |
| 4. Support Return Spring Clip       |  |

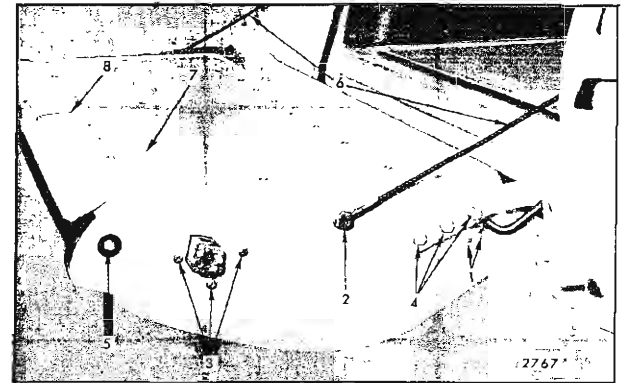

Fig. 9-39—Tail Gate Hardware - Right Side

- |   |                                    |
|---|------------------------------------|
| 1. Torque Rod Bearing Plate Screws      | 5. Glass Run Channel Upper Bolt    |
| 2. Support to Tail Gate Attaching Bolts | 6. Tail Gate Support Cables        |
| 3. Tail Gate Lock Screws                | 7. Tail Gate "Hang-On" Inner Panel |
| 4. Hinge to Tail Gate Attaching Bolts   | 8. Tail Gate Inside Handle         |

## TAIL GATE SUPPORT ASSEMBLIES

### Removal and Installation

1. Support tail gate in open position. This is important so that torque rod, which is under tension, does not disengage.
2. Remove bolts securing support to tail gate and body lock pillar. Disengage support return spring (at body lock pillar or tail gate end) and remove support (Figs. 9-38 and 9-39).
3. To install, reverse removal procedure.

## TAIL GATE ASSEMBLY

The basic hardware of all station wagon single acting tail gates is similar, regardless of style. Figure 9-40 illustrates all hardware components for gates equipped with both manually and electrically operated windows.

### Removal and Installation

1. Open tail gate to an approximate vertical position to relieve torque rod tension. Remove torque rod retainer attaching screws and remove retainer.

**NOTE:** Possible injury could occur if tension is not relieved from torque rod.



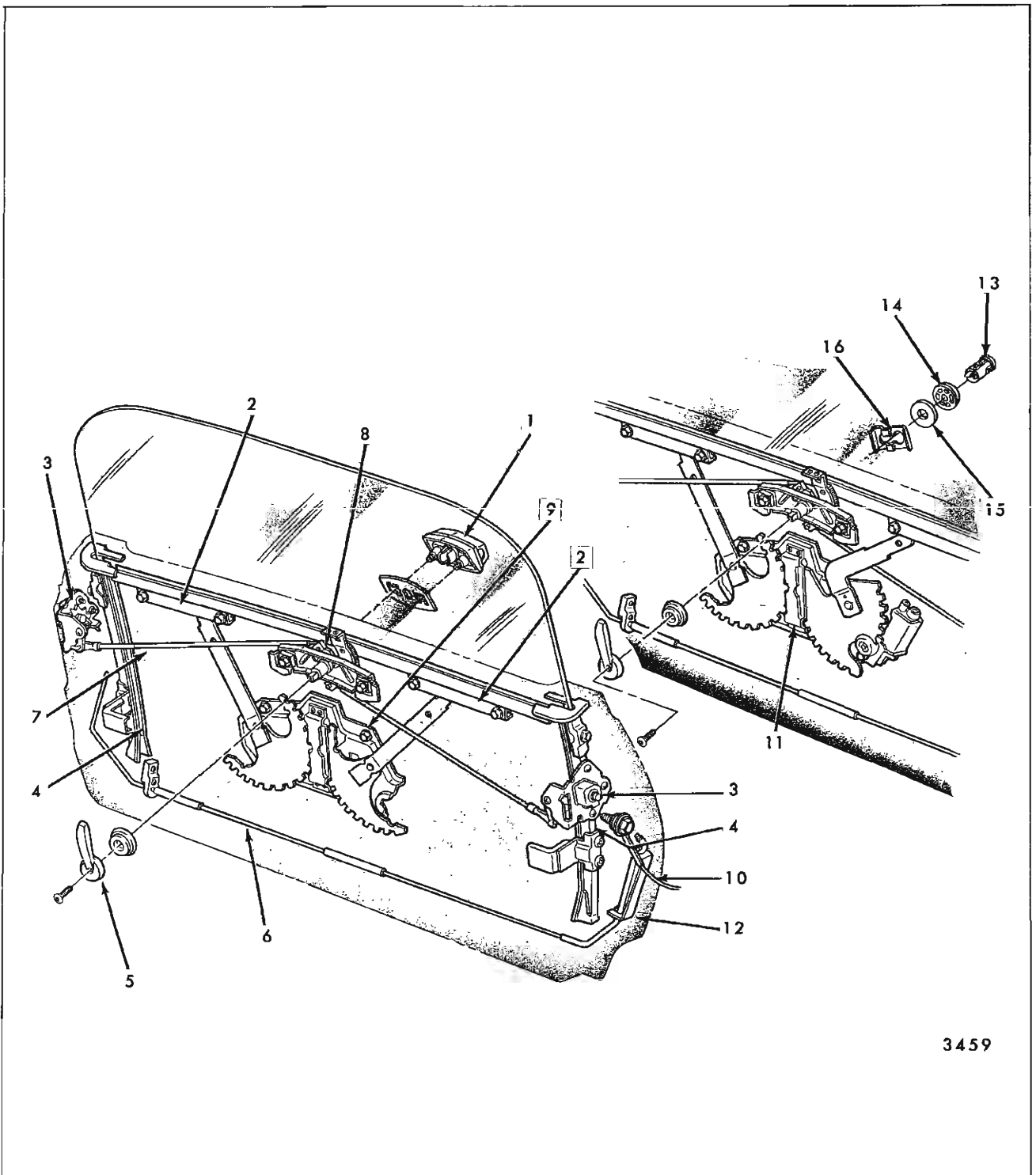

3459

Fig. 9-40—Tail Gate Hardware - Single Acting

- |                             |                                   |                                  |
|-----------------------------|-----------------------------------|----------------------------------|
| 1. Outside Handle           | 6. Torque Rod                     | 12. Torque Rod Retaining Bracket |
| 2. Sash Channel Cams        | 7. Remote Control Connecting Rods | 13. Key Switch                   |
| 3. Locks                    | 8. Remote Control                 | 14. Escutcheon                   |
| 4. Lower Glass Run Channels | 9. Regulator                      | 15. Gasket                       |
| 5. Inside Handle            | 10. Tail Gate Support Cable       | 16. Retainer                     |
|                             | 11. Electric Regulator Assembly   |                                  |

2. On styles equipped with power operated tail gate window, proceed as follows:
  - a. Remove inner panel cover and water deflector.
  - b. Remove tail gate window as described under "Tail Gate Window Assembly, Removal and Installation".
  - c. Disconnect wire harness at key switch, jamb switch and at motor. Remove harness from tail gate.
3. While properly supporting tail gate, remove right and left support cable attaching bolts. (See Figs. 9-38 and 9-39).
4. With the aid of a helper, remove right and left tail gate hinge to gate attaching bolts and remove tail gate from body.
5. To install, reverse removal procedure. Prior to installation, apply a coat of heavy bodied sealer to surface of hinges that contact tail gate.

### Adjustments

Up or down and fore or aft adjustment is provided at hinge to gate attaching bolts. Side to side adjustment is available at hinge to body opening attaching bolts by using shims.

**NOTE:** Following any adjustments of the tail gate, check engagement of locks to strikers as described in "Tail Gate Lock Striker Adjustment".

## TAIL GATE WINDOW ASSEMBLY— MANUAL OR ELECTRIC

### Removal and Installation

1. Remove tail gate inner panel cover, water deflector and both access hole covers.
2. Operate tail gate window to a point that sash channel cam attaching bolts are accessible as depicted in Fig. 9-41.

**NOTE:** On styles equipped with power operating tail gate windows, engage jamb switch (Fig. 9-42) and operate window to position desired. Engaging the tail gate jamb switch makes it possible to operate the window (by key switch) with the gate in the open position.

3. Remove right and left cam attaching bolts. Slide cams to disengage from regulator lift arm rollers and remove cams from tail gate.

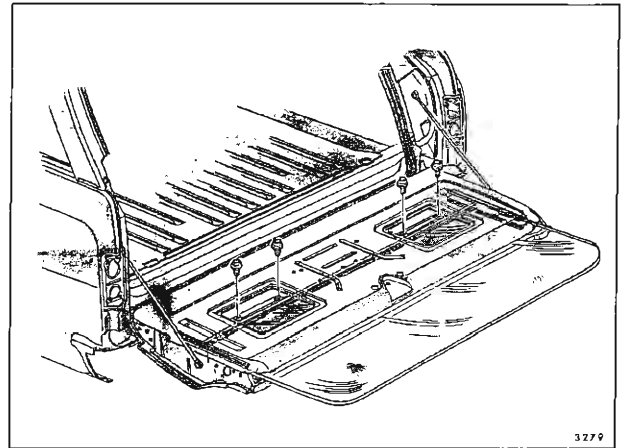

Fig. 9-41—Tail Gate Inner Cam Attachments

4. Pull window straight out to remove from tail gate.
5. To install, reverse removal procedure.

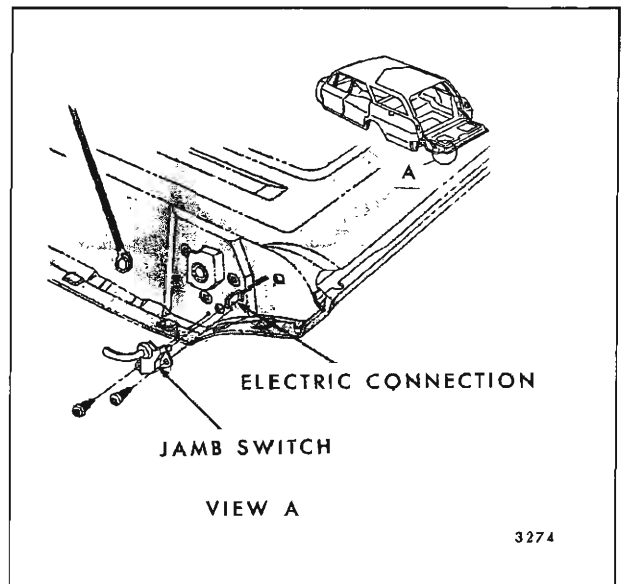

Fig. 9-42—Tail Gate Jamb Switch

### Adjustments

The tail gate glass run channels can be adjusted to relieve a binding glass. To correct a rotated glass condition, loosen window regulator attaching screws and rotate regulator clockwise or counter clockwise as required.

### TAIL GATE WINDOW REGULATOR— Manual and Electric

#### Removal and Installation

1. Remove tail gate window assembly.
2. On styles equipped with a power operated tail gate window assembly, disconnect electric harness at regulator motor connector.
3. Remove bolts securing regulator to support and remove regulator, with motor attached, from tail gate.
4. To install, reverse removal procedure.

### TAIL GATE WINDOW ELECTRIC REGULATOR MOTOR ASSEMBLY

#### Removal

1. Open tail gate and remove tail gate inner cover panel.
2. Detach inner panel water deflector and remove inner panel right access hole cover.

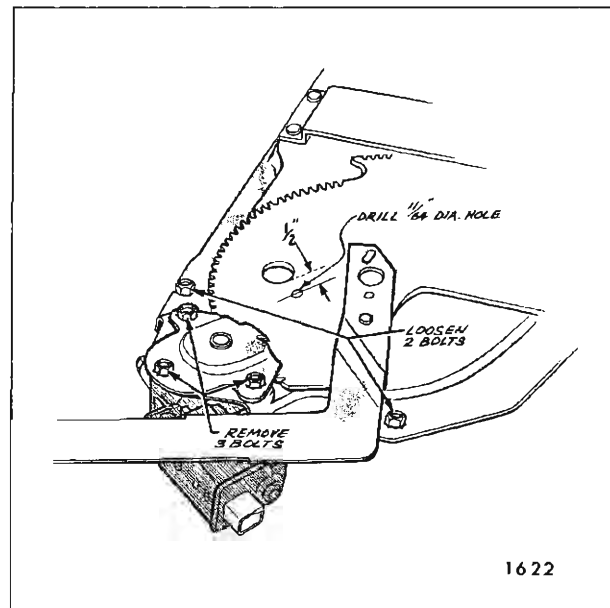

Fig. 9-43—Tail Gate Regulator Motor Assembly

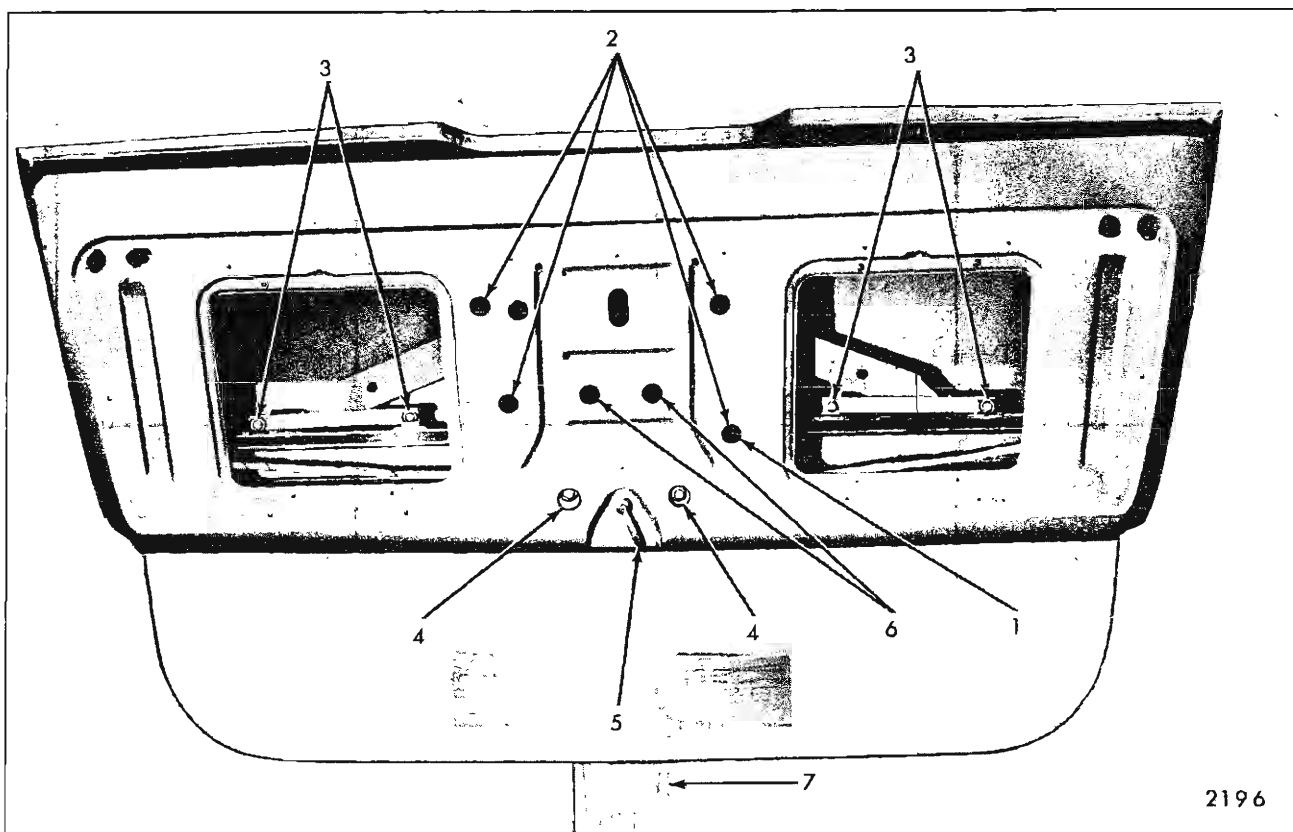

Fig. 9-44—Tail Gate Window Hardware

- |   |  |   |
|---|--|---|
| <ol style="list-style-type: none"> <li>1. Access Hole for Regulator Adjusting Screw</li> <li>2. Access Holes for Window Regulator Attaching Screws</li> </ol> | <ol style="list-style-type: none"> <li>3. Window Lower Sash Channel Cam Attaching Screws</li> <li>4. Lock Remote Control Attaching Screws</li> </ol> | <ol style="list-style-type: none"> <li>5. Lock Remote Control Handle Attaching Screw</li> <li>6. Access Holes for Outside Handle</li> <li>7. Glass Support</li> </ol> |
|---|--|---|

3. Disconnect wire harness connector from motor.

**IMPORTANT:** The following operation must be performed if the window is removed or disengaged from the regulator lift arms. The regulator lift arms, which are under tension from the counter-balance spring, can cause serious injury if the motor is removed without locking the sector gears in position.

4. Drill a 1/8" hole through regulator sector and back plate (See Fig. 9-43). DO NOT drill hole closer than 1/2" to edge of sector gear or back plate. Install a pan head sheet metal tapping screw (#10-12 x 5/8) in drilled hole to lock sector gears in position.
5. Loosen regulator right upper attaching screw. Remove the three regulator motor attaching screws and remove motor assembly from regulator and tail gate.

### Installation

1. Lubricate the motor drive gear and regulator sector teeth with Lubriplate or its equivalent.
2. With tail gate in an open position, install regulator motor to regulator. Make sure the motor pinion gear teeth mesh properly with the sector gear teeth before installing the three motor attaching screws.
3. Tighten regulator attaching screws and remove screw which locks sector gears into a fixed position.
4. Connect wire harness to motor and cycle tail gate window prior to installation of inner panel access hole cover, water deflector and cover panel.

## TAIL GATE WINDOW REGULATOR OUTSIDE HANDLE—Manual or Electric

### Removal

1. Lower tail gate and remove inner panel cover, water deflector and one access hole cover.
2. On manual styles, position tail gate window so that outside handle attaching nuts are accessible through gate inner panel and window regulator access holes (Fig. 9-44). Remove attaching nuts.
3. On electric styles, remove tail gate window regulator. Disengage key switch retainer and disconnect wire harness from connector on escutcheon (Fig. 9-45).
4. To install, reverse removal procedure.

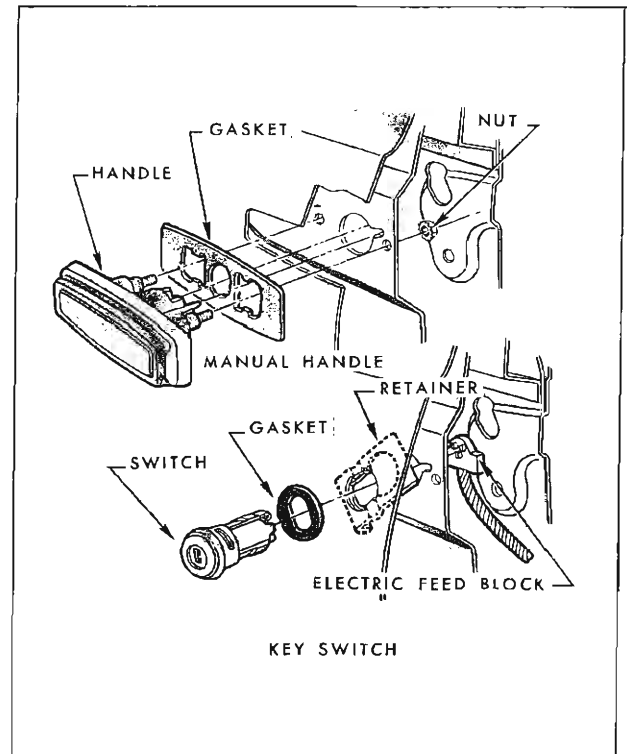

Fig. 9-45—Tail Gate Outside Handle Assemblies

## TAIL GATE WINDOW LOWER GLASS RUN CHANNELS

### Removal and Installation

1. Remove inner panel cover, water deflector and access hole cover on side from which run channel is to be removed.
2. Remove run channel upper and lower attaching bolts.
3. Pull run channel(s) down into tail gate and remove through inner panel access hole.
4. To install, reverse removal procedure.

**NOTE:** It may be necessary to apply silicone to the corner sealing strip portion of the run channel(s) to permit easier removal and installation.

## TAIL GATE JAMB SWITCH— Electric Option

The purpose of the electric jamb switch is to prevent operation of the tail gate glass while the gate is in the open position.

### Removal and Installation

1. Remove jamb switch to tail gate attaching

screws, disconnect feed wire and remove switch (See Fig. 9-46).

2. To install, reverse removal procedure.

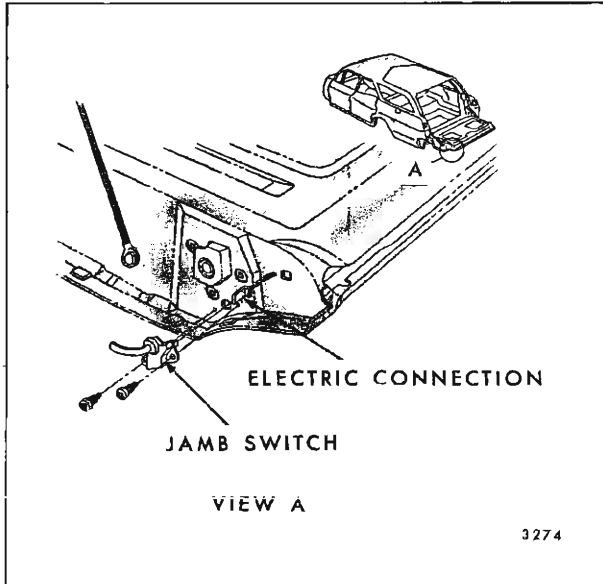

Fig. 9-46—Tail Gate Jamb Switch

### TAIL GATE LOCK REMOTE CONTROL ASSEMBLY

#### Removal and Installation

1. Remove inner panel cover, water deflector and access hole covers.
2. Disconnect remote control to lock connecting rods at remote assembly by sliding clips out of engagement.
3. Remove remote control attaching bolts and remove assembly from tail gate.
4. To install, reverse removal procedure.

**NOTE:** To synchronize operation of right and left locks, adjust remote control by utilizing oversize attaching screw holes.

### TAIL GATE LOCK ASSEMBLY— RIGHT OR LEFT SIDE

#### Removal and Installation

1. Remove inner panel cover, water deflector and access hole cover from side which lock is to be removed.
2. Raise glass assembly to full "up" position and remove tail gate window lower glass run

channel on side from which lock is to be removed.

3. Remove screws securing lock to tail gate (Fig. 9-47).
4. Disengage clip which secures remote rod to lock and remove lock through access hole.
5. To install, reverse removal procedure.

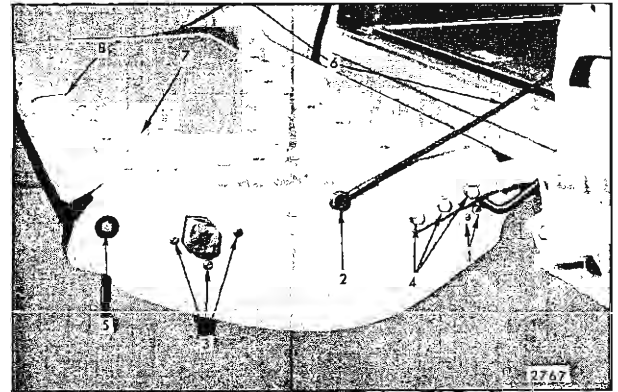

Fig. 9-47—Tail Gate Hardware - Right Side

- |  |                                    |
|--|------------------------------------|
| 1. Torque Rod Bearing Plate Screws     | 5. Glass Run Channel Upper Bolt    |
| 2. Support to Tail Gate Attaching Bolt | 6. Tail Gate Support Cables        |
| 3. Tail Gate Lock Screws               | 7. Tail Gate "Hang-On" Inner Panel |
| 4. Hinge to Tail Gate Attaching Bolts  | 8. Tail Gate Inside Handle         |

### TAIL GATE LOCK STRIKER— RIGHT OR LEFT SIDE

#### Removal and Installation

1. Open tail gate and mark (pencil) position of striker on body pillar.
2. Remove lock striker attaching screws and remove striker and adjusting plates from body pillar.
3. To install, align striker and components within pencil marks and install attaching screws (See Fig. 9-48).

### TAIL GATE LOCK STRIKER ADJUSTMENTS

1. To adjust the tail gate lock striker up or down or forward or rearward, loosen striker attaching screws, shift striker and adjusting plates to desired position and tighten attaching screws.

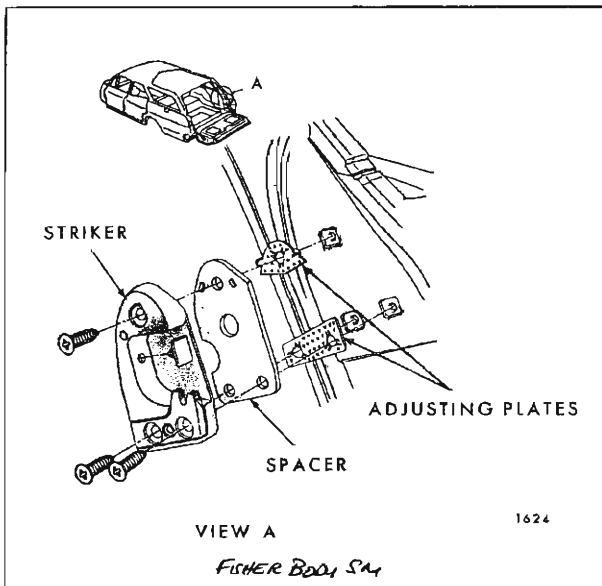

Fig. 9-48—Tail Gate Striker Assembly

**2. DIMENSIONAL SPECIFICATIONS FOR USE OF DOOR LOCK STRIKER SERVICE SPACERS.**

- a. Tail gate should be properly aligned before checking spacer requirements.
- b. To determine if tail gate lock striker service spacers are required, apply modeling clay or body caulking compound in the lock striker notch where the lock extension engages and close tail gate to form a measurable impression in the clay or caulking compound, as shown in Figure 9-49.

When dimension "A" from inside face of striker teeth to center of lock extension is less than 3/16" install service spacers and proper length striker attaching screws as follows:

Dimension "A"	Spacers Required	Thickness	Striker Attaching Screws *
3/16" to 1/8"	1	1/16"	Original Screw
1/8" to 1/16"	1	1/8"	Service Screw (1/8" Longer)
1/16" to 0	1 (1/8" Spacer) 1 (1/16" Spacer)	3/16" (Total)	Service Screw (1/4" Longer)
0 to 1/16"	2 (1/8" Spacer)	1/4" (Total)	Service Screw (1/4" Longer)

\*Zinc or cadmium-plated flat-head cross-recess screw with countersunk washer.

**NOTE:** Dimension "B" from center of lock extension to inside face of striker should never be less than 1/16".

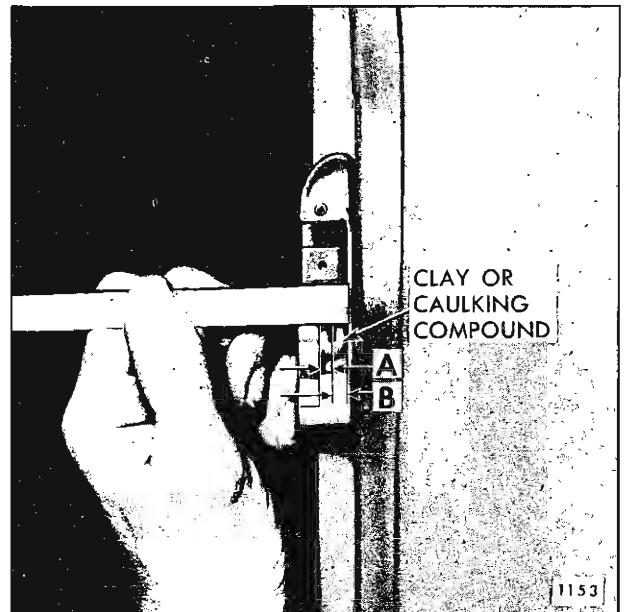

Fig. 9-49—Tail Gate Lock Striker Caulking Check

**TAIL GATE TORQUE ROD—  
Station Wagon Styles**

**Removal and Installation**

1. Remove tail gate window assembly. With tail gate in an approximate vertical position, remove torque rod retainer (Fig. 9-50).
2. Remove torque rod bearing plate (Fig. 9-47).
3. Disengage torque rod from tail gate inner panel retainer (See Fig. 9-51).
4. Remove torque rod silencer (rubber) from torque rod, and work torque rod out through glass loading hole.
5. To install, reverse removal procedure.

**TAIL GATE WINDOW INNER AND  
OUTER STRIP ASSEMBLIES**

**Removal and Installation**

Both strip assemblies are retained by clips in either the inner or outer panel of tail gate. The outer strip is additionally retained by two screws, one at each extreme end. To remove either strip, first remove screws and, using a flat tool, remove

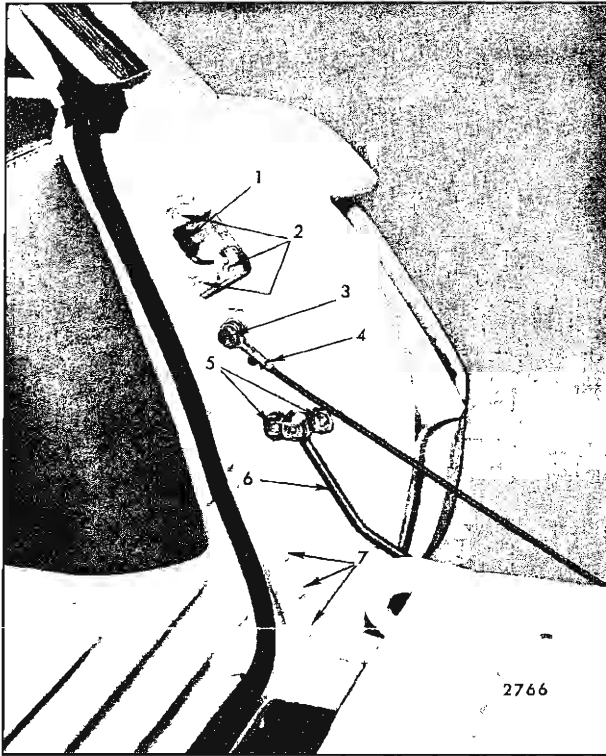

Fig. 9-50—Tail Gate Torque Rod, Hinge and Support Attachments

- |                                     |  |
|-------------------------------------|--|
| 1. Lock Striker Bumper              | 5. Torque Rod Retainer Attaching Screws    |
| 2. Lock Striker Attaching Screws    | 6. Tail Gate Torque Rod                    |
| 3. Tail Gate Support Attaching Bolt | 7. Tail Gate Hinge to Body Attaching Bolts |
| 4. Support Return Spring Clip       |  |

strip assemblies. To install, reverse removal procedure (See Fig. 9-52).

### TAIL GATE BOTTOM DRAIN HOLE SEALING STRIPS

#### Removal and Installation

1. With a flat-bladed tool carefully pry out snap-on fastener at each end of strip and remove sealing strip from tail gate.
2. To install sealing strips, reverse removal procedure. To prevent strip from adhering to the tail gate panel and blocking the drain holes, apply a sparing amount of silicone rubber lubricant on the center section of the sealing strip (See illustration under "Front and Rear Door Bottom Drain Hole Sealing Strips").

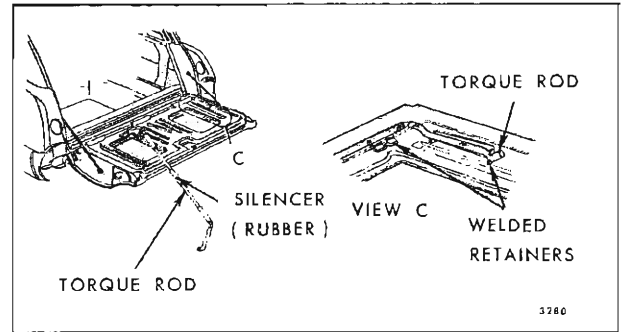

Fig. 9-51—Tail Gate Torque Rod Assembly

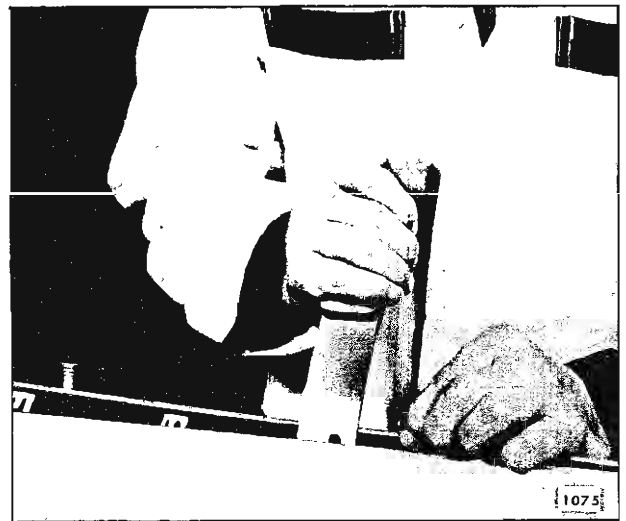

Fig. 9-52—Tail Gate Strip Assembly Removal

### TAIL GATE OPENING WEATHERSTRIP

#### Removal and Installation

1. Open tail gate and remove fasteners and/or screws securing weatherstrip to right and left body pillars (at belt). (See Fig. 9-53).
2. With a flat bladed tool, carefully remove weatherstrip along entire tail gate opening.
3. To install, apply a bead of black weatherstrip cement into retainer along entire opening and reverse removal procedure.

### TAIL GATE WINDOW UPPER GLASS RUN CHANNEL

#### Removal and Installation

1. Open tail gate. With finger pressure only, squeeze run channel at one end and pull channel out of retainer.

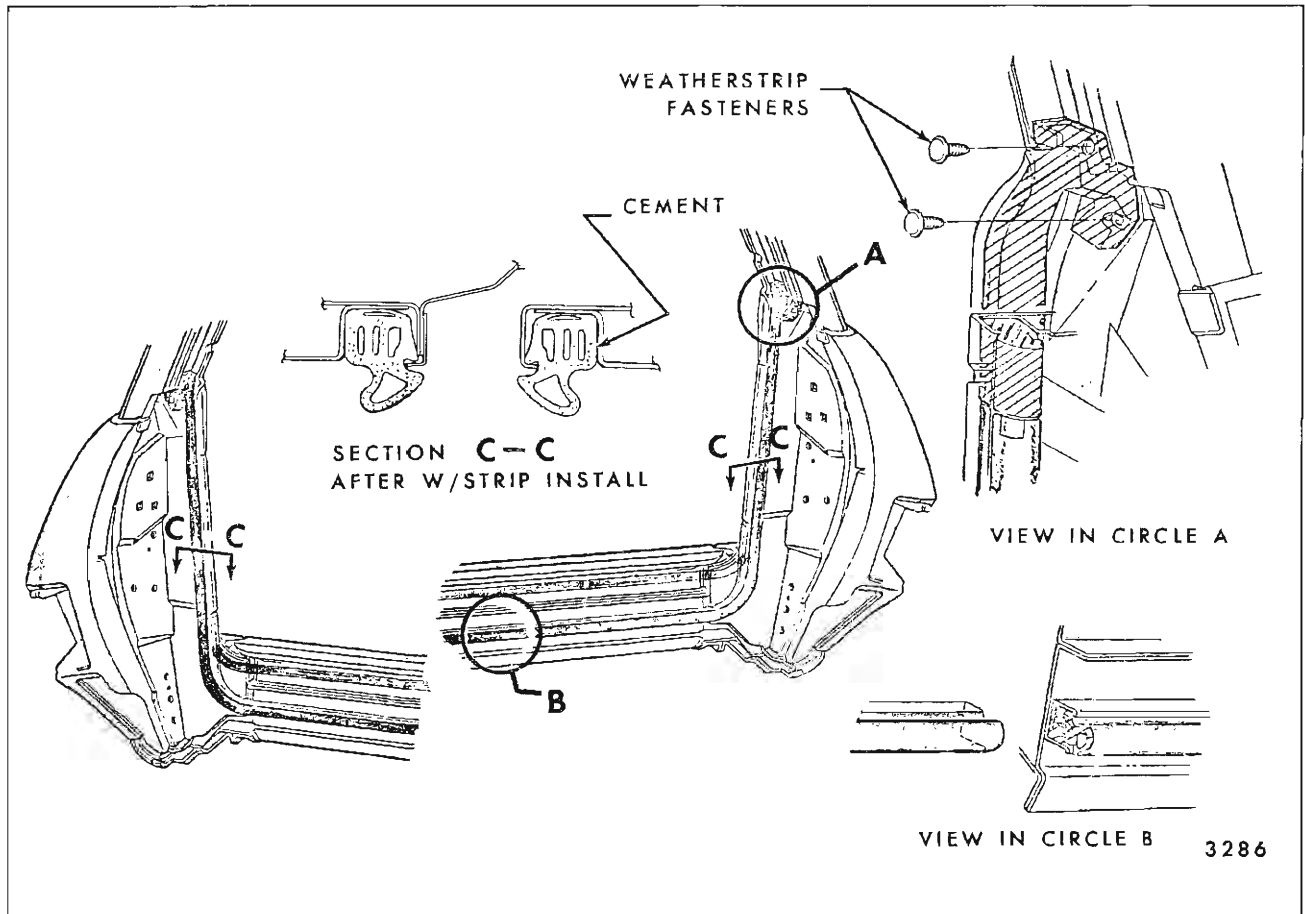
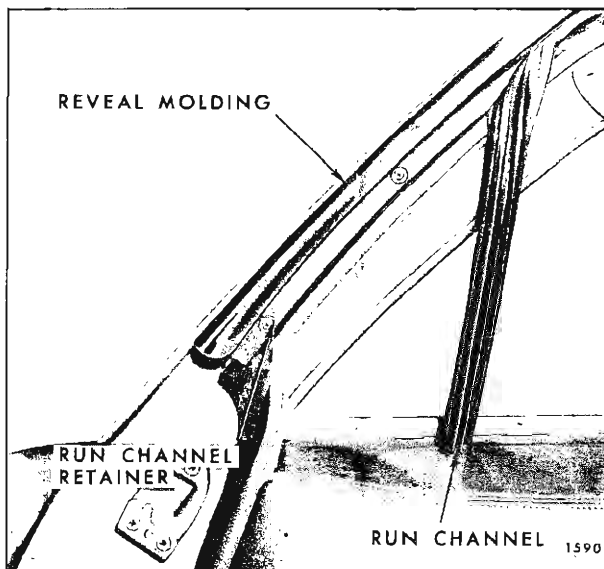

Fig. 9-53—Tail Gate Weatherstrip Installation



2. Once run channel has been removed, the retainer attaching screws are exposed. (See Fig. 9-54) The retainer can be adjusted by loosening attaching screws, shifting retainer to desired position and tightening screws. If retainer is removed, seal retainer with medium bodied sealer prior to installation.
3. To install, reverse removal procedure.

Fig. 9-54—Tail Gate Upper Glass Run Channel Retention



# SECTION 10

## TRIM CLEANING

### INDEX

Subject	Page	Subject	Page
Introduction . . . . .	10-1	Candy . . . . .	10-4
General Instructions . . . . .	10-1	Chewing Gum . . . . .	10-4
Cleaning Fabrics With Volatile Cleaners . . . . .	10-1	Fruit, Fruit Stains, Liquor and Wine . . . . .	10-4
Cleaning Fabrics With Detergents . . . . .	10-2	Grease and Oil . . . . .	10-4
Precautions for Cleaning Fabrics . . . . .	10-2	Ice Cream . . . . .	10-4
Cleaning Genuine Leather and Coated Fabrics . . . . .	10-3	Nausea . . . . .	10-4
Cleaning Folding Top and Fabric Roof Cover Material . . . . .	10-3	Shoe Polish and Dressings . . . . .	10-5
Cleaning Floor Carpets . . . . .	10-3	Tar . . . . .	10-5
Removal of Specific Stains From Automotive Upholstery . . . . .	10-3	Catsup . . . . .	10-5
Blood . . . . .	10-3	Urine . . . . .	10-5
		Lipstick . . . . .	10-5
		Ball Point Ink . . . . .	10-5
		Mustard . . . . .	10-5

### INTRODUCTION

This procedure has been prepared to assist service personnel in cleaning automotive upholstery, floor carpets, headlining and folding tops using the latest approved methods for removing soil and stain.

### GENERAL INSTRUCTIONS

The general types of trim materials used on 1969 model passenger vehicles are as follows:

1. Fabrics that may be either plain fabrics, or pattern fabrics which are manufactured with synthetic fibers (nylon, rayon).
2. Genuine leather.
3. Coated fabrics (vinyl or mylar).

Dust and dirt particles that accumulate on the upholstery of a car should be removed every few weeks, or oftener if the car is given constant hard use. This is done with a whisk broom or vacuum cleaner.

**CAUTION:** Do not use a whisk broom on fabrics having raised tapestry patterns since damage to the fine threads may result.

Before attempting to remove spots or stains from upholstery fabrics, determine as accurately as possible:

1. Nature and age of the spot or stain.

2. The effect of stain removing agents on the color structure and general appearance of the fabric.

For best results, stains should be removed from upholstery as soon as possible after they have been made. If they are allowed to stand for some time, they often become set and removal becomes more difficult, frequently impossible.

There are three basic types of acceptable cleaners available to car owners:

1. Volatile cleaners (colorless liquids).
2. Detergents.
3. Neutral soap (nonalkaline).

Many types of these cleaners can be obtained through GM Dealer or other reputable supply houses.

The volatile cleaners have great solvent powers for grease, oils and general road grime. Detergents generally loosen up stains satisfactorily; however, the use of improper type detergents involves risk of damage to the color or finish of fabrics.

### CLEANING FABRICS WITH VOLATILE CLEANERS

Care should be taken not to use too much solvent and to apply it only with clean cloths. It is the solvent that does the work - so only a minimum of pressure should be applied.

1. Brush away all loose particles of dirt and soil.

2. Dampen a clean cloth (cheese cloth may be used) with the volatile cleaner. Open the cloth and allow a portion of the cleaner to evaporate so that the cloth is just slightly damp.
3. Using very light pressure and a circular lifting motion, rub the stained area, starting at the outer edge and working toward the center until the entire area has been covered. Change to a clean portion of the cloth every few strokes.
4. Using a clean white blotter, blot stained area to remove any excess cleaner. Change to a new portion of the blotter each time stained area is blotted. The blotting action should be repeated until no stain is transferred to the blotter surface.
5. Before proceeding, wait several minutes to allow most of the volatile cleaner to evaporate. DO NOT saturate stained area. This will avoid the danger of the cleaner penetrating to the padding under the upholstery. Certain cleaners will deteriorate sponge rubber which is often used in padding.
6. It may be necessary to repeat steps 2, 3, 4 and 5 several times before the stain has been satisfactorily removed. Each time a clean cloth should be used.
7. If a ring should form on the fabric when removing a stain, the entire area of the trim assembly should be cleaned as described in the preceding steps.
8. The cleaned upholstery should be allowed to dry completely before using.

Some volatile cleaners are toxic and harmful; therefore, the following safety precautions should be used.

1. Always use in a well ventilated area. Car windows and garage doors must be open when such cleaners are used.
2. Avoid prolonged or repeated breathing of vapors from cleaner.
3. Avoid prolonged or repeated contact with the skin.
4. Keep away from eyes and mouth.
5. Some cleaners are flammable and every precaution and care must be exercised in handling these cleaners.
6. Always follow directions specified by the manufacturer of the product used (label directions).

## CLEANING FABRICS WITH DETERGENTS

1. Make a solution of the detergent in lukewarm water, working up thick, frothy suds.
2. With a clean cloth or sponge, dampened with lukewarm water, apply suds only to the surface of the upholstery using light to medium pressure. Repeat several times, applying more suds with a clean portion of the cloth or sponge.
3. With a second clean cloth, dampened with lukewarm water, rub over the area with medium pressure to remove excess detergent and loose material.
4. With a clean dry cloth, wipe off all excess moisture. A vacuum cleaner may also be used.
5. Allow the upholstery to dry partially; then, repeat the above treatment, if necessary, to remove stain.
6. When the upholstery is satisfactorily cleaned, allow to dry completely before using.

## PRECAUTIONS FOR CLEANING FABRICS

1. Solutions containing water are not recommended for general cleaning of broad cloth. Water has great destructive powers on the high face or high gloss finish of broad cloth, causing the nap to curl and roughen to such an extent that the finish is destroyed or made very unsightly. However, in some cases where it is necessary to use a solution containing water to remove a stain, the resultant disturbance to the finish of the material may be preferable to the stain.
2. Do not use a cleaning solvent, any gasoline which is colored or which contains tetraethyl lead.
3. Do not use solvents such as acetone, lacquer thinners, enamel reducers or nail polish remover, as a cleaning solvent.
4. Do not use laundry soaps, bleaches or reducing agents, such as the following: chloride of lime, javelle water, hydrogen peroxide, sodium hydrosulphite, potassium permanganate, chlorine or chlorine water, sulphurous acid (sulphur dioxide), sodium thiosulphate (photographers' hypo). The use of these agents tends to weaken fabric and to change its color.
5. Do not use too much cleaning fluid; some interior trim assemblies are padded with rubber

and volatile cleaners are generally solvents for rubber. The application of too much cleaner may destroy these rubber pads or leave a solvent ring.

## CLEANING GENUINE LEATHER AND COATED FABRICS

Care of genuine leather and coated fabrics is a relatively simple but important matter. The surface should be wiped occasionally with a dry cloth, and whenever dirt accumulates, the following cleaning instructions should be used:

1. Lukewarm water and a neutral soap should be used. Apply a thick suds to the surface, worked up on a piece of gauze or cheesecloth.

**NOTE:** When cleaning coated fabrics, a non-flammable detergent may be substituted for neutral soap.

2. The operation should be repeated, using only a damp cloth and no soap.
3. The surface should then be wiped dry with a soft cloth.

Polishes and cleaners used for auto body finishes, volatile cleaners, furniture polishes, oils, varnishes or household cleaning and bleaching agents should never be used.

## CLEANING FOLDING TOP AND FABRIC ROOF COVER MATERIAL

The top should be washed frequently with neutral soap suds, lukewarm water and a brush with soft bristles. Rinse top with sufficient quantities of clear water to remove all traces of soap.

**IMPORTANT:** Care must be exercised to keep the soaps and cleaners from running onto body finish, as it may cause streaks if allowed to run down and dry.

If the top requires additional cleaning after using soap and water, a mild foaming cleanser can be used. Rinse the whole top with water, then apply a mild foaming type cleanser to the entire top. Scrub with a small, soft bristle hand brush, adding water as necessary until the cleanser foams to a soapy consistency. Remove the first accumulated soilage with a cloth or sponge before it can be ground into the top material. Apply additional cleanser to the area and scrub until the top is clean. After the entire top has been cleaned, rinse the top generously with clear water to remove all traces of cleanser. If desired, the top can be supported from the underside during the scrubbing operations.

After cleaning a convertible top, always be sure the top is thoroughly dry before it is lowered. Lowering the top while it is still wet or damp may cause mildew and unsightly wrinkles.

Do not use volatile cleansers or household bleaching agents on the top material.

**NOTE:** Volatile cleaners may be used in certain instances when stubborn sealer or cement stains are encountered. However, **EXTREME CAUTION** must be exercised as damage to the fabric finish may result.

## CLEANING FLOOR CARPETS

Thoroughly brush or vacuum the floor carpet. In many instances, the floor carpet may require no further cleaning. If carpet is extremely soiled, remove carpet from car and thoroughly vacuum to remove loose dirt; then, with a foaming type upholstery cleaner, clean approximately one square foot of carpet at a time. After each area is cleaned, remove as much of the cleaner as possible with a vacuum cleaner. After cleaning the carpet, use an air hose to "fluff" the carpet pile, then dry the carpet. After the carpet is completely dried, use an air hose to again fluff the carpet pile.

**NOTE:** If the carpet is not extremely soiled, the carpet may be cleaned in the car by applying a sparing amount of foaming type upholstery cleaner with a brush.

If oil or grease spots are still present on the carpet, they may be removed by using a volatile cleaner; however, the cleaner must be used very sparingly since it may have a tendency to remove some of the dye coloring.

## REMOVAL OF SPECIFIC STAINS FROM AUTOMOTIVE UPHOLSTERY

Some types of stains and soilage including blood, ink, chewing gum, etc., require special consideration for most satisfactory results. For these and other stains, specific instructions are outlined in succeeding paragraphs. It must be expected, particularly where water treatment is specified, that discoloration and finish disturbance may occur. In some cases, fabric disturbance may be considered preferable to the stain itself. By following the procedures outlined with normal care and caution, reasonably satisfactory results can be expected.

### Blood

**DO NOT** use hot water or soap and water on blood stains since they will set the stain, thereby making its removal practically impossible.

Rub the stain with a clean cloth saturated with cold water until no more of the stain will come out. Care must be taken so that clean portions of cloth are used for rubbing the stain.

This treatment should remove all of the stain. If it does not, apply a small amount of household ammonia water to the stain with a cloth or brush. After a lapse of about one minute, continue to rub the stain with a clean cloth dipped in clear water.

If the stain remains after the use of water and ammonia, a thick paste of corn starch and cold water may be applied to the stained area. Allow the paste to remain until it has dried and absorbed the stain. Then pick off the dry starch. Brush the surface to remove starch particles that remain. For bad stains, several applications of starch paste may be necessary.

### **Candy**

Candy stains, other than candy containing chocolate, can be removed by rubbing the affected area with a cloth soaked with very hot water. If the stain is not completely removed, rub area lightly (after drying) with a cloth wet with volatile cleaner. This will usually remove the stain.

Candy stains resulting from cream and fruit-filled chocolates can be removed more easily by rubbing with a cloth soaked in lukewarm soapsuds (mild neutral soap) and scraping, while wet with a dull knife. This treatment is followed with a rinsing by rubbing the spot with a cloth dipped in cold water.

Stains resulting from chocolate or milk chocolate can be removed by rubbing the stain with a cloth wet with lukewarm water. After the spot is dry, rub it lightly with a cloth dipped in a volatile cleaner. Using a clean white blotter, blot area to remove excess cleaner and chocolate stain. Repeat blotting action until stain is no longer transferred to surface of blotter.

### **Chewing Gum**

Harden the gum with an ice cube, and scrape off particles with a dull knife. If gum cannot be removed completely by this method, moisten it with a volatile cleaner and work it from the fabric with a dull knife, while gum is still moist.

### **Fruit, Fruit Stains, Liquor and Wine**

Practically all fruit stains can be removed by treatment with very hot water. Wet the stain well by applying hot water to the spot with a clean cloth. Scrape all excess pulp, if present, off the fabric

with a dull knife; then, rub vigorously with a cloth wet with very hot water. If the stain is very old or deep, it may be necessary to pour very hot water directly on the spot, following this treatment with the scraping and rubbing. Direct application of hot water to fabrics is not recommended for general use since discoloration may result.

If the above treatments do not remove stain, allow fabric to dry thoroughly; then, rub lightly with a clean cloth dipped in a volatile cleaner. This is the only further treatment recommended.

Soap and water are not recommended since they will probably set the stain and cause a permanent discoloration. Drying the fabric by means of heat (such as the use of an iron) is not recommended.

### **Grease and Oil**

If grease has been spilled on the material, as much as possible should be removed by scraping with a dull knife or spatula before further treatment is attempted.

Grease and oil stains may be removed by rubbing lightly with a clean cloth saturated with a volatile cleaner. Be sure all motions are toward the center of the stained area, to decrease the possibility of spreading the stain. Use a clean white blotter, blot area to remove excess cleaner and loosened grease or oil. Repeat blotting action until grease or oil stain is no longer transferred to blotter.

### **Ice Cream**

The same procedure is recommended for the removal of ice cream stains as that used in removing fruit stains.

If the stain is persistent, rubbing the spot with a cloth wet with warm soapsuds (mild neutral soap) may be used to some advantage after the initial treatment with hot water. This soap treatment should be followed with a rinsing, by rubbing with a clean cloth wet with cold water. After this dries, rubbing lightly with a cloth wet with volatile cleaner will clear up the last of the stain by removing fatty or oil matter.

### **Nausea**

Sponge with a clean cloth, dipped in clear cold water. After most of the stain has been removed in this way, wash lightly with soap (mild neutral), using a clean cloth and lukewarm water. If odor persists treat area with a water-baking soda solution (1 teaspoon baking soda to 1 cup of tepid water). Then rub with another clean cloth dipped

in cold water. If any of the stain remains after this treatment, gently rub clean with a cloth moistened with a volatile cleaner.

### Shoe Polish and Dressings

On types of shoe dressings which contain starch, dextrine or some water soluble vehicle, allow the polish to dry; then, brush the spot vigorously with a brush. This will probably be all the treatment that is necessary. If further treatment is required, moisten the spot with cold water and after it has dried, repeat the brushing operation.

Paste or wax type shoe polishes may require using a volatile cleaner. Rub the stain gently with a cloth wet with a volatile cleaner until the polish is removed. Use a clean portion of the cloth for each rubbing operation and rub the stained area from outside to center. Blot stained area to remove as much of the cleaner as possible.

### Tar

Remove as much of the tar as possible with a dull knife. Moisten the spot lightly with a volatile cleaner, and again remove as much of the tar as possible with a dull knife. Follow this operation by rubbing the spot lightly with a cloth wet with the cleaner until the stain is removed.

**CAUTION:** It is possible that the cleaner will dissolve the tar causing it to bleed. Generally tar will stain trim materials and this type of stain will be very difficult to remove.

### Catsup

Sponge stain with cool water. If stain remains, rub detergent on stain and work it into fabric. Rinse with clean wet cloth. Repeat operation if necessary.

### Urine

Sponge the stain with a clean cloth saturated with lukewarm soapsuds (mild neutral soap) and then rinse well by rubbing the stain with a clean cloth dipped in cold water. Then saturate a clean cloth with a solution of one part household ammonia water and five parts water. Apply the cloth to the stain and allow solution to remain on affected area for one minute; then, rinse by rubbing with a clean wet cloth.

### Lipstick

The compositions of different brands of lipsticks vary, making the stains very difficult to remove. In some instances, a volatile cleaner may remove the stain. If some stain remains after repeated applications of the volatile cleaner, it is best to leave it rather than try other measures.

### Ball Point Ink

Sponge stain with cool water, work a detergent into it and rinse. Generally this type stain will be very difficult to remove.

### Mustard

Sponge stain with warm water. Rub detergent on dampened stain and work it into fabric. Rinse with clean wet cloth. Repeat operation several times. As mustard is a difficult stain to remove, some discoloration may remain.

# SECTION 11

## HEADLINING

### INDEX

Subject	Page	Subject	Page
Headlining - Cloth and Vinyl Coated (Soft) - All Styles Except "55-56-65-66"		Front Headlining Assembly . . . . .	11-5
Station Wagons . . . . .	11-1	Removal . . . . .	11-5
Description . . . . .	11-1	Installation . . . . .	11-5
Removal . . . . .	11-1	Rear Headlining Assembly . . . . .	11-5
Installation . . . . .	11-3	Removal . . . . .	11-5
Headlining - "55-56-65-66" Station Wagon		Installation . . . . .	11-6
Styles . . . . .	11-3	One Piece Formed Headlining . . . . .	11-6
Description . . . . .	11-3	Description . . . . .	11-6
		Removal . . . . .	11-6
		Installation . . . . .	11-6

## HEADLINING — CLOTH AND VINYL COATED (SOFT)—All Styles Except "55-56" and "65-66" Station Wagons

### DESCRIPTION

The headlining assembly is formed to the contour of the roof panel by concealed listing wires. The listing wires are retained to the headlining by listing wire pockets which are part of the headlining assembly.

Depending upon the body type and style, the listing wires are attached to the side roof rails by either inserting wires directly into holes in side rail or into a clip which is screwed into the side rail.

On certain styles, the listing wires are further attached to the roof panel by snap-in type clips on the front to rear longitudinal roof bow (Fig. 11-1, View "C").

When finishing lace is used at the windshield and back window or back body opening, the headlining is attached by means of cement at those areas.

Where garnish moldings are utilized the headlining is tacked or stapled in addition to being cemented at the windshield and back window or back body opening (See Fig. 11-1, View "A").

The headlining is retained along the side roof rails by cementing or the use of a pronged retainer. Depending upon the style, garnish moldings or finishing lace is also used to assist in retaining the headlining. The side roof rail garnish moldings are secured to the headlining retainer by clips that are located in the molding (See Fig. 11-2).

At the roof extension area, the headlining is se-

cured either by cement to a metal retainer or by tacks or staples to a trim stick.

Quarter upper trim is covered in "Door, Quarter and Shelf Trim" section.

### Removal

1. Place protective coverings over seat cushions and backs.
2. Prior to removing headlining, remove following hardware and trim assemblies if present.
  - a. Windshield side and upper garnish moldings or finishing lace.
  - b. Rear view mirror support.
  - c. Sun shade supports.
  - d. Dome or rear quarter courtesy lamps.
  - e. Coat hooks.
  - f. Side roof rail moldings or finishing lace.
  - g. Back window garnish moldings or finishing lace.
  - h. Center pillar upper trim assembly.
  - i. Rear quarter trim, where necessary.
  - j. Quarter upper trim finishing panel.

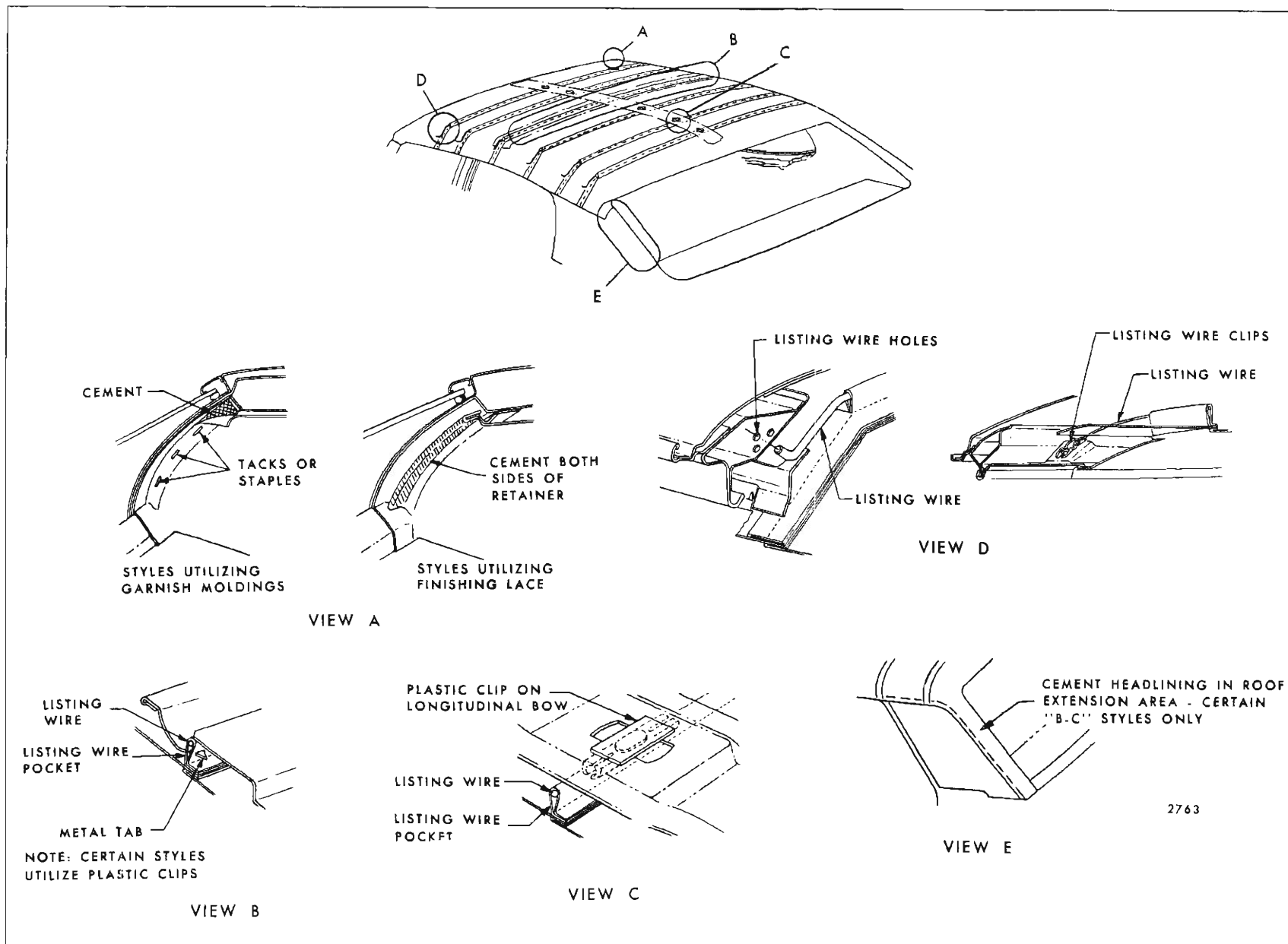

Fig. 11-1—Typical Cloth and Vinyl Headlining Installations

- k. Back body opening garnish moldings or finishing lace.
1. Shoulder strap anchor plate and escutcheon.
3. Carefully remove tacks or staples securing headlining at windshield and back window opening or back body opening.
4. On styles using pronged retainer, use headlining inserting tool, J-2272 or similar wide-bladed tool and carefully disengage headlining from pronged retainers where present.
5. Carefully detach cemented edge of headlining around entire perimeter.
6. Starting at front of body, carefully disengage No. 1 and No. 2 listing wires from side roof inner rails and supporting clips on longitudinal (front to rear) bow on styles so equipped (See Fig. 11-1, View "C"). In like manner, working from rear of body, disengage listing wires from side roof rails and supporting clips on longitudinal bow. Exercise care to keep headlining material clean by gathering or folding headlining with listing wires on outside.
7. Depending on style, bend down tabs securing No. 3 listing wire or disengage No. 3 listing wire from plastic clips on structural bow and remove headlining assembly from body.

**IMPORTANT:** Note in which holes listing wires are installed in side roof rails. Listing wires should be placed in same hole when replacing headlining.

8. If replacing headlining, remove listing wires from pockets of old headlining.

**IMPORTANT:** Listing wires removed from old headlining must be installed in corresponding pockets of new headlining.

### Installation

1. If previously removed, install listing wires into corresponding pockets of new headlining assembly.

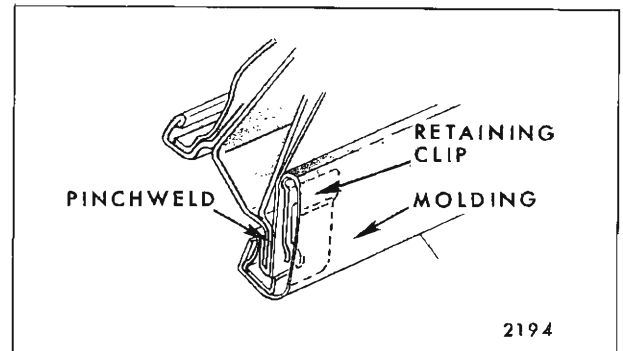

Fig. 11-2—Side Roof Rail Garnish Moldings

2. Apply an approved non-staining trim cement to headlining attaching surface at windshield, side roof rail and back window or back body opening. On styles that utilize finishing lace be certain cement is applied to both sides of retainers (See Fig. 11-1, View "A").
3. Lift headlining assembly into body and install No. 3 listing wire and listing wire pocket over metal tabs at roof bow and bend up tabs to secure wire to bow. On styles that incorporate plastic clips in place of metal tab, snap No. 3 listing wire into clips (See Fig. 11-1, View "B" and "C").
4. Working rearward from No. 3 listing wire, install listing wires in side roof rails and snap listing wires into plastic clips on longitudinal bow (on styles equipped with longitudinal bow). In like manner, working forward, install remaining listing wires (See Fig. 11-1, View "C").

**NOTE:** Listing wires may be adjusted up or down by utilizing appropriate holes in side roof rails. Listing wires should rest tight against roof panel after installation (See Fig. 11-1, view "D").

5. Stretch and secure headlining at windshield and back window or back body opening. Stretch and secure headlining at rear quarters and side roof rails. Permanently attach material removing draws and wrinkles and replace all previously removed inside hardware and trim assemblies.

## HEADLININGS—"55-56" and "65-66" Station Wagon Styles

### DESCRIPTION

The "55-56" and "65-66" station wagon styles use two separate headlining assemblies which may be removed and replace separately. The front head-

lining is formed to the contour of the roof panel by concealed listing wires. The ends of the listing wires are installed into holes in the side roof inner rails, and may be adjusted up and down or fore and aft (View "B", Fig. 11-3).



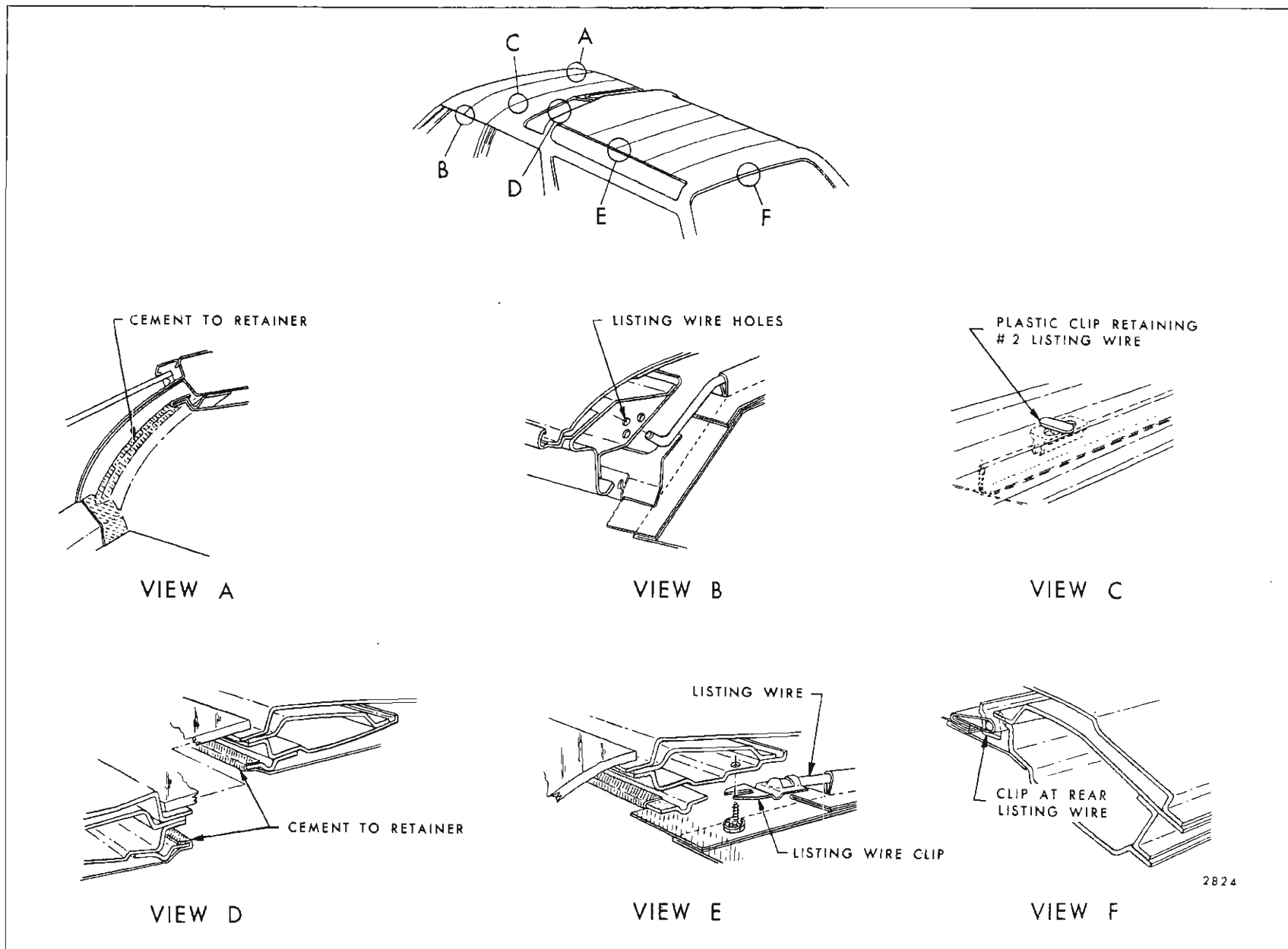

Fig. 11-3—Headlining Installation '55, 65, 56, & 66' Styles

The headlining material is cemented to metal retainers and side roof rail pinchweld flanges (View "A", Fig. 11-3). Escutcheons, moldings, and finishing lace cover the edges and assist in holding the material in place.

The rear headlining is formed to the contour of the roof panel by concealed listing wires. The ends of the listing wires are installed into clips which are secured to the side roof inner rails by screws (View "E", Fig. 11-3). The edges of the material are cemented to the retainer flanges. Finishing lace and moldings cover the edges and assist in holding the material in place.

**CAUTION:** Clean hands are essential when working with headlining material.

## FRONT HEADLINING ASSEMBLY

### Removal

1. Place protective covers over front seat cushion and back.
2. Prior to removal of the front headlining, remove the following items:
  - a. Sunshade supports.
  - b. Rear view mirror support.
  - c. Windshield upper corner escutcheons.
  - d. Center lock pillar upper finishing plates.
  - e. Side skylight front upper garnish molding.
  - f. Courtesy lamps.
  - g. Front headlining finishing lace.
  - h. Rear of headlining finishing lace.
  - i. Finishing lace over front and rear doors.
  - j. Shoulder strap anchor plate and escutcheon.
3. Starting at front, carefully detach all cemented edges of headlining material from retainers and flanges.
4. Disengage No. 2 listing wire from plastic clips on structural bow and remove No. 1 & 2 listing wires from inner rails. Gather or roll headlining with listing wires on outside to keep headlining clean and remove old headlining assembly. (See Fig. 11-3, View "C")

**IMPORTANT:** Note into which holes ends of listing wires are installed in side roof rails.

Listing wires should be placed in same holes when replacing headlining. If replacing headlining remove listing wires from pockets of old headlining.

### Installation

1. If previously removed, install listing wires into pockets of headlining.
 

**IMPORTANT:** Listing wires removed from old headlining must be installed in corresponding pockets of replacement headlining.
2. Apply approved trim cement to headlining attaching surfaces.
3. Apply approved trim cement to metal retainers and flanges.
4. Lift headlining into body, install No. 1 & 2 listing wires into holes in side roof rails and snap No. 2 listing wire into plastic clips on structural bow (see Fig. 11-3, View "B & C").

**NOTE:** Listing wires should rest tight against roof panel. Working from front to rear, attach headlining to retainers and flanges while stretching and removing wrinkles. Reinstall all previously removed parts.

## REAR HEADLINING ASSEMBLY

### Removal

1. Place protective covering over seats and floor.
2. Prior to removing headlining, remove the following items:
  - a. Sunshade supports.
  - b. Side skylight front upper garnish molding.
  - c. Rear roof headlining trim finishing molding.
  - d. All finishing lace around perimeter of headlining.
  - e. Coat hooks.
3. Carefully detach headlining at cemented edges.
4. Starting at front remove listing wires from roof inner rails (see Fig. 11-3, View "E").
5. At rear listing wire, bend down tabs securing wire to bow (see Fig. 11-3, View "F").
6. Gather or roll headlining with listing wires on

outside to keep headlining clean and remove headlining assembly from car.

### Installation

1. If previously removed, install listing wires into pockets of new headlining assembly.

**IMPORTANT:** Listing wires removed from old headlining must be installed in corresponding pockets of new headlining.

2. Apply approved trim cement to attaching surfaces of headlining material.
3. Apply approved trim cement to retaining flanges of roof panel.

4. Lift headlining into body, install center of rear listing wire over metal tabs at rear bow and bend down tabs (see Fig. 11-3, View "F").
5. Working forward install remainder of listing wires into clips and secure clips to roof. (see Fig. 11-3, View "E").
6. Listing wires must rest tight against the roof. If necessary adjust listing wires by moving clips at attaching screws.
7. Attach entire perimeter of headlining to retaining flanges, removing wrinkles by stretching the material as required.
8. Replace previously removed parts.

## ONE-PIECE FORMED HEADLINING

### DESCRIPTION

The one piece formed headliner consists of molded fiber glass covered with foam and nylon facing. The headliner is held in place by two (2) snap fasteners located on the longitudinal roof bow, and two (2) screws located in the quarter inner upper panel area.

The one piece construction requires the headliner be serviced as a complete assembly in all cases.

### Removal

1. Remove the following items:
  - a. Courtesy lamps.
  - b. Rear view mirror support.
  - c. Coat hooks.
  - d. Upper quarter trim finishing panels.
  - e. Side roof rail moldings.
  - f. Windshield and back window garnish moldings.
  - g. Shoulder strap anchor plate and escutcheon.
  - h. Windshield side garnish molding.
  - i. Sunshade support brackets.
2. Remove the screws located in the upper rear corner of the headlining (see Fig. 11-4, View "D").

**NOTE:** These screws are exposed after upper

quarter trim finishing panel is removed (see "Door, Quarter and Shelf Trim" section).

3. Disengage the snap fasteners and carefully lower headliner from roof panel (see Fig. 11-4, View "E" & "B").
4. Lower all windows on both sides of car to the full down position and remove headlining through window openings.

### Installation

1. Load headliner into car through side window openings.
2. Raise one side of headliner to side roof rail, and then the other side.
 

**NOTE:** Headlining must be loaded from the side and positioned to rest on side roof rails.
3. Align holes in rear of headlining with piercings in rear quarter, and cut-outs for sunshade brackets at attaching location.
4. Install screws in the sail area and sunshade brackets (see Fig. 11-4, Views "A" and "D").
5. Install all previously removed hardware.
6. Engage snap fasteners (see Fig. 11-4, View "B" & "E") by placing flat of hand on back side of snap fastener and press upward until it engages.

**CAUTION:** DO NOT ATTEMPT TO ENGAGE FASTENERS BY USE OF ANY TOOL OR SHARP BLOWS.

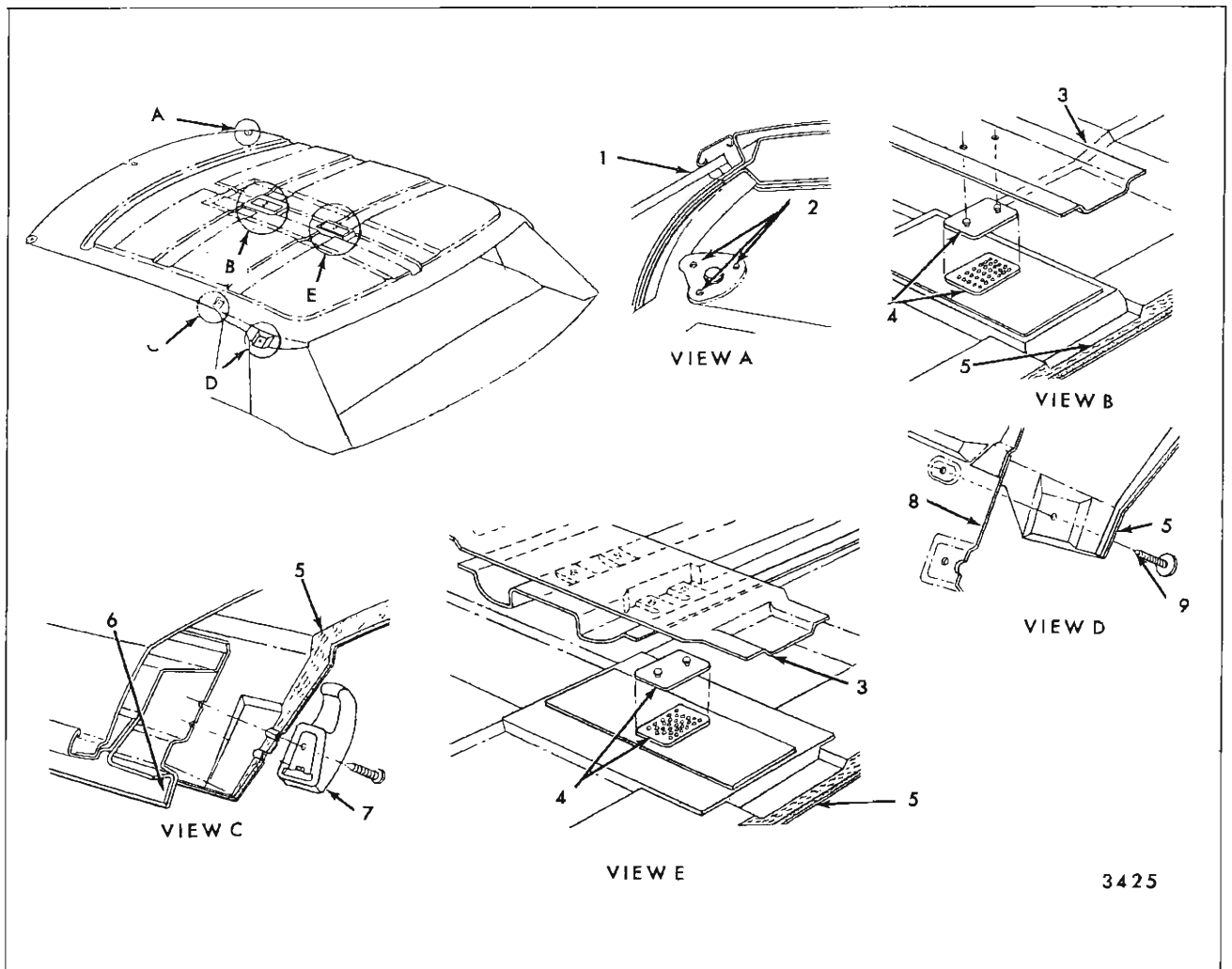

Fig. 11-4—One Piece Headlining

- 1. Windshield
- 2. Sunshade Bracket Holes
- 3. Roof Bow

- 4. Snap Fastener
- 5. Headliner
- 6. Side Roof Rail

- 7. Coat Hook
- 8. Quarter Inner Upper Panel
- 9. Retaining Screw

# SECTION 12 ROOF COVER

## INDEX

Subject	Page	Subject	Page
Fabric Roof Cover (All Styles Except Station Wagons)	12-1	Description	12-10
Description	12-1	Removal	12-10
Removal	12-1	Installation	12-11
Installation - Styles with Pad	12-2	Tail Gate Fabric Cover	12-13
Installation - Styles without Pad	12-3	Description	12-13
Fabric Roof Cover (Station Wagon Styles)	12-10	Removal	12-13
		Installation	12-13

## FABRIC ROOF COVER (ALL STYLES EXCEPT STATION WAGONS)

### DESCRIPTION

The roof panel fabric cover is a vinyl coated fabric made in sections which are dielectrically bonded or stitched at the seams.

Depending upon the car and body type, the fabric cover is applied to the roof panel in one of the following two basic methods using a non-staining vinyl trim adhesive.

1. A padding is cemented to the roof panel surface and then the cover applied over the pad and cemented along the outer perimeter only.
2. The cover is cemented directly to the entire roof panel surface.

In addition, certain roof panel molding treatment may appear with either type of installation. The type of molding treatment will determine whether the cover will extend into the windshield or back window opening and drip molding.

On styles where the cover extends into the windshield and back window opening, the cover is retained in the opening by cement, clips installed over weld-on studs and drive nails or self-sealing screws. When the cover extends into the drip molding, it is retained in the drip by either a flexible retainer or the drip scalp molding.

### Removal

1. The following parts must be removed prior to removing the fabric roof cover.
  - a. Upper and both side windshield and back window reveal moldings (except on styles where the cover does not extend into either the windshield or back window opening).

- b. Roof drip molding scalps (when cover extends into drip molding).
- c. Flexible retainers and Retainer clip in drip moldings (on styles so equipped).
- d. Rear quarter belt reveal moldings and rear end belt reveal moldings.
- e. Roof cover retainer to rear body lock pillar (on styles so equipped).
- f. Roof extension panel emblem or nameplate assembly (if present).
- g. All roof panel moldings and molding retainers (on styles so equipped).
- h. Quarter window lower reveal molding (on styles where fabric cover extends under reveal molding).

2. Remove reveal molding clips across top and sides of windshield and/or back glass openings. On styles where fabric cover extends below back window, remove reveal molding clips along bottom of back window opening.

**NOTE:** In the event a repair type clip has been installed and retaining screw is not accessible, carefully trim roof cover around clip.

3. Remove all drive nails or self-sealing screws that are present in windshield and back window opening and at roof extension area.

**CAUTION:** When removing drive nails or screws, edge of glass must be protected. Two to three layers of cloth body tape should be used.

**NOTE:** Drive nails can best be removed by first driving a screwdriver or suitable tool under the

heads of nails to loosen them. Diagonal cutters or similar tool can then be used to grasp nails and twist them out. Unnecessary enlargement of holes in roof panel should be avoided.

- Prior to removing fabric cover, application of heat to cemented areas will permit easier loosening of cemented edges.

**CAUTION:** Heat may be applied by lamps held 18" (minimum) from fabric only until fabric is warm. If lamps are held too close or fabric cover is heated over 200°F, the fabric may lose its grain, blister, or become very shiny.

- Loosen all cemented edges of fabric roof cover, then, carefully remove fabric cover from remaining cemented area of roof panel.

**IMPORTANT:** On styles where a pad is present, exercise care when removing fabric cover to avoid damage to the pad.

- On styles equipped with pad, inspect padding and replace any damaged area. Padding may be removed by applying xylol solvent such as 3M Adhesive Cleaner, or equivalent, to affected

area. Allow solvent to dissolve adhesive and remove padding. Exercise care to avoid softening of roof panel paint finish.

- Replace pad by cementing pad to roof panel with nitrile vinyl trim adhesive.

### INSTALLATION—Styles with Pad (Including Roof Panel Moldings)

- Completely mask off area of roof panel which is not covered by fabric cover. Extend tape over windshield upper reveal molding so cement will not contact paint or adhesive caulking material.
- Where possible, install new cover at room temperature (approximately 72°), to permit easier fitting and removing of wrinkles from new cover assembly.

**NOTE:** Where new cover is installed at temperatures below 72°, fabricated pliers as shown in Figure 12-1 will aid in removing wrinkles.

- Determine center line of roof panel by marking center points on windshield and back window opening with tape or equivalent.
- Lay cover on roof panel and fold cover lengthwise, precisely at center location. Mark center location at front and rear of cover.
- Remove cover from roof panel and lay cover with lining side upward on a clean flat area.
- Apply nitrile type vinyl trim adhesive to that part of lining side of cover that will contact the metal portion of the roof panel. Cement should be applied so it will overlap the pad approximately 1".

**NOTE:** It is recommended that the vinyl trim adhesive be applied with a spray gun. As an alternate method, a brush or roller may be used. If spraying method is utilized, a spray gun with a pressure cup and specific Fluid Tip and air cap should be used as shown on chart below (or equivalent).

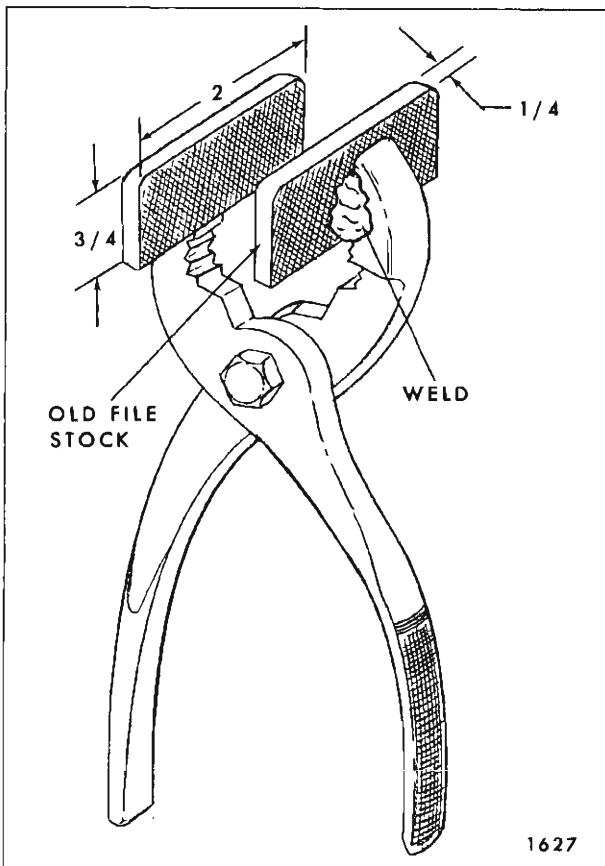

Fig. 12-1—Fabric Roof Cover Pliers

Gun Model	Devilbiss		Binks	
	MBC-510	JGA-502	62	18
1 Qt. Pressure	KB-519	KB-519	80-256	80-210
Air Cap	24	24	66PG	66PG
Fluid Tip	E	E	66	66
Fluid Needle	E	E	365	65

The recommended air pressures are as follows:

- A. Air Line Pressure - 50 lbs.
- B. Cup Pressure - 2 to 4 lbs.

Permalastic or 3M Vinyl Trim Adhesive purchased in the field is of spraying consistency. If rolling method is used, a mohair type roller should be utilized. Make certain cement is applied evenly and there are no highlights from excess cement build-up.

7. Allow cement on fabric roof cover to dry thoroughly.
8. Lay cover on roof panel and align to correspond with centerline of roof panel. Determine proper material overhang at back window openings (approximately 2" overhang at seam area at back window).
9. Cut relief notches in cover at all weld-on studs and angle cuts as required in corners of back window opening. Apply cement to back window opening and cement cover in opening. In the event a reveal molding clip could not be removed, trim cover around clip and cement cover down behind clip (See Fig. 12-2).
10. Making certain the edge of back glass is protected, install drive nails or self-sealing screws at seam areas, installing drive nails or screws as low in opening as possible.
11. Apply cement to one side of exposed roof panel where cover is attached (make certain cement overlaps pad approximately 1") and cement cover to cemented areas. Relief notches must be cut in cover at weld-on studs on roof panel (View "A", Fig. 12-2).
12. Repeat step 11 on opposite half of roof panel.
13. Install drive nails across top and down sides of back window opening approximately 3" apart and 2 in each upper corner. (View "C", Figure 12-2).
14. Carefully install drive nails as low as possible above each reveal molding clip that could not be removed.
15. Apply cement to roof extension areas overlapping pad by 1" and below back window opening.
16. Cement cover below back window opening, and then in roof extension area (right and left side).

**NOTE:** Cement cover at roof extension areas by pulling cover down and rearward. When operation is completed, fabric cover should be free of all wrinkles and draws in this area.

17. Position roof panel molding retainers over weld-on studs and install retaining clips.
18. Trim fabric cover in a line along retainers. DO NOT DAMAGE PAINT FINISH. At front corners, raise cemented edge of cover and using scissors or sharp knife cut radius so roof panel moldings cover cut edge. Recement fabric cover to roof panel. Remove masking tape from roof panel (View "A", Fig. 12-2)
19. Trim material along belt line at roof extension area and below back window, along rear end belt molding area. If it is necessary to trim material from outer edge of fabric cover around back window openings, raise cemented edge and cut as required.
20. Apply a "film" coat of silicone sealant such as Dow Corning Automotive Sealant, General Electric RVP Sealant, or equivalent to the edges of cover in back window opening, at belt area and at edges under roof panel moldings. Make certain edge of material around all reveal molding clips that were not removed, is also sealed (Fig. 12-2).
21. Remove all previously installed protective covering from back glass and body.
22. Install all previously removed moldings and assemblies.

**NOTE:** Normally, minor creases or fold marks will gradually disappear after cover assembly has been in service.

#### Installation—Styles Without Pad

1. On styles equipped with roof panel moldings, completely mask off areas of roof panel which are not covered by fabric cover. Also, mask upper windshield or back window reveal moldings on styles where cover does not extend into these openings. On all styles, mask windshield, back window, all doors and flat painted surfaces (hood, rear compartment lid, etc.).
2. Check all cementing surfaces on body to insure a smooth surface. Cementing surface must be

**NOTE:** When installing drive nails it is best to first use an awl or similar tool to initiate a hole in metal. Strike drive nails only hard enough to seat them. Installation of drive nails should also be as low as possible in back window opening.

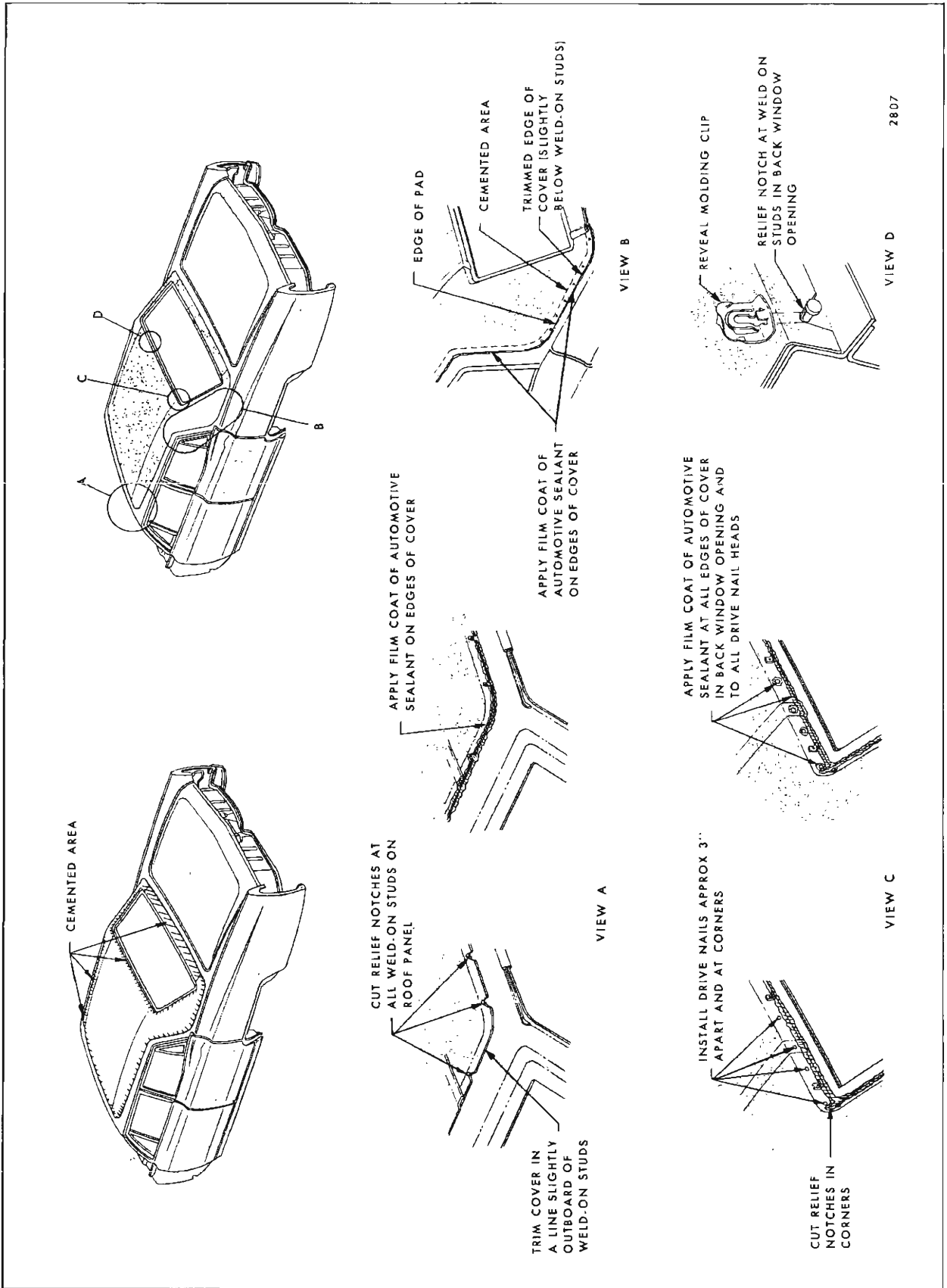

Fig. 12-2—Typical Fabric Roof Cover Installation with Pad and Roof Panel Moldings



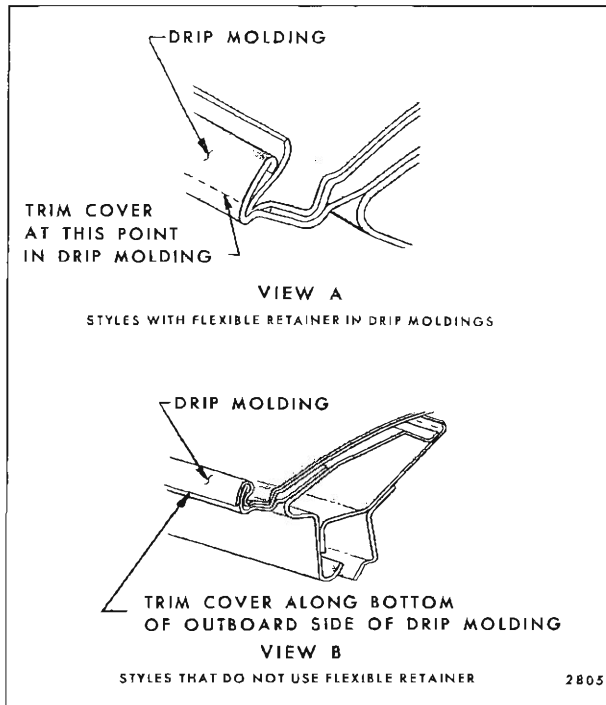

Fig. 12-3—Trimming Fabric Roof Cover at Drip Molding Area

smooth to prevent “highlighting” of excess cement through fabric cover after new cover has been installed. Clean off old cement as required. In the event any metal finishing is performed on roof panel, repaired area must be painted.

**NOTE:** A xylol solvent such as 3M Adhesive Cleaner or equivalent should be used to remove or smooth out excess old cement. Apply solvent and allow to soak before rubbing.

**CAUTION:** Be certain to follow manufacturer’s directions when using cleaner.

3. Where possible, install new cover at room temperature (approximately 72°), to permit easier fitting and removing of wrinkles from new cover assembly.

**NOTE:** Where new cover is installed at temperatures below 72°, fabricated pliers as shown in Figure 12-1 will aid in removing wrinkles.

4. Determine centerline of roof panel by marking center points on windshield and back window opening with tape or equivalent.
5. Lay cover on roof panel and fold cover lengthwise, precisely at center location. Mark center location at front and rear of cover.
6. Remove cover from roof panel and lay cover with lining side upward on a clean flat area.

7. Apply an even application of nitrile non-staining vinyl trim adhesive (such as 3M Vinyl Trim Adhesive or Permalastic Vinyl Trim Adhesive or equivalent) over entire lining side of fabric cover.

**NOTE:** It is recommended that the vinyl trim adhesive be applied with a spray gun. As an alternate method, a brush or roller may be used. If spraying method is utilized, a spray gun with a pressure cup and specific Fluid Tip and air cap should be used as shown on chart below (or equivalent).

	Devilbiss		Binks	
Gun Model	MBC-510	JGA-502	62	18
1 Qt. Pressure	KB-519	KB-519	80-256	80-210
Air Cap	24	24	66PG	66PG
Fluid Tip	E	E	66	66
Fluid Needle	E	E	365	65

The recommended air pressures are as follows:

- A. Air Line Pressure - 50 lbs.
- B. Cup Pressure - 2 to 4 lbs.

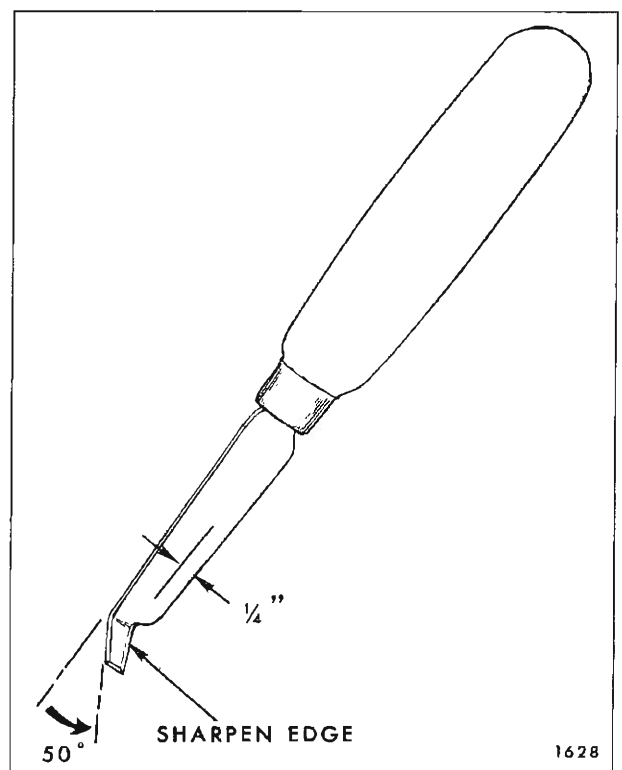
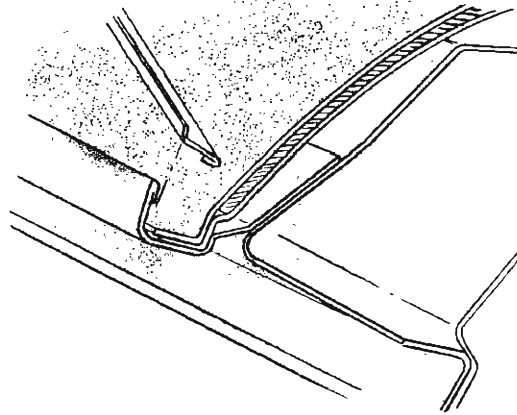
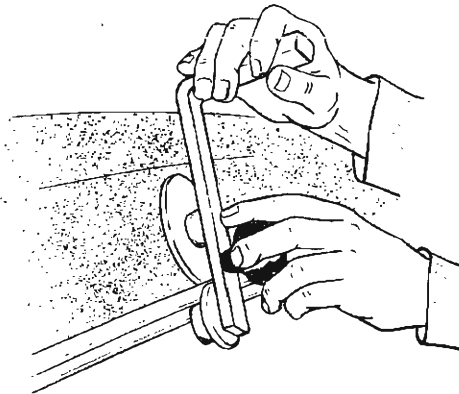

Fig. 12-4—Fabric Cover Trimming Tool



**VIEW A**

**PLACING RETAINER INTO DRIP MOLDING**



**VIEW B**

**SEATING RETAINER INTO DRIP MOLDING WITH TOOL J-22710**

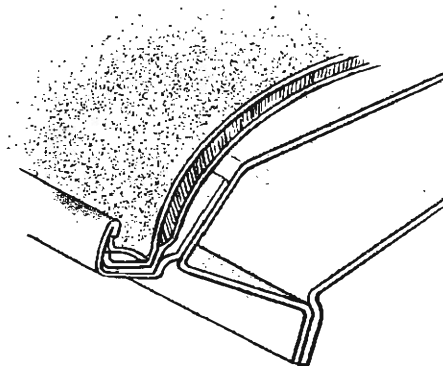

**VIEW C**

**CORRECT POSITION OF INSTALLED RETAINER**

Fig. 12-5—Inserting Plastic Retainer in Drip Molding Using Installation Tool

Permalastic or 3M Vinyl Trim Adhesive purchased in the field is of spraying consistency. If rolling method is used, a mohair type roller should be utilized. Make certain cement is applied evenly and there are no highlights from excess cement build-up.

8. Allow cement on fabric roof cover to dry thoroughly.
9. Lay cover on roof panel and align to correspond with centerline of roof panel. Determine proper material overhang to windshield and back window openings (approximately 2" overhang at seam area at back window and windshield opening).
10. Fold one half of cover back at centerline and apply nitrile type vinyl trim adhesive to exposed half of roof panel (Do not include drip molding or roof extension area). Starting in center at centerline and working toward drip molding, cement cover to area while cement is wet. As cover is being "unfolded" and cemented, it should be thoroughly "slicked" down to avoid wrinkles or air bubbles.
11. Repeat Step 10 on opposite side of roof panel.

**NOTE:** Make certain that cover is free of wrinkles and seams are straight. Fabric cover pliers may be used in aiding removal of wrinkles.

12. On styles where the cover extends into the windshield or back window opening, perform the following (Fig. 12-6):
  - a. Cut relief notches in cover at weld-on studs across top of windshield and back window opening. Also, angle cut in corners as required.
  - b. Apply cement across the top of windshield and back window opening and cement cover. In the event any reveal molding clips could not be removed, trim cover around clip and cement cover down behind clip.
13. Apply cement to roof extension areas and below back window opening on styles where cover extends below back window.
14. On styles where cover extends below back window opening, cement cover in that area prior to performing Step 15.
15. Cement cover at roof extension areas by pulling cover down and rearward. When operation

is completed, fabric cover should be free of all wrinkles and draws in this area.

16. Cement cover into side of back window opening. If weld-on studs are present, cut relief notches in cover.
17. On styles where roof panel cover extends down windshield pillar, cement fabric roof cover to windshield pillar.
18. On styles equipped with roof panel moldings, trim fabric cover in a line slightly outboard of weld-on studs on roof panel. **DO NOT DAMAGE PAINT FINISH.** At front corners, raise cemented edge of cover and using scissors or sharp knife cut radius so roof panel moldings cover cut edge. Recement fabric cover to roof panel. Remove masking tape from roof panel (Fig. 12-7).
19. On all styles, trim material along belt line at roof extension area. On styles where fabric cover extends below back window, trim cover along rear end belt molding area. If it is necessary to trim material from outer edge of fabric cover around windshield or back window opening, raise cemented edge and cut as required.
20. On styles where roof cover extends into drip moldings, perform the following:
  - a. On all styles except "X" bodies, "E" bodies that do not utilize roof panel moldings and "A" body "69 and 80" styles, cement cover into and around outboard side of drip molding as shown in View "B", Figure 12-3 and trim cover along outside bottom edge of molding.
  - b. On all other styles, cement cover into drip molding and trim cover just under lip on inside of drip molding (View "A", Figure 12-3). When trimming cover, tool J-21092 or other suitable knife may be used (Fig. 12-4).
21. On styles outlined in Step 20A, install drip scalp moldings. On these styles, the drip scalp moldings aid in retaining the fabric roof cover.
22. On all other styles, install flexible retainer into drip molding with thin edge toward outboard side. Insert tool J-22710 into rear of drip molding and roll tool toward front end of drip to seat retainer in molding (See Fig. 12-5). In the event tool J-22710 is not avail-

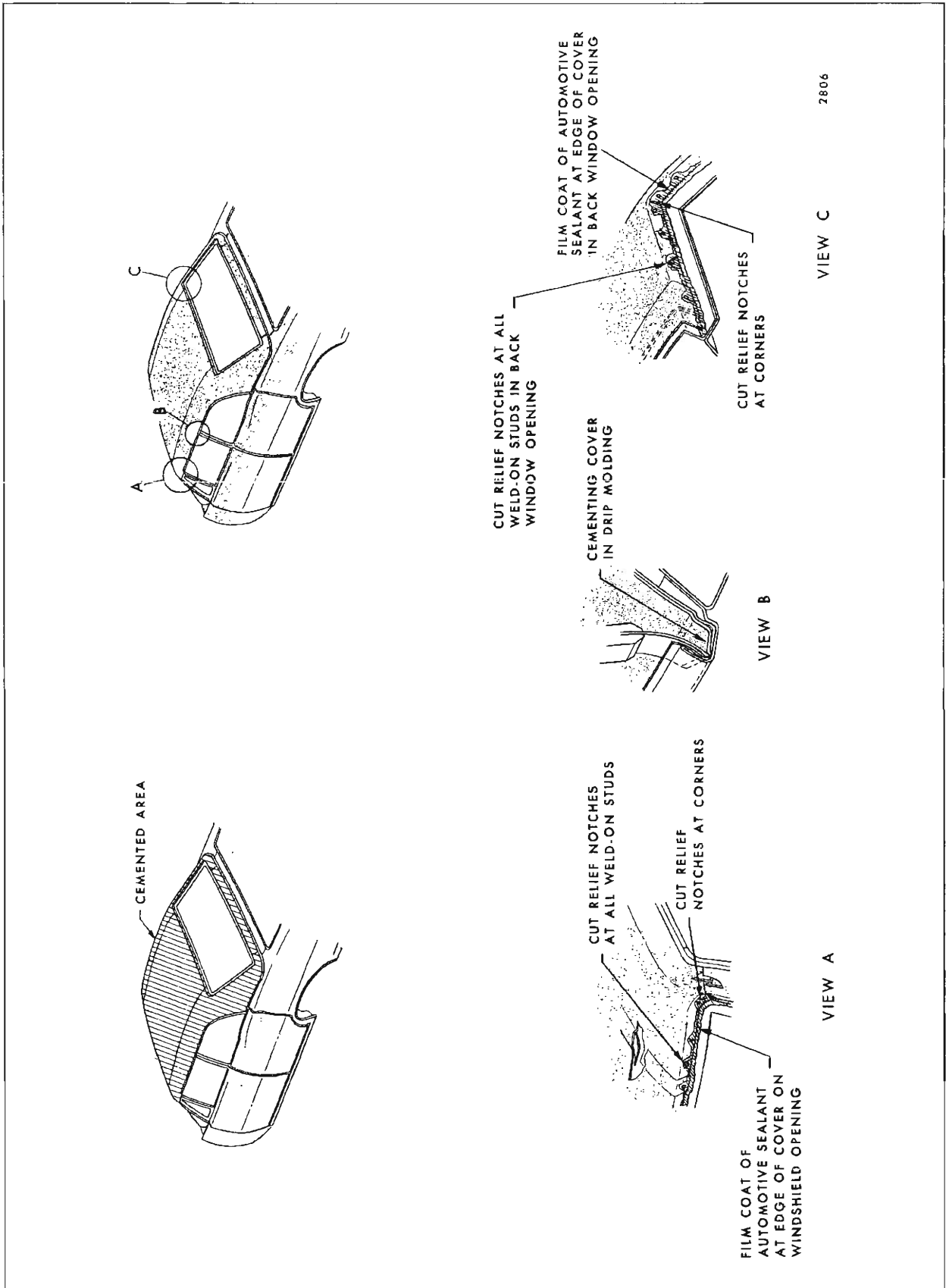

Fig. 12-6—Typical Fabric Roof Cover Installation without Pad or Roof Panel Moldings

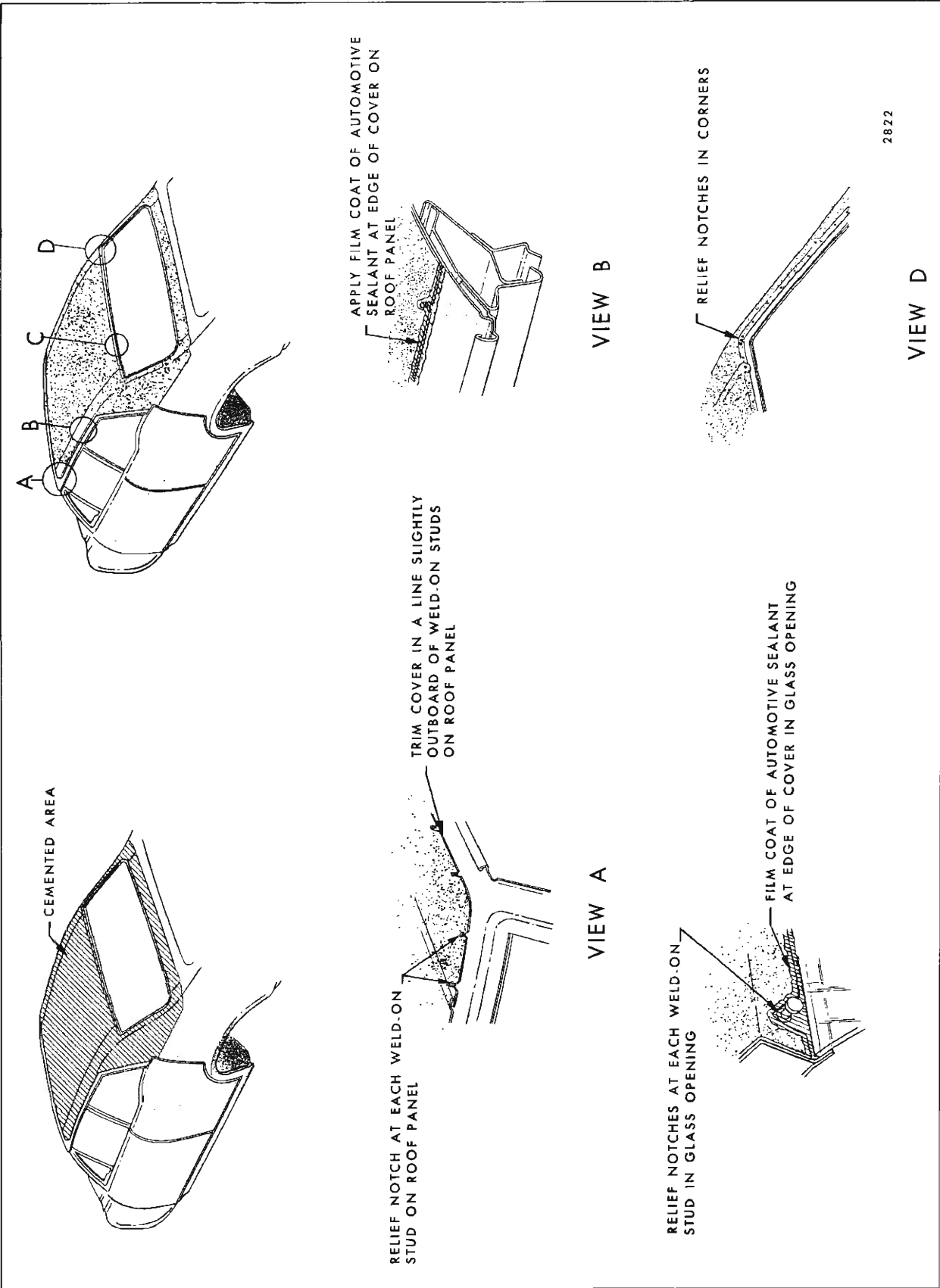

Fig. 12-7—Typical Fabric Roof Cover Installation with Roof Panel Moldings and without Pad

able, retainer can be seated in drip molding using a fibre block with slight concave end. When using this method, retainer is to be inserted so outside edge is just under lip of drip molding flange and then pushed downward with fibre block. DO NOT DAMAGE RETAINER.

23. Apply a "film" coat of silicone sealant such as Dow Corning Automotive Sealant, General Electric RVP Sealant, or equivalent, to the edge of cover in windshield and back window opening and at belt area; also, at edges on roof panel when roof panel moldings are used. Make certain edge of material around all reveal molding clips that were not removed is also sealed. (Figs. 12-6 & 7).
24. Remove all previously installed protective covering from windshield, back glass and body.

25. Install all previously removed moldings and assemblies.

**NOTE:** Normally, minor creases or fold marks will gradually disappear after cover assembly has been in service. In the event slight bubbles or wrinkles exist in fabric cover, they can be repaired as follows:

- a. Pierce bubble with small needle.
- b. Apply a dampened shop towel over area.
- c. Using a low heat home-type flat iron, apply iron to dampened towel using back and forth strokes until wrinkle or bubble disappears. Be certain shop towel does not become dry as excess heat will permanently damage fabric roof cover.

## FABRIC ROOF COVER (STATION WAGON STYLES)

The procedure for removal and installation of the fabric cover on station wagon styles is divided into two sections. The roof panel fabric cover procedure is followed by the tail gate fabric cover procedure.

**NOTE:** The roof panel fabric cover assembly is ordered as a separate service part. The fabric used on the tail gate is ordered as "yardage material" in the normal manner.

### DESCRIPTION

The roof panel fabric cover is cemented to the surface of the roof panel and tail gate with nitrile type vinyl trim adhesive. The fabric cover is also attached in the windshield opening by clips installed on weld-on studs, drive nails or self sealing screws and cement. In the tail gate opening, the cover is retained by two screws, and cement. Cement is also used at the belt line at the back body opening pillar. The roof drip scalp moldings aid in retaining the cover at the drip molding area.

### Removal

1. The following parts must be removed prior to removing the roof panel fabric cover:
  - a. Windshield pillar drip molding.
  - b. Windshield reveal moldings and all clips on weld-on studs in windshield opening. Do not attempt to remove a repair type clip where retaining screw is not accessible.
  - c. Back body opening upper and side reveal moldings.

- d. Roof drip molding scalps.
- e. Back body pillar cover finishing moldings.
- f. Tail gate upper glass run channel.

2. Clean off any excess adhesive caulking material in opening adjacent to windshield.
3. Remove screws, drive nails or staples from edge of fabric roof cover in windshield and back body pillar opening. Make certain edges of windshield are protected. Several layers of body cloth tape may be used. Trim roof cover around any reveal molding clips that could not be removed.

**NOTE:** Drive nails can best be removed by first driving a screwdriver or suitable tool under the heads of the nails to loosen them. Diagonal cutters or similar tool can then be used to grasp nails and twist them out. Unnecessary enlargement of holes in roof panel should be avoided.

4. Prior to removing fabric cover, application of heat to cemented areas will permit easier loosening of cemented edges.

**CAUTION:** Heat may be applied by lamps held 18" (minimum) from fabric only until fabric is warm. If lamps are held too close or fabric cover is heated over 200°F, the fabric may lose its grain, blister, or become very shiny.

5. Loosen cemented edges of fabric roof cover at windshield area, drip moldings, back body opening, and back body pillar areas; then,

carefully remove fabric cover from remaining cemented area of roof panel.

**Installation**

1. Check all cementing surfaces on body to insure a smooth surface. Cementing surface must be smooth to prevent "highlighting" of excess cement through fabric cover after new cover has been installed. Clean off old cement as required.

**NOTE:** A xylol solvent such as 3M Adhesive Cleaner or equivalent, should be used to remove or smooth out excess old cement. Apply solvent and allow to soak before rubbing. In the event any metal finishing is performed on roof panel, repaired area must be painted.

**CAUTION:** Be certain to follow manufacturer's directions when using cleaner.

2. Mask all painted surfaces, windshield, and back body opening.

**CAUTION:** Avoid prolonged contact of saturated masking materials to painted surfaces or paint etching may result.

3. Where possible, install new cover at room temperature (approximately 72°F), to permit easier fitting and removing of wrinkles from new cover assembly.

**NOTE:** Where new cover is installed at temperatures below 72°F, pliers fabricated as shown in Figure 12-1 will aid in removing wrinkles.

4. Determine centerline of roof panel by marking center points on windshield and back body opening with chalk or equivalent.
5. Fold cover lengthwise, precisely at center location. Mark center location at front and rear of cover.
6. Remove cover from roof panel and lay cover with lining side upward on a clean surface.
7. Apply an even application of nitrile non-staining vinyl trim adhesive (such as 3M Vinyl Trim Adhesive or Permalastic Vinyl Trim Adhesive or equivalent) over entire lining side of fabric cover.

**NOTE:** It is recommended that nitrile vinyl trim adhesive be applied by spraying. As an alternate method, a roller or brush may be used. If spraying method is utilized, a spray gun with a pressure cup, and specific Fluid Tip and air cap should be used as shown on chart below (or equivalent).

	Devilbiss		Binks	
Gun Model	MBC-510	JGA-502	62	18
1 Qt. Pressure	KB-519	KB-519	80-256	80-210
Air Cap	24	24	66PG	66PG
Fluid Tip	E	E	66	66
Fluid Needle	E	E	365	65

The recommended air pressures are as follows:

- A. Air Line Pressure - 50 lbs.
- B. Cup Pressure - 2 to 4 lbs.

Permalastic or 3M Vinyl Trim Adhesive purchased in the field is of spraying consistency. If rolling method is used, a mohair type roller should be utilized. Make certain cement is applied evenly and there are no highlights from excess cement build-up.

8. Allow cement on fabric roof cover to thoroughly dry.
9. Lay cover on roof panel and align to correspond with center line of roof panel. Determine proper material overhang to windshield and back body openings (approximately 3" overhang at seam area at back body and windshield opening).
10. Fold one half of cover back at centerline and apply nitrile type vinyl trim adhesive to exposed half of roof panel (including drip molding). Starting in center at centerline and working toward drip molding, immediately cement cover to area. As cover is being "unfolded" and cemented, it should be thoroughly "slicked" down with hands to avoid wrinkles or air bubbles.
11. Repeat Step 10 on opposite side of roof panel.

**NOTE:** Make certain that cover is free of wrinkles and seams are straight. Fabric cover pliers may be used in aiding removal of wrinkles.

12. Cut relief notches in cover at weld-on studs in windshield opening. Also, angle cut at corners as required.
13. Apply cement to windshield pillar and across top and down sides of windshield opening, at back body opening, and cement cover. In the event any reveal molding clips could not be removed, trim cover around clip and cement cover down behind clip.

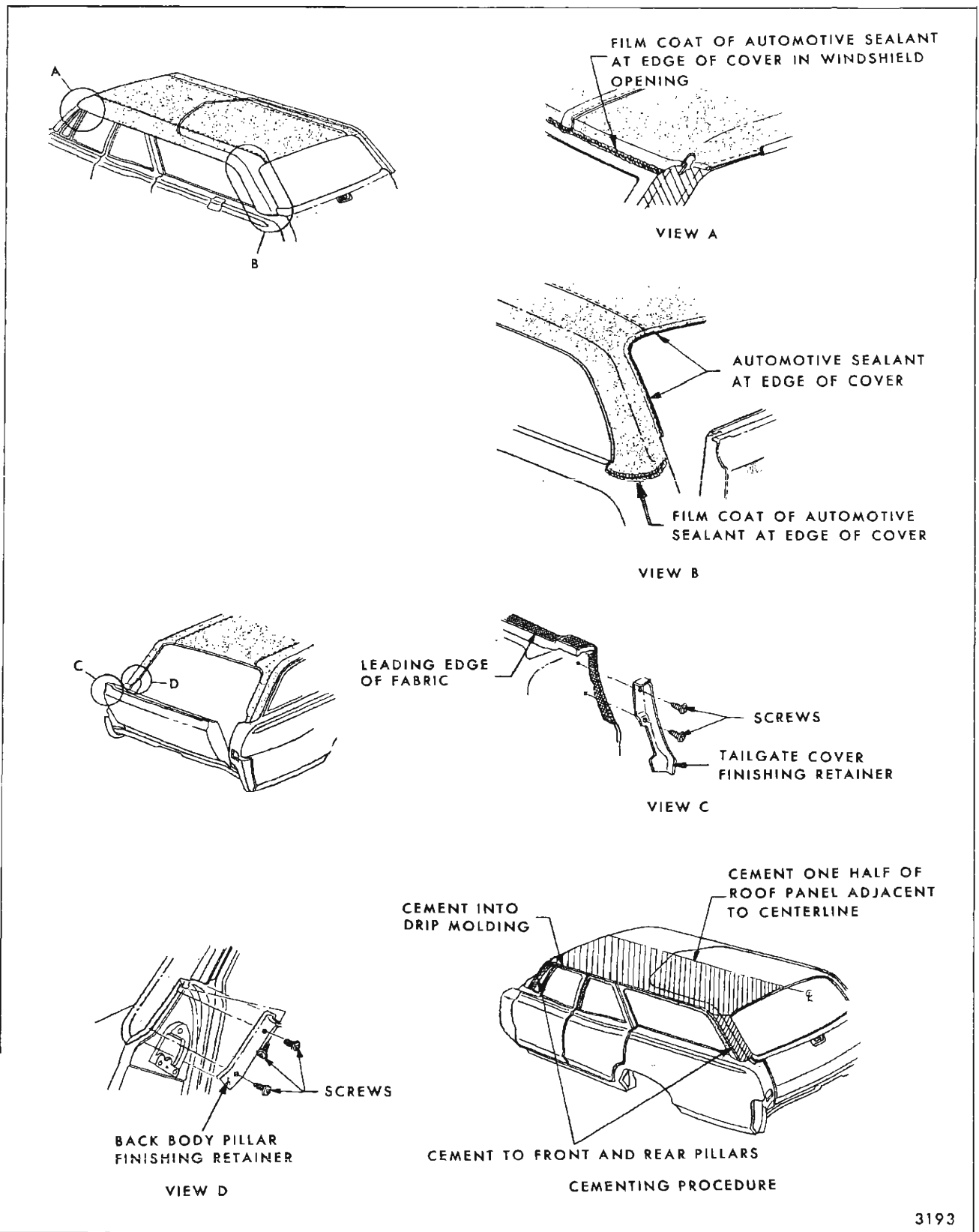

Fig. 12-8—Typical Fabric Roof Cover Installation on Station Wagon Styles



**NOTE:** Make certain a continuous and positive bond exists when cementing cover in windshield opening.

14. Trim off material at windshield opening, windshield pillar, back body opening, and back body pillar.
15. Cement cover into and around outboard side of roof drip molding (View "B", Fig. 12-3).
16. Install drip scalp moldings.
17. Apply a film coat of silicone sealant such as Dow Corning Automotive Sealant, or General Electric RVP, or equivalent, to the edge of cover in windshield and back body opening and at belt area. Make certain edges of material around all reveal molding clips that were not removed are also sealed. (Views A & B, Fig. 12-8).

18. Remove all protective covering.

19. Install all previously removed moldings and assemblies.

**NOTE:** Normally, minor creases or fold marks will gradually disappear after cover assembly has been in service. In the event slight bubbles or wrinkles exist in fabric cover, they can be repaired as follows:

- a. Pierce bubble with small needle.
- b. Apply a dampened shop towel over area.
- c. Using a low heat home-type flat iron, apply iron to dampened towel using back and forth strokes until wrinkle or bubble disappears. Be certain shop towel does not become dry as excess heat will permanently damage fabric roof cover.

## TAIL GATE FABRIC COVER

### DESCRIPTION

The tail gate fabric cover is a vinyl coated fabric of one section and is cemented to the surface of tail gate.

### Removal

1. The following parts must be removed prior to removing the tail gate fabric cover.
  - a. Tail gate belt reveal molding.
  - b. Tail gate window lower reveal molding.
  - c. Tail gate cover finishing retainer.
2. Prior to removing fabric cover, application of heat to cemented areas will permit easier loosening of cemented edges.

**CAUTION:** Heat may be applied by lamps held 18" (minimum) from fabric only until fabric is warm. If lamps are held too close or fabric cover is heated over 200°F, the fabric may lose its grain, blister or become very shiny.

3. Loosen cemented edges of fabric cover on tail gate, then carefully remove cover from remaining cemented area.

### Installation

1. Check cementing surfaces on body to insure a smooth surface. Cementing surface must be

smooth to prevent "highlighting" of excess cement through fabric cover after new cover has been installed. Clean off old cement as required.

**NOTE:** A xylol solvent such as 3M Adhesive Cleaner or equivalent, should be used to remove or smooth out excess old cement. Apply solvent and allow to soak before rubbing.

**CAUTION:** Be certain to follow manufacturer's directions when using cleaner.

2. Mask area below fabric break line on tail gate to protect painted surfaces.

**CAUTION:** Avoid prolonged contact of saturated masking materials to painted surfaces or paint etching may result.

3. To permit easier fitting and removing of wrinkles from new cover assembly, where possible, install new cover at room temperature (approximately 72°).
4. Position and install fabric cover on tail gate as follows:
  - a. Place fabric cover on protected surface with inner layer of material exposed.
  - b. Apply adhesive material to entire inner surface of fabric roof cover and allow to thoroughly dry.

12-14 ROOF COVER

---

**NOTE:** See Note under Step 7 in Fabric Roof Cover (Station Wagon Styles) installation procedure for method in applying cement.

- c. Apply adhesive material to exposed surface of tail gate panel including inner flange.
  - d. Immediately position fabric to top leading edge of tail gate panel and work material down to molding attaching holes.
  - e. Wrap fabric around flange on tail gate.
  - f. Trim off excess material on tail gate flange (View "C", Fig. 12-8).
5. Install all previously removed moldings and assemblies.

**NOTE:** Normally, minor creases or fold marks will gradually disappear after cover assembly has been in service. In the event slight bubbles or wrinkles exist in fabric cover, they can be repaired as follows:

- a. Pierce bubble with small needle.
- b. Apply a dampened shop towel over area.
- c. Using a low heat home-type flat iron, apply iron to dampened towel using back and forth strokes until wrinkle or bubble disappears. Be certain shop towel does not become dry as excess heat will permanently damage fabric roof cover.

## SECTION 13 FOLDING TOP

### INDEX

Subject	Page	Subject	Page
Folding Top Trim Assembly - Complete . . . . .	13-1	Folding Top Manual Lift Assembly - "A, F & Z"	
Description . . . . .	13-1	Styles . . . . .	13-37
Folding Top Cover and Back Curtain Removal . . . . .	13-1	Description . . . . .	13-37
Folding Top Silencer Assembly - Cadillac Styles . . . . .	13-7	Removal and Installation . . . . .	13-37
Removal . . . . .	13-8	Folding Top Catch Clips . . . . .	13-38
Installation . . . . .	13-9	Folding Top Adjustments - "A, B & C" Styles . . . . .	13-38
Folding Top Cover and Back Curtain Installation . . . . .	13-9	Adjustment of Front Roof Rail Guide . . . . .	13-39
Folding Top Cover - Less Back Curtain . . . . .	13-13	Adjustment of Front Roof Rail . . . . .	13-39
Removal . . . . .	13-13	Front Roof Rail Lock Assembly . . . . .	13-39
Installation . . . . .	13-16	Front Roof Rail Lock Adjustment . . . . .	13-39
Back Curtain Assembly . . . . .	13-19	Adjustment of Top Control Link . . . . .	13-39
Removal . . . . .	13-19	Trouble Shooting Chart . . . . .	13-42
Installation . . . . .	13-23	Folding Top Adjustment - "F" Body . . . . .	13-43
Hydro-Lectric System - All Except "Z" Body . . . . .	13-26	Description . . . . .	13-43
Description . . . . .	13-26	Adjustment of Front Roof Rail . . . . .	13-43
Motor and Pump Assembly . . . . .	13-27	Front Roof Rail Lock Assembly . . . . .	13-43
Reservoir Tube . . . . .	13-28	Front Roof Rail Lock Adjustment . . . . .	13-43
Operation of Folding Top . . . . .	13-28	Adjustment of Top Control Link . . . . .	13-44
Operation of Pump Assembly . . . . .	13-28	Adjustment of Top at Male Hinge . . . . .	13-44
Fluid Control Valve . . . . .	13-29	Trouble Shooting Chart . . . . .	13-46
Mechanical Checking Procedure . . . . .	13-29	Folding Top Adjustments - "Z" Body . . . . .	13-48
Electrical Checking Procedure . . . . .	13-30	Description . . . . .	13-48
Hydraulic Checking Procedure . . . . .	13-31	Adjustment of Front Roof Rail Wedge Plate . . . . .	13-49
Folding Top Lift Cylinder . . . . .	13-33	Adjustment of Front Roof Rail . . . . .	13-49
Filling of Hydro-Lectric Reservoir . . . . .	13-33	Front Roof Rail Lock Assembly . . . . .	13-49
Actuator Assembly - "Z" Styles . . . . .	13-35	Front Roof Rail Lock Adjustment . . . . .	13-49
Removal . . . . .	13-35	Adjustment of Top Control Link . . . . .	13-49
Installation . . . . .	13-35	Adjusting Plate . . . . .	13-49
Inoperative Folding Top in Down ("Stacked")		Adjustment of Male Hinge . . . . .	13-50
Position . . . . .	13-37	Trouble Shooting Chart . . . . .	13-50
Top Lift Assembly . . . . .	13-37		

## FOLDING TOP TRIM ASSEMBLY (COMPLETE)

### DESCRIPTION

The "A", "B" and "C" style convertible tops incorporate a one-piece rear belt rail trimstick assembly which mounts directly to the folding top male hinges. For trim repair and replacement purposes, the one-piece trimstick can be disconnected from the male hinges and raised above the rear belt rail. The trimstick, with due care in handling and removal, maintains its full shape and is sufficiently stiff for tacking or stapling operations.

On "F" and "Z" convertible styles, the rear trimstick is of three-piece construction and is secured to the body by attaching bolts completely around the rear belt rail.

All convertible top cover assemblies incorporate a spring loaded hold-down cable along the sides. The cables are retained in a pocket sewn to the top cover and are secured at the front and rear ends

by screws. Under tension, the cables are designed to form a tight fit of the top cover to the side rails to minimize air leakage along the side roof rails.

All "A", "B", and "C" convertible back curtains utilize an integral solid - tempered back window glass. "F" and "Z" convertible styles are equipped with a pliable plastic back window.

### FOLDING TOP COVER AND BACK CURTAIN ASSEMBLY

#### Removal

1. Apply masking tape to rear quarter pinchweld finishing moldings, and apply cover protection on rear deck and other adjacent painted surfaces.
2. Mark position of top cover vertical edges on back curtain valance at rear belt line. Use sharpened grease pencil (Fig. 13-1).

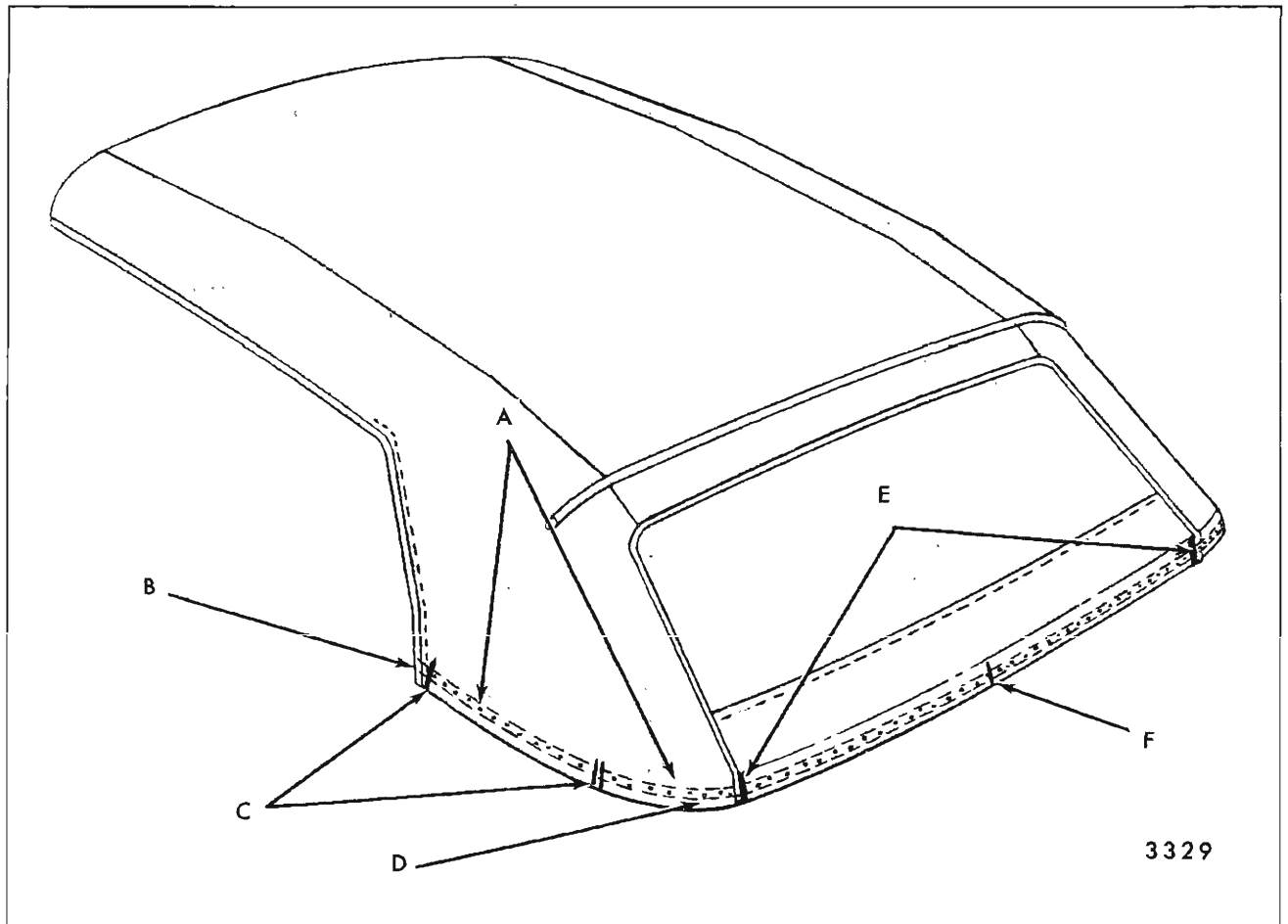

Fig. 13-1—Reference Marks on Top Cover and Back Curtain

A. "A, B, & C" One Piece Trimstick  
 B. Trim Line at Corner Varies by Series  
 C. "F & Z" Quarter Trim Stick

D. "F & Z" Rear Trim Stick  
 E. Top Cover Vertical Edge Reference  
 F. Back Curtain Center Reference

3. Remove rear seat cushion. Disconnect rear seat speaker if present, and remove rear seat back.
4. Remove right and left folding top compartment side trim panels.
5. Lower top part-way, and remove side roof rail rear and center weatherstrips. Then, lower top to stacked position and remove weatherstrips from front roof rail and side roof front rails.
6. Detach top cover from front roof rail. Then raise top and detach top cover flaps from side roof rear rails. Remove escutcheons and wire-on binding from rear bow. Also, detach top cover at rear bow. Note location and spacing of staples before removal.
7. With front roof rail raised several inches off

windshield header, remove attaching screws from front and rear of each hold-down cable (Views "A" and "B" in Fig. 13-2). Remove cables.

8. At underside of front bow, (Fig. 13-3) remove screws securing listing pocket retainer to front bow. Disengage retainer from bow and remove retainer from listing pocket. Note location of screws before removal.
9. Detach folding top compartment bag from rear seat back panel.
10. Lock top to windshield header and install spacer stick along inboard edge of each side stay pad (Fig.13-4).

Spacer sticks can be fabricated as shown in Figure 13-5. Fit spacer sticks snugly between

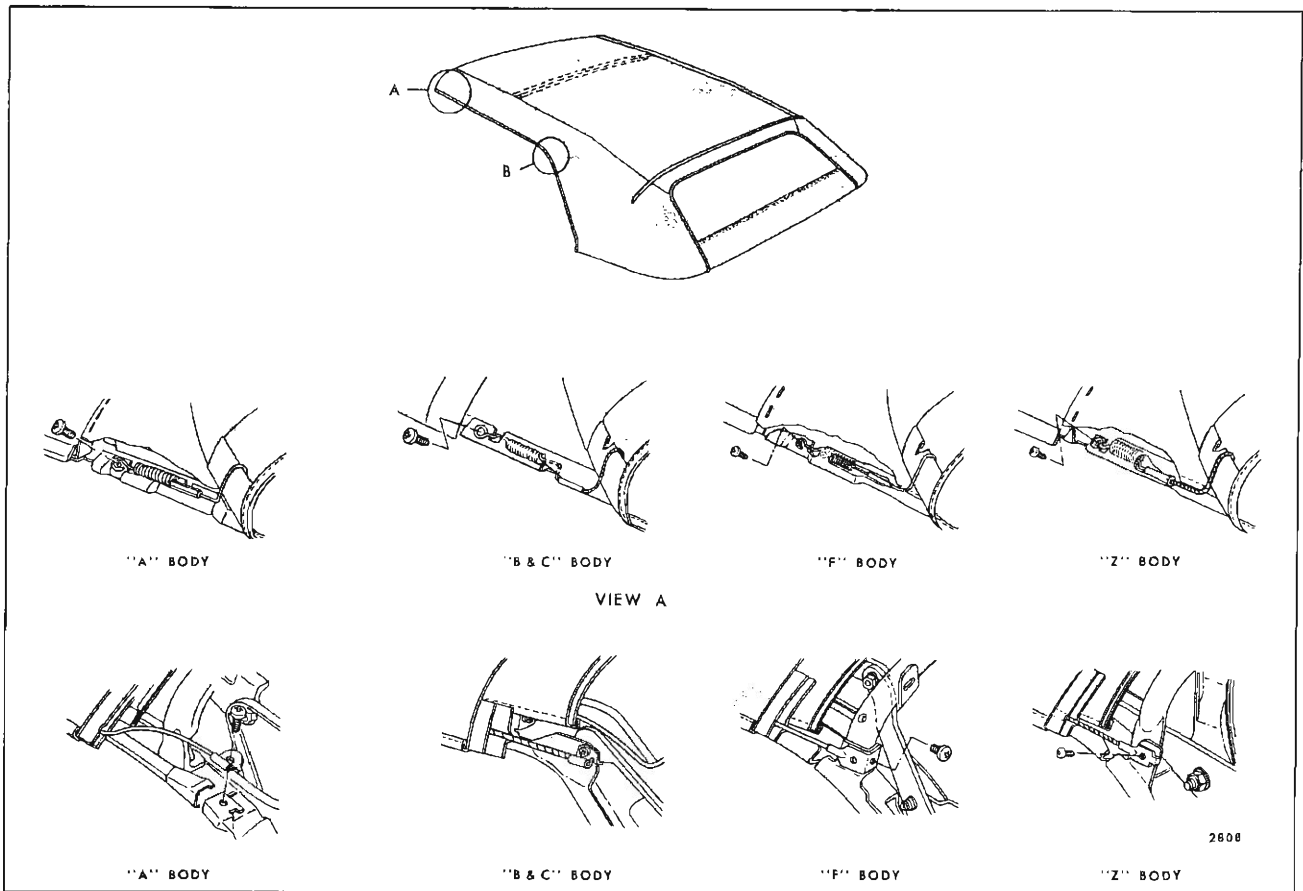

Fig. 13-2—Hold Down Cable Attachment

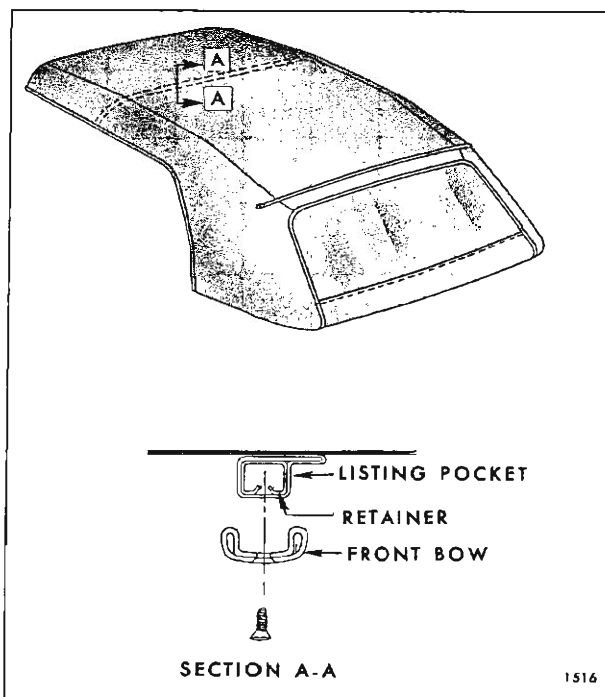

Fig. 13-3—Listing Pocket Retainer

center bow and rear bow, then tighten wing nuts. Spacer sticks are adjustable. Fasten rear bow securely to side roof rear rails.

**NOTE:** The purpose of spacer sticks is to hold the rear bow in a stationary (car installed) position during back curtain and/or side stay pad removal and installation.

**MATERIAL PER STICK**

- Wood - 1/2 x 1 x 14-1/2
- Steel - 1/32 x 1/2 x 2-1/2
- Steel - 1/32 x 1-1/2 x 7
- 2 Screw #6 x 1/2"
- Bolt 1/4 - 20 UNC - 2A x 1"
- Wingnut 1/4 x 20 UNC - 2B
- 2 Washers 1/4" I.D.

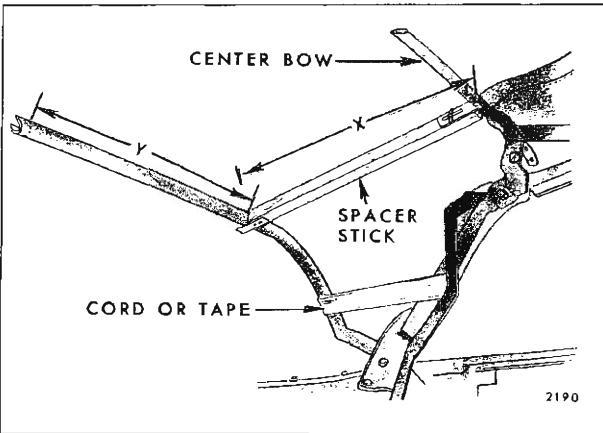

Fig. 13-4—Spacer Stick Installation

11. Raise front roof rail several inches off windshield header and disconnect rear trimstick(s), as required, by removing attaching bolts.

On "A" styles, use a suitable box-socket type wrench to remove each bolt from "outside" surface of male hinge (Fig. 13-6 and 13-7).

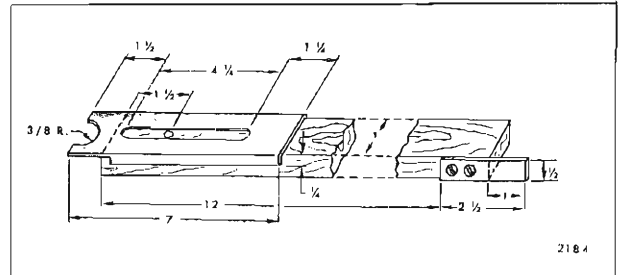

Fig. 13-5—Spacer Stick Fabrication

On "B" and "C" styles, use a conventional type socket and extension to remove each bolt from "inside" surface of male hinge (Fig. 13-8).

On "F" and "Z" styles, remove trimstick attaching bolts by working through rear compartment; or by working inside car. If inside car, access to attaching bolts may be gained by raising and fastening forward end of top compartment bag to center bow (Fig. 13-9 and 13-10).

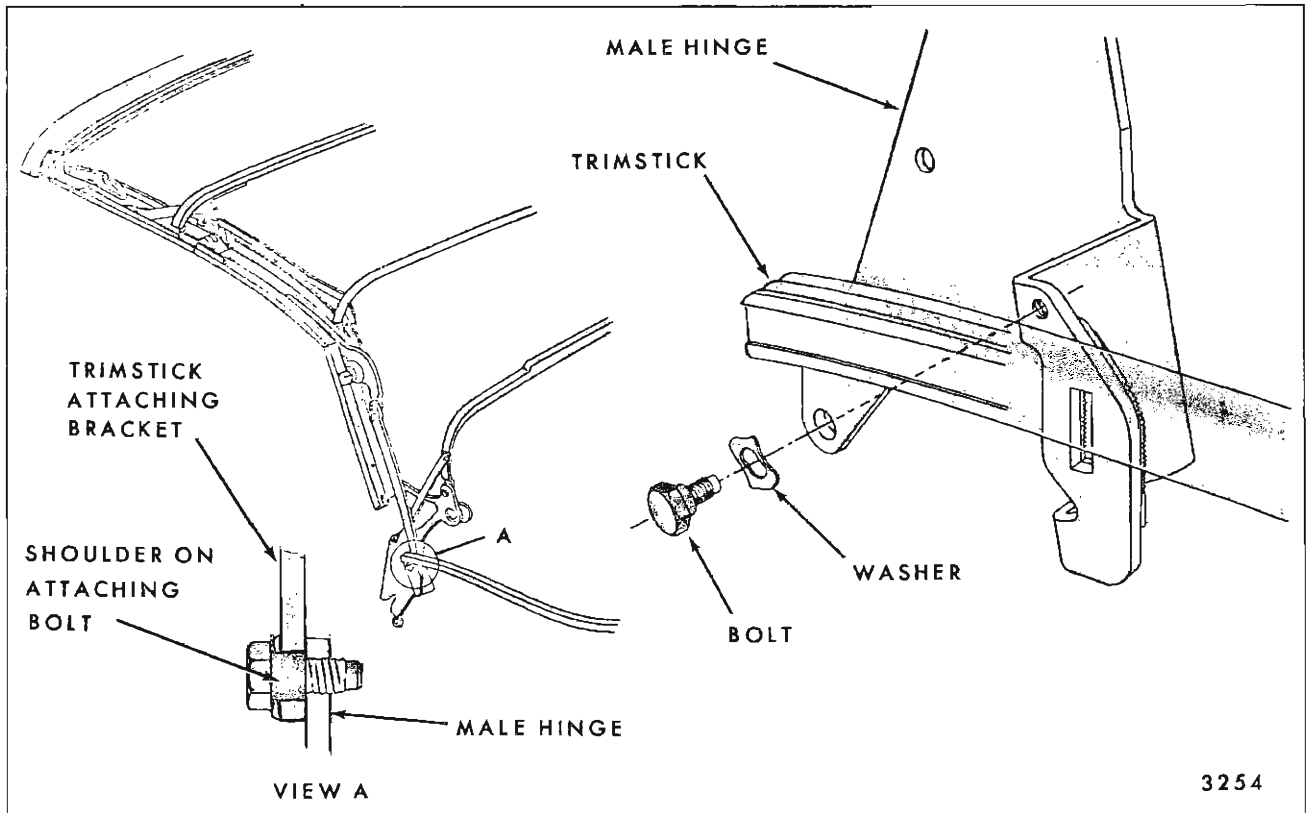

Fig. 13-6—Trimstick Attachment "A" Styles

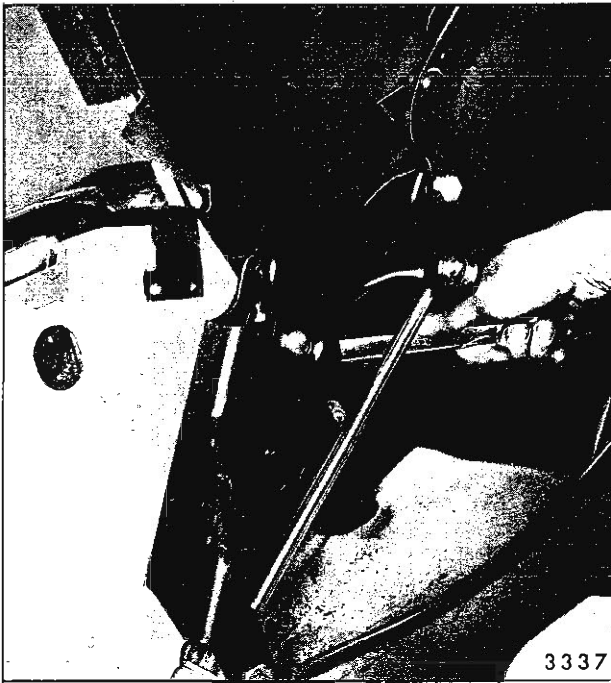

Fig. 13-7—Trimstick Removal "A" Styles

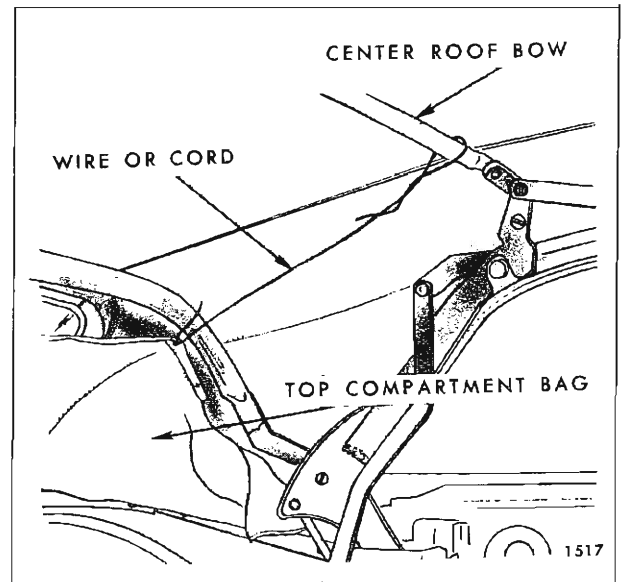

Fig. 13-9—Raising Folding Top Compartment Bag

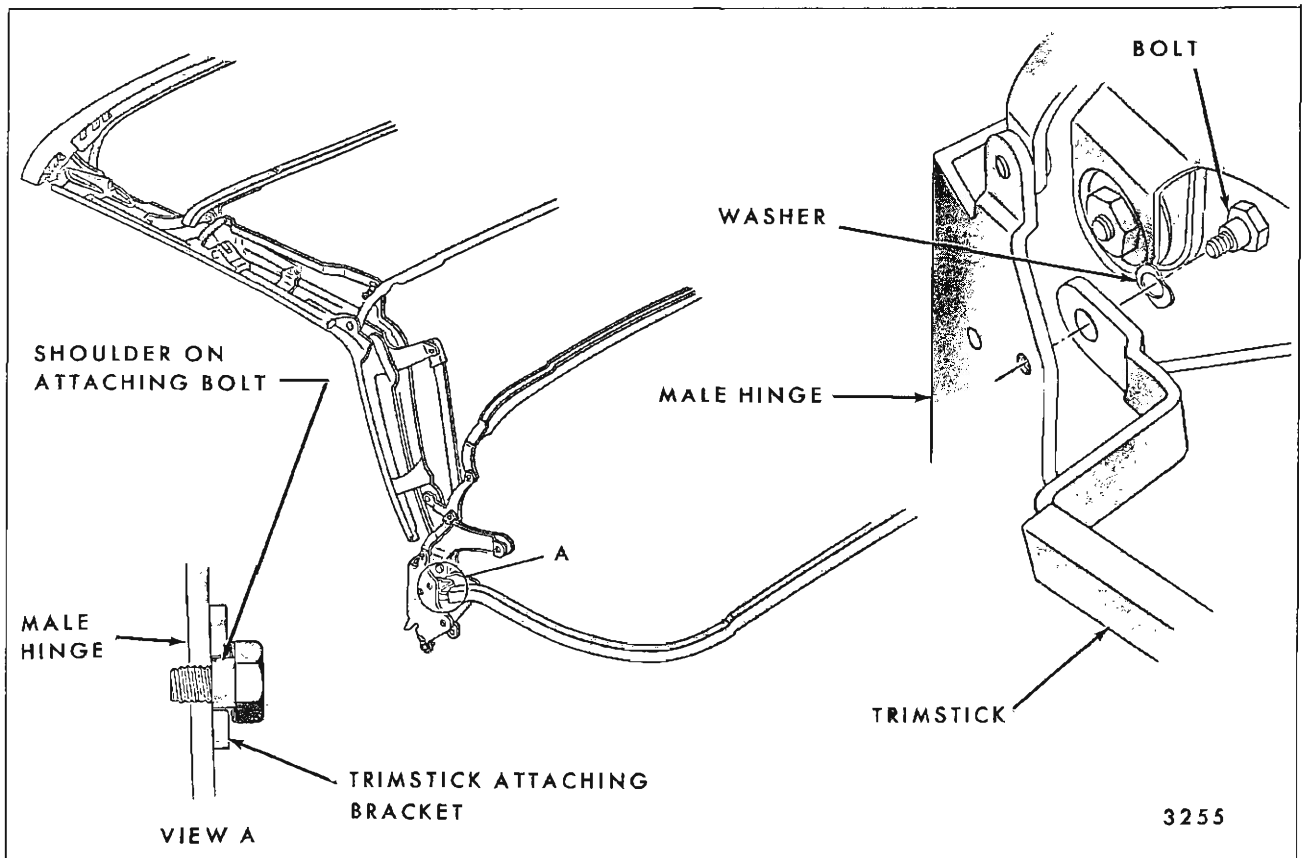

Fig. 13-8—Trimstick Attachment "B & C" Styles

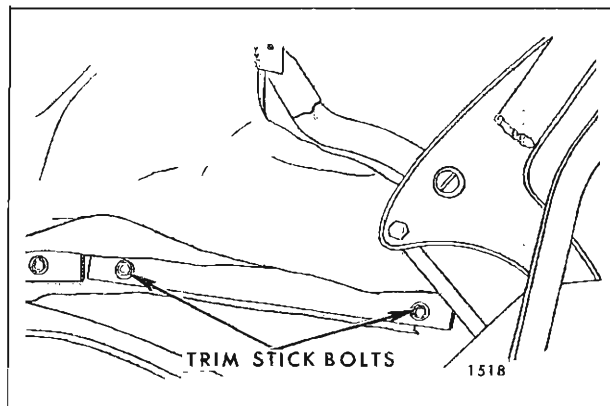

Fig. 13-10—Quarter Trimstick "F & Z" Styles

12. Remove rear trimstick(s) from body and position above quarter pinchweld finishing moldings.

On "A" styles, with top two to four inches off header, move one end of trimstick inward for clearance. Then pry it upward between hinge and body to clear rear side roof rail (Fig. 13-11). Raise removed end of trimstick upward and forward. Then continue by removing balance of trimstick above body belt line (Fig. 13-12 and 13-13).

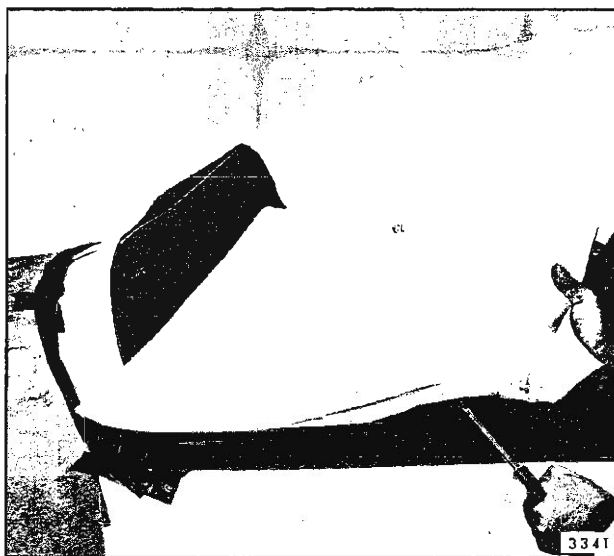

Fig. 13-11—Raising End of Trimstick "A" Styles

On "B" and "C" styles, with top two to four inches off header, move both ends of trimstick down and forward after obtaining clearance at hinges.

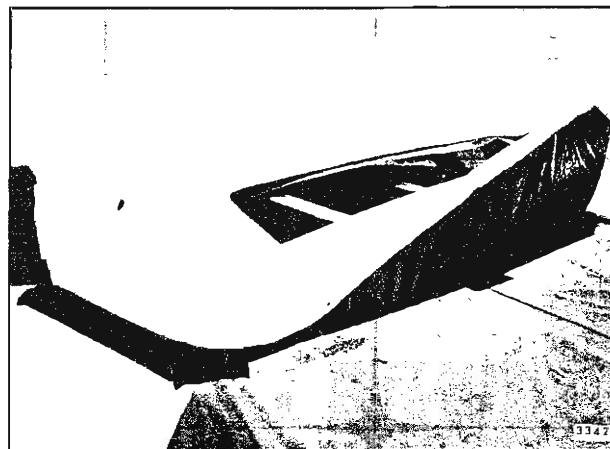

Fig. 13-12—Raising Balance of Trimstick "A" Styles

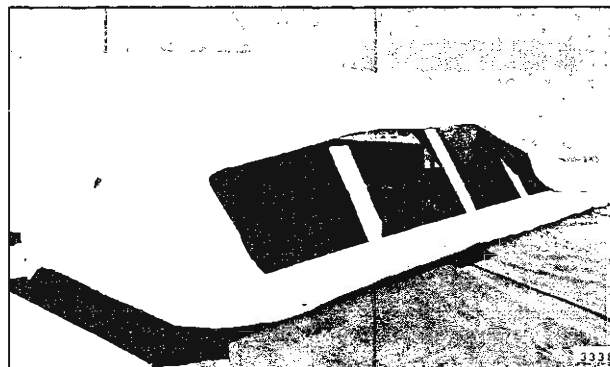

Fig. 13-13—Trimstick Removed "A" Styles

**CAUTION:** Avoid contact with or damage to top lift cylinder piston rod.

Then, move one side of trimstick inward for rear radius of trimstick to clear body radius. Raise one radius of trimstick from body; raise opposite radius of trimstick from body; (Fig. 13-14) then, with aid of helper, lift remainder of trimstick above body belt line.

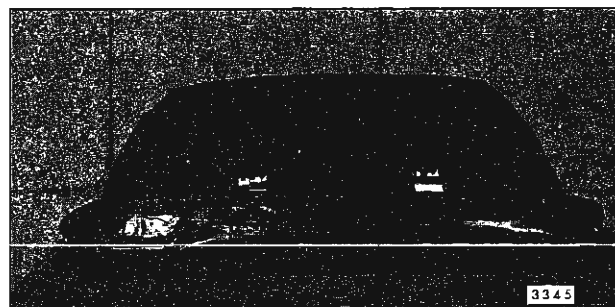

Fig. 13-14—Removing Trimstick From Top Compartment "B & C" Styles



13. Perform this operation on car, or later on bench:

Using a suitably sharp pencil, accurately mark location of complete rear trimstick(s) (upper and lower edges and ends) on outer surface of top cover and on back curtain. Re-check, and mark right and left inner vertical edge of top cover on back curtain at trim stick (Fig. 13-1). Make center mark on curtain at "V" notch on trimstick.

14. Detach and remove top cover from rear trimstick(s). Accurately mark location of balance of trimstick(s) on back curtain. Note spacing of staples before removal.
15. Detach back curtain from rear bow and, with the aid of a helper, remove rear trimstick(s) with attached back curtain and top compartment

bag from body. Place on clean, protected surface. Note location and spacing of staples before removal.

16. Re-check accuracy of trimstick location markings on back curtain, and remove curtain from trimstick(s). Note location and spacing of staples before removal.
17. Remove polyurethane and side stay pads. Stay pads are secured with tacks or staples to front roof rail, front roof bow and rear roof bow, and with screws to center bow (Fig. 13-15 and 13-16).

**NOTE:** On Cadillac styles, silencer assembly must be removed prior to side stay pad webbing. For Removal and Installation procedure, refer to Silencer Assembly section.

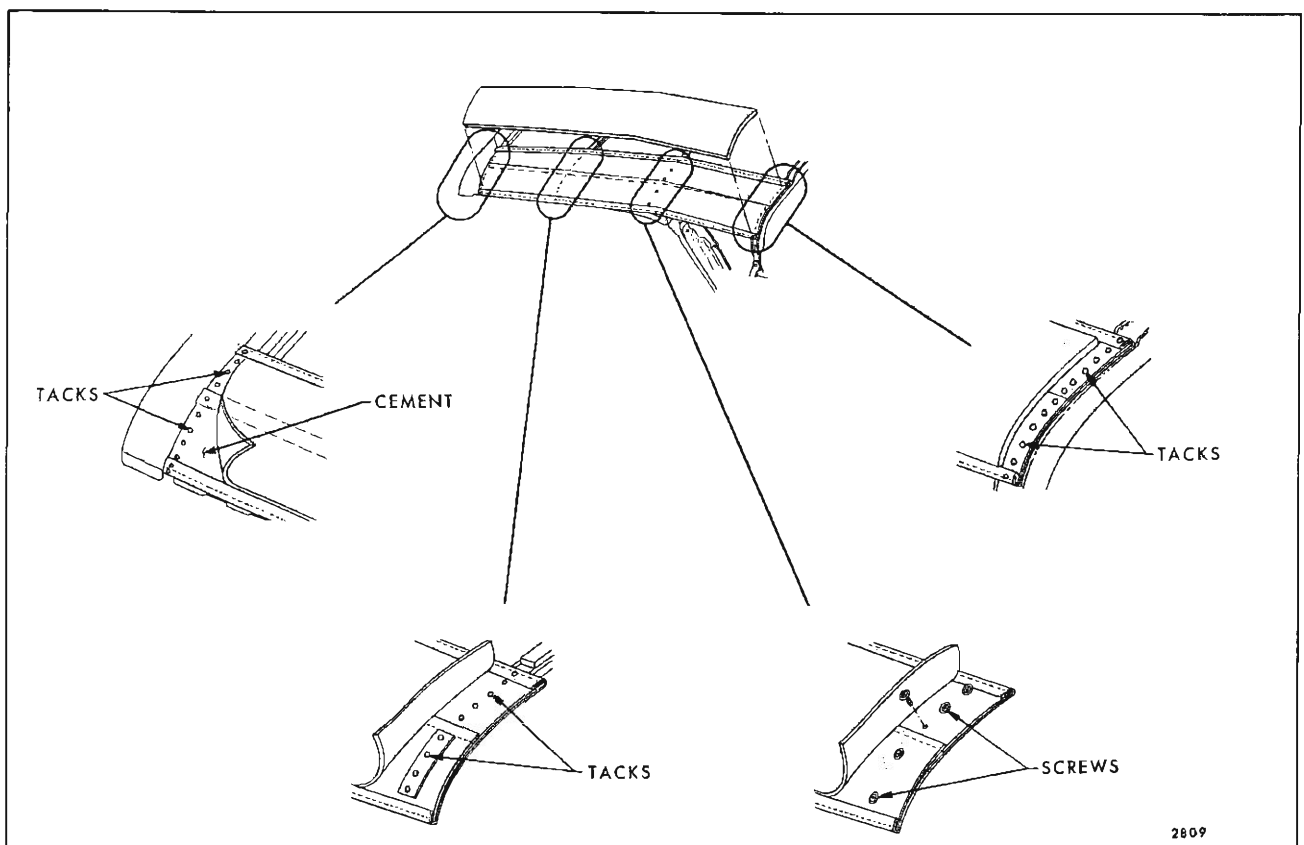

Fig. 13-15—Side Stay Pad Attachment

### FOLDING TOP SILENCER ASSEMBLY CADILLAC STYLES

The Silencer Assembly consists of a piece of dead-

ener material sewn to a lining type material which is serviced as a complete kit. The Silencer Assembly is installed in such a manner as to cover the area between the front roof rail and front roof

bow, and from the right side stay pad to the left side stay pad (Fig. 13-16).

**Removal of Silencer Assembly**

1. Lower top to stacked position.

2. Remove front roof rail front and rear weatherstrips.

3. Remove side rail front weatherstrips.

4. Detach folding top material from front roof rail (Fig. 13-17).

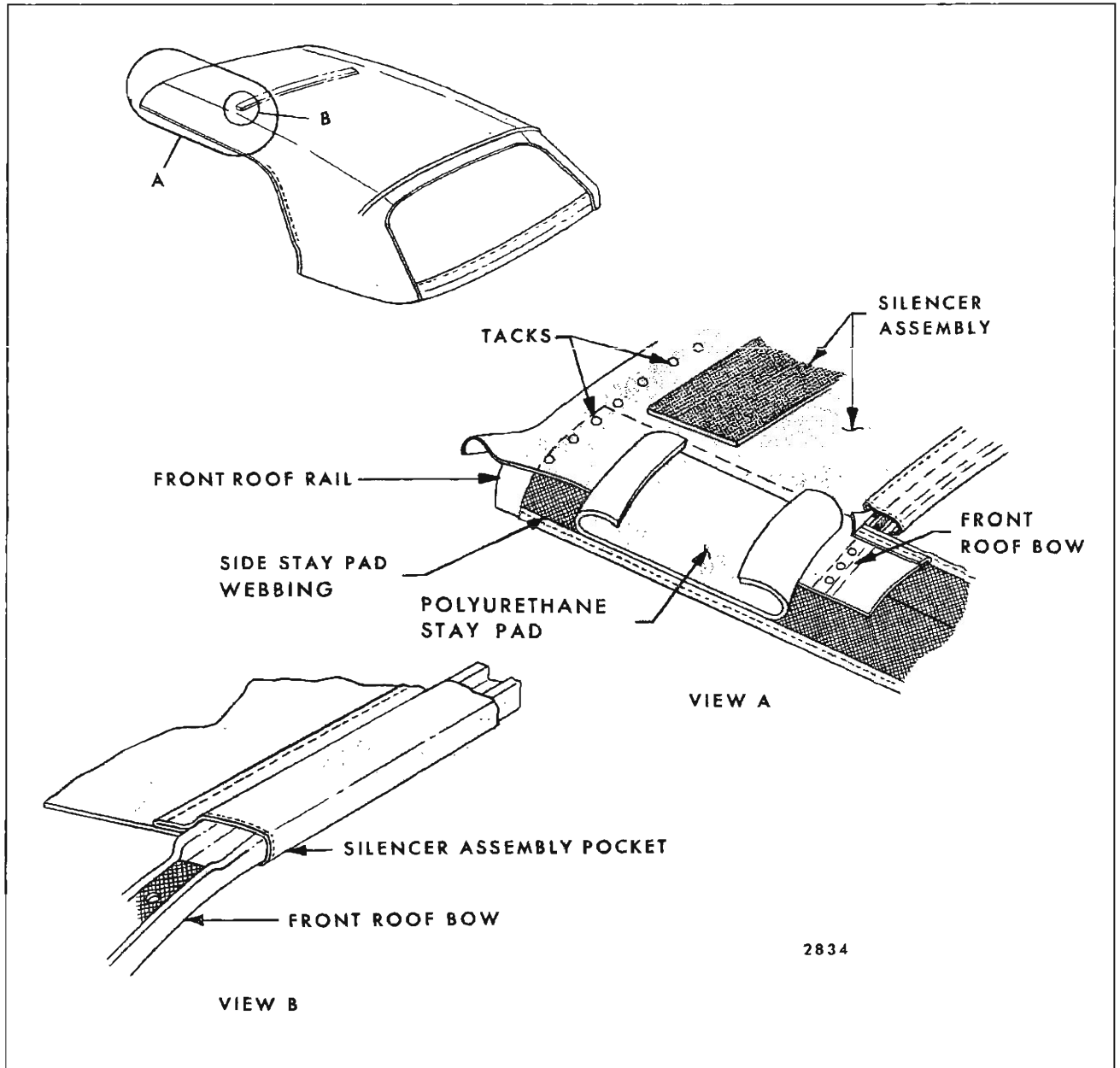

Fig. 13-16—Folding Top Silencer Installation - Cadillac Styles

5. Detach top material flaps from side roof front rails.

6. With front roof rail raised slightly above

windshield header, remove hold down cable screws at front and rear roof rails (View "A", Fig. 13-25).

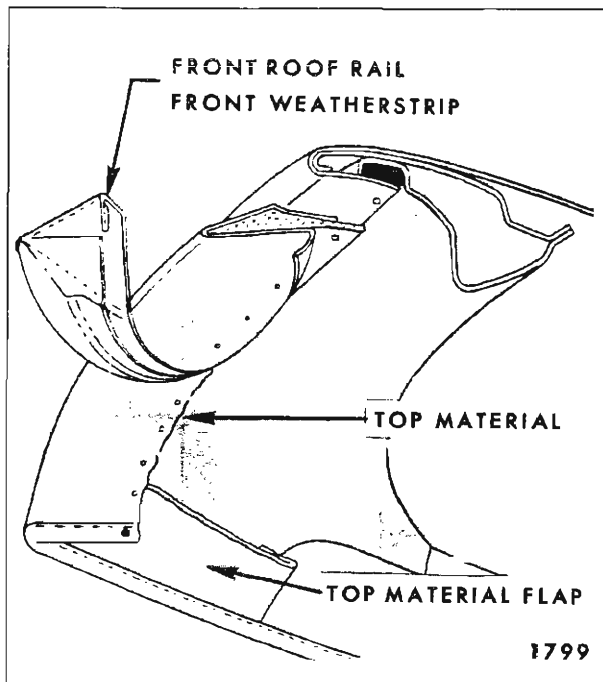

Fig. 13-17—Top Cover at Front Roof Rail

7. At underside of front roof bow, remove screws securing listing pocket retainer to bow (Fig. 13-3).
8. "Peel" folding top material rearward until front roof bow is exposed.
9. From front roof rail to front roof bow, remove polyurethane stay pad.
10. Remove tacks from front roof rail securing Silencer Assembly.
11. Remove Silencer Assembly from entire front roof rail and stay pad webbing (silencer is cemented).
12. Remove screw securing front roof bow to right folding top side roof front rail to front bow link.
13. Slide pocket on Silencer Assembly off front roof bow and remove silencer from car.

#### Installation of Silencer Assembly

1. With deadener pad on top side of assembly, slip pocket on assembly over front roof bow (View "B", Fig. 13-16).
2. Secure right side of front bow to side roof front rail-to-front bow link.

3. Apply nitrile type cement to stay pad webbing and to front roof rail.
4. Stretching assembly taut, cement assembly to front roof rail and stay pad webbing.

**NOTE:** Prior to cementing make certain assembly is centered.

5. Tack outboard ends of assembly to front roof rail (View "A", Fig. 13-16).
6. Cement side polyurethane stay pad to assembly.
7. Refer to steps 16 thru 21 of Installation procedure for Folding Top Cover and Back Curtain.
8. When completed, folding top should be free from wrinkles and draws. Install all previously removed hardware and weatherstrips.

#### FOLDING TOP COVER AND BACK CURTAIN ASSEMBLY

##### Installation

1. With front roof rail locked at windshield header, and with rear bow spacer sticks firmly in place, install side stay pads. Align stay pads with depression in rear bow and tack to secure. Pull stay pads forward for snug fit and tack to front roof rail. Tack stay pads to front bow. Secure stay pads to center bow with screws. Check alignment of polyurethane padding on stay pads to determine cementing area, and remove. Apply an approved trim cement to stay pads uniformly and install polyurethane padding (Fig. 13-15). Trim off selvage end (excess material) of stay pads just forward of rear rolled edge of rear bow. Also, trim at front roof rail as required.
2. Transfer reference marks from removed back curtain to new one as follows: Place new back curtain on clean covered bench with inner surface down. Position removed back curtain correspondingly over new one. Carefully align upper window over lower one. While holding both curtains together securely, carefully lay out trim material of both curtains and transfer following reference marks along bottom: location of trimstick(s) (upper and lower trimstick edges, as well as ends); location of inner vertical edges of top cover; on "F" and "Z" styles, location of bolt holes. Allow 1/2 inch of back curtain material to extend below trimstick(s) (Fig. 13-18 and 13-19).

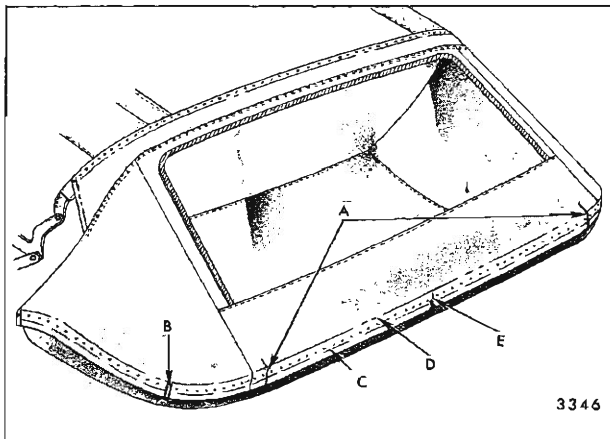

Fig. 13-18—Back Curtain Installation

- A. Top Cover Rear Vertical Edge References
- B. "F & Z" Quarter and Rear Trimstick Ends
- C. Trimstick Lower Edge Reference
- D. Trimstick Upper Edge Reference
- E. Back Curtain Center Reference

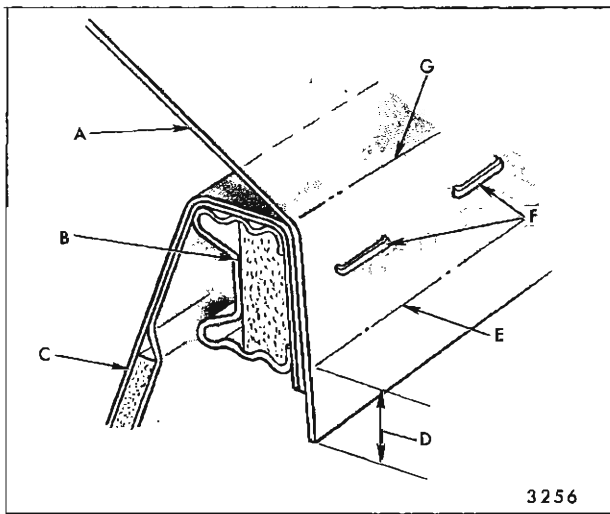

Fig. 13-19—Cross Section at Rear Trimstick - "A, B & C" Styles

- A. Back Curtain
- B. Rear Belt Rail Trimstick Assembly
- C. Folding Top Compartment Bag
- D. 1/2 inch over-hang
- E. Lower Edge Reference Mark
- F. Staples
- G. Upper Edge Reference Mark

Then reverse back curtains by positioning new curtain over removed one as described above. Re-check location of reference marks.

**NOTE:** If any difference is noted, the average

between the two is the correct reference to use. Mark corrected references clearly.

Along bottom, trim off excess material beyond the 1/2 inch allowance. Transfer center mark from bottom center of removed curtain to new one.

**IMPORTANT:** Transfer of reference marks must be done in a highly exacting manner for best results and minimum rework.

3. As a bench operation, position and center new back curtain to trimstick(s) according to reference marks and tack curtain to trimstick(s). Tack from center to ends. Avoid stretching, but keep material flat during tacking operations.

On "F" and "Z" styles, place tacks close to each side of every bolt hole in trimsticks. Then cut out or punch holes for bolts in curtain.

4. On "F" and "Z" styles, inspect and, if necessary, install mastic type fillers around holes of folding top compartment rear panel for proper sealing of bolts (Fig. 13-20).

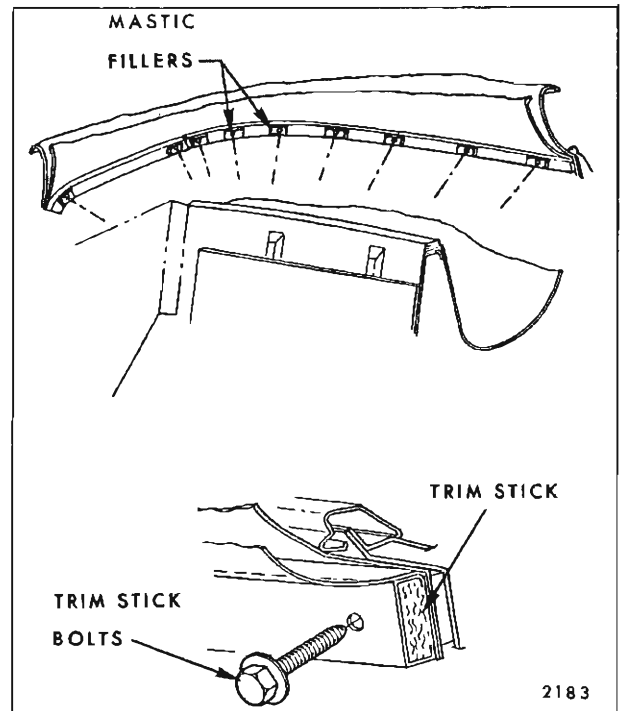

Fig. 13-20—Checking Trim Stick Fillers - "F & Z" Styles

5. Transfer reference marks from removed top cover to new one as follows: Place new top

cover on a suitable clean surface, such as on clean roof of a car to provide proper contour and fullness, with inner surface of cover down. Position removed top cover over new one. Carefully align back window opening upper corners and rear quarter upper corners of both covers. Secure both covers together at these locations. Carefully lay out trim material of sail area of both covers.

Transfer location marks for trimstick(s) (upper and lower trimstick edges, as well as ends, Fig. 13-24).

Then reverse position of covers by positioning new cover over removed one, as described above. Re-check location of reference marks.

**NOTE:** If any difference is noted, the average between the two is the correct reference to use. Mark corrected references clearly.

On "F" and "Z" styles, also transfer bolt hole locations. Allow for 1/2 inch of top cover to extend beyond trimstick(s) (Fig. 13-19). Along bottom, trim off excess material beyond 1/2 inch over-hang.

**IMPORTANT:** Transfer of reference marks must be done in a highly exacting manner for best results and minimum rework.

6. As a bench operation, position and locate top cover to trimstick(s) according to reference marks and tack top cover to trimstick(s). Tack from top cover inner vertical edge reference on back curtain toward front. Avoid excessive stretching, but keep material flat during tacking operations (Fig. 13-24).

On "F" and "Z" styles, place tacks close to each side of every bolt hole in trimstick(s). Then cut out or punch holes for bolts in top cover.

7. With aid of a helper, position rear trimstick(s), with attached bag, cover and back curtain, on rear deck of body. Use care in protecting trim material and back window during this operation. With front roof rail slightly off header, position bag in folding top well and stay-tack edge of back curtain to rear bow to protect back window during trimstick installation. Also, lay top cover on folding top framework.
8. Position rear trimstick(s) into body in reverse of removal operations (See Step 12 of Removal of Folding Top and Back Curtain Trim Assembly, Fig. 13-12 or 13-14).
9. Secure rear trimstick(s) to body assembled position and tighten all attaching bolts (Fig. 13-27, 13-29 and 13-31).

10. With front roof rail locked to windshield header, and with top cover laying on rear deck, tack back curtain to rear bow as follows: Remove all stay tacks except two at outer ends supporting back curtain. Then pull curtain forward to remove all fullness and tack curtain to rear bow. Tack from center toward each end of curtain. Remove stay tacks. Apply forward tension to curtain at each point of tack installation (Fig. 13-21).

**CAUTION:** On "A", "B", and "C" styles, be sure one-piece trimstick is flush to quarter pinchweld finishing molding during all tacking operations. This will require assistance of a helper or a support.

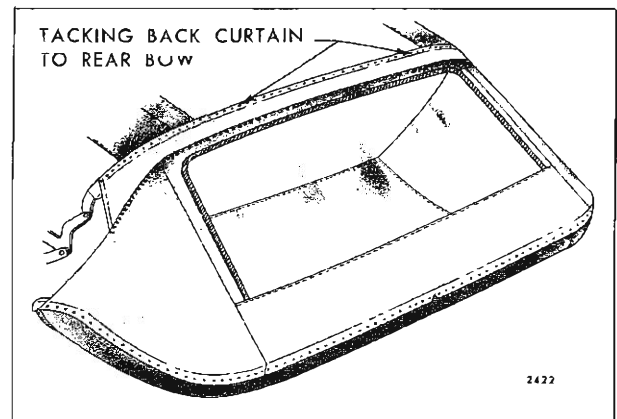

Fig. 13-21—Tacking Back Curtain

11. Insert hold-down cables into top cover listing pockets and secure as follows:

Raise front roof rail slightly above windshield header. A length of welding rod or equivalent wire can be used to facilitate cable insertion by pulling cable through listing pocket. Install attaching screw at rear of cable. Then, apply forward pull on cable and install front attaching screw (Fig. 13-25).

12. Insert and center retainer in top cover listing pocket at front roof bow. Position retainer on front bow and install attaching screws (Fig. 13-26).
13. Apply nitrile cement or neoprene type weather-strip adhesive to cementing surfaces of side roof rear rails and to quarter flaps. Center top cover over rear bow and align quarter flap seams with edges of side roof rear rails to remove all fullness from rear of top cover. A forward draw on cover outer sides will aid this operation. With quarter flap seams aligned with each rear rail, cement quarter flaps securely in place.

**NOTE:** Top cover may require some lateral stretching along rear bow to achieve proper fit of quarter flaps to rear rails, and to remove fullness from top cover valance over rear window.

14. Using an awl or equivalent tool, pierce flaps for side roof rear rail weatherstrip attaching screws. Install weatherstrips to help maintain position of quarter flaps while adhesive is drying.
15. While pulling top cover rearward slightly to straighten material over rear window, install tacks to secure cover to rear bow.

**IMPORTANT:** Tacks must be installed in a straight line in center of rear bow. Tacks outboard of deck seams should not exceed 6 inches. Also, tacking distance outboard of deck seams on each side should be uniform. Pierce hole into top material and tacking strip at each outboard end of rear bow for wire-on binding clip escutcheons.

16. Lock front roof rail to windshield header. Pull top cover straight forward at seams to desired top fullness. While maintaining tension on cover over front roof rail, make pencil mark on cover outer surface along forward edge of front roof rail (Fig. 13-22).

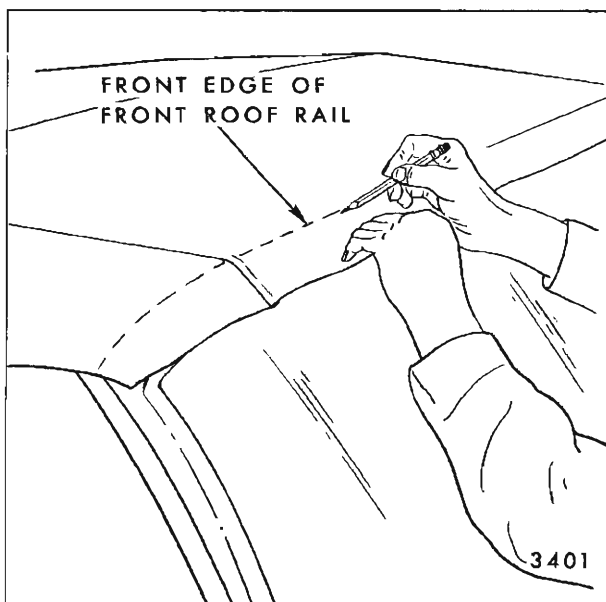

Fig. 13-22—Marking Top Cover at Front Roof Rail

17. Lower top to stacked position. Carefully, apply nitrile cement or neoprene weatherstrip adhesive to cementing area of front roof rail, to

corresponding surface of top cover, and to front corner flaps.

18. Raise top within four inches of windshield header and support roof rail on header with suitable wood block. Secure cover to front roof rail by pulling top cover reference marks slightly beyond target so that pencil marks will be slightly under front edge of roof rail. With doors open, align sides of top cover with forward pull, and secure corner flaps to cemented surfaces. Remove wood block and complete cementing top cover to front roof rail. Lower top and install several stay tacks.
19. Raise top and lock to windshield header. Check appearance of top trim, top operation and locking action of top. If additional tension is needed in top cover, repeat Step 18 and pull top cover further forward. Stay tack and re-check top for proper appearance and operation.
20. Lower top and complete tacking of top cover to front roof rail. Trim off excess material (Fig. 13-23).

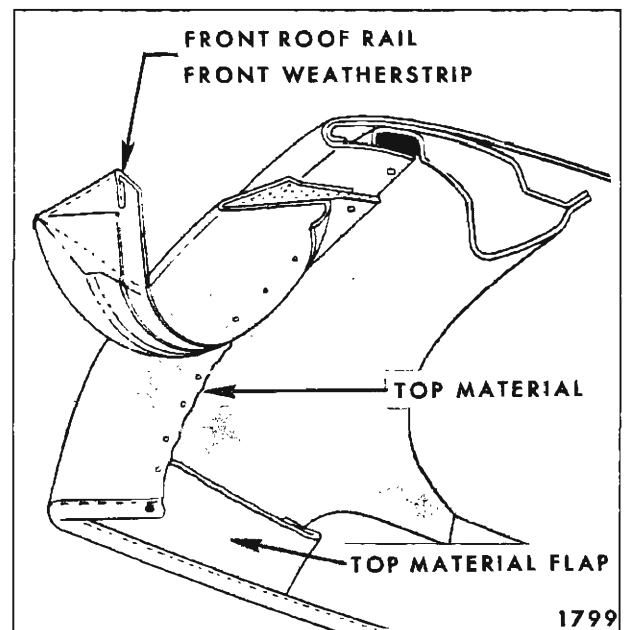

Fig. 13-23—Top Cover at Front Roof Rail

21. Carefully align, seal and install front roof rail and side roof rail weatherstrips.
22. Raise top, and using due caution, apply a bead of neoprene-type weatherstrip adhesive around each rear bow tack head and into two holes pierced into top material for wire-on binding clip escutcheon screws. Applied adhesive must be within area covered by wire-on binding.

23. Install rear bow wire-on binding and escutcheons. Tack from center outward to maintain a snug and straight fit. Length of binding outside of deck seams should not exceed 6 inches and should be of uniform length on each side.
24. When completed, folding top should be free from wrinkles and draws. Install all previously removed trim and hardware. Clean up top material and car as required.

2. Mark position of top cover vertical edges on back curtain valance at rear belt line. Use sharpened grease pencil (Fig. 13-24).
3. Remove rear seat cushion. Disconnect rear seat speaker, if present, and remove rear seat back.
4. Remove right and left folding top compartment side trim panels.
5. Lower top part-way, and remove side roof rail rear and center weatherstrips. Then lower top to stacked position and remove weatherstrips from front roof rail, and side roof front rails.
6. Detach top cover from front roof rail. Then raise top and detach top cover flaps from side roof rear rails. Remove escutcheons and wire-on binding from rear bow. Also, detach top

### FOLDING TOP COVER LESS BACK CURTAIN

#### Removal

1. Apply masking tape to rear quarter pinchweld finishing moldings, and apply cover protection on rear deck and other adjacent painted surfaces.

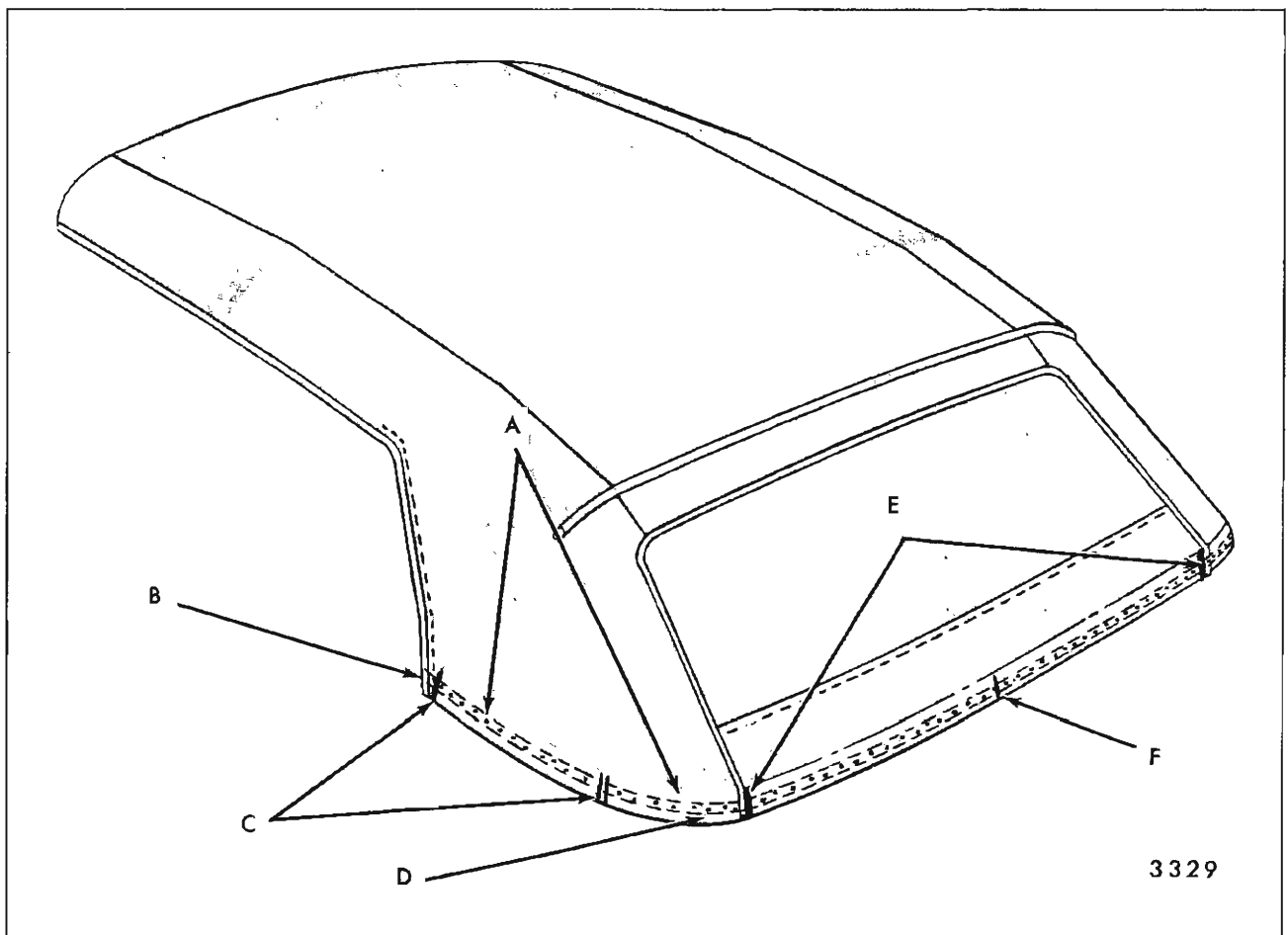

Fig. 13-24—Reference Marks on Top Cover and Back Curtain

A. "A, B, & C" One Piece Trimstick  
 B. Trim Line at Corner Varies by Series  
 C. "F & Z" Quarter Trim Stick

D. "F & Z" Rear Trim Stick  
 E. Top Cover Vertical Edge Reference  
 F. Back Curtain Center Reference

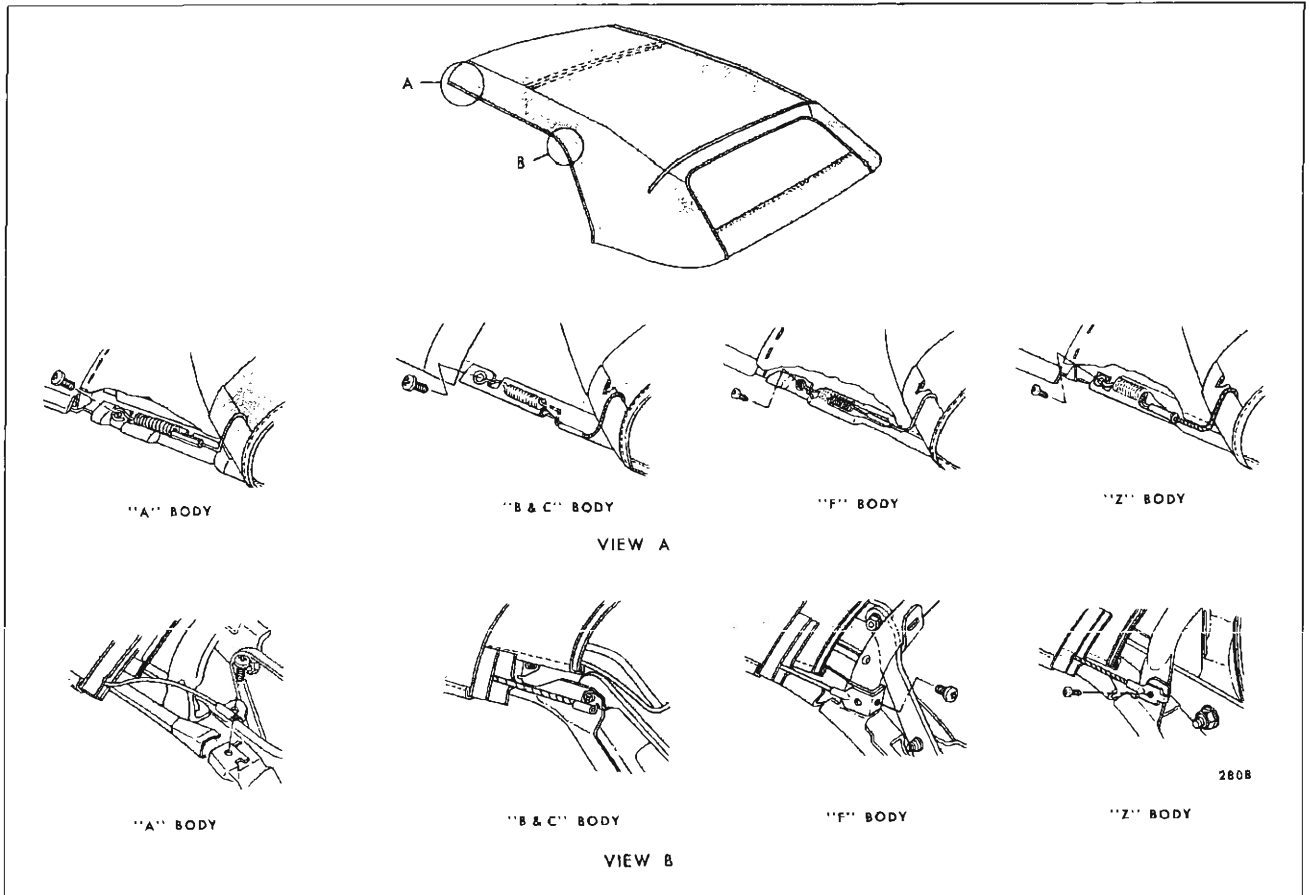

Fig. 13-25—Hold Down Cable Attachment

cover at rear bow. Note location and spacing of staples before removal.

7. With front roof rail several inches off windshield header, remove attaching screws from front and rear of each hold-down cable (Views "A" and "B" in Fig. 13-25) and remove cables.
8. At underside of front bow, (Fig. 13-26) remove screws securing listing pocket retainer to front bow. Disengage retainer from bow and remove retainer from listing pocket. Note location of screws before removal.
9. Detach folding top compartment bag from rear seat back panel.
10. With front roof rail several inches off windshield header, disconnect rear trimstick(s), as required, by removing attaching bolts.

On "A" styles, use a suitable box-socket type wrench to remove each bolt from "outside" surface of male hinge (Fig. 13-27 and 13-28).

On "B" and "C" styles, use a conventional type socket and extension to remove each bolt

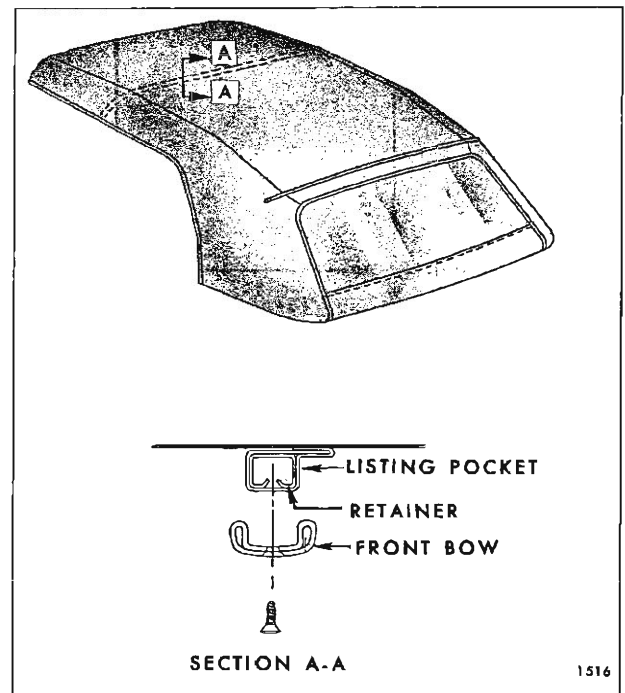

Fig. 13-26—Listing Pocket Retainer



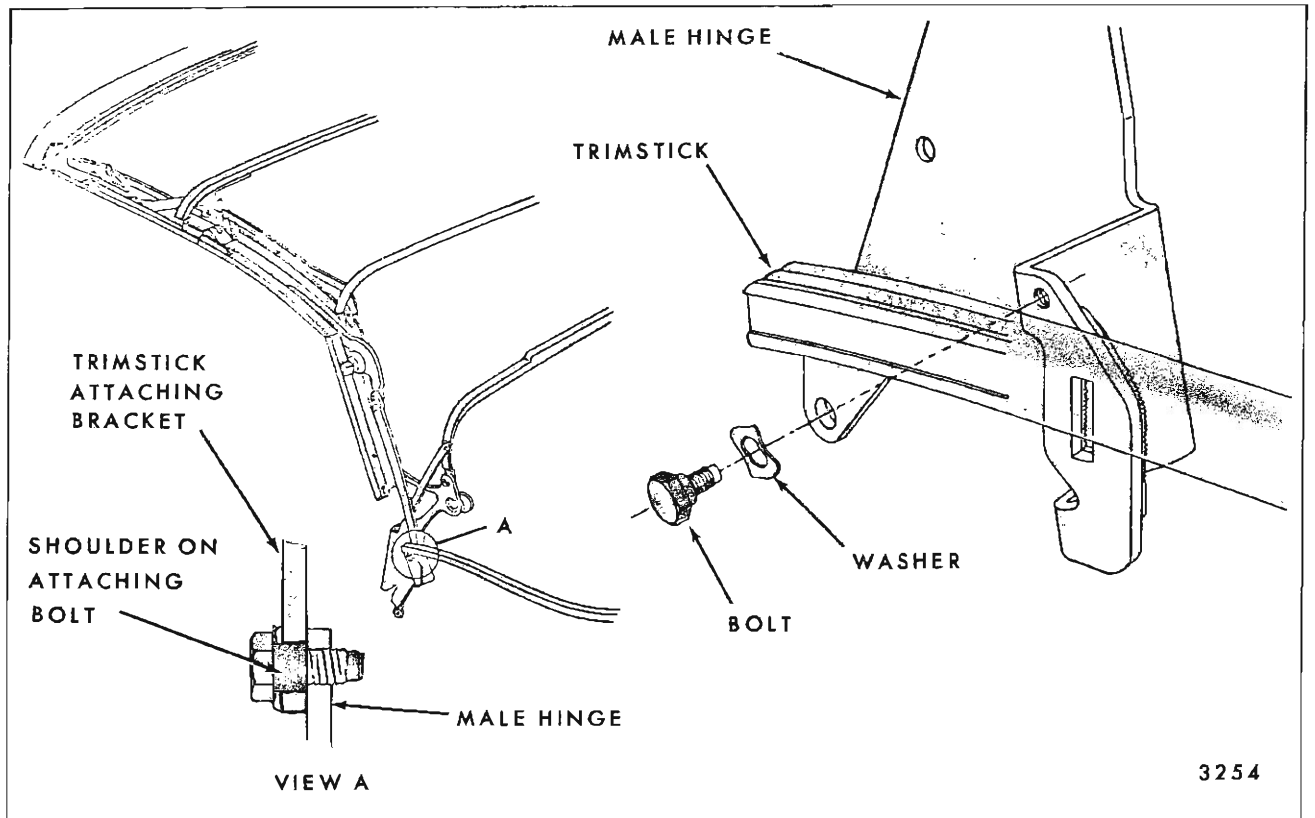

Fig. 13-27—Trimstick Attachment "A" Styles

from "inside" surface of male hinge (Fig. 13-29).

On "F" and "Z" styles, remove trimstick attaching bolts by working inside car or through rear compartment. If inside car, access to attaching bolts may be gained by raising and fastening forward end of top compartment bag to center roof bow (Fig. 13-30 and 13-31).

11. Remove rear trimstick(s) from body and position above quarter pinchweld finishing moldings as follows:

On "A" styles, with top two to four inches off header, move one end of trimstick inward for clearance. Then pry it upward between hinge and body to clear rear roof rail (Fig. 13-32). Raise removed end of trimstick upward and forward. Then continue by removing balance of trimstick above body belt line (Fig. 13-33 and 13-34).

On "B" and "C" styles, with top two to four inches off header, move both ends of trimstick "down" and "forward" after obtaining clearance at hinges.

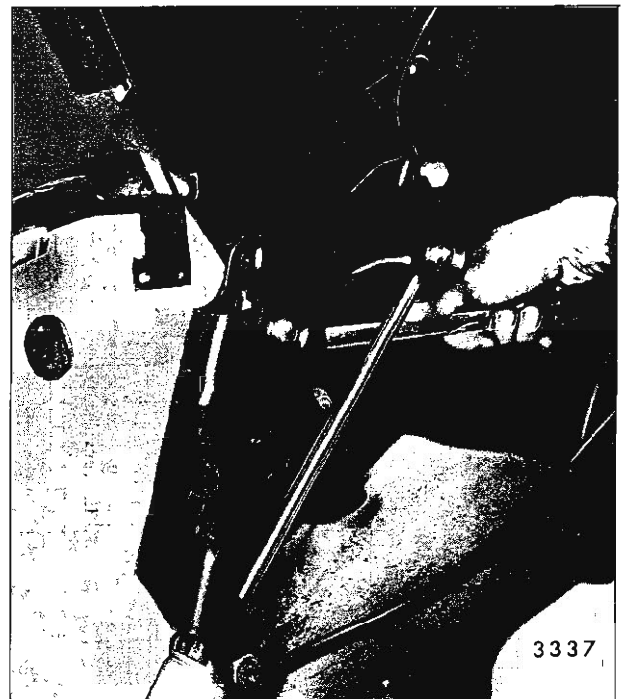

Fig. 13-28—Trimstick Removal "A" Styles

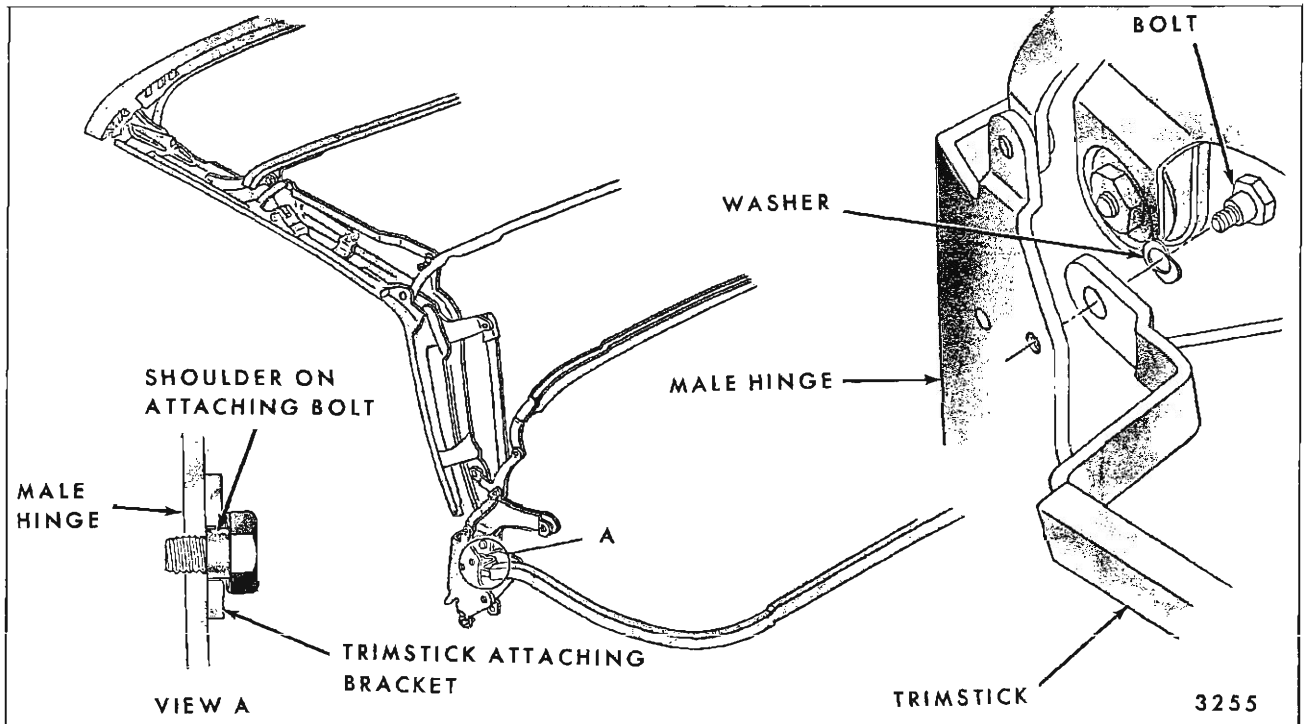

Fig. 13-29—Trimstick Attachment "B & C" Styles

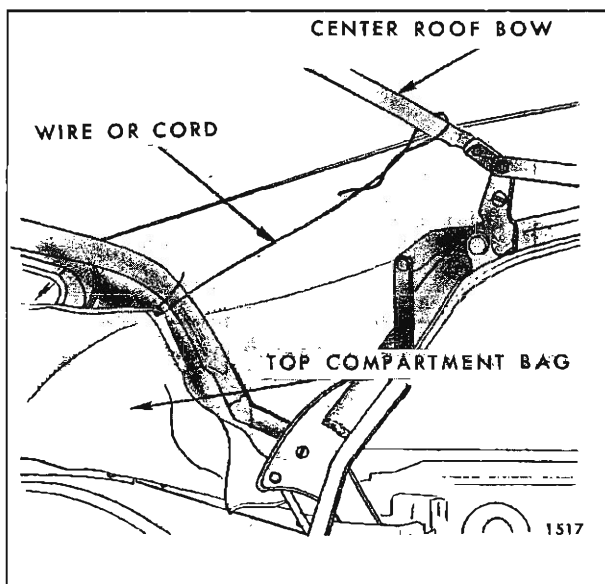

Fig. 13-30—Raising Folding Top Compartment Bag

**CAUTION:** Avoid contact with or damage to top lift cylinder piston rod.

Then, move one side of trimstick inward for rear radius of trimstick to clear body radius. Raise one radius of trimstick from body; raise opposite radius of trimstick from body (Fig. 13-35), then, lift remainder of trimstick above body belt line.

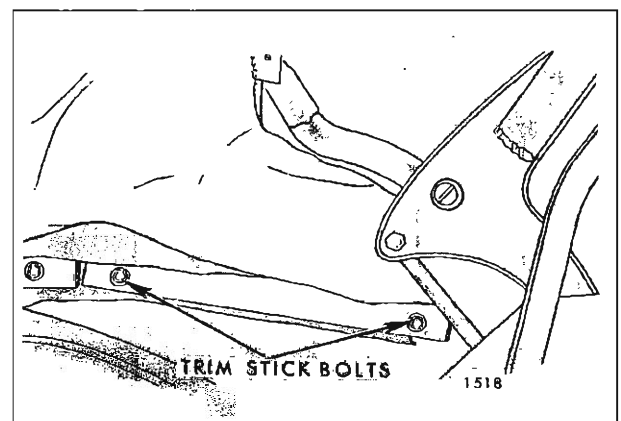

Fig. 13-31—Quarter Trimstick "F & Z" Styles

12. Using a suitably sharp pencil, accurately mark location of complete rear trimstick(s) (upper and lower edges, and ends) on outer surface of top cover. Re-check, and mark right and left inner vertical edge of top cover on back curtain at trim stick (Fig. 13-24).

13. Detach top cover from rear trimstick(s) and remove. Note spacing of staples before removal.

**Installation**

1. Transfer reference marks from removed top

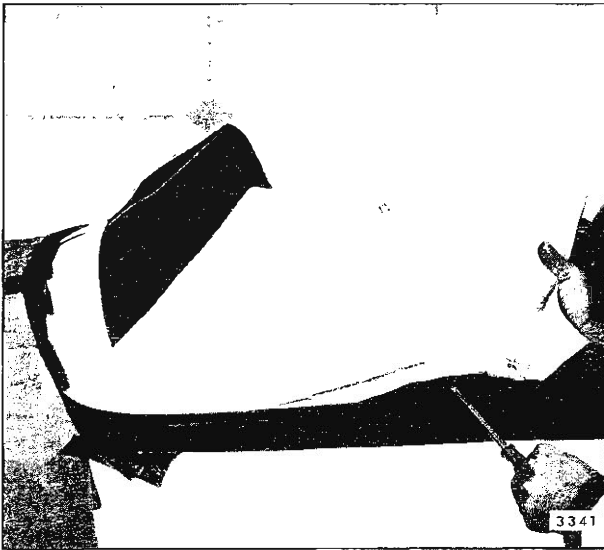

Fig. 13-32—Raising End of Trimstick "A" Styles cover to new one as follows: Place new top cover on a suitable clean surface, such as on clean roof of a car to provide proper contour and fullness, with inner surface of cover down.

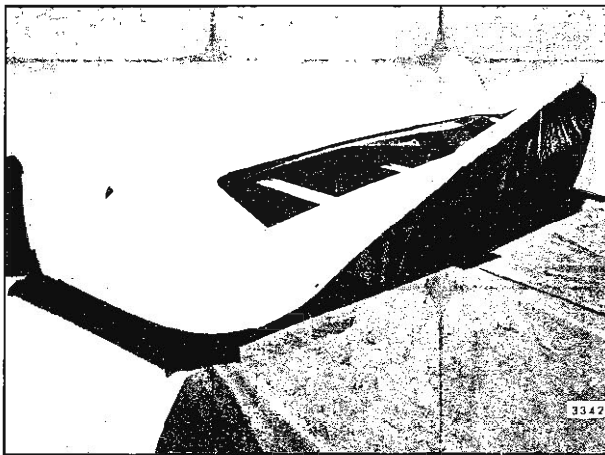

Fig. 13-33—Raising Balance of Trimstick "A" Styles

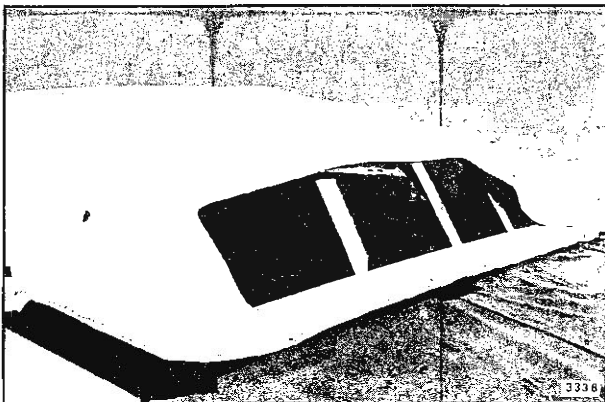

Fig. 13-34—Trimstick Removed "A" Styles



Fig. 13-35—Removing Trimstick From Top Compartment "B & C" Styles

Position removed top cover over new one. Carefully align back window opening upper corners and rear quarter upper corners of both covers. Secure both covers together at these locations. Carefully lay out trim material of sail area of both covers.

Transfer location marks for trimstick(s) (upper and lower trimstick edges, as well as ends, Fig. 13-24).

Then reverse position of covers by positioning new cover over removed one, as described above. Re-check location of reference marks.

**NOTE:** If any difference is noted, the average between the two is the correct reference to use. Mark corrected references clearly.

On "F & Z" styles, also transfer bolt hole locations. Allow for 1/2 inch of top cover to extend beyond trimstick(s) (Fig. 13-36 and 13-24). Along bottom, trim off excess material beyond 1/2 inch over-hang.

**IMPORTANT:** Transfer of reference marks must be done in a highly exacting manner for best results and minimum rework.

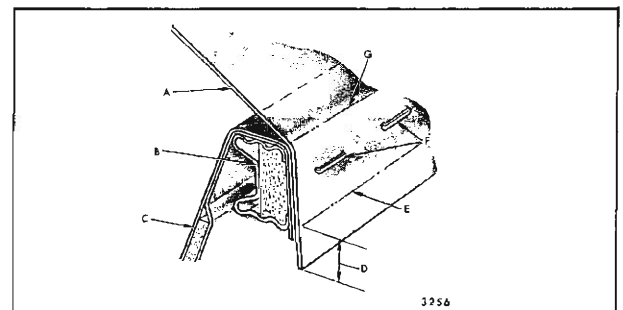

Fig. 13-36—Cross Section at Rear Trimstick - "A, B & C" Styles

- A. Back Curtain
- B. Rear Belt Rail Trimstick Assembly
- C. Folding Top Compartment Bag
- D. 1/2 inch over-hang
- E. Lower Edge Reference Mark
- F. Staples
- G. Upper Edge Reference Mark

- Place folding top cover on folding top framework. Then, position and locate top cover to trimstick(s) according to reference marks, and tack top cover to trimstick(s). Tack from top cover inner vertical edge reference on back curtain toward front. Avoid excessive stretching, but keep material flat during tacking operations (Fig. 13-24).

On "F" and "Z" styles, place tacks close to each side of every bolt hole in trimstick(s). Then cut out or punch holes for bolts in top cover.

- Position rear trimstick(s) into body in reverse of removal operation (See Steps 10 & 11 of Removal of Folding Top Cover Less Back Curtain, Fig. 13-33 or 13-35).
- Secure rear trimstick(s) to body assembled position and tighten all attaching bolts (Fig. 13-43, 13-45 and 13-47).
- Insert hold-down cables into top cover listing pockets and secure as follows:

Raise front roof rail slightly above windshield header. A length of welding rod or equivalent wire can be used to facilitate cable insertion by pulling cable through listing pocket. Install attaching screw at rear of cable. Then, apply forward pull on cable and install front attaching screw (Fig. 13-25).

- Insert and center retainer in top cover listing pocket at front roof bow. Position retainer on front bow and install attaching screws (Fig. 13-26).
- Apply nitrile cement or neoprene-type weatherstrip adhesive to cementing surfaces of side roof rear rails and to quarter flaps. Center top cover over rear bow and align quarter flap seams with edges of side roof rear rails to remove all fullness from top cover. A forward draw on cover outer sides will aid this operation. With quarter flap seams aligned with each rear rail, cement quarter flaps securely in place.

**NOTE:** Top cover may require some lateral stretching along rear bow to achieve proper fit of quarter flaps to rear rails, and to remove fullness from top cover valance over rear window.

- Using an awl or equivalent tool, pierce flaps for side roof rail rear weatherstrip attaching screws. Install weatherstrips to help maintain position of quarter flaps while adhesive is drying.

- While pulling top cover rearward slightly to straighten material over rear window, install tacks to secure cover to rear bow.

**IMPORTANT:** Tacks must be installed in a straight line in center of rear bow (Fig. 13-37). Tacks outboard of deck seams should not exceed 6 inches. Also, tacking distance outboard of deck seams on each side should be uniform. Pierce hole into top material and tacking strip at each outboard end of rear bow for wire-on binding clip escutcheons.

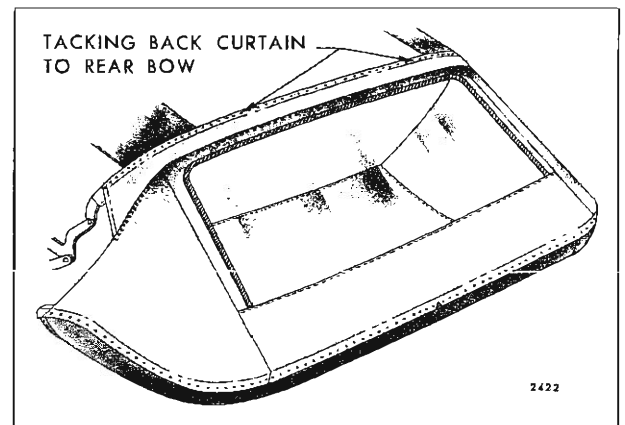

Fig. 13-37—Tacking Back Curtain

- Lock front roof rail to windshield header. Pull top cover straight forward at seams to desired top fullness. While maintaining tension on cover over front roof rail, make pencil mark on cover outer surface along forward edge of front roof rail (Fig. 13-38).

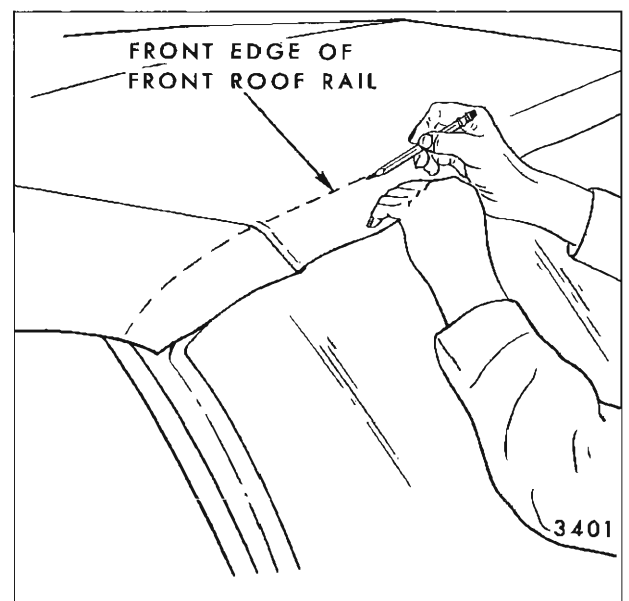

Fig. 13-38—Marking Top at Front Roof Rail

11. Lower top to stacked position. Carefully, apply nitrile cement or neoprene weatherstrip adhesive to cementing area of front rail, to corresponding surface of top cover, and to front corner flaps.
12. Raise top within four inches of windshield header and support roof rail on header with suitable wood block. Secure cover to front roof rail by pulling top cover reference mark slightly beyond target so that pencil marks will be slightly under front edge of roof rail. With doors open, align sides of top cover with forward pull, and secure corner flaps to cemented surfaces. Remove wood block and complete cementing top cover to front roof rail. Lower top and install several stay tacks.
13. Raise top and lock to windshield header. Check appearance of top trim, top operation and locking action of top. If additional tension is needed in top cover, repeat Step 12 and pull top cover further forward. Stay tack and re-check top for proper appearance and operation.
14. Lower top and complete tacking of top cover to front roof rail. Trim off excess material (Fig. 13-39).

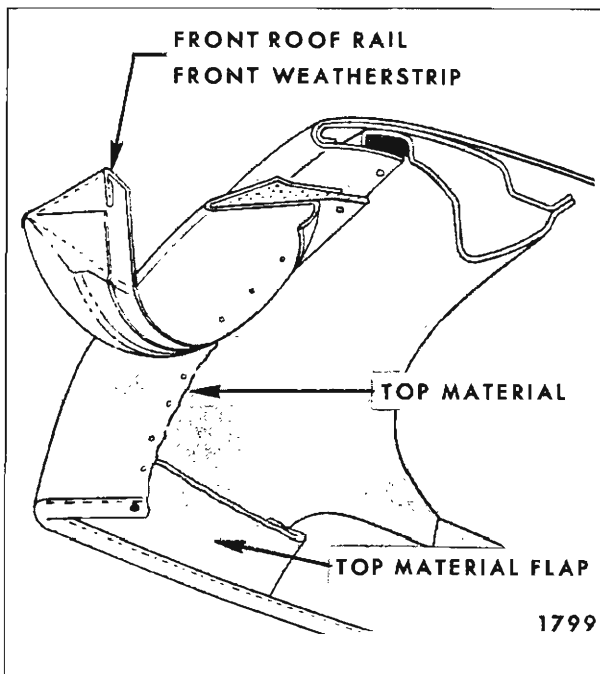

Fig. 13-39—Top Cover at Front Roof Rail

15. Carefully align, seal and install front roof rail and side roof rail weatherstrips.
16. Raise top and using due caution, apply a bead of neoprene-type weatherstrip adhesive around

each rear bow tack head and into two holes pierced into top material for wire-on binding clip escutcheon screws. Applied adhesive must be within area covered by wire-on binding.

17. Install rear bow wire-on binding and escutcheons. Tack from center outward to maintain a snug and straight fit. Length of binding outside of deck seams should not exceed 6 inches and should be of uniform length on each side.
18. When completed, folding top should be free from wrinkles and draws. Install all previously removed trim and hardware. Clean up top material and car as required.

## BACK CURTAIN ASSEMBLY

### Removal

1. Apply masking tape to rear quarter pinchweld finishing moldings, and apply cover protection on rear deck and other adjacent painted surfaces.
2. Mark position of top cover vertical edges on back curtain valance at rear belt line. Use sharpened grease pencil (Fig. 13-40).
3. Remove rear seat cushion. Disconnect rear seat speaker, if present, and remove rear seat back.
4. Remove right and left folding top compartment side trim panels.
5. Lower top part-way, and remove side roof rail rear weatherstrips.
6. Raise and lock top. Mark exact location of following: rear roof bow front and rear edges; wire-on binding escutcheons; and quarter flaps. Note location and spacing of staples before removal. Then, remove escutcheon and wire-on binding. Detach quarter flaps and top cover at rear roof bow.
7. With top several inches off header, remove rear attaching screw from hold-down cables (View "B" Fig. 13-25).
8. Detach folding top compartment bag from rear seat back panel.
9. Lock top to windshield header and install spacer stick along inboard edge of each side stay pad (Fig. 13-41). Spacer sticks can be fabricated as shown in Figure 13-42. Fit spacer sticks snugly between center bow and rear bow, then tighten wing nuts. Spacer sticks are adjustable. Fasten rear bow securely to side roof rear rails.

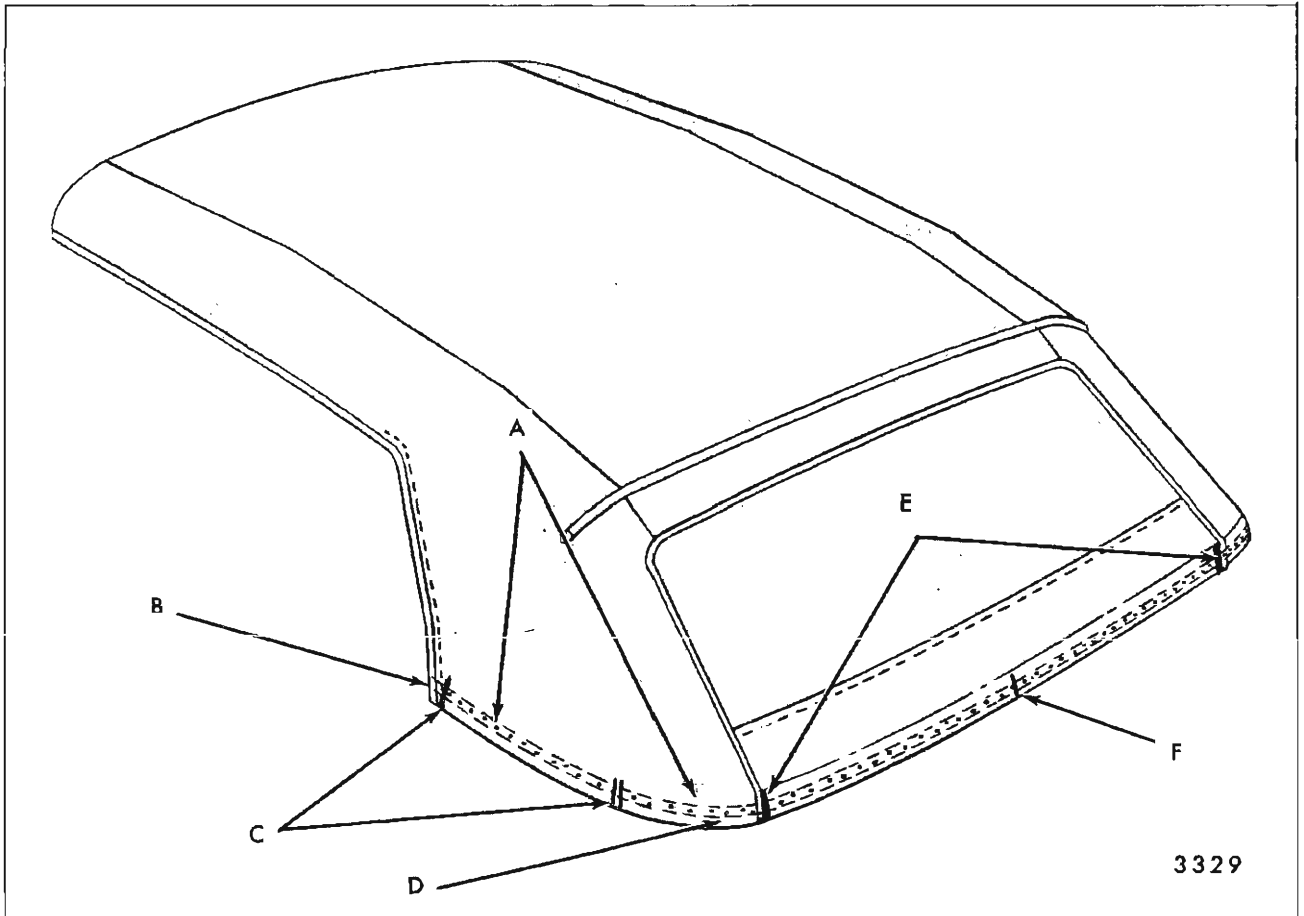

Fig. 13-40—Reference Marks on Top Cover and Back Curtain

- A. "A, B, & C" One Piece Trimstick
- B. Trim Line at Corner Varies by Series
- C. "F & Z" Quarter Trim Stick

- D. "F & Z" Rear Trim Stick
- E. Top Cover Vertical Edge Reference
- F. Back Curtain Center Reference

**NOTE:** The purpose of spacer sticks is to hold the rear bow in a stationary (car installed) position during back curtain and/or side stay pad removal and installation.

On "B" and "C" styles, use a conventional type socket and extension to remove each bolt from "inside" surface of male hinge (Fig. 13-45).

**Material Per Stick**

- Wood - 1/2 x 1 x 14-1/2
- Steel - 1/32 x 1/2 x 2-1/2
- Steel - 1/32 x 1-1/2 x 7
- 2 Screw #6 x 1/2"
- Bolt 1/4 - 20 UNC - 2A x 1"
- Wingnut 1/4 x 20 UNC - 2B
- 2 Washers 1/4" I.D.

10. Raise front roof rail several inches off windshield header and disconnect rear trimstick(s), as required, by removing attaching bolts.

On "A" styles, use a suitable box-socket type wrench to remove each bolt from "outside" surface of male hinge (Fig. 13-43 and 13-44).

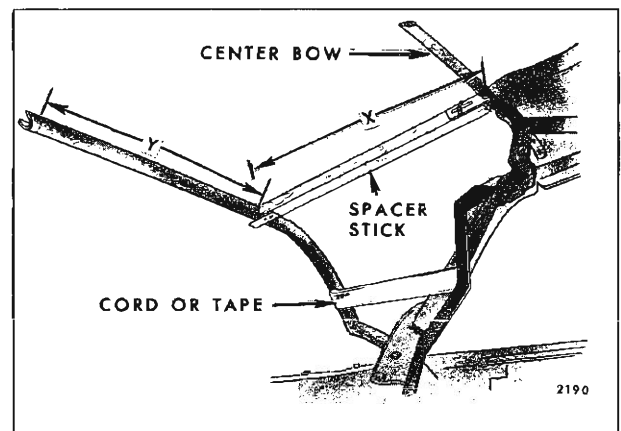

Fig. 13-41—Spacer Stick Installation

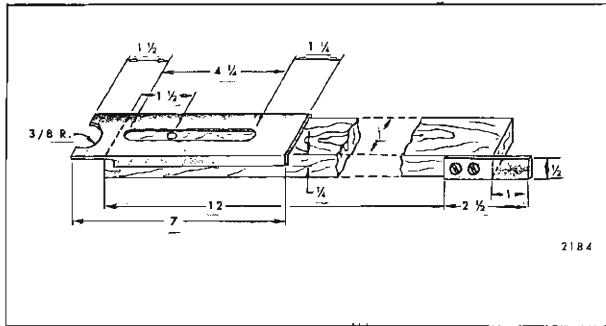

Fig. 13-42—Spacer Stick Fabrication

On "F" and "Z" styles, remove trimstick attaching bolts by working through rear compartment, or by working inside car. If inside car, access to attaching bolts may be gained by raising and fastening forward end of top compartment bag to center roof bow (Fig. 13-46 and 13-47).

11. Remove rear trimstick(s) from body and position above quarter pinchweld finishing moldings.



Fig. 13-44—Trimstick Removal "A" Styles

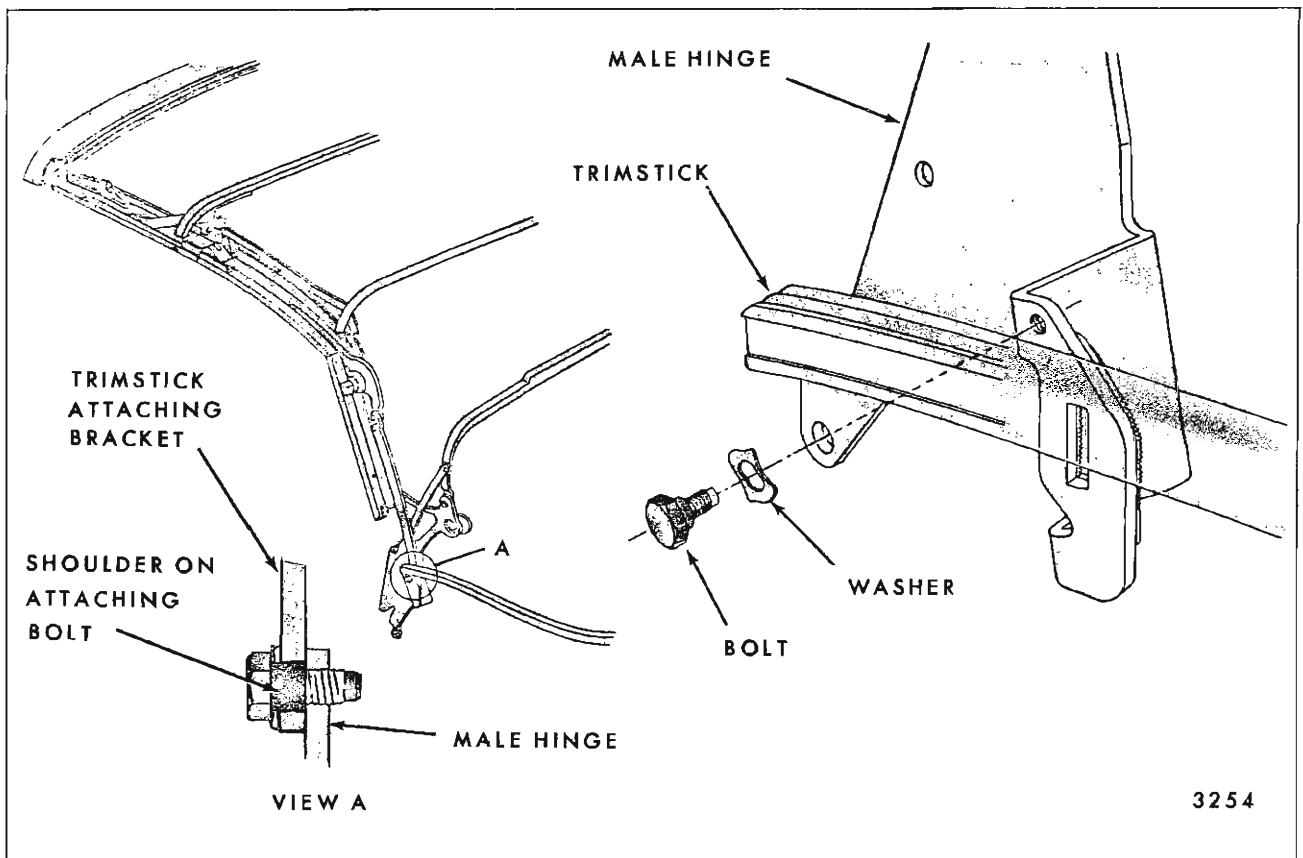

Fig. 13-43—Trimstick Attachment "A" Styles

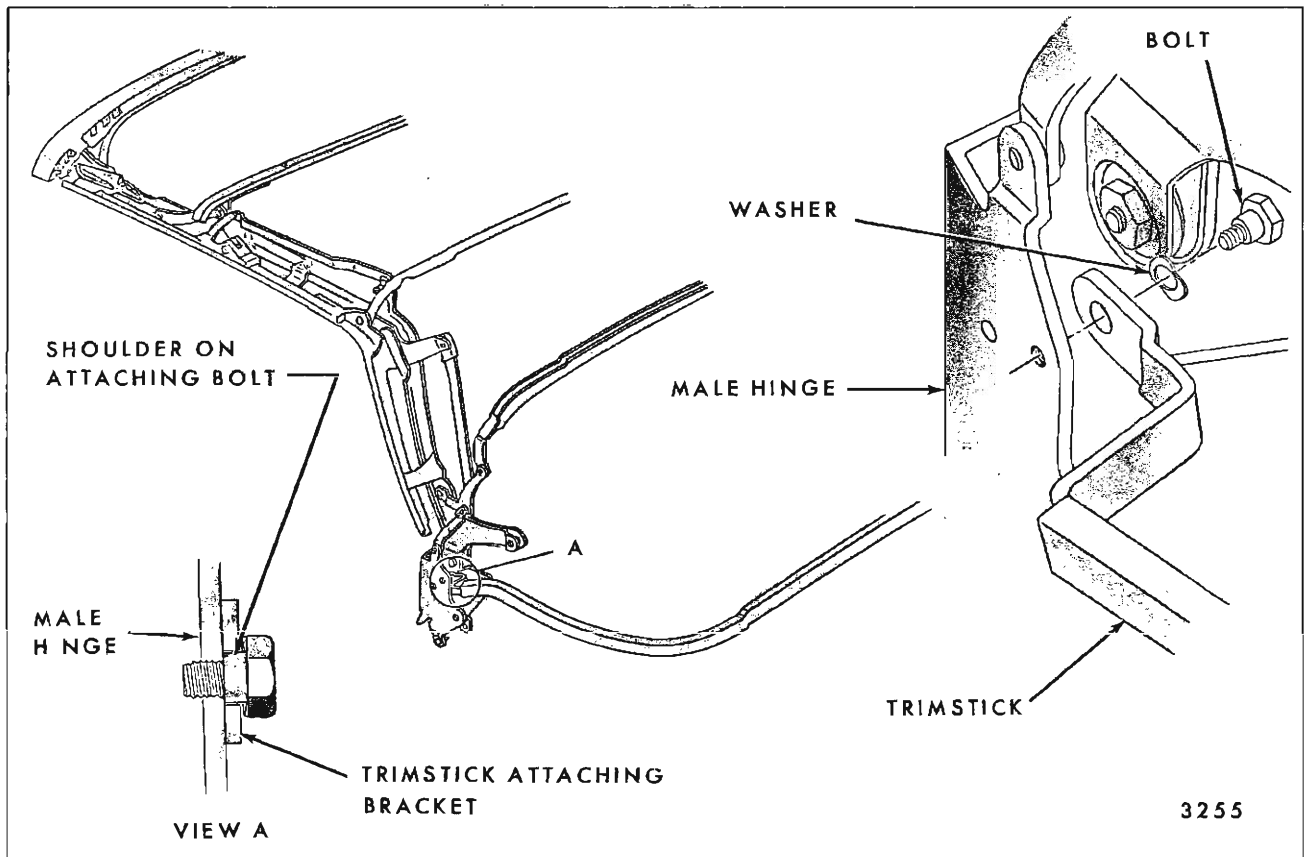

Fig. 13-45—Trimstick Attachment "B & C" Styles

On "A" styles, with top two to four inches off header, move one end of trimstick inward for clearance. Then pry it upward between hinge and body to clear rear roof rail (Fig. 13-48).

Raise removed end of trimstick upward and forward. Then continue by removing balance of trimstick above body belt line (Fig. 13-49 and 13-50).

On "B" and "C" styles, with top two to four inches off header, move both ends of trimstick down and forward after obtaining clearance at hinges.

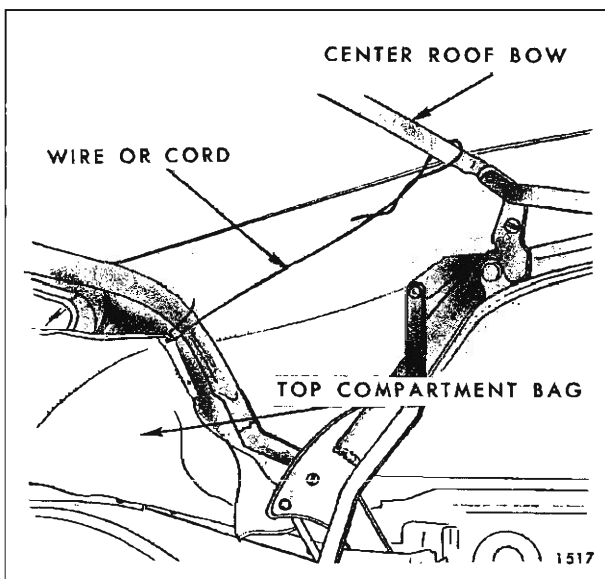

Fig. 13-46—Raising Folding Top Compartment Bag

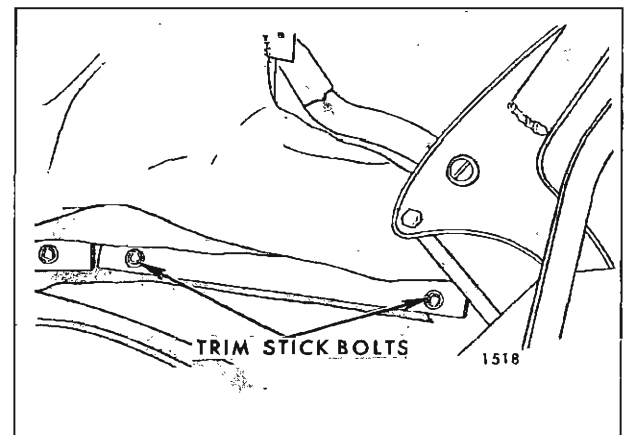

Fig. 13-47—Quarter Trimstick "F & Z" Styles



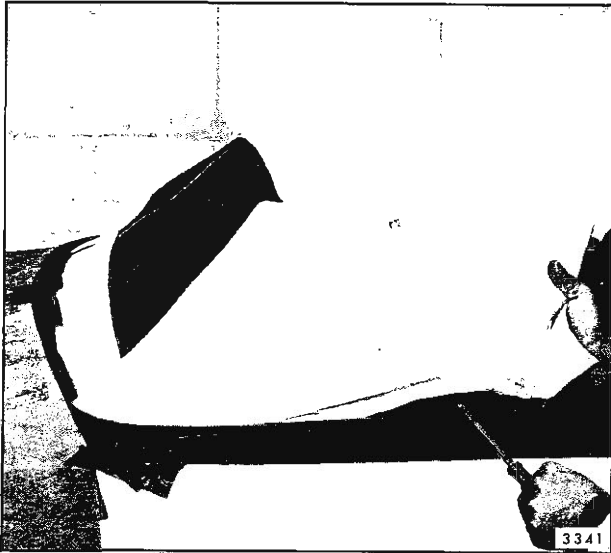

Fig. 13-48—Raising End of Trimstick "A" Styles

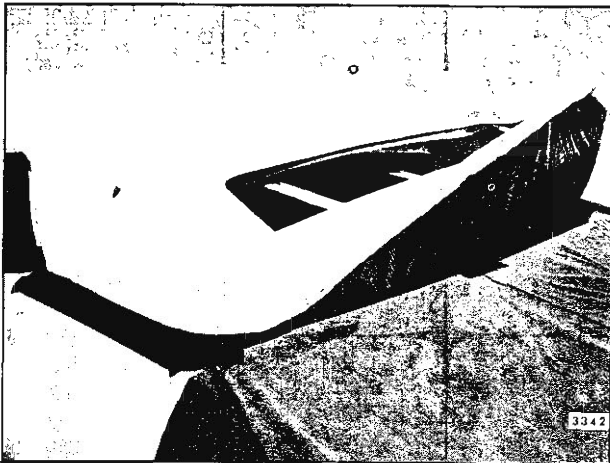

Fig. 13-49—Raising Balance of Trimstick "A" Styles

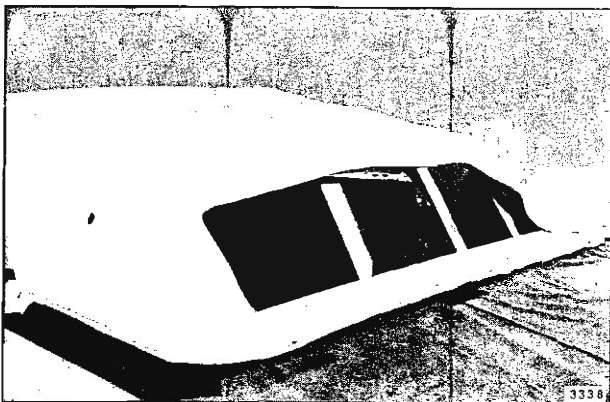

Fig. 13-50—Trimstick Removed "A" Styles

**CAUTION:** Avoid contact with or damage to top lift cylinder piston rod.

Then, move one side of trimstick inward for rear radius of trimstick to clear body radius. Raise one radius of trimstick from body; raise opposite radius of trimstick from body, (Fig. 13-51) then lift remainder of trimstick above body belt line.

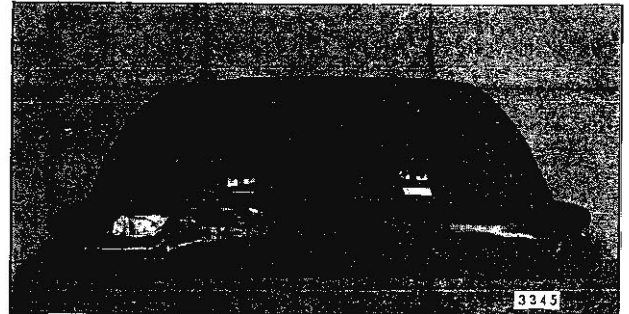

Fig. 13-51—Removing Trimstick From Top Compartment "B & C" Styles

12. Using a sharp pencil, accurately mark location of complete rear trimstick(s) (upper and lower edges and ends) on outer surface of top cover and on back curtain. Re-check, and mark right and left inner vertical edge of top cover on back curtain at trim stick (Fig. 13-40). Make center mark on curtain at "V" notch on trimstick.
13. Detach top cover from rear trimstick(s) and raise cover for access to back curtain. Accurately mark location of balance of trimstick(s) on back curtain.
14. Detach back curtain from rear bow. With aid of a helper, remove rear trimstick(s) with attached back curtain and top compartment bag from body. Place on clean, protected surface. Note location and spacing of staples before removal.
15. Re-check accuracy of trimstick location markings on back curtain, and remove curtain from trimstick(s). Note location and spacing of staples before removal.

### Installation

1. With front roof rail locked at windshield head er, and with rear bow spacer sticks firmly in place (Fig. 13-41), check side stay pads. If necessary, align and secure side stay pads. See Step 1 of "Folding Top Cover and Back Curtain Assembly Installation" (Fig. 13-52).

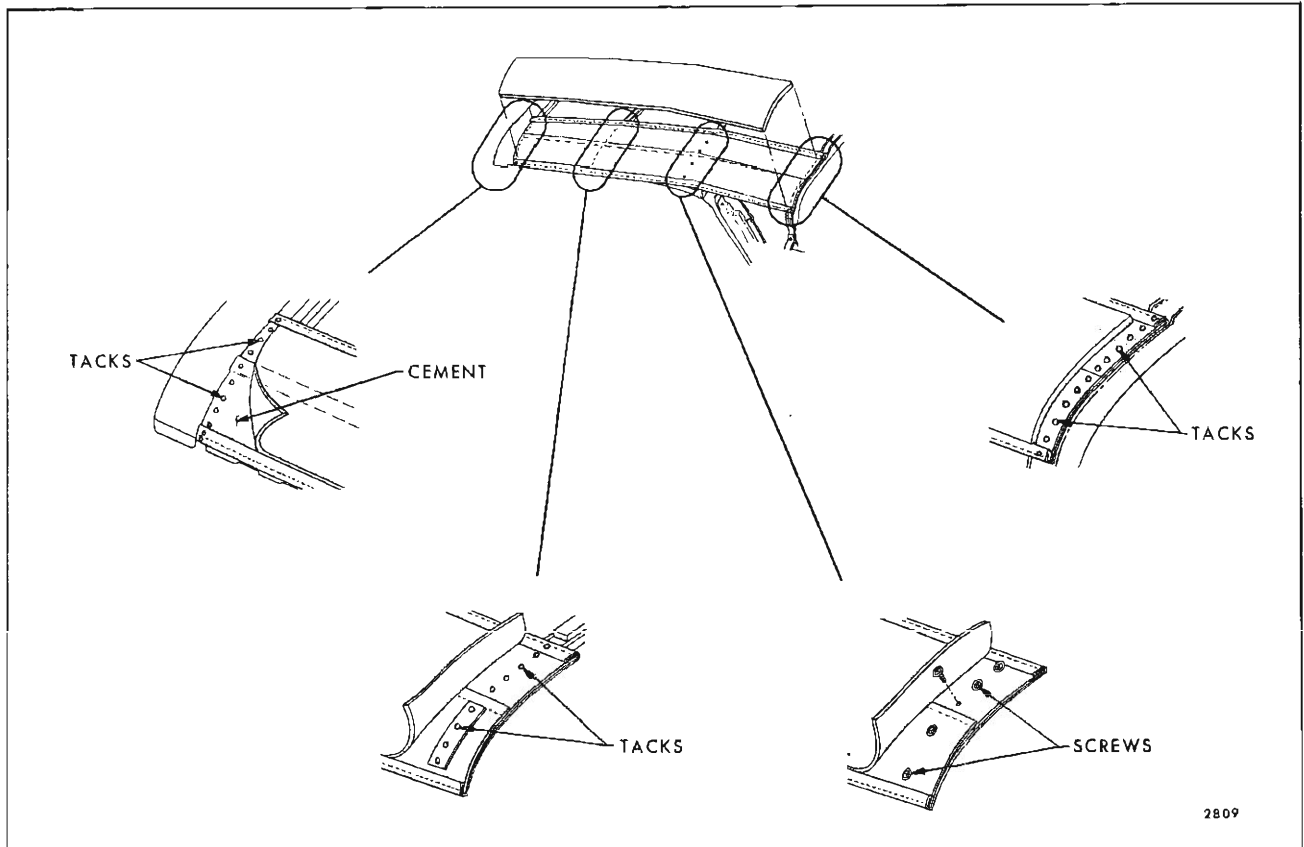

Fig. 13-52—Side Stay Pad Attachment

- Transfer reference marks from removed back curtain to new one as follows: Place new back curtain on clean covered bench with inner surface down. Position removed back curtain correspondingly over new one. Carefully align upper window over lower one. While holding both curtains together securely, carefully lay out trim material of both curtains and transfer following reference marks along bottom: location of trimstick(s) (upper and lower trimstick edges, as well as ends); location of inner vertical edges of top cover; On "F" and "Z" styles, location of bolt holes. Allow 1/2 inch of back curtain material to extend below trimstick(s) (Fig. 13-53 and 13-54).

Then reverse back curtains by positioning new curtain over removed one, as described above. Re-check location of reference marks.

**NOTE:** If any difference is noted, the average between the two is the correct reference to use. Mark corrected references clearly.

Along bottom, trim off excess material beyond the 1/2 inch allowance. Transfer center mark from bottom center of removed curtain to new one.

**IMPORTANT:** Transfer of reference marks must be done in a highly exacting manner for best results and minimum rework.

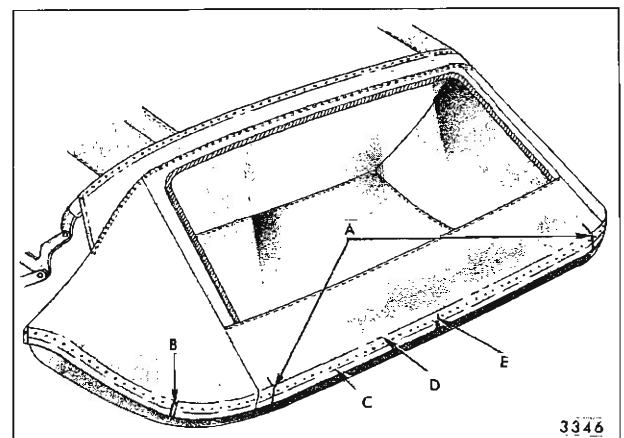

Fig. 13-53—Back Curtain Installation

- Top Cover Rear Vertical Edge References
- "F & Z" Quarter and Rear Trimstick Ends
- Trimstick Lower Edge Reference
- Trimstick Upper Edge Reference
- Back Curtain Center Reference

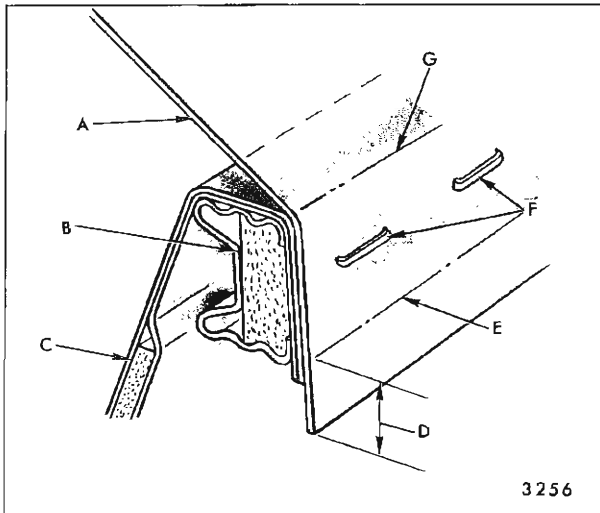

Fig. 13-54—Cross Section at Rear Trimstick - "A, B & C" Styles

- A. Back Curtain
- B. Rear Belt Rail Trimstick Assembly
- C. Folding Top Compartment Bag
- D. 1/2 inch over-hang
- E. Lower Edge Reference Mark
- F. Staples
- G. Upper Edge Reference Mark

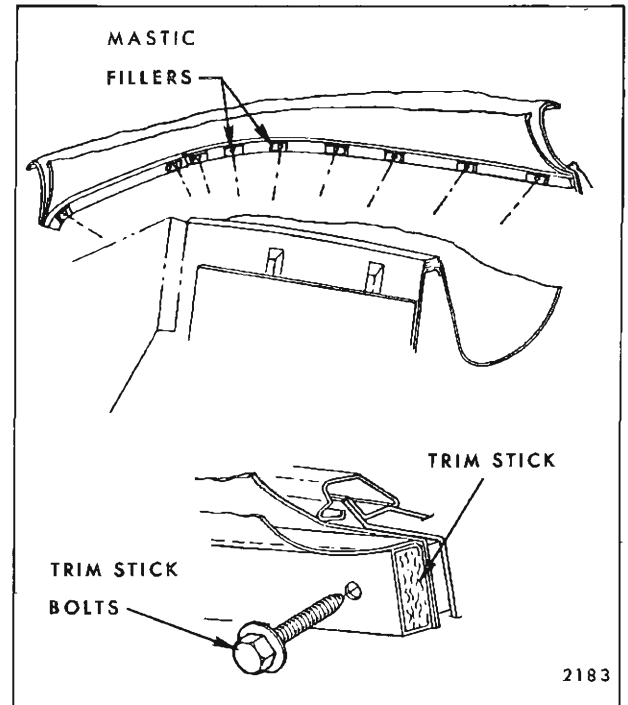

Fig. 13-55—Checking Trim Stick Fillers - "F and Z" Styles

3. As a bench operation, position and center new back curtain to trimstick(s) according to reference marks and tack curtain to trimstick(s). Tack from center to ends. Avoid stretching, but keep material flat during tacking operations.

On "F & Z" styles, place tacks close to each side of every bolt hole in trimsticks. Then cut out or punch holes for bolts in curtain.

4. On "F" and "Z" styles, inspect and, if necessary, install mastic type fillers around holes of folding top compartment rear panel for proper sealing of bolts (Fig. 13-55).
5. With aid of a helper, position rear trimstick(s), with attached bag and back curtain, on rear deck of body. Use care in protecting trim material and back window during this operation. Position bag in folding top well. Stay tack edge of back curtain to rear bow to protect back window during following operations.
6. Position rear trimstick(s) into body in reverse of removal operations. (See Step 10 & 11 of Back Curtain Removal, Fig. 13-49 or 13-51).
7. Secure rear trimstick(s) to body assembled position and tighten all attaching bolts (Fig. 13-43, 13-45 and 13-56).

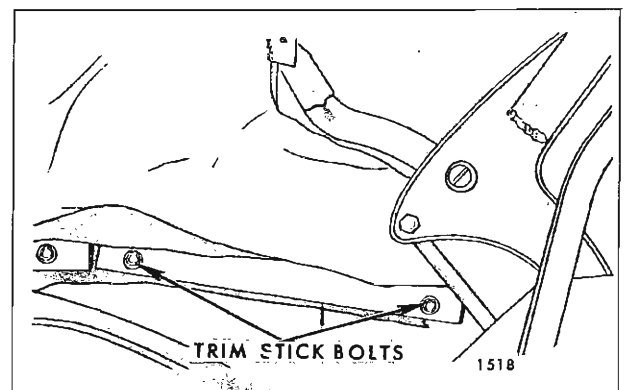

Fig. 13-56—Quarter Trimstick "F & Z" Styles

8. With front roof rail locked to windshield header and with spacer sticks firmly in place, tack back curtain to rear bow as follows:

Remove all stay tacks except two at outer ends supporting back curtain. Then pull curtain forward to remove all fullness and tack curtain to rear bow. Tack from center toward each end of curtain. Remove stay tacks. Apply forward tension to curtain at each point of tack installation (Fig. 13-37).

**CAUTION:** On "A", "B", and "C" styles, be sure one-piece trimstick is flush to quarter

pinchweld finishing molding during tacking operations. This will require assistance of a helper or a support. Trim excess back curtain material at rear bow. Also remove spacer sticks (Fig. 13-41).

9. Disconnect rear trimstick(s) as covered in Step 10 of "Removal of back Curtain" Procedure.
10. Remove rear trimstick(s) from body and position above quarter pinchweld finishing moldings as covered in Step 11 of "Removal of Back Curtain" Procedure.
11. Position and locate top cover to trimstick(s) according to reference marks and tack top cover to trimstick(s). Tack from top cover inner vertical edge reference on back curtain toward front. Avoid excessive stretching, but keep material flat during tacking operations (Fig. 13-40).

On "F" and "Z" styles, place tacks close to each side of every bolt hole in trimstick(s). Then cut out or punch holes for bolts in top cover.

12. Position rear trimstick(s) into body in reverse of removal operations as covered in Step 11 of "Removal of Back Curtain" Procedure.
13. With front roof rail several inches off windshield header, secure rear trimstick(s) to body assembled position and tighten all attaching bolts. This is the reverse of Step 10 of "Removal of Back Curtain" procedure.
14. Align and secure hold down cables at rear with attaching screw (Fig. 13-25).
15. Position front roof rail several inches off windshield header.

Apply nitrile cement or neoprene-type weath-

erstrip adhesive to cementing surfaces of side roof rear rails and to quarter flaps. Position and center top cover reference marks over rear bow. Align quarter flaps and seams with previously scribed marks and edges of side roof rear rails to remove all fullness from top cover. A forward draw on the cover outer sides will aid in this operation. With quarter flap seams aligned with each rear rail, cement quarter flaps securely in place.

**NOTE:** Top cover may require some lateral stretching along rear bow to achieve proper fit of quarter flaps to rear rails, and to remove fullness from top cover valance over rear window.

16. Using an awl or equivalent tool, pierce flaps for side roof rail rear weatherstrip attaching screws. Install weatherstrips to help maintain position of quarter flaps while adhesive is drying.
17. With front roof rail resting on windshield header, and with top cover reference marks aligned with rear bow, tack top cover securely to rear bow. Location and spacing of tacks should be similar to that of removed staples.
18. Using due caution, apply a bead of neoprene-type weatherstrip adhesive around each rear bow tack head, over unused staple holes, and over screw holes for escutcheons.
19. Install rear bow wire-on binding and escutcheons. Tack from center outwardly to maintain a snug and straight fit. Position of binding on top cover should match reference marks.
20. When completed, folding top should be free from wrinkles and draws. Install all previously removed trim and hardware. Clean up top material and car as required.

## HYDRO-LECTRIC SYSTEM ALL EXCEPT "Z" BODY

### DESCRIPTION

The high pressure hydro-lectric unit used in the convertible bodies, consists of a 12 volt reversible type motor, a rotor-type pump, two hydraulic lift cylinders, and an upper and lower hydraulic hose assembly. On the "A" Series the unit is installed in the body directly behind rear seat back support (Fig. 13-57). On the "B, C & F" Series the unit is installed in the body beneath the rear seat back panel (Fig. 13-58).

Figure 13-59 illustrates and identifies the individual parts of the motor and pump assembly.

**NOTE:** When servicing the motor assembly or pump end plate assembly, it is extremely important that the small motor shaft "O" ring seal is properly installed over the motor armature shaft and into the pump end plate assembly prior to installing the pump rotors or the motor shaft drive ball.

## MOTOR AND PUMP ASSEMBLY

### Removal

1. Operate folding top to full "up" position.
2. Disconnect positive battery cable.
3. a. On "A" Styles, place protective covering over rear seat cushion and back.

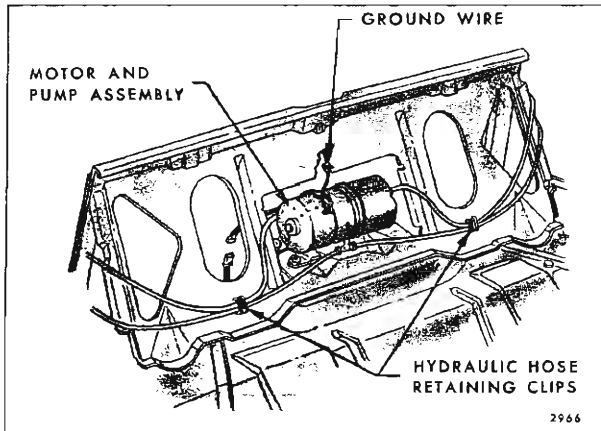

Fig. 13-57—Motor and Pump Installation "A" Styles Shown

- b. On "B, C & F" Styles, remove rear seat cushion and back.
4. Working inside body, detach front edge of folding top compartment bag from rear seat back panel.

5. Remove clips securing wire harness and hydraulic hose to rear seat back panel and support.
6. a. On "A" Body Styles disconnect motor leads from wire harness and ground attaching screws.
- b. On "B, C & F" Body Styles at rear seat back panel, disconnect wiring harness and remove ground wire attaching screw.

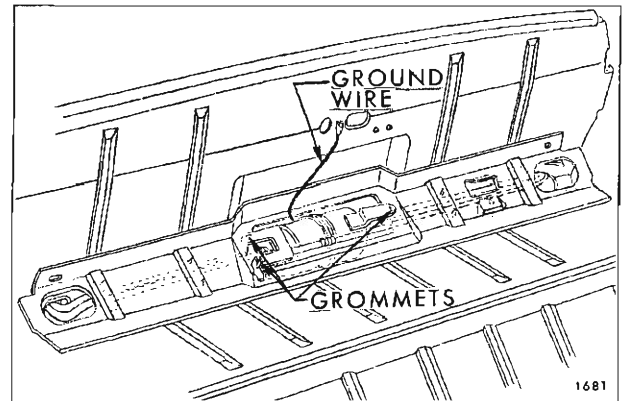

Fig. 13-58—Motor and Pump Installation "B, C & F" Styles

7. To facilitate removal, apply a rubber lubricant to pump attaching grommets; then carefully disengage grommets from floor pan on "B, C & F" and from rear seat back support on "A" Body Styles (Figs. 13-57 and 13-58).

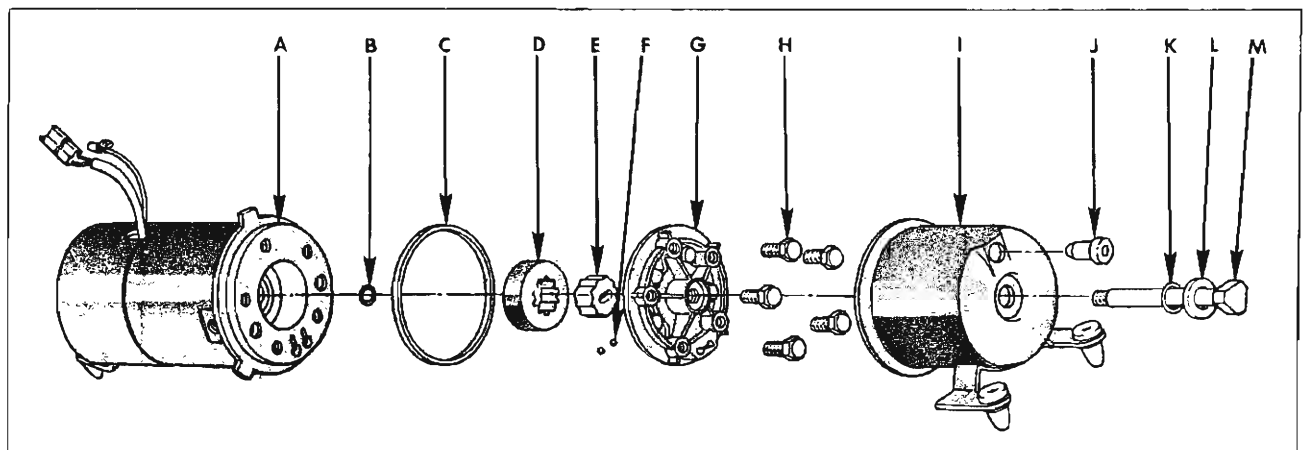

Fig. 13-59—Motor and Pump Components - All 67 Styles Except "Z" Body

- A. Motor Assembly
- B. Motor Shaft "O" Ring Seal
- C. Reservoir Seal
- D. Outer Pump Rotor
- E. Inner Pump Rotor

- F. Fluid Control Valve Balls
- G. Pump Cover Plate Assembly
- H. Pump Cover Attaching Screws
- I. Reservoir Tube and Bracket Assembly

- J. Reservoir Filler Plug
- K. Reservoir End Plate Attaching Bolt
- L. Reservoir End Plate Attaching Bolt Washer
- M. Reservoir End Plate Attaching Bolt

8. Place absorbent rags below hose connections and end of reservoir.
9. Vent reservoir by removing filler plug; then install plug.

**NOTE:** Venting reservoir is necessary in this "sealed-in" unit to equalize air pressure in reservoir to that of the atmosphere. This operation prevents the possibility of hydraulic fluid being forced under pressure from disconnected lines and causing damage to trim or body finish.

10. Disconnect hydraulic lines and cap open fittings to prevent leakage of fluid (Figs. 13-57 and 13-58). Use a cloth to absorb any leaking fluid, then remove unit from rear compartment.

### Installation

1. If a replacement unit is being installed, fill reservoir unit with Dexron or Type "A" transmission fluid. See "Filling of Hydro-Lectric Reservoir".
2. Connect hydraulic hoses, engage attaching grommets in panel and connect wiring.
3. Connect battery and operate top through its up and down cycles until all air has been "bled" from hydraulic circuit. See "Filling of Hydro-Lectric Reservoir".
4. Check connections for leaks and recheck fluid level in reservoir.
5. Install all previously removed parts.

### RESERVOIR TUBE

#### Disassembly From Motor and Pump Assembly

1. Remove motor and pump assembly from body.
2. Scribe a line across pump end plate and reservoir tube to insure a correct assembly of parts. See Figure 13-60.
3. With a straight-bladed screwdriver, remove reservoir filler plug.
4. Drain fluid from reservoir into a clean container.
5. With suitable tool, remove bolt from end of assembly and remove reservoir tube. Note sealing rings around bolt and between end of reservoir tube and pump cover plate assembly.

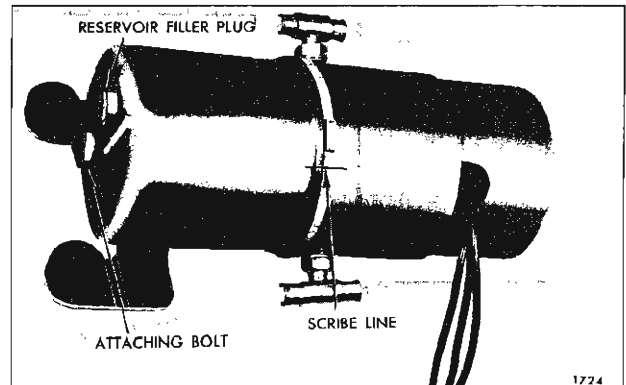

Fig. 13-60—Motor and Pump Assembly - All 67 Styles Except "Z" Body

#### Assembly To Motor and Pump Assembly

1. Position sealing ring on pump and assemble reservoir tube to pump according to scribe marks.

**NOTE:** Bracket assembly on tube should be located at outer end when tube is assembled to pump.

2. Install and tighten attaching bolt.
3. Place unit in horizontal position and fill with fluid until fluid level is within 1/4" of lower edge of filler plug hole.

### OPERATION OF FOLDING TOP

When the control switch is actuated to the "up" position, the battery feed wire is connected to the red motor lead and the motor and pump assembly operate to force the hydraulic fluid through the hoses to the lower ends of the double-acting cylinders. The fluid forces the piston rods in the cylinders upward, thus raising the top. The fluid in the top of the cylinders returns to the pump for recirculation to the bottom of the cylinders. When the control switch knob is actuated to the "down" position, the feed wire is connected to the dark green motor lead and the motor and pump assembly operate in a reversed direction to force the hydraulic fluid through the hoses to the top of the cylinders. The fluid forces the piston rods in the cylinders downward, thus lowering the top. The fluid in the bottom of the cylinders returns to the pump for recirculation to the top of the cylinders.

### OPERATION OF PUMP ASSEMBLY

The rotor type pump assembly is designed to deliver a maximum pressure in the range of 340 psi

to 380 psi. The operation of the pump assembly when raising the top is as follows:

1. Raising the Top. When the red motor lead is energized the motor drive shaft turns the rotors clockwise as indicated by the large arrow in Figure 13-61. The action of the pump rotors forces the fluid under pressure to the bottom of each cylinder forcing the piston upward. This action causes the fluid above the piston in each cylinder to be forced into the pump, which recirculates the fluid to the bottom of the cylinders. The additional fluid required to fill the cylinder due to piston rod displacement is drawn from the reservoir.
2. Lowering the Top. When the green motor lead is energized the motor drive shaft turns the rotors counterclockwise as indicated by the large arrow in Figure 13-62. The action of the pump rotors forces the fluid under pressure to the top of each cylinder. This action causes the fluid below the piston in each cylinder to be forced into the pump which recirculates the fluid to the top of each cylinder. The surplus hydraulic fluid due to piston rod displacement flows into the reservoir.

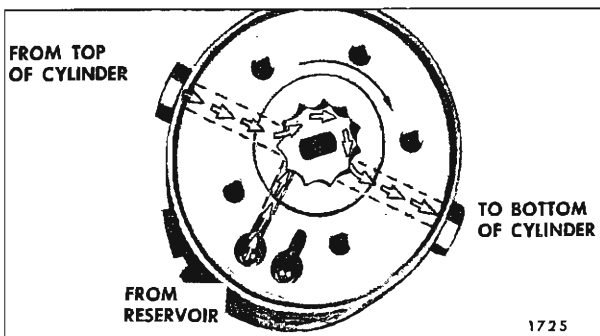

Fig. 13-61—Operation of Pump to Raise Top

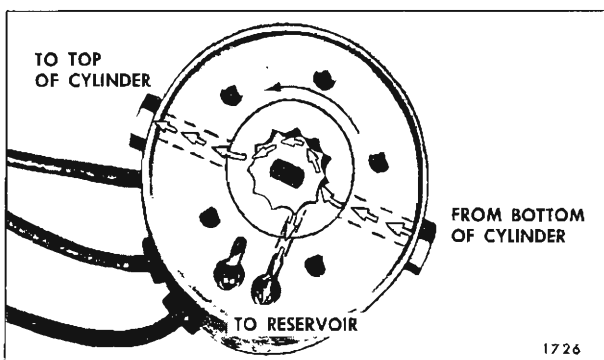

Fig. 13-62—Operation of Pump to Lower Top

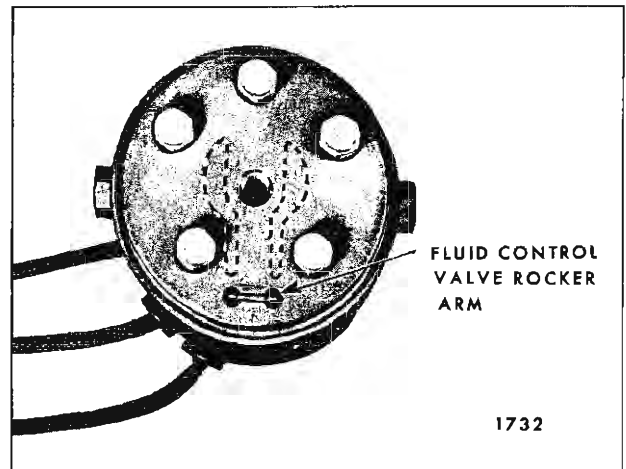

Fig. 13-63—Pump Cover Plate

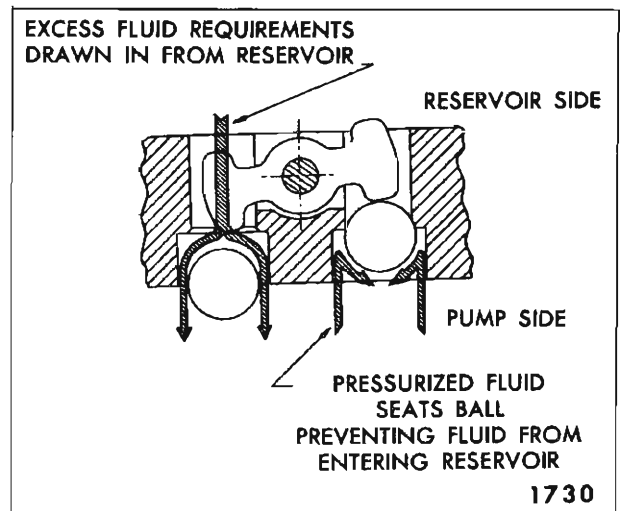

Fig. 13-64—Fluid Control Valve

## FLUID CONTROL VALVE

The fluid control valve consists of a rocker arm installed in the pump cover plate, and two steel balls. Figure 13-63 shows the top surface of the pump cover plate. The dotted lines indicate the cavities on the bottom side of the cover plate. The cavities are designed to permit fluid flow between pump rotors and the reservoir. Figures 13-64 and 13-65 illustrate the operation of the fluid control valve.

## MECHANICAL CHECKING PROCEDURE

If there is a failure in the hydro-lectric system and the cause is not evident the mechanical operation of the top should first be checked. If the folding top assembly appears to have a binding action, discon-

nect the top lift cylinder piston rods from the top linkage and then manually raise and lower the top. The top should travel through its up and down cycle without any evidence of binding action. If a binding action is noted when the top is being locked at the header, check the alignment of the door windows, ventilators and rear quarter windows with relation to the side roof rail weatherstrips. Make all necessary adjustments for correct top alignment. See "Folding Top Adjustments". If a failure continues to exist after a check for mechanical failure has

been completed, the hydro-lectric system should then be checked for electrical or hydraulic failures.

## ELECTRICAL CHECKING PROCEDURE

If a failure in the hydro-lectric system continues to exist after the mechanical operation has been checked, the electrical system should then be checked. A failure in the electrical system may be caused by a low battery, breaks in wiring, faulty connections, mechanical failure of an electrical component, or wires or components shorting to one another or to body metal. Before beginning checking procedures, check battery according to recommended procedure.

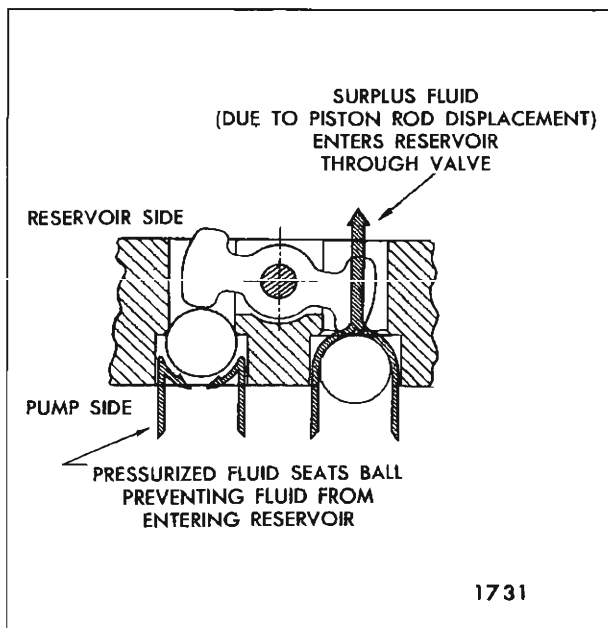

Fig. 13-65—Fluid Control Valve

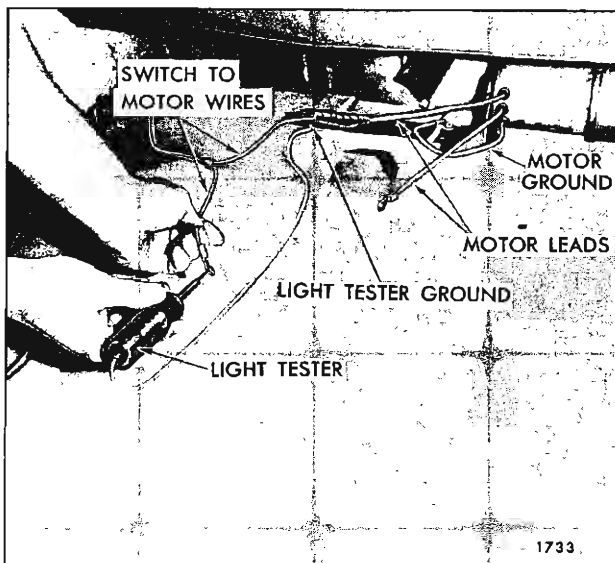

Fig. 13-66—Checking Wire Leads to Motor

### 1. Check for Current at Folding Top Control Switch

- Disengage terminal block from rear of switch.
- Connect light tester to central feed terminal of switch terminal block.
- Ground light tester ground lead to body metal.
- If light tester does not light, there is an open or short circuit between power source and switch.

### 2. Checking the Folding Top Control Switch

If there is current at the feed wire terminal of the terminal block, operation of switch can be checked as follows:

- Place a #12 jumper wire on switch terminal block between center terminal (feed) and one motor wire terminal. If motor operates with jumper wire, but did not operate with switch, switch is defective.
- Connect jumper wire between center terminal and other motor wire terminal on switch terminal block. If motor operates with jumper wire, but did not operate with switch, switch is defective.

### 3. Checking Switch to Motor Lead Wires.

If switch is found to be operating properly, the switch to motor lead wires can be checked as follows: See Figure 13-66.

- Disconnect green switch-to-motor wire from motor lead in rear compartment.
- Connect a light tester to green switch-to-motor wire terminal.



- c. Ground light tester ground lead to body metal.
- d. Actuate switch to "down" position. If tester does not light, there is an open or short circuit in wire.
- e. Disconnect red switch-to-motor wire from motor lead.
- f. Connect light tester to red switch-to-motor wire terminal.
- g. Actuate switch to "up" position. If tester does not light, there is an open or short circuit in wire.

#### 4. Checking the Motor Unit.

If a light tester indicates current at the motor lead terminals of the switch-to-motor wires, but motor unit does not operate from switch, a final check of the motor unit can be made as follows:

- a. Check connection of motor ground wire to body metal. (See Figs. 13-57 and 13-58.)
- b. Connect a #12 jumper wire from battery positive pole to motor lead terminal that connects to green switch-to-motor wire. The motor should operate to lower top.
- c. Connect jumper wire to motor lead terminal that connects to red switch-to-motor wire. The motor should operate to raise top.
- d. If motor fails to operate on either or both of these checks, it should be repaired or replaced.
- e. If motor operates with jumper wire but will not operate from switch-to-motor wires, the trouble may be caused by reduced current resulting from damaged wiring or poor connections.

### HYDRAULIC CHECKING PROCEDURE

Failures in the hydraulic system can be caused by lack of hydraulic fluid, leaks in hydraulic system, obstructions or kinks in hydraulic hoses or faulty operation of a cylinder or pump.

#### 1. Checking Hydraulic Fluid Level in Reservoir.

- a. Operate top to raised position.
- b. On all body styles perform the following operations:

- (1) Detach front edge of folding top compartment bag from rear seat back panel.
- (2) Remove clips securing hydraulic hose to rear seat back panel.
- (3) Disengage pump attaching grommets from compartment pan brace.
- c. Place absorbent rags below reservoir at filler plug.
- d. With a straight-bladed screwdriver, remove filler plug. Fluid level should be within 1/4 inch of lower edge of filler plug hole.
- e. If fluid is low, add Dexron or Type A transmission fluid to bring to specified level. See "Filling of Hydro-Lectric Reservoir".
- f. Install filler plug.
- g. Install motor and pump assembly and all previously removed parts.

#### 2. Checking Operation of Lift Cylinders.

- a. On all styles remove rear seat cushion and back and folding top compartment side panel assemblies. On "F" Body Styles only, remove the body lock pillar to main hinge support extension brace.
- b. Operate folding top control switch and observe lift cylinders during "up" and "down" cycles for these conditions:
  - (1) If movement of cylinder is uncoordinated or sluggish when the motor is actuated, check hydraulic hoses from motor and pump to cylinder for kinks.
  - (2) If one cylinder rod moves slower than the other, cylinder having slower moving rod is defective and should be replaced.
  - (3) If both cylinder rods move slowly or do not move at all, check the pressure of the pump. See "Checking the Pressure of the Pump".

**NOTE:** To insure proper operation of the lift cylinders, the top lift cylinder rods should be cleaned and lubricated at least twice a year. To perform these operations, raise top to "up" position and wipe exposed portion of each top lift cylinder piston rod with a cloth dampened with Type A transmission fluid to remove any oxidation and/or accumulated grime.

**CAUTION:** Exercise care so that transmission fluid does not come in contact with any painted or trimmed parts of the body.

**3. Checking Pressure at the Pump**

- a. Remove motor and pump assembly from rear compartment.
- b. Install plug in one port, and pressure gauge in port to be checked (Figure 13-67).
- c. Actuate motor with applied terminal voltage within range of 9.5 volts to 11.0 volts. Pressure gauge should show a pressure between 340 psi and 380 psi.
- d. Check pressure in other port.

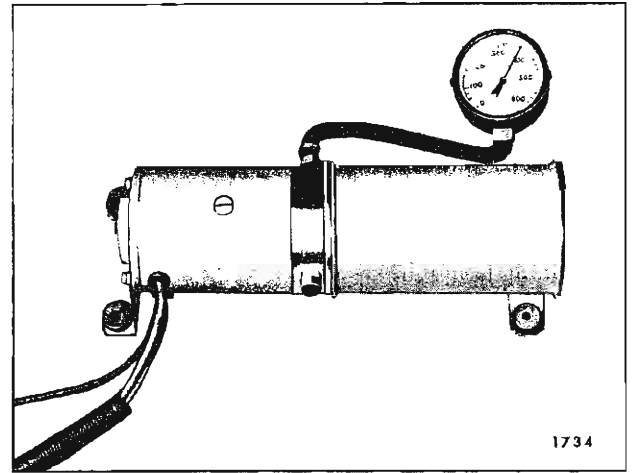

Fig. 13-67—Checking Pump Pressure

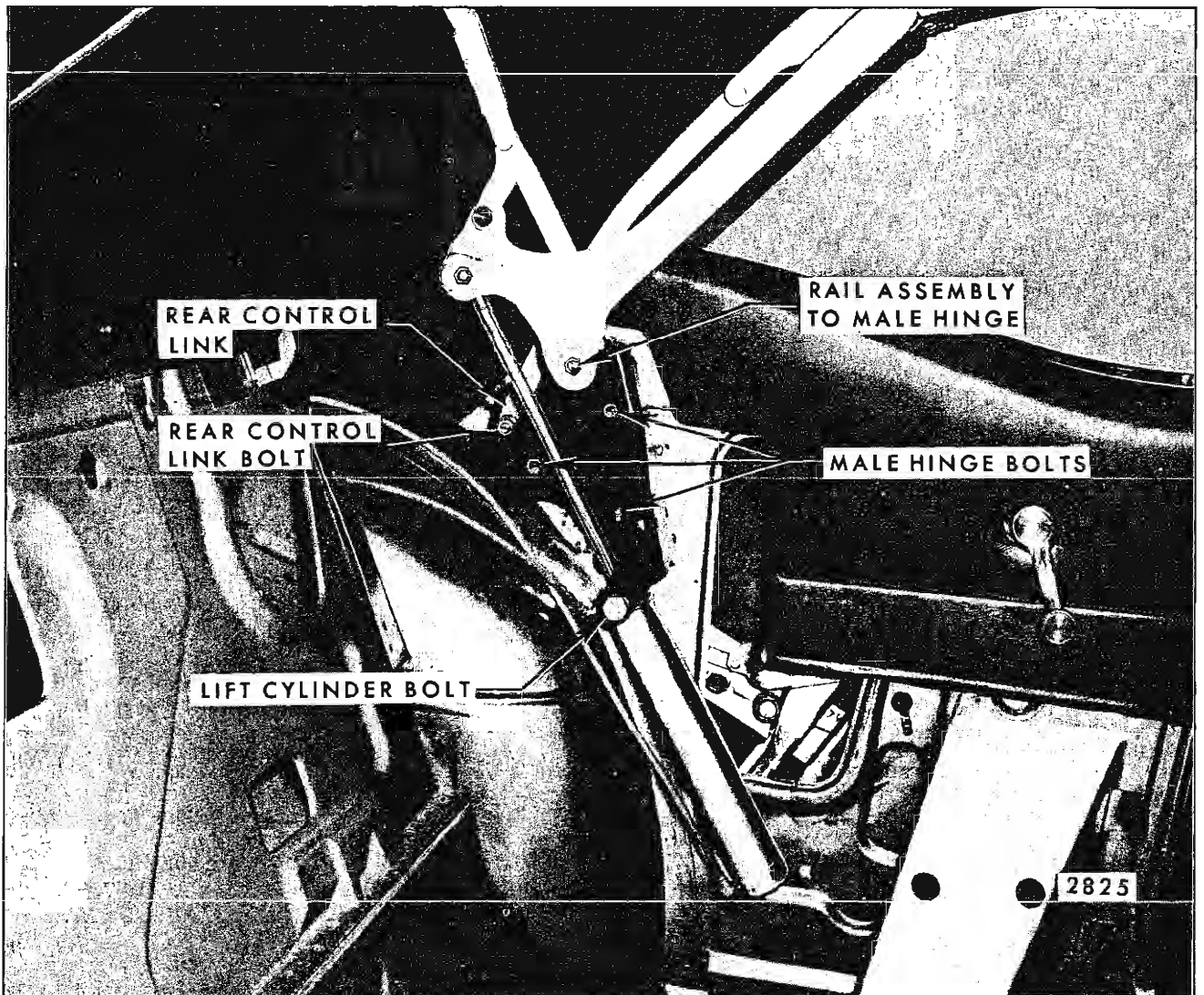

Fig. 13-68—Folding Top Linkage Attachment - "A" Styles Shown, "B & C" Typical

**NOTE:** A difference in pressure readings may exist between the pressure port for top of cylinders and pressure port for bottom of cylinders. This condition is acceptable if both readings are within the limit of 340 psi and 380 psi.

- e. If the pressure is not within specified limits, unit is defective and should be repaired or replaced, as required.

## FOLDING TOP LIFT CYLINDER

### Removal and Installation

1. Lock top to windshield header.
2. Disconnect positive battery cable to prevent accidental operation of motor and pump, particularly when hydraulic hoses are disconnected from cylinder.
3. Remove rear seat cushion and seat back.
4. Remove folding top compartment side trim panel assembly on side affected.
5. Remove clips securing hydraulic hose to rear seat back panel.
6. Remove attaching nut, bolt, bushing and washer from upper end of cylinder rod, Figures 13-68 and 13-69.
7. Remove inner and outer bolt securing cylinder to male hinge (Fig. 13-69).
8. Carefully move cylinder to inboard side of top compartment brace, exposing upper and lower hydraulic hose to cylinder connections.
9. Prior to disconnecting hydraulic connections, place suitable wiping rags under connections to absorb any drippage of hydraulic fluid.
10. Disconnect hydraulic connections from old cylinder and transfer to new cylinder assembly.
11. Install new cylinder to male hinge.
12. Connect positive battery cable to battery terminal.
13. Using power, raise cylinder piston rod to extended position.
14. Attach upper end of cylinder rod to folding top linkage using previously removed nut, bolt, bushing and washer.
15. Operate folding top assembly down and up sev-

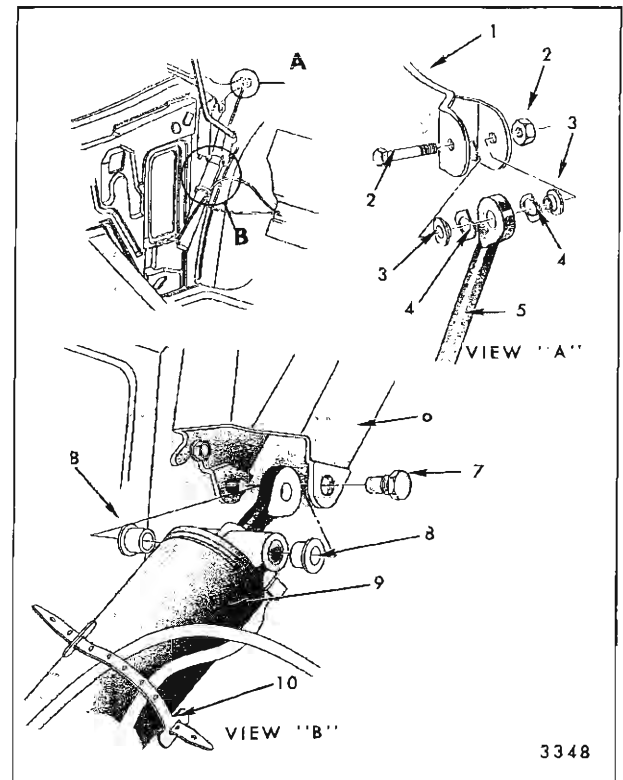

Fig. 13-69—Folding Top Lift Cylinder Attachment  
"B & C" Shown, "A & F" Typical

- |                                      |                             |
|--------------------------------------|-----------------------------|
| 1. Side Roof Rear Rail               | 5. Piston rod               |
| 2. Piston Rod Attaching Bolt and Nut | 6. Male Hinge               |
| 3. Piston Rod Bushing                | 7. Cylinder Attaching Bolt  |
| 4. Piston Rod Anti-Rattle Washer     | 8. Cylinder Bushing         |
|                                      | 9. Top Lift Cylinder        |
|                                      | 10. Hydraulic Hose Retainer |

eral times; then check and correct level of hydraulic fluid in reservoir. See "Filling of Hydro-Lectric Reservoir".

16. Install hydraulic hose to rear seat back panel with clips and install all previously removed trim and hardware.

## FILLING OF HYDRO-LECTRIC RESERVOIR

This procedure virtually eliminates discharge or spillage of hydraulic fluid and possible trim damage while filling and bleeding system.

### Fabrication of Rubber Filler Plug Adapter

1. Obtain a spare rubber filler plug (Part #7596442).
2. Cut approximately 1/2" off male end of plug (end inserted into reservoir) to permit insertion of tubing as shown in sketch.

3. Obtain a 2" length of metal tubing 7/32 O.D. x 5/32 I.D.
4. Insert reworked plug into filler hole in reservoir.
5. Insert metal tubing through hole in reworked filler plug.

**NOTE:** Figure 13-70 illustrates fabricated filler plug adapter.

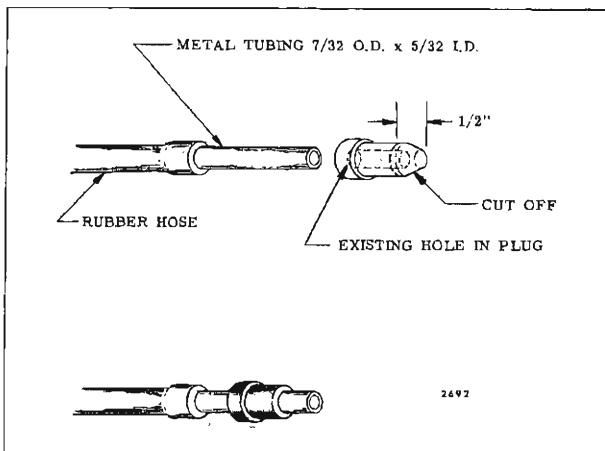

Fig. 13-70—Reservoir Filler Plug Adapter

Filling and Bleeding Reservoir

1. On all body styles, with top in raised position,

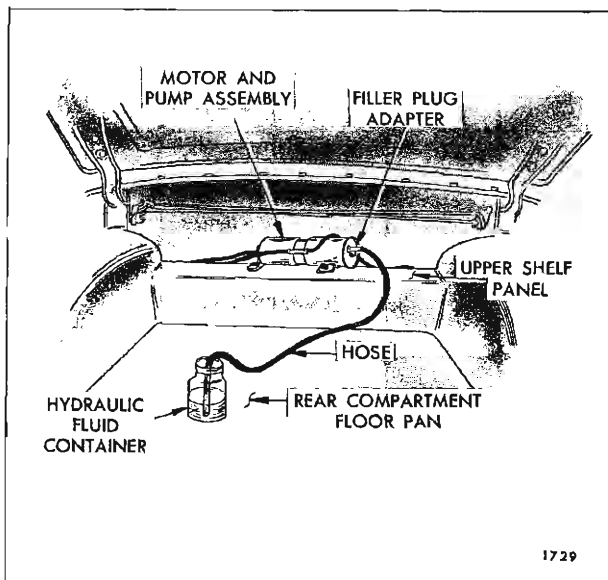

Fig. 13-71—Filling Reservoir with Hydraulic Fluid  
All Styles Except "Z" Body

remove folding top compartment bag material from rear seat back panel.

2. On "B-C & F" body styles, remove rear seat cushion and back.
3. Place absorbent rags below reservoir at filler plug. Using pliers, slowly pull filler plug from reservoir.

**IMPORTANT:** When installing new or overhauled motor and pump assembly as a bench operation, fill reservoir with hydraulic fluid.

This priming operation is necessary prior to performing the following steps in order to avoid drawing excessive amount of air into hydraulic system.

4. Install filler plug adapter to reservoir and attach four or five foot length 5/32 inch I.D. rubber tubing or hose to filler plug tubing.
5. Install opposite end of hose into a container of Type "A" transmission fluid.

**NOTE:** Container should be placed in rear compartment area on "A" bodies and rear floor pan on "B-C & F" bodies, below level of fluid in the reservoir. In addition, sufficient fluid must be available in container to avoid drawing air into hydraulic system (Fig. 13-71).

6. Operate top to down or stacked position. After top is fully lowered continue to operate motor and pump assembly (approximately 15 to 20 seconds), or until noise level of pump is noticeably reduced. Reduction in pump noise level indicates that hydraulic system is filled with fluid.
7. Operate top up and down several times or until operation of top is consistently smooth in both up and down cycles and no further air bubbles are exhausted in container or fluid.
8. With top in down position, remove filler plug tubing and remove filler plug adapter from reservoir.
9. Check level of fluid in reservoir and re-install original filler hole plug.

**NOTE:** Fluid level should be within 1/4 inch of lower edge of filler plug with top in down position.

**CAUTION:** DO NOT OVER-FILL.

## ACTUATOR ASSEMBLY—"Z" STYLES (EQUIPPED WITH ELECTRICALLY OPERATED FOLDING TOPS)

### Removal

1. Remove rear seat cushion and back and folding top compartment side trim panel assembly on side affected.
2. Lock top to windshield header.
3. Fully raise all door and rear quarter windows.
4. Disconnect drive cable from actuator assembly.
5. Remove bolts securing side roof rear rail to sector gear (Fig. 13-72).
6. Mark location of control link adjusting plate on folding top compartment brace (Fig. 13-72).

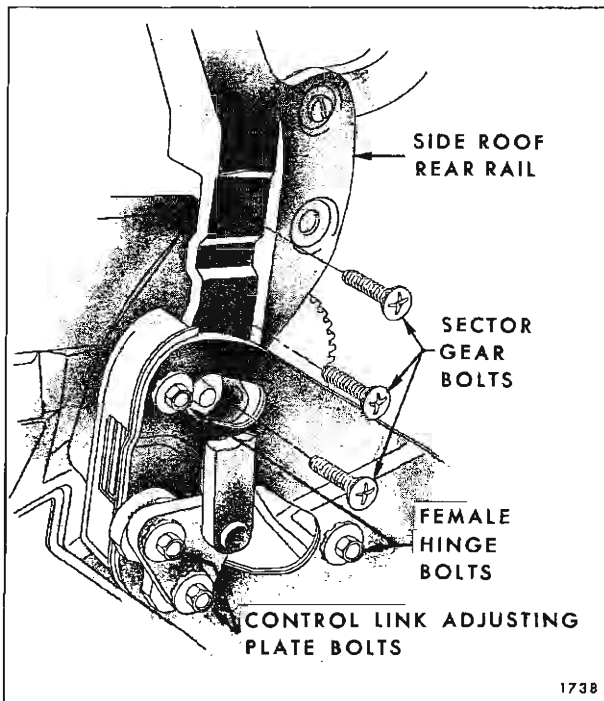

Fig. 13-72—Actuator and Top Control Link Attachment - "Z" Styles

7. Remove control link adjusting plate attaching bolts.
8. Mark location of female hinge attaching bolt washers on folding top compartment brace (Fig. 13-72).

9. Remove female hinge attaching bolts and remove actuator assembly from body.

### Installation

1. Install female hinge attaching bolts to new actuator assembly, using washer scribe marks as guide (Fig. 13-72).
2. Install control link adjusting plate attaching bolts, using scribe mark of control link as guide (Fig. 13-72).

**IMPORTANT:** Be sure female hinge and control link attaching bolts are tight and top is locked to windshield header.

3. Manually move sector gear until all attaching bolts can be easily installed; then tighten sector gear attaching bolts (Fig. 13-72).

**NOTE:** New actuator assembly should now be "in phase" with opposite lift assembly.

4. Connect drive cable to actuator assembly.
5. Unlock top from windshield header.
6. Operate top to down or "stacked" position.

**IMPORTANT:** Care should be exercised when operating top during first test cycle to be sure that both actuators are synchronized or "in phase". Operation of top when actuators are "out of phase" may cause damage to side roof rails, actuators or convertible top material.

7. If electric lift units are "out of phase", proceed as follows:
  - a. Remove compartment bag material from rear seat back panel.
  - b. Disconnect both drive cables from motor assembly (Fig. 13-73).
  - c. Manually raise top above windshield header.
  - d. Lock top to windshield header.
  - e. Connect drive cables to motor.
  - f. Operate top through one or two complete cycles.

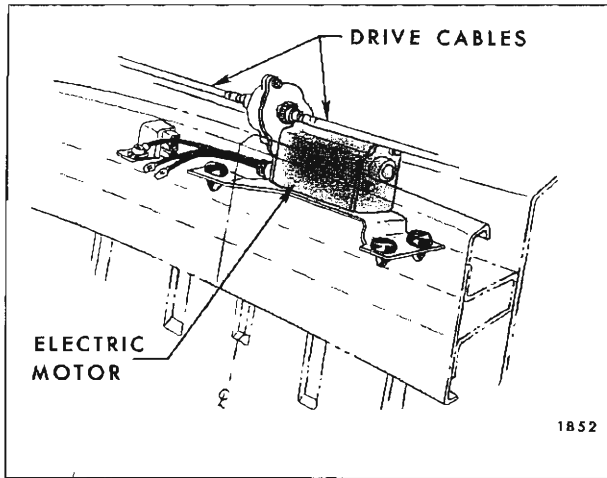

Fig. 13-73—Folding Top Electric Power Unit "Z" Styles

**NOTE:** The above procedure may be repeated on an "as required" basis if top does not appear to be "in phase" after test cycle.

- g. Install compartment bag material to rear seat back panel.
- 8. Install folding top compartment side trim panel and rear seat back and cushion assembly.

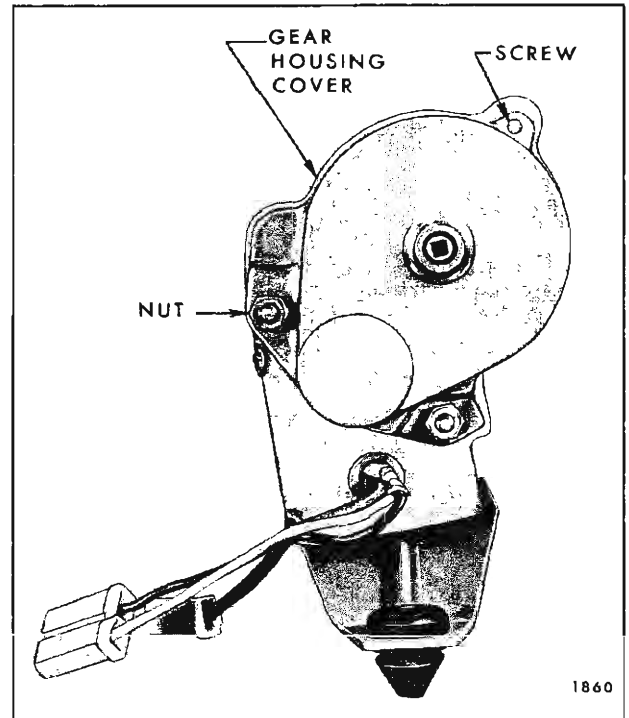

Fig. 13-74—Folding Top Lift Assembly

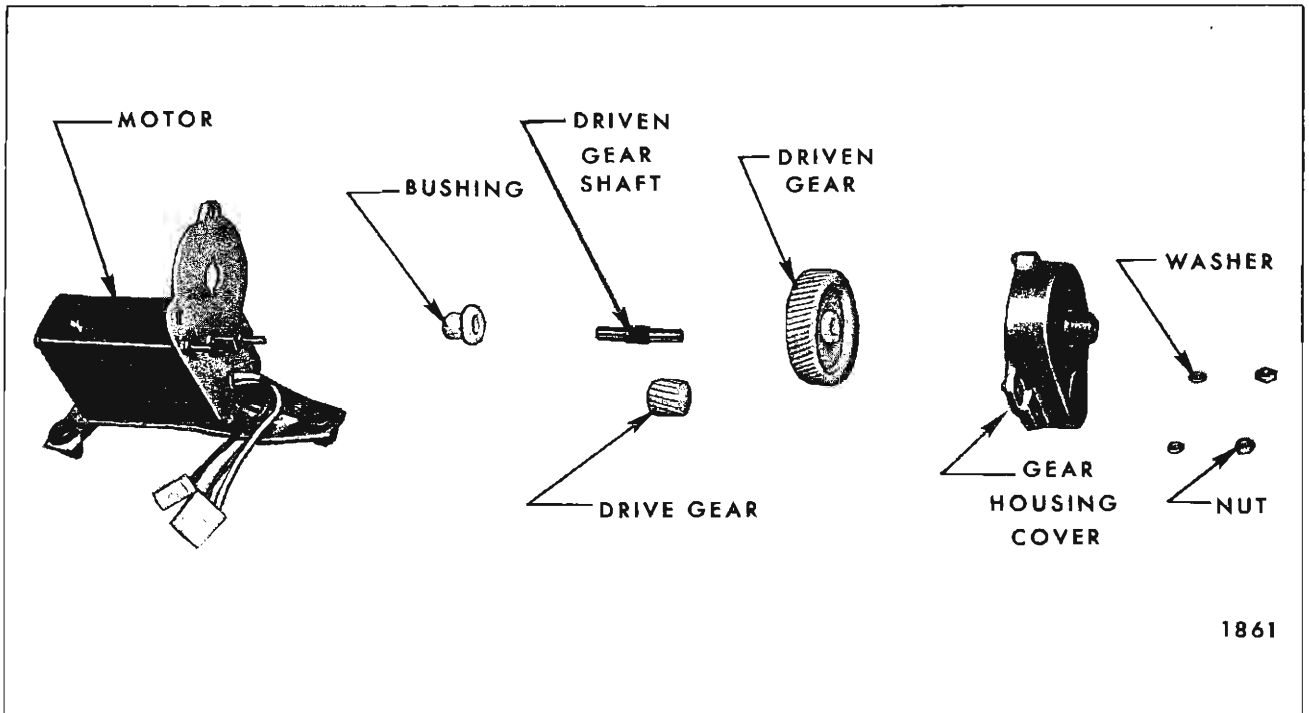

Fig. 13-75—Folding Top Lift Disassembled

## INOPERATIVE FOLDING TOP IN DOWN ("STACKED") POSITION

1. Working over rear seat back, detach top compartment bag material from rear seat back panel.
2. Disconnect both drive cables from motor assembly (Fig. 13-73).
3. With aid of helper, manually raise folding top assembly and lock to windshield header.
4. To replace an actuator assembly see "Folding Top Actuator Assembly" removal and installation procedure.

## TOP LIFT ASSEMBLY

### Disassembly and Assembly

1. Working over rear seat back, detach top compartment bag material from rear seat back panel.
2. Disconnect both drive cables from motor assembly.
3. Remove nuts, washers and screw securing gear housing cover to motor assembly (Fig. 13-74).
4. Disassemble folding top lift assembly as shown in Figure 13-75.
5. To assemble, reverse disassembly procedure.

## FOLDING TOP MANUAL LIFT ASSEMBLY "A, F & Z" STYLES

### Description

The manual lift assembly incorporates a dual-action heavy duty spring which helps compensate for the weight of the folding top mechanism when the top is at or near the full up or full folded positions. When the top is in the up position, the spring is under compression; when it is in the folded or stacked position, the spring is under tension.

**CAUTION:** Do not attempt to detach lift assembly when spring is under tension or compression.

### Removal and Installation

1. On all styles remove rear seat cushion and back and folding top compartment side trim panel assembly on side affected. On "F" Body Styles only, remove the body lock pillar to main hinge support extension brace.
2. Move top to midway position to relieve the manual lift springs. If both lift assemblies are to be serviced, have helper support folding top or place supporting props under front roof rail.
3. Remove attaching nut, bolt, bushing and washer from upper end of lift assembly.
4. On "F & Z" bodies, remove inner and outer bolt securing lift assembly to male hinge; then remove assembly from body. On "A" bodies, remove inner bolt and slightly move lift assembly inboard and remove. (Fig. 13-76 for "A" body, Fig. 13-77 for "F" body, and Fig. 13-78 for "Z" body.)

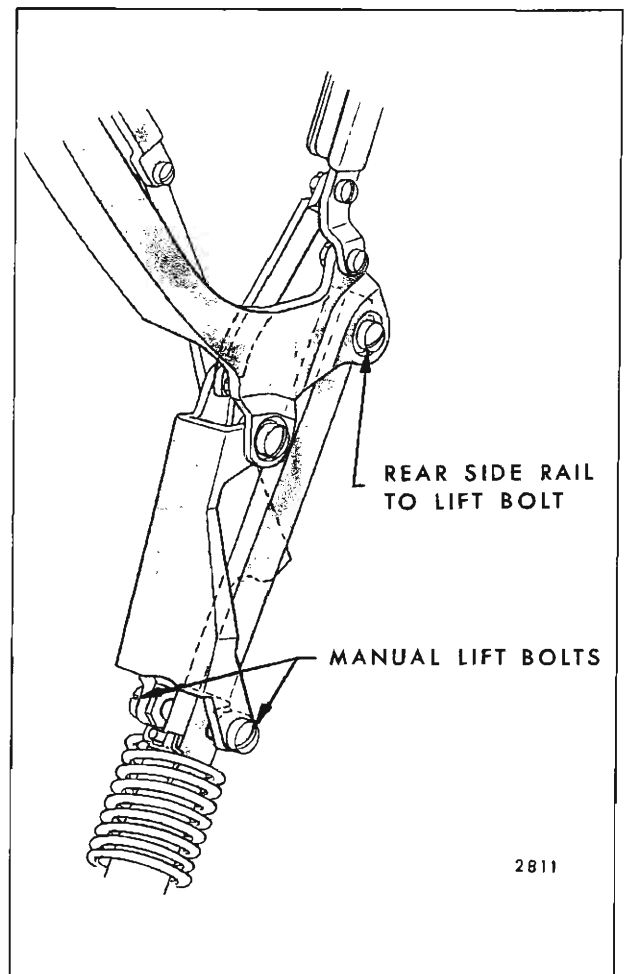

Fig. 13-76—Folding Top Manual Lift Attachment - "A" Styles

5. To install manual lift assembly, reverse removal procedure. Operate folding top assembly down and up several times to insure proper operation.

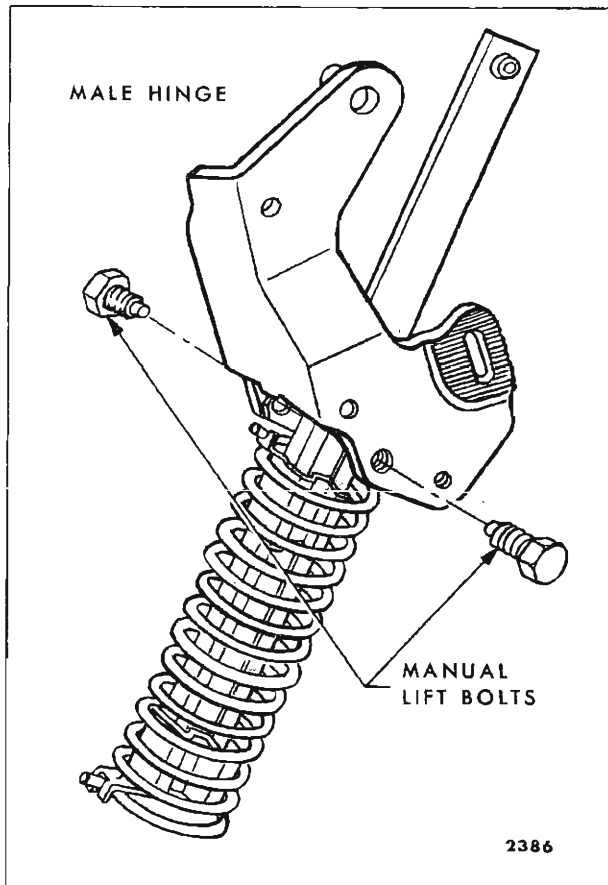

Fig. 13-77—Folding Top Manual Lift Attachment - "F" Styles

### FOLDING TOP CATCH CLIPS

The folding top catch clips snap over the folding top side roof center rails when the top is being lowered to the folded or stacked position. The catch clips

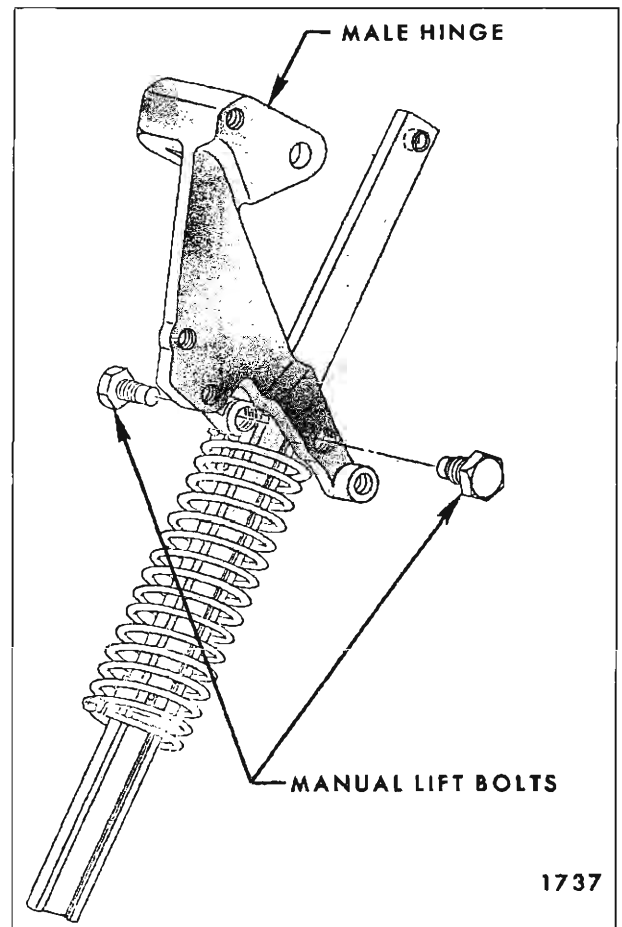

Fig. 13-78—Folding Top Manual Lift Attachment - "Z" Styles

prevent the spring-loaded manual lift arms from raising the top from this position. In order to raise the top, both catch clips must be disengaged from the side roof center rails. Each catch clip is attached to the folding top compartment side panels by two screws. Any adjustments made to change stack height of the folding top (See "Folding Top Adjustments") require corresponding adjustments to the catch clips.

## FOLDING TOP ADJUSTMENTS "A, B & C" STYLES

### Description

The folding top linkage consists of three sections of side roof rails, a front roof rail, hinges, connect-

ing links and bows. The top linkage is attached to the body at the rear quarter area by a stationary, side-mounted male hinge. The front roof rail locks at the windshield header by hook type locks which are integral with the locking handles.



The following information outlines and illustrates procedures which may be used to correct misaligned folding top linkage. To correct some top variations, only a single adjustment is required; other top variations require a combination of adjustments. In conjunction with adjustments of the folding top, it may be necessary to adjust the door, door glass, rear quarter glass, or side roof rail weatherstrips.

### ADJUSTMENT OF FRONT ROOF RAIL GUIDE

If the front roof rail guide does not properly engage with the striker when the top is raised, the guide may be adjusted laterally as follows:

1. Unlatch top and raise it above windshield header.
2. Loosen guide and adjust to desired position; then tighten guide (Fig. 13-79).

**NOTE:** The sunshade support and striker assembly is not adjustable. If additional fore and aft adjustment is required, it must be obtained by adjusting the front roof rail.

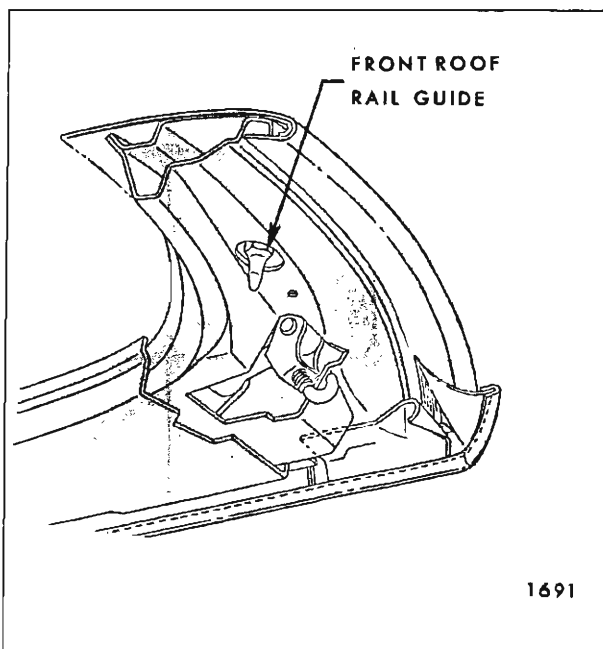

Fig. 13-79—Front Roof Rail Guide and Lock Hook  
"A, B, & C" Styles

### ADJUSTMENT OF FRONT ROOF RAIL

If the top, when raised, is too far forward or does not move forward enough to allow the guide pin to enter the striker, proceed as follows:

1. Unlatch top and raise it above windshield header. Remove side roof rail weatherstrip front attaching screws.
2. Loosen side roof rail lock attaching screws and adjust front roof rail fore or aft as required (Fig. 13-80).
3. Tighten lock attaching screws and install weatherstrip screws.

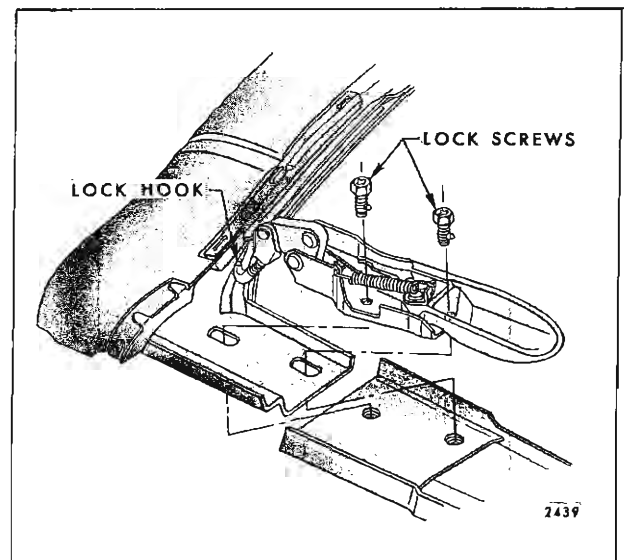

Fig. 13-80—Front Roof Rail and Lock Attachment  
"B & C" Styles Shown, "A" Styles Typical

### FRONT ROOF RAIL LOCK ASSEMBLY

#### Removal and Installation

1. Lower top to half-lowered position, remove lock attaching screws; and remove lock assembly from front roof rail (Fig. 13-80).
2. To install, reverse removal procedure and adjust front roof rail as required.

### FRONT ROOF RAIL LOCK ADJUSTMENT

If locking action of top is unsatisfactory, the hook on the lock assembly may be adjusted as follows:

1. To tighten or increase locking action, turn lock hook clockwise.
2. To reduce or decrease locking action, turn lock hook counterclockwise (Fig. 13-80).

### ADJUSTMENT OF TOP CONTROL LINK

If side roof rails are too high or too low over side

windows, proceed as follows:

**IMPORTANT:** When making top control link adjustments, be sure side roof rail hinge adjusting screw (Fig. 13-82 View "B") is backed off.

1. Operate top to half-lowered position.

2. Loosen bolt securing control link sufficiently to permit adjustment (Fig. 13-81).

3. Adjust top control link as required and tighten bolt.

4. Raise and lock top. Check alignment.

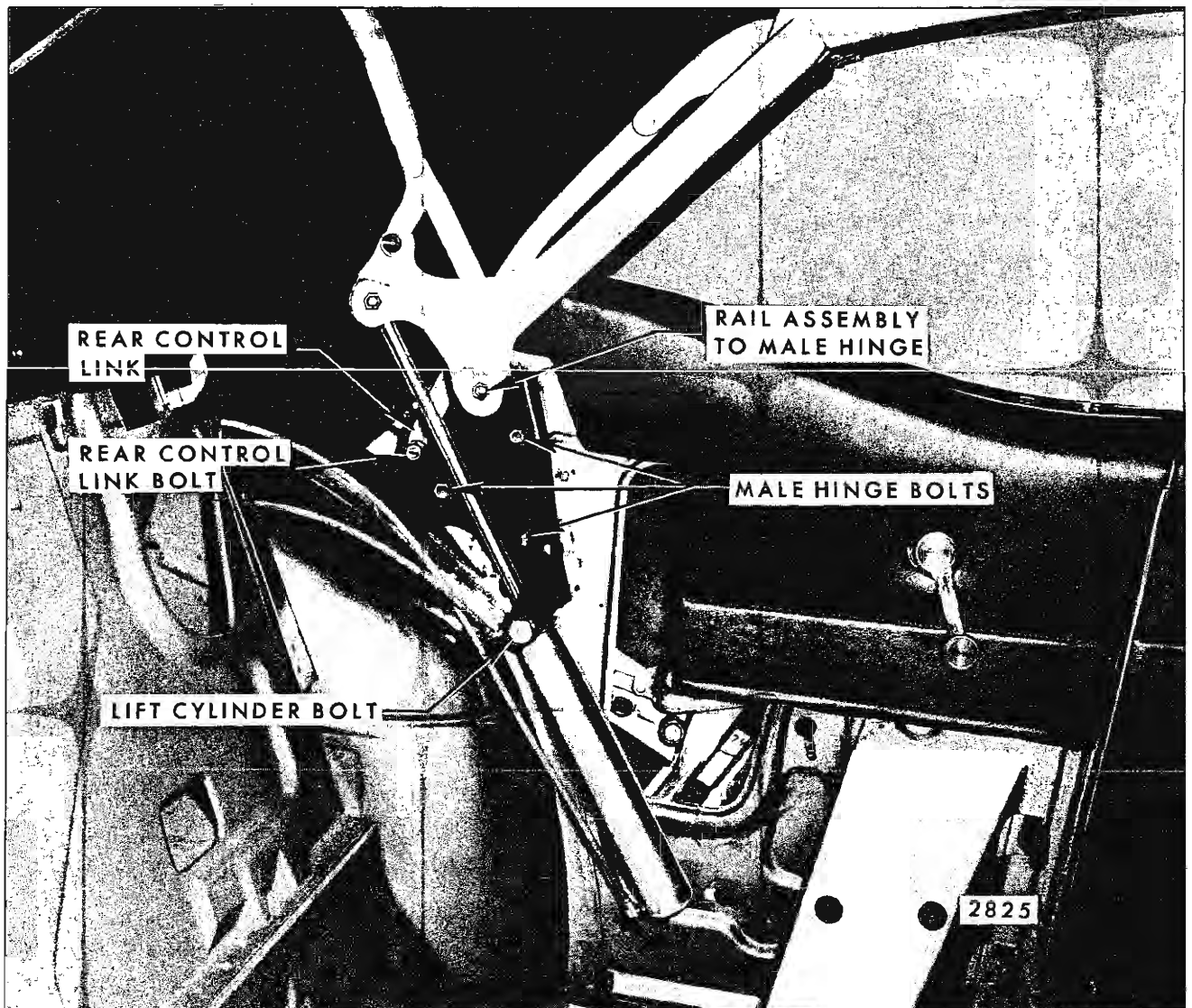
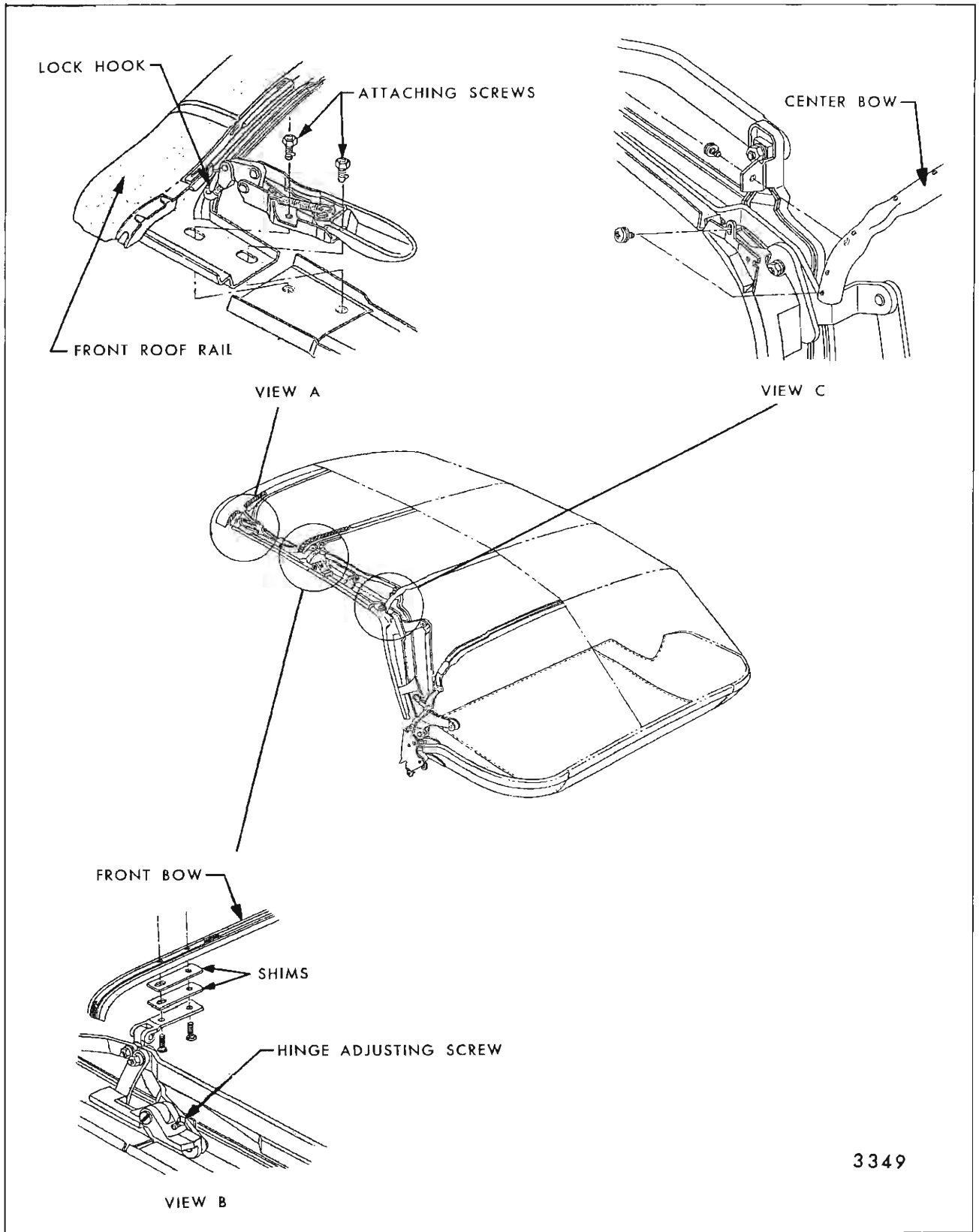

Fig. 13-81—Folding Top Linkage Attachment - "A" Styles Shown, "B & C" Typical



3349

Fig. 13-82—Folding Top Adjustments - "B & C" Styles Shown. "A" Styles Similar

## TROUBLE SHOOTING CHART "A, B &amp; C" STYLES

CONDITION	APPARENT CAUSE	CORRECTION
A. Difficult locking action at front.	<ol style="list-style-type: none"> <li>1. Lock hook too short.</li> <li>2. Misaligned front roof rail front weatherstrip.</li> <li>3. Front roof rail misaligned.</li> </ol>	<p>Adjust lock hook counterclockwise.</p> <p>Loosen, realign and retack front roof rail front weatherstrip.</p> <p>Adjust front roof rail.</p>
B. Top does not lock tight enough to windshield header.	<ol style="list-style-type: none"> <li>1. Lock hook too long.</li> <li>2. Misaligned front roof rail weatherstrips.</li> <li>3. Front roof rail misaligned.</li> </ol>	<p>Adjust lock hook clockwise.</p> <p>Loosen and realign front roof rail weatherstrips.</p> <p>Adjust front roof rail.</p>
C. Top travels too far forward.	<ol style="list-style-type: none"> <li>1. Front roof rail misaligned.</li> </ol>	<p>Adjust front roof rail rearward.</p>
D. Top does not travel forward far enough.	<ol style="list-style-type: none"> <li>1. Front roof rail misaligned.</li> </ol>	<p>Adjust front roof rail forward.</p>
E. Side roof rails low.	<ol style="list-style-type: none"> <li>1. Center side roof rail hinge adjusting screw protrudes.</li> <li>2. Control link misaligned.</li> </ol>	<p>Back off adjusting screw (View "B" Fig. 13-82).</p> <p>Adjust control link downward.</p>
F. Side roof rails high.	<ol style="list-style-type: none"> <li>1. Control link misaligned.</li> </ol>	<p>Adjust control link upward.</p>
G. Folding top dust boot is difficult to install ("A" Style).	<ol style="list-style-type: none"> <li>1. On manual tops, due to improperly adjusted catch clips.</li> </ol>	<p>Adjust catch clips downward as required.</p>
H. Folding Top dust boot fits too loosely ("A" Style).	<ol style="list-style-type: none"> <li>1. On manual tops, due to improperly adjusted catch clips.</li> </ol>	<p>Adjust catch clips upward as required.</p>
I. Top material is too low over windows or side roof rails.	<ol style="list-style-type: none"> <li>1. Front roof bow insufficiently shimmed.</li> <li>2. Excessive width in top material.</li> </ol>	<p>*Install one or two 1/8" shims between front roof bow and slat iron (See View "B" in Fig. 13-82).</p> <p>If top is too large, detach binding along affected area; trim off excessive material along side binding as required; then hand sew binding to top material.</p>
J. Top material is too high over windows or side roof rails.	<ol style="list-style-type: none"> <li>1. Front roof bow shimmed too high.</li> </ol>	<p>*Remove one or two 1/8" shims between front roof bow and slat iron (See View "B" in Fig. 13-82).</p>

## TROUBLE SHOOTING CHART "A, B &amp; C" STYLES (CONT'D.)

CONDITION	APPARENT CAUSE	CORRECTION
K. Top material has wrinkles or draws.	1. Top material improperly installed.	Reposition and retack top material as required.
L. Top material binds at side quarters.	1. Insufficient clearance.	Install shim of necessary thickness between hinge and body.
M. One side staggers upon raising top from folding top compartment ("A" Style).	1. Bind condition in folding top linkage.	With top lowered, remove trim on affected side. Loosen male hinge attaching bolts. Do not loosen top control link. Raise top 3 to 4 feet. Tighten bolts and recheck operation of top. Reinstall trim.

\*When no shims are required or when installing only one shim, use attaching screw part #4412844 (1/4 - 20 x 5/8" oval head with external tooth lock washer, type "T-T" tapping screw, chrome finish).

When two shims are required, use attaching screw part #4412619 (1/4 - 20 x 3/4" oval head with external tooth lock washer, type "T-T" tapping screw, chrome finish).

## FOLDING TOP ADJUSTMENTS "F" BODY

### DESCRIPTION

The following information outlines and illustrates procedures which may be used to correct misaligned folding top linkage. To correct some top variations, only a single adjustment is required; other top variations require a combination of adjustments. In conjunction with adjustment of the folding top, it may be necessary to adjust the door, door glass, rear quarters glass, trim sticks or side roof rail weatherstrips.

**CAUTION:** When operating a manually-operated folding top, hands must be kept clear of side roof rail hinges and connecting linkage.

### ADJUSTMENT OF FRONT ROOF RAIL

If the top, when in a raised position, is too far forward or too far rearward, the front roof rail may be adjusted as follows:

1. Unlatch top and raise it above windshield header. Remove side roof rail weatherstrip front attaching screws.
2. Loosen lock attaching screws on side roof front

rail and adjust front roof rail fore or aft as required (See View "A", Fig. 13-84).

3. Tighten lock assembly and install weatherstrip attaching screws.

**NOTE:** If additional adjustment is required, it can be made at folding top male hinge.

### FRONT ROOF RAIL LOCK ASSEMBLY

#### Removal and Installation

1. Unlock top from windshield header.
2. With top in a half-lowered position, remove lock attaching screws; then remove lock assembly from front roof rail (See View "A", Fig. 13-84).
3. To install, reverse removal procedure and align front roof rail as required.

### FRONT ROOF RAIL LOCK ADJUSTMENT

If the locking action of top is unsatisfactory, the hook on the lock assembly may be adjusted as

follows:

1. To tighten or increase locking action, turn lock hook clockwise.
2. To reduce or decrease locking action, turn lock hook counterclockwise.

### ADJUSTMENT OF TOP CONTROL LINK

1. With top in locked position, if side roof rail is too high or too low, proceed as follows:
  - a. Remove folding top compartment side trim panel.
  - b. Loosen bolt securing control link sufficiently to permit adjustment (See Fig. 13-83).
  - c. Adjust link to desired position; then tighten bolt.
  - d. Reinstall folding top compartment side trim panel.

### ADJUSTMENT OF TOP AT MALE HINGE

Prior to making any adjustment of top linkage at male hinge, loosen two bolts securing rear quarter trim stick to body. This will prevent any possible damage to top cover when it is raised after adjustment. After making an adjustment at male hinge, check top cover at rear quarter area for proper fit and, if necessary adjust trim stick assembly.

1. If there is an excessive opening between side

roof rail rear weatherstrip and rear of rear quarter window, or if front roof rail is too far forward or rearward, proceed as follows:

- a. Scribe location of male hinge attaching bolt washers on folding top compartment brace.
  - b. Loosen male hinge bolts (Fig. 13-83).
  - c. Move hinge fore or aft as required to obtain proper alignment between side roof rail rear weatherstrip and rear quarter window, then tighten bolts.
  - d. Lock front roof rail to windshield header and check fit of top material at rear quarter trim stick; then tighten trim stick attaching bolts.
  - e. On styles equipped with manually operated folding tops adjust both folding top catch clips as required (See "Folding Top Manual Lift Section").
2. If side roof rail is too high or too low at rear quarter window area, proceed as follows:
    - a. Scribe location of male hinge attaching bolt washers and control link on folding top compartment brace.
    - b. Loosen male hinge bolts (See Fig. 13-83).
    - c. Without changing fore and aft location of male hinge, adjust male hinge up or down as required to obtain proper alignment be-

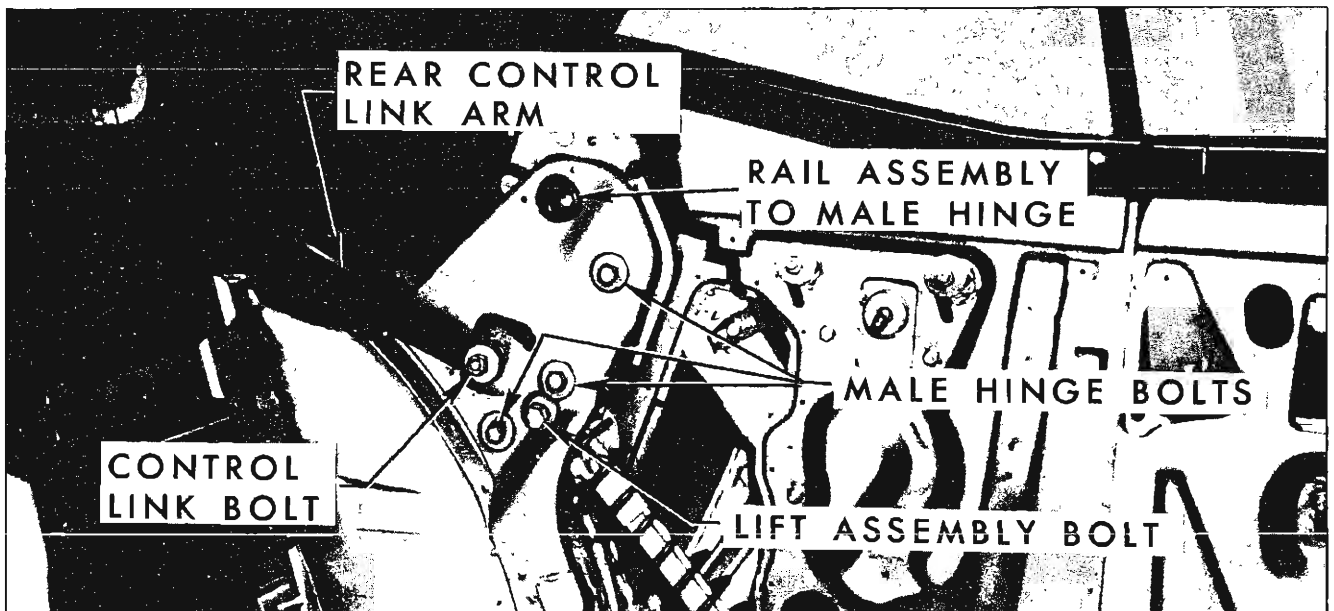

Fig. 13-83—Folding Top Linkage Attachment "F" Styles

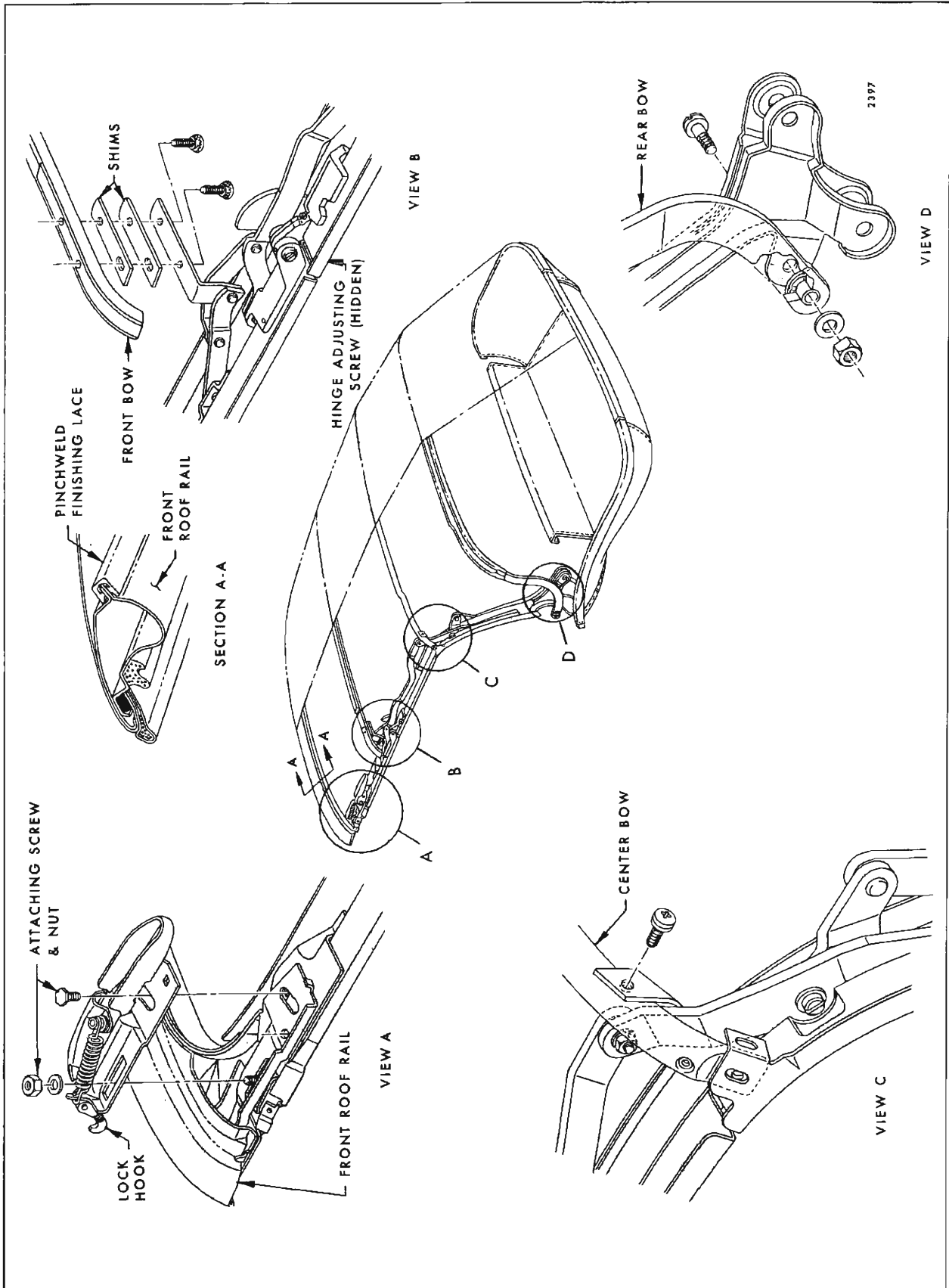

Fig. 13-84—Folding Top Adjustments - "F" Styles

- tween side roof rail and rear quarter window.
- d. Tighten attaching bolts, while maintaining proper alignment of scribe marks.
  - e. Check fit of top material at rear quarter and, if necessary, adjust trim stick.
  - f. On styles equipped with manually-operated folding tops, adjust folding top catch clips as required (See "Folding Top Manual Lift Section").
3. If top does not stack properly when top is in down position proceed as follows:
- a. Scribe location of male hinge attaching bolt washers on folding top compartment brace.
  - b. Loosen male hinge bolts.
  - c. Rotate male hinge forward to lower stack

height or rearward to raise stack height (Fig. 13-83).

**NOTE:** When rotating male hinge be certain position of rear rail to male hinge is maintained (Fig. 13-83):

- d. Tighten attaching bolts, while maintaining proper alignment of scribe marks.
- e. On styles equipped with manually operated folding tops, adjust both folding top catch clips as required (See "Folding Top Manual Lift").

### TROUBLE SHOOTING CHART

The following procedure describes and illustrates various types of folding top misalignment conditions, their apparent causes and the recommended procedure for their correction.

### TROUBLE SHOOTING CHART "F" STYLES

CONDITION	APPARENT CAUSE	CORRECTION
A. Difficult locking action at front roof rail.	<ol style="list-style-type: none"> <li>1. Lock hook too short.</li> <li>2. Misaligned front roof rail front weatherstrip.</li> <li>3. Front roof rail misaligned.</li> </ol>	<p>Adjust lock hook counterclockwise (See View "A" in Fig. 13-84).</p> <p>Loosen, realign and retack front roof rail front weatherstrip.</p> <p>Adjust front roof rail.</p>
B. Top does not lock tight enough to windshield header.	<ol style="list-style-type: none"> <li>1. Lock hook too long.</li> <li>2. Misaligned front roof rail weatherstrips.</li> </ol>	<p>Adjust lock hook clockwise.</p> <p>Loosen and realign front roof rail weatherstrips.</p>
C. Top travels too far forward.	<ol style="list-style-type: none"> <li>1. Front roof rail misaligned.</li> <li>2. Male hinge misaligned.</li> </ol>	<p>Adjust front roof rail rearward.</p> <p>Adjust male hinge rearward (Fig. 13-83).</p>
D. Top does not travel forward far enough.	<ol style="list-style-type: none"> <li>1. Front roof rail misaligned.</li> <li>2. Male hinge misaligned.</li> </ol>	<p>Adjust front roof rail forward.</p> <p>Adjust male hinge forward.</p>
E. Side roof rail rear weatherstrip too tight against rear of rear quarter window.	<ol style="list-style-type: none"> <li>1. Male hinge misaligned.</li> </ol>	<p>Adjust male hinge rearward.</p>



## TROUBLE SHOOTING CHART "F" STYLES (CONT'D.)

CONDITION	APPARENT CAUSE	CORRECTION
F. Gap between side roof rail rear weatherstrip and rear of rear quarter window.	1. Male hinge misaligned.	Adjust male hinge forward and/or shim side roof rail rear weatherstrip forward as required.
G. Side roof rail rear weatherstrip too tight against top of rear quarter window.	1. Male hinge misaligned.	Adjust male hinge upward.
H. Gap between side roof rail rear weatherstrip and top of rear quarter window.	1. Male hinge misaligned.	Adjust male hinge downward and/or shim side roof rail rear weatherstrip downward as required.
I. Side roof rails low.	1. Control link misaligned.  2. Center side roof rail hinge adjusting screw protrudes.	Adjust control link downward (Fig. 13-83).  Back off adjusting screw (See View "B" in Fig. 13-84).
J. Side roof rails high.	1. Control link misaligned.	Adjust control link upward.
K. Folding top dust boot is difficult to install.	1. Improper stack height due to misaligned male hinge assembly.  2. On manual tops, due to improperly adjusted catch clips.	Rotate male hinge forward or rearward as required.  Adjust catch clips downward as required.
L. Folding top dust boot fits too loosely.	1. Improper stack height due to misaligned male hinge assembly.  2. On manual tops, due to improperly adjusted catch clips.	Rotate male hinge rearward as required.  Adjust catch clips upward as required.
M. Top material is too low over windows or side roof rails.	1. Front roof bow improperly shimmed.  2. Excessive width in top material.	*Install one or two 1/8" shims between front roof bow and slat iron.  If top is too large, detach binding along affected area; trim off excessive material along side binding as required; then hand sew binding to top material.

## TROUBLE SHOOTING CHART "F" STYLES (Cont'd.)

CONDITION	APPARENT CAUSE	CORRECTION
N. Top material is too high over windows or side roof rails.	1. Front roof bow improperly shimmed.	*Remove one or two 1/8" shims from front roof bow and slat iron.
O. Top material has wrinkles or draws.	1. Rear quarter trim stick improperly adjusted. 2. Top material improperly installed to center or rear quarter trim stick.	Adjust rear quarter trim stick on side affected. Reposition and retack top material as required.

\*When no shims are required or when installing only one shim, use attaching screw part #4412844 (1/4 - 20 x 5/8" oval head with external tooth lock washer, type "T-T" tapping screw, chrome finish).

When two shims are required, use attaching screw part #4412619 (1/4 - 20 x 3/4" oval head with external tooth lock washer, type "T-T" tapping screw, chrome finish).

## FOLDING TOP ADJUSTMENTS—"Z" BODY

## DESCRIPTION

The following information outlines and illustrates procedures which may be used to correct misaligned folding top linkage. To correct some top variations, only a single adjustment is required; other top variations require a combination of adjustments. In conjunction with adjustment of the folding top, it may be necessary to adjust the door, door glass, rear quarter glass, quarter trim sticks or side roof rail weatherstrips.

**CAUTION:** When operating a manually-operated folding top, hands must be kept clear of side roof rail hinges and connecting linkage.

## ADJUSTMENT OF FRONT ROOF RAIL WEDGE PLATE

The folding top front roof rail wedge plates are designed to contact the side of the sunshade support and striker assembly thus aligning the front roof rail to the striker so that both side roof rail locks will easily engage with the strikers. In addition, the wedge plates act as a spacer between the front roof rail and windshield header when top is in the locked position.

If the front roof rail wedge plates do not contact the sunshade support and striker assemblies when top is locked to the windshield header, the wedge plates may be adjusted as follows:

1. Raise top assembly to half-open position.

2. Remove wedge plate by removing inboard and outboard attaching screws (Fig. 13-85).
3. Using a file, slot inboard screw hole in wedge plate.
4. Install wedge plate and attaching screws.

**NOTE:** Do not tighten screws.

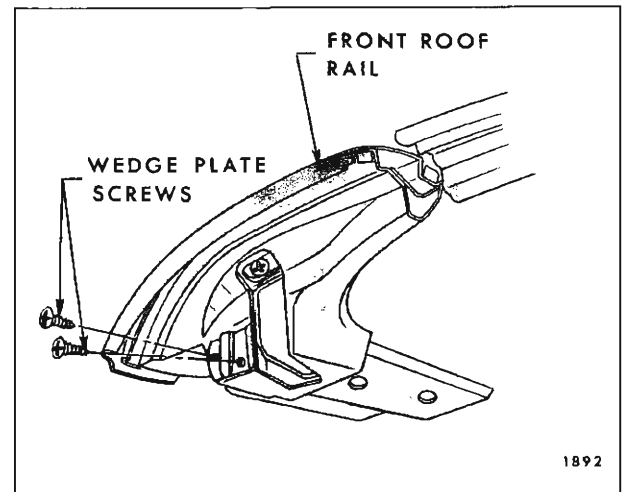

Fig. 13-85—Front Roof Rail Wedge Plate - "Z" Styles

5. Move wedge plate in or out sufficiently so wedge plate will contact side of striker as-

sembly when top is locked to windshield header. Tighten attaching screws.

6. Lock top to windshield header.

**NOTE:** The sunshade support and striker assembly is not adjustable.

### ADJUSTMENT OF FRONT ROOF RAIL

If the top, when in a raised position, is too far forward or too far rearward, the front roof rail may be adjusted as follows:

1. Unlatch top and raise it above windshield header. Remove side roof rail weatherstrip front attaching screws.
2. Loosen side roof front rail lock attaching screws and adjust front roof rail fore or aft as required (Fig. 13-86).
3. When front roof rail is properly adjusted, tighten attaching screws and install weatherstrip attaching screws.

**NOTE:** If additional adjustment is required, it can be made at folding top male hinge.

### FRONT ROOF RAIL LOCK ASSEMBLY

#### Removal and Installation

1. Unlock top from windshield header.
2. With top in a half-lowered position, remove lock attaching screws; then remove lock assembly from front rail (Fig. 13-86).
3. To install, reverse removal procedure and align front roof rail as required.

### FRONT ROOF RAIL LOCK ADJUSTMENT

If the locking action of top is unsatisfactory, the hook on the lock assembly may be adjusted as follows:

1. To tighten or increase locking action, turn lock hook clockwise (Fig. 13-87).
2. To reduce or decrease locking action, turn lock hook counterclockwise (Fig. 13-86).

### ADJUSTMENT OF TOP CONTROL LINK ADJUSTING PLATE

1. With top in "up" position, if side roof rail is too high or too low, proceed as follows:
  - a. Loosen two bolts securing control link ad-

justing plate sufficiently to permit adjustment (Fig. 13-87).

- b. Without changing fore and aft location of adjusting plate, adjust side roof rail up or down allowing adjusting plate to move up or down over serrations on support as required; then tighten bolts.

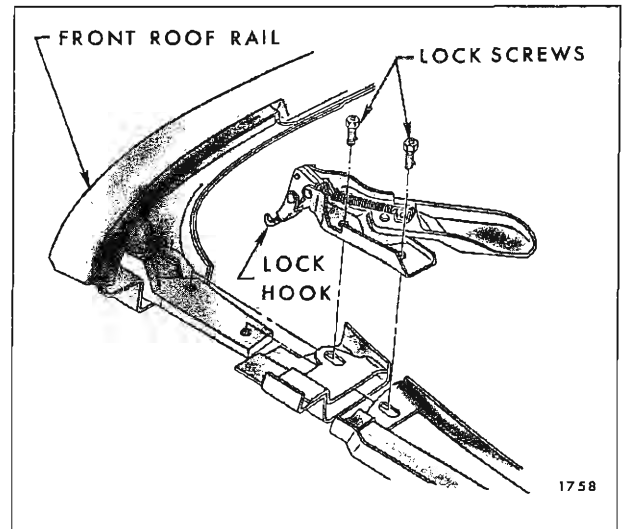

Fig. 13-86—Front Roof Rail and Lock Attachment - "Z" Styles

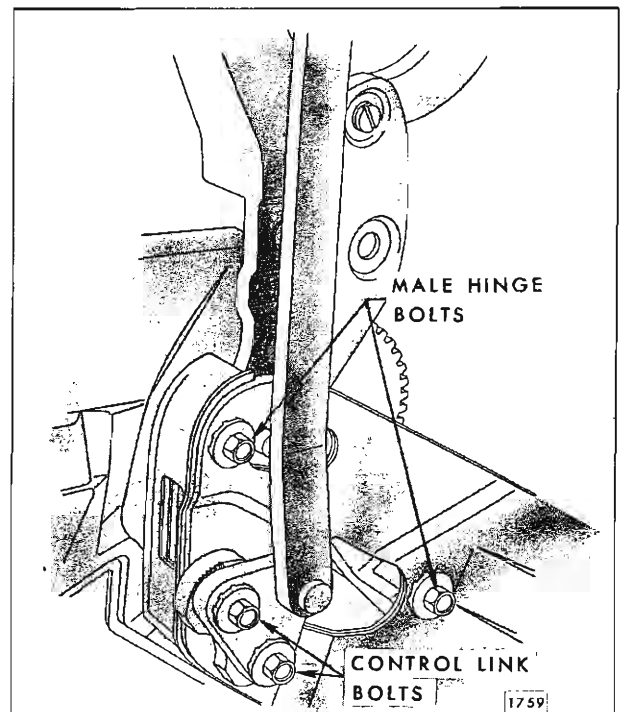

Fig. 13-87—Male Hinge and Top Control Link Attachment "Z" Styles

2. If top assembly does not stack properly when top is in down position, proceed as follows:
  - a. Loosen rear quarter trim stick attaching bolts on side to be adjusted.
  - b. Scribe location of male hinge attaching bolt washers and control link assembly on folding top compartment brace.
  - c. Loosen male hinge and control link attaching bolts (Fig. 13-87).
  - d. Rotate male hinge assembly forward or rearward around linkage pivot point, as required; then tighten attaching bolts, (Fig. 13-88) and check alignment.

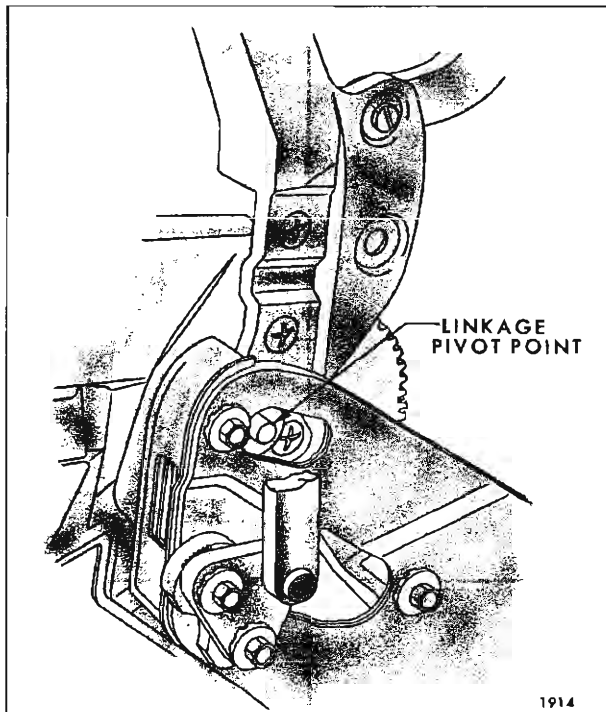

Fig. 13-88—Folding Top Linkage Pivot Point "Z" Styles

- e. On styles equipped with manually operated folding top, adjust both folding top catch clips as required (See "Folding Top Manual Lift").
- f. Lock top to windshield header; then check fit of top material at rear quarter. Adjust trim stick as required.

### ADJUSTMENT OF MALE HINGE

Prior to making any adjustment of top linkage at male hinge, loosen two bolts securing rear quarter trim stick to body. This will prevent possible damage to top cover when it is raised after adjustment. After making an adjustment at male hinge, check top cover at rear quarter area for proper fit and, if necessary, adjust trim stick assembly.

1. If there is an excessive opening between side roof rail rear weatherstrip and rear of rear quarter window, or if front roof rail is too far forward or rearward, proceed as follows:
  - a. Scribe location of male hinge attaching bolt washers and control link on folding top compartment brace.
  - b. Loosen male hinge and control link attaching bolts (Fig. 13-87).
  - c. Move hinge fore or aft as required to obtain proper alignment between side roof rail rear weatherstrip and rear quarter window, then tighten bolts.
  - d. Lock front roof rail to windshield header and check fit of top material at rear quarter trim stick; then tighten trim stick attaching bolts.
  - e. Check top assembly for proper stack height. Where required, adjust control link adjusting plate.
  - f. On styles equipped with manually operated folding tops, adjust both folding top catch clips as required (See "Folding Top Manual Lift Section").
2. If side roof rail is too high or too low at rear quarter window area, proceed as follows:
  - a. Scribe location of male hinge attaching bolt washers and control link on folding top compartment brace.
  - b. Loosen male hinge bolts and control link attaching bolts (Fig. 13-87).
  - c. Without changing fore and aft location of male hinge, adjust male hinge up or down as required to obtain proper alignment between side roof rail and rear quarter window.
  - d. Tighten attaching bolts, while maintaining proper alignment of scribe marks.
  - e. Check fit of top material at rear quarter and, if necessary, adjust trim stick.
  - f. Check top assembly for proper stack height. Where required, adjust control link adjusting plate.
  - g. On styles equipped with manually operated folding tops, adjust both folding top catch clips as required (See "Folding Top Manual Lift Section")

### TROUBLE SHOOTING CHART "Z" STYLES

The following procedure describes and illustrates various types of folding top misalignment conditions, their apparent causes and the recommended procedure for their correction.

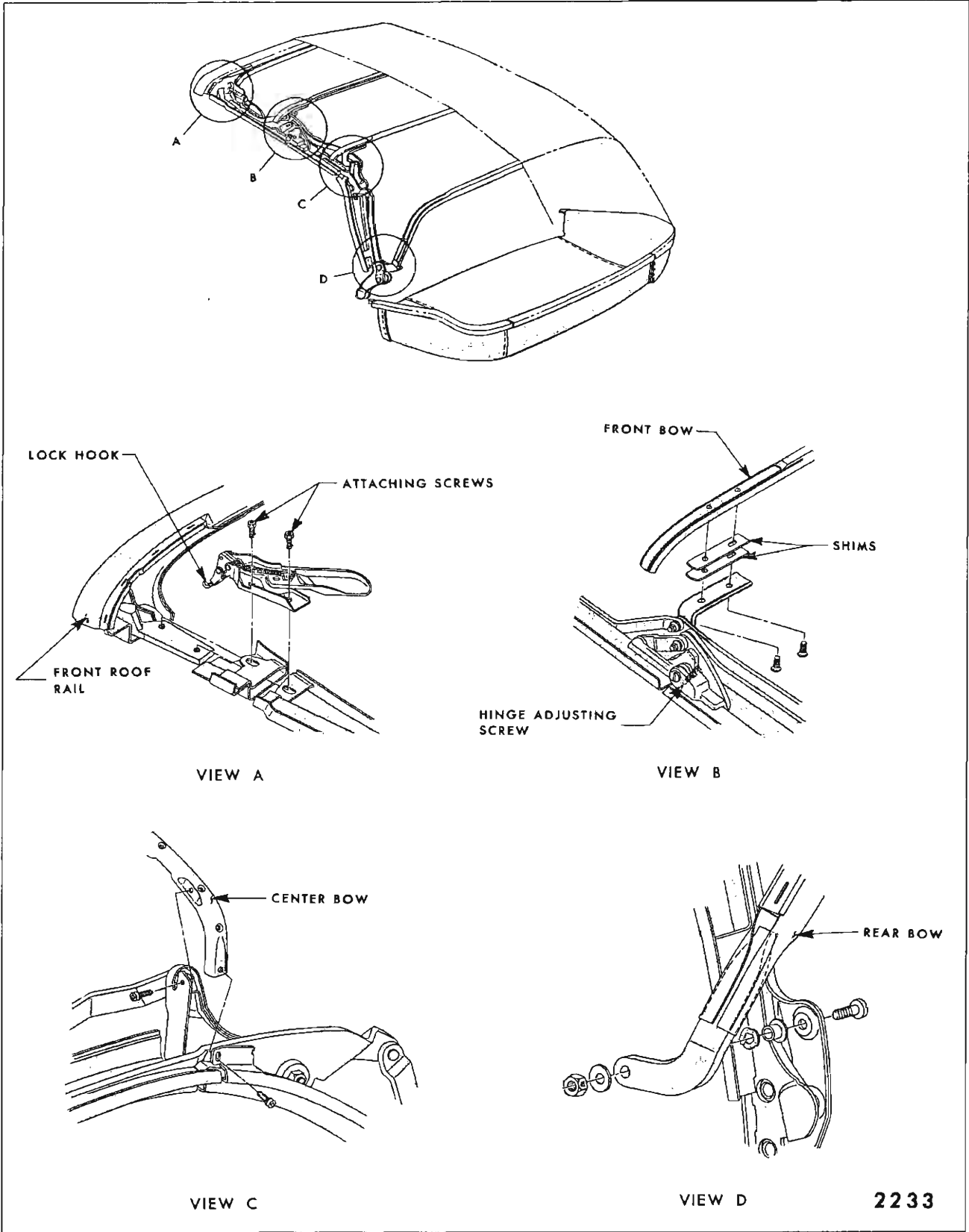

Fig. 13-89—Folding Top Adjustments - "Z" Styles

## TROUBLE SHOOTING CHART "Z" STYLES (Cont'd.)

CONDITION	APPARENT CAUSE	CORRECTION
A. Difficult locking action at front roof rail.	<ol style="list-style-type: none"> <li>1. Lock hook too short</li> <li>2. Misaligned front roof rail weatherstrips.</li> <li>3. Front roof rail misaligned.</li> </ol>	<p>Adjust lock hook counterclockwise (View "A" in Fig. 13-89)-</p> <p>Loosen and realign front roof rail front weatherstrip.</p> <p>Adjust front roof rail.</p>
B. Top does not lock tight enough to windshield header.	<ol style="list-style-type: none"> <li>1. Lock hook too long.</li> <li>2. Misaligned front roof rail weatherstrips.</li> </ol>	<p>Adjust lock hook clockwise.</p> <p>Loosen and realign front roof rail weatherstrips.</p>
C. Top travels too far forward.	<ol style="list-style-type: none"> <li>1. Front roof rail misaligned.</li> <li>2. Male hinge misaligned.</li> </ol>	<p>Adjust front roof rail rearward.</p> <p>Adjust male hinge rearward (Fig. 13-87).</p>
D. Top does not travel forward far enough.	<ol style="list-style-type: none"> <li>1. Front roof rail misaligned.</li> <li>2. Male hinge misaligned.</li> </ol>	<p>Adjust front roof rail forward.</p> <p>Adjust male hinge forward.</p>
E. Side roof rail rear weatherstrip too tight against rear of rear quarter window.	<ol style="list-style-type: none"> <li>1. Male hinge misaligned.</li> </ol>	<p>Adjust male hinge rearward.</p>
F. Gap between side roof rail rear weatherstrip and rear of rear quarter window.	<ol style="list-style-type: none"> <li>1. Male hinge misaligned.</li> </ol>	<p>Adjust male hinge forward and/or shim side roof rail rear weatherstrip forward as required.</p>
G. Side roof rail rear weatherstrip too tight against top of rear quarter window.	<ol style="list-style-type: none"> <li>1. Male hinge misaligned.</li> </ol>	<p>Adjust male hinge upward.</p>
H. Gap between side roof rail rear weatherstrip and top of rear quarter window.	<ol style="list-style-type: none"> <li>1. Male hinge misaligned.</li> </ol>	<p>Adjust male hinge downward and/or shim side roof rail rear weatherstrip downward as required.</p>
I. Side roof rails low	<ol style="list-style-type: none"> <li>1. Control link misaligned.</li> <li>2. Center side roof rail hinge adjusting screw protrudes.</li> </ol>	<p>Adjust control link downward.</p> <p>Back off adjusting screw (View "B" in Fig. 13-89).</p>
J. Side roof rails high	<ol style="list-style-type: none"> <li>1. Control link misaligned.</li> </ol>	<p>Adjust control link upward (Fig. 13-89).</p>

**TROUBLE SHOOTING CHART "Z" STYLES (Cont'd.)**

CONDITION	APPARENT CAUSE	CORRECTION
K. Folding top dust boot is difficult to install.	<ol style="list-style-type: none"> <li>1. Improper stack height due to misaligned male hinge.</li> <li>2. On manual tops, due to improperly adjusted catch clips.</li> </ol>	<p>Rotate male hinge rearward around pivot point (Fig. 13-88).</p> <p>Adjust catch clips downward.</p>
L. Folding top dust boot fits too loosely.	<ol style="list-style-type: none"> <li>1. Improper stack height due to misaligned male hinge.</li> <li>2. Rear seat back assembly is too far rearward.</li> <li>3. On manual tops, due to improperly adjusted catch clips.</li> </ol>	<p>Rotate male hinge forward around pivot point (Fig. 13-88).</p> <p>Relocate rear seat back panel forward until dimension between upper rear edge of rear seat back to forward edge of pinchweld finishing molding is 13" ± 1/16". The dimension is measured at approximate center line of body.</p> <p>Adjust catch clips upward.</p>
M. Top material is too low over windows or side roof rails.	<ol style="list-style-type: none"> <li>1. Front roof bow improperly shimmed.</li> <li>2. Excessive width in top material.</li> </ol>	<p>*Install one or two 1/8" shims between front roof bow and slat iron (View "B" in Fig. 13-89).</p> <p>If top is too large, detach binding along affected area; trim off excessive material along side binding as required; then hand sew binding to top material.</p>
N. Top material is too high over windows or side roof rails.	<ol style="list-style-type: none"> <li>1. Front roof bow improperly shimmed.</li> </ol>	<p>*Remove one or two 1/8" shims between front roof bow and slat iron (See View "B" in Fig. 13-89).</p>
O. Top material has wrinkles or draws.	<ol style="list-style-type: none"> <li>1. Rear quarter trim stick improperly adjusted.</li> <li>2. Top material improperly installed.</li> </ol>	<p>Adjust rear quarter trim stick.</p> <p>Reposition and retack top material as required.</p>

\*When no shims are required or when installing only one shim, use attaching screw part #4413016 (1/4 - 20 x 7/16" oval head with external tooth lock washer, type "T-T" tapping screw, chrome finish).

When two shims are required, use attaching screw part #4412619 (1/4 - 20 x 3/4" oval head with external tooth lock washer, type "T-T" tapping screw, chrome finish).

## SECTION 14

# DOOR, QUARTER AND SHELF TRIM

### INDEX

Subject	Page	Subject	Page
Door Trim . . . . .	14-1	Rear Quarter Rear Trim Panel - Left Side (All "A" Body Station Wagon Styles) . . . . .	14-16
Introduction . . . . .	14-1	Rear Quarter Upper Trim - Above Belt (All Styles) . . . . .	14-16
Door Pull Handles . . . . .	14-1	Center Pillar Trim ("A, B & C" Four-Door Hardtop Styles) . . . . .	14-19
Door Arm Rests . . . . .	14-1	Center Pillar Upper and Lower Trim ("A & X" Four-Door Closed Styles) . . . . .	14-19
Door Outside Mirror Remote Controls and Escutcheon . . . . .	14-3	Center Pillar Upper and Lower Trim ("B & C" Four-Door Closed Styles) . . . . .	14-19
Door Inside Handles . . . . .	14-3	Compartment Shelf Trim . . . . .	14-20
Door Trim Assemblies . . . . .	14-4	Compartment Shelf Trim Assembly (All Styles Except "E & F" Styles and "F-37" Styles with Folding Rear Seat . . . . .	14-20
Door Trim Panel Moldings and Appliques . . . . .	14-7	Compartment Shelf Center Finishing Panel (Olds. and Buick "E" Styles) . . . . .	14-20
Rear Quarter Trim . . . . .	14-7	Compartment Shelf Side Finishing Panels (Olds. and Buick "E" Styles) . . . . .	14-20
Rear Quarter Window Regulator Handle . . . . .	14-7	Compartment Shelf Side and Center Trim Panels (Cadillac "E" Styles) . . . . .	14-20
Rear Quarter Arm Rest . . . . .	14-7	Compartment Front and Shelf Panel Trim Assembly ("Z" Styles with Stationary or Folding Rear Seat Back) . . . . .	14-21
Rear Quarter Trim Assemblies (Two-Door Styles) . . . . .	14-11	Compartment Shelf Trim Assembly ("F-37" Styles with Folding Rear Seat) . . . . .	14-23
Rear Quarter Lower Trim ("A-80" Style and All Four-Door Styles Except Station Wagons) . . . . .	14-12		
Rear Quarter Trim Panel Molding and Appliques . . . . .	14-13		
Rear Quarter Inner Trim Panel - Left Side ("B" Body Station Wagon Styles) . . . . .	14-13		
Rear Quarter Wheelhouse Cover Panel - Right Side ("B" Body Station Wagon Styles) . . . . .	14-13		
Spare Tire Cover Panel (Station Wagon Styles) . . . . .	14-14		
Rear Quarter Front Trim Panel - Right or Left Side ("A" Body Station Wagons) . . . . .	14-14		
Wheelhouse Trim Cover Panel - Right Side (All "A" Body Station Wagon Styles) . . . . .	14-15		

## DOOR TRIM

### INTRODUCTION

This section of the manual contains the service operations that are necessary for the removal and installation of door, rear quarter and compartment shelf trim assemblies.

Body series or style references in the procedures are explained under "General Information", Section I of this manual.

### DOOR PULL HANDLES

Two methods are used to secure door pull handles on 1969 model passenger vehicles. The most common method attaches the handles to the trim pad with clips or screws on the outboard (reverse) side of the trim assembly prior to trim installation, and, then, additionally secures the handle to the door with screws installed from the inboard side after trim installation. With this method of installation, to remove only the pull handle requires removal of the entire door trim assembly (Figs. 14-1 and 14-2). This type of handle is used on all styles except Chevrolet and Pontiac "F" Styles.

The pull handle on "F" styles is retained by screws inserted through the handle hinges into the door inner panel after trim installation. As shown in Figure 14-3, the handle can be removed by merely removing the screws.

To remove the door trim assembly on any style with a door pull handle requires removal of the screws inserted through the handle hinges or handle base into the door inner panel. On styles with snap-on escutcheons covering the handle screws, carefully disengage the escutcheons from the retainers using a flat-bladed tool (Fig. 14-2).

### DOOR ARM RESTS

There are three basic types of door arm rests: those applied after door trim installation, those assembled to the door trim prior to trim installation and arm rests which are an integral part of the door trim assembly and, consequently, are not serviced as a separate service part.

Arm rests can be removed independent of the door trim assembly on all styles except "G" body styles, "E" & "F" body styles with deluxe trim,



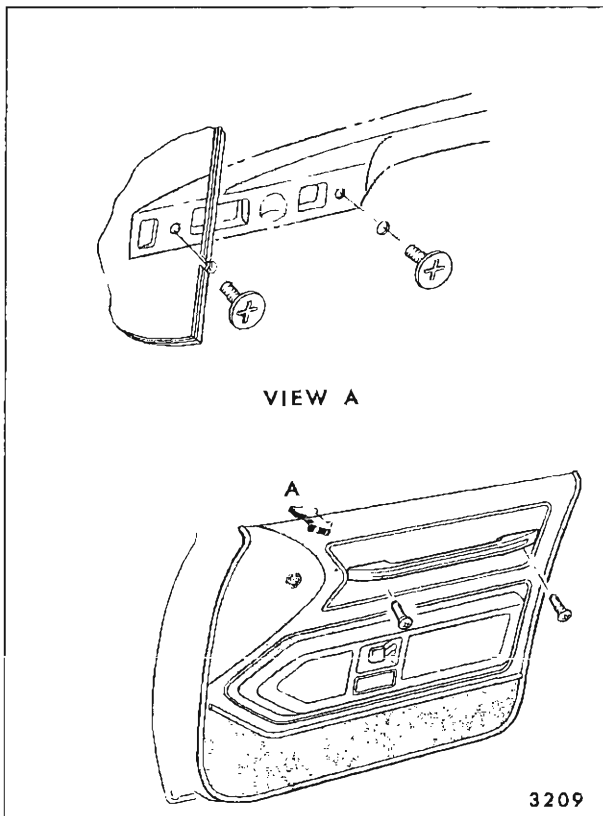

Fig. 14-1—Door Pull Handle Attachment

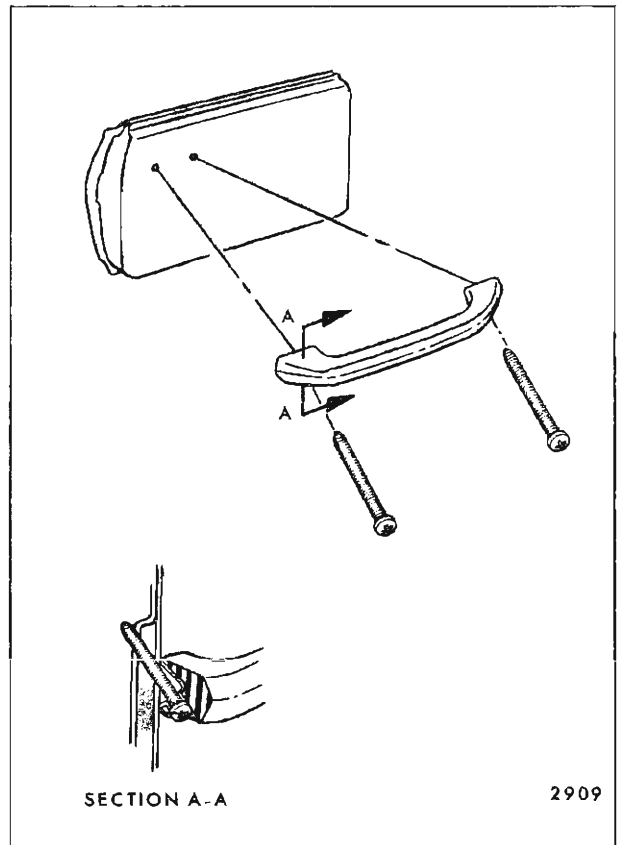

Fig. 14-3—Door Pull Handle Attachment - "F" Styles

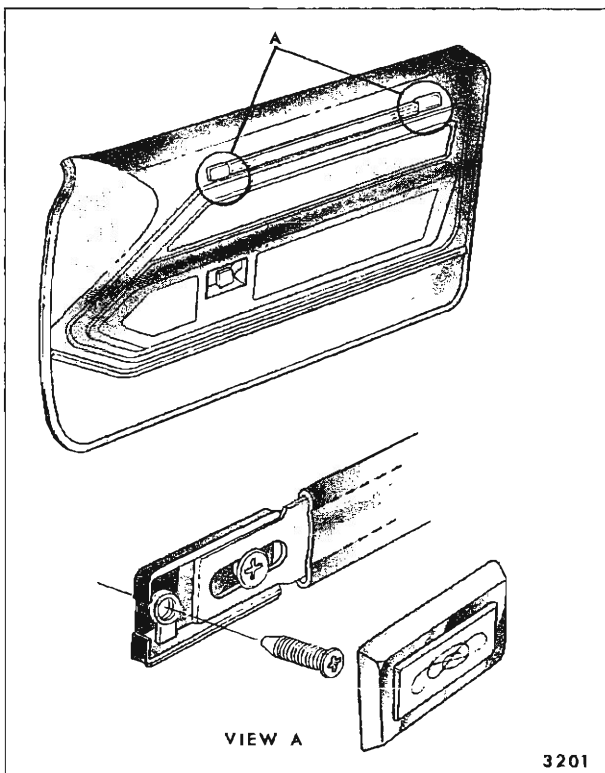

Fig. 14-2—Door Pull Handle Attachment - Cadillac Styles

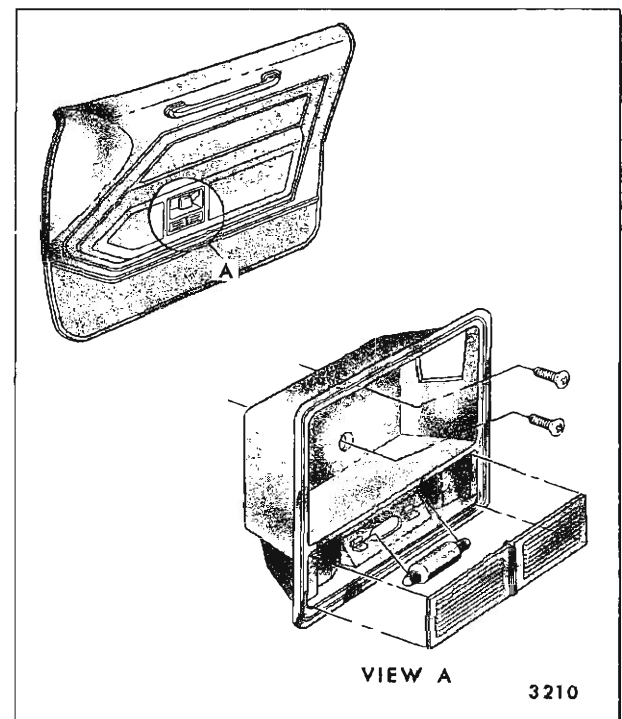

Fig. 14-4—Integral Door Arm Rest - Pontiac & Cadillac Styles

Cadillac Styles, Pontiac 26200 series and 76637 & 39 styles, and Oldsmobile 38400-38600 series except the 38469 style, and the Buick 48467 styles. On "F & G" styles, Cadillac styles and Pontiac 26200 series styles and 76637 & 39 Styles, the arm rest is an integral part of the door trim assembly and cannot be removed as a separate item (Fig. 14-4). On the remaining styles described above, the arm rest can be removed in a bench operation after the door trim and arm rest assembly has been removed from the door (Fig. 14-5).

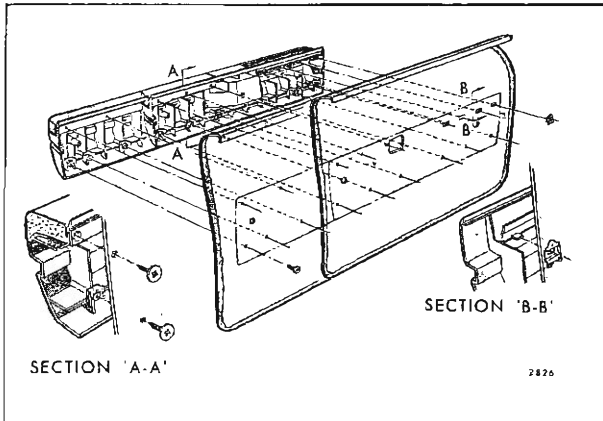

Fig. 14-5—Door Arm Rest to Trim Panel Attachment

Figures 14-6 and 14-7 illustrate the applied-type arm rest which is installed after door trim.

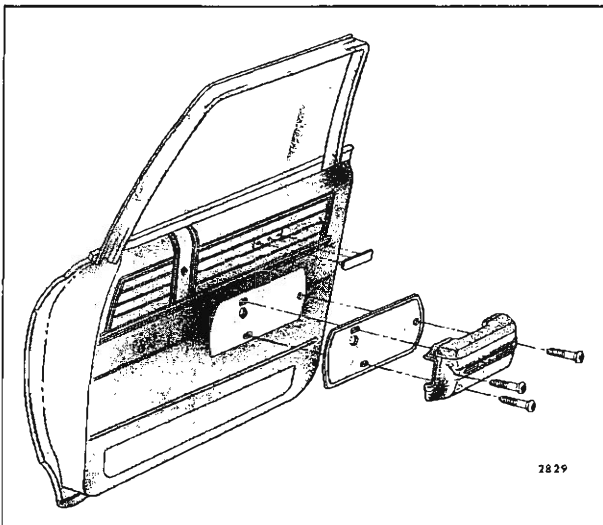

Fig. 14-6—Applied Type Door Arm Rest - "A" Styles Shown

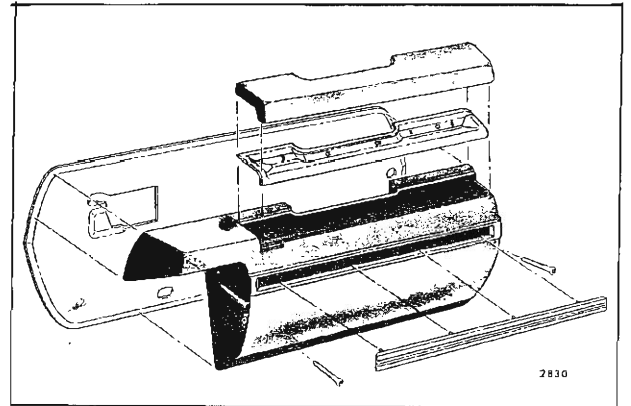

Fig. 14-7—Applied Type Door Arm Rest - "B" Styles Shown

engaged from the door trim assembly or arm rest to permit trim assembly removal.

On Pontiac styles, the escutcheon is a threaded spanner nut, which, when removed, permits removal of the mirror controls from the trim assembly (View 'A', Fig. 14-13).

On the remaining styles that use a remote control mirror, the escutcheon is retained to the trim pad or arm rest with exposed screws. By removing the screws the cable can be pulled inboard sufficiently to disengage the nylon clip securing the mirror controls to the escutcheon (Fig. 14-8).

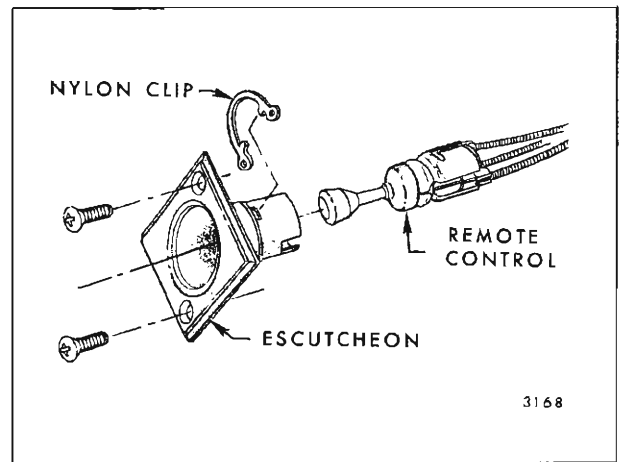

Fig. 14-8—Remote Mirror Control Attachment - Typical All Styles Except Pontiac

### DOOR OUTSIDE MIRROR REMOTE CONTROLS AND ESCUTCHEON

On styles with remote control door outside mirrors, the escutcheon and controls must be dis-

### DOOR INSIDE HANDLES

Door inside handles are retained by either screws or spring clips. On styles with screw retained

handles, the screws are either exposed or covered only by an applied type arm rest that can be removed by the removal of several screws. Figure 14-9 illustrates various type remote control handles.

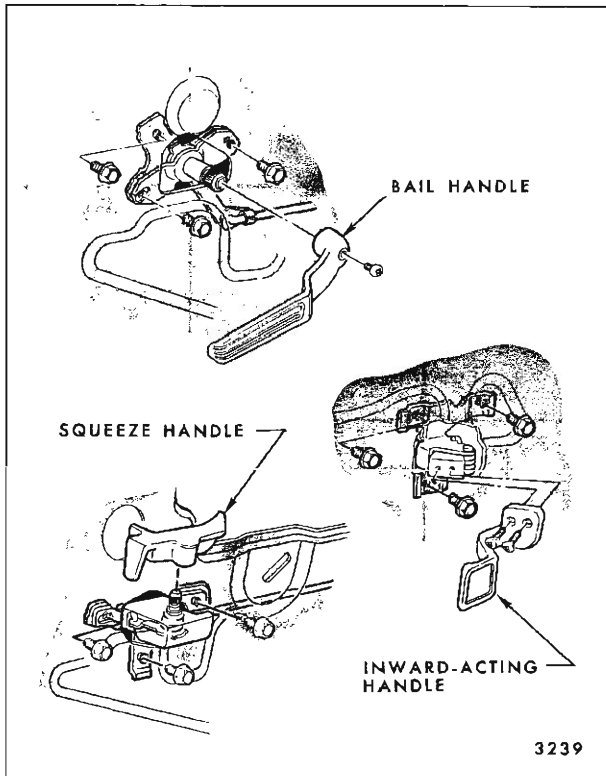

Fig. 14-9—Door Inside Remote Control Handles

On styles with clip retained handles, the clip is either exposed when the arm rest is removed, or else is hidden by the handle (Fig. 14-10). Exposed clips can be disengaged from the remote control spindle with a screwdriver. Clips hidden by the handle can be disengaged as follows:

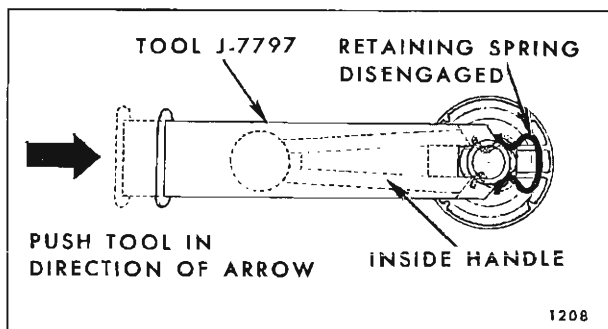

Fig. 14-10—Clip Retained Door Inside Handle Removal

### Removal and Installation (Spring-Clip Retained)

1. Depress door trim assembly sufficiently to permit inserting tool J-7797 or J-9886 between handle and plastic bearing plate.
2. With tool in same plane as handle as shown in Figure 14-10, push tool as indicated to disengage clip. Pull handle inboard to remove from spindle.
3. To install, engage retaining clip on handle. On ventilator and window regulator spindles, position handle at same angle as opposite side handle and press handle outboard until clip engages spindle. On remote control spindles, put handle in horizontal position.

### DOOR TRIM ASSEMBLIES

On all styles except the Chevrolet Corvair, the door trim assembly is secured to the door by a metal trim support which hangs over the door inner panel across the top, by clips or nails down the sides,

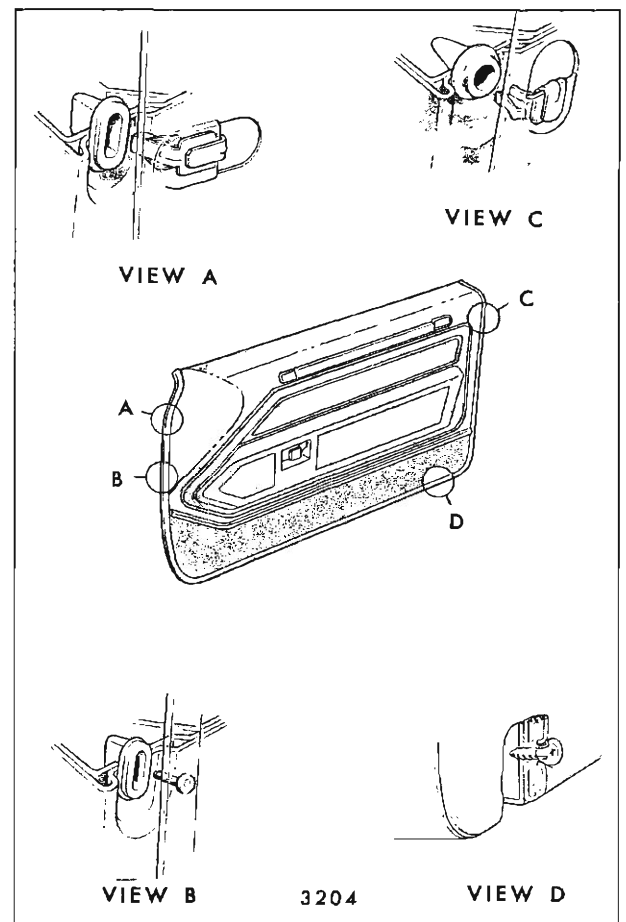

Fig. 14-11—Various Types of Door Trim Retention

and by screws across the bottom (Fig 14-11 is a composite illustration of the various types of door trim panel fasteners). On some upper series styles, additional retention is obtained from arm rest and pull handle attaching screws, which protrude through the trim assembly into the door inner panel (Fig. 14-2).

On Corvair styles, clips are used across the top and down both sides. Screws retain the lower edge.

### Removal and Installation

1. On all styles except 27657, remove door inside handles.
2. Remove door inside locking rod knob (except on Corvair styles).
3. On styles with door pull handles, remove screws inserted through handle into door inner panel. On some styles, removal of these screws removes handle. On most styles, handle will still be retained to trim pad. Refer to "Door Pull Handles" for specific types of retention.
4. On styles with remote control mirror, disengage mirror controls from door trim assembly as previously described.
5. On styles with switch cover plate in door arm rest (Fig. 14-12), remove screws securing cover plate and disconnect switches and vacuum door lock actuator, if present, from wire harness connectors and vacuum hoses.

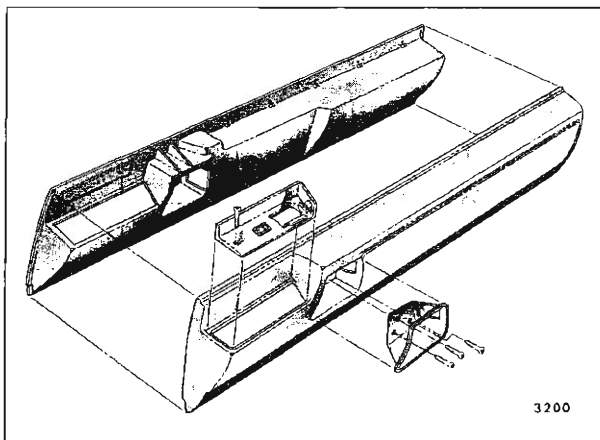

Fig. 14-12—Door Arm Rest - "E" Style Shown, Cadillac "C" Styles Typical

6. On Pontiac 26200 series, 76637 & 39 styles and 27657 style, remove arm rest to hanger plate attaching screw which is exposed when switch cover plate is removed (Section 'B-B', Fig. 14-13).

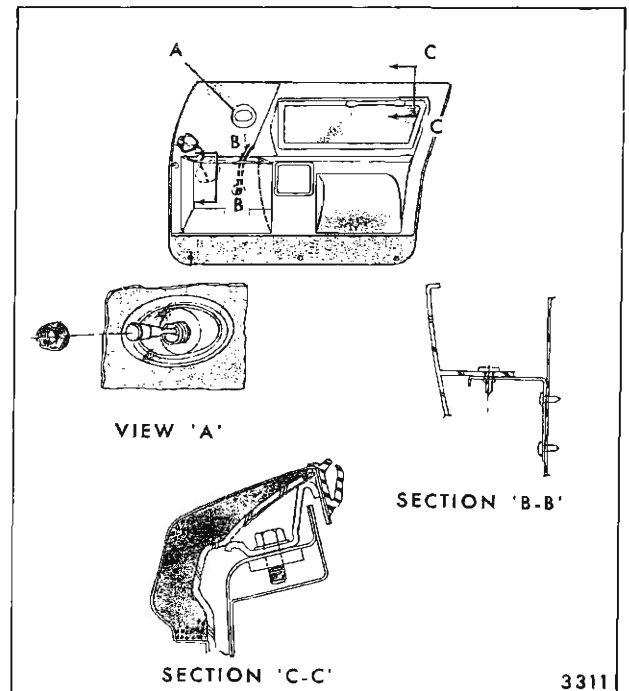

Fig. 14-13—Door Trim Panel Removal - Pontiac Styles

7. On styles with remote control cup in door arm rest, remove exposed screws securing cup and remove cup.

On all Cadillac styles except 62000 series, courtesy lamp is integral part of remote control cup and must be disconnected to permit removal of complete assembly (Fig. 14-14).

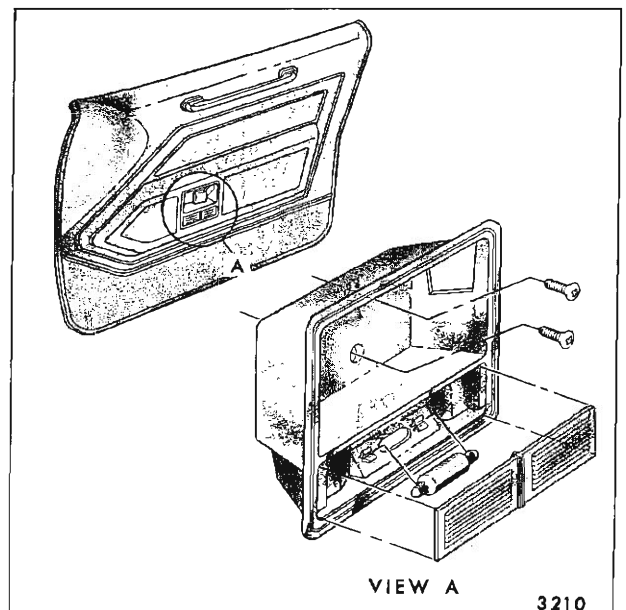

Fig. 14-14—Remote Control Cup and Courtesy Lamp Assy. - Cadillac Styles

8. On Oldsmobile 38000 and Buick 48000 series, remove arm rest moldings to expose arm rest

to door inner panel attaching screws located under moldings (Fig. 14-15).

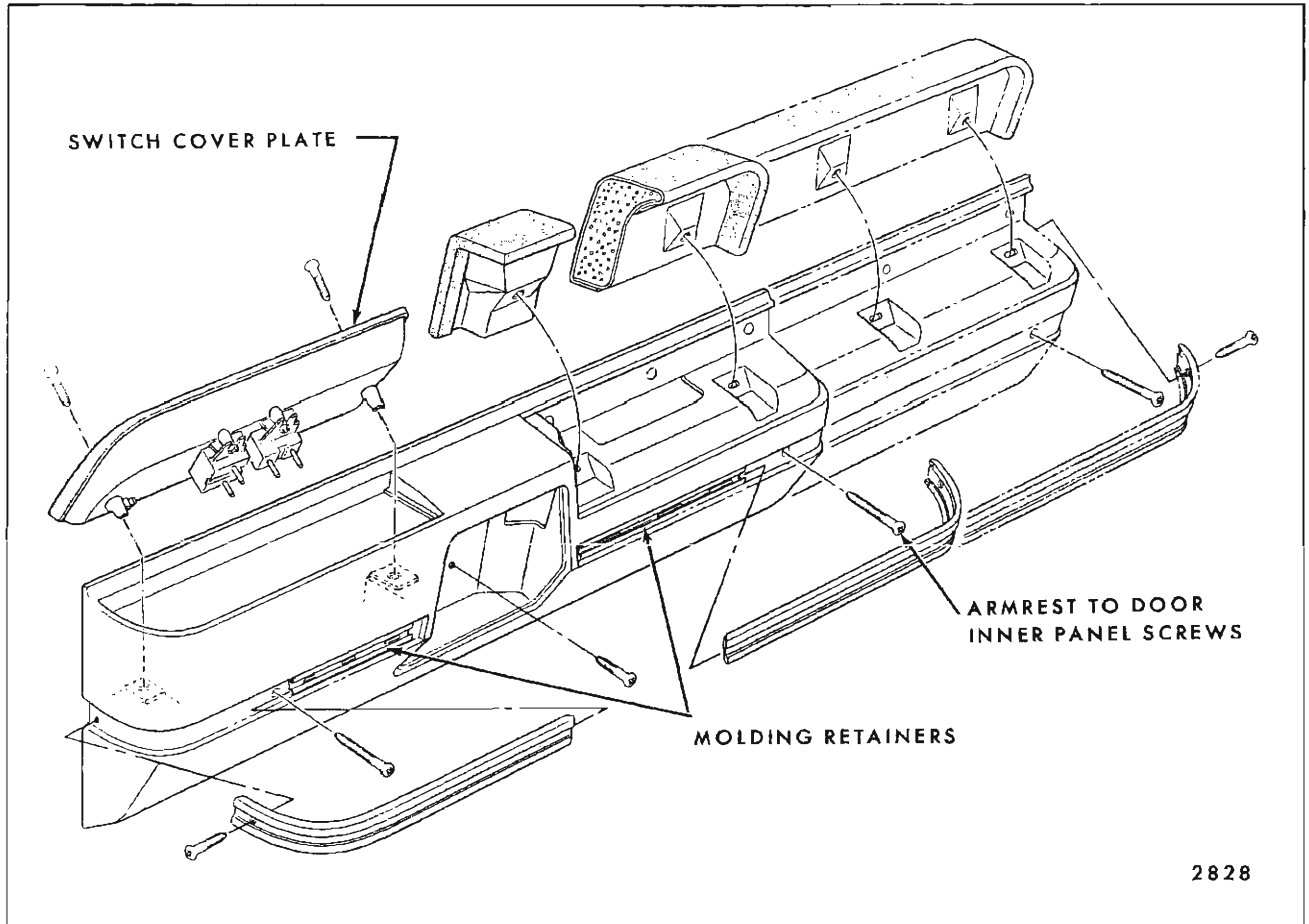

Fig. 14-15—Door Arm Rest Build-Up and Attachments - Buick and Oldsmobile Styles

- To remove moldings, remove screw at front of front molding and rear of rear molding. Slide molding off retainer as indicated in illustration.
9. On styles with pull cup in door arm rest, remove screws inserted through base of cup into arm rest hanger plate.
  10. On Cadillac "E" styles, remove ash tray and cigar lighter at rear of left side door arm rest to expose trim retaining screw.
  11. On Cadillac 68069 and 68169 styles, disconnect windshield wiper control switch from "pod" at left front door upper front corner.
  12. Remove all screws down both sides and across bottom of door trim pad.
  13. Starting at a lower corner, insert tool J-6335 or J-9886 between door inner panel and trim assembly. Working upward, carefully disengage retaining nails or clips from plastic cups inserted in door inner panel (Fig. 14-11).
- NOTE:** Use care not to damage door inner panel water deflector or plastic cups as they must form a watertight seal.
14. Lift trim assembly upward and slide it slightly rearward to disengage it from door inner panel at the beltline. On styles with vacuum door lock or electric window switches located in the door trim assembly, disconnect vacuum hoses and/or wire harness and remove trim assembly from door.
  15. To install door trim assembly, reverse removal procedure.

**NOTE:** On styles with adjustable trim supports at beltline (Section 'C-C', Fig. 14-13), the door trim assembly can be adjusted in or out so as not to restrict door window operation.

### DOOR TRIM PANEL MOLDINGS AND APPLIQUES

Door trim moldings and appliques are secured from the outboard side of the door trim panel with several types of sheet metal fasteners.

Die cast moldings use self-threading nuts applied to the molding studs. As shown in Figure 14-16, the nuts can be removed with a ratchet wrench and hex driver. Depending on nut size, use driver of 5/16" or 3/8" hex cold rolled steel with 3/32" x 3/4" deep hole drilled in driving end.

Some arm rest bases and trim panel appliques are retained by prong type fasteners snapped over plastic studs or bosses ("A", Fig. 14-16).

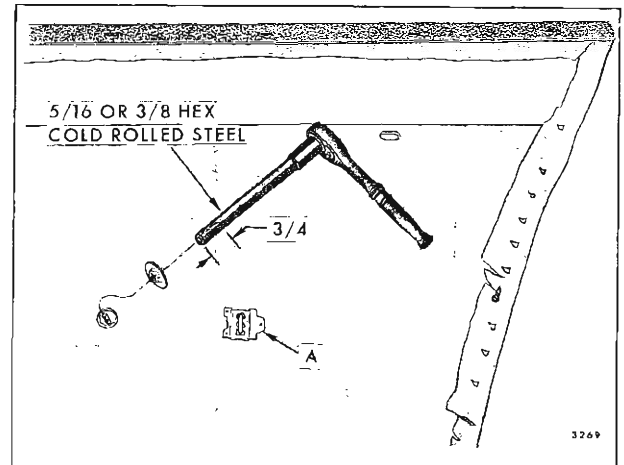

Fig. 14-16—Door Trim Pad Molding and Applique Removal

To remove this type fastener, carefully pry-up on fastener until there is sufficient working space to insert wire cutter; then, cut fastener and discard.

## REAR QUARTER TRIM

### REAR QUARTER WINDOW REGULATOR HANDLE

#### Removal and Installation

1. Depress quarter trim assembly sufficiently to permit insertion of tool J-7797, or J-9886 or equivalent, between handle and plastic bearing plate (Fig. 14-17). As shown in illustration, tool must be in same plane as handle.
2. Push tool to disengage handle spring from spindle and remove bearing plate and handle.
3. To install, engage retaining spring on handle (open end of clip toward handle). Position

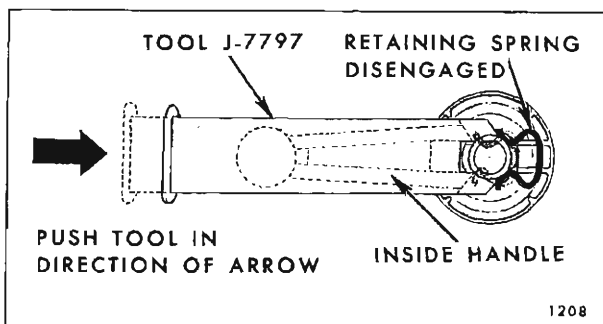

Fig. 14-17—Rear Quarter Window Regulator Handle Removal

handle on spindle at same angle as opposite side handle and push outboard until spring engages spindle.

### REAR QUARTER ARM REST

There are three types of arm rests:

- A. Applied arm rests, which are retained by two screws inserted through the arm rest base into the quarter inner panel (Fig. 14-18).

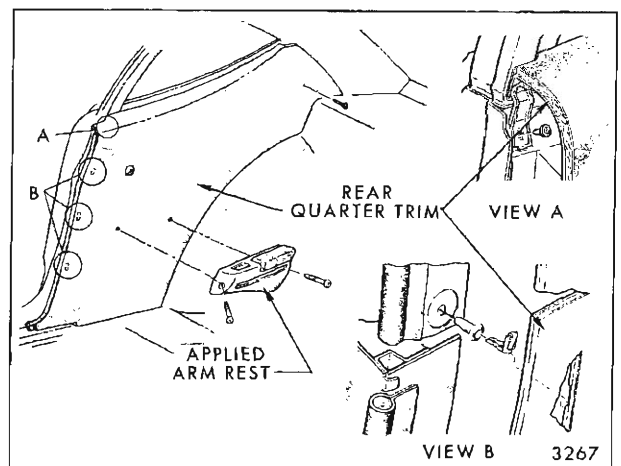

Fig. 14-18—Applied-Type Quarter Arm Rest and Trim Assembly

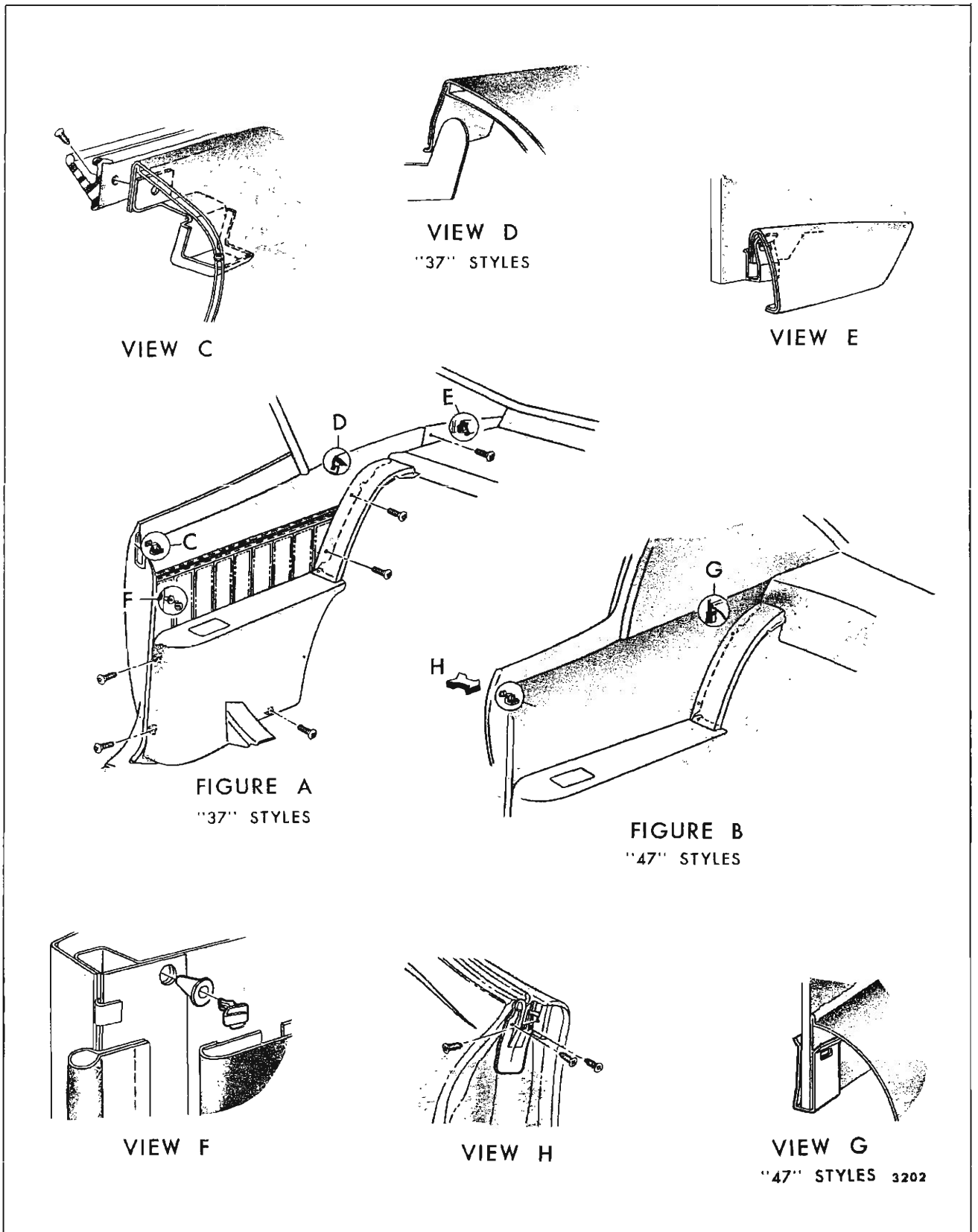

Fig. 14-19—Quarter Arm Rest and Trim Assembly - "B-37, 47" Styles

- B. Floor mounted arm rests which are retained by screws inserted through the arm rest assembly into brackets on the inner panel (Figs. 14-19, 14-20).

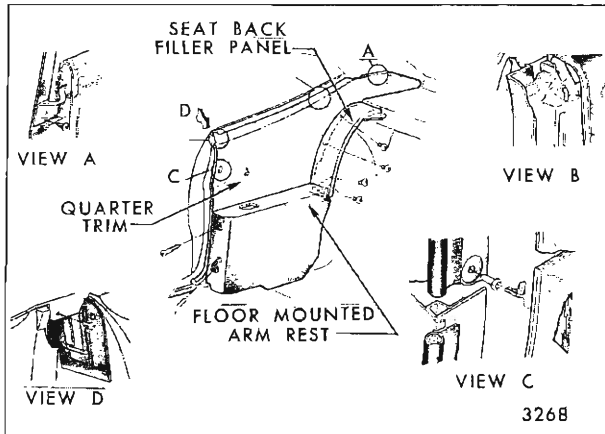

Fig. 14-20—Rear Quarter Arm Rest and Trim Assembly - "A" Two-Door Styles

**NOTE:** On all convertible styles except Cadillac, the floor mounted arm rest is subassembled to the folding top compartment side trim panel and must be removed as an assembly (Fig. 14-22).

- C. Arm rests which are an integral part of the quarter trim assembly and cannot be removed or serviced independently (Fig. 14-21).

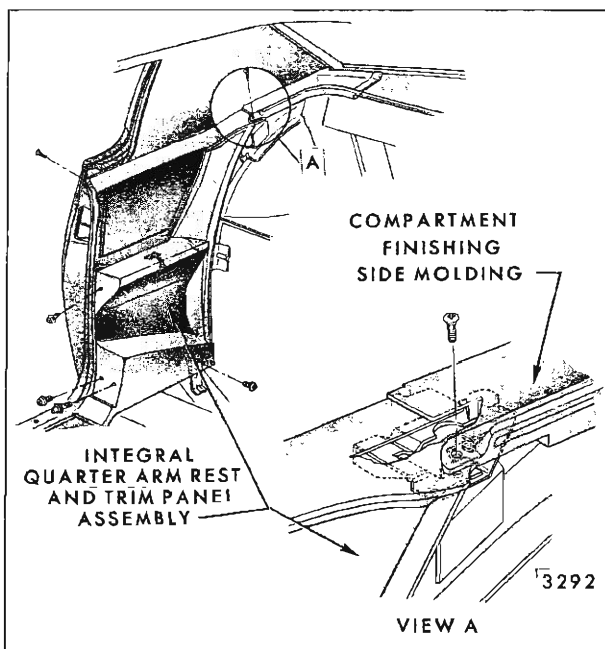

Fig. 14-21—Integral Rear Quarter Arm Rest and Trim Assembly - "69347" Style

## Removal and Installation

1. On styles equipped with applied arm rest, remove two screws in arm rest base and remove arm rest from trim pad.
2. On styles equipped with floor mounted arm rest, perform the following:
  - a. Remove rear seat back and cushion assemblies as described under "Rear Seats".
  - b. On Cadillac "E-47" styles equipped with shoulder straps, remove both screws on shoulder strap buckle retainer as described in "Seat Belt" section.
  - c. On convertible styles, remove exposed screws securing folding top compartment side trim panel (Fig. 14-22).

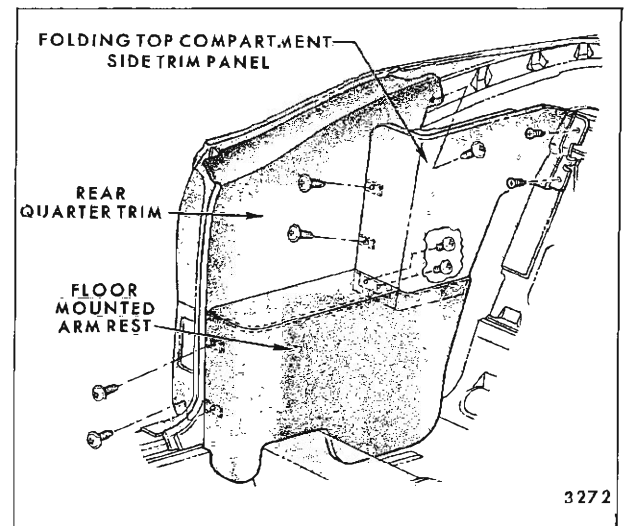

Fig. 14-22—Rear Quarter Trim - "67" Styles - "A" Body Shown, "B-C" Body Similar

- d. On styles equipped with seat back to quarter filler panel, except "F" and Buick-Olds "E" styles, remove attaching screws and remove filler panel.

On "F" styles, filler panel is removed with arm rest as an assembly. Remove compartment front trim panel to expose filler panel inboard attaching screws (Fig. 14-23).

On Olds-Buick "E" styles, filler panel is removed after arm rest.

- e. On all styles remove all arm rest attaching screws present at front, rear and bottom of arm rest assembly.



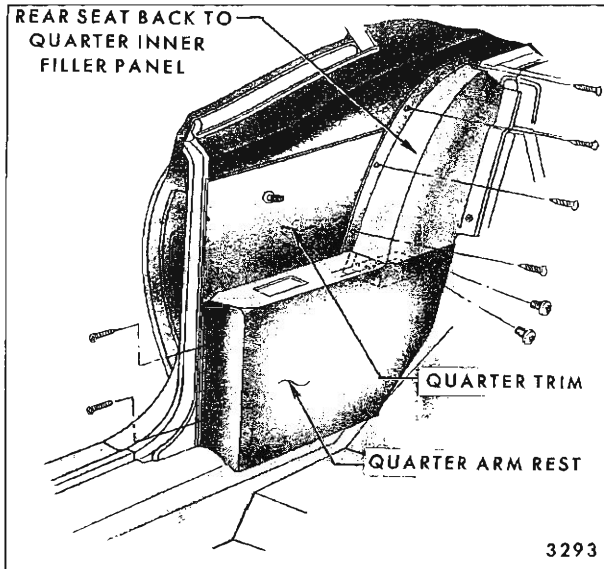

Fig. 14-23—Rear Quarter Trim - "F-37" Styles

f. On styles equipped with rear quarter lamp assemblies, disconnect lamp as shown in Figure 14-24.

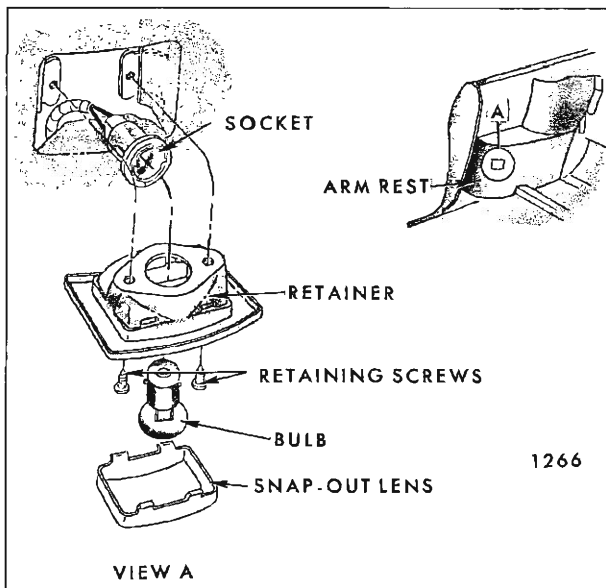

Fig. 14-24—Rear Quarter Arm Rest Courtesy Lamp Assembly

g. On styles with other electrical devices in arm rest assembly, carefully detach arm rest from rear quarter inner panel sufficiently to disconnect wire harness connectors. Figures 14-25 and 14-26 are typical of electrical installation in rear quarter arm rests. Lift arm rest in an upward, inboard movement and remove

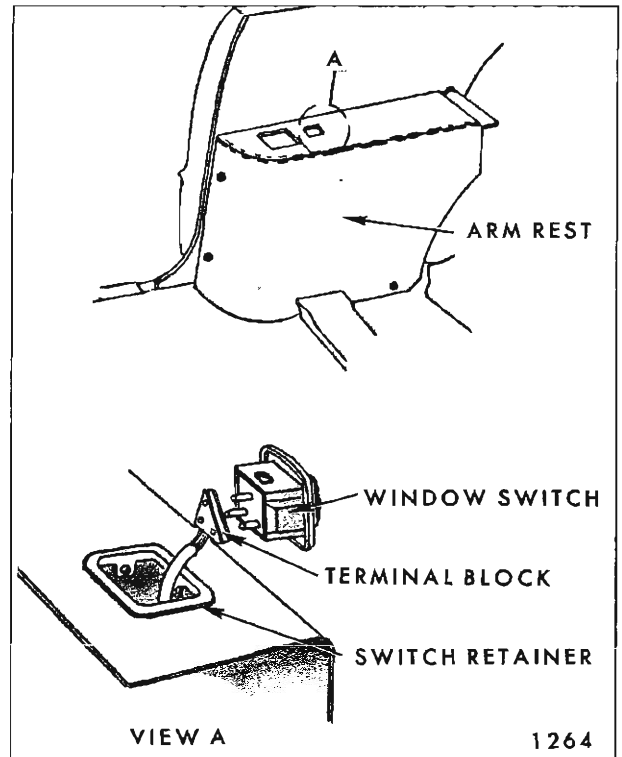

Fig. 14-25—Rear Quarter Arm Rest Window Switch Assembly

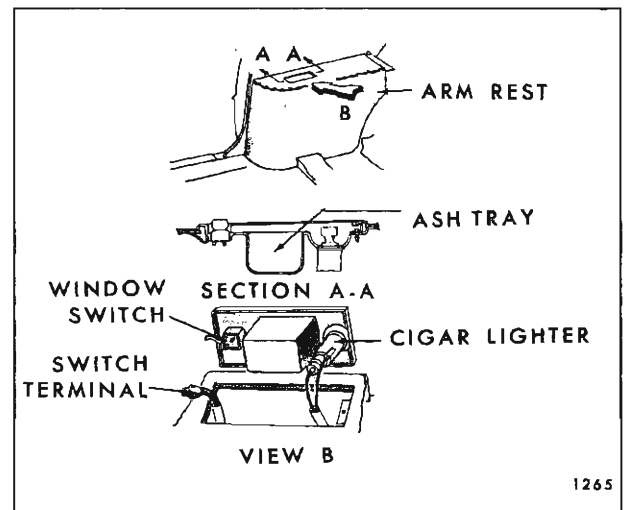

Fig. 14-26—Rear Quarter Arm Rest Ash Tray and Cigar Lighter Assembly

assembly from rear quarter inner panel.

**NOTE:** On convertible styles, folding top compartment side panel and arm rest are removed as an assembly. As a bench operation, the arm rest assembly can be removed from the folding top compartment

side trim assembly by removing screws installed on reverse side.

**NOTE:** On all Cadillac styles, the arm rest is an integral part of the quarter trim assembly and must be removed as an assembly with the quarter trim, as shown in Figure 14-21.

3. To install, reverse removal procedure.

### REAR QUARTER TRIM ASSEMBLY— Two-Door Styles

#### Removal and Installation

1. On all except "F & Z" styles with folding rear seat, remove rear seat back and cushion assemblies as described under "Rear Seats". On "F & Z" styles with folding rear seat, remove rear seat cushion, and lower folding rear seat back.
2. Remove window regulator handle and shoulder strap buckle retainer if so equipped.
3. On styles with floor mounted or applied arm rest, remove arm rest as previously described.
4. On Cadillac "E" styles, remove screw securing compartment side finishing molding to quarter trim (Fig. 14-21).
5. Remove all screws securing trim assembly (Figs. 14-27, 14-28 and 14-21).

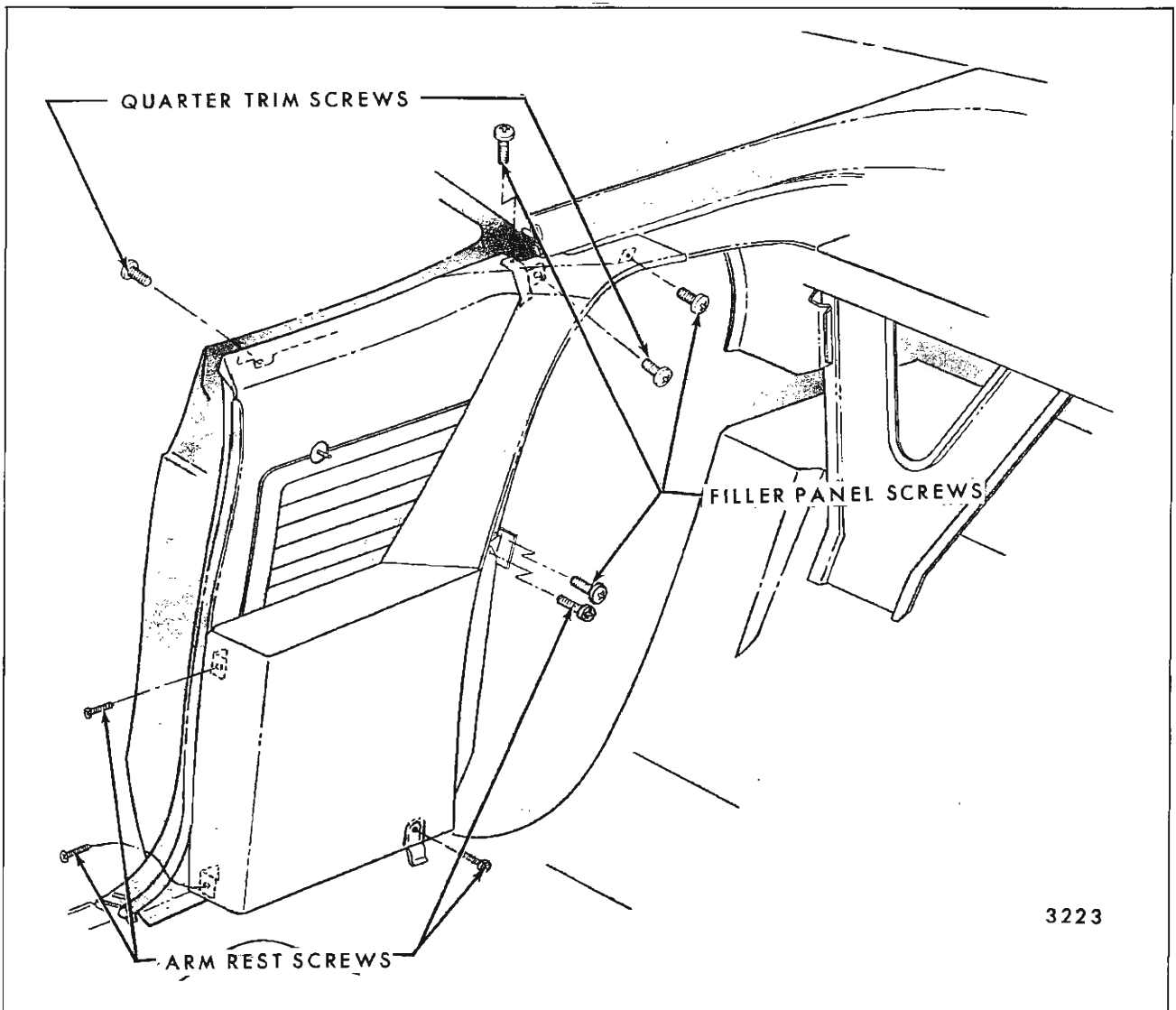

Fig. 14-27—Rear Quarter Arm Rest and Trim Assembly - "39487" Style

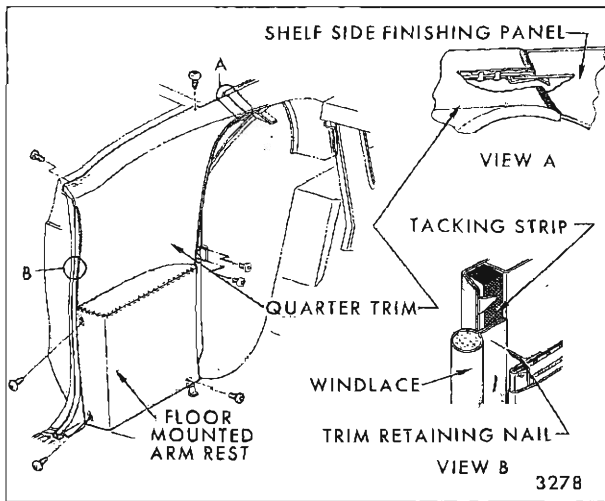

Fig. 14-28—Rear Quarter Arm Rest and Trim Assembly - "49487" Style

6. To remove body lock pillar finishing lace from "F, X and Z" two-door styles, remove door sill plate and disengage finishing lace from lock pillar pinchweld flange. Carefully break cement bond securing leading edge of trim assembly to pinchweld flange and remove trim assembly.

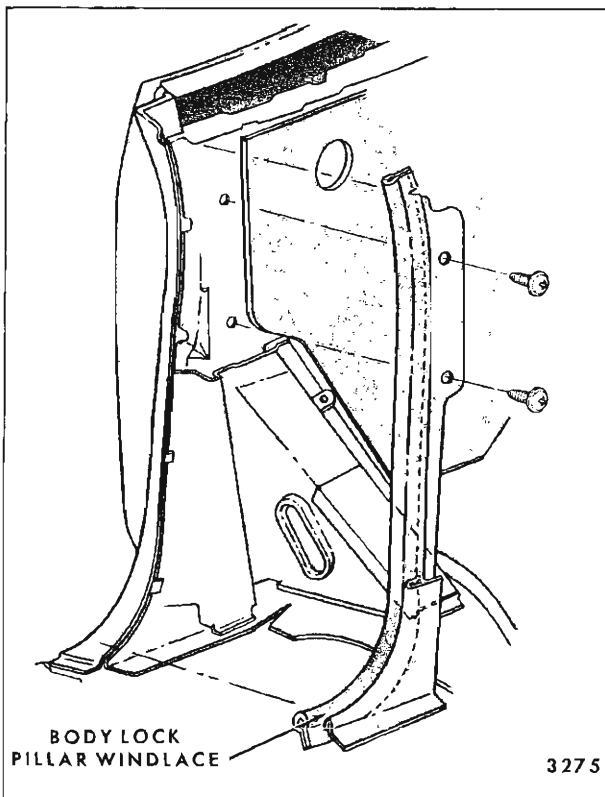

Fig. 14-29—Body Lock Pillar Windlace Assembly - "A-B & C- 37, 47, 57, 67 and 87" Styles

7. Use trim panel removing tool J-6335 or J-9886 or equivalent to disengage body lock pillar windlace retaining nails from tacking strip on "E" body styles (Fig. 14-28), and retaining clips from plastic retaining plugs (View "B", Fig. 14-18, View C, Fig. 14-20 and View F, Fig. 14-19).

**NOTE:** Body lock pillar windlace is sewn to foundation board as a separate assembly on "A, B and C" styles (Fig. 14-29). To remove assembly after quarter trim is off, remove two exposed screws through foundation board and lift away.

8. Lift trim assembly upward to disengage from retainers at top of quarter panel and remove trim assembly from body.
9. To install rear quarter trim assembly, reverse removal procedure.

**NOTE:** Trim pad replacement nailing tabs, retaining clips and plastic retaining plugs are available as service parts.

### REAR QUARTER LOWER TRIM— "A-80" Style and All Four-Door Styles Except Station Wagons

#### Removal and Installation

1. Remove rear seat back and cushion assemblies as described under "Rear Seats".
2. Remove side roof rail rear finishing molding on "C" body styles.
3. On "A, B and X" Styles, remove exposed screws securing trim panel to quarter inner lower panel (Fig. 14-30).

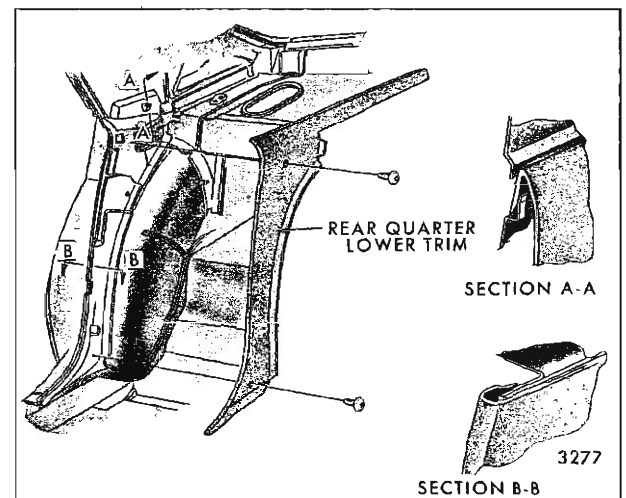

Fig. 14-30—Rear Quarter Trim Assembly - "A, B and X" Four-Door Styles and "A-80" style, Less Station Wagon

4. On "C" body styles, insert tool J-6335 or J-9886 or equivalent under leading edge of trim to pry retaining clip from plastic retaining plugs (View "B", Fig. 14-31).
5. To remove body lock pillar windlace, remove rear door sill plate and disengage windlace retaining nails from tacking strip with tool J-6335, J-9886 or equivalent.
6. Lift trim assembly upward to disengage it from clip retainer at beltline and remove trim assembly from body (View A, Fig. 14-31).
7. To install trim assembly, reverse removal procedure.

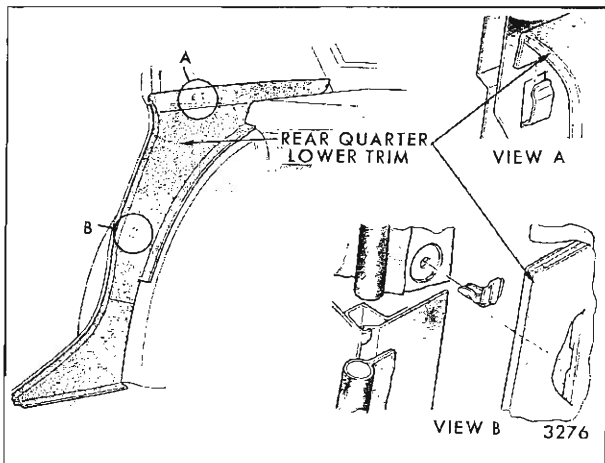

Fig. 14-31—Rear Quarter Trim Assembly -  
"C" Four-Door Style

### QUARTER TRIM PANEL MOLDING AND APPLIQUES

Quarter trim panel moldings and appliques are secured from the outboard side of the quarter trim panel with various different types of sheet metal fasteners. Refer to Figure 14-16, for description and removal procedure.

### REAR QUARTER INNER TRIM PANEL (Left Side)—"B" Body Station Wagon Styles

#### Removal and Installation

1. Remove rear quarter stationary window front and lower garnish moldings.
2. Remove compartment pan side filler panel and compartment floor panel assembly (at kick-up) as described under "Station Wagon Rear Seats".
3. Remove seat back bumper or seat back lock striker (only on styles with optional split seat), as shown in Fig. 14-32.
4. Remove all screws securing trim panel to rear quarter inner panel (Fig. 14-32).
5. With a suitable flat-bladed tool, carefully disengage trim retainers from rear quarter inner panel along leading edge of rear body lock pillar (on front edge of rear quarter front trim assembly) (Fig. 14-32).
6. Lift assembly upward slightly to disengage from rear quarter inner panel and remove assembly from body. On styles equipped with courtesy lamp disconnect feed wire from switch and lamp (Fig. 14-32).
7. To install, reverse removal procedure.

**NOTE:** The rear quarter front trim assembly can be removed at this point, as a bench operation, by breaking cement bond between trim and metal panel of rear quarter inner trim panel assembly. The rear quarter front trim is a sub-assembly of the rear quarter inner trim panel; left and right sides.

### REAR QUARTER WHEELHOUSE COVER PANEL (Right Side)— "B" Body Station Wagon Styles

#### Removal and Installation

1. Remove spare tire cover. (As subsequently described.)
2. Remove compartment pan side filler panel and compartment floor panel assembly (at kick-up) as described under "Station Wagon Rear Seats".
3. Remove rear quarter stationary window front and lower garnish moldings.
4. Remove seat back lock striker as shown in Fig. 14-33.
5. Remove all screws securing trim panel to rear quarter inner panel (Fig. 14-33).
6. With a suitable flat-bladed tool, carefully disengage trim retainers from rear quarter inner panel along leading edge of rear body lock pillar (on front edge of rear quarter front trim assembly). (Fig. 14-33)
7. Remove spare tire cover support.

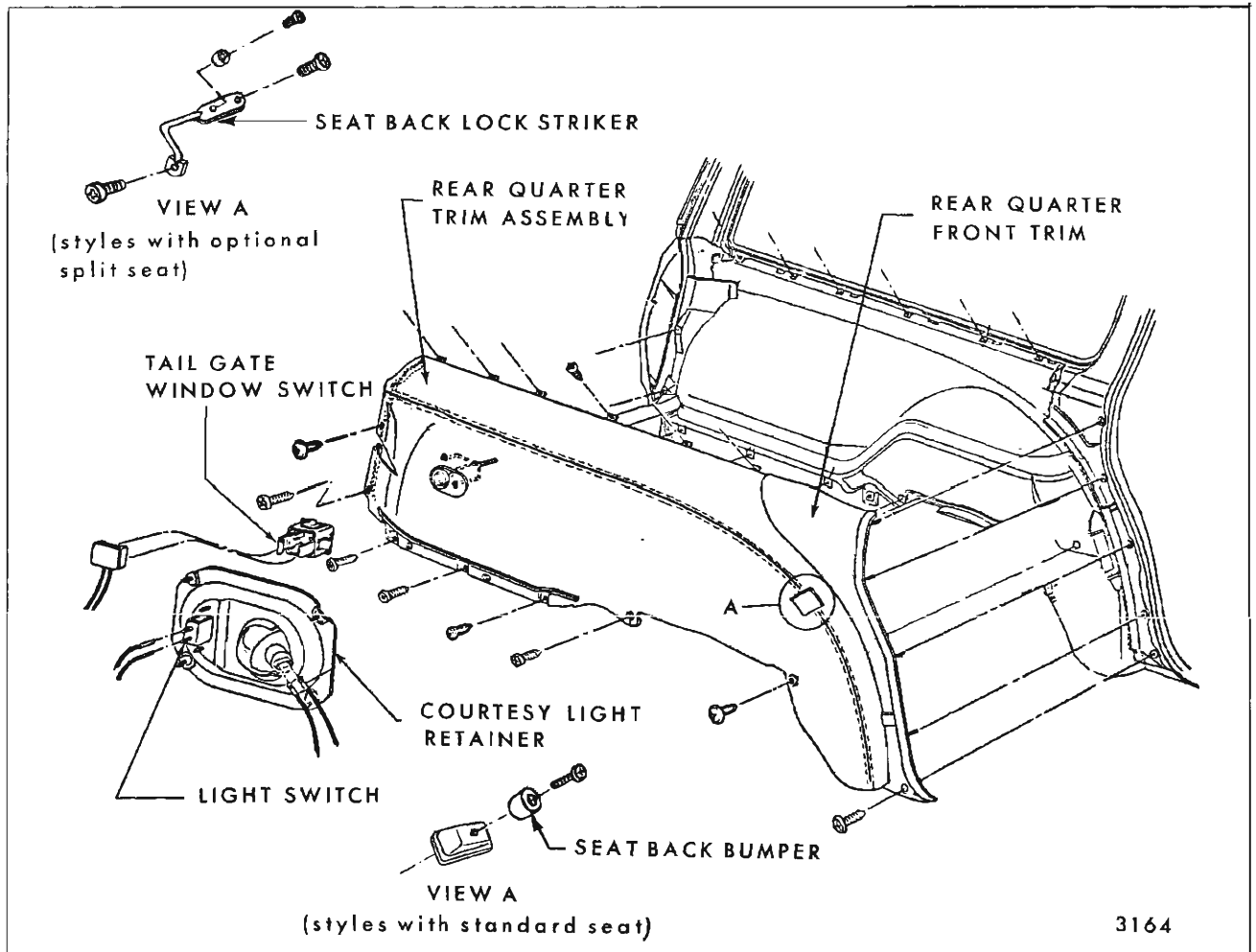

Fig. 14-32—Rear Quarter Trim Panel (Left Side) - "B" Station Wagon

8. Lift assembly upward slightly to disengage from rear quarter inner panel and remove assembly from body.

**NOTE:** On styles with tail gate window defogger or rear radio speaker disconnect wire harness connectors and remove defogger with wheelhouse cover panel.

9. To install, reverse removal procedure.

### SPARE TIRE COVER PANEL— Station Wagon Styles

#### Removal and Installation

The spare tire cover panel is retained at belt line by a screwed-on garnish molding and at the load floor level by a folding (catch-type) handle. To remove cover, open catch handle and swing bottom

edge of assembly upward to disengage upper edge from beneath garnish molding. To install, reverse removal procedure.

**NOTE:** On styles with tailgate window defogger, disconnect defogger hose from defogger outlet grille to complete removal.

### REAR QUARTER FRONT TRIM PANEL (Right or Left Side)— "A" Body Station Wagons

#### Removal and Installation

1. Remove quarter window lower garnish molding. Disengage side roof rail finishing molding sufficiently to allow removal of body lock pillar upper finishing panel and remove finishing panel.
2. Loosen rear of rear door sill plate.

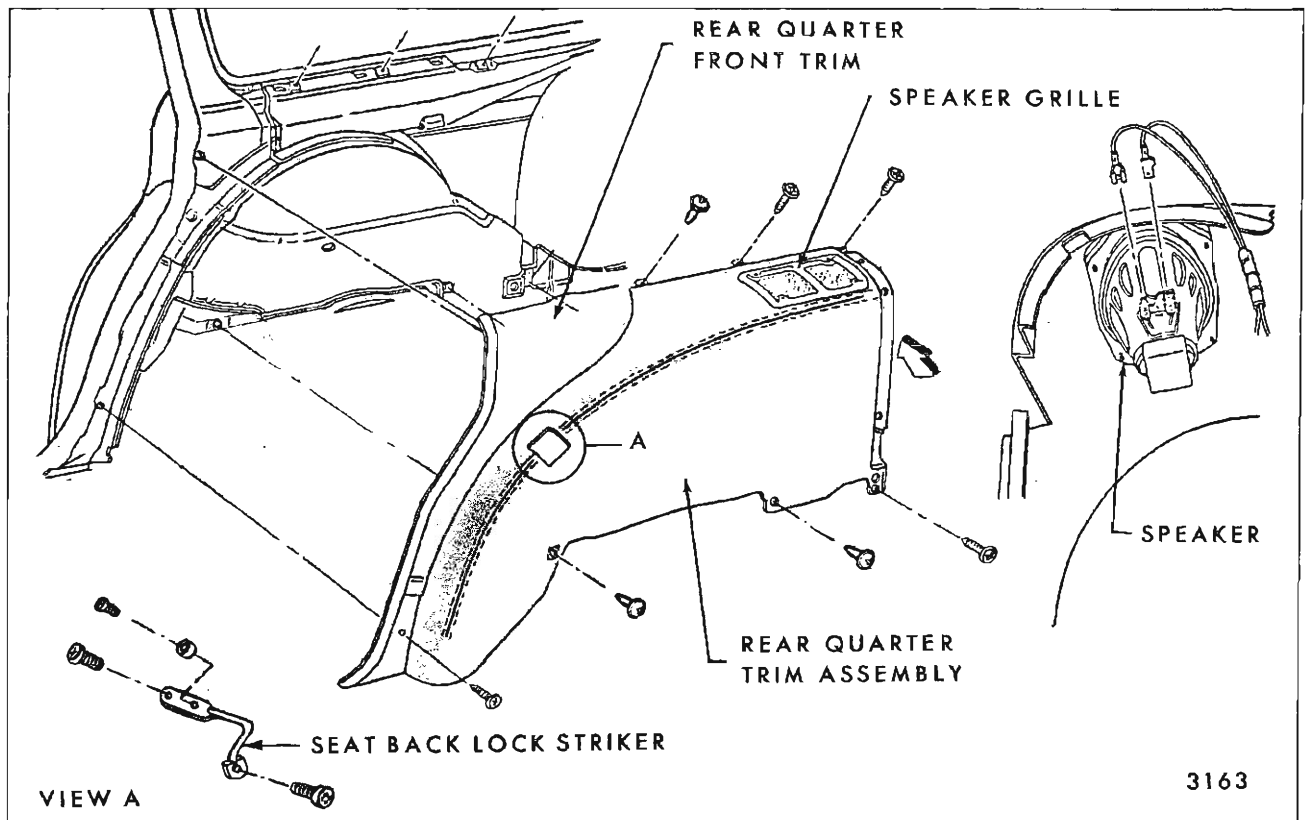

Fig. 14-33—Rear Quarter Trim Panel (Right side) - "B" Station Wagon

3. Remove screws securing trim panel as shown in Fig. 14-34 and remove trim panel.
4. To install reverse removal procedure.

### WHEELHOUSE TRIM COVER PANEL (Right Side)—All "A" Body Station Wagon Styles

#### Removal and Installation

1. Remove rear quarter front trim panel and spare tire cover panel as previously described.
2. Remove second folding seat back lock striker and bumper assembly from wheelhouse (See Fig. 14-35).
3. Remove all trim attaching screws at front, top and bottom of wheelhouse trim panel and remove panel (Fig. 14-35).
4. To install, reverse removal procedure.

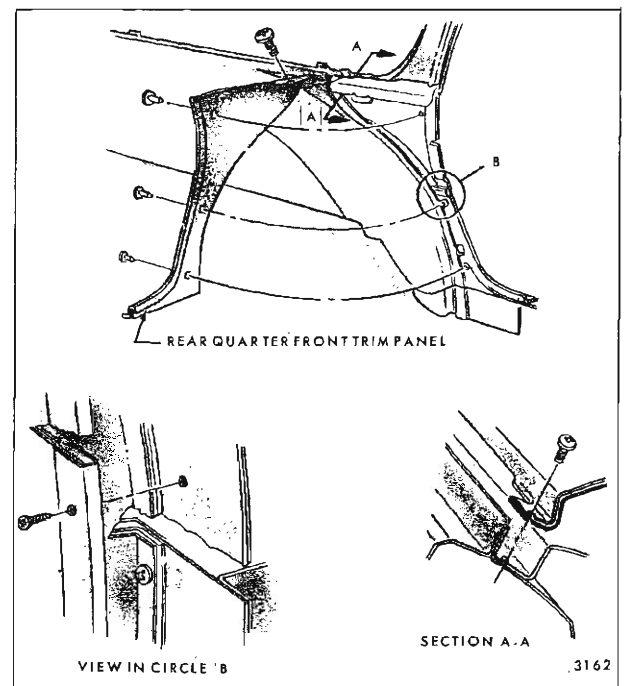

Fig. 14-34—Rear Quarter Front Trim Panel "A" Station Wagon

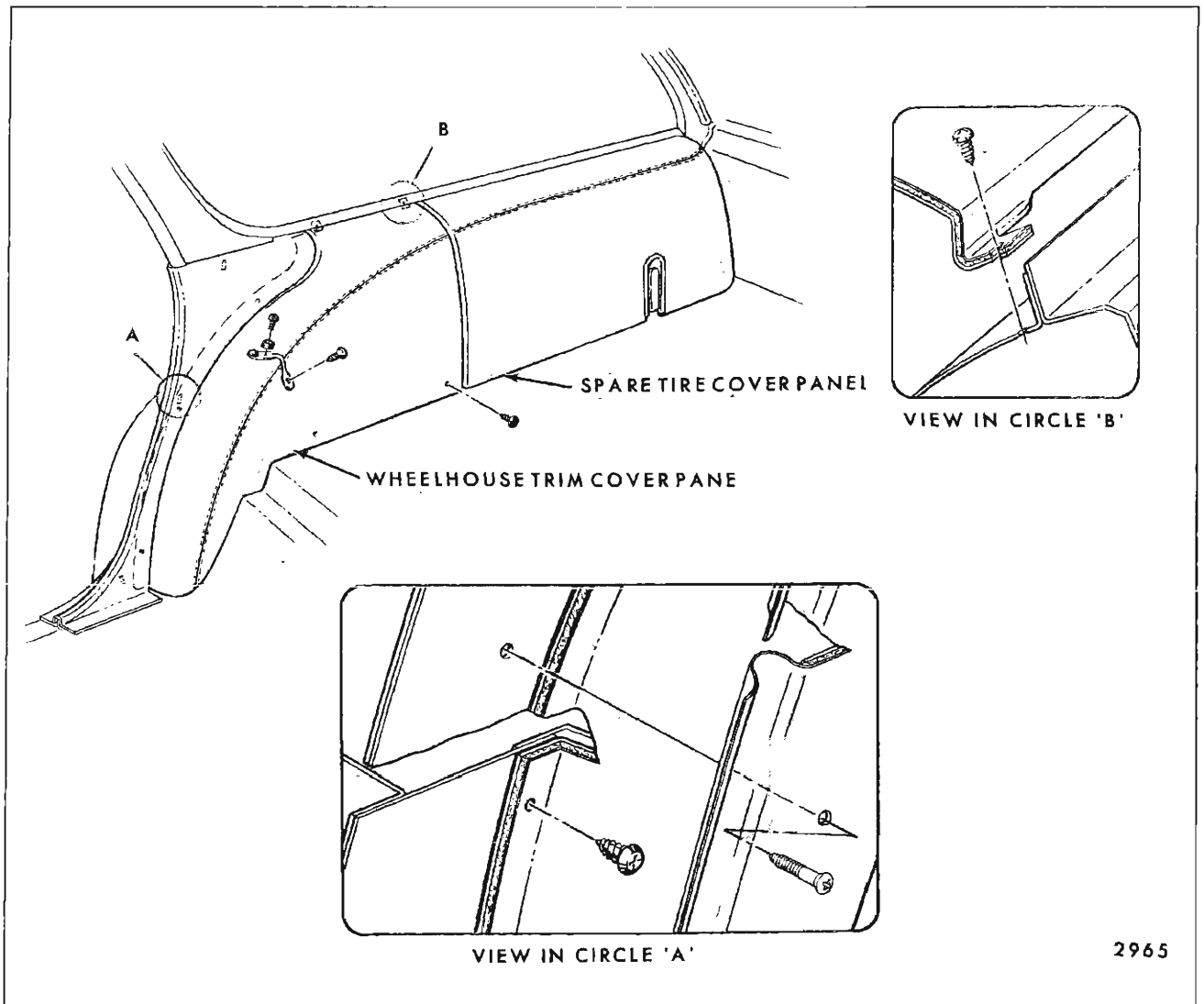

Fig. 14-35—Wheelhouse Cover Panel (Right Side) - "A" Station Wagon

### REAR QUARTER REAR TRIM PANEL (Left Side)—All "A" Body Station Wagon Styles

#### Removal and Installation

1. Remove rear quarter front trim panel as previously described.
2. Remove seat back bumper or seat back lock striker (only on styles with optional split seat), as shown on Fig. 14-36.
3. Remove screws at top, bottom and front of trim panel as shown in Figure 14-36 and remove trim panel from body.

**NOTE:** On styles so equipped, disconnect rear radio speaker, courtesy lamp, and tailgate window switch connectors as shown in Figure 14-36.

4. To install, reverse removal procedure.

### REAR QUARTER UPPER TRIM (Above Belt)—All Styles

#### Removal and Installation

1. Remove back window garnish molding or back window finishing lace.
2. Loosen side roof rail garnish molding or finishing lace in area of rear quarter upper trim.

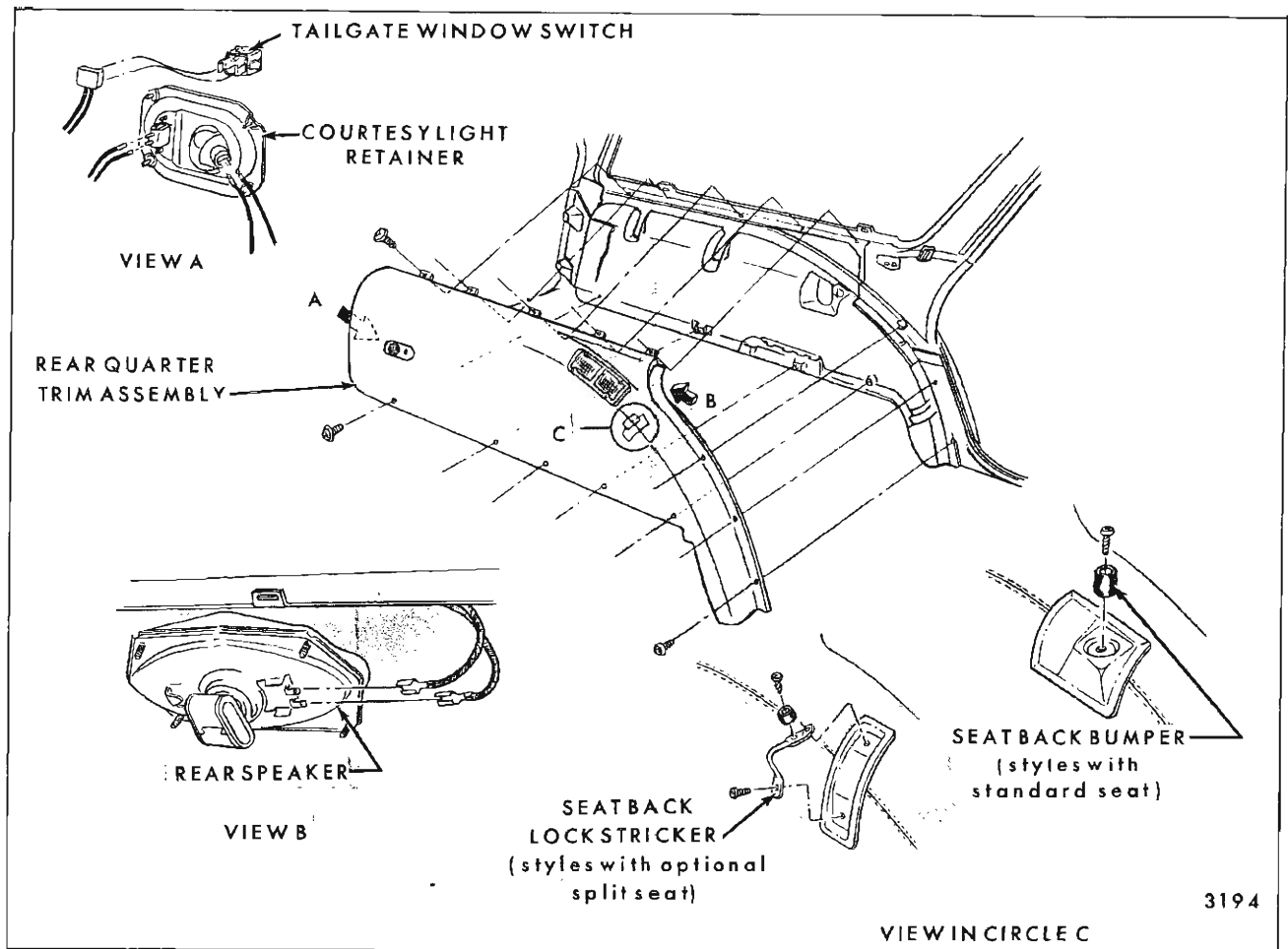

Fig. 14-36—Rear Quarter Trim Panel (Left Side) - "A" Station Wagon

3. If cemented, carefully break cement bond at front and/or rear edge of rear quarter upper trim (See Views "B and D", Fig. 14-37).
4. Detach fasteners from attaching holes, (View "A", Fig. 14-37), and remove rear quarter upper trim panel by pulling upper edge inboard and lifting upward.
 

**NOTE:** On "A-80" styles, and Cad. "E-47" styles equipped with optional rear seat shoulder harness, remove shoulder harness anchor bolts. On styles equipped with courtesy lamps in the rear quarter upper trim, disconnect the lamp at the connector before completely removing the trim panel.
5. To install, connect courtesy lamp wire to connector, position trim assembly by inserting lower edge into lower retainer clip (View "C", Fig. 14-37), and attach fasteners into at-

taching holes. On "A-80" styles, and Cad. "E-47" styles equipped with optional rear seat shoulder harness, install shoulder harness assembly.

**NOTE:** Prior to re-installation of quarter upper trim on Oldsmobile and Buick "E" body styles, remove the lowest foam spacer from the back side of the trim panel. Discard it on Oldsmobile styles and relocate the spacer 1-1/2" upward on the Buick "E" styles, to permit tucking the quarter upper trim behind the parcel shelf trim.

6. Re-cement front and/or rear edge of trim panel to headlining retainer using non-staining vinyl trim adhesive.
7. Install side roof rail garnish molding or finishing lace and back window garnish molding or finishing lace.



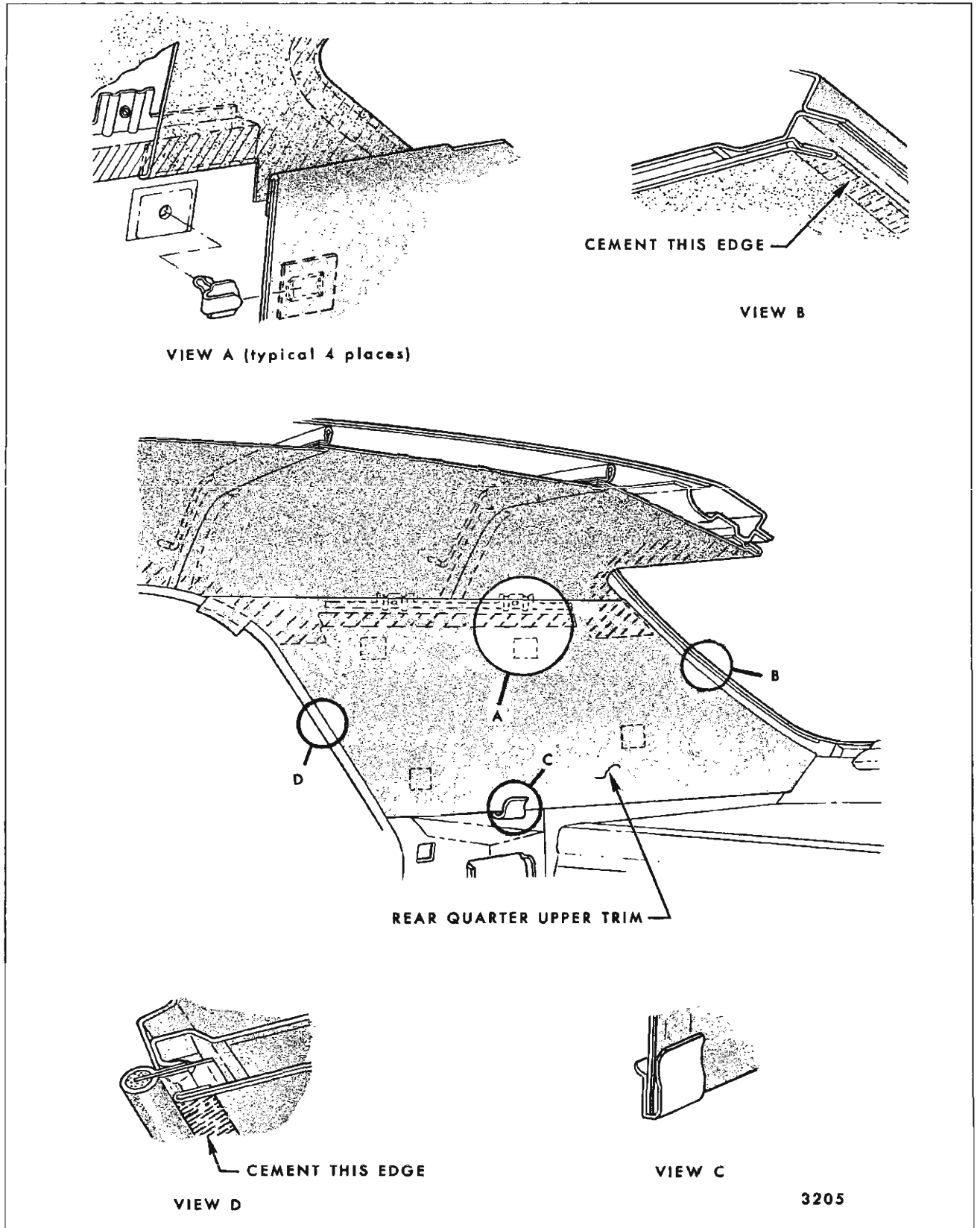

Fig. 14-37—Typical Rear Quarter Upper Trim Installation

## CENTER PILLAR TRIM—"A-B & C" Four-Door Hardtop Styles

### Removal and Installation

1. Remove front and rear door sill plates.
2. Remove attaching screw at top of trim panel on "A" styles; remove two attaching screws from finishing cap on "B-C" styles (See Fig. 14-38).
3. To remove, lift trim panel straight up until free of retaining flanges.
4. To install, reverse removal procedure.

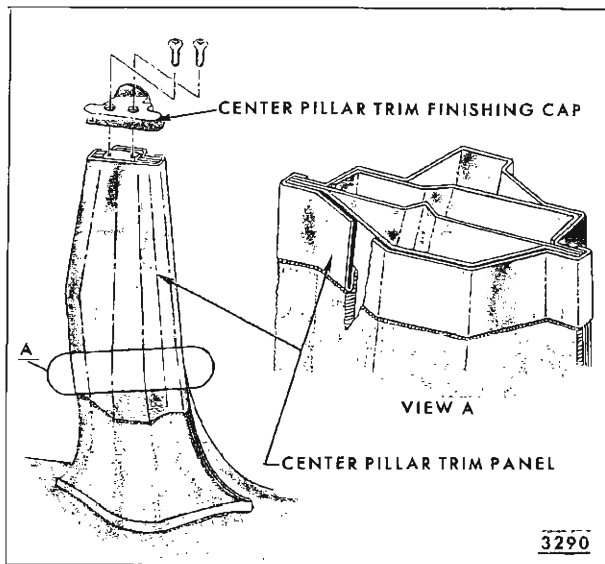

Fig. 14-38—Center Pillar Trim "A-B and C-39, 49" Styles. (26239 Custom, 48439, 682-68349 Styles Shown, Others Similar)

## CENTER PILLAR UPPER AND LOWER TRIM—"A & X" Four-Door Closed Styles

### Removal and Installation

1. Remove two attaching screws from center pillar upper trim and remove trim.
2. Remove front and rear door sill plates.
3. Remove center pillar lower trim by pulling away from pillar.

**NOTE:** On "X" styles, remove two attaching screws in lower trim panel to complete removal.

4. To install, reverse removal procedure.

## CENTER PILLAR UPPER AND LOWER TRIM—"B & C" Four-Door Closed Styles

### Removal and Installation

1. Remove center pillar upper trim by removing exposed screws if present. If no screws are present, gently pry upper trim serrated attaching nails from center pillar panel (Fig. 14-39).
2. Remove front and rear door sill plates.
3. Remove all exposed screws from center pillar lower trim and gently pry attaching clips from center pillar attaching holes. (See Fig. 14-39.)
4. To install, reverse removal procedure.

**NOTE:** Center pillar windlace is attached to foundation board as a separate assembly. To remove assembly, after center pillar lower trim is off, straighten bend-down tabs through foundation board and lift away (Fig. 14-39).

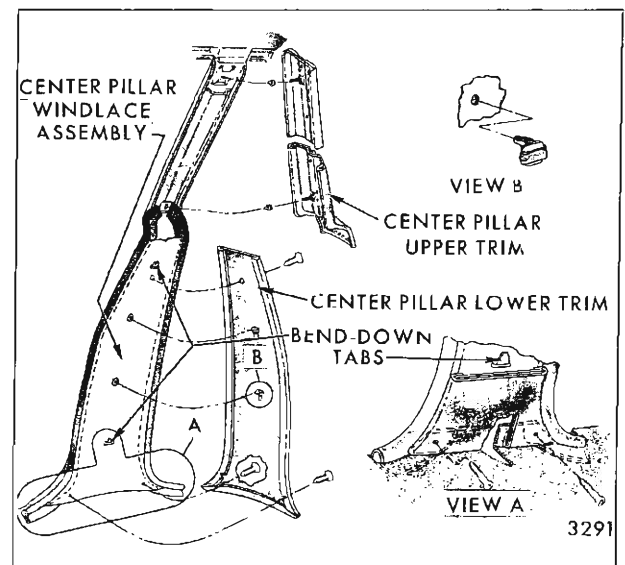

Fig. 14-39—Center Pillar Trim - "A-B-C and X" Four Door Closed Styles.

## COMPARTMENT SHELF TRIM

### COMPARTMENT SHELF TRIM ASSEMBLY— All Styles Except "E & Z" Series, and "F-37" Styles with Folding Rear Seat

#### Removal and Installation

1. Remove rear seat cushion and rear seat back assembly. Detach shoulder straps if so equipped.
2. Remove rear quarter and quarter upper trims as described under "Rear Quarter Trim".
3. Loosen back window lower garnish molding or back window finishing lace in area of parcel shelf trim.
4. Carefully break cement bond at compartment shelf trim panel valance to front of metal shelf panel as shown in Figure 14-40.
5. Remove compartment shelf trim panel by lifting up front edge and pulling forward.
6. To install, position trim assembly to shelf panel by inserting rear edge of trim assembly under garnish molding or feature strip. Push

trim assembly rearward, align center notch with center depression in metal shelf panel.

7. Re-cement compartment shelf trim assembly valance to front of metal shelf panel using non-staining vinyl trim adhesive.

### COMPARTMENT SHELF CENTER FINISHING PANEL—Oldsmobile and Buick "E" Styles

#### Removal and Installation

1. Remove rear seat cushion and seat back assemblies as described under "Rear Seats".
2. From inside rear compartment, remove compartment shelf center finishing panel attaching nuts at locations shown in Section "A-A" in Figure 14-41.
3. From inside body loosen center panel attaching bolts and pull center finishing panel forward sufficiently to disengage both front and rear edge of center finishing panel from retainers (see View "B", Fig. 14-41); then, lift panel upward and remove from shelf panel.
4. To install, reverse removal procedure.

### COMPARTMENT SHELF SIDE FINISHING PANELS—Oldsmobile and Buick "E" Styles

#### Removal and Installation

1. Remove compartment shelf center finishing panel.
2. a. On 39487 style, remove seat back filler panel attaching screws (Fig. 14-42).  
b. On 39687 and 49487 Styles, remove rear quarter trim assembly, as previously described.
3. Remove compartment shelf side finishing panel attaching screws (Fig. 14-41) and remove side finishing panel.
4. To install, reverse removal procedure.

### COMPARTMENT SHELF SIDE AND CENTER TRIM PANELS— Cadillac "E" Styles

The compartment shelf trim assembly consists of three individual panels joined together with screws

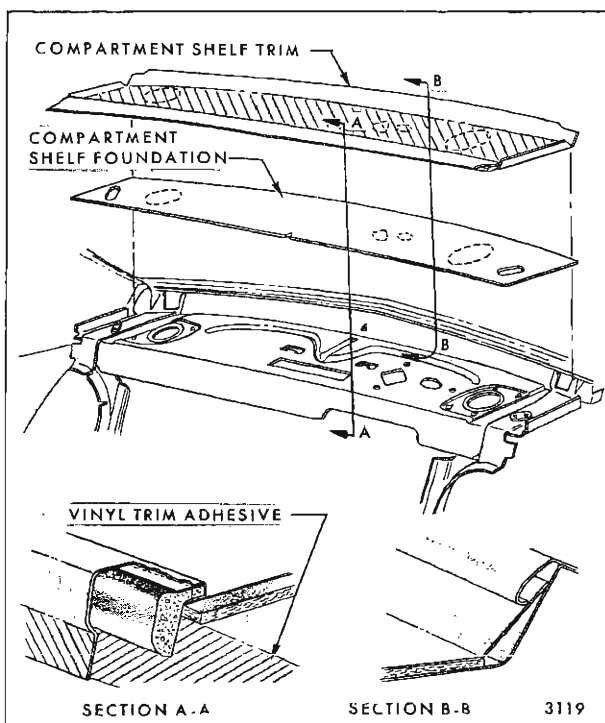

Fig. 14-40—Compartment Shelf Trim Panel - Typical  
All Less "E and Z" Styles

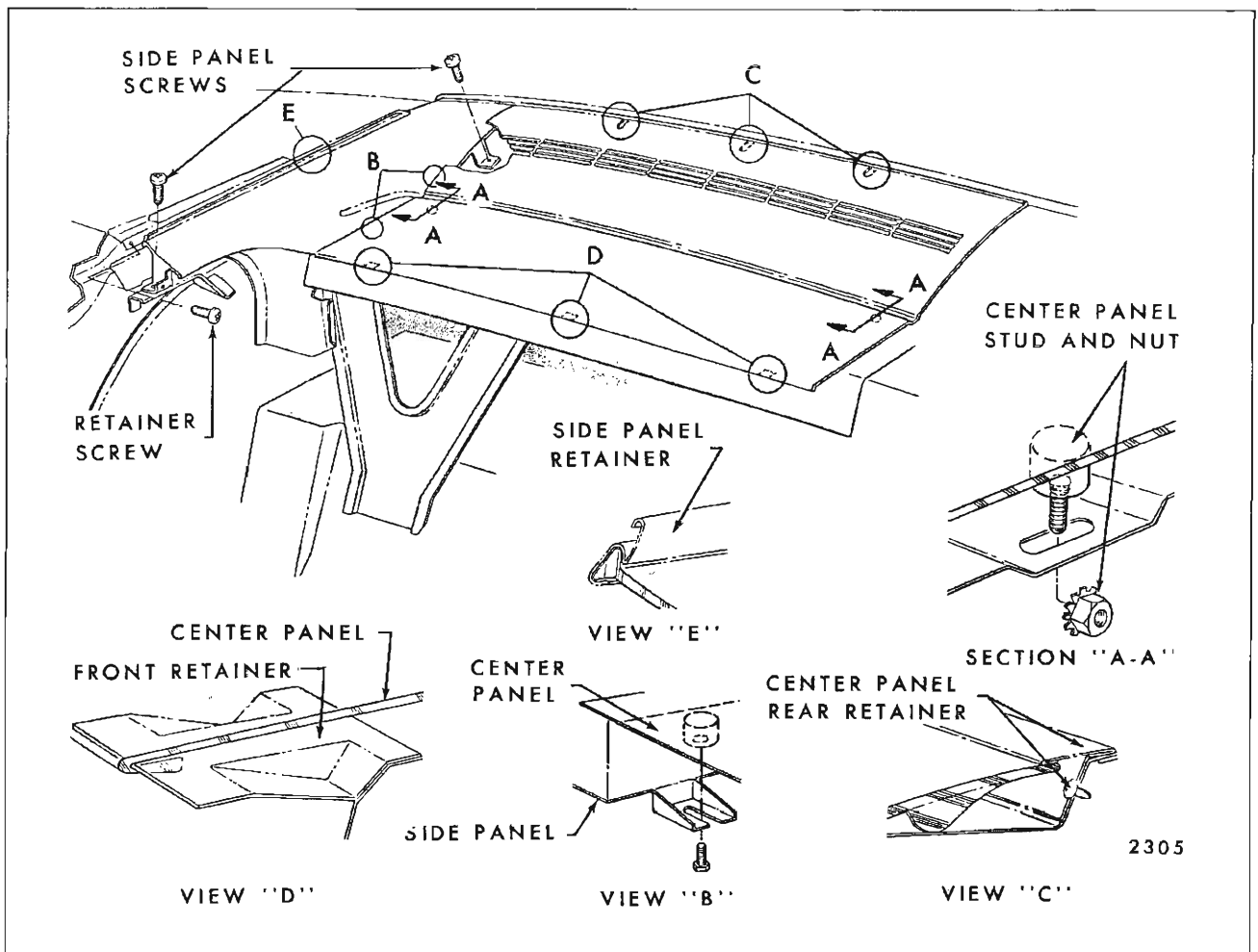

Fig. 14-41—Typical "E" Style Compartment Shelf Trim - Buick "E" Shown

to form a single unit. It is necessary to remove the assembly to service the individual sections. The assembly is retained with integral studs and nuts at five locations. Additional retention is obtained using bend-over metal tabs on the center trim section.

#### Removal and Installation

1. Remove rear seat cushion and rear seat back assemblies as described under "Rear Seats".
2. Remove rear quarter trim assembly as described under "Rear Quarter Trim".
3. Remove back window lower garnish molding and back window lower corner escutcheons.
4. Remove rear compartment side panel attaching screws (View "A", Fig. 14-43). Loosen compartment shelf to metal foundation nuts as

indicated in View "C". Remove center section attaching nuts (View "A & B", Fig. 14-44 and View "A", Fig. 14-43).

5. To remove compartment shelf trim panel from shelf panel, pull panel forward and straight out.
6. To remove the center trim panel, bend metal tabs (Fig. 14-44) to straight down position and detach from shelf panel.
7. To install, reverse removal procedure.

#### COMPARTMENT FRONT AND SHELF PANEL TRIM ASSEMBLY—"Z" Series with Stationary or Folding Rear Seat Back

##### Removal and Installation

1. Remove rear seat cushion and seat back

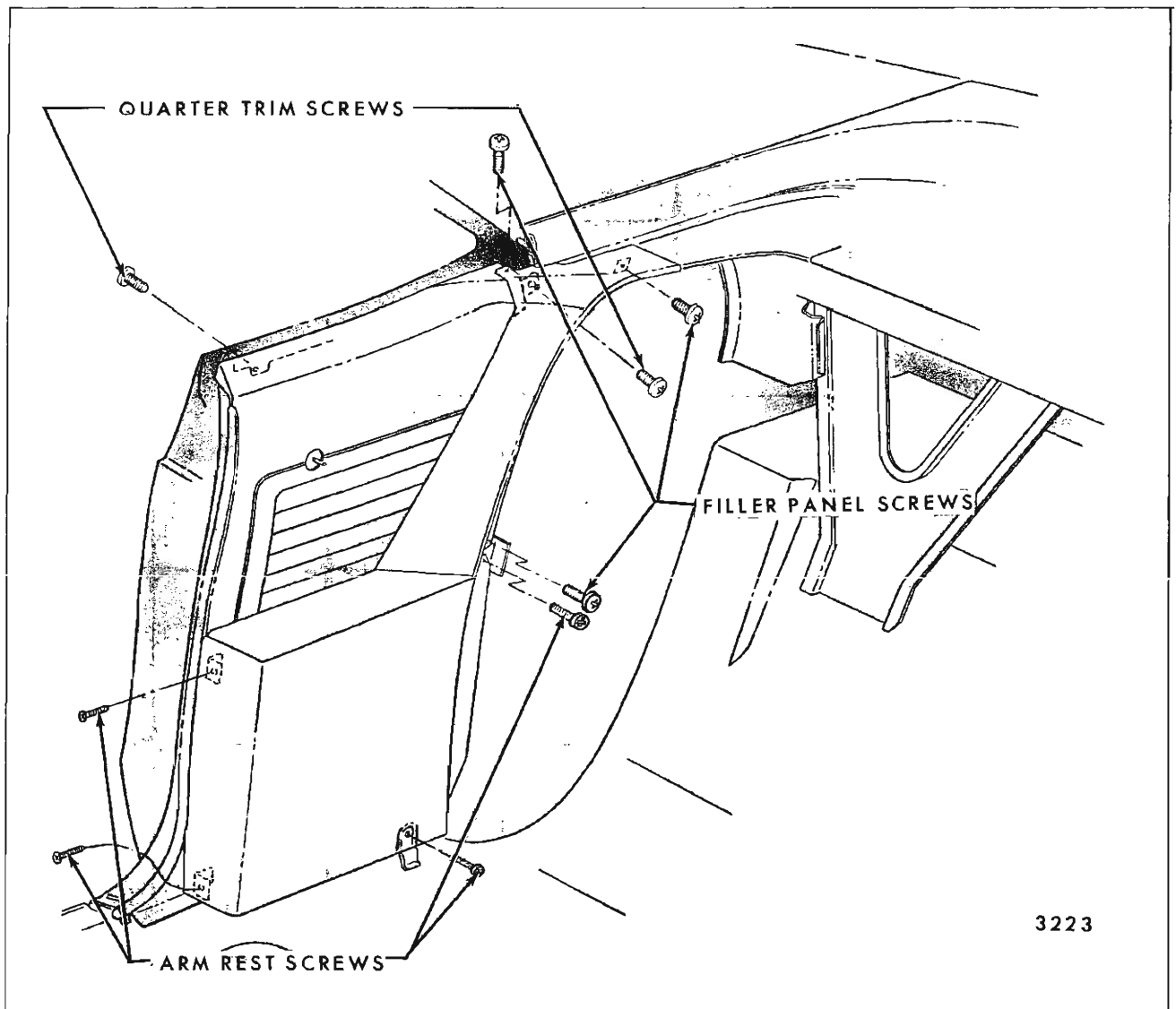

3223

Fig. 14-42—Rear Quarter Trim Assembly - "39487" Style

assemblies from styles with stationary seat back assembly as described under "Rear Seats". On styles with folding rear seat, lower folding rear seat back.

2. Remove back window finishing lace.
3. Remove right and left door sill plates.
4. Remove rear quarter trim assemblies as described under "Door, Quarter and Shelf Trim".
5. Remove all exposed screws from compartment front and shelf panel trim assemblies; seat back bumper and seat back lock from styles

with folding seat back, and rear seat back support assembly from styles with stationary seat back (See Fig. 14-45).

6. Remove optional auxiliary rear shelf panel (on styles equipped with optional back window defogger or rear seat speakers), by removing five attaching screws in front edge of auxiliary panel, lifting panel and removing three attaching screws from inside rear edge (Fig. 14-45).
7. Remove compartment front and shelf panel trim assembly.
8. To install, reverse removal procedure.

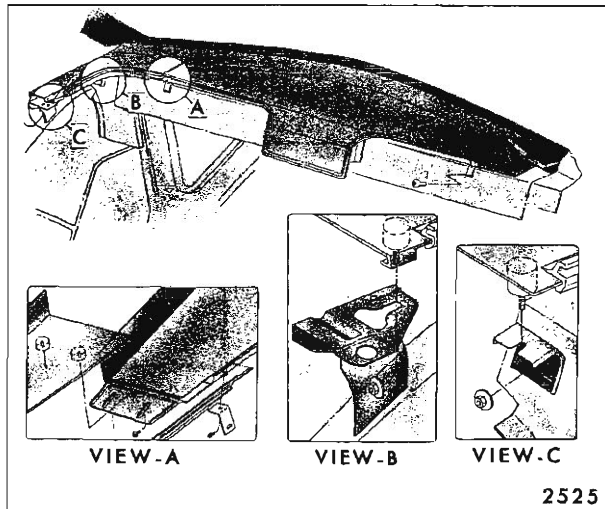

Fig. 14-43—Compartment Shelf Trim Panel -  
Cod. "E" Styles

## COMPARTMENT SHELF TRIM ASSEMBLY— "F-37" Styles with Folding Rear Seat

### Removal and Installation

1. Remove rear seat cushion as described under "Rear Seats", and lower rear seat back.
2. Remove back window lower corner garnish molding escutcheons.
3. Remove rear quarter trim as described under "Rear Quarter Trim", in this section.
4. Remove right and left rear seat back bumpers, and the rear seat back foundation panel by removing all exposed attaching screws.
5. Carefully break cement bond at compartment shelf trim panel valance and front of metal shelf panel as shown in Figure 14-40.

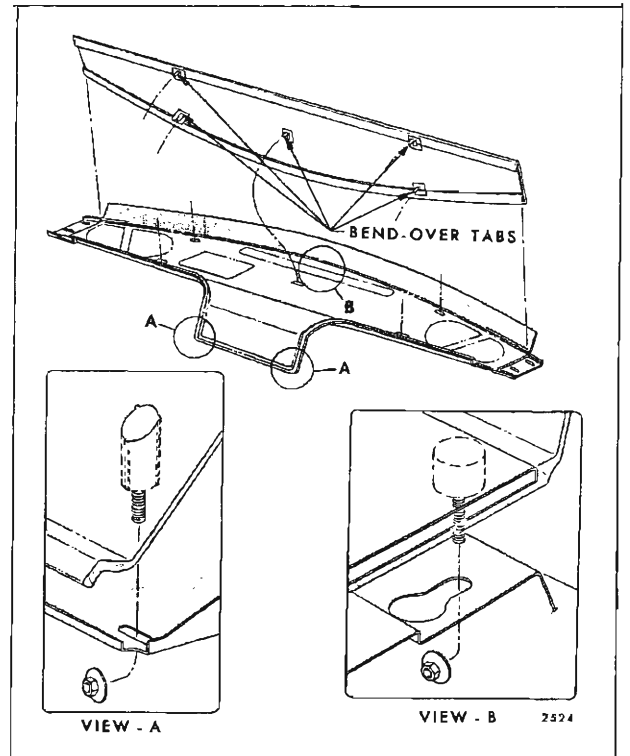

Fig. 14-44—Compartment Shelf Center Trim Panel -  
Cod. "E" Styles

6. Remove compartment shelf trim panel by lifting up front edge and pulling forward.
- NOTE:** On styles so equipped, remove rear seat speaker and/or rear window defogger prior to completely removing compartment shelf trim panel.
7. To install, reverse removal procedure.
  8. Re-cement compartment shelf trim assembly valance to front of metal shelf panel using non-staining vinyl trim adhesive.

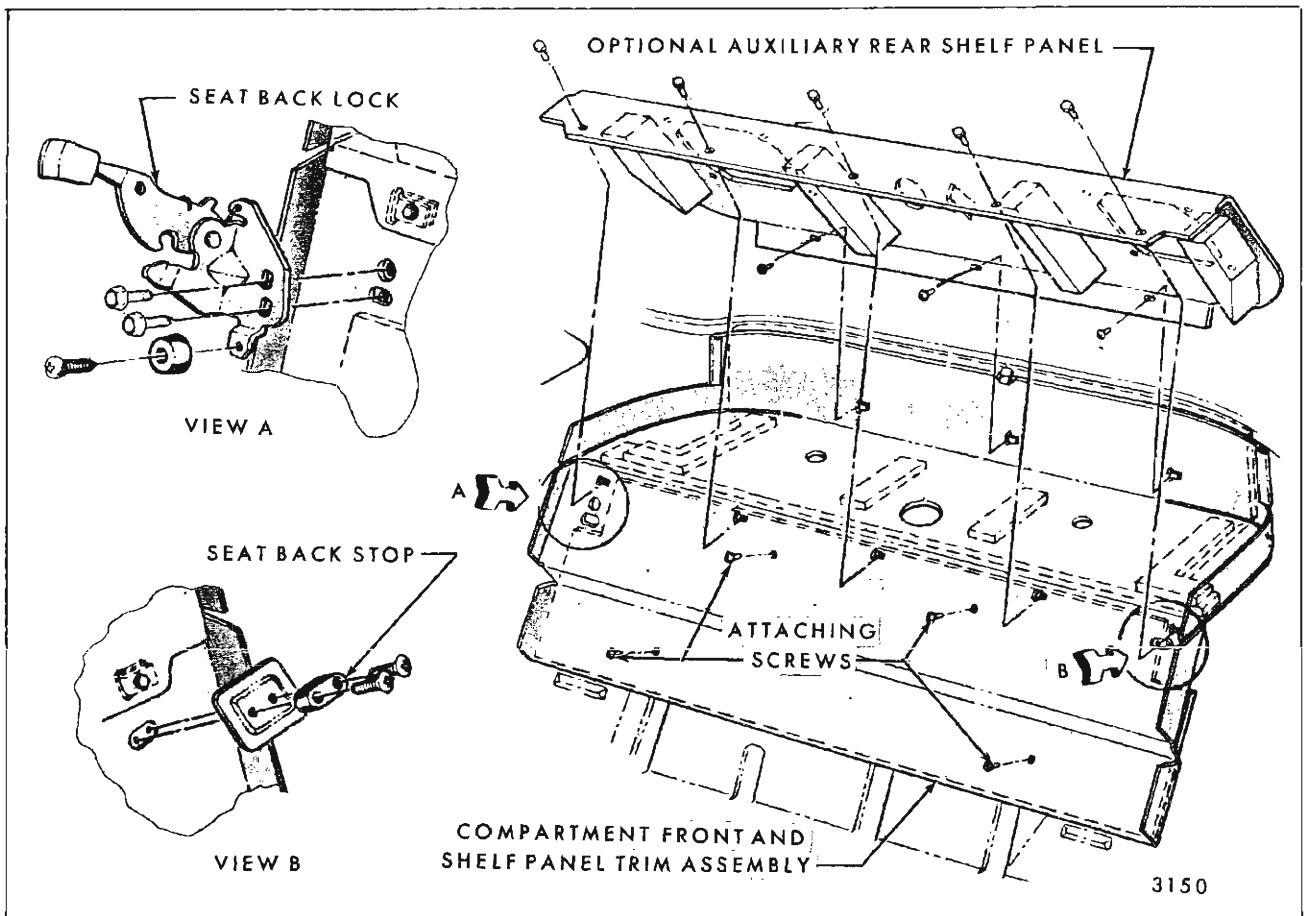

Fig. 14-45—Compartment Shelf Trim and Auxiliary Shelf Trim Panel "Z" Styles

## SECTION 15

# SEATS

### INDEX

Subject	Page	Subject	Page
Introduction . . . . .	15-3	Seat Back Panel Assembly - Cadillac Two or Four Door Styles with Standard Seats . . . . .	15-29
Front Seat Dealer Relocation Provisions . . . . .	15-3	Electric Seat Back Lock - Cadillac Two-Door Styles with Standard Full Width Seats . . . . .	15-29
Seat Adjuster Spacer Usage . . . . .	15-5	Seat Back Lock and Electric Actuator Assembly - Cadillac Two-Door Styles with Standard Full Width Seat . . . . .	15-29
Seat Torque Specifications . . . . .	15-6	Seat Back Head Restraint - Standard Full Width or 60-40 Seat (Drivers or Passenger Side) . . . . .	15-30
Manually Operated Seat Adjuster Control Arm Knob . . . . .	15-6	Seat Back Head Restraint Retainer and Lock - Standard Full Width Seats, 60-40 Seats and "F" Type Seats . . . . .	15-30
Front Seat Assembly - Standard Full Width and 60-40 Seats . . . . .	15-7	Seat Back Head Restraint Guide Tube, Guide Tube Support and Guide Roller - Standard Full Width Seats, 60-40 Seats and "F" Type Seats . . . . .	15-31
Description . . . . .	15-7	Center Arm Rest and Curtain Assembly - Standard Full Width Seat Back . . . . .	15-32
Seat Assembly - Manually Operated . . . . .	15-8	Center Arm Rest and Support Assembly - Standard Full Width Seat Back . . . . .	15-34
Seat Adjuster Assembly - Manually Operated . . . . .	15-8	Center Arm Rest and Curtain Assembly - Notch Down Seat Back and Strato Seat . . . . .	15-34
Seat Assembly - Power Operated . . . . .	15-10	Center Arm Rest Assembly - Notch Down Seat Back and Strato Seat . . . . .	15-34
Seat Adjuster Assembly - Power Operated . . . . .	15-12	Foot Rest Assembly - Cadillac 68169 Style . . . . .	15-34
Two-Way Seat Adjuster Major Components - "C" Body Full Width Seats . . . . .	15-14	Strato-Full Width or Bucket and Standard Bucket Seats . . . . .	15-35
Electric Motor . . . . .	15-14	Description . . . . .	15-35
Horizontal Gearnut Assembly . . . . .	15-14	Strato Full Width Front Seat Assembly . . . . .	15-36
Horizontal Jackscrew . . . . .	15-15	Manually Operated Bucket Seat Assembly . . . . .	15-36
Plastic Slides . . . . .	15-15	Power Operated Horizontal or Four-Way Bucket Seat Assembly . . . . .	15-36
Four-Way Seat Adjuster Major Components - "A" Body Full Width Seats . . . . .	15-15	Manually Operated Bucket Seat Adjuster . . . . .	15-37
Electric Motor . . . . .	15-15	Power Operated Horizontal Bucket Seat Adjuster . . . . .	15-37
Vertical Gearnut . . . . .	15-15	Power Operated Four-Way Bucket Seat Adjuster . . . . .	15-38
Horizontal Actuator . . . . .	15-16	Major Components . . . . .	15-38
Jackscrew . . . . .	15-16	Motor and Transmission Drive Belts and Pulleys Motor Assembly . . . . .	15-39
Horizontal and Vertical Drive Cables . . . . .	15-16	Transmission Assembly and Horizontal and Vertical Drive Cables . . . . .	15-39
Transmission . . . . .	15-17	Disassembly and Assembly of Transmission . . . . .	15-39
Disassembly and Assembly of Transmission . . . . .	15-17	Adjuster Vertical Gearnut . . . . .	15-40
Four-Way Seat Adjuster Major Components - Buick "B-C & E" Full Width Seats . . . . .	15-17	Adjuster Jackscrew . . . . .	15-40
Electric Motor . . . . .	15-17	Adjuster Horizontal Actuator Assembly . . . . .	15-40
Vertical Gearnut . . . . .	15-18	Torque Tube Assembly . . . . .	15-40
Horizontal Actuator . . . . .	15-19	Passenger's Front Bucket Seat Back Stop Cable - Chevrolet "F & Z" Styles with Bucket Seats . . . . .	15-41
Horizontal and Vertical Drive Cables . . . . .	15-19	Bucket Seat Back Assembly - Standard Bucket Seat "F & Z" Styles . . . . .	15-41
Transmission . . . . .	15-19	Seat Back Lock - "F & Z" Body Standard Bucket Seat . . . . .	15-41
Disassembly and Assembly of Transmission . . . . .	15-19	Strato Seat Back Assembly - Full Width Seat with Stationary Seat Backs - All Styles (Except 16639 Style) . . . . .	15-42
Six-Way Seat Adjuster Major Components - "B-C & E" Full Width Seats . . . . .	15-20	Strato Seat Back Assembly - Full Width Seat - 16639 Style . . . . .	15-43
Electric Motor . . . . .	15-20	Strato Seat Back Panel - Four-Door Style with Non Folding Seat Back . . . . .	15-44
Horizontal Actuator . . . . .	15-20	Strato Seat Back Panel - Two-Door Styles with Passengers Reclining Seat Back . . . . .	15-44
Front Vertical Gearnut . . . . .	15-20	Strato Front Seat Back Panel - Two-Door Style Equipped with Reclining Front Passenger Seat Back . . . . .	15-44
Lower or Upper Channel and Plastic Slides . . . . .	15-21		
Transmission . . . . .	15-22		
Disassembly and Assembly of Transmission . . . . .	15-22		
Six-Way Seat Adjuster Major Components - Buick, Oldsmobile and Cadillac 60-40 Seats . . . . .	15-22		
Seat Adjuster Motor . . . . .	15-22		
Rear Vertical Drive Cables . . . . .	15-23		
Horizontal or Front Vertical Drive Cables . . . . .	15-23		
Transmission . . . . .	15-25		
Disassembly and Assembly of Transmission . . . . .	15-26		
Front Seat Back Assembly . . . . .			
Four-door Style with Standard Full Width Seat . . . . .	15-26		
Two-door Style with Standard Full Width Seat or Notch Down Seat with Center Arm Rest (Right or Left) . . . . .	15-27		
All "39" Style Full Width and Buick, Oldsmobile and Cadillac 60-40 Seat with Notch Down Center Arm Rest . . . . .	15-27		
Seat Back Locks - "A, B, X & Z" Body Two- Door Styles with Standard Full Width . . . . .	15-28		
Seat Back Locks - "C & E" Body Two-Door Styles with Standard Full Width and 60-40 Seat . . . . .	15-28		



15-2 SEATS

Subject	Page	Subject	Page
Strato Seat Back Head Restraint Retainer and Guide Tube . . . . .	15-44	Rear Floor Filler Panel - All Styles . . . . .	15-62
Strato Seat Back Lock Assembly - Two-Door Full Width and Bucket Seats (Except Styles with Reclining Seat Back) . . . . .	15-45	Second Seat Cushion - (Full Width or Split Seat) - All Styles . . . . .	15-62
Strato Seat Back Electric Actuator Assembly - Cadillac Two-Door Styles Equipped with Electrically Operated Strato Seat Back Locks	15-45	Folding Second Seat Back Trim and Spring Assembly (Full Width or Split Seat) - All Styles . . . . .	15-62
Strato Bucket Seat Back Assembly - All Except "F & Z" Body Styles and Strato Reclining Seat Back . . . . .	15-46	Folding Second Seat Back Trim, Panel and Linkage Assembly (Full Width or Split Seat) - All Styles . . . . .	15-63
Reclining Front Seat Back . . . . .	15-46	Folding Second Seat Back Linkage Assembly (Full Width Seat - Right or Left Side Split Seat - Outer Linkage Only) . . . . .	15-63
Description . . . . .	15-46	Folding Second Split Seat Back Inner Linkage Assembly . . . . .	15-64
Reclining Seat Back Assembly . . . . .	15-47	Luggage Compartment Lock Cylinder - 15-16000 Two Seat Styles . . . . .	15-64
Reclining Seat Back Positioning Unit . . . . .	15-47	Luggage Compartment Lock - Two Seat Styles	15-64
Reclining Seat Back Lock Striker and Seat Back Lock - Strato Full Width or Bucket Seat . . . . .	15-47	Folding Second Seat Back Lock (Full Width or Split Seat) - All "A & B" Styles (Except "A-55, 56, 65, 66" Styles) . . . . .	15-64
Reclining Seat Back Lock Control Support - Strato Full Width or Bucket Seat . . . . .	15-49	Folding Second Seat Back Lock (Full Width or Split Seat) - All "A & B" Styles (Except "A-55, 56" Styles with Split Seat Option and "65-66" Styles . . . . .	15-65
Reclining Seat Back Lock Control Assembly - Strato Full Width or Bucket Seats . . . . .	15-49	Folding Seats and Floor Panels - "55, 56, 65, 66" Styles . . . . .	15-65
Rear Seats . . . . .	15-50	Folding Second Seat Assembly - "55, 56, 65, 66" Styles . . . . .	15-66
Rear Seat Cushion - All Styles (Except "A-65" Styles) . . . . .	15-50	Folding Second Seat Cushion Assembly - "55, 56, 65, 66" Styles . . . . .	15-66
Rear Seat Back Assembly - All Styles Except Station Wagons and "F & Z" Body with Folding Rear Seat Back . . . . .	15-51	Folding Second Seat Back Trim and Spring Assembly - "55, 56, 65, 66" Styles . . . . .	15-68
Folding Rear Seat Back - "F" Body Styles . . . . .	15-51	Folding Second Seat Front Floor Pan Linkage - "55, 56, 65, 66" Styles . . . . .	15-69
Folding Rear Seat Back Lock - "F" Body Styles . . . . .	15-52	Folding Second Seat Rear Floor Pan Linkage - "55, 56, 65, 66" Styles . . . . .	15-69
Folding Rear Seat Back - "Z" Body Styles . . . . .	15-52	Folding Second Seat Side Inner Linkage - "55, 56, 65, 66" Styles . . . . .	15-69
Folding Rear Seat Back Linkage - "Z" Body Styles . . . . .	15-52	Folding Second Seat Side Outer Linkage - "55, 56, 65, 66" Styles . . . . .	15-69
Folding Rear Seat Back Lock - "Z" Body Styles . . . . .	15-52	Folding Second Seat Back Lock - "55, 56, 65, 66" Styles . . . . .	15-70
Rear Seat Back Center Arm Rest and Curtain	15-52	Folding Second Seat Back Panel and Filler Panel - "55, 56, 65, 66" Styles . . . . .	15-70
Rear Seat Back Center Arm Rest Hanger Plate and Linkage . . . . .	15-52	Folding Third Seat and Floor Panel Assembly - "65-66" Styles . . . . .	15-70
Auxiliary Seat Assembly - Cadillac Limousine Styles . . . . .	15-53	Folding Third Seat Cushion Trim Assembly - "65-66" Styles . . . . .	15-71
Auxiliary Seat Adjustments - Cadillac Limousine Styles . . . . .	15-54	Folding Third Seat Lock Trim Assembly or Seat Back Panel Assembly - "65-66" Styles . . . . .	15-71
Auxiliary Seat Lower Support Assembly - Cadillac Limousine Styles . . . . .	15-56	Folding Third Seat Back Lock - "65-66" Styles	15-72
Seat Trim Buttons . . . . .	15-56	Luggage Compartment Cover Panel and Filler Panel - "55, 56, 65, 66" Styles . . . . .	15-72
Station Wagon Folding Rear Seats and Floor Panels - All Except "55-56-65-66" Styles . . . . .	15-56	Seat Belts and Shoulder Straps	
Rear Floor to Tail Gate Filler Panel Assembly	15-57	General Information . . . . .	15-72
Compartment Pan Side Filler Panels - "B" Body Two-Seat and Three-Seat Styles . . . . .	15-57	Standard Front Seat Belt Retractor - Floor Mount (Includes "X" Body Non-Swivel Retractor) . . . . .	15-73
Luggage Compartment Front and Rear Panel Assembly - Two Seat Styles . . . . .	15-58	Standard Front Seat Belt Retractor (Swivel Type) - "X" Body Coupes . . . . .	15-73
Luggage Compartment Rear Panel Assembly - Two Seat Styles . . . . .	15-60	Deluxe Front Seat Belt Retractor - Floor Mount . . . . .	15-73
Luggage Compartment Front and Rear Panel Hinge Assembly - Two Seat Styles . . . . .	15-60	Self Locking Front Seat Belt . . . . .	15-73
Folding Third Seat Cushion - Three Seat Style	15-60	Rear Seat Belt Bail Type Retractor . . . . .	15-74
Folding Third Seat Cushion Panel Assembly and Support - Three Seat Style . . . . .	15-60	Seat Belts and Shoulder Straps . . . . .	15-75
Folding Third Seat Back Trim Assembly - Three Seat Style . . . . .	15-61		
Folding Third Seat Back Panel Assembly - Three Seat Styles . . . . .	15-61		
Folding Third Seat Back Lock - All "A & B" Body Three Seat Styles . . . . .	15-61		
Compartment Floor Panel Assembly (at Kick-Up) All Styles . . . . .	15-62		

## FRONT AND REAR SEATS

### INTRODUCTION

All front seats incorporate a front seat back head restraint on the driver and passenger seat backs. All two-door front seats and station wagon folding second and third seat backs incorporate seat back locks. On standard front seats ("A, B, X & Z" Body Styles) the seat back lock is actuated by a control lever located at the lower rear of the seat back. On "C & E" Body Styles the control (push button) is located at the outer upper corner of the seat back. On "Strato" seats the seat back lock is actuated by a control button located at the upper center of the seat back. On Strato reclining seats the control button is located at the outer upper corner of the seat back.

Some Oldsmobile, Buick and Cadillac styles feature

60/40 seats consisting of an individually controlled drivers seat (40% of front seat width) and an individually controlled passenger seat (60% of front seat width).

### FRONT SEAT DEALER RE-LOCATION PROVISIONS—Forward or Rearward

Front seat assemblies can be repositioned forward or rearward to accommodate owners comfort on most styles. Refer below for specific dealer relocation provisions of conventional and strato bench seats - "B, C and E" Styles; bench seats - "A, F, X and Z" styles and bucket seats - all styles.

**CAUTION:** Under NO circumstances should seats be repositioned beyond the specifications outlined below.

TYPE OF SEAT	STYLE	TYPE OF ADJUSTER	DEALER RELOCATION PROVISION
(A) Conventional and Strato Bench Seats - "B, C and E" Styles	Chev. "B" and Canadian Pontiac 75-76000 Series (less 4-Speed Trans. and Station Wagon), Olds. and Buick "E" and Cadillac 68247-69	Manual	1" Rearward *
	Chev. and Pont. "B" Station Wagon; Chev. "B" and Canadian Pontiac 75-76000 Series 4-Speed transmission	Manual	None
	Chev. "B" and Canadian Pontiac 75-76000 Series, Olds. and Buick "E" and Cad. "C, D and E" (less 68069-169)	Electric Six-Way	1" Rearward * Not recommended on "D" Body
	Pont. "B" (less Station Wagon and Canadian 75-76000 Series and Olds. and Buick "B and C")	Manual	1" Forward *
	Pontiac "B" (less Canadian-75-76000 Series) Olds. and Buick "B and C" and Cad. 68069-169	Electric Six-Way	1" Forward *
	Olds and Buick "C" and Cadillac 68069-169	Electric Two-Way	1" Forward *
	Buick "B and C"	Electric Four-Way	1" Forward *
	Buick "E"	Electric Four-Way	1" Rearward *
	Cadillac "C, D and E" (less 68247, 68269, 68069 and 68169)	Electric Two-Way	1" Rearward *
	(B) Bench Seats - "A, F, X, and Z" Styles	All "A"	Manual and Electric
Chev. and Pont. "F"		Manual	3/4" Forward **

TYPE OF SEAT	STYLE	TYPE OF ADJUSTER	DEALER RELOCATION PROVISION	
(B) Bench Seats "A, F, X, and Z" Styles (Cont'd.)	Chev. "X"	Manual	3/4" Rearward **	
	Chev. "Z"	Manual	None	
(C) Bucket Seats - All Styles	All "A"	Manual and Electric	None	
	Chev. and Pont. "F"	Manual	3/4" Forward **	
	Chev. "X and Z"	Manual	3/4" Rearward **	
	Chev. "B" and Canadian Pontiac 75-76000 Series and Buick and Olds. "E"	Manual	1" Forward *	
	Chev. "B" and Canadian Pontiac 75-76000 Series and Buick and Olds. and Cad. "E"	Electric Four-Way (Driver Only)	1" Rearward *	
	Pont. (less Canadian 75-76000 Series) and Olds "B", and Buick "B" and "C"	Manual and Electric Four-Way	1" Forward *	
	Buick "C"	Electric Two-Way	1" Forward *	
	Cadillac "E"	Electric Two-Way	1" Rearward *	
	(D) 60/40 Seat - "C" Styles	Buick and Olds. "C"	Manual (Passenger Only)	None
		Buick and Olds "C" and Cadillac 68069-169	Electric Two and Six-Way (Driver Only)	1" Forward *
Buick and Olds "C"		Electric Six-Way (Passenger Only)	None	
Cadillac 68347-49 & 67		Electric Two and Six-Way (Driver Only)	1" Rearward *	
Cadillac 68069-169		Manual and Electric Six-Way (Passenger Only)	1" Forward *	
Cadillac 68347-49 and 67		Manual and Electric Six-Way (Passenger Only)	1" Rearward *	

\*Adjustment provision to move seat assembly forward or rearward at floor pan attachment.

\*\*Adjustment provision to move seat assembly forward or rearward on seat adjuster. Remove seat assembly and screw from front or rear of adjuster upper channel. Install screw at front or rear of channel. Screw is a cross recess screw which is installed in the upper channel of both adjusters on full width seats and in the outer adjuster only on bucket seats. When screw is removed from one end of adjuster upper channel the screw MUST be installed in opposite end of channel.

**NOTE:** After repositioning screw in adjuster upper channel, check if adjuster locking lever engages in the last locking notch for the new adjusted position. If lower channel does not travel sufficiently to engage in the last locking notch, tap lower channel with a rubber or fibre mallet until locking lever engages in last notch.

floor pan or seat adjuster and seat frame, on some styles, to allow for proper clearances between the floor pan, floor tunnel and, if so equipped, to the center console when seat assembly is adjusted to full length of travel in each position. Refer below for specific spacer usage.

### SEAT ADJUSTER SPACER USAGE

Spacers are used between the seat adjuster and

**CAUTION:** Under NO circumstances should seats be repositioned (Spacers removed or installed) beyond the specifications outlined below:

TYPE OF SEAT	USAGE	STYLES	COMMENTS
(A) Conventional Bench Seat	.25 Thick on Floor Front and Rear	Olds "39487" (Elec. 6-way)	Removal by dealer not Recommended Due to Carpet Clearance Condition.
	.25 Thick on Floor Rear Only	Cad. 69723 Elec. 2-Way Elec. 6-Way	Removal by Dealer not Recommended Due to Lack of Seat Back Clearance to Auxiliary Seat.
	.25 Thick Between Front of Adjuster and Seat Frame	Pont. "B" Police Seat	Removal not Permissible
	.25 Thick Between Front of Adjuster and Seat Frame	Chev. "B" Taxi	Removal not Permissible Without Chev. Division Authorization.
	.50 Thick on Floor Front and Rear	Cad. "C" Elec. 2-Way	Removal by Dealer Permissible to Obtain Increased Headroom - Only if Equal Shims are Removed from Both Front and Rear.
(B) 60/40 Seat	.38 Thick on Floor Front and Rear Passenger Outer Adjuster Only	Olds "C" Buick "C" Elec. 6-Way	Removal by Dealer not Permissible.
(C) Bucket Seats	.25 Thick on Floor Front and Rear Driver Inner	Olds & Cad. "E" Elec. 4-Way	Removal by Dealer not Permissible.
	.25 Thick Between Adjuster and Seat Frame Front Mtg. Point	Pont. "F" Manual - Driver and Passenger Elec. 4-Way Driver	Removal by Dealer not recommended.
	.25 Thick on Floor Front and Rear Driver and Passenger Outer	Buick "E" Manual Elec. 4-Way	Removal by Dealer not Permissible. Required by Design.

### SEAT TORQUE SPECIFICATIONS

The following torque specifications should be used when servicing seat assemblies:

BOLT OR NUT LOCATION	TORQUE - FT. LBS.
1. Seat Adjuster-to-Floor Pan Bolts . . . . .	10
2. Seat Adjuster-to-Floor Pan Nuts . . . . .	10
3. Seat Adjuster-to-Seat Frame Bolts . . . . .	10
4. Seat Back Frame-to- Cushion Frame Bolts . . . . .	14 - 18
5. Seat Back Hinge Bolts . . . . .	14 - 16

### MANUALLY OPERATED SEAT ADJUSTER CONTROL ARM KNOB— All Styles with Manually Operated Seat Adjusters

Manually operated seat adjuster control arm knobs

are a press fit on the adjuster control arm. When replacing a manually operated left seat adjuster it will be necessary to remove the control arm knob from the old adjuster and install it on the new adjuster or install a new control arm knob.

**NOTE:** Control arm knobs can generally be removed and reinstalled several times without losing adequate retention.

#### Removal

Using a heavy body spoon, a long drift pin and a piece of wood as a fulcrum, as shown in Figure 15-1, carefully remove knob from adjuster control arm.

**NOTE:** Use Caution not to push drift pin down onto rocker panel sill plate.

#### Installation Equipment

The following equipment is required to install seat adjuster control knob.

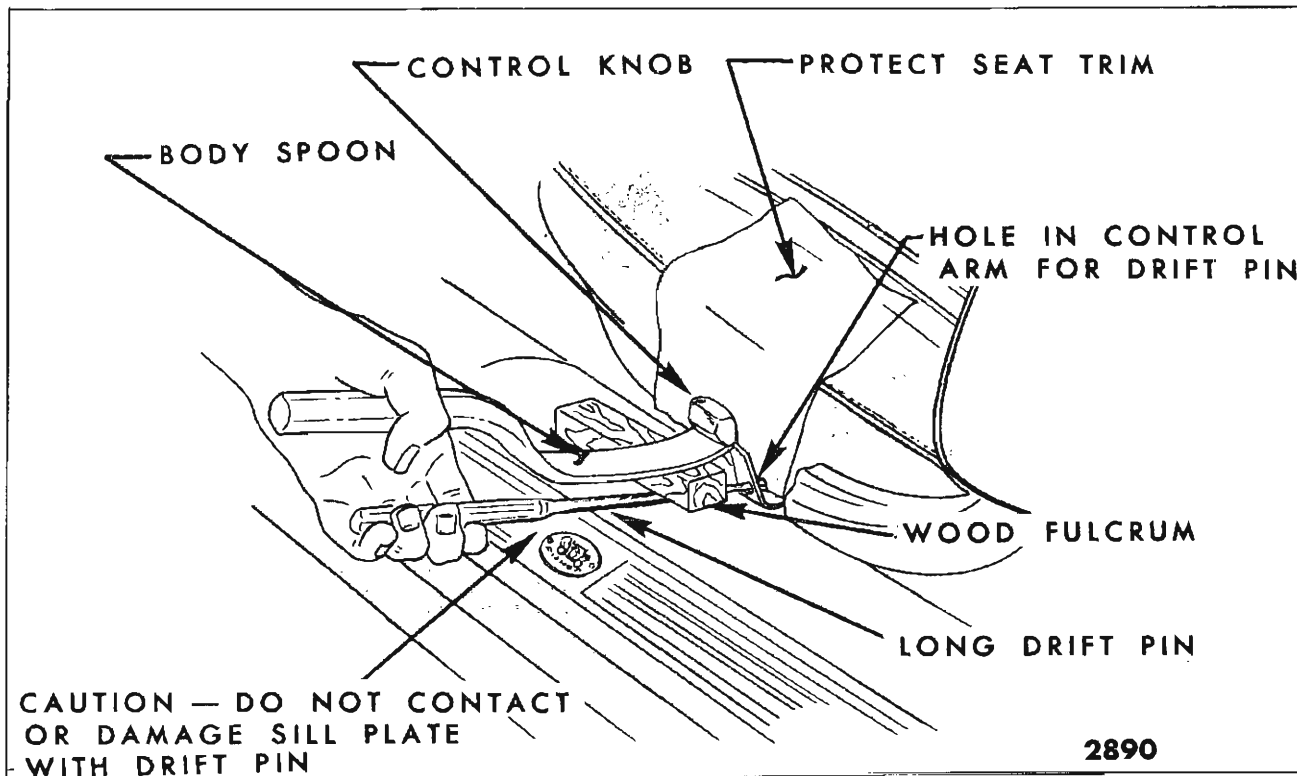

Fig. 15-1—Front Seat Adjuster Control Knob - Removal

1. One four inch "C" clamp.

**NOTE:** Swivel pad of "C" clamp should rotate freely. Where necessary add a drop or two of oil in swivel pad.

2. One round rubber plug (Part No. 4802102 or equivalent) to fit over "C" clamp swivel pad to help prevent swivel pad from slipping off control knob or damaging control knob.

3. One 1/8 inch diameter sheet metal screw approximately one inch long.

**NOTE:** Round off sharp point of screw to prevent possible damage to seat trim.

### Installation Procedure

1. a. Place pencil mark on seat adjuster control arm, one inch down from top edge of arm as a guide for determining when knob is fully installed.
- b. Place seat adjuster control knob in position on control arm and start knob on by hand pressure making certain knob is started on straight.
2. Insert sheet metal screw in hole provided in adjuster control arm and place "C" clamp in position as shown in Figure 15-2. Use round rubber plug (Part No. 4802102 or equivalent) over swivel pad of "C" clamp to prevent damage to knob and to prevent "C" clamp swivel pad from slipping off knob.
- c. Place protective cover over seat trim side facing.

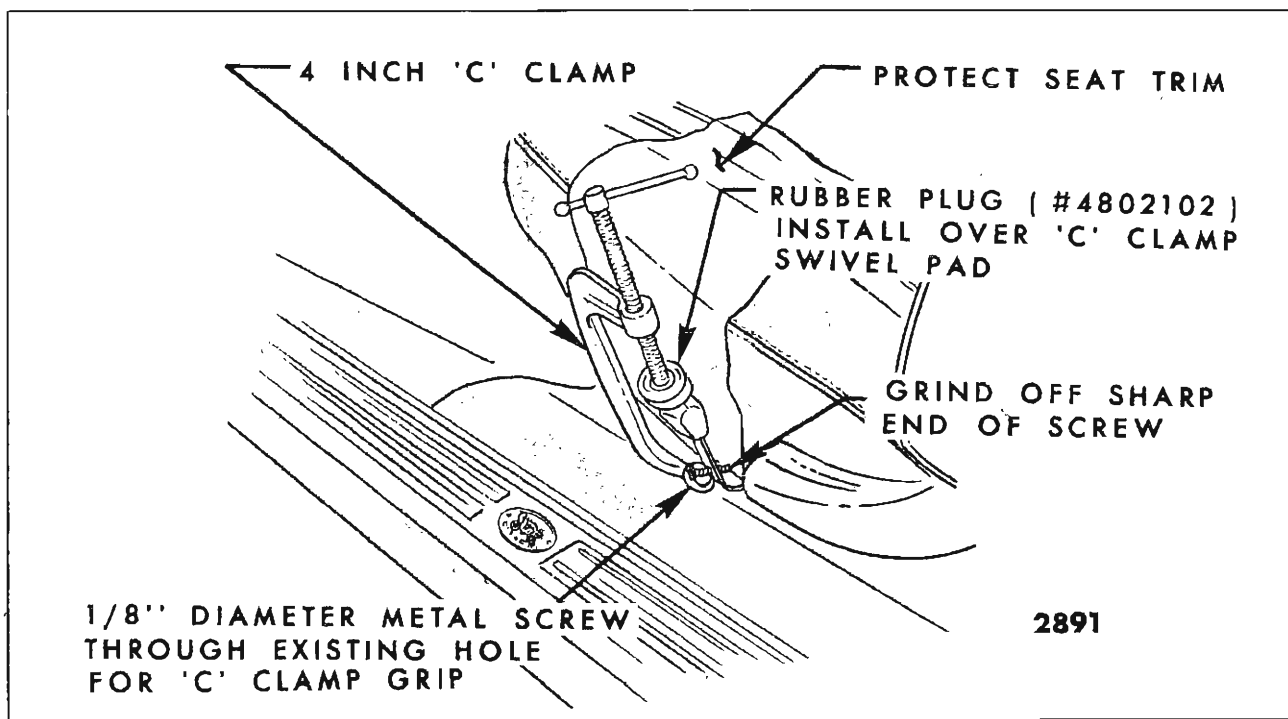

Fig. 15-2—Front Seat Adjuster Control Knob - Installation

3. Carefully press knob on control arm with "C" clamp until bottom edge of knob is down to mark (one inch below edge of arm).

## STANDARD FULL WIDTH AND 60-40 SEATS

### Description

All seat assemblies are secured to the floor pan by either nuts installed on floor pan anchor plate studs or bolts installed into anchor nuts in the floor pan (See Figures 15-3, 15-4, 15-6 and 15-7).

**NOTE:** All electrically operated seats have a ground wire secured to the seat frame and under

the seat adjuster rear attaching bolt or nut.

The new 60-40 seat, available on some Buick, Oldsmobile and Cadillac styles, consists of an individual passenger seat (60% of front seat width) and an individual driver seat (40% of front seat width).

**NOTE:** The 60-40 drivers power operated two-way seat incorporates seat adjusters which are similar to the Strato bucket power operated two-way seat adjusters - for service procedures refer to "Power Operated Horizontal Bucket Seat".

Power operated two-way seat adjusters are standard equipment on the drivers seat and manual seat

adjusters are standard on the passengers side. Six-way power operated seat adjusters are available as optional equipment on both drivers and passengers 60-40 seat.

### FRONT SEAT ASSEMBLY— Manually Operated—Full Width and 60-40 Passenger Seat

The full width manually operated seat assembly and 60-40 passenger seat incorporate manually operated seat adjusters to provide fore and aft movement of the seat. When the control lever is moved forward (rearward on "F" body styles and "Z" body styles with bucket seats), the seat adjusters unlock, permitting horizontal travel of the seat. When the seat is in the desired position and the locking lever is released the seat is locked.

### SEAT ASSEMBLY—Manually Operated Full Width and 60-40 Passenger Seat

#### Removal and Installation

1. Where the front inner seat belts go through the seat assembly, remove seat belt floor pan inner anchor plate attaching bolt.
2. Remove door sill plates and turn back floor mat or carpeting, where necessary, to expose

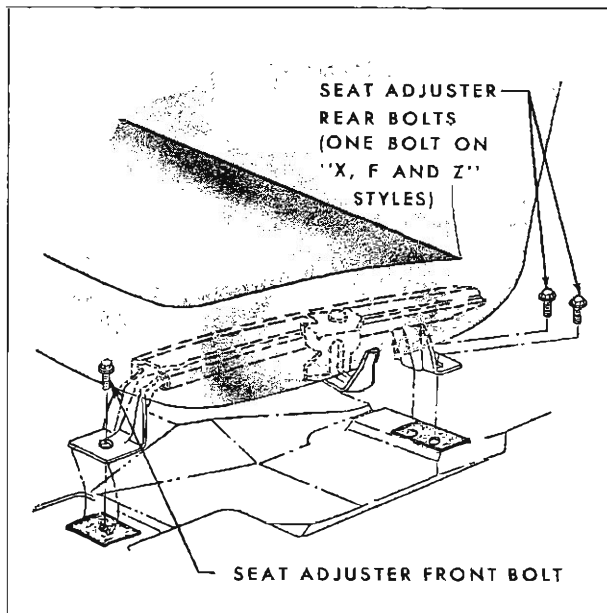

Fig. 15-3—Seat Adjuster Floor Pan Attachment - "A, F, X and Z" Body Full Width Seats

**NOTE:** For seat positioning on floor pan, spacer usage and torque specifications, see charts at beginning of Seat Section.

seat adjuster-to-floor pan attaching nuts or bolts.

3. Operate seat to full forward position.
4. At rear of adjusters, remove adjuster-to-floor pan rear attaching nuts or bolts (Figs. 15-3, 15-4 and 15-7).
5. Operate seat to full rearward position. Remove adjuster-to-floor pan front attaching bolts. On styles with seat back cigar lighter, tilt seat assembly rearward sufficiently to disconnect lighter feed wire. With air of a helper, remove seat assembly from body.
6. To install seat assembly, reverse removal procedure. Where seat adjuster-to-floor pan spacers were present, reinstall spacers in same position - See "Seat Adjuster Spacer Usage" at beginning of Seat Section. Check operation of seat assembly to full limits of travel.

### ADJUSTER ASSEMBLY—Manually Operated Full Width and 60-40 Passenger Seat

#### Removal and Installation

1. Remove front seat assembly with adjusters attached, as previously described, and place upside-down on a clean protected surface.
2. Remove seat adjuster assist spring from adjuster to be removed (Fig. 15-5).
3. Squeeze hooked end of seat adjuster locking wire together and slide retaining spring back over hump in locking wire and remove locking wire from adjuster.
4. Remove adjuster-to-seat bottom frame front and rear attaching bolts (Fig. 15-5) and remove seat adjuster from seat.
5. To install, reverse removal procedure. If left adjuster is being replaced, install new adjuster control knob as described under "Manually Operated Seat Adjuster Control Arm Knob".

**NOTE:** The right and left seat adjuster sliding mechanism should be in same relative position when attaching adjuster to seat bottom frame.

After installing adjuster to seat frame, check operation of adjusters. If adjusters do not lock or unlock satisfactorily when control handle on left

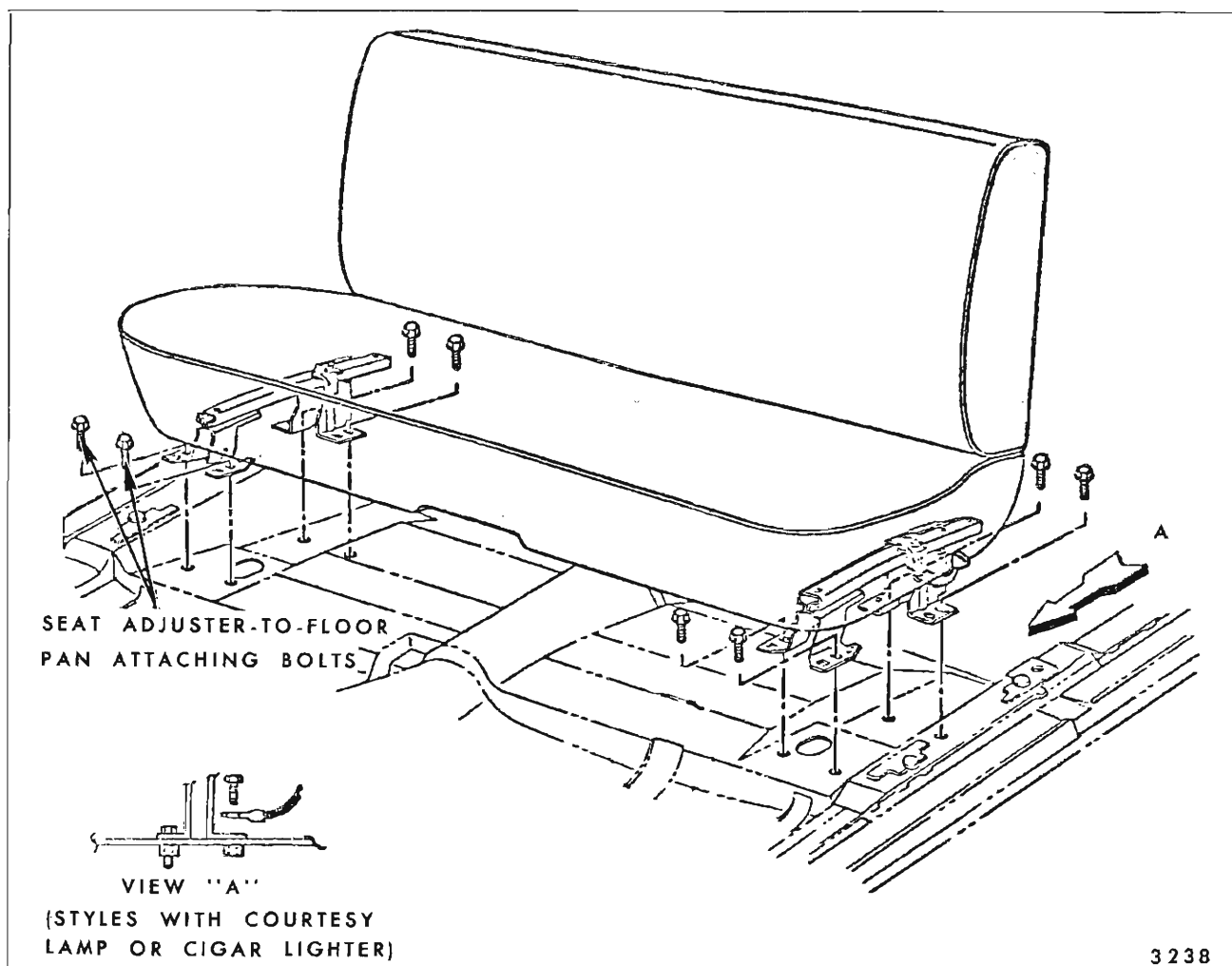

Fig. 15-4—Seat Adjuster Floor Pan Attachment (Standard Full Width Seats - Manual Adjusters)

NOTE: For seat positioning on floor pan, spacer usage and torque specifications, see charts at beginning of Seat Section.

adjuster is operated, disengage locking wire retainer from hole in seat bottom frame and engage retainer in one of adjacent holes to obtain proper tension in wire (Fig. 15-5).

### FRONT SEAT ASSEMBLY—Power Operated Two, Four or Six-Way Full Width and 60-40 Six-Way Seats

#### Description

The seat adjusters are actuated by a 12 volt, reversible, shunt wound motor with a built-in circuit breaker. The motor is energized by a toggle-type control switch installed in the left seat side panel or in the left door arm rest.

On four-way and six-way power operated seats the seat operating mechanism incorporates a transmission assembly which incorporates solenoids and drive cable to the seat adjusters. On the four-way seat one solenoid controls the horizontal movement of the seat while the second solenoid controls the vertical movement of the seat. On the six-way seat one solenoid controls the vertical movement of the front of the seat, the second solenoid controls the horizontal movement of the seat and the third solenoid controls the vertical movement of the rear of the seat. When the control switch is actuated, the motor and one of the solenoids are energized simultaneously. Then the solenoid plunger engages with the driving gear dog. The driving gear rotates the drive cables and operates both adjusters. When the adjusters reach their limit of travel, the drive cables stop their rotating action



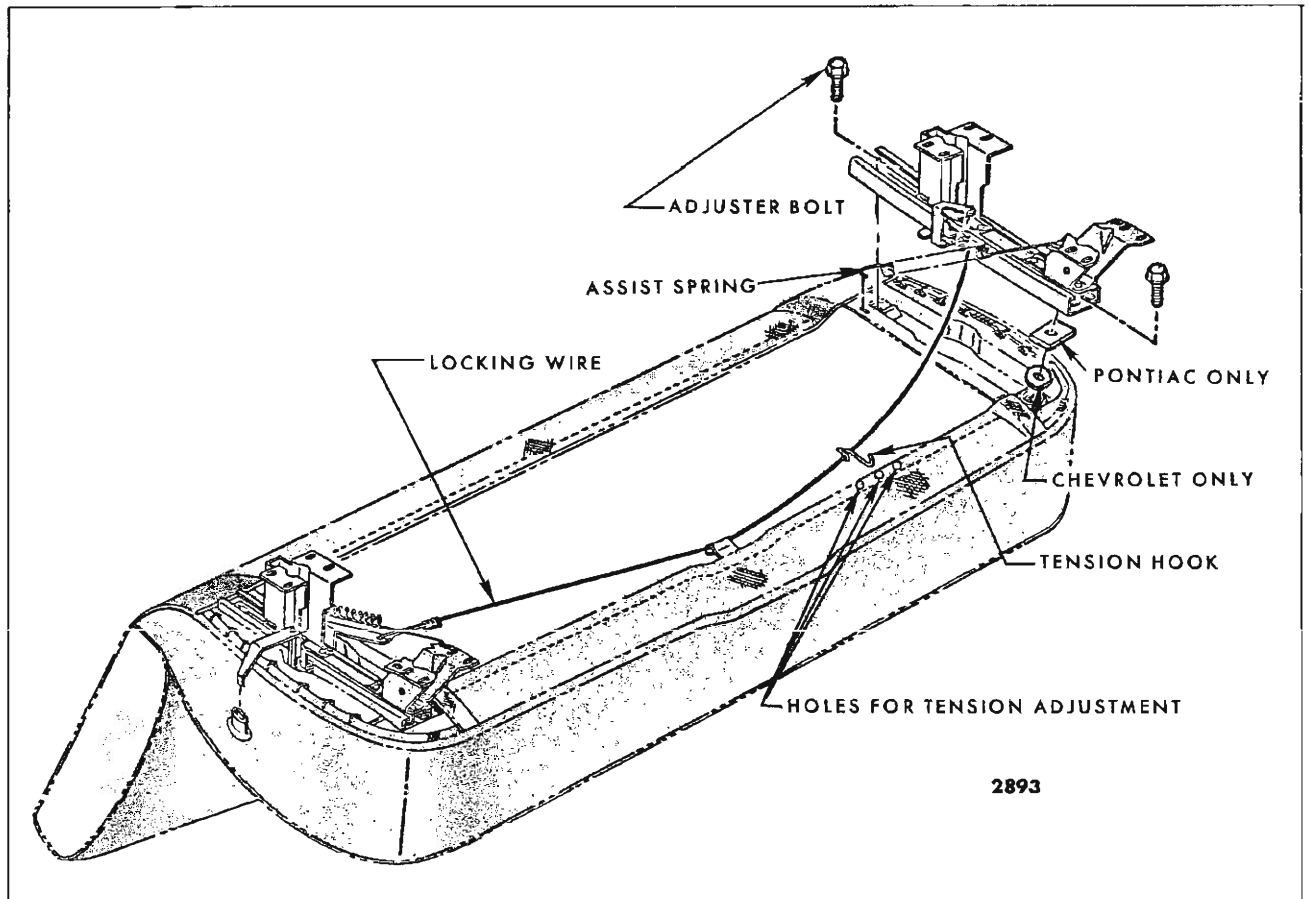

Fig. 15-5—Manual Seat Adjuster Installation - "B & C" Shown, "A, F, X & Z" Typical

NOTE: For seat positioning on floor pan, spacer usage and torque specifications, see charts at beginning of Seat Section.

and torque is absorbed by the rubber coupler connecting the motor and transmission. When the control switch is released, a return spring returns the solenoid plunger to its original position disengaging it from the driving gear dog.

### SEAT ASSEMBLY—Power Operated Two, Four or Six-Way Full Width and 60-40 Six-Way Seats

#### Removal and Installation

1. Operate seat to full forward position. On four-way or six-way power seats, operate seats to full up position.
2. Where front inner seat belts go through the seat assembly, remove seat belt floor pan inner anchor plate attaching bolt.
3. Where necessary, remove sill plates and turn back floor mat or carpeting to expose seat adjuster-to-floor pan attaching nuts or bolts.
4. Remove seat adjuster-to-floor pan rear attaching bolts (Figs. 15-6 and 15-7).
5. Operate seat to full rearward position. Remove adjuster-to-floor pan front attaching bolts. Tilt seat assembly rearward sufficiently to disconnect seat harness feed connector and detach harness from clip on floor pan. On styles with seat back cigar lighter, seat back courtesy lamps or seat back vanity lamp, disconnect electrical feed wire or wires. With aid of a helper remove seat assembly from body.
6. To install seat assembly, reverse removal procedure. Where seat adjuster-to-floor pan spacers were present reinstall spacers in same position - See "Seat Adjuster Spacer Usage" at beginning of Seat Section. Make sure

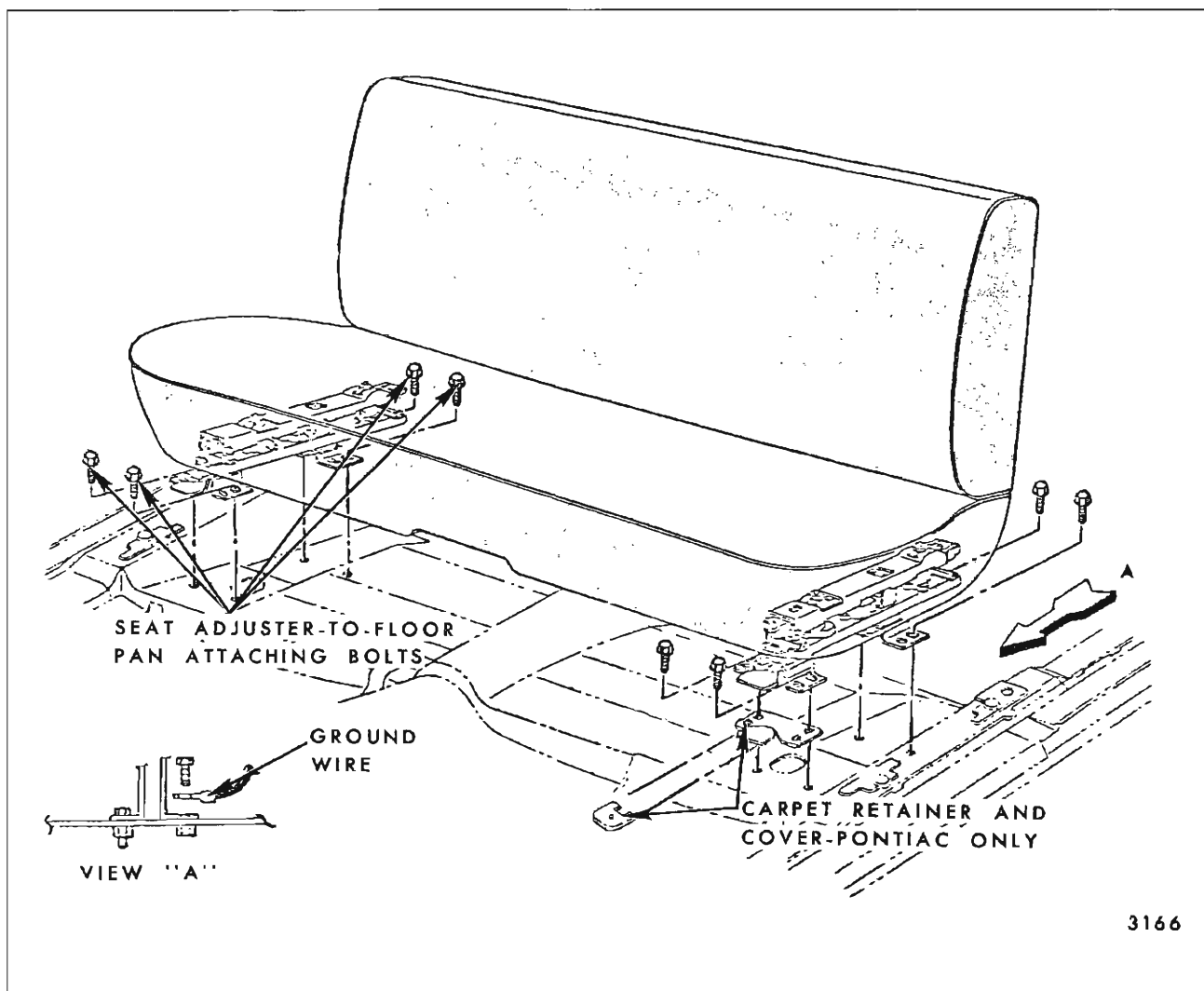

Fig. 15-6—Seat Adjuster Floor Pan Attachment - Full Width Standard Seats (Power Six-Way Shown - Two-Way and Four-Way Typical)

NOTE: For seat positioning on floor pan, spacer usage and torque specifications, see charts at beginning of Seat Section.

ground wire is securely attached under seat adjuster-to-floor pan rear attached bolt (See Figs. 15-6 and 15-7). Check for proper operation of seat adjusters to limits of travel.

**IMPORTANT:** When installing seat assembly in body, seat adjusters should be parallel and "in phase" with each other. In the event the adjusters are "out of phase" (this is, one adjuster reaches its maximum horizontal or vertical travel in a given direction before the other adjuster), proceed as follows:

a. Horizontal Travel - Operate seat control switch until one adjuster reaches full for-

ward position. Detach horizontal drive cable from adjuster which has reached full forward position. Operate seat forward until other adjuster reaches full forward position; then, connect horizontal drive cable and check horizontal travel of seat.

b. Front or Rear Vertical Travel - Operate seat control switch until one adjuster has reached fully raised position at both front and rear vertical travel limits. Disconnect both front and rear vertical drive cables from adjuster which has reached the fully raised position. Operate seat control switch until other adjuster reaches the fully raised

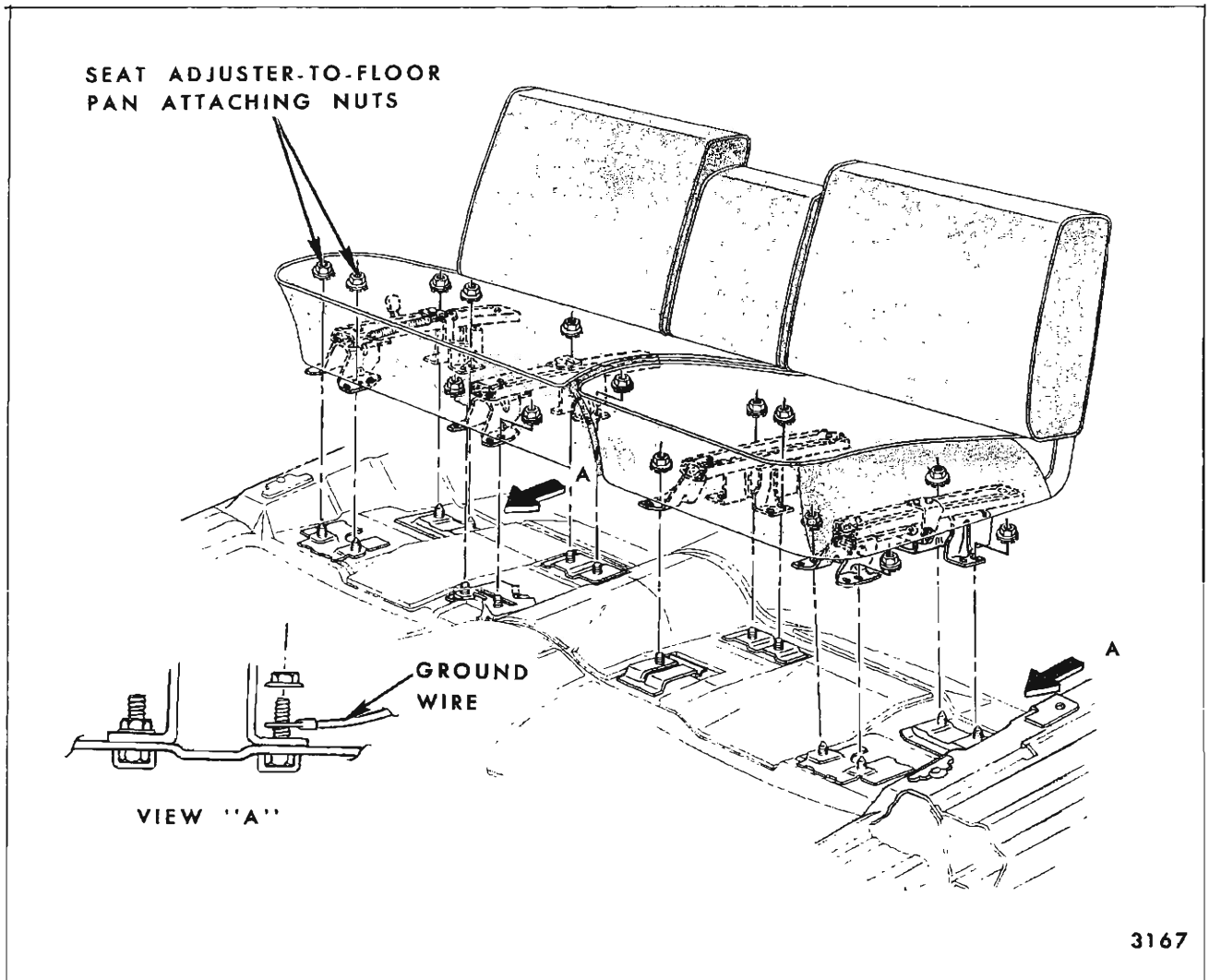

Fig. 15-7 60-40 Seat Adjuster Floor Pan Attachment - Cadillac, Buick and Oldsmobile

Adjusters: Driver—Two-Way Power Standard Passenger — Manual Standard Six-Way Power Option on Both Sides

position at both front and rear vertical travel limits; then, connect previously removed front and rear vertical drive cables. Check vertical travel by operating adjusters through one or two complete cycles. The above operation may be repeated on an "as required" basis if adjusters do not appear to be "in phase" after test cycle.

### ADJUSTER ASSEMBLY—Power Operated Two, Four or Six-Way Full Width Seat

#### Removal and Installation

1. Operate seat to a midway horizontal position;

NOTE: For seat positioning on floor pan, spacer usage and torque specifications, see charts at beginning of Seat Section.

on four-way and six-way seats also operate seat to fully raised position.

2. Remove front seat assembly with adjusters attached, as previously described, and place upside down on a clean protected surface.
3. Detach power drive cables from gear nuts of adjuster to be removed (Figs. 15-8, 15-9, 15-10 and 15-11).
4. Remove adjuster-to-seat bottom frame front and rear attaching bolts and remove adjuster from seat assembly (Figs. 15-8, 15-9, 15-10 and 15-11).

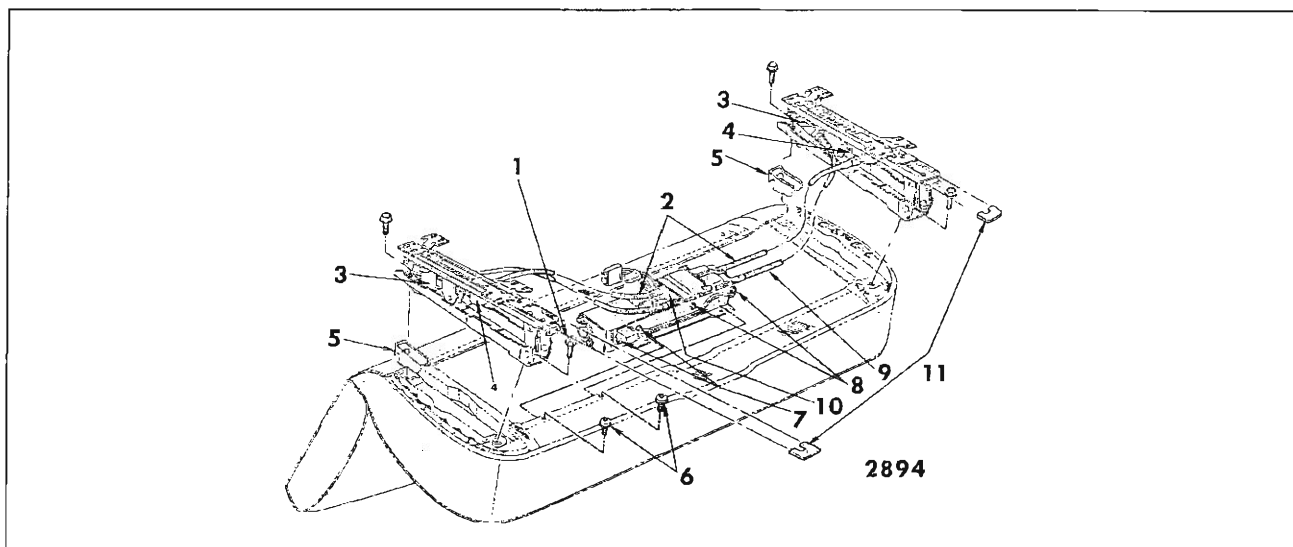

Fig. 15-8—Front Seat Assembly - Four-Way Tilt - Buick "B, C & E" Styles

- |                                     |  |                                  |
|-------------------------------------|--|----------------------------------|
| 1. Adjuster-to-Seat Attaching Bolts | 5. Track Cover                                     | 8. Transmission Attaching Screws |
| 2. Horizontal Cables - Black        | 6. Motor and Transmission Support Attaching Screws | 9. Rear Vertical Cables (Blue)   |
| 3. Vertical Gearnut                 | 7. Motor Attaching Screws                          | 10. Transmission End Plate       |
| 4. Horizontal Actuator              |  | 11. Carpet Retainers             |

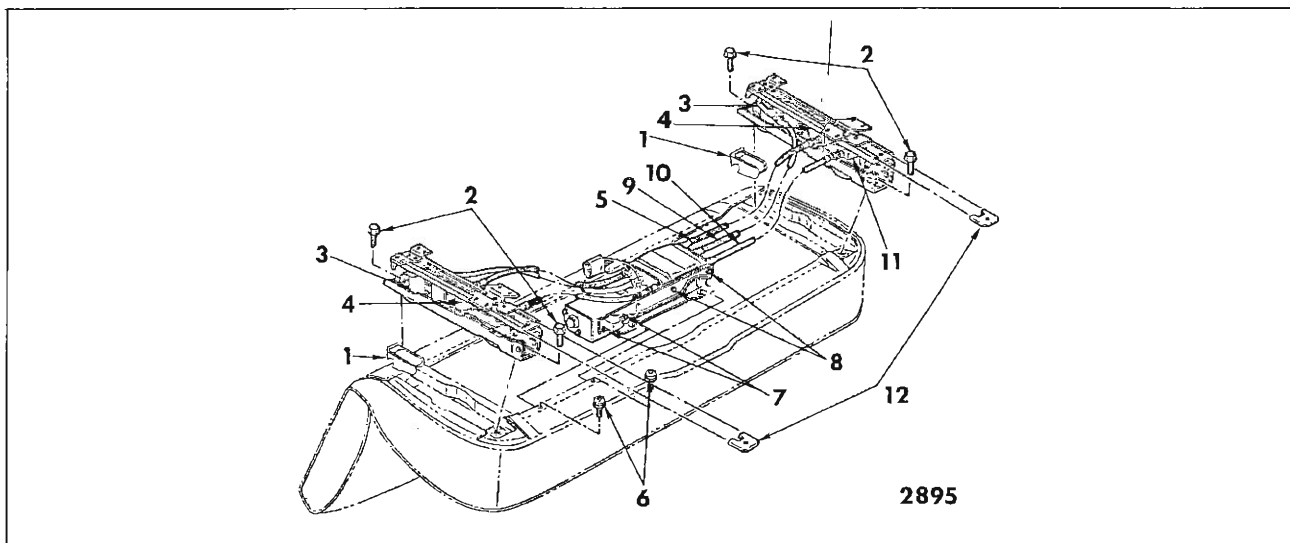

Fig. 15-9—Front Seat Assembly-Six-Way - "B & C" Full Width Seat

- |                                     |                                  |                                    |
|-------------------------------------|----------------------------------|------------------------------------|
| 1. Track Cover                      | 5. Horizontal Cables - Black     | 9. Rear Vertical Cables - Blue     |
| 2. Adjuster-to-Seat Attaching Bolts | 6. Motor and Transmission Screws | 10. Front Vertical Cables - Yellow |
| 3. Rear Vertical Gearnut            | 7. Motor Attaching Screws        | 11. Front Vertical Gearnut         |
| 4. Horizontal Actuator              | 8. Transmission Attaching Screws | 12. Carpet Retainers               |

5. To install seat adjuster assembly, reverse removal procedure. On seats with adjuster upper track covers, make sure track covers are installed between adjuster and seat frame (Figs. 15-8, 15-9, 15-10 and 15-11). Check operation

of seat adjusters and make sure adjusters are "in phase" before installing assembly into body (See Step 6 under "Front Seat Assembly - Removal and Installation").

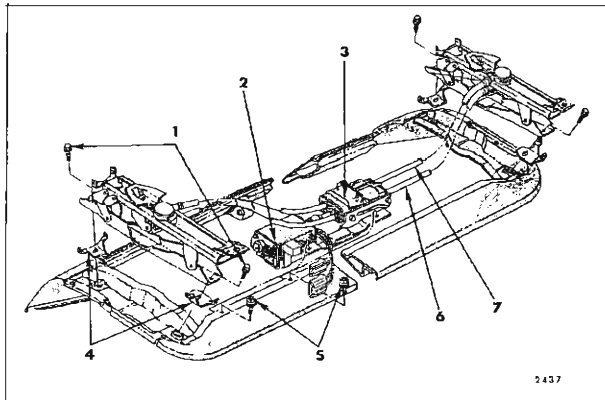

Fig. 15-10—Front Seat Adjuster, Motor and Transmission - "A" Styles - Four-Way Adjusters

- |   |  |
|---|--|
| 1. Adjuster to Seat Frame Attaching Bolts | 5. Motor and Transmission Support Attaching Screws |
| 2. Motor Assembly                         | 6. Vertical Cable (Yellow)                         |
| 3. Transmission Assembly                  | 7. Horizontal Cable (Black)                        |
| 4. Track Cover Supports                   |  |

NOTE: For seat positioning on floor pan, spacer usage and torque specifications, see charts at beginning of Seat Section.

## TWO-WAY SEAT ADJUSTER MAJOR COMPONENTS—"C" Body Full Width Seat

The following service procedures cover replacement of the major component parts of the power operated two-way seat adjusters used on "C" body full width seats or the drivers 60-40 seat.

### ELECTRIC MOTOR—"C" Body Full Width Seat

#### Removal and Installation

1. Remove front seat assembly as previously described and place upside down on a clean protected surface.
2. Disconnect both power drive cables from actuator motor (Fig. 15-10).
3. Remove screws that secure actuator motor support bracket to seat bottom frame and remove actuator motor with attached support bracket from seat assembly (Fig. 15-10).
4. Disconnect feed wire harness from actuator motor.
5. Remove screws securing motor to motor support bracket.

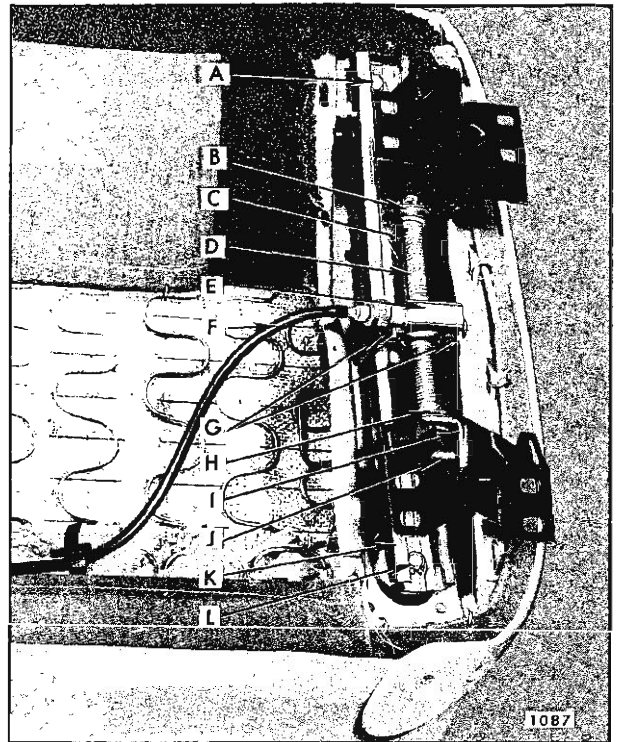

Fig. 15-11—Horizontal Power Adjuster - "C & E" Styles

- |                            |                            |
|----------------------------|----------------------------|
| a. Adjuster Attaching Bolt | g. Shoulder Bolts          |
| b. Rear Stop               | h. Front Stop              |
| c. Adjuster Lower Channel  | i. Stop Bracket            |
| d. Gearnut                 | j. Cross-Pin               |
| e. Jackscrew               | k. Adjuster Upper Channel  |
| f. Drive Cable             | l. Adjuster Attaching Bolt |

NOTE: For seat positioning on floor pan, spacer usage and torque specifications, see charts at beginning of Seat Section.

6. To install, reverse removal procedure. Check for proper seat operation to extreme limits of travel.

### HORIZONTAL GEARNUIT ASSEMBLY—"C" Body Full Width Seat

#### Removal and Installation

1. Remove front seat assembly with adjusters attached and place upside down on a clean, protected surface.
2. Detach power drive cable from gearnut to be removed.
3. Using a "clutch" type screwdriver or other suitable tool, remove two shoulder bolts se-

- curing gearnut to upper slide portion of seat adjuster (Fig. 15-11).
4. Rotate jackscrew assembly upward sufficiently to gain access to cotter pin at rear of jackscrew assembly.
  5. Remove cotter pin, washer and rubber bumper from rear end of jackscrew; then, remove gearnut from jackscrew.
  6. To install, reverse removal procedure. Prior to installing seat assembly in body, be sure adjusters are "in phase". See Step 6 under "Front Seat Assembly - Removal and Installation".
2. Using a suitable tool (preferably a "clutch" type screwdriver), remove two shoulder bolts securing gearnut to upper channel to seat adjuster assembly (Fig. 15-11).
  3. Slide lower track and support base portion of seat adjuster, with attached jackscrew and gearnut, forward until it disengages from upper channel assembly. The four plastic slides may now be disengaged from positioning slots on lower track.
  4. To install, reverse removal procedure making sure that groove in plastic slide slips onto lower track with thinner section of slide protruding above surface of track.

## **HORIZONTAL JACKSCREW— "C" Body Full Width Seat**

### **Removal and Installation**

1. Remove front seat assembly with adjusters attached and place upside down on a clean, protected surface.
2. Detach power drive cable from gearnut and jackscrew assembly to be removed.
3. Using a suitable tool (preferably a "clutch" type screwdriver) remove two shoulder bolts securing gearnut to upper slide portion of seat adjuster assembly (Fig. 15-11).
4. Remove retainer that secures stop bracket crosspin to adjuster front pedestal and remove crosspin (Fig. 15-11).
5. Remove jackscrew assembly from seat adjuster.
6. To install, reverse removal procedure.

**NOTE:** When replacing jackscrew assembly with new part, remove nut, washers, rubber bumper and stop bracket with inserted rubber grommet from front end of jackscrew, as well as gearnut and washers, rubber bumper and cotter pin from rear end of jackscrew and transfer to new jackscrew assembly.

## **PLASTIC SLIDES— "C" Body Full Width Seat**

### **Removal and Installation**

1. Remove front seat adjuster to be serviced from front seat assembly. (See: Front Seat Adjuster - Two-Way Electric - Removal and Installation procedures.)

## **FOUR-WAY SEAT ADJUSTER MAJOR COMPONENTS—"A" Body Full Width Seats**

The following service procedures cover replacement of the major component parts of the power operated four-way seat adjusters used on the "A" Body full width seats.

### **ELECTRIC MOTOR—"A" Body**

#### **Removal and Installation**

1. Remove front seat assembly as previously described and place upside down on a clean protected surface.
2. Disconnect wire harness from motor relay assembly.
3. Remove screws securing motor and transmission support to seat bottom frame (See Fig. 15-10).
4. Remove motor-to-motor support attaching screws and remove motor assembly from support.
5. To install, reverse removal procedure making sure rubber coupler is properly engaged at both motor and transmission ends. Check operation of seat to full limits of travel.

## **VERTICAL GEARNUT—"A" Body**

### **Removal and Installation**

1. Operate seat assembly to fully raised and mid-way horizontal position.
2. Remove front seat assembly from body as previously described and place upside down on a clean protected surface.

3. Detach vertical gearnut drive cable from other adjuster.
4. Using a clutch type screwdriver or other suitable tool, remove shoulder screws securing linkage to vertical gearnut being replaced (Fig. 15-12).

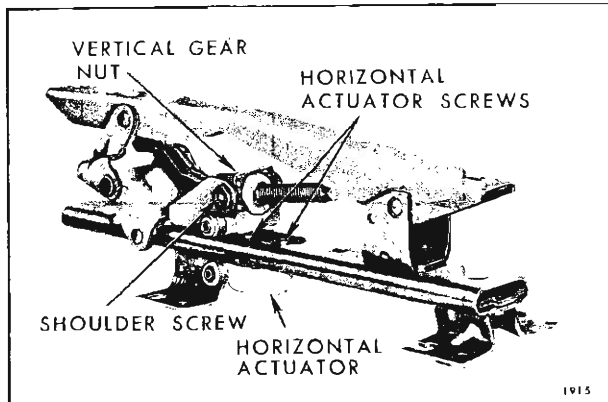

Fig. 15-12—Four-Way Seat Adjuster - "A" Styles

5. If right adjuster gearnut is being replaced, at front of jackscrew, remove double nut that acts as a jackscrew "down" stop.
6. Using a portable power source to energize the motor, actuate vertical gearnut until gearnut is disengaged from jackscrew.

**NOTE:** It may be necessary to manually raise or lower upper rear portion of adjuster to gain clearance for removal of gearnut.

7. Disconnect drive cable from gearnut.
8. To install, reverse removal procedure.

**NOTE:** Check operation of seat adjusters and make sure adjusters are "in phase". See Step 6 under "Front Seat Assembly - Removal and Installation".

## HORIZONTAL ACTUATOR—"A" Body

### Removal and Installation

1. Remove adjuster vertical gearnut as previously described.
2. Disconnect drive cable from horizontal actuator.
3. Remove screws securing horizontal actuator assembly to adjuster lower track; then remove actuator from adjuster assembly (Fig. 15-12).
4. To install, reverse removal procedure.

**NOTE:** When installing horizontal actuator, adjust actuator so that drive gear is fully engaged with teeth on lower channel. When horizontal actuator attaching screws are tightened, there should be no free motion between upper and lower channels. Readjust actuator "as required" until all free motion between channels has been removed. Check operation of seat adjusters and make sure adjusters are "in phase". See Step 6 under "Front Seat Assembly - Removal and Installation".

## JACKSCREW—"A" Body

### Removal and Installation

1. Remove adjuster vertical gearnut as previously described.
2. Remove seat adjuster-to-seat bottom frame front and rear attaching bolts on side affected (Fig. 15-10).
3. As a bench operation, remove jackscrew-to-adjuster linkage attaching rivet and remove jackscrew from adjuster assembly (Fig. 15-13).

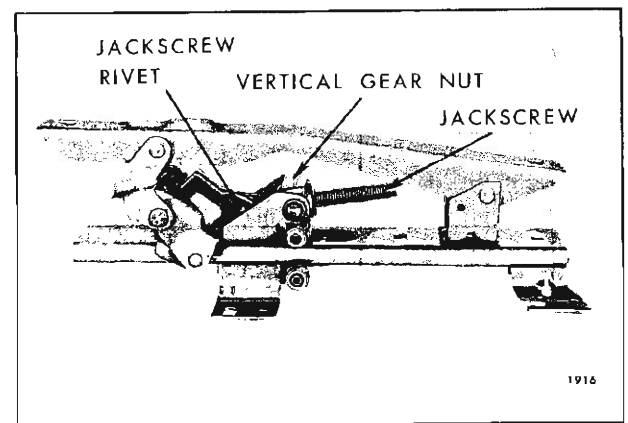

Fig. 15-13—Four-Way Seat Adjuster - "A" Styles

4. To install, reverse removal procedure. Check operation of seat adjusters and make sure adjusters are "in phase". See Step 6 under "Front Seat Assembly - Removal and Installation".

## HORIZONTAL AND VERTICAL DRIVE CABLES—"A" Body

### Removal and Installation

1. Remove front seat assembly from body with attached adjusters, motor and transmission and place upside down on a clean protected surface.

2. Detach both horizontal and vertical cables from seat adjuster.
  3. Remove screws securing horizontal and vertical cable end plate on side of transmission from which cables are being removed and remove cables from seat assembly (Fig. 15-8).
  4. Disengage cable to be replaced from end plate.
  5. To install cables, reverse removal procedure. Check operation of seat to full limits of travel.
3. Remove screws securing horizontal and vertical cable end plate on both sides of transmission and detach cables from transmission.
  4. Remove transmission-to-support attaching bolts; then, disengage transmission from rubber coupler and remove transmission from seat assembly.
  5. To install, reverse removal procedure.

## TRANSMISSION—"A" Body

### Removal and Installation

1. Remove front seat assembly from body with attached adjusters, motor and transmission and place upside down on a clean protected surface.
2. Disconnect wire harness connector from transmission.

## DISASSEMBLY AND ASSEMBLY OF TRANSMISSION

1. Remove front seat adjuster transmission from seat assembly.
2. Remove screws securing gear and solenoid housings together; then, carefully separate housings and remove component parts of transmission assembly (Fig. 15-14).

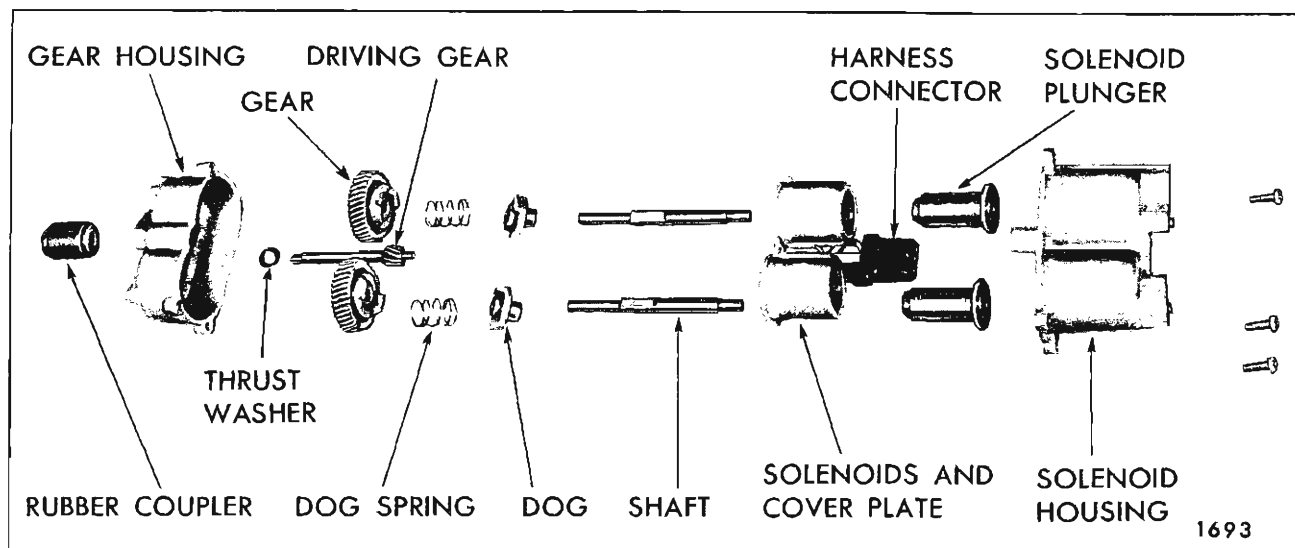

Fig. 15-14—Four-Way Seat Adjuster Transmission

3. To assemble transmission, reverse removal procedure.

**IMPORTANT:** Prior to or during installation, lubricate frictional surfaces of driving gear thrust washer, gears, dog washers, shaft and solenoid plungers with "Lubriplate" (630AAW) or equivalent.

## FOUR-WAY SEAT ADJUSTER MAJOR COMPONENTS—Buick "B-C&E" Full Width Four-Way Power Seat

The following service procedures cover replace-

ment of the major component parts of the power operated four-way seat adjusters used on the Buick "B-C & E" body full width seats.

## ELECTRIC MOTOR—Buick "B-C&E" Body

### Removal and Installation

1. Remove front seat assembly, and place upside down on a clean protected surface.
2. Disconnect wire harness from motor relay assembly.



3. Remove screws securing motor and transmission support to seat bottom frame (Fig. 15-15).

4. Remove motor-to-support attaching screws and remove motor assembly from support.

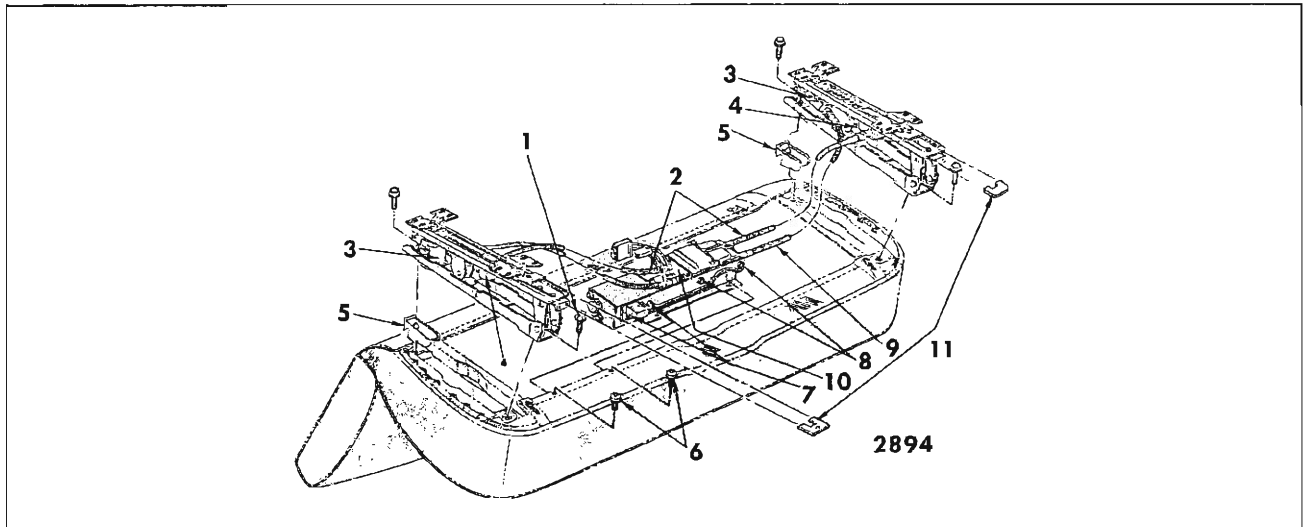

Fig. 15-15—Front Seat Assembly - Four-Way Tilt - Buick "B, C & E" Styles

1. Adjuster-to-Seat Attaching Bolts  
 2. Horizontal Cables - Black  
 3. Vertical Gearnut  
 4. Horizontal Actuator

5. Track Cover  
 6. Motor and Transmission Support  
 Attaching Screws  
 7. Motor Attaching Screws

8. Transmission Attaching Screws  
 9. Rear Vertical Cables (Blue)  
 10. Transmission End Plate  
 11. Carpet Retainers

5. To install, reverse removal procedure making sure rubber coupler is properly engaged at both motor and transmission ends. Check that seat harness is properly secured to seat. Check operation of seat to full limits of travel.

### VERTICAL GEARNUT—Buick "B-C&E" Body

#### Removal and Installation

1. Operate seat to full rearward position; then, remove front seat assembly from body and remove seat adjuster from seat.
2. Remove vertical gearnut attaching nut and gearnut tension spring (Fig. 15-16).
3. Lay adjuster on its side and remove screws securing vertical gearnut to adjuster lower track; then, remove gearnut from adjuster (Fig. 15-16).

**NOTE:** If seat was not in rearward position when removed from car it may be necessary to manually operate the horizontal actuator to gain access to vertical gearnut attaching screws on bottom of lower channel.

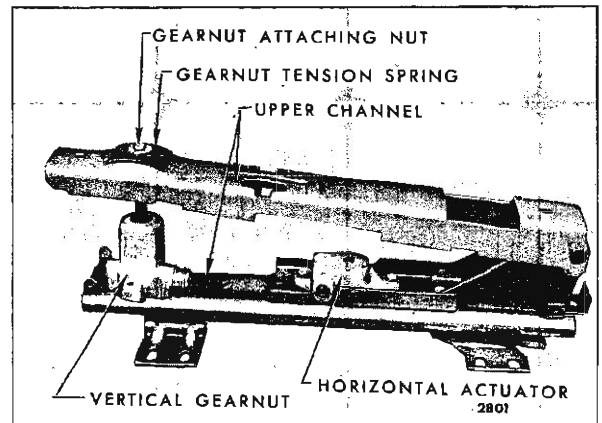

Fig. 15-16—Four-Way Seat Adjuster - Buick "B, C & E" Styles

4. To install, reverse removal procedure.

**NOTE:** Check operation of seat adjusters and make sure adjusters are "in phase". See step 6 under "Front Seat Assembly - Removal and Installation".

## HORIZONTAL ACTUATOR— Buick “B-C&E” Body

### Removal and Installation

1. Remove front seat assembly from body and remove adjuster (from which horizontal actuator is being removed) from seat.
2. Remove vertical gearnut attaching nut and gearnut tension spring.
3. Raise upper portion of upper channel. Remove screws securing horizontal actuator assembly to adjuster lower track; then, remove actuator from adjuster assembly (Fig. 15-17).

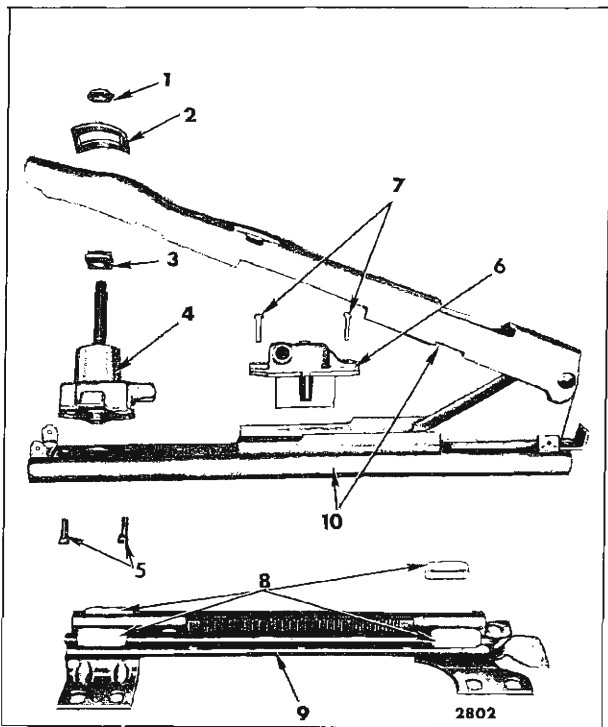

Fig. 15-17—Four-Way Seat Adjuster Components - Buick “B, C & E” Styles

- |   |   |
|---|---|
| 1. Upper Channel to Gearnut Attaching Nut | 5. Vertical Gearnut Attaching Screws    |
| 2. Vertical Gearnut Tension Spring        | 6. Horizontal Actuator                  |
| 3. Vertical Gearnut Shoulder Nuts         | 7. Horizontal Actuator Attaching Screws |
| 4. Vertical Gearnut                       | 8. Plastic Shoes                        |
|   | 9. Lower Channel                        |
|   | 10. Upper Channel                       |

**NOTE:** It may be necessary to manually actuate the horizontal actuator to gain access to attaching screws.

4. To install, reverse removal procedure. Make

sure horizontal actuator is properly adjusted (Fig. 15-16 and 15-17), so that drive gear is fully engaged with teeth on lower channel.

**NOTE:** When horizontal actuator attaching screws are tightened, there should be no free motion between upper and lower channels. Re-adjust actuator “as required” until all free motion between channels has been removed. Check operation of seat adjusters and make sure adjusters are “in phase”. See Step 6 under “Front Seat Assembly - Removal and Installation”.

## HORIZONTAL AND VERTICAL DRIVE CABLES—Buick “B-C&E” BODY

### Removal and Installation

1. Remove front seat assembly, as previously described, and place upside down on a clean protected surface.
2. Detach both horizontal and vertical cables from seat adjuster (See Fig. 15-8).
3. Remove screws securing horizontal and vertical cable end plate on side of transmission from which cables are being removed and remove cables from seat assembly.
4. Disengage cable to be replaced from end plate.
5. To install cables, reverse removal procedure. Check operation of seat to full limits of travel.

## TRANSMISSION—Buick “B-C&E” Body

### Removal and Installation

1. Remove front seat assembly from body and place upside down on a clean protected surface.
2. Disconnect wire harness connector from transmission.
3. Remove screws securing horizontal and vertical cable end plate on both sides of transmission and detach cables from transmission.
4. Remove transmission to support attaching bolts (Fig. 15-8); then, disengage transmission from rubber coupler and remove transmission from seat assembly.
5. To install, reverse removal procedure.

## DISASSEMBLY AND ASSEMBLY OF TRANSMISSION

1. Remove front seat adjuster transmission from seat assembly.

2. Remove screws securing gear and solenoid housings together; then, carefully separate housings and remove component parts of transmission assembly (Fig. 15-14).
3. To assemble transmission, reverse removal procedure.

**IMPORTANT:** Prior to or during installation, lubricate frictional surfaces of driving gear thrust washer, gears, dog washers, shaft and solenoid plungers with "Lubriplate" (630 AAW) or equivalent.

### SIX-WAY SEAT ADJUSTER MAJOR COMPONENTS—"B-C&E" Body Full Width Seats

The following service procedures cover replacement of the major component parts of the power operated six-way seat adjusters used on the "B, C & E" Body full width seats:

#### ELECTRIC MOTOR—"B-C & E" Body Full Width Seats

##### Removal and Installation

1. Remove front seat assembly, as previously described, and place upside down on a clean protected surface.
2. Disconnect motor feed wires from motor control relay.
3. Remove motor and transmission support-to-seat frame attaching bolts (Fig. 15-20).
4. Remove motor-to-support attaching bolts; then, move motor assembly outboard (away from transmission) sufficiently to disengage motor from rubber coupling.
5. To install, reverse removal procedure making sure rubber coupling is properly engaged at both motor and transmission. Check that seat harness is properly secured to seat. Check operation of seat to full limits of travel.

#### HORIZONTAL ACTUATOR—"B-C & E" Body Full Width Seats

##### Removal and Installation

1. Remove seat assembly from body, as previously described and place upside down on a clean protected surface.
2. Detach three power drive cables from adjuster to be removed.

3. Remove screws securing seat adjuster to seat bottom frame and remove adjuster from seat assembly.
4. At top of adjuster remove front and rear vertical gearnut attaching nuts and tension springs (Fig. 15-18).

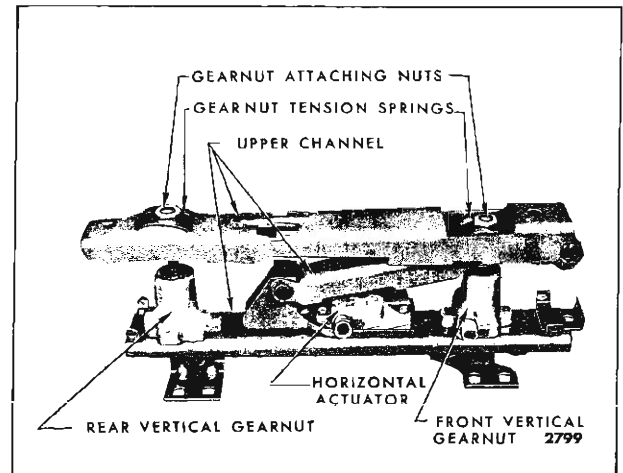

Fig. 15-18—Six-Way Seat Adjuster - "B, C & E" Styles

5. Lift front of adjuster upper channel upward; then remove screws securing horizontal actuator to adjuster upper channel assembly (Fig. 15-18) and remove actuator from adjuster.
6. To install, reverse removal procedure. When installing horizontal actuator, be sure actuator drive gear is fully engaged with teeth on lower channel. With actuator attaching screws tight, there should be no free motion between upper and lower adjusting channels. Re-adjust actuator "as required" until all free motion between channels has been removed. Be sure seat adjusters are "in phase", before installing seat assembly into body (See Step 6 under "Front Seat Assembly - Removal and Installation").

#### FRONT VERTICAL GEARNUT—"B-C & E" Body Full Width Seats

##### Removal and Installation

1. Operate seat to full forward position.
2. Remove front seat assembly from body as previously described and place upside down on a clean protected surface.
3. Detach three power drive cables from adjuster to be removed.
4. Remove screws securing seat adjuster to seat

bottom frame and remove adjuster from seat assembly.

- At top of adjuster, remove both vertical gearnut attaching nuts and tension springs (Fig. 15-19).

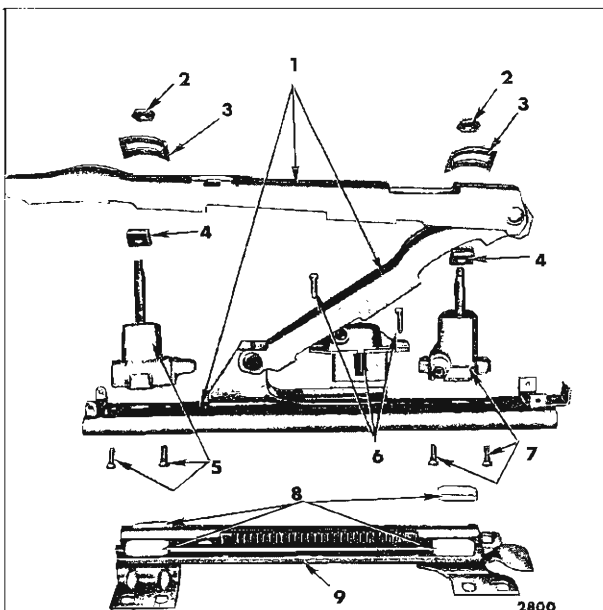

Fig. 15-19—Six-Way Seat Adjuster Components - "B, C & E" Styles

- |   |  |
|---|--|
| 1. Upper Channel Assembly                     | 6. Horizontal Actuator and Attaching Screws    |
| 2. Upper Channel to Gearnut Attaching Bolts   | 7. Front Vertical Gearnut and Attaching Screws |
| 3. Gearnut Tension Springs                    | 8. Plastic Shoes                               |
| 4. Gearnut Shoulder Nuts                      | 9. Lower Channel                               |
| 5. Rear Vertical Gearnut and Attaching Screws |  |

- Lay adjuster on its side and remove front vertical gearnut attaching screws (Fig. 15-19); then, remove gearnut from adjuster.

**NOTE:** If seat was not in forward position when removed from car, it may be necessary to manually operate the horizontal actuator to gain access to vertical gearnut attaching screws on bottom of lower channel.

- If front vertical gearnut is being replaced with a new part, transfer gearnut shoulder nut and tension spring to new gearnut assembly (Fig. 15-19).
- To install, reverse removal procedure. Be sure adjusters are "in phase" before installing seat assembly into body (See Step 6 under "Front Seat Assembly - Removal and Installation").

## LOWER OR UPPER CHANNEL AND PLASTIC SLIDES—"B-C & E" Body Full Width Seats

### Removal and Installation

- Remove seat assembly from body and place upside down on a clean protected surface.
- Detach three power drive cables from adjuster to be removed.
- Remove screws securing seat adjuster to seat bottom frame and remove adjuster from seat assembly.
- At top of adjuster, remove both vertical gearnut attaching nuts and tension springs (Fig. 15-18). Lift front of adjuster upper channel upward; then, remove horizontal actuator attaching screws (Fig. 15-19) and remove horizontal actuator from adjuster.
- Slide lower channel until it is completely disengaged from upper channel. Plastic slides may be removed from lower channel.
- To install upper and lower channel, reverse removal procedure.
  - If replacing lower channel, transfer vertical slides to new lower channel.
  - If replacing upper channel, transfer vertical gearnuts to new upper channel.

**NOTE:** Make sure horizontal gear of lower channel and sliding surface of upper channel are properly lubricated with "Lubriplate" (630 AAW) or equivalent.

Make sure adjusters are "in phase" prior to installing seat assembly into body (See Step 6 under "Front Seat Assembly - Removal and Installation").

Check operation of seat to limits of both horizontal and vertical travel.

## HORIZONTAL AND VERTICAL DRIVE CABLES—"B-C & E" Body Full Width Seats

### Removal and Installation

- Remove front seat assembly from body with attached adjusters, motor and transmission and place upside down on a clean protected surface.
- Detach both horizontal and vertical cables from seat adjuster.
- Remove screws securing horizontal and vertical cable end plate on side of transmission from which cables are being removed (Fig. 15-20) and remove cables from seat assembly; then, disengage cables from end plate.

- To install horizontal and vertical cables, reverse removal procedure. Make sure colored drive cables are installed to proper gearnuts

and horizontal actuator as shown in Figure 15-20).

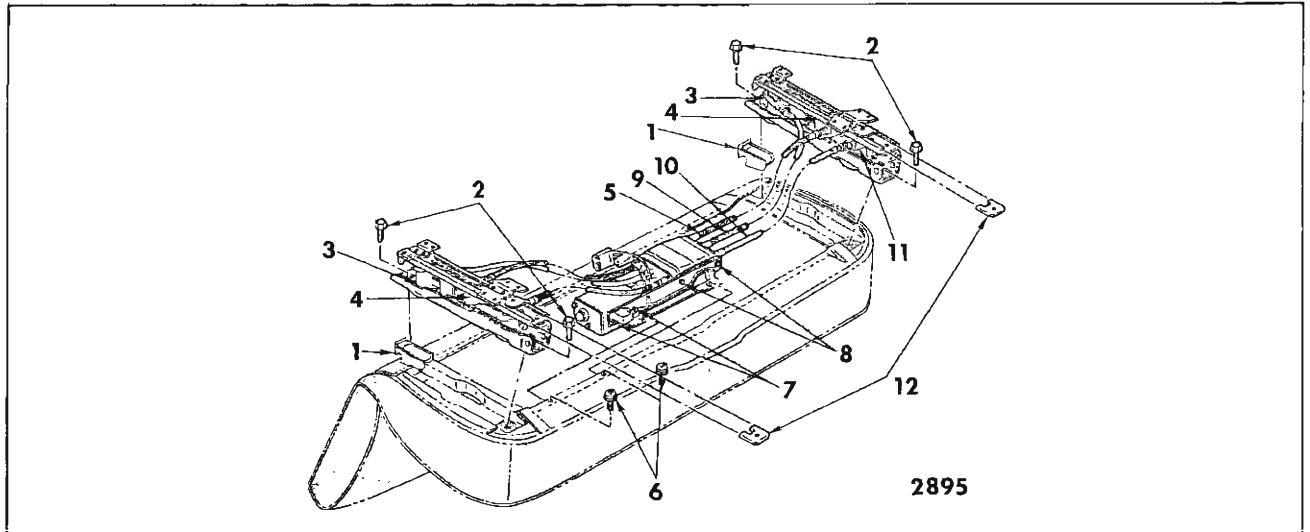

Fig. 15-20—Front Seat Assembly—Six-Way - "B & C" Full Width Seat

- |                                     |                                  |                                    |
|-------------------------------------|----------------------------------|------------------------------------|
| 1. Track Cover                      | 5. Horizontal Cables - Black     | 9. Rear Vertical Cables - Blue     |
| 2. Adjuster-to-Seat Attaching Bolts | 6. Motor and Transmission Screws | 10. Front Vertical Cables - Yellow |
| 3. Rear Vertical Gearnut            | 7. Motor Attaching Screws        | 11. Front Vertical Gearnut         |
| 4. Horizontal Actuator              | 8. Transmission Attaching Screws | 12. Carpet Retainers               |

## TRANSMISSION—"B-C&E" Body Full Width Seats

### Removal and Installation

- Remove front seat assembly from body with attached adjusters, motor and transmission and place upside down on a clean protected surface.
- Disconnect wire harness connector from transmission.
- Remove screws securing horizontal and vertical cable end plate on both sides of transmission and detach cables from transmission (Fig. 15-20).
- Remove transmission to support attaching bolts (Fig. 15-20); then, disengage transmission from motor drive coupling and remove transmission from seat assembly.
- To install, reverse removal procedure. Make sure seat wiring harness is properly secured to seat.

## DISASSEMBLY AND ASSEMBLY OF TRANSMISSION

- Remove front seat adjuster transmission from seat assembly.

- Remove screws securing rear gear housing to the solenoid housing; then, carefully separate housings and remove component parts of transmission assembly (Fig. 15-21).

- To assemble transmission, reverse removal procedure.

**IMPORTANT:** Prior to or during installation, lubricate frictional surfaces of driving gear; thrust washer, large gears, dog washers, gear shafts and solenoid plungers with "Lubriplate" (630 AAW) or equivalent.

## SIX-WAY SEAT ADJUSTER MAJOR COMPONENTS—Buick, Oldsmobile and Cadillac 60-40 Seats

The following service procedures cover replacement of the major component parts of the power operated Six-Way seat adjusters used on the 60-40 seats.

## SIX-WAY ADJUSTER MOTOR—Buick, Oldsmobile and Cadillac 60-40 Seats

### Removal and Installation

- If seat is operable, raise seat assembly to the full "up" position.

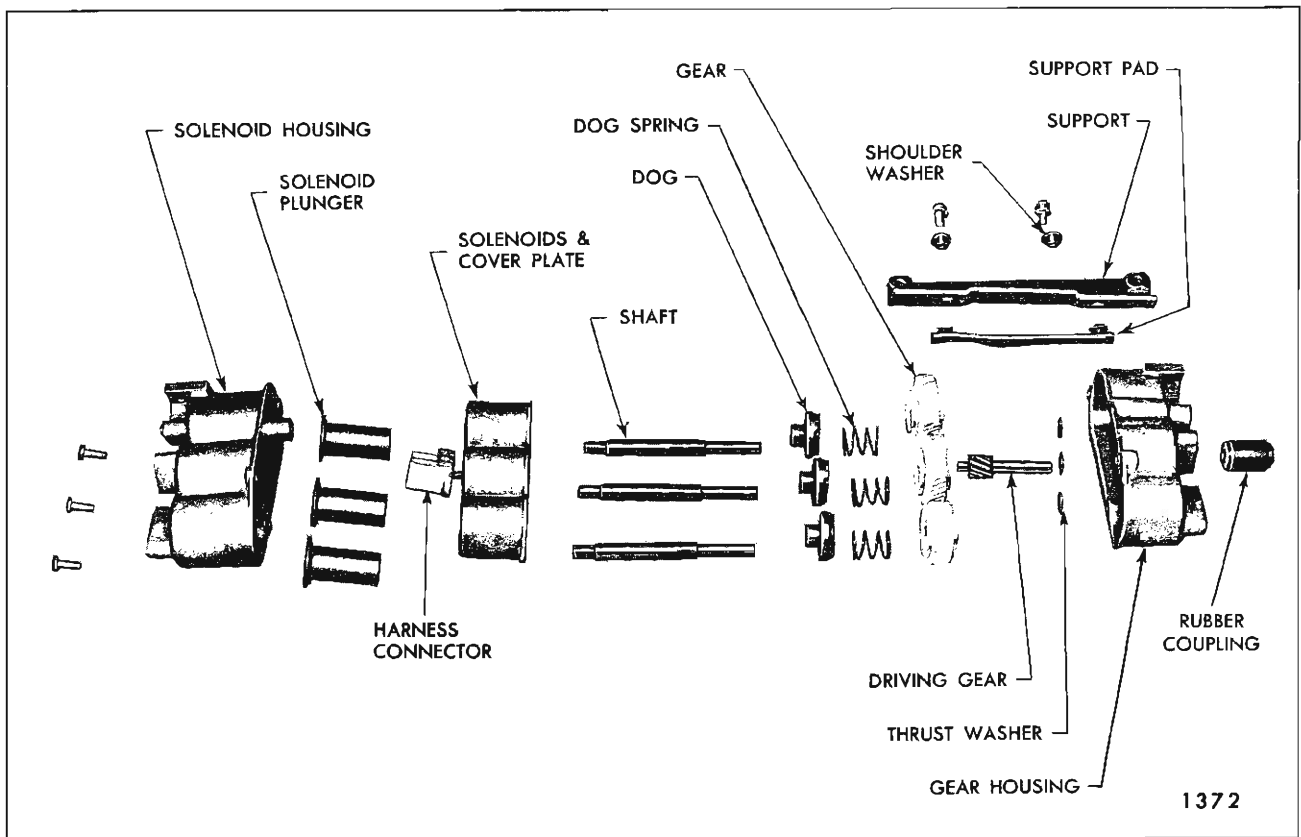

Fig. 15-21—Six-way Seat Adjuster Transmission - "B & C" Full Width Seat

2. Detach motor wire harness connectors from motor relay (Fig. 15-22).
3. From underside of motor and transmission support, remove two motor attaching screws; then, disengage motor from drive coupling and remove motor. If seat is inoperative in "down" position remove motor from under rear of seat.
4. To install, reverse removal procedure. Check operation of seat assembly to limits of horizontal and vertical travel.
3. From under front of seat, remove transmission cable end plate attaching screws (Fig. 15-23 and 15-24); then, slide end plate up cables sufficiently to disengage rear vertical cable from end plate.
4. To install rear vertical cable(s), reverse removal procedure. Check operation of seat assembly to limits of horizontal and vertical travel.

### SIX WAY SEAT ADJUSTER REAR VERTICAL DRIVE CABLE—Buick, Oldsmobile and Cadillac 60-40 Seats.

#### Removal and Installation

1. If seat is operable, raise seat assembly to the full "up" position.
2. Detach rear vertical cable from rear vertical gearnut at rear of adjuster.

### SIX-WAY SEAT ADJUSTER ASSEMBLY AND HORIZONTAL OR FRONT VERTICAL DRIVE CABLES—Buick, Oldsmobile and Cadillac 60-40 Seats

#### Removal and Installation

1. Remove seat assembly from body, as described under "Front Seat Assembly - Power Operated Two, Four or Six-Way Full Width and 60-40 Six-Way Seats - Removal and Installation". Place seat assembly upside down on a clean protected surface.
2. Detach drive cables from adjuster being removed (Fig. 15-22).

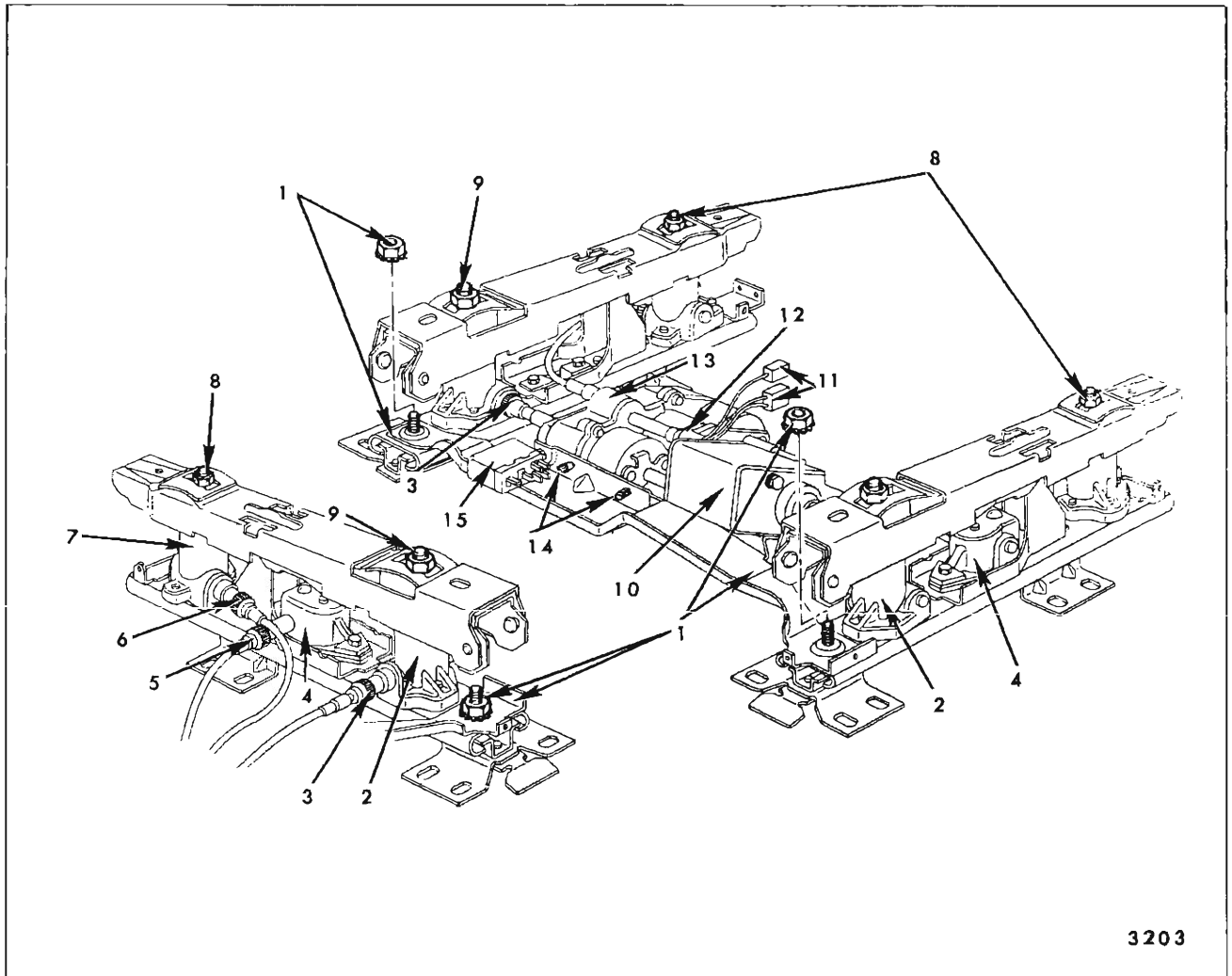

Fig. 15-22—Six-Way Seat Adjuster, Motor, Transmission, Cable and Support Assemblies - Buick, Oldsmobile and Cadillac 60-40 Seats

- |   |   |   |
|---|---|---|
| 1. Motor and Transmission Support-to-Adjuster Attaching Nut | 7. Rear Vertical Gearnut  | 11. Electric Motor-to-Relay Connectors            |
| 2. Front Vertical Gearnut                                   | 8. Adjuster Upper Channel-to-Front Vertical Gearnut Attaching Nut | 12. Electric Motor-to-Transmission Drive Coupling |
| 3. Front Vertical Drive Cable and Nut                       | 9. Adjuster Upper Channel-to-Front Vertical Gearnut Attaching Nut | 13. Transmission Assembly                         |
| 4. Horizontal Actuator                                      | 10. Electric Motor Assembly                                       | 14. Transmission Assembly Attaching Screws        |
| 5. Horizontal Drive Cable and Nut                           |   | 15. Motor and Transmission Relay                  |
| 6. Rear Vertical Drive Cable and Nut                        |   |   |

3. At adjuster being removed, remove nut securing motor and transmission support at front of adjuster (Fig. 15-22). Remove seat adjuster to seat frame front and rear attaching bolts; then, remove adjuster from seat assembly.

4. To remove horizontal and/or front vertical cable(s), remove seat adjuster on side from which cable(s) is being removed. Remove transmission end plate attaching screws (Figs. 15-23 and 15-24); then, slide end plate up

cables sufficiently to disengage cable(s) from end plate.

5. To install seat adjuster assembly or horizontal and/or front vertical drive cable(s) reverse removal procedure. Make sure cables are properly engaged with transmission and adjuster before installing transmission end plate and seat adjuster.

Check operation of seat assembly to limits of horizontal and vertical travel.

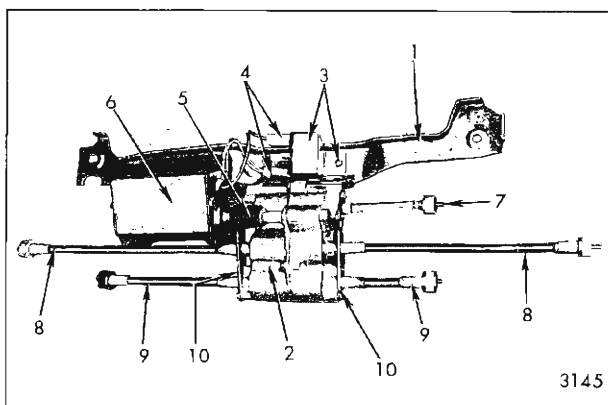

Fig. 15-23—Six-Way Seat Adjuster Motor, Transmission, Cable and Support Assembly

- |  |  |
|--|--|
| 1. Motor, Transmission and Cable Support | 7. Front Vertical Drive Cable (Orange) |
| 2. Transmission Assembly                 | 8. Rear Vertical Drive Cable (Blue)    |
| 3. Motor Relay and Attaching Screw       | 9. Horizontal Drive Cable (Black)      |
| 4. Motor-to-Relay Connectors             | 10. Transmission Cable End Plate       |
| 5. Motor-to-Transmission Coupling        |  |
| 6. Electric Motor                        |  |

## SIX-WAY SEAT ADJUSTER TRANSMISSION ASSEMBLY—Buick, Oldsmobile and Cadillac 60-40 Seats

### Removal and Installation

1. Remove seat assembly from car, place upside down on a clean protected surface and remove one seat adjuster assembly, as previously described.
2. At opposite adjuster, detach drive cables from adjuster and remove nut securing motor and transmission support at front of adjuster (Fig. 15-22).
3. Disengage and remove motor and transmission support from adjuster. As a bench operation, remove screws securing transmission assembly to support; then, disengage transmission from motor drive coupling and remove transmission.
4. To install transmission assembly, reverse removal procedure. Check operation of seat assembly to limits of horizontal and vertical travel.

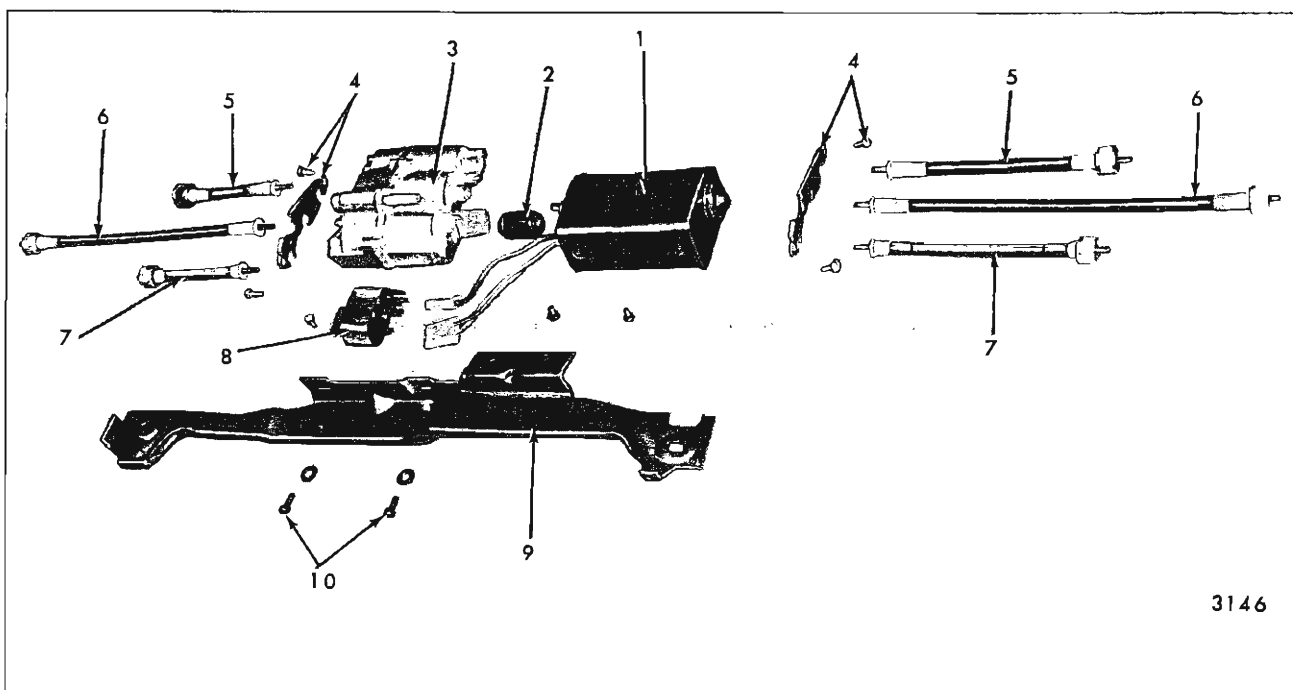

Fig. 15-24—Six-Way Seat Adjuster Motor, Transmission, Cable and Support - Disassembled - Buick, Oldsmobile and Cadillac 60-40 Seats

- |                                   |  |                               |                                    |
|-----------------------------------|--|-------------------------------|------------------------------------|
| 1. Electric Motor                 | 3. Transmission Assembly                       | 5. Front Vertical Drive Cable | 8. Motor Relay and Attaching Screw |
| 2. Motor-to-Transmission Coupling | 4. Transmission End Plate and Attaching Screws | 6. Rear Vertical Drive Cable  | 9. Motor and Transmission Support  |
|                                   |  | 7. Horizontal Drive Cable     | 10. Transmission Attaching Screws  |



### SIX-WAY SEAT ADJUSTER TRANSMISSION ASSEMBLY—Buick, Oldsmobile and Cadillac 60-40 Seats

#### Disassembly and Assembly

1. Remove seat adjuster transmission assembly, as previously described.

2. Remove screws securing solenoid housing to gear housing; then, carefully separate housings and remove component parts of transmission assembly (Fig. 15-25).

3. To assemble transmission, reverse removal procedure.

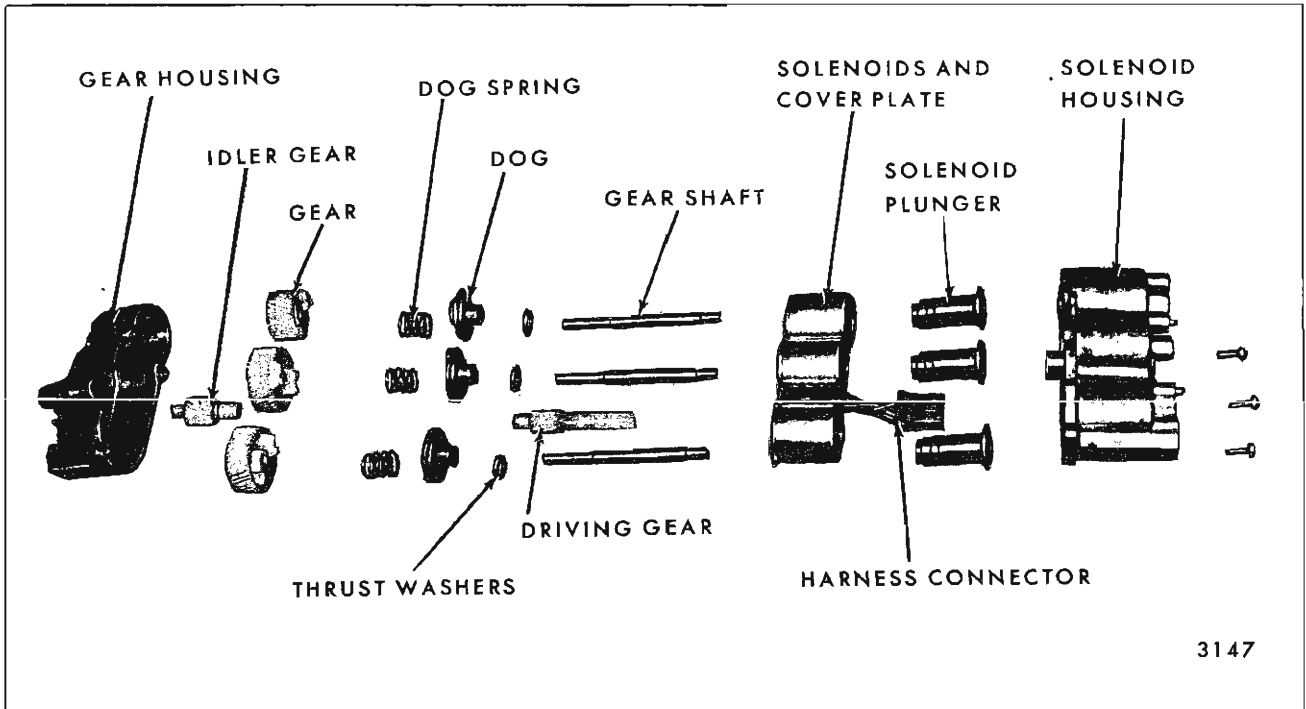

Fig. 15-25—Six-Way Seat Adjuster Transmission - Disassembled - Buick, Oldsmobile and Cadillac 60-40 Seats

**IMPORTANT:** Prior to or during installation, lubricate frictional surfaces of driving gear thrust washer, gears, dog washers, shaft and solenoid plungers with "Lubriplate" (630AAW) or equivalent.

springs (Fig. 15-26). Disengage springs from tabs.

4. At each end of seat, remove hog rings securing lower edge of seat back trim to seat bottom frame. Raise or turn back seat back trim to

### FRONT SEAT BACK ASSEMBLY—Four Door Style with Standard Full Width Seat

#### Removal and Installation

1. Remove front seat assembly from body and place it upside down on a clean protected surface. Remove seat side panels, where present.
2. Remove hog rings securing lower edge of seat back trim to seat cushion springs.
3. On "A-X & Z" body full width front seats, raise lower edge of seat back trim, detach fiberboard breakover foundation and bend out tabs on seat back frame securing seat cushion

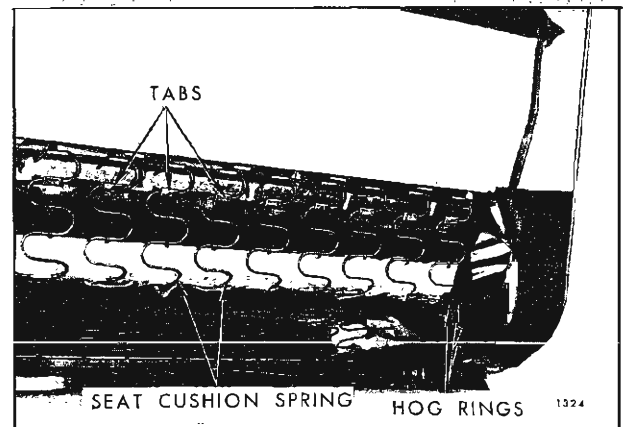

Fig. 15-26—Seat Cushion-to-Back Spring Attachment

expose bolts securing seat back frame to seat cushion frame (Fig. 15-27). Where seat back lighter or courtesy light is present, disconnect wire from seat cushion frame.

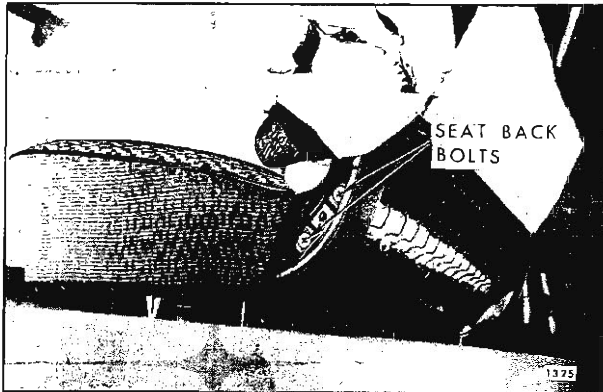

Fig. 15-27—Seat Back Attachment

5. Place seat assembly in upright position. Then with a helper holding seat back assembly, remove seat back attaching bolts on each side of seat and remove seat back assembly.
6. To install seat back assembly, reverse removal procedure.

### SEAT BACK ASSEMBLY—(Right or Left)—Two Door Style with Standard Full Width Seat or Notch Down Seat with Center Arm Rest

#### Removal and Installation

1. a. On seat with seat cushion side panel, remove side panel and detach seat cushion trim sufficiently to expose outer hinge pin and retainer (Fig. 15-28).
  - b. On seats with outer hinge arm cover, remove screw or detach fastener securing cover and remove cover (Fig. 15-28).
2. Using a flat-bladed tool carefully remove retainer, securing seat back outer arm to hinge pin (Fig. 15-28).
3. Carefully disengage seat back outer arm from hinge pin; then, tilt seat back forward and upward to disengage seat back inner arm from hinge pin and remove seat back from body.
4. To install seat back assembly, reverse removal procedure making sure washers are installed over hinge pins prior to installing seat back. If outer retainer is damaged, install new retainer.

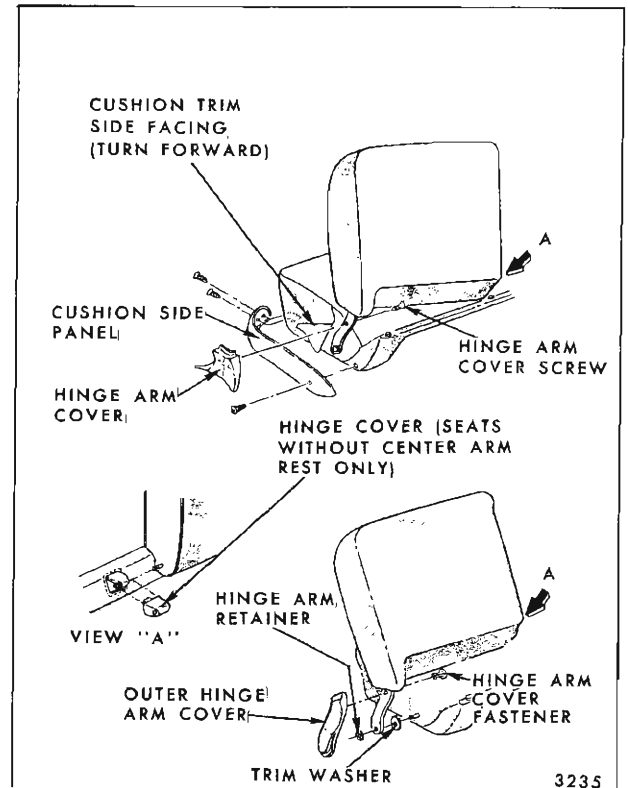

Fig. 15-28—Seat Back Removal - Two-Door Styles

### FRONT SEAT BACK ASSEMBLY—(Right or Left)—“39” Style Full Width Seat and Buick, Oldsmobile or Cadillac 60-40 Seat with Notch Down Center Arm Rest

#### Removal and Installation

1. Remove front seat assembly from body and place upside down on a clean protected surface. Remove seat cushion side panels.
2. Remove hog rings securing lower edge of seat cushion trim bottom facing to seat cushion springs and frame (Fig. 15-29).
3. Remove outer hinge arm cover (Fig. 15-29); then, using a flat bladed tool carefully remove retainer securing seat back outer arm to hinge pin (Fig. 15-29).
4. Turn back seat back trim to expose seat back attaching bolt access holes; then, through access holes remove seat back frame to seat cushion frame attaching bolts (Fig. 15-29).
5. Turn seat assembly right side up. Carefully disengage seat back outer arm from hinge pin;

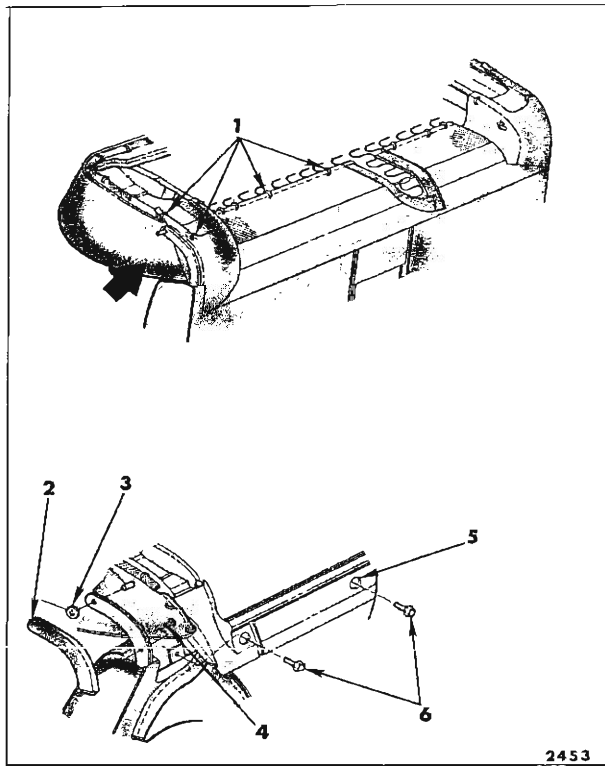

Fig. 15-29—Seat Back Removal (Right or Left) - Full Width Notch Down Seat Back

- |  |  |
|--|--|
| 1. Hog Rings Securing Seat Cushion Trim Bottom | 4. Seat Back Outer Arm Cover Fastener                    |
| 2. Seat Back Outer Arm Cover                   | 5. Seat Back Attaching Bolt Access Hole                  |
| 3. Seat Back Outer Arm Retainer                | 6. Seat Back Frame to Seat Cushion Frame Attaching Bolts |

then, tilt seat back forward and upward to disengage seat back inner arm from hinge pin (Fig. 15-29) and remove seat back from body.

- To install seat back assembly, reverse removal procedure. If seat back outer arm retainer is damaged, install new retainer.

### FRONT SEAT BACK LOCK—(Right or Left) "A-B-X & Z" Body Two-Door Styles with Standard Full Width Seats

#### Removal and Installation

- Remove front seat back assembly from front seat assembly, as previously described.
- Remove front seat back outer side panel and side panel lower support, where present.
- Remove seat back lock handle knob, lock handle escutcheon and lock handle (Fig. 15-30).

- Remove hog rings securing seat back front and rear trim facings at bottom of seat back; then, turn up trim sufficiently to gain access to lock attaching bolts (Fig. 15-30).

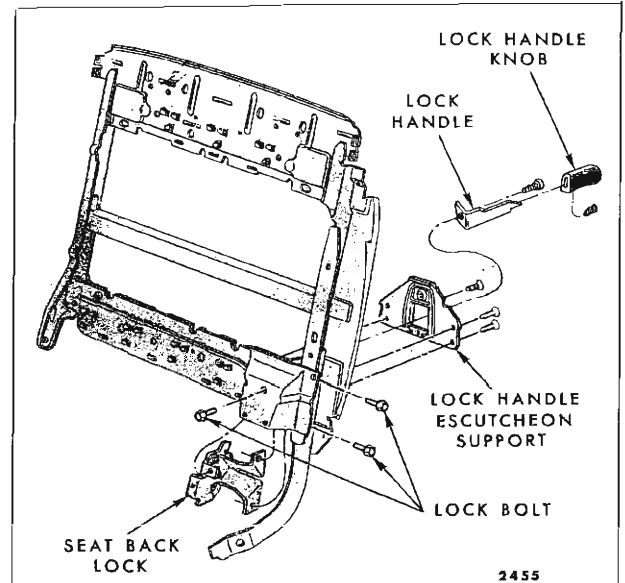

Fig. 15-30—Front Seat Back Lock "A, B & X" Two-Door Styles, Standard Full Width Seat

- Remove seat back lock attaching bolts (Fig. 15-30); then, remove lock assembly from bottom of seat back.
- To install, reverse removal procedure. Check for proper operation of seat back lock.

### FRONT SEAT BACK LOCK, LOCK CONTROL AND LOCK ROD—"C & E" Body Two-Door Styles With Standard Full Width or 60-40 Seats

#### Removal and Installation

- Remove front seat back assembly, as previously described.
- On styles with full seat back panel, remove seat back lock push button escutcheon and remove lock push button and ferrule; then, remove seat back panel (See View "B", in Fig. 15-31). On styles with seat side panel, remove seat side panel; then, remove lock push button and ferrule (See View "A", in Fig. 15-31).
- Remove seat back outer panel. Remove hog rings securing seat back panel or seat back trim panel along bottom and sides of seat. If removing lock, turn back seat trim sufficiently

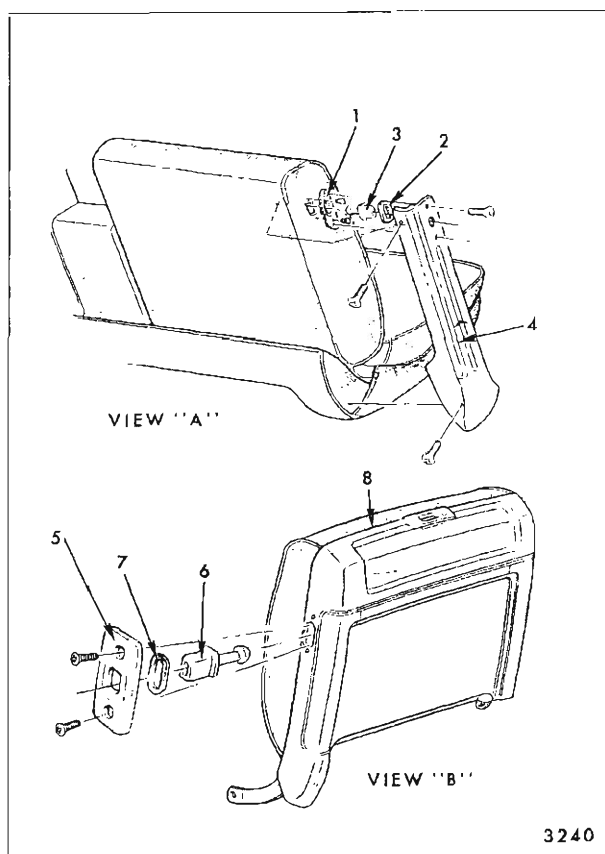

Fig. 15-31—Seat Back Lock Push Button - "C & E"  
Styles with Standard Full Width or 60-40 Seats

View "A" - Typical of Styles with Seat Back Side Panels

- |                  |                |
|------------------|----------------|
| 1. Trim Retainer | 3. Push Button |
| 2. Ferrule       | 4. Side Panel  |

View "B" - Typical of Styles with Seat Back Panel

- |                |                    |
|----------------|--------------------|
| 5. Escutcheon  | 7. Ferrule         |
| 6. Push Button | 8. Seat Back Panel |

to gain access to lock attaching bolts. If removing lock control or rod, turn up trim to gain access to lock control bolts (See Fig. 15-32).

4. a. To remove seat back lock, disengage lock rod clip at lock (Fig. 15-32) and detach rod from lock. Remove lock attaching bolts (Fig. 15-32) and remove lock from bottom of seat back.
- b. To remove seat back lock control, disengage lock rod clip at control (Fig. 15-32) and detach lock rod from control. Remove lock control attaching bolts (Fig. 15-32) and remove lock control from seat back.
- c. To remove lock rod, disengage lock rod clip at lock and at control (Fig. 15-32);

then, detach lock rod from control and lock and remove lock rod from seat back.

5. To install seat back lock, lock control or lock rod, reverse removal procedure. Make certain lock rod and clips are properly engaged and locked at lock lever and lock control lever. Check for proper operation of seat back lock.

### FRONT SEAT BACK PANEL ASSEMBLY— Cadillac Two or Four-Door Styles with Standard Seats

#### Removal and Installation

1. On two-door styles with manually operated seat back lock, remove lock push button escutcheon, push button and ferrule (Fig. 15-33).
2. Remove seat back panel attaching screws (Figs. 15-33 and 15-34).
3. Carefully lift panel upward to disengage upper center of panel from hanger bracket (Fig. 15-33 and 15-34).
4. To remove seat back trim, remove hog rings securing trim and foundation to seat back side upper and lower frames (Fig. 15-33 and 15-34).

**NOTE:** On two-door styles with electric seat back lock, remove lock lever knob prior to removing seat back trim and foundation.

5. To install seat back trim and foundation and seat back panel, reverse removal procedure.

### ELECTRIC SEAT BACK LOCK— Cadillac Two-Door Styles with Standard Full Width Seats

Two-door Cadillacs equipped with electric door locks have electric seat back locks which unlock when either door is opened and lock when both doors are closed. Both seat backs can be unlocked manually by raising the lock lever located at the rear, lower outboard portion of the seat back.

### SEAT BACK LOCK AND ELECTRIC ACTUATOR ASSEMBLIES—Cadillac Two-Door Styles with Standard Full Width Seat

#### Removal and Installation

1. Remove front seat back panel assembly and seat back trim and foundation, as previously described.

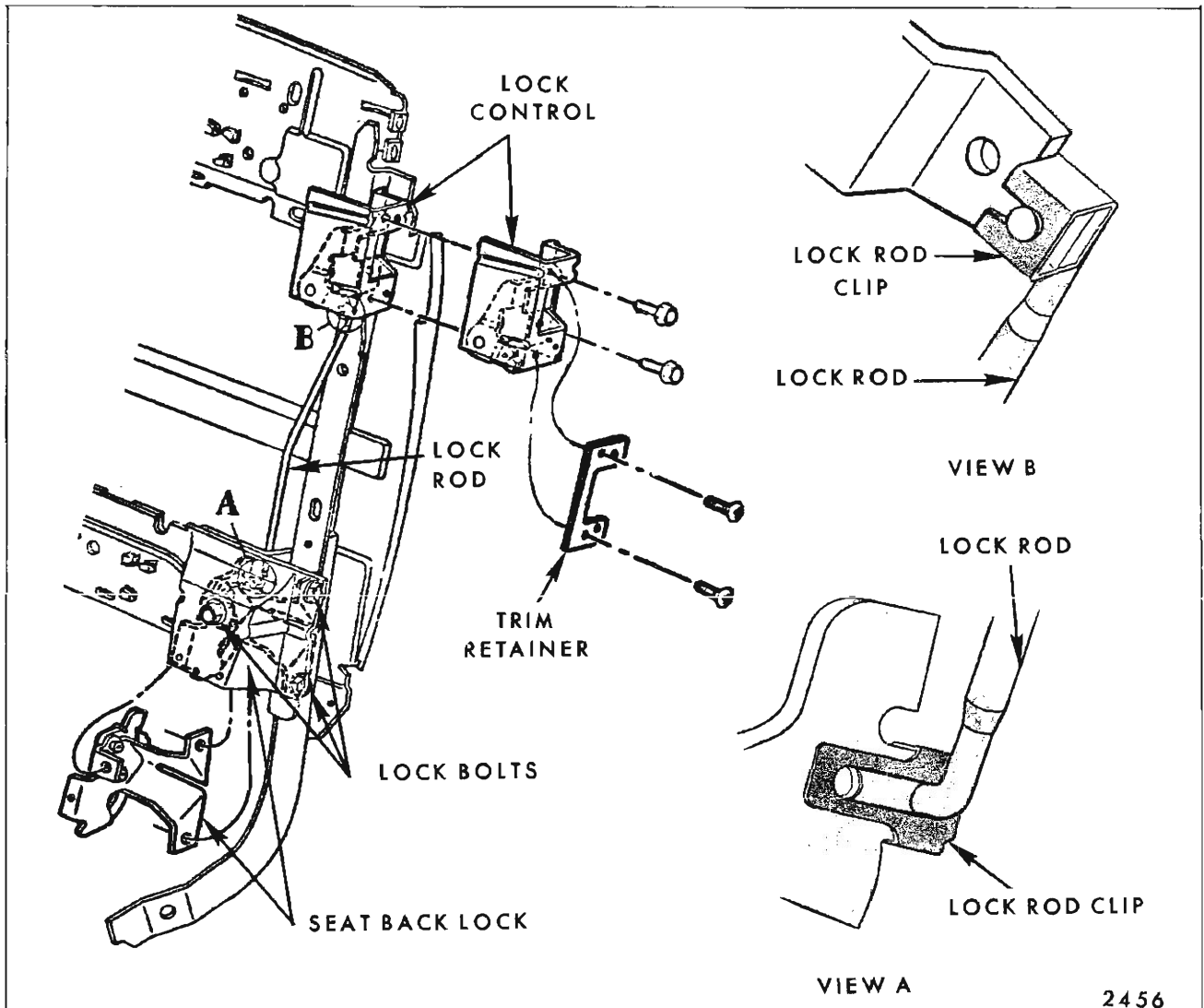

Fig. 15-32—Front Seat Back Lock - "C & E" Styles with Standard Full Width or 60-40 Seats

2. To remove seat back lock disconnect actuator feed wire connector, remove actuator attaching screws and disengage actuator rod at lock (Fig. 15-35).
3. To remove lock assembly, remove electric actuator assembly, as described in Step #2; then, remove lock attaching screws (Fig. 15-35) and remove lock assembly.
4. To install seat back lock or electric actuator, reverse removal procedure.

#### FRONT SEAT BACK HEAD RESTRAINT— Standard Full Width or 60-40 Seat (Drivers or Passengers Side)

Head restraints for the standard full width or

60-40 seat are single post type, which can be adjusted to two positions (low or high) or removed from the seat back by actuating (push forward) the lock lever located at the head restraint post escutcheon and lifting the head restraint out of the seat back.

#### FRONT SEAT BACK HEAD RESTRAINT RETAINER AND LOCK—Standard Full Width Seats, 60-40 Seats and "F" Type Seats

##### Removal and Installation

1. Remove head restraint by actuating (push forward) the lock lever at the post escutcheon and lifting the head restraint out of the seat back.

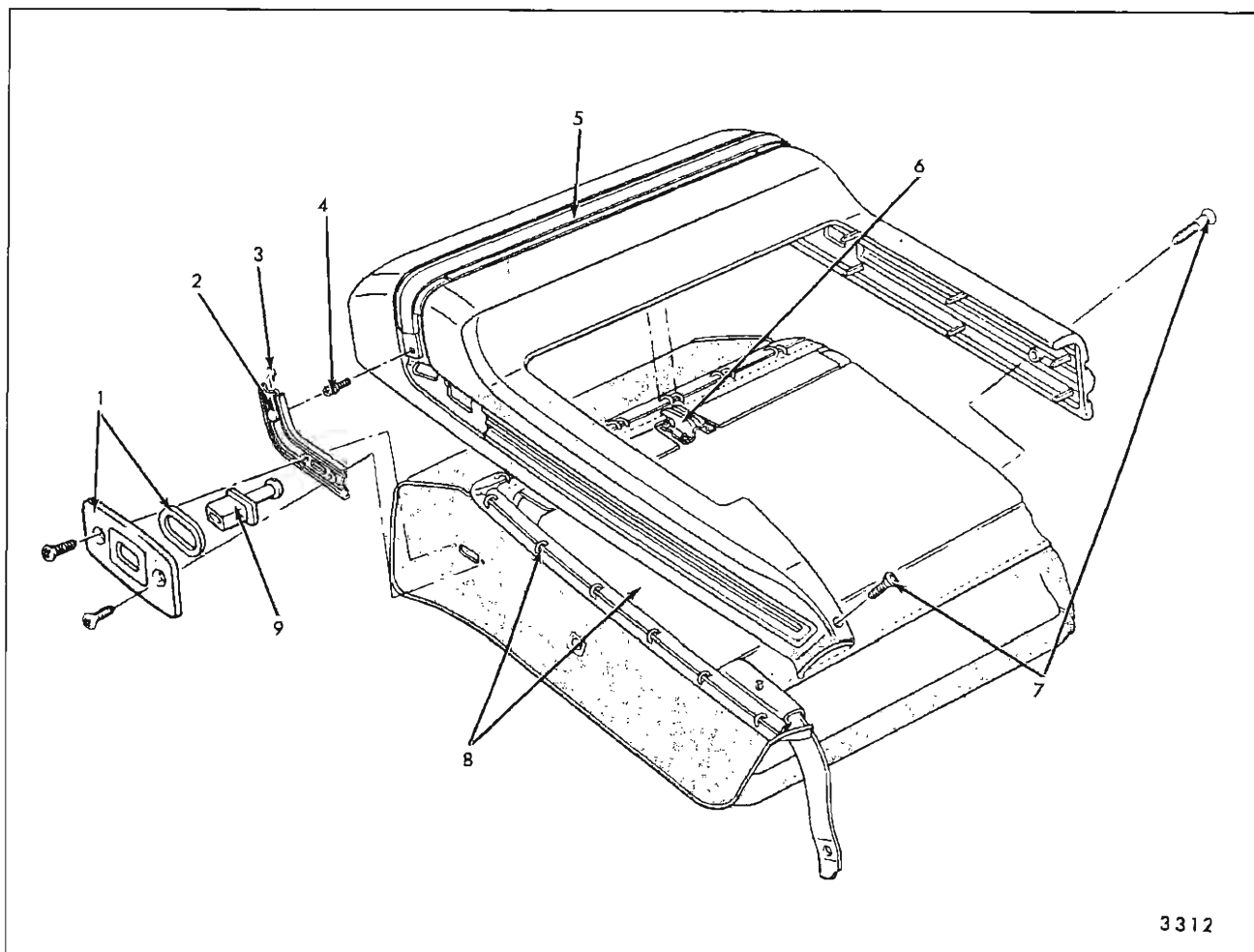

Fig. 15-33—Seat Back Panel and Assist Strap - Cadillac Two-Door Style Standard Seats

- |                                       |   |
|---------------------------------------|---|
| 1. Push Button Escutcheon and Ferrule | 6. Panel Upper Bracket  |
| 2. Assist Strap Outer Escutcheon      | 7. Seat Back Panel Lower Screws                               |
| 3. Assist Strap Spring                | 8. Seat Back Trim and Foundation<br>(Hog-rings to Seat Frame) |
| 4. Assist Strap Anchor Stud           | 9. Push Button  |
| 5. Assist Strap                       |   |

2. Remove escutcheon attaching screws and remove escutcheon (Fig. 15-36).
3. Remove retainer and lock attaching screws and remove assembly (Fig. 15-36).
4. To install, reverse removal procedure. Check operation of head restraint.

### FRONT SEAT BACK HEAD RESTRAINT GUIDE TUBE, GUIDE TUBE SUPPORT AND GUIDE ROLLER—Standard Full Width Seats, 60-40 Seats and "F" Type Seats

The front seat back head restraint guide tube is a

plastic tube inserted through the guide tube support assembly. The guide tube support assembly, which incorporates a riveted-on roller, is welded to the seat back frame on all styles except Cadillac styles, on which the assembly is attached by screws.

### Removal and Installation

1. Remove front seat back and head restraint retainer and lock as previously described.
2. Remove front seat back trim cover assembly.
3. Remove two screws securing guide tube (Fig. 15-37) and slide guide tube out of support.

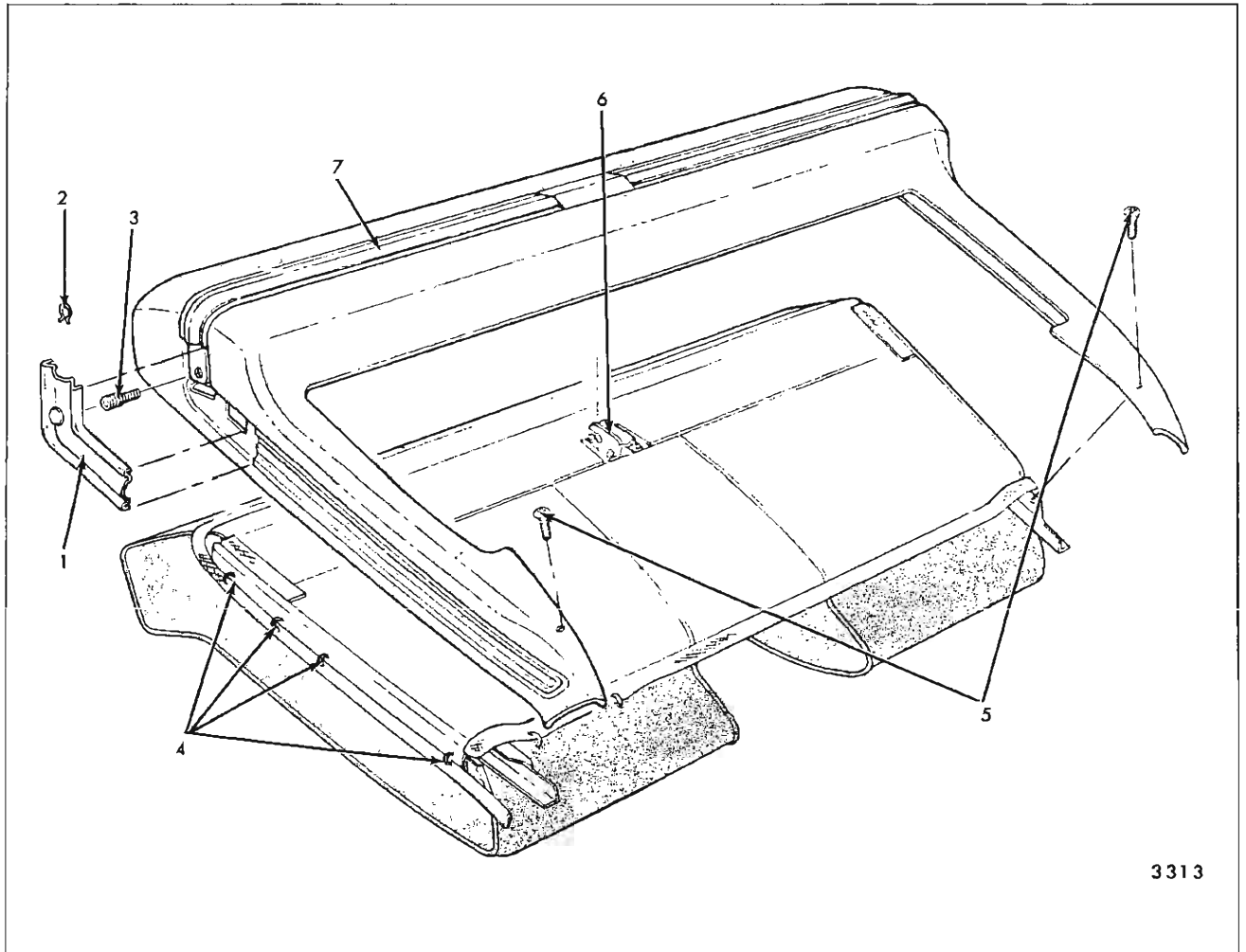

Fig. 15-34—Seat Back Panel and Assist Strap - Cadillac Four-Door Style Standard Seats

- |                                  |  |                        |
|----------------------------------|--|------------------------|
| 1. Assist Strap Outer Escutcheon | 4. Seat Back Trim and Foundation<br>(Hog-Ringed to Seat Frame) | 6. Panel Upper Bracket |
| 2. Assist Strap Spring           | 5. Seat Back Panel Lower Screws                                | 7. Assist Strap        |
| 3. Assist Strap Anchor Stud      |  |                        |

4. To remove guide tube support assembly, which includes roller on Cadillac styles, remove guide tube support attaching screws (Fig. 15-37) and remove support assembly.
5. To remove roller assembly on styles except Cadillac and "F" body type seats, carefully knock out two rivets securing roller assembly to support (Fig. 15-37) and remove roller assembly.
6. To install roller assembly, guide tube support assembly (Cadillac styles only) or guide tube, reverse removal procedure. Roller assembly may be installed with screws not longer than 3/8".

### FRONT SEAT CENTER ARM REST AND CURTAIN ASSEMBLY—Front Seat with Standard Full Width Seat Back

#### Removal and Installation

1. Place center arm rest in down position.
2. At top of arm rest curtain, remove hog rings securing curtain to flange of support plate (Fig. 15-38) and pull curtain forward to expose screws securing arm rest to support linkage.
3. Remove arm rest-to-support linkage screws (Fig. 15-38) and remove arm rest and curtain from seat.
4. To install, reverse removal procedure.

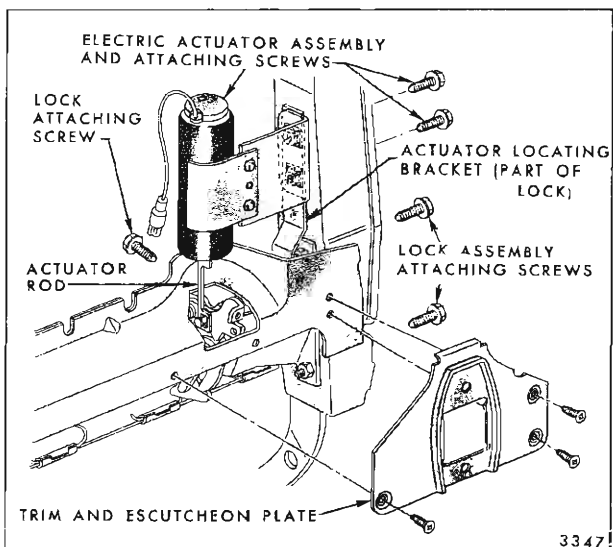

Fig. 15-35—Seat Back Lock and Electric Acuator Assemblies—Cadillac Two-Door Styles with Standard Full Width Seats

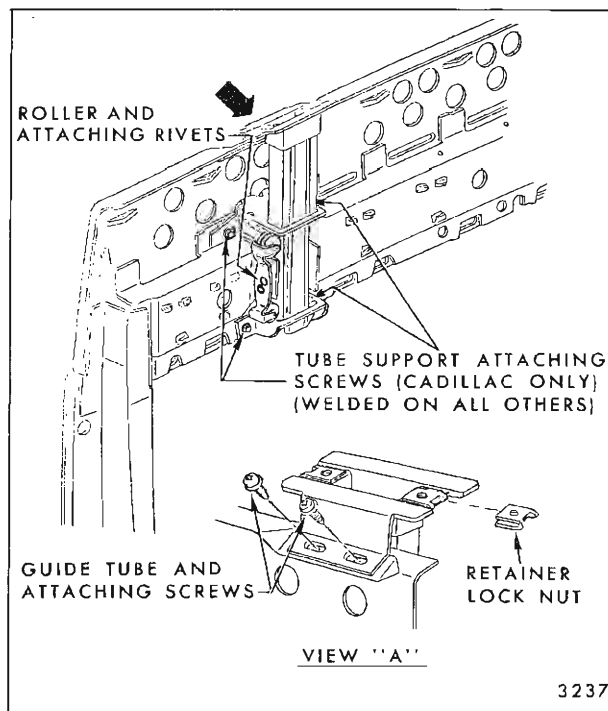

Fig. 15-37—Head Restraint Guide Tube and Roller Typical of All Standard Seats Except Cadillac

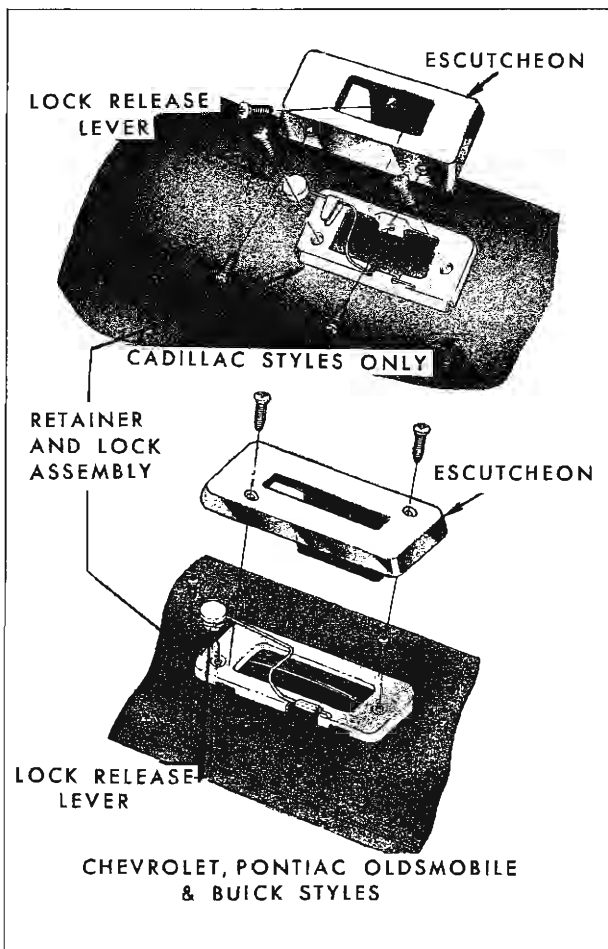

Fig. 15-36—Front Seat Back Head Restraint Retainer, Lock and Escutcheon - Standard Seats

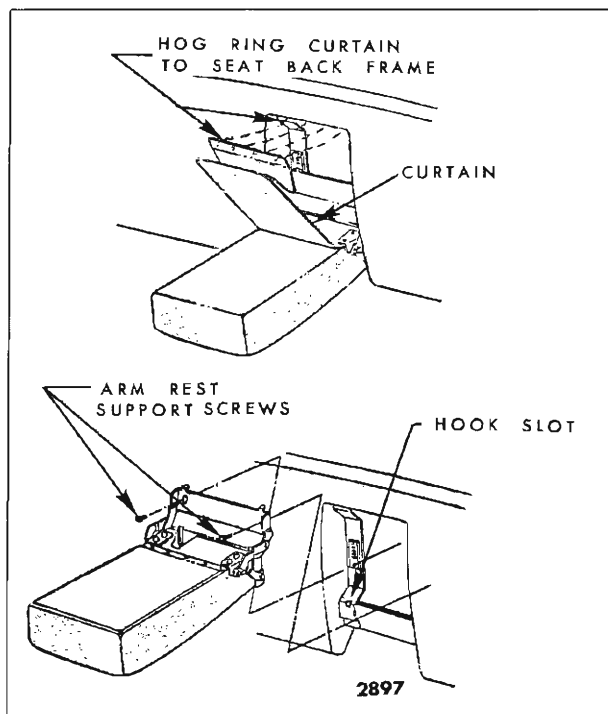

Fig. 15-38—Front Seat Back Center Arm Rest



## ARM REST AND SUPPORT ASSEMBLY— Front Seat with Standard Full Width Seat Back

### Removal and Installation

1. Place center arm rest in down position.
2. At top of arm rest curtain, remove hog rings securing curtain to flange of support plate (Fig. 15-38).
3. Remove two screws securing arm rest to supports on seat back (Fig. 15-38); then, carefully lift arm rest and linkage upward to disengage hooks of arm rest from slots in supports and remove assembly from seat.
4. To install, reverse removal procedure. Prior to installing curtain screws check alignment and operation of arm rest.

## FRONT SEAT CENTER ARM REST AND CURTAIN ASSEMBLY—Front Seat with Notch Down Seat Back and Strato Front Seat

### Removal and Installation

1. Lower arm rest to within approximately 2 inches of full down position.
2. Carefully pull curtain back sufficiently to remove screws securing center arm rest to linkage and loosen outer screws securing curtain lower retainer to arm rest (Fig. 15-39).

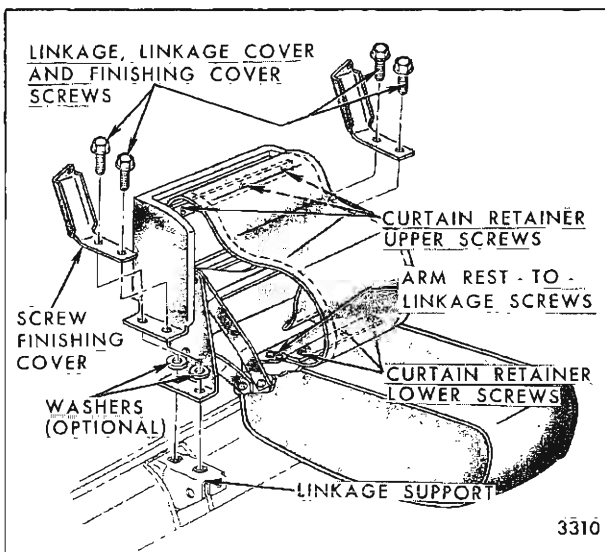

Fig. 15-39—Front Seat Center Arm Rest (Full Width Seat with Notch Down Seat Back)

3. Disengage arm rest from support linkage and turn arm rest upside down on trim panel finishing cover. Remove arm rest curtain upper retainer screws (Fig. 15-39); then, remove arm rest and curtain from seat.

4. To install, reverse removal procedure.

## FRONT SEAT CENTER ARM REST ASSEMBLY—Front Seat with Notch Down Seat Back and Strato Front Seat

### Removal and Installation

1. Place arm rest in up position.
2. Working between arm rest and seat back, remove fastener at both sides of arm rest securing front end of screw finishing covers (Fig. 15-39).
3. On two-door styles, push one seat back to full forward position. Carefully pull up front of screw finishing cover sufficiently to expose arm rest linkage and linkage cover attaching screws; then, remove screws (Fig. 15-39). Repeat this operation on opposite side of arm rest; then, carefully remove arm rest linkage cover and linkage assembly from seat.

**NOTE:** If washers are present between arm rest linkage and linkage supports on seat (Fig. 15-39), note location and number of washers used to facilitate installation in same position. Washer(s) are used to align arm rest to front seat back(s).

4. To install, reverse removal procedure. Prior to bending down screw finishing covers, check alignment and operation of arm rest. Where necessary to align arm rest with seat back(s) install washer(s), as required, between arm rest support and support on seat (Fig. 15-39).

## FOOT REST ASSEMBLY— Cadillac 68169 Styles

The folding foot rest assemblies shown in Figure 15-40, are secured to the seat back by hinges. To remove foot rest assembly, remove hinge-to-seat back attaching screws from both sides of foot rest (Fig. 15-40) and remove foot rest assembly from seat back. To remove trimmed foot rest board remove hinge-to-board attaching screws (Fig. 15-40) and remove hinges from foot rest board. To install, reverse removal procedure. When installing foot rest hinge-to-seat back attaching screws, install machine thread screws in upper attaching hole at each hinge.

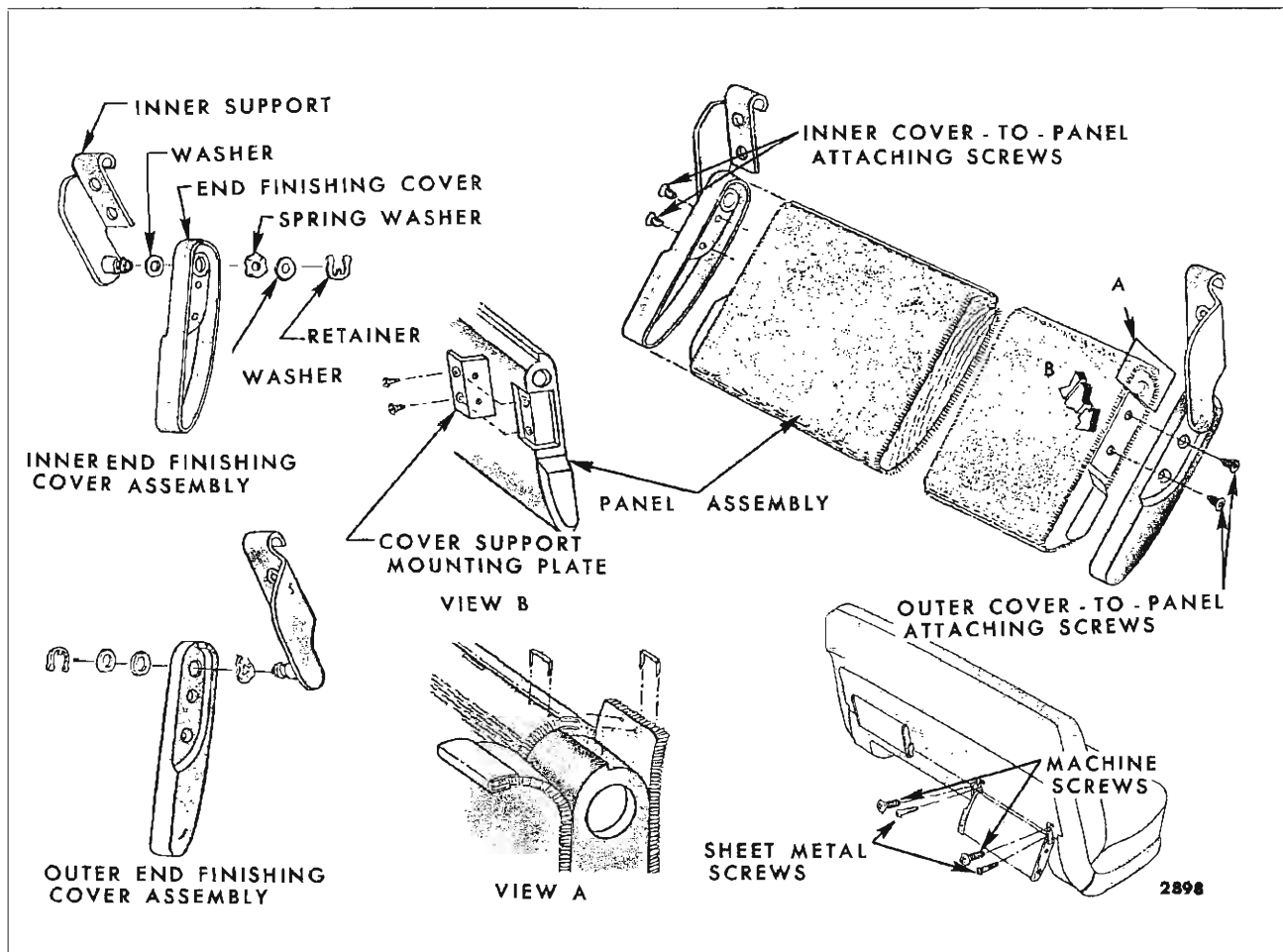

Fig. 15-40—Foot Rest Assembly - Cadillac 68169 Styles

## STRATO FRONT SEATS

### STRATO FULL-WIDTH, STRATO BUCKET AND STANDARD BUCKET SEATS

#### Description

Strato seats are available on Chevrolet "A, B & X", Pontiac, Oldsmobile, Buick and Cadillac styles. Chevrolet "F & Z" and Pontiac "F" body styles have a standard bucket seat. All two-door style strato full-width or bucket seats and standard bucket seats incorporate seat back locks on both the driver's and passenger's seat back. On Chevrolet "F & Z" standard bucket seats the seat back lock is actuated by a control lever located at the lower outboard corner on the rear of the front seat back. On the standard strato seats (two-door styles) the seat back lock is actuated by a control button located at the rear upper center of the seat back, except on styles equipped with passenger reclining

seat back. On styles with passenger reclining seat back, the seat back lock control button is located at the upper outer side of the seat back.

Head restraints for the strato full-width or bucket seats are a dual post type, which can be adjusted to two positions (low or high) or removed from the seat back by actuating (push forward) the lock levers located at the head restraint post excutcheons and lifting the head restraint from the seat back.

On Pontiac, Oldsmobile, Buick and Cadillac "E" styles, a reclining seat back is available on the passenger's side. The reclining seat back is operated by a control lever located at the right side of the seat cushion. When the control lever is pulled upward the seat back can be reclined to any desired position within approximately 30° from normal position.

## STRATO FULL-WIDTH FRONT SEAT ASSEMBLY

### Removal and Installation

The removal and installation procedures for the strato full width seat assembly, seat adjuster and seat adjuster components are the same as for the standard full width front seat assembly - Refer to the appropriate section under "Front Seat Assembly - Full Width".

## MANUALLY OPERATED BUCKET SEAT ASSEMBLY

### Removal and Installation

1. Operate seat to full rearward position.
2. Turn back floor carpeting sufficiently to expose seat adjuster-to-floor pan attaching nuts or bolts (Fig. 15-41 and 15-42).

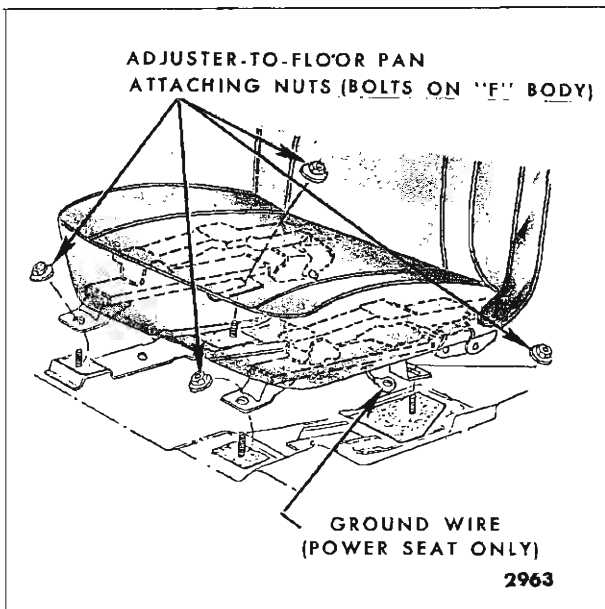

Fig. 15-41—Bucket Seat Floor Pan Attachment - "A, F, X & Z" Styles—Bucket Seat

NOTE: For Seat Positioning, Spacer Usage and Torque Specifications, see charts at beginning of Seat Section.

3. Operate seat to full rearward position. Remove adjuster-to-floor pan front attaching bolts or nuts (Figs. 15-41 and 15-42). Operate seat to full forward position. Remove adjuster-to-floor pan rear attaching bolts or nuts and remove seat assembly from body.
4. To install, reverse removal procedure. Check

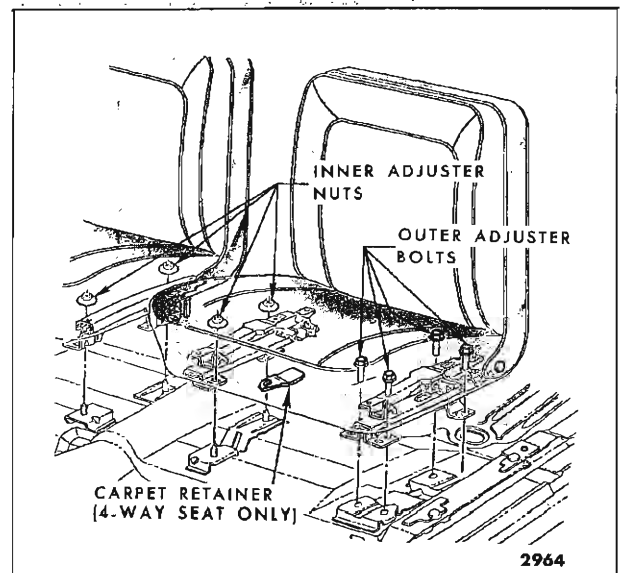

Fig. 15-42—Bucket Seat Floor Pan Attachment - "B, C & E" Styles - Bucket Seats

NOTE: For seat positioning, spacer usage and torque specifications, see charts at beginning of Seat Section.

operation of seat adjusters to full limits of travel.

## POWER OPERATED HORIZONTAL OR FOUR-WAY BUCKET SEAT ASSEMBLY

The two-way and four-way (tilt) seat adjusters are actuated by a 12 volt, reversible shunt wound motor with a built-in circuit breaker.

The four-way seat adjuster operating mechanism incorporates a transmission assembly which includes two solenoids and two drive cables leading to the seat adjusters. One solenoid controls the vertical movement of the seat while the other solenoid controls the horizontal movement of the seat. When the control switch is actuated, the motor drives the transmission by means of a belt and one of the transmission solenoids is energized simultaneously. The solenoid plunger then engages with the drive cables and operates both adjusters. When the adjusters reach their limit of travel, the drive cables stop their rotating action and torque is absorbed by the rubber belt connecting the motor and transmission. When the switch contacts are opened, a return spring returns the solenoid plunger to its original position disengaging it from the driver gear dog.

### Removal and Installation

1. Operate seat to full forward position. On four-way power seats operate seat to full up position. Remove seat cushion side panels, where

present. Where seat adjuster track covers are present, carefully pry out track cover snap-on retainers with a flat-bladed tool and remove track covers.

2. Where necessary, remove sill plates and turn back floor carpeting to expose seat adjuster-to-floor pan attaching nuts and bolts.
3. Remove seat adjuster-to-floor pan rear attaching bolts (Figs. 15-41 and 15-42).
4. Operate seat to full rearward position. Remove seat adjuster-to-floor pan front attaching bolts (Figs. 15-41 and 15-42). Tilt seat rearward sufficiently to disconnect seat harness feed connector and detach harness from clip on floor pan; then, remove seat assembly from body.
5. To install, reverse removal procedure. Make sure ground wire is secured under adjuster inboard rear attaching nut or bolt. Check operation of seat adjusters to full limits of travel. On "A" Body Styles make sure floor carpet is properly positioned around rear supports of adjuster prior to installing carpet retainer on adjuster stud and adjuster rear attaching nuts.

## MANUALLY OPERATED BUCKET SEAT ADJUSTER

### Removal and Installation

1. Remove bucket seat assembly, as previously described, and place seat upside down on a protected surface.
2. If replacing inboard adjuster, remove assist spring (Fig. 15-43).
3. Operate adjuster so that both front and rear adjuster-to-seat frame attaching bolts (Fig. 15-43) are accessible; then, remove attaching bolts and remove adjuster from seat assembly.
4. To install, reverse removal procedure. If left adjuster is being replaced, install new adjuster control knob. Refer to "Manually Operated Seat Adjuster Control Arm Knob".

## POWER OPERATED HORIZONTAL BUCKET SEAT ADJUSTER

### Removal and Installation

1. Operate seat to a midway horizontal position. Remove bucket seat assembly, as previously described, and place seat upside down on a clean protected surface.

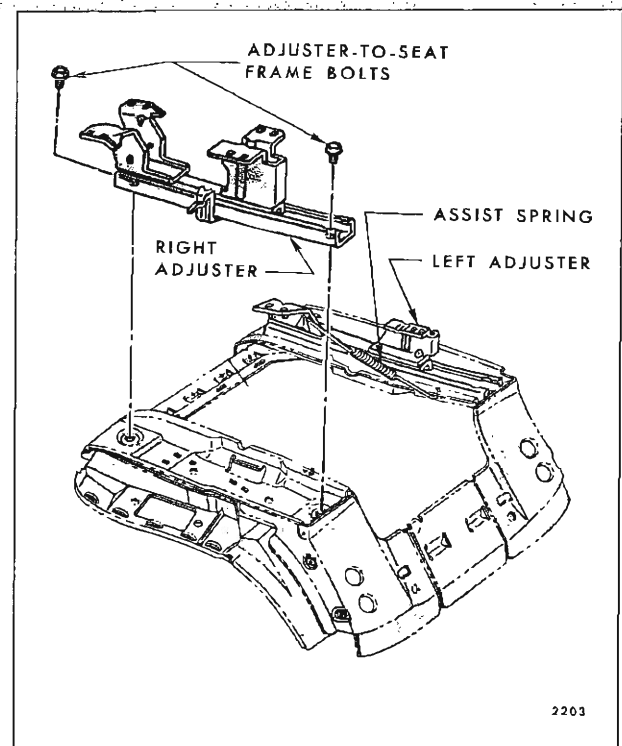

Fig. 15-43—Manual Bucket Seat Adjuster Removal

NOTE: For seat positioning on floor pan, spacer usage and torque specifications, see charts at beginning of Seat Section.

2. Disconnect power drive cable from adjuster gearnut (Fig. 15-44).
3. Remove adjuster-to-seat bottom frame front and rear attaching bolts (Fig. 15-44) and remove adjuster from seat assembly.
4. To install, reverse removal procedure. Where spacers were installed between seat adjuster and floor pan or seat adjuster and seat frame make certain spacers are reinstalled. Check for proper operation of seat to full limits of travel.

## POWER OPERATED FOUR-WAY BUCKET SEAT ADJUSTER

### Removal and Installation

1. Operate seat assembly to fully raised and midway horizontal positions.
2. Remove front seat assembly from body with attached adjusters, motor and transmission, as previously described, and place upside down on a clean protected surface.

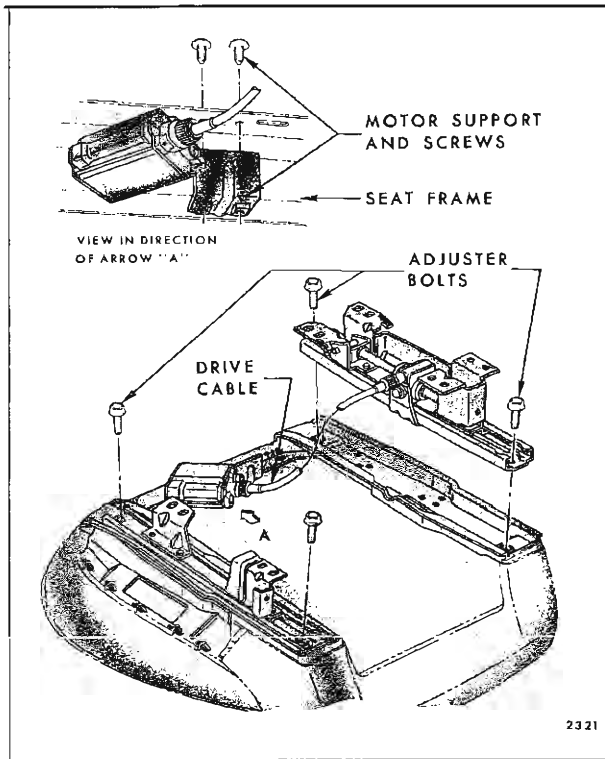

Fig. 15-44—Power Horizontal Bucket Seat Adjuster Removal

NOTE: For seat positioning on floor pan, spacer usage and torque specifications, see charts at beginning of Seat Section.

3. If outboard adjuster is being removed, disconnect both, horizontal and vertical, drive cables from vertical gearnut and horizontal actuator (Fig. 15-45).
4. Remove nuts securing motor and transmission support to adjuster being removed (Fig. 15-46).
5. Remove adjuster-to-seat bottom frame front and rear attaching bolts securing adjuster to be removed (Fig. 15-45).
6. Carefully disengage adjuster from support, and torque tube; then, remove adjuster from seat.
7. To install power operated four-way bucket seat adjuster assembly, reverse removal procedure. Check for proper operation of seat adjusters to limits of travel.

### POWER OPERATED FOUR-WAY BUCKET SEAT ADJUSTER MAJOR COMPONENTS

The following service procedures cover replacement of the major component parts of the power operated four-way seat adjuster used on bucket seats.

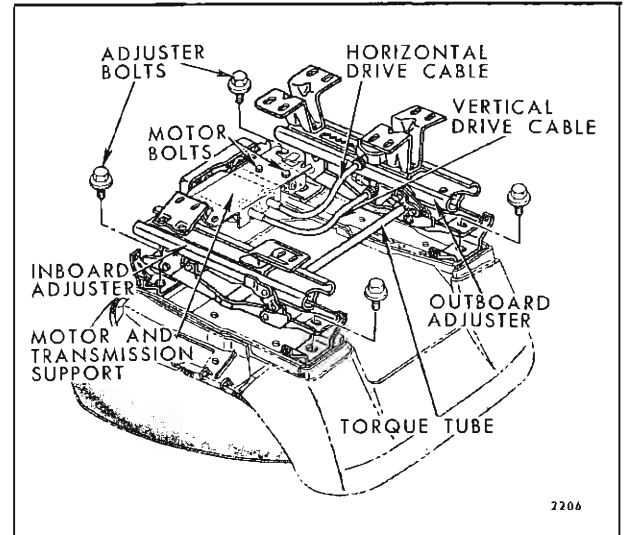

Fig. 15-45—Four-Way Bucket Seat Assembly

NOTE: For seat positioning on floor pan, spacer usage and torque specifications, see charts at beginning of Seat Section.

### MOTOR AND TRANSMISSION DRIVE BELT AND PULLEYS

#### Removal and Installation

1. At front of seat remove motor and transmission drive belt cover attaching screws (Fig. 15-46) and remove cover.
2. Remove drive belt (Fig. 15-46) from both motor and transmission drive pulleys. Pulleys may be removed from either motor or transmission by pulling pulleys off their respective shafts.
3. To install drive belt, reverse removal procedure. Check for proper operation of seats to full limits of travel.

### MOTOR ASSEMBLY

#### Removal and Installation

1. If motor can be operated, operate seat assembly to full "up" position. Disconnect wire harness connector from motor relay.
2. Remove motor-to-transmission drive belt cover and drive belt, as previously described.
3. From under motor and transmission support remove two cap screws securing motor to motor-and-transmission support and remove motor assembly from under seat.

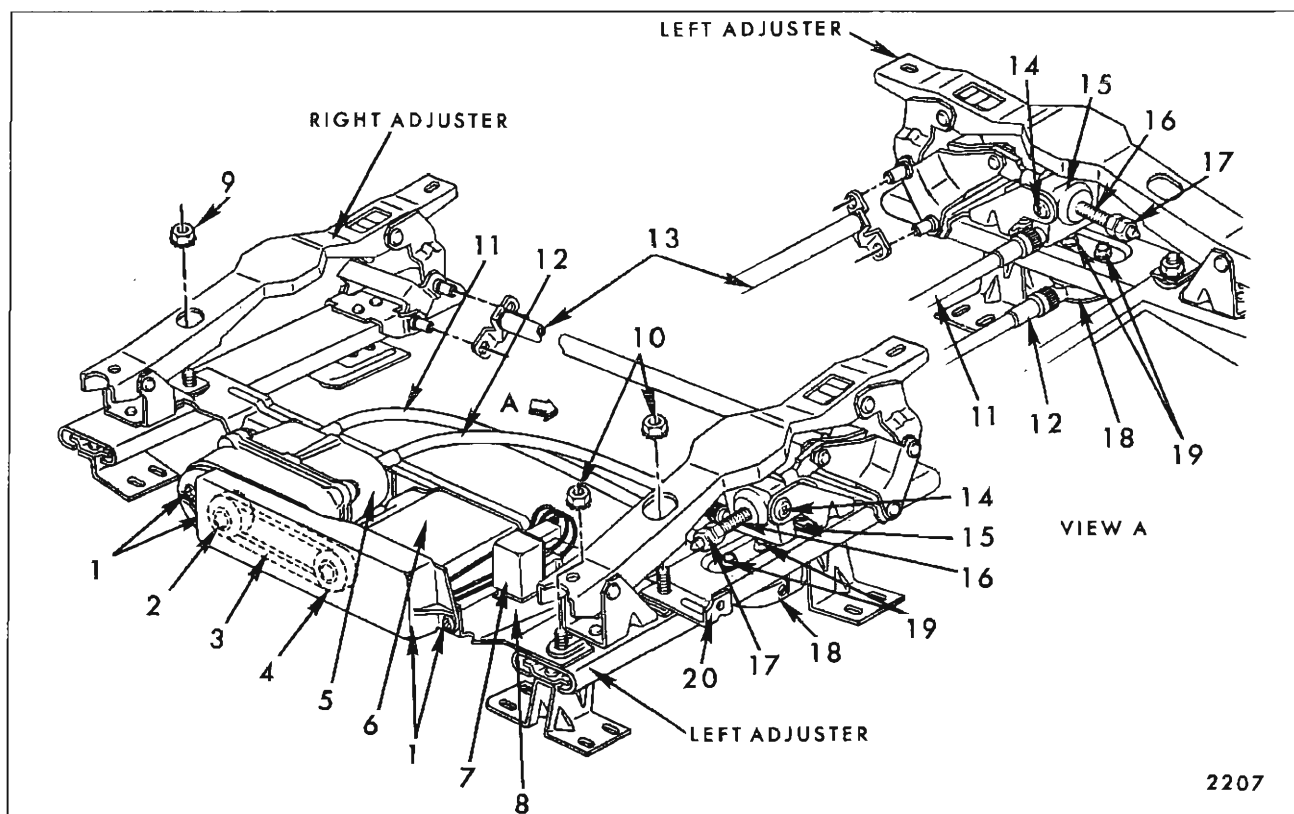

Fig. 15-46—Four-Way Bucket Seat Adjusters

- |   |   |   |
|---|---|---|
| 1. Motor and Transmission Drive Belt Cover and Attaching Screws | 9. Motor and Transmission Support-to-Right Adjuster Attaching Nut | 15. Adjuster Vertical Gearnut Assembly            |
| 2. Transmission Drive Pulley                                    | 10. Motor and Transmission Support-to-Left Adjuster Attaching Nut | 16. Adjuster Vertical Jackscrew                   |
| 3. Transmission and Motor Drive Belt                            | 11. Adjuster Horizontal Drive Cable                               | 17. Adjuster Vertical Jackscrew Stop Nuts         |
| 4. Motor Drive Pulley   | 12. Adjuster Vertical Drive Cable                                 | 18. Adjuster Horizontal Actuator Assembly         |
| 5. Transmission Assembly  | 13. Adjuster Torque Tube  | 19. Adjuster Horizontal Actuator Attaching Screws |
| 6. Electric Motor Assembly                                      | 14. Adjuster Vertical Gearnut Shoulder Screw                      | 20. Seat Side Panel Support                       |
| 7. Electric Motor Relay   |   |   |
| 8. Motor and Transmission Support                               |   |   |

- To install, reverse removal procedure. Check for proper operation of seat to full limits of travel.

## TRANSMISSION ASSEMBLY AND HORIZONTAL AND VERTICAL DRIVE CABLES

### Removal and Installation

- Remove front seat assembly from body with attached adjusters, motor and transmission, as previously described, and place upside down on a protected surface.
- Disconnect wire harness connector from transmission.

- Remove motor and transmission drive belt cover and remove drive belt (Fig. 15-46).

- Remove two screws securing transmission assembly to motor and transmission support; then, move transmission forward to disengage from drive cables and remove transmission from seat.

**NOTE:** To remove horizontal or vertical drive cables, detach drive cable from adjuster and remove cable.

### Disassembly and Assembly of Transmission

- Remove front seat adjuster transmission from seat assembly.

2. Remove screws securing rear and solenoid housings together; then, carefully separate housings and remove component parts of transmission assembly.
3. To assemble transmission, reverse removal procedure.

**IMPORTANT:** Prior to or during installation, lubricate frictional surfaces of driving gear thrust washer, gears, dog washers, shaft and solenoid plungers with "Lubriplate" (630AAW) or equivalent.

4. To install transmission assembly, reverse removal procedure. Make certain drive cables are properly engaged in transmission and properly retained in cut out notches of motor and transmission support prior to installing transmission attaching screws.
5. Check for proper operation of seat to full limits of travel.

## ADJUSTER VERTICAL GEARNUIT

### Removal and Installation

1. Operate seat assembly to full raised and mid-way horizontal position.
2. Remove front seat assembly from body and place upside down on a clean protected surface.
3. Using a clutch type screwdriver or other suitable tool, remove shoulder screws securing linkage to vertical gearnut (Fig. 15-46).
4. Remove jackscrew "down" stop from jackscrew (Fig. 15-46).
5. Using a portable power source to energize the motor, actuate vertical gearnut until gearnut is disengaged from jackscrew.

**NOTE:** It may be necessary to manually raise or lower upper rear portion of adjuster to gain clearance for removal of gearnut.

6. Disconnect drive cable from gearnut.
7. To install, reverse removal procedure. Check seat adjusters for proper operation.

## ADJUSTER JACKSCREW

### Removal and Installation

1. Remove adjuster gearnut as previously described.

2. Remove seat adjuster-to-seat bottom frame front and rear attaching bolts.
3. As a bench operation, remove jackscrew-to-adjuster linkage attaching rivet and remove jackscrew from adjuster assembly (Fig. 15-46).

**NOTE:** It may be necessary to manually raise or lower upper rear portion of adjuster to gain access to jackscrew attaching rivet.

4. To install, reverse removal procedure. Use new rivet to attach jackscrew-to-adjuster linkage. Check seat adjusters for proper operation.

## ADJUSTER HORIZONTAL ACTUATOR ASSEMBLY

### Removal and Installation

1. Remove front seat assembly from body as previously described and place upside down on a clean protected surface.
2. Using a clutch type screwdriver or other suitable tool, remove shoulder screws securing linkage to vertical gearnut (Fig. 15-46).
3. Using a portable power source, actuate vertical gearnut until gearnut is against "down" stop on jackscrew assembly.
4. Disconnect drive cable from horizontal actuator assembly.
5. Remove screws securing horizontal actuator assembly to adjuster lower track; then, remove actuator from adjuster assembly (Fig. 15-46).
6. To install, reverse removal procedure.

**NOTE:** When installing horizontal actuator, adjust actuator so that drive gear is fully engaged with teeth on lower channel. When horizontal actuator attaching screws are tightened, there should be no free motion between upper and lower channels. Re-adjust actuator "as required" until all free motion between channels has been removed. Check seat adjusters for proper operation.

## TORQUE TUBE ASSEMBLY

### Removal and Installation

1. Remove inboard seat adjuster assembly, as previously described.
2. Disengage torque tube from outboard adjuster

(Fig. 15-45 and 15-46) and remove torque tube assembly.

3. To install torque tube assembly, reverse removal procedure. Check for proper operation of seat to full limits of travel.

### PASSENGER'S FRONT BUCKET SEAT BACK STOP CABLE—Chevrolet "F & Z" Styles with Bucket Seats

#### Removal and Installation

1. Using a flat-bladed tool inserted between passenger's seat back inner hinge arm cover and hinge arm, carefully disengage upper portion of cover from fastener and remove cover from inner hinge arm (Fig. 15-47).

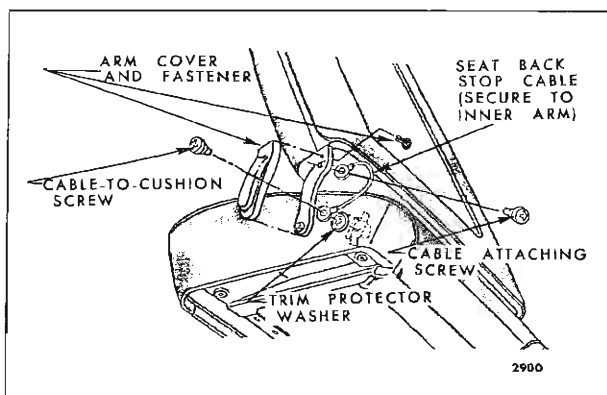

Fig. 15-47—Bucket Seat Back Stop Cable—"F & Z" Styles

2. At inner side of passenger's bucket seat cushion, remove screw securing seat back stop cable and trim protector washer to seat cushion frame (Fig. 15-47).
3. Remove bolt securing seat back stop cable to seat back inner hinge arm (Fig. 15-47) and remove cable from seat.
4. To install seat back stop cable, reverse removal procedure.

### FRONT BUCKET SEAT BACK ASSEMBLY (Right or Left)—Standard Bucket Seat—"F & Z" Styles

#### Removal and Installation

1. Remove front seat assembly as previously described.
2. Using a flat-bladed tool inserted between seat back hinge arm and hinge arm cover, carefully disengage upper portion of cover from fastener

and remove cover from both inner and outer hinge arms (See Fig. 15-47). If removing passenger's seat back on Chevrolet "F & Z" styles, remove screw securing seat back stop cable and trim protector washer to seat cushion frame (Fig. 15-47).

3. Carefully disengage and remove retainer securing both inner and outer hinge arms to seat cushion hinge pins (Fig. 15-47).
4. Pull seat back hinge arms outward sufficiently to disengage hinge arm from hinge pin and remove seat back from seat cushion.
5. To install, reverse removal procedure.

### FRONT SEAT BACK LOCK (Right or Left)—"F & Z" Body Standard Bucket Seats

#### Removal and Installation

1. Remove front seat back assembly, as previously described.
2. Remove seat back lock handle knob (See Fig. 15-48).

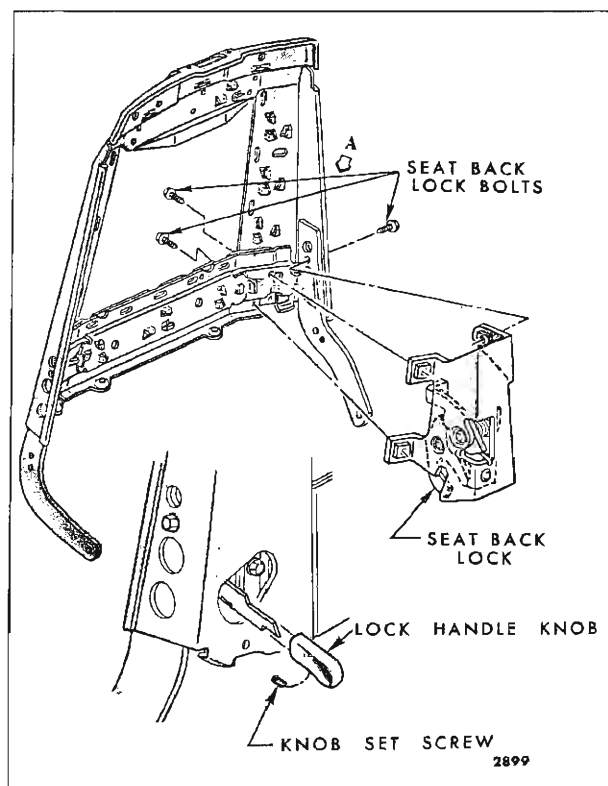

Fig. 15-48—Front Seat Back Lock - "F & Z" Standard Bucket Seats



3. Remove seat back panel and detach seat back trim outer side facing sufficiently to gain access to lock attaching bolts (Fig. 15-48).
4. Remove seat back lock attaching bolts (Fig. 15-48) and remove seat back lock from seat back.
5. To install, reverse removal procedure. Check for proper operation of seat back lock.

**STRATO FRONT SEAT BACK ASSEMBLY—  
(Right or Left)—Full Width Seat with  
Stationary Seat Backs—All Styles  
(Except 16639 Style)**

**Removal and Installation**

1. Remove front seat assembly as described un-

- der, "Full Width Front Seat Assembly - Removal and Installation".
2. At side of seat from which seat back is being removed, remove hog rings securing cushion side trim at rear of seat and fold trim forward sufficiently to expose two seat back outer attaching bolts (Fig. 15-49).
3. At inboard side of seat back, remove screw securing inner attaching bolt cover plate and remove cover plate.
4. Remove seat back inner attaching bolts; then, remove outer attaching bolts and remove seat back assembly from seat.
5. To install seat back assembly, reverse removal procedure. Make certain seat side panel support (Fig. 15-49) is secured under seat back outer attaching bolts.

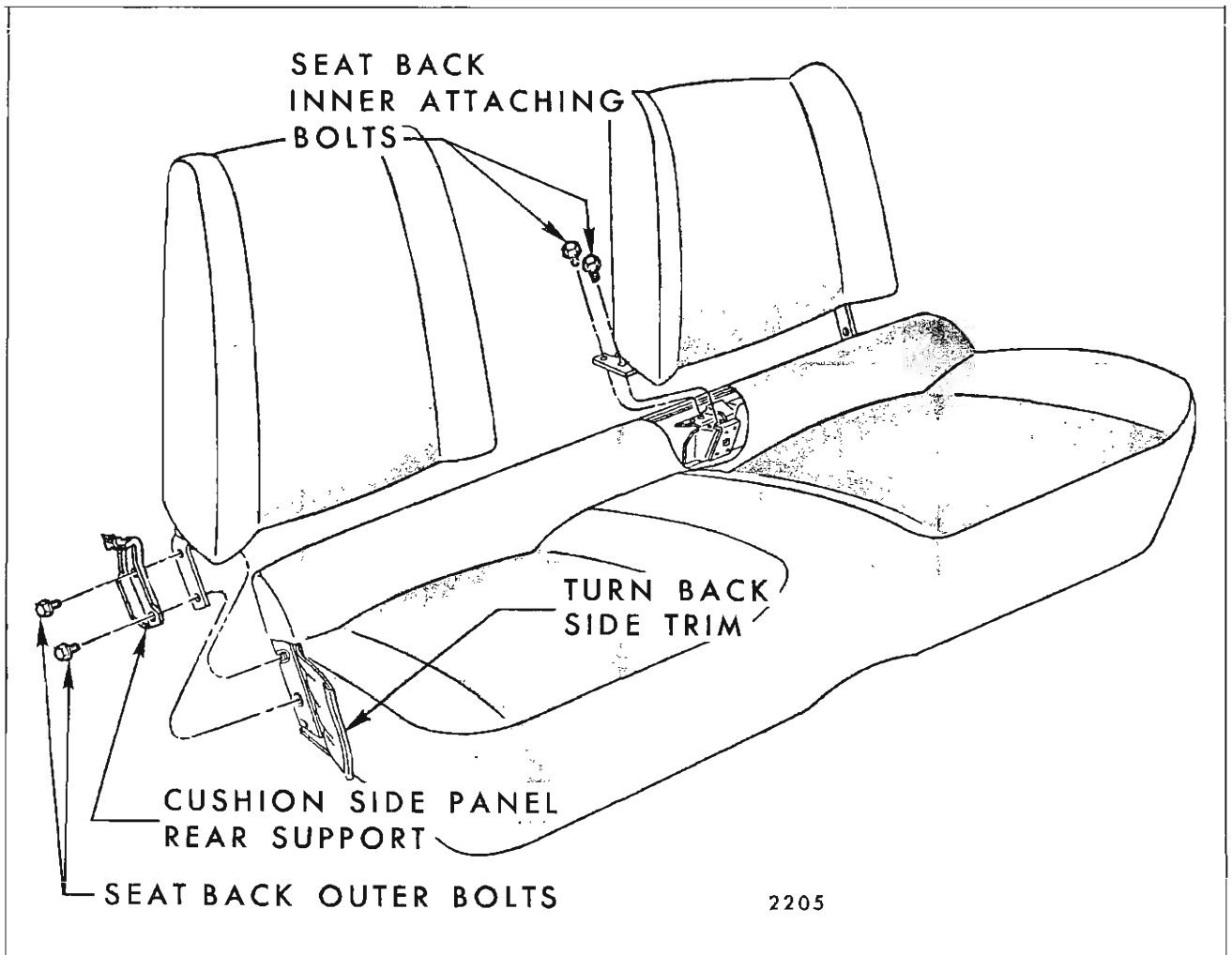

2205

Fig. 15-49—Strato Full Width Seat Back Attachment

## STRATO FRONT SEAT BACK ASSEMBLY (Right or Left)—Full Width Seat— 16639 Style

### Removal and Installation

1. Remove seat assembly from body, as previously described, and place seat right side up on a clean surface.
2. Remove seat side panel on side from which seat back is being removed. Remove hog rings securing seat cushion trim side facing at rear of seat and turn side facing forward sufficiently to expose seat back outer arm attaching bolts (Fig. 15-49).
3. Using a suitable open end wrench between seat

back and seat cushion, at location "A", remove nut locking seat back to inner hinge (See View "A", Fig. 15-50).

4. Remove seat back outer arm attaching bolts (Fig. 15-49).
5. Carefully tilt seat back forward. Remove inner hinge bolt cover plate. Remove inner hinge bolts (Fig. 15-50) and carefully remove seat back from seat assembly.
6. To install, reverse removal procedure.

**NOTE:** It is important that removal procedure is reversed step by step when installing seat back assembly.

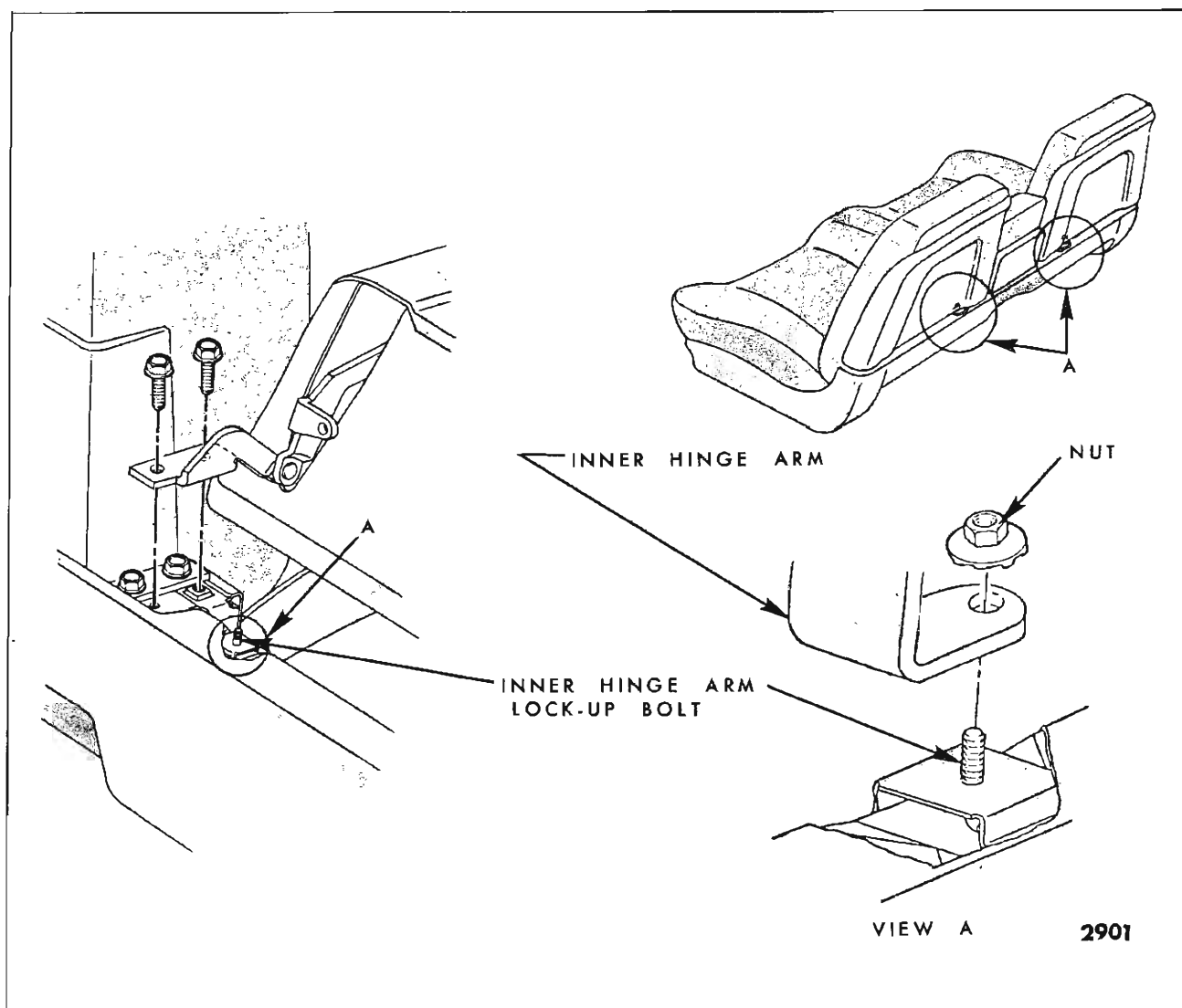

Fig. 15-50—Strato Front Seat Back Assembly (Right or Left) Full Width Seat - 16639 Styles

### STRATO FRONT SEAT BACK PANEL— Four-Door Styles with Non-Folding Seat Back

#### Removal and Installation

1. Remove front seat back assembly as previously described.
2. Remove three screws securing bottom of seat back panel to seat back frame.
3. Pull bottom of seat back panel outward and lift panel upward to disengage panel from upper retainers; then, remove panel from seat back.
4. To install seat back panel, reverse removal procedure.

### STRATO FRONT SEAT BACK PANEL— Two-Door Styles Except Styles with Passengers Reclining Seat Back

#### Removal and Installation

1. Remove head restraint from seat back.
2. Using a flat-bladed tool, carefully snap off seat back lock push button and escutcheon assembly and remove two screws securing seat back panel to lock assembly (Fig. 15-51).

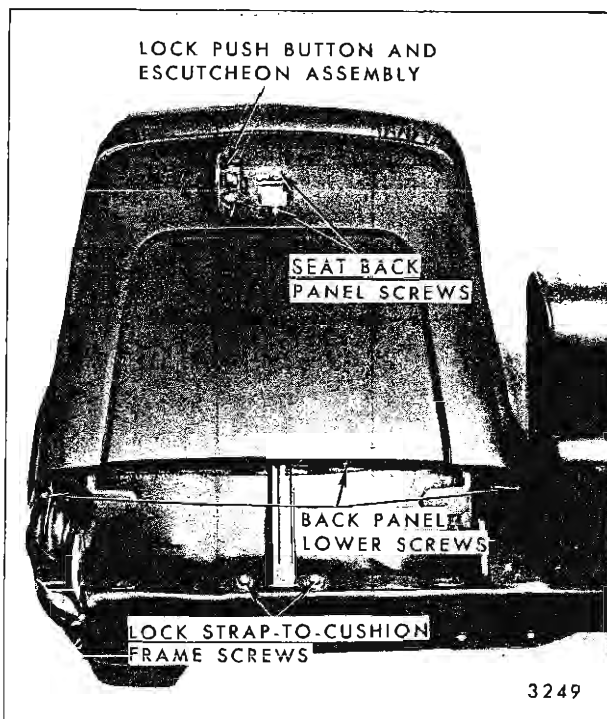

Fig. 15-51—Strato Back Panel Removal - Strato Folding Seats (Except Reclining Seat)

3. Tilt seat back forward and remove three screws securing bottom of seat back panel to seat back frame (Fig. 15-51).
4. Pull bottom of seat back panel outward and lift panel upward to disengage panel from upper retainers; then, remove panel from seat back.
5. To install seat back panel, reverse removal procedure. When snapping on seat back lock push button and escutcheon assembly, make sure assembly is installed right side up with contour of side flanges matching contour of seat back panel.

### STRATO FRONT SEAT BACK PANEL— Two-Door Styles Equipped with Reclining Front Passenger Seat Back

#### Removal and Installation

1. Remove head restraint from seat back.
2. Remove seat back lock push button escutcheon attaching screws and remove push button escutcheon, push button and ferrule.
3. Tilt seat back forward and remove two screws securing bottom of seat back panel to seat back frame.
4. Pull bottom of seat back panel outward and lift panel upward to disengage panel from upper retainers; then, remove panel from seat back.
5. To install seat back panel, reverse removal procedure.

### STRATO FRONT SEAT BACK HEAD RESTRAINTS

#### Operation and Removal

Front seat back head restraints are standard factory installed equipment for the driver and right front passenger. They can be adjusted to two heights (low or high) or removed by moving the locking lever, at the head restraint post escutcheons, forward and adjusting the head restraint "up" or "down" or removing the head restraint from the seat.

### STRATO SEAT BACK HEAD RESTRAINT RETAINER AND GUIDE TUBE

#### Removal and Installation

1. Remove head restraint from seat back. Remove escutcheon attaching screws and remove escutcheon (Fig. 15-52)

2. Remove two screws securing retainer to seat back (Fig. 15-52).

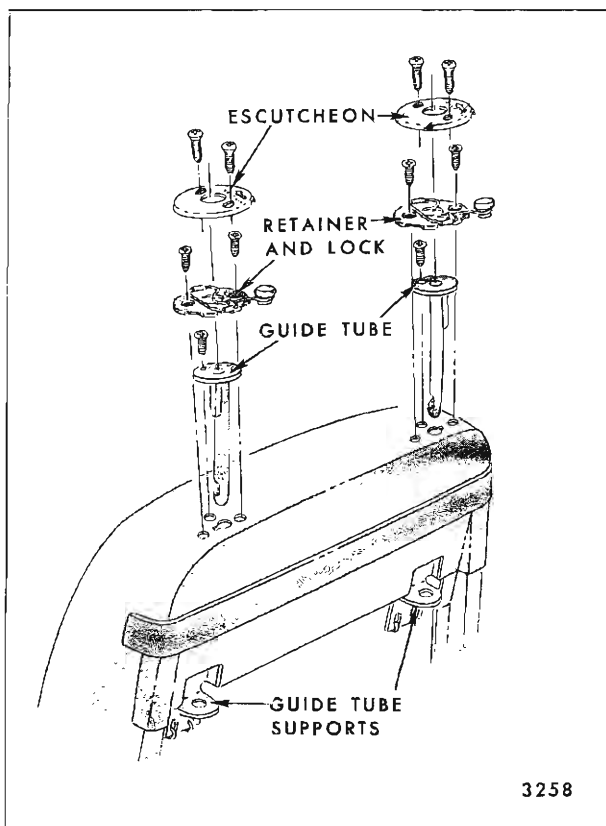

Fig. 15-52—Head Restraint - Strato Seats

3. Remove seat back panel, as previously described.
4. Detach seat back trim cover sufficiently to expose upper end of guide tube.
5. Remove screw securing upper flange of guide tube to seat back frame (Fig. 15-52); then, pull tube out of supports.
6. To install guide tube and retainer, reverse removal procedure.

### STRATO FRONT SEAT BACK LOCK ASSEMBLY—Two-Door Full Width Strato Seat and Strato Bucket Seats (Except Styles with Reclining Seat Back)

#### Removal and Installation

1. Remove front seat back panel, as previously described.
2. **IMPORTANT:** If removing and reinstalling

same lock assembly, install lock-up screw (8-32 x 1/2" screw) at location shown in Figure 15-53.

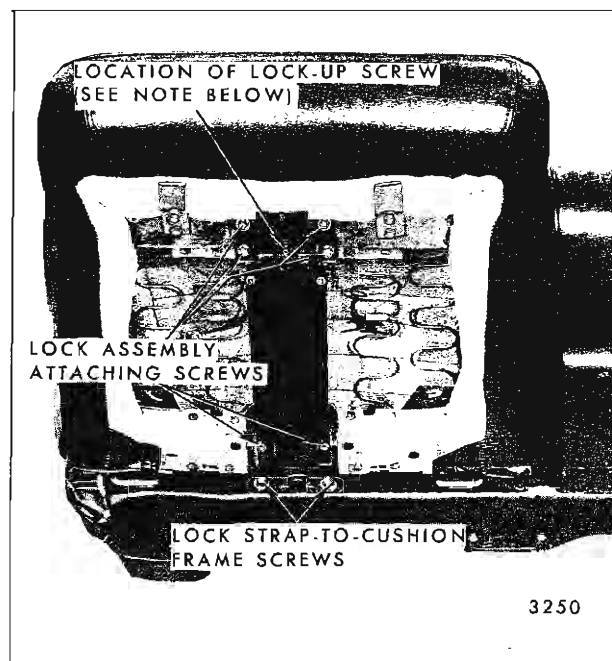

Fig. 15-53—Strato Seat Back Lock Assembly

3. Remove lock strap-to-cushion frame attaching screws (Fig. 15-53).
4. Remove lock assembly attaching screws (Fig. 15-53) and remove lock assembly from seat back.
5. To install seat back lock assembly, reverse removal procedure.

**IMPORTANT:** After all lock assembly attaching screws, including lock strap-to-cushion frame screws, have been tightened, remove lock-up screw at location shown in Figure 15-53.

### STRATO FRONT SEAT BACK ELECTRIC ACTUATOR ASSEMBLY—Cadillac Two-Door Styles Equipped with Electrically Operated Strato Front Seat Back Locks

#### Removal and Installation

1. Remove front seat back panel, as previously described.
2. Disconnect actuator feed wire connector (Fig. 15-54).

3. Remove seat back lock, as described under "Strato Front Seat Back Lock Assembly - Steps 2 through 5".
4. To remove electric actuator assembly, disengage lock connecting rod-to-actuator clip (Fig. 15-54) and disengage rod from actuator.

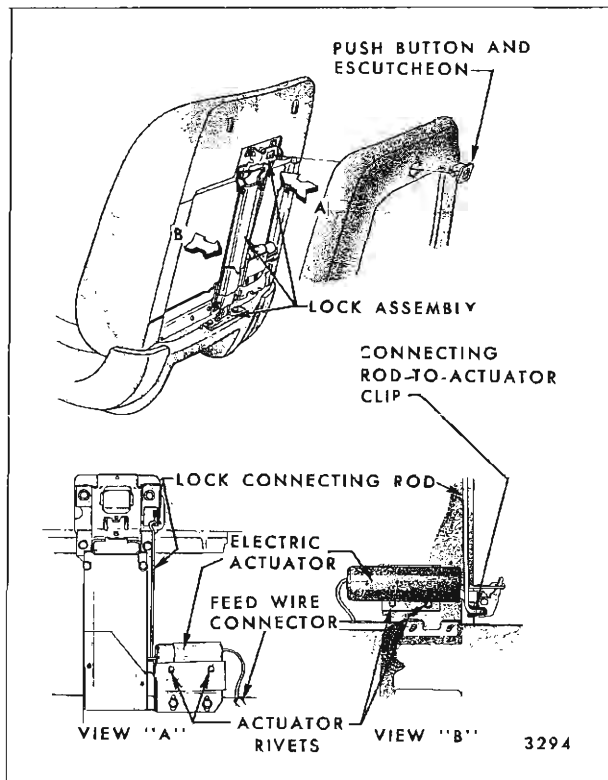

Fig. 15-54—Strato Seat Back Electric Lock and Lock Actuator - Cadillac

5. Remove lock actuator attaching rivets and remove actuator assembly.
6. To install seat back lock or electric actuator assemblies, reverse removal procedure. Install actuator assembly with rivets or nuts and bolts. Prior to installing seat back panel, check operation of seat back lock several times to assure proper operation.

**IMPORTANT:** With lock actuator energized, check amperage draw at feed connector - amperage should not exceed .6 Amps. If current draw is more than .6 Amps., reposition actuator (usually downward) to obtain a holding current of not over .6 Amps. If nuts and bolts are used in conjunction with slotted attaching holes, drill and install a screw to lock actuator in position.

## STRATO BUCKET SEAT BACK ASSEMBLY— All Except "F&Z" Body Styles and Strato Reclining Seat Back

### Removal and Installation

1. Remove seat assembly from body, as previously described, and place on a clean protected surface.
2. On Cadillac styles with electric actuated seat back locks remove seat back panel, as previously described. Disconnect electric actuator feed wire connector (See Fig. 15-54) and pull feed wire out of seat back.
3. With seat side panels removed, remove hog rings securing seat cushion trim at rear of seat and along bottom of seat and turn back trim sufficiently to expose seat back hinge-to-seat cushion frame attaching bolts (Fig. 15-55).

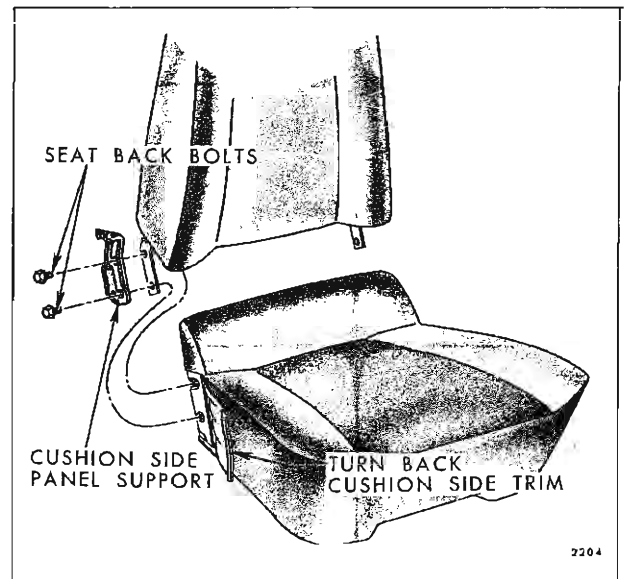

Fig. 15-55—Bucket Seat Back Removal (Without Reclining Seat Back) - All Except Corvair

4. Remove seat back hinge-to-seat cushion frame attaching bolts (Fig. 15-55) from both sides of seat and remove seat back assembly from seat cushion.
5. To install seat back assembly, reverse removal procedure. Check for proper operation of seat back lock.

## RECLINING FRONT SEAT BACK

### Description

The reclining seat back which is available on the passenger seat of the Strato design front seats can

be reclined approximately 30 degrees from the normal seat back position. The reclining unit is a friction operation mechanism and is actuated by a control handle and cable at the right side of the seat.

When the control handle is pulled upward the control cable unlocks the reclining positioning unit in the seat back allowing the seat back to be reclined, by means of rearward pressure on the seat back, to a maximum of approximately 30 degrees or until the control handle is released. When the control handle is released the reclining positioning unit is locked and will not allow the seat back to be reclined further. When the control handle is pulled up and there is no rearward pressure on the seat back, the assist spring in the reclining positioning unit will return the seat to the normal position or to a position at which the handle is released. The friction mechanism of the positioning unit will allow the seat back to be moved forward to the normal position with approximately four pounds manual forward push at the top of the seat back. This "dress-up" feature allows the driver or passenger to return a reclined seat back to its normal position without having to operate the control handle.

## RECLINING SEAT BACK ASSEMBLY

### Removal and Installation

1. Remove seat assembly from body, as previously described, and place on a clean protected surface.
2. On right side of seat with seat side panel removed, remove hog rings securing cushion trim at rear of seat and along bottom of seat and turn back trim sufficiently to expose seat back attaching bolts and reclining control cable attachment at handle control lever (Fig. 15-56).
3. Detach reclining positioning unit control cable from handle control lever; then, pull control cable through cable guide and through grommet in cushion trim (Fig. 15-56).
4. a. On reclining bucket seat remove hog rings securing cushion side trim facing on inboard side of seat and turn trim forward sufficiently to expose seat back attaching bolts. Then remove seat back attaching bolts from both sides of seat and remove seat back assembly from seat.  
b. On reclining full width seat, remove screw at inboard side of seat back attaching bolt cover plate and remove cover plate. Remove seat back inner attaching bolts; then, remove seat back outer attaching bolts and remove seat back assembly from seat.
5. To install seat back assembly, reverse removal procedure. Make certain side panel support (Fig. 15-56) is secured under seat back outer attaching bolts.

## RECLINING SEAT BACK POSITIONING UNIT

### Removal and Installation

1. Remove seat assembly from body, as previously described, and place on a clean protected surface.
2. On right side of seat with seat cushion side panel removed, remove hog rings securing cushion trim at rear of seat and along bottom of seat and turn back trim sufficiently to expose reclining control cable attachment at handle control lever (Fig. 15-56).
3. Remove seat back panel as described under "Strato Front Seat Back Panel - Removal and Installation".
4. Remove hog rings securing right side of seat back trim to seat back frame and turn trim forward sufficiently to expose positioning unit (Fig. 15-56).
5. Detach reclining positioning unit control cable from handle control lever; then, pull control cable through cable guide and through grommet in cushion trim (Fig. 15-56).
6. Using a suitable size drift punch, carefully drive out roll pins securing positioning unit to support on seat back frame and to seat back hinge (Fig. 15-56); then remove positioning unit from seat back.

**IMPORTANT:** If roll pins do not drive out easily use a suitable back up to prevent possible damage or breakage of the positioning unit or mounting brackets.

## RECLINING SEAT BACK LOCK STRIKER, AND SEAT BACK LOCK—Strato Full Width or Bucket Seat

### Removal and Installation

1. Remove front seat assembly, reclining seat back and seat back panel as previously described.
2. At seat back inner hinge assembly remove hog rings and detach seat back trim sufficiently to gain access to seat back lock and lock striker attaching bolts (Fig. 15-57).



2529

Fig. 15-56--Reclining Seat Back and Positioning Unit

- |  |   |
|--|---|
| 1. Reclining Positioning Unit            | 6. Handle Control Lever                 |
| 2. Positioning Unit Attaching Roll Pins  | 7. Control Handle                       |
| 3. Positioning Unit Control Cable        | 8. Seat Back Hinge Attaching Bolts      |
| 4. Control Cable Grommet in Cushion Trim | 9. Seat Cushion Side Panel Rear Support |
| 5. Control Cable Guide                   | 10. Seat Back Hinge                     |

3. Remove seat back lock striker attaching bolts (Fig. 15-57) and remove striker.
4. Disengage clip securing lock rod to lock as shown in View "B", Fig. 15-57 and detach rod from lock.
5. Remove lock-to-hinge attaching bolts (Fig. 15-57) and remove lock assembly from seat back hinge.
6. To install seat back lock assembly, reverse removal procedure. Make certain lock rod and clip are properly engaged at lock lever. Check for proper operation of seat back lock.

### RECLINING SEAT BACK LOCK CONTROL SUPPORT—Strato Full-Width or Bucket Seat

#### Removal and Installation

1. Remove front seat assembly, reclining seat back and seat back panel, as previously described.
2. At right side of seat back remove hog rings and detach seat back trim sufficiently to gain access to seat back lock control support (Fig. 15-57).
3. Remove control support attaching screws (Fig. 15-57) and remove support.
4. To install lock control support, reverse removal procedure. Check for proper operation of seat back lock.

### RECLINING SEAT BACK LOCK CONTROL ASSEMBLY—Strato Full-Width or Bucket Seat

#### Removal and Installation

1. Remove front seat assembly, reclining seat back and seat back panel, as previously described.
2. Remove hog rings securing seat back trim cover and padding to seat back frame and remove seat back trim cover and padding.

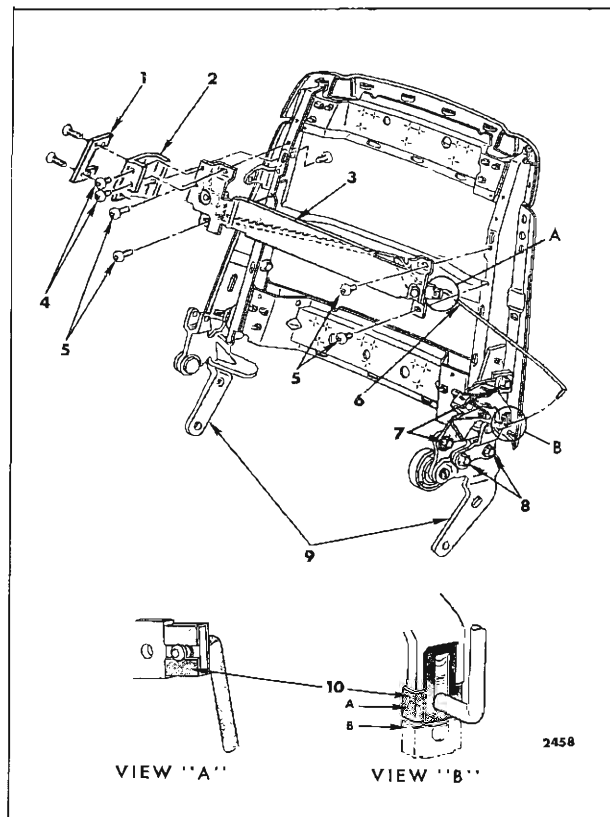

Fig. 15-57—Strato Reclining Seat Back Lock

- |                           |                                 |
|---------------------------|---------------------------------|
| 1. Trim Retainer          | 8. Seat Back Lock Striker Bolts |
| 2. Control Support        | 9. Reclining Seat Back Hinges   |
| 3. Control Assembly       | 10. Lock Rod Clip -             |
| 4. Control Support Screws | a. Engaged Position             |
| 5. Control Screws         | b. Disengaged Position          |
| 6. Lock Rod               |                                 |
| 7. Seat Back Lock Bolts   |                                 |

3. Disengage clip securing lock rod to control assembly (View "A", Fig. 15-57) and detach rod from control assembly.
4. Remove control support and control assembly attaching screws (Fig. 15-57); then, remove control assembly from seat back.
5. To install, reverse removal procedure. Prior to installing seat assembly in body, check for proper operation of seat back lock.



## REAR SEATS

### REAR SEAT CUSHION—All Styles (Except "A-65" Styles)

#### Removal

1. Push lower forward edge of seat cushion rearward; then, lift upward and pull forward on seat cushion frame to disengage cushion frame wires from retainers on rear seat pan (Fig. 15-58).

**NOTE:** If difficulty is experienced in disengaging the front edge of the rear seat cushion from retainers on rear seat pan it may be necessary to kneel (on four-door styles) or stoop (on two-door styles) on the rear floor pan. Grasp lower edge of seat cushion at location of retainer on one side of seat; then, lean forward (towards seat cushion) using leg pressure against hands or arms, exert sufficient rearward pressure to disengage seat from retainers (Fig. 15-58).

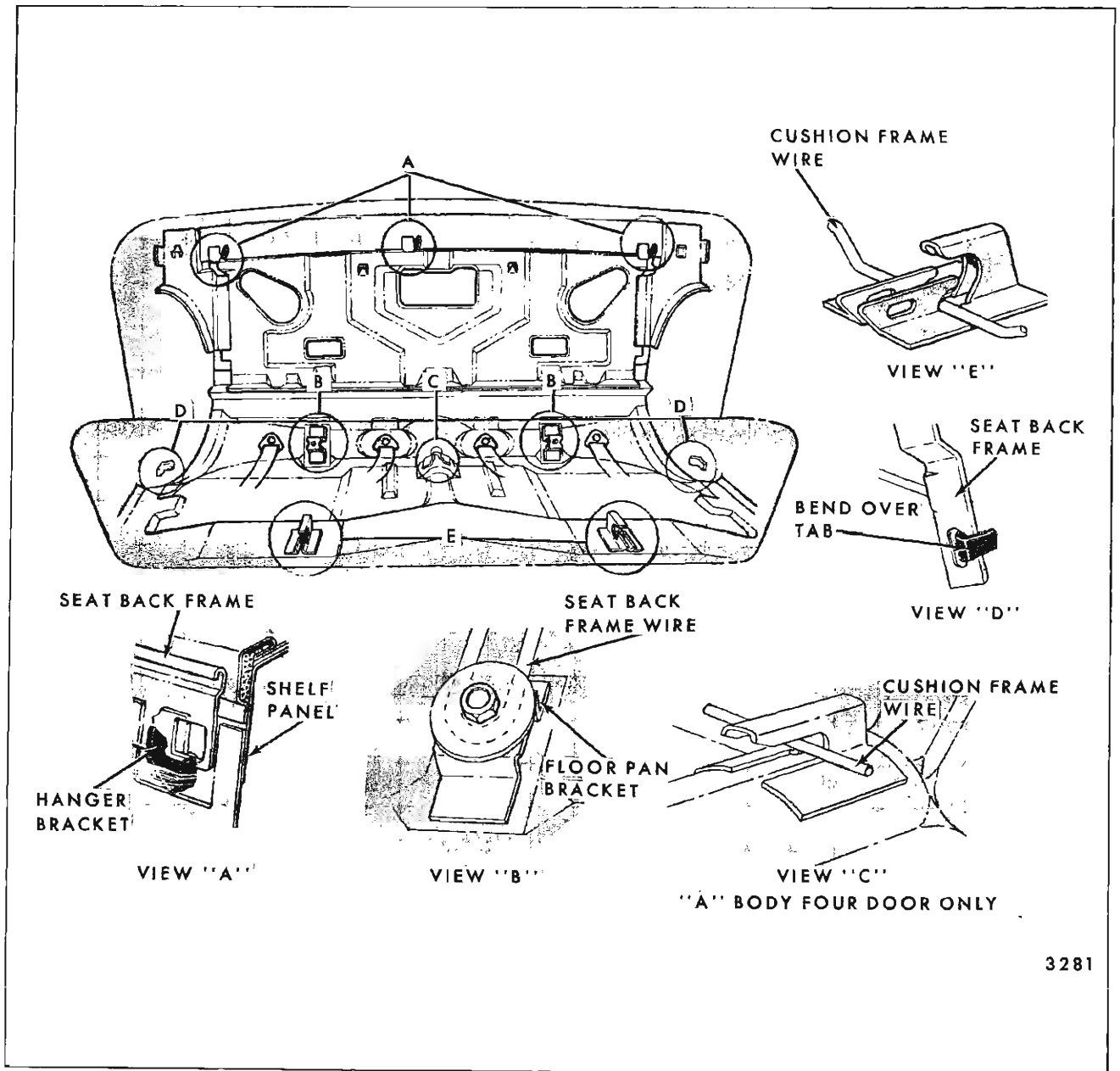

Fig. 15-58—Rear Seat Cushion and Back Installation - All Styles Except Station Wagons and Cadillac Limousine

## Installation

1. Carefully lift cushion into body using caution not to damage adjacent trim.
2. Position rear edge of cushion under rear seat back assembly. On "A" Body four-door styles make certain rear portion of seat cushion frame is engaged with retainer on rear seat pan.
3. Align wire protrusions on front of seat cushion frame with retainers on floor pan. Push seat cushion assembly rearward until protrusions engage in retainers; then, press down and pull cushion forward to fully engage in retainers.

**NOTE:** If difficulty is experienced in engaging front of cushion in retainers, use the same method described under step 1 of "Removal", to engage cushion in retainers.

**IMPORTANT:** If seat cushion frame protrusions are not properly centered in relation to retainers on seat pan, proper engagement and placement of cushion will be extremely difficult.

## REAR SEAT BACK ASSEMBLY— All Styles Except Station Wagons and "F&Z" Body with Folding Rear Seat Back

### Removal and Installation

1. Remove rear seat cushion assembly.
2. At bottom of seat back bend out tabs and where present, remove screws securing the lower portion of the seat back to floor panel. On convertible styles, remove screw from rear side of seat back panel support securing upper corners of seat back to panel.

**NOTE:** If screws are used to secure center of rear side to seat back panel it will be necessary to work from inside rear compartment to remove screws.

3. Pull seat back assembly out at the bottom until seat back clears body tabs; then, on all styles except "E" styles, raise seat back upward until disengaged from hangers on the seat back panel support. On "E" styles push seat back downward until wire protrusions at top of seat back are disengaged from slots in seat back panel support.
4. Remove seat back assembly from body.
5. To install, reverse removal procedure, making certain that all attaching body tabs and hangers

have industrial body tape applied to them to act as an anti-squeak.

## FOLDING REAR SEAT BACK— "F" Body Styles

### Removal and Installation

1. Remove rear seat cushion and lower folding rear seat back.
2. At both right and left seat back link, remove stud nut securing seat back link to anchor plate on floor pan (Fig. 15-59).

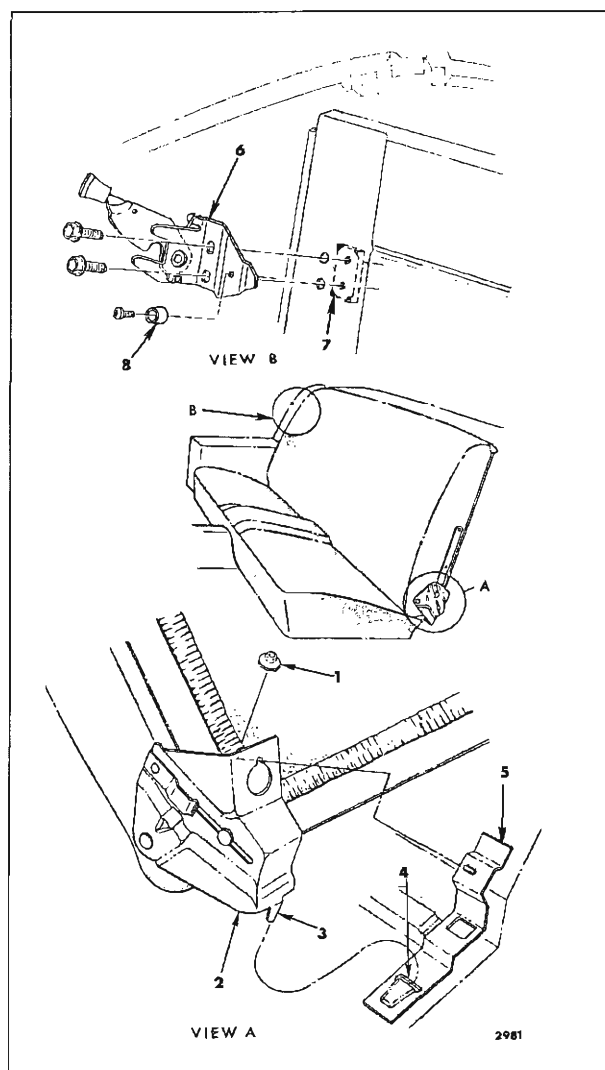

Fig. 15-59—Folding Rear Seat Back Assembly - "F" Body Styles

- |                                    |   |
|------------------------------------|---|
| 1. Link-to-Actuator Plate Stud Nut | 5. Folding Seat Back Link Anchor Plate (on floor pan) |
| 2. Folding Seat Back Link          | 6. Back Lock Assembly                                 |
| 3. Link Tab                        | 7. Lock Anchor Plate                                  |
| 4. Anchor Plate Slot               | 8. Rubber Bumper                                      |

3. Lift seat back assembly upward to disengage tab of link from slot in anchor plate (Fig. 15-59) and remove seat back assembly from body.
4. To install folding seat back assembly, reverse removal procedure.

### **FOLDING REAR SEAT BACK LOCK— “F” Body Styles**

All “F” bodies equipped with a folding rear seat incorporate a positive rear seat back lock located at the right side of the seat back. When the seat back is raised to the “up” position, a lock striker secured to the right side of the seat back frame engages with the lock which is secured to the seat back support. To lower the seat back, raise the lock release lever at the right side of the seat back and lower the seat back.

#### **Removal and Installation**

1. Lower the folding rear seat back.
2. Remove rubber bumper (Fig. 15-59) and remove compartment front trim foundation.
3. Mark location of seat back lock on seat back support panel.
4. While holding the lock anchor plate on the back side of the seat back support, remove lock attaching screws (Fig. 15-59, View “B”) and remove lock and anchor plate.
5. To install rear seat back lock assembly, reverse removal procedure aligning lock with previously made marks.

Check for proper operation of lock and, if necessary, adjust lock up or down for proper operation.

### **FOLDING REAR SEAT BACK— “Z” Body Styles**

#### **Removal and Installation**

1. Remove rear seat back cushion, as previously described.
2. Lower folding seat back; then, remove three screws from both sides of seat back securing seat back to folding linkage (Fig. 15-60).
3. Carefully disengage seat back from linkage and remove folding seat back from body.
4. To install, reverse removal procedure.

### **FOLDING REAR SEAT BACK LINKAGE— “Z” Body Styles**

#### **Removal and Installation**

1. Remove rear seat cushion and folding seat back, as previously described.
2. Mark position of linkage on floor pan. Remove bolts securing folding seat back linkage to floor pan (Fig. 15-60) and remove linkage.
3. To install, reverse removal procedure. Align linkage on floor pan with previously made alignment marks.

### **FOLDING REAR SEAT BACK LOCK— “Z” Body Styles**

#### **Removal and Installation**

1. Lower the folding rear seat back. Mark position of rear seat back lock to facilitate installation in same position.
2. Remove lock attaching screws (Fig. 15-60) and remove lock assembly from rear compartment front panel.
3. To install rear seat back lock assembly, reverse removal procedure aligning lock with previously made marks.

Check for proper operation of lock and, if necessary, adjust lock up or down for proper operation.

### **REAR SEAT BACK CENTER ARM REST AND CURTAIN**

#### **Removal and Installation**

1. Lower rear seat back arm rest. On all styles except 68069 carefully pull upper portion of arm rest curtain out of slot in hanger plate and fold curtain forward. On 68069 styles, fold arm rest flipper forward.
2. Remove four screws securing arm rest to hanger plate linkage then, remove arm rest from seat back.
3. To install, reverse removal procedure.

### **REAR SEAT BACK CENTER ARM REST HANGER PLATE AND LINKAGE**

#### **Removal and Installation**

1. Remove rear seat back center arm rest; then, remove two screws securing arm rest hanger

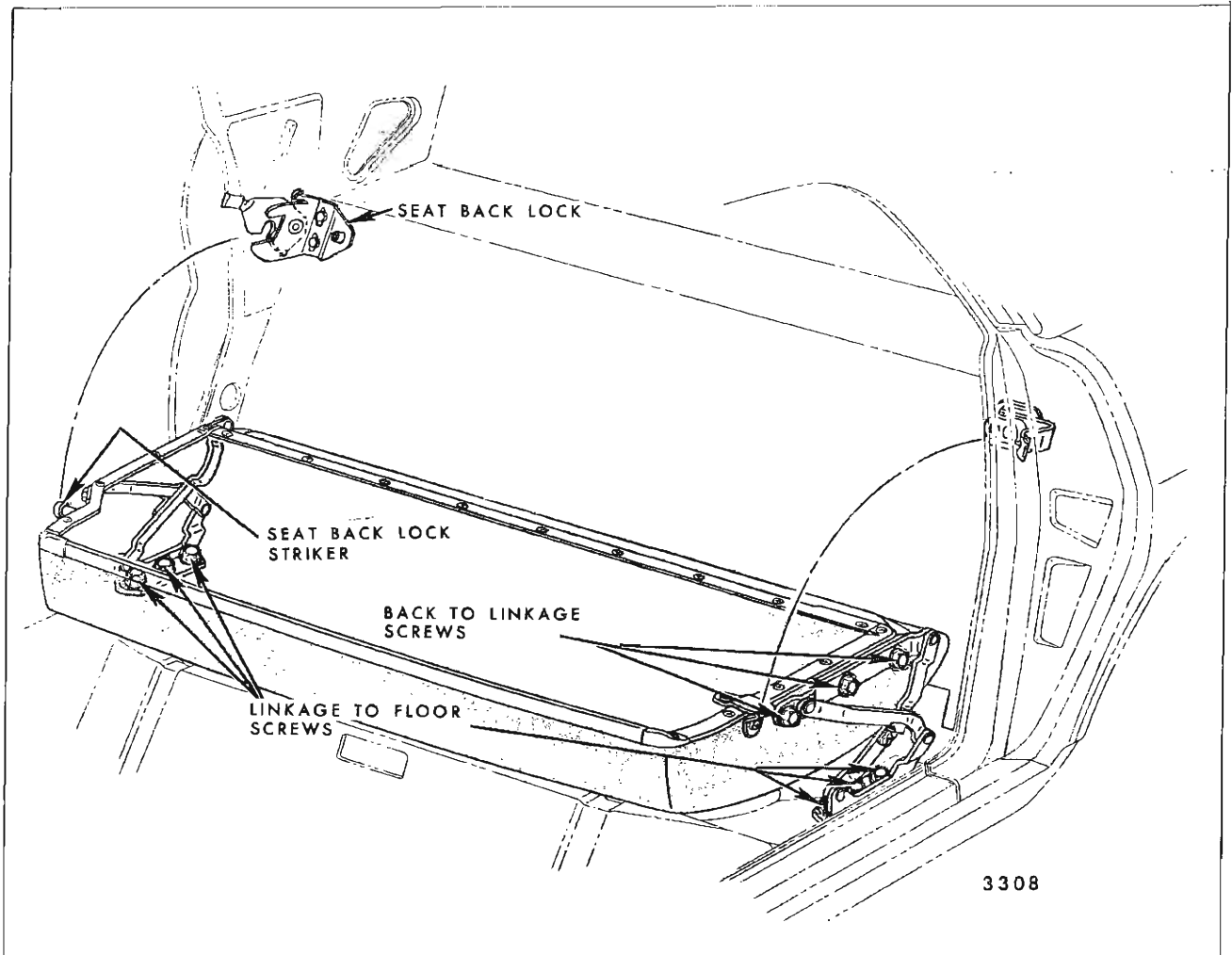

Fig. 15-60—Folding Rear Seat Back and Lock - Corvair

plate to body seat back support brace. Remove rear seat back.

2. On back side of rear seat back, remove four screws securing arm rest hanger plate to seat back supports; then, carefully remove arm rest and hanger plate assembly from seat back (Fig. 15-61).
3. To install, reverse removal procedure. Prior to tightening hanger plate screws move arm rest assembly upward until top is snug against top of opening in seat back.

### AUXILIARY SEAT ASSEMBLY— Cadillac Limousine Styles

#### Removal and Installation

1. Place auxiliary seat in the folded forward position.

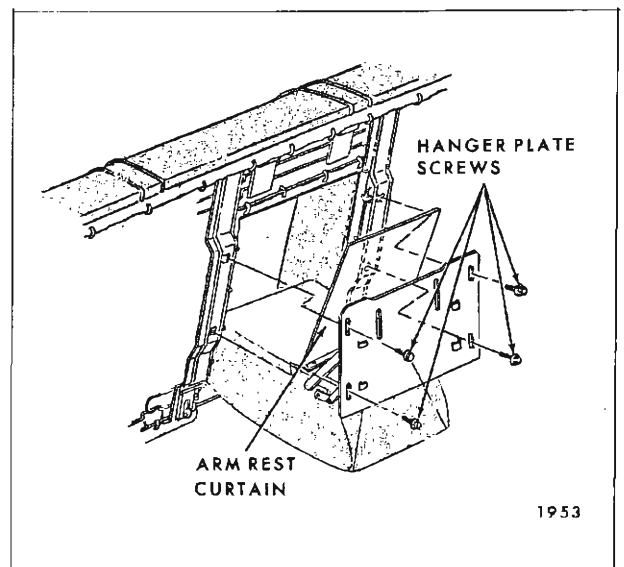

Fig. 15-61—Rear Seat Back Arm Rest and Hanger Plate

2. Move rear seat foot rest rearward; then, un-snap carpet flap. Move foot rest forward and carefully pull carpet flat from under foot rest, as shown in Figure 15-62.

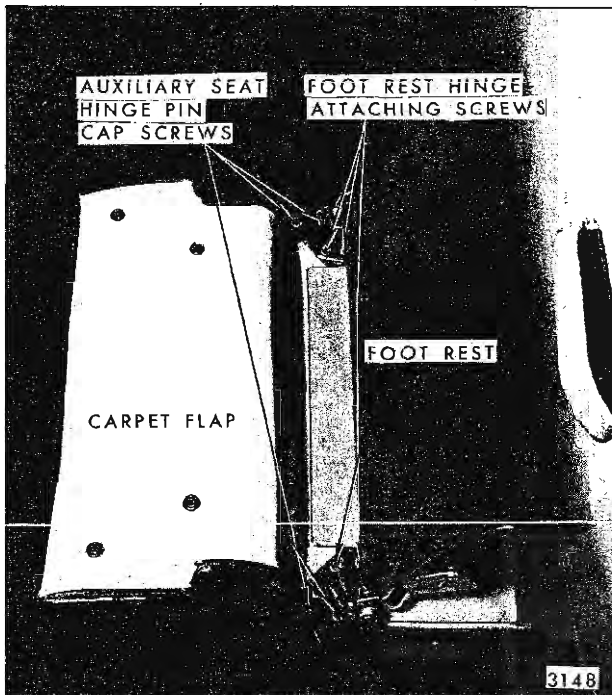

Fig. 15-62—Auxiliary Seat Assembly - Removal and Installation - Cadillac Limousine Styles

3. Remove foot rest hinge attaching screws (Fig. 15-62) and remove foot rest assembly.
4. Remove auxiliary seat hinge pin cap screws (Fig. 15-62); then remove cap and auxiliary seat assembly.
5. To install auxiliary seat assembly, reverse removal procedure.

### AUXILIARY SEAT ADJUSTMENT— Cadillac Limousine Styles

The auxiliary seats in Cadillac Limousine Styles can be adjusted to provide additional leg room for auxiliary seat passengers.

The following procedure describes and illustrates how to adjust the auxiliary seat.

1. Place auxiliary seat in the upright, sitting position.
2. On the front side of the auxiliary seat heel board, turn back foot well carpet flap to expose the auxiliary seat lower outboard and inboard support assemblies (See Fig. 15-63).

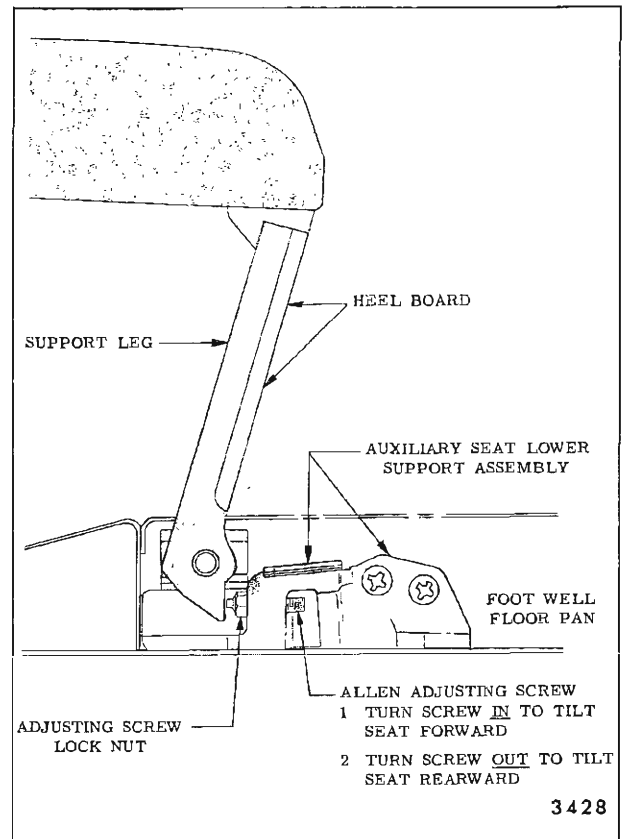

Fig. 15-63—Auxiliary Seat Adjustment - Cadillac Limousine Styles

3. Loosen the allen adjusting screw lock nut at both inboard and outboard supports (See Fig. 15-63).
4. Carefully turn the adjusting screw (See Fig. 15-63) at both supports the same amount to allow the seat to pivot rearward further; thereby, providing additional leg room for the aux-

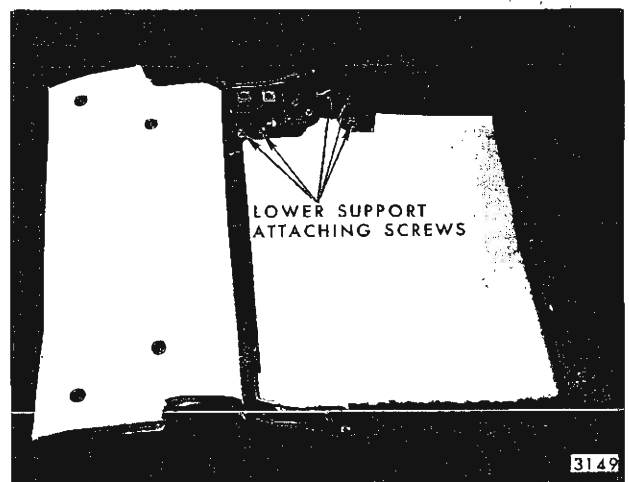
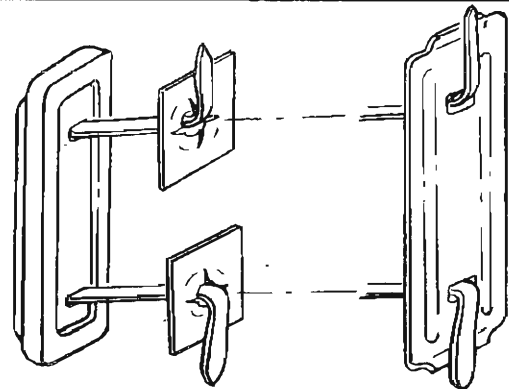
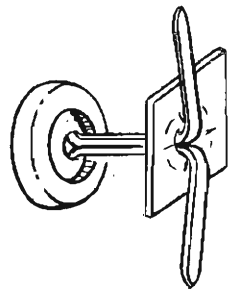
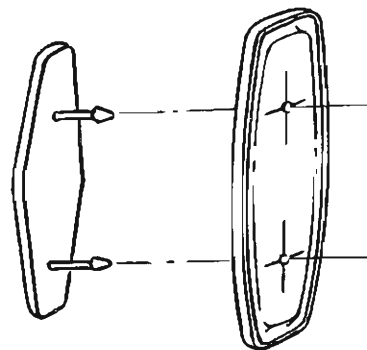
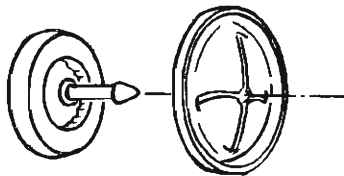

Fig. 15-64—Auxiliary Seat Lower Support - Cadillac Limousine Styles



SINGLE AND DOUBLE LONG PRONG BUTTONS WITH SPRING RETAINERS OR FULL DOUBLE RETAINER



SINGLE AND DOUBLE STUD BUTTONS WITH SHELL RETAINER

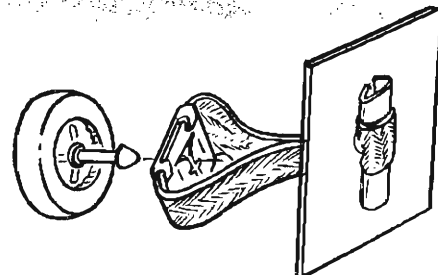
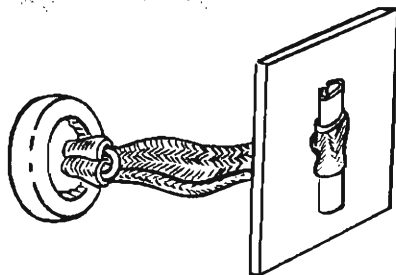

EYELET JIFFY LOOP BUTTON WITH BOARD RETAINER

STUD JIFFY LOOP BUTTON WITH BOARD RETAINER

Fig. 15-65—Typical Seat Trim Buttons and Retainers

iliary seat passenger. Tighten the adjusting screw lock nut at both supports.

When making this adjustment maintain a minimum distance of at least 6 1/4 inches from rear seat cushion to auxiliary seat.

**AUXILIARY SEAT LOWER SUPPORT ASSEMBLY—Cadillac Limousine Styles**

**Removal and Installation**

1. Remove auxiliary seat assembly, as previously described.

2. Remove lower support assembly attaching screws, shown in Figure 15-64, and remove support assembly.

3. To install auxiliary seat lower support assembly, reverse removal procedure.

**SEAT TRIM BUTTONS**

Figure 15-65 illustrates the basic types of seat trim buttons used on 1969 Styles and their method of retention.

**STATION WAGON FOLDING REAR SEATS AND FLOOR PANELS—All Station Wagon Styles Except "55-56-65-66" Styles**

All station wagon second and third seat backs incorporate seat back locks located on the upper right side of the seat backs. On split second seat option, a seat back lock is located at the upper

outer side of each seat back.

The following views are typical of the station wagon folding seats and rear compartment floor panels.

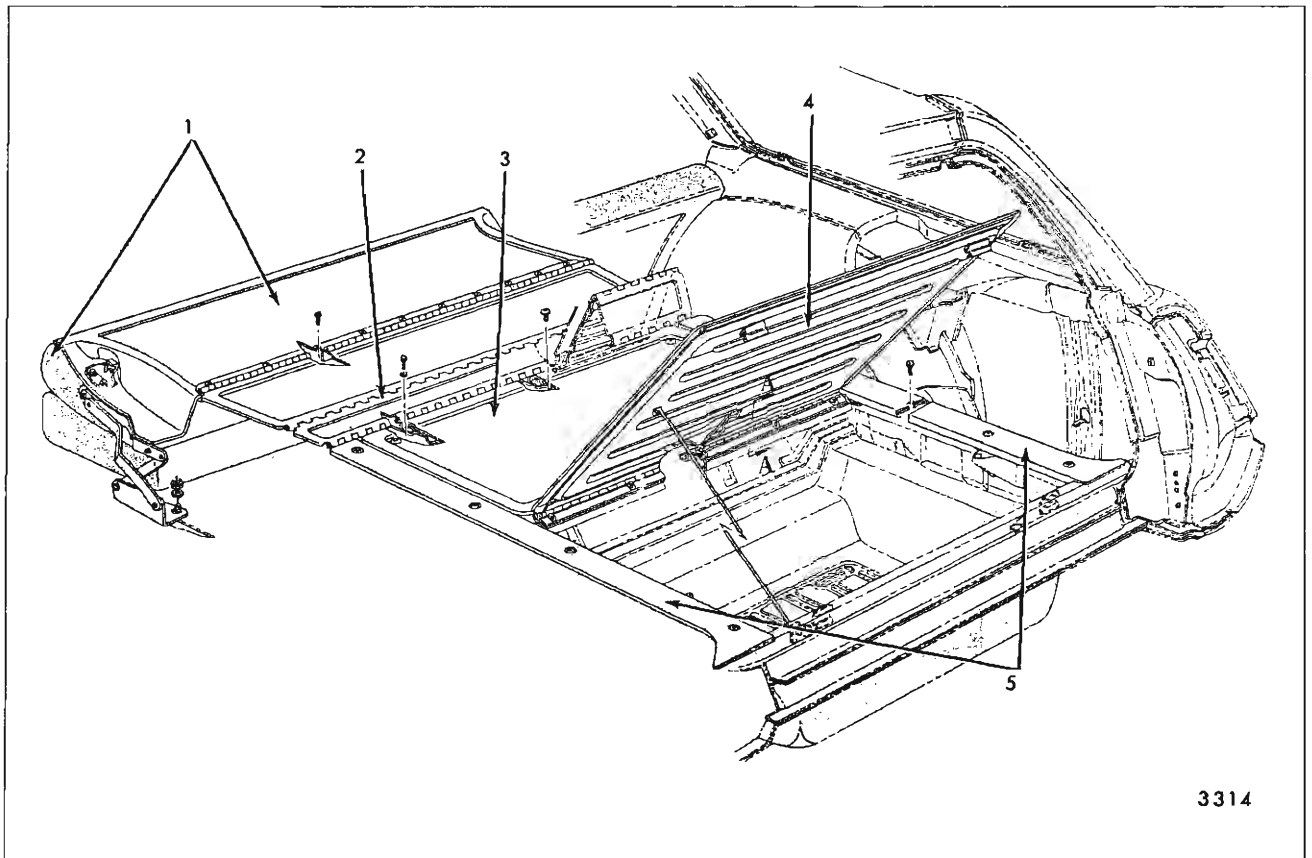

3314

Fig. 15-66—Folding Seats and Load Floor Panels - "A & B" Body Two-Seat Styles

- |   |  |   |
|---|--|---|
| 1. Folding Second Seat Back and Seat Back Panel | 3. Rear Compartment Floor Panel (At Kick-Up) | 5. Rear Floor Side Filler Panels - Left and Right |
| 2. Rear Floor Filler Panel                      | 4. Luggage Compartment Cover Panel           |   |

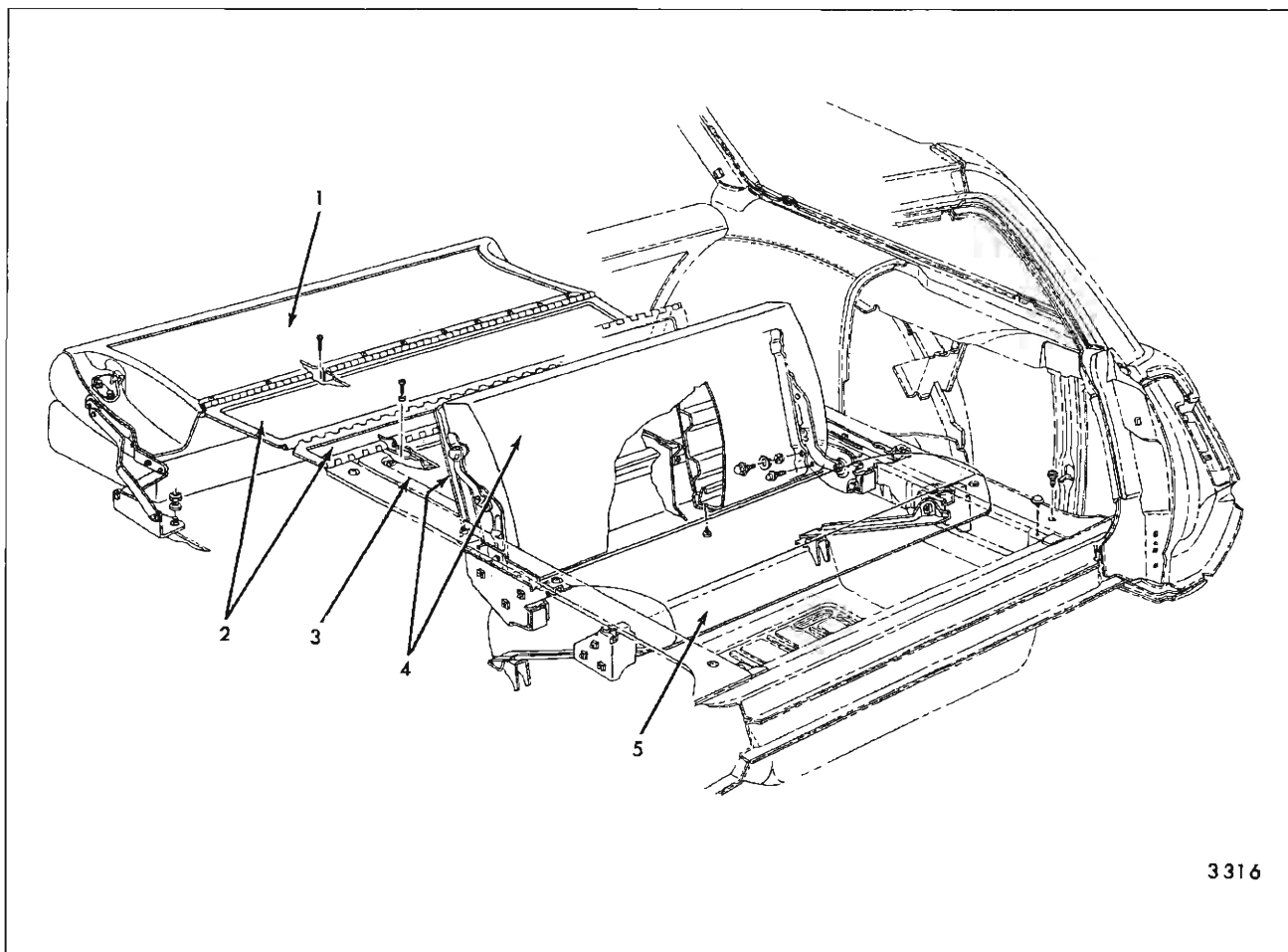

Fig. 15-67—Folding Seats and Load Floor Panels - "A" Body Three-Seat Styles

- |  |   |
|--|---|
| 1. Folding Second Seat Back and Back Panel   | 4. Folding Third Seat Back and Panel    |
| 2. Rear Floor Filler Panel                   | 5. Folding Third Seat Cushion and Panel |
| 3. Rear Compartment Floor Panel (at Kick-Up) |   |

These illustrations identify the component panels of the rear compartment area and their relationship to adjacent panels.

Figure 15-66 is typical of all "A-35 and 36 Series and Chevrolet and Pontiac "B-36" Series two-seat Station Wagons.

Figure 15-67 is typical of Chevrolet "A-45 & 46" Series Three-Seat Station Wagons.

Figure 15-68 is typical of Chevrolet and Pontiac "B-46" Series Three-Seat Station Wagons.

Figure 15-69 is typical of Pontiac "B-36" Series Two-Seat (Split Second Seat Option) Station Wagon.

### REAR FLOOR-TO-TAIL GATE FILLER PANEL ASSEMBLY

Refer to "Tail Gate" Section for Removal and Installation procedures.

### COMPARTMENT PAN SIDE FILLER PANEL (Right or Left Side) "B" Body Two-Seat and Three Seat Styles

#### Removal and Installation

1. On "35" Styles, use handle and fold rear luggage compartment panel forward until it is resting entirely on front luggage compartment panel (Fig. 15-70).



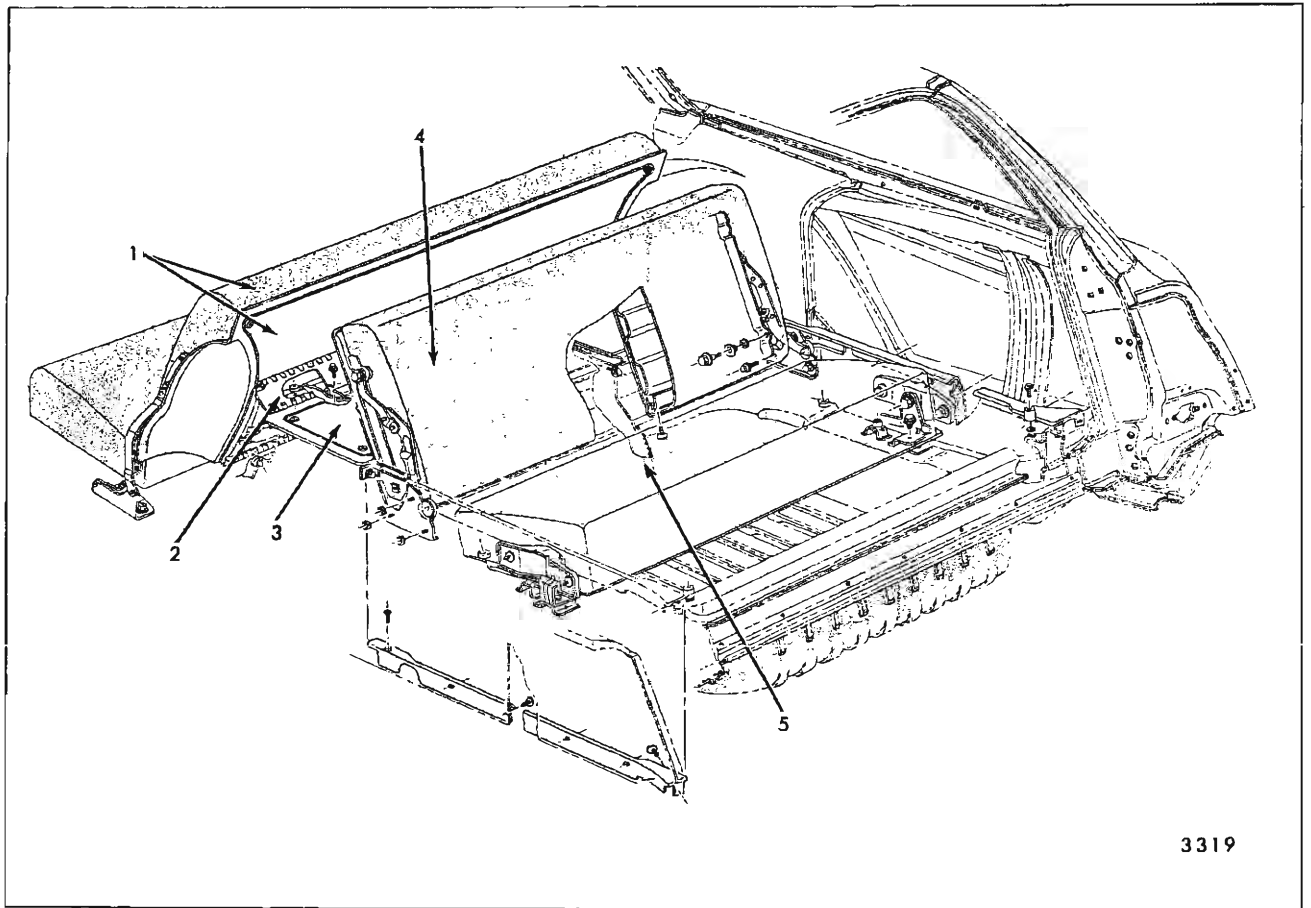

3319

Fig. 15-68—Folding Seats and Load Floor Panels - "B" Body Three-Seat Styles

- |  |   |
|--|---|
| 1. Folding Second Seat Back and Panel        | 4. Folding Third Seat Back and Panel    |
| 2. Rear Floor Filler Panel                   | 5. Folding Third Seat Cushion and Panel |
| 3. Rear Compartment Floor Panel (At Kick-Up) |   |

2. On "45" Styles, raise folding 3rd seat back assembly to up position; then raise 3rd seat bottom cushion assembly to up or "sitting" position.
3. For right floor side panel, remove spare tire cover panel.
4. On left side, remove screw which secures floor side panel to panel support.
5. Along inboard and outboard side facing of right and/or left panel, remove screws which secure panel to panel supports (Fig. 15-70) and remove panel(s) from body.
6. To install, reverse removal procedure. If installing new filler panel, apply cloth body tape

over all screw attaching holes. (See Fig. 15-70).

## LUGGAGE COMPARTMENT FRONT AND REAR PANEL ASSEMBLIES—

### Two-Seat Styles

#### Removal and Installation

1. Using handle, fold rear luggage compartment panel forward until it is resting entirely on front luggage compartment panel.
2. Fold combined front and rear luggage compartment panels to "up" or half open position. (See Fig. 15-70).

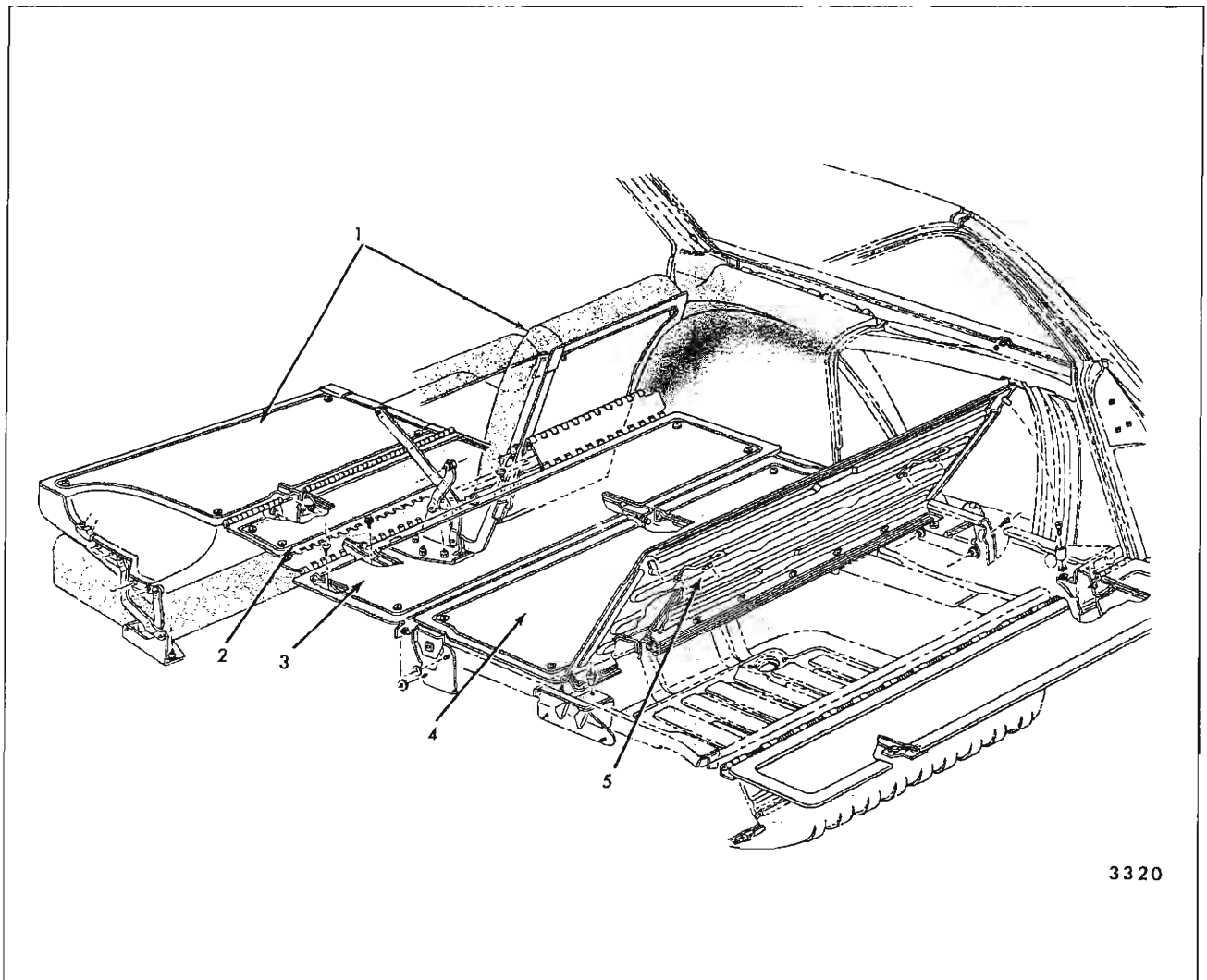

Fig. 15-69—Folding Seats and Load Floor Panels - "B" Body Two-Seat Styles with Split Second Seat Option

- |  |   |   |
|--|---|---|
| 1. Folding Second Seat Back<br>(Split Seat Option) and Back<br>Panel | 2. Rear Floor Filler Panel                      | 4. Luggage Compartment Front<br>Cover Panel |
|  | 3. Rear Compartment Floor Panel<br>(At Kick-Up) | 5. Luggage Compartment Rear<br>Cover Panel  |

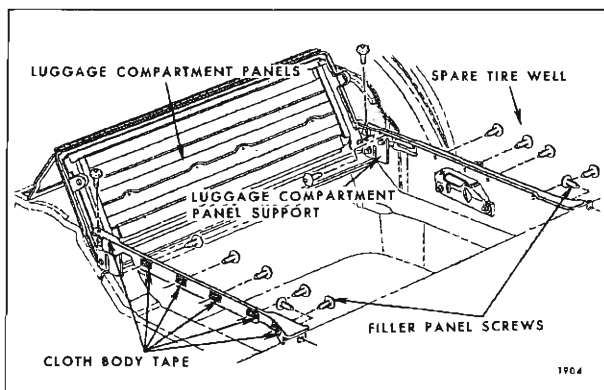

Fig. 15-70—Rear Compartment Pan Side Filler Panels

- Remove bolt (Fig. 15-71) at both sides of front panel securing front and rear panel assemblies to supports; then remove assembly from body.
- To install, reverse removal procedure. Make sure bushing and spring washer are properly installed (Fig. 15-71).

**NOTE:** When replacing front luggage compartment panel with new part, transfer rear luggage compartment panel with attached hinge to new part.

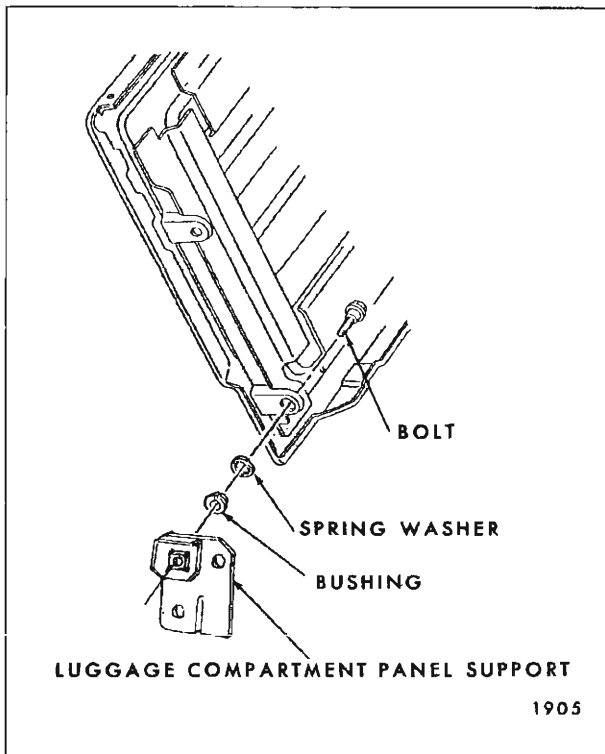

Fig. 15-71—Luggage Compartment Panel Attachment to Body

### LUGGAGE COMPARTMENT REAR PANEL ASSEMBLY—Two Seat Styles (See Figs. 15-66 and 15-69)

#### Removal and Installation

1. Using handle, fold rear luggage compartment panel forward until it is resting entirely on front luggage compartment panel.
2. Remove screws securing hinge assembly to rear luggage compartment panel and remove panel assembly from body.
3. To install, reverse removal procedure.

### LUGGAGE COMPARTMENT FRONT AND REAR PANEL HINGE ASSEMBLY—Two-Seat Styles (See Fig. 15-66 and 15-69)

#### Removal and Installation

1. Using handle, fold rear luggage compartment panel forward until it is resting entirely on front luggage compartment panel.
2. Remove screws securing hinge assembly to both front and rear panels and remove hinge from body.

3. To install, reverse removal procedure.

### FOLDING THIRD SEAT CUSHION—Three-Seat Styles

#### Removal and Installation

1. Lift third seat cushion to half raised position or approximately vertical to floor pan (Fig. 15-72).
2. Remove four seat cushion screws from rearward edge of cushion (Fig. 15-72).

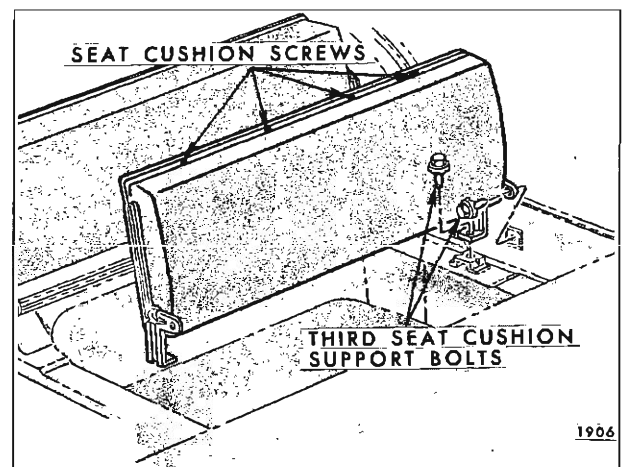

Fig. 15-72—Folding Third Seat Cushion

3. Pull rear edge of cushion away from flange of cushion panel then lift cushion upward to disengage cushion border wire from four tabs on panel. Remove cushion from body and place on a clean protected surface.
4. To install, reverse removal procedure. Make sure cushion border wire is engaged with all four panel tabs prior to installing cushion attaching screws.

### FOLDING THIRD SEAT CUSHION PANEL ASSEMBLY AND SUPPORT—Three-Seat Styles

#### Removal and Installation

1. Lift third seat cushion to a half raised position or approximately vertical to floor pan. (See Fig. 15-72).
2. Remove two bolts at each side of seat securing supports to body (Fig. 15-72), then, remove seat cushion, panel assembly and supports from body and place on a clean protected surface.

To remove support, remove cushion from panel assembly; then remove bolt securing support to cushion (Fig. 15-73).

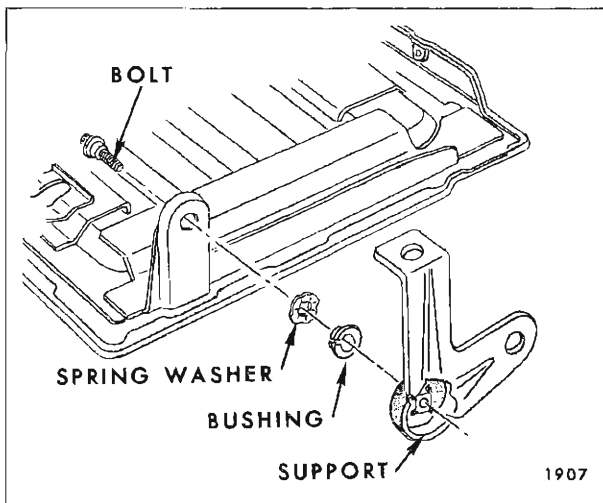

Fig. 15-73—Third Seat Cushion Panel and Support

3. To install, reverse removal procedure. If support was removed from seat cushion panel, make sure bushing and spring washer are properly installed. (See Fig. 15-73).

### FOLDING THIRD SEAT BACK TRIM ASSEMBLY—Three-Seat Styles

#### Removal and Installation

1. Raise third seat back assembly - leave cushion assembly in down position.
2. Remove four screws securing lower edge of seat back trim to seat back panel. (See Fig. 15-74).

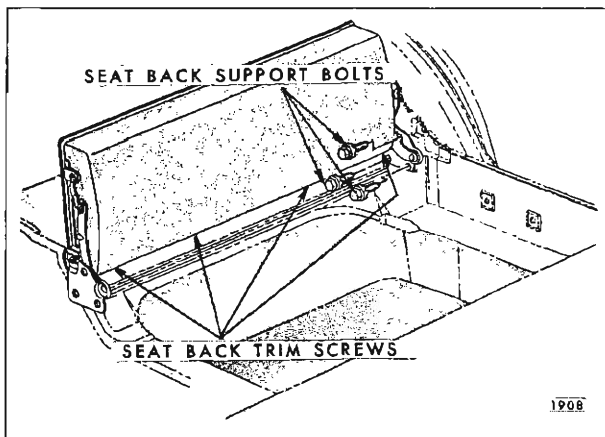

Fig. 15-74—Folding Third Seat Back

3. Pull lower edge of seat back trim slightly rearward; then, lift trim assembly upward to disengage trim border wire from four tabs on upper portion of panel. Remove trim assembly from body and place on a clean protected surface.
4. To install, reverse removal procedure. Make sure seat back trim border wire is engaged with all four panel tabs at upper portion of panel prior to installing seat back trim attaching screws.

### FOLDING THIRD SEAT BACK PANEL ASSEMBLY—Three-Seat Styles

#### Removal and Installation

1. Remove third seat back trim assembly.
2. At both sides of third seat back panel remove seat back linkage bolt (Fig. 15-75) and bolt securing seat back panel to support (Fig. 15-75), then remove seat back panel assembly from body.

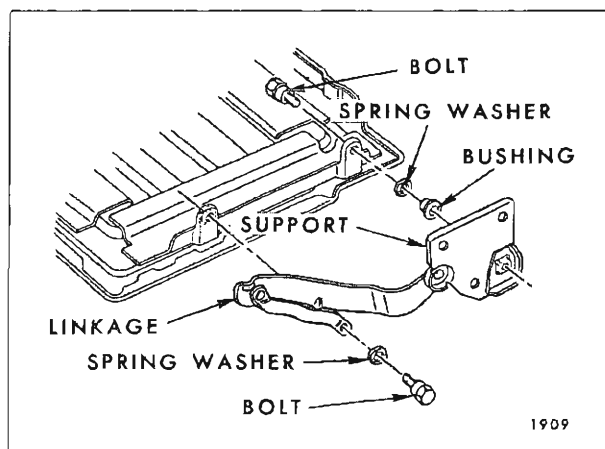

Fig. 15-75—Third Seat Back Panel and Linkage

3. To install, reverse removal procedure.

### FOLDING THIRD SEAT BACK LOCK—All "A&B" Body "45 & 46" Styles

#### Removal and Installation

1. Raise third seat back. At seat back right linkage carefully snap off lock bolt plastic cover.
2. Remove shoulder bolt securing lock latch and

spring to seat back frame (Fig. 15-76) and remove latch, spring and washer.

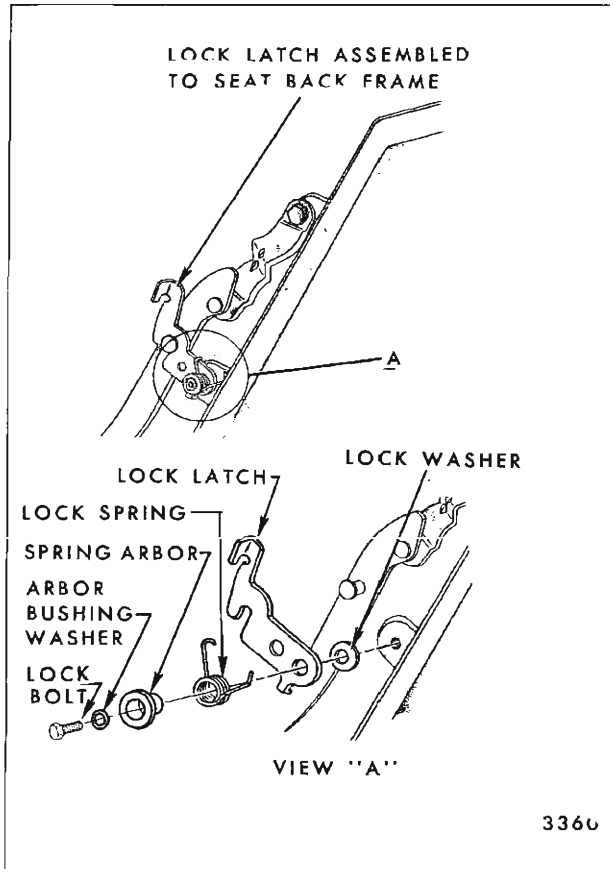

Fig. 15-76—Third Seat Back Lock - "A & B" Body Three-Seat Station Wagons

3. To install seat back lock, reverse removal procedure. Check operation of third seat back to assure proper operation of lock.

### COMPARTMENT FLOOR PANEL ASSEMBLY (At Kick-Up)—All Styles (See Figs. 15-66 15-67 15-68 and 15-69)

#### Removal and Installation

1. On three-seat Styles, remove folding 3rd seat back assembly as previously described.
2. On two-seat Styles, remove luggage compartment front and rear panel assemblies (complete) as previously described.
3. Directly under rear edge of compartment floor panel remove four screws securing panel to floor pan.
4. At front of compartment floor panel remove

five screws securing panel to floor pan; then, remove compartment floor panel from body.

5. To install, reverse removal procedure.

### REAR FLOOR FILLER PANEL—All Styles (See Figs. 15-66 15-67 15-68 and 15-69)

#### Removal and Installation

1. Remove compartment floor panel assembly (at kick-up) as previously described.
2. Along rear edge of filler panel, remove screws which secure panel to floor pan.
3. Fold filler panel forward sufficiently to remove screws which secure panel to folding 2nd seat back assembly and remove filler panel from body.
4. To install, reverse removal procedure.

### SECOND SEAT CUSHION—(Full Width or Split Seat)—All Styles

#### Removal and Installation

1. Push lower forward edge of seat cushion rearward; then, lift upward and pull forward on seat cushion to disengage cushion frame wires from retainers on floor pan. (See Fig. 15-58 which is typical of station wagon two-seat styles).
2. To install, reverse removal procedure. Make certain wires on seat bottom frame are fully engaged in retainers on floor pan.

### FOLDING SECOND SEAT BACK TRIM AND SPRING ASSEMBLY (Full Width or Split Seat)—All Styles

#### Removal and Installation

1. Raise folding second seat back and remove second seat cushion.
2. On underside of second seat back panel, remove screws securing seat back trim assembly to seat back panel (See Fig. 15-77).

**NOTE:** Do not remove screws securing rear floor filler panel hinge to second seat back panel.

3. Pull lower edge of seat back trim slightly forward; then lift trim assembly upward to disengage trim border wire from tabs on upper portion of panel. Remove trim assembly from body and place on a clean protected surface.

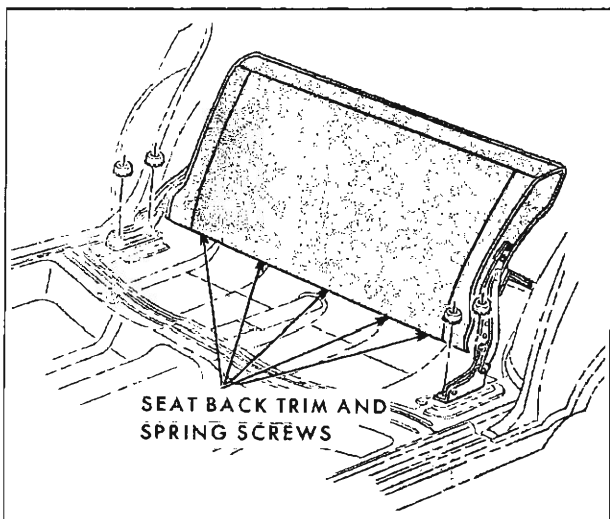

Fig. 15-77—Second Seat Back Trim and Spring Assembly

- To install, reverse removal procedure. Make sure seat back trim border wire is engaged with panel tabs at upper portion of seat back panel prior to installing seat back trim attaching screws.

### FOLDING SECOND SEAT BACK TRIM, PANEL AND LINKAGE ASSEMBLY (Full Width or Split Seat)—All Styles

#### Removal and Installation

- Raise folding second seat back and remove second seat cushion.

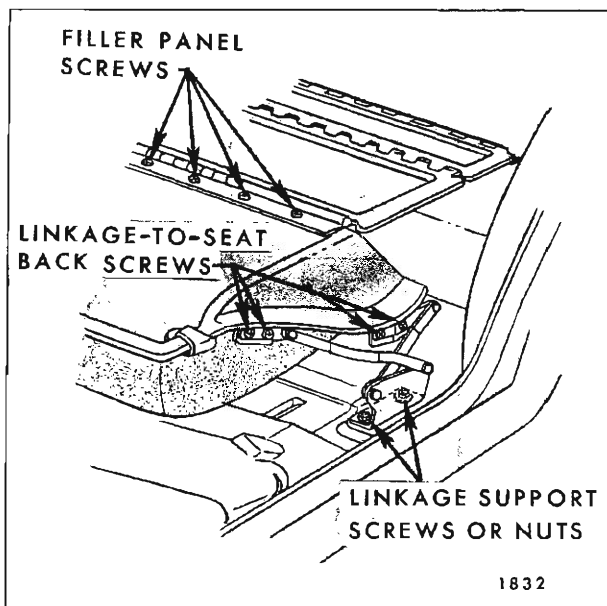

Fig. 15-78—Folding Second Seat Back Linkage and Filler Panel

- On underside of folding second seat back remove screws securing rear floor filler panel hinge to seat back panel.

**NOTE:** Do not remove screws securing seat back trim assembly to seat back panel.

- Mark position of folding second seat back linkage supports on floor pan. Remove nuts from both sides of seat back securing linkage supports to floor pan (See Figure 15-78 for full width seat, Fig. 15-79 for split seat).

Lift seat back assembly with attached linkage from body and place on a clean protected surface.

- To remove linkage from folding second seat back remove linkage-to-seat back panel attaching bolts and remove linkage - See (Fig. 15-78 for full width seat, Fig. 15-79 for split seat).

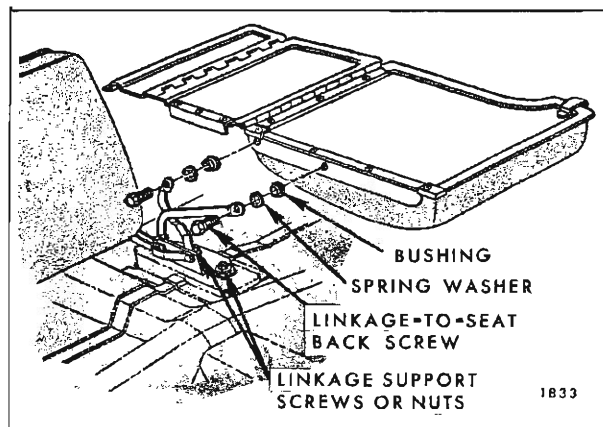

Fig. 15-79—Split Second Seat Inner Linkage

- To install, reverse removal procedure. If linkage was removed from split seat back, make sure bushings and spring washers are properly installed prior to installing linkage attaching bolts. (See Fig. 15-79).

### FOLDING SECOND SEAT BACK LINKAGE ASSEMBLY—(Full Width Seat—Right or Left Side Split Seat—Outer Linkage Only)

If both right and left linkage assemblies are to be removed on full width second seat, remove second seat back trim, back panel and linkage assembly and remove linkage from seat back panel as described under "Folding Second Seat Back Trim, Panel and Linkage Assembly - Removal and Installation".

If one linkage assembly (right or left side) is to be removed proceed as follows:

### Removal and Installation

1. Remove second seat cushion.
2. Move folding second seat back forward just sufficiently to remove two lower linkage-to-seat back panel attaching screws. (See Fig. 15-78).
3. Carefully return seat back to full up position; then, place a support under seat back assembly to support seat back in this position.
4. Remove two upper linkage-to-seat back panel attaching screws. (See Fig. 15-78).
5. Remove nuts securing linkage support to floor pan (See Fig. 15-78), then carefully remove linkage assembly from seat back and floor pan.
6. To install, reverse removal procedure.

### FOLDING SECOND SPLIT SEAT BACK INNER LINKAGE ASSEMBLY

#### Removal and Installation

1. Remove left second seat cushion and place left seat back in full up position. Place a support under right side of left seat back to support seat back in this position.
2. Place right seat back in partially down position (resting on seat cushion).
3. Remove nuts securing inner linkage assembly to floor pan (See Fig. 15-79).
4. Remove inner linkage-to-seat back bolts from both right and left seats (See Fig. 15-79); then carefully disengage inner linkage from seat backs and floor pan studs and remove linkage assembly.
5. To install, reverse removal procedure. Make sure bushings and spring washers are properly installed prior to installing linkage attaching bolts to both right and left seat back panels. (See Fig. 15-79).

### LUGGAGE COMPARTMENT LOCK CYLINDER—15-16000 Two-Seat Styles

#### Removal and Installation

1. Open luggage compartment rear panel.
2. On underside of luggage compartment rear panel remove catch retainer and catch from lock cylinder case (Fig. 15-80), then turn lock

cylinder with key until cylinder can be removed from case.

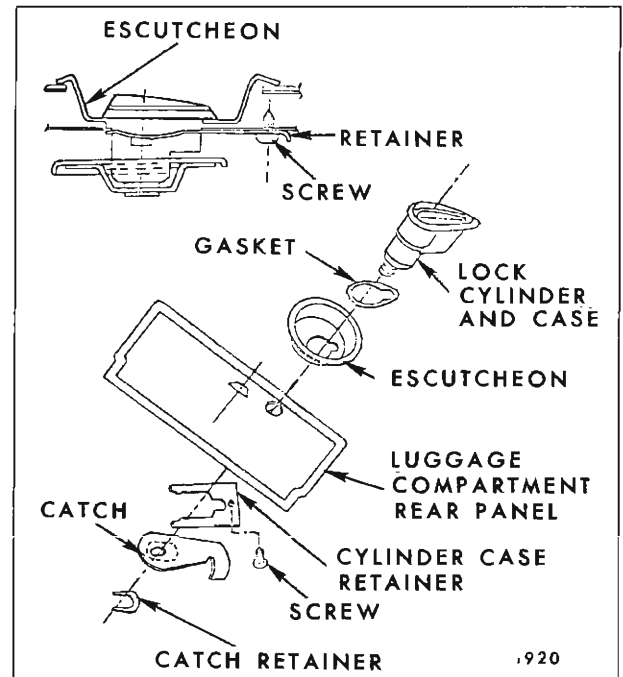

Fig. 15-80—Luggage Compartment Lock - Chevrolet "B" Styles

3. To install, reverse removal procedure.

### LUGGAGE COMPARTMENT Two-Seat Styles

#### Removal and Installation

1. Open luggage compartment rear panel.
2. On underside of luggage compartment rear panel, remove catch retainer and catch (Fig. 15-80).
3. Remove lock cylinder case retainer screw and retainer (Fig. 15-80); then, remove lock cylinder and case, gasket and escutcheon from panel (Fig. 15-80).
4. To install, reverse removal procedure.

### FOLDING SECOND SEAT BACK LOCK (Full Width or Split Seat)—All "A&B" Styles (Except "A-55-56 and 65-66" Styles)

#### Description

The station wagon full width folding second seat

incorporates a seat back lock located on the upper right side of the seat back. On split second seat option a seat back lock is located at the upper outer side of each seat back. The folding second seats can be folded down by actuating the lock handle forward and pulling the seat back down.

### FOLDING SECOND SEAT BACK LOCK (Full Width or Split Seat—All "A&B" Styles (Except "A-55-56 Styles with Split Second Seat Option and 65-66" Styles)

#### Removal and Installation

1. Remove folding second seat back trim and spring assembly, as previously described.
2. Remove seat back lock handle attaching screw (Fig. 15-81) and remove lock handle.

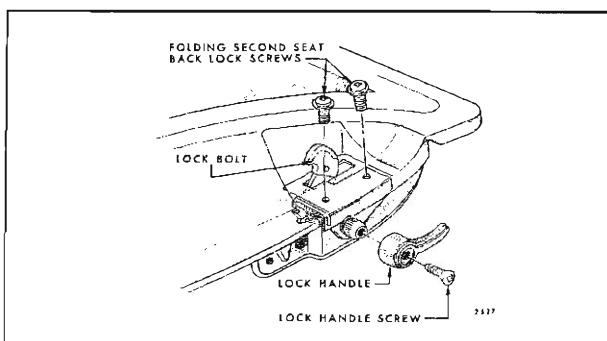

Fig. 15-81—Folding Second Seat Back Lock Installation - All "A & B" Station Wagons (Except Vista Cruiser and Sport Wagon Styles)

3. Remove seat back lock attaching screws (Fig. 15-81) and remove seat back lock from seat back panel.
4. To install seat back lock assembly, reverse removal procedure. A small amount of lock adjustment is available to obtain proper engagement of lock bolt with lock striker on wheelhouse as shown in Fig. 15-82.

### STATION WAGON FOLDING SEATS AND FLOOR PANELS "55-56-65-66" Styles

#### Description

The Vista Cruiser and Sport Wagon "55 & 56" Style Skylight station wagons have a full width folding second seat on which the seat back folds flush with the floor panels. A luggage compartment is provided under the luggage compartment floor panel.

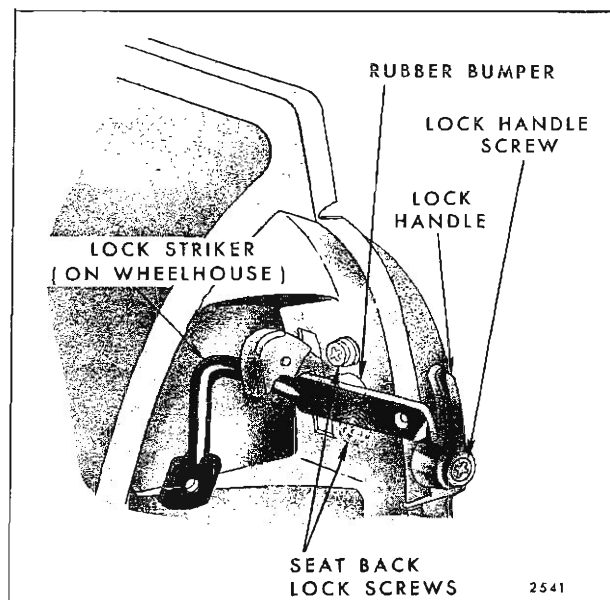

Fig. 15-82—Folding Second Seat Back Lock and Striker - All "A & B" Station Wagons (Except Vista Cruiser and Sport Wagon Styles)

A split folding second seat - 1/3 (left side), 2/3 (right side) is available as an option on the "55 & 56" Style Skylight station wagon. Figure 15-83 identifies the major folding seats and load floor panels on the "55 & 56" station wagon with split second seat option.

The service procedures for the "55" Style station wagon full width folding second seat are the same as for the "B-36" Style station wagon folding second seat.

The "65 & 66" Style station wagons have a full folding split second seat - 1/3 (right side), 2/3 (left side).

Both sections of the folding second seat are hinged to the floor pan and can be folded forward to provide entrance room into the third seat area. Also both sections of the folding second seat back can be folded flush with the floor panels. A seat back lock located at the outer linkage of both right and left folding second seat backs, locks the seat backs in the up position and must be released to fold the seats.

The full 3/4 width folding third seat is provided with a positive acting lock at the right side linkage.

The lock handle is depressed to lock the seat in the up position and pulled upward to release the lock and allow the seat to be folded.



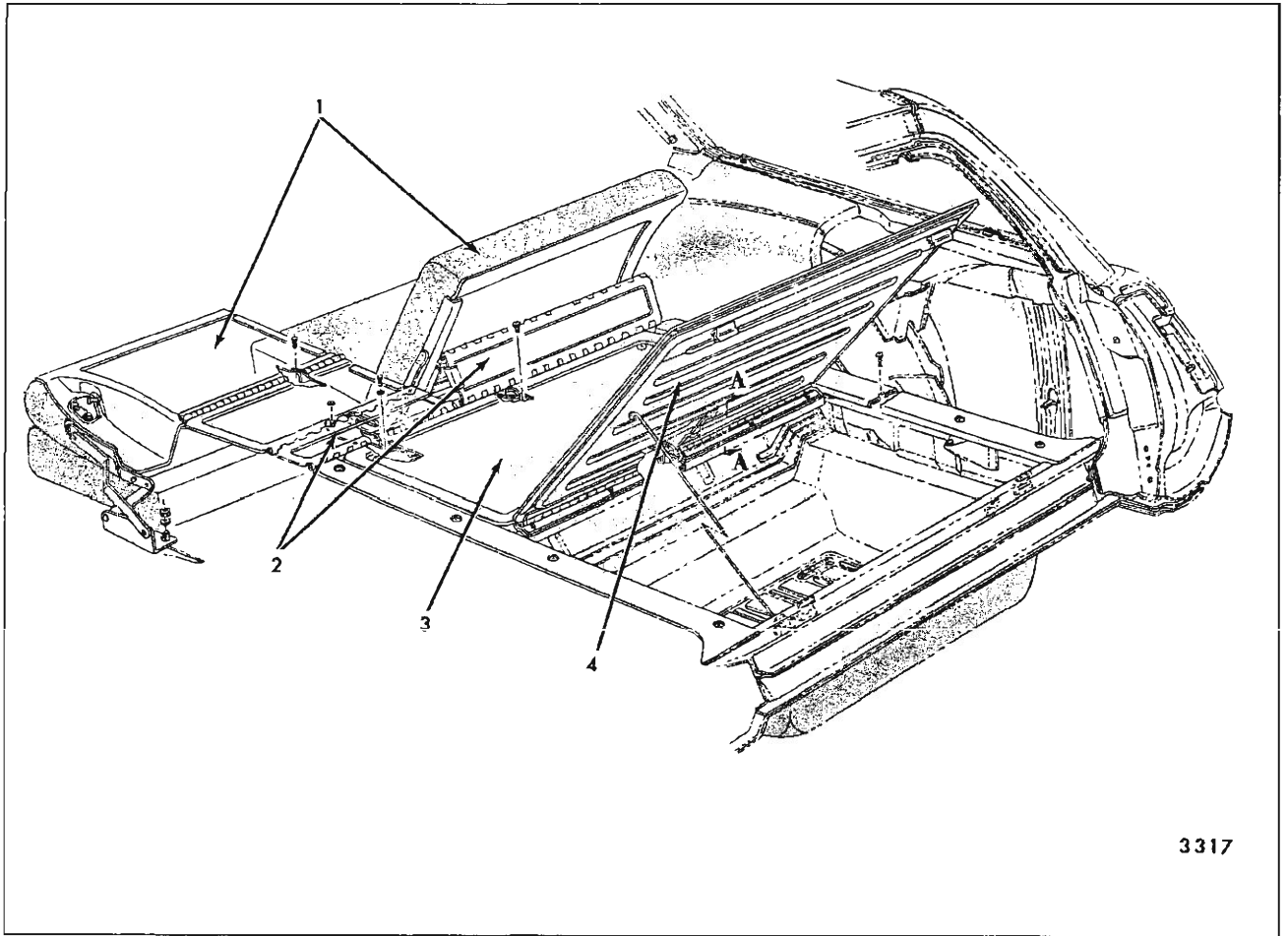

3317

Fig. 15-83—Folding Seats and Load Floor Panels - "A" Body Vista Cruiser and Sport Wagon Two-Seat Styles with Split Second Seat Option

- |   |   |                                       |
|---|---|---------------------------------------|
| 1. Folding Second Seat Back<br>(Split Seat Option) and Back<br>Panels | 2. Rear Floor Filler Panel<br>3. Rear Compartment Floor Panel<br>(At Kick-Up) | 4. Luggage Compartment Cover<br>Panel |
|---|---|---------------------------------------|

Figure 15-84 identifies the major folding seats and load floor panels on the "65 & 66" Style Skylight station wagon.

### FOLDING SECOND SEAT ASSEMBLY— Right or Left Seat—"55-56-65-66" Styles

#### Removal and Installation

1. Remove rear door sill plate and turn back floor carpeting sufficiently to gain access to nuts securing folding seat front and rear linkage to floor pan (Figs. 15-85 and 15-86).
2. Mark position of seat front and rear linkage supports on floor pan to facilitate installation of seat in same position.

3. Remove nut and washer assemblies securing front and rear linkage to floor pan (Figs. 15-85 and 15-86); then, remove seat assembly from body.

4. To install seat assembly, reverse removal procedure. Align linkage floor pan supports with previously made marks prior to tightening nuts.

### FOLDING SECOND SEAT CUSHION ASSEMBLY—Right or Left Side— "55-56-65-66" Styles

#### Removal and Installation

1. Remove folding second seat assembly from

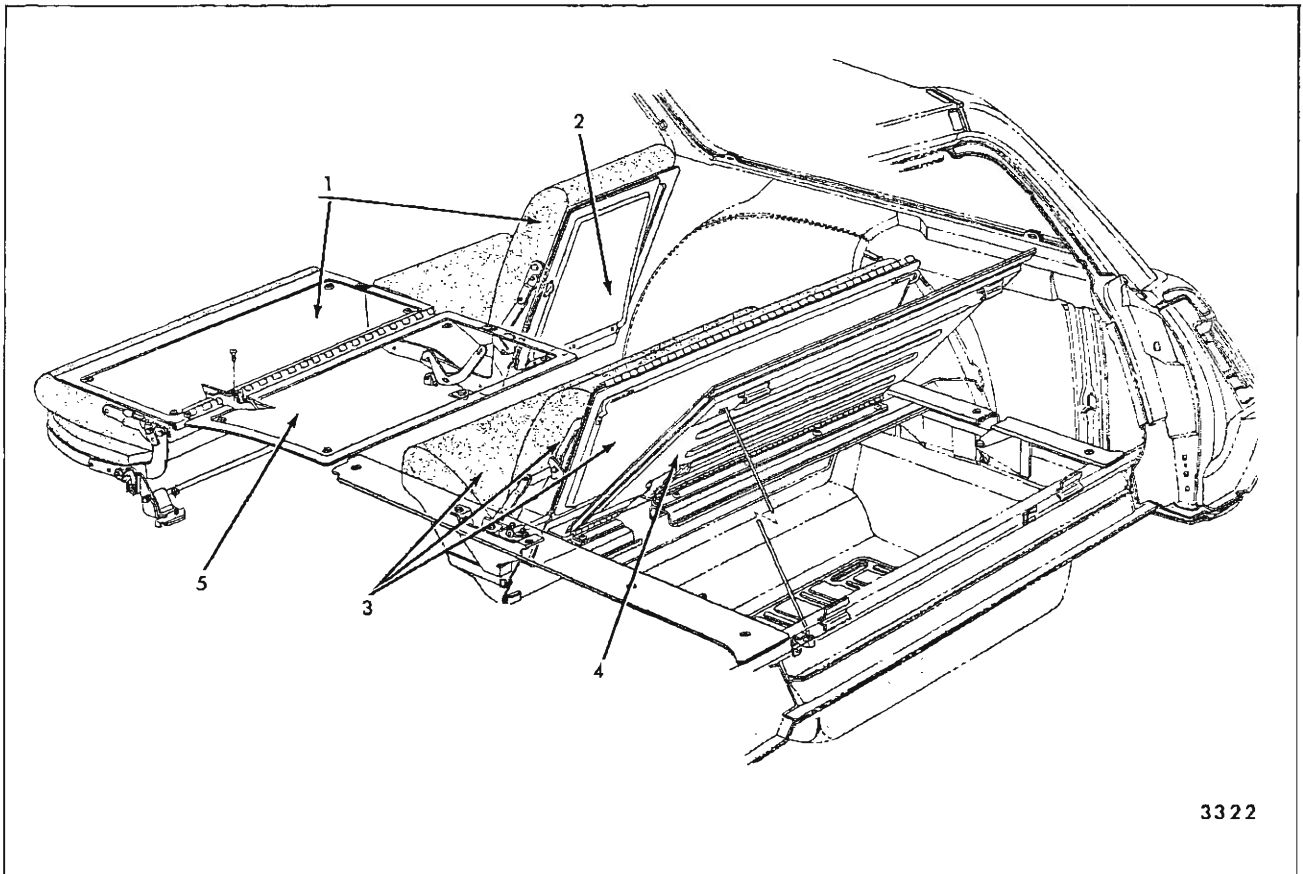

Fig. 15-84—Folding Seats and Load Floor Panels - "A" Body Vista Cruiser and Sport Wagon Three-Seat Styles

- |  |  |                            |
|--|--|----------------------------|
| 1. Folding Second Seat Back and Panel - Left and Right | 3. Folding Third Seat Cushion, Back and Back Panel | 5. Rear Floor Filler Panel |
| 2. Rear Floor Filler Panel - Right and Left            | 4. Luggage Compartment Cover Panel                 |                            |

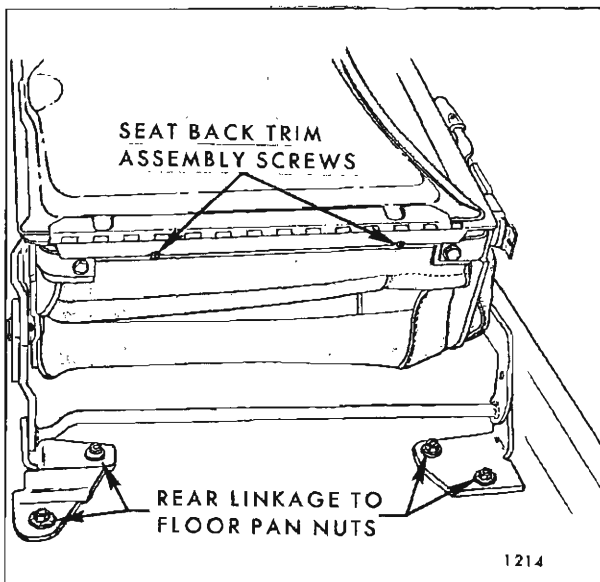

Fig. 15-85—Folding Second Seat Rear Linkage

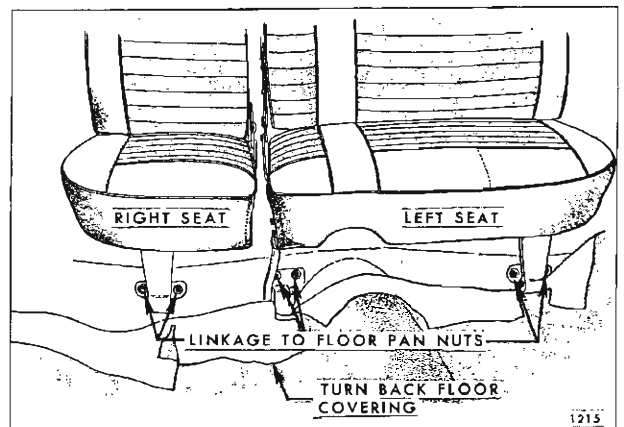

Fig. 15-86—Folding Second Seat Front Linkage (Vista Cruiser and Sport Wagon Styles)

car, as previously described and place on a clean surface.

2. Remove hog rings and detach outboard rear

portion of trim sufficiently to remove three screws securing seat outer link to cushion frame. (Fig. 15-87).

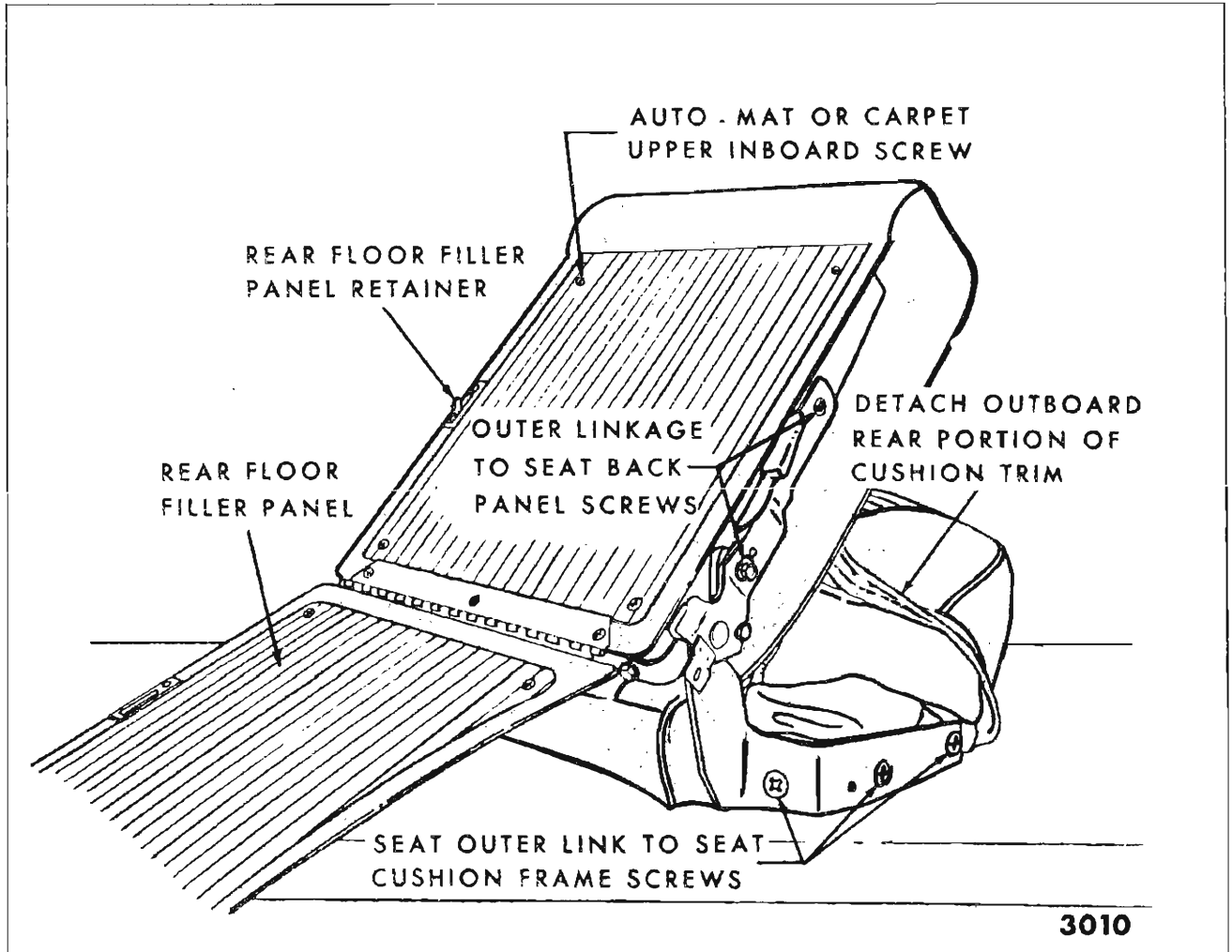

Fig. 15-87—Folding Second Seat Cushion Assembly (Right or Left Side) - Vista Cruiser and Sport Wagon Styles

3. Remove three screws securing seat inner link to cushion frame (Fig. 15-88); then remove seat cushion and frame assembly from linkage. If required, remove cushion front and rear floor pan linkage.

4. To install, reverse removal procedure.

**FOLDING SECOND SEAT BACK TRIM AND SPRING ASSEMBLY—Right or Left Seat—“55-56-65-66” Styles**

**Removal and Installation**

1. Fold second seat back forward.
2. Remove seat back trim assembly attaching screws. (See Fig. 15-85).

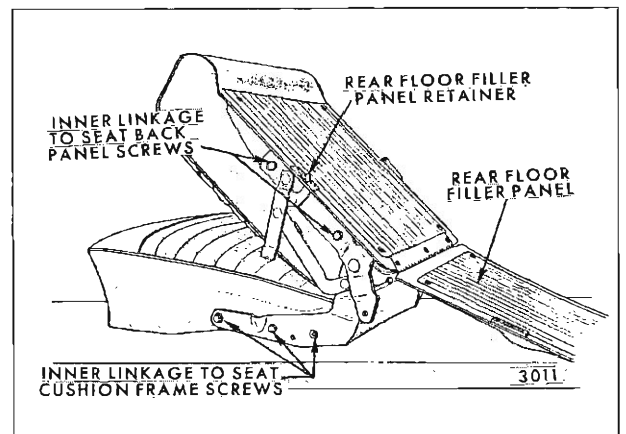

Fig. 15-88—Folding Second Seat Cushion Assembly (Right or Left Side) - Vista Cruiser and Sport Wagon Styles

3. Raise seat back; then, pull seat back trim assembly upward to disengage wire loops at top of seat back trim from slots in seat back panel.

**NOTE:** If seat back trim does not readily disengage from seat back panel, fold rear floor filler panel down and remove upper inboard screw securing automat or carpet (Fig. 15-87). Then remove seat back trim assembly.

4. To install seat back trim assembly, reverse removal procedure.

### FOLDING SECOND SEAT FRONT FLOOR PAN LINKAGE—Right or Left Seat— “55-56-65-66” Styles

#### Removal and Installation

1. Place seat in an up position. Turn back floor carpet sufficiently to gain access to front linkage floor pan attaching nuts.
2. Mark location of front linkage support on floor pan to facilitate installation in same position. Support front of seat. Remove bolts securing linkage to seat and nuts securing linkage to floor pan studs (See Fig. 15-86); then, remove front linkage.
3. To install, reverse removal procedure making sure linkage support on floor pan is aligned with previously made alignment mark.

### FOLDING SECOND SEAT REAR FLOOR PAN LINKAGE—Right or Left Seat— “55-56-65-66” Styles

#### Removal and Installation

1. Remove folding second seat assembly from car as previously described and place on a clean surface.
2. Remove screws securing rear floor pan linkage to each side of seat cushion frame (Fig. 15-89); then, remove linkage assembly from seat.
3. To install, reverse removal procedure. Inserts in Figure 15-89 show relationship of linkage, bushings and attaching screws.

### FOLDING SECOND SEAT SIDE INNER LINKAGE—Right or Left Seat— “55-56-65-66” Styles

#### Removal and Installation

1. Remove folding second seat assembly from car as previously described and place on a clean surface.

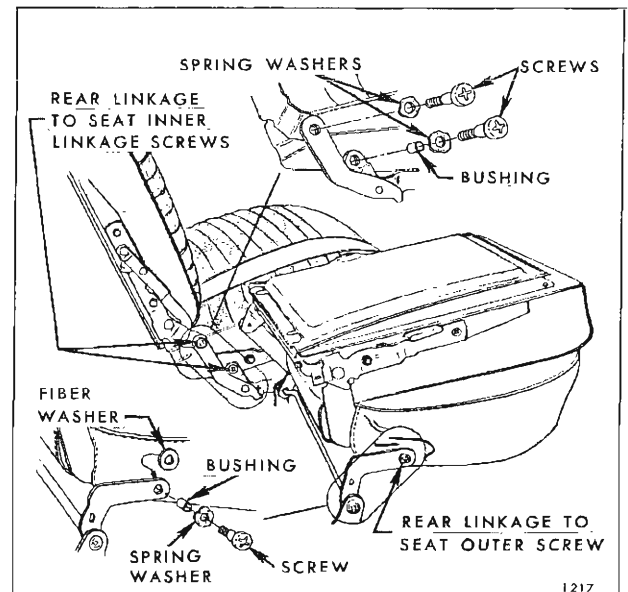

Fig. 15-89—Floor Pan Rear Linkage (Vista Cruiser and Sport Wagon Styles)

2. Remove floor pan rear linkage-to-seat inner linkage attaching screws (Fig. 15-89).
3. Remove seat inner linkage-to-seat back panel and seat cushion frame attaching screws (See Fig. 15-88); then, disengage and remove side linkage from seat.
4. To install, reverse removal procedure. Make sure rear floor filler panel retainer is inserted through slot in seat back panel prior to installing inner linkage-to-seat back panel attaching screws.

### FOLDING SECOND SEAT SIDE OUTER LINKAGE—Right or Left Seat— “55-56-65-66” Styles

#### Removal and Installation

1. Remove folding second seat assembly from car as previously described and place on a clean surface.
2. Remove outer linkage cover. Remove rear floor pan linkage to seat outer attaching screw (Fig. 15-89).
3. Remove hog rings and detach rear portion of trim sufficiently to remove three screws securing outer linkage to seat cushion frame. (See Fig. 15-87).
4. Remove outer linkage-to-seat back panel attaching screws (See Fig. 15-87); then, remove linkage and seat back catch from seat.

5. To install, reverse removal procedure. Install seat back lock and spring as described under "Folding Second Seat Back Lock - Removal and Installation".

### FOLDING SECOND SEAT BACK LOCK— Right or Left Seat—"55-56-65-66" Styles

#### Removal

1. Remove seat back trim assembly, as previously described. Remove outer linkage cover.
2. Remove outer linkage-to-seat back panel attaching screws (See Fig. 15-87).
3. Remove lock handle, spring and bushing from linkage.

#### Installation

1. Position bushing and spring on lock handle.
2. Install lock handle, bushing and spring into position between seat back panel and outer linkage making sure end of spring is engaged in hole in outer link (Fig. 15-90).

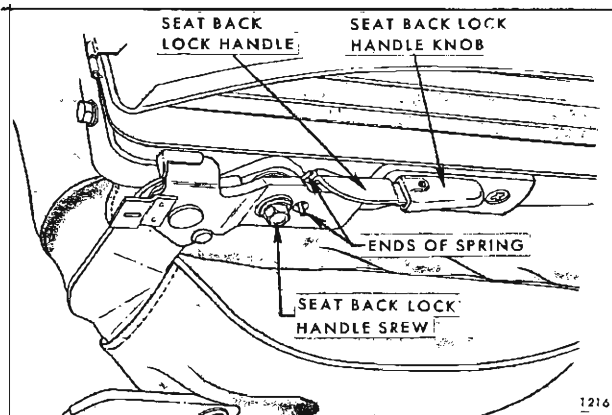

Fig. 15-90—Seat Back Lock (Vista Cruiser and Sport Wagon Styles)

3. Install lock handle attaching screw; then, install outer linkage to seat back panel attaching screws (Fig. 15-87).
4. Install seat back trim assembly and outer linkage cover.

### FOLDING SECOND SEAT BACK PANEL AND FILLER PANEL—Right or Left Seat— "55-56-65-66" Styles

#### Removal and Installation

1. Remove seat back trim assembly, as previously described. Remove outer linkage cover.

2. Remove outer and inner linkage to seat back attaching screws (Fig. 15-91). Remove seat back lock handle, spring and bushing from between outer linkage and seat back panel; then, remove seat back panel and rear floor filler panel from linkage.

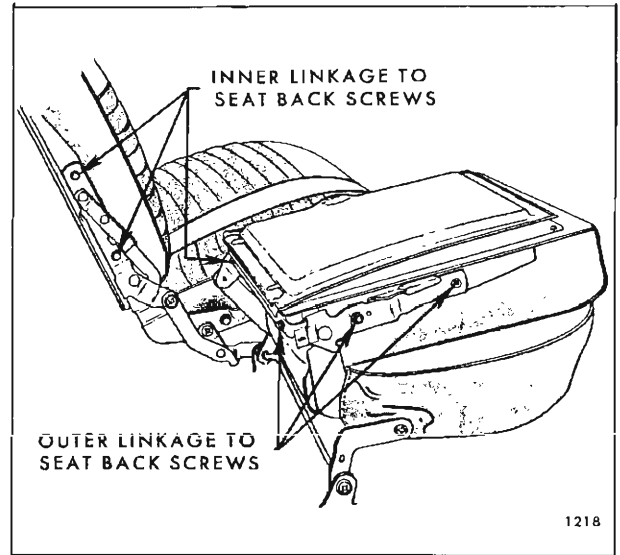

Fig. 15-91—Seat Inner and Outer Linkage (Vista Cruiser and Sport Wagon Styles)

3. To install, reverse removal procedure. To install seat back lock refer to "Folding Second Seat Back Lock - Installation".

### FOLDING THIRD SEAT AND FLOOR PANEL ASSEMBLY—"65-66" Styles

#### Removal and Installation

1. Raise folding third seat. Remove rear compartment left side panel (See Fig. 15-84).
2. Remove seat back linkage-to-compartment side pan attaching bolt (Fig. 15-92) at both right and left sides of seat.
3. At left side of seat remove seat back hinge pin retainer (Fig. 15-92).
4. Carefully move seat back assembly to the left sufficiently to disengage right seat back hinge pin from hinge pin retainer; then, remove folding third seat assembly from body and place on a clean surface.
5. To install folding third seat and floor panel assembly, reverse removal procedure. Make sure a seat back hinge pin bushing is installed over both hinge pins. Also install flat washer

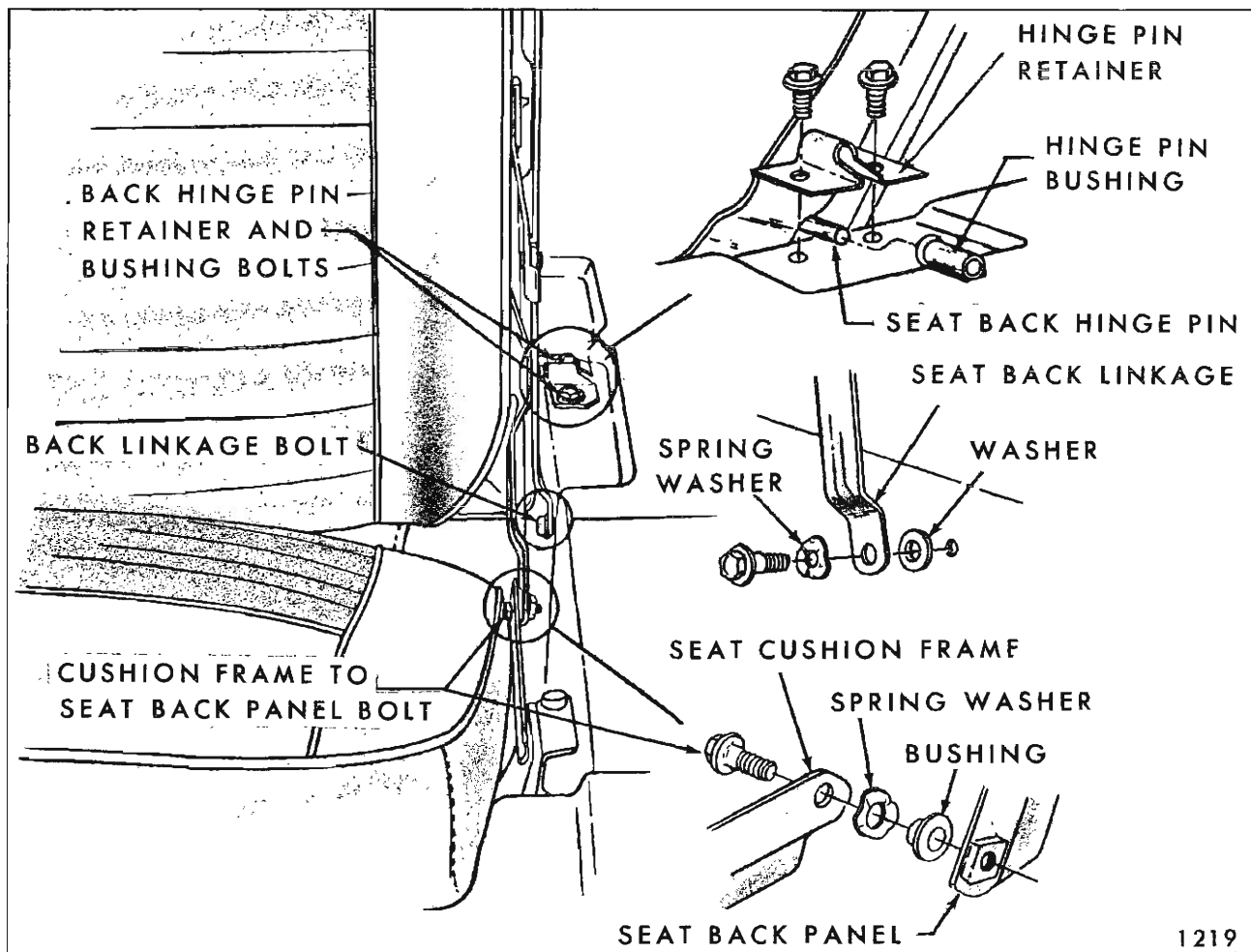

Fig. 15-92—Folding Third Seat (Vista Cruiser and Sport Wagon Styles)

between seat back linkage and compartment side pan and spring washer between linkage and bolt head (Fig. 15-92).

### FOLDING THIRD SEAT CUSHION TRIM ASSEMBLY—"65-66" Styles

#### Removal and Installation

1. Raise folding third seat. Raise front of third seat cushion and prop in up position.
2. Remove hog rings securing seat back trim flap to bottom of seat cushion (Fig. 15-93).
3. Remove seat cushion frame-to-seat back panel attaching bolt (Fig. 15-92) from both sides of seat; then, remove seat cushion assembly and place on a clean surface.
4. As a bench operation remove hex-head screws securing seat cushion trim to seat cushion

frame (Fig. 15-93) and three screws securing rear edge of seat cushion trim to seat cushion frame; then, remove cushion trim assembly from cushion frame.

5. To install, reverse removal procedure. When installing seat cushion frame-to-seat back frame attaching bolts install bolt bushing and spring washer, as shown in insert of Figure 15-92.

### FOLDING THIRD SEAT BACK TRIM ASSEMBLY OR SEAT BACK PANEL ASSEMBLY—"65-66" Styles

#### Removal and Installation

1. Remove folding third seat and floor panel assembly, as previously described, and place on a clean surface.

- Remove hog rings securing seat back trim flap to bottom of seat cushion (Fig. 15-93).

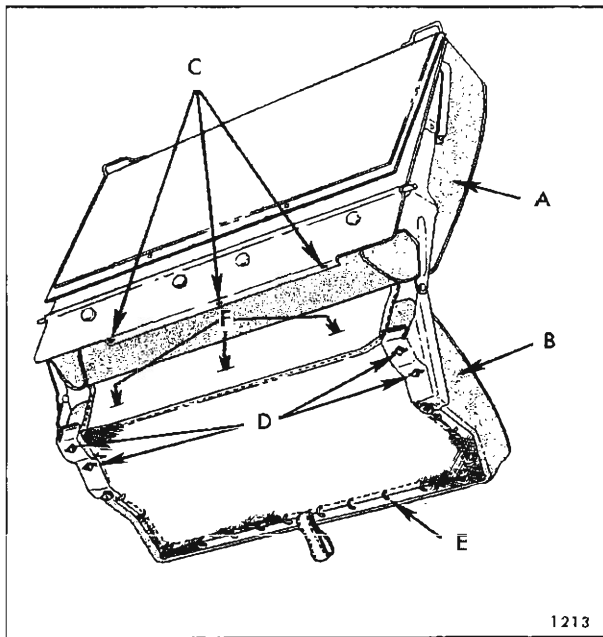

Fig. 15-93—Folding Third Seat Assembly

- |   |   |
|---|---|
| A. Third Seat Back                                    | E. Hog Rings Securing Seat Back Trim Flap                                       |
| B. Third Seat Cushion                                 | F. Location of Cushion Trim to Cushion Frame Attaching Screws (Under Trim Flap) |
| C. Seat Back Trim to Seat Back Panel Attaching Screws |   |
| D. Cushion Trim to Cushion Frame Attaching Screws     |   |

- To remove seat back trim assembly remove seat back trim-to-seat back panel attaching screws (Fig. 15-93); then, lift trim assembly upward to disengage wire loops on seat back trim from slots in seat back panel and remove trim assembly.
- To remove seat back panel assembly, remove seat cushion frame-to-seat back panel attach-

ing bolt (Fig. 15-92); then, remove seat back panel with attached rear floor filler (at kick-up) panel from seat cushion.

- To install, reverse removal procedure. Refer to inserts in Figure 15-92 for correct installation of linkage bolts, bushings and spring washers.

### FOLDING THIRD SEAT BACK LOCK— “65-66” Styles

#### Removal and Installation

- Raise folding third seat back sufficiently to gain access to seat back lock at right side of seat.
- Remove lock attaching bolt finishing cap.
- Remove shoulder bolt securing lock to rear seat compartment side panel and remove lock latch, spring and washer.
- To install seat back lock latch, spring and washer, reverse removal procedure. Check operation of third seat back to assure proper operation of lock.

### LUGGAGE COMPARTMENT COVER PANEL AND FILLER PANEL— “55-56-65-66” Styles

#### Removal and Installation

- Raise luggage compartment cover panel and support cover panel in up position.
- Remove five hex-head screws securing cover panel to cross bar; then remove luggage compartment cover panel and filler panel.
- To install, reverse removal procedure.

## SEAT BELTS AND SHOULDER STRAPS

### General Information—All Styles

Front and rear seat belts and front seat shoulder straps, except convertible shoulder straps, are installed on all cars as standard equipment. Convertible style front seat shoulder straps and rear seat shoulder straps, including station wagon second and third seat shoulder straps, are available as factory optional equipment or as a dealer installed accessory.

Before servicing or replacing seat belts and shoulder straps, refer to the following precautionary items:

- Seat belts must be serviced in matched sets.
  - DO NOT replace one-half of seat belt or shoulder strap set.

- b. DO NOT intermix standard and deluxe seat belts or shoulder straps on front or rear seats.
2. Keep sharp edges and damaging objects away from seat belts or shoulder straps.
3. Exercise caution to avoid bending or damaging any portion of the belt buckle or latch.
4. Do not bleach or re-dye belt or strap webbing (clean with a mild soap solution and water).
5. When installing seat belt or shoulder strap anchor bolt, start bolt by hand to assure that bolt is threaded straight.
6. DO NOT attempt repairs on seat belt retractor mechanisms. Replace defective part with new service replacement parts.
7. Tighten seat belt or shoulder strap floor pan anchor bolts to specified torque - 24 to 45 ft. lbs. Tighten shoulder strap roof rail, quarter panel or shelf panel bolts - 12 to 18 ft. lbs.

**IMPORTANT:** Specified 1/2 inch - 13 UNC - 2A bolts must be used for all seat belt and shoulder strap floor pan anchorages. Shoulder strap roof rail, quarter panel and shelf panel anchorages use specified 5/16 inch - 18 UNC 2A bolts.

### STANDARD FRONT SEAT BELT RETRACTOR—FLOOR MOUNT (Includes "X" Bodies Non-Swivel Retractor)

To disengage standard seat belt retractor cover, carefully exert pressure in direction of arrows, Figure 15-94, to disengage the cover from tabs on the retractor. Lift cover to expose seat belt retractor anchor bolt and remove bolt.

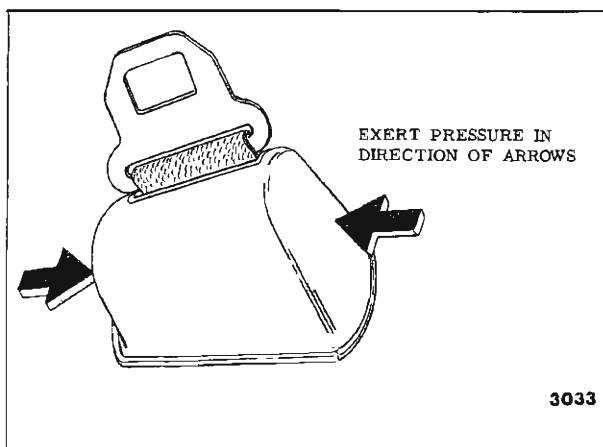

Fig. 15-94—Front Seat Standard Belt Retractor

### STANDARD FRONT SEAT BELT RETRACTOR (Swivel Type—"X" Body Coupes)

To disengage seat belt retractor cover, place finger under outboard rear corner of cover and pull outward while pulling cover "up" with other hand. Lift up cover to expose retractor anchor bolt and remove bolt.

### DELUXE FRONT SEAT BELT RETRACTOR—FLOOR MOUNT

With belt fully extended, insert screwdriver through belt opening in cover, as shown in Figure 15-95,

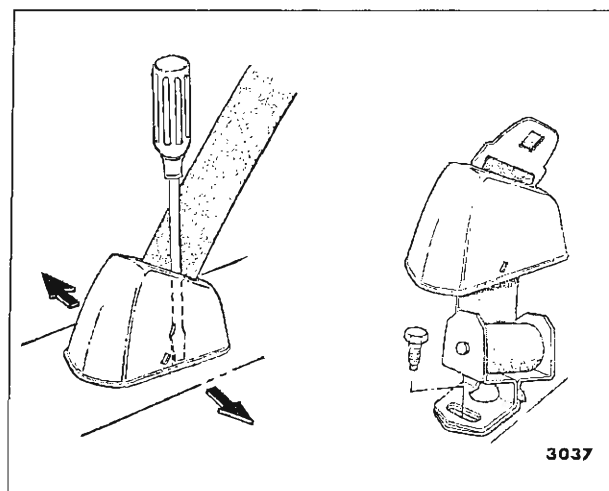

Fig. 15-95—Front Seat Deluxe Belt Retractor

apply just enough outward pressure to inside of cover adjacent to metal tabs to disengage cover from tabs. Lift up cover to expose seat belt retractor anchor bolt.

### SELF LOCKING FRONT SEAT BELT RETRACTORS

#### Removal

1. Position front seat assembly to full forward and up positions.
2. Insert the blade of a 2-1/2" or 4" flat bladed screw driver up under the retractor cover and engage blade of screw driver over top of retaining spring, as shown in Figure 15-96. Press retaining spring downward; then, pull retractor and cover assembly rearward and upward to disengage retractor and cover from anchor plate assembly.
3. Remove anchor plate attaching bolt and remove anchor plate assembly.



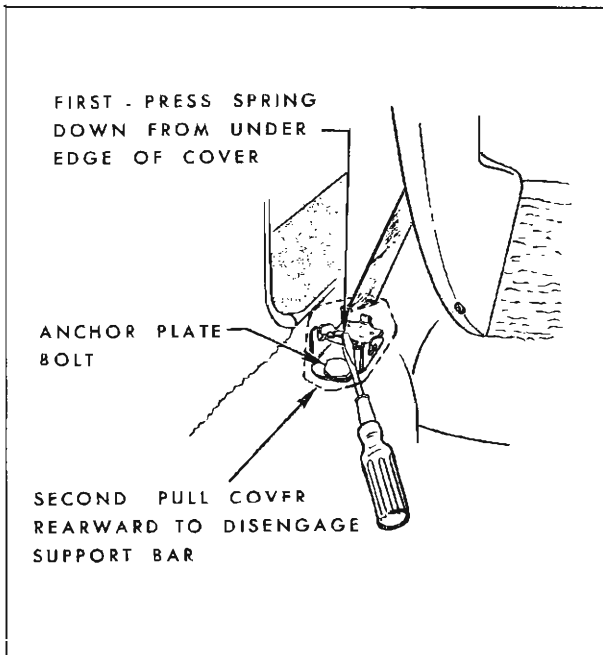

Fig. 15-96—Front Seat Belt Self-Locking Retractor - Removal

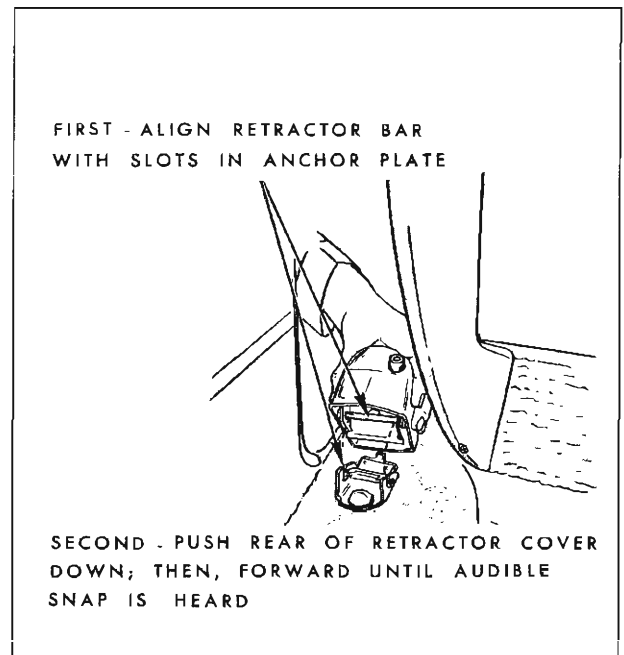

Fig. 15-97—Front Seat Belt Self-Locking Retractor - Installation

**Installation**

1. Properly position anchor plate assembly on floor pan and start attaching bolt by hand. Tighten anchor plate attaching bolt to specified torque (24 to 45 ft. lbs.).
2. Position retractor and cover assembly over anchor plate assembly so that bar in retractor is aligned with slots in anchor plate (See Figure 15-97). Push rear of retractor assembly down and then forward to lock retractor to anchor plate.

**NOTE:** An audible snap will be heard when retaining spring on anchor plate locks retractor bar into position.

3. Check operation of seat belt retractor and locking release knob several times to assure proper operation.

**IMPORTANT:** DO NOT attempt any repairs on either the retractor and cover mechanism or the anchor plate assembly. In addition seat belts must be serviced in matched sets (retractor and cover assembly, anchor plate assembly and buckle end of belt) - DO NOT replace only one part of seat belt set.

**REAR SEAT BELT BAIL TYPE RETRACTOR**

As an option, seat belts are available with bail type seat belt retractors on the outboard rear seat belt only.

**Removal**

1. Extend outboard seat belt to full length.
2. Insert a piece of stiff wire such as a paper clip in slot in roller drum to maintain spring tension of retractor (See Fig. 15-98).

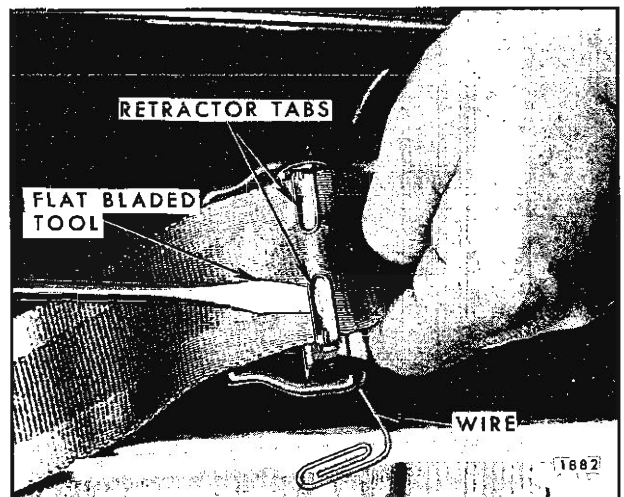

Fig. 15-98—Removal of Bail Type Retractor From Seat Belt

**IMPORTANT:** Keep wire in slot until retractor is reinstalled. In the event that spring tension is lost, drum on retractor can be

turned 8 revolutions by hand to regain spring tension.

3. Using a flat-bladed tool pry open tabs that secure belt webbing on drum and remove retractor from belt (See Fig. 15-98).

### Installation

1. With seat belt fully extended, insert belt under tabs on retractor (tabs of retractor should be on inboard side of belt webbing and bail pointing forward) and position retractor at center of belt webbing.
2. Using pliers, lightly bend down tabs to secure retractor in correct position on belt webbing.
3. Remove wire from slot in drum (when installing a new retractor, remove retaining clip on retractor drum to release spring tension) and allow belt to roll up on retractor.

## SEAT BELTS AND SHOULDER STRAPS

### Removal and Installation

Refer to figures 15-99 through 15-114 and select the appropriate illustration for removing and installing seat belts and shoulder straps.

**NOTE:** Check position of factory installed belt and shoulder strap anchors and reinstall anchor plates in same position. Care must be exercised when making installation that all anchor plates inter-lock, as shown in illustrations.

**NOTE:** To remove full width seat inner seat belt(s) from seat, remove plastic trim protector at rear of seat and carefully pull floor anchor end of belt through seat. When installing belts tighten anchor bolts 24 to 45 lbs. On two-door styles, it is important that seat belt webbing is routed over seat back outer hinge arm and not under arm.

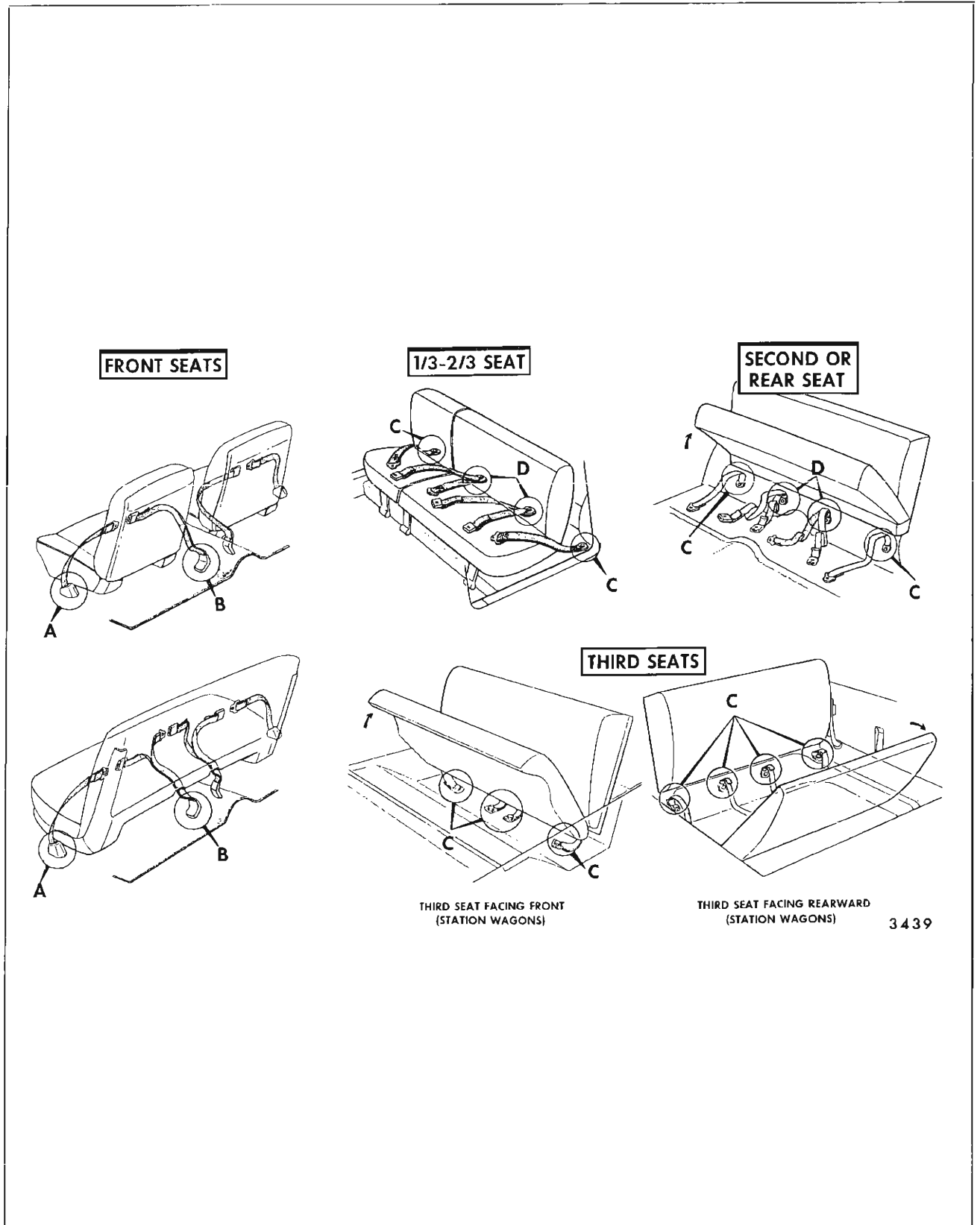
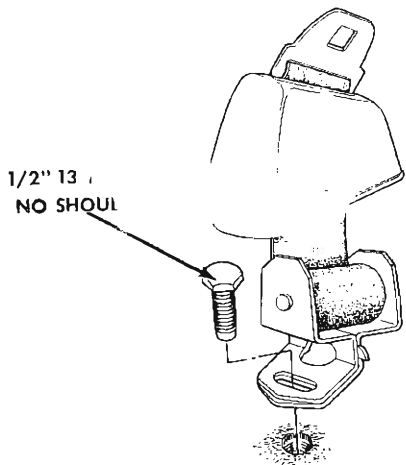
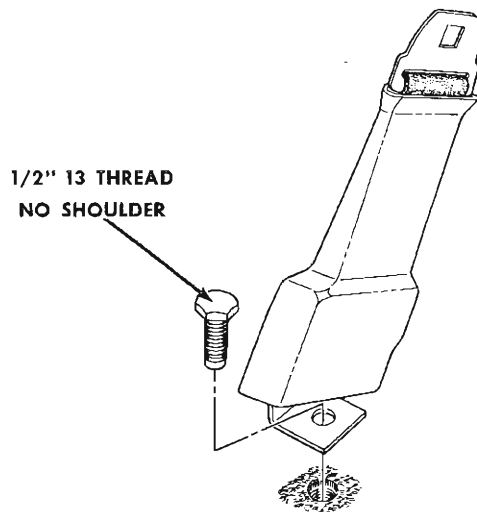

Fig. 15-99—Front and Rear Seat Belts (Including Station Wagon Second and Third Seats)

ALL EXCEPT CHEVY II,  
CAMERO, FIREBIRD &  
CORVAIR



CHEVY II  
COUPES & CONVERTIBLES  
- SWIVEL RETRACTOR -



CAMERO & FIREBIRD

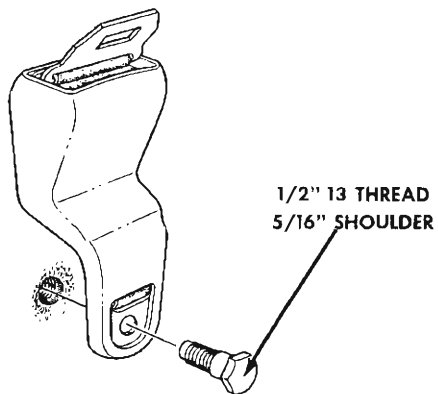

CORVAIR

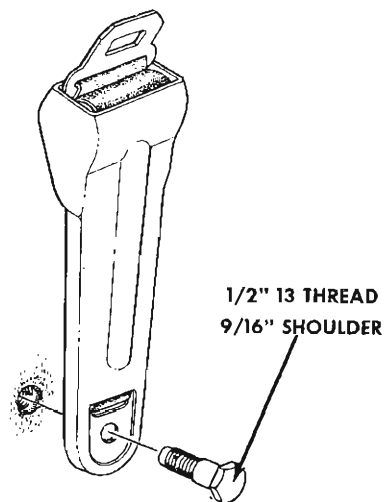

VIEW A

3440

Fig. 15-100—Front and Rear Seat Belt Floor Anchorage (Refer to Fig. 15-99)

$\frac{1}{2}$ " 13 THREAD  
 $\frac{13}{16}$ " SHOULDER

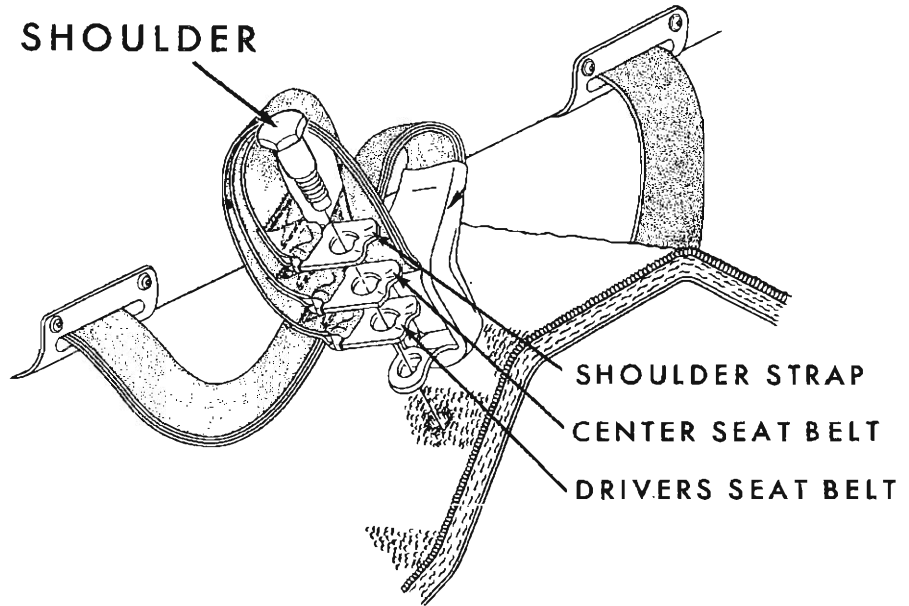

VIEW B

$\frac{1}{2}$ " 13 THREAD  
NO SHOULDER



Fig. 15-101—Front and Rear Seat Belt Floor Anchorage (Refer to Fig. 15-99)

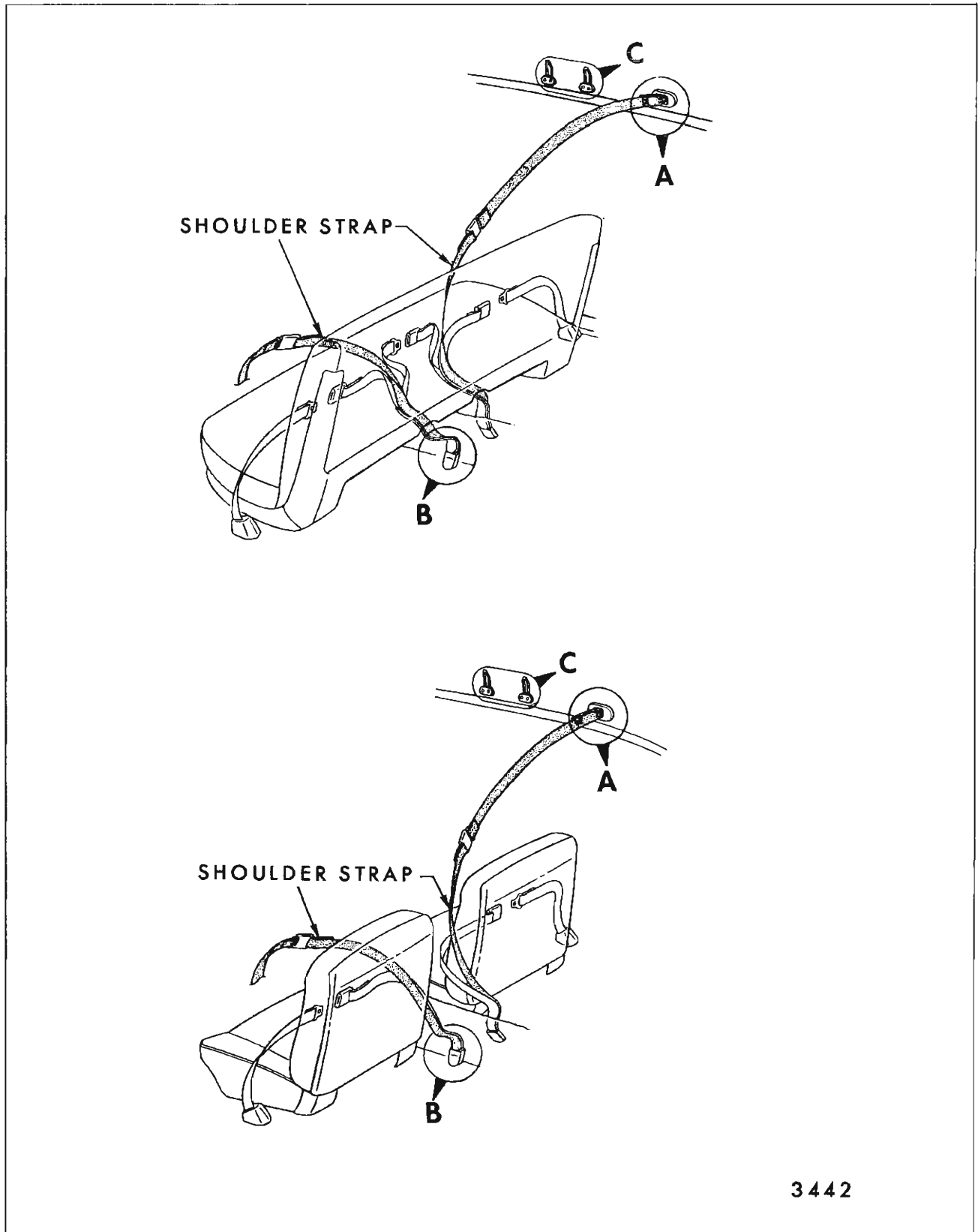

Fig. 15-102—Front Seat Shoulder Strap - All Styles Except Convertibles, "A-80" and "D" Styles

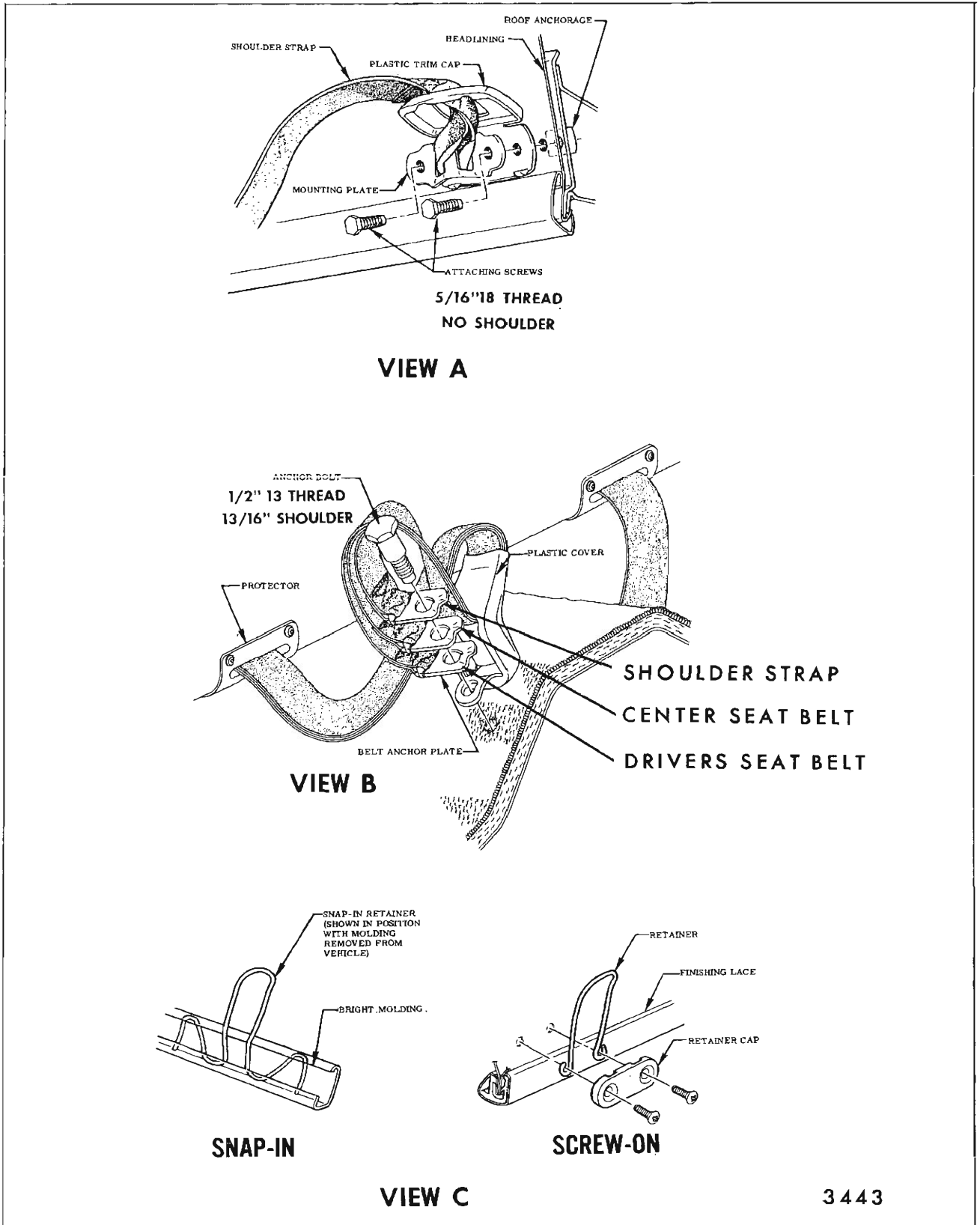

Fig. 15-103—Front Seat Shoulder Strap - All Styles Except Convertibles, "A-80" and "D" Styles (Refer to Fig. 15-102)

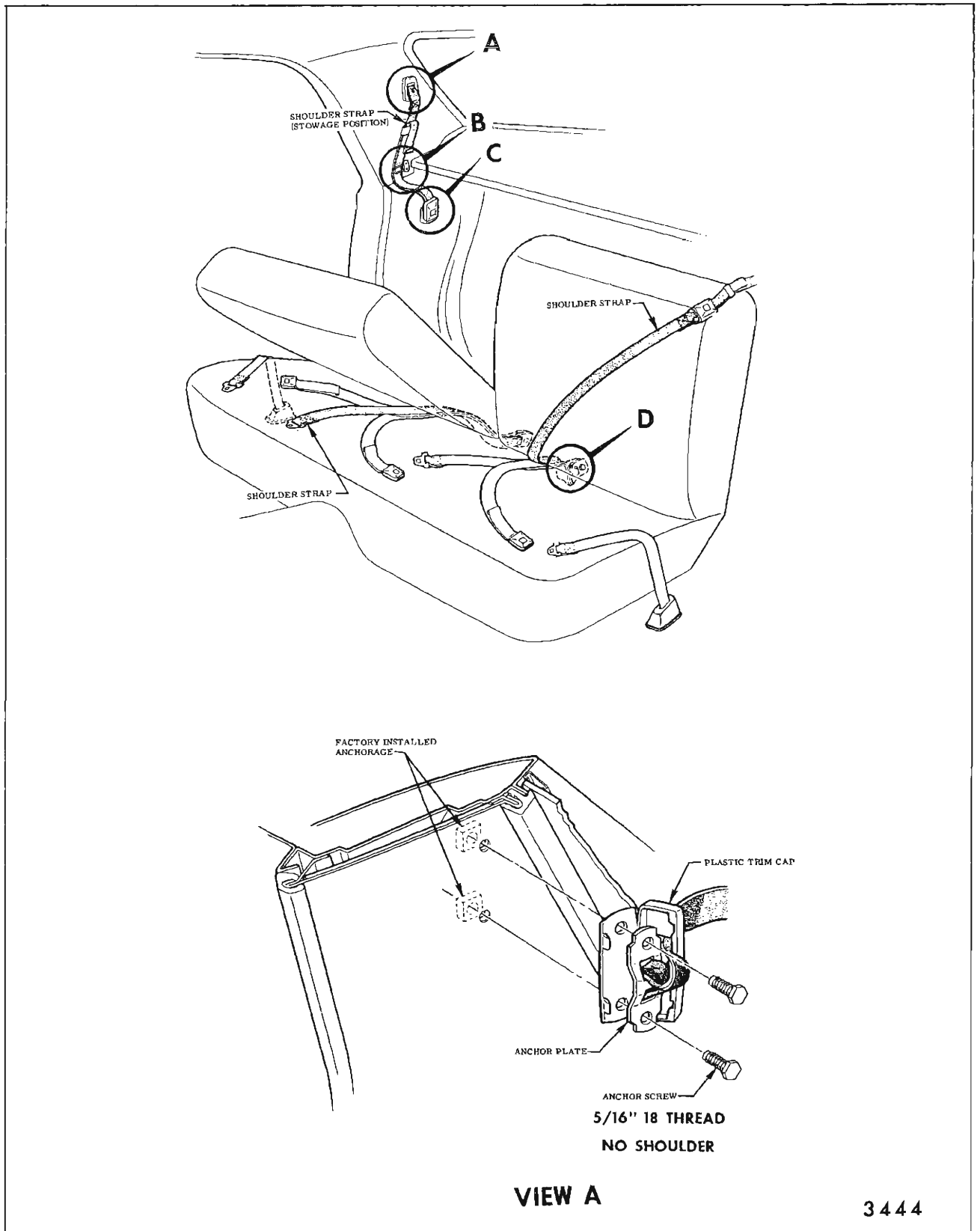

Fig. 15-104—Front Seat Shoulder Strap - "A-80" Styles



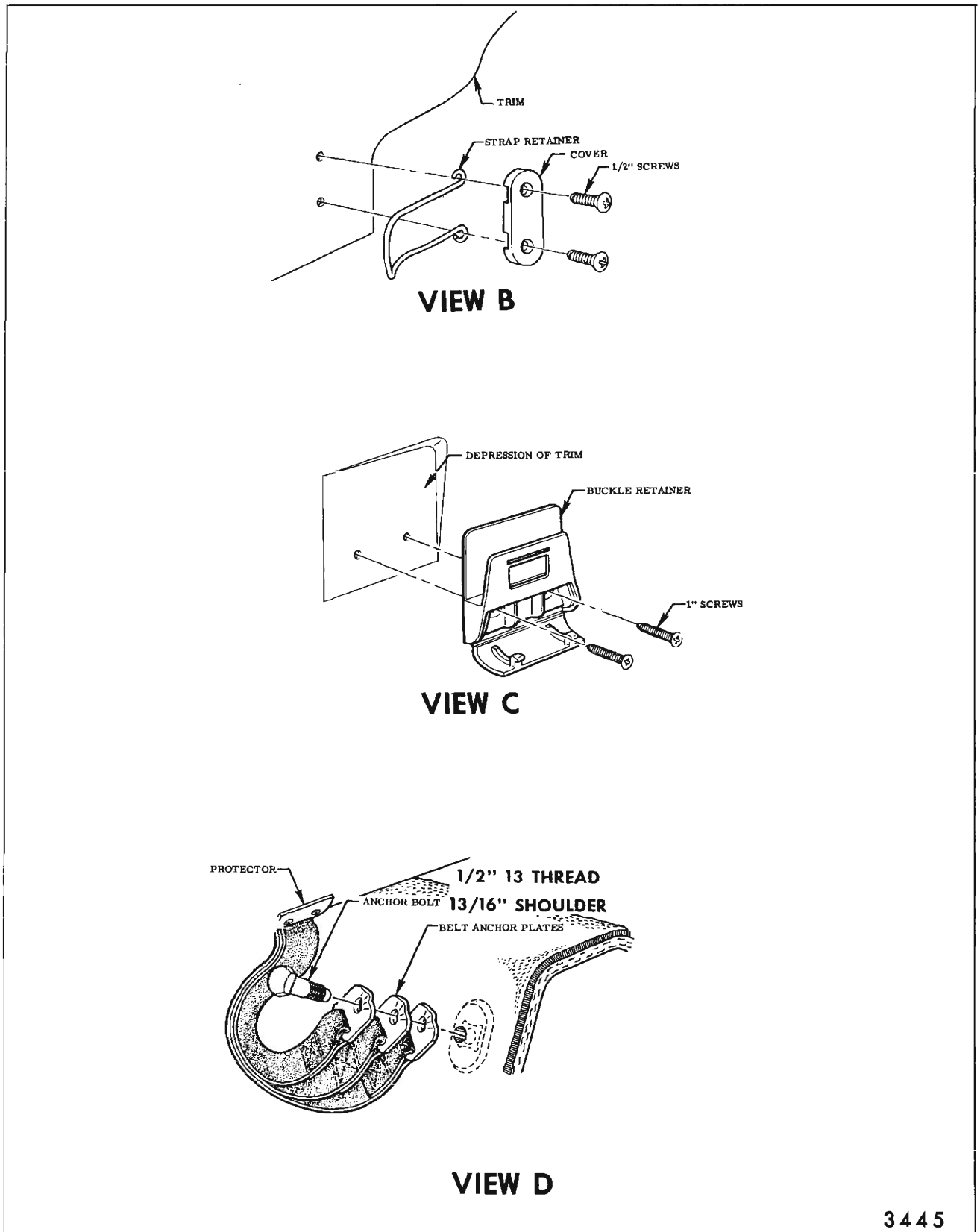

Fig. 15-105—Front Seat Shoulder Strap - "A-80" Styles (Refer to Fig. 15-104)

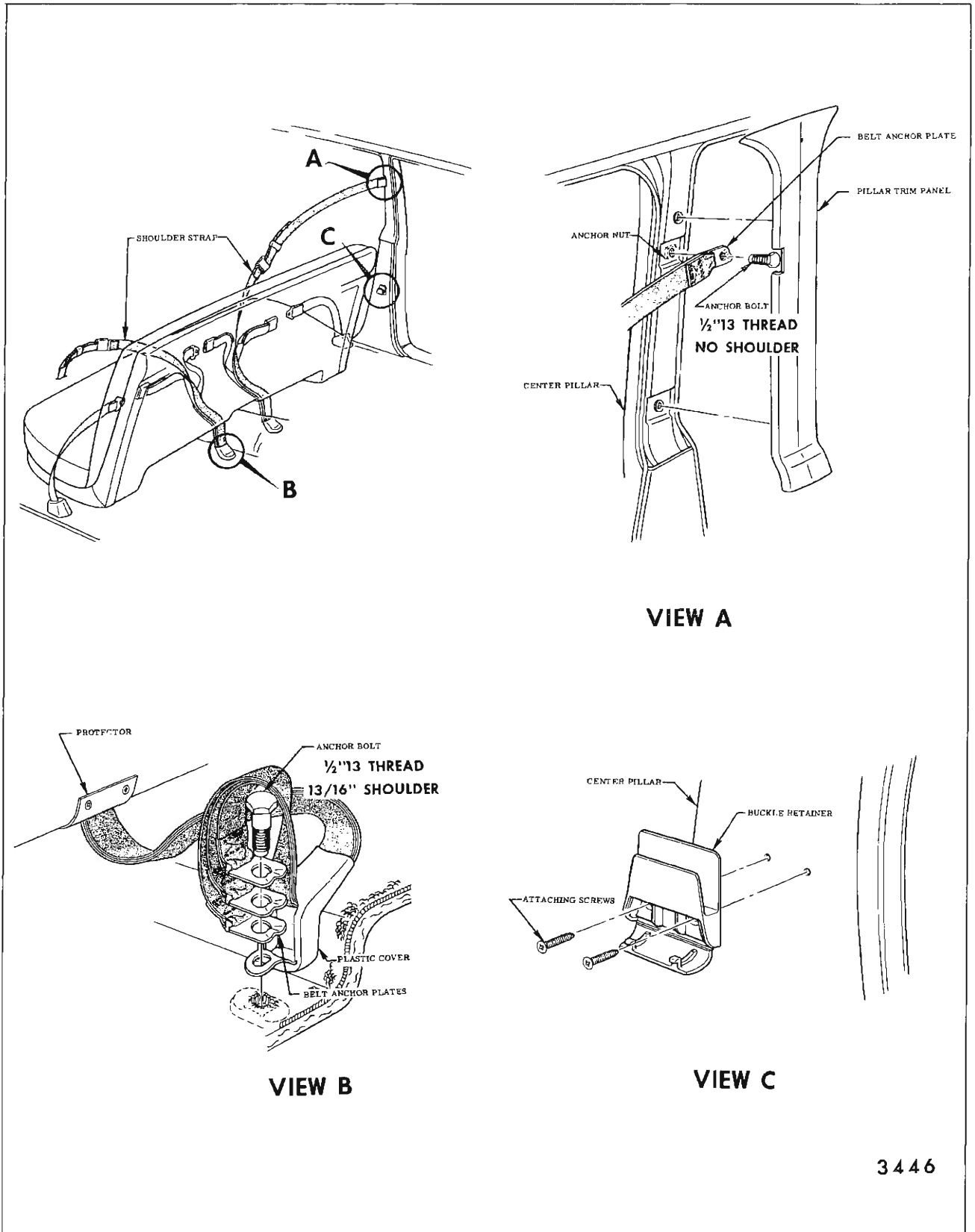
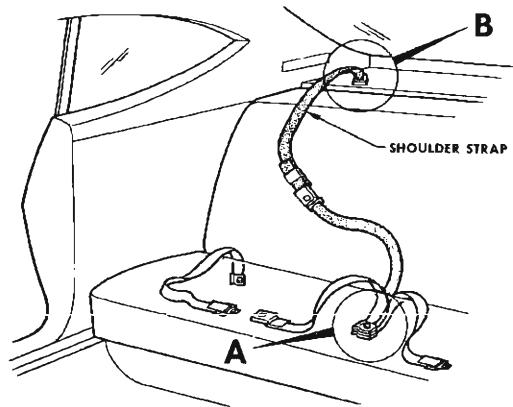
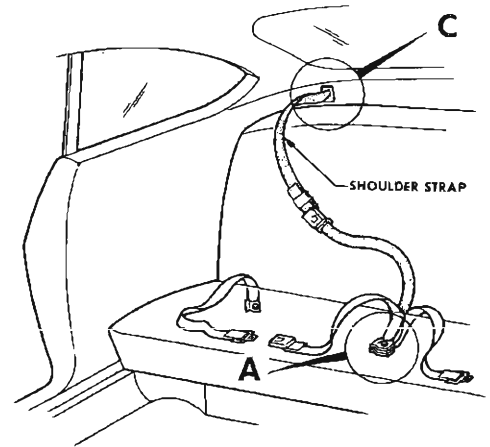

Fig. 15-106—Front Seat Shoulder Straps - "D" Styles

**ALL STYLES EXCEPT CONVERTIBLE,  
STATION WAGON, CORVAIR 2 DOOR HARDTOP,  
OLDSMOBILE TORONADO, BUICK RIVIERA  
& CAD. ELDORADO**



**CORVAIR  
2 DOOR HARDTOP**



**OLDSMOBILE TORONADO  
& BUICK RIVIERA**

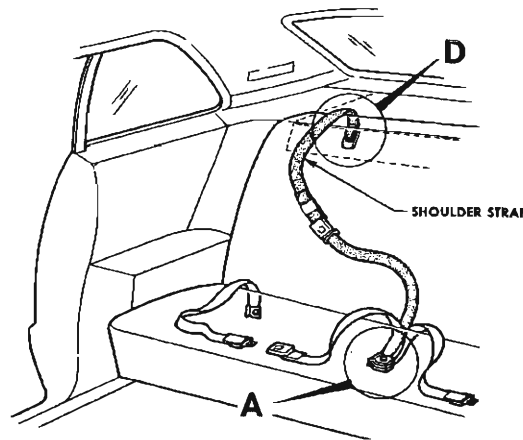

**CADILLAC ELDORADO**

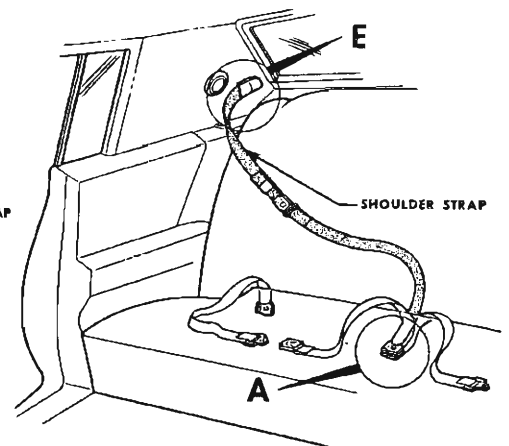

3462

Fig. 15-107—Rear Seat Shoulder Strap - All Styles Except Station Wagons and Convertibles

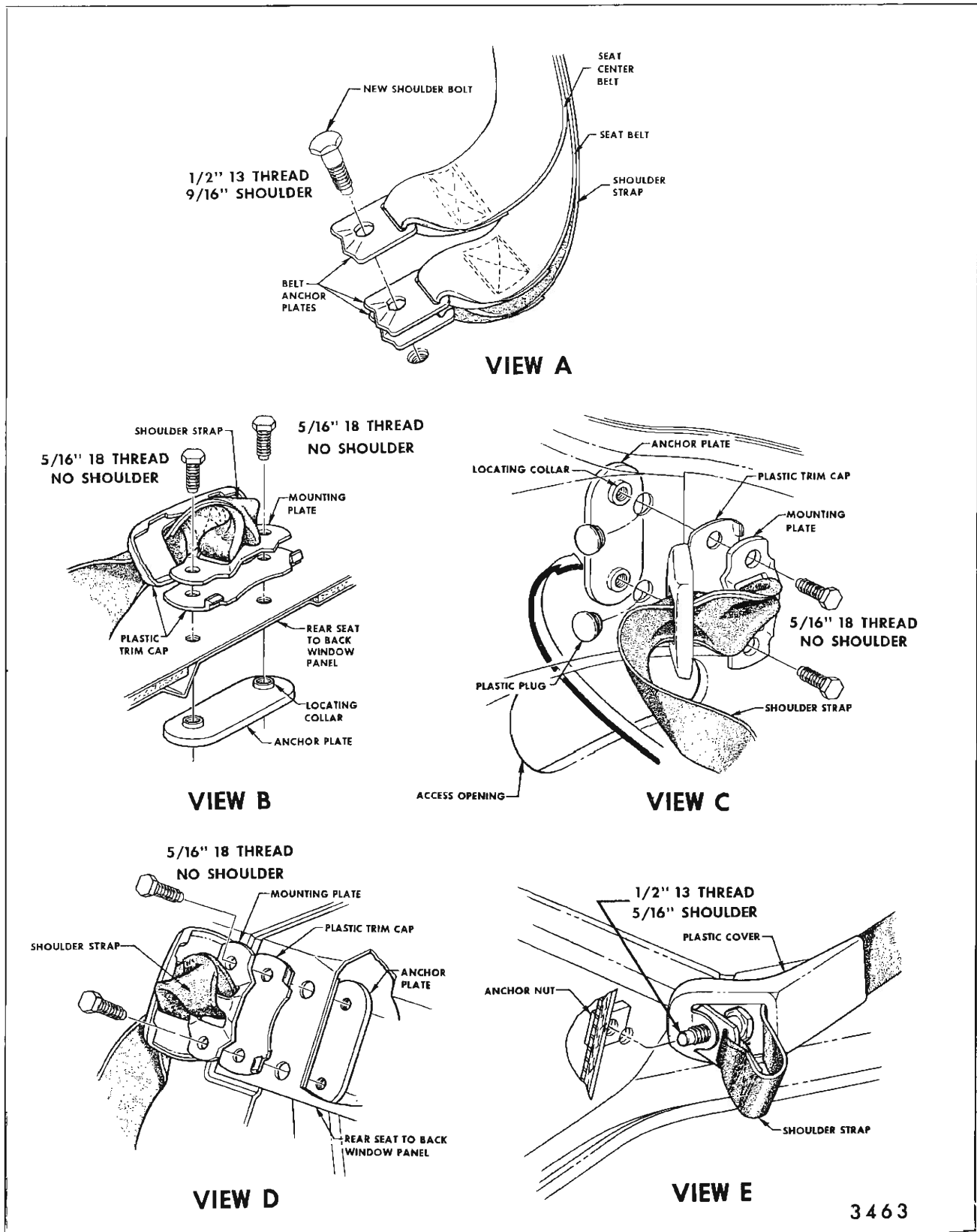

Fig. 15-108—Rear Seat Shoulder Straps - All Styles Except Station Wagons and Convertibles (Refer to Fig. 15-107)

## SECOND SEAT

CHEVROLET

BISCAYNE - BEL AIR - IMPALA & CAPRICE

PONTIAC

CATALINA - STARCHIEF EXECUTIVE SAFARI & BONNEVILLE

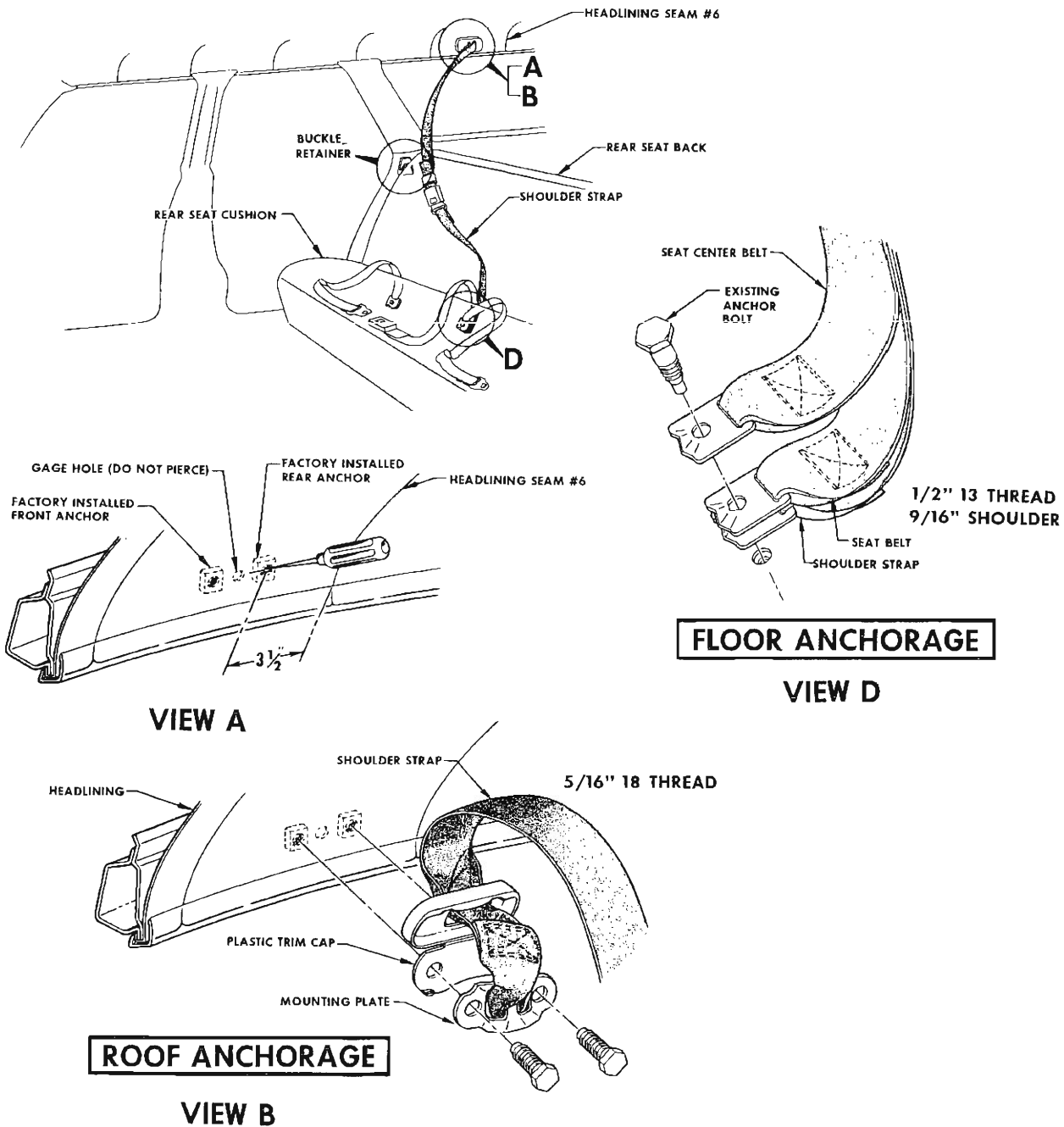

Fig. 15-109—Second Seat Shoulder Strap - "B" Station Wagon Styles

## SECOND SEAT

### CHEVROLET

CHEVELLE NOMAD - NOMAD CUSTOM & CONCOURS

### PONTIAC

TEMPEST CUSTOM & SAFARI

### OLDSMOBILE

CUTLASS "S" & VISTA - CRUISER

### BUICK

SPECIAL DELUXE & SPORT WAGON

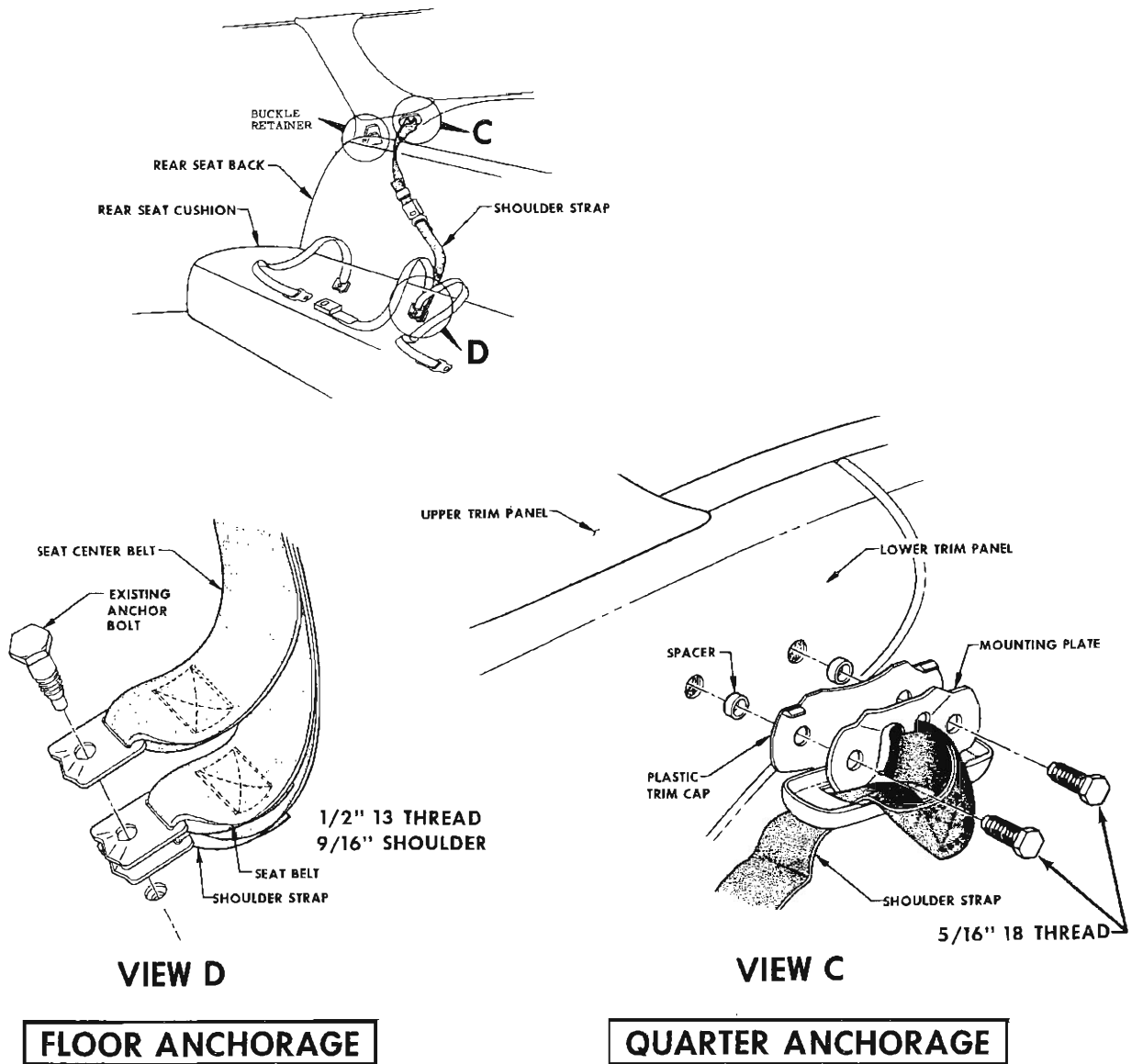

3517

Fig. 15-110—Third Seat Shoulder Strap - "A" Station Wagon Styles

**THIRD SEAT**

**OLDSMOBILE**  
**VISTA CRUISER**  
**BUICK**  
**SPORT WAGON**

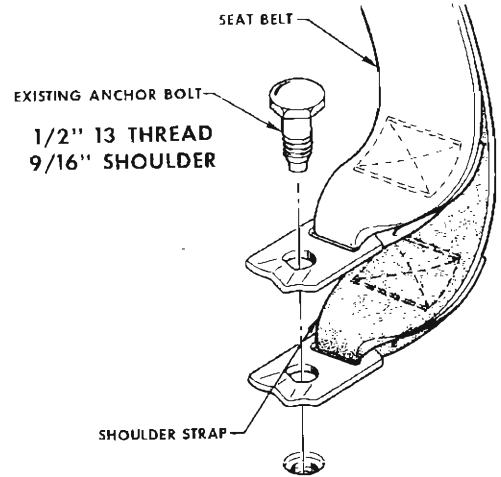
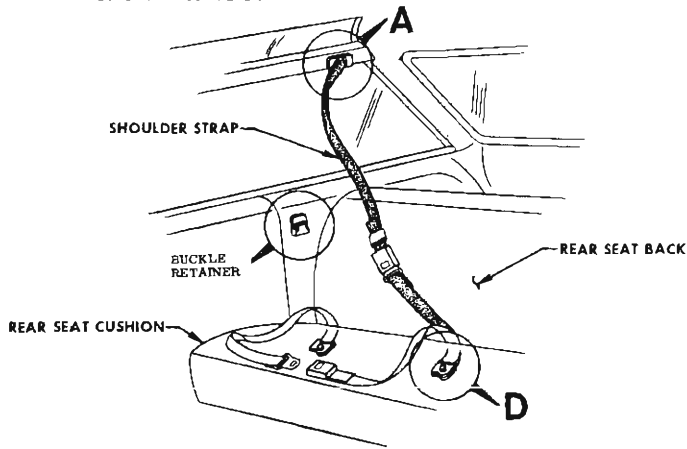

**FLOOR ANCHORAGE**  
**THIRD SEAT**

**VIEW D**

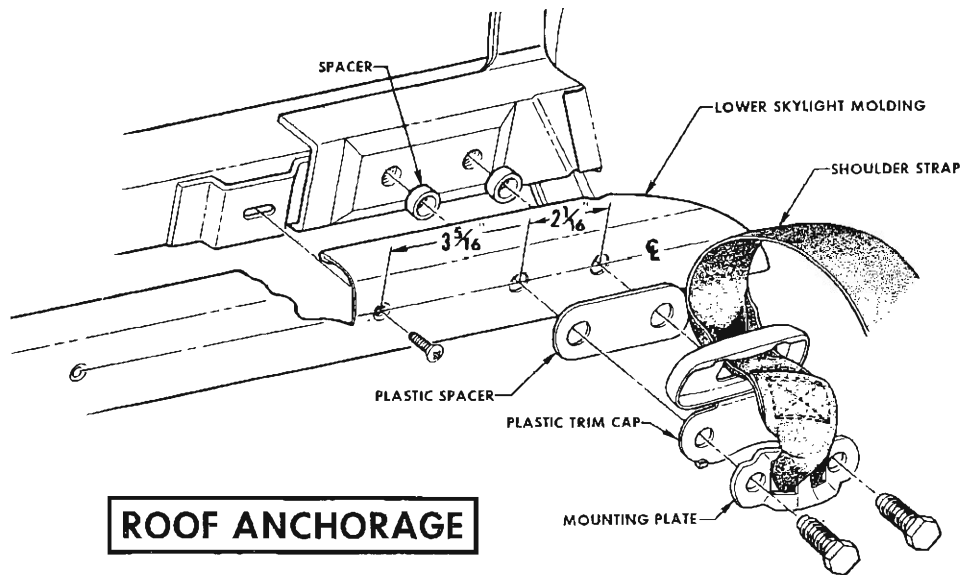

**ROOF ANCHORAGE**

**VIEW A**

5/16" 18 THREAD

3518

Fig. 15-111—Third Seat Shoulder Strap—“A” 65 & 66 Station Wagon Styles

**QUARTER ANCHORAGE**

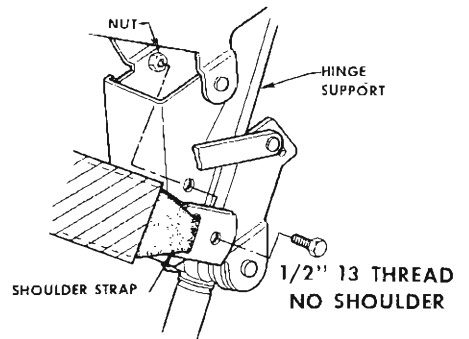
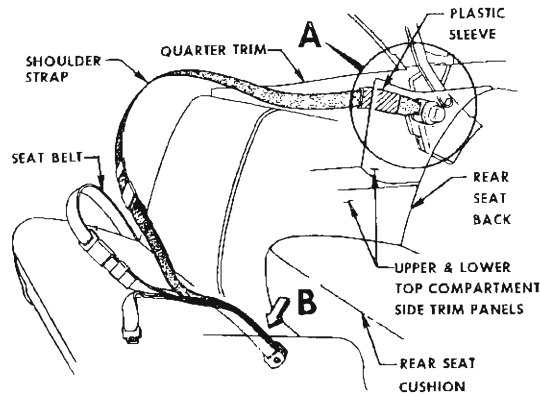

CHEVROLET IMPALA  
PONTIAC CATALINA, GRAND PRIX  
& BONNEVILLE  
OLDSMOBILE EIGHTY EIGHT &  
NINETY EIGHT  
BUICK LA SABRE, WILDCAT, &  
ELECTRA "225"  
CADILLAC DE VILLE

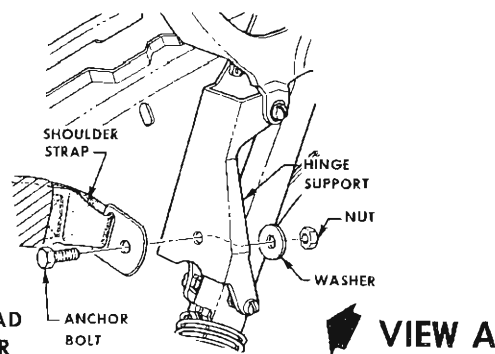

1/2" 13 THREAD  
NO SHOULDER

**VIEW A**

CHEVROLET CHEVELLE  
PONTIAC TEMPEST, LEMANS  
& GTO  
OLDSMOBILE F85, CUTLASS &  
442  
BUICK SKYLARK & GRAN SPORT

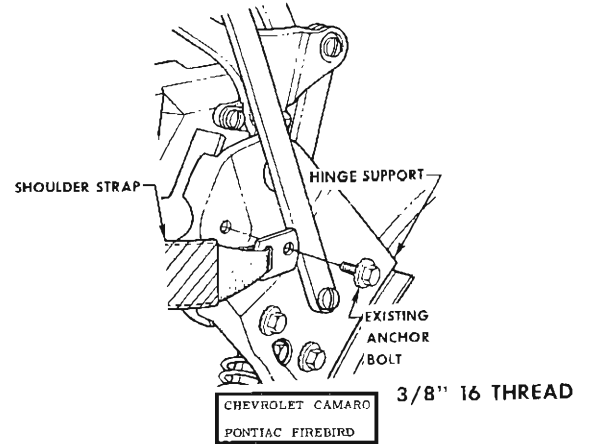

CHEVROLET CAMARO  
PONTIAC FIREBIRD

**VIEW A**

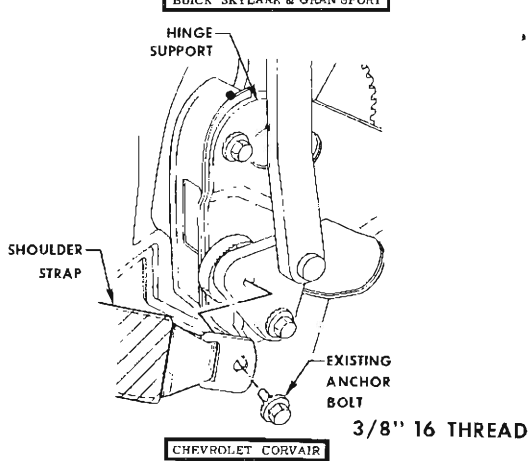

CHEVROLET CORVAIR

**VIEW A**

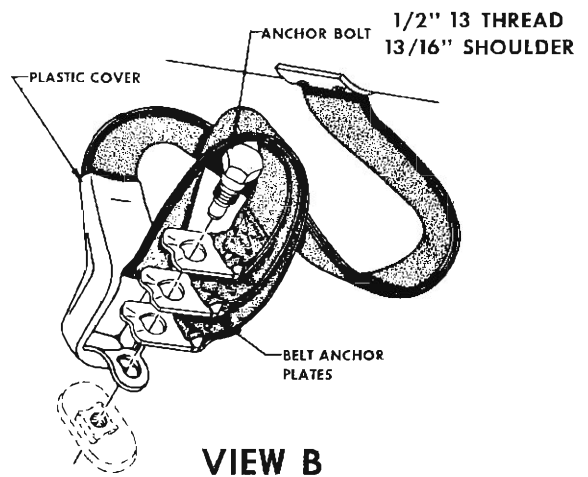

**VIEW B**

**FLOOR ANCHORAGE**

Fig. 15-112—Front Seat Shoulder Strap - All Convertibles



**ALL STYLES EXCEPT CORVAIR**

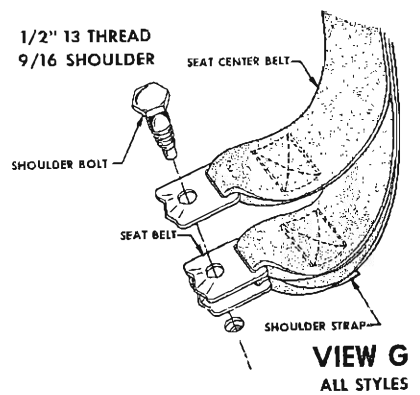
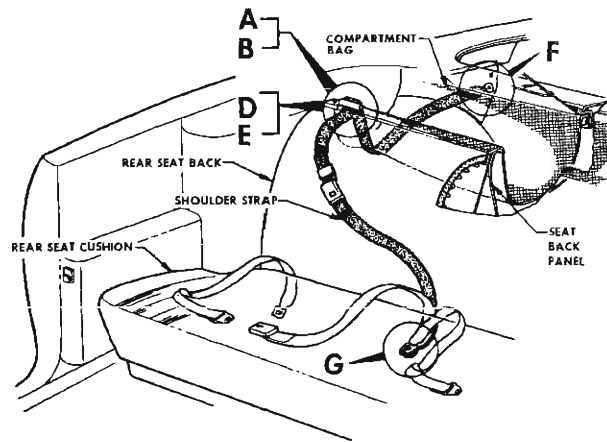

**FLOOR ANCHORAGE**

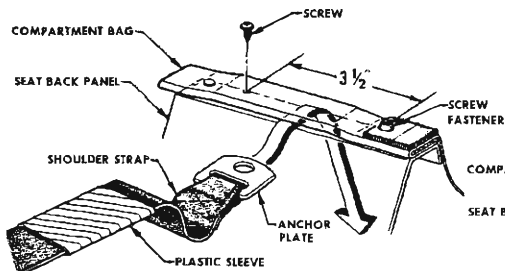

**VIEW A**

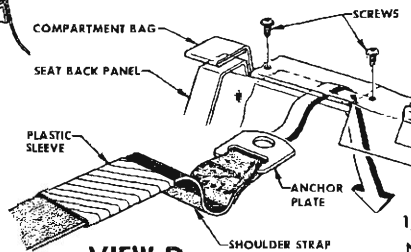

**VIEW D**

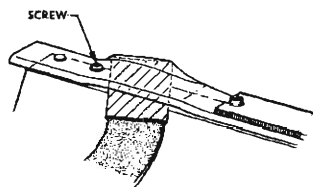

**VIEW B**

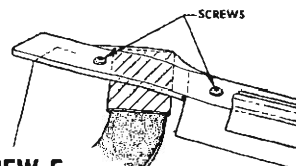

**VIEW E**

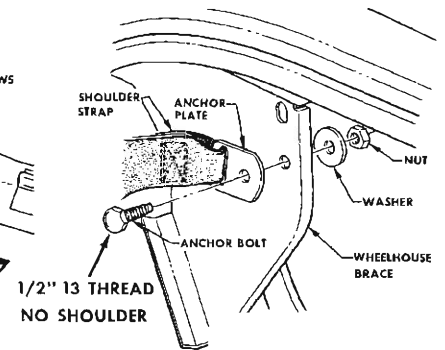

**VIEW F**  
ALL STYLES EXCEPT CORVAIR

**QUARTER ANCHORAGE**

Fig. 15-113—Rear Seat Shoulder Strap - All Convertibles Except Corvaire

### CORVAIR STYLES

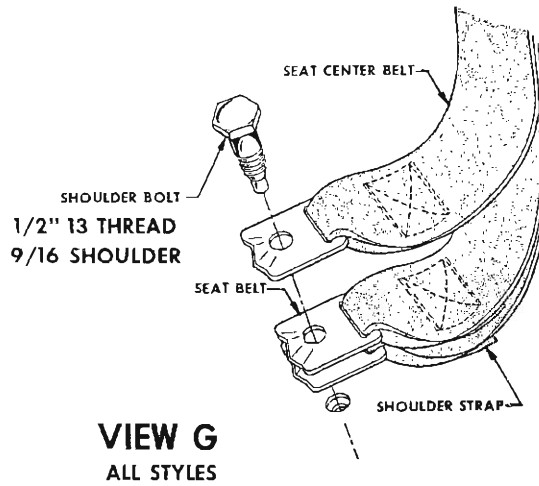
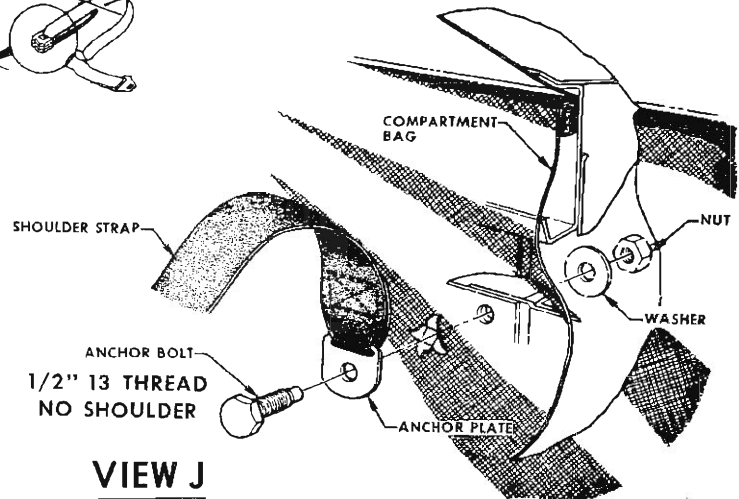
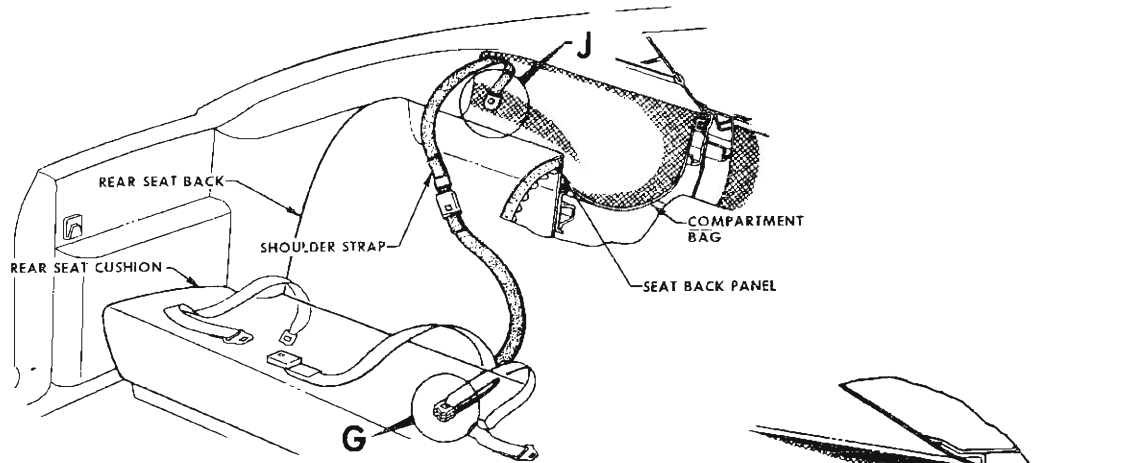

### FLOOR ANCHORAGE

3521

Fig. 15-114—Front Seat Shoulder Strap - Corvaire Convertible

# SECTION 16

# ELECTRICAL

## INDEX

Subject	Page	Subject	Page
Introduction . . . . .	16-2		
Power Windows . . . . .	16-2		
Description . . . . .	16-2		
Cross Over Harness . . . . .	16-2		
Front Door Window Harness . . . . .	16-2		
Feed Harness for Rear Doors or Quarter Windows . . . . .	16-2		
Rear Door Window Harness . . . . .	16-3		
Motor Description . . . . .	16-3		
Relay . . . . .	16-3		
Cut-Out Switch . . . . .	16-3		
Checking Procedures . . . . .	16-3		
Power Window Circuit Checking Procedures . . . . .	16-5		
A. Checking Feed Wire Circuit Continuity at Circuit Breaker . . . . .	16-5		
B. Checking Relay Assembly at Shroud . . . . .	16-5		
C. Checking for Current at Cut-Out Switch (Cadillac Only) . . . . .	16-5		
D. Checking Cut-Out Switch (Cadillac Only) . . . . .	16-5		
E. Checking Feed Circuit Continuity at Window Control Switch . . . . .	16-5		
F. Checking Window Control Switch . . . . .	16-5		
G. Checking Wires Between Door Window Switch and Door Window Motor . . . . .	16-11		
H. Checking Wires Between Quarter Window Switch and Quarter Window Motor . . . . .	16-11		
I. Checking Window Motor . . . . .	16-11		
J. Trouble Shooting of Power Windows . . . . .	16-11		
Power Operated Station Wagon Tail Gate Window . . . . .	16-12		
Electrical Tail Gate Window Circuit . . . . .	16-12		
Checking Procedure . . . . .	16-13		
A. Checking Feed Circuit Continuity at Circuit Breaker . . . . .	16-14		
B. Checking Relay Assembly . . . . .	16-14		
C. Checking Feed Wire Circuit Continuity at Control Switch on Instrument Panel . . . . .	16-14		
D. Checking Control Switch at Instrument Panel . . . . .	16-14		
E. Checking Control Switch on Tail Gate . . . . .	16-29		
F. Checking the Tail Gate Window Motor . . . . .	16-29		
G. Checking Operation of Safety Switch . . . . .	16-29		
H. Trouble Shooting . . . . .	16-29		
Power Seats . . . . .	16-31		
Description . . . . .	16-31		
Trouble Shooting of Horizontal Seat Circuit . . . . .	16-32		
Four-Way Tilt Seat . . . . .	16-33		
Checking Procedure . . . . .	16-34		
A. Checking for Current at Circuit Breaker . . . . .	16-34		
B. Checking Feed Circuit Continuity at Relay on Seat Motor - All Styles . . . . .	16-34		
C. Checking for Current at Seat Control Switch . . . . .	16-34		
D. Checking the Seat Control Switch . . . . .	16-34		
		E. Checking Wires Between Control Switch and Motor Relay . . . . .	16-36
		F. Checking the Relay Assembly . . . . .	16-36
		G. Checking the Motor Assembly . . . . .	16-36
		H. Checking Wires Between Switch and Solenoids . . . . .	16-36
		I. Checking the Solenoid . . . . .	16-36
		J. Trouble Shooting . . . . .	16-37
		Six-Way Tilt Seat . . . . .	16-37
		Description . . . . .	16-37
		Circuit Checking Procedures . . . . .	16-38
		A. Checking Feed Circuit Continuity at Circuit Breaker . . . . .	16-38
		B. Check Feed Circuit Continuity at Seat Control Switch . . . . .	16-38
		C. Checking the Seat Control Switch . . . . .	16-38
		D. Checking Feed Circuit Continuity at Relay on Seat Motor . . . . .	16-39
		E. Checking Wire Between Control Switch and Motor Relay . . . . .	16-39
		F. Checking the Relay Assembly . . . . .	16-40
		G. Checking the Motor Assembly . . . . .	16-40
		H. Checking the Wire Between the Solenoid and Switch . . . . .	16-40
		I. Checking the Solenoid . . . . .	16-40
		J. Three-Way Jumper Wire for Checking Seat Switch . . . . .	16-40
		K. Trouble Shooting . . . . .	16-41
		Tail and Side Marker Lamps . . . . .	16-42
		Description . . . . .	16-42
		Sealing . . . . .	16-42
		Side Marker Lamps . . . . .	16-42
		Tail Lamp Bulb Usage Chart . . . . .	16-43
		Tail Lamp Service Operations	
		Chevrolet, Acadian, Beaumont . . . . .	16-45
		Pontiac . . . . .	16-47
		Oldsmobile . . . . .	16-49
		Buick . . . . .	16-51
		Cadillac . . . . .	16-53
		Interior Lamp Chart (Above Belt) . . . . .	16-54
		Seat Warmers . . . . .	16-54
		Description . . . . .	16-54
		Components . . . . .	16-56
		Operation of Seat Warmer . . . . .	16-56
		Electric Back Window Grid Defogger . . . . .	16-56
		Description . . . . .	16-56
		Electric Seat Back Lock Release . . . . .	16-58
		Description . . . . .	16-58
		Circuit Checking Procedures . . . . .	16-58
		A. Checking Seat Back Lock Release Relay . . . . .	16-58
		B. Checking Door Jamb Switches . . . . .	16-58
		C. Checking Seat Solenoid . . . . .	16-58
		Electric Door Lock . . . . .	16-60
		Description . . . . .	16-60
		Checking Procedures . . . . .	16-60

## INTRODUCTION

The body electrical equipment for all body styles is covered in the following sections:

- Power Windows
- Power Tailgate Window
- Power Seats
- Tail and Side Marker Lamps
- Electric Seat Warmer
- Electric Back Window Grid Defogger
- Electric Seat Back Lock Release
- Electric Door Locks

Each section combines all styles and series together which incorporates the power equipment unless stated otherwise in the procedure.

Round wire is used for body wiring on all styles and for all options.

Typical body wiring and routing diagrams are located at the end of this section.

It is important that inspection for mechanical binds and alignments be completed before electrical diagnosis is attempted.

Circuit wiring for power equipment is protected by a circuit breaker (40 ampere in most cases) and is located as follows:

<u>DIVISION</u>	<u>STYLE</u>	<u>LOCATION</u>
Chevrolet	All	Engine Compartment Bulk-head
Pontiac	All	In fuse block (plug-in type)
Oldsmobile	All	Engine Compartment Bulk-head
Buick	All	In fuse block (plug-in type)
Cadillac	"C-E"	In fuse block (plug-in type)
Canadian		
Pontiac	All	Engine Compartment Bulk-head
Beaumont	All	Engine Compartment Bulk-head
Acadian	All	Engine Compartment Bulk-head

## POWER WINDOWS

### POWER OPERATED WINDOWS— All Series

#### Description

The wiring harness for the electrically operated windows consists of the following major sections:

1. Cross-over harness
2. Feed harness to rear doors or quarter windows
3. Left and right rear door or quarter window harness
4. Left and right front door window harness

### CROSS-OVER HARNESS

This harness is installed beneath the instrument panel and completes the circuit from the right door to the left door windows on all styles except on Cadillac styles.

On Cadillac "C" styles the cross-over harness is part of the body and rear door or quarter feed harness and is installed under the front seat.

On Cadillac "E" styles the cross-over harness is installed at the front of the floor pan.

### FRONT DOOR WINDOW HARNESS

The impact bar and reinforcements incorporated into some door construction reduces accessibility for power window wiring harness. Therefore, if replacement of door harness should become necessary, attach a leader to the end of the harness before removal from the door.

### FEED HARNESS FOR REAR DOORS OR QUARTER WINDOWS

This harness connects to the front cross-over harness on the left side of the shroud (fire wall) and extends rearward in the body wire harness under the driver's seat on all styles except Chevrolet and Pontiac "F" and Cadillac Styles. On all styles, this harness connects directly on the rear quarter window motor on 2-door style and terminates at the base of the center pillar on 4-door styles.

On Chevrolet and Pontiac "F" styles, the feed harness is connected to the cross-over harness at the left and right shroud and is routed on top of the rocker inner panel on each side to the quarter window.

On Cadillac styles the wire harness is routed from the left shroud, along the left rocker inner panel to the front of the drivers seat, then, on 2-door styles,

it crosses over to the body wire harness, is incorporated in the body wire harness conduit and extends rearward to the front of the rear seat area where it separates to each quarter window. On 4-door styles, the wire is routed from the left shroud along the rocker inner panel and separates at the front edge of the drivers seat. The left rear door wiring continues rearward to the left center pillar; the wires to the right center pillar run across the body under the front seat.

## REAR DOOR WINDOW HARNESS

The left and right door harness connects to the feed harness in the base of the center pillar. To disengage the connector, pull harness inboard at base of center pillar for accessibility.

## MOTOR DESCRIPTION

Power windows are operated by a rectangular shaped 12 volt series-wound motor with an internal circuit breaker and a self-locking rubber coupled gear drive. The harness to the door window motor connector is designed with a locking embossment to insure a positive connection. When disengaging the harness connector from the door motor, it is necessary to depress the thumb release. When installing the harness, the thumb release must be held depressed until the embossment on the female connector is locked in the hole of the motor connector.

## RELAY

All styles - In addition to the circuit breaker, a relay is used in the circuit, which prevents the operation of the power windows until the ignition switch is turned "on".

Buick "E" and All "B-C" Styles Except Cadillac - have the ignition relay located on shroud upper panel concealed by the instrument panel assembly.

The ignition relay on Cadillac and all other styles is located on the left shroud side panel.

## CUT-OUT SWITCH

A two position ("Lock-Normal") cut-out switch is installed on the left front door arm rest on Cadillac styles only.

The cut-out switch button should be left in the "NORMAL" position when ignition switch is "ON" to permit normal operation of power windows from all switch locations. If the control button is in the "LOCK" position with the ignition switch on, the windows will operate only from the master control switch.

## CHECKING PROCEDURES

Generally most common failures are "open" and "short" circuits. An "open" circuit is one in which the circuit cannot be completed due to a broken wire, poor terminal contact or improper ground. A "short" circuit is one in which the current is grounding before it reaches the operating unit. This creates an overload and actuates the circuit breaker or "blows" the fuse.

### 1. Defective Components

Occasionally an "open" or "short" circuit exists within a component of the circuit, such as a motor, switch, relay, etc. These units may be checked as covered in the following example:

#### A. Checking an inoperative switch

1. Place a #12 jumper wire on the switch terminal block between the center terminal (feed) and one of the two motor wire terminals. If the motor operates, the switch is defective.

The principle involved here is to by-pass the suspected defective component and this procedure can be applied to check almost all component parts.

### 2. Open Circuits

To check for a broken wire:

#### A. Visually inspect the area of suspected damage.

- B. If no wire damage is apparent, check the wire on the battery side of the suspected area by grounding one end of a light tester and inserting the pointed end of the light tester through the insulation. If the tester lights, current is present.

**NOTE:** To check for current between a switch and an operating unit, the switch must be actuated to insure current in the wire.

- C. Perform the same operation on the opposite end of the wire. If the tester does not light, the break is between the two points checked.

- D. Using the light tester, check for current in the wire midway between the points where current exists and where it does not exist. If the tester does not light, check the wire at intervals in the direction of the power source. If the tester does not light proceed with the tester in the opposite direction until the break is located.

- E. Repair (solder) the break and tape any exposed wire.

### 3. Improper Ground

Many times perfectly sound operating units, such as motors, are considered defective and are replaced because an effective ground is not established.

To check for proper ground:

- A. Attach one end of a #12 gauge jumper wire to the body of the inoperative unit.
- B. Connect the other end to a good ground, such as a bare metal panel.
- C. Energize the unit. If the unit operates, the original ground is defective.
- D. Re-establish the ground.

### 4. "Short" Circuits

When a "short" exists in a given circuit, the circuit breaker will be actuated or a fuse will be blown. However, if the "short" is located between a switch and an operating unit, the circuit breaker will actuate or the fuse will blow only when the switch is actuated. If the "short" occurs between the circuit breaker (or fuse) and the switch, the circuit will be inoperative all the time. This will continue until the "short" is repaired or the battery runs down.

Locating a short circuit depends largely on the symptoms in any given case.

As an aid in locating a "short" in any given circuit, an instrument known as a "short tester" (J-8681 or similar type) may be employed. Its advantage lies in the fact that it is a labor saving device, since trim removal is NOT required prior to testing operations. All short testers have the following parts in common:

Two leads with alligator clips (for by-passing an existing circuit breaker or fuse).

A 10-15 amp circuit breaker (to replace the existing circuit breaker or fuse).

A meter for detecting intermitting electrical current.

The tester meter is designed to react to the magnetic lines of force that surround an energized wire or conductor. However, the current and magnetic lines of force must be interrupted, by means of the

testing device circuit breaker, at intervals in order to cause the meter needle to deflect.

The use of a "short" tester should include the following steps:

- A. Reference should be made to service manual electrical diagrams and particularly wire routing diagrams in order to establish the location of wiring and wire harness accurately.
- B. Disconnect the affected circuit breaker (both wires) or remove blown fuse and substitute either of these items with the circuit breaker of the tester. This is accomplished by connecting the tester leads to the input and output side of the fuse clip or wires, previously removed from the existing circuit breaker.

C. The tester may respond immediately by making a snapping noise. (This sound may be accompanied by a warning light on some testers.) This response is an indication that the "short" is located in a FEED line, between the power source and a switch. If the tester does not respond, proceed as follows:

- i. Turn on or actuate all switches in the suspected circuit (or body).
- ii. Observe all lights or units affected by actuating all switches. The light or unit that DOES NOT operate intermittently, but causes the tester to react, is in the "shorted" circuit, and indicates the side of the car that is affected.

**NOTE:** When the affected circuit has been positively identified, reference should again be made to the proper wire routing diagram as an aid in the steps that follow. In addition, the switch in the circuit being checked must be held in the closed position.

D. Beginning at the power source for the suspected circuit, place the tester meter directly over the wire (or harness) with the meter arrows parallel to the wire(s) being checked. The meter needle will deflect noticeably each time the tester completes the circuit.

**NOTE:** Since this test will most often be made over intervening layers of trim material (cloth, rubber, plastic, metal), it may be necessary to move the meter laterally over the circuit at each check point

to achieve the strongest signal on the meter.

- E. Check progressively with the meter along the circuit from the power source to the inoperative unit. A sharp DECREASE in the AMOUNT of meter needle deflection will indicate the location (within 4-5 inches) of the location of the "short". It must be remembered, however, that the above meter reaction would also occur if the wrong circuit was followed or the meter was not held directly above the circuit (reference "NOTE", in Step #4).
- F. Once the location of the "short" is accurately established, necessary trim parts may be removed to perform repairs.

Wires that serve to complete a ground circuit (i.e., dome lights) may, through missing or damaged insulation, complete the circuit at all times. Such areas may be determined with a "short" tester in the following manner:

- i. Disconnect the affected ground wire at all (jamb) switches, TO PREVENT DAMAGE.
- ii. Connect one lead of the short tester to the source end of the ground wire and connect the other lead to a power source. This action converts a ground wire to a feed wire.
- iii. Check the affected circuit with the tester meter as previously outlined beginning with Step #4.

## POWER WINDOW CIRCUIT CHECKING PROCEDURES

It may be necessary to use only one or all of the procedures outlined to locate an electrical failure in the circuit. If the location of the failure is evident follow only the steps required to check the affected wire or component. If the location of the failure is not evident, follow the procedure as outlined. Be sure to check the harness connectors for proper engagement and become familiar with the typical circuit diagrams. (See Figs. 16-1 through 16-5)

### a. Checking Feed Circuit Continuity at Circuit Breaker

1. Connect one test light lead to battery side of circuit breaker and ground other lead. If tester does not light, there is an open or short circuit in feed circuit to breaker.

2. To check circuit breaker, disconnect the output feed wire (the wire opposite the power source feed to the breaker) from the breaker and with test light, check terminal from which wire was disconnected. If tester does not light, circuit breaker is inoperative.

### b. Checking Relay Assembly at Shroud

1. With test light, check relay feed. If tester does not light, there is an open or short circuit between relay and circuit breaker.
2. Turn ignition switch on and with test light check output terminal of relay. If tester does not light, the relay is inoperative or there is a short or open circuit between ignition switch and relay assembly. (Check fuse at dash panel).

### c. Checking for Current at Cut-Out Switch—(Cadillac Only)

1. With ignition switch on, connect one test light lead to the master window control switch feed terminal (red-white stripe) of the switch block and ground other test lead.
2. If tester does not light, there is an open or short circuit between the relay and cut-out switch.

### d. Checking Cut-Out Switch—(Cadillac Only)

1. With the ignition switch on, connect one end of a #12 gauge jumper wire to lower terminal (master control switch feed - red-white stripe) and the other end in the right and left rear quarter or door and right front door feed terminal (pink-black stripe).
2. Operate control switches. If any of the windows operate with the jumper but not with the cut-out switch, the switch is defective.

### e. Checking Feed Circuit Continuity at Window Control Switch

1. Connect one test light lead to feed terminal of switch block and ground other tester lead to body metal (Fig. 16-6).
2. If tester does not light, there is an open or short circuit between switch and power source.

### f. Checking Window Control Switch

1. Insert one end of a #12 gauge jumper wire to the switch feed terminal and the other end to one of the motor lead terminals in the switch block. Repeat this check on the remaining motor lead terminal (See Fig. 16-7).

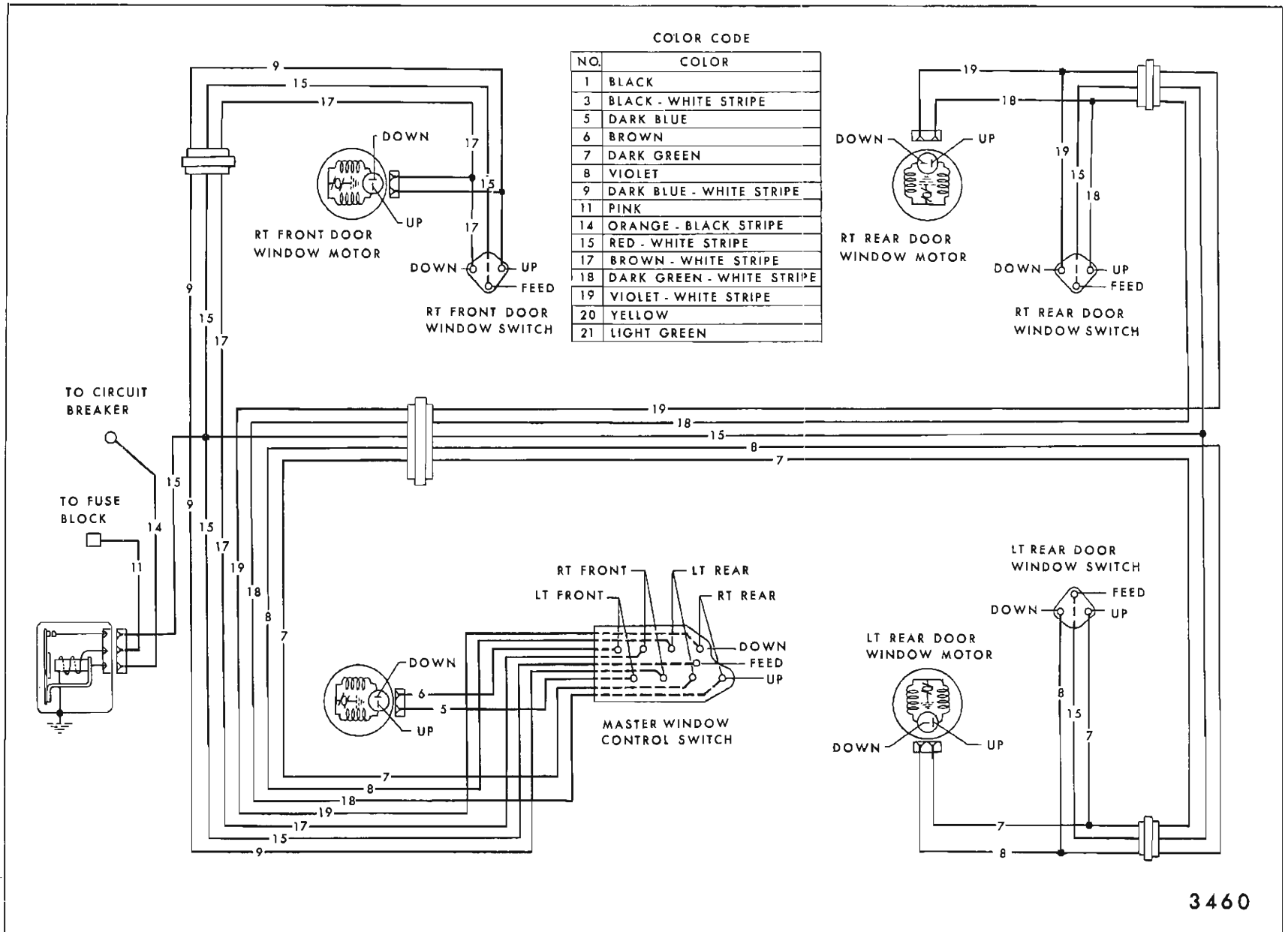

Fig. 16-1—Power Window Circuit - Typical "A" Styles



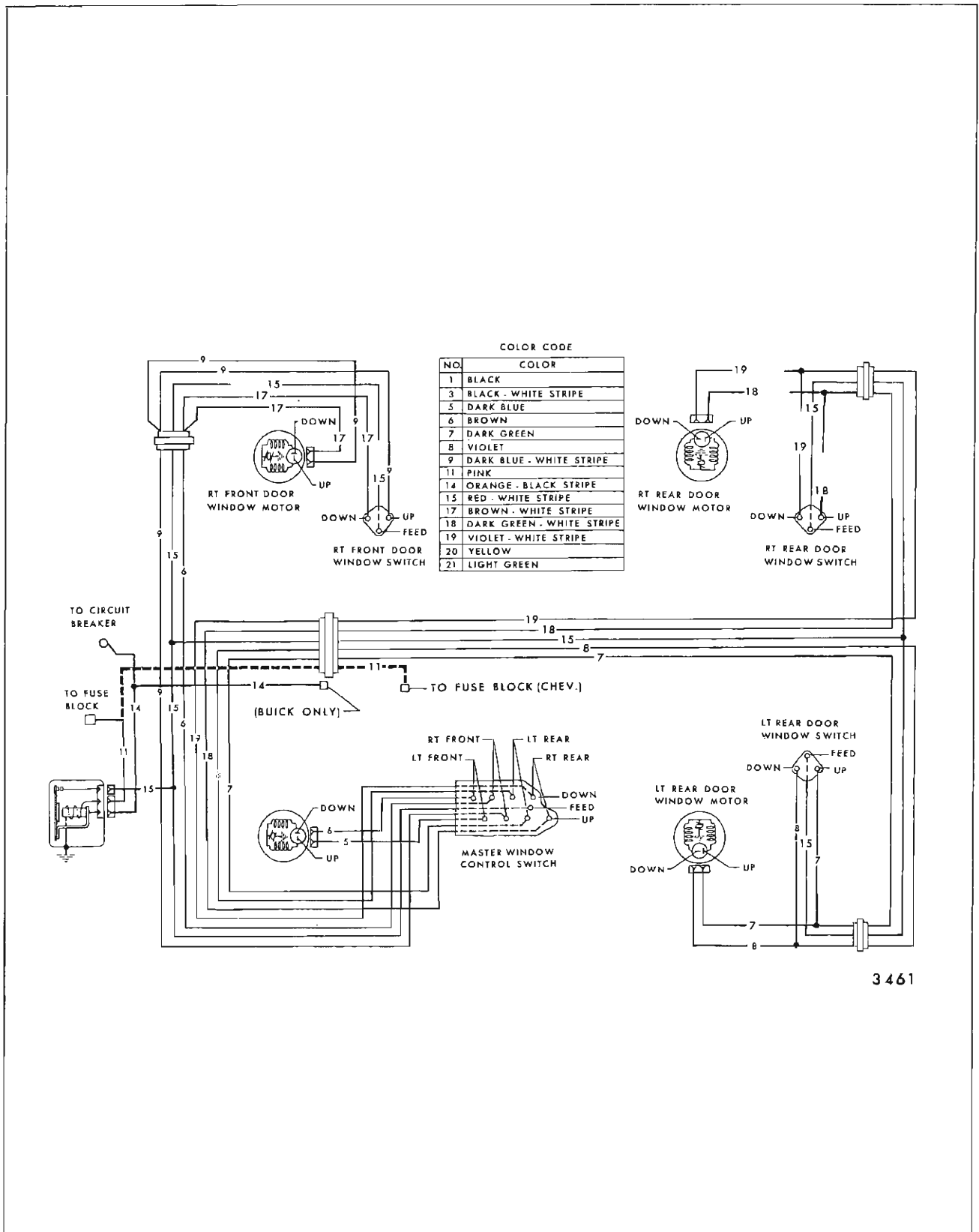
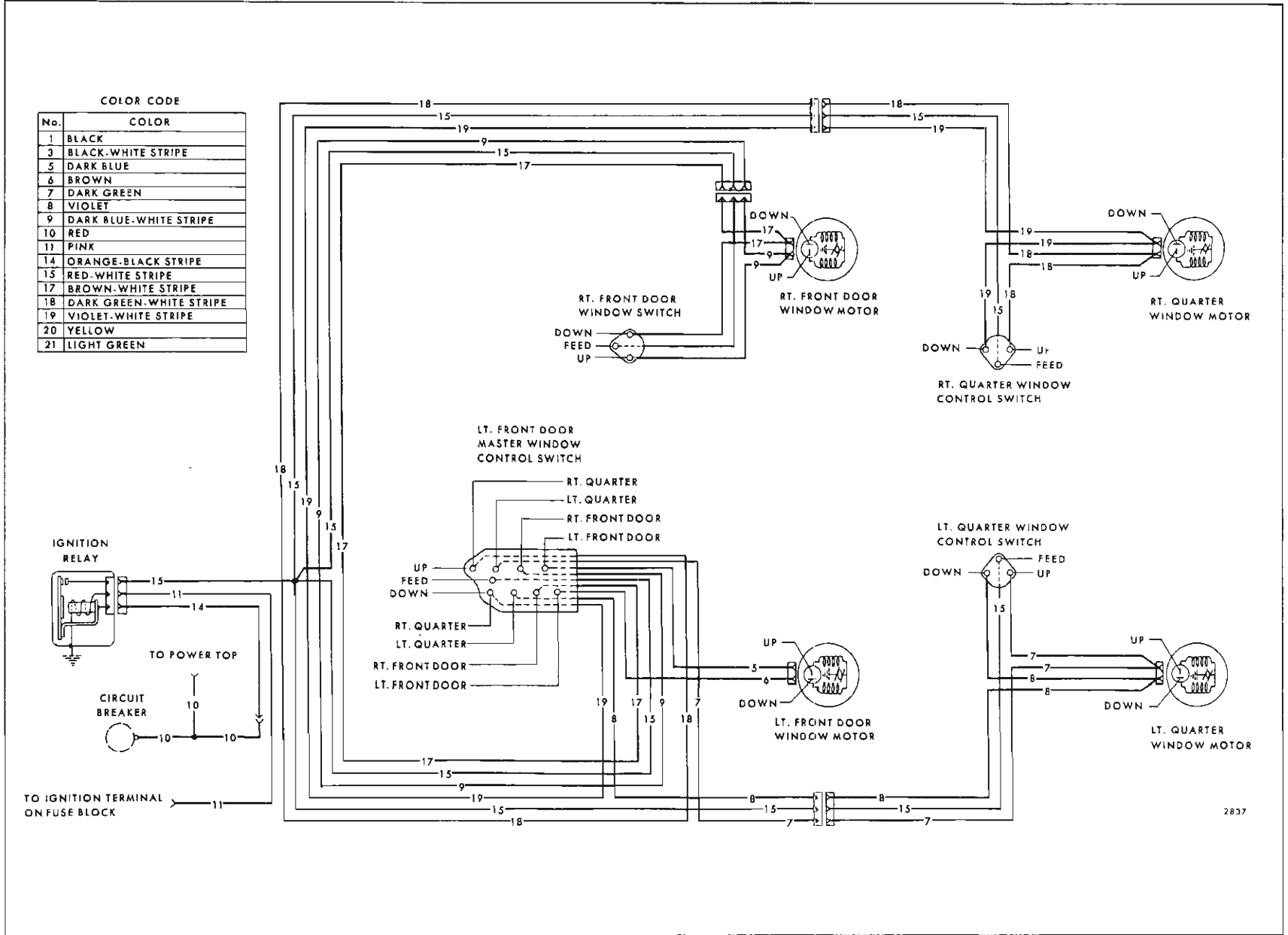

Fig. 16-2—Power Window Circuit - Typical "B" Styles



2837

Fig. 16-3—Power Window Circuit - Chevrolet and Pontiac "F" Styles

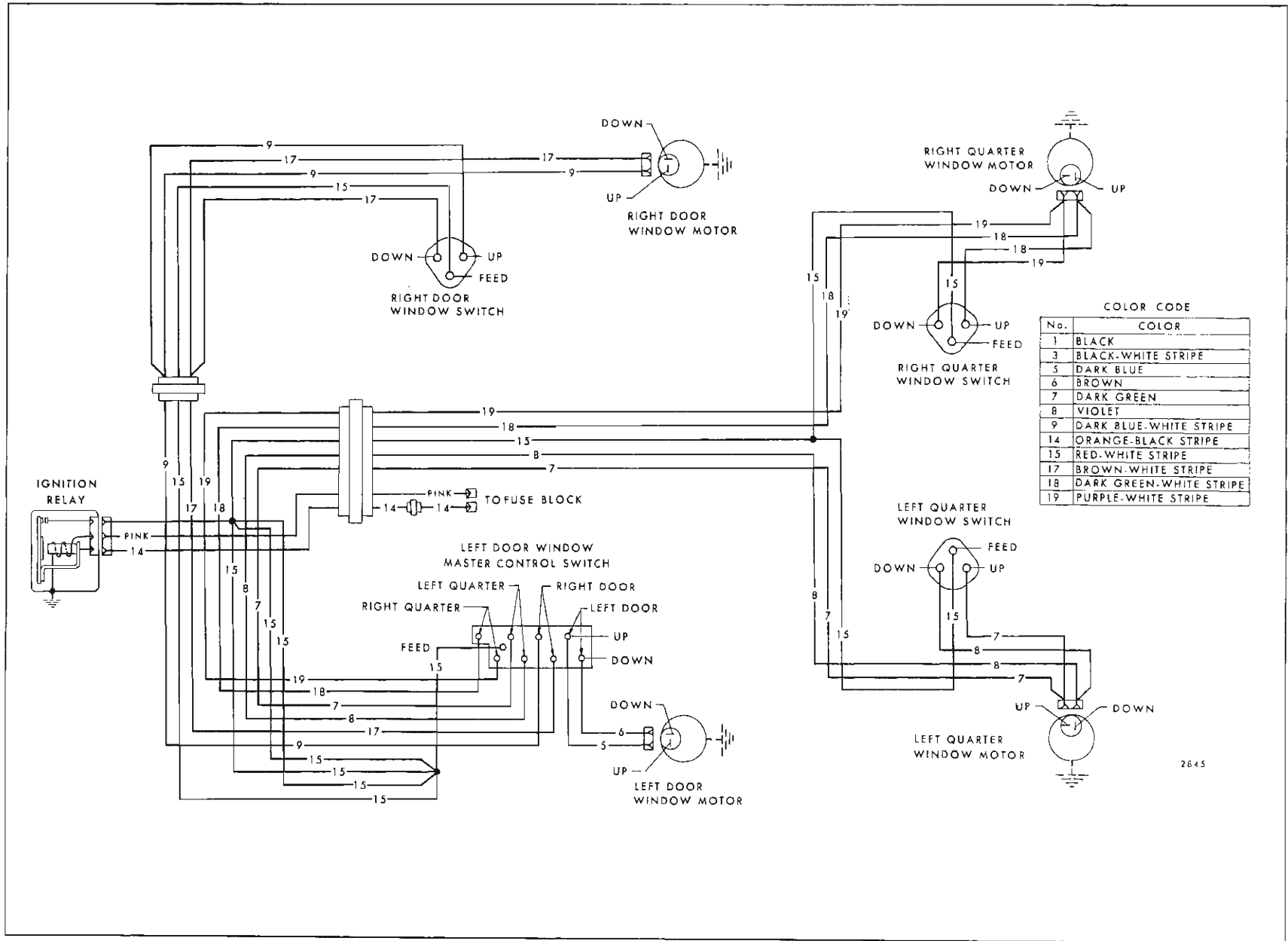

Fig. 16-4—Power Window Circuit - Buick "E" Styles

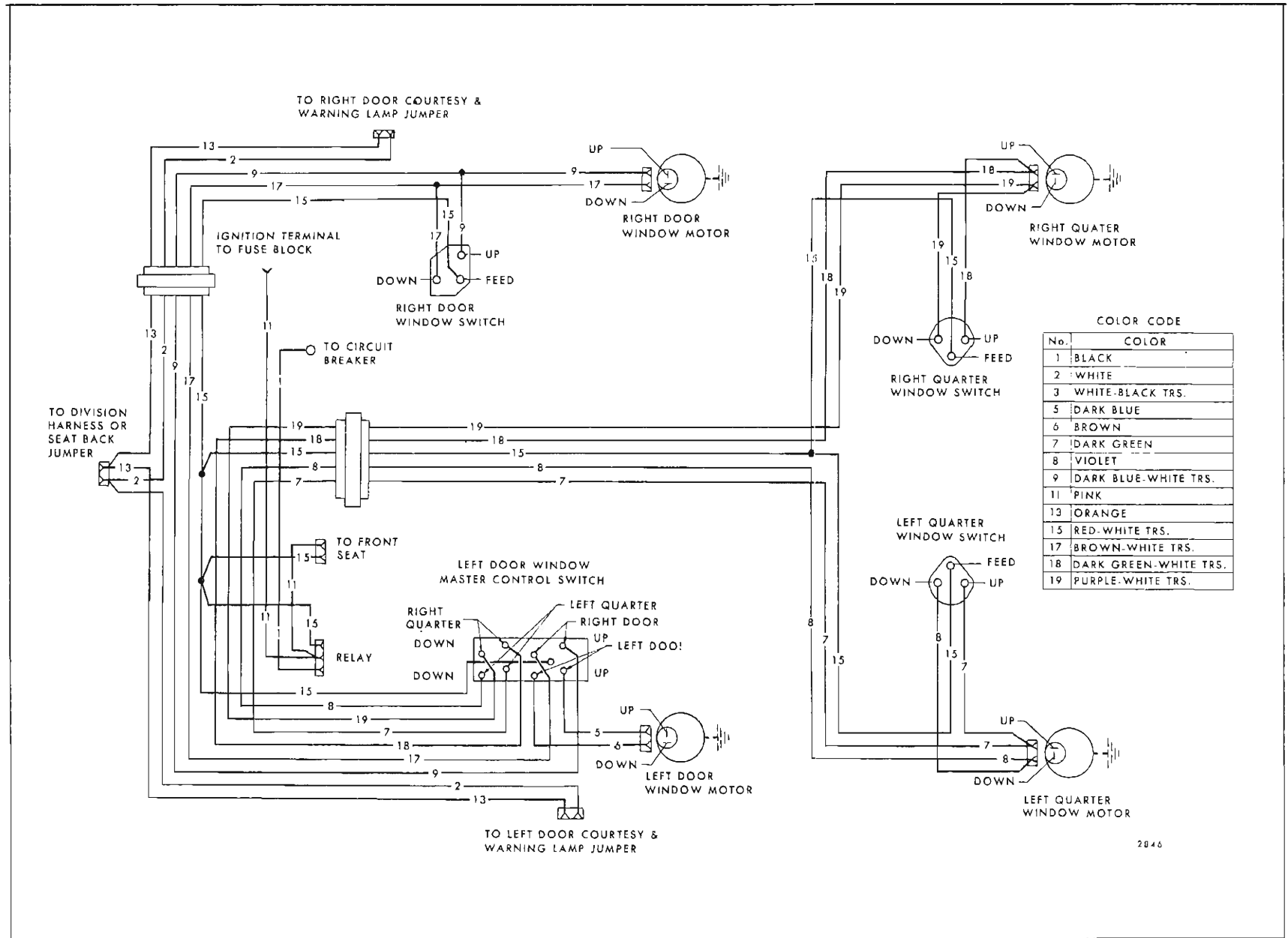

Fig. 16-5—Power Window Circuit - Oldsmobile "E" Styles

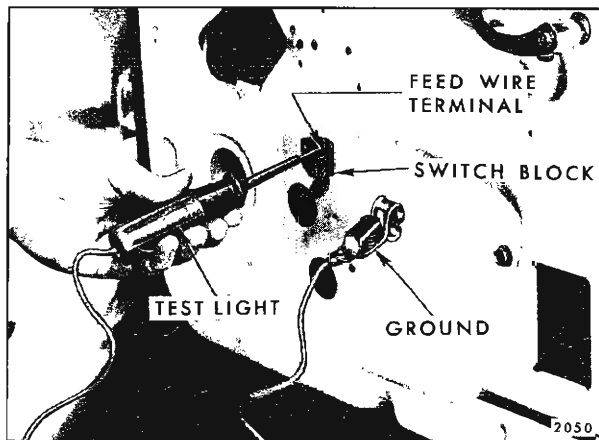

Fig. 16-6—Checking Feed Circuit

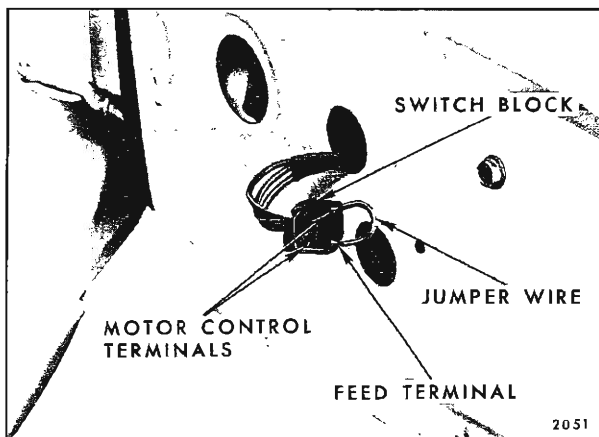

Fig. 16-7—Checking Window Control Switch

2. If the window operates with the jumper wire, but does not operate with the switch, the switch is defective.

#### g. Checking Wires Between Door Window Switch and Door Window Motor

1. Disengage harness connector from window motor connector. The thumb release on the harness connector must be depressed before it can be disengaged from the motor.
2. Insert one end of a #12 gauge jumper wire to the switch feed terminal and the other end to one of the motor lead terminals in the switch block (See Fig. 16-7).
3. With test light, check for current at terminal being tested. If tester does not light, there is an open or short circuit in the harness between the control switch and motor connector (See Fig. 16-8).

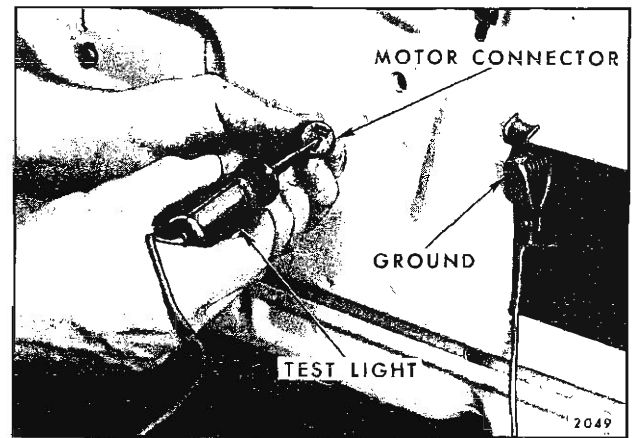

Fig. 16-8—Checking Circuit Between Switch and Motor

4. Check other terminal.

#### h. Checking Wires Between Quarter Window Switch and Quarter Window Motor

1. Insert one end of a #12 gauge jumper wire in the switch feed terminal and the other end in one of the motor lead terminals of the switch block (See Fig. 16-7).
2. With a test light, check for current at the corresponding terminal at the motor connector. If tester does not light, there is an open or short circuit between control switch and motor connector (See Fig. 16-8).

3. Check other terminal.

#### i. Checking Window Motor

1. Check window regulator and channels for possible mechanical bind of window.
2. Check attachment of window motor to insure an effective ground.
3. Connect one end of a #12 gauge jumper wire to the power source and the other end to one of the terminals on the door window motor or the connector for the quarter window motor.
4. If the motor fails to operate with a jumper wire, the motor is defective and should be replaced. Check the other motor lead in the same manner.

#### j. Trouble Shooting of Power Windows

The following typical failures and corrections have been listed as an aid for eliminating electrical failures in the power window electrical circuit. It should be noted that multiple failures in the circuit may lead to a combination of conditions, each of which must be checked separately.

CONDITION	CAUSE	CORRECTION
1. None of the windows will operate with ignition switch on.	Short or open circuit in power feed circuit	A. Check circuit breaker operation. B. Check relay operation C. Check feed connection to power harness beneath instrument panel D. Check the feed circuit wires for possible short or open circuit. E. Check cut-out Switch
2. Right rear door window does not operate from master control switch on left door or from control switches on right rear door. Left door window operates.	A. Short or Open circuit between right rear door harness and power window front harness. B. Short or open circuit in affected window control switch or window motor circuit. C. Possible mechanical failure or bind in window channels. D. Defective window motor.	A. Check harness connectors beneath outer end of instrument panel for proper installation. B. Check wires in power window front harness for possible short or open circuit. C. Check operation of rear door window control switch. D. Check circuit from window control switch to window motor for short or open circuit. E. Check window regulator and channels for possible mechanical failure or bind. F. Check operation of motor.
3. Right door windows will operate from left door master control switch but will not operate from right door control switches. Left door windows operate.	Open or short circuit in front harness feed wire circuit.	Follow up feed wire in front harness for possible short or open circuit.

## POWER OPERATED STATION WAGON TAIL GATE WINDOW

### ELECTRICAL TAIL GATE WINDOW CIRCUIT

The station wagon style power operated tail gate window is controlled by a window regulator assembly, equipped with a rectangular shaped, 12 volt D.C., reversible direction motor with an internal circuit breaker and a self-locking gear drive.

In addition to the internal circuit breaker, the wiring circuit is protected by a 40 amp circuit breaker (See Electrical Introduction for locations).

All Styles - In addition to the circuit breaker, a relay is used in the circuit. The relay prevents the operation of the tail gate window from the instrument panel switch, until the ignition switch is turned "on".

On some nine passenger station wagon styles, a tail gate window control switch is located at the rear of the left rear quarter inner trim panel.

**NOTE:** The "up" cycle wire is not engaged in the switch block but may be connected upon owner request.

To prevent the window from being operated to the "up" position when the tail gate has been lowered, a safety switch is located on the tail gate lock pillar. The safety switch opens the ground circuit of the tail gate window motor, making it inoperative.

The tail gate window harness is enclosed in the body wire harness conduit and consists of two sections. The front section extends from the left center of the toe pan, continues along the left wheel house just below the left quarter window and down the inside of the left body lock pillar, where it connects to the rear harness. The rear harness enters

the tail gate inboard of the lower left hinge assembly. (See Figs. 16-9 and 16-10).

**NOTE:** Should replacement of front harness become necessary, access to front and rear harness connector may be gained by removing left side marker lamp. A leader should be secured to the end of the front harness to aid in installation of replacement harness.

## CHECKING PROCEDURE

Before performing an intensive checking procedure to determine any failure of the circuit, check all the connectors for proper installation. The checking procedures below may be used to check the operation of a switch or motor after the cause of the electrical failure has been isolated to a particular part of the circuit. Refer to the circuit diagrams (See Figures 16-11, 16-12, 16-13, 16-14, 16-15, 16-16, 16-17, 16-18, 16-19, 16-20, 16-21, 16-22).

## WIRING DIAGRAM LEGEND

EXAMPLE:

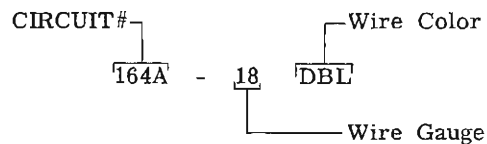

CIRCUIT #	COLOR	CODE	DESCRIPTION
9	Brown	BRN	Tail and License Lamp
18	Yellow	Y	Stop and Direction Lamp or Direction Lamp only - Rear LH
19	Dark Green	DG	Stop and Direction Lamp or Direction Lamp Only - Rear RH
24	Light Green	LG	Back-Up Lamp
30	Tan	T	Fuel Gauge to Tank Unit
31	Dark Blue	DBL	Electric Fuel Pump
39	Pink	P	Feed, Ignition Switch Controlled - Fuse Protected
40	Orange	OR	Feed, Battery - Fuse Protected
60	Orange-Black	OR/B	Feed, Battery - Circuit Breaker Protected
70	Red-White	R/W	Feed, Relay Controlled Circuit - Circuit Breaker Protected
90	Pink-Black	P/B	Feed - Cutout Switch Controlled - Circuit Breaker Protected
150	Black	B	Ground Circuit - Direct
151	Black	B	Ground Circuit - Direct
152	Black	B	Ground Circuit - Direct
153	Black	B	Ground Circuit - Direct
154	Black	B	Ground Circuit - Direct
155	Black	B	Ground Circuit - Direct
156	White	W	Ground Circuit - Switch Controlled - Body Interior Lamps, such as Dome, Courtesy, Map, Warning, Etc.
157	White-Black	W/B	
158	White-Dark Green	W/DG	
160	White	W	Power Antenna - Down

CIRCUIT #	COLOR	CODE	DESCRIPTION
161	Black	B	Power Antenna - Up
162	Gray	GY	Power Top - Up
163	Purple	PUR	Power Top - Down
164	Dark Blue	DBL	Window Control - L.F. - Up
165	Brown	BRN	Window Control - L.F. - Down
166	Dark Blue-White	DBL/W	Window Control - R.F. - Up
167	Brown-White	BRN/W	Window Control - R.F. - Down
168	Dark Green	DG	Window Control - L.R. - Up
169	Purple	PUR	Window Control - L.R. - Down
170	Dark Green-White	DG/W	Window Control - R.R. - Up
171	Purple-White	PUR/W	Window Control - R.R. - Down
172	Light Green	LG	Vent Control - L.F. - Close
173	Yellow	Y	Vent Control - L.F. - Open
174	Light Green-Black	LG/B	Vent Control - R.F. - Close
175	Yellow-Black	Y/B	Vent Control - R.F. - Open
176	Dark Green	DG	Power Seat - Fore
177	Yellow	Y	Power Seat - Aft
178	Dark Green	DG	Power Seat - 6-Way - Fore and Up
179	Tan	T	Power Seat - 6-Way Solenoid - Rear - Up and Down
180	Light Green	LG	Power Seat - 6-Way Solenoid - Front - Up and Down
181	Light Blue	LBL	Power Seat - Solenoid - Fore and Aft
182	Yellow	Y	Power Seat - 6-Way - Aft and Down
183	Light Blue	LBL	Tailgate or Center Partition Window - Up
184	Tan-White	T/W	Tailgate or Center Partition Window - Down
185	Tan	T	Vent Control - L.R. - Open
186	Gray	GY	Vent Control - L.R. - Close
187	Tan-Black	T/B	Vent Control - R.R. - Open
188	Gray-Black	GY/B	Vent Control - R.R. - Close
190	Yellow	Y	Power Seat - 4-Way - Aft and Up
191	Light Green	LG	Power Seat - 4-Way Solenoid - Up and Down
192	Purple	PUR	Defogger - High or Single Speed
193	White-Orange & Purple	W/OR & PUR	Defogger - Lower Speed - .38 OHM/FT

#### a. Checking Feed Circuit Continuity at Circuit Breaker

1. Connect one test light lead to battery side of circuit breaker and ground other lead. If tester does not light, there is an open or short circuit in feed circuit to breaker.
2. To check circuit breaker disconnect the output feed wire (the wire opposite the power source feed to the breaker) from the breaker. Connect one test light lead to the output terminal and ground other lead. If tester does not light, circuit breaker is inoperative.

#### b. Checking Relay Assembly

1. With test light check relay feed. If tester does not light, there is an open or short circuit between relay and circuit breaker.
2. Turn ignition switch on and with test light check output terminal of relay. If tester does

not light, the relay is inoperative or there is a short or open circuit between ignition switch and relay assembly. (Check fuse at dash panel.)

#### c. Checking Feed Circuit Continuity at Control Switch on Instrument Panel

1. Disengage harness connector from switch. Connect one test light lead to feed terminal of switch connector and ground other test lead to body metal. If tester does not light, there is an open or short circuit between switch and power source.

#### d. Checking Control Switch at Instrument Panel

1. Disengage harness connector from switch.
2. Use a #12 gauge jumper wire and insert one end into the feed terminal and the other end into one of the other terminals. Tail gate window motor should operate.



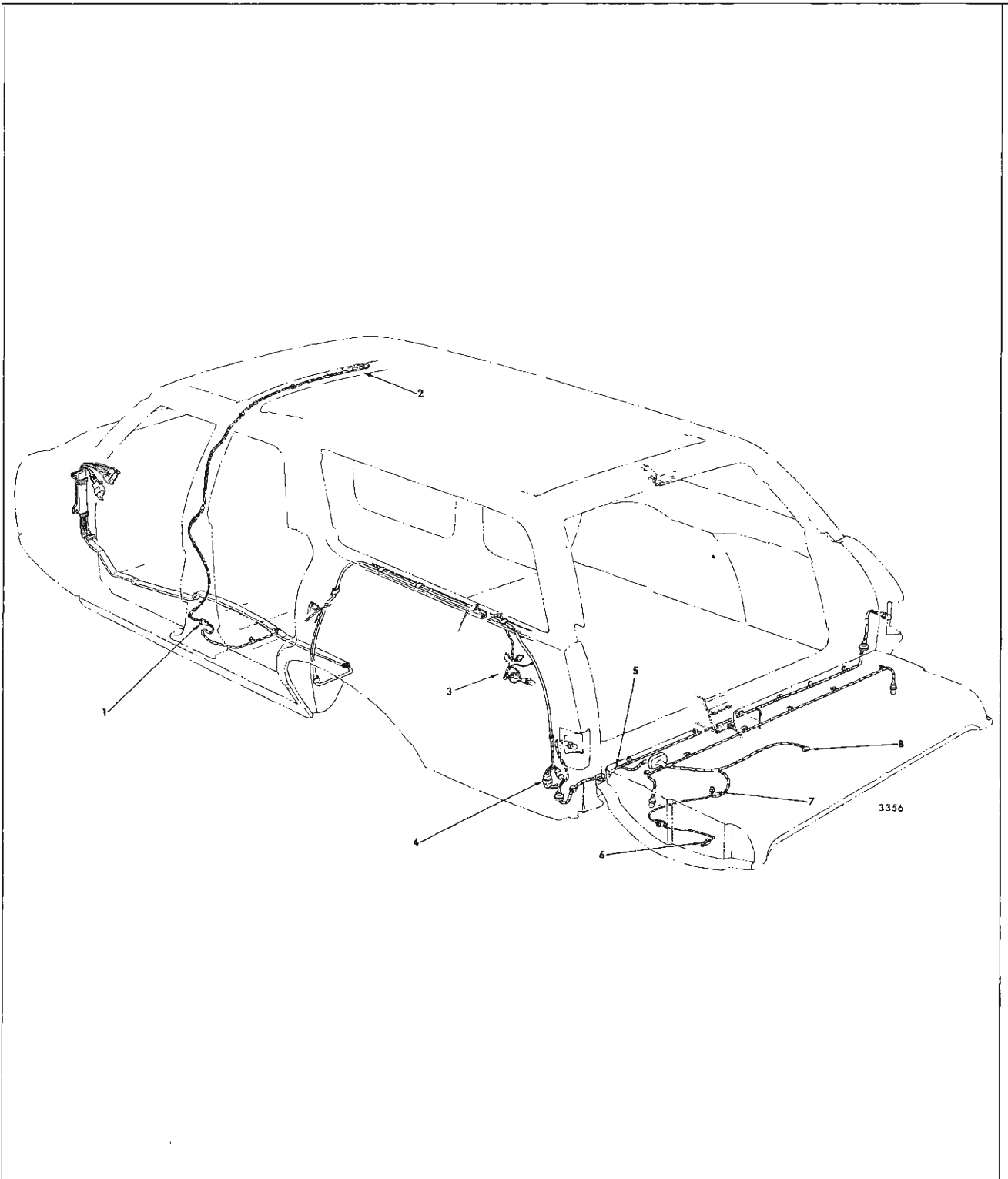

Fig. 16-9—Wire Routing - Typical "A" Style Station Wagon with Single Acting Tail Gate

- |                               |                                    |                                 |
|-------------------------------|------------------------------------|---------------------------------|
| 1. Dome Lamp Connector        | and Switch Also Tail Gate          | 6. Safety Switch Connector      |
| 2. Dome Lamp Clips            | Control Switch                     | 7. Motor Connector              |
| 3. Rear Quarter Courtesy Lamp | 4. Front to Rear Harness Connector | 8. Key Switch Control Connector |
|                               | 5. Rear Harness                    |                                 |

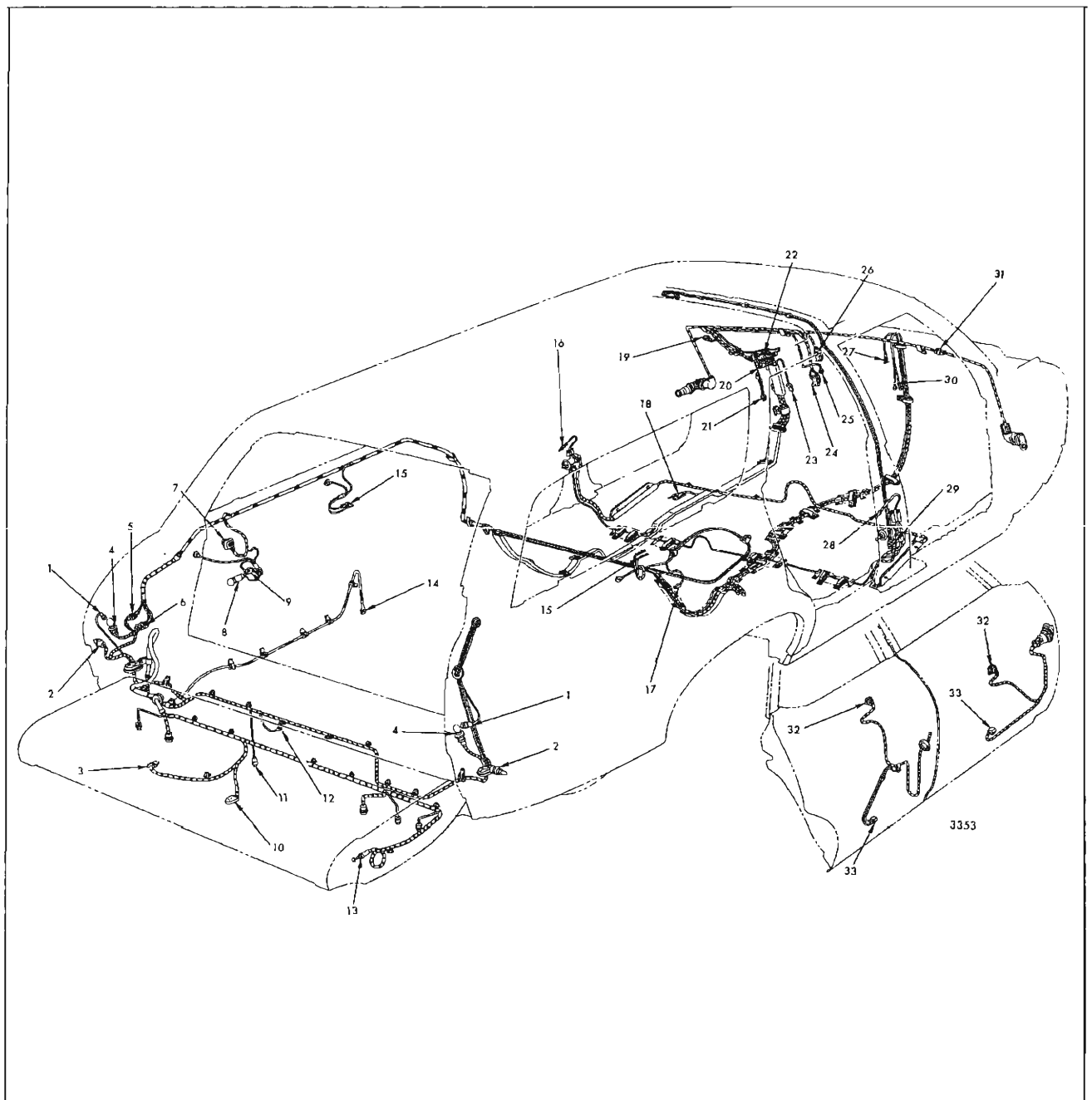

Fig. 16-10—Wire Routing - Typical "B" Style Station Wagon with Dual Acting Tail Gate

- |   |                                      |                                     |  |
|---|--------------------------------------|-------------------------------------|--|
| 1. Direction Lamp                               | 9. Rear Quarter Courtesy Lamp Switch | 19. Ignition Relay Connector        | 29. Dome Lamp Connector                |
| 2. Side Marker Lamp                             | 10. Key Switch Connector             | 20. Rear Power Window Connector     | 30. Stereo Speaker Leads to Radio      |
| 3. Motor Connector                              | 11. License Lamp                     | 21. Rear Defogger Connector         | 31. Right Front Door Harness Connector |
| 4. Tail Lamp                                    | 12. Side Marker Ground               | 22. Main Harness Connector          | 32. Door Window Control Switch         |
| 5. Rear Power Window Harness Connector          | 13. Safety Switch                    | 23. Fuse Block Connector            | 33. Door Window Motor Connector        |
| 6. Rear Harness Connector (Tail Lamps)          | 14. Fuel Gauge Connector             | 24. Rear Defogger Switch Connector  |  |
| 7. Rear Quarter Tail Gate Window Control Switch | 15. Stereo Speaker Leads             | 25. Circuit Breaker Connection      |  |
| 8. Rear Quarter Courtesy Lamp                   | 16. Left Rear Door Jamb Switch       | 26. Rear Power Window Switch        |  |
|   | 17. Rear Speaker Lead                | 27. Rear Speaker Connector to Radio |  |
|   | 18. Power Seat Feed                  | 28. Right Rear Door Jamb Switch     |  |

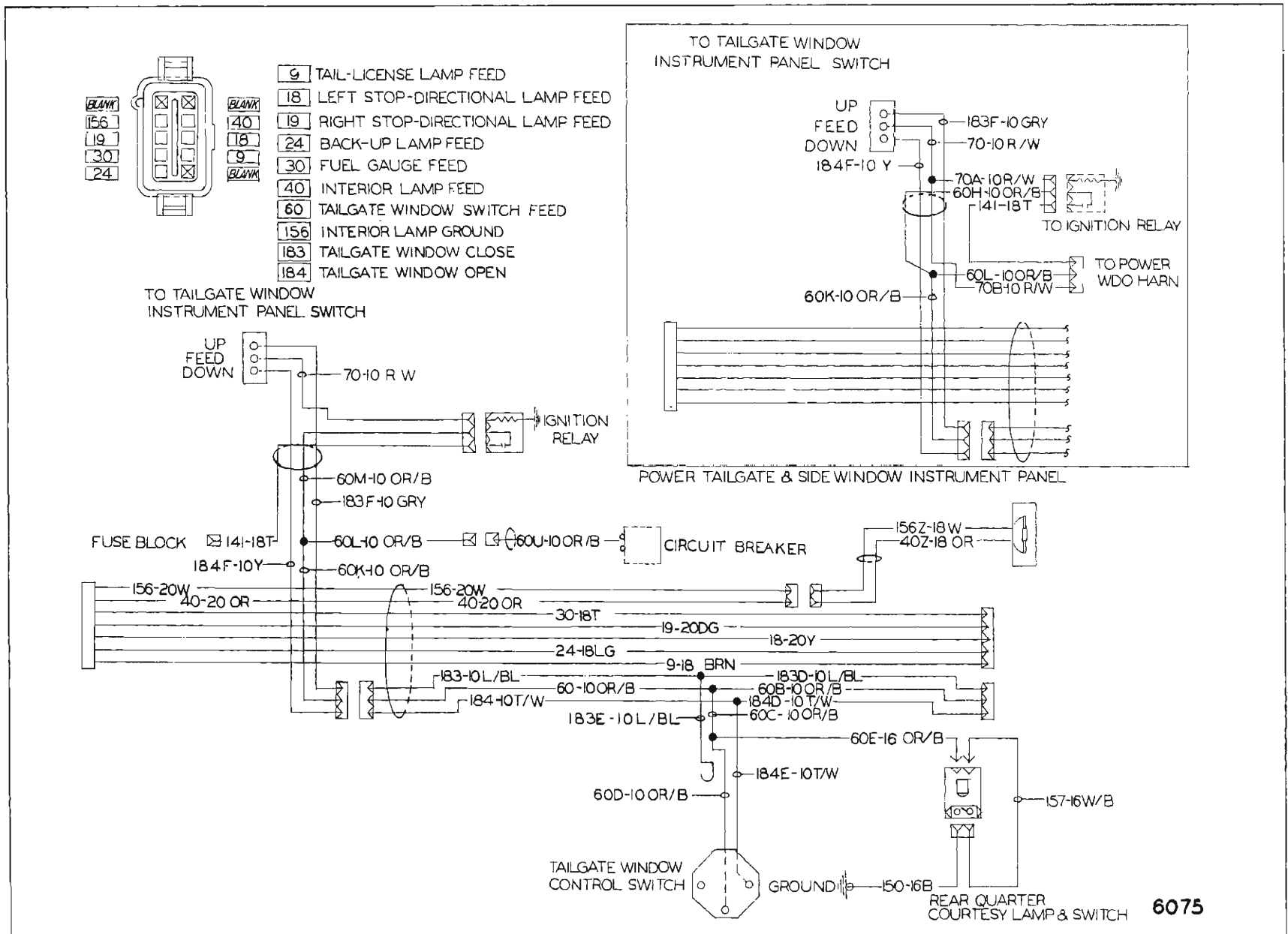
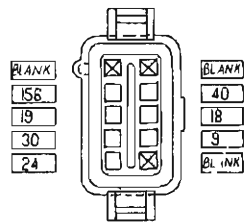
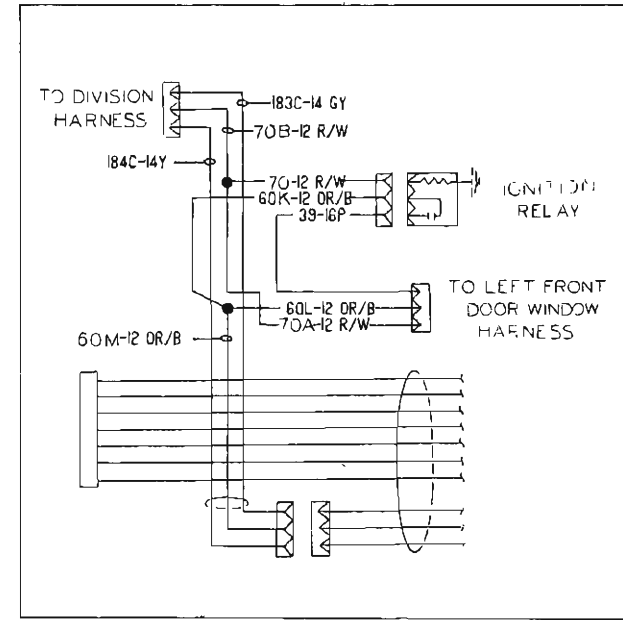
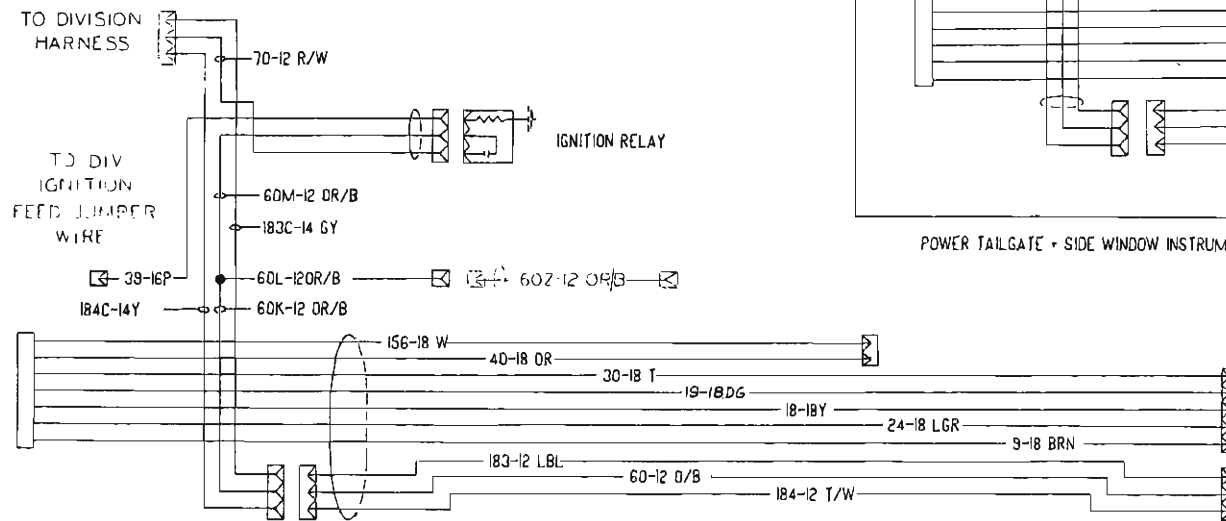

Fig. 16-11—Power Tail Gate Window Front Wiring Circuit - Chevrolet "A" Styles





- 9 TAIL + LICENSE LAMP FEED
- 18 LEFT STOP + DIRECTIONAL LAMP FEED
- 19 RIGHT STOP + DIRECTIONAL LAMP FEED
- 24 BACK-UP LAMP FEED
- 30 FUEL GAUGE FEED
- 40 INTERIOR LAMP FEED
- 156 INTERIOR LAMP GROUND



POWER TAILGATE + SIDE WINDOW INSTRUMENT WIRING

Fig. 16-13—Power Tail Gate Window Front Wiring Circuit - Pontiac "A" Styles

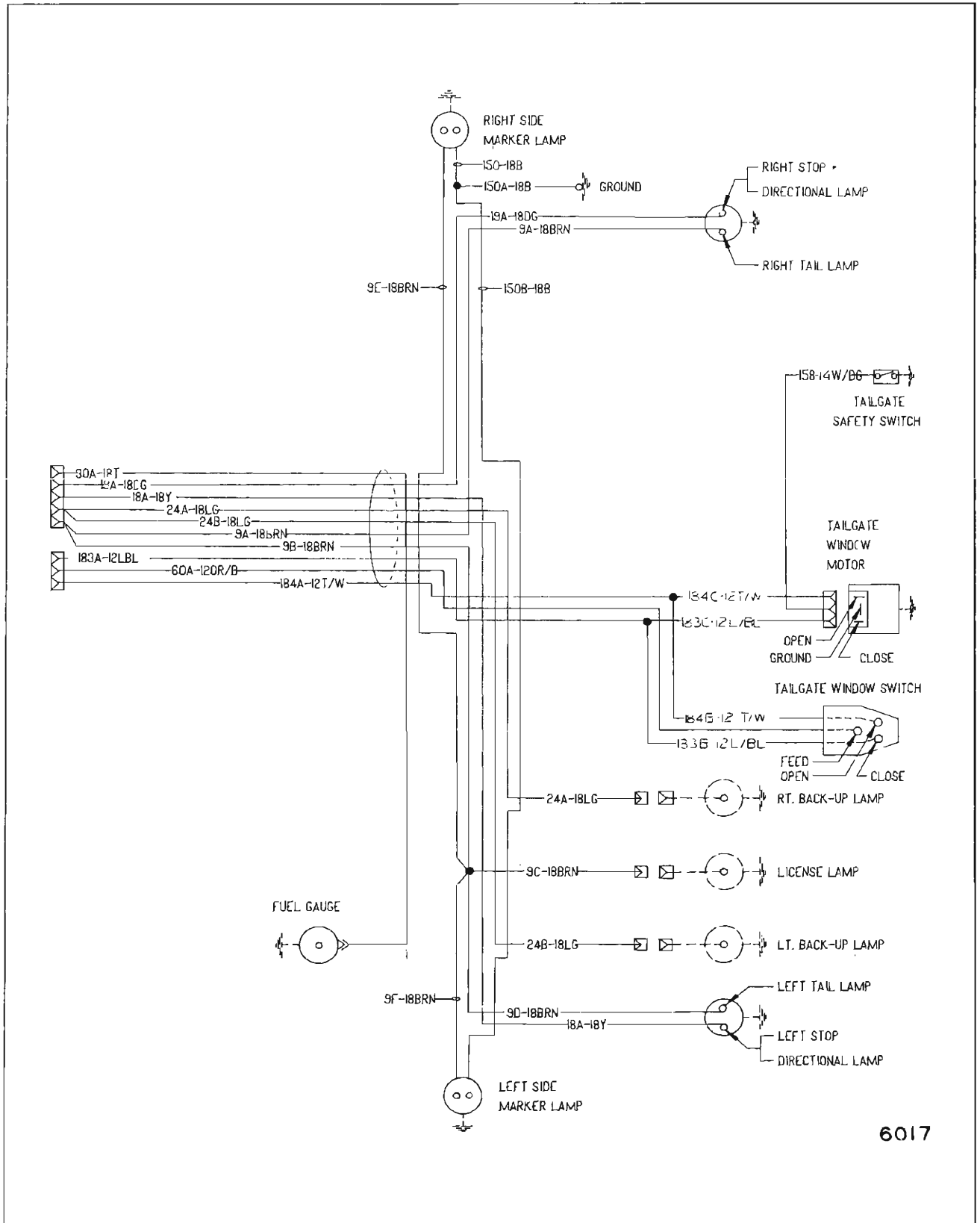

6017

Fig. 16-14—Power Tail Gate Window Rear Wiring Circuit - Pontiac "A" Styles

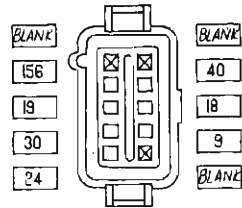

- 9 TAIL-LICENSE + MARKER LAMP FEED
- 18 LT. STOP + DIRECTIONAL LAMP FEED
- 19 RT. STOP + DIRECTIONAL LAMP FEED
- 24 BACK-UP LAMP FEED
- 30 FUEL GAUGE FEED
- 40 INTERIOR LAMP FEED
- 156 INTERIOR LAMP GROUND

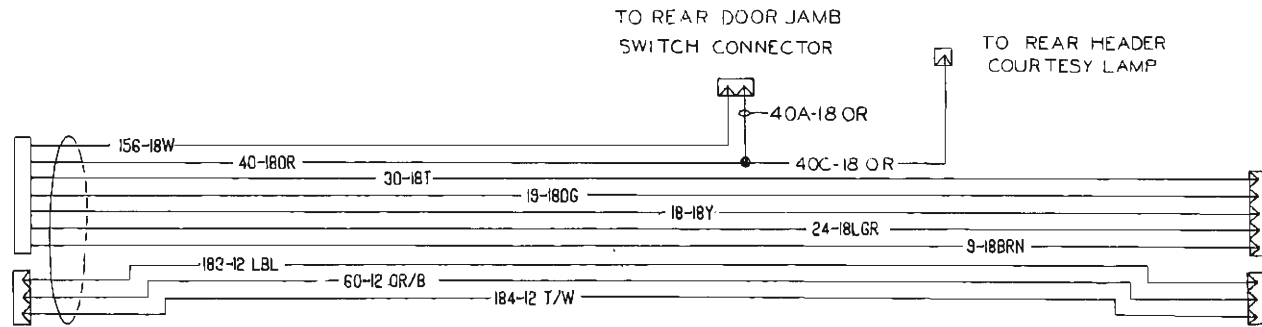

6001

Fig. 16-15—Power Tail Gate Window Front Wiring Circuit - Oldsmobile "A" Styles

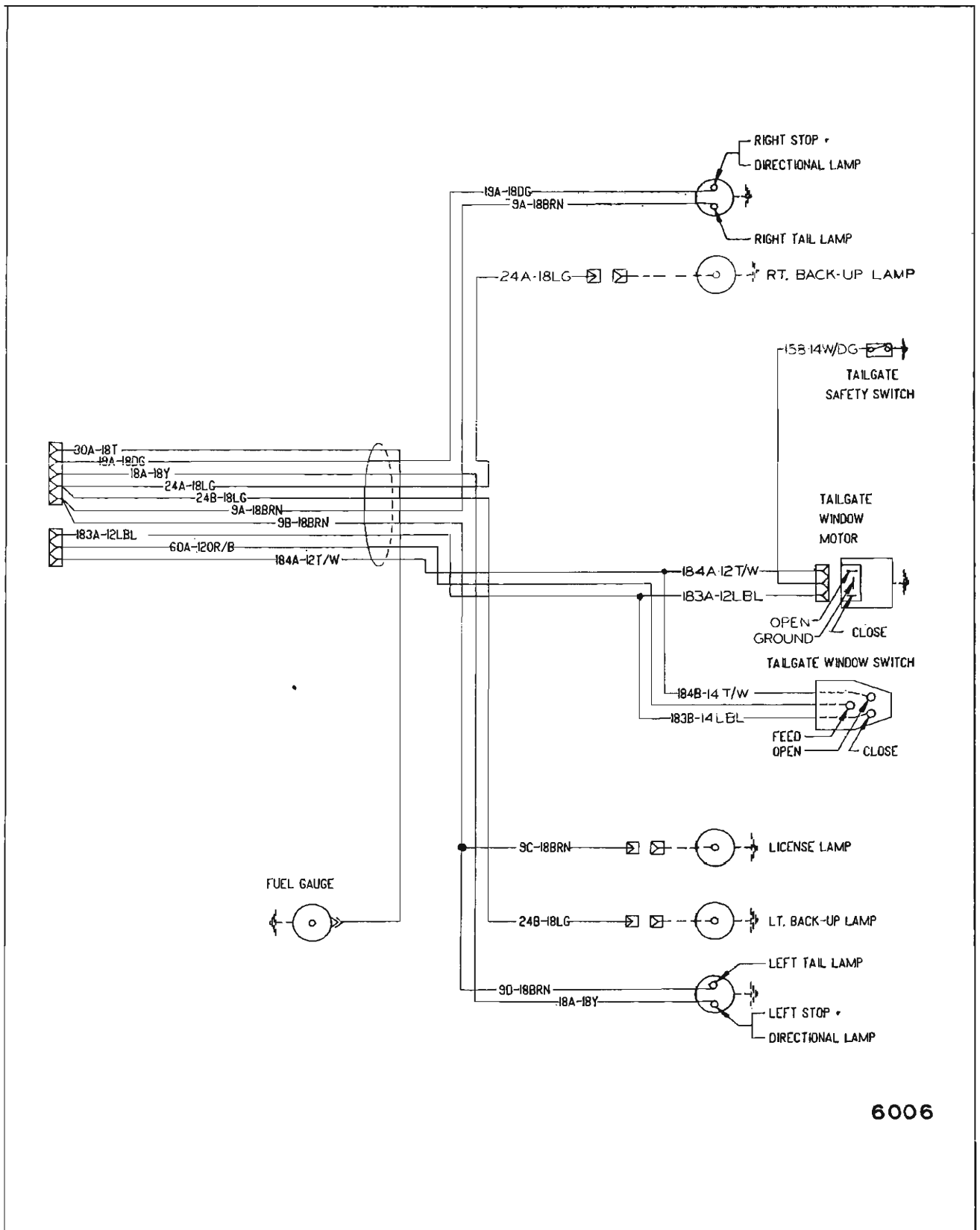

6006

Fig. 16-16—Power Tail Gate Window Rear Wiring Circuit - Oldsmobile "A" Styles



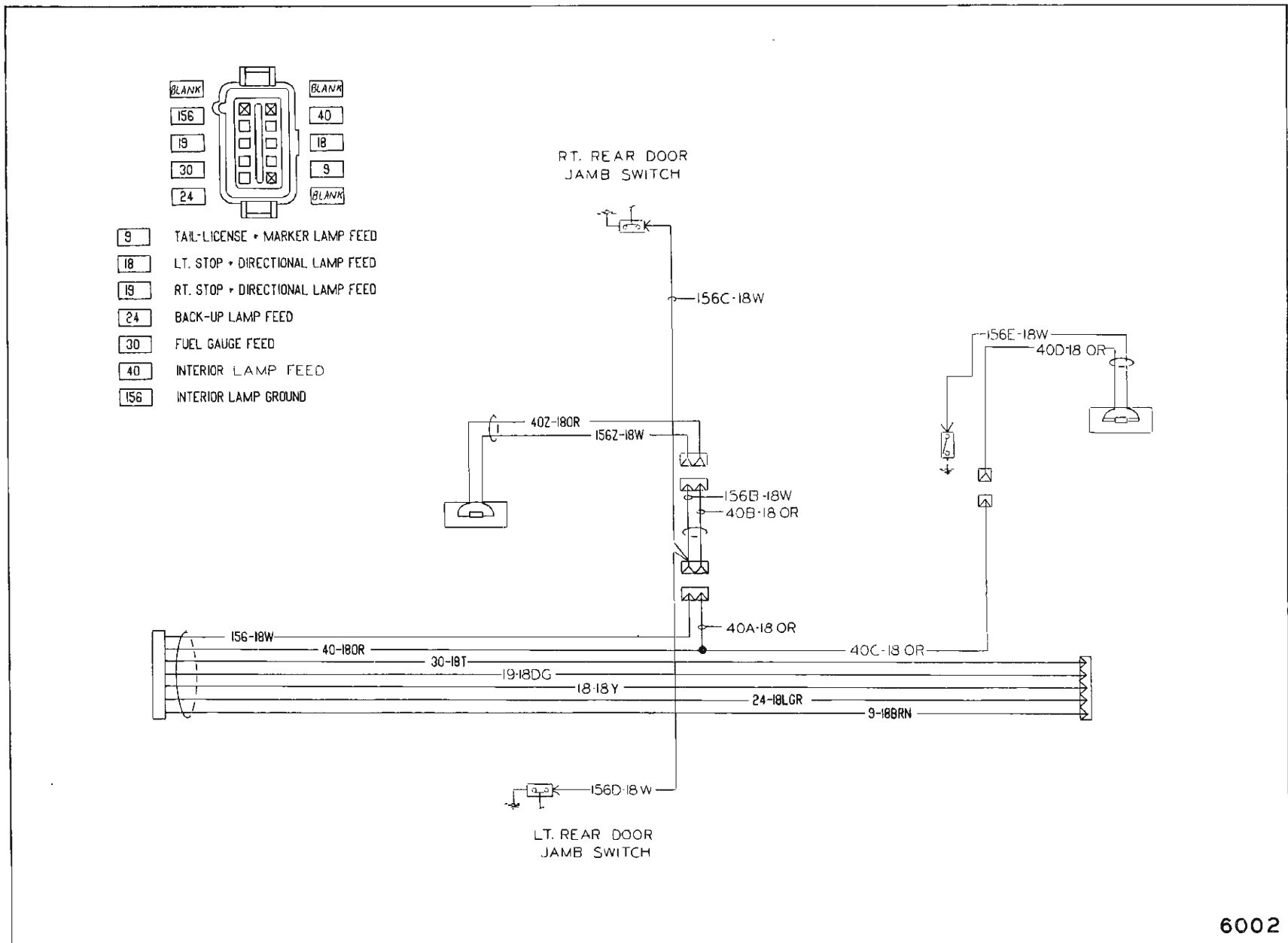
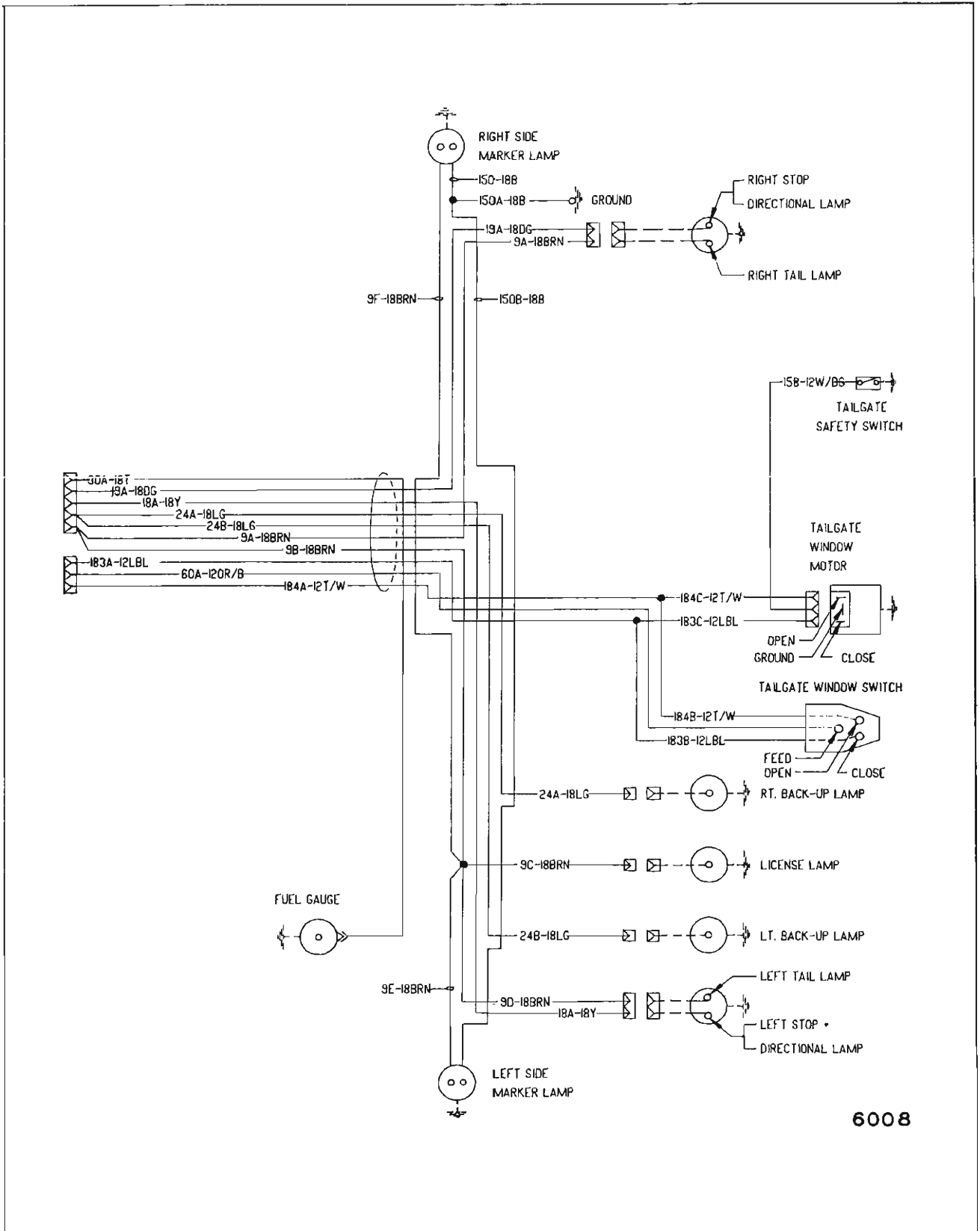

Fig. 16-17—Power Tail Gate Window Front Wiring Circuit - Buick "A" Styles



6008

Fig. 16-18—Power Tail Gate Window Rear Wiring Circuit - Buick "A" Styles

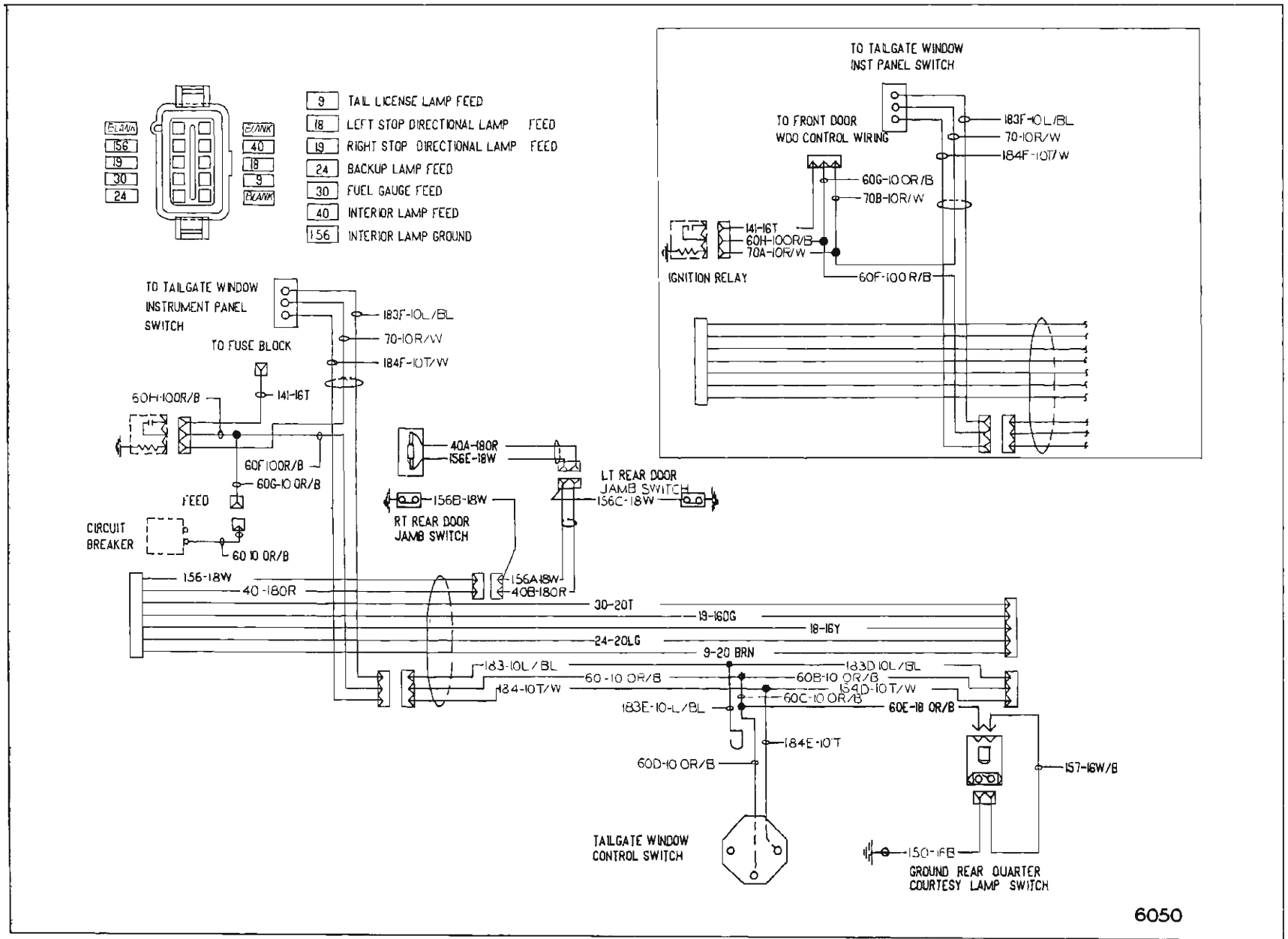
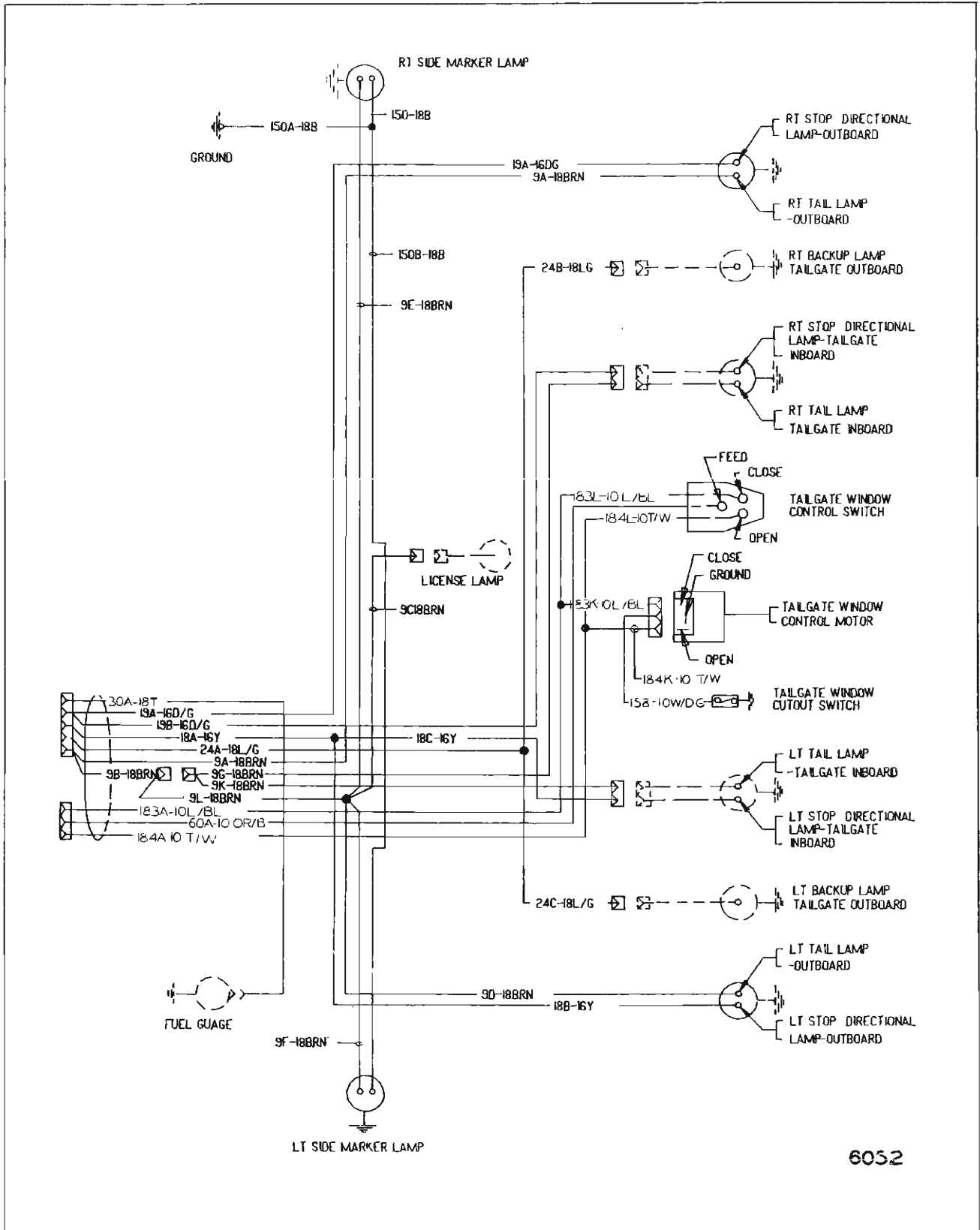

Fig. 16-19—Power Tail Gate Window Front Wiring Circuit - Chevrolet "B" Styles



6032

Fig. 16-20—Power Tail Gate Window Rear Wiring Circuit - Chevrolet "B" Styles

Front Body 54

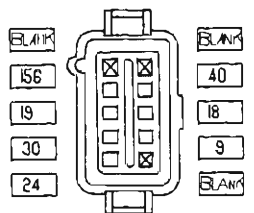

- 9 TAIL LICENSE + MARKER LAMP FEED
- 18 LT. STOP + DIRECTIONAL LAMP FEED
- 19 RT. STOP + DIRECTIONAL LAMP FEED
- 24 BACK-UP LAMP FEED
- 30 FUEL GAUGE FEED
- 40 INTERIOR LAMP FEED
- 56 INTERIOR LAMP GROUND
- 60 TAILGATE WINDOW SWITCH FEED
- 183 TAILGATE WINDOW-CLOSE
- 184 TAILGATE WINDOW-OPEN

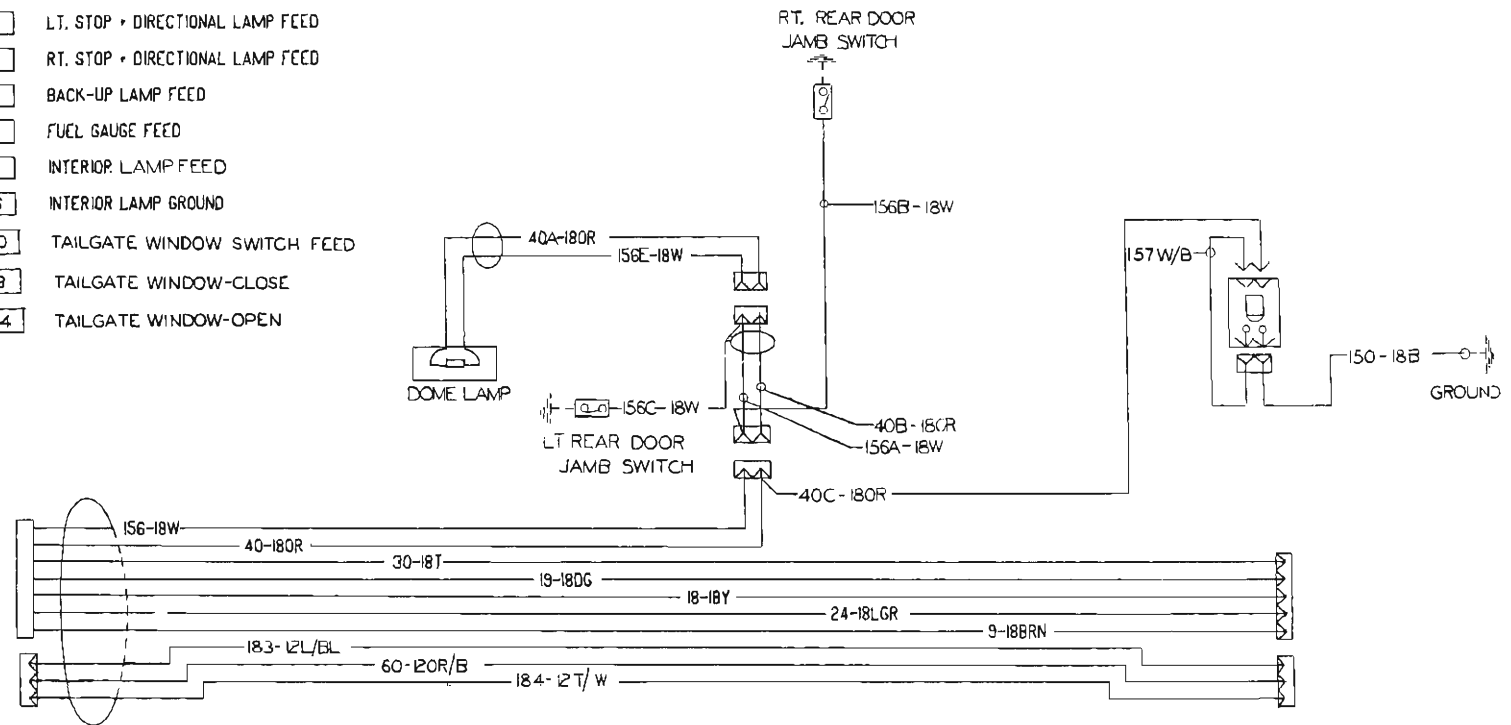

6019

Fig. 16-21—Power Tail Gate Window Front Wiring Circuit - Pontiac "B" Styles



3. Repeat procedure for the other terminal. If the tail gate window motor operates with the jumper wire but does not operate with the control switch, the switch is defective.

#### e. Checking Control Switch on Tail Gate

Remove tail gate switch and escutcheon as described in tail gate section. Disengage connector from switch and determine that there is current at terminal block; then, use a #12 gauge jumper and perform the same checking procedure as outlined for the control switch at the instrument panel.

#### f. Checking the Tail Gate Window Motor

1. Disconnect harness connector from motor.
2. Connect the positive side of power source to the light blue wire terminal (close cycle) on the motor connector and the negative lead to the white - dark green (ground) wire terminal. Motor should operate. To check the reverse operation of the motor connect the power source to the tan - white wire terminal (open cycle). If motor does not operate in both directions, replace motor.

#### h. Trouble Shooting

CONDITION	CAUSE	CORRECTION
1. The tail gate window operates up and down from the tail gate switch but does not operate from the switch at the instrument panel.	A. Open or short circuit from power source to control switch at instrument panel. B. Defective or inoperative control switch.	A. Check affected wiring B. Check operation of switch.
2. With the tail gate closed, the window operates downward but does not operate upward when the switch at the instrument panel or tail gate is actuated.	A. Open or short circuit in up cycle feed wire. B. Defective motor	A. Check affected wiring for open or short circuit. B. Check operation of motor.
3. The window will not operate up or down from any of the control switches.	A. Open or short circuit in circuit from power source to switches or motor. B. Safety switch not connected or poor ground. C. Mechanical bind or failure in tail gate window regulator mechanism. D. Defective tail gate window regulator motor.	A. Check operation of circuit breaker. B. Check affected circuit for open or short circuit. C. Check connectors to safety switch and motor for proper engagement. D. Check tail gate mechanical parts for bind or failure. E. Check operation of motor.

#### g. Checking Operation of Safety Switch

1. With the single acting tail gate open, depress switch arm to simulate the tail gate being closed. (Refer to View A Fig. 16-23).

**CAUTION:** Prior to actuating safety switch on dual acting tailgate place tape over inside center remote control handle.

2. With the dual acting tail gate open as a tail gate, manually trip (View B, Fig. 16-23) upper right and left lock assemblies to lock position to simulate tail gate being closed (Refer to "Tail Gate Section" of Manual).
3. Operate control switch. If motor does not operate, either switch is defective or the circuit is open from the motor to the switch.
4. To check for defective switch, connect one end of test light to a source of power and the other lead to the safety switch terminal. If the tester lights when the switch lever is actuated, the switch is operative.

**NOTE:** Safety switch completes the ground circuit from the motor.

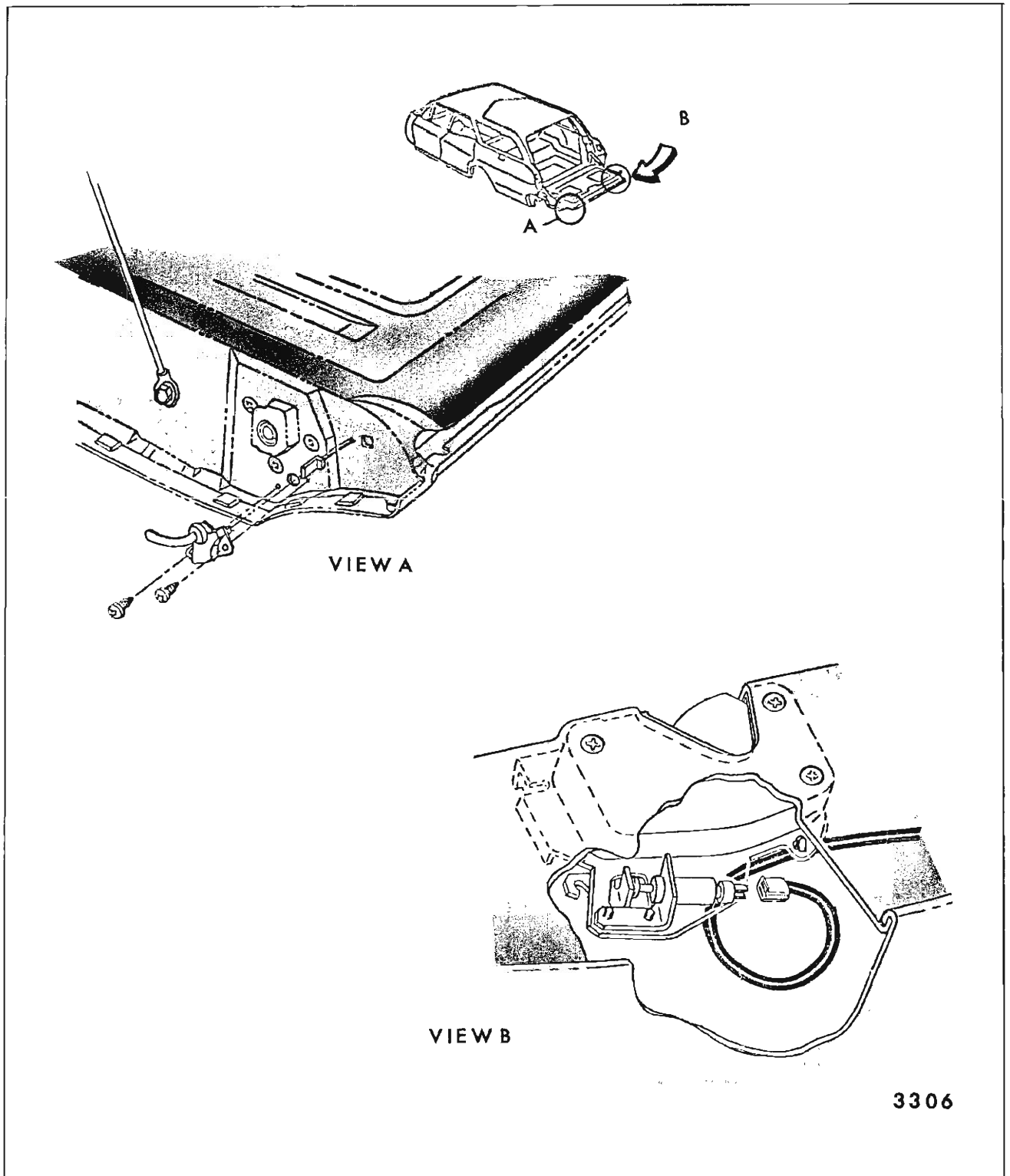

Fig. 16-23—Power Tail Gate Window Safety Switches

- View "A" - Single Acting Tail Gate Safety Switch - Left Side
- View "B" - Dual Acting Tail Gate Safety Switch - Right Side



## POWER SEATS

### HORIZONTAL SEATS

#### Description

The seat adjusters for the bench-type and bucket-type seat are actuated by a 12 volt series-wound motor located near the front left side of the seat bottom frame, and are energized through a control switch installed in the seat side panel or in the door arm rest. For typical wiring installations see Figure 16-24 for bucket-type seats and Figures 16-25 and 16-26 for bench-type seats.

For circuit diagram see Figure 16-27.

The horizontal seat circuit is protected by a circuit breaker (refer to Electrical Introduction for specific location).

The trouble diagnosis chart will help locate typical problems which may occur.

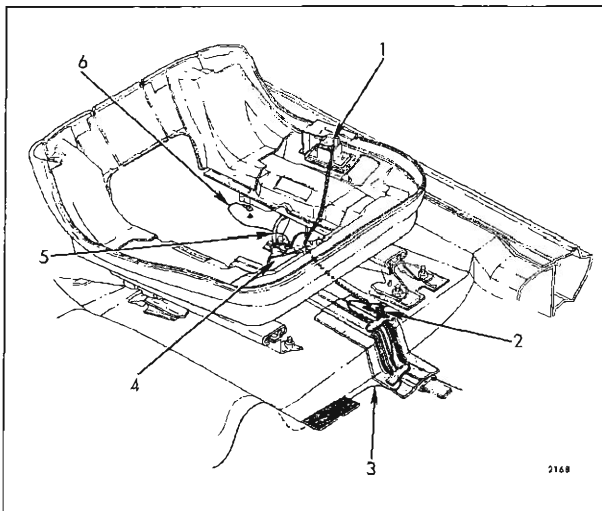

Fig. 16-24—Horizontal Bucket Seat Wiring

1. Control Switch
2. Feed Harness Connector
3. Feed Wire to Passenger Seat
4. Motor
5. Control Cable
6. Ground Wire

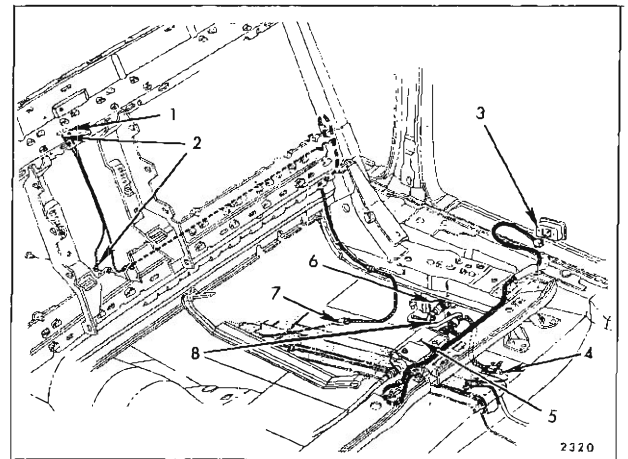

Fig. 16-25—Horizontal Bench Seat Wiring

- |   |  |
|---|--|
| 1. Front Seat Back Switch<br>Feed - White   | 5. Motor   |
| 2. Front Seat Back Switch<br>Ground - Black | 6. Ground Wire   |
| 3. Control Switch                           | 7. Front Seat Back<br>Courtesy Lamp Feed<br>Connector (Cadillac<br>Only) |
| 4. Feed Harness<br>Connector                | 8. Control Cable   |

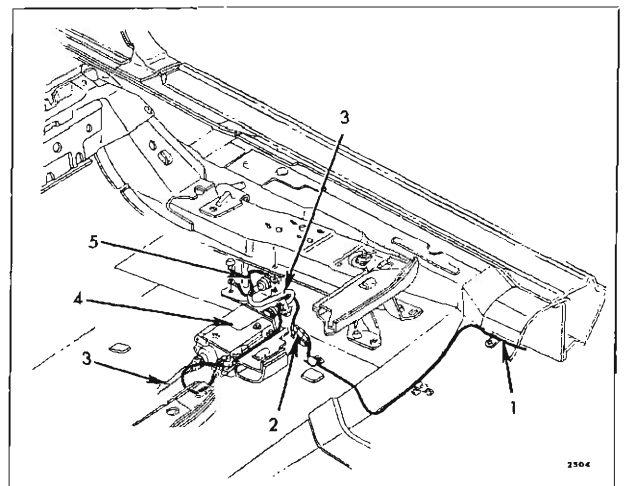

Fig. 16-26—Horizontal Bench Seat Wiring -  
Buick and Oldsmobile "C" Body

- |                                      |                  |
|--------------------------------------|------------------|
| 1. Wiring to Door Arm<br>Rest Switch | 3. Control Cable |
| 2. Feed Harness Connector            | 4. Seat Motor    |
|                                      | 5. Ground Wire   |

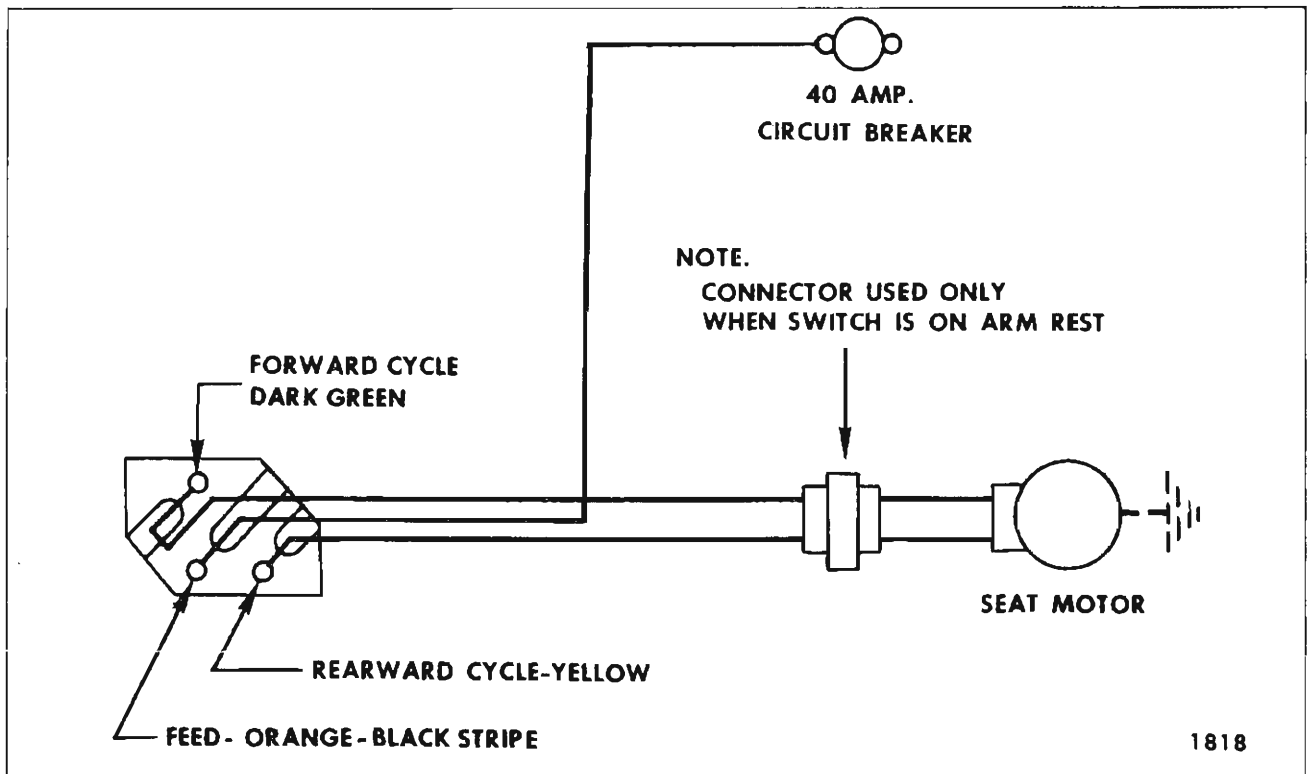

Fig. 16-27—Horizontal Seat Circuit

**Trouble Shooting of Horizontal Seat Circuit**

CONDITION	CAUSE	CORRECTION
1. The seat motor does not operate in either the forward or rearward direction.	<p>A. Open or short circuit in feed harness.</p> <p>B. Inoperative motor.</p>	<p>A. Connect one test light lead to feed terminal of switch block and ground other tester lead to body metal. If tester does not light, there is an open or short circuit between switch and power source.</p> <p>B. Check operation of seat control switch with jumper wire. See "Checking Door Window Control" for similar operation.</p> <p>C. Check circuit from control switch to motor for short or open circuit and check ground wire attachment at adjuster.</p> <p>D. Check operation of motor with #12 gauge jumper wire. Connect one end of jumper wire to power source and the other end to one of the seat motor terminals. Motor should operate.</p> <p>Perform same check at the other motor terminal. If motor does not operate, repair or replace motor as required.</p>

CONDITION	CAUSE	CORRECTION
2. The seat motor operates in only one direction.	A. Defective switch.  B. Open or short circuit in motor feed wires.  C. Defective seat motor.	A. Check operation of seat control switch with jumper wire.  B. Check circuit from control switch to motor for short or open circuit.  C. Check operation of motor with #12 gauge jumper wire. Connect one end of jumper wire to power source and the other end to one of the seat motor terminals. Perform same check at the other motor terminal. If motor does not operate, repair or replace motor as required.

## FOUR-WAY TILT SEAT

### Description

The seat adjusters for the bench-type and bucket-type seats are actuated by a 12 volt, reversible,

shunt-wound motor with a built-in circuit breaker. See Figures 16-28 and 16-29 for the bench seat installation and Figure 16-30 for the bucket seat installation.

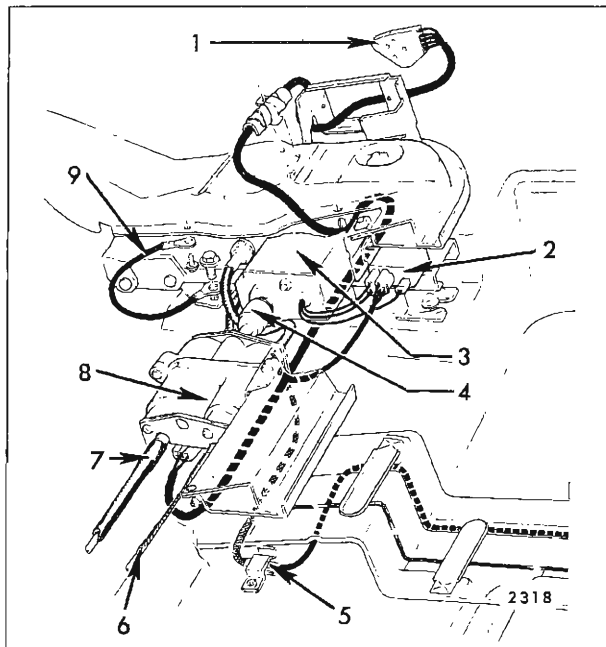

Fig. 16-28—Four-Way Bench Seat Wiring - "A" Body Styles

- |                           |                                   |
|---------------------------|-----------------------------------|
| 1. Control Switch Block   | 6. Vertical Drive Cable (Yellow)  |
| 2. Motor Control Relay    | 7. Horizontal Drive Cable (Black) |
| 3. Motor                  | 8. Transmission Assembly          |
| 4. Rubber Coupler         | 9. Seat Ground Wire               |
| 5. Feed Harness Connector |                                   |

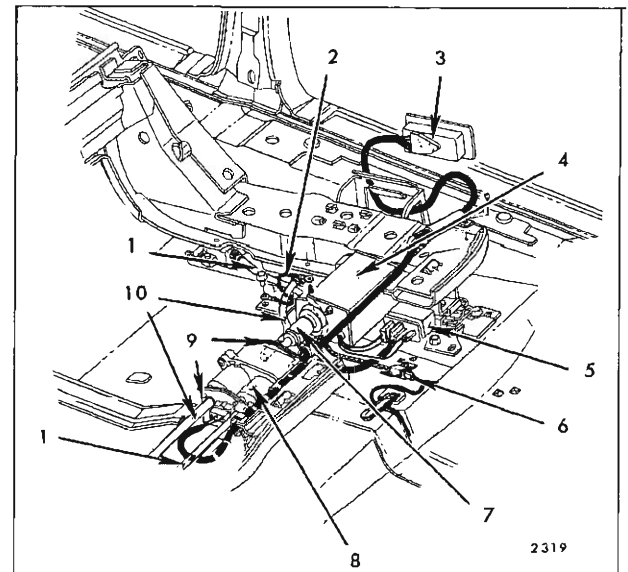

Fig. 16-29—Four-Way Bench Seat Wiring - "B & C" Styles

- |                                      |
|--------------------------------------|
| 1. Vertical Control Cable (Yellow)   |
| 2. Ground Wire                       |
| 3. Control Switch                    |
| 4. Motor                             |
| 5. Motor Control Relay               |
| 6. Feed Harness Connector            |
| 7. Rubber Coupler                    |
| 8. Transmission Assembly             |
| 9. Transmission End Plates           |
| 10. Horizontal Control Cable (Black) |

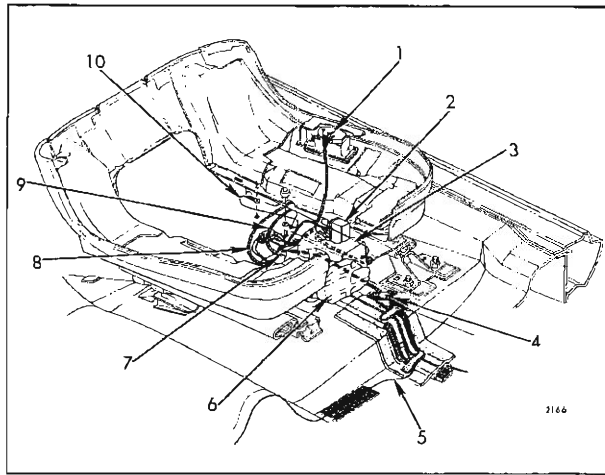

Fig. 16-30—Four-Way "Strato" Bucket Seat Wiring - All Styles

1. Control Switch
2. Motor Control Relay
3. Motor
4. Feed Harness Connector
5. Feed to Passenger Seat
6. Pulley Cover Plate
7. Transmission and Solenoid Assembly
8. Vertical Control Cable (Orange)
9. Horizontal Control Cable (Black)
10. Ground Wire

The seat motor is energized by a toggle-type control switch installed in the left seat side panel or in the left front door arm rest.

The four way seat circuit is protected by a circuit breaker (refer to Electrical Introduction for specific location).

The seat adjuster operating mechanism incorporates a transmission assembly which includes two solenoids and four drive cables on bench-type seats and two drive cables on bucket seats, leading to the seat adjusters. One solenoid controls the rear vertical movement of the seat while the other solenoid controls the horizontal movement of the seat. When the control switch is actuated, the motor and one of the solenoids are energized simultaneously. Then the solenoid plunger causes the shaft dog to engage with the large gear dog.

Power is then transmitted through the transmission shaft on bench seats and through the pulleys on bucket seats, which in turn drives the actuator cables. When the adjusters reach their limit of travel, the drive cables stop their rotating action and torque is absorbed by the rubber coupler connecting the motor and transmission on bench seats. On bucket seats torque is absorbed through the

belt on the pulley. When the control switch lever is released the switch contacts open, a spring returns the shaft dog and solenoid plunger to their original position disengaging the shaft dog from the large gear dog. See "Seat Section" for exploded view of transmission.

## CHECKING PROCEDURE

It may be necessary to use only one or all of the procedures outlined to locate an electrical failure in the circuit. If the location of the failure is evident, follow only the steps required to check the affected wire or component. If the location of the failure is not evident, follow the procedures as outlined. Before performing any extensive check procedures, check the seat adjuster drive cables for proper attachment. In addition, study the seat circuit diagrams to become familiar with the seat circuit (See Fig. 16-31).

### a. Checking for Current at Circuit Breaker

1. Connect one test light lead to battery side of circuit breaker. If tester does not light, there is not current at battery side of circuit breaker.
2. To check circuit breaker, disconnect switch feed wire from breaker, and with a test light check for current at switch side of circuit breaker. If tester does not light, there is no current flowing through circuit breaker.

### b. Checking Feed Circuit Continuity at Relay on Seat Motor—All Styles

1. Disengage three-way connector body from the seat motor relay.
2. Insert one test light lead into the relay power feed connector slot on the harness, and ground other tester lead.
3. If tester does not light, there is not current at end of feed wire. Failure is caused by an open or short circuit in feed circuit.

### c. Checking for Current at Seat Control Switch

1. Connect one test light lead to feed terminal of switch block and ground other test light lead to body metal.
2. If tester does not light, there is not current at switch block. Failure is caused by an open or short circuit between switch block and power source.

### d. Checking the Seat Control Switch

In the following operations which specify the seat control switch to be actuated, a switch that has been

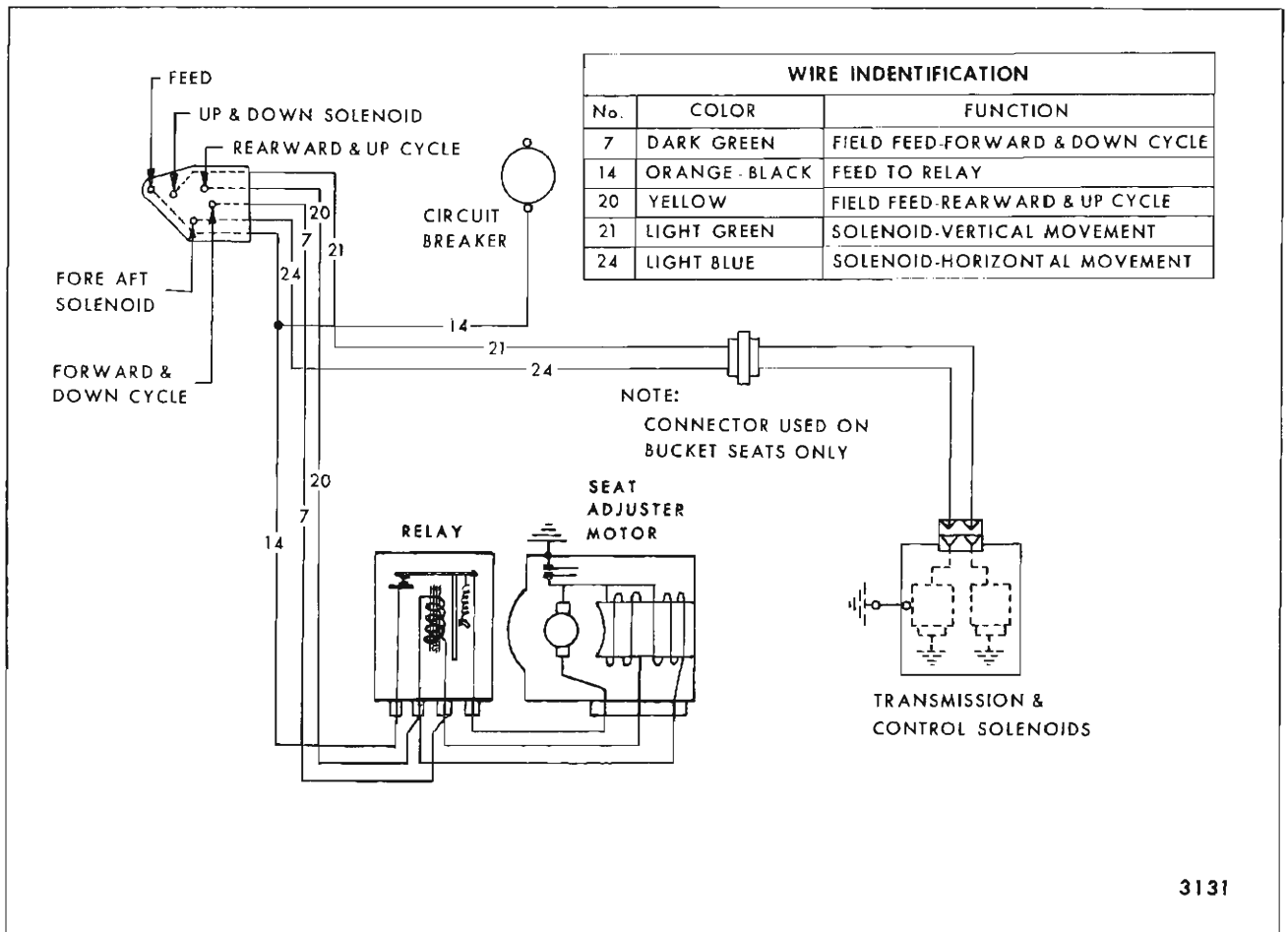

Fig. 16-31—Four-Way Seat Circuit

checked for proper operation may be connected to the switch block. If a switch is not available, a three-way jumper wire can be made to perform the switch function. The method of making the jumper wire and the switch locations to be connected to obtain a specific movement of the seat are shown in Figures 16-32 and 16-33. If a jumper wire is used, number the locations on the switch block as indicated in the illustration.

**NOTE:** To make jumper wire, obtain two pieces of #12 gauge wire, each 4-1/2" long. Join one end of each wire as shown in diagram. The joined end can be inserted in the feed location in the switch block; one of the remaining ends can be inserted into one of the solenoid locations.

1. Obtain switch or jumper wire and connect to switch block.
2. Operate switch if used. If adjusters operate with switch or jumper wire, but did not operate with original switch, the original switch is defective or connector block was not sufficiently engaged.

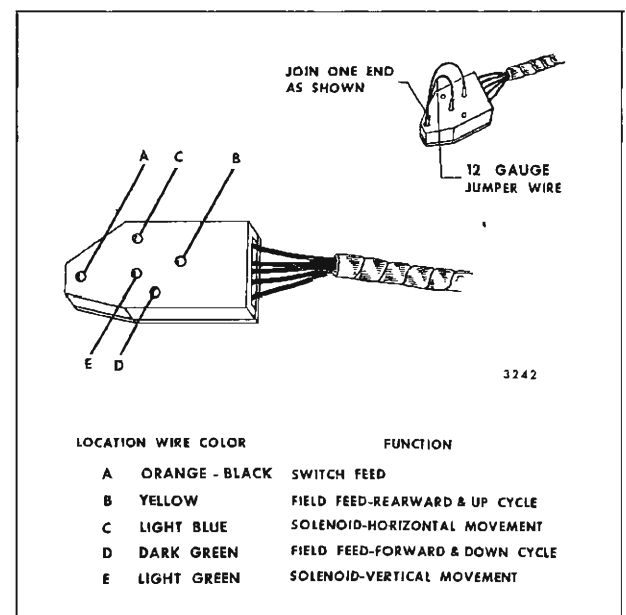

Fig. 16-32—Four-Way Seat Switch Block in Trim Panel

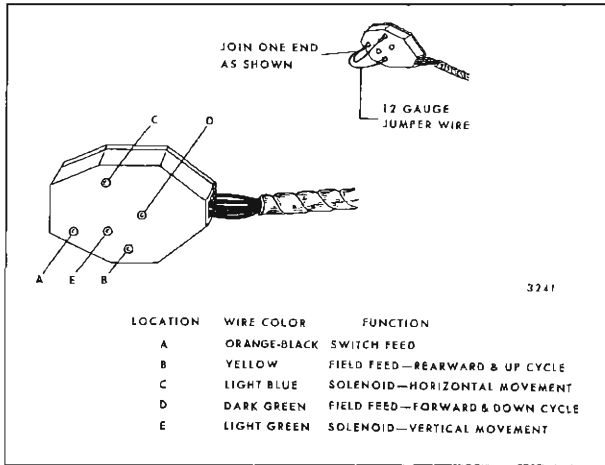

Fig. 16-33—Four-Way Seat Switch Block in Arm Rest

**IMPORTANT:** To obtain a seat movement using a three-way jumper wire at the switch block, the switch feed location, one of the motor field wire locations and one of the solenoid locations have to be connected simultaneously.

The switch locations to be connected to obtain a specific seat movement are outlined as follows:

- To raise seat, place jumper wire in locations "A, B & E".
- To lower seat, place jumper wire in locations "A, D & E".
- To operate seat forward, place jumper wire in locations "A, C & D".
- To operate seat rearward, place jumper wire in locations "A, B & C".

#### e. Checking Wires between Control Switch and Motor Relay

- Disengage three-wire harness connector from relay at motor.
- Insert one test light lead into the motor field connector slot on harness and ground other lead.
- Actuate seat switch to energize field wire being tested.
- If tester does not light, there is not current at end of wire. Failure is caused by an open or short circuit between end of wire and switch. Check other motor field wire in the same manner.

#### f. Checking the Relay Assembly

- Disconnect three leads from relay assembly. These are the wires leading from the motor to the relay.
- Connect one end of a jumper wire to one of the motor field feed studs on the relay and ground the other end of the jumper wire.
- Connect one test light lead to motor armature feed stud on relay and ground other tester lead.
- With jumper wire, energize the field stud which is not grounded.

**CAUTION:** Do not energize grounded side. If tester does not light, the relay is defective.

#### g. Checking the Motor Assembly

- Disconnect motor field feed wires from motor.
- Connect one end of a #12 gauge jumper wire to battery positive pole and other end to one of the motor field and the armature wires.
- If motor does not operate, motor is defective. Check the remaining motor field wire in the same manner.

#### h. Checking Wires between Switch and Solenoids

- Disconnect harness connector from transmission assembly.
- Connect one test light lead to one terminal of power feed and ground other test light lead to body metal.
- Operate switch to wire being tested. If tester does not light, there is no current at the end of harness wire. Failure is caused by an open or short circuit between end of wire and switch or defective switch.
- Check other wire in same manner.

**NOTE:** One wire in connector is a blank. Check wiring diagram for colors of wires actually used.

#### i. Checking the Solenoid

- Check solenoid ground strap attachment for proper ground.
- Connect one end of a #12 gauge jumper wire to the battery positive pole and the other end to the lead of the solenoid being checked.

**CAUTION:** To prevent damaging the solenoid, do not energize solenoid for more than one minute.

3. Operate switch, actuate adjuster motor and solenoid being checked.

4. If adjusters do not operate and there is no mechanical failure of the adjusters, the solenoid is defective.

**NOTE:** If solenoid is functioning properly, a "click" may be heard when solenoid plunger operates.

### j. Trouble Shooting

CONDITION	CAUSE	CORRECTION
1. Seat adjuster motor does not operate.	A. Short or open circuit between power source or switch and motor. B. Defective motor relay. C. Defective motor. D. Defective switch. E. Defective circuit breaker	A. Check circuit from power source and switch to motor to locate failure. B. Replace relay. C. Check motor. If defective, repair or replace as required. D. Replace switch. E. Replace circuit breaker.
2. Seat adjuster motor operates in both directions but seat adjusters are not actuated.	A. Short or open circuit between switch and affected solenoid. B. Defective solenoid. C. Defective switch.	A. Check circuit from switch to solenoid to locate failure. B. Check solenoid. If defective, repair or replace as required. C. Replace switch.
3. Seat Adjuster motor operates in one direction only, seat moves down and forward, but does not move up and rearward.	A. Short or open circuit between one of the motor relay wires and seat control switch. B. Defective field coil in motor. C. Defective switch.	A. Check circuit between affected motor relay wire and seat switch. B. Check motor. If defective, repair or replace as required. C. Replace switch.

## SIX-WAY TILT SEATS

### Description

The seat adjuster for the standard and "STRATO" type 6-way seats are actuated by a 12-volt motor installed at the left side of the seat assembly (See Figs. 16-34 and 16-35).

The motor is energized by a three button-type control switch located in the left seat side panel or in the left front door arm rest.

The power seat circuit is protected by a circuit breaker (refer to Electrical Introduction for location).

The electrical portion of the six-way seat operates as follows:

When the control switch is actuated, current flows to the transmission solenoid which controls the desired seat movement. The energizing of the solenoid coil results in the solenoid plunger dog engaging the gear mechanism to rotate the control cable. The same switch action which energized the solenoid produces a current flow through the motor control relay to one of the motor field coils. The current flows through the relay, closes the contacts between the relay power source and the armature motor lead wire, and results in the operation of the seat motor. When the control switch lever is released, the switch contacts open, a spring returns

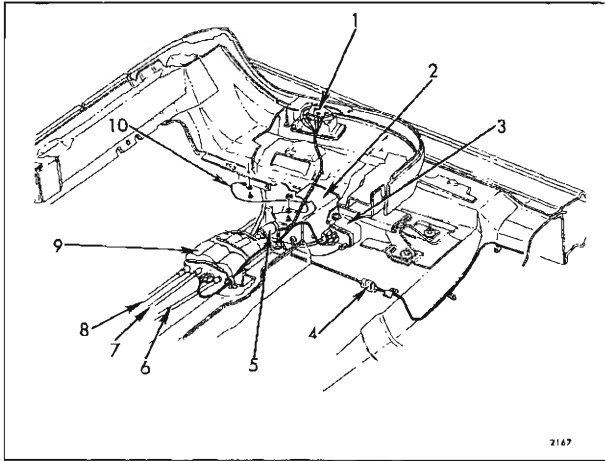

Fig. 16-34—Six-Way "Strato" Seat

1. Control Switch
2. Motor
3. Motor Control Relay
4. Feed Harness Connector
5. Rubber Coupler
6. Front Vertical Control Cable (Yellow)
7. Rear Vertical Control Cable (Blue)
8. Horizontal Control Cable (Black)
9. Transmission and Solenoid Assembly
10. Ground Wire

the shaft dog and solenoid plunger to their original position disengaging them from the gear dog.

### Circuit Checking Procedures

It may be necessary to use only one or all of the procedures outlined to locate an electrical failure in the circuit. If the location of the failure is evident, follow only the steps required to check the affected wire or component. If the location of the failure is not evident, follow the procedure as outlined. Before performing any extensive check procedures, check the seat adjuster drive cables for proper attachment. In addition, study the seat circuit diagrams to become familiar with the seat circuit (See Figure 16-36).

#### a. Checking Feed Circuit Continuity at Circuit Breaker

1. Connect one test light lead to battery side of circuit breaker and ground other lead. If tester does not light, there is an open or short circuit in feed circuit to breaker.
2. To check circuit breaker, disconnect the output feed wire (the wire opposite the power source feed to the breaker) from the breaker

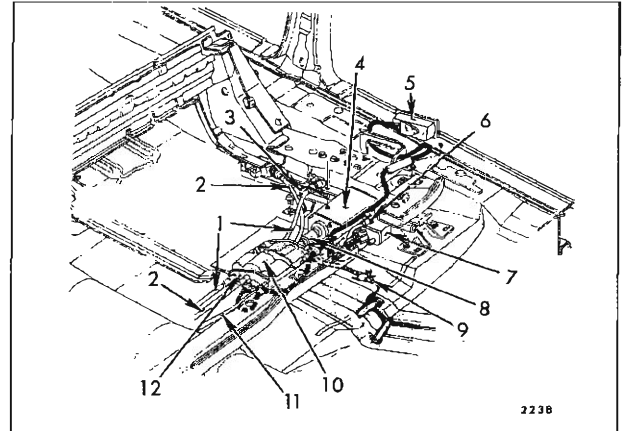

Fig. 16-35—Six-Way Standard Bench Seat

1. Horizontal Control Cable (Black)
2. Rear Vertical Control Cable (Blue)
3. Ground Wire
4. Motor
5. Control Switch
6. Front Vertical Control Cable (Yellow)
7. Motor Control Relay
8. Rubber Coupler
9. Feed Harness Connector
10. Transmission and Solenoid Assembly
11. Front Vertical Control Cable (Yellow)
12. Transmission End Plate

and with test light check terminal from which the wire was disconnected. If tester does not light, circuit breaker is inoperative. Check feed circuit continuity at fuse block.

#### b. Check Feed Circuit Continuity at Seat Control Switch

1. Connect one test light lead to feed terminal of switch block and ground other test lead to body metal.
2. If tester does not light, there is an open or short circuit between switch and power source.

#### c. Checking the Seat Control Switch

**NOTE:** In the following operations which specify the seat control switch to be actuated, a switch that has been checked for proper operation may be connected to the switch block. If a switch is not available, a three-way jumper wire can be made to perform the switch function. The jumper wire and the switch locations to be connected to obtain a specific movement of the seat are shown in Figures 16-37 and 16-38. If a jumper wire is used, letter the locations on the switch block as indicated in the illustration. Details outlining the



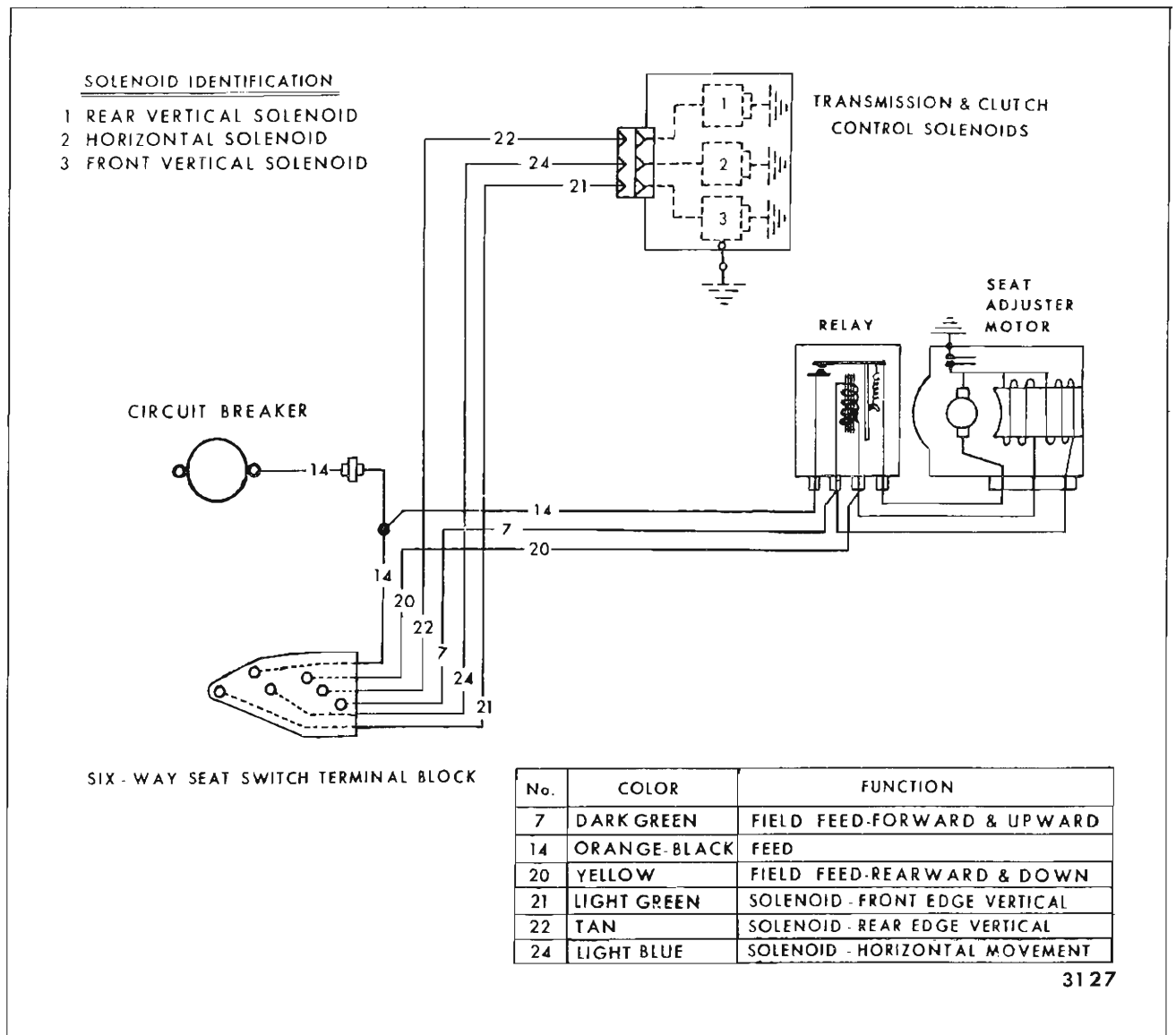

Fig. 16-36—Six-Way Seat Circuit

making and use of the jumper wire follow the checking procedure.

1. Obtain switch or jumper wire and connect to switch block.
2. Operate switch. If adjusters operate with new switch or jumper wire, but did not operate with original switch, the original switch is defective.
3. Check all six movements of seat adjuster.

#### d. Checking Feed Circuit Continuity at Relay on Seat Motor

1. Disengage 3-way connector body from the seat motor relay terminal.

2. Insert one test lead into the relay power feed connector slot on the harness, and ground the other test light lead.

3. If tester does not light, there is no current at end of feed wire. Failure is caused by an open or short in feed circuit.

#### e. Checking Wire between Control Switch and Motor Relay

1. Disengage 3-wire harness connector from relay at motor.
2. Insert one test light lead into the motor field connector slot on harness and ground the other lead.

3. Actuate seat switch to energize field wire being tested.
4. If tester does not light, there is not current at end of wire. Failure is caused by an open or short circuit between end of wire and switch. Check other motor field wire in the same manner.

**f. Checking the Relay Assembly**

1. Disconnect three motor leads from relay assembly. These are the wires leading from the motor to the relay.
2. Connect one end of a jumper wire to one of the motor field feed studs on the relay and ground the other end of the jumper wire.
3. Connect one end of test light to motor armature feed stud on relay and ground other tester lead.
4. With a jumper wire, energize the field stud which is not grounded. If tester does not light, the relay is defective.

**g. Checking the Motor Assembly**

1. Disconnect the motor armature feed lead and one of the motor field feeds from the relay assembly.
2. With a jumper wire, energize the armature feed and one of the field feeds.
3. If motor does not operate, it is defective. Check the other motor field feed in the same manner.

**h. Checking the Wire between the Solenoid and Switch**

1. Disengage harness connector from transmission.
2. Connect one test light lead to end of harness wire being tested and ground other lead.
3. Operate switch to energize wire being tested. If tester does not light, there is no current at end of wire. Failure is caused by an open or short circuit between end of wire and switch.

**i. Checking the Solenoid**

1. Check solenoid ground strap attachment for proper ground.
2. Energize solenoid being checked with jumper wire.

**NOTE:** If solenoid is functioning, a "click" should be heard when solenoid plunger operates "in" and "out".

**CAUTION:** To prevent damaging the solenoid, do not energize solenoid for more than one minute.

3. With solenoid energized, actuate seat control switch to energize adjuster motor.
4. If adjusters do not operate, and there is no mechanical failure in the seat unit, the solenoid is defective.

**j. Three-Way Jumper Wire for Checking Seat Switch**

To make jumper wire, obtain two pieces of #12 gauge wire, each 4-1/2" long, join one end of each wire as shown in Figure 16-37. The joined end can be inserted in the feed location in the switch block; one of the remaining ends can be inserted into one of the field locations in the switch block; the other end can be inserted into one of the solenoid locations.

**IMPORTANT:** To obtain a seat movement using a 3-way jumper wire at the switch block, the switch feed location, one of the motor field wire locations and one of the solenoid locations must be connected simultaneously.

**On Bodies with Switch in Seat Side Panel (See Fig. 16-37)**

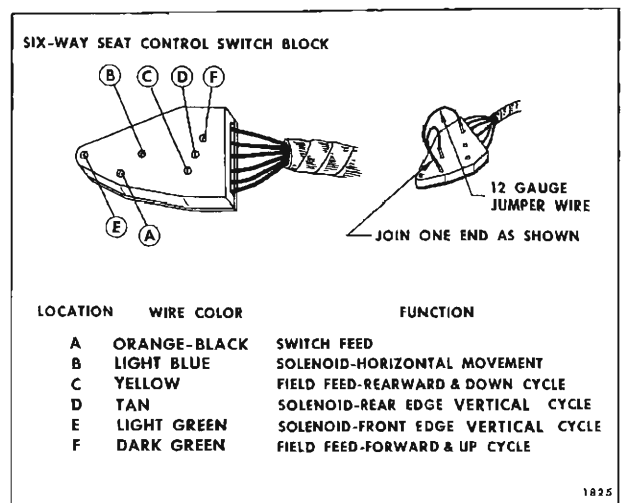

Fig. 16-37—Six-Way Seat Switch Block in Seat Side Panel

1. To raise front end of seat, place jumper in locations A, F and E.
2. To lower front edge of seat, place jumper in locations A, C and E.

3. To raise rear edge of seat, place jumper in locations A, F and D.
4. To lower rear edge of seat, place jumper in locations A, C and D.
5. To move seat forward, place jumper in locations A, B and F.
6. To move seat rearward, place jumper in locations A, C and B.

#### On Bodies with Switch in Arm Rest (See Fig. 16-38)

1. To raise front edge of seat, place jumper in locations A, C and E.
2. To lower front edge of seat, place jumper in locations A, F and E.
3. To raise rear edge of seat, place jumper in locations A, F and D.
4. To lower rear edge of seat, place jumper in locations A, F and D.

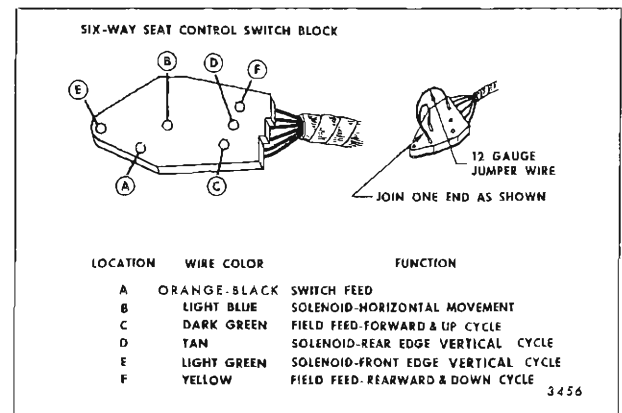

Fig. 16-38—Six-Way Seat Switch Block in Arm Rest

5. To move seat forward, place jumper in locations A, C and B.
6. To move seat rearward, place jumper in locations A, F and B.

#### k. Trouble-Shooting

CONDITION	CAUSE	CORRECTION
1. Seat adjuster motor does not operate	A. Short or open circuit between power source or switch and motor.  B. Defective motor.	A. Check circuit from power source and switch to motor to locate failure.  B. Check motor. If defective, repair or replace as required.
2. Seat adjuster motor operates, but seat adjusters are not actuated.  or	A. Short or open circuit between switch and affected solenoid.  B. Defective solenoid.	A. Check circuit from switch to solenoid to locate failure.  B. Check solenoid. If defective, repair or replace as required.
3. Seat adjuster motor operates, front edge of seat moves up and down and seat moves forward and rearward. The rear edge of seat cannot be operated.		

CONDITION	CAUSE	CORRECTION
4. Seat adjuster motor operates and seat adjusters move front and rear edge of seat up and forward but will not move the seat down and rearward  or	A. Short or open circuit between one of the motor field wires and seat control switch.	A. Check circuit between affected motor field wire and seat switch.
5. Seat adjuster motor operates and seat adjusters move front and rear of seat down and rearward, but will not move the seat up and forward.	B. Defective field coil in motor.	B. Check motor. If defective repair or replace as required.

## TAIL AND SIDE MARKER LAMPS

### DESCRIPTION

Various methods are employed to remove and install the components of tail lamp assemblies. The following charts and illustrations (Figs. 16-40, 16-41, 16-42, 16-43, 16-44 and 16-45) will provide a quick reference for performing the three basic service operations for each Car Division (Bulb Replacement, Lens Replacement and Housing Replacement) on styles where the tail lamp assembly is installed on the body. If the tail lamp assembly is installed in the bumper refer to the chassis manual for service operations.

**CAUTION:** Do not rework or alter the reflective surface of tail lamps or side marker lamps.

### SEALING

Caution should be exercised to prevent waterleaks at the tail lamp area when sealing surfaces are disturbed. Damaged gaskets should be replaced.

If new gaskets are not installed, the use of sealer (body caulking compound or equivalent) is recommended at critical areas and where the old gaskets have taken a set.

The recommended torque for attaching nuts to zinc die cast studs on tail lamp housings and rear fender extensions is 46 to 72 inch pounds. If additional tightening of casting to panel is required, a maximum of 90 inch pounds of torque may be used without stripping the nut.

### SIDE MARKER LAMPS

All styles except Pontiac "G" and Oldsmobile "A" Station Wagons are equipped with rear quarter side marker lamps. The lamps operate in conjunction with the tail lamp circuit. Pontiac "G" has side marker reflector lens in the rear quarter extension housing (See Fig. 16-39).

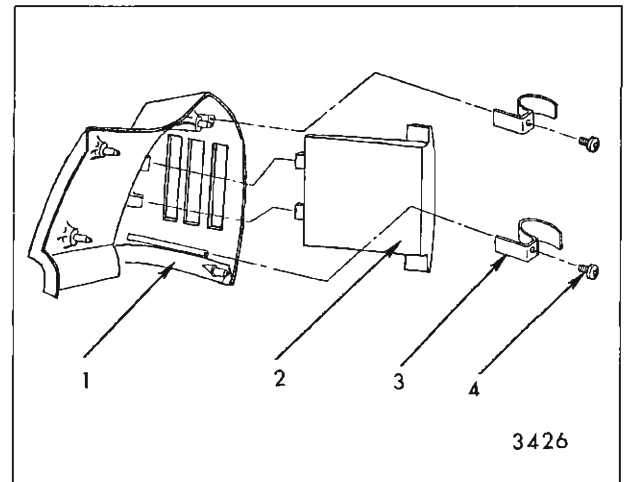

Fig. 16-39—Pontiac "G" Style Side Marker

1. Quarter Extension
2. Reflector Lens
3. Lens Retaining Clip
4. Clip Screw

There are three basic methods of retention for these lamp housings.

1. External Screws - Used on all station wagons.
2. Studs with Nuts Accessible from the Rear Compartment - all except Buick "C & E" and station wagons.
3. Slide-on Spring Retainer - Used on Buick "C & E" styles only.

Views depicting lamp installations are shown with the respective tail lamp installation drawings.

### TAIL BULB USAGE CHART

Trade No.	Candle Power	Use
67	4	Tail Lamp (Inboard) Chevrolet "F"
1156	32	Back-Up Lamp
1157	32 and 4	Combination Tail, Stop and Directional Lamp
194	2	Side Marker - Cadillac "E" Chev., Buick, Oldsmobile, Pontiac (Less 23300-23527- 37-39-67-69 & 23700 Styles) Beaumont & Acadian Styles
1895	2	Side Marker - 23300-23527- 37-39-67-69-23700 Styles

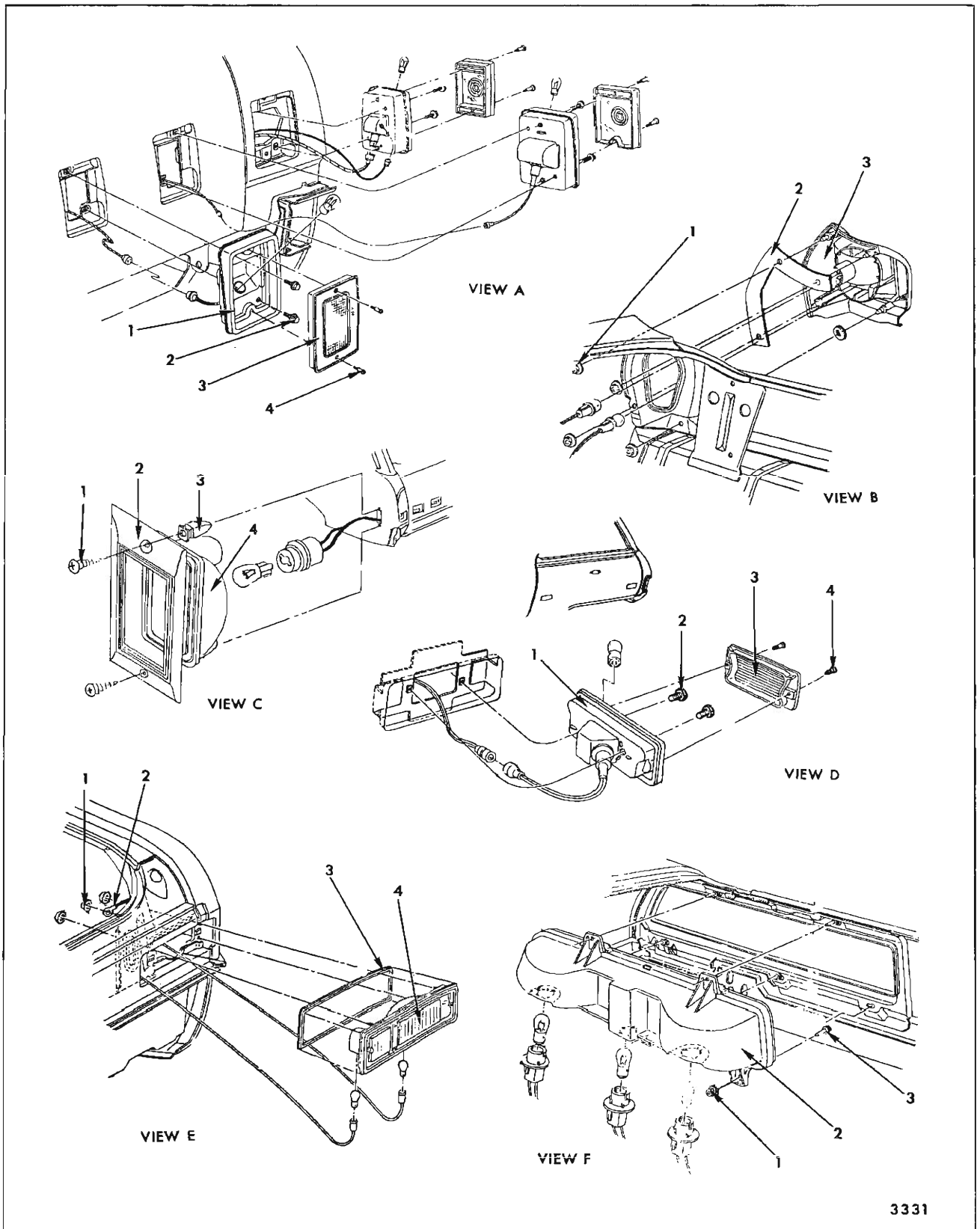

Fig. 16-40—Tail Lamp - Chevrolet - Acadian (Canadian) Styles

## TAIL LAMP OPERATION—CHEVROLET—ACADIAN, BEAUMONT (CANADIAN)

Fig. 16-40 &amp; 16-41

OPERATION	METHOD	BODY TYPE				
		A	A Sta. Wgn.	B Sta. Wgn.	F	X
Bulb Replacement	Remove Lens Outside		X	X		
	Remove Socket (Inside Rear Compartment)	X			X	X
Lens Replacement	Remove Retaining Screws (Outside)		X	X		X
	Remove Housing and Disassemble	X			X	
Housing Replacement	Remove from Outside (Retaining nuts in Rear Compartment)	X View "B"				X View "E"
	Remove From Inside				X View "F"	
	Remove from Outside (Retaining Bolts Under Lens)		X	X View "A"		
	Lower Rear Bumper	X				

## CHEVROLET

- View "A"    1. Lamp Housing  
2. Housing Bolt  
3. Lens  
4. Lens Screw
- View "B"    1. Housing Retaining Nut  
2. Gasket  
3. Lamp Housing
- View "C"    1. Bezel Screw  
2. Bezel  
3. Retaining Nut  
4. Lamp Housing Assembly
- View "D"    1. Back-Up Lamp Housing  
2. Housing Retaining Bolt  
3. Lens  
4. Lens Screw
- View "E"    1. Housing Retaining Nut  
2. Ground Wire  
3. Gasket  
4. Lamp Housing Assembly
- View "F"    1. Housing Retaining Nut  
2. Lamp Housing  
3. Bolt and Clip Assembly

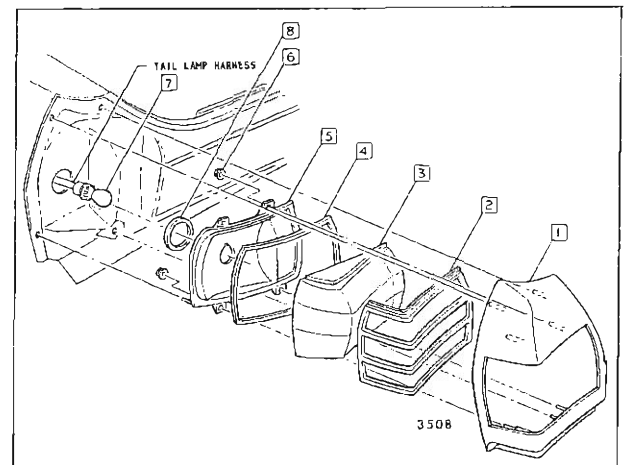

Fig. 16-41—Tail Lamp - Beaumont (Canadian) Styles

1. Rear Quarter Extension  
2. Lamp Bezel  
3. Lens  
4. Lens Gasket  
5. Lamp Housing  
6. Nut  
7. Bulb  
8. Lamp Gasket

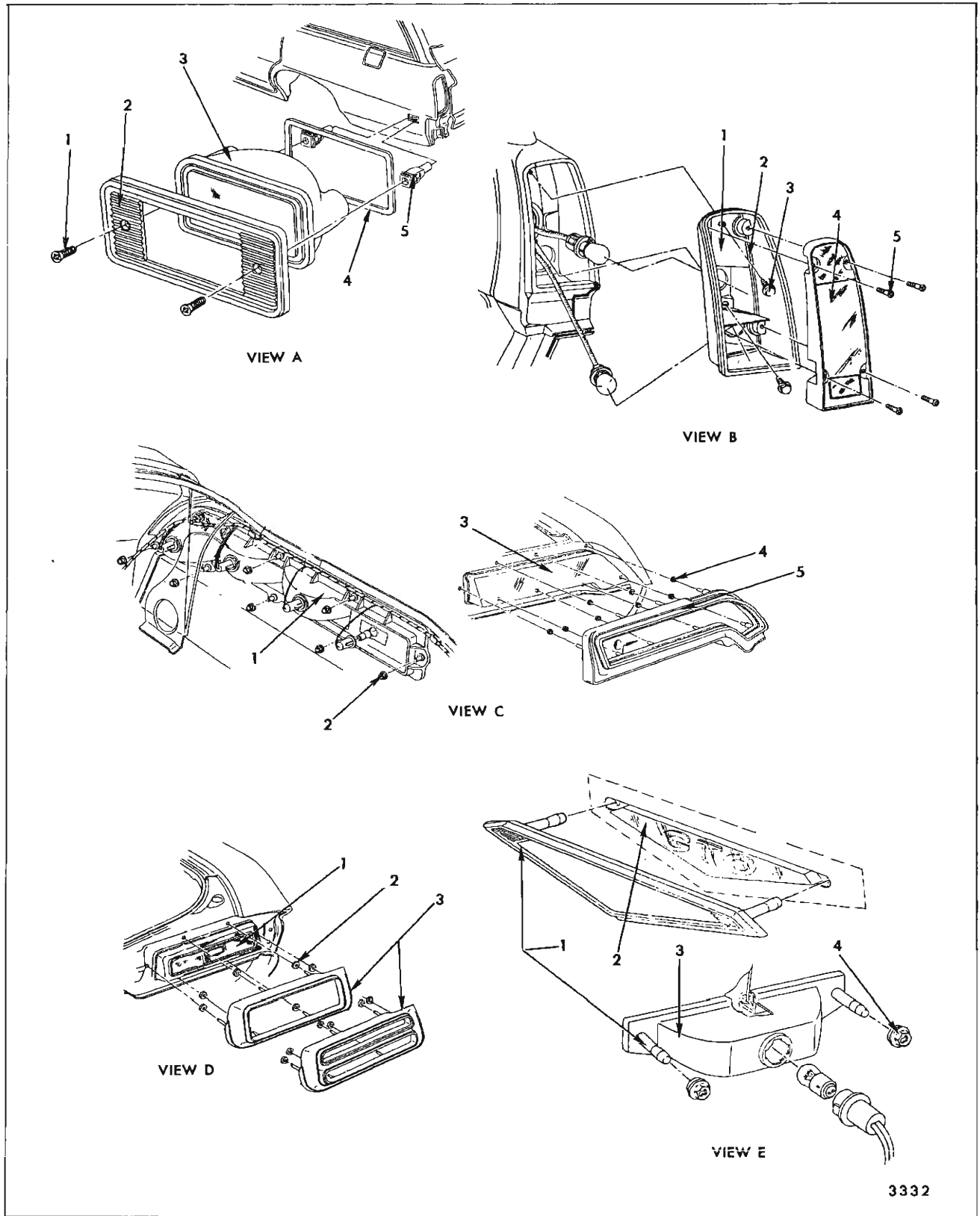

Fig. 16-42—Tail Lamp - Pontiac (U.S. and Canadian) Styles



## TAIL LAMP OPERATION—PONTIAC (U.S. AND CANADIAN STYLES)

Fig. 16-42

OPERATION	METHOD	BODY TYPE				
		A	A Sta. Wgn.	B Sta. Wgn.	B	F
Bulb Replacement	Remove Lens Outside		X	X		
	Remove Socket (Inside Rear Compartment)	X			X	X
Lens Replacement	Remove Retaining Screws (Outside)		X	X		
	Remove Housing and Disassemble	X			X	X
Housing Replacement	Remove from Outside (Retaining nuts in Rear Compartment)					
	Remove From Inside	X View "D"			X View "C"	
	Remove from Outside (Retaining Bolts Under Lens)		X	X View "B"		
	Lower Rear Bumper	X			X	

### PONTIAC

- View "A"    1. Bezel Screw  
              2. Bezel  
              3. Lamp Housing  
              4. Gasket  
              5. Retaining Nut
- View "B"    1. Lamp Housing  
              2. Gasket  
              3. Housing Bolt  
              4. Lens  
              5. Lens Screw
- View "C"    1. Lamp Housing  
              2. Housing Bolt  
              3. Lens  
              4. Spacer  
              5. Bezel
- View "D"    1. Lens and Lamp  
                  Housing Assembly  
              2. Spacer  
              3. Bezel
- View "E"    1. Bezel  
              2. Lens  
              3. Lamp Housing  
              4. Bezel Nut

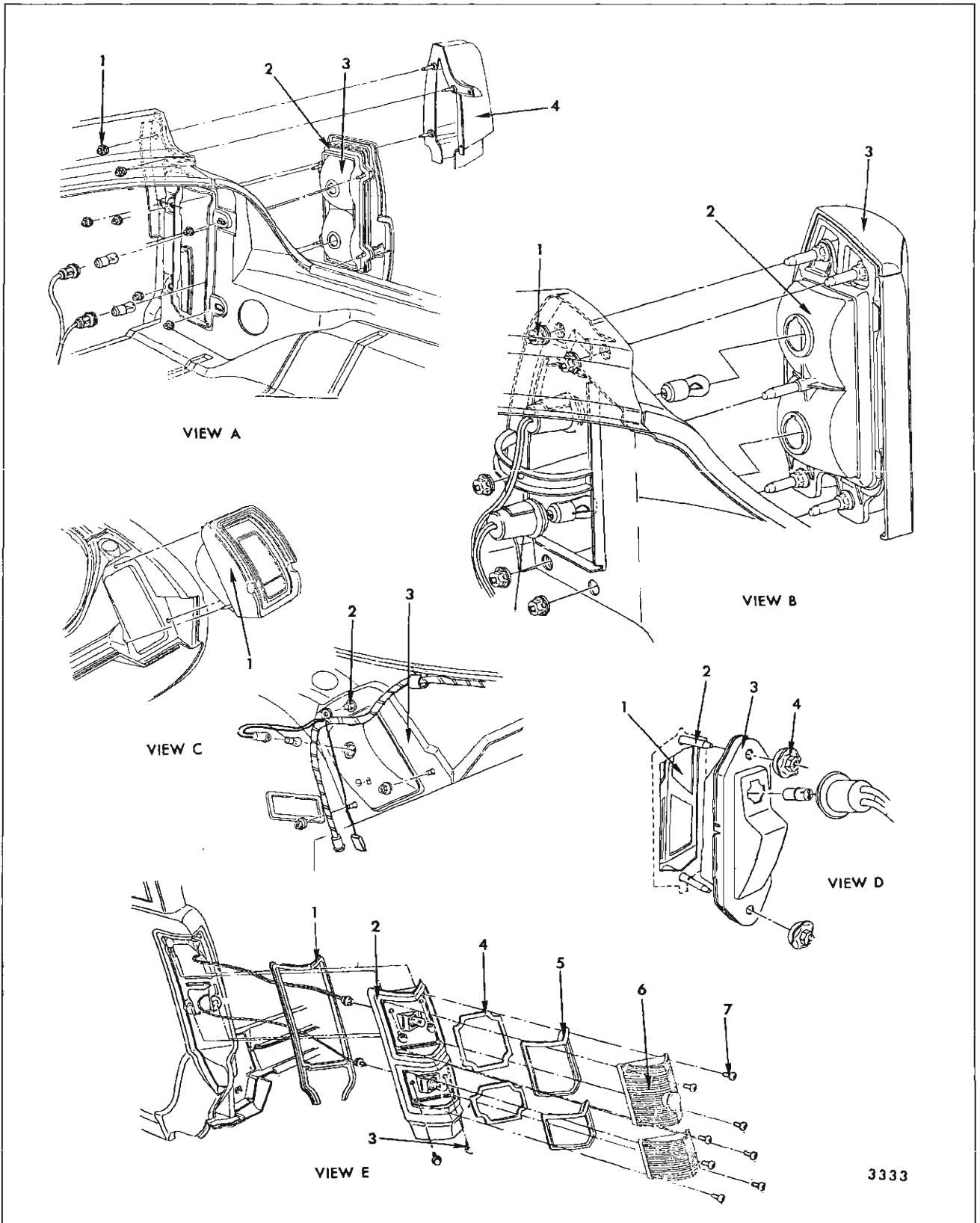

3333

Fig. 16-43—Tail Lamp - Oldsmobile Styles

## TAIL LAMP OPERATION—OLDSMOBILE

Fig. 16-43

OPERATION	METHOD	BODY TYPE			
		A	A Station Wagon	B	C
Bulb Replacement	Remove Lens Outside		X		
	Remove Socket (Inside Rear Compartment)	X		X	X
Lens Replacement	Remove Retaining Screws (Outside)		X		
	Remove Housing and Disassemble	X		X	X
Housing Replacement	Remove from Outside (Retaining nuts in Rear Compartment)	X View "C"		X View "A"	X View "B"
	Remove From Inside				
	Remove from Outside (Retaining Bolts Under Lens)		X View "E"		
	Lower Rear Bumper	X		X	X

### OLDSMOBILE

View "A"    1. Retaining Nut  
              2. Housing Gasket  
              3. Lamp Housing  
              4. Quarter Extension

View "B"    1. Retaining Nut  
              2. Lamp Housing  
              3. Quarter Extension

View "C"    1. Lamp Housing  
              2. Retaining Nut  
              3. Rear End Panel

View "D"    1. Lens  
              2. Bezel  
              3. Lamp Housing  
              4. Retaining Nut

View "E"    1. Housing Gasket  
              2. Lamp Housing  
              3. Housing Screw  
              4. Lens Gasket  
              5. Bezel  
              6. Lens  
              7. Lens Screw

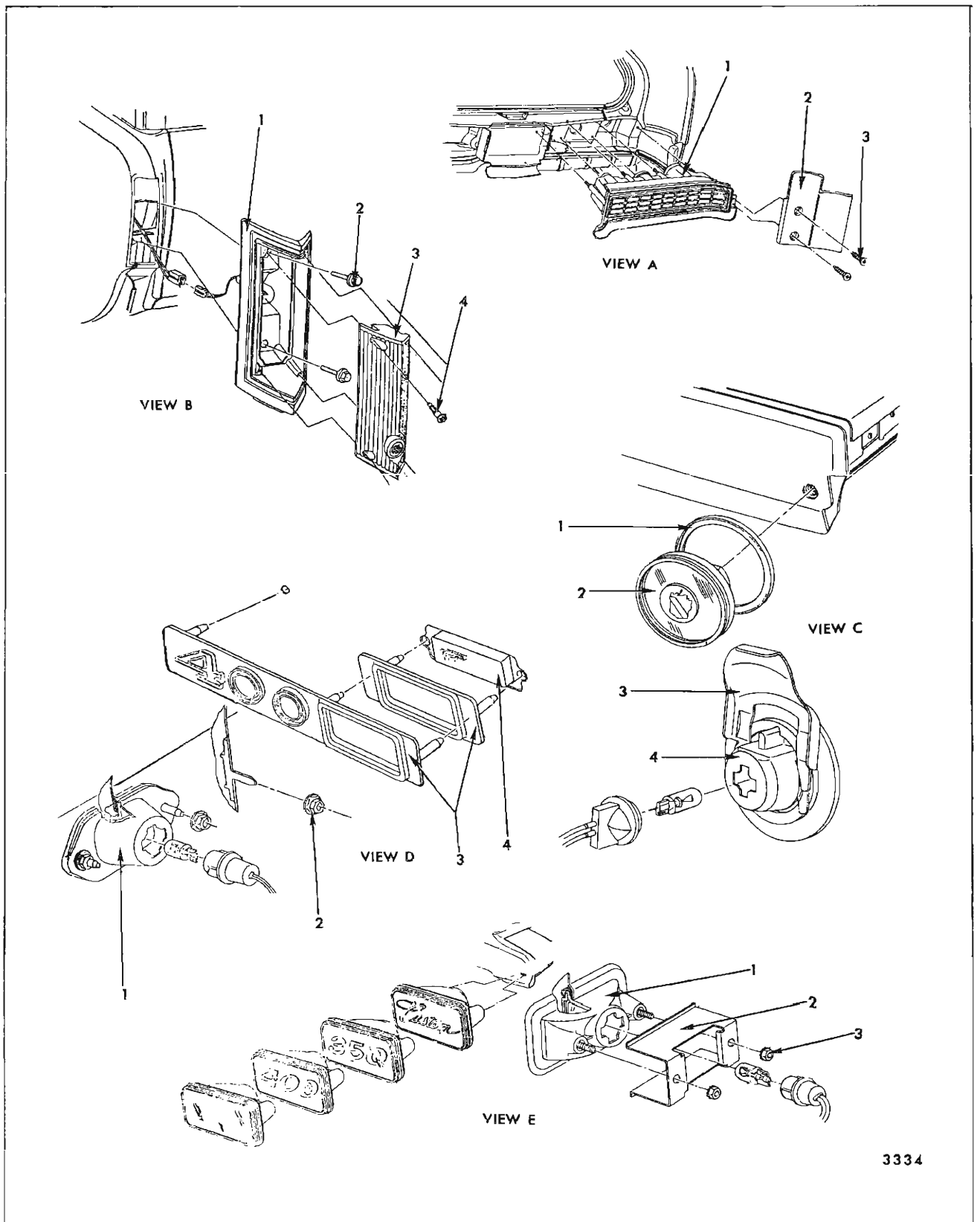

3334

Fig. 16-44—Tail Lamp - Buick Styles

## TAIL LAMP OPERATION—BUICK

Fig. 16-44

OPERATION	METHOD	BODY TYPE	
		A Station Wagon	C
Bulb Replacement	Remove Lens Outside	X	
	Remove Socket (Inside Rear Compartment)		X
Lens Replacement	Remove Retaining Screws (Outside)	X	
	Remove Housing and Disassemble		X
Housing Replacement	Remove from Outside (Retaining nuts in Rear Compartment)		X View "A"
	Remove From Inside		
	Remove From Outside (Retaining Bolts Under Lens)	X View "B"	
	Lower Rear Bumper		X

## BUICK

View "A"  
 1. Lamp Housing  
 2. Filler Molding  
 3. Filler Screws

NOTE: Remove Filler  
 Molding Before  
 Lamp Housing

View "B"  
 1. Lamp Housing  
 2. Housing Screw  
 3. Lens  
 4. Lens Screw

View "C"  
 1. Bezel  
 2. Lens  
 3. Retainer  
 4. Lamp Housing

View "D"  
 1. Lamp Housing  
 2. Retaining Nut  
 3. Bezel  
 4. Lens

View "E"  
 1. Housing Assembly  
 2. Lamp Retainer  
 3. Retaining Nut

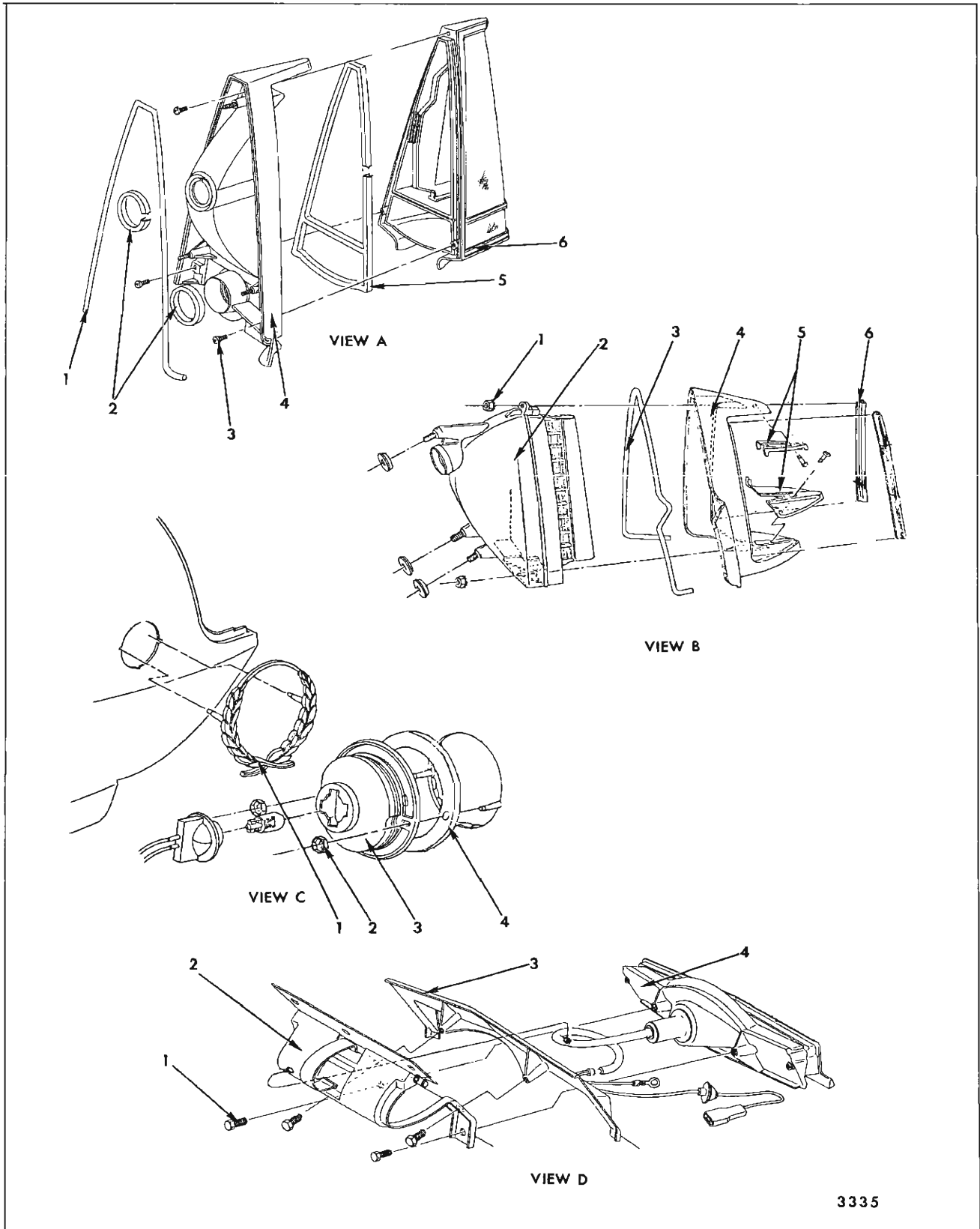

Fig. 16-45—Tail Lamp - Cadillac Styles

## TAIL LAMP OPERATION—CADILLAC

Fig. 16-45

OPERATION	METHOD	BODY TYPE	
		C & D	E
Bulb Replacement	Remove Lens Outside	X	X
	Remove Socket (Inside Rear Compartment)		
Lens Replacement	Remove Retaining Screws (Outside)		
	Remove Housing and Disassemble	X	X
Housing Replacement	Remove from Outside (Retaining nuts in Rear Compartment)	X View "A"	X View "B"
	Remove From Inside		
	Remove from Outside (Retaining Bolts Under Lens)		
	Lower Rear Bumper	X	

### CADILLAC

- View "A"
1. Sealer Strip
  2. Donut Gasket
  3. Bezel Screw
  4. Lamp Housing
  5. Gasket
  6. Lens and Bezel Assembly
- View "B"
1. Extension Retaining Nut
  2. Lamp Housing
  3. Sealer
  4. Quarter Extension
  5. Trim Plates
  6. Molding Strips

- View "C"
1. Bezel
  2. Bezel Nut
  3. Lamp Housing
  4. Gasket
- View "D"
1. Lamp Attaching Bolt
  2. Hinge Assembly
  3. Gas Tank Filler Door
  4. Back-Up Lamp

### INTERIOR LAMP—ABOVE BELT BULB CHART

Lens Shape	Rectangular		Oval		Round		
	6 CP Cart.	12 CP Cart.	6 CP Cart.	12 CP Cart.	6 CP Cart.	12 CP Cart.	15 CP Bay.
Chevrolet "A" "Z-X-F" "B"		Dome		Dome		Dome	
Pontiac All						Dome	
Oldsmobile "A-B" "C" Exc. 38669 38669 "E" 34855-56-65-66	Sail 2/Sail Roof Rail				Sail Sail	Dome Dome	
Buick "A" Wagon "A-B" "A-37" Optional	Roof Rail  Sail	Dome			Sail	Dome	
Cadillac 68169 "C&E" 69723-33	Sail				Front Comp.	A/C Grille	Sail
Canadian Pontiac Beaumont Acadian		Dome		Dome		Dome	

### SEAT WARMERS

#### DESCRIPTION

Seat warmers are available as a factory installed accessory on all 1969 Cadillac styles.

The seat warmers are located in the front seats on all but 69723 and 69733 styles, which have rear seat warmers.

Cloth heating pads with electrical resistance heating elements are located in the seat cushions and backs. The cloth material has a watt density of 25 watts per square foot, requiring an approximate 22-25 ampere current draw at 12 volts. There are three different size pads used, which are identified by a colored band on each.

COLOR	Red	Blue	Yellow
SIZE	17-1/2" x 23-1/4"	17-1/2" x 26"	17-1/2" x 28-1/8"
LOCATION	Seat Cushion	Rear Seat Cushion and Back (69723-33 Styles)	Seat Back
APPROX. CURRENT RANGE IN AMPERES	6.8a to 7.1a	6.0a to 6.4a	5.5a to 5.9a



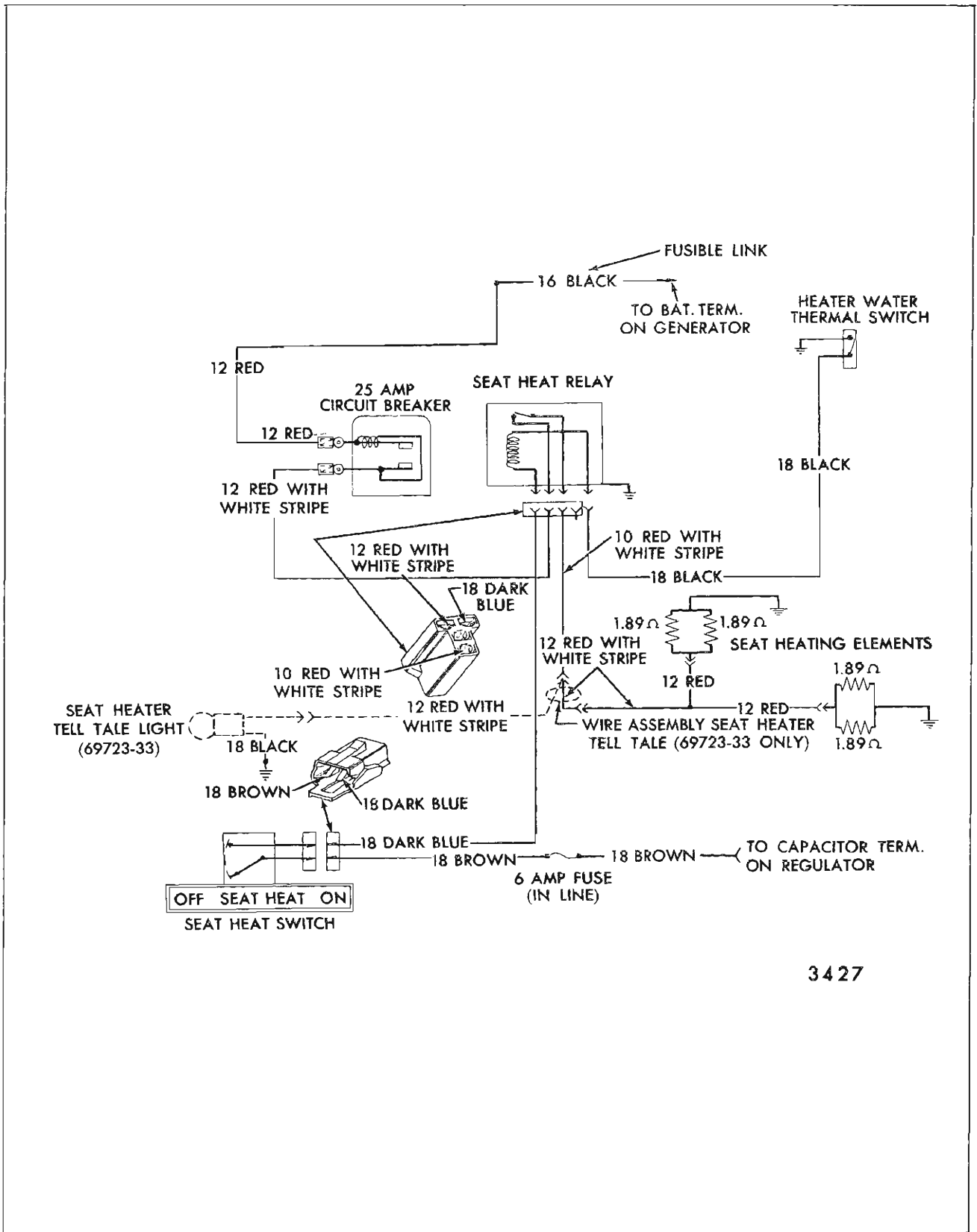

3427

Fig. 16-46—Electric Seat Warmer

## COMPONENTS

The system consists of an ON-OFF switch, thermal switch, relay, cloth heating pads, circuit breaker, fuse and wiring (See Fig. 16-46). The ON-OFF switch is mounted on the instrument panel. The relay and 25 amp. circuit breaker are mounted on the right wheelhouse, or on the evaporator blower assembly on cars equipped with air conditioning. The thermal switch is located in the heater water circuit between the water pump and heater core.

## OPERATION OF SEAT WARMER

In order to operate the seat warmer, the engine

must be running, the ON-OFF switch to "On" and the thermal switch closed (switch opens automatically when water temperature exceeds 150°F.). The seat warmer will shut off automatically when car heater provides adequate heat, or manually when ON-OFF control switch is set to the "Off" position. However, on cars equipped with Automatic Climate Control, the seat warmers will not automatically turn off with the climate control in the "Vent" position, or when the system is providing maximum cooling in any other position. Refer to Cadillac Shop Manual for Seat Warmer Component Testing.

# ELECTRIC BACK WINDOW GRID DEFOGGER

## DESCRIPTION

The optional back window defogger unit consists of ceramic silver compound element lines and bus bar applied to the inside glass surface. The bus bar is backed up by a braided wire soldered on the bus bar to provide adequate conductivity. The wire pigtailed will have double insulation (loom over conventional insulation). The system operates on approximately 17 amps at 12 volts. The side garnish moldings used, must have a snap-in insulator insert.

The electric grid defogger creates a rise in temperature on the glass of approximately 30° - 40°. Therefore, in some cases finger touch may not detect heat in the glass.

See figure 16-47 for Oldsmobile "E" and Buick "E" installation, all others similar.

Connectors for timer unit are shown on left rear seat back diagonal brace.

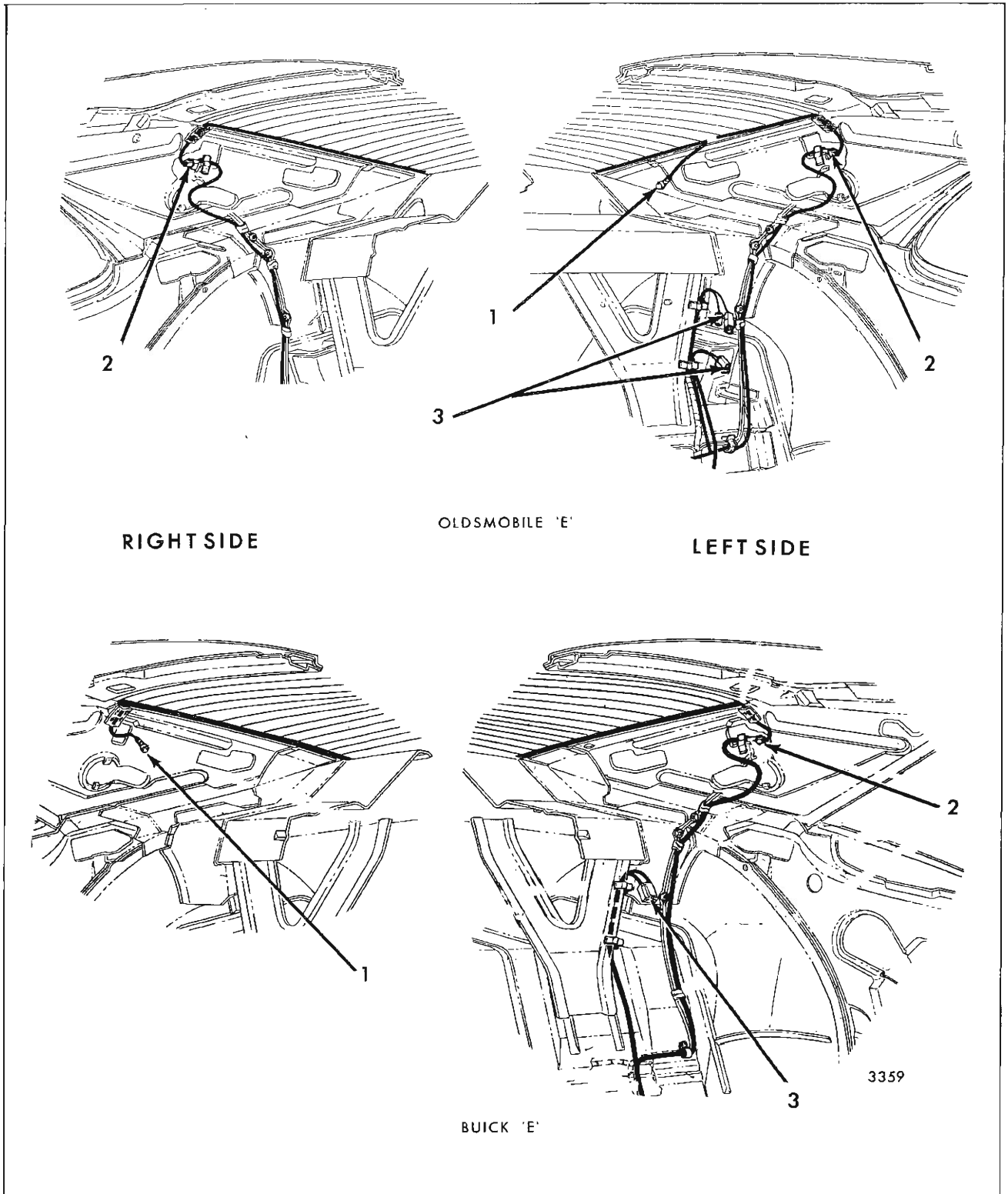

Fig. 16-47—Electric Back Window Grid Defogger

- 1. Ground Connector
- 2. Feed Connectors
- 3. Timer Connector

## ELECTRIC SEAT BACK LOCK RELEASE

### DESCRIPTION

Electric seat back lock release is optional on all 2-door styles equipped with electric door locks. The system utilizes a relay and two solenoids, one each for the driver and passengers seat backs and works in conjunction with the door jamb switches (See Fig. 16-48). When either door is opened, a ground for the lock relay is provided through the door jamb switch. This action closes a set of contacts in the lock relay and allows current to flow to the two grounded solenoids located in the front seat backs, releasing the seat back locks.

Each solenoid incorporates both an "unlock" and a "hold-in" coil. These coils are stacked in tandem around a single plunger and are energized simultaneously. The "unlock" coil draws approximately 14 amps of current and the "hold-in" coil approximately 0.6 amps. When the solenoid plunger reaches its full travel (1/4 inch), it trips an internal limit switch and opens the ground circuit for the "unlock" coil, leaving the "hold-in" coil energized.

When the door(s) is closed the relay contacts open, the solenoid de-energizes and allows the seat back locks to return to the lock position. The seat backs also incorporate a manual over-ride release.

### CIRCUIT CHECKING PROCEDURES

#### a. Checking Seat Back Lock Release Relay

1. With test light, check orange-black feed wire at relay without removing connector. If there

is no light, a short or open circuit exists in the feed wire.

**NOTE:** Insert test prod from harness side of connector.

2. Check yellow wire at relay. If no light, replace relay.

#### b. Checking Door Jamb Switches

1. Insert jumper wire into yellow wire socket and ground. If a "click" is heard, check jamb wiring and connections.

**NOTE:** "Click" sound at relay indicates energizing of relay.

2. Disconnect yellow wire from affected door jamb switch and ground. If relay "click" is heard, replace switch.

#### c. Checking Seat Solenoid

1. With relay energized, insert test prod into black wire socket in relay connector. If no light, replace relay.
2. Remove seat back panel (refer to Seat Section) and insert prod into solenoid connector. If no light, check for open or short circuit.
3. If lamp lights and solenoid is properly grounded, replace solenoid.

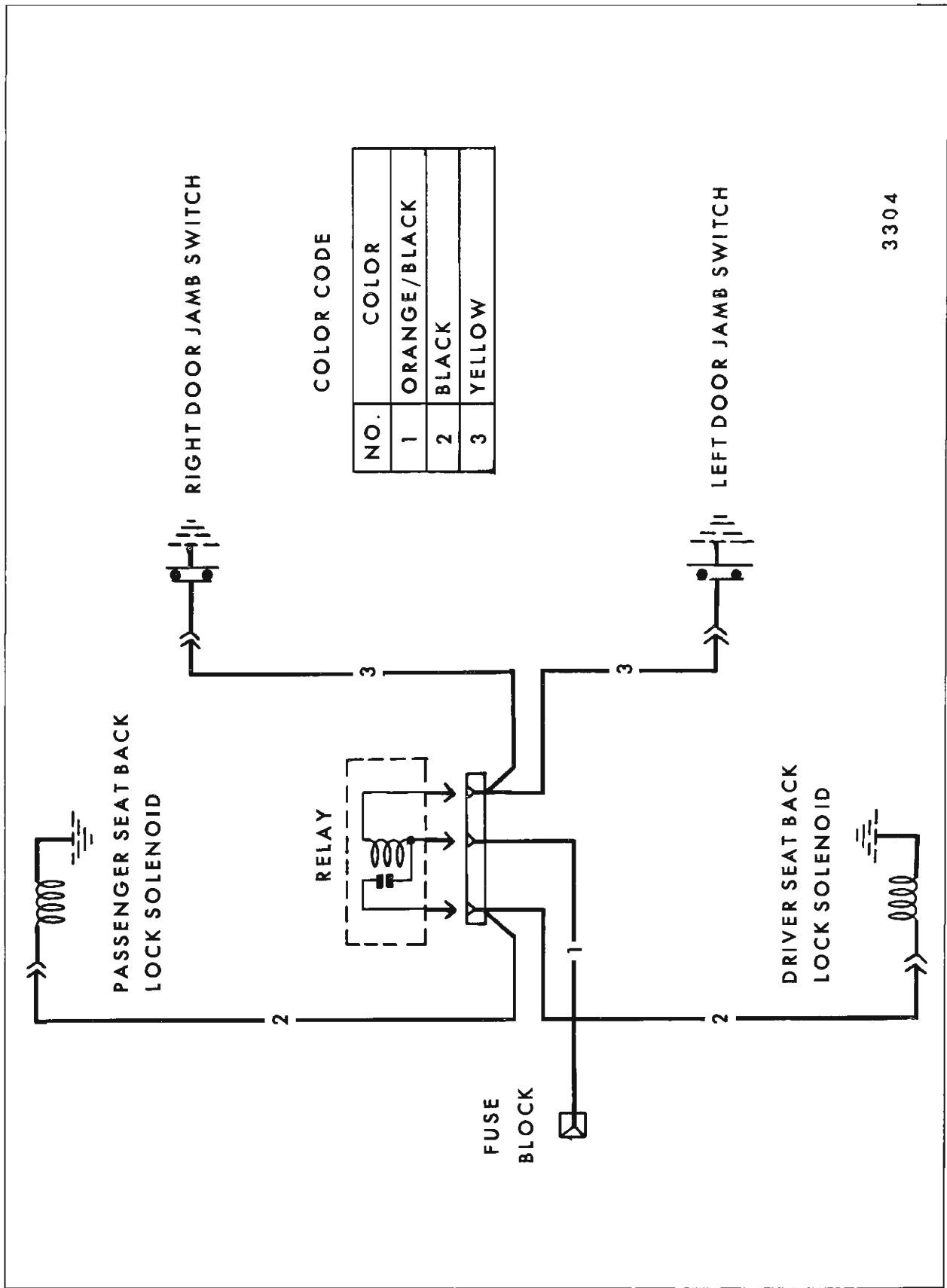

3304

Fig. 16-48—Electric Seat Back Release Wiring Diagram

## ELECTRIC DOOR LOCK

### DESCRIPTION

The optional electric door lock system incorporates a solenoid for each door and a control for each front door. All doors lock and unlock electrically from either front door control and manually from each door in the conventional manner. Each solenoid has an internal circuit breaker which (under extreme conditions) may require up to three minutes to reset.

### CHECKING PROCEDURE

Before beginning electrical checks, be sure system is free of mechanical binds. Refer to Fig. 16-49 for wiring diagram.

#### a. Electric Door Lock System does not Operate:

1. Check output at fuse block.
  - a. Replace fuse if indicated.
2. Remove shroud side trim panel.
3. Check output of power feed at shroud side panel connector.
  - a. Locate and repair any short or open feed wiring.

#### b. System Operates from one Control only:

1. Remove front door trim panel from door with inoperative switch.

2. Check output at switch block feed terminal.
3. Insert jumper from feed to lock (and unlock) position to check for defective switch.
4. Check output at solenoid connector.
  - a. Repair wiring if broken or shorted.
  - b. Check for properly grounded solenoid.
  - c. Replace solenoid if indicated by tests.
5. Remove shroud side trim panel and check connections and wiring.

#### c. Rear Door Lock only, does not Operate in either or both Positions: (Have assistant operate control switch while the following checks are performed).

1. Remove center pillar trim panel.
2. Check output at center pillar connector for lock and unlock positions.
3. Remove rear door trim panel.
4. Check output at solenoid connector (both positions).
  - a. Check solenoid for proper ground.
  - b. Replace solenoid if indicated by tests.

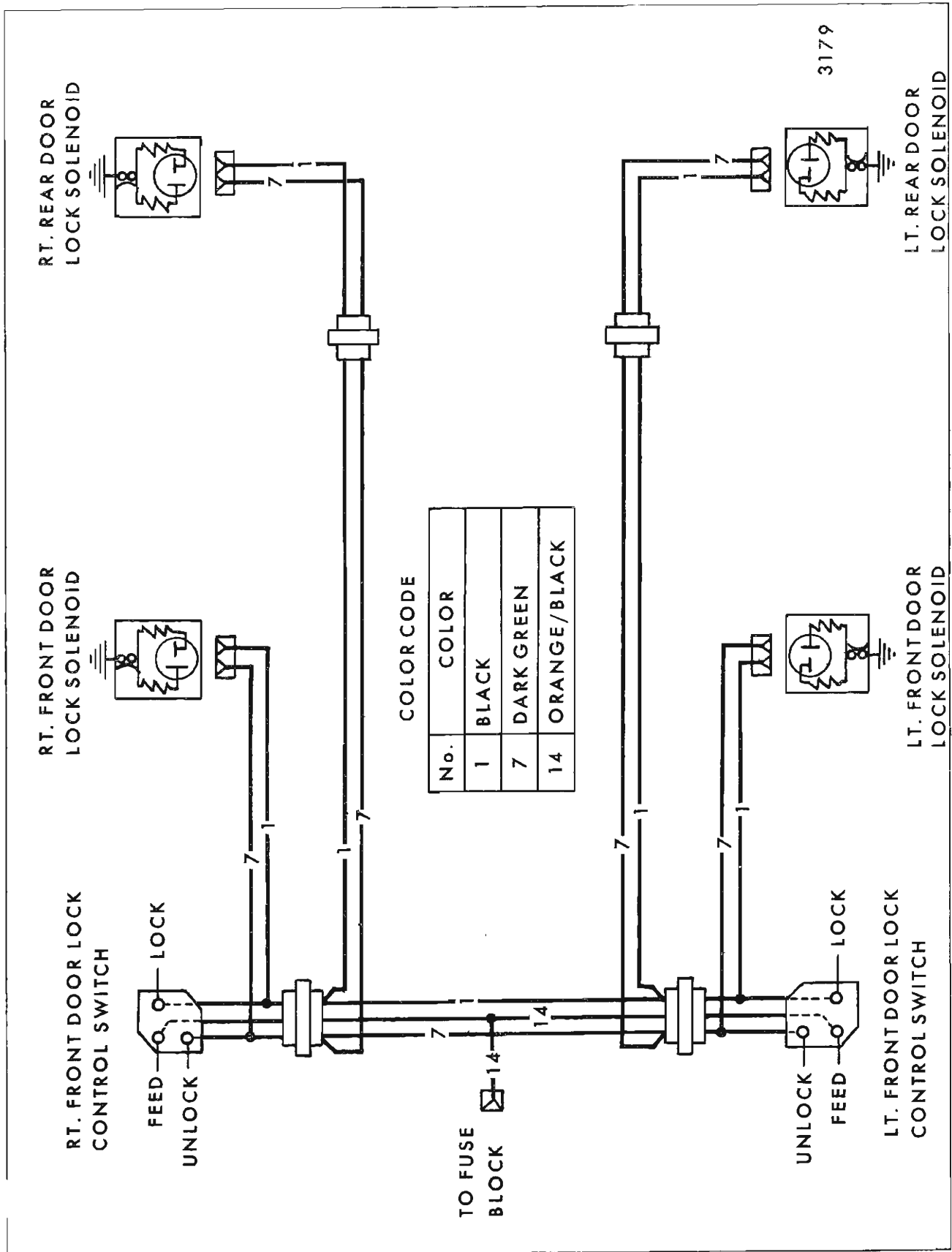
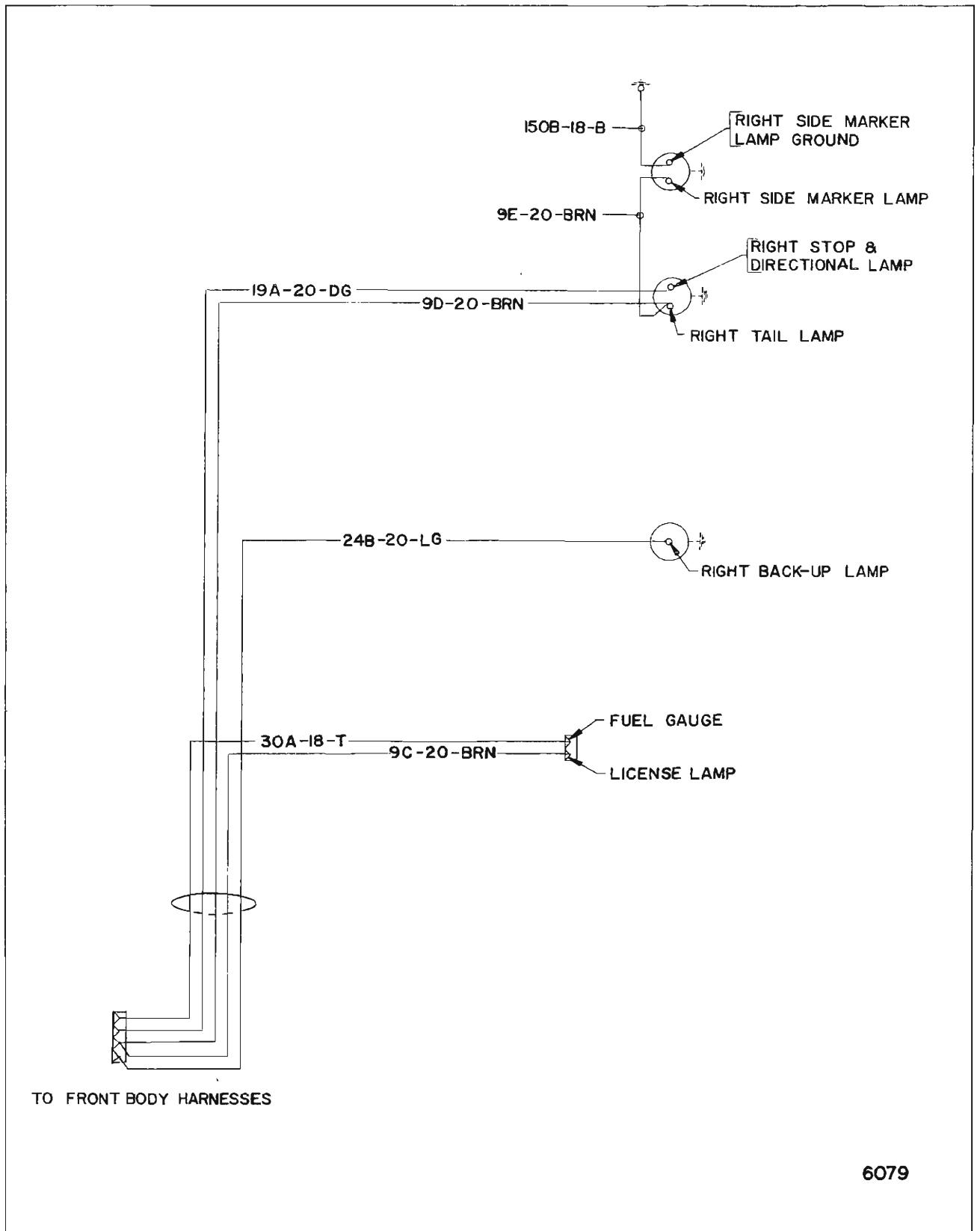

Fig. 16-49—Electric Door Lock Wiring Diagram







6079

Fig. 16-51—Wiring Diagram Rear - Chevrolet "X" Styles

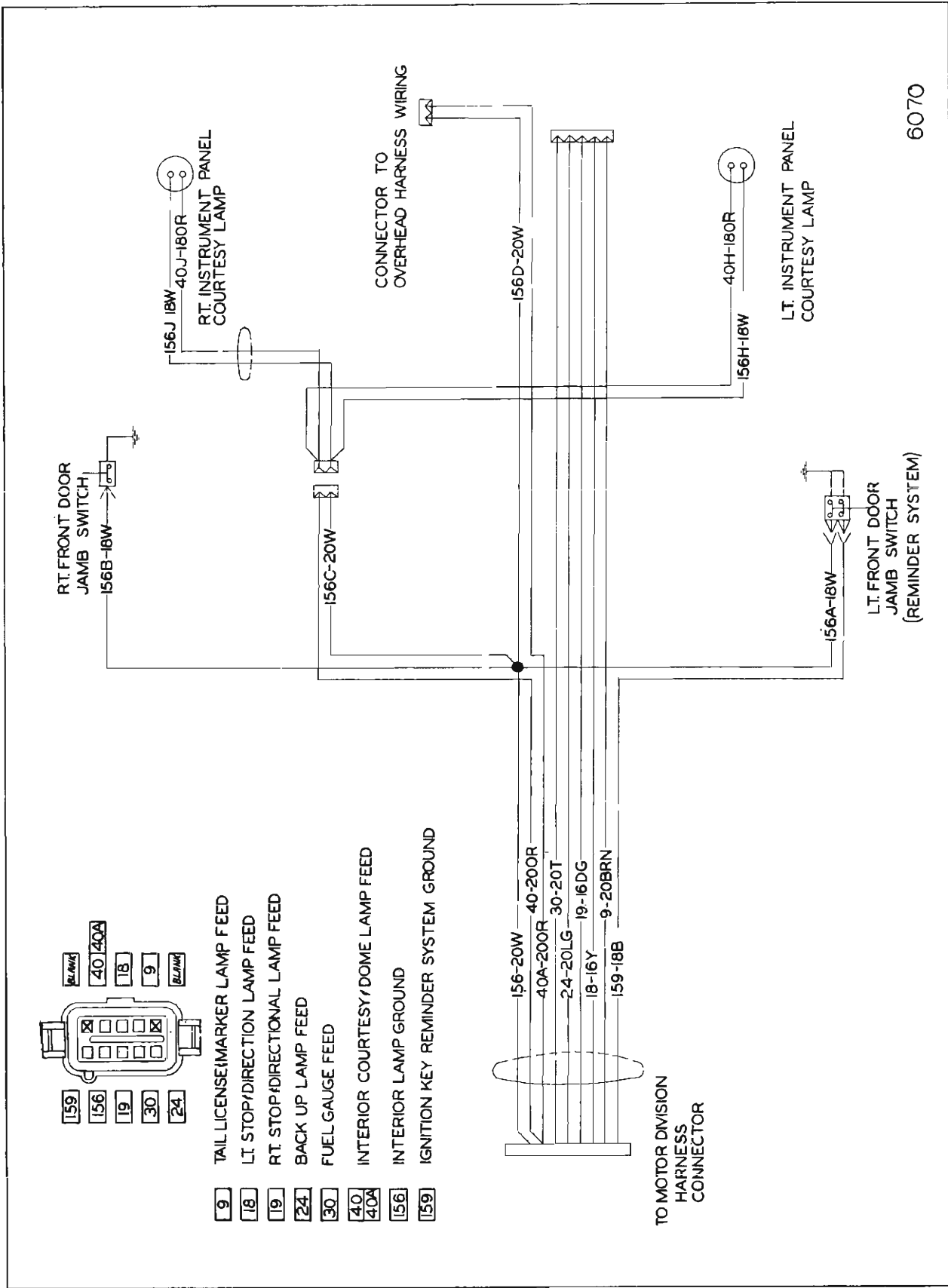
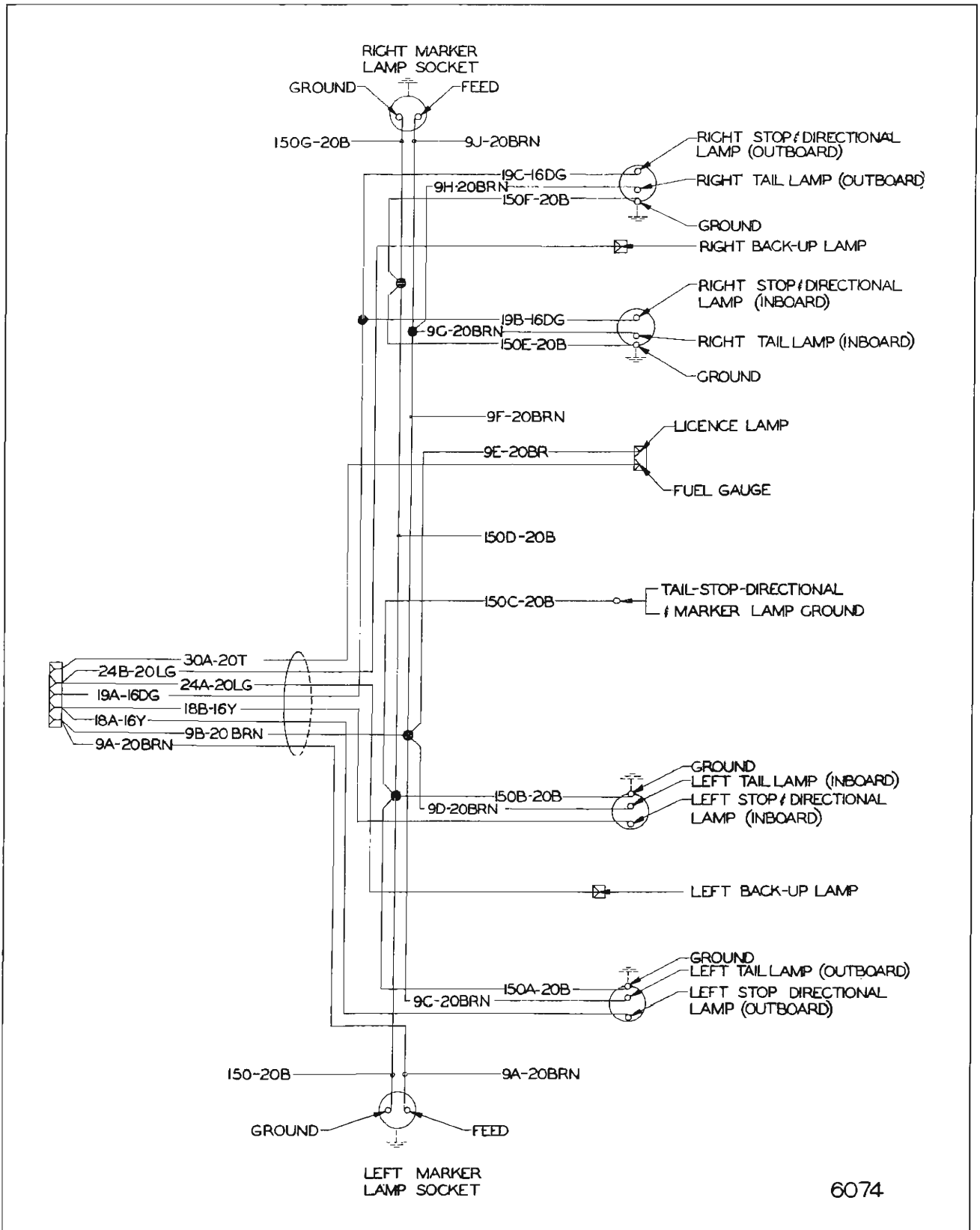
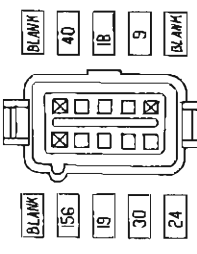
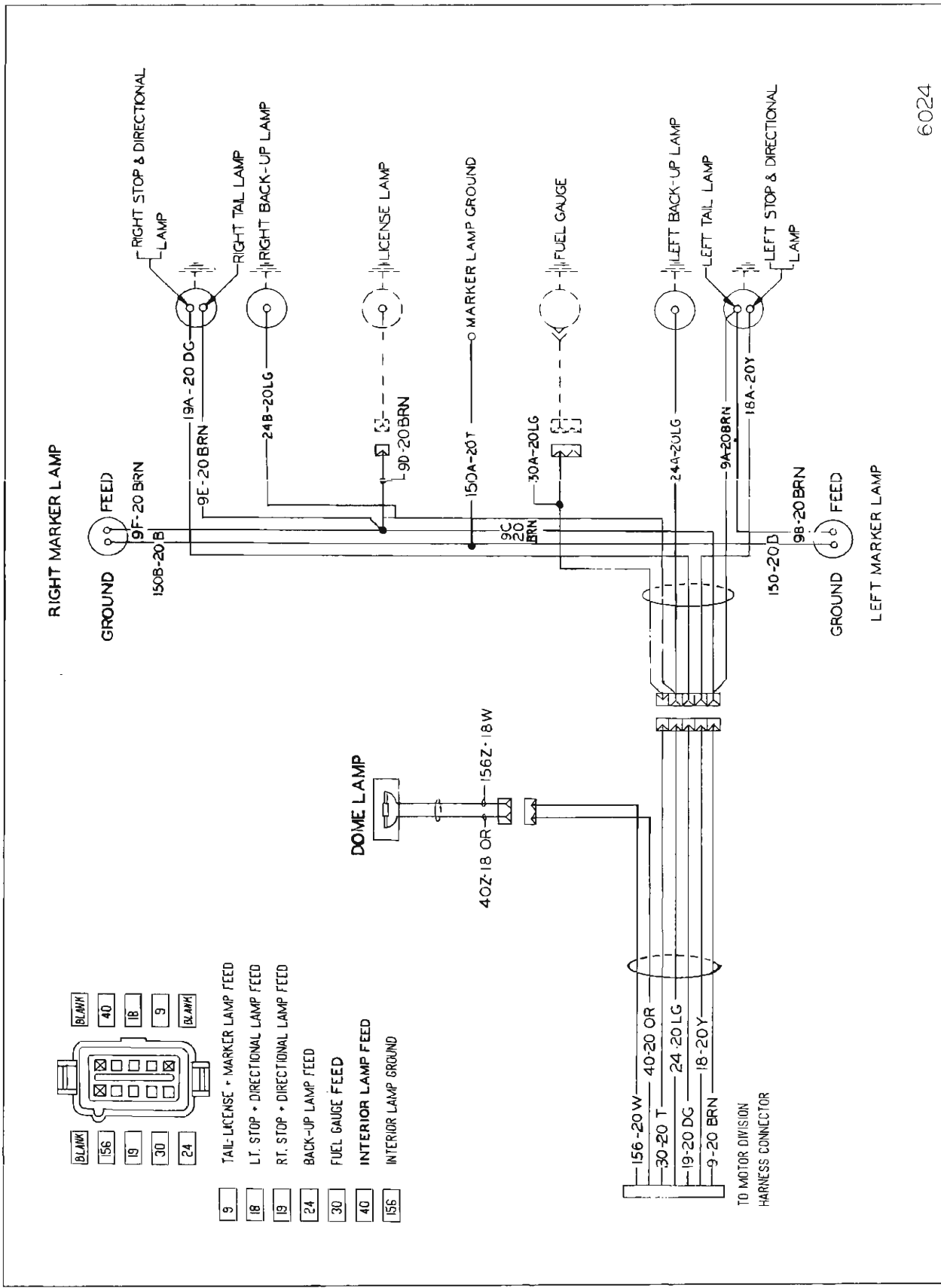

Fig. 16-52—Wiring Diagram Front - Chevrolet "F" Styles



6074

Fig. 16-53—Wiring Diagram Rear - Chevrolet "F" Styles



- 9 TAIL-LICENSE + MARKER LAMP FEED
- 18 LT. STOP + DIRECTIONAL LAMP FEED
- 19 RT. STOP + DIRECTIONAL LAMP FEED
- 24 BACK-UP LAMP FEED
- 30 FUEL GAUGE FEED
- 40 INTERIOR LAMP FEED
- 156 INTERIOR LAMP GROUND

Fig. 16-54—Wiring Diagram - Chevrolet "A" Styles

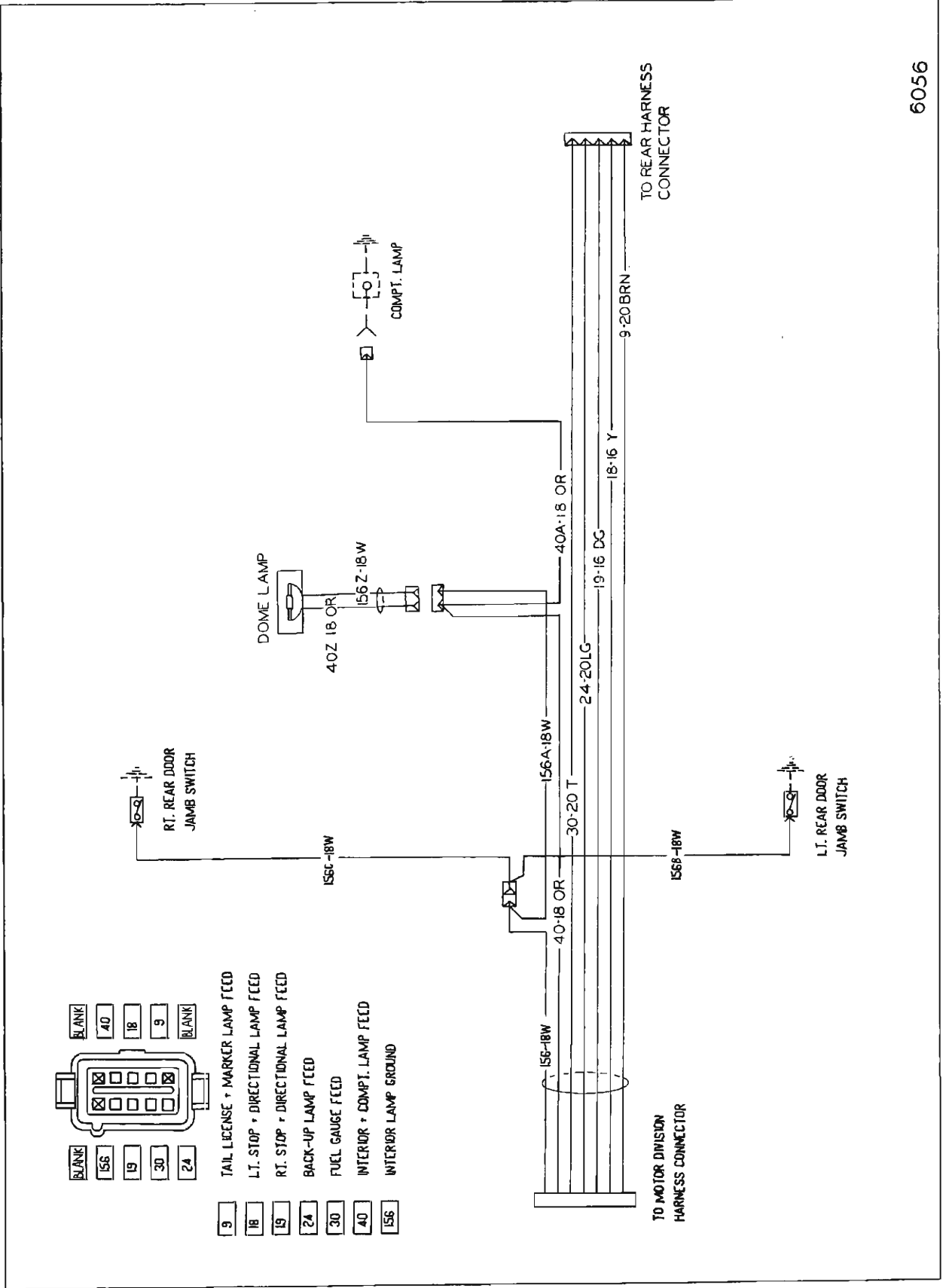

6056

Fig. 16-55—Wiring Diagram Front - Chevrolet "B" Styles

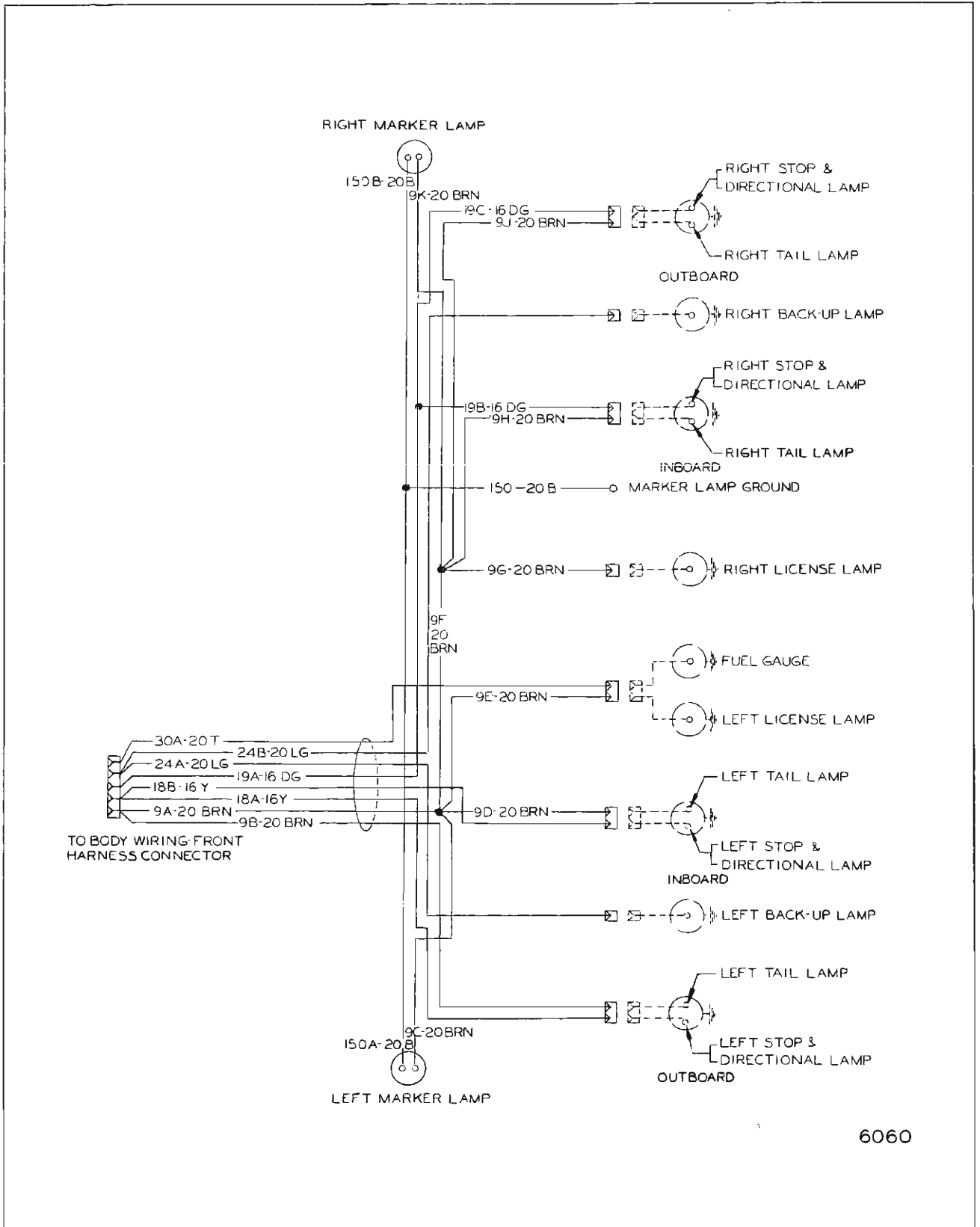
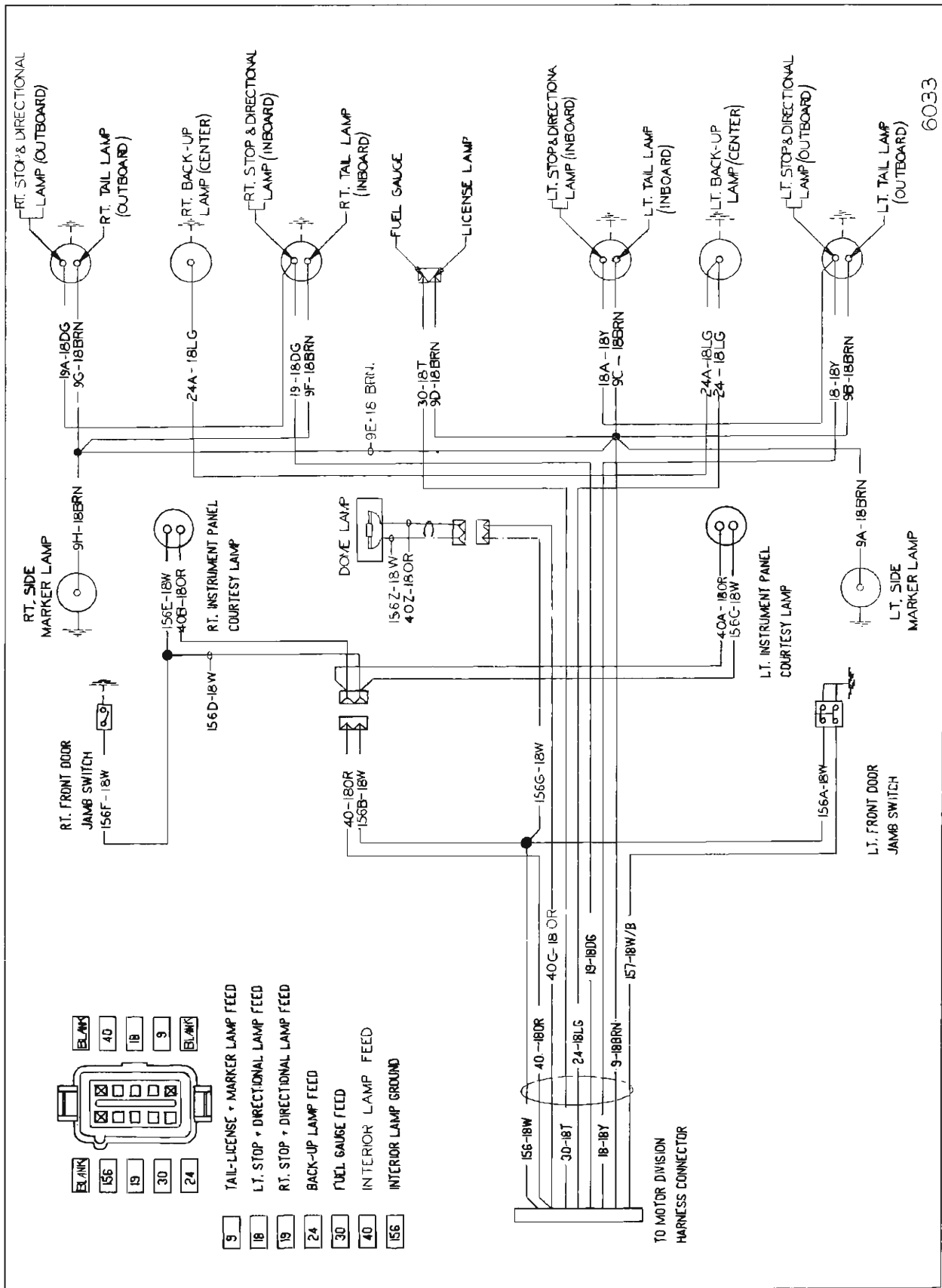
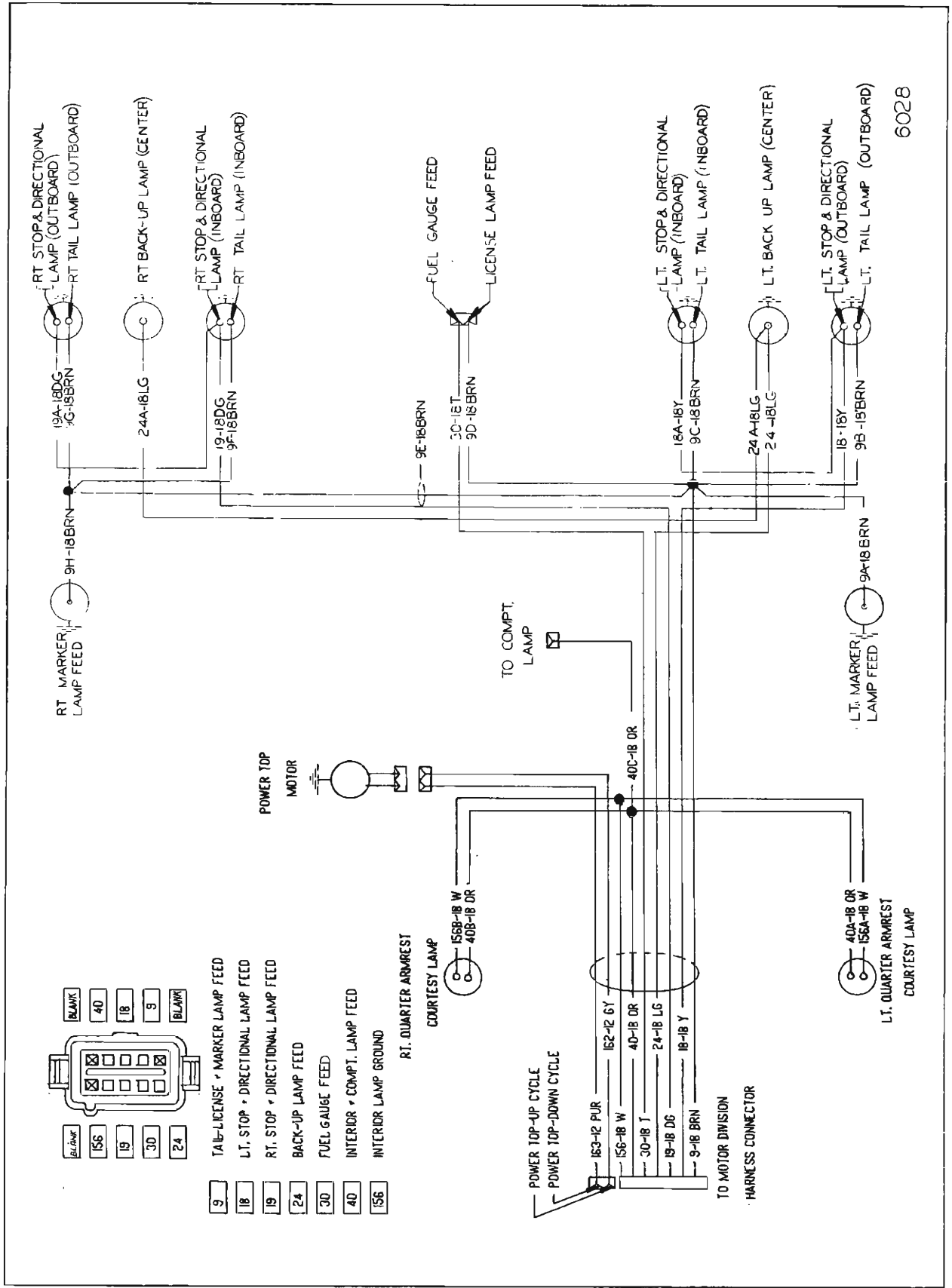

Fig. 16-56—Wiring Diagram Rear - Chevrolet "B" Styles



6033

Fig. 16-57—Wiring Diagram - Pontiac "F" Styles



602B

Fig. 16-58—Wiring Diagram - Pontiac "A" Styles



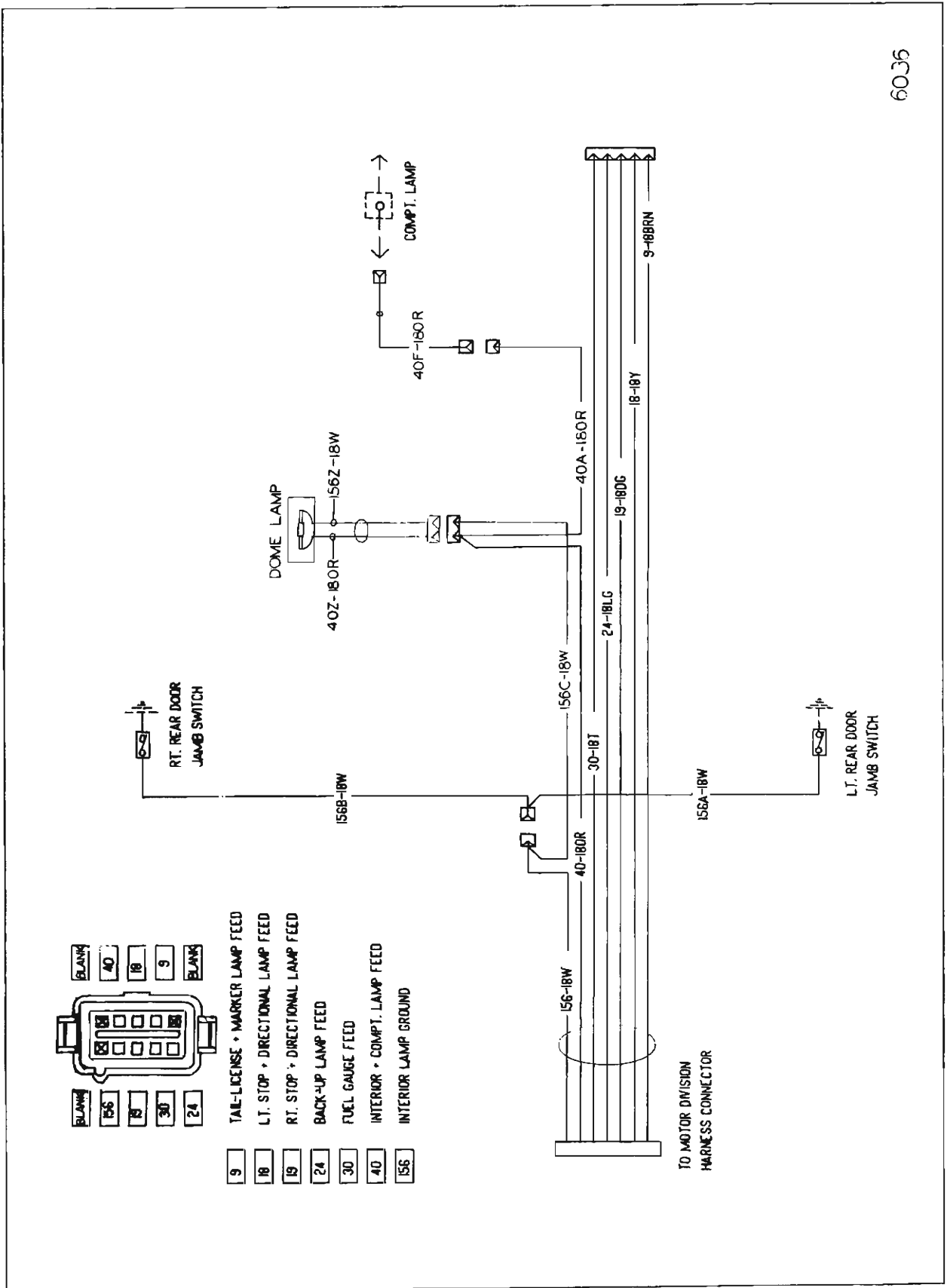

6035

Fig. 16-59—Wiring Diagram Front - Pontiac "B" Styles

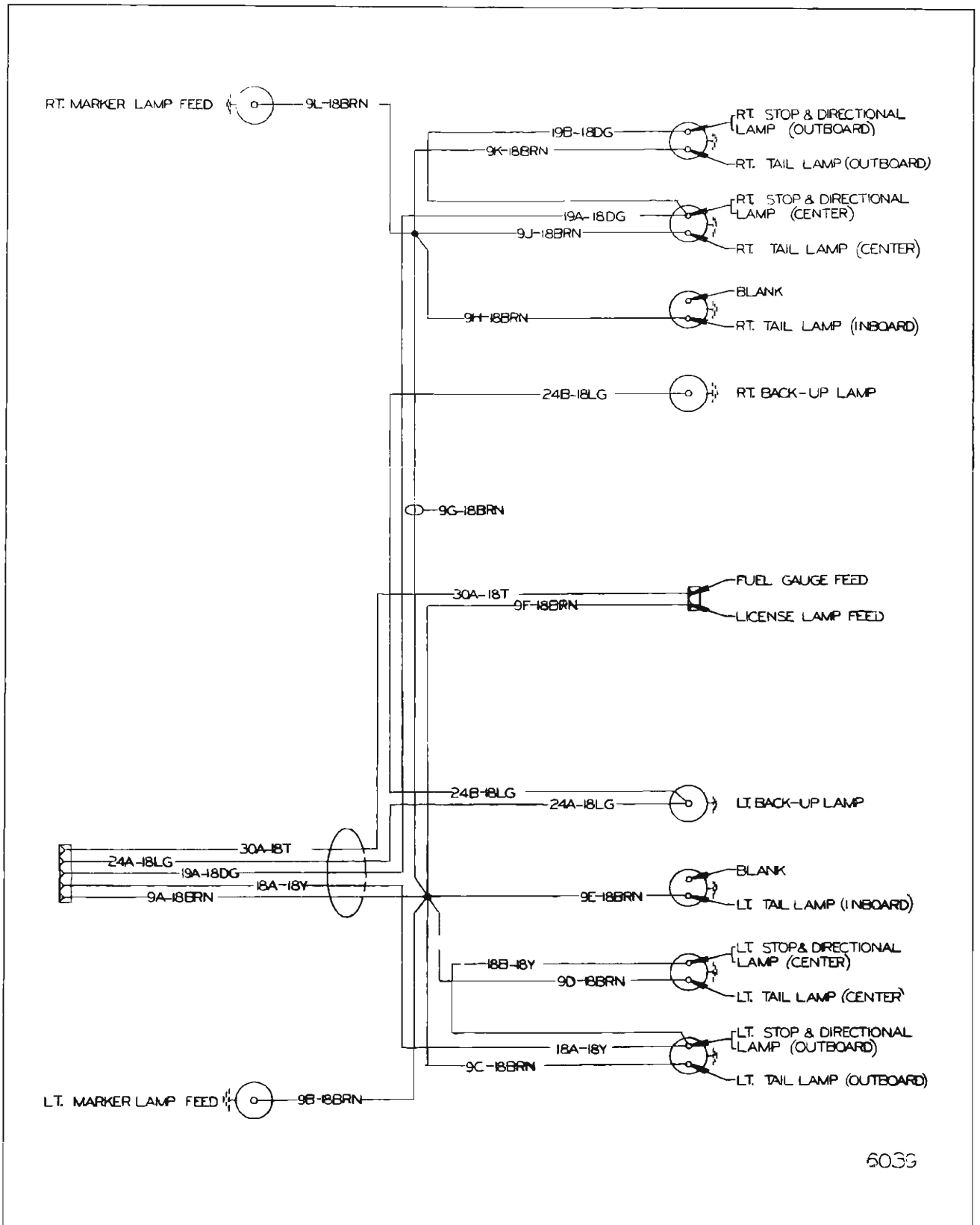

6033

Fig. 16-60—Wiring Diagram Rear - Pontiac "B" Styles

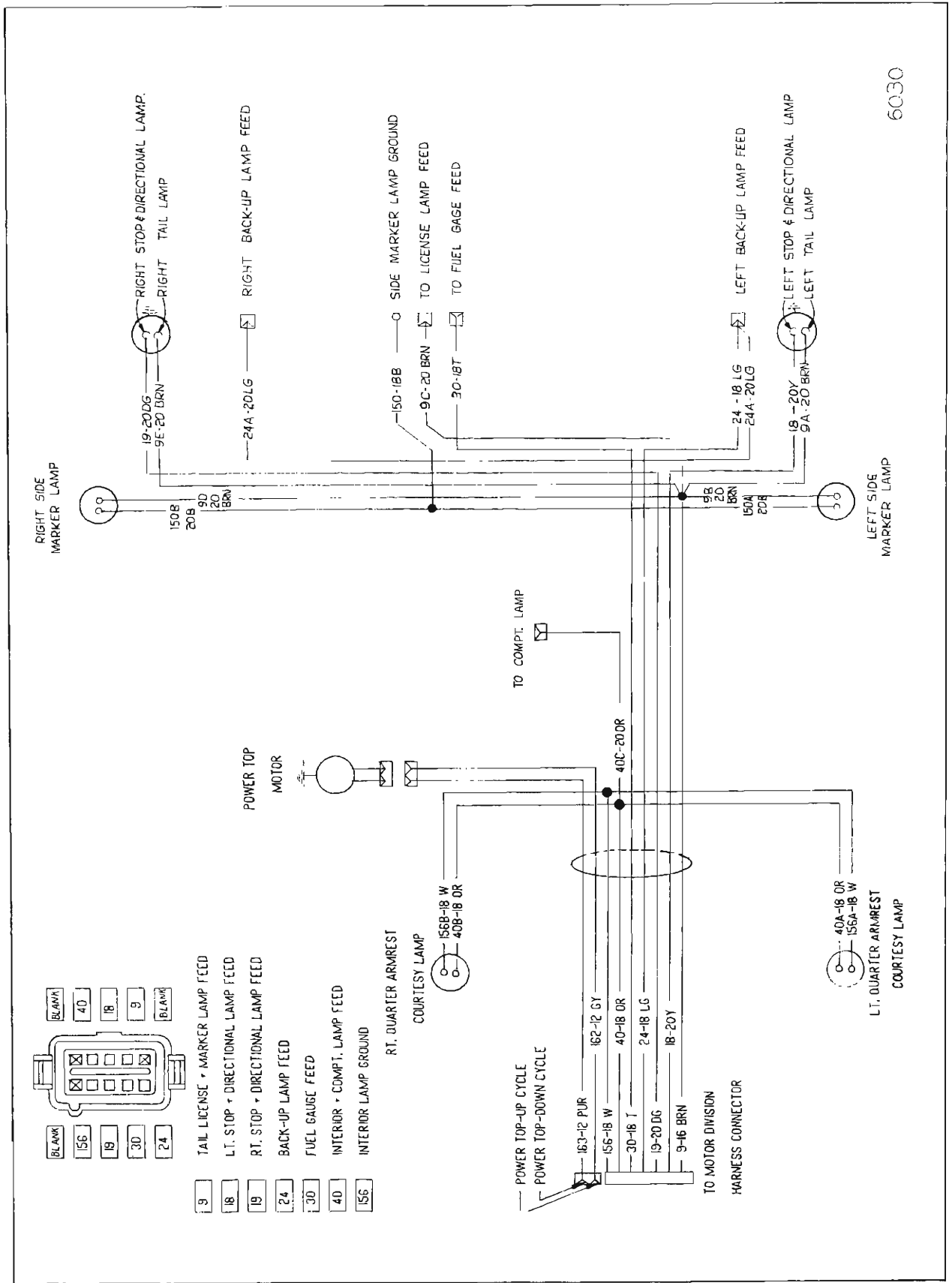

6030

Fig. 16-61—Wiring Diagram - Oldsmobile "A" Styles

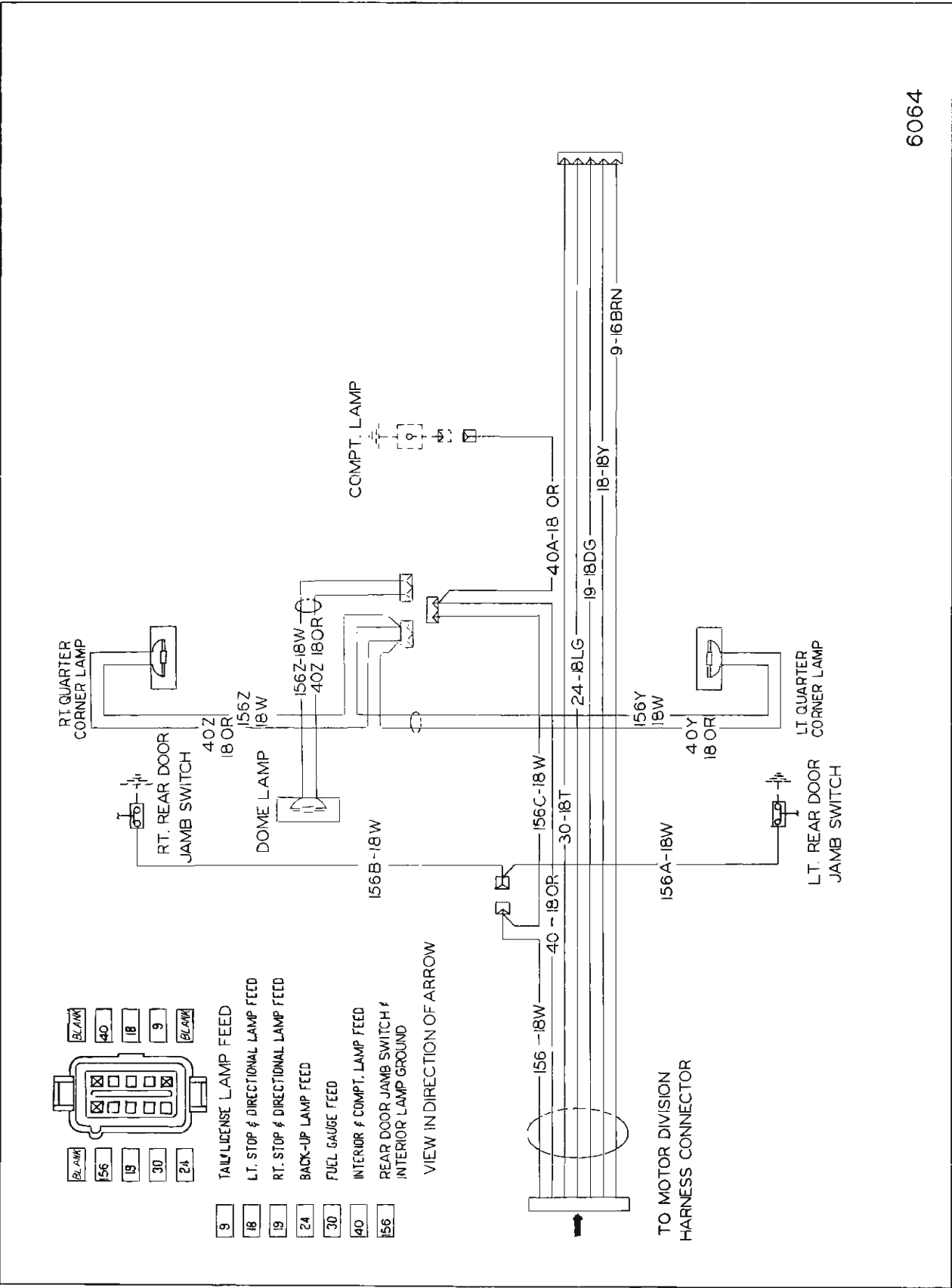

Fig. 16-62—Wiring Diagram Front - Oldsmobile "B" Styles

6099

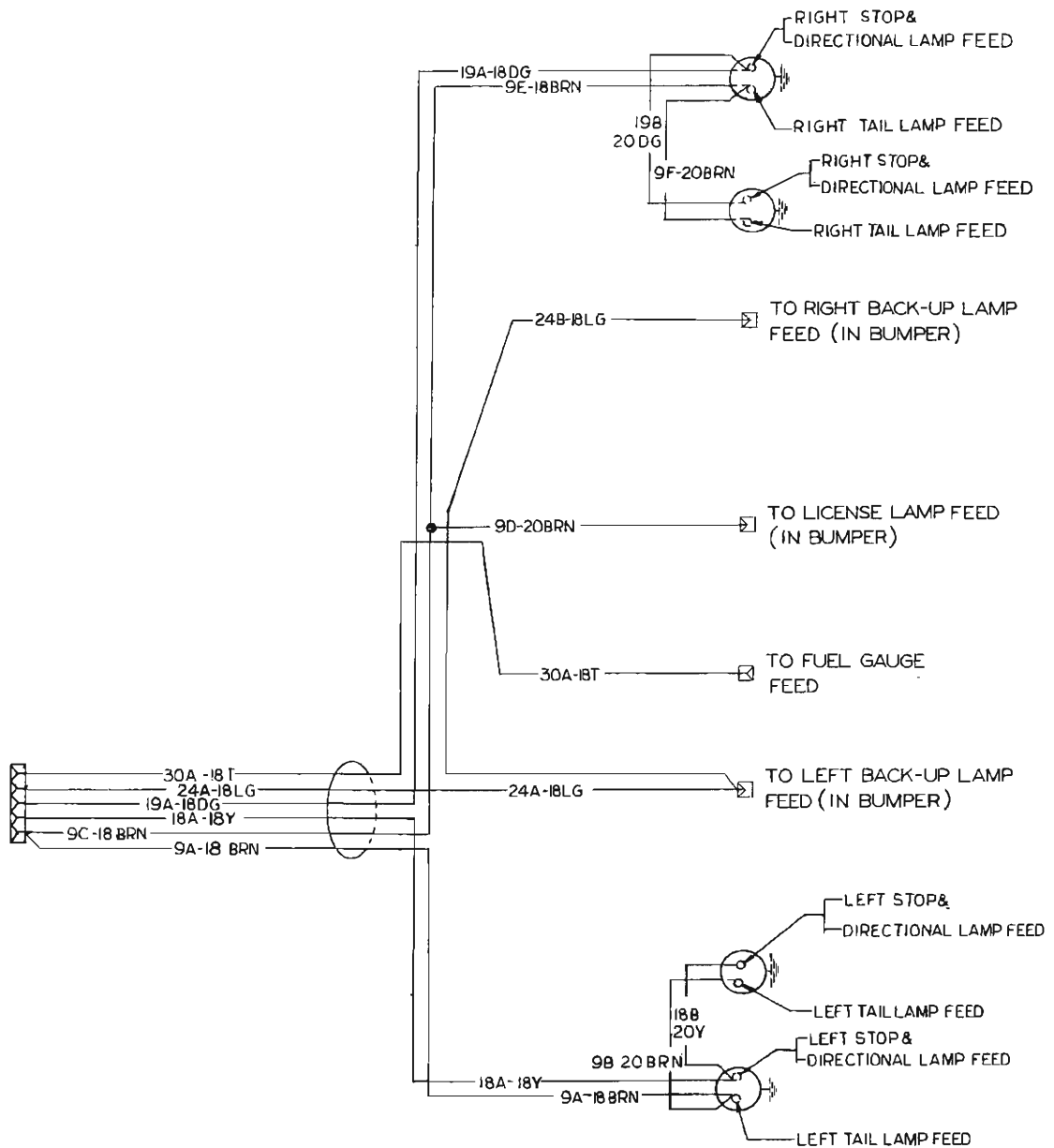

Fig. 16-63—Wiring Diagram Rear - Oldsmobile "B" Styles

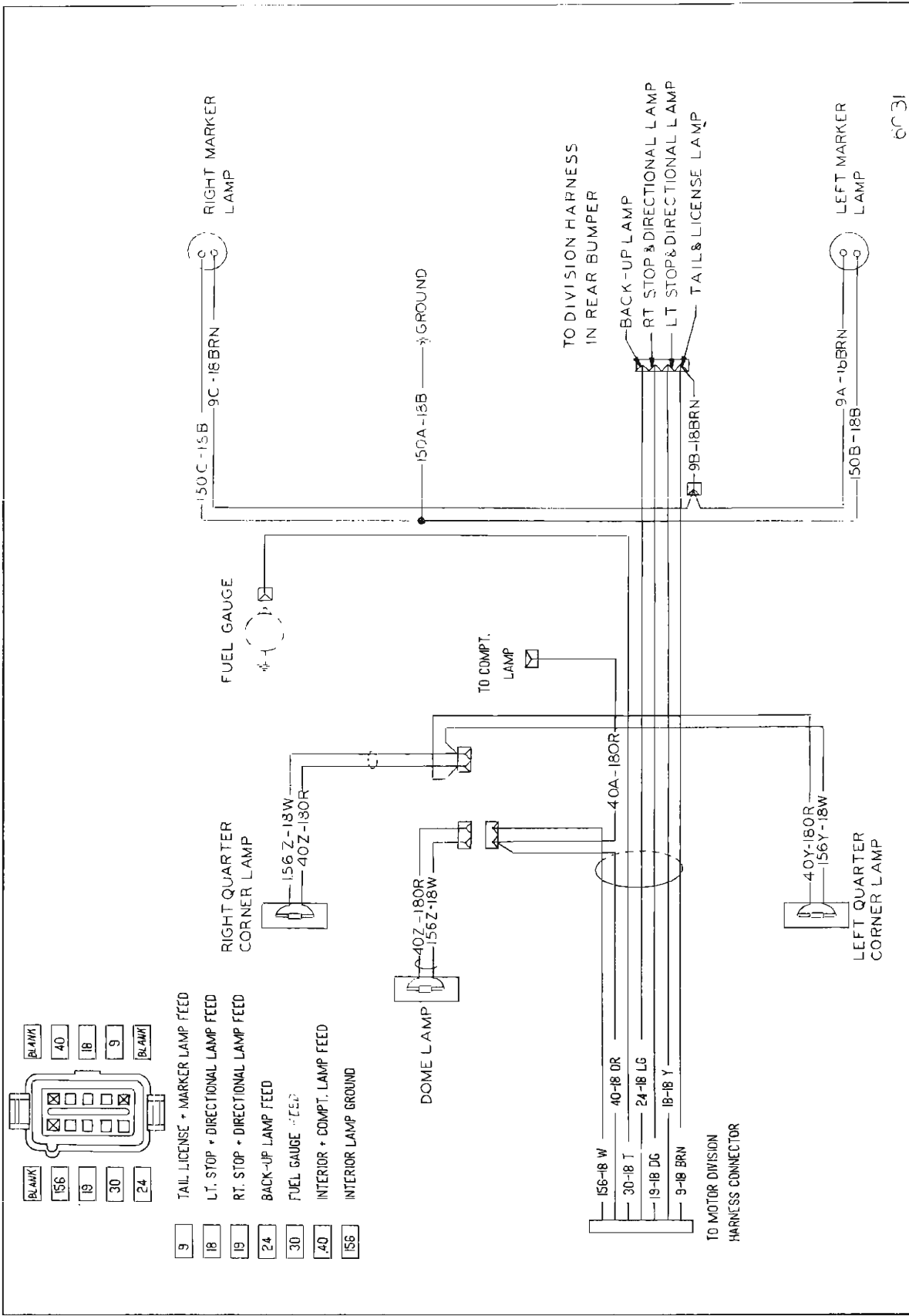

Fig. 16-64—Wiring Diagram - Buick "A" Styles

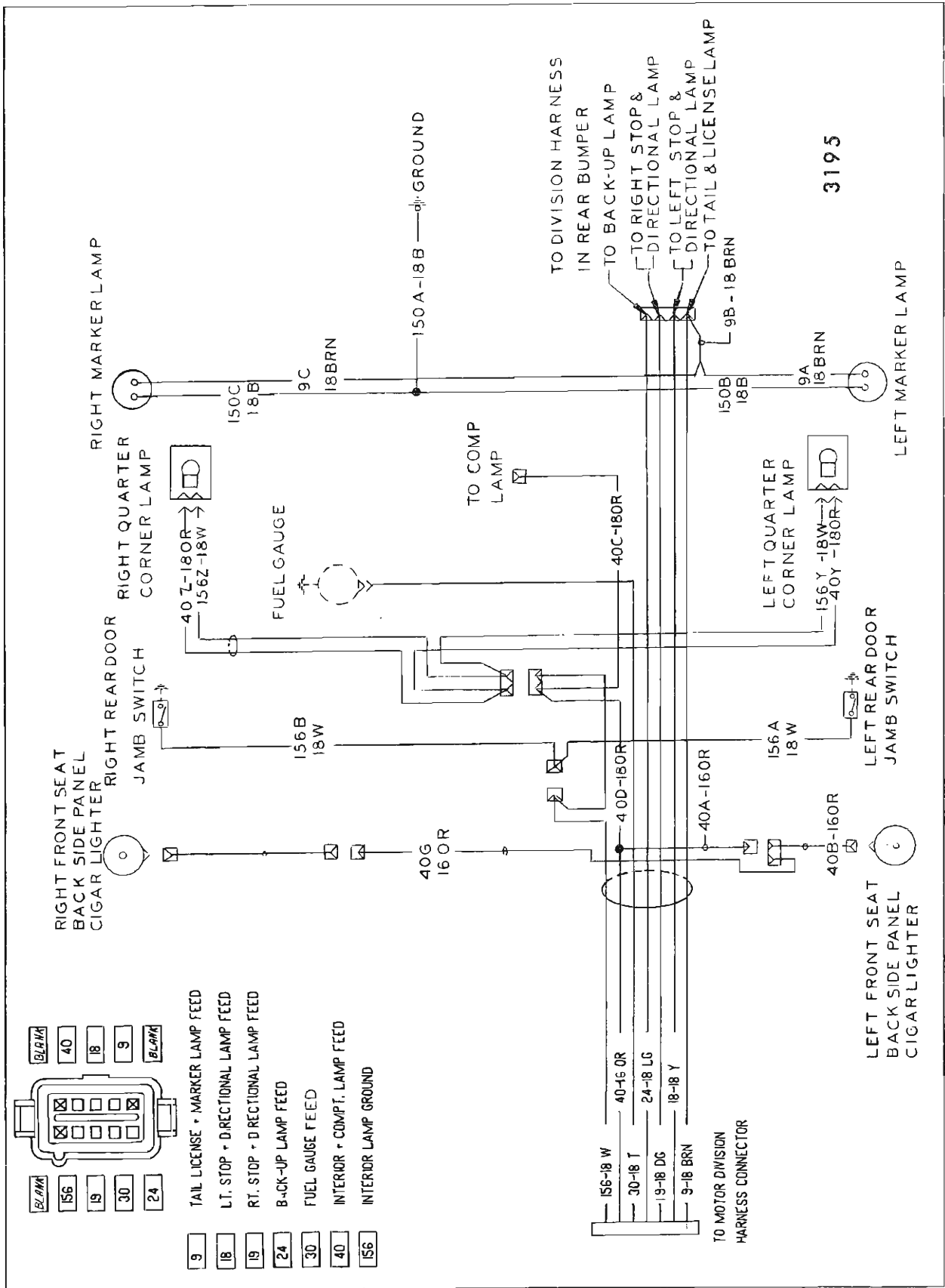

Fig. 16-65—Wiring Diagram - Buick "B" Styles

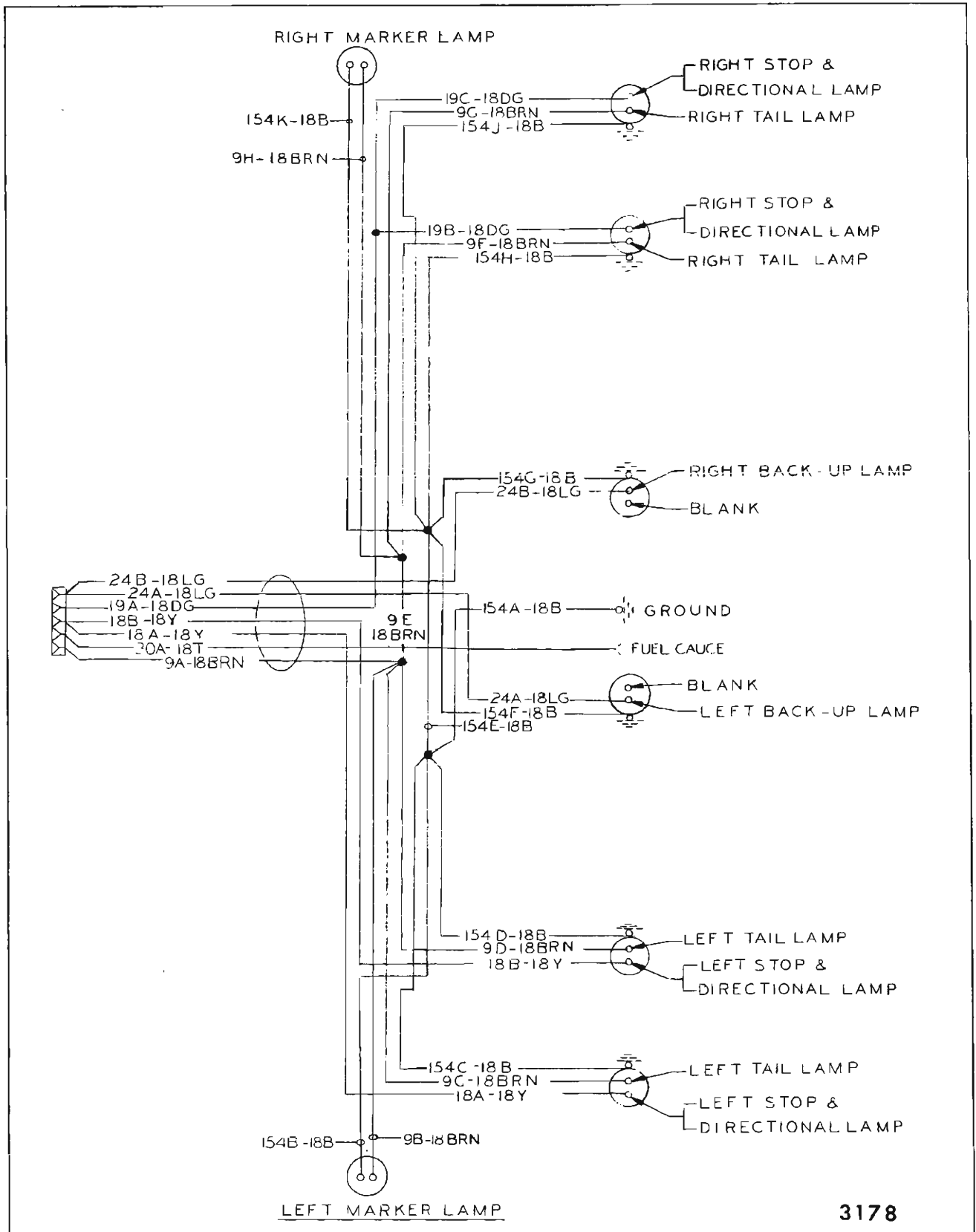
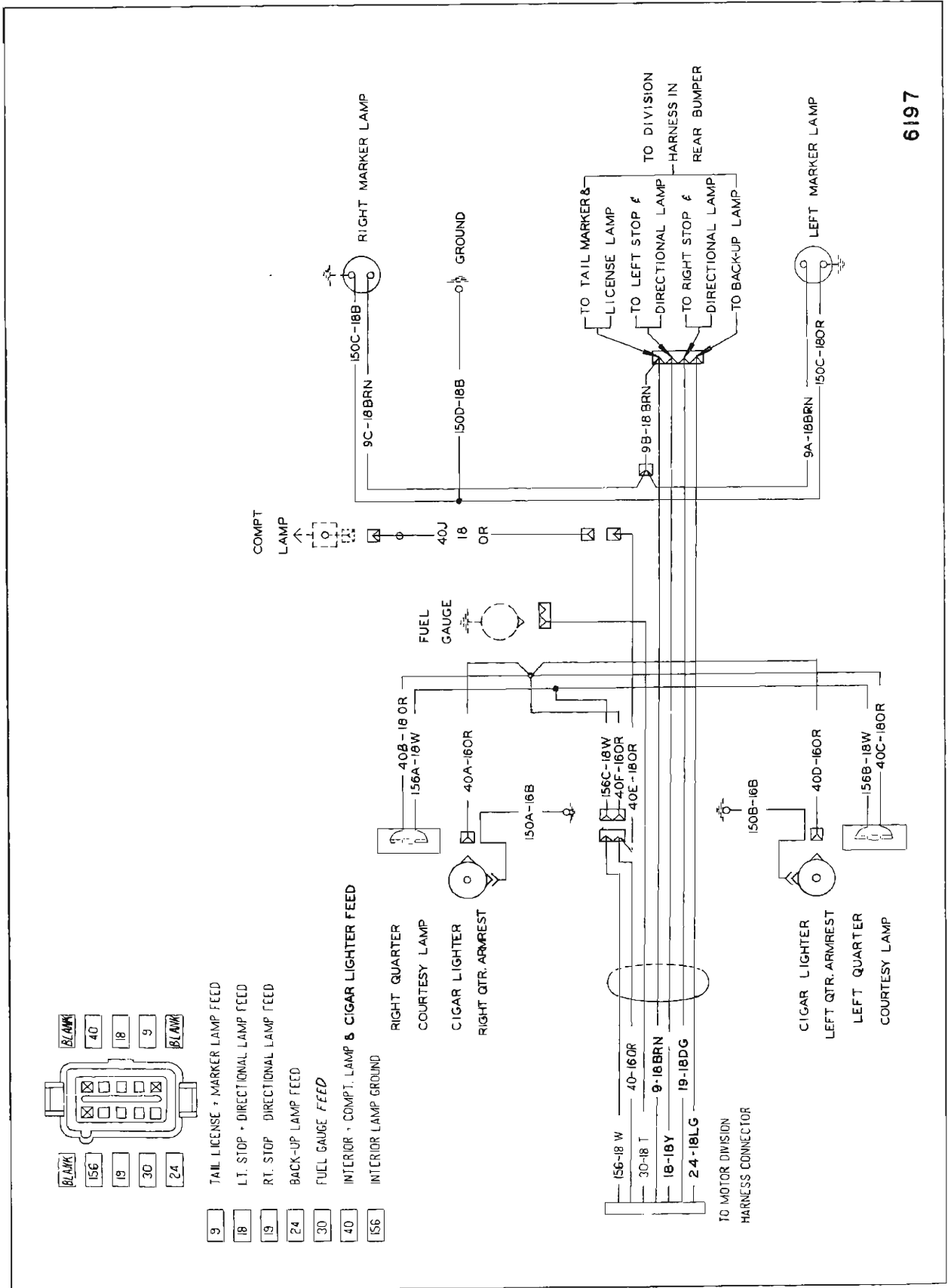

Fig. 16-66—Wiring Diagram Rear - Buick "C" Styles





6197

Fig. 16-67—Wiring Diagram - Buick "E" Styles

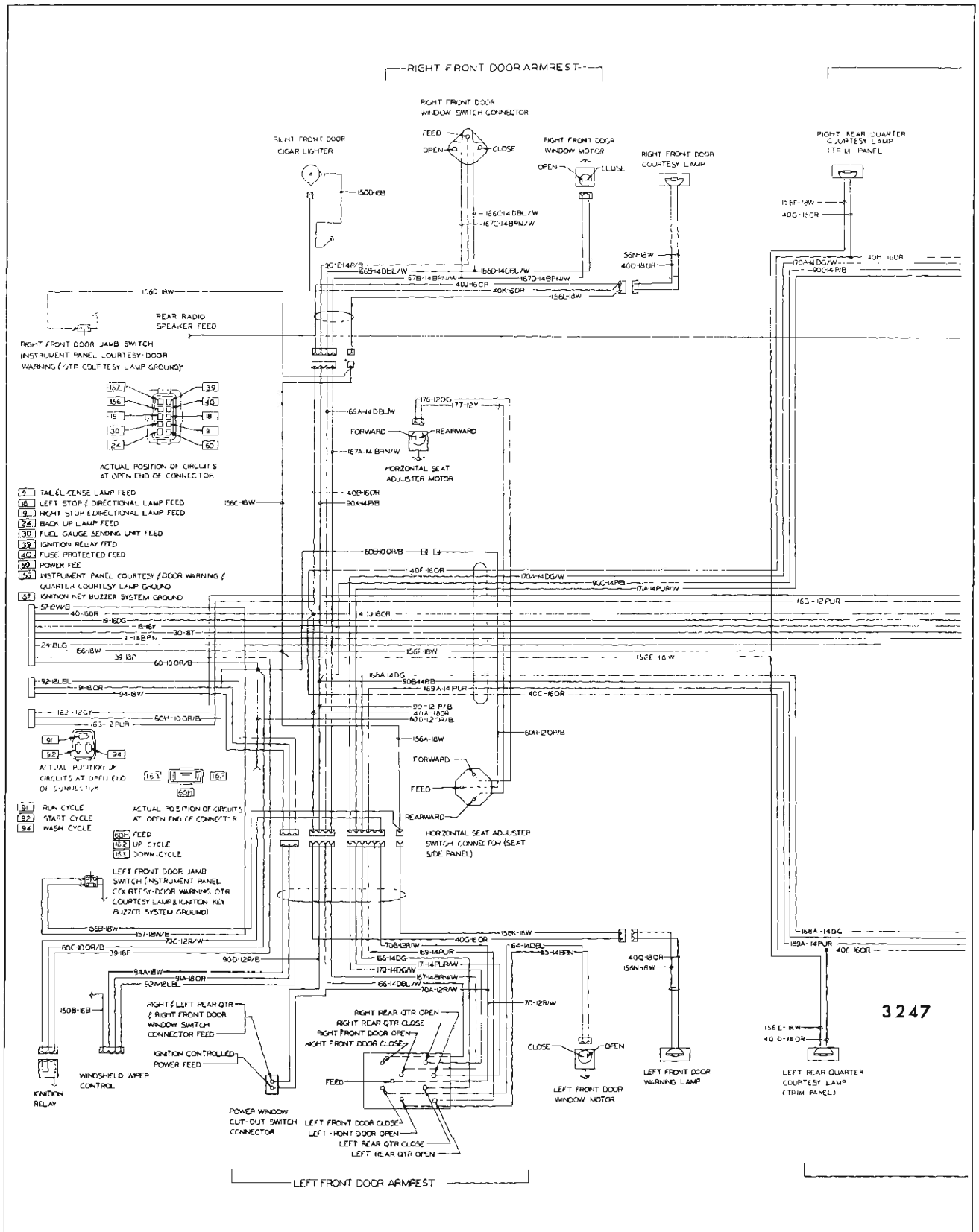

3247

Fig. 16-68—Wiring Diagram - Cadillac "C-67" Styles

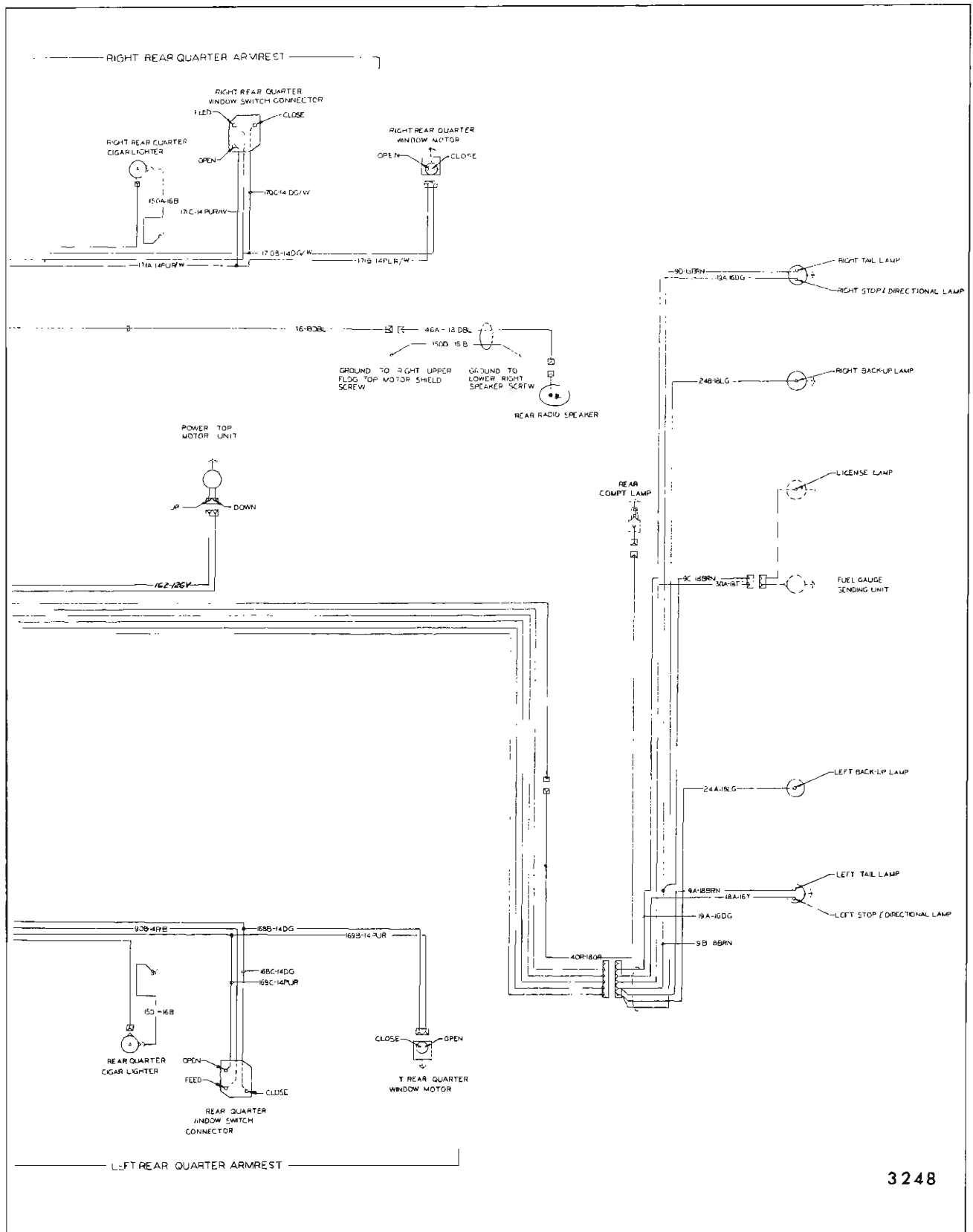
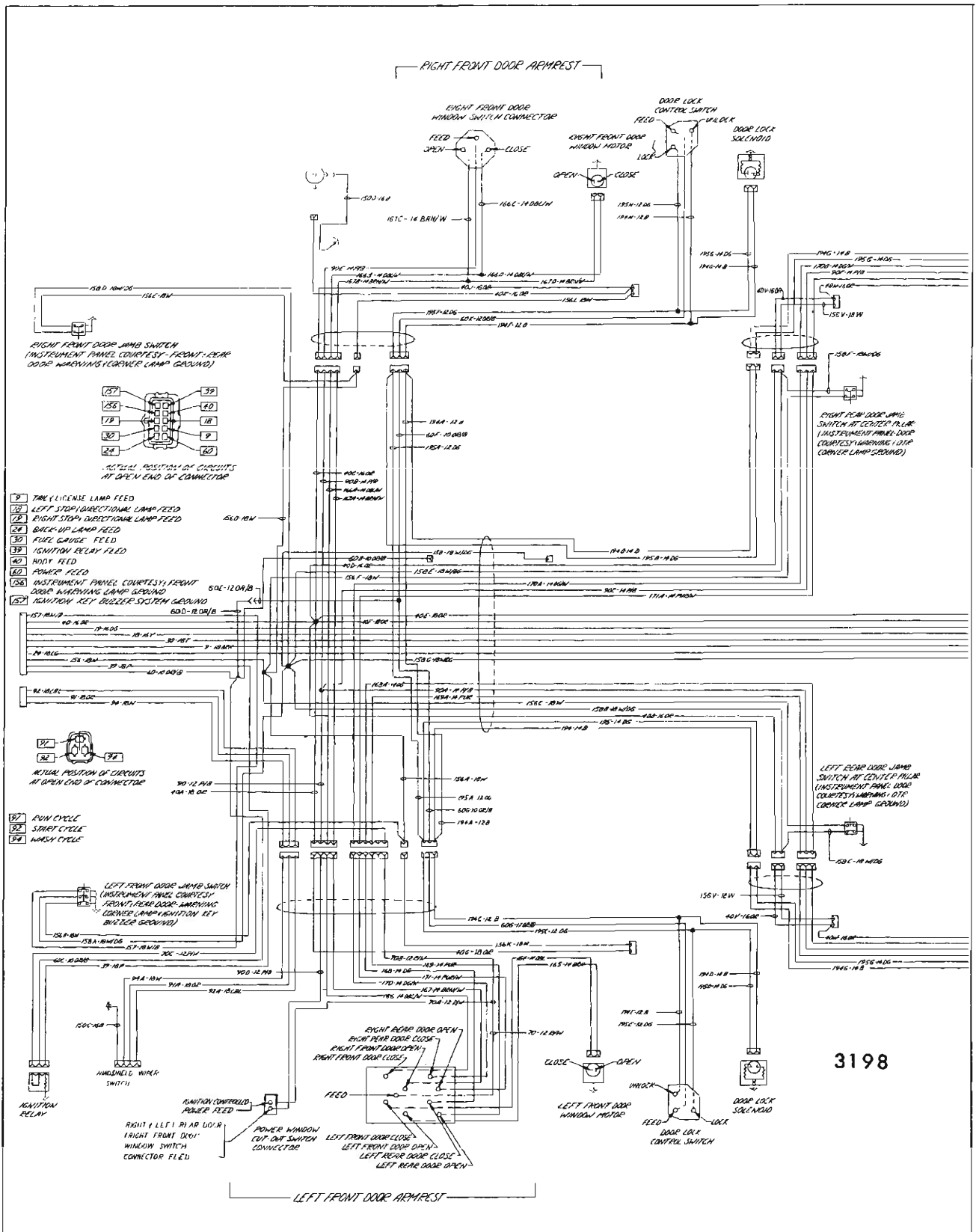
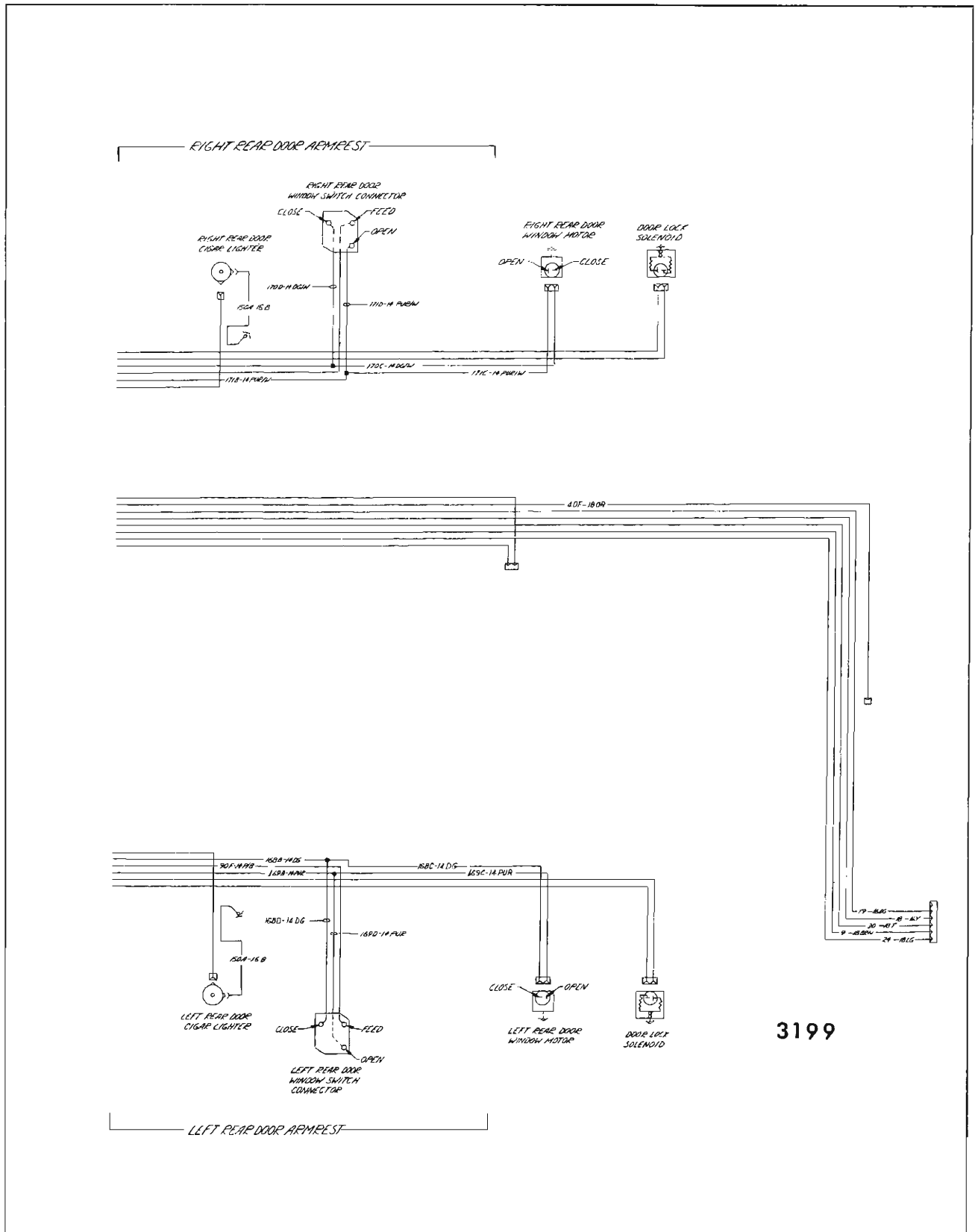

Fig. 16-69—Wiring Diagram - Cadillac "C-67" Styles



3198

Fig. 16-70—Wiring Diagram - Cadillac "68069" Style



3199

Fig. 16-71—Wiring Diagram - Cadillac "68069" Style

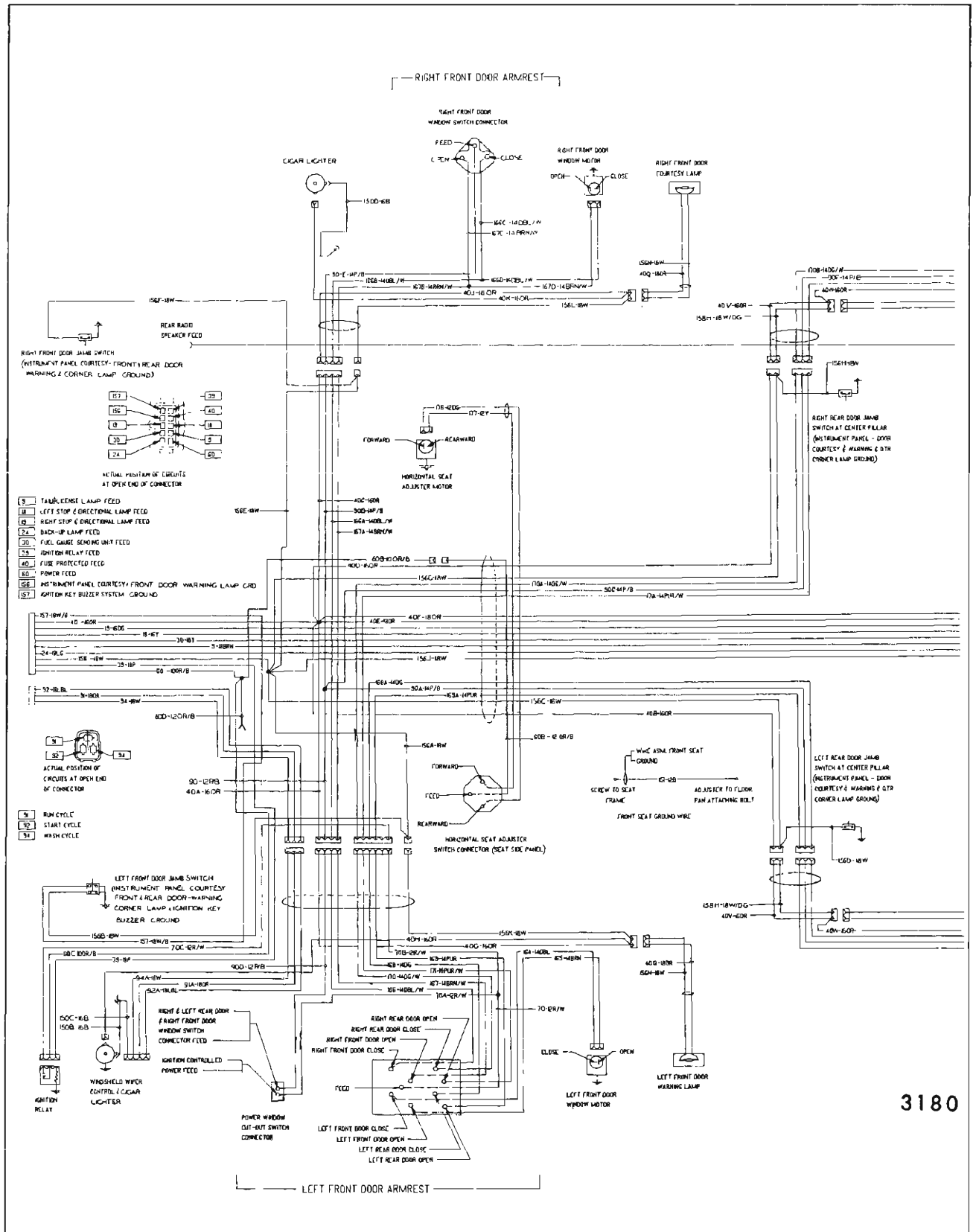

3180

Fig. 16-72—Wiring Diagram - Cadillac "68169" Style









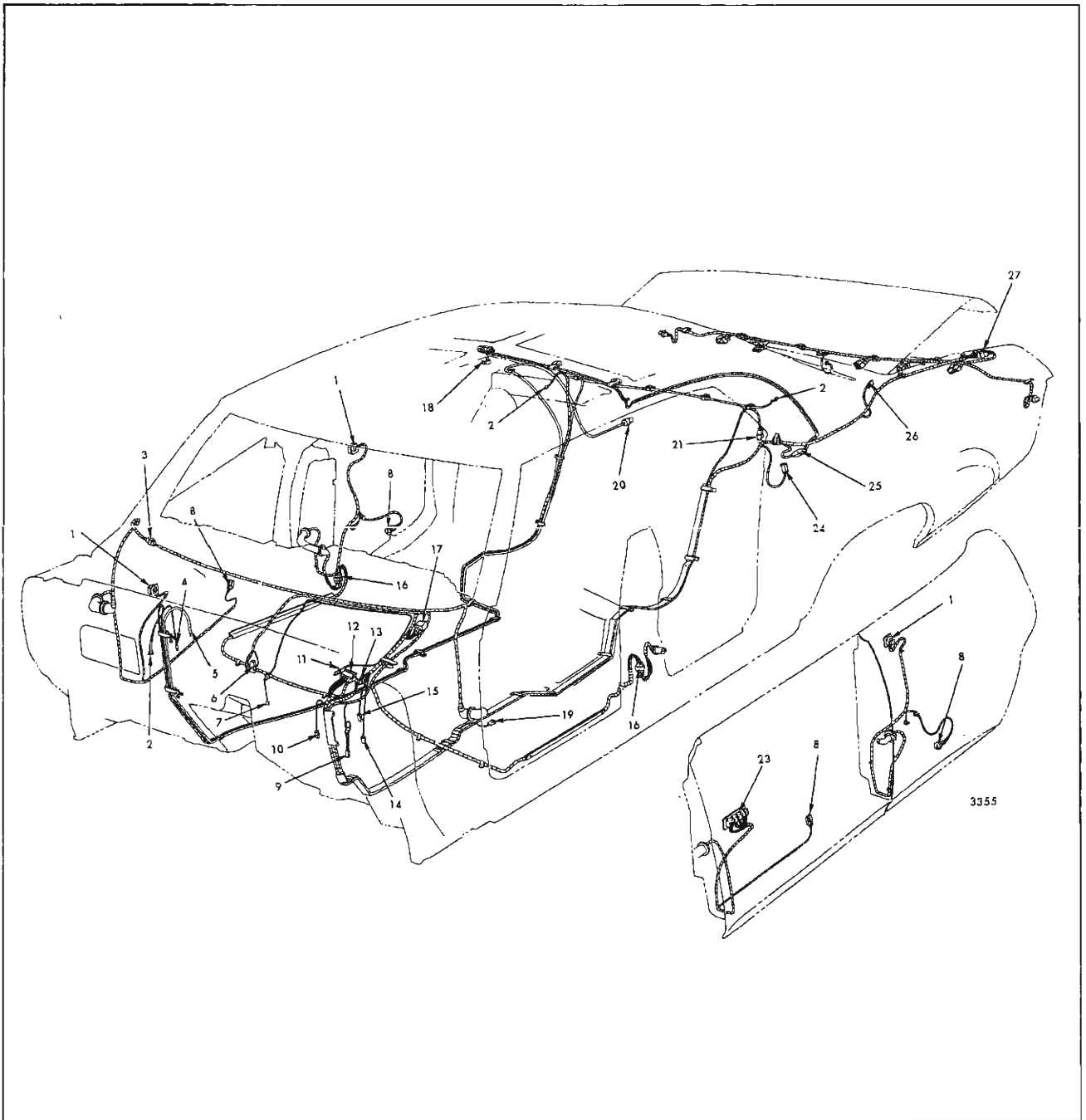

Fig. 16-76—Chevrolet "B-39" Body Wire Routing (Typical)

- |                                       |   |                                     |
|---------------------------------------|---|-------------------------------------|
| 1. Window Control Switch              | 11. Power Feed from Circuit Breaker     | 18. Dome Lamp Connection            |
| 2. Stereo Speaker Leads               | 12. Main Body Harness Connector         | 19. Power Seat Feed                 |
| 3. Right Front Door Harness Connector | 13. Rear Power Window Harness Connector | 20. Antenna Lead                    |
| 4. Rear Speaker Lead                  | 14. Ignition Terminal on Fuse Block     | 21. Power Antenna Connector         |
| 5. Antenna Lead                       | 15. Power Feed to Front Harness         | 23. Master Window Control Switches  |
| 6. Rear Defogger Switch Connector     | 16. Center Pillar Connector             | 24. Rear Defogger Connector         |
| 7. Circuit Breaker Connection         | 17. Ignition Relay                      | 25. Dome Lamp Connector             |
| 8. Window Motor Connector             |   | 26. Rear Compartment Lamp Connector |
| 9. Defogger Feed Connector            |   | 27. Front to Rear Harness Connector |
| 10. Fuse Block Connector              |   |                                     |

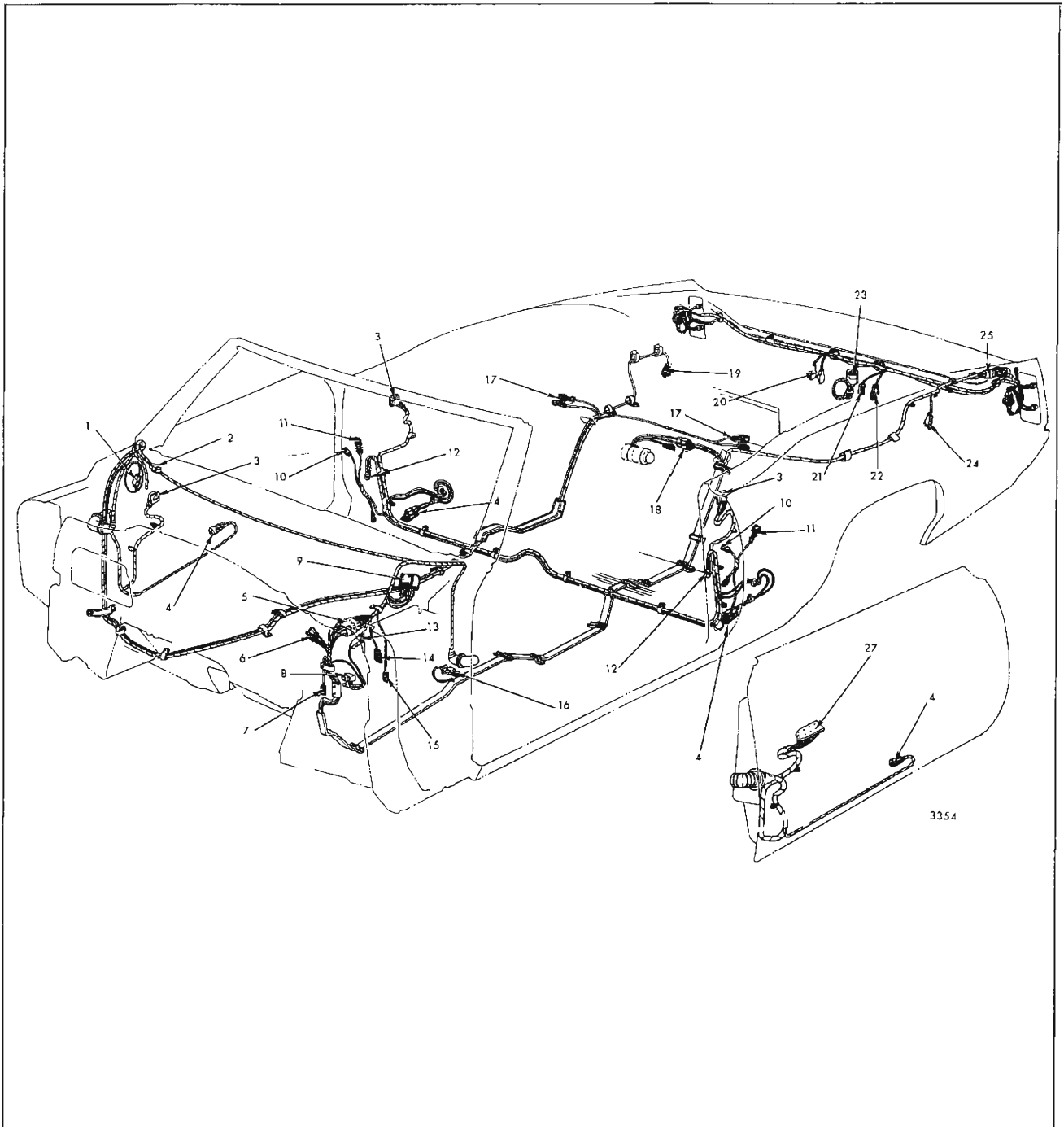

Fig. 16-77—Oldsmobile "B-67" Body Wire Routing (Typical)

- |                                     |                                  |                                     |   |
|-------------------------------------|----------------------------------|-------------------------------------|---|
| 1. Rear or Stereo Speaker Connector | 8. Circuit Breaker               | 14. Power Feed to Front Harness     | 20. License Lamp and Right Back-up Lamp Connector |
| 2. Cross-Over Harness Connector     | 9. Ignition Relay                | 15. Ignition Terminal on Fuse Block | 21. Fuel Gauge Feed                               |
| 3. Window Control Switch            | 10. Quarter Cigar Lighter Feed   | 16. Power Seat Feed                 | 22. Left Back-Up Lamp Connector                   |
| 4. Window Motor Connector           | 11. Quarter Cigar Lighter Ground | 17. Stereo Speaker Leads            | 23. Trailer Adapter                               |
| 5. Main Body Harness Connector      | 12. Quarter Courtesy Lamp        | 18. Power Top Motor Connector       | 24. Rear Compartment Lamp                         |
| 6. Power Top Connector              | 13. Power Feed to Ignition Relay | 19. Power Antenna Feed              | 25. Front to Rear Harness Connector               |
| 7. Harness Fuse Block Connector     |                                  |                                     | 27. Master Window Control                         |

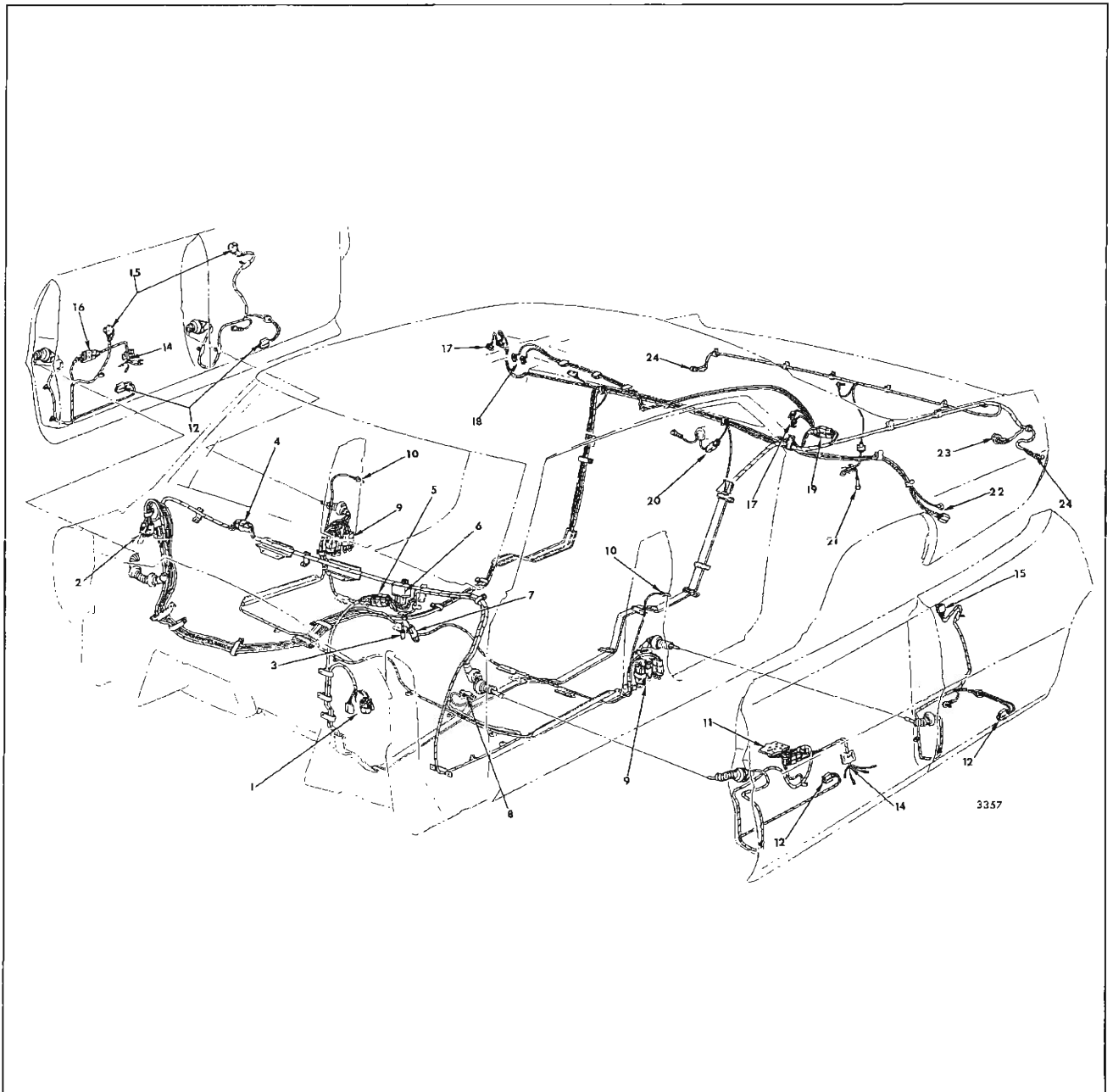

Fig. 16-78—Buick "B-39" Body Wire Routing (Typical)

- |  |   |  |
|--|---|--|
| 1. Main Harness Connector              | 9. Center Pillar Connectors             | 18. Dome Lamp                            |
| 2. Antenna and Speaker Connections     | 10. Rear Door Jamb Switch               | 19. Dome and Sail Lamp Harness Connector |
| 3. Power Feed to Front Harness         | 11. Master Window Control               | 20. Blower Motor Connector               |
| 4. Right Door Harness Connector        | 12. Window Motor Connector              | 21. Gas Gauge Connector                  |
| 5. Rear Power Window Harness Connector | 14. Courtesy and Warning Lamp Leads     | 22. Power Antenna Connections            |
| 6. Ignition Relay                      | 15. Door Window Control Switch          | 23. Tail Lamp Harness Connector          |
| 7. Ignition Terminal on Fuse Block     | 16. Courtesy and Warning Lamp Connector | 24. Side Marker Lamp                     |
| 8. Power Seat Feed Connector           | 17. Sail Lamps                          |  |

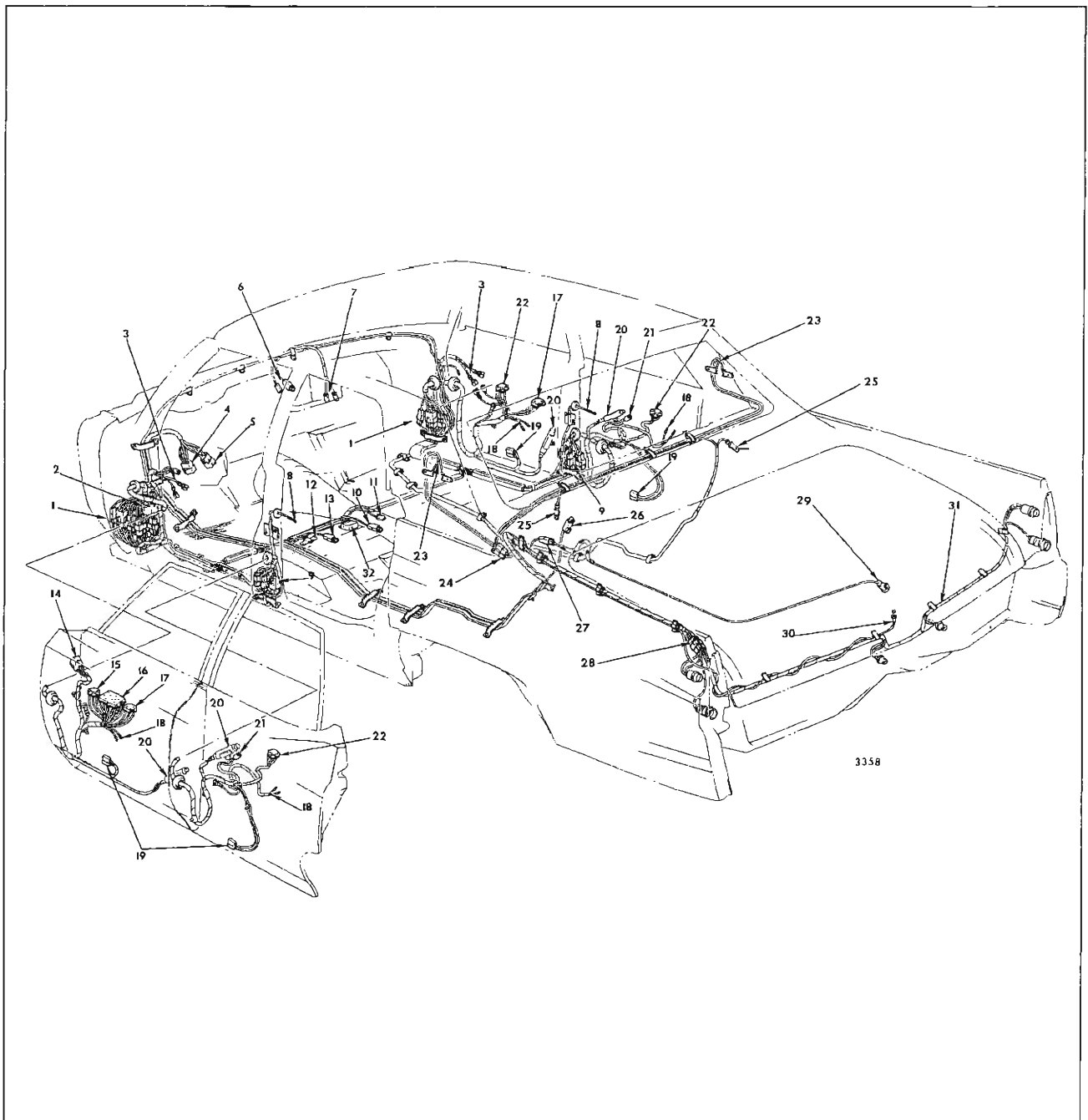

Fig. 16-79—Cadillac "C-69" Body Wire Routing (Typical)

- |   |   |  |  |
|---|---|--|--|
| 1. Shroud Side Connectors                     | 8. Rear Door Jamb Switch                          | 16. Master Control Connector             | 25. Stereo Speaker Leads                           |
| 2. Ignition Relay                             | 9. Center Pillar Connectors                       | 17. Electric Door Lock Control Connector | 26. Rear Defogger Feed                             |
| 3. Front Door Jamb Switch Connectors          | 10. Electric Seat Back Release Feed (2 Door Only) | 18. Courtesy Lamp Feed                   | 27. Rear Compartment Lamp Connector                |
| 4. Main Body Wiring Connector                 | 11. Seat Warmer Feed                              | 19. Window Motor Connector               | 28. Front to Rear Harness Connector                |
| 5. Windshield Wiper Harness Connector         | 12. Power Seat Feed Connector                     | 20. Door Lock Solenoid                   | 29. Rear Compartment Lamp Switch                   |
| 6. Rear and Stereo Speaker Connectors         | 13. Courtesy Lamp Switch Feed                     | 21. Cigar Lighter Connector              | 30. Rear Compartment Jamb Switch                   |
| 7. Rear Compartment Lid Lock and Warning Lamp | 14. Windshield Wiper Control Connector            | 22. Window Control Switch Connector      | 31. Rear Lamp Harness                              |
|   | 15. Cut-Out Switch                                | 23. Sail Lamp Connectors                 | 32. Electric Seat Back Release Relay (2 Door Only) |
|   |   | 24. Sail Lamp Harness Connector          |  |

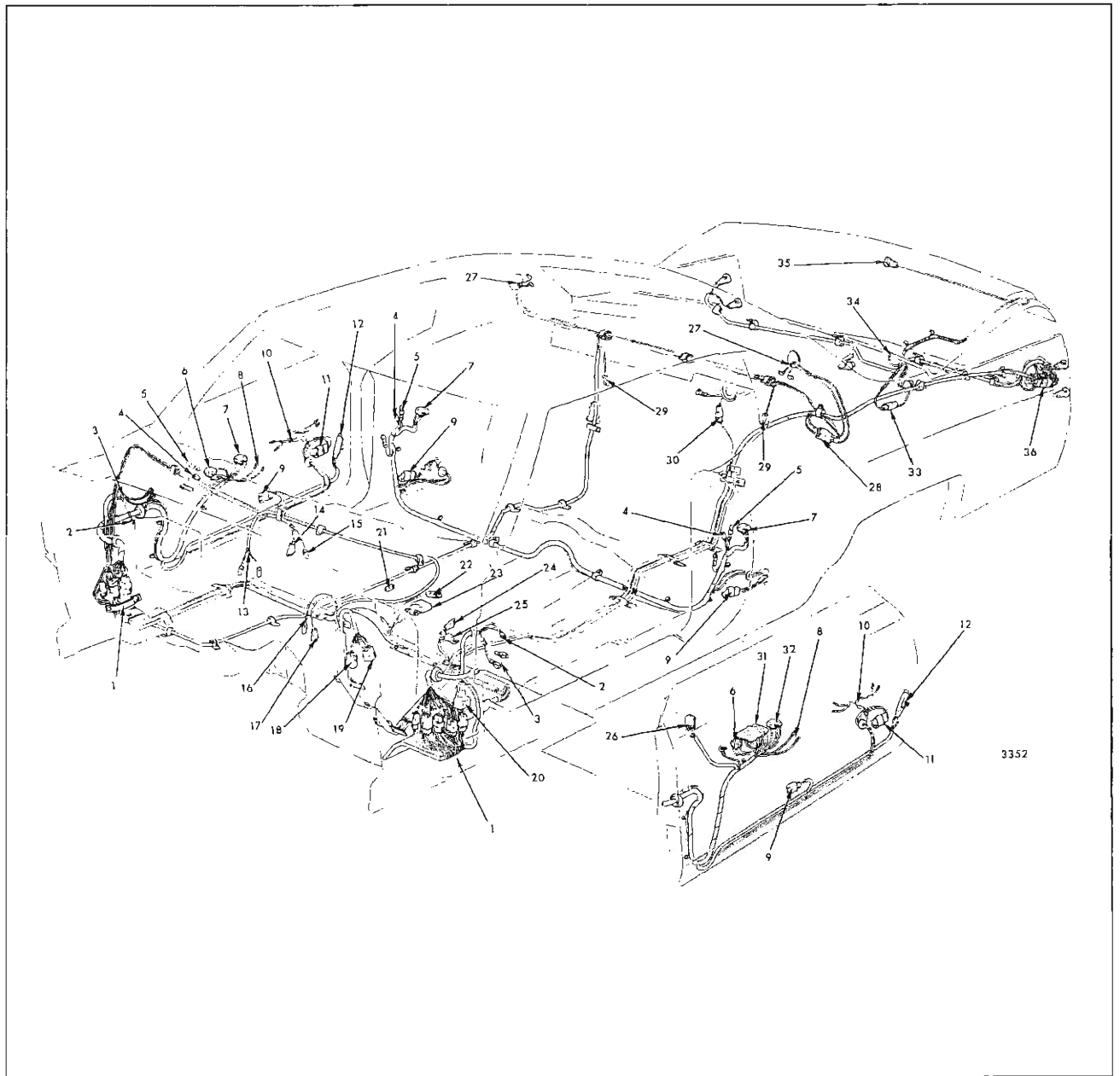

Fig. 16-80—Cadillac "C-47" Style Body Wire Routing (Typical)

- |  |  |   |   |
|--|--|---|---|
| 1. Shroud Side Connectors                        | 10. Warning & Courtesy Lamp Leads (2 Door Styles Only) | 18. Windshield Wiper Control Harness Feed | 27. Sail Lamp Leads                         |
| 2. Front Jamb Connector with Electric Locks      | 11. Warning and Courtesy Lamp Harness Connector        | 19. Main Body Harness Connector           | 28. Sail Lamp Harness Connector             |
| 3. Front Jamb Connector without Electric Locks   | 12. Door Lock Solenoid                                 | 20. Ignition Relay                        | 29. Stereo Speaker Connectors               |
| 4. Cigar Lighter Feed Connector                  | 13. Rear Compartment Lid Lock and Warning Lamp         | 21. Seat Warmer Feed Connector            | 30. Defogger Connector                      |
| 5. Cigar Lighter Ground Connector                | 14. Rear Speaker Connector                             | 22. Electric Seat Back Release Feed       | 31. Window Master Control                   |
| 6. Electric Door Lock Control Connector          | 15. Stereo Speaker Connector When Used with Item 14    | 23. Electric Seat Back Release Relay      | 32. Cut-Out Switch Connector                |
| 7. Window Control Switch Connector               | 16. Seat Warmer Feed Connector to Fuse Block           | 24. Courtesy Lamp Feed                    | 33. Rear Compartment Lamp Harness Connector |
| 8. Warning and Courtesy Lamp Leads (4 Door only) | 17. Rear Defogger Feed Connector                       | 25. Power Seat Feed                       | 34. Rear Compartment Lamp Jamb Switch       |
| 9. Window Motor Connector                        |  | 26. Windshield Wiper Control Connector    | 35. Rear Compartment Lamp                   |
|  |  |   | 36. Front to Rear Harness Connector         |

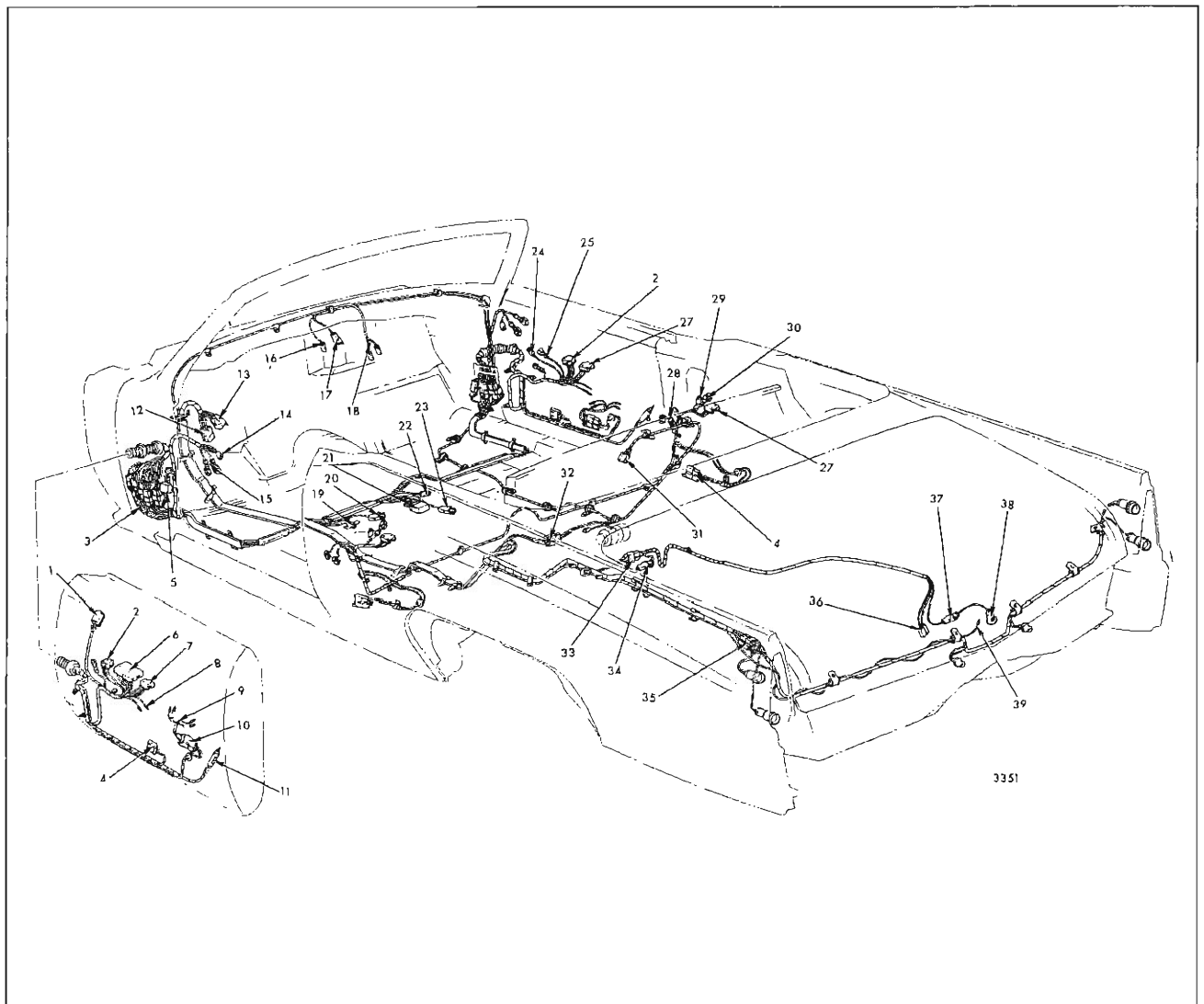

Fig. 16-81—Cadillac "C-67" Styles - Body Wire Routing (Typical)

- |   |  |   |
|---|--|---|
| 1. Windshield Wiper Control Connector                   | 15. Front Jamb Switch Connector without Electric Door Lock | 29. Quarter Cigar Lighter Feed                  |
| 2. Electric Door Lock Control Connector                 | 16. Stereo Speaker Connector Used with Item 17             | 30. Quarter Cigar Lighter Ground Connector      |
| 3. Shroud Side Connectors                               | 17. Rear Speaker Connector                                 | 31. Rear Speaker Connector                      |
| 4. Window Motor Connector                               | 18. Rear Compartment Lid Lock and Warning Lamp Connector   | 32. Power Top Motor Connector                   |
| 5. Ignition Relay                                       | 19. Power Seat Feed  | 33. Rear Compartment Lid Lock Harness Connector |
| 6. Master Window Control                                | 20. Courtesy Lamp Switch Feed                              | 34. Rear Compartment Lid Lamp Harness Connector |
| 7. Cut-Out Switch                                       | 21. Electric Seat Back Release Relay                       | 35. Front to Rear Harness Connector             |
| 8. Warning and Courtesy Lamp Leads - 4 Door Styles      | 22. Electric Seat Warmer Feed                              | 36. Rear Compartment Lid Lock Connector         |
| 9. Warning and Courtesy Lamp Leads - 2 Door Styles      | 23. Electric Seat Back Release Feed                        | 37. Rear Compartment Lid Lamp Connector         |
| 10. Warning and Courtesy Lamp Harness Connector         | 24. Cigar Lighter Feed Connector                           | 38. Rear Compartment Lid Lamp Socket            |
| 11. Electric Door Lock Solenoid                         | 25. Cigar Lighter Ground Connector                         | 39. Rear Compartment Lid Lamp Jamb Switch       |
| 12. Main Body Harness Connector                         | 27. Window Control Switch Connector                        |   |
| 13. Windshield Wiper Harness Connector                  | 28. Quarter Courtesy Lamp Leads                            |   |
| 14. Front Jamb Switch Connector with Electric Door Lock |  |   |

## SECTION 17

# EXTERIOR MOLDING

### INDEX

Subject	Page	Subject	Page
Description . . . . .	17-1	"B-C" Body . . . . .	17-80
General Precautions . . . . .	17-4	"E" Body . . . . .	17-86
Sealing Operation . . . . .	17-4	Buick Styles	
Tools and Care . . . . .	17-4	"A" Body . . . . .	17-92
Zinc Anode Clips . . . . .	17-5	"B-C" Body . . . . .	17-102
Chevrolet Styles		"E" Body . . . . .	17-108
"A" Body . . . . .	17-12	Cadillac Styles	
"B" Body . . . . .	17-23	"C" Body . . . . .	17-113
"F" Body . . . . .	17-30	"D" Body . . . . .	17-118
"X" Body . . . . .	17-34	"E" Body . . . . .	17-121
"Z" Body . . . . .	17-39	Acadian	
Pontiac Styles		"X" Body . . . . .	17-124
"A" Body . . . . .	17-44	Beaumont (Canadian)	
"B" Body . . . . .	17-53	"A" Body . . . . .	17-128
"F" Body . . . . .	17-59	Pontiac (Canadian)	
Oldsmobile Styles		"B" Body . . . . .	17-134
"A" Body . . . . .	17-69		

### DESCRIPTION

The exterior moldings are secured to the body by any one or a combination of the following attachments (Fig. 17-1 and 17-2).

- a. Attaching screws
- b. Bolt and clip assemblies with attaching nuts.
- c. Integral studs with attaching nuts.
- d. "Bath-tub" type snap-on clips.
- e. Side loading type snap-on clips.
- f. "W-base" type snap-in clips.
- g. Weld-on studs and clips.
- h. Snap-in studs on pre-installed retainers.
- i. Snap-in type studs and clips (bayonet type) - (clip is an integral part of the stud).
- j & k. Spring type (self retained).
  1. Pinchweld molding attaching clip (clip shown

used on "A-80" style - skylight molding attaching clip similar).

- m. Stationary glass reveal molding weld stud (Oldsmobile "A" only).
- n. Joint clip

Before using the molding charts the following information will be helpful when installing or removing exterior moldings.

1. Screw locations - the exact location for each screw is not shown or mentioned, but when hidden, the general location is indicated by naming the molding or other part which conceals the screw and therefore must be removed to gain access to the screw.
2. When a molding is overlapped the overlapping molding is indicated in the "Engages with other molding" column and must be removed first.

To use the molding charts, use the following procedure:

1. Locate the illustration of the body. The illustrations are separated by car line and body type.



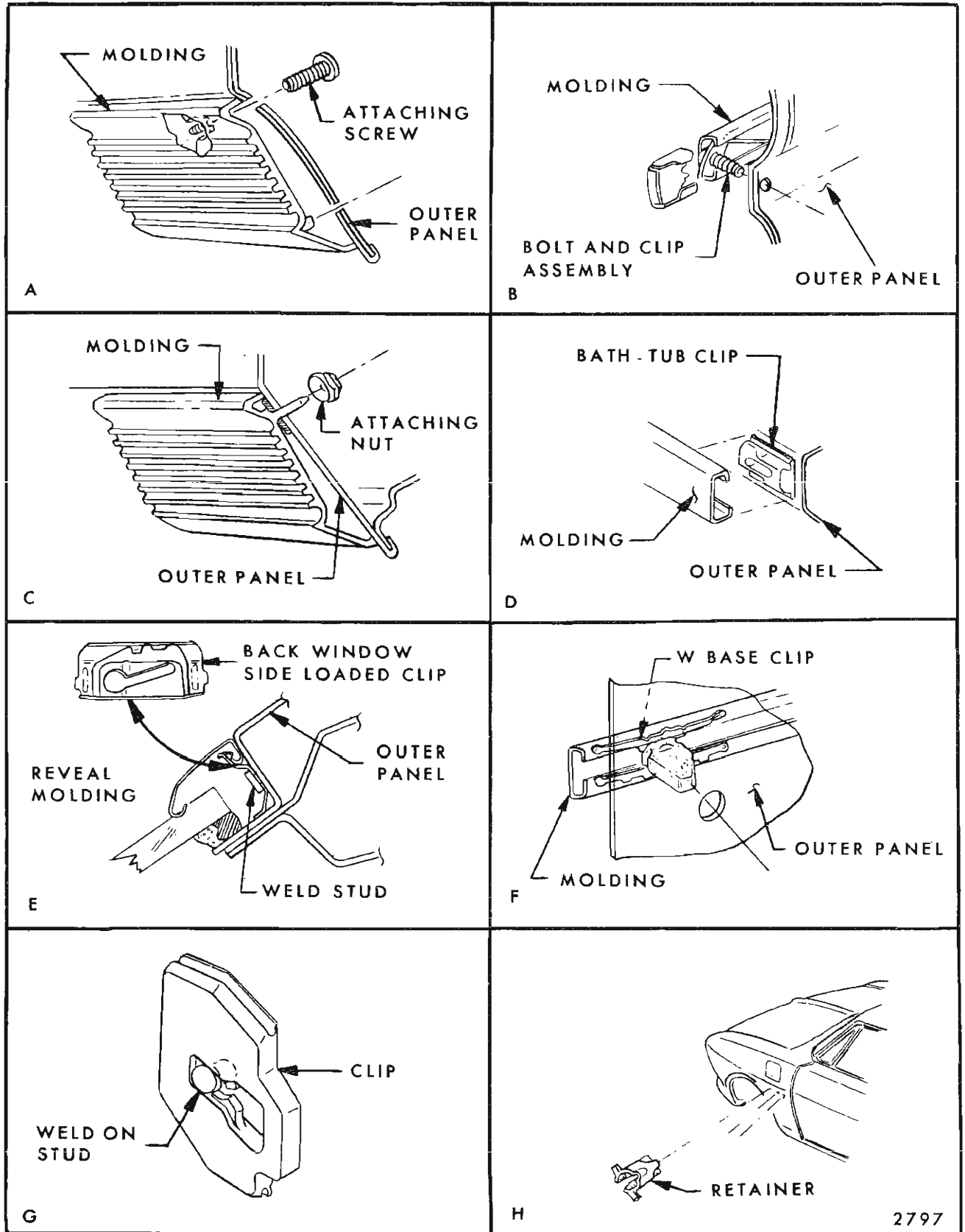

Fig. 17-1—Exterior Molding Attachments

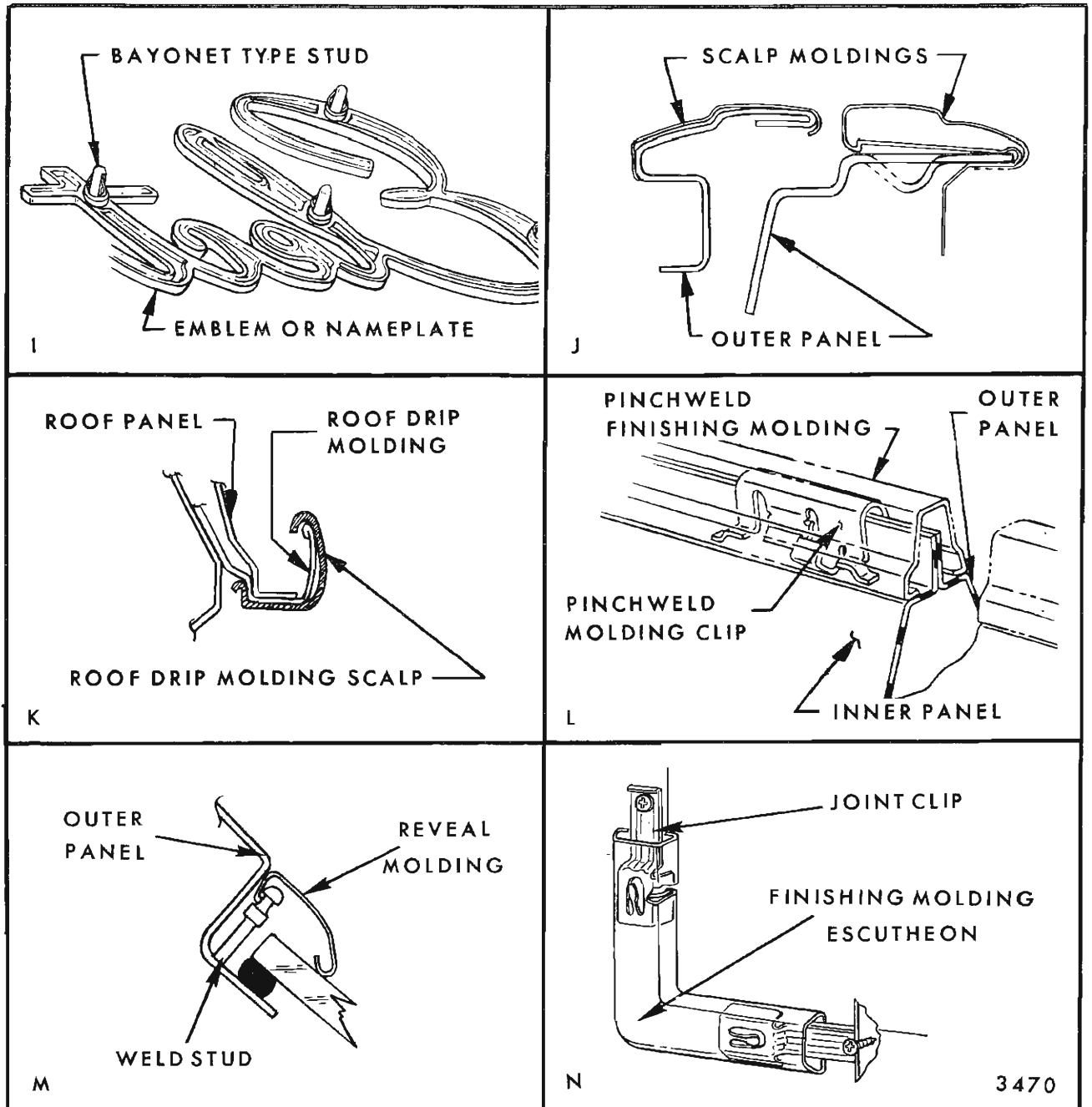

Fig. 17-2—Exterior Molding Attachments

2. Note the number of the molding to be removed.
3. Turn to the molding chart for that particular car line and body type and locate the number noted in step two.

### GENERAL PRECAUTIONS

When removing or installing any body exterior molding certain precautions should be exercised.

1. Adjacent finishes should be protected with masking tape to prevent damage to finish.
2. Proper tools and care should be employed to guard against molding damage.

### SEALING OPERATION

Although detailed sealing operations for each individual molding are not described on the "Molding Removal Chart" the following information is given to permit a satisfactory sealing operation.

Medium-bodied sealer or body caulking compound are the sealers most frequently used to provide a watertight seal or for anti-rattle measures.

Holes in body panels for screws, bolts, or clips that would permit water to enter the interior of the body should be sealed with body caulking compound or presealed screws, nuts or clips.

Drip moldings require a 1/4" bead of medium-bodied sealer along the full length of the inner attaching surface. Door window scalps and center pillar scalps require a 1/8" x 1/4" x 1/4" bead of caulking compound at 5" intervals for anti-rattle purposes. Pinchwelds require medium-bodied sealer on both sides when pinchweld clips are used. The exception is the rear quarter pinchweld on convertible styles which requires waterproof tape over the entire pinchweld, prior to clip installation.

### TOOLS AND CARE

The following groups of moldings are listed with the name or description of the tool which is suitable for molding removal.

Roof Drip Scalps - pointed hook tool.

Door Window Scalps - thin flat-bladed tool (putty knife).

Series	Windshield	Back Window	Quarter Window	Sky Light Window
All GM	J 21549-1 J 21549-5 J 21549-6	J 21549-1 J 21549-3 J 21549-5 J 21549-6	J 21549-1 J 21549-3 J 21549-5 J 21549-6	J 21549-1 J 21549-5 J 21549-6

### TOOLS

J 21549-1	Handle
J 21549-3	Reveal Molding Remover (angle blade) (Use with J 21549-1)
J 21549-5	Reveal Molding Remover (Rt.) (Use with J 21549-1)
J 21549-6	Reveal Molding Remover (Lt.) (Use with J 21549-1)

### DESCRIPTION

Reveal moldings around adhesive caulked glass installations are retained by either clips, which are attached to the body opening by weld-on studs, or specially designed weld-on studs (Oldsmobile "A" styles) which require no clips. A projection on the clip or special weld-on stud (View "M", Fig. 17-2) engages the reveal molding flange, retaining the molding between the clip or special weld-on stud and body metal. To disengage a molding from retaining clips, use appropriate tool (see chart) as shown in Figure 17-3.

If it is necessary to replace a damaged "bath-tub" molding clip, use the following procedure for removal and installation:

1. Insert sharp edge of flat-bladed tool, such as

a putty knife, under edge of clip and hammer tool until base of clip is cut approximately half-way through (Fig. 17-4) then disengage clip from hole.

**NOTE:** In some cases, it may also be necessary to cut clip at opposite end of base.

2. Special tool J-21214 is required when installing metal bath-tub type clips.
3. No special tool is needed to install a new plastic bath-tube type clip.

If a weld stud on an outer panel becomes damaged or broken off, use the following procedure:

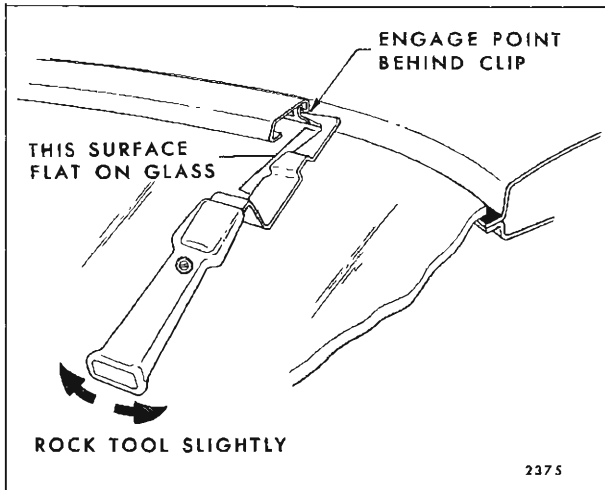

Fig. 17-3—Usage of Reveal Molding Removal Tool

1. Drill a small hole in the panel adjacent to where original weld on stud was installed.
2. Insert a self sealing screw through original clip and into outer panel.

If a weld stud, attaching screw, or molding clip become damaged or broken off and must be replaced in a windshield, back window, quarter window, or skylight opening, use the following procedure:

1. Oldsmobile "A" styles only
  - a. Drill a small hole (#44 drill size) into base of window opening rabbet adjacent to original stud location.
  - b. Insert self-sealing, self-tapping repair stud #8766953 (See View "M", Fig. 17-2).

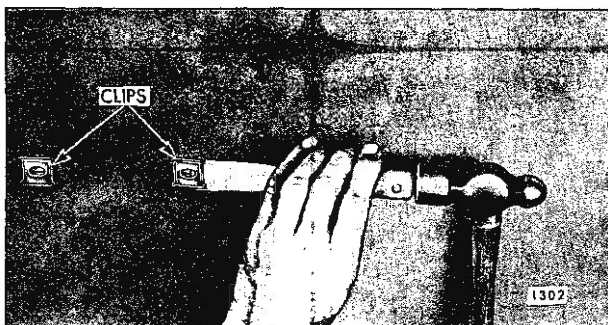

Fig. 17-4—Removal of Bath-Tub Type Molding Clip

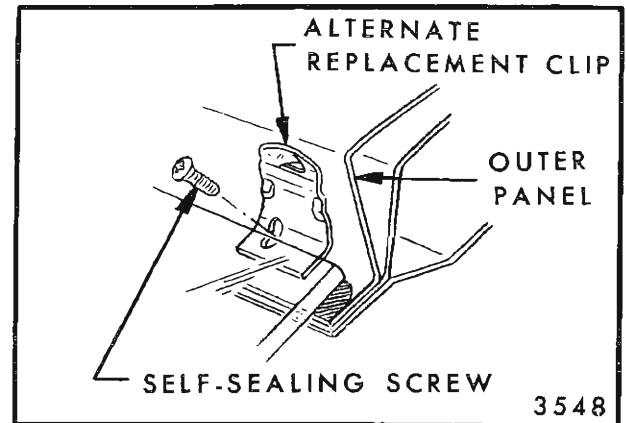

Fig. 17-5—Reveal Molding Clip Alternate Replacement

2. All Styles (Except Oldsmobile "A")
  - a. Drill a small hole in the corner of the window opening rabbet adjacent to where original weld stud or screw was installed.
  - b. Insert a self-sealing screw through alternate replacement clip and into panel (Fig. 17-5).

**CAUTION:** Avoid contact with edge of glass during drilling operation and when installing clip.

### ZINC ANODE CLIPS

As a corrosion preventative feature on certain styles (see Usage Chart), zinc-anode clips are used in the back window, quarter stationary window, and

#### ZINC ANODE CLIP USAGE CHART

Zinc Anode Clip Locations	Styles	No. of Clips At Each Location
Back Window	All A-B-C-D-E-F-G-X-Z Bodies Except 35-36-46-55-56-65-66-67-77-87	Total of 4 2 Each on Rt. & Lt. Sides
Quarter Window Lower Opening	All A-35-36-46-55-56-65-66 Styles All B-36-46 Styles	Total of 4 2 Each on Rt. & Lt. Sides
Front Skylight Window Lower Opening	All A-55-56, 65-66 Styles	Total of 2 1 Each on Rt. & Lt. Sides

17-6 EXTERIOR MOLDINGS

front lower skylight window rabbet areas, and are concealed by the reveal moldings. These clips are attached by standard weld-on type studs.

The clips are of a sacrificing type, so that corrosion attacks the anode clip rather than the body panel.

Replacement clips are available as service parts.

If a zinc anode clip attaching weld stud is damaged or broken off and replacement is necessary, the following procedure should be followed:

1. Drill a small hole adjacent to where the original stud was installed. (Glass should be protected and caution should be exercised when making this replacement.)
2. Install alternate replacement clip (Group 10.096) as shown in Figure 17-6. Use self sealing screw or apply body caulking compound around clip hole to effect a watertight seal.

**NOTE:**

1. Replacement of damaged weld stud may be realized without glass removal.

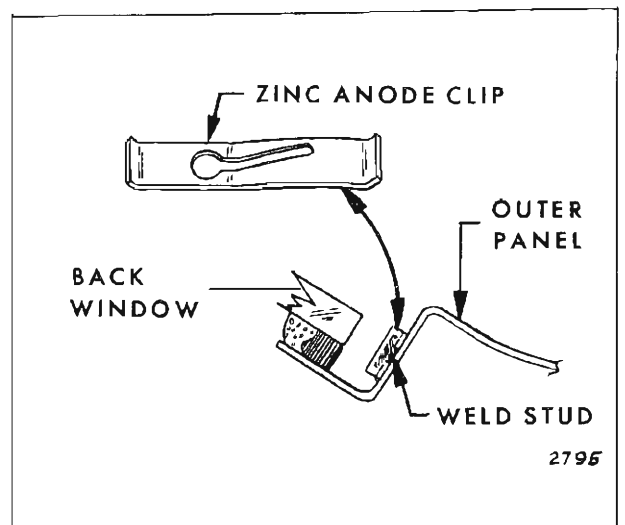

Fig. 17-6—Zinc-Anode Clip Installation

2. Both zinc anode clips and alternate replacement self-sealing screws are available as service parts.

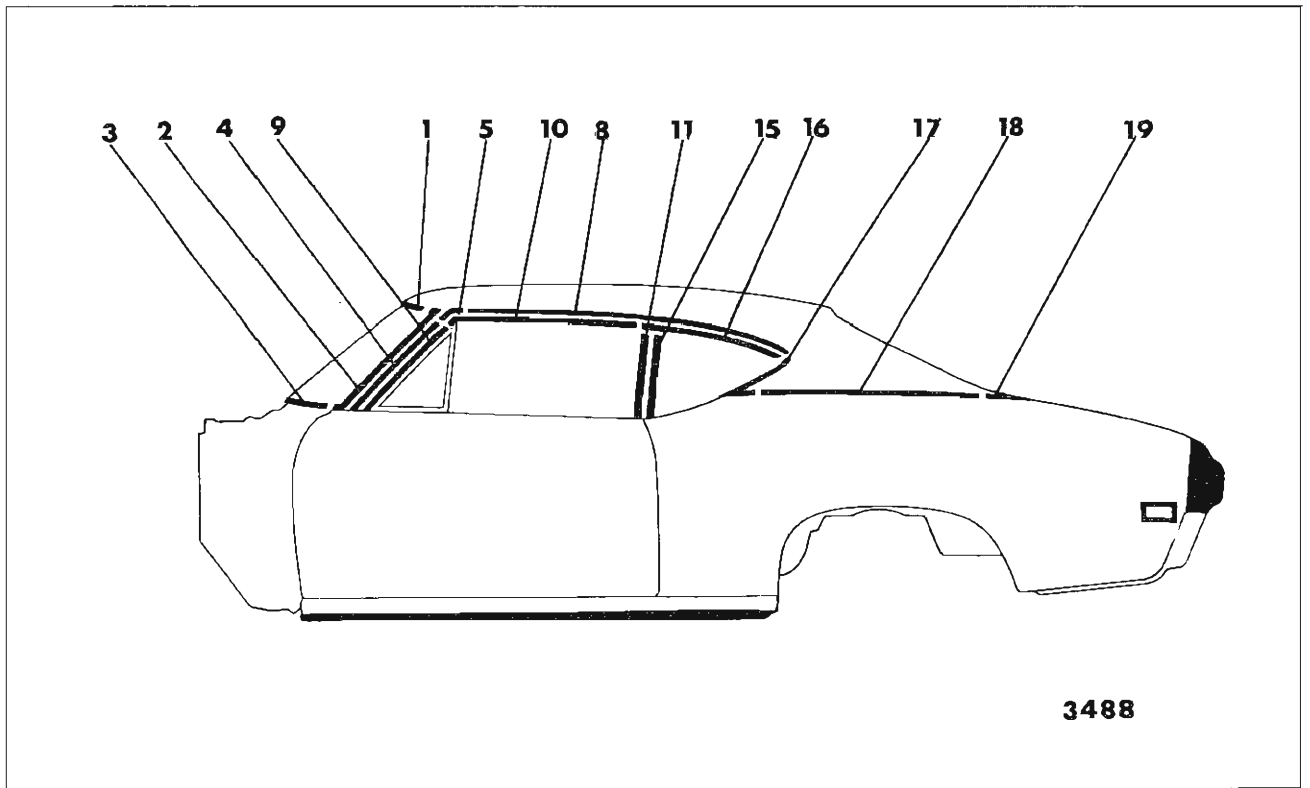

Fig. 17-7—Chevrolet "A-27" Styles

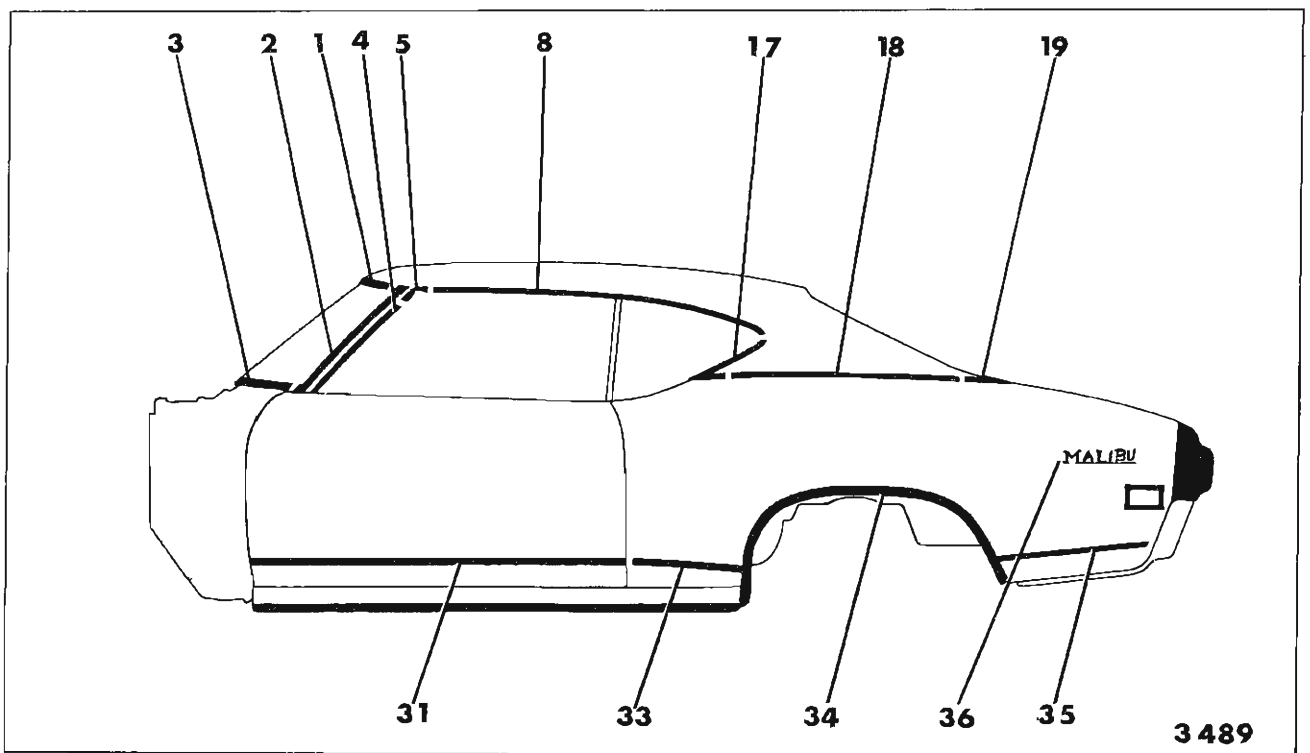

Fig. 17-8—Chevrolet "A-37" Styles ("67" Styles Similar)

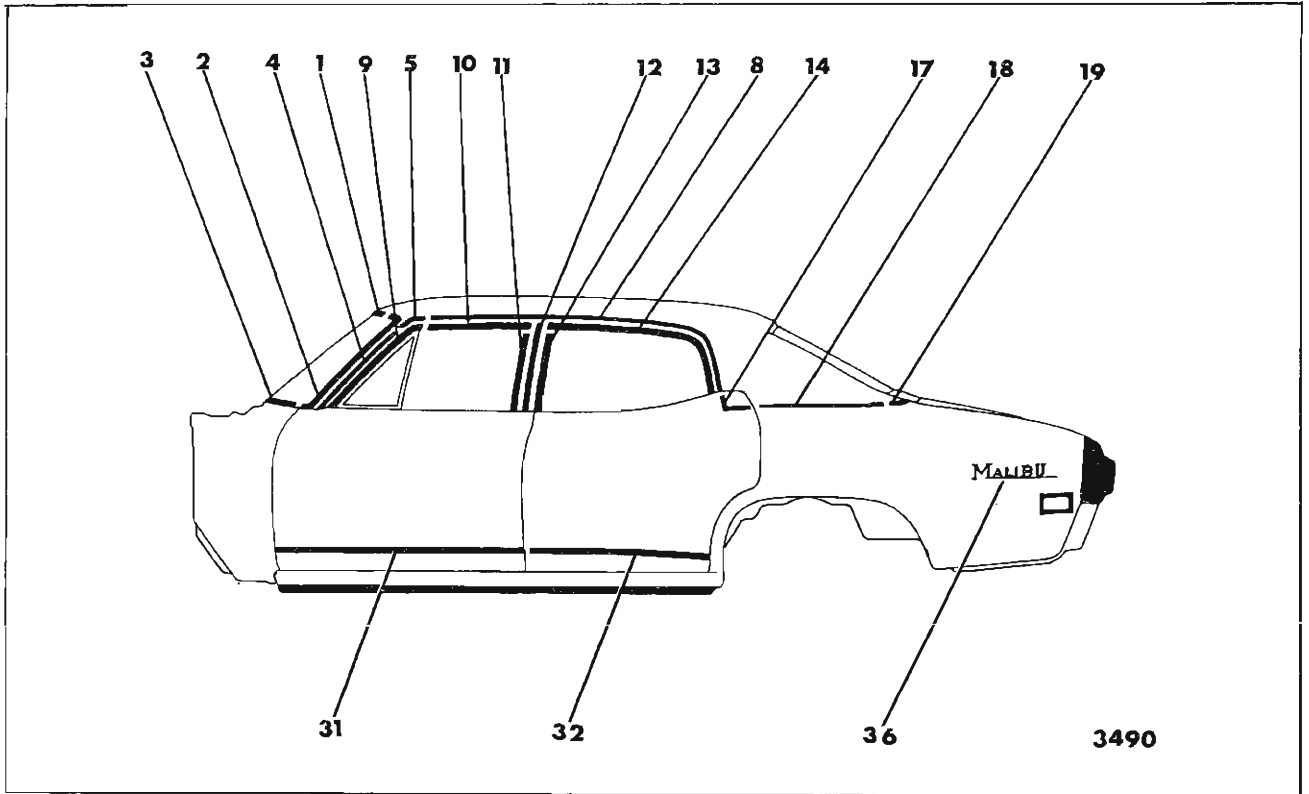

Fig. 17-9—Chevrolet "A-69" Styles

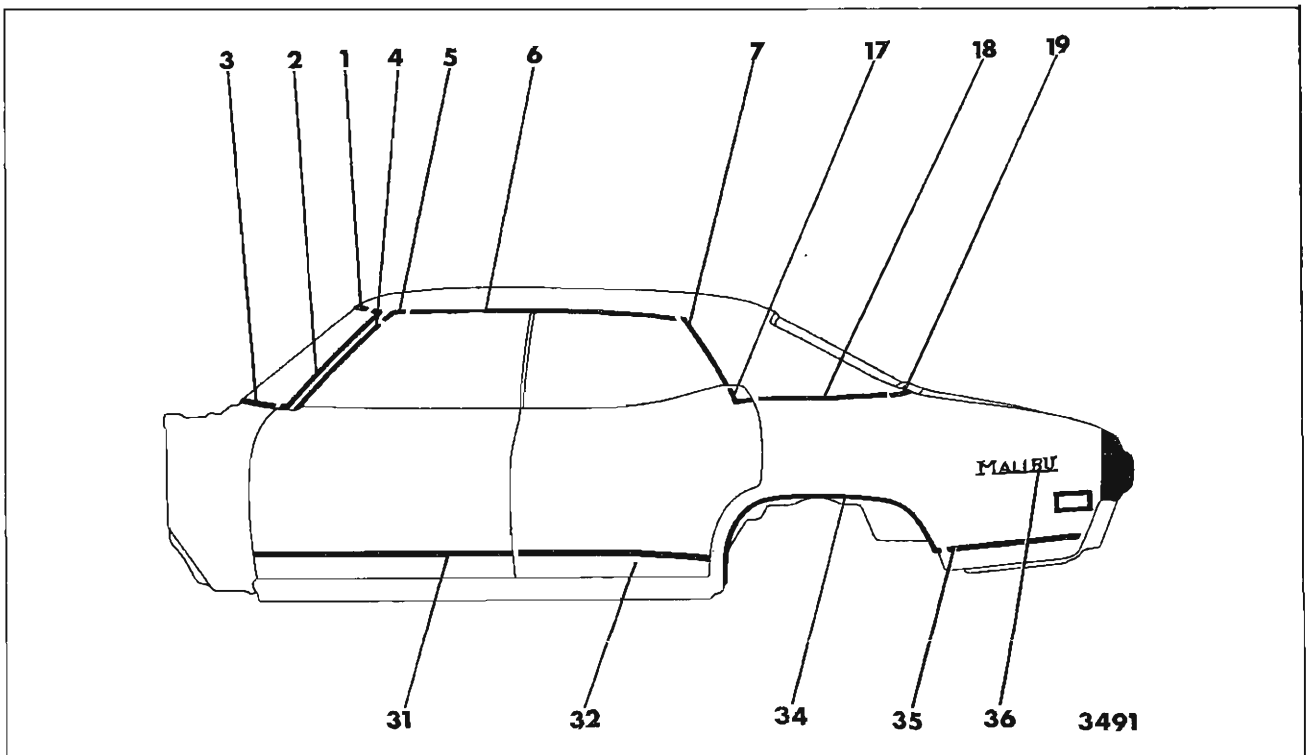

Fig. 17-10—Chevrolet "A-39" Styles

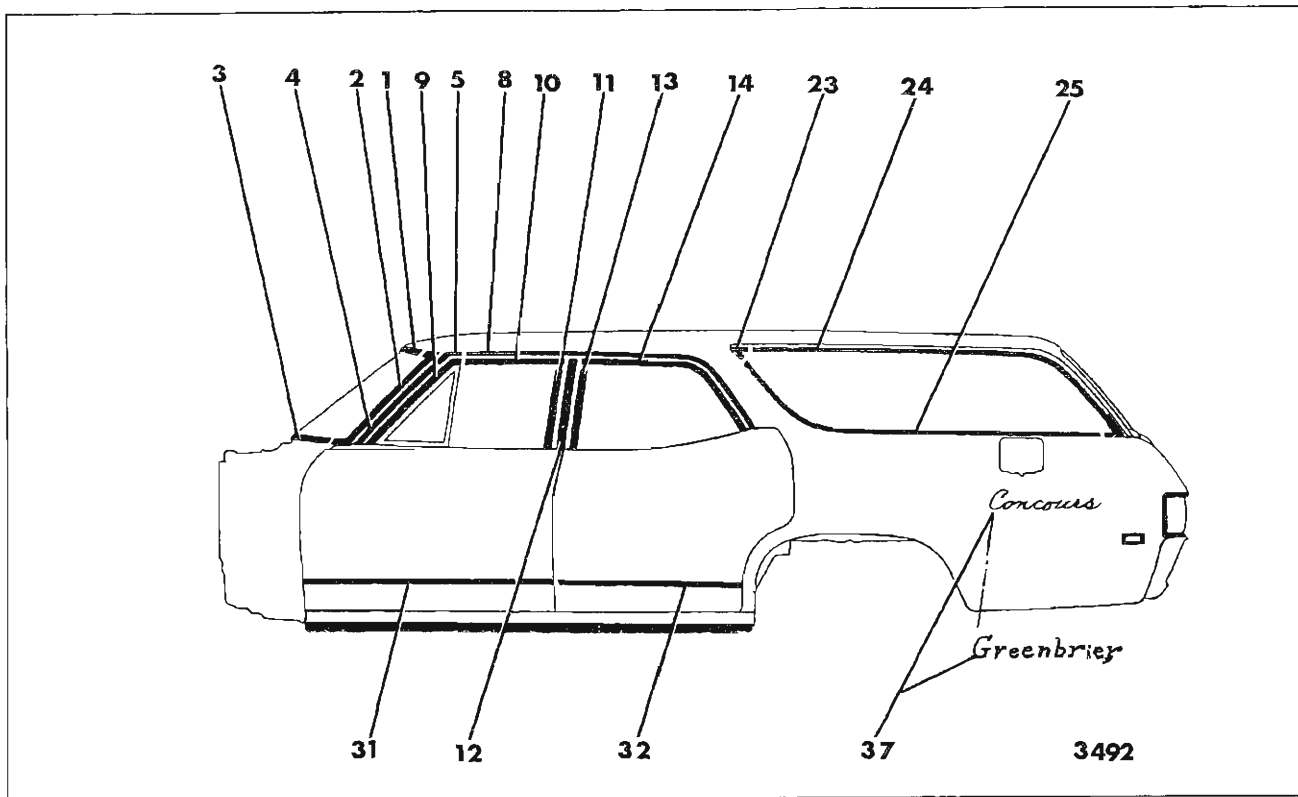

Fig. 17-11—Chevrolet "A-35-36-46" (Less 13836-46)

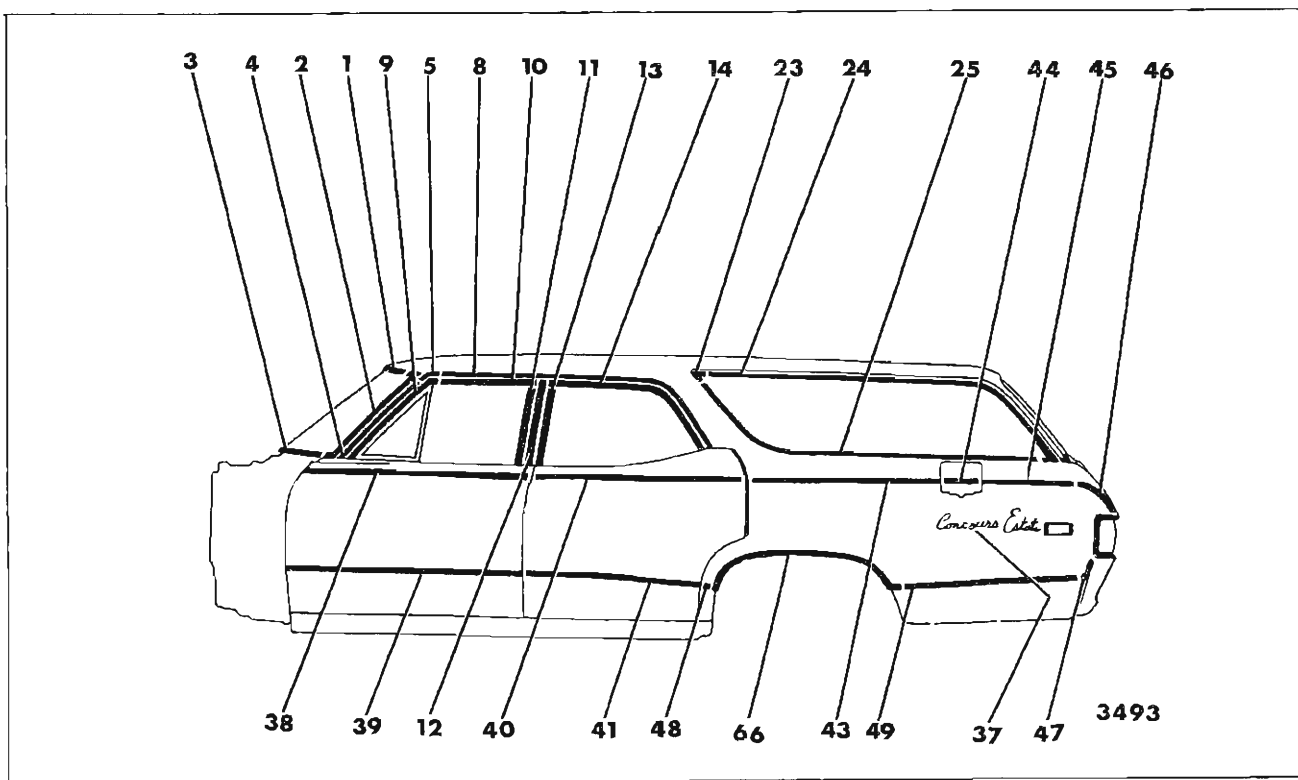

Fig. 17-12—Chevrolet 13836-46 Styles



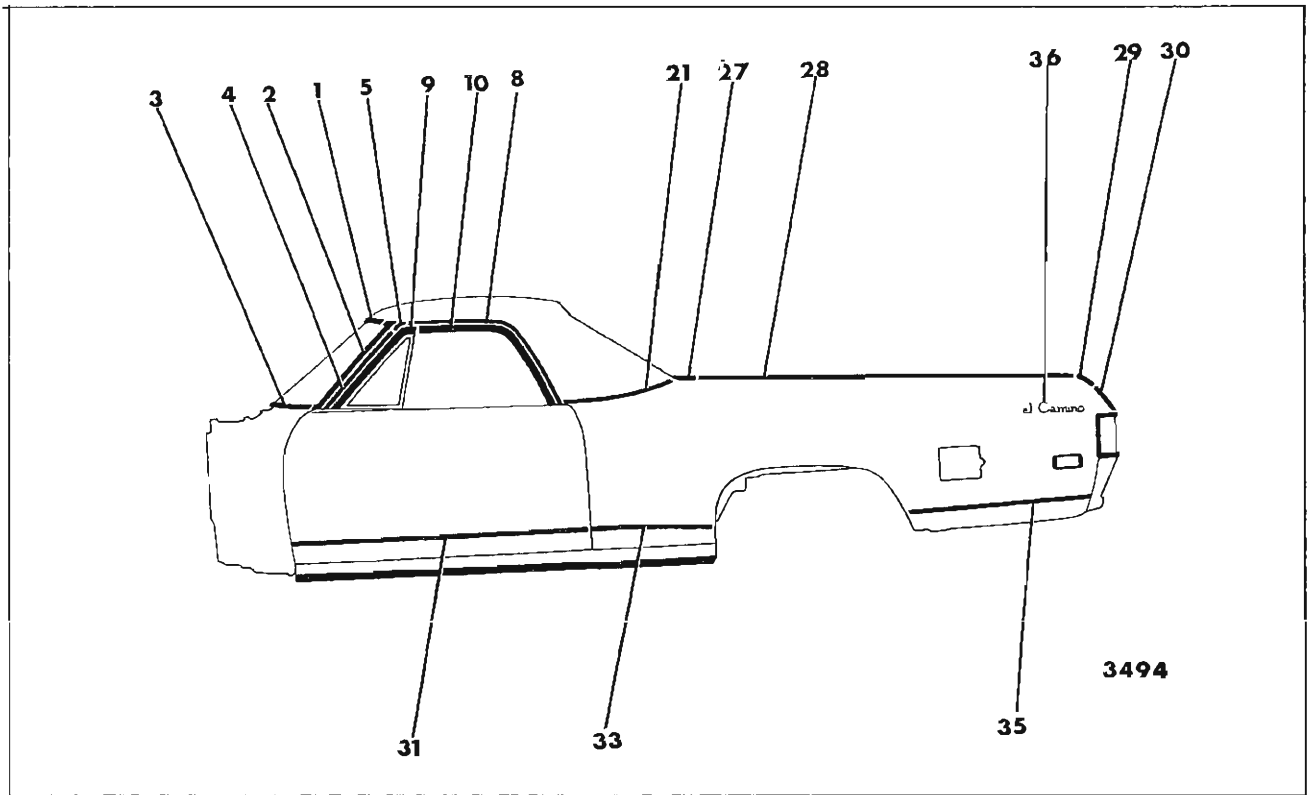

Fig. 17-13—Chevrolet "A-80" Styles

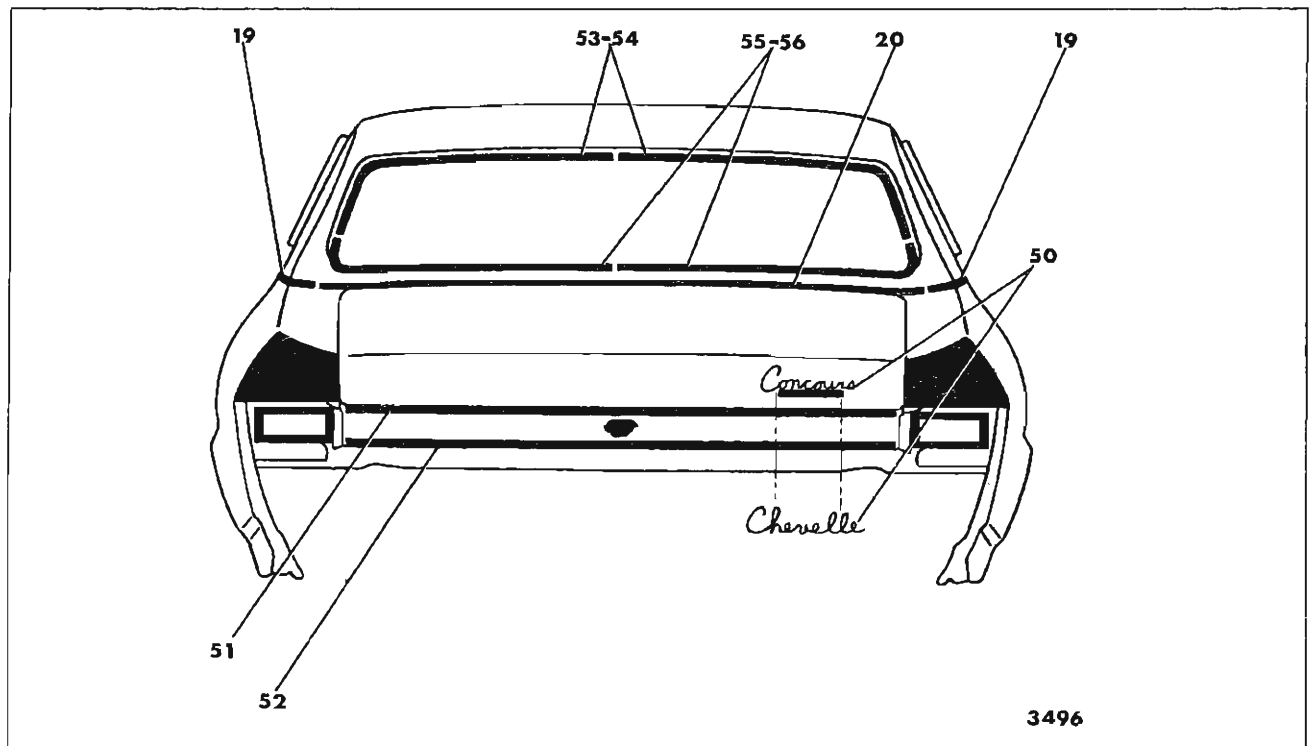

Fig. 17-14—Chevrolet 13200-13400-13600 Styles - (Less 35-36-46-80)

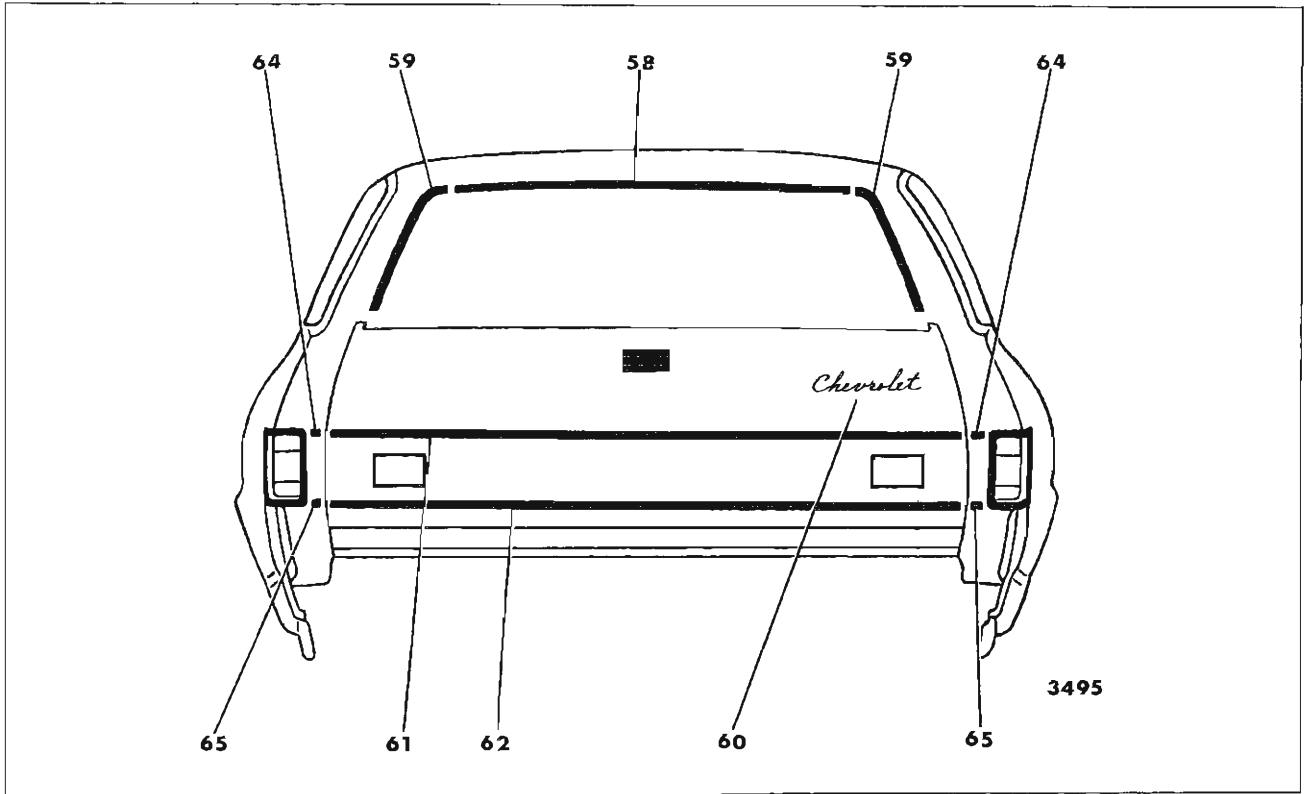

Fig. 17-15—Chevrolet "A-35-36-46"

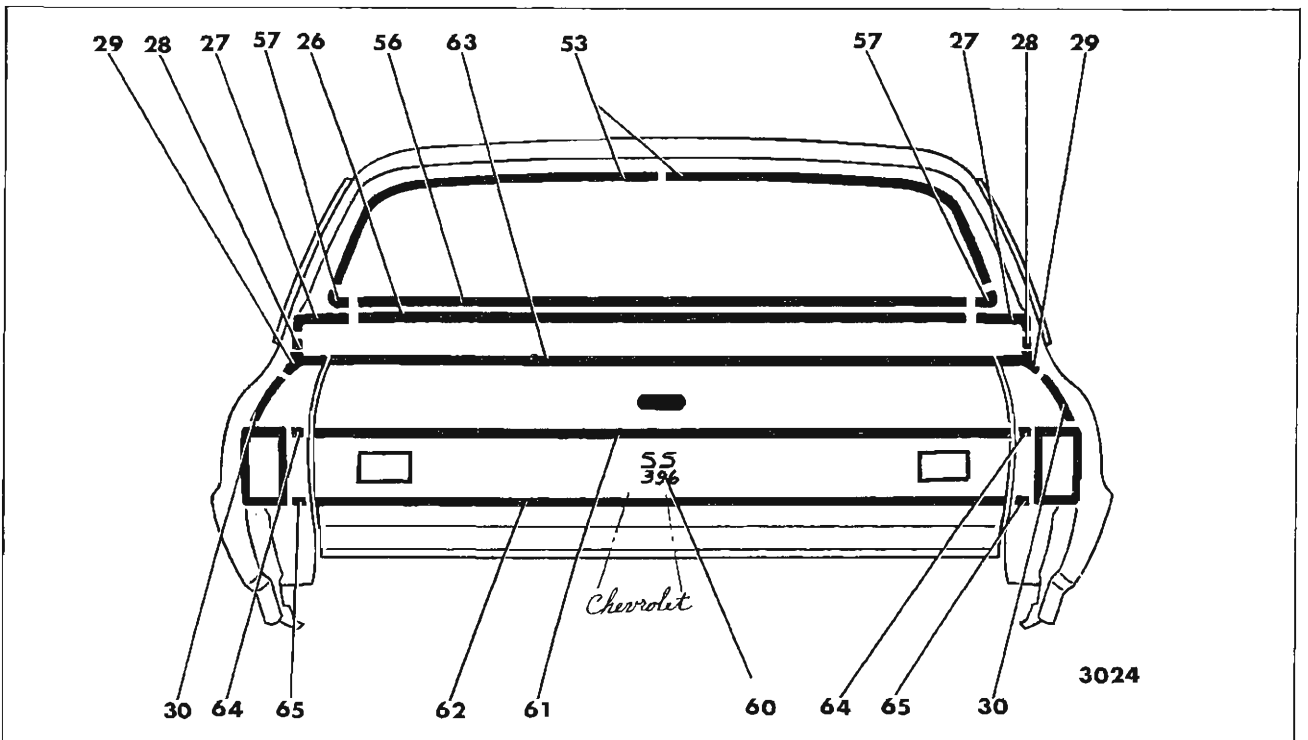

Fig. 17-16—Chevrolet "A-80" Styles

## METHODS OF MOLDING RETENTION

CHEVROLET "A" BODIES - 13000 SERIES  
FIGURES 17-7 THROUGH 17-16

Key	Molding Name	Series or Styles	Screws	Spring (Self-Retained)	Snap-On Clips or Retainers On Panel	Snap-On Clips On Molding	Studs With Attaching Nuts	Engages With Other Moldings	Remove Hardware Or Trim
1	Windshield Reveal Upper	All			X			Windshield Reveal Side	
2	Windshield Reveal Side	All	X (67 Only)		X				
3	Windshield Reveal Lower	All	X					Windshield Reveal Side	
4	Windshield Pillar Drip Scalp	All (Except 67)		View K				Roof Drip Molding Front Scalp Escutcheon	
5	Roof Drip Molding Front Scalp Escutcheon	All (Except 67)		View K				Windshield Pillar Drip Scalp and Roof Drip Scalp	
6	Roof Drip Molding Front Scalp	39 Style		View K				Roof Drip Molding Front Scalp Escutcheon	
7	Roof Drip Molding Rear Scalp	39 Style		View K				Roof Drip Molding Front Scalp	
8	Roof Drip Molding Scalp	All (Except 39-67)		View K				Roof Drip Molding Front Scalp Escutcheon	
9	Front Door Window Frame Front Scalp	27, 35, 36, 46, 69, 80		View J					
10	Front Door Window Frame Upper Scalp	27, 35, 36, 46, 69, 80		View J				Front Door Window Frame Front Scalp	
11	Front Door Window Frame Rear Scalp	27, 35, 36 46, 69		View J				Front Door Window Frame Upper Scalp	
12	Center Pillar Scalp	69	X						
13	Rear Door Window Frame Front Scalp	35, 36, 46, 69		View J				Rear Door Window Frame Upper Scalp	
14	Rear Door Window Frame Upper Scalp	35, 36, 46, 69		View J					

METHODS OF MOLDING RETENTION  
CHEVROLET "A" BODIES - 13000 SERIES  
FIGURES 17-7 THROUGH 17-16

Key	Molding Name	Series or Styles	Screws	Spring (Self-Retained)	Snap-On Clips or Retainers On Panel	Snap-On Clips On Molding	Studs With Attaching Nuts	Engages With Other Moldings	Remove Hardware Or Trim
15	Rear Quarter Window Reveal Front	27 Style			X			Rear Quarter Window Reveal Upper	
16	Rear Quarter Window Reveal Upper	27 Style	X						Quarter Window Glass Run Channel
17	Rear Quarter Belt Reveal Front Corner Escutcheon	27-37 39-69 (Optional)	X				View B	Rear Quarter Belt Reveal (27-37 Styles)	
18	Rear Quarter Belt Reveal	27-37 39-69 (Optional)			X		View B		Trim in Sail Area (39-69 Only)
19	Rear Quarter Belt Reveal Rear Corner Escutcheon	27-37 39-69 (Optional)					X	Rear End Belt Reveal, Rear Quarter Belt Reveal	
20	Rear Belt Reveal	27-37 39-69 (Optional)			X		X		
21	Body Lock Pillar Belt Reveal	80 Style (Optional)			X				
22	Rear Quarter Pinch Weld Finishing	67	X		X				Lower Top Halfway
23	Rear Quarter Window Reveal Front Upper Corner Escutcheon	35, 36, 46			X			Loosen Rear Quarter Window Reveal Upper and Lower at Corner	
24	Rear Quarter Window Reveal Upper	35, 36, 46			X			Rear Quarter Window Reveal Front Upper Corner Escutcheon	
25	Rear Quarter Window Reveal Lower	35, 36, 46			X			Rear Quarter Window Reveal Front Upper Corner Escutcheon	
26	Rear Quarter Belt Finishing at Back Window	80			X		View B		Rear Seat Back

METHODS OF MOLDING RETENTION  
CHEVROLET "A" BODIES - 13000 SERIES  
FIGURES 17-7 THROUGH 17-16

Key	Molding Name	Series or Styles	Screws	Spring (Self-Retained)	Snap-On Clips or Retainers On Panel	Snap-On Clips On Molding	Studs With Attaching Nuts	Engages With Other Moldings	Remove Hardware Or Trim
27	Rear Quarter Pinchweld Belt Finishing Front	80	X					Rear Quarter Belt Finishing at Back Window & Rear Quarter Pinchweld Finishing Rear	
28	Rear Quarter Pinchweld Belt Finishing Rear	80			View L				
29	Rear Quarter Pinchweld Belt Finishing Rear of Rear-Upper	80	X				X	Rear Quarter Pinchweld Belt Finishing Rear and Rear of Rear-Lower	Tail Lamp Pocket
30	Rear Quarter Belt Finishing Rear of Rear-Lower	80					X		Tail Lamp Pocket
31	Front Door Outer Panel	13600	X		X				
32	Rear Door Outer Panel	13600	X		X				
33	Front of Rear Wheel Opening	13637, 67, 80			X		X		Rear Quarter Lower Trim
34	Rear Wheel Opening	13637 13639 (Optional)	X						
35	Rear of Rear Wheel Opening	13600			X		X		
36	Rear Quarter Outer Panel Emblem and/or Nameplate	13637, 39 67, 69, 80					X		Rear Quarter Inner Access Hole Cover (80 - Style Only)
37	Rear Quarter Outer Panel Emblem and/or Nameplate	35, 36, 46				View I			
38	Front Door Outer Panel Upper	13835, 36 46	X		X				

METHODS OF MOLDING RETENTION  
CHEVROLET "A" BODIES - 13000 SERIES  
FIGURES 17-7 THROUGH 17-16

Key	Molding Name	Series or Styles	Screws	Spring (Self-Retained)	Snap-On Clips or Retainers On Panel	Snap-On Clips On Molding	Studs With Attaching Nuts	Engages With Other Moldings	Remove Hardware Or Trim
39	Front Door Outer Panel Lower	13836-46	X		X				
40	Rear Door Outer Panel Upper	13836-46			X		X		
41	Rear Door Outer Panel Lower	13836-46	X		X				
42	Rear Quarter Outer Panel (Rt. Side)	13836-46			X		X		Spare Tire Cover Panel
43	Rear Quarter Outer Panel Front (Lt. Side)	13836-46			X				
44	Rear Quarter Outer Panel at Gas Filler Door (Lt. Side)	13836-46	X						
45	Rear Quarter Outer Panel Rear (Lt. Side)	13836-46			X				
46	Rear Quarter Outer Panel Rear Vertical-Upper	13836-46	X			View F		Rear Quarter Outer Panel (Rt. Side), Rear Quarter Outer Panel Transfer Finishing Rear (Lt. Side)	
47	Rear Quarter Outer Panel Rear Vertical-Lower	13836-46	X			View F		Rear of Rear Wheel Opening Outer Panel Transfer Finishing	
48	Front of Rear Wheel Opening Outer Panel	13836-46	X					Rear Wheel Opening Molding	
49	Rear of Rear Wheel Opening Outer Panel	13836-46			X			Rear Quarter Outer Panel Transfer Finishing Rear Vertical-Lower	

METHODS OF MOLDING RETENTION  
CHEVROLET "A" BODIES - 13000 SERIES  
FIGURES 17-7 THROUGH 17-16

Key	Molding Name	Series or Styles	Screws	Spring (Self-Retained)	Snap-On Clips or Retainers On Panel	Snap-On Clips On Molding	Studs With Attaching Nuts	Engages With Other Moldings	Remove Hardware Or Trim
50	Rear End Panel Emblem and/or Nameplate	All (Except 35, 36, 46, 80)					X		
51	Rear End Outer Panel-Upper	13637, 39, 67, 69			X		X		
52	Rear End Outer Panel-Lower	13637, 39, 67, 69			X		X		
53	Back Window Reveal Upper and Sides	27-37			X				
54	Back Window Reveal Upper	39-69			X				
55	Back Window Reveal Sides and Lower	39-69			X			Back Window Reveal Upper	
56	Back Window Reveal Lower	27-37, 80			X			Back Window Reveal Side	
57	Back Window Reveal Lower Corner Escutcheon	80						Loosen Lower Corner of Back Window Reveal Upper and Sides and Loosen Back Window Lower Reveal	
58	Back Body Opening Upper Reveal	35, 36, 46	X					Back Body Opening Side Reveal	Tail Gate Window Glass Run Channel
59	Back Body Opening Side Reveal	35, 36, 46	X						
60	Tail Gate Outer Panel Emblem and/or Nameplate	35, 36, 46, 80					X		Tail Gate Trim Assembly
61	Tail Gate Outer Panel Upper	13635, 36, 46, 80, 13836, 46	X		X				
62	Tail Gate Outer Panel Lower	13635, 36, 46, 80, 13836, 46	X		X				

METHODS OF MOLDING RETENTION  
CHEVROLET "A" BODIES - 13000 SERIES  
FIGURES 17-7 THROUGH 17-16

Key	Molding Name	Series or Styles	Screws	Spring (Self-Retained)	Snap-On Clips or Retainers On Panel	Snap-On Clips On Molding	Studs With Attaching Nuts	Engages With Other Moldings	Remove Hardware Or Trim
63	Tail Gate Belt Finishing	80					X		Tail Gate Inner Cover Panel
64	Rear of Rear Quarter Outer Panel Upper	13635, 36, 46, 80	X (Right)		X (Left)	View F (Right)			
65	Rear of Rear Quarter Outer Panel Lower	13635, 36, 46, 80	X (Right)		X (Left)	View F (Right)			
66	Rear Wheel Opening Transfer Finishing	13836-46	X						



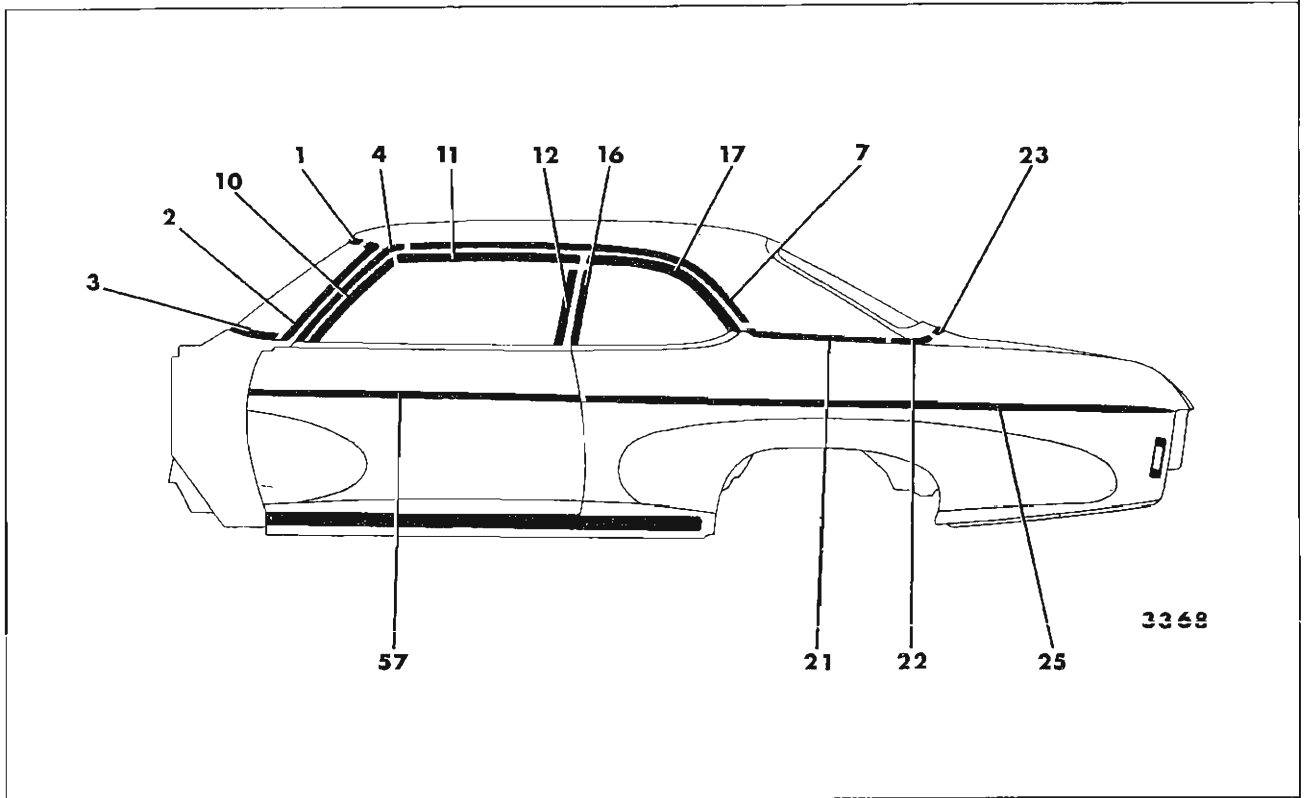

Fig. 17-17—Chevrolet "B-11" Styles

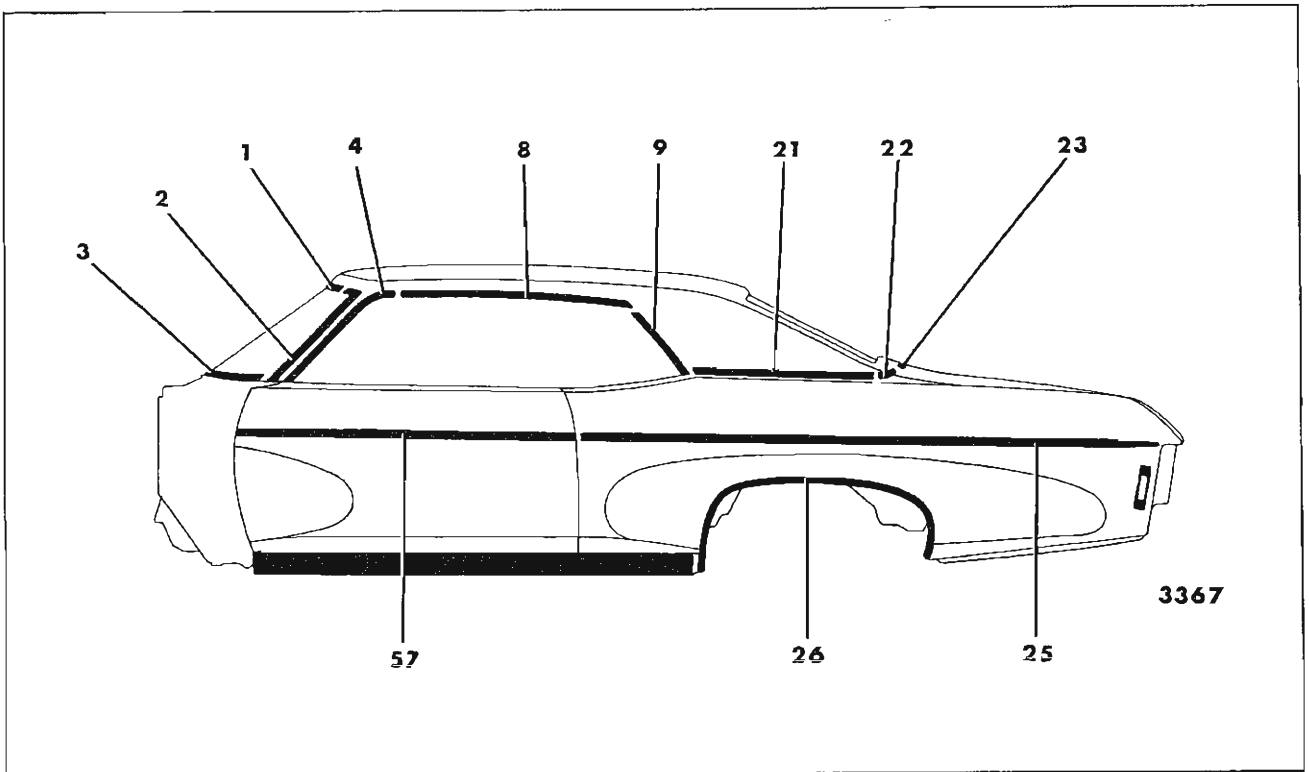

Fig. 17-18—Chevrolet 16437 Styles (16467 Style Similar)

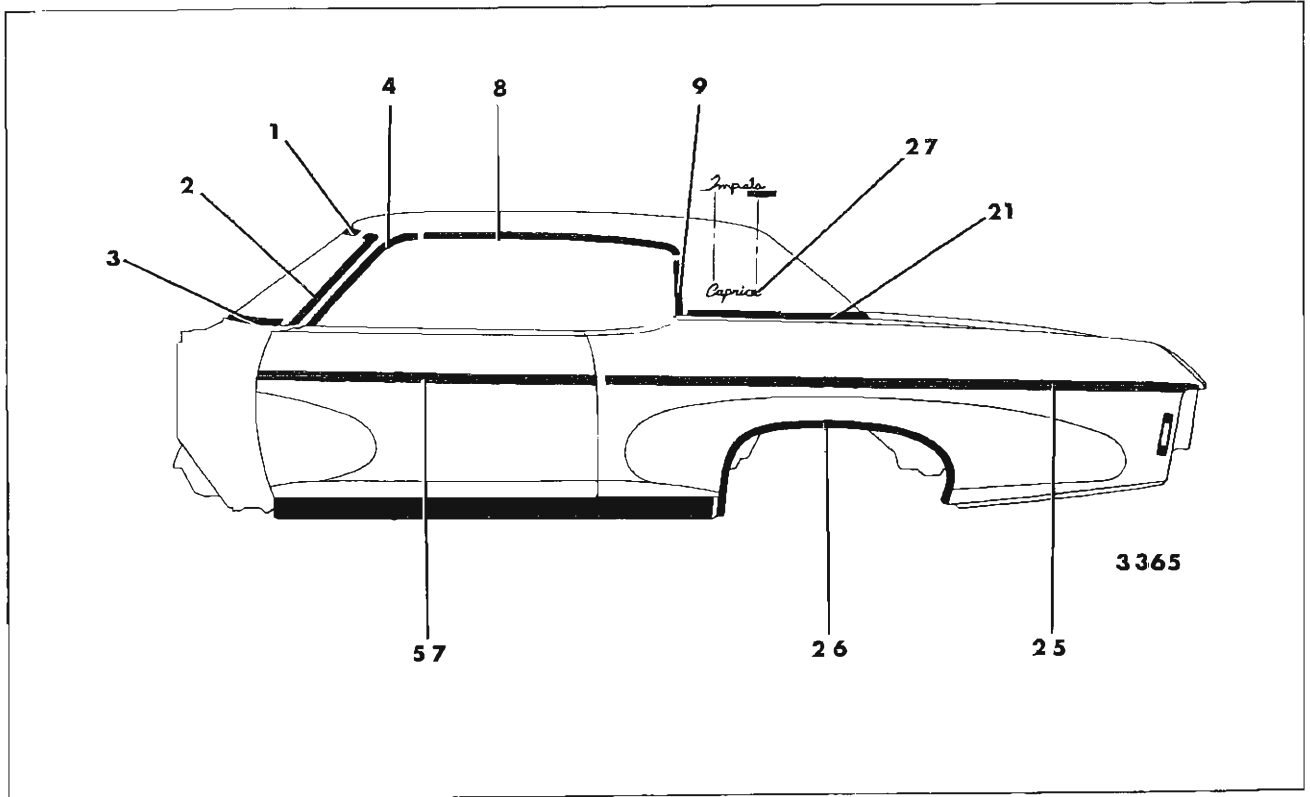

Fig. 17-19—Chevrolet "B-47" Styles

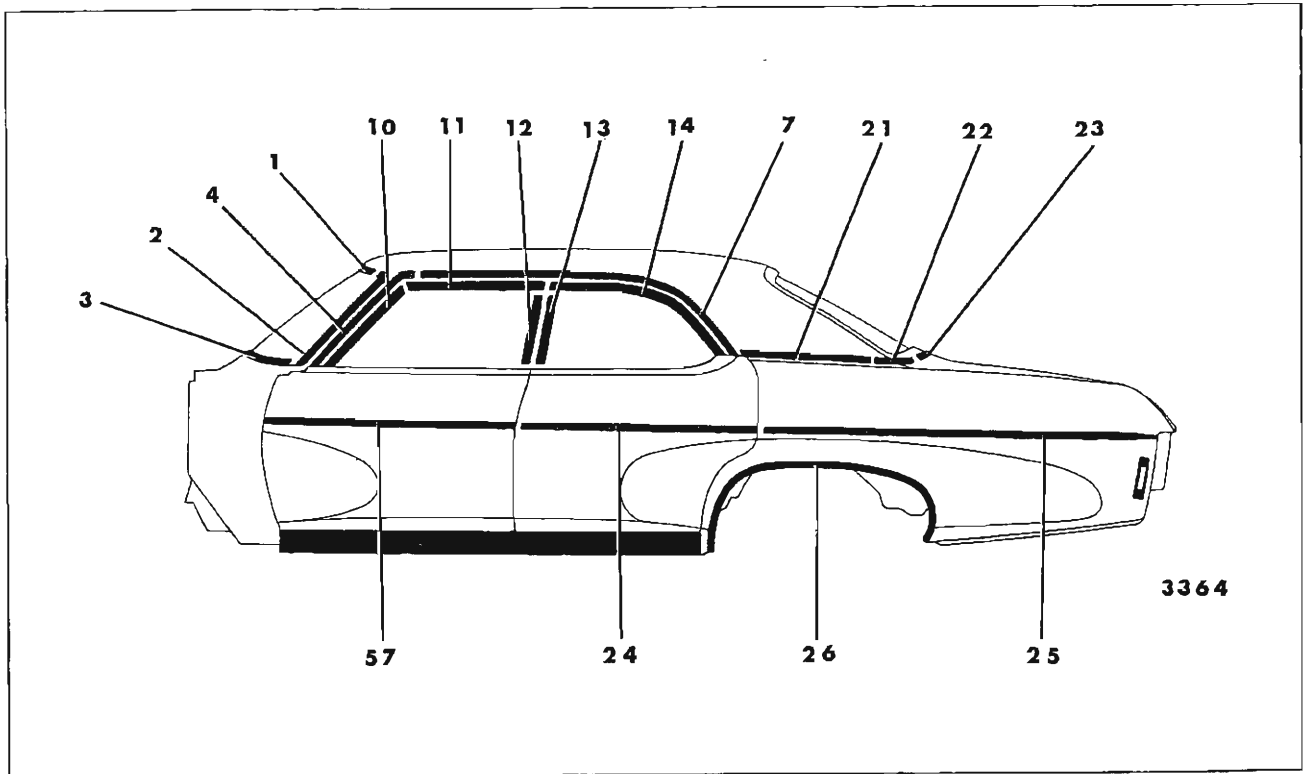

Fig. 17-20—Chevrolet "B-69" Styles

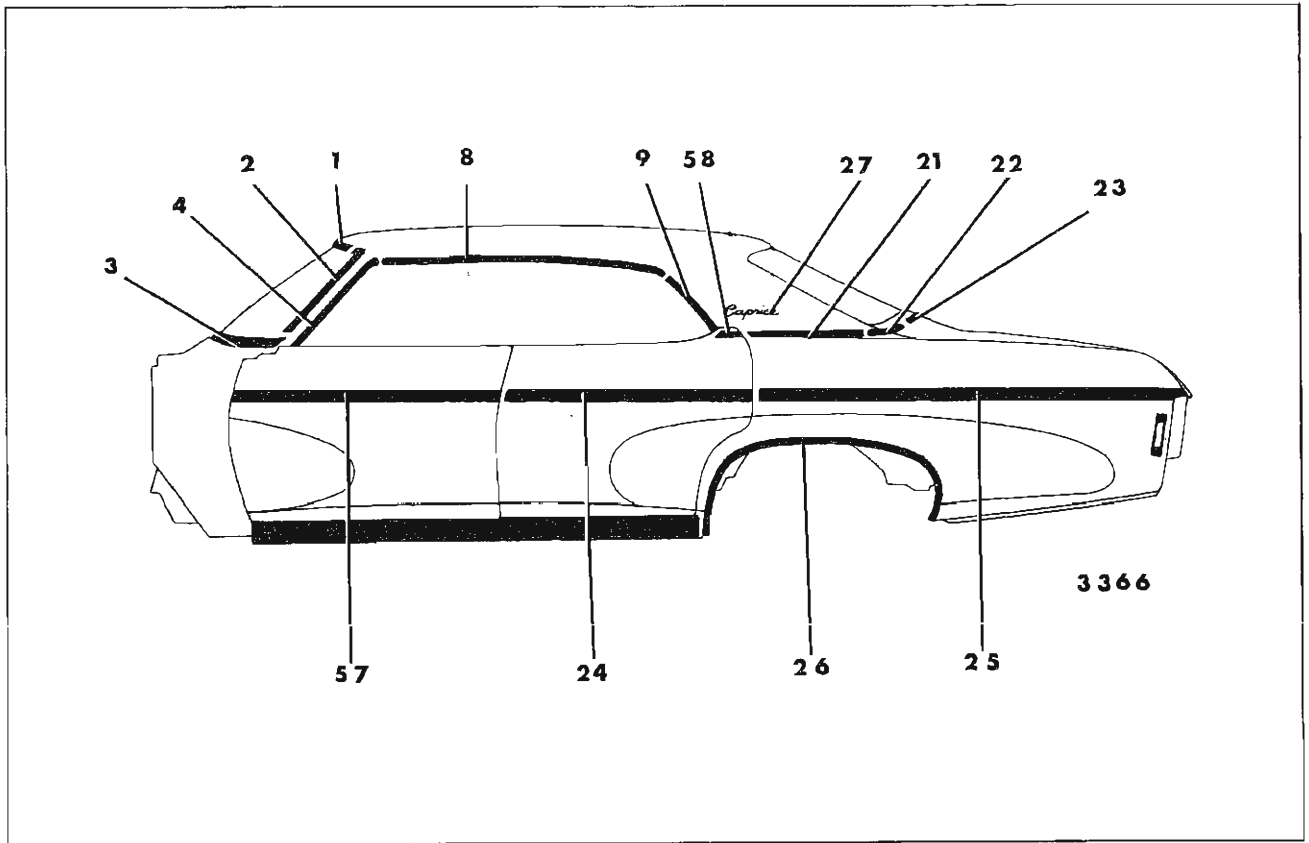

Fig. 17-21—Chevrolet "B-39" Styles

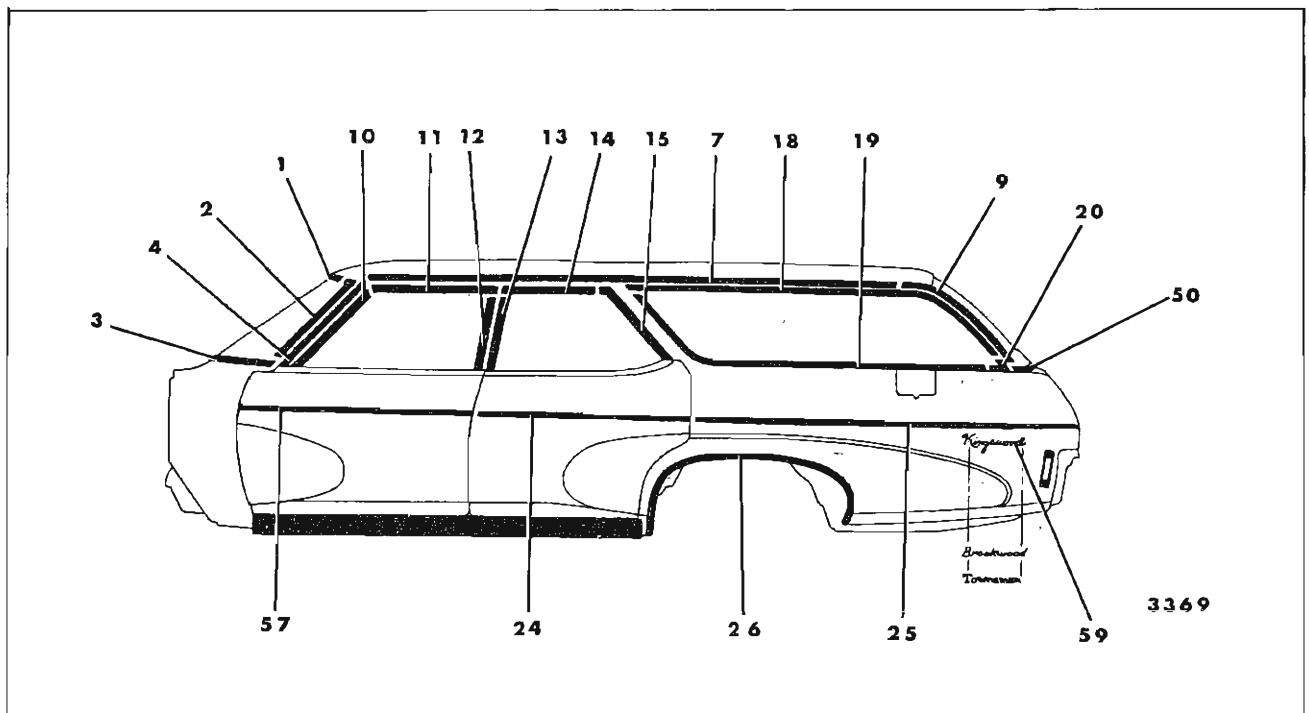

Fig. 17-22—Chevrolet "B-36-46" Styles (Less 16636-46)

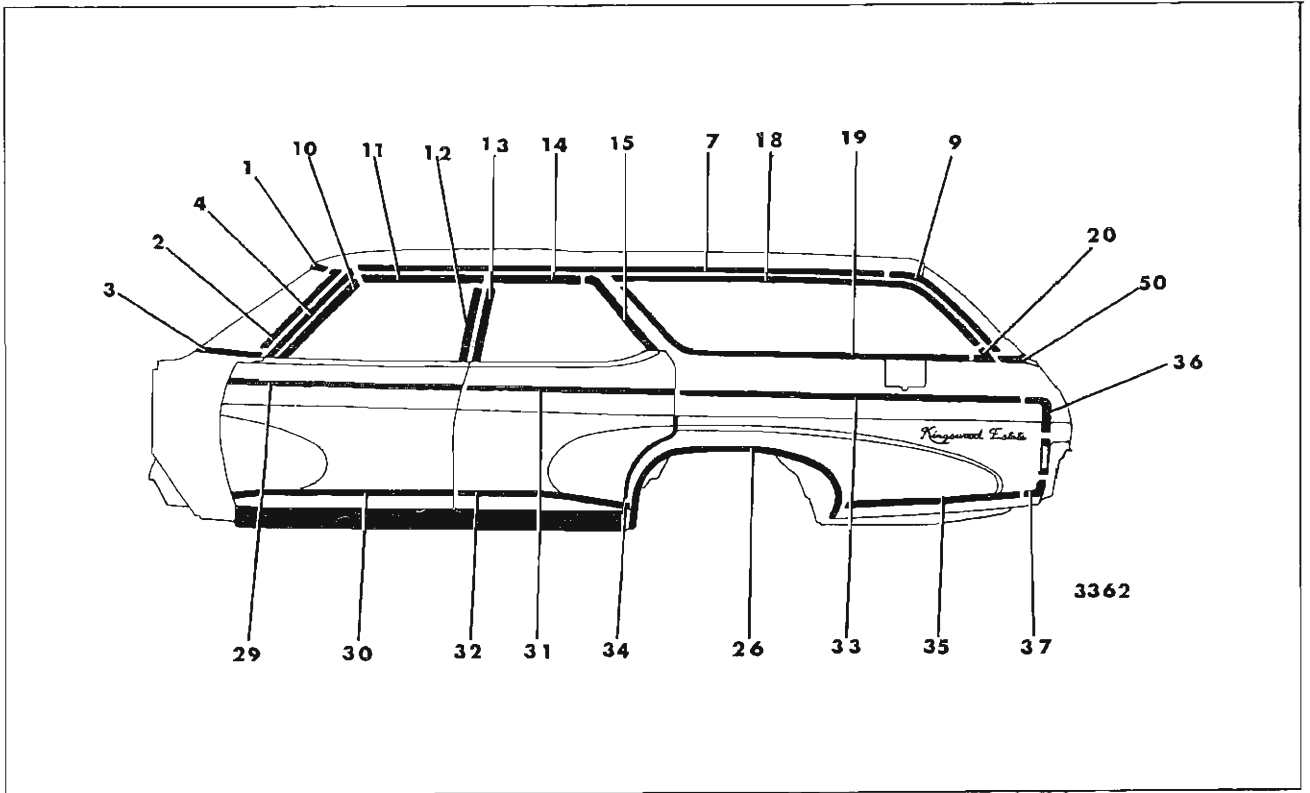

Fig. 17-23—Chevrolet 16636-46 Styles

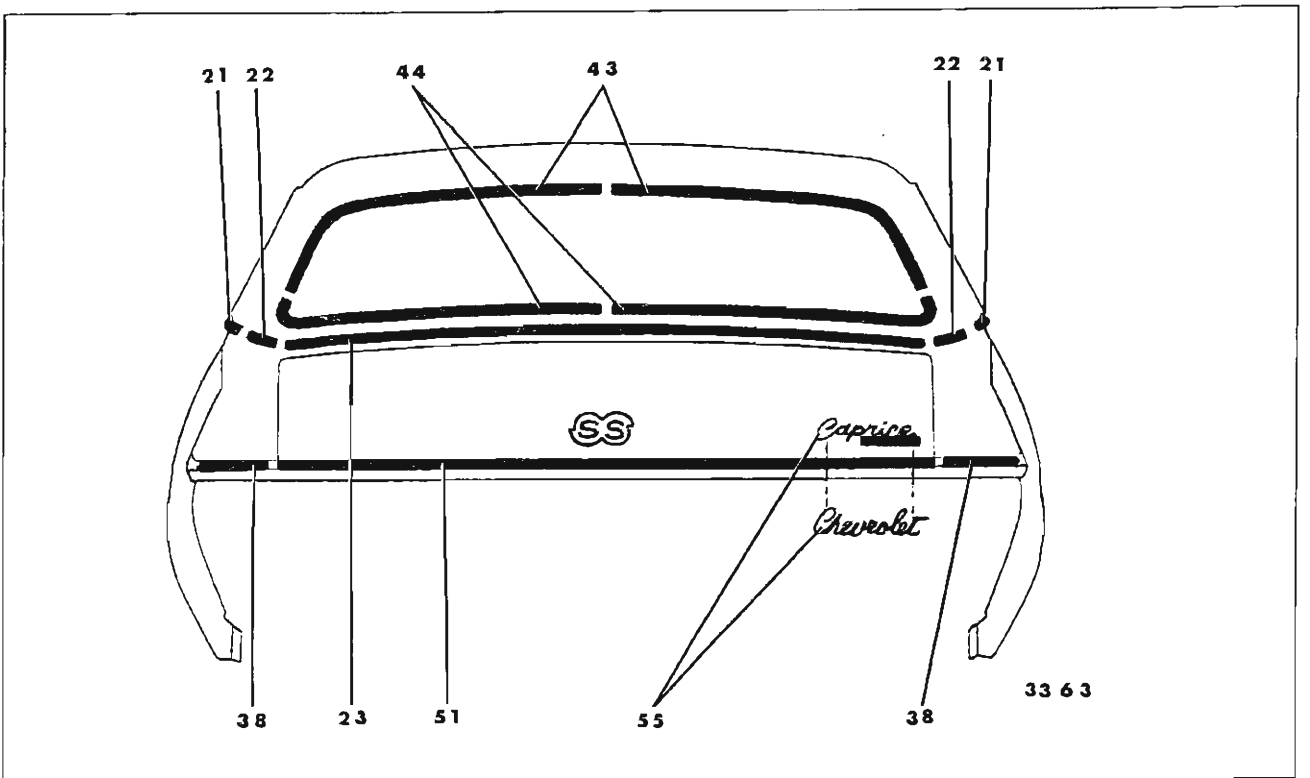

Fig. 17-24—Chevrolet 15400-15600-16400-16600 Styles (Less 36-46)

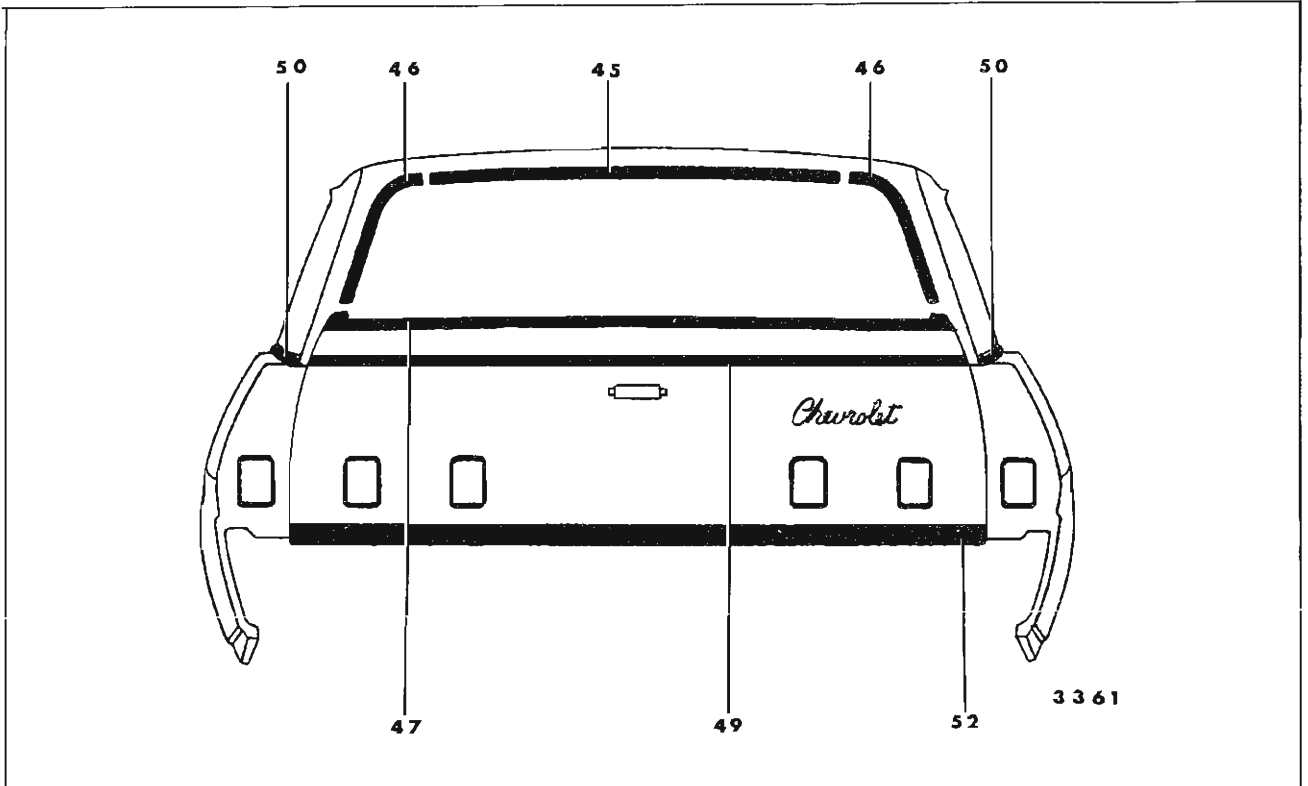

Fig. 17-25—Chevrolet "B-36-46" Styles (Less 16636-46)

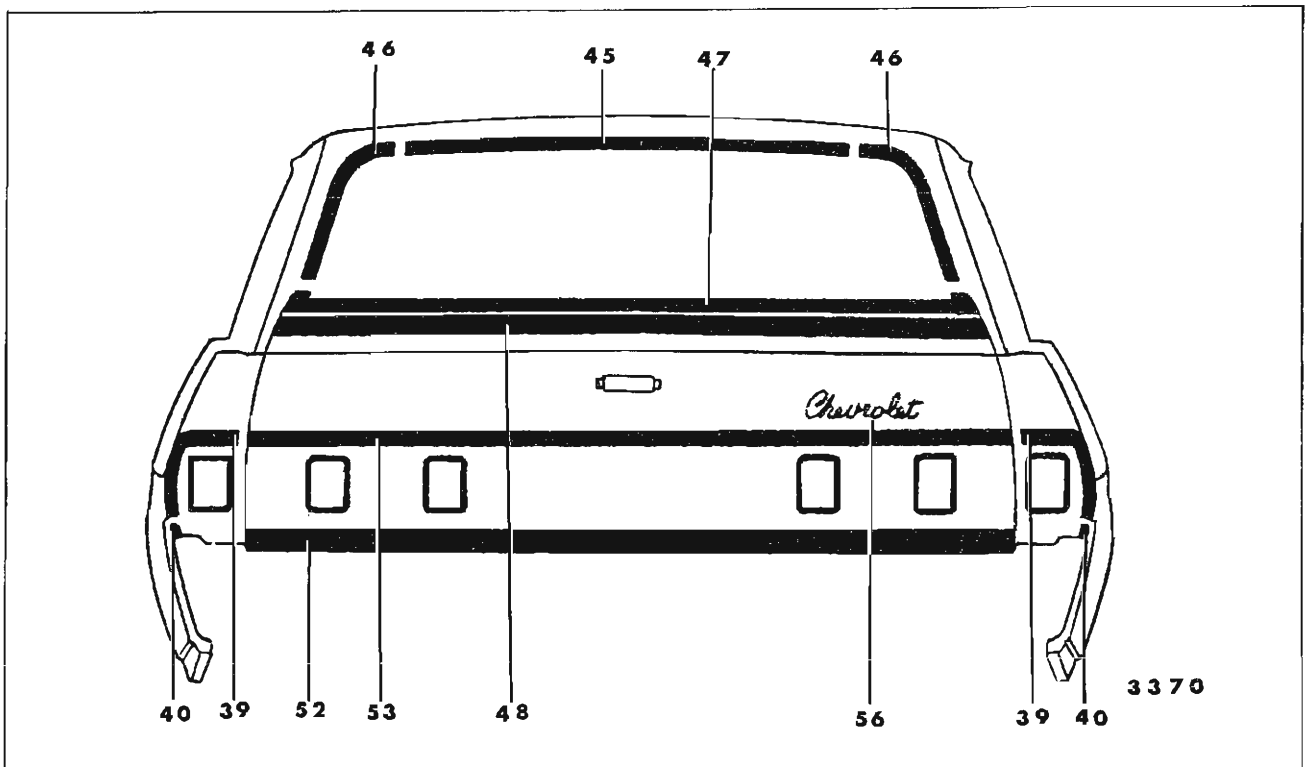

Fig. 17-26—Chevrolet 16636-46 Styles

METHODS OF MOLDING RETENTION  
CHEVROLET "B" BODIES - 15000 AND 16000 SERIES  
FIGURES 17-17 THROUGH 17-26

Key	Molding Name	Series or Styles	Screws	Spring (Self-Retained)	Snap-On Clips or Retainers On Panel	Snap-On Clips On Molding	Studs With Attaching Nuts	Engages With Other Moldings	Remove Hardware Or Trim
1	Windshield Reveal Upper	All			X			Windshield Reveal Side	
2	Windshield Reveal Side	All			X			Windshield Reveal Lower	
3	Windshield Reveal Lower	All	X						
4	Windshield Pillar Drip Scalp	All (Except 67)	X						Windshield Pillar Weatherstrip and Weatherstrip Retainer
5	Windshield Pillar Finishing	67	X						Windshield Pillar Weatherstrip and Weatherstrip Retainer
6	Windshield Header	67	X					Windshield Pillar Finishing, Windshield Upper Reveal and Windshield Upper Garnish Molding	Rear View Mirror Support Sunshade Support
7	Roof Drip Molding Scalp	11, 36, 46, 69		View K				Windshield Pillar Drip	
8	Roof Drip Molding Scalp Front	37, 39, 47		View K				Windshield Pillar Drip	
9	Roof Drip Molding Rear Scalp	37, 39, 47	X (39, 47 Only)	View K				Roof Drip Molding Scalp Front	Rear Garnish Molding & Quarter Window Glass Run Channel (47 Style Only) Roof Rail w/strip & Retainer (39 Style Only)
10	Front Door Window Frame Scalp Front	11, 36, 46, 69		View J					

**METHODS OF MOLDING RETENTION**  
**CHEVROLET "B" BODIES - 15000 AND 16000 SERIES**  
**FIGURES 17-17 THROUGH 17-26**

Key	Molding Name	Series or Styles	Screws	Spring (Self-Retained)	Snap-On Clips or Retainers On Panel	Snap-On Clips On Molding	Studs With Attaching Nuts	Engages With Other Moldings	Remove Hardware Or Trim
11	Front Door Window Frame Scalp Upper	11, 36, 46, 69		View J				Front Door Window Frame Scalp Front	
12	Front Door Window Frame Scalp Rear	11, 36, 46, 69		View J				Front Door Window Frame Scalp Upper	
13	Rear Door Window Frame Scalp Front	36, 46, 69		View J				Rear Door Window Frame Scalp Upper	
14	Rear Door Window Frame Scalp Upper	36, 46, 69		View J				Rear Door Window Frame Scalp Rear (36, 46 Styles Only)	
15	Rear Door Window Frame Scalp Rear	36, 46		View J					
16	Rear Quarter Window Reveal Front	11			X			Rear Quarter Window Reveal Upper	
17	Rear Quarter Window Reveal Upper	11	X						
18	Rear Quarter Window Reveal Upper	36, 46			X			Rear Quarter Window Reveal Lower Escutcheon	
19	Rear Quarter Window Reveal Lower	36, 46			X			Rear Quarter Window Reveal Upper	
20	Rear Quarter Window Reveal Lower Escutcheon	36, 46						Rear Quarter Window Reveal Upper and Rear Quarter Window Reveal Lower	
21	Rear Quarter Belt Reveal	11-69			X		View B		
		37			X		View B		Rr. Quarter Upper Trim
		39			X		View B	Rear End Belt Reveal	
		47					View B		Rr. Quarter Upper Trim

METHODS OF MOLDING RETENTION  
 CHEVROLET "B" BODIES - 15000 AND 16000 SERIES  
 FIGURES 17-17 THROUGH 17-26

Key	Molding Name	Series or Styles	Screws	Spring (Self-Retained)	Snap-On Clips or Retainers On Panel	Snap-On Clips On Molding	Studs With Attaching Nuts	Engages With Other Moldings	Remove Hardware Or Trim
22	Rear Quarter Belt Reveal Corner Escutcheon	11, 37, 69					X	Rear Quarter Belt Reveal Rear End Belt Reveal	
23	Rear End Belt Reveal	11, 37, 39, 69			X		View B		
24	Rear Door Outer Panel	15600, 16400, 16639	X		X				
25	Rear Quarter Outer Panel	15600, 16400 (36-46 Rt. Side Only) 16639-47  15636-46 16436-46 (Lt. Side Only)			X	View F (36-46)  View F	View B		Spare Tire Cover (36-46)
26	Rear Wheel Opening	16400 16600	X						
27	Roof Panel Name Plate "Caprice"	16639-47				View I			
28	Roof Panel Name Plate "Impala Custom"	16447					X		Remove Quarter Upper Trim
29	Front Door Outer Panel Transfer Finishing Upper	16636-46	X		X				
30	Front Door Outer Panel Transfer Finishing Lower	16636-46	X		X				
31	Rear Door Outer Panel Transfer Finishing Upper	16636-46	X		X				
32	Rear Door Outer Panel Transfer Finishing Lower	16636-46	X		X				



METHODS OF MOLDING RETENTION  
CHEVROLET "B" BODIES - 15000 AND 16000 SERIES  
FIGURES 17-17 THROUGH 17-26

Key	Molding Name	Series or Styles	Screws	Spring (Self-Retained)	Snap-On Clips or Retainers On Panel	Snap-On Clips On Molding	Studs With Attaching Nuts	Engages With Other Moldings	Remove Hardware Or Trim
33	Rear Quarter Outer Panel Transfer Finishing Upper	16636-46			X				
34	Front of Rear Wheel Opening Transfer Finishing Lower	16636-46	X						
35	Rear of Rear Wheel Opening Transfer Finishing Lower	16636-46			X				
36	Rear Quarter Outer Panel Transfer Finishing Rear Vertical (Upper)	16636-46	X			View F		Rear Quarter Outer Panel Transfer Finishing Upper	Marker Lamp
37	Rear Quarter Outer Panel Transfer Finishing Rear Vertical (Lower)	16636-46	X			View F		Rear of Rear Wheel Transfer Finishing Lower	Marker Lamp
38	Rear of Rear Quarter Outer Panel	16639-47					X		
39	Rear of Rear Quarter Outer Panel Transfer Finishing	16636-46			X	View F			
40	Rear of Rear Quarter Outer Panel Lower	16636-46	X					Rear of Rear Quarter Outer Panel Transfer Finishing	
41	Back Window Reveal Upper	All (Except 11, 36, 46, 67, 69)			X			Back Window Reveal Side	
42	Back Window Reveal Side	All (Except 11, 36, 46, 67, 69)			X				
43	Back Window Reveal Upper and Sides	11-69			X				

**METHODS OF MOLDING RETENTION**  
**CHEVROLET "B" BODIES - 15000 AND 16000 SERIES**  
**FIGURES 17-17 THROUGH 17-26**

Key	Molding Name	Series or Styles	Screws	Spring (Self-Retained)	Snap-On Clips or Retainers On Panel	Snap-On Clips On Molding	Studs With Attaching Nuts	Engages With Other Moldings	Remove Hardware Or Trim
44	Back Window Reveal Lower	All (Except 36, 46, 67)			X			Back Window Reveal Side	
45	Back Body Opening Upper Reveal	36, 46	X					Back Body Opening Reveal Side	Upper Glass Run Channel
46	Back Body Opening Side Reveal	36, 46	X						
47	Tail Gate Window Reveal	16436-46 16636-46	X			X			
48	Tail Gate Outer Panel Finishing	16636-46	X		X			Tail Gate Window Reveal	
49	Tail Gate Outer Panel Belt Reveal (Optional)	36-46 Except 16636-46	X		X		X		
50	Back Body Pillar Belt Reveal (Optional)	36, 46	X			View F			
51	Rear Compartment Lid Outer Panel	16639-47	X						
52	Tail Gate Outer Panel Lower	16436-46 16636-46			X		X		
53	Tail Gate Outer Panel Transfer Finishing Upper	16636-46			X		X		
54	Rear Compartment Lid Outer Panel Emblem	16437, 47, 67 (Optional)				View I			
55	Rear Compartment Lid Outer Panel Nameplate	All (Except 36, 46)				View I	X		
56	Tail Gate Outer Panel Nameplate	36-46					X		Tail Gate Trim Panel Assembly
57	Front Door Outer Panel	15600-16400 16600 (Except 16636-46)	X		X				

METHODS OF MOLDING RETENTION  
 CHEVROLET "B" BODIES - 15000 AND 16000 SERIES  
 FIGURES 17-17 THROUGH 17-26

Key	Molding Name	Series or Styles	Screws	Spring (Self-Retained)	Snap-On Clips or Retainers On Panel	Snap-On Clips On Molding	Studs With Attaching Nuts	Engages With Other Moldings	Remove Hardware Or Trim
58	Rear Door Corner Finishing	39 Styles Only					X		
59	Rear Quarter Outer Panel Emblem and/or Nameplate	36-46				View 1			
60	Rear Quarter Belt Pinchweld Finishing	67	X						Lower Top Half Way

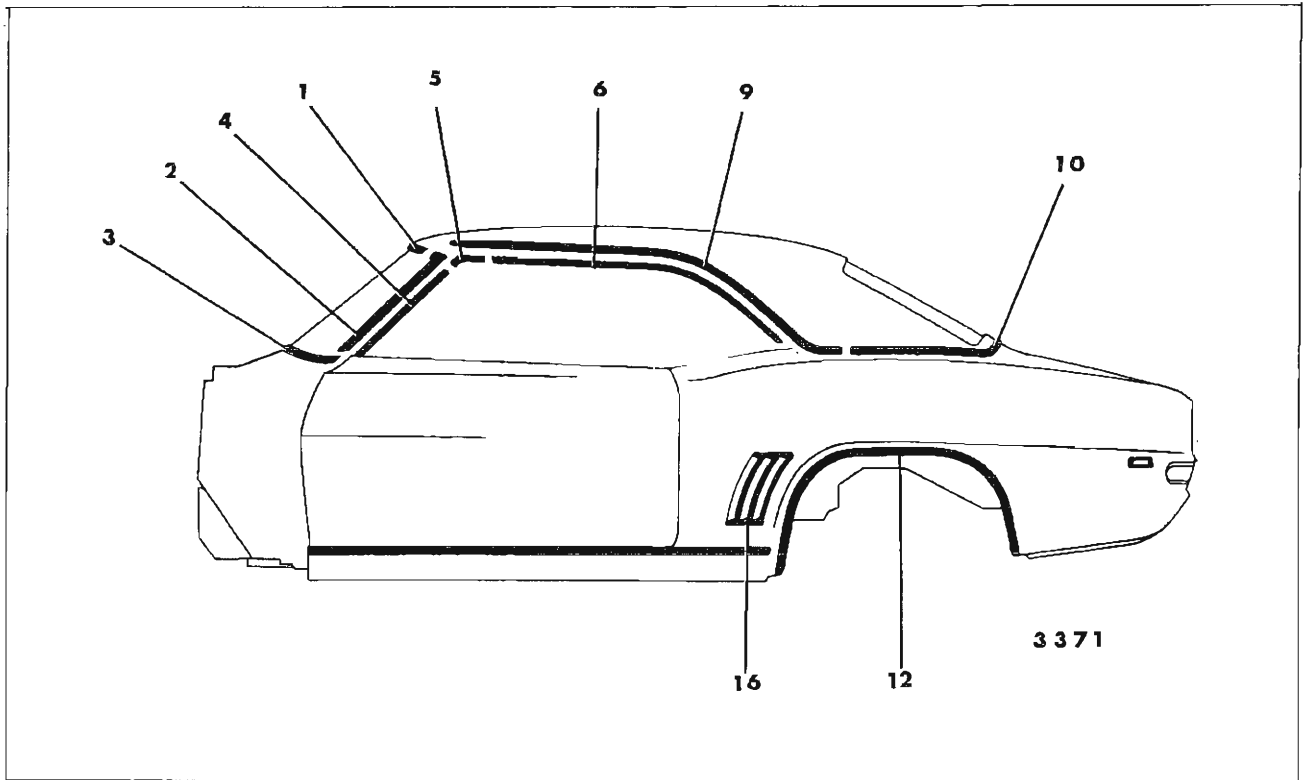

Fig. 17-27—Chevrolet "F-37" Style ("67" Style Similar)

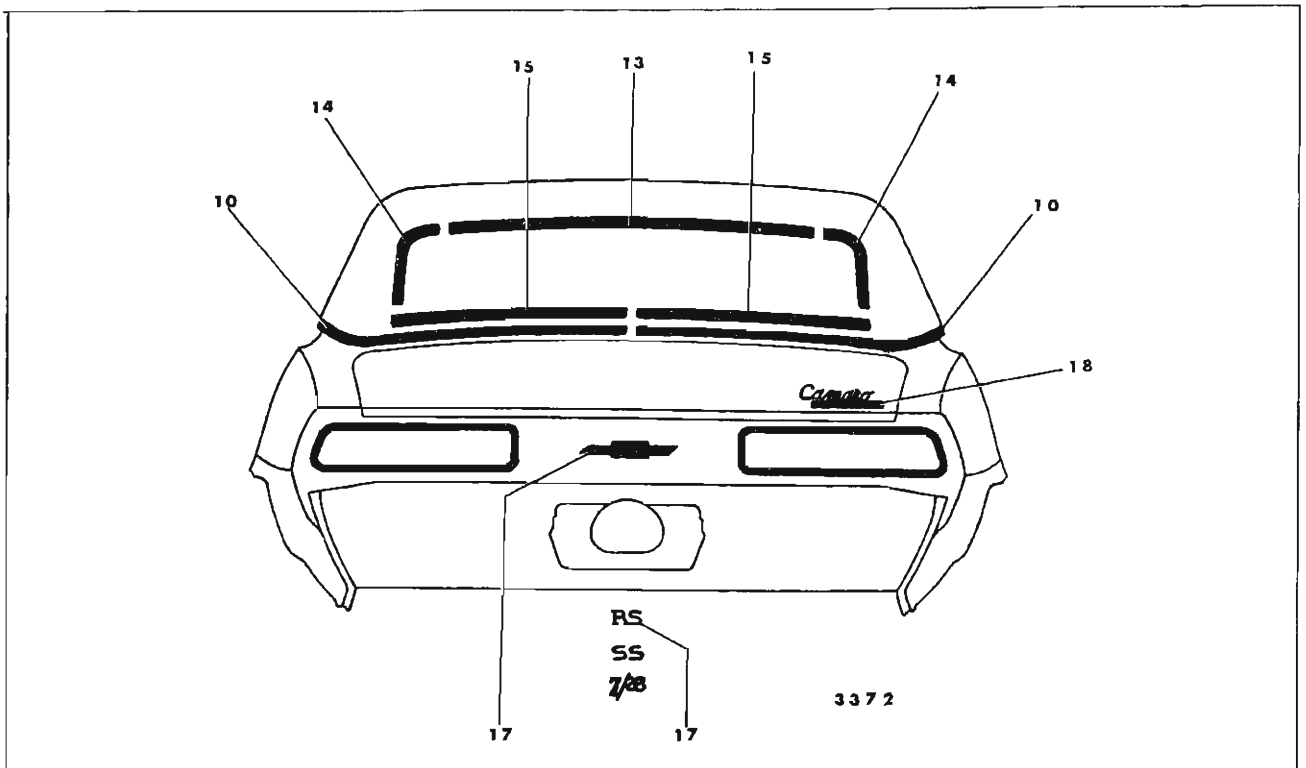

Fig. 17-28—Chevrolet "F-37" Style ("67" Style Similar)

METHODS OF MOLDING RETENTION  
CHEVROLET "F" BODIES - 12000 SERIES  
FIGURES 17-27 THROUGH 17-28

Key	Molding Name	Series or Styles	Screws	Spring (Self-Retained)	Snap-On Clips or Retainers On Panel	Snap-On Clips On Molding	Studs With Attaching Nuts	Engages With Other Moldings	Remove Hardware Or Trim
1	Windshield Reveal Upper	All			X			Windshield Reveal Side	
2	Windshield Reveal Side	All			X			Windshield Reveal Lower	
3	Windshield Reveal Lower	All	X						Cowl Air Intake Grille
4	Windshield Pillar Drip Molding Scalp	37 Style	X					Windshield Pillar Drip Molding Scalp Escutcheon	
5	Windshield Pillar Drip Molding Scalp Escutcheon	37 Style		View K					
6	Roof Drip Molding Scalp	37 Style		View K				Windshield Pillar Drip Molding Scalp Escutcheon	
7	Windshield Pillar Finishing	67 Style	X					Windshield Header Windshield Reveal Side	Windshield Pillar Weatherstrip and Weatherstrip Retainer
8	Windshield Header	67 Style	X					Windshield Reveal Upper and Sides	Rear View Mirror Support, Sunshade and Striker Support, Windshield Pillar Weatherstrip and Weatherstrip Retainer
9	Roof Panel Cover Side	37 Style (Optional)			X				
10	Rear Quarter Belt Reveal	37 Style (Optional)			X			Roof Panel Cover Side	
11	Rear Quarter Pinch Weld Finishing	67 Style	X		View L				Lower Top Halfway

METHODS OF MOLDING RETENTION  
CHEVROLET "F" BODIES - 12000 SERIES  
FIGURES 17-27 THROUGH 17-28

Key	Molding Name	Series or Styles	Screws	Spring (Self-Retained)	Snap-On Clips or Retainers On Panel	Snap-On Clips On Molding	Studs With Attaching Nuts	Engages With Other Moldings	Remove Hardware Or Trim
12	Rear Wheel Opening	All	X						
13	Back Window Reveal Upper	37 Style			X			Back Window Reveal Side	
14	Back Window Reveal Side	37 Style			X			Back Window Reveal Lower	
15	Back Window Reveal Lower	37 Style			X				
16	Rear Quarter Outer Panel Louver	All (Optional)					View C		Rear Quarter Trim Pad
17	Rear Compartment Lid Outer Panel Emblem	All					View C		
18	Rear Compartment Lid Outer Panel Name Plate						X		

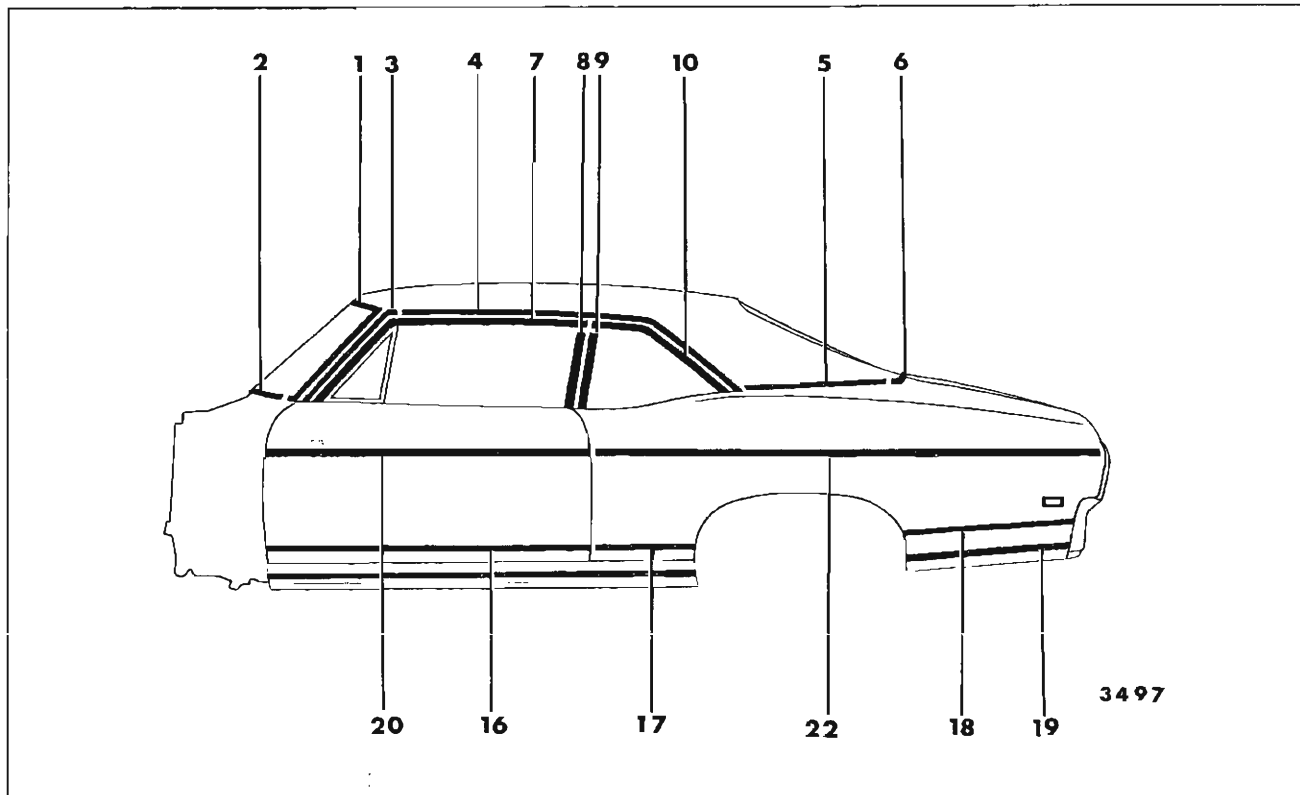

Fig. 17-29—Chevrolet "X-27" Styles

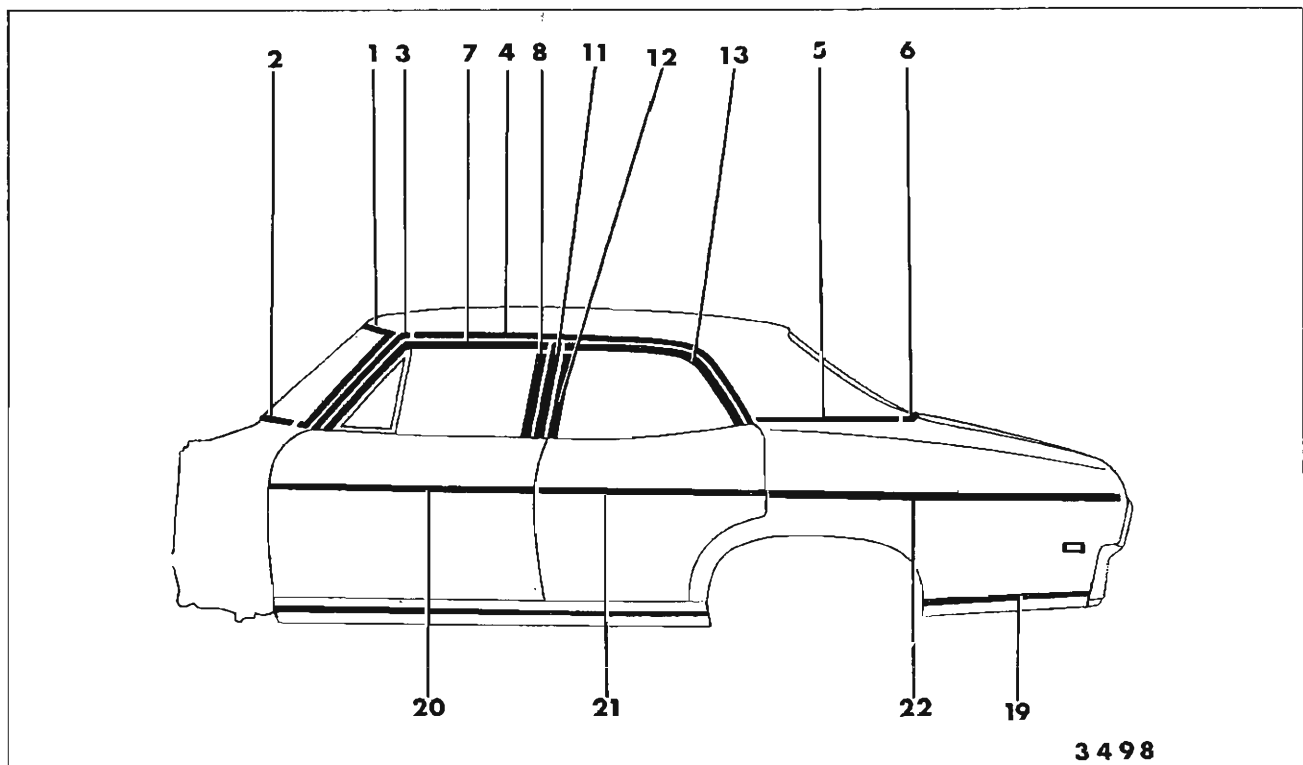

Fig. 17-30—Chevrolet "X-69" Styles

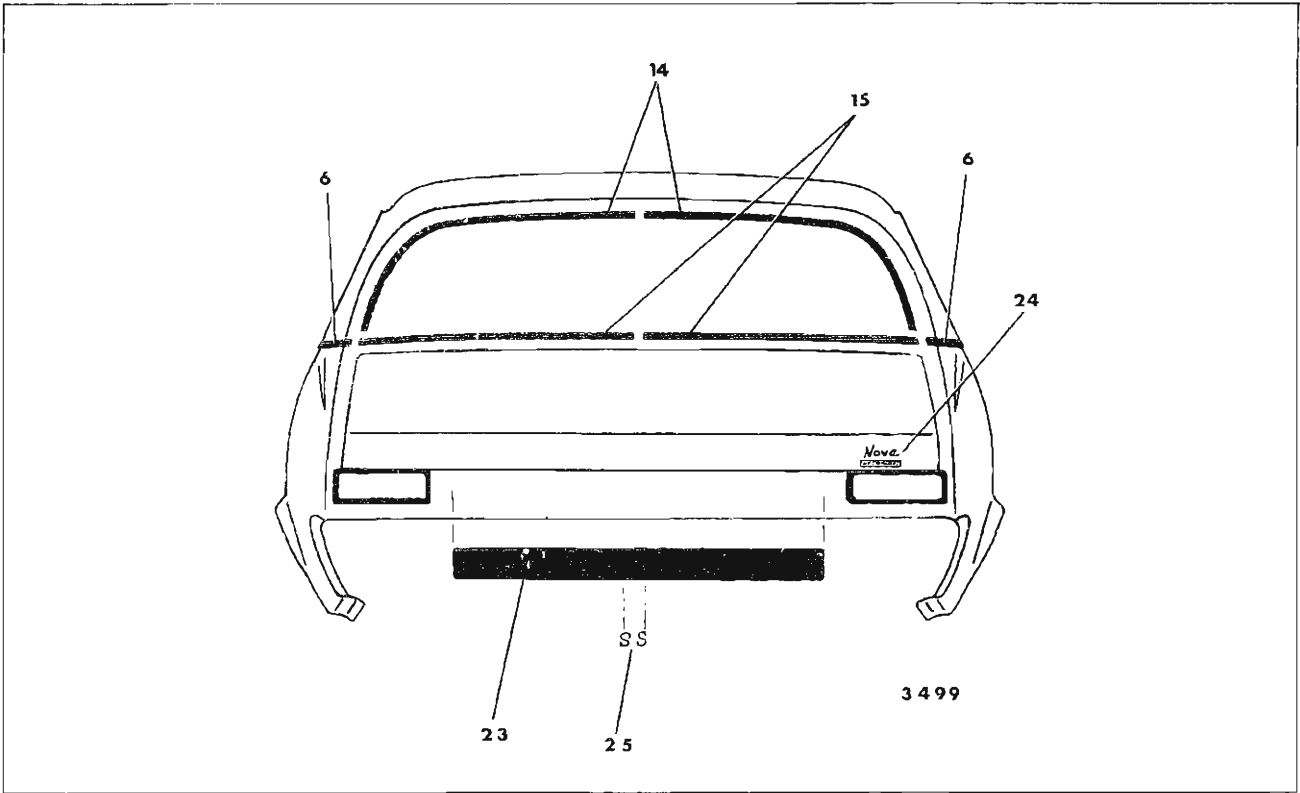

Fig. 17-31—Chevrolet "X-27-69" Styles



METHODS OF MOLDING RETENTION  
CHEVROLET "X" BODIES - 11000 SERIES  
FIGURES 17-29 THROUGH 17-31

Key	Molding Name	Series or Styles	Screws	Spring (Self-Retained)	Snap-On Clips or Retainers On Panel	Snap-On Clips On Molding	Studs With Attaching Nuts	Engages With Other Moldings	Remove Hardware Or Trim
1	Windshield Reveal Upper and Sides	All			X			Windshield Reveal Lower	
2	Windshield Reveal Lower	All	X						Cowl Air Intake Grille
3	Windshield Pillar Drip Scalp	All (Optional)	X						
4	Roof Drip Molding Scalp	All (Optional)		View K				Windshield Pillar Drip Scalp	
5	Rear Quarter Belt Reveal	All (Optional)			X		X		
6	Rear Quarter Belt Reveal Corner Escutcheon	All (Optional)					X		Rear Quarter Belt Reveal
7	Front Door Window Frame Front Scalp	All (Optional)		View J					
8	Front Door Window Frame Rear Scalp	All (Optional)		View J				Front Door Window Frame Front Scalp	
9	Rear Quarter Window Frame Front Scalp	27 Style (Optional)		View J					
10	Rear Quarter Window Frame Upper Scalp	27 Style (Optional)		View J				Rear Quarter Window Frame Front Scalp	
11	Center Pillar Scalp	69 Style (Optional)	X						
12	Rear Door Window Frame Front Scalp	69 Style (Optional)		View J				Rear Door Window Frame Upper Scalp	
13	Rear Door Window Frame Upper Scalp	69 Style (Optional)		View J					
14	Back Window Reveal Upper and Sides	All			X			Back Window Reveal Lower	
15	Back Window Reveal Lower	All	X						

METHODS OF MOLDING RETENTION  
CHEVROLET "X" BODIES - 11000 SERIES  
FIGURES 17-29 THROUGH 17-31

Key	Molding Name	Series or Styles	Screws	Spring (Self-Retained)	Snap-On Clips or Retainers On Panel	Snap-On Clips On Molding	Studs With Attaching Nuts	Engages With Other Moldings	Remove Hardware Or Trim
16	Front Door Outer Panel Lower	27 Style (Optional)	X		X				
17	Front of Rear Wheel Opening	27 Style (Optional)			X		View B		
18	Rear of Rear Wheel Opening	27 Style (Optional)			X	View F			
19	Rear of Rear Wheel Opening Lower	All (Optional)			X		View B		
20	Front Door Outer Panel	All (Optional)	X		X				
21	Rear Door Outer Panel	69 Style (Optional)	X		X				
22	Rear Quarter Outer Panel	All (Optional)			X		View B		
23	Rear End Outer Panel	All (Optional)					View C		
24	Rear Compartment Lid Outer Panel Emblem	All					View C		
25	Rear End Outer Panel Emblem	27 Style (Optional)					X		

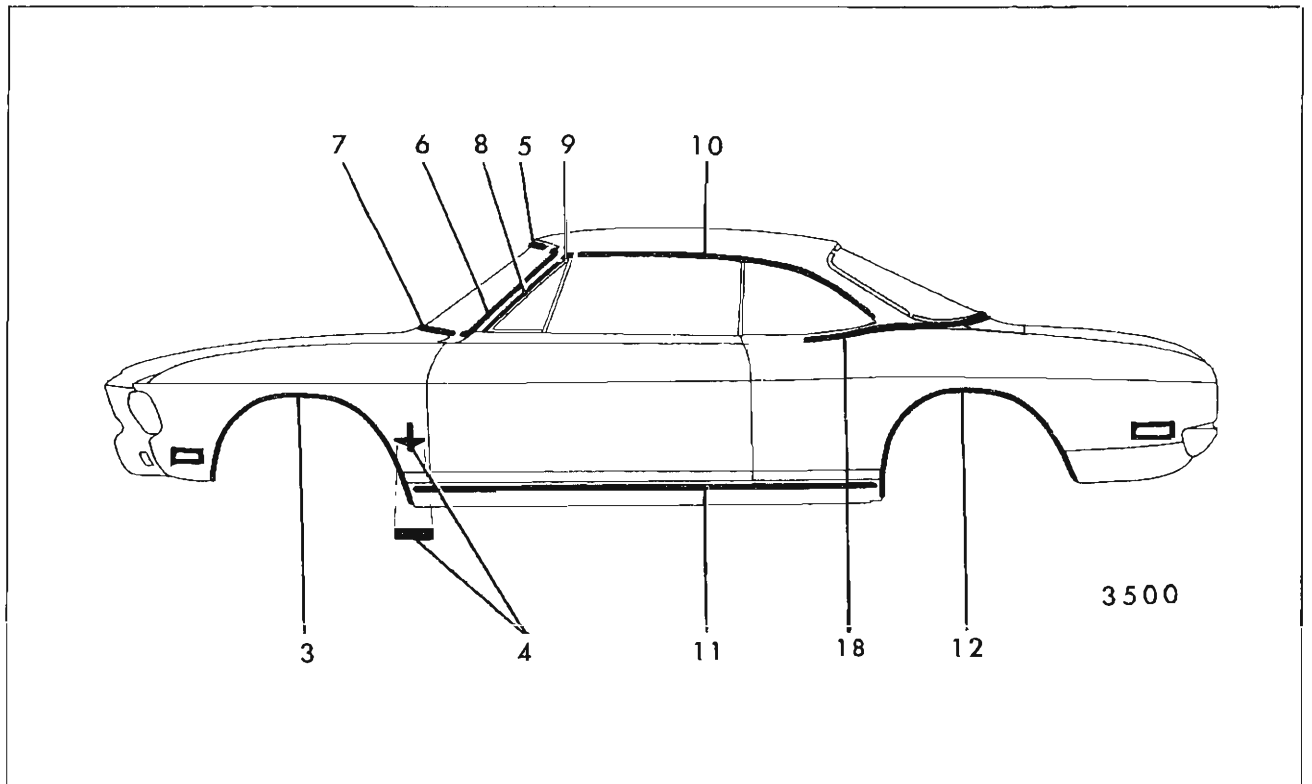

Fig. 17-32—Chevrolet "Z-37-67" Styles

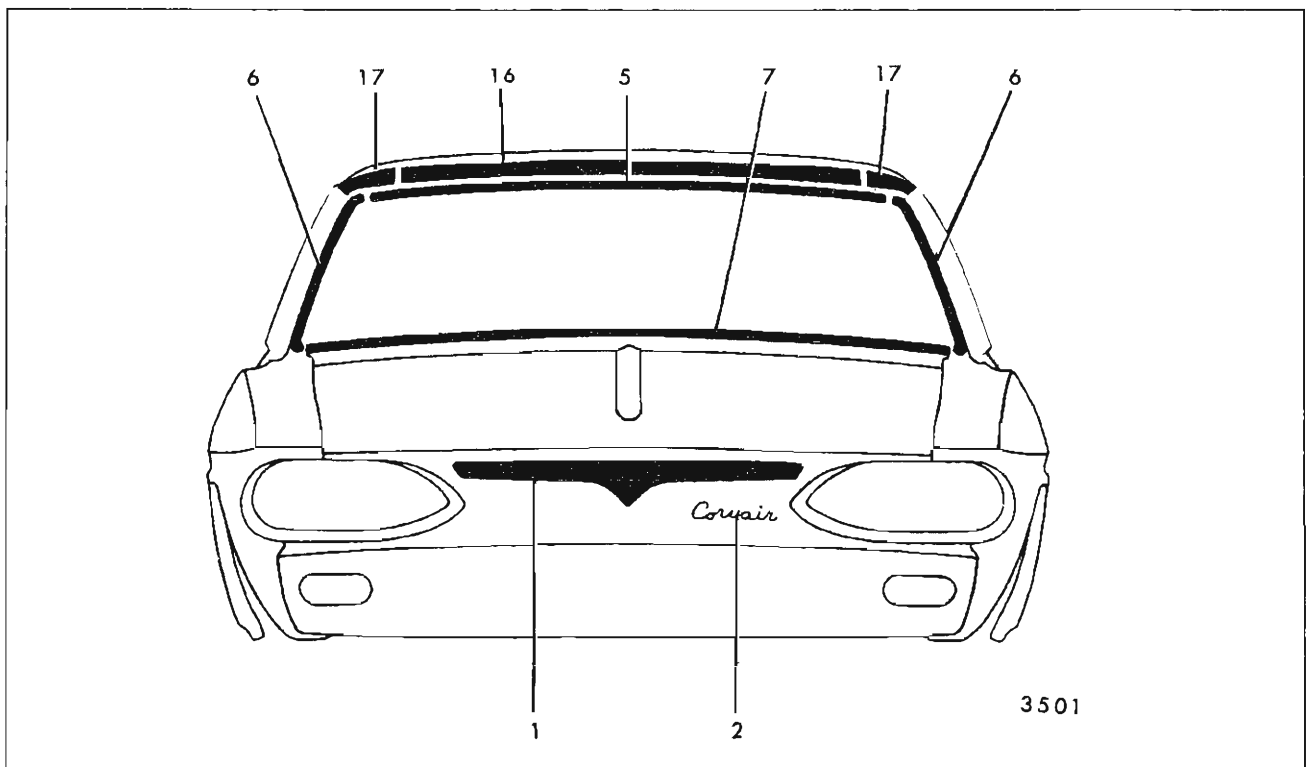

Fig. 17-33—Chevrolet "Z-37-67" Styles

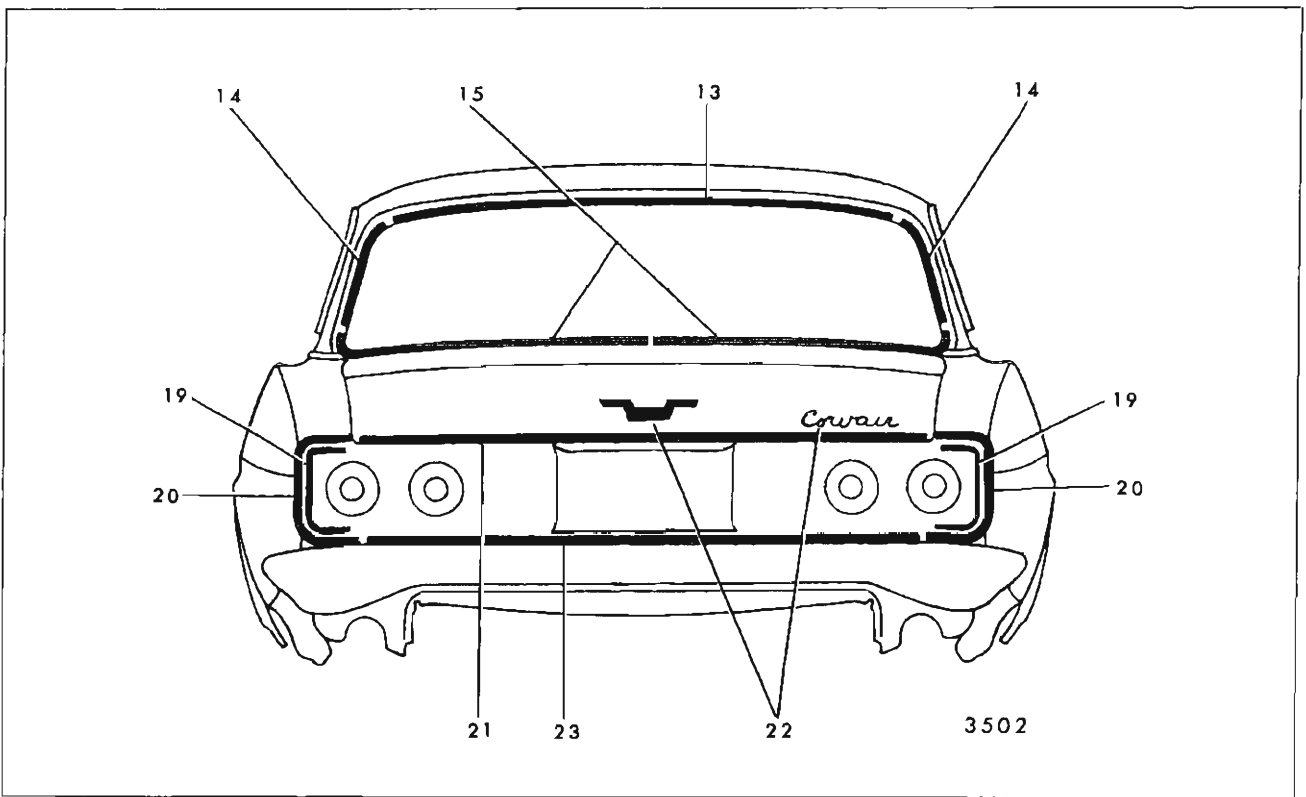

Fig. 17-34—Chevrolet "Z-37-67" Styles

METHODS OF MOLDING RETENTION  
CHEVROLET "Z" BODIES - 10000 SERIES  
FIGURES 17-32 THROUGH 17-34

Key	Molding Name	Series or Styles	Screws	Spring (Self-Retained)	Snap-On Clips or Retainers On Panel	Snap-On Clips On Molding	Studs With Attaching Nuts	Engages With Other Moldings	Remove Hardware Or Trim
1	Front End Outer Panel	All					X		Front Compartment Lock Cylinder and Retainer
2	Front End Outer Panel Nameplate	All					X		
3	Front Wheel Opening	All	X						
4	Front Fender Emblem	All			View H 10137 Lt. Side		X		Front Cowl Trim Foundation
5	Windshield Reveal Upper	All			X				
6	Windshield Reveal Side	All			X			Windshield Reveal Upper	
7	Windshield Reveal Lower	All			X			Windshield Reveal Side	
8	Windshield Pillar Drip Molding Scalp	10537		View K				Windshield Pillar Drip Molding Scalp Escutcheon	
9	Windshield Pillar Drip Molding Scalp Escutcheon	10537		View K					
10	Roof Drip Molding Scalp	10537		View K				Windshield Pillar Drip Molding Scalp Escutcheon	
11	Rocker Outer Panel	10500	X		X				
12	Rear Wheel Opening	10500	X						

METHODS OF MOLDING RETENTION  
CHEVROLET "Z" BODIES - 10000 SERIES  
FIGURES 17-32 THROUGH 17-34

Key	Molding Name	Series or Styles	Screws	Spring (Self-Retained)	Snap-On Clips or Retainers On Panel	Snap-On Clips On Molding	Studs With Attaching Nuts	Engages With Other Moldings	Remove Hardware Or Trim
13	Back Window Reveal Upper	37 Styles			X			Back Window Reveal Sides	
14	Back Window Reveal Side	37 Styles			X				
15	Back Window Reveal Lower	37 Styles			X			Back Window Reveal Sides	
16	Windshield Header Center	10567	X					Windshield Header Sides-Windshield Reveal Upper	Windshield Pillar Weatherstrip Rear View Mirror Support Sunshade and Striker Support
17	Windshield Header-Sides	10567	X					Windshield Reveal Upper and Sides	Windshield Pillar Weatherstrip, Sunshade and Striker Support
18	Rear Quarter Pinchweld Finishing	10567	X		X				
19	Rear of Rear Quarter	All					X		
20	Rear of Rear Quarter Finishing	10500	X					Rear of Rear Quarter	
21	Engine Compartment Lid	10500	X						
22	Engine Compartment Lid Nameplate and/or Emblem	All					X		
23	Rear End Panel	10500					X	Rear of Rear Quarter Finishing	

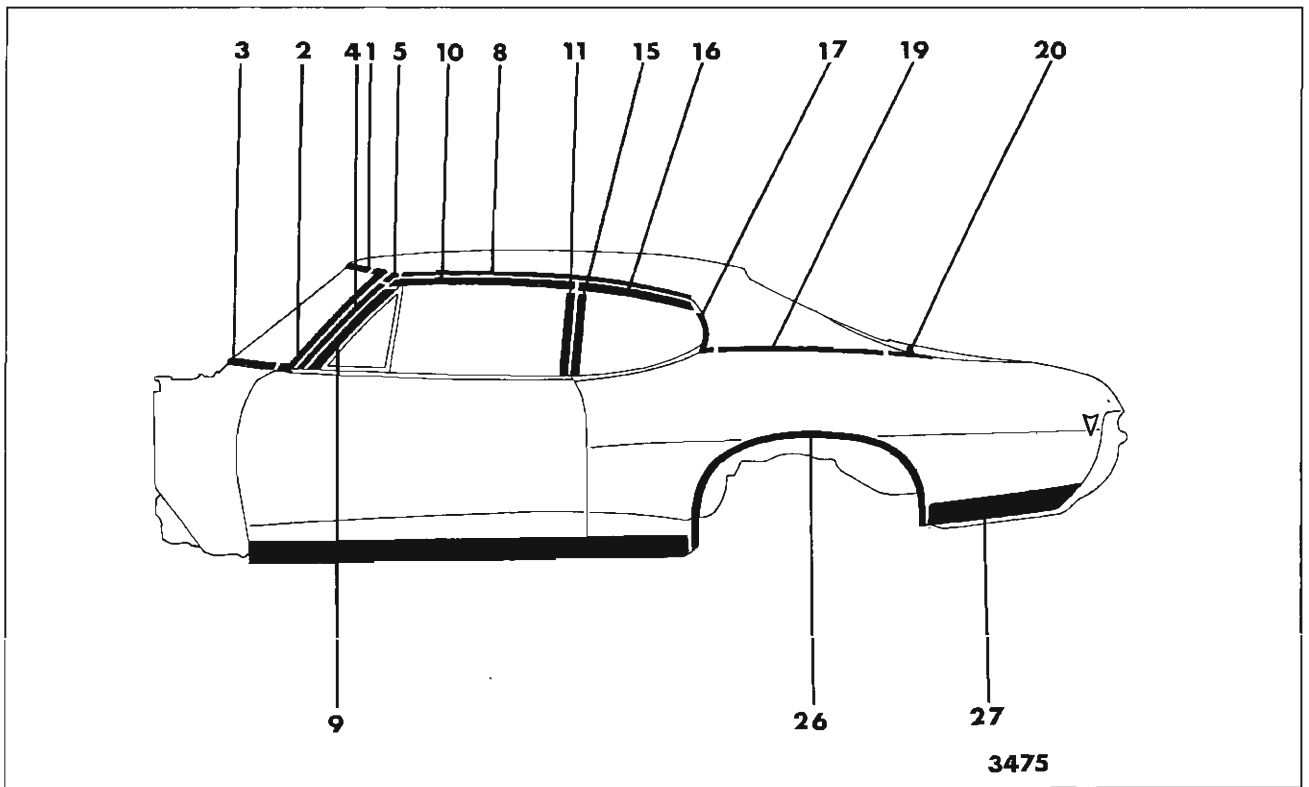

Fig. 17-35—Pontiac "A-27" Styles

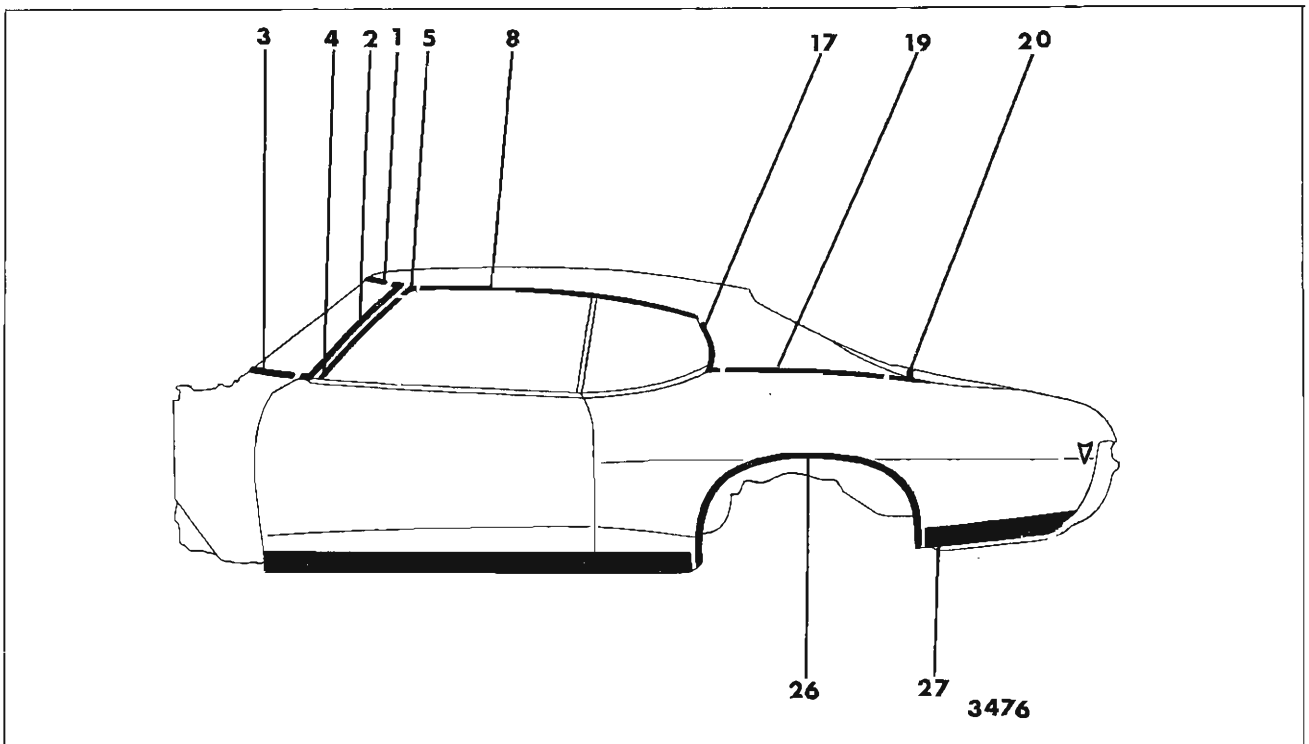

Fig. 17-36—Pontiac "A-37" Styles ("67" Styles Similar)

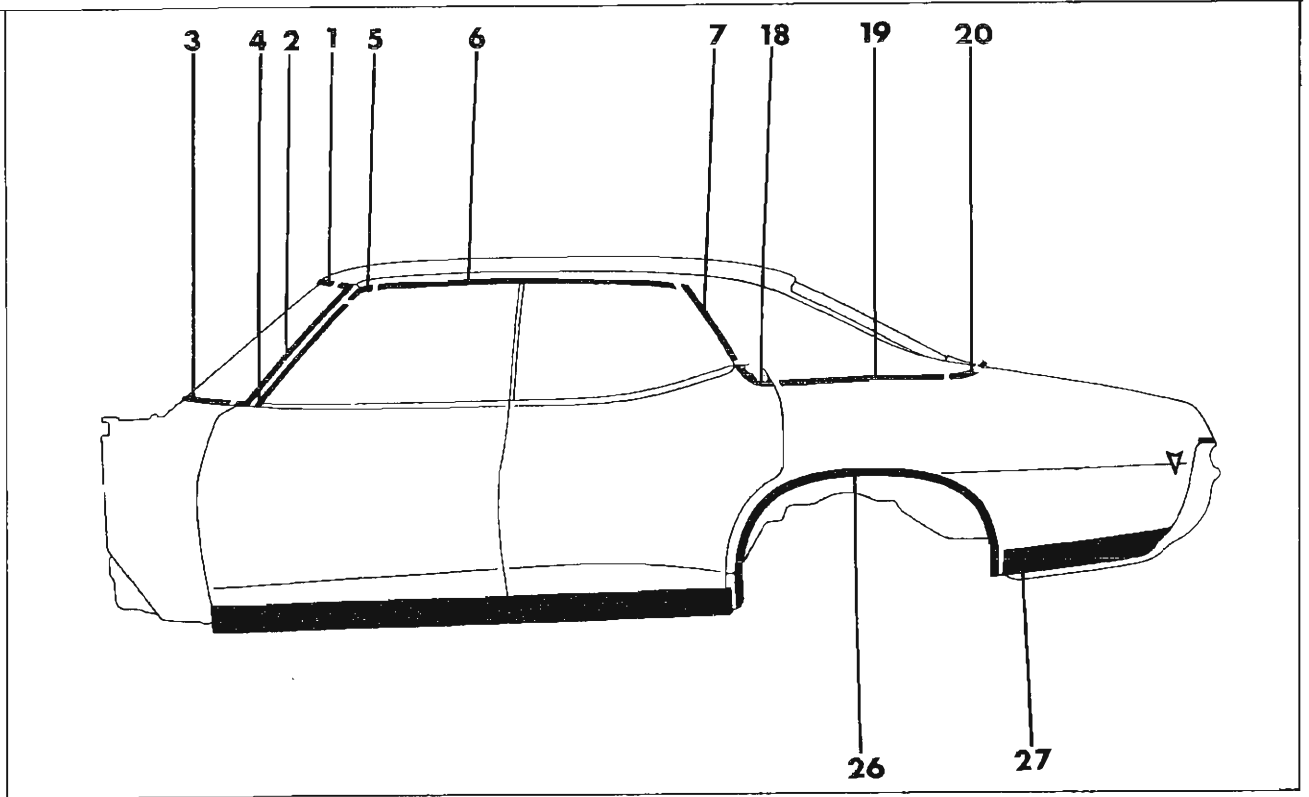

Fig. 17-37—Pontiac "A-39" Styles

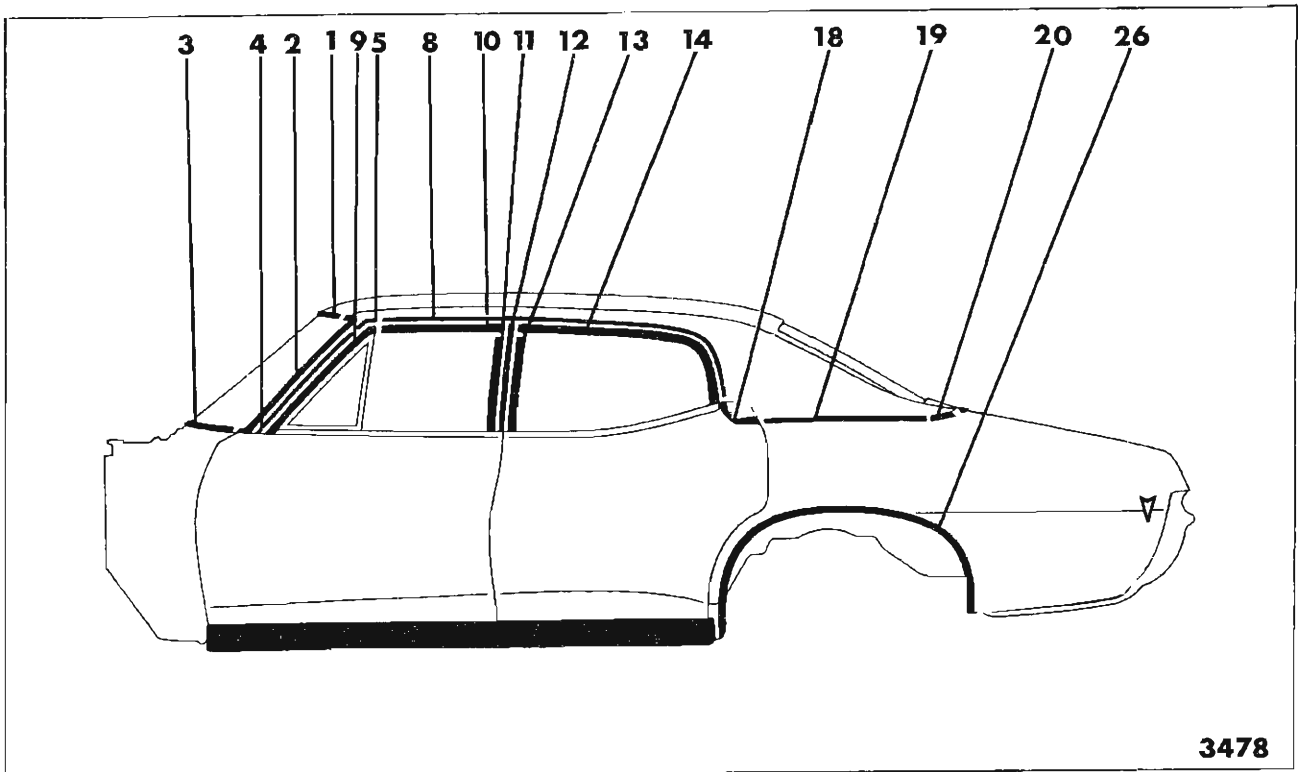

Fig. 17-38—Pontiac "A-69" Styles



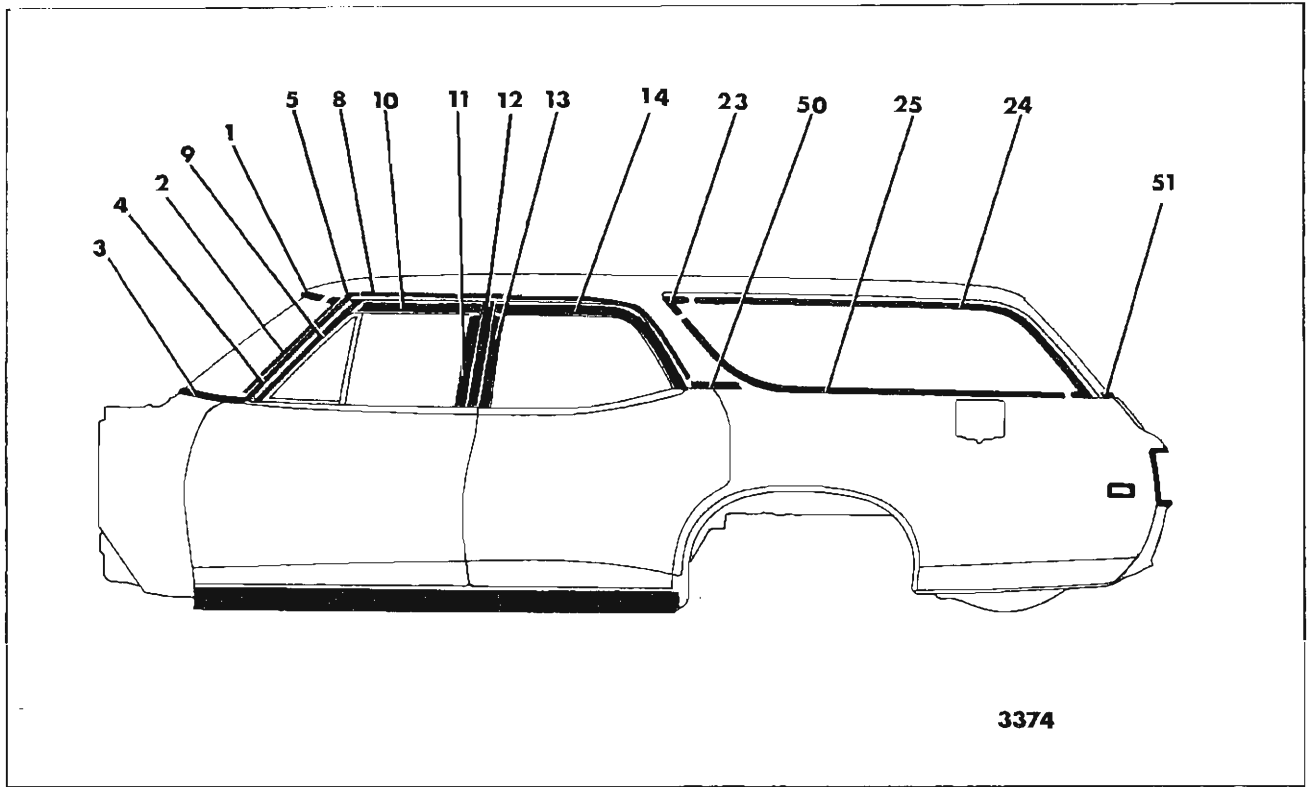

Fig. 17-39—Pontiac "A-35-36" Styles (Less 23936 Style)

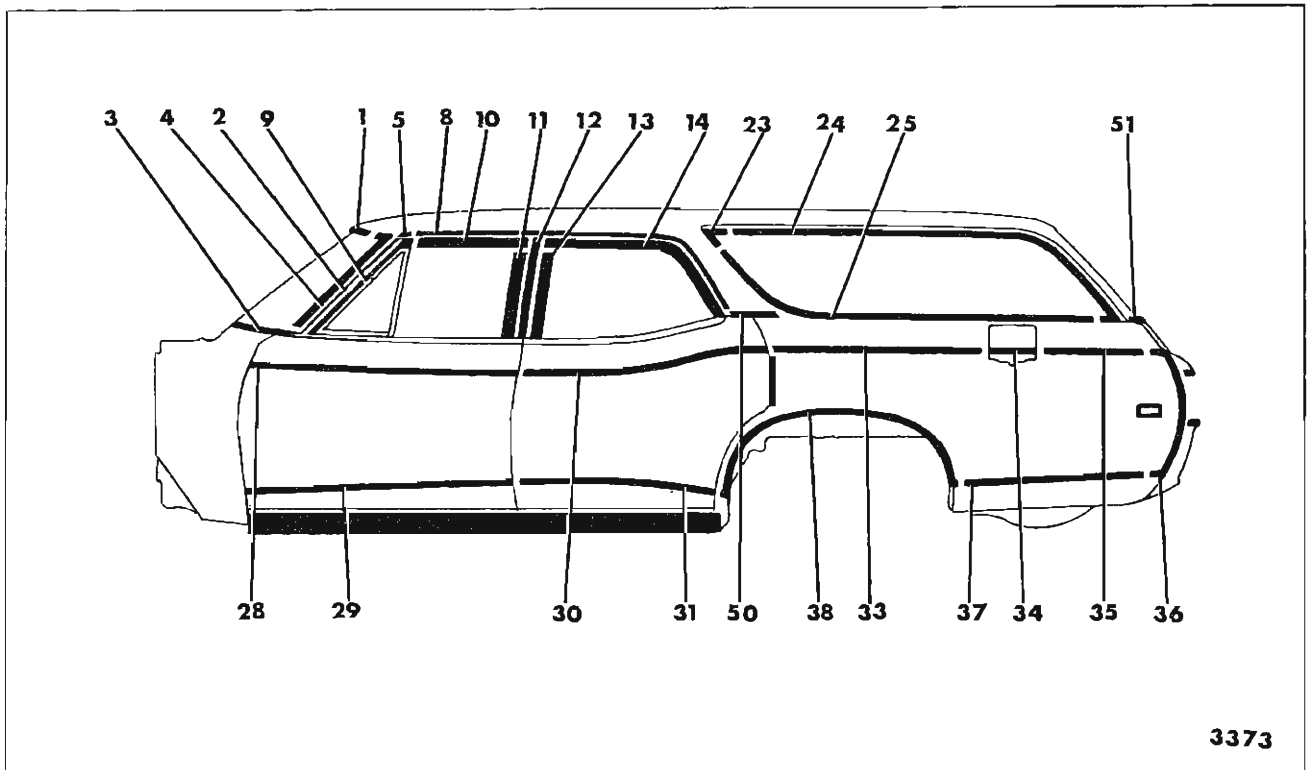

Fig. 17-40—Pontiac 23936 Style

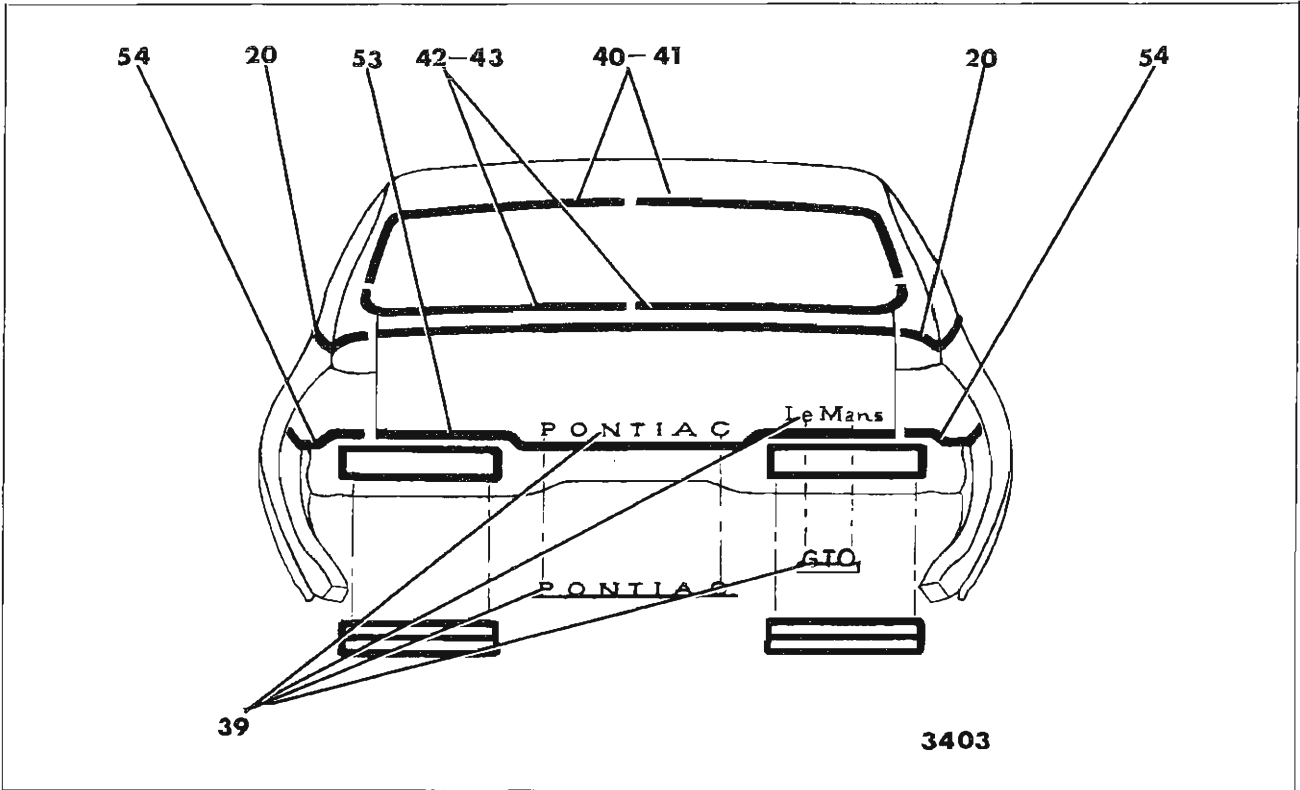

Fig. 17-41—Pontiac 23300-23500-23700-24200 Styles (Less 35-36 Style)

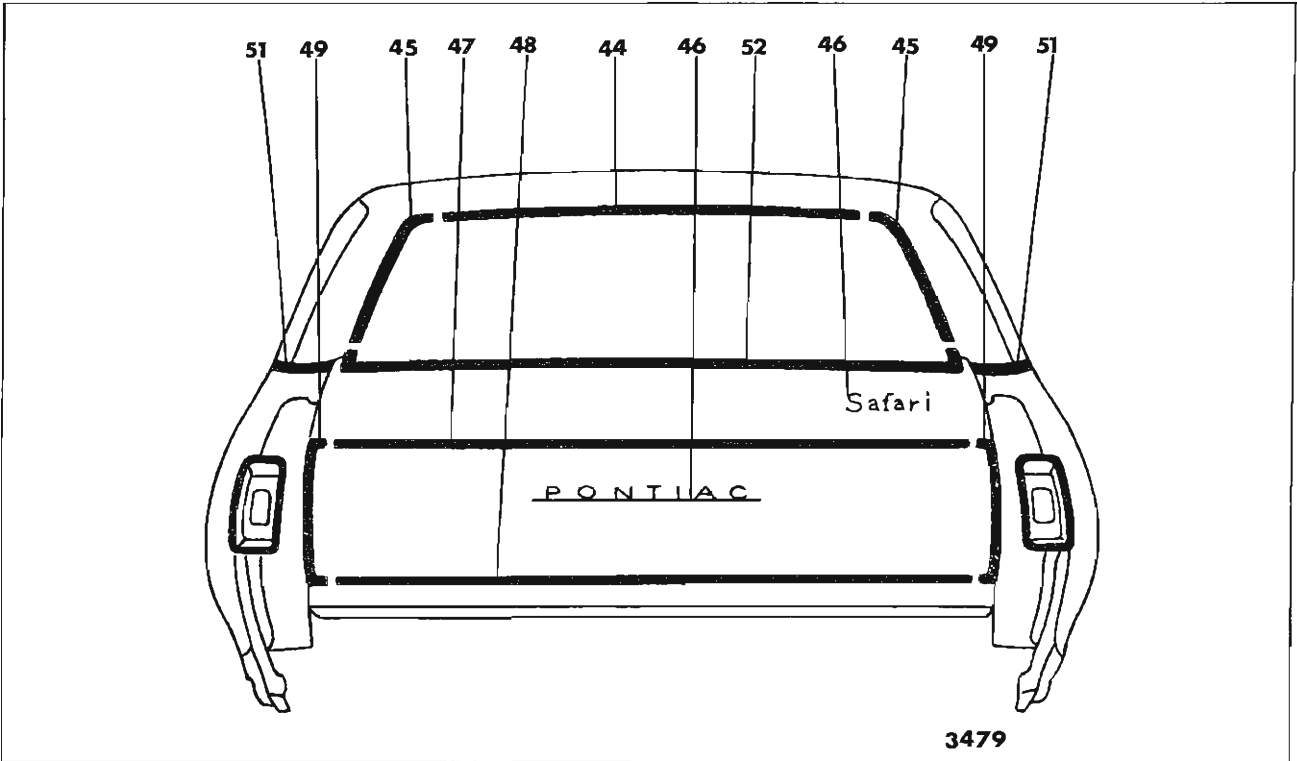

Fig. 17-42—Pontiac "A-35-36" Styles

## METHODS OF MOLDING RETENTION

PONTIAC "A" BODIES - 23000 AND 24000 SERIES

FIGURES 17-35 THROUGH 17-42

Key	Molding Name	Series or Styles	Screws	Spring (Self-Retained)	Snap-On Clips or Retainers On Panel	Snap-On Clips On Molding	Studs With Attaching Nuts	Engages With Other Moldings	Remove Hardware Or Trim
1	Windshield Reveal Upper	All			X			Windshield Reveal Side	
2	Windshield Reveal Side	All	X (67 Only)		X				
3	Windshield Reveal Lower	All	X					Windshield Reveal Side	
4	Windshield Pillar Drip Scalp	All (Except 67)		View K				Roof Drip Molding Front Scalp Escutcheon	
5	Roof Drip Molding Front Scalp Escutcheon	All (Except 67)		View K				Windshield Pillar Drip Scalp and Roof Drip Scalp	
6	Roof Drip Molding Front Scalp	39 Style		View K				Roof Drip Molding Front Scalp Escutcheon	
7	Roof Drip Molding Rear Scalp	39 Style	X					Roof Drip Molding Front Scalp	Side Roof Rail w/strip & W/strip retainer.
8	Roof Drip Molding Scalp	All (Except 39, 67)		View K				Roof Drip Molding Front Scalp Escutcheon	
9	Front Door Window Frame Front Scalp	27, 35, 36, 69		View J					
10	Front Door Window Frame Upper Scalp	27, 35, 36, 69		View J				Front Door Window Frame Front Scalp	
11	Front Door Window Frame Rear Scalp	27, 35, 36, 69		View J				Front Door Window Frame Upper Scalp	
12	Center Pillar Scalp	35, 36, 69	X						
13	Rear Door Window Frame Front Scalp	35, 36, 69		View J				Rear Door Window Frame Upper Scalp	
14	Rear Door Window Frame Upper Scalp	35, 36, 69		View J					

**METHODS OF MOLDING RETENTION**  
**PONTIAC "A" BODIES - 23000 AND 24000 SERIES**  
**FIGURES 17-35 THROUGH 17-42**

Key	Molding Name	Series or Styles	Screws	Spring (Self-Retained)	Snap-On Clips or Retainers On Panel	Snap-On Clips On Molding	Studs With Attaching Nuts	Engages With Other Moldings	Remove Hardware Or Trim
15	Rear Quarter Window Reveal Front	27 Style			X				
16	Rear Quarter Window Reveal Upper	27 Style	X					Quarter Window Glass Run Channel	
17	Rear Quarter Belt Reveal Front Corner Escutcheon	27-37 (Optional)	X			View F			
18	Rear Door Corner Finishing Molding	39-69 (Optional)					View B		
19	Rear Quarter Belt Reveal	27-37 39-69 (Optional)			X		View B		Trim in Sail Area (39-69 Only)
20	Rear Quarter Belt Reveal Rear Corner Escutcheon	27-37 39-69 (Optional)					X	Rear Quarter Belt Reveal Rear End Belt Reveal	
21	Rear End Belt Reveal	27-37 39-69 (Optional)			X		View B		
22	Rear Quarter Pinch-weld Finishing	67	X						Lower Top Halfway
23	Rear Quarter Window Reveal Front Upper Corner Escutcheon	35, 36						Loosen Rear Quarter Window Reveal Upper and Lower at Corner	
24	Rear Quarter Window Reveal Upper	35, 36			X			Rear Quarter Window Reveal Front Upper Corner Escutcheon	
25	Rear Quarter Window Reveal Lower	35, 36			X			Rear Quarter Window Reveal Front Upper and Upper Corner Escutcheon	
26	Rear Wheel Opening	23700 24200	X						

**METHODS OF MOLDING RETENTION**  
**PONTIAC "A" BODIES - 23000 AND 24000 SERIES**  
**FIGURES 17-35 THROUGH 17-42**

Key	Molding Name	Series or Styles	Screws	Spring (Self-Retained)	Snap-On Clips or Retainers On Panel	Snap-On Clips On Molding	Studs With Attaching Nuts	Engages With Other Moldings	Remove Hardware Or Trim
27	Rear of Rear Wheel Opening	23700 24200	X		X				
28	Front Door Outer Panel Transfer Finishing Upper	23936	X		X				
29	Front Door Outer Panel Transfer Finishing Lower	23936	X		X				
30	Rear Door Outer Panel Transfer Finishing Upper	23936	X		X		View B		Rear Door Trim Assembly
31	Rear Door Outer Panel Transfer Finishing Lower	23936	X		X				
32	Rear Quarter Outer Panel Transfer Finishing (Rt. Side)	23936			X		View B		Rear Quarter Wheelhouse Cover Panel
33	Rear Quarter Outer Panel Transfer Finishing Front (Lt. Side)	23936			X				
34	Rear Quarter Outer Panel Transfer Finishing at Gas Filler Door (Lt. Side)	23936	X						
35	Rear Quarter Outer Panel Transfer Finishing Rear (Lt. Side)	23936			X				
36	Rear Quarter Outer Panel Transfer Finishing Rear Vertical	23936	X			View F		Rear Quarter Outer Panel Transfer Finishing (Rt. Side), Rear Quarter Outer Panel Transfer Finishing Upper Rear (Lt. Side), Rear of Rear Wheel Opening Transfer Finishing	

**METHODS OF MOLDING RETENTION**  
**PONTIAC "A" BODIES - 23000 AND 24000 SERIES**  
**FIGURES 17-35 THROUGH 17-42**

Key	Molding Name	Series or Styles	Screws	Spring (Self-Retained)	Snap-On Clips or Retainers On Panel	Snap-On Clips On Molding	Studs With Attaching Nuts	Engages With Other Moldings	Remove Hardware Or Trim
37	Rear of Rear Wheel Opening Outer Panel Transfer Finishing	23936			X				
38	Rear Wheel Opening Transfer Finishing	23936				View F	View B	Rear of Rear Wheel Opening Outer Panel Transfer Finishing	
39	Rear Compartment Lid Outer Panel Emblem and/or Nameplate	All (Except 35, 36)					X		
40	Back Window Reveal Upper and Side	27-37			X				
41	Back Window Reveal Upper	39-69			X				
42	Back Window Reveal Sides and Lower	39-69			X			Back Window Reveal Upper	
43	Back Window Reveal Lower	27-37			X			Back Window Reveal Side	
44	Back Body Opening Upper Reveal	35-36	X					Back Body Opening Side Reveal	Tailgate Window Glass Run Channel
45	Back Body Opening Side Reveal	35-36	X						
46	Tailgate Outer Panel Emblem and/or Nameplate	35-36					X		Tailgate Trim Assembly
47	Tailgate Outer Panel Transfer Finishing Upper	23936			X		View C	Tailgate Outer Panel Transfer Finishing Side	Tailgate Trim Assembly
48	Tailgate Outer Panel Finishing Lower	23936			X		X		

**METHODS OF MOLDING RETENTION**  
**PONTIAC "A" BODIES - 23000 AND 24000 SERIES**  
**FIGURES 17-35 THROUGH 17-42**

Key	Molding Name	Series or Styles	Screws	Spring (Self-Retained)	Snap-On Clips or Retainers On Panel	Snap-On Clips On Molding	Studs With Attaching Nuts	Engages With Other Moldings	Remove Hardware Or Trim
49	Tailgate Outer Panel Transfer Finishing Side	23936					View C		Tailgate Trim Assembly
50	Body Lock Pillar Belt Reveal	35-36 (Optional)			View H		X		Body Lock Pillar Trim
51	Back Body Pillar Belt Reveal	35-36 (Optional)	X			View F			
52	Tailgate Outer Panel Belt Reveal	35-36 (Optional)	X		X				
53	Rear Compartment Lid Outer Panel	23700 24200	X						
54	Rear of Rear Fender Outer Panel	23700 24200	X						

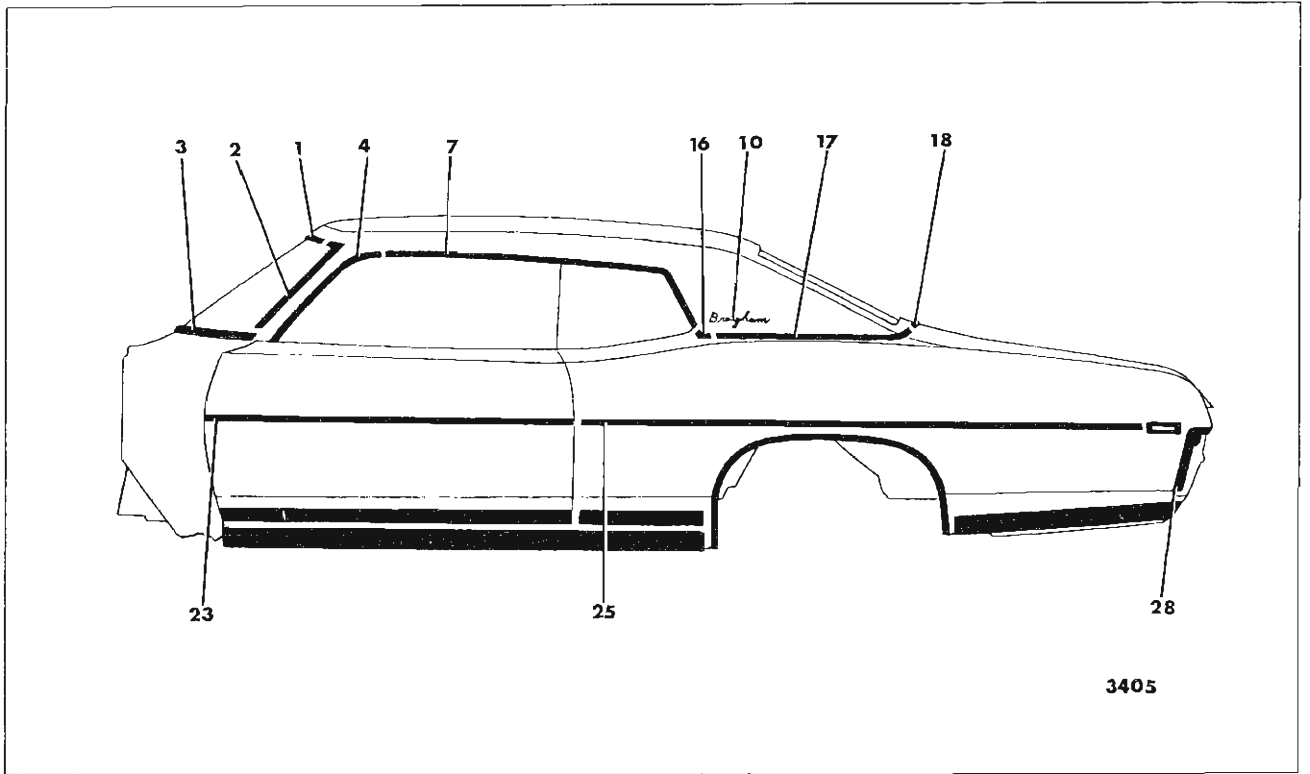

Fig. 17-43—Pontiac "B-37" Styles ("67" Styles Similar)

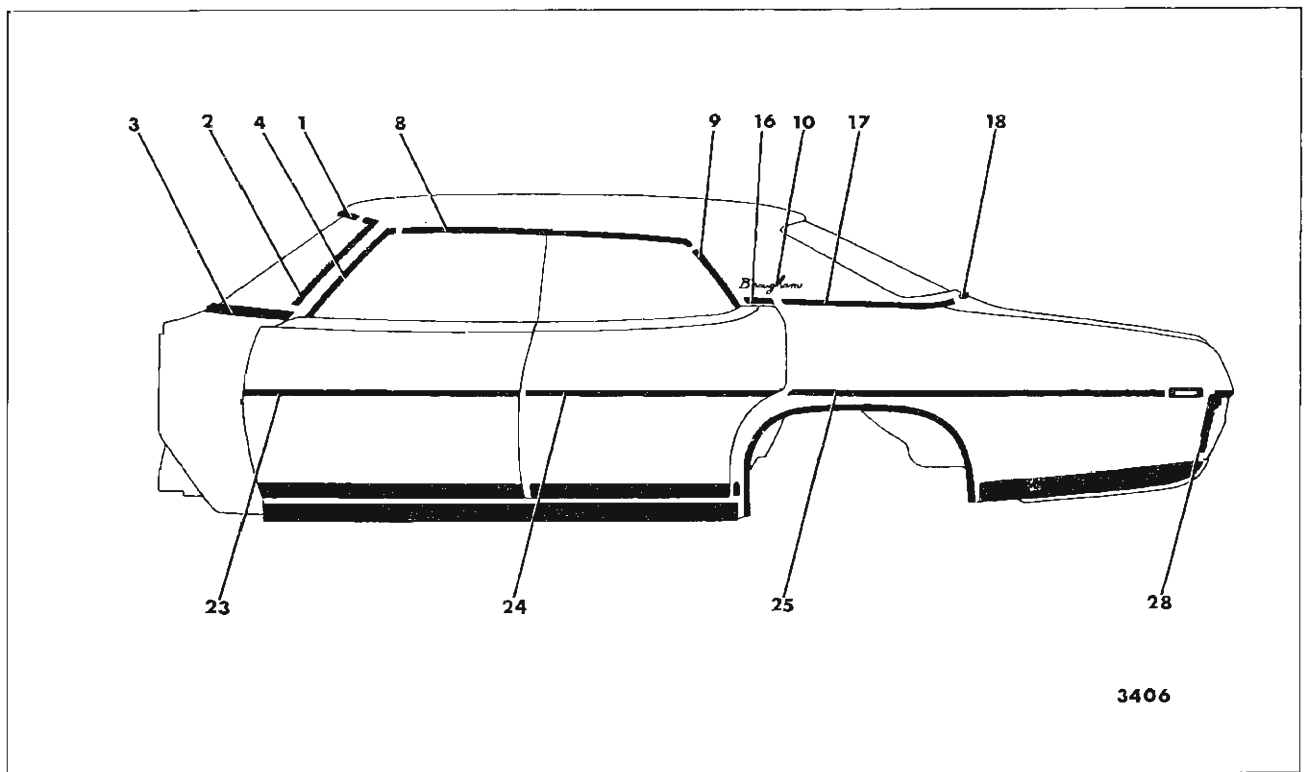
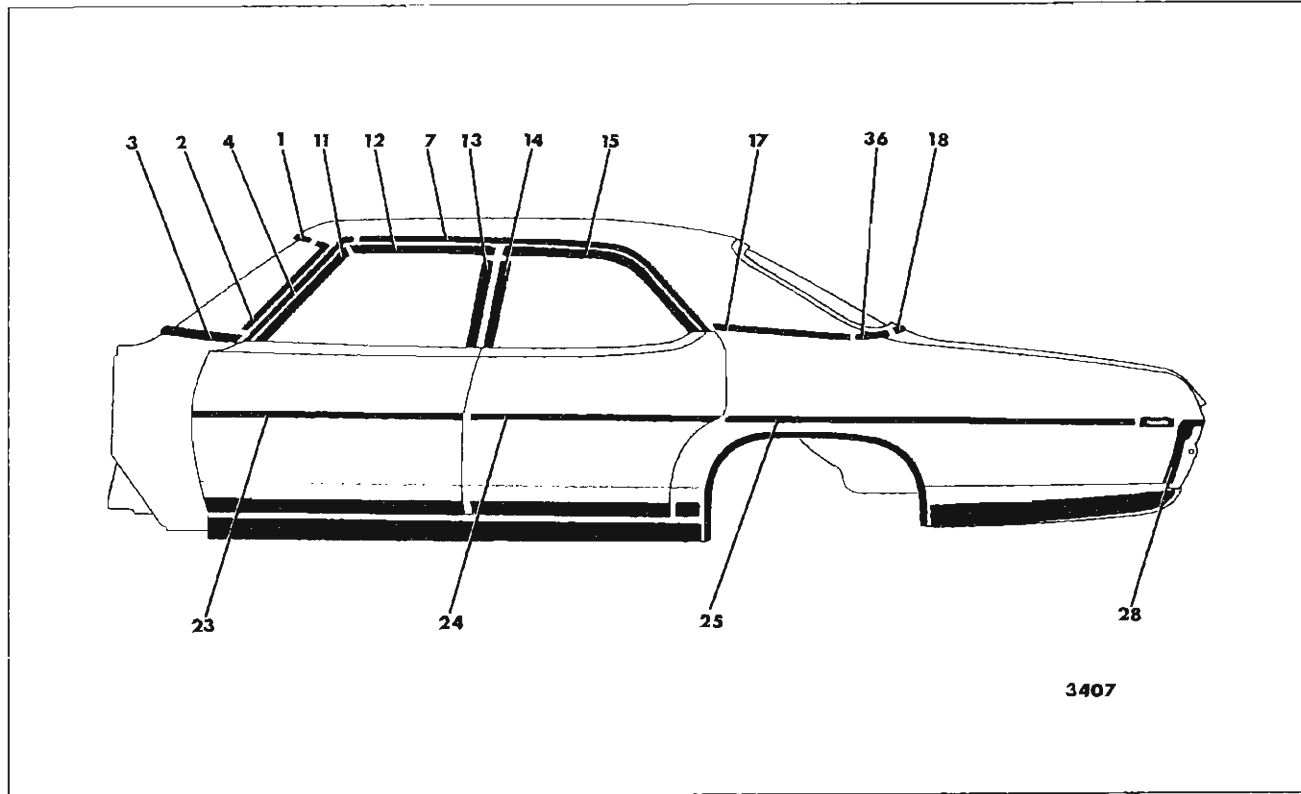

Fig. 17-44—Pontiac "B-39" Styles





3407

Fig. 17-45—Pontiac "B-69" Styles

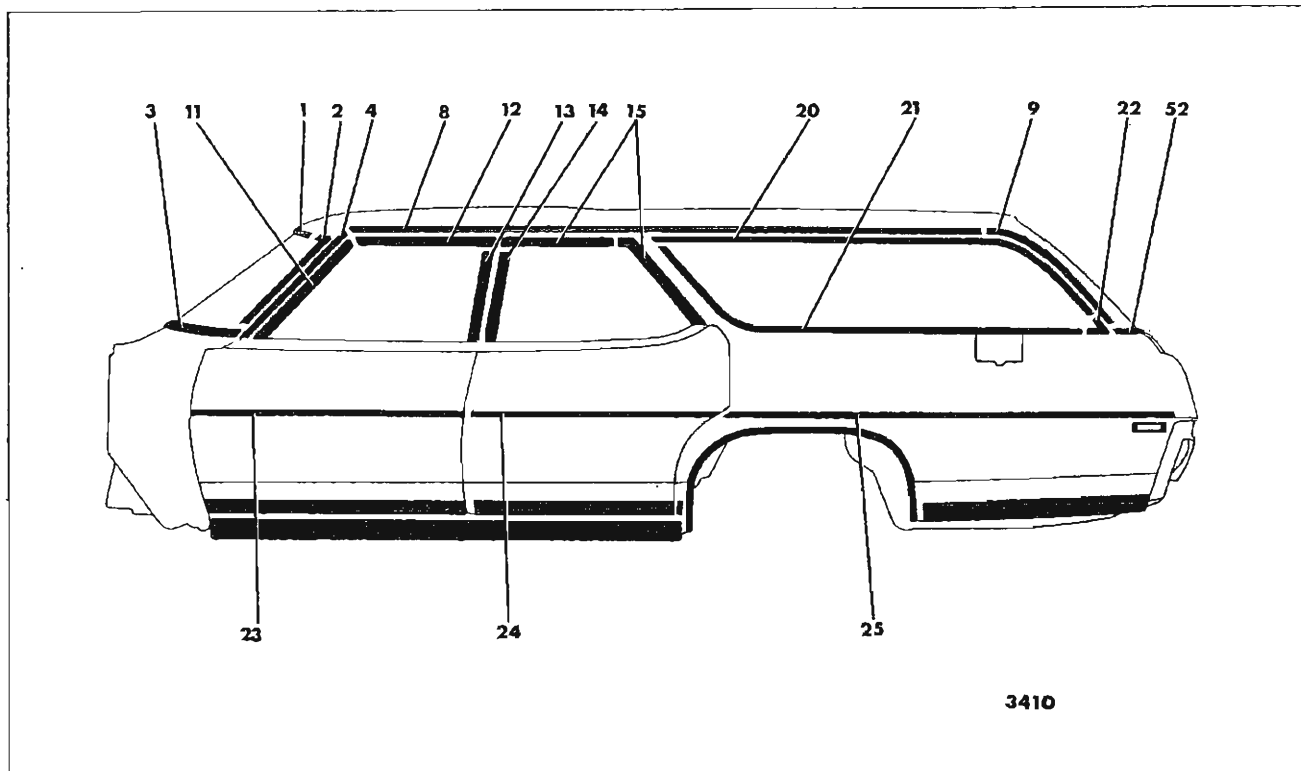

3410

Fig. 17-46—Pontiac "B-36-46" Styles (Less 25636-46 Styles)

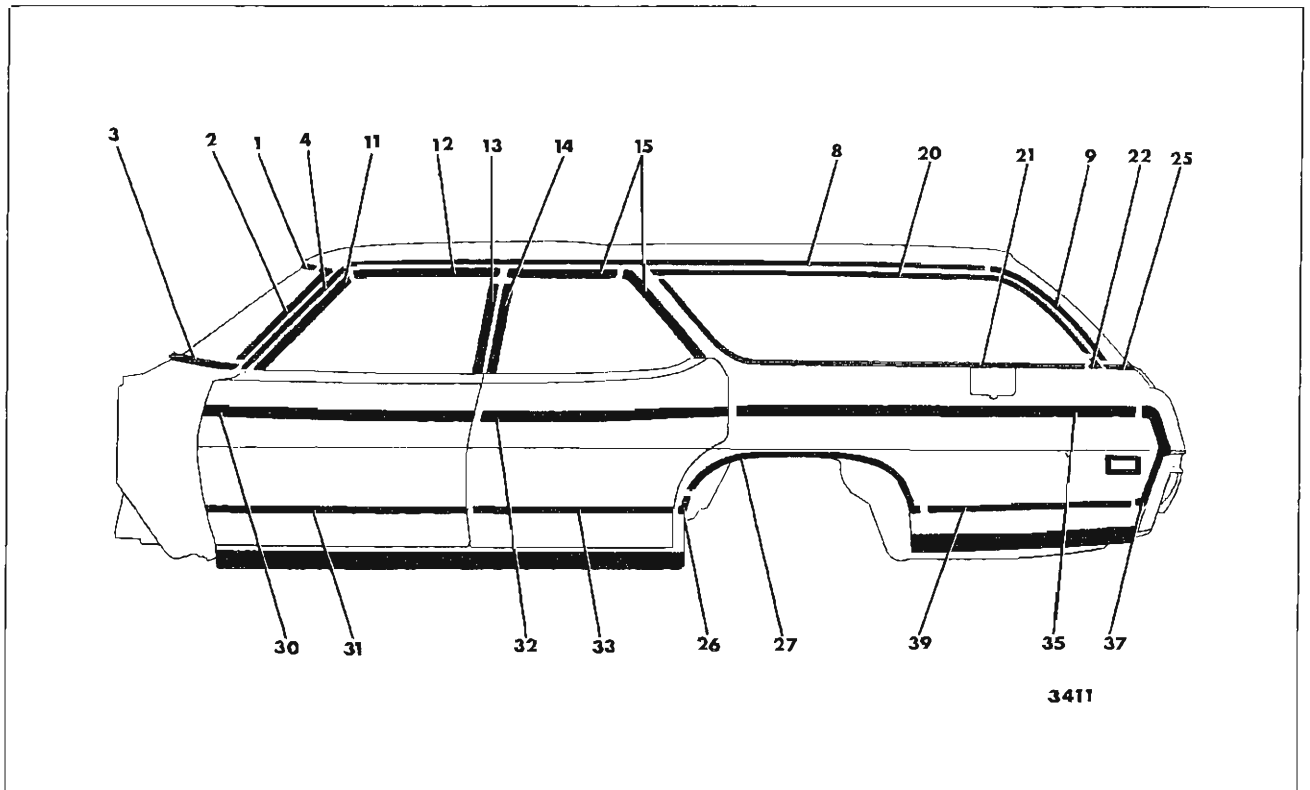

Fig. 17-47—Pontiac 25636-46 Styles

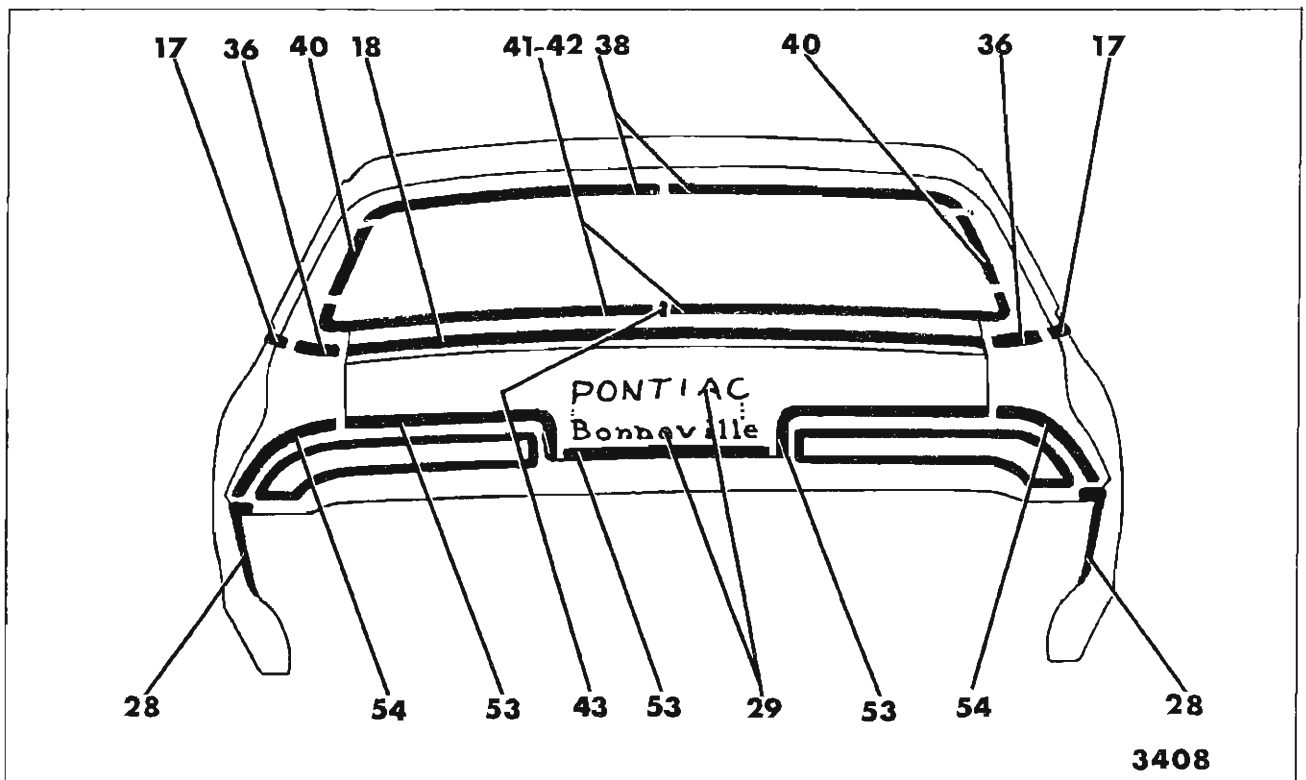

Fig. 17-48—Pontiac 25200-25600-26200 Styles (Less 36-46 Styles)

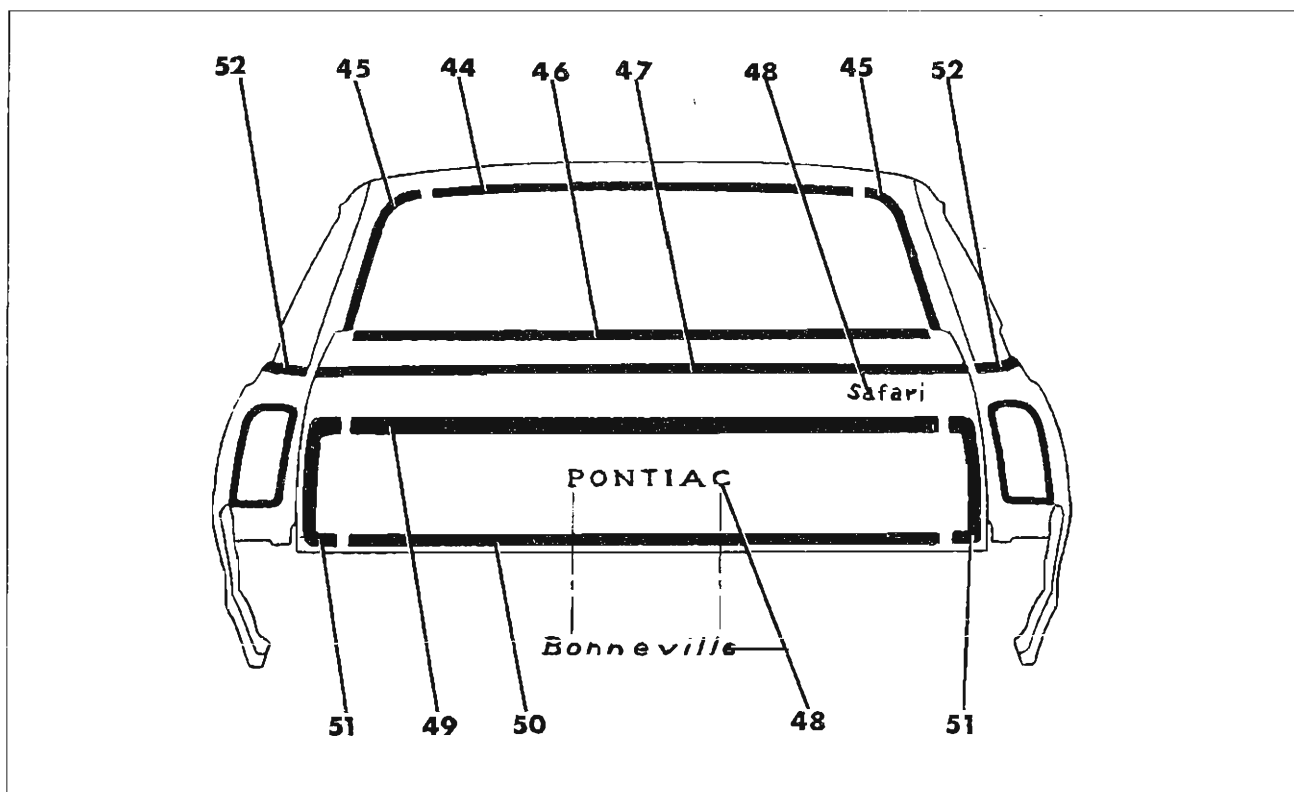

Fig. 17-49—Pontiac "B-36-46" Styles

METHODS OF MOLDING RETENTION  
PONTIAC "B" BODIES - 25000 AND 26000 SERIES  
FIGURES 17-43 THROUGH 17-49

Key	Molding Name	Series or Styles	Screws	Spring (Self-Retained)	Snap-On Clips or Retainers On Panel	Snap-On Clips On Molding	Studs With Attaching Nuts	Engages With Other Moldings	Remove Hardware Or Trim
1	Windshield Reveal Upper	All			X			Windshield Reveal Side	
2	Windshield Reveal Side	All (Except 67)			X				
3	Windshield Reveal Lower	All	X					Windshield Reveal Side	
4	Windshield Pillar Drip Scalp	All (Except 67)	X						Windshield Pillar Weatherstrip and Weatherstrip Retainer
5	Windshield Pillar Finishing	67	X						Windshield Pillar Weatherstrip and Weatherstrip Retainer
6	Windshield Header	67	X					Windshield Reveal Upper, Windshield Pillar Finishing	Rear View Mirror Support, Sunshade Support, Windshield Upper Garnish Molding
7	Roof Drip Molding Scalp	37-69		View K				Windshield Pillar Drip	
8	Roof Drip Molding Scalp Front	36, 39, 46		View K				Windshield Pillar Drip	
9	Roof Drip Molding Scalp Rear	36, 39, 46	X (39 Style Only)	View K (36-46 Only)				Roof Drip Molding Scalp Front	Side Roof Rail Weatherstrip and Weatherstrip Retainer (39 Style only)
10	Roof Panel Name Plate	26237-39				View I			
11	Front Door Window Frame Front Scalp	36, 46, 69		View J					
12	Front Door Window Frame Upper Scalp	36, 46, 69		View J				Front Door Window Frame Front Scalp	

## METHODS OF MOLDING RETENTION

PONTIAC "B" BODIES - 25000 AND 26000 SERIES

FIGURES 17-43 THROUGH 17-49

Key	Molding Name	Series or Styles	Screws	Spring (Self-Retained)	Snap-On Clips or Retainers On Panel	Snap-On Clips On Molding	Studs With Attaching Nuts	Engages With Other Moldings	Remove Hardware Or Trim
13	Front Door Window Frame Rear Scalp	36, 46, 69		View J				Front Door Window Frame Upper Scalp	
14	Rear Door Window Frame Front Scalp	36, 46, 69		View J				Rear Door Window Frame Upper Scalp	
15	Rear Door Window Frame Upper and/or Rear Scalp	36, 46, 69		View J				Rear Door Window Frame Rear Scalp (To Remove Upper-36-46 Only)	
16	Rear Quarter Belt Reveal Front Corner Escutcheon	37-39	X					Rear Quarter Belt Reveal, Roof Drip Scalp Rear	
17	Rear Quarter Belt Reveal	37-39 69			X		X	Rear End Belt Reveal (39-69)	
18	Rear End Belt Reveal	37-39 69			X		X	Rear Quarter Belt Reveal (37 Only)	
19	Rear Quarter Pinch-weld Finishing Molding	67	X						Lower Top Halfway
20	Rear Quarter Window Reveal Upper	36-46			X			Rear Quarter Window Reveal Lower	
21	Rear Quarter Window Reveal Lower	36-46			X			Rear Quarter Window Reveal Lower Escutcheon	
22	Rear Quarter Window Reveal Lower Escutcheon	36-46						Loosen Rear Quarter Window Reveal Upper and Lower at Corner	
23	Front Door Outer Panel	All (Except 25636-46)	X		X				
24	Rear Door Outer Panel	All (Except 25636-46)	X		X				
25	Rear Quarter Outer Panel	All (Except 25636-46)			X		X		Spare Tire Cover (Right Side 36-46), Tail Lite (Left Side 36-46)

## METHODS OF MOLDING RETENTION

PONTIAC "B" BODIES - 25000 AND 26000 SERIES  
FIGURES 17-43 THROUGH 17-49

Key	Molding Name	Series or Styles	Screws	Spring (Self-Retained)	Snap-On Clips or Retainers On Panel	Snap-On Clips On Molding	Studs With Attaching Nuts	Engages With Other Moldings	Remove Hardware Or Trim
26	Rear Wheel Opening Front	25636-46			X			Rear Wheel Opening Rear	
27	Rear Wheel Opening Rear	25636-46					X		
28	Rear of Rear Quarter Outer Panel (In Bumper Cove)	26200 (Less 46)	X						Rear Bumper
29	Rear Compartment Lid Outer Panel Emblem and/or Nameplate	All (Except 36-46)					X		
30	Front Door Outer Panel Transfer Finishing Upper	25636-46	X		X				
31	Front Door Outer Panel Transfer Finishing Lower	25636-46	X		X				
32	Rear Door Outer Panel Transfer Finishing Upper	25636-46	X		X				
33	Rear Door Outer Panel Transfer Finishing Lower	25636-46	X		X				
34	Rear Quarter Outer Panel Transfer Finishing	25636-46			X				
35	Rear Quarter Outer Panel Transfer Finishing Front	25636-46	X						
36	Rear Quarter Belt Reveal Rear Corner Escutcheon	69					X	Rear Quarter Belt Reveal and Rear End Belt Reveal	
37	Rear Quarter Outer Panel Transfer Finishing Rear	25636-46	X			View F		Rear Quarter Outer Transfer Finishing Upper and Lower	

METHODS OF MOLDING RETENTION  
PONTIAC "B" BODIES - 25000 AND 26000 SERIES  
FIGURES 17-43 THROUGH 17-49

Key	Molding Name	Series or Styles	Screws	Spring (Self-Retained)	Snap-On Clips or Retainers On Panel	Snap-On Clips On Molding	Studs With Attaching Nuts	Engages With Other Moldings	Remove Hardware Or Trim
38	Back Window Reveal Upper	All (Except 36, 46, 67)			X			Back Window Reveal Sides	
39	Rear Quarter Outer Transfer Finishing Lower	25636-46	X		X			Rear Wheel Opening Rear	
40	Back Window Reveal Sides	37 Styles			X				
41	Back Window Reveal Sides and Lower	39, 69			X			Back Window Reveal Lower	
42	Back Window Reveal Lower	37			X			Back Window Reveal Sides	
43	Back Window Reveal Lower Center Escutcheon	39, 69						Back Window Reveal Lower and Sides	
44	Back Body Opening Reveal Upper	36-46	X					Back Body Opening Reveal Side	Tail Gate Glass Run Channel
45	Back Body Opening Reveal Side	36-46	X					Back Body Opening Reveal Upper	
46	Tail Gate Window Reveal	36-46	X			X			
47	Tail Gate Outer Panel Belt Reveal (Optional)	36-46			X		X		Tail Gate Trim Assembly
48	Tail Gate Outer Panel Emblem and/or Nameplate	36-46					X		Tail Gate Trim Assembly
49	Tail Gate Outer Panel Transfer Finishing Upper	25636-46			X			Tail Gate Outer Transfer Finishing Side-Right	
50	Tail Gate Outer Panel Transfer Finishing Lower	25636-46			X			Tail Gate Outer Transfer Finishing Side-Right	
51	Tail Gate Outer Transfer Finishing Side	25636-46	X (Left Side)				X	Tail Gate Outer Transfer Finishing Upper and Lower (Left Side Only)	

METHODS OF MOLDING RETENTION  
PONTIAC "B" BODIES - 25000 AND 26000 SERIES  
FIGURES 17-43 THROUGH 17-49

Key	Molding Name	Series or Styles	Screws	Spring (Self-Retained)	Snap-On Clips or Retainers On Panel	Snap-On Clips On Molding	Studs With Attaching Nuts	Engages With Other Moldings	Remove Hardware Or Trim
52	Back Body Pillar Belt Reveal (Optional)	36-46	X			View F			
53	Rear Compartment Lid Rear Molding Outer and Center	26200 (Less 46 Style)	X						
54	Rear of Rear Quarter Outer Panel (At Tail Lamp)	All (Less 36-46)	X						Tail Lamp Assembly and Loosen Rear Bumper



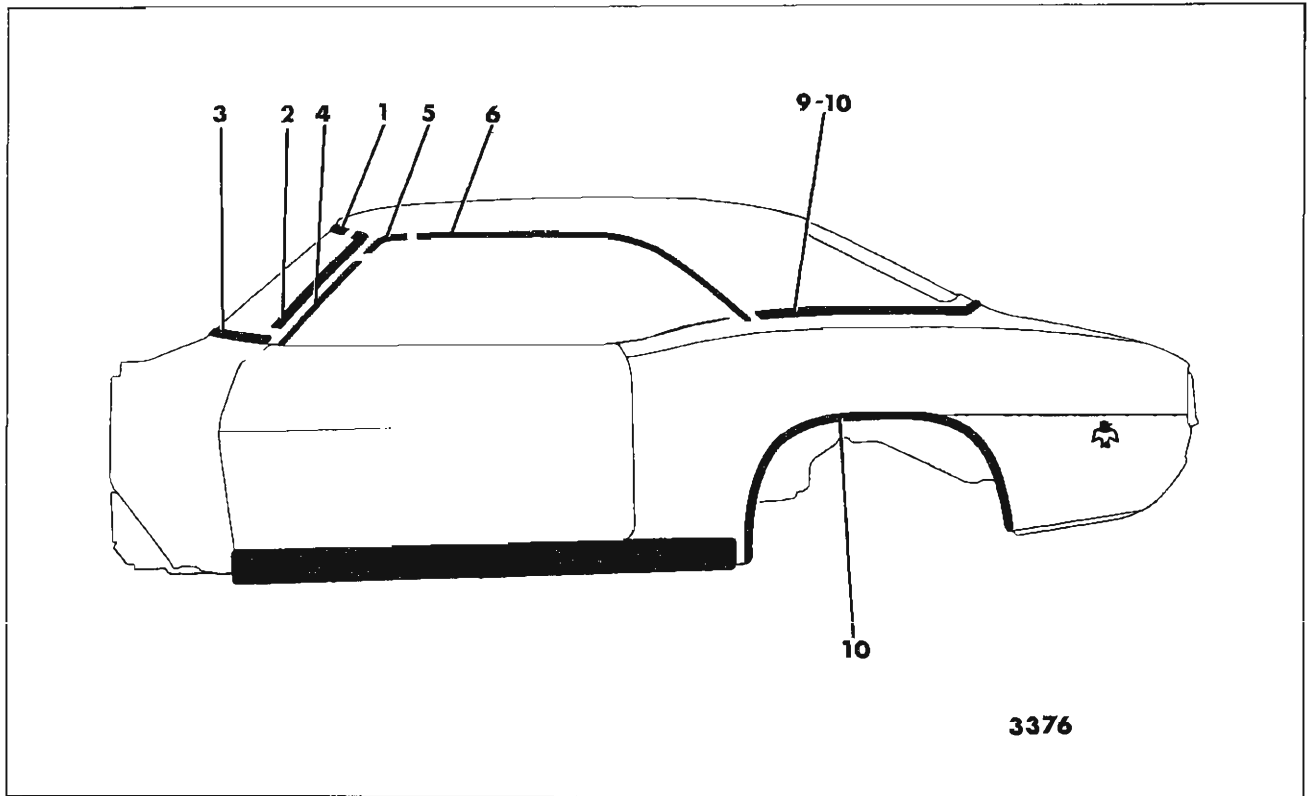

Fig. 17-50—Pontiac "F-37-67" Styles

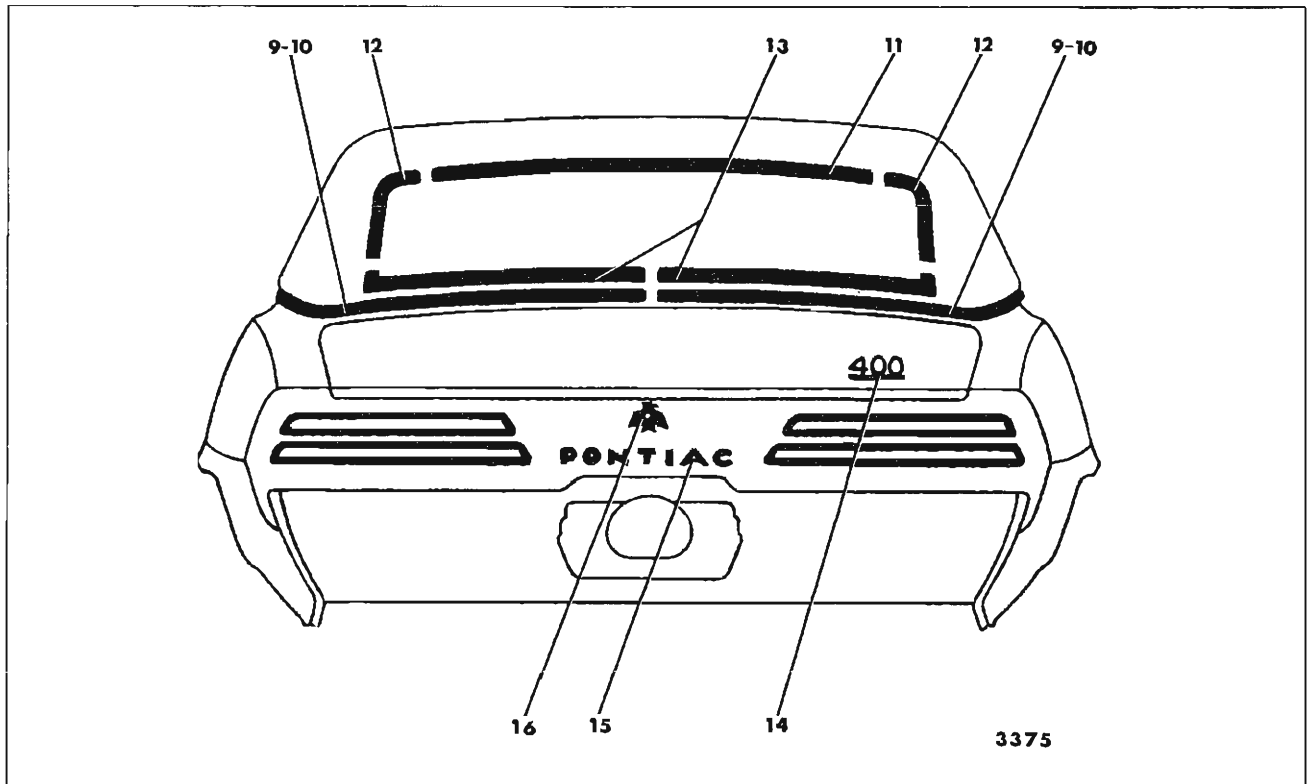

Fig. 17-51—Pontiac "F-37-67" Styles

METHODS OF MOLDING RETENTION  
 PONTIAC "F" BODIES - 22000 SERIES  
 FIGURES 17-50 THROUGH 17-51

Key	Molding Name	Series or Styles	Screws	Spring (Self-Retained)	Snap-On Clips or Retainers On Panel	Snap-On Clips On Molding	Studs With Attaching Nuts	Engages With Other Moldings	Remove Hardware Or Trim
1	Windshield Reveal Upper	All			X			Windshield Reveal Side	
2	Windshield Reveal Side	All			X			Windshield Reveal Lower	
3	Windshield Reveal Lower	All	X						Cowl Air Intake Grille
4	Windshield Pillar Drip Molding Scalp	All	X					Windshield Pillar Drip Molding Scalp Escutcheon	
5	Windshield Pillar Drip Molding Scalp Escutcheon	37 Style		View K					
6	Roof Drip Molding Scalp	37 Style		View K				Windshield Pillar Drip Molding Scalp Escutcheon	
7	Windshield Header	67 Style	X					Windshield Reveal Upper and Sides	Rear View Mirror Support, Sunshade and Striker Support, Windshield Pillar Weatherstrip and Weatherstrip Retainer
8	Windshield Pillar Finishing	67 Style	X					Windshield Header, Windshield Reveal Side	Windshield Pillar Weatherstrip and Weatherstrip Retainer
9	Rear Quarter Belt Reveal	37 Style (Optional)			X		X		

METHODS OF MOLDING RETENTION  
PONTIAC "F" BODIES - 22000 SERIES  
FIGURES 17-50 THROUGH 17-51

Key	Molding Name	Series or Styles	Screws	Spring (Self-Retained)	Snap-On Clips or Retainers On Panel	Snap-On Clips On Molding	Studs With Attaching Nuts	Engages With Other Moldings	Remove Hardware Or Trim
10	Rear Wheel Opening	All (Optional)	X						
11	Back Window Reveal Upper	37 Styles			X			Back Window Reveal Side	
12	Back Window Reveal Side	37 Style			X			Back Window Reveal Lower	
13	Back Window Reveal Lower	37 Style			X				
14	Rear Compartment Lid Emblem "400"	All (Optional)					X		
15	Rear End Panel Name Plate	All					X		
16	Rear End Panel Emblem	All					X		
17	Rear Quarter Pinchweld Finishing	67 Style	X		X				Lower Top Halfway

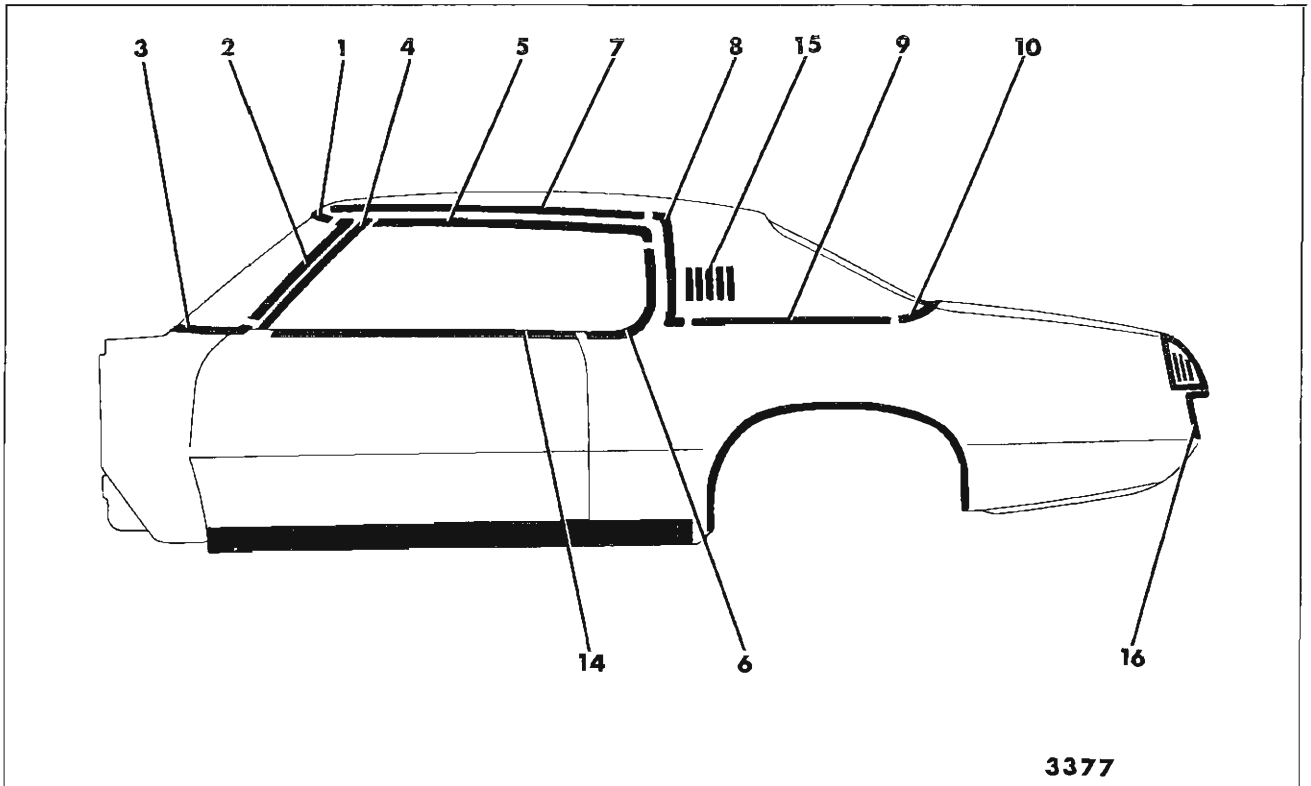

Fig. 17-52—Pontiac 27657 Style

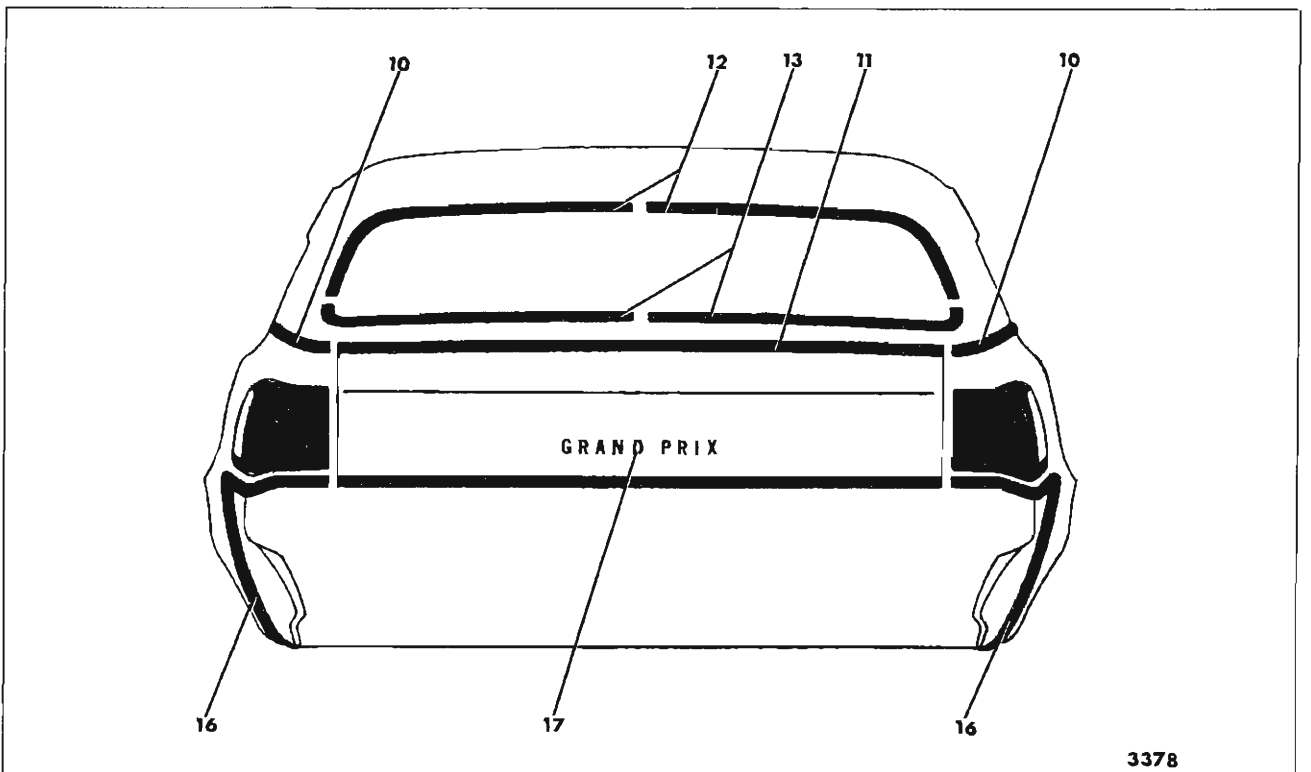

Fig. 17-53—Pontiac 27657 Style

METHODS OF MOLDING RETENTION  
PONTIAC "G" BODIES - 27000 SERIES  
FIGURES 17-52 THROUGH 17-53

Key	Molding Name	Series or Styles	Screws	Spring (Self-Retained)	Snap-On Clips or Retainers On Panel	Snap-On Clips On Molding	Studs With Attaching Nuts	Engages With Other Moldings	Remove Hardware Or Trim
1	Windshield Reveal Upper	All			X			Windshield Reveal Side	
2	Windshield Reveal Side	All			X				
3	Windshield Reveal Lower	All	X					Windshield Reveal Side	
4	Windshield Pillar Drip Scalp	All	X						Windshield Pillar Weatherstrip and Weatherstrip Retainer
5	Roof Drip Molding Scalp Front	All (Optional)		View K					Windshield Pillar Drip Scalp
6	Roof Drip Molding Scalp Rear Vertical	All (Optional)	X						Quarter Window Lower Stop
7	Roof Panel Cover Front	All (Optional)			X				
8	Roof Panel Cover Side Vertical	All (Optional)					X	Roof Panel Cover Front	Rear Quarter Upper Trim
9	Rear Quarter Belt Reveal	All (Optional)			X		X	Roof Panel Cover Side Vertical	
10	Rear Quarter Belt Reveal Rear Corner Escutcheon	All (Optional)					X	Rear Quarter Belt Reveal, Rear End Belt Reveal	
11	Rear End Belt Reveal	All (Optional)			X		X		
12	Back Window Reveal Upper and Sides	All			X				
13	Back Window Reveal Lower	All			X			Back Window Reveal Upper and Sides	

METHODS OF MOLDING RETENTION  
PONTIAC "G" BODIES - 27000 SERIES  
FIGURES 17-52 THROUGH 17-53

Key	Molding Name	Series or Styles	Screws	Spring (Self-Retained)	Snap-On Clips or Retainers On Panel	Snap-On Clips On Molding	Studs With Attaching Nuts	Engages With Other Moldings	Remove Hardware Or Trim
14	Front Door Belt Reveal	All	X						Front Door Window Lower Stop
15	Louvers - Roof Panel (Sail Area)	All					X		Rear Quarter Upper Trim
16	Rear of Rear Quarter Outer Panel	All	X						Rear Bumper
17	Rear Compartment Lid Nameplate	All					X		

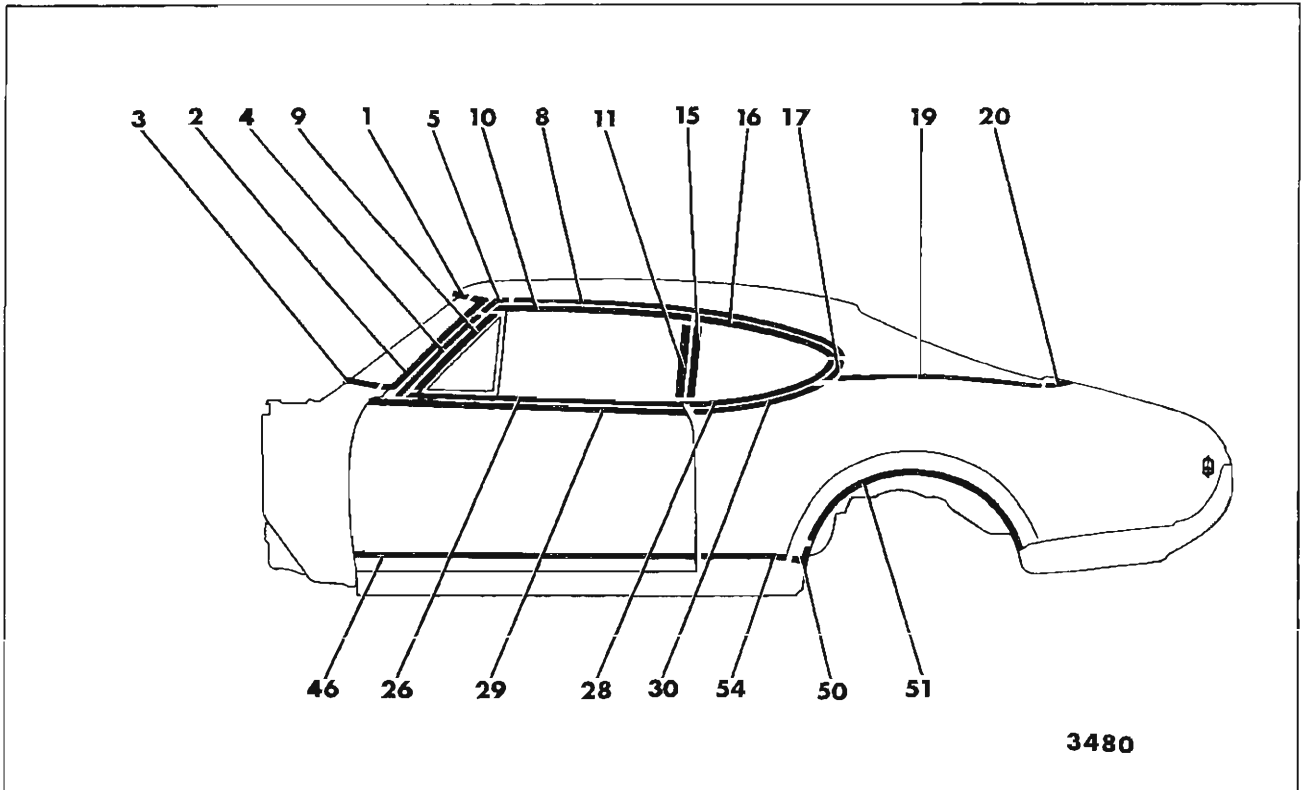

Fig. 17-54—Oldsmobile "A-77" Styles

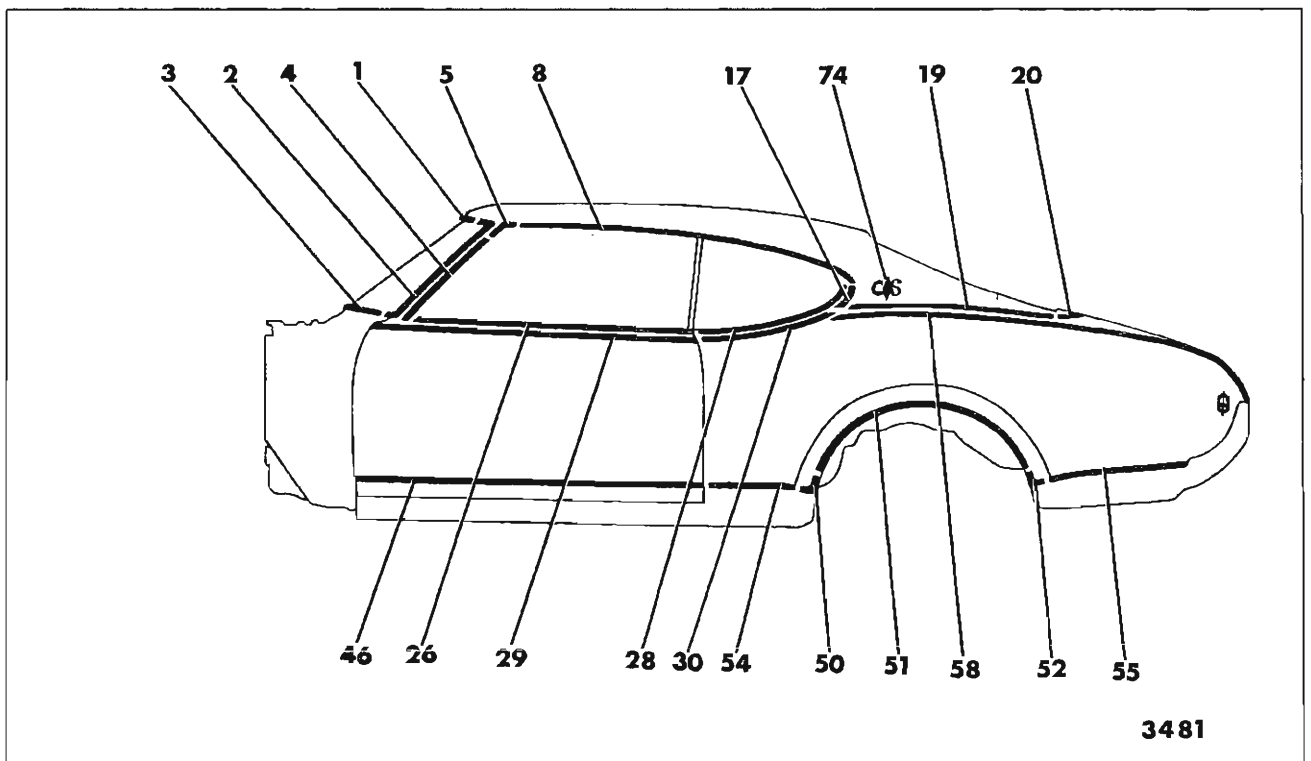

Fig. 17-55—Oldsmobile "A-87" Styles (33667 Style Similar)

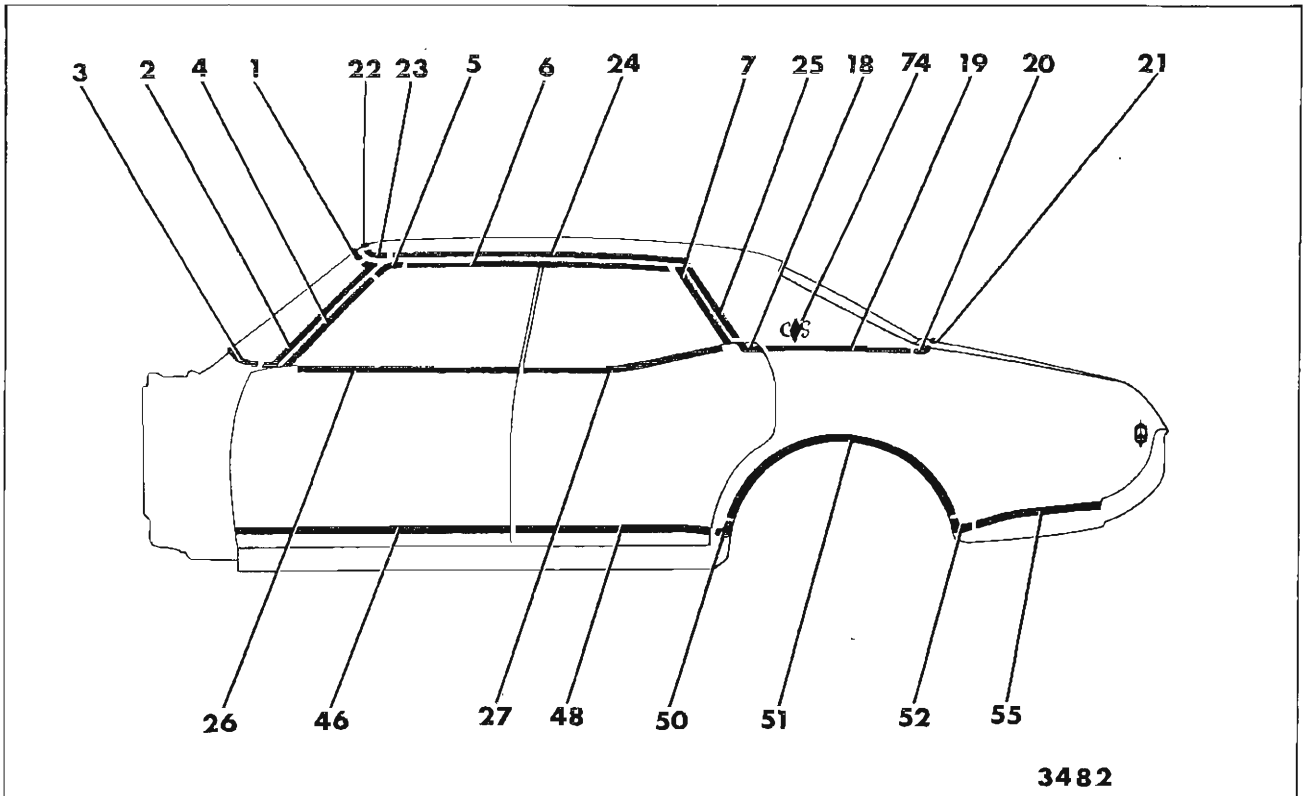

Fig. 17-56—Oldsmobile "A-39" Styles

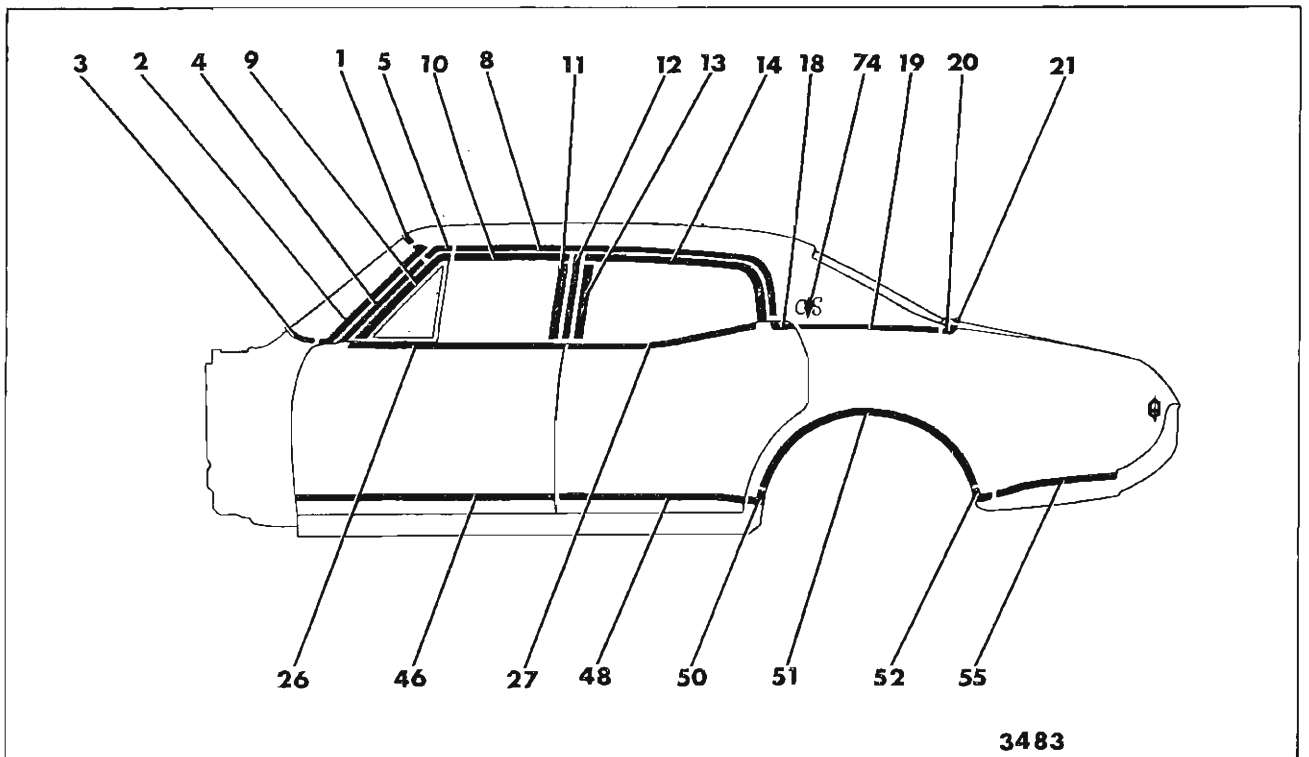

Fig. 17-57—Oldsmobile "A-69" Styles



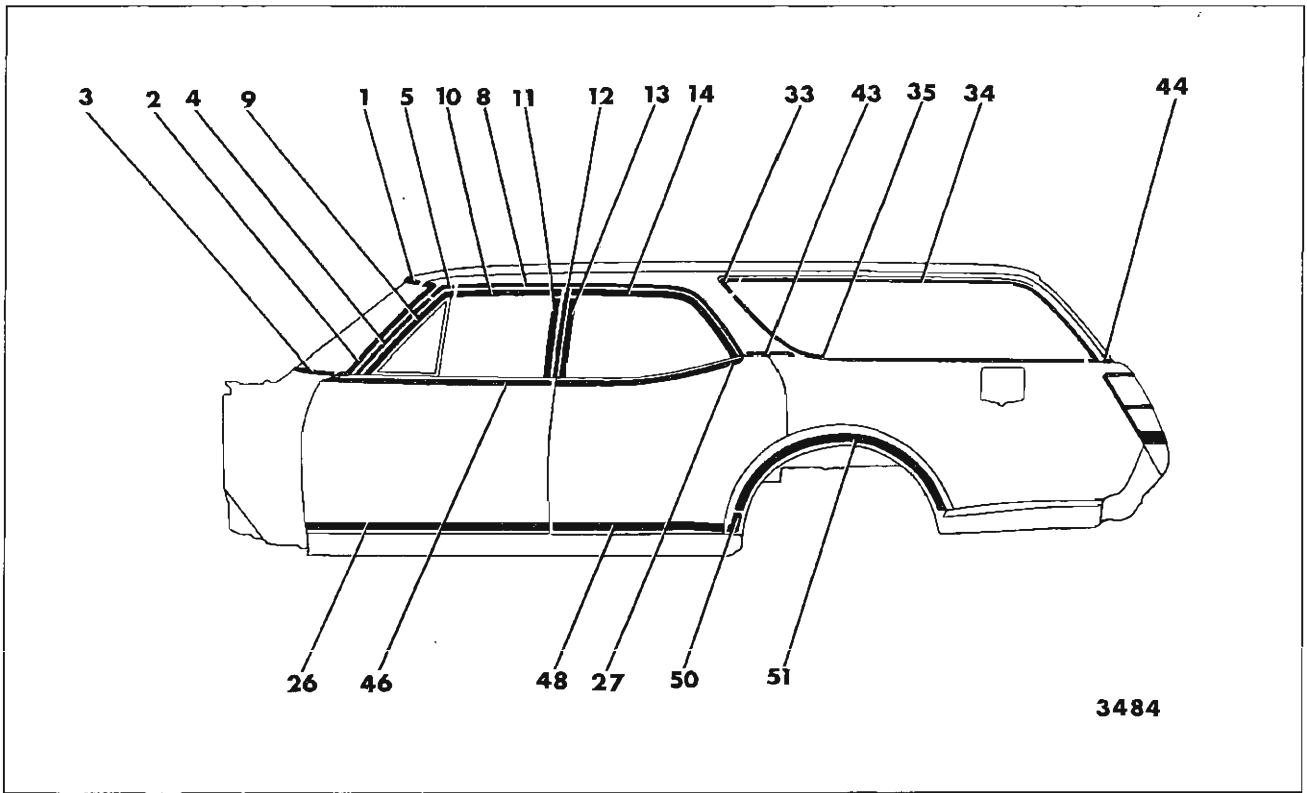

Fig. 17-58—Oldsmobile "A-35-36" Styles

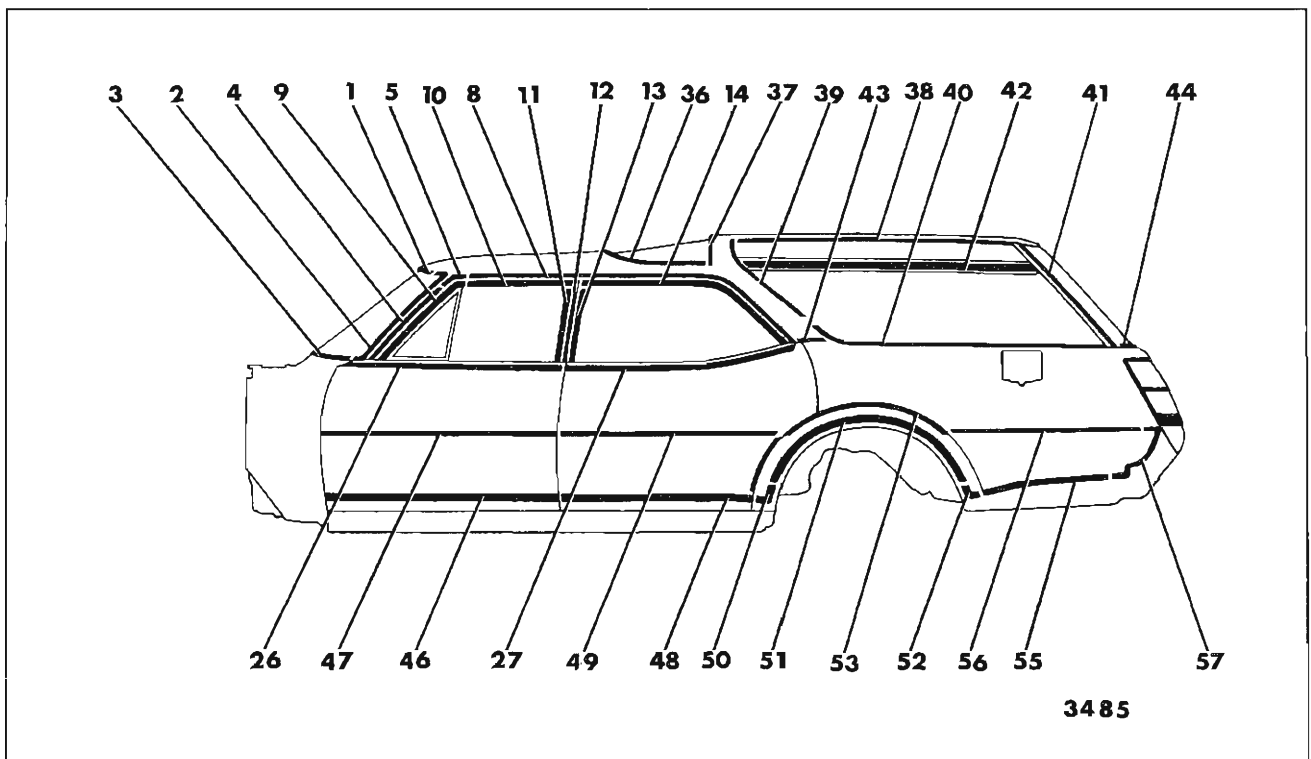

Fig. 17-59—Oldsmobile "A-55-56-65-66" Styles

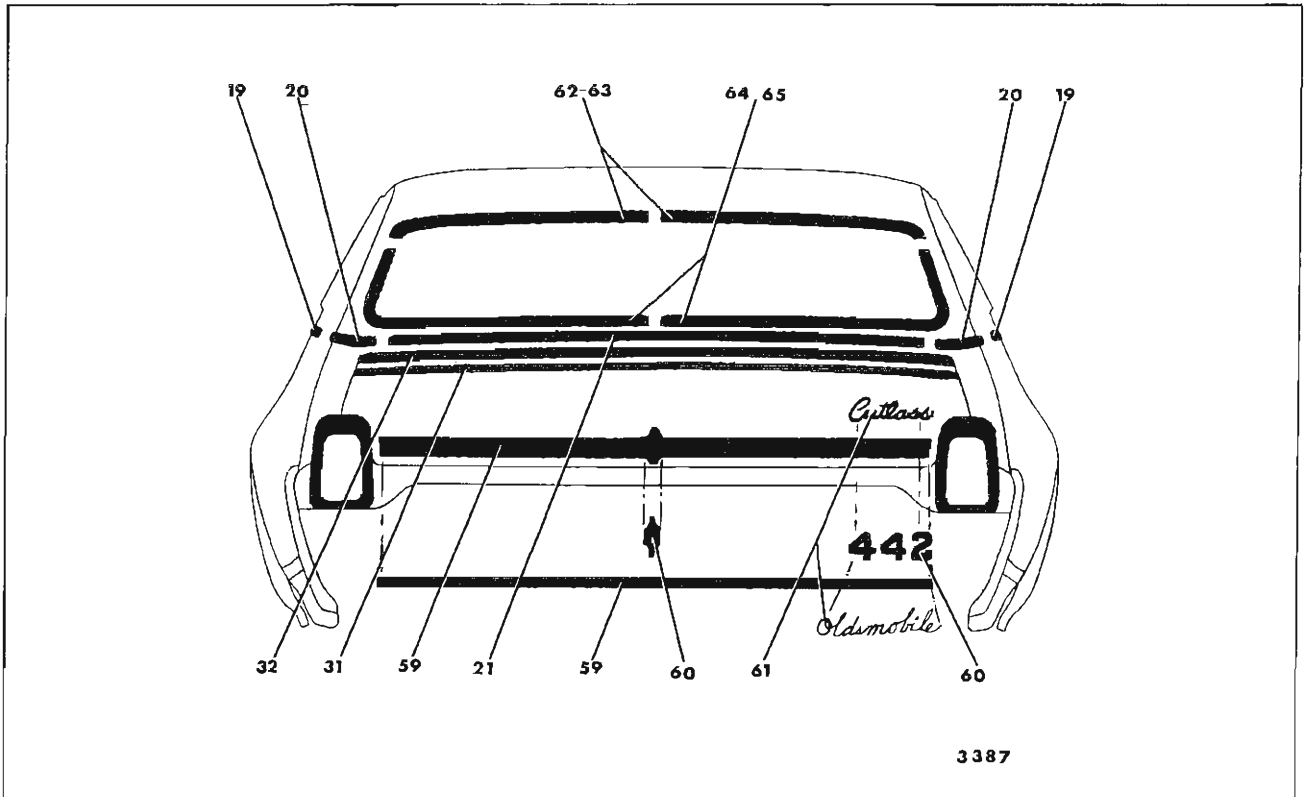

Fig. 17-60—Oldsmobile 33200-33600-34200 Styles (Less 35-36 Styles)

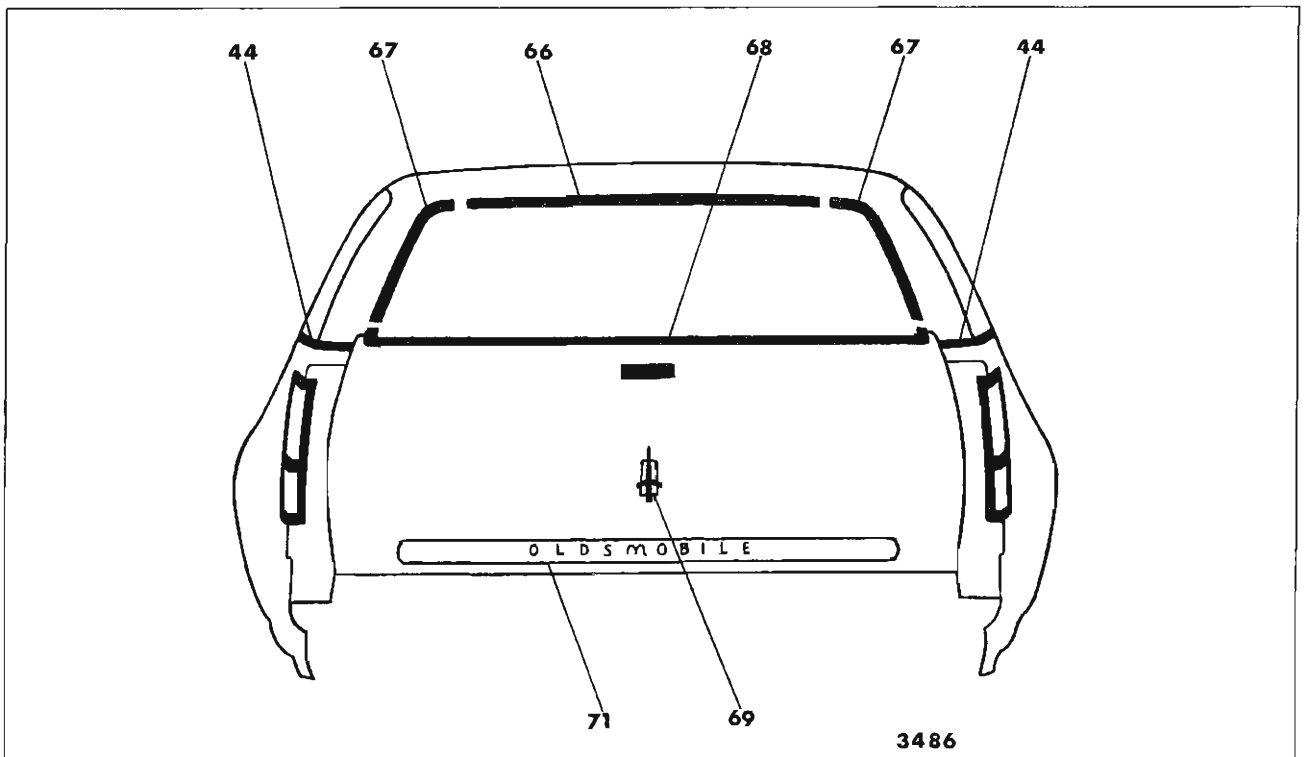

Fig. 17-61—Oldsmobile "A-35-36" Styles

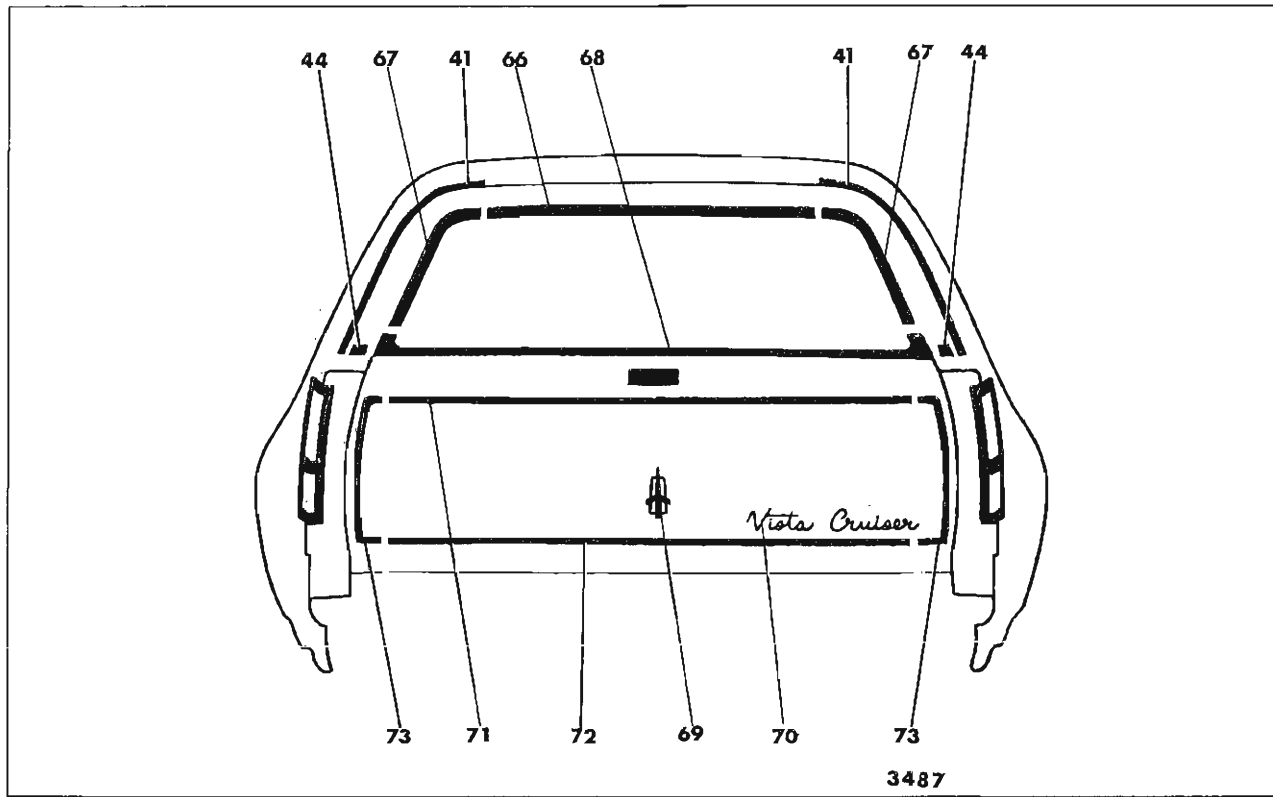

Fig. 17-62—Oldsmobile "A-55-56-65-66" Styles

## METHODS OF MOLDING RETENTION

OLDSMOBILE "A" BODY - 33000 and 34000 SERIES  
FIGURES 17-54 THROUGH 17-62

Key	Molding Name	Series or Styles	Screws	Spring (Self-Retained)	Snap-On Clips or Retainers On Panel	Snap-On Clips On Molding	Studs With Attaching Nuts	Engages With Other Moldings	Remove Hardware Or Trim
1	Windshield Reveal Upper	All			View M			Windshield Reveal Side	
2	Windshield Reveal Side	All	X (67 Only)		View M				
3	Windshield Reveal Lower	All	X					Windshield Reveal Side	
4	Windshield Pillar Drip Scalp	All (Except 67)		View K				Roof Drip Molding Front Scalp Escutcheon	
5	Roof Drip Molding Front Scalp Escutcheon	All (Except 67)		View K				Windshield Pillar Drip Scalp and Roof Drip Scalp	
6	Roof Drip Molding Front Scalp	39 Style		View K				Roof Drip Molding Front Scalp Escutcheon	
7	Roof Drip Molding Rear Scalp	39 Style	X					Roof Drip Molding Front Scalp	
8	Roof Drip Molding Scalp	All (Except 39-67)		View K				Roof Drip Molding Front Scalp Escutcheon	
9	Front Door Window Frame Front Scalp	35-36-55-56-65-66-69-77		View J					
10	Front Door Window Frame Upper Scalp	35-36-55-56-65-66-69-77		View J				Front Door Window Frame Front Scalp	
11	Front Door Window Frame Rear Scalp	35-36-55-56-65-66-69-77		View J				Front Door Window Frame Upper Scalp	
12	Center Pillar Scalp	35-36-55-56-65-66-69	X						
13	Rear Door Window Frame Front Scalp	35-36-55-56-65-66-69		View J				Rear Door Window Frame Upper Scalp	
14	Rear Door Window Frame Upper Scalp	35-36-55-56-65-66-69		View J					

## METHODS OF MOLDING RETENTION

OLDSMOBILE "A" BODY - 33000 and 34000 SERIES  
 FIGURES 17-54 THROUGH 17-62

Key	Molding Name	Series or Styles	Screws	Spring (Self-Retained)	Snap-On Clips or Retainers On Panel	Snap-On Clips On Molding	Studs With Attaching Nuts	Engages With Other Moldings	Remove Hardware Or Trim
15	Rear Quarter Window Reveal Front	77 Style			X			Rear Quarter Window Reveal Upper	
16	Rear Quarter Window Reveal Upper	77 Style	X					Quarter Window Glass Run Channel	
17	Rear Quarter Belt Reveal Front Corner Escutcheon	77-87 (Optional)			X		X	Rear Quarter Upper Trim	
18	Rear Door Corner Finishing	39-69 (Optional)					View B		
19	Rear Quarter Belt Reveal	77-87-39-69 (Optional)			X		View B		Rear Quarter Upper Trim
20	Rear Quarter Belt Reveal Rear Corner Escutcheon	77-87-39-69 (Optional)					X	Rear End Belt Reveal (39-69 Style Only) Rear Quarter Belt Reveal	
21	Rear End Belt Reveal	39-69 (Optional)			X		View B		
22	Roof Panel Cover Front	39 Style			X			Roof Panel Cover Front Corner Escutcheon	
23	Roof Panel Cover Front Corner Escutcheon	39 Style			X				
24	Roof Panel Cover Side	39 Style			X			Roof Panel Cover Front Corner Escutcheon	
25	Roof Panel Cover Rear	39 Style			X			Roof Panel Cover Side	
26	Front Door Belt Reveal	All (Except 67)	X						Front Door Window Lower Stop

## METHODS OF MOLDING RETENTION

OLDSMOBILE "A" BODY - 33000 and 34000 SERIES  
 FIGURES 17-54 THROUGH 17-62

Key	Molding Name	Series or Styles	Screws	Spring (Self-Retained)	Snap-On Clips or Retainers On Panel	Snap-On Clips On Molding	Studs With Attaching Nuts	Engages With Other Moldings	Remove Hardware Or Trim
27	Rear Door Belt Reveal	35-36-39-55-56-65-66-69 (Optional)	X						Rear Door Window Lower Stop
28	Rear Quarter Window Belt Reveal	33677-87	X						Quarter Window Lower Stop
29	Front Door Belt Reveal Lower	33677-87 (Optional)	X		X				
30	Rear Quarter Belt Reveal Lower	33677-87 (Optional)			X		X		Rear Quarter Upper Trim
31	Rear Compartment Lid	77-87 (Optional)	X					Compartment Lid Finishing Molding	
32	Compartment Lid Finishing Molding	77-87 (Optional)	X		X				
33	Rear Quarter Window Reveal Front Upper Corner Escutcheon	35-36			View M			Loosen Rear Quarter Window Reveal Upper and Lower at Corner	
34	Rear Quarter Window Reveal Upper	35-36			View M			Rear Quarter Window Reveal Front Upper Corner Escutcheon	
35	Rear Quarter Window Lower	35-36			View M			Rear Quarter Window Reveal Front Upper and Upper Corner Escutcheon	
36	Front Skylight Front Reveal	55-56-65-66			View M			Front Skylight Rear Reveal	
37	Front Skylight Rear Reveal	55-56-65-66			View M				
38	Side Skylight Upper Reveal	55-56-65-66			View M			Loosen Front Upper Corner of Quarter Window Skylight Front Reveal	

## METHODS OF MOLDING RETENTION

OLDSMOBILE "A" BODY - 33000 and 34000 SERIES

FIGURES 17-54 THROUGH 17-62

Key	Molding Name	Series or Styles	Screws	Spring (Self-Retained)	Snap-On Clips or Retainers On Panel	Snap-On Clips On Molding	Studs With Attaching Nuts	Engages With Other Moldings	Remove Hardware Or Trim
39	Quarter Window Skylight Front Reveal	55-56-65-66			View M			Quarter Window Skylight Rear Reveal	
40	Quarter Window Skylight Lower Reveal	55-56-65-66			View M			Quarter Window Skylight Front Reveal	
41	Quarter Window Skylight Rear Reveal	55-56-65-66			View M			Side Skylight Upper Reveal	
42	Side Skylight - Quarter Window Division Reveal	55-56-65-66				View L		Quarter Window Skylight Rear Reveal	
43	Body Lock Pillar Belt Reveal	35-36-55-56-65-66 (Optional)			View H		X		Body Lock Pillar Trim
44	Back Body Pillar Belt Reveal	35-36-55-56-65-66 (Optional)	X			View F			
45	Rear Quarter Pinch Weld Finishing	67	X						Lower Top Halfway
46	Front Door Outer Panel	33277 33635-36-39-69 - 34200 - 34800	X		X				
47	Front Door Outer Panel - Upper	34855-56-65-66	X		X				
48	Rear Door Outer Panel	33635-36-39-69 34239-69 34855-56-65-66	X		X				
49	Rear Door Outer Panel Upper	34855-56-65-66	X		X				

METHODS OF MOLDING RETENTION  
 OLDSMOBILE "A" BODY - 33000 and 34000 SERIES  
 FIGURES 17-54 THROUGH 17-62

Key	Molding Name	Series or Styles	Screws	Spring (Self-Retained)	Snap-On Clips or Retainers On Panel	Snap-On Clips On Molding	Studs With Attaching Nuts	Engages With Other Moldings	Remove Hardware Or Trim
50	Rear Wheel Opening - Front	33277 (Optional) 33635-36-39-69 34200 - 34800	X			View I		Front of Rear Wheel Opening (34287 Only) Rear Wheel Opening Center	
51	Rear Wheel Opening - Center	33277 (Optional) 33635-36-39-69 34200 - 34800				View I	View B		
52	Rear Wheel Opening - Rear	34200 - 34800	X (34200)				X (34800)	Rear Wheel Opening Center, Rear of Rear Wheel Opening	
53	Rear Wheel Opening - Upper	34855-56-65-66				View F	View B		
54	Front of Rear Wheel Opening	33277 (Optional) 34287			X		X		Rear Quarter Lower Trim
55	Rear of Rear Wheel Opening	34239-69-87 34800			X (34800 Only)		X		
56	Rear of Rear Wheel Opening - Upper	34855-56-65-66				View I		Rear Wheel Opening Upper	
57	Rear of Rear Quarter Outer Vertical	34855-56-65-66	X		View H			Rear of Rear Wheel Opening and Rear of Rear Wheel Opening Upper	
58	Rear Quarter Outer Panel Peak	33667			X		View B		Rear Quarter Trim
59	Rear Compartment Lid Rear	33639-67-69-77-87 34239-69-87	X ("442" Option Only)				X		
60	Rear Compartment Outer Panel Emblem	33200 33600					X		
61	Rear Compartment Outer Panel Nameplate	All					X		



METHODS OF MOLDING RETENTION  
 OLDSMOBILE "A" BODY - 33000 and 34000 SERIES  
 FIGURES 17-54 THROUGH 17-62

Key	Molding Name	Series or Styles	Screws	Spring (Self-Retained)	Snap-On Clips or Retainers On Panel	Snap-On Clips On Molding	Studs With Attaching Nuts	Engages With Other Moldings	Remove Hardware Or Trim
62	Back Window Reveal Upper and Side	77-87			View M				
63	Back Window Reveal Upper	39-69			View M			Back Window Reveal Side	
64	Back Window Reveal Side and Lower	39-69			View M				
65	Back Window Reveal Lower	77-87			View M			Back Window Reveal Side	
66	Back Body Opening Upper Reveal	35-36-55-56-65-66	X					Back Body Opening Side Reveal	Tailgate Window Glass Run Channel
67	Back Body Opening Side Reveal	35-36-55-56-65-66	X						
68	Tailgate Outer Panel Belt Reveal	35-36-55-56-65-66	X		X				
69	Tailgate Outer Panel Emblem	35-36-55-56-65-66					X		Tailgate Trim Panel
70	Tailgate Outer Panel Nameplate	34855-56-65-66					X		Tailgate Trim Panel
71	Tailgate Outer Panel Upper	34855-56-65-66 33635-36			X (34855-56-65-66 Only)		X	Tailgate Outer Panel Side	Tailgate Trim Panel
72	Tailgate Outer Panel Lower	34855-56-65-66			X			Tailgate Outer Panel Side	
73	Tailgate Outer Panel Side	34855-56-65-66					X		
74	Roof Panel Emblem	34239-69-87					X		Rear Quarter Upper Trim

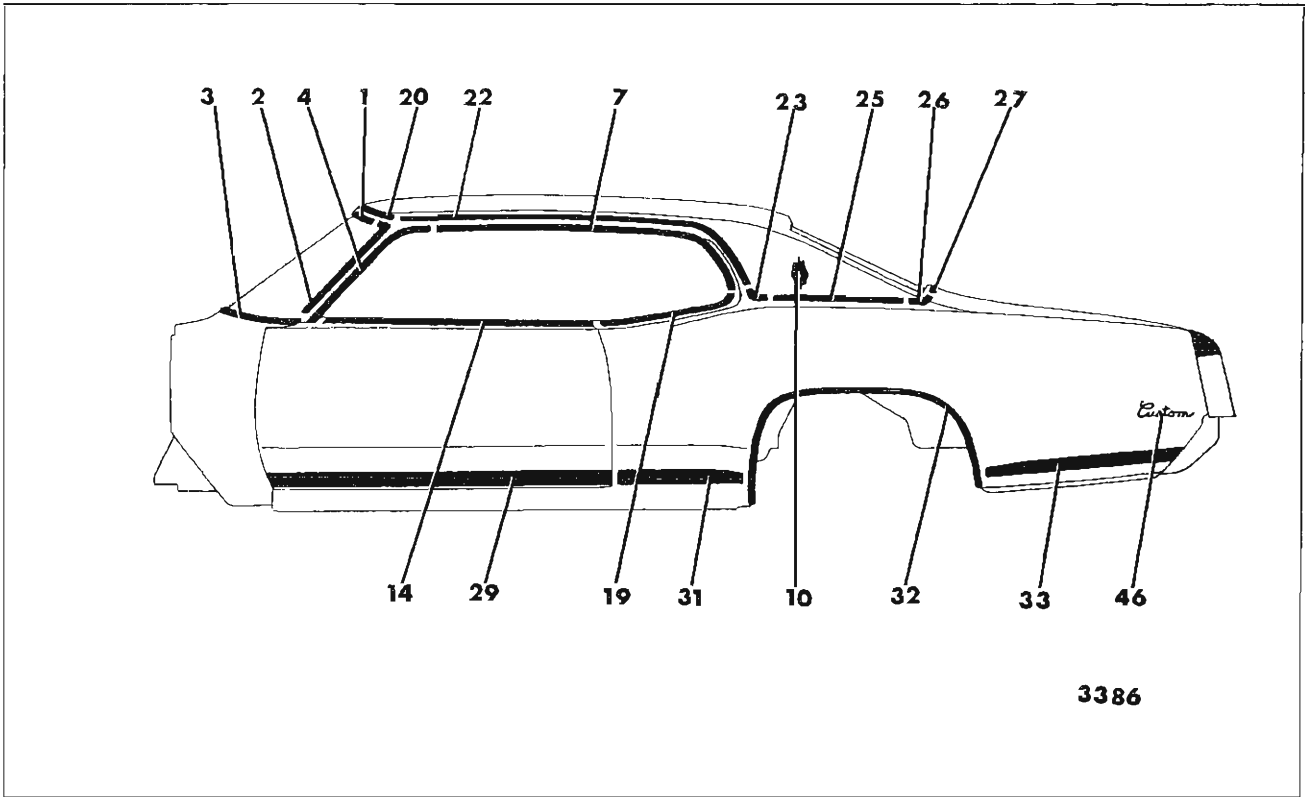

Fig. 17-63—Oldsmobile "B-37" Styles (35467 Styles Similar)

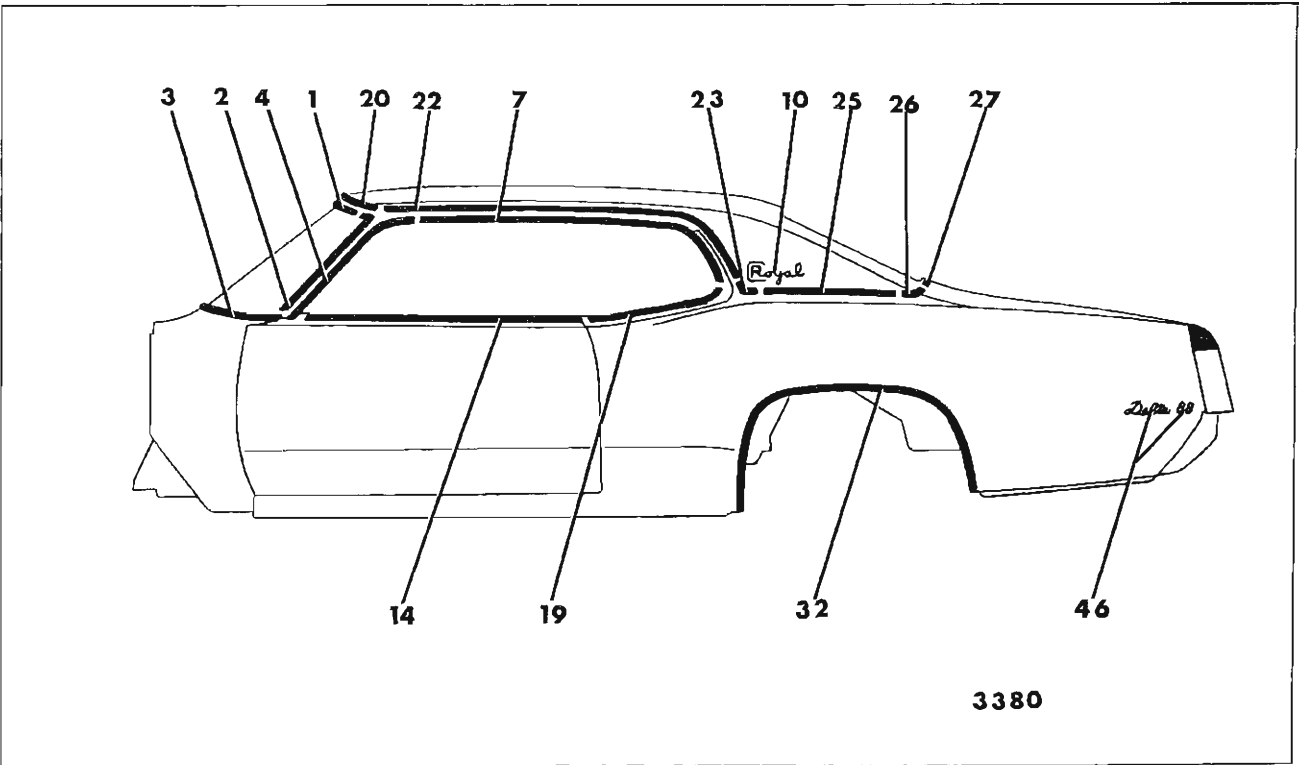

Fig. 17-64—Oldsmobile 36647 Styles

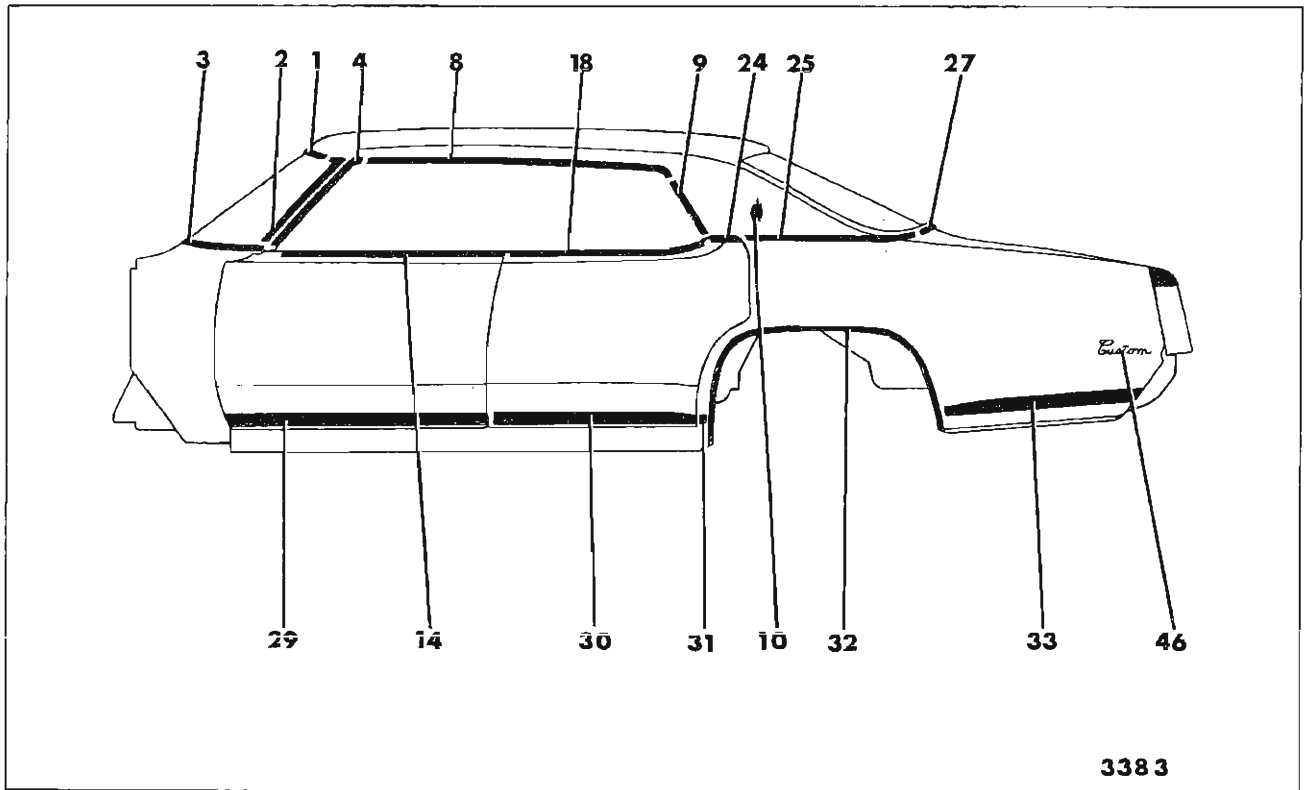

Fig. 17-65—Oldsmobile "B-39" Styles

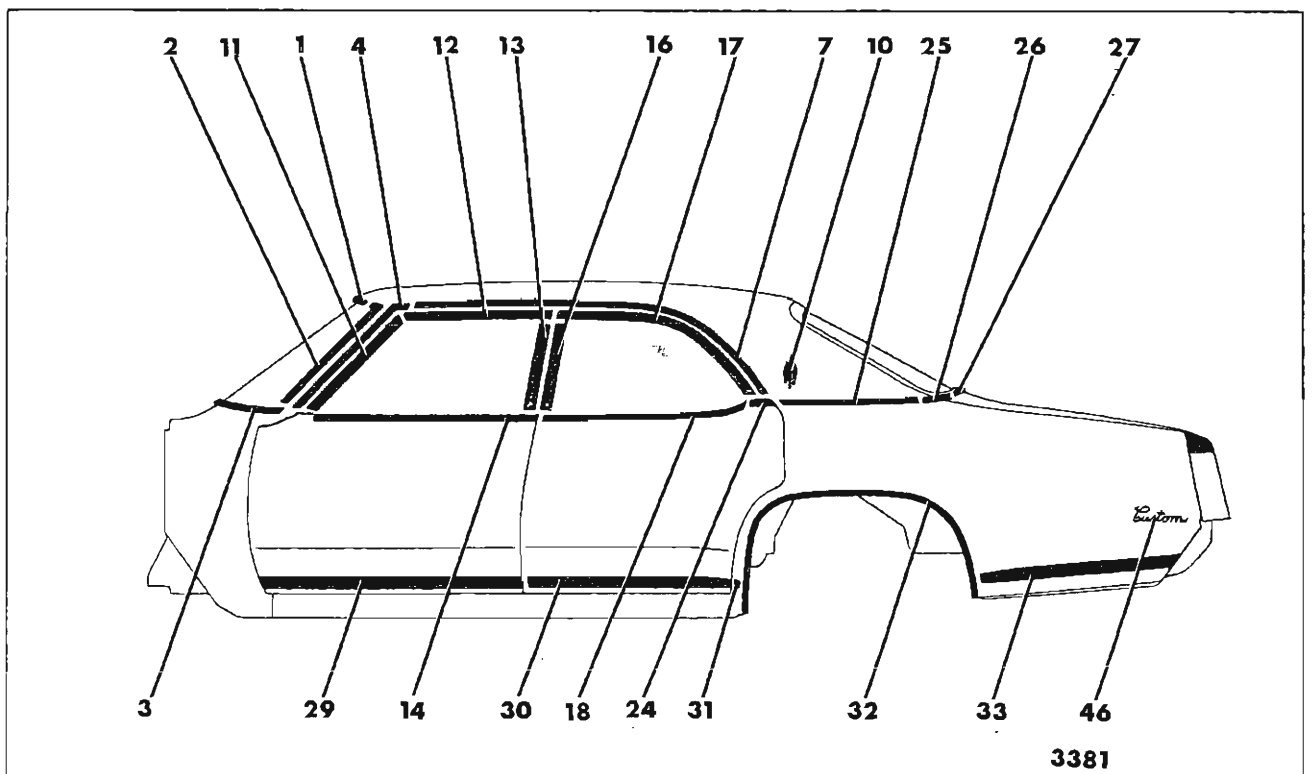

Fig. 17-66—Oldsmobile "B-69" Styles

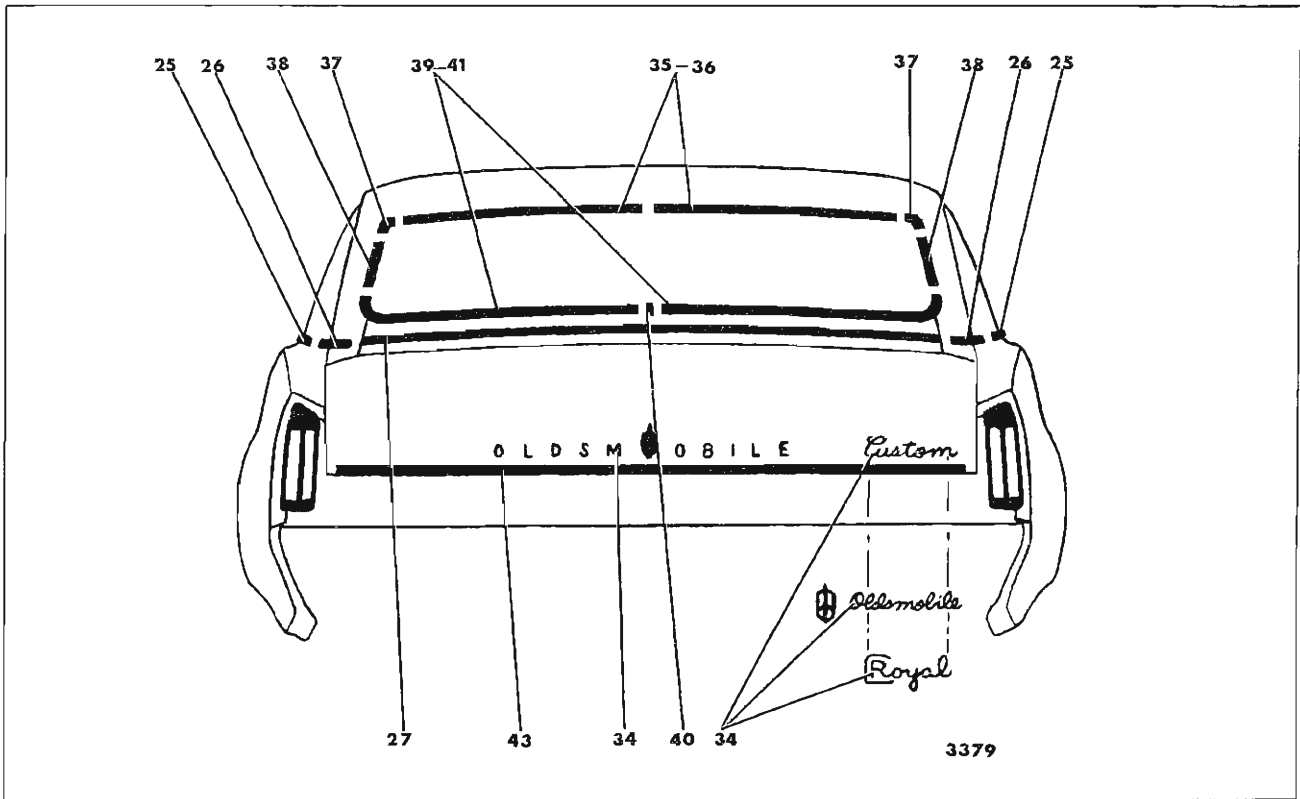

Fig. 17-67—Oldsmobile 35400-36400-36600 Styles

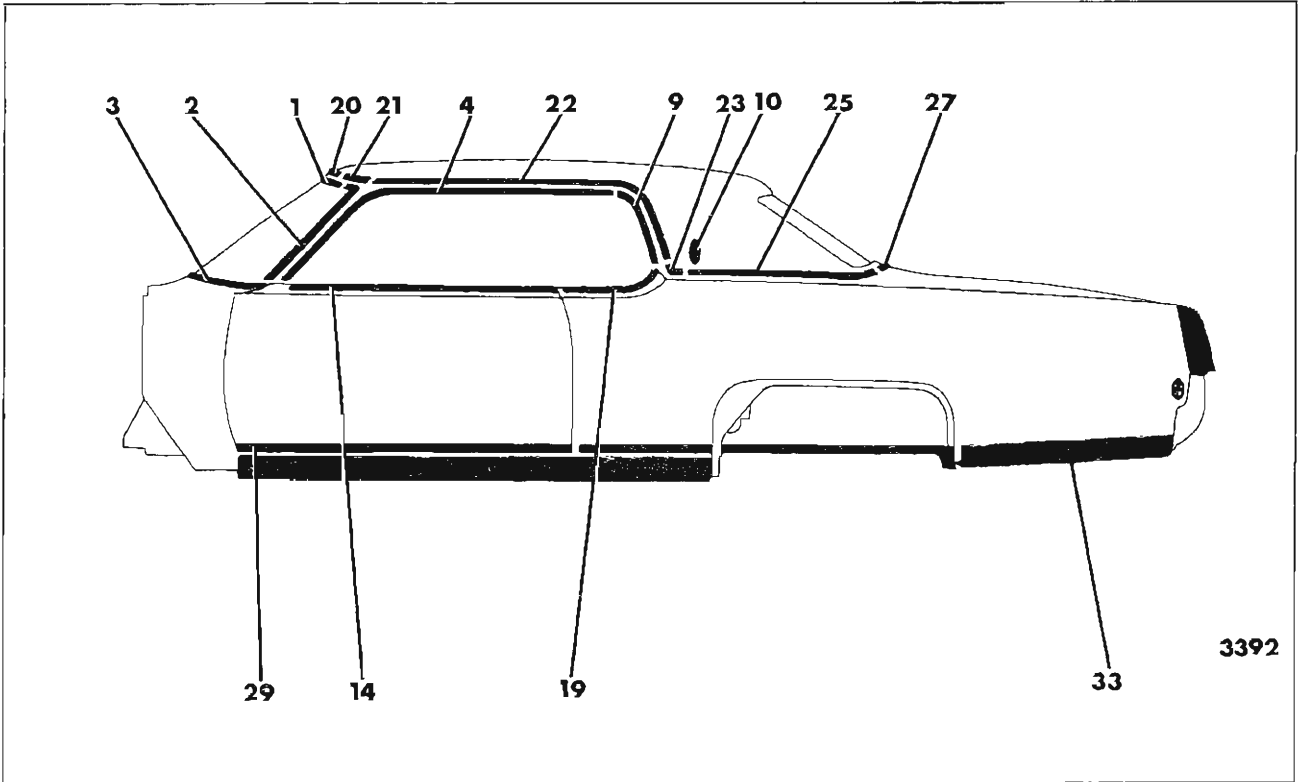

Fig. 17-68—Oldsmobile 38457 Styles (38467 Styles Similar)

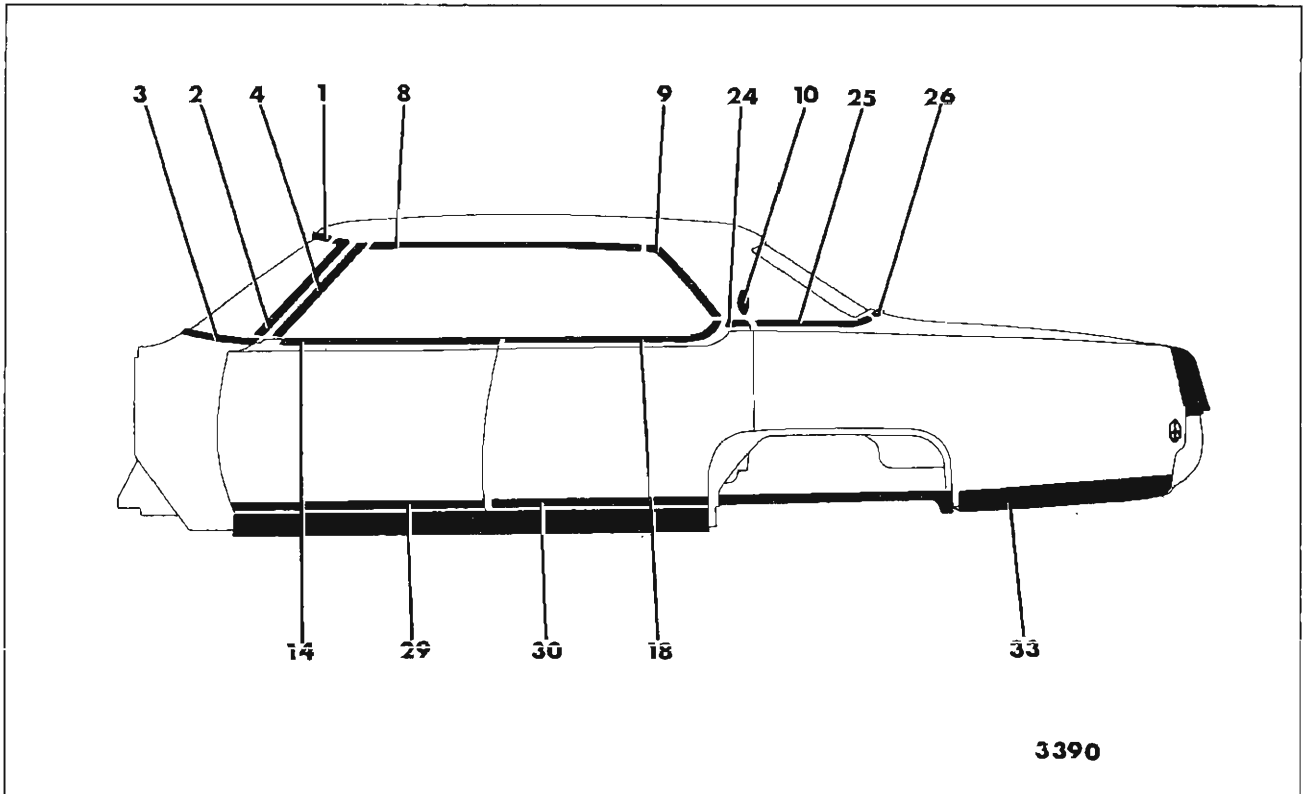

Fig. 17-69—Oldsmobile "C-39" Styles

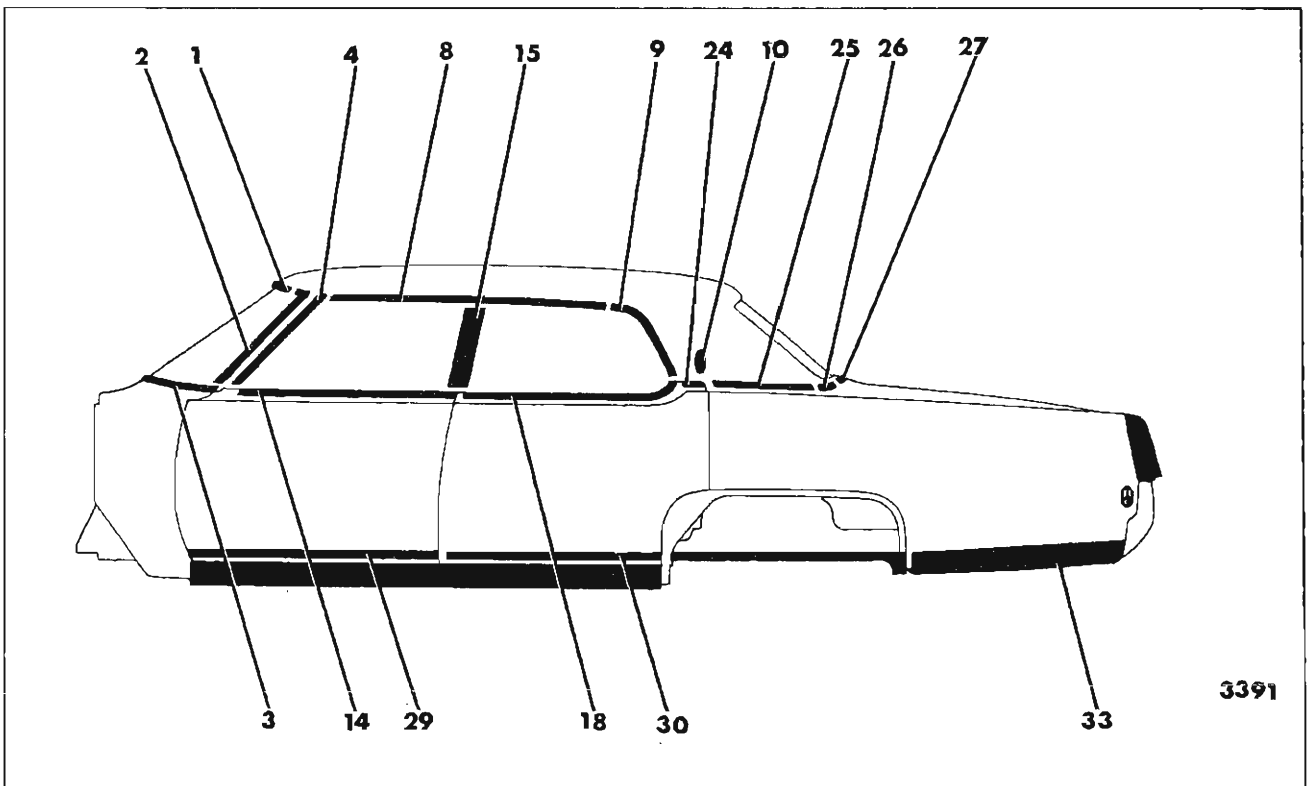

Fig. 17-70—Oldsmobile "C-69" Styles

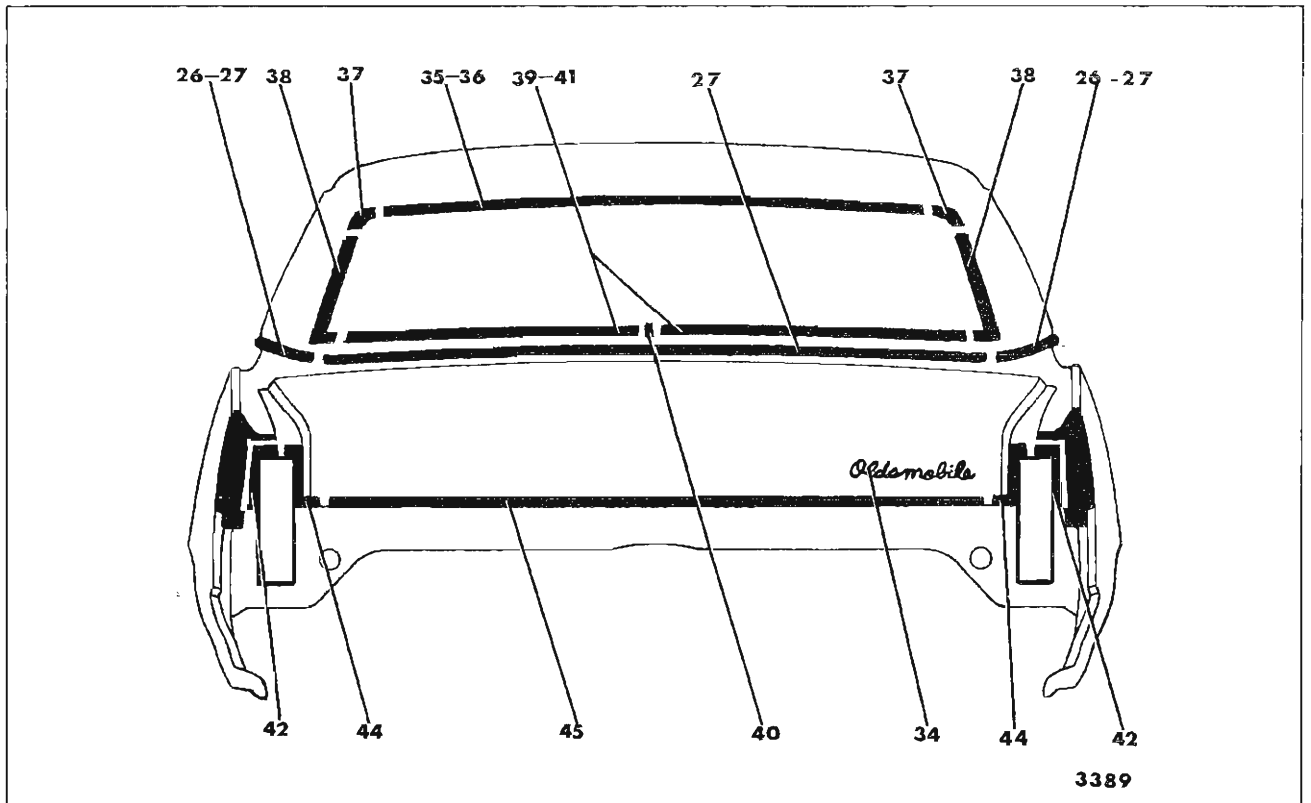

Fig. 17-71--Oldsmobile 38400-38600 Styles

## METHODS OF MOLDING RETENTION

OLDSMOBILE "B-C" BODIES - 35000, 36000 and 38000 SERIES  
 FIGURES 17-63 THROUGH 17-71

Key	Molding Name	Series or Styles	Screws	Spring (Self-Retained)	Snap-On Clips or Retainers On Panel	Snap-On Clips On Molding	Studs With Attaching Nuts	Engages With Other Moldings	Remove Hardware Or Trim
1	Windshield Reveal Upper	All			X			Windshield Reveal Side	
2	Windshield Reveal Side	All (Except 67)			X			Windshield Reveal Lower	
3	Windshield Reveal Lower	All	X						
4	Windshield Pillar Drip Scalp	All (Except 57-67)	X						Windshield Pillar Weatherstrip and Weatherstrip Retainer
5	Windshield Pillar Finishing	67	X						Windshield Pillar Weatherstrip and Weatherstrip Retainer
6	Windshield Header	67	X					Windshield Pillar Finishing, Windshield Reveal Upper	Sunshade Support, Rear View Mirror Support, Windshield Upper Garnish Molding
7	Roof Drip Molding Scalp	B-37-47-69		View K				Windshield Pillar Drip	
8	Roof Drip Molding Front Scalp	B-39, C-39, 57, 69		View K				Windshield Pillar Drip	
9	Roof Drip Molding Rear Scalp	B-39, C-39, 57, 69	X					Roof Drip Molding Front Scalp	Side Roof Rail Weatherstrip and Weatherstrip Retainer
10	Roof Panel Emblem and/or Nameplate	All (less 67)				View I			

## METHODS OF MOLDING RETENTION

OLDSMOBILE "B-C" BODIES - 35000, 36000 and 38000 SERIES  
 FIGURES 17-63 THROUGH 17-71

Key	Molding Name	Series or Styles	Screws	Spring (Self-Retained)	Snap-On Clips or Retainers On Panel	Snap-On Clips On Molding	Studs With Attaching Nuts	Engages With Other Moldings	Remove Hardware Or Trim
11	Front Door Window Frame Front Scalp	69 (Except 38000 Series)		View J					
12	Front Door Window Frame Upper Scalp	69 (Except 38000 Series)		View J				Front Door Window Frame Front Scalp	
13	Front Door Window Frame Rear Scalp	69 (Except 38000 Series)		View J				Front Door Window Frame Upper Scalp	
14	Front Door Window Belt Reveal	All	X						Rubber Bumper on Front Door Window Lower Stop
15	Center Pillar Scalp	38469-38669	X						Side Roof Rail Weatherstrip Front and Rear
16	Rear Door Window Frame Front Scalp	69 (Except 38000 Series)		View J				Rear Door Window Frame Upper Scalp	
17	Rear Door Window Frame Upper Scalp	69 (Except 38000 Series)		View J					
18	Rear Door Window Belt Reveal	39, 69	X						Rubber Bumper on Rear Door Window Lower Stop
19	Rear Quarter Window Belt Reveal	37, 47, 57, 67	X						Rear Quarter Window Lower Stop
20	Roof Panel Cover Front	B-37, 47 C-57			X				
21	Roof Panel Cover Front Corner Escutcheon	C-57	X					Roof Panel Cover Front, Roof Panel Cover Side	



METHODS OF MOLDING RETENTION  
 OLDSMOBILE "B-C" BODIES - 35000, 36000 and 38000 SERIES  
 FIGURES 17-63 THROUGH 17-71

Key	Molding Name	Series or Styles	Screws	Spring (Self-Retained)	Snap-On Clips or Retainers On Panel	Snap-On Clips On Molding	Studs With Attaching Nuts	Engages With Other Moldings	Remove Hardware Or Trim
22	Roof Panel Cover Side	B-37, 47 C-57			X			Roof Panel Belt Reveal Front Corner Escutcheon	
23	Rear Quarter Belt Reveal Front Corner Escutcheon	B-37, 47 C-57						Loosen Rear Edge of Roof Panel Cover Side, and Front Edge of Rear Quarter Belt Reveal	
24	Rear Door Corner Finishing	B&C-39, 69					X		
25	Rear Quarter Belt Reveal	All (Except 67)			X		X (B-37, 39, 47, 69 & C-69 only)	Roof Panel Belt Reveal Front Corner Escutcheon (B-37, 47, C-57 Only). Rear End Belt Reveal (B-39 & C-39, 57, 69 Only)	
26	Rear Quarter Belt Reveal Rear Corner Escutcheon	All (Except 39, 57, 67 & C-69)					X	Rear Quarter Belt Reveal, Rear End Belt Reveal	
27	Rear End Belt Reveal	All (Except 67)			X		X (39, 57, 69 Only)		
28	Rear Quarter Pinch-weld Finishing Molding	67	X						Lower Top Halfway
29	Front Door Outer Panel	35400-36400 38000	X		X				
30	Rear Door Outer Panel	35439-69 36439-69	X		X		View B (36439-69 Only)		Rear Door Trim Pad (36439-69 Only)
		38000	X		X				

METHODS OF MOLDING RETENTION

OLDSMOBILE "B-C" BODIES - 35000, 36000 and 38000 SERIES  
 FIGURES 17-63 THROUGH 17-71

Key	Molding Name	Series or Styles	Screws	Spring (Self-Retained)	Snap-On Clips or Retainers On Panel	Snap-On Clips On Molding	Studs With Attaching Nuts	Engages With Other Moldings	Remove Hardware Or Trim
31	Front of Rear Wheel Opening	35439-69					X		Rear Quarter Trim
		36439-69							
		35437-67			X		X		
		36437					X		
32	Rear Wheel Opening	35400 36400 36600	X					Front of Rear Wheel Opening and Rear of Rear Wheel Opening (36400 Only)	
33	Rear of Rear Wheel Opening	35400 36400			X		X X		
		38000	X			View F View I	X		
34	Rear Compartment Lid Outer Panel Emblem and/or Nameplate	35400 38000 36400				View I (Lettering - "Oldsmobile" 36400 Only)	X		
35	Back Window Reveal Upper	B-37-39-47 C-39-57-69			X			Back Window Upper Corner Escutcheon (B-39) - Back Window Reveal Sides (B-37, 47)	
36	Back Window Reveal Upper and Sides	B-69			X				
37	Back Window Reveal Upper Corner Escutcheon	B-39						Loosen Ends of Sides and Lower, and Upper Reveals	

METHODS OF MOLDING RETENTION  
 OLDSMOBILE "B-C" BODIES - 35000, 36000 and 38000 SERIES  
 FIGURES 17-63 THROUGH 17-71

Key	Molding Name	Series or Styles	Screws	Spring (Self-Retained)	Snap-On Clips or Retainers On Panel	Snap-On Clips On Molding	Studs With Attaching Nuts	Engages With Other Moldings	Remove Hardware Or Trim
38	Back Window Reveal Side	B-37, 47 C-39, 57			X			Back Window Reveal Upper (C-39, 57)	
39	Back Window Reveal Sides and Lower	B-39, C-69			X			Back Window Upper Corner Escutcheon (B-39). Back Window Reveal Upper (C-69)	
40	Back Window Reveal Lower Center Escutcheon	B-39						Back Window Sides and Lower - Right and Left	
41	Back Window Reveal Lower	B-37,47,69 C-39,57			X			Back Window Upper and Sides (B-69) Back Window Reveal Sides (B-37, C-39-57)	
42	Rear of Rear Quarter Outer	38000	X					Rear Quarter Outer Extensions	
43	Rear Compartment Lid Outer Panel	All (Except 38000 Series)	X						
44	Rear Compartment Lid Outer Panel Side	38000	X					Rear Compartment Lid Outer Panel Center	
45	Rear Compartment Lid Outer Panel Center	38000	X						
46	Rear Quarter Outer Panel Emblem and/or Nameplate	36400 36647					X		

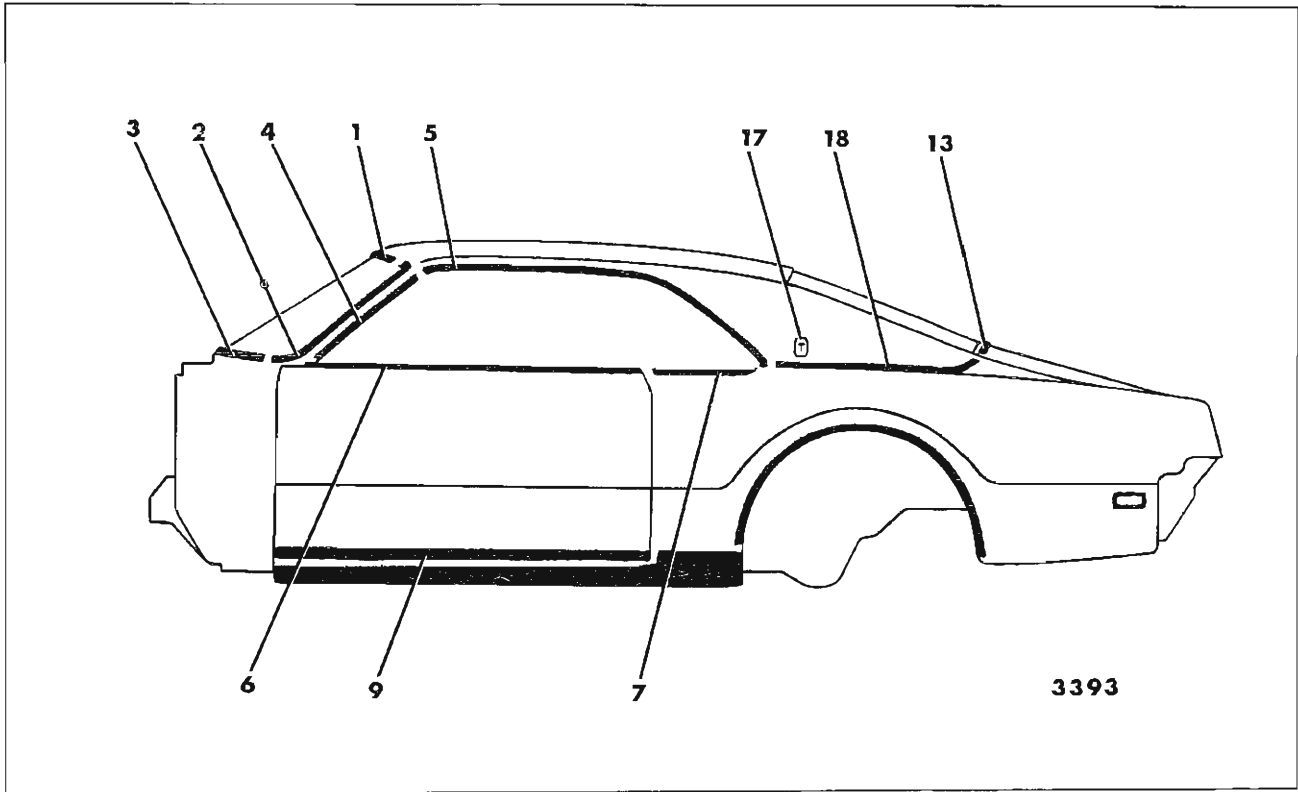

Fig. 17-72—Oldsmobile 39487-39687 Styles

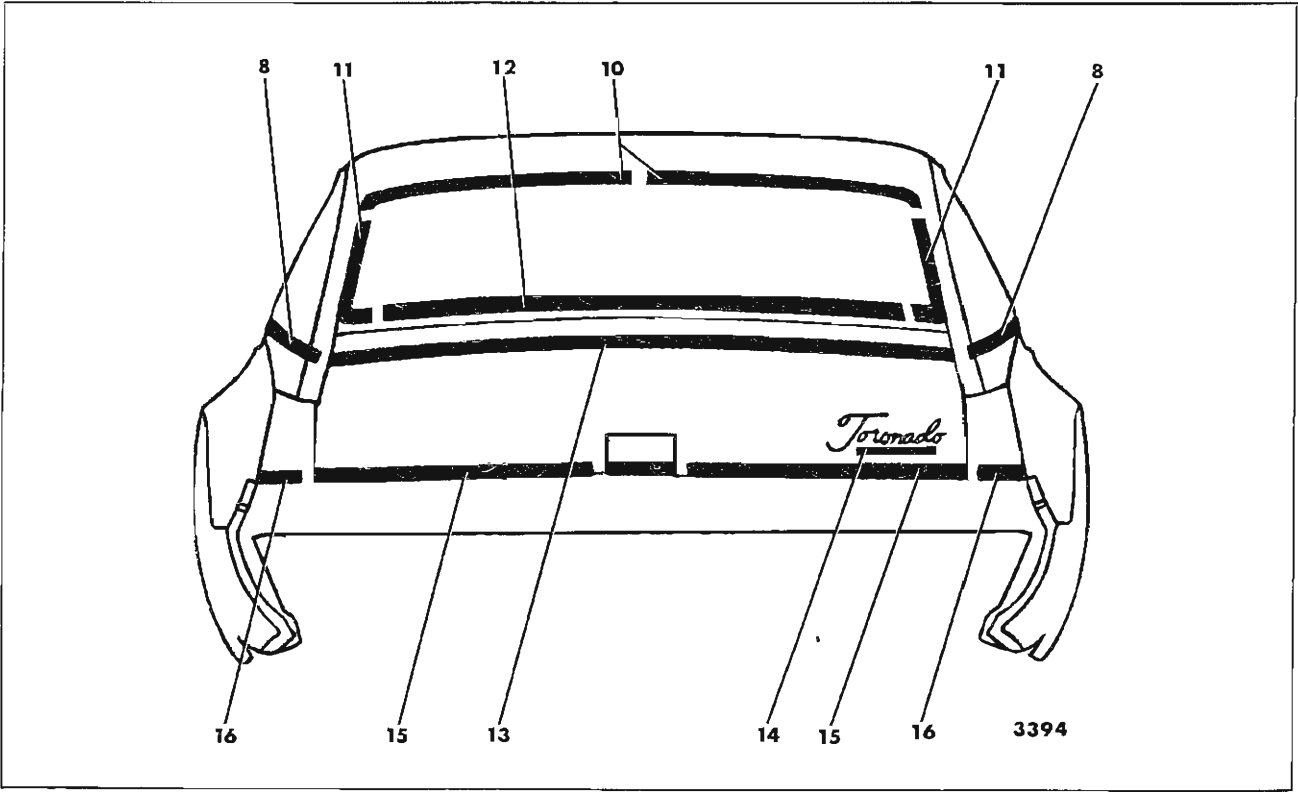

Fig. 17-73—Oldsmobile 39487-39687 Styles

**METHODS OF MOLDING RETENTION**  
**OLDSMOBILE "E" BODIES - 39000 SERIES**  
**FIGURES 17-72 THROUGH 17-73**

Key	Molding Name	Series or Styles	Screws	Spring (Self-Retained)	Snap-On Clips or Retainers On Panel	Snap-On Clips On Molding	Studs With Attaching Nuts	Engages With Other Moldings	Remove Hardware Or Trim
1	Windshield Reveal Upper	All			X				
2	Windshield Reveal Side	All			X			Windshield Reveal Upper	
3	Windshield Reveal Lower	All	X					Windshield Reveal Side	
4	Windshield Pillar Drip Molding Scalp	All		View K					Windshield Pillar Weatherstrip and Weatherstrip Retainer
5	Roof Drip Molding Scalp	All		View K				Windshield Pillar Drip Molding Scalp	
6	Front Door Window Belt Reveal	All	X		X				Rubber Bumper on Front Door Window Lower Stop
7	Rear Quarter Window Belt Reveal	All	X					Roof Drip Molding Scalp	Rear Quarter Window
8	Rear Quarter Belt Reveal	All (Optional)			X		X		Rear Compartment Side Trim Panel
9	Front Door Outer Panel	All	X		X				
10	Back Window Reveal Upper	All			X				
11	Back Window Reveal Side	All			X			Back Window Reveal Upper	
12	Back Window Reveal Lower	All			X			Back Window Reveal Side	
13	Rear Compartment Lid Front	All (With Fabric Roof Cover)	X		X				

METHODS OF MOLDING RETENTION  
 OLDSMOBILE "E" BODIES - 39000 SERIES  
 FIGURES 17-72 THROUGH 17-73

Key	Molding Name	Series or Styles	Screws	Spring (Self-Retained)	Snap-On Clips or Retainers On Panel	Snap-On Clips On Molding	Studs With Attaching Nuts	Engages With Other Moldings	Remove Hardware Or Trim
14	Rear End Outer Panel Emblem and/or Nameplate	All					View C		
15	Rear Compartment Lid Lower - Right and Left	All					View C		
16	Rear of Rear Quarter Outer Panel	All					View C		
17	Roof Panel Emblem	All (Optional)				View I			

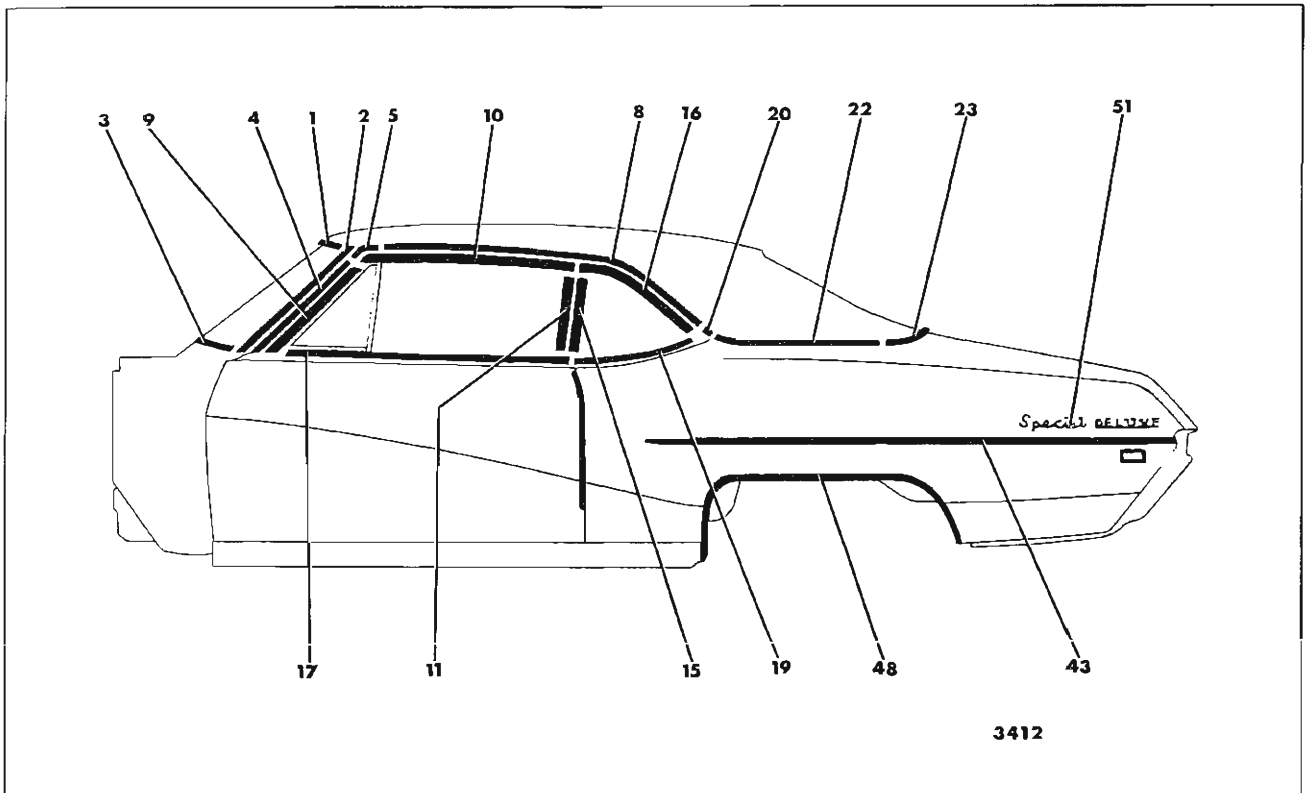

Fig. 17-74—Buick "A-27" Styles

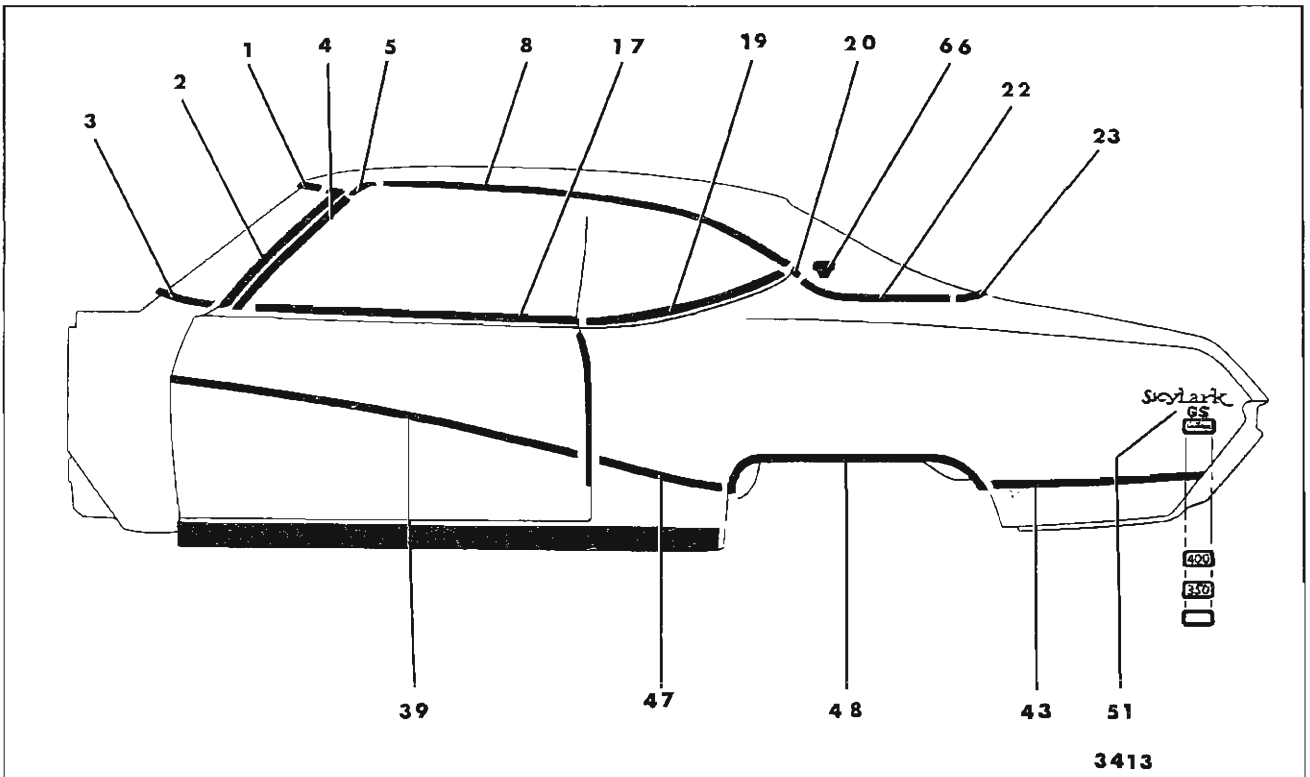

Fig. 17-75—Buick "A-37" Styles ("67" Styles Similar)

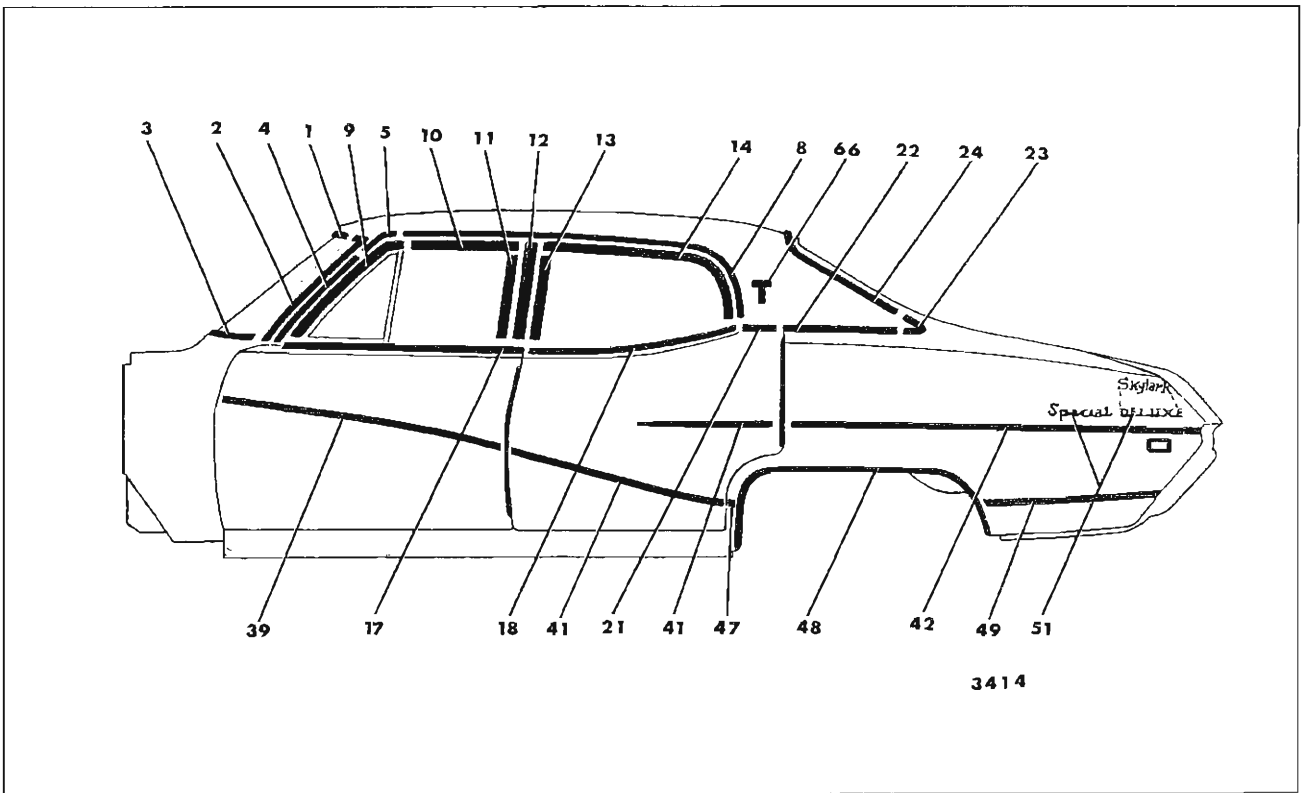

Fig. 17-76—Buick "A-69" Styles

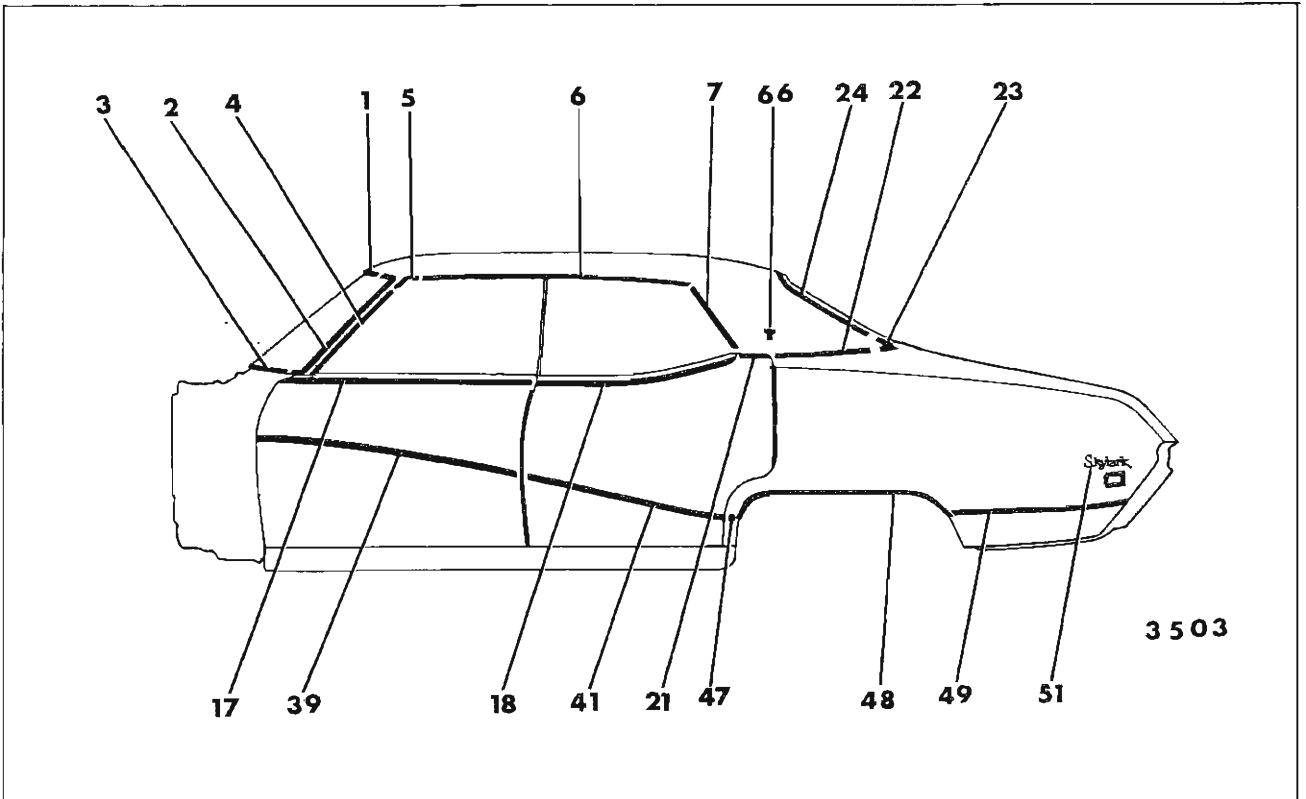

Fig. 17-77—Buick "A-39" Styles



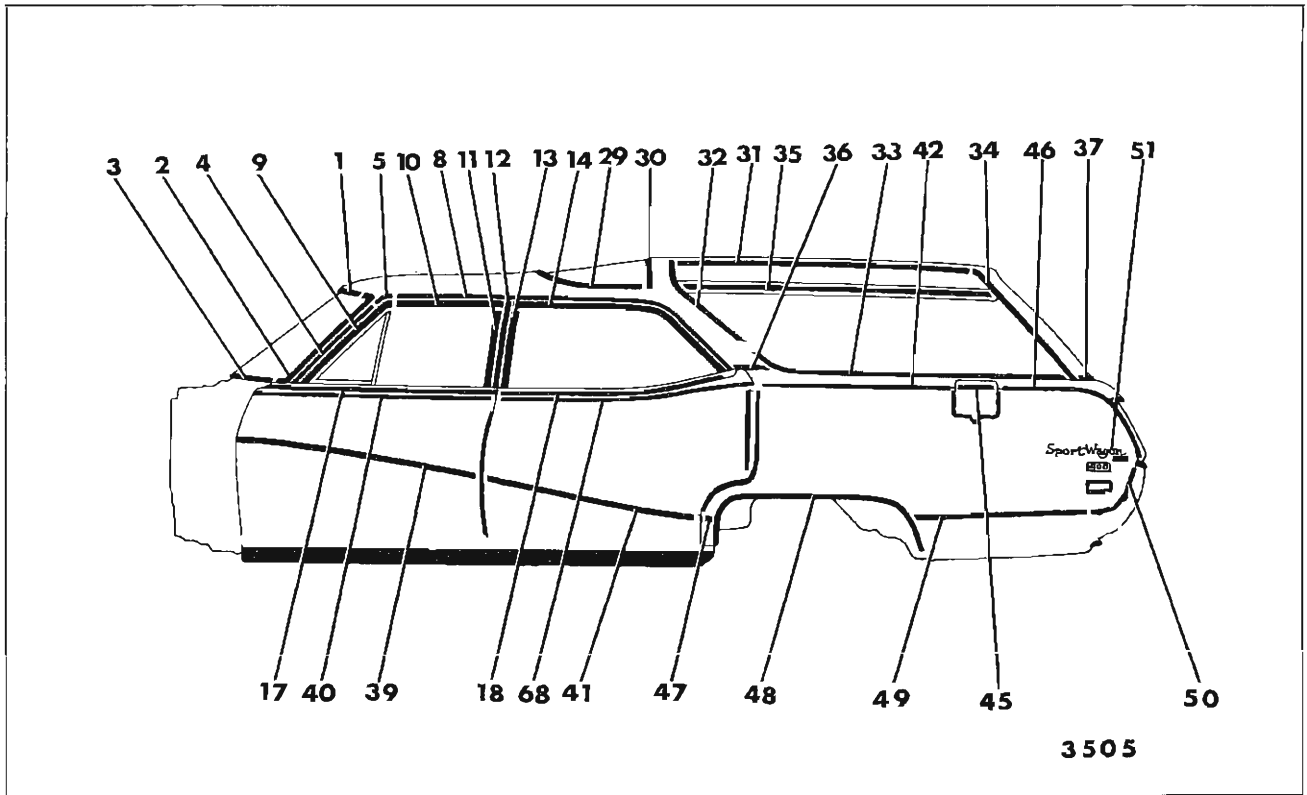

Fig. 17-78—Buick "A-35-36" Styles

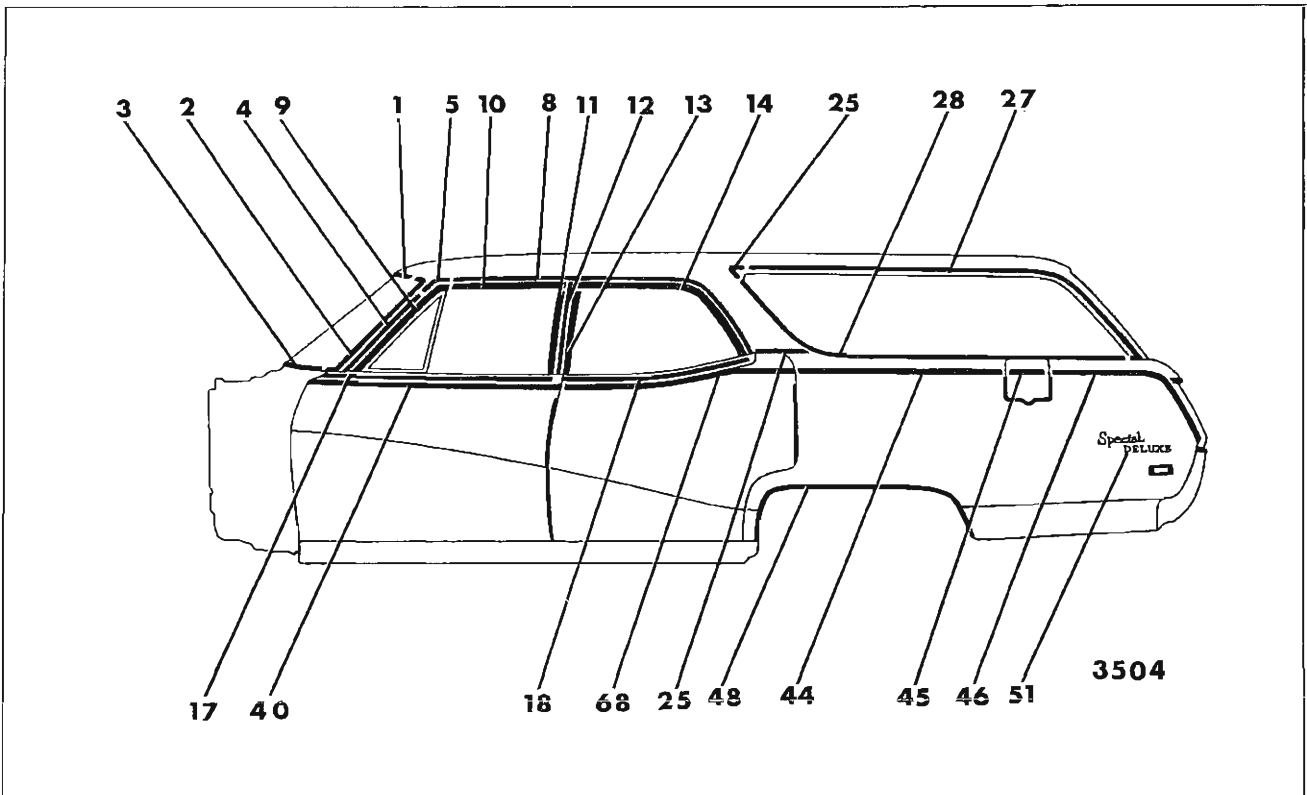

Fig. 17-79—Buick "A-56-66" Styles

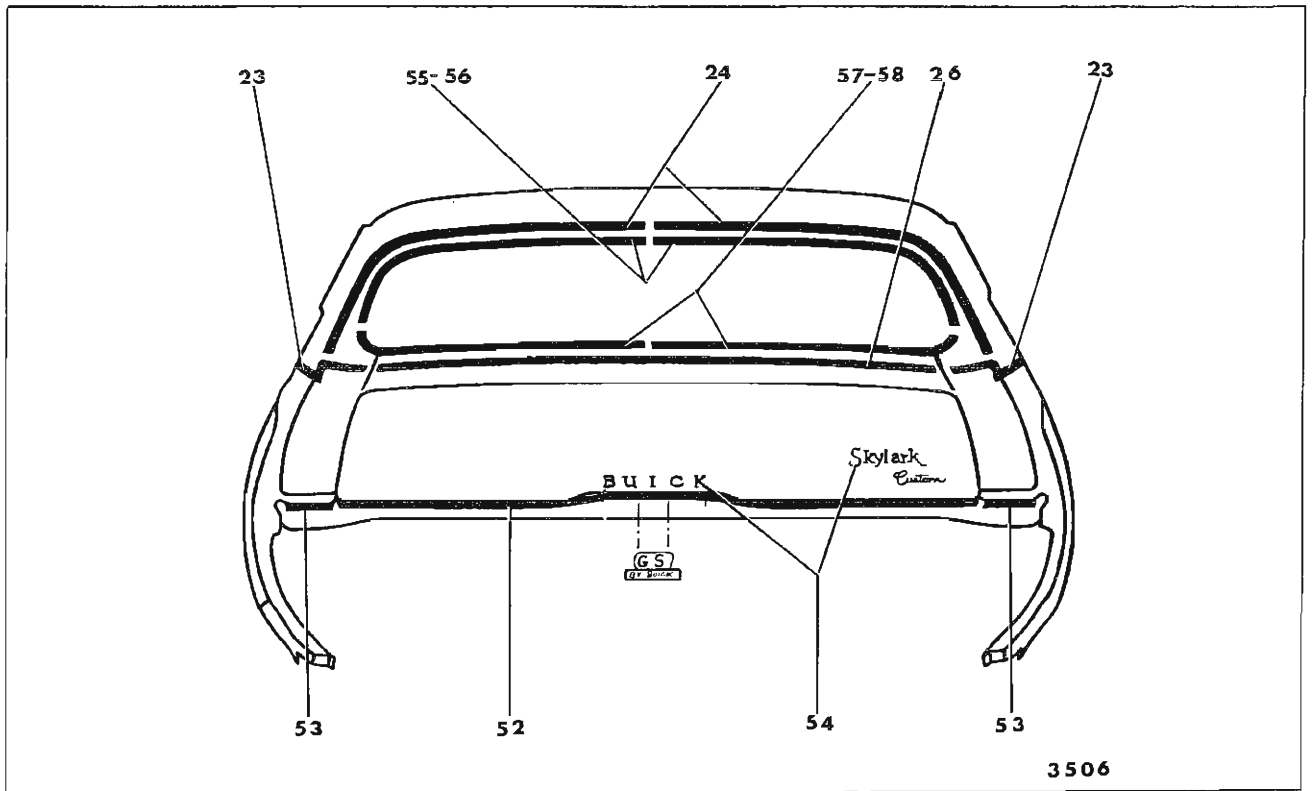

Fig. 17-80—Buick 43300-43400-43500-44400-44600 Styles (Less 35-36-56-66)

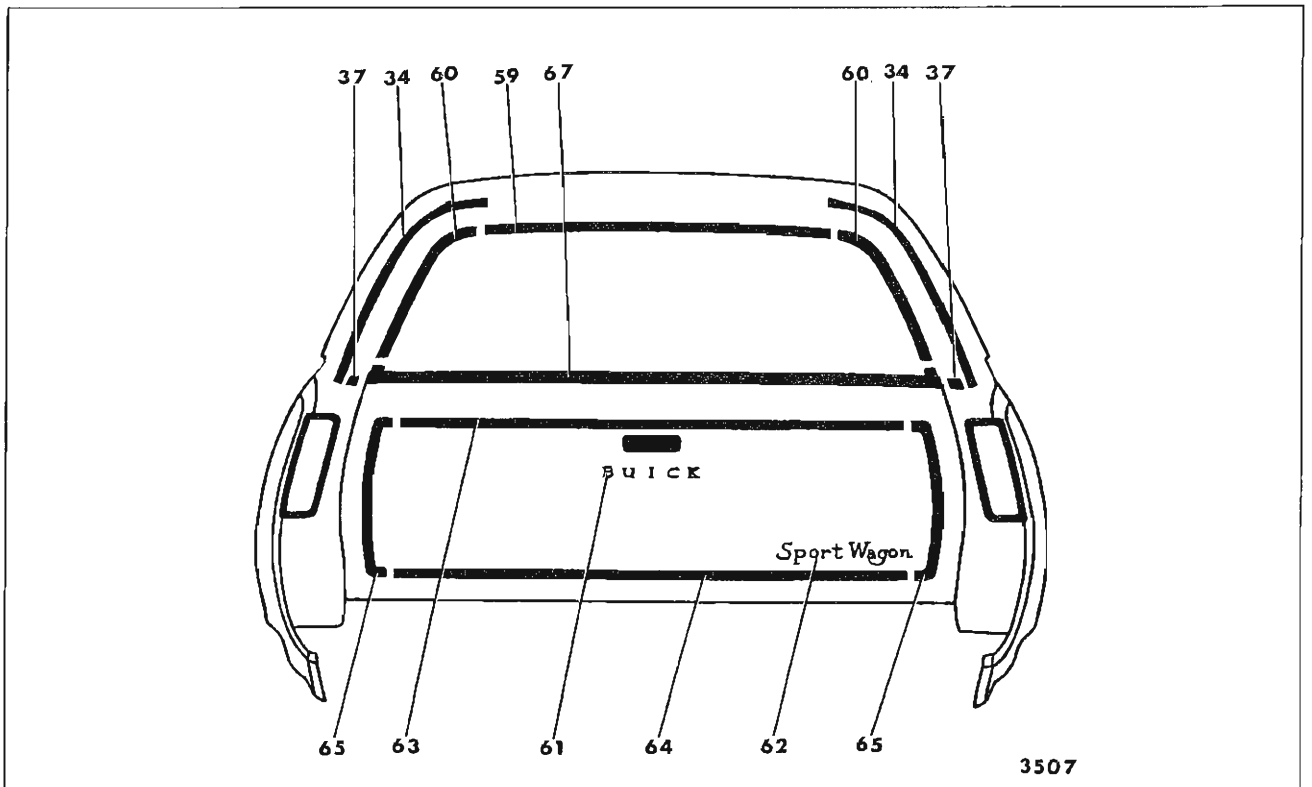

Fig. 17-81—Buick "A-35-36-56-66" Styles

## METHODS OF MOLDING RETENTION

BUICK "A" BODIES - 43000 AND 44000 SERIES  
 FIGURES 17-74 THROUGH 17-81

Key	Molding Name	Series or Styles	Screws	Spring (Self-Retained)	Snap-On Clips or Retainers On Panel	Snap-On Clips On Molding	Studs With Attaching Nuts	Engages With Other Moldings	Remove Hardware Or Trim
1	Windshield Reveal Upper	All			X			Windshield Reveal Side	
2	Windshield Reveal Side	All	X (67 Only)		X				
3	Windshield Reveal Lower	All	X					Windshield Reveal Side	
4	Windshield Pillar Drip Scalp	All (Except 67)		View K				Roof Drip Molding Front Scalp Escutcheon	
5	Roof Drip Molding Front Scalp Escutcheon	All (Except 67)		View K				Windshield Pillar Drip Scalp and Roof Drip Scalp	
6	Roof Drip Molding Front Scalp	39 Style		View K				Roof Drip Molding Front Scalp Escutcheon	
7	Roof Drip Molding Rear Scalp	39 Style	X					Roof Drip Molding Front Scalp	
8	Roof Drip Molding Scalp	All (Except 39-67)		View K				Roof Drip Molding Front Scalp Escutcheon	
9	Front Door Window Frame Front Scalp	27-35-36-56-66-69		View J					
10	Front Door Window Frame Upper Scalp	27-35-36-56-65-66-69		View J				Front Door Window Frame Front Scalp	
11	Front Door Window Frame Rear Scalp	27-35-36-56-66-69		View J				Front Door Window Frame Upper Scalp	
12	Center Pillar Scalp	35-36-56-66-69	X						
13	Rear Door Window Frame Front Scalp	35-36-56-66-69		View J				Rear Door Window Frame Upper Scalp	
14	Rear Door Window Frame Upper Scalp	35-36-56-66-69		View J					

**METHODS OF MOLDING RETENTION**  
**BUICK "A" BODIES - 43000 AND 44000 SERIES**  
**FIGURES 17-74 THROUGH 17-81**

Key	Molding Name	Series or Styles	Screws	Spring (Self-Retained)	Snap-On Clips or Retainers On Panel	Snap-On Clips On Molding	Studs With Attaching Nuts	Engages With Other Moldings	Remove Hardware Or Trim
15	Rear Quarter Window Reveal Front	27 Styles			X			Rear Quarter Window Reveal Upper	
16	Rear Quarter Window Reveal Upper	27 Style	X						Quarter Window Glass Run Channel
17	Front Door Belt Reveal	All (Optional)	X						Front Door Window Lower Stop
18	Rear Door Belt Reveal	35-36-39-56-66-69 (Optional)	X						Rear Door Window Lower Stop
19	Rear Quarter Window Belt Reveal	27-37-67 (Optional)	X						Quarter Window Lower Stop
20	Rear Quarter Belt Reveal Front Escutcheon	27-37 (Optional)	X					Rear Quarter Belt Reveal	
21	Rear Door Corner Finishing	39-69 (Optional)					X		
22	Rear Quarter Belt Reveal	27-37 (Optional)			X		X (27-37 Only)		
23	Rear Quarter Belt Reveal Rear Corner Escutcheon	27-37 39-69 (Optional)					X	Rear Quarter Belt Reveal, Rear End Belt Reveal (27-37 Only) Roof Panel Cover Rear Finishing (39, 69 Only)	
24	Roof Panel Cover Rear Finishing Molding	39-69 (Optional)			X				
25	Rear Quarter Window Reveal Front Upper Corner Escutcheon	35-36						Loosen Rear Quarter Window Reveal Upper and Lower at Corner	

METHODS OF MOLDING RETENTION  
BUICK "A" BODIES - 43000 AND 44000 SERIES  
FIGURES 17-74 THROUGH 17-81

Key	Molding Name	Series or Styles	Screws	Spring (Self-Retained)	Snap-On Clips or Retainers On Panel	Snap-On Clips On Molding	Studs With Attaching Nuts	Engages With Other Moldings	Remove Hardware Or Trim
26	Rear End Belt Reveal	27-37 (Optional)			X				
27	Rear Quarter Window Reveal Upper	35-36			X			Rear Quarter Window Reveal Front Upper Corner Escutcheon	
28	Rear Quarter Window Reveal Lower	35-36			X			Rear Quarter Window Reveal Front Upper, and Upper Corner Escutcheon	
29	Front Skylight Front Reveal	56-66			X			Front Skylight Rear Reveal	
30	Front Skylight Rear Reveal	56-66			X				
31	Side Skylight Upper Reveal	56-66			X			Loosen Front Upper Corner of Quarter Window Skylight Front Reveal	
32	Quarter Window Skylight Front Reveal	56-66			X			Quarter Window Skylight Rear Reveal	
33	Quarter Window Skylight Lower Reveal	56-66			X			Quarter Window Skylight Front Reveal	
34	Quarter Window Skylight Rear Reveal	56-66			X			Side Skylight Upper Reveal	
35	Side Skylight - Quarter Window Division Reveal	56-66				View L		Quarter Window Skylight Rear Reveal	
36	Body Lock Pillar Belt Reveal	35-36-56-66 (Optional)			View H		X		Body Lock Pillar Trim
37	Back Body Pillar Belt Reveal	35-36-56-66 (Optional)	X		View F				
38	Rear Quarter Pinch-weld Finishing	67	X						Lower Top Halfway

METHODS OF MOLDING RETENTION  
BUICK "A" BODIES - 43000 AND 44000 SERIES  
FIGURES 17-74 THROUGH 17-81

Key	Molding Name	Series or Styles	Screws	Spring (Self-Retained)	Snap-On Clips or Retainers On Panel	Snap-On Clips On Molding	Studs With Attaching Nuts	Engages With Other Moldings	Remove Hardware Or Trim
39	Front Door Outer Panel	44400 44456-66 (Optional)	X		X				
40	Front Door Outer Panel Peak	43435-36 44456-66 (Optional)	X		X				
41	Rear Door Outer Panel	43369 44439-69 44456-66 (Optional)	X		X		View B (43369 Only)		Rear Door Trim (43369 Only)
42	Rear Quarter Outer Upper Panel	44456-66 (Optional) 43435-36 (Right Side Only)			X		X		Tail Lamp Assembly
43	Rear Quarter Outer Panel - Lower	43327-39			X		X		Rear Quarter Trim (43327 Only)
44	Rear Quarter Outer Upper Panel - Front	44456-66 (Optional) 43435-36 (Left Side)			X				
45	Rear Quarter Outer Gas Tank Filler	44456-66 (Optional) 43435-36 (Left Side)	X						
46	Rear Quarter Outer Upper Panel - Rear	44456-66 (Optional) 43435-36 (Left Side)			X		X		Tail Lamp Assembly
47	Front of Rear Wheel Opening	44400 44456-66 (Optional)	X (4 Door Styles Only)		X (2 Door Styles Only)		X (2 Door Styles Only)		Rear Quarter Trim (2 Door Styles) Rear Wheel Opening (4 Door Styles)
48	Rear Wheel Opening	43327-69 (Optional) 43400 43500 44400 44600	X						

METHODS OF MOLDING RETENTION  
BUICK "A" BODIES - 43000 AND 44000 SERIES  
FIGURES 17-74 THROUGH 17-81

Key	Molding Name	Series or Styles	Screws	Spring (Self-Retained)	Snap-On Clips or Retainers On Panel	Snap-On Clips On Molding	Studs With Attaching Nuts	Engages With Other Moldings	Remove Hardware Or Trim
49	Rear of Rear Wheel Opening	44400 (44456-66 Optional)			X		X		
50	Rear Quarter Outer Rear Vertical	44456-66 (Optional)	X		View H			Rear Quarter Outer Panel - Rear of Rear Wheel Opening	
51	Rear Quarter Outer Panel Emblem and/or Nameplate	43300 43400 43500 44400 44600				View I (43435-36 & 44456-66 Only)	X		
52	Rear Compartment Outer Panel	43400 43500 (Optional) 44400 44600 (Less 35-36-56-66)					X		
53	Rear of Rear Quarter Panel	43400 43500 (Optional) 44400 44600 (Less 35-36-56-66)					X		
54	Rear Compartment Lid Outer Panel Emblem and/or Nameplate	All (Except 35, 36, 56,66)				View I (Skylark and Custom Nameplates Only)	X		
55	Back Window Reveal Upper and Side	27-37-69			X				
56	Back Window Reveal Upper	39			X				
57	Back Window Reveal Side and Lower	39			X			Back Window Reveal Upper	

## METHODS OF MOLDING RETENTION

BUICK "A" BODIES - 43000 AND 44000 SERIES  
FIGURES 17-74 THROUGH 17-81

Key	Molding Name	Series or Styles	Screws	Spring (Self-Retained)	Snap-On Clips or Retainers On Panel	Snap-On Clips On Molding	Studs With Attaching Nuts	Engages With Other Moldings	Remove Hardware Or Trim
58	Back Window Reveal Lower	27-37-69			X			Back Window Reveal Side	
59	Back Body Opening Upper Reveal	35-36-56-66	X					Back Body Opening Side Reveal	Tail Gate Window Glass Run Channel
60	Back Body Opening Side Reveal	35-36-56-66	X						
61	Tailgate Outer Panel Nameplate "Buick"	35-36-56-66			View H		X		Tailgate Trim
62	Tailgate Outer Panel Nameplate "Sport Wagon"	56-66					X		Tailgate Trim
63	Tailgate Outer Panel Upper	35-36-56-66			X			Tailgate Outer Panel Side	
64	Tailgate Outer Panel Lower	35-36-56-66			X			Tailgate Outer Panel Side	
65	Tailgate Outer Panel Side	35-36-56-66					X		
66	Roof Panel Emblem	43537-69 44437-39-69					X		Rear Quarter Upper Trim
67	Tailgate Outer Panel Belt Reveal	35-36-56-66	X		X				
68	Rear Door Outer Panel Peak	43435-36 44456-66 (Optional)	X		X				



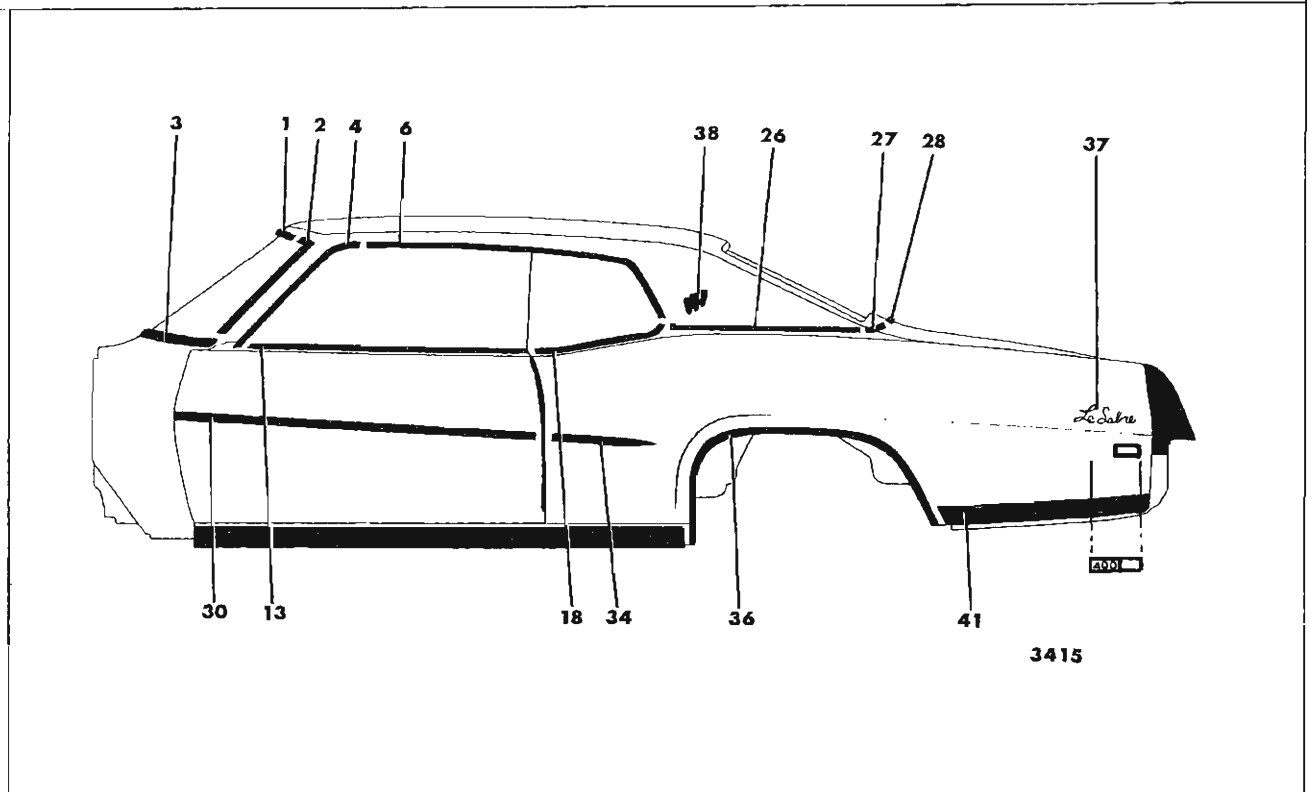

Fig. 17-82—Buick "B-37" Styles ('67" Style Similar)

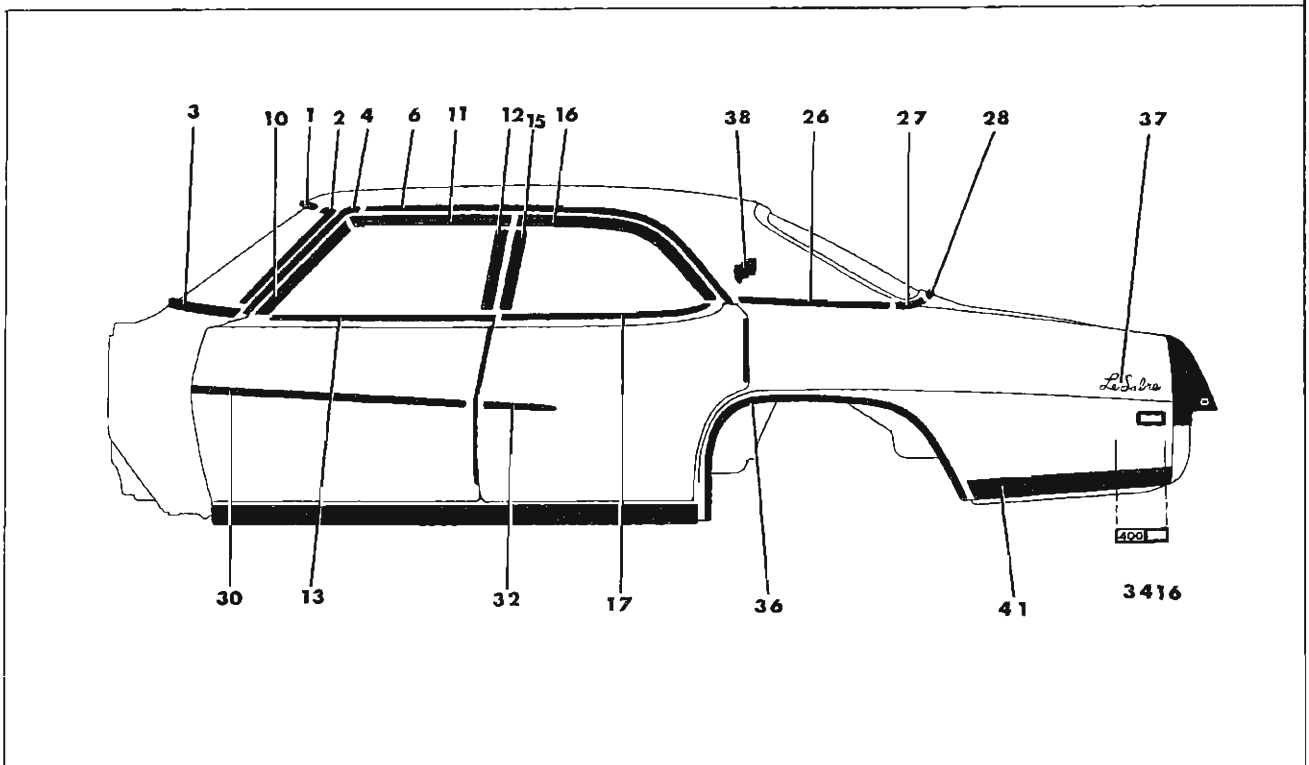

Fig. 17-83—Buick "B-69" Styles

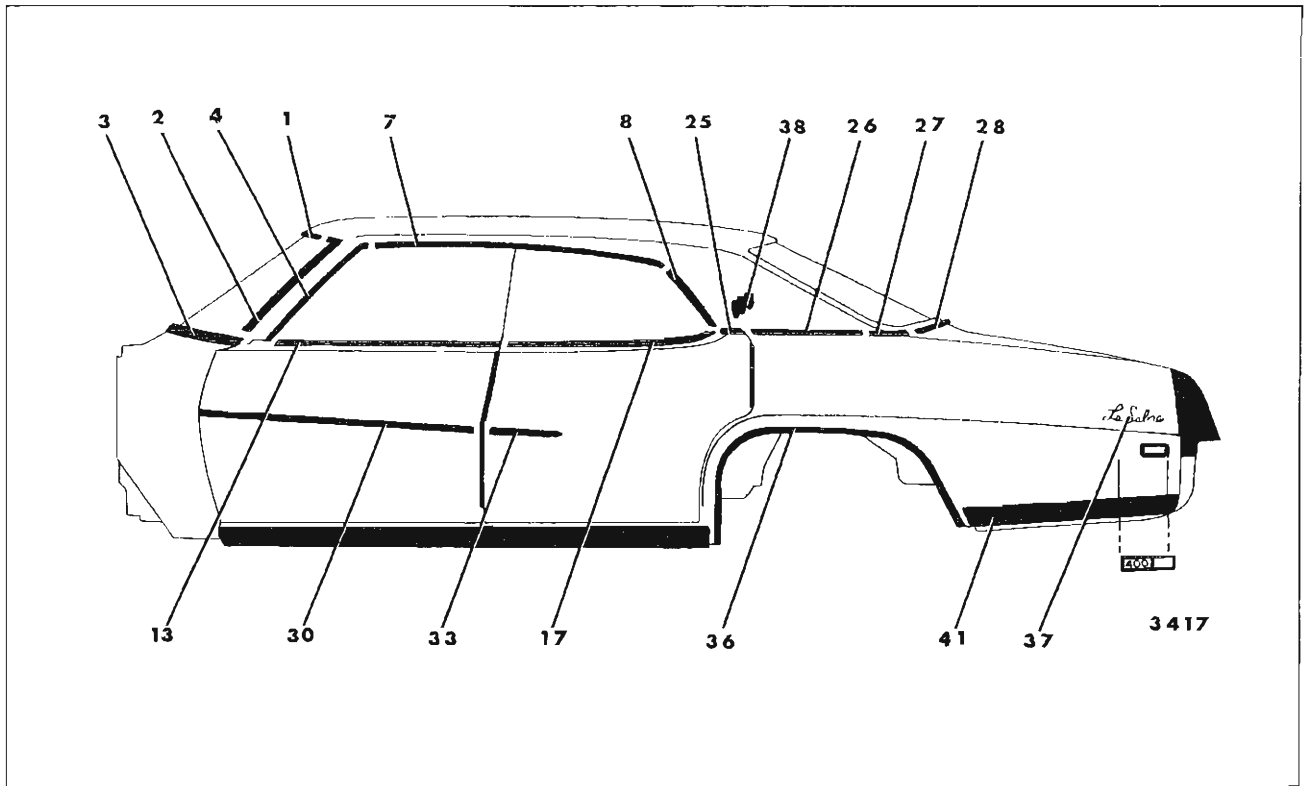

Fig. 17-84—Buick "B-39" Styles

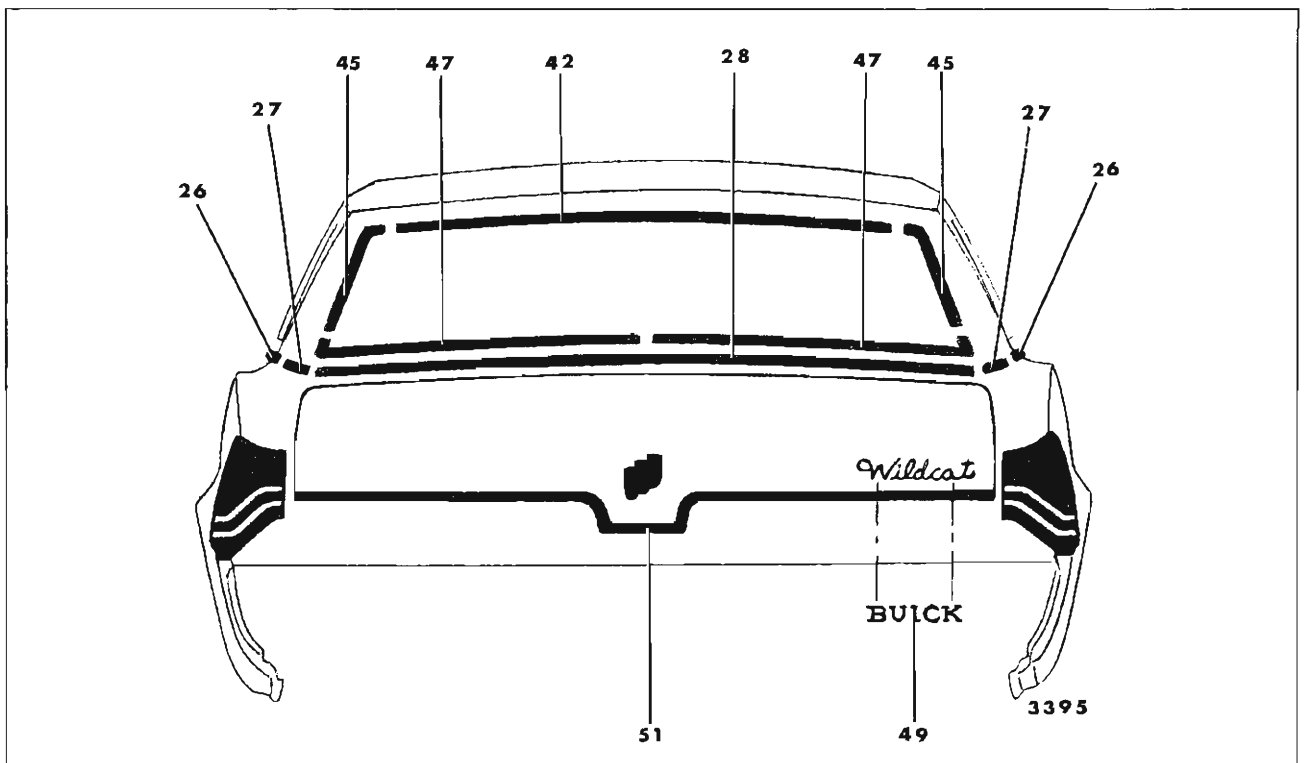

Fig. 17-85—Buick 45200-45400-46400-46600 Styles

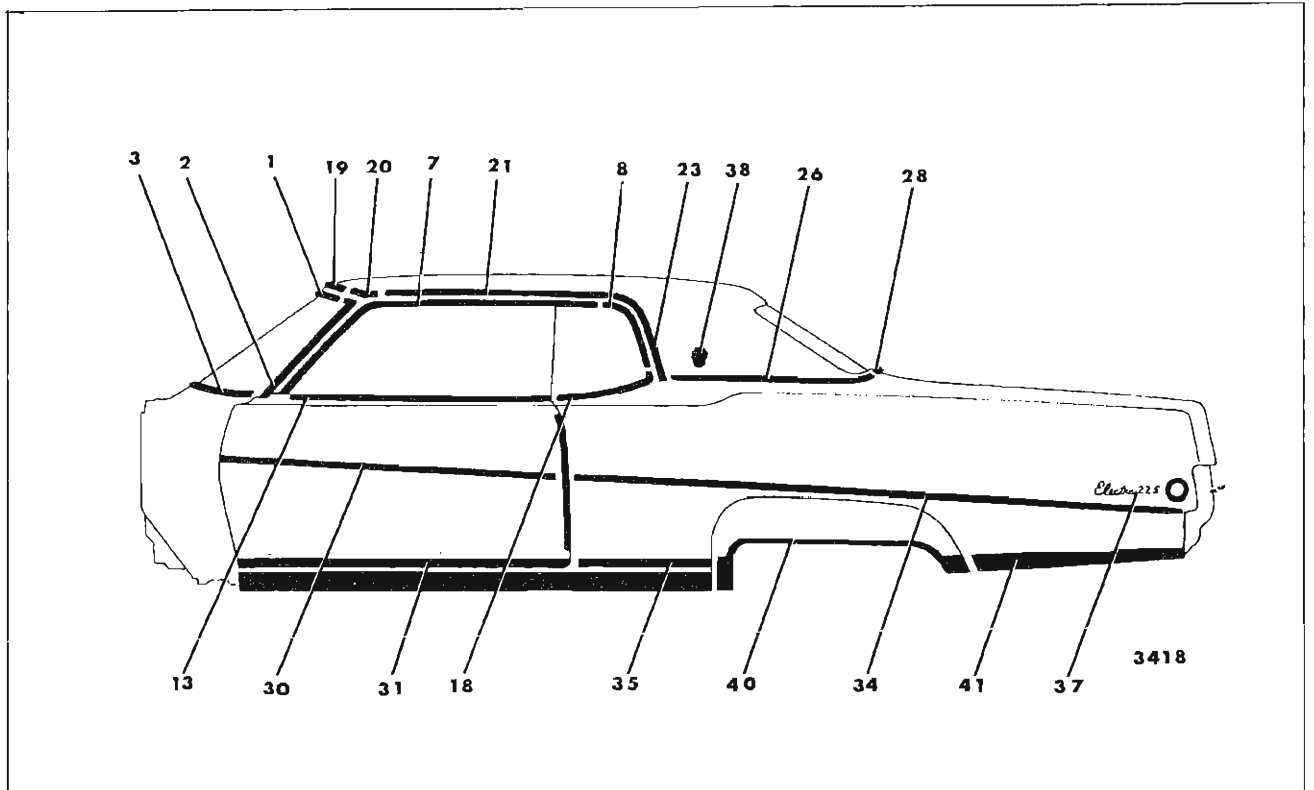

Fig. 17-86—Buick "C-57" Styles ("67" Style Similar)

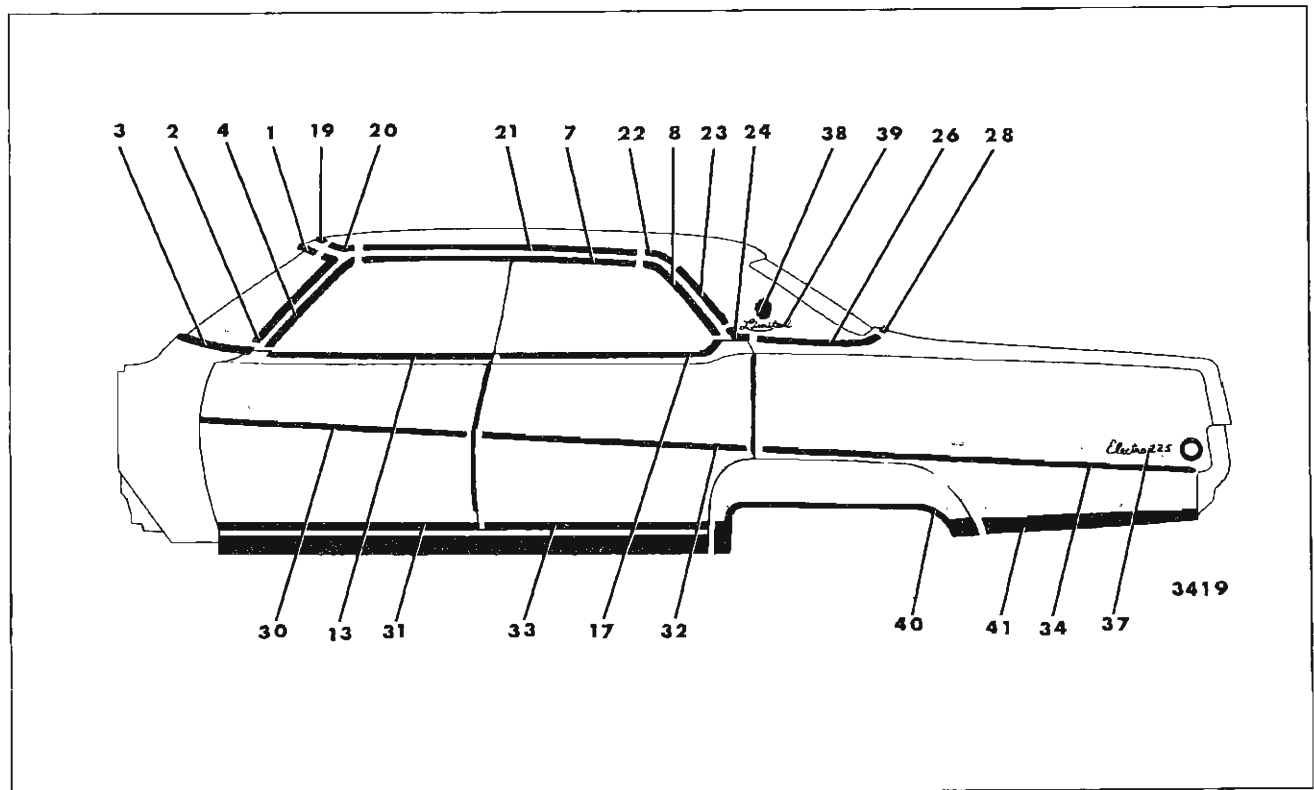

Fig. 17-87—Buick "C-39" Styles

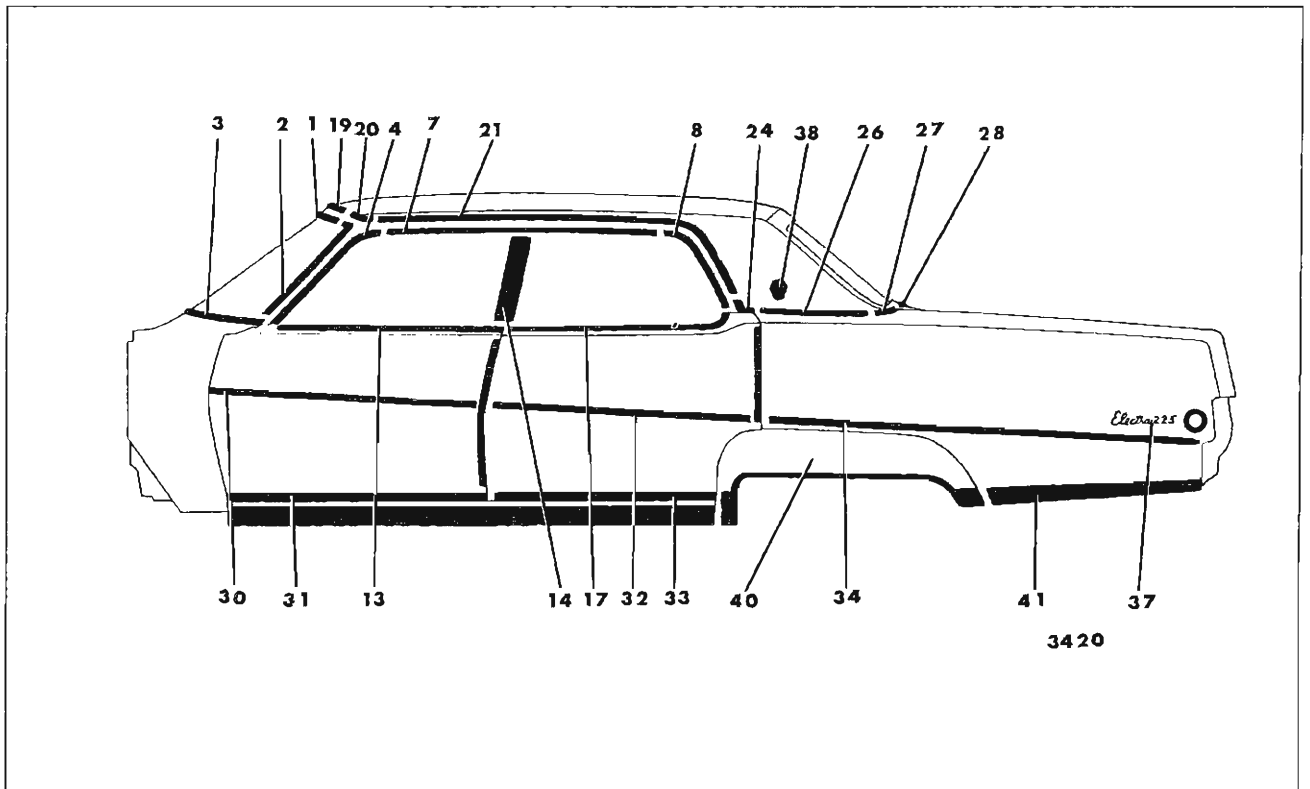

Fig. 17-88—Buick "C-69" Styles

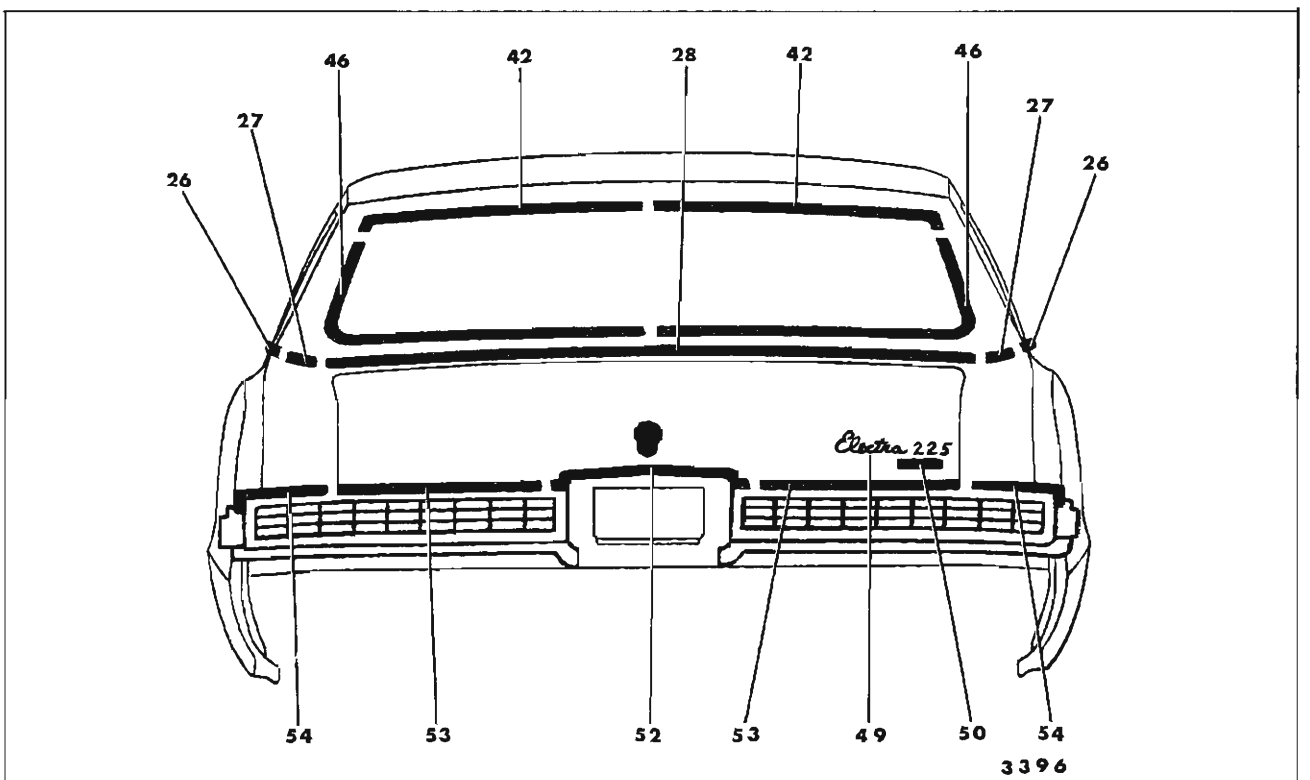

Fig. 17-89—Buick 48200-48400 Styles

## METHODS OF MOLDING RETENTION

BUICK "B-C" BODIES - 45000, 46000 AND 48000 SERIES  
 FIGURES 17-82 THROUGH 17-89

Key	Molding Name	Series or Styles	Screws	Spring (Self-Retained)	Snap-On Clips or Retainers On Panel	Snap-On Clips On Molding	Studs With Attaching Nuts	Engages With Other Moldings	Remove Hardware Or Trim
1	Windshield Reveal Upper	All			X			Windshield Reveal Side	
2	Windshield Reveal Side	All			X			Windshield Reveal Lower	
3	Windshield Reveal Lower	All	X						
4	Windshield Pillar Drip Scalp	All (Except 57-67)	X						Windshield Pillar Weatherstrip and Weatherstrip Retainer
5	Windshield Pillar Finishing	67	X						Windshield Pillar Weatherstrip and Weatherstrip Retainer
6	Roof Drip Molding Scalp	B-37-69		View K				Windshield Pillar Drip Scalp	
7	Roof Drip Molding Front Scalp	B-39, C-39-57-69		View K				Windshield Pillar Drip Scalp	
8	Roof Drip Molding Rear Scalp	B-39, C-39, 57-69	X					Roof Drip Molding Front Scalp	Side Roof Rail Weatherstrip and Retainer
9	Windshield Header	67	X					Windshield Pillar Finishing Windshield Reveal Upper	Sunshade Support, Rear View Mirror Support, Windshield Upper Garnish Molding
10	Front Door Window Frame Front Scalp	69 (Except 48000 Series)		View J					
11	Front Door Window Frame Upper Scalp	69 (Except 48000 Series)		View J				Front Door Window Frame Front Scalp	
12	Front Door Window Frame Rear Scalp	69 (Except 48000 Series)		View J				Front Door Window Frame Upper Scalp	

METHODS OF MOLDING RETENTION  
 BUICK "B-C" BODIES - 45000, 46000 AND 48000 SERIES  
 FIGURES 17-82 THROUGH 17-89

Key	Molding Name	Series or Styles	Screws	Spring (Self-Retained)	Snap-On Clips or Retainers On Panel	Snap-On Clips On Molding	Studs With Attaching Nuts	Engages With Other Moldings	Remove Hardware Or Trim
13	Front Door Window Belt Reveal	All	X						Rubber Bumper on Door Window Lower Stop
14	Center Pillar Scalp	48269 48469	X						Side Roof Rail Weatherstrip Front and Rear at Center Pillar
15	Rear Door Window Frame Front Scalp	69 (Except 48000 Series)		View J				Front Door Window Frame Upper Scalp	
16	Rear Door Window Frame Upper Scalp	69 (Except 48000 Series)		View J					
17	Rear Door Window Belt Reveal	39, 69	X						Rubber Bumper on Rear Door Window Lower Stop
18	Rear Quarter Window Belt Reveal	37, 57, 67	X						Rear Quarter Window Lower Stop
19	Roof Panel Cover Front Finishing	C-39,57,69			X				
20	Roof Panel Cover Front Finishing Corner Escutcheon	C-39,57,69	X					Roof Panel Cover Front and Side Finishing	
21	Roof Panel Cover Side Finishing	C-39,57,69			X			Rear Quarter Belt Reveal Front Corner Escutcheon (C-57 Only)	
22	Roof Panel Cover Finishing Cover Corner Escutcheon	C-39						Roof Panel Cover Side and Rear Vertical Finishing	
23	Roof Panel Cover Rear Vertical Finishing	C-39, 57			X			Rear Quarter Belt Reveal Front Corner Escutcheon (C-57 Only)	

METHODS OF MOLDING RETENTION  
 BUICK "B-C" BODIES - 45000, 46000 AND 48000 SERIES  
 FIGURES 17-82 THROUGH 17-89

Key	Molding Name	Series or Styles	Screws	Spring (Self-Retained)	Snap-On Clips or Retainers On Panel	Snap-On Clips On Molding	Studs With Attaching Nuts	Engages With Other Moldings	Remove Hardware Or Trim
24	Rear Quarter Belt Reveal Front Corner Escutcheon	B-37 (with Two-tone paint option) C-39-69				View I		Roof Panel Cover Front Finishing (C-39-69). Roof Drip Molding Scalp (B-37) Rear Quarter Belt Reveal	
25	Rear Door Corner Finishing	B-39					X		
26	Rear Quarter Belt Reveal	B-37,39-69 C-39-57-69			X		X	Rear End Belt Reveal (B-39, C-69 Only)	
27	Rear Quarter Belt Reveal Rear Corner Escutcheon	B-37-69					X	Rear Quarter Belt Reveal. Rear End Belt Reveal	
28	Rear End Belt Reveal	B-37,39,69 C-39,57,69			X		X	Rear Quarter Belt Reveal (C-39,57 Only)	
29	Rear Quarter Belt Pinch Weld Finishing	67	X						Lower Top Halfway
30	Front Door Outer Panel	45000 46000 (48000 - Optional)	X		X				
31	Front Door Outer Panel - Lower	48000	X		X				
32	Rear Door Outer Panel	452-454- 46439-69, 46639 482-48439, 69 (Optional)	X		X				
33	Rear Door Outer Panel - Lower	482-48439-69	X		X				
34	Rear Quarter Outer Panel	B-37,67 C-All (Optional)			X		X		Rear Quarter Trim ("B" Styles Only)
35	Front of Rear Wheel Opening	48257- 48457-67				View F	X		

METHODS OF MOLDING RETENTION  
 BUICK "B-C" BODIES - 45000, 46000 AND 48000 SERIES  
 FIGURES 17-82 THROUGH 17-89

Key	Molding Name	Series or Styles	Screws	Spring (Self-Retained)	Snap-On Clips or Retainers On Panel	Snap-On Clips On Molding	Studs With Attaching Nuts	Engages With Other Moldings	Remove Hardware Or Trim
36	Rear Wheel Opening	45200 (Optional) 45400 46400 46600	X						
37	Rear Quarter Outer Panel Nameplate	45200-45400 48000				View I (48000 Only)	X		
38	Roof Panel Emblem	B-37,39,69 C-39,57,69				View I			
39	Roof Panel Nameplate	48439				View I			
40	Rear Wheel Opening Cover	48000	X				X		
41	Rear of Rear Wheel Opening	45400 46400 46600 48000	X		X		X		
42	Back Window Reveal Upper	B-37,39 C-39-57-69	X			View I		Back Window Upper Corner Escutcheon (B-39). Back Window Reveal Side (B-37)	
43	Back Window Reveal Upper Corner Escutcheon	B-39						Loosen Ends of Sides and Lower and Upper Reveals	
44	Back Window Reveal Upper and Sides	B-69			X				
45	Back Window Reveal Side	B-37 C-39-57			X			Back Window Reveal Upper (C-39-57)	
46	Back Window Reveal Lower and Sides	B-39 C-69			X			Back Window Reveal Upper Corner Escutcheon (B-39). Back Window Reveal Upper (C-69)	



**METHODS OF MOLDING RETENTION**  
**BUICK "B-C" BODIES - 45000, 46000 AND 48000 SERIES**  
**FIGURES 17-82 THROUGH 17-89**

Key	Molding Name	Series or Styles	Screws	Spring (Self-Retained)	Snap-On Clips or Retainers On Panel	Snap-On Clips On Molding	Studs With Attaching Nuts	Engages With Other Moldings	Remove Hardware Or Trim
47	Back Window Reveal Lower	B-37, 69 C-39, 57			X			Back Window Upper and Sides (B-69) Back Window Reveal Side (B-37, C-39-57)	
48	Back Window Reveal Lower Center Escutcheon	B-39						Back Window Side and Lower - Right and Left	
49	Rear Compartment Lid Outer Panel Nameplate	All				View !	X (45200, 45400 Only)		
50	Rear Compartment Lid Outer Panel Emblem	All (Except 48000)					X		
51	Compartment Lid Outer Panel	46000					X		
52	Compartment Lid Outer Panel - Center	48000					X		
53	Compartment Lid Outer Panel - Side	48000	X					Compartment Lid Outer Panel - Center	
54	Rear of Rear Quarter Outer Panel	46000 48000	X (46000 Only)				X		Quarter Outer Extension

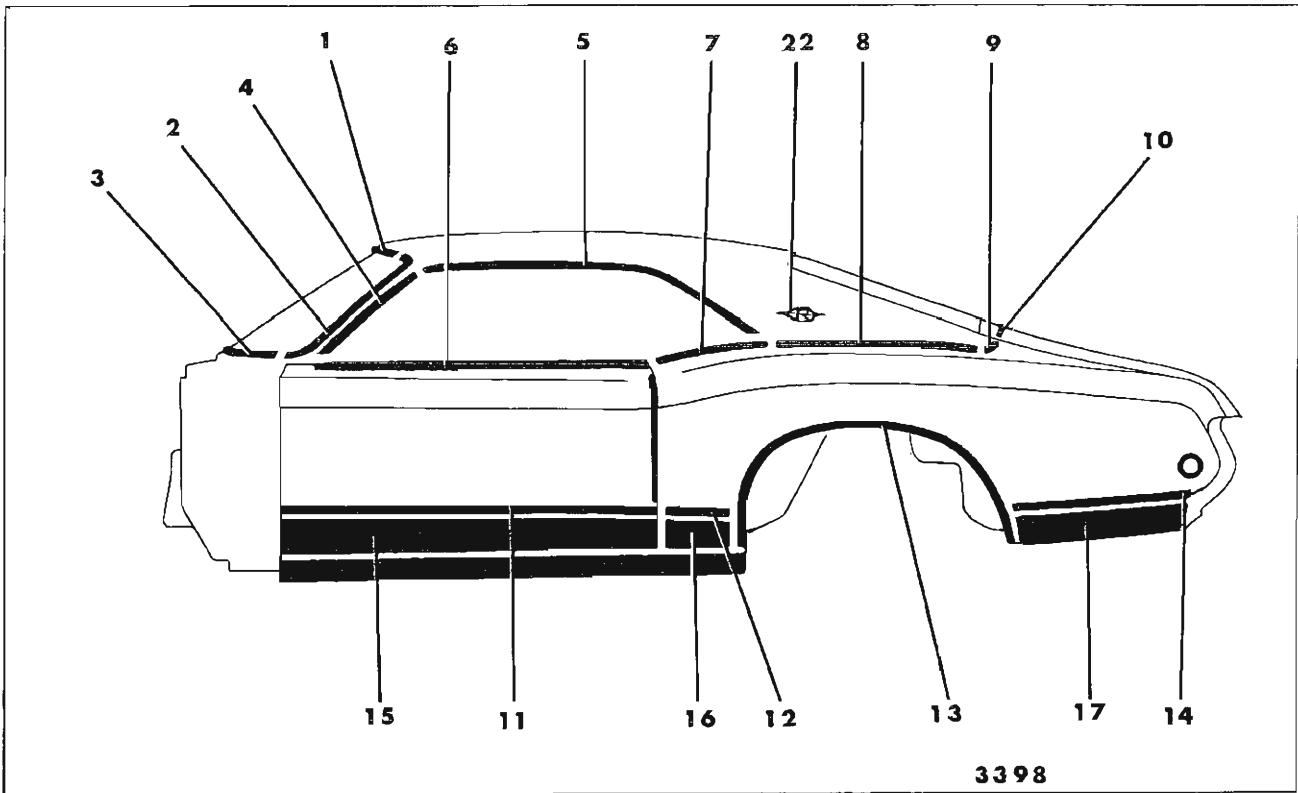

Fig. 17-90—Buick 49487 Style

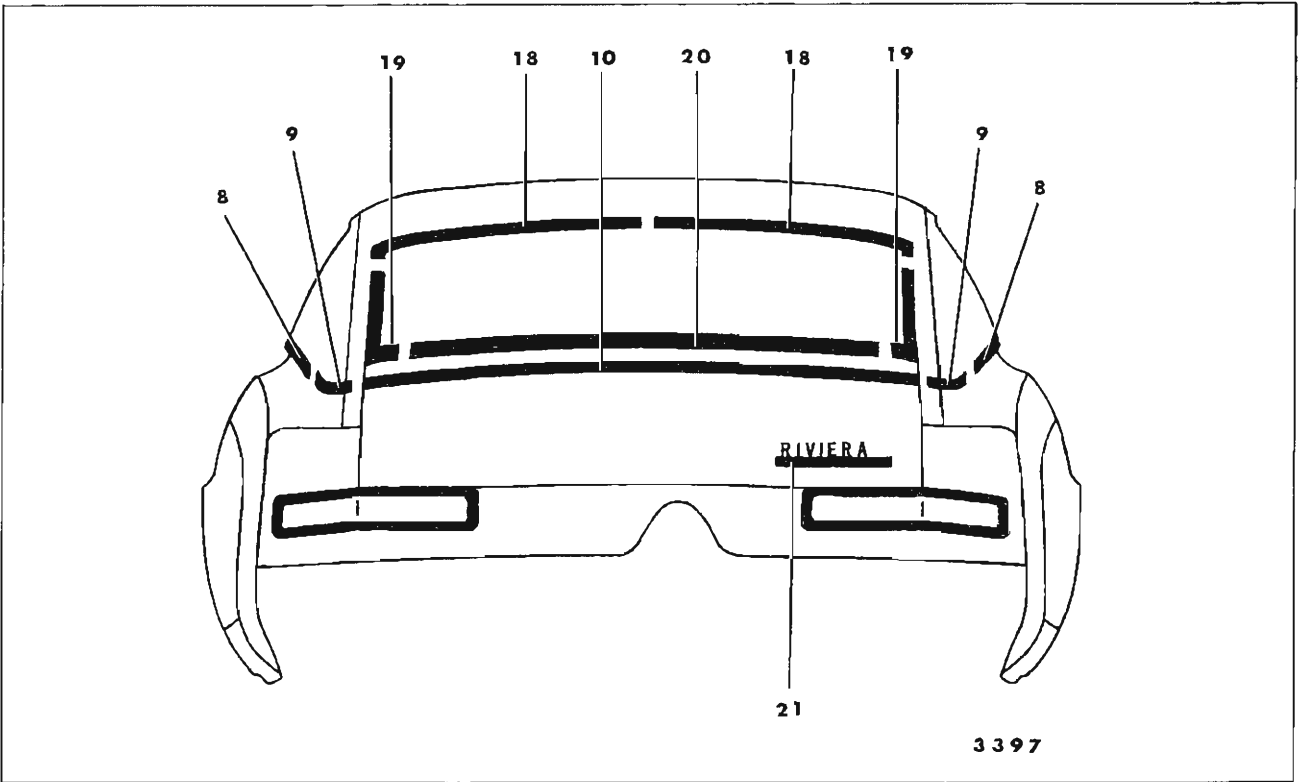

Fig. 17-91—Buick 49487 Style

## METHODS OF MOLDING RETENTION

BUICK "E" BODIES - 49000 SERIES  
FIGURES 17-90 THROUGH 17-91

Key	Molding Name	Series or Styles	Screws	Spring (Self-Retained)	Snap-On Clips or Retainers On Panel	Snap-On Clips On Molding	Studs With Attaching Nuts	Engages With Other Moldings	Remove Hardware Or Trim
1	Windshield Reveal Upper	All			X				
2	Windshield Reveal Side	All			X			Windshield Reveal Upper	
3	Windshield Reveal Lower	All	X					Windshield Reveal Side	
4	Windshield Pillar Drip Molding Scalp	All		View K					Windshield Pillar Weatherstrip and Weatherstrip Retainer
5	Roof Drip Molding Scalp	All	X	View K				Windshield Pillar Drip Molding Scalp	
6	Front Door Window Belt Reveal	All	X						Rubber Bumper on Front Door Window Lower Stop
7	Rear Quarter Window Belt Reveal	All	X						Rear Quarter Window
8	Rear Quarter Belt Reveal	All (Optional)			X		X	Rear Quarter Belt Reveal Corner Escutcheon	Rear Compartment Side Trim Panel
9	Rear Quarter Belt Reveal Corner Escutcheon	All (Optional)					X		Rear Compartment Side Trim Panel
10	Rear Compartment Front Panel	All (Optional)					X		Rear Compartment Front Panel Grille
11	Front Door Outer Panel Upper	All	X		X				

## METHODS OF MOLDING RETENTION

BUICK "E" BODIES - 49000 SERIES  
FIGURES 17-90 THROUGH 17-91

Key	Molding Name	Series or Styles	Screws	Spring (Self-Retained)	Snap-On Clips or Retainers On Panel	Snap-On Clips On Molding	Studs With Attaching Nuts	Engages With Other Moldings	Remove Hardware Or Trim
12	Front of Rear Wheel Opening Upper	All			X		X		Rear Quarter Trim
13	Rear Wheel Opening	All	X						
14	Rear of Rear Wheel Opening - Upper	All			X		X		
15	Front Door Outer Panel - Lower	All (Optional)	X					Front Door Outer Panel Upper	
16	Front of Rear Wheel Opening Lower	All (Optional)	X					Front of Rear Wheel Opening Upper	
17	Rear of Rear Wheel Opening Lower	All (Optional)	X					Rear of Rear Wheel Opening Upper	
18	Back Window Reveal Upper	All			X				
19	Back Window Reveal Side	All			X			Back Window Reveal Upper	
20	Back Window Reveal Lower	All			X			Back Window Reveal Side	
21	Rear Compartment Lid Outer Panel Emblem and/or Nameplate	All					X		
22	Roof Panel Emblem	All (Optional)					X		Quarter Upper Trim

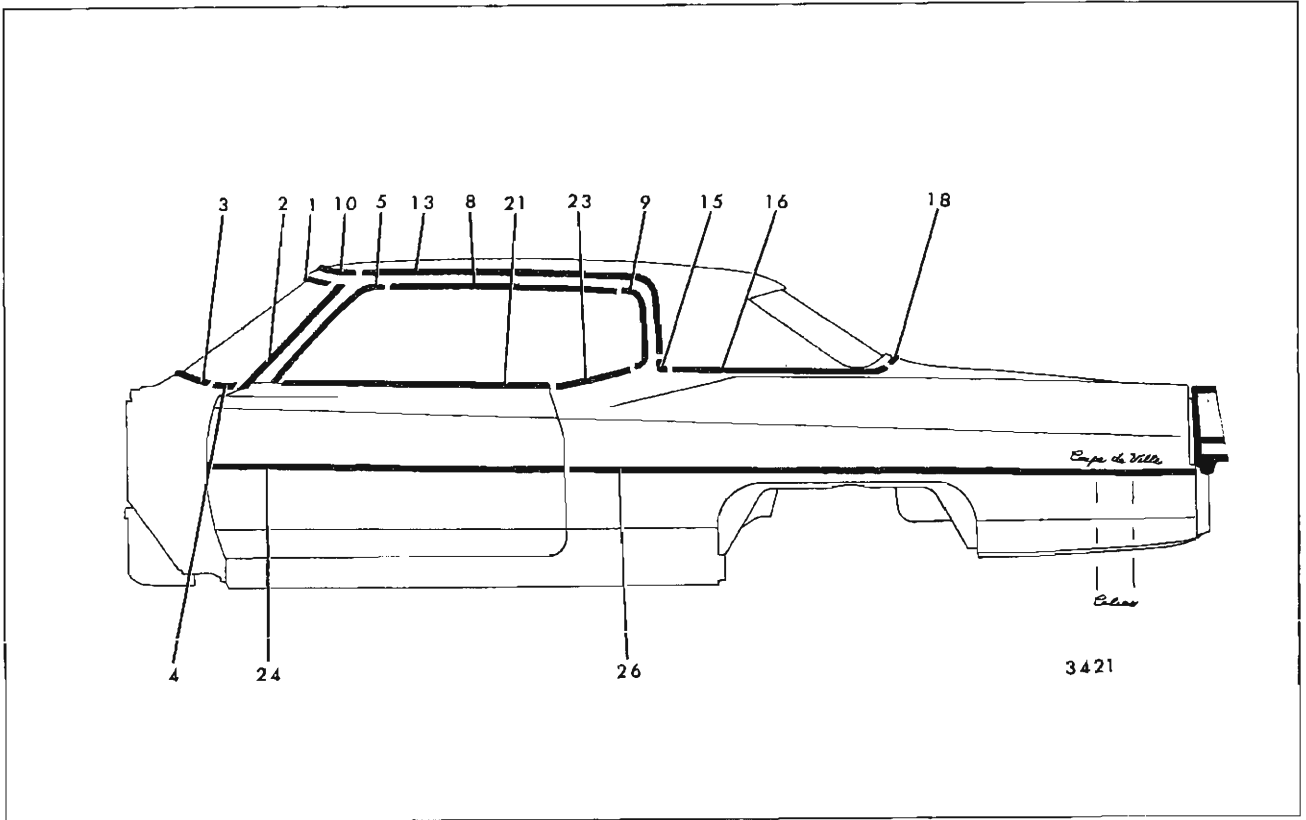

Fig. 17-92—Cadillac 68247-68347 Styles

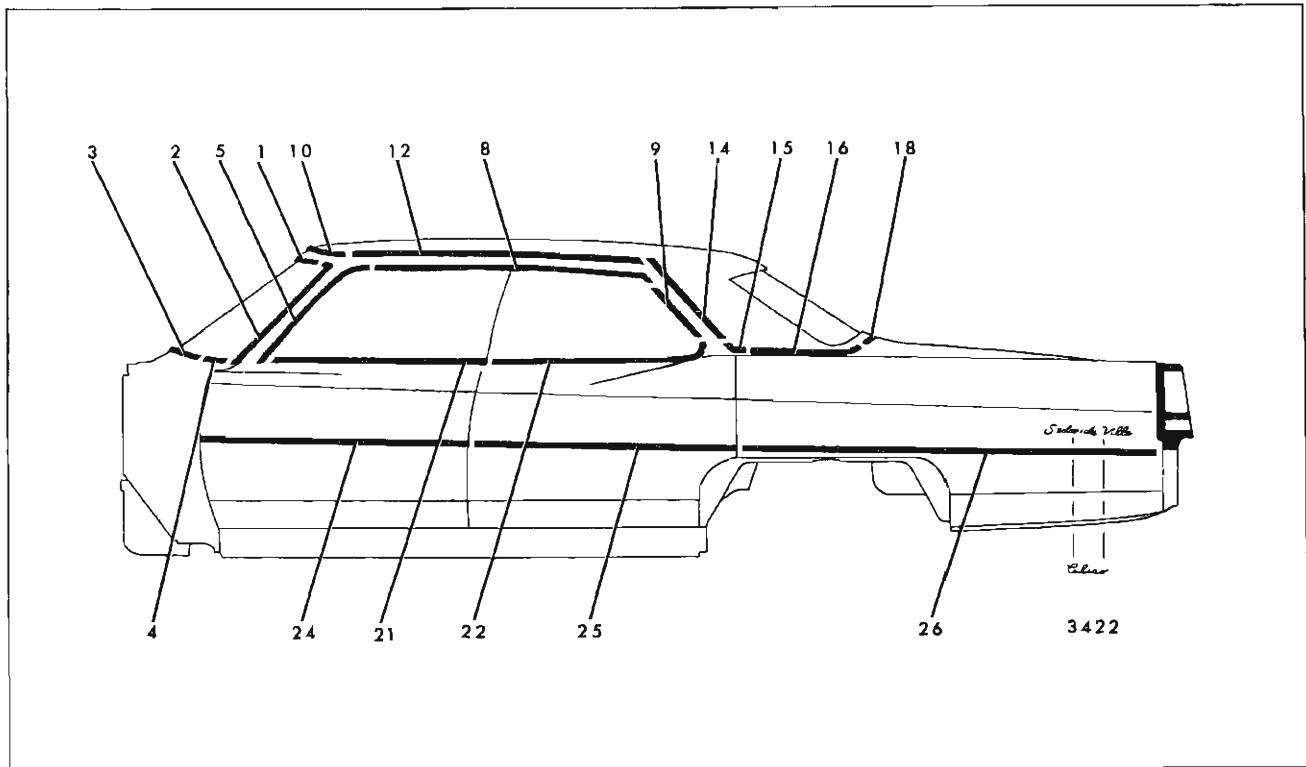

Fig. 17-93—Cadillac 68249-68349 Styles

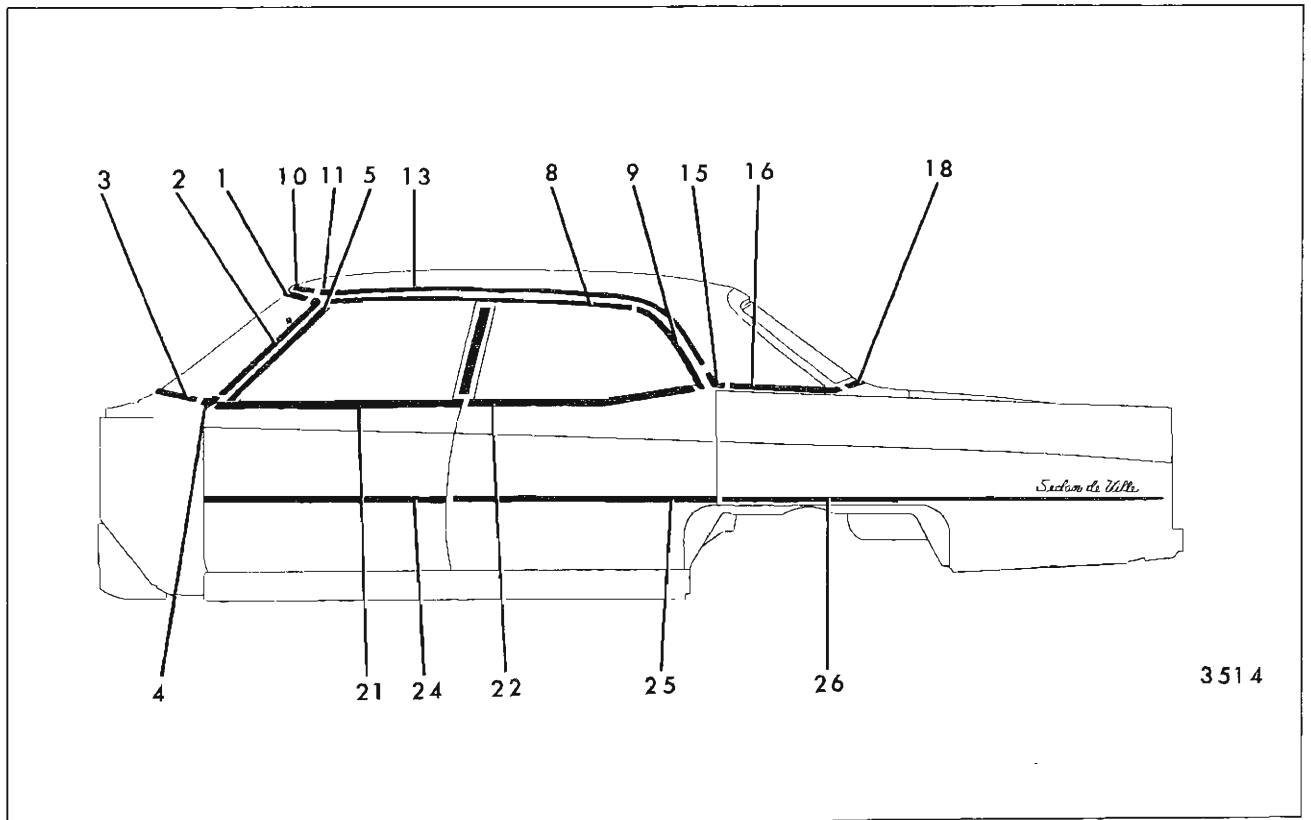

Fig. 17-94—Cadillac 68369 Styles

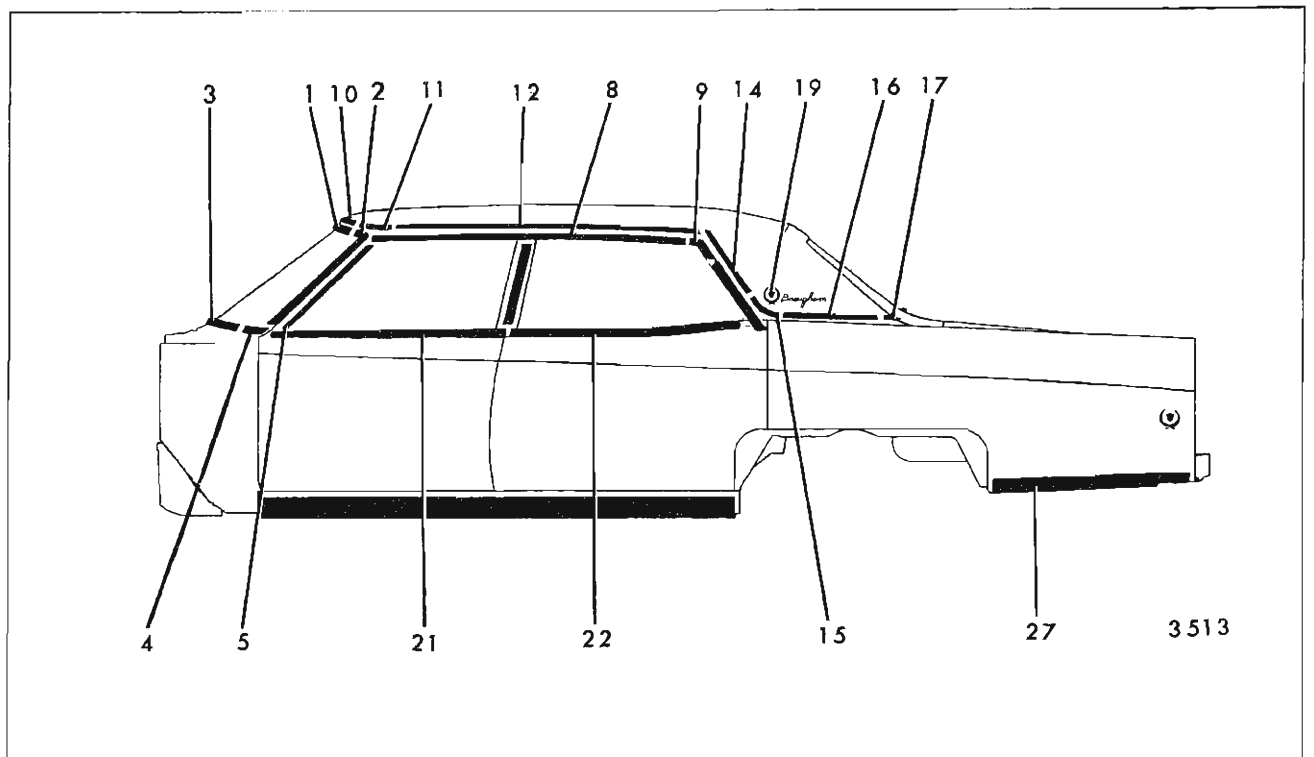

Fig. 17-95—Cadillac 68069-68169 Styles

17-112 EXTERIOR MOLDINGS

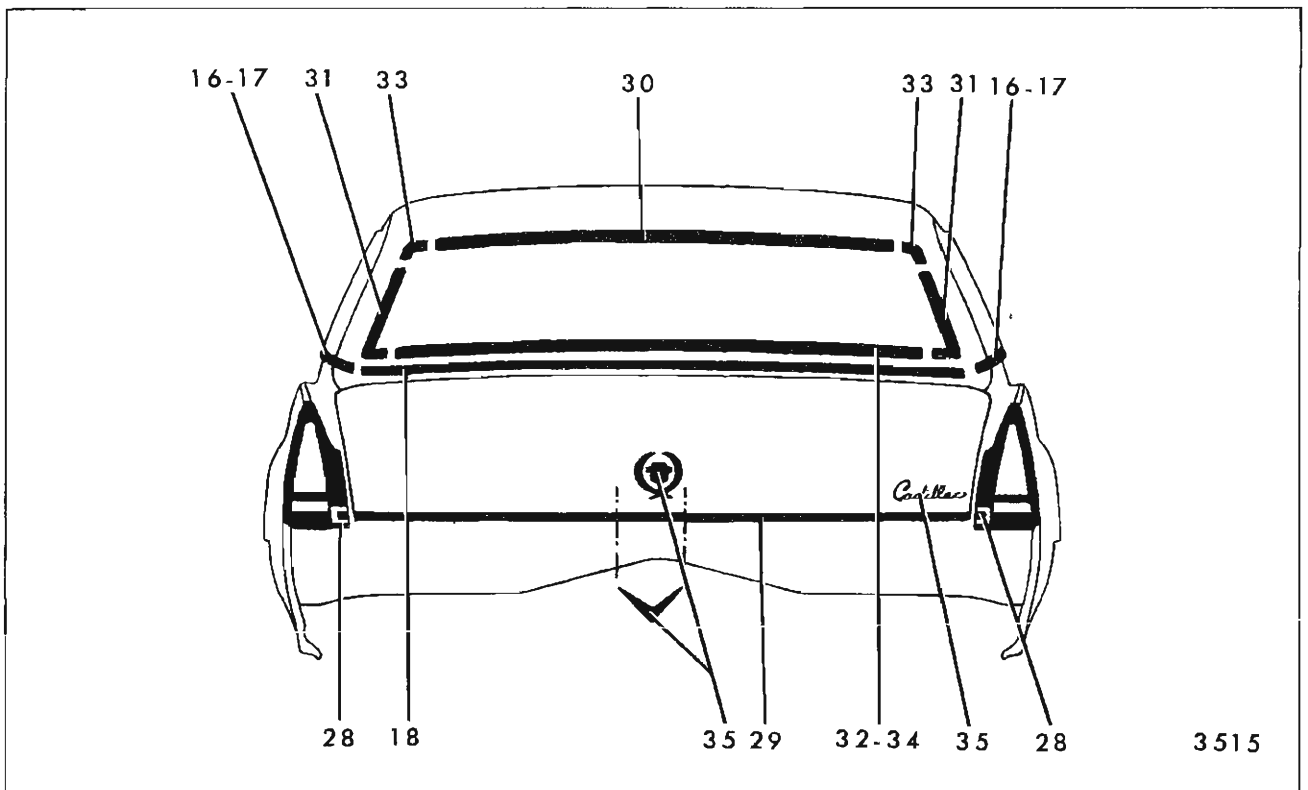

Fig. 17-96—Cadillac 68000-68200-68300 Styles

METHODS OF MOLDING RETENTION  
 CADILLAC "C" BODIES - 68000 SERIES  
 FIGURES 17-92 THROUGH 17-96

Key	Molding Name	Series or Styles	Screws	Spring (Self-Retained)	Snap-On Clips or Retainers On Panel	Snap-On Clips On Molding	Studs With Attaching Nuts	Engages With Other Moldings	Remove Hardware Or Trim
1	Windshield Reveal Upper	All			X			Windshield Reveal Side	
2	Windshield Reveal Side	All			X			Windshield Reveal Lower - Corner	
3	Windshield Reveal Lower - Center	All	X					Windshield Reveal Lower Corner	
4	Windshield Reveal Lower - Corner	All (Except 67)	X					Windshield Reveal Lower Center	
5	Windshield Pillar Drip Scalp	All (Except 67)	X						Windshield Pillar Weatherstrip and Weatherstrip Retainer
6	Windshield Pillar Finishing	67	X					Windshield Side Reveal	Windshield Pillar Weatherstrip and Weatherstrip Retainer
7	Windshield Header	67	X					Windshield Pillar Finishing, Windshield Reveal Upper	
8	Roof Drip Molding Front Scalp	All (Except 67)		View K				Windshield Pillar Drip Scalp	
9	Roof Drip Molding Rear Scalp	All (Except 67)		View K				Roof Drip Molding Front Scalp	Side Roof Rail Rear Weatherstrip and Weatherstrip Retainer
10	Roof Panel Cover Front Finishing	All (Except 67)	X		X			Roof Panel Front Escutcheon	
11	Roof Panel Cover Front Corner Escutcheon	68069 68169 68369	View N (68369 Only)		X (68169 68069 Only)			Roof Panel Cover Side Finishing, Roof Panel Cover Front Finishing	



METHODS OF MOLDING RETENTION  
 CADILLAC "C" BODIES - 68000 SERIES  
 FIGURES 17-92 THROUGH 17-96

Key	Molding Name	Series or Styles	Screws	Spring (Self-Retained)	Snap-On Clips or Retainers On Panel	Snap-On Clips On Molding	Studs With Attaching Nuts	Engages With Other Moldings	Remove Hardware Or Trim
12	Roof Panel Cover Side Front Finishing	68069 68169 "49" Styles	X		X			Roof Panel Front Corner Escutcheon, Roof Panel Side Rear Finishing	
13	Roof Panel Cover Side Finishing	68369 "47" Styles			X				
14	Roof Panel Cover Side Rear Finishing	68069 68169 "49" Styles	X (68069 68169 Only)		X			Roof Panel Cover Side - "49" Only	
15	Quarter Belt Reveal Front Corner Escutcheon	All (Except 67)	View N					Quarter Belt Reveal, Roof Panel Cover Side and Rear Finishing	
16	Quarter Belt Reveal	All (Except 67)	X (68369 Only)		X		X (47-49 Only)	Rear End Belt (68369)	
17	Quarter Belt Reveal Rear Corner Escutcheon	68069 68169	X					Rear End Belt Reveal, Quarter Belt Reveal	
18	Rear End Belt Reveal	All (Except 67)			X		X	Quarter Belt Reveal	
19	Roof Panel Emblem and/or Name Plate	68169					X		Quarter Upper Trim
20	Rear Quarter Pinch-weld Finishing	67	X					Rear Quarter Window Belt Reveal	Lower Top Halfway
21	Front Door Window Belt Reveal	All	X						Rubber Bumper on Front Door Window Lower Stop
22	Rear Door Window Belt Reveal	49, 69	X						Rubber Bumper on Rear Door Window Lower Stop

METHODS OF MOLDING RETENTION  
 CADILLAC "C" BODIES - 68000 SERIES  
 FIGURES 17-92 THROUGH 17-96

Key	Molding Name	Series or Styles	Screws	Spring (Self-Retained)	Snap-On Clips or Retainers On Panel	Snap-On Clips On Molding	Studs With Attaching Nuts	Engages With Other Moldings	Remove Hardware Or Trim
23	Rear Quarter Window Belt Reveal	47, 67	X						Rear Quarter Window Lower Stop
24	Front Door Outer Panel	68200 68300	X		X				
25	Rear Door Outer Panel	68249 68349-69	X		X		X		
26	Rear Quarter Outer Panel	68247 68347-67				X	X		Rear Quarter Trim Panel, Rear Compartment Side Trim
		68249 68349-69				X	X		Rear Compartment Side Trim
27	Rear of Rear Wheel Opening	68069 68169	X		X				
28	Rear of Rear Quarter Outer Panel at Compartment Lid	All					X		
29	Rear Compartment Lid Outer Panel	All	X						
30	Back Window Reveal Upper	68200-68300 68069-68169 (Except 67)			X			Back Window Reveal Upper Corner Escutcheon, Back Window Reveal Side	
31	Back Window Reveal Side	All (Except 68367-69)			X			Back Window Reveal Lower	
32	Back Window Reveal Lower	All (Except 68367-69)			X			Back Window Reveal Upper Corner Escutcheon (68069, 68169 Styles)	

METHODS OF MOLDING RETENTION  
 CADILLAC "C" BODIES - 68000 SERIES  
 FIGURES 17-92 THROUGH 17-96

Key	Molding Name	Series or Styles	Screws	Spring (Self-Retained)	Snap-On Clips or Retainers On Panel	Snap-On Clips On Molding	Studs With Attaching Nuts	Engages With Other Moldings	Remove Hardware Or Trim
33	Back Window Reveal Upper Corner Escutcheon	All (Except 68367-69)			X			Back Window Reveal Upper	
34	Back Window Reveal Upper and Sides	68369			X				
35	Rear Compartment Lid Outer Panel Emblem and/or Nameplate	All					X		

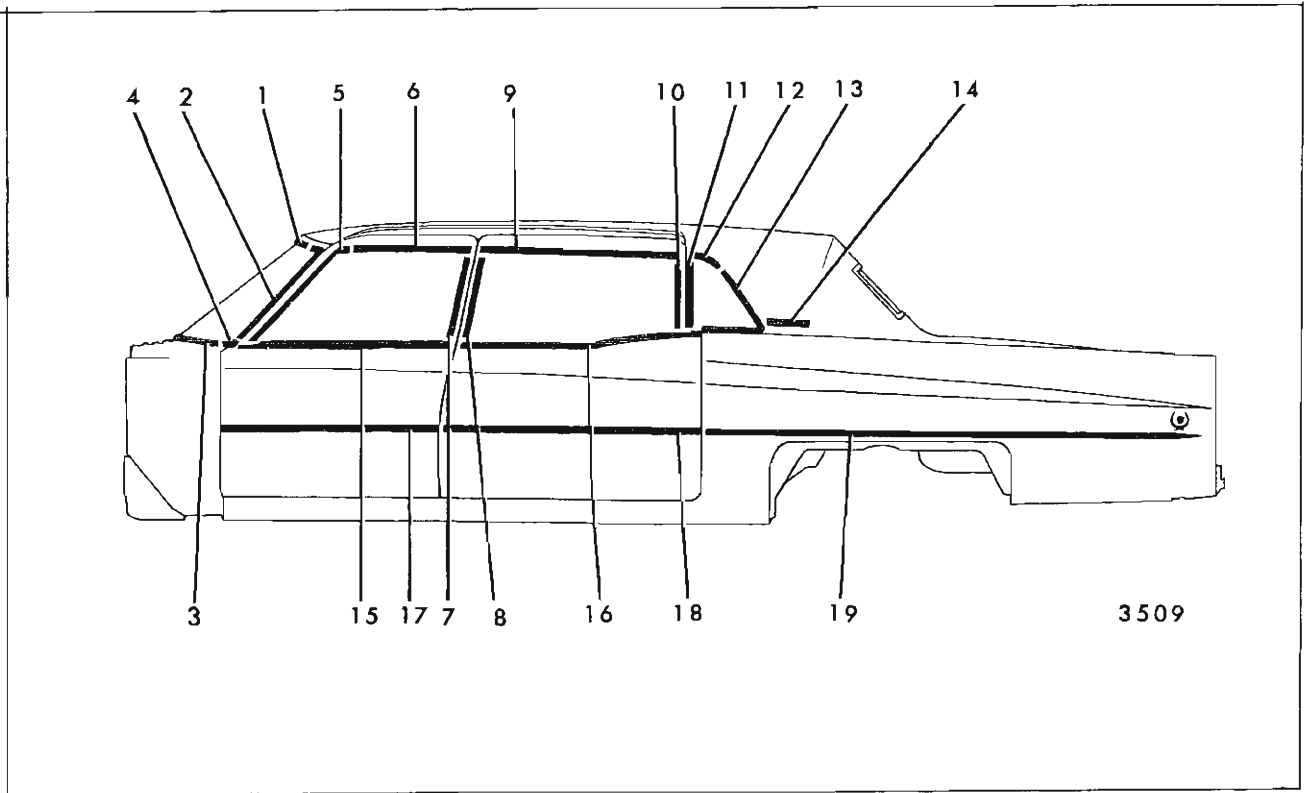

Fig. 17-97—Cadillac 69723-33 Styles

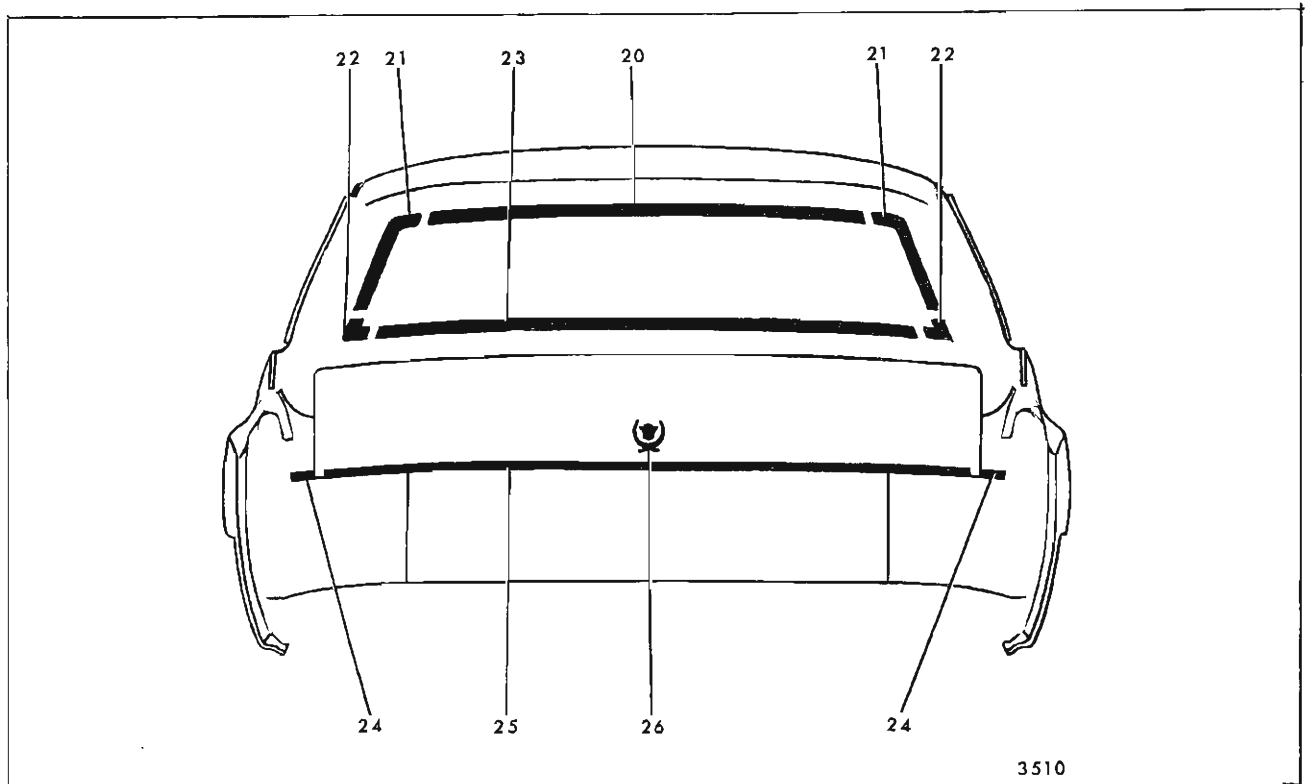

Fig. 17-98—Cadillac 69723-33 Styles

METHODS OF MOLDING RETENTION  
 CADILLAC "D" BODIES - 69700 SERIES  
 FIGURES 17-97 THROUGH 17-98

Key	Molding Name	Series or Styles	Screws	Spring (Self-Retained)	Snap-On Clips or Retainers On Panel	Snap-On Clips On Molding	Studs With Attaching Nuts	Engages With Other Moldings	Remove Hardware Or Trim
1	Windshield Reveal Upper	All			X			Windshield Reveal Side	
2	Windshield Reveal Side	All			X			Windshield Reveal Lower Corner	
3	Windshield Reveal Lower Center	All	X					Windshield Reveal Lower Corner	
4	Windshield Reveal Lower Corner	All	X						
5	Front Door Window Frame Front Reveal	All	X						
6	Front Door Window Frame Upper Reveal	All	X					Front Door Window Frame Front Reveal	
7	Front Door Window Frame Rear Reveal	All		View J				Front Door Window Frame Upper Reveal	
8	Rear Door Window Frame Front Reveal	All		View J				Rear Door Window Frame Upper Reveal	
9	Rear Door Window Frame Upper Reveal	All	X						
10	Rear Door Window Frame Rear Reveal	All		View J				Rear Door Window Frame Upper Reveal	
11	Rear Quarter Window Reveal Vertical	All	X					Rear Quarter Window Reveal Upper Front, Rear Quarter Window Reveal Upper Rear and Lower	Weatherstrip and Retainer
12	Rear Quarter Window Reveal Upper Front	All	X						Headlining at Sail Area

METHODS OF MOLDING RETENTION  
 CADILLAC "D" BODIES - 69700 SERIES  
 FIGURES 17-97 THROUGH 17-98

Key	Molding Name	Series or Styles	Screws	Spring (Self-Retained)	Snap-On Clips or Retainers On Panel	Snap-On Clips On Molding	Studs With Attaching Nuts	Engages With Other Moldings	Remove Hardware Or Trim
13	Rear Quarter Window Reveal Upper Rear and Lower	All	X					Rear Quarter Window Reveal Upper Front	Rear Quarter Trim Pad
14	Roof Panel Emblem	All (with Fabric Roof Cover)					X		Headlining at Quarter Area
15	Front Door Window Belt Reveal	All	X						Front Door Trim Pad
16	Rear Door Window Belt Reveal	All	X						Rear Door Trim Pad
17	Front Door Outer Panel	All	X		X				
18	Rear Door Outer Panel	All	X		X				
19	Rear Quarter Outer Panel	All				X	X		Rear Quarter Trim Pad, Rear Compartment Side Trim
20	Back Window Reveal Upper	All			X			Back Window Reveal Side	
21	Back Window Reveal Side	All			X				
22	Back Window Reveal Lower Corner Escutcheon	All						Back Window Reveal Side, Back Window Reveal Lower	
23	Back Window Lower Reveal	All			X				
24	Rear of Rear Quarter Panel at Compartment Lid	All	X				X		Rear Bumper Assembly
25	Rear Compartment Lid Outer Panel	All	X						
26	Rear Compartment Lid Outer Panel Emblem	All					X		

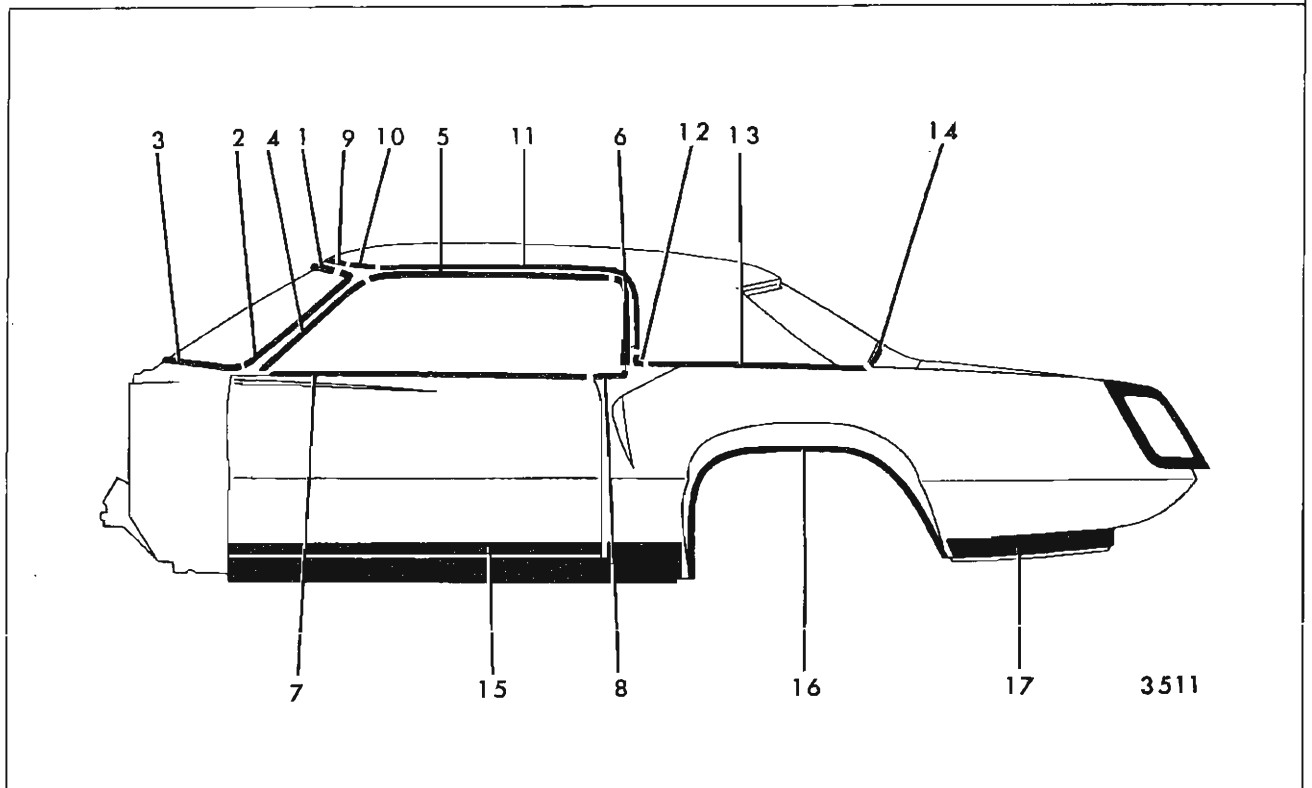

Fig. 17-99—Cadillac 69347 Styles

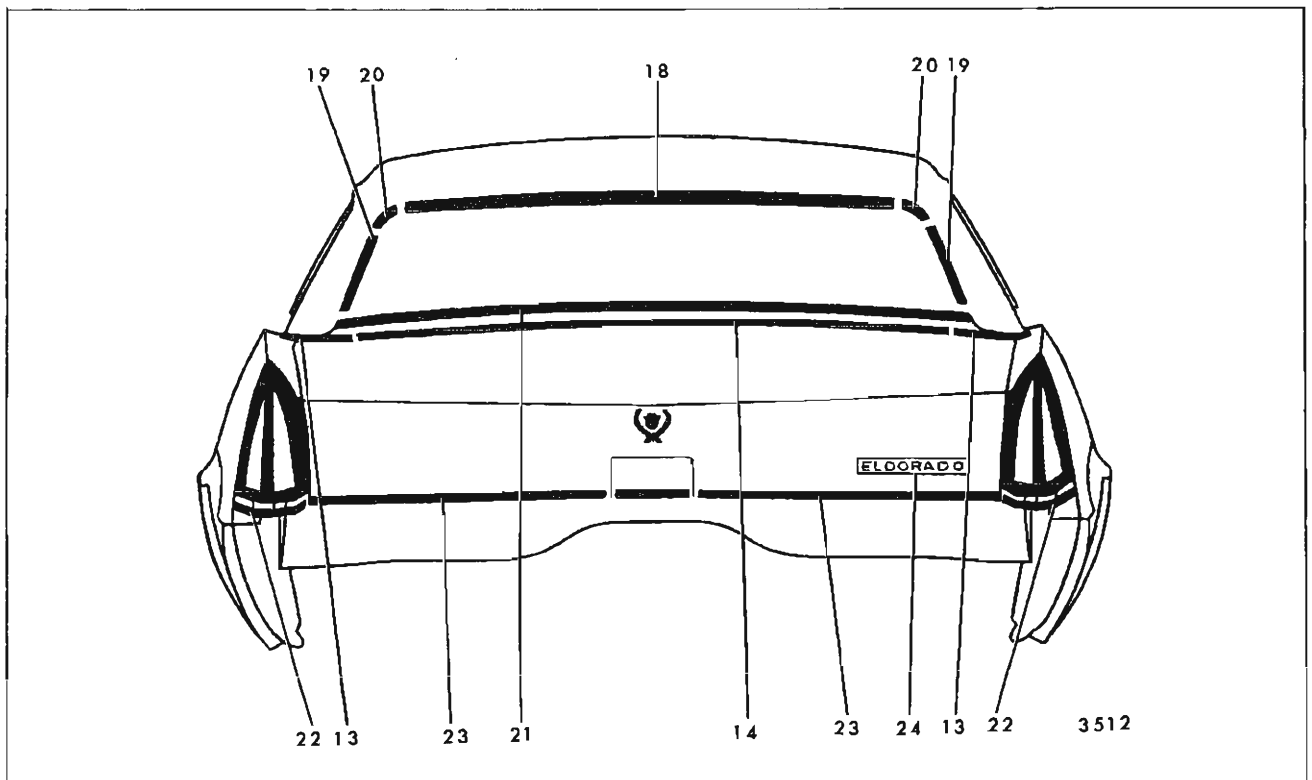

Fig. 17-100—Cadillac 69347 Styles

METHODS OF MOLDING RETENTION  
 CADILLAC "E" BODIES - 69300 SERIES  
 FIGURES 17-99 THROUGH 17-100

Key	Molding Name	Series or Styles	Screws	Spring (Self-Retained)	Snap-On Clips or Retainers On Panel	Snap-On Clips On Molding	Studs With Attaching Nuts	Engages With Other Moldings	Remove Hardware Or Trim
1	Windshield Reveal Upper	All				X		Windshield Reveal Side	
2	Windshield Reveal Side	All				X			
3	Windshield Reveal Lower	All	X					Windshield Reveal Side	
4	Windshield Pillar Drip Scalp	All		View K					
5	Roof Drip Molding Front Scalp	All		View K				Windshield Pillar Drip Scalp	
6	Roof Drip Molding Rear Scalp	All	X	X				Roof Drip Molding Front Scalp	Rear Garnish Molding, Quarter Trim, Disengage Quarter Window Glass Rear Stop
7	Front Door Window Belt Reveal	All	X				X		Rubber Bumper on Front Door Window Lower Stop
8	Rear Quarter Window Belt Reveal	All	X				X	Roof Drip Molding Rear Scalp	
9	Roof Panel Cover Front Finishing	All (Optional with Fabric Roof Cover)				X		Roof Panel Cover Front Corner Escutcheon	
10	Roof Panel Cover Front Corner Escutcheon	All (Optional with Fabric Roof Cover)	View N					Roof Panel Cover Front and Side Finishing	
11	Roof Panel Cover Side Finishing	All (Optional with Fabric Roof Cover)				X			



METHODS OF MOLDING RETENTION  
 CADILLAC "E" BODIES - 69300 SERIES  
 FIGURES 17-99 THROUGH 17-100

Key	Molding Name	Series or Styles	Screws	Spring (Self-Retained)	Snap-On Clips or Retainers On Panel	Snap-On Clips On Molding	Studs With Attaching Nuts	Engages With Other Moldings	Remove Hardware Or Trim
12	Quarter Belt Front Corner Escutcheon	All (Optional with Fabric Roof Cover)	View N					Quarter Belt Reveal, Roof Panel Cover Side Finishing	
13	Quarter Belt Reveal	All (Optional with Fabric Roof Cover)			X			Rear End Belt Reveal	
14	Rear End Belt Reveal	All (Optional with Fabric Roof Cover)			X				
15	Front Door Outer Panel Lower	All	X		X				
16	Rear Wheel Opening	All	X						
17	Rear of Rear Wheel Opening	All	X		X				
18	Back Window Reveal Upper	All			X			Back Window Reveal Upper Corner Escutcheon	
19	Back Window Reveal Side	All			X			Back Window Reveal Upper Corner Escutcheon	
20	Back Window Reveal Upper Corner Escutcheon	All			X				
21	Back Window Reveal Lower	All			X			Back Window Reveal Sides	
22	Rear of Rear Quarter Extension	All	X						
23	Rear Compartment Lid Outer Panel	All	X						
24	Rear Compartment Lid Outer Panel Emblem and/or Nameplate	All					X		

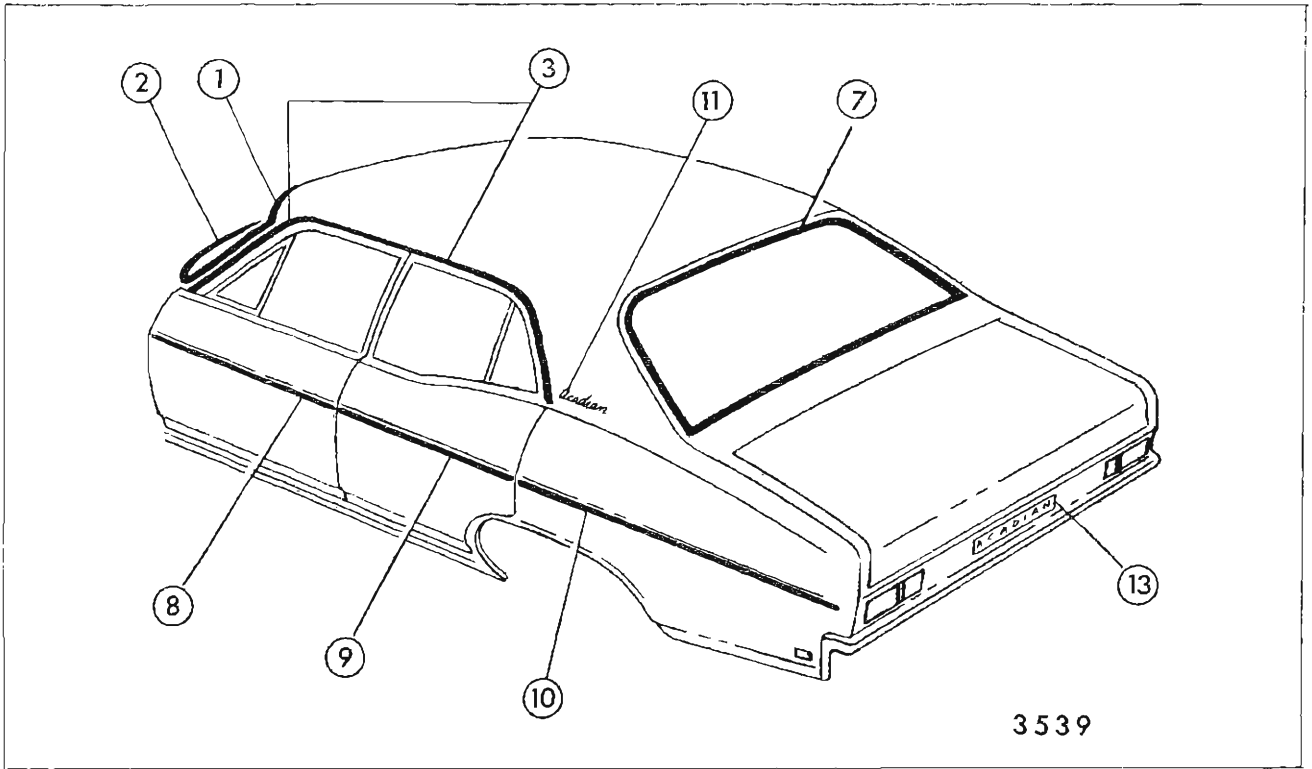

Fig. 17-101—Acadian 71369-71469 (Canadian)

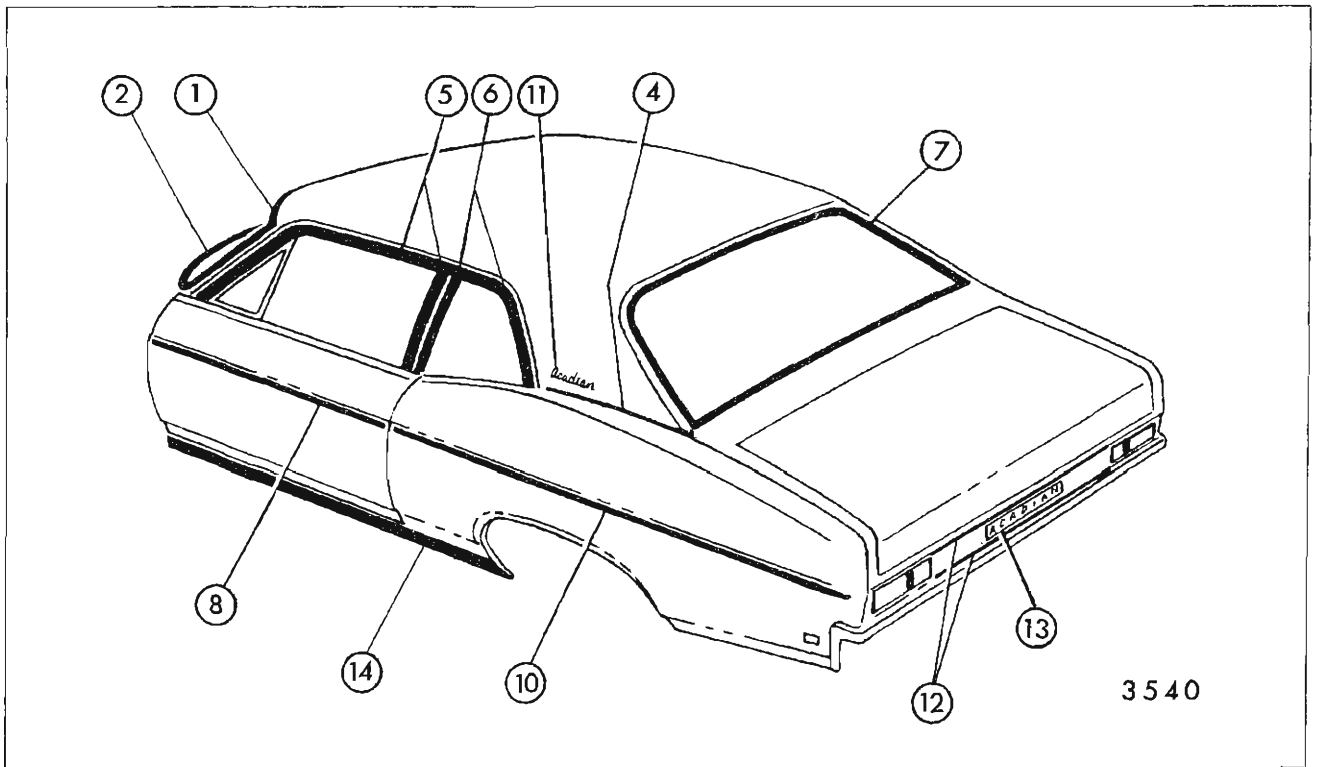

Fig. 17-102—Acadian 71327-71427 (Canadian)

**METHODS OF MOLDING RETENTION**  
**ACADIAN "X" BODIES - 71000 SERIES**  
**FIGURES 17-101 THROUGH 17-102**

Key	Molding Name	Series or Styles	Screws	Spring (Self-Retained)	Snap-On Clips or Retainers On Panel	Snap-On Clips On Molding	Studs With Attaching Nuts	Engages With Other Moldings	Remove Hardware Or Trim
1	Windshield Reveal Upper Sides	All			X			Windshield Reveal Lower	Cowl Air Intake Grille
2	Windshield Reveal Lower	All	X						
3	Windshield Pillar Drip Scalp	69 Style (Optional)	X						
	Roof Drip Molding Scalp	69 Style (Optional)		View K				Windshield Pillar Drip Scalp	
4	Rear Quarter Belt Reveal	All (Optional)			X		X		
	Rear Quarter Belt Reveal Corner Escutcheon	All (Optional)					X	Rear Quarter Belt Reveal	
5	Front Door Window Frame Front Scalp	27 Style (Optional)		View J					
	Front Door Window Frame Rear Scalp	27 Styles (Optional)		View J				Front Door Window Frame Front Scalp	
6	Rear Quarter Window Frame Front Scalp	27 Style (Optional)		View J					
	Rear Quarter Window Frame Upper Scalp	27 Style (Optional)		View J				Rear Quarter Window Frame Front Scalp	
7	Back Window Reveal Upper and Sides	All			X			Back Window Reveal Lower	
	Back Window Reveal Lower	All	X						
8	Front Door Outer Panel	All (Optional)	X		X				
9	Rear Door Outer Panel	69 Style (Optional)	X		X				

METHODS OF MOLDING RETENTION  
 ACADIAN "X" BODIES - 71000 SERIES  
 FIGURES 17-101 THROUGH 17-102

Key	Molding Name	Series or Styles	Screws	Spring (Self-Retained)	Snap-On Clips or Retainers On Panel	Snap-On Clips On Molding	Studs With Attaching Nuts	Engages With Other Moldings	Remove Hardware Or Trim
10	Rear Quarter Outer Panel	All (Optional)			X		View B		
11	Roof Panel Emblem	All					X		Quarter Upper Trim
12	Rear End Outer Panel Upper	All (Optional)					View C		
	Rear End Outer Panel Lower	All (Optional)					View C		
13	Rear End Outer Panel Nameplate	All					X		
14	Outer Rocker Panel	All (Optional)	X						

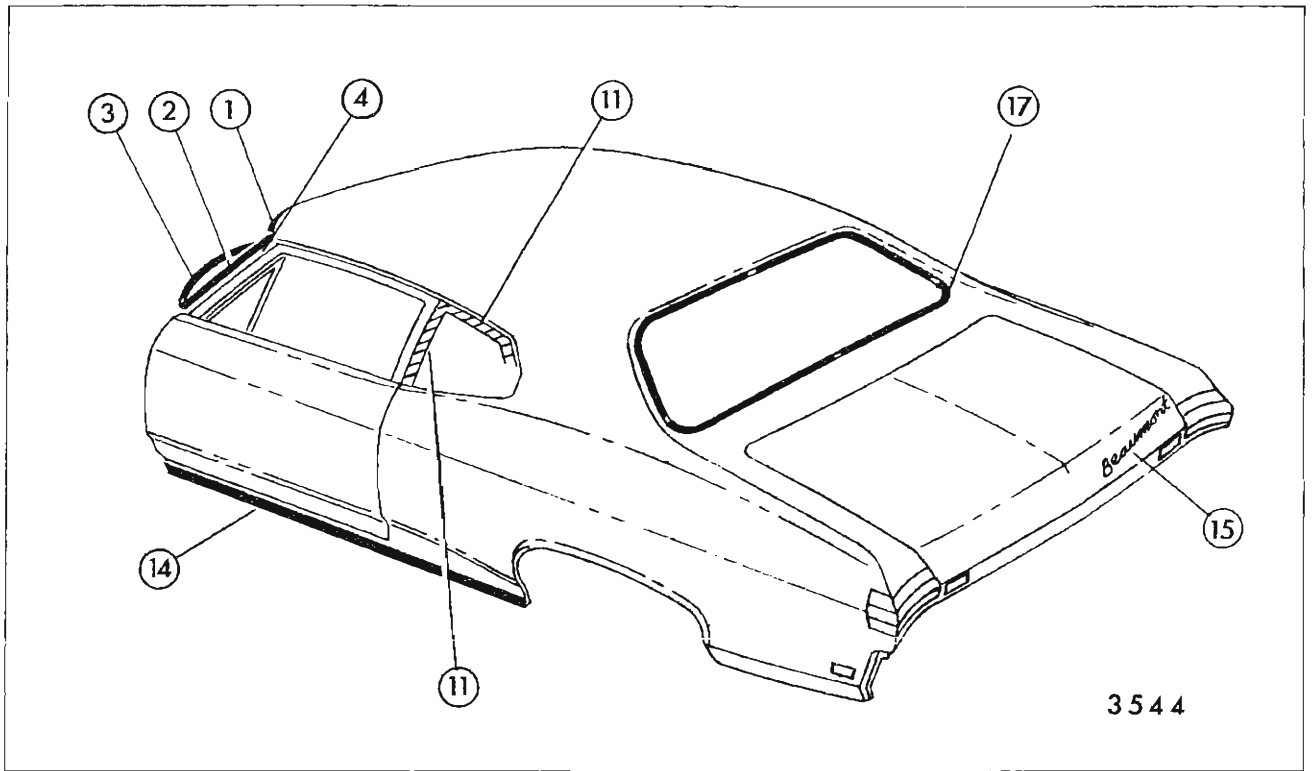

3544

Fig. 17-103—Beaumont 73327-73427 (Canadian)

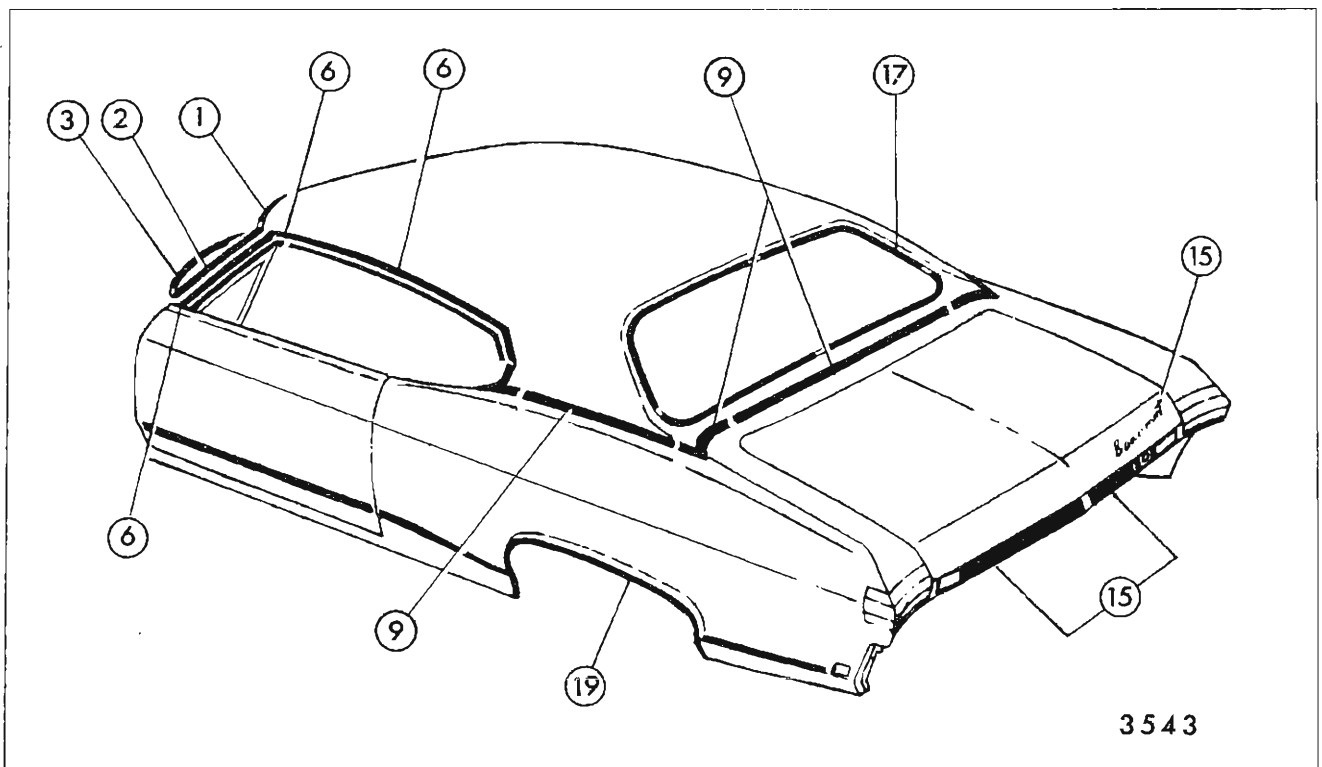

3543

Fig. 17-104—Beaumont 73637 (Canadian)

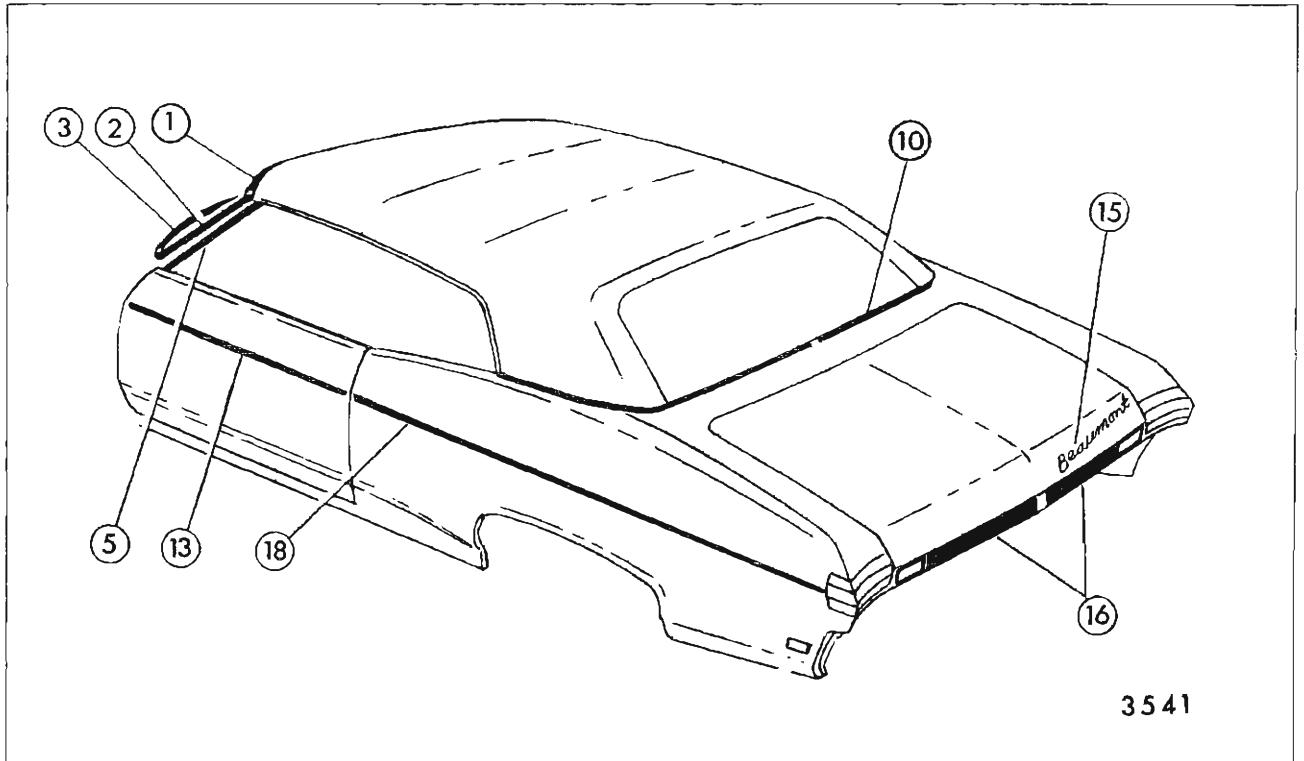

Fig. 17-105—Beaumont 73567-73667 (Canadian)

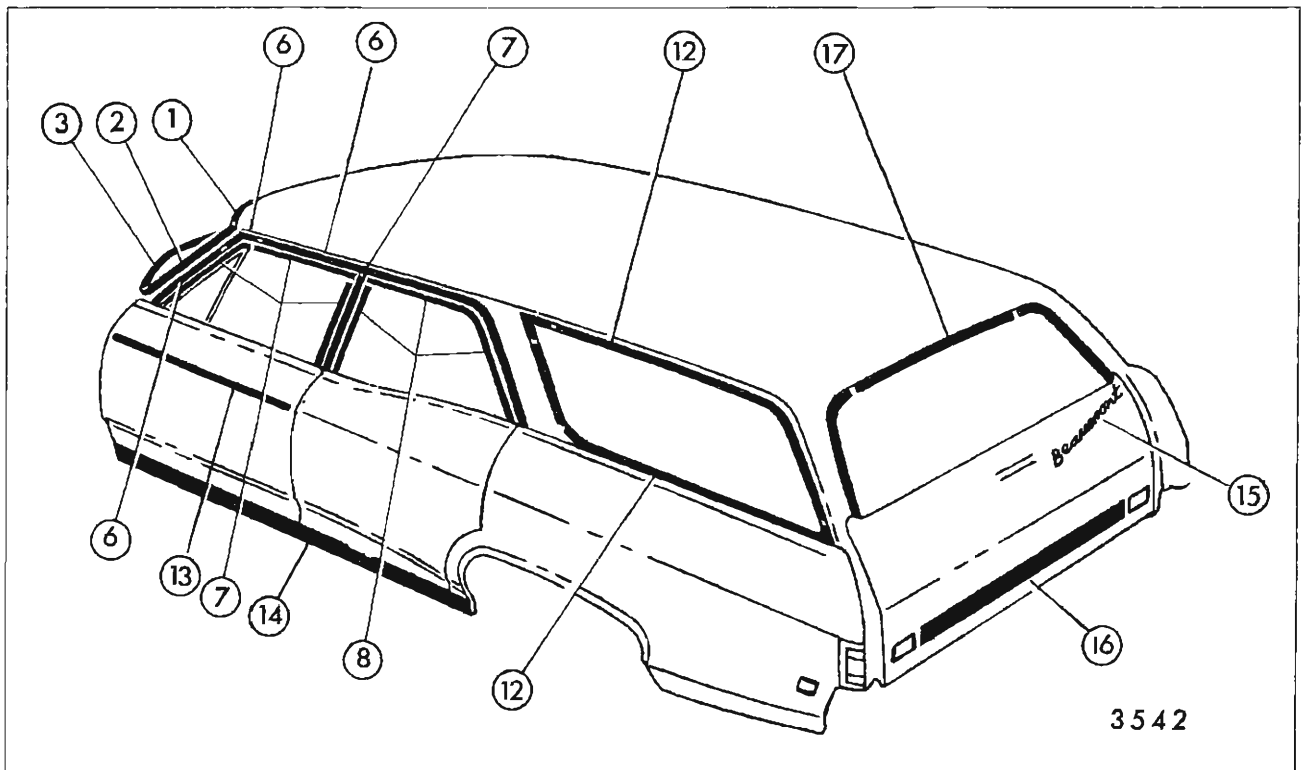

Fig. 17-106—Beaumont 73535-73635 (Canadian)

**METHODS OF MOLDING RETENTION**  
**BEAUMONT "A" BODIES - 73000 SERIES (CANADIAN)**  
**FIGURES 17-103 THROUGH 17-106**

Key	Molding Name	Series or Styles	Screws	Spring (Self-Retained)	Snap-On Clips or Retainers On Panel	Snap-On Clips On Molding	Studs With Attaching Nuts	Engages With Other Moldings	Remove Hardware Or Trim
1	Windshield Reveal Upper	All			X				
2	Windshield Reveal Side	All			X			Windshield Reveal Upper	
3	Windshield Reveal Lower	All	X					Windshield Reveal Side	
4	Windshield Pillar Drip Scalp	All	X						
5	Windshield Pillar Finishing	67	X						Windshield Pillar Weatherstrip and Weatherstrip Retainer
	Windshield Header Center	67	X					Windshield Header Side	Rear View Mirror Support
	Windshield Header Side	67	X					Windshield Reveal Upper and Sides	Sunshade Support, Windshield Pillar Weatherstrip and Weatherstrip Retainer
6	Windshield Pillar Drip Molding Scalp	37-39 735-3635, 36, 69		X					
	Roof Drip Molding Front Scalp	39		X				Roof Drip Molding Scalp Escutcheon	
	Roof Drip Molding Scalp Escutcheon	37, 35, 39, 69		X					
	Roof Drip Molding Rear Scalp	39		X				Roof Drip Molding Scalp Escutcheon	
	Roof Drip Molding Scalp	37, 35, 39, 36		X					

**METHODS OF MOLDING RETENTION**  
**BEAUMONT "A" BODIES - 73000 SERIES (CANADIAN)**  
**FIGURES 17-103 THROUGH 17-106**

Key	Molding Name	Series or Styles	Screws	Spring (Self-Retained)	Snap-On Clips or Retainers On Panel	Snap-On Clips On Molding	Studs With Attaching Nuts	Engages With Other Moldings	Remove Hardware Or Trim
7	Front Door Window Frame Front Scalp (Optional)	27, 35, 36, 69		X					
	Front Door Window Frame Upper Scalp (Optional)	27, 35, 36, 69		X				Front Door Window Frame Front Scalp	
	Front Door Window Frame Rear Scalp (Optional)	27, 35, 36, 69		X				Front Door Window Frame Upper Scalp	
	Center Pillar Scalp (Optional)	35, 69, 36	X						
8	Rear Door Window Frame Front Scalp (Optional)	35, 69, 36		X				Rear Door Window Frame Upper Scalp	
	Rear Door Window Frame Upper Scalp (Optional)	35, 69, 36		X				Rear Door Window Frame Rear Scalp	
	Rear Quarter Window Rear Reveal (Optional)	27, 37		X					
9	Rear Quarter Belt Reveal (Optional)	27, 37, 39, 69			X	X	X		
	Rear End Belt Side Reveal	27, 37					X		
	Rear End Belt Reveal	27, 37			X		X		
	Center Reveal (Optional)	27, 37, 39, 69			X		X		
10	Rear Quarter Pinch Weld Finishing	67		X		X			Rear Quarter and Rear End Trim Sticks
11	Rear Quarter Window Front Reveal	27				X			
	Rear Quarter Window Upper Reveal	27	X						



**METHODS OF MOLDING RETENTION**  
**BEAUMONT "A" BODIES - 73000 SERIES (CANADIAN)**  
**FIGURES 17-103 THROUGH 17-106**

Key	Molding Name	Series or Styles	Screws	Spring (Self-Retained)	Snap-On Clips or Retainers On Panel	Snap-On Clips On Molding	Studs With Attaching Nuts	Engages With Other Moldings	Remove Hardware Or Trim
12	Rear Quarter Window Reveal Upper	35, 36			X			Rear Quarter Window Reveal Lower	
	Rear Quarter Window Reveal Lower	35, 36			X			Rear Quarter Window Reveal Upper	
13	Front Door Outer Panel	735-73600			X		X		
	Front Door Outer Panel Pressure Sensitive Adhesive	731-732-733-73400 (Optional)	X		X				
	Rear Door Outer Panel Pressure Sensitive Adhesive	731-732-733-73400 (Optional)	X		X				
14	Rocker Panel	733-73400, 735-73635, 36, 39, 69	X			X			
15	Rear Compartment Lid Nameplate	All					X		
16	Rear End Panel and/or Nameplate	735-73635, 36, 37, 39, 67, 69					X		
17	Back Window Reveal Upper and Side	27, 37			X			Back Window Reveal Lower	
	Back Window Reveal Lower and Side	39, 69			X				
	Back Window Reveal Upper	39, 69			X			Back Window Reveal Lower and Side	
	Back Window Reveal Lower	27, 37			X				
	Tailgate Window Opening Upper Reveal	35, 36			X			Tailgate Window Opening Side Reveal	
	Tailgate Window Opening Side Reveal	35, 36			X				

**METHODS OF MOLDING RETENTION**  
**BEAUMONT "A" BODIES - 73000 SERIES (CANADIAN)**  
**FIGURES 17-103 THROUGH 17-106**

Key	Molding Name	Series or Styles	Screws	Spring (Self-Retained)	Snap-On Clips or Retainers On Panel	Snap-On Clips On Molding	Studs With Attaching Nuts	Engages With Other Moldings	Remove Hardware Or Trim
18	Rear Quarter Panel Outer	735-73637, 67			X		X		
	Rear Quarter Outer Panel Pressure Sensitive Adhesive	731, 732-733-73400 (Optional)			X		X		
19	Rear Wheel Opening Molding	73637 (L-34 or L-35 Only)	X						



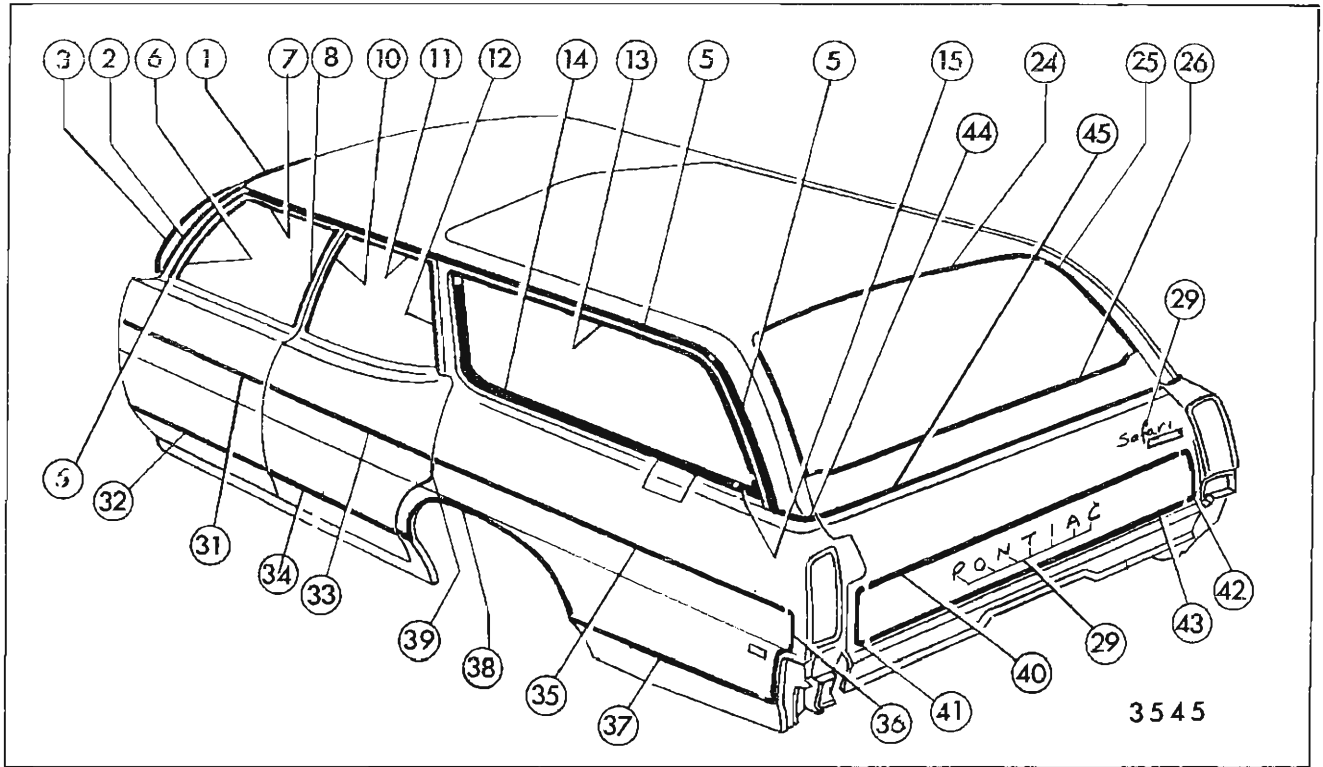

Fig. 17-109—Pontiac 76636 (Canadian)

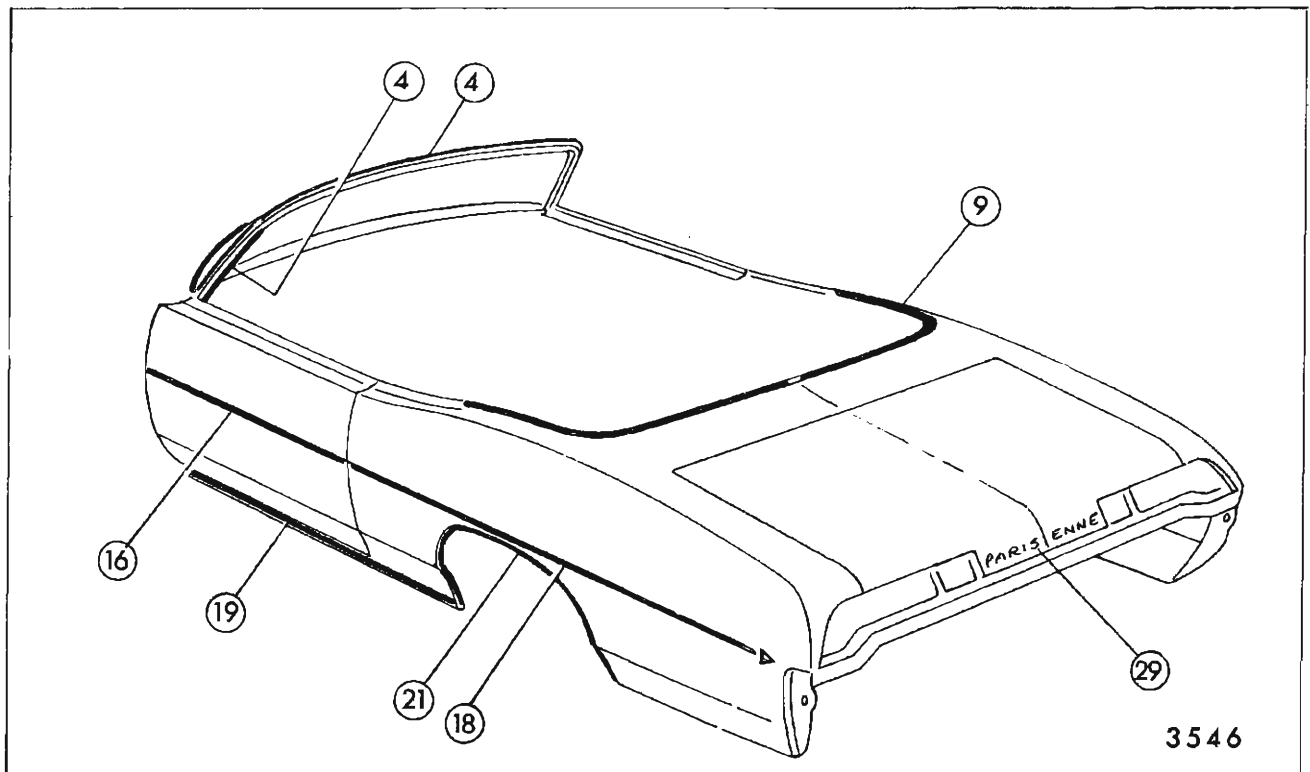

Fig. 17-110—Pontiac 76467 (Canadian)

## METHODS OF MOLDING RETENTION

PONTIAC "B" BODIES - 75-76000 SERIES (CANADIAN)  
 FIGURES 17-107 THROUGH 17-110

Key	Molding Name	Series or Styles	Screws	Spring (Self-Retained)	Snap-On Clips or Retainers On Panel	Snap-On Clips On Molding	Studs With Attaching Nuts	Engages With Other Moldings	Remove Hardware Or Trim
1	Windshield Reveal Upper	All			X			Windshield Reveal Side	
2	Windshield Reveal Side	All			X				
3	Windshield Reveal Lower	All	X					Windshield Reveal Side	
4	Windshield Pillar Drip	All (Except 67)	X						Windshield Pillar Weatherstrip and Weatherstrip Retainer (Hardtop Styles Only)
	Windshield Pillar Finishing	67	X						Windshield Pillar Weatherstrip and Weatherstrip Retainer
	Windshield Header	67	X					Windshield Pillar Finishing, Windshield Upper Reveal	Rear View Mirror Support, Sunshade Support
5	Roof Drip Scalp	All 37,39, 69 Except 753-75469 (& Optional)		X				Windshield Pillar Drip	
	Roof Drip Molding Scalp Front	36,46 Except 753-75436,46 (& Optional)		X				Windshield Pillar Drip	
	Roof Drip Molding Scalp Rear	36,46 Except 753-75436,46 (& Optional)		X				Roof Drip Molding Scalp Front	
6	Front Door Window Frame Scalp Front	763-764-76636, 46,69		X					

## METHODS OF MOLDING RETENTION

PONTIAC "B" BODIES - 75-76000 SERIES (CANADIAN)  
 FIGURES 17-107 THROUGH 17-110

Key	Molding Name	Series or Styles	Screws	Spring (Self-Retained)	Snap-On Clips or Retainers On Panel	Snap-On Clips On Molding	Studs With Attaching Nuts	Engages With Other Moldings	Remove Hardware Or Trim
7	Front Door Window Frame Scalp Upper	763-764-76636,46,69		X				Front Door Window Frame Scalp Front	
8	Front Door Window Frame Scalp Rear	763-764-76636,46,69		X				Front Door Window Frame Scalp Upper	
9	Rear Quarter Belt Reveal	37,39,36,46,69 (Optional)			X				
	Rear Quarter Belt Pinchweld Finishing	67	X						
10	Rear Door Window Frame Scalp Front	763-764-76636,46,69		X				Rear Door Window Frame Scalp Upper	
11	Rear Door Window Frame Scalp Upper	763-764-76636,46,69		X				Rear Door Window Frame Scalp Rear (36,46 Models Only)	
12	Rear Door Window Frame Scalp Rear	763-764-76636,46		X					
13	Rear Quarter Window Reveal Upper	763-764-76636,46			X			Rear Quarter Window Reveal Lower Escutcheon	
14	Rear Quarter Window Reveal Lower	763-764-76636,46			X			Rear Quarter Window Reveal Upper	
15	Rear Quarter Window Reveal Lower Escutcheon	763-764-76636,46			X				
16	Front Door Outer Panel	755-75600 (All) 76000 (Except 36,46)	X		X				
	Front Door Outer Panel Pressure Sensitive Adhesive	753-75400 (Optional)	X		X				

## METHODS OF MOLDING RETENTION

PONTIAC "B" BODIES - 75-76000 SERIES (CANADIAN)

FIGURES 17-107 THROUGH 17-110

Key	Molding Name	Series or Styles	Screws	Spring (Self-Retained)	Snap-On Clips or Retainers On Panel	Snap-On Clips On Molding	Studs With Attaching Nuts	Engages With Other Moldings	Remove Hardware Or Trim
17	Rear Door Outer Panel	755-75636, 46,69 763-76436, 39,46,69	X		X				
	Rear Door Outer Panel Pressure Sensitive Adhesive	753-75400 (Optional)	X		X				
18	Rear Quarter Outer Panel	755-756-763-764-76600 (Except 36,46) 756-76436,46				X	X		
	Rear Quarter Outer Panel Pressure Sensitive Adhesive	753-75400 (Optional)			X		X		Rear Quarter Trim
19	Outer Rocker Panel	763-76400, 76637,39	X						
20	Rear of Rear Wheel Opening	76637,39	X						
21	Rear Wheel Opening	763-764-76800	X				X		
22	Back Window Reveal Upper and/or Side	All (Except 36,46)			X				
23	Back Window Reveal Lower	All (Except 36,46)	X						
24	Back Body Opening Reveal	36,46	X					Back Body Opening Reveal Side	Upper Glass Run Channel
25	Back Body Opening Reveal Side	36,46	X						

METHODS OF MOLDING RETENTION  
PONTIAC "B" BODIES - 75-76000 SERIES (CANADIAN)  
FIGURES 17-107 THROUGH 17-110

Key	Molding Name	Series or Styles	Screws	Spring (Self-Retained)	Snap-On Clips or Retainers On Panel	Snap-On Clips On Molding	Studs With Attaching Nuts	Engages With Other Moldings	Remove Hardware Or Trim
26	Tailgate Window Reveal	764-76636	X			X			
27	Rear Compartment Lid Outer Panel Belt Reveal	37,39,69 (Optional)	X		X				
28	Rear Compartment Lid Finishing	76637,39		X					
29	Rear Compartment Lid Outer Panel Nameplate	All (Except 36,46)					X		
	Rear Compartment Lid Outer Panel Emblem	76800					X		
	Tailgate Outer Panel Nameplate						X		Tailgate Trim Panel Assembly
30	Roof Panel Emblem	76637-39, 69 (Optional)					X		Rear Quarter Upper Trim
31	Front Door Transfer Finishing Upper Insert	76636,46	X		X				
32	Front Door Transfer Finishing Lower Insert	76636,46	X		X				
33	Rear Door Transfer Finishing Upper Insert	76636,46	X		X				
34	Rear Door Transfer Finishing Lower Insert	76636,46	X		X				
35	Rear Quarter Outer Panel Transfer Finishing Upper Insert	76636,46			X			Rear Quarter Outer Panel Transfer Finishing Rear Vertical	
36	Rear Quarter Outer Panel Transfer Finishing Rear Vertical	76636,46					X		Rear Quarter Trim



## METHODS OF MOLDING RETENTION

PONTIAC "B" BODIES - 75-76000 SERIES (CANADIAN)  
FIGURES 17-107 THROUGH 17-110

Key	Molding Name	Series or Styles	Screws	Spring (Self-Retained)	Snap-On Clips or Retainers On Panel	Snap-On Clips On Molding	Studs With Attaching Nuts	Engages With Other Moldings	Remove Hardware Or Trim
37	Rear Quarter Outer Panel Transfer Finishing Lower Insert	76636,46			X		X	Rear Quarter Outer Panel Transfer Finishing Rear Vertical and Rear Wheel Opening	
38	Rear Wheel Opening Transfer Finishing	76636,46					X		
39	Rear Quarter Outer Panel Transfer Finishing Front	76636,46	X						
40	Tailgate Outer Panel Transfer Finishing Upper	76636,46			X			Tailgate Outer Panel Transfer Finishing Vertical	
41	Tailgate Outer Panel Transfer Finishing Vertical L.H.	76636,46	X				X		Tailgate Trim Panel Assembly
42	Tailgate Outer Panel Transfer Finishing Vertical R.H.						X		Tailgate Trim Panel Assembly
43	Tailgate Outer Panel Transfer Finishing Lower	76636,46			X			Tailgate Outer Panel Transfer Finishing Vertical	
44	Back Body Pillar Belt Finishing	36,46 (Optional)	X		X	X			
45	Tailgate Outer Panel Finishing	36,46 (Optional)			X				

## SECTION 18

## INDEX

Subject	Page No.	Subject	Page No.
<b>A</b>			
Access Hole Cover, Dual Acting Tail		Alignment, Underbody	
Gate Inner Panel . . . . .	9-4	Corvaire "Z" Styles . . . . .	3-1
Access Hole Cover, Single Acting Tail		Camaro and Firebird "F" Bodies . . . . .	3-5
Gate Inner Panel . . . . .	9-28	Chevy Nova and Acadian "X" Bodies . . . . .	3-5
Actuator Assembly, Folding Top -		Appliques and Moldings, Door Trim Panel . . . . .	14-7
"Z" Styles . . . . .	13-35	Appliques and Moldings, Rear Quarter	
Actuator or Electric Solenoid, Front and		Trim Panel . . . . .	14-13
Rear Door Vacuum . . . . .	6-17	Arm Rest (Center) and Curtain Assembly -	
Adhesive Caulked Glass - All Styles . . . . .	4-1	Standard Full Width Seat Back . . . . .	15-32
Adjuster Horizontal Actuator Assembly,		Arm Rest (Center) and Support Assembly -	
Strato - Full Width or Bucket and		Standard Full Width Seat Back . . . . .	15-34
Standard Bucket Seats . . . . .	15-40	Arm Rests, Door . . . . .	14-1
Adjuster Jackscrew - Strato - Full Width		Arm Rest, Rear Quarter . . . . .	14-7
or Bucket and Standard Bucket Seats . . . . .	15-40	Auxiliary Sealing Strip, Front and Rear	
Adjuster Mechanism Lubrication,		Door Bottom . . . . .	6-4
Folding Seat . . . . .	2-7	Auxiliary Seat Adjustments, Rear -	
Adjuster Vertical Gearnut - Strato - Full		Cadillac Limousine Styles . . . . .	15-54
Width or Bucket and Standard Bucket		Auxiliary Seat Assembly, Rear -	
Seats . . . . .	15-40	Cadillac Limousine Styles . . . . .	15-53
Adjusting Plate, Folding Top -		Auxiliary Seat Lower Support Assembly,	
"Z" Body . . . . .	13-49	Rear - Cadillac Limousine Styles . . . . .	15-56
Adjustment of Front Roof Rail,		<b>B</b>	
Folding Top Adjustments "A, B & C"		Back Curtain Assembly - Complete . . . . .	13-39
Styles . . . . .	13-39	Ball Point Ink - Stain Removal . . . . .	10-5
Adjustment of Front Roof Rail,		Blood - Stain Removal . . . . .	10-3
Folding Top - "F" Body . . . . .	13-43	Body Opening Clearance Tolerances,	
Adjustment of Front Roof Rail,		Specified - Front and Rear Doors . . . . .	6-10
Folding Top - "Z" Body . . . . .	13-49	Bucket Seat Back Assembly - Standard	
Adjustment of Front Roof Rail Guide,		Bucket Seat "F & Z" Styles . . . . .	15-41
Folding Top Adjustments - "A, B & C"		Bucket Seat (front) Back Stop Cable,	
Styles . . . . .	13-39	Passenger - Chevrolet "F & Z" Styles . . . . .	15-41
Adjustment of Front Roof Rail Wedge		<b>C</b>	
Plate, Folding Top - "Z" Body . . . . .	13-49	Cams and Guides Lubrication, Door	
Adjustment of Male Hinge, Folding Top -		Window Regulator - Styles without	
"Z" Body . . . . .	13-50	Upper Frames . . . . .	2-4
Adjustment of Top Control Link, Folding		Cams and Guides Lubrication, Rear	
Top, - "A, B & C Styles . . . . .	13-39	Quarter Window Regulator . . . . .	2-5
Adjustment of Top Control Link,		Cam, Inner Panel, Front Door - All	
Folding Top - "F" Body . . . . .	13-44	Styles Except "A and X-69" Styles . . . . .	6-58
Adjustment of Top Control Link,		Cam, Rear Door Inner Panel - All	
Folding Top - "Z" Body . . . . .	13-49	Except "A and X-69" Styles . . . . .	6-88
Adjustment of Top at Male Hinge,		Cams, Sector Gear and Window Regulator	
Folding Top - "F" Body . . . . .	13-44	Lubrication, Tail Gate (All Station	
Air Duct Outlet and Door, Shroud Side -		Wagons) . . . . .	2-6
Buick and Cadillac "E" Styles . . . . .	5-7	Cams and Window Regulator Lubrication,	
Air Outlet and Door, Shroud Center		Door - on Styles with Door Upper	
Duct Upper -		Frames . . . . .	2-3
"B and C" Styles . . . . .	5-4	Candy - Stain Removal . . . . .	10-4
"A and G" Styles . . . . .	5-4	Carpets, Floor - Cleaning . . . . .	10-3
"F" Styles . . . . .	5-4	Catch Clips, Folding Top . . . . .	13-38
Air Outlet Duct and Shroud Side Finishing		Catsup - Stain Removal . . . . .	10-5
Panel - "Z-67" Styles . . . . .	5-6		

Subject	Page No.	Subject	Page No.
Center Arm Rest and Curtain Assembly - Notch Down Seat Back and Strato Seat . . .	15-34	Compartment Lid Lock Assembly, Front - Corvair . . . . .	5-13
Center Arm Rest and Curtain Assembly - Standard Full Width Seat Back . . . . .	15-32	Compartment Lid Lock Cylinder Assembly, Front - Corvair . . . . .	5-13
Center Arm Rest and Support Assembly - Standard Full Width Seat Back . . . . .	15-34	Compartment Lid Lock - Lubrication, Front . . . . .	2-1
Center Duct Upper Air Outlet and Door, Shroud - "B and C" Styles . . . . .	5-4	Compartment Lid Lock Lubrication, Compartment Lid Lock Lubrication, Rear . .	2-8
"A and G" Styles . . . . .	5-4	Compartment Lid Lock Striker, Front - Corvair . . . . .	5-13
"F" Styles . . . . .	5-4	Compartment Lid, Rear - All Styles Except Corvair . . . . .	8-1
Center Finishing Panel, Compartment Shelf - Oldsmobile and Buick "E" Styles . . . . .	14-20	Compartment Lid Support Lubrication, Engine . . . . .	2-8
Center Pillar Trim ("A, B & C" Four- Door Hardtop Styles) . . . . .	14-19	Compartment Lid Torque Rods, Front - Corvair . . . . .	5-12
Center Pillar Upper and Lower Trim ("A & X" Four-Door Closed Styles) . . . . .	14-19	Compartment Shelf Center Finishing Panel - Oldsmobile and Buick "E" Styles . . . .	14-20
Center Pillar Upper and Lower Trim - ("B & C" Four-Door Closed Styles) . . . . .	14-19	Compartment Shelf Side and Center Trim Panels - Cadillac "E" Styles . . . . .	14-20
Center Pillar Weatherstrips, Front and Rear Doors - "C-69" Styles . . . . .	66-9	Compartment Shelf Side Finishing Panels - Oldsmobile and Buick "E" Styles . . . .	14-20
Center and Side Trim Panels, Compartment Shelf - Cadillac "E" Styles . . . . .	14-20	Compartment Shelf Trim Assembly - All Styles Except "E & F" Styles and "F-37" Styles with Folding Rear Seat . .	14-20
Channel (Lower or Upper) and Plastic Slides, Six-Way Seat Adjuster - "B-C & E" Body Full Width . . . . .	15-21	Compartment Shelf Trim Assembly - "F-37" Styles with Folding Rear Seat . .	14-23
Checking Procedure, Four-Way Tilt Seat - Electrical . . . . .	16-34	Components, Ventilation System - Non- Air Conditioning . . . . .	5-1
Checking Procedures, Power Windows - Electrical . . . . .	16-3	Connecting Rod and Lock Remote Control, Front Door - All Styles . . . . .	6-55
Checking Procedure, Tail Gate Window - Electrical . . . . .	16-13	Control Arm Knob, Manually Operated Seat Adjuster . . . . .	15-6
Chewing Gum - Stain Removal . . . . .	10-4	Convertible Top Hinge Mechanism Lubrication . . . . .	2-7
Circuit Checking Procedures, Electric Seat Back Lock Release . . . . .	16-58	Covers, Instrument Panel - Chevrolet "A, X & Z" and Pontiac "F" Styles . . .	5-10
Circuit Checking Procedures, Power Window . . . . .	16-5	Cover Panel, Rear Quarter Wheelhouse - Right Side ("B" Body Station Wagon Styles) . . . . .	14-13
Circuit Checking Procedures, Six-Way Tilt Seat - Electrical . . . . .	16-38	Cover Panel, Spare Tire (Station Wagon Styles) . . . . .	14-14
Clips, Front and Rear Door Spring . . . . .	6-10	Cover Panel, Wheelhouse Trim - Right Side (All "A" Body Station Wagon Styles) . . . . .	14-15
Compartment Door Hinge Lubrication, Instrument Panel . . . . .	2-2	Cover, Single Acting Tail Gate Inner Panel . . . . .	9-25
Compartment Door, Instrument Panel - Buick "A & E" Styles . . . . .	5-9	Cross Over Harness, Power Windows - Electrical . . . . .	16-2
Compartment Door Lock Cylinder and Lock, Instrument Panel - Buick "A & E" Styles, All Chevrolet Styles . . . . .	5-9	Curtain Assembly, Back - Complete . . .	13-19
Compartment Floor Panel Assembly (at Kick-Up) Rear Seat All Styles . . . .	15-62	Cushion Assembly, Folding Second Seat - "55, 56, 65, 66" Styles . . . . .	15-66
Compartment, Front - Corvair . . . . .	5-11	Cushion, Second Seat - (Full Width or Split Seat) Rear - All Styles . . . . .	15-62
Compartment Front and Shelf Panel Trim Assembly - "Z" Styles with Stationary or Folding Rear Seat Back . . . . .	14-21	Cushion Trim Assembly, Folding Third Seat - "65-66" Styles . . . . .	15-71
Compartment Hinge Lubrication, Rear . . .	2-8	Cut-Out Switch, Power Windows - Electrical . . . . .	16-3
Compartment Lid, Front - Corvair . . . . .	5-11	Cylinder Assembly, Front Compartment Lid Lock - Corvair . . . . .	5-13
Compartment Lid Gutter Weatherstrip, Front - Corvair . . . . .	5-14		
Compartment Lid Hinge and Torque Rod - Lubrication, Front . . . . .	2-1		

Subject	Page No.	Subject	Page No.
Cylinder Assy, Rear Compartment Lid Lock - All Styles . . . . .	8-7		
<b>D</b>			
Dealer Relocation Provisions, Front Seat . . . . .	15-3	Drive Cables - Horizontal or Front Vertical, Six-Way Seat Adjuster - Buick, Oldsmobile and Cadillac 60-40 Seats . . . . .	15-23
Deluxe Front Seat Belt Retractor - Floor Mount . . . . .	15-73	Drive Cables, Horizontal and Vertical Four-Way Seat Adjuster - "A" Body Full Width . . . . .	15-16
Door Arm Rests . . . . .	14-1	Drive Cables - Horizontal and Vertical, Four-Way Seat Adjuster - Buick "B-C & E" Body Full Width . . . . .	15-19
Door Bottom Auxiliary Sealing Strip, Front and Rear Door . . . . .	6-4	Drive Cables, Horizontal and Vertical and Transmission Assembly - Strato Full Width or Bucket and Standard Bucket Seats . . . . .	15-39
Door Bottom Drain Hole Sealing Strips, Front and Rear Doors . . . . .	6-4	Drive Cables - Rear Vertical, Six-Way Seat Adjuster - Buick, Oldsmobile and Cadillac 60-40 Seats . . . . .	15-23
Door Hinge Assembly Lubrication, Front . . . . .	2-2	Dual Acting Tail Gate . . . . .	9-1
Door Hinge Assembly Lubrication, Rear . . . . .	2-2	<b>E</b>	
Door Hinge, Front - All Styles . . . . .	6-54	Electric Actuator Assembly and Seat Back Lock - Cadillac Two-Door Styles with Standard Full Width Seat . . . . .	15-29
Door Hinges, Front - All Styles . . . . .	6-53	Electric Back Window Grid Defogger . . . . .	16-56
Door Hinge Lubrication, Gas Tank Filler . . . . .	2-7	Electric Door Lock . . . . .	16-60
Door Hinge Lubrication, Instrument Panel Compartment . . . . .	2-2	Electric Motor, Four-Way Seat Adjuster - "A" Body Full Width . . . . .	15-15
Door Hinges, Rear - All Styles . . . . .	6-80	Electric Motor, Four-Way Seat Adjuster - Buick "B-C & E" Body Full Width . . . . .	15-17
Door Inside Handles . . . . .	14-3	Electric Motor, Front and Rear Door Window Regulator Removal - All Styles Except "E" Styles . . . . .	6-24
Door, Instrument Panel Compartment - Buick "A & E" Styles . . . . .	5-9	Electric Motor Removal, Front and Rear Door Window Regulator - "E" Styles . . . . .	6-30
Door Jamb Switch Lubrication . . . . .	2-3	Electric Motor, Six-Way Seat Adjuster - "B-C & E" Body Full Width . . . . .	15-20
Door Lock Cylinder and Lock, Instrument Panel Compartment - Buick "A & E" Styles, All Chevrolet Styles . . . . .	5-9	Electric Motor, Six-Way Seat Adjuster - Buick, Oldsmobile and Cadillac 60-40 Seats . . . . .	15-22
Door Lock, Electric . . . . .	16-60	Electric Motor, Two-Way Seat Adjuster - "C" Body Full Width . . . . .	15-14
Door Lock Fork Bolt Lubrication . . . . .	2-3	Electric Regulator Motor Assembly, Single Acting Tail Gate Window . . . . .	9-33
Door Locking Mechanism and Lock Parts Lubrication . . . . .	2-3	Electric Seat Back Lock - Cadillac Two- Door Styles with Standard Full Width Seats . . . . .	15-29
Door Outside Mirror Remote Controls and Escutcheon . . . . .	14-3	Electric Seat Back Lock Release . . . . .	16-58
Door Outside Remote Control Mirror, Front - All Styles Without Door Ventilators . . . . .	6-58	Electrical Checking Procedure, Folding Top Hydro-Lectric System . . . . .	13-30
Door Pull Handles . . . . .	14-1	Electrical Checking Procedure - Power Window Circuit . . . . .	16-5
Door Removal and Installation - All Styles . . . . .	6-53	Electrical Checking Procedures, Power Windows . . . . .	16-3
Door Trim . . . . .	14-1	Electrical Tail Gate Window Circuit . . . . .	16-12
Door Trim Assemblies . . . . .	14-4	Engine Compartment Latch Striker - Corvaire Styles . . . . .	8-7
Door Trim Panel Moldings and Appliques . . . . .	14-7	Engine Compartment Lid Latch - Corvaire Styles . . . . .	8-4
Door Wedge Plates, Front Door - "67" Styles . . . . .	6-79	Engine Compartment Lid Support - Corvaire Styles . . . . .	8-4
Door Window Regulator and Cams Lubrication on Styles with Door Upper Frames . . . . .	2-3		
Door Window Regulator Cams and Guides Lubrication - Styles without Upper Frames . . . . .	2-4		
Drain Hole Sealing Strips - Dual Acting Tail Gate . . . . .	9-21		
Drain Hole, Sealing Strips, Front and Rear Door Bottom . . . . .	6-4		
Drain Hole Sealing Strips - Single Acting Tail Gate . . . . .	9-37		

Subject	Page No.	Subject	Page No.
Engine Compartment Lid Support Lubrication . . . . .	2-8	Finishing Panel, Shroud Side - "F" Styles	5-6
Escutcheon and Remote Controls, Door Outside Mirror . . . . .	14-3	Floor Carpets - Cleaning . . . . .	10-3
Exterior Moldings -		Floor Pan Linkage, Folding Second Seat Front - "55, 56, 65, 66" Styles . . . . .	15-69
Chevrolet "A" Body . . . . .	17-12	Floor Pan Linkage, Folding Second Seat Rear - "55, 56, 65, 66" Styles . . . . .	15-69
"B" Body . . . . .	17-23	Fluid Control Valve, Folding Top Hydro-Lectric System . . . . .	13-29
"F" Body . . . . .	17-30	Folding Rear Seat Back - "F" Body Styles . . . . .	15-51
"X" Body . . . . .	17-34	Folding Rear Seat Back - "Z" Body Styles . . . . .	15-52
"Z" Body . . . . .	17-39	Folding Rear Seat Back Linkage - "Z" Body Styles . . . . .	15-52
Pontiac "A" Body . . . . .	17-44	Folding Rear Seat Back Lock - "F" Body Styles . . . . .	15-52
"B" Body . . . . .	17-53	Folding Rear Seat Back Lock - "Z" Body Styles . . . . .	15-52
"F" Body . . . . .	17-59	Folding Seat Adjuster Mechanism Lubrication . . . . .	2-7
Oldsmobile "A" Body . . . . .	17-69	Folding Seat Linkage Lubrication . . . . .	2-7
"B-C" Body . . . . .	17-80	Folding Seats and Floor Panels - "55, 56, 65, 66" Styles . . . . .	15-65
"E" Body . . . . .	17-86	Folding Second Seat Assembly - "55, 56, 65, 66" Styles . . . . .	15-66
Buick "A" Body . . . . .	17-92	Assembly (Full Width Seat - Right or Left Side Split Seat - Outer Linkage Only) . . . . .	15-63
"B-C" Body . . . . .	17-102	Folding Second Seat Back Lock (Full Width or Split Seat) - All "A & B" Styles (Except "A-55, 56, 65, 66" Styles) . . . . .	15-64
"E" Body . . . . .	17-108	Folding Second Seat Back Lock (Full Width or Split Seat) - All "A & B" Styles (Except "A-55, 56" Styles with Split Seat Option and "65-66" Styles . . . . .	15-65
Cadillac "C" Body . . . . .	17-113	Folding Second Seat Back Lock - "55, 56, 65, 66" Styles . . . . .	15-70
"D" Body . . . . .	17-118	Folding Second Seat Back Panel and Filler Panel - "55, 56, 65, 66" Styles . . . . .	15-70
"E" Body . . . . .	17-121	Folding Second Seat Back Trim, Panel and Linkage Assembly (Full Width or Split Seat) - All Styles . . . . .	15-63
Acadian "X" Body (Canadian) . . . . .	17-124	Folding Second Seat Back Trim and Spring Assembly (Full Width or Split Seat) - All Styles . . . . .	15-62
Beaumont "A" Body (Canadian) . . . . .	17-128	Folding Second Seat Back Trim and Spring Assembly - "55, 56, 65, 66" Styles . . . . .	15-68
Pontiac "B" Body (Canadian) . . . . .	17-134	Folding Second Seat Cushion Assembly - "55, 56, 65, 66" Styles . . . . .	15-66
Exterior Molding Sealing Operation . . . . .	17-4	Folding Second Seat Front Floor Pan Linkage - "55, 56, 65, 66" Styles . . . . .	15-39
Exterior Molding Tools and Care . . . . .	17-4	Folding Second Seat Rear Floor Pan Linkage - "55, 56, 65, 66" Styles . . . . .	15-69
Exterior Molding Zinc Anode Clips . . . . .	17-5	Folding Second Seat Side Inner Linkage - "55, 56, 65, 66" Styles . . . . .	15-69
<b>F</b>			
Fabric Roof Cover (All Styles Except Station Wagons) . . . . .	12-1		
Fabric Roof Cover (Station Wagon Styles) . . . . .	12-10		
Fabric Roof Cover and Folding Top - Cleaning . . . . .	10-3		
Fabric Cover, Tail Gate . . . . .	12-13		
Feed Harness for Rear Doors or Quarter Windows, Power Windows - Electrical . . . . .	16-2		
Filler Door Hinge Lubrication, Gas Tank . . . . .	2-7		
Filler Panel Assembly, Rear Floor to Tail Gate, Compartment Pan Side Filler Panels - "B" Body Two-Seat and Three Seat Styles . . . . .	15-57		
Filler Panel, Rear Floor Rear Seats - All Styles . . . . .	15-62		
Filling of Hydro-Lectric Reservoir, Folding Top . . . . .	13-33		
Finishing Panel and Air Duct Outlet, Shroud Side - "Z-67" Styles . . . . .	5-6		
Finishing Panel, Compartment Shelf Center - Oldsmobile and Buick "E" Styles . . . . .	14-20		
Finishing Panel, Compartment Shelf Side - Oldsmobile and Buick "E" Styles . . . . .	14-20		
Finishing Panel, Shroud Side - "A, G, B, C, X and Z-37" Styles . . . . .	5-4		

Subject	Page No.	Subject	Page No.
Folding Second Seat Side Outer Linkage - "55, 56, 65, 66" Styles . . . . .	15-69	Four-Way Seat Adjuster Major Components - Buick "B-C & E" Body Full Width . .	15-17
Folding Second Split Seat Back Inner Linkage Assembly . . . . .	15-64	Four-Way Seat Adjuster Transmission - "A" Body Full Width . . . . .	15-17
Folding Third Seat Back Lock - All "A & B" Body Three Seat Styles . . . .	15-61	Four-Way Seat Adjuster Transmission - Buick "B-C & E" Body Full Width . .	15-19
Folding Third Seat Back Lock - "65-66" Styles . . . . .	15-72	Four-Way Seat Adjuster Vertical and Horizontal Drive Cables - "A" Body Full Width . . . . .	15-16
Folding Third Seat Back Panel Assembly - Three Seat Styles . . . . .	15-61	Four-Way Seat Adjuster Vertical and Horizontal Drive Cables - Buick "B-C & E" Body Full Width . .	15-19
Folding Third Seat Back Trim Assembly - Three Seat Style . . . . .	15-61	Four-Way Seat Adjuster Vertical Jackscrow - "A" Body Full Width . .	15-16
Folding Third Seat Cushion - Three Seat Style Folding Third Seat Cushion Panel Assembly and Support - Three Seat Style . . . . .	15-60	Four-Way Tilt Seat, Electrical Checking Procedure . . . . .	16-34
Folding Third Seat Cushion Trim Assembly - "65-66" Styles . . . . .	15-71	Four-Way Tilt Seat, Power Seats - Electrical . . . . .	16-33
Folding Third Seat and Floor Panel Assembly - "65-66" Styles . . . . .	15-70	Front Compartment - Corvair . . . . .	5-11
Folding Third Seat Lock Trim Assembly or Seat Back Panel Assembly - "65-66" Styles . . . . .	15-71	Front Compartment Lid - Corvair . . . .	5-11
Folding Top Adjustments - "A, B & C" Styles . . . . .	13-38	Front Compartment Lid Gutter Weatherstrip - Corvair . . . . .	5-14
Folding Top Adjustment - "F" Body . . . .	13-43	Front Compartment Lid Hinge and Torque Rod Lubrication . . . . .	2-1
Folding Top Adjustments - "Z" Body . . . .	13-48	Front Compartment Lid Lock Assembly - Corvair . . . . .	5-13
Folding Top Catch Clips . . . . .	13-38	Front Compartment Lid Lock Cylinder Assembly - Corvair . . . . .	5-13
Folding Top Cover and Back Curtain Installation - Complete . . . . .	13-9	Front Compartment Lid Lock Lubrication . . . . .	2-1
Folding Top Cover and Back Curtain Removal - Complete . . . . .	13-1	Front Compartment Lid Lock Striker - Corvair . . . . .	5-13
Folding Top Cover - Less Back Curtain . .	13-13	Front Compartment Lid Torque Rods - Corvair . . . . .	5-12
Folding Top and Fabric Roof Cover - Cleaning . . . . .	10-3	Front Door Hinge Assembly Lubrication . .	2-2
Folding Top Lift Cylinder, Hydro- Lectric System . . . . .	13-33	Front Door Hinges - All Styles . . . . .	6-53
Folding Top Manual Lift Assembly - "A, F & Z" Styles . . . . .	13-37	Front Door Window Harness, Power Windows - Electrical . . . . .	16-2
Folding Top Operation - Hydro-Lectric System . . . . .	13-28	Front Guide and Bracket Assembly, Rear Door Window - "A-39" Styles . . .	6-97
Folding Top Silencer Assembly - Cadillac Styles . . . . .	13-7	Front Guide, Front Door Window - "A-37, 67 and 87" Styles and "G-57" Styles . . . . .	6-76
Folding Top Trim Assembly - Complete . .	13-1	Front Guide, Front Door Window - "B and C" Hardtop & Convertible Styles . . . . .	6-76
Fork Bolt Lubrication, Door Lock . . . .	2-3	Front Guide, Front Door Window - "E" Styles . . . . .	6-77
Fork Bolt Lubrication, Tail Gate Lock (Right and Left) - Station Wagon Styles with Dual Acting Tail Gate . . . . .	2-5	Front Guide, Front Door Window - "F" Styles . . . . .	6-77
Foot Rest Assembly - Cadillac 68169 Style . . . . .	15-34	Front Guide, Rear Door Window - "B-39 and C-39, 49 & 69" Styles . . . .	6-97
Four-Way Seat Adjuster Electric Motor - "A" Body Full Width . . . . .	15-15	Front Headlining Assembly . . . . .	11-5
Four-Way Seat Adjuster Electric Motor - Buick "B-C & E" Body Full Width . .	15-17	Front Panel Rear Compartment - Buick & Olds. "E" Styles . . . . .	8-3
Four-Way Seat Adjuster Horizontal Actuator - "A" Body Full Width . . . .	15-16	Front and Rear Panel Assembly, Luggage Compartment Two Seat Styles . . . . .	15-58
Four-Way Seat Adjuster Horizontal Actuator - Buick "B-C & E" Body Full Width . .	15-19	Front and Rear Panel Hinge Assembly, Luggage Compartment - Two Seat Styles .	15-60
Four-Way Seat Adjuster Major Components - "A" Body Full Width . . . . .	15-15		

Subject	Page No.	Subject	Page No.
Front Roof Rail, Folding Top Adjustment - "Z" Body . . . . .	13-49	Gearnut (Front Vertical), Six-Way Seat Adjuster - "B-C & E" Body Full Width . . . . .	15-20
Front Roof Rail Lock Adjustment, Folding Top - "A, B & C" Styles . . . . .	13-39	Gearnut (Vertical), Four-Way Seat Adjuster - "A" Body Full Width . . . . .	15-15
Front Roof Rail Lock Adjustment, Folding Top - "F" Body . . . . .	13-43	Gearnut (Vertical), Four-Way Seat Adjuster - Buick "B-C & E" Body Full Width . . . . .	15-18
Front Roof Rail Lock Adjustment, Folding Top - "Z" Body . . . . .	13-49	Genuine Leather and Coated Fabrics, Cleaning . . . . .	10-3
Front Roof Rail Lock Assembly, Folding Top Adjustments "A, B & C" Styles . . . . .	13-39	Glass, Adhesive Caulked - All Styles . . . . .	4-1
Front Roof Rail Lock Assembly, Folding Top Adjustments - "F" Body . . . . .	13-43	Glass Run Channel, Front Door Window - "A and X" Closed Styles . . . . .	6-77
Front Roof Rail Lock Assembly, Folding Top - "Z" Body . . . . .	13-49	Glass Run Channel, Front Door Window - "B" Closed Styles . . . . .	6-77
Front Seat Adjuster Assembly - Manual - Full Width . . . . .	15-8	Glass Run Channels, Lower - Single Acting Tail Gate . . . . .	9-34
Front Seat Adjuster Assembly - Power - Full Width . . . . .	15-12	Glass Run Channel, Rear Door Window - All "A & X" Closed Styles . . . . .	6-97
Front Seat Assembly - Manual - Full Width . . . . .	15-8	Glass Run Channel, Rear Door Window - All "B" Closed Styles . . . . .	6-98
Front Seat Assembly - Power - Full Width . . . . .	15-10	Glass Run Channel, Rear - Front Door Window - "Z" Styles . . . . .	6-77
Front Seat Assembly - Standard Full Width and 60-40 Seats . . . . .	15-7	Glass Run Channel Sealing Strip Assemblies, Front and Rear Door . . . . .	6-4
Front Seat Assembly, Strato Full Width . . . . .	15-36	Glass Run Channels, Upper - Single Acting Tail Gate . . . . .	9-37
Front Seat Back Assembly, All "39" Style Full Width and Buick, Oldsmobile and Cadillac 60-40 Seat with Notch Down Center Arm Rest . . . . .	15-27	Glass Run Channel, Upper Dual Acting Tail Gate Window . . . . .	9-24
Front Seat Back Assembly, Four-door - Full Width . . . . .	15-26	Grease and Oil - Stain Removal . . . . .	10-4
Front Seat Back Assembly, Seat Back Locks - "A, B, X & Z" Body Two-Door Styles with Standard Full Width . . . . .	15-28	Guide Tube, Guide Tube Support and Guide Roller, Seat Back Head Restraint - Standard Full Width Seats 60-40 Seats and "F" Type Seats . . . . .	15-31
Front Seat Back Assembly, Seat Back Locks - "C & E" Body Two-Door Styles with Standard Full Width and 60-40 Seat . . . . .	15-28	Guides and Cams Lubrication, Door Window Regulator - Styles without Upper Frames . . . . .	2-4
Front Seat Back Assembly, Two-door Style with Standard or Notch Down Seat . . . . .	15-27	Guides and Cams Lubrication, Rear Quarter Window Regulator . . . . .	2-5
Front Seat Dealer Relocation Provisions . . . . .	15-3	Gutter Weatherstrip, Front Compartment Lid - Corvair . . . . .	5-14
Front and Shelf Panel Trim Assembly, Compartment - "Z" Styles with Stationary or Folding Rear Seat Back . . . . .	14-21		
Front Trim Panel, Rear Quarter - Right or Left Side ("A" Body Station Wagons) . . . . .	14-14	<b>H</b>	
Front Vertical Gearnut, Six-Way Seat Adjuster - "B-C & E" Body Full Width . . . . .	15-20	Handle, Door Inside . . . . .	14-3
Fruit, Fruit Stains, Liquor and Wine - Stain Removal . . . . .	10-4	Handle, Door Pull . . . . .	14-1
		Handle, Outside - Dual Acting Tail Gate Window Regulator (Manual) . . . . .	9-13
<b>G</b>		Handle, Outside - Front and Rear Doors . . . . .	6-10
Gas Tank Filler Door Hinge Lubrication . . . . .	2-7	Handle, Rear Quarter Window Regulator . . . . .	14-7
Gearnut Assembly (Horizontal), Two-Way Seat Adjuster - "C" Body Full Width . . . . .	15-14	Head Restraint Guide Tube, Guide Tube Support and Guide Roller, Seat Back - Standard Full Width Seats 60-40 Seats and "F" Type Seats . . . . .	15-31
		Head Restraint Retainer and Lock, Seat Back - Standard Full Width Seats, 60-40 Seats and "F" Type Seats . . . . .	15-30
		Head Restraint, Seat Back - Standard Full Width or 60-40 Seat (Drivers or Passenger Side) . . . . .	15-30

Subject	Page No.	Subject	Page No.
Headlining - "55-56-65-66" Station Wagon Styles . . . . .	11-3	Ink, Ball Point - Stain Removal . . . . .	10-5
Headlining Assembly, Front . . . . .	11-5	Inner and Outer Strip Assemblies, Single Acting Tail Gate Window . . . . .	9-36
Headlining Assembly, Rear . . . . .	11-5	Inner Panel Access Hole Covers - Dual Acting Tail Gate . . . . .	9-4
Headlining - Cloth and Vinyl Coated (Soft) - All Styles Except "55-56-65-66" Station Wagons . . . . .	11-1	Inner Panel Access Hole Cover - Single Acting Tail Gate . . . . .	9-28
Headlining, One Piece Formed . . . . .	11-6	Inner Panel Cam, Front Door - All Styles Except "A and X-69" Styles . . . . .	6-58
Hinge Assembly, Dual Acting Tail Gate . . . . .	9-9	Inner Panel Cam, Rear Door - All Except "A and X-69" Styles . . . . .	6-88
Hinge Assembly Lubrication, Front Door . . . . .	2-2	Inner Panel Cover - Single Acting Tail Gate . . . . .	9-25
Hinge Assembly Lubrication, Rear Door . . . . .	2-2	Inner Panel Sealing . . . . .	7-1
Hinge Assembly, Luggage Compartment Front and Rear Panel - Two Seat Styles, Rear . . . . .	15-60	Inner Panel Water Deflector - Dual Acting Tail Gate . . . . .	9-3
Hinge Assembly - Single Acting Tail Gate . . . . .	9-29	Inner Panel Water Deflectors, Front and Rear Doors . . . . .	6-4
Hinge, Front Door - All Styles . . . . .	6-54	Inner Panel Water Deflector - Single Acting Tail Gate . . . . .	9-28
Hinge Lubrication, Gas Tank Filler Door . . . . .	2-7	Inner Trim Panel, Rear Quarter - Left Side ("B" Body Station Wagon Styles) . . . . .	14-13
Hinge Lubrication, Instrument Panel Compartment Door . . . . .	2-2	Inoperative Folding Top in Down ("Stacked") Position, Folding Top - Actuator Assembly . . . . .	13-37
Hinge Lubrication, Rear Compartment . . . . .	2-8	Inside Handle, Dual Acting Tail Gate Door Operation - Remote Control Right Side . . . . .	9-15
Hinge Lubrication, Tail Gate (All Station Wagons) . . . . .	2-6	Inside Handle, Remote Control Dual Acting Tail Gate Operation (Center) . . . . .	9-14
Hinge Mechanism Lubrication, Folding Top . . . . .	2-7	Inside Handles, Door . . . . .	14-3
Hinge and Striker Assembly, Upper - Dual Acting Tail Gate . . . . .	9-21	Inside Locking Rod, Front Door - Coupe Styles . . . . .	6-54
Hinge and Torque Rod Lubrication, Front Compartment Lid . . . . .	2-1	Instrument Panel Compartment Door - Buick "A & E" Styles . . . . .	5-9
Hinges, Front Door - All Styles . . . . .	6-53	Instrument Panel Compartment Door Hinge Lubrication . . . . .	2-2
Hinges, Rear Door - All Styles . . . . .	6-80	Instrument Panel Compartment Door Lock Cylinder and Lock - Buick "A & E" Styles, All Chevrolet Styles . . . . .	5-9
Horizontal Actuator, Four-Way Seat Adjuster - "A" Body Full Width . . . . .	15-16	Instrument Panel Covers - Chevrolet "A, X & Z" and Pontiac "F" Styles . . . . .	5-10
Horizontal Actuator, Four-Way Seat Adjuster - Buick "B-C & E" Body Full Width . . . . .	15-19	Interior Lamp Chart (Above Belt) . . . . .	16-54
Horizontal Actuator, Six-Way Seat Adjuster - "B-C & E" Body Full Width . . . . .	15-20		
Horizontal or Front Vertical Drive Cables, Six-Way Seat Adjuster - Buick, Oldsmo- bile and Cadillac 60-40 Seats . . . . .	15-23	<b>J</b>	
Horizontal Gearnut Assembly, Two-Way Seat Adjuster - "C" Body Full Width . . . . .	15-14	Jamb Switch (Electric Option), Single Acting Tail Gate . . . . .	9-34
Horizontal Jackscrew, Two-Way Seat Adjuster - "C" Body Full Width . . . . .	15-15	Jamb Switch Lubrication, Door . . . . .	2-3
Horizontal Seat Circuit, Trouble Shooting - Electrical . . . . .	16-32	<b>L</b>	
Horizontal and Vertical Drive Cables, Four-Way Seat Adjuster - "A" Body Full Width . . . . .	15-16	Lamp Chart, Interior (Above Belt) . . . . .	16-54
Horizontal and Vertical Drive Cables, Four-Way Seat Adjuster - Buick "B-C & E" Body Full Width . . . . .	15-19	Lamps - Tail and Side Marker . . . . .	16-42
Hydraulic Checking Procedure, Folding Top Hydro-Lectric System . . . . .	13-31	Latch Striker Engine Compartment - Corvaire Styles . . . . .	8-7
Hydro-Lectric System - All Except "Z" Body . . . . .	13-26	Leather and Coated Fabrics, Cleaning . . . . .	10-3
<b>I</b>		Left Lock Assembly - Dual Acting Tail Gate . . . . .	9-18
Ice Cream - Stain Removal . . . . .	10-4		



Subject	Page No.	Subject	Page No.
Lid, Front Compartment - Corvair . . . . .	5-11	Lock Assembly, Front Roof Rail Folding Top Adjustment - "A, B & C" Styles . . .	13-39
Lid Gutter Weatherstrip, Front Compartment - Corvair . . . . .	5-14	Lock Assembly, Front Roof Rail Folding Top Adjustments - "F" Body . . . . .	13-43
Lid Hinge and Torque Rod Lubrication, Front Compartment . . . . .	2-1	Lock Assembly Front Roof Rail, Folding Top - "Z" Body . . . . .	13-49
Lid Latch Engine Compartment - Corvair Styles . . . . .	8-4	Lock Assembly, Rear Door - All Styles . . .	6-86
Lid Lock Assembly, Front Compartment - Corvair . . . . .	5-13	Lock Assembly, Single Acting Tail Gate - Right or Left Side . . . . .	9-35
Lid Lock Cylinder Assembly, Front Compartment - Corvair . . . . .	5-13	Lock Cylinder Assembly, Front Compartment Lid - Corvair . . . . .	5-13
Lid Lock Cylinder Assy Rear Compartment - All Styles . . . . .	8-7	Lock Cylinder Assembly, Front Door - All Styles . . . . .	6-56
Lid Lock Lubrication, Front Compartment	2-1	Lock Cylinder and Lock, Instrument Panel Compartment Door - Buick "A & E" Styles, Chevrolet (All Styles) . . . . .	5-9
Lid Lock Lubrication, Rear Compartment . .	2-8	Lock Cylinder, Luggage Compartment - 15-16000 Two Seat Styles Rear . . . . .	15-64
Lid Lock Striker, Front Compartment - Corvair . . . . .	5-13	Lock Electric Release Unit, Rear Compartment Lid - Styles Equipped with Option . . . . .	8-14
Lid Support Engine Compartment - Corvair Styles . . . . .	8-4	Lock, Folding Second Seat Back - "55, 56, 65, 66" Styles . . . . .	15-70
Lid Support Lubrication, Engine Compartment . . . . .	2-8	Lock, Folding Second Seat Back (Full Width or Split Seat) - All "A & B" Styles (Except "A-55, 56, 65, 66" Styles) Rear . . . . .	15-64
Lid Torque Rods, Front Compartment - Corvair . . . . .	5-12	Lock, Folding Second Seat Back (Full Width or Split Seat) - All "A & B" Styles (Except "A-55, 56" Styles with Split Seat Option and "65, 66" Styles . . .	15-65
Lift Assembly, Folding Top Actuator Assembly . . . . .	13-37	Lock, Folding Third Seat Back - All "A & B" Body Three Seat Styles . . . . .	15-61
Lift Assembly, (Manual) Folding Top - "A, F & Z" Styles . . . . .	13-37	Lock, Folding Third Seat Back - "65-66" Styles . . . . .	15-72
Lift Cylinder, Folding Top Hydro- Lectric System . . . . .	13-33	Lock Fork Bolt Lubrication, Door . . . . .	2-3
Linkage Assembly, Folding Second Seat Back (Full Width Seat Right or Left Side Split Seat - Outer Linkage Only) Rear . . . . .	15-63	Lock Fork Bolt Lubrication, Tail Gate (Right and Left) - Station Wagon Styles with Dual Acting Tail Gate . . . . .	2-5
Linkage Assembly, Folding Second Split Seat Back Inner - Rear Seats . . . . .	15-64	Lock and Lock Cylinder, Instrument Panel Compartment Door - Buick "A & E" Styles, All Chevrolet Styles . . . . .	5-9
Linkage, Folding Second Seat Side Inner - "55, 56, 65, 66" Styles . . . . .	15-69	Lock Lubrication, Front Compartment Lid . . . . .	2-1
Linkage, Folding Second Seat Side Outer - "55, 56, 65, 66" Styles . . . . .	15-69	Lock Lubrication, Rear Compartment Lid . . . . .	2-8
Linkage Lubrication, Folding Seat . . . . .	2-7	Lock Parts and Locking Mechanism Lubrication, Door . . . . .	2-3
Lipstick - Stain Removal . . . . .	10-5	Lock Remote Control Assembly, Dual Acting Tail Gate Operation (Center) . . .	9-15
Liquor, Wine, Fruit and Fruit Stains - Stain Removal . . . . .	10-4	Lock Remote Control Assembly, Front and Rear Door Vacuum . . . . .	6-19
Lock Actuator, Front and Rear Door Vacuum or Electric Solenoid . . . . .	6-17	Lock Remote Control Assembly, Single Acting Tail Gate . . . . .	9-35
Lock Adjustment, Front Roof Rail Folding Top - "A, B & C" Styles . . . . .	13-39	Lock Remote Control and Connecting Rod, Front Door - All Styles . . . . .	6-55
Lock Adjustment, Front Roof Rail Folding Top - "F" Body . . . . .	13-43	Lock Remote Control, Rear Door - All Styles . . . . .	6-86
Lock Adjustment, Front Roof Rail Folding Top - "Z" Body . . . . .	13-49	Lock, Seat Back - "F & Z" Body Standard Bucket Seat . . . . .	15-41
Lock Assembly, Dual Acting Tail Gate - Left . . . . .	9-18		
Lock Assembly - Dual Acting Tail Gate, Lower Right Side . . . . .	9-21		
Lock Assembly, Dual Acting Tail Gate - Upper Right Side . . . . .	9-15		
Lock Assembly, Front Compartment Lid - Corvair . . . . .	5-13		
Lock Assembly, Front Door - All Styles . .	6-56		

Subject	Page No.	Subject	Page No.
Lock Selector Valves, Front and Rear Door Vacuum . . . . .	6-17		
Lock Storage Tank, Front and Rear Door Vacuum . . . . .	6-19		
Lock Striker Adjustments, Single Acting Tail Gate . . . . .	9-35		
Lock Striker Assembly, Single Acting Tail Gate - Right or Left . . . . .	9-35		
Lock Striker Engagement, Rear Compartment Lid - All Styles Except Corvair and Cadillac Styles with Mechanical Closing Unit Option . . . . .	8-15		
Lock Striker, Front Compartment Lid - Corvair . . . . .	5-13		
Lock Striker Lubrication, Tail Gate . . . . .	2-5		
Lock Striker, Rear Compartment . . . . .	8-15		
Lock Strikers, Front and Rear Doors - All Styles . . . . .	6-10		
Lock Synchronization Check - Tail Gate . . . . .	9-28		
Lock Trim Assembly or Seat Back Panel Assembly, Folding Third Seat - "65-66" Styles . . . . .	15-71		
Lock Trouble Diagnosis Procedure, Front and Rear Door Vacuum . . . . .	6-20		
Locking Mechanism and Lock Parts Lubrication, Door . . . . .	2-3		
Locking Rod, Front Door Inside - Coupe Styles . . . . .	6-54		
Lower Glass Run Channels, Single Acting Tail Gate . . . . .	9-34		
Lower Lock Assembly, Dual Acting Tail Gate - Right Side . . . . .	9-21		
Lower Run Channels, Dual Acting Tail Gate Window . . . . .	9-14		
Lower Striker and Support Assembly, Dual Acting Tail Gate - Right Side . . . . .	9-21		
Lower Support Assembly, Auxiliary Rear Seat - Cadillac Limousine Styles . . . . .	15-56		
Lower Trim, Rear Quarter - "A-80" Style and All Four-Door Styles Except Station Wagons . . . . .	14-12		
Lower and Upper Trim, Center Pillar ("A & X" Four-Door Closed Styles) . . . . .	14-19		
Lower and Upper Trim, Center Pillar - "B & C" Four-Door Closed Styles . . . . .	14-19		
Luggage Compartment Cover Panel and Filler Panel - "55, 56, 65, 66" Styles . . . . .	15-72		
Luggage Compartment Front and Rear Panel Assembly - Two Seat Styles, Rear Seats . . . . .	15-58		
Luggage Compartment Front and Rear Panel Hinge Assembly - Two Seat Styles, Rear . . . . .	15-60		
Luggage Compartment Lock Cylinder - 15-16000 Two Seat Styles Rear . . . . .	15-64		
Luggage Compartment Rear Panel Assembly - Two Seat Styles, Rear Seats . . . . .	15-60		
		<b>M</b>	
		Male Hinge, Folding Top Adjustment - "Z" Body . . . . .	13-50
		Manual Lift Assembly, Folding Top - "A, F, & Z" Styles . . . . .	13-37
		Manually Operated Bucket Seat Adjuster . . . . .	15-37
		Manually Operated Bucket Seat Assembly . . . . .	15-36
		Manually Operated Seat Adjuster Control Arm Knob . . . . .	15-6
		Mechanical Checking Procedure, Folding Top Hydro-Lectric System . . . . .	13-29
		Mechanical Pull-Down Unit Adjustments, Rear Compartment Lid - All Cadillac Styles . . . . .	8-12
		Mechanical Pull-Down Unit Cable, Rear Compartment - All Cadillac Styles . . . . .	8-11
		Mechanical Pull-Down Unit Hydraulic Cylinder, Rear Compartment Lid - All Cadillac Styles . . . . .	8-12
		Mechanical Pull-Down Unit, Rear Compartment Lid - All Cadillac Styles . . . . .	8-11
		Mirror, Door Outside Remote Control, Front - All Styles Without Door Ventilators . . . . .	6-58
		Mirror Remote Controls and Escutcheon, Door Outside . . . . .	14-3
		Molding and Appliques, Door Trim Panel . . . . .	14-7
		Molding and Appliques, Rear Quarter Trim Panel . . . . .	14-13
		Molding Sealing Operation, Exterior . . . . .	17-4
		Molding Tools and Care, Exterior . . . . .	17-4
		Molding Zinc Anode Clips, Exterior . . . . .	17-5
		Motor Description, Power Windows - Electrical . . . . .	16-3
		Moldings, Exterior - Chevrolet "A" Body . . . . .	17-12
		"B" Body . . . . .	17-23
		"F" Body . . . . .	17-30
		"X" Body . . . . .	17-34
		"Z" Body . . . . .	17-39
		Pontiac "A" Body . . . . .	17-44
		"B" Body . . . . .	17-53
		"F" Body . . . . .	17-59
		Oldsmobile "A" Body . . . . .	17-69
		"B-C" Body . . . . .	17-80
		"E" Body . . . . .	17-86
		Buick "A" Body . . . . .	17-92
		"B-C" Body . . . . .	17-102
		"E" Body . . . . .	17-108
		Cadillac "C" Body . . . . .	17-113
		"D" Body . . . . .	17-118
		"E" Body . . . . .	17-121
		Acadian "X" Body (Canadian) . . . . .	17-124
		Beaumont "A" Body (Canadian) . . . . .	17-128
		Pontiac "B" Body (Canadian) . . . . .	17-134

Subject	Page No.	Subject	Page No.
Motor and Pump Assembly, Folding Top - Hydro-Lectric System . . . . .	13-27	Passenger's Front Bucket Seat Back Stop Cable - Chevrolet "F & Z" Styles with Bucket Seats . . . . .	15-41
Motor and Transmission Drive Belts and Pulleys Motor Assembly, Strato- Full Width or Bucket and Standard Bucket Seats . . . . .	5-39	Pillar Trim, Center ("A, B & C" Four- Door Hardtop Stylez) . . . . .	14-19
Mustard - Stain Removal . . . . .	10-5	Plastic Slides, and Lower or Upper Channel - Six-Way Seat Adjuster - "B-C & E" Body Full Width . . . . .	15-21
<b>N</b>			
Nausea - Stain Removal . . . . .	10-4	Plastic Slides, Two-Way Seat Adjuster - "C" Body Full Width . . . . .	15-15
Notch Down Seat Back and Strato Seat, Center Arm Rest and Curtain Assembly . . . . .	15-34	Power Operated Four-Way Bucket Seat Adjuster . . . . .	15-37
<b>O</b>			
Oil and Grease - Stain Removal . . . . .	10-4	Power Operated Four-Way Bucket Seat Adjuster Major Components . . . . .	15-38
One Piece Formed Headlining . . . . .	11-6	Power Operated Horizontal Bucket Seat Adjuster . . . . .	15-37
Operation of Folding Top, Hydro- Lectric System . . . . .	13-28	Power Operated Horizontal or Four-Way Bucket Seat Assembly . . . . .	15-36
Operation of Pump Assembly, Folding Top Hydro-Lectric System . . . . .	13-28	Power Operated Station Wagon Tail Gate Window - Electrical . . . . .	16-12
Operation of Seat Warmer - Electrical . .	16-56	Power Seats - Electrical . . . . .	16-31
Outer and Inner Strip Assemblies, Single Acting Tail Gate Window . . . . .	9-36	Power Window Circuit Checking Procedures - Electrical . . . . .	16-5
Outlet Duct, Shroud Side Finishing Panel Air - "Z-67" Styles . . . . .	5-6	Power Windows - Electrical . . . . .	16-2
Outside Handle, Dual Acting Tail Gate Window Regulator (Manual) . . . . .	9-13	Pressure Relief Valve - "A, B, C, E, F & G" Styles . . . . .	5-8
Outside Handles, Front and Rear Doors . .	6-10	Pull Handles, Door . . . . .	14-1
Outside Handle, Single Acting Tail Gate Window Regulator (Manual or Electric)	9-34	Pump Assembly Operation, Folding Top Hydro-Lectric System . . . . .	13-28
Outside Mirror Remote Controls and Escutcheon, Door . . . . .	14-3	<b>Q</b>	
<b>P</b>			
Panel Assembly, Compartment Floor (at Kick-up) Rear - All Styles . . . . .	15-62	Quarter Arm Rest, Rear . . . . .	14-7
Panel Assembly, Folding Third Seat Back - Three Seat Styles Rear . . . . .	15-61	Quarter Front Trim Panel, Rear - Right or Left Side ("A" Body Station Wagons) .	14-14
Panel Assembly, Folding Third Seat and Floor - "65-66" Styles . . . . .	15-70	Quarter Inner Trim Panel, Rear - Left Side ("B" Body Station Wagon Styles) . . . . .	14-13
Panel Assembly, Folding Third Seat Lock Trim Assembly or Seat Back - "65-66" Styles . . . . .	15-71	Quarter Lower Trim, Rear - "A-80" Style and All Four-Door Styles Except Station Wagons . . . . .	14-12
Panel and Filler Panel, Luggage Compartment Cover - "55, 56, 65, 66" Styles . . . . .	15-72	Quarter Rear Trim Panel, Rear - Left Side (All "A" Body Station Wagon Styles) . . . . .	14-16
Panel, Folding Second Seat Back Panel and Filler - "55, 56, 65, 66" Styles . . .	15-70	Quarter Trim Panel Molding and Appliques, Rear . . . . .	14-13
Panel and Linkage Assembly, Folding Second Seat Back Trim (Full Width or Split Seat) Rear - All Styles . . . . .	15-63	Quarter Trim, Rear . . . . .	14-7
Panel Moldings and Appliques, Door Trim . . . . .	14-7	Quarter Trim Assemblies, Rear - Two-Door Styles . . . . .	14-7
Panel Sealing, Inner . . . . .	7-1	Quarter Upper Trim, Rear - Above Belt (All Styles) . . . . .	14-16
Panels, Folding Seats and Floor - "55, 56, 65, 66" Styles . . . . .	15-65	Quarter Wheelhouse Cover Panel, Rear - Right Side ("B" Body Station Wagon Styles) . . . . .	14-13
		Quarter Window Regulator Cams and Guides Lubrication, Rear . . . . .	2-5
		Quarter Window Regulator Handle, Rear .	14-7

Subject	Page No.	Subject	Page No.
<b>R</b>			
Rear Compartment Front Panel - Buick & Olds, "E" Styles . . . . .	8-3	Rear Headlining Assembly . . . . .	11-5
Rear Compartment Hinge Lubrication . . . . .	2-8	Rear Panel Assembly, Luggage Compartment - Two Seat Styles Rear Seats . . . . .	15-60
Rear Compartment Lid - All Styles Except Corvair . . . . .	8-1	Rear Quarter Arm Rest . . . . .	14-7
Rear Compartment Lid Lock Cylinder Assy - All Styles . . . . .	8-7	Rear Quarter Front Trim Panel - Right or Left Side ("A" Body Station Wagons) . . . . .	14-14
Rear Compartment Lid Lock Electric Release Unit - Styles Equipped with Option . . . . .	8-14	Rear Quarter Inner Trim Panel - Left Side ("B" Body Station Wagon Styles) . . . . .	14-13
Rear Compartment Lid Lock Lubrication . . . . .	2-8	Rear Quarter Lower Trim - "A-80" Style and All Four-Door Styles Except Station Wagons . . . . .	14-12
Rear Compartment Lid Lock Striker . . . . .	8-15	Rear Quarter Upper Trim - Above Belt (All Styles) . . . . .	14-16
Rear Compartment Lid Lock Striker Engagement - All Styles Except Corvair and Cadillac Styles with Mechanical Closing Unit Option . . . . .	8-15	Rear Quarter Rear Trim Panel - Left Side (All "A" Body Station Wagon Styles) . . . . .	14-16
Rear Compartment Lid Mechanical Pull- Down Unit Adjustments - All Cadillac Styles . . . . .	8-12	Rear Quarter Trim . . . . .	14-7
Rear Compartment Lid Mechanical Pull-Down Unit - All Cadillac Styles . . . . .	8-11	Rear Quarter Trim Assemblies - Two-Door Styles . . . . .	14-7
Rear Compartment Lid Mechanical Pull- Down Unit Cable - All Cadillac Styles . . . . .	8-11	Rear Quarter Trim Panel Molding and Appliques . . . . .	14-13
Rear Compartment Lid Mechanical Pull- Down Unit Hydraulic Cylinder - All Cadillac Styles . . . . .	8-12	Rear Quarter Wheelhouse Cover Panel - Right Side ("B" Body Station Wagon Styles) . . . . .	14-13
Rear Compartment Torque Rod Adjustment . . . . .	8-3	Rear Quarter Window Regulator Cams and Guides Lubrication . . . . .	2-5
Rear Compartment Lid Vacuum Release System - Styles Equipped with Option . . . . .	8-13	Rear Quarter Window Regulator Handle . . . . .	14-7
Rear Compartment Weatherstrip - All Styles . . . . .	8-16	Rear Seat Back Assembly - All Styles Except Station Wagons and "F & Z" Body with Folding Rear Seat Back . . . . .	15-51
Rear Door Hinges - All Styles . . . . .	6-80	Rear Seat Back Center Arm Rest and Curtain . . . . .	15-52
Rear Door Hinge Assembly Lubrication . . . . .	2-2	Rear Seat Back Center Arm Rest Hanger Plate and Linkage . . . . .	15-52
Rear Door Window Harness, Power Windows - Electrical . . . . .	16-3	Rear Seat Belt Bail Type Retractor . . . . .	15-74
Rear Floor To Tail Gate Filler Panel Assembly Compartment Pan Side Filler Panels - "B" Body Two-Seat and Three-Seat Styles . . . . .	15-57	Rear Seat Cushion - All Styles (Except "A-65" Styles) . . . . .	15-50
Rear Floor Filler Panel Rear Seats - All Styles . . . . .	15-62	Rear Seats . . . . .	15-50
Rear Guide, Front Door Window - "A-37, 67 and 87" Styles and "G-57" Styles . . . . .	6-76	Rear Seats (Folding) and Floor Panels, Station Wagon - All Except "55, 56, 65, 66" Styles . . . . .	15-56
Rear Guide, Front Door Window - "A-39" Styles . . . . .	6-75	Rear Trim Panel, Rear Quarter - Left Side (All "A" Body Station Wagon Styles) . . . . .	14-16
Rear Guide, Front Door Window - "B and C" Hardtop and Convertible Styles . . . . .	6-76	Rear Vertical Drive Cables, Six-Way Seat Adjuster - Buick, Oldsmobile and Cadillac 60-40 Seats . . . . .	15-23
Rear Guide, Front Door Window - "B-36, 46 and 69" Styles . . . . .	6-76	Reclining Front Seat Back . . . . .	15-46
Rear Guide, Front Door Window - "E" Styles . . . . .	6-77	Reclining Seat Back Assembly, Front . . . . .	15-47
Rear Guide, Front Door Window - "F" Styles . . . . .	6-77	Reclining Seat Back Lock Control Assembly - Strato Full Width or Bucket Seats . . . . .	15-49
Rear Guide, Rear Door Window - "A-39" Styles . . . . .	6-97	Reclining Seat Back Lock Control Support - Strato Full Width or Bucket Seat . . . . .	15-49
Rear Guide, Rear Door Window - "B-39" & "C-39, 49 & 69" Styles . . . . .	6-97	Reclining Seat Back Lock Striker and Seat Back Lock - Strato Full Width or Bucket Seat . . . . .	15-47
		Reclining Seat Back Positioning Unit - Front . . . . .	15-47

Subject	Page No.	Subject	Page No.
Regulator Cams and Guides Lubrication, Door Window - Styles without Upper Frames . . . . .	2-4	Reservoir Tube, Folding Top Hydro-Lectric System . . . . .	13-28
Regulator Cams and Guides Lubrication, Rear Quarter Window . . . . .	2-5	Rod Locking, Front Door Inside - Coupe Styles . . . . .	6-54
Regulator and Cams Lubrication, Door Window - On Styles with Door Upper Frames . . . . .	2-3	Roof Cover, Fabric (All Styles Except Station Wagons) . . . . .	12-1
Regulator, Cams and Sector Gear Lubrication, Tail Gate Window (All Station Wagons) . . . . .	2-6	Roof Cover, Fabric (Station Wagon Styles) . . . . .	12-10
Regulator-Electric, Front Door Window - "A-37, 67 and 87", "G-57" and All "B and C" Styles . . . . .	6-75	Roof Cover and Folding Top, Fabric - Cleaning . . . . .	10-3
Regulator Handle, Rear Quarter Window . . . . .	14-7	Roof Rail Weatherstrip and Retainer - Front and Rear Doors, Side . . . . .	6-6
Regulator-Manual and Electric, Front Door Window - "A-39" Styles . . . . .	6-74	Run Channels, Lower - Dual Acting Tail Gate Window . . . . .	9-14
Regulator-Electric, Front Door Window - "A" Closed Styles . . . . .	6-74	Run Channels, Lower - Single Acting Tail Gate Glass . . . . .	9-34
Regulator-Manual, Front Door Window - "A and X" Closed Styles . . . . .	6-74	Run Channel, Window Front - All Closed Styles . . . . .	7-7
Regulator-Manual and Electric, Front Door Window - "E" Styles . . . . .	6-75	Run Channel, Window Rear - All Closed Styles . . . . .	7-3
Regulator-Manual and Electric, Front Door Window - "F" Styles . . . . .	6-75	<b>S</b>	
Regulator-Manual, Front Door Window - "A-37, 67 and 87", "G-57" All "B and C" Styles . . . . .	6-75	Sealing Operation, Exterior Molding . . . . .	17-4
Regulator-Manual, Front Door Window - "Z" Styles . . . . .	6-75	Sealing Strip, Front and Rear Door Glass . . . . .	6-4
Regulator Motor Assembly, Electric - Single Acting Tail Gate Window . . . . .	9-33	Sealing Strip, Window Rear Vertical Inner - "B-37, 47" "C-47, 57" and "G-57" Styles . . . . .	7-2
Regulator Motor Electric, Dual Acting Tail Gate Window . . . . .	9-9	Sealing Strip, Window Rear Vertical Outer - "B-47", "C-47, 57" and Pontiac, Olds. and Buick "B-37" Styles . . . . .	7-3
Regulator Outside Handle, Dual Acting Tail Gate Window (Manual) . . . . .	9-13	Seat Adjuster Assembly, Front (Manual) Full Width . . . . .	15-8
Regulator Outside Handle, Single Acting Tail Gate Window (Manual or Electric) . . . . .	9-34	Seat Adjuster Assembly, Front (Power) Full Width . . . . .	15-12
Relay, Power Windows - Electrical . . . . .	16-3	Seat Adjuster Control Arm Knob, Manually Operated . . . . .	15-6
Relief Valve, Pressure - "A, B, C, E, F, & G" Styles . . . . .	5-8	Seat Adjuster Electric Motor, Four-Way - "A" Body Full Width . . . . .	15-15
Remote Control Assembly, Front and Rear Door Lock Vacuum . . . . .	6-19	Seat Adjuster Electric Motor, Four-Way - Buick "B-C & E" Body Full Width . . . . .	15-17
Remote Controls and Escutcheon, Door Outside Mirror . . . . .	14-3	Seat Adjuster Electric Motor, Six-Way - "B-C & E" Body Full Width . . . . .	15-20
Remote Control Inside Handle, Dual Acting Tail Gate Operation (Center) . . . . .	9-14	Seat Adjuster Electric Motor, Six-Way - Buick, Oldsmobile and Cadillac 60-40 Seats . . . . .	15-22
Remote Control Inside Handle, Dual Acting Tail Gate - Door Operation Right Side . . . . .	9-15	Seat Adjuster Electric Motor, Two-way - "C" Body Full Width . . . . .	15-14
Remote Control Lock Assembly, Dual Acting Tail Gate Operation (Center) . . . . .	9-15	Seat Adjuster Horizontal Actuator, Four-Way - "A" Body Full Width . . . . .	15-16
Remote Control Lock Assembly, Single Acting Tail Gate . . . . .	9-35	Seat Adjuster Horizontal Actuator, Four-Way - Buick "B-C & E" Body Full Width . . . . .	15-19
Remote Control Lock and Connecting Rod, Front Door - All Styles . . . . .	6-55	Seat Adjuster Horizontal Actuator, Six-Way - "B-C & E" Body Full Width . . . . .	15-20
Remote Control Lock, Rear Door - All Styles . . . . .	6-86	Seat Adjuster Horizontal or Front Vertical Drive Cables, Six-Way - Buick, Oldsmobile and Cadillac 60-40 Seats . . . . .	15-23
Remote Control Mirror, Front Door Outside - All Styles Without Door Ventilators . . . . .	6-58	Seat Adjuster Horizontal Gearnut Assembly, Two-Way - "C" Body Full Width . . . . .	15-14

Subject	Page No.	Subject	Page No.
Seat Adjuster Horizontal Jackscrew, Two-Way - "C" Body Full Width . . . . .	15-15	Seat Assembly, Auxiliary (Rear) Cadillac Limousine Styles . . . . .	15-53
Seat Adjuster Horizontal and Vertical Drive Cables, Four-Way - "A" Body Full Width . . . . .	15-16	Seat Assembly, Bucket - Manually Operated . . . . .	15-36
Seat Adjuster Horizontal and Vertical Drive Cables, Four-Way - Buick "B-C & E" Body Full Width . . . . .	15-19	Seat Assembly, Folding Second - "55, 56, 65, 66" Styles . . . . .	15-66
Seat Adjuster Lower or Upper Channel and Plastic Slides, Six-Way - "B-C & E" Body Full Width . . . . .	15-21	Seat Assembly, Front (Manual) Full Width .	15-8
Seat Adjuster Major Components, Four-Way - "A" Body Full Width . . . . .	15-15	Seat Assembly, Front (Power) Full Width .	15-10
Seat Adjuster Major Components, Four-Way - Buick "B-C & E" Body Full Width . . . . .	15-17	Seat Assembly, Power Operated Hori- zontal or Four-Way Bucket . . . . .	15-36
Seat Adjuster Major Components, Power Operated - Four-Way Bucket . . . . .	15-38	Seat Assembly, Strato Full Width - Front . . . . .	15-36
Seat Adjuster Major Components, Six-Way - "B-C & E" Body Full Width . . . . .	15-20	Seat Back Assembly (Front), All "39" Style Full Width and Buick, Oldsmobile and Cadillac 60-40 Seat with Notch Down Center Arm Rest . . . . .	15-27
Seat Adjuster Major Components, Six-Way - Buick, Oldsmobile and Cadillac 60-40 Seats . . . . .	15-22	Seat Back Assembly (Front), Four-Door - Full Width . . . . .	15-26
Seat Adjuster Major Components, Two- Way - "C" Body Full Width . . . . .	15-14	Seat Back Assembly, Front Reclining . . . . .	15-47
Seat Adjuster, Manually Operated - Bucket . . . . .	15-37	Seat Back Assembly (Front), Seat Back Locks - "A, B, X & Z" Body Two-Door Styles with Standard Full Width . . . . .	15-28
Seat Adjuster Mechanism Lubrication, Folding . . . . .	2-7	Seat Back Assembly (Front), Seat Back Locks - "C & E" Body Two-Door Styles with Standard Full Width and 60-40 Seat . . . . .	15-28
Seat Adjuster Plastic Slides, Two-Way - "C" Body Full Width . . . . .	15-15	Seat Back Assembly (Front), Two-Door Styles with Standard or Notch Down Seat . . . . .	15-27
Seat Adjuster, Power Operated - Four-Way Bucket . . . . .	15-37	Seat Back Assembly, Rear - All Styles Except Station Wagons and "F & Z" Body with Folding Rear Seat Back . . . . .	15-51
Seat Adjuster, Power Operated-Horizontal Bucket . . . . .	15-37	Seat Back Assembly - Standard Bucket Seat "F & Z" Styles . . . . .	15-41
Seat Adjuster Rear Vertical Drive Cables, Six-Way - Buick, Oldsmobile and Cadillac 60-40 Seats . . . . .	15-23	Seat Back Assembly, Strato Bucket - All Except "F & Z" Body Styles and Strato Reclining Seat Back . . . . .	15-46
Seat Adjuster Spacer Usage . . . . .	15-5	Seat Back Assembly, Strato - Four-Door Style with Non Folding Seat Back . . . . .	15-44
Seat Adjuster Transmission, Four-Way - "A" Body Full Width . . . . .	15-17	Seat Back Assembly, Strato - Full Width - 16639 Style . . . . .	15-43
Seat Adjuster Transmission, Four-Way - Buick "B-C & E" Body Full Width . . . . .	15-19	Seat Back Assembly, Strato - Full Width with Stationary Seat Backs, All Styles Except 16639 Style . . . . .	15-42
Seat Adjuster Transmission, Six-Way - "B-C & E" Body Full Width . . . . .	15-22	Seat Back Center Arm Rest and Curtain, Rear . . . . .	15-52
Seat Adjuster Transmission, Six-Way - Buick, Oldsmobile and Cadillac 60-40 Seats . . . . .	15-25	Seat Back Center Arm Rest Hanger Plate and Linkage, Rear . . . . .	15-52
Seat Adjuster Vertical Gearnut, Four-Way - "A" Body Full Width . . . . .	15-15	Seat Back Electric Actuator Assembly, Strato - Cadillac Two-Door Styles Equipped with Electrically Operated Strato Seat Back Locks . . . . .	15-45
Seat Adjuster Vertical Gearnut, Four-Way - Buick "B-C & E" Body Full Width . . . . .	15-18	Seat Back, Folding Rear - "F" Body Styles . . . . .	15-51
Seat Adjuster Vertical Gearnut, Six-Way - "B-C & E" Body Full Width . . . . .	15-20	Seat Back, Folding Rear - "Z" Body Styles . . . . .	15-52
Seat Adjuster Vertical Jackscrew, Four- Way - "A" Body Full Width . . . . .	15-16	Seat Back Head Restraint Guide Tube, Guide Tube Support and Guide Roller - Standard Full Width Seats, 60-40 Seats and "F" Type Seats . . . . .	15-31
Seat Adjustments, Auxiliary (Rear) - Cadillac Limousine Styles . . . . .	15-54		

Subject	Page No.	Subject	Page No.
Seat Back Head Restraint Retainer and Guide Tube, Strato . . . . .	15-44	Seat Back Panel and Filler Panel, Folding Second - "55, 56, 65, 66" Styles . . . . .	16-70
Seat Back Head Restraint Retainer and Lock - Standard Full Width Seats, 60-40 Seats and "F" Type Seats . . . . .	15-30	Seat Back Panel (Front), Strato - Two-Door Style Equipped with Reclining Front Passenger Seat Back . . . . .	15-44
Seat Back Head Restraint - Standard Full Width or 60-40 Seat (Drivers or Passenger Side) . . . . .	15-30	Seat Back Panel, Strato - Two-Door Styles with Passengers Reclining Seat Back . . . . .	15-44
Seat Back Inner Linkage Assembly, Folding Second Split Rear Seats . . . . .	15-64	Seat Back Positioning Unit, Front Reclining . . . . .	15-47
Seat Back Linkage Assembly, Folding Second (Full Width Seat Right or Left Side Split Seat - Outer Linkage Only) Rear . . . . .	15-63	Seat Back, Reclining Front . . . . .	15-46
Seat Back Linkage, Folding Rear - "Z" Body Styles . . . . .	15-52	Seat Back Trim Assembly, Folding Third - Three Seat Styles Rear . . . . .	15-61
Seat Back Lock Assembly, Strato - Two-Door Full Width and Bucket Seats (Except Styles with Reclining Seat Back) . . . . .	15-45	Seat Back Trim, Panel and Linkage Assembly, Folding Second (Full Width or Split Seat) Rear - All Styles . . . . .	15-63
Seat Back Lock - "F & Z" Body Standard Bucket Seat . . . . .	15-41	Seat Back Trim and Spring Assembly, Folding Second (Full Width or Split Seat) Rear - All Styles . . . . .	15-62
Seat Back Lock Control Assembly, Reclining - Strato Full Width or Bucket Seats . . . . .	15-49	Seat Back Trim and Spring Assembly, Folding Second - "55, 56, 65, 66" Styles . . . . .	15-63
Seat Back Lock Control Support, Reclining - Strato Full Width or Bucket Seat . . . . .	15-49	Seat Belt, Bail Type Retractor - Rear . . . . .	15-74
Seat Back Lock and Electric Actuator Assembly - Cadillac Two-Door Styles with Standard Full Width Seat . . . . .	15-29	Seat Belt Retractor, Deluxe Front - Floor Mount . . . . .	15-73
Seat Back Lock, Folding Rear - "F" Body Styles . . . . .	15-52	Seat Belt Retractor, Standard Front - Floor Mount (includes "X" Body Non-Swivel Retractor) . . . . .	15-73
Seat Back Lock, Folding Rear - "Z" Body Styles . . . . .	15-52	Seat Belt Retractor, Standard Front - (Swivel Type) - "X" Body Coupes . . . . .	15-73
Seat Back Lock, Folding Second - "55, 56, 65, 66" Styles . . . . .	15-70	Seat Belt, Self Locking Front . . . . .	15-73
Seat Back Lock, Folding Third - All "A & B" Body Three Seat Styles . . . . .	15-61	Seat Belts and Shoulder Straps . . . . .	15-75
Seat Back Lock, Folding Third - "65-66" Styles . . . . .	15-72	Seat Belts and Shoulder Straps - General Information . . . . .	15-72
Seat Back Lock, Front Seat Back Assembly - "A, B, X & Z" Body Two-Door Styles with Standard Full Width . . . . .	15-28	Seat Cushion Assembly, Folding Second - "55, 56, 65, 66" Styles . . . . .	15-66
Seat Back Lock, Front Seat Back Assembly - "C & E" Body Two-Door Styles with Standard Full Width and 60-40 Seat . . . . .	15-28	Seat Cushion, Folding Third - Three Seat Style Folding Third Seat Cushion Panel Assembly and Support - Three Seat Style . . . . .	15-60
Seat Back Lock Release, Electric . . . . .	16-58	Seat Cushion, Rear - All Styles (Except "A-65" Styles) . . . . .	15-50
Seat Back Lock Release, Electric Circuit Checking Procedures . . . . .	16-58	Seat Cushion Trim Assembly, Folding Third - "65-66" Styles . . . . .	15-71
Seat Back Lock Striker and Seat Back Lock, Reclining - Strato Full Width or Bucket Seat . . . . .	15-47	Seat, Electric Horizontal . . . . .	16-32
Seat Back - Notch Down and Strato Seat, Center Arm Rest and Curtain Assembly . . . . .	15-34	Seat, Electric Four-Way Tilt . . . . .	16-33
Seat Back Panel Assembly - Cadillac Two or Four Door Styles with Standard Seats . . . . .	15-29	Seat, Electric Six-Way Tilt . . . . .	16-37
Seat Back Panel Assembly, Folding Third - Three Seat Styles Rear . . . . .	15-61	Seat and Floor Panel Assembly, Folding Third - "65-66" Styles . . . . .	15-70
		Seat Front Floor Pan Linkage, Folding Second - "55, 56, 65, 66" Styles . . . . .	15-69
		Seat Linkage Lubrication, Folding . . . . .	2-7
		Seat Lock Trim Assembly or Seat Back Panel Assembly, Folding Third - "65-66" Styles . . . . .	15-71
		Seat, Rear . . . . .	15-50
		Seat Rear Floor Pan Linkage, Folding Second - "55, 56, 65, 66" Styles . . . . .	15-69
		Seat Side Inner Linkage, Folding Second - "55, 56, 65, 66" Styles . . . . .	15-69

Subject	Page No.	Subject	Page No.
Seat Side Outer Linkage, Folding Second - "55, 56, 65, 66" Styles . . . . .	15-69	Side Marker and Tail Lamps . . . . .	16-42
Seat - Strato-Full Width or Bucket and Standard Bucket . . . . .	15-35	Side Roof Rail Weatherstrip and Retainer, Front and Rear Door . . . . .	6-6
Seat Torque Specifications . . . . .	15-6	Silencer Assembly, Folding Top - Cadillac Styles . . . . .	13-7
Seat Trim Buttons - Rear . . . . .	15-56	Single Acting Tail Gate . . . . .	9-25
Seat Warmer Components - Electrical . . . . .	16-56	Six-Way Seat Adjuster Electric Motor - "B-C & E" Full Width . . . . .	15-20
Seat Warmers - Electrical . . . . .	16-54	Six-Way Seat Adjuster Electric Motor - Buick, Oldsmobile and Cadillac 60-40 Seats . . . . .	15-22
Seats, Power - Electrical . . . . .	16-31	Six-Way Seat Adjuster Horizontal Actuator - "B-C & E" Body Full Width . . . . .	15-20
Second Seat Cushion - (Full Width or Split Seat) Rear Seats - All Styles . . . . .	15-62	Six-Way Seat Adjuster Horizontal or Front Vertical Drive Cables - Buick, Oldsmobile and Cadillac 60-40 Seats . . . . .	15-23
Sector Gear, Window Regulator and Cam Lubrication, Tail Gate (All Station Wagon) . . . . .	2-6	Six-Way Seat Adjuster Lower or Upper Channel and Plastic Slides - "B-C & E" Body Full Width . . . . .	15-21
Self Locking Front Seat Belt . . . . .	15-73	Six-Way Seat Adjuster Major Components - "B-C & E" Body Full Width . . . . .	15-20
Service Operations - Tail Lamp . . . . .	16-45	Six-Way Seat Adjuster Major Components - Buick, Oldsmobile and Cadillac 60-40 Seats . . . . .	15-22
Servicing Procedures Chart - Tail Gate . . . . .	9-24	Six-Way Seat Adjuster Rear Vertical Drive Cables - Buick, Oldsmobile and Cadillac 60-40 Seats . . . . .	15-23
Shelf Center Finishing Panel, Compartment - Oldsmobile and Buick "E" Styles . . . . .	14-20	Six-Way Seat Adjuster Transmission - "B-C & E" Body Full Width . . . . .	15-22
Shelf Side and Center Trim Panels, Compartment - Cadillac "E" Styles . . . . .	14-20	Six-Way Seat Adjuster Transmission - Buick, Oldsmobile and Cadillac 60-40 Seats . . . . .	15-25
Shelf Side Finishing Panel, Compartment - Oldsmobile and Buick "E" Styles . . . . .	14-20	Six-Way Tilt Seat - Electrical . . . . .	16-37
Shelf Trim Assembly, Compartment - "F-37" Styles with Folding Rear Seat . . . . .	14-23	Six-Way Tilt Seat, Electrical Checking Procedure . . . . .	16-38
Shelf Trim Assembly, Compartment - All Styles Except "E & F" Styles and "F-37" Styles with Folding Rear Seat . . . . .	14-20	Spare Tire Cover Panel (Station Wagon Styles) . . . . .	14-14
Shelf Trim, Compartment . . . . .	14-20	Specified Body Opening Clearance Tolerances, Front and Rear Doors . . . . .	6-10
Shoe Polish and Dressings - Stain Removal . . . . .	10-5	Spring Clips, Front and Rear Doors . . . . .	6-10
Shoulder Straps and Seat Belts . . . . .	15-75	Standard Front Seat Belt Retractor - Floor Mount (Includes "X" Body Non- Swivel Retractor) . . . . .	15-73
Shroud Center Duct Upper Air Outlet and Door - "B and C" Styles . . . . .	5-4	Standard Front Seat Belt Retractor (Swivel Type) - "X" Body Coupes . . . . .	15-73
"A and G" Styles . . . . .	5-4	Station Wagon Folding Rear Seats and Floor Panels - All Except "55-56-65-66" Styles . . . . .	15-56
"F" Styles . . . . .	5-4	Strato Bucket Seat Back Assembly - All Except "F & Z" Body Styles and Strato Reclining Seat Back . . . . .	15-46
Shroud Side Air Duct Outlet and Door (Buick and Cadillac "E" Styles . . . . .	5-7	Strato Front Seat Back Panel - Two-Door Style Equipped with Reclining Front Passenger Seat Back . . . . .	15-44
Shroud Side Air Duct Outlet and Door - Oldsmobile "E" Style . . . . .	5-7	Strato-Full Width or Bucket and Standard Bucket Seats . . . . .	15-35
Shroud Side Finishing Panel - "A, G, B, C, X and Z-37" Styles . . . . .	5-4	Strato-Full Width or Bucket and Standard Bucket Seats - Adjuster Horizontal Actuator Assembly . . . . .	15-40
Shroud Side Finishing Panel - "F" Styles . . . . .	5-6		
Shroud Side Finishing Panel and Air Duct Outlet - "Z-67" Styles . . . . .	5-6		
Side Air Duct Outlet and Door, Shroud - Buick and Cadillac "E" Styles . . . . .	5-7		
Side Air Duct Outlet and Door, Shroud - Oldsmobile "E" . . . . .	5-7		
Side and Center Trim Panels, Compartment Shelf - Cadillac "E" Styles . . . . .	14-20		
Side Finishing Panel and Air Duct Outlet, Shroud - "Z-67" Styles . . . . .	5-6		
Side Finishing Panel, Shroud - "A, G, B, C, X and Z-37" Styles . . . . .	5-4		
Side Finishing Panel, Shroud - "F" Styles . . . . .	5-6		
Side Finishing Panels, Compartment Shelf - Oldsmobile and Buick "E" Styles . . . . .	14-20		



Subject	Page No.	Subject	Page No.
Strato-Full Width or Bucket and Standard Bucket Seats - Adjuster Jackscrew . . . . .	15-40	Tail Gate Assembly - Dual Acting . . . . .	9-6
Strato-Full Width or Bucket and Standard Bucket Seats - Adjuster Vertical Gearnut . . . . .	15-40	Tail Gate (Dual Acting) Door Operation, Remote Control Inside Handle (Right Side) . . . . .	9-15
Strato-Full Width or Bucket and Standard Bucket Seats - Disassembly and Assembly of Transmission . . . . .	15-39	Tail Gate (Dual Acting) Drain Hole Sealing Strips . . . . .	9-21
Strato-Full Width or Bucket and Standard Bucket Seat - Motor and Transmission Drive Belts and Pulleys Motor Assembly . . . . .	5-39	Tail Gate (Dual Acting) Hinge Assembly . . . . .	9-9
Strato-Full Width or Bucket and Standard Bucket Seats - Torque Tube Assembly . . . . .	15-40	Tail Gate (Dual Acting) Inner Panel, Access Hole Cover . . . . .	9-4
Strato Full Width Front Seat Assembly . . . . .	15-36	Tail Gate (Dual Acting) Left Lock Assembly . . . . .	9-18
Strato Seat Back Assembly - Full Width 16639 Style . . . . .	15-43	Tail Gate (Dual Acting) Lower Lock Assembly - Right Side . . . . .	9-21
Strato Seat Back Assembly - Full Width Seat with Stationary Seat Backs, All Styles Except 16639 Style . . . . .	15-42	Tail Gate (Dual Acting) Lower Striker and Support Assembly - Right Side . . . . .	9-21
Strato Seat Back Electric Actuator Assembly - Cadillac Two-Door Styles Equipped with Electrically operated Strato Seat Back Locks . . . . .	15-45	Tail Gate (Dual Acting) Operation (Center) - Remote Control Inside Handle . . . . .	9-14
Strato Seat Back Head Restraint Retainer and Guide Tube . . . . .	15-44	Tail Gate (Dual Acting) Remote Control Lock Assembly (Center) . . . . .	9-15
Strato Seat Back Lock Assembly - Two-Door Full Width and Bucket Seats (Except Styles with Reclining Seat Back) . . . . .	15-45	Tail Gate (Dual Acting) Safety Switch . . . . .	9-11
Strato Seat Back Panel - Four-Door Style with Non Folding Seat Back . . . . .	15-44	Tail Gate (Dual Acting) Torque Rods . . . . .	9-6
Strato Seat Back Panel - Two-Door Styles with Passengers Reclining Seat Back . . . . .	15-44	Tail Gate (Dual Acting) Upper Hinge and Striker Assembly . . . . .	9-21
Striker, Front Compartment Lid Lock - Corvair . . . . .	5-13	Tail Gate (Dual Acting) Upper Lock Assembly - Right Side . . . . .	9-15
Striker Lubrication, Tail Gate Lock . . . . .	2-5	Tail Gate (Dual Acting) Weatherstrips . . . . .	9-21
Striker Adjustments, Single Acting Tail Gate Lock . . . . .	9-35	Tail Gate (Dual Acting) Window Assembly - Manual or Electric . . . . .	9-5
Striker Assembly, Single Acting Tail Gate Lock - Right or Left . . . . .	9-35	Tail Gate (Dual Acting) Window Regulator - Manual or Electric . . . . .	9-9
Striker and Support Assembly, Lower Right Side - Dual Acting Tail Gate . . . . .	9-21	Tail Gate Fabric Cover . . . . .	12-13
Strikers, Front and Rear Door Lock - All Styles . . . . .	6-10	Tail Gate Hinge Lubrication (All Station Wagons) . . . . .	2-6
Strip Assemblies, Window Inner and Outer - All Styles . . . . .	7-7	Tail Gate Lock Fork Bolt Lubrication (Right and Left) - Station Wagon Styles with Dual Acting Tail Gate . . . . .	2-5
Support Assemblies - Single Acting Tail Gate . . . . .	9-30	Tail Gate Lock Striker Lubrication . . . . .	2-5
Support Lubrication, Engine Compartment Lid . . . . .	2-8	Tail Gate Torque Rod Lubrication (All Station Wagons) . . . . .	2-6
Switch, Jamb (Electric Option) - Single Acting Tail Gate . . . . .	9-34	Tail Gate Upper Glass Run Channels - Single Acting . . . . .	9-37
Switch Lubrication, Door Jamb . . . . .	2-3	Tail Gate Weatherstrip - Single Acting . . . . .	9-37
		Tail Gate Window Circuit - Electrical . . . . .	16-12
<b>T</b>		Tail Gate Window (Dual Acting) Upper Glass Run Channel . . . . .	9-24
Tail Gate, Dual Acting . . . . .	9-1	Tail Gate Window, Power Operated - Electrical . . . . .	16-12
Tail Gate Adjustments - Dual Acting . . . . .	9-9	Tail Gate Window Regulator, Cams and Sector Gear Lubrication (All Station Wagons) . . . . .	2-6
		Tail Gate - Single Acting . . . . .	9-25
		Tail Gate Assembly - Single Acting . . . . .	9-30
		Tail Gate Drain Hole Sealing Strips - Single Acting . . . . .	9-37
		Tail Gate Hinge Assembly - Single Acting . . . . .	9-29
		Tail Gate Inner Panel Access Hole Cover - Single Acting . . . . .	9-28
		Tail Gate Inner Panel Cover - Single Acting . . . . .	9-25

Subject	Page No.	Subject	Page No.
Tail Gate Inner Panel Water Deflector - Single Acting . . . . .	9-28	Torque Rod Lubrication, Tail Gate (All Station Wagons) . . . . .	2-6
Tail Gate (Single Acting) Jamb Switch - Electric Option . . . . .	9-34	Torque Rod - Single Acting Tail Gate . . .	9-36
Tail Gate Lock Assembly, Single Acting - Right or Left Side . . . . .	9-35	Torque Rods, Front Compartment Lids - Corvaire . . . . .	5-12
Tail Gate Lock Remote Control Assembly - Single Acting . . . . .	9-35	Torque Specifications, Seat . . . . .	15-6
Tail Gate Lock Striker Adjustments - Single Acting . . . . .	9-35	Torque Tube Assembly - Strato-Full Width or Bucket and Standard Bucket Seats . . . . .	15-40
Tail Gate Lock Striker Assembly, Single Acting - Right or Left . . . . .	9-35	Transmission Assembly and Horizontal and Vertical Drive Cables - Strato Full Width or Bucket and Standard Bucket Seats . . . . .	15-39
Tail Gate Lower Glass Run Channel - Single Acting . . . . .	9-34	Transmission, Disassembly and Assembly - Strato-Full Width or Bucket and Standard Bucket Seats . . . . .	15-39
Tail Gate Support Assemblies - Single Acting . . . . .	9-30	Transmission, Four-Way Seat Adjuster - "A" Body Full Width . . . . .	15-17
Tail Gate Torque Rod - Single Acting . . .	9-36	Transmission, Four-Way Seat Adjuster - Buick "B-C & E" Body Full Width . . .	15-19
Tail Gate Window Assembly - Single Acting (Manual or Electric) . . . . .	9-32	Transmission, Six-Way Seat Adjuster - "B-C & E" Body Full Width . . . . .	15-22
Tail Gate Window Electric Regulator Motor Assembly - Single Acting . . . . .	9-33	Transmission, Six-Way Seat Adjuster - Buick, Oldsmobile and Cadillac 60-40 Seats . . . . .	15-25
Tail Gate Window Inner and Outer Strip Assemblies - Single Acting . . . . .	9-36	Trim Assembly, Compartment Shelf - "F-37" Styles with Folding Rear Seat . .	14-23
Tail Gate Window Regulator - Single Acting (Manual or Electric) . . . . .	9-32	Trim Assembly, Folding Third Seat Back - Three Seat Styles Rear . . . . .	15-61
Tail Gate Window Regulator Outside Handle - Single Acting (Manual or Electric) . . . . .	9-34	Trim Assemblies, Door . . . . .	14-4
Tail Lamp Bulb Usage Chart . . . . .	16-43	Trim Assemblies, Folding Top - Complete	13-1
Tail Lamp Service Operations		Trim Assemblies, Rear Quarter - Two-Door Styles . . . . .	14-7
Chevrolet, Acadian Beaumont . . . . .	16-45	Trim Buttons, Rear Seat . . . . .	15-56
Pontiac . . . . .	16-47	Trim Cover Panel, Wheelhouse - Right Side (All "A" Body Station Wagon Styles) . . . . .	14-15
Oldsmobile . . . . .	16-49	Trim, Door . . . . .	14-1
Buick . . . . .	16-51	Trim Panel Molding and Appliques, Rear Quarter . . . . .	14-13
Cadillac . . . . .	16-53	Trim Panel Moldings and Appliques, Door . . . . .	14-7
Tail Lamps and Side Marker Lamps . . . .	16-42	Trim Panel, Rear Quarter Front - Right or Left Side ("A" Body Station Wagons) .	14-14
Tar - Stain Removal . . . . .	10-5	Trim Panel, Rear Quarter Inner - Left Side ("B" Body Station Wagon Styles) . .	14-13
Tire Cover Panel, Spare (Station Wagon Styles) . . . . .	14-14	Trim Panel, Rear Quarter Rear - Left Side (All "A" Body Station Wagon Styles) . . . . .	14-16
Tools and Care, Exterior Molding . . . . .	17-4	Trim Panels, Compartment Shelf Side and Center - Cadillac "E" Styles . . . .	14-20
Top Control Link, Folding Top Adjustments - "A, B & C" Styles . . . . .	13-39	Trim, Rear Quarter . . . . .	14-7
Top Control Link, Folding top Adjustment - "F" Body . . . . .	13-44	Trim and Spring Assembly, Folding Second Seat Back (Full Width or Split Seat) Rear - All Styles . . . . .	15-62
Top Control Link, Folding Top Adjustment - "Z" Body . . . . .	13-49	Trim and Spring Assembly, Folding Second Seat Back - "55, 56, 65, 66" Styles . . . . .	15-68
Top Cover, Folding and Back Curtain Installation - Complete . . . . .	13-9	Two-Way Seat Adjuster Plastic Slides - "C" Body Full Width . . . . .	15-15
Top Cover, Folding - Less Back Curtain . .	13-13		
Top and Fabric Roof Cover, Folding - Cleaning . . . . .	10-3		
Top Hinge Mechanism Lubrication, Folding . . . . .	2-7		
Top Lift Assembly, Folding Top Actuator Assembly . . . . .	13-37		
Torque Rod Adjustment - Rear Compartment . . . . .	8-3		
Torque Rod, Dual Acting Tail Gate . . . . .	9-6		
Torque Rod and Lid Hinge Lubrication, Front Compartment . . . . .	2-1		

Subject	Page No.	Subject	Page No.
Trouble Shooting Chart, Folding Top Adjustments - "A, B & C" Styles . . . . .	13-42	Ventilator Assembly, Front Door - "A-39" Styles . . . . .	6-59
Trouble Shooting Chart, Folding Top Adjustments - "F" Body . . . . .	13-50	Ventilator Assembly, Front Door - "A" Closed Styles . . . . .	6-58
Trouble Shooting Chart, Folding Top - "Z" Body . . . . .	13-50	Ventilator Assembly, Front Door - "X" Styles . . . . .	6-61
Trouble Shooting of Horizontal Seat Circuit - Electrical . . . . .	16-32	Ventilator Assembly, Front Door - "Z" Styles . . . . .	6-61
Two-Way Seat Adjuster Electric Motor - "C" Body Full Width . . . . .	15-14	Ventilator Assembly Weatherstrip, Front Door - "Z" Styles . . . . .	6-62
Two-Way Seat Adjuster Horizontal Jackscrew - "C" Body Full Width . . . . .	15-15	Ventilator Disassembly and Assembly, Front Door - "A" Closed Styles . . . . .	6-59
Two-Way Seat Adjuster Major Components - "C" Body Full Width . . . . .	15-14	Ventilator Disassembly and Assembly, Front Door - "A-39" Styles . . . . .	6-60
<b>U</b>			
Underbody Alignment		Ventilator Regulator, Front Door - "A" Styles . . . . .	6-58
Corvaire "Z" Styles . . . . .	3-1	Ventilation System Components - Non-Air Conditioning . . . . .	5-1
Camaro and Firebird "F" Bodies . . . . .	3-5	Vertical (Rear) Drive Cables, Six-Way Seat Adjuster - Buick, Oldsmobile and Cadillac 60-40 Seats . . . . .	15-23
Chevy Nova and Acadian "X" Bodies . . . . .	3-5	Vertical Gearnut, Four-Way Seat Adjuster - "A" Body Full Width . . . . .	15-15
Upper Air Outlet and Door, Shroud		Vertical Gearnut, Four-Way Seat Adjuster - Buick "B-C & E" Body Full Width . . . . .	15-18
Center Duct -		Vertical Gearnut (Front), Six-Way Seat Adjuster "B-C & E" Body Full Width . . . . .	15-20
"B and C" Styles . . . . .	5-4	Vertical and Horizontal Drive Cables, Four-Way Seat Adjuster - "A" Body Full Width . . . . .	15-16
"A and G" Styles . . . . .	5-4	Vertical and Horizontal Drive Cables, Four-Way Seat Adjuster - Buick "B-C & E" Full Width . . . . .	15-19
"F" Styles . . . . .	5-4	Vertical Jackscrew, Four-Way Seat Adjuster - "A" Body Full Width . . . . .	15-16
Upper Glass Run Channel - Single Acting Tail Gate . . . . .	9-37	<b>W</b>	
Upper Hinge and Striker Assembly - Dual Acting Tail Gate . . . . .	9-21	Water Deflectors, Front and Rear Door Inner Panel . . . . .	6-4
Upper Lock Assembly, Dual Acting Tail Gate - Right Side . . . . .	9-15	Water Deflector, Inner Panel - Dual Acting Tail Gate . . . . .	9-3
Upper and Lower Trim, Center Pillar - "B & C" Four-Door Closed Styles . . . . .	14-19	Water Deflector, Single Acting Tail Gate Inner Panel . . . . .	9-28
Upper and Lower Trim, Center Pillar ("A & X" Four-Door Closed Styles) . . . . .	14-19	Weatherstrips - Dual Acting Tail Gate . . . . .	9-21
Upper Trim, Rear Quarter - Above Belt (All Styles) . . . . .	14-16	Weatherstrip, Front Compartment Lid Gutter - Corvaire . . . . .	5-14
Urine - Stain Removal . . . . .	10-5	Weatherstrip, Front Door Ventilator - "Z" Styles . . . . .	6-62
<b>V</b>			
Vacuum Door Lock System, Front and Rear Doors . . . . .	6-16	Weatherstrips, Front and Rear Doors . . . . .	6-1
Vacuum Lock Actuator or Electric Solenoid, Front and Rear Doors . . . . .	6-17	Weatherstrips, Front and Rear Door Center Pillar - "C-69" Styles . . . . .	6-9
Vacuum Lock Remote Control Assembly, Front and Rear Door . . . . .	6-19	Weatherstrip, Rear Compartment - All Styles . . . . .	8-16
Vacuum Lock Selector Valves, Front and Rear Doors . . . . .	6-17	Weatherstrip and Retainer, Front and Rear Door Side Roof Rail . . . . .	6-6
Vacuum Lock Storage Tank, Front and Rear Door . . . . .	6-19	Weatherstrip - Single Acting Tail Gate . . . . .	9-37
Vacuum Lock Trouble Diagnosis Procedure, Front and Rear Door . . . . .	6-20	Wedge Plate, Adjustment of Front Roof Rail - Folding Top - "Z" Body . . . . .	13-48
Vacuum Release System, Rear Compart- ment Lid - Styles Equipped with Option . . . . .	8-13		
Valve, Fluid Control - Folding Top Hydro-Lectric System . . . . .	13-29		
Valve, Pressure Relief - "A, B, C, E, F, & G" Styles . . . . .	5-8		

Subject	Page No.	Subject	Page No.
Wedge Plates, Front Door - "67" Styles . . . . .	6-79	Window Assembly, Rear Door - "X-69" Styles . . . . .	6-96
Wheelhouse Cover Panel, Rear Quarter - Right Side ("B" Body Station Wagon Styles) . . . . .	14-13	Window Assembly, Single Acting Tail Gate (Manual or Electric) . . . . .	9-32
Wheelhouse Trim Cover Panel - Right Side (All "A" Body Station Wagon Styles) . . . . .	14-15	Window Electric Regulator Motor Assembly - Dual Acting Tail Gate . . . . .	9-9
Wine, Liquor, Fruit and Fruit Stains - Stain Removal . . . . .	10-4	Window Electric Regulator Motor Assembly - Single Acting Tail Gate . . . . .	9-33
Window Adjustments, Rear Door "A-39" Styles . . . . .	6-90	Window Front Guide and Bracket Assembly, Rear Door - "A-39" Styles . . . . .	6-97
Window Adjustments, Rear Door - "A" Closed Styles . . . . .	6-90	Window Front Guide Assembly - "Z-37 & 67" and "E-87" Styles . . . . .	7-33
Window Adjustments, Rear Door - "B-39" and "C-39, 49 & 69" Styles . . . . .	6-94	Window Front Guide, Front Door - "A-37, 67 and 87" Styles and "G-57" Styles . . . . .	6-76
Window Adjustments, Rear Door - "B" Closed Styles . . . . .	6-93	Window Front Guide, Front Door - "B and C" Hardtop & Convertible Styles . . . . .	6-76
Window Assembly - "A-27 & 77", "B-11" and "X-27" Styles . . . . .	7-3	Window Front Guide, Front Door - "E" Styles . . . . .	6-77
Window Assembly - "A-37, 87 & 67" and "G-57" Styles . . . . .	7-7	Window Front Guide, Front Door - "F" Styles . . . . .	6-77
Window Assembly - "B & C-37, 47, 57 & 67" Styles . . . . .	7-14	Window Front Guide, Rear Door - "B-39 and C-39, 49 & 69" Styles . . . . .	6-97
Window Assembly - "E-47" Styles . . . . .	7-19	Window Front Run Channel - All Closed Styles . . . . .	7-7
Window Assembly - "E-87" Styles . . . . .	7-17	Window Glass Run Channel, Front Door - "A and X" Closed Styles . . . . .	6-77
Window Assembly - "F-37 and 67" Styles . . . . .	7-21	Window Glass Run Channel, Front Door - "B" Closed Styles . . . . .	6-77
Window Assembly - "Z-37 & 67" Styles . . . . .	7-21	Window Glass Run Channel, Rear Door - All "A & X" Closed Styles . . . . .	6-97
Window Assembly, Dual Acting Tail Gate - Manual or Electric . . . . .	9-5	Window Glass Run Channel, Rear Door - All "B" Closed Styles . . . . .	6-98
Window Assembly, Front Door - "A-37, 67 and 87" Styles and "G-57" Styles . . . . .	6-64	Window Guide Assembly - All "F" Styles . . . . .	7-33
Window Assembly, Front Door - "A-39" Styles . . . . .	6-62	Window Guide Assembly - "A, G, B & C" Hardtop and Convertibles . . . . .	7-33
Window Assembly, Front Door - "A and X" Closed Styles . . . . .	6-62	Window Harness, Power Windows Front Door - Electrical . . . . .	16-2
Window Assembly, Front Door - "B and C-37, 47, 57 and 67" Styles . . . . .	6-67	Window Harness, Power Windows Rear Door - Electrical . . . . .	16-3
Window Assembly, Front Door - "B-11" Styles . . . . .	6-66	Window Inner and Outer Strip Assemblies - All Styles . . . . .	7-7
Window Assembly, Front Door - "B-36, 46 and 69" Styles . . . . .	6-66	Window Inner and Outer Strip Assemblies - Single Acting Tail Gate . . . . .	9-36
Window Assembly, Front Door - "B-39" and "C-39, 49 and 69" Styles . . . . .	6-68	Window Lower Run Channels - Dual Acting Tail Gate . . . . .	9-14
Window Assembly, Front Door - "E" Styles . . . . .	6-70	Window Motor - "A-27, 37, 77 & 87" and "G-57" and "F-37, 67" Styles . . . . .	7-29
Window Assembly, Front Door - "F" Styles . . . . .	6-71	Windows, Power - Electrical . . . . .	16-2
Window Assembly, Front Door - "Z" Styles . . . . .	6-72	Window Rear Glass Run Channel, Front Door - "Z" Styles . . . . .	6-77
Window Assembly, Rear Door - "A-39" Styles . . . . .	6-90	Window Rear Guide Assembly - "Z-37 & 67" and "E-87" Styles . . . . .	7-34
Window Assembly, Rear Door - "A" Closed Styles . . . . .	6-88	Window Rear Guide, Front Door - "A-39" Styles . . . . .	6-75
Window Assembly, Rear Door - "B-39" and "C-39, 49 & 69" Styles . . . . .	6-94	Window Rear Guide, Front Door - "A-37, 67 and 87" Styles and "G-57" Styles . . . . .	6-76
Window Assembly, Rear Door - "B" Closed Styles . . . . .	6-93		

Subject	Page No.	Subject	Page No.
Window Rear Guide, Front Door - "B and C" Hardtop and Convertible Styles . . . . .	6-76	Window Regulator (Manual or Electric) - "A, E, F, G & Z" Hardtop and Convertible Styles . . . . .	7-28
Window Rear Guide, Front Door - "B-36, 46 and 69" Styles . . . . .	6-76	Window Regulator (Manual or Electric) - "A-27 & 77", "B-11" and "X-27" Styles . . . . .	7-24
Window Rear Guide, Front Door - "E" Styles . . . . .	6-77	Window Regulator (Manual or Electric) - "B-C" Hardtop and Convertible Styles . . . . .	7-29
Window Rear Guide, Front Door - "F" Styles . . . . .	6-77	Window Regulator-Manual and Electric, Front Door - "E" Styles . . . . .	6-75
Window Rear Guide, Rear Door - "A-39" Styles . . . . .	6-97	Window Regulator-Manual and Electric, Front Door - "F" Styles . . . . .	6-75
Window Rear Guide, Rear Door - "B-39" & "C-39, 49 & 69" Styles . . . . .	6-97	Window Regulator-Manual, Front Door - "A and X" Closed Styles . . . . .	6-74
Window Rear Run Channel - All Closed Styles . . . . .	7-3	Window Regulator-Manual, Front Door - "A-37, 67 and 87", "G-57" All "B and C" Styles . . . . .	6-75
Window Rear Vertical Inner Sealing Strip - "B-37, 47", "C-47, 57" and "G-57" Styles . . . . .	7-2	Window Regulator-Electric, Front Door - "A-37, 67 and 87", "G-57" and All "B and C" Styles . . . . .	6-75
Window Rear Vertical Outer Sealing Strip - "B-47", "C-47, 57" and Pontiac, Olds. and Buick "B-37" Styles . . . . .	7-3	Window Regulator-Manual and Electric, Front Door - "A-39" Styles . . . . .	6-74
Window Regulator Cams and Guides Lubrication, Door - Styles without Upper Frames . . . . .	2-4	Window Regulator-Manual, Front Door - "Z" Styles . . . . .	6-75
Window Regulator Cams and Guides Lubrication, Rear Quarter . . . . .	2-5	Window Regulator-Manual, Rear Door - "A-39 & 69" Styles . . . . .	6-96
Window Regulator and Cams Lubrication, Door - On Styles with Door Upper Frames . . . . .	2-3	Window Regulator-Manual, Rear Door - "B and C" Styles . . . . .	6-96
Window Regulator, Cams and Sector Gear Lubrication, Tail Gate (All Station Wagons) . . . . .	2-6	Window Regulator Outside Handle, Dual Acting Tail Gate - Manual . . . . .	9-13
Window Regulator, Dual Acting Tail Gate - Manual or Electric . . . . .	9-9	Window Regulator Outside Handle, Single Acting Tail Gate - Manual or Electric . . . . .	9-34
Window Regulator-Electric, Front Door - "A" Closed Styles . . . . .	6-74	Window Regulator, Rear Door "X-69" Styles . . . . .	6-97
Window Regulator Electric Motor Removal, Front and Rear Door - "E" Styles . . . . .	6-30	Window Regulator, Single Acting Tail Gate - Manual or Electric . . . . .	9-32
Window Regulator Electric Motor Removal, Front and Rear Door - All Styles Except "E" Styles . . . . .	6-24	Window Run Channel - "E-47" Styles . . . . .	7-34
Window Regulator Electric Motor Removal, Rear Door - All Styles . . . . .	6-96	Window Stationary Ventilator Assembly, Rear Door "X-69" Styles . . . . .	6-95
Window Regulator-Electric, Rear Door - "A, B and C" Styles . . . . .	6-96	Window Stationary Ventilator Division Channel Rear Door - "X-69" Styles . . . . .	6-95
Window Regulator Handle, Rear Quarter . . . . .	14-7	Window Upper Glass Run Channel - Dual Acting Tail Gate . . . . .	9-24

**Z**

Zinc Anode Clips, Exterior Molding . . . . . 17-5