

D E L O R E A N

DE LOREAN MOTOR CARS

**DMC**

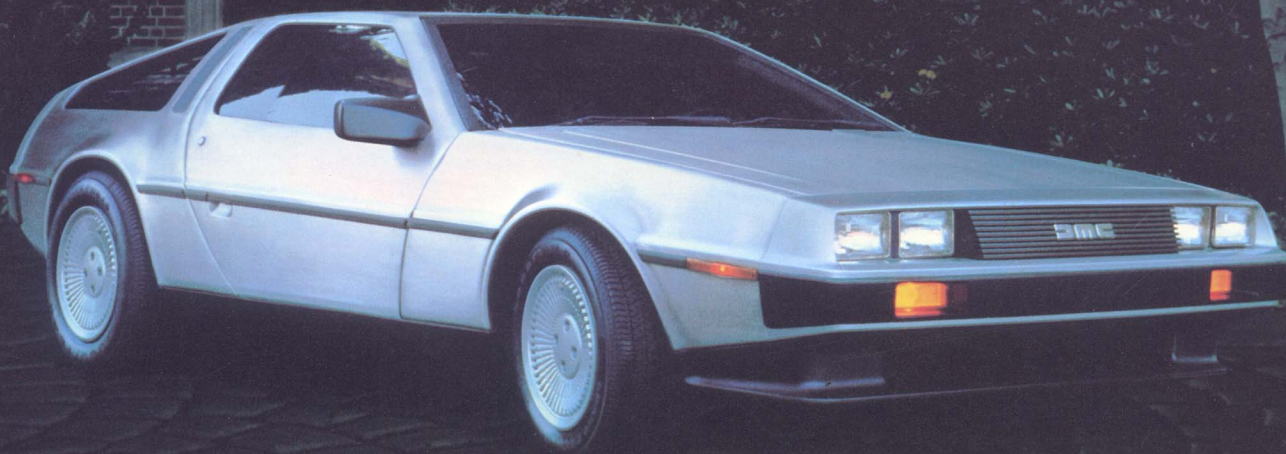



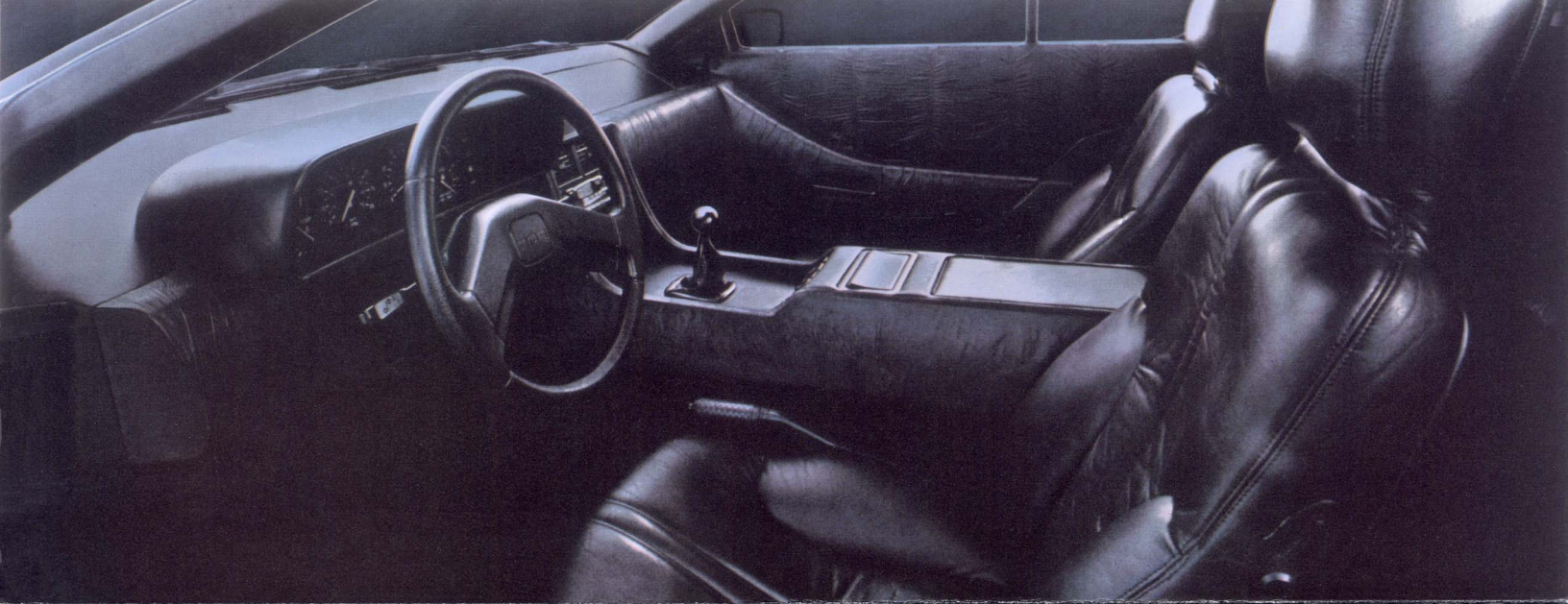

**1981 DE LOREAN SPORTS CAR SPECIFICATIONS**

**ENGINE**

Type: Light-alloy 90° V6, two overhead camshafts. Displacement: 2.85 liters. Bore and Stroke: 91 x 73 mm. Compression Ratio: 8.8:1. Block Construction: Light-alloy w/cast iron cyl. liners. Cylinder Heads: Light-alloy, cross-flow, hemi-chambers. Cooling System: Water/Ethylene Glycol, radiator forward w/twin thermostatically controlled fans. Fuel System: C.I.S. Fuel-injection, Bosch K-Jetronic. Ignition System: Breakerless, electronic/Bosch. Emission Control: Lambda Sond/catalytic, unleaded fuel.

**DRIVE TRAIN**

Engine Location: Aft-mounted. Transmission: 5 speed, fully synchronized or 3 speed automatic. Final Drive: Trans-axle/dbl. univ. half-shafts, ratio 3.44:1.

**BODY**

Construction: Structural-composite single piece underbody w/corrosion free outer body panels; 304 stainless steel.

**CHASSIS**

Construction: Corrosion protected steel backbone frame w/fore and aft wishbones, supporting cross members and 4-wheel independent suspension; controlled impact crush.

**SUSPENSION**

Front: Compliant, unequal length wishbones and coil boxed spring, telescopic shock absorbers and anti-roll bar. Rear: Compliant, diagonal trailing radius arms with upper and lower links, coil spring with telescopic shock absorbers.

**STEERING**

Type: Rack and pinion, designed neutral to mild understeer; 10.7 m turning circle.

**BRAKES**

Front/Rear: Power assisted 4-wheel discs 254/267 mm diameter.

**WHEELS/TIRES**

Wheels Front/Rear: Cast light-alloy 357 x 152/381 x 203 mm. Tires Front/Rear: Steel belted radial, Goodyear Formula 1 Rain Tread, 195/60, 235/60, Sized for balanced cornering power front and rear.

**DIMENSIONS & CAPACITIES**

Wheelbase: 2410 mm. Track Front/Rear: 1661/1593 mm. Length: 4267 mm. Width: 1854 mm. Height: 1168 mm. Weight: 1065 kg. Fuel Capacity: 60.56 liters, 16 gal. Luggage Capacity: 396 liters, 14 cu. ft.

**STANDARD FEATURES**

Stainless steel body panels. Counter-balanced gull-wing doors with cryogenically pre-set stainless steel torsion bars. Leather seats and trim. Air conditioning. Multi-speaker, high output stereo system. Power windows. Adjustable steering wheel. Electric door mirrors. Full instrumentation. Electrical locking system. Tinted glass.

DMC-01-0040  
Litho U.S.A.

All details and specifications shown are subject to change without notice.

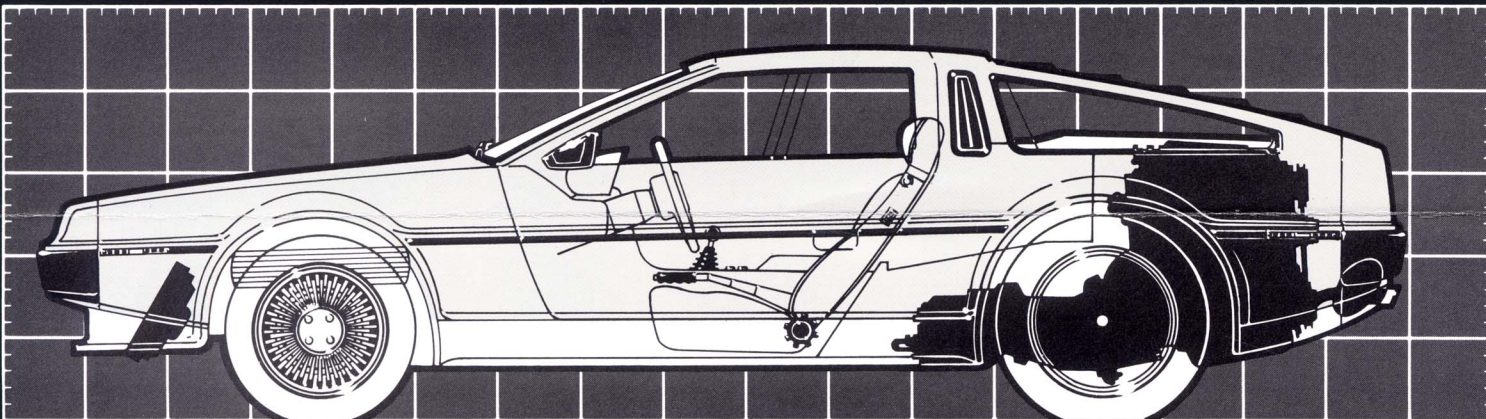

Scale: 10 in. (254mm) Divisions

