

Audi Brand | 2014

It's Audi because

we're driven by human achievement.

More than just cars, more than just performance. Audi is about the nature of perception, determining how people will respond to and interact with innovative design. It's about applied physics, how things glide through the air and overcome inertia through the application of power, acceleration and exhilaration.¹ It's about artistry, and the way materials elicit a tactile response and provoke an emotional response. It's

chemistry and how it bonds with you. It's poetry written in metal, engineering and design. Audi is the product of learning and application of knowledge. At its best, it is a dynamic example of what humans can create when they are vested in creating something better and bolder. So Audi is not just about cars. But then again, of course, it's also about cars.



¹ Obey all speed and traffic laws.

It's Audi because

**luxury tells the ornate, the garish,
the gilded and the over-indulgent...**

→ Ornate elements don't help to tell time →

→ Gilt prone to dull →

→ Unnecessary weight means mantle and not wall →



1 Always pay careful attention to the road, and do not drive while distracted. The features and technologies discussed above are optional, may require an additional subscription with separate terms and conditions, and should be used only when it is safe and appropriate. The Wi-Fi® hotspot feature is intended for passenger use only. 2 Features and technologies listed will not be available on all models.

...time's up.



← Precise design and improved accuracy ←

← Easily processed information at a glance ←

← Design allows for hanging, for improved viewing angle ←

Excessive luxury is not our goal. But we feel that luxury doesn't mean "more," it means "proper." Proper design, proper fit, proper precision—what Audi thinks of as design purity. Our engineers and designers know that a baroque clock won't tell time any better than a streamlined one, and all the distractions that surround it actually detract from the purpose of the clock itself. Unless, of course, the purpose is just to be noticed, instead of used to its greatest

potential. We think the real purpose of design is simplicity, elegantly rendered. We think you'll see and feel that concept throughout our Audi models. In the clean design lines of the exterior, the streamlined dash, and Audi MMI® interface. In our intuitive available Audi connect®¹, the seamless fit and finish of our materials and the unmistakable look of our Audi Singleframe® grille.² They all work in concert for a pure aesthetic of timeless taste and precision.

It's Audi because

our reputation hinges on the quality of things you don't see.

It's said that when one door closes, another one opens. It sounds as if whoever said it spent some time at an Audi research and development facility. After all, while you'll open and close the door on your Audi thousands of times without thinking about it, we've obsessed about it for you, in detail. **Not just about the reliability of it opening and closing,** obviously, but on the proper weight that will make it more pleasing to close. What it should sound like when it is shut. How the locks should click when they are engaged. The optimal acoustic placement for the speaker port. There are the

hinges too, of course. And the door itself, which is designed to take the brunt of side-collision impacts, along with several dozen other considerations that we take into account when designing our doors (to say nothing of the countless other components, processors, sensors, features and the inner workings most people will never see). Our doors are more than a symbol of welcoming you into your vehicle, they are products of Audi engineering, and our reputation hinges on them as much as our hinges help support the door.

Award-winning design

When Audi engineers set out to build the perfect door, they had one very important goal—lighten the load. By using fully pressed aluminum doors, the weight of the Audi A6 door structure was reduced by an astonishing 44 lb, compared to the previous model. This feat, combined with the strength of its door hinges and ability to retain all of its mechanical, safety and infotainment features, is why it won the Doors and Closures Innovation Award!

Acoustic enhancements

We spend countless hours listening, so you don't have to. By using soft-mounts on our window regulator, or a sound absorber backing within the door cavity itself, as well as a simple foam liner on our door-release cable, Audi engineers have nearly eliminated all of the ambient noise associated with other less-than-acute manufacturing practices.

Speaker placement and enclosure

We work with our partners to select optimal placement of our speakers, a vital aspect of our door design, in order to deliver the most engaging and extraordinary sound you can find in the automotive space. Woofers use a specialized lightweight and ported enclosure to ensure optimum low-frequency reproduction.

40% ← Asymmetric torque split^{1,2} → 60%

Sport differential²

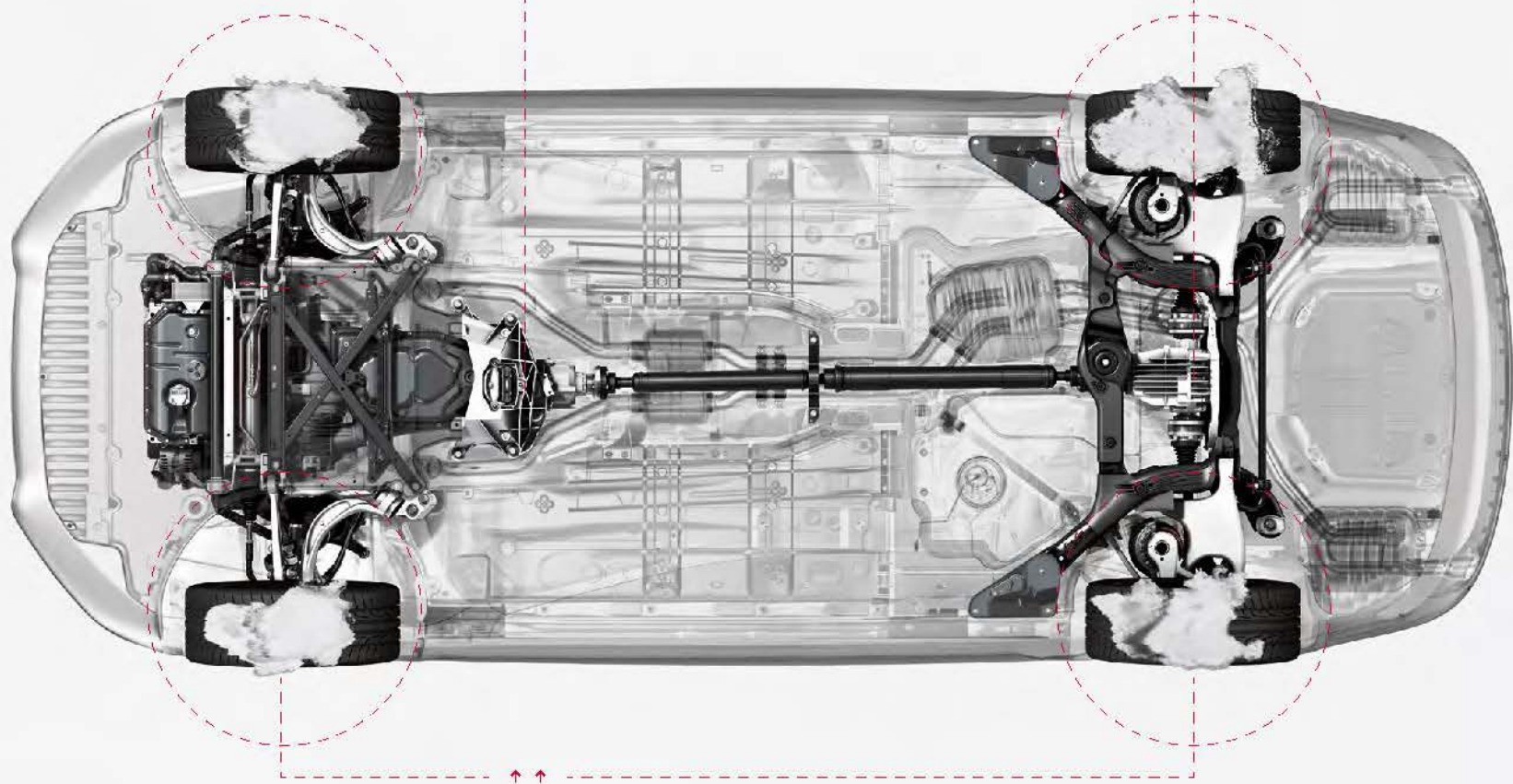

Torque vectoring²

You'll find truth in your corner. Torque vectoring is a handling feature so advanced that it seems to respond to your impulses even before you turn the steering wheel. An evolution of cross-axle lock, this system works within the Audi quattro® all-wheel drive system while utilizing Electronic Stability Control (ESC) and the Anti-lock Braking System (ABS) to help sense reduced load or wheel-spin on the inside cornering tire, helping to make turns smoother and more responsive.²



It's Audi because

conditions don't have to dictate how you stick it to the road.



As you can see, we've always felt that the best ideas are the ones that stick. And nowhere is that more true than with Audi quattro® all-wheel drive. Since 1980, we've been stuck on articulating an expanding vision of what progressive all-wheel drive technology can deliver. We didn't simply look at it as something to use in poor conditions, but rather as a performance technology that's built to handle roads from the Alps to the autobahn—and points beyond. You've seen quattro® capabilities in the way we dominated the World Rally Championship for years, in the grip you have in inclement weather,

and in the variable rear-wheel-biased power you enjoy in good conditions.¹ For more than 30 years and with five million quattro® systems installed in Audi vehicles, we have continued to refine the technology, developing a rear sport differential to help maximize performance, and torque vectoring to assist with cornering traction while helping to improve handling.² We boldly stuck to what worked while the world was trying to catch up, and we built on our vision by adding to a gripping heritage of Audi Sport® performance.

European model shown with optional equipment. ¹ Torque split ratio will vary from model to model. ² Optional features. Features and technologies listed will not be available on all models.



—
Ants can carry up to 50 times their body weight. That got us thinking about lightweight structures, smart engineering and true performance.

It's Audi because

power is measured by strength, not size.

It's perfectly fine for us to admit that other engines have more cylinders, have more horsepower and have larger displacements. It's just that we've made our engines lighter and more efficient than others, to optimize what we call power density.¹ Because anyone who has driven an Audi knows unmistakable power when they feel it. It means strength that pulses with torque at the moment of acceleration, provides a true, quick response as you change lanes, and turns the most routine cloverleaf into a joyful application of performance

handling. Sure, we love hitting the throttle and feeling the thrust of acceleration;² but we also want our drivers to experience the balance and precision of Audi engineering. From the A3 to our track-bred line of Audi performance cars, we are in the business of engineering emotion using more compact engines that concentrate power, while using less weight to your advantage, helping improve handling to the point where others just feel heavy.

TDI®

A turbocharged, fuel-sipping variant, our TDI® clean diesel engine delivers uncompromising Audi performance with bold efficiency.¹ Yes, it gets better mileage per gallon than comparable gasoline engines, but it also produces more low-end torque, which is best expressed in the elasticity you have when passing in the 30- to 60-mph range.

FSI®

The Audi FSI direct injection fuel management and delivery system directly injects fuel into the combustion chambers at precisely managed times and depths. What that means for drivers is that a fully homogenized intake charge helps increase power while also reducing fuel consumption and emissions, making efficiency more powerful.¹

TFSI®

At Audi, TFSI represents a combination of two of the brand's core areas of expertise—direct injection and forced induction. By adding forced induction (turbocharging or supercharging) to Audi FSI direct injection, the pressurized intake charge is cooled by directly injected fuel, thus achieving efficiency and performance combined with higher compression ratios—previously only attainable by naturally aspirated engines.¹

¹ See www.fueleconomy.gov for EPA estimates. Your mileage will vary. ² Obey all speed and traffic laws.



Mobile Wi-Fi® hotspot

Provides high-speed connectivity for up to eight passenger devices through an onboard wireless hub.^{1,3}



City events

Get information about current events, exciting locations and places of interest at your travel destination, current location or other chosen location instantly.³



myAudi features

Plan travel from your personal computer. Send your desired destinations to your vehicle ahead of time and access your route from your vehicle later.³

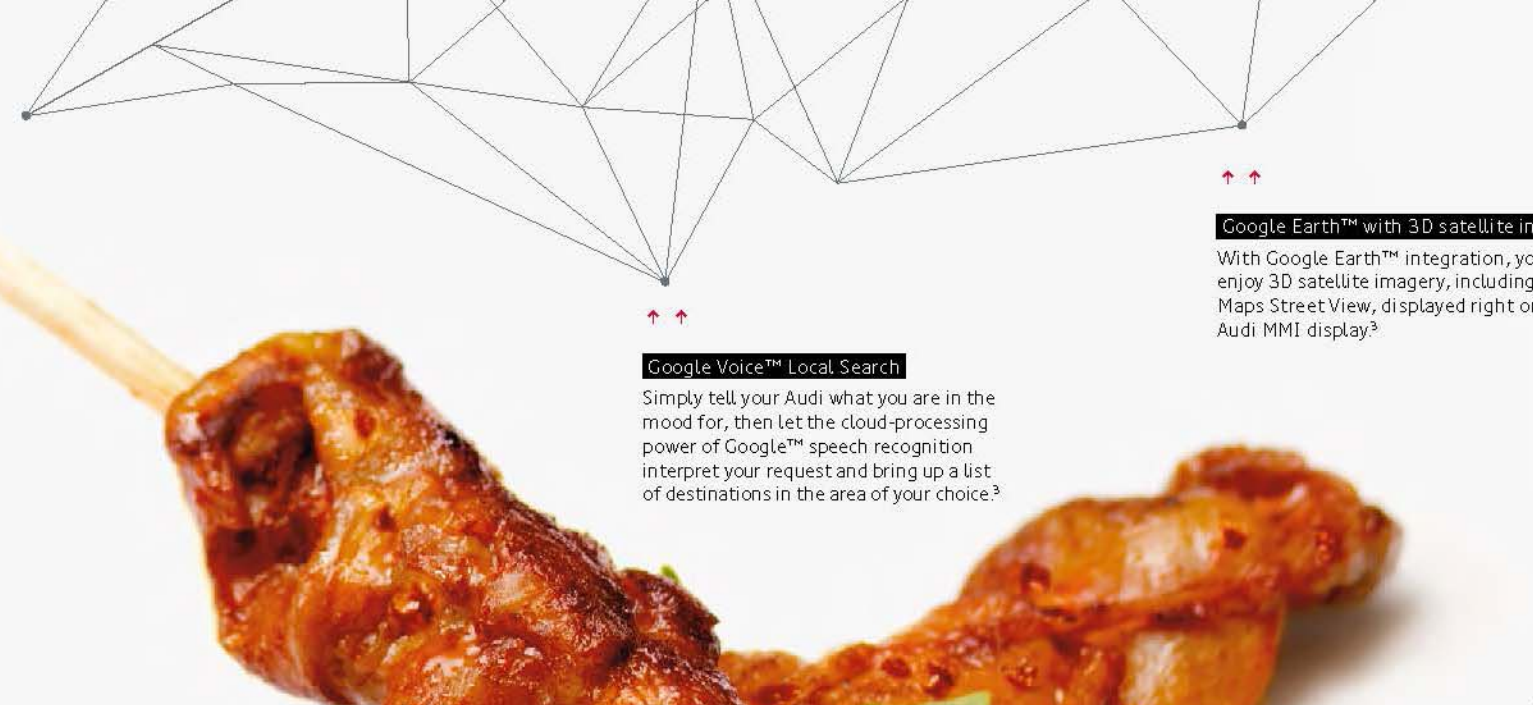

Google Earth™ with 3D satellite imagery

With Google Earth™ integration, you'll enjoy 3D satellite imagery, including Google Maps Street View, displayed right on the Audi MMI display.³



Google Voice™ Local Search

Simply tell your Audi what you are in the mood for, then let the cloud-processing power of Google™ speech recognition interpret your request and bring up a list of destinations in the area of your choice.³

It's Audi because

spicy chicken is your destiny.

If you are craving an Audi, we know your tastes run a little bold. But what happens when you crave spicy chicken, or a nice vindaloo, or some pepper salsa? Well, in your Audi, you can just say the word, and we'll help find the heat. With available Audi connect®,¹ we've developed a way to seek out your destiny, even if that's just finding the closest gas station, or the best hotel. Audi connect integrates Google™ technolo-

gies, like Google Earth™ with 3D satellite imagery, with Audi MMI® Navigation plus.² It also provides Wi-Fi® connectivity for up to eight passenger devices to help you stay informed. Check local fuel prices, weather information and, yes, the closest Szechuan restaurant using Google™ Local Search capabilities. Think of where that might take you.^{1,3}



1. Always pay careful attention to the road, and do not drive while distracted. The features and technologies discussed above are optional, may require an additional subscription with separate terms and conditions, and should be used only when it is safe and appropriate. The Wi-Fi® hotspot feature is intended for passenger use only. 2. Audi MMI® Navigation plus depends on signals from the worldwide Global Positioning Satellite network. The vehicle's electrical system and existing wireless and satellite technologies must be available and operating properly for the system to function. The system is designed to provide you with suggested routes in locating addresses, destinations and other points of interest. Changes in street names, construction zones, traffic flow, points of interest and other road system changes are beyond the control of Audi of America, Inc. Complete detailed mapping of lanes, roads, streets, toll roads, highways, etc., is not possible, therefore you may encounter discrepancies between the mapping and your actual location. Please rely on your individual judgment in determining whether or not to follow a suggested Audi MMI® Navigation plus route. Periodically mapping updates will be available for purchase at an additional cost. Consult your dealer or call 1-800-FOR-AUDI for details. 3. Optional features. Features and technologies listed will not be available on all models.

↑ ↑
Elephant skull

How nature solved the apparent conundrum of an elephant's skull didn't escape the notice of Heinrich Timm, the longtime lead engineer for Audi. The weight of the tusks and the general size of an elephant's head would seem to make it impossible for the animal to actually be able to carry it. But the design genius behind the elephant's skull is actually to make it lightweight, yet sturdy. Its predominantly hollow design is buffered by thin, connective bone walls, which act as strong, weight-bearing cells. Audi designers used that idea when building our aluminum and steel structures. Reducing weight, yet enabling strength.

→
Aluminum

→
Our large aluminum castings are a telling example of Audi ultra® lightweight technology. Primarily used in high-stress areas, these multifunctional castings achieve exceptional rigidity while also allowing for freedom of design, all while remaining extremely lightweight!

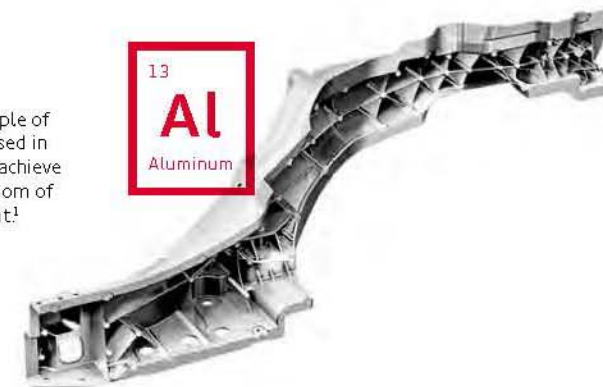
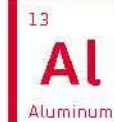

It's Audi because

the elegant structure of nature becomes a blueprint of efficiency.

It seems strange to say that, while we build strong, complex and high-performing machines, we're naturalists at heart. Then again, it might not be that unusual, seeing **how nature itself builds strong, complex and high-performing machines** as well. When we developed the thinking behind our Audi ultra® lightweight technology initiative, we knew that nature would serve as an inspiration to greater structural efficiency. Take the structure of the elephant skull pictured here. It has to be lightweight, yet capable of carrying a heavy load. It's porous, but its structure is such that it enhances its stability and

strength. We do the same, for example, with aluminum. Positioned one way, aluminum materials can be flexible. Positioned another, they are strong and rigid, and give **better support**. We also looked to bamboo, which is strong at the conjoined areas (nodes), and flexible along its stem. Our designs allow for both rigidity and flexibility where each is most needed, and for efficiency overall? As we continue to develop strategies to improve the performance aspects and efficiency of our vehicles, we don't shy away from the world around us? We boldly engage it even closer still.



It's Audi because

you I.D. our eye queue.

Even if you knew nothing about Audi, you'd still know if you were staring at one because we are unafraid to stare back. In fact, that exchange might just be love at first sight. That's how much our iconic LED lighting technology stands out from the pack. So we had the bright idea to make our LED daytime running lights look even more in-

tense. Now featuring a solid, sleek diode design that ingeniously reinvents our signature style, Audi LED lighting technology is once again unmistakably ours. It is an efficient, beautiful way to help you see and be seen during dawn and dusk. Look deeply into our eyes, and you'll know the truth of our attraction.¹

¹ Features listed are available on all models.



- 1 Steering wheel**
The Audi steering wheel is both an ergonomic command center and an elegant structure of performance. Easily accessed controls on the wheel give you control over your MMI® and Audi connect®, while it is designed to give you effortless access to visual information on the driver information display.^{1,2}
- 2 Audi connect and MMI**
Simple voice or finger motions can help you access information, music and BLUETOOTH® enabled features.^{1,2}
- 3 Electromechanical parking brake**
Properly positioned in the center console, the parking brake control is another small, but telling, design cue for Audi. The parking brake control serves to enhance the overall ergonomic intent of the vehicle, while delivering easy access and simple functionality.¹
- 4 Bang & Olufsen® Advanced Sound System**
With retractable acoustic lenses and speakers positioned around the Audi specifically to optimize sound quality, Bang & Olufsen® engineers have worked tirelessly with Audi sound designers to create an immersive audio experience.¹

It's Audi because

optimized design makes your commute shine a little brighter.

Get away from it all, every day, around 6 p.m., when you leave work and enter into a customized world that's completely dedicated to your comfort and entertainment. This place, of course, is the cabin of your Audi. Optimized luxury, designed by committed craftsmen who have you in mind when they choose the leather seating surfaces, create the adjustable seats or provide the refinement of ergonomic design and a more intuitive MMI. There are small touches that help simplify the overall design, like a

stylish contoured electromechanical parking brake at the foot of the center stack and an available Bang & Olufsen® retracting acoustic lens, perfectly positioned for richly detailed sound quality. And there are large statements, like a steering wheel with easily accessed controls to help you feel comfortably at ease. It is your Audi interior, where you leave the world behind, even when the world might seem in front of you on the way home.¹

1. Optional features. Features and technologies listed will not be available on all models. 2. Always pay careful attention to the road, and do not drive while distracted. The features and technologies discussed above are optional, may require additional subscription with separate terms and conditions, and should be used only when it is safe and appropriate. The Wi-Fi hotspot feature is intended for passenger use only.

It's Audi because

it's as if we have SPF for seats.

With innovative pigments and dyes, the Thermocool technology Audi uses in select leather seating surfaces just might prevent that startling moment on hot sunny days. You know the one, when you sit down and feel, immediately, an intense, searing feeling on your leg. Now you can keep your cool. This supple leather doesn't heat up as

much in direct sunlight as traditional leather does. In fact, the difference between untreated leather and the temperature on your seat treated with Thermocool can be as much as 86°. A perfect solution for your Audi A5 Cabriolet, TT Roadster or R8 Spyder, Thermocool technology is Audi to its core. Because it keeps its cool, you can keep yours.

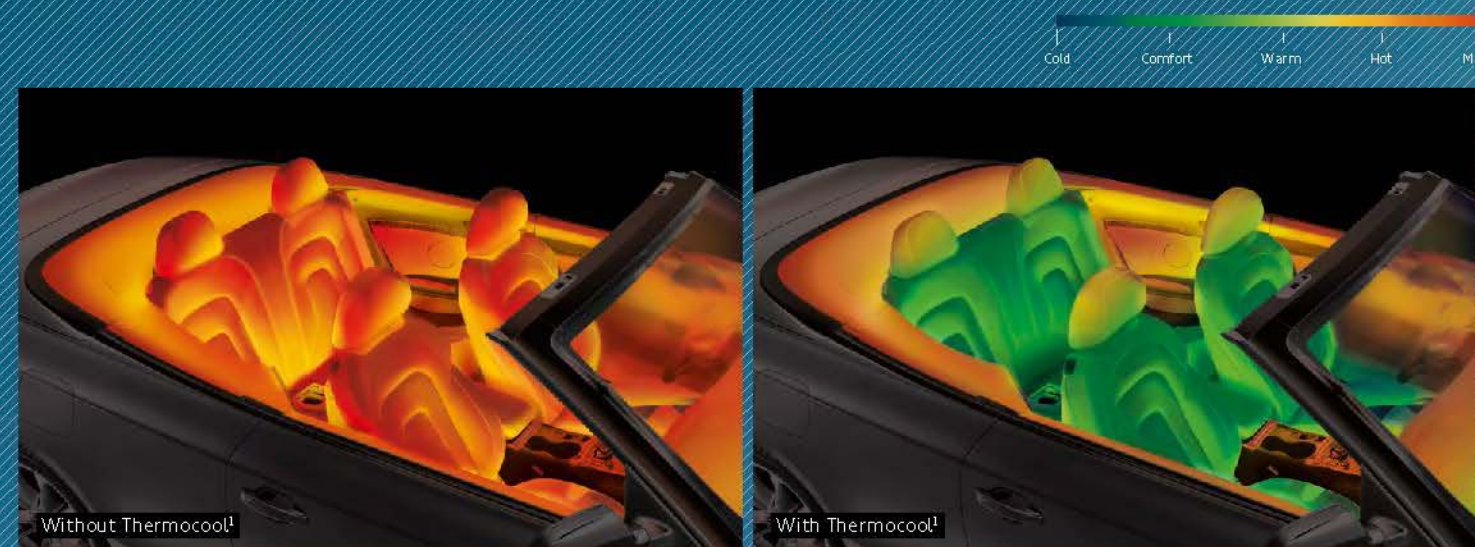

¹ Images shown are for dramatization purposes only.

It's Audi because

you find the model that moves you most.

We are Audi because we offer innovative, authentic luxury that never compromises on our principal goal—engineering the finest vehicles in the world. And that guiding principle helps us deliver a wide range of models that deliver segment-defining technology, performance and emotion. Every Sedan, every SUV, every Cabriolet, everything we do is geared toward providing a premium driving experience for discerning customers. All that's left is for you to decide which one you most want to fall in love with and pursue it with abandon.

A3

A3 | A3 TDI®

Innovating mobility has been concentrated. We started by re-imagining the all-new 2015 Audi A3 to be a dynamically designed, agile luxury sedan. Then we made **technologies usually reserved for flagship vehicles available**. More specifically, you can get many of the innovative features found on the Audi A6 and A8. We then provide the option of two potent **TFSI® engines** along with available Audi quattro® all-wheel drive performance¹ or a torque-happy, and highly efficient, **TDI® clean diesel engine** to choose from. In the end, you have a vehicle that comes with all the luxury, technology and prestige that one would expect an Audi to have, regardless of size.

For more information on the all-new 2015 Audi A3, download our interactive Audi Library at the iTunes® store, or Google Play.™

2015 model shown. Available early 2014. Please see your dealer for details.

A4

The Audi A4 is defined by the way it entices, delivering progressive luxury through ample power and sleek design. Choose the **available Audi quattro® all-wheel drive** for performance or an optional elegant Bang & Olufsen® Sound System to enhance the sound and mood of an already stylish drive, then add a finely tuned **220-hp 2.0-liter TFSI® engine** delivering potent 0- to 60-mph acceleration in as little as **6.2 seconds**.



¹ EPA estimate not available at time of printing. See www.fueleconomy.gov for updated information. Your mileage will vary.

S4

With classic sports sedan written all over the Audi S4, we know you'll be writing your own story together. For starters, style isn't prologue. It's intrinsic to the story. Beautifully rendered front and rear fasciae, Aluminum-optic mirrors, available sport differential and **bold quad exhaust outlets** all add to the plot. The climax of any S4 story comes from the power produced by the supercharged **3.0-liter TFSI® V6 engine**, which pumps out **333 hp** and delivers an impressive **325 lb-ft of torque**.¹ With the option of a six-speed manual or a **seven-speed Audi S tronic® dual-clutch transmission**, you can serve up the performance any way you like it—and that's a line worthy of any well-told story.



allroad

The Audi allroad® has a difficult task. To follow a beloved legend. The previous generation allroad won over a demanding audience—those concerned with not only how they looked at the slopes, but getting to them in the first place. Through strong design, **Audi quattro® all-wheel drive** capabilities and impressive performance, the allroad stands to win a legion of new fans while satisfying the dedicated drivers who owned **the legend**. **Built for any season**, the allroad features **available Audi connect®**;² leather seating surfaces, an **elevated 7.1-inch ground clearance** and a **220-hp TFSI® engine**. It might be time to follow a **new legend**.



1. Obey all speed and traffic laws. 2. Always pay careful attention to the road, and do not drive while distracted. The features and technologies discussed above are optional, may require additional subscription with separate terms and conditions, and should be used only when it is safe and appropriate. The Wi-Fi hotspot feature is intended for passenger use only.

A5

Coupe | Cabriolet

The Audi A5 is a prime example of passionate, expressive style and finely tuned performance. In either its Coupe or Cabriolet identity, the **A5 is a showcase of personality**—as it should be—with its assured handling, smart interior and assertive stance, to say nothing of its distinctive available LED daytime running lights and Audi Singleframe® grille. It's technologically advanced, fully stacked with available advanced technologies like **Audi MMI® Navigation plus¹** and a **Bang and Olufsen® Sound System**, and viscerally powerful whenever you hit the throttle, with a potent **220-hp 2.0-liter TFSI® engine** that offers athleticism with a smile.



S5

Coupe | Cabriolet

Consider the Audi S5. In either Coupe or Cabriolet, the S5 brings more to the road, from its Platinum Gray Audi Singleframe® grille to its quad exhaust. **Its iconic style never lets you forget the performance potential of the 3.0-liter TFSI V6 engine** that delivers a substantial **333 hp²**, all funneled to the road through a six-speed manual (Coupe only) or **available seven-speed Audi S tronic® dual-clutch transmission** and standard **Audi quattro® all-wheel drive**. With already brilliant driving dynamics and tight sport suspension calibration that puts you in total control, the S5 is ready for the most challenging drive in the world. The next one that really excites you.



¹ Audi MMI® Navigation plus depends on signals from the worldwide Global Positioning Satellite network. The vehicle's electrical system and existing wireless and satellite technologies must be available and operating properly for the system to function. The system is designed to provide you with suggested routes in locating addresses, destinations and other points of interest. Changes in street names, construction zones, traffic flow, points of interest and other road system changes are beyond the control of Audi of America, Inc. Complete detailed mapping of lanes, roads, streets, toll roads, highways, etc., is not possible, therefore you may encounter discrepancies between the mapping and your actual location. Please rely on your individual judgment in determining whether or not to follow a suggested Audi MMI® Navigation plus route. Periodically mapping updates will be available for purchase at an additional cost. Consult your dealer or call 1-800-FOR-AUDI for details. ² Obey all speed and traffic laws.

RS 5

Coupe | Cabriolet

The Audi RS 5 doesn't come with a sign that says, "For Serious Drivers Only." It doesn't have to—everyone just knows on sight. Track-proven, factory-tuned and stunningly executed, this progressive performance car showcases an aggressive front end, **wide fender flares** and speed-deployed adaptive rear spoiler on the Coupe. The RS 5 features a **4.2-liter FSI® V8 engine** that produces **450 hp** capable of hitting **8,500 rpm** at the redline¹ along with a **seven-speed Audi S tronic® dual-clutch transmission** that funnels power through seamless shifting and instant response, while still providing everyday comfort.



A6

A6 | A6 TDI®

The Audi A6 brings class to the road—with available Audi connect®, Google Earth™ with 3D satellite imagery, Audi MMI® touch with advanced handwriting-recognition technology, and Wi-Fi connectivity, of course.² And with the suite of available driver assistance technologies that monitor and help you react to the traffic environment around you, it becomes **a celebration of automobile technology**. The Audi A6 also boasts a **2.0-liter 220-hp TFSI® engine** or an available **3.0-liter 310-hp TFSI V6**, as well as adding the new **3.0-liter 240-hp TDI® clean diesel** to the mix, making it a clear demonstration of what progressive luxury can be—and something so much more than your everyday luxury vehicle.



1. Obey all speed and traffic laws. 2. Always pay careful attention to the road, and don't drive while distracted. The features and technologies discussed above are optional, may require additional subscription with separate terms and conditions, and should be used only when it is safe and appropriate. The Wi-Fi hotspot feature is intended for passenger use only.

S6

The Audi S6 isn't here to play nice, no matter how composed it feels. In a lineup of progressive performance, you have to stand out in your own way. Effortlessly unleashing its **4.0-liter TFSI® V8 engine** to produce an unrelenting **420 hp** helps give you a seemingly endless stream of power. But what is power without control? That's where the legendary **Audi quattro® all-wheel drive with sport differential** and S6 tuned **Audi adaptive air suspension** comes into play. **Never have stature, sophistication and sport felt so playfully powerful.**



A7

A7 | A7 TDI®

Design something no one has ever seen before. And make it an **ultrastylish**, sport luxury vehicle so bold it wants to transform the world around it. We're now in the rarified air of the Audi A7, a five-door luxury performance coupe that's a **beacon of unconventional thinking**. It gives power a lot of style. It gives design some serious technology. And the new **Audi A7 TDI® clean diesel** has power, style and efficiency to spare, giving people something to think about even when they think they have seen it all.¹



1. Obey all speed and traffic laws. 2. 24 city/38 highway mpg (2014 A7 TDI® clean diesel with eight-speed Tiptronic® automatic transmission and Audi quattro all-wheel drive). EPA estimates. Your mileage will vary.

S7

Think of our Audi S7 as a soulfully designed, head-turning **piece of performance art**—with the emphasis on performance. The **420-hp 4.0-liter TFSI® V8** takes full advantage of its aerodynamic shape to own impressive 0-to-60 times,¹ while driving in full control with permanent **Audi quattro® all-wheel drive**. And when you are simply cruising, the **Audi cylinder on demand™ engine efficiency technology** uses only the piston power that's necessary, helping make your drive more efficient.² The Audi S7 is finely designed performance that sizzles on the pavement, while the look burns even when standing still.



RS 7

Not so much unveiled as unleashed. The power felt after one look at the all-new Audi RS 7 might only be rivaled by the power felt after one listen. The stunning lines of its unmistakable roofline are matched by the guttural rumble of its finely tuned **560-hp 4.0-liter TFSI V8 engine**.¹ The RS 7 is the kind of automotive moonshot that was created as a dare by designers, a challenge to the brand to produce a vehicle loaded with as many engineering innovations and as much power as could be installed in a single, vital package.¹ As such, it practically pulsates with iconic bravado. **This is confidence.** This is desire articulated in a powertrain and pure style. **This is the Audi RS 7.**



¹ Obey all speed and traffic laws. ² EPA estimates not available at time of printing. See www.fueleconomy.gov for updated information. Your mileage will vary.

A8

A8 | A8 TDI®

It's a new class of flagship. The Audi A8 represents the pinnacle of prestige. Exuding style and performance, it is luxury unshackled from traditional expectations. Which is why, along with Audi engineering and design expertise, the A8 offers new technological possibilities, to better connect the driver to the drive while others seem to stand still. And with powertrains that produce the same kind of fuel efficiency as that found in comparable hybrids,¹ you can understand the premise of Audi ultra® lightweight technology. Its available TDI® clean diesel engine surpasses every luxury standard with an impressive commitment to power and efficiency,² delivering relentless torque in complete comfort. It is innovation and power wrapped in an indelible package of progressive luxury.



S8

For those who strive for power on a grand scale, we'd like to introduce the Audi S8. From the 4.0-liter TFSI® V8 engine delivering an astonishing 520 hp and 481 lb-ft of torque³ to the ingenious fuel-saving Audi cylinder on demand™ engine efficiency technology, the S8 is as athletic as it is innovative.⁴ And with dramatic driving characteristics made possible by the signature Audi ASF® aluminum construction and Audi quattro® all-wheel drive with sport differential—and stunning exterior design lines ripped from a perfectionist's drafting board—the S8 confidently delivers an ultrapowerful sports luxury experience. And more.



1. Based on EPA estimates for 2013 Mercedes-Benz S400 hybrid (19 city/25 hwy mpg) and 2014 Audi A8 L TDI® clean diesel (24 city/36 hwy mpg) models. Your mileage will vary. 2. 24 city/36 highway (2014 A8 L TDI® with eight-speed Tiptronic® automatic transmission and Audi quattro® all-wheel drive). EPA estimates. Your mileage will vary. 3. Obey all speed and traffic laws. 4. EPA estimates not available at time of printing. See www.fueleconomy.gov for updated information. Your mileage will vary.

TT

Coupe | Roadster

The Audi TT is a sports car **designed to accelerate and elevate**. Start with the impressive engineering, inspired design and gripping performance of the TT. Raise the game with advanced driving dynamics and a powerfully **efficient TFSI® engine**.¹ Coupe or Roadster, with **Audi quattro® all-wheel drive** and **ASF® aluminum construction** standard throughout the lineup, Audi builds on the belief that this is the car for drivers who enjoy unrivaled design and true performance while they also enjoy the view.



TTS

Coupe | Roadster

The Audi TTS guarantees you'll be heard, with a potent **265-hp 2.0-liter TFSI engine** and **quad exhaust outlets**,² as well as seen, with the strong stance and dramatic curves that showcase a performance profile designed to get noticed. Add a bold S model Audi Singleframe® grille with Aluminum-optic double-blade crossbars, and a **rapid-fire six-speed Audi S tronic® dual-clutch transmission with launch control**² to define its muscularity, and its **overarching statement is one of blistering performance**.



¹ EPA estimates not available at time of printing. See www.fueleconomy.gov for updated information. Your mileage will vary. ² Obey all speed and traffic laws.

R8

V8 Coupe | Spyder

Muscular. Resonant. Stylish. The Audi R8. A supercar, yes, but it's not unapproachable, if you can find one in captivity. When still, it's an eye-catching, design-forward sculpture, now further defined by the progressively redesigned full LED headlights. When unleashed, its **430-hp V8 FSI® engine¹** makes hearts beat harder with just a single rev as power courses through a new available seven-speed **Audi S tronic® dual-clutch transmission** or a gated six-speed manual. **But it's how easy it is to embrace track-ready handling in a car that you can drive anytime that makes the most lasting impression.**



R8

V10 Coupe | Spyder
V10 plus Coupe

R8 V10

A stunning classic that's anything but a museum piece. The R8 V10 offers full LED headlight technology, while proudly **sporting the R8 style and power (at 525 hp)¹** that has challenged the competition and captured enthusiasts' eyes since its debut. And while the exterior and specs articulate performance, the interior delivers the Audi touch, with Fine Nappa leather seats and door-panel inserts, a Bang & Olufsen® Sound System and Audi Navigation plus² with 3D navigation display.

R8 V10 plus

In this arena, you'd better do more than hold your ground. It has to move underneath you. Fast. Enter the Audi R8 V10 plus Coupe. **A supercar's supercar.** Powered by a **5.2-liter FSI® V10 engine** that expresses **550 hp and 398 lb-ft of torque** in very strong terms, the V10 plus variant of our signature performance car goes from **0 to 60 mph in 3.3 to 3.7 seconds¹**. It is more of more, with black, round exhaust outlets, the Carbon Fiber Sigma sideblades, front spoiler lip, rear diffuser, exterior side mirrors housings and elite integral touches.



1. Obey all speed and traffic laws. 2. Audi Navigation plus depends on signals from the worldwide Global Positioning Satellite network. The vehicle's electrical system and existing wireless and satellite technologies must be available and operating properly for the system to function. The system is designed to provide you with suggested routes in locating addresses, destinations and other points of interest. Changes in street names, construction zones, traffic flow, points of interest and other road system changes are beyond the control of Audi of America, Inc. Complete detailed mapping of lanes, roads, streets, toll roads, highways, etc., is not possible, therefore you may encounter discrepancies between the mapping and your actual location. Please rely on your individual judgment in determining whether or not to follow a suggested Audi Navigation plus route. Periodically mapping updates will be available for purchase at an additional cost. Consult your dealer or call 1-800-FOR-AUDI for details.

Q5

Q5 | Q5 TDI®

While the competition might be trying to figure it out, we here at Audi know exactly what the Audi Q5 is. Call it an SUV, call it an evolved crossover, but whatever you call it, **the Q5 is unmistakably an Audi**, and features a finely honed interior, a sleek exterior style and a well-tuned engine. Engage the **available Audi drive select** to discover a **dynamic power profile**. Or choose the **all-new Audi Q5 TDI® clean diesel** model that delivers **240 hp, 428 lb-ft of torque**, and impressive efficiency, all with trademark Audi fit and finish.¹ Introduce yourself to a confident Q5, and arrive in **stylish comfort**.



Q5

hybrid

The Audi Q5 hybrid has set out to prove that **performance doesn't have to be sacrificed in the name of efficiency**. And by all metrics, it has done just that. By coupling our legendary Audi 2.0-liter TFSI® engine with a **54-hp electric motor**, the total combined system output jumps to **245 hp and 354 lb-ft of torque**, ensuring that the Q5 hybrid lives up to the strict performance standards of Audi while celebrating the kind of fuel efficiency that turns "hybrid" into a one-of-a-kind Audi.²



1. 24 city/31 highway (2014 Q5 TDI® with eight-speed Tiptronic® automatic transmission and Audi quattro® all-wheel drive). EPA estimates: Your mileage will vary. 2. EPA estimates not available at time of printing. See www.fueleconomy.gov for updated information. Your mileage will vary.

SQ5

It's a riveting, powerfully rendered **solution to a long-standing conundrum about finding the "sport" in SUV.** With the all-new Audi SQ5, it's been found. It is versatile in performance and handling, with **Audi quattro® all-wheel drive** making its presence felt. It is crisply stylish, an SUV smartly streamlined by signature design lines. It has the necessary cargo space for weekend trips or family vacations. But it is also **sculpted muscle** and **luxury refinement.** It has the numbers: **354 hp, 346 lb-ft of torque, eight-speed Tiptronic® automatic transmission**¹ And it wears its **available Fine Nappa leather** seating surfaces well. It is an Audi SUV literally shaped and imbued by Audi power.² The SQ5 defines sport in an elevated performance utility vehicle.



Q7

Q7 | Q7 TDI®

A design **detail can define the character of an entire piece.** So that's one way to think of the Audi Q7: a collection of small, stylish details that add up to one impressively large canvas. Maybe you'll fall in love with the grain of the Burled Walnut Wood decorative inlays, the **spacious interior that seats seven** or the touch of the leather seating surfaces. Or maybe you'll like the **available TDI® clean diesel** model's efficiency? But no matter which detail you favor, you'll **appreciate the Q7 for delivering the room, style and stature of a premium SUV,** while taking performance as seriously as it does its sizable comforts.



Audi Truth in Engineering

2014 | Brand

Audi of America
Audiusa.com
Facebook.com/Audi

AoA1414238

Note: A word about this brochure. Audi of America, Inc., believes the specifications in this brochure to be correct at the time of printing. However, specifications, standard equipment, options, fabrics, and colors are subject to change without notice. Some equipment may be unavailable when your vehicle is built. Please ask your dealer for advice concerning current availability of standard and optional equipment, and your dealer will verify that your vehicle will include the equipment you ordered. Vehicles in this brochure are shown with optional equipment. See your dealer for complete details on the New Vehicle Limited Warranty, twelve-year limited warranty against corrosion perforation, and Audi 24/7 Roadside Assistance. (Roadside assistance coverage provided by Road America in the U.S. Certain conditions apply; see your dealer for details.) Tires supplied by various manufacturers. "Audi," all model names, "allroad," "Audi connect," "Audi Sport," "ASF," "cylinder on demand," "FSI," "MMI," "quattro," "S tronic," "Singleframe," "TFSI," "Truth in Engineering," "ultra," and the four rings logo are registered trademarks of AUDI AG. "TDI" is a registered trademark of Volkswagen AG. "Bang & Olufsen" is a registered trademark of Bang & Olufsen. The BLUETOOTH word mark and logos are owned by the Bluetooth SIG, Inc., and any use of such marks by AUDI AG is under license. "Google," "Google Earth" and "Google Voice" are trademarks of Google Inc. "Tiptronic" is a registered trademark of Dr. Ing. h.c. F. Porsche AG. All other trademarks are the property of their respective owners. Some European models shown.

© 2013 Audi of America, Inc. Printed in U.S.A.