



**SMARTWIRE
INSTALLATION MANUAL**

Table of Contents

Introduction.....	0
SmartWire Package Contents	1
Technical Specifications	2
Becoming Familiar with the SmartWire Installation	3
Pre-Install notes:	3
Example Installation Overview.....	4
SmartWire External Features.....	6
SmartWire Mounting	7
SmartWire Connections	8
Power Supply: Main Stud.....	8
Ground Supply: Pin A19, A20, B19.....	8
Shutdown: Pin B20.....	8
Hardwired Direct Inputs	9
Outputs.....	9
SmartWire 23 Pin Connector Pinout.....	10
SmartWire Wiring.....	11
Datalink Wire Sizer App. (shown only in standalone applications).....	12
Connector Requirements: 23 Pin Amp Connectors.....	13
Wire.....	13
Wire Preparation	13
Tooling.....	13
Socket Crimping	14
Connector Assembly.....	15
Connector Disassembly	16
Seal Plug.....	16
External Devices	17
Starter Solenoid.....	17
Ignition.....	17
ECU or EFI.....	17
Solenoids.....	17
Windshield Wipers.....	18
Channel/Pin Chart.....	20

Disclaimer

Competition Systems Inc. Racepak make no representations or warranties of any type with respect to the contents in this manual. Competition Systems Inc. Racepak disclaim any implied warranties or fitness for any particular purpose. Competition Systems Inc. Racepak is not liable for any errors contained within or for incidental or consequential damages in connection with the supply, performance or use of the hardware and software or this manual.

Competition Systems Inc. Racepak reserve the right to revise this installation and user manual at any time, without obligation to notify any person of revisions.

Warranty

Competition Systems Inc. Racepak make every effort to insure our products and services are of the highest quality and standards. It is our intention to maintain a mutually beneficial and cordial relationship with each and every customer.

Competition Systems Inc. Racepak warrants all merchandise manufactured by Competition Systems Inc. Racepak against defects in workmanship or material for a period of six months after the date of purchase. This warranty applies to the first retail purchaser and covers only those products exposed to normal use or service. It does not apply to those products used for a purpose for which said products were not designed, or which has been altered in any way that would be detrimental to the performance or life of the product, or misapplication, misuse, negligence, or accident. Any part or product found to be defective after examination by Competition Systems Inc. Racepak will be repaired or replaced. Competition Systems Inc. Racepak assumes no responsibility for diagnosis, removal and/or installation labor, loss of vehicle use, loss of time, inconvenience or any other consequential expenses.

This warranty is in lieu of any other expressed or implied warranties, including any implied warranty or merchantability or fitness, and any other obligation on the part of Competition Systems Inc. Racepak, or selling dealer.

If you have any questions regarding warranty, please contact customer service at Competition Systems Inc. Racepak. 949-709-5555

Introduction

Solving the wiring complexity of a modern race car, the Racepak SmartWire is a fully programmable power control module. While traditional wiring provides control of vehicle electronic components through the routing of single, or multi-fuse, relay, and circuit breaker panels, the Racepak SmartWire functions as a central “command center” for all vehicle wiring.

Based on Racepak’s exclusive single cable V-Net technology, the Racepak SmartWire unit is the electronic “starting point”, with a direct main power connection from the vehicle battery to the SmartWire unit. Each output is user defined, both in function, current requirement and current limit via a USB connection to the user’s PC. The design of the SmartWire unit will reduce overall installation weight / clutter, while contributing to a quicker reacting electronic system, through the solid state switching design.

Manual activation can be achieved through the 12 hardwired direct inputs on the SmartWire unit, or through the use of the optional Racepak Switch Panel or Switch Module units. When utilized, a single small cable is routed to the Switch Panel/Smart Module from the Racepak SmartWire unit, reducing wiring clutter. Users needing additional switch panel capabilities can easily expand through the use of an additional “jumper” cable to a second Racepak Switch Panel/Smart Module.

The Racepak V-Net compatibility of the SmartWire unit insures a seamless integration with existing Racepak V-Net equipped vehicles. When connected with existing V-Net equipment, these items provide additional inputs, control modules and instrumentation, compared to when utilized as a standalone power control module.

This manual will guide by step through the installation, setup, and operation of the SmartWire unit. During this process, the manual may refer to system worksheets and individual instruction sheets originally provided with other Racepak sensor modules and devices.

To get the most out of the Racepak SmartWire unit, it is highly recommended to thoroughly read the entire manual before installation and use of the Racepak SmartWire unit. In addition, test the SmartWire unit and settings/functions before use. The race track is not the place to determine something is not working properly!

SmartWire Package Contents



- SmartWire main unit
- Connector kit
- USB programming Cable
- Programming Software

Technical Specifications

Output Capacity:	125 Amps
Current Consumption:	180 mA typical operation (<1 mA in shutdown mode)
Min/Max Power Supply:	8-20 Volts
Operating Power Supply:	12-16 volt automotive applications.
Inputs:	12 hardwired direct (voltage triggered (>2.7V) or ground triggered (<2.5V))
Outputs:	30 (8 outputs @ 20 Amps, 22 outputs @ 10Amps)
Response:	3.0 milliseconds max.
Programming:	USB (or via V-Net when used with a V-Net data recorder)
Dimensions:	Length 6.5" (16.51 cm), Width 5.5" (13.97 cm), Height 2.0" (5.08 cm)
Weight:	25.8 ounces (731.4 grams)

Note: All current ratings are for 12 volt operation. For 16 volt systems, subtract 25 percent.

Connections:

- Two - 23 pin Ampseal, (hardwired direct inputs, outputs, grounds and shutdown pin)
- One - 1/4"x 20 Main Stud, (main power supply)
- One USB mini (programming when utilized without a compatible data recorder)
- One Switch CAN bus (connection for optional Switch Panel and/or Switch Module)
- One V-Net CAN bus (connection for optional V-Net sensors and/or compatible data recorders)

Outputs are:

- Monitored for Current, Voltage, and Status
- Protected via user settable limits for over-current situations
- Protected from short circuits and/or thermal overload situations
- Function programmable as:
 - Constant On
 - Flash
 - Latch On
 - Single Pulse
 - Windshield Wiper (only available on channel 19)
- Time Delayed for On or Off
- Outputs are controlled via any combinations of:
 - Switchable inputs
 - Programmed logic operations;
 - (Equal to, Not Equal to, Greater than, Greater than or Equal to, Less than, Less than or Not Equal to)
 - V-Net attached sensors (Temperatures, Pressures, RPM, etc.)
 - Other Outputs

Racepak

30402 Esperanza, Rancho Santa Margarita, CA 92688 USA
Phone: 949-709-5555 Fax: 949-709-5556 www.racepak.com

Becoming Familiar with the SmartWire Installation

This manual is designed to provide guidance through the hardware installation of the SmartWire unit. Use of this manual, along with the SmartWire Software/Programming manual, will provide complete installation and programming instructions. Below is an overview of a typical installation and setup.

1. Utilizing the SmartWire Software/Programming manual, install the DatalinkII software on PC
2. Install **only** the main power and grounds on the SmartWire
3. Connect SmartWire to PC using supplied USB cable
4. Utilizing the SmartWire Programming Installation manual, open the configuration file on PC
5. Sync the configuration file with the SmartWire
6. Name, program, and send each of input (Hardwired direct inputs). Smart Panel/Smart Module and V-Net items can be programmed at this time if connected. Or, each can be programmed at a later date.
7. Name, program, and send each of the outputs (ensure correct Amperage rating for each device)
8. Wire each of the inputs per programmed settings (see Hardware Installation Manual)
9. Wire each of the outputs per programmed settings (see Hardware Installation Manual)
10. Test each of the input and output settings. Insure each circuit operates as intended

Pre-Install notes:



It is recommended to initially install the Main Power and Ground wires first in order to program each input and output. Once programmed, terminate and wire only the necessary connections. Do not terminate every connection, unless a device will be connected.



The SmartWire can be installed and used as a standalone unit (i.e. not connected to a data recorder) or is compatible with the following Racepak Data Recorders:

- V300 (firmware version 41 or higher)
- V300SD (firmware version 22 or higher)
- V500 (firmware version 56 or higher)
- IQ3 Logger Dash (firmware version 15 or higher)
- IQ3 Display Only non-logger Dash (firmware version 17 or higher)
- G2X Pro (firmware version 57 or higher)

If the PC does not meet the above firmware requirement, contact Racepak for update details.



Portions of this manual will call out two installing/programming types; Standalone *AND* with a Data Recorder. In Standalone mode, all programming is performed via USB cable between the PC and the SmartWire unit.



When utilized with Racepak V-Net sensors or in conjunction with a Racepak data recorder, programming is performed via serial connection between the PC and the data recorder unit.

Racepak

30402 Esperanza, Rancho Santa Margarita, CA 92688 USA
Phone: 949-709-5555 Fax: 949-709-5556 www.racepak.com

Example Installation Overview

In a standard switch/device application, power is routed to a switch, with this switch controlling one device. Depending on the device current (Amperage) requirement, this switch controls a relay, when triggered, allows a large amount of current flow to the device. Activating the device requires manually flipping a switch.

Standard switch installation:

- One switch for each device.
- Switch on, device on.

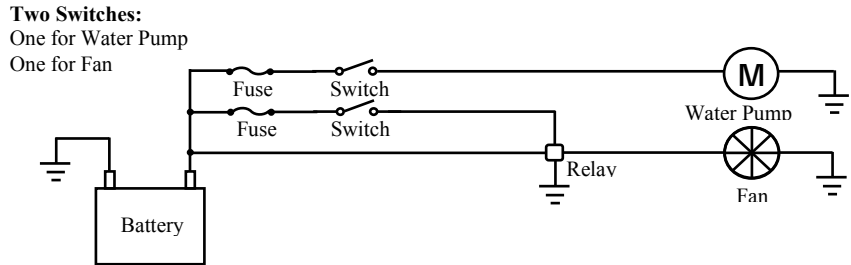

Basic SmartWire installation

- One switch for each device.
- Switch on, device on.
- Monitors on both devices for:
 - Current (Amps)
 - Voltage
 - Status (on/off/blown fuse)

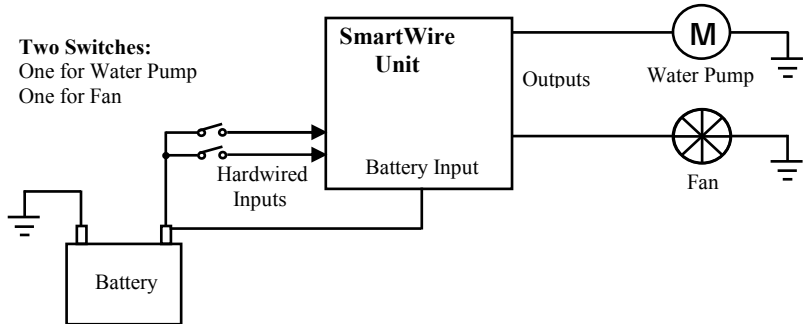

Option #1 SmartWire installation

- One switch for both devices.
- Switch on, both devices on.
- SmartWire can toggle both devices on/off at set timer intervals
- Monitors both devices for:
 - Current (Amps)
 - Voltage
 - Status (on/off/blown fuse)

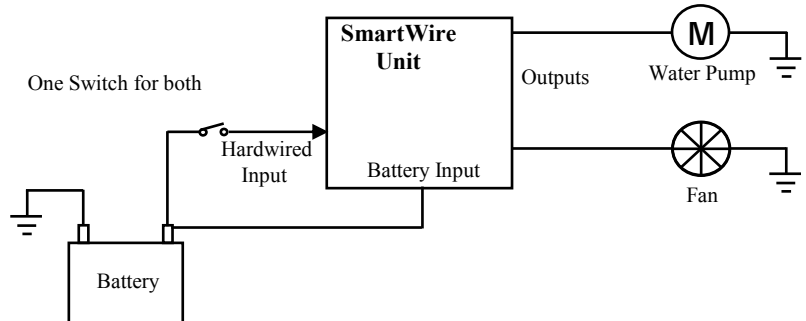

Option #2 SmartWire installation

- One switch for manual override, V-Net sensor used for trigger
- Switch on, devices on regardless of temperature input.
- Switch off; SmartWire is programmed to automatically turn both devices on at user set temperatures based on V-Net input. SmartWire can toggle both devices on/off at set timer intervals
- Sensor failure, SmartWire can be programmed to force devices **on** should temperature go outside sensor readable scale regardless of switch position.
- Monitors both outputs/devices for:
 - Current (Amps)
 - Voltage
 - Status (on/off/blown fuse)

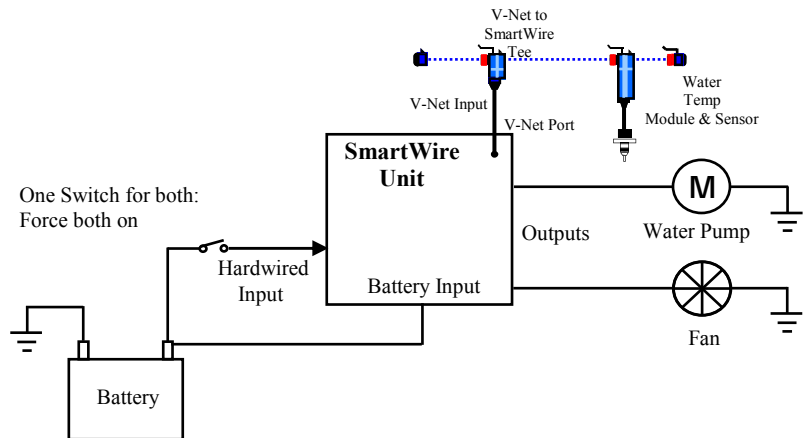

Racepak

30402 Esperanza, Rancho Santa Margarita, CA 92688 USA
 Phone: 949-709-5555 Fax: 949-709-5556 www.racepak.com

Option #3 SmartWire installation in conjunction with Racepak V-Net data recorder

When connected to a V-Net data recorder, each sensor can be utilized for on/off function or logic control of each device connected to the SmartWire. Optional Racepak Switch Panels or Switch Modules can also be added and connected to the SmartWire for more inputs and/or control.

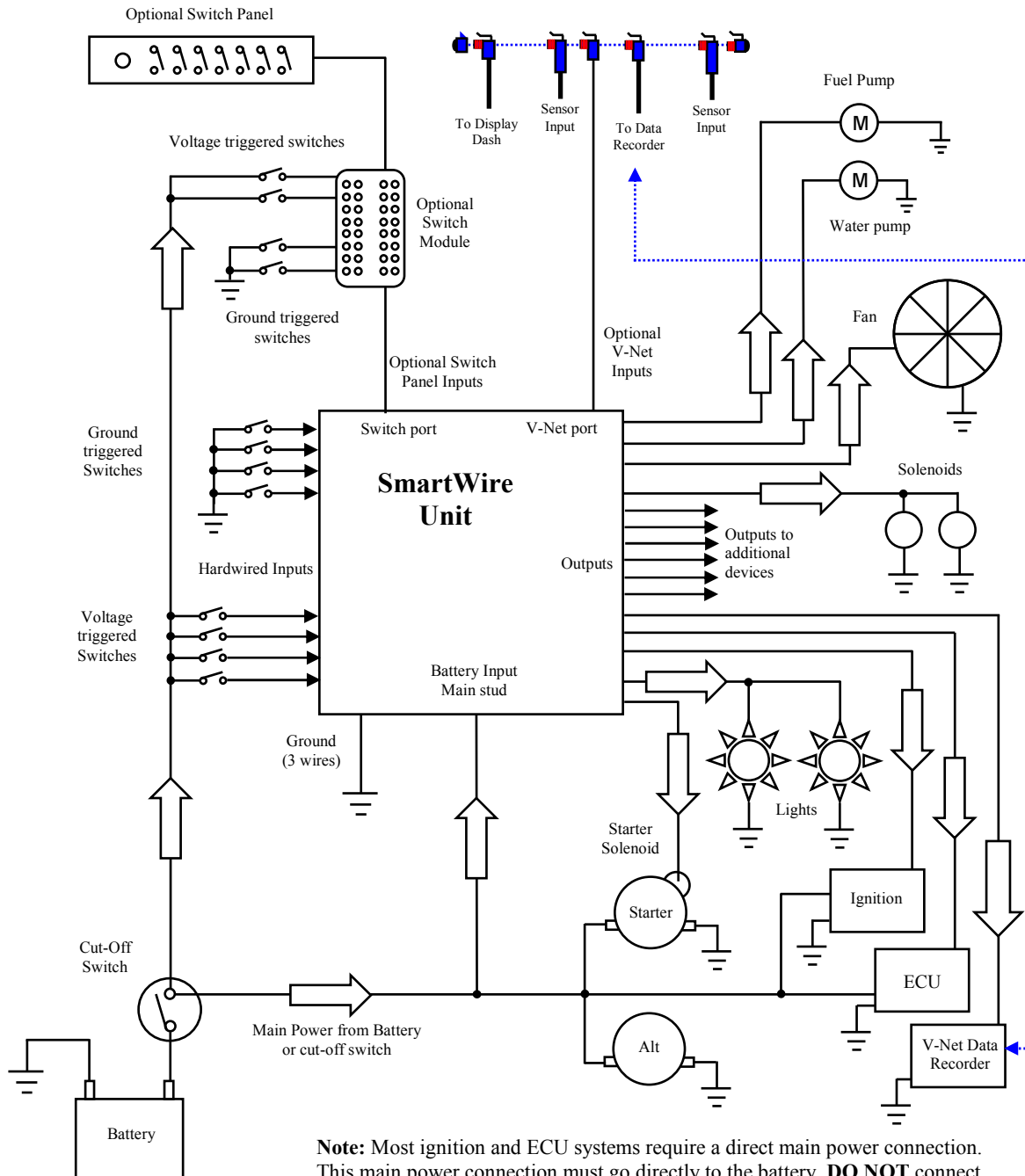

Note: Most ignition and ECU systems require a direct main power connection. This main power connection must go directly to the battery. **DO NOT** connect the main power wire from these devices to the SmartWire outputs. Each of these devices will also have a small wire requiring an ignition switched power source. This small wire will connect to an output from the SmartWire.

SmartWire External Features

Two 23 Pin Amp connectors for:

- Thirty Outputs: Output to all vehicle devices requiring switched power
- Twelve Hardwired Direct Inputs: Inputs from switches and buttons
- Three SmartWire Ground: Main grounding for SmartWire unit
- One Shutdown Pin: Main power shutdown for SmartWire when grounded

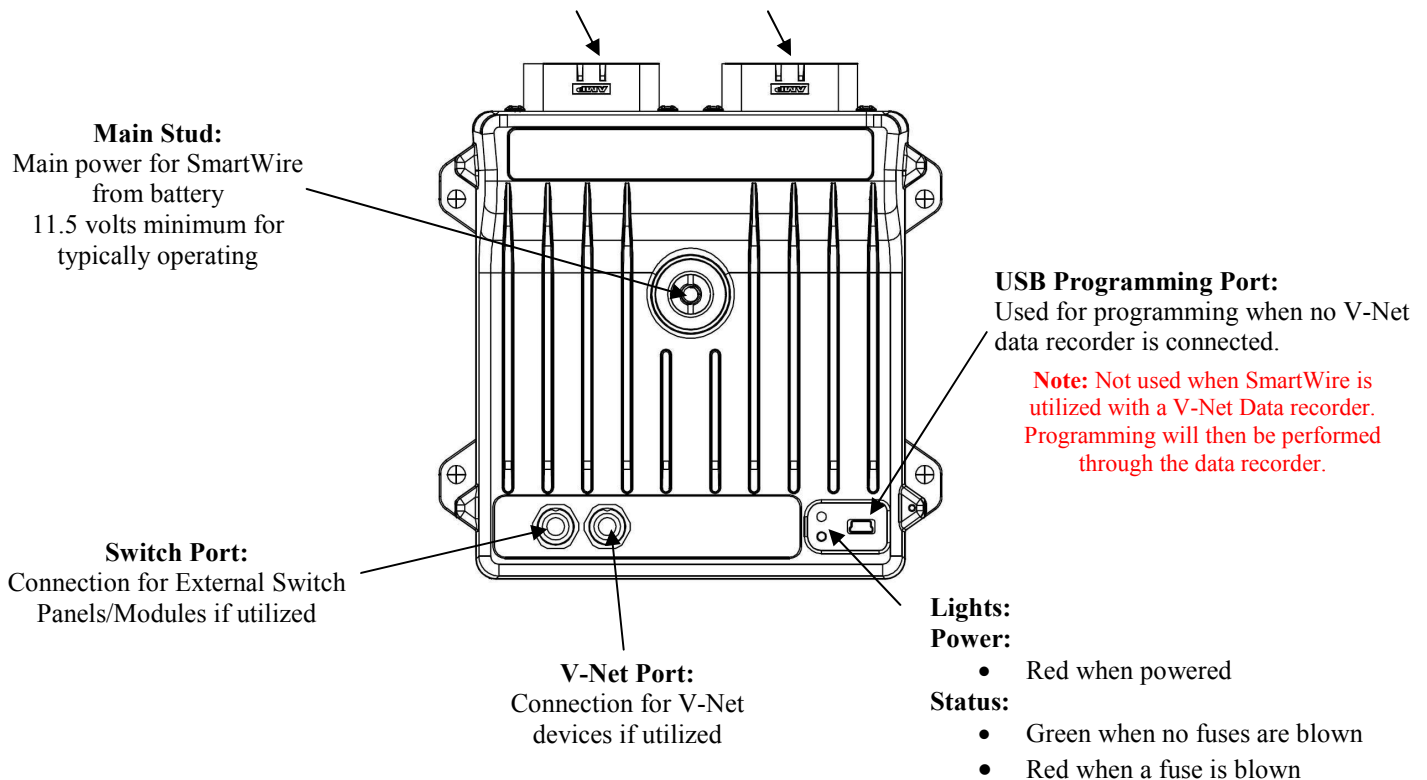

Racepak

30402 Esperanza, Rancho Santa Margarita, CA 92688 USA
Phone: 949-709-5555 Fax: 949-709-5556 www.racepak.com

SmartWire Mounting

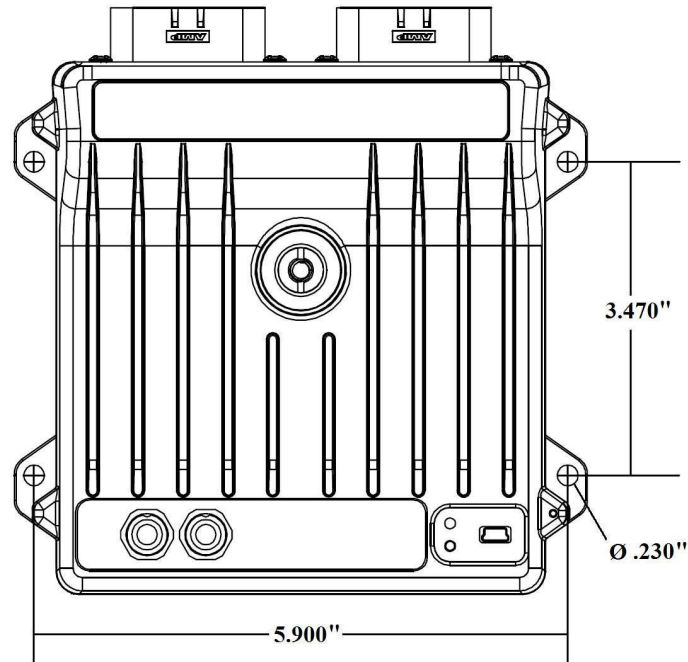

The most important consideration, when mounting the SmartWire unit, is selecting the proper location. Several issues were covered in the previous section regarding installation. The following additional requirements should be taken into consideration.

1. Choose a mounting location that allows easy access to the USB port and the main 23 pin wire connectors.
2. Avoid mounting the SmartWire directly on or near a heat source, on the floor near the exhaust system, under the hood, etc.
3. Avoid mounting the SmartWire unit directly near the ignition box or any other electronic ignition components. Maintain a minimum of 18 inches of clearance between the SmartWire unit and any of these type items.
4. Choose a location that will allow easy routing of the interconnecting cables. Care must be taken to prevent the cables from interfering with the driver, safe operation of the vehicle, any maintenance, or repair services.
5. Temperature. The internal temperature should be checked to ensure no more than a 50 °F difference between ambient and internal. Internal SmartWire unit temperature can be viewed in the DatalinkII software while connected to the PC.

Mounting hole size: .1875" / .476 cm. The mount feet locations and correct positioning are shown above.

SmartWire Connections

Before terminating the 23 pin connectors, it is highly recommended that the DatalinkII software be installed and the SmartWire outputs are programmed. This will dictate which output connections will be utilized. Do not insert every socket in the connector unless a device will be connected. See SmartWire Programming Manual for details.

Power Supply: Main Stud

Power is supplied to the SmartWire unit using the main Battery + ¼” stud on the unit. The main power stud will be connected direct to the positive terminal on the battery. In situations where a main power cut-off switch is required, the SmartWire main power should connect to switched side of the cut-off switch to ensure power is removed from battery as per the rules.

Wire gauge to be based on maximum wire temperature and the accepted voltage drop for the application. (*See wiring section*)



NOTE: The SmartWire is designed as a switching control unit. The SmartWire unit is not designed as a main power feed for certain high current items. These items include, but not limited to ignition and electronic fuel systems. Refer to device manual for power requirements.



If the manufacturer recommends the main power be connected to the main direct battery power, follow the manufacturer’s requirement and DO NOT connect items through the SmartWire.

Ground Supply: Pin A19, A20, B19

A grounding path is supplied by the SmartWire unit using three individual terminals on the two main connectors. Pins A19, A20, and B19 must be securely connected to the battery negative terminal or to a secure chassis ground. Since each switched device connected to the SmartWire outputs will have its own ground path, the three connections will carry a low amount of current. Each ground requires a minimum 18 gauge wire.

DO NOT connect the three wires together and run a single wire to ground. Three separate, correctly sized wires need to be connected to the battery negative post.

Shutdown: Pin B20

A master shutdown is incorporated into the SmartWire unit, which enables complete power cut off to both the main unit and all outputs. When pin B20 is grounded, all power between the main stud and the SmartWire will be completely terminated/disabled. When this function is enabled, the SmartWire unit will draw less than 1 Milliamp of current. The SmartWire unit retains all program settings during this off period. Once ground is removed from this pin, the unit will resume normal operation.

Racepak

30402 Esperanza, Rancho Santa Margarita, CA 92688 USA
Phone: 949-709-5555 Fax: 949-709-5556 www.racepak.com

Hardwired Direct Inputs

The SmartWire unit contains 12 pins for direct switch inputs. Using the DatalinkII software, each input can be programmed to accept a voltage triggered input or a ground triggered input.

The trigger levels are:

- Ground Trigger: Input is triggered/active when the pin/connection is grounded. (From open to a ground or from a voltage to ground)
- Voltage Trigger: Input is triggered/active when the pin/connection has voltage* applied. (From open to voltage or from a ground to voltage), minimum 4 volts required.

* Minimum trigger voltage requirement: 4 Volts. Voltages higher than 19.5 are not recommended.

Wire size: 20 gauge wire, as switch inputs do not require a large amount of current.

Outputs

The SmartWire unit contains a total of 30 pins for output switching.

- 8 channels at 20 amp maximum
- 22 channels at 10 amp maximum

Each output is switched to battery power when its channel parameters are activated. All channels have programmable logic control, current limiting and overload protection settings.

Output channels can be wired in parallel to increase current but must be of same type:

2 x 20Amp = 40 Amp (two 20Amp outputs to create a single 40Amp output)

or

2 x 10 Amp = 20 Amp (two 10Amp outputs to create a single 20Amp output)

When output channels are wired in parallel, special channel logic is required.

 **DO NOT wire channels of different output together (i.e. do not connect a 20Amp with a 10Amp output).**

 **When connecting to devices, if the manufacturer of the device recommends the main power be connected to the main direct battery power, follow the manufacturer's requirement and DO NOT connect items through the SmartWire.**

SmartWire 23 Pin Connector Pinout

Pin numbers are located on wire connector.
SmartWire unit is labeled A or B above each port.

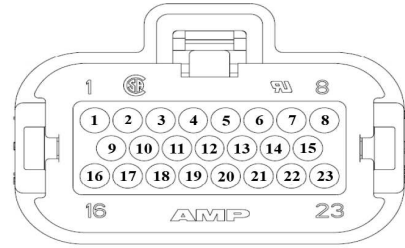

Table 1 - Input Pins (hardwired direct)

"A" Connector		"B" Connector	
PIN#	Input Channel#	PIN#	Input Channel#
10	1	10	7
11	3	11	8
12	4	12	9
13	5	13	10
14	6	14	11
18	2	18	12

Defaulted Channel name in software shown below

SM1 Inputs

Table 2 - 20 Amp Output pins

"A" Connector			"B" Connector		
PIN#	Output Channel#	AMP	PIN#	Output Channel#	AMP
1	4	20	1	5	20
3	1	20	3	7	20
6	2	20	6	8	20
8	3	20	8	6	20

Defaulted Channel names in software shown below

SM1 Output #1	SM1 Output #5
SM1 Output #2	SM1 Output #6
SM1 Output #3	SM1 Output #7
SM1 Output #4	SM1 Output #8

Table 3 - 10 Amp Output pins

"A" Connector			"B" Connector		
PIN#	Output Channel#	AMP	PIN#	Output Channel#	AMP
2	10	10	2	22	10
4	11	10	4	28	10
5	13	10	5	25	10
7	15	10	7	26	10
9	12	10	9	21	10
15	20	10	15	27	10
16	9	10	16	18	10
17	19	10	17	24	10
21	14	10	21	23	10
22	16	10	22	29	10
23	17	10	23	30	10

Defaulted Channel name in software shown below

SM1 Output #9	SM1 Output #20
SM1 Output #10	SM1 Output #21
SM1 Output #11	SM1 Output #22
SM1 Output #12	SM1 Output #23
SM1 Output #13	SM1 Output #24
SM1 Output #14	SM1 Output #25
SM1 Output #15	SM1 Output #26
SM1 Output #16	SM1 Output #27
SM1 Output #17	SM1 Output #28
SM1 Output #18	SM1 Output #29
SM1 Output #19	SM1 Output #30

Table 4 - Other

"A" Connector		"B" Connector	
PIN#	Function	PIN#	Function
19	Ground	19	Ground
20	Ground	20	Shutdown

Racepak

30402 Esperanza, Rancho Santa Margarita, CA 92688 USA
Phone: 949-709-5555 Fax: 949-709-5556 www.racepak.com

SmartWire Wiring

The SmartWire unit is equipped with socket terminals and main connectors for the end user to assemble the harness connection to the main unit. Typical harness wire gauge will be 16-24 AWG.

When wiring the SmartWire unit, utilize the proper wire type for the application. Wire is rated both on current and temperature. Verify both the correct wire size and casings/insulation, based on current draw and location of wiring, in the vehicle.

Below are common wire types:

- GPT wire (SAE J1128-GPT)
- SXL (SAE J1128-SXL)
- GXL (SAE J1128-GXL)
- TXL (SAE J1128-TXL)
- ETFE - (TEFZEL) MIL22579
- PTFE - (TEFLON) MIL22579

Teflon and/or Tefzel are the preferred wire type for automotive application. Higher quality Teflon or Tefzel wire utilize silver plated conductors.

General wire selection guidelines:

- The smaller the wire diameter, the greater the resistance and thus lower current capability over a given length. In most cases, larger gauge wire can be utilized. When in doubt, as the load increases, so should the wire gauge (larger wire).
- Other factors can affect the load capacity of wire, besides length
 - Environment Temperature
 - Duration of load
 - Stranded vs. Solid wire
 - Wire plating.
- Higher capacity wiring utilizes silver plating with a higher strand count and as such will typically have a higher capacity, when compared to copper stranded wires.

The actual maximum current capacity rating of a particular wire size is affected by the operating temperature of the wire. Wire gauge should be chosen according to the wire temperature limit and acceptable voltage drop. In most instances, a 3% voltage drop is the recommended limit. The temperature of the wire is affected by the ambient temperature, air circulation, current, wire gauge, the temperature of any surrounding wires and the covering sheath. Wire gauge is based on maximum wire temperature and the accepted voltage drop for the application.

Racepak

30402 Esperanza, Rancho Santa Margarita, CA 92688 USA
Phone: 949-709-5555 Fax: 949-709-5556 www.racepak.com

As a general rule, the following charts can be utilized. Shown values are the maximum recommended length in feet, for each wire size at the shown current (Amps). When planning for both, power and ground, make sure the wire will support the total calculated length of both runs.

Max run in feet at 12 volts with a max 3% voltage drop @ 25C (77F)

AWG	Current (Amperage)					
	3	5	7.5	10	15	20
22	7.4	4.5	3.0	2.2	1.5	1.1
20	11.8	7.1	4.7	3.5	2.4	1.8
18	18.8	11.3	7.5	5.6	3.8	2.8
16	29.9	17.9	12.0	9.0	6.0	4.5
14	47.5	28.5	19.0	14.3	9.5	7.1
12	75.6	45.3	30.2	22.7	15.1	11.3
10	120.1	72.1	48.1	36.0	24.0	18.0

Max run in feet at 12 volts with a max 3% voltage drop @ 100C (212F)

AWG	Current (Amperage)					
	3	5	7.5	10	15	20
22	5.1	3.1	2.1	1.5	1.0	0.8
20	8.2	4.9	3.3	2.4	1.6	1.2
18	12.9	7.8	5.2	3.9	2.6	1.9
16	20.6	12.4	8.2	6.2	4.1	3.1
14	32.8	19.7	13.1	9.8	6.6	4.9
12	52.1	31.3	20.8	15.6	10.4	7.8
10	82.9	49.7	33.1	24.9	16.6	12.4

Datalink Wire Sizer App. (shown only in standalone applications)

To aid in selecting the correct wire gauge, the SmartWire configuration file contains a wire sizer app. If you haven't done so yet, install the Datalink software. The wire sizer app is located in the Run Log area. This can be found by opening the Datalink program → Selecting → File → Open Car Configuration → SmartWire → Click OK → View → Organize Panes → Locate SmartWire Plug Wire Sizer across the bottom of the window.

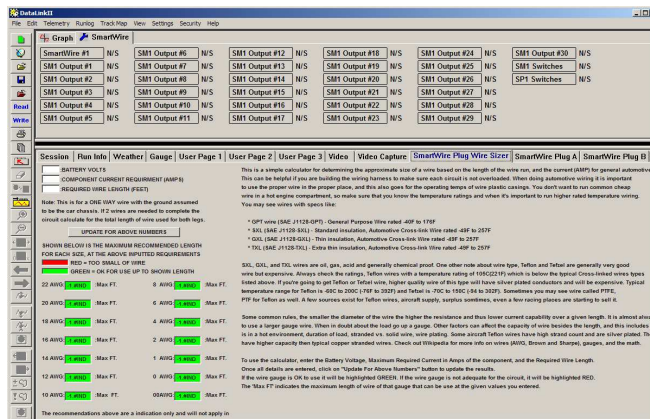

Connector Requirements: 23 Pin Amp Connectors

Wire

Wire Selection

The socket will accept wire ranging in size from 20 to 16 AWG and 1.5 mm. Wire insulation diameter should be a minimum 1.7 mm, maximum 2.7mm. Smaller wire gauge can be used but will require careful preparation to correctly fit during the crimping process.

Wire Preparation

Wire should be stripped approximately .2” (5.1mm). Care should be taken during the stripping process to ensure the wire (conductor) is not nicked, scraped, or cut.

Tooling

The appropriate crimp pliers must be used to ensure a proper secure crimp designed for the 23 pin AMP connector.

Below are the part numbers for the correct crimper tool:

Racepak:	# 800-XP-CRIMPAMP	Racepak AMP Automotive Crimp Tool
Tyco:	# 58529-1	PRO-CRIMPER III Hand Tool with Die Assembly #58529-2

Extra SmartWire connector and pins are available for purchase.

Racepak:	# 810-CN-AMP23	(1 connector and 25 sockets)
----------	----------------	------------------------------



The ends of the insulation barrel shall be wrapped around the wire insulation, leaving no sharp points to damage the rubber wire seal.

Socket Crimping

The sockets should be crimped and then inspected for conditions shown below:

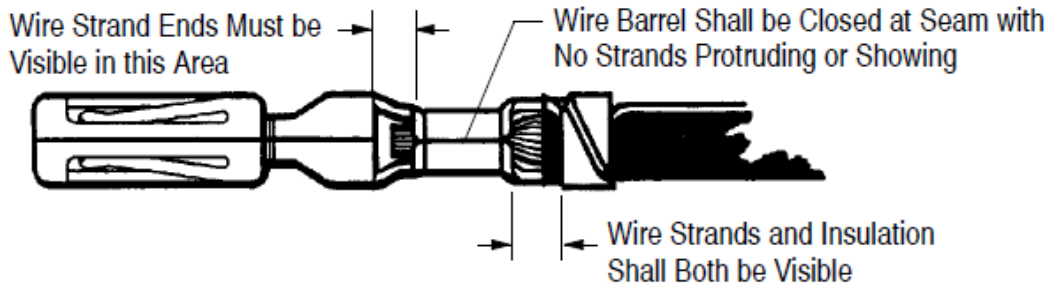

Proper Crimping on wire insulation required for socket to insert correctly.

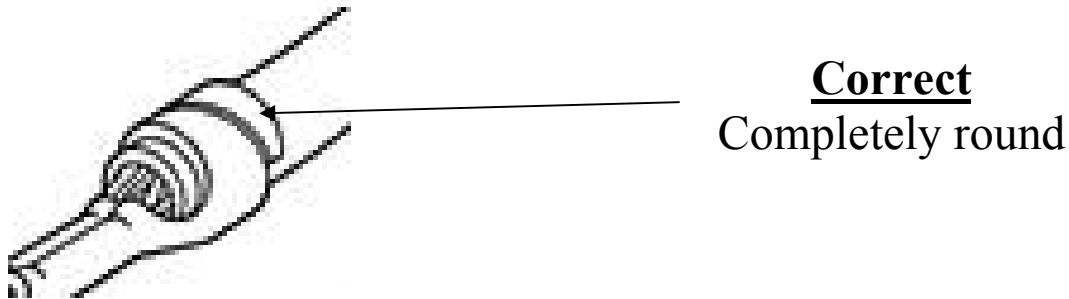
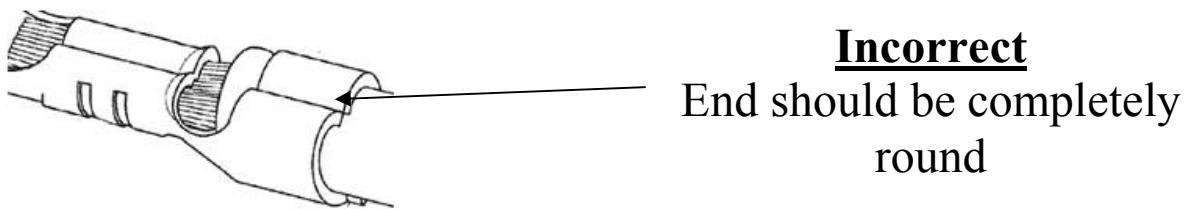

NOTE: Wire stripping tool jaws may leave corrugated indentations on the surface of the wire insulation. This is especially severe with cross-linked polyethylene (high temperature) insulation. If these indentations occur at the location of the wire seal, leakage may result. Insulation surface within 26 mm from the tip of the contact must be smooth and free of residual indentations.



Care should be taken to ensure that the wire insulation is not cut or broken during the crimping operation, and to ensure that the insulation is not crimped into the wire barrel.



The ends of the insulation barrel shall be wrapped around the wire insulation, leaving no sharp points to damage the rubber wire seal.

Racepak

30402 Esperanza, Rancho Santa Margarita, CA 92688 USA
Phone: 949-709-5555 Fax: 949-709-5556 www.racepak.com

Connector Assembly

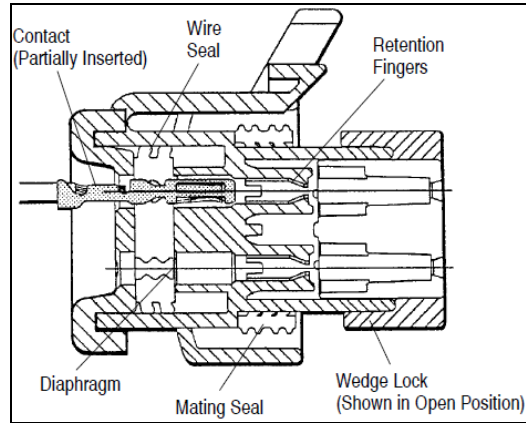
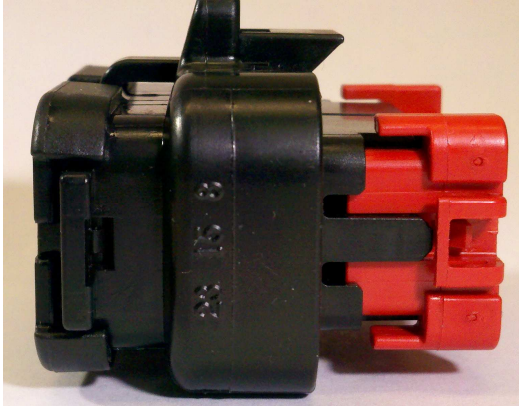

1. Verify the wedge lock is in the open position (shown above).
2. Insert socket and push in straight into the selected circuit cavity as far as it will go (shown below)
3. Gently pull back on socket/wire to be sure the retention fingers are holding the socket

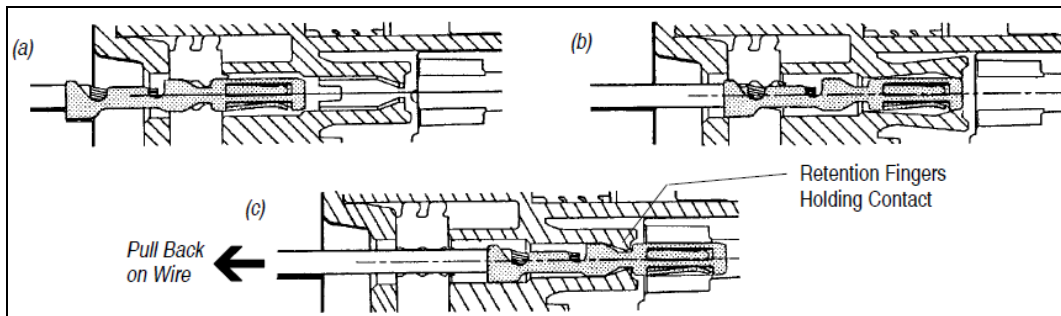

4. After all wire/sockets have been inserted, the wedge lock must be closed to its locked position.
5. Release the locking latches by squeezing them inward (shown below)

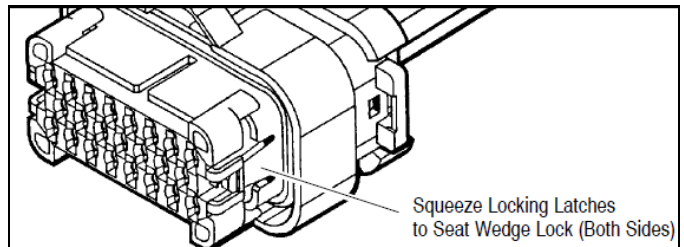

6. Slide the wedge lock into the housing until it is flush with the housing (shown below)

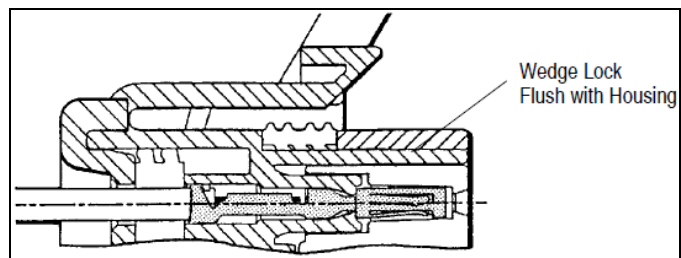
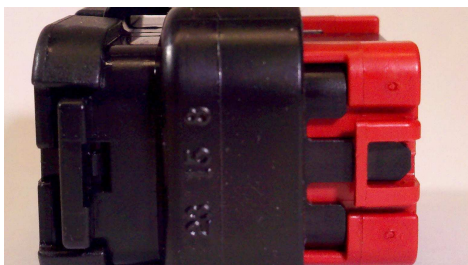

Racepak

30402 Esperanza, Rancho Santa Margarita, CA 92688 USA
Phone: 949-709-5555 Fax: 949-709-5556 www.racepak.com

Connector Disassembly

1. Do not damage the connector during disassembly. As shown below, insert small screw driver between mating seal and one of the red wedge lock tabs.

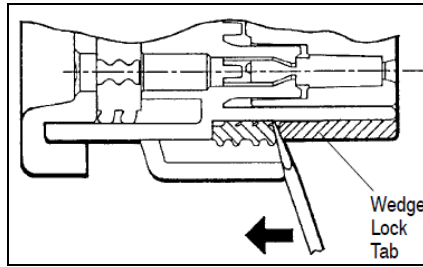
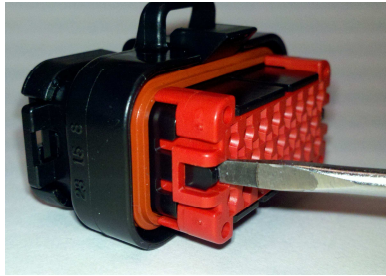

2. Gently pry open the wedge lock to the open position.
3. While rotating the wire back and forth (at least a 1/4 turn in each direction), gently pull the wire until the wire/socket is removed.

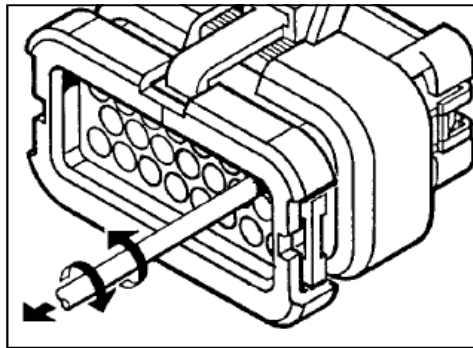

NOTE: The wedge lock should never be removed from the housing for insertion or removal of the sockets.

Seal Plug

All circuits are sealed by a diaphragm in the rubber wire seal. During plug connector assembly, the diaphragm is pierced as the contact passes through it. Unused circuit cavities, unless accidentally perforated, will remain sealed. A seal plug is available and designed to keep out contaminant if the diaphragm is pierced.

To install seal plug, insert seal plug large end first, into circuit cavity as far as it will go. An insertion tool is not required. (See below)

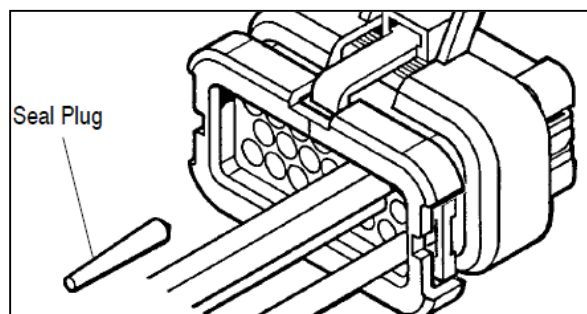

Racepak

30402 Esperanza, Rancho Santa Margarita, CA 92688 USA
Phone: 949-709-5555 Fax: 949-709-5556 www.racepak.com

External Devices

Starter Solenoid

The starter solenoid in most cases will require a 20 Amp output. In some cases, the starter solenoid can draw greater than 20 Amps, especially during extended cranking periods. Due to the SmartWire design, the output current can exceed the current fuse limitation for short periods of time (typically <4 seconds). Should the current exceed the fuse setting for extended periods (i.e. more than 5-10 seconds) the output will be deactivated. A re-try setting is available for both time and number of retries (see programming manual for further details).

Ignition

Most ignition systems have two power inputs. One is a main power feed for the system (normally accompanied with a main ground feed) and the other is a switched power designed for an ignition switched power source. The SmartWire unit is not designed as a main power feed for the ignition unit. The SmartWire is designed as a switching control unit, the main power and ground wires from the ignition system should connect directly to the battery and ground.

ECU or EFI

Most engine management or electronic fuel injection systems have two power inputs. One is a main power feed for the system (normally accompanied with a main ground feed) and the other is a switched power designed for an ignition switched power source. The SmartWire unit is not designed as a main power feed for the fuel injection system. Since the SmartWire is designed as a switching control unit, the main power and ground wires from the ignition system should connect directly to the battery and ground.

Solenoids

When connecting the SmartWire to solenoids for items such as trans-brake, nitrous, water injection, etc., insure the current draw of the solenoid does not exceed the maximum rating for the output.



When connecting to devices, if the manufacturer of the device recommends the main power be connected to the main direct battery power, follow the manufacturer's requirement and DO NOT connect items through the SmartWire.

Windshield Wipers

The SmartWire unit can operate windshield wiper motors within the following guidelines: Most wiper motors have multiple speeds, slow and fast. The SmartWire **cannot** be connected to both fast and slow terminals at the same time due to voltage being generated by the internal windings of the wiper motor during operation.

NOTE: The following methods are for ‘common-ground’ wiper assemblies. For ‘common-positive’ wiper assemblies, the methods would need to be adjusted accordingly.

1. Utilizing the factory OEM controller

The below method utilizes the vehicles factory wiper controller. The SmartWire is used to supply power only to the factory controller. The controller handles all wiper motor functions such as the intermittent and motor braking.

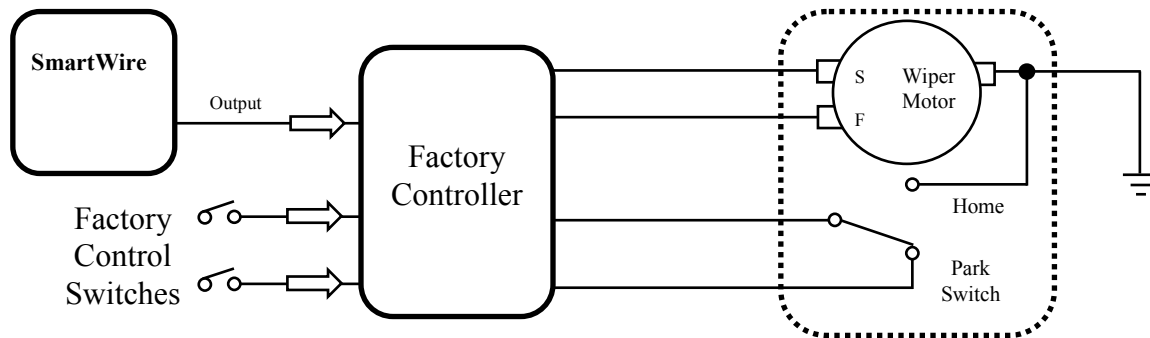

2. Utilizing two switches, one output

Below method uses two external switches.

- One switch for supplying power to the wiper motor,
- One switch used to toggle the wiper speed.

The SmartWire supplies only the power. The braking function for the wiper motor is handled between the use of the power switch and the internal park switch. Intermittent operation cannot be done since a single power supply is used. Removal of this power source (instead of using the on/off switch) will cause the wipers not to park in the correct position.

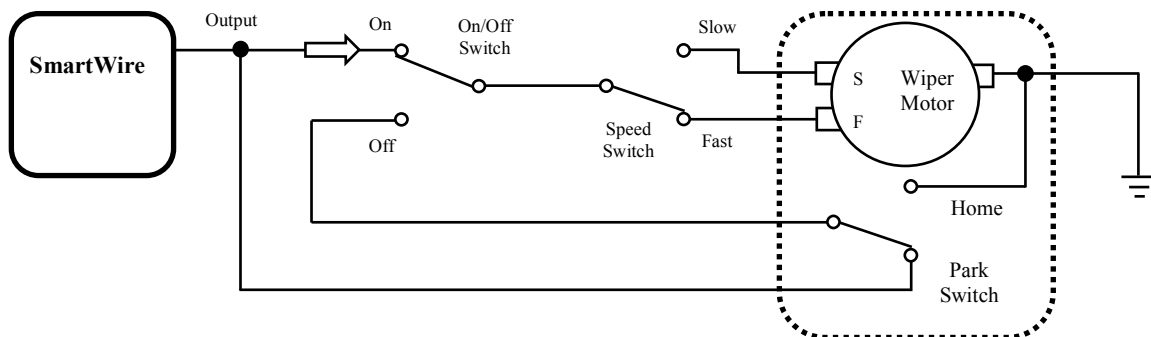

Racepak

30402 Esperanza, Rancho Santa Margarita, CA 92688 USA
 Phone: 949-709-5555 Fax: 949-709-5556 www.racepak.com

3. Utilizing a relay, two outputs

Below method uses a single external switch and a relay. This method provides the ability for intermittent operation.

Two SmartWire outputs are required for this method.

- One output controls a relay for intermittent operation
- One output supplies power through the same relay for the main wiper motor power

The braking function for the wiper motor is handled between the use of the power relay and the internal park switch. Intermittent function is controlled by turning the relay off momentarily. The delay time setting can be determined by the end user and programmed on the output controlling the relay. The other output is the main power feed for the motor. When the relay is energized, the power is fed to the motor via direct or through the speed switch. When the relay is de-energized, power is fed through the park switch to the relay and then to the motor either direct or through the speed switch. When the Park switch is on, power will continue to the Relay. When the park switch is off, power is cutoff to the motor.

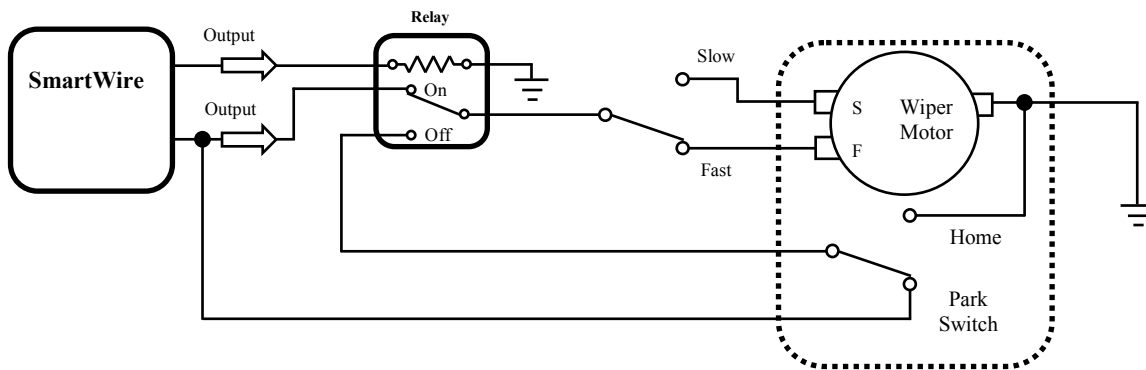

4. Direct (Only available on output channel 19), one output, one input

When a direct method is required, a reference channel must be selected in order to Park the wipers in the correct location. Output channel 19 (pin A17) has this ability when its Output Function is configured for Windshield Wiper. This method is only available on output channel 19 (pin A17).

When set to this, a Wiper Brake Control Channel becomes selectable. This is the channel that will be referenced for the Park position. Any input can be used, although we will describe the use of a hardwired direct input. Connect the Park switch as shown below. The input channel settings need to be set appropriately (ground triggered as shown below). When the Park switch is in the home position, the input channel will be grounded. This will make the input channel true, causing the wiper motor to stop. Other inputs channels can be selected for use. The input can be either a hardwired direct input or a V-Net sensor input (not requiring the use of the hardwired direct input).

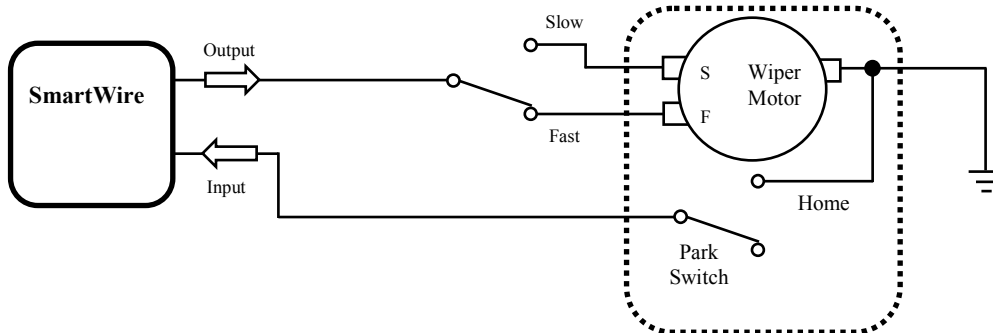

Racepak

30402 Esperanza, Rancho Santa Margarita, CA 92688 USA
Phone: 949-709-5555 Fax: 949-709-5556 www.racepak.com

Channel/Pin Chart

Sorted by Pin Number

"A" Connector				"B" Connector			
PIN	CH#	Type	AMP	PIN	CH#	Type	AMP
A1	4	Output	20	B1	5	Output	20
A2	10	Output	10	B2	22	Output	10
A3	1	Output	20	B3	7	Output	20
A4	11	Output	10	B4	28	Output	10
A5	13	Output	10	B5	25	Output	10
A6	2	Output	20	B6	8	Output	20
A7	15	Output	10	B7	26	Output	10
A8	3	Output	20	B8	6	Output	20
A9	12	Output	10	B9	21	Output	10
A10	1	Input		B10	7	Input	
A11	3	Input		B11	8	Input	
A12	4	Input		B12	9	Input	
A13	5	Input		B13	10	Input	
A14	6	Input		B14	11	Input	
A15	20	Output	10	B15	27	Output	10
A16	9	Output	10	B16	18	Output	10
A17	19	Output	10	B17	24	Output	10
A18	2	Input		B18	12	Input	
A19	NA	ground		B19	NA	Ground	
A20	NA	ground		*B20	On/Off	Shutdown*	
A21	14	Output	10	B21	23	Output	10
A22	16	Output	10	B22	29	Output	10
A23	17	Output	10	B23	30	Output	10

*Grounding the Shutdown pin will turn off power to the SmartWire unit and all outputs.

Sorted by Channel Number

"A" Connector				"B" Connector			
CH#	Type	PIN	AMP	CH#	Type	PIN	AMP
1	Output	A3	20	5	Output	B1	20
1	Input	A10		6	Output	B8	20
2	Output	A6	20	7	Output	B3	20
2	Input	A18		7	Input	B10	
3	Output	A8	20	8	Output	B6	20
3	Input	A11		8	Input	B11	
4	Output	A1	20	9	Input	B12	
4	Input	A12		10	Input	B13	
5	Input	A13		11	Input	B14	
6	Input	A14		12	Input	B18	
9	Output	A16	10	18	Output	B16	10
10	Output	A2	10	21	Output	B9	10
11	Output	A4	10	22	Output	B2	10
12	Output	A9	10	23	Output	B21	10
13	Output	A5	10	24	Output	B17	10
14	Output	A21	10	25	Output	B5	10
15	Output	A7	10	26	Output	B7	10
16	Output	A22	10	27	Output	B15	10
17	Output	A23	10	28	Output	B4	10
19	Output	A17	10	29	Output	B22	10
20	Output	A15	10	30	Output	B23	10
NA	ground	A19		NA	Ground	B19	
NA	ground	A20		On/Off	Shutdown*	*B20	

*Grounding the Shutdown pin will turn off power to the SmartWire unit and all outputs.

Racepak

30402 Esperanza, Rancho Santa Margarita, CA 92688 USA
 Phone: 949-709-5555 Fax: 949-709-5556 www.racepak.com

POWER
STATUS

V-NET

BATTE
*



30402 Esperanza, Rancho Santa Margarita, California 92688

949-709-5555

www.RACEPAK.com